

DOCUMENT RESUME

ED 212 804

CE 031 198

AUTHOR Newton, Lawrence R.
TITLE Shop Math for the Metal Trades. Combination Welder Apprentice, Machinist Helper, Precision Metal Finisher, Sheet Metal Worker Apprentice. A Report on Metal Trades Industry Certified, Single-Concept, Mathematical Learning Projects to Eliminate Student Math Fears.

INSTITUTION Weber State Coll., Ogden, Utah.
SPONS AGENCY Department of Education, Washington, D.C.; Utah State Office of Education, Salt Lake City. Adult Education Unit.

PUB DATE Jul 81
NOTE 415p.
AVAILABLE FROM Utah State Office of Education, Adult Education Unit, 250 East 500 South, Salt Lake City, UT 84111 (Report: \$20.00 each; Machinist Helper and Precision Metal Finisher Handouts: \$20.00 each).

EDRS PRICE MF01/PC17 Plus Postage.
DESCRIPTORS Course Content; Job Skills; Learning Activities; Learning Modules; Machinists; *Mathematical Applications; *Mathematics Anxiety; Mathematics Curriculum; *Mathematics Instruction; *Metal Working; Postsecondary Education; Pretests Posttests; Sheet Metal Work; Shop Curriculum; Skilled Occupations; *Student Projects; *Technical Education; Two Year Colleges; Vocational Education; Welding
IDENTIFIERS Utah

ABSTRACT

This project (1) identifies basic and functional mathematics skills (shop mathematics skills), (2) provides pretests on these functional mathematics skills, and (3) provides student learning projects (project sheets) that prepare metal trades students to read, understand, and apply mathematics and measuring skills that meet entry-level job requirements as defined by the metal trades industry for the following occupations: combination welder apprentice, machinist helper, precision metal finisher, and sheet metal worker apprentice. Each project sheet contains three elements: (1) identification of information, training conditions, training plan, and training goal; (2) review of basic mathematics principles; and (3) shop problems. The project sheets are included in the overall training outline, called the Student Training Record, for each of the occupations listed above. Each Record lists the milestones (major training subjects) and projects (learning activities) the student is to accomplish. Along with teaching the mathematics skills needed for the four occupations, the guide is also intended to reduce the students' mathematics anxiety. Input for the project was obtained from metal trades employers, instructors, and students throughout Northern Utah. (Author/KC)

ED212804

SHOP MATH FOR THE METAL TRADES ©

Combination Welder Apprentice
Machinist Helper
Precision Metal Finisher
Sheet Metal Worker Apprentice

A REPORT ON

Metal Trades Industry Certified, Single-Concept, Mathematical
Learning Projects to Eliminate Student Math Fears

by

Lawrence R. Newton
Curriculum Development Coordinator
Weber State College Skills Center

Weber State College Skills Center
1100 Washington Blvd.
Ogden, Utah

U.S. DEPARTMENT OF EDUCATION
NATIONAL INSTITUTE OF EDUCATION
EDUCATIONAL RESOURCES INFORMATION
CENTER (ERIC)

✓ This document has been reproduced as
received from the person or organization
originating it
Minor changes have been made to improve
reproduction quality

• Points of view or opinions stated in this docu-
ment do not necessarily represent official NIE
position or policy

July 1981

2

"PERMISSION TO REPRODUCE THIS
MATERIAL HAS BEEN GRANTED BY

Brent Gubler

TO THE EDUCATIONAL RESOURCES
INFORMATION CENTER (ERIC)."

8611098

FUNDING INFORMATION

Project Title: Shop Math for the Metal Trades: Combination Welder Apprentice, Machinist Helper, Precision Metal Finisher, Sheet Metal Worker Apprentice

Contract Number:

Educational Act Under Which Funds were Administered: Section 310 of Adult Education Act (Public Law 93-380)

Source of Contract: Utah State Office of Education
Adult Education Unit
250 East 500 South
Salt Lake City, Utah 84111

Project Officer: C. Brent Wallis, Director
Weber State College Skills Center
1100 Washington Blvd.
Ogden, Utah 84404

Project Director: Michael J. Bouwhuis, Special Projects Coordinator
Weber State College Skills Center

Project Coordinator: Lawrence R. Newton, Curriculum Development Coordinator
Weber State College Skills Center

Disclaimer: The activity which is the subject of this report was supported in whole or in part by the U.S. Office of Education and the Utah State Office of Education. However, the opinions expressed herein do not necessarily reflect the position or policy of the United States Office of Education or the Utah State Office of Education, and no official endorsement by these offices should be inferred.

Discrimination Prohibited: The program assures that "No person in the United States shall, on the grounds of race, color, sex, handicap, age or national origin, be excluded from participation in, be denied the benefits of, or be subjected to discrimination under any program or activity receiving Federal financial assistance."

Amount of Contract: \$15,000

PROJECT PERSONNEL

Lawrence R. Newton, Project Coordinator, is Curriculum Development Coordinator at Weber State College Skills Center, Ogden, Utah. He has worked as a Video Training Specialist with Lockheed Missiles and Space Co., Sunnyvale, California, writing and producing video training programs and written materials for Polaris, Posiedon and Trident missile systems. He has also worked in commercial radio and television as announcer, engineer, production technician, and editor. Mr. Newton received his B.A. from Humboldt State University, Arcata, California, and his M.A. in Education from San Jose State University, San Jose, California.

Jack Cline, Project Math Consultant, is a Curriculum Writer and Mathematics Instructor at Weber State College Skills Center, Ogden, Utah. He has taught math at the secondary and post-secondary levels and has tutored extensively in the technical and engineering fields. Mr. Cline is a retired Air Force Colonel with thirty-five years service. His most recent assignments included duties as Division Chief of Engineering Services at Hill A.F.B., Utah and Division Chief of Engineering and Maintenance at the Pentagon, Washington, D.C. He is the author of numerous technical documents on various Aerospace Weapon Systems. He received his B.S. at Oregon State College, Corvallis, Oregon; an M.S. degree in Aerospace Engineering at the University of Colorado, Boulder; and an M.S. degree in Applied Mathematics at Sacramento State College, Sacramento, California.

Barbara A. Smith, Project Writer, is a Curriculum Writer at Weber State College Skills Center, Ogden, Utah. She has taught in several elementary schools and has helped teach in-service classes in Ethnic Heritage and Colorado History. She is the author of a field trip guide, Historic Denver for Kids, University of Denver, 1978. She wrote some of the activities for Teaching About Energy: 33 Activities, University of Denver, 1979. She also wrote test items for a national social studies assessment for the National Assessment of Educational Progress of the Education Commission of the States, 1979. Ms. Smith received her B.A. and M.A. degrees at the University of Northern Colorado at Greeley.

Alice Taylor, Project Illustrator, is a Curriculum Writer, Graphic Artist and Photographer for Weber State College Skills Center, Ogden, Utah. She was Display Artist for Marshall Field, Chicago; Sears Roebuck; and the Utah State Fair Association. She has been an illustrator for Meridian Publishing Co., Carlsen Printing, and Permaloy Corporation. She has taught at Weber State College, Eccles Art Center, and Ogden Headstart Program, Ogden, Utah. Ms. Taylor received a B.F.A. from the Art Institute of Chicago, University of Chicago. She has taken additional art seminar work at Alfred University, N.Y.; the University of Wisconsin; and University of Utah.

Luana Richardson, Project Layout Typist, is Curriculum Secretary at Weber State College Skills Center, Ogden, Utah. Ms. Richardson has worked extensively as an administrative secretary, stenographer and typist.

ABSTRACT

This Project (1) identifies basic and functional math skills (shop math skills), (2) provides pre-tests on the above functional math skills, and (3) provides student learning projects (Project Sheets) which prepare metal trades students to read, understand and apply mathematics and measuring skills that meet entry level job requirements as defined by the metal trades industry for the following occupations:

Combination Welder Apprentice	D.O.T. 819.284-008
Machinist Helper	D.O.T. 600.280-026
Precision Metal Finisher	D.O.T. 705.484-010
Sheet Metal Worker Apprentice	D.O.T. 804.281-010

Input for this project was obtained from metal trades employers, instructors, and students throughout Northern Utah (Wasatch Front North). Each student project provides (1) a review of needed mathematical principles, and (2) selected simulated on-the-job word problems for students to solve (Shop Problems).

Copies of this report, as well as pre-tests and student handouts for each occupation, may be obtained from:

Utah State Office of Education
Adult Education Unit
250 East 500 South
Salt Lake City, UT 84111

Cost of report:	\$20.00
Cost of Student Handouts:	
Combination Welder Apprentice:	\$18.00
Machinist Helper:	\$20.00
Precision Metal Finisher:	\$20.00
Sheet Metal Worker Apprentice:	\$18.00

TABLE OF CONTENTS

Section	Title	Page
	Funding Information.....	i
	Project Personnel.....	ii
	Abstract.....	iii
	Table of Contents.....	iv
1	INTRODUCTION.....	1-1
2	CHAPTER 1: Shop Math Student Training Records.....	2-1
	Shop Math for Machinists.....	2-2
	Shop Math for Precision Metal Finishers.....	2-3
	Shop Math for Sheet Metal Workers.....	2-4
	Shop Math for Welders.....	2-5
3	CHAPTER 2: Shop Math for Machinist Helper Pre-Test and Student Learning Projects.....	3-1
	1. Math Pre-Tests.....	3-2
	Shop Math for Metal Trades: Pre-Test, Part 1.....	3-2
	Shop Math for Metal Trades: Pre-Test, Part 1 (Computerized)....	3-10
	Shop Math for Metal Trades: Pre-Test, Part 2.....	3-22
	Shop Math for Metal Trades: Pre-Test, Part 2 (Computerized)....	3-29
	Shop Math for Metal Trades: Pre-Test, Part 3.....	3-37
	Shop Math for Metal Trades: Pre-Test, Part 3 (Computerized)....	3-46
	Shop Math for Metal Trades: Pre-Test, Part 4.....	3-60
	Shop Math for Metal Trades: Pre-Test, Part 4 (Computerized)....	3-67
	2. Math for Measuring Instruments.....	3-74
	Project 1: Addition and Subtraction of Fractions.....	3-74
	Project 2: Multiplication and Division of Fractions.....	3-82
	Project 3: Addition and Subtraction of Decimals.....	3-94
	Project 4: Multiplication and Division of Decimals.....	3-106
	Project 5: Fraction-Decimal Conversions.....	3-117
	Project 6: Review of Measurement Numbers.....	3-127
	Project 7: Working With Metrics.....	3-137
	3. Specialized Math Skills.....	3-149
	Project 1: Shop Algebra: Part 1.....	3-149
	Project 2: Shop Algebra: Part 2.....	3-170
	Project 3: Shop Algebra: Part 3.....	3-206
	Project 4: Shop Geometry: Part 1.....	3-238
	Handout: Formulas for Plane Geometric Figures.....	3-273
	Project 5: Shop Geometry: Part 2.....	3-275
	Handout: Formulas for Solid Geometric Figures.....	3-312
	Project 6: Introduction to Trigonometry.....	3-314
	Project 7: Shop Trigonometry: Part 1.....	3-334
	Project 8: Shop Trigonometry: Part 2.....	3-364
4	CHAPTER 3: Conclusions and Recommendations.....	4-1
5	APPENDIX A.....	5-1
	Machinist Helper Student Training Record.....	5-2
	Precision Metal Finisher Student Training Record.....	5-8
	Sheet Metal Worker Apprentice Student Training Record.....	5-13
	Combination Welder Apprentice Student Training Record.....	5-16

This project was accomplished between January 5 and June 30, 1981.

This report contains the training outline, called Student Training Record, for each of the occupations listed above. The training outlines titled "Shop Math for Combination Welder Apprentice", "Shop Math for Machinist Helper", "Shop Math for Precision Metal Finisher", and "Shop Math for Sheet Metal Worker Apprentice" identify the basic functional math skills needed for each occupation.

Each Student Training Record lists the Milestones (major training subjects) and Projects (learning activities) the student is to accomplish.

This report also contains the individualized, single-concept, student learning projects, called Project Sheets, pre-tests and handouts for Shop Math for Machinist Helper.

Each Project Sheet contains three elements:

1. Front Page--Listed here are the following instructions and information:
 - A. Heading: Listed at the top of the page is the Cluster, Occupation, Module, Milestone and Project to properly identify where the project is contained within the specific Student Training Record.
 - B. Training Conditions: Listed here are the equipment, tools, etc. needed to successfully perform and complete the Training Project.
 - C. Training Plan: First, an explanation of WHAT will be done and WHY it must be learned are given (i.e., the purpose and objective of the project). Second, a step-by-step procedure of HOW to do the project is given.
 - D. Training Goal: This entry identifies exactly how well the student is expected to do in solving the Shop Problems at the end of the Project Sheet.
2. Review of Basic Math Principles--The first part of the text of each Project Sheet contains a brief review of the basic math principles, along with example problems, to help the student see the application of the math principles. This review, as well as the example problems, are designed to help the student successfully complete the Shop Problems at the end of each Project Sheet.
3. Shop Problems--At the end of each Project Sheet are a series of eight to fifteen typical shop problems the student will incur on the job. These problems are all descriptive shop problems which challenge the student as if he or she were an employee with the Shop Problems as an assignment.

Project Sheets for shop math for each of the other three occupations listed above differ only in slight wording changes of example problems as well as different Shop Problems for students to solve.

The pre-test is a criterion referenced assessment instrument designed to determine out the student's level of knowledge of math for his/her metal trade occupation. Both a comprehensive version of the pre-test (fill-in the blanks) and multiple-choice version suitable for computer scoring are provided in this report.

INTRODUCTION

Research has shown that most math students do not see the relationship of numbers, letters, hypotheses or theorems and how they are or may be used in their daily living at home or on the job. In the Spring/Summer 1980 issue of Science Education News, published by the American Association for the Advancement of Science, Robert Davis, associate director of the Computer-Based Educational Research Laboratory at the University of Illinois said, "Most students believe mathematics doesn't make any sense. They think it's a dumb game that really doesn't work." Davis goes on to say that most students she has observed don't see any connection between the mathematics symbols they manipulate on paper and anything else.

At Weber State College Skills Center* we found a similar math application barrier in training students for entry level jobs in the metal trades. Students had difficulty in applying their classroom math skills toward the solution of practical shop problems associated with the metal trades. One level of math proficiency is the ability to solve groups of similarly written problems that require little or no ingenuity. This is the level that students normally reach during high school math. Our vocational students need a higher level--the level beyond the math application barrier. Students in the metal trades, and perhaps in other trades as well, must have the ability to select and apply the appropriate math skills required to solve the job at hand. For example, a machinist must know whether a particular problem can best be solved by using the techniques of Geometry or Trigonometry. Once the selection has been made, the machinist must also have the ability to apply appropriate math skills that will result in a meaningful solution. This project provides the vocational student a means of eliminating the math application barrier.

In this project, we set out to achieve two goals:

1. Identify basic and functional math skills which prepare metal trades students to read, understand, and apply mathematics and measuring skills that effectively meet entry level job requirements as defined by metal trades industry for:

Combination Welder Apprentice	D.O.T. 819.284-008
Machinist Helper	D.O.T. 600.280-026
Precision Metal Finisher	D.O.T. 705.484-010
Sheet Metal Worker Apprentice	D.O.T. 804.281-010

2. Develop individualized, self-paced, single concept, student learning projects which prepare students to read, understand, and apply basic and functional mathematics and measuring skills required for entry level jobs in the four occupations listed above.

*Weber State College Skills Center is a vocational training facility operated by Weber State College. The purpose of Skills Center is to increase the employability of the individual--through a partnership with employers. In addition to developing specific job skills, students learn other things that lead to success in the work environment--things like a good attitude, the ability to communicate, and the importance of dependability and punctuality. Skills Center is open to all applicants 16 and over who will benefit from the training and be an employable age when their training program is complete.

The handouts listed on the Student Training Record are summaries of geometric area and volume formulas introduced in the Project Sheets.

A complete list of the Training Modes employed at Weber State College Skills Center appears in Table A.

All student materials for this project were written for metal trades vocational training students. The reading level for student learning materials is fifth to eighth grade.

Permanent copies of this report as well as copies of materials developed for Combination Welder Apprentice, Precision Metal Finisher and Sheet Metal Worker are on file and available from:

Utah State Office of Education
Adult Education Unit
250 East 500 South
Salt Lake City, Utah 84111

Copies of the complete Student Training Records for each of the four metal trades occupations cited in this report, appear in Appendix A.

WSC SKILLS CENTER LEARNING MODES

PRINTED

DEMONSTRATION

AUDIO-VISUAL

Code	Training Mode
PS	<u>Project Sheet</u> : Individualized self-paced, single concept, graded reading student handout.
TX	<u>Text</u> : Reading assignment in a textbook or shop manual.
HO	<u>Handout</u> : Written materials other than Project Sheets. May be given to the student to keep.
QZ	<u>Quiz</u> : Written evaluation of essential points within a Module or Milestone.

Code	Training Mode
LT	<u>Lecture</u> : Lecture-style presentation. May involve one student, a small group, or the entire class.
DC	<u>Discussion</u> : Group discussion led by Instructor.
DM	<u>Demonstration</u> : Demonstration of an activity--Instructor demonstrates to student(s), or student(s) demonstrate proficiency to Instructor and/or other class members.
RP	<u>Role Play</u> : Group of students role play and discuss an on-the-job situation.
TR	<u>Field Trip</u> : Students visit an off-Center facility.
RV	<u>Review</u> : Verbal evaluation of essential points within a Module or Milestone.

Code	Training Mode
MP	<u>Motion Picture</u> : 16mm sound motion picture film.
ST	<u>Slide-Tape</u> : 35mm slides in carousel with audio cassette.
FT	<u>Filmstrip-Tape</u> : Filmstrip with audio cassette.
CT	<u>Cartridge</u> : Visual and audio presentation in one self-contained unit.
VC	<u>Video</u> : 3/4 inch U-matic cartridge or 1/2 inch EIAJ reel-to-reel video tape.
TP	<u>Transparencies</u> : Overhead transparencies.
AT	<u>Audio Tape</u> : Cassette tape.
CI	<u>Computer Assisted Instruction</u> : Computer terminal.

Table A

CHAPTER 1

SHOP MATH STUDENT TRAINING RECORDS

MODULE: SHOP MATH FOR MACHINISTS

Item No	6/81 TRAINING MODULES AND MILESTONES	DATE		PERFORMANCE (x)			
		Start	Complete	On his/her Own	with		Additional Training
					Min Super	Max Super	
	1. Math Pretest						
	2. Math for Measuring Instruments						
201	PS: Addition and Subtraction of Fractions						
202	PS: Multiplication and Division of Fractions						
203	PS: Addition and Subtraction of Decimals						
204	PS: Multiplication and Division of Decimals						
205	PS: Fraction-Decimal Conversions						
206	PS: Review of Measurement Numbers						
207	PS: Working with Metrics						
	3. Specialized Math Skills						
208	PS: Shop Algebra: Part 1						
209	PS: Shop Algebra: Part 2						
210	PS: Shop Algebra: Part 3						
211	PS: Shop Geometry: Part 1						
212	HO: Formulas for Plane Geometric Figures						
213	PS: Shop Geometry: Part 2						
214	HO: Formulas for Solid Geometric Figures						
215	PS: Introduction to Trigonometry						
216	PS: Shop Trigonometry: Part 1						
217	PS: Shop Trigonometry: Part 2						

MODULE: SHOP MATH FOR SHEET METAL WORKERS

Item No	6/81 TRAINING MODULES AND MILESTONES	DATE		PERFORMANCE (x)		
		Start	Complete	On his/her Own	with	
					Min Super	Max Super
	1. Math Pretest					
	2. Math for Measuring Instruments					
101	PS: Addition and Subtraction of Fractions					
102	PS: Multiplication and Division of Fractions					
103	PS: Addition and Subtraction of Decimals					
104	PS: Multiplication and Division of Decimals					
105	PS: Fraction-Decimal Conversions					
106	PS: Review of Measurement Numbers					
107	PS: Working with Metrics					
	3. Specialized Math Skills					
108	PS: Shop Algebra: Part 1					
109	PS: Shop Algebra: Part 2					
110	PS: Shop Geometry: Part 1					
111	HQ: Formulas for Plane Geometric Figures					
112	PS: Shop Geometry: Part 2					
113	HQ: Formulas for Solid Geometric Figures					
114	PS: Introduction to Trigonometry					

CHAPTER 2

SHOP MATH FOR MACHINIST HELPER
PRE-TEST AND STUDENT LEARNING PROJECTS

SHOP MATH FOR THE METAL TRADES: PRETEST

PART 1

Work the problems and write the correct answers in the blanks.

Add and subtract the fractions as indicated in the following problems. Reduce answers to simplest terms.

$$1. \frac{1}{8} + \frac{1}{16} + \frac{3}{16} + \frac{3}{4} + \frac{1}{2} = \underline{\hspace{2cm}}$$

$$2. 2\frac{1}{8} + 3\frac{3}{16} + 2\frac{3}{4} = \underline{\hspace{2cm}}$$

$$3. \frac{3}{4} + \frac{13}{32} + 3\frac{3}{8} + \frac{15}{16} = \underline{\hspace{2cm}}$$

$$4. \frac{1}{16} + \frac{5}{8} - \frac{3}{4} - \frac{3}{16} = \underline{\hspace{2cm}}$$

$$5. 2\frac{1}{3} - 3\frac{2}{9} + 5\frac{5}{9} = \underline{\hspace{2cm}}$$

$$6. \frac{4}{5} + \frac{9}{10} - \frac{3}{5} - \frac{1}{20} = \underline{\hspace{2cm}}$$

7. In the sketch below find the dimensions x and y .

x _____ y _____

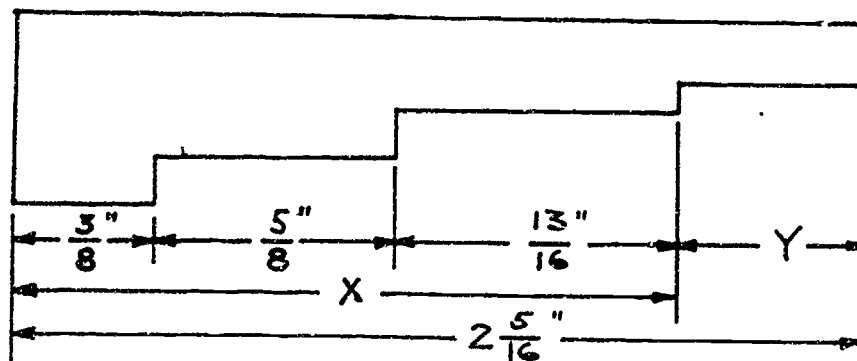

8. In the sketch below find the total length of the bar.

Length _____

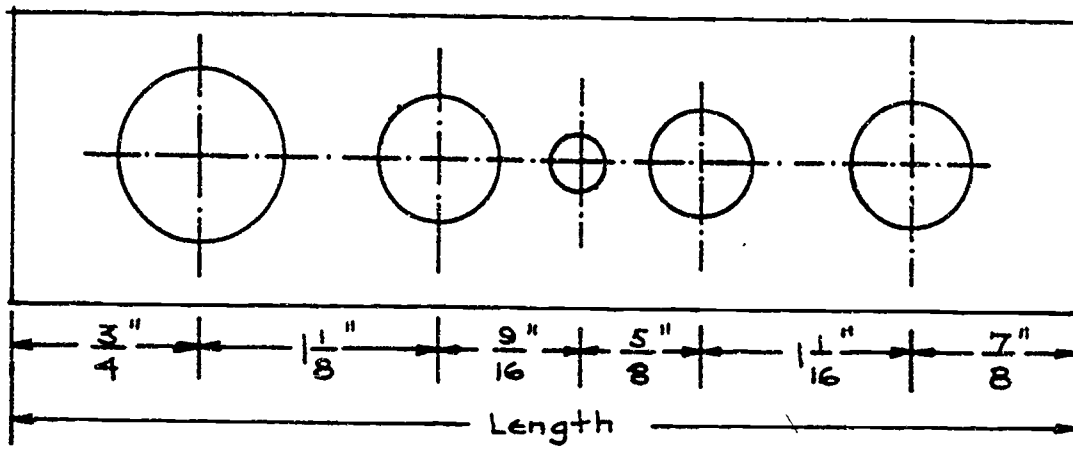

9. Find the dimensions x , y , and z shown in the sketch below.

x _____ y _____ z _____

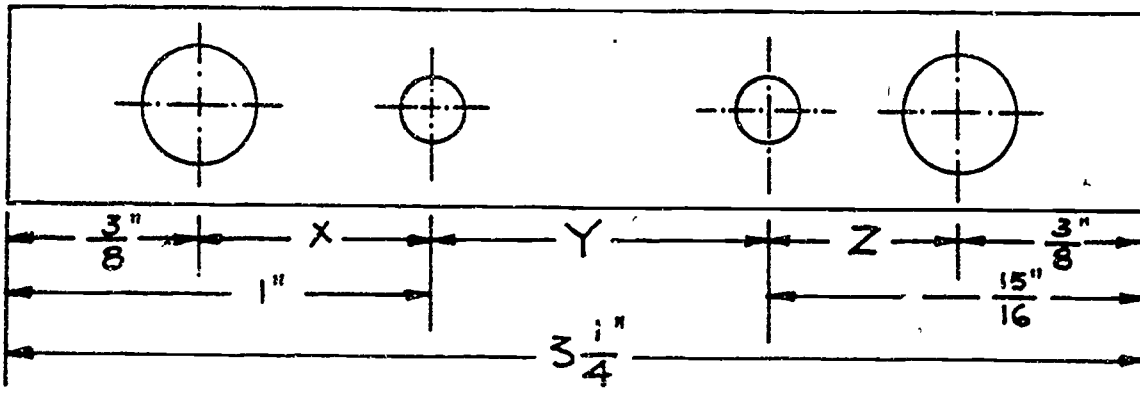

10. Find the total length of the profile gage shown in the sketch below.

Length _____

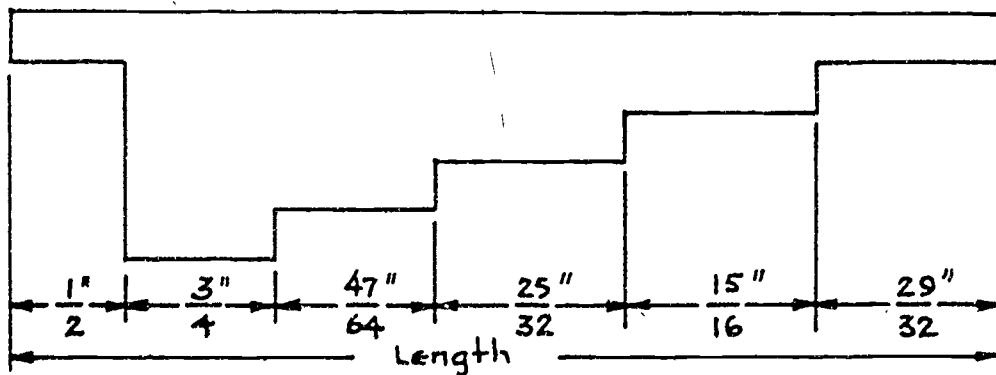

Multiply the following fractions as indicated below and reduce to simplest terms.

11. $\frac{1}{3} \times \frac{4}{5} \times \frac{6}{7} =$ _____

12. $1\frac{1}{2} \times 2\frac{1}{4} \times 2\frac{7}{8} =$ _____

13. $\frac{4}{3} \times \frac{6}{5} \times 1\frac{1}{8} =$ _____

14. $2\frac{1}{7} \times \frac{3}{4} \times \frac{2}{9} =$ _____

Divide the following fractions and reduce to simplest terms.

15. $\frac{7}{8} \div \frac{3}{4} =$ _____

16. $1\frac{3}{4} \div \frac{2}{3} =$ _____

17. $\frac{25}{8} \div 2\frac{1}{4} =$ _____

18. $3\frac{2}{3} \div \frac{4}{5} =$ _____

19. You are required to make 22 pieces of pipe, each $\frac{3}{4}$ " long. If you allow $\frac{1}{16}$ " waste for each piece of pipe, how long a piece of pipe stock is required for the 22 pieces?

Length of pipe stock _____

20. If you assume no waste, what is the greatest number of $\frac{5}{16}$ " pieces you can make from a piece of bar stock $12\frac{1}{2}$ " long? Look at the sketch below.

Total number of pieces _____

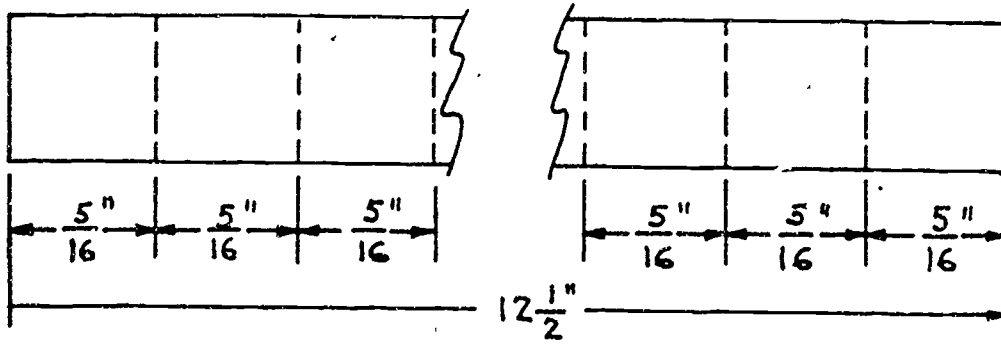

Add and subtract the decimal numbers as indicated below.

21. $0.4615 + 7.32 - 4.325 =$ _____

22. $5.671 - 2.3 - 0.0421 =$ _____

23. $6.3 + 0.452 + 8.623 - 10.5001 =$ _____

24. $4.1 + 0.322 - 2.6 - 0.315 =$ _____

25. You have listed the following cost items for a certain job: materials, \$157.24; grinding, \$175.56; Machining and polishing, \$452.75; painting, \$145.40; and profit, \$275.00. How much do you charge the customer?

Charge _____

26. You have the following information about 4 pieces of sheet metal: Their total weight is 100.76 pounds. One sheet weighs 42.67 pounds, another sheet weighs 20.42 pounds, and the third sheet weighs 11.86 pounds. How much does the fourth sheet weigh?

Weight of fourth sheet _____

27. What are the dimensions A, B, and C in the sketch below.

A _____ B _____ C _____

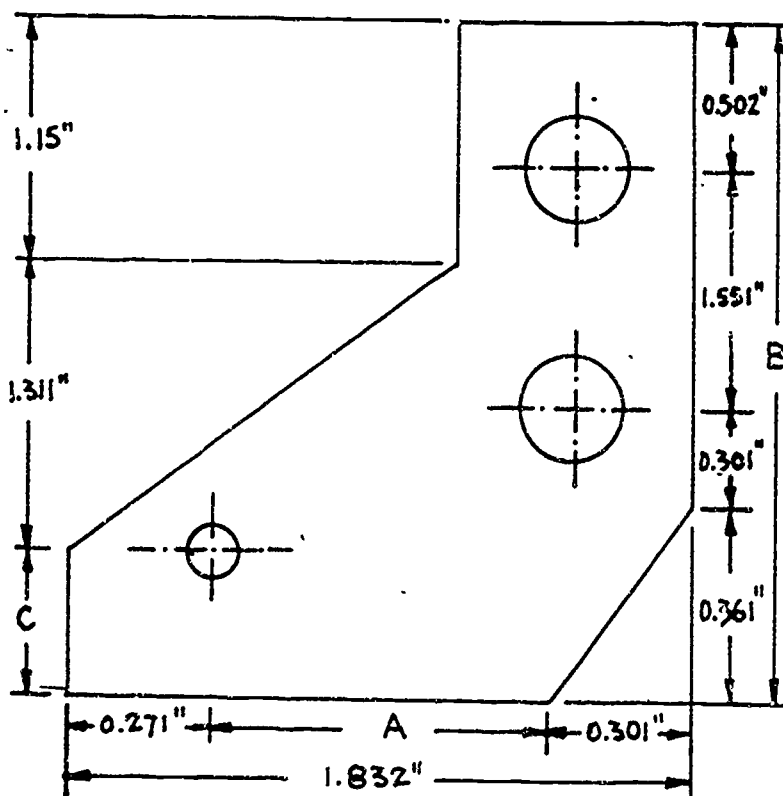

The next four problems should be done the long way without a calculator. Multiply or divide as indicated the decimals below.

28. $3.76 \times 5.32 =$ _____
 29. $0.521 \times 2.24 =$ _____
 30. $69.6 \div 4.35 =$ _____
 31. $63.45 \div 4.23 =$ _____

32. A rectangular piece of sheet metal measures 2.62" wide by 4.51" long. What is the area? Remember, the area is equal to the length times the width.

Area to the nearest hundredth of an inch _____

33. You have measured a circular casting five times to get an average diameter. The readings are: 1.312", 1.311", 1.319", 1.320" and 1.315". What is the average diameter of the casting to the nearest thousandth of an inch?

Average diameter _____

34. If you charge \$3.55 for a welded bracket, how many brackets can a customer buy for \$78.10?

Number of brackets _____

Work the next five problems the long way without a calculator.

Change the following fractions to decimal numbers. Round to the nearest thousandth.

35. $\frac{2}{13} =$ _____

36. $\frac{5}{17} =$ _____

37. $\frac{375}{1000} =$ _____

38. $\frac{1}{47} =$ _____

39. $\frac{75}{121} =$ _____

40. Find the dimensions A, B, C, D, and E in decimal form to the nearest thousandth of an inch. Look at the sketch below.

A _____ B _____ C _____ D _____ E _____

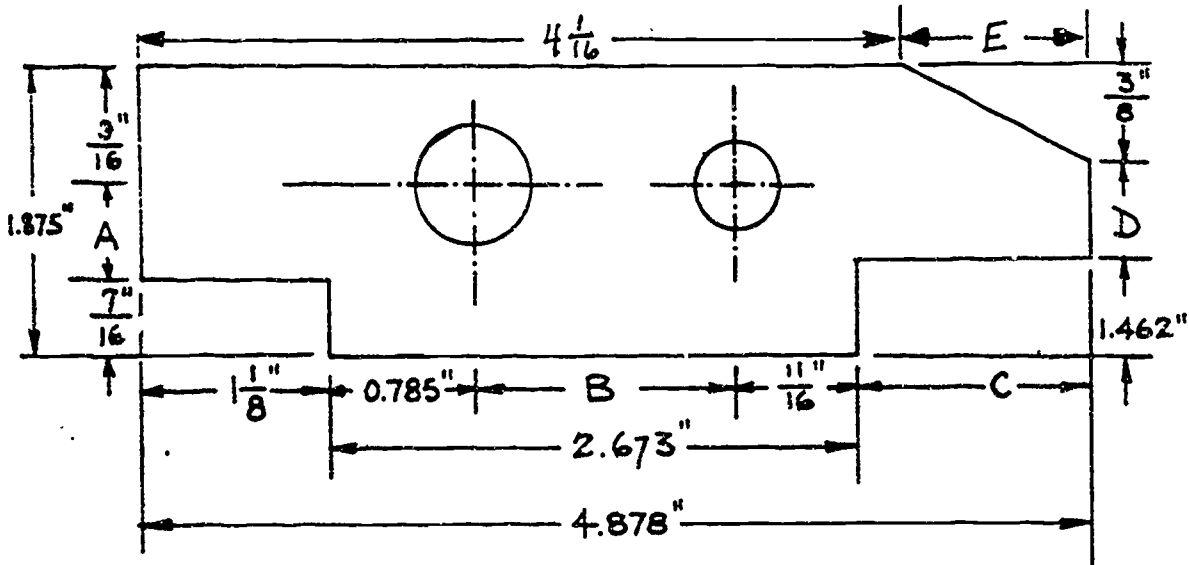

Hint: Change all fractions to their decimal form before adding or subtracting.

Change the following decimals to fractions as indicated below.

41. Change 0.0462" to the nearest 32nd of an inch. _____

42. Change 0.543" to the nearest 64th of an inch. _____

43. Change 0.925" to the nearest 16th of an inch. _____

44. In the sketch below change the decimal dimensions, width, length, and hole diameter to the nearest 64th of an inch.

W _____ L _____ Hole diameter d _____

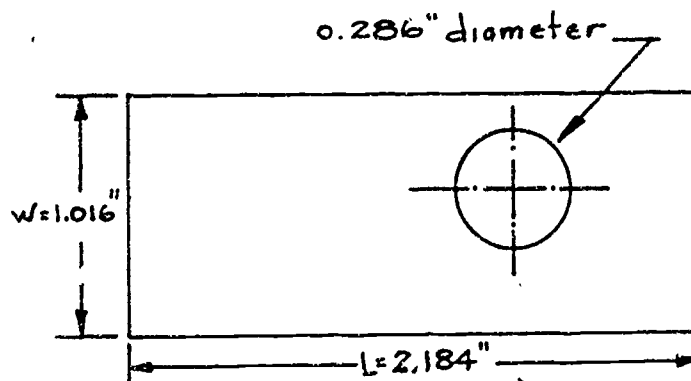

Use the following conversion factors to work problems 56 through 62.

<u>When you know</u>	<u>You can find</u>	<u>If you multiply</u>
inches, in.	millimeters, mm	25.40
inches, in.	centimeters, cm	2.54
feet, ft.	meters, m	0.3048
miles, mi.	kilometers, km	1.6093
millimeters, mm	inches, in.	0.03937
centimeters, cm	inches, in.	0.3937
meters, m	feet, ft.	3.2808
kilometers, km	miles, mi.	0.6214
square inches, in. ²	square centimeters, cm ²	6.452
square feet, ft. ²	square meters, m ²	0.093
square centimeters, cm ²	square inches, in. ²	0.155
square meters, m ²	square feet, ft. ²	10.764
cubic inches, in. ³	cubic centimeters, cm ³	16.387
cubic feet, ft. ³	liters, <i>l</i>	28.317
gallons, gal.	liters, <i>l</i>	3.785
cubic centimeters, cm ³	cubic inches, in. ³	0.061
liters, <i>l</i>	cubic feet, ft. ³	0.035
liters, <i>l</i>	gallons, gal.	0.264
pounds, lb.	kilograms, kg	0.454
ounces, oz.	grams, g	28.350
kilograms, kg	pounds, lbs.	2.205
grams, g	ounces, oz.	0.0353

45. If you are traveling at 82 kilometers per hour, are you exceeding the 55 mile per hour speed limit?

Yes _____ No _____

46. Look at the sketch below and find the total surface area of the rectangular block in square centimeters and its volume in cubic centimeters.

Total surface area _____ Volume _____

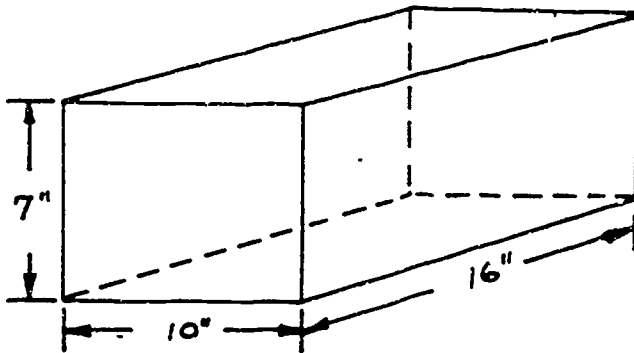

Hint: The total surface area is the sum of the areas of the 6 faces of the rectangular block.

47. How many kilograms are there in a ton? (Ton = 2,000 pounds)

Kilograms in a ton _____

48. In the sketch below, change the length and width dimensions and their tolerances to millimeters. Round to the nearest hundredth of a millimeter.

Length dimension _____ Width dimension _____

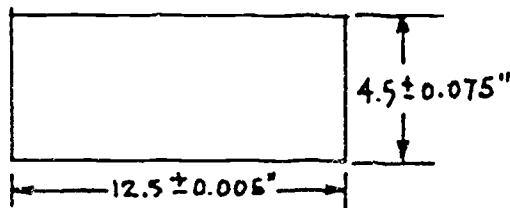

49. If your car gets 9.35 kilometers per liter, how many miles per gallon does it get?

Miles per gallon _____

50. Find the circumference in centimeters and the area in square centimeters of the circle shown in the sketch below. Remember, the circumference of a circle equals π times the diameter where $\pi = 3.14$, and the area equals π times the radius squared and π still equals 3.14.

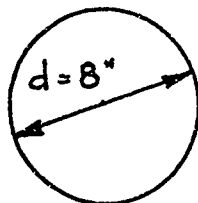

Circumference _____

Area _____

SHOP MATH FOR METAL TRADES: PRETEST

PART 1 (COMPUTERIZED)

Choose the best answer for each of the following questions.

In problems 1 through 6, add and subtract the fractions as indicated. Reduce answers to lowest terms.

1. $\frac{1}{8} + \frac{1}{16} + \frac{3}{16} + \frac{3}{4} + \frac{1}{2} =$

- a. $1 \frac{5}{8}$
- b. $1 \frac{5}{16}$
- c. $\frac{9}{16}$
- d. $1 \frac{1}{16}$

2. $2 \frac{1}{8} + 3 \frac{3}{16} + 2 \frac{3}{4} =$

- a. $8 \frac{1}{16}$
- b. $7 \frac{1}{16}$
- c. $1 \frac{1}{16}$
- d. $9 \frac{1}{16}$

3. $1 \frac{1}{16} + \frac{5}{8} - \frac{3}{4} - \frac{3}{16} =$

- a. $1 \frac{3}{16}$
- b. $1 \frac{3}{8}$
- c. $\frac{3}{4}$
- d. $\frac{3}{16}$

4. $\frac{3}{4} + \frac{13}{32} + 3 \frac{3}{8} + \frac{15}{16} =$

- a. $5 \frac{7}{16}$
- b. $5 \frac{15}{32}$
- c. $3 \frac{15}{32}$
- d. $3 \frac{3}{8}$

5. $2 \frac{1}{3} - 3 \frac{2}{9} + 5 =$

- a. $4 \frac{1}{9}$
- b. $4 \frac{1}{3}$
- c. $3 \frac{1}{9}$
- d. $4 \frac{2}{3}$

6. $\frac{4}{5} + \frac{9}{10} - \frac{3}{5} - \frac{1}{20} =$

- a. $1 \frac{3}{20}$
- b. $1 \frac{1}{5}$
- c. $1 \frac{1}{10}$
- d. $1 \frac{1}{20}$

In problems 7 and 8, look at the sketch below. Find the dimensions x and y .

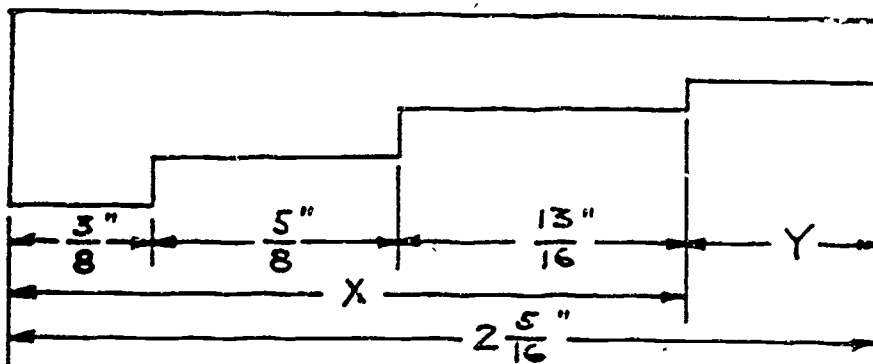

7. x equals:

- a. $\frac{13''}{16}$
- b. $1 \frac{3''}{4}$
- c. $1 \frac{3''}{8}$
- d. $1 \frac{13''}{16}$

8. y equals:

- a. $\frac{5''}{8}$
- b. $\frac{9''}{10}$
- c. $\frac{1''}{2}$
- d. $1 \frac{1''}{2}$

9. In the sketch below, what is the total length of the bar?

- a. $4\frac{3}{4}$ b. $5\frac{1}{16}$ c. $4\frac{7}{8}$ d. 5"

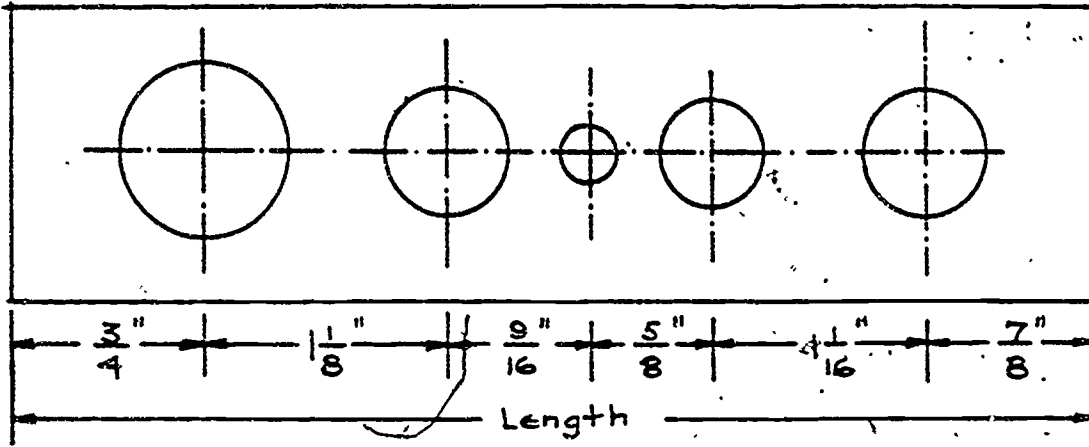

In problems 10 through 12, look at the sketch below and find the dimensions x , y , and z .

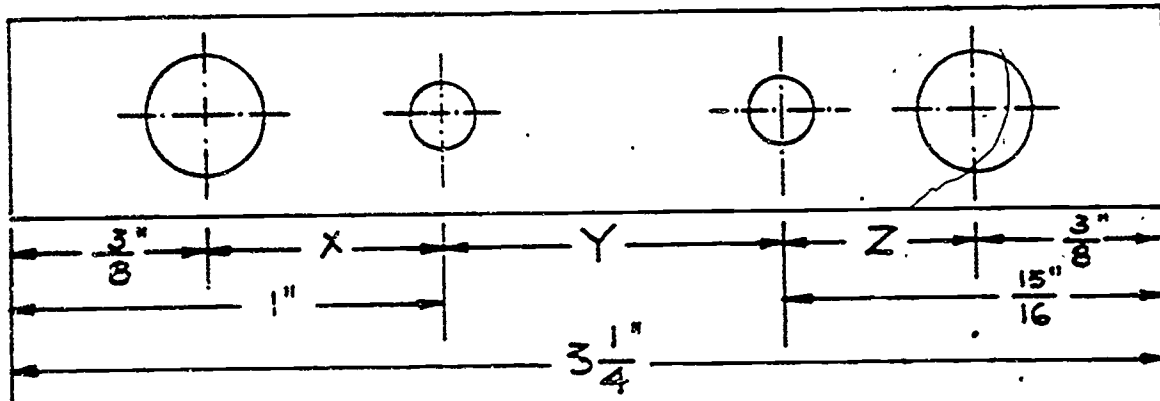

10. Dimension x equals: 11. Dimension y equals: 12. Dimension z equals:

- | | | |
|---------------------|-----------------------|----------------------|
| a. $\frac{3}{8}$ " | a. $1\frac{1}{4}$ " | a. $\frac{5}{8}$ " |
| b. $\frac{5}{8}$ " | b. $2\frac{1}{4}$ " | b. $1\frac{9}{16}$ " |
| c. $\frac{5}{16}$ " | c. $1\frac{5}{16}$ " | c. $1\frac{5}{16}$ " |
| d. $1\frac{3}{8}$ " | d. $1\frac{15}{16}$ " | d. $\frac{9}{16}$ " |

13. Find the total length of the profile gage shown in the sketch below.

a. $4\frac{39}{64}$

b. $4\frac{49}{64}$

c. $4\frac{3}{8}$

d. $4\frac{61}{64}$

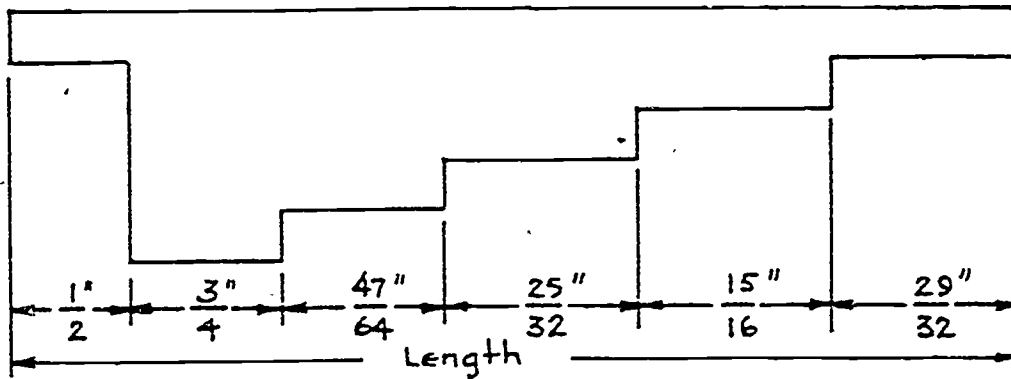

In problems 14 through 17, multiply the following fractions as indicated below and reduce to simplest terms.

14. $\frac{1}{3} \times \frac{4}{5} \times \frac{6}{7} =$

a. $\frac{2}{3}$

b. $\frac{8}{35}$

c. $\frac{24}{35}$

d. $\frac{7}{12}$

15. $1\frac{1}{2} \times 2\frac{1}{4} \times 2\frac{7}{8} =$

a. $8\frac{23}{32}$

b. $9\frac{25}{32}$

c. $9\frac{55}{64}$

d. $9\frac{45}{64}$

16. $\frac{4}{3} \times \frac{6}{5} \times 1\frac{1}{8} =$

a. $1\frac{4}{5}$

b. $3\frac{3}{8}$

c. $1\frac{3}{8}$

d. $2\frac{4}{5}$

17. $2\frac{1}{7} \times \frac{3}{4} \times \frac{2}{9} =$

a. 1

b. $\frac{1}{3}$

c. $1\frac{1}{3}$

d. $\frac{5}{14}$

In problems 18 through 21, divide the fractions as indicated and reduce to the simplest terms.

18. $\frac{7}{8} \div \frac{3}{4} =$

a. $\frac{21}{32}$

b. $1\frac{1}{6}$

c. $\frac{5}{6}$

d. $1\frac{1}{8}$

19. $1\frac{3}{4} \div \frac{2}{3} =$

a. $4\frac{7}{8}$

b. $1\frac{1}{6}$

c. $2\frac{5}{8}$

d. $2\frac{1}{6}$

20. $2\frac{5}{8} \div 2\frac{1}{4} =$

a. $1\frac{1}{5}$

b. $5\frac{5}{29}$

c. $\frac{25}{42}$

d. $1\frac{1}{6}$

21. $3\frac{2}{3} + \frac{4}{5} =$

a. $4\frac{7}{12}$

b. $2\frac{14}{15}$

c. $13\frac{1}{3}$

d. $8\frac{8}{15}$

22. You are required to make 22 pieces of pipe, each $\frac{3}{4}$ " long. If you allow $\frac{1}{16}$ " for waste for each one of the 22 pieces, how long a piece of pipe stock is needed for the 22 pieces?

Pipe stock length equals: a. $16\frac{7}{8}$ "

b. $17\frac{7}{8}$ "

c. $29\frac{3}{16}$ "

d. $16\frac{9}{16}$ "

23. If you assume no waste, what is the greatest number of $\frac{5}{16}$ " pieces you can make from a $12\frac{1}{2}$ " length of bar stock? Look at the sketch below.

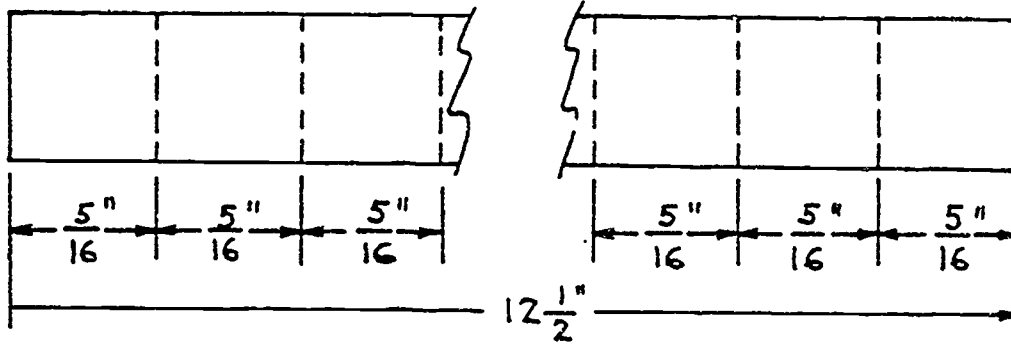

Number of pieces equals:

- a. 4 b. 40 c. 20 d. 14

In problems 24 through 27, add and subtract the decimal numbers as indicated below:

24. $0.4615 + 7.32 - 4.325 =$

- a. 2.4515
b. 12.1065
c. 3.4565
d. 7.61

25. $5.671 - 2.3 - 0.0421 =$

- a. 3.3289
b. 7.9289
c. 3.4131
d. 8.0131

26. $6.3 + 0.452 + 8.623 - 10.5001 =$

- a. 13.2751
b. 4.8749
c. 25.8751
d. 3.9709

27. $4.1 + 0.322 - 2.6 - 0.315 =$

- a. 1.507
b. 7.337
c. 1.328
d. 1.7905

28. The following cost items have been listed for a certain job: materials, \$157.24; grinding, \$175.56; Machining and polishing, \$452.75; painting, \$145.40; and profit, \$275.00. How much do you charge the customer?

- Customer's charge equals: a. \$1030.39 b. \$1205.95
c. \$1048.71 d. \$ 753.20

29. You have the following information about 4 pieces of sheet metal: Their total weight is 100.76 pounds. One sheet weighs 42.67 pounds, another sheet weighs 20.42 pounds, and the third sheet weighs 11.86 pounds. How much does the fourth sheet weigh?

The 4th sheet weighs: a. 15.85 lbs b. 68.48 lbs
c. 37.67 lbs d. 25.81 lbs

In problems 30 through 32, look at the sketch below and find the dimensions A, B, and C.

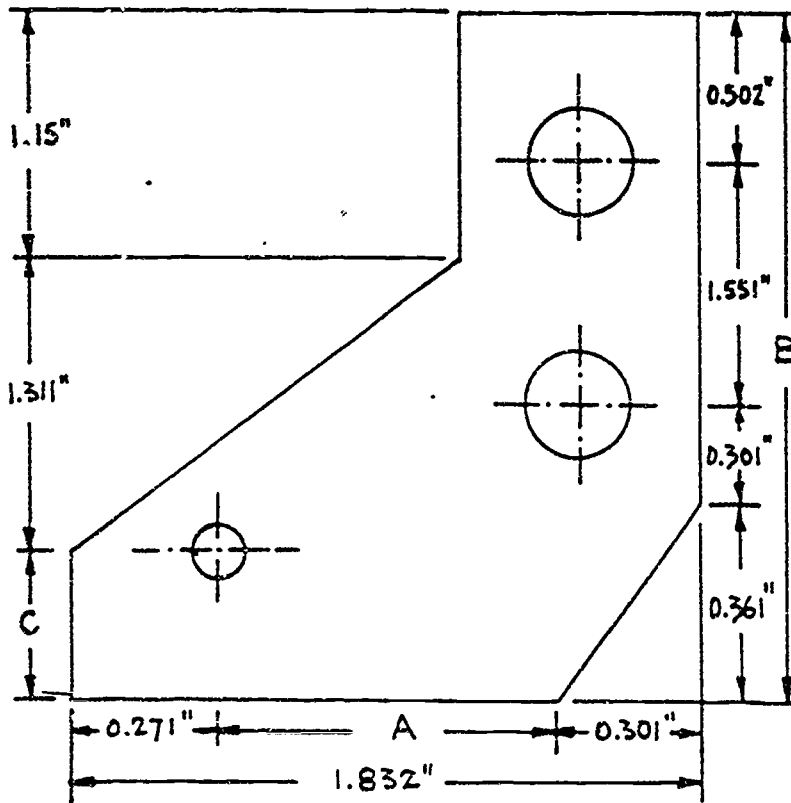

30. Dimension A equals:

- a. 1.531"
b. 1.26"
c. 1.802"
d. 0.572"

31. Dimension B equals:

- a. 5.964"
b. 2.715"
c. 5.404"
d. 1.319"

32. Dimension C equals:

- a. 3.911"
b. 1.434"
c. 3.503"
d. 0.254"

Work problems 33 through 36 the long way without a calculator. Multiply or divide the decimal expressions as indicated.

33. $3.76 \times 5.32 =$

- a. 20.0032
b. 16.9822
c. 16.7932
d. 19.0032

34. $0.521 \times 2.24 =$

- a. 1.16704
b. 1.15604
c. 1.06704
d. 1.04704

35. $69.6 \div 4.35 =$

- a. 16.5
- b. 1.65
- c. 1.6
- d. 16

36. $63.45 \div 4.23 =$

- a. 150
- b. 0.15
- c. 15
- d. 1.5

37. A rectangular piece of sheet metal measures 2.62" wide by 4.51" long. What is the area? Remember, the area is equal to the length times the width.

Area to the nearest hundredth of an inch equals:

- a. 118.16 sq in
- b. 11.86 sq in
- c. 11.81 sq in
- d. 11.82 sq in

38. You have measured a circular casting five times to get an average diameter. The readings you made were: 1.312", 1.311", 1.319", 1.320" and 1.315". What is the average diameter of the casting to the nearest thousandth of an inch?

Average diameter to the nearest 1000th of an inch equals:

- a. 1.215"
- b. 1.315"
- c. 0.99"
- d. 1.052"

39. If you charge \$3.55 for a welded bracket, how many brackets can a customer buy for \$78.10?

Number of brackets equals:

- a. 22
- b. 23
- c. 21
- d. 20

Work problems 40 through 44 the long way without a calculator. Change the following fractions to decimal numbers. Round to the nearest 1000th.

40. $\frac{2}{13} =$ a. 1.54 b. 0.159 c. 0.154 d. 0.015

41. $\frac{5}{17} =$ a. 0.284 b. 2.945 c. 0.294 d. 0.029

42. $\frac{375}{1000} =$ a. 0.038 b. 0.375 c. 0.033 d. 0.004

43. $\frac{1}{47} =$ a. 0.221 b. 0.024 c. 0.236 d. 0.021

44. $\frac{75}{121} =$ a. 0.619 b. 6.198 c. 0.062 d. 0.620

In problems 45 through 49, look at the sketch below and find the dimensions A, B, C, D, and E in decimal form to the nearest thousandth of an inch.

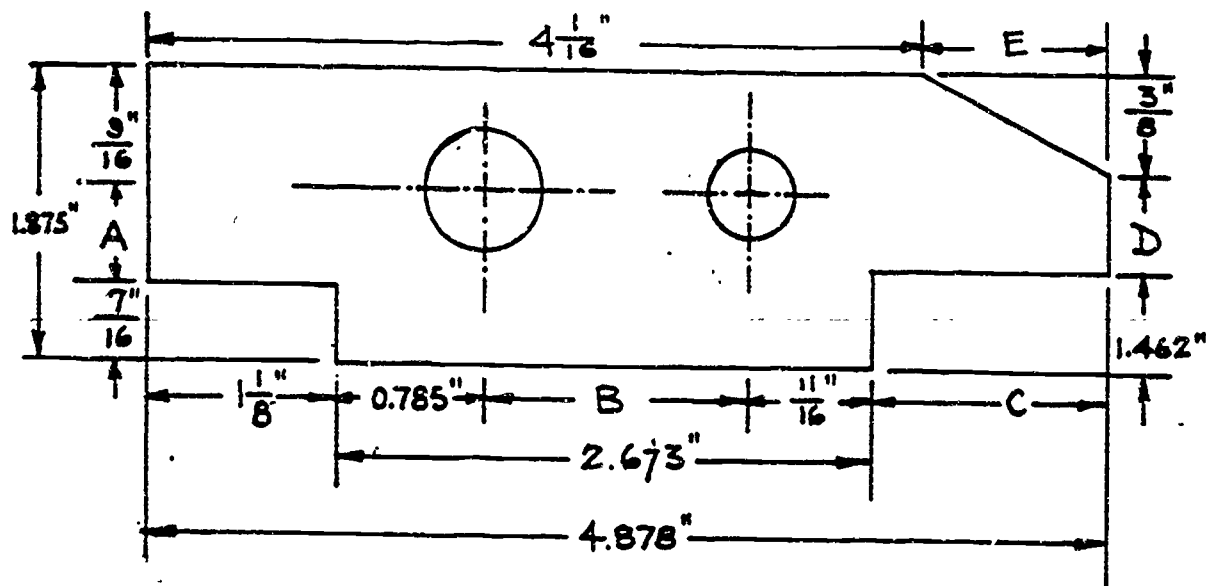

Hint: Change all fractions to their decimal form before adding or subtracting.

45. Dimension A equals:
- 1.313"
 - 0.874"
 - 1.438"
 - 1.000"
46. Dimension B equals:
- 1.101"
 - 1.986"
 - 1.201"
 - 1.888"
47. Dimension C equals:
- 1.080"
 - 2.205"
 - 0.221"
 - 0.108"
48. Dimension D equals:
- 0.875"
 - 0.413"
 - 0.038"
 - 1.5"
49. Dimension E equals:
- 0.108"
 - 0.878"
 - 0.305"
 - 0.816"

In problems 50 through 52, change the decimals to fractions as indicated:

50. Change 0.0462" to the nearest 32nd inch:

- a. $\frac{1}{8}$ b. $\frac{3}{32}$ c. $\frac{1}{32}$ d. $\frac{1}{16}$

51. Change 0.543" to the nearest 64th inch:

- a. $\frac{1}{8}$ b. $\frac{35}{64}$ c. $\frac{33}{64}$ d. $\frac{9}{16}$

52. Change 0.925" to the nearest 16th inch:

- a. $\frac{15}{16}$ b. $\frac{17}{16}$ c. $\frac{13}{16}$ d. $\frac{7}{8}$

In problems 53 through 55, look at the sketch below and change the decimal dimensions (width, length and hole diameter) to the nearest 64th of an inch.

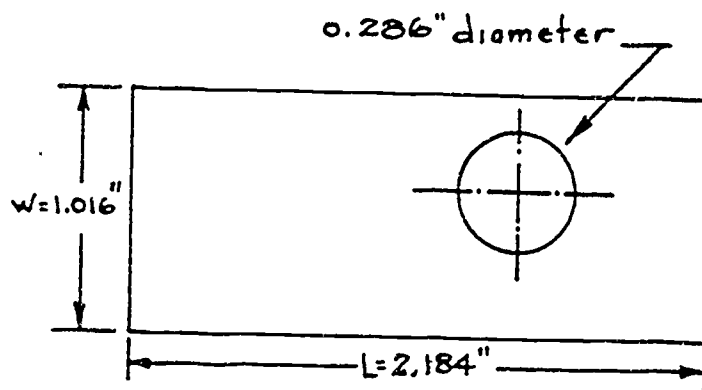

53. Width w equals

- a. $1\frac{1}{64}$
b. $1\frac{2}{64}$
c. $1\frac{3}{64}$
d. $1\frac{4}{64}$

54. Length L equals:

- a. $2\frac{13}{64}$
b. $2\frac{11}{64}$
c. $2\frac{12}{64}$
d. $2\frac{10}{64}$

55. Diameter d equals:

- a. $\frac{19}{64}$
b. $\frac{20}{64}$
c. $\frac{17}{64}$
d. $\frac{18}{64}$

Use the following conversion factors to work problems 56 through 62.

<u>When you know</u>	<u>You can find</u>	<u>If you multiply</u>
inches, in.	millimeters, mm	25.40
inches, in.	centimeters, cm	2.54
feet, ft.	meters, m	0.3048
miles, mi.	kilometers, km	1.6093
millimeters, mm	inches, in.	0.03937
centimeters, cm	inches, in.	0.3937
meters, m	feet, ft.	3.2808
kilometers, km	miles, mi.	0.6214
square inches, in. ²	square centimeters, cm ²	6.452
square feet, ft. ²	square meters, m ²	0.093
square centimeters, cm ²	square inches, in. ²	0.155
square meters, m ²	square feet, ft. ²	10.764
cubic inches, in. ³	cubic centimeters, cm ³	16.387
cubic feet, ft. ³	liters, l	28.317
gallons, gal.	liters, l	3.785
cubic centimeters, cm ³	cubic inches, in. ³	0.061
liters, l	cubic feet, ft. ³	0.035
liters, l	gallons, gal.	0.264
pounds, lb.	kilograms, kg	0.454
ounces, oz.	grams, g	28.350
kilograms, kg	pounds, lbs.	2.205
grams, g	ounces, oz.	0.0353

56. If you are traveling at 82 kilometers per hour, are you exceeding the 55 mile per hour speed limit?

- a. Yes b. No

In problems 57 and 58, look at the sketch below and find the total surface area of the rectangular block in square centimeters and its volume in cubic centimeters.

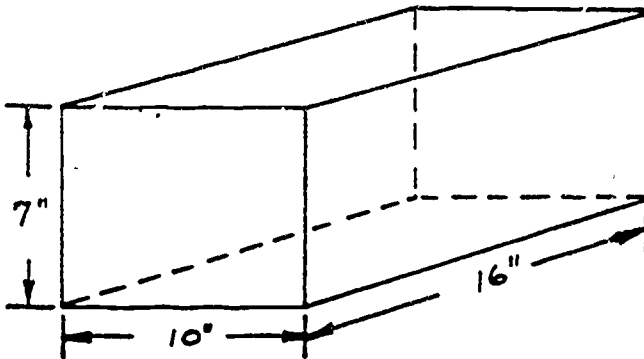

HINT: The total surface area is the sum of the areas of the 6 faces of the rectangular block.

57. The total surface area equals:

- a. 4412.89 sq cm
b. 3793.78 sq cm
c. 588 sq cm
d. 2890.5 sq cm

58. The volume equals:

- a. 1120 cu cm
b. 1147.1 cu cm
c. 18353.44 cu cm
d. 7226.24 cu cm

59. If a ton equals 2000 pounds, how many kilograms are there in a ton?

- a. 4410 kg
b. 70.6 kg
c. 1000 kg
d. 908 kg

Using the sketch below, for problems 60 and 61, change the length and width dimensions and their tolerances to millimeters. Round to the nearest hundredth of a millimeter.

60. Length dimension equals:

- a. $317.627 \pm 0.005\text{mm}$
- b. $317.5 \pm 0.13\text{mm}$
- c. $31.75 \pm 0.0127\text{mm}$
- d. $216.5 \pm .13\text{mm}$

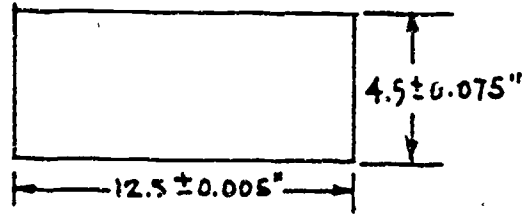

61. Width dimension equals:

- a. $114.3 \pm 1.91\text{mm}$
- b. $113.1 \pm 0.19\text{mm}$
- c. $11.43 \pm 0.19\text{mm}$
- d. $116.2 \pm 1.91\text{mm}$

62. If your car gets 9.35 kilometers per liter, how many miles per gallon does it get?

- a. 5.8 mpg
- b. 25 mpg
- c. 35.4 mpg
- d. 22 mpg

For problems 63 and 64, find the circumference in centimeters and the area in square centimeters of the circle shown in the sketch below. Remember, the circumference of a circle equals π times the diameter, where $\pi = 3.14$, and the area equals π times the radius squared, and π still equals 3.14.

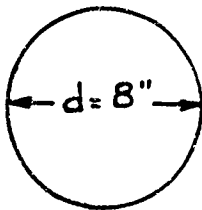

63. Circumference equals:

- a. 50.24 cm
- b. 324.13 cm
- c. 25.12 cm
- d. 63.80 cm

64. Area equals:

- a. 324.13 cu cm
- b. 63.80 cu cm
- c. 50.24 cu cm
- d. 200.96 cu cm

SHOP MATH FOR METAL TRADES: PRETEST

PART 2

1. Simplify the algebraic expressions given below by combining like terms.

a. $14c^2 + 6c^2 =$ _____.

b. $2(x+1) + 4(x+1) =$ _____.

c. $8ab^2 - 3cb - 5ab^2 + 6cb =$ _____.

d. $3x + 4y - x + 2y + 3x - 3y =$ _____.

2. Simplify the algebraic expressions given below by removing parentheses and combining like terms.

a. $x^2 + (2y - 2x^2) - (y + x^2) =$ _____.

b. $3 - (6x + 4) + (12x - 2) =$ _____.

c. $(x + y) + (x - y) - (x - y) =$ _____.

d. $s^2 - (p^2 + s^2) - (2p^2 + 4s^2) =$ _____.

3. Simplify the algebraic expressions given below by multiplying as indicated to remove parentheses and then combining like terms.

a. $3(x^2 + y^2) + 2(x^2 - y^2) =$ _____.

b. $3(R + S) - (R + S) =$ _____.

c. $2(3x - 1) - 3(2x + 2) =$ _____.

d. $4(a - b) + 3(2a - 6b) =$ _____.

4. Simplify the algebraic expressions given below by multiplying common terms to remove parentheses and then combine like terms.

a. $2x^2(x^3 + x^2y) + x^3(xy + 4x^2) =$ _____.

b. $10x^2y^2a^2(x^2a^2 + a^2y^2 + x^2y^2) =$ _____.

c. $3y^2(3x^2)(3x^2y^2) =$ _____.

d. $(-2a^2b^2)(a^2 - b^2) =$ _____.

5. Simplify the algebraic expressions given below by using the rule of exponents ($x^m + x^n = x^{m+n}$, $x^m + x^n = x^{m-n}$)

a. $(x^6y^5)(x^3y^4) =$ _____.

b. $(x^3y^6) \div (x^2y^4) =$ _____.

c. $(a^3b^3)(a^2b^3) =$ _____.

d. $(y^4w^5) \div (y^3w^2) =$ _____.

6. Solve the following equations by transposing and isolating the unknown letter.

a. $3x - 2(x + 6) = -6$, $x = \underline{\hspace{2cm}}$.

b. $4a + 3(a + 3) = 23$, $a = \underline{\hspace{2cm}}$.

c. $6x - 3(x + 4) = 12 - x$, $x = \underline{\hspace{2cm}}$.

d. $6w + 2(8 - w) = 10 - 2w$, $w = \underline{\hspace{2cm}}$.

7. Use the formula shown below to find the volume V.

$$V = \pi r^2 h, \pi = 3.14$$

$r = \text{radius, } 6''$
 $h = \text{height, } 4.5''$

Volume $V = \underline{\hspace{2cm}}$.

8. Use the formula shown below to find the weight W.

$$W = \frac{DH(A - \pi R^2)}{3.67}, \quad \begin{array}{l} D = \text{diameter, } 24 \text{ mm} \\ H = \text{height, } 60 \text{ mm} \\ A = 12 \text{ m m} \\ B = 20 \text{ m m} \end{array} \quad \begin{array}{l} \pi = 3.14 \\ R = \text{radius, } 6.25 \text{ mm} \\ 3.67 = \text{constant number} \end{array}$$

Weight $W = \underline{\hspace{2cm}}$ grams

9. Use the formula shown below to find the length L.

$$L = 4x + 3y + \frac{T}{2} + 6.34h, \quad \begin{array}{l} x = \text{dimension, } 12'' \\ y = \text{dimension, } 14'' \\ T = \text{thickness, } 0.667'' \\ h = \text{height, } 8'' \end{array}$$

Length $L = \underline{\hspace{2cm}}$.

10. Use the formula shown below to find the chord length L.

$$L = 2\sqrt{2RH - H^2}, \quad \begin{array}{l} R = \text{radius, } 7.5'' \\ H = \text{height, } 3.33'' \end{array}$$

Chord length $L = \underline{\hspace{2cm}}$. 39

11. Use the formula shown below to find the radius r .

$$W = (0.1) \left(\frac{4}{3} \pi r^3 \right), \quad W = 25$$

$$\pi = 3.14$$

radius $r =$ _____.

12. Use the formula shown below to find the dimension a .

$$A = \pi r^2 - ab, \quad A = \text{area, } 168 \text{ sq mm}$$

$$\pi = 3.14$$

$$r = \text{radius, } 25 \text{ mm}$$

$$b = \text{dimension, } 20 \text{ mm}$$

dimension $a =$ _____.

13. If the cross sectional area of a square heating duct must be 75 square inches, what is the length of one side of the duct?

Length of side _____

14. Translate the following English sentence into an algebraic equation:

"The horsepower required to overcome vehicle ~~air-resistance~~ is equal to the cube of the vehicle speed in MPH times the frontal area of the vehicle divided by 150,000."

Algebraic equation: _____

15. Translate the following English Sentence into an algebraic equation:

"The engine speed is equal to 168 times the overall gear reduction multiplied by the speed in MPH and divided by the radius of the tire."

Algebraic equation: _____

16. Solve the following problem involving two equations and two unknowns.

A 16" piece of stock is to be cut into two pieces. The long piece is to be three times the length of the short piece. What are the lengths of the two pieces?

Long piece _____ Short piece _____

17. If the gear ratio of a set of gears is 6:1 and the larger gear has 36 teeth on it, how many teeth does the smaller gear have?

Number of teeth _____

18. In the sketch below the two figures are similar. What is the distance H?

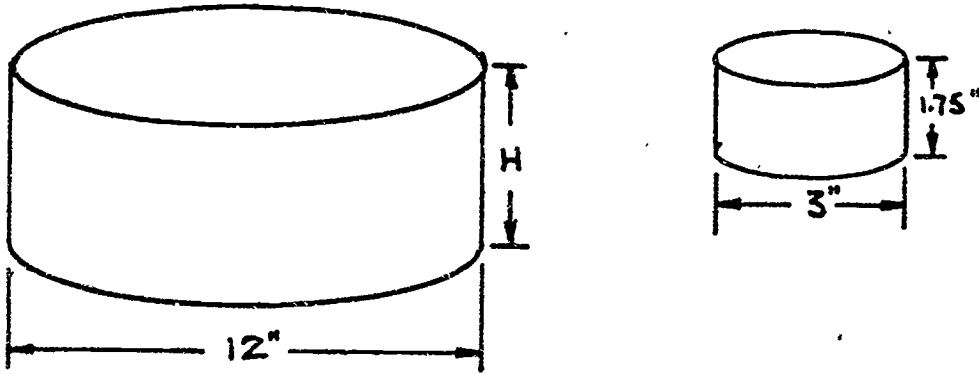

Distance H _____

19. If a metal worker can produce 83 doojiggers in 1 hour and 15 minutes, how many can he or she produce in 6 hours?

Number of doojiggers _____

20. Pressure is inversely proportional to volume if the temperature remains the same. When the volume in a pressure chamber is 300 cubic inches, the pressure is 120 pounds per square inch. If the temperature stays the same and the volume is decreased to 175 cubic inches, what does the new pressure equal?

Pressure _____

21. The speed of a gear is inversely proportional to the number of teeth on the gear. In the sketch below, how fast is gear B turning?

RPM of Gear B _____

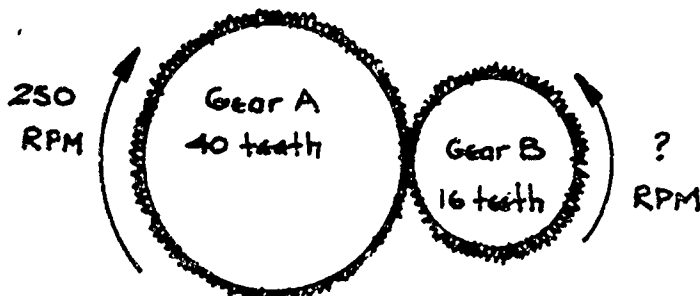

22. The speed of a pulley wheel is inversely proportional to its diameter. In the sketch below, what is the diameter D of pulley wheel A?

Diameter of pulley wheel A _____

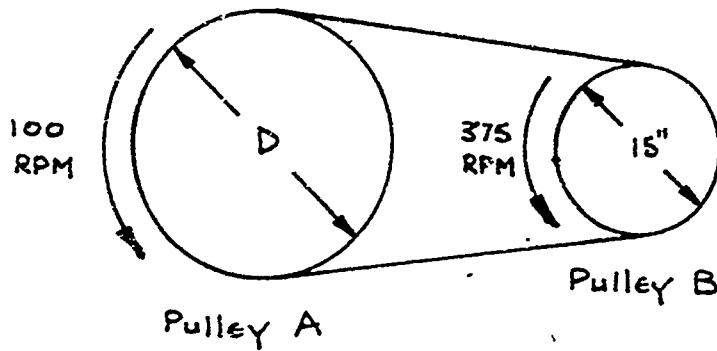

23. The forces and lever arm distances for a lever are inversely proportional. In the sketch below, find the amount of force, F_w , applied to the weight, W .

Force on weight W _____

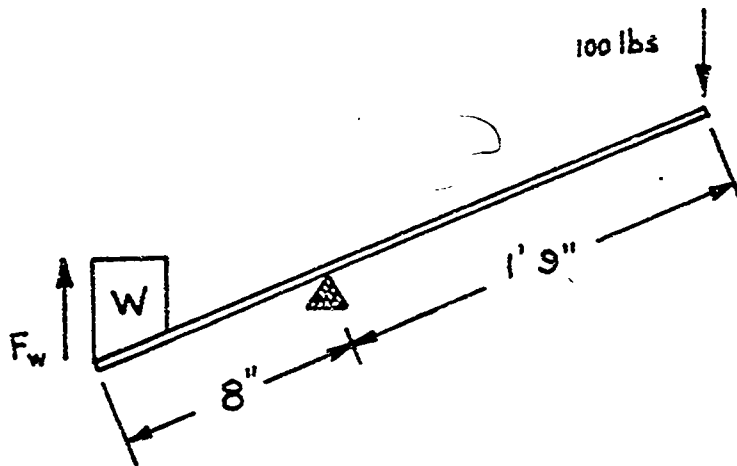

24. If six gallons of paint will cover 288 square feet of surface, how many gallons does it take to paint 1296 square feet of surface?

Gallons of paint required _____

25. Two people own a business. Tom owns 3 times more of the business than Bill. If the business is worth \$12,400, how much does Bill own? How much does Tom own?

Bill's share _____ Tom's share _____

Solve the systems of equations given below. First multiply one equation or both equations by appropriate constant numbers, then add or subtract the equations to eliminate one or the other of the unknowns, and finally, solve for the unknowns.

Problem 26.
$$\left. \begin{array}{l} \textcircled{1} \quad 5x + 6y = 14 \\ \textcircled{2} \quad 3x - 2y = -14 \end{array} \right\} \quad x = \underline{\hspace{2cm}}, y = \underline{\hspace{2cm}}.$$

Problem 27.
$$\left. \begin{array}{l} \textcircled{1} \quad -x - 2y = 1 \\ \textcircled{2} \quad -2x + 3y = -19 \end{array} \right\} \quad x = \underline{\hspace{2cm}}, y = \underline{\hspace{2cm}}.$$

Problem 28.
$$\left. \begin{array}{l} \textcircled{1} \quad 4s - 3r = -2 \\ \textcircled{2} \quad 3s + 2r = 7 \end{array} \right\} \quad s = \underline{\hspace{2cm}}, r = \underline{\hspace{2cm}}.$$

29. The total value of an order of nuts and bolts is \$7.30. The nuts cost 10 cents each and the bolts cost 15 cents each. The number of nuts is 3 more than twice the number of bolts. How many of each are there?

Nuts _____ Bolts _____

30. The perimeter of a sheet of metal is 72 inches. The length of the sheet is 12 inches more than twice the width. Find the dimensions of the sheet.

Width _____ Length _____

31. A person buys 10 identical shims and 5 identical brackets for \$8.75. Another person buys 5 of the shims and 10 of the brackets for \$10.75. How much does a shim cost and how much does a bracket cost?

Shim cost _____ Bracket cost _____

32. A two foot piece of pipe is to be cut into 2 pieces. The length of the long piece is 4 inches less than 3 times the length of the short piece. Find the lengths of the two pieces.

Long piece _____ Short piece _____

Solve the following quadratic equations by first putting them in the standard form, $ax^2 + bx + c = 0$, where a , b , and c are numbers, and then use the quadratic equation to solve for the unknown letter.

Quadratic equation: $x = \frac{-b \pm \sqrt{b^2 - 4ac}}{2a}$

standard form: $ax^2 + bx + c = 0$

Problem 33. $2x^2 + 80 = 26x$ $x = \underline{\hspace{1cm}}, \underline{\hspace{1cm}}$.

Problem 34. $5s + 12 = 2s^2$ $s = \underline{\hspace{1cm}}, \underline{\hspace{1cm}}$.

Problem 35. $R^2 + 2(R - 35) = 2(R - 3)$ $R = \underline{\hspace{1cm}}, \underline{\hspace{1cm}}$.

36. You are given a right triangle with the dimensions shown in the sketch below. You are to lay out a similar right triangle with dimensions h (height) and b (base) such that it will have an area twice that of the given right triangle. Find the dimensions h and b .

h _____ b _____

A_2 is to be twice A_1 , or
 $A_2 = 2A_1$

Area $A_2 = \frac{(b)(h)}{2}$

Area $A_1 = \frac{(9)(4)}{2}$

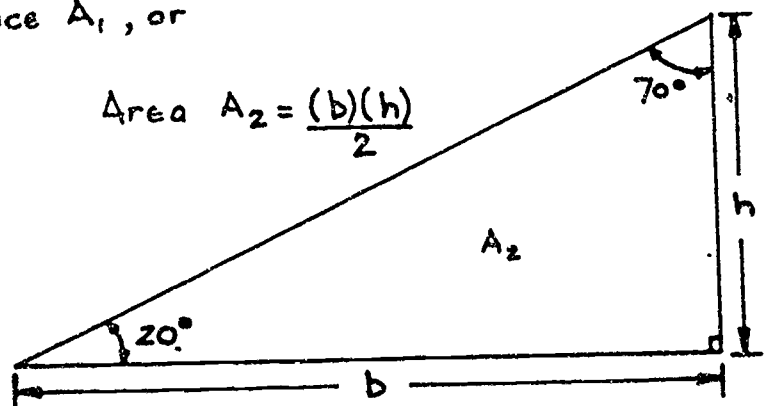
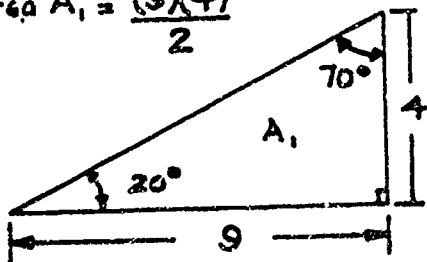

SHOP MATH FOR METAL TRADES: PRETEST
PART 2 (Computerized)

Choose the best answer for each problem.

In problem 1 through 4, simplify the algebraic expression by removing parentheses and then combining like terms.

1. $(x+1) - (2x+3) =$

- a. $-x-2$
- b. $-x-4$
- c. $3x+4$
- d. $3x-2$

2. $x^2 + (2Y - 2x^2) - Y - x^2 =$

- a. $4x^2 + Y$
- b. Y
- c. $-2x^2 - Y$
- d. $-2x^2 + Y$

3. $(x+Y) + (x-Y) - (x-Y) =$

- a. $x-Y$
- b. $x+Y$
- c. $3x-2Y$
- d. $2x+Y$

4. $s^2 - (p^2 + s^2) - (2p^2 + 4s^2) =$

- a. $4s^2 - 3p^2$
- b. $4s^2 - p^2$
- c. $-4s^2 - 3p^2$
- d. $-4s^2 - p^2$

In problems 5 through 8, simplify each algebraic expression by multiplying as indicated to remove parentheses and then by combining like terms.

5. $3(x^2 + Y^2) - 2(x^2 - Y^2) =$

- a. $x^2 + Y^2$
- b. $x^2 + 5Y^2$
- c. $x^2 - Y^2$
- d. $x^2 + 4Y^2$

6. $2(3x-1) - 3(2x-2) =$

- a. $x-6$
- b. -8
- c. $x+4$
- d. 4

7. $4(a-b) + 3(2a-6b) =$

- a. $10-14b$
- b. $10a-22b$
- c. $9a-13b$
- d. $10a-7b$

8. $-(3x+4) - 2(5x-3) =$

- a. $-13x+10$
- b. $-13x-7$
- c. $-13x+2$
- d. $-13x-2$

In problems 9 and 10, simplify the algebraic expressions by multiplying terms to remove parentheses and then by combining like terms.

9. $(3y^2)(3x^2)(3x^2y^2) =$

- a. $27x^2y^2$
- b. $27x^4y^4$
- c. $3x^4y^4$
- d. $9x^4y^4$

10. $-3ab(2a^2b - 4ab^2) =$

- a. $-6a^2b^3 + 12a^3b^2$
- b. $-5a^3b^2 + 7a^2b^3$
- c. $6a^3b^2 + 12a^2b^3$
- d. $-6a^3b^2 + 12a^2b^3$

In problems 11 through 14, use the rules of exponents ($x^m \cdot x^n = x^{m+n}$; $x^m \div x^n = x^{m-n}$).

11. $(x^4y^6) \div (x^2y^3) =$

- a. x^6y^9
- b. x^2y^3
- c. x^2y^2
- d. x^8y^3

12. $(a^3y^2)(a^2y^3) =$

- a. a^5y^5
- b. a^6y^6
- c. a^5y^5
- d. a^6y^6

13. $rs^2(r^3s^2 - r^4s^3) =$

- a. $r^3s^4 - r^4s^3$
- b. $r^3s^4 - r^5s^6$
- c. $r^4s^4 - r^5s^5$
- d. $r^3s^4 - r^4s^6$

14. $(d^2c^2 - d^4c^4) \div (-d^2c) =$

- a. $-c + d^2c^3$
- b. $-dc - d$
- c. $-c - d^4c^4$
- d. $c + d^2c^3$

In problems 15 through 18, solve the equations by transposing and solving for the unknown letter.

15. $4x - 2(x + 6) = 6$

- a. $x = 3$
- b. $x = -1$
- c. $x = 9$
- d. $x = -3$

16. $6w + 2(8 - w) = 10 - 2w$

- a. $w = -1$
- b. $w = 3$
- c. $w = 2$
- d. $w = 1$

17. $-(a - 3) = 2a - 6$

- a. $a = 1$
- b. $a = 3$
- c. $a = -3$
- d. $a = -1$

18. $3(M + 4) = 24 - M$

- a. $M = 18$
- b. $M = 9$
- c. $M = 3$
- d. $M = 5$

46

19. Use the formula given below to find the volume V.

$$V = \pi r^2 h, \pi = 3.14; r = \text{radius}, 6"; h = \text{height}, 4.5"$$

- The volume V equals:
- 84.78 cu in
 - 508.68 cu in
 - 162.2 cu in
 - 113.04 cu in

20. Use the formula given below to find the weight W.

$$W = \frac{DH(AB - \pi R^2)}{3.67}, \quad D = 24 \text{ mm}; H = 60 \text{ mm}; R = 6.25 \text{ mm}$$

$$A = 12 \text{ mm}; B = 20 \text{ mm}; \pi = 3.14$$

- Weight W equals:
- 345,567 grams
 - 176,550 grams
 - 94,135 grams
 - 46,045 grams

21. Use the formula given below to find the length L.

$$L = 4x + 3y + \frac{T}{2} + 6.34h, \quad x = 12"; y = 14";$$

$$T = 0.67"; h = 8"$$

- Length L equals:
- 155.39"
 - 105.01"
 - 141.05"
 - 363.05"

22. Use the formula shown below to find the chord length L.

$$L = 2\sqrt{2RH - H^2}, \quad R = 7.5"; H = 3.33"$$

- Chord length L equals:
- 6.67"
 - 43.29"
 - 12.47"
 - 88.25"

23. Use the formula shown below to find the radius r .

$$W = (0.1) \left(\frac{4}{3} \pi r^3 \right), \quad W = 25 \text{ lbs}; \pi = 3.14$$

$0.1 = \text{constant number}; r = \text{radius}$

Radius r equals:

- a. 3.91"
- b. 7.73"
- c. 2.44"
- d. 2.00"

24. Use the formula below to find the dimension a .

$$A = \pi r^2 - ab, \quad A = 168 \text{ sq mm}; r = 25 \text{ mm}$$

$\pi = 3.14; b = 20 \text{ mm}$

Dimension a equals:

- a. 0.004 mm
- b. 0.086 mm
- c. 89.73 mm
- d. 4.48 mm

25. If the cross sectional area of a square heating duct must be 75 square inches, what is the dimension of the side of the duct?

Dimension of the duct side equals:

- a. 8.66"
- b. 12.55"
- c. 5.66"
- d. 7.5"

26. Translate the following English sentence into an algebraic equation:

"The engine speed is equal to 168 times the overall gear reduction multiplied by the speed in MPH and divided by the radius of the tire."

a. $E = \frac{168 G}{sr}$

b. $E = \frac{168 Gs}{r}$

c. $E = \frac{168}{Gsr}$

d. $E = \frac{168r}{Gs}$

18

27. Solve the following problem which includes two equations and two unknowns:

A 16" piece of bar stock is to be cut into two pieces. The length of the long piece is to be 2 inches more than 3 times the length of the short piece. What are the lengths of the two pieces?

- a. long piece = 14", short piece = 2"
- b. long piece = 13", short piece = 3"
- c. long piece = 12.5", short piece = 3.5"
- d. long piece = 11.5", short piece = 4.5"

28. In the sketch below, if the two cylinders are similar, what is the height H of the larger cylinder?

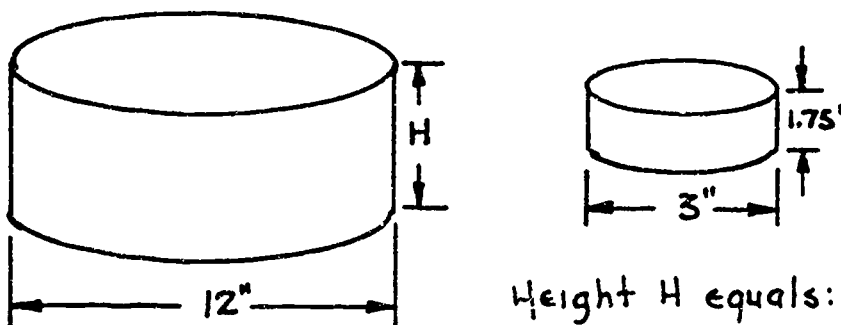

Height H equals:

29. Pressure is inversely proportional to volume if the temperature remains the same. When the volume in a pressure chamber is 300 cubic inches, the pressure is 120 pounds per square inch. If the temperature remains the same and the volume is decreased to 175 cubic inches, what does the new pressure equal?

Pressure P equals:

- a. 205.71 psi
- b. 437.5 psi
- c. 70 psi
- d. 175 psi

30. The speed of a gear is inversely proportional to the number of teeth on the gear. In the sketch below, how fast is gear B turning?

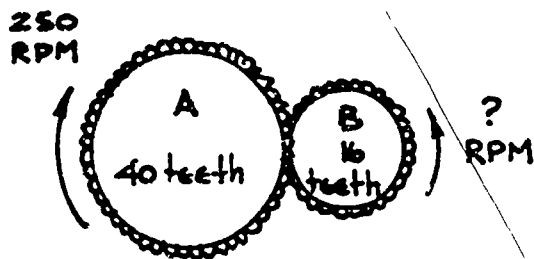

Gear B speed equals:

31. The speed of a pulley wheel is inversely proportional to its diameter. In the sketch below, what is the diameter D of the large pulley wheel?

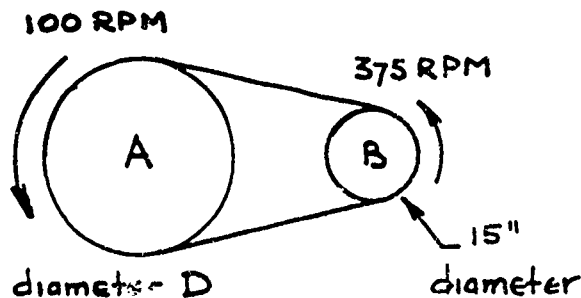

Diameter D equals:

32. If 6 gallons of paint will cover 2880 square feet of surface, how many gallons of paint will it take cover 12,960 square feet of surface?

- a. 45 gals
 b. 13.33 gals
 c. 270 gals
 d. 27 gals

33. Two people own a business. Luana owns 4 times more of the business than Alice. If the total business is worth \$125,000; how much each do Luana and Alice own?

- a. Luana - \$75,000 ; Alice - \$50,000
 b. Luana - \$87,500 ; Alice - \$37,500
 c. Luana - \$100,000 ; Alice - \$25,000
 d. Luana - \$92,500 ; Alice - \$32,500

50

In problems 34 through 36, solve the systems of two equations and two unknowns. First multiply one equation or both equations by appropriate constant numbers. Then add or subtract the equations to eliminate one of the unknown letters. Finally, solve for the unknown.

34. $\textcircled{1} 5x + 6y = 14$
 $\textcircled{2} 3x - 2y = -14$

- a. $x = 4, y = -1$
 b. $x = 2, y = 10$
 c. $x = 2, y = -4$
 d. $x = -2, y = 4$

35. $\textcircled{1} -x - 2y = 1$
 $\textcircled{2} -2x + 3y = -19$

- a. $x = -5, y = 2$
 b. $x = -3, y = 1$
 c. $x = -1, y = -7$
 d. $x = 5, y = -3$

36. $\textcircled{1} 3s + 2p = 7$
 $\textcircled{2} 4s - 3p = -2$

- a. $s = -1, p = 5$
 b. $s = -3, p = 8$
 c. $s = 1, p = 2$
 d. $s = 3, p = -1$

37. The total value of an order of nuts and bolts is \$7.30. The nuts cost 10 cents each and the bolts cost 15 cents each. The number of nuts is 3 more than twice the number of bolts. How many of each are there?

Number of Nuts and Bolts equals:

- a. Nuts = 33, Bolts = 15
 b. Nuts = 43, Bolts = 20
 c. Nuts = 53, Bolts = 25
 d. Nuts = 34, Bolts = 26

38. The perimeter of a sheet of metal is 72 inches. The length of the sheet is 12 inches more than twice the width. Find the area of the sheet.

Area of the metal Sheet equals:

- a. Area = 288 sq in
 b. Area = 640 sq in
 c. Area = 224 sq in
 d. Area = 322.56 sq in

39. A three foot piece of pipe is to be cut into two pieces. The length of the long piece is 4 inches less than 3 times the length of the short piece. What are the lengths of the two pieces of pipe?

Lengths of long piece and short piece equal:

- a. Long piece = 20", short piece = 16"
 b. Long piece = 26", short piece = 10"
 c. Long piece = 22", short piece = 14"
 d. Long piece = 28", short piece = 8"

In problems 40 through 42, solve the quadratic equations by first putting them in the standard form, $ax^2 + bx + c = 0$, where a , b , and c are numbers, and then use the quadratic equation to solve for the unknown letter.

$$\text{Quadratic Equation: } x = \frac{-b \pm \sqrt{b^2 - 4ac}}{2a}$$

40. $2x^2 + 80 = 26x$

a. $x = 8, 5$

b. $x = -8, 5$

c. $x = 8, -5$

d. $x = -8, -5$

41. $20 + 5(3-s) = s^2 - 3s$

a. $s = -5, 2$

b. $s = 5, -2$

c. $s = -5, -2$

d. $s = 5, 2$

42. $w(w+3) = 8(w+8) - 5w$

a. $w = 8, -8$

b. $w = 16, -16$

c. $w = 8, 8$

d. $w = 16, -4$

43. You are given a right triangle with the dimensions given in the sketch below. You are to lay out a similar right triangle with dimensions h and b such that it will have an area three times that of the given right triangle. Find the dimensions h and b .

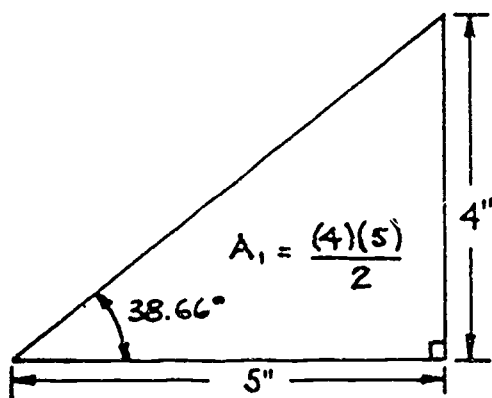

$$A_2 = 3A_1$$

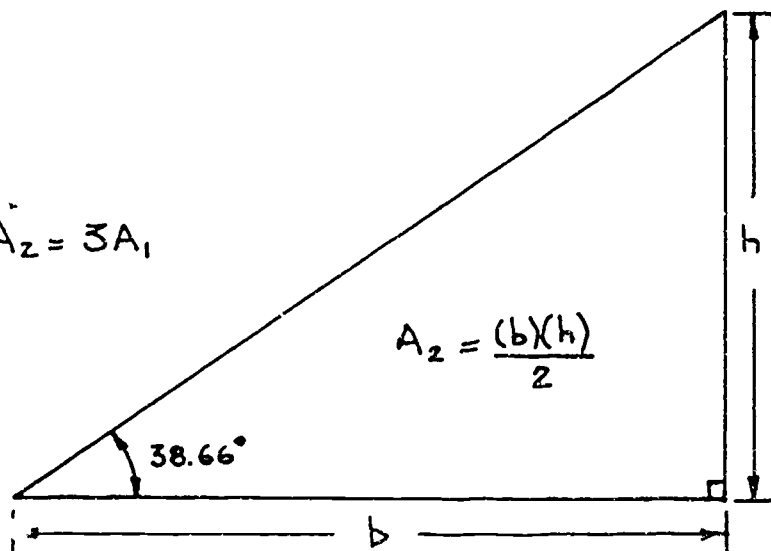

Dimensions h and b equal:

a. $h = 5.75"$, $b = 10.43"$

b. $h = 12"$, $b = 5"$

c. $h = 6.93"$, $b = 8.66"$

d. $h = 10"$, $b = 6"$

52

SHOP MATH FOR METAL TRADES: PRETEST PART 3

Work the problems and write the correct answers in the blanks.

1. In the sketch below, find angles a , b , c , d , e , f , and g .

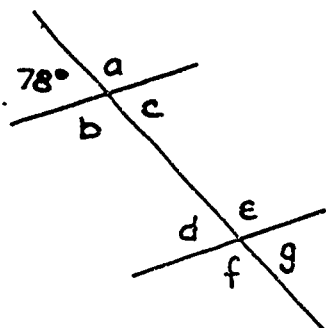

$\angle a =$ _____	$\angle e =$ _____
$\angle b =$ _____	$\angle f =$ _____
$\angle c =$ _____	$\angle g =$ _____
$\angle d =$ _____	

2. In the sketch below, find angle A .

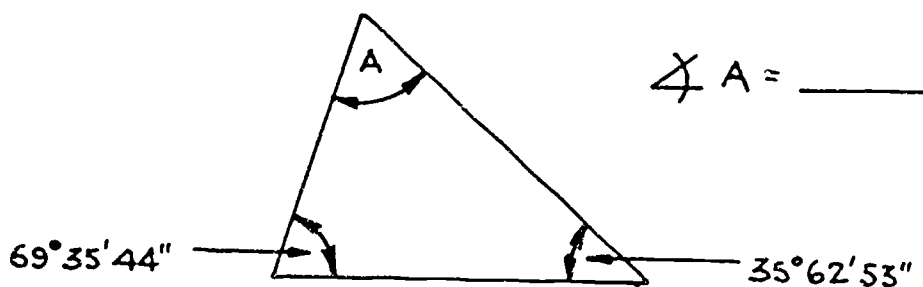

$\angle A =$ _____

3. Find the area and the perimeter of the rectangle shown in the sketch below.

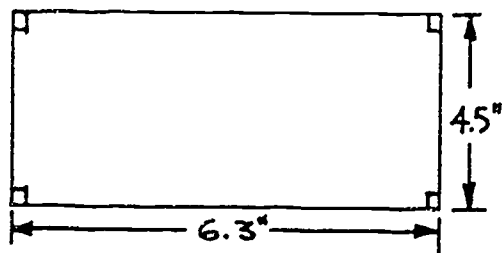

Perimeter equals the distance around the figure.
Area equals the base times the height.

Perimeter = _____ Area = _____

4. If the area of a square is 169 square inches, what is the length of its side

Length of side _____

5. In the sketch below, find the area of the parallelogram.

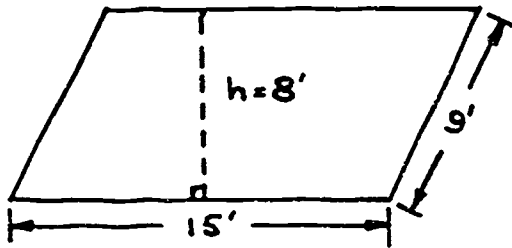

Area of a parallelogram
equals base \times height

Area of parallelogram = _____.

6. The formula for the area of a trapezoid is given in the sketch below. Find the area and the perimeter of the trapezoid.

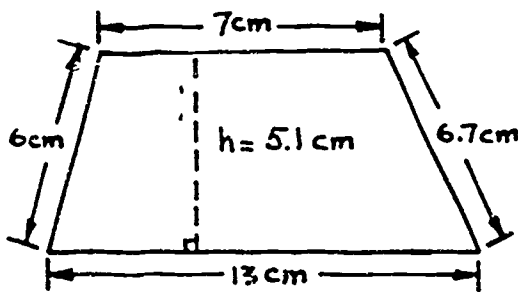

Area of a trapezoid = $\frac{(b_1 + b_2)h}{2}$,

where b_1 and b_2 are the top
and bottom bases and h is
the height.

Perimeter = _____

Area of the trapezoid = _____.

7. The line that is the height of an isosceles triangle is perpendicular to, and bisects the base of the triangle. Find the area of the isosceles triangle shown in the sketch below.

Hint: First find the height of the triangle by using the Pythagorean Theorem and then use the formula:

$$\text{Area} = \frac{\text{base times height}}{2}$$

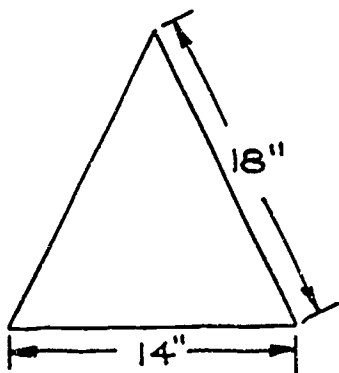

Area of isosceles
triangle = _____.

Pythagorean Theorem:

The square of the hypotenuse
of a right triangle equals the
sum of the squares of the other
two sides. See below

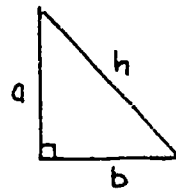

$$h^2 = a^2 + b^2$$

8. In the sketch below, find the length of the ladder required for you to climb a wall that has a trench in front of it.

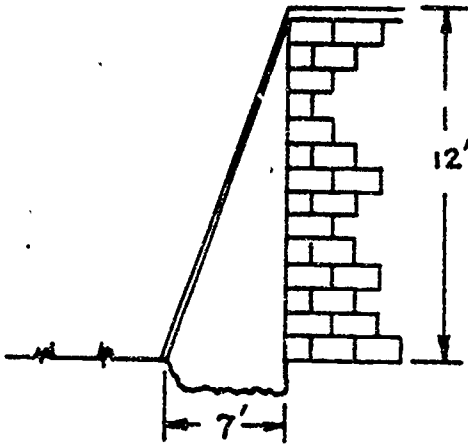

Length of ladder = _____.

9. What is the missing dimension x in the sketch of the taper punch shown below?

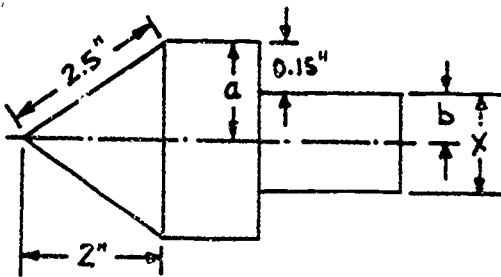

Hint: first find a , then b , and finally x .

x = _____.

10. Find the area of each of the three triangles shown below. You may need to use the Pythagorean Theorem to find the height.

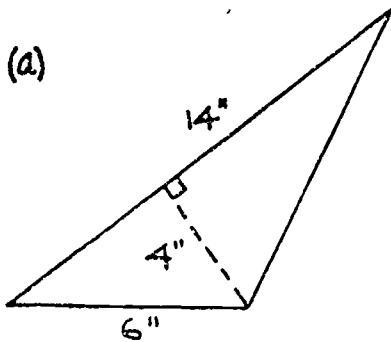

Area = _____.

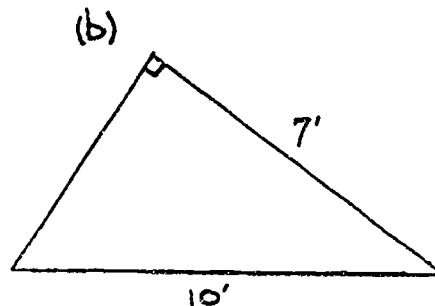

Area = _____.

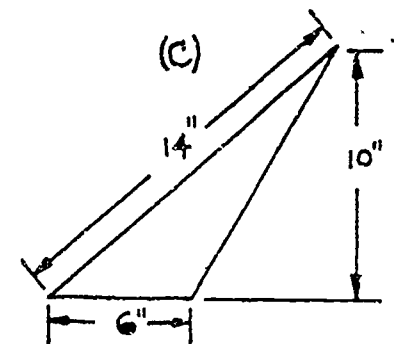

Area = _____.

11. Find the area of the triangle shown in the sketch below by using Hero's Formula.

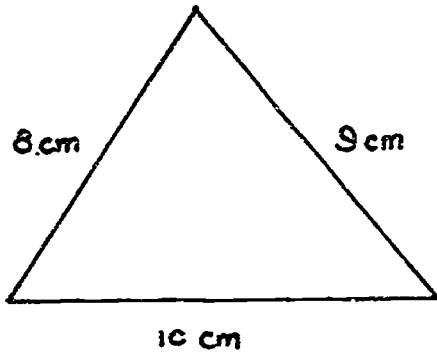

Area = _____.

Hero's Formula:

$$\text{Area} = \sqrt{s(s-a)(s-b)(s-c)}$$
 where $s = \frac{a+b+c}{2}$, and
 a, b, and c are the sides of the triangle.

12. Find the area of the geometric figure shown in the sketch below.

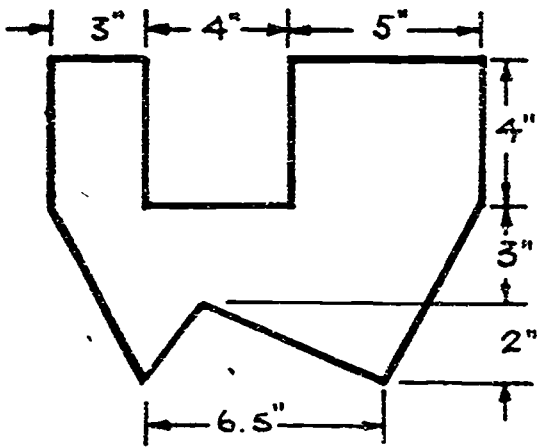

Area of rectangle = $a \cdot b$, where a and b are the sides.

Area of a triangle = $\frac{b \cdot h}{2}$, where b is the base and h is the height.

Area of a trapezoid = $\frac{(b_1 + b_2)h}{2}$, where b_1 and b_2 are the top and bottom bases and h is the height.

Area of the figure = _____.

13. Find the area of the geometric figure shown below.

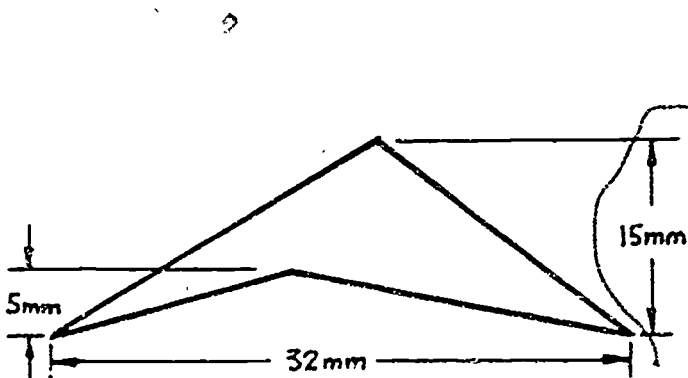

Area of triangle = $\frac{b \cdot h}{2}$, where b equals the base and h equals the height.

Area of the figure = _____.

56;

14. Find the area of the geometric figure shown below.

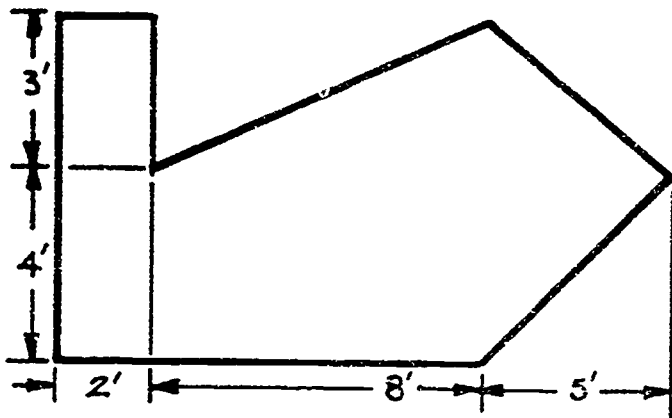

$$\text{Area of a trapezoid} = \frac{(b_1 + b_2)h}{2}$$

$$\text{Area of a rectangle} = a \cdot b$$

$$\text{Area of a triangle} = \frac{b \cdot h}{2}$$

$$\text{Area of the figure} = \underline{\hspace{2cm}}$$

15. Find the radius R of the circle with center at point P as shown in the sketch below.

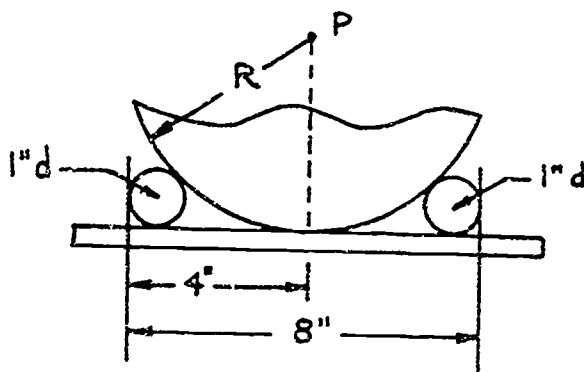

Hint: Use the
Pythagorean Theorem

$$\text{Radius } R = \underline{\hspace{2cm}}$$

16. Find the side s , the perimeter p , and the area A of the regular pentagon shown in the sketch below. Remember, the perimeter equals the distance around the figure. Also remember that in a regular pentagon all five sides are equal.

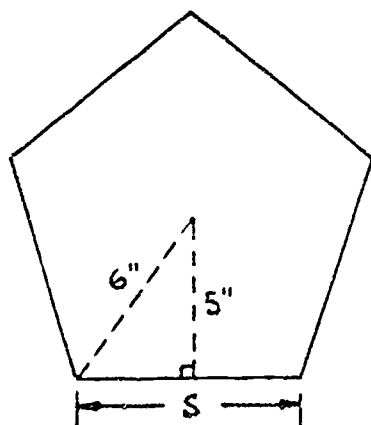

Hint: first use the
Pythagorean Theorem.

$$\text{Side } s = \underline{\hspace{2cm}}$$

$$\text{Perimeter } p = \underline{\hspace{2cm}}$$

$$\text{Area} = \underline{\hspace{2cm}}$$

17. Given a circle with a diameter of 16.7 inches, find the circumference and the area. Let $\pi = 3.14$.

Circumference _____ Area _____

18. What is the length of a piece of ornamental iron needed to make the design shown in the sketch below? Let $\pi = 3.14$.

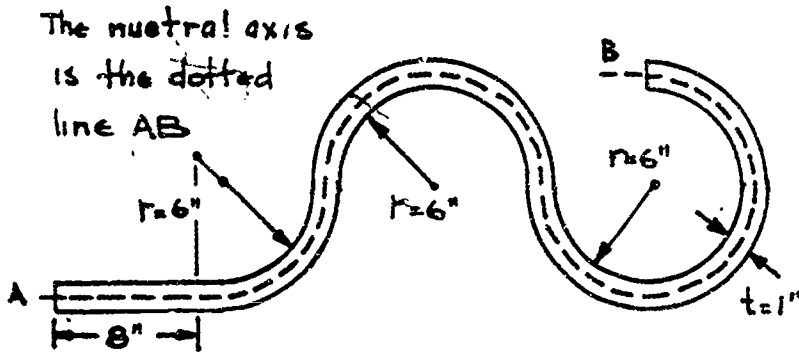

Hint: Find the total length along the neutral axis. The neutral axis is the center line of the ornamental iron.

Length _____

19. In the sketch below, find angles a , b , and c . Lines AB and AC are tangent to the circle at points D and E. Lines PD and PE are radii of the circle.

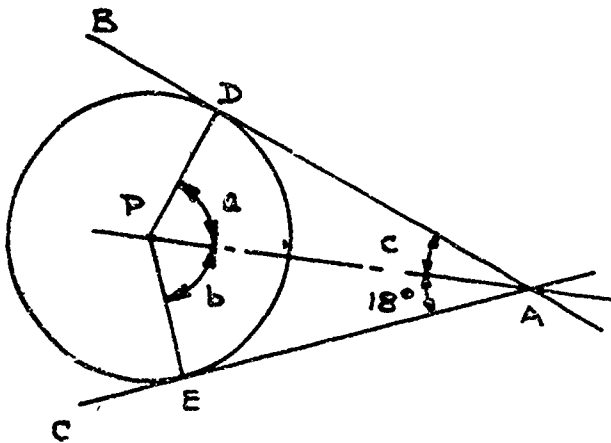

$\angle a =$ _____

$\angle b =$ _____

$\angle c =$ _____

20. Find the volume of the rectangular right prism shown in the sketch at the right.

The volume of a right prism equals the cross-sectional area of the prism times the height of the prism.

Volume _____

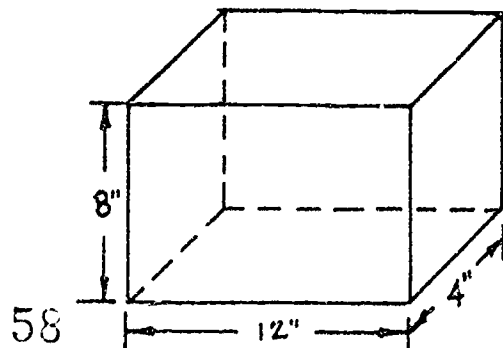

21. Find the lateral surface area, total surface area, and volume of the cone shown in the sketch below.

Lateral surface area _____ Total surface area _____

Volume _____

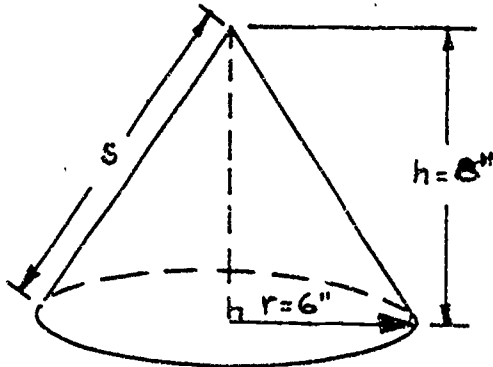

$s =$ slant height
 Lateral surface Area $= \pi r s$, $\pi = 3.14$
 Total surface Area $= \pi r s + \pi r^2$
 Volume $= \frac{1}{3} \pi r^2 h$

Hint: Use the Pythagorean Theorem to find s .

22. Find the surface area, total surface area, and volume of the pyramid shown in the sketch below.

Surface area _____ Total surface area _____

Volume _____

Surface area = area of the sides

Total surface area = area of the sides plus area of the base

Volume $= \frac{1}{3}$ (height times area of base)

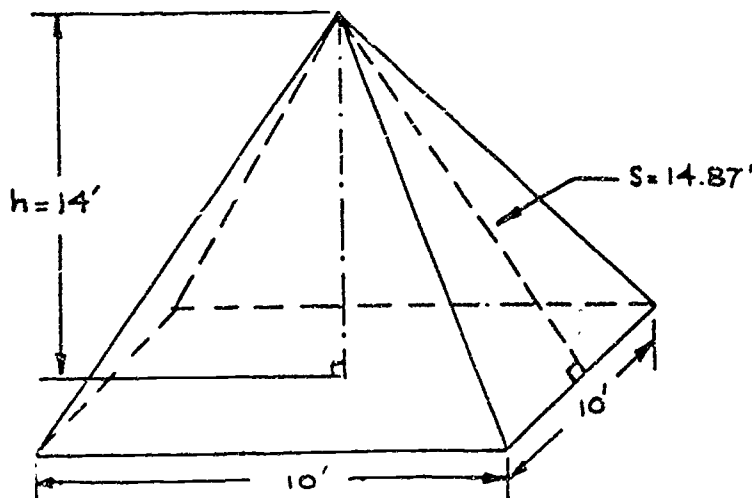

23. Find the total surface area and the volume of the composite shape shown below.

Hint: Remember the total surface area is the total outer surface area. Also, use the Pythagorean Theorem to find the slant height.

Total surface area _____ Volume _____

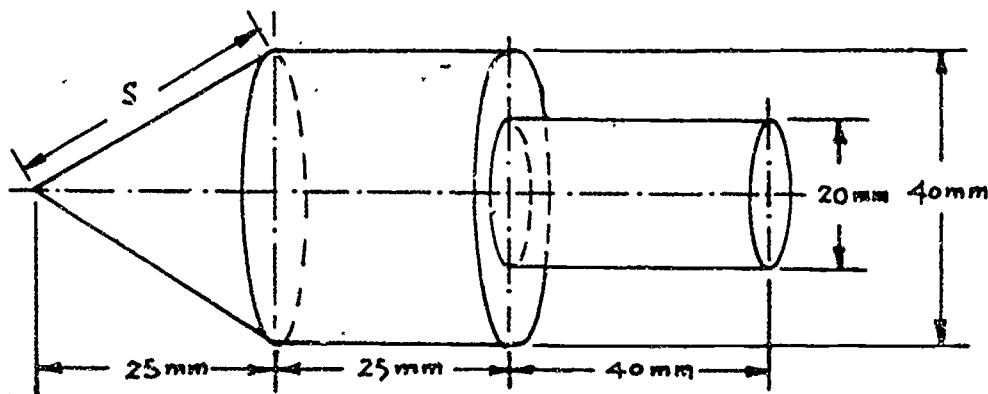

Surface area of a cone = $\pi \times \text{radius} \times \text{slant height}$
 Surface area of a cylinder = $2\pi \times \text{radius} \times \text{height}$
 Volume of a cone = $\frac{1}{3}\pi \times \text{radius squared} \times \text{height}$

Area of the base of cylinder = $\pi \times \text{radius squared}$
 Volume of a cylinder = $\pi \times \text{radius squared} \times \text{height}$

24. Find the volume of the conic frustrum shown in the sketch below.

Volume _____

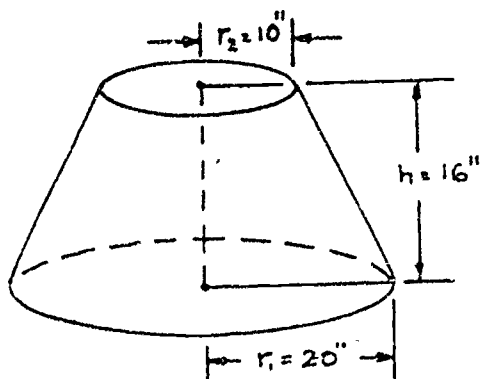

$$V = \frac{1}{3}h (A_1 + A_2 + \sqrt{A_1 A_2})$$

where $A_1 = \pi r_1^2$; $A_2 = \pi r_2^2$;
 and $\pi = 3.14$

61)

25. Find the volume of the frustrum of a pyramid as shown in the sketch below.

Volume _____

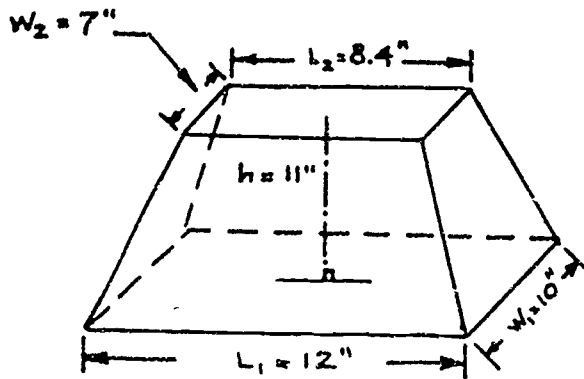

$$V = \frac{1}{3} h (A_1 + A_2 + \sqrt{A_1 A_2})$$

Where $A_1 = L_1 W_1$ and $A_2 = L_2 W_2$

26. In the sketch below, line AB is the diameter of a circle with center at point P. Lines PC and PD are radii of the circle. Find angles a and b .

angle a _____

angle b _____

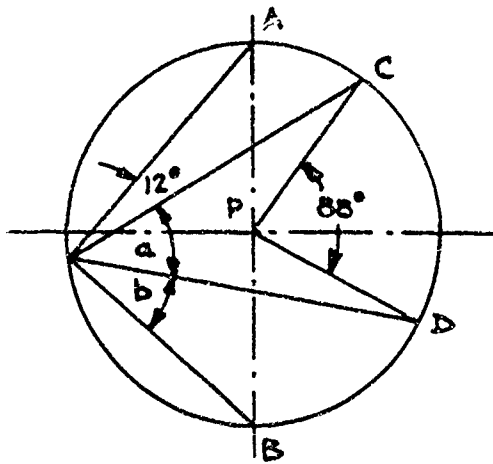

SHOP MATH FOR METAL TRADES: PRETEST

PART 3 (COMPUTERIZED)

Choose the best answer for each of the following problems.

In problems 1 through 7, look at the sketch shown below and find angles

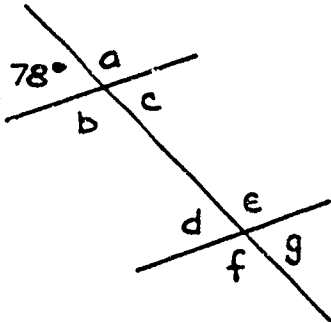

1. Angle a equals:

- a. 102°
- b. 78°
- c. 88°
- d. 12°

2. Angle b equals:

- a. 12°
- b. 102°
- c. 78°
- d. 88°

3. Angle c equals:

- a. 12°
- b. 88°
- c. 102°
- d. 78°

4. Angle d equals:

- a. 78°
- b. 88°
- c. 12°
- d. 102°

5. Angle e equals:

- a. 102°
- b. 78°
- c. 88°
- d. 12°

6. Angle f equals:

- a. 12°
- b. 102°
- c. 78°
- d. 88°

7. Angle g equals:

- a. 12°
- b. 88°
- c. 102°
- d. 78°

8. In the sketch below, find angle A. Angle A equals:

- a. $75^\circ 21' 23''$
- b. $74^\circ 21' 23''$
- c. $76^\circ 23' 23''$
- d. $75^\circ 23' 23''$

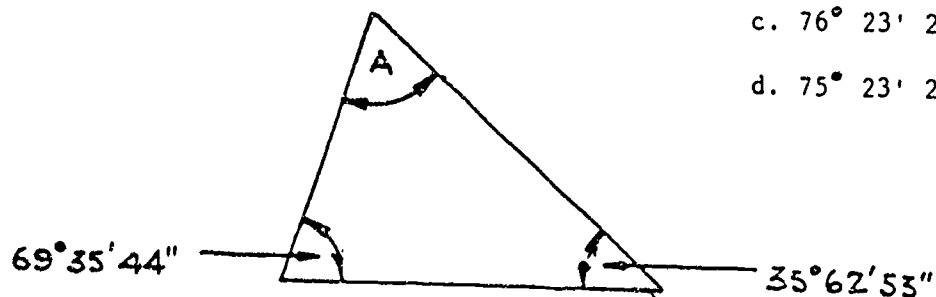

In problems 9 and 10, look at the sketch below and find the perimeter and the area of the rectangle.

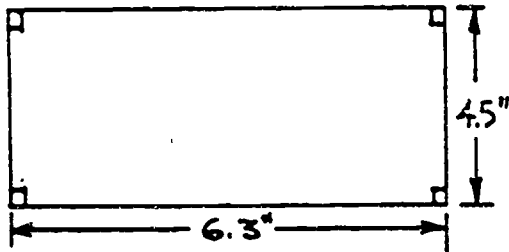

Perimeter equals the distance around the figure.
Area equals the base times the height.

9. The perimeter equals:

- a. 20.6 in
- b. 18 in
- c. 21.6 in
- d. 25.2 in

10. The area equals:

- a. 27.1 sq in
- b. 29.25 sq in
- c. 28.35 sq in
- d. 21.6 sq in

11. If the area of a square is 169 square inches, what is the length of its side?

- a. 16 in
- b. 21.25 in
- c. 42.25 in
- d. 13 in

In problems 12 and 13, find the perimeter and area of the parallelogram shown in the sketch below.

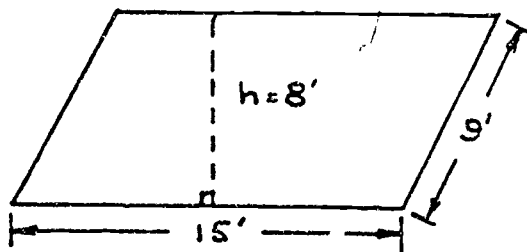

Area of a parallelogram equals base x height

12. The perimeter equals:

- a. 34 ft
- b. 46 ft
- c. 48 ft
- d. 47 ft

13. The area equals:

- a. 120 sq ft
- b. 135 sq ft
- c. 72 sq ft
- d. 225 sq ft

In problems 14 and 15, find the perimeter and area of the trapezoid shown in the sketch below.

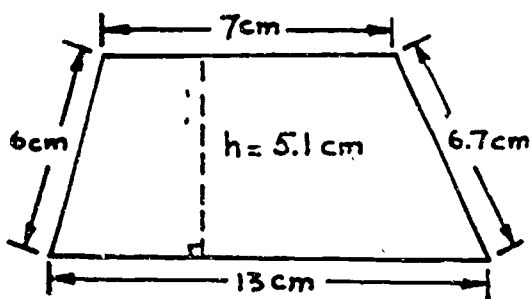

$$\text{Area of a trapezoid} = \frac{(b_1 + b_2)h}{2}$$

where b_1 and b_2 are the top and bottom bases and h is the height.

14. The perimeter equals:

- a. 36.2 cm
- b. 32.7 cm
- c. 24.2 cm
- d. 30.2 cm

15. The area equals:

- a. 102 sq cm
- b. 40 sq cm
- c. 51 sq cm
- d. 67 sq cm

16. The line that is the height of an isosceles triangle is perpendicular to, and bisects the base of the triangle. Find the area of the isosceles triangle shown in the sketch below.

Hint: First find the height of the triangle by using the Pythagorean Theorem and then use the formula:

$$\text{Area} = \frac{\text{base times height}}{2}$$

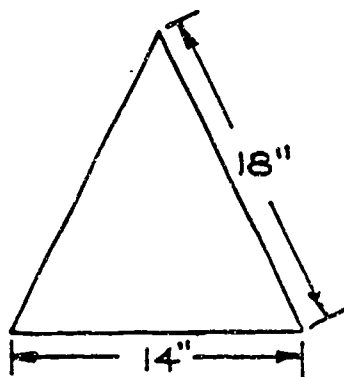

- a. 158.39 sq in
- b. 79.19 sq in
- c. 126 sq in
- d. 116.08 sq in

Pythagorean Theorem:

The square of the hypotenuse of a right triangle equals the sum of the squares of the other two sides. See below

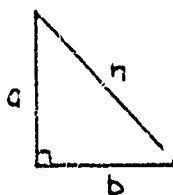

$$h^2 = a^2 + b^2$$

17. In the sketch below find the length of the ladder required for you to climb a wall that has a trench in front of it.

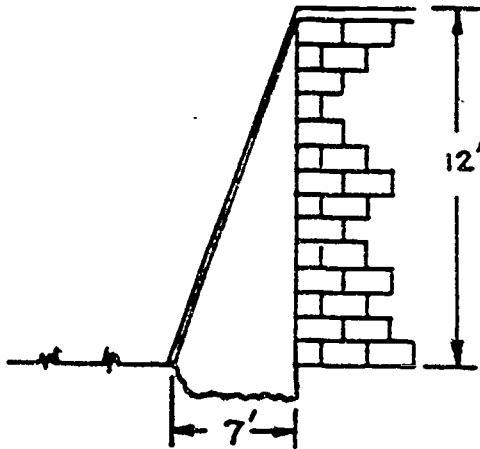

The length of the ladder equals:

- a. 19 ft
 - b. 13.89 ft
 - c. 11.70 ft
 - d. 14.37 ft
18. What is the missing dimension x in the sketch of the taper punch shown below?

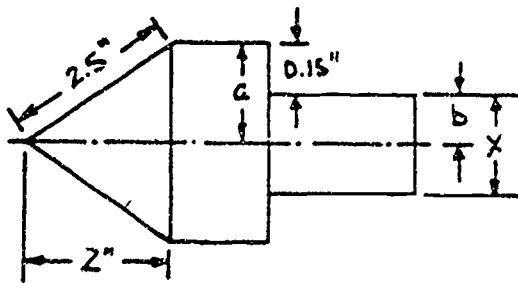

Hint: first find a ,
then b , and finally x .

The dimension x equals:

- a. 2.2"
- b. 2.7"
- c. 2.85"
- d. 1.5"

85

In problems 19 through 21, find the areas of the triangles shown in the sketch below. You may need to use the Pythagorean Theorem to find the height.

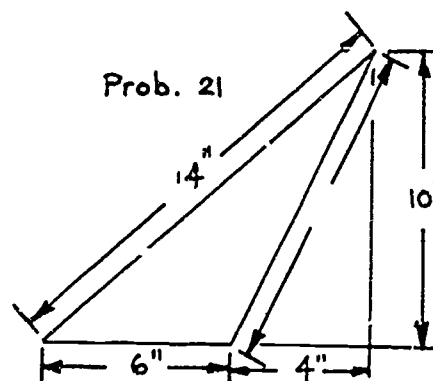
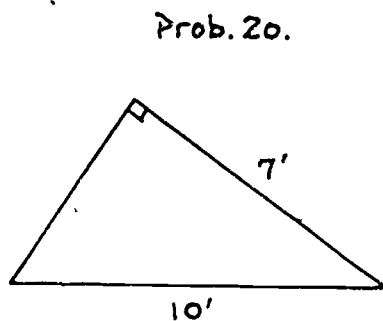
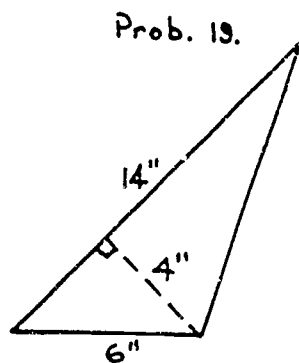

19. The area equals:

- a. 12 sq in
- b. 42 sq in
- c. 28 sq in
- d. 24 sq in

20. The area equals:

- a. 39 sq ft
- b. 35.7 sq ft
- c. 28 sq ft
- d. 25 sq ft

21. The area equals:

- a. 70 sq in
- b. 30 sq in
- c. 50 sq in
- d. 42 sq in

22. Find the area of the triangle shown in the sketch below by using Hero's Formula.

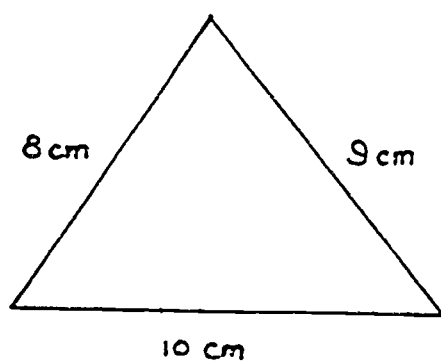

Hero's Formula:

$$\text{Area} = \sqrt{s(s-a)(s-b)(s-c)},$$

where $s = \frac{a+b+c}{2}$, and

a , b , and c are the sides of the triangle.

The area of the triangle equals:

- a. 34.20 sq cm
- b. 396.2 sq cm
- c. 76.25 sq cm
- d. 42.5 sq cm

23. Find the area of the geometric figure shown in the sketch below.

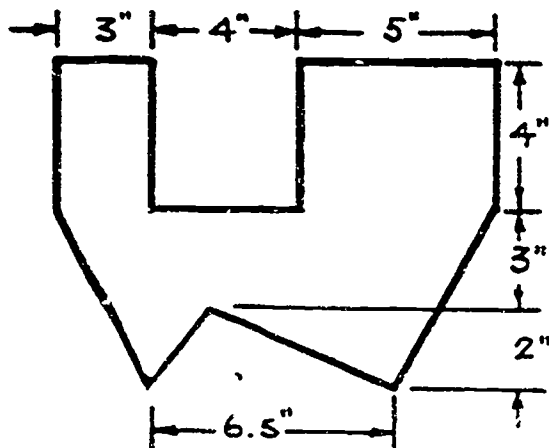

Area of rectangle = $a \cdot b$, where a and b are the sides.

Area of a triangle = $\frac{b \cdot h}{2}$, where b is the base and h is the height.

Area of a trapezoid = $\frac{(b_1 + b_2)h}{2}$, where b_1 and b_2 are the top and bottom bases and h is the height.

The area equals:

- a. 86 sq in
- b. 71.75 sq in
- c. 55.125 sq in
- d. 78.25 sq in

24. Find the area of the geometric figure shown below.

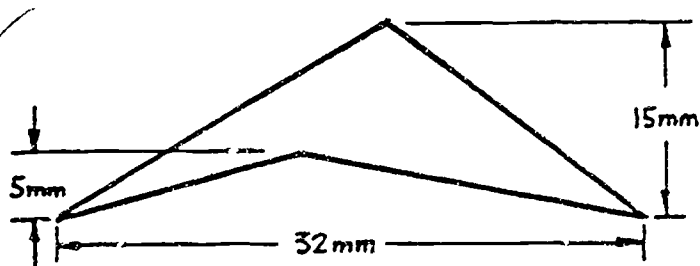

Area of triangle = $\frac{b \cdot h}{2}$, where b

equals the base and h equals the height.

The area equals:

- a. 320 sq mm
- b. 160 sq mm
- c. 80 sq mm
- d. 390 sq mm

25. Find the area of the geometric figure shown below.

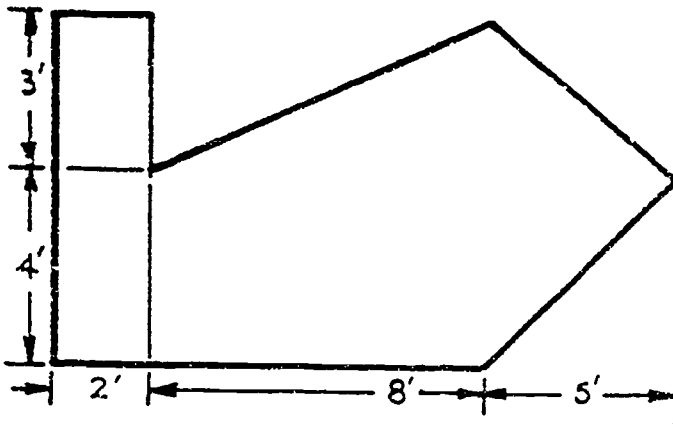

$$\text{Area of a trapezoid} = \frac{(b_1 + b_2)h}{2}$$

$$\text{Area of a rectangle} = a \cdot b$$

$$\text{Area of a triangle} = \frac{b \cdot h}{2}$$

The area equals:

- a. 127.5 sq ft
- b. 105 sq ft
- c. 75.5 sq ft
- a. 63.5 sq ft

26. Find the radius R of the circle with center at point P as shown in the sketch below.

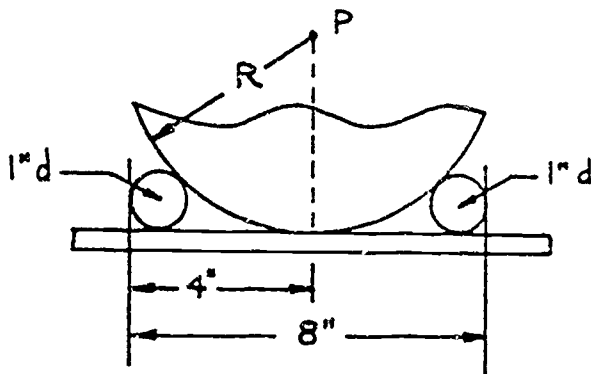

Hint: Use the
Pythagorean Theorem

The radius R equals:

- a. 8 inches
- b. 2.5 inches
- c. 4 inches
- d. 6.125 inches

In problems 27 through 29, find the length of the side S , the perimeter p , and the area A of the regular pentagon shown in the sketch below. Remember, the perimeter equals the distance around the figure. Also remember that in a regular pentagon, all five sides are equal.

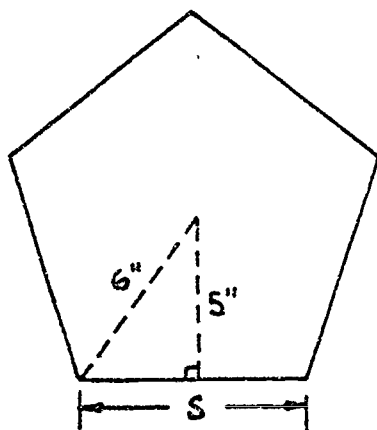

Hint: first use the Pythagorean Theorem.

27. Side S equals:

- a. 11 in
- b. 3.32 in
- c. 6.63 in
- d. 6 in

28. Perimeter p equals:

- a. 33.15 in
- b. 16.6 in
- c. 30 in
- d. 25 in

29. Area A equals:

- a. 165.75 sq in
- b. 75 sq in
- c. 150 sq in
- d. 82.875 sq in

In problems 30 and 31, find the circumference and area of a circle with a diameter of 16.7 inches. Let π equal 3.14.

30. The circumference equals:

- a. 52.44 in
- b. 26.22 in
- c. 5.32 in
- d. 10.64 in

31. The area equals:

- a. 218.93 sq in
- b. 437.86 sq in
- c. 88.82 sq in
- d. 875.71 sq in

32. What is the length of a piece of ornamental iron needed to make the design shown in the sketch below. Let $\pi = 3.14$.

The neutral axis is the dotted line AB.

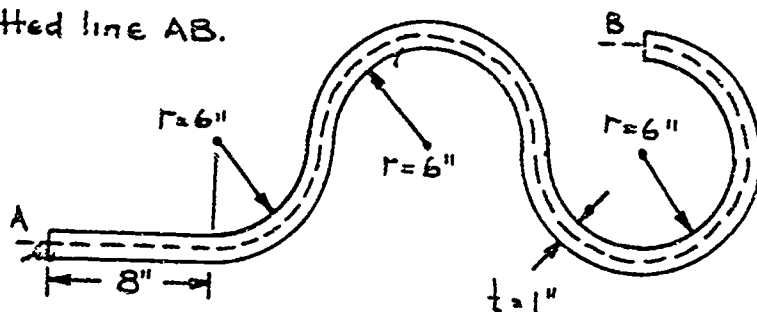

Hint: Find the total length along the neutral axis. The neutral axis is the center line of the ornamental iron.

Length equals:

- 38.62 in
- 64.52 in
- 69.23 in
- 36.26 in

In problems 33 through 35, use the sketch below to find angles a , b , and c . Lines AB and AC are tangent to the circle at points D and E. Lines PD and PE are radii of the circle.

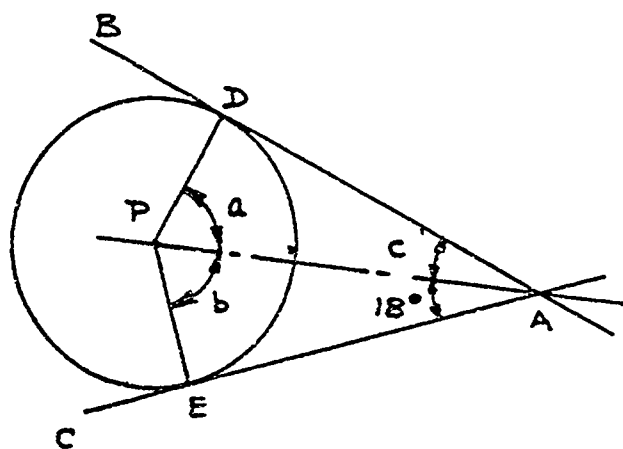

33. Angle a equals:

- 90°
- 72°
- 78°
- 82°

34. Angle b equals:

- 90°
- 82°
- 72°
- 78°

35. Angle c equals:

- 16°
- 18°
- 20°
- 22°

36. Find the volume of the rectangular right prism shown in the sketch at the right.

The volume of a right prism equals the cross-sectional area of the prism times the height of the prism.

Volume equals:

- a. 96 cu in
- b. 48 cu in
- c. 384 cu in
- d. 192 cu in

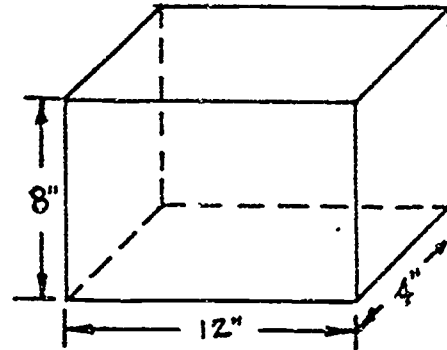

- In problems 37 and 39, find the lateral surface area, total surface area, and volume of the cone shown in the sketch below.

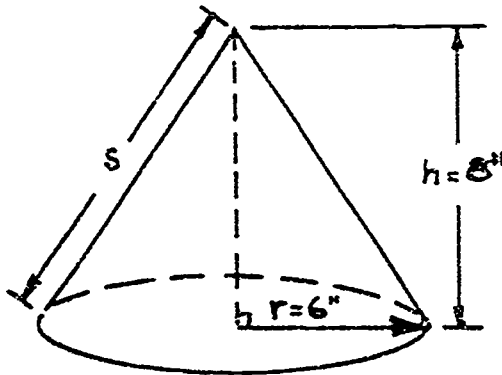

$s = \text{slant height}$
 Lateral surface Area = $\pi r s$, $\pi = 3.14$
 Total surface Area = $\pi r s + \pi r^2$
 Volume = $\frac{1}{3} \pi r^2 h$

Hint: Use the Pythagorean Theorem to find s .

37. Lateral surface area equals:
- a. 263.76 sq in
 - b. 188.4 sq in
 - c. 150.72 sq in
 - d. 251.2 sq in
38. Total surface area equals:
- a. 640.56 sq in
 - b. 301.44 sq in
 - c. 364.24 sq in
 - d. 263.76 sq in
39. Volume equals:
- a. 376.8 cu in
 - b. 1205.76 cu in
 - c. 301.44 cu in
 - d. 401.92 cu in

In problems 40 through 42, find the lateral surface area, total surface area, and volume of the pyramid shown in the sketch below.

Lateral surface area = area of the sides

Total surface area = area of the sides plus area of the base

Volume = $\frac{1}{3}$ (height times area of base)

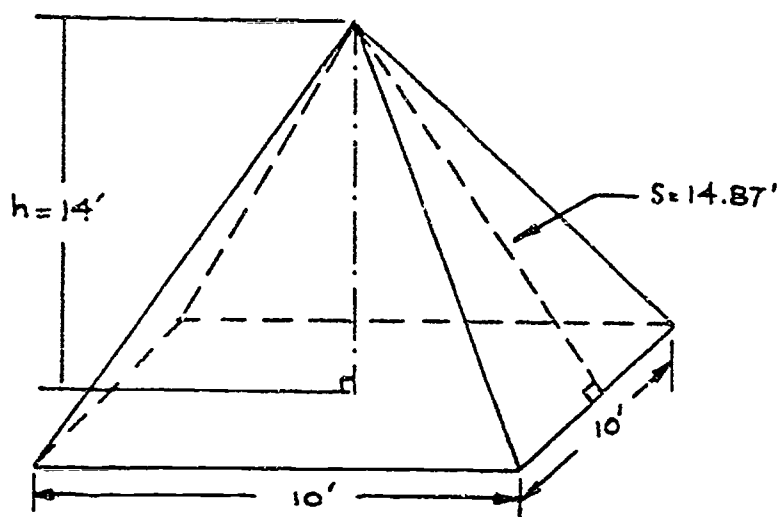

40. Lateral surface area equals:

- a. 280 sq ft
- b. 297.4 sq ft
- c. 594.8 sq ft
- d. 560 sq ft

41. Total surface area equals:

- a. 397.4 sq ft
- b. 380 sq ft
- c. 660 sq ft
- d. 694.8 sq ft

42. Volume equals:

- a. 495.67 cu ft
- b. 693.93 cu ft
- c. 466.67 cu ft
- d. 700 cu ft

In problems 43 and 44, find the total surface area and the volume of the composite shape shown below.

Hint: Remember the total surface area is the total outer surface area. Also, use the Pythagorean Theorem to find the slant height.

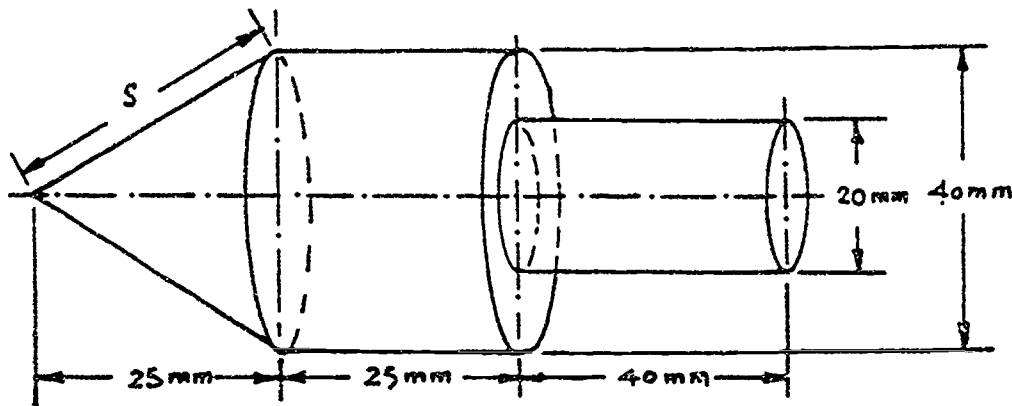

Surface area of a cone = $\pi \times \text{radius} \times \text{slant height}$

Surface area of a cylinder = $2\pi \times \text{radius} \times \text{height}$

Volume of a cone = $\frac{1}{3}\pi \times \text{radius squared} \times \text{height}$

Area of the base of cylinder = $\pi \times \text{radius squared}$

Volume of a cylinder = $\pi \times \text{radius squared} \times \text{height}$

43. The surface area equals:

- a. 7662.86 sq mm
- b. 8604.86 sq mm
- c. 8918.86 sq mm
- d. 7976.86 sq mm

44. The volume equals:

- a. 54,426.67 cu mm
- b. 85,826.41 cu mm
- c. 186,306.60 cu mm
- d. 36,466.67 cu mm

45. Find the volume of the conic frustrum shown in the sketch below.

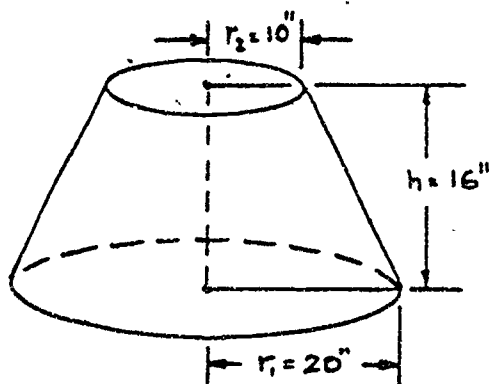

$$V = \frac{1}{3} h (A_1 + A_2 + \sqrt{A_1 A_2})$$

$$\text{where } A_1 = \pi r_1^2; A_2 = \pi r_2^2;$$

and $\pi = 3.14$

- The volume equals:
- a. 46,890.6 cu in
 - b. 2,930.67 cu in
 - c. 11,722.67 cu in
 - d. 732.67 cu in

46. Find the volume of the frustrum of a pyramid as shown in the sketch below.

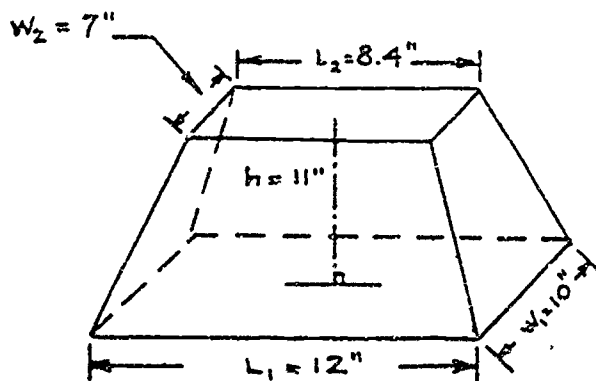

$$V = \frac{1}{3} h (A_1 + A_2 + \sqrt{A_1 A_2})$$

$$\text{where } A_1 = L_1 W_1 \text{ and } A_2 = L_2 W_2$$

The volume equals:

- a. 803 cu in
- b. 1,156.32 cu in
- c. 2,890.8 cu in
- d. 963.6 cu in

In problems 47 and 48, find angle a and angle b as shown in the sketch below. Line AB is the diameter of a circle with center at point P . Lines PC and PD are radii of the circle.

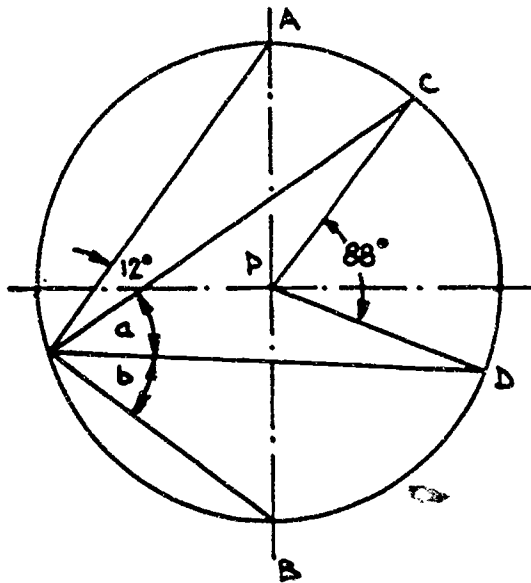

47. Angle a equals:

- a. 46°
- b. 76°
- c. 34°
- d. 44°

48. Angle b equals:

- a. 46°
- b. 34°
- c. 44°
- d. 56°

75

1. Change the following angles expressed in decimal form, to angles expressed as degrees, minutes and seconds.

a. $53.37^\circ \longrightarrow$ $\underline{\quad}^\circ \underline{\quad}' \underline{\quad}''$

b. $108.25^\circ \longrightarrow$ $\underline{\quad}^\circ \underline{\quad}' \underline{\quad}''$

c. $287.14^\circ \longrightarrow$ $\underline{\quad}^\circ \underline{\quad}' \underline{\quad}''$

d. $27.77^\circ \longrightarrow$ $\underline{\quad}^\circ \underline{\quad}' \underline{\quad}''$

2. Change the following angles expressed as degrees, minutes and seconds, to angles expressed in decimal form. Round your answers to two decimal places.

a. $51^\circ 26' 44'' \longrightarrow$ $\underline{\quad}.\underline{\quad}^\circ$

b. $108^\circ 57' 37'' \longrightarrow$ $\underline{\quad}.\underline{\quad}^\circ$

c. $16^\circ 45' \longrightarrow$ $\underline{\quad}.\underline{\quad}^\circ$

d. $78^\circ 13' 46'' \longrightarrow$ $\underline{\quad}.\underline{\quad}^\circ$

3. In the sketch below, find the missing angles a , b , c , d , and e , and express them in degrees and minutes.

a $\underline{\quad}^\circ \underline{\quad}'$ b $\underline{\quad}^\circ \underline{\quad}'$ c $\underline{\quad}^\circ \underline{\quad}'$ d $\underline{\quad}^\circ \underline{\quad}'$ and
e $\underline{\quad}^\circ \underline{\quad}'$

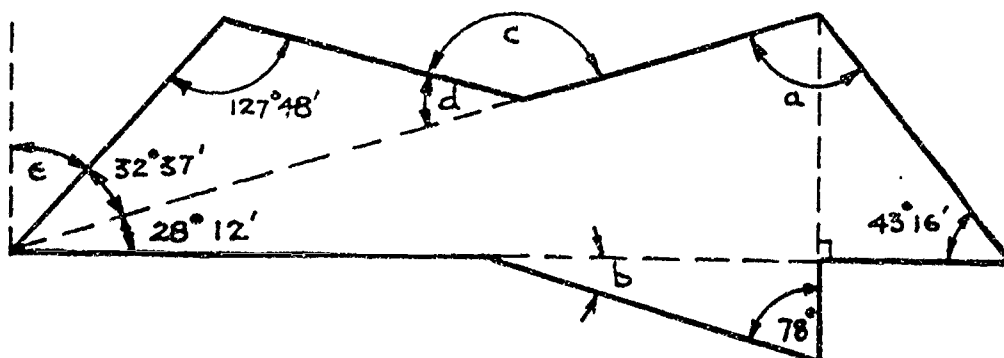

4. In the sketch below, find the missing dimensions R, D, and M. The circumference of the circle is equal to 41.667". The center of the circle is point P.

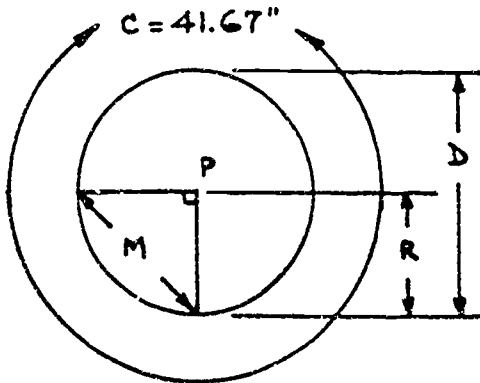

R _____

D _____

M _____

5. Find the missing dimensions in the triangles shown below.

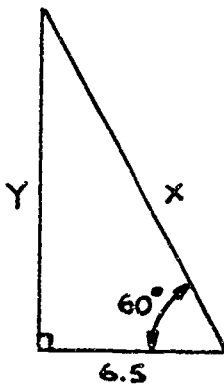

x = _____

Y = _____

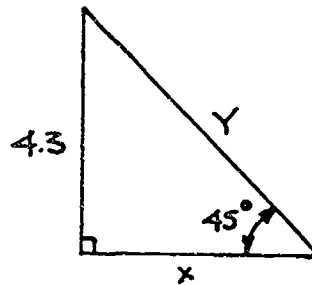

x = _____

Y = _____

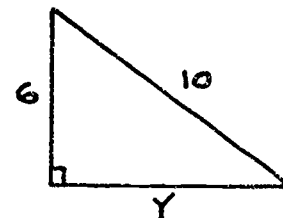

Y = _____

77

6. Find the missing dimensions, x and y in the triangles shown below. Use the Pythagorean theorem and the fact that the sides of similar triangles are proportional.

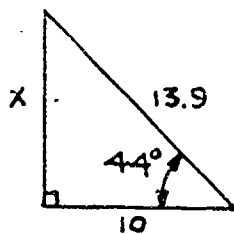

$x = \underline{\hspace{2cm}}$

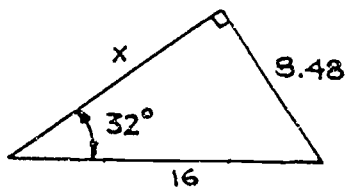

$x = \underline{\hspace{2cm}}$

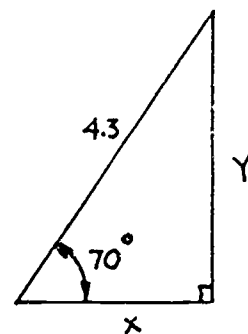

$x = \underline{\hspace{2cm}}, y = \underline{\hspace{2cm}}$

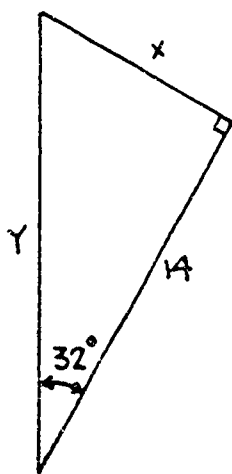

$x = \underline{\hspace{2cm}}$

$y = \underline{\hspace{2cm}}$

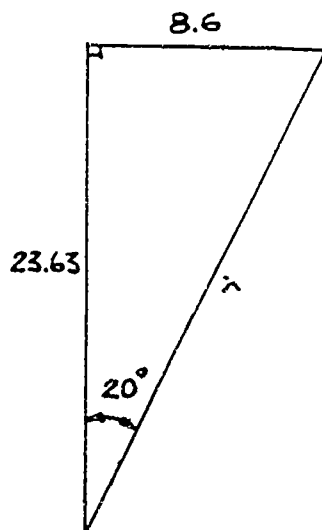

$x = \underline{\hspace{2cm}}$

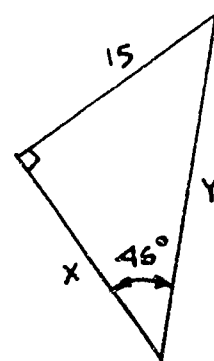

$x = \underline{\hspace{2cm}}, y = \underline{\hspace{2cm}}$

7. In the following triangles solve for x and y by using trigonometry functions. (Sin α , cos α , or tan α where α is the given acute angle.)

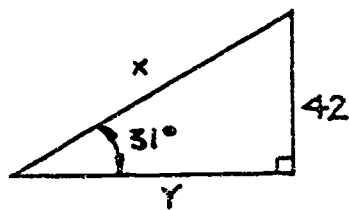

$x = \underline{\hspace{2cm}}, y = \underline{\hspace{2cm}}$

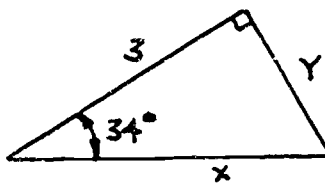

$x = \underline{\hspace{2cm}}, y = \underline{\hspace{2cm}}$

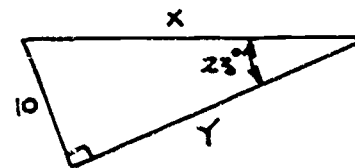

$x = \underline{\hspace{2cm}}, y = \underline{\hspace{2cm}}$

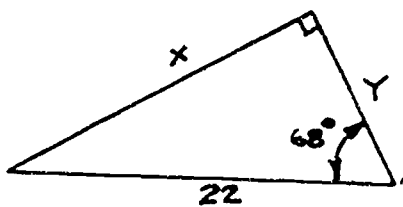

$x = \underline{\hspace{2cm}}, y = \underline{\hspace{2cm}}$

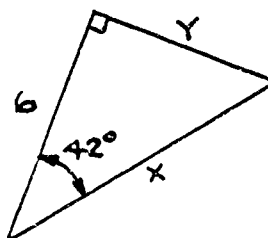

$x = \underline{\hspace{2cm}}, y = \underline{\hspace{2cm}}$

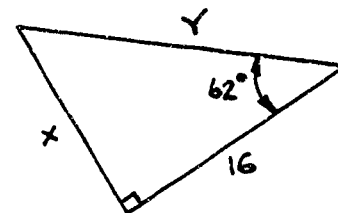

$x = \underline{\hspace{2cm}}, y = \underline{\hspace{2cm}}$

8. In the sketch shown below, find the distance M by using trigonometric procedures. Round your answer to the nearest hundredth of an inch.

$M = \underline{\hspace{4cm}}$

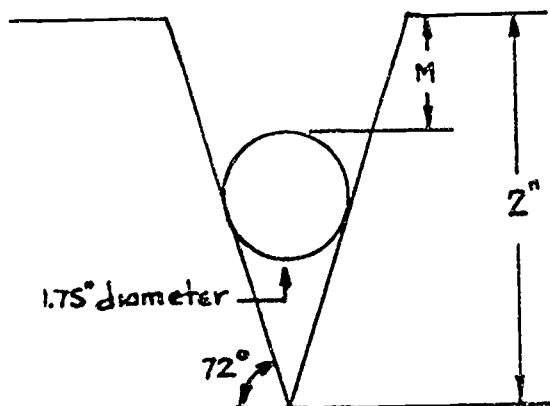

9. In the sketch below, find the angle α by using trigonometric procedures. Round off your answer to the nearest hundredth of a degree.

$A =$ _____

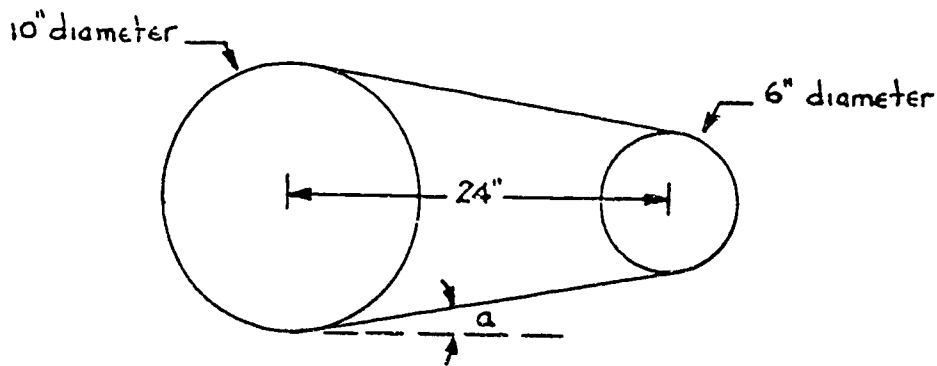

10. In the sketch shown below, find the distance x to the nearest one-hundredth of a millimeter.

$x =$ _____

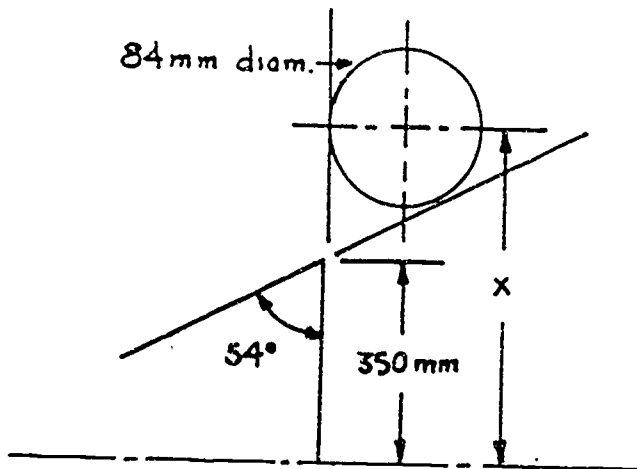

11. Find the head angle A of the bolt shown in the sketch below. Round to the nearest hundredth of a degree.

Head Angle $A =$ _____

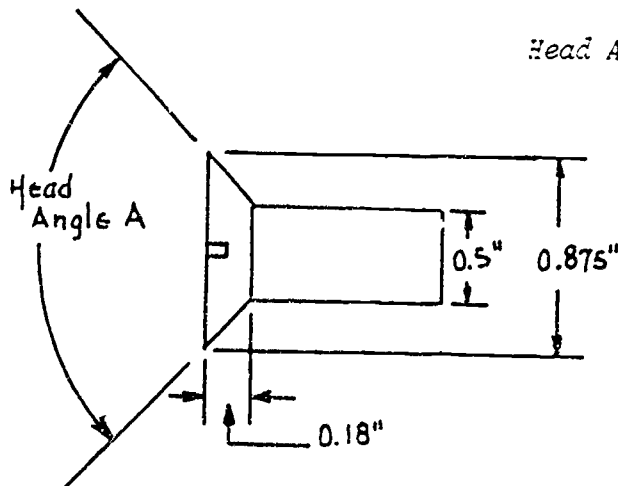

12. Find the missing dimensions shown in the sketch below. Round off your answers to the nearest hundredth of a unit if required.

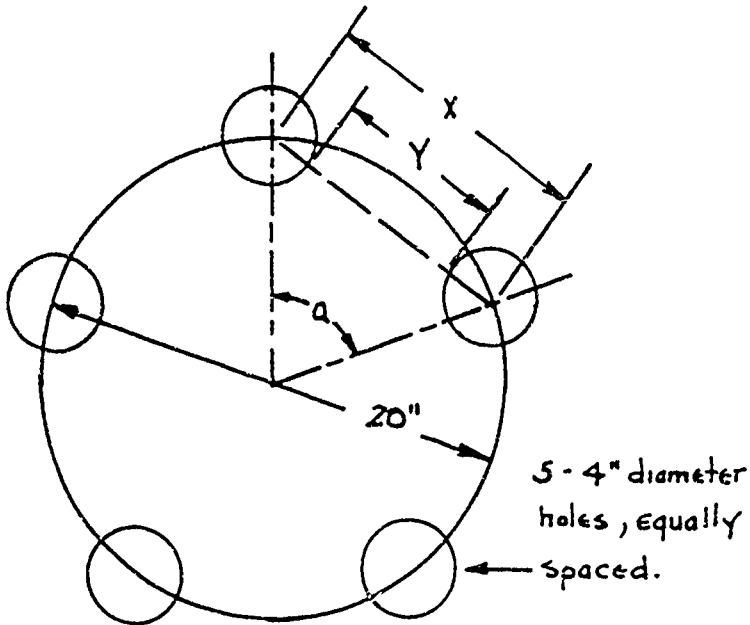

x _____
 y _____
 a _____

13. In the sketch at the right, find the width of the river, W .

$W =$ _____

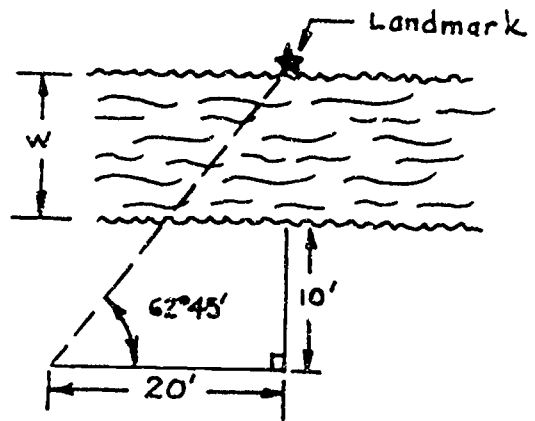

14. Find the missing dimensions in the sketch below. Use the Law of Sines. Round your answers to the nearest hundredth.

Angle A _____ Side b _____ Side c _____

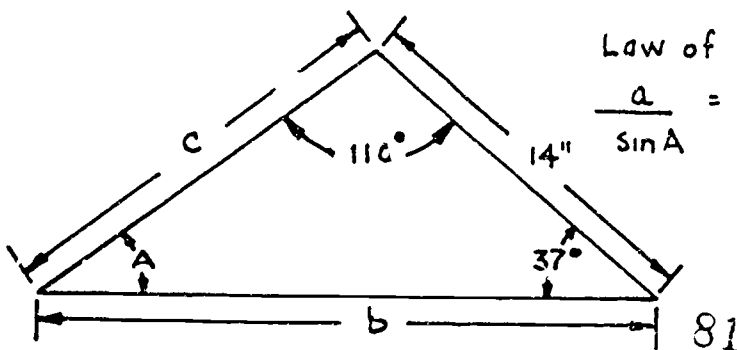

Law of Sines:

$$\frac{a}{\sin A} = \frac{b}{\sin B} = \frac{c}{\sin C}$$

15. Find the missing dimensions in the sketch below. First use the Law of Cosines, then use the Law of Sines. Round your answers to the nearest hundredth of a unit.

a _____ Angle 1 _____ Angle 2 _____

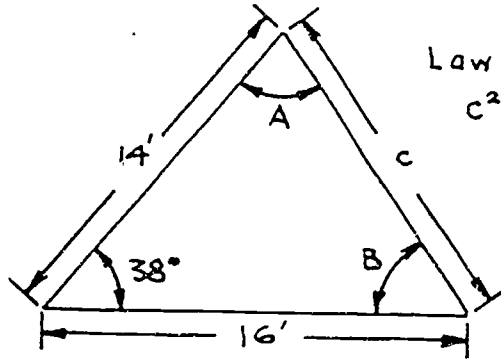

Law of Cosines:

$$c^2 = a^2 + b^2 - 2ab \cos C$$

SHOP MATH FOR METAL TRADES: PRETEST

PART 4 (COMPUTERIZED)

Choose the best answer for each of the following problems.

1. The angle 53.37° is equal to how many degrees, minutes and seconds?

a. $53^\circ 6' 17''$

c. $53^\circ 30' 7''$

b. $53^\circ 22' 12''$

d. $53^\circ 18' 42''$

2. The angle $78^\circ 13' 46''$ is equal to how many degrees?

a. 78.81°

c. 78.4°

b. 78.32°

d. 78.23°

3. In the figure shown below, find angle A.

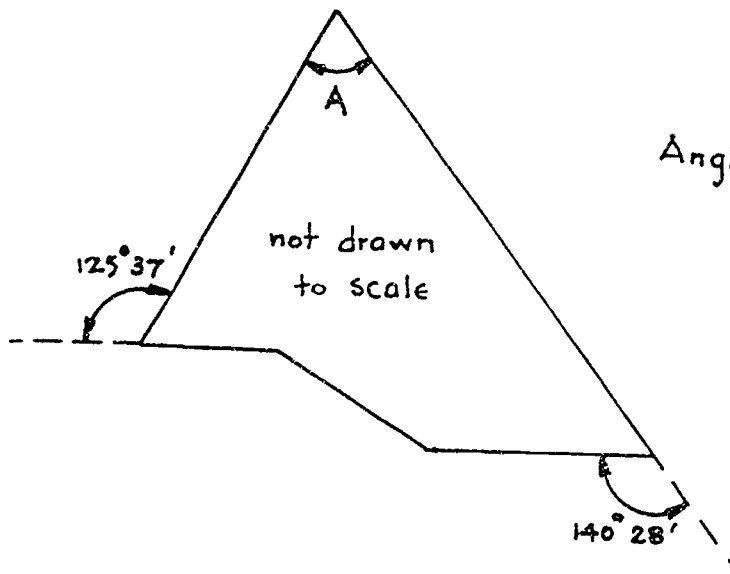

Angle A equals:

a. $35^\circ 37'$

b. $86^\circ 05'$

c. $93^\circ 55'$

d. $50^\circ 28'$

4. In the sketch on the right, the circumference of the circle is 41.67". What is the dimension M?

Distance M equals:

a. 9.38"

b. 18.76"

c. 6.63"

d. 13.36"

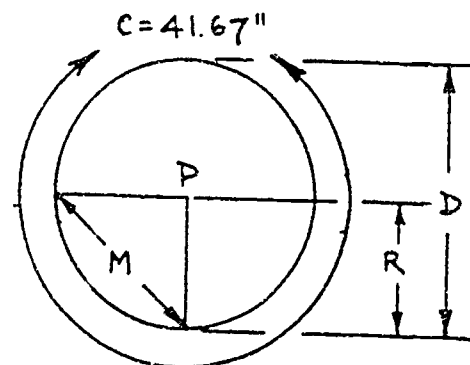

center of the circle
is point P.

5. In the sketch below, find the missing dimension x.

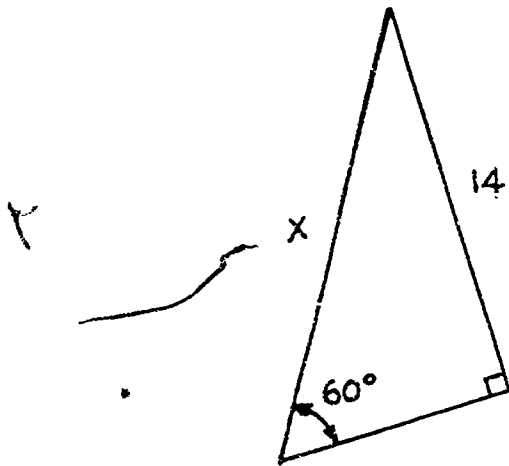

Dimension

x equals:

a. $14\sqrt{3}$

b. $7\sqrt{3}$

c. $28\sqrt{3}$

d. $\frac{28}{\sqrt{3}}$

6. In the sketch below, find the missing dimension R.

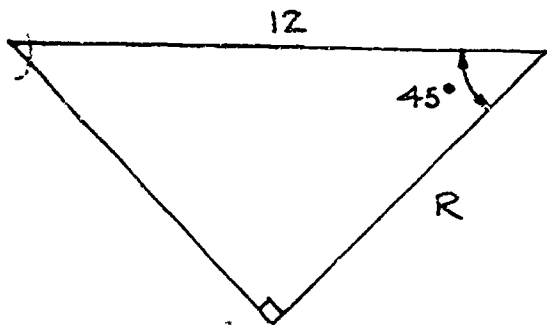

Dimension

R equals:

a. 6

b. $6\sqrt{2}$

c. $\frac{12}{\sqrt{2}}$

d. $12\sqrt{2}$

7. In the sketch below, find the missing dimension A.

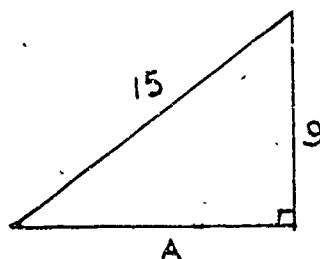

Dimension

A equals:

a. $7.5\sqrt{3}$

b. $9\sqrt{2}$

c. $\frac{15}{\sqrt{2}}$

d. 12

84

Directions for problems 8 through 13: Using the Pythagorean Theorem and the fact that the corresponding sides of similar triangles are proportional, find the dimensions A, B, C, D, E and F.

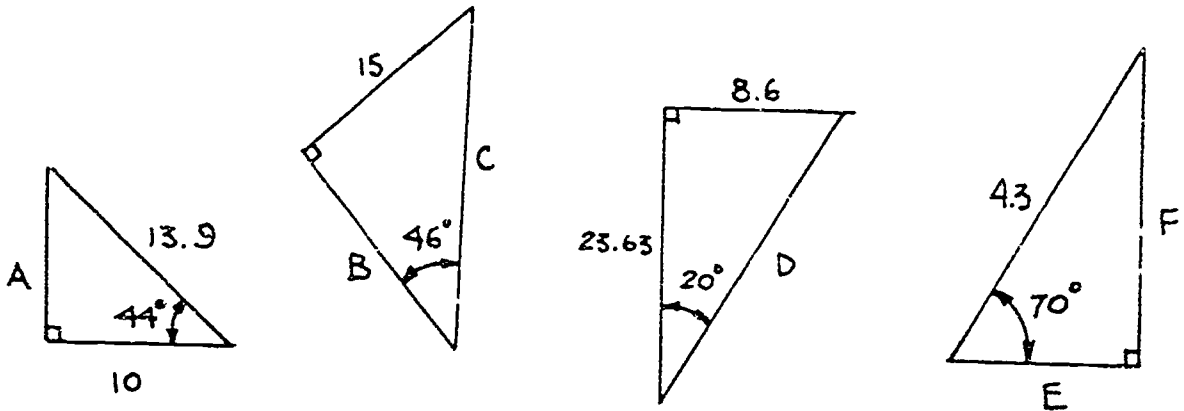

8. Dimension

A equals:

- a. 9.65
- b. 17.12
- c. 15.21
- d. 15

9. Dimension

B equals:

- a. 14.48
- b. 20.85
- c. 9.65
- d. 13.9

10. Dimension

C equals:

- a. 14.48
- b. 21.21
- c. 20.85
- d. 13.9

11. Dimension

D equals:

- a. 22.01
- b. 25.15
- c. 26.5
- d. 25.63

12. Dimension

E equals:

- a. 2.15
- b. 1.47
- c. 8.26
- d. 11.8

13. Dimension F

equals:

- a. 8.6
- b. 4.54
- c. 2.89
- d. 4.04

Directions for problems 14 through 19: Use the trigonometric functions ($\sin A$, $\cos A$, or $\tan A$, where A is the given angle) to find the dimensions U , V , W , X , Y and Z .

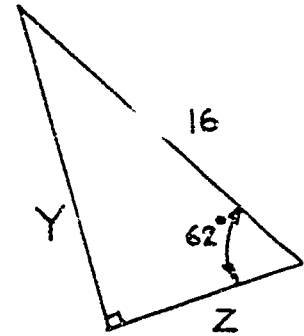
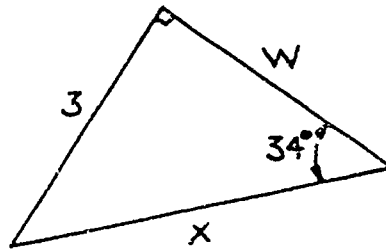
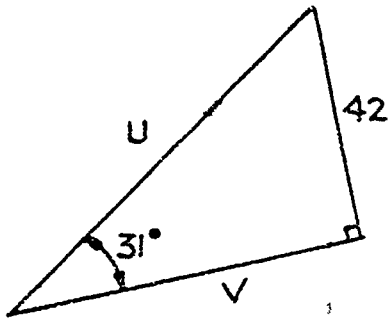

14. Dimension

U equals:

- a. 81.55
- b. 49.0
- c. 79.26
- d. 69.9

15. Dimension

W equals:

- a. 79.26
- b. 69.9
- c. 49.0
- d. 81.55

16. Dimension

W equals:

- a. 2.49
- b. 4.45
- c. 2.02
- d. 3.62

17. Dimension

X equals:

- a. 3.62
- b. 5.36
- c. 4.45
- d. 5.12

18. Dimension

Y equals:

- a. 14.12
- b. 7.51
- c. 30.09
- d. 18.12

19. Dimension

Z equals:

- a. 7.51
- b. 14.12
- c. 18.12
- d. 30.09

20. In the sketch shown below, find the distance M by using trigonometric procedures.

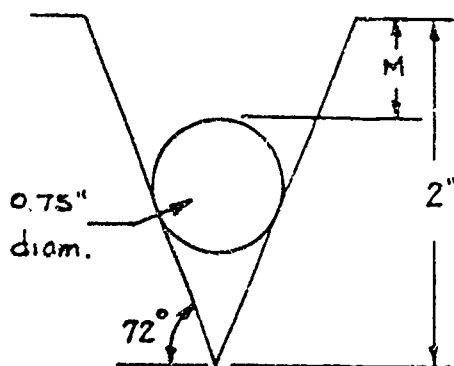

Dimension

M equals:

- a. 1.235"
- b. 0.41"
- c. 0.47"
- d. 0.39"

86

21. In the sketch below, find the angle A by using trigonometric procedures.

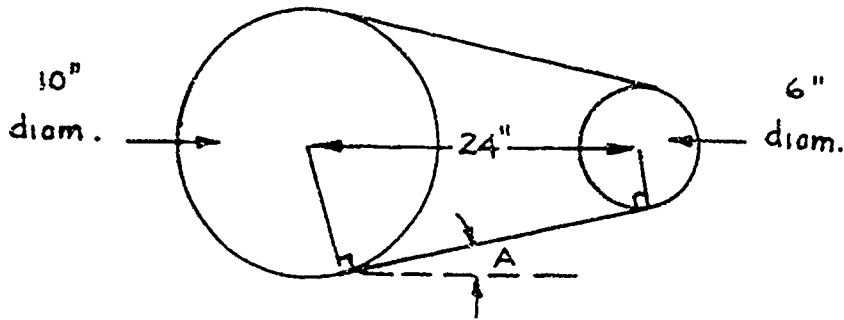

- Angle A equals:
- a. 9.59°
 - b. 9.46°
 - c. 4.76°
 - d. 4.78°

22. In the sketch below, find the distance x.

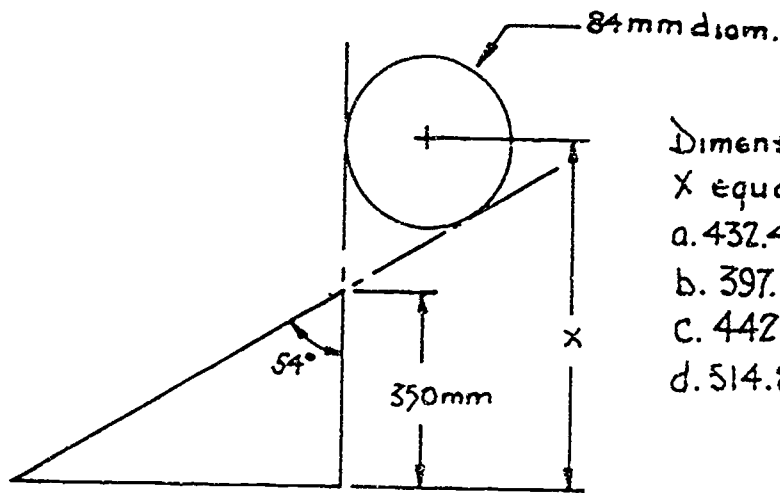

- Dimension X equals:
- a. 432.43 mm
 - b. 397.13 mm
 - c. 442.51 mm
 - d. 514.85 mm

23. In the sketch below, find the head angle A.

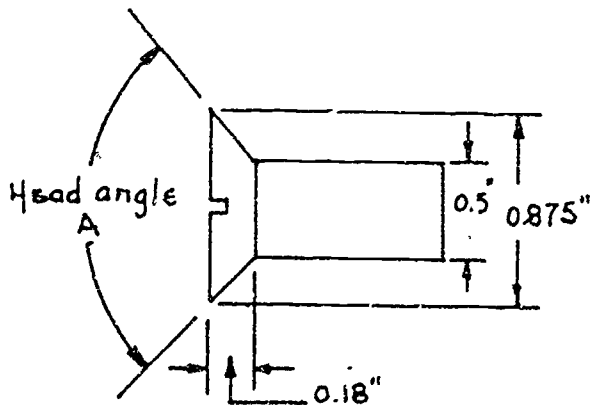

- Head angle A equals:
- a. 87.66°
 - b. 122.62°
 - c. 92.34°
 - d. 51.28°

24. In the sketch below, find the distance Y.

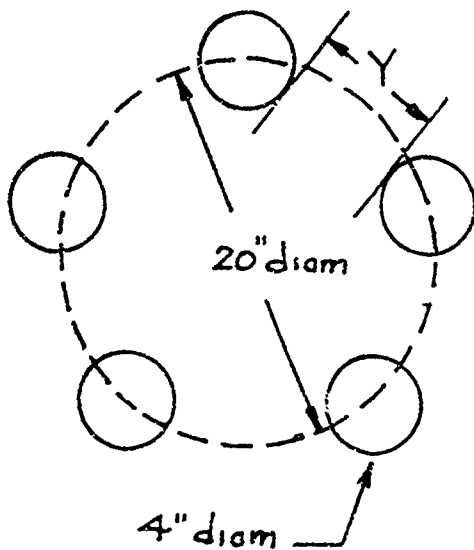

five equally spaced 4" diameter holes drilled around a 20" diameter circle.

Dimension

Y equals:

a. 3.88"

b. 7.76"

c. 6.09"

d. 12.18"

25. In the sketch below, find the width of the river W.

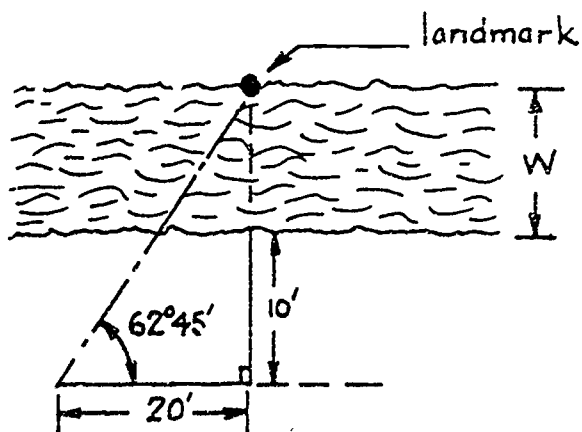

Dimension

W equals:

a. 21.84'

b. 28.83'

c. 33.68'

d. 12.50'

In problems 26 through 28, use the Law of Sines to find the missing dimensions as shown in the sketch below.

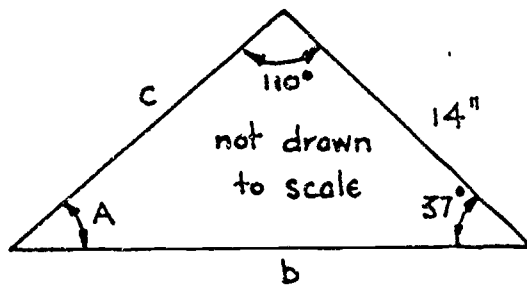

Law of Sines:

$$\frac{a}{\sin A} = \frac{b}{\sin B} = \frac{c}{\sin C}$$

26. Angle A

equals:

- a. 53°
- b. 70°
- c. 143°
- d. 33°

27. Side b

equals:

- a. 21.86"
- b. 15.47"
- c. 24.15"
- d. 8.11"

28. Side c

equals:

- a. 8.97"
- b. 24.15"
- c. 15.47"
- d. 12.67"

In problems 29 through 31, first use the Law of Cosines, then use the Law of Sines to find the missing dimensions as shown in the sketch below.

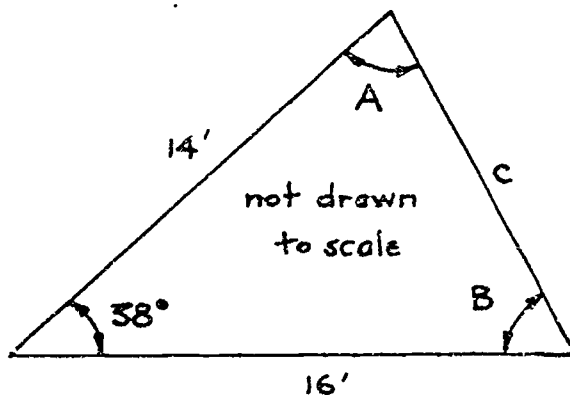

Law of Cosines:

$$c^2 = a^2 + b^2 - 2ab \cos C$$

29. Side c equals:

- a. 21.26'
- b. 9.95'
- c. 28.37'
- d. 20.32'

30. Angle A equals:

- a. 81.89°
- b. 60.02°
- c. 52°
- d. 118.08°

31. Angle B equals:

- a. 81.98°
- b. 60.11°
- c. 23.92°
- d. 27°

7/81



201

1 of 8

PROJECT SHEET

Name _____ Date _____

Cluster Metal Trades Occupation Machinist Helper

Training Module Shop Math for Machinists

Training Milestone 2. Math for Measuring Instruments

PROJECT 1

ADDITION AND SUBTRACTION OF FRACTIONS

TRAINING CONDITIONS:

● Here's what you will need:

1. This Project Sheet.
2. A pen or pencil to answer the problems in this Project Sheet.

TRAINING PLAN:

● Here's what you do:

In this Project Sheet, you will review addition, subtraction and reduction of fractions. You will also work some problems of the type you will find on your job. This work will help you to use measuring tools accurately and to apply their use to practical shop problems.

1. Read and study the math review and example problems on pages 2 to 4 of this Project Sheet.
2. Work the Shop Problems on pages 5 to 8.
3. Have your Instructor check your work and record your score on your Student Training Record.
4. Ask your Instructor for your next Project Sheet.

TRAINING GOAL:

● Here's how well you must do:

1. You must correctly answer 8 out of 10 Shop Problems.
2. You must answer questions about this Project Sheet to the approval of your Instructor.

3-74 (9)

ADDING AND SUBTRACTING FRACTIONS

To determine the length of materials—sheet metal, bar stock, pipe, wire, etc.—needed for a job, you often have to add and subtract fractional numbers.

ADDITION is the process of finding the *sum* of two or more numbers.

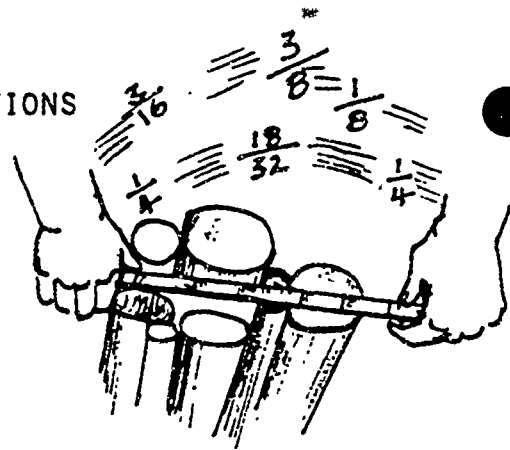

EXAMPLE PROBLEM 1: Find the length of x :

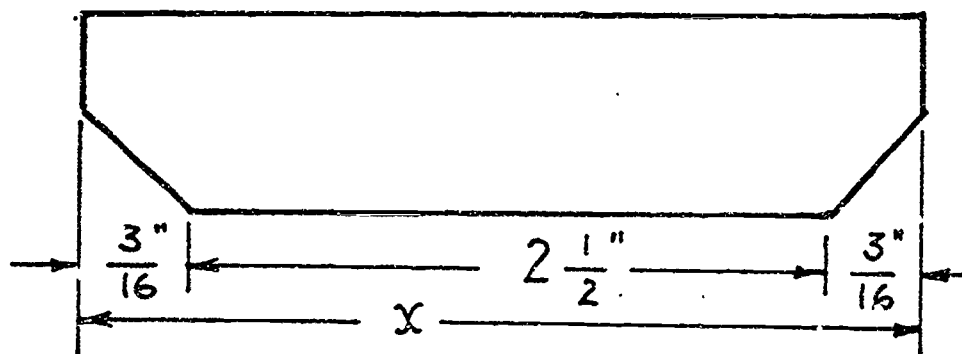

Figure 1: Solve for x .

SOLUTION: Look at Figure 1.
 x = the sum of the three given dimensions.

$$x = \frac{3}{16} + 2\frac{1}{2} + \frac{3}{16}$$

Remember that a fraction is made of two parts: a numerator (new-mer-ray-ter) and a denominator (dee-nomm-i-nay-ter). Look at Figure 2. The numerator is the numeral on *top* and the denominator is the one on the *bottom*.

$$\frac{3}{16} \quad \leftarrow \text{Numerator}$$

$$\quad \quad \quad \leftarrow \text{Denominator}$$

Figure 2: The two parts of a fraction.

When you add (or subtract) fractions, you must first change the denominator of all the fractions to the *least common denominator*, sometimes written as the LCD.

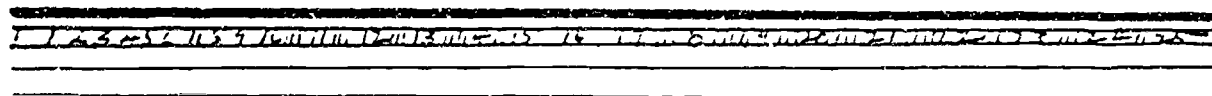

Now on with the problem:

$$x = \frac{3''}{16} + 2\frac{1''}{2} + \frac{3''}{16}$$

$$= \frac{3''}{16} + \frac{(2 \times 2 + 1)''}{2} + \frac{3''}{16} \leftarrow \text{Change } 2\frac{1}{2} \text{ to a fraction as shown. } 2 \times 2 + 1 \text{ is the numerator and 2 the denominator.}$$

$$= \frac{3''}{16} + \frac{5''}{2} + \frac{3''}{16}$$

$$= \frac{3''}{16} + \frac{5 \times 8''}{2 \times 8} + \frac{3''}{16} \leftarrow 16 \text{ is the common denominator so change } \frac{5}{2} \text{ to 16 tenths by multiplying } 5 \times 8 \text{ and } 2 \times 8 \text{ as shown.}$$

$$= \frac{3''}{16} + \frac{40''}{16} + \frac{3''}{16}$$

$$= \frac{3'' + 40'' + 3''}{16} \leftarrow \text{Since all numerators are "over" a common denominator 16, add the numerators directly.}$$

$$= \frac{46''}{16}$$

$$= 2\frac{14''}{16} \leftarrow \text{Divide 46 by 16 getting 2 with a remainder of 14. Then 14 is the numerator and 16 is the denominator.}$$

$$= 2\frac{7''}{8} \leftarrow \text{Divide 14 and 16 by a common number 2 to reduce to lowest terms.}$$

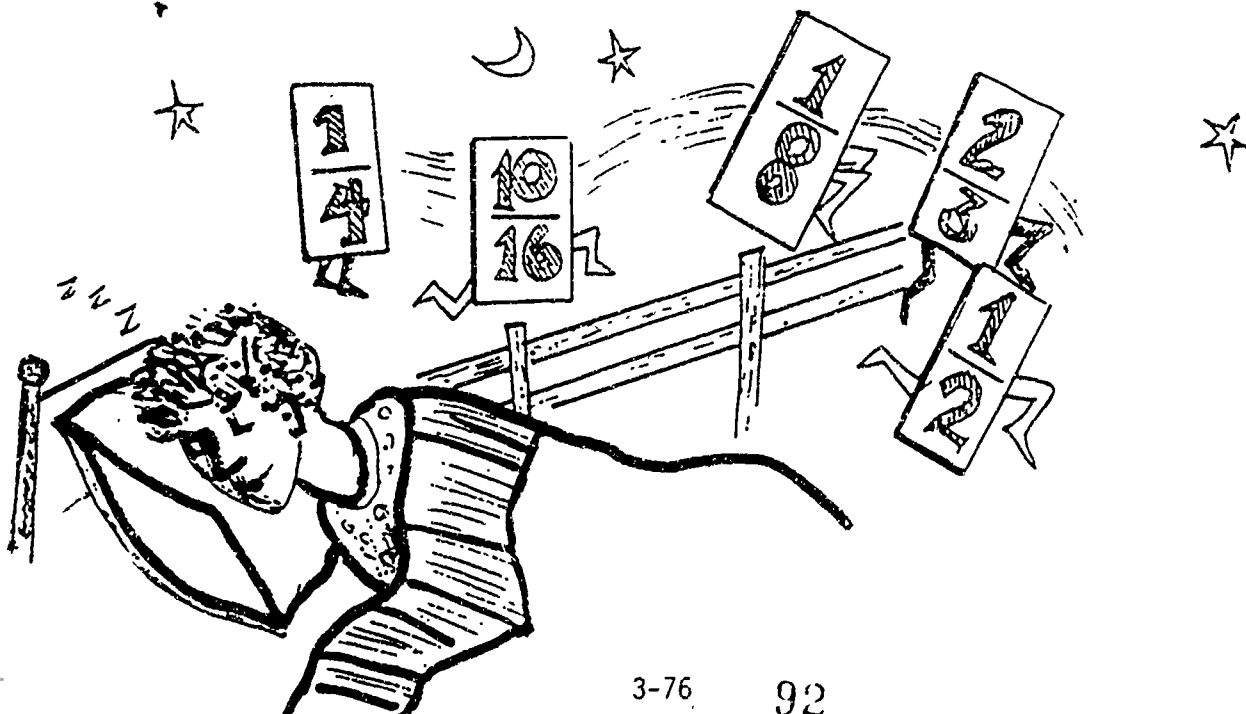

EXAMPLE PROBLEM 2: Find the length x in Figure 3.

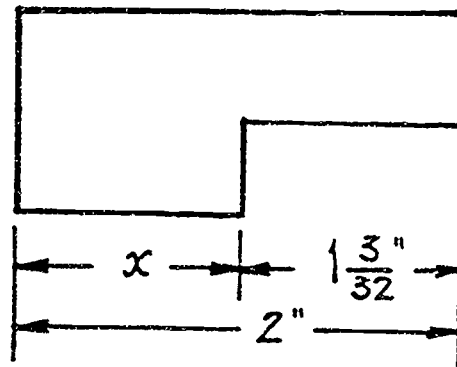

Figure 3: Solve for x .



SOLUTION: Look at Figure 3.

You need to find the length of the dimension shown as x
 You find x by subtracting $1\frac{3}{32}$ from 2 as shown below.

$$x = 2'' - 1\frac{3}{32}''$$

$$= 2'' - \frac{(32 \times 1 + 3)''}{32} \quad \leftarrow \text{change } 1\frac{3}{32}'' \text{ to a fraction.}$$

$$= 2'' - \frac{35''}{32}$$

$$= \frac{2''}{1} - \frac{35''}{32} \quad \leftarrow \text{note that } 2'' = \frac{2''}{1}$$

$$= \frac{2 \times 32''}{1 \times 32} - \frac{35''}{32} \quad \leftarrow \begin{array}{l} 32 \text{ is the least common denominator} \\ \text{So change } \frac{2''}{1} \text{ to } 32\text{nds as shown.} \end{array}$$

$$= \frac{64''}{32} - \frac{35''}{32}$$

$$= \frac{64'' - 35''}{32} \quad \leftarrow \text{Subtract } 35 \text{ from } 64 \text{ directly since they are both "over" the common denominator } 32$$

$$= \frac{29''}{32} \quad \leftarrow \text{Answer is in lowest terms since no common number will divide into both } 29 \text{ and } 32.$$

If you have any questions about the sample problems, ask your Instructor.

SHOP PROBLEMS

1. You need to cut four pieces of bar stock with the following measurements:

$$2\frac{3}{4}'' , 3\frac{1}{2}'' , 1\frac{3}{4}'' , \text{ and } 3\frac{1}{4}''$$

How long should your original bar stock be? Lengths: _____
(Don't worry about waste.)

2. Your supervisor wants you to find out the total length of the bar in Figure 4. Length _____

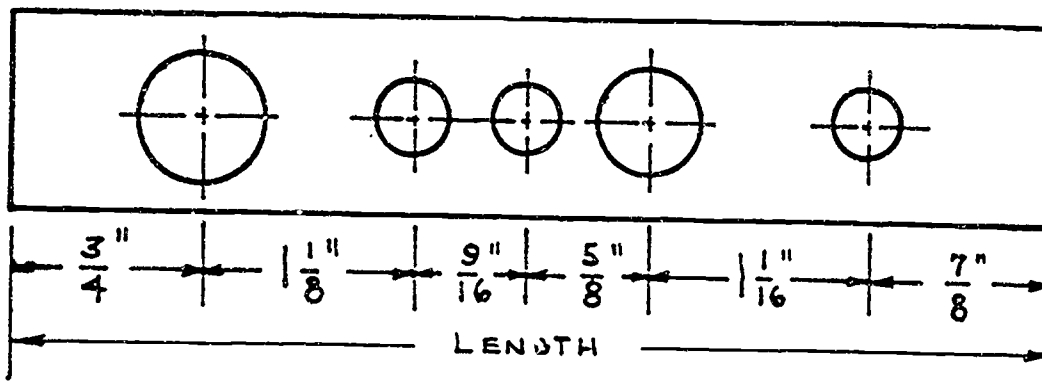

Figure 4: How long is this bar?

3. Your boss gives you the sketch in Figure 5. You are to find the lengths of x , y and z .

Length of: x _____ y _____ z _____

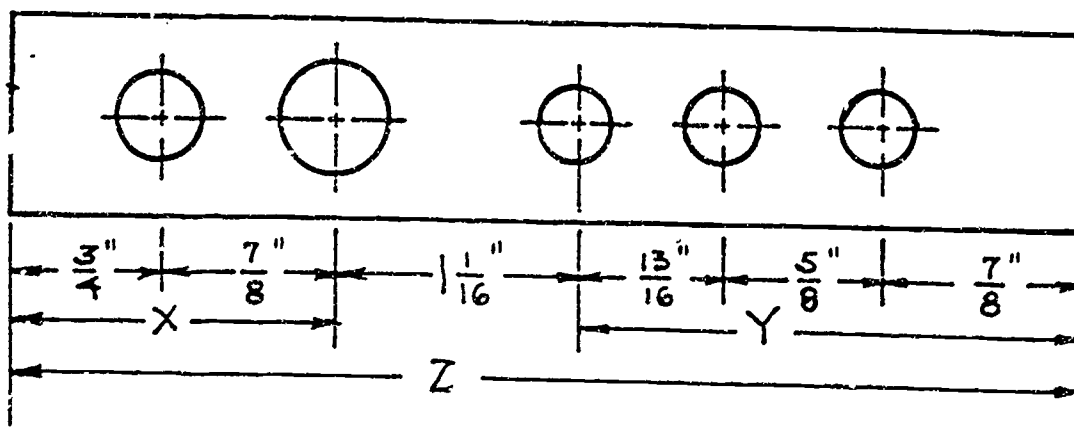

Figure 5: Solve for x , y and z .



4. Your supervisor hands you a machined part like the one shown in Figure 6. You need to find the lengths of the parts labeled x , y , and z .

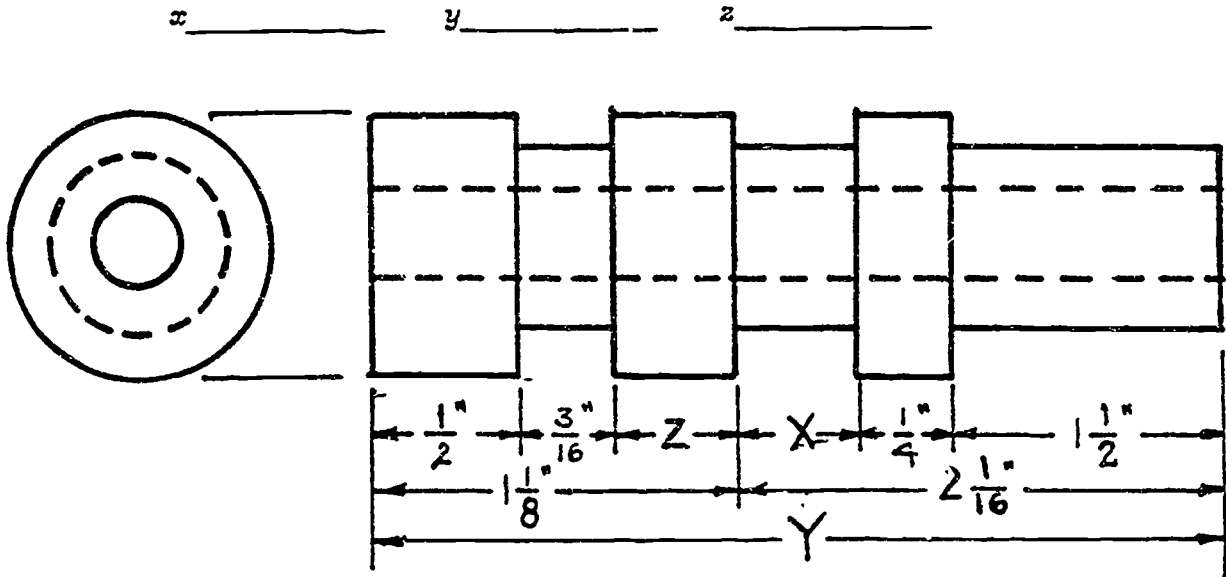

Figure 6: Solve for x , y and z .

5. Your supervisor gives you the sketch shown in Figure 7. You are to find the lengths of x , y and z .

x _____ y _____ z _____

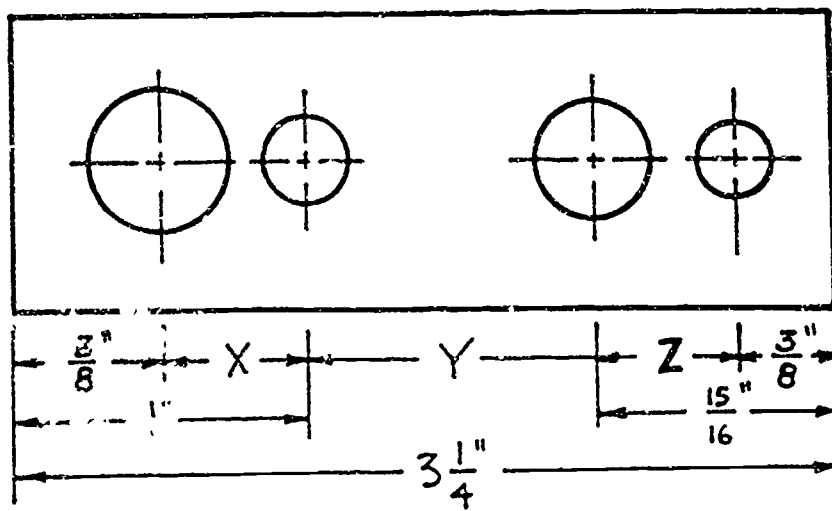
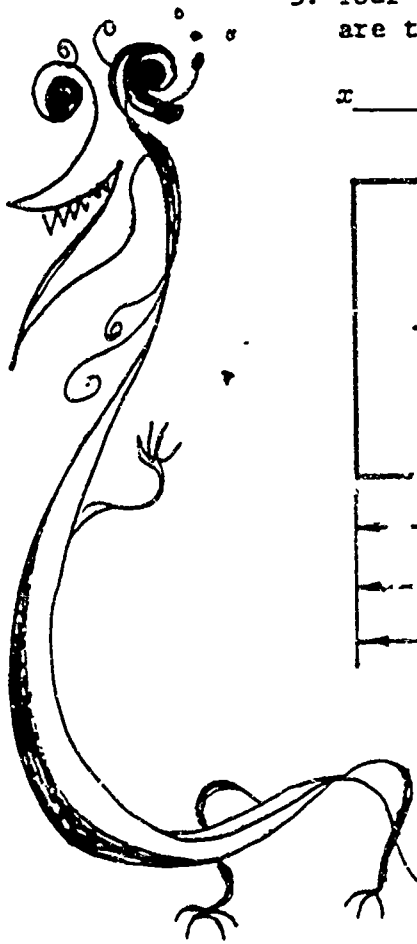

Figure 7: Solve for x , y and z .



x y z x y z

6. You were given the front view sketch of a machined part as shown in Figure 8. You are to find the lengths of the parts labeled w , x , y and z .

w _____ x _____ y _____ z _____

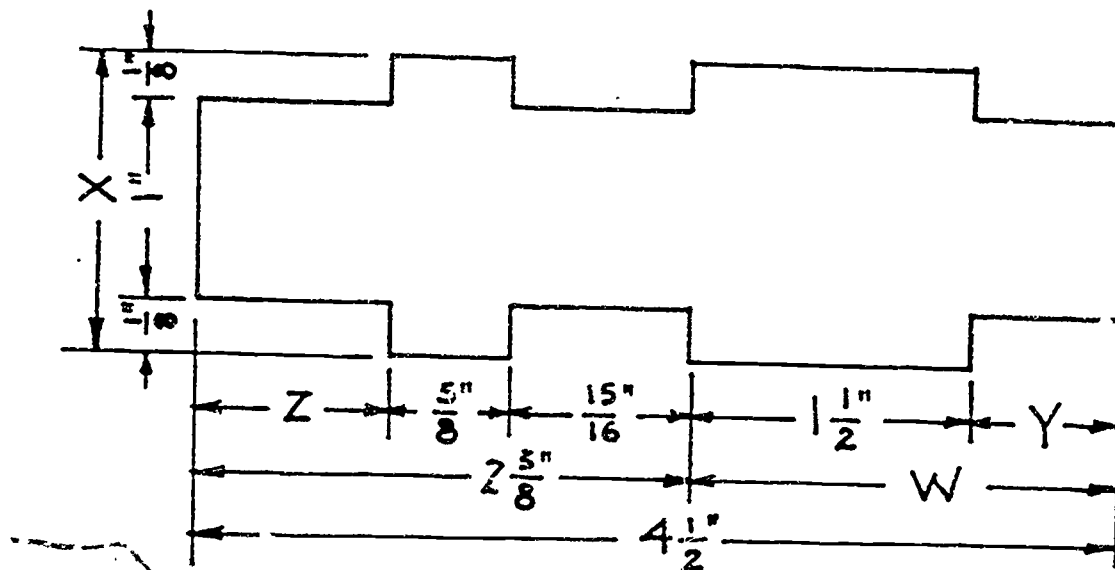

Figure 8: Solve for w , x , y and z .

7. You must make five shims of different lengths from a piece of bar stock. Allow $\frac{1}{16}$ " waste for each shim. The measurements of the shims are: $\frac{3}{8}$ ", $2\frac{3}{16}$ ", $\frac{7}{8}$ ", $\frac{15}{16}$ ", and $\frac{3}{4}$ ".

What is the total length of bar stock that you need?

Length _____

8. When measuring items that are irregular or hard to reach, it is sometimes difficult to get an accurate measurement. Sometimes the best thing to do is to find an *average measurement*. This is done by making more than one measurement (or reading), adding the measurements together, and dividing by the number of measurements taken. For example, if you made three readings, you would add the three together and divide by three. That would give you an average measurement.

Now, suppose you have taken the following readings:

$\frac{19}{64}$ " , $\frac{9}{32}$ " , $\frac{1}{4}$ " , and $\frac{15}{64}$ " . What is the average measurement?

Average measurement _____

9. Figure 9 is a sketch of a profile gage used for checking work in a machine shop. The dimensions on the sketch are the lengths of the different steps. Your supervisor wants you to find overall length of the gage.

Length _____

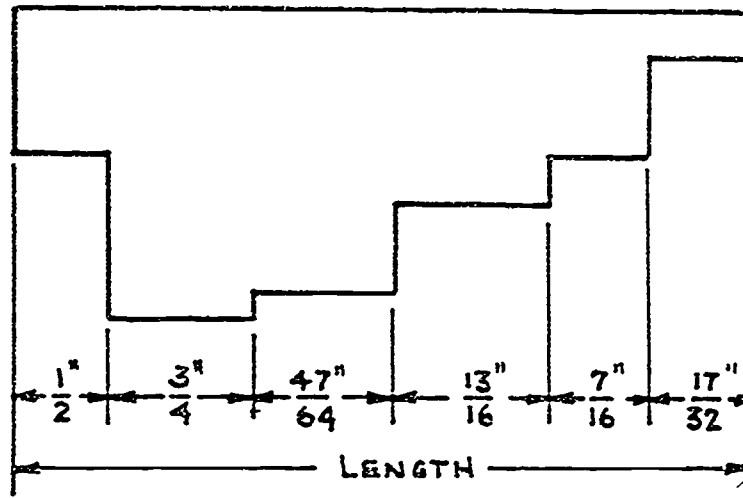

Figure 9: How long is this profile gage?

10. Your boss asks you to find the average of the following five readings:

$$\frac{5}{16} \text{ "}, \frac{1}{4} \text{ "}, \frac{9}{32} \text{ "}, \frac{17}{64} \text{ "}, \text{ and } \frac{7}{32} \text{ "}$$

Average reading _____

SHOW YOUR WORK TO YOUR INSTRUCTOR.

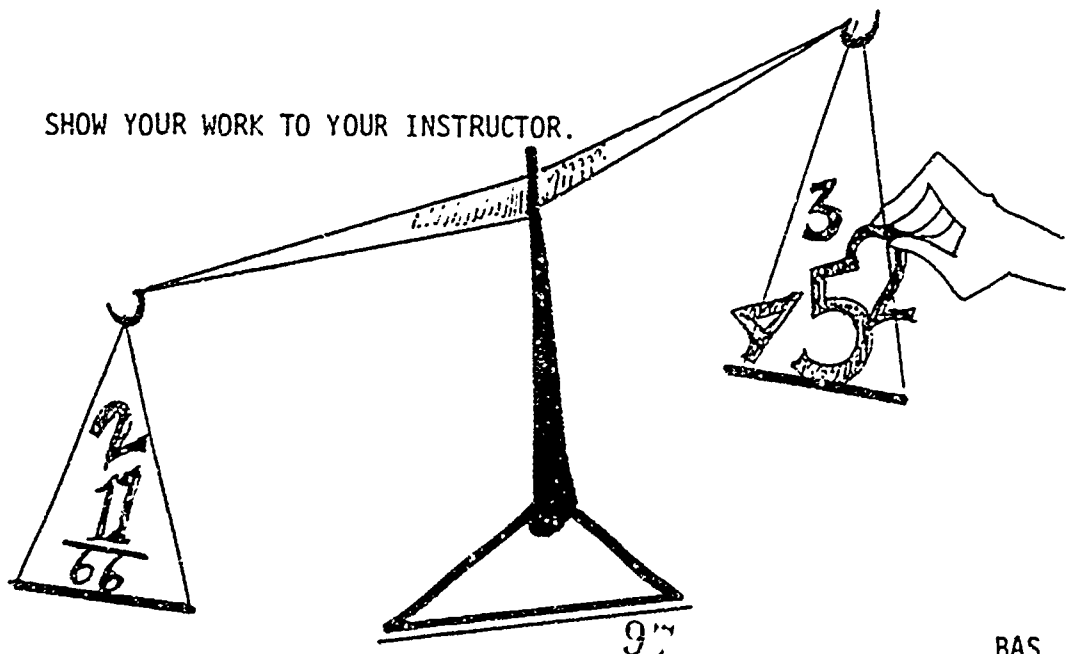

PROJECT SHEET



202

Name _____ Date _____

Cluster Metal Trades Occupation Machinist HelperTraining Module Shop Math for MachinistsTraining Milestone 2. Math for Measuring Instruments

PROJECT 2

MULTIPLICATION AND DIVISION OF FRACTIONS

TRAINING CONDITIONS:

- Here's what you will need:

1. This Project Sheet.
2. A pen or pencil to answer the problems in this Project Sheet.

TRAINING PLAN:

- Here's what you do:

In this Project Sheet, you will review multiplication and division of fractions. You will also work some problems of the type you will find on your job. This work will help you to use measuring tools accurately and to apply their use to practical shop problems.

1. Read and study the math review and Example Problems on pages 2 to 8 of this Project Sheet.
2. Work the Shop Problems on pages 9 to 12.
3. Have your Instructor check your work and record your score on your Student Training Record.
4. Ask your Instructor for your next Project Sheet.

TRAINING GOAL:

- Here's how well you must do:

1. You must correctly answer 12 out of 15 shop problems.
2. You must answer some questions about this Project Sheet to the approval of your Instructor.

MULTIPLYING AND DIVIDING FRACTIONS

As a Precision Metal Finisher, you will need to multiply and divide fractions. Here is a review of the required steps to do these operations.

MULTIPLYING FRACTIONS

First, to *multiply* two or more fractions, multiply the numerators together and multiply the denominators together. Look at Figure 1.

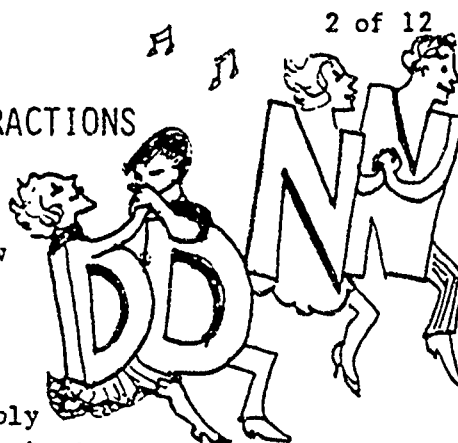

$$\begin{array}{ccc} \text{Multiply the numerators} \swarrow & & \swarrow \text{Product of the numerators} \\ \frac{2}{3} \times \frac{3}{4} = \frac{2 \times 3}{3 \times 4} = \frac{6}{12} \\ \nwarrow \text{Product of the denominators} & & \nwarrow \text{Multiply the denominators} \end{array}$$

Figure 1: Multiply numerators and denominators.

The *product* of the numerators is written over the product of the denominators.

Now, *reduce* the resulting fraction to *lowest terms*. Look at Figure 2. Remember that you reduce a fraction to its lowest terms by dividing evenly the numerator and the denominator by a common number.

$$\frac{6}{12} = \frac{1}{2} \quad \text{because} \quad \frac{6 \div 6}{12 \div 6} = \frac{1}{2}$$

Figure 2: Reduce your fraction to lowest terms.

When you can no longer find a common number that will divide evenly into *both* the numerator and the denominator, the fraction has been reduced to its lowest terms.

There are several different kinds of fractions:

PROPER FRACTIONS: These have denominators that are *larger* than their numerators:

Examples: $\frac{1}{2}$, $\frac{5}{7}$, $\frac{13}{16}$, $\frac{781}{3972}$, ...

IMPROPER FRACTIONS: These have denominators that are *smaller* than their numerators. They are "top heavy":

Examples: $\frac{2}{1}$, $\frac{7}{5}$, $\frac{16}{13}$, $\frac{3972}{781}$, ...

MIXED NUMBERS: These are made up of a whole number with a proper fraction. Look at Figure 3. A mixed number equals the *sum* of its whole number and its fraction.

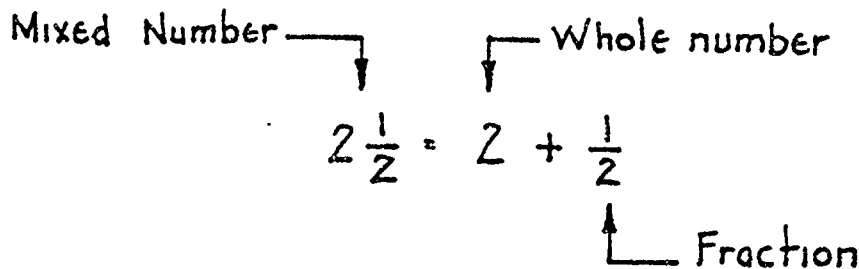
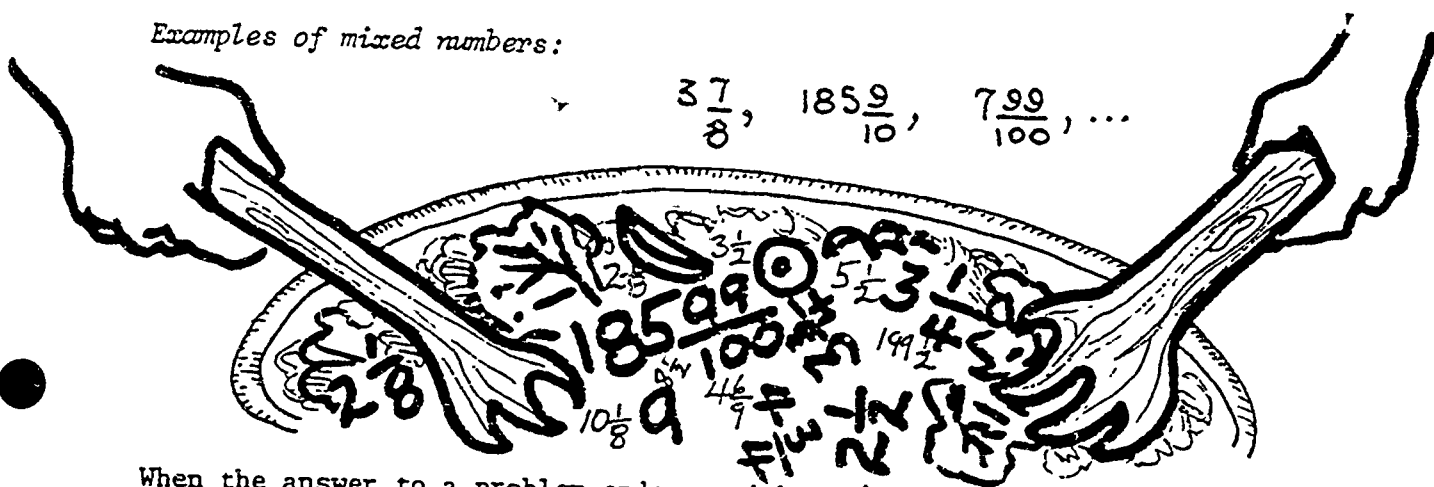

Figure 3: Mixed number = whole number + fraction.

Examples of mixed numbers:



When the answer to a problem ends up with an *improper* fraction, you must change it to a *mixed* number.

Here's how to change it:

Start by dividing the numerator by the denominator. Look at Figure 4.

$\frac{13}{6}$ is the improper fraction.

$2 \frac{1}{6}$ is the mixed number equal to $\frac{13}{6}$.

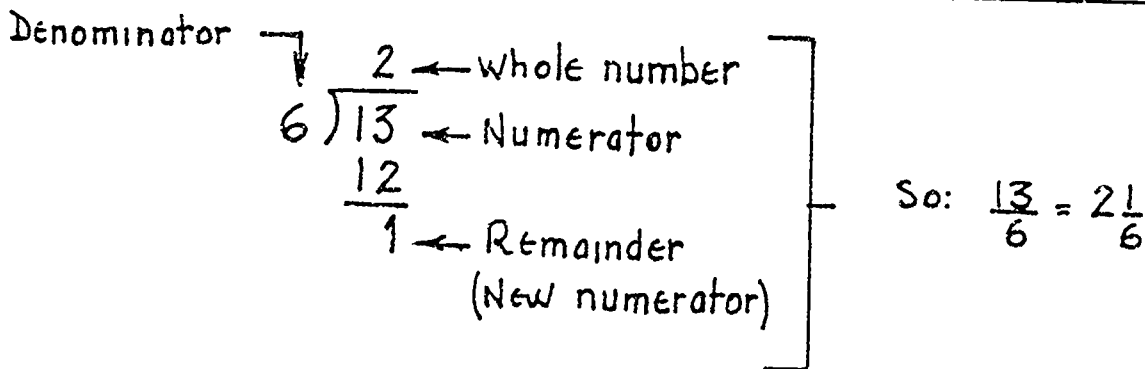

Figure 4: Changing an improper fraction to a mixed number.

EXAMPLE PROBLEM 1: Multiply $\frac{5}{7} \times 3$

$$\text{SOLUTION: } \frac{5}{7} \times 3 = \frac{5}{7} \times \frac{3}{1} = \frac{5 \times 3}{7 \times 1} = \frac{15}{7} = 2\frac{1}{7}$$

Note: A whole number can be written as a fraction by using "1" as the denominator. So in Example Problem 1, 3 is written as $\frac{3}{1}$.

Also, $\frac{15}{7}$ is in its lowest terms, and is changed to the mixed number $2\frac{1}{7}$.

EXAMPLE PROBLEM 2: Multiply $\frac{6}{7} \times \frac{2}{3} \times \frac{1}{4}$

$$\text{SOLUTION: } \frac{6}{7} \times \frac{2}{3} \times \frac{1}{4} = \frac{6 \times 2 \times 1}{7 \times 3 \times 4} = \frac{12}{84}$$

The answer to Example Problem 2, $\frac{12}{84}$, needs to be reduced to lowest terms. Both the numerator and the denominator can be evenly divided by 12. Look at Figure 5.

$$\frac{12}{84} = \frac{12 \div 12}{84 \div 12} = \frac{1}{7}$$

Figure 5: Divide numerator and denominator by 12.

Here is a way to solve the problem more easily. The *method of cancellation* can be used. This method is a way of dividing out numbers that are common to both the numerator and the denominator. For example, the problem can be done this way: (Look at Figure 6.) First, divide out the 3 in Step A. Next, divide out a 2 as in Step B, and then divide out another 2 as in Step C.

$$\begin{array}{ccccccc} \begin{array}{c} 2 \\ \cancel{6} \times 2 \times 1 \\ 7 \times \cancel{3} \times 4 \end{array} & = & \begin{array}{c} 1 \\ 2 \times \cancel{2} \times 1 \\ 7 \times 1 \times \cancel{4} \end{array} & = & \begin{array}{c} 1 \\ \cancel{2} \times 1 \times 1 \\ 7 \times 1 \times \cancel{2} \end{array} & = & \begin{array}{c} 1 \times 1 \times 1 \\ 7 \times 1 \times 1 \end{array} = \frac{1}{7} \\ \uparrow & & \uparrow & & \uparrow & & \\ \text{Step A} & & \text{Step B} & & \text{Step C} & & \end{array}$$

Figure 6: Method of cancellation.

101

Figure 6 shows dividing out numbers in three steps, but it is possible to use just *one* step. Look at Figure 7.

Figure 7: Method of cancellation using one step.

$$\frac{\overset{1}{\cancel{2}} \times \overset{1}{\cancel{2}} \times 1}{7 \times \underset{1}{\cancel{3}} \times \underset{2}{\cancel{4}}} = \frac{1}{7}$$

DIVIDING FRACTIONS

To divide fractions, you first *invert* the number of the fraction that is the *divisor*. The divisor is the number or fraction that you are dividing by. Now, multiply the two fractions and reduce to lowest terms.

When you *invert* a fraction, *turn it over* so the numerator and the denominator change places. Look at Figure 8.

$$\frac{9}{14} \text{ inverted is } \frac{14}{9}$$

Figure 8: Inverting a fraction.

Remember, the divisor is the number or fraction that you are dividing *by*.

For example, if you divide $\frac{3}{4}$ by $\frac{1}{2}$, $(\frac{3}{4} \div \frac{1}{2})$, then $\frac{1}{2}$ is the divisor.

EXAMPLE PROBLEM 3: Divide $\frac{6}{7}$ by $\frac{2}{3}$, $(\frac{6}{7} \div \frac{2}{3})$ (The divisor is $\frac{2}{3}$).

First invert the divisor and multiply. Look at Figure 9.

$$\frac{6}{7} \div \frac{2}{3} = \frac{6}{7} \times \frac{3}{2} = \frac{18}{14}$$

Figure 9: Invert divisor and multiply.

Then reduce to lowest terms. Look at Figure 10.

$$\frac{18}{14} = \frac{18 \div 2}{14 \div 2} = \frac{9}{7} = 1\frac{2}{7}$$

Figure 10: Reduce the answer.

MULTIPLYING AND DIVIDING MIXED NUMBERS

Whenever you multiply or divide fractions, you must change any *mixed* numbers to improper fractions. First, think of the mixed number as its whole numbers *plus* its fractional part. Look at Figure 11.

$$4\frac{2}{3} = 4 + \frac{2}{3}$$

Figure 11: Separating a mixed number.

Then, multiply the whole number by the denominator of the fraction. Put the answer you get over the original denominator. Add that answer to the fractional part. Look at Figure 12.

$$4\frac{2}{3} = 4 + \frac{2}{3} = \frac{4 \times 3}{1 \times 3} + \frac{2}{3} = \frac{12}{3} + \frac{2}{3} = \frac{12+2}{3}$$

Figure 12: Multiply whole number by denominator, put over denominator, then add fraction.

Now, add the two numerators directly. Look at Figure 13. The mixed number is now in fractional form.

$$4\frac{2}{3} = \frac{12+2}{3} = \frac{14}{3}$$

Figure 13: Adding numerators.

The steps shown in Figures 12 and 13 can be done in one step: Multiply the denominator by the whole number and add what you get to the numerator of the fractional part. Put that sum over the denominator. In Figure 13, 3 times 4 plus 2 equals 14 over 3. Look at Figure 13 again.

MULTIPLYING MIXED NUMBERS

EXAMPLE PROBLEM 4:	$2\frac{3}{8} \times 3\frac{5}{6}$
--------------------	------------------------------------

When you are finished multiplying fractions and are unable to divide a common number into both the numerator and denominator, the fraction will be in its lowest terms. Look at Figure 14.

$$2\frac{3}{8} \times 3\frac{5}{6} = \frac{19}{8} \times \frac{23}{6} = \frac{19 \times 23}{8 \times 6} = \frac{437}{48}$$

Figure 14: Multiplying mixed numbers.

You must change the improper fraction to a mixed number. Look at Figure 15.

$$\frac{437}{48} = 437 \div 48 = 9 + \frac{5}{48} = 9\frac{5}{48}$$

Figure 15: Changing improper fractions to mixed numbers.

DIVIDING MIXED NUMBERS

EXAMPLE PROBLEM 5:	$4\frac{1}{8} \div 6\frac{3}{5}$
--------------------	----------------------------------

First write the mixed numbers as improper fractions. Look at Figure 16.

$$4\frac{1}{8} \div 6\frac{3}{5} = \frac{33}{8} \div \frac{32}{5}$$

Figure 16: Change mixed number to improper fraction.

Then invert the divisor and multiply. Look at Figure 17.

DIVISOR

$$\frac{33}{8} \div \boxed{\frac{32}{5}} = \frac{33}{8} \times \frac{5}{32} = \frac{165}{256}$$

Figure 17: Invert divisor and multiply.

After you multiply, the fraction will be in its lowest terms since you cannot divide a common number into the numerator and the denominator. In this case, the answer can't be changed to a mixed number because it is a proper fraction. That is, the "top" is smaller than the "bottom".

EXAMPLE PROBLEM 6: How many $\frac{3}{4}$ " shims can be cut from a piece of shim stock $13\frac{1}{8}$ " long? Allow $\frac{3}{8}$ " for total waste.

SOLUTION: First you must find how much shim stock you will have after allowing for waste. So, first subtract the waste from the shim stock.

$$\begin{aligned}
 13\frac{1}{8} - \text{waste} &= 13\frac{1}{8} - \frac{3}{8} \quad \leftarrow \text{subtract waste.} \\
 &= \frac{(13 \times 8 + 1)}{8} - \frac{3}{8} \quad \leftarrow \text{change the mixed number to a fraction.} \\
 &= \frac{104 + 1 - 3}{8} \quad \leftarrow \text{add and subtract the numerators} \\
 &= \frac{102}{8} \quad \leftarrow \text{Since you have a common denominator (8). Shim stock remaining after allowing for waste.}
 \end{aligned}$$

Now find the number of shims you can make after allowing for waste, divide as shown below:

$$\begin{aligned}
 \frac{102}{8} \div \frac{3}{4} &= \frac{102}{8} \times \frac{4}{3} \quad \leftarrow \text{invert divisor and multiply} \\
 &= \frac{\cancel{102}^3}{\cancel{8}_2} \times \frac{\cancel{4}^1}{\cancel{3}_1} \quad \leftarrow \text{divide 102 by 3 and 3 by 3; divide 8 by 4 and 4 by 4; this is called cancellation} \\
 &= \frac{34 \times 1}{2 \times 1} \quad \leftarrow \text{multiply numerators } 34 \times 1, \text{ and denominators } 2 \times 1 \\
 &= \frac{34}{2} \quad \leftarrow \text{reduce to whole number by dividing 34 by 2.} \\
 &= 17 \text{ shims} \quad \leftarrow \text{Final Answer.}
 \end{aligned}$$

If you have any questions about the examples above, see your Instructor.

SHOP PROBLEMS

1. Your boss asks you to cut brass cylinders from a piece of brass pipe. How many brass cylinders can you cut from a piece of pipe $16\frac{1}{8}$ " long if each cylinder is $1\frac{1}{4}$ " and you are to allow $\frac{3}{32}$ " waste for each cylinder?

Number of cylinders: _____

2. You are required to make 22 pieces of pipe, each $\frac{3}{4}$ " long. How long a piece of pipe stock do you need? Allow $\frac{1}{16}$ " waste for each piece of pipe.

Length of pipe stock: _____

3. Your supervisor has given you the pattern and dimensions in Figure 18. What is the greatest number of pieces you can make from the bar stock?

Total pieces: _____ (Assume no waste)

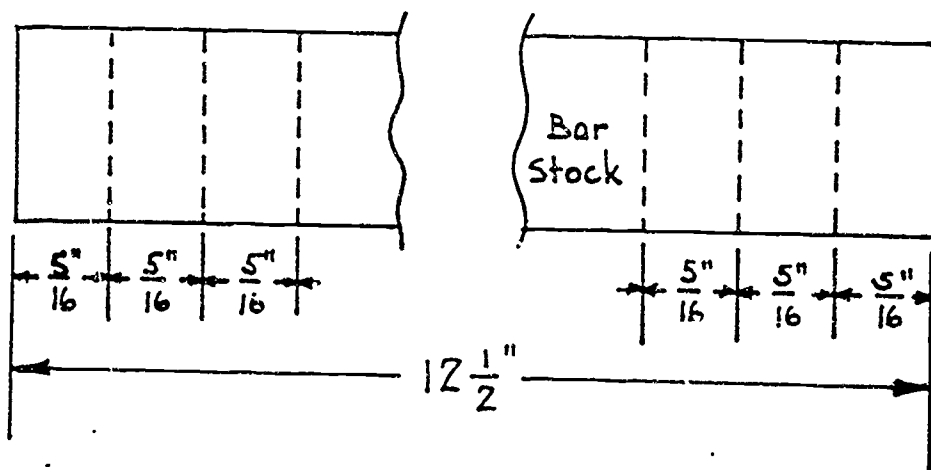

Figure 18: How many pieces can you cut from this bar stock?

4. You must stack boxes $3\frac{1}{4}$ " high in a 62" high bin. How many boxes can you get in the bin?

Boxes: _____

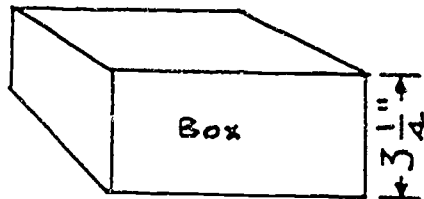

Figure 19: How many boxes?

5. You need to cut pipe to $2\frac{1}{8}$ " long as a support for a large piece of equipment. Your supervisor only has a 7' 1" piece of pipe. How many supports can you cut from the stock? Do not worry about waste. (Hint: Before dividing, make sure you have changed 7' 1" to inches so you will be dividing inches by inches.) *Number of pieces:* _____
6. You are given a blueprint in which $\frac{1}{4}$ " = 1 foot. How long should an 18' pipe be on your drawing? *Inches:* _____
7. You need to stack as many sheets of $\frac{1}{8}$ " sheet metal as possible in a 4' 6" bin. How many sheets will you be able to stack? (Hint: Again, make sure you have changed 4' 6" to inches so you will be dividing inches by inches.) *Number of sheets:* _____
8. Your boss quickly sketched the drawing in Figure 20 and asked you to drill the holes in the stock as shown. How many holes must you drill?
Number of holes: _____

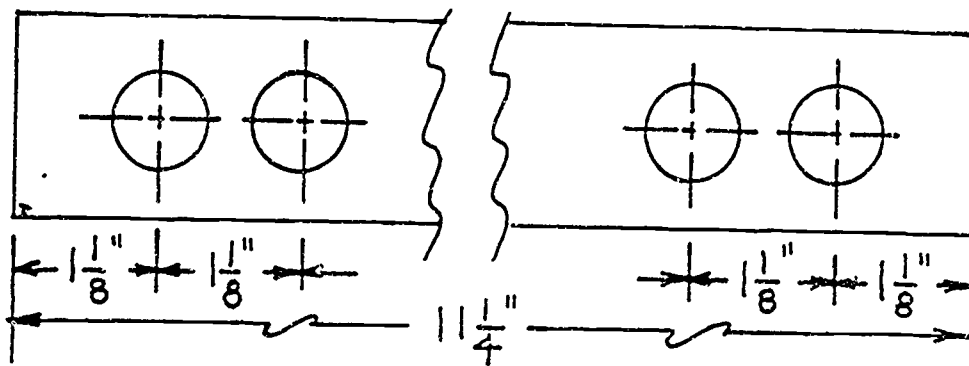
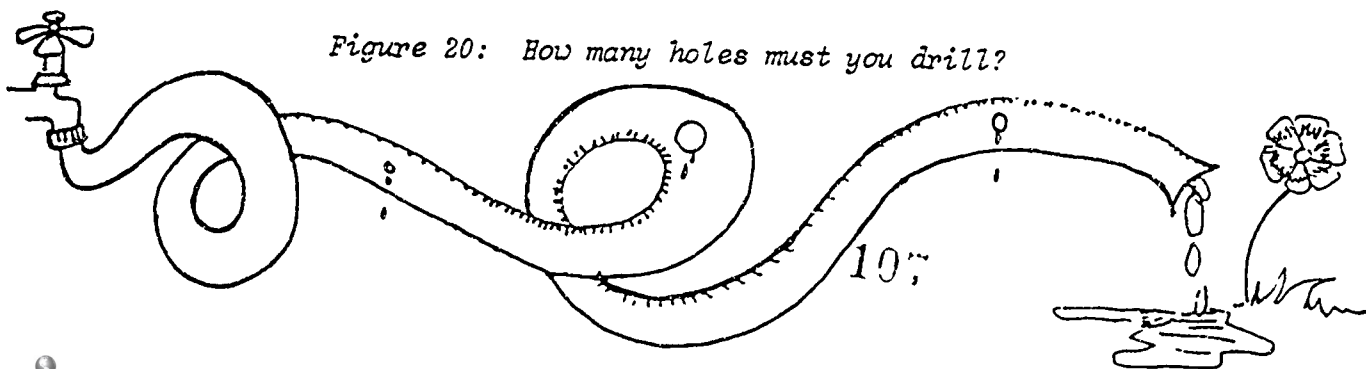

Figure 20: How many holes must you drill?



9. Your company needs to know how many square inches (volume) are in a package they make. The package dimensions are in Figure 21. What is the volume of the package? (Hint: The volume is found by multiplying the height times length times width.) *Volume:* _____

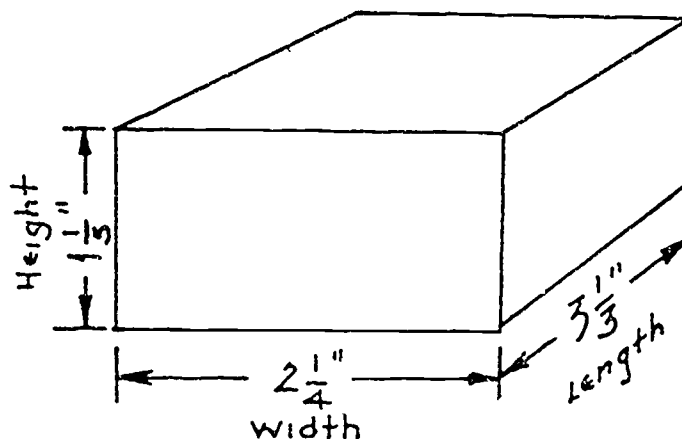
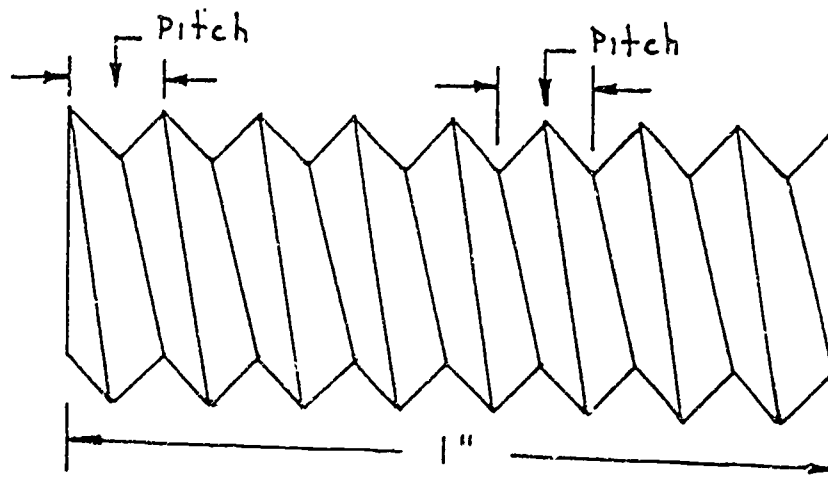

Figure 21: What is the volume of the box?

10. You need to order a $12\frac{1}{2}$ foot long steel bar. You know the bar weighs $1\frac{1}{4}$ pounds per foot. If steel costs $7\frac{3}{4}$ cents per pound, what is the cost of the steel bar? *Cost:* _____
11. Your supervisor asks you to get a new screw like the one in Figure 22. You measure the example and find it has 8 threads per inch. What thread pitch are you going to ask for? The *pitch* of a screw thread is defined as the distance from a given point on a screw thread to a corresponding point (the same kind of point) on the next thread. *Pitch:* _____

Figure 22: What is the pitch of this screw?



3-92 105

12. If you are able to machine a certain part in $1\frac{1}{8}$ hours, how many hours will it take you to machine 32 parts?

Hours: _____

13. How long a piece of stock will you need to cut 15 washers, each $\frac{3}{32}$ " thick if $\frac{1}{16}$ " waste is allowed for each cut? Length: _____

14. The circumference of a circle is very near to $3\frac{1}{7}$ times its diameter. Find the circumference of a circle whose diameter is $3\frac{2}{11}$.

Circumference: _____

15. If it takes you $\frac{3}{4}$ of an hour to sharpen a cutting tool, how many cutting tools can you sharpen during a six hour shift?

Number of tools _____

SHOW YOUR WORK TO YOUR INSTRUCTOR.



BAS

PROJECT SHEET



203

Name _____ Date _____

Cluster Metal Trades Occupation Machinist HelperTraining Module Shop Math for MachinistTraining Milestone 2. Math for Measuring Instruments

PROJECT 3

ADDITION AND SUBTRACTION OF DECIMALS

TRAINING CONDITIONS:

● Here's what you will need:

1. This Project Sheet.
2. A pen or pencil to complete the problems in this Project Sheet.

TRAINING PLAN:

● Here's what you do:

In this Project Sheet, you will review what decimal numbers are. You will review the addition and subtraction of decimals. You will also work some problems of the type you will find on your job. This work will help you to use measuring tools accurately and to apply their use to practical shop problems.

1. Read and study the math review and Example Problems on pages 2 to 7 of this Project Sheet.
2. Work the Shop Problems on pages 8 to 12.
3. Have your Instructor check your work and record your score on your Student Training Record.
4. Ask your Instructor for your next Project Sheet.

TRAINING GOAL:

● Here's how well you must do:

1. You must correctly answer 8 out of 10 Shop Problems.
2. You must answer questions about this Project Sheet to the approval of your Instructor.

ADDITION AND SUBTRACTION OF DECIMALS

Because decimals are easier to use, decimal measurement is more popular than fractional measurement. In everyday shop problems, decimals are now replacing fractions wherever possible. As a Precision Metal Finisher, you will need to know how to use decimals well.

HERE'S WHAT A DECIMAL IS

A decimal number is a fraction whose denominator is 10 or some multiple of 10.

Look at Figure 1.

<u>Decimal Form</u>		<u>Fraction Form</u>
.6	= 6 tenths	= $\frac{6}{10}$
.05	= 5 hundredths	= $\frac{5}{100}$
.32	= 32 hundredths	= $\frac{32}{100}$
.004	= 4 thousandths	= $\frac{4}{1000}$
.267	= 267 thousandths	= $\frac{267}{1000}$

Figure 1: Decimal and fraction forms.

A decimal number less than one is usually written with a zero to the left of the decimal point. For example, .532 would be written as 0.532, .4 as 0.4, and .001 as 0.001. This is done because it is possible to mistake .4 for 4, but you cannot overlook the difference between 0.4 and 4. Also, the zero to the left of the decimal point will help you remember where the decimal point is.

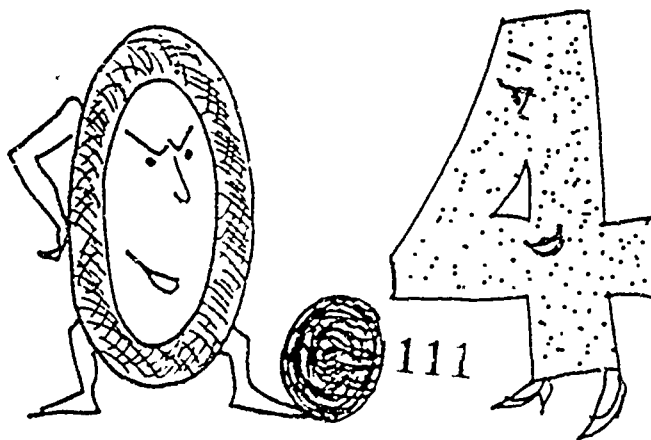

PARTS OF DECIMAL NUMBERS

A decimal number may have both a whole number part and a fraction part. For example, look at Figure 2 below to see what the number 343.213 means.

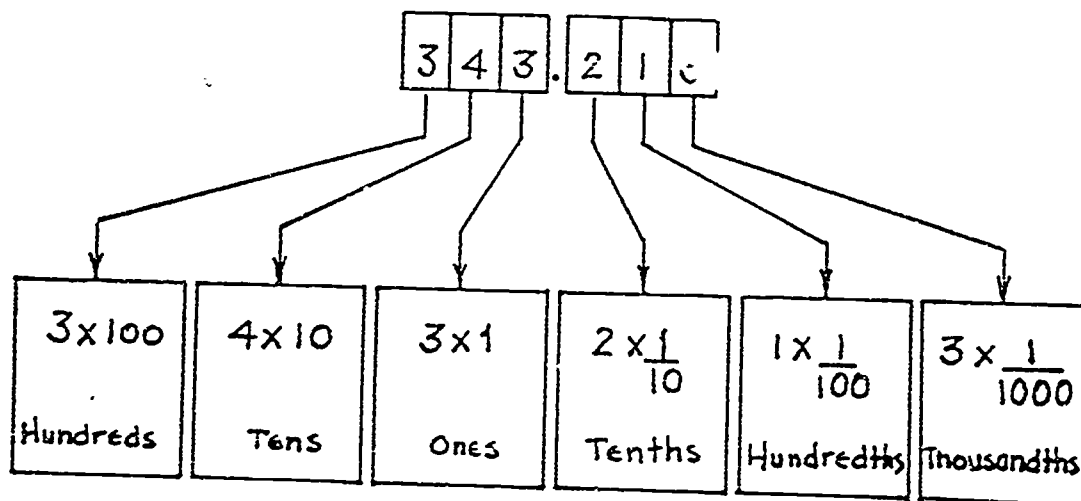

Figure 2: See what each digit means.

Notice that the denominators in the decimal fractions change by a factor of 10. Look at Figure 3 below.

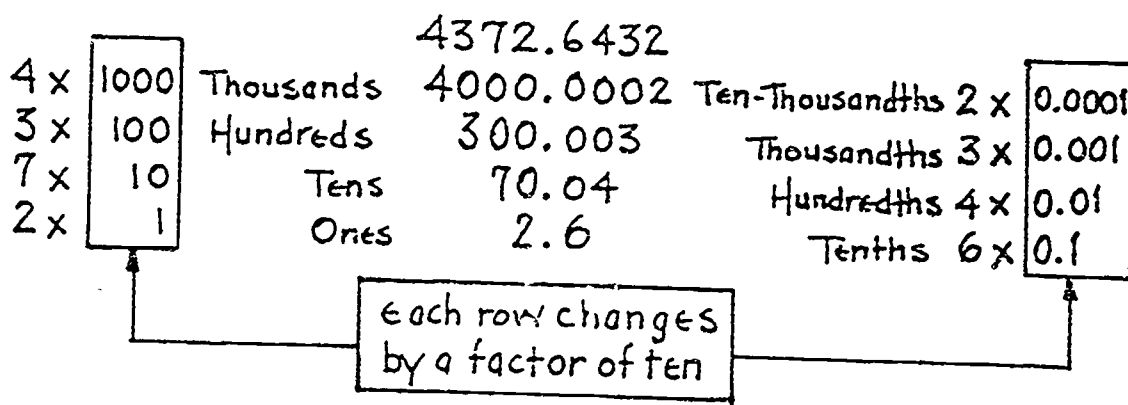

Figure 3: Each denominator changes by a factor of 10.

DECIMAL DIGITS

In the number 45.361, the digits 3, 6 and 1 are called *decimal digits*. They are the digits to the right of the decimal point—they name the *fractional* part of the decimal. You will use the idea of decimal digits often in doing arithmetic with decimal numbers.



The decimal point is a place marker. It separates the whole number part from the fractional part. In whole numbers without any fractional part, the decimal point usually is not written, but is understood to be there. Look at Figure 4.

$$2 = 2. \leftarrow \text{Decimal Point}$$

$$324 = 324. \leftarrow \text{Decimal Point}$$

Figure 4: Decimal points go to the right of whole numbers.

It is important for you to know where the decimal points go.

Additional zeros can be attached to the decimal number without changing its value. For example:

$$6.4 = 6.40 = 6.400 \text{ and so on.}$$

$$5 = 5. = 5.0 = 5.00 \text{ and so on.}$$

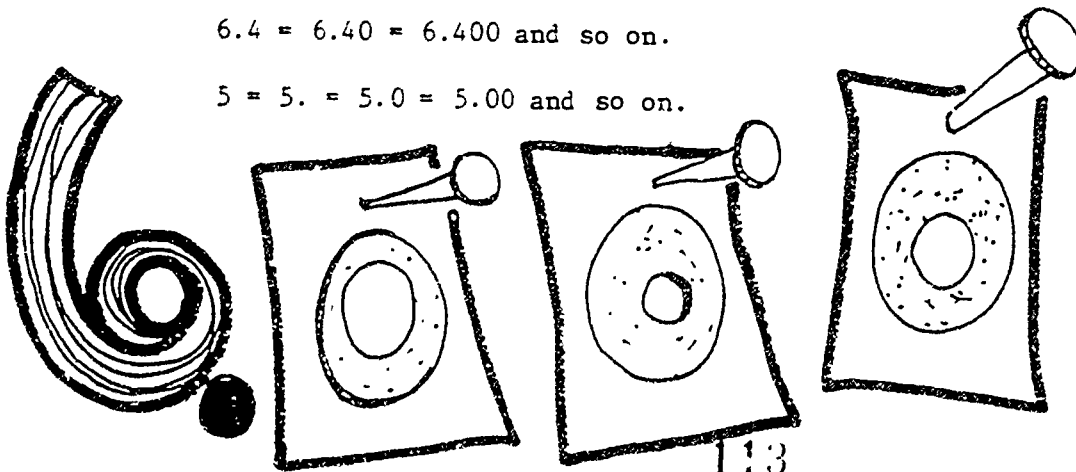

ADDITION AND SUBTRACTION

Because decimal numbers represent fractions with denominators equal to multiples of 10, addition and subtraction are very simple. Look at Figure 5.

$$\begin{array}{r}
 4.32 = 4 + \frac{3}{10} + \frac{2}{100} \\
 3.16 = 3 + \frac{1}{10} + \frac{6}{100} \\
 \hline
 7 + \frac{4}{10} + \frac{8}{100} = 7.48
 \end{array}$$

adding like fractions

Figure 5: Adding decimal numbers.

Of course, you do not actually add and subtract decimals in the way shown above in Figure 5. You simply line up the decimal points. If one number is written with fewer decimal digits than the other, write in as many zeros as needed so both will have the same number of decimal digits. Then, add or subtract as you would with whole numbers. Look at Figure 6.

$$\begin{array}{r}
 5.4 + 6.671 = 5.400 \\
 \quad \quad \quad + 6.671 \\
 \hline
 \quad \quad \quad 12.071
 \end{array}$$

$$\begin{array}{r}
 5.89 - 4.321 = 5.890 \\
 \quad \quad \quad - 4.321 \\
 \hline
 \quad \quad \quad 1.569
 \end{array}$$

you must line up the decimal points right in order to get the right answer

Figure 6: Line up the decimal points and add zeros where needed.

EXAMPLE PROBLEM: Find the missing dimensions on the sketch shown below. Look at Figure 7.

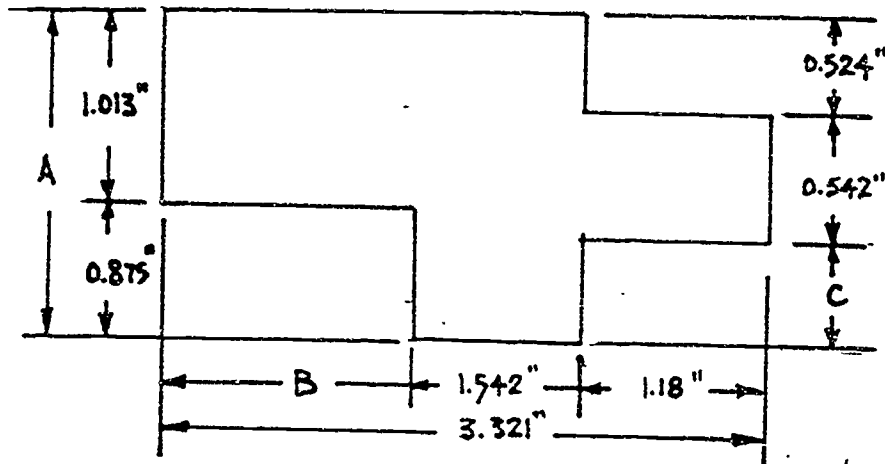

Figure 7: Find the missing dimensions.

You can see that A and B can be solved directly. When you know A, you can find C. First, find the length of A.

$$A = 1.013'' + 0.875''$$

$$\begin{array}{r} 1.013'' \\ + .875'' \\ \hline A = 1.888'' \end{array}$$

Then find B:

$$B = 3.321'' - (1.542'' + 1.18'')$$

$$B = 3.321'' - \begin{array}{r} 1.542'' \\ + 1.180'' \\ \hline 2.722'' \end{array}$$

$$B = 3.321'' - 2.722''$$

$$\begin{array}{r} 3.321'' \\ - 2.722'' \\ \hline B = 0.599'' \end{array}$$

And finally, find C:

$$C = A - (0.524 + 0.542), \quad A = 1.888 \text{ from above.}$$

Then substituting for A, you have:

$$C = 1.888 - \begin{array}{r} 0.524 \\ + 0.542 \\ \hline 1.066 \end{array}$$

$$C = 1.888 - 1.066 \longrightarrow \begin{array}{r} 1.888 \\ - 1.066 \\ \hline C = 0.822 \end{array}$$

Now, you can try some sample Shop Problems and see how much easier decimals are than fractions. If you have any questions about the Example Problems, ask your Instructor for help.

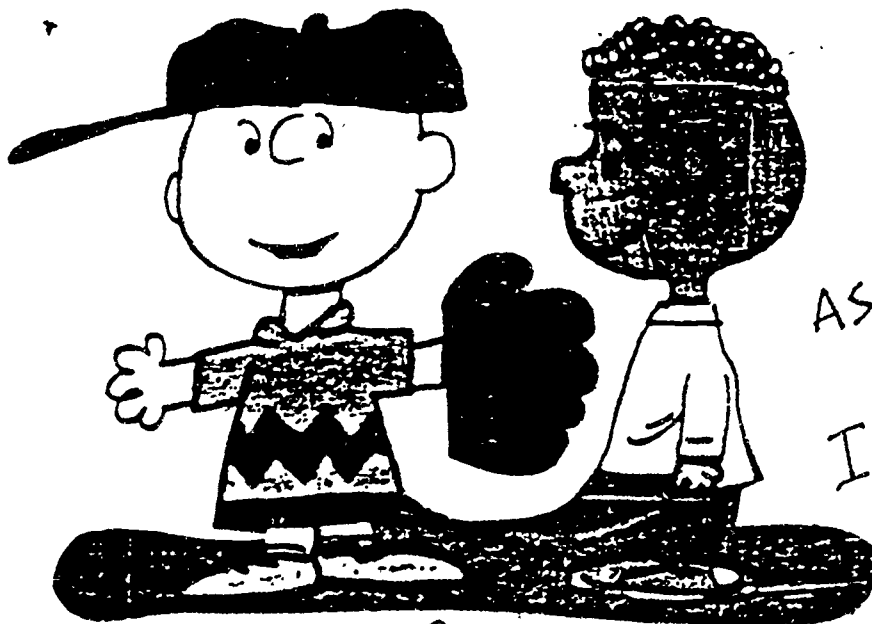

ASK
YOUR
INSTRUCTOR

© UNITED FEATURES, INC.

3-100 116

SHOP PROBLEMS

1. Your supervisor has given you 5 shims. You must find their total thickness. You have measured the individual shims and found them to be 0.008", 0.125", 0.0075", 0.625" and 0.0425". What is their total thickness? *Total thickness* _____

2. Your Instructor has given you 5 common gages of wire to measure with a micrometer. You find the diameter of the 5 gages of wire and tabulate your results as follows:

#10 gage wire = 0.102" diameter

#11 gage wire = 0.090" diameter

#12 gage wire = 0.081" diameter

#14 gage wire = 0.064" diameter

#16 gage wire = 0.051" diameter

Your Instructor then asks you the following questions about the wire.

A. How much smaller is the diameter of the #16 gage wire than the diameter of the #14 gage wire? *Difference* _____

B. How much smaller is the diameter of the #14 gage wire than the diameter of the #10 gage wire? *Difference* _____

C. What are the combined diameters of the 5 gages of wire you measured? *Combined diameters* _____

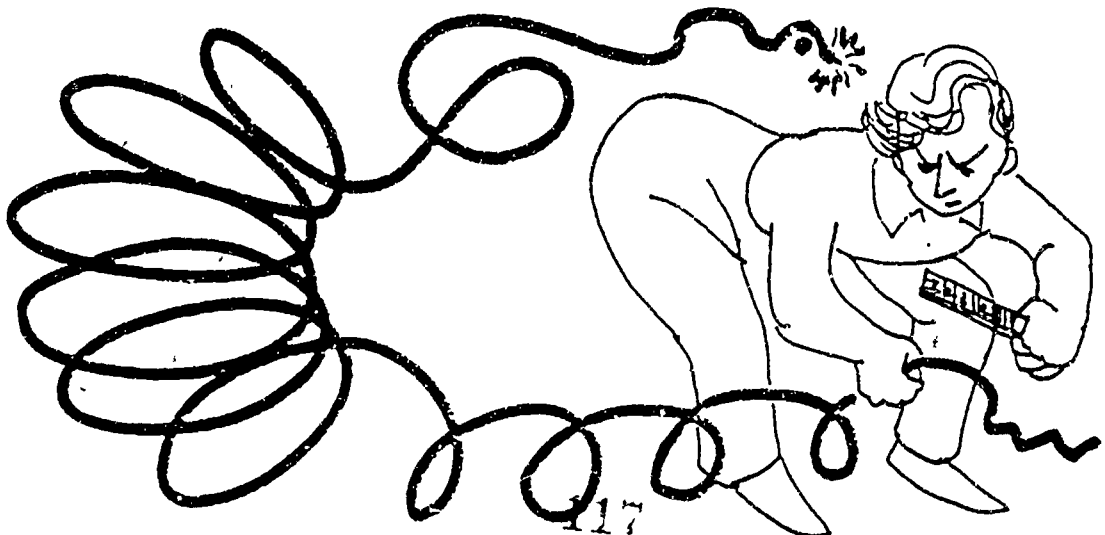

3. You have just finished a job and your boss wants to know how much to bill the customer. You have kept track of the following cost items:

Material - \$157.24
 Machining - 175.56
 Drilling - 182.47
 Finishing - 246.72
 Painting - 36.50

Your boss wants you to add in \$255.50 for profit. How much do you bill the customer?

Bill _____

4. Your foreman has given you the following information about 4 pieces of sheet metal. Their combined weight is 100.76 pounds. One sheet weighs 42.67 pounds, one sheet weighs 20.42 pounds, and one sheet weighs 11.86 pounds. The foreman wants to know how much the fourth sheet weighs.

Weight of 4th sheet _____

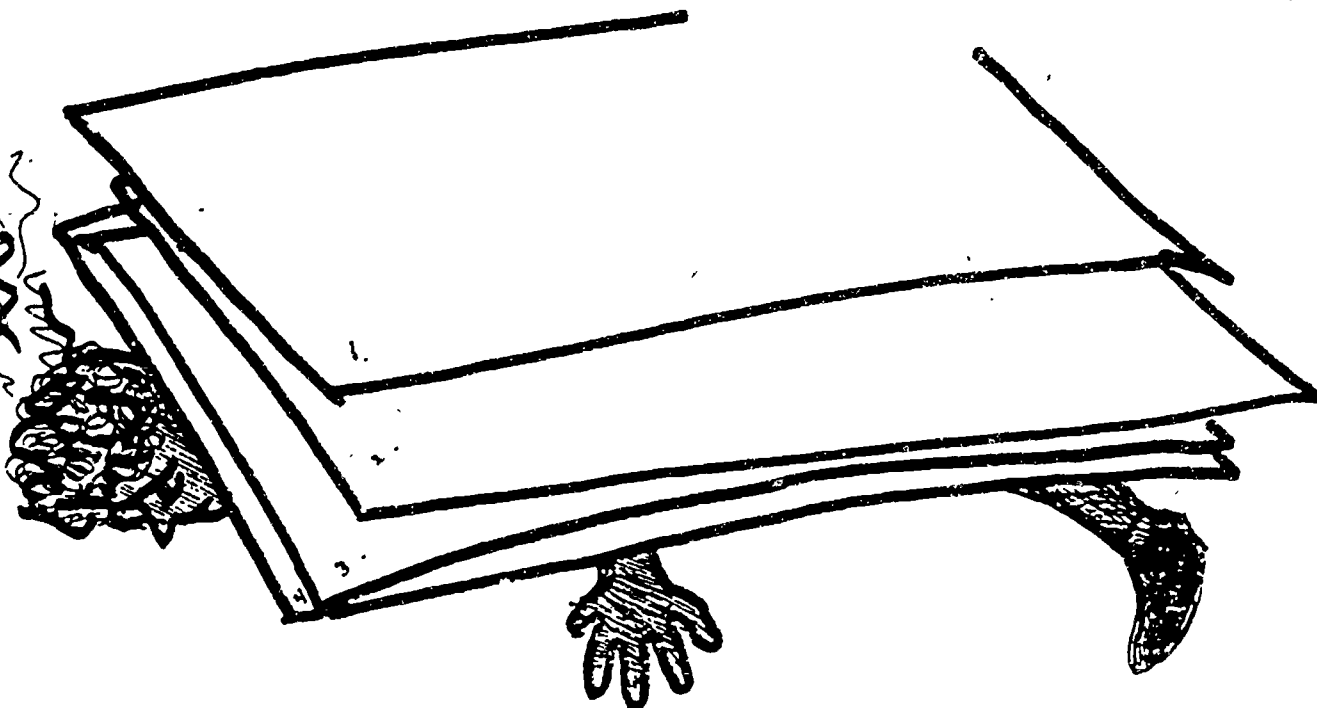

5. Your shop foreman gives you a sketch of a gage to be cut from sheet metal. Look at Figure 8 below. You notice that before you can lay it out, you must find some missing dimensions. What are the lengths of A, B and C?

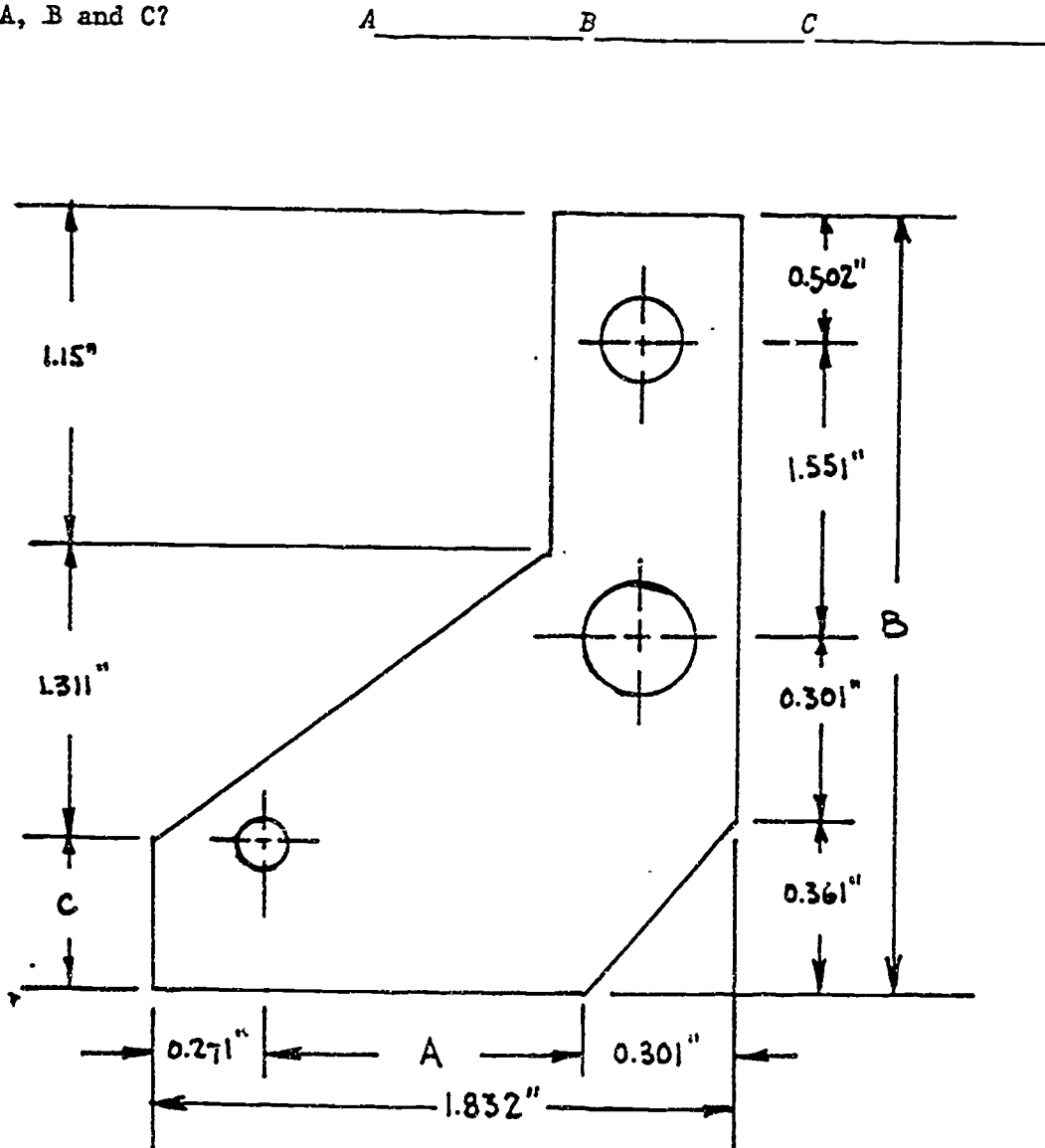

Figure 8: Find the missing dimensions.

6. Your supervisor gives you the job of machining and finishing a 1.265" thick part. You are to machine off 0.0125" and finish off 0.001". What will be the thickness of the finished machine part?

Finished thickness _____

7. Your job is to take a drawing sketch (Look at Figure 9), lay it out on sheet metal for cutting. Before you can lay it out you must find some missing dimensions. What are the missing dimensions A, B, C, D, and E?

A _____ B _____ C _____ D _____ E _____

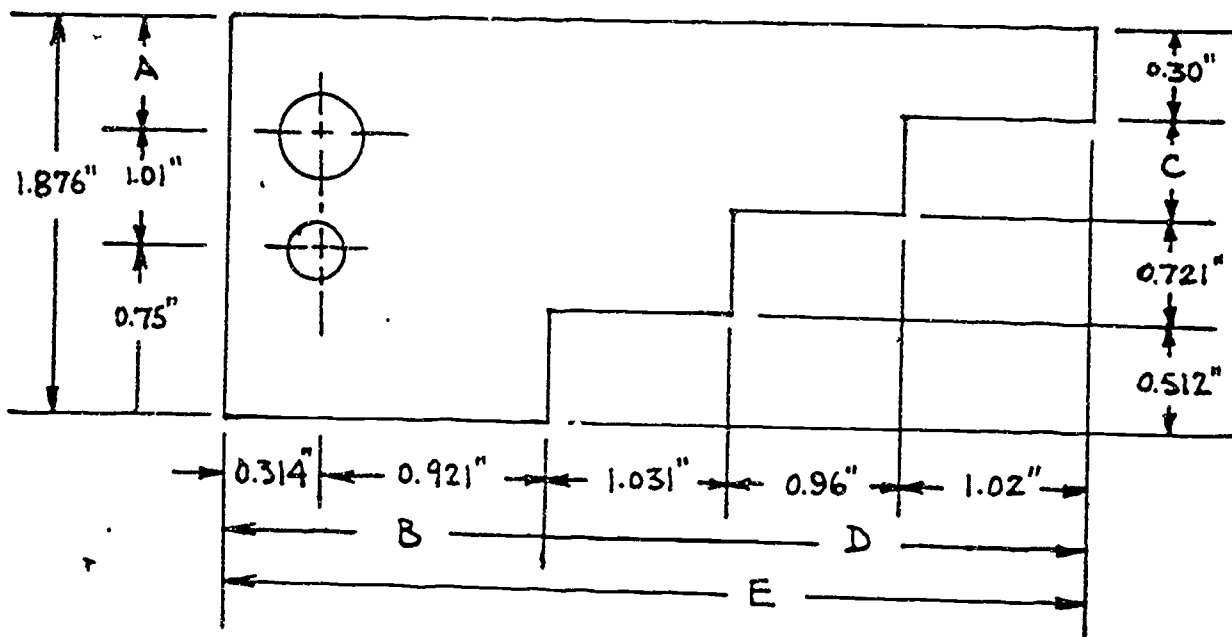

Figure 9: Find the missing dimensions.

8. Your Instructor gives you a 1.135" thick machine part for you to grind and polish. You are to grind off 0.005". If the finished part is to be 1.129" thick, how much do you need to polish off?

Thickness to be polished off _____

9: A customer has paid you \$175.00 for a certain machining, drilling and finishing process. If you used \$39.50 for metal stock, \$14.50 for paint, and \$32.75 for general overhead, how much did you make?

Profit _____

10. You are to make a precision gage from a sketch given to you by your Instructor. Look at Figure 10. Before you can lay it out for cutting, you find you need to figure out some missing dimensions. What are the dimensions of A, B and C?
 A _____ B _____ C _____

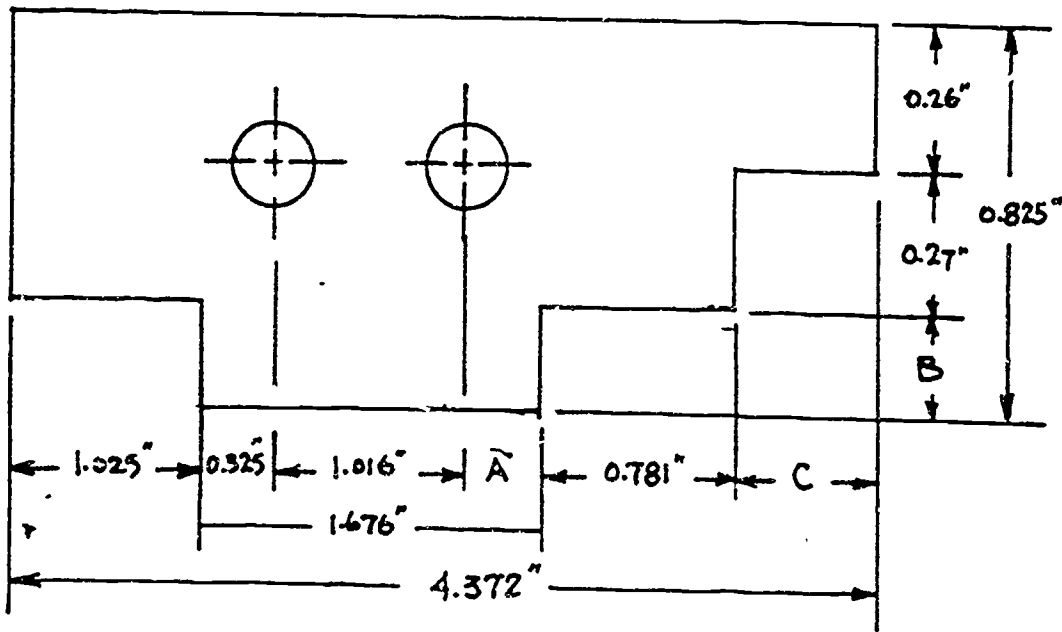

Figure 10: Find the dimensions of A, B and C.

SHOW YOUR WORK TO YOUR INSTRUCTOR.

PROJECT SHEET



204

Name _____ Date _____

Cluster Metal Trades Occupation Machinist HelperTraining Module Shop Math for MachinistsTraining Milestone 2. Math for Measuring Instruments

PROJECT 4

MULTIPLICATION AND DIVISION OF DECIMALS

TRAINING CONDITIONS:

- Here's what you will need:

1. This Project Sheet.
2. A pen or pencil to answer the problems in this Project Sheet.

TRAINING PLAN:

- Here's what you do:

in this Project Sheet, you will review multiplication and division of decimals. You will also work some problems of the type you will find on your job as a Machinist Helper. This work will help you to use measuring tools accurately and to apply their use to practical shop problems.

1. Read and study the math review and Example Problems on pages 2 to 9 of this Project Sheet.
2. Work the Shop Problems on pages 10 and 11.
3. Have your Instructor check your work and record your score on your Student Training Record.
4. Ask your Instructor for your next Project Sheet.

TRAINING GOAL:

- Here's how well you must do:

1. You must correctly answer 8 out of 10 Shop Problems in this Project Sheet.
2. You must answer questions about this Project Sheet to the approval of your Instructor.

MULTIPLICATION AND DIVISION OF DECIMALS

MULTIPLICATION OF DECIMALS

When you multiply decimals, you do it much the same way you multiply whole numbers except you must keep track of decimal points.

For example: Multiply 3.2×0.41

Step 1: Multiply, ignoring decimal points.

$$\begin{array}{r} 32 \\ \times 41 \\ \hline 32 \\ 128 \\ \hline 1312 \end{array}$$

Step 2: Count decimal digits in each number.

3.2 has *one* decimal digit (the 2) and

0.41 has *two* decimal digits (the 4 and the 1).

The total number of decimal digits in the factors is *three*. Therefore, the answer will have three decimal digits. Count over three digits from right to left.

1.312

 three decimal digits from right to left.

Check: 3.2×0.41 is roughly $3 \times \frac{1}{2}$ or about $1\frac{1}{2}$.

The answer 1.312 agrees with your rough guess of $1\frac{1}{2}$.

Remember, even if you use a calculator to do your actual arithmetic, you should always *estimate* your answer and then check it afterwards to be sure your decimal is in the right place.

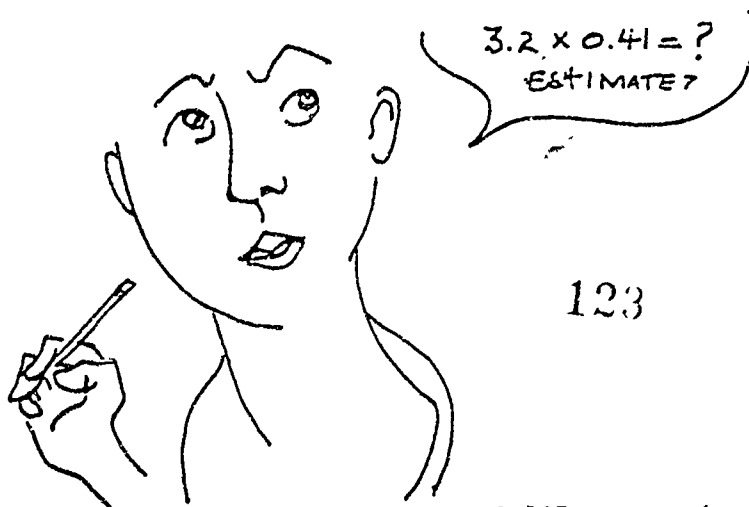

EXAMPLE PROBLEM 1: Multiply 0.00622×0.0041

Step 1: Forget the decimal points and multiply normally.

$$\begin{array}{r} 622 \times 41 = \\ \quad \quad \quad \underline{x\ 41} \\ \quad \quad \quad 622 \\ \quad \underline{2488} \\ 25502 \end{array}$$

Step 2: Count the total decimal digits in the original two factors. Then count in your answer, from right to left, the number of total decimal digits as shown below.

$$\begin{array}{c} \uparrow \\ 0.0041 \\ \text{four decimal} \\ \text{digits} \end{array} \times \begin{array}{c} \uparrow \\ 0.00622 \\ \text{five decimal} \\ \text{digits} \end{array} = \begin{array}{c} \uparrow \\ 0.000025482 \\ \text{nine total} \\ \text{decimal digits} \end{array}$$

NOTE: In this case, you must add the right number of zeros (4) to get the right number of total decimal digits (9).

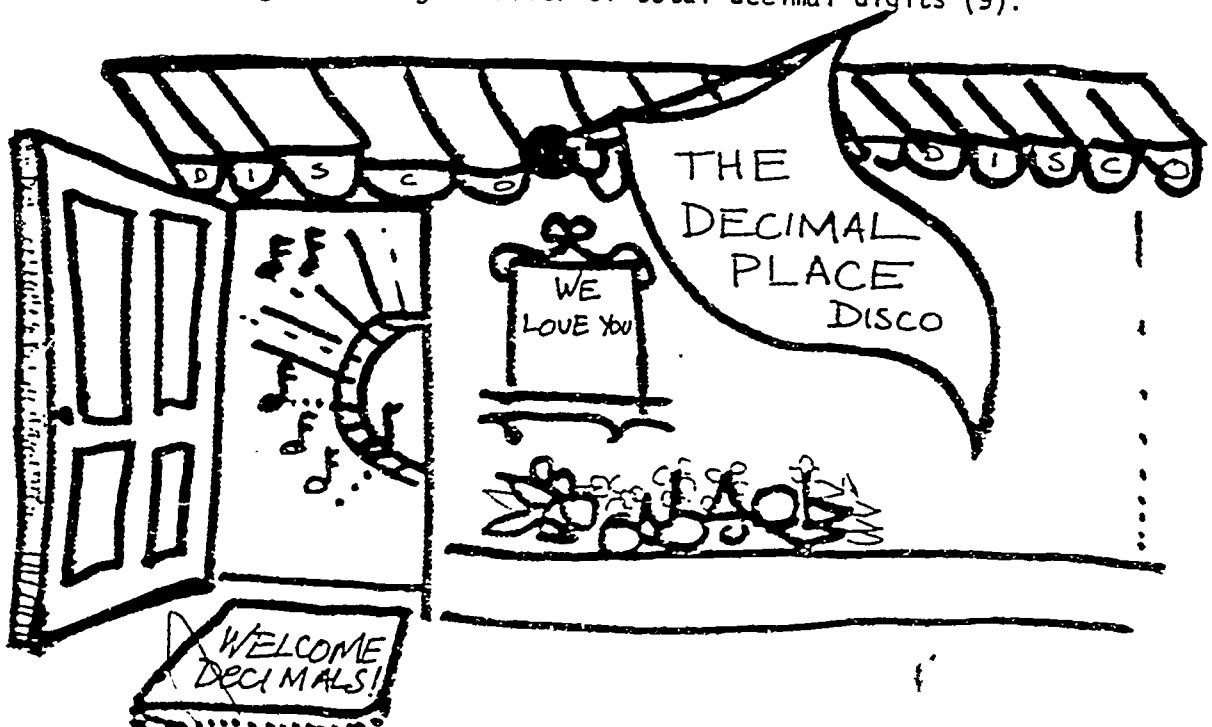

EXAMPLE PROBLEM 2: Your supervisor asks you to find the volume of the box in Figure 1.

(Remember that the volume is equal to the length times depth times height and is expressed in cubic units--like cubic inches, etc.)

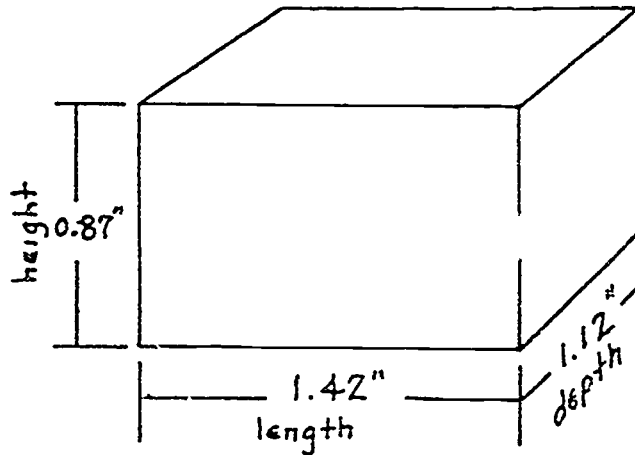

Figure 1: Find the volume.

Step 1: Ignore the decimal digits and multiply any two of the three factors. Then multiply that answer by the third factor as shown below. It doesn't matter which factors you multiply first.

$$\begin{array}{r}
 142 \times 87 = \begin{array}{r} 142 \\ \times 87 \\ \hline 994 \\ 1136 \\ \hline 12354 \end{array} \quad \begin{array}{l} \nearrow \\ \searrow \end{array} \quad \begin{array}{r} 12354 \times 112 = \begin{array}{r} 12354 \\ \times 112 \\ \hline 24708 \\ 12354 \\ \hline 12354 \\ \hline 1383648 \end{array}
 \end{array}$$

Step 2: Count the total decimal digits in the original three factors. Then count in your answer, from right to left, the number of total decimal digits as shown below.

$$\begin{array}{ccccccc}
 \begin{array}{c} \uparrow \\ 1.42'' \\ \downarrow \\ \boxed{\text{two decimal digits}} \end{array} & \times & \begin{array}{c} \uparrow \\ 0.87'' \\ \downarrow \\ \boxed{\text{two decimal digits}} \end{array} & \times & \begin{array}{c} \uparrow \\ 1.12'' \\ \downarrow \\ \boxed{\text{two decimal digits}} \end{array} & = & \begin{array}{c} \uparrow \\ 1.383648 \text{ cu in} \\ \downarrow \\ \boxed{\text{six decimal digits}} \end{array} \\
 & & + & & + & = & \\
 & & \boxed{\text{two decimal digits}} & & \boxed{\text{two decimal digits}} & & \boxed{\text{six decimal digits}}
 \end{array}$$

125

Check: $1.42 \times 0.87 \times 1.12$ is roughly equal to $1\frac{1}{2} \times 1 \times 1 = 1\frac{1}{2}$. The answer, 1.383648 cubic inches, agrees with your rough guess of $1\frac{1}{2}$. You can tell the decimal point is in the right place.

DIVISION OF DECIMALS

The division of decimals is a little more difficult, but if you follow the steps carefully, you will do accurate work. Remember, it is important for you to *estimate* your answer and then check it afterwards. Your estimate will tell you if your decimal point is in the right place.

DIVIDENDS AND DIVISORS

Recall the definitions of the words *dividend* and *divisor*. In a division problem, the dividend is the number that is to be divided. The divisor is the number that is doing the dividing. You always divide the dividend by the divisor. Look at Figure 2.

$$0.4012 \div 0.017 = \frac{0.4012}{0.017} \begin{array}{l} \leftarrow \text{Dividend} \\ \leftarrow \text{Divisor} \end{array}$$

Figure 2: Dividend and divisor.

STEPS IN DIVIDING DECIMALS

To divide decimal numbers, you should use the following step-by-step procedures.

Step 1: Write the dividend and divisor in standard long division form.

$$\rightarrow 4.012 \div 0.017 = 0.017 \overline{)4.012}$$

Step 2: Move the decimal point in the divisor as many places to the right as necessary to make the divisor a whole number.

$$\rightarrow = \underline{.017} \overline{)4.012}$$

three places

Step 3: Move the decimal point in the dividend the *same number of places*. Add zeros if necessary.

$$\begin{array}{r} .017. \overline{)4.012.} \\ \hline \end{array}$$

Step 4: Place the decimal point in the answer space directly above the new decimal position in the dividend.

$$\begin{array}{r} 17. \overline{)4012.} \\ \hline \end{array}$$

Step 5: Complete the division just as you would with whole numbers. Forget the decimal points in the divisor and dividend.

$$\begin{array}{r} 236. \\ 17. \overline{)4012.} \\ \underline{34} \\ 61 \\ \underline{51} \\ 102 \\ \underline{102} \\ 0 \end{array}$$

You can check your answer by multiplying the answer by the divisor. You should get the dividend.

Here is a type of problem that gives many people trouble. Work this problem by following these steps:

$$0.365 \div 18.25 = 18.25 \overline{)365}$$

Write in standard long division form.

$$\begin{array}{r} 18.25. \overline{)36.5} \\ \hline \end{array}$$

Move the decimal point in the divisor as many places to the right to make it a whole number. Move the decimal point in the dividend the *same* number of places to the right. Place the decimal point in the space directly above the new decimal position in the dividend. Complete the division forgetting the decimal point in the divisor and dividend.

$$\begin{array}{r} .0 \\ 1825 \overline{)36.50} \\ \hline \end{array}$$

1825 does not go into 365, so you must place zero above the 5 and add another zero to the 5 in the dividend.

$$\begin{array}{r} .02 \\ 1825 \overline{)36.50} \\ \underline{36.50} \\ 0 \end{array}$$

1825 goes into 3650 two times.

$$\text{check: } 1825 \times .02 = 0.365$$

127

EXAMPLE PROBLEM 3: Your boss wants to know how many pieces of pipe 1.24" long can be cut from a long piece of pipe stock 19.84" long. Don't worry about waste. Look at Figure 3.

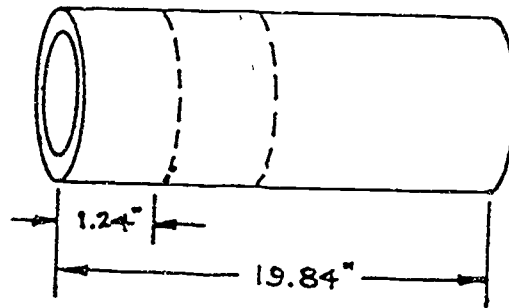

Figure 3: How many pieces can you cut?

Solution:

Write in standard long division form.

$$19.84 \div 1.24 = 1.24 \overline{)19.84}$$

Locate new decimal point in answer space by moving the decimal point two places in the divisor and dividend.

$$124 \overline{)1984.}$$

Then complete the division as you would with whole numbers.

$$\begin{array}{r} 16. \\ 124 \overline{)1984.} \\ \underline{124} \\ 724 \\ \underline{724} \\ 0 \end{array}$$

Check: $16 \times 124 = 1984$

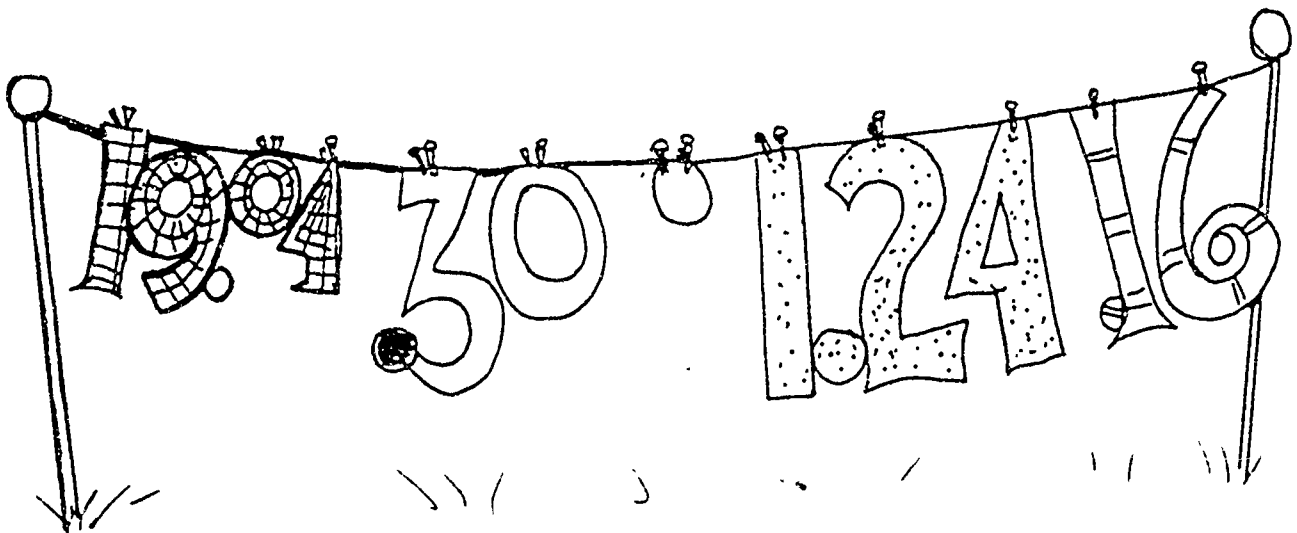

HOW TO NAME DECIMAL NUMBERS

The decimal number 3,254,935.4728 should be thought of as:

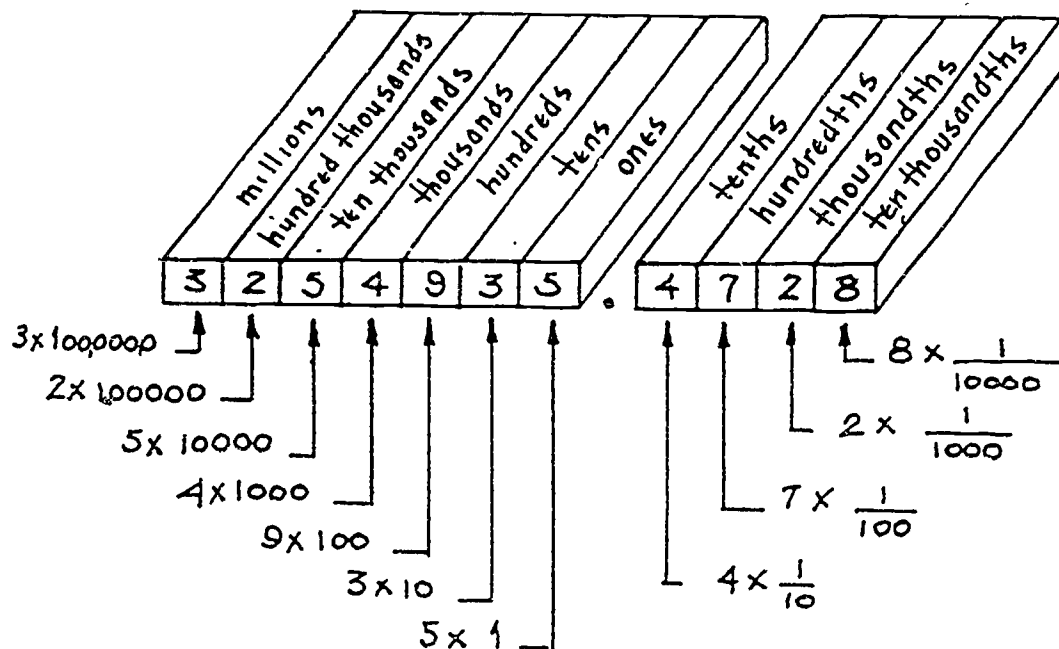

This number may be read, *three million, two hundred fifty-four thousand, nine hundred thirty five and four thousand seven hundred and twenty-eight ten-thousandths*. Notice that you read the decimal point as *and*.

ROUNDING

Rounding is a method of *estimating* a number. To *round* a number means to find another number roughly equal to the given number but expressed in simpler terms. For example:

- \$432.57 = \$400 rounded to the nearest hundred dollars,
- = \$430 rounded to the nearest ten dollars,
- = \$432 rounded to the nearest dollar,
- = \$432.60 rounded to the nearest ten cents.

Other examples of rounding:

- 1.376521 = 1. rounded to the nearest whole number
 = 1.4 rounded to one decimal place, or rounded to the nearest tenth
 = 1.38 rounded to two decimal places, or rounded to the nearest hundredth
 = 1.377 rounded to three decimal places, or rounded to the nearest thousandth
 = 1.3765 rounded to four decimal places, or rounded to the nearest ten-thousandth

For most rounding, you can use these simple steps:

Suppose you want to round 3.462 to one decimal place.

Step 1: Figure out the number of digits or the place where the number is to be rounded. Mark it with a \wedge .

Round 3.462 to one decimal

3.462
 \wedge

Step 2: If the digit to the right of the \wedge is 5 or *larger* than 5, increase the digit to the left by 1.

3.462 - 6 is
 \wedge
 larger than 5 so
 increase the 4 by
 1 and 3.462
 becomes 3.5.

If the digit to the right of the \wedge is *less* than 5 leave the digit to the left of \wedge as it is.

If you round 3.422 to one decimal place using Steps 1 and 2 above, you get
 $3.422 = 3.422 = 3.4$
 \wedge

(3.4 is the right answer because the 2 in the hundredths place is less than 5.)

If you have any questions about this review or the Example Problems, see your Instructor.

SHOP PROBLEMS

1. You have measured a machine part five times with a vernier micrometer. You get readings of 1.0231", 1.0234", 1.0229", 1.0235" and 1.0230". Your boss wants you to first find the *average reading*, and then *round off* the average reading to three decimal places. Remember that average reading equals the sum of the readings divided by the number of readings taken.

Average reading _____ Rounded reading _____

2. You have measured a piece of rectangular sheet metal and found it to be 2.62" long and 4.51" wide. Your boss wants to know the *area* of the sheet to the nearest hundredth of an inch. Remember that area equals length times width.

Area to nearest hundredth of an inch _____

3. On your job you make gages for a machine shop. For each gage, it costs you \$3.55 for material, \$2.80 labor, \$1.05 for overhead, and \$2.25 for profit. How much do you charge the machine shop for 28 gages?

Charge for gages _____

4. On your job, you need to know the average thickness of a piece of sheet metal to four decimal places. To do this accurately, you separate the 20 sheets into 4 batches of 5 sheets each and then measure each batch. The measurements of the four batches are 1.2124", 1.2127", 1.2129" and 1.2131". What is the *average thickness* of one piece of stock sheet metal?

Average thickness to four decimal places _____

5. Your boss wants to know the average diameter of a metal casting. You measured the diameter of the casting at five different places. Your measurements are 1.312", 1.311", 1.319", 1.32" and 1.315". What is the average diameter of the casting, to the nearest thousandth of an inch?

Average diameter to the nearest thousandth inch _____

6. At your shop you are scheduled to receive a shipment of sheet metal stock. The average cost of the sheet metal stock is \$1173.12. The cost per sheet is \$3.76. How many sheets are you going to receive?

Number of sheets _____

7. On your job, you are given a piece of metal plate to lay out a pattern of small rectangular gage blanks. The dimensions are shown in Figure 4 below. If you forget about waste, how many blanks can you make from the sheet?

Number of blanks _____

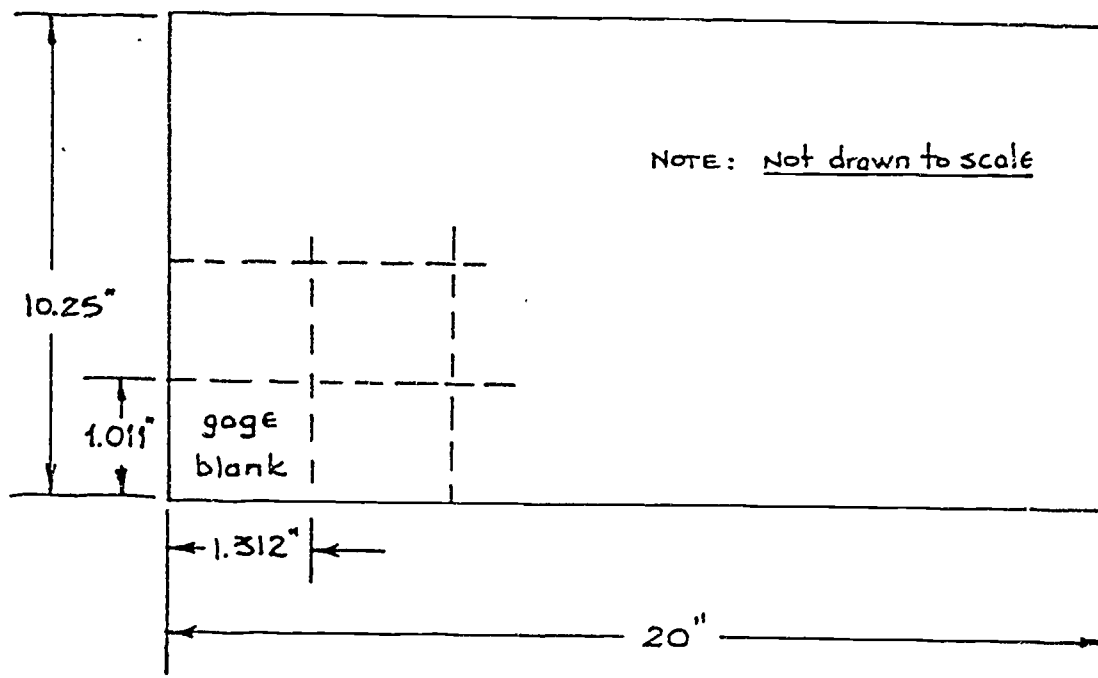

Figure 4: Dimensions for one gage blank.

8. In your shop, you are asked to saw spacer blocks from a 48" piece of bar stock. The blocks are 2.34" thick. If you allow 0.125" waste for each saw cut, how many spacer blocks can you make?

Number of blocks _____

9. On your job, the foreman asks you to figure out the cost of some sheet metal that has been ordered. The sheets measure 4.25 feet wide and 8.40 feet long. The cost of the sheet metal is \$1.70 per square foot. If the foreman ordered 25 sheets, what is the total cost of the sheet metal? Remember, to get square feet, you multiply length times width.

Cost of sheet metal _____

10. Your shop charges \$3.55 for a machined ornamental bracket. How many brackets can you build for \$78.10?

Number of brackets _____

HAVE YOUR INSTRUCTOR CHECK YOUR WORK

BAS

PROJECT SHEET



205

Name _____ Date _____

Cluster Metal Trades Occupation Machinists HelperTraining Module Shop Math for Machinists HelperTraining Milestone 2. Math for Measuring Instruments

PROJECT 5

FRACTION-DECIMAL CONVERSIONS

TRAINING CONDITIONS:

- Here's what you will need:
 1. This Project Sheet.
 2. A pencil or pen to answer the problems in this Project Sheet.

TRAINING PLAN:

- Here's what you do:

In this Project Sheet, you will review the methods of changing fractions to decimals. You will also work some problems of the kind you will find on your job. This work will help you to apply their use to practical shop problems.

 1. Read and study the math review on pages 2 to 6 of this Project Sheet.
 2. Work the Shop Problems on pages 7 to 9.
 3. Have your Instructor check your work and record your score on your Student Training Record.
 4. Ask your Instructor for your next Project Sheet.

TRAINING GOAL:

- Here's how well you must do:
 1. You must correctly answer 7 out of 8 Shop Problems.

CHANGING FRACTIONS TO DECIMALS

In working with Project Sheets 1 through 4, you have probably discovered it is much easier to do math with decimals than with fractions. So, in this Project Sheet, you will practice changing fractions to decimals. In many cases, using decimals rather than fractions will make your math work easier.

Here's how you do it:

To change any fraction to decimal form, divide the numerator (top) by the denominator (bottom). If the division has zero remainder, the decimal number is called a *terminating decimal*.

For example:

change $\frac{5}{8}$ to a decimal number.

$$\begin{array}{r} .625 \\ 8 \overline{) 5.000} \\ \underline{48} \\ 20 \\ \underline{16} \\ 40 \\ \underline{40} \\ 0 \end{array}$$

← Attach as many zeros as needed.

← Zero remainder; therefore, the decimal *terminates* or *ends*.



ROUNDING DECIMALS

If the decimal does not terminate, you may round it to any number of decimal digits.

For example:

Change $\frac{2}{13}$ to a decimal number.

$$\begin{array}{r}
 .1538 \\
 13 \overline{) 2.0000} \\
 \underline{13} \\
 70 \\
 \underline{65} \\
 50 \\
 \underline{39} \\
 110 \\
 \underline{104} \\
 6
 \end{array}$$

← Attach zeros.

← Remainder not equal to zero, therefore, the decimal does not terminate or end.

Therefore $\frac{2}{13} = 0.154$ rounded

to three decimal places.

To round to *three* places, an answer must be carried to *four* places. Here is a rule to remember: YOU MUST CARRY OUT YOUR DIVISION ONE MORE DECIMAL PLACE THAN YOU WISH TO ROUND TO.

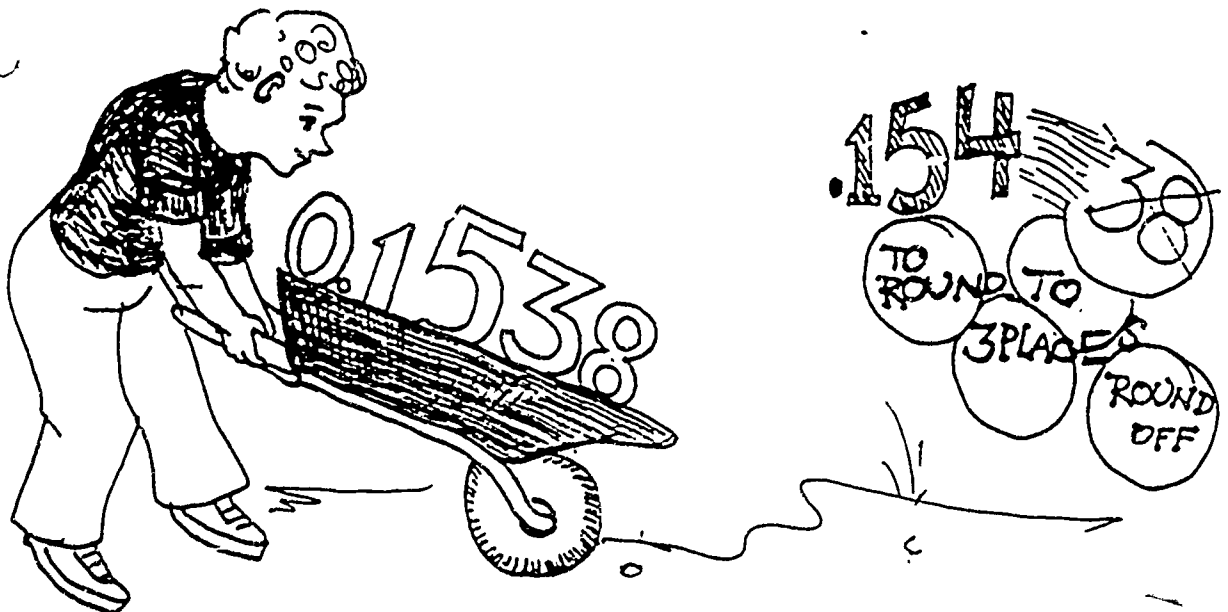

REPEATING DECIMALS

Some decimal numbers that do not *terminate* will *repeat* a group of digits. This kind of decimal number is called a *repeating decimal*.

For example:
change $\frac{5}{9}$ to a decimal number

$$\begin{array}{r} .555\dots \\ 9 \overline{) 5.000} \\ \underline{45} \\ 50 \\ \underline{45} \\ 50 \\ \underline{45} \\ 5 \end{array}$$

Therefore, $\frac{5}{9} = 0.555\dots$

The three dots mean "and so on". That tells you the digit 5 continues without end.

similarly $\frac{2}{3} = 0.666\dots$

and $\frac{3}{11}$ is:

$$\begin{array}{r} .27 \\ 11 \overline{) 3.00} \\ \underline{22} \\ 80 \\ \underline{77} \\ 3 \end{array}$$

The remainder 3 is equal to the original dividend 3. Therefore, the decimal answer repeats itself.

Then $\frac{3}{11} = 0.2727\dots$ rounded to 4 decimal places.

BAR NOTATION FOR REPEATING DECIMALS

Sometimes on blueprints, you may see an engineer's or draftsman's shorthand for repeating decimals. Their shorthand looks like this:

$$\frac{3}{11} = 0.\overline{27} \text{ means } 0.2727\dots$$

$$\frac{17}{7} = 2.\overline{428571} \text{ means } 2.428571428571\dots$$

The digits under the bar repeat endlessly.

$$\frac{1}{3} = 0.\overline{3}, \text{ or } \frac{2}{3} = 0.\overline{6}$$

EXAMPLE PROBLEM: Change $\frac{41}{33}$ to a repeating decimal using bar notation.

$$\frac{41}{33} = 33 \overline{) 41.000} \leftarrow \text{Add zeros as necessary.}$$

$$\begin{array}{r} \overline{) 41.000} \\ \underline{33} \\ 80 \\ \underline{66} \\ 140 \\ \underline{132} \\ 8 \\ \hline \end{array}$$

These remainders are the same.

$$\text{Then } \frac{41}{33} = 1.\overline{24}$$

So you know that further division will produce a repeat of the digits 24 in the answer.

MULTIPLES OF 10

There is another type of problem that you can do quickly and easily if you remember the following:

Dividing by a multiple of ten is done by shifting the decimal point to the left. To divide by a multiple of ten (i.e., 10, 100, 1000, 1,000,000), move the decimal point as many places to the left as there are zeros in the multiple of ten.

For example: $\frac{95}{100} = 0.95$

two zeros ————

move the decimal point two places to the left.

and, $\frac{17}{1,000} = 0.017$

three zeros ————

move the decimal point three places to the left.

Now you can try some problems.

If you have any questions about the Example Problems or the review above, see your Instructor.

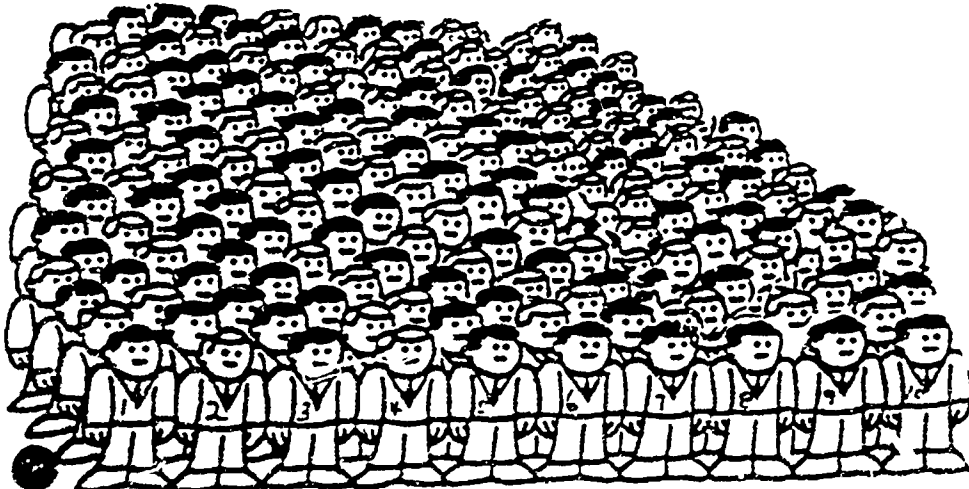

CHANGING DECIMALS TO FRACTIONS:

As you have seen, it is very handy to change fractions to decimals. Many times it is necessary to change decimals back to fractions, particularly when you must do your work to a given tolerance. Now is a good time to learn how to convert decimals to fractions. You will learn more about the methods of changing decimals to fractions in a later Project Sheet.

EXAMPLE PROBLEMS

1. You wish to convert 3.7654" to fractional form using 64ths of an inch.

$$3.7654 = 3 + .7654$$

$$0.7654 \times \frac{64}{64}$$

$$\frac{(0.7654)(64)}{64} = \frac{48.9856}{64}$$

$$\frac{48.9856}{64} = \frac{49}{64}$$

$$\text{then } 3.7654" = 3\frac{49}{64}"$$

Multiply only the decimal portion of the number by the unity fraction ($\frac{64}{64}$) you wish to convert to.

Round off the numerator to the nearest whole number.

2. Convert 7.3654" to 32nds of an inch.

$$\frac{(0.3654)(32)}{32} = \frac{11.6928}{32}$$

$$\frac{11.6928}{32} = \frac{12}{32}$$

$$\frac{12}{32} = \frac{3}{8}$$

$$\text{then } 7.3654" = 7\frac{3}{8}"$$

Multiply decimal portion by unity fraction you wish to convert to.

Round off the numerator to the nearest whole number.

If the fraction can be reduced to lower terms, do so.

3. Convert 4.7085" to 64ths.

$$\frac{(0.7085)(64)}{64} = \frac{45.344}{64}$$

$$\frac{45.344}{64} = \frac{45}{64}$$

$$\text{then } 4.7085" = 4\frac{45}{64}"$$

SHOP PROBLEMS

1. On your job, you are asked to lay out the pattern shown in Figure 1 below. Find the missing dimensions.

(To do this, you must first change the fractions to decimals and then add or subtract as needed.)

Round all decimal dimensions to three decimal places.

Dimensions: A = _____ B = _____ C = _____ D = _____ E = _____

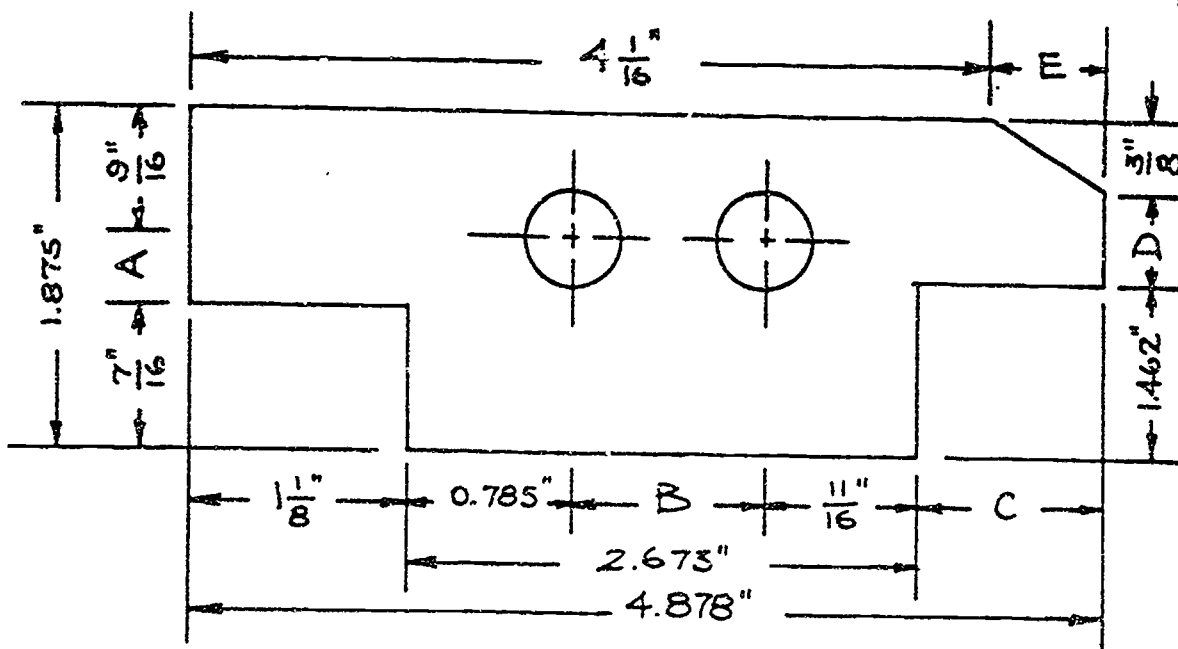

Figure 1: Find the missing dimensions.

2. You work $6\frac{3}{4}$ hours per day, five days a week for \$7.50 per hour. How much do you make per week, rounded off to the nearest penny?

Weekly pay _____

1.411

3. Your supervisor tells you to make 25 shims $\frac{5}{16}$ " thick. You are to allow .075" waste for each shim. How long a piece of stock do you need? (Round to three decimal places. Remember: to round to three places, you must do all your calculations to four places.)

Length of stock _____

4. To lay out a certain pattern for a machinists gage, you must round the following dimensions to the nearest thousandth of an inch (3 decimal places).

a. $\frac{3}{16}$ " = _____.

b. $0.\overline{6}$ " = _____.

c. $\frac{7}{32}$ " = _____.

d. 0.64862 " = _____.

e. $\frac{15}{16}$ " = _____.

5. On a job you use a certain amount of different types of metal plate with the following costs:

<u>Metal Plate Used</u>	<u>Cost of Material</u>
155 sq. ft. of type A	\$20.50 per 100 sq. ft.
1028 sq. ft. of type B	\$52.00 per 1000 sq. ft.
328 sq. ft. of type C	\$46.00 per 100 sq. ft.
4320 sq. ft. of type D	\$ 9.75 per 100 sq. ft.

What did the materials cost altogether? Material cost _____

6. You are to make as many $2\frac{5}{16}$ " spacer blocks as you can from a piece of bar stock that is 60.125 " long. If you allow $\frac{1}{8}$ " waste for each block, how many can you make? *Number of spacer blocks* _____

7. On a certain job you use $12\frac{3}{4}$ feet of iron rod that costs \$4.75 per foot; $24\frac{1}{4}$ feet of extrusion that costs \$3.15 per foot; and $47\frac{3}{4}$ square feet of sheet metal that costs \$1.50 per square foot. You get \$9.40 per hour and you work $15\frac{1}{4}$ hours. How much do you charge for materials and labor? *Materials and labor cost* _____

8. You must lay out a gage block for your Instructor who has given you the sketch shown below in Figure 2. Find the missing dimensions A, B, C, D, and E. *A = _____ B = _____ C = _____ D = _____ E = _____*

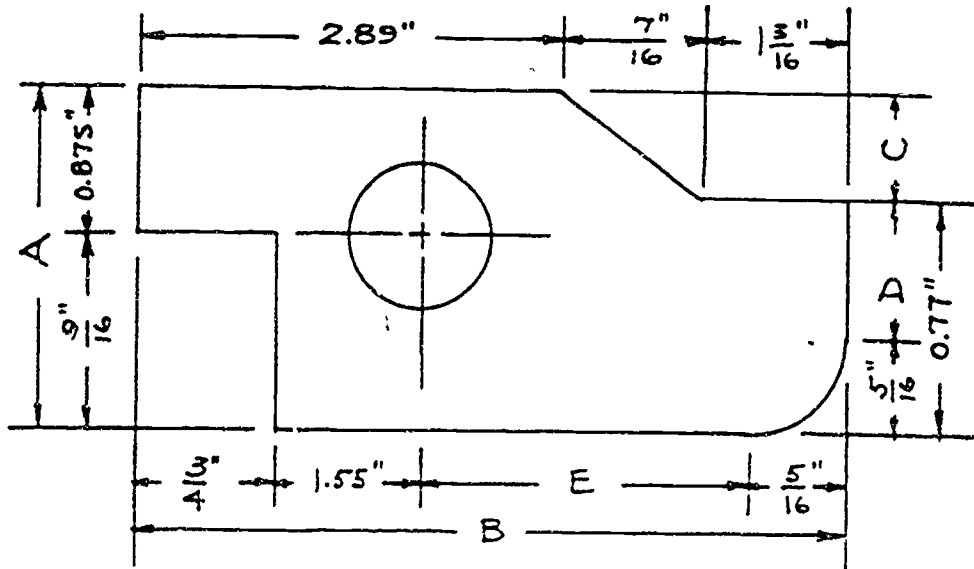

Figure 2: Find the missing dimensions.

ASK YOUR INSTRUCTOR TO CHECK YOUR WORK.



**SKILLS
CENTER**

206

1 of 10

PROJECT SHEET

Name _____ Date _____

Cluster Metal Trades Occupation Machinist Helper

Training Module Shop Math for Machinists

Training Milestone 2. Math for Measuring Instruments

PROJECT 6

REVIEW OF MEASUREMENT NUMBERS

TRAINING CONDITIONS:

- Here's what you will need:

1. This Project Sheet.
2. A pen or pencil to answer the Shop Problems in this Project Sheet.

TRAINING PLAN:

- Here's what you do:

In this Project Sheet, you will review addition, subtraction, multiplication and division of measurement numbers. Then you will work some problems of the type you will find on your job. This work will help you to use measuring tools accurately and to apply their use to practical shop problems.

1. Read and study pages 2 to 8 of this Project Sheet.
2. Work the Shop Problems on pages 9 and 10 of this Project Sheet.
3. Have your Instructor check your work and record your score on your Student Training Record.
4. Ask your Instructor for your next Project Sheet.

TRAINING GOAL:

- Here's how well you must do:

1. You must correctly answer 6 out of 8 Shop Problems.

REVIEW OF MEASUREMENT NUMBERS

TOLERANCE IN MEASURING

Some measuring instruments are more accurate than others. When you take measurements to get your *measurement number*, your reading is never *exact*. That's because the instrument you use and the way you read it is subject to some error. It all depends on the accuracy of your instrument and your ability to use it right.

That is why many drawings and specifications have a *tolerance* included. The tolerance tells you just how accurate your measuring must be. The tolerance also helps you choose the right measuring instrument.

Here's an example: If you see $2.835'' \pm 0.004$, it means the measure must be accurate to within 4 thousandths of an inch. The sign (plus or minus) \pm means it can either be 4 thousandths of an inch *more* or 4 thousandths of an inch *less*. ($2.835''$ could be as much as $2.839''$ or as little as $2.831''$.) Also, you must choose an instrument that will allow you to read thousandths of an inch.

LABELING MEASUREMENTS

When you use a measurement number, there must be a *label* telling what the *units* are. Otherwise, the number doesn't make sense. Some examples of measurement numbers are 8 feet, 5 inches, 7 miles, and 10 pounds. The *units* in these examples are feet, inches, miles, and pounds.

Whenever you must add, subtract, multiply or divide measures, the units must agree (be the same). It's not possible to add oranges to elephants and get an answer that makes any sense.

ADDING AND SUBTRACTING MEASUREMENTS

Here are three steps to follow when adding or subtracting measurements:

Step 1 Make sure all the units are the same. If they're not...
change whatever you must to make the units the same.

Step 2 Add or subtract the numerical part.

Step 3 Write the name of the units.

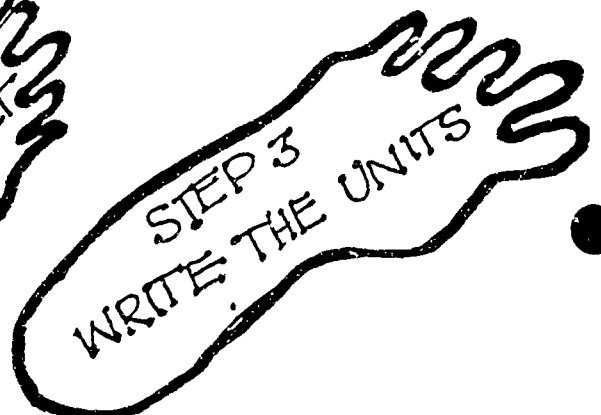
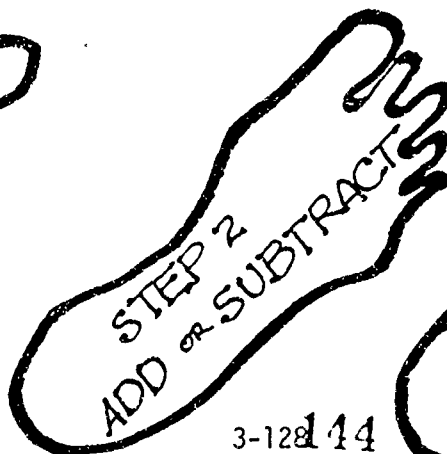

EXAMPLE PROBLEM 1: $6.2 \text{ inches} + 1.5 \text{ feet} = \underline{\hspace{2cm}}$ inches

First, do Step 1: Change 1.5 feet to inches so the units will all be the same:

1.5 feet means 1.5 *times* 1 foot

1 foot = 12 inches

So, 1.5 feet = $1.5 \times 12 \text{ inches} = 18 \text{ inches}$

Now the problem reads $6.2 \text{ inches} + 18 \text{ inches} = \underline{\hspace{2cm}}$ inches.

Now do Step 2: Add the numbers:

$$\begin{array}{r} 6.2 \\ + 18.0 \\ \hline 24.2 \end{array}$$

And now Step 3: Label the answer: 24.2 inches

Therefore, $6.2 \text{ inches} + 1.5 \text{ feet} = 24.2 \text{ inches}$.

Subtraction works the same way.

MULTIPLYING AND DIVIDING MEASUREMENTS

There are three steps to follow when you multiply or divide measurements:

Step 1 Make sure all the units are the same. If they're not...
change whatever you must to make the units the same.

Step 2 Multiply or divide the numerical part.

Step 3 Multiply or divide the *units* to label your answer.



When measurement numbers are added or subtracted, the units named in the answer are the *same* as the units in the problem. When dividing or multiplying unit numbers, the *units* must also be divided or multiplied. That makes the units in the answer different from the ones in the problem.

Use the steps at the bottom of page 3 to work Example Problem 2.

EXAMPLE PROBLEM 2: 4.3 feet x 3.6 feet = ?

First, do Step 1: The units are both feet so they don't need to be changed.

Then, do Step 2:

$$\begin{array}{r} 4.3 \\ \times 3.6 \\ \hline 258 \\ 129 \\ \hline 15.48 \end{array}$$

And then Step 3: Feet times feet = square feet

So, the answer is 15.48 square feet

Here's why:

- 4.3 ft. x 3.6 ft. is the same as (4.3 x 1 foot) x (3.6 x 1 foot)
- When you group numerals and units you get (4.3 x 3.6) x (1 foot x 1 foot)
- Then multiply and you get 15.48 x 1 square foot
- Which equals 15.48 square feet

After the three steps are completed, you can round off the answer if you need to:

15.48 sq. ft. to the nearest tenth = 15.5 sq. ft

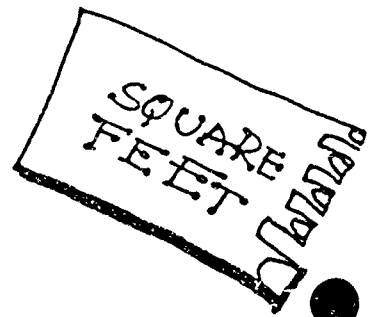
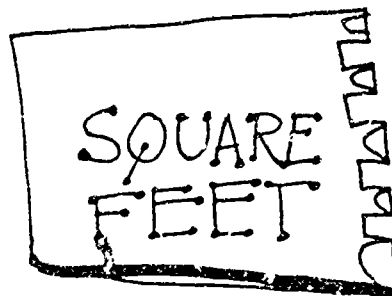

EXAMPLE PROBLEM 3: 18 inches x 2.3 feet = ? sq. ft.
(Rounded to the nearest tenth of an inch.)

First, do Step 1: Make sure the units are the same. In this case they are not. Since the answer must be in square feet, you must change 18 inches to feet. Here's how:

$$\begin{aligned} 18 \text{ inches} &= 18 \times 1 \text{ inch} \\ &= 18 \times \frac{1}{12} \text{ foot} \quad (\text{because } 1 \text{ inch} = \frac{1}{12} \text{ foot.}) \\ &= 1.5 \text{ feet} \end{aligned}$$

Do Step 2: Multiply numerical parts.

$$\begin{array}{r} 1.5 \\ \times 2.3 \\ \hline 3.45 \end{array}$$

Do Step 3: Multiply the units.

$$\begin{aligned} 1 \text{ foot} \times 1 \text{ foot} &= 1 \text{ square foot,} \\ \text{and } 18 \text{ inches} \times 2.3 \text{ feet} &= 3.45 \text{ sq. ft.} \end{aligned}$$

Then round the answer as necessary:

$$3.45 \text{ sq. ft.} = 3.5 \text{ sq. ft. (to the nearest tenth)}$$

DIVIDING

Division with measurement numbers requires the same special care with units as multiplication. Look at Example Problem 4.

EXAMPLE PROBLEM 4: 4.32 sq. ft. \div 3.1 ft. = ?
(Rounded to the nearest hundredth)

First, do Step 1: Make sure the units are the same. In this problem, the units are both a form of feet so they'll work with division.

Do Step 2: Divide the numerals.

$$4.32 \div 3.1 = 1.39$$

$$\begin{array}{r} 3.1 \overline{) 4.320} \\ \underline{31} \\ 122 \\ \underline{93} \\ 290 \\ \underline{279} \\ 11 \end{array}$$

Then do Step 3: Divide the units.

$$\begin{aligned} \text{sq. ft.} \div \text{ft.} &= (1 \text{ ft.} \times 1 \text{ ft.}) \div (1 \text{ ft.}) \\ &= \frac{1 \text{ ft.} \times 1 \text{ ft.}}{1 \text{ ft.}} \\ &= 1 \text{ ft.} \end{aligned}$$

Then round the answer as necessary.

$$4.32 \text{ sq. ft.} \div 3.1 \text{ ft.} = 1.39 \text{ ft. rounded to the nearest hundredth}$$

EXAMPLE PROBLEM 5: You have measured a piece of sheet metal and found it to be 16.43 inches long and 3.25 inches wide. How many square feet is the sheet? Round to the nearest hundredth of a square foot.

Step 1: The units are the same.

Step 2: Multiply the numerical parts.

$$16.43 \times 3.25 = 53.3975$$

Step 3: Multiply units

$$1 \text{ inch} \times 1 \text{ inch} = 1 \text{ sq. in.}$$

Since the question asks how many square feet, you must change your answer to square feet.

So:

$$\begin{aligned} 53.3975 \text{ sq in} &= 53.3975 \times (1 \text{ in} \times 1 \text{ in}), \\ &\quad 1 \text{ in} = \frac{1}{12} \text{ ft, then} \\ &= 53.3975 \times \left(\frac{1}{12} \text{ ft} \times \frac{1}{12} \text{ ft} \right) \\ &= \frac{53.3975}{144} \times (1 \text{ ft} \times 1 \text{ ft}) \\ &= 0.3708 \text{ sq ft} \\ &= 0.37 \text{ sq ft to nearest hundredth} \end{aligned}$$

CHANGING DECIMALS TO FRACTIONS - TOLERANCES

A common Shop Problem is to rewrite a decimal number to the nearest 32nd or 64th of an inch. Then you must determine how much error is involved in using the fraction number rather than the decimal number. Look at Example Problem 6 and Example Problem 7.

EXAMPLE PROBLEM 6: What is the fraction, to the nearest 32nd of an inch, equal to 0.462 inch?

The rule is to multiply the decimal by the fraction $\frac{32}{32}$.

$$\begin{aligned}
 0.0462 \text{ in} &= 0.0462 \text{ in} \times \frac{32}{32} \\
 &= \frac{0.0462 \times 32}{32} \text{ in} \\
 &= \frac{14.784}{32} \text{ in} \quad \leftarrow \text{Round the top number} \\
 &\quad \text{to the nearest unit} \\
 &= \frac{15}{32} \text{ in} \quad \leftarrow \text{Rounded to the nearest} \\
 &\quad \text{32nd of an inch}
 \end{aligned}$$

The error involved is the difference between

$$\frac{15}{32} \text{ in. and } \frac{14.784}{32} \text{ in. , or } \frac{15 - 14.784}{32} \text{ in.}$$

$$\text{and } \frac{15 - 14.784}{32} = \frac{0.216}{32} \text{ in.}$$

$$= 0.00675 \text{ in.}$$

$$= 0.0068 \text{ in. rounded to the nearest ten-thousandth.}$$

EXAMPLE PROBLEM 7: The specifications for a bracket you are building call for a hole $0.637" \pm 0.005"$. Will a $\frac{41}{64}"$ hole be within the required tolerance?

$$\begin{aligned}
 0.637 \text{ in} \times \frac{64}{64} &= \frac{0.637 \times 64}{64} \text{ in} \\
 &= \frac{40.768}{64} \quad \leftarrow \text{Round to nearest unit} \\
 &= \frac{41}{64} \text{ in} \quad \leftarrow \text{Round to nearest 64th inch}
 \end{aligned}$$

Therefore the error is:

$$\begin{aligned}
 \frac{41 - 40.768}{64} \text{ in} &= \frac{0.232}{64} \text{ in} \\
 &= 0.003625 \text{ in} \\
 &= 0.0036 \text{ in} \quad \leftarrow \text{Rounded to nearest ten thousandth}
 \end{aligned}$$

The specification tolerance called out was $\pm 0.005"$. Your error when using $\frac{41}{64}"$ hole is $0.0036"$. You are within tolerance because $0.0036"$ is less than $0.005"$.

If you have any questions about the Example Problems, see your Instructor. Otherwise, work the Shop Problems beginning on the next page.

SHOP PROBLEMS

1. You are working from a sketch of a certain part that calls for a length of 0.769 inches and a width of 0.353 inches. You wish to use a rule that is marked off in 32nds of an inch. What will your new dimensions be measured in 32nds of an inch?

Length _____ Width _____

2. How much will it cost you to buy a piece of sheet metal that measures 42.5" by 90.7" if the metal costs \$2.27 per square foot?

Cost of metal: _____

3. On your job, you are using a certain type of bar stock that weighs 1 pound 4 ounces per inch. When you finish the job, you find you have used 78 inches of the stock. If the stock costs 37¢ per pound, how much do you charge for material? Remember: There are 16 ounces in a pound.

Cost of bar stock _____

4. The decimal dimensions of a machinists taper gage are given in Figure 1 below. Your boss asks you to lay it out using 64ths of an inch. Can you use 64th of an inch and still be within tolerance?

Yes or no _____

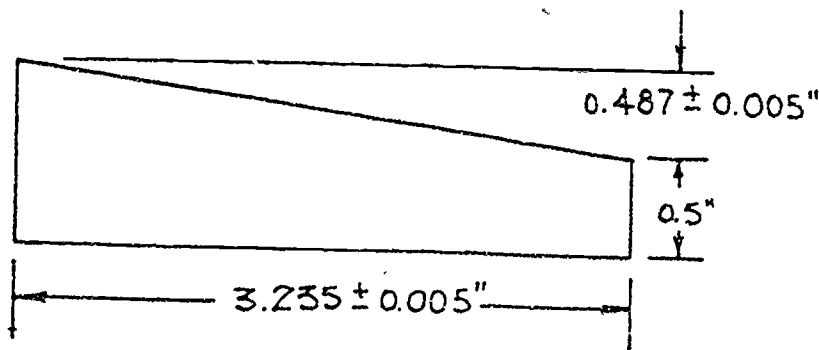

Figure 1: Taper gage.

5. Your supervisor gave you a sketch to lay out a brace for a bracket assembly. Look at Figure 2. Calculate to the nearest 64th of an inch the length, width and hole diameter. Your supervisor told you not to worry about tolerance. Length _____ Width _____ Hole diameter _____

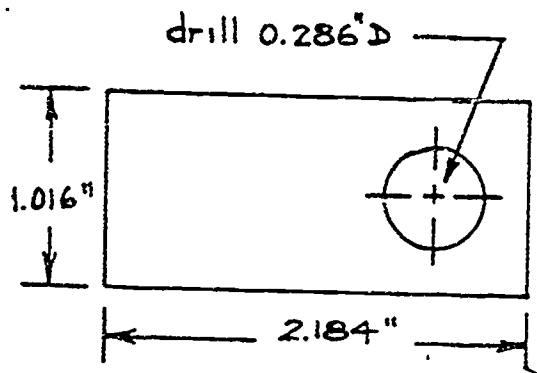

Figure 2: Bracket brace.

6. Your boss asks you to make a _____ lid for a storage bin. You don't know the dimensions of the bin but you know the bottom is a square. Also, you know it is $6\frac{1}{2}$ feet high and has a volume of 101,088 cubic inches. What are the dimensions of the square lid?

Dimensions: _____ by _____

7. On your job you must make a shim to help position two parts. They are supposed to be 0.008" apart. Your supervisor measures them as $\frac{1}{32}$ " apart. How thick should you make your shim (to the nearest thousandth of an inch)? Shim thickness: _____

8. A certain dimension on a taper gage drawing is given as 0.348". Your only rule is marked off in 32nds of an inch. What will be your error to the nearest ten-thousandth of an inch?

Error: _____

SHOW YOUR WORK TO YOUR INSTRUCTOR



207

PROJECT SHEET

Name _____ Date _____

Cluster Metal Trades Occupation Machinist Helper

Training Module Shop Math for Machinists

Training Milestone 2. Math for Measuring Instruments

PROJECT 7

WORKING WITH METRICS

TRAINING CONDITIONS:

● Here's what you will need:

1. This Project Sheet.
2. A pen or pencil to answer the questions in this Project Sheet.

TRAINING PLAN:

● Here's what you do:

In this Project Sheet, you will learn how to use the metric system of measurement. You will also learn to convert from the English system (inches, feet, yards, pounds...) to the metric system. You will work some problems of the type you will find on your job. This work will help you use metric tools accurately and to apply their use to practical shop problems.

1. Learn the units of the metric system and study the sample problems on pages 2 to 9 of this Project Sheet.
2. Work the Shop Problems on pages 10 to 12.
3. Have your Instructor check your work and record your score on your Student Training Record.
4. Ask your Instructor for your next Project Sheet.

TRAINING GOAL:

● Here's how well you must do:

1. You must score 8 out of 10 correct on the Shop Problems.

THE METRIC SYSTEM

The United States is steadily changing to the metric system of measurement. At present, 95% of the world uses the metric system. Therefore, it is important for you to know this system. Also, knowledge of the metric system will give you an edge in the job market.

The most common units in the metric system are those for length, distance, speed, weight, volume, area and temperature. In this Project Sheet, you will mainly work with length, distance, weight, volume, and area. Time units...year, day, hour, minute and second...are the same in the metric system as in the English system.

The basic unit of length in the metric system is the *meter*, pronounced meat-er, and abbreviated m. One meter is just a little bigger than one yard. All other units of length in the metric system are defined in terms of the meter. These units differ from one another by multiples of ten. For example, the *centimeter*, pronounced sent'-a-meat'-er, and abbreviated cm, is defined as exactly one-hundredth of a meter. The *kilometer*, pronounced kill-ah'-mutt-er, and abbreviated km, is defined as exactly 1000 meters.

$$1 \text{ centimeter (cm)} = \frac{1}{100} \text{ of a meter} = 0.01 \text{ meter (m)}$$

$$1 \text{ kilometer (km)} = 1000 \text{ meters (m)}$$

Because metric units increase or decrease by multiples of ten, they may be named by using *prefixes* attached to a basic unit. For length, the basic unit is *meter*.

METRIC LENGTH UNIT	PREFIX	MULTIPLIER	LIKE MONEY
kilometer	kilo-	1000 x 1 meter	\$1000
hectometer	hecto-	100 x 1 meter	\$100
decameter	deca-	10 x 1 meter	\$10
meter	---	1 meter	\$1
decimeter	deci-	0.1 x 1 meter	10c
centimeter	centi-	0.01 x 1 meter	1c
millimeter	milli-	0.001 x 1 meter	1/10c

CONVERTING METRIC LENGTHS

The prefixes and their multipliers in the chart on the previous page are important for you to know. They are the same for all basic metric units, such as the liter and gram, as well as the meter. The units of length you will use most often are kilometer, meter, centimeter and millimeter. Figure 1 will help you to remember how to convert from one to the other.

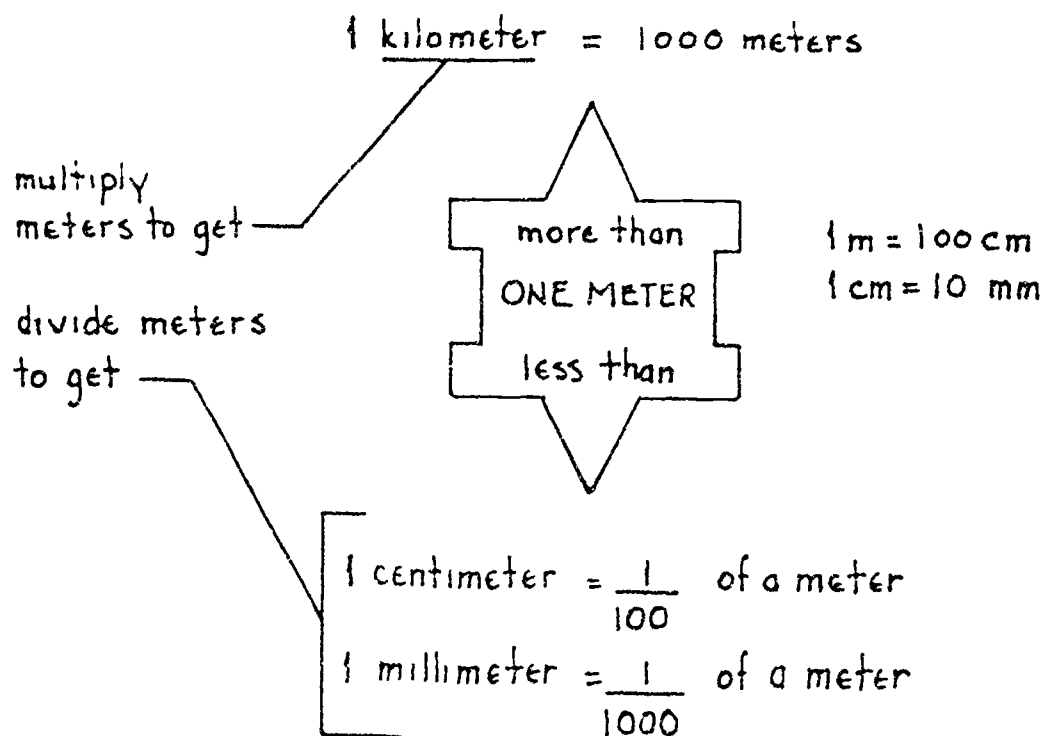

Figure 1: Conversions from m to km, cm, and mm.

INCHES TO FEET TO YARDS

The metric system is much easier to work with than the English system. Here's why. You can easily convert from one metric unit to the other by simply moving the decimal point. With the English system there are hard-to-remember conversion factors. For example, here is how you would change 137 inches to feet to yards.

$$\begin{aligned}
 137 \text{ in.} &= 137 \times \frac{1}{12} \text{ ft} = \frac{137}{12} \text{ ft} \\
 &= \frac{137}{12} \times \frac{1}{3} \text{ yd} = \frac{137}{36} \text{ yd} \\
 &= 2 \frac{29}{36} \text{ yd}
 \end{aligned}$$

As you can see, you must divide by 12 to go from inches to feet, and divide by 3 to go from feet to yards. You nearly always get clumsy fractions.

The metric system is much simpler to work with. The same length can easily be converted. (137 inches equals 348 cm.) Look at Figure 2.

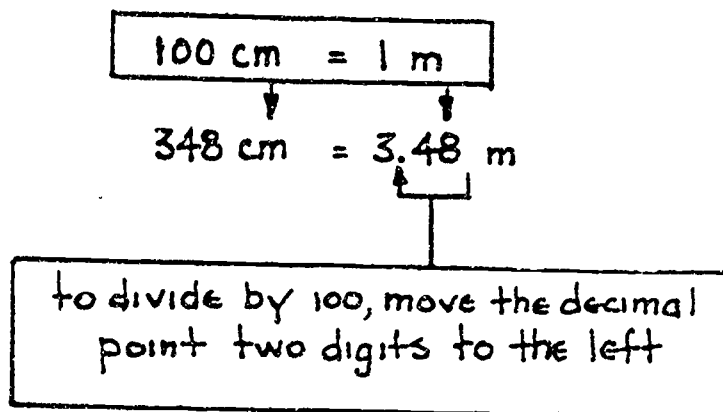

Figure 2: Conversion from cm to m.

You may also use the unity conversion fractions to convert metric measurements:

$$\begin{aligned}
 348 \text{ cm} &= 348 \cancel{\text{cm}} \times \frac{1 \text{ m}}{100 \cancel{\text{cm}}} \leftarrow 1 \text{ m} = 100 \text{ cm}, \\
 &= \frac{348}{100} \text{ m} \quad \text{therefore} \\
 &= 3.48 \text{ m} \quad \frac{1 \text{ m}}{100 \text{ cm}} = 1
 \end{aligned}$$

Now, you try some examples:

- | | |
|---------------------|-----------------------|
| a. 147 cm = _____ m | b. 3.1 m = _____ cm |
| c. 21 cm = _____ m | d. 11.65 m = _____ cm |
| e. 210 mm = _____ m | f. 109 m = _____ km |

If you did not write the answers directly by shifting decimal points, you can follow through the above examples by using the unity conversion fractions shown on the next page.

$$\begin{aligned} \text{a. } 147\text{cm} &= 147\cancel{\text{cm}} \times \frac{1\text{m}}{100\cancel{\text{cm}}} \\ &= \frac{147}{100}\text{m} \\ &= 1.47\text{m} \end{aligned}$$

$$\begin{aligned} \text{b. } 3.1\text{m} &= 3.1\cancel{\text{m}} \times \frac{100\text{cm}}{1\cancel{\text{m}}} \\ &= 3.1 \times 100\text{cm} \\ &= 310\text{cm} \end{aligned}$$

$$\begin{aligned} \text{c. } 21\text{cm} &= 21\cancel{\text{cm}} \times \frac{1\text{m}}{100\cancel{\text{cm}}} \\ &= \frac{21}{100}\text{m} \\ &= 0.21\text{m} \end{aligned}$$

$$\begin{aligned} \text{d. } 11.65\text{m} &= 11.65\cancel{\text{m}} \times \frac{100\text{cm}}{1\cancel{\text{m}}} \\ &= 11.65 \times 100\text{cm} \\ &= 1165\text{cm} \end{aligned}$$

$$\begin{aligned} \text{e. } 210\text{mm} &= 210\cancel{\text{mm}} \times \frac{1\text{m}}{1000\cancel{\text{mm}}} \\ &= \frac{210}{1000}\text{m} \\ &= 0.210\text{m} \end{aligned}$$

$$\begin{aligned} \text{f. } 109\text{m} &= 109\cancel{\text{m}} \times \frac{1\text{km}}{1000\cancel{\text{m}}} \\ &= \frac{109}{1000}\text{km} \\ &= 0.109\text{km} \end{aligned}$$

To convert from the English system to the metric system, or from the metric system to the English system, you can use the *conversion factors* shown in the tables on the next two pages.

It would probably be a good idea for you to cut these four tables out of this Project Sheet and put them in your wallet for future use.

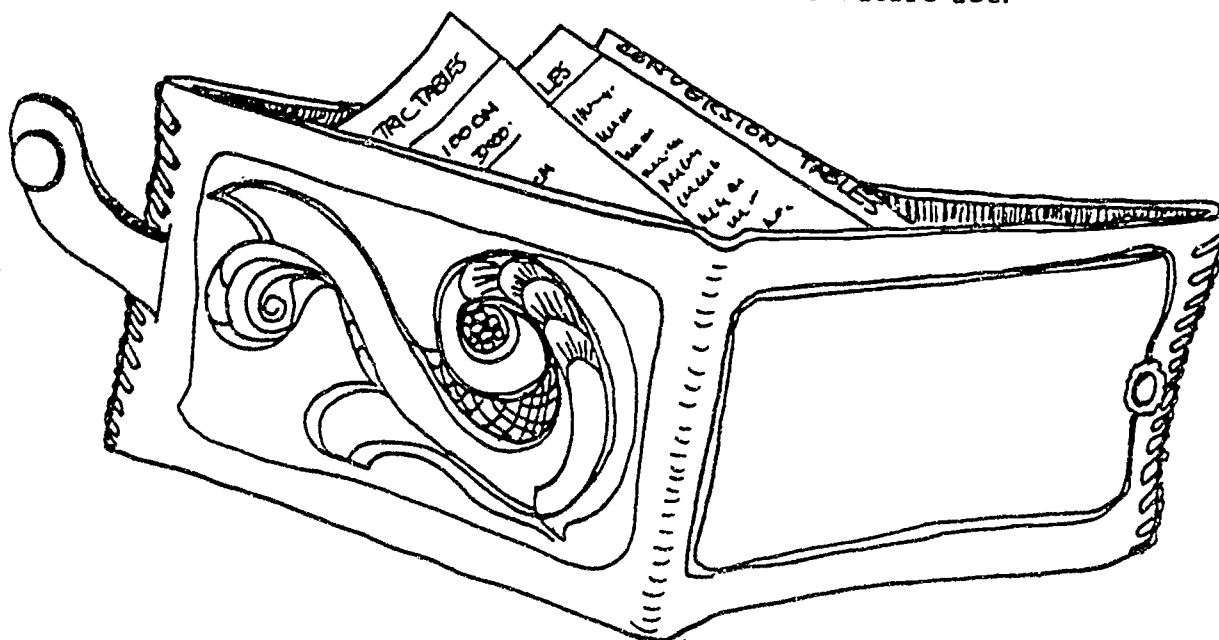

APPROXIMATE CONVERSION FACTORS: LENGTH

<u>When you know</u>	<u>You can find</u>	<u>If you multiply by</u>
inches, in.	millimeters, mm	25.40
inches, in.	centimeters, cm	2.54
feet, ft.	centimeters, cm	30.48
feet, ft.	meters, m	0.3048
yards, yd.	meters, m	0.9144
miles, mi.	kilometers, km	1.6093
millimeters, mm	inches, in.	0.03937
centimeters, cm	inches, in.	0.3937
centimeters, cm	feet, ft.	0.0328
meters, m	feet, ft.	3.2808
meters, m	yards, yds.	1.0936
kilometers, km	miles, mi.	0.6214

Table 1: Conversion Factors: Length

APPROXIMATE CONVERSION FACTORS: AREA

<u>When you know</u>	<u>You can find</u>	<u>If you multiply by</u>
square inches, in. ²	square centimeters, cm ²	6.452
square feet, ft. ²	square meters, m ²	0.093
square yards, yd. ²	square meters, m ²	0.836
square centimeters, cm ²	square inches, in. ²	0.155
square meters, m ²	square feet, ft. ²	10.764
square meters, m ²	square yards, yd. ²	1.196

Table 2: Conversion Factors: Area

158

APPROXIMATE CONVERSION FACTORS: VOLUME

<u>When you know</u>	<u>You can find</u>	<u>If you multiply by</u>
cubic inches, in. ³	cubic centimeters, cm ³	16.387
cubic feet, ft. ³	liters, <i>l</i>	28.317
quarts (liquid), qt.	liters, <i>l</i>	0.946
gallons, gal.	liters, <i>l</i>	3.785
cubic yards, yd. ³	cubic meters, m ³	0.765
fluid ounce, fl. oz.	cubic centimeters, cm ³	29.574
cubic centimeters, cm ³	cubic inches, in. ³	0.061
liters, <i>l</i>	cubic feet, ft. ³	0.035
liters, <i>l</i>	quarts, qt.	1.057
liters, <i>l</i>	gallons, gal.	0.264
cubic meters, m	cubic yards, yd.	1.307

Table 3: Conversion Factors: Volume

APPROXIMATE CONVERSION FACTORS: WEIGHT

<u>When you know</u>	<u>You can find</u>	<u>If you multiply by</u>
pounds, lb.	kilograms, kg	0.454
ounces, oz.	grams, g	28.350
tons, T	kilograms, kg	907.19
tons, T	metric tons, t	0.907
kilograms, kg	pounds, lb.	2.205
grams, g	ounces, oz.	0.0353
kilograms, kg	tons, T	0.0011
metric tons, t	tons, T	1.102

Table 4: Conversion Factors: Weight

Example Problems

A. From Table 1. Conversion Factors: Length

1. Convert 4.3 yd to m

$$4.3 \times (0.9144) = \underline{3.93 \text{ m}} \text{ (rounded)}$$

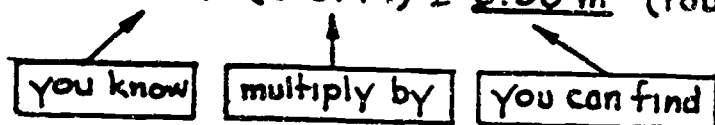

2. Convert 2.67 m to in., first convert meters to feet

$$2.67 \times (3.280) = 8.7576 \text{ ft, then convert ft to in.}$$

$$8.7576 \times 12 = \underline{105.09 \text{ in.}} \text{ (rounded)}$$

B. From Table 2. Conversion Factors: Area

1. Convert 32.5 ft² to m²

$$32.5 \times (0.093) = \underline{3.02 \text{ m}^2} \text{ (rounded)}$$

2. Convert 63.75 m² to yd²

$$63.75 \times (1.196) = \underline{76.25 \text{ yd}^2} \text{ (rounded)}$$

C. From Table 3. Conversion Factors: Volume

1. Convert 672 ft³ to m³ - first convert ft³ to yd³

$$672 \times \left(\frac{1}{3} \text{ yd}\right) \times \left(\frac{1}{3} \text{ yd}\right) \times \left(\frac{1}{3} \text{ yd}\right) = \frac{672}{9} \text{ yd}^3$$

then convert yd³ to m³,

$$\frac{672}{9} \times (0.765) = \underline{57.12 \text{ m}^3}$$

2. Convert 23.8 l to gal

$$23.8 \times (0.264) = \underline{6.28 \text{ gal}} \text{ (rounded)}$$

D. From Table 4. Conversion Factors: Weight

1. Convert 1.5 lb to g, first convert lb to oz (1 lb = 16 oz)

$$1.5 \times 16 = 24 \text{ oz, then convert oz to g}$$

$$24 \times (28.35) = \underline{680.4 \text{ g}}$$

2. Convert 22.46 k to lb

$$22.46 \times (2.205) = \underline{49.52 \text{ lb}} \text{ (rounded)}$$

160

DUAL DIMENSIONING

You will probably run into blueprints or specifications with dual dimensioning. When both English and metric dimensions are given, it is called *dual dimensioning*. You might be given some dimensions or specifications as shown in Figure 3.

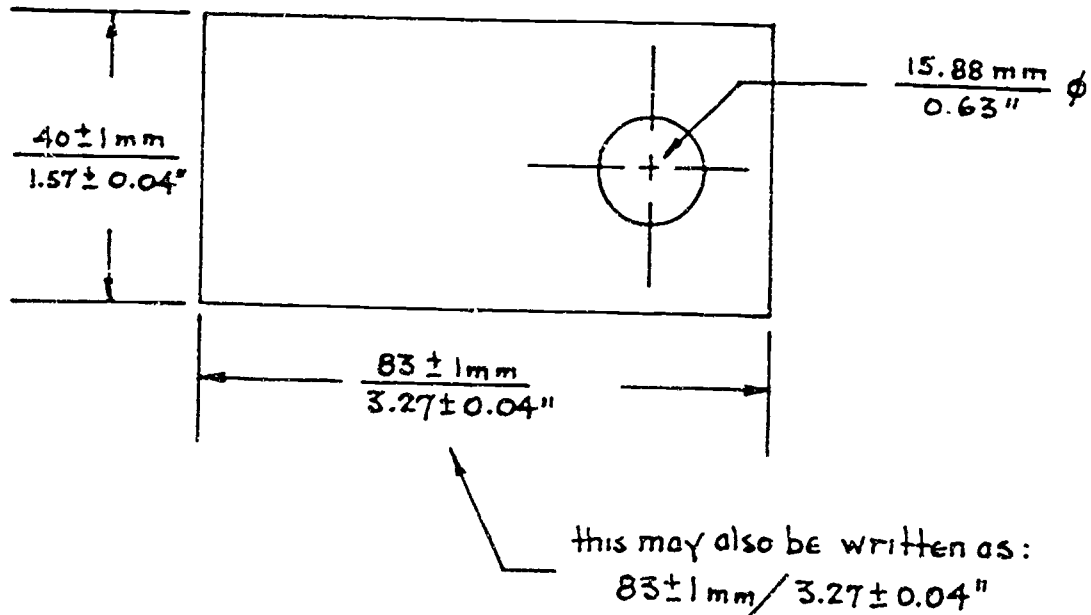

Figure 3: Dual dimensioning.

In Figure 3, note that the metric measurement is written first, or on top of the fraction bar. Diameter dimensions are marked with the symbol ϕ .

Now you can do the Shop Problems starting on the next page. If you have any questions about the review and example problems, see your Instructor.



SHOP PROBLEMS

1. You are given a sketch of a gage to lay out. Before you lay it out, your Instructor wants you to complete the dimensioning on the sketch by using the rules of *dual dimensioning*. Look at Figure 4. Find dimension "A" to the nearest ten-thousandth and dimensions "C" through "S" to the nearest hundredth.

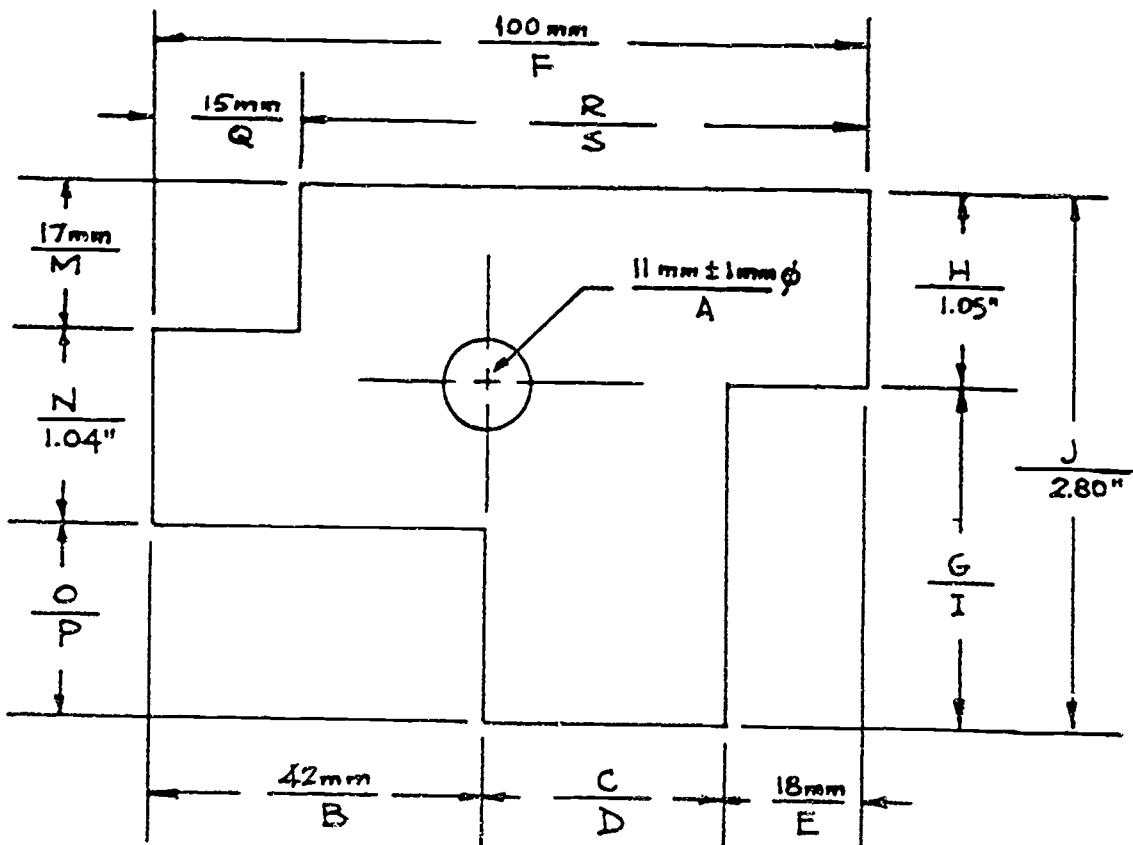
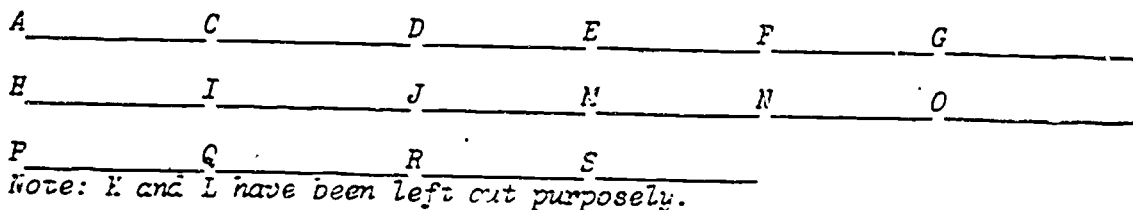

Figure 4: Dual dimensions.

2. A certain piece of sheet metal costs \$3.48 a square foot. On your job, you used a total of 128 m. What was the cost of the sheet metal?

Sheet metal cost _____

3. You have machined a certain bracket piece. The specification called for its final thickness to be $10 + 0.05$ mm. You measure it with a vernier micrometer and find it to be 0.3960". How much more do you need to remove to bring the piece within tolerance? (Hint: Round all conversion computations to four decimal places.)

Metal to remove _____

4. You are using a bar stock to make spacers. Each spacer, including waste, is 1.45" thick. You have made 347 of them. If the bar stock costs \$32.50 per meter, what is the total cost of the stock?

Bar stock cost _____

5. You are getting ready to ship a lathe to Europe. The dimensions of the box are shown in Figure 5. The receiver in Europe needs to know the volume of the shipment in cubic meters. (Hint: Change the dimensions to yards before you use the conversion table shown on page 7 of this Project Sheet.)

Volume in cubic meters _____

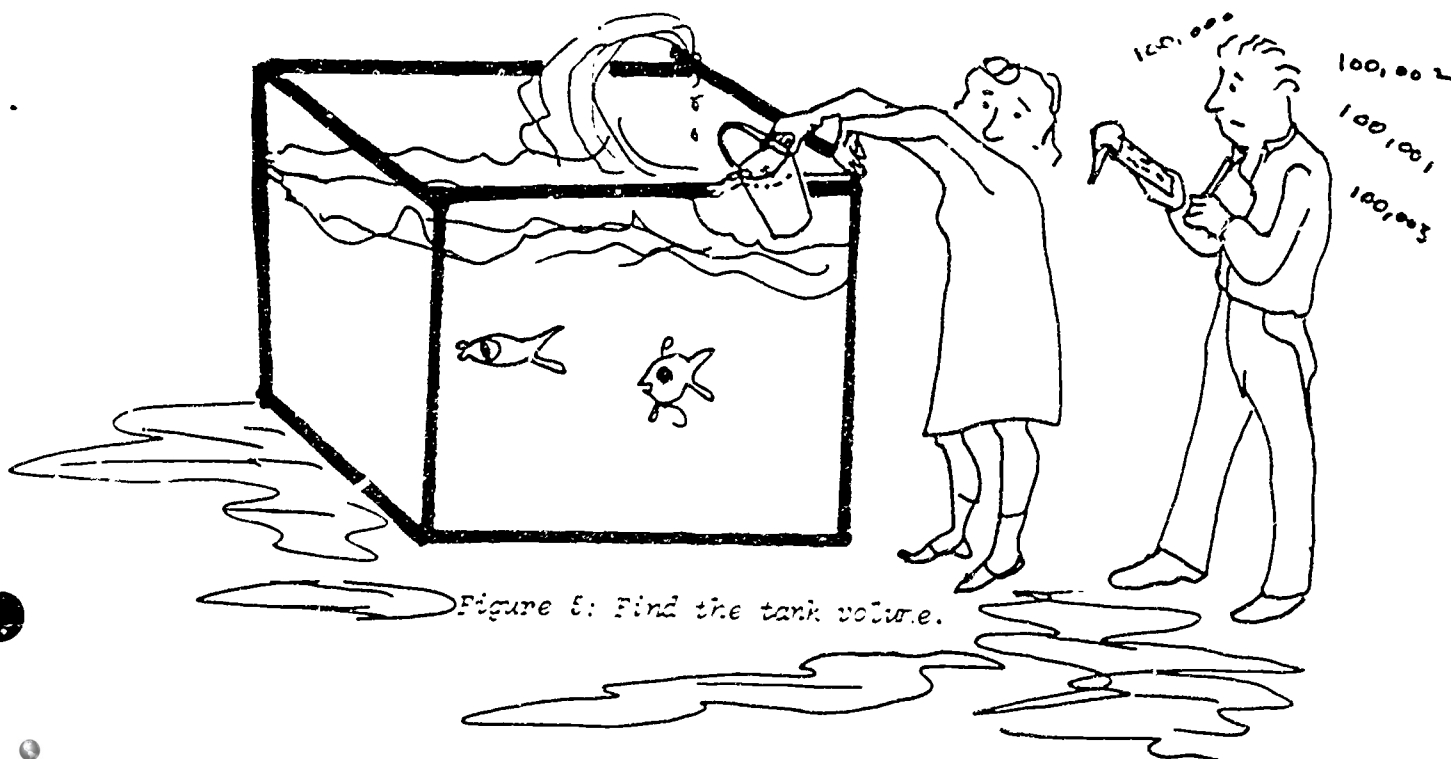
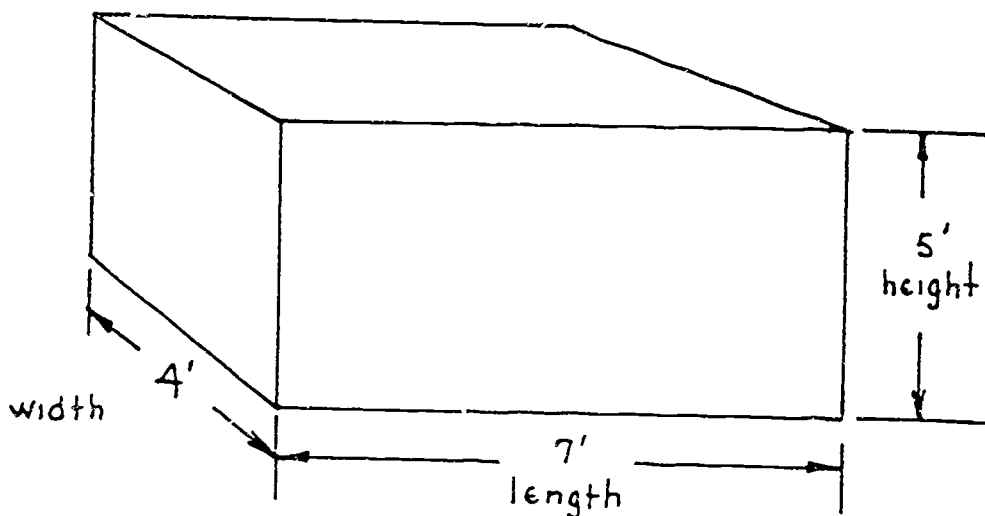

Figure 5: Find the tank volume.

6. On your job, you have machined and polished 250 gage blocks. Each gage block weighs 0.075 kilograms. If the steel you used costs \$32.50 per pound, what is the total cost of the steel for the 250 blocks.

Cost of steel _____

7. You have measured a piece of bar stock to the nearest hundredth of a meter and found it to be 4.75 meters long. How many centimeters long is the pipe? How many millimeters long is the pipe?

Pipe length: Centimeters _____ *millimeters* _____

8. You have just finished a gage for a machined part. The specification called for one of its dimensions to be 3.475 ± 0.0025 in. You measure it and find it to be 88.32 mm. Are you within tolerance to the nearest ten-thousandth. If not, are you on the high side or the low side?

Tolerance: Yes or no _____ *if not, high or low* _____

9. Sheet metal costs \$22.50 per square meter. You have used a piece that measures 3 feet long by 9 inches wide. How much did the metal cost?

Cost of metal _____

10. Your boss wants you to order a special paint. You find that there are two companies with the paint you need. The Ajax company sells it for \$7.50 per gallon. The Smear-It-On company sells it for \$2.00 per liter. Which is the best buy, Ajax or Smear-It-On?

Best buy _____

SHOW YOUR WORK TO YOUR INSTRUCTOR

BAS

101



**SKILLS
CENTER**

208

PROJECT SHEET

Name _____ Date _____

Cluster Metal Trades Occupation Machinist Helper

Training Module Shop Math for Machinists

Training Milestone 3. Specialized Math Skills

PROJECT 1

SHOP ALGEBRA: PART I

TRAINING CONDITIONS:

- Here's what you will need:
 1. This Project Sheet.
 2. A pen or pencil to answer the problems in this Project Sheet.

TRAINING PLAN:

- Here's what you do:

In this Project Sheet, you will begin your review of basic algebra. This review will include the addition, subtraction, multiplication and division of simpler algebraic expressions. You will apply your knowledge of simple algebraic formulas to solve a great variety of practical machinist shop problems.

 1. Read and study pages 2 to 18 of this Project Sheet.
 2. Work the Shop Problems on pages 19 to 21.
 3. Have your Instructor check your work and record your score on your Student Training Record.
 4. Ask your Instructor for your next Project Sheet.

TRAINING GOAL:

- Here's how well you must do:
 1. You must score 8 out of 10 correct on the Shop Problems.

SHOP ALGEBRA: PART 1

THE LANGUAGE OF ALGEBRA

The most obvious difference between algebra and arithmetic is that in algebra letters are used to replace or represent numbers. A mathematical statement in which letters are used to represent numbers is called a *literal expression*.

Most of the usual arithmetic symbols have the same meaning in algebra as in arithmetic. For example, the signs for addition (+) and subtraction (-) are used in exactly the same way. However, the arithmetic times sign (x) looks just like the letter x. That would be confusing in expressions with letters. So, in algebra, other ways are used to show multiplication. The product of two algebra quantities c and d (c times d) may be written in any of the following ways:

Using a dot	$c \cdot d$
With parentheses	$(c)d$ or $c(d)$ or $(c)(d)$ or (cd)
With nothing at all	cd

For example: 6 times $b = 6b$

8 times s times $w = 8sw$

4 times x times $x = 4x^2$

Note that x times x is written as x^2

Similarly x times x times $x = x^3$

x times x times x times $x = x^4$ and so on.

Parentheses () and brackets [] are used to show that whatever is enclosed in them should be treated as a single quantity.

$(3ax^2 + bx - c)^2$ should be thought of as (something)².

Similarly, the expression $(2x + 3x - 4) - (x^2 - 2)$ should be thought of as (first quantity) - (second quantity).

In arithmetic, you write 48 divided by 2 as $2\sqrt{48}$ or $48 \div 2$, but this way of writing division is seldom used. In algebra, division is usually written as a fraction:

a divided by b is written $\frac{a}{b}$

$(2x + 1)$ divided by $(x - 1)$ is written as $\frac{(2x + 1)}{(x - 1)}$ or $\frac{2x + 1}{x - 1}$

Look at the following examples:

1. 8 times $(2x + 5) = 8(2x + 5)$
2. $(a + b)$ times $(a - b) = (a + b)(a - b)$
3. x divided by $\frac{1}{2} = \frac{x}{\frac{1}{2}}$
4. $(x + 2)$ divided by $(2x - 1) = \frac{(x + 2)}{(2x - 1)}$

The word *expression* is used very often in algebra. An expression is a general name for any collection of letters and numbers connected by arithmetic signs. For example:

$x + 4$, $2x^2 + 3$, $3(x^2 + 2x)$, $(x - 1)^3$ are all algebraic expressions.

If the algebraic expression is made up of quantities that are to be multiplied, each multiplier is called a *factor* of the expression.

<u>Expression</u>	<u>Factor</u>
ab	a and b
$2x(x + 1)$	2 , x , and $(x + 1)$
$(F - 1)(F - 2)$	$(F - 1)$ and $(F - 2)$
$3ab$	3 , a , and b

ALGEBRA OPERATIONS

There are three simple algebra operations you must understand and learn to do in practical situations. These operations are:

Operation 1: Adding and subtracting like terms.

Example: $2x + 5x = 7x$

Operation 2: Adding and subtracting expressions.

Example: $(2x + 3) + (x + 3) = 3x + 2$

Operation 3: Multiplying simple factors.

Example: $(2x)(3x) = 6x^2$

Look at them in order.

Operation 1: Adding and subtracting like terms.

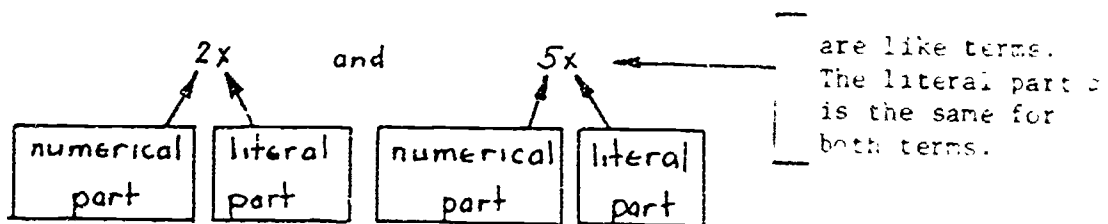

The number multiplying the letters is called the *numerical coefficient* of the term.

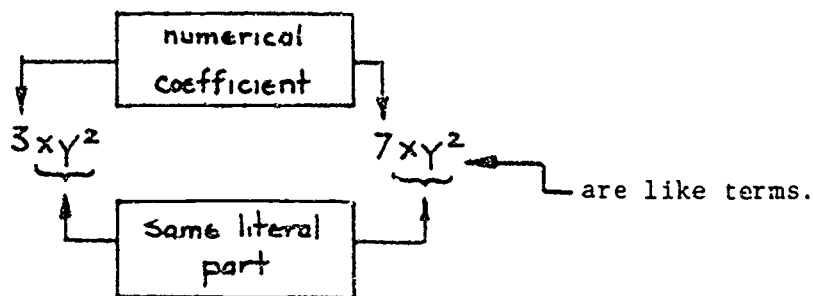

But

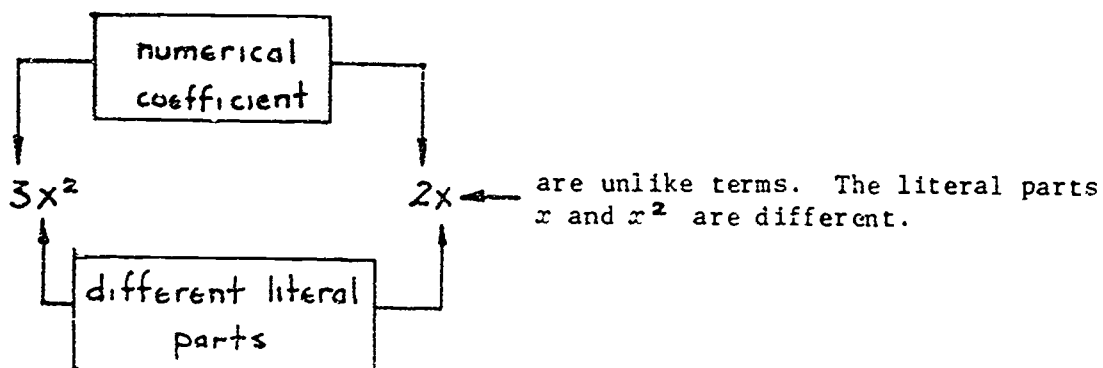

To add or subtract like terms, add or subtract their numerical coefficients and keep the same literal part. For example:

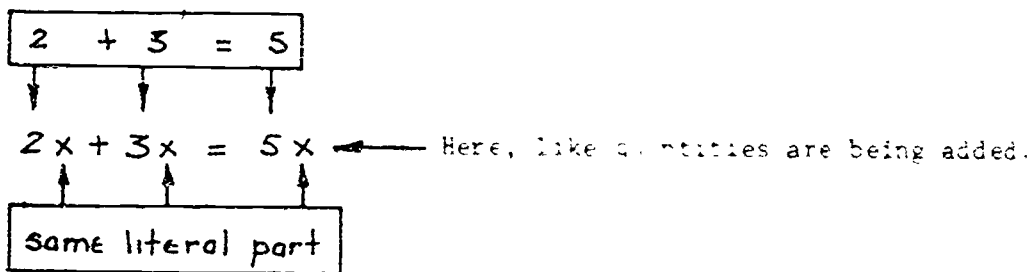

Another example:

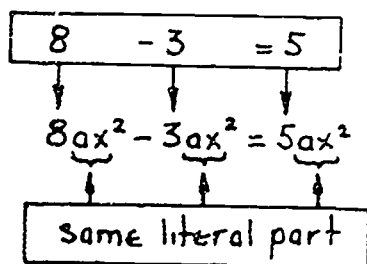

10

Example Problems:

$$1. 12d^2 + 7d^2 = 19d^2$$

$$2. 3(y+1) + 9(y+1) = 12(y+1)$$

$$3. x + 6x - 2x = 5x$$

$$4. 2ax - ax + 5ax = 6ax$$

$$5. 8x^2 + 2xy - 2x^2 = 6x^2 + 2xy$$

$$6. 4xy - xy + 3xy = 6xy$$

In general, to simplify a series of terms being added or subtracted--first, group together all the like terms, then add or subtract.

For example:

$$3x + 4y - x + 2y + 3x - 3y \text{ becomes} \\ (3x - x + 3x) + (4y + 2y - 3y) = 5x + 3y$$

be careful not
to lose the
negative sign on x

be careful not
to lose the
negative sign on y

Example Problems:

$$1. 5x + 4xy - 2x - 3xy = (5x - 2x) + (4xy - 3xy) \\ = 3x + xy$$

$$2. 3ab^2 + a^2b - ab^2 + 3a^2b = (3ab^2 - ab^2) + (a^2b + 3a^2b) \\ = 2ab^2 + 4a^2b$$

$$3. x + 2y - 3z - 2x - y + 5z - x + 2y - z \\ = (x - 2x - x) + (2y - y + 2y) + (-3z + 5z - z) \\ = -2x + 3y + z$$

$$4. 17pq + 9ps - 6pq + ps - 6ps - pq \\ = (17pq - 6pq - pq) + (9ps + ps - 6ps) \\ = 10pq + 4ps$$

$$5. 4x^2 - x^2 + 2x + 2x^2 + x = (4x^2 - x^2 + 2x^2) + (2x + x) \\ = 5x^2 + 3x$$

Operation 2: Adding and subtracting expressions.

Parentheses are used in algebra to group together terms that are to be treated as a unit. Adding and subtracting usually involves working with parentheses.

For example: To add:

$$(a+b) + (a+d)$$

First: remove parentheses $(a+b) + (a+d)$
 $= a+b+a+d$

Second: add like terms $= \underbrace{a+a} + b + d$
 $2a+b+d$

You should be careful when you remove parentheses. It can be tricky. You need to remember these two rules.

Rule 1: If the parenthesis has a plus sign (+) in front of it, simply remove the parentheses.

Example:

$$1 + (3x + y) = 1 + 3x + y$$

Example:

$$2 + (a - 2b) = 2 + a - 2b$$

Diagram showing the removal of parentheses from $2 + (a - 2b)$ to $2 + a - 2b$. A box labeled "Same sign" has arrows pointing to the plus sign and the terms inside the parentheses. Another box labeled "same sign" has arrows pointing to the plus sign and the minus sign inside the parentheses.

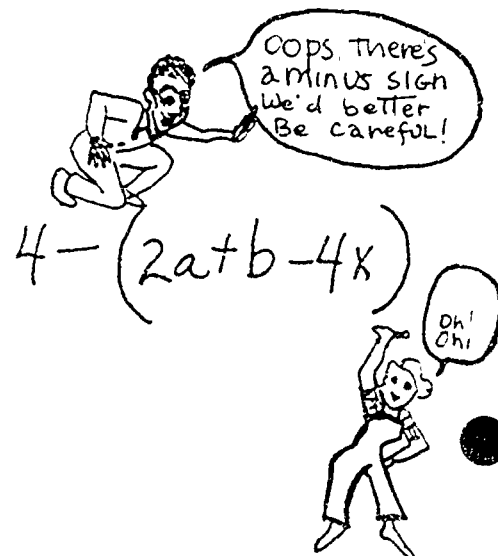
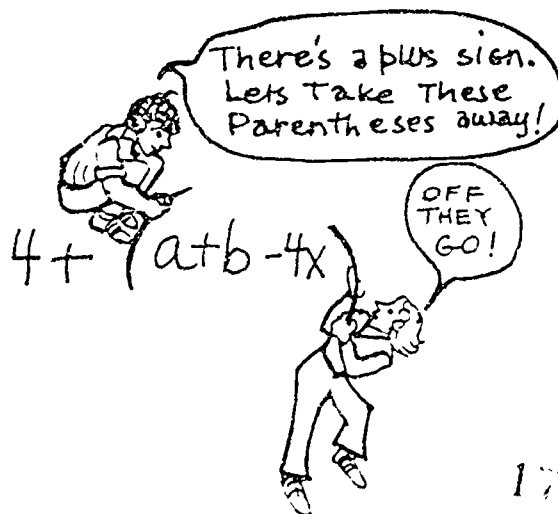

Rule 2: If the parenthesis has a minus sign (-) in front of it, change the sign of each term inside, then remove the parentheses.

change sign from
+ to -

Example: $2 - (x + 2y) = 2 - x - 2y$

change sign from
+ to -

change signs

Example: $a - (2x - y) = a - 2x + y$

change signs

change signs

Example: $5 - (-2a + b) = 5 + 2a - b$

change signs

Example Problems:

1. $x + (2y - a^2) = x + 2y - a^2$

2. $4 - (x^2 - y^2) = 4 - x^2 + y^2$

3. $-(x + 1) + (y + 2) = -x - 1 + y + 2$
 $= -x + y + 1$

4. $ab - (a - b) = ab - a + b$

5. $(x + y) - (x - y) = x + y - x + y$
 $= 2y$

6. $-(-x - 2y) - (a + 2b) = x + 2y - a - 2b$

7. $3 + (-2p - q^2) = 3 - 2p - q^2$

8. $-(x - y) + (-3x^2 + y^2) = -x + y - 3x^2 + y^2$

Rule 3: If the parenthesis has a multiplier in front, multiply each term inside the parentheses by the multiplier.

Example: $+2(a + b) = +2a + 2b$

Think of this as $(+2)(a + b) = (+2)a + (+2)b = +2a + 2b$

Each term inside the parentheses is multiplied by +2.

Example: $-2(x + y) = -2x - 2y$

Think of this as $(-2)(x + y) = (-2)x + (-2)y = -2x - 2y$

Each term inside the parentheses is multiplied by -2.

Example: $-2(a - b) = -2a + 2b$

Think of this as $(-2)(a - b) = (-2)a + (-2)(-b) = -2a + 2b$.

(Remember that when $-b$ is multiplied by -2 the sign comes out +.
A minus times a minus equals a plus.)

Example: $-(x - y) = (-1)(x - y)$
 $= (-1)(x) + (-1)(-y) = -x + y$

Notice that you must multiply every term inside the parentheses by the number outside the parentheses. Once the parentheses have been removed you can add and subtract like terms as explained in Operation 1 on pages 3, 4 and 5 of this Project Sheet.

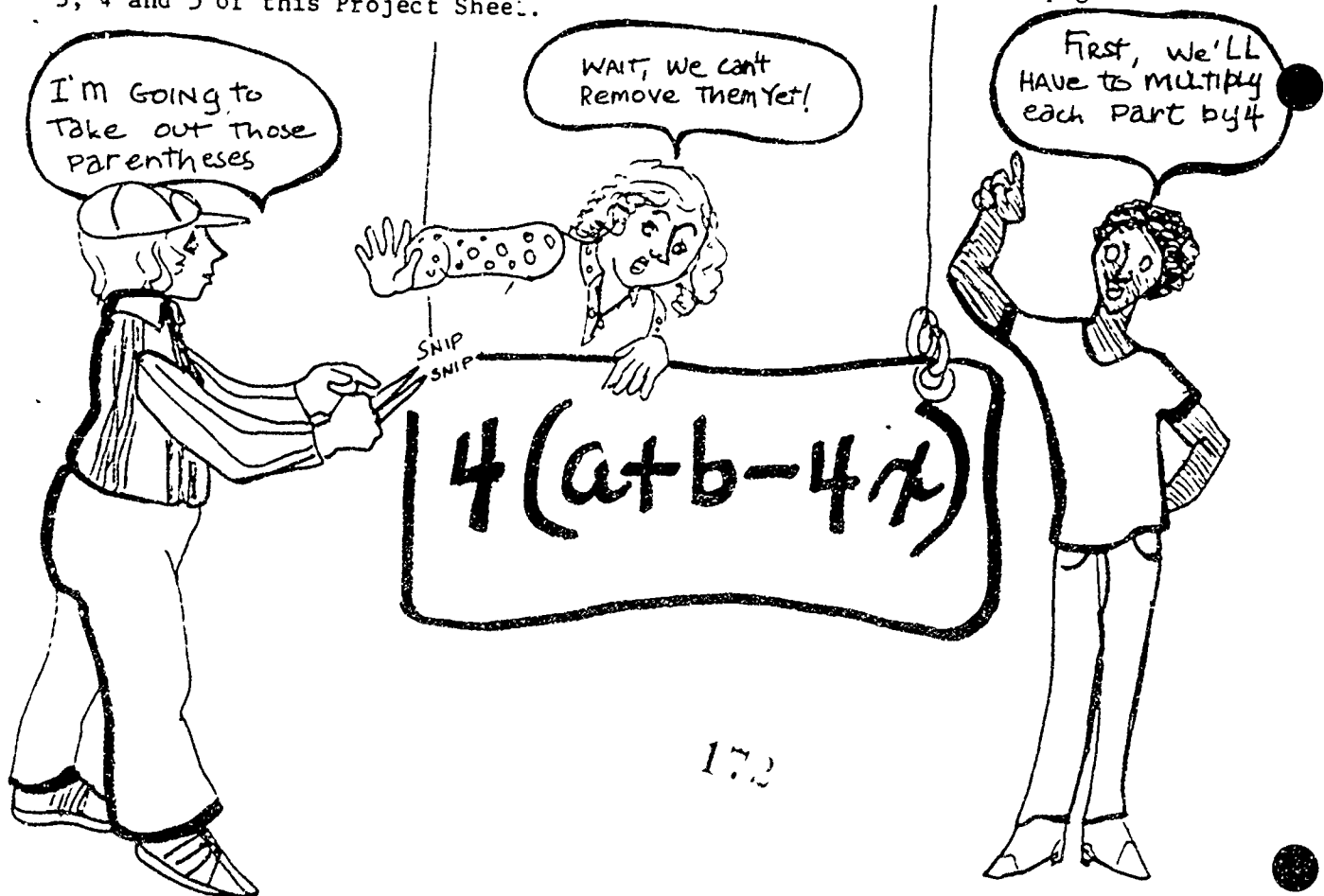

EXAMPLE PROBLEMS

Simplify the following expressions by removing parentheses. Be sure you use the three rules.

Example Problems :

1. $2(2x-3y) = 4x-6y$
2. $1-4(x+2y) = 1-4x-8y$
3. $a-2(b-2a) = a-2b+4a$
4. $x^2-3(x-y) = x^2-3x+3y$
5. $x^2-2(-y-2x) = x^2+2y+4x$
6. $p^2-2(-p-3t) = p^2+2p+6t$

Once you can simplify expressions by removing parentheses, it is easy to add and subtract them.

For example:

$$\begin{aligned}
 3x - y - 2(x - 2y) &= 3x - y - 2x + 4y && \text{Simplify by removing parentheses.} \\
 &= \underbrace{3x - 2x} - \underbrace{y + 4y} && \text{Group like terms.} \\
 &= x + 3y && \text{Combine like terms.}
 \end{aligned}$$

Example Problems :

1. $(3y+2) + 2(y+1) = 3y+2+2y+2 = 5y+2y+2+2 = 5y+4$
2. $(2x+1) + 3(4-x) = 2x+1+12-3x = 2x-3x+1+12 = -x+13$
3. $(a+b) - (a-b) = a+b-a+b = a-a+b+b = 2b$
4. $2(a+b) - 2(a-b) = 2a+2b-2a+2b = 2a-2a+2b+2b = 4b$
5. $2(x+y) - 3(x-y) = 2x+2y-3x+3y = 2x-3x+2y+3y = -x+5y$
6. $2(x+1) - 3(x-2) = 2x+2-3x+6 = 2x-3x+2+6 = -x+8$
7. $(x^2-2x) - 2(x-2x^2) = x^2-2x-2x+4x^2 = x^2+4x^2-2x-2x = 5x^2-4x$
8. $-2(3x-5) - 4(x-1) = -6x+10-4x+4 = -6x-4x+10+4 = -10x+14$

Operation 3: Multiplying simple factors.

In order to multiply two terms such as $2x$ and $3xy$, first remember that $2x$ means two times x . Second, recall that the order in which you do multiplication does not make any difference.

$$\text{For example: } 2 \cdot 3 \cdot 4 = (2 \cdot 4) \cdot 3 = (3 \cdot 4) \cdot 2$$

$$\text{In algebra: } a \cdot b \cdot c = (a \cdot c) \cdot b = (c \cdot b) \cdot a$$

$$\text{or } 2 \cdot x \cdot 3 \cdot x \cdot y = 2 \cdot 3 \cdot x \cdot x \cdot y$$

Remember that

$$x^2 = x \cdot x$$

$$x^3 = x \cdot x \cdot x$$

$$x^4 = x \cdot x \cdot x \cdot x$$

and so on.

$$\text{Therefore } 2x \cdot 3xy = 2 \cdot 3 \cdot x \cdot x \cdot y$$

$$= 6x^2y$$

The following examples show how to multiply two terms

Example 1.

$$a \cdot 2a = a \cdot 2 \cdot a$$

$$= 2 \cdot \underbrace{a \cdot a}$$

↑
Group like factors

$$= 2 \cdot a^2$$

$$= 2a^2$$

Example 2.

$$2x^2 \cdot 3xy = 2 \cdot x \cdot x \cdot 3 \cdot x \cdot y$$

$$= \underbrace{2 \cdot 3} \cdot \underbrace{x \cdot x \cdot x} \cdot y$$

↑ ↑
Group like factors

$$= 6 \cdot x^3 \cdot y$$

$$= 6x^3y$$

Example 3.

$$3x^2yz \cdot 2xy = 3 \cdot x \cdot x \cdot y \cdot z \cdot 2 \cdot x \cdot y$$

$$= \underbrace{3 \cdot 2} \cdot \underbrace{x \cdot x \cdot x} \cdot \underbrace{y \cdot y} \cdot z$$

↑ ↑ ↑
Group like factors

$$= 6 \cdot x^3 \cdot y^2 \cdot z$$

$$= 6x^3y^2z$$

171

Example Problems:

1. $x \cdot y = xy$
2. $2x \cdot 5xy = 2 \cdot x \cdot 5 \cdot x \cdot y = 2 \cdot 5 \cdot x \cdot x \cdot y = 10x^2y$
3. $2x \cdot 3x = 2 \cdot x \cdot 3 \cdot x = 2 \cdot 3 \cdot x \cdot x = 6x^2$
4. $4a^2b \cdot 2a = 4 \cdot a \cdot a \cdot b \cdot 2 \cdot a = 4 \cdot 2 \cdot a \cdot a \cdot a \cdot b = 8a^3b$
5. $3x^2y \cdot 4xy^2 = 3 \cdot x \cdot x \cdot y \cdot 4 \cdot x \cdot y \cdot y = 3 \cdot 4 \cdot x \cdot x \cdot x \cdot y \cdot y \cdot y = 12x^3y^3$
6. $5xyz \cdot 2ux^2 = 5 \cdot x \cdot y \cdot z \cdot 2 \cdot a \cdot x \cdot x = 5 \cdot 2 \cdot x \cdot x \cdot x \cdot y \cdot z \cdot a = 10x^3YZa$
7. $3x \cdot 2y^2 \cdot 2x^2y = 3 \cdot x \cdot 2 \cdot y \cdot y \cdot 2 \cdot x \cdot x \cdot y = 3 \cdot 2 \cdot 2 \cdot x \cdot x \cdot x \cdot y \cdot y \cdot y = 12x^3y^3$
8. $x^2y^2 \cdot 2x \cdot y^2 = x \cdot x \cdot y \cdot y \cdot 2 \cdot x \cdot y \cdot y = 2 \cdot x \cdot x \cdot x \cdot y \cdot y \cdot y \cdot y = 2x^3y^4$
9. $2x^2(x + 3x^2) = 2x^2 \cdot x + 2x^2 \cdot 3x^2 = 2 \cdot x \cdot x \cdot x + 2 \cdot x \cdot x \cdot 3 \cdot x \cdot x$
 $= 2 \cdot x \cdot x \cdot x + 2 \cdot 3 \cdot x \cdot x \cdot x \cdot x$
 $= 2x^3 + 6x^4$
10. $-2a^2b(a^2 - 3b^2) = -2 \cdot a \cdot a \cdot b \cdot a \cdot a + 2 \cdot a \cdot a \cdot b \cdot 3 \cdot b \cdot b$
 $= -2 \cdot a \cdot a \cdot a \cdot a \cdot b + 2 \cdot 3 \cdot a \cdot a \cdot b \cdot b \cdot b$
 $= -2a^4b + 6a^2b^3$

MULTIPLYING NUMBERS IN EXPONENTIAL FORM

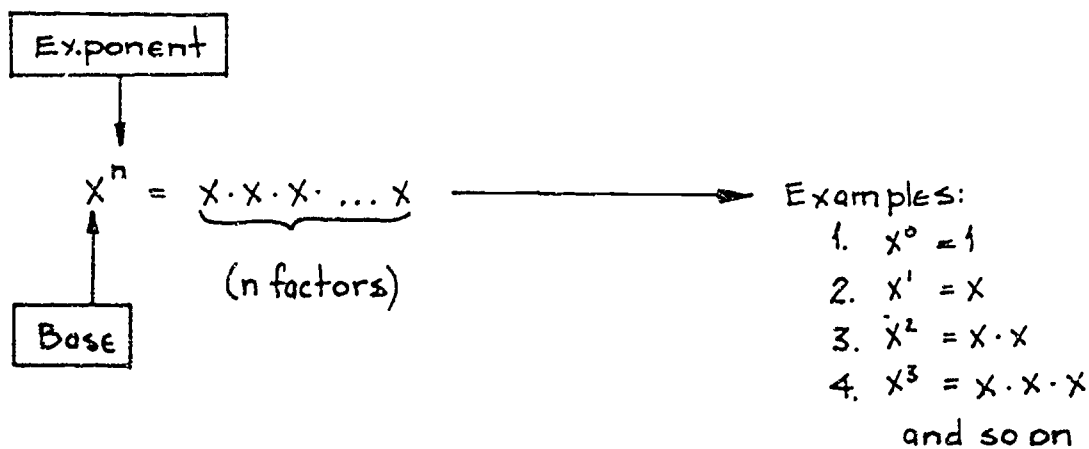

Rule 1: To multiply numbers written in exponential form having the same base, add the exponents.

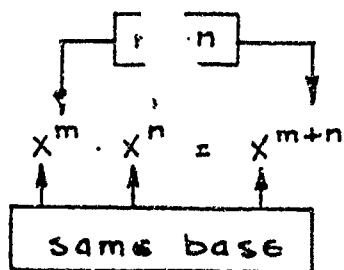

Example:

$$x^2 \cdot x^3 = x^{2+3}$$

$$= x^5$$

Rule 2: To divide numbers written in exponential form having the same base, subtract the exponents.

$$\frac{x^m}{x^n} = x^{m-n}$$

Example:

$$\begin{aligned} x^7 \div x^3 &= \frac{x^7}{x^3} \\ &= x^{7-3} \\ &= x^4 \end{aligned}$$

Rule 3: Use negative exponents to indicate a reciprocal. (Remember that a reciprocal of a number is simply 1 divided by that number.)

$$x^{-n} = \frac{1}{x^n}$$

Example: $x^{-3} = \frac{1}{x^3}$

Example: $2^{-1} = \frac{1}{2}$

With these three rules the ten example problems on page 11 should be much easier and quicker for you to work. For example, look again at number 9 and number 10.

$$\begin{aligned} 9. \quad 2x^2(x + 3x^2) &= 2x^2 \cdot x + 2x^2 \cdot 3x^2 = 2 \cdot x^{2+1} + 2 \cdot 3 \cdot x^{2+2} \\ &= 2 \cdot x^3 + 6 \cdot x^4 \\ &= 2x^3 + 6x^4 \end{aligned}$$

$$\begin{aligned} 10. \quad -2a^2b(a^2 - 3b^2) &= -2 \cdot a^2 \cdot b \cdot a^2 + 2 \cdot a^2 \cdot b \cdot 3 \cdot b^2 \\ &= -2 \cdot a^{2+2} \cdot b + 2 \cdot 3 \cdot a^2 \cdot b^{1+2} \\ &= -2a^4b + 6a^2b^3 \end{aligned}$$

EVALUATING FORMULAS

One of the most useful and important skills for shop work involves finding the value of an algebraic expression when the letters are given numerical values. A *formula* is a rule for calculating the numerical value of one quantity from the values of other quantities.

Here are a few rules and formulas that are used in the metal trades.

1. The rim speed of a pulley, in feet per minute, equals the circumference of the pulley in inches times the speed of the pulley in revolutions per minute divided by 12.

Formula: $S = \frac{CN}{12}$

176

2. The unit stress, in pounds per square inch, equals the external load or force, in pounds, acting upon the body, divided by the cross-sectional area upon which the load or force acts, in square inches.

$$\text{Formula: } S = \frac{P}{A}$$

3. The circular pitch of a full depth tooth gear equals pi times the pitch diameter divided by the number of teeth.

$$\text{Formula: } P = \frac{\pi D}{N}$$

Evaluating a formula or algebraic expression means to find its value by substituting numbers for the letters in the expression. An example is the equation for the volume of a cylinder. Look at Figure 1.

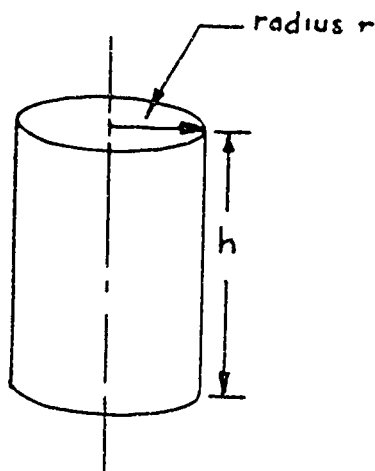

$$V = \pi r^2 h, \text{ where } V = \text{volume in cubic inches}$$

$$r = \text{radius in inches}$$

$$h = \text{height in inches}$$

$$\pi = 3.14 \text{ (rounded)}$$

Find the Volume V if the radius $r = 3$ in.
and the height $h = 14$ in.

$$V = \pi r^2 h = \pi (3") (3") (14")$$

$$= 3.14 (9 \text{ in}^2) (14 \text{ in})$$

$$= 395.84 \text{ in}^3$$

Figure 1: Volume of a cylinder.

Another example is the formula for the area of a trapezoid. Look at Figure 2.

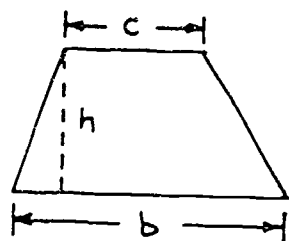

$$A = \frac{h(b+c)}{2}, \text{ where } A = \text{area in square inches}$$

$$h = \text{height in inches}$$

$$b = \text{long base in inches}$$

$$c = \text{short base in inches}$$

Find the area A if $h = 3$ in., $b = 8$ in., and $c = 4$ in.

$$A = \frac{(3)[(8) + (4)]}{2} = \frac{(3)(8+4)}{2}$$

$$A = \frac{3(12)}{2} = \frac{36}{2} = 18 \text{ square inches}$$

Figure 2: Area of a trapezoid.

Note that in both examples, Figures 1 and 2 on the previous page, the numbers being substituted were placed in parentheses, then substituted in the formulas, and then the arithmetic was done.

Example: Find $A = x^3 + 2$ for $x = 5$

$$A = (5)^3 + 2 \leftarrow \text{put } 5 \text{ in parenthesis}$$

$$A = (5 \cdot 5 \cdot 5) + 2 \leftarrow \text{do arithmetic}$$

$$A = 125 + 2$$

$$A = 127$$

Example: Find $B = x^2 - Y^2$ for $x = 6, Y = 4$

$$B = (6)^2 - (4)^2 \leftarrow \text{put the numbers in parenthesis}$$

$$B = (6 \cdot 6) - (4 \cdot 4) \leftarrow \text{do the arithmetic}$$

$$B = 36 - 16$$

$$B = 20$$

Using parentheses in this way may seem like extra work for you, but is a sure way to keep from making mistakes when evaluating formulas.

When you evaluate formulas, remember the following helpful hints:

Hint 1: Do the operations inside the parentheses first.

Example: $(2+3) + 4 = 5 + 4 = 9$

Do this first

Example: $4(3+5) = 4 \cdot 8 = 32$

Do this first

Hint 2: If the formula contains several sets of parentheses, do the calculations inside each set first, then combine them.

Example: $(2+3) - (4-1) = 5 - 3 = 2$

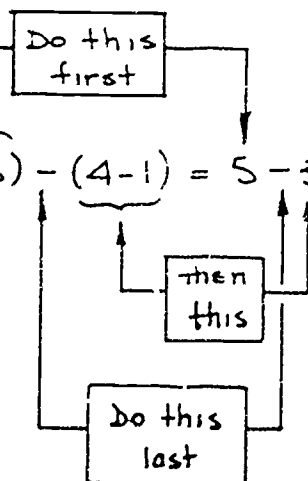

Exponents tell you the order to do the arithmetic.

17

Hint 3: If the formula contains a square, cube, or some other power, find the value of the factor first.

Example: $A = 3.14 R^2$, $R = 3$
 $A = 3.14 (3)^2$ ← find this value first
 $A = 3.14 (9)$ ← then multiply
 $A = 28.26$

Hint 4: If the formula is the sum or difference of terms, find the numerical value for each term first, then add or subtract.

Example: $P = ab - s^2$, $a = 3$, $b = 4$, $s = 2$
 find this first
 $P = (3)(4) - (2)^2$ ← then this
 $P = 12 - 4$ ← subtract last
 $P = 8$

Hint 5: Unless parentheses tell you to do otherwise, do multiplications and divisions before adding or subtracting.

Example: $4 + 2 \cdot 6 = 4 + 12 = 16$

multiply first

To summarize:

1. First, do any operations inside parentheses.
2. Then find all powers.
3. Then do all multiplications and divisions.
4. And finally, do all additions and subtractions.

Example Problem: Evaluate the formula $W = D(AB - \pi R^2)H$, for $D = 8$, $A = 8$, $B = 6$, $\pi = 3.14$, $R = 2$, and $H = 10$.

$$\begin{aligned} W &= D(AB - \pi R^2)H = 8(8 \cdot 6 - 3.14 \cdot 2^2)10 = 8(48 - 3.14 \cdot 4)10 \\ &= 8(48 - 12.56)10 \\ &= 8(35.44)10 \\ &= 283.52(10) \\ &= 2835.2 \end{aligned}$$

EXAMPLE SHOP PROBLEM: To make a right angle bend in sheet metal, the length of sheet used is given by the formula $L = x + y + \frac{T}{2}$. Look at Figure 3.

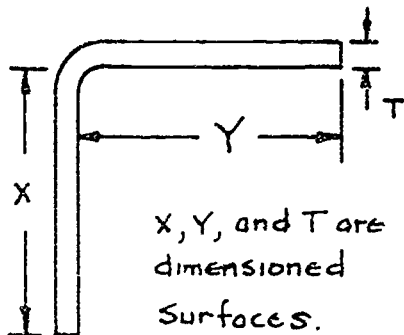

solve for L , when $x = 6.25$, $y = 11.875$, and $T = 0.125$

1. Substitute known values in parentheses.

$$L = (6.25) + (11.875) + \frac{(0.125)}{2}$$

2. Do work in parentheses

$$L = 6.25 + 11.875 + 0.0625$$

3. Do arithmetic

$$L = 18.1875$$

Figure 3: Formula for length of sheet.

FINDING SQUARE ROOTS

One mathematical operation you must know is how to find a square root. You know that when you multiply a number by itself you get a square. For example 7 times 7 = 49. You say that 7 squared = 49. When you find the square root you do the opposite. For example, if you want to find the square root of 64 you need to find a number that when multiplied by itself will equal 64.

FINDING SQUARE ROOT WITH A CALCULATOR

If you have a calculator you can find square roots easily. Nearly all calculators have a function that gives you the square root of any number or decimal number directly.

OTHER WAYS TO FIND SQUARE ROOT

If you do not have a calculator there are three other ways to find square roots: (1) square root tables, (2) the long arithmetic method, and (3) the short arithmetic method. The tables of squares and square root are found in nearly any technical handbook and are self-explanatory and easy to use. The long arithmetic method is exact but very complex to learn. The short arithmetic method is simple and quick. Work through the step-by-step method shown on the next 2 pages.

EXAMPLE PROBLEMS - SQUARE ROOT (Using the short arithmetic method.)
--

1. Find the square root of 89.67: ($\sqrt{89.67}$)

Step 1. *Estimate* the square by using your knowledge of multiplication. You know that 9 squared = 81, and 10 squared = 100. So you guess that 9.5 time 9.5 is about equal to 89.67.

Step 2. Then multiply 9.5 by 9.5 to see how close your estimate is. $9.5 \times 9.5 = 90.25$. You can see that 9.5 is just a bit too large.

Redo Steps 1 and 2 until you get the desired accuracy. For example, since 9.5 was too large, try another number slightly smaller, say 9.4.

$$9.4 \times 9.4 = 88.36$$

9.4 is too small so try a number that is slightly larger than 9.4 but still smaller than 9.5 which was too large. Try 9.45.

$$9.45 \times 9.45 = 89.30$$

9.45 is still too small so try a slightly larger number, say 9.47.

$$9.47 \times 9.47 = 89.68$$

89.68 is within 0.01 of 89.67 and is probably close enough. If you need greater accuracy just continue the operation.

2. Find the square root of 128.5 ($\sqrt{128.5}$)

Step 1. Try 11.25 since $11 \times 11 = 121$ and $12 \times 12 = 144$.

Step 2. $11.25 \times 11.25 = 126.56$ which is too small.

Redo Steps 1 and 2. Try 11.3. $11.3 \times 11.3 = 127.69$ which is still too small.

Try 11.31. $11.31 \times 11.31 = 127.91$ which is still too small.

Try 11.33. $11.33 \times 11.33 = 128.37$ which is still too small.

Try 11.34. $11.34 \times 11.34 = 128.59$ which is too large but within 0.09. If you want greater accuracy continue the estimation.

Try 11.335. $11.335 \times 11.335 = 128.48$

Try 11.337. $11.337 \times 11.337 = 128.52$

Try 11.336. $11.336 \times 11.336 = 129.505$ within 0.005.

3. Find the square root of 0.564 ($\sqrt{0.564}$)

You know that $0.7 \times 0.7 = 0.49$ and $0.8 \times 0.8 = 0.64$ so try 0.74.

$0.74 \times 0.74 = 0.5476$, too small

Try 0.745. $0.745 \times 0.745 = 0.555$

Try 0.748. $0.748 \times 0.748 = 0.5595$.

Try 0.75. $0.75 \times 0.75 = 0.5625$.

Try 0.752. $0.752 \times 0.752 = 0.565504$. too large

Try 0.751. $0.751 \times 0.751 = 0.564001$ within 0.000001.

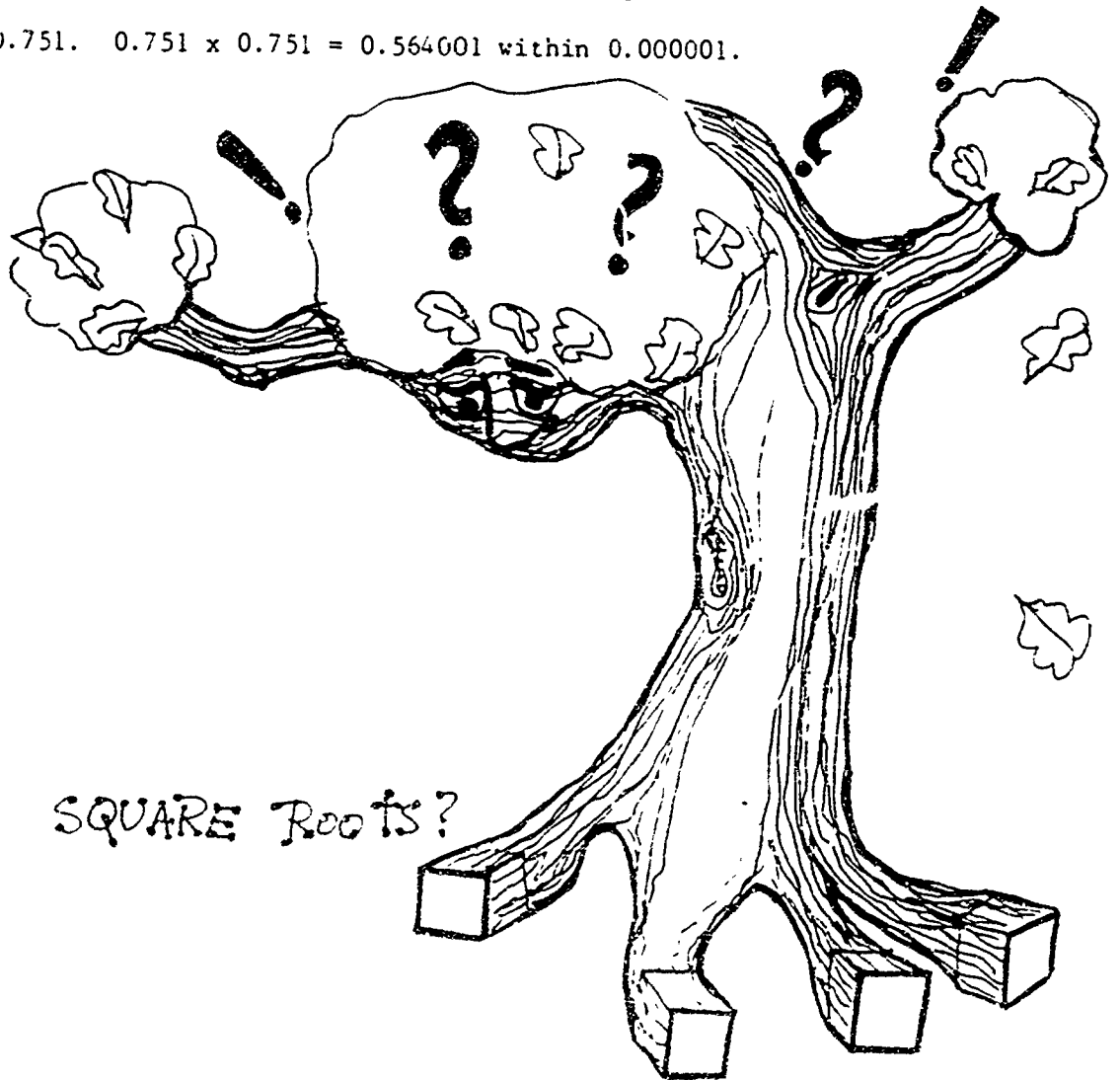

132

YOU CAN NOW TRY SOME SHOP PROBLEMS

SHOP PROBLEMS

1. Your supervisor wants you to find out how many minutes it will take a lathe to make 17 cuts, each 24.5 inches in length, on a steel shaft if the tool feed F is 0.065 inches per revolution and the shaft turns at 163 RPM. Use the formula.

$$T = \frac{LN}{FR}$$

Where T = cutting time in minutes
 N = number of cuts
 L = length of cut, in inches
 F = tool feed rate, inches per revolution
 R = work piece RPM

Time T _____ minutes

2. Your boss gave you a cone with a radius of 5 inches, and a slant height of 12 inches. You are to find the lateral surface area. Look at Figure 4. Use the formula.

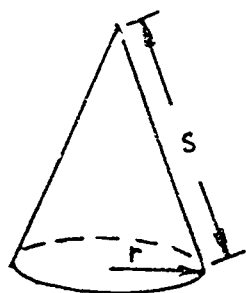

$$L = \pi r s, \text{ where } L = \text{Lateral surface area}$$

$$\pi = 3.14$$

$$r = \text{radius of cone base}$$

$$s = \text{slant height of cone}$$

Lateral surface area _____ in²

Figure 4. Lateral surface area.

3. Your boss asks you to lay out the pattern as shown below in Figure 5. You must find the length of the chord L . Use the formula.

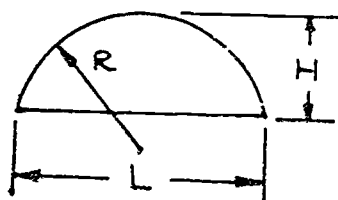

$$L = 2\sqrt{2RH - H^2}, \text{ where } L \text{ equals}$$

$$\text{the chord length, } R = 7.75''$$

$$\text{and } H = 2.35''$$

Chord Length L _____ in.

Figure 5. Chord length.

4. You must find the length L of a pulley belt that is used on a motor and pulley that drives your band saw. Look at Figure 6. Use the formula:

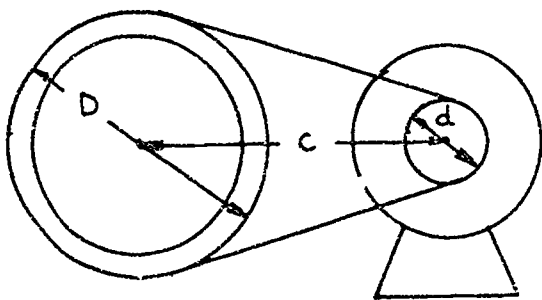

$$L = 2C + 1.57(D+d) + \frac{(D+d)^2}{4C}$$

D = diameter of large pulley = 24"

d = diameter of small pulley = 4"

C = distance between large and small pulleys = 36 in.

Pulley belt length L = _____ in

Figure 6. Pulley belt length.

5. You need to convert a temperature of 278° Fahrenheit to degrees Celsius. Use the formula $C = \frac{5}{9}(F - 32)$, where F equals degrees Fahrenheit and C equals degrees Celsius.

Temperature in degrees Celsius _____

6. You are asked to find the pitch diameter E of a standard National Form thread screw. Use the formula:

$$E = M + \frac{0.8662}{N} - 3G, \text{ where } E = \text{pitch diameter in inches}$$

M = measurement over the wire = 0.25"

N = number of threads per inch = 12

G = wire diameter = 0.0025"

Pitch diameter E _____

7. Your boss wants you to lay out the trapezoid as shown in Figure 7 below. You need to find the height h . Use the formula.

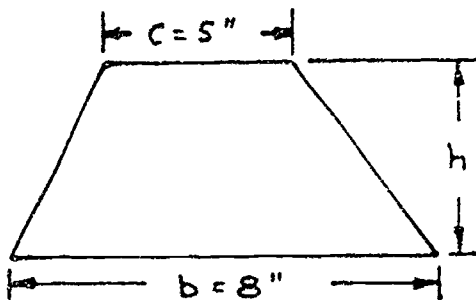

$$h = \frac{2A}{b+c}, \text{ where } h = \text{height}$$

A = area = 78 in^2

b = long base = 8 in

c = short base = 5 in

height h = _____

Figure 7. Trapezoid area.

8. Your supervisor asks you to find the cross-sectional area of an "I" beam as shown in Figure 8. Use the formula $A = ht + 2a(m + n)$.

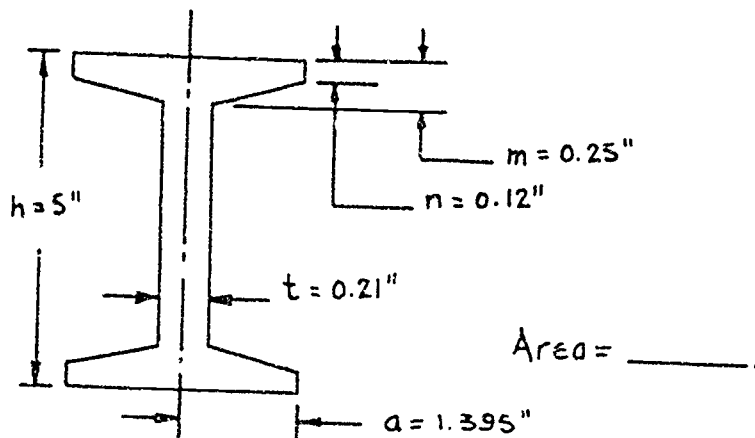
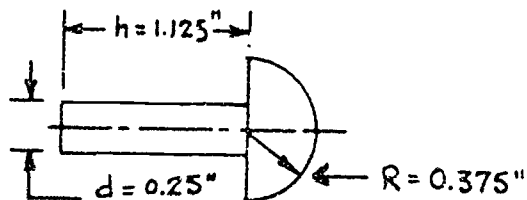

Figure 8: Area of an "I" beam.

9. You are asked to find the weight of a gross of steel rivets as shown in Figure 9. Use the formula.

$$W = (144)(0.28) \left(\frac{2}{3} \pi R^3 + \frac{\pi}{4} d^2 h \right), \text{ where } W \text{ equals weight in pounds for one gross (144) of steel rivets.}$$



Weight _____ lbs.

Figure 9: weight of rivets.

10. To find the taper of a gage or part, the following formula is used:

$$t = \frac{12(D - d)}{L}, \text{ where } t = \text{taper per foot in inches}$$

D = large diameter in inches
d = small diameter in inches
L = length in inches

Find the small diameter d if $t = 1.5$ inches, $D = 14$ inches and $L = 16$ inches.

$d =$ _____ inches.

SHOW YOUR WORK TO YOUR INSTRUCTOR

BAS



PROJECT SHEET

Name _____ Date _____

Cluster Metal Trades Occupation Machinist Helper

Training Module Shop Math for Machinists

Training Milestone 3. Specialized Math Skills

209

PROJECT 2

SHOP ALGEBRA: PART 2

TRAINING CONDITIONS:

● Here's what you will need:

1. This Project Sheet.
2. A pen or pencil to answer the problems in this Project Sheet.

TRAINING PLAN:

● Here's what you do:

In this Project Sheet, you will continue your review of basic algebra. You will review the solution of algebraic equations and ratio-proportion problems. This Project Sheet will also include some equations for you to solve and some ratios and proportions to set up. You will apply your knowledge of algebra in solving many practical machinist shop problems.

1. Read and study pages 2 to 33 of this Project Sheet.
2. Work the Shop Problems on pages 34 to 36.
3. Have your Instructor check your work and record your score on your Student Training Record.
4. Ask your Instructor for your next Project Sheet.

TRAINING GOAL:

● Here's how well you must do:

1. You must score 8 out of 10 correct on the Shop Problems.

SHOP ALGEBRA: PART 2

SOLVING EQUATIONS

In this section, you will first learn what a solution to an algebraic equation is, and how to recognize it. Then you will learn what a *linear* equation looks like and how to solve linear equations.

A *variable* is a letter symbol such as x , y , w , A ... that stands for a number. Each value of the variable that makes an equation true is called a *solution* to the equation. For example, the solution of $x + 3 = 7$ is $x = 4$.

Another example: $2x - 9 = 18 - 7x$ the solution is $x = 3$.

$$\begin{aligned} 2(3) - 9 &= 18 - 7(3) \\ 6 - 9 &= 18 - 21 \\ -3 &= -3 \end{aligned}$$

Certain equations have more than one value of the variable which makes the equation true. For example, the equation $x^2 + 6 = 5x$ is true for $x = 2$.

$$\begin{aligned} \text{Check: } (2) + 6 &= 5(2) \\ 4 + 6 &= 5 \cdot 2 \\ 10 &= 10 \end{aligned}$$

and it is also true for $x = 3$

$$\begin{aligned} \text{Check: } (3) + 6 &= 5(3) \\ 9 + 6 &= 5 \cdot 3 \\ 15 &= 15 \end{aligned}$$

Try these:

- (a) $4 + x = 11$
- (b) $x + 2 = 9$
- (c) $x - 1 = 6$
- (d) $8 - x = 1$

$x = 7$. Every equation has the same solution. If you replace the letter x with the number 7, all four equations are true.

We can say that an equation written with the variable x is solved if it can be put in this form

$$x = \square \text{ where } \square \text{ is some number}$$

For example, the solution to the equation $2x - 1 = 7$ is $x = 4$
 because $2(4) - 1 = 7$
 or $8 - 1 = 7$ is a true statement

Equations as simple as the one above are easy to solve by guessing. But guessing is not a very good way to do mathematics. You need some kind of rule that allows you to rewrite the equation to be solved, ($2x - 1 = 7$ for example) as an equivalent equation ($x = 4$).

187

The general rule is to treat every equation as a balance of the two sides. Look at Figure 1.

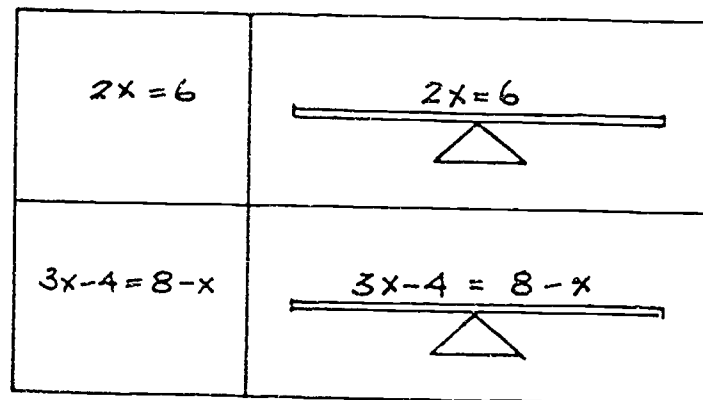

Figure 1: Balancing an equation. Any changes in the equation must not disturb the balance.

Any operation done on one side of the equation must be done on the other side. There are two kinds of operations:

Example :

1. Adding or subtracting a number on both sides of the equation does not change the balance;

and

2. Multiplying or dividing (but not zero) by a number does not change the balance.

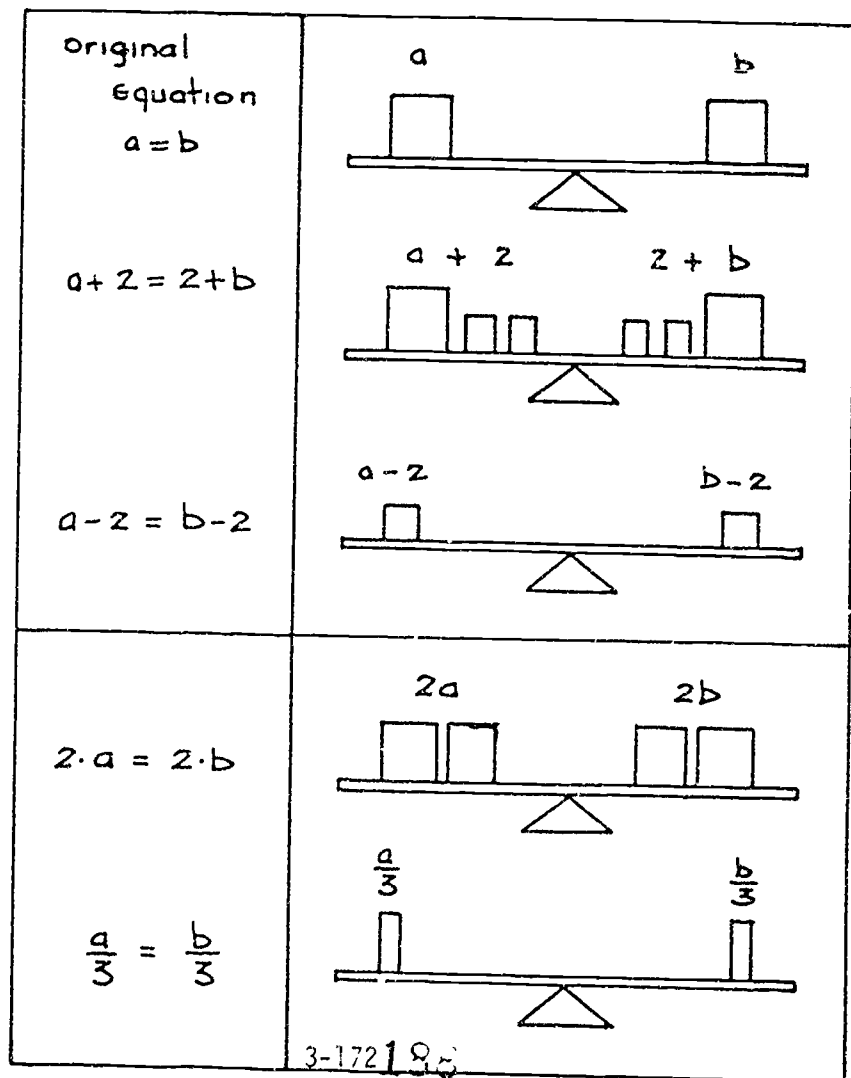

Here's an example: Solve $x - 4 = 2$

Step 1: You must change the equation so that only x remains on the left, so you add $\boxed{4}$ to each side of the equation.

$$(x - 4) + \boxed{4} = 2 + \boxed{4}$$

Step 2: Combine terms

$$\underbrace{x - 4 + \boxed{4}}_{=0} = 2 + \boxed{4}$$

Solution $x = 6$

Check: $x - 4 = 2, x = 6$
 $(6) - 4 = 2$
 $2 = 2$

Now work step-by-step through some example problems.

EXAMPLE PROBLEMS

1. $11 - x = 2$
 $(11 - x) - 11 = (2) - 11$ ← Subtract 11 from each side
 $-x + 11 - 11 = 2 - 11$ ← Combine terms
 $-x = -9$
 $(-x)(-1) = (-9)(-1)$ ← Multiply each side by -1
 $x = 9$ solution

Check: $11 - (9) = 2$
 $2 = 2$

2. $8.4 = 3.1 + x$
 $(8.4) - 3.1 = (3.1 + x) - 3.1$ ← Subtract 3.1 from each side
 $8.4 - 3.1 = x$ ← Combine terms
 $5.3 = x, \text{ or}$
 $x = 5.3$ solution $5.3 = x$ is the same as $x = 5.3$

Check: $8.4 = 3.1 + (5.3)$
 $8.4 = 8.4$

3. $4 = 1 - x$
 $(4) - 1 = (1 - x) - 1$ ← Subtract 1 from each side
 $3 = -x, \text{ or}$
 $(-1)3 = (-1)(-x)$ ← Multiply each side by -1
 $-3 = x, \text{ or}$
 $x = -3$ ← Always put your answer in the form:
 $x = (\text{some number})$

Check: $4 = 1 - (-3)$
 $4 = 4$

$$4. \quad \frac{1}{4} = x - \frac{1}{2}$$

$$\left(\frac{1}{4}\right) + \frac{1}{2} = \left(x - \frac{1}{2}\right) + \frac{1}{2} \quad \longleftarrow \text{Add } \frac{1}{2} \text{ to each side}$$

$$\frac{3}{4} = x - \frac{1}{2} + \frac{1}{2} \quad \longleftarrow \frac{1}{4} + \frac{1}{2} = \frac{3}{4}$$

$$\frac{3}{4} = x \quad \longleftarrow \frac{1}{2} - \frac{1}{2} = 0$$

$$x = \frac{3}{4}$$

$$\text{Check: } \frac{1}{4} = \left(\frac{3}{4}\right) - \frac{1}{2}$$

$$\frac{1}{4} = \frac{1}{4}$$

$$5. \quad 2x + 6 = x$$

$$(2x + 6) - x = x - x \quad \longleftarrow \text{Subtract } x \text{ from each side}$$

$$2x - x + 6 = 0 \quad \longleftarrow \text{Combine terms}$$

$$x + 6 = 0$$

$$(x + 6) - 6 = -6 \quad \longleftarrow \text{Subtract } 6 \text{ from each side}$$

$$x = -6$$

$$\text{Check: } 2(-6) + 6 = -6$$

$$-12 + 6 = -6$$

$$-6 = -6$$

Equations such as number 5 above, where the variable appears on both sides of the equation are very common in algebra. Solve them in the usual way by collecting all terms with the variables on the same side of the equation.

Here is a slightly different problem.

$$\text{Solve: } 2x = 14$$

Step 1: You must change the equation so the x is alone on the left, so you divide each side by 2.

$$\text{Step 2: } x = \frac{14}{2} \qquad \frac{2x}{2} = \left(\frac{2}{2}\right)x = x$$

$$x = 7$$

$$\text{Check: } 2(7) = 14$$

$$14 = 14$$

Now work step-by-step through some more example problems.

EXAMPLE PROBLEMS

1. $7x = 35$

$$\frac{7x}{7} = \frac{35}{7} \quad \longleftarrow \quad \text{Divide both sides by 7}$$

$$x = \frac{35}{7} \quad \frac{7x}{7} = \left(\frac{7}{7}\right)x = x$$

$$x = 5$$

Check: $7(5) = 35$

$$35 = 35$$

2. $\frac{1}{2}x = 14$

$$\left(\frac{1}{2}x\right) 2 = (14)2 \quad \longleftarrow \quad \text{Multiply both sides by 2}$$

$$\left(x \cdot \frac{1}{2}\right) 2 = 14 \cdot 2 \quad \longleftarrow \quad \frac{1}{2} \cdot x = x \cdot \frac{1}{2}$$

$$x\left(\frac{1}{2} \cdot 2\right) = 28 \quad \longleftarrow \quad \frac{1}{2} \cdot 2 = \frac{2}{2} = 1$$

$$x = 28$$

Check: $\frac{1}{2}(28) = 14$

$$14 = 14$$

3. $\frac{2x}{3} = 6$

$$\left(\frac{2x}{3}\right) 3 = 6 \cdot 3 \quad \longleftarrow \quad \text{Multiply both sides by 3}$$

$$2x = 18 \quad \longleftarrow \quad \left(\frac{2x}{3}\right) 3 = \frac{2 \cdot x \cdot \cancel{3}}{\cancel{3}} = 2 \cdot x$$

$$\frac{2x}{2} = \frac{18}{2} \quad \longleftarrow \quad \text{Divide both sides by 2} \quad \frac{\cancel{2}x}{\cancel{2}} = x$$

$$x = 9$$

Check: $\frac{2}{3}(9) = 6$

$$\frac{18}{3} = 6$$

$$6 = 6$$

4. $3x = 0$
 $\frac{3x}{3} = \frac{0}{3}$ ← Divide both sides by 3
 $x = 0$ ← Zero divided by any positive or negative number is still zero.

You need to use both operations, addition/subtraction and multiplication/division, when you solve most simple algebraic equations. For example:

Solve: $2x + 6 = 14$

Step 1: You must change this equation to place one x , or terms with x on the left side. So subtract 6 from each side.

$$(2x + 6) - 6 = 14 - 6$$

$$2x + 6 - 6 = 14 - 6$$
 ← Combine terms

$$2x = 8$$

Step 2: $\frac{2x}{2} = \frac{8}{2}$ ← Divide each side by 2

$$x = 4$$
 ← $\frac{2x}{2} = x$

Try some more example problems.

EXAMPLE PROBLEMS

1. $18 - 5x = 3$

$$(18 - 5x) - 18 = 3 - 18$$
 ← Subtract 18 from each side

$$-5x + 18 - 18 = 3 - 18$$
 ← Rearrange terms

$$-5x = -15$$
 ← Multiply both sides by -1

$$5x = 15$$

$$\frac{5x}{5} = \frac{15}{5}$$
 ← Divide both sides by 5

$$x = 3$$

Check: $18 - 5(3) = 3$

$$18 - 15 = 3$$

$$3 = 3$$

2. $2(x + 4) = 27$
 $2x + 8 = 27$ ← Multiply each term inside the parentheses by 2
 $(2x + 8) - 8 = 28 - 8$ ← Subtract 8 from each side
 $2x = 19$
 $\frac{2x}{2} = \frac{19}{2}$ ← Divide both sides by 2
 $x = 9\frac{1}{2}$

Check: $2(9\frac{1}{2} + 4) = 27$

$$2(13\frac{1}{2}) = 27$$

$$27 = 27$$

3. $3(x - 2) = x + 1$
 $3x - 6 = x + 1$ ← Multiply each term in the parentheses by 3
 $(3x - 6) - x = (x + 1) - x$ ← Subtract x from each side
 $3x - x - 6 = x - x + 1$ ← Rearrange terms
 $2x - 6 = 1$ ← Combine terms
 $2x - 6 + 6 = 1 + 6$ ← Add 6 to each side
 $2x = 7$
 $\frac{2x}{2} = \frac{7}{2}$ ← Divide each side by 2
 $x = 3\frac{1}{2}$

Check: $3(3\frac{1}{2} - 2) = (3\frac{1}{2}) + 1$

$$3(1\frac{1}{2}) = 4\frac{1}{2}$$

$$4\frac{1}{2} = 4\frac{1}{2}$$

4. $2(B - 1) = 3(B + 1)$
 $2B - 2 = 3B + 3$ ← Multiply each term in the parentheses by 2 and on the other side by 3
 $(2B - 2) - 3B = (3B + 3) - 3B$ ← Subtract 3B from each side
 $2B - 3B - 2 = 3B - 3B + 3$ ← Rearrange terms
 $-B - 2 = 3$
 $(-B - 2) + 2 = 3 + 2$ ← Add 2 to each side
 $-B = 5, \text{ or}$
 $B = -5$ ← Solve for B, not -B

$$\begin{aligned} \text{Check: } 2(-5 - 1) &= 3(-5 + 1) \\ 2(-6) &= 3(-4) \\ -12 &= -12 \end{aligned}$$

REMEMBER

1. Do only legal operations: add or subtract the same quantity from both sides of the equation; multiply or divide both sides of the equation by the same non zero quantity.
2. Remove all parentheses carefully.



3. Combine like terms when they are on the same side of the equation.
4. Use legal operations to change the equation so you have only x by itself on one side of the equation and a number on the other side of the equation.
5. Always check your answer.

TRANSPOSITION

You may have noticed something when you added or subtracted a number from both sides of an equation. For example:

1. $x + 6 = 12$
2. $(x + 6) - 6 = 12 - 6$ ← You subtracted 6 from both sides.
3. $x = 12 - 6$ ← Note that the +6 on the left side
4. $x = 6$ of the equation became a -6 on the right side of the equation.

Rather than subtract -6 from both sides of the equation as in line 2 above, simply go directly from line 1 to line 3 by moving the +6 from the left and changing its sign to a -6 on the right side. For example:

1. $x + 6 = 12$, omit line 2 and go to line 3
3. $x = 12 - 6$
4. $x = 6$

Another example:

$$\begin{aligned} 2x - 6(x + 2) &= 24 - 5x \\ 2x - 6x - 12 &= 24 - 5x \end{aligned}$$

← Move $-5x$ from the right side to the left side and change the sign. Move -12 from the left side to the right side and change the sign.

$$\begin{aligned} 2x - 6x + 5x &= 24 + 12 \\ x &= 36 \end{aligned}$$

This process is called *Transposition*.

You also may have noticed something when you multiplied or divided both sides of an equation by the same number. For example:

$$1. \quad x + 12 = 6 - \frac{3}{2}x$$

$$2. \quad x + \frac{3}{2}x = 6 - 12$$

$$3. \quad \frac{5}{2}x = -6$$

$$4. \quad \frac{2}{5} \cdot \frac{5}{2}x = \frac{2}{5} \cdot (-6) \quad \leftarrow \text{You multiplied both sides of the equation by } \frac{2}{5} \text{ to isolate } x.$$

$$5. \quad \frac{2}{5} \cdot \frac{5}{2}x = -\frac{12}{5}$$

$$x = -\frac{12}{5}$$

Rather than multiply both sides of the equation by $\frac{2}{5}$, simply invert the coefficient of x (the number $\frac{5}{2}$ inverted is $\frac{2}{5}$), remove it from the side x is on, and multiply the other side by the inverted coefficient. For example:

$$1. \quad 2x + 3(6x - 4) = 14x + 18$$

$$2. \quad 2x + 18x - 12 = 14x + 18 \quad \leftarrow \text{Transpose the } -12 \text{ from the left side to the right side, transpose the } 14x \text{ from the right side to the left side.}$$

$$3. \quad 2x + 18x - 14x = 18 + 12$$

$$4. \quad 6x - 30 \quad \leftarrow \text{Invert the coefficient of } x \text{ (which is } 6) \text{ and multiply the other side of the equation by } \frac{1}{6}.$$

$$5. \quad x = \frac{1}{6} (30)$$

$$6. \quad x = 5$$

Another example:

$$\frac{1}{5}x + 4 = -2\left(\frac{3}{5}x + 12\right)$$

$$\frac{1}{5}x + 4 = -\frac{6}{5}x - 24$$

$$\frac{1}{5}x + \frac{6}{5}x = -24 - 4$$

$$\frac{7}{5}x = -28$$

$$x = \frac{5}{7} \cdot (-28)$$

$$x = -20$$

You must be careful to invert the *complete* coefficient of x when you multiply it by the other side of the equation. For example:

$\left(\frac{3-a}{4b}\right)x = 12$, $\left(\frac{3-a}{4b}\right)$ is the entire coefficient of x .

$$x = \left(\frac{4b}{3-a}\right) 12$$

$$x = \frac{48b}{3-a}$$

EXAMPLE PROBLEMS

$$\begin{aligned} 1. \quad 2(x-1) &= 3(x+1) \\ 2x-2 &= 3x+3 \\ 2x-3x &= 3+2 \\ -x &= 5 \\ x &= -5 \end{aligned}$$

$$\begin{aligned} \text{Check: } 2(-5-1) &= 3(-5+1) \\ 2(-6) &= 3(-4) \\ -12 &= -12 \end{aligned}$$

$$\begin{aligned} 3. \quad 2x + (4 - 6x) &= 24 \\ 2x - 6x &= 24 - 4 \\ -4x &= 20 \\ x &= \frac{1}{4}(20) \\ x &= -5 \end{aligned}$$

$$\begin{aligned} \text{Check: } 2(-5) + 4 - 6(-5) &= 24 \\ -10 + 4 + 30 &= 24 \\ -6 + 30 &= 24 \\ 24 &= 24 \end{aligned}$$

$$\begin{aligned} 2. \quad x + 5.8 &= 3x + 1.4 \\ x - 3x &= 1.4 - 5.8 \\ -2x &= -4.4 \\ -x &= \frac{1}{2}(-4.4) \end{aligned}$$

$$\begin{aligned} -x &= -2.2 \\ x &= 2.2 \end{aligned}$$

$$\begin{aligned} \text{Check: } 2.2 + 5.8 &= 3(2.2) + 1.4 \\ 8 &= 6.6 + 1.4 \\ 8 &= 8 \end{aligned}$$

$$\begin{aligned} 4. (x-2) - (4-5x) &= 18 \\ x-2-4+5x &= 18 \\ x+5x &= 18+2+4 \\ 6x &= 24 \\ x &= \frac{1}{6}(24) = 4 \end{aligned}$$

$$\begin{aligned} \text{Check: } (4-2) - (4-5 \cdot 4) &= 18 \\ 2-3+20 &= 18 \\ -2+20 &= 18 \\ 18 &= 18 \end{aligned}$$

$$\begin{aligned}
 5. \quad 4 - (2x - 7) &= 5 \\
 4 - 2x + 7 &= 5 \\
 -2x &= 5 - 4 - 7 \\
 -2x &= -6
 \end{aligned}$$

$$\begin{aligned}
 x &= \frac{1}{2} \cdot 6 \\
 x &= 3
 \end{aligned}$$

$$\begin{aligned}
 \text{Check: } 4 - (2 \cdot 3 - 7) &= 5 \\
 4 - 6 + 7 &= 5 \\
 -2 + 7 &= 5 \\
 5 &= 5
 \end{aligned}$$

SIMPLE FACTORING

Remember that in algebra, when an expression is formed by multiplying quantities, each multiplier is called a *factor*. Factoring is the process of separating the common elements from an algebraic expression.

Expression

Factored form

$$ax + bx$$

$$x(a + b)$$

x has been factored out

$$5y + ay$$

$$y(5 + a)$$

y has been factored out

$$ar^2 + br$$

$$r(ar + b)$$

r has been factored out

In solving equations, it may be necessary to factor out the variable that you are solving for. For example:

$$\begin{aligned}
 ax + 3x - 6 &= b(x + 3) && \longleftarrow \text{solve for } x \\
 ax + 3x - 6 &= bx + 3b && \longleftarrow \text{remove parenthesis} \\
 ax + 3x - bx &= 6 + 3b && \longleftarrow \text{isolate the expressions containing } x \\
 x(a + 3 - b) &= 6 + 3b && \longleftarrow \text{factor out the } x \\
 x &= \frac{1}{(a + 3 - b)} \cdot (6 + 3b) && \longleftarrow \text{invert and multiply by the entire} \\
 &&& \text{coefficient of } x \\
 x &= \frac{6 + 3b}{a + 3 - b}
 \end{aligned}$$

another example:

$$\begin{aligned}
 xR^2 - x(3 + b) &= 16 + 2(a + x) && \longleftarrow \text{solve for } x \\
 xR^2 - 3x - bx &= 16 + 2a + 2x && \longleftarrow \text{remove all parentheses} \\
 xR^2 - 3x - bx - 2x &= 16 + 2a && \longleftarrow \text{isolate expressions with } x \\
 x(R^2 - 3 - b - 2) &= 16 + 2a && \longleftarrow \text{factor out the } x \\
 x(R^2 - b - 5) &= 16 + 2a && \longleftarrow \text{combine terms} \\
 x &= \frac{1}{R^2 - b - 5} \cdot (16 + 2a) && \longleftarrow \text{invert and multiply by the} \\
 &&& \text{entire coefficient of } x \\
 x &= \frac{16 + 2a}{R^2 - b - 5}
 \end{aligned}$$

197

SOLVING FORMULAS

To solve a formula for some letter means to rewrite the formula so the letter is isolated on the left side of the equal sign. For example, the equation for the area of a triangle is given as:

$$A = \frac{BH}{2} \quad \text{where } A \text{ is the area, } B \text{ is the length of the base, and } H \text{ is the height.}$$

Solving for B gives the equivalent formula: $B = \frac{2A}{H}$

Solving for H gives the equivalent formula: $H = \frac{2A}{B}$

Solving formulas is a very important part of practical algebra. Sometimes a formula you know will not be in its most useful form. You may need to rewrite the formula solving it for the letter you need to evaluate.

To solve a formula, use the same transposing, inverting, and multiplying process you used for solving equations. For example, solve this formula:

d.

$$S = \frac{R+P}{2} \quad \text{Solve for } R$$

$$S = \frac{1}{2} (R+P)$$

$$2S = R+P$$

$$2S - P = R$$

$$R = 2S - P$$

← [invert and multiply the coefficient of (R+P) by the quantity on the other side of the equation
 ← transpose the +P in order to isolate R
 ← the letter you are solving for, R in this case, is usually written on the left side of the equal sign.

EXAMPLE PROBLEMS

1. $V = \frac{3K}{T}$, for K

$$V = \left(\frac{3}{T}\right) K$$

$$\frac{TV}{3} = k$$

$$K = \frac{TV}{3}$$

2. $Q = 1 - R + T$, for R

$$Q - 1 - T = -R$$

$$-Q + 1 + T = R$$

$$R = 1 + 1 - Q$$

$$\begin{array}{ll}
 3. & V = \pi R^2 H - AB, \text{ for } H \\
 & V + AB = \pi R^2 H \\
 & V + AB = (\pi R^2)H \\
 & \left(\frac{1}{\pi R^2}\right) \cdot (V + AB) = H \\
 & \frac{V + AB}{\pi R^2} = H \\
 & H = \frac{V + AB}{\pi R^2} \\
 5. & F = \frac{9C}{5} + 32, \text{ for } C \\
 & F - 32 = \left(\frac{9}{5}\right) \cdot C \\
 & \left(\frac{5}{9}\right)(F - 32) = C \\
 & C = \frac{5(F - 32)}{9} \\
 4. & Y = MX + B, \text{ for } X \\
 & Y - B = MX \\
 & \frac{Y - B}{M} = X \\
 & X = \frac{Y - B}{M} \\
 6. & V = \frac{LT}{6} + 2, \text{ for } L \\
 & V - 2 = \left(\frac{T}{6}\right) L \\
 & \left(\frac{6}{T}\right)(V - 2) = L \\
 & L = \frac{6V - 12}{T}
 \end{array}$$

USING SQUARE ROOTS IN SOLVING EQUATIONS

In the last Project Sheet, Shop Algebra: Part 1, you learned how to estimate a square root. Little was said about how to solve an equation by taking square roots. That's because in most of the equations so far, the letter you have solved for is to the first power. When the variable appears only to the first power, the equation is said to be *linear*. When the variable is raised to higher powers, such as x^2 , y^3 , w^4 , the equation is said to be *non-linear*. When you have a non-linear equation such as $x = a$, where a is some positive number, you can solve for x easily by taking the square root of each side of the equation.

$$x^2 = a, \text{ then } \sqrt{x^2} = \sqrt{a}, \text{ or } x = \sqrt{a}$$

Example:

$$\begin{array}{l} \text{Solve } x^2 = 36 \\ \sqrt{x^2} = \sqrt{36} \end{array}$$

$$x = +6, \text{ or } -6 \text{ (usually written as } \pm 6)$$

There are two possible solutions because $(+6)(+6) = 36$ and $(-6)(-6) = 36$. So you must be careful. One of the solutions, usually the negative one, may not be reasonable when you are doing shop problems.

EXAMPLE PROBLEM: If the cross-sectional area of a square heating duct is 75 square inches, what must be the width of the duct?

Solve $x^2 = 75$
 $\sqrt{x^2} = \sqrt{75}$
 $x = \pm 8.7$ in (rounded) the answer -8.7 in is meaningless so you choose $x = +8.7$ in.

TRANSLATING ENGLISH TO ALGEBRA .

Algebra is a useful tool in solving real problems. To use algebra, you may have to translate English sentences and phrases into mathematical expressions and equations. In technical work, the formulas to be used are often given in the form of English sentences. They must be rewritten as algebraic formulas before they can be used. For example, the statement:

"Horsepower required to overcome vehicle air resistance is equal to cube of the vehicle speed in MPH multiplied by the frontal area in square feet divided by 150,000."

This statement translates to the following formula:

$$HP = \frac{(MPH^3)(Area)}{150,000}, \text{ or in algebraic form}$$

$$HP = \frac{V^3 A}{150,000}$$

Try the following problem. You find this statement in a technical manual:

"The pitch diameter of a cam gear is twice the diameter of the crank gear."

The equation is $P = 2C$ Where P is the pitch diameter of the cam gear, and C is the diameter of the crank gear.

You may use any letters you wish, but normally you choose letters that remind you of the quantities they represent: P for pitch and C for crank.

Certain words and phrases appear again and again in statements to be translated. These certain words and phrases are signals alerting you to the mathematical operations to be used. Here is a handy list of *signal words* and their mathematical translations.

SIGNAL WORDS		
ENGLISH TERM	MATH TRANSLATION	EXAMPLE
Equals, is equal to, the same as, the result is, gives, makes, leaves	=	$A = B$
Plus, sum of, increased by, more than	+	$A + B$
Minus B, subtract B, less B, decreased by B, take away B, diminished by B, B subtracted from A, difference between A and B	-	$A - B$
Times, multiply, of, product of	x	AB
Divide, divided by B, quotient of	÷	$A \div B$ or $\frac{A}{B}$
Twice, doubled, twice as much	x 2	$2A$
Squared		A^2
Cubed		A^3

Examples:

$$\text{Length plus 3 inches} = L + 3$$

$$\text{Weight divided by 12.5} = \frac{W}{12.5}$$

$$\text{One-half of the original torque} = \frac{T}{2}$$

$$\text{The sum of two lengths} = L_1 + L_2$$

$$\text{The voltage decreased by 10.5} = V - 10.5$$

$$\text{8" more than twice the height} = 8 + 2h$$

You can translate complete sentences or complete problems in a similar manner. For example:

The size of a drill for a tap is equal to the tap diameter minus the depth.

$$20^{\frac{1}{2}} S = T - d$$

Follow these steps when you translate a sentence into an algebraic equation or formula:

Step 1. Cross out all unnecessary words.

The size ~~of a drive for a tap~~ is equal to ~~the~~ tap diameter minus ~~the~~ depth.

Step 2. Make a word equation using parentheses.

(Size)(is equal to)(tap diameter)(minus)(depth)

Step 3. Substitute a letter or arithmetic symbol for each parentheses.

↓ ↓ ↓ ↓ ↓
S = T - D

Step 4. Combine and simplify as necessary.

$$S = T - D$$

In most formulas, the units for the quantities involved must be given. In the formula above, T and D are in inches.

Translating English sentences or verbal rules into algebra formulas requires that you read the sentences very differently from the way you read stories or newspaper articles. Very few people are able to write out the math formula after reading the problem only once. You should expect to read it several times. You'll want to read it slowly. No speed reading here.

The ideas in technical work and formulas are usually concentrated in a few key words, and you must find them. If you find a word you do not recognize, stop reading and look it up in a dictionary, textbook, or manual. It may be important. Translating and working with formulas is one of the skills you must have if you are to succeed at any technical occupation.

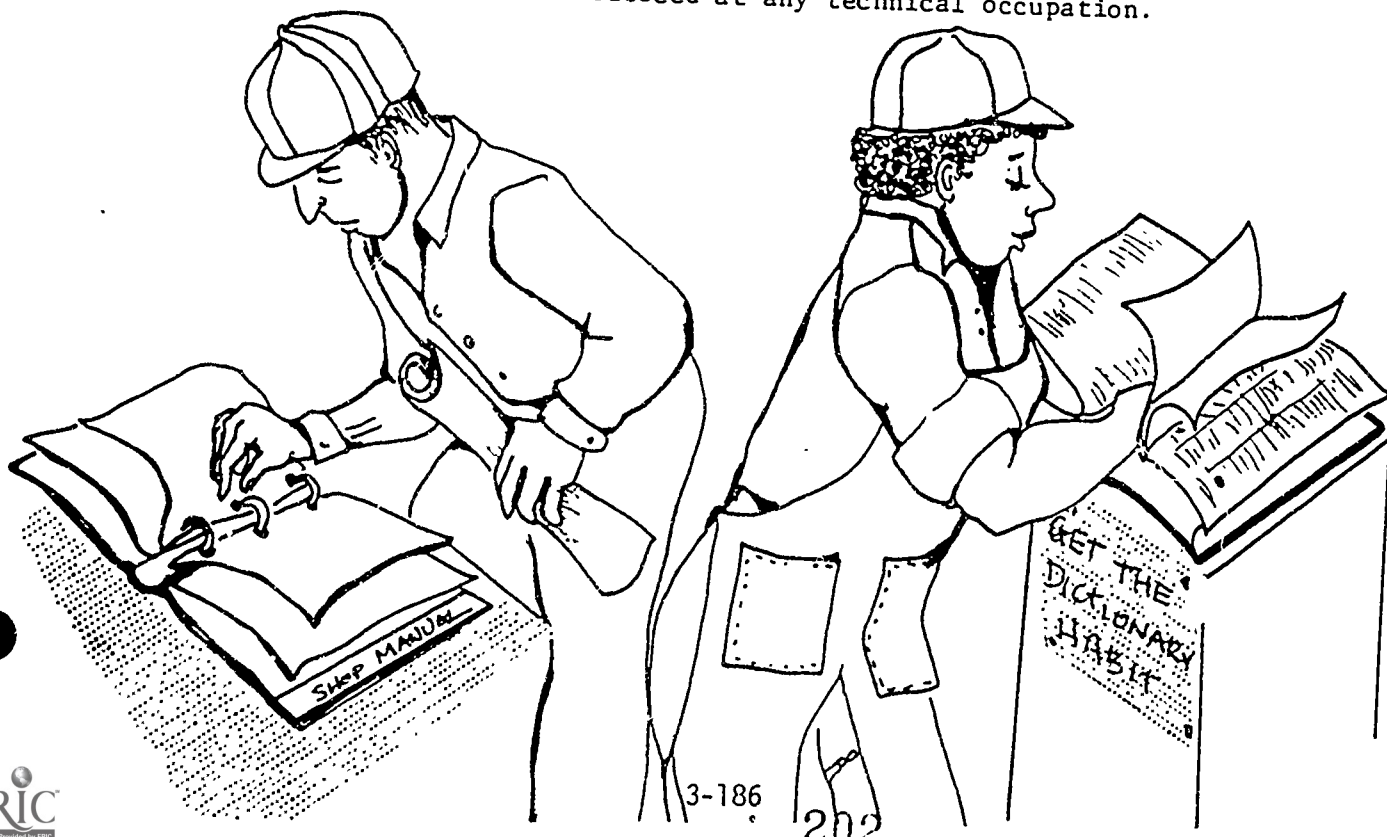

EXAMPLE PROBLEMS

1. The electrical resistance of a length of wire is equal to the resistivity of the metal times the length of the wire divided by the square of the wire diameter.

Step 1. Eliminate all but key words. ...resistance...is equal to...resistivity...
times...length...divided by the square...diameter.

Step 2. Substitute letters and symbols. $R = \frac{rL}{d}$ R = resistance, r = resistivity,
L = wire length, d = wire diameter

2. A sheet metal worker measuring a dust cover finds the width is 8.5 inches less than the height.

$$W = H - 8.5, \quad W = \text{width}, H = \text{height}$$

3. A 24-inch piece of steel is cut into two pieces so that the longer piece is 5 times the length of the shorter. (Hint: write two equations.)

$$24 = L + S \quad \text{and} \quad L = 5S, \quad L = \text{long piece and } S = \text{short piece}$$

4. The volume of an elliptical tank is approximately equal to 0.7854 times the product of its height, length and width.

$$V = 0.7854 HLW, \quad V = \text{volume}, H = \text{height}, L = \text{length}, W = \text{width}$$

5. Two shims are to have a combined thickness of 0.090 inches. The larger shim must be 3.5 times thicker than the smaller shim. (Hint: write two equations.)

$$L + S = 0.090 \quad \text{and} \quad L = 3.5S. \quad \text{Where } L = \text{thicker shim}, S = \text{thinner shim}.$$

6. The engine speed is equal to 168 times the overall gear reduction multiplied by the speed in MPH and divided by the rolling radius of the tire.

$$S = \frac{168GV}{r}. \quad \text{Where } S = \text{engine speed}, G = \text{gear reduction}, V = \text{speed in MPH},$$

$$r = \text{rolling radius of the tire}.$$

Note that in problems 3 and 5 you wrote two equations. These can be combined to form a single equation.

$$3. \quad 24 = L + S \quad \text{and} \quad L = 5S \quad \text{give you: } 24 = 5S + S \quad \text{or} \quad 24 = 6S$$

$$5. \quad L + S = 0.090 \quad \text{and} \quad L = 3.5S \quad \text{give you: } 3.5S + S = 0.090 \quad \text{or} \quad 4.5S = 0.090$$

GENERAL WORD PROBLEM EXAMPLES

1. A 14-foot long steel rod is cut into two pieces. The long piece is 2.5 times the length of the shorter piece. Find the lengths of both pieces.

$$\begin{aligned} \text{Let the short piece} &= x \\ \text{then the long piece} &= 2.5x \\ \text{and } x + 2.5x &= 14 \\ 3.5x &= 14 \\ x &= 4 \text{ (short piece)} \\ 2.5x &= 2.5(4) = 10 \text{ (long piece)} \end{aligned}$$

2. Find the dimensions of a rectangular cover plate if its length is 6 inches longer than its width and if its perimeter is 68 inches. (Hint: perimeter = 2 · length + 2 · width)

$$\begin{aligned} \text{let } L &= \text{length, then} \\ L &= 6 + W \\ \text{Perimeter} &= 68 = 2(L) + 2(W) \\ 68 &= 2(6 + W) + 2(W) && \longleftarrow \text{Remove parentheses} \\ 68 &= 12 + 2W + 2W && \longleftarrow \text{Combine terms} \\ \text{or } 4W + 12 &= 68 \\ 4W &= 68 - 12 && \longleftarrow \text{Transpose the 12} \\ 4W &= 56 && \longleftarrow \text{Divide by 4} \\ W &= 14 \\ \text{length} &= 6 + W = 20 \end{aligned}$$

3. Ike and Mike are partners in a sheet metal shop. Because Ike provided more of the capital, they have agreed that Ike's share of the profit should be 25 greater than Mike's. The total profit for the first quarter was \$17,550. How should they divide it?

$$\begin{aligned} \text{let } M &= \text{Mike's share and} \\ I &= \text{Ike's share, then} \\ I &= \text{Mike's share plus .25 of Mike's share, or} \\ I &= M + .25M, \text{ or } 1.25M, \text{ then} \\ M + I &= 17,550, \text{ or} \\ M + 1.25M &= 17,550 && \longleftarrow \text{Combine terms} \\ 2.25M &= 17,550 && \longleftarrow \text{Divide by 2.25} \\ M &= 7800 \\ I &= 1.25M \text{ or } 9750 \end{aligned}$$



4. You want to cut a 12-foot steel rod into three pieces. The longest piece must be 3 times longer than the shorter piece and the middle size piece is two feet longer than the shorter piece.

let x = short piece, then

$x + 2$ = middle size piece, and

$3x$ = longest piece

then $(x) + (x + 2) + (3x) = 12$ ← Combine terms

$5x + 2 = 12$ ← Transpose the 2

$5x = 12 - 2$

$5x = 10$ ← Divide by 5

$x = 2$ ← The short piece

$x + 2 = 4$ ← The middle sized piece

$3x = 6$ ← The longest piece

RATIO AND PROPORTION

Machinists, sheet metal-workers, metal finishers, welders, mechanics, and many others in technical trades use the ideas of ratio and proportion to solve many different technical problems. The compression ratio of a car, the gear ratio of a machine, the lengths of pulley belts, the voltage ratio in a transformer, the pitch of a roof are all practical examples of the ratio concept.

RATIO

A ratio is a comparison of two quantities of the same kind, both expressed in the same units. For example, the grade of a highway up a hill can be written as the ratio of its height to its horizontal extent. Look at Figure 2.

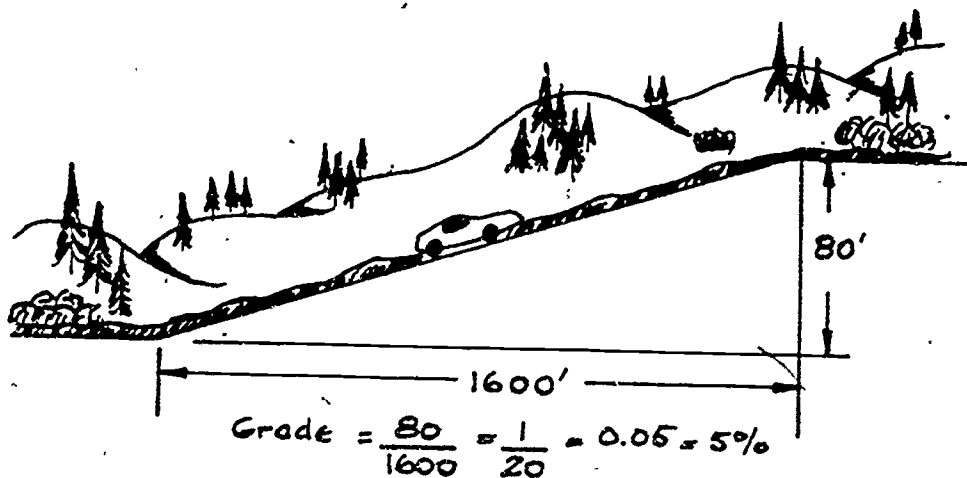
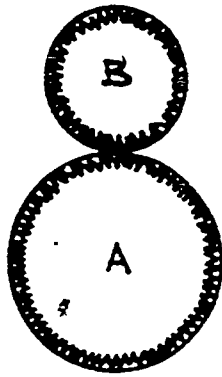

Figure 2: Highway grade.

A ratio can be expressed as a decimal number, percent or a fraction. If it is a fraction it is usually expressed in its lowest terms. Look at Figure 3.



Gear A has 64 teeth
Gear B has 16 teeth

The gear ratio of A to B is:

$$\frac{A}{B} = \frac{64}{16} = \frac{4}{1}$$

always reduce fraction to lowest terms

Figure 3: Gear ratio.

Very often, a colon (:) is used to express a ratio. For example, the gear ratio in Figure 3 could have been expressed as 4:1.

If you are given the value of a ratio, and one of its terms, you can easily find the other term. For example, if the pitch of a roof is supposed to be 1 to 5 or 1:5 and the span is 20 feet, what must the rise be?

Pitch = $\frac{\text{rise}}{\text{span}}$ and 1:5 can be written as $\frac{1}{5}$, so

$$\frac{1}{5} = \frac{\text{rise}}{20}, \text{ or } \frac{1}{5} = \frac{R}{20} \quad \longleftarrow \text{Multiply both sides by 5}$$

$$1 = \frac{5R}{20} \quad \longleftarrow \text{Multiply both sides by 20}$$

$$20 = 5R \quad \longleftarrow \text{Divide both sides by 5}$$

$$4 = R$$

$$\text{or } R = 4 \quad \longleftarrow \text{The rise is 4 feet}$$

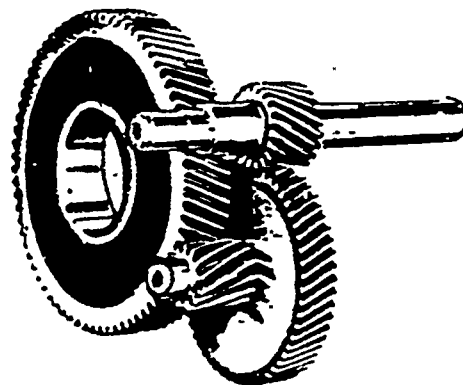

EXAMPLE PROBLEMS

1. If a gear ratio on a cutting machine is 6:1 and the smaller gear has 12 teeth, how many teeth are on the larger gear?

$$\text{Gear ratio} = \frac{\text{teeth on large gear}}{\text{teeth on small gear}}$$

$$\frac{6}{1} = \frac{x}{12} \quad \leftarrow \text{Multiply both sides by 12}$$

$$(12)(6) = x$$

$$x = 72 \text{ teeth on the larger gear}$$

2. The pulley system on a lathe has a pulley diameter ratio of 4. If the larger pulley has a diameter of 15 inches, what is the diameter of the smaller pulley?

$$\text{Pulley ratio} = \frac{\text{diameter of large pulley}}{\text{diameter of smaller pulley}}$$

$$4 = \frac{15}{x} \quad \leftarrow \text{Multiply both sides by } x$$

$$4x = 15 \quad \leftarrow \text{Divide both sides by 4}$$

$$x = \frac{15}{4}$$

$$x = 3.75" \text{ diameter of the small pulley}$$

3. The compression ratio of a Datsun 280Z is 8.3 to 1. If the compressed volume of the cylinder is 36 cubic cm, what is the expanded volume?

$$\text{Compression ratio} = \frac{\text{expanded volume}}{\text{compressed volume}}$$

$$\frac{8.3}{1} = \frac{V}{36} \quad \leftarrow \text{Multiply both sides by 36}$$

$$\frac{(8.3)(36)}{1} = V \quad \leftarrow \frac{(8.3)(36)}{1} = (8.3)(36)$$

$$V = 298.8 \text{ cu cm}$$

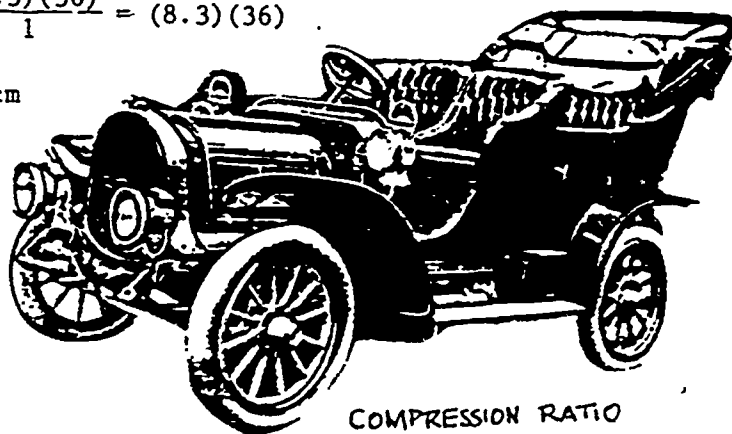
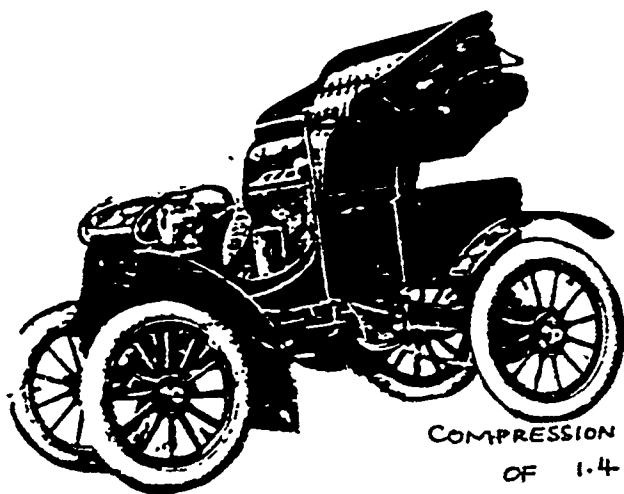

207

PROPORTION

A *proportion* is a statement that two ratios are equal. It can be given as a sentence in words, but most often a proportion is an algebra equation.

For example, the arithmetic equation $\frac{3}{5} = \frac{21}{35}$ is a proportion.

The algebraic equation $\frac{11}{4} = \frac{x}{5}$ is a proportion.

Look at the storage bin shown below. The ratio of the actual length to the scale-drawing length is equal to the ratio of the actual width to the scale-drawing width.

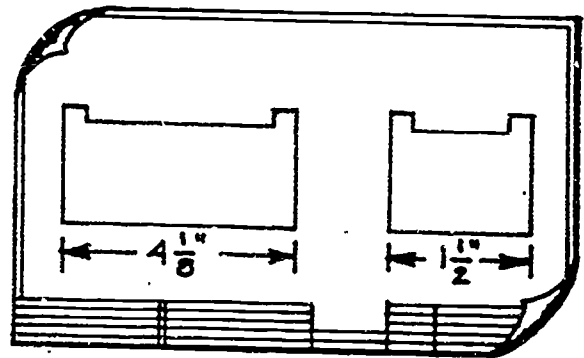
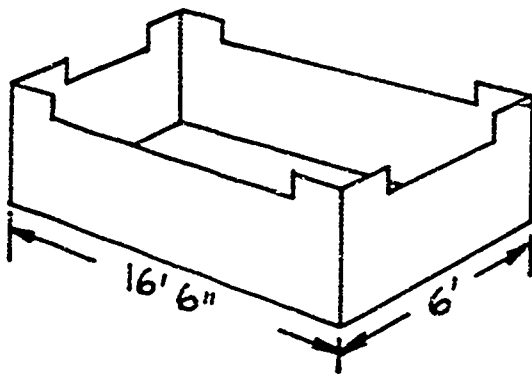

$$\frac{\text{actual length}}{\text{drawing length}} = \frac{\text{actual width}}{\text{drawing width}}$$

$$\frac{16' 6''}{4 \frac{1}{8}''} = \frac{6'}{1 \frac{1}{2}''}$$

← this equation is a proportion

↑
ratio of
lengths

↑
ratio of
widths

Figure 4: Proportion.

Rewrite all quantities in the same units: $\frac{198''}{4 \frac{1}{8}''} = \frac{72''}{1 \frac{1}{2}''}$

You should notice first of all that each side of the equation is a ratio. Each side is a ratio of *like* quantities: lengths on the left and widths on the right.

Second, notice that the ratio $\frac{198''}{4\frac{1}{8}''}$ is equal to $\frac{48}{1}$.

$$\begin{aligned} \text{Divide it out: } 198 \div 4\frac{1}{8} &= 198 \div \frac{33}{8} \\ &= 198 \times \frac{8}{33} \\ &= 48 \end{aligned}$$

Notice also that the ratio $\frac{72''}{1\frac{1}{2}''} = \frac{48}{1}$

The common ratio $\frac{48}{1}$ is called the *scale* factor of the drawing.

The four parts of the proportion are called its terms.

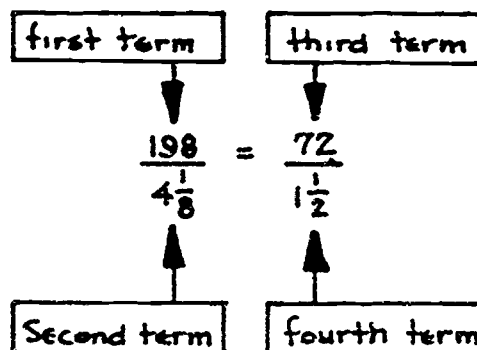

If one of the terms of the proportion is unknown, you can replace it with a letter and solve the proportion as an algebraic equation. For example, suppose the actual cut in the side of the bin is one foot down.

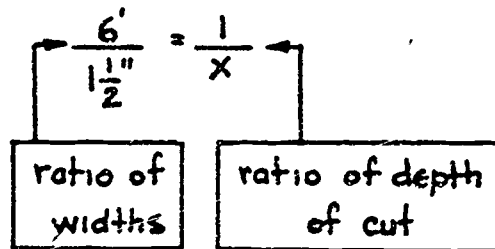

$$\begin{aligned} \text{then } \frac{72''}{1\frac{1}{2}''} &= \frac{12''}{x''}, & \left(\frac{72}{1\frac{1}{2}}\right)x &= \left(\frac{12}{x}\right)x & \leftarrow \text{multiply each side by } x \\ & & \left(\frac{72x}{1\frac{1}{2}}\right) \cdot \frac{1}{2} &= 12 \left(1\frac{1}{2}\right) & \leftarrow \text{multiply each side by } 1\frac{1}{2} \\ & & \frac{72x}{72} &= \frac{18}{72} & \leftarrow \text{divide both sides by } 72 \\ & & x &= \frac{1}{4} & \end{aligned}$$

Therefore, on the drawing the cut will be $\frac{1}{4}$ inch deep.

A very easy way to solve proportion equations is to use the *cross-product rule*.

<p>THE CROSS PRODUCT RULE</p> <p>if $\frac{a}{b} = \frac{c}{d}$, then $ad = bc$</p>

The cross-products of the terms of a proportion are equal.

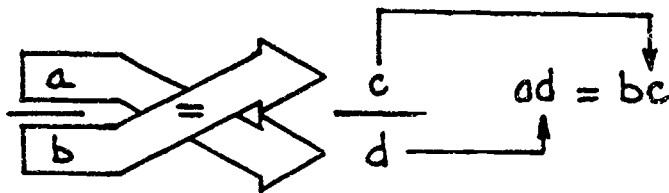

For example: if $\frac{2}{3} = \frac{18}{27}$, use the cross product rule to get

$$2 \cdot 27 = 3 \cdot 18$$

$$54 = 54$$

or in the previous equation:

$$\frac{72}{1\frac{1}{2}} = \frac{12}{x}, \text{ then } 72x = 12 \cdot 1\frac{1}{2}$$

$$72x = 18$$

$$x = \frac{18}{72} = \frac{1}{4}$$

EXAMPLE PROBLEMS

Use the cross-product rule to solve the following:

1. $\frac{B}{7} = \frac{3}{4}$

$$4B = 21$$

$$B = \frac{21}{4} = 5\frac{1}{4}$$

2. $\frac{7}{16} = \frac{21}{A}$

$$7A = 336$$

$$A = 48$$

3. $\frac{21}{12} = \frac{R}{6}$

$$12R = 126$$

$$R = 10.5$$

4. $\frac{0.4}{1.5} = \frac{12}{E}$

$$0.4E = 18$$

$$E = 45$$

210

SIMILAR FIGURES

In general, two geometric figures that have the same shape but not the same size are said to be *similar* figures. The blueprint drawing and the actual object are a pair of similar figures. An enlarged photograph and the smaller original are similar.

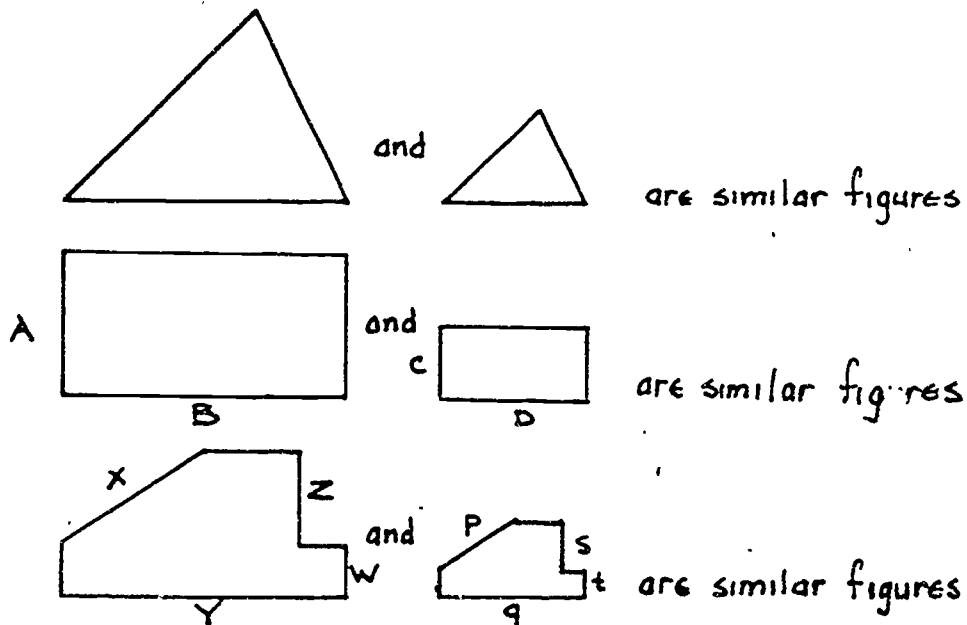

In any two similar figures, all pairs of corresponding dimensions have the same ratio. For example, in the rectangles above,

$$\frac{A}{C} = \frac{B}{D} \quad \text{In the irregular figure above, } \frac{x}{p} = \frac{y}{q} = \frac{z}{r} = \frac{w}{t}$$

EXAMPLE PROBLEMS

Find the missing dimension in each of the following pairs of similar figures.

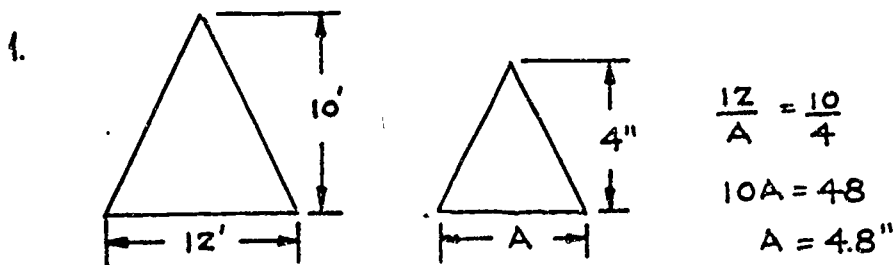

2.

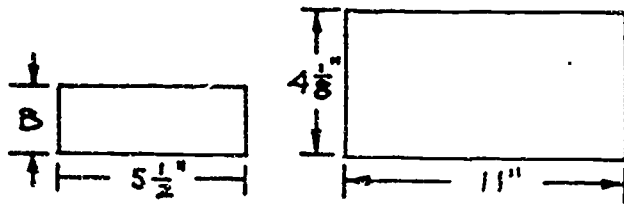

$$\frac{B}{4\frac{1}{8}} = \frac{5\frac{1}{2}}{11}$$

$$11B = 22.6875$$

$$B = 2.0625"$$

3.

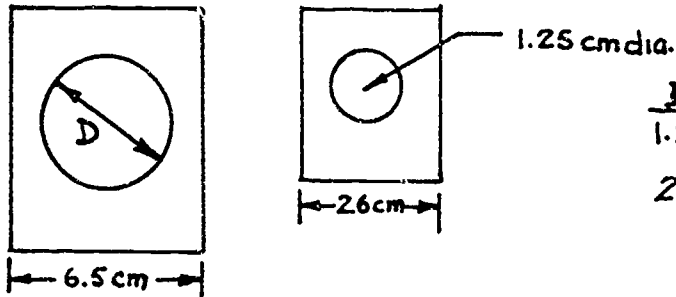

$$\frac{D}{1.2} = \frac{6.5}{2.6}$$

$$2.6D = 8.125$$

$$D = 3.125\text{ cm}$$

4.

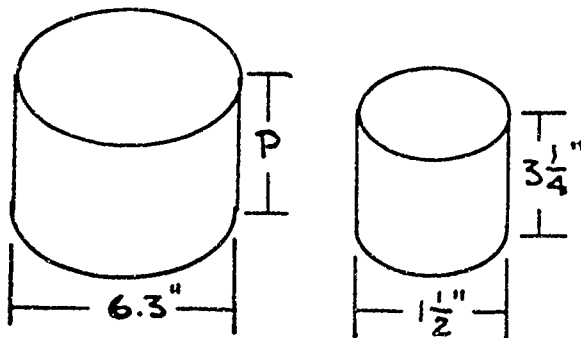

$$\frac{P}{3\frac{1}{4}} = \frac{6.3}{1\frac{1}{2}}$$

$$1.5P = 20.475$$

$$P = 13.65"$$

DIRECT AND INVERSE PROPORTION

Many shop problems can be solved by setting up a proportion involving four related quantities. It is important that you recognize that there are *two* types of proportion - direct and inverse. Two quantities are said to be *directly proportional* if an increase in one quantity leads to a proportional increase in the other quantity, or if a decrease in one leads to a proportional decrease in the other.

DIRECT PROPORTION

increase \longrightarrow increase

decrease \longrightarrow decrease

For example, the electrical resistance of a wire is directly proportional to its length: the longer the wire, the greater the resistance. If one foot of nichrome heater element wire has a resistance of 1.65 ohms, what length of wire is needed to provide a resistance of 19.8 ohms?

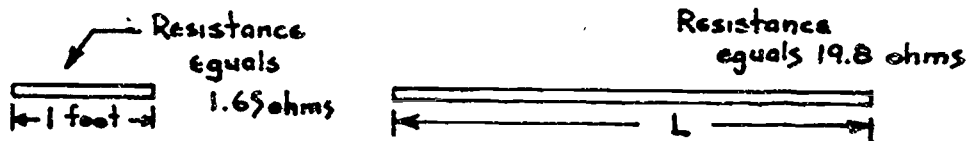

First: Recognize that this problem is a *direct* proportion--as the length of wire increases, the resistance increases proportionally.

as L increases... R increases

$$\frac{L}{1\text{ft}} = \frac{R}{1.65}$$

Both ratios increase in size when L increases.

Second: Set up a direct proportion and solve.

$$\frac{L}{1\text{ ft.}} = \frac{19.8\text{ ohms}}{1.65\text{ ohms}}$$

$$1.65 L = 19.8$$

$$L = 12\text{ ft.}$$

EXAMPLE PROBLEMS

1. If a widget machine produces 88 widgets in 2 hours, how many will it produce in $3\frac{1}{2}$ hours?

$$\frac{88}{2\text{ hrs.}} = \frac{x}{3.5\text{ hrs.}}$$

$$2x = 154\text{ widgets} \leftarrow \text{Direct proportion--the longer it works, the more it makes.}$$

213

2. If one gallon of paint covers 825 square feet, how many gallons of paint are needed to cover 2640 square feet?

$$\frac{1 \text{ gal.}}{825 \text{ sq. ft.}} = \frac{x}{2640 \text{ sq. ft.}}$$

$$825x = 2640$$

$$x = 3.2 \text{ gal.} \quad \leftarrow \text{Direct proportion--the bigger the area, the more paint you need.}$$

3. Twelve square feet of sheet metal costs \$4.95. How much will 32.5 square feet cost?

$$\frac{\$4.95}{12 \text{ sq. ft.}} = \frac{x}{32.5 \text{ sq. ft.}}$$

$$12x = 160.875$$

$$x = \$13.41 \text{ (rounded)} \quad \leftarrow \text{Direct proportion--the more the area, the more the cost.}$$

4. A cylindrical tank holds 450 gallons of cooling oil when it is completely filled to its height of 8 feet. How many gallons does it hold when it is filled to a height of 2 feet 3 inches?

$$\frac{450}{8} = \frac{x}{2.25}$$

$$8x = 1012.5$$

$$x = 126.56 \text{ gal. (rounded)} \quad \leftarrow \text{Direct proportion--the smaller the height the smaller the volume.}$$

Two quantities are said to be *inversely proportional* if an increase in one quantity leads to a proportional decrease in the other quantity, or if a decrease in one leads to a proportional increase in the other.

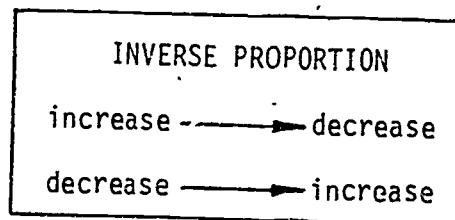

For example, the time required for a trip of a certain length is inversely proportional to the speed of travel. If a certain trip takes two hours at 50 MPH, how long will it take at 60 MPH?

The correct proportion is:

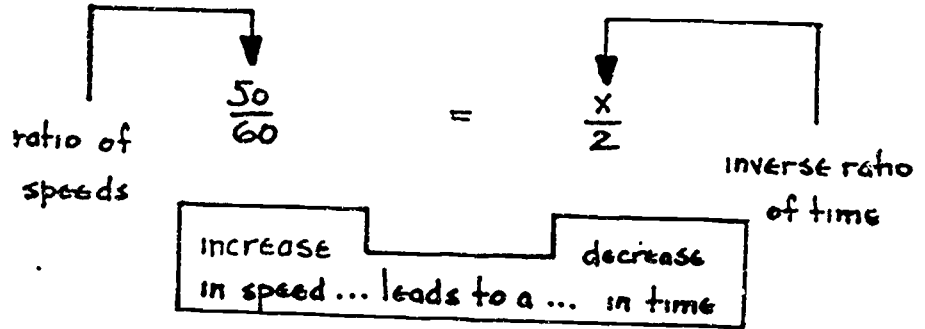

Before you try to solve the problem, make an estimate of the answer. The time to make the trip at 60 MPH will surely be less than the time it would take to make the same trip at 50 MPH. The correct answer should be less than 2 hours.

$$60x = 100 \quad x = 1.67 \text{ hours}$$

Remember, in a direct proportion,

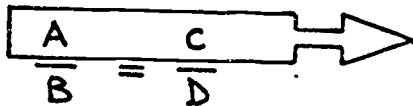

these two terms go together—
an increase in A goes with
an increase in C

In an inverse proportion,

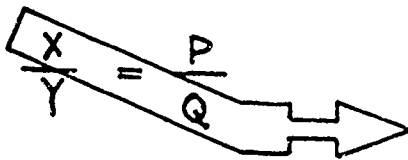

these two terms go together—
an increase in X goes with
a decrease in Q

Follow through this example: Pressure is inversely proportional to volume if the temperature remains the same. If the volume of gas in a cylinder is 300 cu cm when the pressure is 20 psi (pounds per square inch), what is the volume when the pressure is increased to 80 psi?

$$\frac{P_1}{P_2} = \frac{V_2}{V_1}$$

$$\frac{20 \text{ psi}}{80 \text{ psi}} = \frac{V_2}{300 \text{ cu cm}}$$

$$80V_2 = 6000$$

$$V_2 = 75 \text{ cu cm}$$

Since pressure is inversely proportional to volume, you can expect that as the pressure increases, the volume decreases. Therefore, the answer should be less than 300 cu cm.

GEARS AND PULLEYS

A particularly useful kind of inverse proportion deals with the size of a gear or pulley and the speed with which it rotates. In the sketch shown below, the larger gear drives the smaller gear.

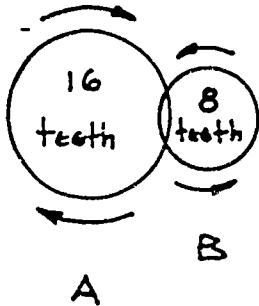

Because A has twice as many teeth as B, when A turns one turn, B will make two turns. If gear A turns at 10 turns per second, B will turn 20 turns per second. The speed of the gear is inversely proportional to the number of teeth.

$$\frac{\text{speed of gear A}}{\text{speed of gear B}} = \frac{\text{number of teeth on gear B}}{\text{number of teeth on gear A}}$$

this ratio has the A term on top
this ratio has the B term on top

In this proportion, gear speed is measured in revolutions per minute which is abbreviated RPM.

In the example of gear A and gear B above, if gear A turns at 40 RPM what will be the speed of gear B?

Because the relation is an *inverse* proportion, you know that B will turn faster than A.

$$\frac{40 \text{ RPM}}{B} = \frac{8 \text{ teeth}}{16 \text{ teeth}}$$

$$8B = 320$$

$$B = 80 \text{ RPM}$$

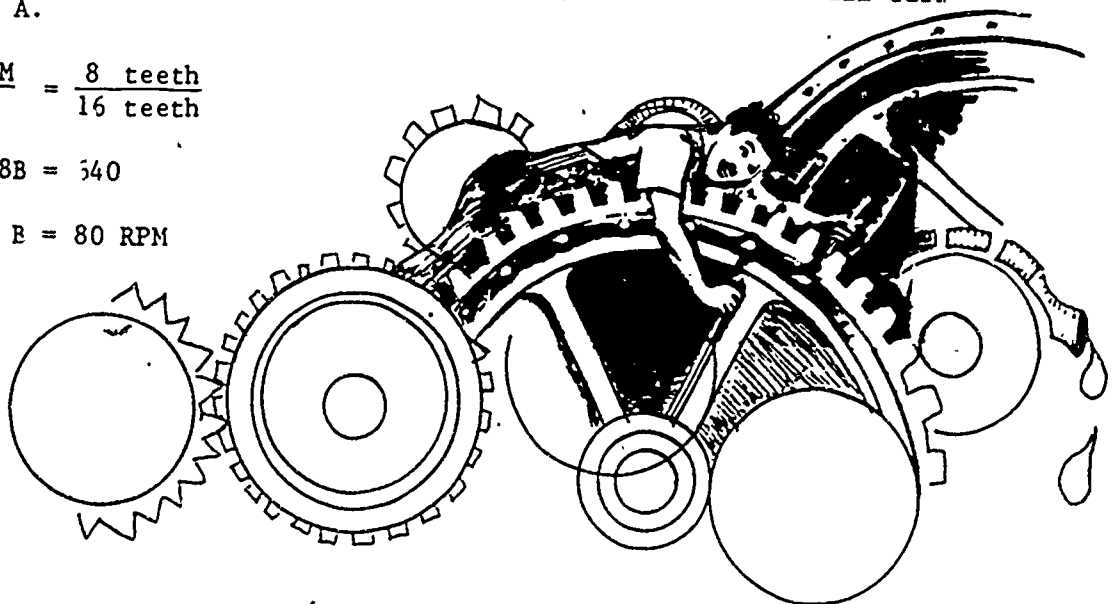

Pulleys transfer power in much the same way as gears. For the pulley system the speed of the pulley is inversely proportional to its diameter.

In the sketch to the right, pulley A has a diameter twice that of pulley B. When pulley A makes one turn, pulley B will make two turns, assuming of course, that there is no belt slippage.

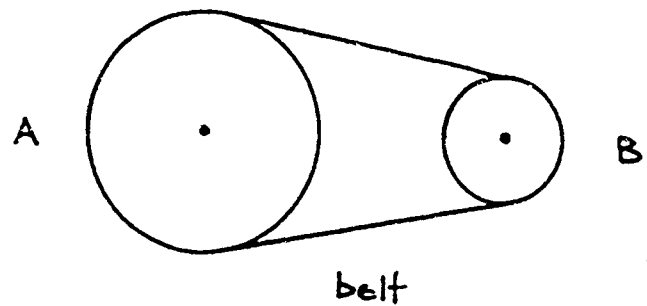

$$\frac{\text{speed of Pulley A}}{\text{speed of Pulley B}} = \frac{\text{Diameter of Pulley B}}{\text{Diameter of Pulley A}}$$

this ratio has
the A term on top

this ratio has
the B term on top

If pulley B is 16 inches in diameter and is rotating at 240 RPM, what is the speed of pulley A if its diameter is 20 inches?

$$\frac{A}{240 \text{ RPM}} = \frac{16}{20}$$

$$20A = 3840$$

$$A = 192 \text{ RPM}$$

EXAMPLE PROBLEMS: Solve each of the following problems by setting up an inverse proportion.

1. A 9-inch pulley on a drill press rotates at 1260 RPM. It is belted to a 5-inch pulley on an electric motor. Find the speed of the motor shaft.

$$\frac{\text{Speed of electric motor shaft}}{\text{Speed of drill press pulley}} = \frac{\text{diameter of drill press pulley}}{\text{diameter of electric motor pulley}}$$

$$\frac{x}{1260} = \frac{9}{5}$$

$$5x = 11340$$

$$x = 2268 \text{ RPM}$$

2. A 12-tooth gear mounted on a motor shaft drives a bigger gear. The motor shaft rotates at 1450 RPM. If the speed of the large gear is to be 425 RPM, how many teeth must the large gear have?

$$\frac{\text{teeth on large gear}}{\text{teeth on small gear}} = \frac{\text{speed of small gear}}{\text{speed of large gear}}$$

$$\frac{T}{12} = \frac{1450}{425}$$

$$425T = 17400$$

$$T = 40.94$$

$$T = 41 \text{ teeth (rounded)}$$

3. If five assembly machines can complete a job in three hours, how many hours will it take for two assembly machines to complete the job?

$$\frac{5}{2} = \frac{x}{3}$$

$$2x = 15$$

$$x = 7.5 \text{ hours}$$

4. The forces and lever arm distances for a lever are inversely proportional. Look at the sketch below.

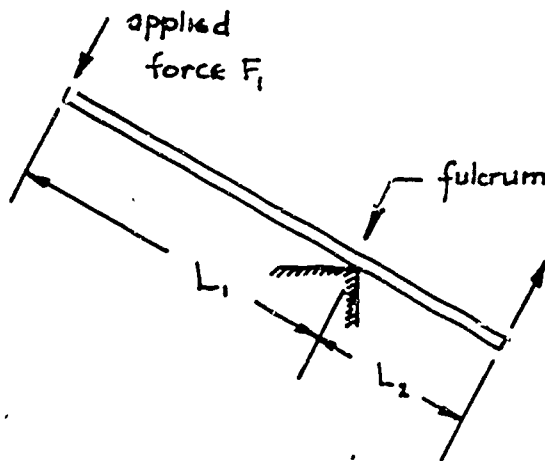

If a 100 lb. force is applied to a 22" crowbar pivoted 2" from the end, what lift force is exerted?

$$\frac{100}{x} = \frac{2}{20}$$

$$2x = 2000$$

$$x = 1000 \text{ lbs.}$$

$$\frac{\text{applied force } F_1}{\text{lift force } F_2} = \frac{\text{length of lift force arm } L_2}{\text{length of applied force arm } L_1}$$

REMEMBER:

$$\frac{X_1}{X_2} = \frac{Y_1}{Y_2}$$

in a direct proportion, these are the related terms

$$\frac{X_1}{X_2} = \frac{Y_2}{Y_1}$$

in an inverse proportion these are the related terms

Complete the Shop Problems beginning on the next page.

SHOP PROBLEMS

1. Your boss wants you to set up a drill press to do a certain job. The output of your motor is 1200 RPM and the diameter of the pulley on the motor shaft is 8 inches. You know that in order to drill your material properly you need a drill RPM of 800. What diameter drill pulley do you need. (Hint: Recall that this relationship is an inverse proportion.)

Diameter of drill pulley _____

2. At your job, you are using a grinder that is receiving power from a line shaft which is rotating at 250 RPM. The line shaft is connected to a 5-inch diameter pulley on the grinding wheel. If you need the grinder to turn at 1200 RPM, what size pulley wheel should be on the line shaft? Look at Figure 5 below.

Diameter of line shaft pulley _____

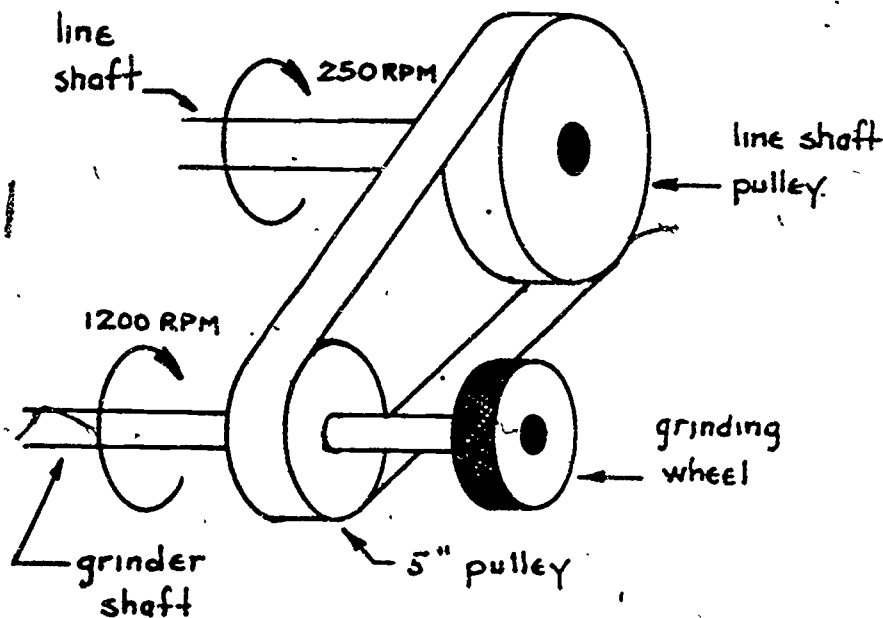

Figure 5: Find the diameter of the line shaft pulley.

3. On a layout, your supervisor wants you to find the length of an arc of a sector of a circle. Look at Figure 6. The formula is given by

$$L = \frac{2\pi Ra}{360}$$

Where $\pi = 3.14$

R = radius of the circle
and a = angle of the circle sector

Find the length of arc L .

$L =$ _____

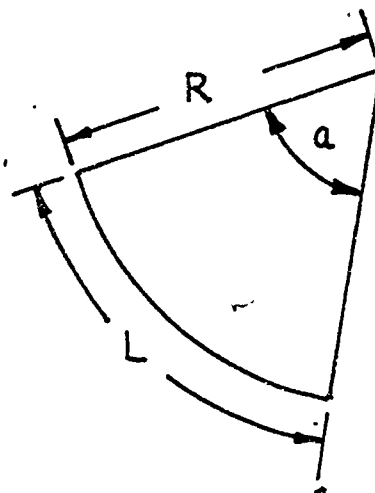

$$a = 42^\circ$$

$$R = 10.75''$$

find L , the length of arc

Figure 6: Find length of arc.

4. Machinists and sheet metal workers use a formula known as Pomeroy's formula to determine the approximate power required by a metal punch machine. This is the formula:

$$P \approx \frac{t^2 d N}{3.78}$$

Where P is the power needed in horsepower,
 t is the thickness of the metal being punched,
 d is the diameter of the hole being punched, and
 N is the number of holes punched at one time.

If the power available is 0.6 horsepower and the thickness of the sheet is 0.25 inches, how many 3-inch diameter holes can you punch at one time?

Number of holes N = _____

5. Your supervisor asked you to translate the following word statements into algebraic equations:

- a. The cutting time for a lathe operation is equal to the length of the cut divided by the product of the tool feed rate and the revolution rate per minute of the workpiece.

Equation _____

- b. The volume of a cone is equal to one-third times π times the height times the square of the radius of the base.

Equation _____

- c. The weight of a metal cylinder is approximately equal to 0.785 times the height of the cylinder times the density of the metal times the square of the diameter of the cylinder.

Equation _____

6. Solve the following formulas for the designated letter:

a. $V = \frac{\pi L T^2}{6} + 2$ for L $L =$ _____

b. $S = \frac{1}{2} g t^2$ for g $g =$ _____

c. $A = \frac{\pi R^2 S}{360}$ for S $S =$ _____

d. $E = MC^2$ for C $C =$ _____

7. On your job you get a paycheck of \$154.78 for 16 hours of work. What amount should you be paid for 36.5 hours at the same rate of pay?

Amount of pay for 36.5 hrs. _____

8. In your shop you are using a drive gear with 16 teeth and it is rotating at 1200 RPM. You need to have 720 RPM from the output gear (the gear being driven). How many teeth do you need on your output gear?

Number of teeth _____

9. Your supervisor wants you to find the taper of the gage shown in Figure 7. (Hint: Recall that the formula for taper is given as $t = \frac{12(D - d)}{L}$ where D is the large diameter, d is the small diameter, L is the length and t is the taper.

$t =$ _____

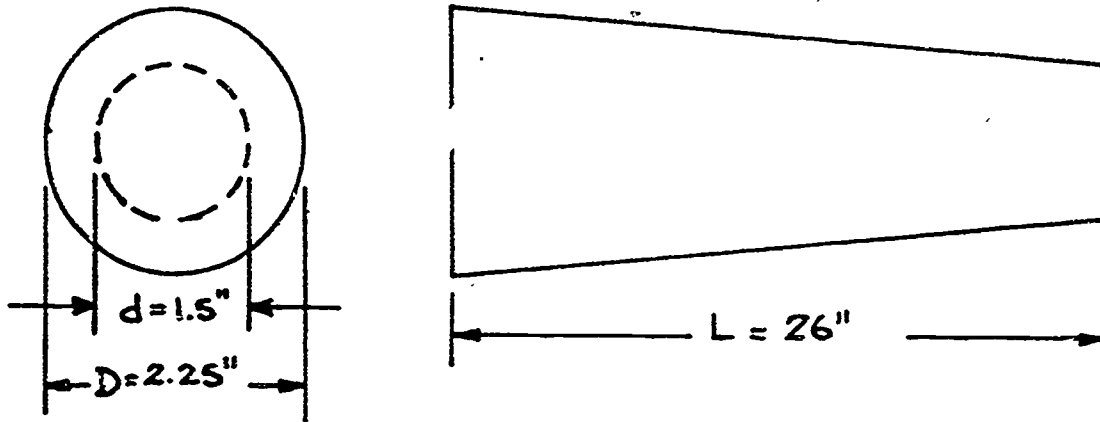
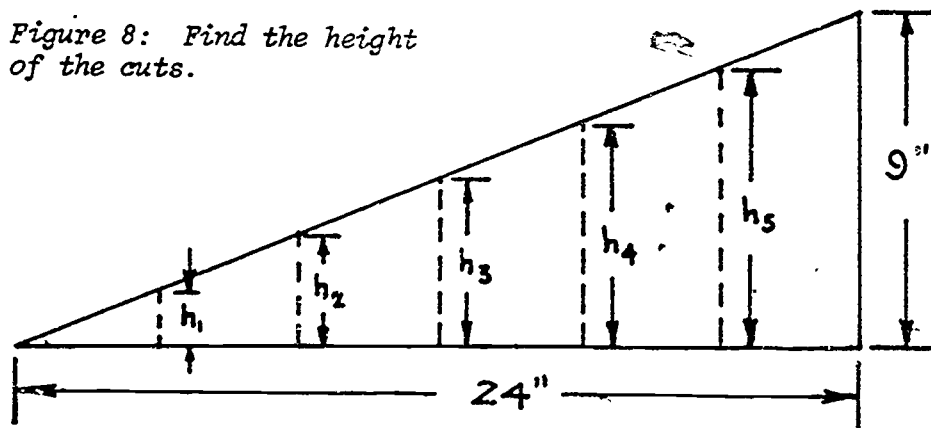

Figure 7: Find the taper t .

10. Look at Figure 8. You have cut a triangular plate into 6 equally wide sections. Find the height of each cut as indicated below.

Figure 8: Find the height of the cuts.



$h_1 =$ _____, $h_2 =$ _____, $h_3 =$ _____, $h_4 =$ _____, $h_5 =$ _____.

SHOW YOUR WORK TO YOUR INSTRUCTOR.

221

BAS



**SKILLS
CENTER**

(210)

PROJECT SHEET

Name _____ Date _____

Cluster Metal Trades Occupation Machinist Helper

Training Module Shop Math for Machinists

Training Milestone 3. Specialized Math Skills

PROJECT 3

SHOP ALGEBRA: PART 3

TRAINING CONDITIONS:

- Here's what you will need:
 1. This Project Sheet.
 2. A pen or pencil to answer the problems in this Project Sheet.

TRAINING PLAN:

- Here's what you do:

In this Project Sheet, you will finish your review of basic algebra. You will review the solutions of Systems of Equations and the solutions of Quadratic Equations. After completing this Project Sheet, you will know how to solve any shop problems that require the application of basic algebra.

1. Read and study pages 2 to 29 of this Project Sheet.
2. Work the Shop Problems' on pages 30 to 32.
3. Have your Instructor check your work and record your score on your Student Training Record.
4. Ask your Instructor for your next Project Sheet.

TRAINING GOAL:

- Here's how well you must do:
 1. You must score 8 out of 10 correct on the Shop Problems.

SHOP ALGEBRA: PART 3

SYSTEMS OF EQUATIONS

A *system of equations* is a set of equations with a common solution. For example, the pair of equations:

$$2x + y = 11$$

$$4y - x = 8$$

have the common solution $x = 4, y = 3$

This pair of numbers will make each equation a true statement. If you substitute 4 for x and 3 for y , the first equation becomes:

$$2(4) + 3 = 8 + 3 = 11 \text{ and the second equation} \\ \text{becomes } 4(3) - 4 = 12 - 4 = 8$$

Therefore, the single set of numbers $x = 4, y = 3$ satisfies both equations.

Another example: By substituting, show that the numbers $x = 2, y = -5$ give the solution to the pair of equations:

$$5x - y = 15$$

$$x + 2y = -8$$

The first equation is: $5(2) - (-5) = 10 + 5 = 15$ which is correct.
The second equation is: $(2) + 2(-5) = 2 - 10 = -8$ which is correct.

SOLUTION BY SUBSTITUTION

In this Project Sheet, you will learn two methods of solving a system of two *linear* equations with two variables. Remember that a linear equation has variables raised only to the first power. For example, $x + y = 12$ is a linear equation because the variables x and y are raised to the first power.

To solve the pair of equations: $y = 3 - x$

$3x + y = 11$ follow these steps:

Step 1: Solve the first equation for x or y and substitute this expression in the second equation.

The first equation is already solved for y , $y = 3 - x$.

Substituting this expression for y in the second equation,

$$3x + y = 11$$

$$3x + [3 - x] = 11$$

223

Substitute
this for Y

Step 2: Solve the resulting equation:

$$\begin{aligned} 3x + (3 - x) &= 11 \\ 3x + 3 - x &= 11 \\ 3x - x &= 11 - 3 \\ 2x &= 8 \\ x &= 4 \end{aligned}$$

Step 3: Substitute this value for x into the first equation and find a value for y .

$$\begin{aligned} y &= 3 - x \\ y &= 3 - 4 \\ y &= -1 \end{aligned}$$

Then the solution for the system of two unknowns and the two equations is $x = 4, y = -1$

Step 4: Check your solution by substituting the values of x and y back into the second equation.

$$\begin{aligned} 3x + y &= 11 \text{ becomes} \\ 3(4) + (-1) &= 11 \\ 12 - 1 &= 11 \text{ which is correct} \end{aligned}$$

EXAMPLE PROBLEMS: Solve the following system of 2 equations and 2 variables by substitution.

$$\begin{aligned} 1. \quad x - 2y &= 3 \\ x - 3y &= 7 \end{aligned}$$

Step 1: Solve the first equation for x .

$$\begin{aligned} x - 2y &= 3 \\ x &= 3 + 2y \end{aligned} \quad \leftarrow \text{transpose the term } 2y$$

Substitute this expression for x in the second expression.

$$2[(3+2y)] - 3y = 7$$

Substitute
this for x

Step 2: Solve

$$\begin{aligned} 2(3 + 2y) - 3y &= 7 \\ 6 + 4y - 3y &= 7 \\ 4y - 3y &= 7 - 6 \\ y &= 1 \end{aligned}$$

Step 3: Substitute this value of y in the first equation to find x .

$$\begin{aligned} x - 2y &= 3 \\ x - 2(1) &= 3 \\ x - 2 &= 3 \\ x &= 5 \text{ and } y = 1, \text{ or } (5, 1); \end{aligned}$$

Note that the x value is written first.

Step 4: Check the solution by substituting x and y values in the second equation.

$$\begin{aligned} 2x - 3y &= 7 \\ 2(5) - 3(1) &= 7 \\ 10 - 3 &= 7 \quad \text{correct} \end{aligned}$$

It does not matter which variable, x or y , you solve for in Step 1, or which equation you use in Step 3. The idea is to pick the equation for Step 1 that is easiest to solve for either x or y . Do the same thing for Step 3. Look at problem 2 below.

$$\begin{aligned} 2. \quad 2x + 3y &= 22 \\ x - y &= 1 \end{aligned}$$

Step 1: Solve the second equation for x .

$$x = 1 - y$$

Then substitute into the first equation.

$$2(1 - y) + 3y = 22$$

Step 2: Solve

$$\begin{aligned} 2 - 2y + 3y &= 22 \\ 5y &= 22 - 2 \\ 5y &= 20 \\ y &= 4 \end{aligned}$$

Step 3: Substitute the value for y in the second equation.

$$\begin{aligned} x - y &= 1 \\ x - 4 &= 1 \\ x &= 5 \text{ and } y = 4, \text{ or } (5, 4); \text{ remember the } x \text{ value is} \\ &\text{written first.} \end{aligned}$$

Step 4: Check the solution by substituting x and y values in the first equation.

$$\begin{aligned} 2(5) + 3(4) &= 22 \\ 10 + 12 &= 22 \quad \text{correct} \end{aligned}$$

$$\begin{aligned} 3. \quad 3x + y &= 1 \\ y - 5x &= 9 \end{aligned}$$

$$\begin{aligned} 3x + y &= 1 && \text{Solve the first equation for } y. \\ y &= 1 - 3x \\ (1 - 3x) - 5x &= 9 && \text{Substitute the value for } y \text{ in the second} \\ -8x &= 9 - 1 && \text{equation and solve for } x. \\ -8x &= 8 \\ x &= -1 \end{aligned}$$

$$\begin{aligned}
 y - 5(-1) &= 9 && \longleftarrow \text{Substitute the value for } x \text{ in the second} \\
 y + 5 &= 9 && \text{equation and solve for } y. \\
 y &= 9 - 5 \\
 y &= 4, x = -1, \text{ or } (-1, 4) \text{ is the solution.}
 \end{aligned}$$

$$\begin{aligned}
 3x + y &= 1 && \longleftarrow \text{Check: Substitute } x \text{ and } y \text{ values in the} \\
 3(-1) + 4 &= 1 && \text{first equation.} \\
 -3 + 4 &= 1 \\
 1 &= 1 \text{ correct}
 \end{aligned}$$

$$\begin{aligned}
 4. \quad y &= 4x \\
 2y - 6x &= 0
 \end{aligned}$$

$$\begin{aligned}
 y &= 4x && \longleftarrow \text{Solve the first equation for } y. \\
 2(4x) - 6x &= 0 && \longleftarrow \text{Substitute the value of } y \text{ in the second} \\
 8x - 6x &= 0 && \text{equation; solve for } x. \\
 2x &= 0 \\
 x &= 0
 \end{aligned}$$

$$\begin{aligned}
 y &= 4x && \longleftarrow \text{Substitute value for } x \text{ in the first} \\
 y &= 4(0) && \text{equation.} \\
 y &= 0, x = 0, \text{ or } (0, 0) \text{ is the solution.}
 \end{aligned}$$

$$\begin{aligned}
 2y - 6x &= 0 && \longleftarrow \text{Check: Substitute } x \text{ and } y \text{ values in the} \\
 2(0) - 6(0) &= 0 && \text{second equation.} \\
 0 &= 0 \text{ correct}
 \end{aligned}$$

A system of equations with a single solution--one pair of numbers, such as the four you have just worked through, are called *consistent* systems. However, it is possible for a system of equations to have no solution at all, or to have many solutions:

For example, the system of equations

$$\begin{aligned}
 y + 3x &= 5 \\
 2y + 6x &= 10
 \end{aligned}$$

has no solution. If you solve for y in the first equation,

$$y = 5 - 3x$$

and substitute this expression into the second equation,

$$\begin{aligned}
 2y + 6x &= 10, \text{ or } 2(5 - 3x) + 6x = 10 \\
 10 - 6x + 6x &= 10 \\
 10 &= 10
 \end{aligned}$$

But this does not solve for either x or y . There is no one set of numbers that will give you a solution. When this happens, the number-pair solution is said to be *dependent*, which really means the equations are the same equation. In the above example, note that the second equation $2y + 6x = 10$ is exactly twice the first equation $y + 3x = 5$. There is an infinite number of pairs of numbers that will satisfy the two equations.

For example: $x = 0, y = 5$; $x = 1, y = 2$; $x = 2, y = 1$; and so on...

Example of a dependent system:

$$\begin{aligned} 3x - y &= 5 \\ 6x - 10 &= 2y \end{aligned}$$

$$y = 3x - 5 \quad \longleftarrow \text{Solve for } y \text{ in the first equation.}$$

$$6x - 10 = 2(3x - 5) \quad \longleftarrow \text{Substitute in the second equation and solve for } x.$$

$$6x - 10 = 6x - 10$$

$$0 = 0$$

\longleftarrow Although this is true, the variables have dropped out and you cannot get a unique solution. This system is *dependent*.

If a system of equations is such that your attempts to solve them produces a false statement, the equations are said to be *inconsistent*. For example, the pair of equations

$$\begin{aligned} y - 1 &= 2x \\ 2y - 4x &= 7 \end{aligned} \text{ is inconsistent.}$$

If you solve the first equation for y

$$y = 2x + 1$$

And substitute this value for y into the second equation

$$2(2x + 1) - 4x = 7$$

$$4x + 2 - 4x = 7$$

$$\text{or } 2 = 7 \text{ which is false.}$$

All the variables have dropped out of the equation and you are left with an incorrect statement. The original pair of equations is said to be inconsistent and the system has no solution.

Example of an inconsistent system:

$$\begin{aligned} 2x - y &= 5 \\ 2y - 4x &= 3 \end{aligned}$$

$$2x - y = 5 \quad \longleftarrow \text{Solve for } y \text{ in the first equation}$$

$$-y = 5 - 2x$$

$$y = 2x - 5$$

$$2(2x - 5) - 4x = 3 \quad \longleftarrow \text{Substitute in the second equation and solve for } x.$$

$$4x - 10 - 4x = 3$$

$$-10 = 3 \quad \longleftarrow \text{Inconsistent since the variables disappeared and you are left with an incorrect statement.}$$

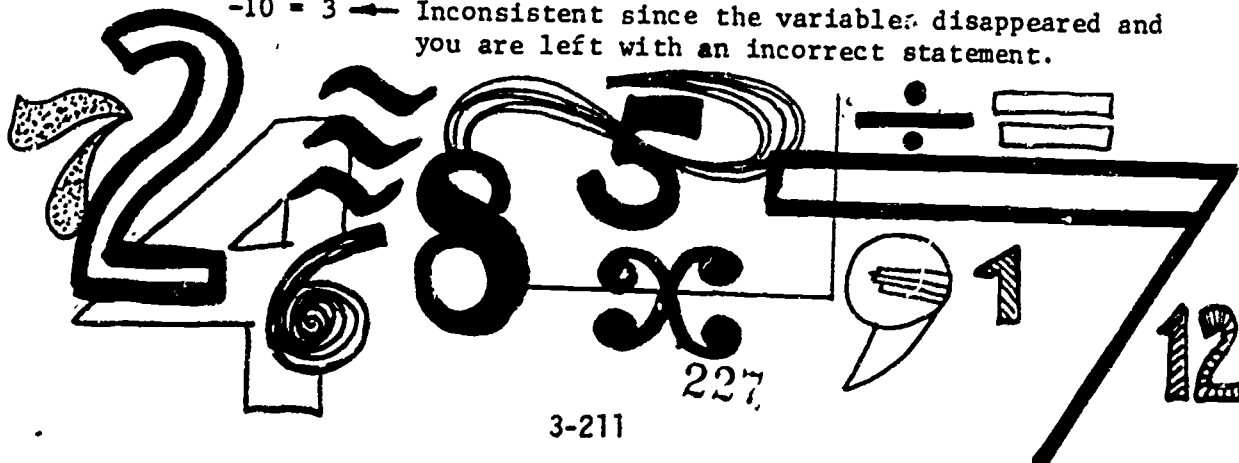

SOLUTION BY ELIMINATION

The second method for solving a system of equations is called the *method of elimination*. When it is difficult or messy to solve one of the equations for either x or y , the method of elimination may be the simplest way to solve the system of equations. For example, in the system of equations:

$$\begin{aligned} 2x + 3y &= 7 \\ 4x - 3y &= 5 \end{aligned}$$

neither equation can be solved for x or y without introducing fractions that are difficult to work with. But you can simply add the two equations together and the y terms will be eliminated.

$$\begin{array}{r} 2x + 3y = 7 \\ 4x - 3y = 5 \quad \leftarrow \text{Add like terms} \\ \hline 6x + 0 = 12 \\ 6x = 12 \\ x = 2 \end{array}$$

Now substitute this value of x back into either one of the original equations and solve for y . The first equation becomes:

$$\begin{aligned} 2x + 3y &= 7 \\ 2(2) + 3y &= 7 \\ 4 + 3y &= 7 \\ 3y &= 7 - 4 \\ 3y &= 3 \\ y &= 1, \quad x = 2 \text{ or } (2, 1) \text{ is the solution.} \end{aligned}$$

Check the solution by substituting the values for x and y back into the second equation.

$$\begin{aligned} 4x - 3y &= 5 \\ 4(2) - 3(1) &= 5 \\ 8 - 3 &= 5 \quad \text{correct} \end{aligned}$$

Another example:

$$\begin{array}{r} 2x - y = 3 \\ y + x = 9 \quad \leftarrow \text{Add like terms} \\ 2x + y - y + x = 12 \\ 2x + 0 + x = 12 \quad \leftarrow \text{Combine terms} \\ \hline 3x = 12 \\ x = 4 \end{array}$$

Substitute the value for x into the second equation

$$\begin{aligned} y + x &= 9 \\ y + 4 &= 9 \\ y &= 9 - 4 \\ y &= 5, \quad x = 4 \text{ or } (4, 5) \text{ is the solution} \end{aligned}$$

Check by substituting the values for x and y back into the first equation.

$$\begin{aligned} 2x - y &= 3 \\ 2(4) - 5 &= 3 \\ 8 - 5 &= 3 \quad \text{correct} \end{aligned}$$

When adding the two equations you may find it easier to rewrite the equations as you need to, to line up the variables and the constant terms into the same columns. Look at Figure 1.

$$\begin{aligned} 5 + x &= 3y \\ -x + y &= 10 \end{aligned}$$

Rewrite the first equation as
 $x - 3y = -5$

$$\begin{array}{r} \boxed{x} - \boxed{3y} = \boxed{-5} \\ \boxed{-x} + \boxed{y} = \boxed{10} \end{array}$$

↑
↑
↑

x column
y column
constant terms

Figure 1: Lining up variables and constants.

EXAMPLE PROBLEMS: Solve the following systems of two equations by using elimination.

1.

$$\begin{array}{r} x + 5y = 17 \\ -x + 3y = 7 \\ \hline 0 + 8y = 24 \quad \leftarrow \text{Add like terms} \\ 8y = 24 \\ y = 3 \end{array}$$

Substitute the value of y in the first equation.

$$\begin{aligned} x + 5(3) &= 17 \\ x + 15 &= 17 \\ x &= 17 - 15 \\ x &= 2, y = 3 \text{ or } (2, 3) \end{aligned}$$

Check by substituting the values for x and y back into the second equation:

$$\begin{aligned} -x + 3y &= 7 \\ (-2) + 3(3) &= 7 \\ -2 + 9 &= 7 \quad \text{correct} \end{aligned}$$

$$2. \quad \begin{aligned} 3x - 4y &= 30 \\ 4y + 3x &= -6 \end{aligned}$$

Rearrange the order of the terms in the second equation.

$$\begin{aligned} 3x - 4y &= 30 \\ 3x + 4y &= -6 \\ \hline 6x + 0 &= 24 \quad \leftarrow \text{Add like terms.} \\ 6x &= 24 \\ x &= 4 \end{aligned}$$

Substitute the value of x in the first equation.

$$\begin{aligned} 3(4) - 4y &= 30 \\ 12 - 4y &= 30 \\ -4y &= 30 - 12 \\ -4y &= 18 \\ y &= \frac{-18}{4} = -4\frac{1}{2}, \quad x = 4 \text{ or } (4, -4\frac{1}{2}) \end{aligned}$$

Check by substituting the values for x and y back into the second equation.

$$\begin{aligned} 3x + 4y &= -6 \\ 3(4) + 4(-4\frac{1}{2}) &= -6 \\ 12 - 18 &= -6 \quad \text{correct} \end{aligned}$$

$$3. \quad \begin{aligned} 6x - y &= 5 \\ y - x &= -5 \end{aligned}$$

Rearrange the order of the terms in the second equation:

$$\begin{aligned} 6x - y &= 5 \\ -x + y &= -5 \\ \hline 5x &= 0 \quad \leftarrow \text{Add like terms} \\ x &= 0 \end{aligned}$$

Substitute the value for x in the first equation:

$$\begin{aligned} 6x - y &= 5 \\ 6(0) - y &= 5 \\ -y &= 5 \\ y &= -5, \quad x = 0 \text{ or } (0, -5) \end{aligned}$$

Check by substituting the values for x and y back into the second equation.

$$\begin{aligned} y - x &= -5 \\ -5 - (0) &= -5 \\ -5 &= -5 \quad \text{correct} \end{aligned}$$

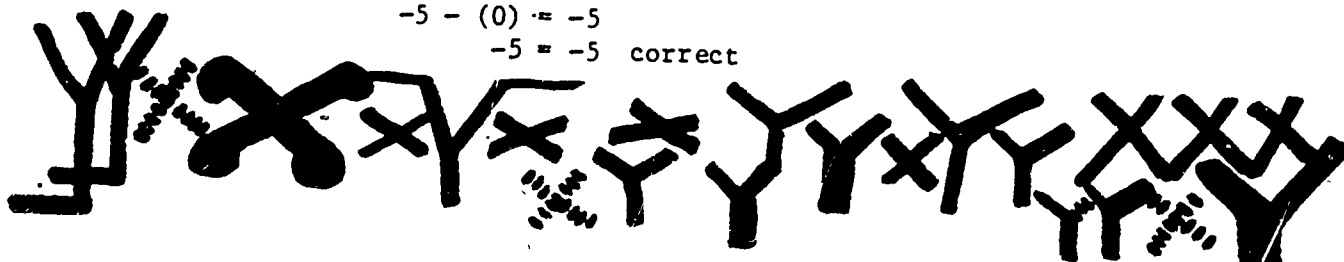

4.

$$\begin{aligned}\frac{1}{2}x + 2y &= 10 \\ y + 1 &= \frac{1}{2}x\end{aligned}$$

Rearrange the second equation:

$$\frac{1}{2}x + 2y = 10$$

$$\frac{1}{2}x + y = -1$$

$$\begin{array}{r} 3y = 9 \\ y = 3 \end{array} \quad \leftarrow \text{Add like terms}$$

Substitute the value for y in the first equation:

$$\frac{1}{2}x + 2y = 10$$

$$\frac{1}{2}x + 6 = 10$$

$$\frac{1}{2}x = 4$$

$$x = 8, y = 3, \text{ or } (8,3)$$

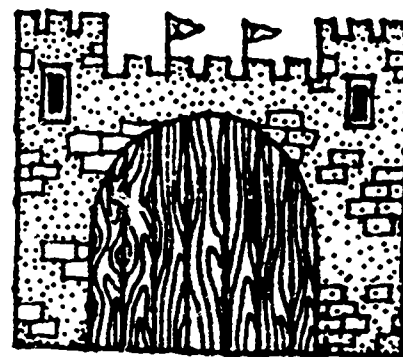
Check by substituting the values of x and y back into the second equation.

$$y + 1 = \frac{1}{2}x$$

$$3 + 1 = \frac{1}{2}(8)$$

$$4 = 4 \text{ correct}$$

In some systems of equations neither x nor y can be eliminated by simply adding like terms. For example in the system

$$\begin{aligned}3x + y &= 17 \\ x + y &= 7\end{aligned}$$

adding like terms will not eliminate either variable. To solve this system of equations, you can *subtract* like terms as follows:

$$\begin{array}{r} 3x + y = 17 \\ x + y = 7 \\ \hline 3x - x + y - y = 17 - 7 \\ 2x + 0 = 10 \\ x = 5 \end{array}$$

Then, as before, substitute the value for x in the second equation:

$$x + y = 7$$

$$5 + y = 7$$

$$y = 2, x = 5, \text{ or } (5,2)$$

Check by substituting the values for x and y back into the first equation:

$$3x + y = 17$$

$$3(5) + (2) = 17$$

$$15 + 2 = 17 \text{ correct}$$

231

EXAMPLE PROBLEMS: Solve the following systems of two equations by elimination.

$$\begin{array}{r}
 1. \quad 2x + 7y = 29 \\
 \quad \quad 2x + y = 11 \\
 \hline
 2x - 2x + 7y - y = 29 - 11 \leftarrow \text{Subtract like terms} \\
 \quad \quad 0 + 6y = 18 \\
 \quad \quad y = 3
 \end{array}$$

$$\begin{array}{r}
 2x + 3 = 11 \\
 2x = 11 - 3 \\
 2x = 8 \\
 x = 4, y = 3, \text{ or } (4,3)
 \end{array}$$

Check:

$$\begin{array}{r}
 2x + 7y = 29 \\
 2(4) + 7(3) = 29 \\
 8 + 21 = 29 \text{ correct}
 \end{array}$$

$$\begin{array}{r}
 2. \quad 2x + 3y = 21 \\
 \quad \quad 2x + y = 15 \\
 \hline
 (2x - 2x) + 3y - y = 21 - 15 \\
 \quad \quad 0 + 2y = 6 \\
 \quad \quad y = 3
 \end{array}$$

$$\begin{array}{r}
 2x + (3) = 15 \\
 2x = 12 \\
 x = 6, y = 3, \text{ or } (6,3)
 \end{array}$$

Check:

$$\begin{array}{r}
 2x + 3y = 21 \\
 2(6) + 3(3) = 21 \\
 12 + 9 = 21 \text{ correct}
 \end{array}$$

In some cases, you cannot eliminate either variable by adding or by subtracting equations. For example,

$$\begin{array}{r}
 2x + 4y = 26 \\
 3x - 2y = 7
 \end{array}$$

Note that the y term can be eliminated easily if the second equation is multiplied by 2.

The y column

$+4y$
$-2y$

becomes

$+4y$
$-4y$

 when you multiply the second equation by 2.

The second equation becomes: $-2(3x) - 2(2y) = 2(7)$ or $6x - 4y = 14$

and the system can then be rewritten as another equal system as follows:

$$\begin{array}{r}
 2x + 4y = 26 \\
 6x - 4y = 14 \\
 \hline
 8x + 0 = 40 \leftarrow \text{Add like terms} \\
 x = 5
 \end{array}$$

$$\begin{array}{r}
 2(5) + 4y = 26 \\
 4y = 16 \\
 y = 4, x = 5, \text{ or } (5,4)
 \end{array}$$

Check: $6(5) - 4(4) = 14$
 $30 - 16 = 14$ correct

EXAMPLE PROBLEMS: Solve the system of equations by multiplying one equation or the other by another number, then add the two equations, and then use the process of elimination.

1.
$$\begin{aligned} 5x + 6y &= 14 \\ 3x - 2y &= -14 \end{aligned}$$

$$3(3x) + 3(-2y) = 3(-14) \longleftarrow \text{Multiply the second equation by 3.}$$

$$9x - 6y = 42$$

$$\begin{array}{r} 5x + 6y = 14 \\ 9x - 6y = -42 \\ \hline 14x + 0 = -28 \\ x = -2 \end{array}$$

$$\begin{aligned} 5(-2) + 6y &= 14 \\ -10 + 6y &= 14 \\ 6y &= 14 + 10 \\ 6y &= 24 \\ y &= 4, x = -2, \text{ or } (-2, 4) \end{aligned}$$

Check:

$$\begin{aligned} 3x - 2y &= -14 \\ 3(-2) - 2(4) &= -14 \\ -6 - 8 &= -14 \quad \text{correct} \end{aligned}$$

2.
$$\begin{aligned} 5x - y &= 1 \\ 2y + 3x &= 11 \end{aligned}$$

$$2(5x) + 2(-y) = 2(1) \longleftarrow \text{Multiply the first equation by 2.}$$

$$10x - 2y = 2$$

$$\begin{array}{r} 10x - 2y = 2 \\ 3x + 2y = 11 \\ \hline 13x + 0 = 13 \\ x = 1 \end{array}$$

$$\begin{aligned} 5x - y &= 1 \\ 5(1) - y &= 1 \\ 5 - y &= 1 \\ -y &= 1 - 5 \\ y &= 4, x = 1, \text{ or } (1, 4) \end{aligned}$$

Check:

$$\begin{aligned} 2y + 3x &= 11 \\ 2(4) + 3(1) &= 11 \\ 8 + 3 &= 11 \quad \text{correct} \end{aligned}$$



$$3. \quad \begin{aligned} -x - 2y &= 1 \\ -2x + 3y &= -19 \end{aligned}$$

$$\begin{aligned} -2(-x) - 2(-2y) &= -2(1) \quad \longleftarrow \text{Multiply the first equation by } -2. \\ 2x + 4y &= -2 \end{aligned}$$

$$\begin{aligned} 2x + 4y &= -2 \\ -2x + 3y &= -19 \\ \hline 7y &= -21 \\ y &= -3 \end{aligned}$$

$$\begin{aligned} -x - 2(-3) &= 1 \\ -x + 6 &= 1 \\ -x &= -5 \\ x &= 5, y = -3, \text{ or } (5, -3) \end{aligned}$$

$$\begin{aligned} \text{Check: } -2(5) + 3(-3) &= -19 \\ -10 - 9 &= -19 \quad \text{correct} \end{aligned}$$

Look at this system of equations:

$$\begin{aligned} 3x + 2y &= 7 \\ 4x - 3y &= -2 \end{aligned}$$

You can see that there is no single number you can use as a multiplier to eliminate one of the variables when the equations are added. Instead, you must convert each equation so that when the two new equations are added, one of the variables is eliminated. For example, to eliminate the y variable in the system of equations above, you must multiply the first equation by 3 and the second equation by 2.

$$\begin{array}{l} \text{First equation: } \boxed{3x + 2y = 7} \quad \xrightarrow{\text{multiply by 3}} \quad \boxed{9x + 6y = 21} \\ \text{Second equation: } \boxed{4x - 3y = -2} \quad \xrightarrow{\text{multiply by 2}} \quad \boxed{8x - 6y = -4} \end{array}$$

The new system of equations becomes:

$$\begin{aligned} 9x + 6y &= 21 \\ 8x - 6y &= -4 \\ \hline 17x + 0 &= 17 \quad \longleftarrow \text{Proceed as before} \\ x &= 1 \end{aligned}$$

$$\begin{aligned} 9(1) + 6y &= 21 \\ 6y &= 21 - 9 \\ 6y &= 12 \\ y &= 2, x = 1, \text{ or } (1, 2) \end{aligned}$$

$$\begin{aligned} \text{Check: } 8x - 6y &= -4 \\ 8(1) - 6(2) &= -4 \\ 8 - 12 &= -4 \quad \text{correct} \end{aligned}$$

Now try this system of equations: $2x - 5y = 9$
 $3x + 4y = 2$

First equation: $2x - 5y = 9$ multiply by -3 \rightarrow $-6x + 15y = -27$

Second equation: $3x + 4y = 2$ multiply by 2 \rightarrow $6x + 8y = 4$

$$\begin{array}{r} -6x + 15y = -27 \\ 6x + 8y = 4 \\ \hline 23y = -23 \\ y = -1 \end{array} \quad \leftarrow \text{Proceed as before.}$$

$$\begin{array}{r} 6x + 8(-1) = 4 \\ 6x - 8 = 4 \\ 6x = 12 \\ x = 2, y = -1, \text{ or } (2, -1) \end{array}$$

Check: $-6x + 15y = -27$
 $-6(2) + 15(-1) = -27$
 $-12 - 15 = -27$ correct

EXAMPLE PROBLEMS: Solve the systems of equations by multiplying one equation by one number, the other equation by another number. Add the two equations. Then use the process of elimination.

1. $2x + 2y = 4$
 $5x + 7y = 18$

First equation: $2x + 2y = 4$, multiply by 5 \rightarrow $10x + 10y = 20$
 Second equation: $5x + 7y = 18$, multiply by -2 \rightarrow $-10x - 14y = -36$

$$\begin{array}{r} 10x + 10y = 20 \\ -10x - 14y = -36 \\ \hline -4y = -16 \\ y = 4 \end{array} \quad \leftarrow \text{Proceed as before.}$$

$$\begin{array}{r} 2x + 2y = 4 \\ 2x + 2(4) = 4 \\ 2x = 4 - 8 \\ 2x = -4 \\ x = -2, y = 4, \text{ or } (-2, 4) \end{array}$$

Check: $5x + 7y = 18$
 $5(-2) + 7(4) = 18$
 $-10 + 28 = 18$ correct

$$2. \quad \begin{aligned} 3x + 2y &= 10 \\ 2x &= 5y - 25 \end{aligned}$$

First equation: $3x + 2y = 10$, multiply by 2 $\longrightarrow 6x + 4y = 20$
 Second equation: $2x = 5y - 25$, multiply by $-3 \longrightarrow -6x = -15y + 75$

Rewrite the second equation as $-6x + 15y = 75$, then

$$\begin{array}{r} 6x + 4y = 20 \\ -6x + 15y = 75 \\ \hline 19y = 95 \\ y = 5 \end{array} \longleftarrow \text{Proceed as before}$$

$$\begin{aligned} 6x + 4(5) &= 20 \\ 6x &= 20 - 20 \\ x &= 0, y = 5, \text{ or } (0, 5) \end{aligned}$$

Check: $-6x + 15y = 75$
 $-6(0) + 15(5) = 75$
 $75 = 75$ correct

$$3. \quad \begin{aligned} -7x - 13 &= 2y \\ 3y + 4x &= 0 \end{aligned}$$

Rewrite both equations as: $-7x - 2y = 13$
 $4x + 3y = 0$

First equation: $-7x - 2y = 13$, multiply by 3 $\longrightarrow -21x - 6y = 39$
 Second equation: $4x + 3y = 0$, multiply by 2 $\longrightarrow 8x + 6y = 0$

$$\begin{array}{r} -21x - 6y = 39 \\ 8x + 6y = 0 \\ \hline -13x = 39 \\ x = -3 \end{array} \longleftarrow \text{Proceed as before}$$

$$\begin{aligned} 8(-3) + 6y &= 0 \\ 6y &= 24 \\ y &= 4, x = -3, \text{ or } (-3, 4) \end{aligned}$$

Check: $-21x - 6y = 39$
 $-21(-3) - 6(4) = 39$
 $63 - 24 = 39$ correct

SOLVING SHOP PROBLEMS

In practical shop problems, you must solve a system of equations; you must also learn to write the equations. You may need to review the material in Project 2, entitled "Algebra 2" covering signal words and how to translate English sentences into mathematical equations and expressions.

Here's an example: The sum of two numbers is 26 and their difference is 2.
(Let x and y stand for the two numbers.)

The sum of two numbers, is 26

$$\begin{array}{ccc} \downarrow & & \downarrow \downarrow \\ x+y & = & 26 \end{array}$$

... their difference, is 2

$$\begin{array}{ccc} \downarrow & & \downarrow \downarrow \\ x-y & = & 2 \end{array}$$

The two equations are: $x + y = 26$
 $x - y = 2$

Solving as before by elimination you get:

$$\begin{array}{r} x + y = 26 \\ x - y = 2 \\ \hline 2x = 28 \\ x = 14 \end{array}$$

$$\begin{array}{r} x + y = 26 \\ 14 + y = 26 \\ y = 26 - 14 \\ y = 12, x = 14, \text{ or } (14, 12) \end{array}$$

Check:

$$\begin{array}{r} x - y = 2 \\ 14 - 12 = 2 \text{ correct} \end{array}$$

Another example: The difference of two numbers is 14 and the larger number is three more than twice the smaller number. Let L = the larger number and S = the smaller number.

The first should be translated as:

The difference of two numbers, is 14

$$\begin{array}{ccc} \downarrow & & \downarrow \downarrow \\ L - S & = & 14 \end{array}$$

and the second phrase should be translated as:

... the larger number is three more than twice the smaller...

$$\begin{array}{ccccccc} \downarrow & & \downarrow & & \downarrow & & \downarrow \\ L & = & 3 & + & 2S & & \end{array}$$

The second equation would be:

$$\dots \text{the number of bolts} \text{ is four more than twice the number of nuts } \dots$$

$$\downarrow \quad \downarrow \quad \downarrow \quad \downarrow \quad \downarrow$$

$$B = 4 + 2N$$

The system of two equations is:

$$5N + 10B = 140$$

$$B = 4 + 2N$$

Use substitution: Substitute the value of B in the second equation into the first equation.

$$5N + 10(4 + 2N) = 140$$

$$5N + 40 + 20N = 140$$

$$25N = 100$$

$$N = 4$$

$$B = 4 + 2N$$

$$B = 4 + 2(4)$$

$$B = 4 + 8$$

$$B = 12, N = 4$$

Check in the first equation:

$$5N + 10B = 140$$

$$5(4) + 10(12) = 140$$

$$20 + 120 = 140 \quad \text{correct}$$

2. The perimeter of a sheet of metal is 350 inches. The length of the sheet is 10 inches more than twice the width. Find the dimensions of the sheet. Let L = length and W = width. Recall that the perimeter is two times the length plus two times the width.

The first equation becomes:

$$\text{The perimeter of a sheet of metal is 350 inches}$$

$$\downarrow \quad \downarrow \quad \downarrow$$

$$2L + 2W = 350''$$

The second equation becomes:

$$\dots \text{the length of the sheet is 10 inches more than twice the width } \dots$$

$$\downarrow \quad \downarrow \quad \downarrow \quad \downarrow$$

$$L = 10'' + 2W$$

The system of two equations is:

$$\begin{aligned} 2L + 2W &= 350 \\ L &= 10 + 2W \end{aligned}$$

Substitute the value of L in the second equation into the first equation:

$$\begin{aligned} 2(10 + 2W) + 2W &= 350 \\ 20 + 4W + 2W &= 350 \\ 6W &= 330 \\ W &= 55 \end{aligned}$$

$$\begin{aligned} L &= 10 + 2W \\ L &= 10 + 2(55) \\ L &= 10 + 110 \\ L &= 120, W = 55 \end{aligned}$$

Check:

$$\begin{aligned} 2L + 2W &= 350 \\ 2(120) + 2(55) &= 350 \\ 240 + 110 &= 350 \text{ correct} \end{aligned}$$

3. A lab technician wishes to mix a 5% salt solution and a 15% salt solution to obtain 4 liters of a 12% salt solution. How many liters of each solution must be added. Draw a chart of your information first.

Solution	Amount (liters)	Salt fraction	total salt
5%	A	.05	.05A
15%	B	.15	.15B

The final solution is to contain 4 liters. Therefore, the first equation can be:

$$A + B = 4$$

The second equation can represent the total amount of salt.

$(.05)A + (.15)B = 4(.12)$, multiplying this equation by 100 to eliminate the fractions, the system of two equations becomes

$$\begin{aligned} A + B &= 4 \\ 5A + 15B &= 48 \end{aligned}$$

Multiply the first equation by -5.

$$\begin{aligned} A + B &= 4 \text{ multiplied by } -5 \longrightarrow = -5A - 5B = -20 \\ -5A - 5B &= -20 \\ \underline{5A + 15B} &= \underline{48} \\ 10B &= 28 \\ B &= 2.8 \end{aligned}$$

$$\begin{aligned}
 A + B &= 4 \\
 A + 2.8 &= 4 \\
 A &= 4 - 2.8 \\
 A &= 1.2, B = 2.8
 \end{aligned}$$

Check:

$$\begin{aligned}
 5A + 15B &= 48 \\
 5(1.2) + 15(2.8) &= 48 \\
 6 + 42 &= 48 \quad \text{correct}
 \end{aligned}$$

QUADRATIC EQUATIONS

So far in algebra you have only worked with linear equations. Remember, in a linear equation the variables x , y , A , B , ... appear only to the first power. For example, $3x - 2y = 6$ is a linear equation. The variables appear as x which is equal to x , or y which is equal to y . No powers of x or y appear as x^2 , x^3 , y^2 , y^3 , ... in the equations.

An equation in which a variable appears in the second power is called a *quadratic equation*.

The following are examples of quadratic equations:

1. $x^2 = 49$
2. $x + y^2 = 4 - y$
3. $5x^2 + 2x - 9 = 0$
4. $y^2 + x^2 = 28$
5. $y + 2x = y^2$

Every quadratic equation can be put into a *standard quadratic form*.

$$\begin{array}{c}
 ax^2 + bx + c = 0, \text{ where } a \text{ cannot equal } 0 \\
 \uparrow \quad \uparrow \quad \uparrow \\
 \boxed{x^2 \text{ term}} \quad \boxed{x \text{ term}} \quad \boxed{\text{constant term}}
 \end{array}$$

Every quadratic equation must have an x term, although the x term and the constant term may be missing. For example, $x^2 + 6 = 0$ is a quadratic equation in the standard form. The x term is missing but the other terms are in the right order and the equation could be written as:

$$x^2 + 0(x) + 6 = 0$$

The following quadratic equations are in the standard form:

1. $x^2 + 3x = 0$
2. $x^2 + 12 = 0$
3. $x^2 = 0$
4. $x^2 + 5x - 16 = 0$

The following quadratic equations are *not* in the standard form:

1. $3x + 6 = 5x^2$
2. $3x = 4x^2$
3. $16 = 5x - 2x^2$
4. $32 + x^2 = 16x$

To put any quadratic equation in the standard form, simply transpose all the terms on the right side of the equation to the left side. Then beginning on the left, write the x^2 term, the x term and then the constant.

EXAMPLES:

1. $16 = 4x^2 + 2x$ ← Transpose all terms to the left.
 $16 - 4x^2 - 2x = 0$ ← Arrange in the order of x^2 , x , and constant terms.
 $-4x^2 - 2x + 16 = 0$ ← Multiply by (-1) to make the coefficient of the squared term positive.
 $4x^2 + 2x - 16 = 0$ ← Standard form.
2. $x = 16 - 2x^2$ ← Transpose all terms to the left.
 $x - 16 + 2x^2 = 0$ ← Arrange in the order of x^2 , x , and constant terms.
 $2x^2 + x - 16 = 0$ ← Standard form.
3. $x^2 - 6x + 9 = 49$ ← Transpose all terms to the left.
 $x^2 - 6x + 9 - 49 = 0$ ← Arrange in the order of x^2 , x , and constant terms.
 $x^2 - 6x - 40 = 0$ ← Standard form.
4. $3x + 1 = x^2 - 5$ ← Transpose all terms to the left.
 $3x + 1 - x^2 + 5 = 0$ ← Arrange in the order of x^2 , x , and constant terms.
 $-x^2 + 3x + 6 = 0$ ← Multiply by (-1) .
 $x^2 - 3x - 6 = 0$ ← Standard form.

SOLVING QUADRATIC EQUATIONS

The solution to a linear equation is a single number. The solution to a quadratic equation is a *pair* of numbers. Each number satisfies the equation. Sometimes the two solutions may be the same number. In practical problems there are generally two different solutions. For instance, the quadratic equation $x^2 - 5x + 6 = 0$ has the solution $x = 3$ and $x = 2$. To check this, substitute the two values of x into the equation.

$$x = 3 \quad (3)^2 - 5(3) + 6 = 0$$

$$9 - 15 + 6 = 0 \quad \text{correct}$$

$$x = 2 \quad (2)^2 - 5(2) + 6 = 0$$

$$4 - 10 + 6 = 0 \quad \text{correct}$$

$$\begin{array}{l}
 3. \quad 9x^2 = 49 \\
 \quad \quad x = \frac{49}{9} \\
 \quad \quad \sqrt{x^2} = \sqrt{\frac{49}{9}} \\
 \quad \quad x = \frac{7}{3}, \quad = \frac{-7}{3}
 \end{array}$$

$$\begin{array}{l}
 \text{Check: } x = \frac{7}{3}, \quad 9\left(\frac{7}{3}\right)^2 = 49 \\
 \quad \quad \quad \quad \quad 9\left(\frac{49}{9}\right) = 49 \\
 \quad \quad \quad \quad \quad 49 = 49 \quad \text{correct} \\
 \\
 \quad \quad \quad \quad \quad x = \frac{-7}{3}, \quad 9\left(\frac{-7}{3}\right)^2 = 49 \\
 \quad \quad \quad \quad \quad 9\left(\frac{49}{9}\right) = 49 \\
 \quad \quad \quad \quad \quad 49 = 49 \quad \text{correct}
 \end{array}$$

$$\begin{array}{l}
 4. \quad 6 - x^2 = 0 \\
 \quad \quad -x^2 = -6 \\
 \quad \quad x^2 = 6 \\
 \quad \quad \sqrt{x^2} = \sqrt{6} \\
 \quad \quad x = \sqrt{6} \\
 \quad \quad x = 2.45, \quad x = -2.45 \text{ (rounded)}
 \end{array}$$

$$\begin{array}{l}
 \text{Check: } x = 2.45, \quad 6 - (2.45)^2 = 0 \\
 \quad \quad \quad \quad \quad 6 - (6) = 0 \quad \text{correct} \\
 \\
 \quad \quad \quad \quad \quad x = -2.45 \quad 6 - (-2.45)^2 = 0 \\
 \quad \quad \quad \quad \quad 6 - (6) = 0 \quad \text{correct}
 \end{array}$$

You should notice that an equation like $x^2 = -16$ has no solution. There is no real number x whose square is a negative number.

In general, a quadratic equation will have all three terms: an x^2 term, an x term, and a constant term. The solution of any quadratic equation in standard form:

$$ax^2 + bx + c = 0 \text{ is}$$

$$x = \frac{-b + \sqrt{b^2 - 4ac}}{2a}, \text{ or } x = \frac{-b - \sqrt{b^2 - 4ac}}{2a}$$

which is generally written as:

$$x = \frac{-b \pm \sqrt{b^2 - 4ac}}{2a} \quad \leftarrow \text{The Quadratic Formula}$$

For example, to solve the quadratic equation $2x^2 - 10x + 12 = 0$, follow these steps:

Step 1: Identify the coefficients a , b , and c for the quadratic equation:

$$\begin{array}{c}
 2x^2 - 10x + 12 = 0 \\
 \uparrow \quad \uparrow \quad \uparrow \\
 \boxed{a=2} \quad \boxed{b=-10} \quad \boxed{c=12}
 \end{array}$$

Step 2: Substitute these values a , b , and c into the quadratic formula:

$$x = \frac{-(-10) \pm \sqrt{(-10)(-10) - 4(2)(12)}}{2(2)}$$

Step 3: Simplify this equation for x :

$$x = \frac{10 \pm \sqrt{100 - 96}}{4}$$

$$x = \frac{10 \pm \sqrt{4}}{4}$$

$$x = \frac{10 + 2}{4} = \frac{12}{4} = 3, \text{ and}$$

$$x = \frac{10 - 2}{4} = \frac{8}{4} = 2$$

→ $x = 2$, and $x = 3$

Step 4: Check the solution numbers by substituting them into the original equation:

check: $2x^2 - 10x + 12 = 0$

$x = 3$, $2(3)^2 - 10(3) + 12 = 0$

$2(9) - 30 + 12 = 0$

$18 - 30 + 12 = 0$, correct

$x = 2$, $2(2)^2 - 10(2) + 12 = 0$

$2(4) - 20 + 12 = 0$

$8 - 20 + 12 = 0$, correct

EXAMPLE PROBLEMS: Solve the quadratic equations that begin on the next page. First write them in the standard form and then use the quadratic formula.

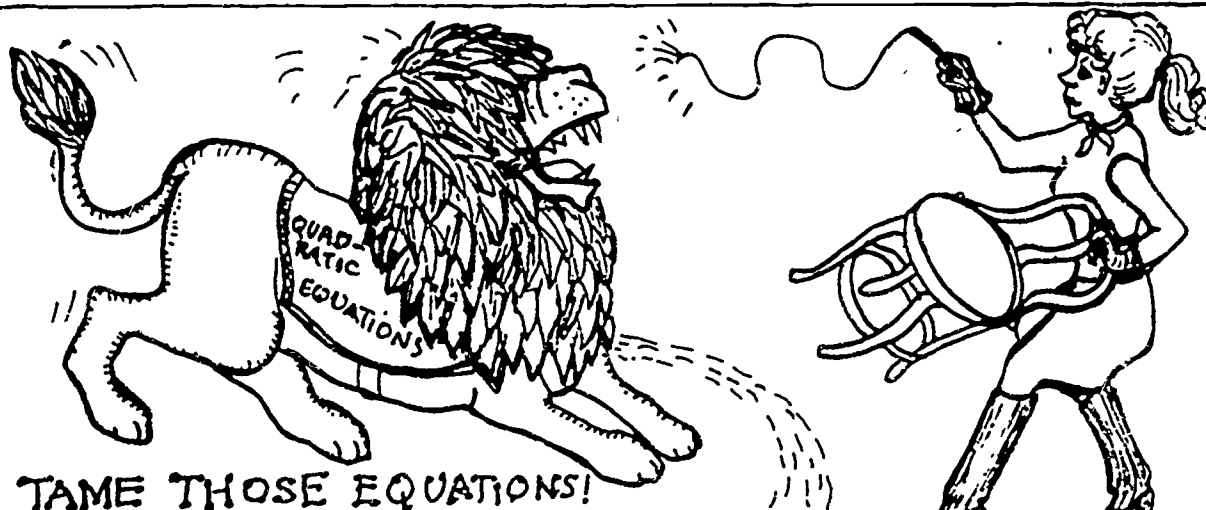

1. $14 = x^2 + 5x$

$x^2 + 5x - 14 = 0$ ← standard form

Step 1: $a=1, b=5, c=-14$

Step 2: $x = \frac{-5 \pm \sqrt{(5)^2 - 4(1)(-14)}}{2(1)}$

Step 3: (simplify)

$x = \frac{-5 \pm \sqrt{25+56}}{2}$

$x = \frac{-5 \pm \sqrt{81}}{2}$

$x = \frac{-5 \pm 9}{2}$

$x = \frac{-5+9}{2}, \quad x = \frac{-5-9}{2}$

$x = 2, \quad x = -7$

Step 4: (check)

$x^2 + 5x - 14 = 0$

$x=2, \quad (2)^2 + 5(2) - 14 = 0$

$4 + 10 - 14 = 0, \text{ correct}$

$x=-7, \quad (-7)^2 + 5(-7) - 14 = 0$

$49 - 35 - 14 = 0, \text{ correct}$

2. $3x^2 - 7x = 5$

$3x^2 - 7x - 5 = 0$ ← standard form

Step 1: $a=3, b=-7, c=-5$

Step 2: $x = \frac{-(-7) \pm \sqrt{(-7)^2 - 4(3)(-5)}}{2(3)}$

Step 3: (simplify) $x = \frac{7 \pm \sqrt{49+60}}{6}$

$x = \frac{7 \pm \sqrt{109}}{6}$

$x = \frac{7+10.44}{6}, \quad x = \frac{7-10.44}{6}$

$x = \frac{17.44}{6}, \quad x = \frac{-3.44}{6}$

$x = 2.91, \quad x = -0.57$

Step 4: Check

$3x^2 - 7x - 5 = 0, \quad x = 2.91$

$3(2.91)^2 - 7(2.91) - 5 = 0$

$25.40 - 20.37 - 5 \approx 0, \text{ correct}$

$x = -0.57$

$3(0.57)^2 - 7(0.57) - 5 = 0$

$0.975 + 3.99 - 5 \approx 0, \text{ correct}$

246

3. $8x^2 = 19 - 5x$, $8x^2 + 5x - 19 = 0$ ← standard form

Step 1. $a = 8$, $b = 5$, $c = -19$

Step 2. $x = \frac{-5 \pm \sqrt{5^2 - 4(8)(-19)}}{2(8)}$

Step 3. (simplify) $x = \frac{-5 \pm \sqrt{25 + 608}}{16}$

$$x = \frac{-5 \pm \sqrt{633}}{16}$$

$$x = \frac{-5 + 25.16}{16}, \quad x = \frac{-5 - 25.16}{16}$$

$$x = \frac{20.16}{16}, \quad x = \frac{-30.16}{16}$$

$$x = 1.26, \quad x = -1.89$$

Step 4. Check $8x^2 + 5x - 19 = 0$

$$x = 1.26, \quad 8(1.26)^2 + 5(1.26) - 19 = 0$$

$$12.7 + 6.3 - 19 = 0$$

correct

$$x = -1.89$$

$$8(-1.89)^2 + 5(-1.89) - 19 = 0$$

$$28.5 - 9.48 - 19 = 0$$

correct

4. $2x^2 - 5x + 17 = 0$ standard form

Step 1: $a = 2$, $b = -5$, $c = 17$

Step 2: $x = \frac{-(-5) \pm \sqrt{(-5)^2 - 4(2)(17)}}{2(2)}$

Step 3: (simplify) $x = \frac{5 \pm \sqrt{25 - 136}}{4}$

$$x = \frac{5 \pm \sqrt{-111}}{4}$$

← But the square root of a negative number is impossible

to find if our answer must be a real number.

Therefore this quadratic equation has no solution.

WORD PROBLEMS AND QUADRATIC EQUATIONS

Consider the following problem:

One side of a rectangular opening of a heating pipe is 3 inches longer than the other side. If the total cross sectional area is 70 square inches, find the dimensions of the cross section.

Let L = length, W = width

Then $L = 3 + W$, and the area = LW , or $70 = LW$

Substituting $L = 3 + W$ in the expression for area, you get
 $70 = (3 + W)(W) = 3W + W^2$, then $W^2 + 3W - 70 = 0$ ← Standard form

$a = 1$, $b = 3$, $c = -70$

$$W = \frac{-3 \pm \sqrt{(3)^2 - 4(1)(-70)}}{2(1)}$$

$$W = \frac{-3 \pm \sqrt{9 + 280}}{2}$$

$$W = \frac{-3 \pm \sqrt{289}}{2}$$

$$W = \frac{-3 + 17}{2}, \quad W = \frac{-3 - 17}{2}$$

$$W = \frac{14}{2}, \quad W = \frac{-20}{2}$$

$$W = 7, \quad W = -10$$

Only the positive value makes sense. The answer is $W = 7$ inches.
 Substituting back into the equation, $L = 3 + W$, $L = 3 + 7$, or $L = 10$.
 Check to see if $LW = 70$. It does.

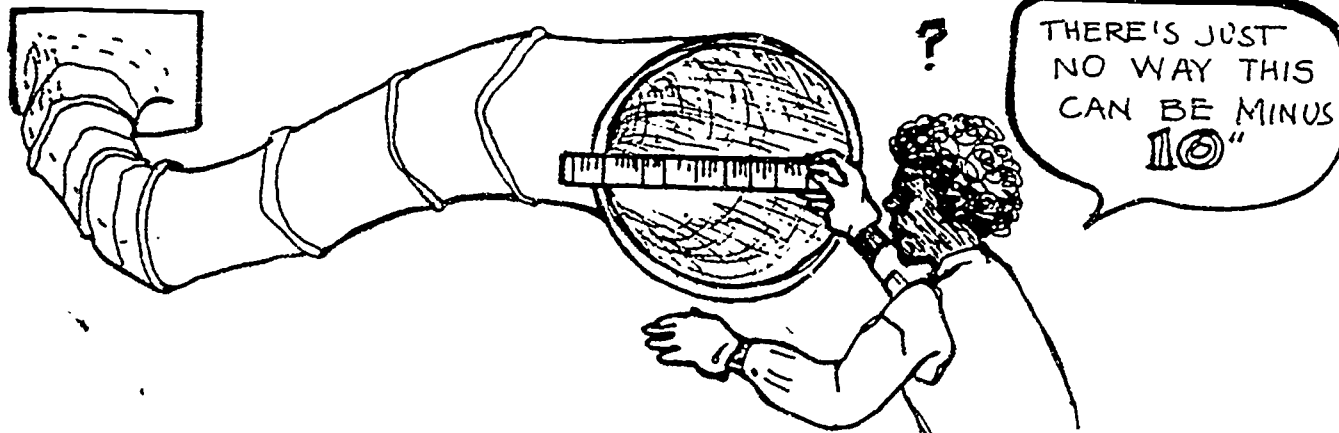

248
3-232

EXAMPLE PROBLEMS: Solve the following word problems by using the quadratic formula.

1. One side of a rectangular plate is 6 inches longer than the other. The total area of the plate is 216 square inches. How long is each side?

Let L = length of rectangle, and
 W = width of rectangle

Then $L = 6 + W$ and $LW = 216$;

Substitute $L = 6 + W$ into the
 expression for area :

$$(6 + W)W = 216, \text{ and } 6W + W^2 = 216$$

$$W^2 + 6W - 216 = 0 \leftarrow \text{standard form}$$

$$a = 1, b = 6, c = -216$$

$$W = \frac{-6 \pm \sqrt{(6)^2 - 4(1)(-216)}}{2(1)}$$

$$W = \frac{-6 \pm \sqrt{36 + 864}}{2} = \frac{-6 \pm \sqrt{900}}{2}$$

$$W = \frac{-6 + 30}{2}, \quad W = \frac{-6 - 30}{2}$$

$$W = \frac{24}{2}, \quad W = \frac{-36}{2}$$

$$W = 12, \quad W = -18$$

Only the positive value makes sense so, $W = 12$ inches. Substituting back into the equation, $L = 6 + W$, $L = 6 + 12$, or $L = 18$ inches. Check to see if $LW = 216$. It does.

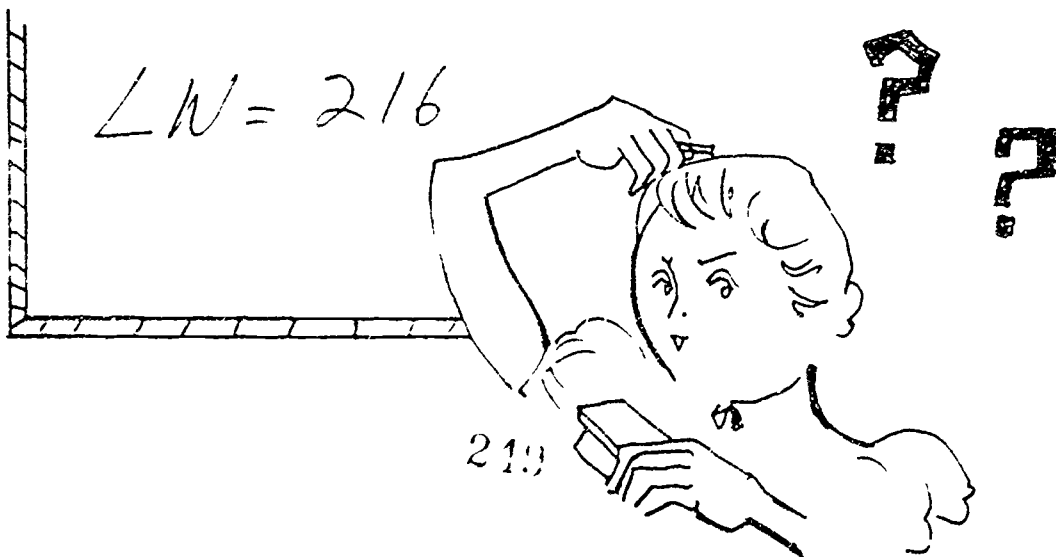

2. The cross sectional area of a rectangular duct must be 144 square inches. If one side must be twice as long as the other, find the length of each side.

Let L = the long side and W = short side
 Then $L = 2W$, and $LW = 144$; Substitute $L = 2W$ into the expression for Area :

$$LW = 144, (2W)(W) = 144, 2W^2 = 144$$

$$2W^2 - 144 = 0 \leftarrow \text{standard form}$$

$$a = 2, b = 0, c = -144$$

$$W = \frac{-b \pm \sqrt{b^2 + 4ac}}{2a}$$

$$W = \frac{\pm \sqrt{1152}}{4}$$

$$W = \frac{33.94 \text{ (rounded)}}{4}, \quad W = \frac{-33.94 \text{ (rounded)}}{4}$$

$$W = 8.49 \text{ (rounded)}, \quad W = -8.49 \text{ (rounded)}$$

Only the positive value makes sense so, $W = 8.49$ inches. Substituting back into the equation, $L = 2W$, $L = 2(8.49) = 16.98$. Check to see if $LW = 144$. It checks.

Now you can try some Shop Problems.

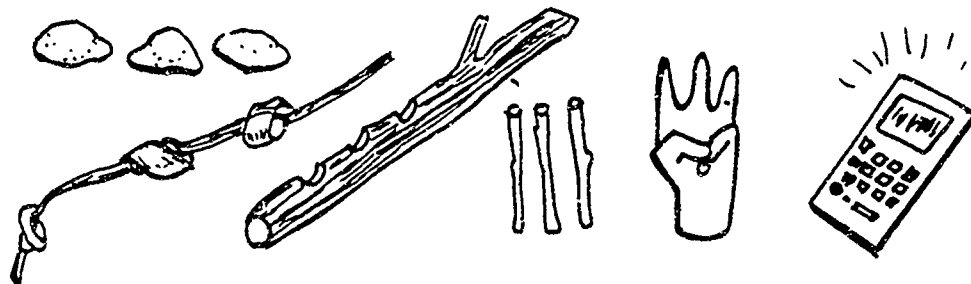

FIGURING THINGS OUT !

SHOP PROBLEMS

1. Your boss gave you a strip of sheet metal 14 inches wide. You must make a rectangular duct with a cross sectional area of 12 square inches. What will be the dimensions of the cross section? Look at Figure 2.

L _____ W _____

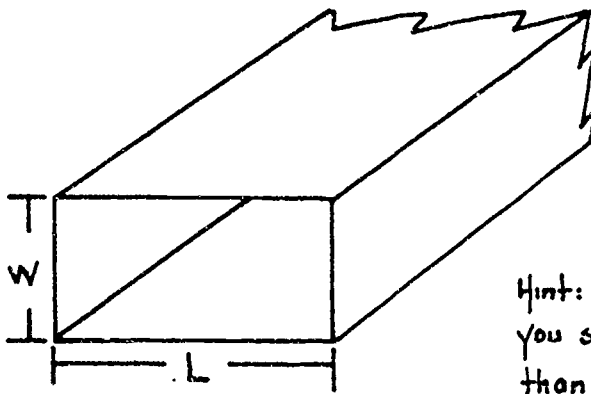

Hint: $2w + 2L = 14$; note that you should consider L larger than w .

Figure 2: Rectangular duct. Find L and w .

2. The perimeter of a piece of sheet metal is 288 inches. Your supervisor asked you to find the length and width of the sheet. The length is 3 inches more than twice the width. Remember that the perimeter is $2L + 2W$ if L = length and W = width.

L _____ W _____

3. Your boss asked you to cut a 36-inch piece of steel rod into two pieces. The longest piece should be 6 inches less than 4 times the length of the short piece. What is the length of the long piece? What is the length of the short piece?

Long piece _____ Short piece _____

4. A customer buys 8 identical shims and 6 identical brackets for \$16.80. Another customer buys 6 of the shims and 8 of the brackets for \$15.40. How much does a bracket cost? How much does a shim cost?

Shim cost _____ Bracket cost _____

5. You wish to mix a 20% solution of cutting oil with a 5% solution of cutting oil to get 2 gallons of 10% solution of cutting oil. How many gallons of each solution should be mixed? (Hint: Refer to example problem No. 3 on page 19 of this Project Sheet.)

Gallons of 20% solution _____

Gallons of 5% solution _____

6. You have a mixture of nuts and bolts which total 175. The number of bolts is 25 more than twice the number of nuts. How many nuts and bolts are there?

Nuts _____ Bolts _____

7. Your boss gives you the layout of a right triangle as shown in Figure 3. You are to lay out a similar right triangle so that its area will be twice the area of the given right triangle. Remember that the area of a triangle is one-half times its base times its height.

$$(A = \frac{b \cdot h}{2})$$

h _____ b _____

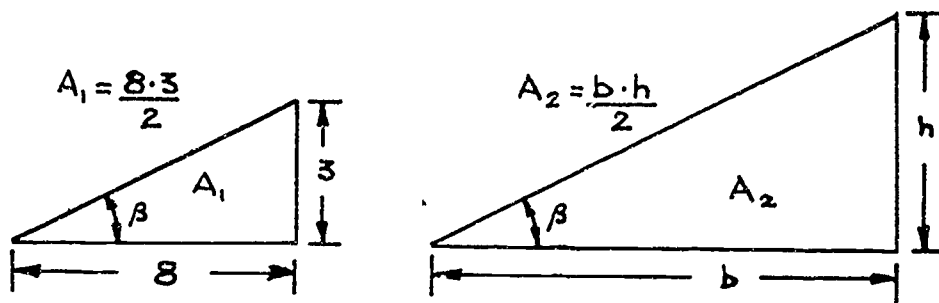

hint: recall that corresponding sides of similar triangles are proportional.

Figure 3: Area of similar triangle.

8. Your supervisor asked you to cut a piece of sheet metal such that the length is 3 inches more than twice the width. The difference between the length and width is 18 inches. What is the area? (Hint: First find the length and width.)

Area _____

9. Here's a good practice problem. Although it may not be a shop problem, it will make you use your abilities in translating English statements into algebraic expressions. If 4 times the larger of two numbers is added to 3 times the smaller, the result is 26. If three times the larger is decreased by twice the smaller, the result is 11. Find the two numbers.

Large number _____ Small number _____

10. Your boss wants you to machine a channel as shown below in Figure 4. The inside cross sectional area is to be 3 square inches. The inside width of the channel is to be 12 times the inside height of the channel. What are the dimensions of the inside width and the inside height?

Inside width _____ Inside height _____

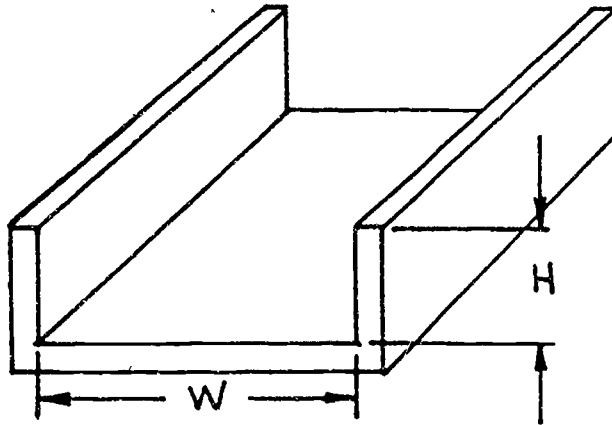

Figure 4: Find inside width and height.

SHOW YOUR WORK TO YOUR INSTRUCTOR.

253

BAS

PROJECT SHEET



211

Name _____ Date _____

Cluster Metal Trades Occupation Machinist HelperTraining Module Shop Math for MachinistsTraining Milestone 3. Specialized Math Skills

PROJECT 4

SHOP GEOMETRY: PART 1

TRAINING CONDITIONS:

Here's what you will need:

1. This Project Sheet.
2. A protractor to measure the angles on page 3.
3. A pen or pencil to answer the problems in this Project Sheet.

TRAINING PLAN:

Here's what you do:

This Project Sheet is about geometry. You will learn about angles and their measurements. You will learn what a polygon is and how to find the area and perimeter of different kinds of polygons. This Project Sheet will help you to solve many shop problems using geometry.

1. Read and study the basic rules and formulas on pages 2 to 31.
2. Work the Shop Problems on pages 32 to 35.
3. Have your Instructor check your work and record your score on your Student Training Record.
4. Ask your Instructor for your next Project Sheet.

TRAINING GOAL:

Here's how well you must do:

1. You must score 8 out of 10 correct on the Shop Problems.
2. You must answer questions about this Project Sheet to the approval of your Instructor.

ANGLE MEASUREMENT

An angle is a measure of the size of the opening between two intersecting lines. (Lines are said to intersect when they cross each other.) The point of intersection (the place where they cross) is called the vertex, and the lines forming the opening are the sides.

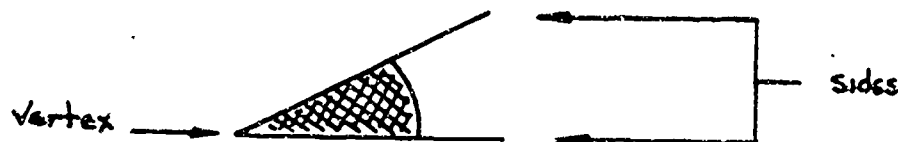

An angle may be identified in any one of the following ways:

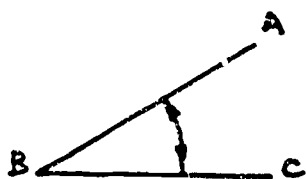

ΔABC or ΔCBA
Vertex letter in
the middle

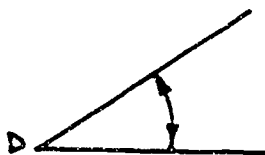

ΔD
vertex letter
only

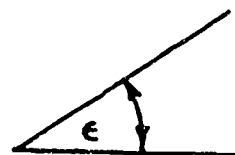

ΔE
a letter or number
placed inside the angle

As an example, the angle shown below may be named in four different ways:

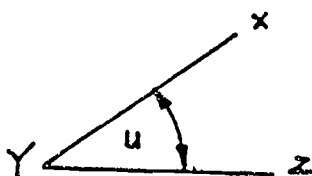

1. ΔXYZ (vertex letter in the middle)
2. ΔY (vertex letter only)
3. ΔZYX (vertex letter in the middle)
4. Δu (letter placed inside the angle)

The basic unit of measurement of angle size is called the degree. A degree is defined as $\frac{1}{360}$ th of a circle. In other words, one full circle equals 360 degrees. The symbol for degree is $^\circ$.

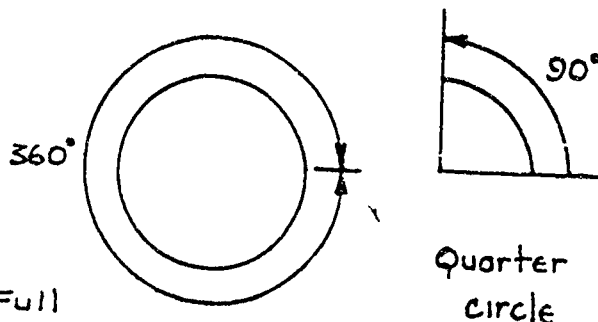

The degree can be subdivided into smaller angle units known as minutes and seconds (which are not related to units of time). The symbol for minutes is ' (the same as the symbol for feet), and the symbol for seconds is " (the same as the symbol for inches).

$$1 \text{ degree or } 1^\circ = 60 \text{ minutes or } 60'$$

$$1 \text{ minute or } 1' = 60 \text{ seconds or } 60''$$

An angle of 46 degrees 32 minutes and 14 seconds is written as $46^\circ 32' 14''$. For your work in the metal trades the required accuracy is usually to the nearest degree, sometimes to the nearest minute, and very rarely to the nearest second.

You measure angles with a protractor. Below is a picture of one. It is quite simple to measure angles with a protractor. If you need help, ask your instructor for assistance.

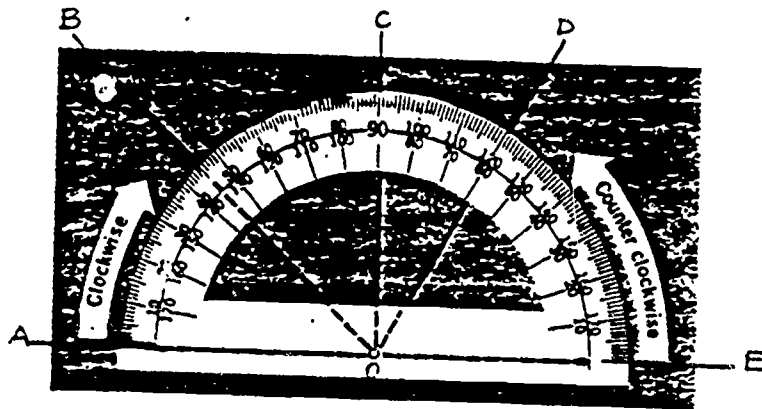

To measure an angle, place the protractor over it so that the zero-degree mark is lined up with one side of the angle, and the center mark is on the vertex. Read the measure in degrees where the other side of the angle intersects the scale of the protractor. When reading an angle clockwise, use the upper scale and, when reading counterclockwise, use the lower scale.

In the drawing, $\angle AOB$ should be read clockwise from the 0° mark on the left. $\angle AOB = 45^\circ$.

$\angle EOD$ should be read counterclockwise from the 0° mark on the right. $\angle EOD = 60^\circ$.

Use your protractor to measure the following angles:

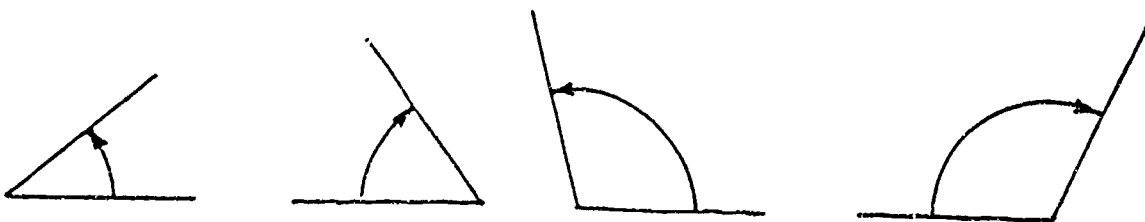

(1) 40°

(2) 54°

(3) 103°

(4) 116°

If you don't get the above answers ask your instructor for assistance

FACTS ABOUT ANGLES

1. An acute angle is less than 90° .
2. An obtuse angle is more than 90° .
3. A right angle is 90° .
4. A straight angle is 180° .

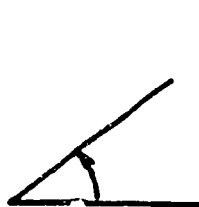

acute angle
(less than 90°)

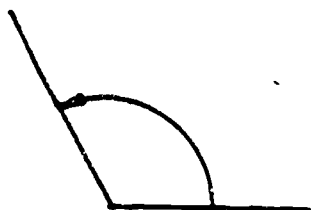

obtuse angle
(more than 90°)

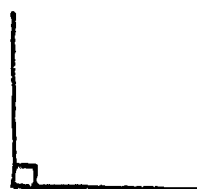

right angle
(equal to 90°)



straight angle
(equal to 180°)

5. Two lines that meet in a right or 90° angle, are said to be perpendicular. The symbol for perpendicular lines is \perp .
6. The symbol for a right or 90° angle is \sphericalangle .
7. The sides of a straight or 180° angle make a straight line.
8. Two angles that add up to 90° are said to be complementary angles. (For example, 47° and 43° are complementary angles since $47^\circ + 43^\circ = 90^\circ$.)
9. Two angles that add up to 180° are said to be supplementary angles. (For example, 132° and 48° are supplementary angles since $132^\circ + 48^\circ = 180^\circ$.)
10. When two straight lines intersect, the opposite angles are equal and the vertical angles are equal. (See below)

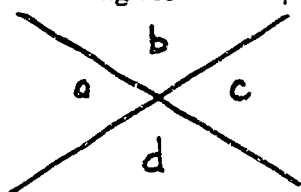

$$\sphericalangle a = \sphericalangle c \quad (\text{opposite angles})$$

$$\sphericalangle b = \sphericalangle d \quad (\text{vertical angles})$$

note that vertical angles can also be considered as opposite angles.

11. When two straight lines intersect, the adjacent angles (two angles with a common side) always add up to 180° . (See below)

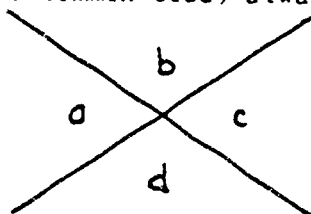

$$\sphericalangle a + \sphericalangle b = 180^\circ \quad (\sphericalangle\text{'s } a \text{ and } b \text{ are adjacent } \sphericalangle\text{'s})$$

$$\sphericalangle b + \sphericalangle c = 180^\circ \quad (\sphericalangle\text{'s } b \text{ and } c \text{ are adjacent } \sphericalangle\text{'s})$$

$$\sphericalangle c + \sphericalangle d = 180^\circ \quad (\sphericalangle\text{'s } c \text{ and } d \text{ are adjacent } \sphericalangle\text{'s})$$

$$\sphericalangle d + \sphericalangle a = 180^\circ \quad (\sphericalangle\text{'s } d \text{ and } a \text{ are adjacent } \sphericalangle\text{'s})$$

12. The interior angles of any triangle add up to 180° .

13. Two lines that are always the same distance apart are parallel. 5 of 35

14. When parallel lines are cut by a third line there are some special relationships between certain angles. When you know the facts about these relationships you can figure out a lot about all the angles with just a little bit of information. As you read through the list of facts below, locate each angle or pair of angles in the drawing.

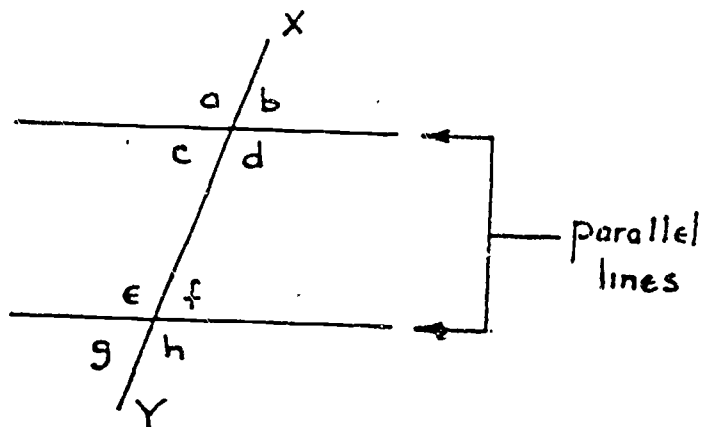

∠'s c , d , e , f are called interior angles. They are inside or interior to the parallel lines.

∠'s a , b , g , h are called exterior angles. They are outside or exterior to the parallel lines.

∠'s c and f are called alternate interior angles. They are interior angles that are on opposite sides of line XY .

∠'s d and e are also called alternate interior angles. They are interior angles that are on opposite sides of the line XY .

∠'s a and h are called alternate exterior angles. They are exterior angles that are on opposite sides of the line XY .

∠'s b and g are also called alternate exterior angles. They are exterior angles that are on opposite sides of the line XY .

Here is the importance of the above definitions:

Alternate interior angles are equal.

$$\angle c = \angle f \text{ and } \angle d = \angle e$$

Alternate exterior angles are equal.

$$\angle a = \angle h \text{ and } \angle b = \angle g$$

Other pairs of equal angles can be proven:

$$\angle a = \angle e, \angle c = \angle g, \angle b = \angle f, \angle d = \angle h$$

EXAMPLE PROBLEMS: Use some of the above **FACTS ABOUT ANGLES** TO SOLVE THE following problems:

1.

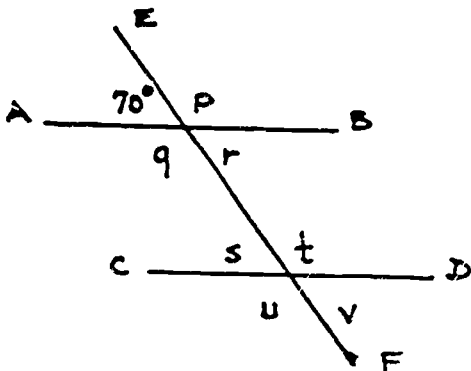

Given: Line segment AB is parallel to CD. Line segments AB and CD are cut by line segment EF. (NOTE: A line segment is part of a line.)

Find: $\angle p$, $\angle q$, $\angle r$, $\angle s$, $\angle t$, $\angle u$, $\angle v$.

- $\angle p = 110^\circ$, since $70^\circ + \angle p = 180^\circ$.
- $\angle q = 110^\circ$, since p and q are opposite angles.
- $\angle r = 70^\circ$, since $\angle r$ is opposite the 70° angle.
- $\angle s = 70^\circ$, since $\angle s = \angle r$ (alternate interior angles).
- $\angle t = 110^\circ$, since $\angle t = \angle q$ (alternate interior angles).
- $\angle u = 110^\circ$, since $\angle u = \angle p$ (alternate exterior angles).
- $\angle v = 70^\circ$, since $\angle u + \angle v = 180^\circ$.

2. Given: Set of parallel line cut by a third line.

Find: Angles z , y , s , u , t , x , w

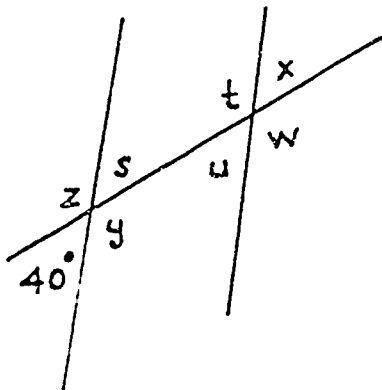

- $\angle z = 140^\circ$ (straight angle = 180°)
- $\angle y = 140^\circ$ (opposite angles are equal)
- $\angle s = 40^\circ$ (opposite angles are equal)
- $\angle u = 40^\circ$ (alternate interior angles are equal)
- $\angle t = 140^\circ$ (alternate interior angles are equal)
- $\angle x = 40^\circ$ (alternate exterior angles are equal)
- $\angle w = 140^\circ$ (alternate exterior angles are equal)

5. Find all the indicated angles shown in the diagram below.

7 of 35

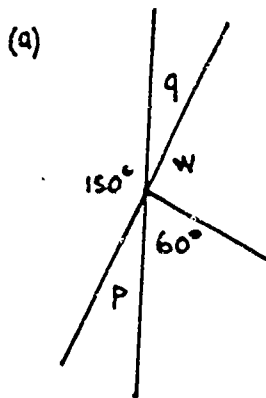

$$\begin{aligned} \angle p &= 30^\circ \text{ (straight angles = } 180^\circ\text{)} \\ \angle w &= 90^\circ \text{ (straight angles = } 180^\circ\text{)} \\ \angle q &= 30^\circ \text{ (opposite angles are equal)} \end{aligned}$$

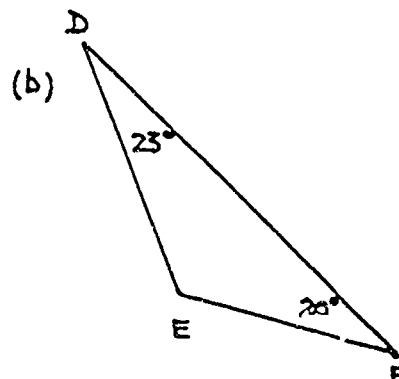

$$\begin{aligned} \angle E &= 180^\circ - (23^\circ + 20^\circ) \\ \angle E &= 180^\circ - 43^\circ \\ \angle E &= 137^\circ \end{aligned}$$

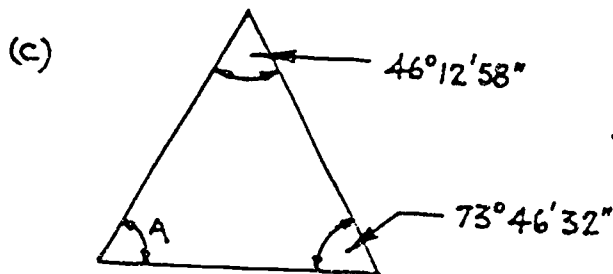

$$\begin{aligned} \angle A &= 180^\circ - (46^\circ 12' 58'' + 73^\circ 46' 32'') \\ \angle A &= 180^\circ - \left[\begin{array}{r} 46^\circ 12' 58'' \\ + 73^\circ 46' 32'' \\ \hline 119^\circ 58' 90'' = 119^\circ 58' + (1' 30'') = 119^\circ 59' 30'' \end{array} \right] \\ \angle A &= 180^\circ - 119^\circ 59' 30'' = 179^\circ 59' 60'' \text{ — note that } 180^\circ = 179^\circ 59' 60'' \\ &\quad \underline{- 119^\circ 59' 30''} \\ \angle A &= 60^\circ 0' 30'', \text{ or } \angle A = 60^\circ 30'' \end{aligned}$$

A polygon is a closed plane figure containing three or more angles and bounded by three or more straight sides. The word "polygon" means many sides. The following figures are polygons:

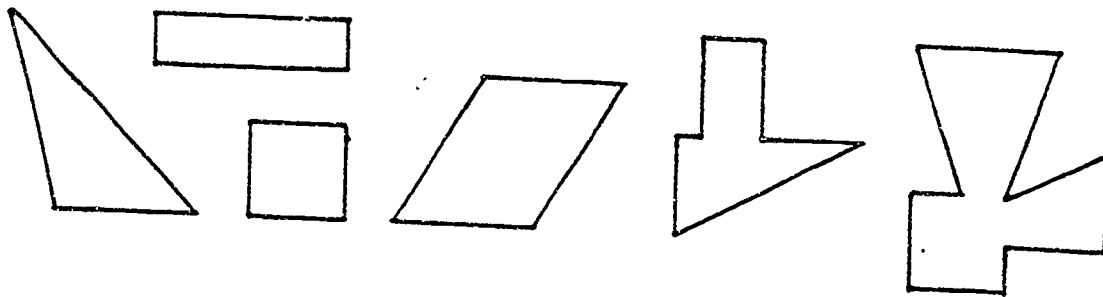

A figure with a curved side is not a polygon.

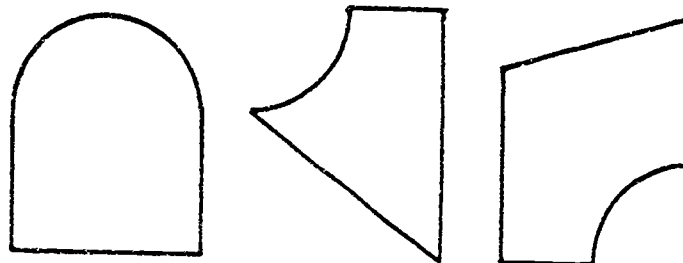

These are not polygons

It is important for every metal trades worker to understand polygons. In this section you will learn how to identify the parts of a polygon, recognize the different kinds of polygons, and compute the perimeter and area of any polygon.

In the general polygon shown in Figure 1 below, each vertex (or corner) is labeled with a letter A, B, C, D, and E. The polygon is simply named polygon ABCDE.

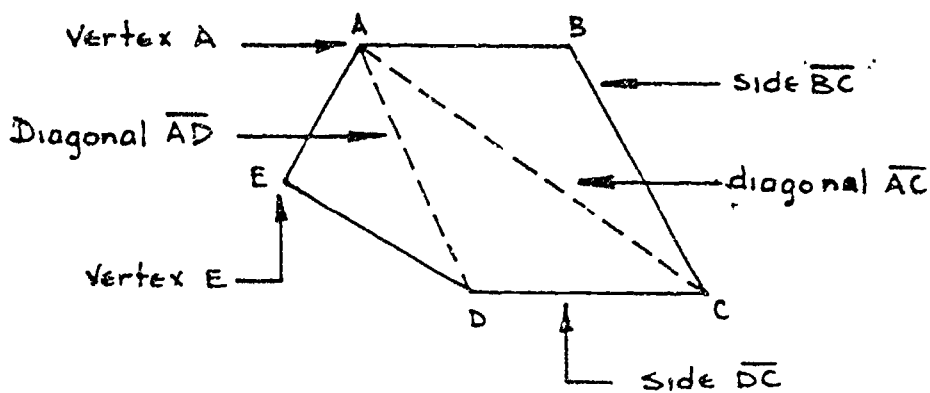
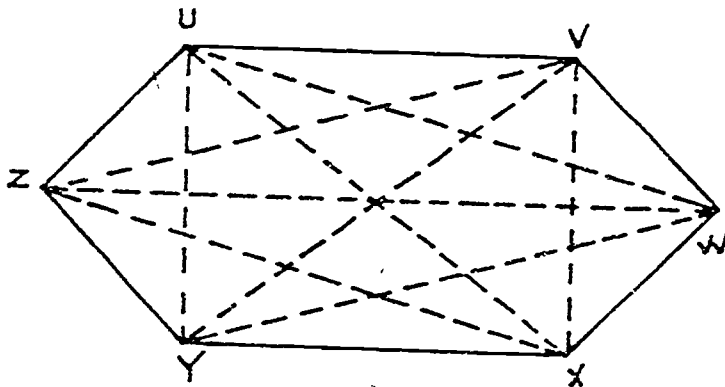

Figure 1: A general polygon. 251

The sides of the polygon are named by the line segments that form each side: \overline{AB} , \overline{BC} , \overline{CD} , and so on. Notice that a bar is placed over the letters to indicate a side.

The diagonals of a polygon are the line segments connecting nonconsecutive vertices (vertices that are not next to each other) such as \overline{AC} and \overline{AD} . These are shown as dotted lines in Figure 1 on page 8. Look at Figure 1 again.

In the sketch below, identify all the sides, vertices, and diagonals of the given polygon.



1. Vertices:

U, V, W, X, Y, Z

2. Sides:

$\overline{UV}, \overline{VW}, \overline{WX}, \overline{XY}, \overline{YZ}, \overline{ZU}$

3. Diagonals:

$\overline{VX}, \overline{VY}, \overline{VZ}, \overline{UY}, \overline{UX}, \overline{UW}$
 $\overline{XZ}, \overline{YW}, \overline{ZW}$

The most important polygon measurements you will find in practical shop problems are the perimeter and the area. The perimeter is the distance around the outside of the polygon. The perimeter of any polygon is found by adding the lengths of the sides.

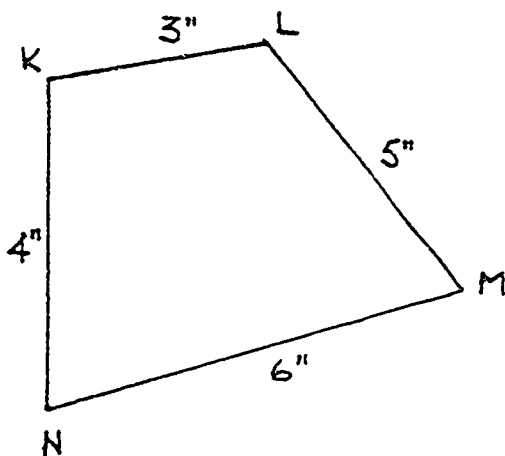

In the polygon $KLMN$ the perimeter is $3'' + 4'' + 6'' + 5'' = 18''$.

The perimeter is a length, so it has length units, in this case, inches.

Adding up the lengths of the sides will always give you the perimeter of a polygon. Finding the area is a little more complicated. There are some handy formulas you can use to calculate the area of a polygon. Before you can use these formulas, you must learn to identify the different types of polygons. First look at the quadrilateral or four-sided polygon.

The first type of quadrilateral is a parallelogram. In a parallelogram the sides opposite each other are parallel and equal in length. Look at the sketch below:

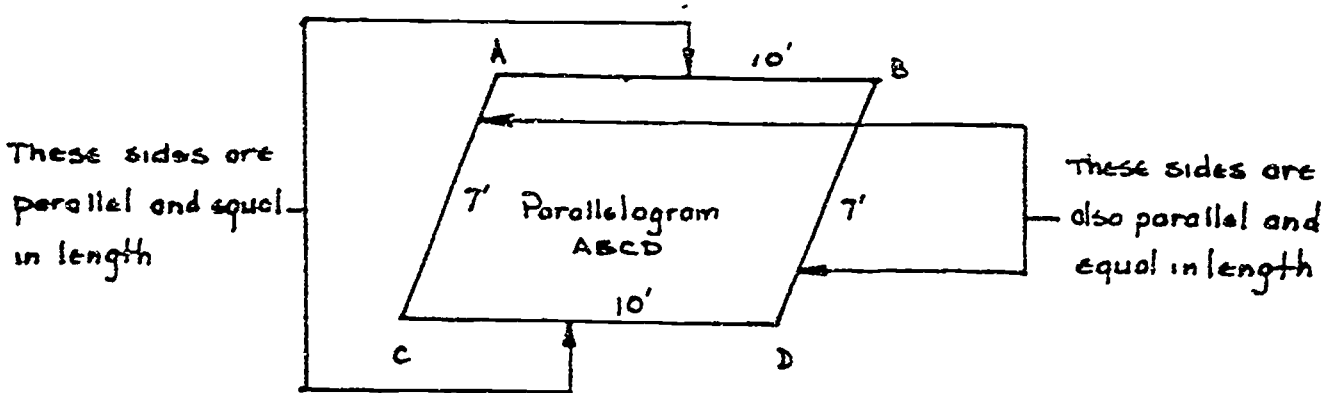

Figure EFHG at the right is a rectangle, a parallelogram in which the four corner angles are right angles. The \perp symbol at the vertices means right angles. Such a rectangle is a parallelogram because opposite sides are equal and parallel.

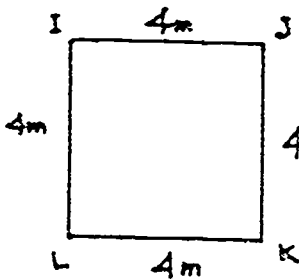
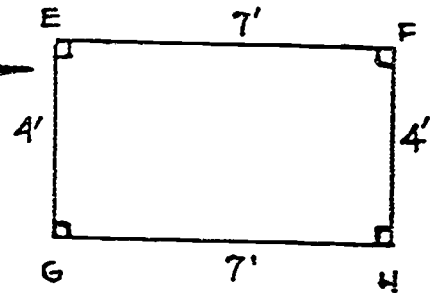
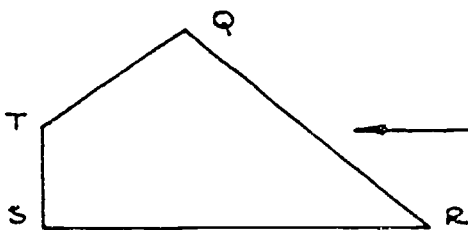
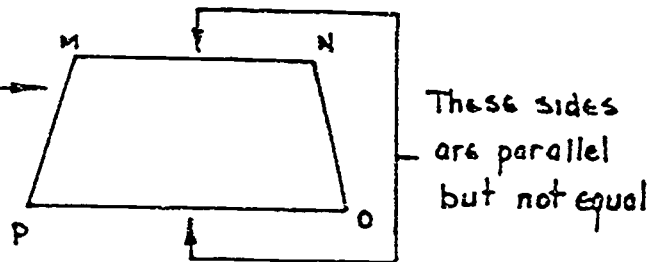

Figure IJKL at the left is a square, a rectangle with all sides equal.

Figure MNOP at the right is a trapezoid. A trapezoid contains two parallel sides and two nonparallel sides. MN and OP are parallel. MP and NO are not.



If a four-sided polygon has none of the above special features--no parallel sides--we call it a quadrilateral. QRST to the left is a quadrilateral.

The area of any plane figure is the number of square units of surface within the figure.

For example, in the rectangle shown below:

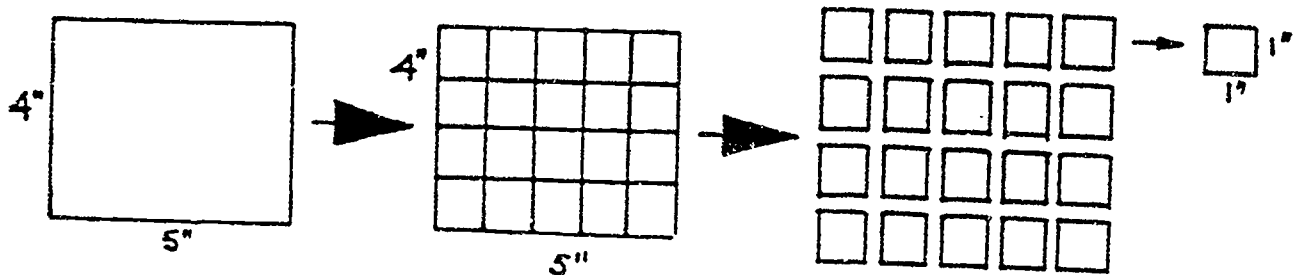

you can divide the surface into exactly 20 small squares, each one inch on a side. By counting squares you can see that the area of this 4-inch by 5-inch rectangle contains 20 square inches. Twenty square inches can be abbreviated 20 sq. in, or 20 in².

Of course, there is no need to draw lines and count squares in such a basic manner. You can find the area by multiplying the two dimensions of the rectangle. Look at Figure 2.

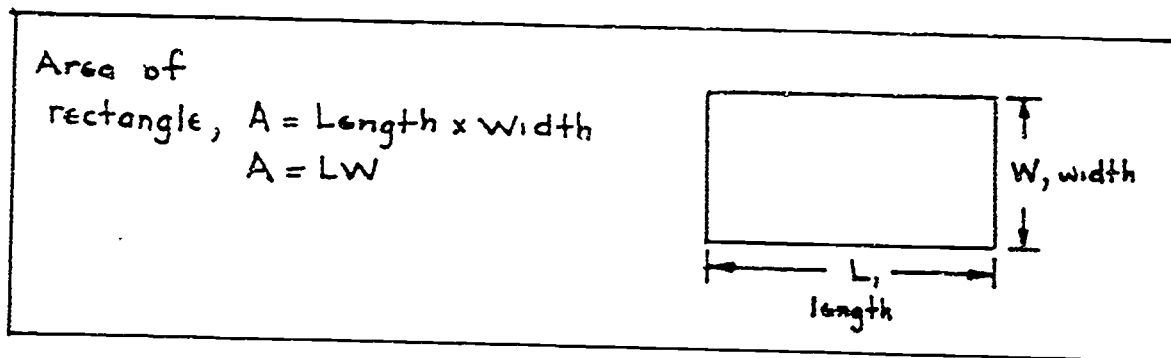

Figure 2: Area of a rectangle.

Another example:

Find the area of rectangle EFGH.

$$L = 9 \text{ inches}$$

$$W = 5 \text{ inches}$$

$$A, \text{ area} = LW = (9 \text{ in})(5 \text{ in})$$

$$A = 45 \text{ sq in}$$

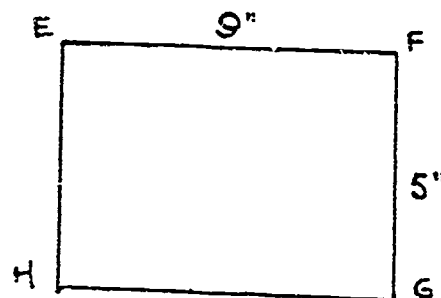

The formula is easy to use, but be careful! It is only good for rectangles. If you use this formula with a different polygon, you will not get the correct answer.

The formula $A = LW$ may also be used to find L or W when the other quantities are known. As you learned in Algebra I and Algebra II, the following formulas are all equivalent:

$$A = LW \quad L = \frac{A}{W} \quad W = \frac{A}{L}$$

For example, a sheet metal worker must build a heating duct in which a rectangular vent 6" high must have the same area as a rectangular opening 8" by 9". Find the length of the vent. Look at the sketch below.

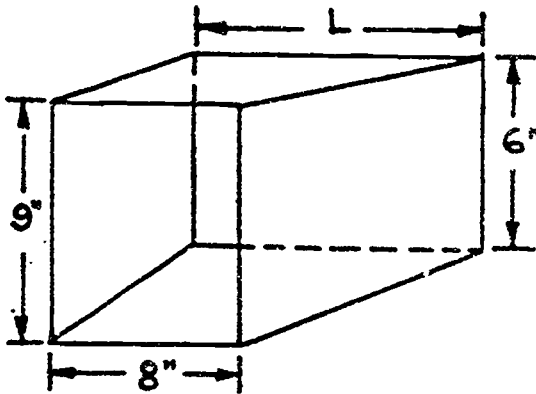

Area of the opening is $A = LW$
 $A = 8" \times 9" = 72 \text{ sq.in.}$

The length of the vent is $L = \frac{A}{W}$

$$L = \frac{72 \text{ sq.in.}}{6 \text{ in.}} = 12 \text{ in.}$$

Another formula that you will need to know for many types of shop problems is for finding the perimeter of a rectangle if you know its length and width. Look at Figure 3.

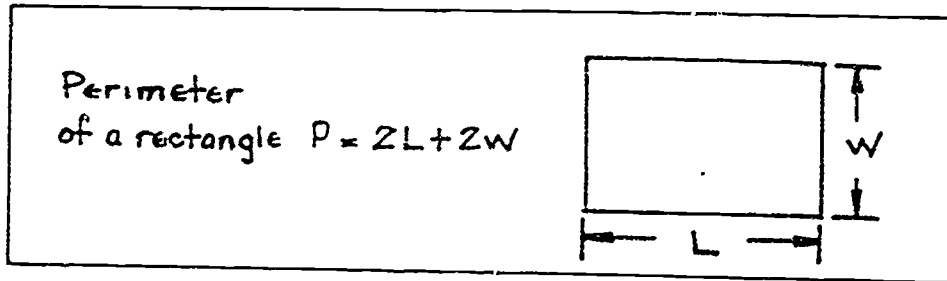
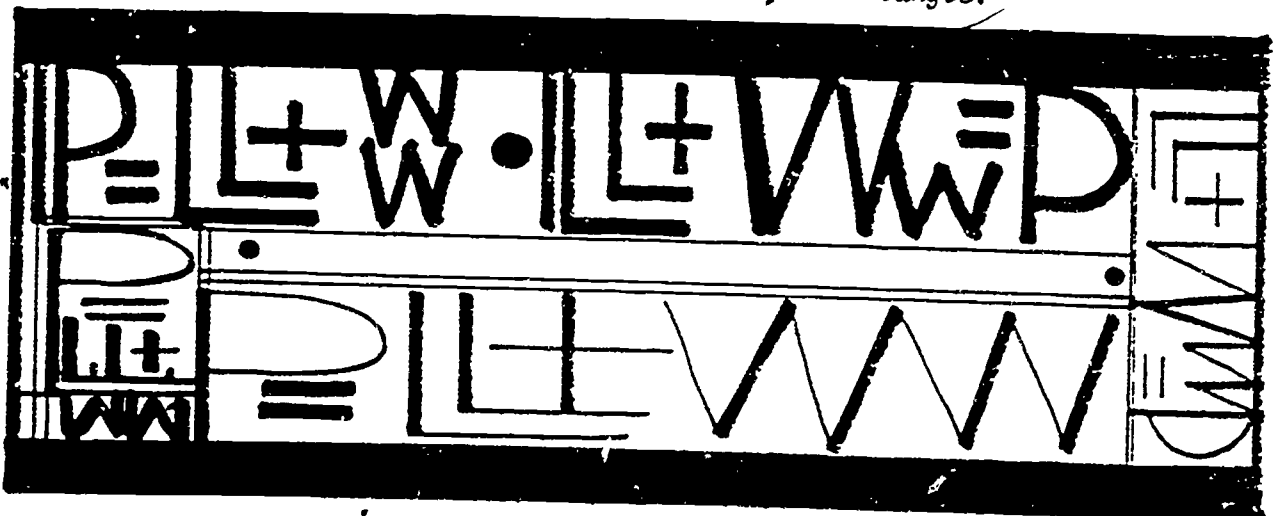
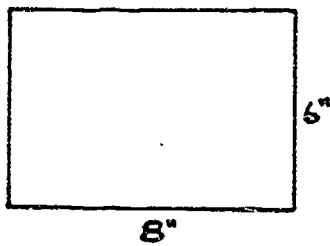

Figure 3: Perimeter of a rectangle.



EXAMPLE PROBLEMS: Work through these problems on areas and perimeters of rectangles.

1. Find the area and perimeter of the rectangles shown below:



(a)

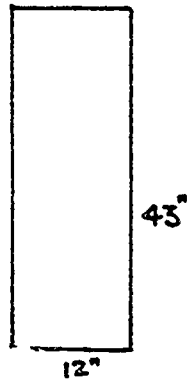

(b)

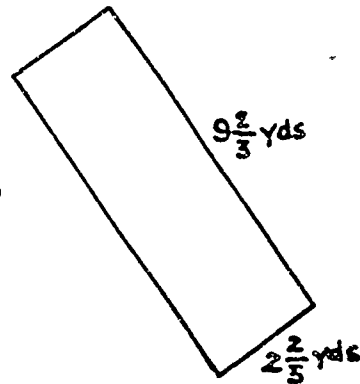

(c)

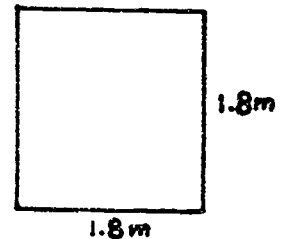

(d)

$$\begin{aligned} \text{(a) } A &= LW \\ A &= (8'')(6'') \\ A &= 48 \text{ sq in} \end{aligned}$$

$$\begin{aligned} P &= 2L + 2W \\ P &= 2(8'') + 2(6'') \\ P &= 16'' + 12'' \\ P &= 28 \text{ in} \end{aligned}$$

$$\begin{aligned} \text{(b) } A &= LW \\ A &= (43'')(12'') \\ A &= 516 \text{ sq in} \end{aligned}$$

$$\begin{aligned} P &= 2L + 2W \\ P &= 2(43'') + 2(12'') \\ P &= 86'' + 24'' \\ P &= 110 \text{ in} \end{aligned}$$

$$\begin{aligned} \text{(c) } A &= LW \\ A &= (9.667 \text{ yd})(2.667 \text{ yd}) \\ A &= 25.78 \text{ sq yd} \end{aligned}$$

$$\begin{aligned} P &= 2L + 2W \\ P &= 2(9.667 \text{ yd}) + 2(2.667 \text{ yd}) \\ P &= 19.33 \text{ yd} + 5.33 \text{ yd} \\ P &= 24.67 \text{ yd} \end{aligned}$$

$$\begin{aligned} \text{(d) } A &= LW \\ A &= (1.8 \text{ m})(1.8 \text{ m}) \\ A &= 3.24 \text{ sq m} \end{aligned}$$

$$\begin{aligned} P &= 2L + 2W \\ P &= 2(1.8 \text{ m}) + 2(1.8 \text{ m}) \\ P &= 3.6 \text{ m} + 3.6 \text{ m} \\ P &= 7.2 \text{ m} \end{aligned}$$

NOTE: in problem (d) above, the rectangle is a special rectangle—a square. Look at Figure 4 below.

Area of a square, $A = S^2$
Perimeter of a square, $P = 4S$

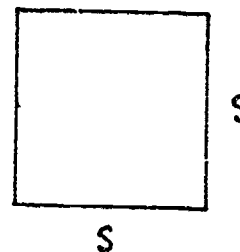

Figure 4: Perimeter and area of a square.

3-250 266

From Figure 4 on page 13 you can find the side of a square if you know the area.

$$S^2 = A \quad \leftarrow \text{Solve for } S$$

$$\sqrt{S^2} = \sqrt{A} \quad \leftarrow \text{Take the square root of both sides of the equation.}$$

$$S = \sqrt{A}$$

PARALLELOGRAMS

You should remember that a parallelogram is a four-sided figure whose opposite pairs of sides are equal and parallel. Here are some parallelograms.

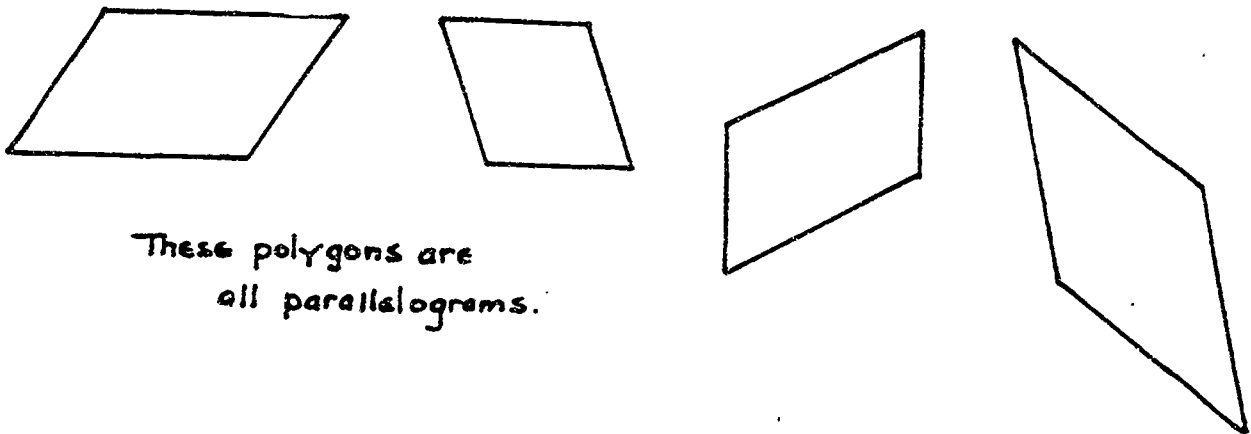

These polygons are
all parallelograms.

To find the area of a parallelogram use the following formula in Figure 5.

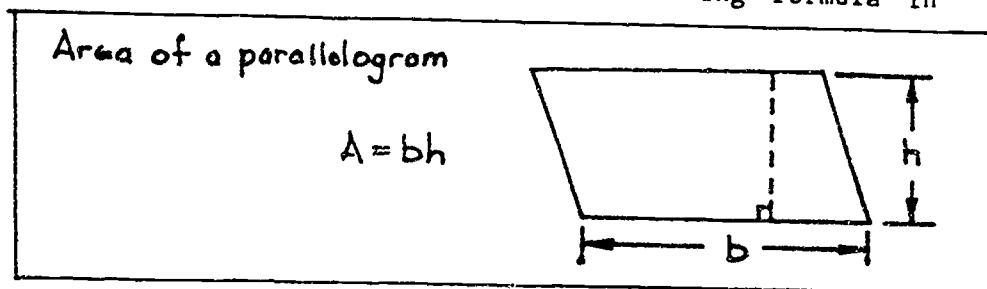

Figure 5: Area of a parallelogram.

NOTE: You do not use only the length of a side to find the area of a parallelogram. The height h is the perpendicular distance between the parallel sides at top and bottom. The height h is perpendicular to the base b .

For example, in parallelogram CDBA the base is 7" and the height is 10". Find its area.

First: Write the formula $A = bh$

Second: Substitute given values: $A = (7'')(10'')$

Third: Calculate the area $A = 70 \text{ sq in}$

Notice that you ignore the slant height 12 inches.

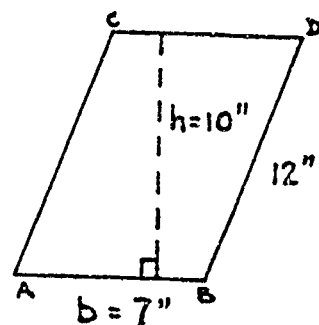

Now, find the area of the parallelogram shown below. Be sure you use the correct dimensions.

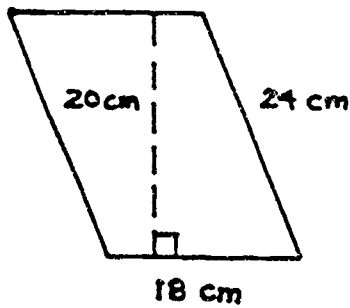

$$\text{Area} = bh$$

$$A = (18 \text{ cm})(20 \text{ cm})$$

$$A = 360 \text{ sq cm}$$

Try another example:

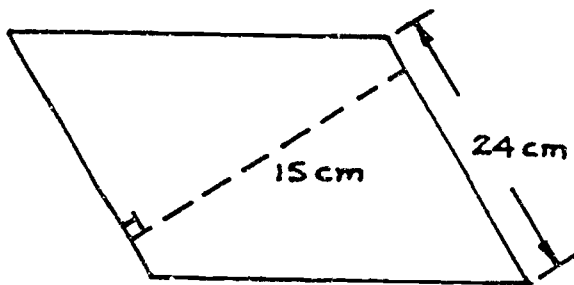

$$\text{Area} = bh$$

$$A = (24 \text{ cm})(15 \text{ cm})$$

$$A = 360 \text{ sq cm}$$

TRAPEZOIDS

A trapezoid is a four-sided figure with only one pair of sides parallel. Here are some trapezoids:

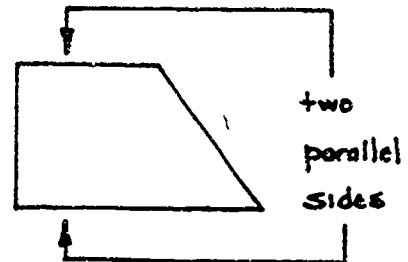
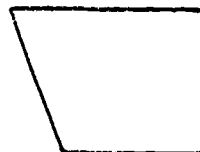

To find the area of a trapezoid, use the formula shown in Figure 6.

$$\text{Area of a trapezoid, } A = \left(\frac{b_1 + b_2}{2}\right)h$$

$$\text{or } A = \frac{h}{2}(b_1 + b_2)$$

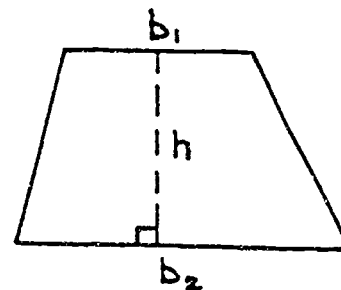
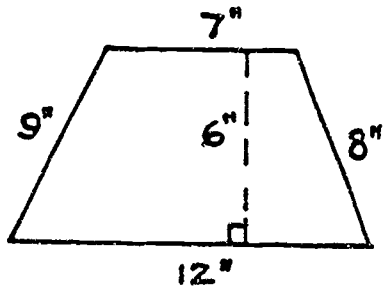

Figure 6: Area of a trapezoid.

The factor $\frac{(b_1 + b_2)}{2}$ is the average length of the two parallel sides b_1 and b_2 . The height h is the perpendicular distance between the two parallel sides b_1 and b_2 . For example, find the area of a trapezoid-shaped piece of metal as shown below.



The parallel sides, b_1 and b_2 , have lengths of 7" and 12"; the height h is 6". Then:

$$A = \left(\frac{b_1 + b_2}{2}\right) h = \left(\frac{7" + 12"}{2}\right) 6"$$

$$A = \left(\frac{19"}{2}\right) 6" = (9.5") 6"$$

$$A = 57 \text{ sq in}$$

EXAMPLE PROBLEMS: Work through the example problems below and find the area and perimeter of each of the following trapezoids.

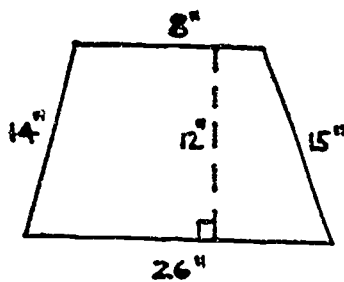

(a)

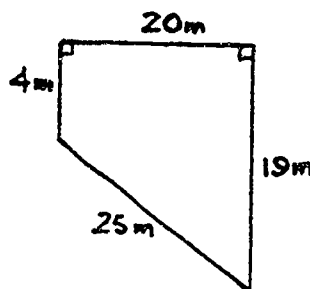

(b)

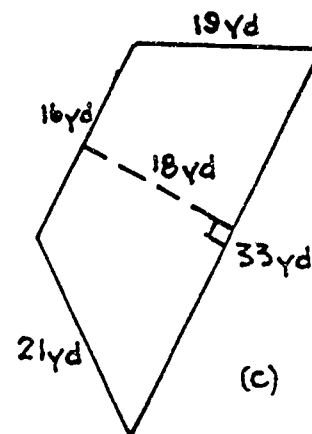

(c)

$$(a) \quad A = \left(\frac{8" + 26"}{2}\right) 12" = \left(\frac{34"}{2}\right) 12"$$

$$A = (17") 12"$$

$$A = 204 \text{ sq in}$$

$$P = 14" + 8" + 15" + 26"$$

$$P = 63 \text{ in}$$

$$(b) \quad A = \left(\frac{4\text{m} + 19\text{m}}{2}\right) 20\text{m} = \left(\frac{23\text{m}}{2}\right) 20\text{m}$$

$$A = (11.5\text{m}) 20\text{m}$$

$$A = 230 \text{ sq m}$$

$$P = 4\text{m} + 20\text{m} + 19\text{m} + 25\text{m}$$

$$P = 68 \text{ m}$$

$$(c) \quad A = \left(\frac{16\text{yd} + 33\text{yd}}{2}\right) 18\text{yd} = \left(\frac{49\text{yd}}{2}\right) 18\text{yd}$$

$$A = (24.5\text{yd}) 18\text{yd}$$

$$A = 441 \text{ sq yd}$$

$$P = 16\text{yd} + 19\text{yd} + 33\text{yd} + 21\text{yd}$$

$$P = 89\text{yd}$$

TRIANGLES

A triangle is a polygon with three sides. It is the most simple of all plane figures.

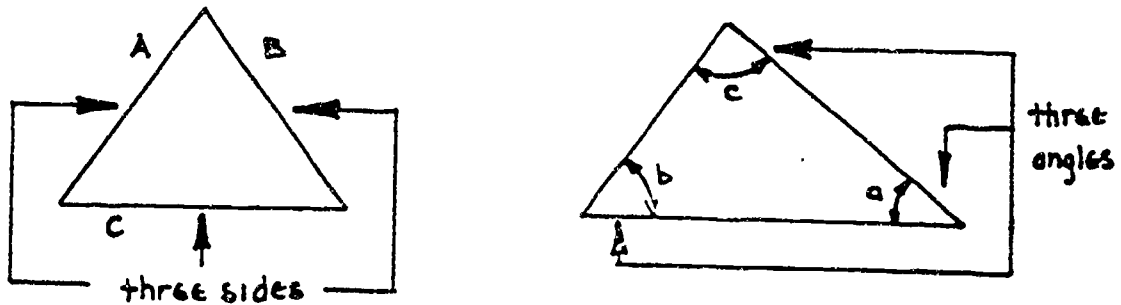

Just as there are several varieties of four-sided figures—squares, rectangles, parallelograms, and trapezoids—there are several varieties of triangles. With triangles, one formula can be used to find area. First you need to know how to identify the many kinds of triangles that will appear in your shop work.

An equilateral triangle is one in which all three sides have the same length. An equilateral triangle is also equiangular. When three sides are equal, the three angles are also equal. Each angle of an equilateral triangle will equal 60° since the sum of the three angles of any triangle equal 180° .

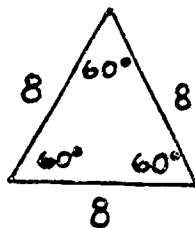

Equilateral, Equiangular
triangle

An isosceles triangle is one in which two of the three sides are equal. It is always true that the two angles opposite the equal sides are always equal.

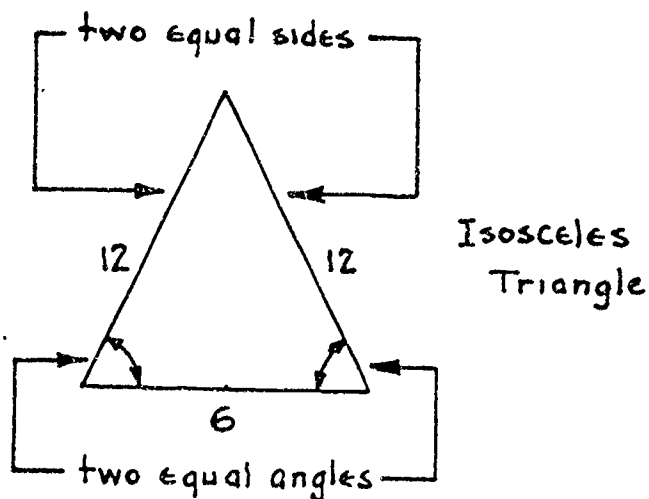

A right triangle contains a 90-degree angle. Two of the sides are perpendicular to each other. The longest side of a right triangle is always the side opposite to the right angle. This side is called the hypotenuse.

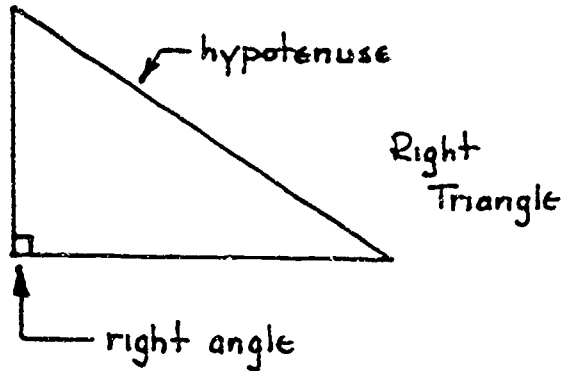

A scalene triangle is one in which no sides are equal. A right triangle can be a scalene triangle.

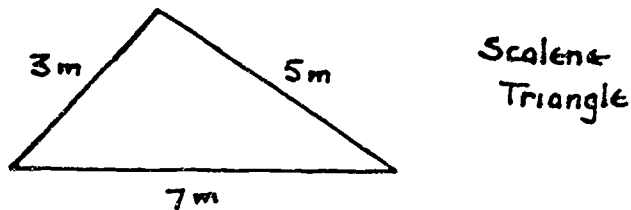

Identify the triangles shown below as equilateral, isosceles, or scalene. Also name the ones that are right triangles.

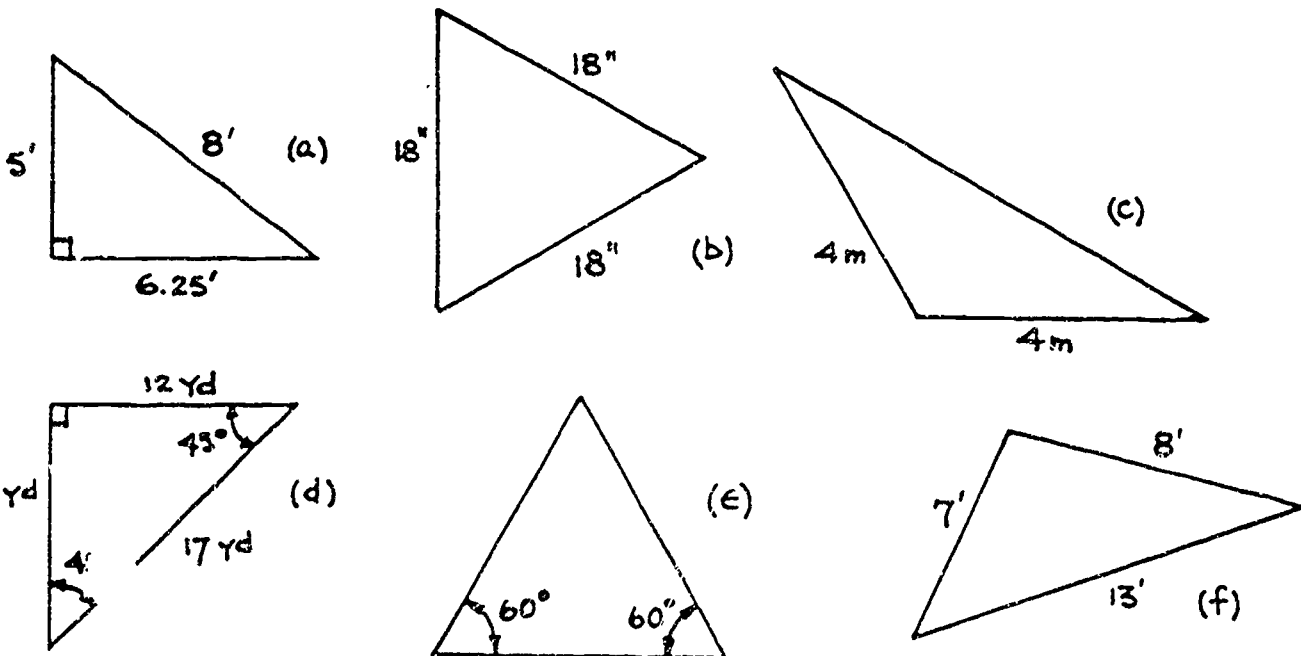

(a) _____ (b) _____ (c) _____

(d) _____ (e) _____ (f) _____

Check your answers with the list on the next page.

- (a) scalene - all sides are unequal
- (b) equilateral - all sides are equal
- (c) isosceles - two sides are equal
- (d) isosceles - two sides are equal
- (e) equilateral - two angles equal 60° so the third angle must equal 60° since $3 \times 60^\circ = 180^\circ$. Therefore, all angles are equal.
- (f) scalene - all sides are unequal
- (a) is also a right triangle since one of the angles is labeled \perp which means right angle.
- (d) is also a right triangle. Two of the angles total 90° ($45^\circ + 45^\circ$) so the third angle must equal 90° since all three angles must add up to 180° .

PYTHAGOREAN THEOREM

The Pythagorean Theorem is a rule or formula that allows you to calculate the length of one side of a right triangle when you know the lengths of the other two sides. This formula is named after Pythagoras, an ancient Greek mathematician. Look at Figure 7.

Figure 7: Pythagorean Theorem: For any right triangle, the square of the hypotenuse is equal to the sum of the squares of the other two sides.

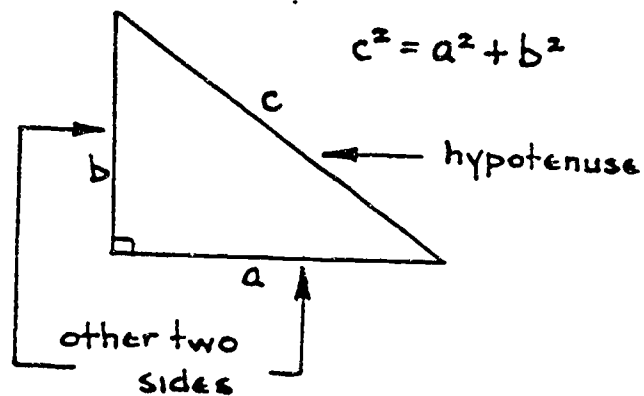

You can use this formula to solve many different types of shop problems. For example, in the sketch below, find the unknown length of a triangular piece of sheet metal.

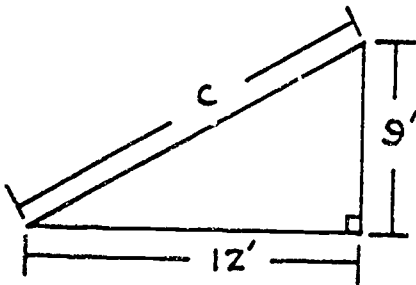

Find c - since c is the hypotenuse, write

$$c^2 = (12')^2 + (9')^2$$

$$c^2 = 144 \text{ sq ft} + 81 \text{ sq ft}$$

$$c^2 = 225 \text{ sq ft}$$

$$c = \sqrt{225 \text{ sq ft}}$$

$$c = 15 \text{ ft}$$

This rule may be used to find any of the three sides of a right triangle if the other two sides are given. The basic formula $c^2 = a^2 + b^2$ can be rewritten as:

$$c = \sqrt{a^2 + b^2}$$

$$a = \sqrt{c^2 - b^2}$$

$$b = \sqrt{c^2 - a^2}$$

Remember: This is only true for a right triangle--a triangle with a right or 90° angle.

Solve the following problem:

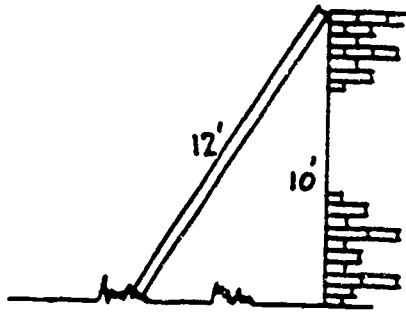

A carpenter wants to use a 12-foot ladder to reach the top of a 10-foot wall. How far must the foot of the ladder be from the base of the wall?

See below:

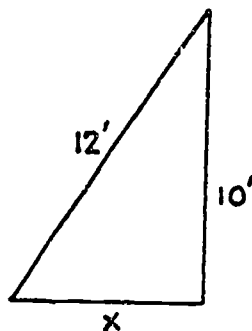

Use the formula $a = \sqrt{c^2 - b^2}$, then

$$x = \sqrt{(12')^2 - (10')^2}$$

$$x = \sqrt{(144 \text{ sq ft}) - (100 \text{ sq ft})}$$

$$x = \sqrt{44 \text{ sq ft}}$$

$$x = 6.6 \text{ ft (rounded)}$$

EXAMPLE PROBLEMS: Work through the following problems using the Pythagorean Theorem.

1. What is the distance between the center of two pulleys if one is placed 9" to the left and 6" above the other?

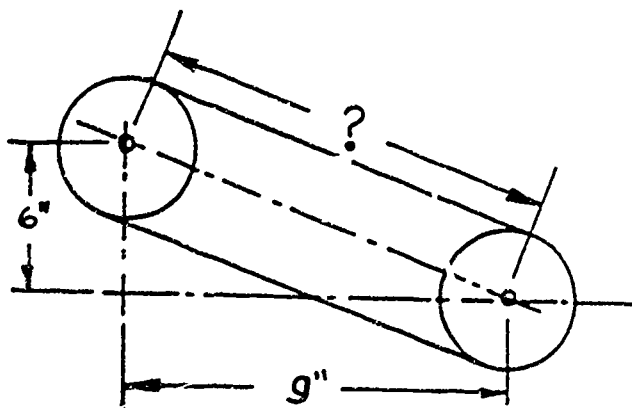

$$c = \sqrt{a^2 + b^2}$$

$$c = \sqrt{(6'')^2 + (9'')^2}$$

$$c = \sqrt{36 \text{ sq in} + 81 \text{ sq in}}$$

$$c = \sqrt{117 \text{ sq in}}$$

$$c = 10.82 \text{ in (rounded)}$$

27.)

2. What is the length of the horizontal dimension on the blueprint of a piece of sheet metal with three holes drilled as shown?

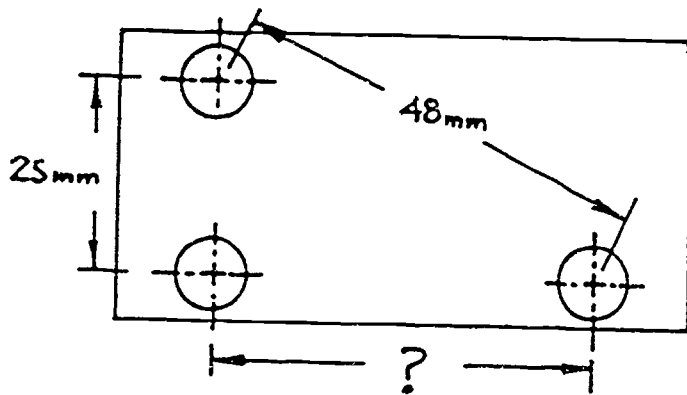

$$b = \sqrt{c^2 - a^2}$$

$$b = \sqrt{(48\text{mm})^2 - (25\text{mm})^2}$$

$$b = \sqrt{2304\text{mm}^2 - 625\text{mm}^2}$$

$$b = \sqrt{1679\text{mm}^2}$$

$$b = 40.98\text{mm (rounded)}$$

3. What is the missing dimension x in the sketch of a taper punch shown below?

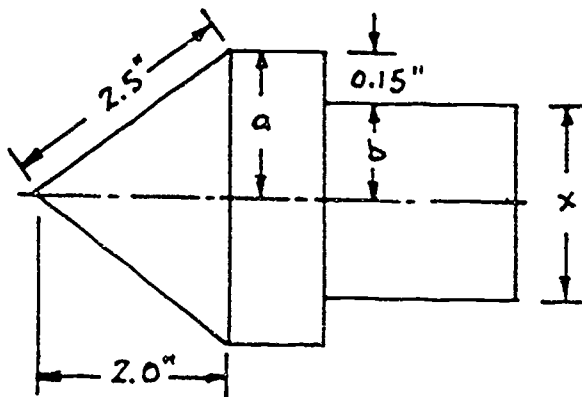

First, find dimension a

$$a = \sqrt{c^2 - b^2}$$

$$a = \sqrt{(2.5\text{in})^2 - (2.0\text{in})^2}$$

$$a = \sqrt{6.25\text{in}^2 - 4\text{in}^2}$$

$$a = \sqrt{2.25\text{in}^2}$$

$a = 1.5\text{in}$, then find b

$$b = a - 0.15\text{in}$$

$$b = 1.5\text{in} - 0.15\text{in}$$

$b = 1.35\text{in}$, then find x

$$x = 2b$$

$$x = 2(1.35) = 2.70\text{in}$$



(1) 3-4-5 triangle

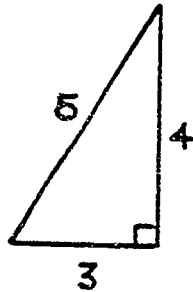

If you draw a triangle with legs 3 units, 4 units and 5 units long, it will always be a right triangle.

(2) 30°-60°-90° triangle

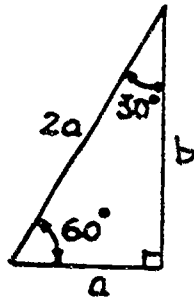

In a triangle with angles 30°, 60°, and 90°, the shortest side will always be exactly one-half the longest side. Side *b* is about 1.732*a*.

(3) 45°-45°-90° triangle

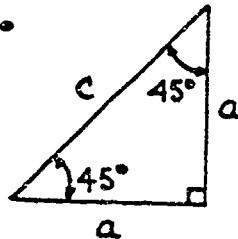

If the two legs of a right triangle are equal, the angles will be 45°, 45°, and 90°. The hypotenuse *c* will be $\sqrt{2}$ times the length of the other side. This kind of a triangle is called a right-isosceles triangle.

$$\text{hypotenuse } c = a\sqrt{2}$$

$$c \approx 1.41a(\text{rounded})$$

AREA OF A TRIANGLE

The area of any triangle, no matter what its size or shape, can be found by using the same simple formula. Look at Figure 8.

Area of a triangle

$$\text{Area, } A = \frac{1}{2}bh, \text{ or}$$

$$A = \frac{bh}{2}$$

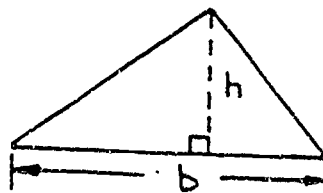

Figure 8: Area of a triangle. 275

For example in the triangle below, the base is 13" and the height is 8". Applying the formula,

$$\text{Area} = \frac{1}{2}bh$$

$$A = \frac{(13" \times 8")}{2}$$

$$A = \frac{104 \text{ in}^2}{2}$$

$$A = 52 \text{ sq in}$$

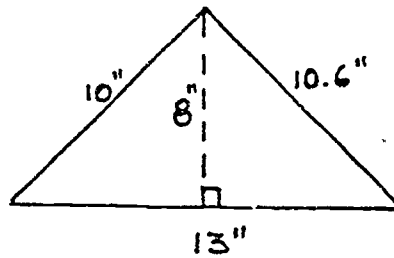

Of course the base does not need to be the bottom of the triangle. Use any side of the triangle as the base, but be certain the height you use is perpendicular to that base. For example in the triangle at the right:

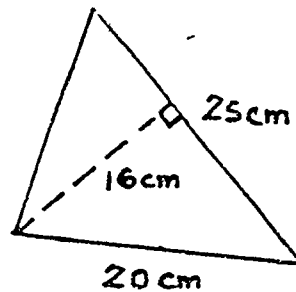

$$b = 25 \text{ cm}$$

$$h = 16 \text{ cm}$$

$$\text{Area, } A = \frac{1}{2}(25)(16)$$

$$A = 200 \text{ cm}^2$$

In some triangles the height may not be given directly and some additional math must be done to find the area. For example, find the area of the isosceles triangle shown below:

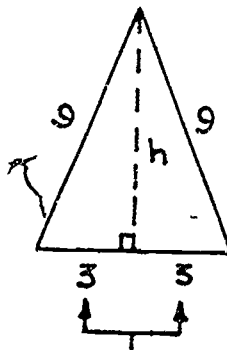
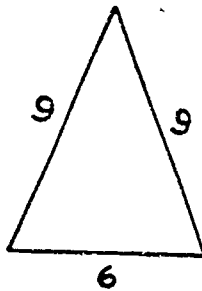

You must first find the height by using the Pythagorean Theorem

$$h = \sqrt{(9)^2 - (3)^2}$$

$$h = \sqrt{81 - 9}$$

$$h = \sqrt{72}$$

$$h = 8.5 \text{ (rounded)}$$

Now find the Area

$$A = \frac{1}{2}bh$$

$$A = \frac{1}{2}(6)(8.5) = 25.5$$

note that the height of an isosceles triangle divides the base into two equal parts

In general, to find the area of an isosceles triangle, use the following formula. Look at Figure 9.

Area of an Isosceles Triangle

Area, $A = \frac{1}{2} b \sqrt{a^2 - \left(\frac{b}{2}\right)^2}$

or $A = \frac{b \sqrt{4a^2 - b^2}}{4}$

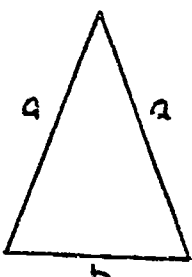
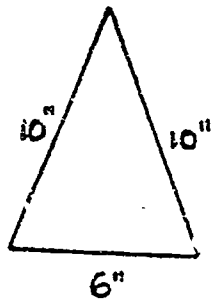

Figure 9: Area of an Isosceles Triangle.

For example: A piece of sheet metal is shaped like an isosceles triangle as shown below. Find the area.



$$A = \frac{1}{2} b \sqrt{a^2 - \left(\frac{b}{2}\right)^2}$$

$$A = \frac{6}{2} \sqrt{10^2 - \left(\frac{6}{2}\right)^2}$$

$$A = 3\sqrt{100 - 9}$$

$$A = 3\sqrt{91}$$

$$A = 28.62 \text{ sq in}$$

For the area of an equilateral triangle, the formula shown in Figure 10 can be used.

Area of an Equilateral Triangle

$A = \frac{\sqrt{3} a^2}{4}$

$A = 0.433 a^2$ (rounded)

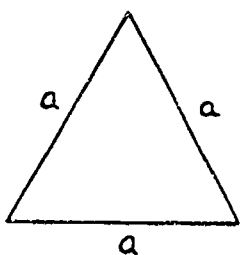
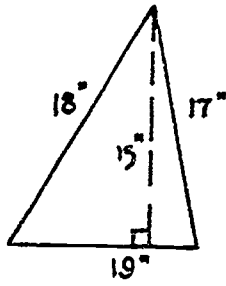

Figure 10: Area of an equilateral triangle.

EXAMPLE PROBLEMS: Find the areas of the different triangles shown below.
Use the triangle area formulas you have just learned.



(1)

$$1. A = \frac{1}{2} b \cdot h$$

$$A = \frac{15 \cdot 19}{2}$$

$$A = 142.5 \text{ sq in}$$

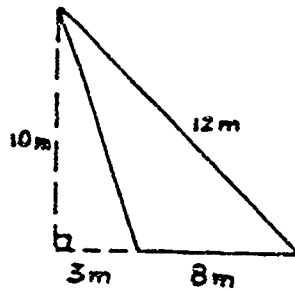

(2)

$$2. A = \frac{1}{2} b \cdot h$$

$$A = \frac{8 \cdot 10}{2}$$

$$A = 40 \text{ sq m}$$

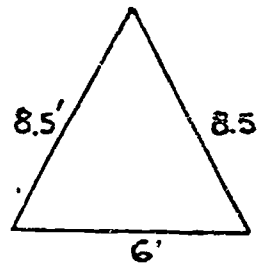

(3)

$$3. A = \frac{b}{2} \sqrt{a^2 - \left(\frac{b}{2}\right)^2}$$

$$A = \frac{6}{2} \sqrt{(8.5)^2 - \left(\frac{6}{2}\right)^2}$$

$$A = 3 \sqrt{72.25 - 9}$$

$$A = 3 \sqrt{63.25}$$

$$A = 23.86 \text{ sq ft (rounded)}$$

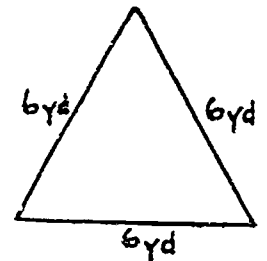

(4)

$$4. A = .433 a^2$$

$$A = .433 (6)^2$$

$$A = .433 (36)$$

$$A = 15.59 \text{ sq yd (rounded)}$$

HERO'S FORMULA

It is possible to find the area of any triangle from the lengths of its sides. The formula that tells you how was developed nearly 2000 years ago by Hero, a Greek mathematician. It looks like a difficult formula and you may feel like a hero when you learn how to use it. Look at Figure 11.

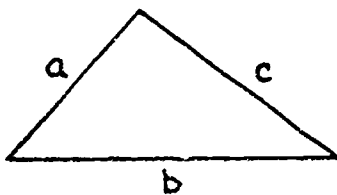

$$\text{Area} = \sqrt{s(s-a)(s-b)(s-c)}, \text{ where } s = \frac{a+b+c}{2}$$

s is called the half-perimeter

For Example:

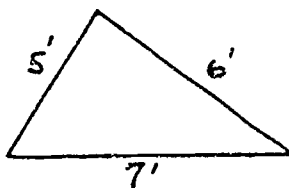

$$\text{first: } s = \frac{a+b+c}{2} = \frac{5+6+7}{2} = 9$$

$$A = \sqrt{9(9-5)(9-6)(9-7)}$$

$$A = \sqrt{9(2)(3)(4)}$$

$$A = \sqrt{216}$$

$$A = 14.7 \text{ sq in (rounded)}$$

Figure 11: Hero's Formula

REGULAR POLYGONS

A polygon is a plane geometric figure with three or more sides. A regular polygon is one in which all sides are the same length and all angles are equal. The equilateral triangle and the square are both regular polygons.

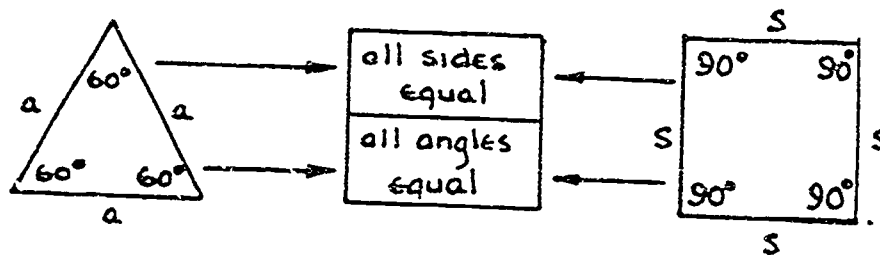

A five-sided regular polygon is called a pentagon.

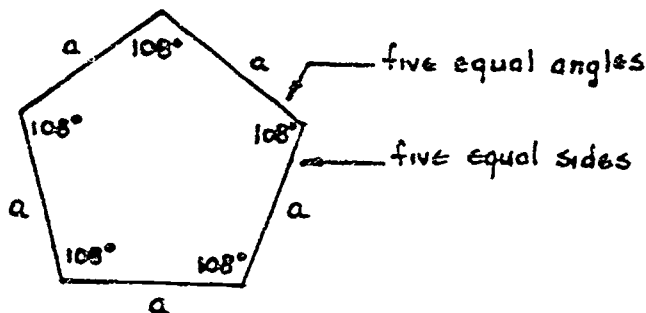

The regular hexagon is a six-sided polygon in which each interior angle is 120° and all sides are the same length.

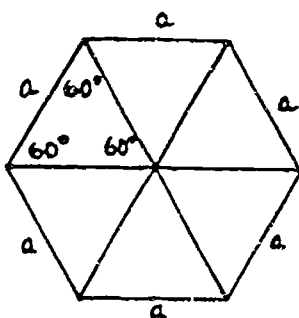

If you draw the three diagonals, six equilateral triangles are formed. Since the formula for the area of an equilateral triangle is $0.433a^2$, the area of a hexagon will be six times $0.433a^2$, or

$$\text{Area, } A = 2.598a^2 \text{ (rounded)}$$

$$\text{For example, if } a = 6 \text{ cm, } A = 2.598(6)^2$$

$$A = 2.598(36)$$

$$A = 93.5 \text{ sq cm (rounded)}$$

Dimensions of a Hexagon

d = distance across corners

$$d = 2a, \text{ or } a = 0.5d$$

f = distance across flats

$$f = 1.732a \text{ (approx.)}, \text{ or } a = 0.577f \text{ (approx)}$$

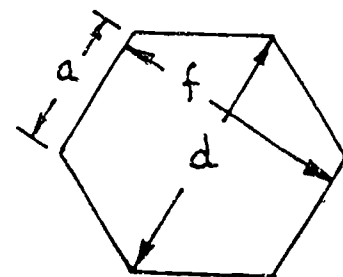

For example, a hex nut has a side length of $\frac{1}{4}$ inch. From the following list of wrenches pick the smallest size wrench that will fit the nut:

- (a) $\frac{1}{4}$ " (b) $\frac{3}{8}$ " (c) $\frac{7}{16}$ " (d) $\frac{1}{2}$ " (e) $\frac{5}{8}$ "

Look at the sketch below:

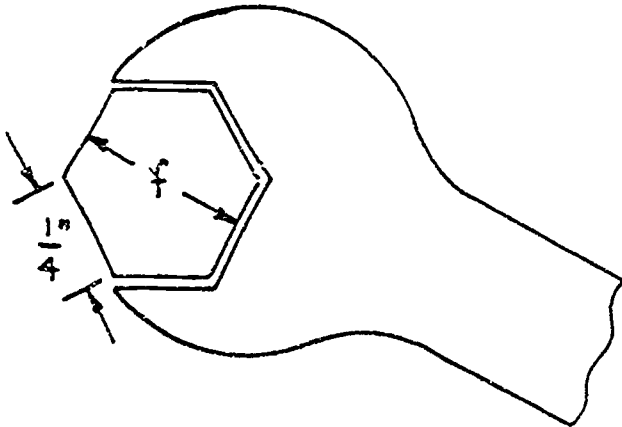

$$f = 1.732a$$

$$f = 1.732(.25)$$

$$f = 0.433"$$

Converting the given fractions to decimals you get:

$$(a) \frac{1}{4} = 0.25", (b) \frac{3}{8} = 0.375", (c) \frac{7}{16} = 0.4375"$$

$$(d) \frac{1}{2} = 0.5", (e) \frac{5}{8} = 0.625"$$

Therefore the $\frac{7}{16}$ " wrench is the smallest size that will fit.

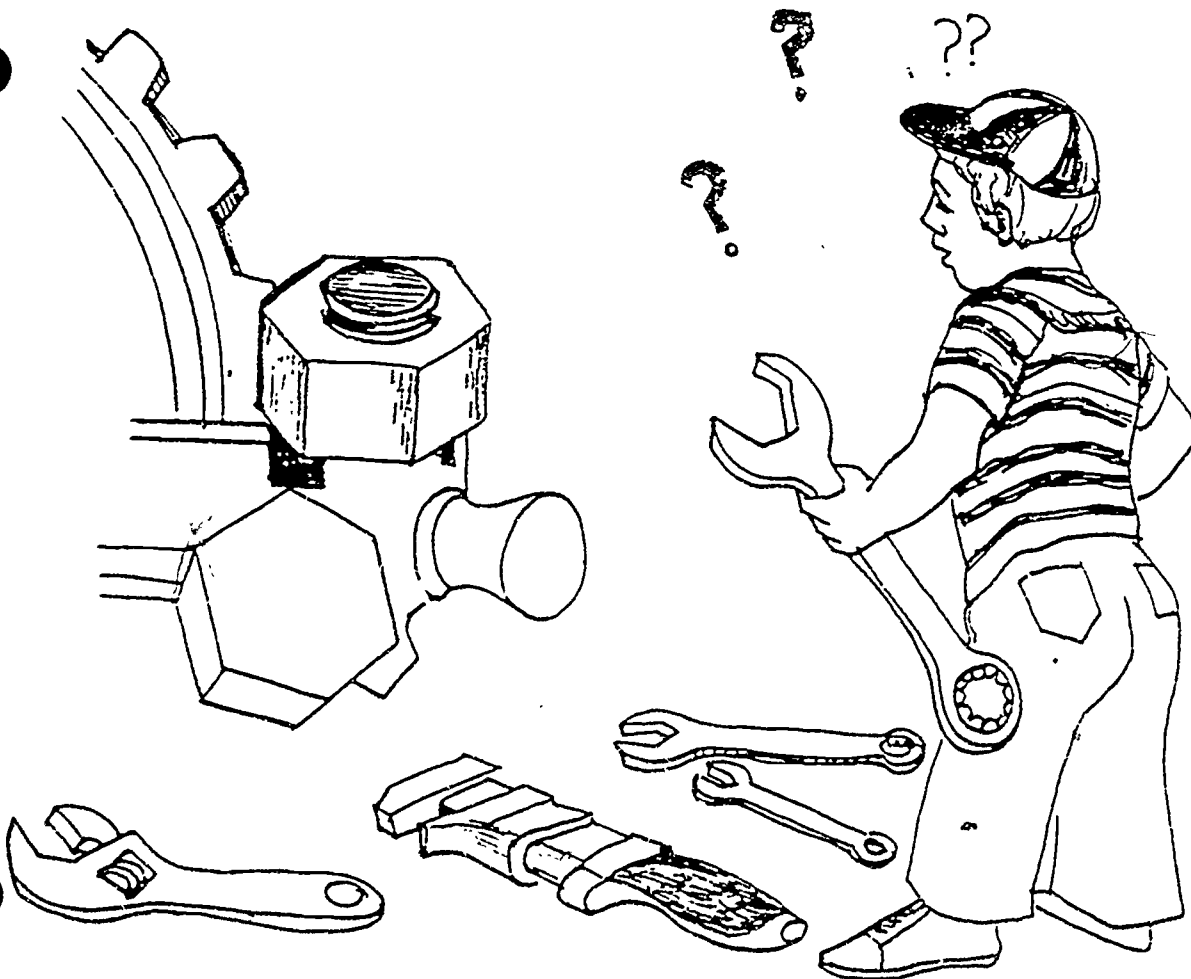

IRREGULAR POLYGONS

Many times the shapes of polygons that appear in practical work are not the simple geometric figures that you have seen so far. The easiest way to work with irregular polygon shapes is to divide them into simpler, more familiar figures. Look at the L-shaped figure shown below:

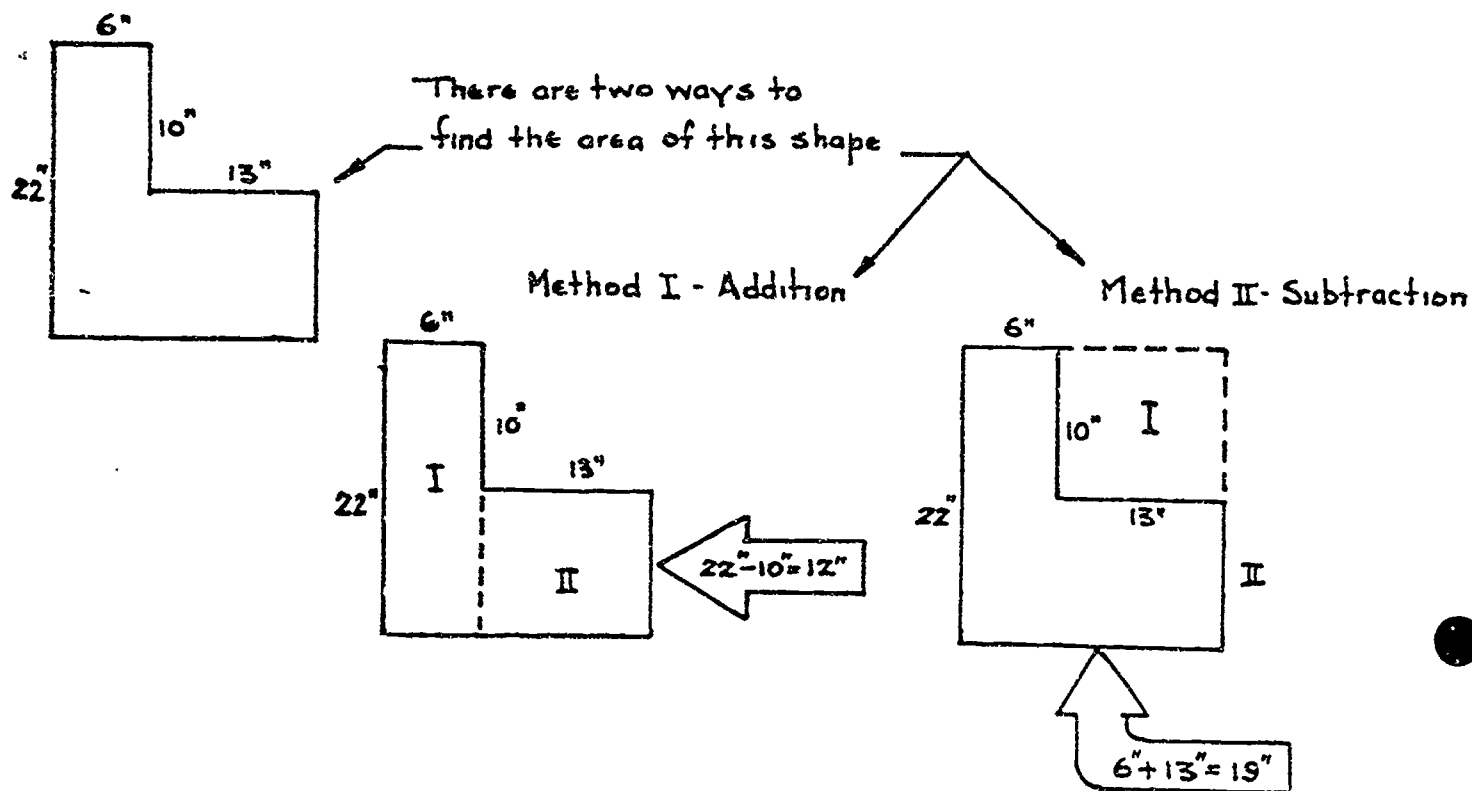

METHOD I

By drawing the dotted line, the figure is divided into two rectangles, I and II.

$$\begin{aligned} \text{Total area} &= \text{Area I} + \text{Area II} \\ A &= (22)(6) + (13)(12) \\ A &= 132 + 156 \\ A &= 288 \text{ sq in} \end{aligned}$$

METHOD II

In this method, subtract the area of the small rectangle I from the area of the large rectangle II.

$$\begin{aligned} \text{Total Area} &= \text{Area II} - \text{Area I} \\ A &= (22)(19) - (10)(13) \\ A &= 418 - 130 = 288 \text{ sq in} \end{aligned}$$

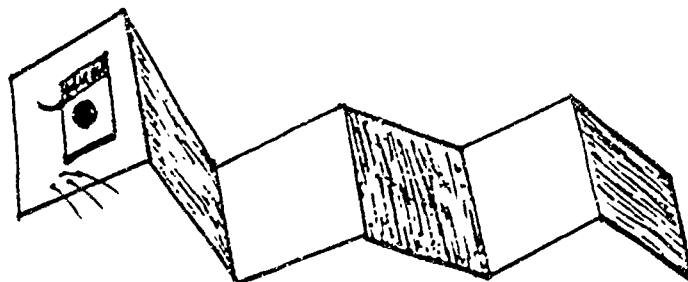

Find the area of the shape shown below:

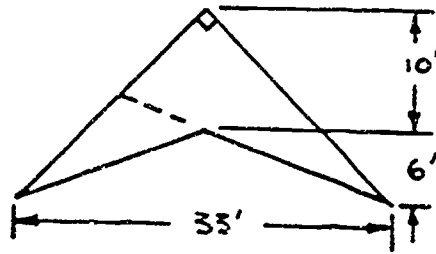

You may want to try to divide the figure into two triangles as shown by the dotted line, but that would be impossible because of the given dimensions.

The only method you can use is to subtract triangle I from triangle II.

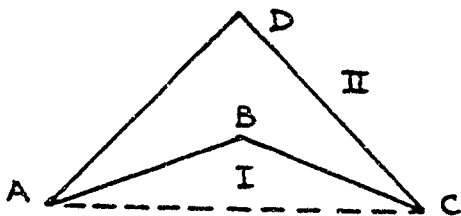

Triangle I is $\triangle ABC$

Triangle II is $\triangle ADC$

$$\text{Area of } \triangle I = \frac{bh}{2} = \frac{(33)(6)}{2} = 99 \text{ sq ft}$$

$$\text{Area of } \triangle II = \frac{bh}{2} = \frac{(33)(16)}{2} = 264 \text{ sq ft}$$

$$\text{Area of shape} = \text{Area } \triangle II - \text{Area } \triangle I$$

$$A = 264 \text{ sq ft} - 99 \text{ sq ft}$$

$$A = 165 \text{ sq ft}$$

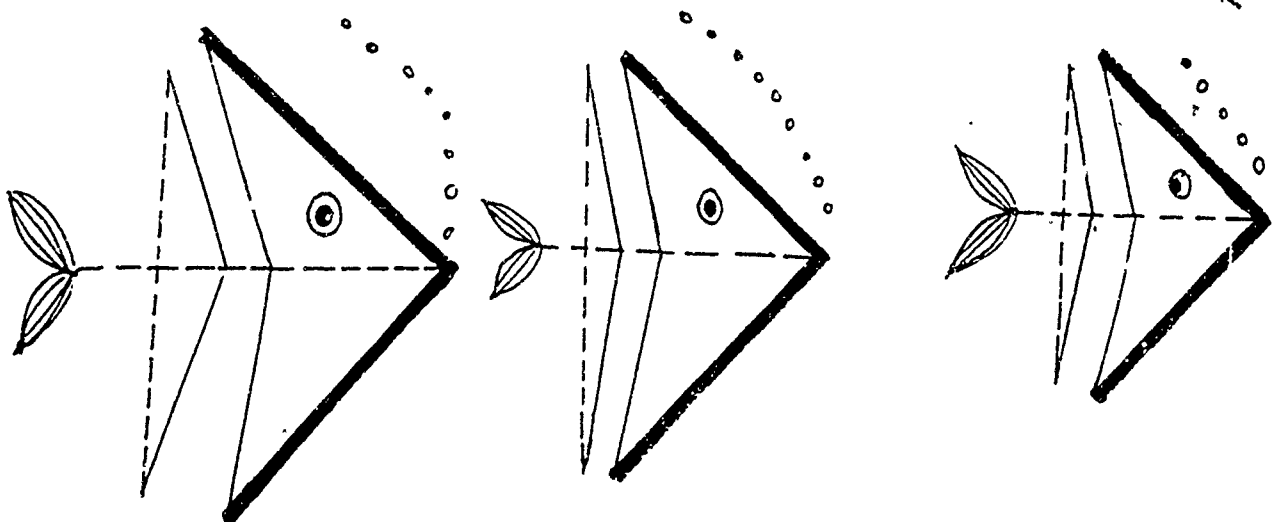

EXAMPLE PROBLEM: Find the area of the shape below.

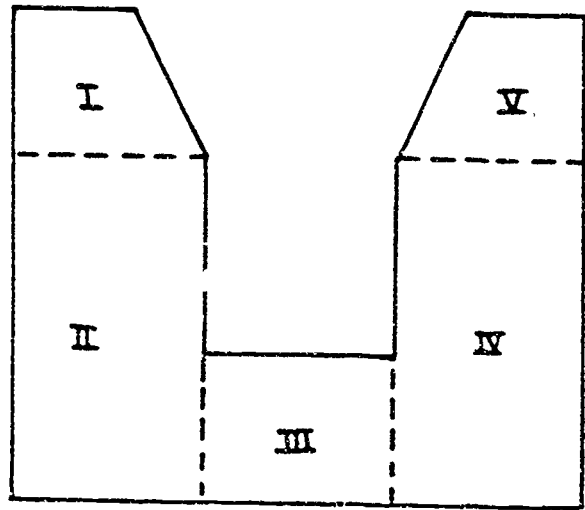
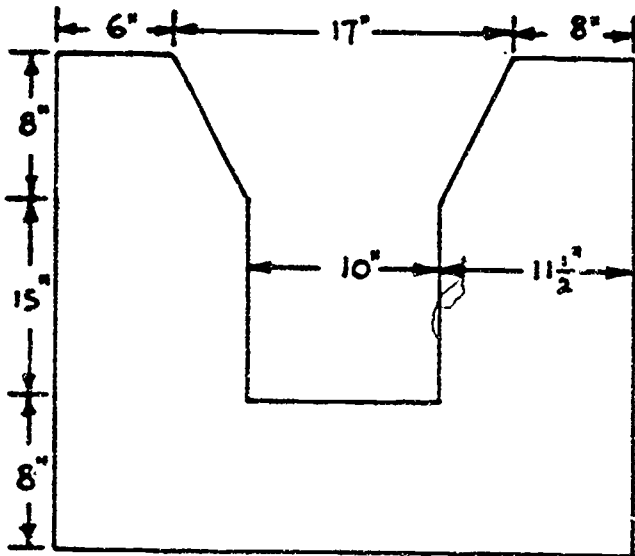

You might have been tempted to cut the figure into 5 shapes as shown on the right. This would work, but there is a much easier way. Look at the sketch below. Did you think of finding the area this way? You only need to compute three areas and then subtract II and III from the area of I.

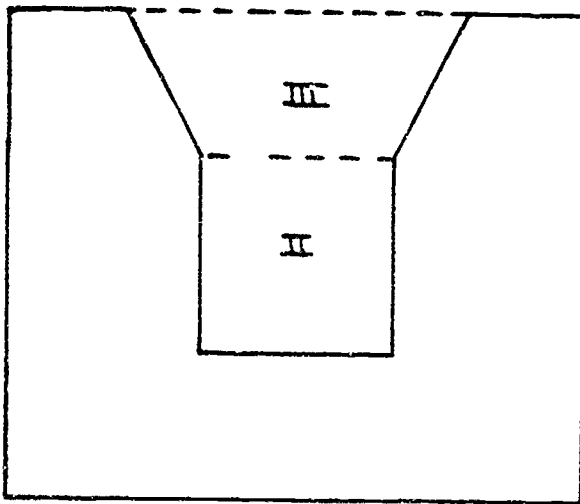

$$\text{Total Area} = \text{Area I} - \text{Area II} - \text{Area III}$$

$$\text{Area} = 961 - 150 - 108$$

$$A = 961 - (150 + 108)$$

$$A = 961 - 258$$

$$A = 703 \text{ sq in}$$

The outside rectangle is Area I

I

$$\text{Figure I: base} = 6 + 17 + 8 = 31$$

$$\text{height} = 8 + 8 + 15 = 31$$

$$\text{Area} = hb = (31)(31)$$

$$A = 961 \text{ sq in}$$

$$\text{Figure II: base} = 10$$

$$\text{height} = 15$$

$$A = hb = (10)(15)$$

$$A = 150 \text{ sq in}$$

$$\text{Figure III: (Trapezoid)}$$

$$\text{bases} = 17 \text{ and } 10$$

$$\text{height} = 8$$

$$A = \frac{(b_1 + b_2)h}{2}$$

$$A = \frac{(17 + 10)8}{2}$$

$$A = (27)(4) = 108 \text{ sq in}$$

You can easily see that when working with complex figures, neatness will help you to eliminate mistakes. Now you can try some more example problems.

EXAMPLE PROBLEMS: Work through the following problems and find the area of each shape shown.

1.

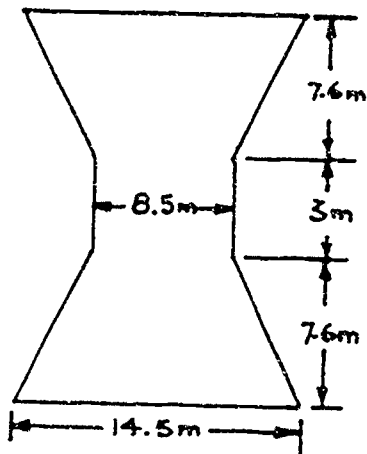

Make two equal trapezoids (I and III) and one rectangle (II).

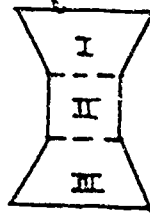

Shape Area = 2 · Area I + Area II

$$A = 2 \left(\frac{b_1 + b_2}{2} \right) h + bh$$

$$A = 2 \left(\frac{8.5 + 14.5}{2} \right) 7.6 + (8.5)(3)$$

$$A = 23(7.6) + (8.5)(3)$$

$$A = 200.3 \text{ sq m}$$

2.

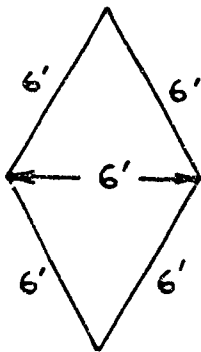

Make two equal equilateral triangles

Area of shape = 2 (Area of I)

Use the area formula for equilateral triangles

Area of shape = 2 (0.433 a²)

$$A = 2(0.433)(6^2)$$

$$A = 2(0.433)(36)$$

$$A = 31.2 \text{ sq ft (rounded)}$$

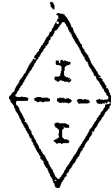

3.

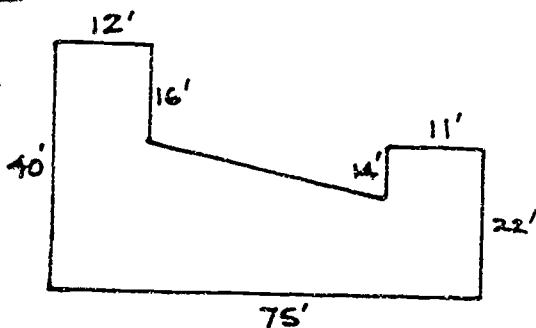

Make two rectangles and one trapezoid
Shape Area = Area I + Area II + Area III

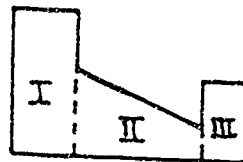

$$\text{Area I} = (12)(40) = 480 \text{ sq ft}, \text{ Area III} = (22)(11) = 242 \text{ sq ft}$$

$$\text{Area II} = \left(\frac{b_1 + b_2}{2} \right) h, \quad h = 75 - (12 + 11) = 52$$

$$b_1 = 40 - 16 = 24$$

$$b_2 = 22 - 14 = 8$$

$$A = \left(\frac{24 + 8}{2} \right) 52$$

$$A = (16)(52) = 832 \text{ sq ft}$$

Then Total Area = Area I + Area II + Area III

$$A = 480 + 242 + 832$$

$$A = 1554 \text{ sq ft}$$

NOW YOU CAN DO SOME SHOP PROBLEMS.

SHOP PROBLEMS

1. In the piece of steel shown in the sketch below, your boss has asked you to drill four 4-inch diameter holes, spaced at equal intervals around a 12-inch diameter inner circle. You must find the dimension S . HINT: Use the Pythagorean Theorem.

Distance S _____

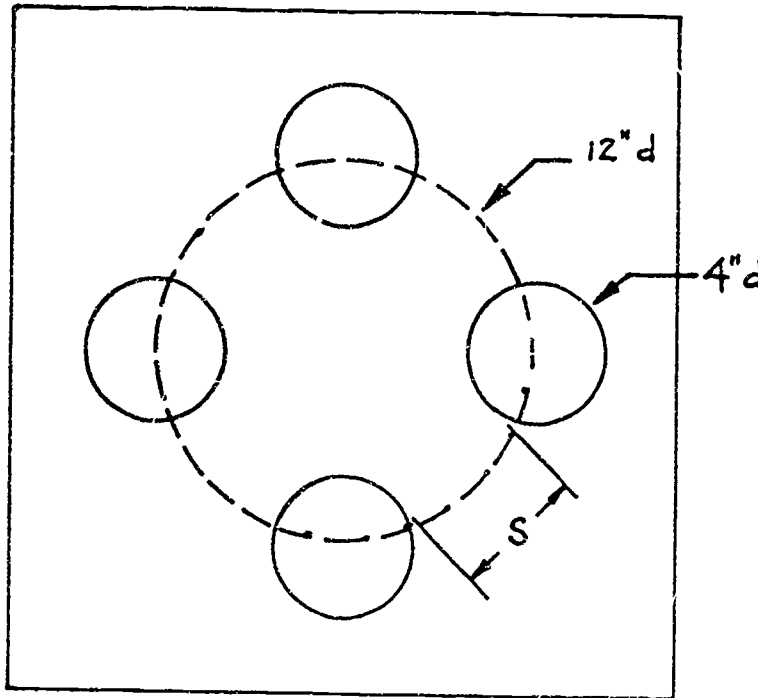

2. You have circular bar stock with diameters of 2", $1\frac{3}{4}$ ", $1\frac{1}{2}$ ", $1\frac{1}{4}$ ", and 1". If you must mill a square rod with dimensions 1" by 1", which diameter circular rod do you choose? Look at the sketch below.

Diameter of bar stock _____

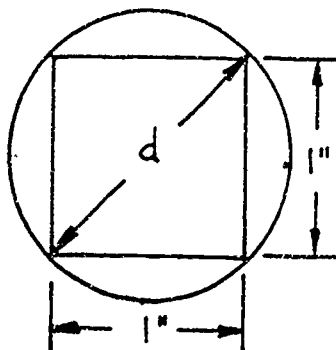

295

3. You have finished machining a pattern gage as shown in the sketch below. You must find the area of the gage in order to know how much to charge for material. What is the area?

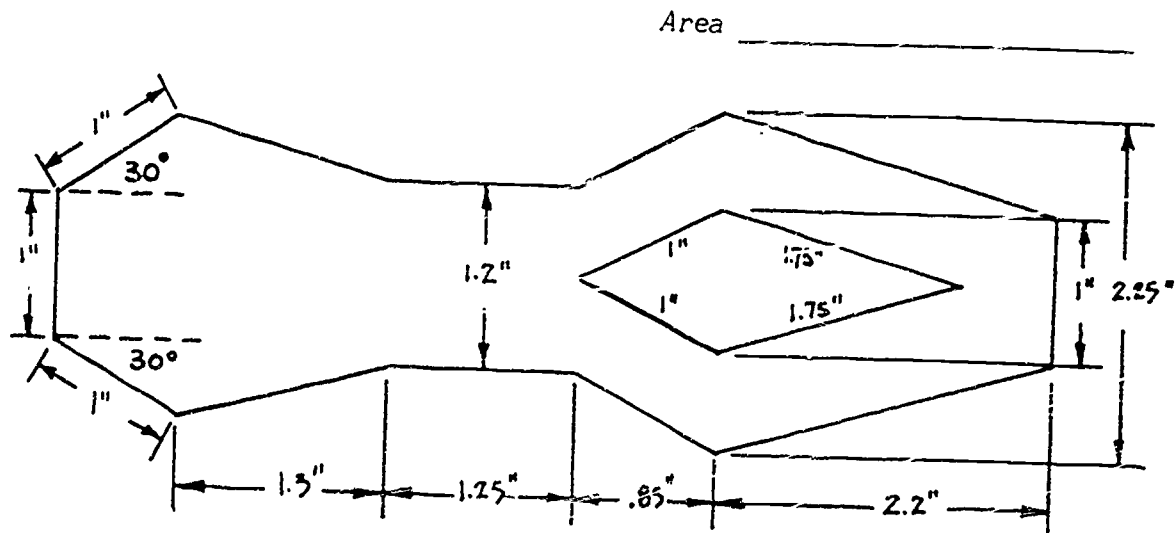

4. You have milled a triangular gage as shown below. You need to know the area to the nearest thousandth of a square millimeter. (Remember, if you need to know the answer to the nearest thousandth--three decimal places--you need to do all your figuring to four decimal places or more and then round to three decimal places.)

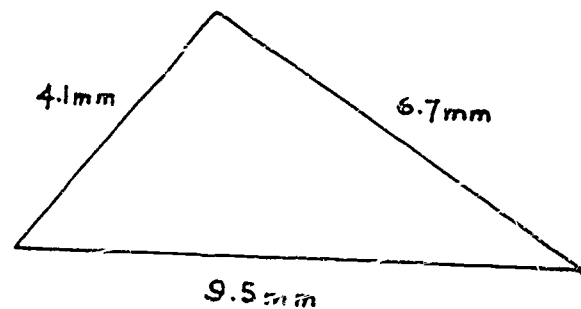

HINT: Use Hero's formula shown on page 25, Figure 11 of this Project Sheet.

Area _____

5. Your boss gives you the sketch of a gage pattern that you must cut and grind to close tolerance. To make this gage pattern, you need to know the missing dimensions and the area to the closest thousandth of an inch. Look at the sketch below and find the area A and the missing dimensions x , s , and h .

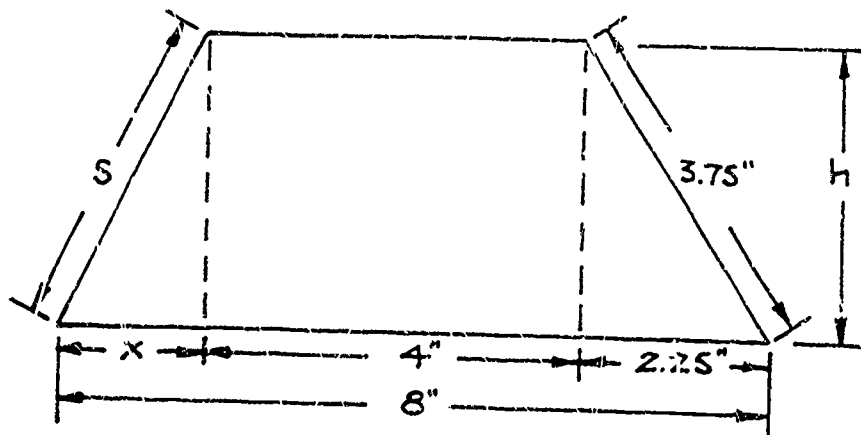

$A =$ _____
 $x =$ _____
 $s =$ _____
 $h =$ _____

6. Your supervisor wants you to machine a pentagon-shaped gage as a part of a fixture. You need to find the missing dimension s , the perimeter, and the area. Look at the sketch on the right.

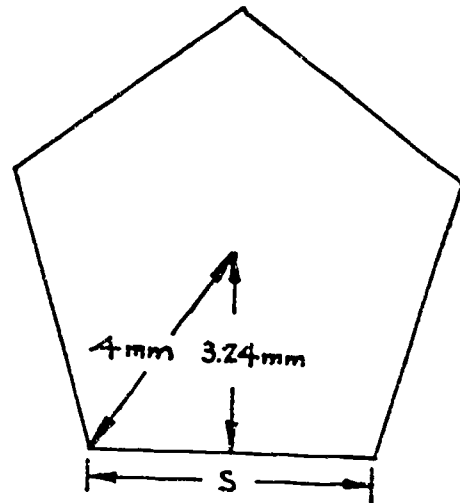

s _____
 Perimeter _____
 Area _____

7. You need to mill a hexagonal shape from circular bar stock. You have a selection of stock with diameters of 1.75", 1.5", 1.375", 1.25" and 0.75". If you minimize your waste, which diameter of circular bar stock is best to use? Look at the sketch below.

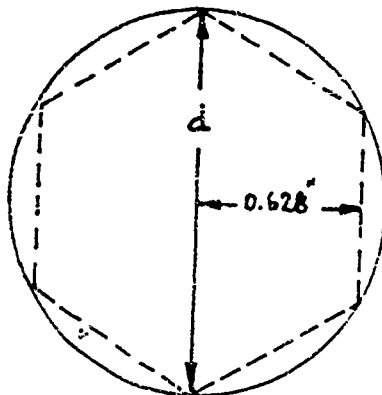

hint: look at
 page 26 of this
 Project Sheet

Diameter of bar stock _____

8. You have just finished cutting and machining a pattern. Look at the sketch below. If your boss charges his customers a total fee of \$8.75 per square inch for this type of machine work, how much does he charge for the pattern you have made?

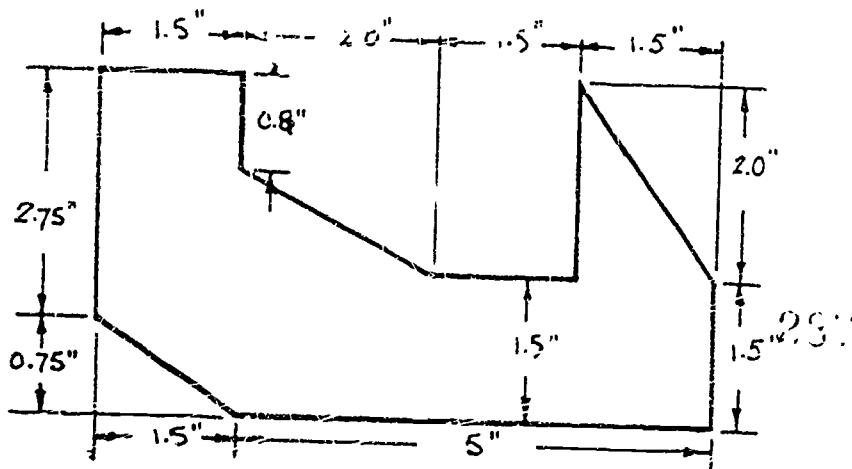

Cost \$ _____

9. Your boss has given you the job of machining a taper punch. You must find the missing dimension L on the sketch shown below before you can do the job.

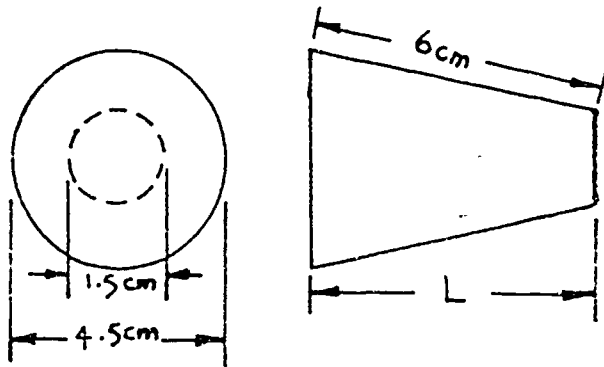

L _____

10. Look at the sketch below. You must find the radius R of the circular wheel with center at O . You have placed two round pins with centers at A and B and radii of 0.5 inches. With a micrometer, you then very accurately measure the distance a and find it to be 8 inches. With the above given dimensions, what is the radius R ?

R _____

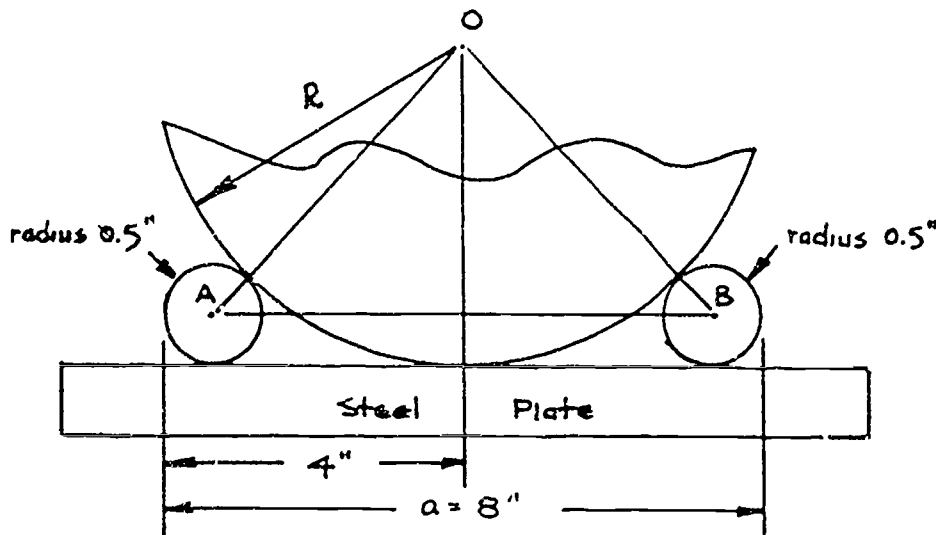

SHOW YOUR WORK TO YOUR INSTRUCTOR.

BAS



Full Text Provided by ERIC

FIGURE:

1. RECTANGLE

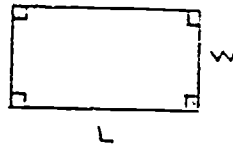

AREA

$$A = LW$$

PERIMETER

$$P = 2L + 2W$$

2. SQUARE

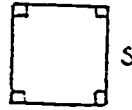

$$A = S^2$$

$$P = 4S$$

3. PARALLELOGRAM

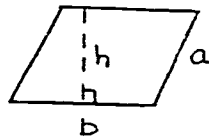

$$A = bh$$

$$P = 2a + 2b$$

4. TRIANGLE

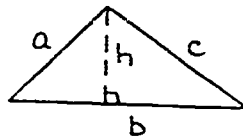

$$A = \frac{bh}{2}$$

$$P = a + b + c$$

5. EQUILATERAL TRIANGLE

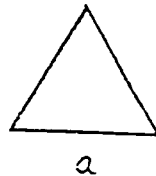

$$A = 0.433a^2$$

$$P = 3a$$

6. ISOSCELES TRIANGLE

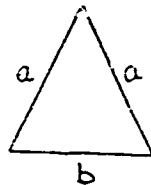

$$A = \frac{b}{2} \sqrt{a^2 - \left(\frac{b}{2}\right)^2}$$

$$P = 2a + b$$

7. TRAPEZOID

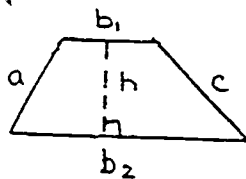

$$A = h \left(\frac{b_1 + b_2}{2} \right)$$

$$\text{or } \frac{h}{2} (b_1 + b_2)$$

$$P = a + b_1 + b_2 + c$$

8. REGULAR HEXAGON

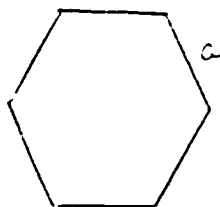

$$A = 2.598a^2$$

$$P = 6a$$

FIGURE:

9. CIRCLE

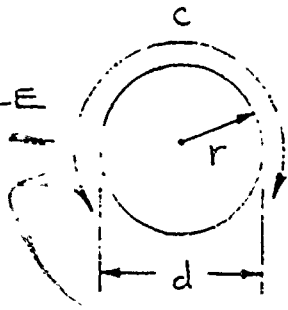

AREA

PERIMETER

$$A = \pi r^2$$

$$A = 0.7854 d^2$$

$$C = \pi d$$

$$C = 2\pi r$$

10. RING

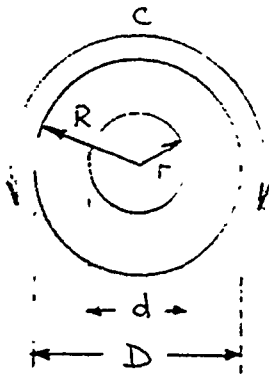

$$A = \pi(R^2 - r^2)$$

$$A = 0.7854(D^2 - d^2)$$

$$C = 2\pi R$$

11. CIRCULAR SECTOR

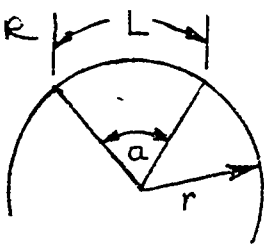

$$A = 0.00873 r^2 a$$

$$A = \frac{ML}{2}$$

$$L = 0.01745 r a$$

$$a = \frac{57.296 L}{r}$$

12. CIRCULAR SEGMENT

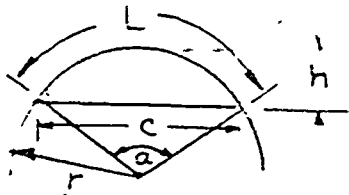

$$A = \frac{1}{2} [rL - c(r-h)]$$

$$c = 2\sqrt{h(2r-h)}$$

$$L = 0.01745 r a$$

$$M = \frac{c^2 \pm 4h^2}{8h}$$

$$a = \frac{57.296 L}{r}$$

3 Sides of a Triangle (3 Sides Known): + HERON'S FORMULA

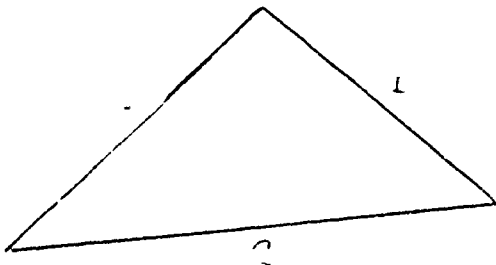

$$A = \sqrt{s(s-a)(s-b)(s-c)}$$

$$s = \frac{a+b+c}{2}$$

PROJECT SHEET



213

Name _____ Date _____

Cluster Metal Trades Occupation Machinist HelperTraining Module Shop Math for MachinistsTraining Milestone 3. Specialized Math Skills

PROJECT 5

SHOP GEOMETRY: PART 2

TRAINING CONDITIONS:

● Here's what you will need:

1. This Project Sheet.
2. A pen or pencil to answer the Shop Problems in this Project Sheet.

TRAINING PLAN:

● Here's what you do:

In this Project Sheet, you will learn more about Geometry. You will learn about circles and many rules that relate to circles. You will learn about solid figures including prisms, pyramids, frustrums, cones, cylinders and spheres. You will learn to find the areas of circles. You will also learn to find the surface area and the volume of solid figures. The information in this Project Sheet will help you solve many shop problems using Geometry.

1. Read and study pages 2 to 33 of this Project Sheet.
2. Work the Shop Problems on pages 34 to 37.
3. Have your Instructor check your work and record your score on your Student Training Record.
4. Ask your Instructor for your next Project Sheet.

TRAINING GOAL:

● Here's how well you must do:

1. You must score 8 out of 10 correct on the Shop Problems.

SHOP GEOMETRY: PART 2

CIRCLES

A circle is probably the most familiar and the simplest plane figure. A circle is the geometric shape that is most often used in shop work. The definition of a circle is: A closed curve with every point on the curve an equal distance from a point interior to the closed curve. You don't have to remember that definition. You do have to remember the sketch and the definition shown below.

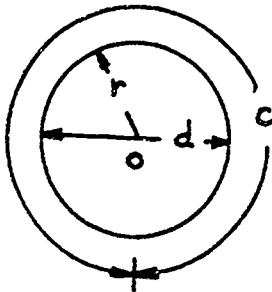

r = radius ← Radius is the distance from the center point O of the circle to any point on the circle.

d = diameter ← Diameter is the straight line distance across the circle through the center point O .

c = circumference ← Circumference is the distance around the circle. The circumference of a circle is similar to the perimeter of a polygon.

For all circles the ratio of the circumference to the diameter is always the same number. That means that the relationship between the distance around a circle and the distance across the circle will always be the same number.

$$\frac{\text{circumference}}{\text{diameter}} = 3.14159\dots = \pi$$

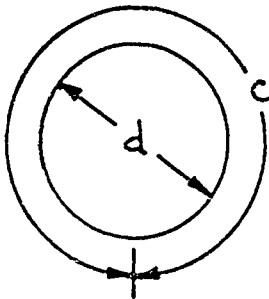

The value of this ratio has been given the label π , the Greek letter pi. The value of pi is approximately 3.14, but the number has no simple decimal form. The digits continue without ending or repeating. For most practical work use $\pi = 3.1416$.

Remember: Pi has no dimensions or units. Pi is a ratio.

The relationships between radius, diameter, and circumference are shown in Figure 1 below:

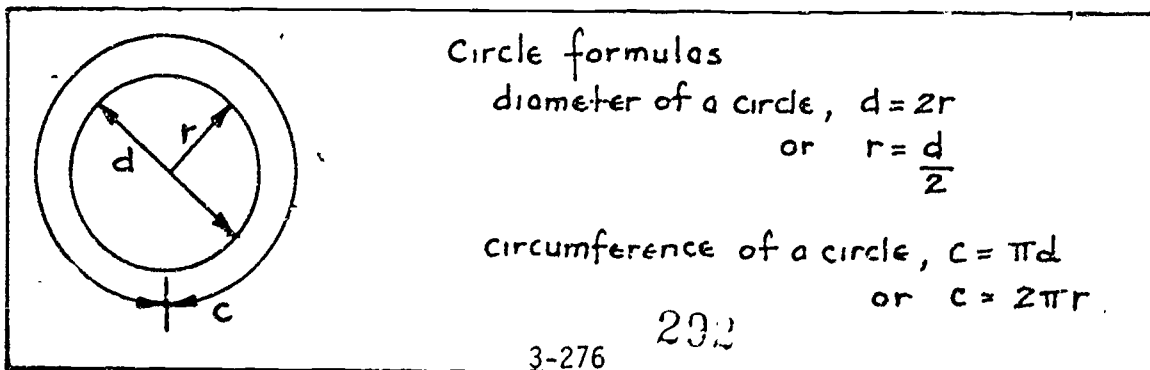

Figure 1: Circle Formulas

EXAMPLE PROBLEMS

1. Your boss wants you to know the radius and circumference of a hole you have drilled with a $\frac{3}{4}$ " drill.

A $\frac{3}{4}$ " drill has a diameter of $\frac{3}{4}$ " or 0.75".

$$\text{The radius } r = \frac{d}{2} = \frac{0.75}{2}$$

$$r = 0.375" \leftarrow \text{radius}$$

$$\text{The circumference } c = \pi d = 3.1416 (0.75)$$

$$c = 2.3562" \leftarrow \text{circumference}$$

2. You must bend a piece of sheet metal into a circular tube having a diameter of 3.25 feet. What is the required length of sheet metal?

The length of the sheet metal will equal the circumference,

$$\text{so } c = d$$

$$c = (3.1416) (3.25)$$

$$c = 10.2102 \text{ ft.}$$

3. You must space 8 bolts equally around a circular steel plate at a radius of 9 inches. What must be the spacing between the bolt holes along the curve? Look at the sketch below.

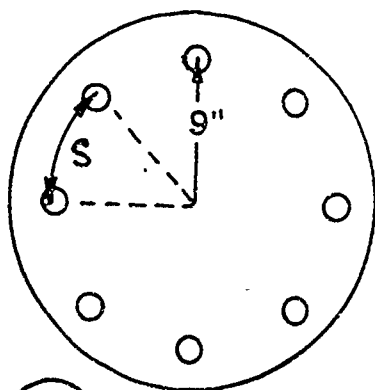

$$\text{circumference } c = \pi d, \quad d = 2r$$

$$c = \pi (2 \cdot 9) = \pi (18)$$

$$c = 3.1416 (18)$$

$$c = 56.5488$$

since the spacing distance s equals $\frac{1}{8}$ of the circumference,

$$s = \frac{c}{8} = \frac{56.5488}{8}$$

$$s = 7.0686"$$

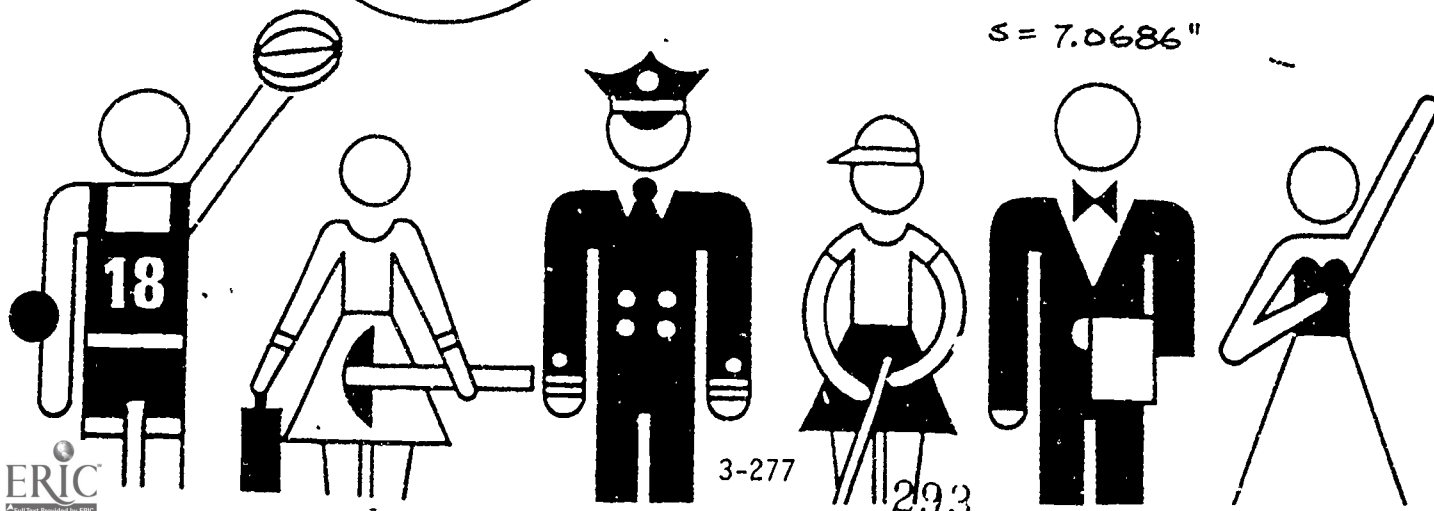

FINDING PARTS OF CIRCLES

As a sheet metal worker or machinist, you will be required to find the lengths of portions of circles. A common problem is to find the length of something that is partly curved and partly straight.

When you calculate the length of a curved section of metal, you must remember that the material on the inside of the curve is compressed (smaller) and the material on the outside is stretched. Therefore, you must calculate the length along a neutral axis. Look at the sketch below.

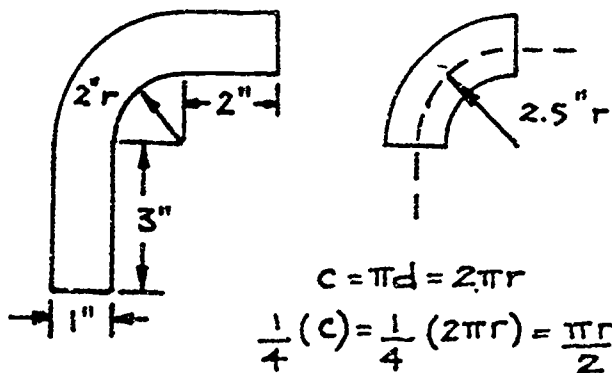

The inside radius is 2". The stock is 1" thick. Therefore, the midline or neutral axis has a radius of 2.5".

The curved section of the bar is one-quarter of a circle so the curved section is one-fourth of C.

$$C = \pi d = 2\pi r$$

$$\frac{1}{4}(C) = \frac{1}{4}(2\pi r) = \frac{\pi r}{2}$$

$$\frac{C}{4} = \frac{\pi r}{2} = \frac{(3.14)(2.5)}{2} = 3.93"$$

Then the total length will be the sum of the two straight segments and the curved segment.

$$\text{Length } L = 3" + 2" + 3.93"$$

$$L = 8.93"$$

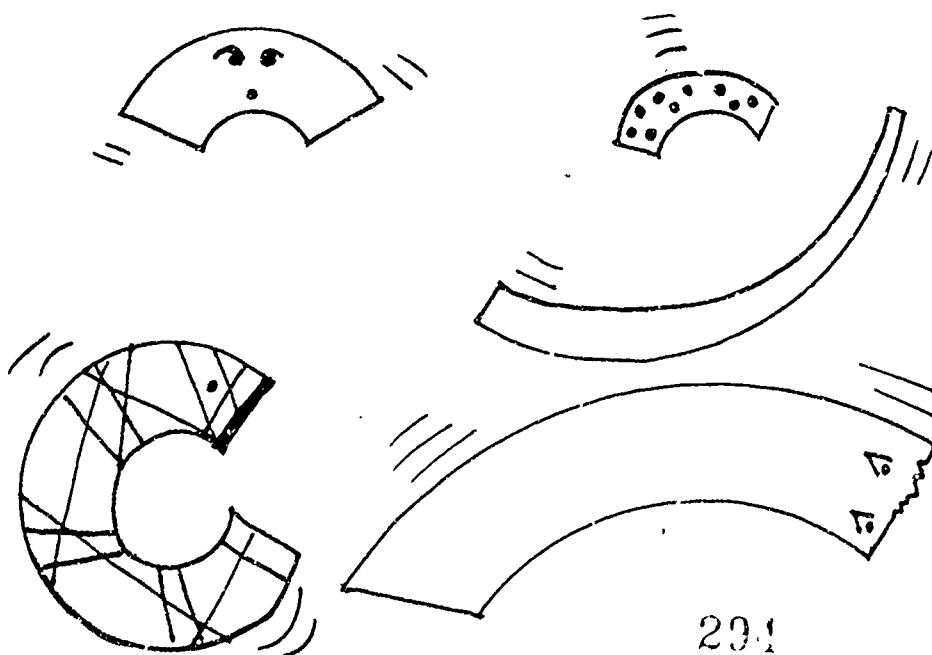

EXAMPLE PROBLEMS

1. Find the length of the ornamental piece of iron grill needed to bend the shape shown in the sketch below.

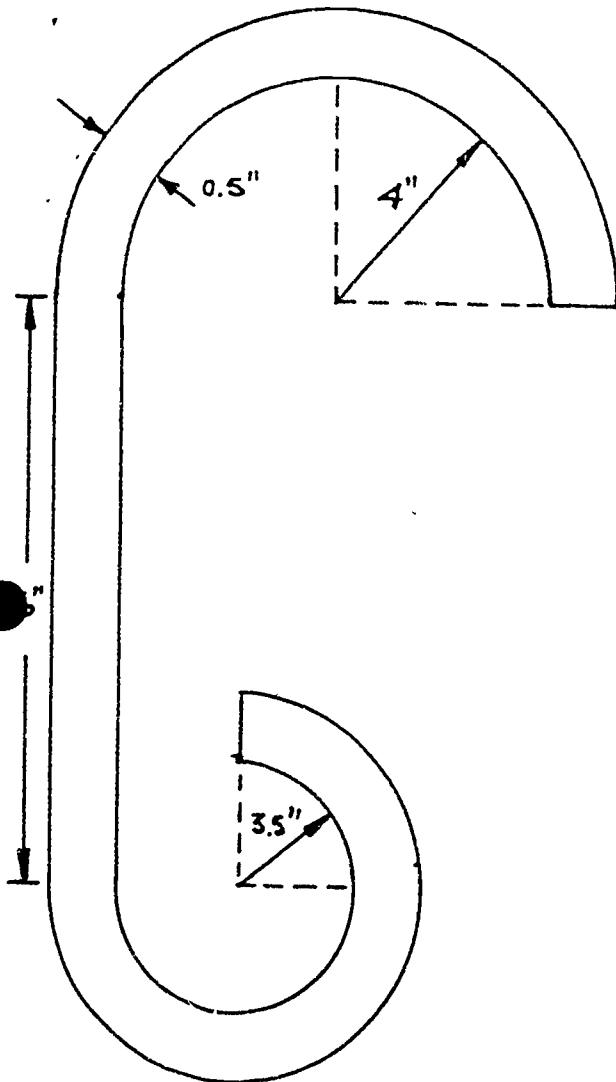

- a. the upper curved section:
 radius of the neutral axis is ;
 $r = 4 + 0.25 = 4.25''$
 half of the circumference is ;
 $\frac{1}{2} C = \frac{1}{2} (2\pi r) = \pi r = 3.1416 (4.25)$
 $\frac{1}{2} C = 13.35''$ (rounded)
- b. the lower curved section:
 radius of the neutral axis is ;
 $r = 3.5 + 0.25 = 3.75''$
 three-fourths of the circumference ;
 $\frac{3}{4} C = \frac{3}{4} (2\pi r) = \frac{6(3.1416)(3.75)}{4}$
 $\frac{3}{4} C = 17.67''$ (rounded)
- c. total length = sum of straight piece
 plus curved sections a and b above.
 $L = 6'' + 13.35'' + 17.67''$
 $L = 37.02''$

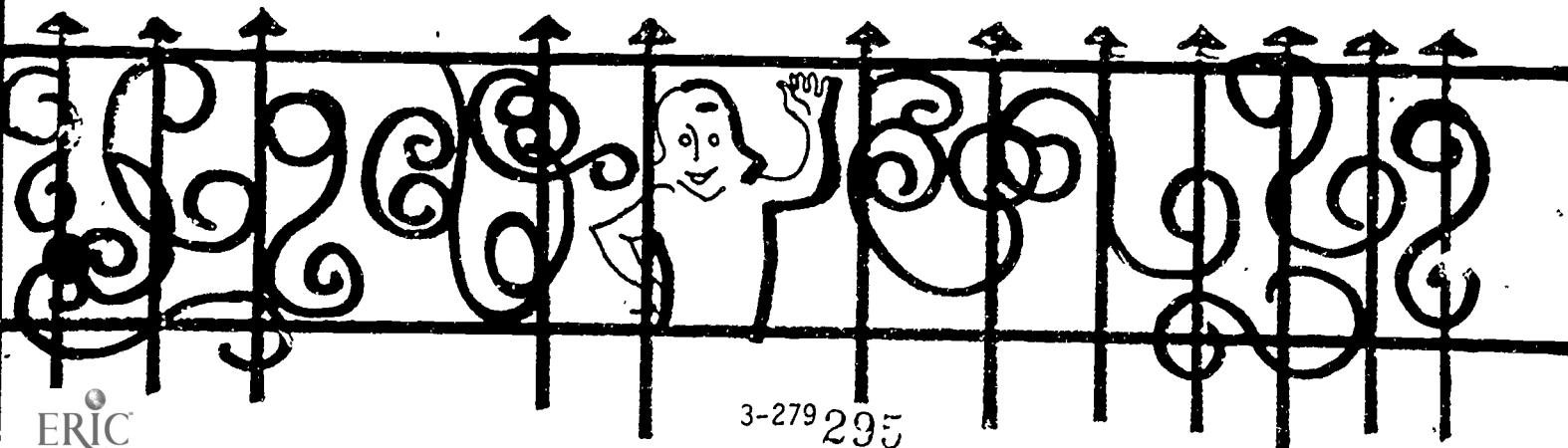

2. Find the length of round stock needed to form the U-shaped form shown in the sketch below.

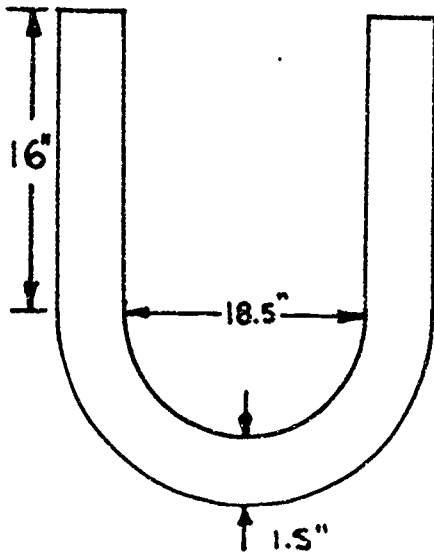

- a. the two straight sections:

$$L = 16 + 16 = 32''$$

- b. the lower curved section:

radius of the neutral axis is;

$$\frac{18.5}{2} + \frac{1.5}{2} = 9.25 + .75 = 10.0''$$

$$\begin{aligned} \text{circumference} &= 2\pi r, \text{ half of the} \\ \text{circumference} &= \pi r = 3.1416(10) \\ &= 31.416'' \end{aligned}$$

- c. total length equal sum of a and b above:

$$L = 32 + 31.416 = 63.416''$$

FINDING THE AREA OF A CIRCLE

To find the area of a circle, use the formulas shown in Figure 2.

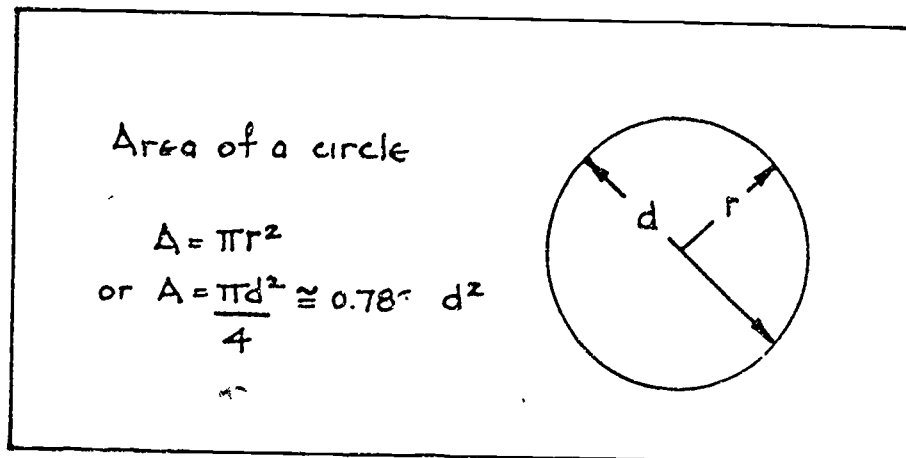
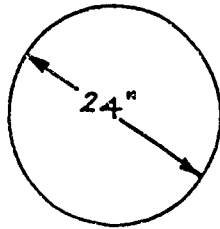

Figure 2: Area of a circle.

296

EXAMPLE PROBLEMS

1. How much sheet metal is needed to make a circular metal table top with a diameter of 24 inches? Look at the sketch below:



$$A = \frac{\pi d^2}{4} \approx 0.7854 d^2$$

$$A = 0.7854 (24^2)$$

$$A = 452.3904 \text{ sq in}$$

2. What is the area of the largest circle that can be cut from a square piece of sheet metal 4 feet 6 inches on a side? Round your answer to the nearest hundredth. Look at the sketch below:

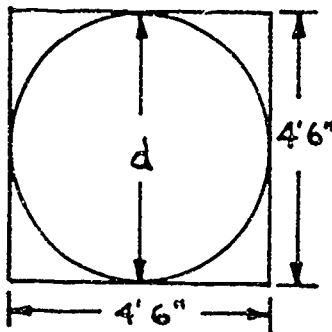

$$A = \frac{\pi d^2}{4} \approx 0.7854 d^2$$

$$A = 0.7854 (4.5^2), \text{ note: } 4'6" = 4.5'$$

$$A = 0.7854 (20.25)$$

$$A = 15.90 \text{ sq ft (rounded)}$$

A circular ring is defined as the area between two concentric circles. Two circles are concentric when they have the same center point but different radii. A washer is a ring. So is the cross-section of a pipe or a cylinder.

To find the area of a circular ring, subtract the area of the inner circle from the area of the outer circle. Use the formula shown in Figure 3.

Area of a ring

Area = Area of Outer circle
minus area of inner circle

$$\text{Area} = \pi R^2 - \pi r^2 = \pi (R^2 - r^2)$$

or $A = \frac{\pi D^2}{4} - \frac{\pi d^2}{4} = \frac{\pi}{4} (D^2 - d^2)$

$$A \approx 0.7845 (D^2 - d^2)$$

The diagram shows two concentric circles. The outer circle has radius 'R' and diameter 'D'. The inner circle has radius 'r' and diameter 'd'. The area between them is the ring.

Figure 3: Area of a ring.

For example, to find the cross-sectional area of the wall of a steel pipe whose inside diameter (i.d.) is 8 inches and whose outside diameter (o.d.) is 8.5 inches, substitute $D = 8.5''$ and $d = 8''$ into the second formula. Look at the sketch below:

$$A = \frac{1}{4}(3.1416)(8.5^2 - 8^2)$$

$$A = (0.7854)(72.25 - 64)$$

$$A = (0.7854)(8.25)$$

$$A = 6.48 \text{ sq in (rounded)}$$

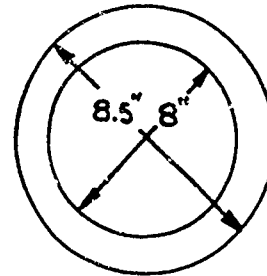

Notice that $\frac{\pi}{4}$ rounded to four decimal places is 0.7854.

Also notice that the diameters are squared first and then the results subtracted.

EXAMPLE PROBLEMS

1. What is the cross-sectional area of a steel collar 0.6 cm thick with an inside diameter of 9.4 cm? Look at the sketch below:

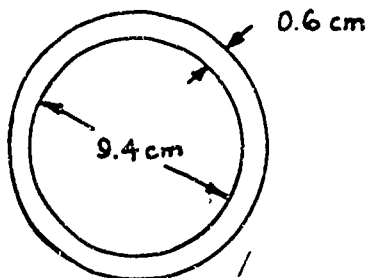

$$\text{i.d.} = 9.4$$

$$\text{o.d.} = 9.4 + 0.6 + 0.6 = 10.6$$

$$A = 0.7854(10.6^2 - 9.4^2)$$

$$A = 0.7854(112.36 - 88.36)$$

$$A = 18.85 \text{ cm (rounded)}$$

2. For a cross section of a pipe with an i.d. of 8 inches, how much more material is needed to make the pipe 0.5 inches thick than to make it 0.375 inches thick?

- a. 0.5" thick

$$A = 0.7854(9^2 - 8^2)$$

$$A = 0.7854(81 - 64)$$

$$A = 0.7854(17)$$

$$A = 13.35 \text{ sq in (rounded)}$$

- b. 0.375" thick

$$A = 0.7854(8.75^2 - 8^2)$$

$$A = 0.7854(76.5625 - 64)$$

$$A = 0.7854(12.5625)$$

$$A = 9.87 \text{ sq in (rounded)}$$

Cross-sectional area of a pipe 0.5" thick = 13.35 sq in.

Cross-sectional area of a pipe 0.375" thick = 9.87 sq in.

Material difference = 13.35 sq in - 9.87 sq in
= 3.48 sq in.

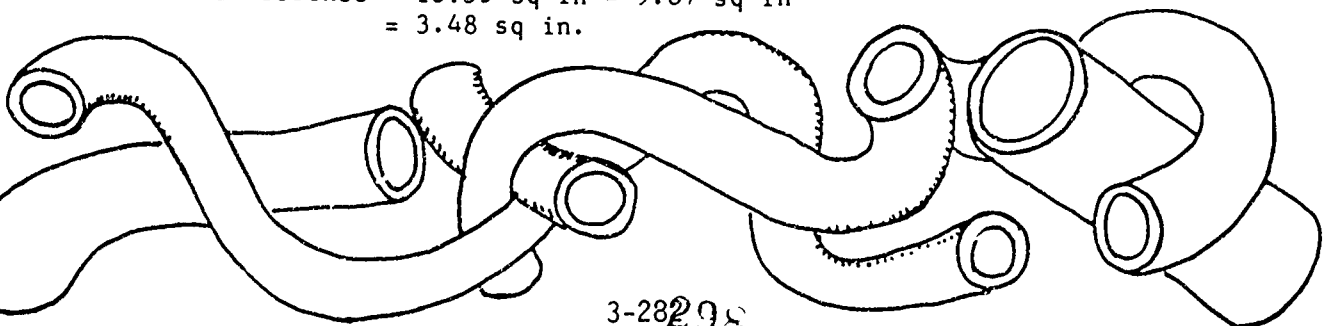

OTHER TERMS AND RULES RELATING TO CIRCLES

So far, you have learned about radii, diameters, circumferences, and areas of circles. In shop work, there are other definitions and formulas you will need to know. Look at Figure 4.

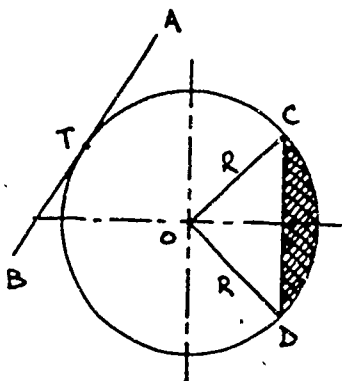

Figure 4: Terms relating to a circle.

1. The straight line joining the points C and D is called a chord of a circle.
2. The distance on the circle between C and D is an arc of the circle and is sometimes written as \widehat{CD} .
3. The shaded area between the arc and the chord is called a segment.
4. The area of the segment plus the area of the triangle OCD is called the sector COD.
5. A line outside a circle which touches the circle at only one place is called a tangent line. In the sketch at the left, line AB is tangent to the circle at point T. Point T is called a point of tangency.

Look at Figure 5 to see further terms relating to a circle.

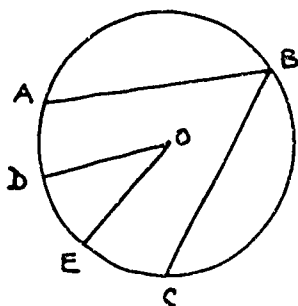
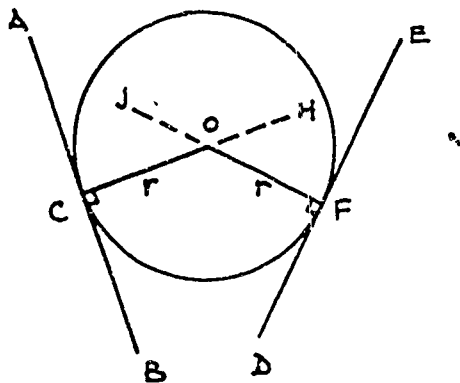

Figure 5: More terms relating to circles.

1. A central angle is an angle whose vertex is at the center of the circle and whose sides are radii of the circle. In Figure 5, angle DOE is a central angle.
2. An angle drawn inside a circle with its vertex on the circumference is called an inscribed angle. In Figure 5, angle ABC is an inscribed angle.
3. Both central angles and inscribed angles are said to intercept the arcs between their sides. For example, central angle DOE intercepts the arc \widehat{DE} and inscribed angle ABC intercepts the arc \widehat{AC} .

RULE 1: A line drawn tangent to a given circle is perpendicular to the radius drawn to the point of tangency; conversely, a line perpendicular to a radius at its extremity (where it touches the circle), is tangent to the circle. Look at Figure 6.



Line AB is tangent to circle O, then line AB is perpendicular to the radius r at the point of tangency C.

Conversely: Line ED is drawn perpendicular to radius r at its extremity (point F), then line ED is tangent to circle O at point F.

Additionally, any line perpendicular to the tangent at the point of tangency must pass through the center of the circle. (For example, line JF is perpendicular to the tangent line at the point of tangency F; therefore, JF goes through the center O. Also, line HC passes through the center O.)

Figure 6: Rule 1.

RULE 2: If two lines are drawn tangent to a circle from an outside point, these lines are equal to each other. Also, the angles made by these two tangent lines and a line from the outside point through the center of the circle are equal. Look at Figure 7.

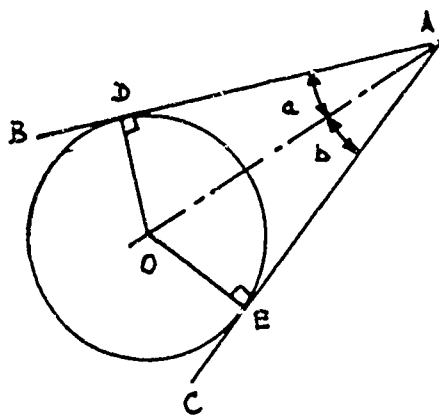

Line AB and line AC are tangent to the circle at O, then line AD = line AE.

Also, line OA bisects angle DAE, or angle $a = \text{angle } b$.

Remember: The word bisect means divide into two equal parts.

Figure 7: Rule 2.

300

RULE 3: If an angle is inscribed in a circle, the angle is equal to one-half the number of degrees of its intercepted arc. Also, an inscribed angle is always equal to one-half of the central angle if both angles intercept the same arc. Look at Figure 8.

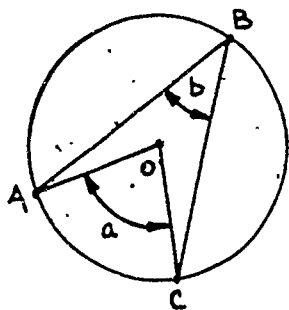

Angle ABC is an inscribed angle. (It has its vertex on the circumference of circle O.) Then angle ABC equals one-half the number of degrees of arc AC.

Also, angle AOC is a central angle. (It has its vertex at the center of the circle O.) Then angle ABC equals one-half of angle AOC, or $\angle b = \frac{\angle a}{2}$.

Figure 8: Rule 3.

RULE 4: An inscribed angle based on the diameter of a given circle is a right angle since the intercepted arc is 180 degrees. (That is, the inscribed angle equals one-half of the intercepted arc, or the inscribed angle equals one-half of 180 degrees, or 90 degrees.) Look at Figure 9.

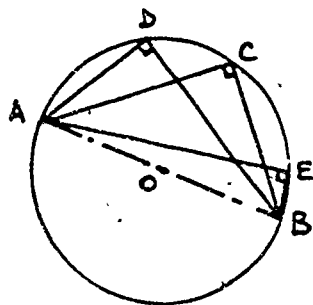

Line AB is the diameter of a circle with its center at O. Angles ADB, ACB and AEB are all inscribed angles based on the diameter AB. Therefore, angles ADB, ACB and AEB are all equal to 90 degrees.

Figure 9: Rule 4.

RULE 5: If a perpendicular is drawn from the center of a circle through any chord in the circle, the chord is bisected and so is the intercepted arc. Look at Figure 10.

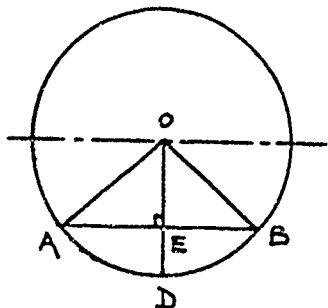

Chord AB intercepts arc \widehat{AB} , line OD is perpendicular to chord AB, then chord AB is bisected. (Line segment AE equals line segment EB.) Also, arc \widehat{AB} is bisected by line OD (arc \widehat{AD} equals arc \widehat{DB}).

Figure 10: Rule 5.

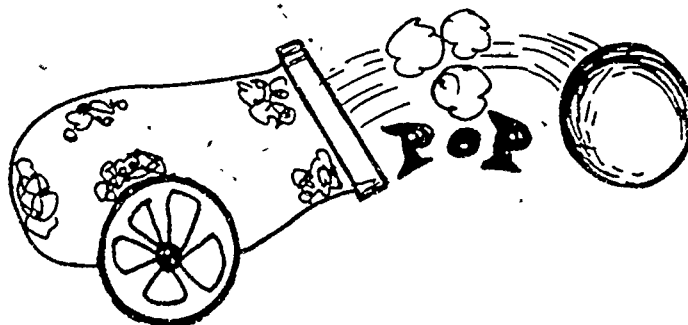

RULE 6: When two lines cut through a circle and intersect the outside of the circle, the included angle between these two lines is measured by one-half the difference of the intercepted arcs. Look at Figure 11.

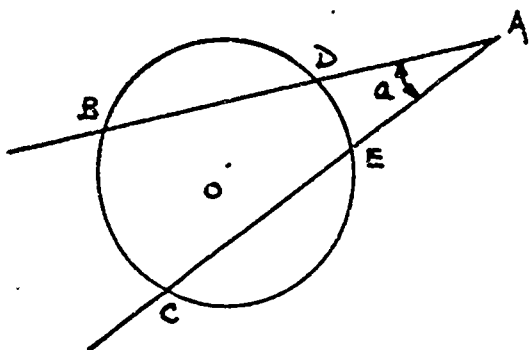

Lines AB and AC cut through the circle with the center at O and intersect outside the circle at point A.

Angle BAC intercepts arcs \widehat{DE} and \widehat{BC} . Then angle BAC equals one-half the difference of the intercepted arcs \widehat{BC} and \widehat{DE} , or angle $a = \frac{\widehat{BC} - \widehat{DE}}{2}$

Figure 11: Rule 6.

SOLID FIGURES

Plane figures have only two dimensions: length and width or base and height. A plane figure can be drawn exactly on a flat plane surface. Solid figures have three dimensions: length, width, and height. Making an exact model of a solid figure requires shaping it from clay, wood, plastic, paper, or other materials. A square is a two-dimensional or plane figure. A cube is a three-dimensional or solid figure.

Metal workers encounter solid figures in the form of tanks, pipes, ducts, gears, shafts, etc. As a metal worker, you must identify a solid shape and its component parts. You must learn to compute surface area and volume.

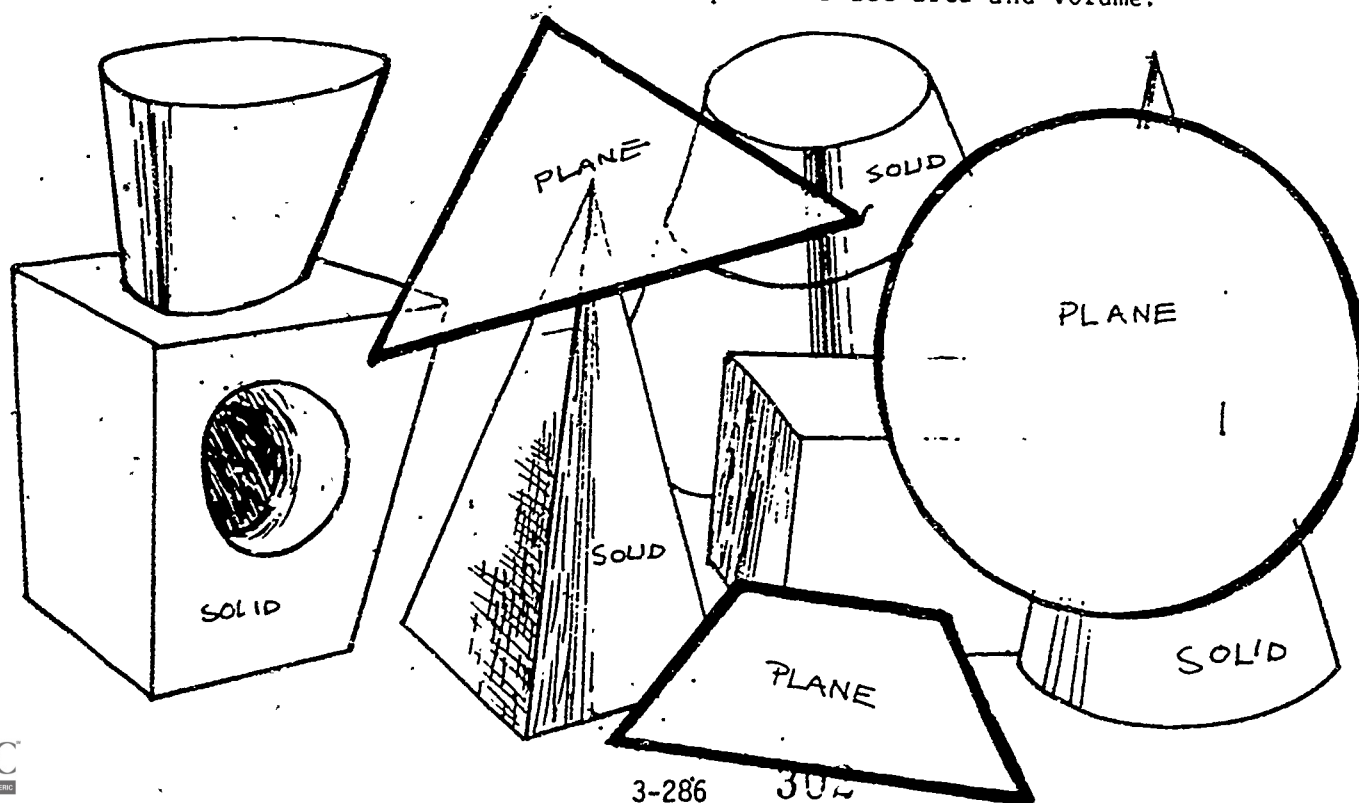

PRISMS

A prism is a solid figure having at least one pair of parallel surfaces that create a uniform cross-section. The sketch below shows a hexagonal prism.

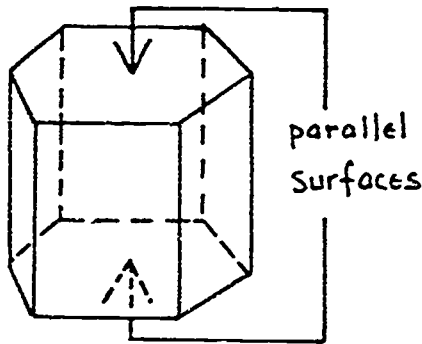

Cutting the prism anywhere parallel to the hexagonal surfaces produces the same hexagonal cross section.

All of the polygons that form the prism are called faces. The faces that create the uniform cross section are called the bases. The shape of the bases give the prism its name. The other faces are called lateral faces.

The sides of the polygon are the edges of the prism, and the corners are called vertices. The perpendicular distance between the bases is called the altitude.

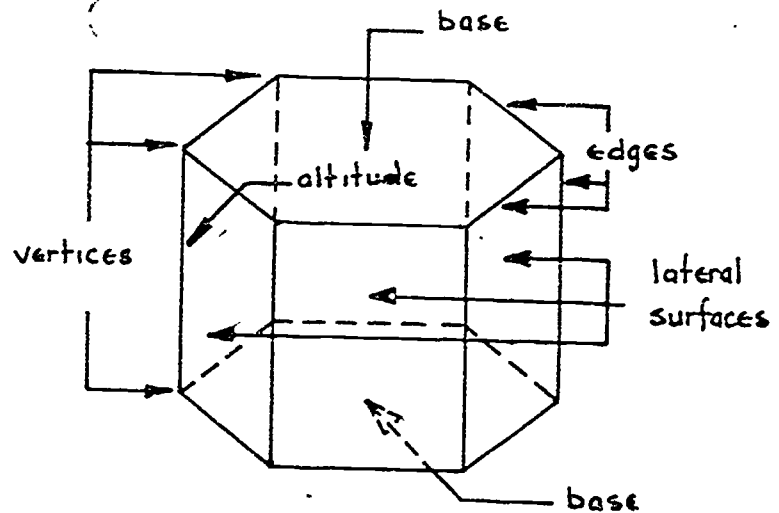

In a right prism, the lateral edges are perpendicular to the bases and the lateral faces are rectangles. Look at the sketch below. In this Project Sheet you will learn about right prisms.

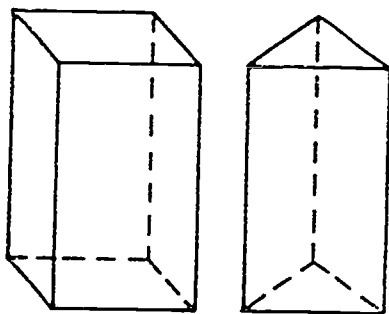

Right Prisms

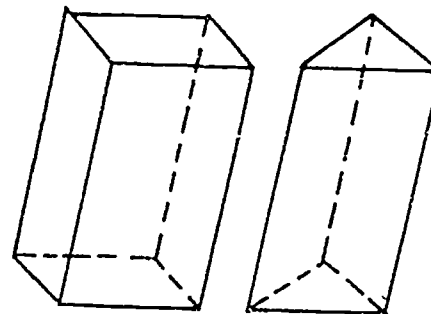

Not Right Prisms

In the sketch below, count the number of faces, vertices, and edges.

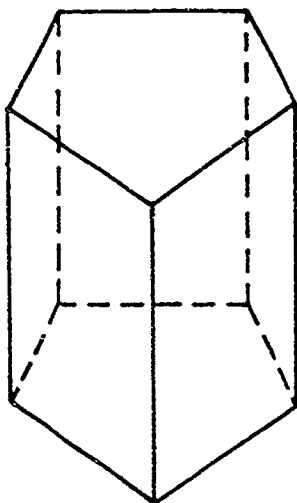

Number of faces = _____
 Number of Edges = _____
 Number of Vertices = _____

Answers:

There are 7 faces (2 bases and 5 lateral faces), 15 edges, and 10 vertices on the above prism.

RECTANGULAR PRISM

The most common solid in practical work is the rectangular prism. All opposite faces are parallel, so any pair can be chosen as the bases. Every face is a rectangle. The angles at all vertices is 90 degrees because the edges are all perpendicular.

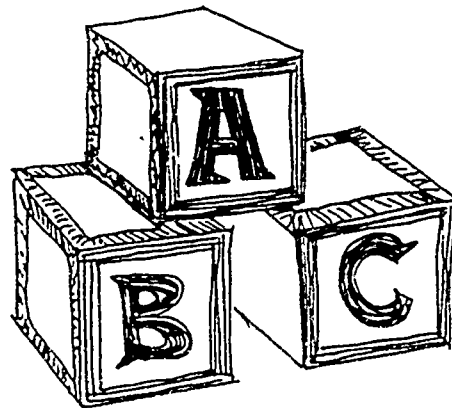
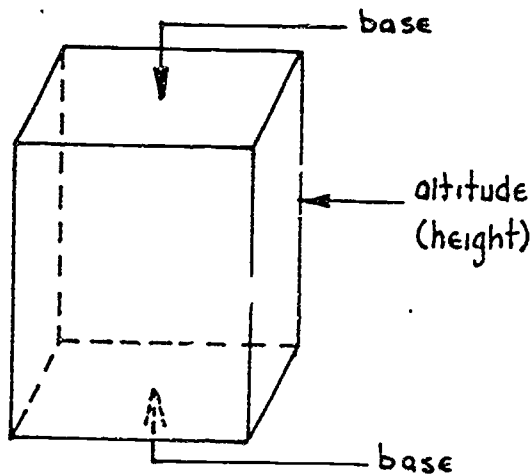

CUBE

A cube is a rectangular prism in which all edges are the same length. Each face is a square.

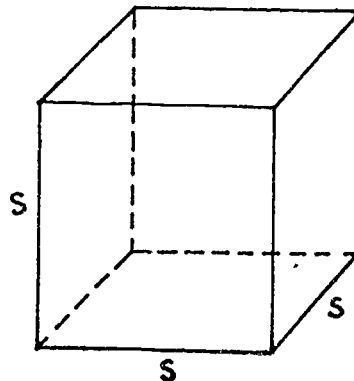

304

TRIANGULAR PRISM

In a triangular prism the bases are triangular.

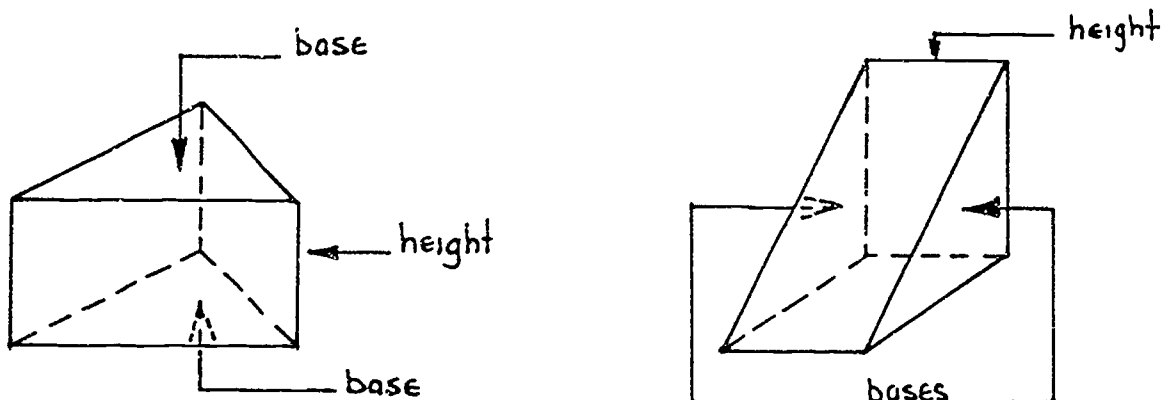

TRAPEZOIDAL PRISM

In a trapezoidal prism the bases are identical trapezoids.

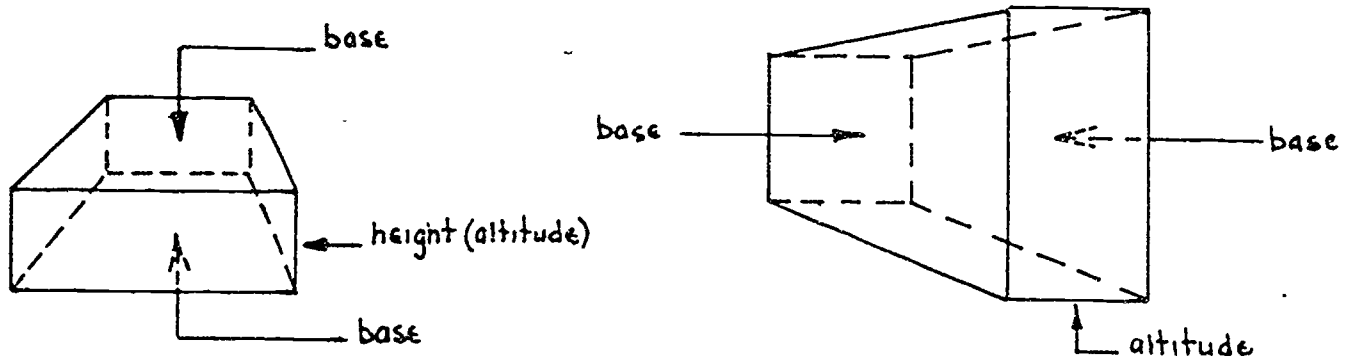

You can tell that the trapezoids and not the other faces are the bases because cutting the prism anywhere parallel to the trapezoid faces produces another trapezoidal prism.

Three important quantities may be calculated for any prism: the lateral surface area, the total surface area, and the volume. The formulas in Figure 12 apply to all prisms.

<p> $h = \text{height}$ $p = \text{perimeter of base, or}$ $p = \text{sum of the edges of}$ $\quad \text{the base}$ $A = \text{area of the base}$ </p>		<p> Lateral Surface Area: $L = ph$ Total Surface Area: $S = L + 2A$ or $S = ph + 2A$ Volume: $V = Ah$ </p>
---	--	---

Figure 12: Formulas for right prisms.

From Figure 12 on page 15:

1. The lateral surface area L is the area of all surfaces except the bases.

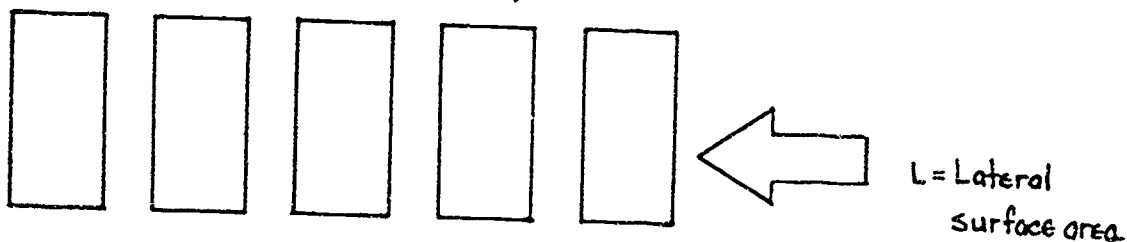

2. The total surface area S is the area of all surfaces plus the area of the two bases.

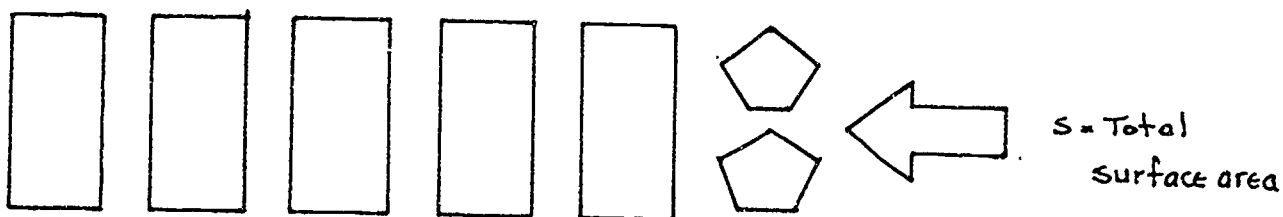

3. The volume or capacity of a prism is the total amount of space inside the prism.

EXAMPLE PROBLEM: Look at the sketch below and find the lateral surface area L , the total surface area S , and the volume V .

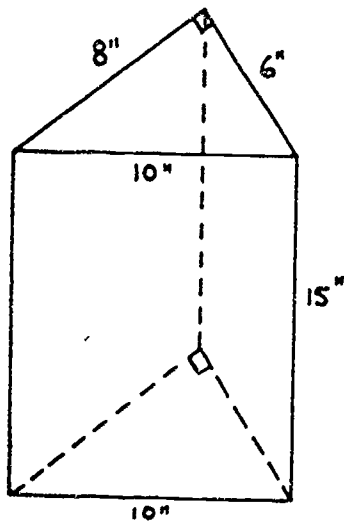

- a. The perimeter of the base is:

$$P = 6'' + 8'' + 10'' = 24''$$

Then the lateral surface area is:

$$L = ph = (24'')(15'')$$

$$L = 360 \text{ sq in}$$

- b. In this prism the bases are right triangles, so the area of each base is:

$$A = \frac{1}{2}bh = \frac{(6)(8)}{2} = 24 \text{ sq in}$$

Then the total surface area is:

$$S = L + 2A = 360 \text{ sq in} + 2(24 \text{ sq in})$$

$$S = 360 \text{ sq in} + 48 \text{ sq in}$$

$$S = 408 \text{ sq in}$$

- c. The volume V of the prism is:

$$V = hA = 15 \text{ in}(24 \text{ sq in})$$

$$V = 360 \text{ cu in}$$

In practical problems it is often necessary to convert volume units from cubic inches or cubic feet to gallons or other units. Here are some more examples of conversion factors:

$$1 \text{ cu ft} = 1728 \text{ cu in}$$

$$1 \text{ cu yd} = 27 \text{ cu ft}$$

$$= 7.48 \text{ gal}$$

$$= 28.3 \text{ liters}$$

$$1 \text{ cu in} = 16.38 \text{ cu cm}$$

$$= 0.0283 \text{ cu m}$$

$$= 0.806 \text{ bushels}$$

$$1 \text{ gal} = 231 \text{ cu in}$$

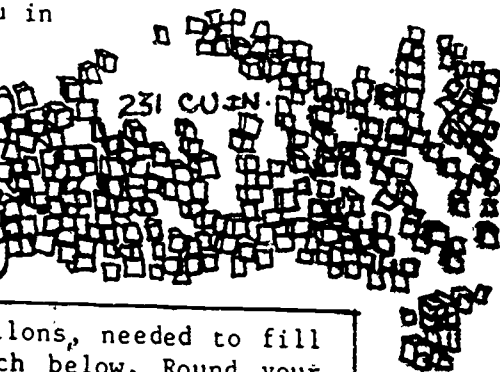
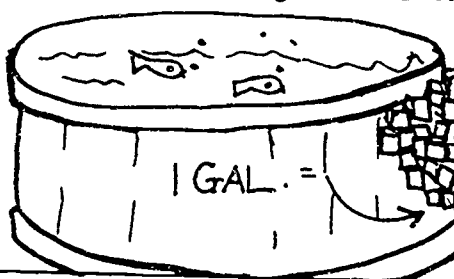
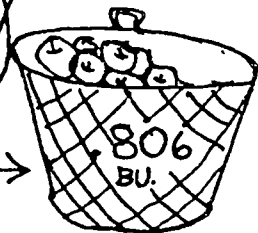

EXAMPLE PROBLEM : Calculate the volume of water, in gallons, needed to fill the swimming pool shown in the sketch below. Round your answer to the nearest hundred gallons.

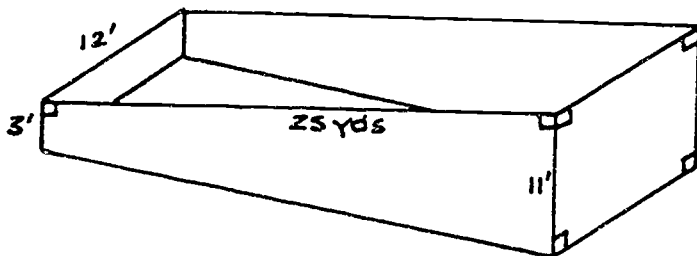

First: Find the area of a base that gives a constant cross section. In this case it will be the side of the pool, which is a trapezoid.

$$A = \frac{(3' + 11')}{2} \cdot 25 \text{ yds}; \text{ remember to change yds. to ft.}$$

$$A = \frac{(14' \times 75')}{2} = 525 \text{ sq ft}; \text{ then find the volume}$$

$$V = hA = (12') \times (525 \text{ sq ft})$$

$$V = 6300 \text{ cu ft}; \text{ then to find the number of gallons, use conversion factor from table above}$$

$$1 \text{ cu. ft. of volume} = 7.48 \text{ gal}; \text{ then the conversion factor is } \frac{7.48 \text{ gal}}{1 \text{ cu ft.}}$$

$$\text{Then the volume in gallons is: } V = \frac{7.48 \text{ gal}}{1 \text{ cu ft.}} \cdot 6300 \text{ cu ft}$$

$$V = (7.48 \text{ gal})(6300) = 47124 \text{ gal, or}$$

$$V = 47100 \text{ gal (rounded)}$$

EXAMPLE PROBLEM: In many practical problems the prisms you work with have irregular polygons for their bases. Find the volume of the slotted bar as shown in the sketch below. If steel weighs 0.283 lb per cu in, what would be the weight of this bar?

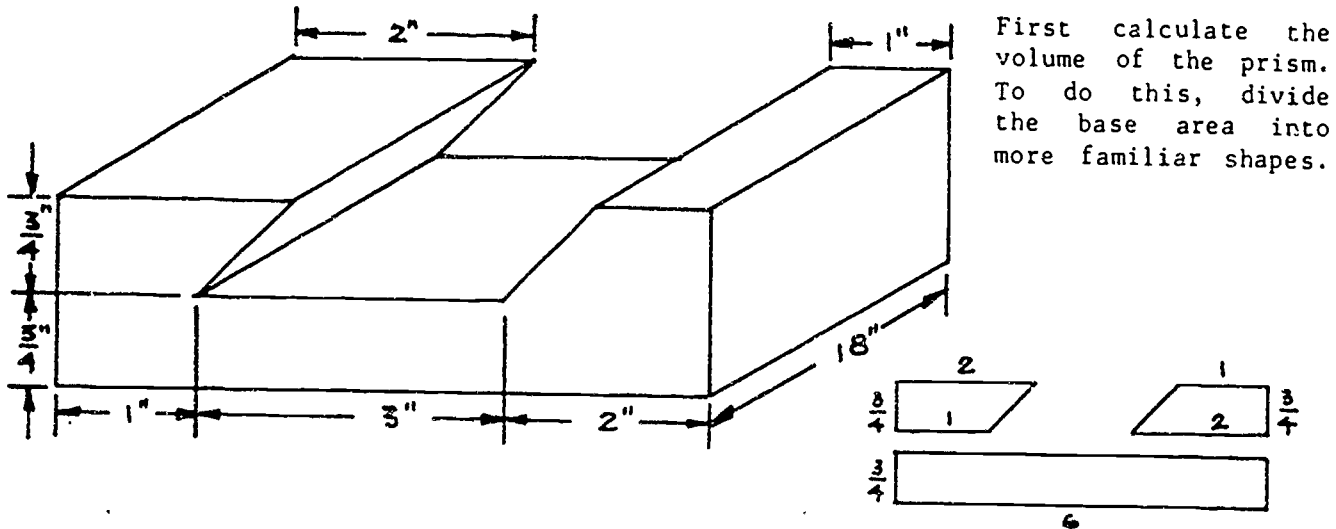

First calculate the volume of the prism. To do this, divide the base area into more familiar shapes.

The area of the bases of the three base shapes is:

$$A = \left(\frac{1+2}{2}\right)\left(\frac{3}{4}\right) + \left(\frac{2+1}{2}\right)\left(\frac{3}{4}\right) + (6)\left(\frac{3}{4}\right)$$

$$A = 6.75 \text{ sq in}$$

The volume of the bar is $V = A \cdot h$

$$V = 6.75(18)$$

$$V = 121.5 \text{ cu in}$$

The weight of the bar is $W = (121.5 \text{ cu in})\left(\frac{0.283 \text{ lb}}{\text{cu in}}\right)$

$$W = 34.3845 \text{ lb or } 34.4 \text{ lb (rounded)}$$



The most common source of errors in most calculating of this kind is carelessness. Organize your work neatly. Work slowly and carefully!

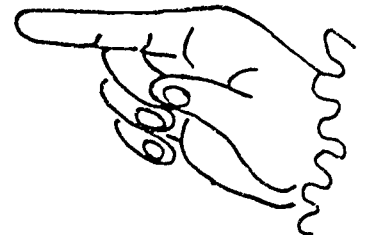

305

Now try this problem. Remember, organize your work and work slowly and carefully. Find the weight of a piece of brass shown in the sketch below. Brass weighs 0.2963 lb per cu in. Round to the nearest tenth.

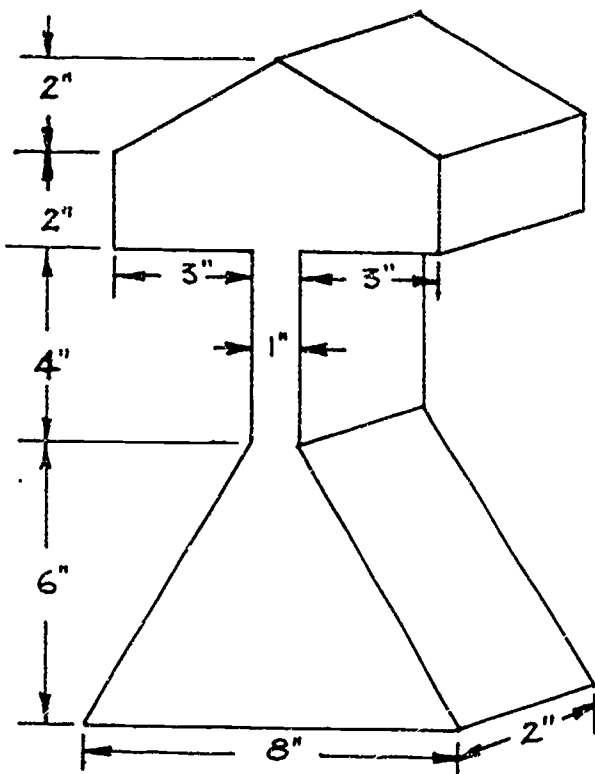

Separate the bases into the shapes as shown below.

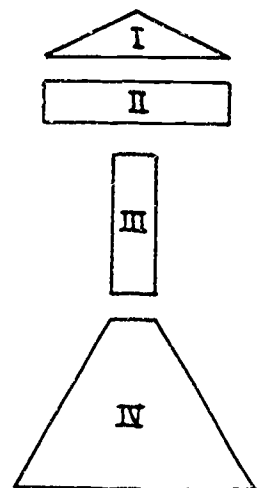

Volume I, $V = (2)(7)\left(\frac{1}{2}\right)2 = 14 \text{ cu in}$

Volume II, $V = (2)(7)(2) = 28 \text{ cu in}$

Volume III, $V = (1)(4)(2) = 8 \text{ cu in}$

Volume IV, $V = \frac{(1+8)(6)(2)}{2} = 54 \text{ cu in}$

Sum of volumes

I, II, III, and IV :

$V_T = 14 + 28 + 8 + 54$

$V_T = 104 \text{ cu in}$

Then $W = (104 \text{ cu in})(0.2963 \text{ lb})$

$W = 30.8152 \text{ lb} = 30.8 \text{ lb (rounded)}$

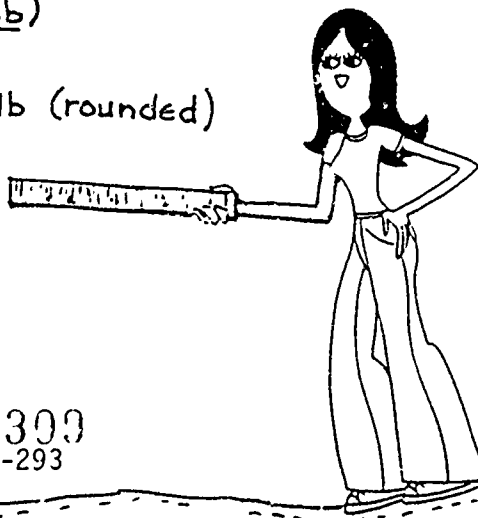

PYRAMIDS

A pyramid is a solid object with one base and three or more lateral faces that taper to a single point opposite the base. This single point is called the apex.

A right pyramid is one whose base is a regular polygon and whose apex is centered over the base. You will learn about right pyramids in this Project Sheet.

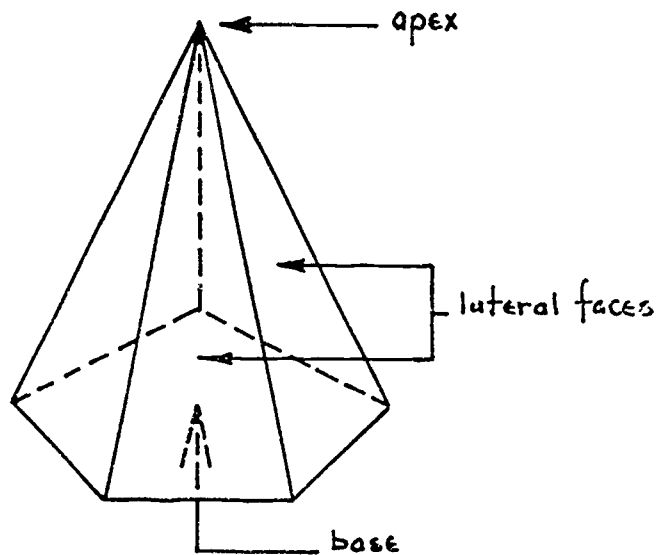

The altitude of a pyramid is the perpendicular distance from the apex to the base. The slant height is the height of one of the lateral faces.

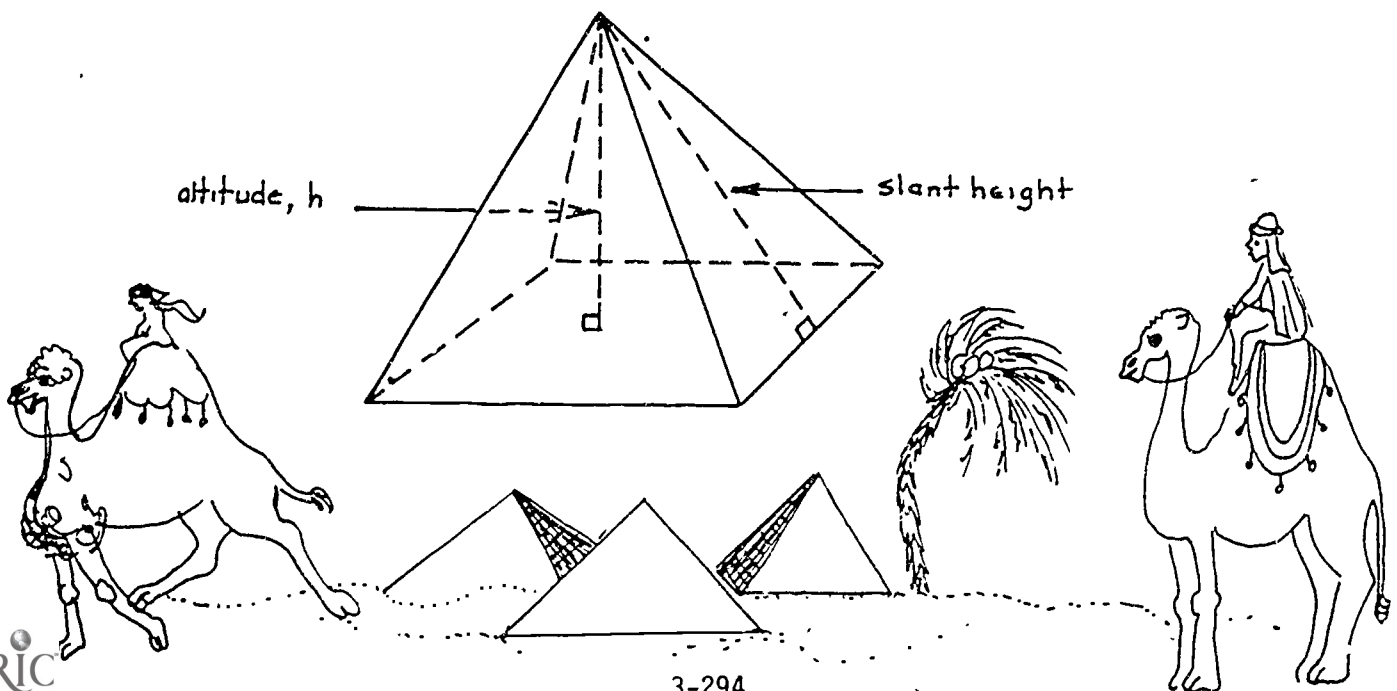

Several kinds of pyramids can be constructed:

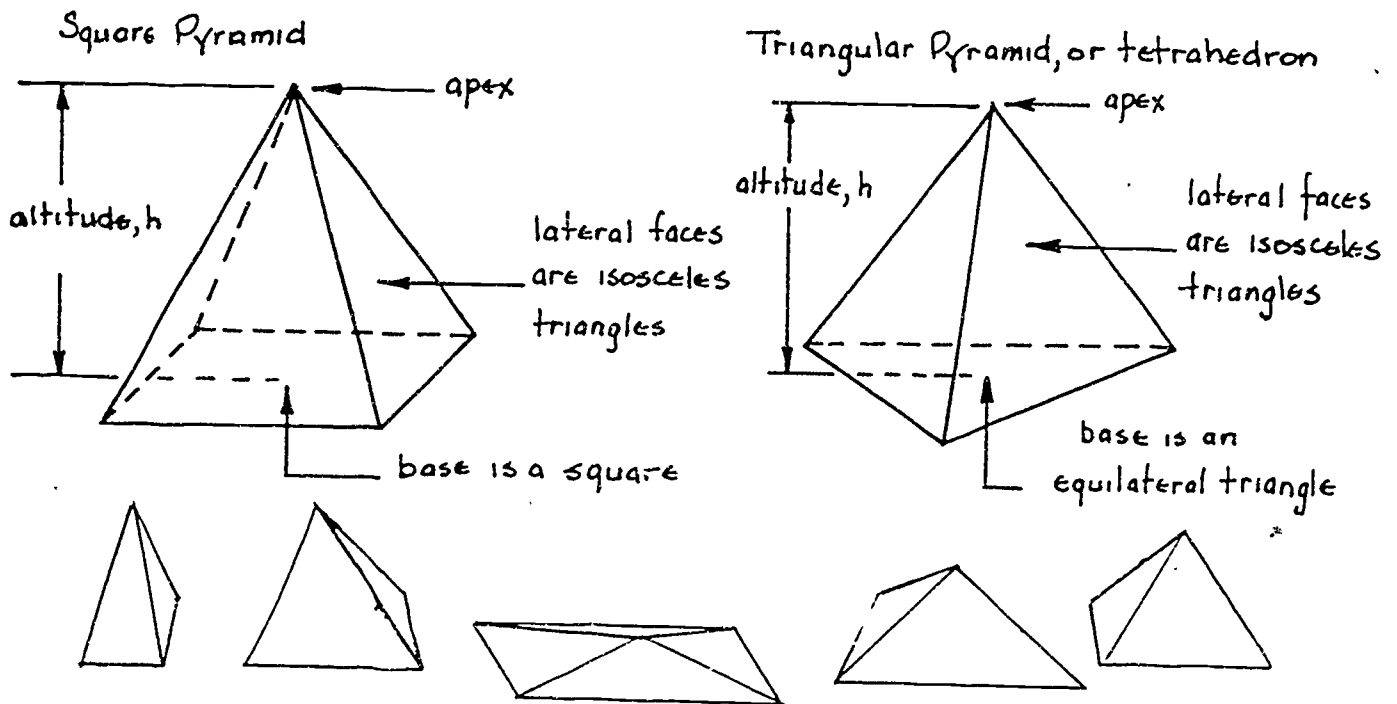

There are several useful formulas relating to pyramids. Look at Figure 13.

Pyramids

Lateral Surface Area:

$$L = \frac{ps}{2}$$

Volume:

$$V = \frac{Ah}{3}$$

where : p = perimeter of base
 s = slant height of a lateral face
 A = Area of the base
 h = altitude

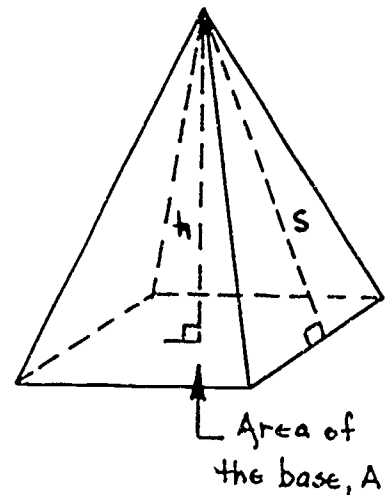
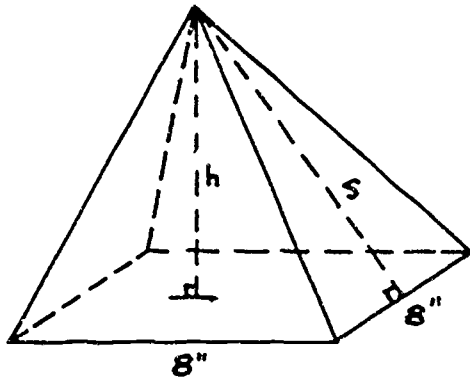

Figure 13: Pyramid formulas.

Using the formulas from Figure 13 on page 21, find the lateral surface area and volume of the square pyramid shown in the sketch below:



$$s = 10.8", h = 10", p = 8 + 8 + 8 + 8 = 32"$$

$$A = (8^2) = 64 \text{ sq in}$$

$$\text{then, } L = \frac{ps}{2} = \frac{(32)(10.8)}{2}$$

$$L = (16)(10.8) = 172.8 \text{ sq in}$$

(area of the 4 triangular faces)

$$\text{and, } V = \frac{Ah}{3} = \frac{64(10)}{3}$$

$$V = 213.3 \text{ cu in (rounded)}$$

EXAMPLE PROBLEM: Find the lateral surface area and volume of this triangular prism. (Remember, the base is an equilateral triangle.) Look at the sketch below.

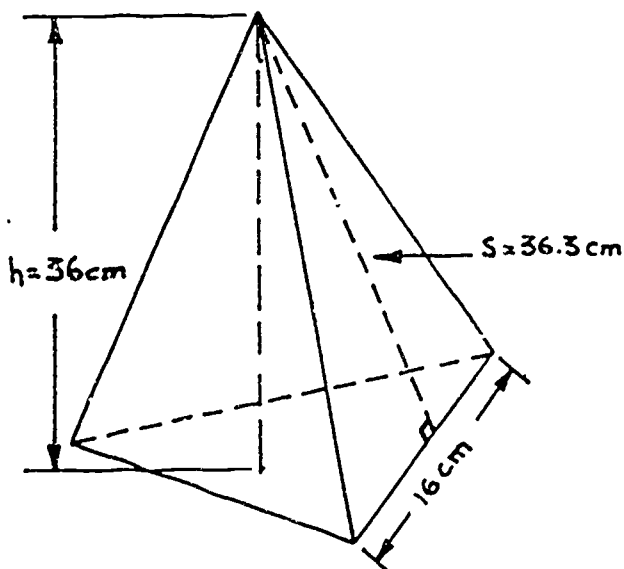

$$\text{perimeter, } p = 16 + 16 + 16 = 48 \text{ cm}$$

$$L = \frac{ps}{2} = \frac{(48)(36.3)}{2}$$

$$L = 871.2 \text{ sq cm}$$

$$V = \frac{Ah}{3}, \text{ recall that the area of an equilateral triangle is } A = 0.433 s^2, \text{ where } s \text{ is the side of the triangle. Then;}$$

$$V = \frac{1}{3} (0.433)(16^2)(36)$$

$$V = \frac{(0.433)(16)(16)(36)}{3} = 1330.176 \text{ cu cm}$$

312

CYLINDERS

A cylinder is a solid object with two identical circular bases. The altitude of a cylinder is the perpendicular distance between the circular bases. Look at the sketch below:

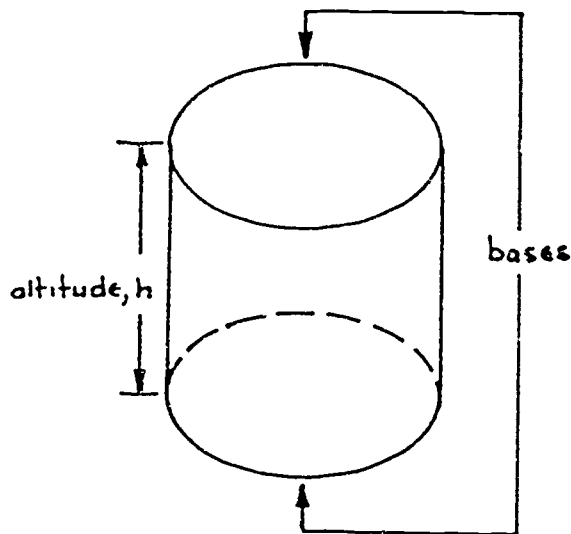

A right cylinder is one whose curved side walls are perpendicular to its circular base. Whenever you talk about the radius, diameter, or circumference of a cylinder, you are talking about the dimensions of the cylinder's circular base.

You can find the lateral surface area and the volume of a cylinder by using the two formulas shown in Figure 14.

Cylinder

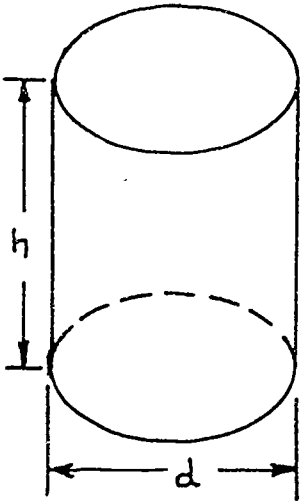

Lateral Surface Area:
 $L = ch$
or $L = \pi dh$

Volume:
 $V = \pi r^2 h$
or $V = 0.7854 d^2 h$ approx.

c = circumference of the base
 r = radius of the base
 d = diameter of the base
 h = altitude of the cylinder

Figure 14: Cylinder formulas.

EXAMPLE PROBLEMS: Work through the problems shown below.

1. Find the lateral surface area and volume for a cylinder with a radius of 11 inches and a height of 24 inches.

$$\text{Lateral surface area } L = ch = \pi dh = 2\pi rh$$

$$L = 2\pi(11)(24)$$

$$L = 1658.7609 \text{ sq in}$$

$$L = 1659 \text{ sq in (rounded)}$$

$$\text{Volume } V = \pi r^2 h$$

$$V = \pi(11)(11)(24)$$

$$V = 9123.1851 \text{ cu in}$$

$$V = 9123 \text{ cu in (rounded)}$$

2. Find the lateral surface area and the volume in gallons of the cylindrical storage tank shown in the sketch below. Round answers to the nearest unit.

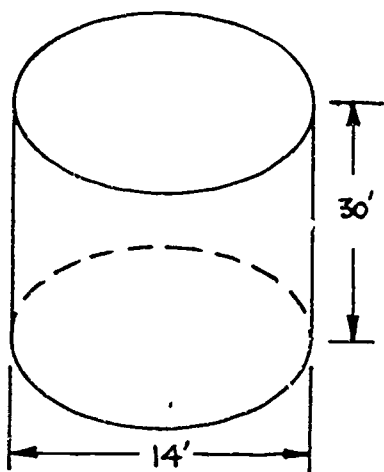

$$L = ch = \pi dh$$

$$L = \pi(14)(h) = 1319 \text{ sq ft (rounded)}$$

$$V = 0.7854d^2h = 0.7854(14)(14)(30)$$

$$V = 4618 \text{ cu ft (rounded)}$$

Then change cubic feet to gallons:

$$V = (4618 \text{ cu ft}) \left(\frac{7.48 \text{ gal}}{1 \text{ cu ft}} \right)$$

$$V = (4618)(7.48) = 34540 \text{ gal (rounded)}$$

3. A pipe 3 inches in diameter and 40 feet high is filled to the top with water. If one cu ft of water weighs 62.4 lb, what is the weight of the water at the base of the pipe?

$$V = 0.7854 d^2 h$$

$$V = 0.7854(.25)^2(40) \leftarrow \text{NOTE:}$$

$$V = 1.9635 \text{ cu ft}$$

Then change cubic feet to pounds:

$$W = (1.9635 \text{ cu ft}) \left(\frac{62.4 \text{ lb}}{1 \text{ cu ft}} \right)$$

$$W = 122.5 \text{ lb (rounded)}$$

You want your answer in cu ft, so you must change the diameter dimensions to feet (3 in = .25 ft).

311

4. The inside walls and bottom of the tank shown below are to be lined with copper sheet metal. How many square feet of copper sheet metal are required for the lining?

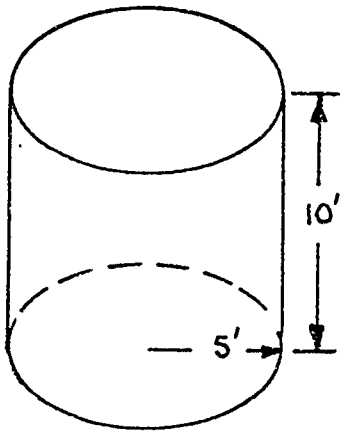

First find the lateral surface area:

$$L = 2\pi rh$$

$$L = 2(\pi)(5)(10)$$

$$L = 314.2 \text{ sq ft}$$

Then find the area of the base:

$$A = \pi r^2 = \pi(5)(5)$$

$$A = 78.54 \text{ sq ft}$$

Then add the surface area and the base area:

$$L + A = 314.2 + 78.5 = 392.7 \text{ sq ft}$$

CONES

A cone is a pyramid-like solid figure with a circular base. The radius and diameter of a cone refer to the dimensions of its circular base. The altitude is the perpendicular distance from the apex to the base. The slant height is the distance from the apex to the base along the surface of a cone.

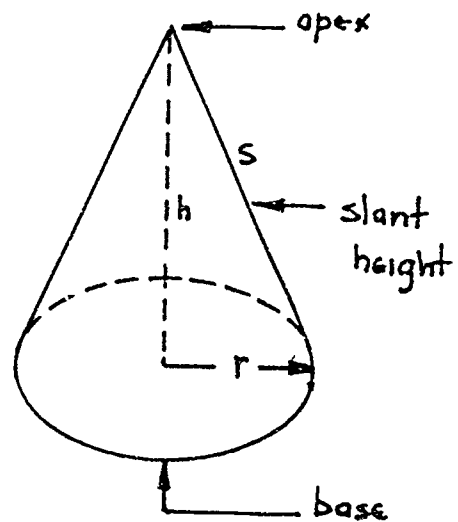

You can find the lateral surface area and volume of a cone by using the formulas shown in Figure 15.

Cone

Lateral Surface Area:

$$L = \pi r s$$

or $L = \frac{\pi d s}{2}$

Volume:

$$V = \frac{1}{3} \pi r^2 h$$

or $V \approx 0.2618 d^2 h$

where r = radius of the base
 h = altitude
 s = slant height

Figure 15: Cone formulas.

Find the lateral surface area and volume of the cone shown in the sketch below:

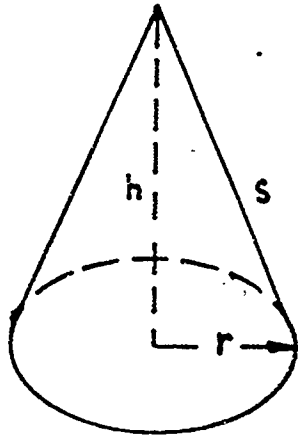

$$h = 15'' \quad L = \pi r s = \pi (10)(18)$$

$$s = 18'' \quad L = 565.5 \text{ sq in (rounded)}$$

$$r = 10''$$

$$V = \frac{1}{3} \pi r^2 h = \frac{1}{3} \pi (10)(10) 15$$

$$V = 1571 \text{ cu in (rounded)}$$

You should remember that for any cone the radius, slant height, and altitude are related:

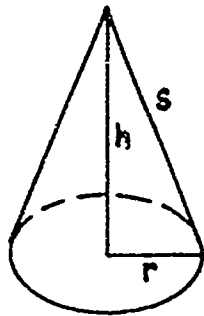

$$s^2 = h^2 + r^2$$

Therefore, if you are given any two of the three quantities, you can easily find the third.

Another thing for you to remember is that the volume of a cone is exactly one-third the volume of the cylinder that just fits around it.

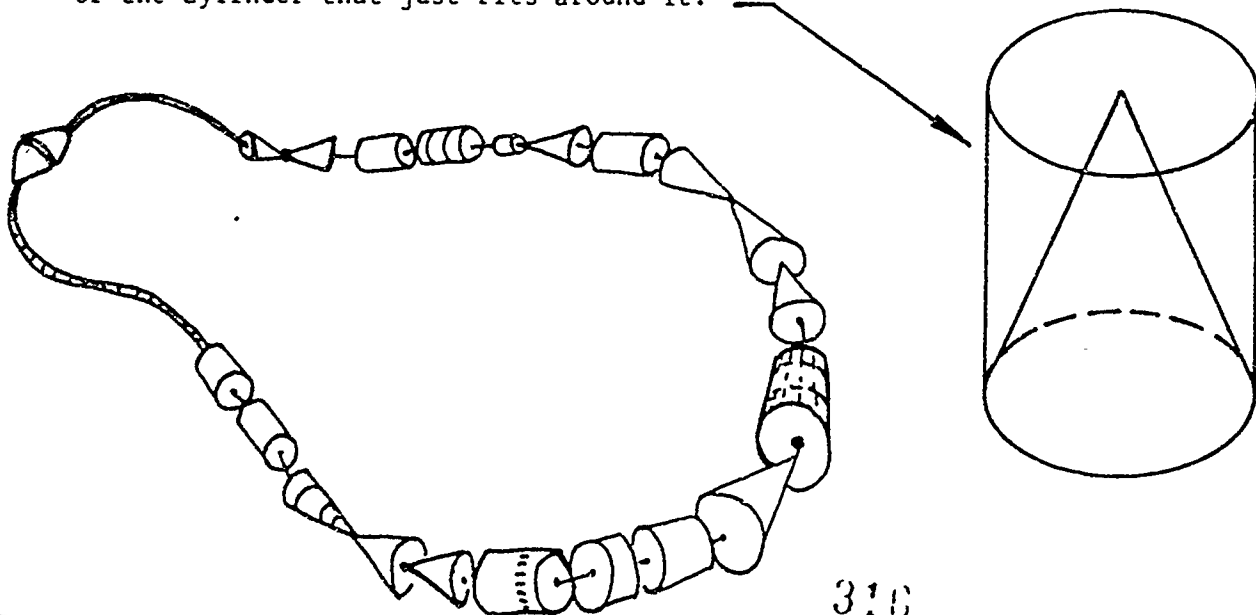

310

EXAMPLE PROBLEMS: Work through the problems shown below:

1. A pile of sand dumped by a hopper is cone-shaped. The diameter of the base is 18'3" and the altitude is 8'6". How many cubic feet of sand is in the pile? Round your answer to the nearest tenth.

First: Since the problem asks how many cu ft, put all the dimensions in feet.

$$d = 18'3'' = 18.25'$$

$$h = 8'6'' = 8.5', \text{ then}$$

$$V \approx 0.2618d^2h$$

$$V = 0.2618(18.25)(18.25)(8.5)$$

$$V = 741.2 \text{ cu ft (rounded)}$$

2. You have been asked to machine a punch as shown in the sketch below. What is the volume of the punch? Round your answer to the nearest hundredth.

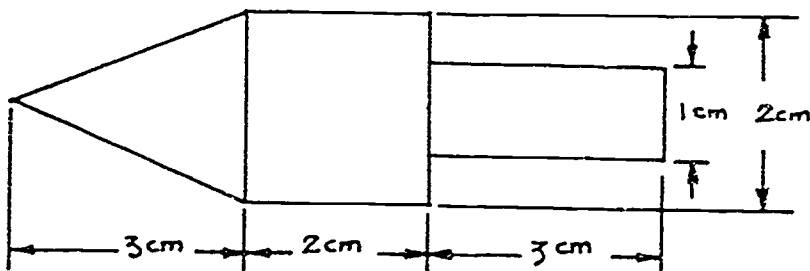

First recognize that you must find the volume of one cone and two cylinders.

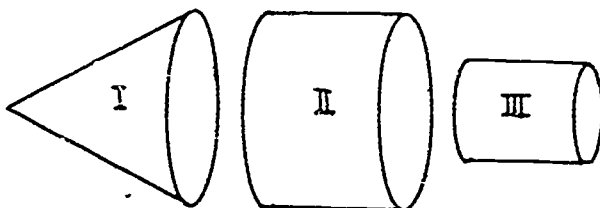

$$\text{The } V \approx 0.2618 d^2 h$$

$$V_1 = 0.2618 (2^2)(3)$$

$$V_1 = 3.1416 \text{ cu cm}$$

$$V_2 = \pi r^2 h = \pi (1^2)2$$

$$V_2 = 6.2832 \text{ cu cm}$$

$$V_3 = \pi r^2 h = \pi (0.5^2)3$$

$$V_3 = 2.3562 \text{ cu cm, the total volume} = V_1 + V_2 + V_3$$

$$V_T = 3.1416 + 6.2832 + 2.3562 \text{ cu cm}$$

$$V_T = 11.78 \text{ cu cm (rounded)}$$

3. Find the lateral surface area of a cone with a diameter of 12 inches and a height of 10 inches.

First you must find the slant height s . Look at the sketch below.

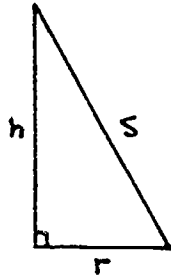
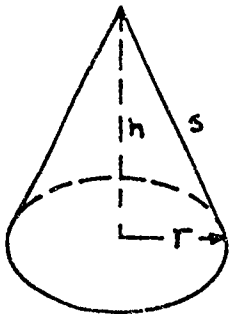

$$s^2 = h^2 + r^2, \quad h = 10 \text{ in.}, \quad r = \frac{d}{2} = \frac{12}{2} = 6 \text{ in.}$$

$$s^2 = (10)(10) + (6)(6)$$

$$s^2 = 136 \text{ in}^2$$

$$s = \sqrt{136} = 11.66 \text{ in (rounded), then}$$

$$L = \pi r s = 3.14 (6)(11.66)$$

$$L = 219.67 \text{ sq in (rounded)}$$

FRUSTRUM

The frustum of a pyramid or cone is the solid figure remaining after the top of the pyramid or cone is cut off parallel to the base.

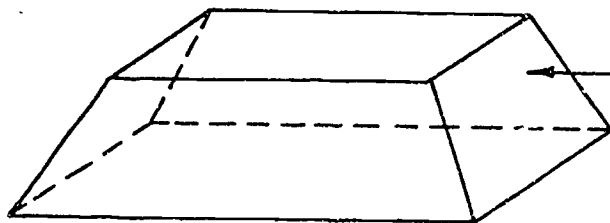
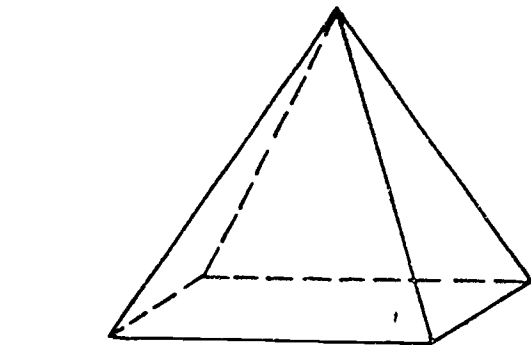

frustum

frustum

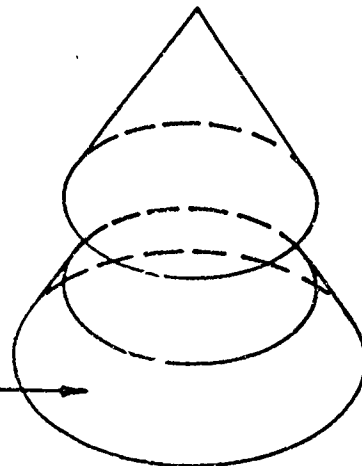

Frustum shapes appear as containers, building foundations, funnels, transition sections of ducts, machine parts and so on.

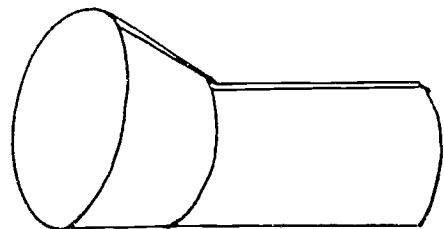
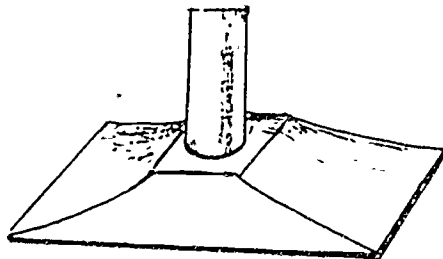

Every frustum has two bases, upper and lower, that are parallel and different in size. The altitude is the perpendicular distance between bases.

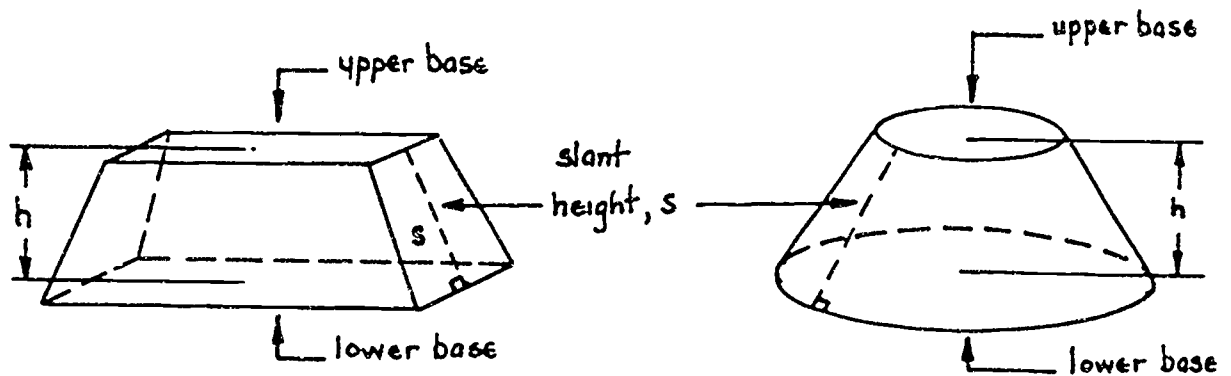

The following formulas are used to find the lateral area and volume of any frustum (pyramid or cone). Look at Figure 16.

Frustums:

Lateral Surface Area:

$$L = \frac{1}{2} (P_1 + P_2) s$$
 or
$$L = \frac{1}{2} \pi (d_1 + d_2) s$$

Volume:

$$V = \frac{1}{3} h (A_1 + A_2 + \sqrt{A_1 A_2})$$

Figure 16: Frustum formulas.

Remember that in the formulas in Figure 16:

P_1 and P_2 are the upper and lower perimeter for a pyramid frustum.

d_1 and d_2 are the upper and lower diameter for a cone frustum.

A_1 and A_2 are the upper and lower areas for any frustum.

Find the lateral surface and volume of the pyramid frustum shown below:

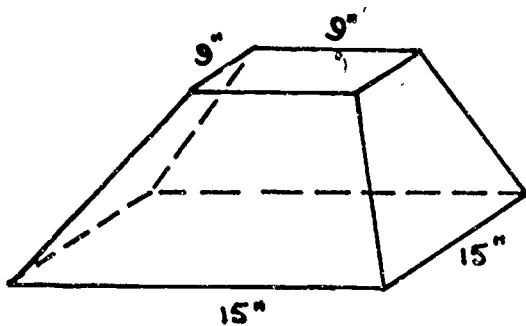

$$\begin{aligned}
 h &= 4'' & \text{upper perimeter } P_1: \\
 s &= 5'' & P_1 = 9 + 9 + 9 + 9 = 36'' \\
 & & \text{lower perimeter } P_2: \\
 & & P_2 = 15 + 15 + 15 + 15 \\
 & & P_2 = 60'' \\
 & & A_1 = 9 \cdot 9 = 81 \text{ sq in} \\
 & & A_2 = 15 \cdot 15 = 225 \text{ sq in}
 \end{aligned}$$

Lateral Surface Area:

$$L = \frac{1}{2} (P_1 + P_2) s = \frac{1}{2} (36 + 60) 5$$

$$L = 240 \text{ sq in}$$

Volume:

$$V = \frac{1}{3} h (A_1 + A_2 + \sqrt{A_1 A_2})$$

$$V = \frac{1}{3} (4)(81 + 225 + \sqrt{81 \cdot 225})$$

$$V = \frac{1}{3} (4)(441)$$

$$V = 588 \text{ cu in}$$

Look at the sketch below and find the total surface area and volume of the cone frustum.

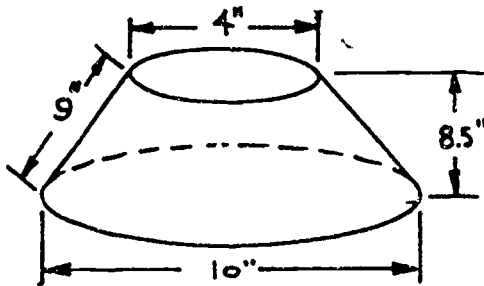

Lateral Surface Area:

$$L = \frac{1}{2} \pi (d_1 + d_2) s = \frac{3.14}{2} (4 + 10) 9$$

$$L = 197.92 \text{ sq in (rounded)}$$

You must now find the areas of the upper and lower bases and then add these areas to the lateral surface area.

$$\text{Total Area} = L + A_1 + A_2$$

$$A_T = 197.92 + \pi r_1^2 + \pi r_2^2 = 197.92 + \pi (2^2) + \pi (5^2)$$

$$A_T = 197.92 + 12.57 + 78.54$$

$$A_T = 289.03 \text{ sq in (rounded)}$$

$$\text{Volume } V = \frac{1}{3} h (A_1 + A_2 + \sqrt{A_1 A_2})$$

$$V = \frac{1}{3} (8.5)(12.57 + 78.54 + \sqrt{(12.57)(78.54)})$$

$$V = \frac{1}{3} (8.5)(122.53) = 347.17 \text{ cu in (rounded)}$$

EXAMPLE PROBLEMS: Work through the problems shown below.

1. Find the lateral surface area and volume of the frustrum shown in the sketch below:

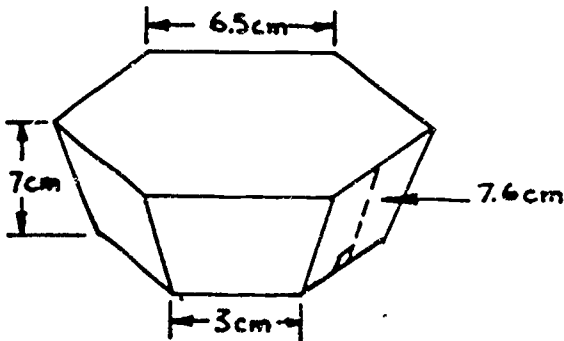

First find P_1 and P_2 ; A_1 and A_2
 $P_1 = (6)(6.5) = 39 \text{ cm}$, $P_2 = (6)(3) = 18 \text{ cm}$
 From Geometry Part I, Area of a hexagon = $2.598 a^2$, where a is a side.
 $A_1 = 2.598(6.5)^2 = 109.77 \text{ sq cm (rounded)}$
 $A_2 = 2.598(3)^2 = 23.38 \text{ sq cm (rounded)}$

Then Lateral Surface Area $L = \frac{1}{2} (P_1 + P_2) s$

$$\text{Volume } V = \frac{1}{3} h (A_1 + A_2 + \sqrt{A_1 A_2})$$

$$L = \frac{1}{2} (39 + 18)(7.6)$$

$$V = \frac{1}{3} (7)(109.77 + 23.38 + \sqrt{(109.77)(23.38)})$$

$$L = 216.6 \text{ sq cm}$$

$$V = \frac{7}{3} (183.81) = 428.89 \text{ cu cm}$$

2. A connection must be made between two square vent openings in an air conditioning system. Find the total amount of sheet metal needed. Look at the sketch below.

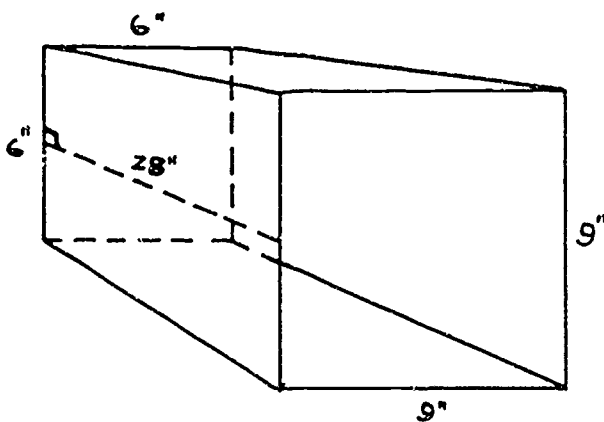

First find P_1 and P_2

$$P_1 = 6 + 6 + 6 + 6 = 24 \text{ in}$$

$$P_2 = 9 + 9 + 9 + 9 = 36 \text{ in}$$

Then Lateral Surface Area:

$$L = \frac{1}{2} (P_1 + P_2) s = \frac{1}{2} (24 + 36) 28$$

$$L = \frac{(60)(28)}{2}$$

$$L = 840 \text{ sq in}$$

3. How many cubic yards of concrete are needed to pour the foundation shown in the sketch below. (Watch your units!) Round the answer to the nearest hundredth.

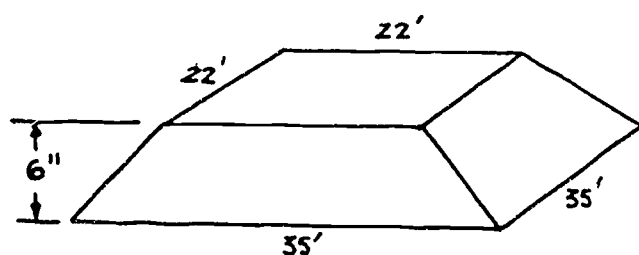

First find A_1 and A_2

$$A_1 = (22)(22) = 484 \text{ sq ft}$$

$$A_2 = (35)(35) = 1225 \text{ sq ft}$$

Then the volume $V = \frac{1}{3} h (A_1 + A_2 + \sqrt{A_1 A_2})$, note $h = 6''$ or $0.5'$

$$V = \frac{0.5}{3} (484 + 1225 + \sqrt{484 \cdot 1225})$$

$$V = 413.17 \text{ cu ft}, \quad 1 \text{ cu yd} = 27 \text{ cu ft}, \quad \text{then}$$

$$V = 413.17 \text{ cu ft} \times \frac{1 \text{ cu yd}}{27 \text{ cu ft}} = \frac{413.17}{27} \text{ cu yd}$$

$$V = 15.3 \text{ cu yd}$$

SPHERES

The sphere is the simplest of all solid geometric figures. Geometrically, it is defined as the surface whose points are all equidistant from a given point called the center. The radius is the distance from the center to any point on the surface. The diameter is the straight line distance across the sphere through the center. Look at Figure 17.

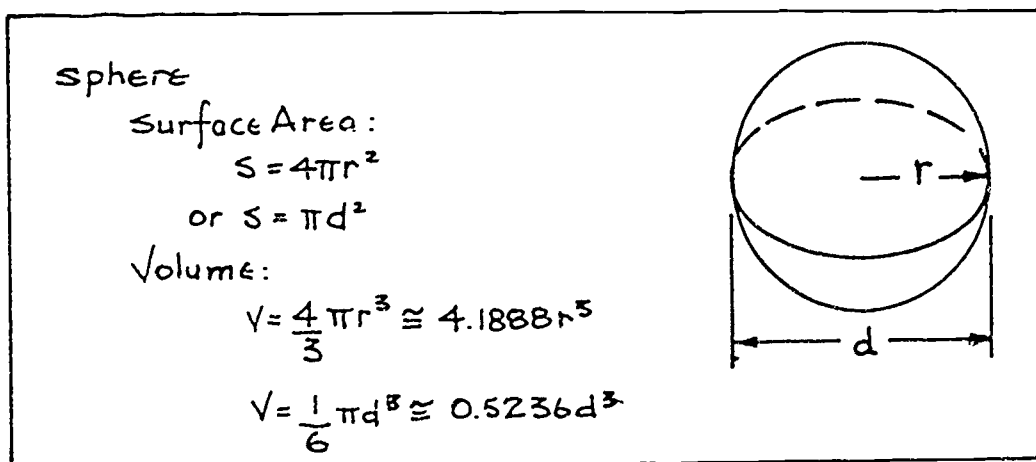

Figure 17: Formulas for finding surface area and volume of a sphere.

Find the surface area and volume of a basketball with a diameter of $9\frac{1}{2}$ ".

Round your answer to the nearest hundredth.

Surface Area:

$$S = \pi d^2 = (3.14)(9.5)^2$$

$$S = 283.53 \text{ sq in}$$

Volume:

$$V = \frac{\pi d^3}{6} = \frac{3.14}{6} (9.5)^3$$

$$V = 448.92 \text{ cu in (rounded)}$$

Summary of Solid Figure Formulas

Figure	Lateral Surface Area	Volume
Prism	$L = ph$	$V = Ah$
Pyramid	$L = \frac{ps}{2}$	$V = \frac{Ah}{3}$
Cylinder	$L = \pi dh$ or $L = 2\pi rh$	$V = \pi r^2 h$ or $V = 0.7854 d^2 h$
Cone	$L = \frac{\pi ds}{2}$ or $L = \pi rs$	$V = \frac{\pi r^2 h}{3}$ or $V = 0.2618 d^2 h$
Frustum of a Pyramid	$L = \frac{1}{2} (P_1 + P_2) s$	$V = \frac{h}{3} (A_1 + A_2 + \sqrt{A_1 A_2})$
Frustum of a cone	$L = \frac{\pi}{2} (d_1 + d_2) s$	$V = \frac{h}{3} (A_1 + A_2 + \sqrt{A_1 A_2})$
Sphere	$S = 4\pi r^2$ or $S = \pi d^2$	$V = \frac{4}{3} \pi r^3$ or $V = 4.1888 r^3$ or $V = \frac{\pi d^3}{6}$ or $V = 0.5236 d^3$

NOW TRY SOME SHOP PROBLEMS.

SHOP PROBLEMS

1. You are asked by your boss to find the weight per gross of wrought iron rivets. (1 gross = 12 dozen = 144). Wrought iron weighs 0.28 lb per cu in. Look at the sketch below.

HINT: First find the volume of one rivet. then multiply the volume of one rivet by 144, and finally multiply the weight per cu in by the total volume.

Weight of one gross of rivets _____

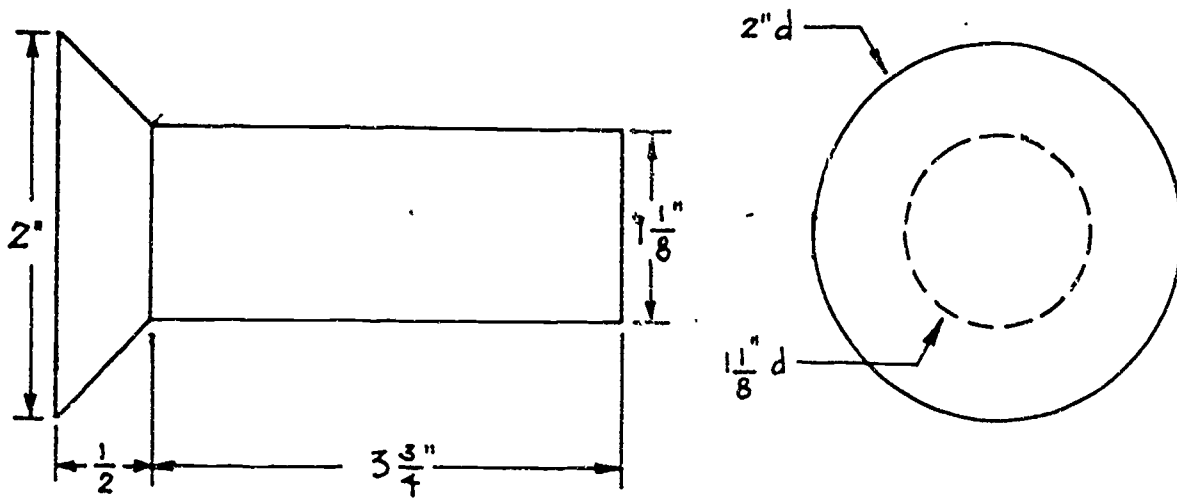

2. You have machined the aircraft part shown at the right out of aluminum. The weight must be known to the nearest one-hundredth of a pound. If aluminum weighs 0.0975 lb per cu in, what is the weight of your machined part?

Weight _____

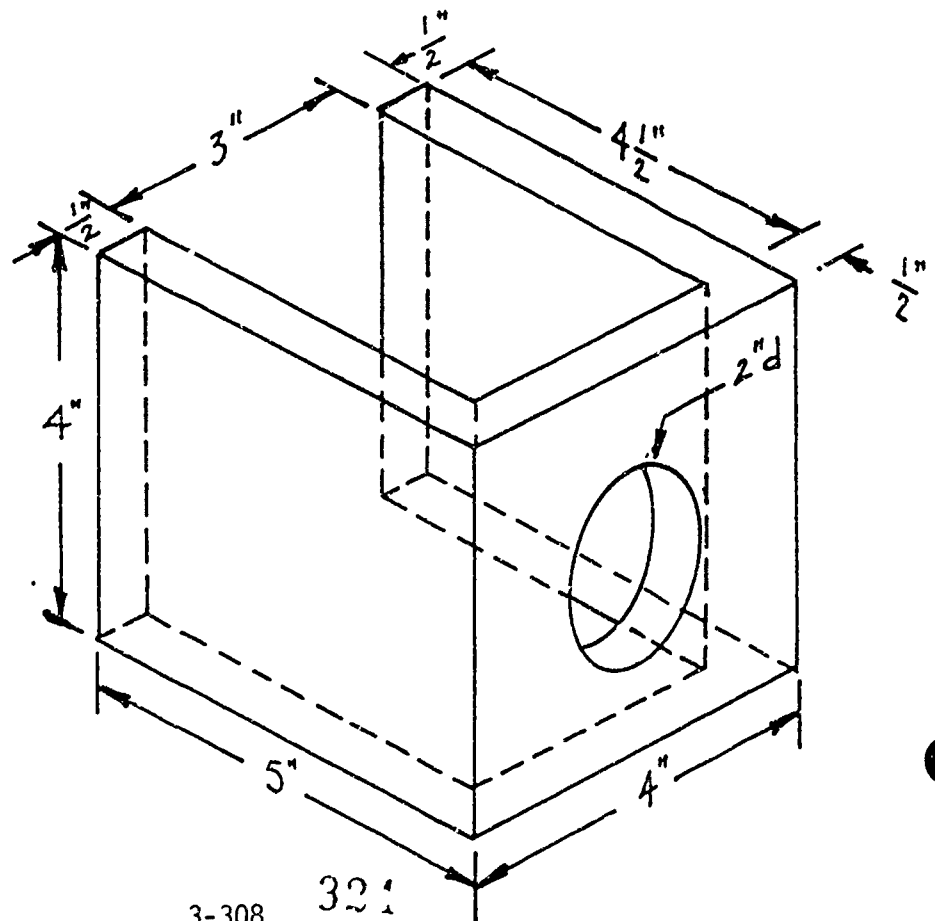

3. Your supervisor wants to know the weight of the taper bushing that you have machined. It is made of steel which weighs 0.2833 lb per cu in. Look at the sketch below.

Weight _____

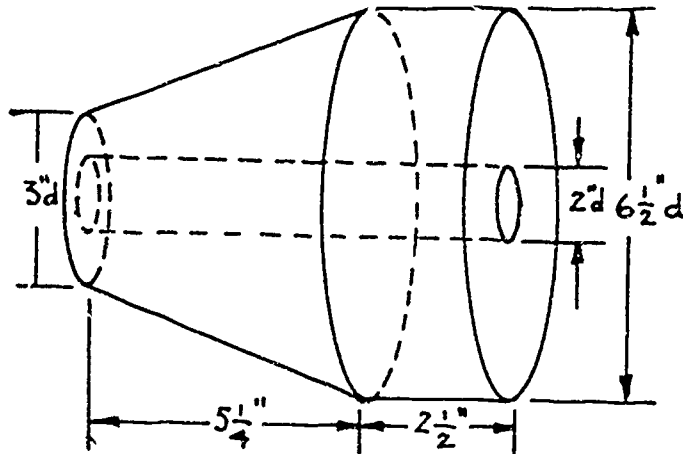

4. Cast iron weighs 0.2607 lb per cu in. You weigh the cast iron shape shown in the sketch at the right and find it to be 5.90 lbs. Are your scales correct to the nearest hundredth of a pound?

Yes _____ No _____

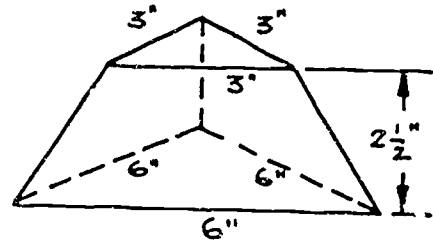

5. You must space 5 holes equally on a circle whose diameter is 14 inches. What is the arc distance s between each hole? Look at the sketch.

Arc distance _____

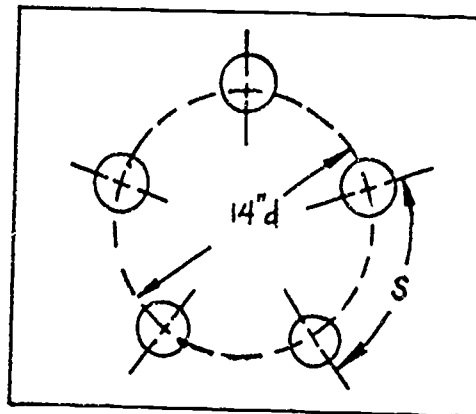

6. The sketch below was given to you to lay out. In order to find the dimensions you will need, you must first find angle a. What is the size of angle a?

Angle a _____

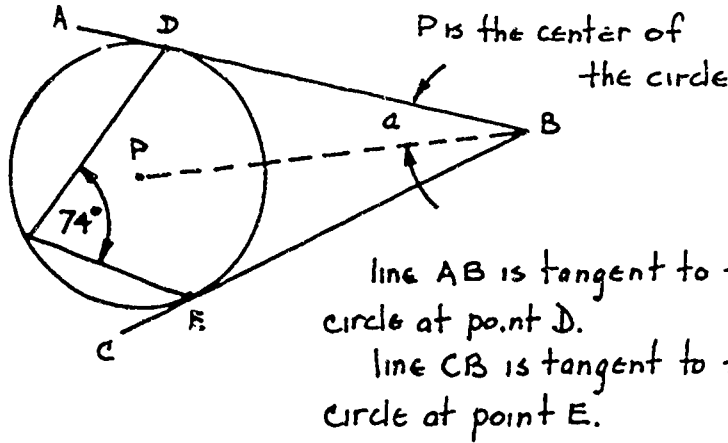

7. Steel weighs 0.000017 lbs per cu mm. How much do 1200 hex nuts weigh? The dimensions are given in the sketch shown at the left.

Weight _____

HINT: Area of a hexagon equals $2.598a$, where a = length of a side of the hexagon.

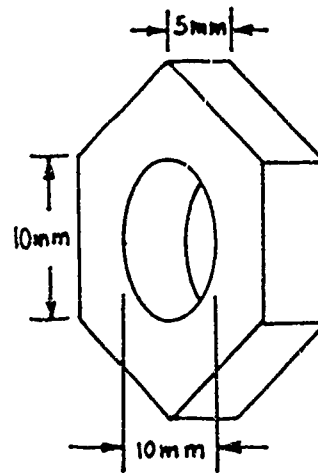

8. You must shape a steel rod as shown in the sketch below. How long must the rod be to begin with?

HINT: Refer to example problems 1 and 2 on pages 5 and 6 of this Project Sheet.

Length _____

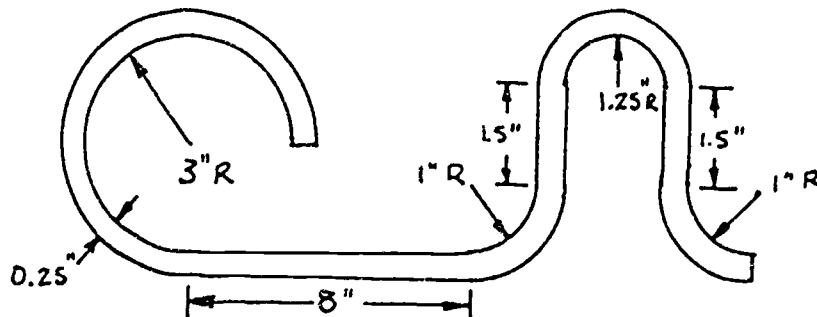

9. Your boss wants to know the weight of an aircraft part that you have machined. Look at the sketch below. Aluminum weighs 0.0925 lb per cu in. Use π equal to 3.1416 and round to the nearest thousandth.

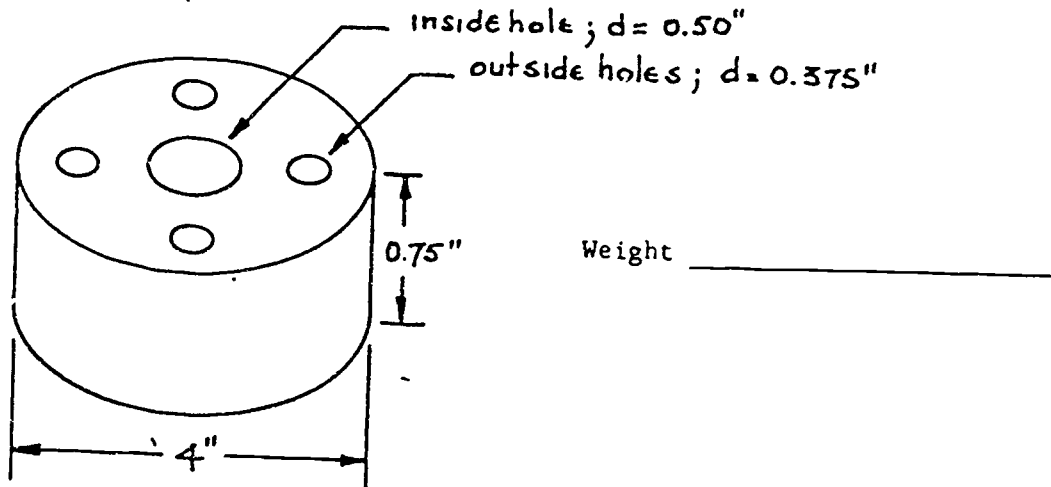

10. You have machined a hollow cylindrical liquid gage that is supposed to hold an exact amount of fluid. Before you can send it to packing and shipping, you must fill out a form. One of the questions on the form is: How many cu in of liquid does the gage hold when filled to the top? Look at the sketch below.

cu in of liquid _____

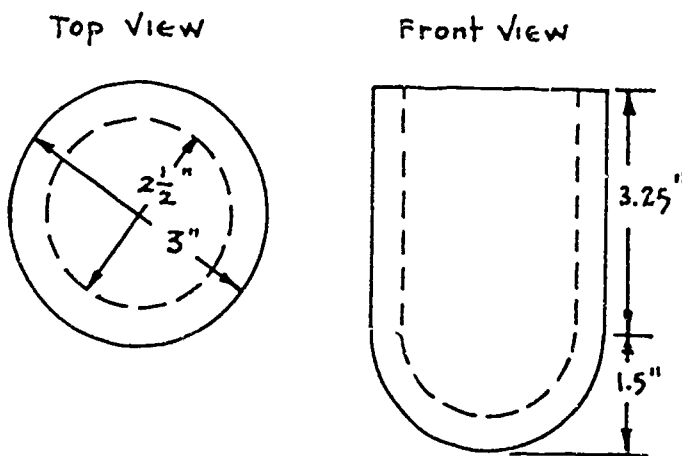

SHOW YOUR WORK TO YOUR INSTRUCTOR

Ask your Instructor for your next Project Sheet.

BAS

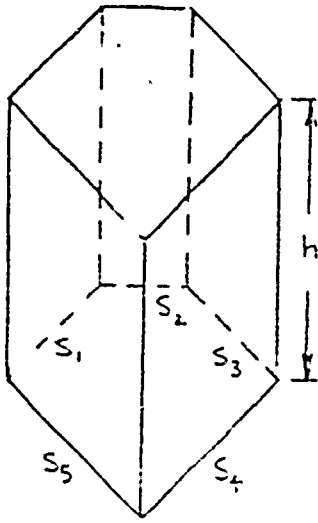

RIGHT PRISMS

Lateral Surface Area $L = ph$
 Total Surface Area $S = L + 2A$
 Volume $V = hA$

h = altitude
 p = perimeter of the base
 $p = s_1 + s_2 + \dots + s_n$
 A = area of the base.

for right prisms only

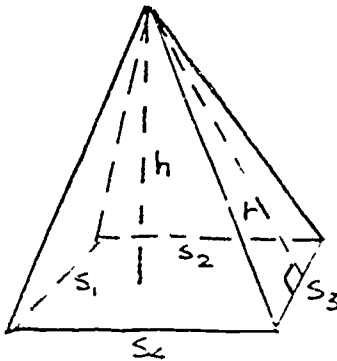

RIGHT PYRAMIDS

Lateral Surface Area $L = \frac{1}{2}ps$

Volume $V = \frac{1}{3}hA$

s = slant height
 p = perimeter of base
 $p = s_1 + s_2 + \dots + s_n$
 A = area of the base

CYLINDERS

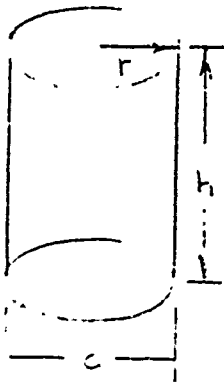

Lateral Surface Area $L = ch$
 or $L = \pi dh$
 or $L = 2\pi rh$

h = height
 C = circumference
 $C = \pi d$
 $C = 2\pi r$

Volume $V = \pi r^2 h$
 or $V = 0.7854 d^2 h$

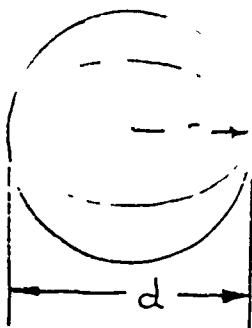

SPHERE

Surface Area
 $S = 4\pi r^2$
 or $S = \pi d^2$

Volume
 $V = \frac{4}{3}\pi r^3 \approx 4.19 r^3$
 or $V = \frac{\pi d^3}{6} \approx 0.52 \frac{d^3}{328}$

3-312

CONES

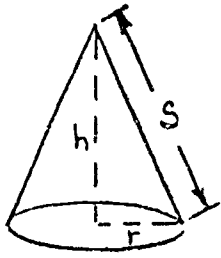

Lateral Surface Area $L = \pi r s$
 or $L = \frac{1}{2} \pi d s$

Volume $V = \frac{1}{3} \pi r^2 h$
 or $V \cong 0.2618 d^2 h$

r = radius of base
 s = slant height
 d = diameter of base

FRUSTRUMS

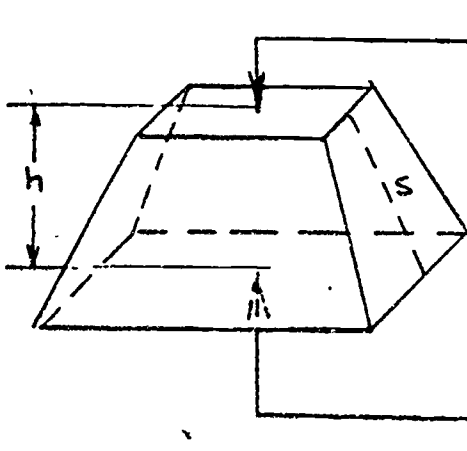

s = slant height
 h = height

Lateral Surface Area $L = \frac{1}{2} (p_1 + p_2) s$

Volume $V = \frac{1}{3} h (A_1 + A_2 + \sqrt{A_1 A_2})$

Pyramid Frustum

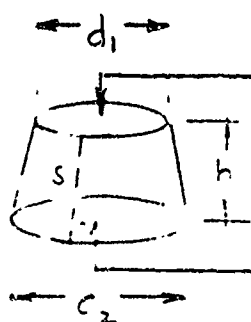

s = slant height
 h = height

Lateral Surface Area $L = \frac{1}{2} \pi (d_1 + d_2) s$

Volume $V = \frac{1}{3} h (A_1 + A_2 + \sqrt{A_1 A_2})$

Cone frustum

329



**SKILLS
CENTER**

215

1 of 20
PROJECT SHEET

Name _____ Date _____

Cluster Metal Trades Occupation Machinist Helper

Training Module Shop Math for Machinists

Training Milestone 3. Specialized Math Skills

PROJECT 6

**TRAINING
CONDITIONS:**

INTRODUCTION TO TRIGONOMETRY

● Here's what you will need:

1. This Project Sheet.
2. A pen or pencil to answer the questions in this Project Sheet.
3. A hand-held calculator with scientific functions.

**TRAINING
PLAN:**

● Here's what you do:

In this Project Sheet, you will review some basic triangle geometry. You will learn about the measurement of angles. You will also learn about triangles, especially right triangles. This will prepare you for your next Project Sheet which is about trigonometry. This work will help you solve many shop problems.

1. Read and study the geometry review on pages 2 to 16 of this Project Sheet.
2. Work the Shop Problems on pages 17 to 20.
3. Have your Instructor check your work and record your score on your Student Training Record.
4. Ask your Instructor for your next Project Sheet.

**TRAINING
GOAL:**

● Here's how well you must do:

1. You must score 8 out of 10 correct Shop Problems.
2. You must answer questions about this Project Sheet to the approval of your Instructor.

INTRODUCTION TO TRIGONOMETRY

This Project Sheet is an introduction to the next Project Sheet about trigonometry. When you work in a shop, you will use trigonometry to find missing dimensions on a blueprint or drawing, to do layout work, and to use gages to check tolerances.

ANGLES AND THEIR MEASUREMENT

Angles are measured in degrees, minutes, and seconds.

DEGREES:	($^{\circ}$) unit of measure of angles
MINUTES:	($'$) unit of measure of angles, one degree = 60 minutes
SECONDS:	($''$) unit of measure of angles, one minute = 60 seconds, one degree = 60 minutes one degree = 3,600 seconds

The symbol for angle is \sphericalangle . There are four types of angles. Look at Figure 1.

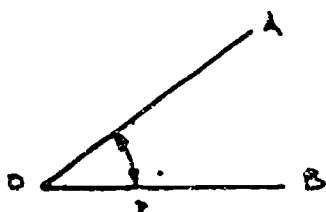

acute angle : $\sphericalangle AOB$ is more than 0° but less than 90°

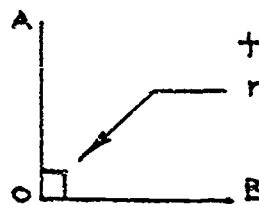

the symbol for a right angle is \square

right angle : $\sphericalangle AOB = 90^{\circ}$



obtuse angle : $\sphericalangle AOB$ is more than 90° but less than 180°



straight angle : $\sphericalangle AOB = 180^{\circ}$

Figure 1: Four kinds of angles.

An angle can be named in one of two different ways. Look at Figure 2.

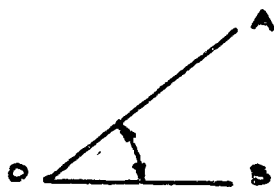

$\angle AOB$ or $\angle BOA$:
A is the end of one side of the angle, B is the end of the other side of the angle, and O is the vertex of the angle where the two sides meet.

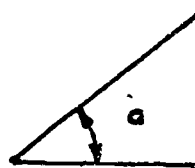

$\angle a$: a simply names the angle. This is the most common way of naming angles.

Figure 2: Naming an angle.

Most angular measurement on sketches, specifications, or blueprints are given in degrees, minutes and seconds. When you use a calculator in your work you will have to know how to convert an angle measured in degrees, minutes and seconds, to its equivalent in decimal numbers.

For Example:

$$1. 17^\circ 20' = 17^\circ + \left(20' \times \frac{1^\circ}{60'}\right)$$

$$= 17^\circ + \frac{20^\circ}{60}$$

$$= 17^\circ + 0.33^\circ$$

$$= 17.33^\circ$$

Divide the minutes by 60 to get the decimal part.

$$2. 22^\circ 46' 14'' = 22^\circ + 46' + \left(14'' \times \frac{1'}{60''}\right)$$

$$= 22^\circ + 46' + \frac{14'}{60}$$

$$= 22^\circ + 46' + 0.233'$$

$$= 22^\circ + 46.233'$$

$$= 22^\circ + \left(46.233' \times \frac{1^\circ}{60'}\right)$$

$$= 22^\circ + \frac{46.233^\circ}{60}$$

$$= 22^\circ + 0.771^\circ$$

$$= 22.771^\circ$$

Divide seconds by 60 to get decimal part of minutes.

Divide minutes by 60 to get decimal part of degrees.

It may also become necessary to change a decimal form of degrees back to minutes and seconds.

For example:

$$\begin{aligned}
 1. \quad 45.7^\circ &= 45^\circ + (0.7 \times \frac{60'}{1^\circ}) \quad \leftarrow \text{Multiply the decimal part of} \\
 &= 45^\circ + 42' \quad \text{degrees to get minutes.} \\
 &= 45^\circ 42'
 \end{aligned}$$

$$\begin{aligned}
 2. \quad 73.84^\circ &= 73^\circ + (0.84 \times \frac{60'}{1^\circ}) \quad \leftarrow \text{Multiply the decimal part} \\
 &= 73^\circ + 50.4' \quad \text{of degrees to get minutes.} \\
 &= 73^\circ + 50' + (0.4 \times \frac{60''}{1'}) \quad \leftarrow \text{Multiply the decimal part} \\
 &= 73^\circ + 50' + 24'' \quad \text{of minutes to get seconds.} \\
 &= 73^\circ 50' 24''
 \end{aligned}$$

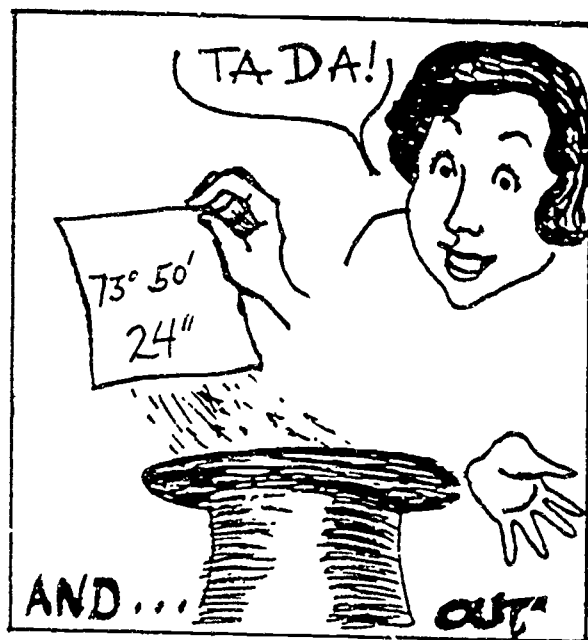
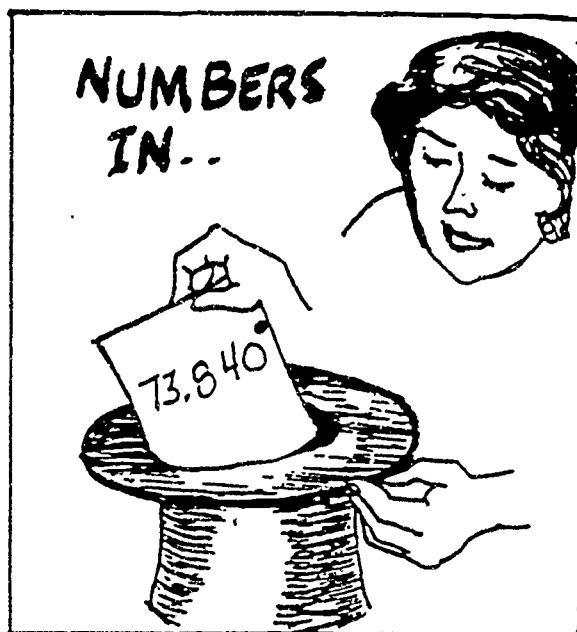

PI AND RADIANS

You will work with the constant number called *pi* (a Greek letter), normally written as π . The value of pi can be figured in many ways, but it will be enough for you to know that it is the ratio of the *circumference* of any circle to its *diameter*. Look at Figure 3 below:

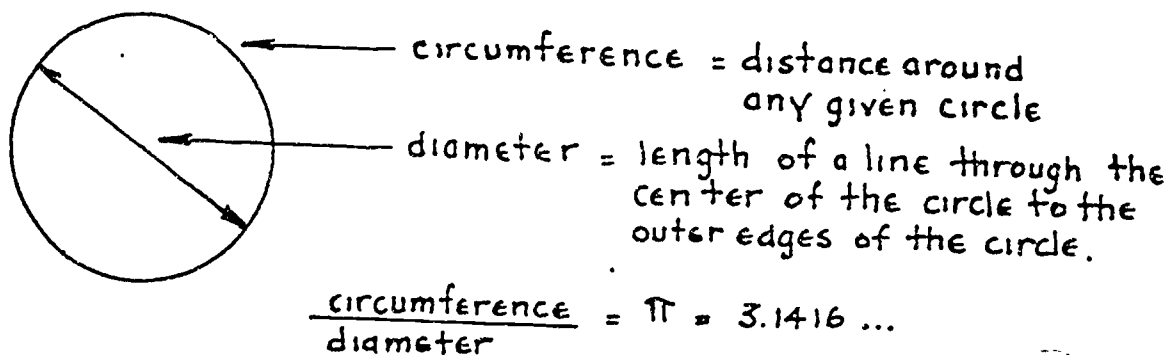

Since π is not an exact number use the following values:

$\pi = 3.1416$ to the nearest ten thousandth

$\pi = 3.142$ to the nearest thousandth

$\pi = 3.14$ to the nearest hundredth

Figure 3: π = the circumference of a circle divided by the diameter.

In some technical measurements you may run into a measurement of angles called *radians*. It is enough for you to know how radians and degrees are related and how to convert from one to the other.

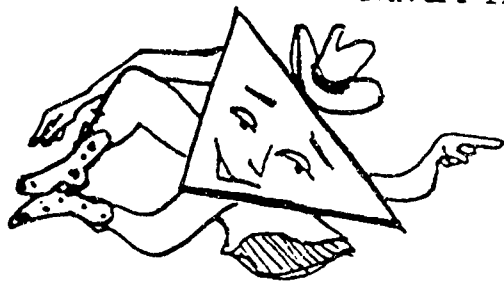

1 radian = 57.296 degrees

1 degree = 0.0175 radians

Here's how to convert radians and degrees:

1. Convert 0.76 radians to degrees

degrees = 0.76 radians \times (57.296) \leftarrow multiply radians by 57.296 to find degrees

therefore, 0.76r = 43.54°

2. Convert 72.5 degrees to radians.

$$\text{radians} = 72.5 \text{ degrees} \times (0.0175) \leftarrow \begin{array}{l} \text{multiply degrees by (0.0175)} \\ \text{to find radians} \end{array}$$

$$\text{therefore, } 72.5^\circ \approx 1.27r$$

You should also know that there are 2π radians in a circle.

$$\begin{aligned} 2 \times \pi \times 1 \text{ radian} &= 2 \times 3.1416 \times 57.296 \\ &= 360.00^\circ \\ &= 360^\circ \text{ (the number of} \\ &\quad \text{degrees in any circle)} \end{aligned}$$

TRIANGLES

Before you can learn trigonometry, you must know all about triangles. You must know how the sides and angles of a triangle are related.

A very important thing about triangles is that the sum of the three angles in *any* triangle is equal to 180 degrees. Look at Figure 4 below:

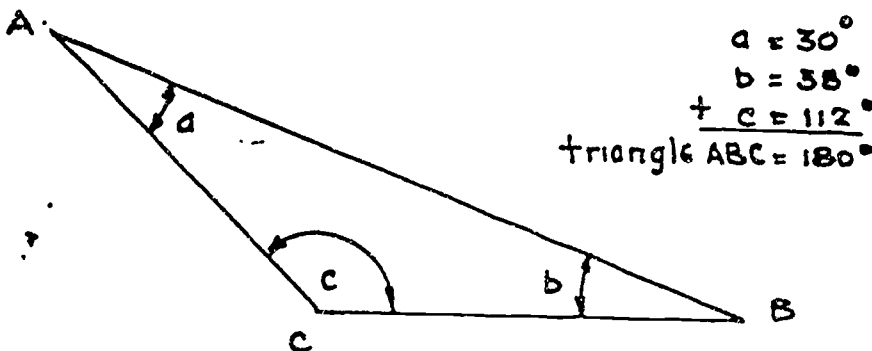
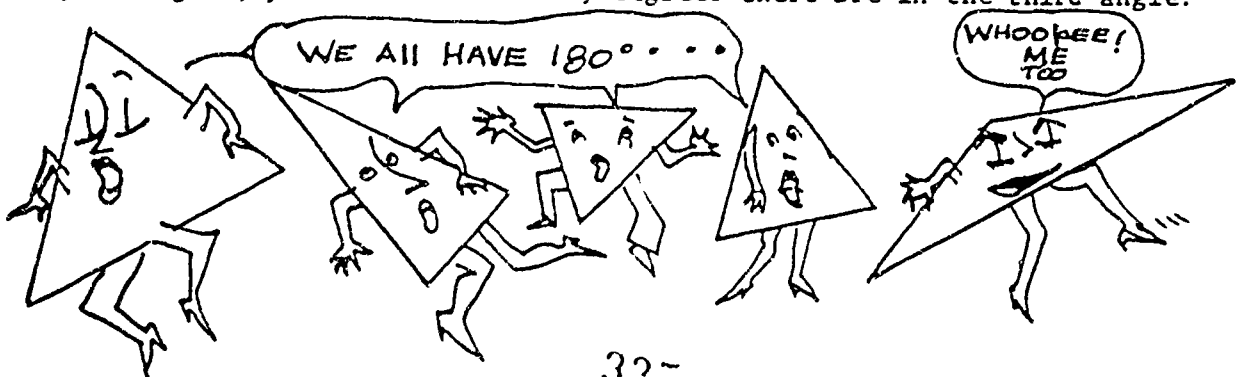
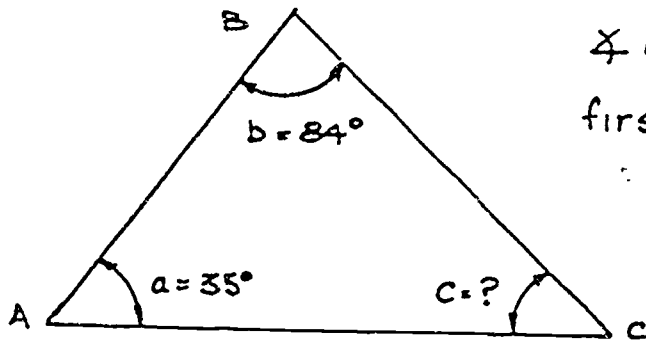

Figure 4: Triangles have 180 degrees.

Figure 4 shows that if you know how many degrees there are in any two angles of any triangles, you can find how many degrees there are in the third angle.



To see how to find the size of an angle in a triangle when you know the other two angles, look at Figure 5:



$\angle a = 35^\circ$, $\angle b = 84^\circ$, Find $\angle c$

first add $\angle a + \angle b = 35^\circ + 84^\circ$
 $= 119^\circ$

then subtract that
 total from 180° , or

$180^\circ - 119^\circ = \angle c$, or

$\angle c = 61^\circ$

Figure 5: How many degrees are in angle C?

Remember: In *all* triangles, the sum of the three angles *always* equals 180° .

RIGHT TRIANGLES

A right triangle is a triangle with one angle equal to 90 degrees. In other words, it is a triangle that has two of its sides *perpendicular* to each other. Look at Figure 6.

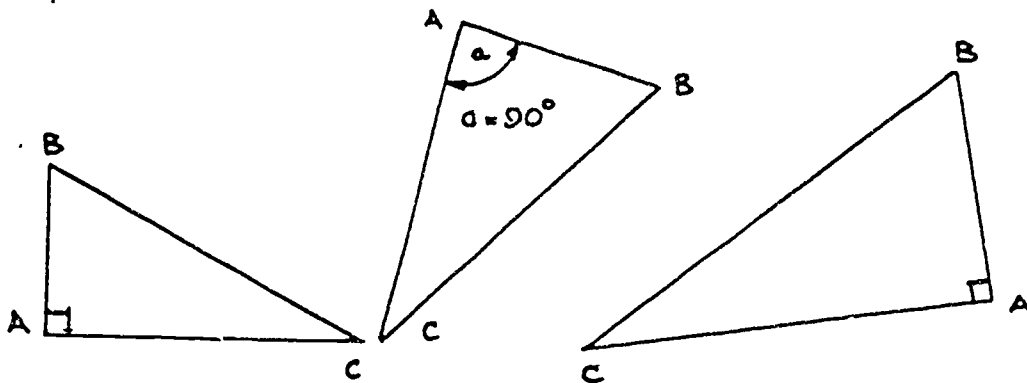
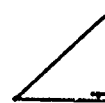
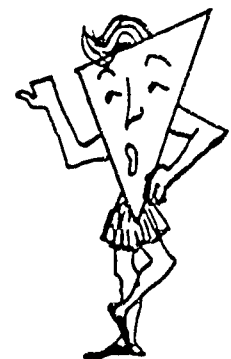

Figure 6: Right triangles.

The 90 degree angle in a right triangle is marked with a little square:



Perpendicular: (\perp) when two lines meet in a right or 90 degree angle.



The three angles in a right triangle always add up to 180° just like all other triangles. The right angle in a right triangle equals 90° so the other two angles must add up to 90° to make the sum of 180° . Look at Figure 7.

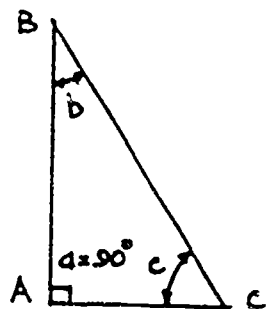

you know that
 $\angle a + \angle b + \angle c = 180^\circ$
 $90^\circ + (\angle b + \angle c) = 180^\circ$
 $90^\circ + (90^\circ) = 180^\circ$
 and you can see that
 $\angle b + \angle c = 90^\circ$

Figure 7: The sum of the two acute angles of a right triangle equal 90 degrees.

When you use trigonometry it is much easier to work with triangles in a *standard position*. Of the right triangles below, only triangle ABC is in the standard position.

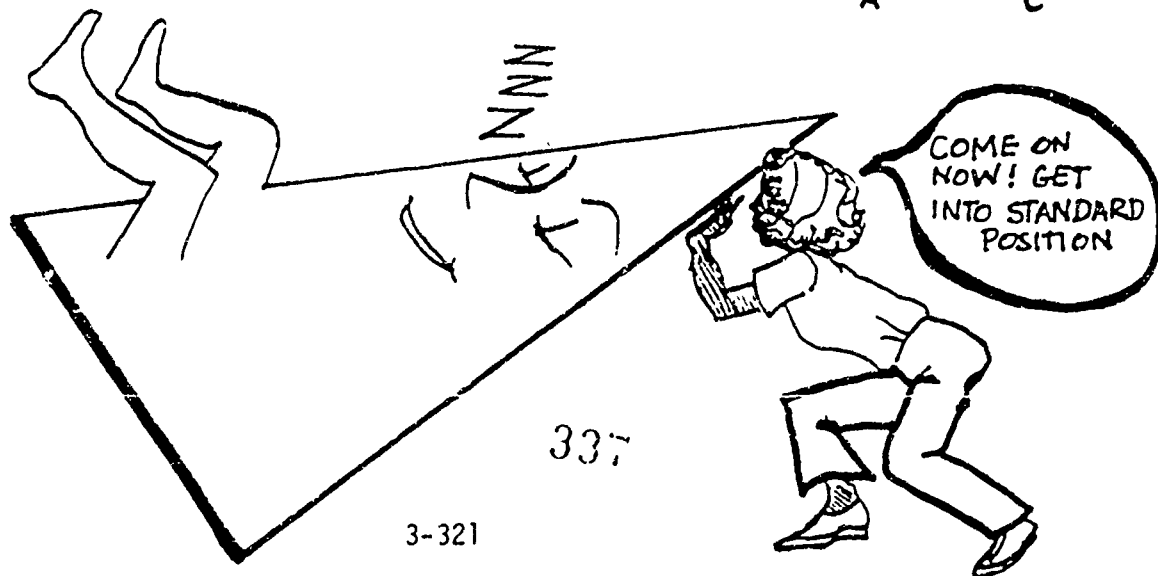
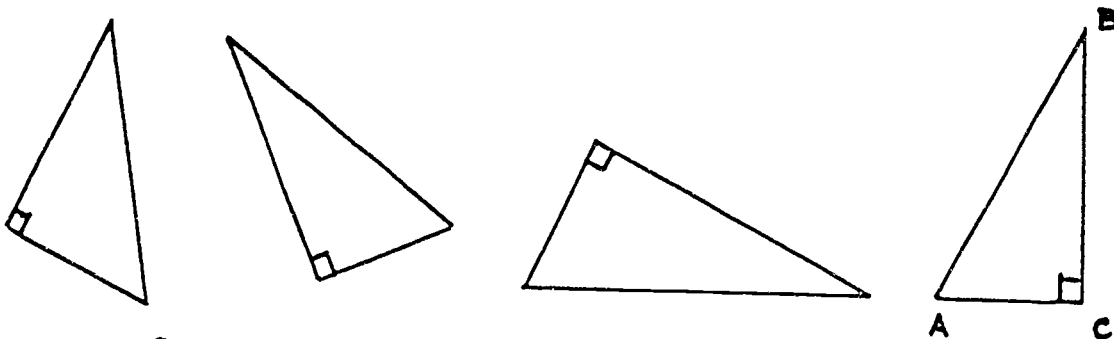

To see how to place a right triangle in the standard position, look at Figure 8.

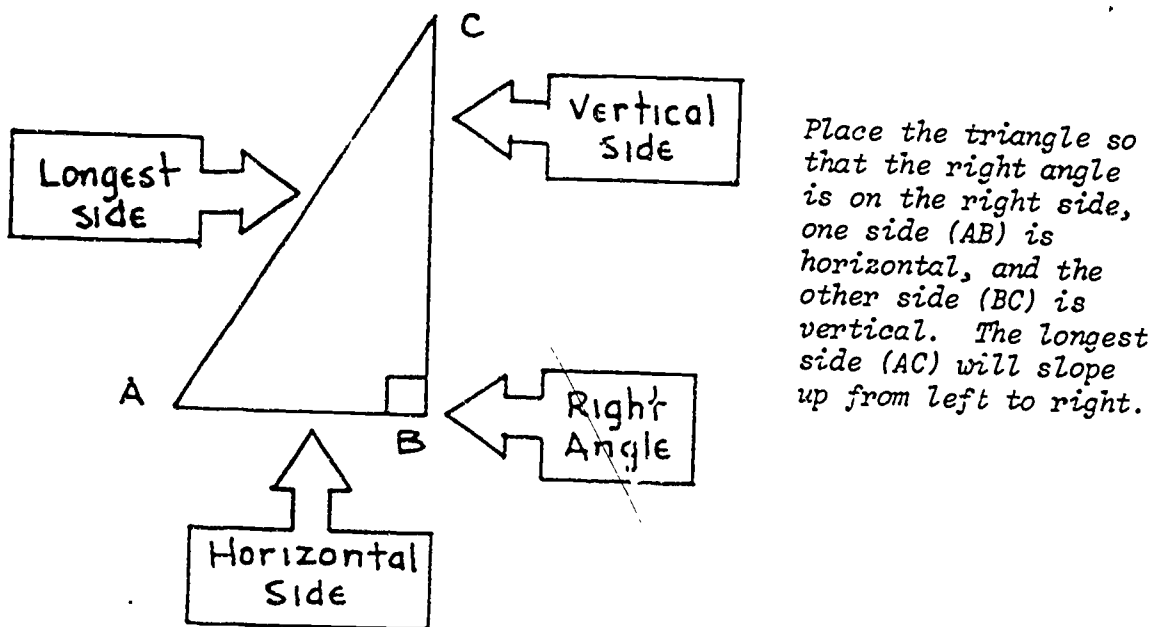

Figure 8: Standard position for a right triangle.

Look at Figure 9. You can see how each triangle has been turned to be in standard position.

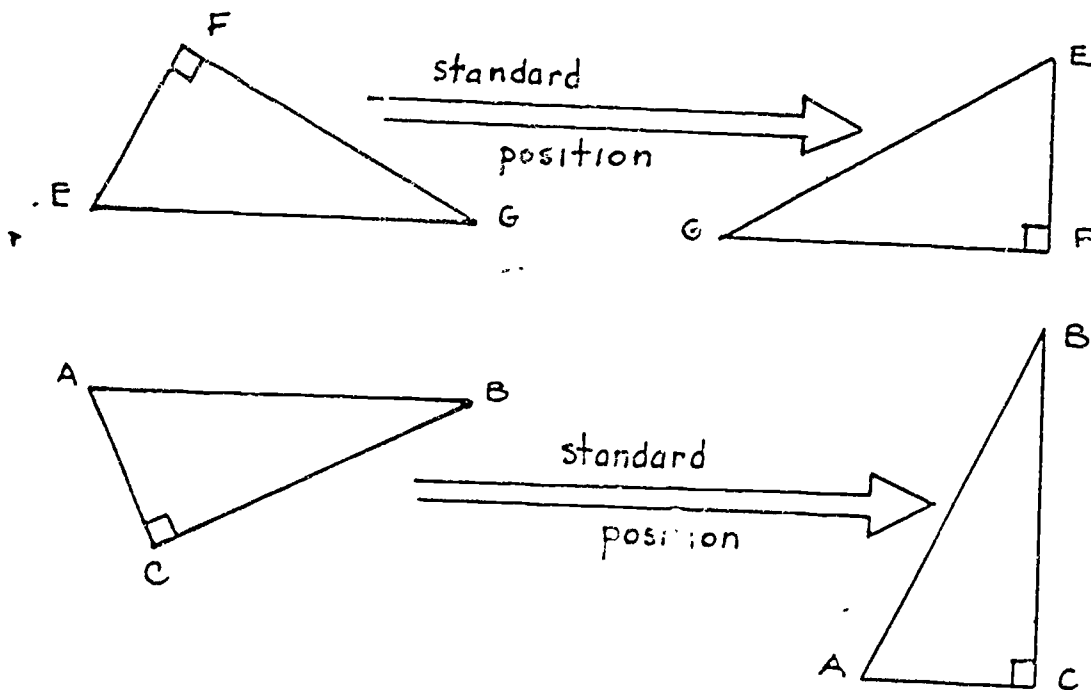

Figure 9. More about standard position.

Now that you understand standard position, you can *name* the sides of a right triangle in a way that has also become standard. Look at Figure 10.

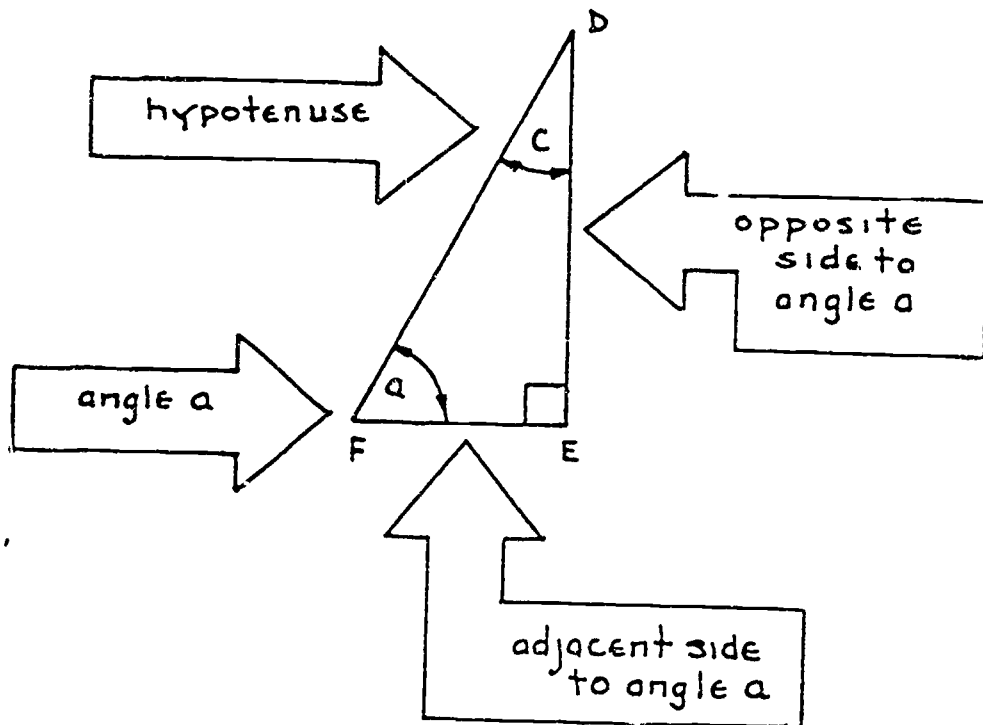
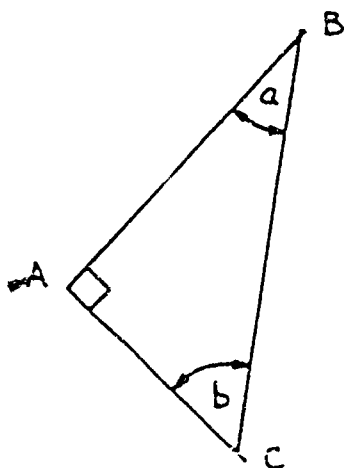

Figure 10: The language of right triangles.

Look at Figure 10 again. Angle E is the right angle. The longest side, FD, opposite the right angle, is called the *hypotenuse* (high-pot'-a-noose). For angle a, the side DE is called the *opposite side*, and the side, FE is called the *adjacent side*. For angle c, FE is the opposite side, DE is the adjacent side, and FD is still the longest side or hypotenuse.

Check your understanding of the above names by figuring out which sides are which for the triangle shown in Figure 11.



1. Side opposite $\angle a$ _____
2. Hypotenuse _____
3. Side adjacent to $\angle b$ _____
4. Side adjacent to $\angle a$ _____
5. Side opposite $\angle b$ _____

Figure 11: More standard names for right triangles.

Did you get these answers in Figure 11?

1. AC 2. BC 3. AC 4. AB 5. AB

If you had any trouble getting the above answers, look at Figure 10 again and compare the names to the questions in Figure 11.

PYTHAGOREAN THEOREM

A very important thing to know about right triangles is the *Pythagorean theorem*, or law. Pythagoras was a Greek. You don't need to remember that, but you do need to remember his theorem. Look at Figure 12.

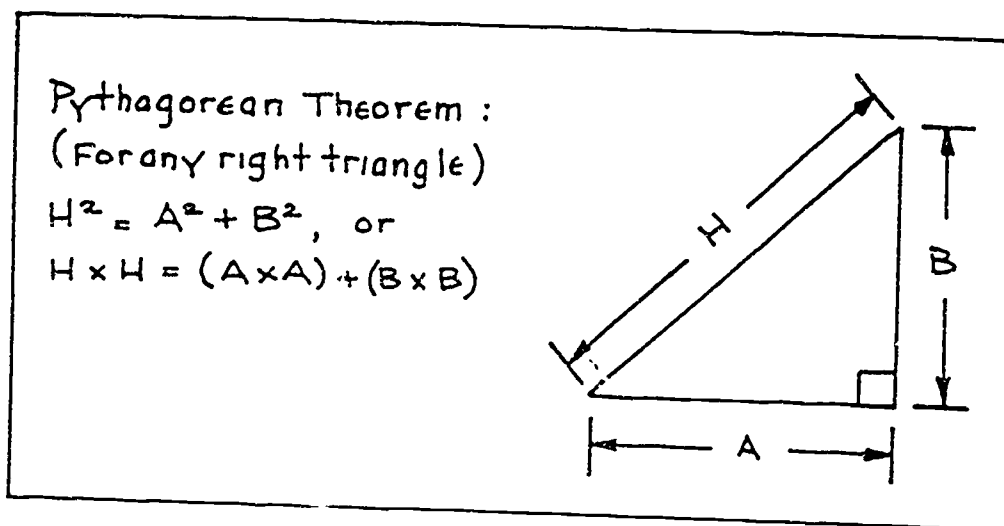
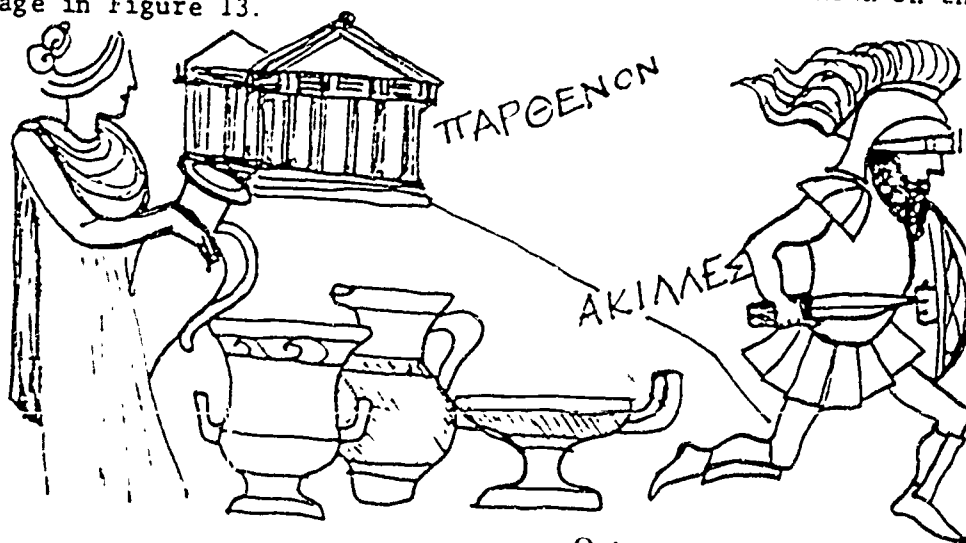

Figure 12: The Pythagorean theorem.

In words, Figure 12 says; For *any* right triangle, the square of the hypotenuse equals the sum of the squares of the other two sides of the right triangle.

Another way of thinking about the Pythagorean theorem is shown on the next page in Figure 13.



The area of the square A, with sides a , plus the area of the square B, with sides b , is equal to the area of the square C, with sides c , or:

$$\begin{aligned} \text{Area of A} + \text{Area of B} &= \text{Area of C} \\ (a \times a) + (b \times b) &= (c \times c) \\ a^2 + b^2 &= c^2 \end{aligned}$$

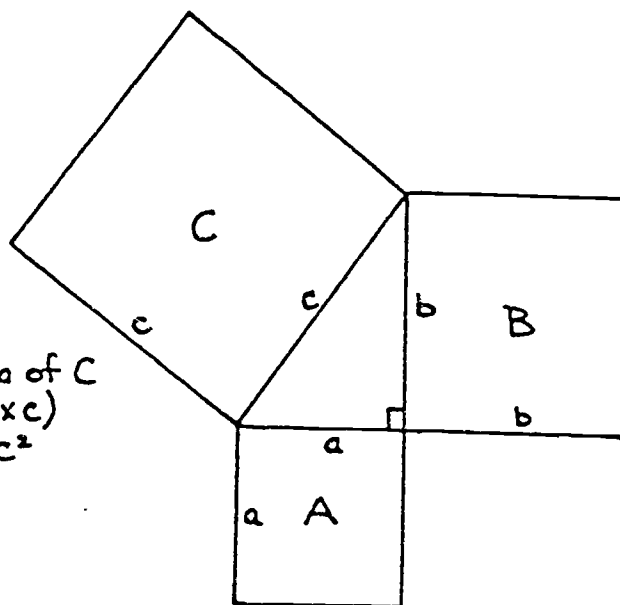

Figure 13: Another way of thinking about the Pythagorean theorem.

SPECIAL RIGHT TRIANGLES

There are three special right triangles that are used very often in practical shop problems. If you can work with these triangles your shop work will be easier and quicker. Look at Figure 14.

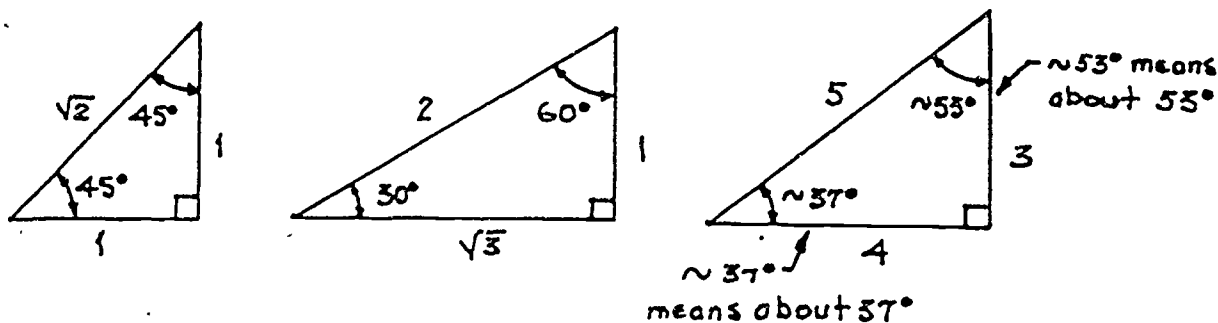

Figure 14: Three special right triangles.

The first triangle is a 45 degree right triangle. Its angles are 45 degrees, 45 degrees and 90 degrees; and it is formed by the diagonal and two sides of a square. It is an *isosceles triangle*. An isosceles triangle has two of its sides equal. Look at Figure 15 on the next page.

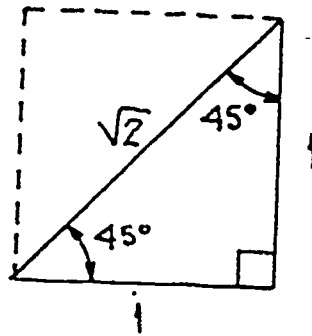
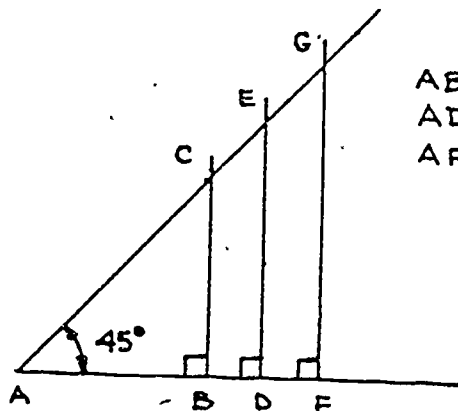

Figure 15: Forty-five degree right triangle.

The triangle in Figure 15 has the shorter sides, each 1 unit long. You can draw a 45 degree right triangle with any length sides. If you increase the length of one side, the other sides *increase in proportion*, while the angles stay the same size. Look at Figure 16.



ABC is a 45° right triangle
 ADE is a 45° right triangle
 AFG is a 45° right triangle
 and so on ...

If AB = 1 unit, then
 BC = 1 unit, and
 AC = $\sqrt{2}$ units

if AD = 2 units, then
 DE = 2 units, and
 AE = $2\sqrt{2}$ units

if AF = 3 units, then
 FG = 3 units, and
 AG = $3\sqrt{2}$ units

Figure 16: Forty-five degree right triangle.

In Figure 16, you can see that in a 45 degree triangle the sides are always in a proportion of 1, 1, and $\sqrt{2}$. That means that the two shorter sides are always equal and the long side, or hypotenuse, is always $\sqrt{2}$ (about 1.4) times the length of the short side.

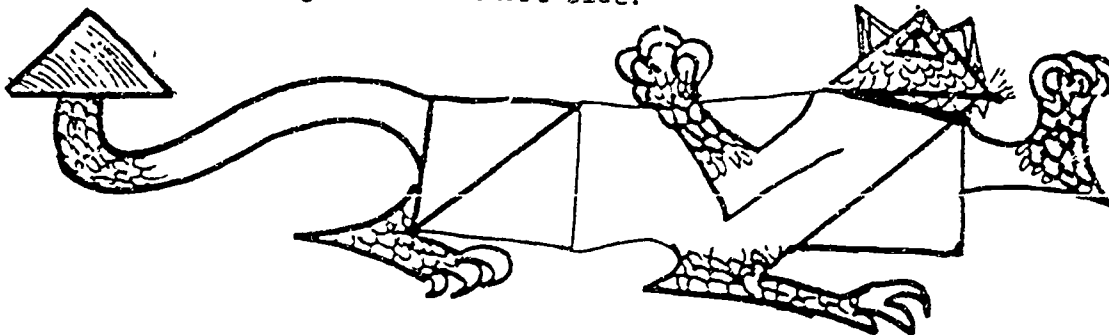

EXAMPLE PROBLEM: In triangle ABC below, if $AB = 4.63''$, what is the length of AC; what is the length of BC?

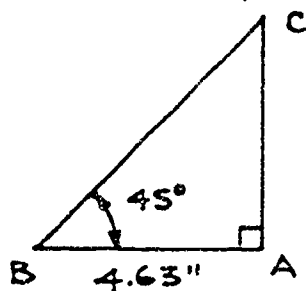

Solution: ABC is a 45° right triangle.
Therefore you know that
 $AB = AC$, or $AC = 4.63''$
and $BC = 4.63'' \times \sqrt{2}$
 $= 4.63'' \times 1.414$
 $= 6.548''$

Remember this: No matter what the size of the triangle--if one angle is 90 degrees, and if the second angle is 45 degrees, then the third angle is 45 degrees also. The two shorter sides are equal, and the hypotenuse is or about 1.4 times the length of a side.



The symbol \approx means nearly equal to

$$\sqrt{2} \approx 1.4$$

In Figure 14 on page 12, the second special triangle is the 30-degree/60-degree right triangle.

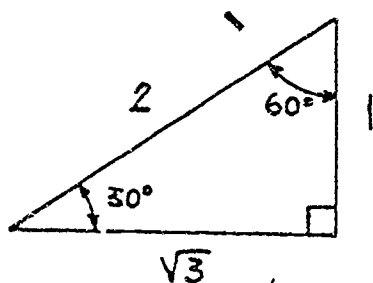

In this triangle the length of the side opposite the 30-degree angle (the shortest side) is exactly one half the length of the hypotenuse (the longest side).

The length of the third side is $\sqrt{3}$ times the length of the shortest side.

In any 30-degree/60-degree right triangle, the hypotenuse is twice the length of the shortest side. The other side is $\sqrt{3}$ or about 1.7 times the shortest side.

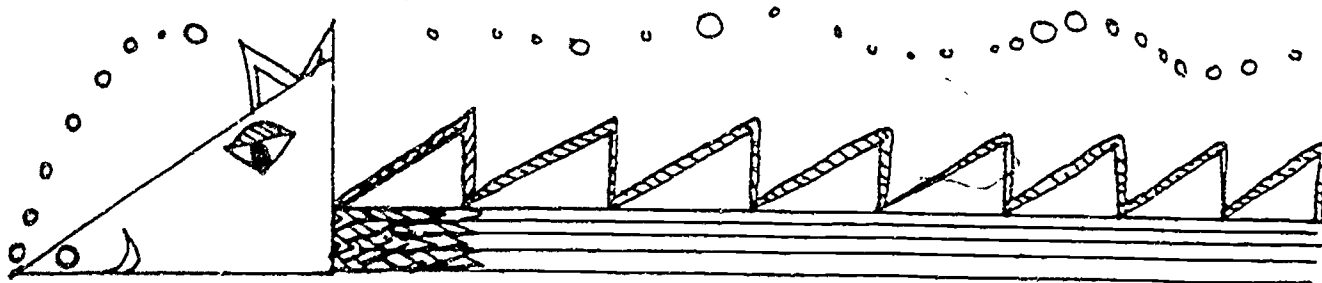

EXAMPLE PROBLEM: In Figure 17, $CB = 24$ units. Find $\angle a$, AB , and AC .

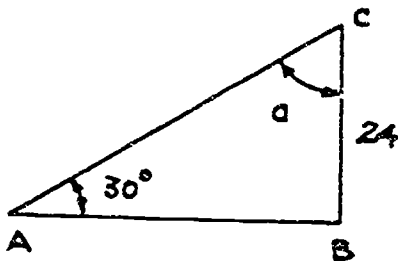

Figure 17: 30° right triangle.

Solution: In a right triangle the sum of the two angles that are not right angles is equal to 90° . Therefore
 $\angle a + 30^\circ = 90^\circ$
 $\angle a = 60^\circ$

$$\begin{aligned} \text{Side AC} &= 2 \times \text{Side BC} \\ &= 2 \times 24 \text{ units} \\ &= 48 \text{ units} \end{aligned}$$

$$\begin{aligned} \text{Side AB} &= \sqrt{3} \times \text{Side BC} \\ &= 1.73 \times 24 \text{ units} \\ &= 41.52 \text{ units} \end{aligned}$$

In Figure 14, the third special right triangle is the 3 - 4 - 5 right triangle. If a triangle has sides equal to 3 units, 4 units and 5 units long, it must be a right triangle. If you multiply 3, 4, and 5 by the same number, you will get a new triangle that is a right triangle. For instance, multiplying 3, 4 and 5 by 3; you will get a new right triangle with sides 9, 12 and 15, and so on.

You can use this 3-4-5 right triangle in layout work to set up a right triangle. Look at Figure 18 on the next page to see how.

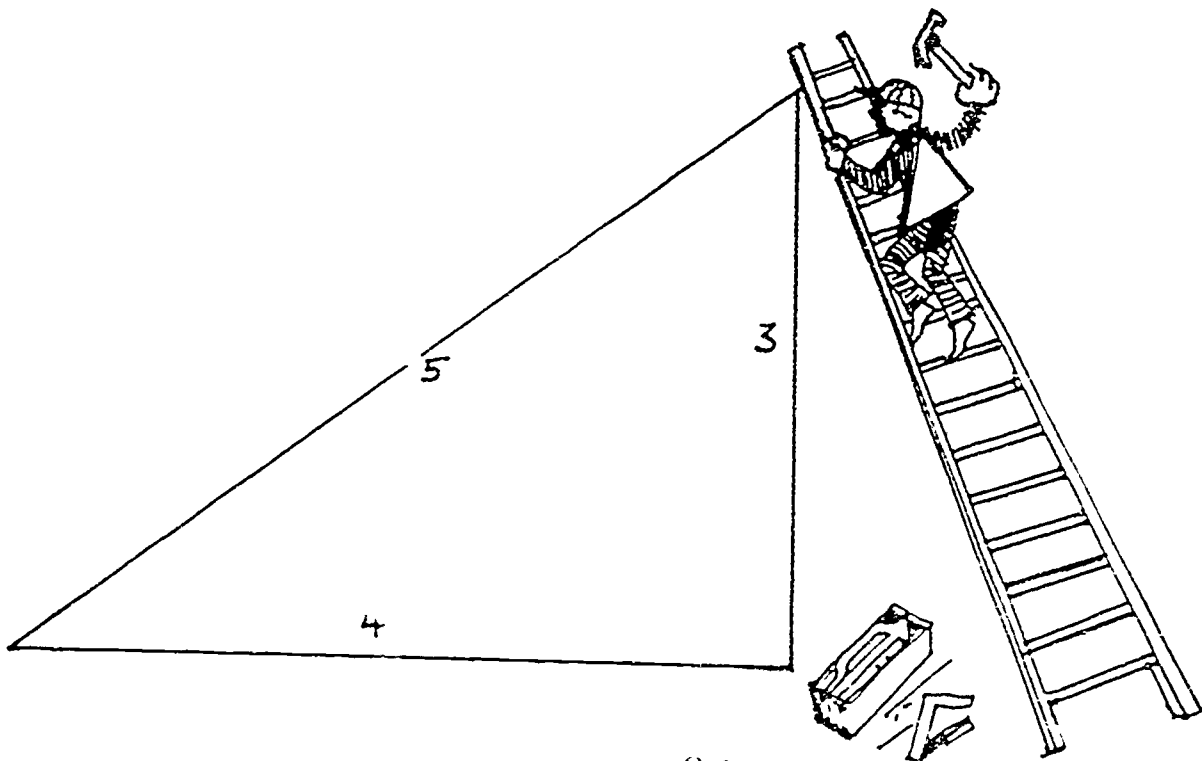

311

CONSTRUCTING A RIGHT TRIANGLE

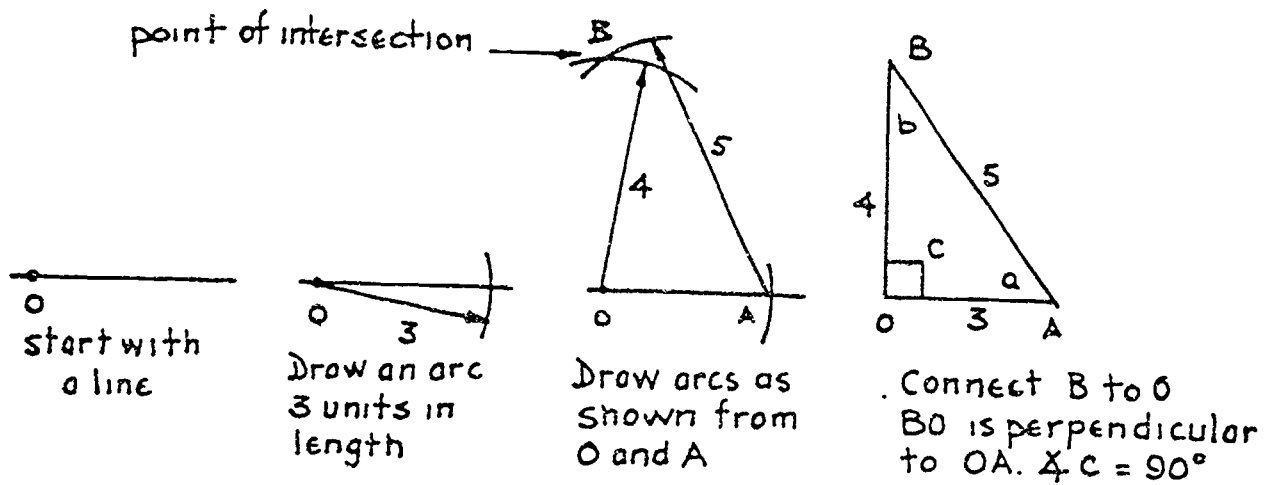

In any 3-4-5 right triangle the acute angles ($\angle a$ and $\angle b$) are approximately 37° and 53° . The smallest angle is always opposite the shortest side.

Figure 18: It's easy to construct a 3-4-5 right triangle.

The three special right triangles you just read about will appear often in triangle trigonometry.

If you have any questions about this review or the Example Problems, see your Instructor. Otherwise, turn to the next page and work the Shop Problems.

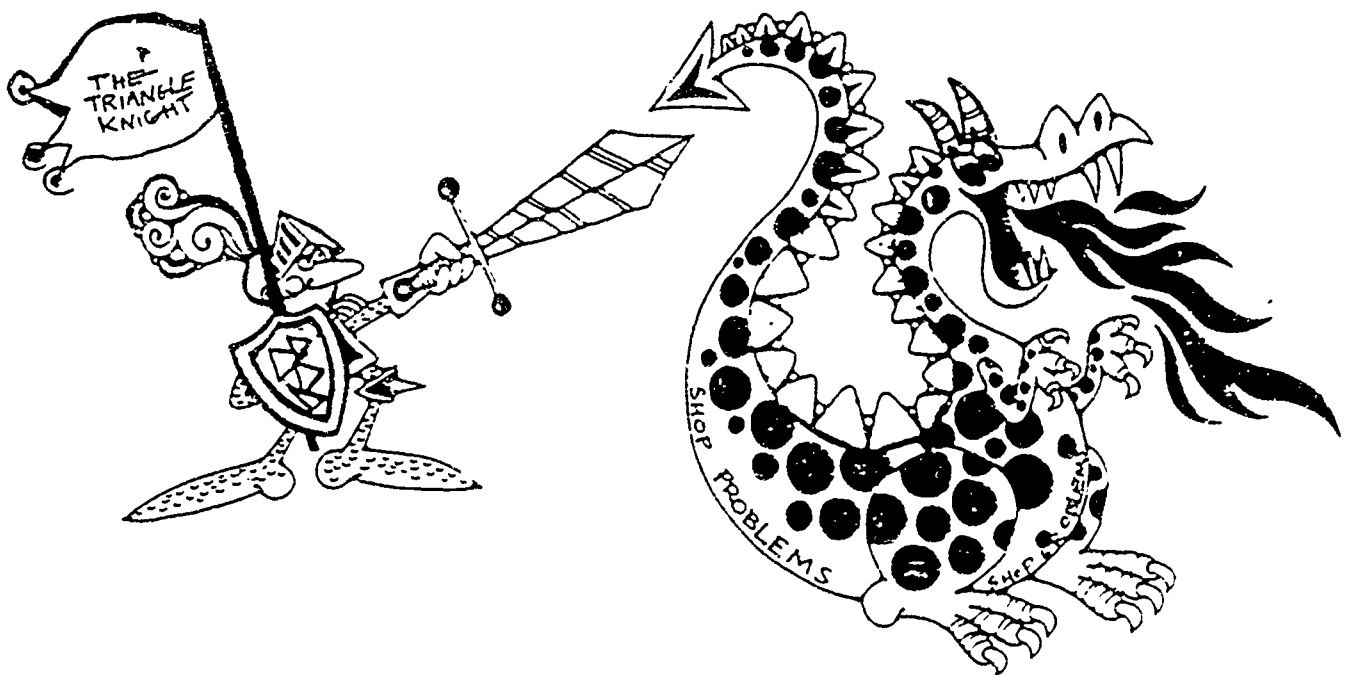

SHOP PROBLEMS

1. You have a calculator that accepts angular measurement in decimal form only. You need to make some calculations using the angles listed below. Find the decimal form of the angles to the nearest hundredth of a degree.

(1) 34 degrees and 16 minutes = _____

(2) 15 degrees and 47 minutes = _____

(3) 64 degrees and 51 minutes = _____

2. You have been given the angles below in decimal form. Convert each one to the nearest degree, minute and second.

(1) 48.65 degrees = _____

(2) 65.37 degrees = _____

(3) 15.12 degrees = _____

3. You have been given the angles below in radian measurement. You need to convert each one to degrees in decimal form to the nearest thousandth of a degree.

(1) 0.432 radians = _____

(2) 0.714 radians = _____

(3) 1.521 radians = _____

4. You are given the sketch shown below in Figure 19. Your Instructor wants you to find the missing angles.

a = _____ b = _____ c = _____ d = _____

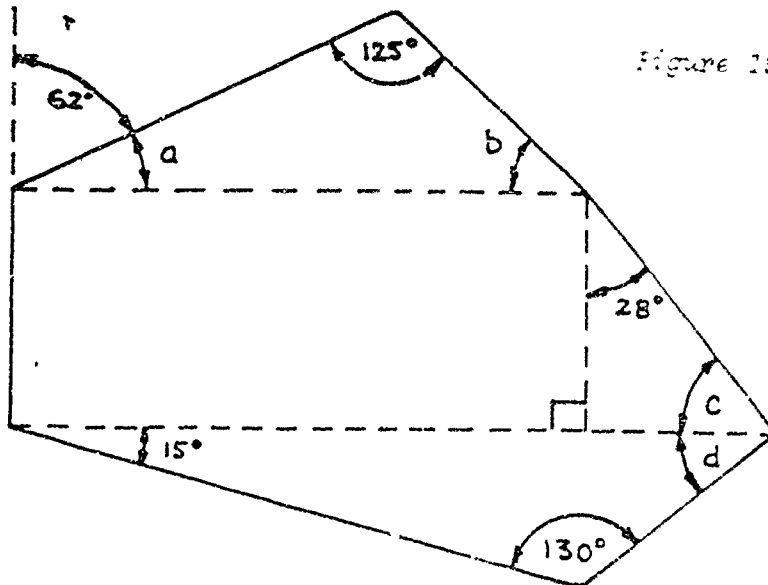

Figure 19: Find the missing angles a , b , c , and d .

Not drawn
to scale.

5. Your supervisor gives you a rough sketch of a profile gage as shown in Figure 20. You are to calculate the missing angles. Find angles a, b, c, d, e, f, g and h.

a = _____ b = _____ c = _____ d = _____ e = _____ f = _____ g = _____ h = _____

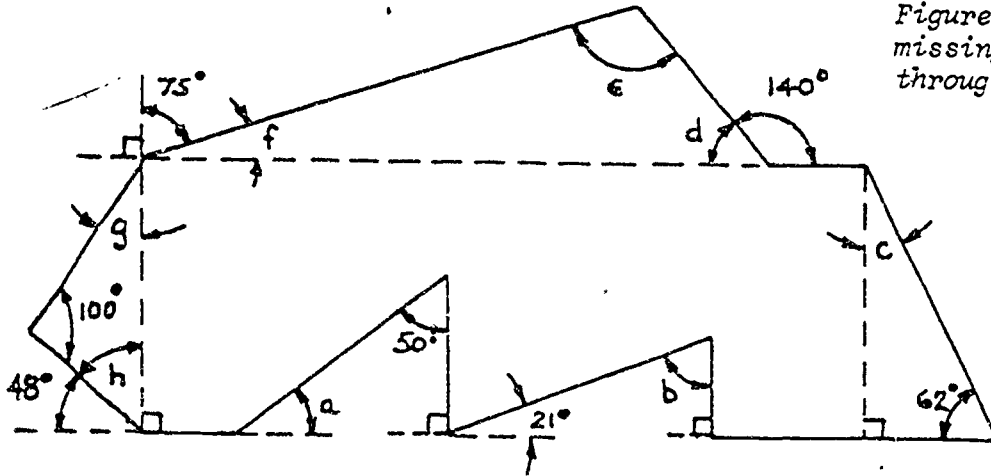

Figure 20: Find the missing angles, a through h.

6. To understand trigonometry you must know the names of the three sides of the right triangle in relation to a given angle and the right angle. Look at Figure 21. Fill in the chart. The first triangle has been done for you.

Triangle	hypotenuse (longest side)	side opposite to $\angle a$	side adjacent to $\angle a$
1	AC	BC	AB
2			
3			
4			
5			
6			
7			
8			

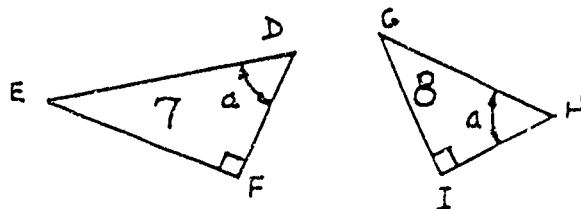
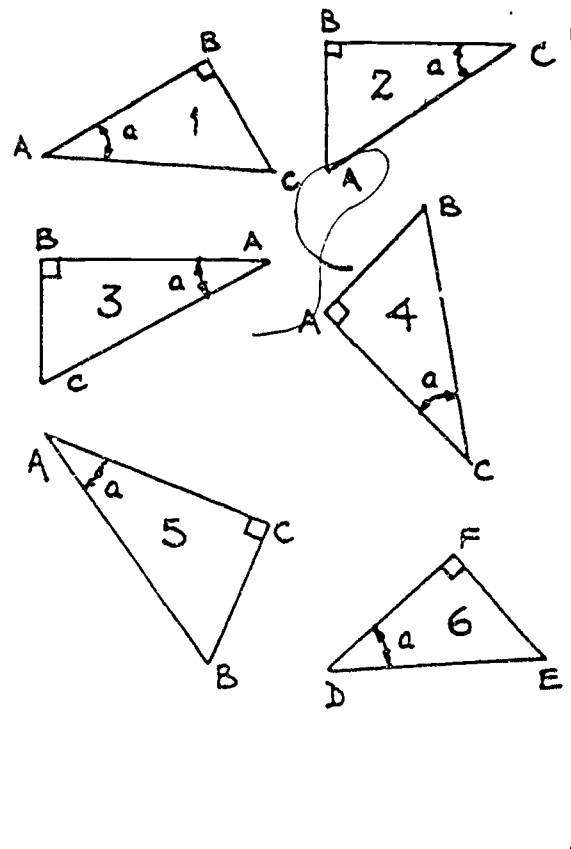

Figure 21: Names of the important parts of a right triangle.

7. Your boss wants you to layout the gage block shown in Figure 22. Find the missing dimensions to the nearest tenth of an inch.

A = _____ B = _____ C = _____ D = _____

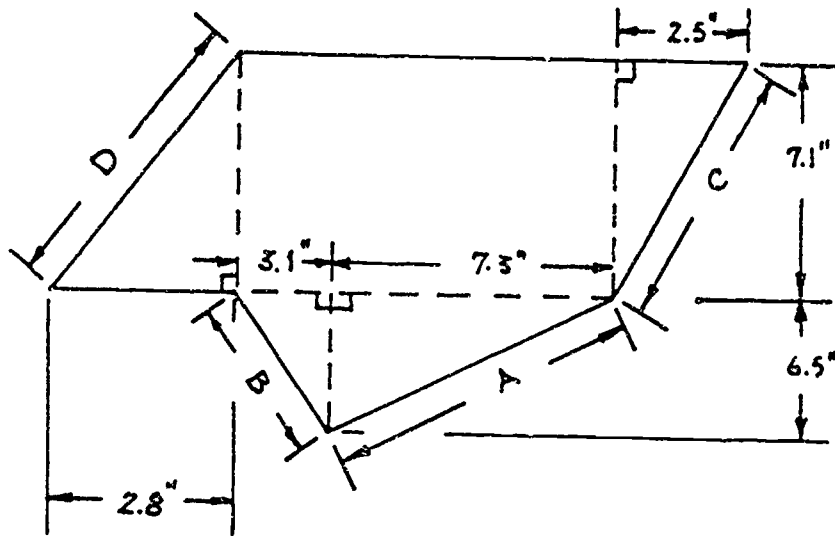

Figure 22: Find the missing dimensions A, B, C and D.

8. On your job you are given the following sketch of a gage pattern to layout and cut. You must find the missing dimensions A, B, C, D, E, F, C, H and J. Look at Figure 23.

A = _____ B = _____ C = _____ D = _____ E = _____ F = _____ G = _____

H = _____ J = _____

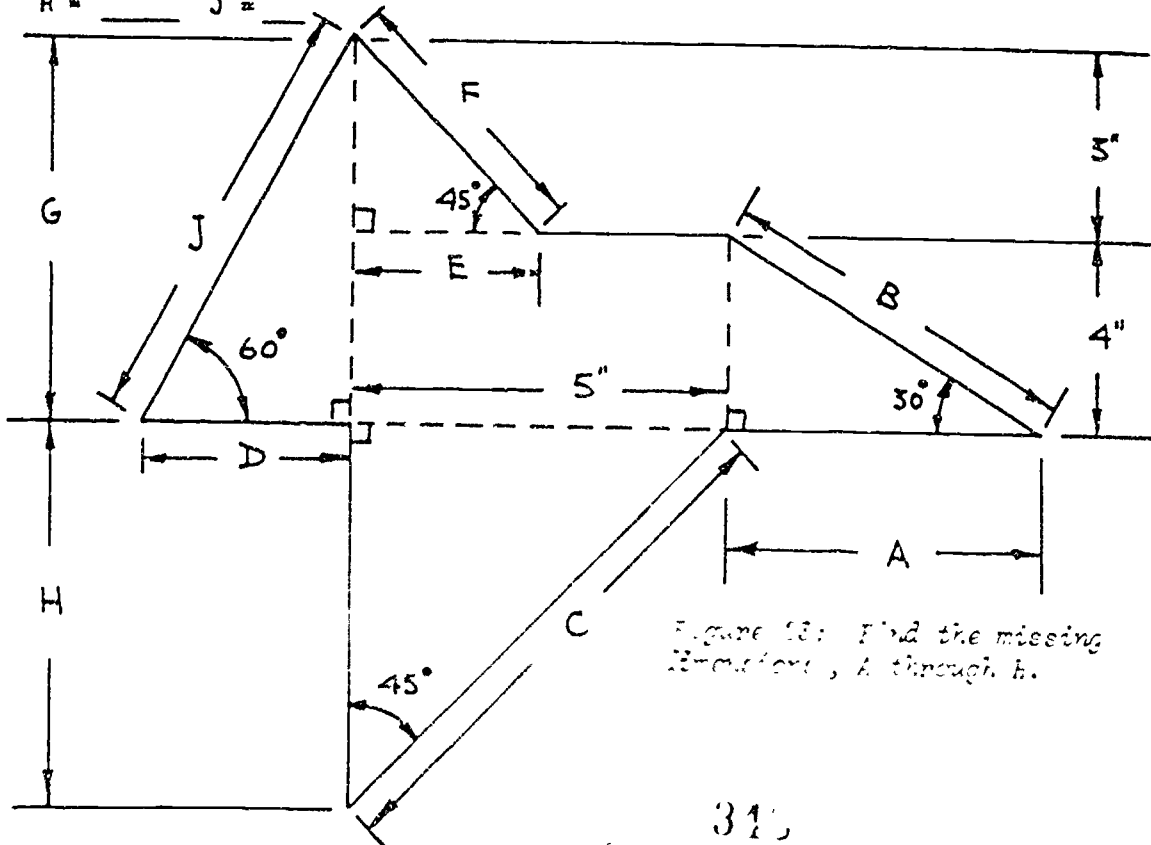

Figure 23: Find the missing dimensions, A through h.

9. You were told by your supervisor to lay out a right triangle. After you finished, you measured the three sides and found them to be 12 cm, 13 cm, and 5 cm long. Did you, in fact, lay out a right triangle?

Yes _____ No _____

10. Your boss asks you to cut a brace from bar stock for a platform as shown in Figure 24. Find the length of the brace to the nearest hundredth of a foot. (Hint: The square root of 3 = 1.73.)

Length of brace = _____

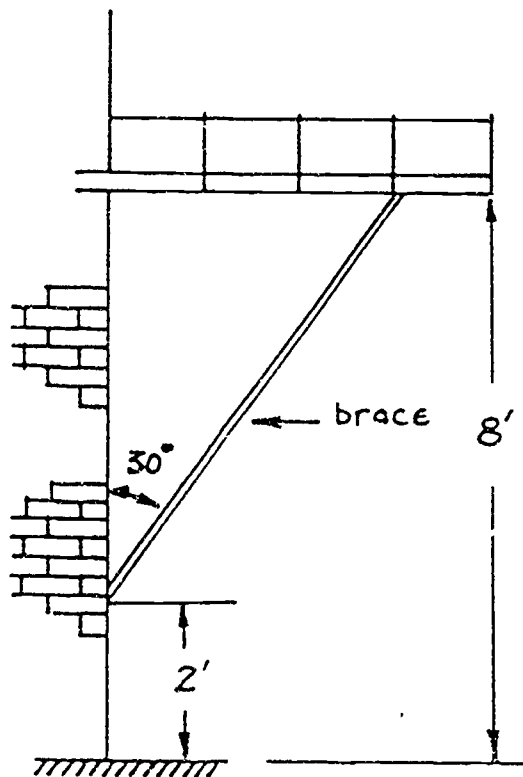

Figure 24: How long is the brace?

ASK YOUR INSTRUCTOR TO CHECK YOUR WORK.

BAS

PROJECT SHEET



(216)

Name _____ Date _____

Cluster Metal Trades Occupation Machinist HelperTraining Module Shop Math for MachinistsTraining Milestone 3. Specialized Math Skills

PROJECT 7

SHOP TRIGONOMETRY-PART 1

TRAINING CONDITIONS:

- Here's what you will need:
 1. This Project Sheet.
 2. A pen or pencil to answer the problems in this Project Sheet.
 3. A hand-held calculator with scientific functions.

TRAINING PLAN:

- Here's what you do:

In this Project Sheet, you will learn the basic trigonometry of right triangles (a triangle with one angle equal to 90°). This Project Sheet will help you to solve many shop problems using trigonometry.

1. Read and study pages 2 to 26 of this Project Sheet.
2. Work the Shop Problems on pages 27 to 30.
3. Have your Instructor check your work and record your score on your Student Training Record.
4. Ask your Instructor for your next Project Sheet.

TRAINING GOAL:

- Here's how well you must do:
 1. You must correctly answer 8 or more of the 10 Shop Problems in this Project Sheet.

SHOP TRIGONOMETRY-PART 1

In this Project Sheet, you will learn some basic trigonometry. You will learn how to find and work with sines, cosines and tangents. What you learn will help you find the dimensions of angles and sides of right triangles. These are things you will need to know to do certain shop work.

TRIGONOMETRIC RATIOS

A *ratio* (ray-she-o) is a comparison of two quantities of the same kind, expressed in the same units. You will compare the sides of a right triangle. This comparison will be expressed as a *quotient* (quo-shunt). A quotient is the answer you get when you divide one number into another number. The quotient has no dimensions of length such as feet, inches, yards, etc. but is simply a number. Look at Figure 1.

$$X = \frac{\text{length of side A}}{\text{length of side B}} \leftarrow \begin{array}{l} \text{ratio of two} \\ \text{sides, A and B,} \\ \text{of a triangle} \end{array}$$

quotient
(no dimensions)

Figure 1: Quotient equals a ratio.

The key to understanding trigonometric ratios is to realize that in *every* right triangle there is a fixed relationship (or ratio) connecting the lengths of the hypotenuse, adjacent side, opposite side and the angle that determines the right triangle. Look at Figure 2.

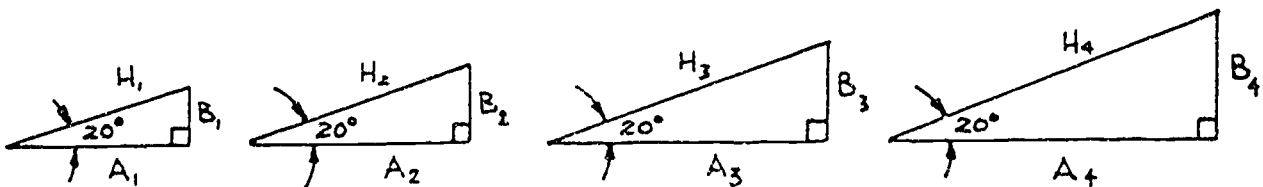

The quotient, or ratio, of $\frac{\text{adjacent side}}{\text{hypotenuse}} = \frac{A_1}{H_1} = \frac{A_2}{H_2} = \frac{A_3}{H_3} = \frac{A_4}{H_4} = \dots \text{ etc.}$
 ≈ 0.9397

Figure 2: Right triangles with a 20-degree angle.

There are *six* of these trigonometric ratios relating the side lengths of a right triangle. You will only need to know *three* of them.

THE FIRST RATIO: SINE

The first of these ratios is called the *sine* of angle x (sine rhymes with dine) and is written as $\sin x$. Look at the right triangle in Figure 3.

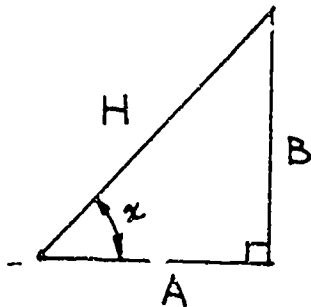

the ratio $\sin x$ is defined as:

$$\sin x = \frac{\text{opposite side}}{\text{hypotenuse}}, \text{ or}$$

$$\sin x = \frac{B}{H}$$

Figure 3: The ratio $\sin x$.

EXAMPLE PROBLEM 1: In the triangle shown in Figure 4, find the sin of 60° and the sin of 30° .

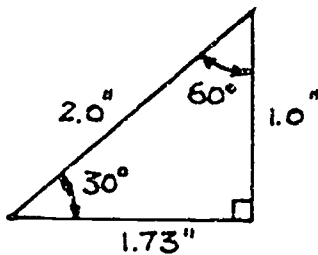

$$\begin{aligned} \sin 60^\circ &= \frac{\text{Side opposite } 60^\circ}{\text{hypotenuse}} \\ &= \frac{1.732''}{2''} \\ &\approx 0.866 \text{ (rounded)} \end{aligned}$$

$$\begin{aligned} \sin 30^\circ &= \frac{\text{Side opposite } 30^\circ}{\text{hypotenuse}} \\ &= \frac{1''}{2''} \\ &= 0.5 \end{aligned}$$

Figure 4: Finding the sin of 60° and the sin of 30° .

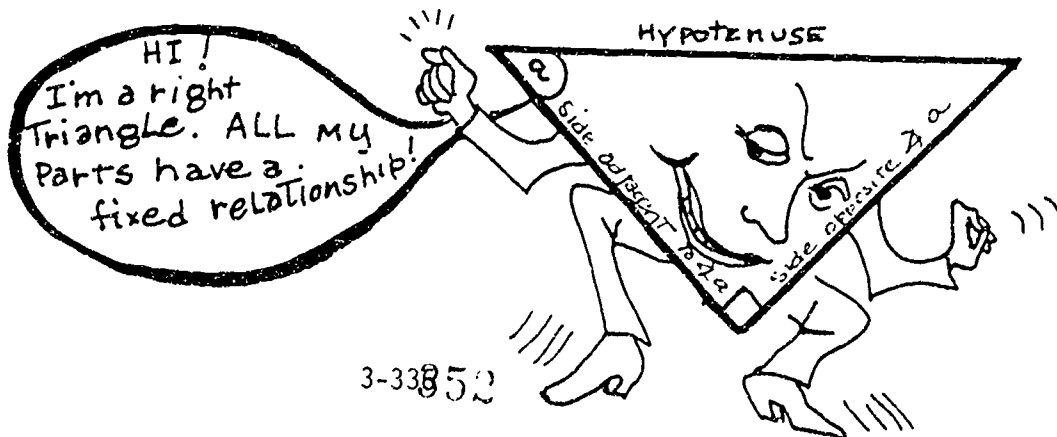

3-33852

Every possible angle x will have some number, $\sin x$, relating to it. Also, you can calculate the value of $\sin x$ from any right triangle that contains the angle x . For example, you can find the sin of 40° in the triangle shown below.

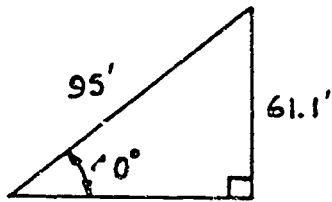

$$\sin 40^\circ = \frac{61.1'}{95'} = \frac{\text{opposite side}}{\text{hypotenuse}}$$

$$\approx 0.643 \text{ (rounded)}$$

EXAMPLE PROBLEM 2: Find the sin of 0° and the sin of 90° .

To find $\sin 0^\circ$, draw a triangle with a very small angle for angle x .

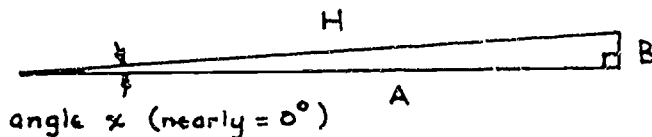

$$\sin 0^\circ = \frac{0}{H}$$

$$= 0$$

$\sin x = \frac{B}{H}$, you can see that as angle x gets closer to 0° , B gets smaller and smaller. When angle x equals 0° , B equals 0 and 0 divided by H equals 0.

To find $\sin 90^\circ$, draw a triangle with a very large angle for angle x .

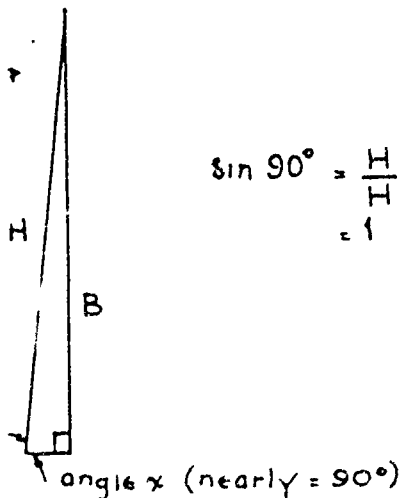

$$\sin 90^\circ = \frac{H}{H}$$

$$= 1$$

$\sin x = \frac{B}{H}$, you can see that as angle x gets closer and closer to 90° , B gets closer and closer to H . When angle x equals 90° , $B = H$ and B divided by H equals 1.

From the above, you can see that for any angle x equal to 0 or 90 degrees, or between 0 and 90 degrees, the sin of the angle x varies between 0 and 1.

Or you can say that the sin of angle x between 0 and 90 degrees can never be less than 0 or greater than 1.

This is a good thing for you to remember so as you will be able to estimate your answers and to find mistakes.

THE SECOND RATIO: COSINE

The second ratio is called the *cosine* of angle x . It is written as $\cos x$. Look at Figure 5.

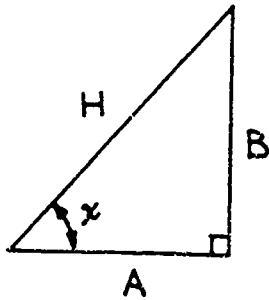

The ratio $\cos x$ is defined as:

$$\cos x = \frac{\text{adjacent side}}{\text{hypotenuse}}, \text{ or}$$

$$\cos x = \frac{A}{H}$$

Figure 5: The ratio $\cos x$.

EXAMPLE PROBLEM 3: In the triangle shown in Figure 6, find the \cos of 60° and the \cos of 30° .

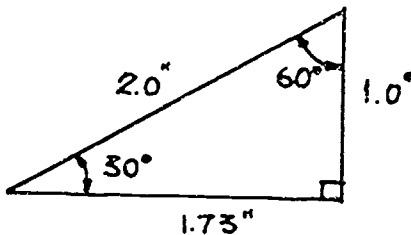

$$\begin{aligned} \cos 60^\circ &= \frac{\text{side adjacent to } 60^\circ}{\text{hypotenuse}} \\ &= \frac{1.0''}{2.0''} \\ &= 0.5 \end{aligned}$$

$$\begin{aligned} \cos 30^\circ &= \frac{\text{side adjacent to } 30^\circ}{\text{hypotenuse}} \\ &= \frac{1.73''}{2.0''} \\ &\cong 0.866 \text{ (rounded)} \end{aligned}$$

Figure 6: $\cos 60^\circ$ and $\cos 30^\circ$.

As before with $\sin x$, every possible angle x will have some number, $\cos x$, relating to it. You can calculate the value of $\cos x$ from any right triangle that contains the angle x . For example, you can find the \cos of 36° in the triangle below:

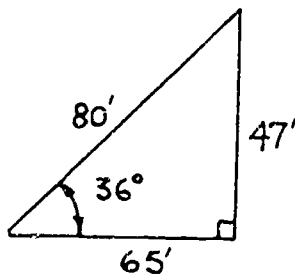

$$\begin{aligned} \cos 36^\circ &= \frac{65'}{80'} = \frac{\text{adjacent side}}{\text{hypotenuse}} \\ &\cong 0.81 \text{ (rounded)} \end{aligned}$$

EXAMPLE PROBLEM 4: Find the cos of 0° and the cos of 90° .

To find the cos of 0° draw a triangle with a very small angle for angle x .

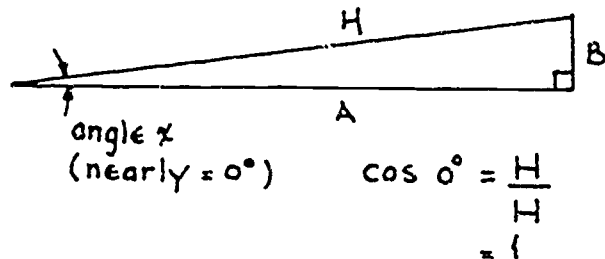

$\cos x = \frac{A}{H}$, you can see that as angle x gets closer to 0, A gets closer to H . When angle $x = 0^\circ$, $A = H$ and A divided by H equals 1.

To find $\cos 90^\circ$ draw a triangle with a very large angle for angle x .

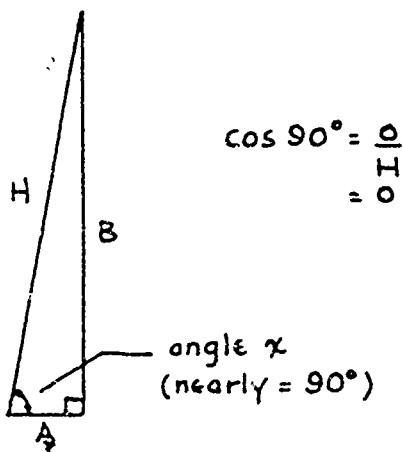

$\cos 90^\circ = \frac{A}{H}$, you can see that as angle x gets closer and closer to 90° , A gets smaller and smaller. When angle x equals 90° , $A = 0$ and A divided by $H = 0$.

From the above, you can see that the cos of the angle x varies much like the sin of the angle. For any angle x that is equal to 0 or 90 degrees, or between 0 and 90 degrees, the cos of the angle x varies between 0 and 1.

Or again you can say that the cos of angle x between 0 and 90 degrees can never be less than 0 or greater than 1.

This is a good thing to remember. It will help you to estimate answers and to find errors.

THE THIRD RATIO: TANGENT

The third of the three ratios is called the *tangent* x . It is written as $\tan x$. Look at the triangle in Figure 7.

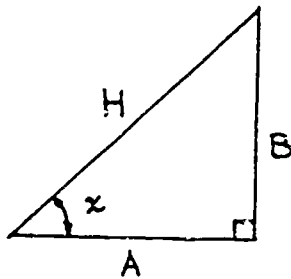

The ratio $\tan x$ is defined as:

$$\tan x = \frac{\text{opposite side}}{\text{adjacent side}}, \text{ or}$$

$$\tan x = \frac{B}{A}$$

Figure 7: Tangent x .

EXAMPLE PROBLEM 5: In the triangle shown in Figure 8 find the \tan of 60° and the \tan of 30° .

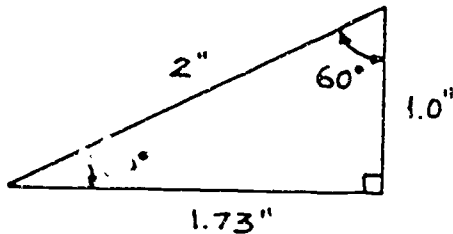

$$\begin{aligned} \tan 60^\circ &= \frac{\text{Side opposite } 60^\circ}{\text{Side adjacent } 60^\circ} \\ &= \frac{1.73''}{1''} \\ &\approx 1.73 \end{aligned}$$

$$\begin{aligned} \tan 30^\circ &= \frac{\text{Side opposite } 30^\circ}{\text{Side adjacent } 30^\circ} \\ &= \frac{1''}{1.73''} \\ &\approx 0.578 \end{aligned}$$

Figure 8: $\tan 60^\circ$ and $\tan 30^\circ$.

As before with $\sin x$ and $\cos x$, every possible angle x will have some number, $\tan x$, relating to it. You can calculate the value of $\tan x$ from any right triangle that contains the angle x . For example, you can find the tangent of 36° in the triangle below.

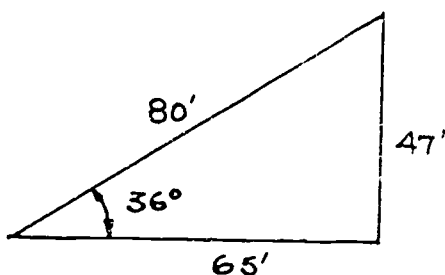

$$\tan 36^\circ = \frac{47'}{65'} = \frac{\text{opposite side}}{\text{adjacent side}}$$

$$\approx 0.72 \text{ (rounded)}$$

350

EXAMPLE PROBLEM 6: Find the $\tan 0^\circ$ and the $\tan 90^\circ$.

To find $\tan 0^\circ$, draw a triangle with a very small angle for angle x .

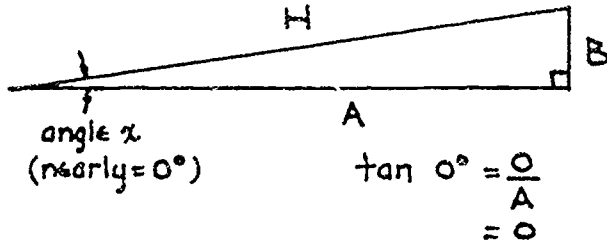

$\tan x = \frac{B}{A}$, you can see that as angle x gets closer to 0° , B gets closer to 0. When angle $x = 0^\circ$, $B = 0$ and B divided by $A = 0$.

To find $\tan 90^\circ$, draw a triangle with a very large angle for angle x .

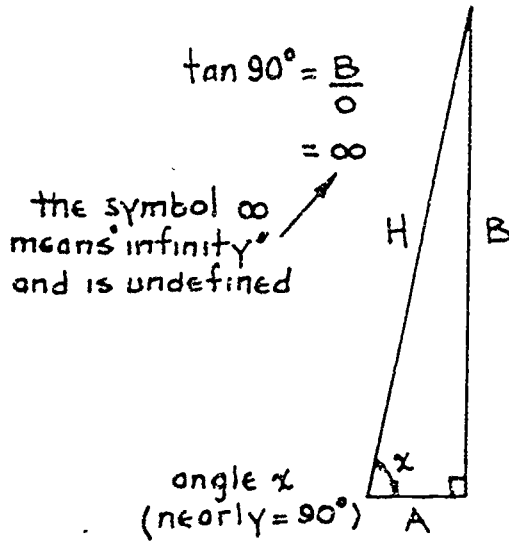

$\tan x = \frac{B}{A}$, you can see that as angle x gets closer to 90° , A gets closer to 0. When angle $x = 90^\circ$, $A = 0$ and B divided by A is said to be infinity, or undefined, because there is no number big enough to define B divided by 0.

Trigonometric ratios are very important. You should memorize them. To review what you have learned about the ratios so far, look at Figure 9.

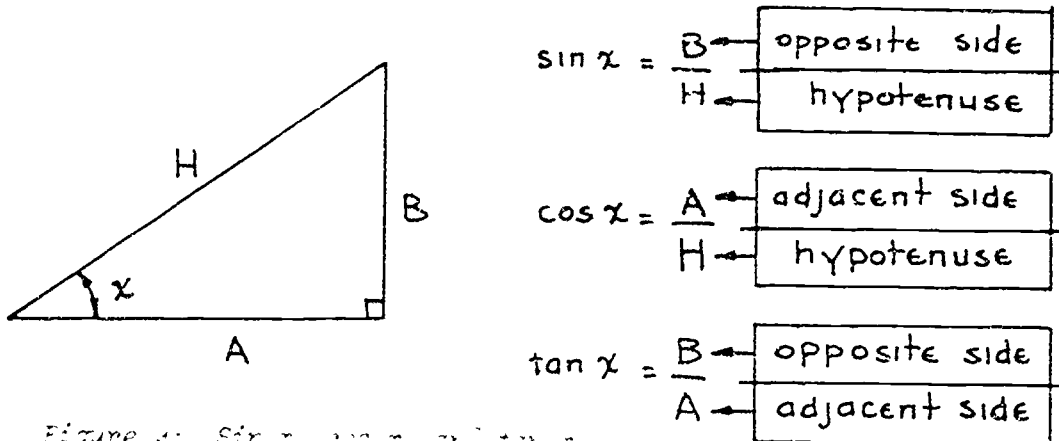

Figure 9: $\sin x$, $\cos x$, and $\tan x$

TRIGONOMETRIC TABLES

You have been asked to calculate these trig ratios in this Project Sheet to help you get a feel for how the ratios are defined and to memorize a few values. In actual shop application of trigonometry, the values of the ratios for any angle are found directly by looking them up in a Table of Trigonometric Functions or Trig Table, or by using a scientific calculator. To see a portion of a page from a typical Trig Table, look at Figure 10.

Table of Trigonometric Functions

Angle	Sine	Cosine	Tangent
0°	0.000	1.000	0.000
1°	.018	.999	.018
2°	.035	.999	.035
3°	.052	.999	.052
4°	.070	.998	.070
5°	.087	.996	.088
6°	.105	.995	.105
7°	.122	.993	.123
8°	.139	.991	.141
9°	.156	.988	.158
10°	.174	.985	.176
11°	.191	.982	.194
12°	.208	.978	.213
13°	.225	.974	.231
14°	.242	.970	.249
15°	.259	.966	.268
16°	.276	.961	.287
17°	.292	.956	.306
18°			

Sample values:

$$\sin 6^\circ = 0.105$$

$$\cos 10^\circ = 0.985$$

$$\tan 14^\circ = 0.249$$

$$\sin 15^\circ = 0.259$$

$$\cos 3^\circ = 0.999$$

$$\tan 5^\circ = 0.088$$

Figure 10: A part of a Trig Table.

To use the table, first locate the angle in the left column. Second, move to the right to the column with the trig function (sin, cos, or tan) that you want to find. Then read the trig ratio.

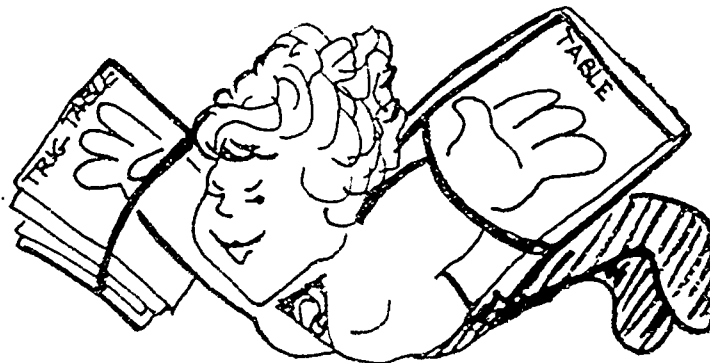

For example, find the sin of 53°. Look at Figure 11.

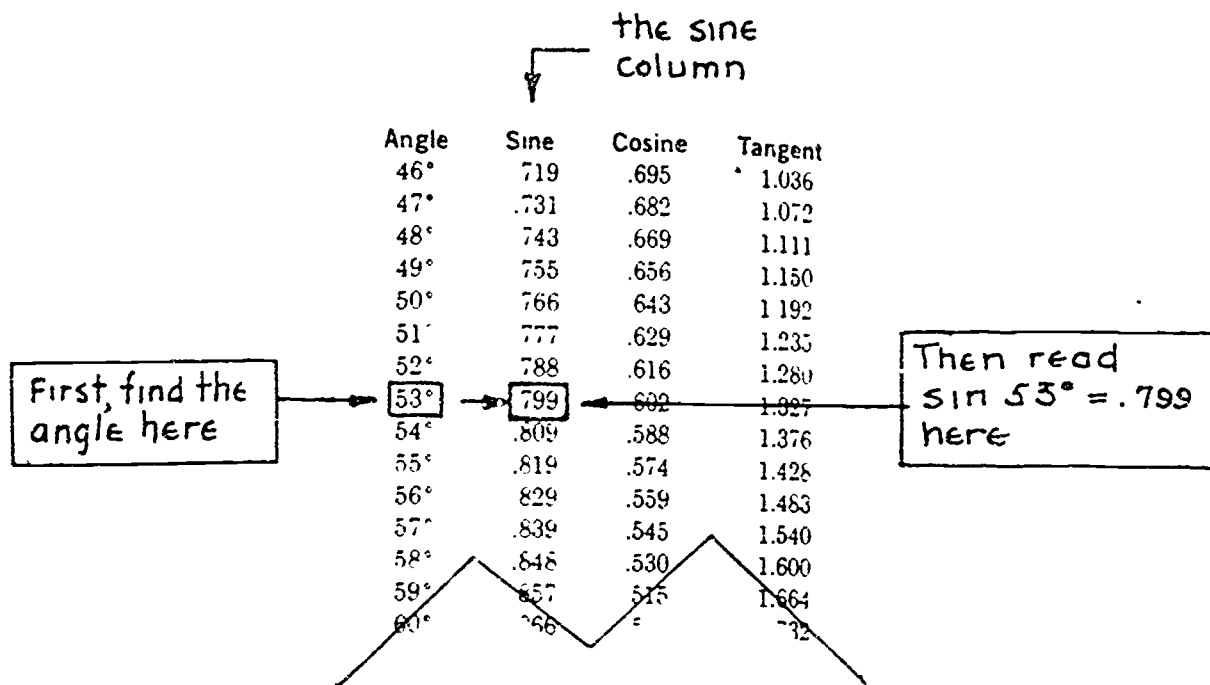
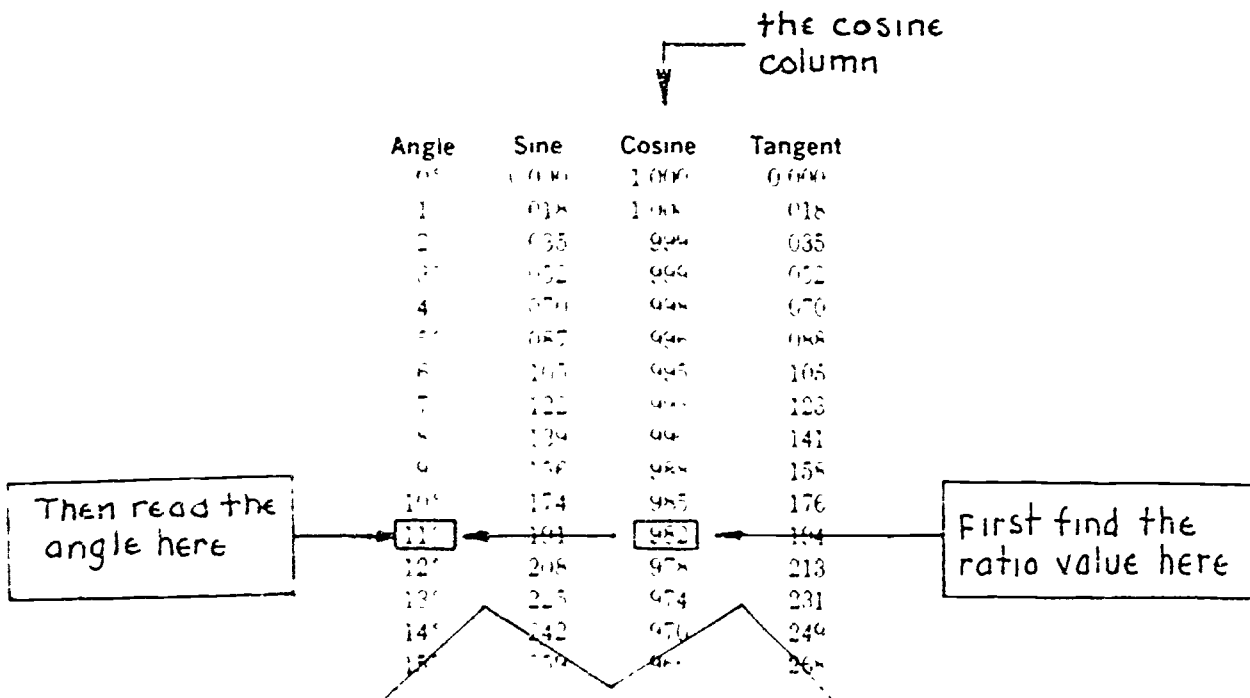

Figure 11: $\sin 53^\circ = .799$.

Many times in trigonometry you will know the value of the trigonometric ratio and you need to work backwards to find the angle associated with the ratio. For example, in Figure 12, find the angle whose cosine is 0.982.



EXAMPLE PROBLEM 7: From the portion of a Trig Table shown in Figure 13, find the following trig ratios and angles.

Angle	Sine	Cosine	Tangent
46°	719	695	1.036
47°	731	682	1.072
48°	743	669	1.111
49°	755	656	1.150
50°	766	643	1.192
51°	777	629	1.235
52°	788	616	1.280
53°	799	602	1.327
54°	809	588	1.376
55°	819	574	1.428
56°	829	559	1.483
57°	839	545	1.540
58°	848	530	1.600
59°	857	515	1.664
60°	866	500	1.732
61°	875	485	1.804
62°	883	470	1.881
63°	891	454	1.963
64°	899	438	2.050
65°	906	423	2.142
66°	914	407	2.240
67°	921	391	2.356
68°	927	375	2.475
69°	934	358	2.605
70°	940	342	2.747
71°	946	326	2.904
72°	951	309	3.075
73°	956	292	3.271
74°	961	276	3.487
75°	966	259	3.732

Figure 13: Partial trigonometry table.

(1) You know the angle. Find the ratio.

A. Find the $\cos 58^\circ$.

1. First find 58° under the *angle* column.
2. Then move to the right and find the required trig ratio column (in this case the *cosine* column).
3. Then read the ratio value. You get $\cos 58^\circ = 0.530$.

B. Find the $\tan 67^\circ$.

1. First find the angle 67° .
2. Then move to the right to find the tangent column.
3. Then read $\tan 67^\circ = 2.356$.

(2) You know the ratio. Find the angle.

A. Find the angle whose tangent = 1.732.

1. First find the *tangent* column and locate the ratio.
2. Then move to the left to the *angle* column.
3. Then read 60° .

B. Find the angle whose $\sin = 0.799$.

1. First find the ratio 0.799 in the *sin* column.
2. Then move to the left to the *angle* column and read 53° .

When you solve problems like 2A and 2B, as shown above, you are finding the *inverse* of a trig ratio. These inverses are written mathematically in two different ways.

The inverse of the sin is known as the *arc sin* and is abbreviated as the \sin^{-1} . The arc sin of a number means that you are working backward from that number to get the angle.

For example:

1. If $\sin 30^\circ = 0.5$ then

$$30^\circ = \text{arc sin } 0.5, \text{ or} \\ 30^\circ = \sin^{-1} 0.5$$

in words this is \rightarrow 30° is the angle whose sin is 0.5

Similarly:

2. If $\cos 45^\circ = 0.707$ then

$$45^\circ = \text{arc cos } 0.707, \text{ or} \\ 45^\circ = \cos^{-1} 0.707$$

in words this is \rightarrow 45° is the angle whose cos is 0.707

3. If $\tan 60^\circ = 1.732$ then

$$60^\circ = \text{arc tan } 1.732, \text{ or} \\ 60^\circ = \tan^{-1} 1.732$$

in word this is \rightarrow 60° is the angle whose tan is 1.732

The notation \sin^{-1} , \cos^{-1} , and \tan^{-1} appears on nearly all scientific calculators.

ESTIMATING OR INTERPOLATION

If you use an electronic scientific calculator to find the values of the trigonometric ratios you can find the value for any angle or fraction of an angle quickly and easily. Some tables, like the ones you have been using here, have no values for fractional degrees. To include fractional degrees would require a much larger table. However, it is possible to estimate or interpolate the value for fractions of a degree.

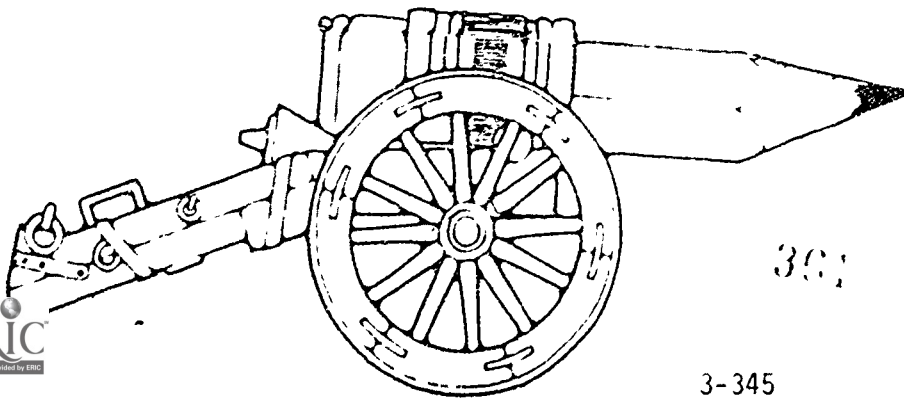

FRAC-TIONS
ESTIMATE
FRAC-TIONS
FRAC-TIONS
INTERPOLATE

301

EXAMPLE PROBLEM 8: Using the table shown in Figure 14, find the value of
 (1) $\sin 56^\circ$ and 15 minutes, and (2) $\cos 49.6^\circ$.

Angle	Sine	Cosine	Tangent
46°	.719	.695	1.036
47°	.731	.682	1.072
48°	.743	.669	1.111
49°	.755	.656	1.150
50°	.766	.643	1.192
51°	.777	.629	1.235
52°	.788	.616	1.280
53°	.799	.602	1.327
54°	.809	.588	1.376
55°	.819	.574	1.428
56°	.829	.559	1.483
57°	.839	.545	1.540
58°	.848	.530	1.600
59°	.857	.515	1.664
60°	.866	.500	1.732

(1) Find $\sin 56^\circ$ and 15 minutes.

Solution:

Step 1. Convert the angle to degrees and decimal part of degrees.

$$56^\circ 15' = 56^\circ + \frac{15}{60} = 56.25^\circ$$

Step 2. From Figure 14, find the values of the trig ratios for the whole number degrees on either side of the angle given.

$$\sin 56^\circ = 0.829$$

$$\sin 57^\circ = 0.839$$

$\sin 56.25$ degrees will be between 0.829 and 0.839.

Figure 14: Trig Table.

Step 3. Multiply the (.25) degree decimal by the difference in the whole angle sin values (.010). Then add that result to the sin value of the smaller angle (.829) since the sin values are *increasing*.

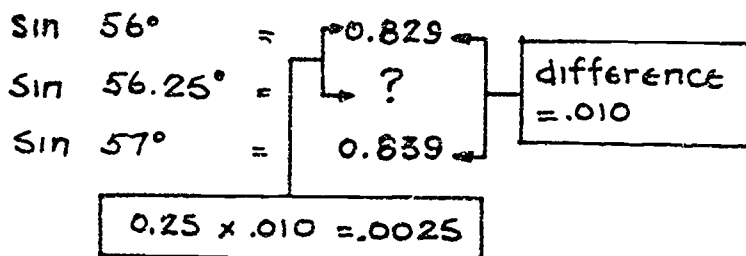

$$\text{then } \sin 56.25^\circ = 0.829 + .0025 \\ = 0.8315$$

(2) Find $\cos 49.6^\circ$.

Solution:

Step 1. Convert angle to degrees and decimal part of degrees. (49.6° is already in decimal form.)

Step 2. From Figure 14, find the values of the trig ratios for the whole number degrees on either side of the angle given.

$$\cos 49^\circ = 0.656$$

$$\cos 50^\circ = 0.643$$

$\cos 49.6$ degrees will be between 0.656 and 0.643.

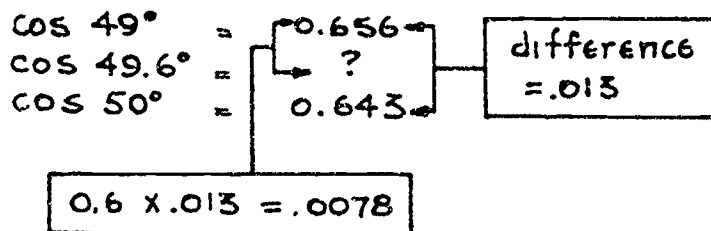

$$\text{then } \cos 49.6^\circ = 0.656 - .0078 \\ = 0.6482$$

Step 3: Multiply the degree decimal (0.6) by the difference in the whole number cos values (0.013). Then *subtract* that result from the smaller whole angle cos value (0.656) since the cos values are *decreasing*.

In other words, subtract .013 from the cos value of 49° .

You may need to do the opposite of the above process of *estimating or interpolation*. You may need to find an angle whose trig ratio lies between two of the values on the table.

EXAMPLE PROBLEM 9: Using the table shown in Figure 14 on the previous page, find the value of (1) the angle whose sin is 0.751 and (2) the angle whose cos is 0.512.

- (1) Find the angle whose sin is 0.751.

Solution:

Step 1: Find the values in the table in Figure 14 on either side of the given values.

$$\sin 48^\circ = 0.743$$

$$\sin 49^\circ = 0.755$$

The angle you are looking for is between 48 and 49 degrees.

Step 2: Find the difference between the table values and the difference between the given trig ratio value and the *smaller angle* table value.

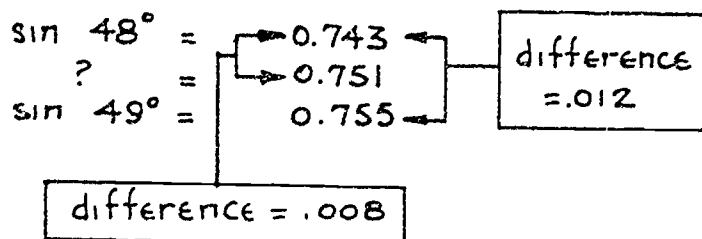

Step 3: Use these differences to find the decimal part of the angle.

$$\frac{0.008}{0.012} = \frac{8}{12} = 0.667$$

The angle you are looking for is 0.667 of the way between 48 and 49 degrees.

Therefore, the angle whose $\sin = 0.751$ is 48.667° , or written in other ways:

$$\begin{aligned} \sin^{-1} 0.751 &= 48.667 \text{ degrees} \\ \text{arc sin } 0.751 &= 48.667 \text{ degrees} \end{aligned}$$

(2) Find the angle whose \cos is 0.512

Solution:

Step 1: Find the values in the table in Figure 14 on either side of the given values.

$$\cos 59^\circ = 0.515$$

$$\cos 60^\circ = 0.500$$

The angle you are looking for is between 59 and 60 degrees.

Step 2: Find the difference between the table values and the difference between the given trig ratio value and the smaller angle table value.

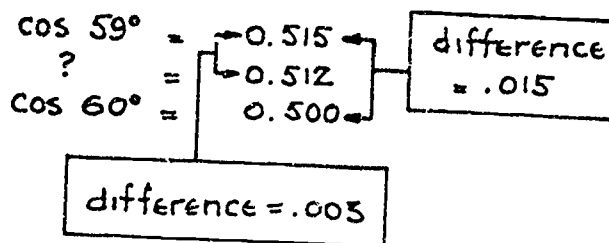

Step 3: Use the differences to find the decimal part of the angle.

$$\frac{0.003}{0.015} = \frac{3}{15} = 0.2$$

The angle you are looking for is 0.2 of the way between 59 and 60 degrees.

Therefore, the angle whose $\cos = 0.512$ is 59.2° , or written in other ways:

$$\begin{aligned} \cos^{-1} 0.512 &= 59.2 \text{ degrees} \\ \text{arc cos } 0.512 &= 59.2 \text{ degrees} \end{aligned}$$

ANGLES BETWEEN 90 AND 180 DEGREES

If you have a scientific calculator, any angle between 0 and 180 degrees can be entered directly. But if you need to use tables you must know some rules about angles bigger than 90 degrees. This is because most tables only go to 90 degrees. You do not need to worry about angles bigger than 180 degrees. Look at Figure 15.

Trig ratios for angles between 90° and 180°

Trig ratios for angles between 90° and 180°

to find values of sine, cosine, and tangent ratios for angles greater than 90° and less than 180° use the following:

$$\begin{aligned} \cos(90^\circ + a) &= -\sin a \\ \sin(90^\circ + a) &= \cos a \\ \tan(90^\circ + a) &= -\tan(90^\circ - a) \end{aligned}$$

For example: Find $\cos 140^\circ$

step 1. Break angle down to 90° plus some smaller angle. $\cos 140^\circ = \cos(90 + 50^\circ)$

step 2. Find the right formula from above. $\cos(90 + 50^\circ) = -\sin 50^\circ$

step 3. Look up value of the smaller angle in the trig table figure 14.

$$\underline{-\sin 50^\circ = -0.766 = \cos 140^\circ}$$

Further examples:

Find $\sin 150^\circ$

$$\sin 150^\circ = \sin(90^\circ + 60^\circ)$$

$$\sin(90^\circ + 60^\circ) = \cos 60^\circ$$

$$\underline{\cos 60^\circ = 0.500 = \sin 150^\circ}$$

Find $\tan 125^\circ$

$$\tan 125^\circ = \tan(90^\circ + 35^\circ)$$

$$\tan(90^\circ + 35^\circ) = -\tan(90^\circ - 35^\circ)$$

$$-\tan(90^\circ - 35^\circ) = -\tan 55^\circ$$

$$\underline{-\tan 55^\circ = -1.428 = \tan 125^\circ}$$

Figure 15 Trig ratios for angles between 90 and 180 degrees.

SOLVING RIGHT TRIANGLES

So far in this Project Sheet, you have learned about the trigonometric ratios, their definitions and how to look them up in a table. You have learned to find these ratios from their angles, and you have learned to do the inverse. The inverse was when you found the angles from the given ratios.

For now you are only working with right triangle trigonometry. That is where one of the angles of the triangle is equal to 90° . If you know one of the acute angles (less than 90°) and one side of the triangle, you can find the other two sides and the other angle. If you know two sides, you can find the other side and the two acute angles.

If you do not have a scientific calculator, use the table in Figure 16 on the next page to do the Example Problems that begin on page 19.

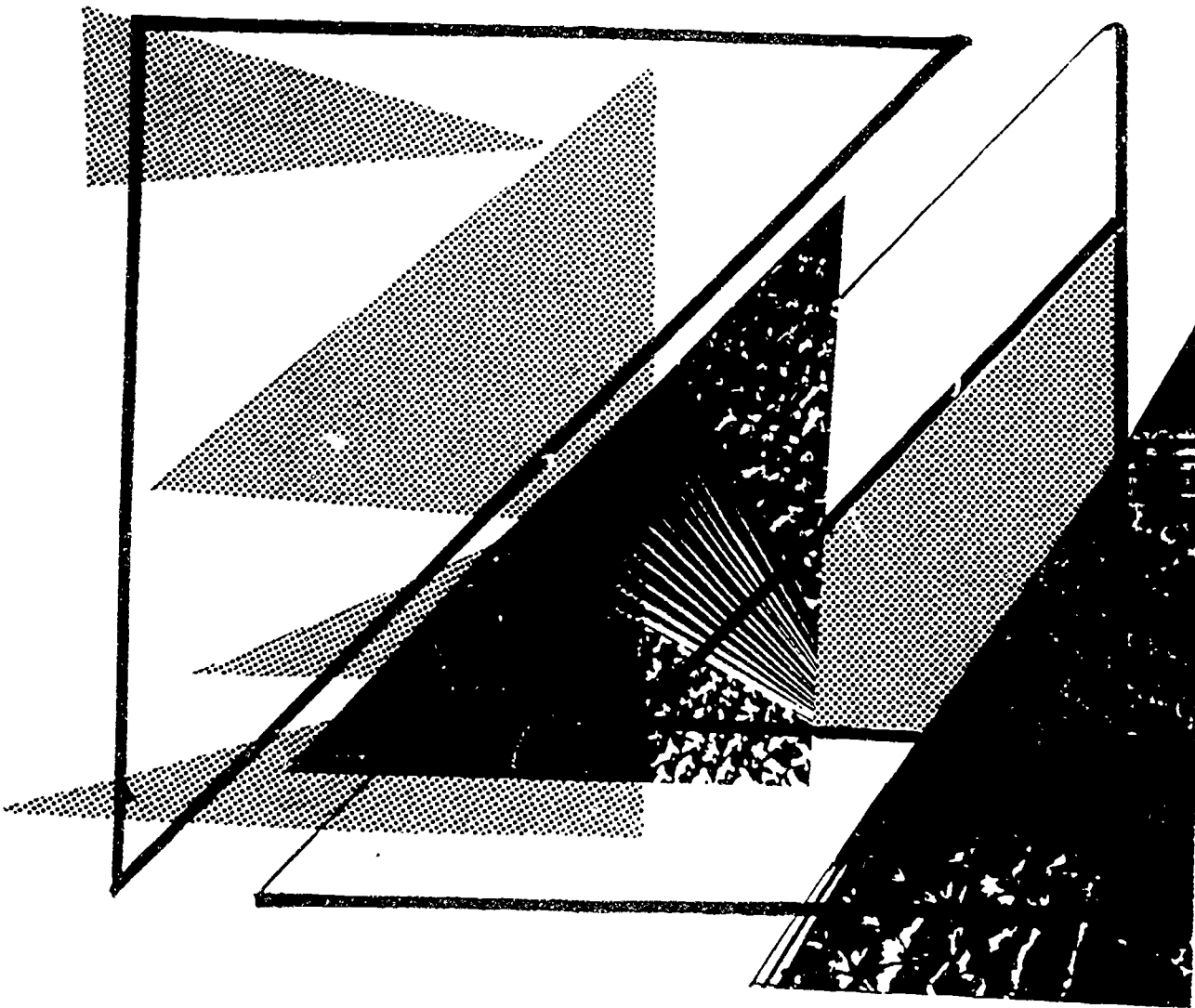

Table of Trigonometric Functions

Angle	Sine	Cosine	Tangent	Angle	Sine	Cosine	Tangent
0°	0.000	1.000	0.000	46°	.719	.695	1.036
1°	.018	1.000	.018	47°	.731	.682	1.072
2°	.035	.999	.035	48°	.743	.669	1.111
3°	.052	.999	.052	49°	.755	.656	1.150
4°	.070	.998	.070	50°	.766	.643	1.192
5°	.087	.996	.088	51°	.777	.629	1.235
6°	.105	.995	.105	52°	.788	.616	1.280
7°	.122	.993	.123	53°	.799	.602	1.327
8°	.139	.990	.141	54°	.809	.588	1.376
9°	.156	.988	.158	55°	.819	.574	1.428
10°	.174	.985	.176	56°	.829	.559	1.483
11°	.191	.982	.194	57°	.839	.545	1.540
12°	.208	.978	.213	58°	.848	.530	1.600
13°	.225	.974	.231	59°	.857	.515	1.664
14°	.242	.970	.249	60°	.866	.500	1.732
15°	.259	.966	.266				
16°	.276	.961	.287	61°	.875	.485	1.804
17°	.292	.956	.306	62°	.883	.470	1.881
18°	.309	.951	.325	63°	.891	.454	1.963
19°	.326	.946	.344	64°	.899	.438	2.050
20°	.342	.940	.364	65°	.906	.423	2.145
21°	.358	.934	.384	66°	.914	.407	2.246
22°	.375	.927	.404	67°	.921	.391	2.356
23°	.391	.921	.425	68°	.927	.375	2.475
24°	.407	.914	.445	69°	.934	.358	2.605
25°	.423	.906	.466	70°	.940	.342	2.747
26°	.438	.899	.488	71°	.946	.326	2.904
27°	.454	.891	.510	72°	.951	.309	3.078
28°	.470	.883	.532	73°	.956	.292	3.271
29°	.485	.875	.554	74°	.961	.276	3.487
30°	.500	.866	.577	75°	.966	.259	3.732
31°	.515	.857	.601	76°	.970	.242	4.011
32°	.530	.848	.625	77°	.974	.225	4.331
33°	.545	.839	.649	78°	.978	.208	4.705
34°	.559	.829	.675	79°	.982	.191	5.145
35°	.574	.819	.700	80°	.985	.174	5.671
36°	.588	.809	.727	81°	.988	.156	6.314
37°	.602	.799	.754	82°	.990	.139	7.115
38°	.616	.788	.781	83°	.993	.122	8.144
39°	.629	.777	.810	84°	.995	.105	9.514
40°	.643	.766	.839	85°	.996	.087	11.43
41°	.656	.755	.869	86°	.998	.070	14.30
42°	.669	.743	.900	87°	.999	.052	19.08
43°	.682	.731	.933	88°	.999	.035	28.64
44°	.695	.719	.966	89°	1.000	.018	57.29
45°	.707	.707	1.000	90°	1.000	.000	∞

... that start on the ...



EXAMPLE PROBLEM 10: In Figure 17, solve for the length of side A.

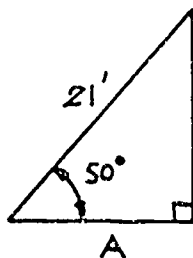

Figure 17: Find the length of side A.

Step 1: Decide which trig ratio is the right one to use. In this case, you know the hypotenuse (21 feet), and you know the angle (50°). You need to find the adjacent side (A). So, pick the trig ratio with the angle, hypotenuse and adjacent side. From before:

$$\cos a = \frac{\text{adjacent side}}{\text{hypotenuse}}$$

Step 2: Substitute the known values of the given triangle in the cosine relationship in Step 1 above.

$$\cos 50^\circ = \frac{A}{21}$$

Step 3: Solve the equation for the unknown quantity (in this case A). Find the $\cos 50^\circ$ from your calculator or from the table in Figure 16.

$$\begin{aligned} \cos 50^\circ &= \frac{A}{21'} \\ \frac{A \times \cancel{21'}}{\cancel{21'}} &= 21' \times \cos 50^\circ \leftarrow \text{multiply both sides} \\ &= 21' \times 0.643 \quad \text{of the equation by } 21' \\ A &= 13.503' \\ A &= 13.5' \text{ (rounded)} \end{aligned}$$

EXAMPLE PROBLEM 11: In Figure 18, solve for the length of side M.

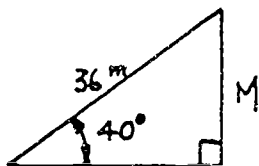

Figure 18: Find the length of side M.

Step 1: Decide which trig ratio to use. You know the hypotenuse (36 m) and you know the angle (40°). You need to find the opposite side (M). So, pick the trig ratio with the angle, hypotenuse, and opposite side. From before:

$$\sin a = \frac{\text{opposite side}}{\text{hypotenuse}}$$

Step 2: Substitute the known values of the given triangle in the sine relationship in Step 1 above.

$$\sin 40^\circ = \frac{M}{36\text{m}}$$

Step 3: Solve the equation for the unknown quantity (in this case M).
Find the $\sin 40^\circ$ using your calculator or the table in Figure 16.

$$\sin 40^\circ = \frac{M}{36\text{ m}}$$

$$\frac{M}{36\text{ m}} \times 36\text{ m} = 36\text{ m} \times \sin 40^\circ \leftarrow \begin{array}{l} \text{multiply both sides} \\ \text{of the equation by } 36\text{ m} \end{array}$$

$$M = 36\text{ m} \times 0.643$$

$$M = 23.148\text{ m}$$

$$M = 23.15\text{ m (rounded)}$$

EXAMPLE PROBLEM 12: In Figure 19, solve for the length of side C.

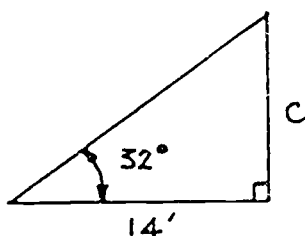

Figure 19: Find the length of side C.

Step 1: Decide which trig ratio to use. You know the adjacent side (14 feet), and the angle (32°). You need to find the opposite side (C). So pick the trig ratio with the angle, adjacent side and opposite side. From before:

$$\tan \alpha = \frac{\text{opposite side}}{\text{adjacent side}}$$

Step 2: Substitute the known values of the given triangle in the tangent relationship in Step 1 above.

$$\tan 32^\circ = \frac{C}{14'}$$

Step 3: Solve the equation for the unknown quantity (in this case C).
Find the tangent of 32° from your calculator or from the table in Figure 16.

$$\tan 32^\circ = \frac{C}{14'}$$

$$14' \times C = 14' \times \tan 32^\circ \leftarrow \begin{array}{l} \text{multiply both sides} \\ \text{of the equation by } 14' \end{array}$$

$$14' C = 14' \times 0.625$$

$$C = 8.748'$$

$$C = 8.75' \text{ (rounded)}$$

EXAMPLE PROBLEM 13: In Figure 20, solve for the angle a .

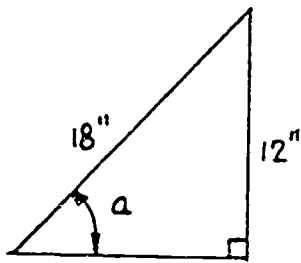

Figure 20: Find angle a .

Step 1: Decide which trig ratio to use. You know the hypotenuse (18 inches) and the opposite side (12 inches). You need to find the angle a . So, pick the trig ratio with the angle a , the opposite side and the hypotenuse from before:

$$\sin a = \frac{\text{opposite side}}{\text{hypotenuse}}$$

Step 2: Substitute the known values from the given triangle in the sine relationship in Step 1 above.

$$\sin a = \frac{12'}{18''}$$

Step 3: Solve the equation for the unknown quantity (in this case the angle a).

$$\sin a = \frac{12}{18}$$

$$\sin a = 0.667$$

$$a = \sin^{-1} 0.667$$

$$a = 41.810^\circ$$

$$a = 41.8^\circ \text{ (rounded)}$$

Write as the inverse sin (\sin^{-1}) which says: a is the angle whose sin is 0.667. To find the angle, use the inverse on your calculator, or use the method in Example Problem 9 on page 14 of this Project Sheet.

EXAMPLE PROBLEM 14: In Figure 21, find the length of side P .

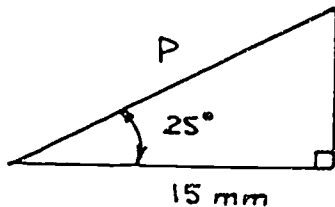

Figure 21: Find side P .

Step 1: Decide which trig ratio to use. You know the angle (25°), and the adjacent side (15mm). You need to find the side which is the hypotenuse. So, pick the trig ratio with the angle, the adjacent side and the hypotenuse. From before:

$$\cos a = \frac{\text{adjacent side}}{\text{hypotenuse}}$$

Step 2: Substitute the known values from the given triangle in the cosine relationship in Step 1 above.

$$\cos 25^\circ = \frac{15\text{mm}}{P}$$

3563710

Step 3: Solve the equation for the unknown quantity (in this case P). Find the cos 25° from your calculator or from the table in Figure 16.

$$\cos 25^\circ = \frac{15 \text{ mm}}{P}$$

$$P \times \cos 25^\circ = \frac{15 \text{ mm} \times \cancel{P}}{\cancel{P}} \leftarrow \begin{array}{l} \text{multiply both sides} \\ \text{of the equation by } P \end{array}$$

$$P \times 0.906 = 15 \text{ mm}$$

$$\frac{P \times 0.906}{0.906} = \frac{15 \text{ mm}}{0.906} \leftarrow \begin{array}{l} \text{divide both sides} \\ \text{of the equation by } 0.906 \end{array}$$

$$P = \frac{15 \text{ mm}}{0.906}$$

$$P = 16.556 \text{ mm}$$

$$P = 16.56 \text{ mm (rounded)}$$

EXAMPLE PROBLEM 15: In Figure 22, find the angle a .

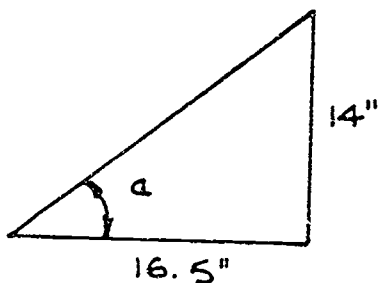

Step 1: Decide which trig ratio to use. You know the opposite side (14") and the adjacent side (16.5"). You need to find the angle a . So, pick a trig ratio with the angle a , the opposite side and the adjacent side. From before:

$$\tan a = \frac{\text{opposite side}}{\text{adjacent side}}$$

Figure 22: Find angle A . Step 2: Substitute the known values from the given triangle in the tangent relationship in Step 1 above.

$$\tan a = \frac{14''}{16.5''}$$

Step 3: Solve the equation for the unknown quantity (in this case angle a).

$$\tan a = \frac{14''}{16.5''}$$

$$\tan a = 0.848$$

$$a = \tan^{-1} 0.848$$

$$a = 40.298^\circ$$

$$a = 40.3^\circ \text{ (rounded)}$$

Write as the inverse tan (\tan^{-1}) which says: a is the angle whose tangent is 0.848. To find the angle, use the inverse on your calculator, or use the method in Example Problem 9 on page 14.

371

EXAMPLE PROBLEM 16: In the sketch shown in Figure 23, you are to find the dimension x and the angle a .

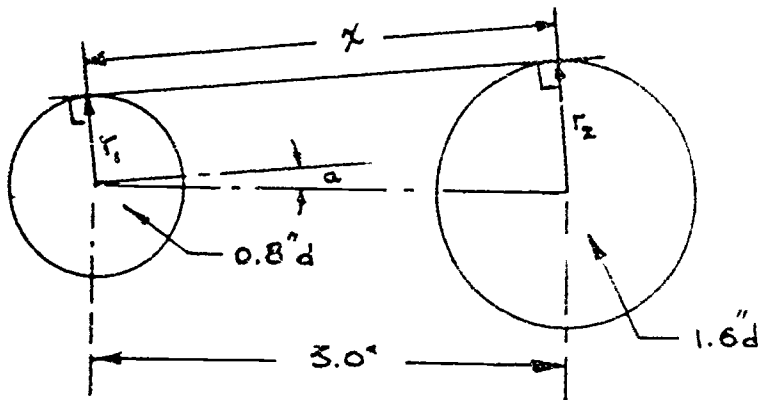
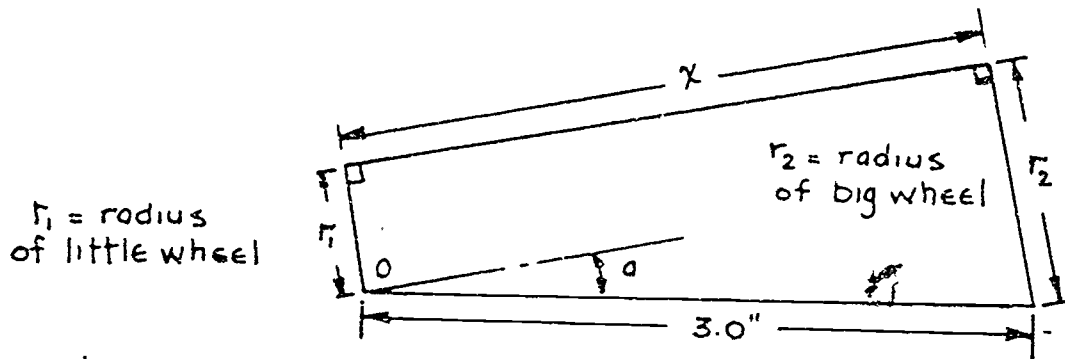
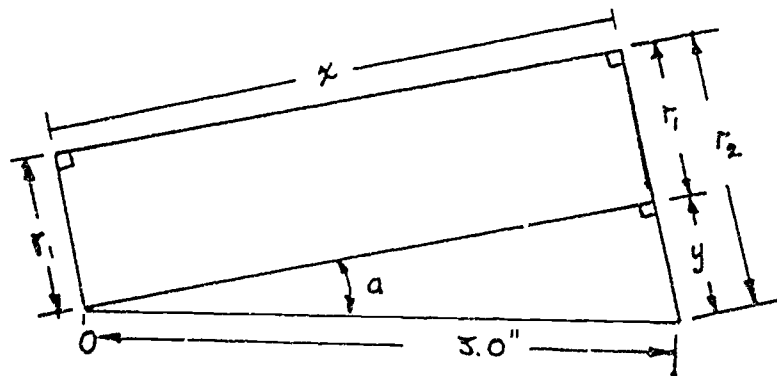

Figure 23: Find the angle a and the dimension x .

You must first find out which triangle you are going to work with. You know you must work with angle x , dimension x , and the dimension equal to 3 inches. Look at the sketch shown below:



In this sketch you can see from geometry that you can extend a line from point O , parallel to line x , over to the radius of the big wheel, and the length of that line will be equal to x . Now look at the sketch below.



From Figure 23 the diameter of the little wheel is 0.8" and the diameter of the big wheel is 1.6". Therefore, the radius r_1 of the little wheel is 0.4" and the radius r_2 of the big wheel is 0.8". Then you can find the dimension y as follows:

$$\begin{aligned} y + r_1 &= r_2 \\ y + 0.4" &= 0.8" \\ y &= 0.8" - 0.4" \\ y &= 0.4" \end{aligned}$$

Then you have the triangle you need and the information you need. Now look at the sketch below:

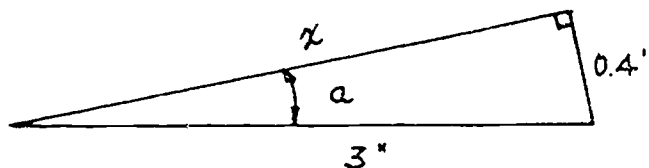

Notice that your triangle is upside down from the way you have normally worked with triangles--but the names of the sides are the same. The side adjacent is x , 3" is the longest side or hypotenuse (it is opposite the right angle) and 0.4" is the side opposite angle a . The easiest way to find the unknowns is to first find angle a . So choose the trig ratio that involves angle a , opposite side and hypotenuse. You've done that before.

$$\sin a = \frac{\text{opposite side}}{\text{hypotenuse}}$$

$$\sin a = \frac{0.4"}{3"}$$

$$a = \sin^{-1} 0.1333$$

$$a = 7.66^\circ (\text{rounded})$$

Now that you know the angle a , to solve for x choose another trig ratio that involves x , angle a , and either 0.4" or 3". If you choose the ratio that involves x (adjacent side), 0.4" (opposite side) and angle a , you have:

$$\tan a = \frac{0.4"}{x}$$

If you choose the ratio that involves x (adjacent side), 3" (hypotenuse) and angle a , you have:

$$\cos a = \frac{x}{3"}$$

Although either ratio will give you the same answer, the cosine ratio is easier to calculate, especially if you don't have a computer.

$$\cos a = \frac{x}{3''}$$

$$3'' \times \cos a = \frac{x}{3''} \times 3'' \quad \leftarrow \text{Multiply both sides of the equation by } 3''.$$

$$3'' \times \cos 7.66^\circ = x$$

$$3'' \times 0.991 = x$$

$$x = 2.97'' \text{ (rounded)}$$

EXAMPLE PROBLEM 17: To know if you have machined deep enough on certain "V" notch type cuts, a rod of known dimensions is used as shown in Figure 24. You cannot measure the dimension shown as 1.00" to check for depth because of the radius shown at the bottom of the "V" cut. However, you can measure dimension A. When you are deep enough, what should dimension A be?

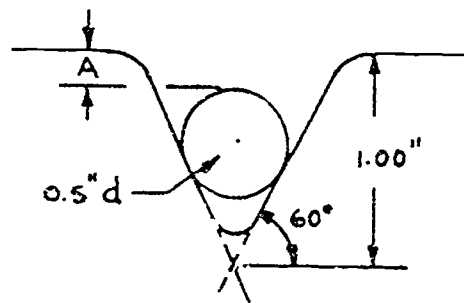
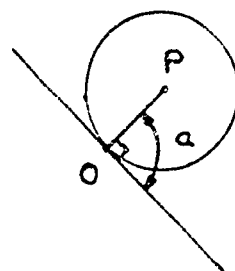

Figure 24: Find A.

Solution: First of all, you must know a little geometry. When a circle is tangent (or just touching) to a line, another line from the point of tangency to the center of the circle makes a 90° angle. Look at the sketch below.



P is the center of the circle

angle $a = 90^\circ$

O is the point of tangency

line PO is the radius of the circle

Next find out what you must know to find the answer. Then pick out the triangle you have to work with. If you can find the distance y from the top of the circular rod and subtract it from 1.00", you will have A . Look at the sketch below:

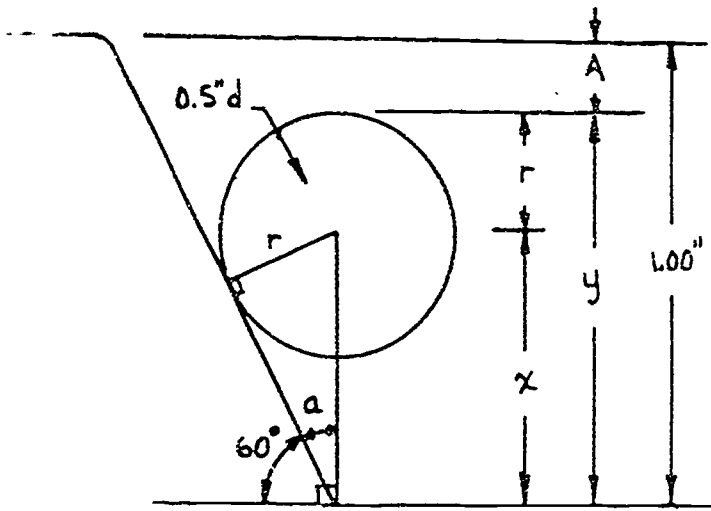

you know

$$1. r = \frac{d}{2} = \frac{0.5''}{2}$$

$$r = 0.25''$$

$$2. \text{ angle } a = 90^\circ - 60^\circ$$

$$a = 30^\circ$$

Since you need to know x , pick a trig ratio involving angle a , r , and x .

Now look at the sketch below:

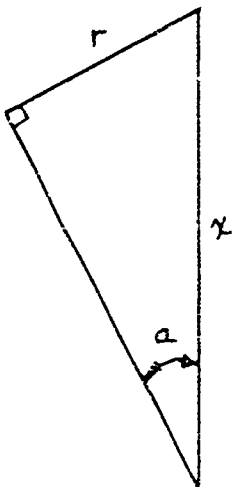

$$\sin a = \frac{\text{opposite side}}{\text{hypotenuse}} = \frac{r}{x}$$

$$\sin 30^\circ = \frac{0.25''}{x}$$

$$x \times \sin 30^\circ = \frac{0.25'' \times x}{x} \leftarrow \text{multiply both sides of the equation by } x$$

$$\frac{x \times (0.5)}{(0.5)} = \frac{0.25''}{(0.5)} \leftarrow \text{divide both sides of the equation by } \sin 30^\circ = 0.5$$

$$x = \frac{0.25''}{0.5}$$

$$x = 0.5''$$

then from before :

$$\text{distance } y = x + r$$

$$y = 0.5'' + 0.25''$$

$$y = 0.75''$$

and

$$A = 1.00'' - y$$

$$A = 1.00'' - 0.75''$$

$$A = 0.25''$$

So when $A = 0.25''$ you have cut deep enough. Now you can try some Shop Problems.

5. OP 10 10 MS

1. You are using a computer operated cutter. To cut a certain slope you need to find the distance above a base line to position your cutter. In the sketch below the cutter is shown in the required position. You need to find the dimension shown as L. (Round to nearest hundredth)

Distance L _____

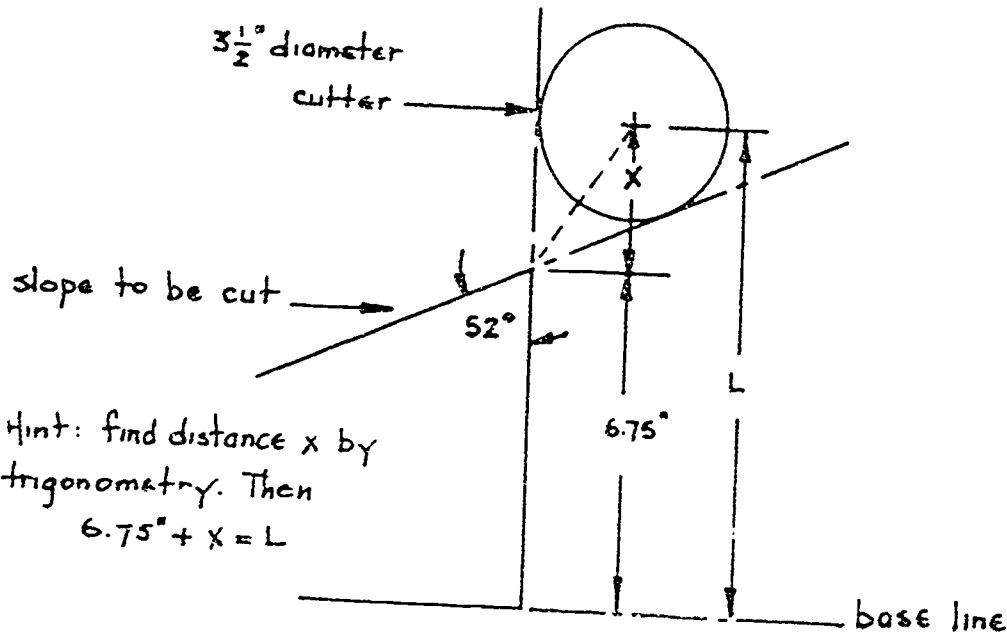

Hint: find distance x by trigonometry. Then $6.75 + x = L$

2. You need to use a screw with a head angle A of no less than 65° and no larger than 70°. Your supervisor gave you the screw shown in Figure 26. Will it be satisfactory?

Yes _____ No _____

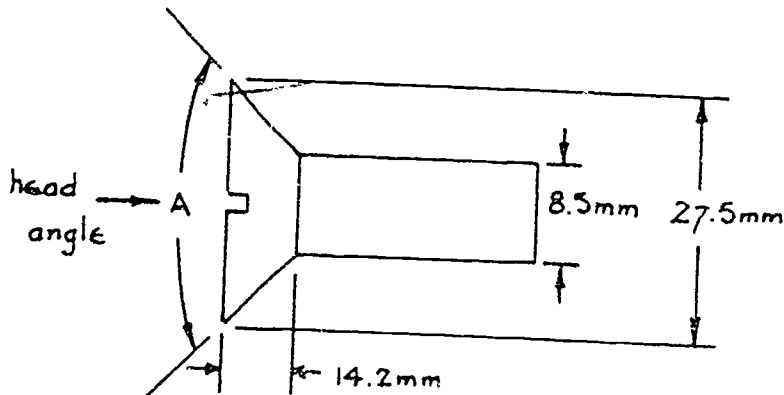

Figure 26: Find the head angle A.

3. You need a screw with a pitch of 4mm. If the angle of the V thread is 36.5° , what does the depth D of the thread need to be? Look at Figure 27.

Depth D _____

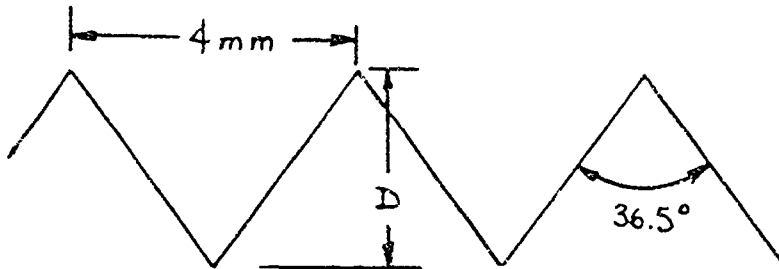
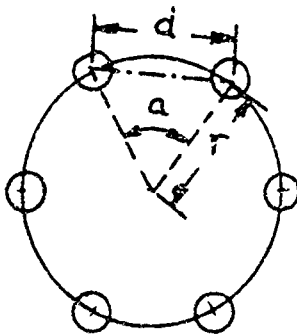

Figure 27: Find the depth D .

4. Your boss gave you a sketch to lay out a pattern of holes to be drilled. In order to do this you need to find some missing dimensions. Look at Figure 28. Find the missing dimensions.

$d =$ _____, $r =$ _____ angle $a =$ _____



6 holes evenly spaced around a circle whose circumference is 28"
Find d , r and angle a .

Figure 28: Pattern of holes to be drilled.

5. You are given the job of making a punch as shown in the sketch below. The taper of the punch is to be 15%. You must find the angle a and the diameter P .

angle a _____ diameter P _____

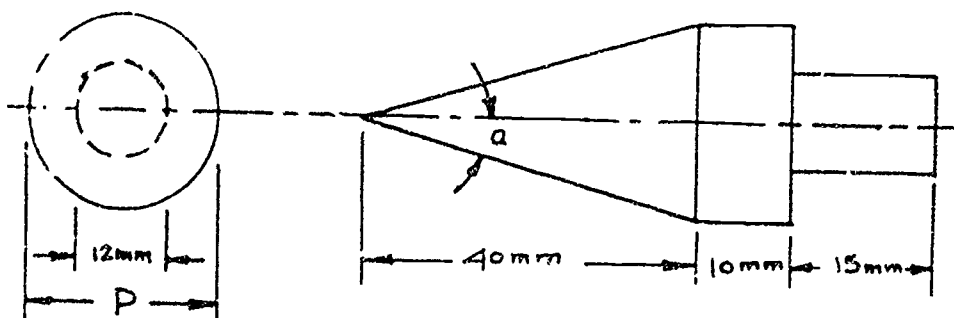

Hint: a 15% taper means a ratio of

$$\frac{15}{100} \text{ So: } \frac{15}{100} = \frac{P/2}{40}$$

6. You have cut a V notch in a steel bar to a control depth of 2.00". By using a steel rod of 1-inch diameter, you are able to measure the dimension B. Assuming the V notch has been cut to the proper depth, what should dimension B read? Look at Figure 30.

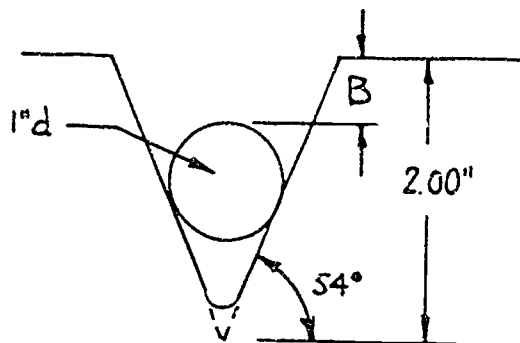

B = _____

Hint: Look at example problem 17, page 25 of this Project Sheet.

Figure 30: Find dimension B.

7. Your boss needs to know the taper angle of a shaft with known dimensions. Look at Figure 31. What is angle a?

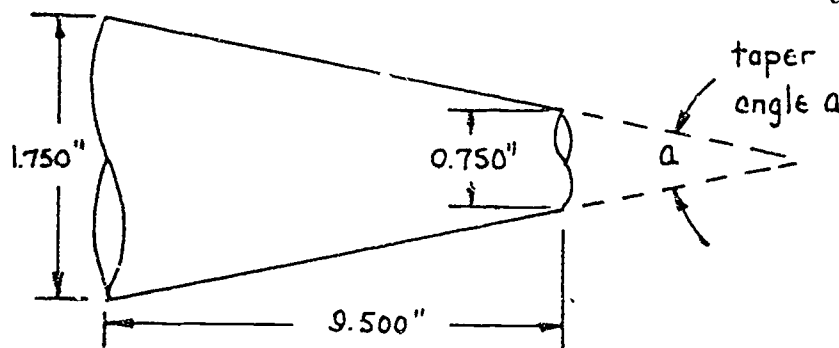

Angle a = _____

Figure 31: Find taper angle a.

8. You have drilled three holes in a steel plate according to the pattern shown in Figure 32. Your boss wants to know the distances between the holes. Find dimensions A, B, and C.

A = _____ B = _____
C = _____

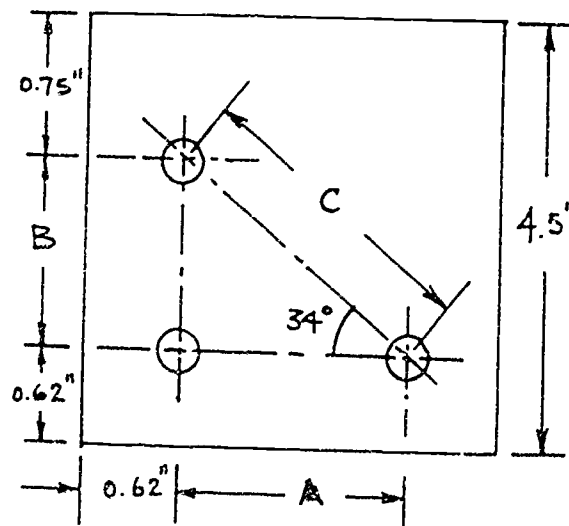

378

Figure 32: Find dimensions A, B and C.

9. You have drilled and reamed 8 holes equally spaced around the circumference of a circle as shown in Figure 33 below. To check the accuracy of your work, two stick pins are placed in two adjacent holes. You then make a measurement M across the two pins ($M=3.0620''$). This measurement is then compared to the corresponding dimension M which you must compute by trigonometry. To the closest ten-thousandth of an inch, what is the difference between your measurement $M=3.0620''$ and the dimension you computed by trigonometry?

Difference (accuracy) _____ in.

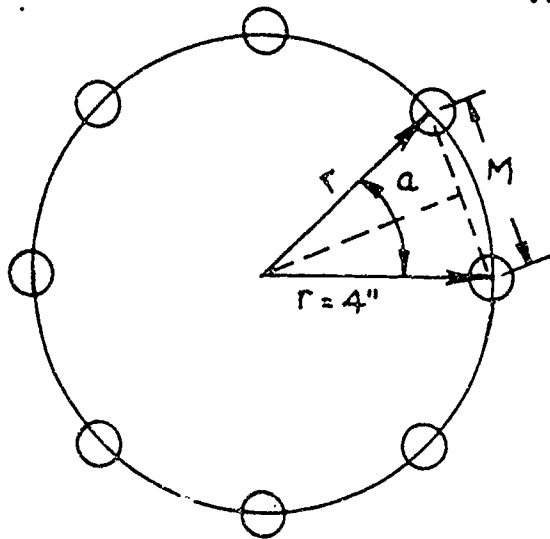

hint: angle $a = \frac{360^\circ}{8}$
 $a = 45^\circ$

Figure 33: Find the accuracy of dimension M .

10. You have machined a tool punch as shown in Figure 34 below. You measure angle E as 50.29° . To check your accuracy against the drawing, you must compute angle E by trigonometry and compare it to your measured angle $E = 50.29^\circ$. What is the difference, to the nearest one-hundredth of a degree, between your measured angle E and your computed angle E .

Difference (accuracy) _____ degrees.

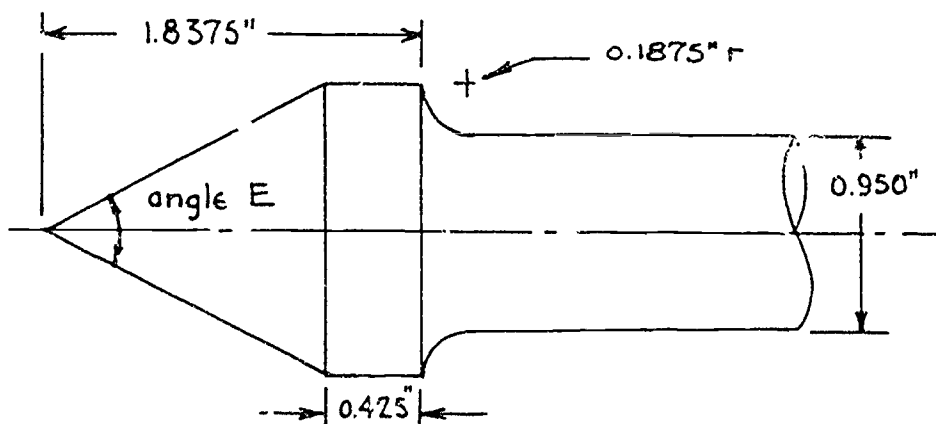

Figure 34: Find the accuracy of angle E .

ASK YOUR INSTRUCTOR TO CHECK YOUR WORK



PROJECT SHEET

Name _____ Date _____

Cluster Metal Trades Occupation Machinist Helper

Training Module Shop Math for Machinist Helper

Training Milestone 3. Specialized Math Skills

217

PROJECT 8

SHOP TRIGONOMETRY: PART 2

TRAINING CONDITIONS:

- Here's what you will need:
 1. This Project Sheet.
 2. A pen or pencil to answer the Shop Problems in this Project Sheet.
 3. A hand-held calculator with scientific functions.

TRAINING PLAN:

- Here's what you do:

In this Project Sheet, you will learn the basic trigonometry of oblique triangles. Although there are many other laws and methods in trigonometry, this Project Sheet only deals with the Law of Sines and the Law of Cosines. This Project Sheet, along with Shop Trigonometry-Part 1, will give you the ability to solve the majority of all shop problems dealing with trigonometry.

1. Read and study pages 2 to 10 of this Project Sheet.
2. Work the Shop Problems on pages 11 and 12 of this Project Sheet.
3. Have your instructor check your work and record your score on your Student Training Record.
4. Ask your instructor for your next Project Sheet.

TRAINING GOAL:

- Here's how well you must do:
 1. You must understand the Law of Sines and the Law of Cosines well enough to score 4 out of 5 of the Shop Problems in this Project Sheet.

SHOP TRIGONOMETRY-PART 2

In the previous Project Sheet, Shop Trigonometry-Part 1, you learned how to solve many types of shop problems by solving right triangles. Sometimes you solved oblique triangles by reducing the oblique triangle to a series of right triangles. In many cases, it was hard to do and it took too much time. So, in this Project Sheet, you will learn two shorter and direct methods of solving oblique triangles.

SOLVING OBLIQUE TRIANGLES

An oblique triangle has no angle equal to 90° --no right angles. Any oblique triangle can be solved with trigonometric ratios if *three* elements are known and *one* of those elements is a *side*. Problems that can be reduced to oblique triangles, and solved, are usually divided into four groups--depending on which parts of the triangle are given. You can find all the rest of the dimensions of a triangle if you know the dimensions given in any of these four groups:

- Group 1: Any two angles and one side are given.
- Group 2: Any two sides and the angle opposite one of the sides are given.
- Group 3: Any two sides and the angle between the two sides are given.
- Group 4: When all the sides are given.

TWO SIMPLE FORMULAS

There are two simple formulas, the *Law of Sines* and the *Law of Cosines*. With these two formulas, you can easily and quickly solve the above four groups of oblique triangles. In this Project Sheet, you will see how the formulas come from making right triangles out of oblique triangles. You *don't* need to remember how to get the formulas. You *do* need to remember what the formulas are. You'll also need to learn how to use the formulas to solve the Shop Problems.

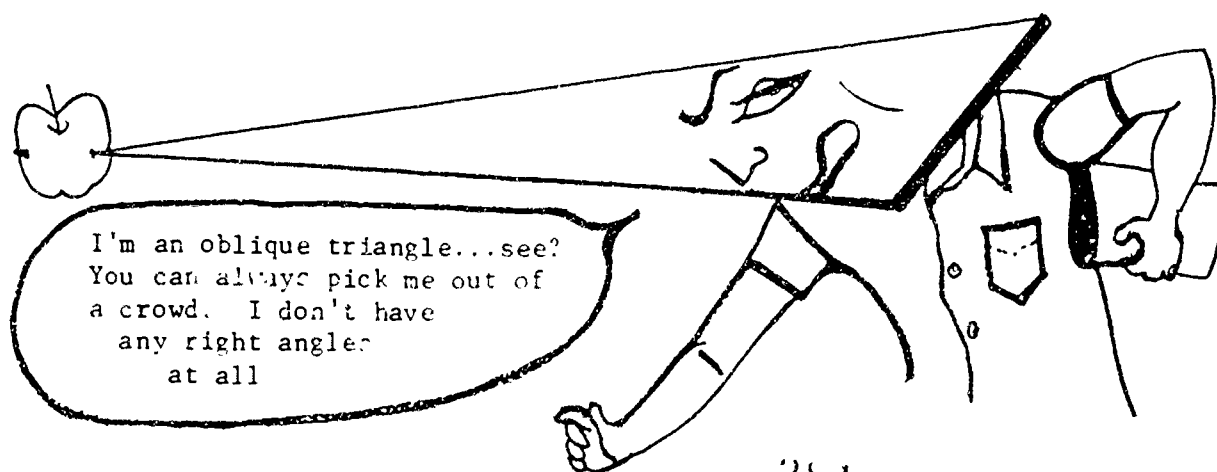

THE LAW OF SINES

Look at Figure 1. Name the sides of triangle ABC as a , b , and c . Name the angles opposite these sides as A , B , and C . Draw the perpendicular h and you get two right triangles, ABL and BCL.

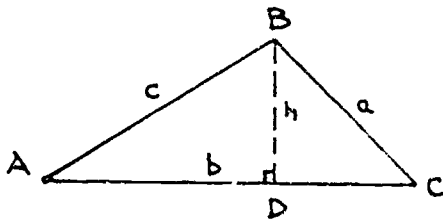

in right $\triangle ABD$, $\frac{h}{c} = \sin A$, or $h = c \sin A$

in right $\triangle BDC$, $\frac{h}{a} = \sin C$, or $h = a \sin C$

equating the two expressions for h : $c \sin A = a \sin C$, or

$$\frac{a}{\sin A} = \frac{c}{\sin C} \quad \leftarrow \text{equation (1)}$$

now redraw $\triangle ABC$ by drawing a perpendicular h from an extension of side c the point C (see below).

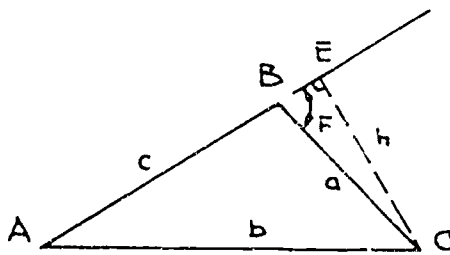

in right $\triangle AEC$, $\frac{h}{b} = \sin A$, or $h = b \sin A$

in right $\triangle BEC$, $\frac{h}{a} = \sin F$, or $h = a \sin F$

from geometry $F = 180^\circ - B$, so $h = a \sin(180^\circ - B)$

it can be shown that $\sin(180^\circ - B) = \sin B$, then $h = a \sin B$

then equating the two expressions for h : $b \sin A = a \sin B$, or

$$\frac{a}{\sin A} = \frac{b}{\sin B} \quad \leftarrow \text{equation (2)}$$

combining equations (1) and (2):

$$\frac{a}{\sin A} = \frac{b}{\sin B} = \frac{c}{\sin C} \quad \leftarrow \text{Law of Sines}$$

Figure 1: how the Law of Sines is derived from right triangles.

Sometimes the Law of Sines is written as three equations:

$$\frac{a}{\sin A} = \frac{b}{\sin B}$$

$$\frac{a}{\sin A} = \frac{c}{\sin C}$$

$$\frac{b}{\sin B} = \frac{c}{\sin C}$$

Each of these equations contains *four* elements of the given triangle. If any three elements are given (in any one equation) the fourth element may easily be found.

In other words, this says: In any triangle, right or oblique, any side is proportional to the sines of its opposite angle.

Call us group 1 triangles. You know two of our angles and one of our sides. You can solve us with the law of Sines. Yea!

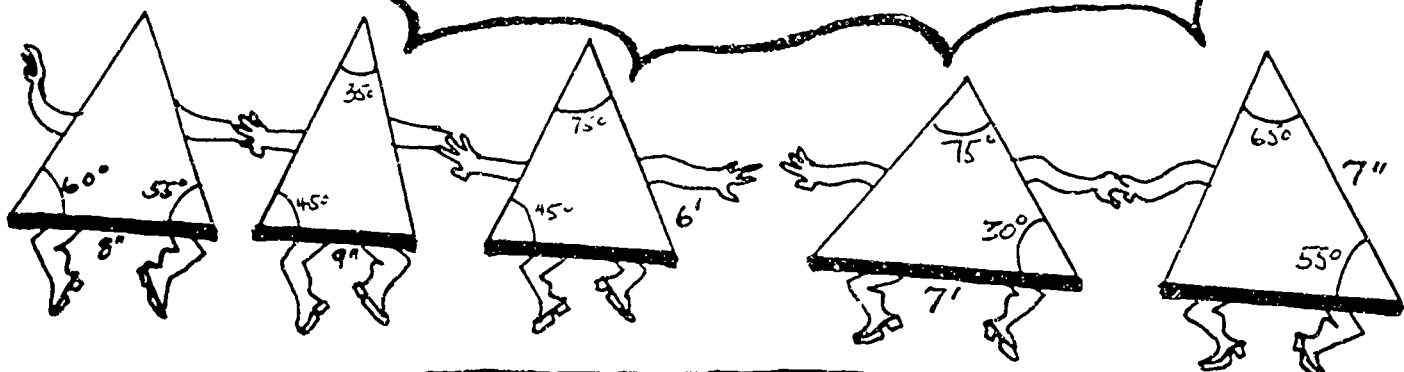

We're group 2 triangles. You know two of our sides and the angle opposite one of those sides. Solve US with the law of Sines. Hooray!

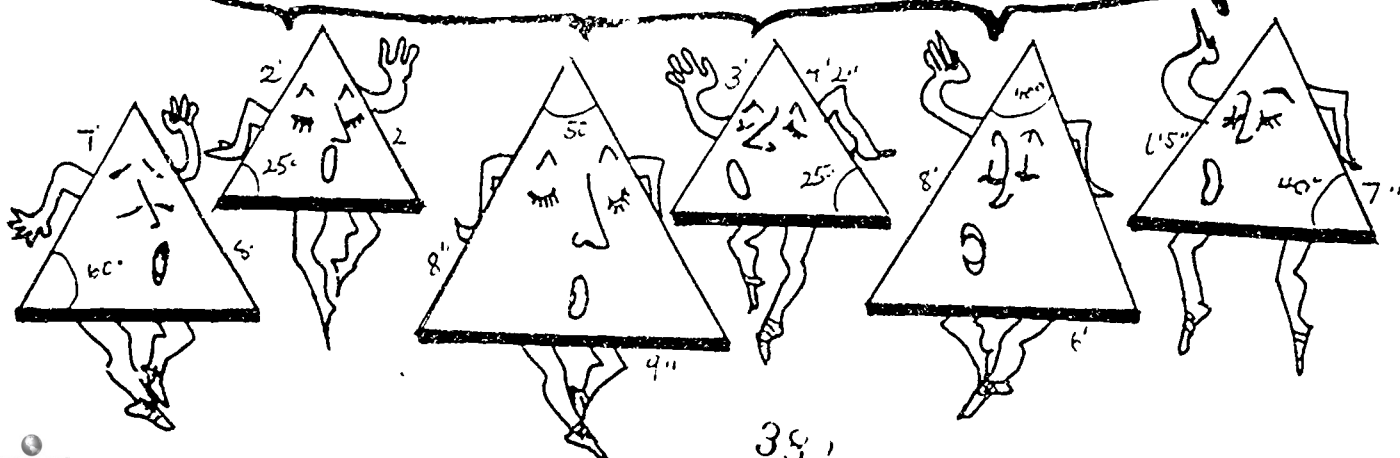

383

THE LAW OF COSINES

Look at Figure 2. Name the sides of triangle ABC as a , b , and c . Draw the perpendicular h and you get two right triangles ABD and BCD. Divide b into m and n as shown below.

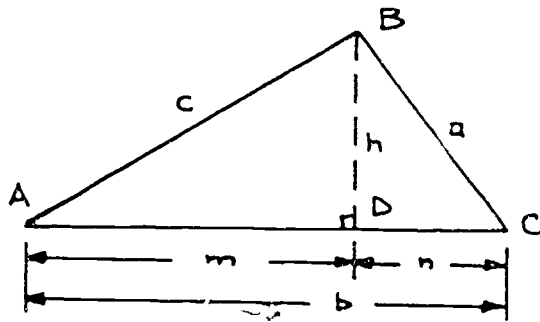

In the right $\triangle BDC$:

$$a^2 = h^2 + n^2 \leftarrow \text{Pythagorean (1)} \\ \text{Theorem}$$

$$\text{also } n = b - m,$$

In right $\triangle ABD$ $m = c \cos A$, then

$$n = b - c \cos A$$

$$n^2 = b^2 - 2bc \cos A + c^2 \cos^2 A \leftarrow (2)$$

Also in right $\triangle ABD$; $h = c \sin A$

$$h^2 = c^2 \sin^2 A \leftarrow (3)$$

Substituting equations (2) and (3) into equation (1)

$$a^2 = c^2 \sin^2 A + b^2 - 2bc \cos A + c^2 \cos^2 A, \text{ rearranging}$$

$$a^2 = b^2 + c^2 \sin^2 A + c^2 \cos^2 A - 2bc \cos A, \text{ factoring } c^2$$

$$a^2 = b^2 + c^2 (\sin^2 A + \cos^2 A) - 2bc \cos A$$

$\sin^2 x + \cos^2 x = 1$ is a trigonometric identity, then

$$a^2 = b^2 + c^2 (1) - 2bc \cos A$$

$$a^2 = b^2 + c^2 - 2bc \cos A, \text{ similarly}$$

$$b^2 = a^2 + c^2 - 2acc \cos B$$

$$c^2 = a^2 + b^2 - 2abc \cos C$$

$$a^2 = b^2 + c^2 - 2bc \cos A$$

$$b^2 = a^2 + c^2 - 2acc \cos B$$

$$c^2 = a^2 + b^2 - 2abc \cos C$$

\leftarrow Law of Cosines

Figure 1: how the Law of Cosines is derived from right triangles.



Full Text Provided by ERIC

Again, each of these equations contains four elements of the given triangle. If any *three* elements are given (in any one equation), the fourth element may easily be found.

In other words, this says: In any triangle, right or oblique, the square of any side is equal to the sum of the squares of the other two sides, less double the product of these two sides multiplied by the cosine of the angle included between the two sides.

Don't worry if you don't understand how to get the sine and cosine formulas. All you need to know is what the formulas are and how to use them in your shop.

We're group 3 triangles., Cha Cha Cha.
You know two of our sides and the angles between. Solve us by using the law of cosines.

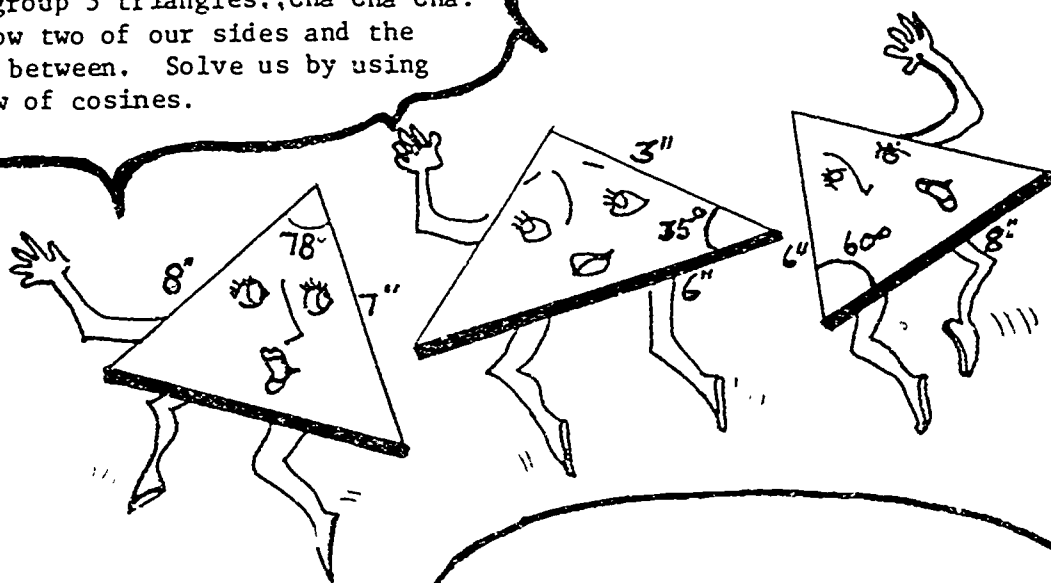

Hi there! I'm a group 4 triangle.
You know all my sides but NONE
of my angles. Find all my angles
and solve me by using the law of Cosines.

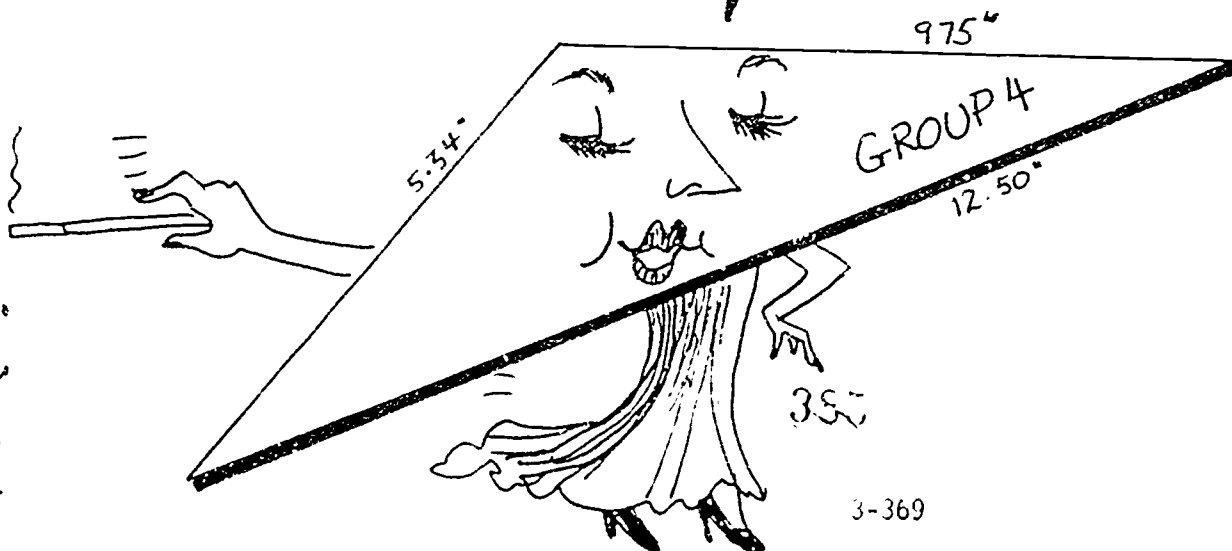

HOW TO USE THE LAW OF SINES AND THE LAW OF COSINES

Now you are prepared to solve problems dealing with the four groups of oblique triangles listed on page 2 of this Project Sheet. The groups are also shown on pages 4 and 6 in the illustrations. When you have an oblique triangle to solve, you must first choose which formula to use. Find the formulas from the Law of Sines or the Law of Cosines according to the information you have about the triangle. Pick a formula that uses the three elements you know and the one you want to find. Substitute the numerical values you know into the formula. Then calculate the value of the unknown element.

Group 1: Any two angles and any one side are given. Look at Figure 3. Given that the length of $c = 3.480$. You need to find angle B, length of side a , length of side b .

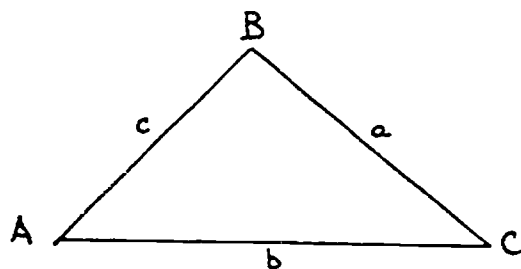

Solution:

Remember that $\angle A + \angle B + \angle C = 180^\circ$

then: $\angle B = 180^\circ - \angle A - \angle C$

$\angle B = 180^\circ - 23.5^\circ - 64.6^\circ$

$\angle B = 180^\circ - 88.1^\circ$

$\angle B = 91.9^\circ$

An equation from the Law of Sines is selected since, now, all angles and one side are known. Therefore, any of the remaining sides may be found.

$\frac{a}{\sin A} = \frac{c}{\sin C}$, and $a = \frac{c \sin A}{\sin C}$, substitute the known elements

$$a = \frac{(3.480)(\sin 23.5^\circ)}{\sin 64.6^\circ} = \frac{(3.480)(0.3988)}{0.9033}$$

$$a = 1.536''$$

Now, select another equation involving side b from the law of sines.

$\frac{b}{\sin B} = \frac{c}{\sin C}$, and $b = \frac{c \sin B}{\sin C}$

$$b = \frac{(3.480)(\sin 91.9^\circ)}{\sin 64.6^\circ} = \frac{(3.480)(0.999)}{0.9033} = 3.850''$$

Figure 3: Solving a triangle for a and b with the Law of Sines.

380

GROUP 2: Any two sides and the angle opposite one of the sides are given. Look at Figure 4. Given that length of $a = 2.864''$, the length of $b = 4.228''$, and angle $B = 82.4^\circ$. You need to find the length of side c , angle A , and Angle C .

Solution: Since two sides and an angle opposite one of the sides is given, you can first solve for the second angle with an equation from the Law of Sines.

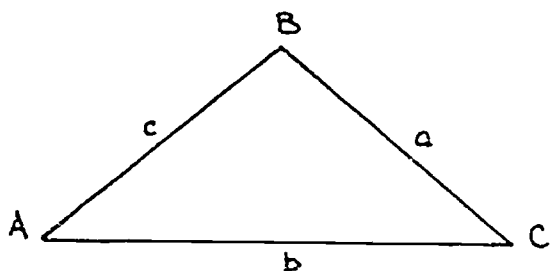

$$\frac{a}{\sin A} = \frac{b}{\sin B}, \text{ then:}$$

$$\sin A = \frac{a \sin B}{b}, \text{ substitute known values}$$

$$\sin A = \frac{(2.864'')(\sin 82.4^\circ)}{4.228''}$$

$$\sin A = \frac{(2.864'')(0.9912)}{4.228''} = 0.6714$$

then $A = \sin^{-1} 0.6714$, and $\angle A = 42.18^\circ$

then to find $\angle C$:

$$180^\circ = \angle A + \angle B + \angle C$$

$$\angle C = 180^\circ - \angle A - \angle B$$

$$\angle C = 180^\circ - 42.18^\circ - 82.4^\circ = 55.42^\circ$$

now select another equation, involving side c , from the Law of Sines.

$$\frac{c}{\sin C} = \frac{b}{\sin B}, \text{ then } c = \frac{b \sin C}{\sin B}$$

$$c = \frac{(4.228'')(\sin 55.42^\circ)}{\sin 82.4^\circ}$$

$$c = \frac{(4.228'')(0.8234)}{(0.9912)}$$

$$c = 3.512''$$

Figure 4: Solving a triangle for two sides and one angle.

Group 3: Any two sides and the angle included between them are given. Look at Figure 5. Given that the length of $a = 5.274''$, the length of $b = 9.836''$, and angle $C = 23.78^\circ$. You need to find the length of side c , angle A , and angle B .

Solution: A problem of this type cannot be solved directly by the Law of Sines because the given data does not include a single ratio between any one side and the sine of its opposite angle. Therefore, use the Law of Cosines first to find the side c opposite the given angle C . Then solve the rest of the triangle by using the Law of Sines.

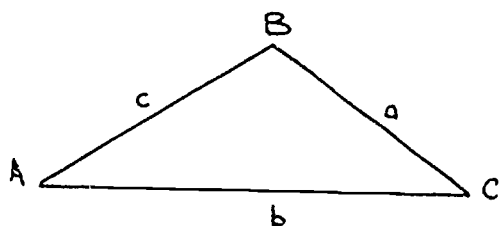

$$c^2 = a^2 + b^2 - 2ab \cos C$$

$$c = \sqrt{a^2 + b^2 - 2ab \cos C}$$

substitute known values

$$c = \sqrt{(5.274^2) + (9.836)^2 - 2(5.274)(9.836)(0.9151)}$$

$$c = \sqrt{29.62}$$

$$c = 5.442''$$

then select an equation involving $\angle A$ or $\angle B$, from the Law of Sines.

$$\frac{a}{\sin A} = \frac{c}{\sin C}, \text{ then } \sin A = \frac{a \sin C}{c}$$

$$\sin A = \frac{(5.274'')(\sin 23.78^\circ)}{(5.442'')}$$

$$\sin A = \frac{(5.274'')(0.403)}{(5.442'')} = 0.3906$$

$$A = \sin^{-1} 0.3906 = 22.99^\circ$$

then to find $\angle B$: $\angle B = 180^\circ - \angle A - \angle C$

$$\angle B = 180^\circ - 22.99^\circ - 23.78^\circ$$

$$\angle B = 133.23^\circ$$

Figure 5: Solving a triangle from two sides and the included angle using the Law of Cosines.

Group 4: All the sides are given. Look at Figure 6. Given that the length of $a = 4.146''$, the length of $b = 6.264''$, and the length of $c = 8.786''$. You need to find angle A, B, and C.

Solution: This problem is like Group 3. You cannot use the Law of Sines first because you don't know any angles. Therefore, as a first step you must use the Law of Cosines to find one of the angles.

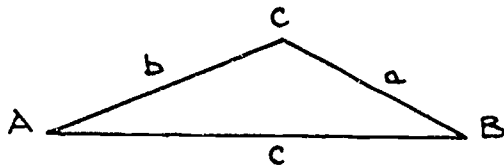

$$a^2 = b^2 + c^2 - 2bc \cos A$$

Solve the above equation for $\cos A$

$$\cos A = \frac{b^2 + c^2 - a^2}{2bc}$$

Substitute the known elements:

$$\cos A = \frac{(6.264'')^2 + (8.786'')^2 - (4.146'')^2}{2(6.264'')(8.786'')}$$

$$\cos A = \frac{39.24 \text{ in}^2 + 77.19 \text{ in}^2 - 17.19 \text{ in}^2}{110.07 \text{ in}^2}$$

$$\cos A = \frac{99.24 \text{ in}^2}{110.07 \text{ in}^2} = 0.90161, \text{ then}$$

$$A = \cos^{-1} 0.90161$$

$$A = 25.63^\circ$$

then select an equation involving $\angle B$ or $\angle C$ from the Law of Sines

$$\frac{a}{\sin A} = \frac{b}{\sin B}$$

$$\sin B = \frac{b \sin A}{a}, \text{ substitute known elements}$$

$$\sin B = \frac{(6.26'')(\sin 25.63^\circ)}{(4.146'')} = \frac{(6.26'')(0.43261)}{(4.146'')}$$

$$\sin B = 0.65361, \text{ then}$$

$$B = \sin^{-1} 0.65361, \text{ and } B = 40.81^\circ$$

then to find $\angle C$: $\angle A + \angle B + \angle C = 180^\circ$

$$\angle C = 180^\circ - (25.63^\circ + 40.81^\circ)$$

$$\angle C = 180^\circ - 66.44^\circ$$

$$\angle C = 113.56^\circ$$

Figure 6: Solving a triangle from Group 4 with the Law of Cosines.

COMPLETE THE SHOP PROBLEMS BEGINNING ON THE NEXT PAGE.

SHOP PROBLEMS

1. A sketch with dimensions as shown in Figure 7 is given to you to lay out prior to machining. To complete the layout, you must find dimensions x , y and z .

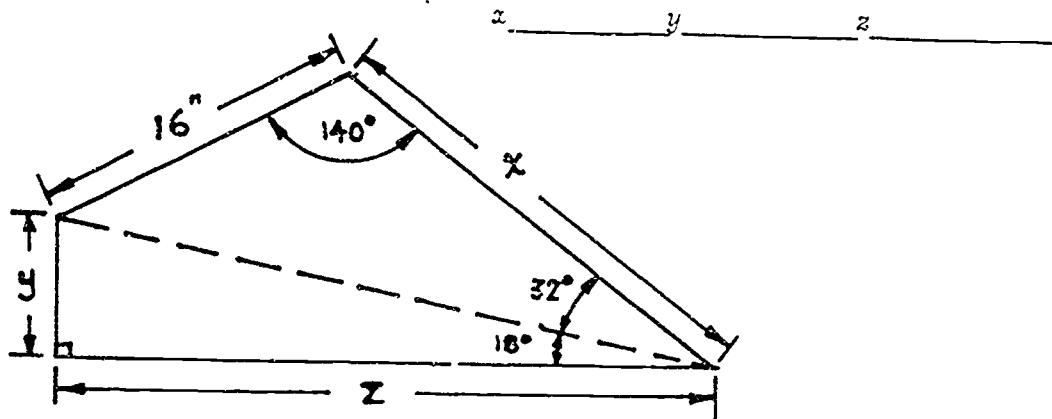

Figure 7: Find x , y , and z .

2. You are given a layout to check a certain dimension for accuracy. Look at Figure 8. You measure dimension A, the distance between the points of tangency M and N, to be 4.234". How many thousandths of an inch is dimension A in error? (Hint: Solve for dimension A by trigonometric methods. Then compare the trig A to your measured A. The difference is the error.)

Error _____ to the closest thousandth.

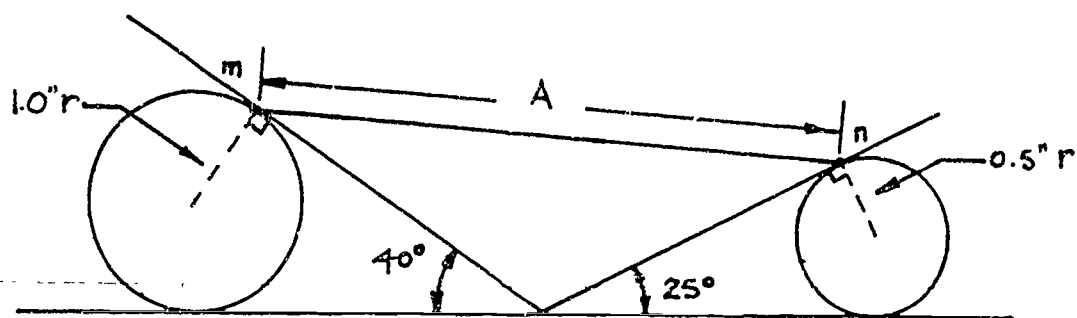

Figure 8: Find the error of A to the nearest thousandth.

3. You are given a triangular pattern to lay out. You know the dimensions of the three sides but your problem is how to place it with respect to a horizontal base line. You need to find angle A. Look at Figure 9.

Angle A _____

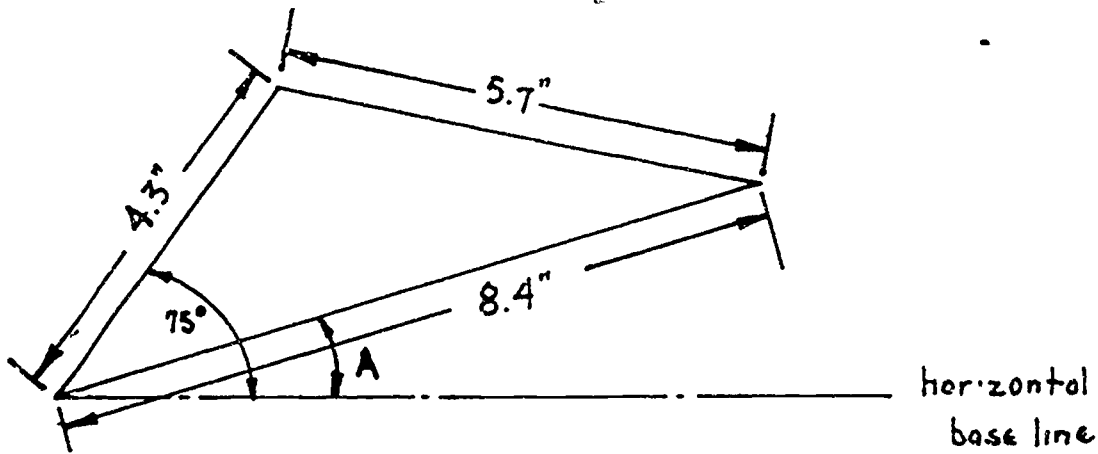

Figure 9: Find angle A.

4. You have been given a pattern of three holes to be drilled. Look at Figure 10. To check the accuracy of the position of the three holes, you need to find angles A, B, and C.

Angle A _____

Angle B _____

Angle C _____

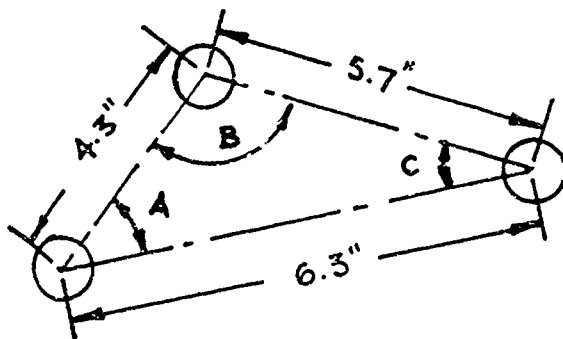

Figure 10: Find angles A, B and C.

5. You have been given the hole pattern shown in Figure 11 to lay out. To do this, you must find the missing dimensions A, B, and C.

A = _____

B = _____

C = _____

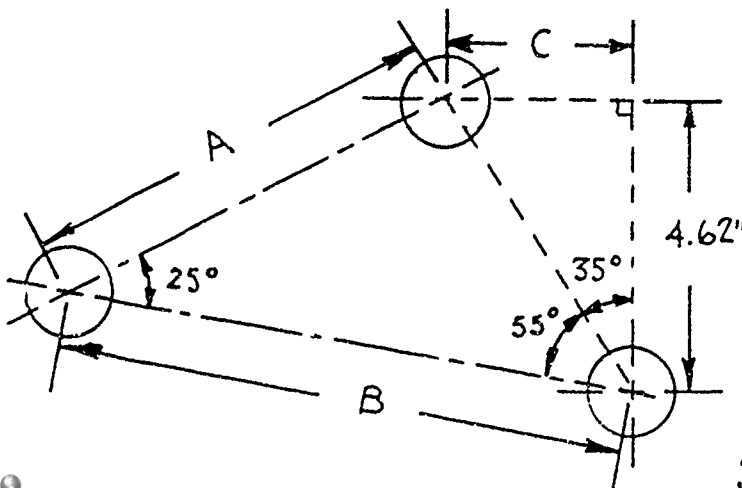

Figure 11: Find A, B, and C.

SHOW YOUR WORK TO YOUR INSTRUCTOR.

BAS

CHAPTER 3

CONCLUSIONS AND RECOMMENDATIONS

CONCLUSIONS

Through this project, we found that metal trades vocational training students (average age approximately 25 years) are requiring further applied practical shop math training after completing high school algebra, geometry and trigonometry, to meet metal trades industry job requirements. Further, students must receive hands-on vocational training in a specific metal trade occupation concurrent with applied shop math training for that occupation.

Most students showed significant improvement in solving metal trades on-the-job math problems after receiving 30 to 40 hours applied practical shop math training in a small (5 to 15), open-entry, open-exit class setting.

RECOMMENDATIONS

Develop and add the following materials to those identified previously in this report:

1. Individualized learning projects, called Project Sheets, on percentages and Charts and Graphs for metal trades.
2. Training outlines, Student Training Records, for Building Trades:

Bricklayer Apprentice	D.O.T. 861.381-022
Cabinet Maker Apprentice	D.O.T. 660.280-014
Carpenter Apprentice	D.O.T. 860.381-026

as defined by job requirements of the building industry.

3. Individualized learning projects, Project Sheets, for each building trade occupation cited above.
4. Criterion referenced shop math pretests and posttests which will measure the math entry level and exit level of each metal trades and building trades student.

Evaluate the materials:

1. Administer shop math pretests and posttests;
2. Analyze results of the above tests;
3. Revise training materials as necessary. (See Table B)

PROPOSED
MATHEMATICS PACKAGE

Application →

Milestone 1 - Math Pretest

1. Arithmetic
2. Algebra
3. Geometry
4. Trigonometry
5. Percentages - Charts and Graphs

Metal Trades			
PMF	Machinist	Sheet Metal	Welder
x	/	/	/
x	/	x	/
x	x	x	x
/	/		
x	/	/	/

Bldg Trades		
Bricklayer	Cabinet M	Carpenter
/	/	/
/	/	/
/	/	/
/	/	/

Milestone 2 - General Math (Proj. Sheets)

1. Addition - Subtraction (Fractions)
2. Multiplication - Division (Fractions)
3. Addition - Subtraction (Decimals)
4. Multiplication - Division (Decimals)
5. Conversation - Fractions and Decimals
6. Measurement Numbers
7. Working with Metrics

x	x	x	x
x	x	x	/
x	x	/	/
x	x	x	x
x	x	/	/
x	x	x	/
x	x	/	/

/	/	/
/	/	/
/	/	/
/	/	/
/	/	/
/	/	/
/	/	/

Milestone 3 - Specialized Math Skills (Proj. Sheets)

1. Algebra I
2. Algebra II
3. Algebra III
4. Geometry I
5. Geometry II
6. Introduction to Trigonometry
7. Trigonometry I
8. Trigonometry II
9. Percentages
10. Charts and Graphs

x	x	/	x
x	x	x	x
	x		
x	x	x	x
x	x	x	x
x	x	x	x
x	x	x	x
	x		
x	/	x	/
x	x	/	/

/	/	/
x	/	/
x	/	x
x	x	/
	x	/
/	/	/
/	/	/

Milestone 4 - Math Final Test

1. Arithmetics
2. Algebra
3. Geometry
4. Trigonometry
5. Percentages - Charts and Graphs

/	/	/	/
x	/	/	x
/	/	x	/
/	/		
x	/	/	/

/	/	/
/	/	/
/	x	/
	/	/
x	/	/

KEY: → completed → proposed

CHART B

APPENDIX A

4/81

STUDENT TRAINING RECORD



Name _____

Cluster Metal Trades

Occupation Machinist Helper D.O.T. 600.280-026

Date Started _____ Date Terminated _____

The training modules and milestones listed below are required for the student to seek entry-level employment in the occupation shown above. The D.O.T. number is a Job Service code for this occupation. Appropriate D.O.T. codes may be listed in the training outline to give the student alternate employment options. Copies of this record will be prepared and issued upon request from the student.

TRAINING MODULES AND MILESTONES	DATE		PERFORMANCE (x)			
	Start	Complete	On his/her Own	with		Additional Training
				Min Super	Max Super	
ORIENTATION						
1. Introduction to Machining						
LT: You and Machining						
2. Shop and Job Safety						
ST: "Shop Safety-Think Safety"						
ST: "Machine Tool-General Machine Shop Safety"						
ST: "Shop Safety-General Shop Hazards"						
ST: "Introduction to Machine/Metal Shop Safety"						
ST: "Shop Safety-Hand Saws, Chisels and Files"						
ST: "Shop Safety-Drill Presses and Lathes"						
MATH FOR MACHINISTS (See STR)						
SHOP MATH FOR MACHINISTS (See STR)						
BLUEPRINT READING FOR MACHINISTS (See STR)						
MEASUREMENT						
1. HO/CT: Measure with steel rule						
2. HO/CT: Measure with outside micrometer						
3. HO/CT: Measure with vernier caliper						
4. HO/CT: Measure with inside mike						
5. HO/CT: Measure with small hole gage						
6. HO/CT: Measure with telescoping gage						
7. HO: Measure with depth rule						
8. HO/CT: Measure with depth mike						
9. HO: Measure with depth vernier						
10. HO: Measuring with protractors						
11. HO: Measuring with dial indicator						
12. HO: Measuring angles and taper with sine plate						
13. HO: Measure with dial bore gage						
14. HO/CT: Measure with intra-micrometer						
15. HO/CT: Measure with radius gages						
16. HO: Measure with optical comparator						
17. HO: Measuring with thread micrometer						
18. HO/CT: Measure thread pitch diameter (Go, No Go)						
19. HO/CT: Check concentricity (Center and indicator)						

5-2

390

TRAINING MODULES AND MILESTONES	DATE		PERFORMANCE (x)			
	Start	Complete	On his/her Own	with		
				Min Super	Max Super	Additional Training
1. HO: Measuring with thread plug gage						
22. HO: Measure hardness of metal with Rockwell Hardness Tester						
23. HO: Measuring with toolmakers microscope						
24. HO: Check hole location by coordinate method						
25. HO: Check hole location by true position method						
26. HO: Check precision square for squareness with cylindrical square						
27. HO/CT: Check squareness with precision square						
28. HO/CT: Checking surface finish with surface comparator gage						
29. HO/CT: Measure hole diameter with deltronic pins						
LAYOUT AND BENCH WORK						
1. HO: Rough layout						
2. HO: Precision layout						
3. HO: Sawing with hand hack saw						
4. HO: Straight and draw filing						
5. HO: Sizing holes with hand reamers						
6. HO: Cutting threads by hand with taps						
7. HO/CT: Hand methods of deburring parts						
8. HO: Hand methods of removing broken studs						
9. HO: Cutting threads by hand with dies						
10. HO: Lapping a surface on lap plate						
11. HO: Filing a contour with reciprocating filing machine						
14. HO: Broaching keyway using an arbor press						
15. HO: Center drilling on center drilling machine						
DO-ALL SAW						
1. Contour Saw Operation PS/CT: Operating a Do-All Contour Saw						
2. Butt Welding a Blade PS/CT: Butt Welding a Blade						
3. Mounting Saw Guides PS/CT: Mounting a Set of Saw Guides						
4. Mounting and Removing Bands PS/CT: Saw Bands PS: File Bands						
5. Sawing to Layout Lines PS: Layout and Sawing						
DRILLING MACHINE						
1. HO/CT: Drill press operational control familiarity						
HO/CT: Sharpen a drill by hand						
2. HO: Mount and hold work on the drill press						
4. HO: Drill holes to layout lines						

TRAINING MODULES AND MILESTONES	DATE		PERFORMANCE (x)			
	Start	Complete	On his/her Own	with		
				Min Super	Max Super	Additional Training
5. HO: Drill holes through center of round stock						
6. HO/CT: Step drill holes accurately to size						
8. HO/CT: Countersink, counterbore and spot-face						
9. HO/CT: Ream holes to size						
11. HO/CT: Tap holes in drill press by hand						
LATHES						
1. PS/CT: Grinding a Right Hand Turning Tool						
2. HO/CT: Lathe operator control familiarity						
2A. HO/CT: Lathe operator control for 17X36 LeBlond Regal						
3. HO/CT: Install and remove chucks and face plates-cam lock						
4. HO/CT: Install and remove chucks and face plates-third nose						
5. HO/CT: Install and remove chucks and face plates-taper key						
6. HO/CT: Rough centering in 4-jaw chuck						
7. HO/CT: Facing in a chuck						
8. HO/CT: Center drilling in chucks and collets						
9. HO/CT: Alignment of lathe centers						
10. HO/CT: Mounting work between centers						
11. HO/CT: Straight turning between centers						
12. HO/CT: Knurling						
13. HO: Taper cutting-offset method						
14. HO/CT: Straight turning work in a chuck						
15. HO/CT: Precision centering in a 4-jaw chuck						
16. HO/CT: Cutting steep tapers and chamfers						
17. HO/CT: Drilling in a lathe						
18. HO/CT: Reaming in a lathe						
19. HO: Grooving and parting operations						
20. HO/CT: Grind 60° threading tool						
21. HO: Cutting external threads						
22. HO/CT: Grinding a radius tool						
23. HO/CT: Grinding a round nose form tool						
24. HO/CT: Radius and fillet turning						
25. HO: Boring with an engine lathe						
26. HO/CT: Cutting internal threads						
27. HO: Center drilling work between centers						
28. HO/CT: Grinding a right hand facing tool						
29. HO/CT: Facing work to length between centers						
30. HO: Taper turning-taper attachment						
31. HO/CT: Tapping threads in a lathe						
32. HO: Mounting facing and turning work on a mandrel						
33. HO: Rough and finish turning using cemented carbides and ceramics						
35A. HO: Changing jaws in a 4-jaw independent chuck						
35B. HO: Changing jaws in a 3-jaw universal chuck with inside and outside jaws						
35C. HO: Reversing jaws in a 3-jaw universal chuck with cap screw mounting jaws						

TRAINING MODULES AND MILESTONES	DATE		PERFORMANCE (x)			
	Start	Complete	On his/her Own	with		
				Min Super	Max Super	Additional Training
36. HO: Machining a part with tracing attachment						
37. HO: Reaming a tapered hole						
38. HO: Using a steady rest						
POWER HACK SAW						
1. HO/CT: Power hack saw operational control familiarity						
2. HO/CT: Install hack saw blade						
3. HO/CT: Cut off stock using power hack saw						
HORIZONTAL MILLING MACHINE						
1. HO: Operation control familiarity						
2. HO/CT: Install arbor in spindle						
3. HO/CT: Install cutter on arbor						
4. HO/CT: Slab mill a piece square held in vise						
5. HO/CT: Face mill part clamped to table						
6. HO/CT: Straddle mill a part clamped to table						
7. HO: Mount dividing head and foot stock						
8. HO: Cut teeth on spur gear						
9. HO: Cut keyway in shaft with plain milling cutter						
13. HO: Machine external radius						
14. HO: Mill angular slot						
17. HO: Slit work held in vise						
8. HO: Mill multi-level surfaces						
VERTICAL MILLING MACHINE						
1. HO/CT: Vertical milling operational control familiarity						
2. HO/CT: Chuck end mill in collet in spindle						
3. HO/CT: Align spindle perpendicular to table						
4. HO/CT: Mount and align vise to table						
5. HO/CT: Square work clamped to table						
6. HO/CT: Square work held in vise						
7. HO: Locate, drill and ream holes using coordinate method						
8. HO: Locate and bore holes using coordinate method						
9. HO/CT: Stop drilling holes accurately to size						
10. HO/CT: Locate and mill slot or pocket						
11. HO/CT: Countersinking, counterboring and spotfacing						
12A. HO: Mill a square on workpiece						
12B. HO: Mill a hexagon on workpiece						
13. HO/CT: Machine flat surface using fly cutter						
14A. HO/CT: Drill and ream equally spaced holes on bolt circle using direct indexing						
14B. HO/CT: Drill and ream equally spaced holes on bolt circle using simple indexing						
15. HO: Mill a part using tracer unit						
16. HO/CT: Mill multi-level surfaces accurately						

STUDENT EMPLOYABILITY REPORT

Weber State College Skills Center • 1100 Washington Blvd., Ogden, Utah 84404

Student Name _____

Occupational Program Machinist Helper Date Started _____ Date Terminated _____

Copies of this report will be prepared and issued upon request from the student.

1. SUCCESS FACTORS			
Initiative	Dependability	Attitude	Willingness
<input type="checkbox"/> seeks work <input type="checkbox"/> meets requirements <input type="checkbox"/> needs prompting	<input type="checkbox"/> keeps word <input type="checkbox"/> dependable <input type="checkbox"/> needs encouragement	<input type="checkbox"/> excellent <input type="checkbox"/> good <input type="checkbox"/> needs encouragement	<input type="checkbox"/> tries to please <input type="checkbox"/> goes along <input type="checkbox"/> needs encouragement
Follows Directions	Works with Others	Accepts Criticism	Appearance
<input type="checkbox"/> very well <input type="checkbox"/> acceptable <input type="checkbox"/> needs follow-up	<input type="checkbox"/> very well <input type="checkbox"/> acceptable <input type="checkbox"/> needs encouragement	<input type="checkbox"/> very well <input type="checkbox"/> acceptable <input type="checkbox"/> needs encouragement	<input type="checkbox"/> very neat <input type="checkbox"/> acceptable <input type="checkbox"/> needs improvement

2. CERTIFICATES AND HONORS			
Certificate(s) of Proficiency Yes <input type="checkbox"/> No <input type="checkbox"/>	Date(s) Presented	Honor(s) and Comments:	
Certificate of Completion Yes <input type="checkbox"/> No <input type="checkbox"/> <small>(MIN 65% of STR)</small>	Percent Completed	Date Mailed	Special Projects and Comments:

3. CERTIFICATE OF COMPLETION PROFICIENCIES			
SHOP AND JOB SAFETY	Mount Bands/Saw to Lines	Cut Teeth on Spur Gear	
BASIC SHOP MATH	DRILLING MACHINE OPERATION	VERTICAL MILLING MACHINE	
BLUEPRINT READING	Mount Work	Align Spindle/Mount Vise	
MEASURING TOOLS	Drill, Ream, Tap Holes	Square Work	
Micrometers: Inside/Outside	LATHE OPERATION	Drill, Ream, Bore Holes	
Vernier Calipers	Grind Tool Bits/Chase Thrds	Countersink/Counterbore	
Radius/Feeler Gauges	Turn Tapers/Drill/Ream	Spotface	
Protractors/Dial Indicators	Bore/Knurl/Steady Rest	Index Head	
LAYOUT AND BENCH WORK	Turn Between Centers	Fly Cutter	
Layout/Saw/File/Tap/Deburr	Tracer Attachment	SPECIAL TRAINING PROJECTS	
Remove Broken Studs	POWER HACK SAW OPERATION		
DO-ALL SAW OPERATION	HORIZONTAL MILLING MACHINE		
Weld Blades/Mount Guides	Slab Mill/Face Mill		
	Straddle Mill/Cut Keyway		

4. JOB PLACEMENT			
Employed By _____	Termination Code _____		
Address _____	Telephone _____		
Job Title _____	Wage _____		
Date Placed _____	Referred By _____		

Advisor/Instructor _____ Date _____ Supervisor _____

5/81

STUDENT TRAINING RECORD



Name _____

Cluster Metal Trades

Occupation Precision Metal Finisher D.O.T. 705.484-010

Date Started _____ Date Terminated _____

The training modules and milestones listed below are required for the student to seek entry-level employment in the occupation shown above. The D O T number is a Job Service code for this occupation. Appropriate D.O.T. codes may be listed in the training outline to give the student alternate employment options. Copies of this record will be prepared and issued upon request from the student.

Item No.	TRAINING MODULES AND MILESTONES	DATE		PERFORMANCE (x)			
		Start	Complete	On his/her Own	with		
					Min Super	Max Super	Additional Training
	ORIENTATION						
	1. Introduction to Metal Finishing						
	LT: Instructor Interview-Shop Tour						
1	PS: Precision Metal Finishing Shop Rules						
2	PS: Introduction to PMF						
3	PS: Layout and Cutting Circles and Squares						
	ST: "Shop Safety-Think Safety"						
	ST: "Introduction to Machine/Metal Shop Safety"						
	ST: "Shop Measuring Instruments-Steel Rules and Related Instruments"						
	ST: "Bench Metalwork-Introduction, Tools and Processes"						
	ST: "Measuring Instruments"						
	ST: "Shop Measuring Instruments-Micrometers"						
4	PS: Finish It Safely						
5	PS: Steel Rules and Feeler Gauges						
6	HO: Measuring						
7	OZ: Measuring Instruments						
	2. Metal Finishing Tools						
8	PS: Tools and Their Use						
	ST: "Shop Measuring Instruments-Calipers and Dividers"						
	ST: "Shop Measuring Instruments-Vernier Instruments"						
9	PS: The Vernier Caliper						
	ST: "Machine Tool-General Machine Shop Safety"						
10	PS: Operating a Do-All Contour Saw						
	ST: "Machine Tool-Introduction to the Metal Cutting Band Saw"						
	ST: "Machine Tool-Operating the Band Saw"						
	ST: "Bench Metalwork-Files and the Filing Process"						
11	PS: Filing and Grinding a Flat Aluminum Block						
	ST: "Machine Tool-Introduction to the Drill Press"						
		5-8	402				

Item No.	TRAINING MODULES AND MILESTONES	DATE		PERFORMANCE (x)		
		Start	Complete	On his/her Own	with	
					Min Super	Max Super
12	PS: Drilling Holes					
13	PS: How to Drill, Counterbore and Thread Aluminum Stock					
14	PS: Pre-Vocational Summary* (Pre-Vocational Exploration Complete)					
	BASIC BLUEPRINT READING (See Basic Blueprint Reading STR)					
	SHOP MATH FOR PRECISION METAL FINISHERS (See Shop Math for Precision Metal Finishers STR)					
	SHEET METAL ORIENTATION					
	1. Introduction to Sheet Metal					
	LT: Instructor Interview					
	ST:"Sheet Metalwork: Introduction and Overview"					
15	PS: The Sheet Metal Industry					
	2. Shop and Job Safety					
16	PS: Why Safety is Important to the Sheet Metal Worker					
	ST:"Shop Safety: Think Safety" (review)					
	ST:"Shop Safety: General Shop Hazards"					
	ST:"Shop Safety: Hand Saws, Chisels and Files"					
	ST:"Shop Safety: Screwdrivers, Wrenches, Sheet Metal and Welding Tools"					
	RV: Instructor Interview-Shop Rules					
	3. Basic Metals					
17	PS: Basic Metals and Sheet Gauges					
18	PS: Your Guide to Basic Metals					
	HAND TOOL IDENTIFICATION AND USE					
	1. Measuring Tools					
	ST:"Shop Measuring Instruments: Steel Rules and Related Instruments" (review)					
	ST:"Measuring Instruments" (review)					
	ST:"Shop Measuring Instruments: Micrometers" (review)					
	ST:"Shop Measuring Instruments: Calipers and Dividers"					
	2. Scribing Tools					
20	DM: Using Scribing Tools					
21	PS: Scribing on Metal*					
	3. Hand Operated Cutting Tools					
	ST:"Sheet Metalwork: Cutting Methods"					
	ST:"Bench Metalwork: Cutting Processes"					
22	PS: Your Hand Cutting Tools					
23	PS: Cutting Exercises*					
24	PS: Cutting Circles*					
25	PS: Cutting Squares*					
26	PS: Cutting Straight Lines*					

Item No.	TRAINING MODULES AND MILESTONES	DATE		PERFORMANCE (x)			
		Start	Complete	On his/her Own	with		Additional Training
					Min Super	Max Super	
	4. Hand Operated Bending Tools and Machines						
	ST:"Sheet Metalwork: Drilling, Forming and Bending-Part 1"						
	ST:"Sheet Metalwork: Forming and Bending-Part 2"						
	DM: Leaf Brake						
	DM: Slip Roll						
	DM: Hand Seamer						
	ST:"Sheet Metalwork: Straight Line Pattern Development"						
27	PS: Forming Pipe*						
	DM: Pittsburg Seaming Machine						
28	PS: Forming Letter Box*						
	DM: Box and Pan Brake						
29	PS: Forming Box with Sliding Top*						
30	PS: Forming Dust Pan*						
31	PS: Soldering *						
32	PS: Forming Chime Box*						
	PRECISION METAL FINISHING						
	1. Precision Measuring Tools Application						
	ST:"Shop Safety: Hand Saws, Chisels and Files" (review)						
33	PS: Making Chimes with Electrical Metallic Tubing						
34	PS: Using Feeler Gauges*						
	ST:"Machine Tool: Introduction to the Pedestal Grinder"						
	ST:"Machine Tool: Grinding Wheel Construction and Types"						
	ST:"Machine Tool: Mounting and Dressing the Grinding Wheel"						
35	PS: Hole Punching Machines						
36	PS: Drill Punch and Deburr Flat Stock						
	ST:"Shop Safety: Drill Presses and Lathes"						
	ST:"Machine Tool: Introduction to the Drill Press" (review)						
	ST:"Machine Tool: Operating the Drill Press"						
	ST:"Machine Tool: The Supporting Tools Of the Drill Press"						
37	PS: Precision Drilling Safety wire Hole						
	ST:"Machine Tool: Introduction to Measuring Instruments"						
38	PS: Micrometers						
	ST:"Shop Measuring Instruments: Vernier Instruments"						
39	PS: The Vernier Caliper Review						
	ST:"Machine Tool: Grinding the Twist Drill by Free Hand"						
40	PS: Metal Blending a Pipe Fitting						
41	PS: Making Aircraft Doors						
42	PS: Blending and Finishing a Weld Assembly						
	ST:"Shop Measuring Instruments: Dial Indicators"						
		5-10					

STUDENT EMPLOYABILITY REPORT

Weber State College Skills Center • 1100 Washington Blvd., Ogden, Utah 84404

Student Name _____

Occupational Program Precision Metal Finisher Date Started _____ Date Terminated _____

Copies of this report will be prepared and issued upon request from the student.

1. SUCCESS FACTORS

Initiative	Dependability	Attitude	Willingness
<input type="checkbox"/> seeks work <input type="checkbox"/> meets requirements <input type="checkbox"/> needs prompting	<input type="checkbox"/> keeps word <input type="checkbox"/> dependable <input type="checkbox"/> needs encouragement	<input type="checkbox"/> excellent <input type="checkbox"/> good <input type="checkbox"/> needs encouragement	<input type="checkbox"/> tries to please <input type="checkbox"/> goes along <input type="checkbox"/> needs encouragement
Follows Directions	Works with Others	Accepts Criticism	Appearance
<input type="checkbox"/> very well <input type="checkbox"/> acceptable <input type="checkbox"/> needs follow-up	<input type="checkbox"/> very well <input type="checkbox"/> acceptable <input type="checkbox"/> needs encouragement	<input type="checkbox"/> very well <input type="checkbox"/> acceptable <input type="checkbox"/> needs encouragement	<input type="checkbox"/> very neat <input type="checkbox"/> acceptable <input type="checkbox"/> needs improvement

2. CERTIFICATES AND HONORS

Certificate(s) of Proficiency Yes <input type="checkbox"/> No <input type="checkbox"/>	Date(s) Presented	Honor(s) and Comments:	
Certificate of Completion Yes <input type="checkbox"/> No <input type="checkbox"/> (MIN 65% of STR)	Percent Completed	Date Mailed	Special Projects and Comments:

3. CERTIFICATE OF COMPLETION PROFICIENCIES

Safety in Industry	Metals Blending
Precision Measuring Tools	Metal Deburring
Power Hand Tools	Math for Metal Finishing
Metal Cutting Band Saw	Basic Blueprint Reading
Drill Press	
Basic Sheet Metals	
Hand Operated Cutting Tools	
Hand Operated Bending Tools and Machines	

4. JOB PLACEMENT

Employed By _____	Termination Code _____
Address _____	Telephone _____
Job Title _____	Wage _____
Date Placed _____	Referred By _____

Advisor/Instructor _____ Date _____ Supervisor _____



STUDENT TRAINING RECORD



Name _____

Cluster Metal Trades

Occupation Sheet-Metal-Worker Apprentice D.O.T. 804.281-014

Date Started _____ Date Terminated _____

The training modules and milestones listed below are required for the student to seek entry-level employment in the occupation shown above. The D.O.T. number is a Job Service code for this occupation. Appropriate D.O.T. codes may be listed in the training outline to give the student alternate employment options. Copies of this record will be prepared and issued upon request from the student.

Item No.	TRAINING MODULES AND MILESTONES	DATE		PERFORMANCE (x)		
		Start	Complete	On his/her Own	with Min Super	Max Super
	ORIENTATION					
	1. Introduction to Sheet Metal					
1	LT: Instructor Interview					
2	ST:"Sheet Metalwork: Introduction and Overview"					
3	PS: The Sheet Metal Industry					
	2. Shop and Job Safety					
4	PS: Why Safety is Important to the Sheet Metal Worker					
5	ST:"Shop Safety:Think Safety"					
6	ST:"Shop Safety:General Shop Hazards"					
7	ST:"Shop Safety:Hand Saws, Chisels, and Files"					
8	ST:"Shop Safety:Screwdrivers, Wrenches-Sheet Metal and Welding Tools"					
9	PS: Your Sheet Metal Shop Rules					
10	RV: Instructor Interview-Shop Rules					
	3. Basic Metals					
11	PS: Basic Metals and Sheet Gauges					
12	PS: Your Guide to Basic Metals					
	BASIC BLUEPRINT READING (See STR)					
	BASIC MATH (See Basic Math STR)					
	SHOP MATH FOR SHEET METAL WORKERS (See STR)					
	HAND TOOL IDENTIFICATION AND USE					
	1. Measuring Tools					
13	ST:"Shop Measuring Instruments: Steel Rules and Related Instruments"					
	ST:"Measuring Instruments"					
14	PS: Reading a Rule					
15	PS: Using the Circumference Rule					
16	ST:"Shop Measuring Instruments: Micrometers"					
17	PS: Micrometers					
18	ST:"Shop Measuring Instruments: Calipers and Dividers"					
	2. Scribing Tools					
20	DM: Using Scribing Tools					
21	PS: Scribing on Metal					
	3. Hand Operated Cutting Tools					
	ST:"Sheet Metalwork:Cutting Methods"	5-13				

STUDENT EMPLOYABILITY REPORT

Weber State College Skills Center • 1100 Washington Blvd., Ogden, Utah 84404

Student Name _____

Occupational Program: Sheet Metal Worker Apprentice Date Started _____ Date Terminated _____

Copies of this report will be prepared and issued upon request from the student.

1. SUCCESS FACTORS

Initiative	Dependability	Attitude	Willingness
<input type="checkbox"/> seeks work <input type="checkbox"/> meets requirements <input type="checkbox"/> needs prompting	<input type="checkbox"/> keeps word <input type="checkbox"/> dependable <input type="checkbox"/> needs encouragement	<input type="checkbox"/> excellent <input type="checkbox"/> good <input type="checkbox"/> needs encouragement	<input type="checkbox"/> tries to please <input type="checkbox"/> goes along <input type="checkbox"/> needs encouragement
Follows Directions	Works with Others	Accepts Criticism	Appearance
<input type="checkbox"/> very well <input type="checkbox"/> acceptable <input type="checkbox"/> needs follow-up	<input type="checkbox"/> very well <input type="checkbox"/> acceptable <input type="checkbox"/> needs encouragement	<input type="checkbox"/> very well <input type="checkbox"/> acceptable <input type="checkbox"/> needs encouragement	<input type="checkbox"/> very neat <input type="checkbox"/> acceptable <input type="checkbox"/> needs improvement

2. CERTIFICATES AND HONORS

Certificate(s) of Proficiency Yes <input type="checkbox"/> No <input type="checkbox"/>	Date(s) Presented	Honor(s) and Comments:	
Certificate of Completion Yes <input type="checkbox"/> No <input type="checkbox"/> <small>(MIN: 65% of STR)</small>	Percent Completed	Date Mailed	Special Projects and Comments:

3. CERTIFICATE OF COMPLETION PROFICIENCIES

Safety in Industry	Power Hand Tools	Basic Blueprint Reading
Basic Metals	Radial Line Layout	Math for Sheet Metal
Measuring Tools	Parallel Line Layout	
Hand Operated Cutting Tools	Triangulation Layout	
Hand Operated Bending Tools and Machines	Bend Allowances	
Hand Operated Cutting Machines	Power Shear Machine	
	Power Press Machine	
Seams and Fasteners	Furnace Operation	
Spot Welding and Soldering	Furnace Repair	

4. JOB PLACEMENT

Employed By _____	Termination Code _____
Address _____	Telephone _____
Job Title _____	Wage _____
Date Placed _____	Referred By _____

Advisor/Instructor _____ Date _____ Supervisor _____

STUDENT TRAINING RECORD



Name _____

Cluster Metal TradesOccupation Combination Welder Apprentice D.O.T. 819.384-008

Date Started _____ Date Terminated _____

The training modules and milestones listed below are required for the student to seek entry-level employment in the occupation shown above. The D.O.T. number is a Job Service code for this occupation. Appropriate D.O.T. codes may be listed in the training outline to give the student alternate employment options. Copies of this record will be prepared and issued upon request from the student.

Item No.	TRAINING MODULES AND MILESTONES	DATE		PERFORMANCE (x)			
		Start	Complete	On his/her Own	with		
					Min Super	Max Super	Additional Training
	Gas Welder Apprentice D.O.T. 811.684-010						
	ORIENTATION TO OXY-ACETYLENE WELDING						
	1. Introduction to Oxy-Acetylene Welding						
	LT: Instructor Interview - Shop Tour						
1	PS: You and Your Welding Program						
2	PS: The Welder's Job						
	ST: "Your Future as a Welder Helper" No. 1						
	MP: Orientation: "Futures in Welding"						
	CT: "Introduction to Oxy-Acetylene Welding" (KC-1)						
	2. Oxy-Acetylene Shop and Safety						
3	PS: Oxy-Acetylene Safety (Part 1)						
4	PS: Oxy-Acetylene Safety (Part 2)						
	ST: "Oxy-Acetylene Safety" (Part 1) No. 2						
	ST: "Oxy-Acetylene Safety" (Part 2) No. 3						
	LT: Safety Lecture						
	MP: Safety Film:						
	DM: Oxy-Acetylene Shop Safety Procedures						
	BASIC MATH FOR WELDERS (See STR)						
	SHOP MATH FOR WELDERS (See STR)						
	BASIC BLUEPRINT READING (See STR)						
	BLUEPRINT READING FOR WELDERS (See STR)						
	OXY-ACETYLENE PROCESSES						
	1. Oxy-Acetylene Welding Equipment						
5	PS: Setting Up Your Equipment						
6	PS: Lighting Your Torch						
	CT: "Welding Equipment Orientation" (KC-2)						
	MP: "Hottest Flame on Earth" (WSC)						
	DM: Setting Up Oxy-Acetylene Equipment						
	OXY-ACETYLENE WELDING POSITIONS						
	1. Welding in the Flat Position						
7	PS: Making Beads Without Rod						
8	PS: Making Beads With Filler Rod						
9	PS: Welding Butt Joints						
10	PS: Welding Lap Joints						
11	PS: Welding Tee Joints						
	CT: "Setup and Basic Welds" (KC-3)						
	CT: "Butt and Lap Joints" (KC-4)						
	CT: "Tee and Corner Welds" (KC-5)						
		5-16					

Item No.	TRAINING MODULES AND MILESTONES	DATE		PERFORMANCE (x)		
		Start	Complete	On his/her Own	with	
					Min Super	Max Super
	CT: "Heavy Gauge Metal" (KC-6)					
	MP: "Compressed Gasses Under Your Control" (Optional) (Cur)					
	DM: Oxy-Acetylene Welding in Flat Position					
	2. Welding in Vertical/Horizontal Positions					
12	PS: Welding Vertical Lap Joints					
13	PS: Welding Vertical Tee Joints					
14	PS: Welding Vertical Butt Joints					
	CT: "Horizontal Applications" (KC-7)					
	CT: "Vertical Applications" (KC-8)					
	LT: Metal Characteristics					
	LT: Metals Identification					
	MP: "Preventing Cutting and Welding Fires" (Optional) (Cur)					
	DM: Oxy-Acetylene Welding in Vertical Position					
	DM: Oxy-Acetylene Welding in Horizontal Position					
	3. Welding in Overhead Position					
15	PS: Welding Overhead Lap Joints					
16	PS: Welding Overhead Tee Joints					
17	PS: Welding Overhead Butt Joints					
	CT: "Overhead Position Welding" (KC-9)					
	CT: "Oxy-Acetylene Welding Test" (WEL 1)					
	DM: Oxy-Acetylene Welding Overhead					
	FLAME CUTTING					
	1. Freehand and Machine Flame Cutting					
18	PS: Flame Cutting Fundamentals					
19	PS: Cutting Steel Scrap					
20	PS: Cut and Pierce Steel Plate					
21	PS: Introduction to Machine Flame Cutting					
22	PS: Machine Flame Cutting 30 Degree Bevels					
	CT: "Fundamentals of Flame Cutting" (KC-13)					
	CT: "Multiple Uses of Flame Cutting" (KC-14)					
	MP: "Fundamentals of Oxy-Fuel Cutting"					
	MP: "Safety in Oxy-Fuel Welding and Cutting"					
	CI: "Oxy-Acetylene Cutting Test" (WEL 2)					
	DM: Freehand Flame Cutting					
	DM: Machine Flame Cutting					
	HAND TOOLS					
	1. Hand Tools Used in Welding					
23	PS: Reading a Rule					
24	HO: Electric Drills					
25	HO: Nut and Bolt Fasteners					
26	HO: Screwdrivers					
27	HO: Pliers and Cutters					
28	HO: Files and Rasps					
	ST: "Shop Safety: Screwdrives, Wrenches-Sheet Metal and Welding" No. 4					
	DM: Use of Hand Tools					



Item No.	TRAINING MODULES AND MILESTONES	DATE		PERFORMANCE (x)			
		Start	Complete	On his/her Own	with		
					Min Super	Max Super	Additional Training
	BRAZING (Optional)						
	1. Brazing Steel and Dis-similar Metals						
29	PS: The Basics of Brazing						
30	PS: Brazing Lap, Butt and Tee Joints						
31	PS: Brazing Copper Tubing						
32	HO: Brazing Torches						
	CI: "Braze Welding" (KC-10)						
	ST: "Brazing and Soldering" No. 5						
	LT: Weld Joints						
	LT: Rod Identification						
	DM: Brazing						
	OXY-FUEL PIPE WELDING						
	1. Pipe Welding						
	CI: "Cast Iron and Hard Surfacing" (KC-11)						
	CI: "Heating and Flame Treating" (KC-12)						
	CI: "Oxy-Acetylene Welding Safety Test- Part 1" (WELS 02)						
	CI: "Oxy-Acetylene Welding Safety Test- Part 2" (WELS 03)						
	DM: Oxy-Acetylene Pipe Welding						
	Arc Welder Apprentice D.O.T. 210.384-010						
	ORIENTATION TO ELECTRIC ARC WELDING						
	1. Introduction to Electric Arc Welding						
33	PS: Your Future as an Arc Welder*						
34	HO: Glossary of Electric Arc Terms						
	CI: "Introduction to Welding" (KC-1)						
	MP: "AC-DC Generation"						
	MP: "Metals and Non-Metals"						
	2. Electric Arc Shop and Job Safety						
	ISSUE SAFETY GLASSES						
35	PS: Electric Arc Safety						
	ST: "Arc Welding Safety" (ARC-1)						
	LT: Electric Arc Safety Lecture						
	DM: Electric Arc Shop Safety Procedures						
	ELECTRIC ARC PROCESSES						
	1. Electric Arc Welding						
36	PS: Basics of Arc Welding - and You						
37	PS: Arc Welding Current and Processes						
38	PS: Electrode Classification						
	CI: "Using the Miller Welder" (KC-2)						
	CI: "The Welding Arc" (KC-3)						
	MP: "Arc Welding Methods" (WSC)						
	DM: Setting Up Electric Arc Equipment						
	ELECTRIC ARC WELDING POSITIONS						
	1. Arc Welding in Flat Position						
39	PS: How to Start Your Arc and Run Stringer Beads						
40	PS: How to Make Parallel Beads						
41	PS: How to Make Square Butt Joints						
42	PS: How to Make Good Lap Joints						
	PS: How You Make Fillet Welds						
	PS: Weaving Lap and Fillet Welds						
		5-18					

Item No.	TRAINING MODULES AND MILESTONES	DATE		PERFORMANCE (x)		
		Start	Complete	On hs/her Own	with	
					Min Super	Max Super
45	PS: Beveled Butt and Fillet Welds					
46	PS: How You Make Outside Corner Welds					
47	PS: Deep Groove and Reverse Polarity Welding					
	CT: "Fundamental Arc Welding Tasks" (KC-4)					
	CT: "Welding Joints" (KC-5)					
	CT: "Electrode Classification" (KC-6)					
	CT: "Electrode Experiments" (KC-7)					
	ST: "Running a Bead" (ARC-2)					
	ST: "Process, Equipment and Safety" (AP " ")					
	ST: "Position Welding" (ARC-4)					
	ST: "Welding and Electricity" (ARC-5)					
	ST: "Electrode Classification" (ARC-6)					
48	H0: Electrode Classification					
	ST: "The Welding Arc" (ARC-7)					
	LT: Electrodes and Welding Joints					
	CI: "Electric Arc Welding" (WELS 03)					
	CI: "Arc Welding Safety" (WELS 01)					
	DM: Arc Welding in Flat Position					
	2. Arc Welding in Vertical/Horizontal Positions					
49	PS: How to Weld Straight Beads in the Horizontal Position					
50	PS: Welding Straight Beads in the Vertical Position					
51	PS: Horizontal Butt Welding					
52	PS: Welding Vertical Butt Joints					
53	PS: Welding Horizontal Lap Joints					
54	PS: Welding Vertical Lap Joints					
55	PS: Welding Horizontal Tee Joints					
56	PS: Welding Vertical Tee Joints					
	CT: "Welding and Electricity" (KC-8)					
	CT: "Horizontal Welding" (KC-9)					
	CT: "Vertical Welding" (KC-10)					
	ST: "Single Groove Butt Joints" (ARC-8)					
	ST: "Welding Beads on Vertical Plane" (ARC-9)					
	ST: "Welding Lap Joints" (ARC-10)					
	ST: "Welding Square Butt Joints" (ARC-11)					
	DM: Arc Welding in Vertical Position					
	DM: Arc Welding in Horizontal Position					
	3. Arc Welding in Overhead Position					
57	PS: Overhead Arc Welding - Running Straight Beads					
58	PS: Welding Overhead Lap Joints					
59	PS: Welding Overhead Tee Joints					
60	PS: Overhead Arc Welding - Butt Joints					
	CT: "Overhead Welding" (KC-11)					
	CT: "Working With Metals" (KC-12)					
	MP: "Competitive Edge" (Optional) (Cur)					
	DM: Arc Welding in Overhead Position					
	POWER MACHINES					
	1. Drill Press					
	DM: Drill Press Safety and Operation					
	2. Power Metal Saws					
	DM: Power Hack Saw Safety and Operation					
	DM: Band Saw Safety and Operation					



Item No.	TRAINING MODULES AND MILESTONES	DATE		PERFORMANCE (x)			
		Start	Complete	On his/her Own	with		Additional Training
					Min Super	Max Super	
	3. Working With Metals						
	ST: "Working With Metals" (ARC-12)						
	ST: "Arc Welding Cast Iron/Hard Surfacing Farm Equipment" (ARC-13)						
	ST: "Cutting Torch/Arc-Air Torch/Grinder" (ARC-14)						
	ADVANCED WELDING (Optional)						
	1. Gas Metal Arc Welding (GMA!!)						
61	PS: Basics of GMAW Welding						
62	PS: Your GMAW Equipment						
63	PS: GMAW Welding Methods						
	DM: GMAW Welding						
	2. Gas Tungsten Arc Welding (GTAW)						
	TX: Basic TIG and MIG Welding, pp 1-77						
	DM: GTAW Welding						
	MP: "Wealth Out of Waste" (Cur)						
	MP: "Light, Strong and Beautiful" (Cur)						
	MP: "Aluminum: An Investment in Energy" (Cur)						
	MP: "House That Recycling Built" (Cur)						
	MP: "Aluminum Welding - Different Not Difficult" (Cur)						
	MP: "The Effect of Arc Variations on Aluminum Welds" (Cur)						
	3. Pipe Welding						
64	PS: Welding Pipe by Electric Arc						
	ST: "Vertical Lap Joints" (A-1)						
	ST: "Vertical Tee Joints" (A-2)						
	ST: "Vertical Tee Joints" (A-3)						
	ST: "Vertical Tee-Groove Joints" (A-4)						
	ST: "Overhead Tee Joints" (A-5)						
	ST: "Overhead Vee Butt Joints" (A-6)						
	ST: "Horizontal and Vertical Pipe Welding" (A-7)						
	ST: "All Position Pipe Welding" (A-8)						
	DM: All Position Pipe Welding						
	4. Advanced Blueprint Reading for Welders						
	DM: Reading Complex Blueprints						
	5. Welder Certification						

*Modes Not Developed



STUDENT EMPLOYABILITY REPORT

Weber State College Skills Center • 1100 Washington Blvd., Ogden, Utah 84404

Student Name _____

Occupational Program Combination Welder Apprentice Date Started _____ Date Terminated _____

Copies of this report will be prepared and issued upon request from the student.

1. SUCCESS FACTORS			
Initiative	Dependability	Attitude	Willingness
<input type="checkbox"/> seeks work <input type="checkbox"/> meets requirements <input type="checkbox"/> needs prompting	<input type="checkbox"/> keeps word <input type="checkbox"/> dependable <input type="checkbox"/> needs encouragement	<input type="checkbox"/> excellent <input type="checkbox"/> good <input type="checkbox"/> needs encouragement	<input type="checkbox"/> tries to please <input type="checkbox"/> goes along <input type="checkbox"/> needs encouragement
Follows Directions	Works with Others	Accepts Criticism	Appearance
<input type="checkbox"/> very well <input type="checkbox"/> acceptable <input type="checkbox"/> needs follow-up	<input type="checkbox"/> very well <input type="checkbox"/> acceptable <input type="checkbox"/> needs encouragement	<input type="checkbox"/> very well <input type="checkbox"/> acceptable <input type="checkbox"/> needs encouragement	<input type="checkbox"/> very neat <input type="checkbox"/> acceptable <input type="checkbox"/> needs improvement

2. CERTIFICATES AND HONORS			
Certificate(s) of Proficiency Yes <input type="checkbox"/> No <input type="checkbox"/>	Date(s) Presented	Honor(s) and Comments:	
Certificate of Completion Yes <input type="checkbox"/> No <input type="checkbox"/> <small>(MIN: 65% of STR)</small>	Percent Completed	Date Mailed	Special Projects and Comments:

3. CERTIFICATE OF COMPLETION PROFICIENCIES			
Shop and Job Safety	Oxy-Acetylene Pipe Welding		
Blueprint Reading for Welders	Electric Arc Welding (flat position only)		
Math for Welders	Electric Arc Welding (all positions)		
Hand Tools	Electric Arc Pipe Welding		
Power Tools and Machines	Gas Metal Arc Welding		
Oxy-Acetylene Welding (all positions)	Gas Tungsten Arc Welding		
Oxy-Acetylene Cutting	AWS Certified		
Brazing			

4. JOB PLACEMENT			
Employed By _____	Termination Code _____		
Address _____	Telephone _____		
Job Title _____	Wage _____		
Date Placed _____	Referred By _____		

Advisor/Instructor _____ Date _____ Supervisor _____