

DOCUMENT RESUME

ED 212 802

CE 031 196

TITLE Wheeled Vehicle Drive Lines, Axles, and Suspension Systems. Military Curriculum Materials for Vocational and Technical Education.

INSTITUTION Army Ordnance Center and School, Aberdeen Proving Ground, Md.; Ohio State Univ., Columbus. National Center for Research in Vocational Education.

SPONS AGENCY Office of Vocational and Adult Education (ED), Washington, D.C.

PUB DATE [81]

NOTE 300p.; For related documents see CE 031 194-197.

EDRS PRICE MF01/PC12 Plus Postage.

DESCRIPTORS *Auto Mechanics; Correspondence Study; Engines; Experiential Learning; Independent Study; Inservice Education; Job Training; Learning Modules; *Military Training; *Motor Vehicles; Postsecondary Education; *Repair; Secondary Education; *Technical Education; Vocational Education

IDENTIFIERS Axles; Military Curriculum Project; *Suspension Systems (Automotive)

ABSTRACT

This course is one of several subcourses that make up the entire Army correspondence course on wheeled vehicle maintenance. The subcourse is designed to provide the student with information about the operation, malfunction diagnosis, maintenance, and repair of wheeled vehicle drive lines, axles, and suspension systems. It provides the basic theory, and also includes on-the-job task assignments. The subcourse is divided into six lessons covering the following topics: propeller shaft assemblies; introduction to axle assemblies; maintenance of axles; introduction to suspension system components; maintenance of springs, shock absorbers, and frames; and maintenance of tires and wheels. Each lesson contains objectives, text, task assignments, and review exercises. Answers for the exercises are provided after the final lesson, along with an examination and application task test. This subcourse is designed for student self-study, but could be used in small group learning situations. (KC)

 * Reproductions supplied by EDRS are the best that can be made *
 * from the original document. *

ED212802

EO 3/196

Military Curriculum Materials for Vocational and Technical Education

U.S. DEPARTMENT OF EDUCATION
NATIONAL INSTITUTE OF EDUCATION
EDUCATIONAL RESOURCES INFORMATION
CENTER (ERIC)

This document has been reproduced as
received from the person or organization
originating it.
Minor changes have been made to improve
reproduction quality.

- Points of view or opinions stated in this document do not necessarily represent official I E position or policy.

WHEELED VEHICLE DRIVE LINES, AXLES, AND SUSPENSION SYSTEMS

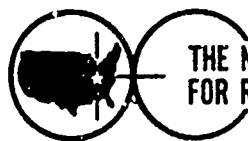

**THE NATIONAL CENTER
FOR RESEARCH IN VOCATIONAL EDUCATION**
THE OHIO STATE UNIVERSITY
1960 KENNY ROAD • COLUMBUS, OHIO 43210

MILITARY CURRICULUM MATERIALS

The military-developed curriculum materials in this course package were selected by the National Center for Research in Vocational Education Military Curriculum Project for dissemination to the six regional Curriculum Coordination Centers and other instructional materials agencies. The purpose of disseminating these courses was to make curriculum materials developed by the military more accessible to vocational educators in the civilian setting.

The course materials were acquired, evaluated by project staff and practitioners in the field, and prepared for dissemination. Materials which were specific to the military were deleted, copyrighted materials were either omitted or approval for their use was obtained. These course packages contain curriculum resource materials which can be adapted to support vocational instruction and curriculum development.

The National Center Mission Statement

The National Center for Research in Vocational Education's mission is to increase the ability of diverse agencies, institutions, and organizations to solve educational problems relating to individual career planning, preparation, and progression. The National Center fulfills its mission by:

- Generating knowledge through research
- Developing educational programs and products
- Evaluating individual program needs and outcomes
- Installing educational programs and products
- Operating information systems and services
- Conducting leadership development and training programs

FOR FURTHER INFORMATION ABOUT Military Curriculum Materials

WRITE OR CALL

Program Information Office
The National Center for Research in Vocational
Education
The Ohio State University
1960 Kenny Road, Columbus, Ohio 43210
Telephone: 614/486-3655 or Toll Free 800/
848-4815 within the continental U.S.
(except Ohio)



THE NATIONAL CENTER
FOR RESEARCH IN VOCATIONAL EDUCATION
The Ohio State University • 1960 Kenny Road • Columbus, Ohio 43210
Tel. (614) 486-3655
Cable: CVOCEDUSU/Columbus, Ohio

Military Curriculum Materials for Vocational and Technical Education

Information and Field
Services Division

The National Center for Research
in Vocational Education



Military Curriculum Materials Dissemination Is . . .

an activity to increase the accessibility of military-developed curriculum materials to vocational and technical educators.

This project, funded by the U.S. Office of Education, includes the identification and acquisition of curriculum materials in print form from the Coast Guard, Air Force, Army, Marine Corps and Navy.

Access to military curriculum materials is provided through a "Joint Memorandum of Understanding" between the U.S. Office of Education and the Department of Defense.

The acquired materials are reviewed by staff and subject matter specialists, and courses deemed applicable to vocational and technical education are selected for dissemination.

The National Center for Research in Vocational Education is the U.S. Office of Education's designated representative to acquire the materials and conduct the project activities.

Project Staff:

Wesley E. Budke, Ph.D., Director
National Center Clearinghouse
Shirley A. Chase, Ph.D.
Project Director

What Materials Are Available?

One hundred twenty courses on microfiche (thirteen in paper form) and descriptions of each have been provided to the vocational Curriculum Coordination Centers and other instructional materials agencies for dissemination.

Course materials include programmed instruction, curriculum outlines, instructor guides, student workbooks and technical manuals.

The 120 courses represent the following sixteen vocational subject areas:

Agriculture	Food Service
Aviation	Health
Building & Construction	Heating & Air Conditioning
Trades	Machine Shop Management & Supervision
Clerical Occupations	Meteorology & Navigation
Communications	Photography
Drafting	Public Service
Electronics	
Engine Mechanics	

The number of courses and the subject areas represented will expand as additional materials with application to vocational and technical education are identified and selected for dissemination.

How Can These Materials Be Obtained?

Contact the Curriculum Coordination Center in your region for information on obtaining materials (e.g., availability and cost). They will respond to your request directly or refer you to an instructional materials agency closer to you.

CURRICULUM COORDINATION CENTERS

EAST CENTRAL
Rebecca S. Douglass
Director
100 North First Street
Springfield, IL 62777
217/782-0759

NORTHWEST
William Daniels
Director
Building 17
Airdustrial Park
Olympia, WA 98504
206/753-0879

MIDWEST
Robert Patton
Director
1515 West Sixth Ave.
Stillwater, OK 74704
405/377-2000

SOUTHEAST
James F. Shill, Ph.D.
Director
Mississippi State University
Drawer DX
Mississippi State, MS 39762
601/325-2510

NORTHEAST
Joseph F. Kelly, Ph.D.
Director
225 West State Street
Trenton, NJ 08625
609/292-6562

WESTERN
Lawrence F. H. Zane, Ph.D.
Director
1776 University Ave.
Honolulu, HI 96822
808/948-7834

SCHOOL CODE

091

SUBCOURSE

HB6306

ED

5

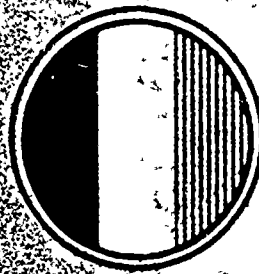

**U. S. Army Training Support Center
Fort Eustis, Virginia**



★ AIPD



**WHEELS, VEHICLE DRIVE LINES, AXLES,
AND SUSPENSION SYSTEMS**

**ARMY INSTITUTE FOR
PROFESSIONAL DEVELOPMENT**

-- IMPORTANT --

STUDY THIS SHEET

before beginning the subcourse

General

Your cooperation in following these instructions will

- enable you to make the maximum rating commensurate with your ability.
- help us to process your lessons promptly and efficiently.

Scan the CHECKLIST OF TEXTS AND MATERIALS FURNISHED.
Scan the INTRODUCTION to the subcourse.

Procedure

- Beginning with Lesson 1, scan the LESSON ASSIGNMENT SHEET. It lists the lesson title, lesson objective, credit hours required, texts required, and suggestions.
- When the words STUDY TEXT follow the Lesson Assignment Sheet, the information you must digest is found in a text(s), memorandum, pamphlet, and/or other separate material(s).
- When the words STUDY GUIDE AND ATTACHED MEMORANDUM follow the Lesson Assignment Sheet, the information you must digest is either.
 - found in texts and in this subcourse booklet, or
 - found entirely in this booklet.
- When you are referred to a paragraph or an illustration in a manual, turn to the specified paragraph at once and scan or study the text assignment as directed. Continue this procedure until you reach the LESSON EXERCISE.

Lesson Exercise

- Study and answer each question.
- CAUTION: Check to insure that all questions have been answered.
- Your answers MUST be based on subcourse materials, NOT on your experience or opinions.

Assistance

If you require explanation or clarification of subcourse materials or questions, write to the U. S. Army Ordnance Center and School, ATTN: Department of Army Wide Training Support. Constructive comments are appreciated.

Include NAME and SOCIAL SECURITY ACCOUNT NUMBER on all correspondence.

WHEELED VEHICLE DRIVE LINES, AXLES, AND
SUSPENSION SYSTEMS
63B206

Correspondence Course 8-15 /

Developed by:

United States Army

Development and
Review Dates:

September 1975

Occupational Area:

Engine Mechanics

Print Pages:

287

Availability:

ERIC

National Center Clearinghouse

Suggested Background:

None

Target Audiences:

Grades 10-Adult

Organization of Materials:

Text, Objectives, Exercises, Examination

Type of Instruction:

Individualized

Type of Materials:

No. of Pages:

Average
Completion Time:

Lesson 1 - Propeller Shaft Assemblies	29	2 Hours
Lesson 2 - Introduction to Axle Assemblies	40	3 Hours
Lesson 3 - Maintenance of Axles	45	3 Hours
Lesson 4 - Introduction to Suspension Systems Components	49	4 Hours
Lesson 5 - Maintenance of Springs, Shock Absorbers, and Frames	34	3 Hours
Lesson 6 - Maintenance of Tires and Wheels	58	3 Hours
Exercise Response List	29	3 Hours

Supplementary Materials Required:

None

1a

Course Description:

This course is one of several subcourses that make up the entire correspondence course on wheeled vehicle maintenance. The subcourse is designed to provide the student with information about the operation, malfunction diagnosis, maintenance, and the repair of wheeled vehicle drive lines, axles, and suspension systems. It provides the basic theory, and also includes on-the-job task assignments.

The subcourse is divided into six lessons with objectives, task assignments, and review exercises.

Lesson 1 - Propeller Shaft Assemblies. Construction and operation of propeller shafts and universal joints; inspecting, testing, and repair of propeller shaft assemblies; and removal and replacement of assemblies and repair parts components.

Lesson 2 - Introduction to Axle Assemblies. Construction, operation, and lubrication of axle assemblies; types and principles of axle shafts; and principles of bevel gear differentials.

Lesson 3 - Maintenance of Axles. Inspection, testing, and repair of axle assemblies; and removal and replacement of assemblies and repair parts components.

Lesson 4 - Introduction to Suspension System Components. Construction and operation of springs, shock absorbers, frames, and bogie suspension systems; construction of wheels and tires; and removal and installation of assemblies.

Lesson 5 - Maintenance of Springs, Shock Absorbers, and Frames. Inspection, testing, and repair of leaf and coil springs, spring shackles and mountings, bogie assemblies, direct and indirect single acting and double acting shock absorbers, and conventional truck frames; and removal and replacement of repair parts components.

Lesson 6 - Maintenance of Tires and Wheels. Inspection, testing, and repair of tires from snapping and drop-center type wheels.

This subcourse is designed for student self-study, but could be effective in small group learning situations. Each lesson contains objectives, text, and review exercises. Answers for the exercises are provided after the final lesson, along with an examination and application task test.

TABLE OF CONTENTS

<u>Lesson</u>		<u>Page</u>
1	Propeller Shaft Assemblies	3
2	Introduction to Axle Assemblies	32
3	Maintenance of Axles	72
4	Introduction to Suspension Systems Components	117
5	Maintenance of Springs, Shock Absorbers, and Frames	166
6	Maintenance of Tires and Wheels	200
	Exercise Response List	258

I M P O R T A N T: READ AND POST

Change 1 to Exercise Response List
28 January 1976

Ordnance Subcourse 63B206
Wheeled Vehicle Drive Lines,
Axles, and Suspension Systems
September 1975

Page 2, Response Number 142. Change to read:

Para 2b

Page 2, Response Number 154. Change to read:

Para 2d

Page 2, Change to be made. Add response number 164:

164 Para 7c

Page 3, Response Number 200. Change to read:

Para 4b

Page 5, Response Number 256. Change to read:

Para 4f

Page 5, Response Number 260. Change to read:

Para 6c

Page 5, Response Number 273. Change to read:

Para 10

Page 5, Response Number 276. Change to read:

Para 4d

Page 6, Response Number 307. Change to read:

Para 4b

Page 8, Response Number 363. Change to read:

Para 2d

I M P O R T A N T: READ AND POST

Page 1 of 2

I M P O R T A N T: READ AND POST

Change 1 to Exercise Response List (Continued)
28 January 1976

Ordnance Subcourse 63B206
Wheeled Vehicle Drive Lines,
Axles, and Suspension Systems
September 1975

Page 9, Response Number 404. Change to read:

Para 4a

Page 12, Response Number 510. Change to read:

Para 4d

Page 12, Response Number 512. Change to read:

CORRECT. The special studs are threaded on the mounting studs, while the outer nuts are threaded on to the special studs. Remember, the special studs must be tight before the outer nuts are installed.

Page 12, Response Number 537. Change to read:

Para 4f

Page 14, Response Number 591. Change to read:

Para 5b

Page 16, Response Number 643. Change to read:

Para 5b

Page 16, Response Number 664. Change to read:

Para 2b

Page 16, Response Number 666. Change to read:

Para 4a

Page 17, Response Number 682. Change to read:

Para 6c

I M P O R T A N T: READ AND POST

Page 2 of 2

14

I M P O R T A N T: READ AND POST

Lesson Change 1
28 January 1976

Ordnance Subcourse 63B206
Wheeled Vehicle Drive Lines,
Axles, and Suspension Systems
September 1975

Lesson 1, Page 1-20, Question 14. Change choice b to read:

b. Roller or needle

Lesson 4, Page 4-29. Change to read:

Change paragraph "e" to "d".

Lesson 6, Page 6-53, Question 119. Change choice b to read:

b. 9:00X16

I M P O R T A N T: READ AND POST



3

**ENLISTED MOS
CORRESPONDENCE/OJT COURSE**

**ORDNANCE SUBCOURSE 63B206
WHEELED VEHICLE DRIVE LINES, AXLES,
AND SUSPENSION SYSTEMS**

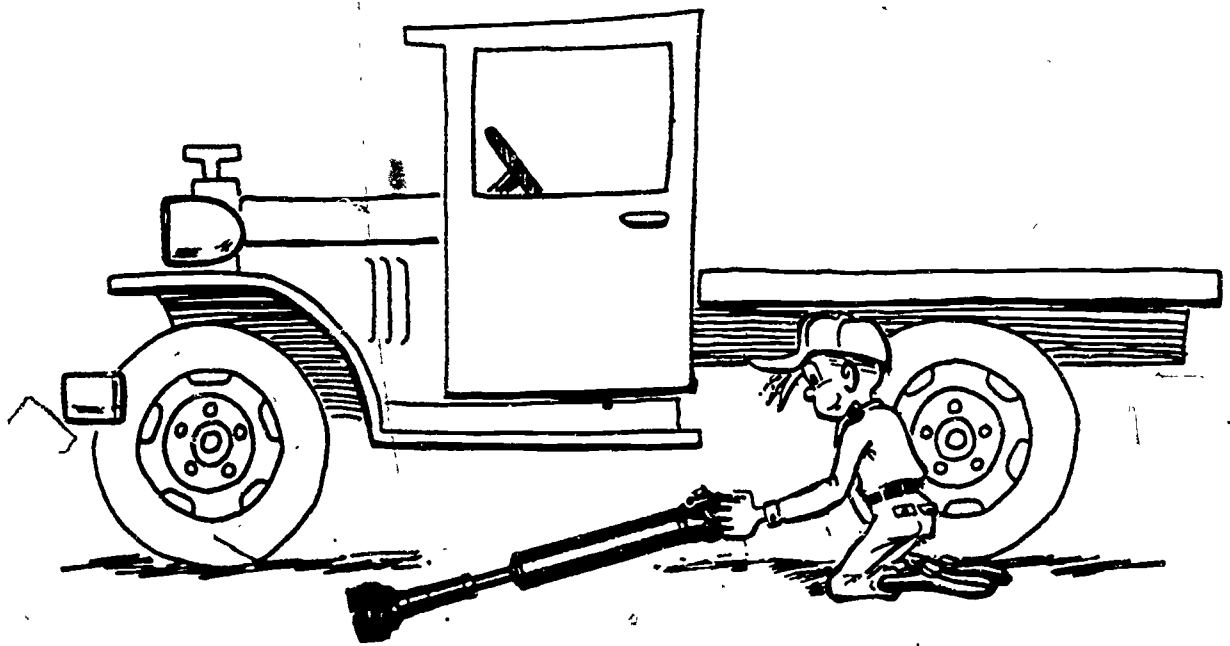

**LESSON 1
PROPELLER SHAFT ASSEMBLIES**

SEPTEMBER 1975

**DEPARTMENT OF ARMY WIDE TRAINING SUPPORT
US ARMY ORDNANCE CENTER AND SCHOOL
ABERDEEN PROVING GROUND, MARYLAND**

LESSON EXERCISE QUESTIONS

Instructions for use of the answer sheet:

1. The procedure by which you will answer the exercise questions in this subcourse is probably new to you. The information is presented in a programmed instruction format where you immediately know whether or not you have answered the questions correctly. If you have selected an incorrect answer, you will be directed to a portion of the study text that will provide you with additional information.
2. To use this system proceed as follows:
 - a. Arrange this subcourse booklet and your answer sheet (on reverse side of response list cover) so that they are convenient. Each exercise question has three choices lettered a, b, and c. Your answer sheet has three groups of numbers for questions 1 through 200. The numbers indicated for each question represent the a, b, or c choices.
 - b. Read the first exercise question and select the choice you think answers the question correctly. Go to the question 1 area of your answer sheet and circle the 3-digit number that corresponds with the choice you selected.
 - c. After you have identified the 3-digit number, locate it in the exercise response list. If you selected the right choice, the first word of the response will be "CORRECT." This tells you that you have answered the question correctly. Read the rest of the response which tells why your choice was correct and then go to the next question.
 - d. If the word "CORRECT" is NOT the first word of the response, you have selected the wrong answer. Read the response and then turn to the area in your study text that is mentioned. There you will find the information necessary for you to make another choice. Line out the incorrect 3-digit response on your answer sheet.
 - e. After you have reread the reference, select another answer and circle the 3-digit response for that choice. Again check the number of this second choice with the response list to see if your choice is now correct and to obtain more information about your choice. If your second choice is still not correct, line out the 3-digit response on the answer sheet and continue until the correct answer is selected. When you have answered all of the questions in an exercise, count the number of lined out responses and see how well you did.
 - f. You will notice that the lesson exercise question numbers continue consecutively from lesson to lesson. This allows you to use one answer sheet for the entire subcourse.

IMPORTANT - Study these directions before going further.

5

DIRECTIONS FOR THE STUDENT

1. Congratulations. You are starting a new and different type of self-training subcourse called a correspondence/OJT subcourse. It is different from regular subcourses because it has tasks to be practiced on the job in addition to the usual lessons to be studied. This way, you can learn both the job skills and the job knowledge and become completely qualified in the subcourse matter.

2. Of course, you must be able to get to the equipment to practice these tasks. Some of you may not be able to do this. This is why you were asked to pick one of two options, or ways, that you wanted to take the subcourse.

a. If you are enrolled in the correspondence only option, you will study the lessons but you will not practice the tasks on the equipment. This means you will learn only the job knowledge of the subcourse. You will have to practice the job tasks sometime later when you can get to the equipment in order to learn the job skills. You will test yourself after each lesson by answering the lesson exercise questions using your answer sheet. Then you will be tested at the end of the whole subcourse by taking the enclosed final examination.

b. If you are enrolled in the correspondence/OJT option, you will do the whole subcourse. You will study all the lessons and practice all the tasks listed in each study text on the equipment. This way you will learn both the knowledge and the skills of the subcourse. Then you will be completely qualified in the part of your military occupational specialty (MOS) that is covered by this subcourse. You will test yourself after each lesson by answering the lesson exercise questions using your answer sheet. And, you will also take a subcourse multiple choice examination. However, in addition to these tests, you will take an application task test after finishing the subcourse examination. This application task test will be sent to your unit commander who will see that you are tested on the job tasks. It is important that you practice the tasks while you are studying the lessons so that you will be ready for the task test when you finish the subcourse.

c. You can understand that it is important to remember which of the two options you are enrolled in because the work you must do and the tests you must take will depend upon your option.

6 3. This subcourse is one of several subcourses that make up the entire enlisted MOS correspondence/OJT course. If you are enrolled in the entire course, you will take this and all the other subcourses in order. If you are not enrolled in the entire course, then you will only take this and any other subcourses you asked for. Of course, you cannot become qualified in the complete MOS job unless you take the entire course. If you want to take the entire course later, you will be given credit for the subcourse(s) you have already passed.

4. Please check this subcourse packet to make sure that you have the following things:

- a. A lesson booklet for each lesson listed in the introduction of lesson 1.
- b. A lesson exercise response list and an answer sheet.
- c. A multiple choice subcourse examination.

If any of these things are missing, please let us know right away.

5. If you are enrolled in the entire enlisted MOS correspondence/OJT course you must finish at least 60 credit hours or three subcourses each enrollment year. Your enrollment year begins the day you receive your first subcourse. If you are enrolled in certain subcourses only, you must finish each subcourse within 6 months after you receive it. However, you should finish each subcourse as quickly as you can so that you will qualify earlier for promotions.

6. You must study the subcourse material starting with lesson 1 and progress through the rest. Beginning with lesson 1, scan the lesson assignment sheet. It lists the lesson title, credit hours assigned to the lesson, lesson objective, study assignment, and suggestions.

- a. Go through the lesson exactly as you are told by the study assignment and the suggestions in the lesson assignment. Also follow any directions given throughout the study text.
- b. Read the lesson through once; reread and study any portion that you did not understand. After you are sure you understand the study material, answer the exercise questions at the end of the lesson. Then practice the job tasks on the equipment.

7

CONTENTS

		Paragraph	Page
	DIRECTIONS FOR THE STUDENT		i
	INTRODUCTION TO SUBCOURSE		iii
	LESSON ASSIGNMENT		1-1
STUDY TEXT			
Section	I. Propeller Shafts		
	Introduction	1	1-2
	Construction and operation	2	1-3
	II. Universal Joints		
	Construction and operation	3	1-4
	Types	4	1-6
	III. Maintenance of Propeller Shafts and Universal Joints		
	Inspection procedures	5	1-8
	Replacement of propeller shafts and universal joints on M151-series 1/4-ton trucks	6	1-9
	Replacement of propeller shafts and universal joints on 2-1/2-ton 6x6 trucks	7	1-13
	IV. Conclusion		
	Summary	8	1-21
	Practice tasks	9	1-21
APPENDIX	A. References		1-22
	B. Practice task list		1-24

US ARMY ORDNANCE CENTER AND SCHOOL

CORRESPONDENCE/OJT COURSE

8

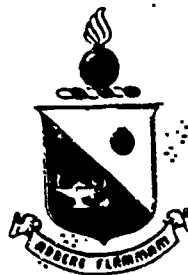

ORDNANCE SUBCOURSE NUMBER 63B206
WHEELED VEHICLE DRIVE LINES, AXLES, AND SUSPENSION SYSTEMS
(19 Credit Hours)

INTRODUCTION

Automotive drive lines and suspension systems have changed quite a bit since the first automobile was built. At first, automobile axles were attached directly to the main frame of the vehicle. This caused many problems. For example, the vehicle produced a very rough ride. The rigid construction did not work well on rough ground because sometimes one of the wheels would not touch the ground. If the wheel not touching the ground was a drive wheel, the vehicle lost traction and would stop. This problem proved a need for a more flexible vehicle.

The problem was corrected by using springs between the axles and the frame. The early springs were the same type used on the horse-drawn buggy. They allowed the wheels and axles to move up and down separate from the body. The body moved very little when compared to the wheels and axles, and the ride was much smoother.

Allowing the axles to move separate from the body also kept the wheels on the ground over rough roads, but this started a new problem. The old drive train between the engine and the axle would not work. The train had to be made to move more. This was done by adding movable joints in the drive shaft known as universal joints. Some early vehicles used only one universal joint on the drive shaft, while later vehicles used two universal joints on the drive shaft. Drive shafts are now usually called propeller shafts. Some long wheel base trucks now use as many as four propeller shafts between the transmission and the drive axle. These propeller shafts are connected by universal joints.

9 Early automobiles were made up of a body, a powerplant, and a running gear. The running gear was made up of the wheels, axles, springs, drive shaft, and transmission. The transmission was often mounted midway between the engine and rear axle. It was connected to the engine and the rear axle by drive shafts.

The term "running gear" has gradually fallen by the wayside. A new term, "chassis," is now used to identify the old running gear plus the powerplant. In later vehicles the transmission is generally mounted on the engine and is, therefore, part of the powerplant.

The chassis of modern military tactical vehicles, especially the frame, spring, and axles, must be very strong and yet quite flexible. You will learn how this is possible in this subcourse. This subcourse has six lessons, an examination, and an application task test as follows:

Lesson 1 Propeller Shaft Assemblies

Scope— Construction and operation of propeller shafts and universal joints; inspecting, testing, and repair of propeller shaft assemblies; and removal and replacement of assemblies and repair parts components.

Lesson 2 Introduction to Axle Assemblies

Scope— Construction, operation, and lubrication of axle assemblies; types and principles of axle shafts; and principles of bevel gear differentials.

Lesson 3 Maintenance of Axles

Scope— Inspection, testing, and repair of axle assemblies; and removal and replacement of assemblies and repair parts components.

Lesson 4 Introduction to Suspension System Components

Scope— Construction and operation of springs, shock absorbers, frames, and bogie suspension systems; construction of wheels and tires; and removal and installation of assemblies.

Lesson 5 Maintenance of Springs, Shock Absorbers, and Frames

Scope— Inspection, testing, and repair of leaf and coil springs, spring shackles and mountings, bogie assemblies, direct and indirect single acting and double acting shock absorbers, and conventional truck frames; and removal and replacement of repair parts components.

Lesson 6 Maintenance of Tires and Wheels

Scope— Inspection, testing, and repair of tires, tubes, and wheels; and dismounting of tires from snapping and drop-center type wheels.

Examination

US ARMY ORDNANCE CENTER AND SCHOOL
CORRESPONDENCE/OJT COURSE

10



LESSON ASSIGNMENT SHEET

Ordnance Subcourse No 63B206 . . . Wheeled Vehicle Drive Lines, Axles,
and Suspension Systems

Lesson 1. Propeller Shaft Assemblies

Credit Hours. Two

Lesson Objective After studying this lesson you will be
able to:

1. Describe the construction and operation of propeller shafts.
2. Describe the construction of universal joints.
3. Explain the operation of universal joints.
4. State the types of universal joints.
5. Describe the procedures for inspecting universal joints.
6. Describe the procedures for replacing the propeller shafts and universal joints of a 1/4-ton truck M151.
7. Describe the procedures for replacing the propeller shafts and universal joints of a 2-1/2-ton, 6x6 truck.

Materials Required ALL STUDENTS. Answer sheet and
exercise response list.
CORRESPONDENCE/OJT STUDENTS.
See appendix B.

Suggestions Refer to the illustrations while reading
the text.

11

STUDY TEXT

SECTION I. PROPELLER SHAFTS

1. INTRODUCTION. On vehicles equipped with a transfer case, power is transferred from the vehicle's transmission to the transfer case and onto the axle assemblies by propeller shafts.

a. A propeller shaft may also be called a drive shaft. However, "propeller shaft" is the more common name and some repairmen shorten this to "prop shaft." The illustration shows the power transmission system, including the propeller shafts in one type of wheeled vehicle. Notice that three propeller shafts are used to drive the vehicle. One transmits torque from the transmission to the transfer case, one delivers rotary motion from the transfer case to the rear differential, and the other delivers torque to the front differential.

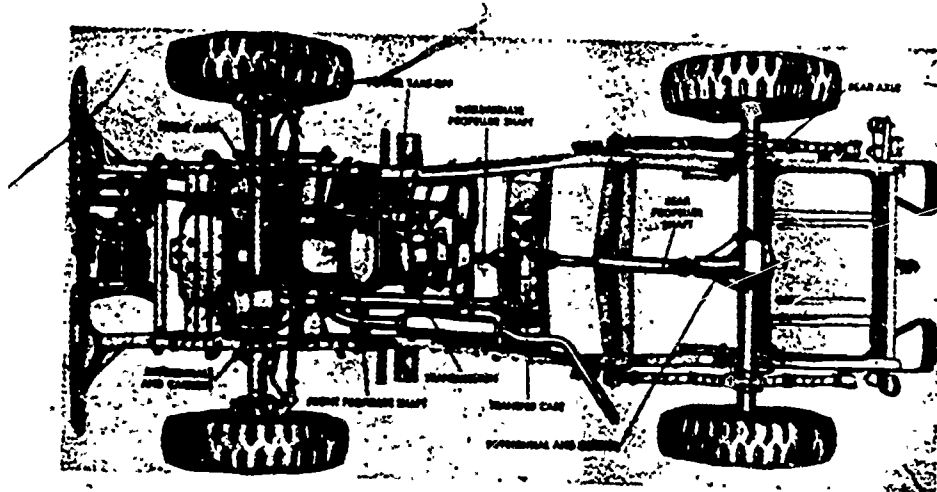

b. If the vehicle has more than two sets of driving wheels, more propeller shafts are required to drive them. One way this can be done is shown in the accompanying figure.

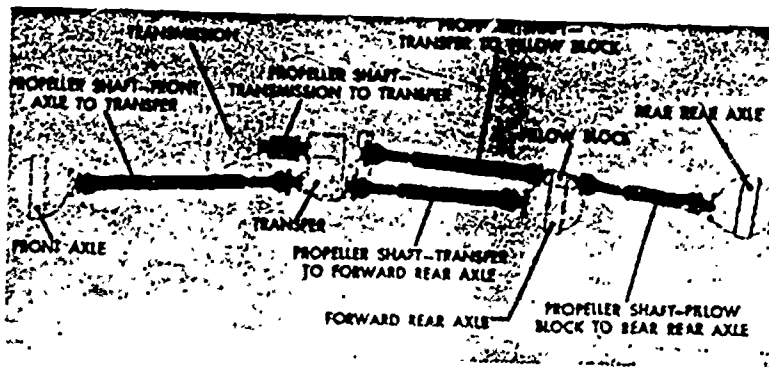

2. CONSTRUCTION AND OPERATION. Propeller shafts are made in many different sizes, shapes, and strengths, depending on the needs of the different types of vehicles. One end of the shaft is built to house a universal joint. The other end is usually splined to a slip joint. The shafts may be made of solid steel or may be hollow (tubular). A hollow propeller shaft is usually preferred.

a. The twisting force (torque) applied to one end of a shaft is transmitted through the shaft to its opposite end. The strain (stress) created within the shaft ranges from a minimum at the shaft's rotational center (axis) to a maximum at its outside surface. Since the center part of a shaft carries only a small portion of the load, tubular (hollow) propeller shafts are used whenever possible. A solid shaft is stronger than a tubular shaft of the same thickness (diameter). A tubular shaft, however, is much stronger than a solid shaft of the same weight and length.

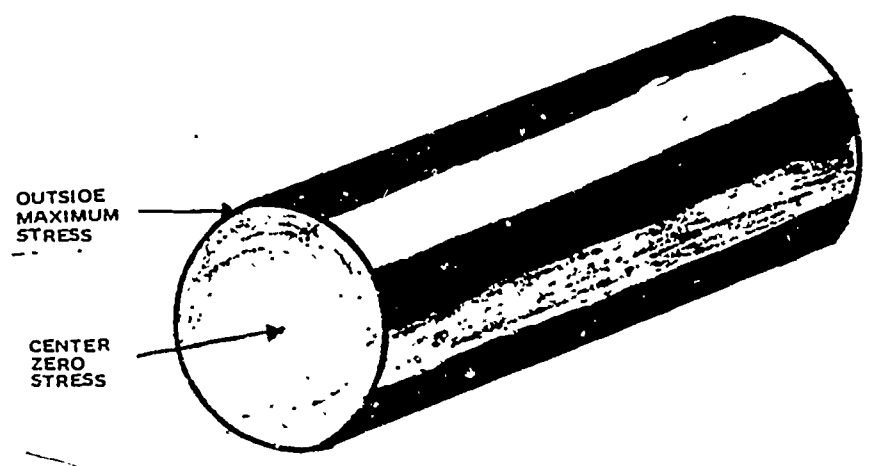

b. The power transmission system must be flexible in order to use springs in the vehicle's suspension system. Increasing or decreasing a vehicle's load or driving it on a rough road causes the springs to flex up and down. As the springs flex, the axle assemblies move backward and forward and up and down. This causes the angles and distances between the axle assemblies and the transfer case to constantly change. Slip joints and universal joints installed on propeller shafts provide the flexibility to permit these changes in the power transmission system.

- 13 c. A slip joint, installed at one end of the propeller shaft, allows the propeller shaft to lengthen or shorten. This provides the flexibility needed when the position of the axle changes. A typical slip joint has a male and female spline. It usually contains a lubrication fitting and an oil seal. The male spline is a part of the propeller shaft and the female spline is fixed to a universal joint. The slip joint is located at the power input end of a propeller shaft, which is the end nearest the transmission. It allows lengthwise freedom of movement of the propeller shaft, and at the same time it is able to transmit rotary motion.

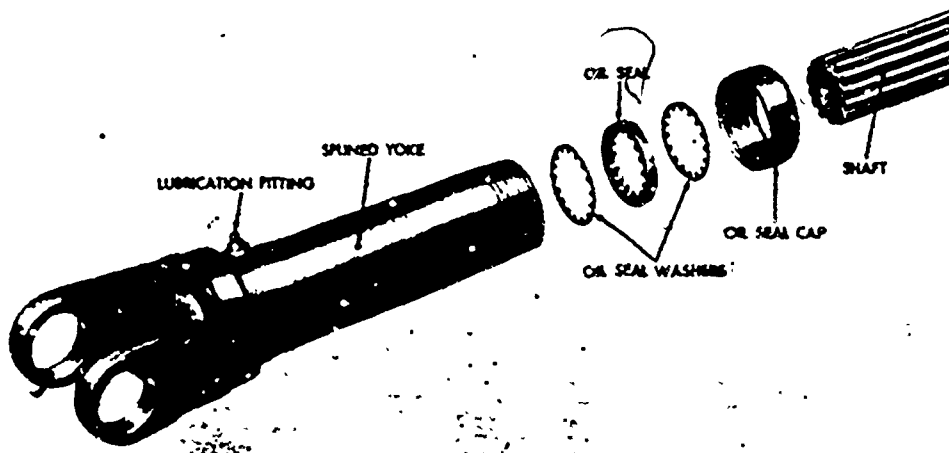

SECTION II. UNIVERSAL JOINTS

3. CONSTRUCTION AND OPERATION. A universal joint is a flexible coupling between two shafts that permits one shaft to drive another at an angle. It is flexible in the sense that it will transmit power while the angle between the shafts is constantly changing. A simple universal joint consists of three basic parts: a journal and two yokes. The two yokes are set crosswise (at right angles) to each other and their open ends are joined by the journal. This construction permits each yoke to turn (pivot) on the journal while transmitting rotary motion from one yoke to the other.

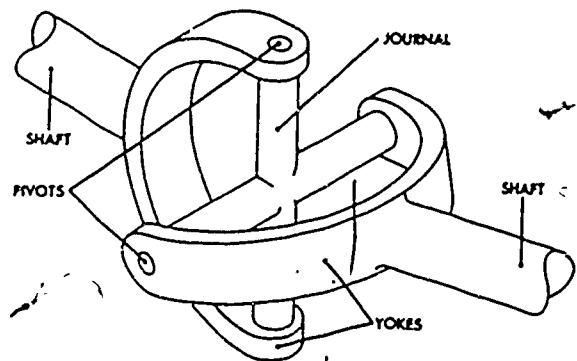

a. An odd feature of the operation of a simple conventional universal joint causes some problems in its use. It causes the driven shaft to speed up and slow down twice during each turn with respect to the driving shaft. The amount of change (fluctuation) in speed depends on the amount of the angle between the two shafts. As the angle between the driving and driven shaft is increased, the speed changes will increase. When the shafts are at a 30° angle, the fluctuation in speed is about 30 percent of the driving speed. Notice that the driving shaft speed fluctuates from about 850 to 1,150 RPM. If these speed fluctuations are transmitted to the axle assemblies, stress will be placed on power train parts. In addition, a fluctuating force will be applied to the driving wheels.

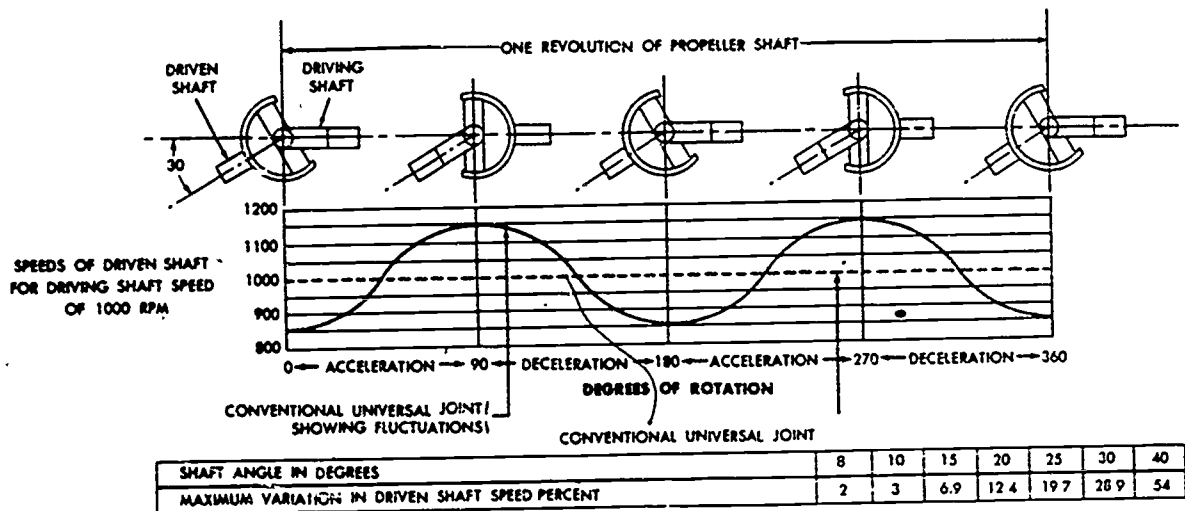

b. Speed fluctuations cannot be eliminated with a simple universal joint, but the effect can be reduced by using two joints (one at each end of the shaft). Fluctuations created by one joint will be canceled out by the other. However, certain conditions must be met before cancellation of fluctuations will take place. The angle between the transmission output shaft and the propeller shaft must be the same as the angle between the propeller shaft and the axle assembly input shaft. In addition, the two yokes on the propeller shaft must be aligned with each other. With this

15

arrangement, one joint is turning at its greatest speed while the second joint is turning at its slowest speed. This results in an almost constant output speed to the driving wheels for a given input engine speed. The speed of the propeller shaft between the two joints, however, still fluctuates.

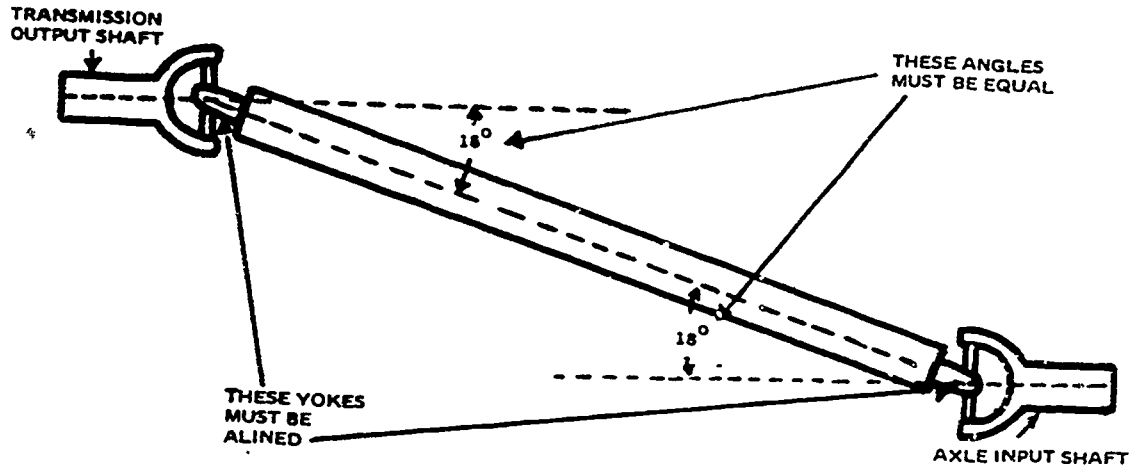

4. TYPES. In a universal joint, bearings are included at the four points where the journal is attached to the yokes. There are several different kinds of journal-type universal joints. The main differences between the different kinds is the way in which the bearings are attached to the yokes.

a. Consider the universal joint shown in this figure. The journal is placed in the slip yoke, and the bearing assemblies are inserted from the outside and secured by spring retainers (also called snaprings) inside the yoke. The bearings on the other ends of the journal are secured to the flange yoke by clamps and clamp bolts.

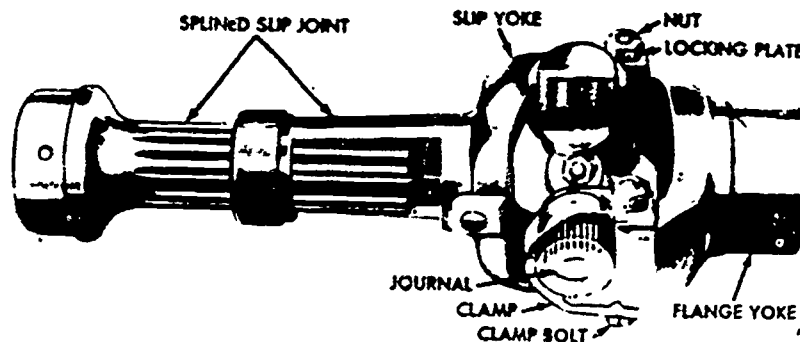

1-6

16

b. The universal joint shown here differs in the way it is attached to the flange yoke. In this joint, two of the bearing assemblies are contained in bearing blocks. The blocks are mounted against the flange yoke and secured with bolts that extend through the flange and bearing blocks.

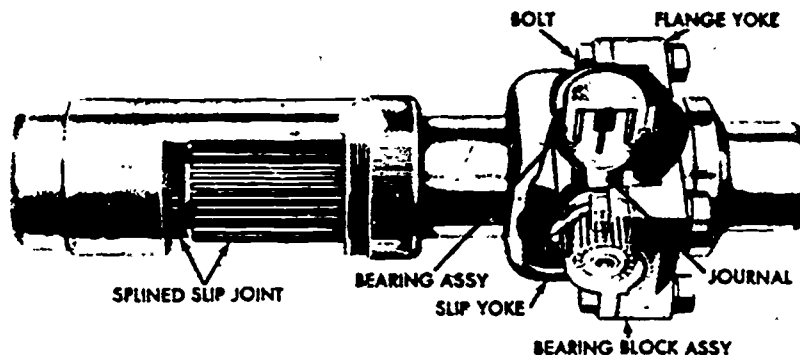

c. Two more journal-type universal joints are shown in this figure. In both of these joints the journal (spider) is placed in the yoke and the bearing assemblies are inserted from the outside. In the first joint the bearings are secured by lugs, locking straps, and bolts. Retaining rings, installed inside the bearing bores at the rear of the bearings, secure the bearings in the second joint.

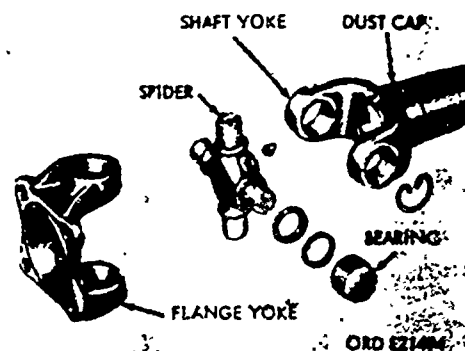
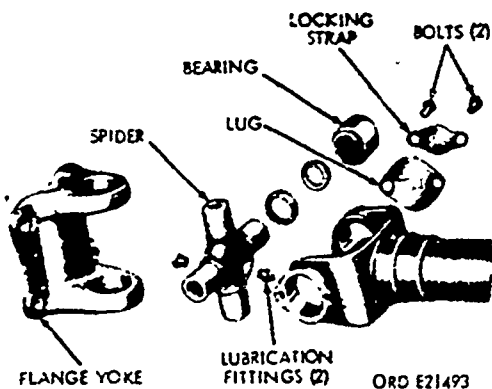

d. The above types of joints are also called cardan joints, Spicer joints, or mechanic's joints.

17

e. In another type of universal joint (ball-and-trunnion type), the universal joint itself contains a feature that eliminates the need for a slip joint. Notice

the cutaway view of a ball-and-trunnion type universal joint. In this type of joint a trunnion pin is pressed through a hole in the end of the propeller shaft. The pin is fitted with balls which ride

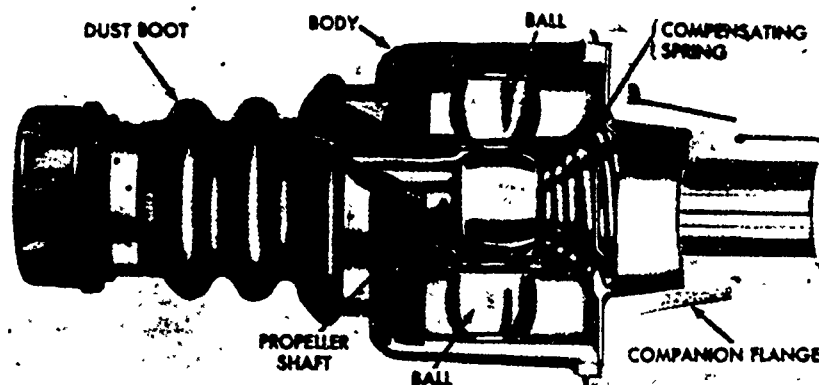

balls which ride in grooves in the flanged body. The balls are assembled on bearings so they can rotate with little friction. Compensating springs at each end of the propeller shaft hold the shaft in a centered position. Changes in drive line length are permitted by the endwise movement of the balls in the body grooves. Changes in the angle between shafts are made possible by inward and outward movement of the balls on the trunnion pin. The ball-and-trunnion universal joint is easily recognized by the flexible dust boot that covers the propeller shaft end.

SECTION III. MAINTENANCE OF PROPELLER SHAFTS AND UNIVERSAL JOINTS

5. INSPECTION PROCEDURES. The serviceability of propeller shafts, slip joints, and universal joints can be determined by inspection while they are still installed in the vehicle. In general, these parts are inspected in the same manner on all vehicles. If a rear propeller shaft is to be inspected, place shocks in the front and rear of the front wheels. Raise the wheels that are connected to the propeller shaft to be examined so that they are free to turn.

a. Look the propeller shaft over very carefully for big dents that would cause it to be bent or out of balance. Inspect for breaks or cracks at the welded seams at each end. Clean off any excess dirt or tar that may be stuck to the shaft causing it to be unbalanced. Check for proper mounting, making sure that the propeller shaft has been installed with the slip joint end nearest the transmission. Also, make sure the yokes on each end of the propeller shaft are alined.

b. Examine the slip joint oil seal and the universal joints. Make sure that the slip joint oil seal cover is in place and is tight. The universal joint mounting bolts must be tight and must have no stripped threads. Check each universal joint bearing for breaks or cracks. Cracks usually occur in the bearing at the inside of the yokes. At this time inspect for missing and cracked bearing grease seals which are also at the inside of the yokes. Look for broken or missing bearing retaining snaprings.

c. Universal and slip joints should be properly lubricated before inspecting for looseness. Lubricate the joints according to the lubrication order that applies to that particular vehicle that you are working on. All grease fittings that have been damaged badly should be replaced. The fittings should also be replaced if grease does not pass through it easily or if grease comes out of the fitting after removing the grease gun. After lubricating, shake the propeller shaft and note any looseness. Now, with the handbrake applied and the wheels off the ground, attempt to rotate the propeller shaft back and forth, again noting any looseness. No looseness is allowed at the universal joint bearings, but a very small amount of slack is normal at the slip joint splines. Place the transmission in neutral and turn the propeller shaft by hand while listening for squeaking, grinding, or grating sounds. These noises indicate improperly lubricated or defective bearings.

6. REPLACEMENT OF PROPELLER SHAFTS AND UNIVERSAL JOINTS ON M151-SERIES 1/4-TON TRUCKS. The power transmission system of the M151-series trucks has a front and a rear propeller shaft. The shafts are of welded steel tubing with steel yokes at each end. Journal-type universal joints are fastened in each yoke by retaining snaprings. Replacement and repair procedures for both propeller shaft assemblies are the same.

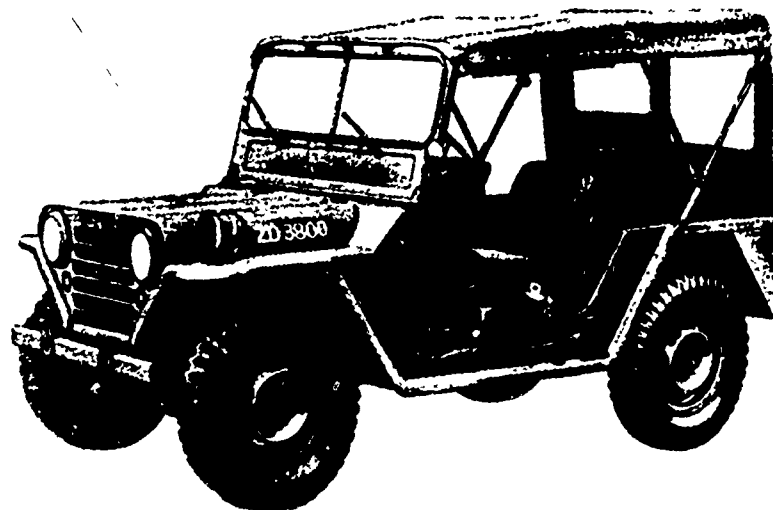

1-9

19

a. The following procedures should be followed when you remove, repair, and install a propeller shaft on an M151 truck. Place chocks in the front and rear of the wheels that are not driven by the propeller shaft to be removed. Use a jack to lift the other wheels off the ground, and then place safety stands under the vehicle. Place the transmission and transfer in neutral and release the handbrake.

b. The tools required to remove universal joint mounting bolts on the M151-series 1/4-ton trucks will vary by model.

(1) The older model M151 trucks requires a special wrench to fit the 12-sided heads of the mounting bolts.



SOCKET WRENCH
(810900459)
5120-893 0064

(2) The new models M151A1 and M151A2 use the standard 6-sided bolt head, and a regular socket or box wrench can be used on them.

c. To remove the propeller shaft and universal joint assembly, proceed as follows:

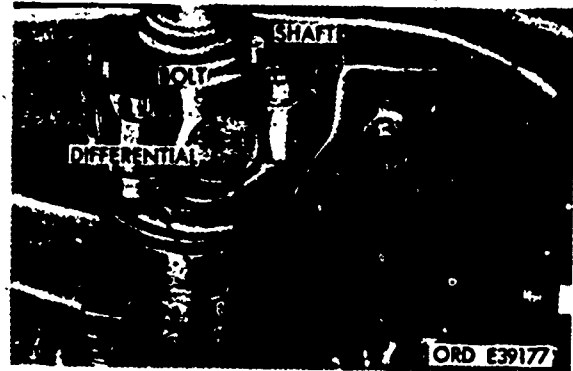

MODEL M151

(1) Remove the four mounting bolts that secure the universal joint to the differential flange.

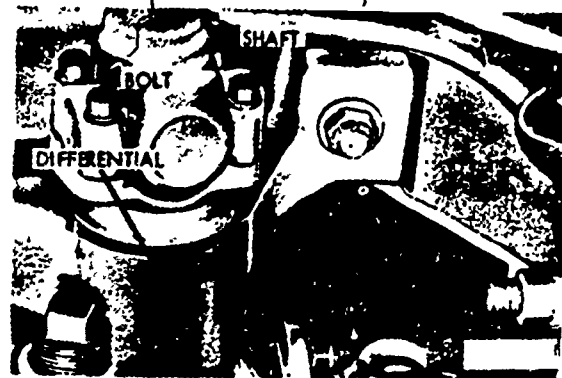

MODELS M151A1 AND M151A2

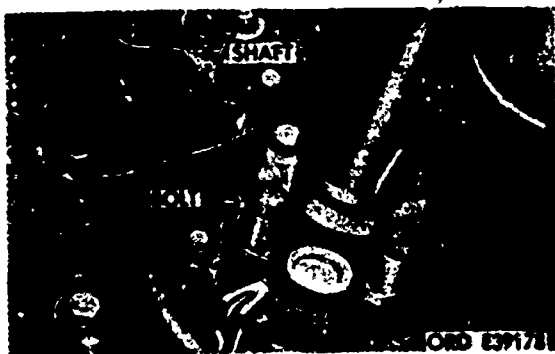

ORD E39178

MODEL M151



MODELS M151A1 AND M151A2

(2) Remove the four mounting bolts that secure the universal joint to the transfer case output shaft flange.

d. The two universal joints on the ends of the propeller shaft are interchangeable. Notice the view of the universal joint shown. If the universal joint has never been disassembled, you may find that the two bearing blocks will be connected together by a strap. Cutting this strap with a chisel enables you to slip the bearing blocks from the journal.

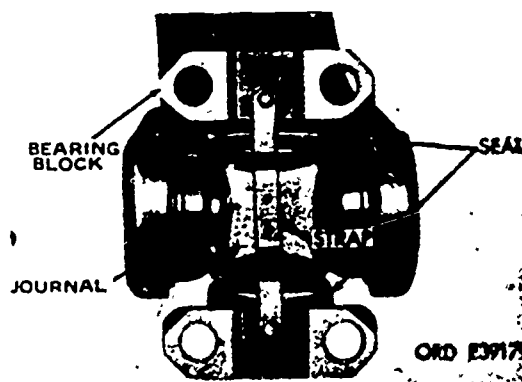

ORD E39178

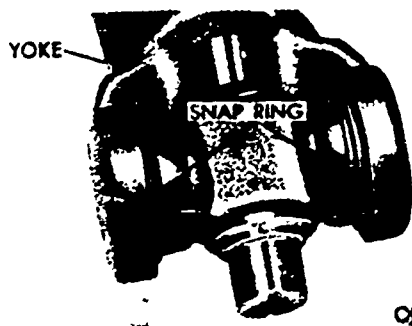

ORD E5543

e. The two bearing assemblies in the yoke are held in place by snaprings. Pry out and remove both of these snaprings.

21

f. Using a brass drift and a hammer, drive one bearing into the yoke until the opposite bearing is pushed out far enough to be removed. Remove the remaining bearing by driving the journal in the opposite direction with the brass drift. Lift the journal from the yoke and remove its lubrication fitting. Remove the seals from the bearings and bearing blocks, using care to prevent losing any rollers. There are 23 rollers in each bearing.

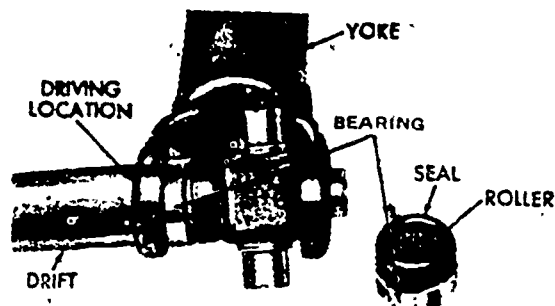

ORD E39180

g. Clean all parts in dry-cleaning solvent or volatile mineral spirits, and dry with compressed air. A complete inspection of all parts is performed after cleaning. Inspect the yokes for bends, cracks, and worn or damaged surfaces. Inspect the journal for damaged or worn bearing surfaces. The bearings are inspected for worn or cracked races, rollers, or seals. Light marks on bearing surfaces can be removed with a fine stone. Replace all parts that are unfit for further service. When any part that is included in a universal joint parts kit (other than the mounting bolts) is defective, install a complete parts kit. Parts that are contained in a universal joint parts kit are two bearing block races, two yoke bearing races, two snaprings, four bearing seals, 92 rollers, one journal, and four mounting bolts with lockwashers. The mounting bolts and lockwashers can also be ordered separately from the kit.

h. Before putting the universal joint in the yoke, work some automotive and artillery grease (GAA) into each bearing race until the rollers are well lubricated. Install the grease fitting in the journal and position the journal in the yoke. The journal should be positioned so that the grease fitting is toward the propeller shaft and is aligned with the grease fitting at the other end of the shaft. Place one bearing assembly in place against the yoke and journal and drive it into place using a brass drift. Install a snapring in place on the installed bearing and drive the second bearing into place. Secure the second bearing with a snapring and tap each bearing outward until both snaprings are against the yoke. Put both bearing block assemblies on the journal, placing tape around the block assemblies to hold them in place.

22

i. When installing a propeller shaft in the M151-series vehicles, either end of the shaft may be installed toward the transmission. The front and rear propeller shafts, however, cannot be changed from one end of the vehicle to the other end. Hold the shaft in place at the transfer yoke (transmission end), remove the tape around the bearing blocks, and start the mounting bolts. Do the same at the differential end and then torque all eight universal joint mounting bolts. The bolts with 12-sided heads should be torqued to 28-33 lb-ft. Hex-head bolts should be torqued to 15-20 lb-ft. Before lowering the wheels to the ground, lubricate the universal joints according to LO 9-2320-218-12.

7. REPLACEMENT OF PROPELLER SHAFTS AND UNIVERSAL JOINTS ON 2-1/2-TON, 6X6 TRUCKS. The M151 does not use slip joints on its propeller shafts due to the arrangement of its power train components. When you repair propeller shafts in a wheeled vehicle such as the 2-1/2-ton, 6x6 truck, the slip joint will then have to be considered. The following instructions tell you how to remove and replace a splined slip joint yoke on the rear rear axle propeller shaft on a 2-1/2-ton truck:

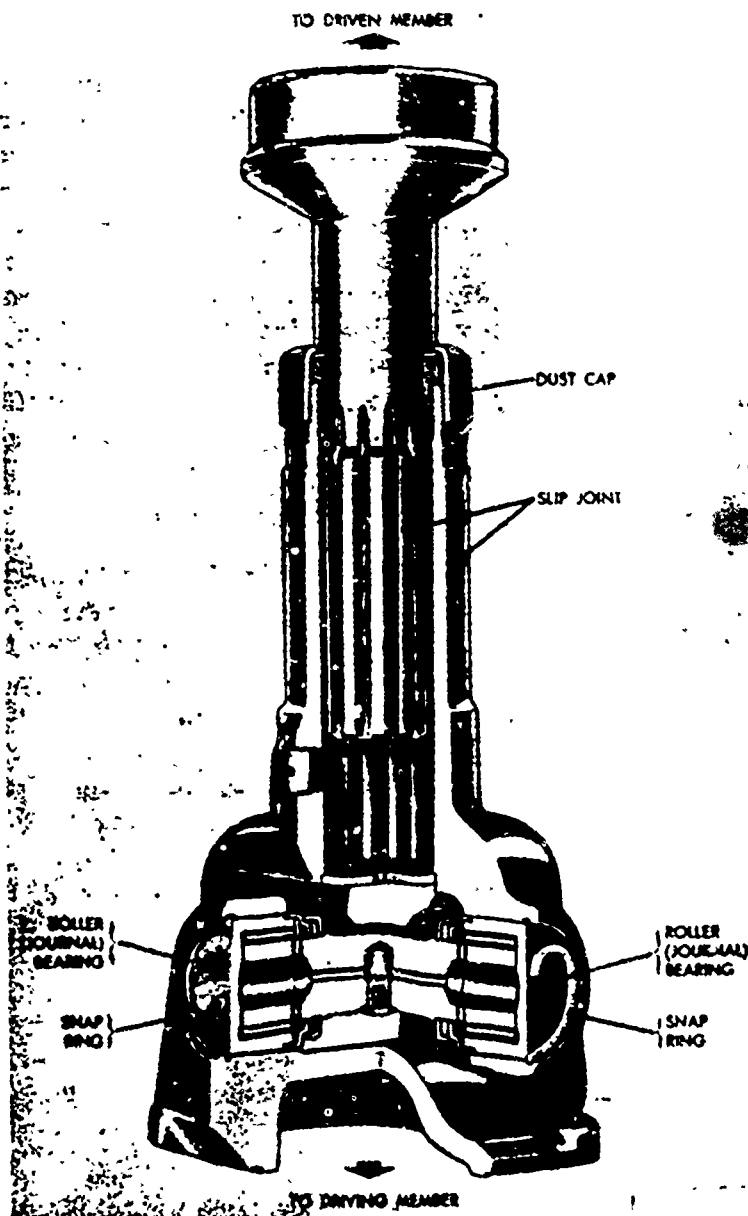

23

a. Place chocks in the front and rear of the front wheels to prevent the truck from rolling while it is being worked on. The rear rear axle propeller shaft is located between the rear axle assemblies. The 2-1/2-ton truck has enough road clearance to allow you to work under it, but a jack is still used to perform this job. Always jack up one wheel of the axle driven by the propeller shaft to be removed. This prevents possible injury to yourself, due to windup of the shaft.

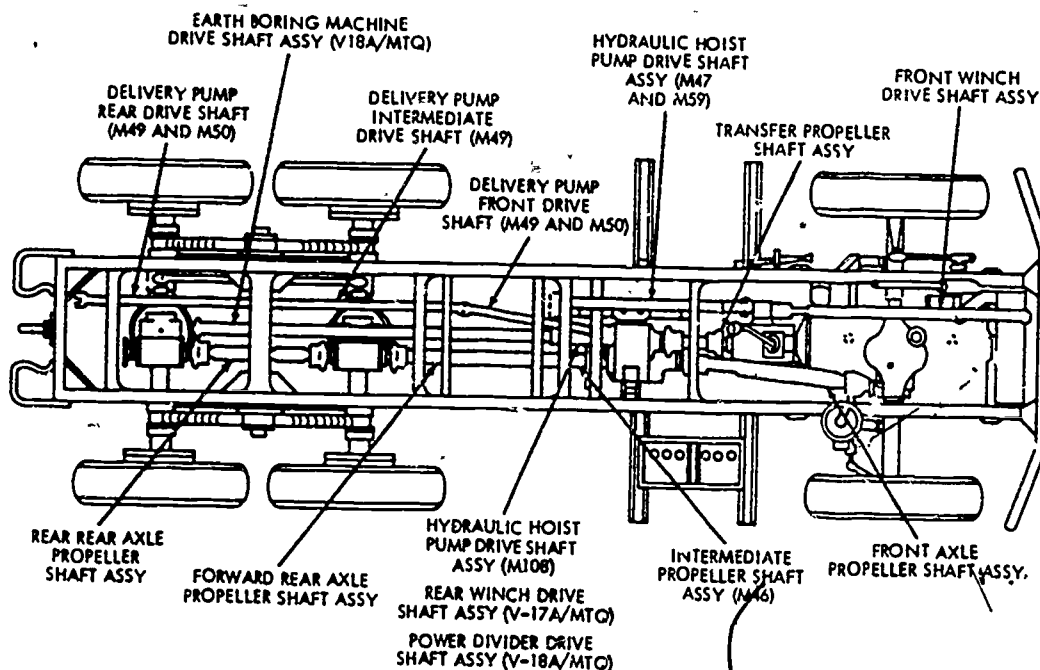

b. Remove the flange mounting bolts from the slip joint end of the propeller shaft. Before removing anything else, look for two alignment arrow marks that are stamped on the shaft and sleeve yoke. If you cannot see any arrow marks, mark the shaft and sleeve yourself so that they can be re-assembled in the same position. Next, remove the mounting bolts on the rear axle end of the shaft and remove the propeller shaft.

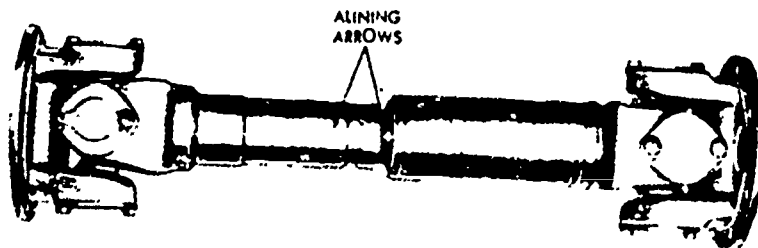

c. Unscrew the slip joint oil seal cap and slide the splined sleeve yoke from the shaft splines. Remove the snaprings and universal joint bearings from the splined yoke. Clean and inspect the splined yoke for distortion, cracks, and worn or damaged splines or bearing bores.

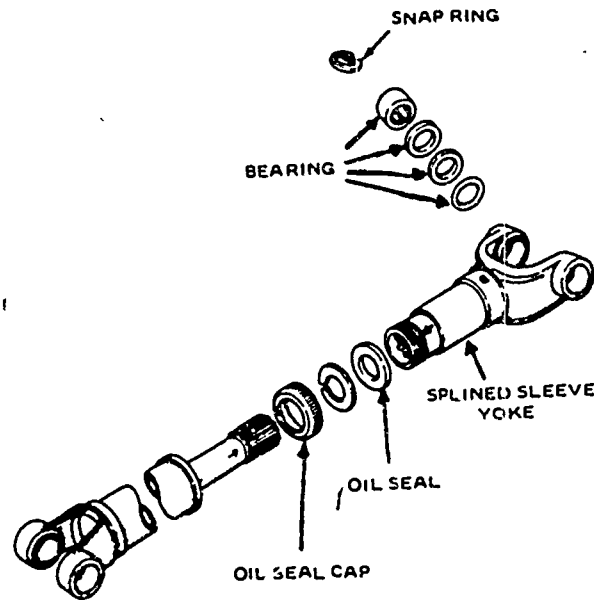

d. The propeller shaft is assembled by reversing the procedure used to take it apart. There are several things that must be considered when putting it together, though. The three grease fittings, one at each of the universal joints and one at the slip yoke, must be alined. A new slip joint seal and universal joint snaprings must be installed on the splined sleeve yoke. Sometimes you will find that the sleeve yoke can be installed on the propeller shaft in only one position. This is due to a blind spline, which is one spline of double width on the propeller shaft and yoke. When a blind spline is used, the sleeve yoke cannot be installed on the propeller shaft out of alinement. However, you must still position the universal joints so that their grease fittings will aline with the slip joint grease fitting. After the propeller shaft has been secured back in the vehicle, lubricate it according to LO 9-2320-209-12.

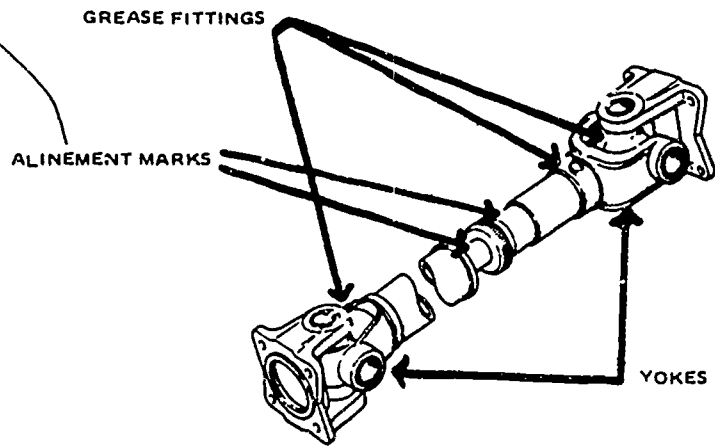

EXERCISE

25

1. At what point on a propeller shaft does the twisting force (torque) create the greatest strain?
 - a. At the center of the shaft
 - b. On the outer surface of the shaft
 - c. Midway between the center and the outer surface of the shaft

2. What causes the distance between the axle assemblies and the transfer case to change?
 - a. Slip joints
 - b. Universal joints
 - c. Flexing springs

3. The speed fluctuations of a universal joint are the greatest when the shafts are positioned at an angle of
 - a. 10° .
 - b. 20° .
 - c. 30° .

4. Which type of universal joint eliminates the need for a slip joint?
 - a. Ball and trunnion
 - b. Yoke and spider
 - c. Cross and yoke

5. The spring retainers used on some universal joints to secure the bearing in the yoke are also called
 - a. tab locks.
 - b. C-washers.
 - c. snaprings.

6. The angle between the transmission output shaft and the propeller shaft must be the same as the angle between the axle assembly input shaft and the propeller shaft in order to reduce
 - a. drive line vibrations.
 - b. speed fluctuations.
 - c. excessive torque.

26

7. In addition to tar from the road, what else is likely to cause a propeller shaft to become unbalanced?
- Worn slip joints
 - Dents or bends
 - Loose U-joints
8. The bolts used to secure the U-joints on the early 1/4-ton truck M151 have
- recessed heads.
 - square heads.
 - 12-point heads.
9. The oil seal on the slip joint of the 2-1/2-ton, 6x6 truck is held in place by a
- snapping.
 - threaded cap.
 - setscrew.
10. What is used on a slip joint to make sure the joint can be installed in only one position?
- Blind spline
 - Arrows
 - Woodruff key
11. What tactical wheeled vehicle does not have slip joints on the propeller shafts between the transfer case and the differential?
- M35
 - M35A1
 - M151
12. When a conventional universal joint is driving at an angle, how many times will it speed up or slow down during each revolution?
- Two
 - Three
 - Four

- 13. Which type of U-joint has a compensating spring?
 - a. Journal and yoke
 - b. Cardan joint
 - c. Ball and trunnion

- 14. What types of bearings are used on the journals of most universal joints?
 - a. Ball and roller
 - b. Roller and needle
 - c. Needle and sleeve

- 15. What should be used to remove light marks from the bearing surfaces of U-joint journals?
 - a. Flat file
 - b. Sandpaper
 - c. Fine stone

SECTION IV. CONCLUSION

8. **SUMMARY.** In this lesson we discussed the construction and operation of propeller shafts and universal joints. We also discussed procedures for maintaining them. You now have the knowledge you will require for this task. Your skill will have to be developed through practice.

9. **PRACTICE TASKS.** Appendix B of this lesson contains a list of tasks associated with propeller shafts and universal joints. They are representative of tasks you will be required to perform as a wheeled vehicle mechanic. Perform all of the tasks listed. Be sure you are under the supervision of an officer, NCO, or specialist who is qualified in the MOS when you practice the tasks. If you find you are having difficulty in certain tasks, restudy the appropriate training material and practice the tasks until you become proficient in each one.

29.

APPENDIX A
REFERENCES

AR 611-201	Enlisted Military Occupational Specialties *	Jan 67
AR 750-1	Army Materiel Maintenance Concepts and Policies	May 72
DA Pam 351-20	Announcement of Army Correspondence Courses	Mar 72
OS Pam 27	USAOC&S Catalog of Correspondence Courses	1974-75
TM 9-871A	1/4-Ton, 2-Wheel Trailer M100	Jul 51
TM 9-2320-206-20	Organizational Maintenance of 10-Ton, 6x6, M123 Series Truck Tractor	Oct 71
TM 9-2320-209-20	Organizational Maintenance of 2-1/2-Ton, 6x6, M34, M35, and M36 Series Trucks	Apr 65
TM 9-2320-211-20	Organizational Maintenance of 5-Ton, 6x6 Tractor Trucks, Cargo Trucks, and Wreckers	Mar 63
TM 9-2320-218-20	Organizational Maintenance of 1/4-Ton, 4x4, M151 Series Trucks	Sep 71
TM 9-2320-244-20	Organizational Maintenance of 1-1/4-Ton, 4x4 Trucks M715 and M725	Aug 71
TM 9-2330-202-14P	Maintenance and Repair Parts for 3/4-Ton, 2-Wheel Trailers M101 and M101A1	Aug 62
TM 9-2330-213-14	Maintenance of 1-1/2-Ton, 2-Wheel Trailers M104 and M105 Series	Jan 64
TM 9-2610-200-20	Pneumatic Tires and Inner Tubes	Jan 71
TM 9-8000	Principles of Automotive Vehicles	Jan 56
TM 9-8014	Organizational Maintenance of 1/4-Ton, 4x4, M38 Series Trucks	Apr 55
TM 9-8024	Organizational Maintenance of GMC Series 2-1/2-Ton, 6x6 Trucks	Oct 55
TM 9-8030	Organizational Maintenance of 3/4-Ton, 4x4, M37 Series Trucks	May 55

APPENDIX B

PRACTICE TASK LIST

Practice Objective After practicing the following tasks you will be able to:

- 1. Locate propeller shafts and universal joints on various wheeled vehicles.
- 2. Inspect propeller shafts and universal joints.
- 3. Lubricate propeller shafts and universal joints.
- 4. Remove and replace propeller shafts and universal joints.

Practice Tasks.

- 1. Look at the propeller shafts on vehicles in your unit. Pay particular attention to the differences in propeller shafts on the 1/4-ton vehicle and the 2-1/2-ton or 5-ton vehicles. Notice the short propeller shaft that connects the transmission to the transfer on the heavier vehicles.
- 2. Find the universal joints on the same vehicles. Notice how they connect each shaft to a gear train component. Look for the slip joints. Remember that some propeller shafts on the 1/4-ton have no slip joints in the shafts.
- 3. While you are under the vehicle, make a visual inspection of the propeller shafts and universal joints. Look for loose bolts and bent or dented shafts. Inspect the area around the universal joint spider and the bearing. Look for what looks like loose rust in this area. This indicates the bearing area is probably out of lubricant (grease).
- 4. Observe propeller shafts being lubricated. Notice how the vehicle is moved to position the grease fittings right. If possible, assist the lubrication personnel during the lubricating procedures.
- 5. Assist another mechanic in the removal and disassembly of a propeller shaft. Notice how the spiders are removed from the propeller shafts. Inspect each of the components of the disassembled universal joints and determine whether or not they are serviceable.



31

6. Assemble and disassemble several types of universal joints. It is suggested that you work with parts that have been declared unserviceable.

44

1-25



32

ENLISTED MOS

CORRESPONDENCE/OJT COURSE

ORDNANCE SUBCOURSE 63B206

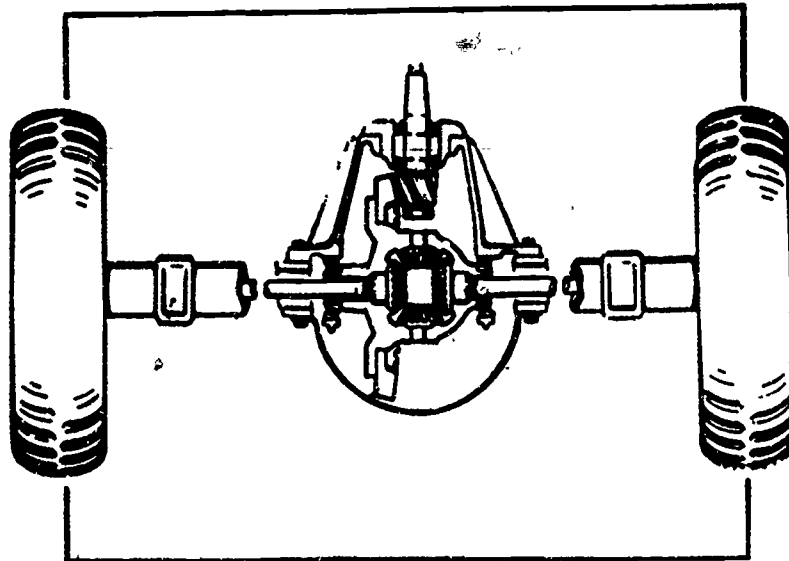

LESSON 2

INTRODUCTION TO AXLE ASSEMBLIES

SEPTEMBER 1975

**DEPARTMENT OF ARMY WIDE TRAINING SUPPORT
US ARMY ORDNANCE CENTER AND SCHOOL
ABERDEEN PROVING GROUND, MARYLAND**

CONTENTS

	Paragraph	Page
LESSON ASSIGNMENT SHEET.		2-1
STUDY TEXT		
Introduction	1	2-3
Use of axles	2	2-3
Dead axles	3	2-3
Live axles	4	2-8
Operation of live rear axles	5	2-20
Construction of live front axles	6	2-24
Operation of live front axles.	7	2-30
Lubrication of live axles	8	2-30
Drive axles of 1/4-ton trucks	9	2-31
Front-wheel drive on heavy trucks.	10	2-32
Summary	11	2-33
Practice tasks.	12	2-33
Appendix		2-37

US ARMY ORDNANCE CENTER AND SCHOOL CORRESPONDENCE/OJT COURSE



LESSON ASSIGNMENT SHEET

Ordnance Subcourse No 63B206 . . . **Wheeled Vehicle Drive Lines, Axles, and Suspension Systems**

Lesson 2. **Introduction to Axle Assemblies**

Credit Hours. **Three**

Lesson Objective **After studying this lesson you will be able to:**

1. Describe the types of axle assemblies used on tactical wheeled vehicles.
2. Describe the construction of the I-beam type axle assembly.
3. Explain the purpose of a dead axle assembly.
4. Describe the construction of live axle assemblies.
5. Explain the purpose of a differential assembly.
6. Describe the purpose of axle shafts.
7. State the purpose of axle housings.



- 8. Describe the operation of live rear axle assemblies.
- 9. Describe the operation of a final drive and differential assembly.
- 10. Explain how axles are lubricated.
- 11. Describe the drive axles of the 1/4-ton truck M151.
- 12. Describe the combination shaft and gear type live front axle used on heavy front-wheel drive trucks.

Materials Required ALL STUDENTS. Answer sheet and exercise response list.
CORRESPONDENCE/OJT STUDENTS. See appendix.

Suggestions When reading the study assignments carefully study all accompanying illustrations.

1. INTRODUCTION. The term "wheeled vehicle" means that wheels instead of tracks, runners, or skids are used to support the weight of the vehicle and to propel the vehicle. To do the job, however, wheels must be secured to a device that will hold them in the position needed so that they can roll and support the load.

This device is called an axle. It is a cross support between the wheels that is strong enough to meet the demands in accordance with the size of the vehicle. The design of an axle assembly depends on what it is supposed to do. If

you think of a front axle, you can see how it must support the wheels in such a manner that they will roll and, in addition, turn in different directions for steering. If you think of a rear axle, it doesn't have to have a steering ability but it does have to deliver torque to the wheels to make the vehicle move. We therefore have two major types of axles: the dead axle, such as would be used for the front of a vehicle if the wheels weren't powered, and the live axle for the rear where the wheels must be made to rotate.

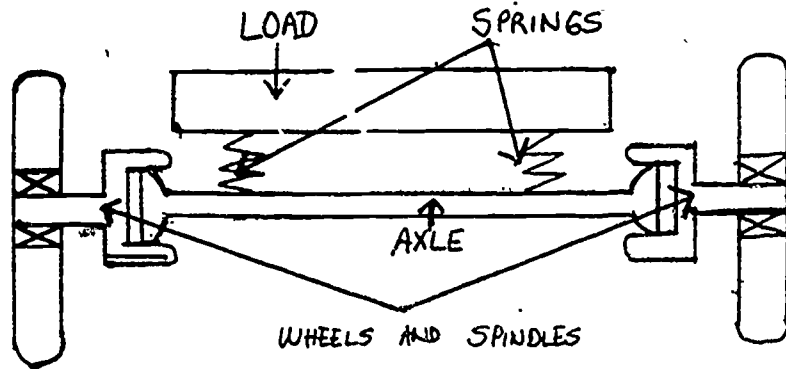

2. USE OF AXLES. Most commercial trucks use dead axles in the front and live axles in the rear. Tactical vehicles in the Army use live axles in the front and rear. One exception to this is the 1/4-ton truck M151 which uses a separate type of drive which we will discuss later. It uses an independent suspension system on each wheel. Civilian cars also use the independent suspension system in the front and some use it for all four wheels.

3. DEAD AXLES. Dead axles are used on the front of trucks that do not have front-wheel drive. They are also used on trailers. When used in the front of a vehicle they must provide for the steering system. When used on a trailer they only need to hold the wheels in an upright position and be strong enough to support the trailer load. Dead axles are usually held in line with the vehicle frame by the springs that support the vehicle load. There are several types of dead axle designs.

37

a. The I-beam type axle is made from a high grade steel that is forged into the proper shape and heat-treated to form the axle I-beam.

This type of construction produces an axle that is light in weight and has great strength. The I-beam axle is shaped so that the center part is several inches below the ends. This permits the body of the vehicle to be mounted lower than it would be if the axle were straight. A vehicle body that is

closer to the road has a lower center of gravity and holds the road better. Let's take a closer look at this axle and see how it is made.

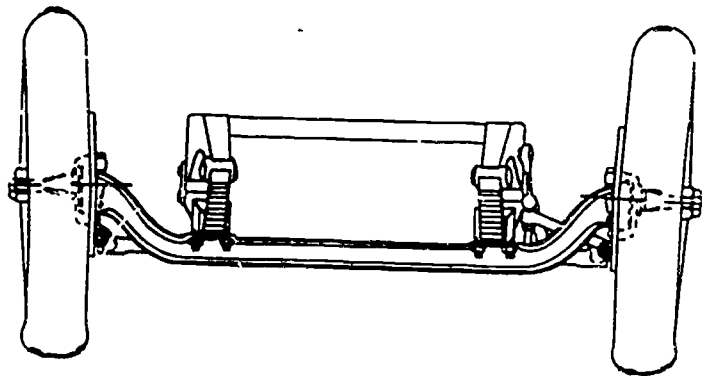

(1) On the top of the axle you can see that flat, smooth surfaces or pads are provided to mount the springs. The mounting surfaces are

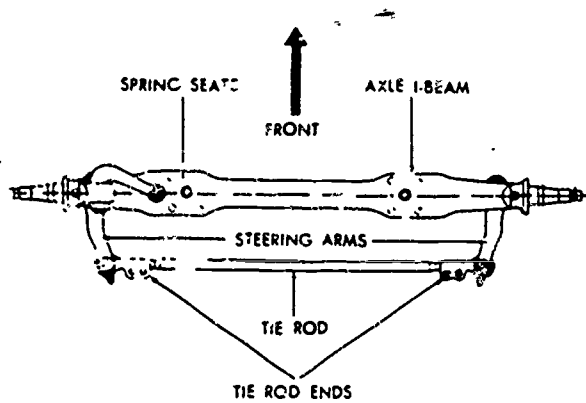

called spring seats and will usually have five holes. The four holes on the outer edge of the mounting surface are for the U-bolts which hold the spring and axle together. The center hole provides an anchor point for the center bolt of the spring. The head of the spring center bolt, seated in the center hole in the mounting surface, insures proper alinement of the axle with the vehicle frame.

(2) A hole is located in each end of the I-beam section. It is bored at a slight angle and provides a mounting point for the steering knuckle or kingpin. A small hole is drilled from front to rear at a right angle to the steering knuckle pinhole. It enters the larger kingpin hole very slightly. The kingpin retaining bolt is located in this hole and holds the kingpin in place in the axle.

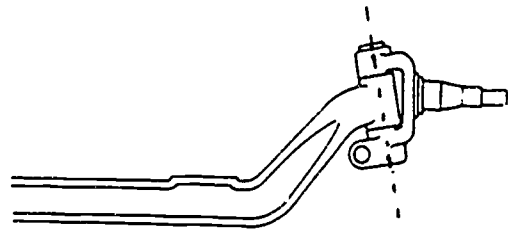

(3) The steering knuckle is made with a yoke at one end and a spindle at the opposite end. 38

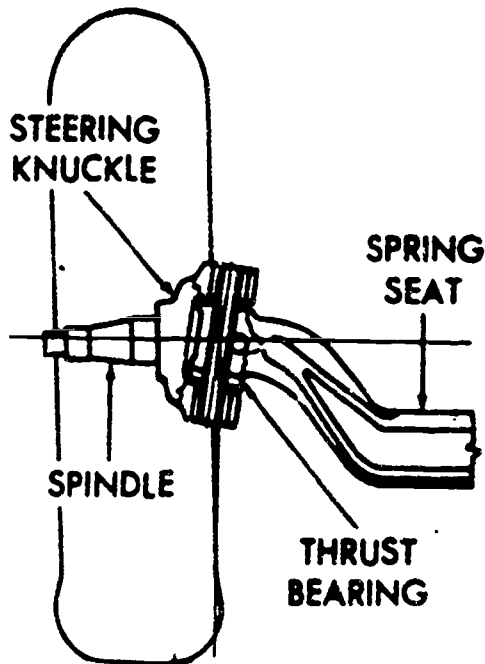

and lower arms of the yoke, through which the kingpin passes. These bushings provide replaceable bearing surfaces. A lubrication fitting and a drilled passage provide a method of forcing grease onto the bearing surfaces of the bronze bushings. The spindle is a highly machined, tapered, round shaft that has mounting surfaces for the inner and outer wheel bearings. The outer end of the spindle is threaded. These threads are used for installing a nut to secure the wheel bearings in position. A flange is located between the spindle and yoke. It has drilled holes around its outer edge. This flange provides a mounting surface for the brakedrum backing plate and brake components.

(4) The kingpin acts much like the pin of a door hinge as it connects the steering knuckles to the ends of the axle I-beam. When installed, the kingpin passes through the upper arm of the knuckle yoke, through the end of the I-beam and a thrust bearing, and then through the lower arm of the knuckle yoke. The kingpin retaining bolt locks the pin in position. The ball-type thrust bearing is installed between the I-beam and lower arm of the knuckle yoke so that the end of the I-beam rests upon the bearing. This provides a ball bearing for the knuckle to pivot, or turn, upon as it supports the vehicle's weight.

(5) When the vehicle is not in motion, the only job that the axle has to perform is holding the wheels in proper alignment and supporting part of the weight. As the vehicle goes into motion, the axle receives the twisting stresses of driving and braking. When the vehicle operator applies the brakes, the brakeshoes, which are mounted to the backing plate and bolted to the spindle, are pressed against the moving wheel drum. This action tries to make the axle turn. When the brakes are applied suddenly, the axle twists against the springs and actually twists out of its normal upright position. Some vehicles use additional rods or springs to oppose the twisting action of the axle. In addition to twisting during braking, the front axle also moves up and down as the wheels move over rough road surfaces. Steering controls and linkages provide the means of turning the

steering knuckles to steer the vehicle. As the vehicle makes a turn while moving, a side thrust is received at the wheels and transferred to the axle and springs. These forces act on the axle from many different directions. You can see, therefore, that the axle has to be constructed quite rugged to keep all the parts in proper alinement.

b. Now that we have discussed the I-beam type dead axle used on the front of some vehicles, let's look at the type of dead axle that is used on towed vehicles or trailers. The axles used on trailers are designed to mount the wheels and support the weight of the vehicle. Most smaller trailers use a single axle, while larger ones normally have two-axle assemblies. The size of trailers varies from the small 1/4-ton models to the large 50-ton transporters. As the vehicle size increases, heavier axle assemblies are used. Since trailer wheels are not powered, the axles used are all of the dead type. Larger trailer axles are equipped with service brakes to assist in stopping the moving vehicle.

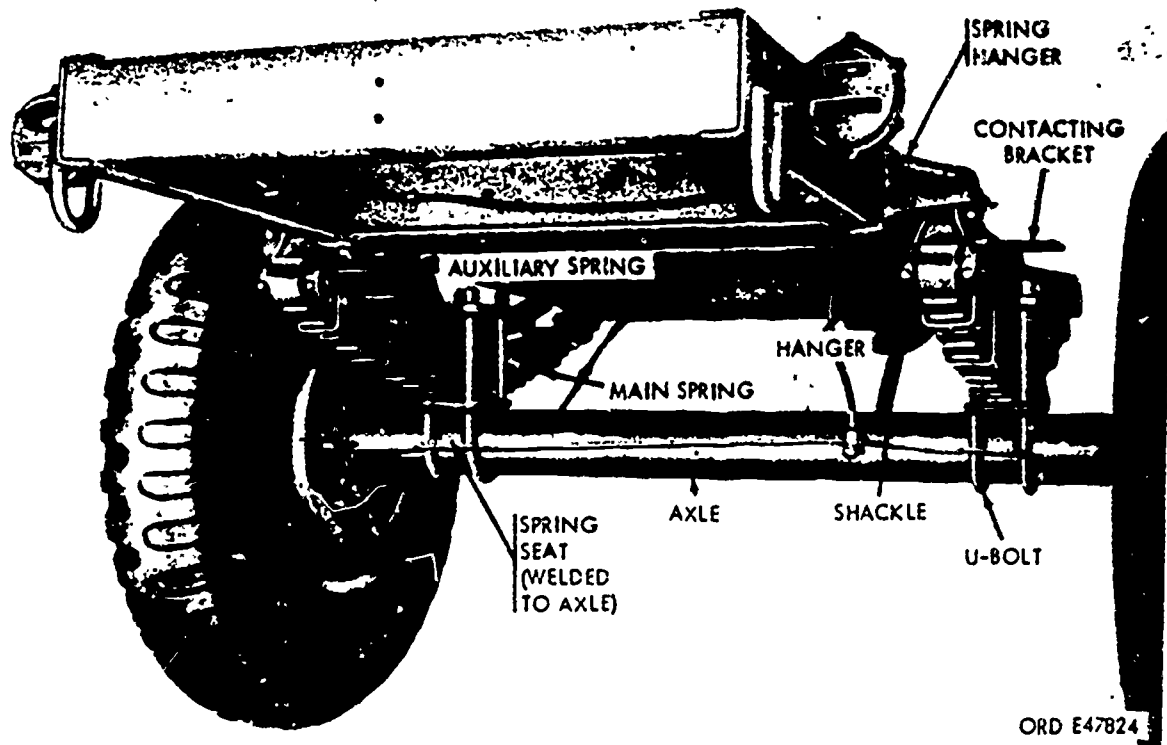

ORD E47824

(1) The axle that is used on most military trailers is usually a straight, round steel shaft or tube. Smooth machined surfaces at the ends of the shaft provide mounting surfaces for the wheel bearings and the wheel bearing seals. The threads on the ends of the axle shaft hold the wheel

bearing retaining nuts. A locking plate for the wheel bearing nuts fits into a keyway or slot to prevent the nuts from working loose. Two steel pads, welded to the axle shaft, provide seating surfaces to connect the axle to the leaf-type springs.

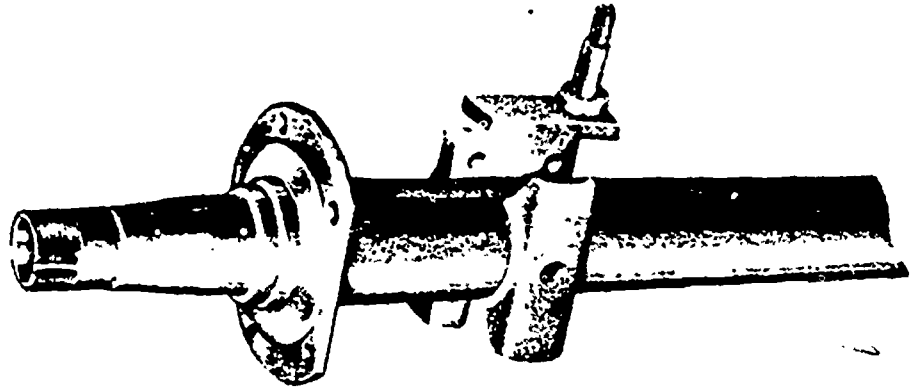

A machined flange with holes located around the outer edge is located just inside the wheel bearing surfaces. It provides a mount for the brake backing plates.

(2) On semitrailers with tandem or two axles (one behind the other), the axles are not usually bolted directly to the leaf-type spring. The springs are mounted on a central trunnion shaft with spring seats so that they aid in holding the axle in line. The spring ends rest upon spring bearing plates welded to the axle shafts. The tip of the springs can slide forward and backward on the bearing plate. Torque rods are used to hold the axles in the proper position. Later in the lesson you will see a similar spring arrangement that is used on tandem live axles.

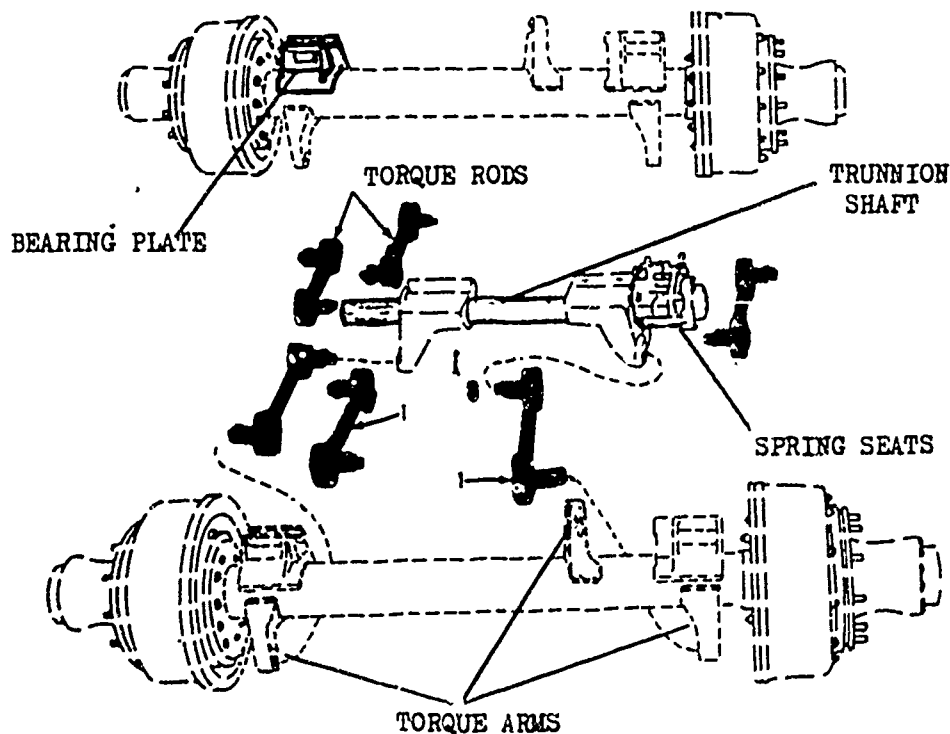

41
(3) A trailer axle may support almost all or just part of the total vehicle weight. On small single-axle trailers most of the weight is supported by the axle assembly. Large semitrailers are designed so that the towing vehicle (truck tractor) supports as much of the load as the trailer axles. On the trailers that have brakes controlled by the operator of the towing vehicle, the axle must withstand the twisting force of the wheels as the brakes are applied. While in motion the axle will move up and down under the load of the trailer as the wheels follow the surface of the road.

(4) With only a few moving parts, the dead axle assembly does not require a large amount of lubrication. The wheel bearings are removed from the assembly and packed with automotive and artillery grease (GAA) at the intervals required by the lubrication order (LO). Steering knuckles and linkages found on front axles are lubricated with automotive and artillery greases by means of lubricating fittings.

4. LIVE AXLES. The major difference between the dead and live axle is that the live axle can drive each of the wheels it mounts. Being able to drive the wheels means there are considerable differences in the construction, operation, and cost of the live axles over a dead axle. In past lessons the methods of developing power and delivering it to the axles have been presented. Let's find out what is needed in a live, or drive, axle to make it function and what types of axles are used.

a. The speed of the output from the transmission or transfer assembly is too fast to connect to the drive wheels. If it were connected at this speed,

there would not be enough torque to pull the loads the vehicle is designed to pull. The vehicle would also travel entirely too fast. The live axle is constructed so that it will lower the speed and increase the torque or pulling power. This is done by using

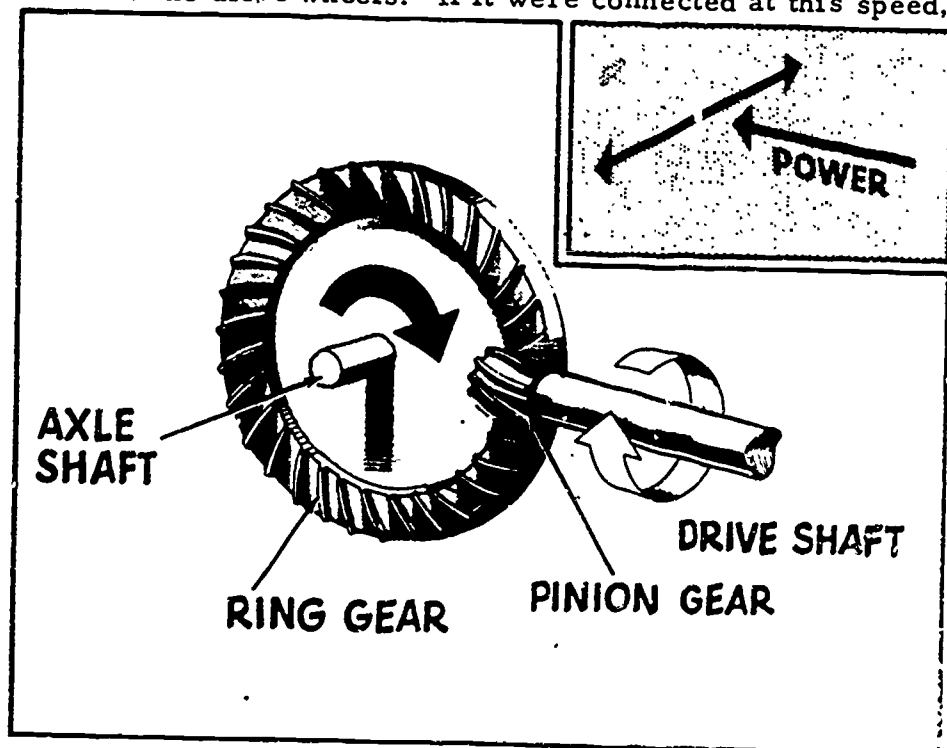

reduction gearing or a small gear driving a larger gear. The axle is also constructed so that the power flow can turn 90 degrees in each direction (from the propeller shaft to the right and left wheels). This is needed to direct the power flow to the drive wheels on each side of the vehicle. This change of direction is done by the use of worm gears or bevel drive gears. Notice that the pinion gear is the smallest and the ring gear is the largest. These two gears provide a reduction in speed and change the direction of the power flow. Let's see what else is needed in the live axle assembly.

b. As the vehicle moves around a turn, the wheels on opposite ends of the axle must turn at different speeds. This is because the wheel on the outside of the turn must travel a larger circle or path than the wheel on the inside of the turn. If both wheels were rigidly mounted to a single solid shaft, the tires would be forced to slide on the road surface when the vehicle

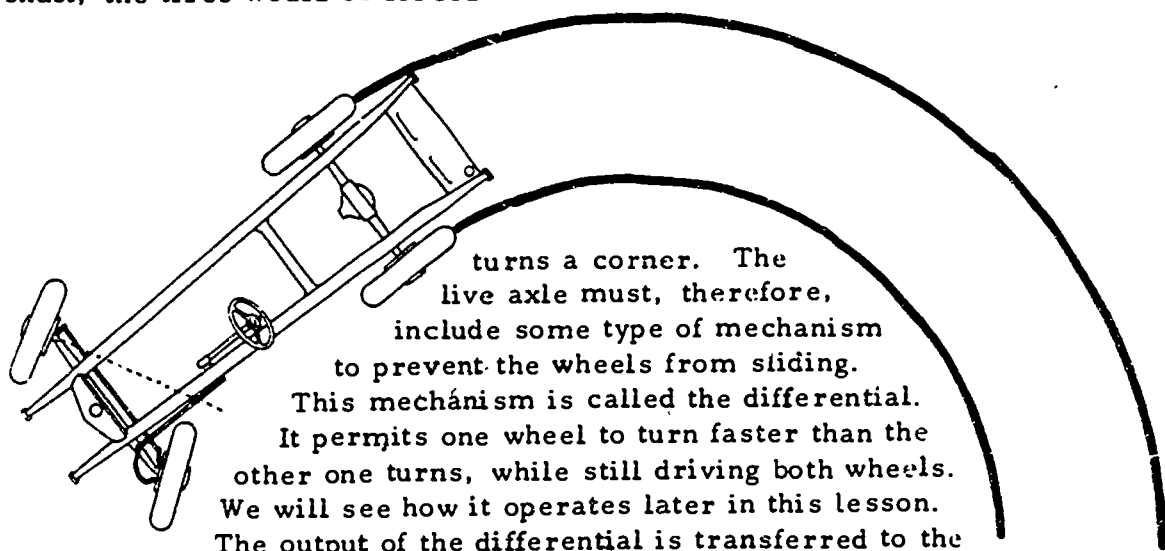

what is needed in a live axle, let's find out more about the construction of these axles.

c. The live axles are grouped into four general types. These types are based upon the way that the load is supported. An easy way to identify these axles is the manner in which the axle shafts are mounted. The four types are the plain, semifloating, three-quarter floating, and full-floating axles. Each rear live axle assembly consists of a gear box or final drive in the center and axle shafts extending to the wheels on either side.

(1) Early vehicles used a live axle known as the plain or nonfloating axle. The axle resembled the semifloating axle (discussed in the next paragraph) on the outside. However, the axle shafts were supported by a different method. The axle shafts were supported by two roller bearings. One roller bearing was located just inside of the outer end of the axle shaft housing. The other roller bearing was located at the center of the axle

43

shaft and inside the axle shaft housing. The inner ends of the axles were connected to the differential side gears by keys and keyways. These axle shafts had to carry the weight of the differential assembly on the inner ends. The vehicle wheels were attached to the outer ends of the axle shafts. Therefore, the outer ends of the axle shafts carried the entire weight of the rear of the vehicle. End thrust on the axle shafts was absorbed, or taken-up, by a ball-type bearing located on each side of the differential case and a block between the inner ends of the axles. This type axle assembly is not used on any of the modern automobiles or trucks.

(2) A second type of axle, the semifloating axle, is used on most passenger and light commercial vehicles. The difference between the semifloating and plain axle is the method of mounting the differential assembly and the support of the axle shafts.

On the semifloating axle assembly, the differential housing is supported in the axle housing on bearings rather than on the inner ends of the axle shafts. This design relieves the axles of the weight and some of the operating stresses of the differential assembly. The inner ends of the axle shafts are splined to gears in the differential and have only to transmit turning effort. The outer ends of the axle shafts are mounted similar to the plain type axle, with the shafts supporting vehicle weight and withstanding wheel side thrust. The outer end of the axle is supported on a tapered roller bearing. With this type of construction, the wheel may come off of the vehicle if the axle shaft should break. This is also true of the plain type axle above.

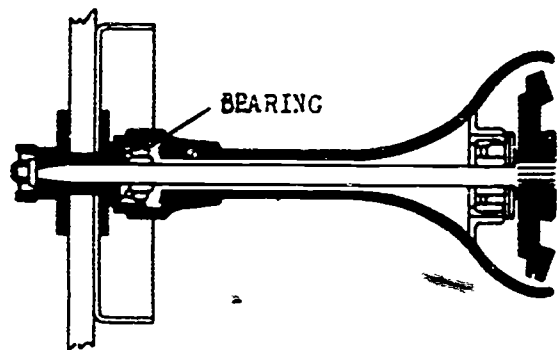

(3) A third type of axle, the three-quarter floating axle, was also used on some earlier commercial vehicles. The bearing supporting the

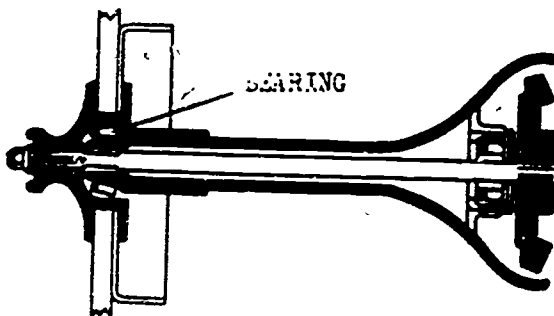

outer end of the axle shaft is moved from inside the axle housing to the outside. This method of mounting the axles places most of the weight of the vehicle on the ends of the axle housing rather than the ends of the axle shafts. Since the wheel is solidly keyed to a taper on the end of the axle shaft, side thrust as the vehicle turns or skids is still taken by the axle shaft.

(4) Now let's look at the fourth type of axle, which is known as the full-floating type axle. The major difference in the three-quarter and full-floating axle is that two bearings are used to mount the wheel on the axle housing instead of one bearing.

With this method of construction, the axle shaft may be removed without disturbing the wheel or differential assembly. This type of construction is used on military tactical wheeled vehicle axles. The axle shaft on full-floating axles has a flange at the outer end. The flange connects the axle shaft to the hub of the wheel. It is, therefore, through the flange that the axle shaft drives the wheel. On rear axles the flange is a part of the axle shaft. On front axles the end of the shaft is splined and a splined flange slides over the end of the shaft and is bolted to the wheel hub.

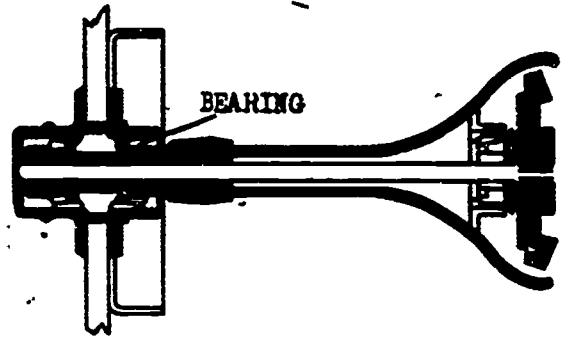

d. Now that we know how axles are classified, let's find out what types of gears are used in the final drive. A final drive is that part of the power train between the propeller shaft and the differential. It is the part of the axle assembly that provides the 90-degree change in direction of the power flow and an increase in torque or turning force. The final drives used in most military tactical vehicles are either single or double reduction units. The single reduction axles are used on light wheeled vehicles. They consist of one set of reduction gearing. These same gears are also used to change the direction of power flow. The double reduction units have a second set of reduction gears, giving them the name "double reduction." These final drives are used on heavy modern wheeled vehicles where a large amount of reduction is needed.

(1) Some early vehicles that were built to haul heavy loads often used a worm gear type final drive. This type gearing provided a large amount of reduction and worked quite well for heavy, slow-moving trucks. The gearing consisted of two gears: a worm and a large worm gear. The worm is similar to a coarse-threaded bolt. The threads of the worm mesh with the worm gear. Most worms used in live axles have only one continuous thread, just like the thread on a bolt. When the worm is turned one complete turn, it moves the worm gear the distance of one tooth. This means if the worm gear has 25 teeth, the worm must rotate 25 times to turn the worm gear one complete turn or revolution. The gear ratio of this gear set would, therefore, be 25:1. This type gearing creates a lot of friction between the two gears and at the end of the worm and is not adaptable to the high-speed operation of modern vehicles.

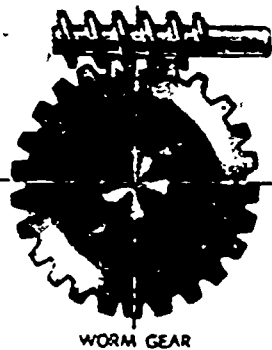

45

(2) A second type of gear that is used in the final drive of live axles is known as the bevel gear. Like the worm gears, bevel gears can be used to change the direction of power flow and also provide a reduction. Bevel gears, or bevel drive gears as they are sometimes called, are found as two general types. One type has straight teeth and is therefore known as spur bevel gears. On the other type the teeth look like they have been twisted and are called spiral bevel gears. Bevel gear final drives used in live axles consist of two gears. The smaller, called a pinion, is connected to the propeller shaft. The larger gear, which looks like a ring with teeth cut on an angle on the side, is called a ring gear. The spur bevel gear final drives used on many early vehicles were noisy and not strong enough. This was due to the meshing gears having only one tooth in contact, which is a characteristic of all spur type gears.

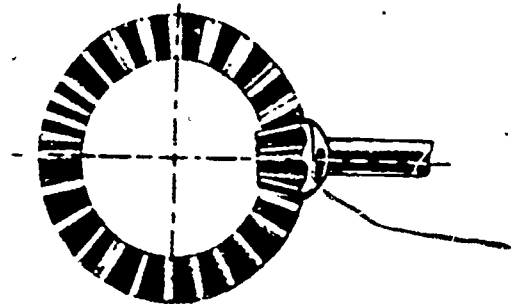

SPUR BEVEL GEAR

(3) By "twisting" the teeth of a spur gear, the contact surface of the gear teeth is longer and more than one tooth is in contact at one time.

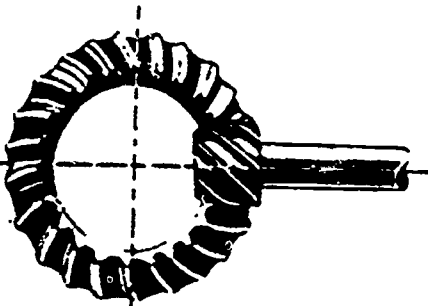

SPIRAL BEVEL GEAR

Therefore, spiral bevel gears, as they are called, eventually replaced spur gears in live axles because they are stronger and quieter. The pinion is connected to the propeller shaft while the ring gear drives the axle shafts through the differential case and gearing. We will learn more about the differential gearing later in the lesson.

(4) It was found that by lowering the pinion below the centerline of the bevel ring gear that the teeth in mesh could be longer. This meant that the gear set would still be stronger than the spiral bevel set. It also lowered the propeller shaft and allowed the vehicle body to be lowered. This improved version of the spiral bevel gear set is known as the hypoid gearing. It is used in many commercial and military vehicles. The pinion and ring gear are both mounted on the same type bearings as the spiral bevel gearing. Live axles using this type of gearing are found with the pinion below the ring gear centerline and sometimes above the ring gear centerline. If you compare the illustrations of the spiral bevel gears and the hypoid gears you can see that the pinion in the hypoid set is located below the ring gear centerline.

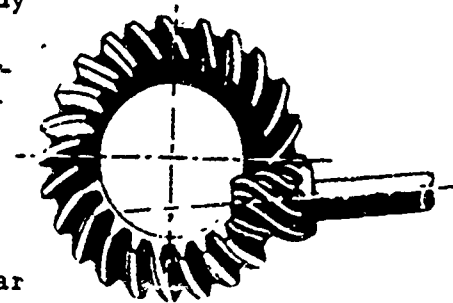

HYPOID GEAR

c. The size of the gears used in final drives depends on the needs of the vehicle. The relationship of the pinion and ring gear is known as the gear ratio, just as in the worm gears. We learned earlier that worm gears provided a lot of reduction. Bevel drive gears do not provide the same amount of reduction per size. The ratio of the gears can be obtained by dividing the number of gear teeth on the pinion into the number of gear teeth on the ring gear. This will show how many revolutions the pinion makes when the ring gear makes one revolution or turn. For example, if the pinion has 10 teeth and the ring gear has 50 teeth, the ring gear has 5 times as many teeth and the ratio is 5:1 (5 to 1). The drive ratio of automobile drive axles ranges from 2.5:1 to 5:1. Larger trucks have gear ratios ranging from 5:1 to 15:1.

(1) Lighter vehicles that are not required to haul heavy loads can use a comparatively low ratio set of gears. For example, a small commercial truck may have a gear set with a ratio of 5:1. This ratio can easily be obtained with one set of reduction gears such as the single reduction gear sets discussed above.

(2) Larger trucks need gear ratios up to as much as 15:1. This would mean that if 10 teeth were on the pinion, there would have to be 150 teeth on the ring gear. A ring gear of this size would take up too much room. Instead, the ratio or total reduction is divided up between two sets of reduction gears. This type gear arrangement is known as the double reduction drive. This way, if the bevel gears supply about a 3:1 reduction and the second reduction gearing a 5:1 reduction, the overall ratio would, therefore, be 15:1 and none of the gears would be large enough to take up too much room.

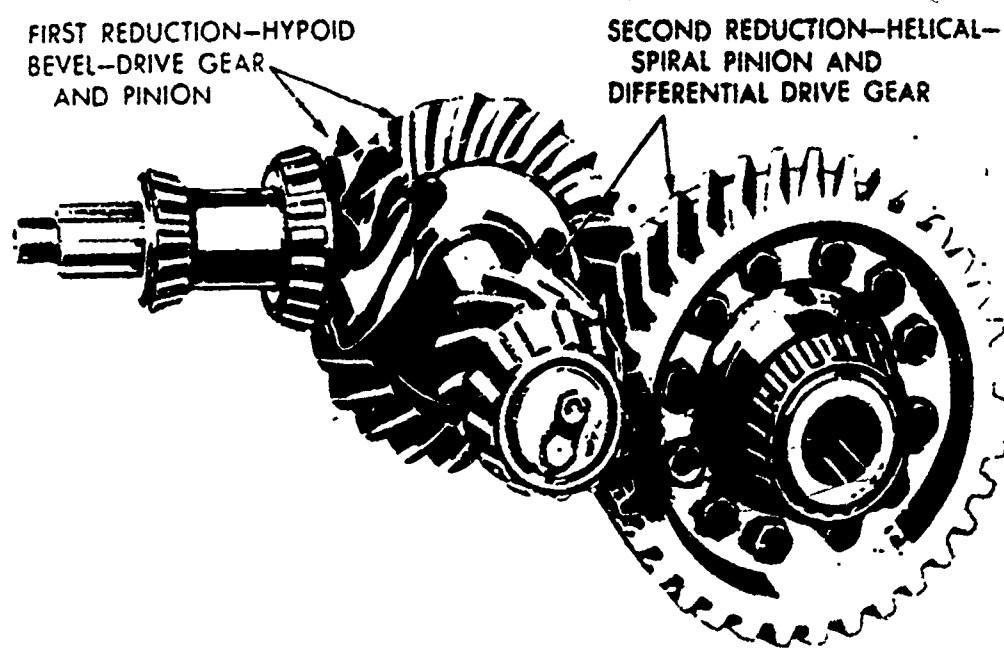

47

(3) The double reduction axle should not be confused with the two-speed axle. Some commercial trucks use a drive axle that has two different ratios or reductions. The driver can select which ratio he needs with controls that are located in the truck cab. This type axle has a "low" range and "high" range. The ranges are actually two different ratio reductions. Two-speed axles are known as dual ratio and double reduction-dual ratio axles. Notice in the illustration of a double reduction-dual ratio final drive that the ring gear has changed names to the bevel drive gear. You should also notice that the differential case is located in the larger gear area.

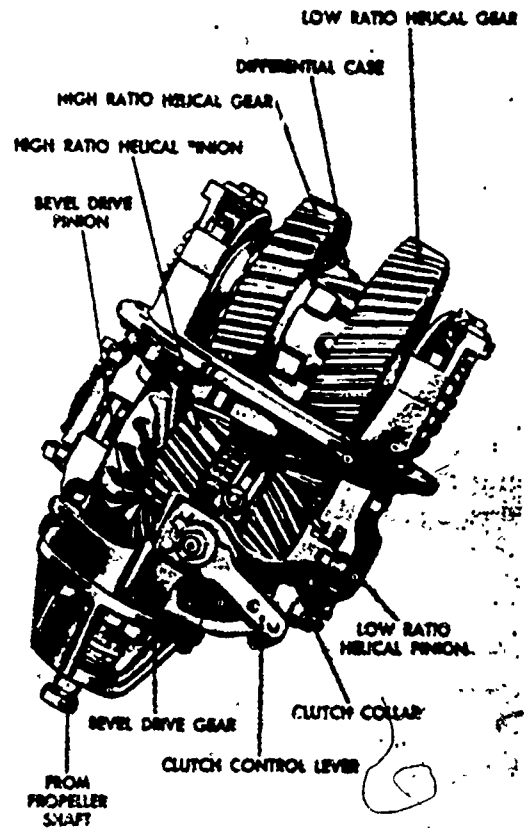

f. On live axles, one wheel must turn at a different speed than the other as the vehicle goes around a corner. Additional gearing is required to allow for the difference in the speed of the wheels. This gearing must also continue to drive each wheel at the same time. The gearing assembly designed to do this job is called a differential. The differential assembly is mounted in the axle housing and is bolted to and driven by the final drive ring gear.

(1) The differential case consists of two or more steel castings bolted together to form a single solid unit. The right and left ends of the case are machined to provide for the mounting of tapered roller bearings. These roller bearings support the entire differential assembly in the axle housing. When mounted in the proper position, the differential will rotate in the same direction as the wheels and tires. The axle shafts enter the differential assembly from the right and left side. The ring gear of the final drive is bolted or riveted to a mounting flange on the differential case.

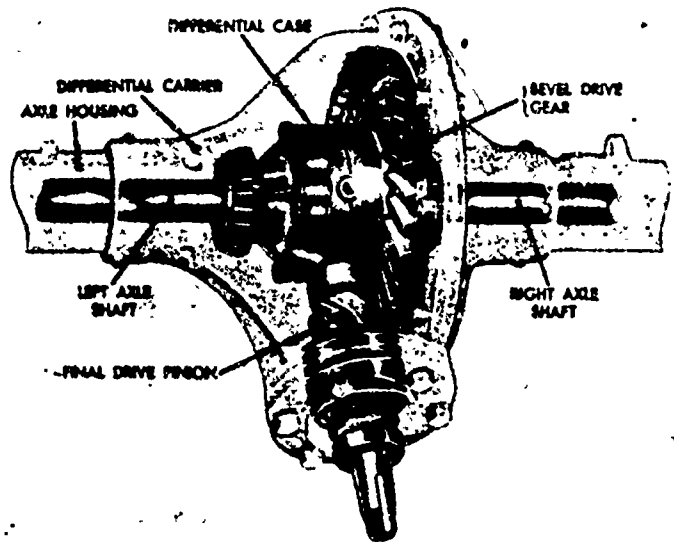

The roller bearings support the entire differential assembly in the axle housing. When mounted in the proper position, the differential will rotate in the same direction as the wheels and tires. The axle shafts enter the differential assembly from the right and left side. The ring gear of the final drive

is bolted or riveted to a mounting flange on the differential case.

(2) Notice the location of each component in the phantom view of an assembled differential.

The differential bearings are mounted on the sides of the case. They, in turn, seat in their races in the axle housing. With this type of mounting, the inner ends of the axle shafts do not support any of the weight or strain of the differential. Through their splined ends in the side gears, the shafts only deliver the output torque of the differential to the wheels.

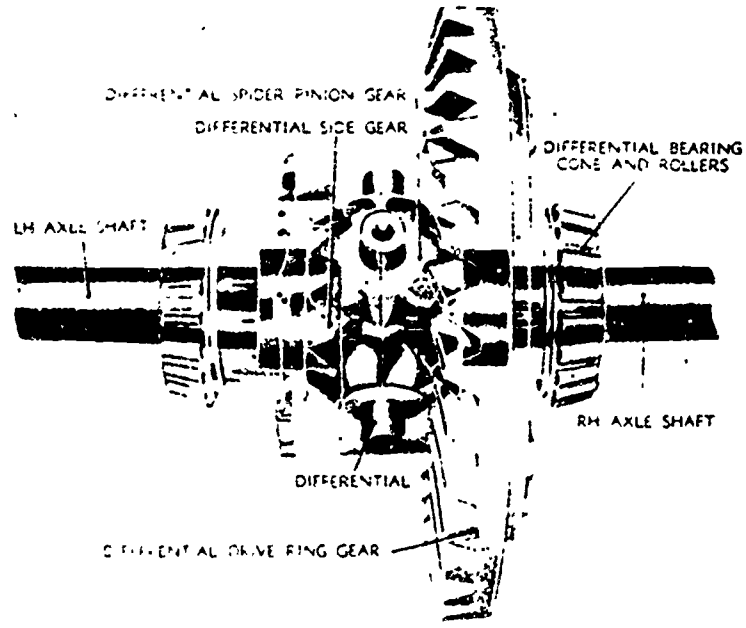

49

(3) Now let's see what the differential looks like when it is dis-assembled. Notice the holes in the two halves of the case where the four stems of the spider can seat. When the two halves of the case are bolted together with the spider or cross-shaft in place and the ring gear is bolted in place to the left half of the case, the entire unit must rotate any time the ring gear turns. Also notice that there is a bearing surface in the two sides of the case to support the machined shoulders of the bevel side gears. To assemble this unit we start by placing the left side gear and spacer in the left half of the case. Then place the four spider bevel pinions and spacers on the spider and position this assembly against the left side of the case so that the four fingers are seated in the half holes provided. When this is done you can see how the four bevel pinions will all be in mesh with the left side bevel gear. Next, place the right side gear in the right half of the case. Now, when the two halves of the case are bolted together, the right side gear will be in mesh with the four spider pinions and the spider cross-shaft will be secured in position. After bolting the ring gear to the differential case and placing the carrier bearings and shims on the case, the assembly is ready to put into the axle housing.

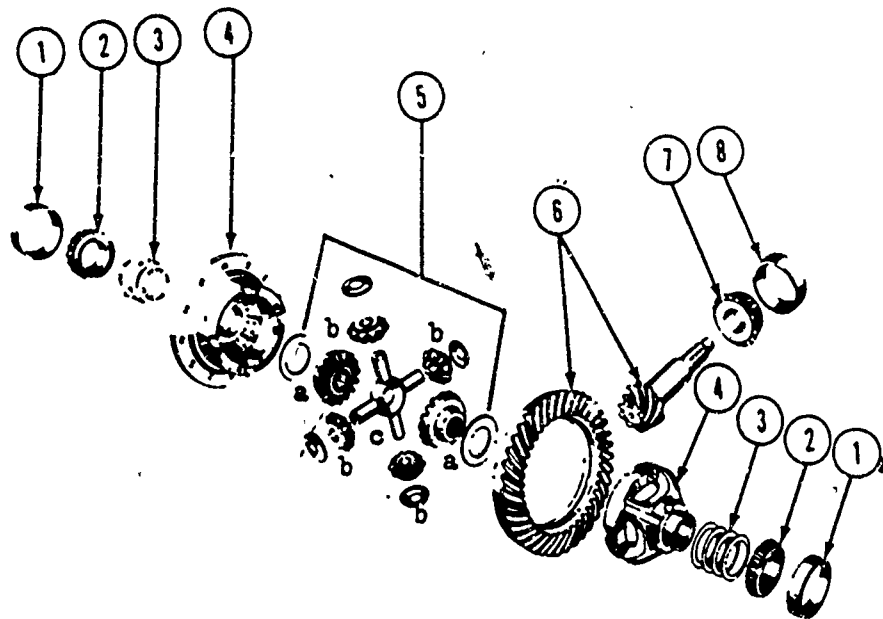

- 1,2,3 - DIFFERENTIAL CARRIER BEARINGS AND SHIMS
- 4 - RIGHT AND LEFT CASE ENDS
- 5 - DIFFERENTIAL GEARING
 - a - RIGHT AND LEFT SIDE GEARS
 - b - SPIDER PINIONS AND SPACERS
 - c - SPIDER CROSS SHAFT
- 6 - FINAL DRIVE PINION AND RING GEAR
- 7,8 - FINAL DRIVE PINION BEARING

(4) Some lighter vehicles only use two spider pinions in the differential. In this type a straight shaft instead of a four-fingered spider supports the spider pinions. Something to remember is that the side gears are free to turn on their bearing surfaces of the case and the spider pinions are also free to turn on the spider cross-shaft.

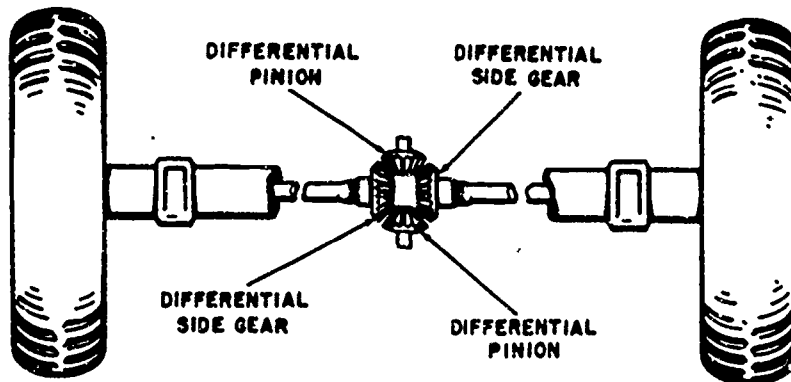

(5) Two types of differential gearing are in use in standard axle assemblies. The conventional design gears deliver equal twisting effort or torque to each axle at all times and the high-traction type delivers variable torque to each side gear, depending on the traction of the wheels. Notice in the conventional design that the teeth of the spider pinions are placed opposite each other. Also, the teeth have the normal spur gear tooth shape so that as one tooth comes out of mesh on one side of the gear, the tooth on the opposite side does the same thing. Now look at the shape of the teeth on the high-traction gears. If the ring gear was forcing the unit to rotate so the spider pinion was moving down, teeth 1 and 2 would be forcing the side gears, axle shafts, and wheels to rotate, also. However, look at the difference in the point of contact for the two teeth. The leverage from the center of the spider to the point of contact for tooth 1 is much longer than that for tooth 2. If you recall the principles of gears, this arrangement will apply a greater force on tooth 2 than on tooth 1.

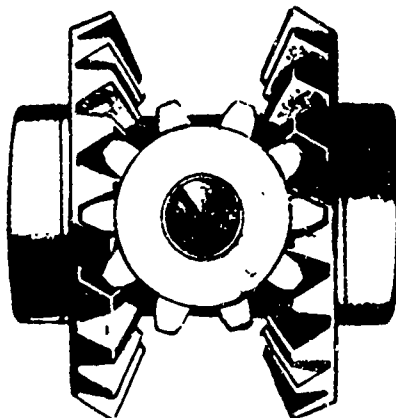

CONVENTIONAL DIFFERENTIAL PINION AND SIDE GEARS

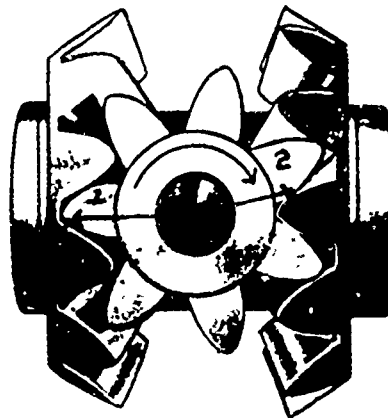

HIGH TRACTION DIFFERENTIAL PINION AND SIDE GEARS

51

(6) Now let's imagine that the wheel driven by tooth 2 slipped a little on ice while the wheel driven by tooth 1 had good traction. This would mean that the right side gear would rotate a little more than the left side gear because the wheel driven by the right side gear had slipped. When this happens, the spider pinion will rotate a small amount in the direction shown by the arrow. Now tooth 2 will slide out of the right side gear a small amount and be driving the side gear with the point of the tooth. At the same time tooth 1 will have moved to a position where the part of the tooth pushing down on the left side gear will be closer to the center of the pinion. This will now place a greater leverage on the left side gear, which is driving the wheel that has good traction.

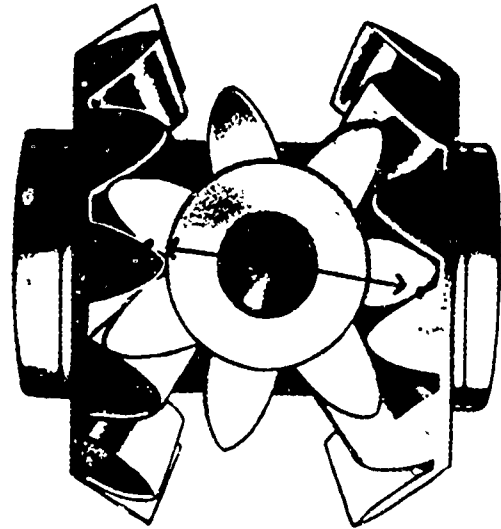

AFTER SPIDER GEAR HAS ROTATED

(7) The high-traction type gearing works very well where only a small amount of wheel slippage is involved. In the event one wheel is on a large piece of ice and the other wheel has good traction, it will not provide enough change in torque to keep the one wheel from spinning.

g. The axle shafts must be strong enough to deliver the twisting force necessary to move the vehicle under all conditions. The full-floating axle shaft is splined on one end to fit the splines of the differential side gear. The other end can either contain a flange that can be bolted to the wheel hub, or it may be splined and require a splined flange that slides onto the shaft first and is then bolted to the hub. The semifloating axle is mounted a little different. Remember, they support some of the weight of the vehicle so the wheel end is tapered and the wheel hub is keyed to it and held in place with an axle nut.

h. The axle housing is usually a steel casting that will vary in size according to the vehicle design and size. The housing mounts the wheels, axle shafts, final drive, and differential assembly. Seats or flat surfaces are provided either on the top or bottom of the housing for springs. On vehicles with more than one rear axle, torque rods are connected to arms located on the top and bottom of the housing. Like the tandem trailer axles, the torque rods and leaf springs keep the axles in position.

(1) More than one type of axle housing is used on wheeled 52 vehicles. Some early vehicles used an axle housing that was made of two sections. These consisted of a right and left section that were joined in the center with bolts. Axles using this type of housing are called split type. The split construction requires that the axle be removed first and then completely disassembled for inspection or repair of the differential. A standard type differential assembly is supported by tapered roller bearings in the right and left housings. The drive pinion and shaft are mounted in the front of either the right or left section. Notice in the illustration that the housings for the axle shafts and the differential are made as separate items and then riveted together. An arrangement similar to the center section is used on the 1/4-ton truck M151, as you will see later in this lesson.

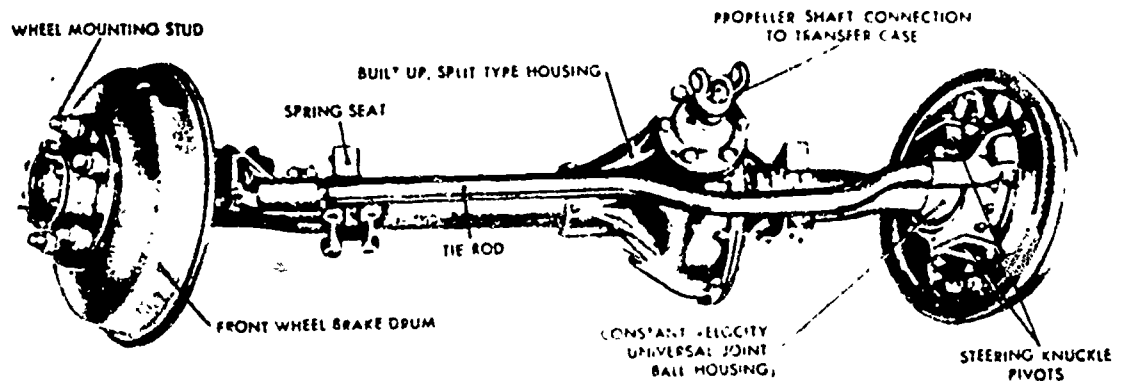

(2) Most present-day vehicles use a banjo-type rear axle. With this type of construction the differential and final drive assemblies are made as a single unit. The axle housing is a large single unit with a large opening in the center to receive the differential assembly. The differential and final drive are bolted into the front of the housing, and the axle shafts installed from the right and left ends. It is possible with this type of axle housing to remove and repair the differential without complete disassembly of the axle assembly. Two different banjo-type axle housings are presently in use on military wheeled vehicles. One type mounts the final drive assembly in the front or rear of the housing. For example, the banjo axle in the accompanying illustration is a rear axle and the final drive (differential and carrier) is mounted on the front of the housing.

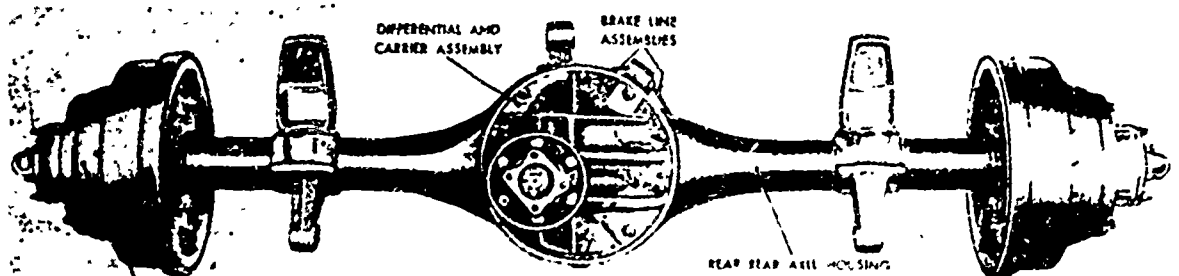

53

(3) The second type of banjo axle mounts the final drive gearing on the top of the axle housing. This type axle assembly is used on most of the military tandem axle trucks. It is used as a front steering and drive axle as well as for both rear driving axles. On military vehicles, this type axle uses the double-reduction final drive gearing.

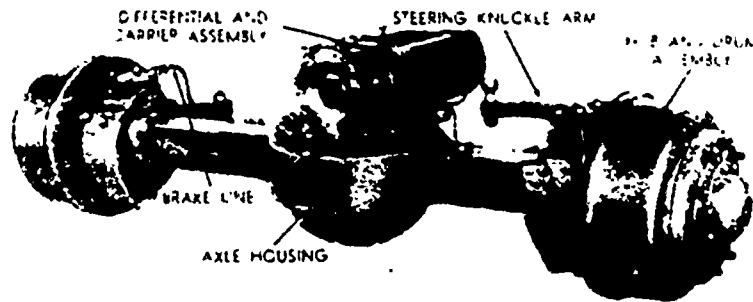

5. OPERATION OF LIVE REAR AXLES. As the vehicle operator engages the clutch, the rotating motion of the engine is transmitted through the transmission and transfer case to the axle by the propeller shafts. The propeller shaft is connected to the pinion shaft by means of a flange or yoke at the front of the axle and turns the pinion shaft and gear of the final drive. This forces the ring gear, which is in mesh with the pinion gear, to turn in the direction driven by the pinion. Since the ring gear has more teeth than the pinion, it will rotate more slowly. There is, therefore, a loss of speed and a gain in torque between the pinion and ring gear. The ring gear is solidly fastened to the differential case. Therefore, the entire differential assembly turns when the ring gear turns. The spider or differential pinion shafts that are mounted in the case are carried along at the same speed as the case. When the vehicle is moving straight ahead on a smooth surface, the differential pinion gears do not rotate on the spider or cross-shaft. As the pinions are carried along with the differential case, they drive the two side gears at the same speed as the case. Each side gear receives the same torque. The right and left axles are splined to the differential side gears and are driven at the same speed as the turning differential assembly. The outer ends of the two axles drive the wheels at the same speed. Now let's see what happens in the differential when the vehicle makes a turn.

a. Let's say that a vehicle goes around a short right turn. Notice that when the center of the rear axle has traveled a given distance in the turn, the two wheels have traveled two different distances. The outer wheel had to travel almost 4 extra feet to keep up with the inner wheel. This means the outer wheel had to travel faster than the inner wheel to travel the greater distance. This also means the differential side gears travel at two different speeds.

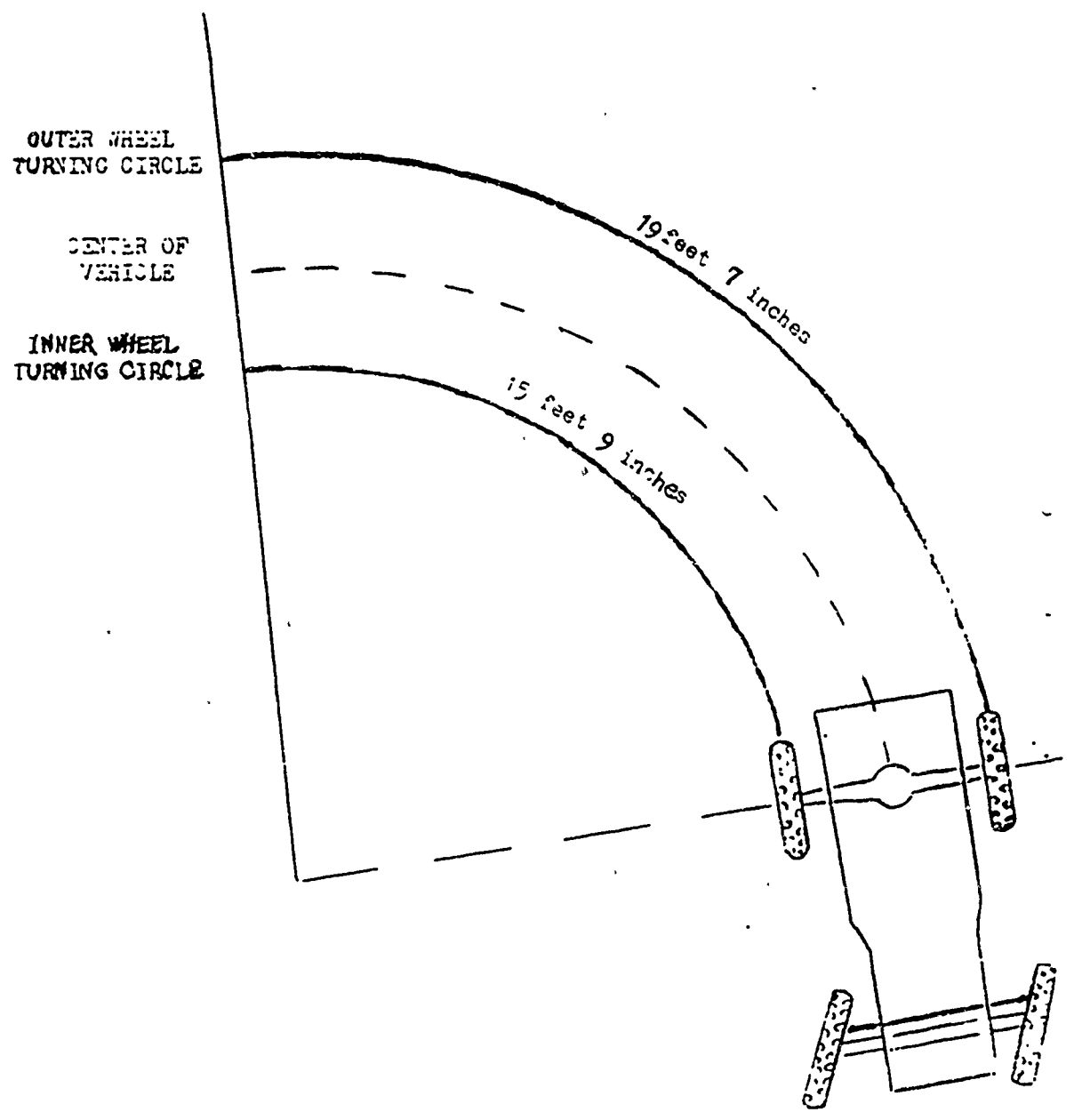

(1) When the differential side gears rotate at two different speeds, they cause the pinions or spider gears to rotate on their shafts. The pinions

walk around the slower side gear and force the other side gear to turn faster or speed up. The faster side gear must turn the speed of the final drive ring gear plus whatever rotation is being caused by the rotating pinion. The pinion rotates as it travels between the two side gears. The pinions continue to rotate on their shafts as long as the side gears are at different speeds. If the vehicle turns in the opposite direction, the pinions will again rotate on their shafts but in the opposite direction.

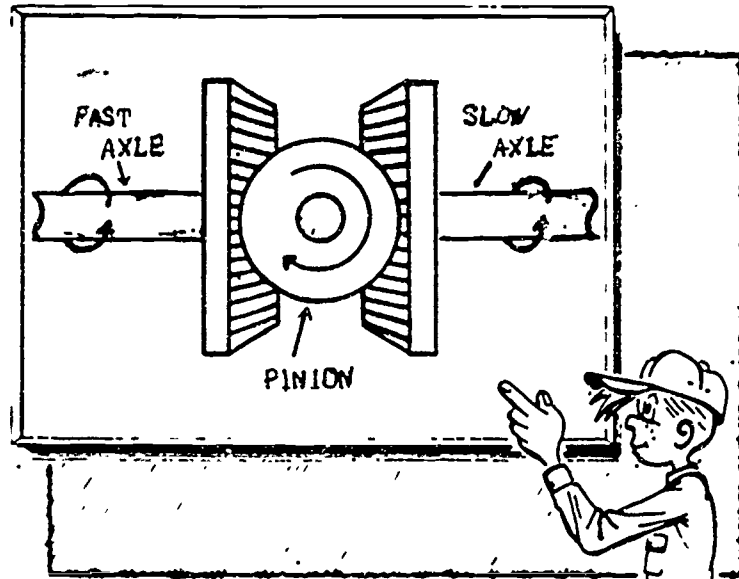

(2) When the inner wheel slows down in a turn, the outer wheel speeds up the same amount. For example, let's say the ring gear and differential case are rotating at 100 revolutions per minute (RPM) as the vehicle makes a turn that causes the inside wheel to slow down to 70 RPM. This is 30 RPM slower than the ring gear. The outer wheel therefore has to be rotating 30 RPM faster than the ring gear, or 130 RPM. If you look at the illustration you can see an example of the speed relationship of the two wheels. Notice that the ring gear and, therefore, the speed of the vehicle are being kept at one speed throughout the example.

	LEFT WHEEL	RING GEAR	RIGHT WHEEL
STRAIGHT AHEAD -	100	100 RPM	100
SHARP LEFT TURN -	70	100 RPM	130
SLIGHT RIGHT TURN -	110	100 RPM	90

differential case are rotating at 100 revolutions per minute (RPM) as the vehicle makes a turn that causes the inside wheel to slow down to 70 RPM. This is 30 RPM slower than the ring gear. The outer wheel therefore has to be rotating 30 RPM faster than the ring gear, or 130 RPM. If you look at the illustration you can see an example of the speed relationship of the two wheels. Notice that the ring gear and, therefore, the speed of the vehicle are being kept at one speed throughout the example.

56

(3) If torque is being applied to the rear axle, such as when going up a hill, the torque enters the rear axle through the pinion and is then increased as it passes through the ring gear. It is then transferred to the differential case and the differential pinion shaft and pinions. The pinions then apply equal torque to each axle side gear and the torque is transferred to the wheels by the axle shafts.

b. If the tires on one side of an axle with a conventional differential lose their grip on the road surface, the wheel will spin. With traction or grip on the road gone on one side, that wheel becomes very easy to turn. The opposite wheel that still has good traction is hard to turn. This being the case, the power flow takes the path of least resistance and goes to the slipping wheel. This is possible because of the differential gearing. One of the side gears is hard to turn and the other very easy. The driving differential pinions walk around the hard-to-turn side gear and at the same time drive the easy-to-turn side gear faster than normal. This is an undesirable feature, but it has not proven enough of a problem to cause a change to the types of axles used on military vehicles.

c. A great amount of force is needed to move a heavy vehicle when it is stopped. When engine torque is applied to the rear axle, there are forces attempting to move in many directions. As the pinion gear tries to turn the ring gear, the two gears will tend to be forced apart. Keep in mind that as the engine tries to move the vehicle, the vehicle will resist and try to remain at rest. If the pinion gear is of the straight bevel type, the force being applied will try to push the driving pinion to the front of the vehicle and to the side away from the ring gear. A spiral bevel pinion may be pulled inward toward the differential as it tries to drive the ring gear. At the same time the ring gear will try to move to the side away from the driving pinion. Some axle assemblies include a thrust pad mounted on the case to the rear of the ring gear to limit the amount the gear can move sideways. As the ring gear is forced away from the pinion, a twisting force is received by the differential carrier bearings. Also, as the ring gear drives the differential, the resistance from the wheels causes the assembly to drive against the mounting bearings. Inside the case, the differential gears try to push themselves apart as torque is applied. This causes both the pinions and side gears to press against the thrust washers between the gear and the case. When a sudden heavy force is applied to the axle shafts, they tend to twist or wind up. The entire axle assembly tries to twist the mounting springs as it drives the wheels. The vehicle's springs or torque rods are designed to control the twisting effort of the axle assembly.

57
6. CONSTRUCTION OF LIVE FRONT AXLES. One of the requirements for tactical military vehicles is all-wheel drive. To provide this, the front axle must be similar to a live rear axle assembly. The main difference between the live front and live rear axles is that the front wheels must be able to pivot for steering purposes. This also means that the driving axle shafts must be able to deliver torque at an angle to the wheels when they are turned. There is very little difference in the final drive and differential assemblies of most front and rear live axles. On some models of vehicles the differential assemblies are made the same in both the front and rear so that they may be interchanged. We will, therefore, only cover the construction of those parts not found in the rear axle.

a. The axle housing is a large steel hollow casting that acts as the base or mount for all the other parts. On the front axle housing the final drive and differential assembly are often mounted off of the center position. This is to allow the driving propeller shaft to bypass the engine oil pan. The axle housing extends all of the way across the front of the vehicle. Each end of the housing contains components for the steering mechanism. As with the dead axle, these are the parts of the axle that are hinged to turn and provide steering. On the live axle the steering knuckle appears to be a large ball joint with each end of the axle housing shaped like a ball.

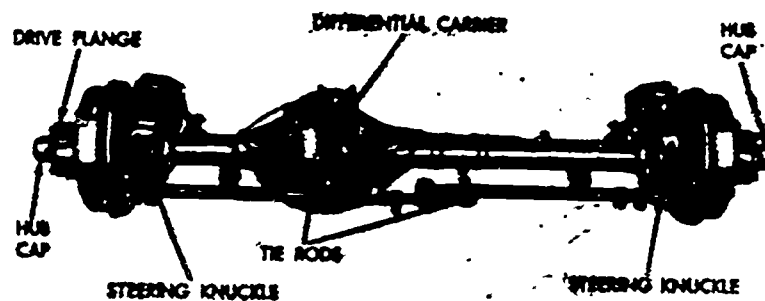

(1) The top and bottom of the round end of the housing contain mounting points for the spindle or knuckle bearing. Around the outside and partly covering most of the round ends of the axle housing are the steering knuckle housings. The steering knuckle housing is connected to the end of the axle housing by upper and lower knuckle bearings. On this type axle a kingpin cannot be used to hold the bearings in position, because

it cannot pass completely through the housing of a live axle. Two short kingpins are used on the top and bottom of each end of the axle to align the bearings. These kingpins may be mounted on the axle housing or on a plate that bolts to the top and bottom of the steering knuckle housing.

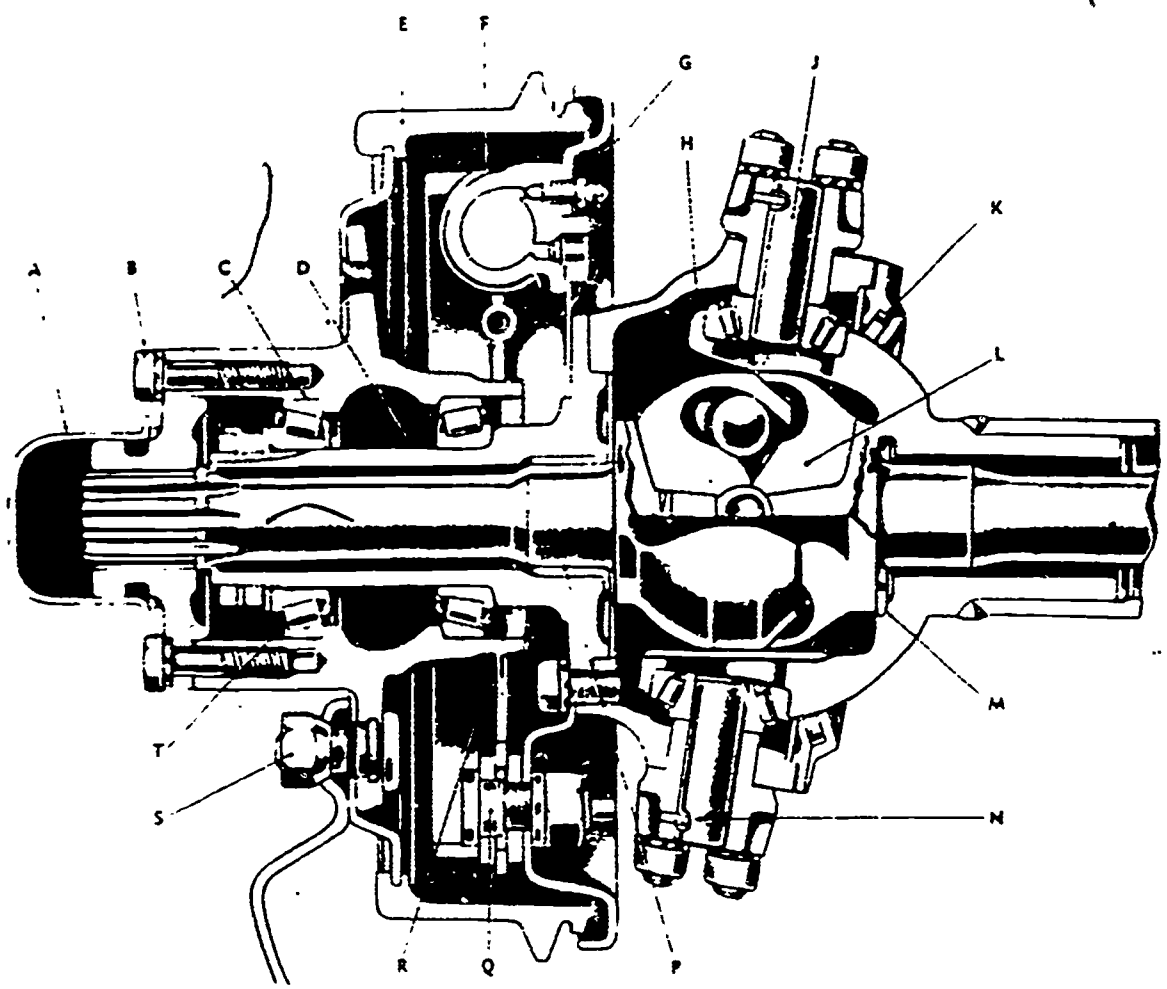

- | | | |
|---------------------------|---------------------------------------|---------------------------------|
| A—HUB CAP | H—KING PIN BEARING CUP | N—KING PIN LOCK PIN |
| B—DRIVE FLANGE SCREW | J—KING PIN | P—WHEEL BEARING SPINDLE BEARING |
| C—FRONT WHEEL BEARING CUP | K—OIL SEAL | Q—BRAKE SHOE ANCHOR PIN |
| D—WHEEL BEARING SPINDLE | L—BENDIX-WEISS UNIVERSAL JOINT | R—HUB OIL SEAL |
| E—BRAKE DRUM | M—WHEEL SPINDLE BEARING THRUST WASHER | S—HUB BOLT—NUT |
| F—WHEEL BRAKE CYLINDER | | T—FRONT WHEEL BEARING CONE |
| G—BRAKE LOCKING PLATE | | |

59

(2) Tapered roller bearings help support the vehicle and keep the steering knuckle in proper alignment. The bearings also provide a pivot or turning point for steering the wheels. Shims are used at the bearing mounting surfaces to insure proper adjustment. An oil seal, mounted on the inner side of the steering knuckle housing, rides on the round surface at the ends of the axle housing. The spindle has a flange that bolts to the outside of the steering knuckle housing. The spindle also serves as a mounting point for the wheel hub and bearings.

b. The axle shafts are designed to operate in the hollow tube sections on each end of the axle housing. The inner end of the axle shaft is splined to a side gear in the differential assembly. On most tactical military vehicles, the outer end of the axle shaft is splined to a flange. This flange is bolted to the wheel hub and provides the means of driving the front wheel. The front axle shafts must be able to pivot in the steering knuckle. A universal joint provides a means of transmitting power at an angle. A single conventional universal joint (the type used in the propeller shaft) does not meet military requirements for use on the front axle assembly. Remember from an earlier lesson that there are slight fluctuations or changes in speed of the driven member when a standard U-joint is operated at an angle. During steering, the axle shaft in the front live axle assembly must operate at angles up to 30° . Because of the large driving angles, a joint has to drive the output the same as the input without speed changes. This type of universal joint is called a constant velocity (CV) joint. There are three types of CV-joints presently in use in military vehicles. These are the Rzeppa, Bendix-Weiss, and Tracta types. All of the axle shafts have an inner and outer section. The sections are connected together by the parts that make up the constant velocity universal joint. The CV-joint is housed in the steering knuckle. Let's see how each type of constant velocity joint is constructed.

(1) The Rzeppa-type joint uses six smooth steel balls to provide the flexible drive. These balls are mounted between an inner and outer race. The outer race is made as a part of the outside axle shaft. The inner race is a separate part splined to the outside end of the inside axle shaft. A cage is made to fit around the six driving balls and hold them in the proper position during vehicle turns. To control the movement of the cage and balls, a pilot, spring, and pin are mounted in the center of the outside axle at the CV-joint. These control items insure that the steel balls are on a line that divides the angle made by the inner and outer axle shafts.

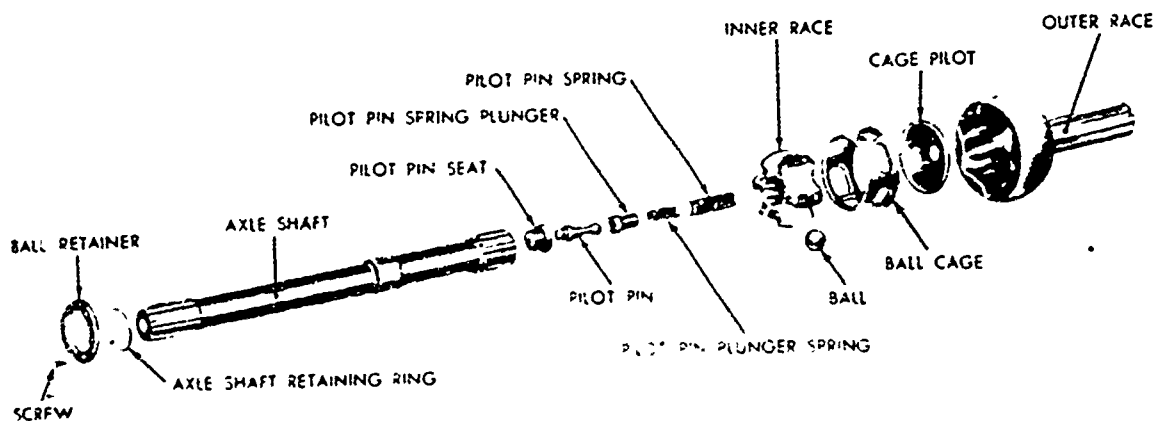
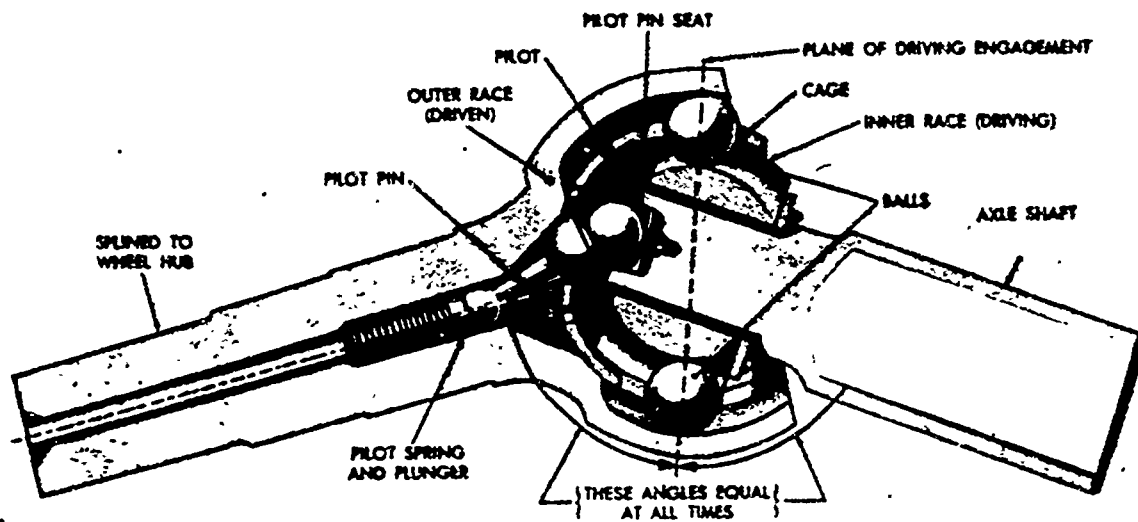

61

(2) The Bendix-Weiss is another constant velocity joint that uses steel balls to transmit power at an angle, but with slightly different construction. Notice in the illustration that both the inner and outer axle shafts have yokes made as part of the shaft. The yokes contain races for smooth steel balls. These races are long grooves that permit the balls to move back and forth as the shaft's drive angle changes. There are four balls mounted between the two yokes in the races. A fifth ball is mounted in the center to lock the four outer balls in place. The center ball is held in place with a pin. When the joint is assembled, the steel balls form a tight fit between the inner and outer shafts. The tight fit is necessary since there is no cage to move the balls, and movement is controlled by friction between the connecting parts.

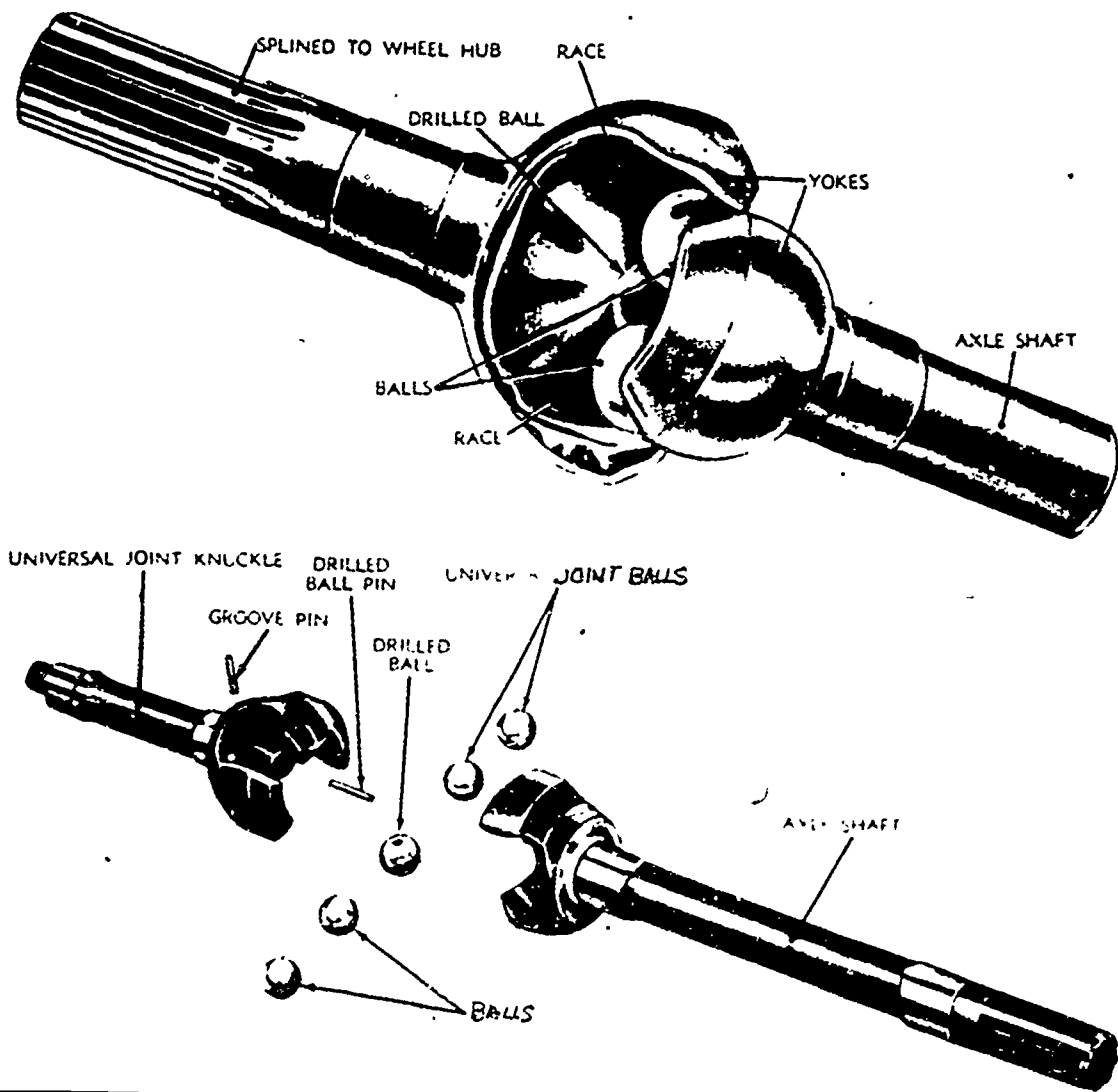

(3) The Tracta type constant velocity joint is not like the other types, since no steel balls are used to provide the flexible drive. In place of the balls, two tongue and groove portions are made to mount between the inner and outer axles. These two portions, or halves, are called a universal joint. The two halves of the universal joint are made as male and female to fit together in a floating or movable connection. Each of the two center portions is also made to be mounted on one of the axle shaft yokes. The yoke, which is made on the inner end of each axle shaft, provides a floating connection at the constant velocity joint. When assembled, each of the two center portions are able to pivot, or turn, between the other portion and connecting axle. The axle shafts are supported in the housing by bushings located on each side of the constant velocity joint.

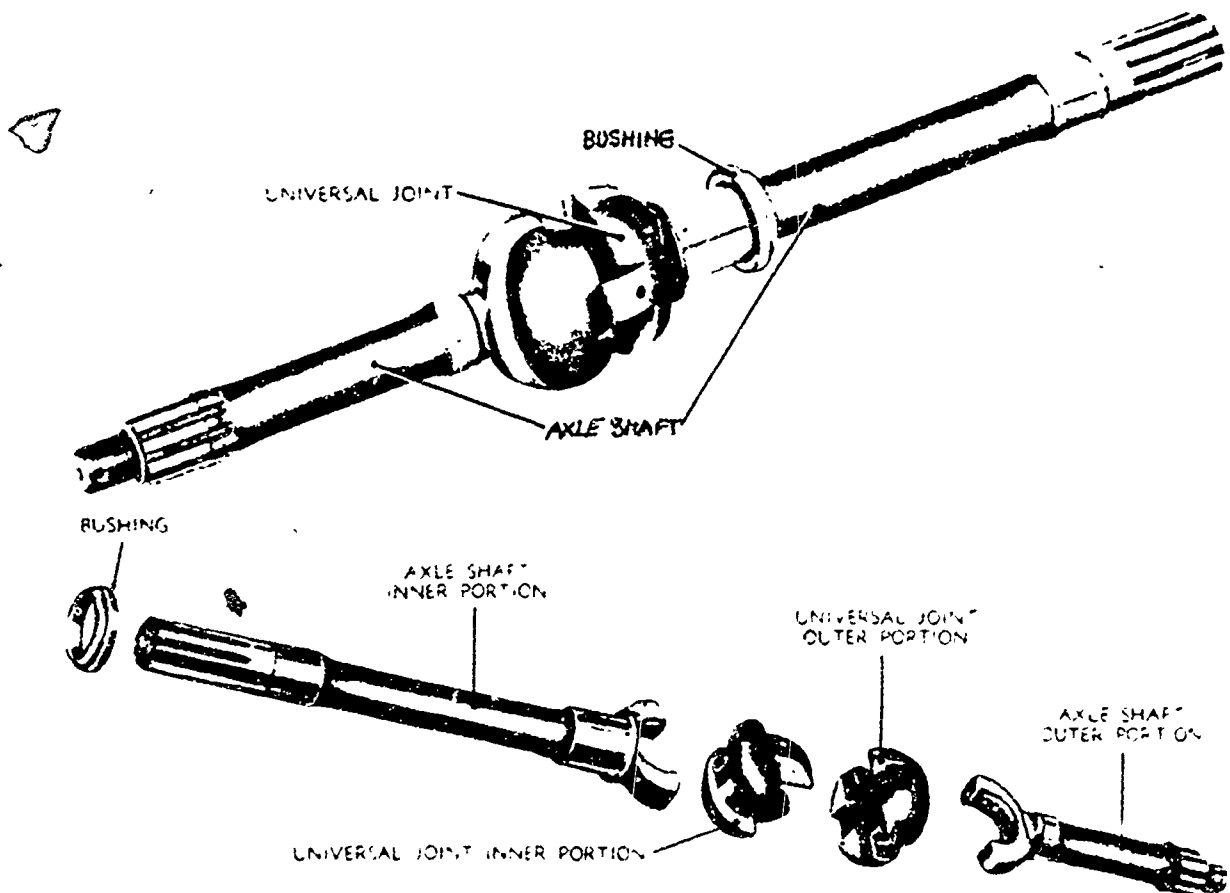

63

7. OPERATION OF LIVE FRONT AXLES. The operation of the final drive and differential assemblies in the live front axle is the same as those in a rear axle. Gear ratios designed to increase engine torque will be the same as those of the rear axles on the vehicle. None of the front axle assemblies used in wheeled vehicles are designed to be operated under power all of the time. Some vehicles have a control in the cab that permits the driver to engage the front axle when it is needed. Other vehicles have a device made into the transfer assembly to automatically engage the front-wheel drive when the rear tires lose traction and spin. When the vehicle is traveling straight ahead, both the inner and outer axle shafts are on the same line. If the front axle is engaged to the power train, the inner axle shaft will drive the constant velocity (CV) joint. The CV-joint will, in turn, drive the outer axle shafts which are splined to the wheel hubs. As steering arms and rods turn the knuckles, the axle shafts will flex at the CV-joint. During the turn, the CV-joint will continue to deliver a smooth, steady flow of torque. The steering linkage is designed to move both steering knuckles at the same time to the proper angle for the turn.

8. LUBRICATION OF LIVE AXLES. Any time the vehicle is moving, the gears of the final drive and differential are turning. The lower part of the gear box is filled with gear oil to a required level. This causes the lower part of the gearing to turn through a pool of oil each time the unit rotates and thereby lubricates all of the working parts. On some types of axle assemblies, oil flows down each axle shaft housing to lubricate the bearings that support the outer ends of the axle shafts or wheel bearings. Lubrication of the CV-joints is generally done by packing the joints with GAA (grease, automotive and artillery). Breather valves are installed in the axle assembly to allow excess pressure to escape. Pressure will build up in the gear box as the unit heats up during operation. The breather valve must be able to perform this job without allowing dirt or water to enter from the outside.

64

9. DRIVE AXLES OF 1/4-TON TRUCKS. The 1/4-ton utility truck M151-series has a final drive that differs from those used in other vehicles. Each truck of this model is equipped with individual wheel suspension. This means that each wheel has its own separate mounting and is not solidly connected to any of the other wheels. Any of the wheels may move up and down as the vehicle follows the road surface without affecting any of the other wheels. This type of construction does away with the solid axle that extends across the vehicle below the body and frame. The final drive and differential assembly is made as a separate unit. Both the front and rear differential assemblies are mounted to the frame of the vehicle rather than in an axle housing. Power is carried from the differential assembly to the wheels by means of standard propeller shafts. Universal joints, made in the propeller shafts, allow for movement of the wheels. This type of axle is known as a swing axle.

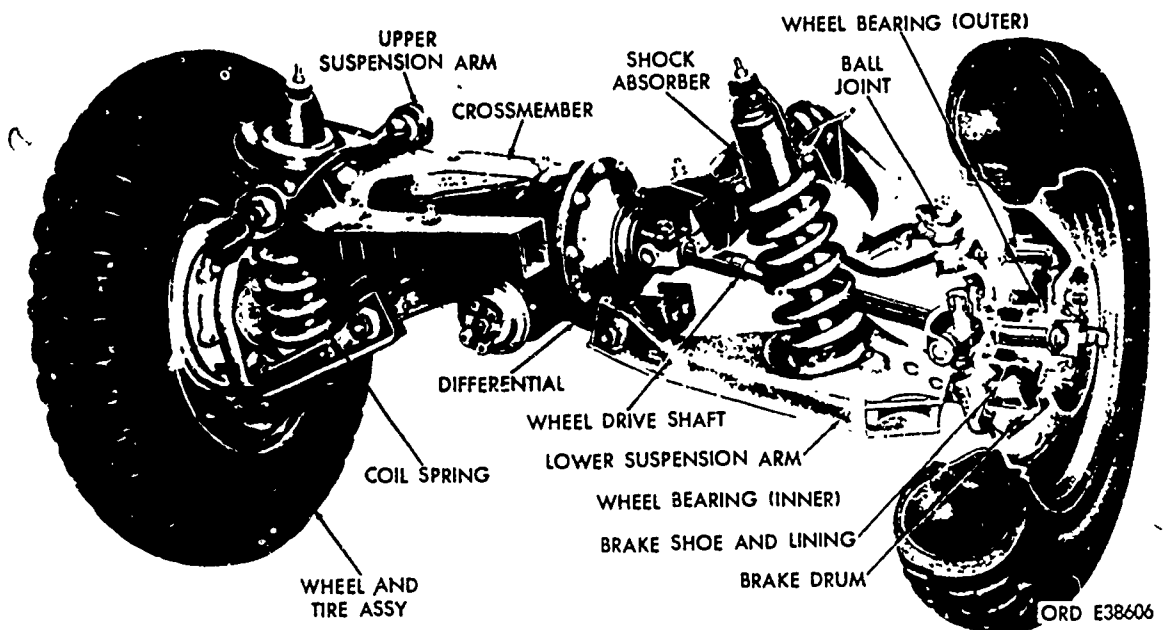

65

10. FRONT-WHEEL DRIVE ON HEAVY TRUCKS. Some larger trucks used by the Army have a front-wheel drive that does not have a CV-joint or universal joint in the front axle shafts. The wheels are driven with a combination of shafts and gears. A double set of bevel gears replaces the CV-joint. Notice in the illustration how torque is delivered to the front wheels using gears. The axle shafts drive the pinion of the first set of gears. The driven gear of the first set is solidly connected to the driving gear of the second set. The driven gear of the second set is made as part of the wheel hub. Both gear sets use spiral bevel type gearing similar to that in the final drive.

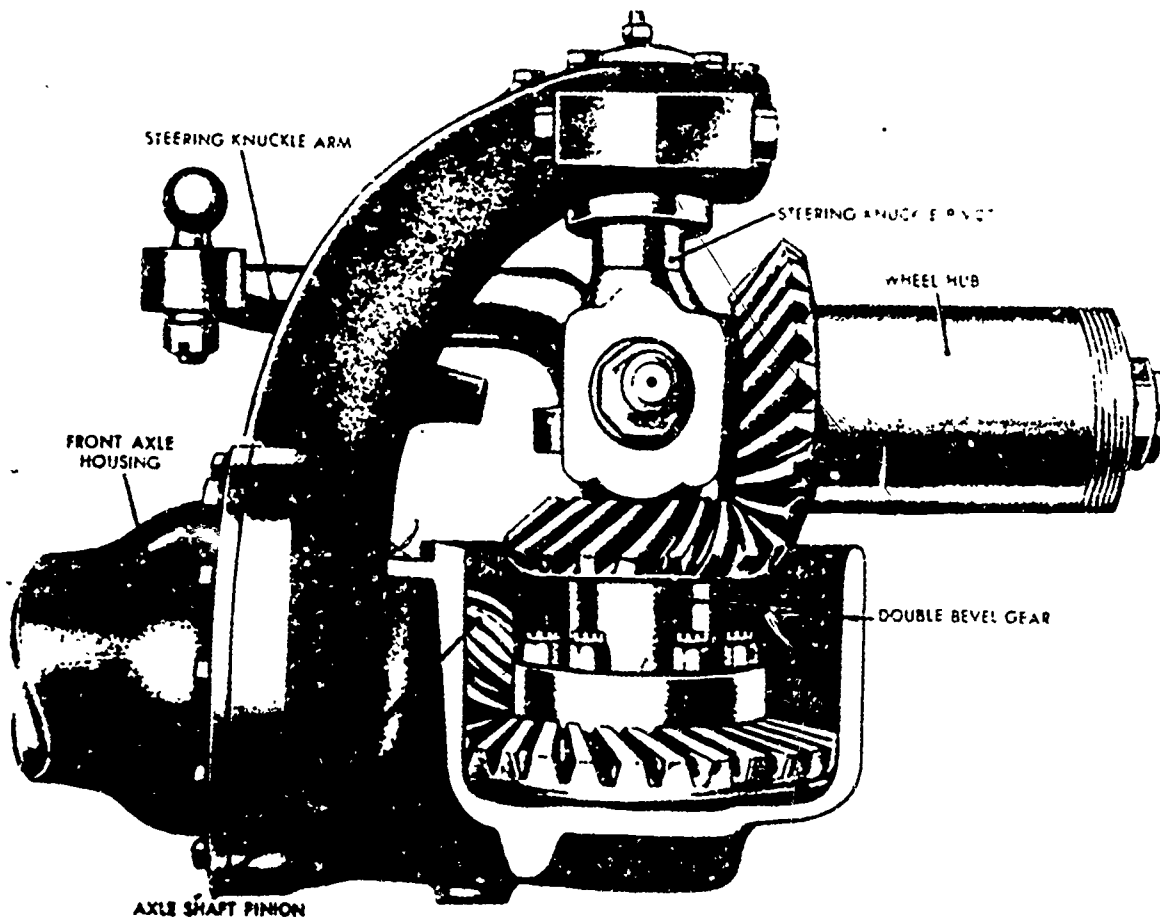

a. When the wheel is mounted on the wheel hub, power can flow from the axle shaft to the wheel. The gearing provides a smooth, even flow of power. If the steering linkage is moved to turn the wheels, the gear mounted on the wheel hub walks around the driving gear. Two sets of bevel gears must be used. The first set of gears turns the power flow 90° or at a right angle. A second set of gears is necessary to once more change the power flow 90° .

2-32

78

b. This type front-wheel drive can also provide part of needed axle gear reduction in these bevel gears. Notice in the illustration above that the axle shaft pinion is driving a much larger gear. This is part of the axle gear reduction. Some heavy military vehicles have three different gear reductions in one front-driving axle. You can see an example of this type axle in the accompanying illustration. Notice that the axle has one gear reduction in the differential and carrier area and two gear reductions near each wheel at the steering pivot.

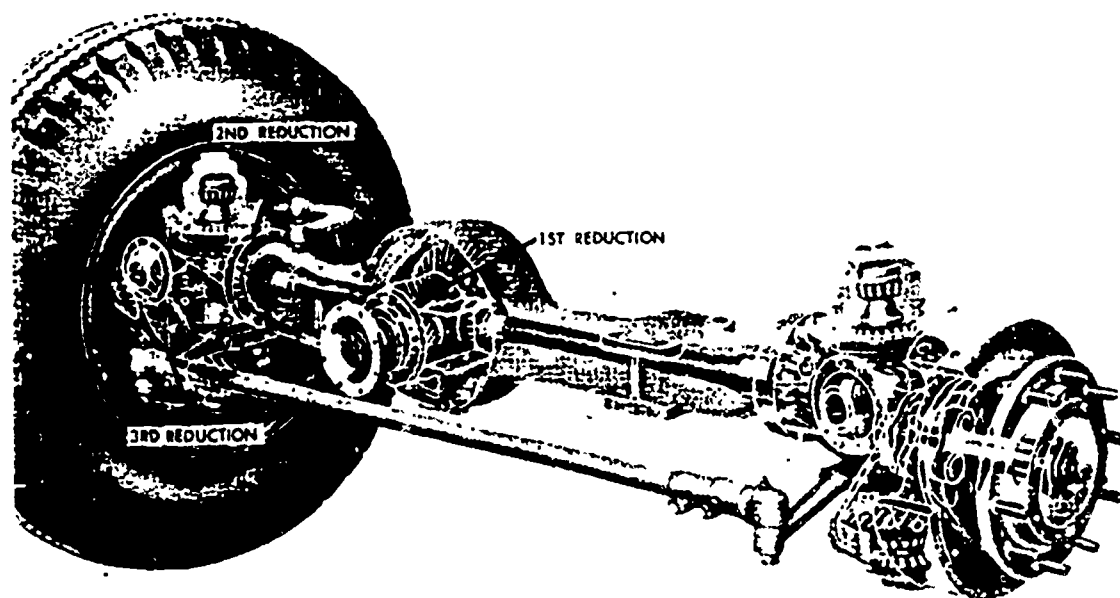

11. SUMMARY. In this lesson we have discussed the construction, operation, and use of live and dead axle assemblies. We covered the fundamentals of differential and constant velocity universal joint operation and how they are used in various vehicles. You should now be able to look at various axle components and identify them by type and understand their operation.

12. PRACTICE TASKS. The appendix of this lesson contains a list of tasks associated with the construction, operation, and types of axle shafts and the lubrication of them. They are representative of the tasks you will be required to perform as a wheeled vehicle mechanic. Perform all of the tasks listed. Be sure you are under the supervision of an officer, NCO, or specialist who is qualified in the MOS when you practice the tasks. If you find you are having difficulty in certain tasks, restudy the appropriate training material and practice the tasks until you become proficient in each one.

67
EXERCISE

Note. - Complete exercises 16 through 35 before continuing to lesson 3.

16. The driven gear in a single reduction final drive is called a
- hypoid gear.
 - spur gear.
 - ring gear.
17. In which type of axle can the axle shaft be removed without removing the wheel?
- Semifloating
 - Three-quarter floating
 - Full-floating
18. What type of wheeled vehicle always uses a live front axle?
- Commercial
 - Tactical
 - Transport
19. What type of universal joints are used in the live front axles of most types of military vehicles?
- Ball and trunnion
 - Mechanic's
 - Constant velocity
20. Which type of joint used in live front axles does not use steel balls?
- Tracta
 - Bendix-Weiss
 - Rzeppa
21. The bevel drive reduction gears in a single reduction final drive consist of the pinion and the
- spider gear.
 - ring gear.
 - side gear.

- 22. On which type of axle is most of the vehicle weight and wheel side thrust absorbed by the axle housing?
 - a. Full-floating
 - b. Three-quarter floating
 - c. Semifloating

- 23. If the driving gear in a final drive has 10 teeth and the driven gear has 45 teeth, the gear ratio is
 - a. 4.5:1.
 - b. 3.5:1.
 - c. 1:4.5.

- 24. In a live axle the inner ends of the axle shafts are connected to the differential
 - a. spider gears.
 - b. side gears.
 - c. case.

- 25. The type of axles used on the 1/4-ton truck M151 are known as
 - a. plain live axles.
 - b. independent axles.
 - c. swing axles.

- 26. Which statement is true in regard to wheel speed when a vehicle is making a turn?
 - a. The inside wheel rotates slower than the outside wheel
 - b. The outside wheel rotates slower than the inside wheel
 - c. Both the inside and outside wheels rotate at the same speed

- 27. What is one undesirable feature in the bevel gear differential?
 - a. It will not move the vehicle if one wheel loses traction
 - b. It is difficult to lubricate satisfactorily
 - c. It cannot be used on vehicles with swing axles

- 28. An axle that delivers no power to the wheels is called a
 - a. steering axle.
 - b. dead axle.
 - c. suspension axle.



- 69.
29. What part of the drive mechanism is bolted or riveted to the differential case?
- Pinion gear
 - Ring gear
 - Side gear
30. Which statement is true in regard to differential side gear operation when a wheeled vehicle is rounding a turn in reverse?
- The gears turn in the same direction at the same speed
 - The gears turn in the same direction at different speeds
 - The gears turn in opposite directions at the same speed
31. What is a disadvantage of the split-type live axle assembly?
- Full-floating axles cannot be used due to housing design
 - Final drive gearing and differential are exposed to dirt and water
 - Entire assembly must be removed from vehicle to service differential
32. In what part of a live front axle housing are the CV-joints located?
- Spindle
 - Knuckle
 - Differential
33. Why is the center of a dead front axle usually dropped several inches below its ends?
- Increases the road clearance
 - Lowers the vehicle's center of gravity
 - Decreases the weight on the springs
34. The steering knuckle pin in a dead front axle is also called a
- kingpin.
 - lockpin.
 - pivot pin.
35. What components of a live front axle assembly are packed with GAA (grease, automotive and artillery) for lubrication purposes?
- Differential gears
 - Final drive gears
 - Constant velocity joints

APPENDIX

PRACTICE TASK LIST

Practice Objectives After practicing the following tasks you will be able to:

1. Locate the axles on vehicles in your organization.
2. Differentiate between a dead axle assembly and a live axle assembly.
3. Trace the power flow through a final drive assembly to the wheels of a 1/4-ton truck M151.
4. Point out the location of the components of the 2-1/2-ton front axle assembly.
5. Locate the lubrication points on various axles.

Practice Tasks.

1. Now that you have studied this lesson you should look at actual axle assemblies on vehicles within your organization. By practicing the following tasks you should have a better understanding of wheeled vehicle axle construction and operation:

a. Locate the axles on several types of vehicles in your unit. Pay particular attention to how they are used to support the vehicle.

b. Compare dead axles used on trailers with those used on the front of commercial-type vehicles. Mentally identify the differences.

c. Compare the dead and live front axles of vehicles. Identify these differences in the steering pivots of the front axles.

d. Jack up the wheels on one end of a 1/4-ton truck. Rotate the drive shaft and observe the wheels turning. Hold one wheel and notice how the rotating wheel speeds up.

e. Point out the location of the components of a 2-1/2-ton live front axle. Determine if the final drive is a single reduction or a double reduction type gearing.

71

f. Locate the lubrication points and vents on various axles. Notice the levels of lubricant in the final drives of each axle.

g. If possible, look at a live front axle that has been disassembled. Identify the types of gears in the final drives and determine what type CV-joint is used in the axle.

2. If you have any problems with any of the practice tasks, study the lesson some more to help you with the tasks.

73

CONTENTS

	Paragraph	Page
LESSON ASSIGNMENT SHEET.		3-1
STUDY TEXT		
Section		
I. Inspection of Axle Assemblies		
Introduction	1	3-3
Inspection procedures	2	3-4
Inspection of M151-series truck axles	3	3-7
II. Repair of Axle Assemblies		
Removal and replacement of front axle shafts on 2-1/2- ton trucks	4	3-8
Replacement of steering knuckle boot on 2-1/2-ton trucks	5	3-14
Replacement of inner wheel bearing seal	6	3-17
Wheel bearing and seal replace- ment on 1/4-ton trucks M151	7	3-17
Replacement of differential pinion seal on M151 trucks.	8	3-27
Replacement of differential side gear seals on M151 trucks	9	3-29
III. Replacement of Axle Assemblies		
2-1/2-ton truck front axle assembly replacement	10	3-31
2-1/2-ton truck rear axle assembly replacement	11	3-34
M151 truck differential replacement	12	3-35
IV. Conclusion		
Summary	13	3-37
Practice tasks	14	3-37
APPENDIX		
Practice Task List.		3-42



74

US ARMY ORDNANCE CENTER AND SCHOOL
CORRESPONDENCE/OJT COURSE



LESSON ASSIGNMENT SHEET

Ordnance Subcourse No 63B206 . . . **Wheeled Vehicle Drive Lines,
Axles, and Suspension Systems**

Lesson 3. **Maintenance of Axles**

Credit Hours. **Three**

Lesson Objectives **After studying this lesson you will
be able to:**

1. Explain the procedures for inspecting axle assemblies.
2. Describe the procedures for removing and replacing the front axle shaft of a 2-1/2-ton truck.
3. Describe the procedures for steering knuckle boot replacement.
4. Describe the procedures for inner wheel bearing seal replacement.

5. Describe the procedures for wheel bearing and seal replacement on a 1/4-ton truck M151.
6. Describe the procedures for differential pinion seal replacement.
7. Describe the procedures for replacing the differential side gear seal.
8. Describe removal procedures for the front axle assembly of a 2-1/2-ton truck.
9. Describe the procedures for replacing the rear axle assembly of a 2-1/2-ton truck.
10. Describe the procedures for replacing the differential of a 1/4-ton truck M151.

Materials Required: ALL STUDENTS. Answer sheet and exercise response list.

CORRESPONDENCE/OJT students.
See appendix.

Suggestions Refer to the illustrations while reading the text.

STUDY TEXT

76

SECTION I. INSPECTION OF AXLE ASSEMBLIES

1. INTRODUCTION. Wheeled vehicle axles are subject to rough treatment any time the vehicle is moving over an uneven surface. This is especially true of military tactical vehicles when they travel cross country without the use of improved roads. Due to the rough usage of axles, you will have to inspect them quite often and attempt to find small troubles before they develop into big troubles.

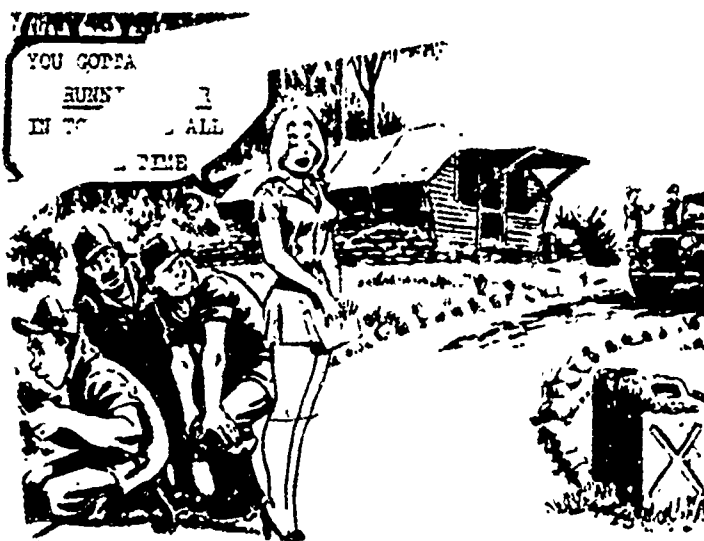

a. There are two major types of axles or axle arrangements you will work on mostly. As discussed in the previous lesson, we have the inde-



pendent suspension type that is used with the M151-series 1/4-ton trucks, and then we have the solid-

housing type used on most other trucks. Inspection procedures for all solid types are about the same, while those for the independent suspension type will differ considerably.

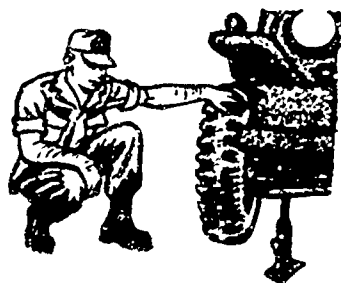

7. b. Axles must be inspected and serviced properly if they are to do their job properly. Faults such as loose bolts, cracked housings, leaking seals, and other minor troubles will eventually lead to a major repair job if they aren't corrected as soon as possible. If minor repairs are not made when they occur, a vehicle could very well have to be evacuated to higher levels of maintenance at a later date.



c. Our discussion in this lesson will cover the various maintenance procedures for inspecting, repairing, and replacing front and rear axle assemblies and axle components on the M151-series 1/4-ton trucks and 2-1/2-ton, 6X6 trucks.

2. INSPECTION PROCEDURES. The first types of axle assemblies we will discuss are those used on the 2-1/2-ton trucks, M35A1 and M35A2. These trucks have one driving front axle assembly and two driving rear axles. All axles are of the top-mounted, double-reduction, single-speed type. The two rear axle assemblies are exactly alike. The front axle is similar but contains additional features to allow the front wheels to pivot to steer the truck.

a. Like almost everything else, before any repair is done on an axle assembly, you should know what needs repairing. One way to find this out is by a thorough inspection. Let's see how you go about inspecting the axle assemblies.

b. When inspecting the rear axle assemblies of a 2-1/2-ton truck M35A1 or M35A2, use the following as a guide:

- (1) Take a look at the axle assembly. Can you see anything that would make the axle assembly unserviceable?
- (2) Use a lug wrench to see if all lug nuts are tight.

(3) Check all other nuts, bolts, and screws to see if they are present and tight. 78

(4) Check the spring guide bracket, torque rods, and torque rod brackets for condition and secure mounting. Check the differential for leaking seals or gaskets.



(5) Check for plugged or leaking housing vents.

(6) Check for loose or damaged companion flanges (where the propeller shaft is attached to the differential).

(7) Check the lube level in the differentials.

(8) Check for broken axle shafts. First, block all wheels not being checked and then jack up the wheel that is driven by the shaft being checked. Put the transmission and transfer case in gear. Try to turn the wheel. If the wheel turns without turning the propeller shaft, the axle is broken or the differential is unserviceable.

(9) Check all areas of the axle assemblies for brake fluid and lubricant leaks.

(10) Check wheel bearing adjustment. If the wheel bearings are adjusted properly, only a slight amount of movement between the brake drum and the backing plate will be found. (The wheel must be jacked up for this check.)

(11) Check the entire axle assembly for excess dirt or damage that may be seen.

(12) Road test the vehicle. Listen for excessive or unusual noises in both the front and rear axle assemblies.

79

c. To inspect the front axle assembly of a 2-1/2-ton truck M35A1 or M35A2, make all of the checks that were made on the rear axle, plus those for the steering system. Check for bent or damaged steering components. Examine the tires for excessive wear due to misalignment of axle steering components. Before making a toe-in check and adjustment, the wheel bearings must be properly adjusted and the tires must be inflated to the correct pressure. The vehicle must be on a smooth, level surface, with the wheels in the straight-ahead position. There are two methods that can be used to check and adjust the toe-in of an M35A1 or M35A2 truck.

(1) Place a toe-in gage between the tires ahead of the axle and with the ends of the gage against the tires' sidewalls (the figure shows the toe-in gage being used on a different type vehicle, but it is used the same

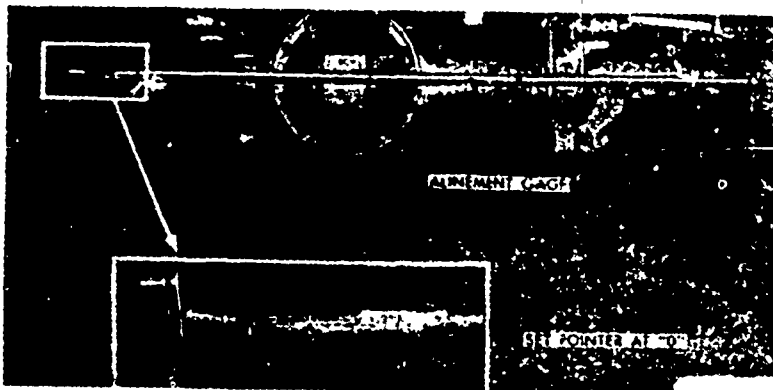

way on the M35A1 and M35A2). Both chains must be the same distance from the floor in order to make sure the gage is positioned properly on each wheel. Set the gage so the pointer measures zero. Move the truck forward until the chains are the same distance from the floor in back of the axle as they were in front.

The pointer will now show the amount the wheels are either toed-in or toed-out in the front. The correct setting is 1/16th to 3/16th of an inch closer in front than in back for vehicles using 9.00X20 tires. On trucks having 11.00 X20 tires, the correct toe-in is 1/16th to 1/8th of an inch. Corrections to toe-in are made by changing the length of the tie rod with the tie rod end adjustments. Toe-in adjustment is made by adjusting the tie rod. Lengthen the tie rod to increase toe-in. Shorten the tie rod to decrease toe-in.

(2) The second method consists of making a scribe mark in the center of the front of each front tire at the same height from the floor as the center of the axle. Using a steel tape, measure the distance between the two marks. Then roll the vehicle forward until the marks are the same distance from the floor as they were in front, and measure the distance between them. Make the necessary adjustments to the tie rod to bring the toe-in to the proper amount.

3. INSPECTION OF M151-SERIES TRUCK AXLES. Now let's take a look ⁸⁰ at the 1/4-ton truck M151. This vehicle does not have an axle assembly as we know it. Instead, it has a drive assembly bolted to the frame rails and swing axles to the wheels. This is true of both front and rear drive assemblies.

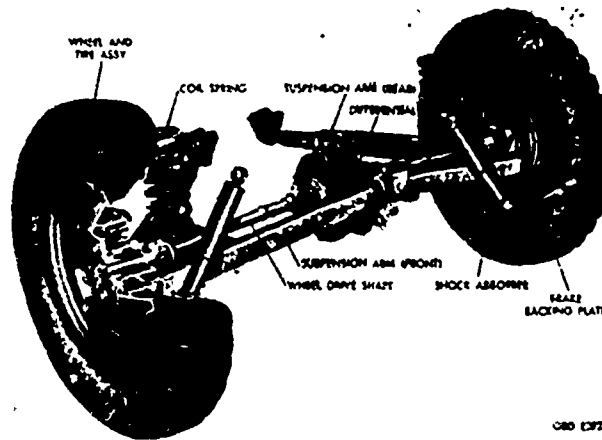

a. To inspect these drive assemblies, use the following as a guide

(1) Check the differential for secure mounting, leaking seals and gaskets, and for damage to the drive and side gear flanges.

(2) Check the breather valve. It is located at the top of the differential.

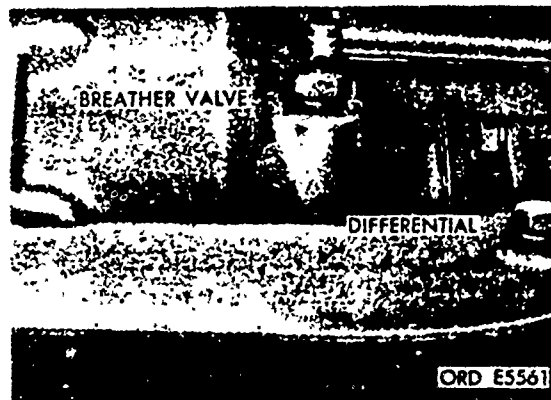

(3) Check the wheel drive shafts and universal joints for wear, damage, and proper mounting. (The slip joint end should be connected to the differential.)

(4) Check the wheel drive flanges and the spindle hub for damage and secure mounting.

(5) Road test the vehicle and listen for excessive or unusual noise in both the front and rear drive assemblies.

81 b. When inspecting the front drive assembly of the M151 truck, use the same procedures used on the rear. In addition, inspect the ball joints for serviceability and examine the tires for excessive wear due to misalignment of steering components.

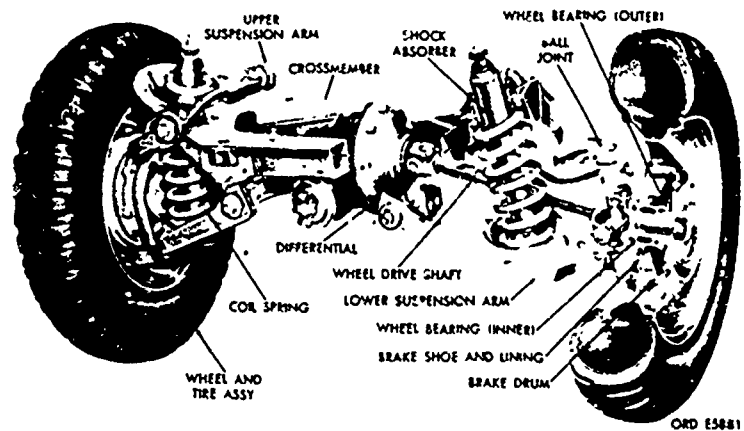

c. Use the same procedures listed for the 2-1/2-ton truck M35A1 to check and adjust the toe-in on the 1/4-ton truck M151. The toe-in on the M151 should be centered with the steering wheel approximately 1-5/16 turns back from the stop. One spoke of the steering wheel should be in line with the center of the steering column. This is the straight-ahead position. The toe-in setting is 1/32 to 5/32 of an inch.

SECTION II. REPAIR OF AXLE ASSEMBLIES

4. REMOVAL AND REPLACEMENT OF FRONT AXLE SHAFTS ON 2-1/2-TON TRUCKS. At times when you are servicing or repairing 2-1/2-ton trucks, it will be necessary for you to remove and install the front axle CV-joints and shafts. The procedures we will discuss in this lesson apply to the M35A1 and M35A2 trucks. However, the procedures for other 2-1/2-ton trucks are much the same.

a. First, block the front and rear wheels that you won't be working on. Make sure the vehicle cannot roll forward or backward when you have the front axle up on jacks and blocks. Anytime you are working on heavy equipment and have it jacked up, use extra care so that you will not be injured by the equipment falling.

(1) Jack up a front wheel and support the axle with blocks or a jack stand. (Never trust a jack alone.)

(2) After the wheel is raised the wheel and tire must be removed.

87
(3) Next you need to remove the bolts and washers that hold the drive flange to the hub.

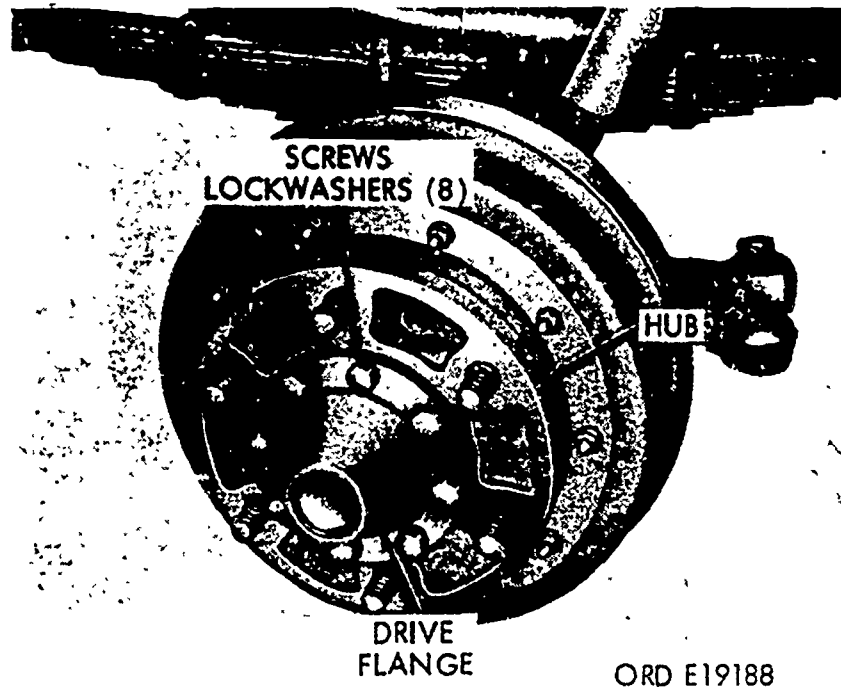

(4) You can now remove the flange and discard the gasket.

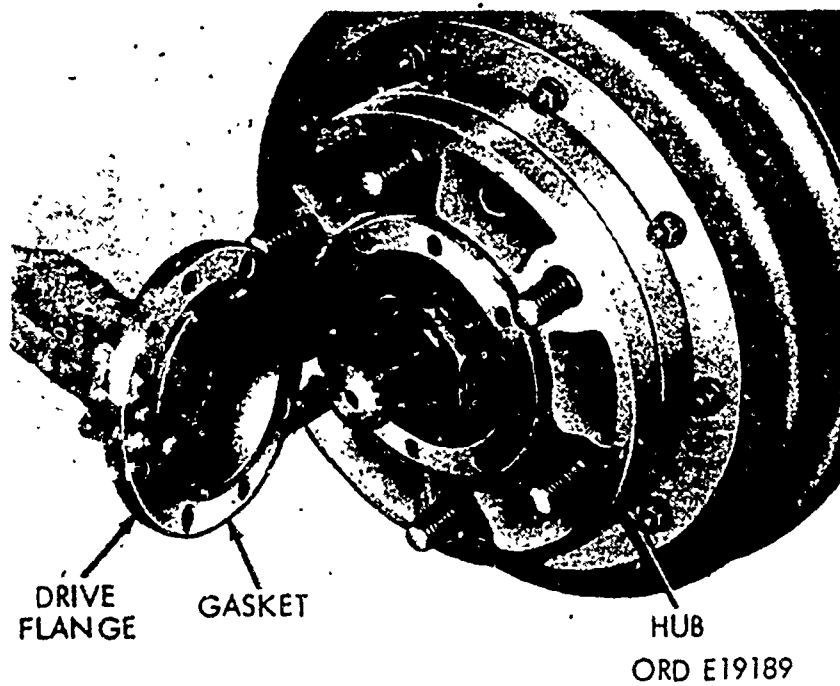

3-9

- 43 (5) The bent-over part of the adjusting nut lock must be straightened.

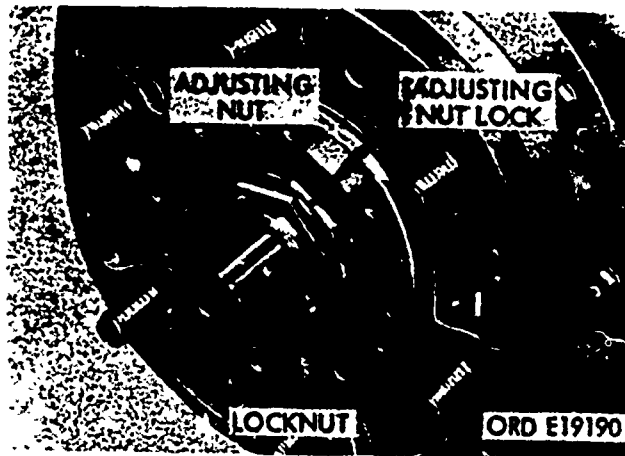

- (6) This frees the outer wheel bearing adjusting nut so it can be removed by using a wheel bearing nut wrench.

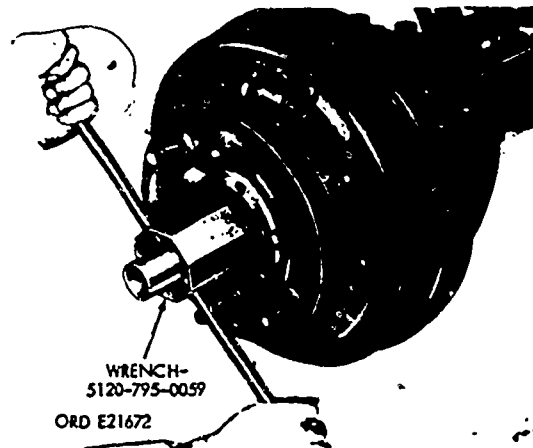

- (7) The adjusting nut lock and the inner adjusting nut can now be removed.

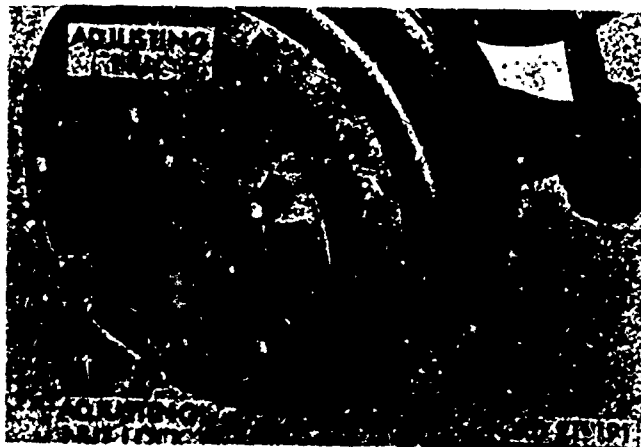

3-10

98

(8) Move the brakedrum until the outer bearing moves out on the spindle. Remove the bearing, using caution not to get it dirty or drop it on the floor. The hub and brakedrum can now be removed.

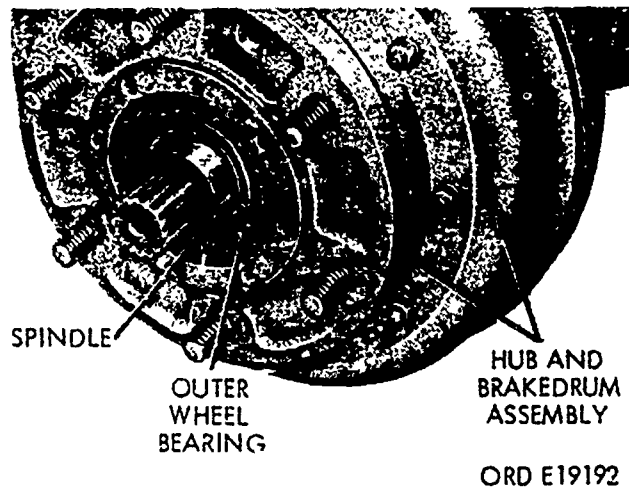

(9) Slide the inner wheel bearing off from the spindle by grasping the back of it with your fingertips. If the bearing is stuck on the spindle, pry it gently with a rolling head pry bar until it breaks loose. After the bearing is removed, the brakedrum oil slinger (oil seal), seated behind the inner bearing, can be removed.

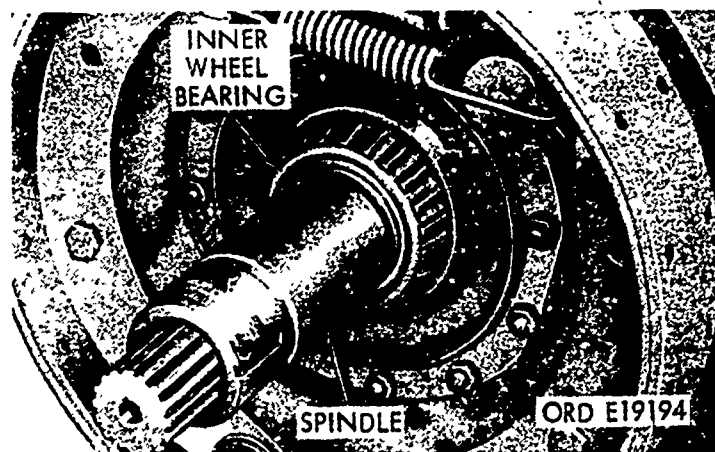

85 (10) Now remove the nuts and lockwashers that secure the backing plate and spindle to the steering knuckle. Remove the backing plate slowly so that you don't damage the flexible brake line connected to the back of the plate. Using heavy cord or lacing wire, fasten the backing plate up to the truck spring or frame in a location behind the spindle.

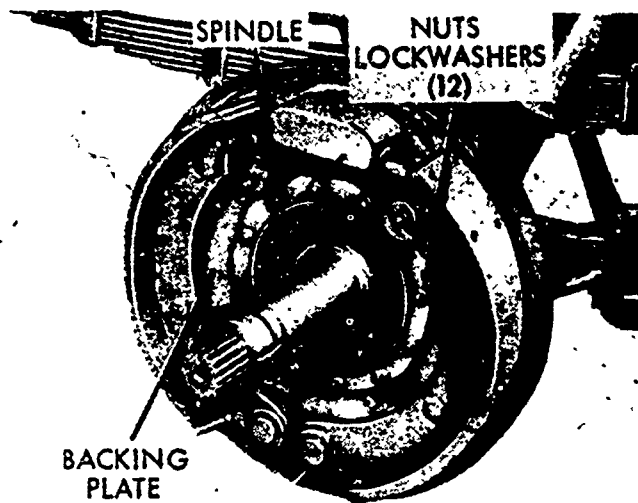

ORD E19266

(11) Slide the steering spindle off from the steering knuckle studs and off the end of the axle shaft.

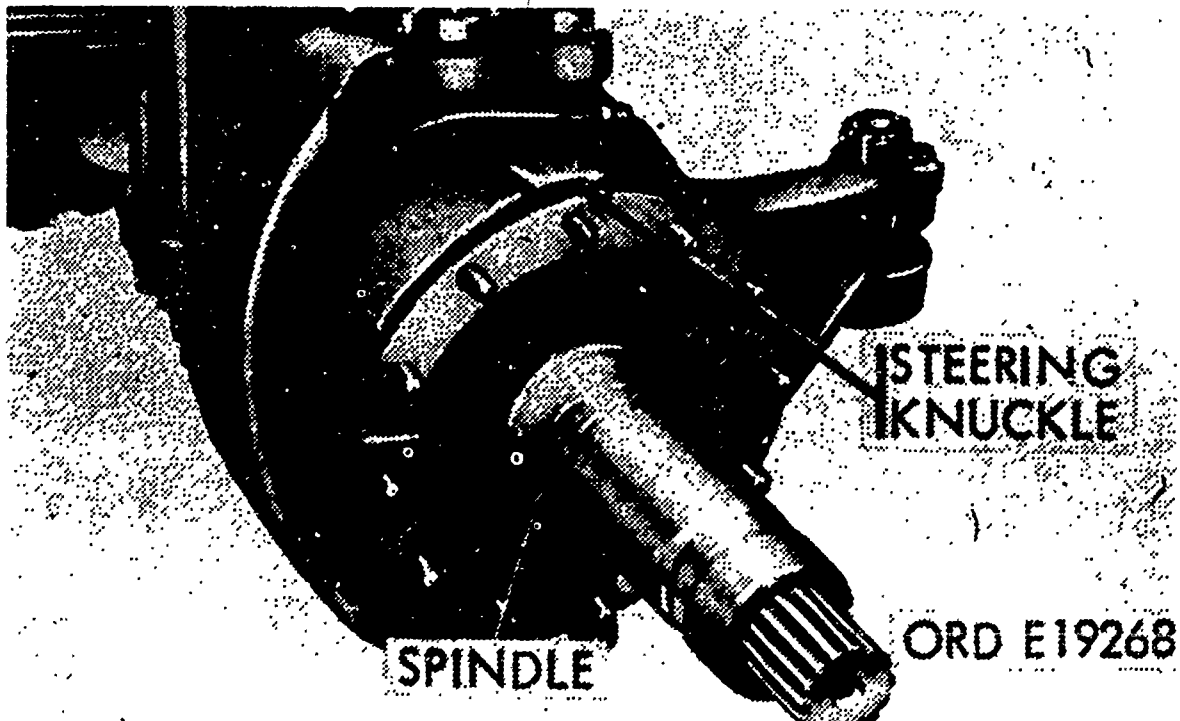

ORD E19268

3-12

(12) The front axle shaft can now be pulled from the axle housing. When the shaft is removed it should be inspected to see if it is serviceable.

Before doing this you should thoroughly wash the axle shaft and universal joint in dry-cleaning solvent or mineral spirits paint thinner. Also wash the inside of the steering knuckle and the outer end of the housing.

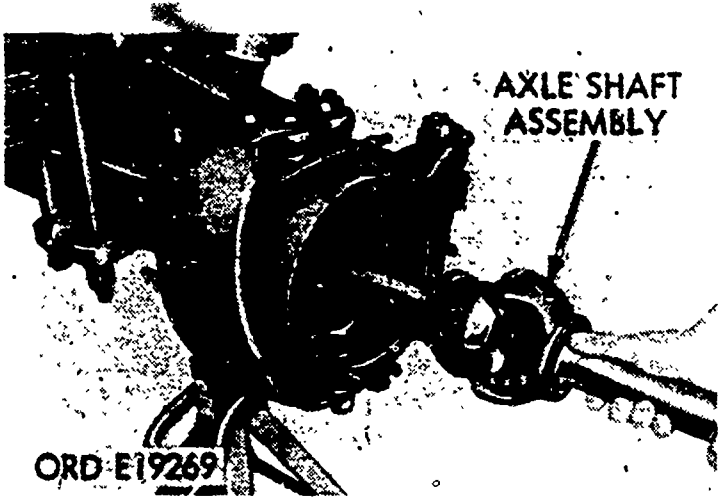

b. The balls and races should be inspected for grooves, scratches, or pits. Now place the axle shaft assembly in a vise with the outer shaft up. The jaws of the vise should grip the inner shaft just below the universal joint. Wood or soft metal protectors should be used in the jaws of the vise. To check for wear, push down on the outer shaft so it rests on the intermediate ball and, at the same time, try to twist the joint in both directions. There should be no play or backlash. The shaft should be examined for nicks, cracks, or other damage. If either the inner or outer shaft is twisted, bent, damaged, or excessively worn, a new axle shaft and universal joint assembly must be installed. If the splines on the side gear end of the inner shaft are worn excessively, it is possible that the side gear splines are also worn in a similar manner. In this case you should notify direct support of this condition. If the axle shaft is serviceable, prepare to install it in the axle assembly.

c. Before reinstalling the front axle shaft and universal joint, it must be lubricated. To do this, pack new lubricant well into the universal joint. Use GAA (grease, automotive and artillery) for this purpose. Fill all the spaces between the balls and the universal joint yokes. Also spread lubricant on the surfaces which contact the spacers and bushing-type bearing. Lubrication Order (LO) 9-2320-209-12 covers the type lubricant to use.

d. After the axle shaft and universal joint assembly is lubricated, it can be inserted into the axle housing. Care must be taken not to damage the oil seal in the outer end of the housing. Also, the splined end of the inner shaft must be guided into the splined differential side gear.

87

- (1) Position the steering spindle on the steering knuckle studs.
- (2) Then install the brake backing plate and secure it in place. Slide the oil slinger and inner bearing in place on the spindle.
- (3) Replace the hub and drum and outer bearing cone. Start the inner adjusting nut. Do not install the nut lock and outer adjusting nut at this time. The wheel bearings still have to be adjusted, so now replace the wheel and tire.

e. To adjust the bearings, turn the wheel and, at the same time, tighten the inner nut until the wheel binds. Use the wheel bearing nut wrench to tighten the nut. Now, back the nut off about 1/8th of a turn, so the wheel will turn freely. To check the adjustment, either grasp the tire at the top and pull back and forth, or use a pry bar under the tire. Almost no movement should be seen between the brakedrum and the brake backing plate flange.

f. After the bearings are adjusted, install a new adjusting nut lock and bend the tabs over the inner nut, install the outer nut, and tighten. Recheck the adjustment; then bend the adjusting nut lock to lock both nuts in place. Install the drive flange (use a new gasket) and install the washers and bolts securing the drive flange to the hub.

5. REPLACEMENT OF STEERING KNUCKLE BOOT ON 2-1/2-TON TRUCKS. Another job of the organizational mechanic is to remove and replace the front axle steering knuckle boot on a 2-1/2-ton truck M35A1 or M35A2.

a. To do this you must remove the two screws and two retaining nuts that secure the steering knuckle boot guard and remove the guard.

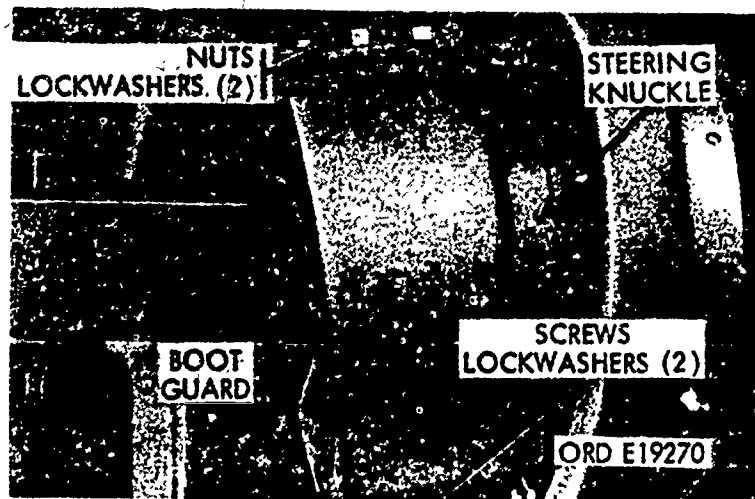

- 88
- (1) Cut the old boot off from the axle, and loosen the outer clamp.

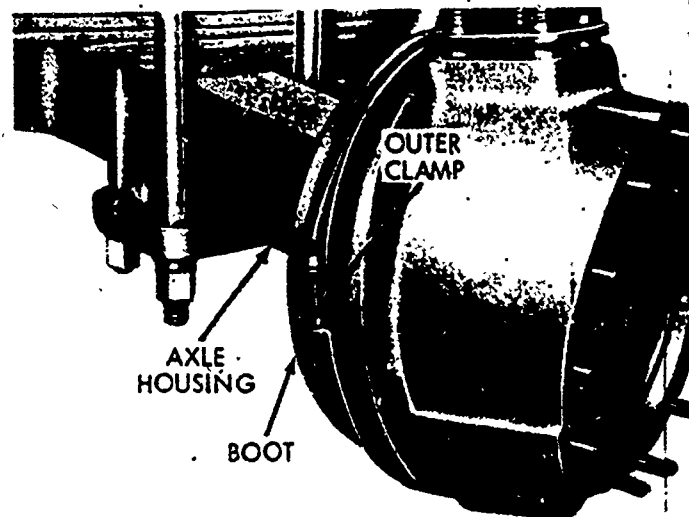

ORD E19271

- (2) Next, loosen the inner clamp and remove the remainder of the boot.

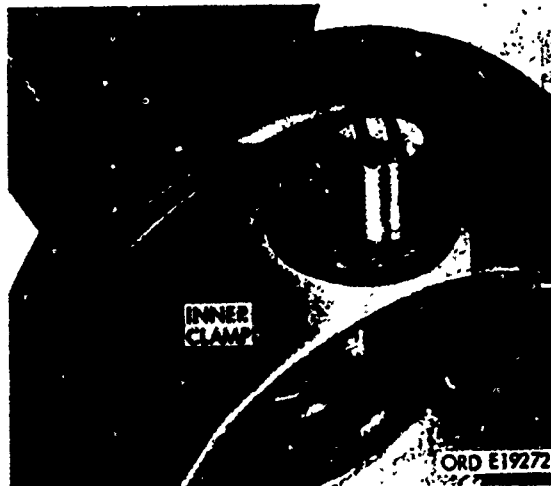

ORD E19272

b. Replacement boots are cut along the mold line and have a zipper vulcanized or sewed in place to the inside of the boot. The boot is part of a kit which contains one boot and a tube of sealer cement. The boot must be installed inside out over the axle housing, with the zipper side of the boot away from the axle. After the boot is in place, close the zipper and seal the zipper with the cement furnished with the kit.

3-15

89

(1) Next, position the boot with the word "TOP" alined with the center of the steering knuckle upper sleeve. Work the clamp groove, which is in the small diameter end of the boot, over the clamp groove in the axle housing. Install the inner clamp and tighten it; making sure that the boot is in the axle groove and well sealed. The boot must now be pulled right side out over the inner clamp.

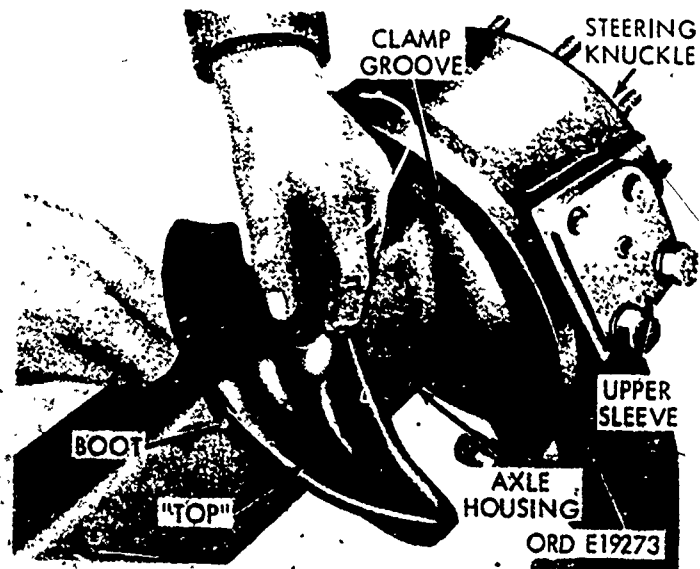

(2) Next, work the large diameter of the boot over the groove in the steering knuckle. Be sure the boot does not twist. Now install the

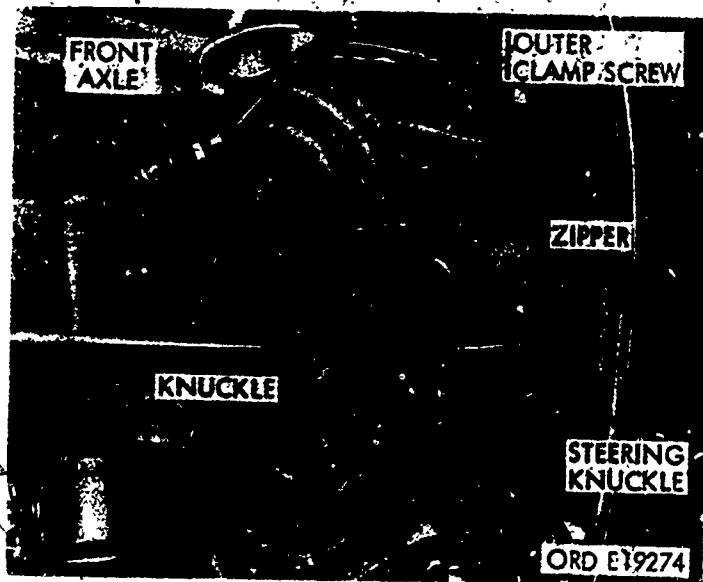

outer clamp and tighten it, making sure that the boot is clamped in the knuckle groove. The zipper should then be locked with fine wire near the edge of the boot and the excess zipper cut off. After this, apply cement to the zipper and the inside of the cut in the boot.

(3) Finally, install the boot guard and secure it to the knuckle with the screws and lockwashers.

6. REPLACEMENT OF INNER WHEEL BEARING SEAL. A leaking front axle inner wheel bearing seal on a 2-1/2-ton truck M35A1 or M35A2 is also replaced at the organizational maintenance level. To do this, jack up the wheel and support the axle with blocks or a jack stand. The wheel and tire and hub and drum assembly should be removed as described in the replacement of the front axle shaft.

a. Slide the inner bearing from the spindle and remove the inner bearing seal.

b. Install the new seal and inner wheel bearing on the spindle. After installing the hub and drum, the wheel bearings will have to be adjusted as described earlier in this lesson. After the bearings are adjusted, replace the axle flange and remove the blocks or jack stand.

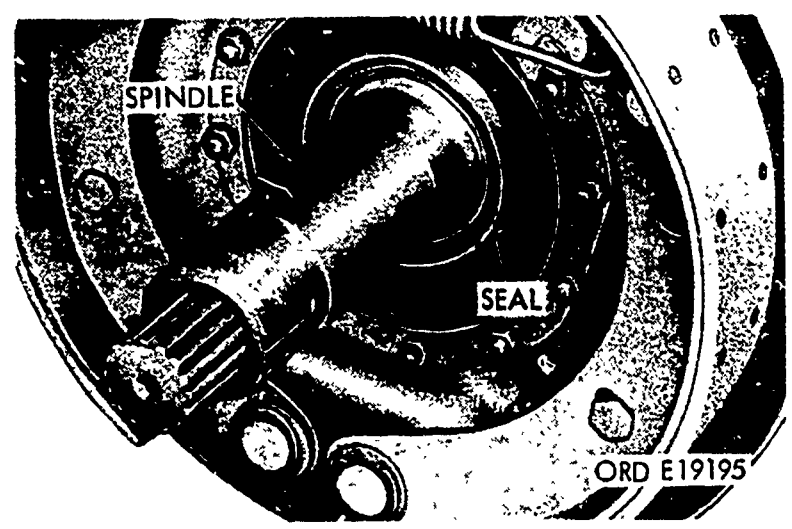

7. WHEEL BEARING AND SEAL REPLACEMENT ON 1/4-TON TRUCKS M151. We found during the inspection portion of this lesson that the 1/4-ton truck M151 does not have an axle assembly like the 2-1/2-ton truck. So let's take a look at how you should go about replacing some of the parts on this type of front suspension and drive (also known as a swing axle).

a. To replace the inner and outer seals, wheel bearings, and cups on a 1/4-ton truck M151, remove the locknut and lifting eye.

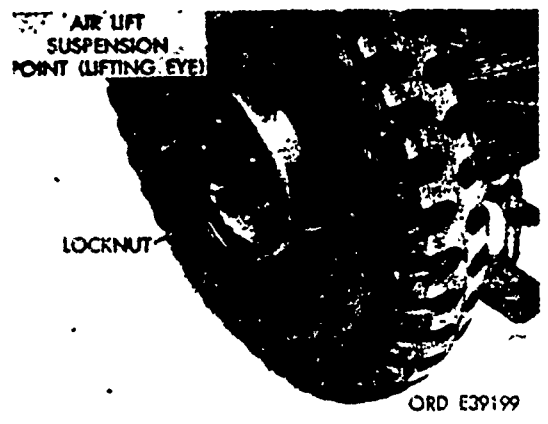

91

(1) Raise the front wheel clear of the ground and support the vehicle with blocks or a jack stand.

(2) Remove the wheel and tire assembly and back the brake shoes away from the drum.

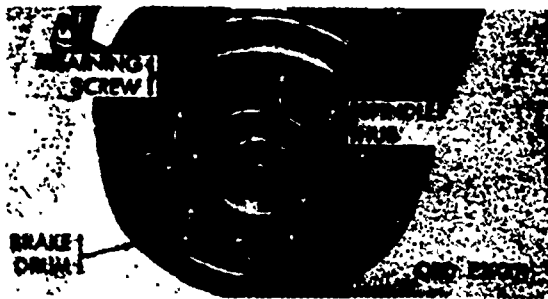

(3) Now remove the retaining screws and slide the brake drum off of the spindle hub. These screws and the wheel lug bolts secure the drum on the hub.

(4) Next, remove the cotter pin, flange nut, washer, and spindle hub from the spindle flange.

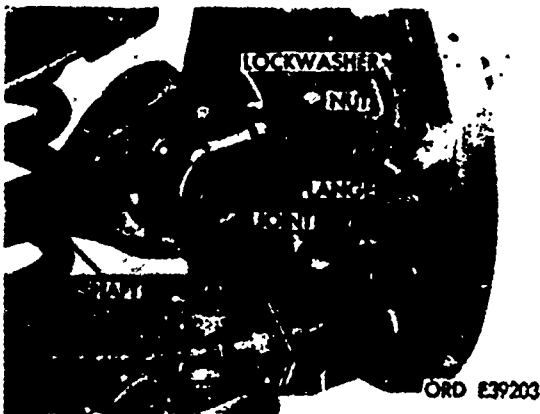
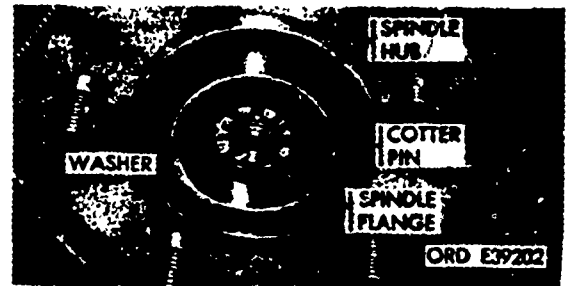

(5) The next step is to remove the nuts and lockwashers and disconnect the universal joint at the drive flange.

3-18104

(6) Move the wheel drive shaft aside and pull the wheel drive flange from the support.

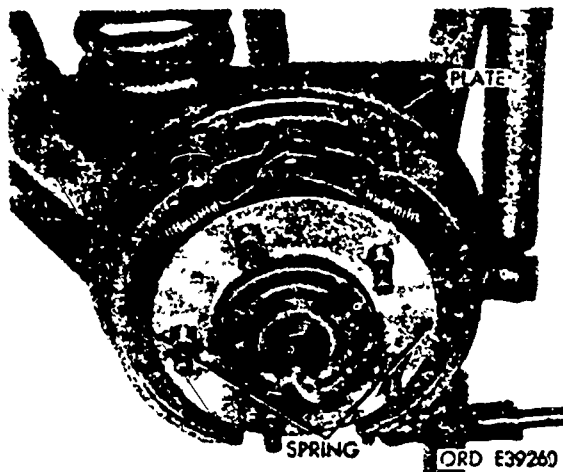
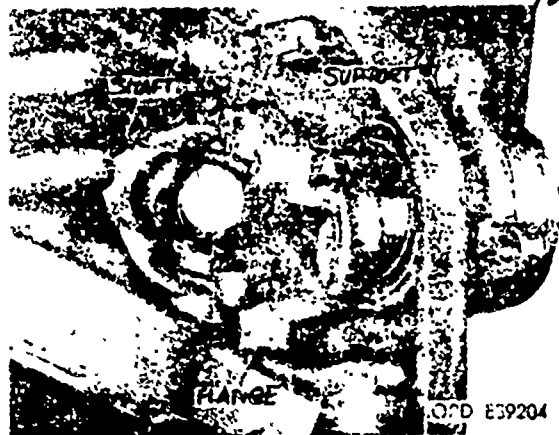

b. If the brakeshoes are to be replaced, insert a suitable tool in the conical brakeshoe holddown spring. Push the spring through the backing plate and force it to one side until it is free of the holddown anchor.

(1) You can now unhook and remove the shoe retracting spring from the anchor pin and brakeshoe.

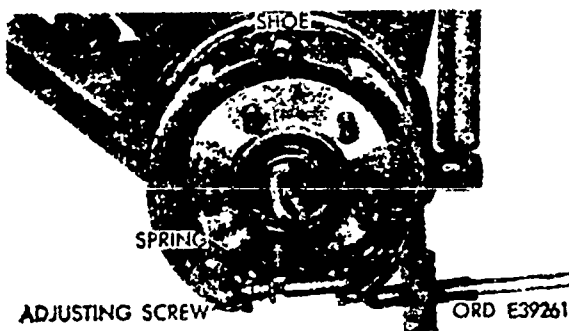
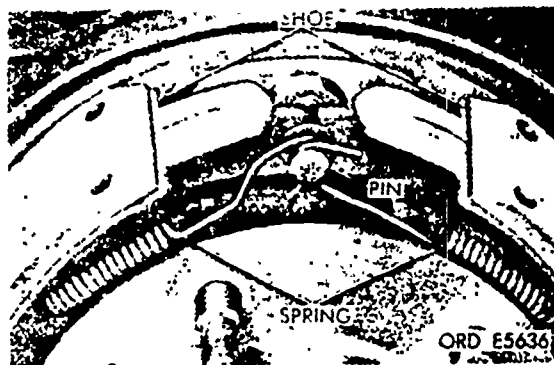

(2) Both brakeshoes, with their adjusting screw and adjusting spring, can now be removed from the backing plate.

3-19

93

c. Remove the cotter pin and nut securing the tie rod end to the steering spindle arm.

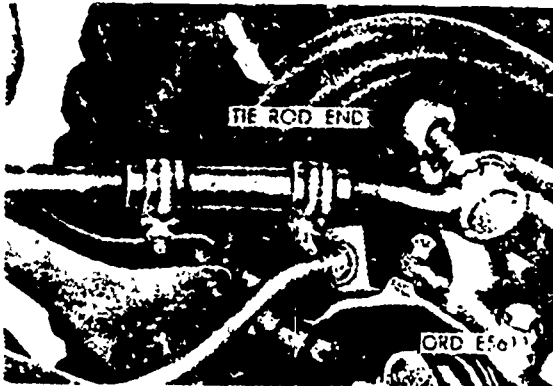
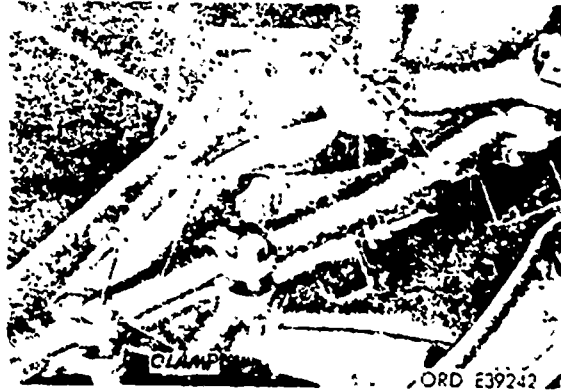

(1) Using a suitable puller, separate the tie rod end from the spindle arm.

(2) Now loosen the nut and disconnect the brake cylinder tube from the backing plate.

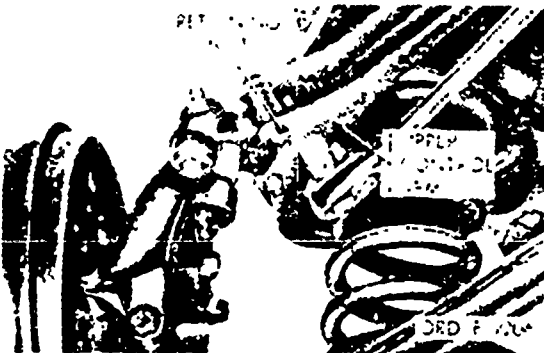
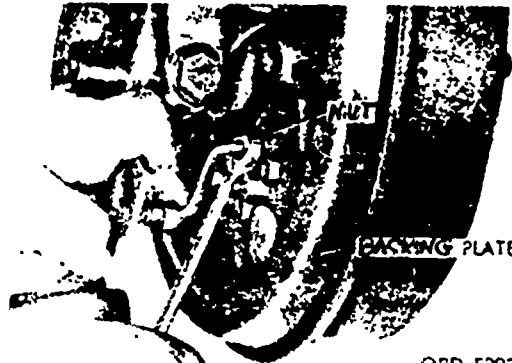

(3) After this, remove the three ball joint retaining nuts and bolts from the upper control arm.

(4) Do the same with the three bolts and nuts on the lower control arm. You can now remove the support and backing plate.

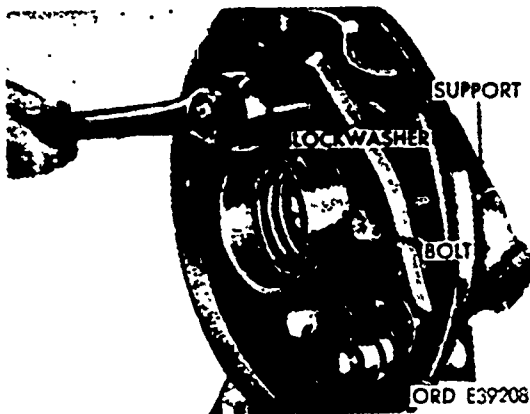
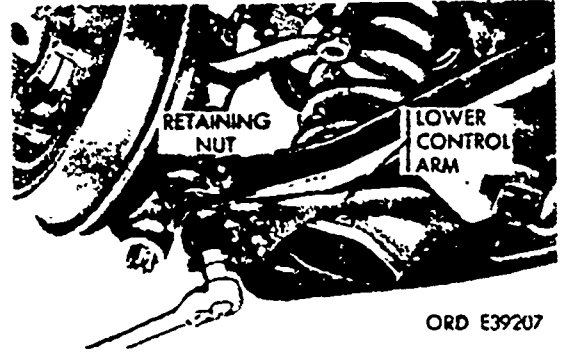

(5) To separate the backing plate from the support, remove the brake backing plate retaining bolts and lockwashers and remove the backing plate from the support.

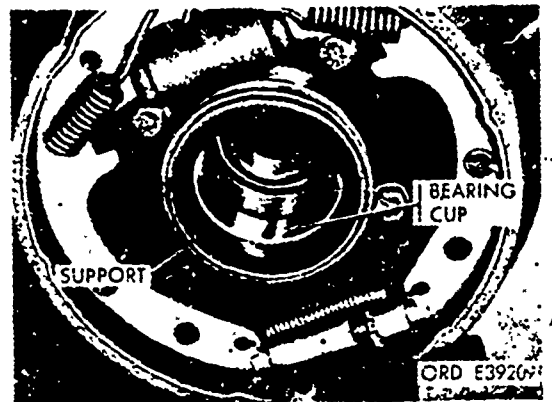

(6) Now pry the outer seal and retainer from the support. Using a brass drift, loosen the bearing cup and remove it from the support.

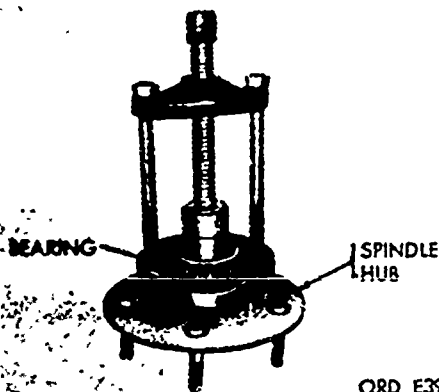

(7) The outer bearing should now be removed from the spindle hub.

95

(8) Next, loosen the inner bearing cup and seat, using a block of wood or a soft metal drift.

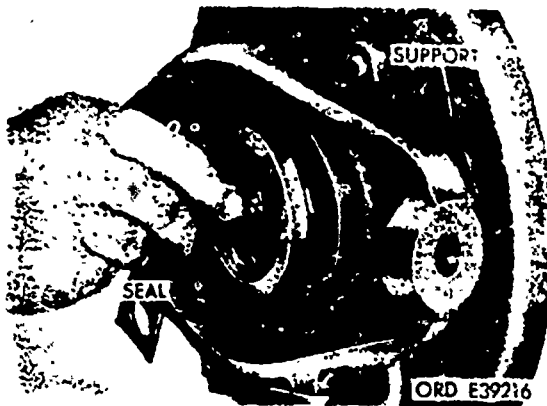
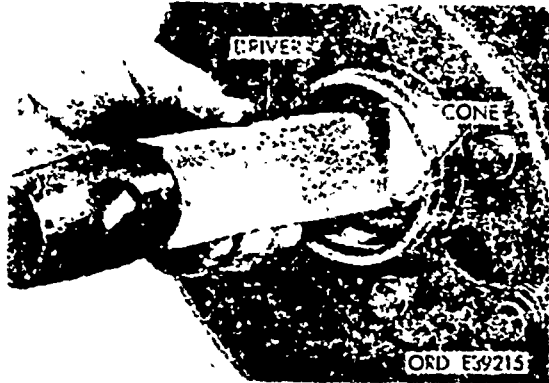

(9) Remove the seal from the support.

(10) Then remove the bearing and cone and cup.

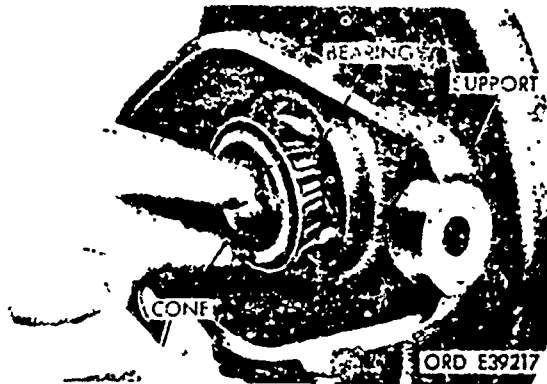

d. You are now ready to start installing the new parts.

(1) First, position the new inner bearing cone in the spindle support.

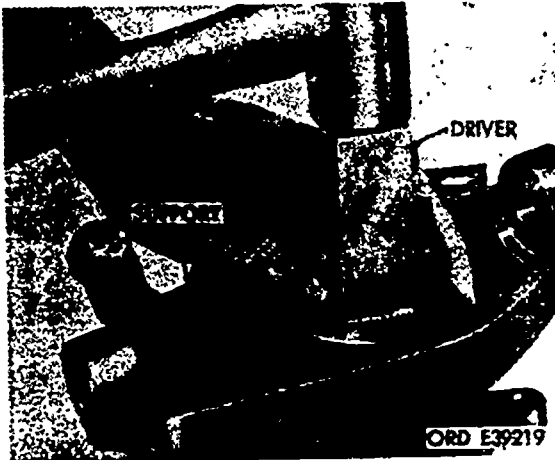
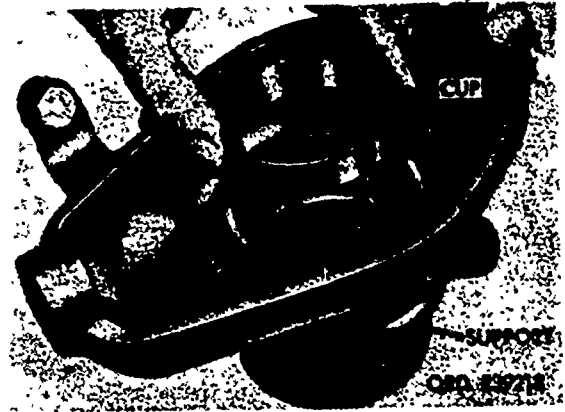

(2) Next, seat the cup, using a suitable driver.

(3) The bearing and cone will now have to be packed with automotive and artillery grease (GAA) and positioned in the cup. Before installing the seal, coat the outside seating surfaces with sealer and the lip of the seal with grease.

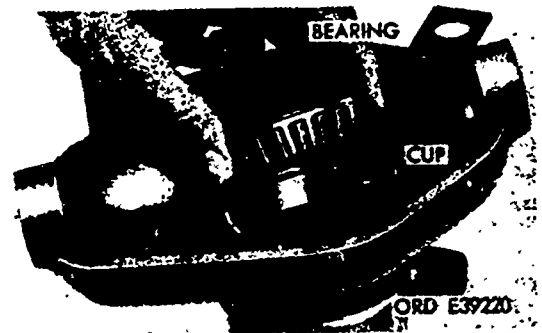

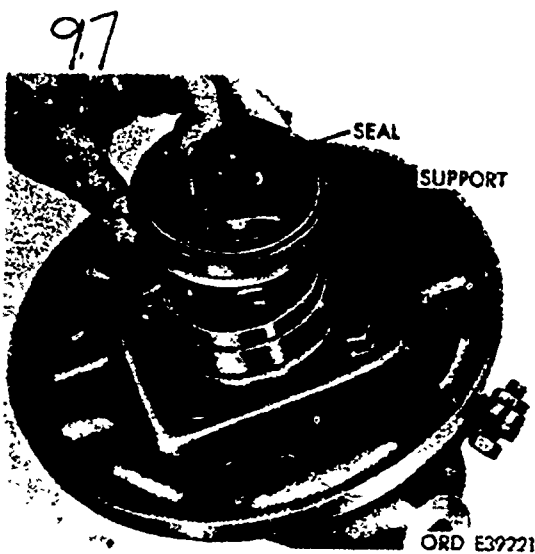

(4) Position the seal in the support.

(5) Seat the seal, using a special replacer.

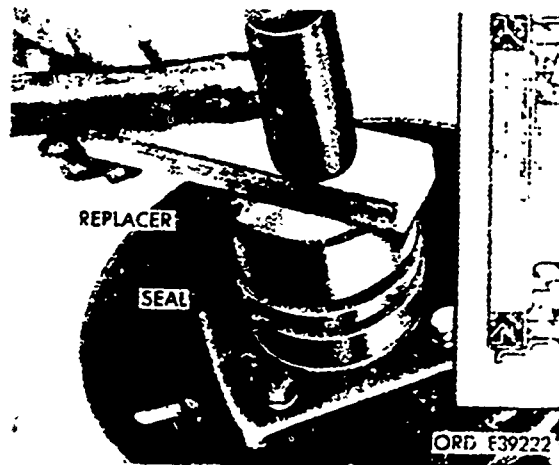

(6) Coat the inside of the support bearing bore with a 1/16th-inch layer of grease (GAA).

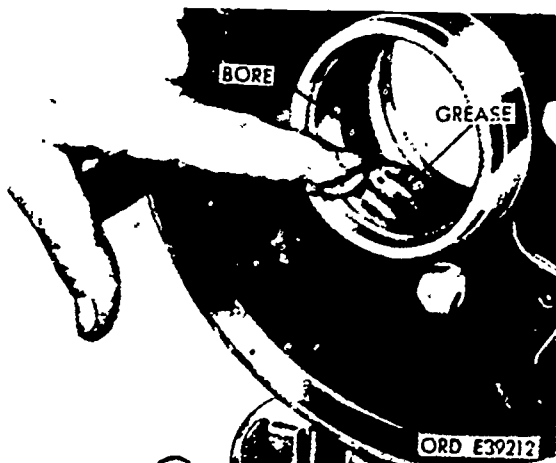

(7) Next, coat a quarter section of the space between the bearings with GAA. Now coat the lips of the seal with GAA, and coat the seating surfaces with sealing compound.

(8) Install the seal on the support, using a special replacer.

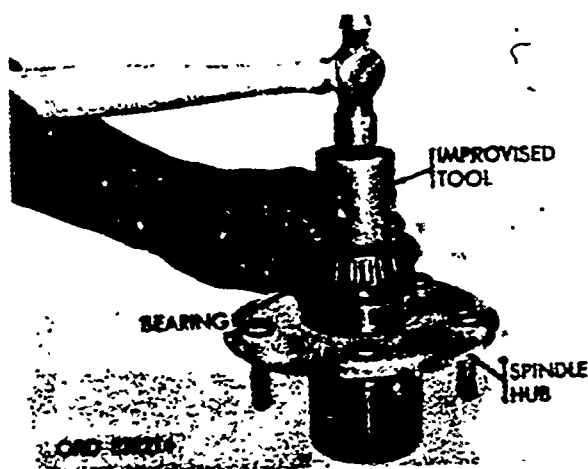
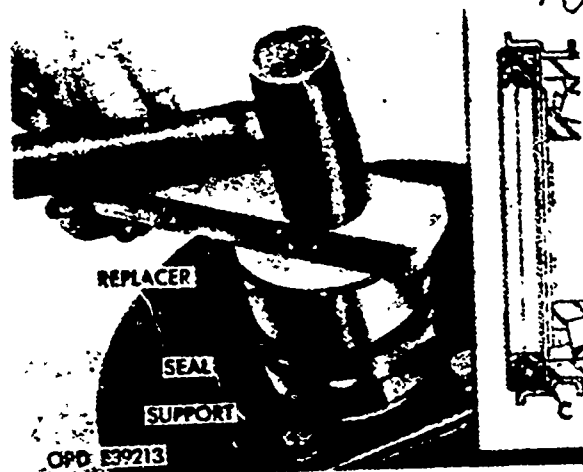

(9) The outer bearing cone should be packed with GAA and installed on the spindle hub with an improvised tool.

(10) After the bearing has been installed, position the backing plate on the support and replace the retaining bolts and lockwashers.

e. Position the support and backing plate on the suspension arms, and replace the ball joint retaining bolts and nuts in the lower control arm and in the upper control arm.

(1) Next, connect the brake cylinder tube to the backing plate and tighten the nut.

(2) The tie rod end should now be replaced in the steering spindle arm.

99

3) When replacing the nut securing the tie rod end joint to the steering spindle arm, it should be torqued to 50-60 lb-ft and the cotter pin replaced.

(4) If the brakeshoes were removed, position them with the adjusting screw assembly and the adjusting spring on the backing plate.

(5) Next, install the shoe retracting spring.

(6) Now push the wheel drive flange into the support.

(7) Connect the universal joint to the drive flange and replace the nuts and lockwashers.

(8) Reinstall the spindle hub, washer, and flange nut. Do not install the cotter pin at this time for the wheel bearings still have to be adjusted.

(9) Replace the brakedrum and retaining screws.

(10) The flange nut should now be tightened to 30 lb-ft torque. Turn the spindle while tightening to insure the proper seating of the bearing assemblies.

(11) Next, back the flange nut off one complete nut castellation to align the cotter pin holes. This adjusts the wheel bearings. Notice that the drive flange has two through holes for the cotter pin. Install the cotter pin, using the hole that allows backing off of the flange nut the distance of one castellation.



f. The wheel and tire can now be installed and the brakes adjusted.

(1) To adjust the brakes you will have to first pry the cover from the adjusting hole in the backing plate. Use the hole toward the front of the vehicle.

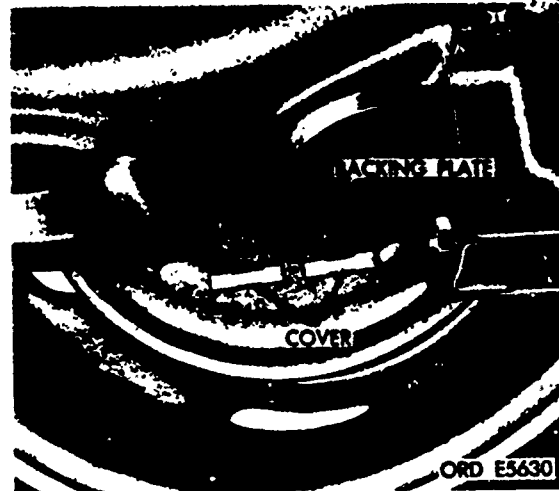

(2) After the cover is removed, insert the adjusting tool through the opening and engage the star wheel of the adjusting screw assembly.

(3) Turn the adjusting screw until the wheel cannot be turned with one hand. Then back the adjusting screw off 11 clicks. Check your adjustment and install the adjusting hole cover. This should be done on all wheels.

8. REPLACEMENT OF DIFFERENTIAL PINION SEAL ON M151 TRUCKS. The organizational maintenance mechanic is authorized to replace a differential pinion seal on a 1/4-ton truck M151, so let's see how you would go about doing this job.

a. Remove the universal joint bolts from the differential end of the propeller shaft.

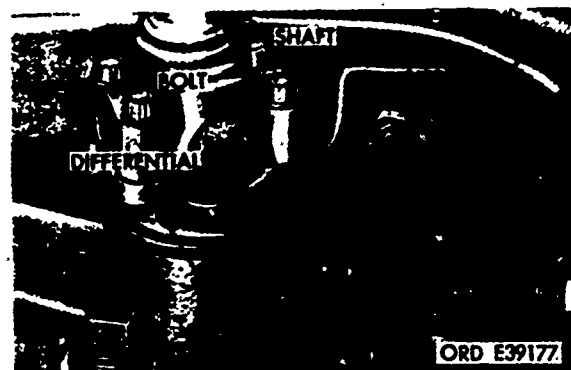

101

b. Next, remove the transmission end of the propeller shaft.

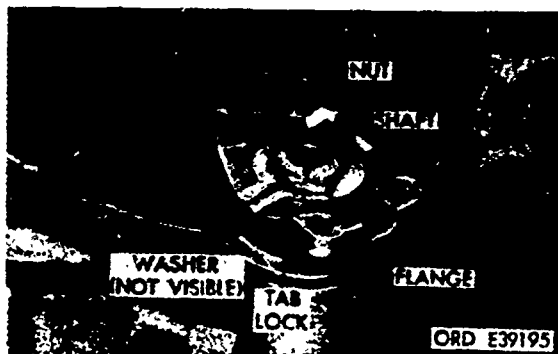
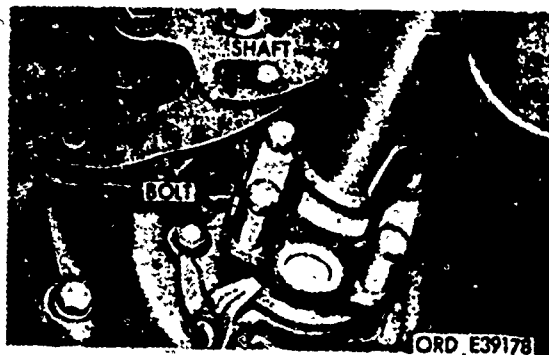

c. After the propeller shaft is removed, straighten the tabs at the end of the pinion drive flange and remove the nut and washer from the pinion.

(1) Remove the tab lock and pull the flange from the shaft. The seal can now be removed.

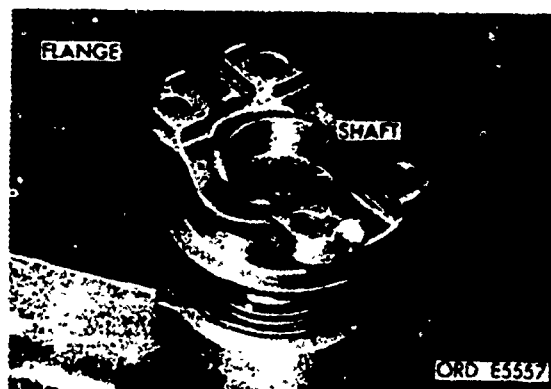

(2) Before installing the new seal, lubricate the pinion shaft seal lips with GAA and coat the outside seating surface with sealing compound.

(3) Position the new seal with its lip toward the differential, and install it by tapping lightly on the rim.

(4) After the seal is seated, replace the flange on the pinion shaft.

(5) Next, replace the tab lock, washer, and nut on the pinion shaft. Torque the nut to 40-45 lb-ft and bend the tab lock over it.

d. The propeller shaft has to be reinstalled, so position the transmission end of the propeller shaft on the drive flange.

(1) Install the universal joint retaining bolts and torque them to 28-33 lb-ft.

(2) Finally, position the differential end of the propeller shaft and universal joint, install the retaining bolts, and torque to 15-20 lb-ft.

9. REPLACEMENT OF DIFFERENTIAL SIDE GEAR SEALS ON M151 TRUCKS. The differential side gear seal can also be replaced at the organizational maintenance level.

a. To do this, remove the nuts, lockwashers, and U-bolts securing the wheel drive shaft universal joint to the drive flange of the differential.

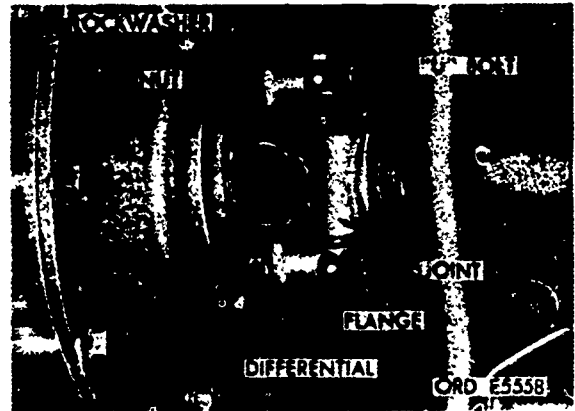

(1) You should secure the loose universal joint bearings with tape to keep them from falling off the cross.

(2) Now slide the wheel drive shaft universal joint yoke toward the wheel to separate the universal joint from the flange.

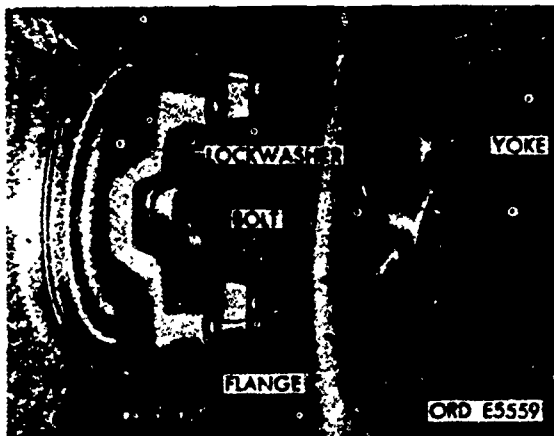

(3) Remove the flange mounting bolt and lockwasher from the differential side gear.

(4) Pull the flange off the side gear.

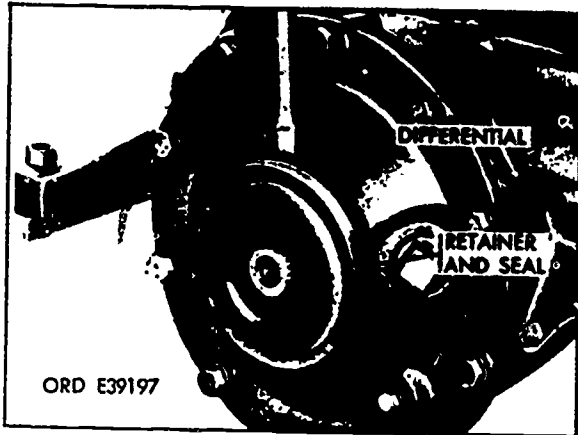
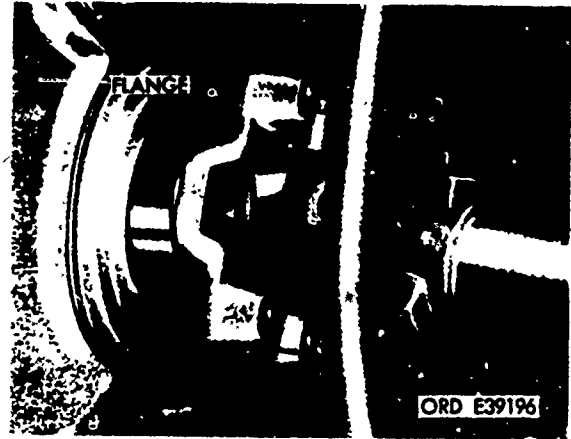

(5) Pry the side gear flange seal and retainer from the differential.

b. Next, install the new side gear flange seal and retainer and replace the flange on the side gear. Install the bolts and lockwashers. The bolts should be torqued to 40-45 lb-ft. Finally, remove the tape and position the universal joint and install the U-bolts and nuts.

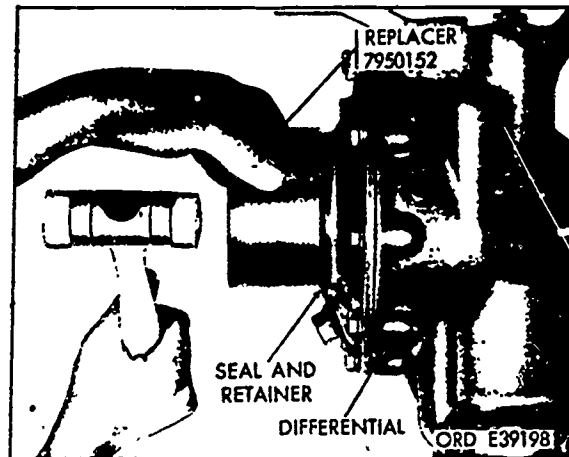

SECTION III. REPLACEMENT OF AXLE ASSEMBLIES

10. 2-1/2-TON TRUCK FRONT AXLE ASSEMBLY REPLACEMENT. The removal and replacement of axle assemblies and drive differentials is not usually done at the organizational maintenance level. However, you may be working with support maintenance teams at your unit and you will then have need for a knowledge of how the job is done.

a. The first job we will cover is the removal and replacement of a front axle assembly on a 2-1/2-ton truck M35A1 or M35A2.

(1) The truck should be placed on a level surface, with the hand-brake applied to prevent the truck from rolling.

(2) Then place a dolly-type jack under the differential housing and raise the front end of the truck high enough to allow the axle assembly to be removed.

(3) Place blocks under the frame side rails at the rear of the front spring hanger bracket.

(4) Lower the jack until the weight of the front end rests on the blocks, but leave the jack high enough to support the axle.

(5) The wheels and tires should now be removed and the propeller shaft disconnected at the front end. After the propeller shaft is disconnected, it should be taped to prevent the universal joint from becoming damaged or filled with dirt.

b. Remove the cotter pin from the steering arm end of the drag link and unscrew the adjusting plug as far as possible without removing it.

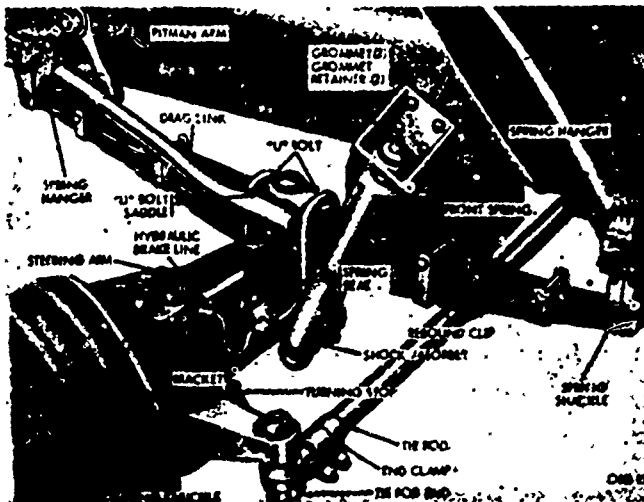

105

(1) Turn the steering wheel in both directions to loosen the stud ball in the seat. After the seats are loose, remove the adjusting plug from the steering arm end of the drag link and pull the link from the steering arm. Be careful not to lose any of the drag link parts. Tip the link down and remove the ball seats, spring, and safety plug.

(2) Disconnect the flexible brake line between the front axle and the frame at the frame end.

(3) Remove the nut, grommet retainer, and grommet from the lower end of the shock absorber.

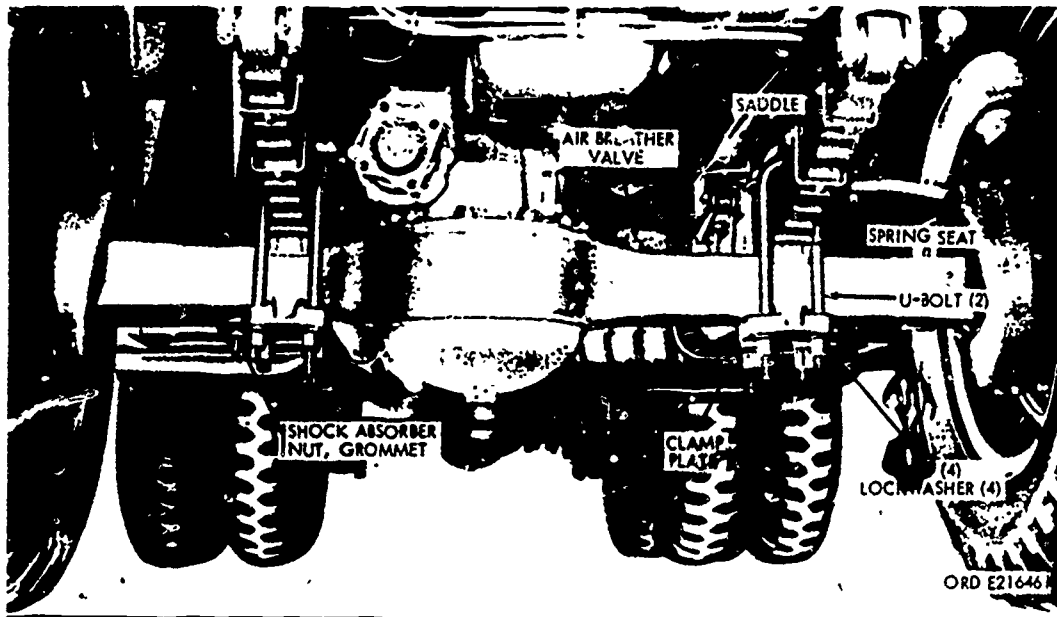

(4) Next, remove the nuts and lockwashers from the U-bolts and remove both clamp plates.

c. You can now lower the jack until the axle clears, remove the spring seats from the axle, and pull the axle from under the truck. Make sure the brake lines are not damaged. Remove the second grommet and retainer from the shock absorbers. The axle air breather valve will be used on the new axle, so remove and clean the valve and install it in the new axle.

d. Place the new axle on a dolly-type jack and move it into position under the truck. With the axle in position, place the spring seats on the axle and raise the axle in position against the springs. Be sure the spring center bolt heads enter the alignment holes in the axle spring seats.

106
(1) Now place the saddles on the springs and install the U-bolts.

(2) Next, install the clamp plates and install the lockwashers and nuts on the U-bolts. The nuts should be tightened to 170-180 lb-ft torque.

(3) Now install one retainer and mounting grommet in place on each stud at the lower end of the shock absorbers. After you collapse the absorbers you can insert the studs in the clamp plates. Then install the second grommet and retainer on each stud end and secure them with the hex nuts.

e. You can now connect the hydraulic line. The front end of the propeller shaft can also be connected to the axle assembly.

(1) Next, install the safety plug in the steering arm end opening of the drag link. Be sure the small diameter of the plug is facing the opening. Now install the spring and one ball seat.

(2) After those parts are in the drag link, position it on the steering arm. Press the link over the ball so that the ball enters the ball opening and mates with the cupped surface of the ball seat.

(3) Install the second ball seat in the end of the link and screw the adjusting plug into the link.

(4) To adjust the drag link, screw the adjusting plug in tight and back off about one-half turn or less, or just enough so that a new cotter pin can be installed.

(5) Mount the wheels and tires; then remove the blocks and jack from under the truck. With the weight of the truck now resting on the springs, all the nuts on the spring mounting bolts should be checked for tightness.

f. The front-wheel brakes must be bled after replacing the axle. Brake bleeding is covered in a later subcourse. Finally, check the lubrication of the axle assembly and the universal joints as instructed in LO 9-2320-209-12.

107

11. 2-1/2-TON TRUCK REAR AXLE ASSEMBLY REPLACEMENT. If one of the rear axle assemblies on the 2-1/2-ton truck M35A1 or M35A2 is to be replaced, the procedure will be a little different. Let's see what has to be done on this task. Again the truck should be on a level surface. The front wheels should be securely blocked to keep the truck from rolling. After the wheels are blocked, raise the rear of the truck with a hoist and a suitable sling under the frame. Use spreader bars to protect the truck body and soft wood blocks where the sling wraps around the corners of the body. The frame of the truck should be supported with safety jacks. Place the safety jacks in front of the rear axle assembly, under the right- and left-hand frame rails. Another method that can be used is to raise both sides of the rear axle assembly with lifting jacks. Then place the safety jacks under the frame rails and remove the lifting jacks from the rear axle. This removes the weight of the vehicle from the springs. Now place a dolly-type jack under the center of the axle to be removed and raise it enough to take the weight off of the axle.

a. Next, remove the wheels and tires from the axle housing.

(1) Disconnect the brake lines and propeller shaft or shafts, as necessary, to free the axle.

(2) Remove the torque rods from the upper and lower brackets on the axle. With the axle resting on the dolly, move it to the front or rear, as necessary, until the spring ends are free of the guide brackets. Then remove the axle from under the truck.

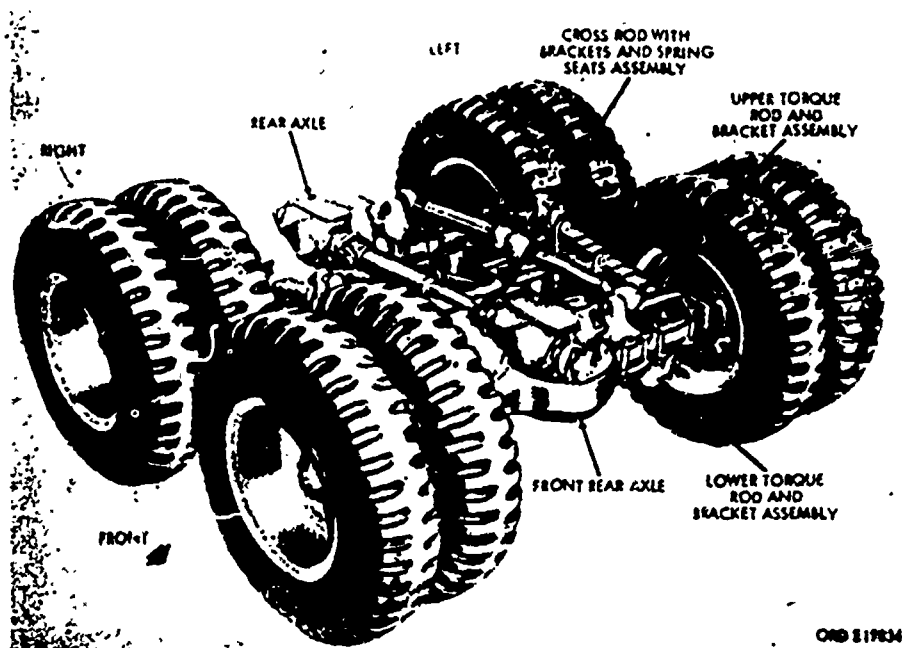

OND 817634

108

b. As on the front axle, the breather valve must be removed, cleaned, and installed on the new axle assembly. Then you will need to place the axle on a dolly-type jack and move it into position under the truck. Guide the spring ends into the guide brackets on the axle housing as you raise the axle into position. Next, install the torque rods on the brackets of the axle and connect the propeller shaft or shafts as necessary.

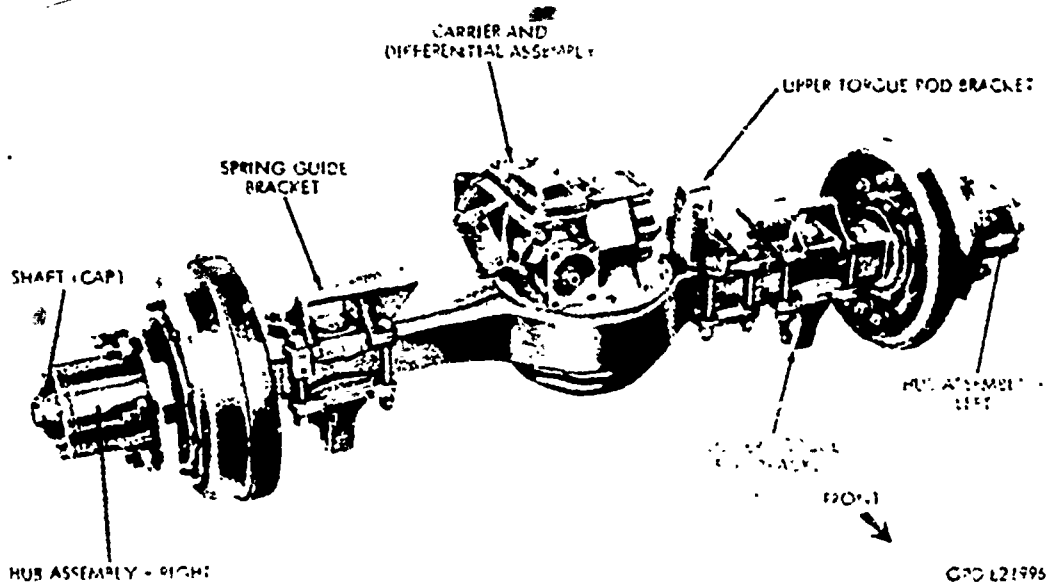

(1) Connect the brake lines and bleed the brakes.

(2) After bleeding the rear wheel brakes, install the wheels and tires. The safety jacks can now be removed and the vehicle lowered to the ground. The axle and propeller shaft universal joints should be lubricated as directed in LO 9-3320-209-12.

12. M151 TRUCK DIFFERENTIAL REPLACEMENT. As we have mentioned before, the 1/4-ton truck M151 does not have an axle assembly like the 2-1/2-ton truck. But it does have differentials, so let's see how you would go about removing and replacing the front one.

109

a. First, remove the two nuts, bolts, and lockwashers securing the flange guard to the bumper. The flange guard is also attached to the differential by two screws, flat washers, and lockwashers. After these are removed the flange guard can be removed.

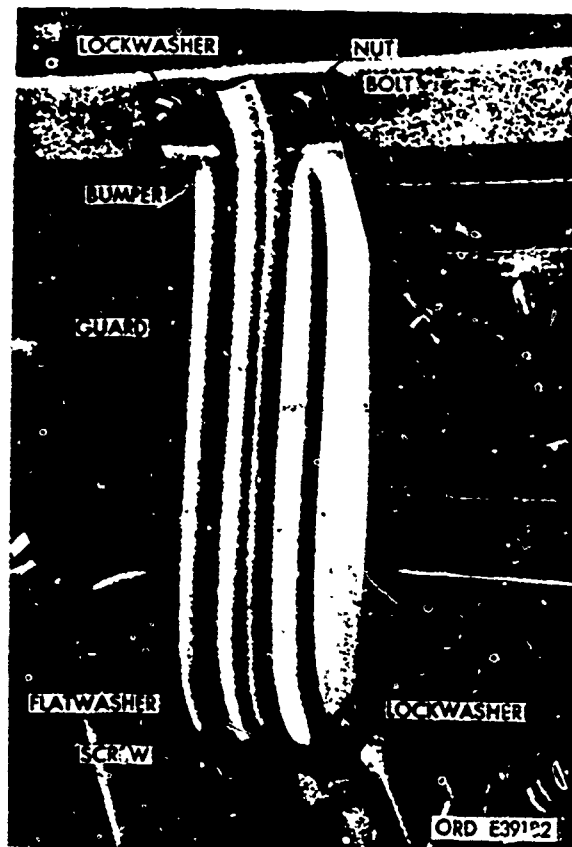

(1) Next, remove the nuts, lockwashers, and U-bolts securing the wheel drive shaft universal joints to the differential.

(2) Remove the bolts securing the front propeller shaft universal joint to the differential drive flange.

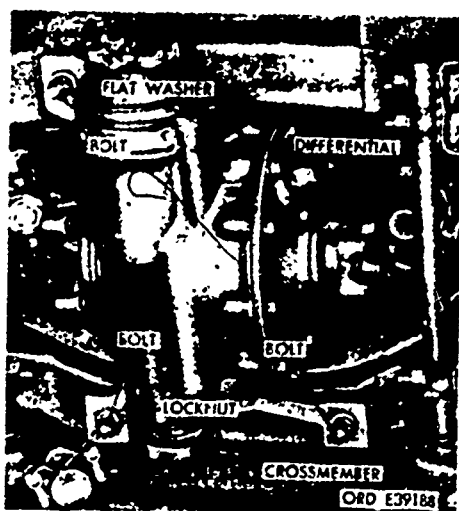

(3) Remove the bolts, flat washers, and locknuts that secure the differential assembly to the front crossmember and remove the differential.

110
b. Position the new differential under the crossmember and install the retaining bolts. Torque the bolts to 35-50 lb-ft. Next, position the propeller shaft and universal joint on the differential drive flange and replace the retaining bolts. The bolts should be torqued to 15-20 lb-ft.

c. The next step is to position the differential flange guard and replace the flat washers and screws securing the flange guard to the differential. Then replace the lockwashers, bolts, and nuts securing the flange guard to the bumper. After you lubricate the differential and universal joints according to LO 9-2320-218-12, the job is completed.

SECTION IV. CONCLUSION

13. SUMMARY. In this lesson we have discussed the procedures involved in the inspection and maintenance of axles used on military tactical vehicles. Although our discussion was limited to the 1/4-ton truck M151-series and the 2-1/2-ton trucks M35A1 and M35A2, the procedures apply with only minor changes to all other vehicles. Whenever you are in doubt about the maintenance of any vehicle axles, always consult the vehicle TM.

14. PRACTICE TASKS. The following appendix contains a list of tasks associated with maintaining axle assemblies. They are representative of the tasks you will be required to perform as a wheeled vehicle mechanic. Perform all of the tasks listed. Be sure you are under the supervision of an officer, NCO, or specialist who is qualified in the MOS when you practice the tasks. If you find you are having difficulty in certain tasks, restudy the appropriate training material and practice the tasks until you become proficient in each one.

/// EXERCISE

Note. - Review the lesson exercise directions in lesson 1.

36. What should be done before checking for a broken axle shaft on an M35A2 truck?
 - a. Shift transmission into neutral
 - b. Remove propeller shaft
 - c. Raise one wheel off of the ground
37. What should be the first step in the maintenance of an axle assembly?
 - a. Road test the vehicle
 - b. Inspect the axle assembly
 - c. Repair the axle assembly
38. What precaution must be taken when inserting the axle shaft with a Rzeppa CV-joint into the axle housing?
 - a. Tape the joint to keep the balls from falling out
 - b. Use care not to damage the oil seal
 - c. Be sure the vent valve is not plugged
39. What is done to increase the front-wheel toe-in on the 2-1/2-ton truck?
 - a. Lengthen the tie rod
 - b. Shorten the tie rod
 - c. Tighten the drag link
40. On the 1/4-ton truck M151, the slip joint ends of the wheel drive shafts are bolted to the drive flanges on the
 - a. spindles.
 - b. differential.
 - c. hubs.
41. During a road test, the axle assemblies on the 2-1/2-ton truck M35A2 should be checked for
 - a. leaking gaskets.
 - b. loose mounting bolts.
 - c. excessive noise.

42. The vent (breather) valve for the front drive assembly of the M151 ¹¹² truck is located in the
- intake manifold.
 - top of the differential case.
 - spindle support.
43. In addition to the spindle flange and the oil slinger, what item is bolted solidly to the steering knuckle on the M35A2 truck?
- Brake backing plate
 - Wheel hub
 - Steering tie rod
44. Before checking a 2-1/2-ton truck M35A2 CV-joint for wear, what part of the shaft or joint assembly should be clamped in a vise?
- Outer shaft
 - Driving yokes
 - Inner shaft
45. Before the front axle shaft and CV-joint assembly are installed in the M35A2 axle assembly, the CV-joint should be
- coated with oil.
 - packed with grease.
 - sprayed with powdered graphite.
46. What is the correct toe-in setting on the 1/4-ton truck M151?
- 1/64 to 5/64 inch
 - 1/32 to 5/32 inch
 - 1/16 to 5/16 inch
47. What is another name for the suspension and drive assembly used on the 1/4-ton truck M151?
- Swing axle
 - Independent drive
 - Transverse axle
48. What is used to close the boots used to seal the steering knuckles on M35A1 and M35A2 trucks?
- Snaps
 - Clamps
 - Zippers

113

49. When adjusting the wheel bearings on the 2-1/2-ton truck M35A1 or M35A2, the inner adjusting nut should be tightened until the wheel binds and then backed off
- 1/16 turn.
 - 1/8 turn.
 - 1/4 turn.
50. On the 2-1/2-ton truck front axle assembly, be sure to install a new gasket on the drive flange before bolting it to the
- pinion.
 - hub.
 - axle shaft.
51. The lower ball joint on the 1/4-ton truck M151 is secured to the lower control arm by
- a single bolt and nut.
 - two hardened rivets.
 - three bolts and nuts.
52. What is threaded to the outer end of each wheel hub on the 1/4-ton truck M151?
- Lifting eye
 - Dust cover
 - Bearing adjusting nut
53. The brakedrums on the 1/4-ton truck M151 are secured to the hub by two retaining screws and the
- wheel bearing adjusting nut.
 - spindle support retaining bolts.
 - wheel lug bolts.
54. What is used to assure that each end of the gage is the same distance from the floor when checking the toe-in of a 2-1/2-ton truck M35A1?
- Graduated scale
 - Pair of chains
 - Level bubble

114

55. The inner end of the front axle shafts on 2-1/2-ton trucks M35A1 and M35A2 are splined to the

- a. CV-joints.
- b. wheel hubs.
- c. differential side gears.



PRACTICE TASK LIST

Practice Objectives After practicing the following tasks you will be able to:

1. Locate the vents, filler and drain plugs, and constant velocity joints on the axle assemblies of 2-1/2- or 5-ton trucks.
2. Inspect the axle assemblies on a 2-1/2- or 5-ton truck and evaluate the results.
3. Check and adjust the front-wheel bearings on a 2-1/2- or 5-ton truck.
4. Check and adjust the toe-in on a 2-1/2- or 5-ton truck.
5. Inspect the drive assemblies and drive axles on a 1/4-ton truck M151.
6. Check the ball joints on a 1/4-ton truck M151 and evaluate the results.
7. Check and adjust the wheel bearings on a 1/4-ton truck M151.
8. Check and adjust the toe-in on a 1/4-ton truck M151.

Practice Tasks.

1. In order to become more proficient in the maintenance of axle assemblies, here are a few things you should practice on your company vehicles.

a. Locate the vents, filler and drain plugs, and constant velocity joints on the axle assemblies of a 2-1/2- or 5-ton truck.

b. Inspect the axle assemblies on a 2-1/2- or 5-ton truck and evaluate the results.

c. Check and adjust the front-wheel bearings on a 2-1/2- or 5-ton truck.

- 116
- d. Check and adjust the toe-in on a 2-1/2- or 5-ton truck.
 - e. Inspect the drive assemblies and drive axles of a 1/4-ton truck M151.
 - f. Check the ball joints on a 1/4-ton truck M151 and evaluate the results.
 - g. Check and adjust the wheel bearings on a 1/4-ton truck M151.
 - h. Check and adjust the toe-in on a 1/4-ton truck M151.
2. Whenever possible, work with an experienced repairman when he is performing maintenance on axle assemblies, especially when he is doing such things as replacing oil seals, servicing constant velocity joints, and troubleshooting the assemblies.



117

**ENLISTED MOS
CORRESPONDENCE/OJT COURSE**

ORDNANCE SUBCOURSE 63B206

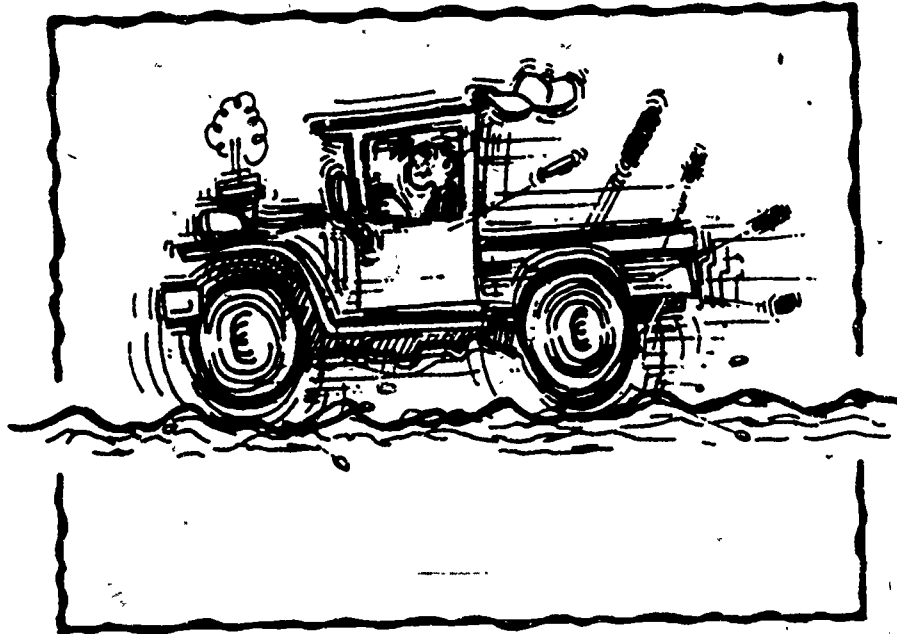

**LESSON 4
INTRODUCTION TO SUSPENSION SYSTEMS COMPONENTS**

SEPTEMBER 1975

**DEPARTMENT OF ARMY WIDE TRAINING SUPPORT
US ARMY ORDNANCE CENTER AND SCHOOL
ABERDEEN PROVING GROUND, MARYLAND**

CONTENTS

	Paragraph	Page
LESSON ASSIGNMENT SHEET		4-1
STUDY TEXT		
Section	I. Frames, Springs, and Shock Absorbers	
	Introduction to suspension systems	1 4-3
	Frame construction	2 4-3
	Construction of springs and shackles	3 4-6
	Construction and operation of shock absorbers	4 4-17
	II. Tires, Tubes, Wheels, and Rims	
	Construction and types of tires and tubes	5 4-22
	Construction of wheels and rims	6 4-26
	III. Component Replacement	
	Wheel and tire assembly on a 2-1/2-ton truck	7 4-31
	Wheel and tire assembly on a 1/4-ton truck	8 4-34
	Shock absorbers	9 4-36
	IV. Conclusion	
	Summary	10 4-44
	Practice tasks	11 4-45
APPENDIX	Practice Task List	4-46

119

US ARMY ORDNANCE CENTER AND SCHOOL CORRESPONDENCE/OJT COURSE



LESSON ASSIGNMENT SHEET

Ordnance Subcourse No 63B206 . . . **Wheeled Vehicle Drive Lines, Axles, and Suspension Systems**

Lesson 4 **Introduction to Suspension System Components**

Credit Hours **Four**

Lesson Objectives **After studying this lesson you will be able to:**

1. Describe frame construction.
2. State the purpose and construction of springs and shackles.
3. Explain how shock absorbers are constructed and how they operate.
4. Describe the construction and types of tires and tubes.

5. Describe the construction of wheels and rims.
6. Explain the procedures for removing and replacing 2-1/2-ton, 6x6 truck wheels and tires.
7. Describe the procedures for M151 1/4-ton truck wheel and tire replacement.
8. Describe the procedures for removing and replacing shock absorbers on an M151 1/4-ton truck.

Materials Required. ALL STUDENTS. Answer sheet and exercise response list.
 CORRESPONDENCE/OJT STUDENTS. See appendix.

Suggestions Refer to the illustrations while reading the text

SECTION I. FRAMES, SPRINGS, AND SHOCK ABSORBERS

1. INTRODUCTION TO SUSPENSION SYSTEMS. The purpose of the vehicle suspension system is to support the weight of that vehicle. A perfect suspension system would give a smooth ride on rough roads while keeping the wheels pressed firmly to the ground for traction. It would allow the vehicle to carry small or very large loads without changing any of its other good features. Unfortunately, it is not practical to build all vehicles with perfect suspension. Instead, in each type of vehicle, the suspension system is built for a particular type of job. Because most military vehicles must travel over rough roads and carry heavy loads, their suspension systems are very strong and stiff. However, there are some vehicles used by the military that have a more flexible suspension system. As a wheeled vehicle mechanic you must have a knowledge of both types. In this lesson we will discuss suspension system components, to include frames, springs, bogie suspension systems, shock absorbers, wheels, and tires.

2. FRAME CONSTRUCTION. In order to provide a rigid foundation for the vehicle body, as well as providing a solid mounting for the suspension system, a frame of some sort is necessary. The plan and construction of a frame depend upon the type of vehicle and the service for which the vehicle is intended. Two major types of frames are in common use. They are the conventional frame and the integral frame. The conventional frame is made separately from the body, and the various vehicle parts are bolted to it. In the integral-type frame, the frame and body are made as a unit and welded together.

a. Conventional frames for passenger cars and trucks are built of side rails, crossmembers, and gussets. Gussets are angular pieces of metal used for strengthening the points where the side rails and crossmembers join. These parts, when riveted together, look like some form of a letter, such as "A," "X," "Y," or "K." The assembled frame combines stiffness and strength with light weight.

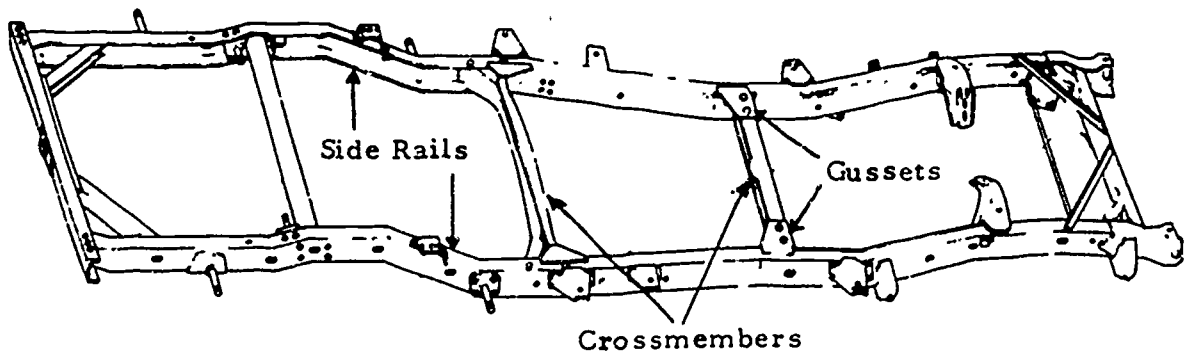

122

(1) The conventional frame is usually not more than 30 inches wide in front so that the wheels will not rub on it when making a sharp turn. It may be widened to 48 inches at the rear for increased body stability. Kickups (humps) over the axles allow the vehicle's body to set closer to the ground.

(2) For large trucks the frames are simply made of rugged channel iron. The side rails are usually set at standardized widths to permit the mounting of stock transmissions, transfer assemblies, axles, etc. Trucks which are to be used as wreckers or tractors have an additional reinforcement of the side rails and rear crossmembers so they will stand up under the added towing stresses.

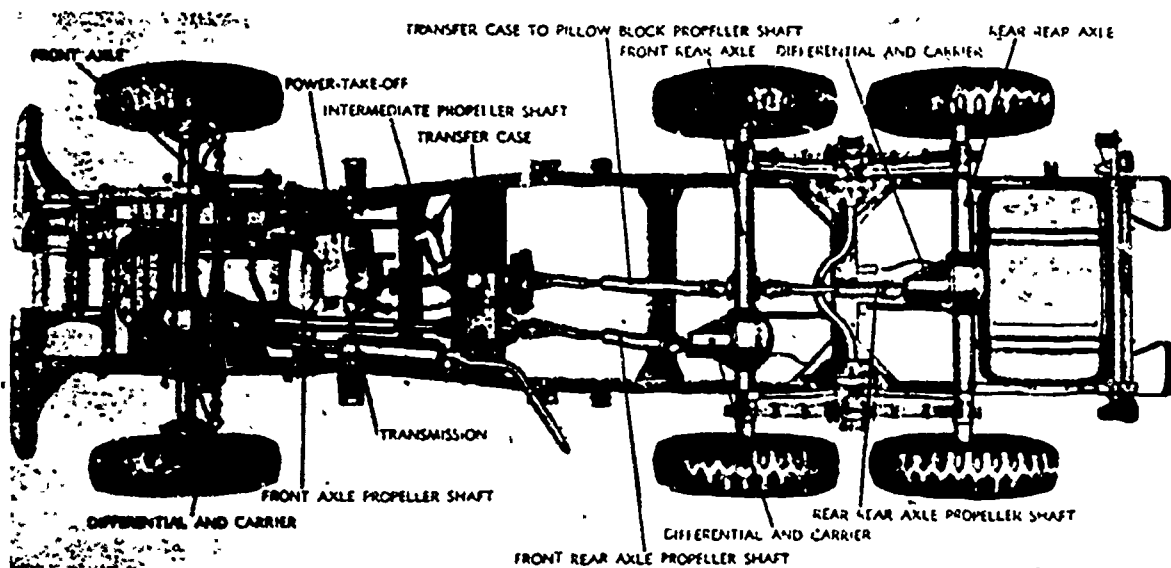

Truck frame with drive train and suspension system.

123

(3) The frame members serve as supports to which suspension arms, radiators, transmissions, and the like may be attached. Additional brackets and supports are added for the mounting of running boards, springs, bumpers, engines, towing hooks, shock absorbers, gas tanks, and spare tires. Rubber insulator blocks are usually used between the frame and body attachment points to reduce the transfer of bothersome vibrations and road noise.

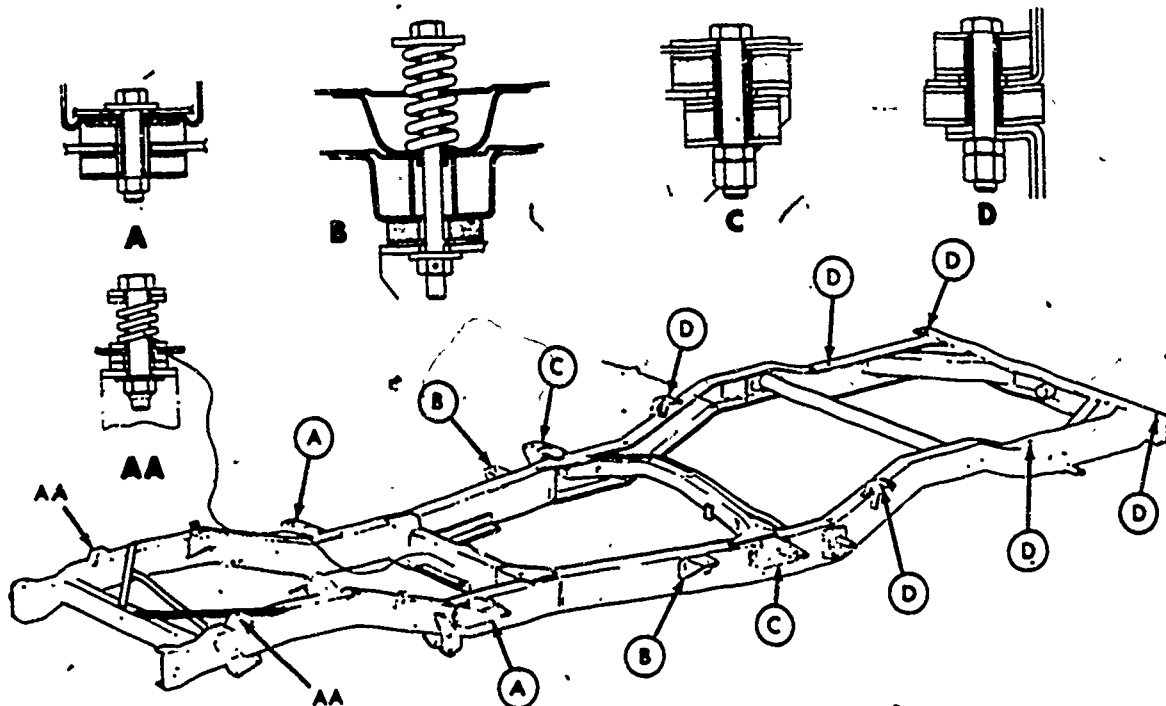

AA Radiator guard holddown
 A Front cab insulator
 B Rear cab insulator

C Front cargo box insulator
 D Rear cargo box insulator

AT 14716

124

b. In the integral-type frame, various body sections are used as structural strength members. All of these sections are welded together into what is usually referred to as the unitized body and frame. The 1/4-ton truck M151 body and frame shown is of the integral type. The rigid body sections have reinforced points for mounting various items, such as the suspension system

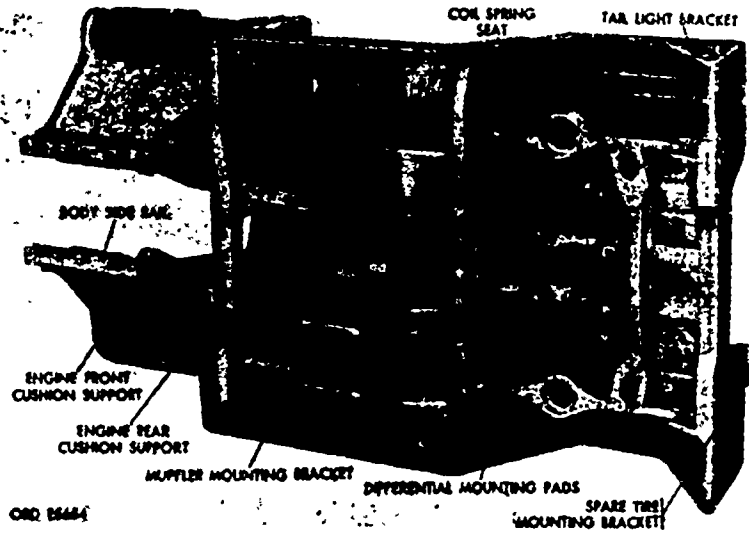

Unitized body and frame

parts, engine, and differentials. Another example of the integral frame is the hull or body of a combat tank. A tank hull is an assembly of heavy armorplate. It serves not only as a frame, but also to house and protect the crew and equipment.

3. CONSTRUCTION OF SPRINGS AND SHACKLES. The key parts of the suspension system are the springs. One of the first types of springs to be used in suspension systems was the elliptic leaf type as shown in view A of the accompanying illustration.

LEAF-TYPE SPRINGS

It is referred to as an elliptic spring because it has an oval shape, like a football or an egg. The spring is made stronger by adding more leaves, as in view B. The spring then becomes known as an elliptic laminated leaf spring. More variations of this spring are the semielliptic laminated leaf and the quarter elliptic laminated leaf, which are shown in views C and D.

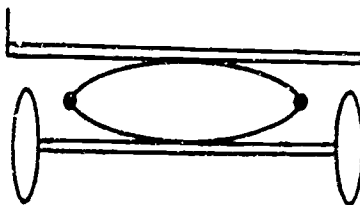

a. Elliptic leaf spring



b. Elliptic laminated leaf



c. Semielliptic laminated leaf



d. Quarter elliptic laminated leaf

The semielliptic laminated leaf springs are the most commonly used on modern trucks. They are also used on many passenger cars.

a. The semielliptic laminated leaf spring consists of several spring leaves of different lengths, a center bolt, and spring leaf clips. The spring leaves are assembled according to length, ranging from the shortest at one side to the longest at the other side of the spring. The center bolt passes through a hole in the spring leaves and is secured with a nut. The center bolt holds the spring leaves in place and its head is generally engaged in the spring seat to assist in axle alignment. The spring leaf clips are fitted around the spring, and each one is secured with a bolt, spacer, and nut. The clips hold the ends of the leaves together when the vehicle bounces over rough roads. They are often called rebound clips. The ends of the first, or main, leaf are often rolled into circles that are called the spring eyes. A bushing-type bearing is pressed into each spring eye. Usually this is a smooth brass or a bronze bushing, but sometimes it may be a rubber or threaded-steel type.

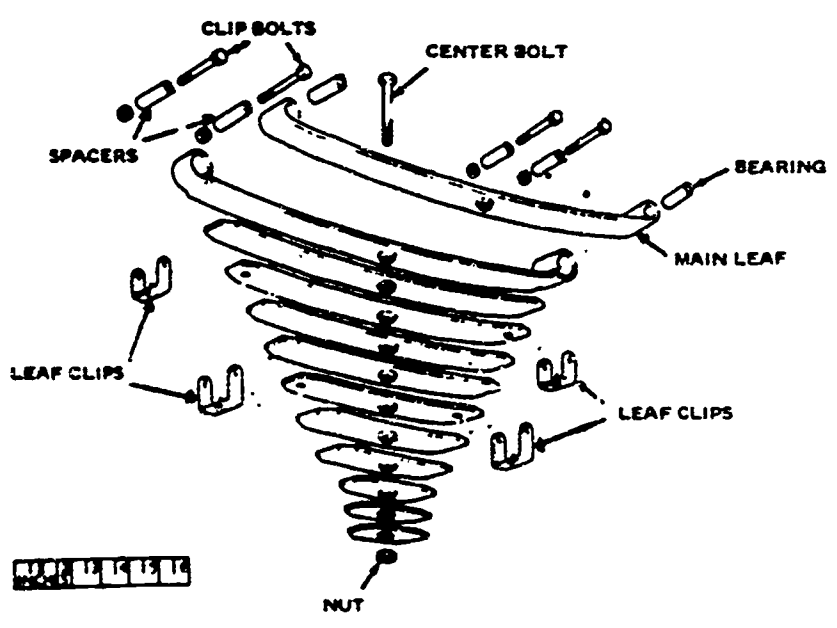

Spring assembly - exploded view.

126

(1) On light trucks, two semielliptic laminated leaf springs are generally used to mount each axle assembly. The ends of each spring are fastened to the vehicle frame, lengthwise to the vehicle. The axle assemblies are fastened to the springs at or near their center. The springs hold the axle assemblies in alignment with the vehicle frame. Unless some other means is provided, the springs also prevent the axle housing from turning when a turning force (torque) is applied to the wheels.

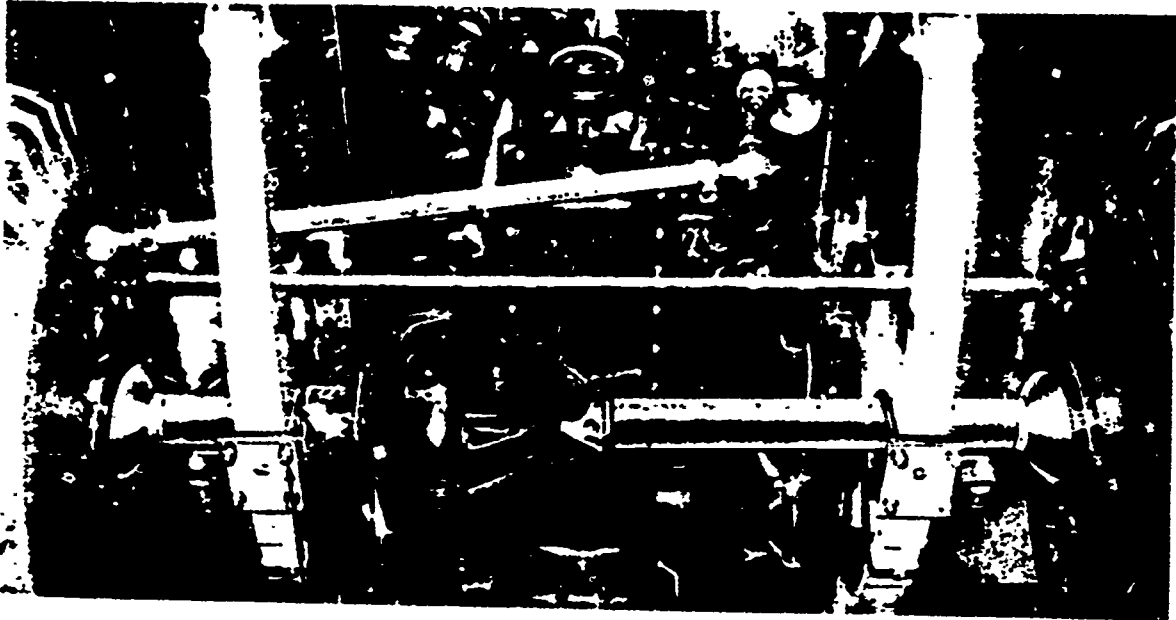

139

4-8

(2) In a typical mounting of a spring in a military vehicle, one end of the spring is fastened to the vehicle frame by a spring hanger and pin. The spring hanger is fastened securely to the frame by rivets. A pin passes through holes in the spring hanger and the bearing in the spring eye. The pin serves as a pivot for the spring and has a drilled passage and grease fitting for lubrication purposes. The other end of the spring is fastened to the frame by a spring hanger, two pins, and a spring shackle. One pin passes through holes in the hanger and shackle, leaving the shackle free to pivot on the pin. The shackle is then fastened to the spring by the remaining pin. Grease fittings and drilled passageways are also provided in both of these pins for lubrication purposes. The springs flex as the weight of the vehicle load is changed and as the vehicle travels over rough roads. Flexing of a spring causes its length to change. The spring shackle swings on its pivot to allow for the changes in the spring length as it flexes. The flexing action of the laminated leaf-type spring is restricted by the friction of the leaves rubbing together.

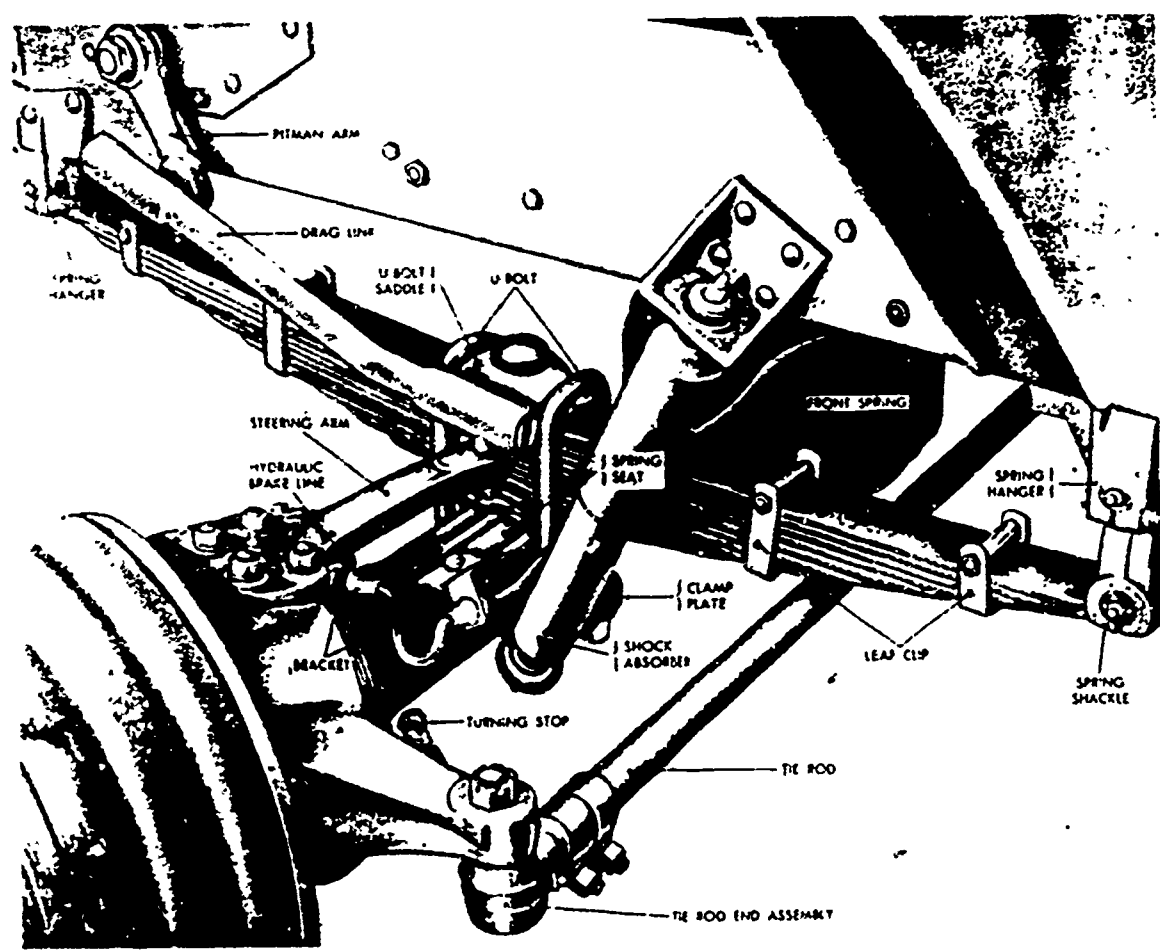

b. There are several different types of spring shackles used. The bolt-type shackle has two flat side pieces. The pins are made like bolts, with a head on one end and threaded on the other end to receive a nut. Note the grease fitting and passages that permit lubrication to be applied at the center of the bearing.

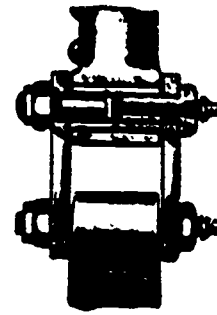

BOLT TYPE

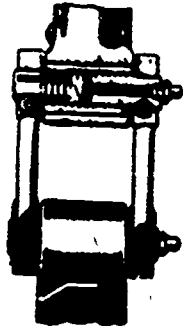

STRAIGHT THREADED TYPE

(1) In the straight threaded-type shackle the bearings have internal threads. Threaded pins are then screwed into each bearing. The ends of the pins are fitted into holes in the shackle side pieces. Bolts or small pins are placed in holes in the side pieces, engaging grooves cut in the threaded pins. This holds the side pieces on the threaded pins.

(2) The U-type shackle is a one-piece, U-shaped bolt that is threaded on both ends. The bearings are threaded both internally and externally. In order to assemble the U-type shackle, the shackle must first be placed inside the bearing bores of the spring and spring hanger. The threaded bearing is then screwed into the bearing bore and onto the shackle at the same time.

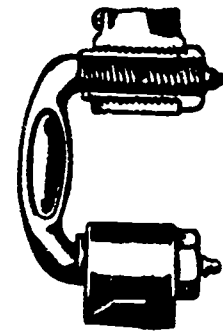

U-TYPE

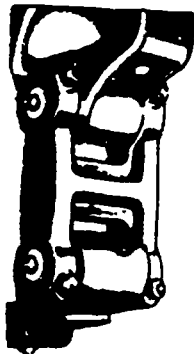

PIN AND BOLT TYPE

(3) The pin-and-bolt-type shackle usually has a one-piece shackle that resembles the letter "H." The shackle is fastened to the spring and spring hanger by straight pins. The pins are locked in place by bolts similar to the method used on the straight threaded-type shackle.

(4) The center bolt-type shackle consists of two side pieces, a center bolt, and two threaded pins that are tapered on their ends. The bearings are threaded on the inside to receive the threaded pins. The shackle side pieces have tapered holes that fit over the tapered ends of the pins. The center bolt passes through the side pieces and holds them tight on the tapers. In another variation of this shackle, the pins have a threaded portion extending beyond the tapers. Nuts and washers are then used to secure the side pieces instead of the center bolt.

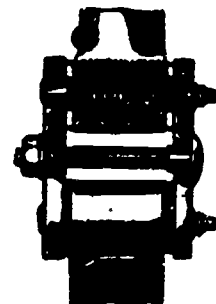

CENTER BOLT TYPE

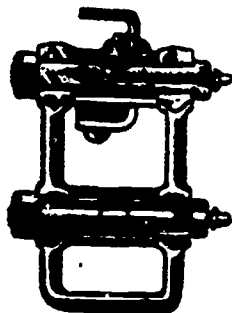

SINGLE PIECE LINK SHACKLE

(5) The single-piece link shackle has a one-piece U-shaped shackle that forms both side pieces. Bolt-type pins secure the shackle to the spring and spring hanger.

(6) The Y-shackle is a one-piece shackle that has the shape of the letter "Y." One of the bearings is contained in the shackle itself.

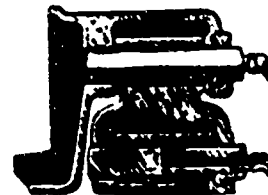

Y-SHACKLE

130

c. For a number of years many passenger vehicles have used coil-type springs in their suspension systems. At first they were used mainly in independent suspension of the front wheels. At the present, coil springs are widely used on both the front and rear of passenger vehicles and some light trucks.

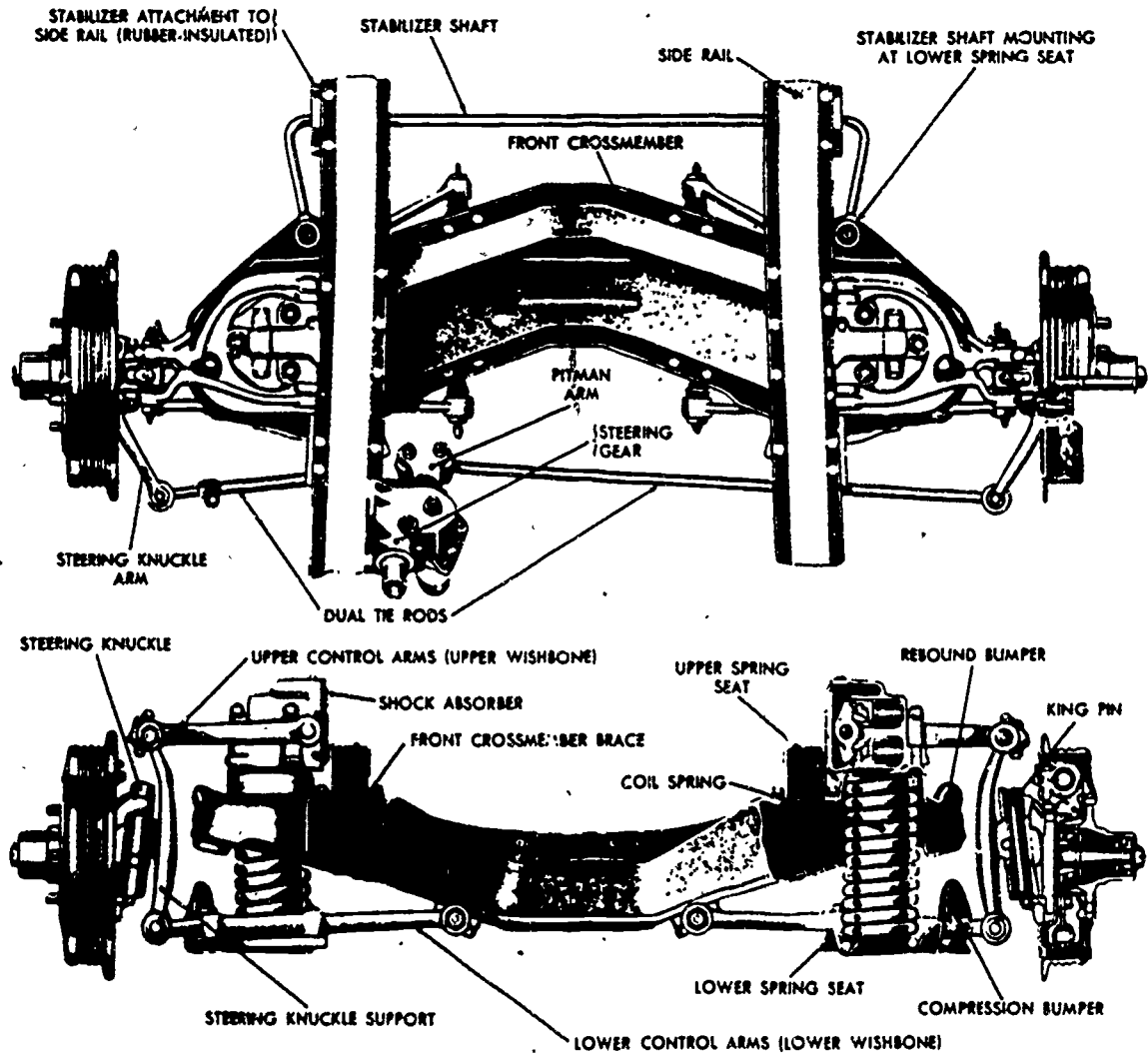

(1) One military vehicle that uses coil-spring suspension at both the front and rear is the 1/4-ton truck M151. Coil springs have a wide application because they cost less to make, they are compact, and they are effective. The main disadvantage is that excessive bouncing of the vehicle results from their frictionless action, making the use of shock absorbers a necessity.

131

(2) Coil springs are made of special steel rods, heated and wound in the shape of a spiral coil. One end contacts the vehicle frame and the other end contacts the axle or the suspension device used. A rubber-like pad or insulator is used at the end of the spring that contacts the frame. The insulator prevents vibrations from transferring from the spring to the vehicle frame.

d. The volute spring is a coil spring made from flat steel instead of a round steel rod. The flat steel is tapered both in width and in thickness. It is wound in a spiral that is large at one end of the spring and gets smaller with each turn or coil. Each coil overlaps the one next to it, with the widest and thickest part of the flat steel being at the larger end of the spring. Volute springs have been used mainly on tracklaying vehicles. This type of spring is desirable when heavy loads must be supported but there is not enough space available to use a conventional coil or laminated leaf spring.

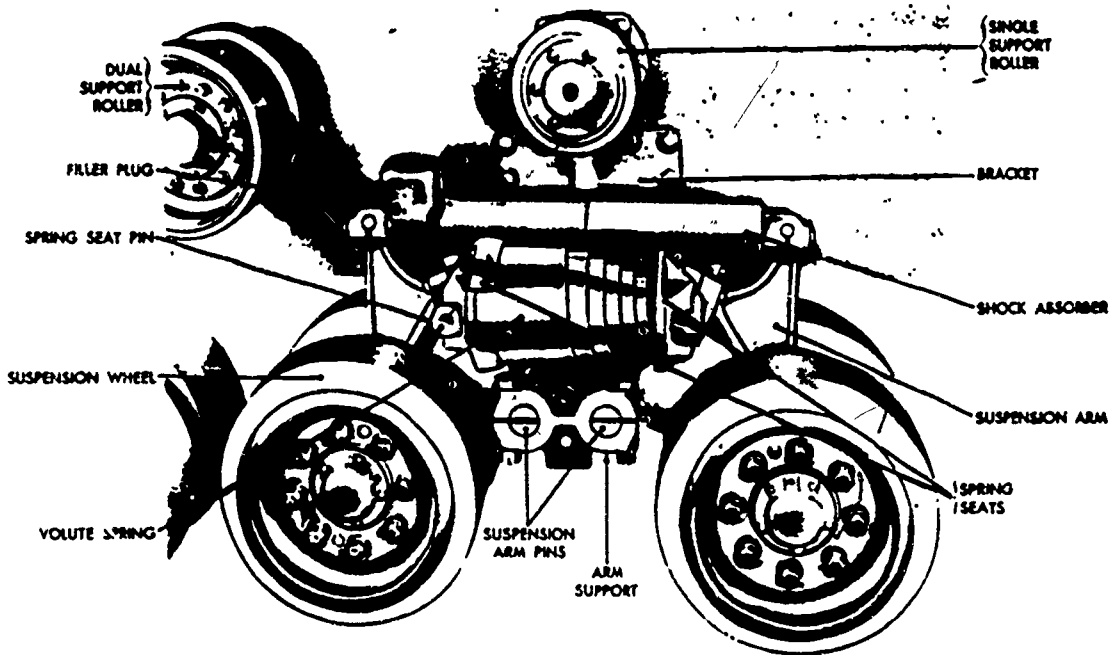

132

e: Another type of suspension spring that is used in tracklaying vehicles is the torsion bar. The torsion bar is also being successfully used in some passenger cars and trucks. This suspension spring consists of a long spring steel bar. One end of the bar is secured to a nonmovable mounting called an anchor. The other end is fastened to a suspension arm or lever. When the lever arm is moved up, it twists the long torsion bar. The bar resists the twisting and gives a spring action, always returning to its original position unless it is overloaded. Torsion bars are usually made to take stress in one direction only and often are marked by an arrow stamped into the metal to indicate the direction of stress.

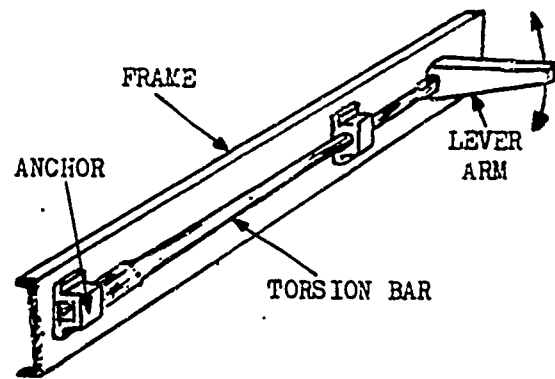

f. Large wheeled vehicles are built to carry both heavy and light loads. Several methods have been used to change the load rating of the spring suspension as the vehicle load is changed. Auxiliary springs, often called secondary springs, are commonly used in addition to the main springs for this purpose. The secondary spring is often secured to the frame at its center, with its ends free. When the vehicle load is increased to a certain amount, the main spring is compressed, bringing the free ends of the secondary spring against the axle. Both springs now support the load, and their load ratings are added. This arrangement permits the vehicle to carry heavy loads without compressing the mainspring too much.

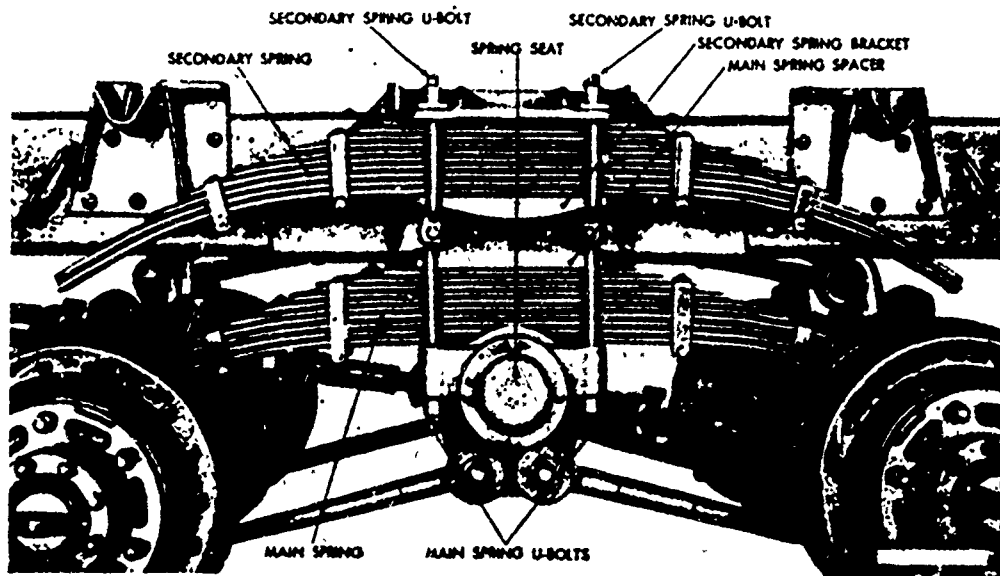

4-14

g. Another variable-load suspension system provides a spring arrangement that increases the effective strength of the springs as the load is increased. The springs are made with flat ends which bear against curved bearing plates. With a light load the spring ends make contact with the outer edges of the curved bearing plates. This is the part of the bearing plate that is farthest away from the center of the spring. As the load is increased, the spring compresses, causing the points of contact to move toward the inner edges of the bearing plates. This decreases the effective length of the spring, giving it a higher load rating. This method is commonly referred to as a variable-load spring arrangement.

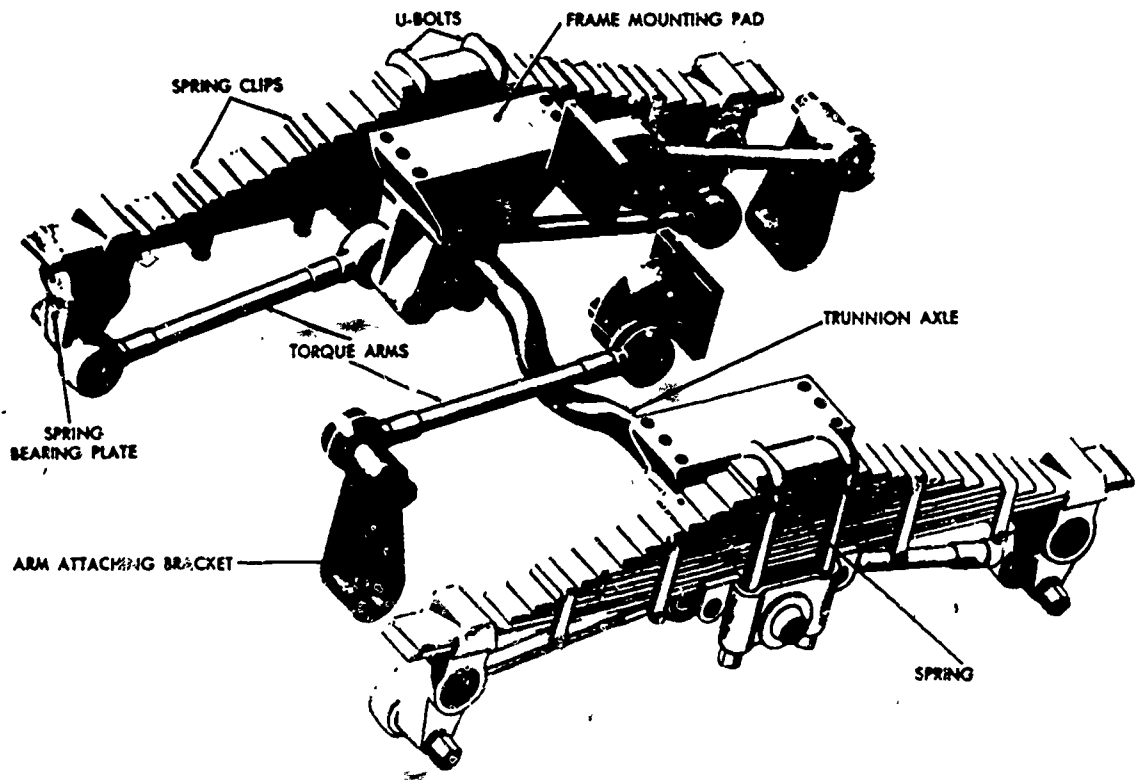

h. Two rear axles are used on many of the heavy vehicles to reduce the load on each rear wheel. In addition, the use of two axles will decrease the effects of road shocks and increase traction. A typical rear end of a heavy vehicle consists of an axle mounted at each end of the rear springs. The load of the vehicle is applied at the center of the springs by means of a spring seat which is supported on the frame. The rear springs carry the same load as they do with a single rear axle. However, the load is divided between two axles instead of being applied to one. The drive is usually applied to both rear axles on military vehicles. Torque rods transmit the driving force to the frame and are arranged so that none of the turning force is applied to the springs.

(1) The rear suspension of a truck having two rear axles is usually called a bogie suspension unit. It consists of two axles joined by springs that pivot on bearing-mounted spring seats. The spring seat bearings fit around a trunnion axle which is rigidly attached to the frame through mounting pads. The ends of each spring rest on hardened steel bearing plates on the two axle housings. Both springs are clamped to the spring seats by means of U-bolts.

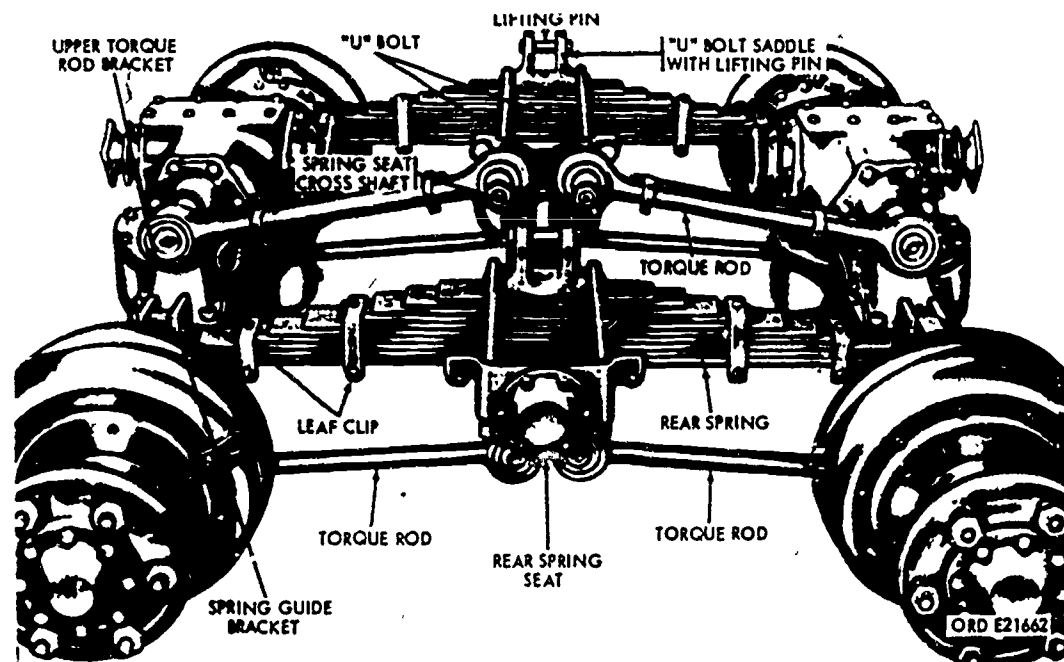

(2) When the vehicle travels over uneven surfaces, the springs pivot on the tapered roller bearings. As a result, the weight remains divided between the four wheels even though one wheel may be on a lower or higher surface. This allows the vehicle to carry heavier loads without exceeding the safe tire load. Also, when one wheel hits a bump, the spring pivots on the seat bearings so that both ends of the spring absorb the shock. Thus, the effects of road shocks to the vehicle frame and body are reduced by one half. When only one axle is deflected up or down, the trunnion axle and the vehicle frame are raised or lowered only half the amount. In this manner, bogie axles reduce by half the impact, or shock, not only to the vehicle frame, but also to the tires.

135
4: CONSTRUCTION AND OPERATION OF SHOCK ABSORBERS. When a vehicle is traveling on a level road and the wheels strike a bump, the spring is compressed quickly. The compressed spring will attempt to return to its normal loaded length, and in so doing will rebound past its normal height, causing the body to be lifted. The weight of the vehicle will then push the spring down below its normal loaded height. This, in turn, causes the spring to rebound again. This bouncing process is repeated over and over, a little less each time, until the up-and-down movement finally stops.

a. If bouncing is allowed to go uncontrolled, it will not only cause an uncomfortable ride but will make handling of the vehicle very difficult. To overcome bouncing, assemblies called shock absorbers are used. The main function of a shock absorber is to control (regulate) the spring rebound. Shock absorbers which check (resist) only the spring rebound are single-acting.

(1) A shock absorber may also deaden (regulate) the compression of the spring by absorbing part of the energy as the spring is depressed. Shock absorbers which regulate compression in addition to rebound are double-acting. Most shock absorbers used at the present time are double-acting, because they permit the use of more flexible springs and, thus, a more comfortable ride.

(2) Many types of shock absorbers have been used. Some that have been used were operated by friction and spring tension. Those used at present are usually hydraulically operated. These depend upon the resistance of a liquid flowing through small openings to check the action of the spring.

b. A typical cam-operated (also known as an indirect-acting) hydraulic shock absorber is attached to the frame of the vehicle and contains a lever that pivots in the housing. The lever is pinned to a link that is attached to the spring clamp assembly. Rubber grommets are used at both ends of the link to prevent metal-to-metal contact and to provide flexibility. Whenever the spring compresses and rebounds, the shock absorber lever is operated.

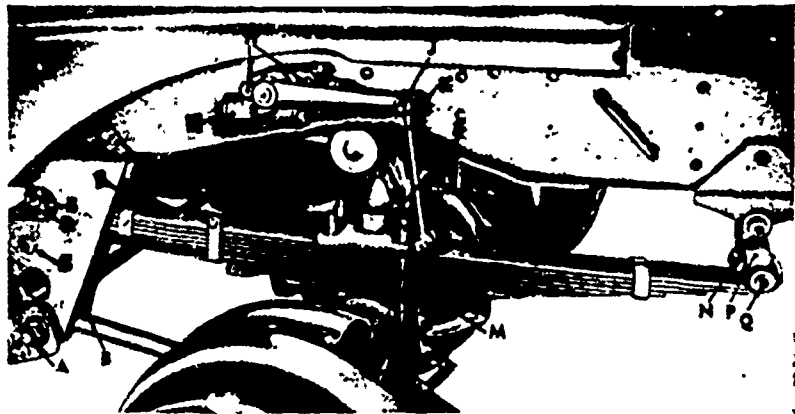

A—STABILIZER BAR END PLATE
B—LOWER TORQUE ROD
C—REAR SHACKLE BOLT
D—REAR SHACKLE
E—REAR SHACKLE PIN
F—FRONT SPRING
G—SHOCK ABSORBER
H—SHOCK ABSORBER MOUNTING CAP SCREW

J—LINK PIN NUT
K—SHOCK ABSORBER LINK ASSY
L—SPRING BUMPER BLOCK
M—“U” BOLT
N—FRONT SHACKLE BOLT
P—FRONT SHACKLE
Q—FRONT SHACKLE PIN

136

(1) One cam-operated shock absorber is made to check the rebound only (single-acting). The housing, or body, contains an oil-filled reservoir and cylinder. A cam-operated piston is located in the cylinder. The cam is mounted on a shaft to which the shock absorber lever is connected. The piston is held against the cam by a coil spring in the cylinder. An intake or check valve, which permits oil to enter the cylinder from the outer reservoir, is located in the piston head.

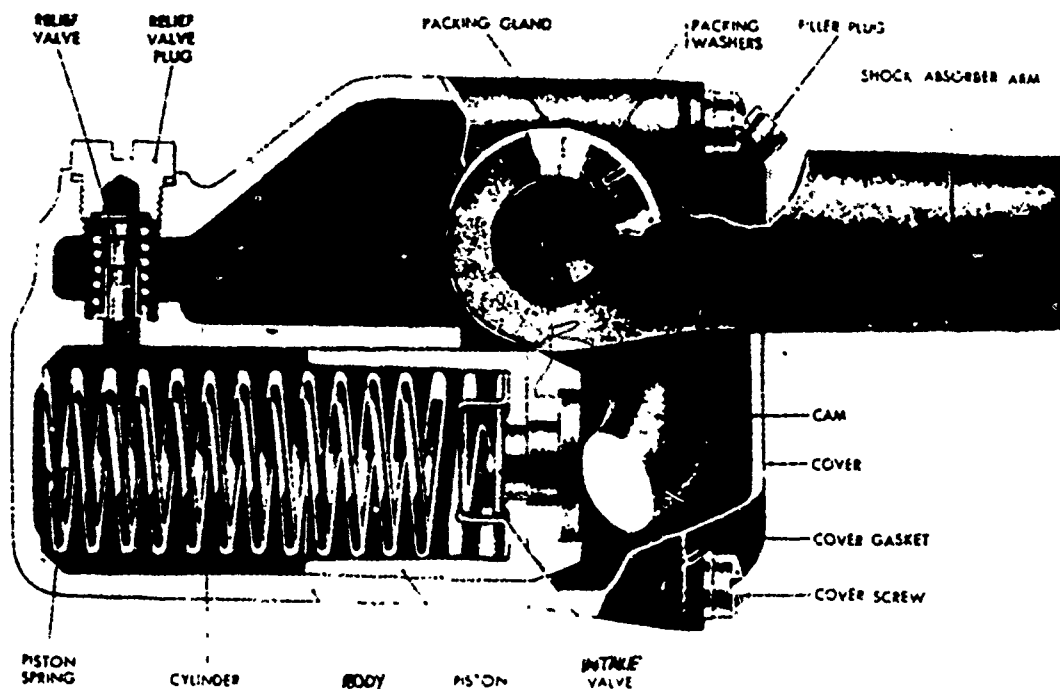

(2) The cam moves to the right when the vehicle spring is compressed. The piston spring forces the piston to follow the cam, opening the intake valve and allowing oil to flow into the cylinder. This valve has a large port opening, so it offers little resistance to the flow of oil. Therefore, it has little effect upon the action of the piston when the spring is being compressed.

(3) When the vehicle spring rebounds, the cam is moved in the reverse direction. This forces the piston to the left against the oil in the cylinder, closing the intake valve. The motion of the piston forces the oil from the cylinder through a small opening in the relief valve. Liquids are not compressible under ordinary pressures, and it takes a certain amount of time for oil to flow through the small relief valve opening. Therefore, the rebound of the vehicle spring is slowed down. The flow of oil and the vehicle spring rebound is regulated by the size of the valve opening. In addition, some regulation is also obtained by the valve spring pressure holding the relief valve against its seat. The instant the vehicle spring stops its rebound, the relief valve is closed by its valve spring.

137

c. The operating principle of the double-acting cam-operated shock absorber is the same as the single-acting shock absorber except that it checks spring action in both directions. A cam-operated double-acting shock absorber has two pistons. One regulates vehicle spring rebound and the other spring compression.

d. The shock absorber that is the most widely used is the direct-acting shock absorber. These shocks are often referred to as airplane-type shocks. The direct-acting shock is mounted directly to both the vehicle frame and the axle or suspension arm. As the frame rises and falls in relation to the axle, the shock absorber must telescope out and in. The shock's resistance to telescopic movement dampens (hinders or slows down) this up-and-down movement. The shock may have eyes made on its ends for mounting or it may have threaded studs. Rubber bushings are used inside the eyes and rubber grommets on the studs to prevent metal-to-metal contact and to provide flexible mounting.



(1) The direct-acting shock absorber consists of an inner cylinder, an outer cylinder, a piston, a piston rod, and, in most cases, an outer dust and rock shield. A series of valves in the piston and at the bottom of the inner cylinder control the movement of oil within the shock. A reservoir which contains a supply of oil surrounds the inner cylinder.

138

(2) The direct-acting shock absorber is double-acting. When the vehicle spring is compressed, the shock absorber telescopes in (gets shorter). This moves the piston down, putting pressure on the oil under the piston. In order for the piston to continue to move downward, it is necessary for the oil to pass through the compression valve. Oil flows through the compression valve into the upper section of the inner cylinder. Oil flow and spring compression are regulated by the size of the compression valve port holes and the spring.

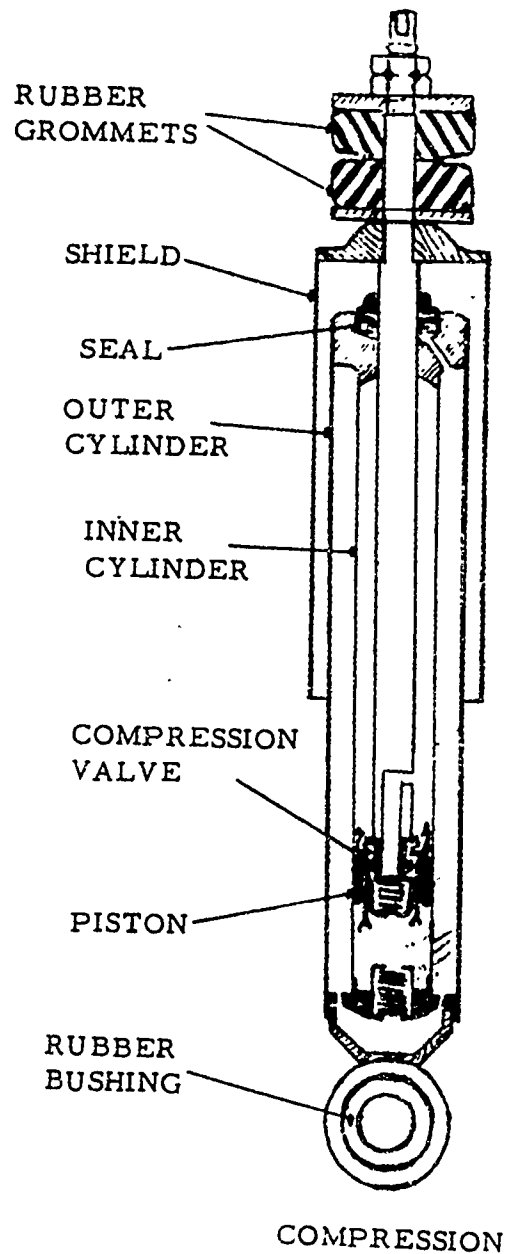

4-20

(3) When the spring rebounds, the piston is moved up and the oil trapped above the piston must travel through the rebound valve. To make up for the reduced amount of rod that is now in the inner cylinder, additional fluid is pulled in from the reservoir through the intake valve. Regulation of oil flow and spring movement is controlled by the size of the rebound valve opening and its spring. Sometimes a series of valves are used to provide better regulation of the oil flow in the shock absorber to produce a smoother ride.

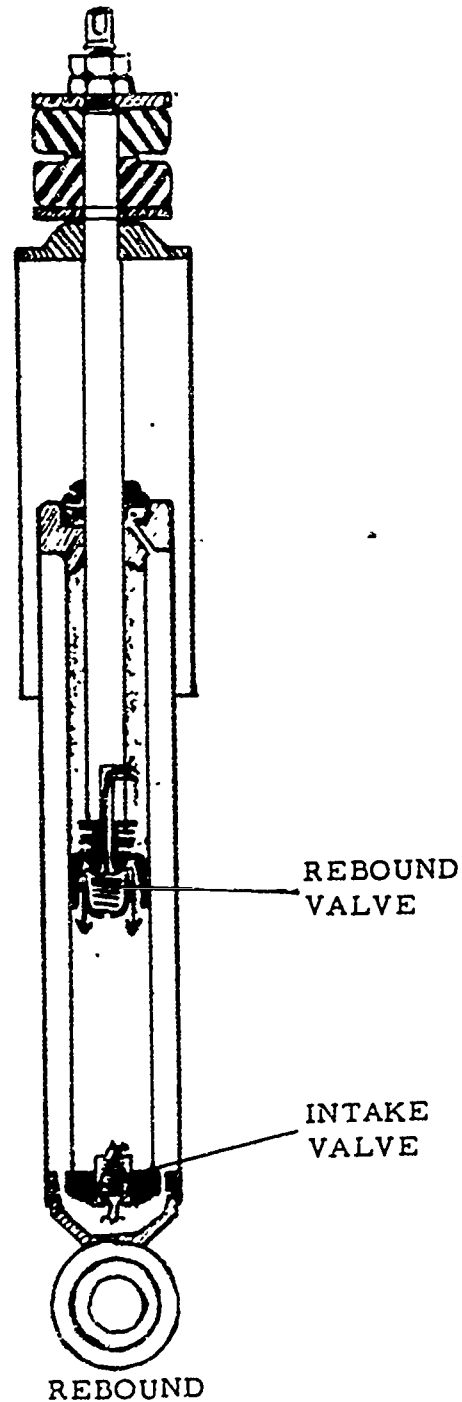

4-21

SECTION II. TIRES, TUBES, WHEELS, AND RIMS

5. CONSTRUCTION AND TYPES OF TIRES AND TUBES. Additional cushioning and traction qualities are provided by the vehicle's tires. The tire assembly generally used on trucks consists of the tire, inner tube, and flap. The inner tube contains the air and the flap protects the tube in the rim and bead area.

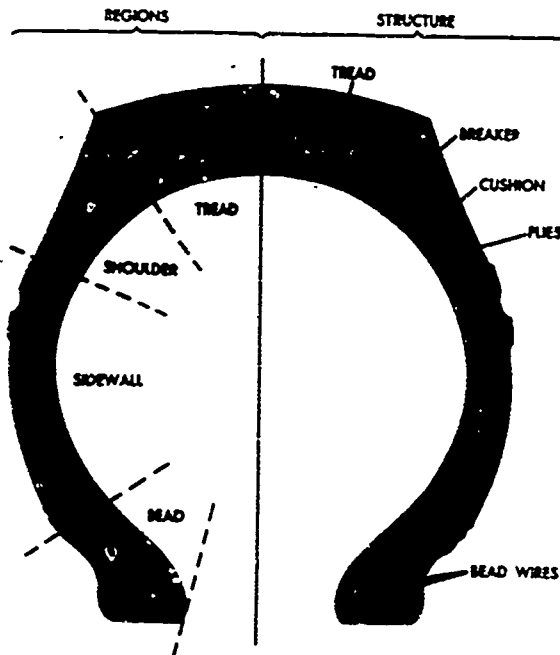
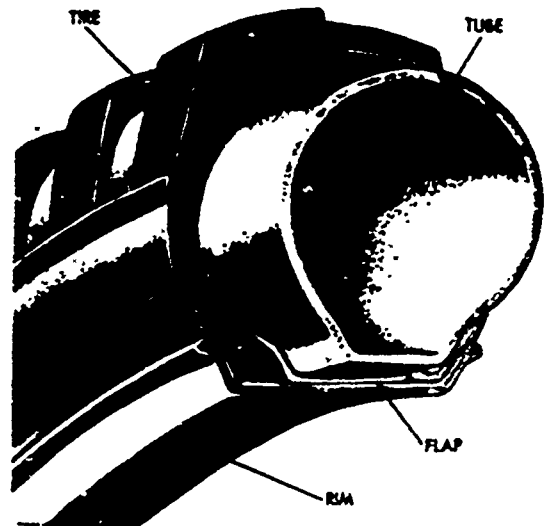

a. The parts that make up the tire are the tread, breaker, cushion, plies, and bead. Each part of the tire serves a definite purpose as explained below.

(1) The tread is a layer of rubber on the outside of the tire. It is the part that contacts the road and is the wearing surface. The tread is designed to reduce skids and to increase the traction needed for driving and braking the vehicle. The tread also protects the cords from cuts, bruises, and moisture. Rubber extends from the tread down over the sidewalls of the tire to protect the cords.

(2) Breakers are layers of rubber-covered cords (strings), similar to plies, except the cords are spaced farther apart. When the tire hits a bump, the breakers spread out the shock. This prevents a lot of strain from being placed on one small section of the plies. The breakers also prevent the tread from separating from the tire. 141

(3) The cushion is soft, heat-resisting rubber. It absorbs road shocks and bonds (fastens) the breakers to the plies. Cord plies have strength to resist internal pressures, to support loads, and to absorb road shocks.

(4) The bead is that part of the tire which secures the tire to the rim. It consists of hard rubber molded in and around steel wire cables. The cord plies are wrapped around the bead to secure it to the tire sidewalls.

b. Some tires are built for use without inner tubes. These are called tubeless tires and have a soft rubber liner on their insides to prevent air leaks.

c. Combat tires have the same basic construction as standard tires. However, combat tires are built so they can operate without air pressure for a limited distance in an emergency. They should be operated without air pressure only in combat where the tactical situation requires it. A combat tire is of much heavier construction than a standard tire. It has more rigid (stiff) sidewalls and its heavily cushioned plies are spaced wider apart. On the inside there is a heavy section of rubber. A beadlock fits between the beads to hold the tire in place when it is operated without air pressure. These tires are marked with the word "combat" on the serial-number side of the tire.

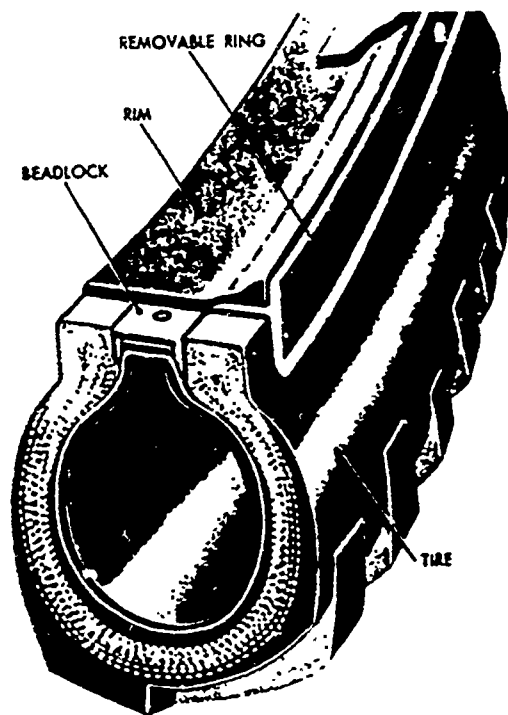

142

d. Markings on the sidewalls of tires give the manufacturers' name and information that is important to their use. The size and ply marking (7.50-20, 8 ply) of a tire are shown. The first figure, 7.50, is the tire's approximate width in inches when it is properly mounted. This measurement is taken with the specified amount of air pressure in the tire, but not supporting the vehicle weight. The second number, 20, is the inside diameter of the bead in inches.

The third part, 8 ply, is the number of plies of cord fabric. If this number is shown as 8PR (8 ply rating), it means the tire is as strong as a standard 8-ply tire. However, the tire actually contains a lesser number of plies.



(1) On some of the smaller tires there is a small round mark, about one-quarter of an inch across, on the sidewall near the bead. This is a balance mark. When the tire is assembled on the wheel, the mark should be aligned with the valve of the tube.

(2) Both standard and combat tires have serial numbers. Each individual tire is assigned a different serial number for identification purposes. Serial numbers are always indented figures in the sidewall of the tire. Figures that are raised are made by the tire mold and should not be confused with the serial number.

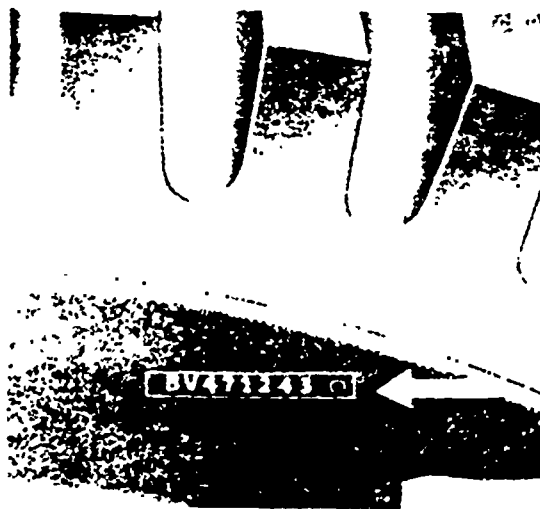

4-24

e. The inner tube is a doughnut-shaped rubber container that fits inside the tire. It holds the air that supports the vehicle, but is strong enough to hold only a few pounds of air pressure when out of the tire. However, the tube will hold very high pressures when enclosed in the tire. Because tubes are made of soft rubber, they are easily chafed, pinched, punctured, or otherwise damaged. Most tubes are made of synthetic rubber, which holds air better than natural rubber. Synthetic rubber is manmade and is sometimes referred to as butyl-type rubber.

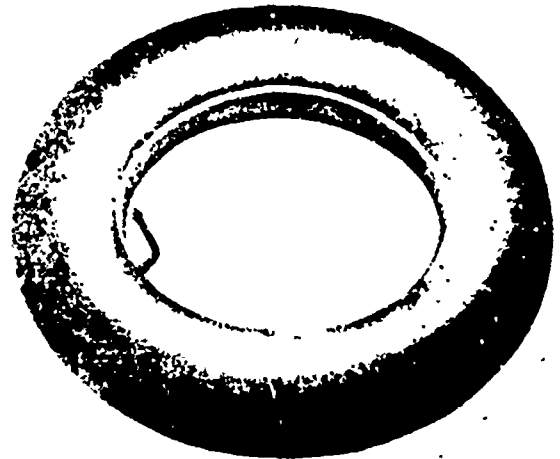

(1) Standard tubes are made of one layer of rubber and are used for standard-type tires. Tubes for combat tires are constructed the same as standard tubes, except they are smaller than standard tubes with the same size markings. This is because combat tires are smaller on the inside due to their heavier construction. Combat tubes are stamped "combat" and should be used in combat tires only.

(2) Some tubes are built to automatically seal bullet punctures. These tubes are made of thick soft rubber. Bullet-resisting tubes are identified by their extra weight and thickness and generally have green-painted valve stems.

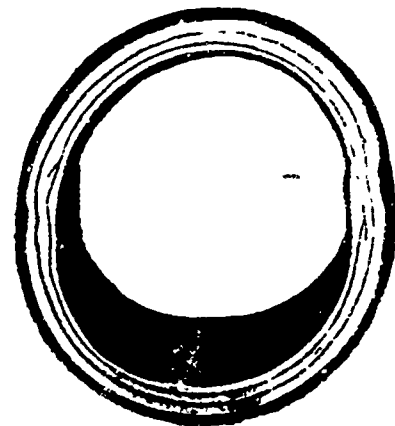

144 (3) Air pressure is forced into the inner tube through a valve in the valve stem. The valve stem is threaded on the inside to allow the installation of a valve core. The valve core fits airtight against a tapered seat inside the stem. It permits air under pressure to enter, but prevents it from escaping. The valve stem is threaded on the outside at its outer end to permit installation of the valve cap. The valve cap keeps the valve core clean and serves as the final seal.

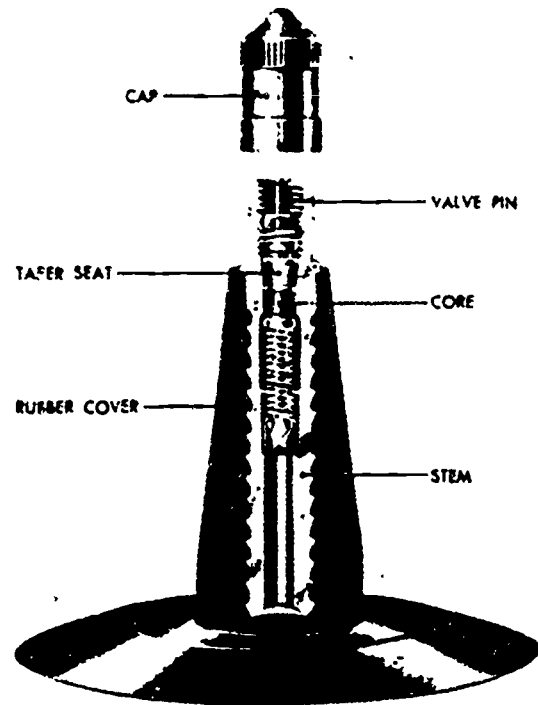

6. CONSTRUCTION OF WHEELS AND RIMS. The tire assembly is mounted on a wheel and rim assembly. Wheels must have enough strength to carry the weight of the vehicle, transfer driving and braking forces, and withstand side thrusts. Passenger cars are driven at high speeds, which means that they must be set close to the ground. Therefore, they use perfectly balanced wheels of small diameter. Even a slightly unbalanced wheel and tire assembly will cause steering problems and rapid tire wear at high speeds. Small balance weights are often attached to the wheel to offset an unbalanced condition.

145

a. Passenger car wheels are usually of the steel-disk type. The disk can be solid or it may have slotted or round holes in it to reduce weight and to provide ventilation for cooling. The disk is welded or riveted to the rim and bolted to the brakedrum and axle. Some passenger cars use wire wheels which are light and easy on tires. They consist of a pressed steel hub and rim connected by spokes that are welded at each end. In both types of wheels, the wheel is dished to bring the point of ground contact under the large wheel bearing.

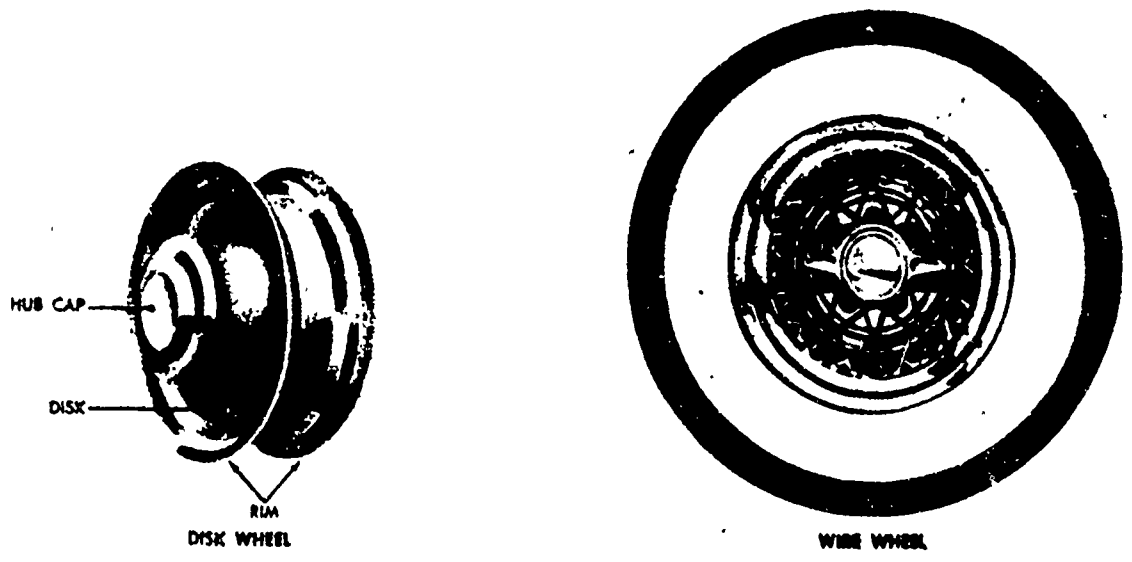

b. Two disk-type wheels that are used on trucks are shown in this figure. One of the rim flanges can be removed to aid in removing and replacing tires. Truck wheels are dished enough to permit the mounting of dual wheels.

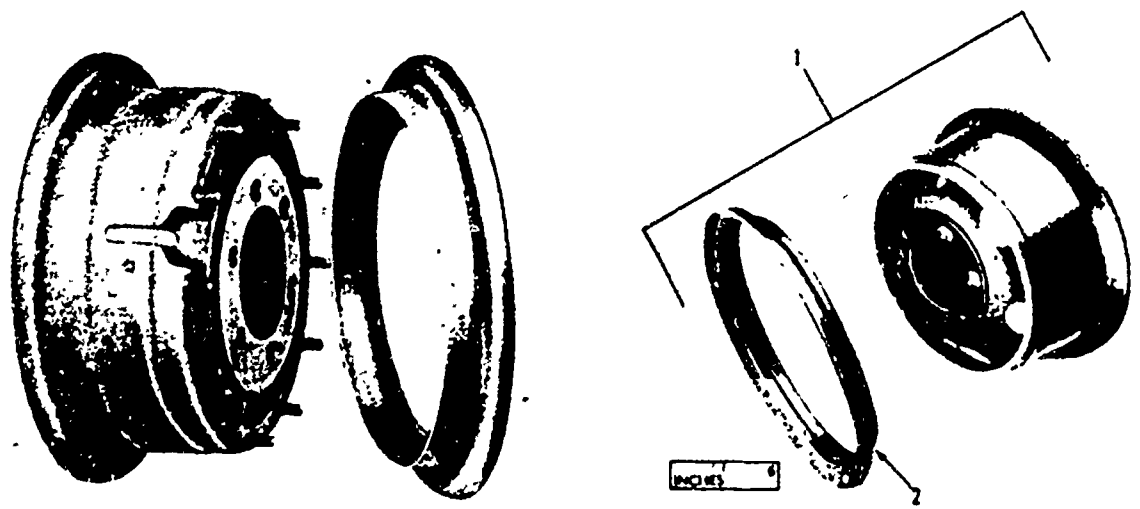

4-27

146
The purpose of the wheel rim is to complete the enclosure for the tube, hold the tire beads in place, and connect the tire to the wheel. Several different types of rims are used. For correct mounting, demounting, and tire fit, it is necessary to be familiar with the differences in rim types.

(1) The drop-center rim is made in one piece and is permanently fastened to the wheel disk. Its important feature is a deep well which permits mounting and demounting the tire. On some wheels the well is to one side of the rim center. Then the tire must be removed and replaced from the side of the rim that contains the well. Drop-center rims are generally used on smaller vehicles, such as passenger cars and 1/4-ton, 4X4 trucks. Some passenger cars and light trucks are equipped with safety-type drop-center rims. Safety rims have a slight hump at the inside edge of the bead ledges. This holds the tire beads in place when the tire goes flat.

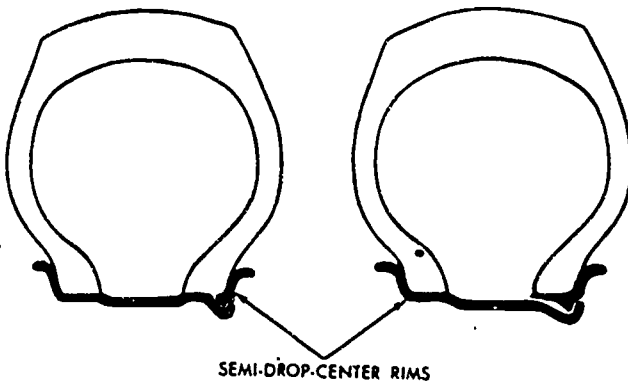
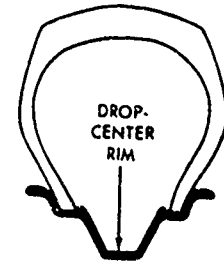

(2) The semidrop-center rim has a shallow well in the rim. It has tapered bead seats to fit the shape of the beads on the tire. A demountable rim flange or side ring fits into a groove (gutter) on the outside edge of the rim to hold the tire in place. It is necessary to remove this side ring to remove and replace the tire.

(3) The flat-base rim has a flat seat for the bead, and the tires must also have flat beads. As its name suggests, the rim is flat with no well. This type rim has a demountable side ring to permit mounting and demounting the tire. Flaps are required on the flat-base rim to protect that part of the tube not protected by the tire. Flat-base rims are no longer being built for use on the modern vehicle.

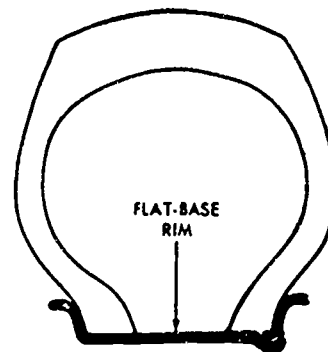

(4) The advanced rim is similar to the flat-base rim except that it has a slight taper (5 degrees) on each bead seat. The taper provides a squeeze fit of the tire beads to prevent slippage between the rim and tire. Different manufacturers make the side rings and their mating grooves (gutters) in different shapes, which prevents interchangeability.

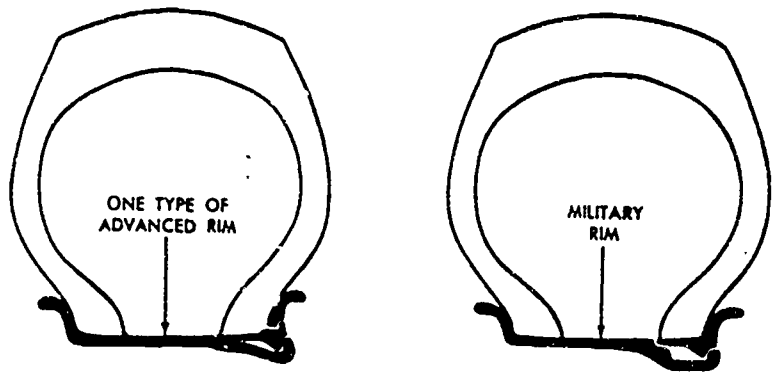

Military vehicles use advanced rims with all side rings and rim gutters shaped the same, which permits interchangeability. This rim is known as the military or the military standard rim.

e. In order to operate a vehicle in combat without air pressure in its tires, it is necessary to have some device that locks the tire beads in place. The tire beads may be locked into place on the rim by either beadlocks or bead clips. Bead clips are metal clips that fit tight on the tire bead and the rim. Five or six clips are equally spaced on each bead of the tire. When bead clips are used, a flap is generally required to protect the tube.

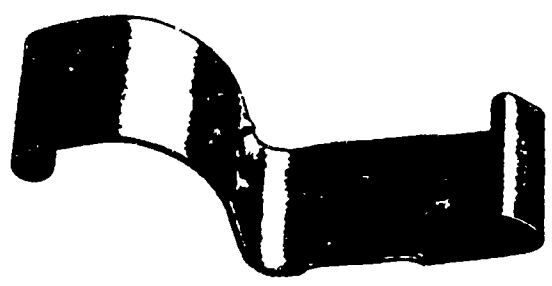

Bead clip.

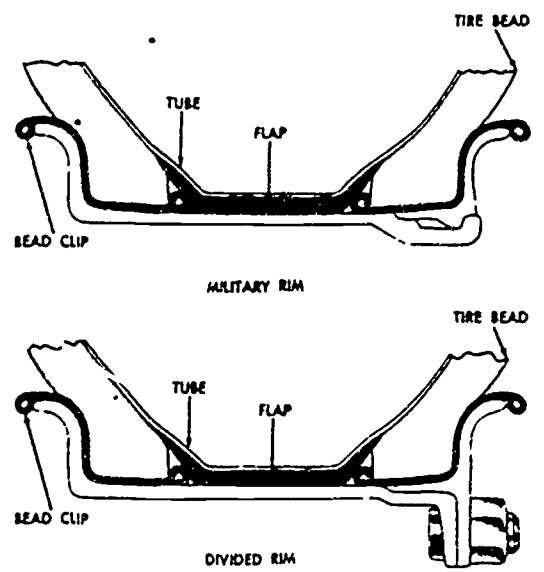

Bead clips installed.

148

(1) The beadlock is a metal device that fits between the beads of the tire. The beadlock is slightly wider than the space between the tire beads with the tire mounted on the rim. Therefore, when the rim side flange is installed and tightened, pressure is applied to the tire beads. This locks the beads in place so that they will not slip on the rim and will hold the tire in position.

(2) The continuous, or channel-type, beadlock is a solid band of steel which is inserted in position between the tire beads. Flaps are not required with the channel-type beadlock.



CHANNEL

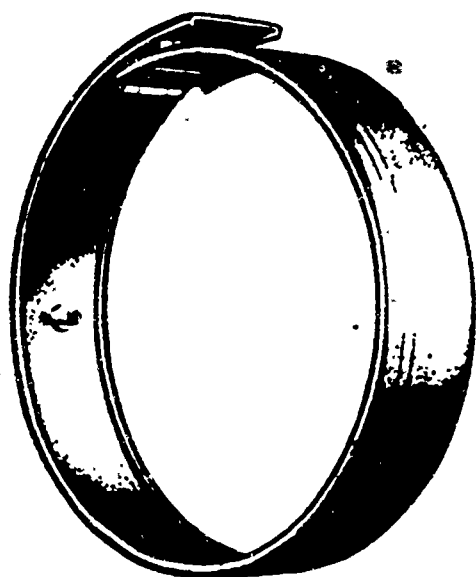

HINGED

(3) The hinged beadlock, through the use of a hinge, will collapse. This makes the beadlock smaller so it can be inserted and positioned between the tire beads much easier. Flaps are not necessary with the hinged beadlock.

(4) The segmental, or spacer-block, beadlock has blocks of metal which are fastened together with a flexible steel band. The flexible band allows the beadlock to be collapsed for removal and installation into the tire. The segmental beadlock requires the use of a flap to protect the tube.



SEGMENTAL

SECTION III. COMPONENT REPLACEMENT

149

7. **WHEEL AND TIRE ASSEMBLY ON A 2-1/2-TON TRUCK.** The following explanations tell you how to replace the wheel and tire assembly on a 2-1/2-ton, 6x6 truck. On the 2-1/2-ton military truck with single wheels, the tire size is 11.00X20. Dual-wheeled 2-1/2-ton trucks use 9.00X20 tires.

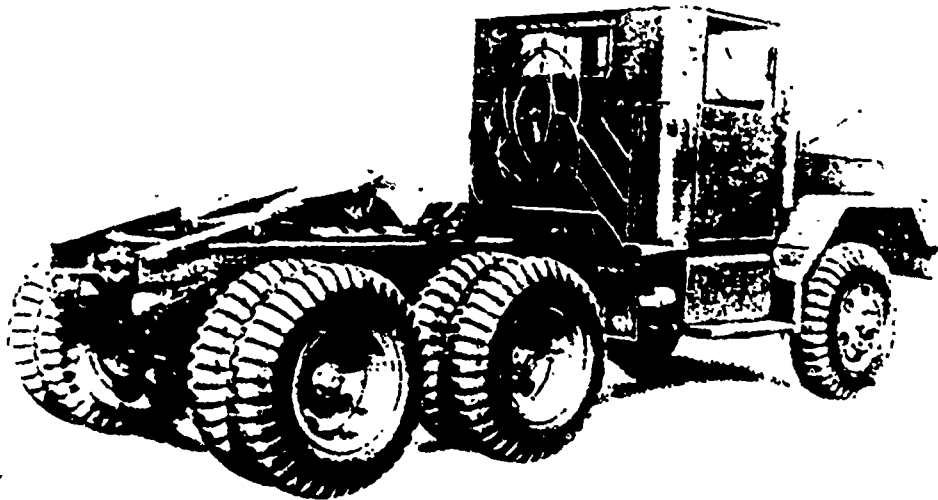

2-1/2-ton, 6x6 tractor truck M275 - right rear view.

a. Before attempting the removal of any wheels, position the truck on level ground and shut off the engine. Place the transmission in the fifth gear position and set the parking brake to make sure the vehicle does not roll. Obtain the special wheel stud nut wrench and a truck jack. These tools will be located in the tool compartment of the truck. The stud nut wrench is about 15 inches long and has a 1-1/2-inch hex opening on one end and a 13/16-inch square opening on the opposite end. A steel bar is inserted through holes near its ends for leverage.

150

b. Loosen, but do not remove, the six nuts on the wheel studs of the wheel to be removed. On the left side of the vehicle, all of the lug nuts have left-hand threads. On the right side, the lug nuts have right-hand threads. After all six nuts are loosened, place the jack under the vehicle axle and raise the wheel off the ground. Remove the nuts and lift off the wheel. If the vehicle has single wheels, install the replacement wheel according to installation procedures given later in this lesson.

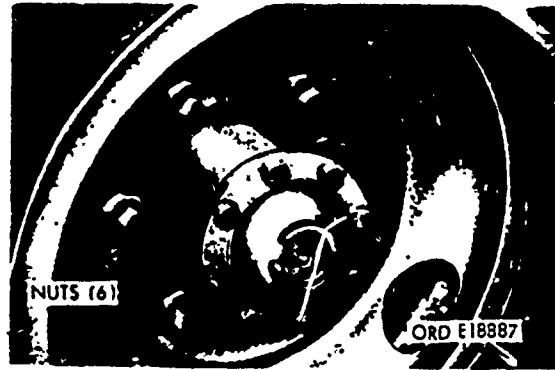

If the vehicle has dual wheels and the inner wheel is to be replaced, proceed with the following directions.

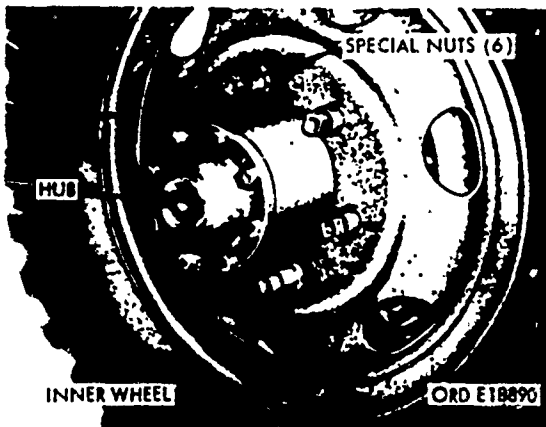

c. Lower the jack until the inner wheel rests firmly on the ground. Using the 13/16-inch square opening of the stud nut wrench, loosen the six special nuts holding the inner wheel. These nuts are threaded on the inside to screw over the wheel studs and the outside to receive the nuts just removed. After loosening the special nuts, raise the jack to lift the wheel off the ground. Remove the special nuts and the inner wheel and inspect the thread condition of wheel nuts and studs. All damaged nuts and

studs must be replaced. Use a wire brush to remove rust and dirt from the mating surfaces of the brakedrum and wheels. Clean and lubricate the threads on the wheel nuts and studs.

d. The replacement tire and wheel should be inspected very closely for the size and type of tread. The outside diameter or height of the replacement tire should be within one-eighth inch of the other tires on the vehicle, particularly on the same axle. When the tread type and tire size are identical on all tires on the vehicle, proper steering and even tire wear can be achieved.

e. On vehicle axles with single wheels, and on the inner wheel of dual-wheel vehicles, install the wheel with the dished (cupped) side toward the vehicle. Install the six wheel nuts, regular wheel nuts for single-wheel vehicles and special nuts for the inner wheel of dual-wheel vehicles. Tighten the wheel nuts evenly to prevent warping the wheels or brakedrums. This is done by first tightening a nut until snug and then tightening the nut that is directly opposite. Continue this procedure until all six wheel nuts are snug. Next, lower the wheel until it rests firmly on the ground to assist in holding the wheel stationary. Then tighten the nuts to 400 to 450 pound-feet torque, alternating to opposite nuts.

f. On dual-wheel vehicles the axle is lifted again to install the outer wheel. The outer wheel is installed with the dished or cupped side facing away from the vehicle. In addition, the position of the wheel ventilating holes and the valve stem is to be considered. The ventilating holes of the inner and outer wheels should be aligned to permit a free flow of air to cool the wheels and brakedrum. The valve stems of the two wheels are placed directly opposite each other so they can be located quickly and are easier to service. When the wheel is properly positioned, install the six wheel nuts and tighten them using the same procedures used on the inner wheel.

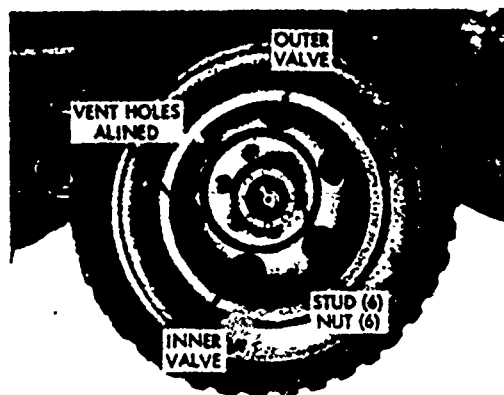

g. Always make sure that the tire pressure is correct when a tire and wheel assembly is replaced. Recommended tire pressures for the 2-1/2-ton, 6X6 truck are shown in the accompanying table. The amount of pressure needed is determined by operating conditions, size of the tire, and the engine type. Pressures given in the table are for cool tires. If the tires are hot the pressures will increase and should not be reduced.

Tire Inflation Data

Conditions	Gasoline		Multifuel	
	11:00 x 20	9:00 x 20	11:00 x 20	9:00 x 20
Highway (psi)	70	45	70	50
Cross-country (psi)	35	25	35	35
Mud, snow, and sand (psi)	15	15	15	15

Note. In areas where the temperatures reach -50° F. or colder, inflate truck tires 20 pounds above normal for long standby periods or overnight. Before operating the vehicle, reduce the tire pressures to normal.

152
8. WHEEL AND TIRE ASSEMBLY ON A 1/4-TON TRUCK. The M151 has four wheels and a spare. The wheels may be either cast magnesium alloy or steel, and of the safety rim drop-center type. Each wheel is secured to the wheel spindle by five special nut and washer assemblies. All wheel retaining nuts have right-hand threads and are, therefore, interchangeable from left to right sides of the vehicle. Tires are low-pressure type, size 7.00-16, 4-ply, and have a 6-ply rating. This vehicle has individual suspension and uses four coil springs and direct-acting, double-action shock absorbers.

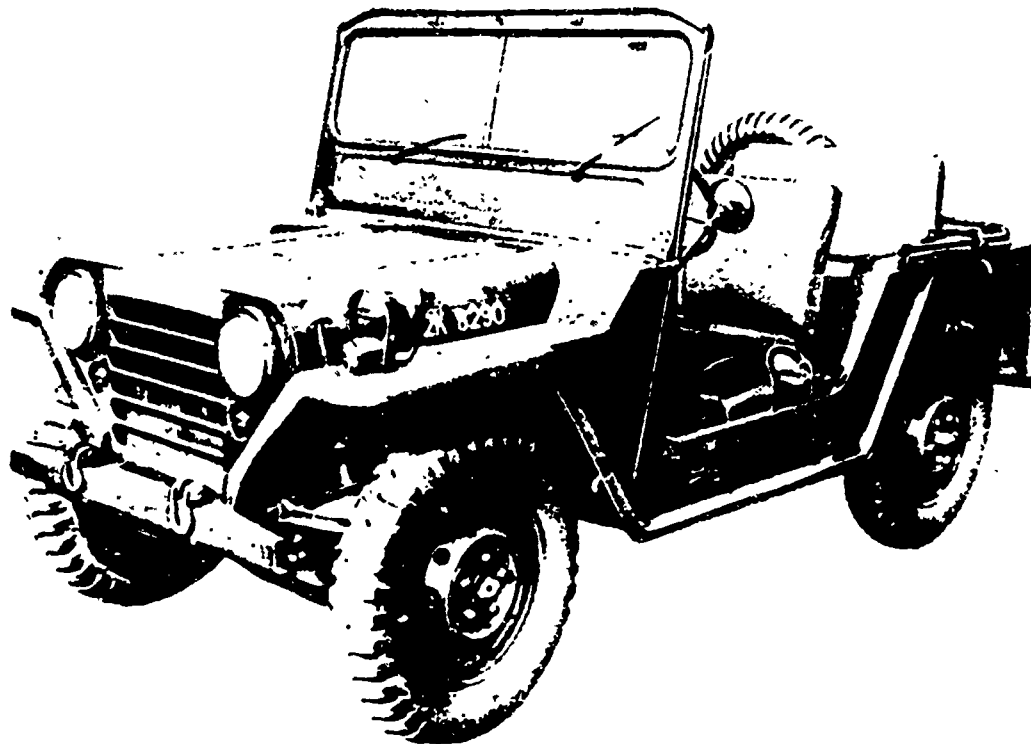

a. The M151 truck tires are rotated after about 2,000 miles of service to assist in maintaining even tire wear. While doing this job, inspect all wheels for cracks and bends and for worn or damaged mounting stud holes. Inspect the mounting studs and nuts for worn or stripped threads. Replace defective wheels or wheel nuts.

b. Inspect the condition of all tires and check their air pressures. Replace any tire that has a noticeable cut on the tread or sidewall. If uneven wear is noticed, check the toe-in adjustment. If incorrect toe-in is not the cause, report this condition to higher maintenance personnel. Check pressures when the tires are cold, and correct as needed. When rotating the tires of an M151 truck, the air pressure in the tires must always be changed as the pressures are different in the front and rear tires. For highway use the recommended air pressures are 20 PSI for the front tires and 25 PSI for the rear. For cross country it is 18 PSI for the front and 22 PSI for the rear. Use in mud, sand, and snow calls for air pressures of 12 PSI in the front tires and 18 PSI in the rear tires. Tires operated with pressures that are too low are easily damaged. Make sure valve caps are installed to prevent loss of air. Wheel nuts are tightened evenly to 65-70 pound-feet torque.

c. The spare must be included with each tire rotation to maintain even wear on all tires. The rotation can be completed by jacking up one wheel at a time if the following procedure is used: Start by placing the spare tire and wheel on the vehicle's left front, move the left front to the right rear, the right rear to the left rear, and the left rear to the right front. The tire removed from the right front will now be used for the spare. This same plan should be used every time the tires are rotated. Then each tire will be run at all four points on the vehicle before being returned to the spare position.

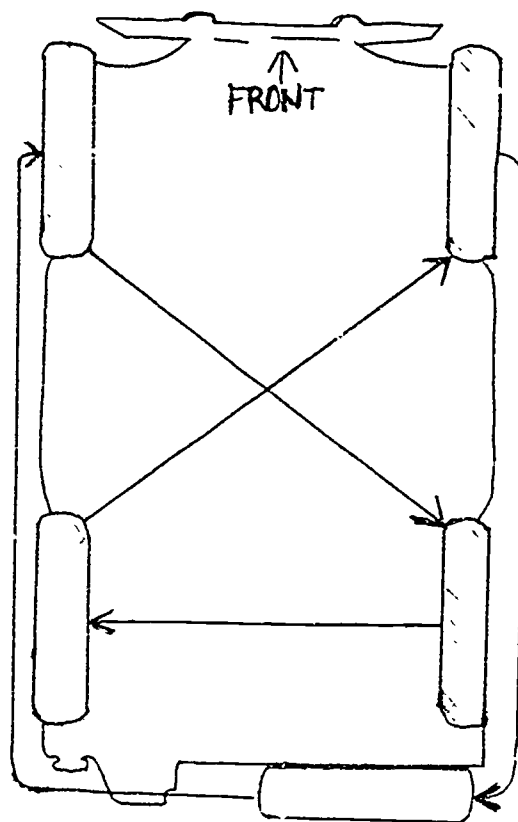

Tire rotation plan

154
9. SHOCK ABSORBERS. Due to the frictionless action of the coil springs on the M151 truck, shock absorbers play an important role in the suspension system. In addition to controlling bouncing of the vehicle, the shock absorbers have internal hydraulic stops which limit the distance suspension parts can move. Bad shock absorbers can cause rapid tire wear, poor steering, and excessive bottoming of the suspension. Generally, it is not considered good practice to replace just one shock absorber. All shock absorbers must perform equally to control the side pitching and swaying of the vehicle. If the vehicle has one new shock and three old ones, equal performance is not likely to occur. The following explains how to replace the shock absorbers of the M151 truck:

a. Replacement of the front shock absorbers is the same for either side of the vehicle. They pass through the center of the coil spring and are attached to the lower suspension arm at the bottom and to the crossmember at the top. Disconnect the lower end of the shock absorber by removing the locknut on the shock absorber shaft. Remove the washer and the rubber insulator (also called a grommet) from the shaft.

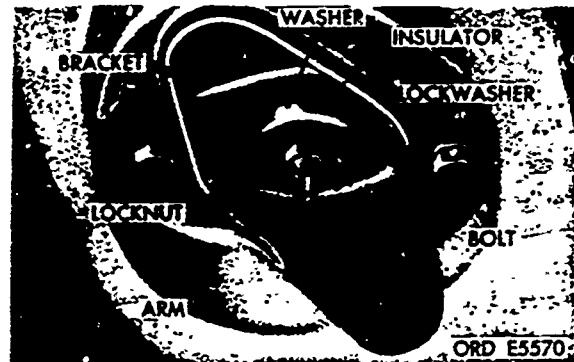

(1) Remove the two bolts and lockwashers that secure the mounting bracket to the suspension arm.

(2) Raise the front wheel and secure the vehicle safely with stands or cribbing.

(3) Rotate the shock absorber mounting bracket and remove it from the inside of the suspension arm. Remove the inner insulator and washer from the shock absorber shaft.

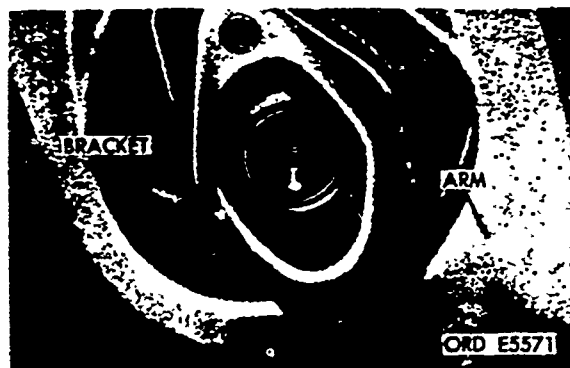

(4) At the upper end of the shock absorber, remove the locknut, washer, and insulator. The shock absorber can then be removed through the opening in the lower suspension arm.



(5) It is possible to install the shock absorbers of an M151 truck upside down, which will prevent their proper operation. The shield that protects the shock absorber shaft must always be installed toward the top on the M151. The top end of some shock absorbers may be marked by the word "top" or an arrow pointing toward the top. Check the action of a shock absorber before installing it in the vehicle. This is done by telescoping it in and out several times by hand while holding the shock top side up. Its resistance to movement may be uneven and jerky the first few strokes. However, the action should smooth out and provide an even resistance to movement through the entire length of the stroke. Smooth action does not necessarily mean that the shock absorber is good, but an uneven or jerky action definitely means that it is not good.

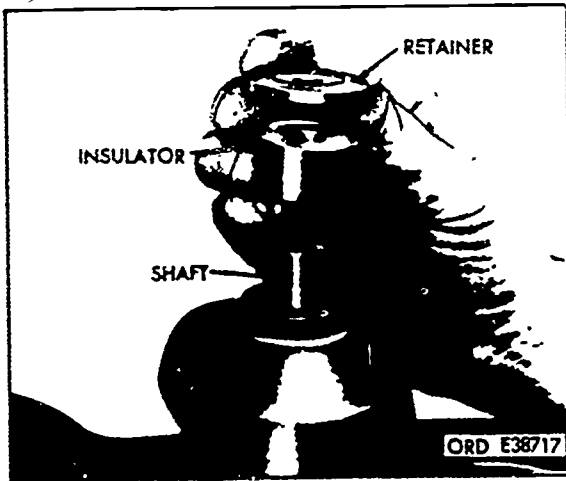

(6) Prepare the shock absorber for installation by extending it to its greatest length. Place a retaining washer and then an insulator on the top end of the shock absorber shaft. Insert the shock absorber through the hole in the lower suspension arm, passing it through the center of the coil spring. Position the shock absorber shaft through the crossmember and install the outer insulator, retainer, and nut. Tighten the nut to 25-30 pound-feet.

156

(7) At the lower end of the shock absorber, place a retainer and then an insulator on its shaft. Position the shock absorber mounting bracket on the shaft and secure the bracket to the lower suspension arm with two bolts and lockwashers.

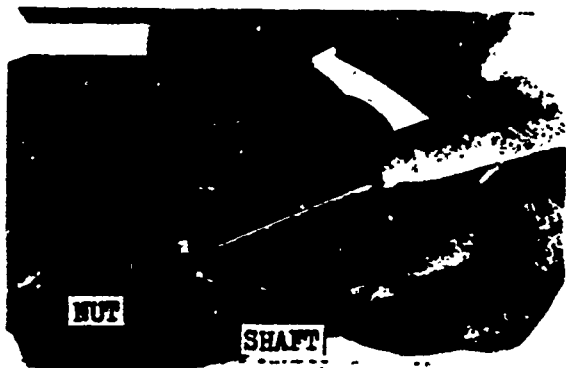
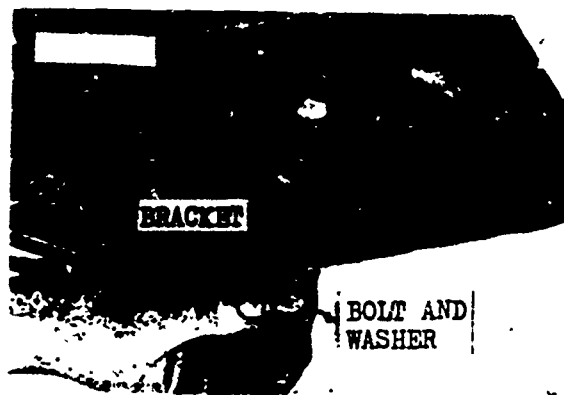

(8) Lower the wheel and place the lower insulator, retainer, and nut on the shock absorber shaft. Tighten the nut to 25-30 pound-feet.

b. The rear shock absorbers on the M151 truck are located differently and have a different type mounting than the front shock absorbers. Replacement procedures for the rear shock absorbers are the same on both the right and left sides of the vehicle. The bottom of each shock absorber is attached to the lower suspension arm. The top end is attached to the integral-type body and frame. Mounting eyes are welded to each end of the shock absorber assembly. Removal and installation procedures for the rear shock absorbers are given in the following paragraphs.

157

(1) Disconnect the lower end of the shock absorber by unscrewing the locknut from the mounting bolt and removing the mounting bolt. The shock absorber mounting eye contains a two-piece rubber bushing.

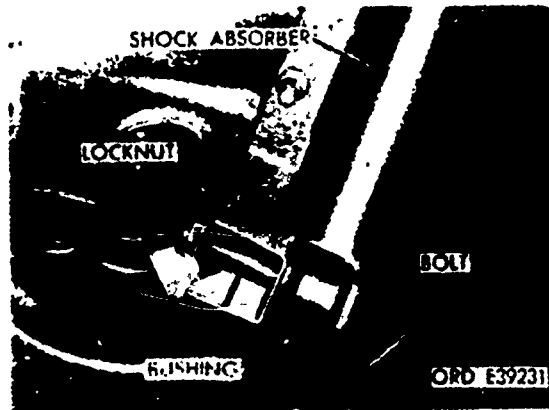

(2) Disconnect the top end of the shock absorber by unscrewing the locknut and removing the mounting bolt as on the lower end. A two-piece rubber bushing is also used in the top mounting eye of the shock absorber. Two additional mounting parts, a plug and a washer, are also used at the upper end of the shock absorber. These are nonsupply items, so use care to prevent losing them when the shock is removed.

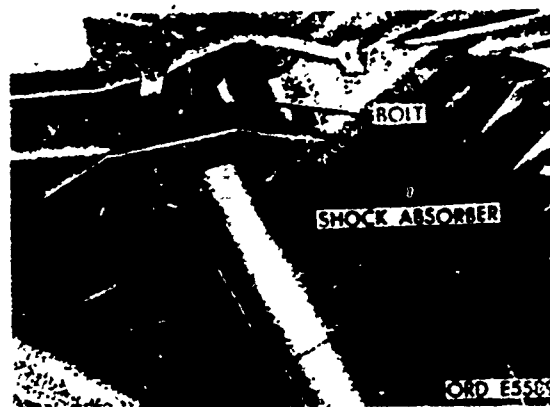

158

(3) When replacing the rear shock absorbers, connect the top end of the shock absorber first. Each half of the two-piece rubber bushing is made with a short taper on one end and a longer taper on the other end. The end with the longest taper is inserted into the shock absorber mounting eye. Tighten the upper mounting nut to 50-60 pound-feet and the lower mounting nut to 40-50 pound-feet.

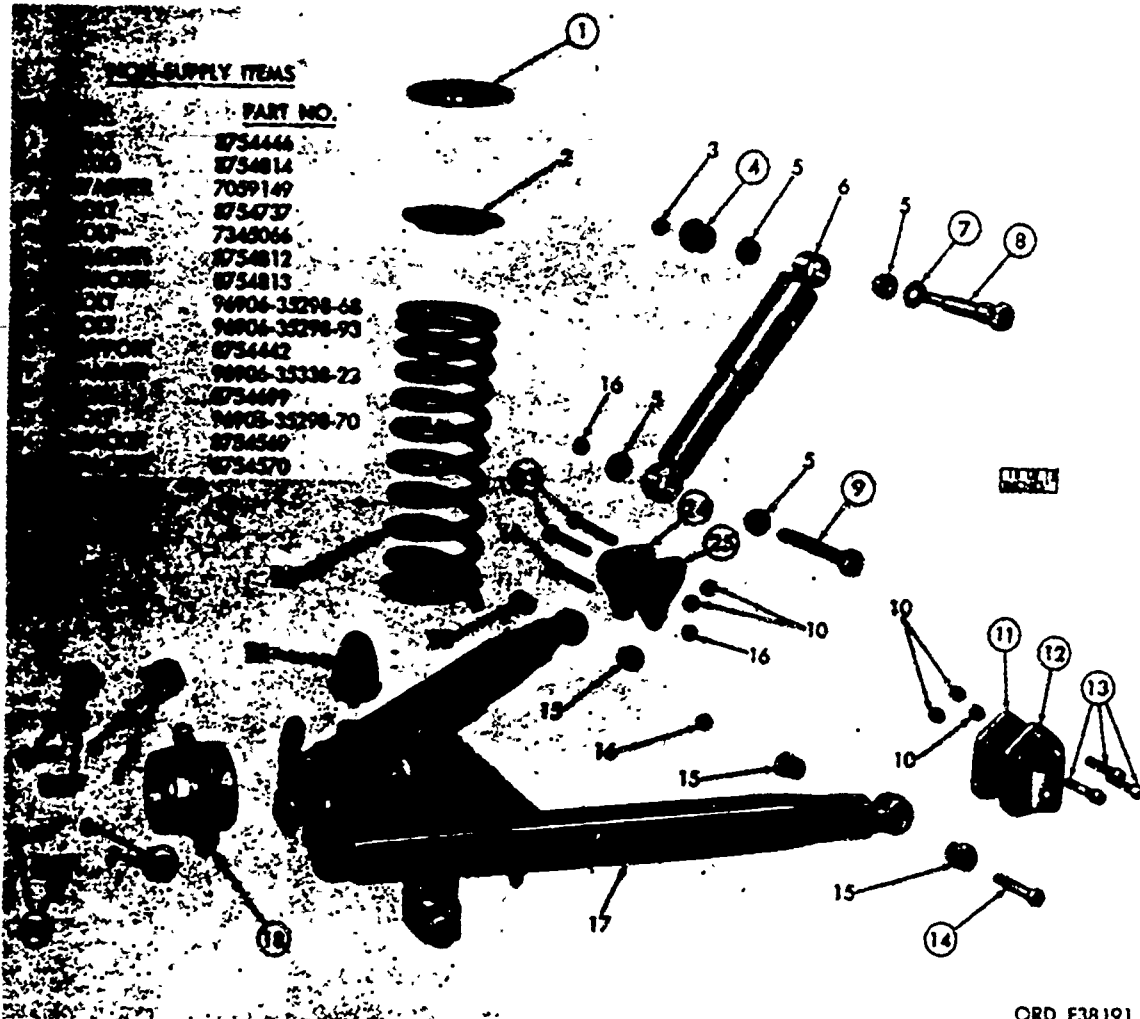

Rear suspension and related parts — exploded view.

SUPPLY ITEMS

- | | |
|---------------------------------|----------------------------------|
| 2. Insulator, spring suspension | 15. Bushing, suspension arm |
| 3. Nut, self-locking | 16. Nut, self-locking |
| 5. Bushing, shock absorber | 17. Arm, rear suspension |
| 6. Shock absorber | 21. Bumper, rear suspension |
| 10. Nut, self-locking | 22. Coil spring, rear suspension |

EXERCISE

Note. - Complete the following questions before continuing to lesson 5.

56. The integral-type frame is also called the
- combination frame.
 - conventional body and frame.
 - unitized body and frame.
57. Which is the most commonly used elliptical leaf-type spring?
- Full
 - Semi
 - Quarter
58. What part of the spring assembly allows the leaf spring to lengthen or shorten as it flexes?
- Leaf clip
 - Center bolt
 - Shackle
59. In the bogie suspension system, which item is mounted on tapered roller bearings?
- Bearing plate
 - Spring seat
 - Mounting pad
60. What type of spring shackle has external threads on both ends?
- Y
 - H
 - U
61. Which type of spring causes excessive bouncing due to its frictionless action?
- Coil
 - Leaf
 - Volute

160

62. What is the primary purpose of a shock absorber?
- Limit spring compression
 - Regulate spring rebound
 - Act as helper spring
63. A direct-acting shock absorber telescopes in and out and is commonly called
- a vane-type shock absorber.
 - a control-type shock absorber.
 - an airplane-type shock absorber.
64. The arrow on a torsion bar indicates the
- anchor end of the bar.
 - direction in which the bar should twist.
 - direction in which the bar should unwind.
65. What is used to protect the inner tube when it is installed with a tire on a flat-based rim?
- Breaker
 - Cushion
 - Flap
66. If a spring is made up of several leaves bolted together, the spring is called a
- laminated leaf spring.
 - variable rate spring.
 - stacked leaf spring.
67. In addition to holding the spring leaves together, the spring center bolt may also help to hold the
- U-bolts in position.
 - axle in alignment.
 - clips in place.
68. If a tire size is 7.50 x 20, the figure 7.50 indicates the tire's approximate
- width.
 - diameter.
 - circumference.

69. When rotating the tires on the 1/4-ton truck M151, which tire is moved to the spare position?
- Left front
 - Right front
 - Right rear
70. On the 1/4-ton truck M151, the front shock absorbers are attached to the front crossmember and to the
- lower suspension arm.
 - coil spring.
 - frame rail.
71. The rubber insulators used on each end of the telescoping shock absorbers are also known as
- washers.
 - supports.
 - grommets.
72. What forces the hydraulic pistons to move in the double-acting, indirect (linkage type) shock absorbers?
- Springs
 - Cams
 - Valves
73. The spring clips around the leaf-type spring are most important when the spring is
- compressing.
 - loading.
 - rebouncing.
74. The advanced rim used on the wheels of large military vehicles is
- tapered slightly at each head seat.
 - flat-based with fixed side rings.
 - the safety-type with a drop center.
75. The inside lug nuts used with dual wheels on the right side of a large military truck have
- inner and outer left-hand threads
 - inner and outer right-hand threads
 - inner threads right hand, outer threads left hand

162

SECTION IV. CONCLUSION

10. SUMMARY

a. Some trucks and cars use separate frames, while others use the integral frame and body type of construction. Where the separate conventional frame is used, the steel side rails, cross-members, gussets, and mounting brackets are riveted together. In the integral frame and body the various body sections are welded together.

b. There are three major types of springs used to suspend cars and trucks. They are the leaf spring, coil spring, and torsion bar. Common practice is to use leaf springs with axle-type suspension and coil springs with individual wheel suspension. However, coil springs may also be used with axle suspension and leaf springs with individual wheel suspension. Torsion bars are generally used with individual wheel suspension. The rear ends of many trucks are supported by bogie suspension units.

c. Hydraulic shock absorbers are used to control vehicle bounding. The most commonly used type of shock absorber is direct-acting and regulates spring action on both compression and rebound.

d. Tires are an important part of the suspension system. They provide the traction for driving and braking besides acting as a cushion to absorb road shock. Markings on the sidewall of a tire give the tire size, the number of cord plies, and the tire's serial number. Rubber, fabric, and steel wires are used in the construction of the tires.

e. The drop-center wheel rim is used on cars and small trucks. The drop center of the wheel permits the removal and installation of the tire with a one-piece wheel. Semidrop, flat-base, and advanced rim wheels are used on large trucks. On these wheel rims, a side ring must be removed before a tire can be removed or installed.

f. Tools and equipment for removing and installing tire and wheel assemblies are provided in a toolkit that is supplied with each car and truck. On dual wheel trucks, each tire and wheel assembly must be removed and installed separately. When loosening or tightening wheel nuts, let the wheel rest on the ground to keep it from turning. Replacement wheels should be inspected for correct size, conditioning, and proper air pressure. Dual wheels should be installed so that airflow around the brakedrum and between the wheels is not restricted and so the air valves can be gotten to easily and quickly.

163

g. Tires and wheels should be rotated regularly to insure even tire wear. The same rotation plan which includes the spare must be used each time the tires are rotated. The best way to be sure that the same rotation plan is always used is for everyone to use the rotation plan described in the vehicle TM.

h. The vehicle TM should be followed very carefully when replacing items such as shock absorbers to insure that rubber insulators, etc, are positioned and tightened properly. Extreme caution must be observed when disconnecting suspension parts to make sure that tension on the suspension springs is not released suddenly. This is a sure way to be a casualty.

11. PRACTICE TASKS. The appendix of this lesson contains a list of tasks associated with suspension systems. They are representative of the tasks you will be required to perform as a wheeled vehicle mechanic. Perform all of the tasks listed. Be sure you are under the supervision of an officer, NCO, or specialist who is qualified in the MOS when you practice the tasks. If you find you are having difficulty in certain tasks, restudy the appropriate training material and practice the tasks until you become proficient in each one.

APPENDIX

PRACTICE TASK LIST

Practice Objective After practicing the following tasks you will be able to:

1. Locate the frame and suspension components on wheeled vehicles in your unit.
2. Inspect the condition of the frame, shock absorbers, springs, and shackles on wheeled vehicles.
3. Locate the tire size on various wheeled vehicles and determine the tire condition.
4. Demonstrate how to replace the shock absorber on a 1/4-ton truck.

Practice Tasks.

1. Look at the frames on as many different types and sizes of wheeled vehicles as possible in your unit. Pay particular attention to how the frame is attached to the rest of the vehicle. See how many frame components you can name correctly.
2. Inspect the condition of the frame to include the crossmembers and reinforcement gussets. Look for any defect or damage that should be repaired or that would require the item to be replaced.
3. Locate the suspension components on each of the vehicles. Notice the different types and sizes of components used on the various vehicles. Notice how the springs and shock absorbers are connected to the axles and to the frames.
4. Inspect the condition of the shock absorbers, springs, and shackles by looking for defects and damage. On the 1/4-ton truck you can try bouncing the vehicle to test the resistance of the shock absorbers. Make sure you test all four corners of the vehicle.
5. Locate the tire size on each of the vehicles. Using the information you have gained from this lesson, determine if the tires are matched in their initial size and their present wear.

165
6. Remove or assist in the removal and installation of the shock absorbers on a 1/4-ton truck. Inspect the condition of the grommets and mounting points. When installing the shock absorbers, make sure the retaining nuts and bolts are tightened correctly.

7. If any defects or damage was detected during your inspection of the frame and suspension, make sure you report this to the specialist, NCO, or officer who is supervising the practice tasks. This information could prevent an expensive and time-consuming breakdown of the vehicle at a later date.



166

**ENLISTED MOS
CORRESPONDENCE/OJT COURSE**

ORDNANCE SUBCOURSE 63B206

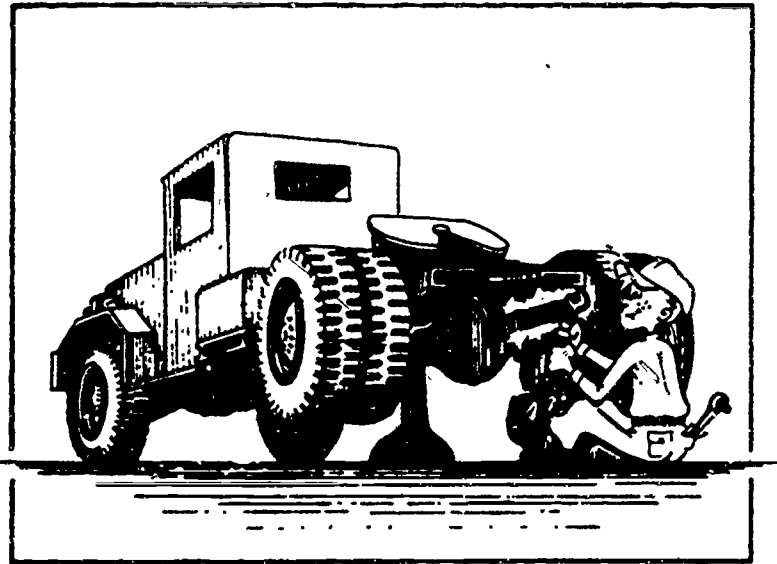

**LESSON 5
MAINTENANCE OF SPRINGS, SHOCK ABSORBERS,
AND FRAMES**

SEPTEMBER 1975

**DEPARTMENT OF ARMY WIDE TRAINING SUPPORT
US ARMY ORDNANCE CENTER AND SCHOOL
ABERDEEN PROVING GROUND, MARYLAND**

167

CONTENTS

		Paragraph	Page
LESSON ASSIGNMENT SHEET.			5-1
STUDY TEXT			
Section	I. Frame and Suspension Systems of the 1/4-ton Truck M151		
	Introduction	1	5-2
	Inspection and test pro- cedures	2	5-3
	Suspension system components removal and replacement .	3	5-10.
	II. Frame and Suspension Components On The M35-Series 2-1/2-Ton Trucks		
	Frame alinement inspection procedures	4	5-16
	Spring malfunctions	5	5-19
	Spring and spring seat repair or replacement	6	5-20
	III. Conclusion		
	Summary	7	5-26
	Practice tasks	8	5-26
Appendix	Practice Task List.		5-31

US ARMY ORDNANCE CENTER AND SCHOOL ¹⁶⁸
CORRESPONDENCE/OJT COURSE



LESSON ASSIGNMENT SHEET

Ordnance Subcourse No 63B206 Wheeled Vehicle Drive Lines,
Axles, and Suspension Systems

Lesson 5 Maintenance of Springs, Shock
Absorbers, and Frames

Credit Hours Three

Lesson Objective After studying this lesson you
will be able to:

1. Describe the procedures for inspecting and testing the frame and suspension system of a 1/4-ton truck M151.
2. Describe the procedures for locating cracks in a frame.
3. Explain the methods used to identify malfunctions in a suspension system.
4. Describe the procedures for inspecting and testing ball joint type suspension systems.

- 5. Explain the procedures used to remove and replace suspension system components on the 1/4-ton truck.
- 6. Describe the procedures for inspecting and testing the suspension system components of the 1/4-ton truck.
- 7. Explain the methods determine a malfunctioning vehicle suspension spring.
- 8. Describe the procedures used to remove and replace a rear spring seat on a tandem axle truck.

Materials Required ALL STUDENTS, Answer sheet and exercise response list.

CORRESPONDENCE/OJT STUDENTS.
See appendix.

Suggestions When studying the lesson be sure to study the illustrations along with the text.

SECTION I. FRAME AND SUSPENSION SYSTEMS OF THE
1/4-TON TRUCK M151

1. INTRODUCTION. Have you ever watched a dog trotting down a road? If you looked closely you probably noticed that the dog was trotting sideways. This is because his hind legs followed to one side of his front legs so that they would not hit each other.

a. This sideways movement might work all right for dogs, but it just doesn't work on wheeled vehicles. They are designed to travel with the rear end tracking the front end, except when turning corners.

b. This does not mean that all rear wheels must follow in the front wheel tracks even when the vehicle is following in a straight line. This factor depends on the distance between the wheels of each axle and the conditions of the roadbed. This does mean, however, that the rear wheels, when on a level, straight road, should track in proportion to the front wheels.

c. If a wheeled vehicle travels sideways on a straight, level road, you can rest assured that something is wrong. The problem could be caused by a bent frame, broken spring, improperly assembled parts, as well as many other things. It is not hard to see when a vehicle is not traveling or tracking properly, but finding the cause is sometimes quite a task. The first step, and quite often a very effective step, in finding the cause is to make a visual inspection of the frame and suspension components. Let's see how an inspection is made. We will start with the 1/4-ton truck.

2. INSPECTION AND TEST PROCEDURES. When inspecting and testing the suspension system and unitized body and frame, the vehicle should be on level ground (preferably a concrete floor) and unloaded.

a. Before attempting to check the frame for alignment, inspect the tires to see if they are worn evenly. A vehicle that is not aligned properly will cause tires to scuff and wear rapidly. Bring the air pressure for each tire up to the required amount. A low tire will give you false readings when checking the frame.

- 171 b. The first check will be to determine if the vehicle is setting level with the floor. Refer to the illustration as we discuss the following check.

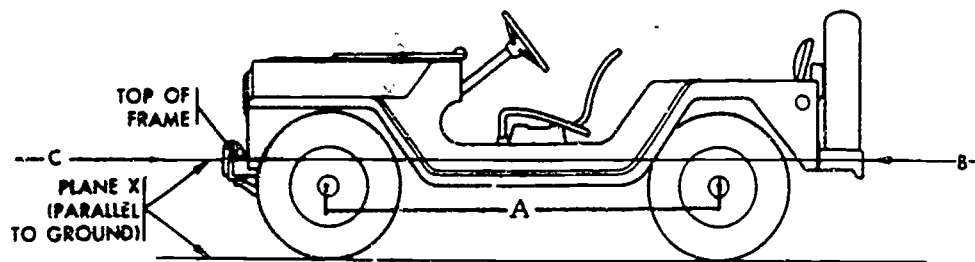

REAR BODY PANEL LOWER SILL AT C OF VEHICLE TO BE $.30 \pm .012$ HIGHER THAN THE TOP OF FRAME AT FRONT OF GRILLE GUARD.

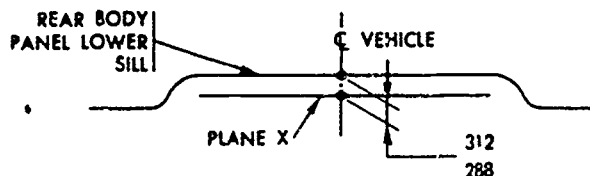

- (1) At the front of the vehicle, measure the distance from the top of the frame (just below the grille guard) to the floor, and record the reading.
- (2) Next, measure the distance from the rear body panel sill to the floor.
- (3) The distance measured at the rear of the vehicle should be $3/10$ th of an inch greater than the distance measured at the front.

c. The next check is made to see if the front and rear drives are properly aligned from side to side. The check consists of measuring the distance indicated by "A" in the illustration above on both sides of the vehicle. This test requires an assistant, two punches, and a piece of string long enough to reach from the center of the front wheels to the center of the rear wheels.

- (1) Tie one end of the string around the shank of a center punch. Have your assistant hold the point of the punch in the hole in the end of the lifting eye on the front hub. Insert the second center punch in the hole in the end of the lifting eye in the rear hub. Pull the string taut and wrap it around the punch. Hold the string so it cannot unwind from the punch and move to the other side of the vehicle. Measure the distance between the hub lifting eyes on that side.

172

(2) The distances from one side to the other must be within $1/4$ inch. Be sure the front wheels are in the straight-ahead position when measuring these distances. If the difference in these distances exceeds $1/4$ inch, the rear wheels will not track behind the front wheels. This indicates something is out of alignment.

(3) Usually, if the rear wheels fail to track, the fault lies with the frame or the suspension system. On the M151, however, with its unitized body and frame and independent suspension, other components such as the suspension arms or the body itself could be at fault.

d. The unitized body and frame can be checked with acceptable accuracy by using a plumb bob, chalk, and a tape measure. The accompanying illustration shows the front suspension and drive assembly of a $1/4$ -ton truck M151 removed from the vehicle. The assembly includes the front crossmember, which is bolted to the two rails of the frame at the front of the vehicle. The arrows, identified by the letter "A," point to the holes through which two of the bolts that secure the crossmember to the frame are located.

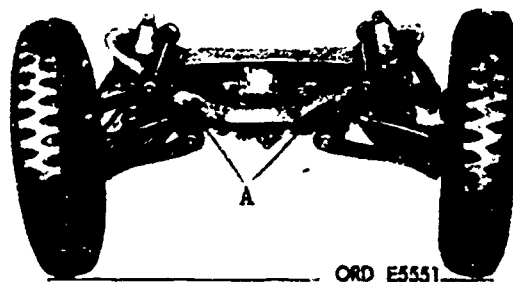

(1) With the front suspension and drive assembly mounted to the frame of the vehicle, suspend a plumb bob from the bolts through these two holes to a point just above the floor. Use a piece of chalk and place a mark on the floor under the plumb bobs. Be sure your chalk marks are directly under the plumb bobs.

173

(2) With the rear suspension and drive assembly in place under the vehicle, use the plumb bob under the bolts indicated by the letter "B." Mark the spot directly under the plumb bob at each point with a piece of chalk.

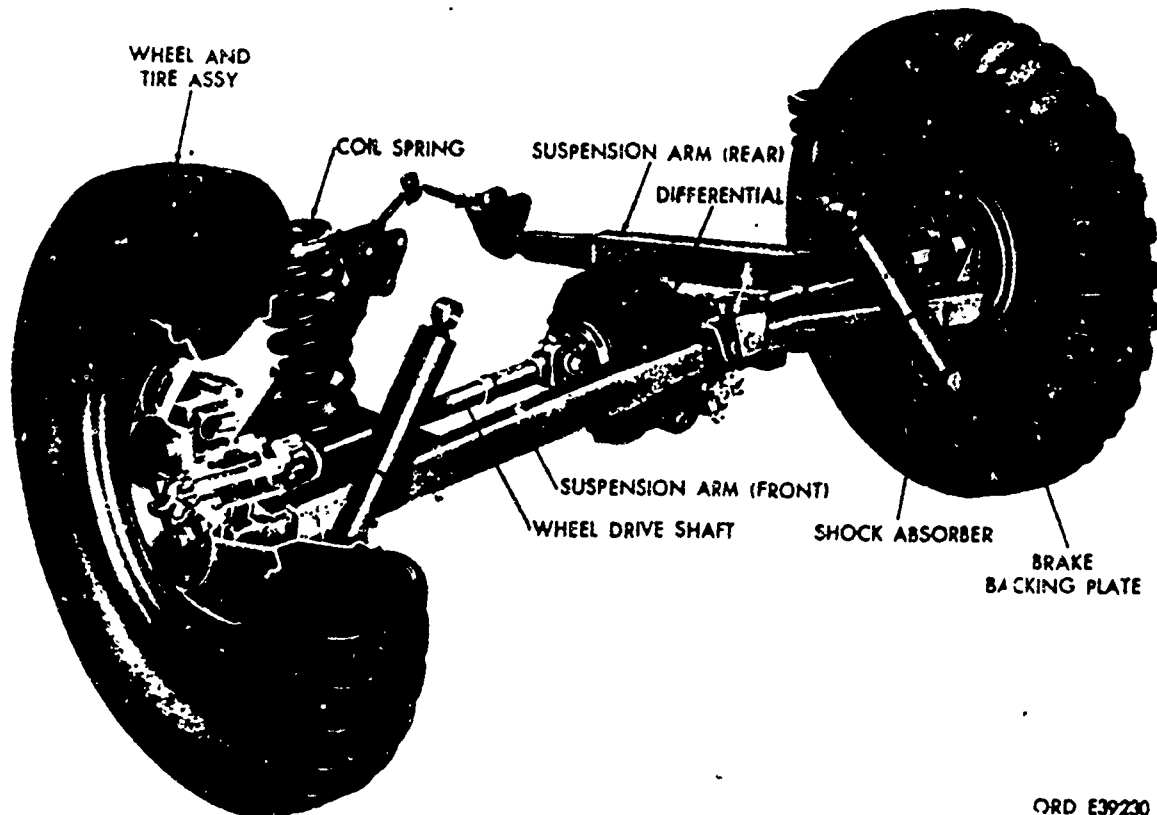

ORD E39230

(3) Now roll the vehicle forward, being careful not to roll the wheels over your chalk marks on the floor. Measure the distance from the chalk mark made under point "A" on the left front side of the vehicle to the chalk mark made under point "B" on the right rear side of the vehicle. Record this distance, and then measure from point "A" on the right front side of the vehicle to point "B" on the left rear side. If these two distances are not within 1/4 inch, some component of the unitized body and frame is bent, twisted, or cracked.

5186

174

(4) If the alinement check just described reveals that the frame and body are not alined properly, try to find out why. Look for broken welds, evidence of an accident, or cracked frame rail extensions. On the M151 truck, look especially for broken welds. Notice in the illustration of the unitized body and frame used on the M151 that all joints are welded - no bolts or rivets are used.

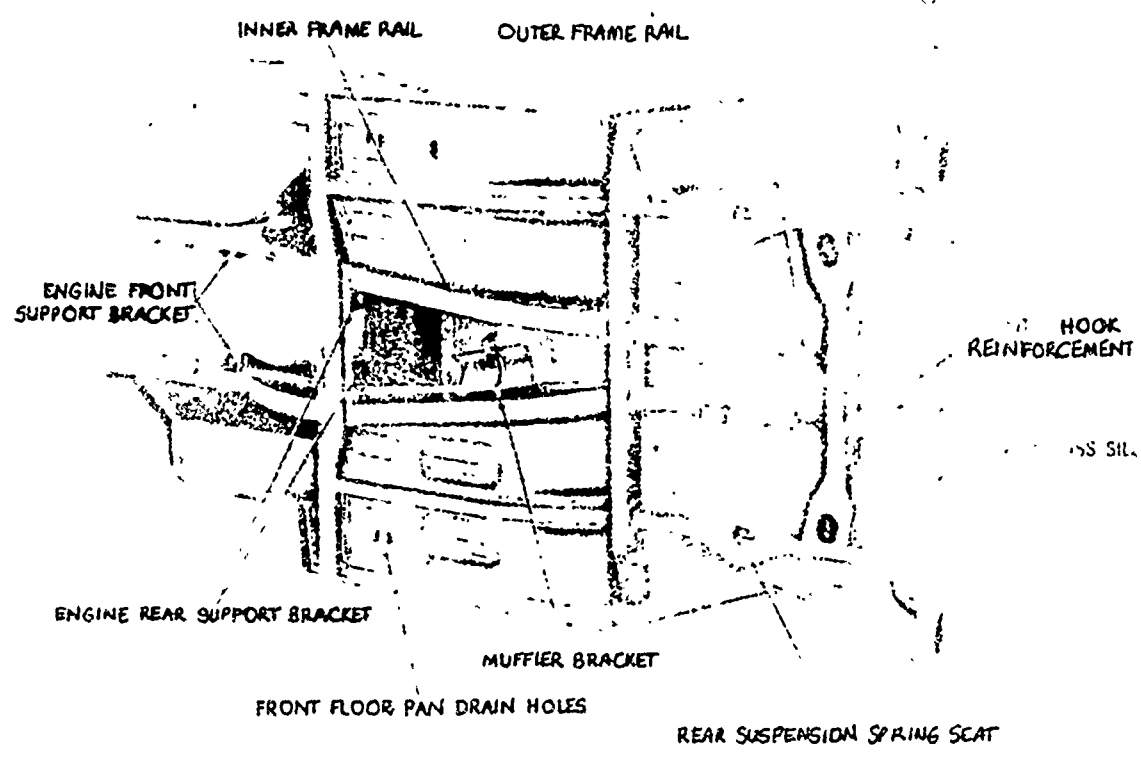

175

e. Frames will often crack from strain. The crack shown is on the frame of an M38A1 truck, but similar cracks can occur on almost any vehicle frame. Repairs involving the frame and body cannot be made by organizational maintenance personnel. When such faults are found, notify your support maintenance unit. The fact that you are not authorized to make the repairs, however, does not mean you are not allowed to locate the fault.

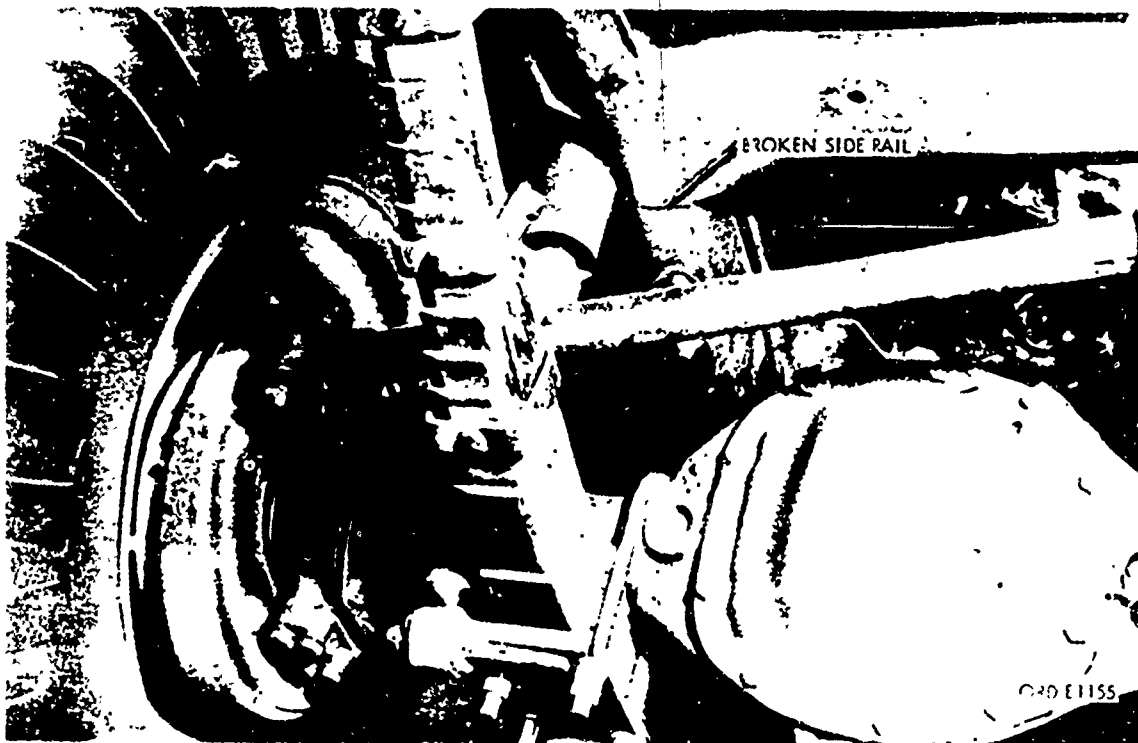

f. Most suspension system faults can be corrected at the organizational maintenance level. The replacement of shock absorbers was explained in the preceding lesson, so this one will deal with the other suspension system components.

(1) If you recall, the M151 truck has coil springs at all four wheels. If one of the coil springs is weak, the vehicle will lean toward the side with the weak spring. Notice that the illustration shows a method of determining if either of the front springs or related parts are causing the vehicle to sag.

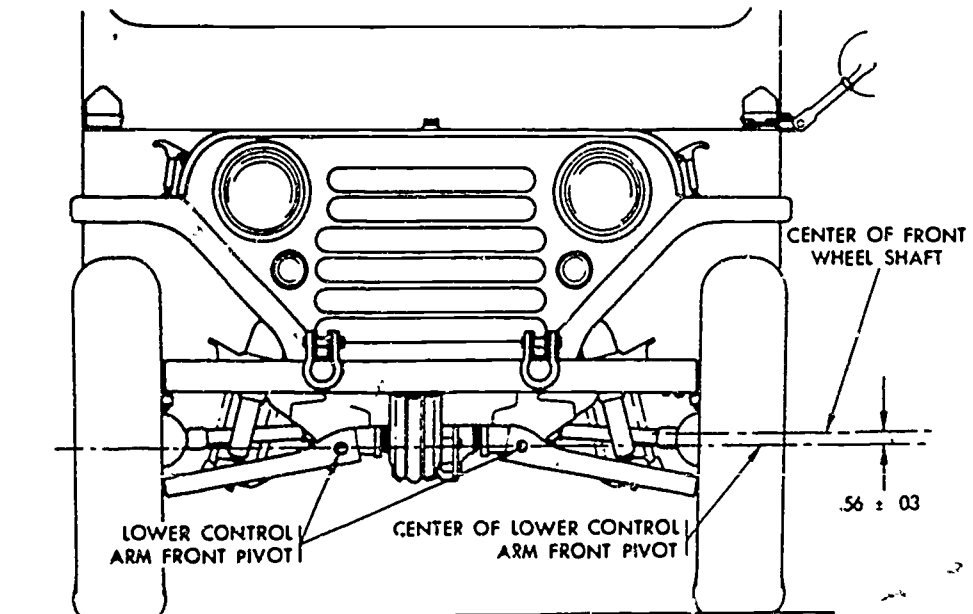

CENTER OF THE FRONT WHEEL SHAFT TO BE
.56 ± .03 HIGHER THAN THE CENTER OF THE
LOWER CONTROL ARM FRONT PIVOT.

ORD E38729

(2) Stretch a string across both front tires at the point where the string will cross the center of the lower control arm pivots. With the string in position, measure the distance from the string to the center of the wheel shaft on both sides. If either spring is sagging, the height of the wheel shaft above the string line will be less than the amount shown (0.56 inch).

(3) Before condemning the spring on the sagging side of an M151 truck, check all other suspension components. Worn control arm pivots, spring seats, or ball joints can also cause the vehicle to sag.

g. The ball joint suspension system on the 1/4-ton truck has quite a job. The lower ball joint supports most of the load while the upper joint has the primary purpose of maintaining alignment. The lower joint normally wears faster than the top joint. This wear can be checked using the following method:

177 (1) To check the lower ball joint, use a caliper as shown in the illustration, and measure the distance from the top of the ball joint to the bottom of the bolt (while the front wheel is on the floor and the joint is supporting the load). Then place a jack under the front axle drive gear case and raise the vehicle until the front wheel clears the floor. Jacking up the vehicle in this manner will relieve the lower ball joint of its normal load.

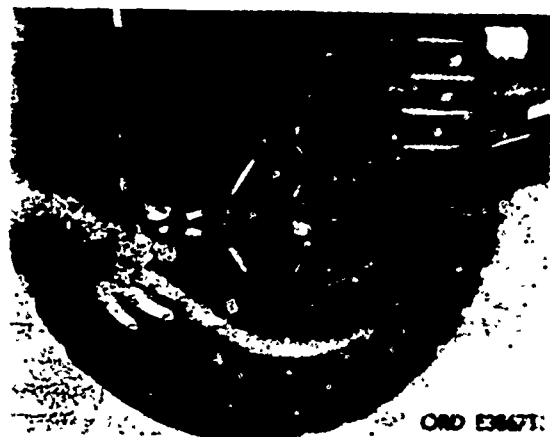

(2) Now measure the joint again with the caliper. The measurement of the joint will now be greater because the ball inside the joint can drop slightly in its socket. It should not drop more than 1/8 inch, however. If the overall height of the joint increases by more than 1/8 inch when the joint is relieved of its load, it must be replaced. If the increase is less than 1/8 inch, the ball joint is OK and need not be replaced.

h. Two other points where excessive wear can occur are the control arm pivots. Worn pivot bushings will allow the control arms to shift. If the bolts that secure these pivots to the crossmember are loose, the effects on both the steering alignment and the suspension system will be the same as with worn pivot bushings. Any loosener at these points must be corrected.

i. Make a complete inspection of the suspension system before replacing any of the unserviceable parts. Such an inspection can save you a lot of work, because if several components are defective you can replace all such components at one time.

3. SUSPENSION SYSTEM COMPONENTS REMOVAL AND REPLACEMENT. Most of the suspension components can be replaced with the front suspension and drive assembly under the vehicle. However, if defective components are to be replaced on both sides of the assembly, it may be easier to remove the entire assembly from the vehicle. The crossmember of the front suspension and drive assembly is secured to the two frame rails by eight bolts. For the purposes of this lesson we will describe the procedures to be followed with the suspension and drive installed under the vehicle, although for reasons of clarity some of the illustrations will show the assembly removed from the vehicle.

a. To replace either front spring, support the vehicle on jack stands. Place the stands under the unitized body and frame at the point where the front frame rails are welded to the body.

(1) Remove the shock absorber from the center of the spring, following the procedure described in the preceding lesson.

(2) Now place a jack under the lower control arm at the point where the shock absorber lower bracket was installed. Raise the jack just enough to relieve any of the weight on the lower control arm. Loosen the three nuts and bolts that secure the lower control arm pivot to the crossmember. To help you see the points more clearly, this illustration shows the suspension system out from under the vehicle and upside down.

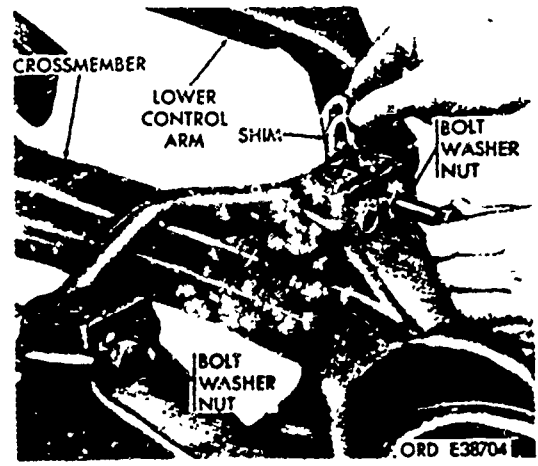
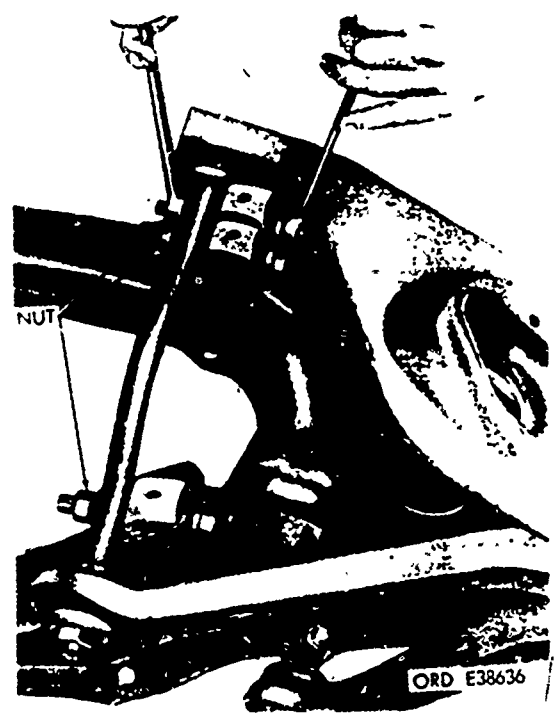

(3) Wedge the lower control arm pivot away from its mounting brackets and remove the alignment shims. Keep the shims from each bolt separate so they can be replaced in the same location.

179

(4) With the bolts removed from the pivot, lower the jack under the lower control arm. The spring can now be lifted off of its seat in the control arm.

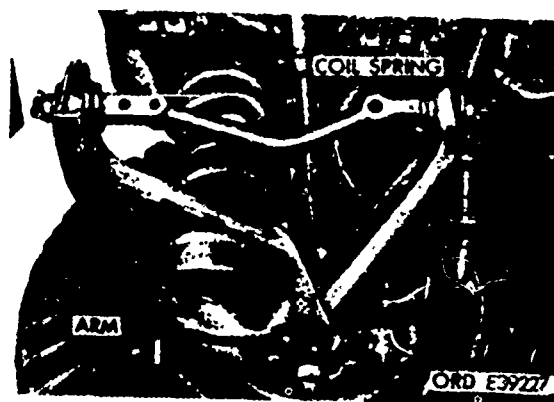

(5) Inspect the insulator located in the spring seat in the crossmember. If it is torn or otherwise damaged, replace it.

(6) To install a new spring, just reverse the removal procedures. Seat the end of the coil of the spring in the lower control arm and install the lower control arm pivot bolts, nuts, and shims. Torque the two smaller nuts to 45-55 lb-ft and the larger nut to 60-70 lb-ft.

(7) Install the shock absorber and then make a thorough inspection of your work to make sure the job is complete. Finally, recheck the vehicle to make sure it does not sag to one side.

b. To replace the ball joints, support the vehicle and the lower control arm in the manner described for the front spring replacement. Unscrew the lug nuts and remove the wheel and tire. Disconnect the universal joint at the spindle flange.

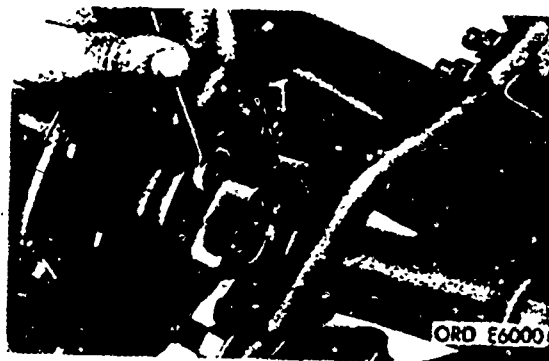

192

5-12

(1) Remove the cotter key and nut from the tie rod end. The portion of the tie rod end that extends through the steering arm is tapered so that it is wedged in the arm when properly tightened. To remove it, use a hammer to strike the steering arm. Do not attempt to drive the tie rod out of the arm by hammering on its threaded end.

(2) Remove the lock clip that secures the brake hose to its tang. Then disconnect the hose from the tube.

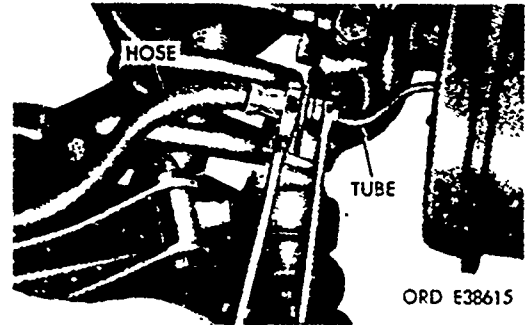
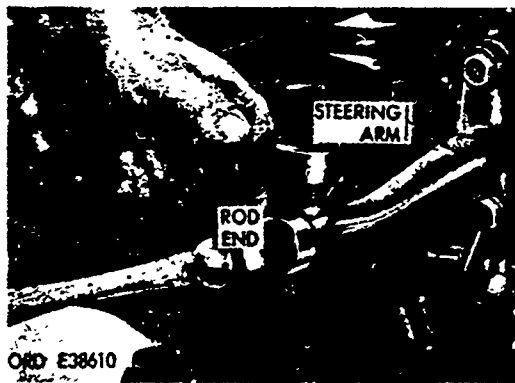
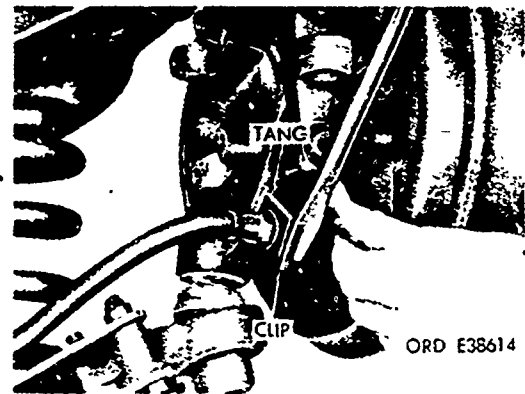
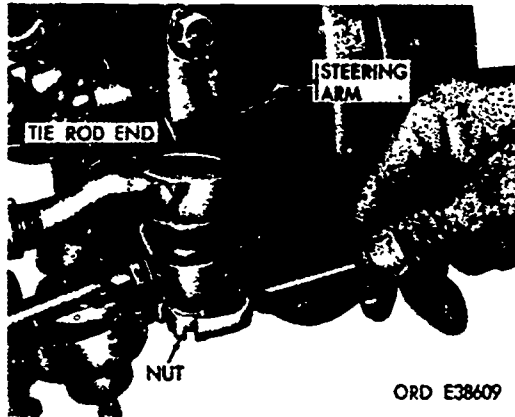

181

(3) Now remove the three bolts and nuts that attach the lower ball joint to the lower control arm. Then remove the nuts and bolts that secure the upper ball joint to the upper control arm. Again these illustrations are shown upside down so that the working points are easier to see.

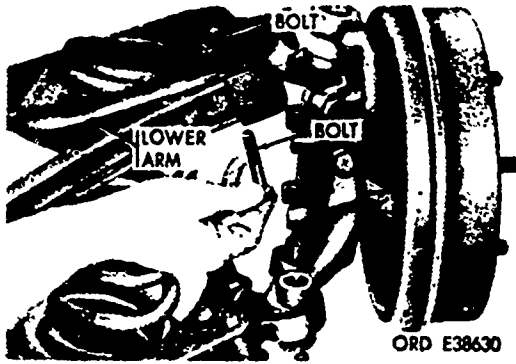

(4) Be sure the jack is supporting the lower control arm and coil spring assembly. Pull the spindle support assembly and wheel hub away from the upper and lower control arms and mount the spindle support in a vise.

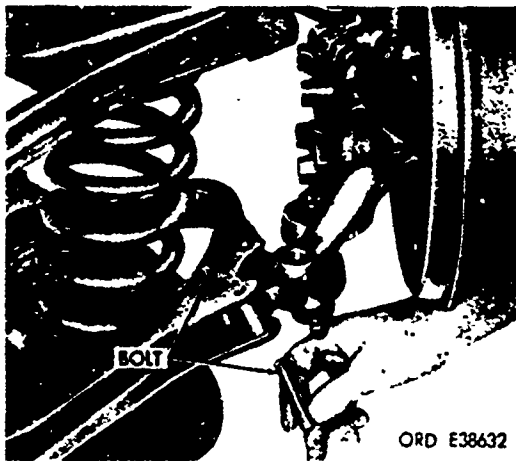
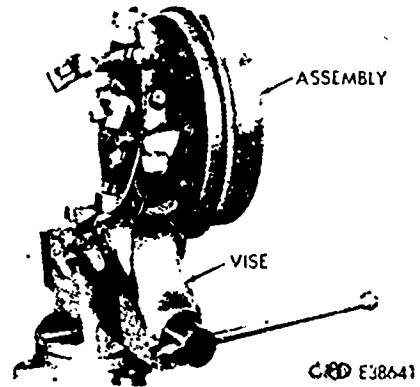

(5) Remove the cotter key and loosen the ball joint nut. Back off on the nut until it is flush with the end of the threads on the ball joints. The ball joint stud is tapered like the tie rod end, so it is wedged in the spindle support.

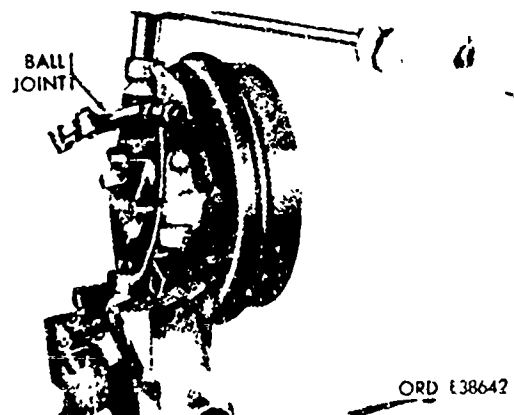

(6) To remove the stud from the spindle support, tap on the nut with a soft hammer. At the same time tap vigorously on the spindle support with a hard-faced (machinist) hammer.

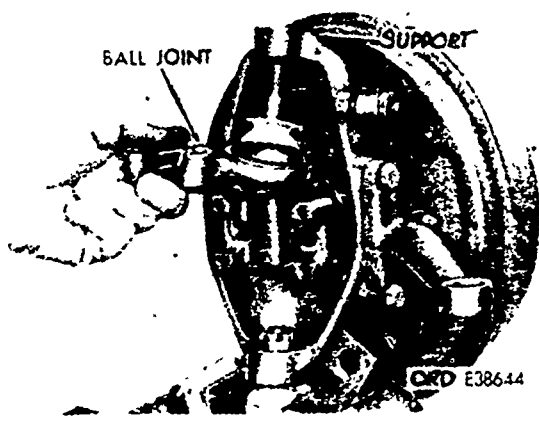
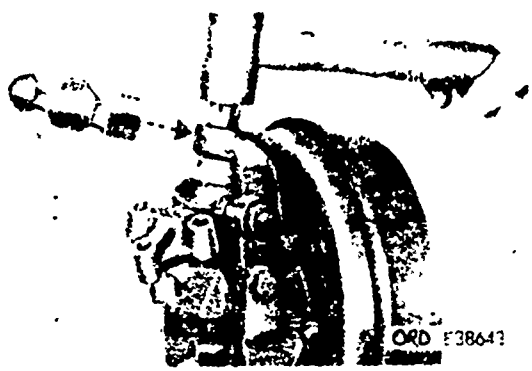

(7) When the ball joint is loose in the spindle support, finish removing the nut and remove the ball joint from the spindle support. Repeat this operation for the other ball joint to remove it from the spindle support.

(8) Lubricate the new ball joints and install them in the spindle support. Tighten both nuts to 60-70 lb-ft of torque; then install and secure the cotter key.

(9) Install the spindle assembly by reversing the steps followed to remove it. Tighten the nuts on the bolts that secure the ball joints to the upper and lower control arms to 35-40 lb-ft torque.

(10) You should bleed the brakes after the brake hose is connected to the tube to remove any air that might have entered the system while the brake hose was disconnected. Procedures for bleeding the brakes are explained in a later lesson.

c. Once the suspension is completely assembled, the front end or wheel alignment should be checked. This includes the caster, camber, and toe-in of the front wheels. Even though you did not have to replace any parts, the play or clearance between the bolts and bolt holes of the various parts can cause the wheel alignment to be wrong. Wheel alignment is performed by support maintenance personnel. Before the vehicle is driven to the support maintenance shop, however, the toe-in should be checked and set if necessary. This task, which you are authorized to do, will prevent

183

the tires from wearing excessively while the vehicle is being driven to the support maintenance shop. The toe-in can be checked using the same toe-in gage that was discussed in an earlier lesson on a 2-1/2-ton truck. If an adjustment must be made, make sure that you turn both tie rod sleeves an equal amount. This procedure can prevent the need for recentering the steering wheel and gearing at the support maintenance shop. The toe-in, when correct, should be between 1/32d and 5/32d of an inch.

d. Above all, be safety conscious when working on the suspension system. REMEMBER, UNDER NORMAL CONDITIONS, THE SPRING IS UNDER CONSIDERABLE TENSION. IF YOU DISCONNECT ANY ITEM THAT HELPS TO HOLD THE SPRING IN PLACE WITHOUT PROVIDING ALTERNATE SUPPORT, YOU COULD BE SERIOUSLY HURT. A coil spring will react violently if its support is disconnected while it is under tension. A leaf spring, if suddenly relieved of its support, is dangerous, too. ALWAYS MAKE CERTAIN THAT COMPONENTS ARE WELL SUPPORTED BEFORE YOU DISCONNECT ANYTHING.

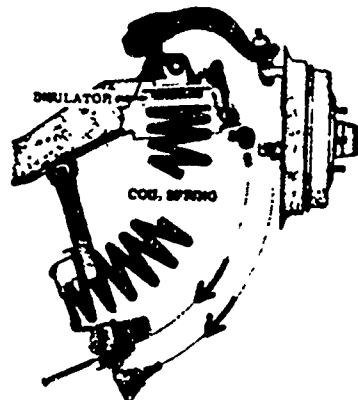

SECTION II. FRAME AND SUSPENSION COMPONENTS ON THE M35-SERIES 2-1/2-TON TRUCKS

4. FRAME ALIGNMENT INSPECTION PROCEDURES. Many of the procedures for inspecting and checking the M151 truck will also apply to larger vehicles.

a. For example, we can check the ability of the rear wheels to track the front ones on large vehicles the same way we checked them on the 1/4-ton truck. Using an assistant, two punches, and a piece of string, check distances A and B the same way you made the check on the 1/4-ton truck.

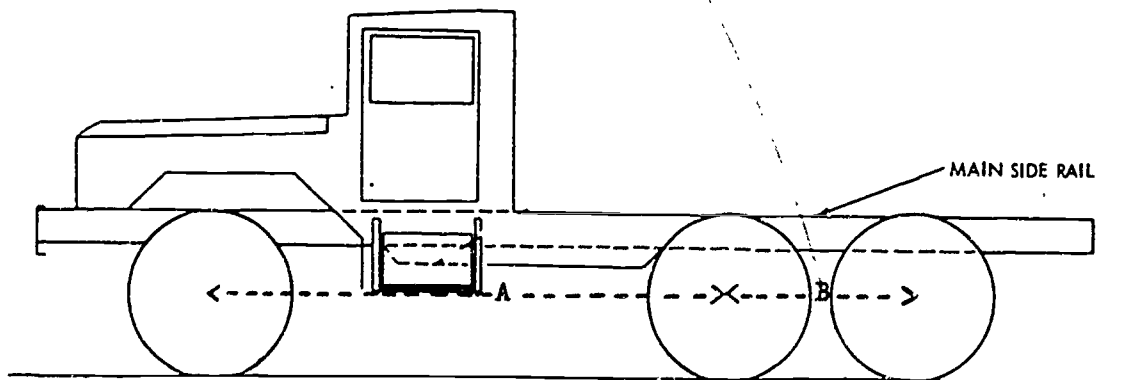

5-16

184

(1) The frames used on medium and heavy trucks usually have parallel rails. The alinement of such a frame can be checked with a plumb bob, a piece of chalk, and a tape measure in a manner similar to that used to check the unitized body and frame on the M151 truck.

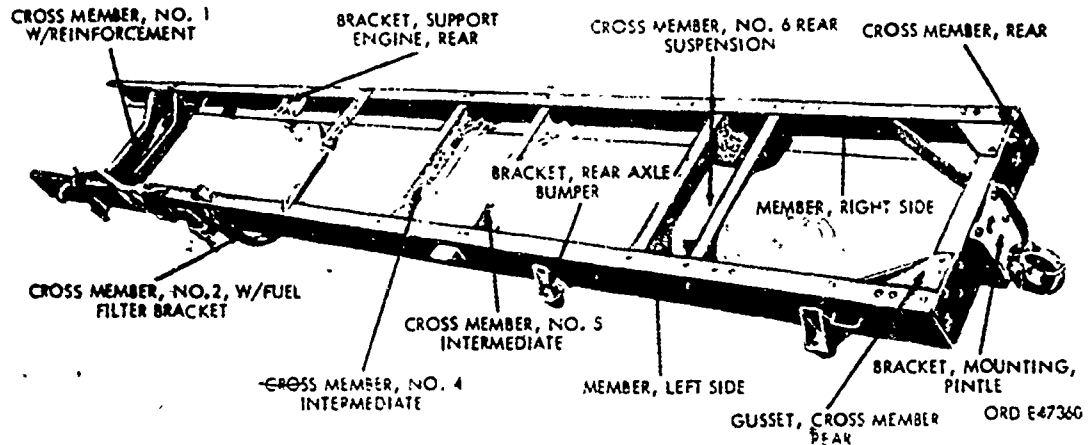

(2) On larger trucks, however, more measurements are needed. Notice in the illustration that distance A should equal distance B, Distances C and D should also be equal, as well as distances E and F. If these distances are not equal within 1/4 inch, the frame is bent, sprung, or broken.

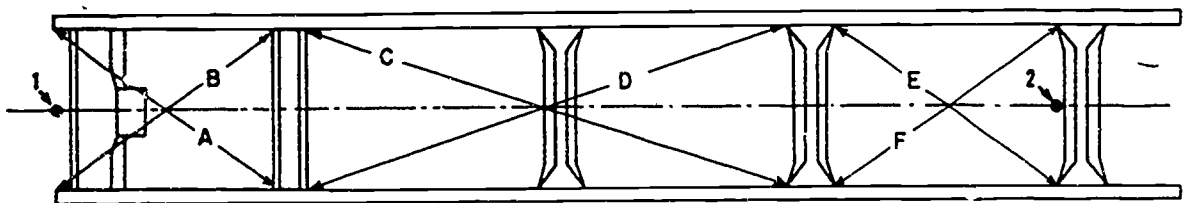

b. Even if the measurements are satisfactory, the frame should be thoroughly inspected for cracks and for missing bolts or rivets. A frame can be cracked and still be perfectly in line.

185

(1) Notice the appearance of a typical crack in a 6X6 truck frame. The illustration also shows that one of the rivets that attaches the reinforcing plate to the frame rail is missing.



(2) Some cracked frames can be welded by maintenance support units. The organizational mechanic should not attempt to repair such cracks. However, he can replace missing or loose rivets and bolts. He can also alert the unit motor officer or sergeant about such conditions so they can take action to have cracked frames or frames with loose or missing bolts and rivets repaired.

(3) Cracked frames are most often the result of overloading the vehicles or subjecting them to high-impact loads. Most cargo trucks have long wheel bases, which means, of course, the frames are also long. In cross-country operation, severe stresses are placed on the frame members as the wheels climb over stumps or rocks. Vehicles that have been subjected to such operations should be thoroughly inspected for cracked frames and missing bolts or rivets.

5-18

198

186

(4) Loose rivets in frame members must be removed and replaced by bolts. Do not use a conventional cold chisel to cut off the heads of loose rivets. A cold chisel actually cuts the rivet and, as a result of the hammer blows, can enlarge the rivet holes. The proper tool to use is a rivet buster. It resembles a cold chisel, but its cutting edge is different. It "pops" or wedges the head off of a rivet instead of cutting it off. There is less chance of enlarging the rivet hole if the rivet buster is used.

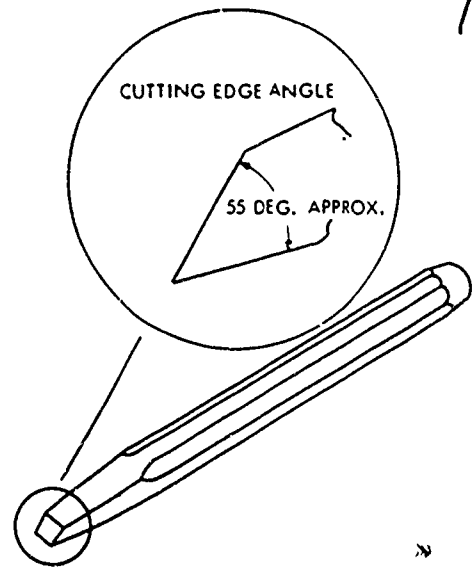

ORD E1154

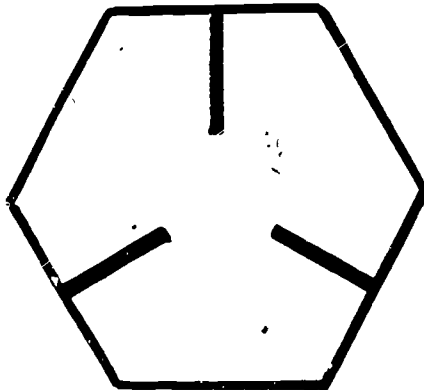

(5) Always use SAE (Society of Automotive Engineers) grade 5 bolts of the proper diameter and self-locking nuts to replace the rivets. Grade 5 bolts can be identified by the three lines radiating out from the center of the head of the bolt. Such bolts have much greater holding strength than lesser grades.

5. SPRING MALFUNCTIONS. A vehicle with a weak spring will sag to the side of the weak spring. On a vehicle equipped with leaf springs, the weak spring can usually be located by comparing the positions of the spring shackles on each side when the vehicle is unloaded. With the truck unloaded and parked on level ground, the spring should be arched (item B) and the shackle should form a right angle, or an angle close to it, with the frame rail (item 2). If, however, the spring is weak, it will have lost much of its arch and the shackle will have moved closer to the frame (A and C).

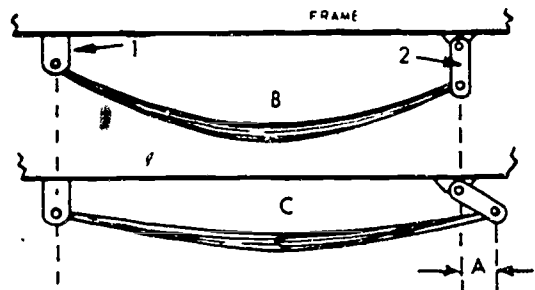

187
 6. **SPRING AND SPRING SEAT REPAIR OR REPLACEMENT.** Probably the most common problem with leaf-type springs is the spring center bolt. This bolt usually breaks as a result of loose U-bolts. The spring center bolt not only binds the leaves together, but it also maintains the alignment of the spring and axle. In fact, if the axles are not in alignment, or if the wheels fail to track, the spring center bolt is the most probable cause.

a. Notice the exploded view of a typical leaf spring. Items 6 and 9 are the spring center bolt and nut. Items 1 and 2 are the spring rebound clips, and items 3 and 4 are the spacers and bolts that clamp the rebound clips around the assembled spring. Item 5 is the mounting pin. The eyes at the end of the first leaf (item 7) slide into the eyes of the second leaf (item 8). This gives the spring more strength than a single leaf for supporting the load.

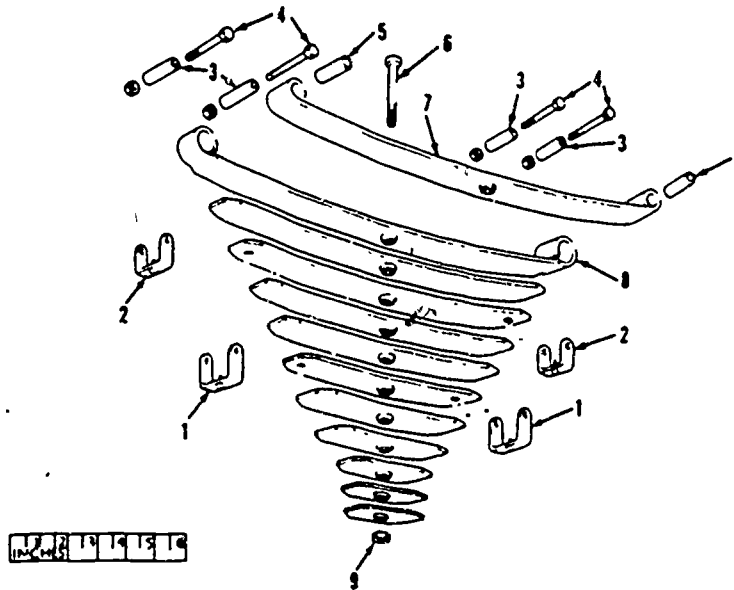

b. When assembled, the head of the spring center bolt fits into an alignment hole on the axle housing. It is clamped in the alignment hole by the two U-bolts. If the U-bolts are loose, the head of the spring center bolt is usually sheared off by the impact caused by the axle attempting to shift when the wheel hits an obstruction such as a hole in the road or a stump.

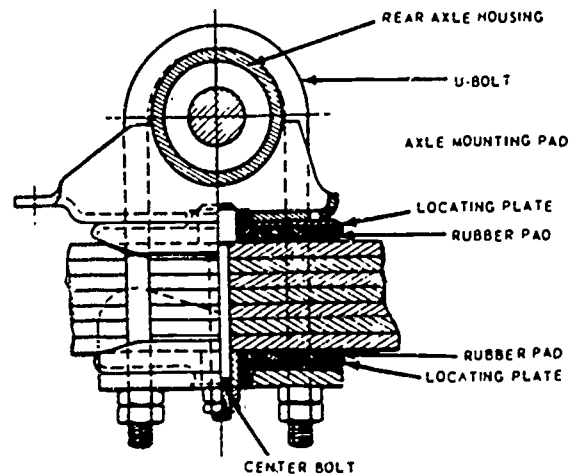

5-20

c. With the spring center bolt broken, the spring leaves can shift or the axle can shift. Either way the axle alignment with the frame is lost, and the load carrying capacity of the spring is reduced. When the center bolt is broken on either a front or rear spring, the spring must be removed from the vehicle for repair.

d. To remove a 2-1/2-ton truck M35A1 front spring, proceed as follows:

(1) Position a jack under the frame rail at the rear of the spring shackle and raise the vehicle enough to relieve the spring of the load, but leave the wheel resting on the floor.

(2) Use a jack stand to support the raised frame rail.

(3) Remove the U-bolt nuts and the U-bolts that secure the axle to the springs. (If you desire, you can remove the shock absorber first to have it out of your way.)

(4) Remove the bolt that holds the spring shackle pin in place and drive out the shackle pin with a drift and a hammer.

(5) Remove the spring pivot pin at the opposite end of the spring, following the same procedure used to remove the shackle pin.

(6) Lift the spring off of its seat on the axle housing and remove it from the vehicle.

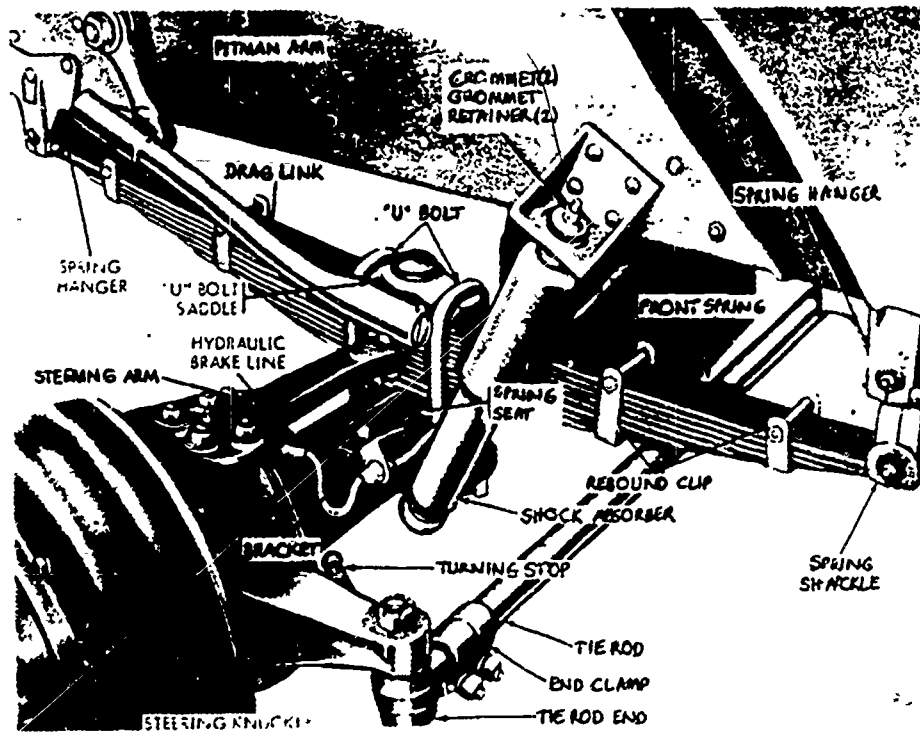

189. When assembled, the spring is under tension. So if you are going to disassemble the spring, be careful. Clamp the spring in a vise before removing the spring center bolt or the clips. After the center bolt is removed, open the vise until the tension is relieved.

(1) Clean all of the leaves of the disassembled spring and inspect each leaf for cracks or excessive wear. Check the pins and bushings for proper fit in the spring eyes. If it is necessary to replace the spring eye bushings, a press should be used to remove the old bushings and to install the new ones.

(2) When assembling the spring, stack the leaves in their proper order, starting with the longest leaf. Clamp the assembled leaves in a vise or other clamping device and insert the spring center bolt. After tightening the nut, use the rounded head of a ball peen hammer and peen the end of the bolt over the nut. This keeps the nut from accidentally backing off. Then install and secure all spring clips.

f. When installing a new or rebuilt spring under the vehicle, it is usually easier to rest the spring on the axle housing first. Install the pin that secures the front of the spring to the front spring hanger; then install the shackle at the rear of the spring.

(1) Shift the axle housing back and forth until the head of the spring center bolt drops into the alignment hole in the spring pad on the axle housing. Now you can install and tighten the spring-to-axle housing U-bolts. If you removed the shock absorber, it can now be put back in place.

(2) Remove the jack stand from under the frame rail and lower the vehicle. With the weight of the vehicle now on the spring, retighten the U-bolt nuts.

g. On 6X6 trucks equipped with bogie axles, the spring-axle relationship can be upset by a broken spring center bolt or loose U-bolts. The relationship can also be changed by bent torque rods or loose or worn spring seat bearings.

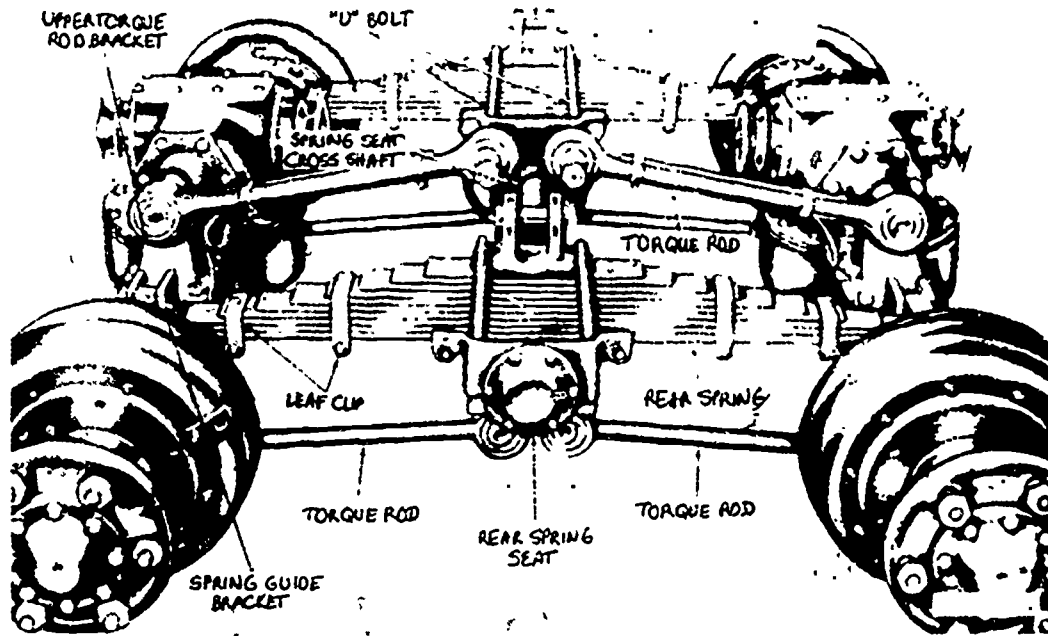

h. To remove the rear spring on the 2-1/2-ton truck, proceed as follows:

- (1) Park the vehicle on level floor and block both front wheels.
- (2) Jack up both rear axles and place jack stands under each one.
- (3) If both rear springs are to be removed, remove all rear wheels. Otherwise, remove the wheels on the side of the spring to be removed.
- (4) Using a suitable hoist or wrecker, raise the vehicle frame and body enough to remove the load on the rear springs.
- (5) Place jack stands under the frame rails to support the vehicle and take the weight off of the springs.

191

(6) Remove the nuts from the spring U-bolts and remove the bolts and saddle (items E and F).

(7) Slide the spring assembly forward or backward in its bracket guides (items A and B) until the other end of the spring clears its bracket guide. Lift out the spring.

(8) Notice in the illustration that the spring guide plates (items A and P) are replaceable. If the spring has worn these items excessively, be sure to install new ones.

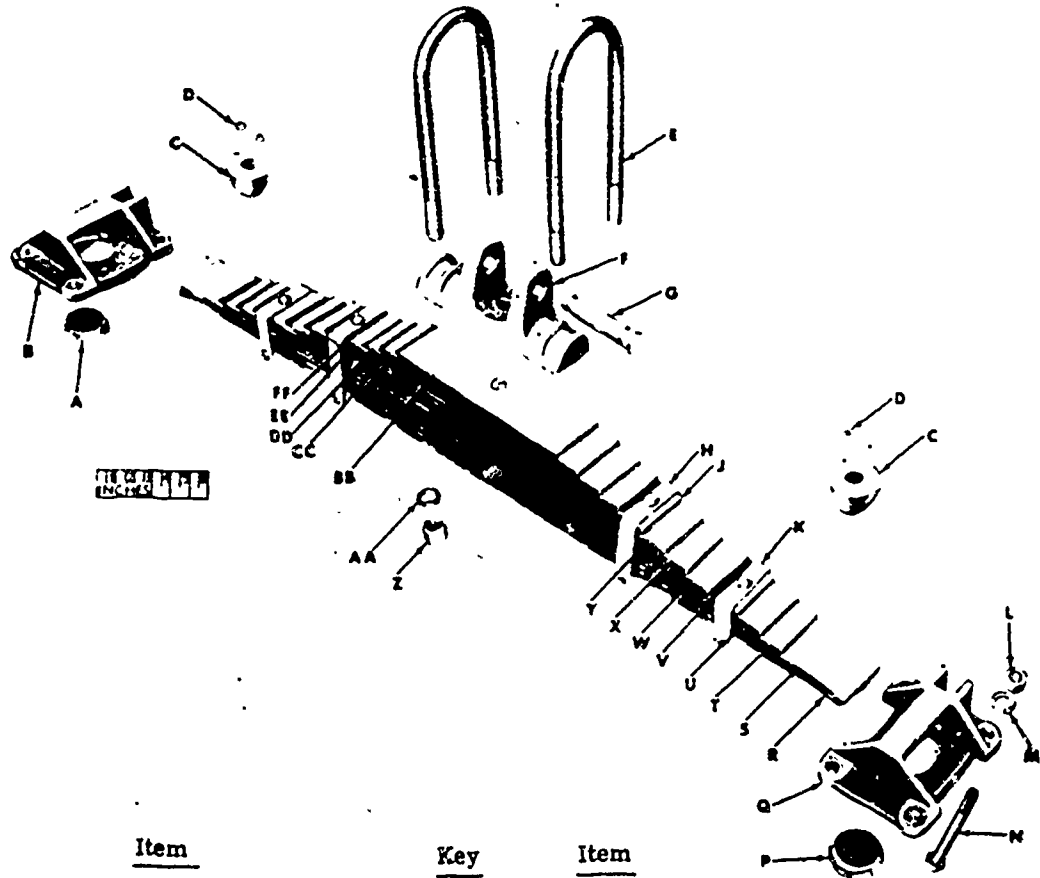

ORD E47182

Key	Item	Key	Item
A	Plate, spring guide, bottom	R	Leaf, spring
B	Bracket, guide	S	Leaf, spring
C	Bumper, rubber	T	Leaf, spring
D	Nut, hex	U	Leaf, spring
E	Bolt, U-	V	Leaf, spring
F	Saddle, spring	W	Leaf, spring
G	Pin, lifting, spring saddle	X	Leaf, spring
H	Clip, spring leaf	Y	Leaf, spring
J	Leaf, spring	Z	Nut, hex
K	Clip, spring leaf	AA	Washer, lock
L	Nut, hex	BB	Bolt, center
M	Washer	CC	Leaf, spring
N	Bolt, hex	DD	Leaf, spring
P	Plate, spring guide, bottom	EE	Leaf, spring
Q	Bracket, guide	FF	Leaf, spring

5-24

204

i. With the spring removed, check the spring seat bearings on the Arunnon shaft (also called the bogie shaft or spring seat cross-shaft).

(1) First, remove the six bearing capscrews. Then straighten the tang on the adjusting nut lock.

(2) Using the wheel bearing wrench, remove the outer nut or locknut. Lift the lock off the bearing shaft and remove the inner or adjusting nut. Now slide the spring seat and outer tapered roller bearing off of the shaft. The inner bearing will remain on the shaft.

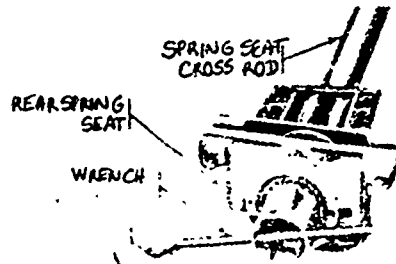

193

(3) Replace and/or lubricate the bearing cones, races, and seals as necessary. Then install the spring seat on its shaft. With the bearings, spacer, and adjusting nut in place, tighten the adjusting (inner) nut to 60-75 lb-ft torque. Install the tang lock and locknut. Torque the locknut to 100-150 lb-ft; then bend a tang of the lock over the locknut. Finally, install a new gasket and replace the bearing cap.

j. Install the spring by reversing the procedures followed to remove it. Tighten the spring U-bolts securely. Mount the wheels and tires on the hubs and remove the jack stands. Road test the vehicle; then reinspect your work.

k. Always replace torque rods if they are bent or if the ball sockets are excessively worn. To remove a torque rod, first, remove the nuts on the ball socket studs. Then, using a suitable drift (preferably brass) and a heavy hammer, drive the studs out of the tapered holes in the suspension and axle mounting brackets. Install a new torque rod and tighten the ball socket stud nuts to 350-400 lb-ft torque.

SECTION III. CONCLUSION

7. **SUMMARY.** In this lesson we discussed procedures that can be used when maintaining the suspension system of a wheeled vehicle. However, just knowing the procedures is not enough. You must also develop your skill, and this can only be done through practice.

8. **PRACTICE TASKS.** The appendix of this lesson contains a list of tasks associated with the maintenance of springs, shock absorbers, and frames. They are representative of the tasks you will be required to perform as a wheeled vehicle mechanic. Perform all of the tasks listed. Be sure you are under the supervision of an officer, NCO, or specialist who is qualified in the MOS when you practice the tasks. If you find you are having difficulty in certain tasks, restudy the appropriate training material and practice the tasks until you become proficient in each one.

EXERCISE

Note - Review the lesson exercise directions in lesson 1.

76. Before removing the center bolt from an assembled leaf-type spring, the spring should be:
- cleaned with solvent.
 - inspected for cracks.
 - clamped in a vise.
77. The ends of the springs on a bogie suspension system are supported by:
- shackles.
 - seats.
 - guide plates.
78. What tool or equipment is used to measure the wear of the lower ball joint on a 1/4-ton truck M151?
- Plumb bob
 - String and two punches
 - Caliper
79. A weak leaf-type spring can be detected by checking the position of its:
- U-bolt.
 - shackle.
 - pivot pin.
80. Where are the alignment shims located on the suspension system of the 1/4-ton truck M151?
- Between the upper and lower ball joints
 - On the lower control arm mounting bolts
 - Under the coil spring insulator
81. What grade bolts should be used to replace missing rivets in the frame of a 1-1/2-ton truck?
- 3
 - 4
 - 5

195

82. Spring center bolts are usually broken as a result of loose
- U-bolts.
 - shackles.
 - pivot pins.
83. What is done to keep the spring center bolt nut tight on the bolt threads?
- A cotter key is installed and secured through the bolt
 - The end of the bolt is peened with a hammer
 - The tangs of a lock are bent over the flats on the nut
84. Frame alinement can be checked on the 1/4-ton and 2-1/2-ton trucks by using a tape measure, a piece of chalk, and a
- carpenter's square.
 - machinist caliper.
 - plumb bob.
85. The spring seat bearings on a bogie axle suspension system are mounted on a
- trunnion shaft.
 - torsion bar.
 - torque rod.
86. How much torque should be applied to the spring seat bearing adjusting nut on the 2-1/2-ton M35-series truck?
- 30-45 lb-ft
 - 60-75 lb-ft
 - 100-150 lb-ft
87. During an inspection of a 2-1/2-ton truck you find that the frame has a small crack in the side rail. What action should you, as a wheeled vehicle mechanic, take to repair the frame?
- Plate the frame on the outside
 - Notify direct support of the damage
 - Weld the crack on both sides of the frame

- 196
88. How is the front crossmember secured to the frame rails on the 1/4-ton truck M151?
- Bolted
 - Riveted
 - Welded
89. What component must be removed before the coil spring can be removed from the front suspension and drive assembly on the M151 truck?
- Shock absorber
 - Lower ball joint
 - Spindle support
90. Which item must be disconnected on the 1/4-ton truck M151 in order to remove the front spindle support?
- Lower control arm pivot
 - Shock absorber
 - Hydraulic brake hose
91. What type of wrench is used to turn the spring seat bearing adjusting nuts on the 2-1/2-ton M35-series trucks?
- Wheel bearing wrench
 - Face spanner wrench
 - Wheel lug nut wrench
92. If the rear wheels of a 1/4-ton truck do not follow the path of the front wheels when the vehicle moves straight down a level road, we say the rear wheels are not
- alining.
 - dogging.
 - tracking.
93. When removing a front spring from the 1/4-ton truck M151, the jack stands should be placed under the
- crossmember.
 - frame rails.
 - control arm.

197

94. When installed, the ball socket stud nuts on the torque rods used on the 2-1/2-ton trucks should be tightened with a torque wrench to a minimum of
- a. 150-200 lb-ft.
 - b. 250-300 lb-ft.
 - c. 350-400 lb-ft.
95. You have just replaced a bent spindle support on a 1/4-ton truck M151. The truck must be driven about 10 miles to a support maintenance shop for wheel alinement. What portion of the wheel alinement should be correct before the vehicle leaves the organizational maintenance shop?
- a. Camber
 - b. Toe-in
 - c. Caster

1978

APPENDIX

PRACTICE TASK LIST

Practice Objective After practicing the following tasks you will be able to:

1. Inspect and test the frame and suspension system of a 1/4-ton truck M151.
2. Inspect a vehicle with a cracked frame.
3. Troubleshoot a suspension system for malfunctions.
4. Inspect and test a ball joint type suspension system.
5. Remove and replace suspension system components.
6. Inspect and test the suspension system components of the M35-series trucks.
7. Troubleshoot a malfunctioning vehicle suspension spring.
8. Remove and replace a broken spring bolt.

Practice Tasks.

1. We no doubt often take the vehicle's suspension system and its components for granted and maybe more or less ignore them. Moreover, like most everything, they do require some maintenance. Therefore, you should be able to do that portion of this job that applies to organizational maintenance. To become skilled in the inspection and testing of this system, here are some of the things you should practice:

a. Visually inspect several vehicles in your unit for bent or damaged components such as:

- (1) Broken or weak springs.

199

- (2) Loose or missing mountings and bolts.
- (3) Defective shock absorbers.
- (4) Cracked frame, loose or missing mounting rivets, and cracked welds.

b. Check frame and suspension for alinement.

(i) Check frame and body for alinement.

(2) Check front and rear drives for alinement.

2. While some of the work on the suspension system may have to be done at support maintenance, here are a few things you should practice on the 2-1/2-ton and 1/4-ton M151 vehicles in your unit:

- a. Remove and replace the springs and shock absorbers.
- b. Check the ball joints for wear and replace if necessary.
- c. Check the condition of the control arm pivots and repair as necessary.

3. Assist contact teams from your support maintenance in the following maintenance tasks:

a. Removal and replacement of front- and rear-drive systems on a 1/4-ton M151 vehicle.

b. Removal and replacement of a bogie suspension system on a 2-1/2-ton cargo truck.

212



200

ENLISTED MOS

CORRESPONDENCE/OJT COURSE

ORDNANCE SUBCOURSE 63B206

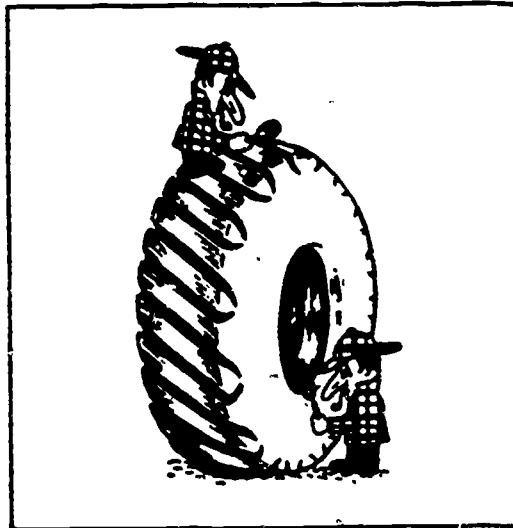

LESSON 6

MAINTENANCE OF TIRES AND WHEELS

SEPTEMBER 1975

**DEPARTMENT OF ARMY WIDE TRAINING SUPPORT
US ARMY ORDNANCE CENTER AND SCHOOL
ABERDEEN PROVING GROUND, MARYLAND**

CONTENTS

	Paragraph	Page
LESSON ASSIGNMENT SHEET.		6-1
STUDY TEXT		
Section	I. Tools and Equipment	
	Introduction.	1 6-2
	Wheel removal tools	2 6-2
	Tire removal tools and equipment	3 6-4
	Tire inspection and repair equipment	4 6-6
	II. Identification and Inspection of Tires and Wheels	
	Identification of tires	5 6-12
	Inspection of tires	6 6-15
	Inspection of wheels	7 6-24
	Rotation of tires.	8 6-25
	III. Removal and Installation of Wheels, Tires, and Tubes	
	General	9 6-26
	Passenger cars and small trucks	10 6-26
	Large trucks	11 6-36
	IV. Repair of Tires and Tubes	12
	Tire repair	12 6-41
	Tube repair	13 6-46
	V. Conclusion	
	Summary.	14 6-48
	Practice tasks	15 6-49
Appendix	Practice Task List	6-55

202

US ARMY ORDNANCE CENTER AND SCHOOL
CORRESPONDENCE/OJT COURSE



LESSON ASSIGNMENT SHEET

Ordnance Subcourse No 63B206. Wheeled Vehicle Drive Lines,
Axles, and Suspension Systems

Lesson 6. Maintenance of Tires and Wheels

Credit Hours Three

Lesson Objectives. After studying this lesson you will
be able to:

1. Describe the tools and equipment needed to remove wheels and tires from wheeled vehicles.
2. Describe the tools and equipment used to inspect and repair tires and tubes.
3. Explain the procedures for inspecting wheels and tires.
4. State the purpose and explain the procedures for rotating wheels and tires.
5. Explain how wheels, tires, and tubes are removed and installed on military wheeled vehicles.
6. Describe the methods of repairing tubes and tubeless tires.

²⁰³
Materials Required ALL STUDENTS. Answer sheet and exercise response list.
CORRESPONDENCE/OJT OPTION STUDENTS. See appendix.

Suggestions When reading the study assignments, carefully study all of the accompanying illustrations.

STUDY TEXT

SECTION I. TOOLS AND EQUIPMENT.

1. INTRODUCTION. The cushion of air inside the tires on the wheels of the vehicle is one of the things that permits the high-speed operation of sedans and trucks. Early trucks were equipped with solid rubber tires. Picture, if you will, what it would be like to travel at high speed on solid wheels, even on the modern superhighway. The road shocks might well be more than the passengers or vehicle could endure. The invention of the pneumatic (air-filled) tire permitted a great increase in vehicle speeds. A pneumatic tire is able to absorb road shocks or at least reduce their effect. This means that the cushion of air is also important to the vehicle that must operate off of the road on rough ground.

a. Tires used on a tactical military vehicle must be able to withstand more punishment than similar civilian tires. This is due to the fact that a tactical vehicle is designed for off-the-road operation. Failure of the tires on a military vehicle can mean the failure of an entire operation or mission. Under combat conditions, the loss of a vehicle due to tire failure can be especially serious. There is no way to prevent tire wear. As long as the vehicle is in use, the tread will wear from the tires, but it is possible to extend tire life with proper care and timely repair. As an example, a flat tire may be only slightly damaged when it first goes flat, but continued operation of the vehicle on the flat can completely destroy the tire.

b. A wheeled vehicle mechanic assigned to an organizational-type maintenance unit will have to spend some of his time making tire repairs. The vehicle operator is only required to perform daily inspection and remove damaged tires from the vehicle. It is the organizational mechanic that repairs damaged tires. Also, the mechanic must inspect tires to determine if repairs are needed at higher levels of maintenance.

2. WHEEL REMOVAL TOOLS. In order to inspect, maintain, and repair vehicle tires, the mechanic should first become familiar with the tools for doing the job. Since you may be required to supervise or instruct the operator in tire removal, it is also necessary to be familiar with the tools issued with various vehicles.

a. Among the tools issued with, and stored on, the vehicle are those needed by the operator to remove the wheels. These normally consist of a jack with a handle and a wheel lug nut wrench.

204

(1) Smaller vehicles may have a screw-type jack and a single-piece wheel nut wrench.

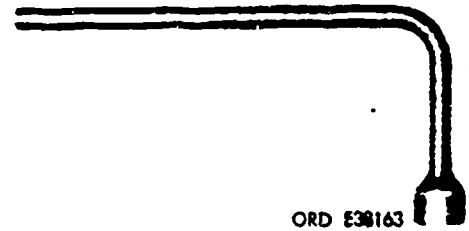
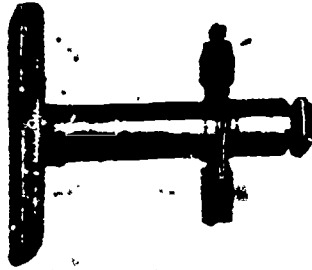

(2) Most larger vehicles use a hydraulic jack and a heavy two-piece wheel nut wrench. The two pieces consist of a long, round handle and the wrench section. At the larger end of the wrench is a six-point socket that will fit the outer wheel nut on a set of dual wheels. The smaller end of the wrench has a square socket to fit the inner wheel lug nuts.



b. In addition to the tools on the vehicle, the organizational mechanic has additional tools available at his unit motor pool. Organizational-type units are normally supplied with either the No 1 or No 2 common organizational automotive maintenance toolkit. The tools for tire repair are very similar in each set.

(1) To speed up and ease the removal of the wheels from the vehicle, the toolroom may also have a geared socket wheel stud nut wrench or a hand impact wrench set.

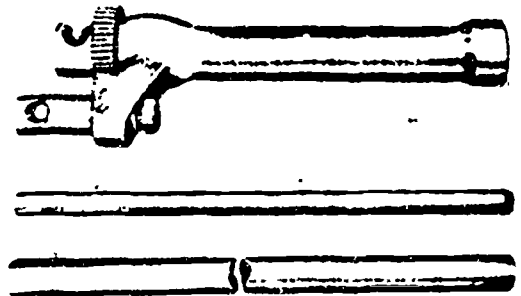

205 (2) A 12-ton hydraulic jack is included in each organizational toolkit.



3. TIRE REMOVAL TOOLS AND EQUIPMENT. The largest single piece of equipment available to the organizational mechanic for tire removal is the pneumatic tire demounter. It consists of a large cone-shaped metal base that supports a cross frame containing four sliding arms. The upper section is mounted upon a screw shaft that permits the upper portion to be drawn downward with great force. A 90° handle is used to turn the large screw shaft. The demounter is capable of handling wheels containing tires from size 9.00X16 through 14.00X20.

a. Some motor pools that have a large number of administrative vehicles may be equipped with a commercial-type tire demounter for small tires. These demounters are the same as those found in most automotive repair garages and service stations. Each consists of a stand to securely hold the wheel while special-purpose tools designed to work with the demounter are used to remove or install the tire on the wheel.

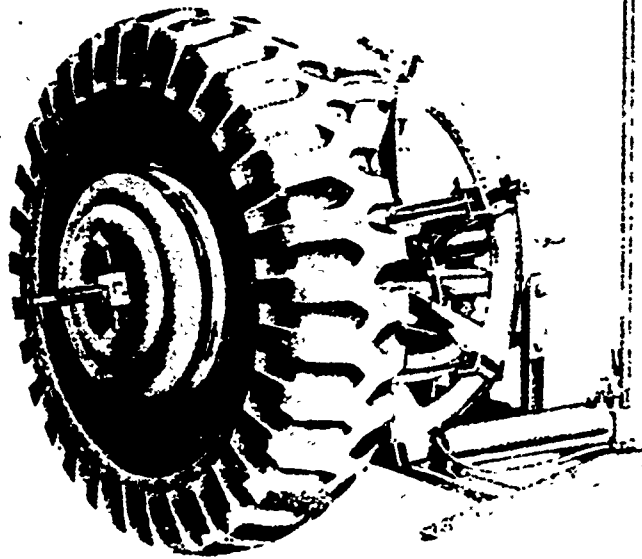

A—TIRE DEMOUNTER IN USE

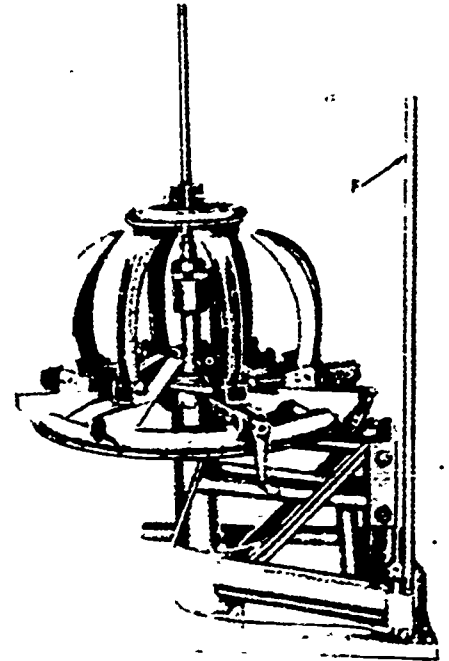

C—HORIZONTAL MOUNTING

207

b. In the tactical units, five types of tire irons are available, in addition to the demounter. Each of the tire irons are of a different size and shape, which allows some irons to do certain jobs better than others. Some of the irons may be good for the removal of lockrings, and others to ease the tire from the wheel.

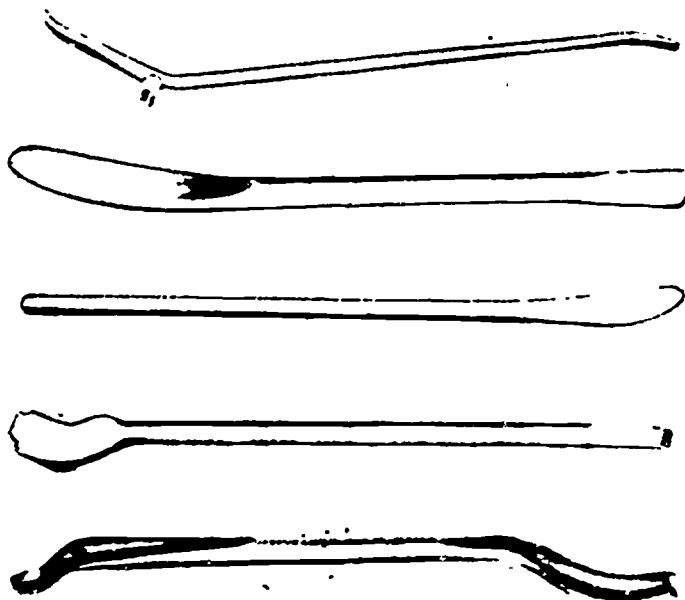

4. TIRE INSPECTION AND REPAIR EQUIPMENT. To aid in the inspection of tires on military vehicles, the mechanic may have available a steel tape measure and the tire tread depth gage. The tape is found in the No 2 common set, and the tread gage is found in both the No 1 and No 2 common tool set. The steel tape is $\frac{3}{8}$ th of an inch wide and 20 feet long. It is housed in a case with a hinged-type rewind handle mounted in the side. A clip on the tire tread depth gage aids in preventing the loss of the tool when it is carried in the pocket. The tread gage is marked off in $\frac{1}{32}$ d of an inch, with a maximum depth of 1 inch. A 3-inch metal tread contact plate is mounted at right angle on the tube-shaped main body of the gage.



a. A tubeless tire repair kit is available in the organizational motor pool shops on an as-required basis. This means that if your unit has vehicles equipped with tubeless tires, the kit may be requisitioned (ordered) through normal supply channels.

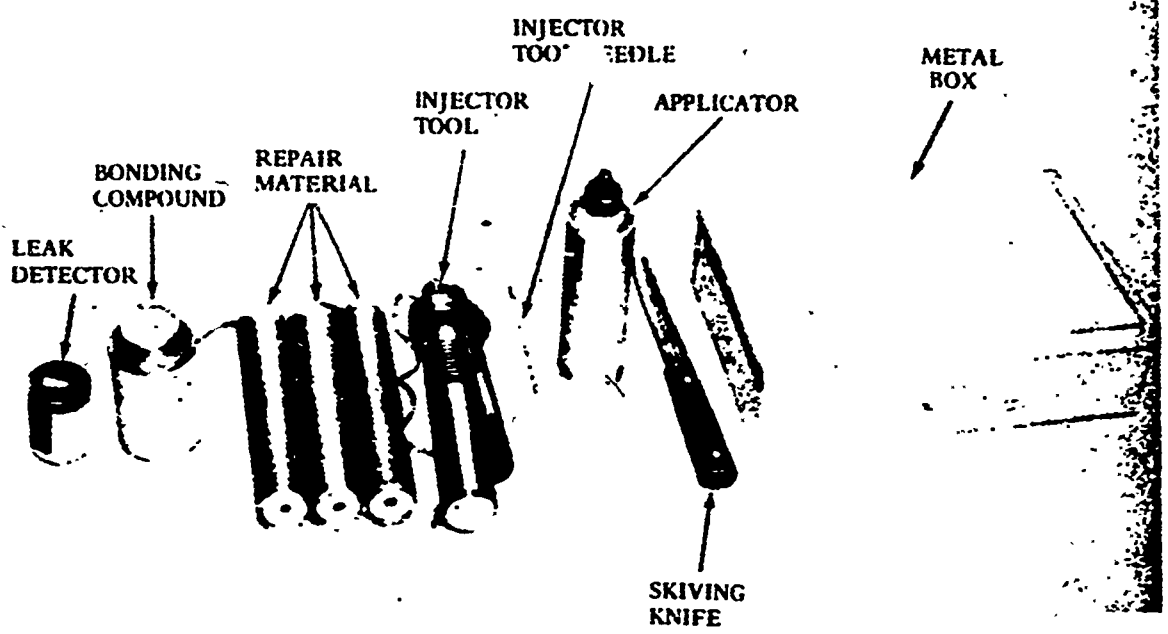

209

(1) For use in the repair of tire tubes, a hot patch vulcanizer is included in organizational tool sets. The way the vulcanizer is made may vary from manufacturer to manufacturer, with some models having hinged upper portions that are held in the working position by a lock screw. Each vulcanizer set includes a clamp that is hand-tightened by means of a long screw and handle. A heavy metal plate forms the base of the clamp. A roughing tool is usually attached to the assembly with a chain. In most motor pools the vulcanizer is permanently mounted to a bench by means of bolts or screws. This solidly mounts the tool for repairing tire tubes.

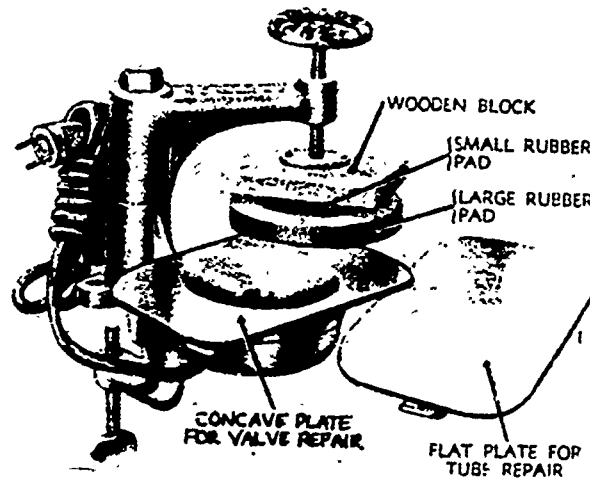

A—ELECTRIC-TYPE VULCANIZER—41-V-595

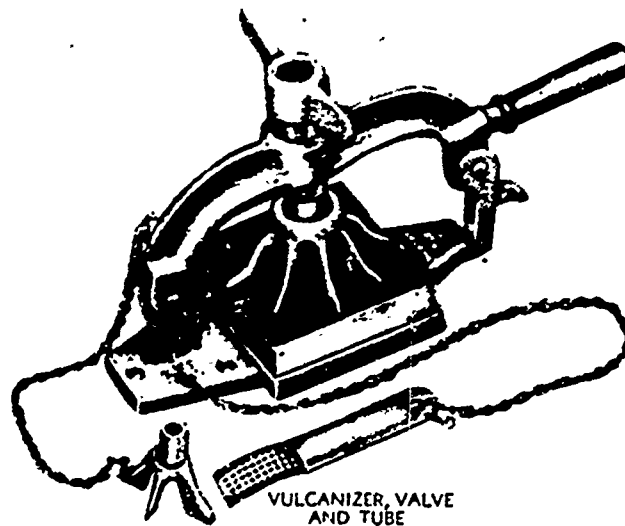

B—FUEL-TYPE VULCANIZER—41-V-615

(2) There are also tools provided in the organizational sets for repairing tire valves and valve stems. The valve stem repair tool is, in reality, a combination of tools. It includes taps, dies, and wrenches that fit standard tire valves.

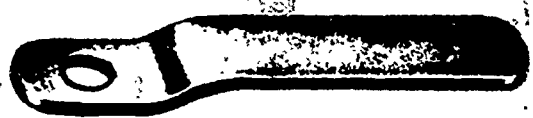
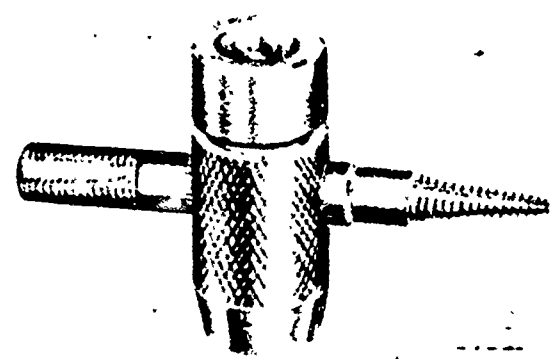

(3) A valve holding tool, which is also available, consists of a long steel plate with a small offset containing a tapped or threaded hole. This tool is designed for use with the long metal-type valve stems used on large trucks.

b. The fishing tool, which is also available, consists of a valve cap and handle connected together by a short chain and is used to pull the valve through its hole in the rim.

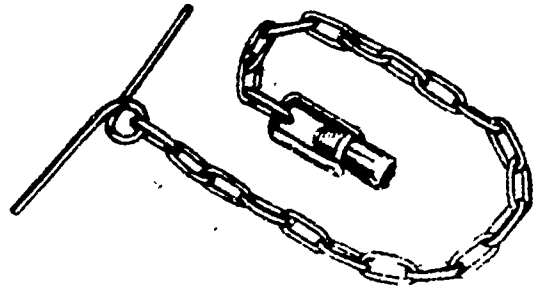

2/c. A number of items used for inflating (pumping up) tires are available in organizational maintenance sets. Each set, for example, includes a gasoline engine powered air compressor. Organizational toolkit No 1 has a 5-cubic feet per minute (CFM) compressor, while organizational toolkit No 2 includes a 15-CFM compressor.

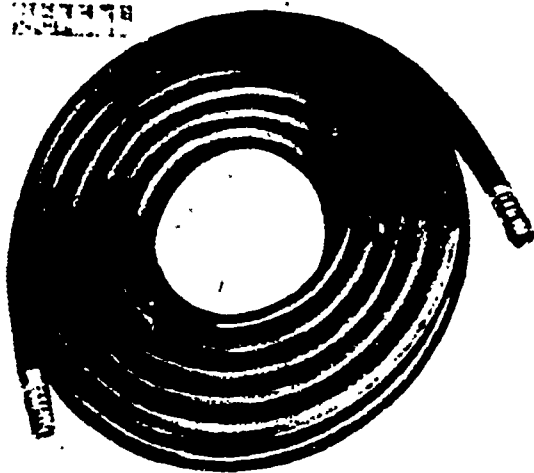
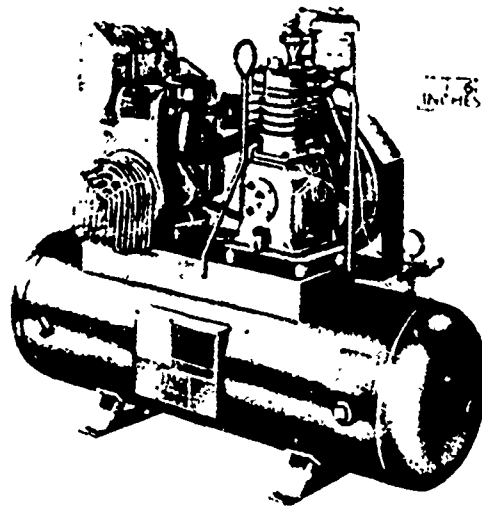

(1) Each kit includes lengths of airhose, a chuck, and a gage. The hoses are generally in 25-foot lengths. Kit No 1 includes three lengths, whereas kit No 2 includes five lengths of hose.

212

(2) These hoses can be connected to each other by threading the ends together or by a quick-couple connector method. With this method each hose includes a male quick-couple half and a female quick-couple half. The female half seals itself when the hoses are separated.

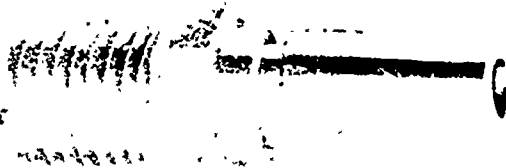

(3) The outer end of the hose has a device known as an inflator-gage assembly. It includes a trigger-operated valve, a gage to indicate how much pressure is in the tire, and a double-faced chuck. The chuck is known as a dual foot chuck and can be used for single- or dual-type wheels. To use the inflator-gage, the chuck is held against the end of the valve stem firmly. The gage will then indicate how much pressure is in the tire. It is graduated from 10 to 120 PSI (pounds per square inch). To inflate the tire, pull the trigger to the rear and air will be forced into the tire. Release the trigger and the gage can again be read.

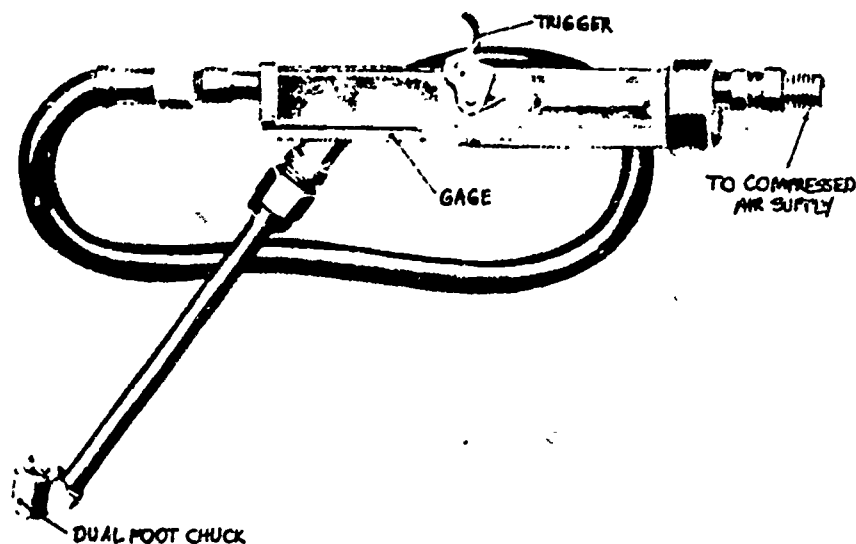

6-11

SECTION II. IDENTIFICATION AND INSPECTION OF TIRES AND WHEELS

5. **IDENTIFICATION OF TIRES.** Vehicles within the unit will, from time to time, enter the shop for scheduled or unscheduled maintenance. During these maintenance periods the mechanic should inspect the vehicle tires for serviceability. In other instances the vehicle operators may call upon unit repairmen for assistance with inspections. Let's take a look at some of the types of tires you may find.

a. Just as the type and size of tires vary on civilian vehicles, so do the tires used on military vehicles. Commercial-type vehicles in the military service normally use the same type of tires as most civilian vehicles. These tires have a regular tread that gives maximum mileage and quiet operation. The regular tread is designed for use by sedans, trucks, and buses on hard-surface roads. On many military posts, administrative motor pools may install commercial-type snow tires on commercial vehicles during the winter months. This type of tire has a special tread for use on the driving wheels to provide greater traction in snow or mud.

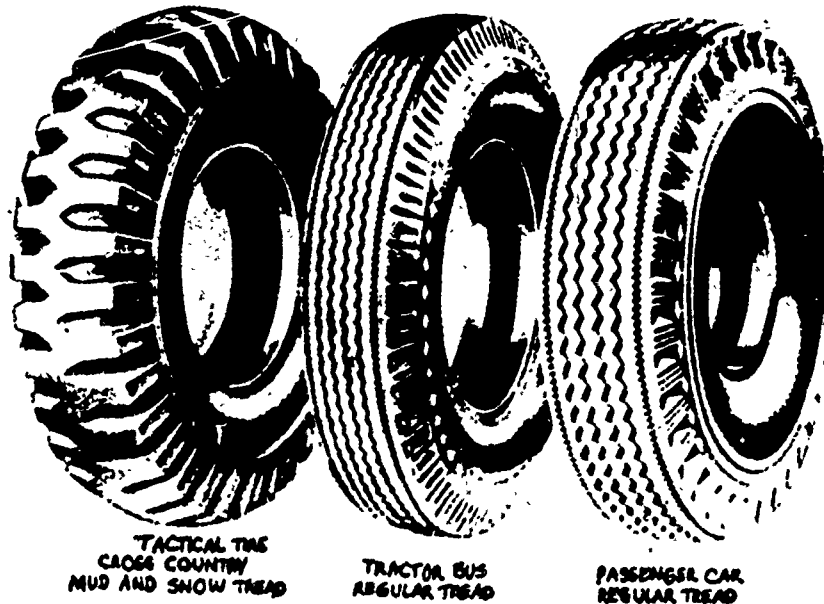

(1) Since a tactical vehicle may be required to operate off the road at any time, and all wheels are able to drive, the nondirectional mud and snow tires are mounted on the vehicle for all seasons of the year.

(2) Road construction equipment and materials handling equipment often are equipped with tires that have special-purpose treads. Tractors will often have a rib-type tread on the front tires and a traction tread on the rear. The traction tread is of the directional type. This means the lugs of the tread are on the tire at an angle so that mud that collects in the grooves will tend to be forced off to the side as the wheel drives. For the directional tire to operate correctly, the tire must be mounted so that the point of the V-shaped tread drives into the road surface. If the tire is not mounted this way, the self-cleaning action is lost. The tires used on earth-moving equipment are often very large, with a diameter of 6 feet or more. Different types of tread designs for regular, rock, or mud and snow operations may be found on earth movers.



A—TRACTOR OR IMPLEMENT TIRE—RIB TREAD

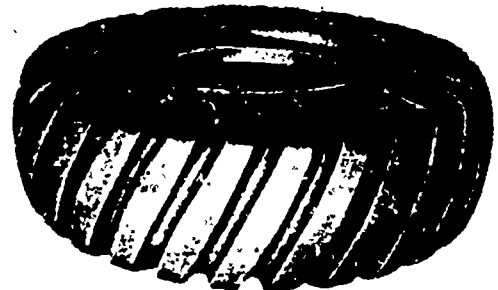

A—ROCK-SERVICE TIRE



B—TRACTOR REAR TIRE—TRACTION TREAD

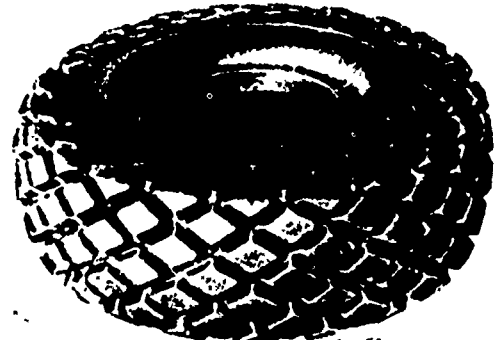

B—EARTH-MOVER TIRE



C—IMPLEMENT TIRE

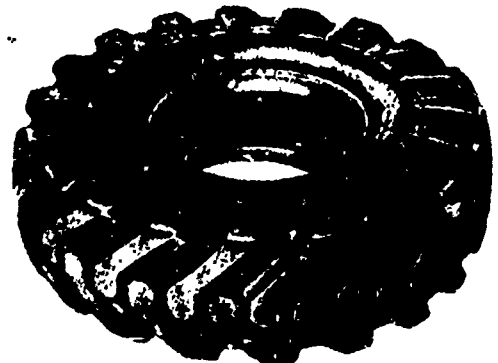

C—GRADER TIRE—MUD-AND-SNOW TREAD

215

b. To assure that the correct size tire is on the vehicle, the mechanic can compare the size markings on the side of the tire with those listed in the proper technical manual.

(1) The tire size is molded on the sidewall of each tire at the time of manufacture. The first number of the size is the width of the tire, in inches, when properly inflated upon the wheel and without a load. The second number is the inside diameter of the bead of the tire. For example, an 8.25-20 marking means the tire is approximately 8-1/4 inches wide when inflated and mounts upon a wheel with a 20-inch diameter rim. Other markings on the side of the tire that are of interest to the mechanic are the number of plies, the balance point, and "type" markings. The ply number indicates the number of layers of rayon or nylon cord plies used in the construction of the tire. The greater the number of plies, the greater the strength of the tire. A sedan tire will normally have a tire with two to four plies, while a heavy truck may have a tire with eight or more plies. While additional plies can make the tire stronger, they also tend to make it more rigid. This can be a factor in sedan tires where it is desirable to have the tires flex easily for greater riding comfort. Tires of the same size will not necessarily have the same type or number of plies.

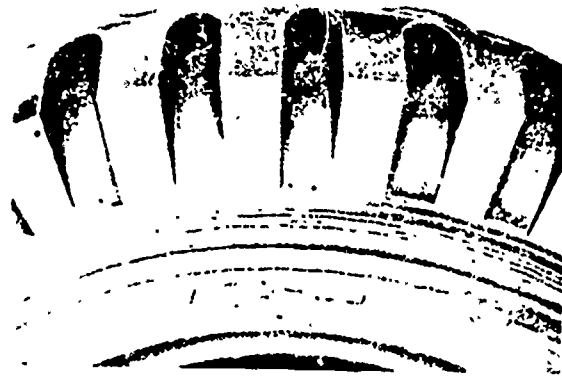

(2) The small red dot on the sidewall of the tire near the bead indicates the balance point. The valve of the tire is placed at the balance mark when the tire is installed on the wheel to obtain the best wheel balance. Notice the balance point indicated by an arrow in the accompanying figure.

216

6. **INSPECTION OF TIRES.** When in use, the tires of a vehicle are constantly in danger of being damaged. The tires may run over any number of sharp objects or strike large obstructions such as curbs or rocks. When the tires are being inspected during any type of service, the mechanic should be alert for all types of cuts, punctures, and bruises. When inspecting cuts, remove the tire for repair if the cut extends to or through any of the fabric of the plies. When there are small cuts in the tread which do not reach the fabric, the tire need not be removed for repair. A bulge or unusual lump on any part of the tire indicates internal damage to the plies, and the tire should be removed for repair or replacement. The driver will normally remove sharp objects which have entered the rubber of the tire.

a. On trucks equipped with dual tires in the rear, a visual check should be made to insure that no large rocks are lodged between the tires. In addition to possible damage to the tires, these rocks can be thrown for great distances by the fast-turning wheels. Drivers are sometimes guilty of driving a truck equipped with dual rear wheels when one of the tires is flat. With two tires mounted together, a good tire supports a flat tire during operation. However, the good tire is overloaded and is likely to blow out, or the flat tire can slip on the rim and destroy the tube or cause further damage to the tire.

b. A mechanic will normally check dual tires by striking both tires with his foot or some object that will not bruise the tire. The flat tire mounted on one of the dual wheels can be found by the lack of resistance or bounce from the blow. This method is not useful in determining if a tire has low air pressure, but it will determine one that is completely flat.

c. Excess heat will cause damage to the tires. If a tire flexes too much due to low air pressure, too much heat is generated and the rubber may separate from the fabric.

d. One of the more difficult decisions in tire inspection is "when to remove the tire for recapping." Care must be exercised not to permit the tire to remain on the vehicle too long or all of the rubber will be worn from the tire and the fabric will be exposed. When worn to the fabric, it is not practical to repair the tire or apply a new tread. If the tire is removed too soon, rubber will be wasted since all of the possible wear has not been used.

217 (1) On the nondirectional mud and snow tires used on tactical vehicles, the tires should be removed for recapping when the center of the tread is worn smooth. At this time the ridges formed by the grooves of the tread are worn off at the tire center.

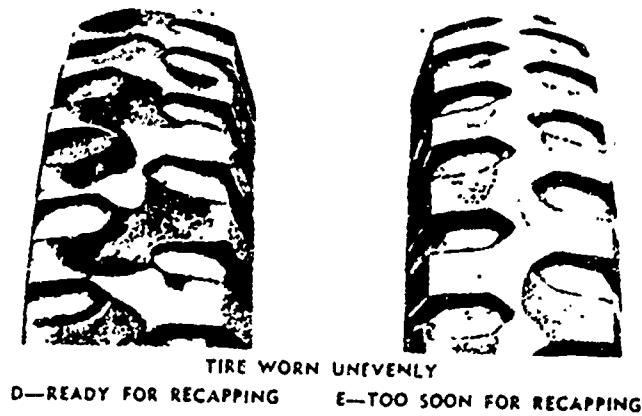
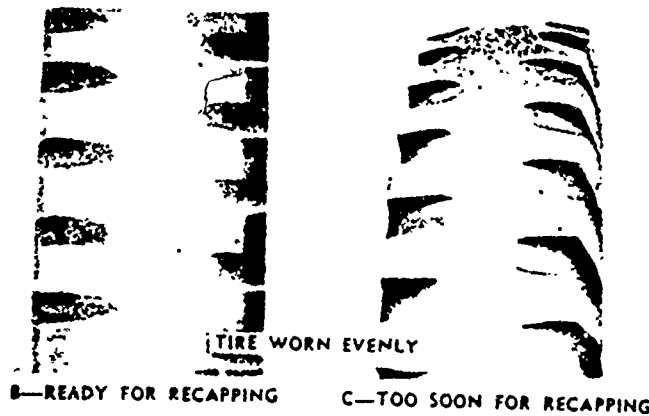
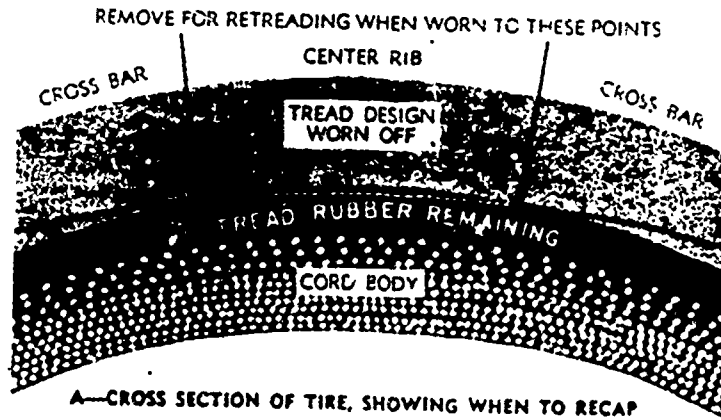

218

(2) On commercial-type treads, the tread gage issued with the organizational tool sets may be used to check depth. Normally, the tread should not be less than 1/16th of an inch.



e. Some of the causes of rapid tire wear are misaligned wheels, excessive speed, improper loading, grabbing brakes, and improper vehicle operation. A tire will normally wear with a smooth surface, but when forced to slide or drag on the road the surface becomes rough and scuffed. Operating a vehicle in front-wheel drive when it is not required can also increase tire wear. During the winter months when tire chains are in use, improper installation or use of chains can chew pieces out of the tires. When installed on the wheel, sharp edges of tire chains should face away from the tire.

219

f. If the tire has been operated too long while not wearing evenly, it may be damaged beyond repair. Once the wear has extended into the fabric of the plies, it is unlikely the tire can be repaired. Uneven wear can be caused by improper air pressure, incorrect steering adjustments, faulty brakes, bad shock absorbers, loose wheel bearings, and poor driving by the operators. Front tires on a vehicle with too much toe-in will wear the outer edges at a fast rate.



A—CUT INTO FABRIC

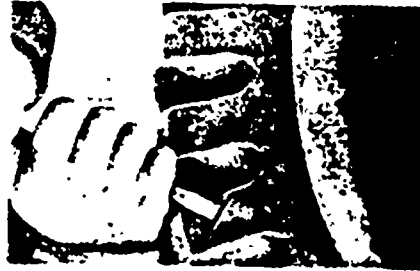

B—MINOR CUT—NOT INTO FABRIC



C—BULGE INDICATING INTERNAL INJURY



D—START OF IRREGULAR WEAR—TIME TO ROTATE TIRE POSITIONS



E—IRREGULAR WEAR—TIME TO ROTATE TIRE POSITIONS



F—TIRE WORN BY IMPROPER "TOE-IN"

(1) If the front tires toe-out when the vehicle is traveling straight ahead, the tires will wear rapidly on the inner edges. Improper toe-in or toe-out forces the tires to slide or drag sideways as they roll over the road surface. A sharp featheredge is left on the edges of the tire treads due to the sliding motion.

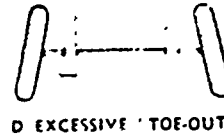
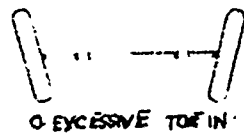

(2) Too much free play in the steering linkages, loose wheel mountings, or loose wheel bearings can also cause uneven wear on the front tires. Brakeshoes that grab on any of the wheels of a vehicle will cause the tire to slide and wear unevenly. Any hard-driving practices by the operator, such as moving through turns too fast and stopping and starting too quickly, will cause uneven wear on the tires. It is the responsibility of the vehicle operator to insure that the tires have the correct tire pressure. If the driver fails in this job, the tires can wear unevenly or fail too early.

221

(3) When a tire is operated with too little air pressure, the center of the tire will buckle inward and the outer edges will carry the load. This causes the outer edges to wear very fast. Also, a tire without enough air pressure will flex more than it should and generate too much heat. If operated with too much tire pressure, the vehicle will ride on the crown or center of the over-expanded tire and, thus, wear the center of the tread too fast.

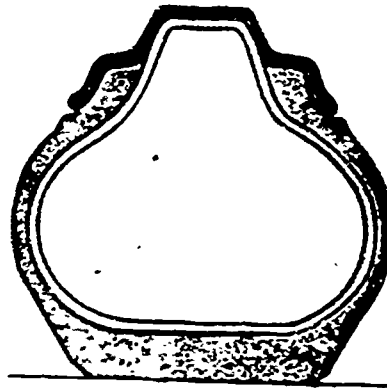

A—CORRECT AIR PRESSURE

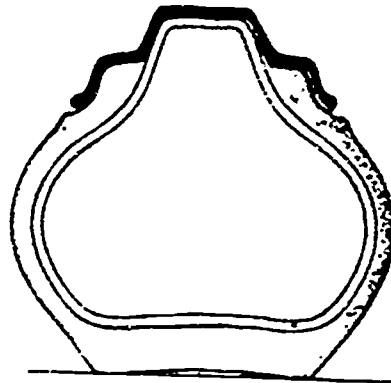

B—UNDERINFLATED

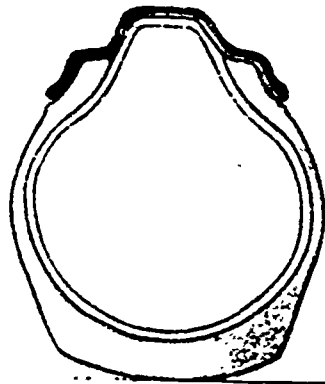

C—OVERINFLATED

6-20

234

222

g. The driver and the mechanic should make every effort to keep all of the tires on a vehicle wearing at an even rate. One of the checks a mechanic will make is to measure the circumference or distance around the outside of the tires. This is done with a tape measure found in the organizational tool set No 2. The allowable tolerances for matching dual tires is determined in accordance with the outside diameter. Differences in the sizes of tires can cause increased wear on the tires and drive train and make steering and braking difficult. Tires of different size on either side of the front of the vehicle can affect the steering and braking functions. On any of the driving axles, unequal size tires on opposite sides of the vehicle will force the differential to work more than necessary. When two unequal size tires are mounted side by side on rear dual wheels, the tire with the most tread or larger diameter will be forced to carry more of the load. With one tire carrying the load of two, the working tire is much more likely to fail. On vehicles that have more than one driving axle, each axle will be driven at exactly the same speed. If the tires on the different axles have different diameters, some of the tires will be forced to slip to keep the wheel speeds matched. This is due to the larger tire covering more ground during each revolution.

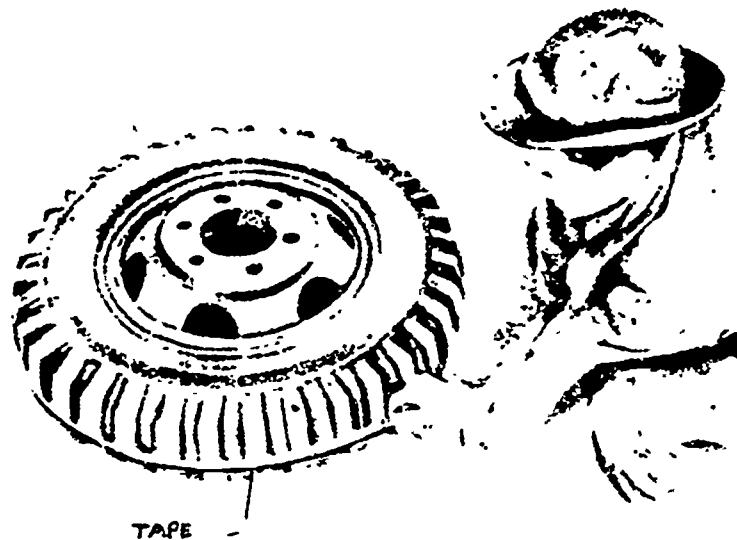

—MEASURING CIRCUMFERENCE OF TIRE

Outside diameter of tires	Permissible difference	
	In diameter	In circumference
Under 30 inches	$\frac{1}{4}$ inch	$\frac{3}{4}$ inch
From 30 to 40 inches	$\frac{3}{8}$ inch	1 $\frac{1}{8}$ inches
Over 40 inches	$1\frac{1}{2}$ inch	1 $\frac{1}{2}$ inches

223

h. Often the vehicle driver will be careless of the valve caps because they are not absolutely necessary to keep the vehicle running. The mechanic should check to see if the caps are present each time the tires are inspected, because they can prevent failure of the tires due to leaking valves. When the caps are not present, mud, dirt, or other foreign matter can enter the tire valve openings. This can prevent proper closing of the valve and allow dirt and moisture to be forced into the tire tube as it is inflated with air. Most valve caps contain a seal or gasket that provides a safeguard against a leaky valve. In order to function properly and to prevent small air leaks, the valve caps must be snug when installed.

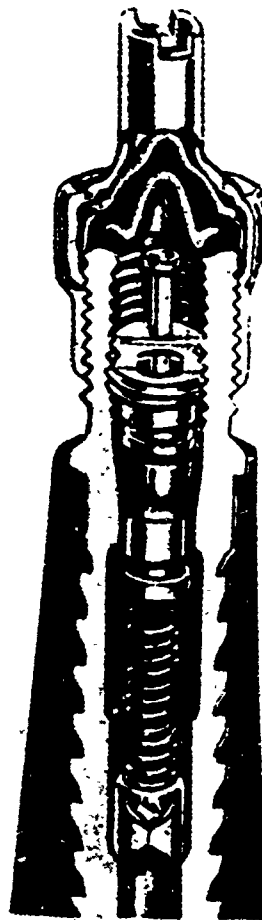

VALVE CLOSED
AND CAPPED

236

6-22

224

i. As the tire and tube are assembled, the mechanic must take care that the tire valve is properly installed. When inspecting a vehicle with dual rear wheels, note the position of the valves. To be correct, the two valves should be 180° apart or, to put it another way, one valve must be directly opposite the other. This aids in the location of the valve stems under all conditions. The valves of the inner wheel will face the outside of the vehicle. If not installed this way on the inner tire of the rear dual wheels, it will be very difficult to check air pressure or to inflate the tires.

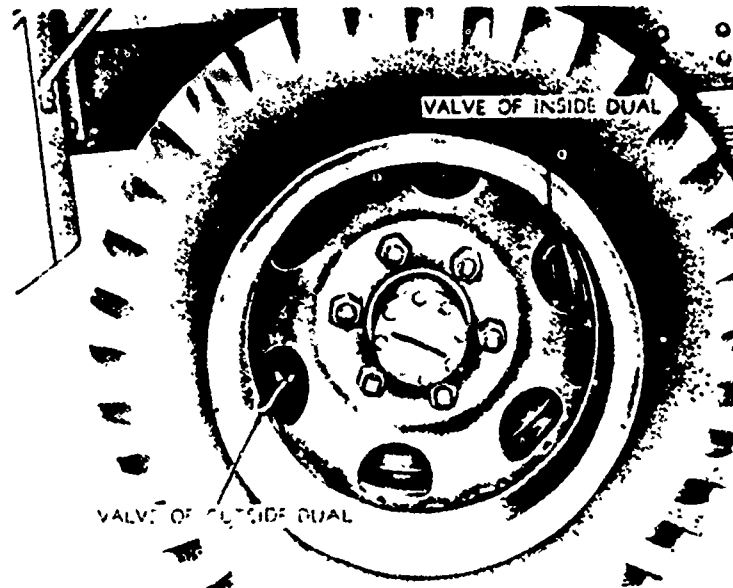

VALVES CORRECTLY POSITIONED ON DUAL TIRES

j. The lug nuts that retain the wheels may work loose during the operation of the vehicle. While inspecting, the mechanic should check all lug nuts by trying to tighten them with a wrench. When loose lug nuts are found, the nuts should be tightened to the specifications listed in the proper technical manual.

k. Loose front-wheel bearings, which can cause excess tire wear, can be located by jacking the vehicle up and rocking the wheels back and forth. The free play can be felt at the wheel. This check may also reveal free play in kingpins, steering knuckles, or control arms. The mechanic should first determine exactly where the free play is located. If loose wheel bearings are found, they should be adjusted in accordance with the proper vehicle technical manual. If any other looseness is found, refer to the maintenance allocation chart (MAC) to determine who is responsible for the repair.

225

l. Cracks in the outside rubber of the tire should be carefully inspected. These cracks usually spread out from the center of the tire and may extend all the way around the sidewall of the tire. The cracks are caused by the cord plies below the rubber becoming weak and spreading apart. This forces the rubber to crack open. Failure of the fabric of the tire is usually due to age and/or dry rot. As the cracks open in the rubber, water will enter and the complete failure of the fabric is speeded up. Once the fabric of the tire becomes weak, there is danger of a blowout any time a load is applied. When it is felt there is danger of a failure due to dry rot, the tire should be replaced. In those cases where there is doubt as to the serviceability of a tire, the mechanic should seek help from the maintenance supervisor.

m. If the tire was carefully inspected prior to removal from the wheel, only those areas that could not be seen while mounted need to be inspected. If no inspection has been made, make all of the checks listed for a mounted tire. In addition, check the inside surfaces and beads. Check the bead for damage. This type of damage often occurs during installation and removal of the tire from the wheel. It is particularly important to check the outside of the bead on the tubeless tires since this area acts as a seal to retain the air. Check the inner surface of the tire for cuts, punctures, and bulges. If the cord plies have been pulled loose from the normally smooth inner surface, it is an indication the tire has been operated on the vehicle while flat.

7. INSPECTION OF WHEELS. Inspect the wheel for cracks, dents, and oversize mounting holes. When a vehicle is operated with the wheel mounting nuts loose, the wheel will move against the studs and enlarge the mounting holes. If allowed to continue, the holes for mounting the wheel will become so enlarged that it will be impossible to tighten the wheel properly. Cracks may develop in any part of the wheel, but the area around the mounting holes will usually be the first place they appear. Large dents are usually the result of an accident, such as a wheel striking a log, a curb, or another vehicle. A warped wheel is difficult to detect when off of the vehicle. It is often possible to detect a wheel that is warped while the vehicle is moving due to a noticeable weaving in and out. If the vehicle is in the shop, the mechanic can raise the wheel off of the floor and rotate the assembly. By looking at the tire from the front as it spins, or comparing it with a stationary object, a warped wheel can be detected. If the damage is enough to make the wheel unserviceable or unsafe, it should be replaced.

8. **ROTATION OF TIRES.** Preventive tire maintenance consists mainly of jobs that are performed regularly to make certain that the tires are kept in operating condition. The most important feature of maintenance is the regular inspection by the operator and mechanic to detect any trouble before the complete failure occurs. When the cause of tire wear or damage is due to improper mounting or alignment, the mechanic can correct the mechanical faults or direct the vehicle to higher maintenance for repair. During normal operation the front tires of a vehicle will normally wear at a slightly faster rate than the rear tires. The spare tire may be out of use for a long period and, therefore, will not have the wear of the tires which are mounted for operation on the road. To obtain equal wear on all of the tires on a vehicle, an inspection is performed every 2,000 miles to determine if the tires and wheels are in need of rotation. If not rotated earlier, the tires of all wheeled vehicles will be rotated after 6,000 miles of operation. The pattern for the rotation will vary, depending on each type of vehicle and also on the specific vehicle. You can see an example of the tire rotating sequence for the 1/4-ton truck M151 in the accompanying illustration. The technical

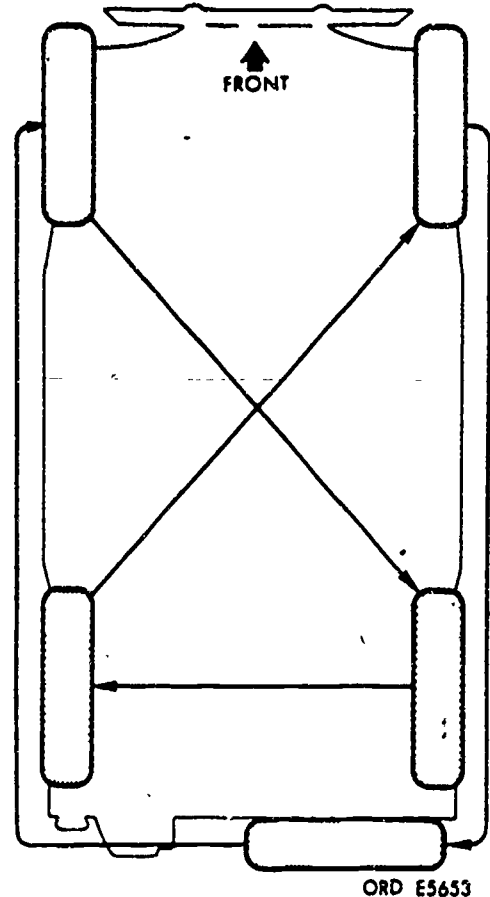

manual for each vehicle should include rotation procedures for that specific vehicle. Follow that procedure for that vehicle. You must also take into consideration the size of the tires being rotated. For example, the tires on each axle must be as near the same size as possible. If the tires, once rotated, end up with a good tire from the spare on one rear wheel and an excessively worn tire on the other rear wheel, the differential will wear excessively. The worn tire should then be replaced with a tire matching the good tire in size. Rotation of tires is done to keep all tires wearing about the same. If one tire becomes worn excessively, the wheel alignment, wheel bearings, and brakes on that wheel should be checked out.

227

SECTION III. REMOVAL AND INSTALLATION OF WHEELS, TIRES, AND TUBES

9. **GENERAL.** There are various methods used to remove and install the tires on wheeled vehicles. These methods vary, depending on the type of rim or wheel and the tire. Let's find out how the tires are removed, starting with the smaller vehicle.

10. **PASSENGER CARS AND SMALL TRUCKS.** Drop-center and safety-rim type wheels are used on the 1/4-ton tactical vehicle, commercial sedans, and small commercial trucks in the military service. You may already be familiar with the drop-center wheel, since it is the type used on many civilian cars.

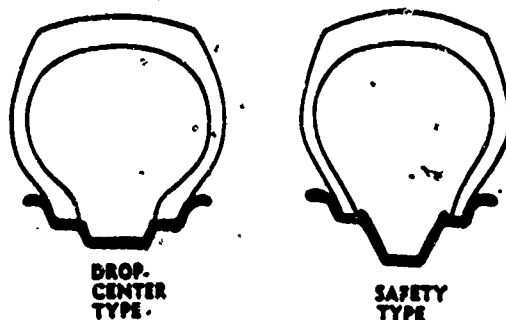

a. The wheel is of one-piece construction and the center well is the feature that permits the removal of the tire without the disassembly of the wheel. When the tire is inflated, the beads are forced against the rims and the tire is locked into position on the wheel by the pressure of the air. The tire may be removed from the wheel only after removing the air. The driver will normally remove the wheel and tire from the vehicle; however, the mechanic must also be able to perform the task. The paragraphs below describe the steps for doing this job on the 1/4-ton truck. Make sure you study all of the steps. These steps are typical of most small vehicles.

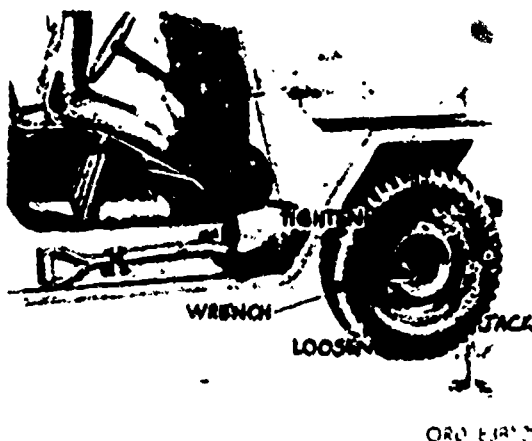

(1) First, set the parking brake and then block (chock) the opposite wheel for extra safety precautions. Then loosen the wheel nuts, but **DO NOT REMOVE THEM.**

240.

(2) Next, put the jack under the lower suspension arm so that the upper end fits in the recess in the suspension arm. Then jack the wheel off the ground.

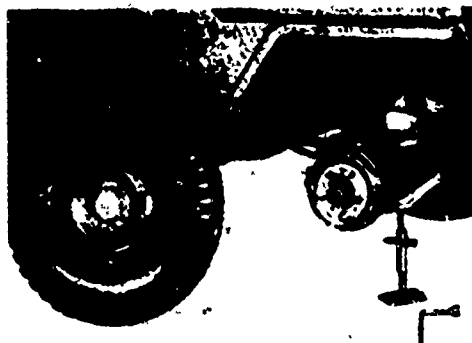
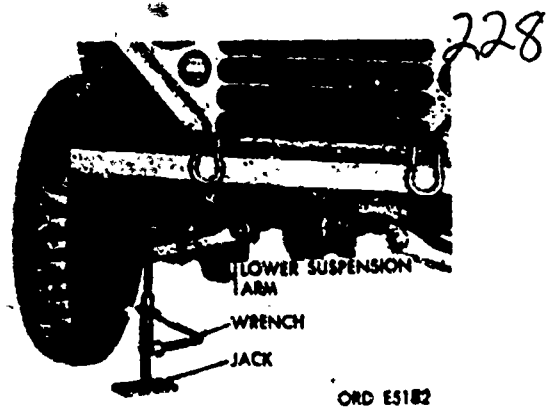

ORD E38140

(3) Now remove the wheel nuts. If necessary, have someone apply the service brakes if the wheel nuts are still too tight. Next, remove the wheel and tire from the hub and brakedrum.

(4) Next, remove the spare from its stowed position and place it on the hub and drum. Install the wheel nuts and turn them snugly against the wheel. Lower the jack until the tire and wheel are supporting some of the weight of the vehicle. Finish tightening the wheel nuts. Then finish lowering the jack completely and stow it in the proper place on the vehicle. If the tire is unserviceable it must be removed from the wheel.

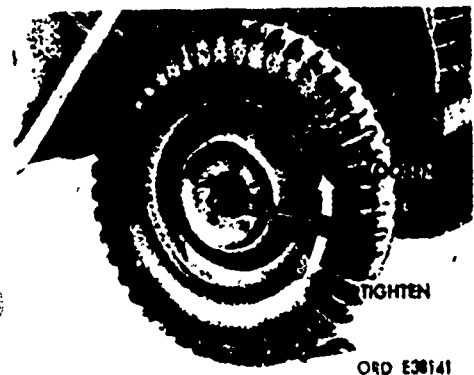

229

b. The following procedures are used for removing the tire from the wheel. Make sure all of the air is released from the tire before starting to remove it.

(1) First, loosen the beads from both sides of the wheel rim by stepping on the sidewall of the tire near the wheel rim. If the tire has been on the wheel for a long period of time, it may be difficult to break the bead away from the wheel. In these cases, place the wheel under some object such as the vehicle bumper. Place the bottom plate of the jack on the tire sidewall near the wheel rim and the top under the bumper. As the jack is raised the weight of the vehicle will force downward on the tire and move the bead away from the wheel rim. Tools such as chisels and large hammers should not be used to break loose the bead. A careless blow with a sledge hammer can bruise and damage the sidewall of a tire. Driving upon the tire sidewall with another vehicle may break down the fabric areas of the tire and cause complete tire failure.



LOOSENING BEAD
FROM RIM FLANGE

(2) Force both of the tire sidewalls together on each side of the wheel. This allows the beads at this point to enter the well in the center of the wheel. Once this is done the tire can be shifted to one side on the wheel and enough free play will be available to remove the tire from the wheel.

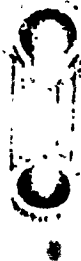

PRINCIPLE OF
DROP-CENTER
RIM

212

(3) Carefully slide a tire iron between the wheel rim and tire bead opposite the point where the beads are shifted into the wheel well. Force the handle of the tire iron inward and downward toward the center of the wheel. Be careful that you do not pinch the tube (if so equipped) with the tire iron. This draws the bead of the tire over the edge of the wheel rim. It may be necessary to use two tire irons to work the bead over the edge of the rim a few inches at a time. When the halfway point is passed, the bead can be lifted off of the wheel with ease. If a tube is used, remove it from the tire at this time.

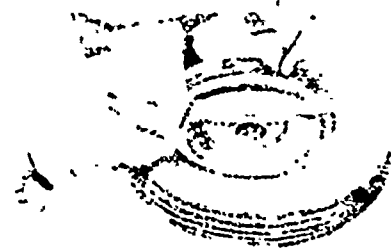

LIFTING OUTSIDE BEAD OVER RIM

(4) To complete the removal of the second bead, stand the tire on the tread. Force the wheel downward to gain as much free play as possible, as the bottom of the bead moves into the wheel well. At the top of the wheel, insert a tire iron between the inside bead and the rim and force the wheel out of the tire. Use additional tire irons, if necessary, to aid in tire removal.

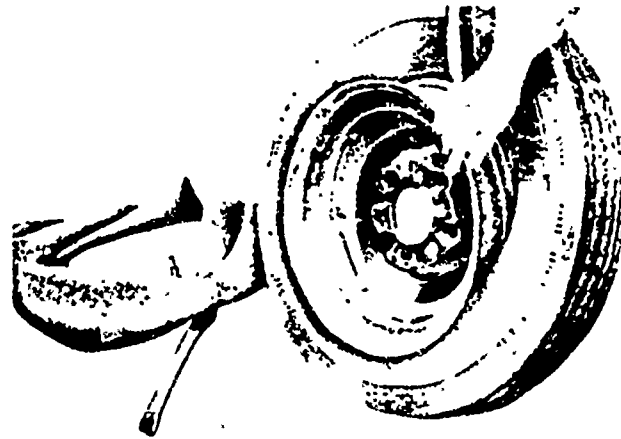

REMOVING INSIDE BEAD

231 c. Install a tire on the drop-center type rim using the following procedures:

(1) While holding the tire upright, force the wheel into the opening in the center of the tire. If the tire is of the tube type, the side of the wheel containing the valve hole should be forced into the tire first. Force downward on the wheel until the bead at the bottom of the tire moves into the wheel center well.

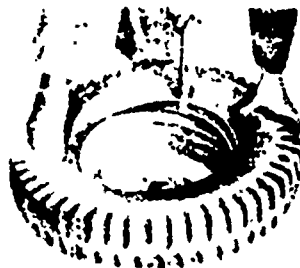
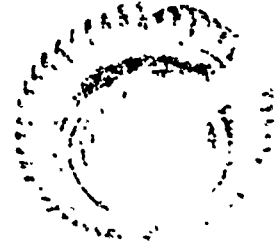

LIFTING INSIDE
BEAD OVER RIM

(2) Using tire irons, as necessary, work the remaining portion of the inside bead onto the wheel rim. Installation will be easier if a soap solution or approved tire lubricant is used on the beads of the tire. This lubricates the tire and rim and, therefore, aids in sliding the tire into the proper position. Care must be taken not to use any lubricant that is made from petroleum, as this will damage the rubber of the tire.

(3) If a tube is required, place the wheel and tire on a flat surface, with the valve hole in the wheel facing up, and install the deflated tube. On some large tires it may be necessary to fold the tube to insert it into the tire. Once inside the tire, the tube is unfolded and moved into the proper position. Inflating the tube with a small amount of air at this time will aid in preventing pinching of the tube during further installation. Care must be exercised not to use too much air or it will not be possible to force the outside bead into position.

232

(4) Aline and install the valve stem of the tube into the hole provided in the wheel. A fishing tool may be threaded to the end of the valve stem at this point. The tool prevents the valve from drawing back into the tire and becoming lost as the outside bead is forced into position. If the tire is of the tubeless type, only a valve need be installed at this time. The tubeless tire valve is a separate item that mounts in a hole in the wheel.

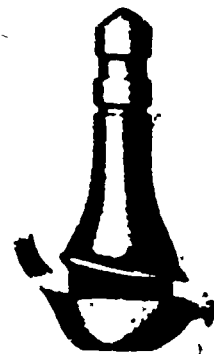

(5) A special valve tool (4910-305-0350) is used to install or remove the tubeless valve. The tool consists of a metal head that is threaded to match the outside threads of the valve, and a wooden handle. The valve is installed from inside the wheel. Lubricate the valve with a soap solution, insert it in the hole in the wheel, and attach the valve tool. Draw the valve into position in the wheel by pulling away from the wheel on the tool handle and at the same time rotating the handle in small circles. To remove an unserviceable valve, first, cut the inside of the valve stem off with a knife; then thread the valve tool on the valve stem and pull outward on the tool handle to pull the valve from the wheel.

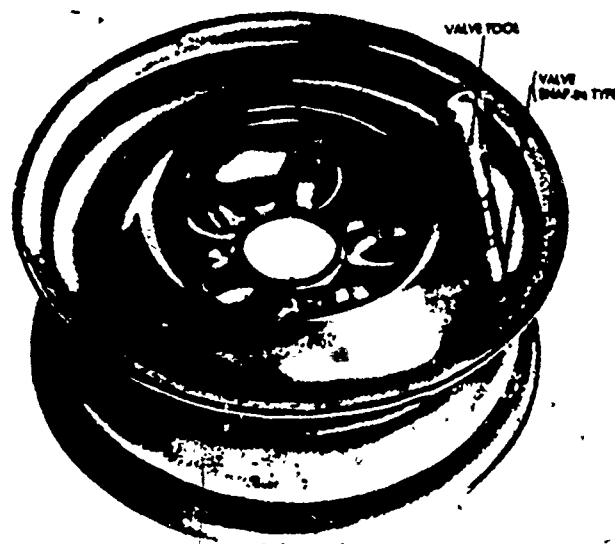

233 (6) After the tube or valve has been installed, the outside bead of the tire is forced into position. On the side opposite the valve, force as much of the outside bead as possible over the wheel rim with the hand or foot. Hold this portion of the tire in the deep well with the foot as the remainder of the bead is worked into position with tire irons.



PLACING OUTSIDE
BEAD IN WELL

d. Now that the tire is on the wheel, you should prepare to inflate, or pump up, the tire. If the tire is a tube-type tire, the task is quite easy. Let's see how it's done.

(1) Lay the tire and wheel down (with the valve side up) on a hard surface or an area free from loose rocks and tall grass. This will prevent rocks and grass from being caught between the wheel and tire bead when the tire is pumped up. Keep the valve fishing tool connected to the valve of tube-type tires during this entire operation.

(2) Next, center the wheel in the tire. This can be done by sliding the wheel until the tire beads are lined up with the bead shoulder on the wheel. Then pull the valve out through the hole in the wheel as far as possible and remove the fishing tool. Hold the valve tightly with your fingers and apply air to the valve. It is best to pump the tire up and release the air temporarily. This allows the tube to straighten out in the tire. Then pump the tire up to the specified amount and install the valve cap.

e. If the tire is of the tubeless type, you may run into another problem. A tubeless tire cannot be pumped up unless the beads are at least started on the bead shoulders of the wheel. Sometimes, by first lubricating the wheel and tire with a soap solution, you can push the beads onto the shoulders by hand. On new tires, however, this is generally not possible. A constrictor bead expander can be used, however, to solve this problem. Your unit should have a constrictor bead expander for this purpose. It will be one of two types.

(1) One type has a metal strap that is connected to a metal screw. The screw is turned to pull the ends of the metal strap closer together.

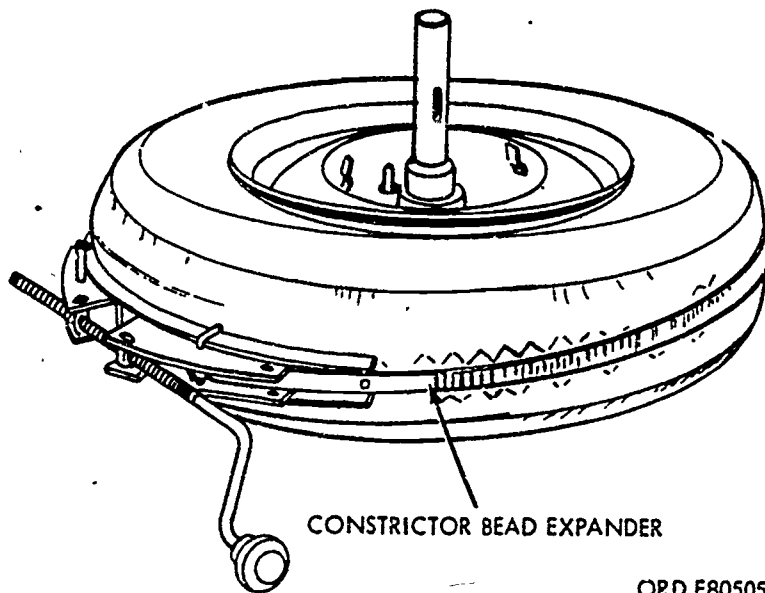

(2) The other type is made up of a web-type strap. A ratchet on one end of the strap is used to pull the ends of the strap together. The web-type strap constrictor bead expander can be used on a large range of tire sizes, whereas the steel-band type is limited to a small range of tire sizes.

Tie-Down Strap

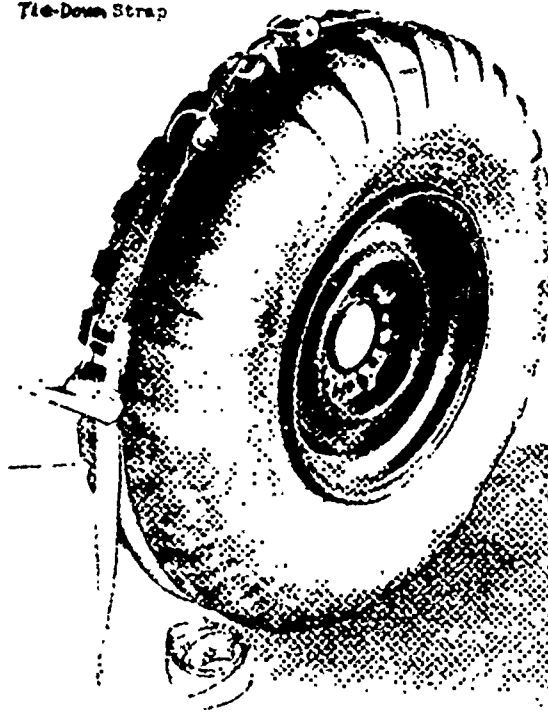

235

(3) To use the steel-band type constrictor bead expander, you should first turn the screw (handcrank) counterclockwise until the ends of the steel band are spread as far apart as possible. Then slide the constrictor bead expander over the tire until it is in the center of the tread. If the tool is too small to fit over the tire, the ends of the strap can be moved in the end brackets. This can be done by using a different set of holes farther from the center. When the tool is positioned properly, you should be able to tighten the band against the tire with only a few turns (2 or 3) of the screw in a clockwise direction. If you have to turn the screw a long ways to contact the tire, you will not have enough threads left to squeeze the tire in and push the beads out. In this case, the ends of the strap should be moved into holes that are closer to the center.

(4) Once the tool is in place, turn the crank until the beads move out onto the bead shoulders of the wheel. It is not necessary to push the beads all the way on to the shoulders, just enough to stop any air that could leak by. Then apply air to the valve ONLY until the beads start to move on the shoulders. Then loosen and remove the constrictor bead expander. NEVER continue to pump the tire up with the tool still tight. The tire pressure can break the tool and injure you or someone else. If this does not happen, the tightener screw will be too tight to turn with the tire pumped up. Once the tool is removed, continue to force the beads onto the shoulders by increasing the air pressure. The beads will "pop" in place before the specified tire pressure is reached.

(5) The web-type constrictor bead expander differs only in the way it is tightened. Adjust it so that it fits the tire tread by sliding the web-type strap through the ratchet device. Then move the ratchet handle back and forth until the beads are started on the shoulders. Apply enough air to hold the beads onto the shoulders. Then move the ratchet handle in the tighten direction just enough to release the ratchet pawl. Push the pawl in and allow the ratchet to come back one notch at a time. Continue this same procedure until the strap is loose on the tire and the constrictor bead expander can be removed. Then continue pumping the tire up to the specified pressure.

f. When removing tubeless tires from wheels, it is important not to damage the bead area. This area must be without nicks or cuts so that it will seal against the wheel rim flange. This seal must be airtight, as there is no inner tube to hold the air. Your unit may have equipment to break the bead away from the flange and off the shoulders with no damage to the bead. This method works as well with tube-type tires as it does with tubeless tires. You can see an example of this piece of equipment in the accompanying illustration. This equipment pushes both beads away from the flange with either a push or a pull on the handle. Let's see how it is used.

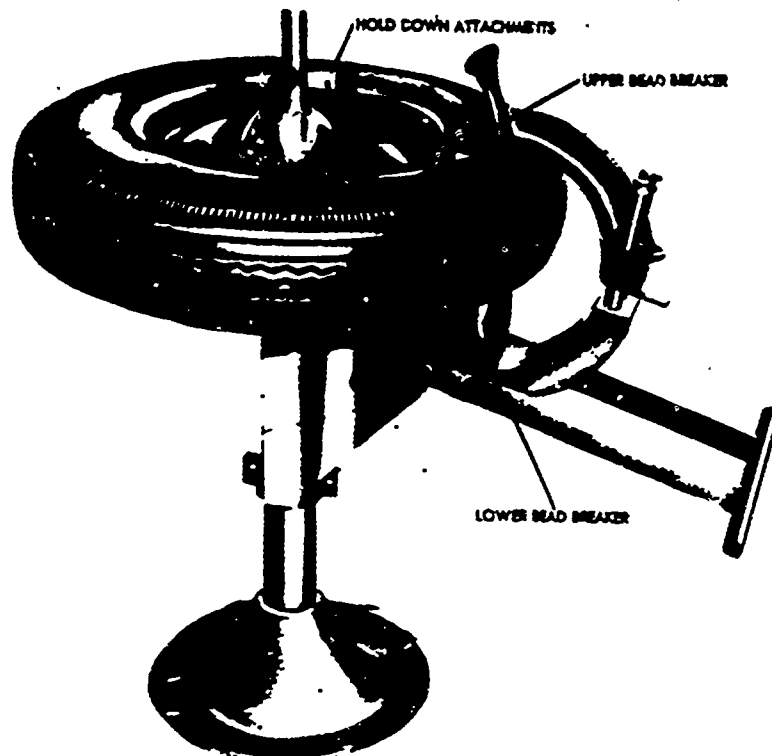

(1) Position the wheel and tire on the equipment as shown in the illustration in the above paragraph. Then position the upper and lower bead breakers against the tire and as close to the rim as possible. Make sure all of the air is released from the tire.

(2) Raise up on the handle to break the lower bead loose. Push down on the handle to break the upper bead loose. It may be necessary to move the bead breakers to two different positions on the tire to push the head completely off the shoulders. This piece of equipment is a big help when a tire is stuck on the wheel bead shoulder.

237
11. **LARGE TRUCKS.** Wheel rims used on large trucks have a demountable side rim or retaining ring. The sidewalls of truck tires are very stiff and there is very little drop in the center of the wheel rim. Therefore, one side of the rim must be removable in order to get the tire on or off the wheel rim. On some wheel rims the retaining ring is bolted on, but most rims have a split-type retaining ring. Most Army trucks use an offset disk-type wheel that is permanently fastened to the rim instead of the spoke-type wheel with a removable rim.

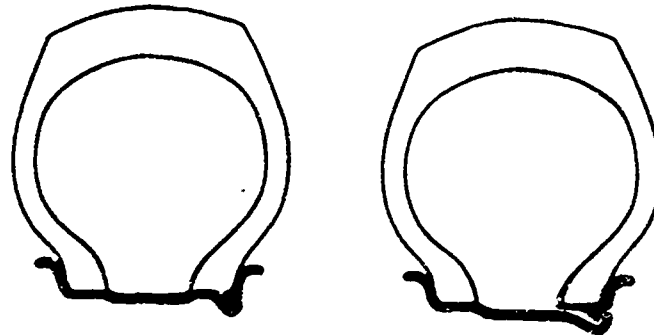

SEMIDROP-CENTER TYPE

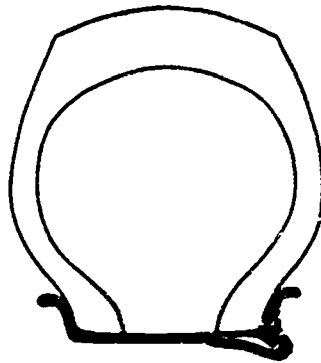

ADVANCED TYPE

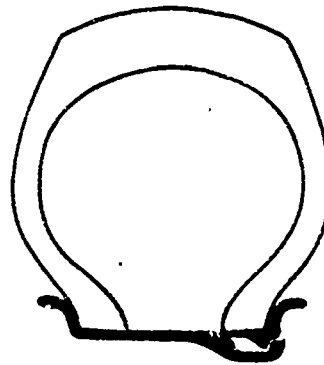

MILITARY TYPE

251

a. On many trucks with dual wheels, two types of nuts are used to hold the wheels on the hubs. The outer dual wheel is held on by a hex nut, while the inner wheel is secured by a special stud with both inner and outer threads. The hex nut screws on the special stud. When removing the wheels, the hex nuts and outer wheel must be removed first, then the special studs and inner wheel can be removed. Once the wheel is removed from the truck the tire can be removed from the wheel.

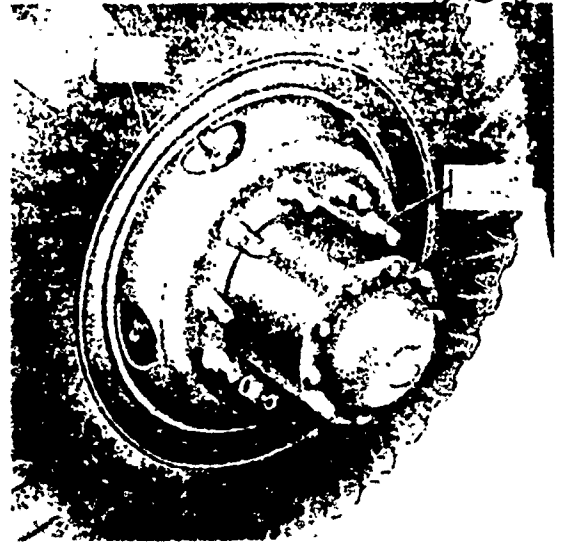

b. Now let's take a look at how you would go about removing a tire from a wheel that has a split retaining ring.

(1) Use a valve stem repair tool or a valve cap with a slotted top to unscrew the core from the valve stem. When all the air has escaped, screw the cap back on the valve stem to protect the stem threads and to keep dirt out of the tube.

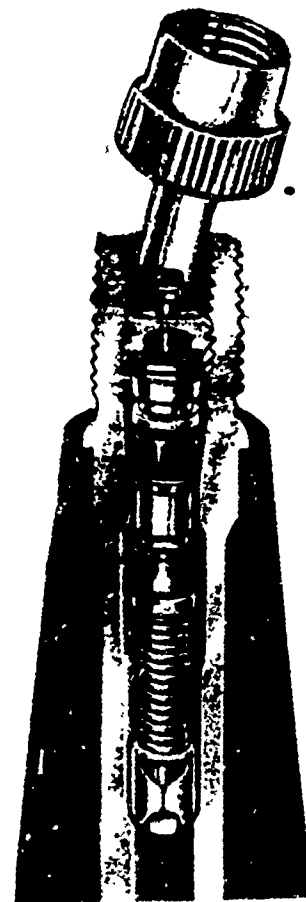

6-37

239

(2) The beads of the tire must be forced away from the wheel rim. Since the rim bead seats are slightly tapered so the beads slide on with a squeeze fit, it may take considerable force to loosen the beads. If there is a pneumatic tire demounter available, use it for this job. The upper assembly of the demounter is lifted off the base. The tire and wheel assembly is then placed on the demounter with the demounter cone through the wheel to center the wheel. The upper assembly is placed back on the demounter base over the wheel so that its fingers contact the tire sidewall close to the outer edge of the rim. As the handle of the screw shaft is turned clockwise, the fingers of the demounter are forced down against the tire, forcing the bead away from the rim. Once the bead is loose on one side, the wheel can be turned over and the opposite side loosened in the same manner.

(3) If a pneumatic tire demounter is not available, you can use a goose-neck tire tool to loosen the beads. To do this, lay the wheel and tire on the floor. Drive the goose-neck tire tool between the tire bead and the rim. Work all the way around the bead in this fashion until it is loosened in the same manner.

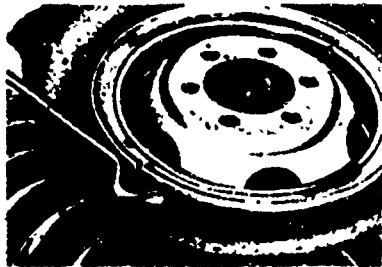
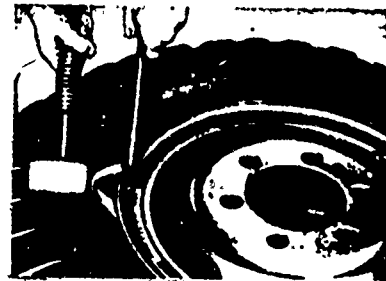

(4) Once the beads have been loosened by either method, lay the wheel so the retaining ring is up and pry the head down away from the ring. You can do this by placing the goose-neck tire tool between the bead and the ring and prying sideways. Make sure the bead is down far enough, all the way around the rim, so it will not interfere with the removal of the retaining ring.

(5) To remove the retaining ring, insert the straight end of a tire tool into the pry notch next to the split in the ring. Then, using the wheel as a fulcrum, pry the retaining ring up out of the rim gutter. While pulling up on the free end of the retaining ring, work around the retaining ring with the tire iron, prying it from the rim.

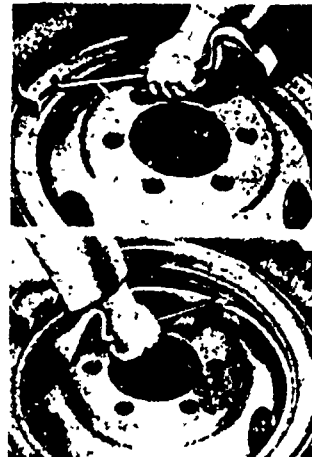

252

6-38

(6) Turn the wheel over so that the retaining ring side is down. Place a block of wood under the center of the wheel so that the block supports the entire weight of the wheel and tire. The block should be 8 to 10 inches high and smaller than the wheel so the tire can drop down off the wheel. Usually, if two men lift the tire and wheel assembly and drop it so the wheel strikes squarely on the block, the tire will drop from the wheel. If hammers or bars are needed to drive the tire off, use extreme care to prevent bruising or cutting the tire.

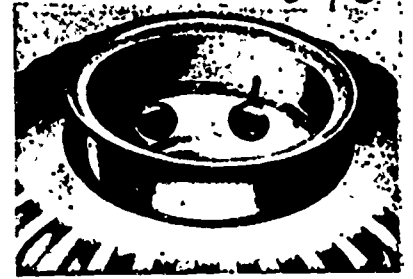

(7) If a tire flap is used in the tire opening between the beads to protect the tube of the wheel rim, remove the flap and save it for use in the reassembly. Remove the tube from the tire.

c. Assemble the tire and wheel in the following manner:

(1) Insure that the wheel, tire, and tube are serviceable. Remove any foreign matter that may have collected on the inside of the tire. Check the tube to make sure that it is stamped with the same size as the size markings on the tire. As a rule an old tube should not be used in a new tire. Clean all rust and dirt from the tire beads and wheel rim, using a wire brush if necessary.



(2) Install the tube in the tire, replace the valve core if it was removed, and inflate the tube with a small amount of air. Put just enough air in the tube so it fits smoothly in the tire without wrinkles. If the tire has a balance mark (red dot), align the tire valve with the mark. If a flap is used, slide the valve stem through the stem hole in the flap and position the flap in the tire. The flap must lay smoothly against the tube between the beads.

(3) Lay the wheel on a flat surface with the retaining ring side up. Place the tire on the wheel, aligning the valve stem with the valve slot in the wheel. Make sure that the valve stem is pointed up toward the retaining ring side of the wheel. On some wheels the valve stem opening is not slotted. On these wheels the tire must be started over the wheel at an angle so the valve stem can be inserted in the stem hole. Once the stem is positioned properly, slide the tire onto the wheel rim. Use soap on the beads for lubricant if necessary.

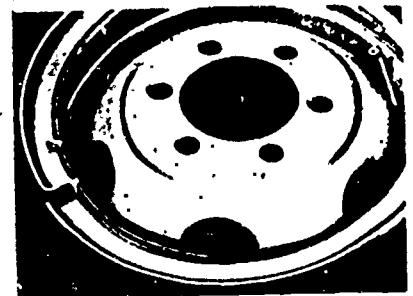

241

(4) Place the split retaining ring on the tire with the split opposite the valve stem. Force one end of the ring between the tire bead of the rim until it seats in the rim gutter (groove). Work progressively around the wheel, prying the retaining ring down into the rim gutter. Pry with a tire tool inserted through the openings in the wheel disk. Make sure that the retaining ring is fully seated in the rim gutter all the way around. Tapping lightly with a hammer may aid in seating the ring.

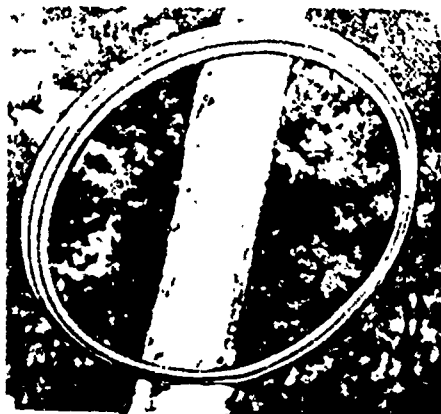

IMPROPERLY SEATED
RING BLOWN ON TREE

(5) Special care must be exercised when inflating tires on wheel rims with retaining rings. If the ring does not seat and lock properly in the wheel rim gutter, the high pressure used in truck tires can blow the ring from the wheel with great force. A flying retaining ring can easily break your arm or even inflict fatal injury.

(6) Some units build special cages to place the wheel and tire in while it is being inflated after a repair job. The cages are not standard items of issue; therefore, the mechanic may have to use other precautionary measures to guard against injury.

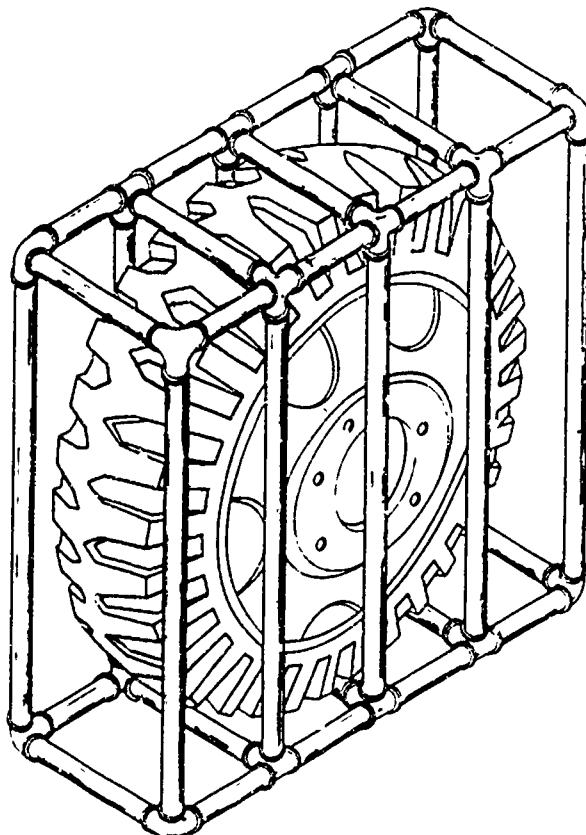

6-40

254

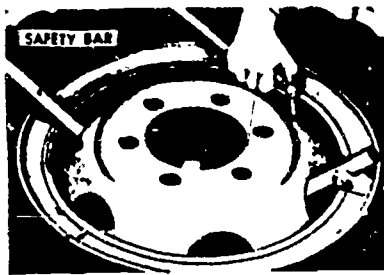

242
(7) A safety bar may be inserted through the holes in the wheel disk. The bar must be positioned so it would block the retaining ring if the ring should blow off. In place of a safety bar, a chain can be wrapped around both the tire and wheel to secure the retaining ring.

(8) If some safety device is not available, the mechanic should at least make sure that the retaining ring is not turned toward him while he is inflating the tire. If he lays the wheel on the ground with the ring pointed downward, he can inflate the tire from above. If the ring should blow off, the force of the wheel and tire blowing upward will be somewhat less than that of the retaining ring.

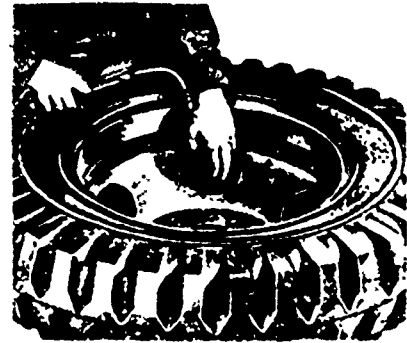

SECTION IV. REPAIR OF TIRES AND TUBES

12. TIRE REPAIR. The repair of tires and tubes by the unit repairman will consist mainly of the repair of punctures. Repairs such as section reinforcement, spot repair, and recapping will be performed by depot maintenance personnel. On tubeless-type tires the puncture in the tire is repaired, while on tube-type tires the repair is made to the tube and sometimes minor repair to the tire. Let's start with the tubeless tire and see how it's repaired.

a. If the tire is removed from the wheel, a patch can be installed over the puncture on the smooth surface inside the tire. A hot patch is recommended for this purpose. A hot patch consists of a gun, rubber patch on a metal fuel pan. The fuel pan contains a solid fuel that can be ignited with a match. Apply the hot patch in the following manner:

(1) Spread and block the tire beads at the puncture so there is ample working space. Position the tire so that the particles of rubber will fall away from the puncture when it is being buffed.

(2) Clean around the puncture inside the tire, using the special rubber solvent and swab provided for this purpose. The solvent is extremely flammable, so do not use it around an open flame or sparks.

(3) Gently buff an area around the puncture slightly larger than the fuel pan of the hot patch to be used. This is to rough up the rubber so the patch will stick better. A buffing tool that is made for this purpose or a clean wire brush may be used. Do not use a power buffer.

(4) Remove rubber particles by lightly dusting the buffed area with a dry, clean swab. Brush from the puncture to the outside of the buffed area to prevent filling the puncture with rubber particles.

(5) Select the sealant compound furnished with the patching material and insert it into the puncture from the tread side of the tire. Completely fill the puncture with sealant. Then remove any of the compound, dirt, rubber particles, or other foreign material that has been pushed to the inside of the puncture.

(6) Select the proper size hot patch to cover the puncture. Do not attempt to use a patch that is too large to follow the curvature of the tire. Prepare the patch according to the instructions received with the repair material. Center the fuel pan over the puncture, patch side down, and press it firmly against the inside surface of the tire.

(7) Install the vulcanizing U-clamp over the tire with the spider part of the clamp over the patch. Make sure that the clamp spider contacts the patch fuel pan squarely; then turn the clamp handwheel down to clamp the patch firmly to the tire.

(8) Use compressed air to blow any solvent and sealer fumes from the inside of the tire. These fumes are heavier than air so they can collect in the bottom of the tire and flash when the hot patch is ignited.

(9) Ignite the fuel in the patch fuel pan with a match. If the fuel is difficult to ignite, scratch the top surface with a screwdriver or knife blade. Leave the patch undisturbed for at least 10 minutes after the fuel has burned out.

(10) Remove the U-clamp and the hot patch fuel pan, making sure that none of the charred bits of fuel are left in the tire. Inspect the patch to make sure that it is stuck firmly to the tire.

b. By using the tubeless tire repair kit, emergency repairs can be made on a tubeless tire without removing the tire from the wheel. In fact, a small leak can be repaired with the air still in the tire and the wheel and tire assembly installed on the vehicle.

244

(1) Before the leak can be located, all mud and dirt will have to be removed from the tire and the tire will have to be inflated. Locate the plastic applicator bottle and the container of leak detector powder in the tubeless tire repair kit. Fill the applicator cap with detector powder and pour it into the applicator. Fill the applicator with water and shake to dissolve the powder. Squeeze the applicator bottle to spray the solution on the tire at suspected leak areas. Tiny white bubbles will show the location of the leak. Be sure to check the bead and the valve for leaks.



(2) If the leak is at the bead, the tire will have to be removed from the wheel and inspected for bead or rim damage. If the valve stem is leaking where it seats in the wheel rim, the tire will need to be removed in order to replace the valve stem. If the valve core is leaking, replace the core. Most of the time, however, the leak will be through a puncture in the tread caused by a sharp object such as a nail, a piece of glass, etc. Let's proceed, assuming that the leak is a puncture in the tread.

(3) Make sure the wheel is raised to remove all weight from the injured tire. Remove all foreign objects, such as nails, glass, rocks, etc, from the puncture. Wipe the puncture area and blow around the wound with compressed air so it is completely dry.

(4) Remove the injector tool from the repair kit. Notice that the tool has a needle with an eye in its outer end. A lever is pivoted at the needle holder and extends along the tool handle. The needle can be slipped freely in and out of the tool after lifting outward on the lever. Pressing the lever inward locks the needle in place. The canister-type handle can be unscrewed from the tool and a spool of thread repair material installed inside the handle.

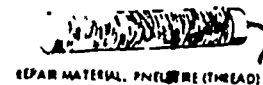

245

(5) Use the injector tool to probe the puncture in the tire. Extend the needle so its tip is 2 inches from the holder. Lubricate the needle by dipping about 1/2 inch of it into the can of bonding compound. Grip the handle and lever of the tool to lock the needle in place, and press the needle into the puncture to find the direction of the injury. Force the needle through to the inside of the tire, following the puncture to coat the inside of the hole with bonding compound; then withdraw the needle.

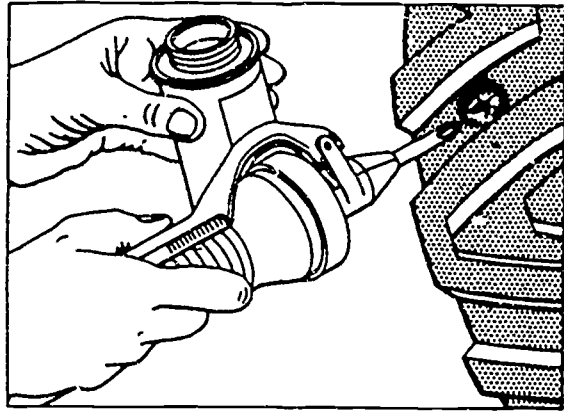

(6) Unscrew the canister handle and place a spool of repair thread in the canister, thread end out. Pass the end of the thread through the hole in the injector tool base and screw the canister back in place.

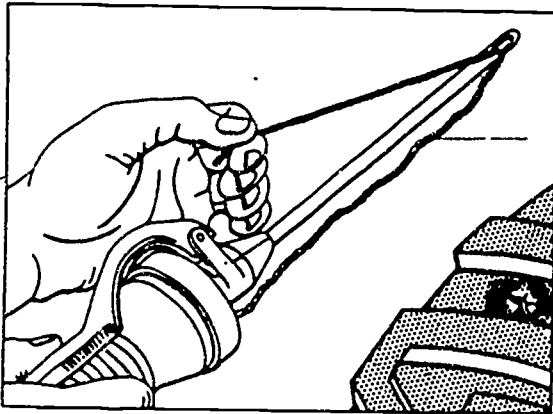

(7) Thread the needle with the repair material. To do this, extend the needle to full length. Pull the repair material through the hole in the tool base and pass it through the needle eye. Pass 4 inches of material through the eye for a light duty tire, and 8 inches for a heavy duty tire. If the puncture is small, like a nail hole, this should be enough material to plug the hole.

(8) A double strand of material should be used to repair large punctures. To make a double strand, pull additional material from the canister and thread the needle for a single strand. Then double the material back and pass the end through the needle eye from the opposite direction. If difficulty is encountered in passing the tip of the material through the needle eye, cut the material at an angle so that it has a sharp tip.

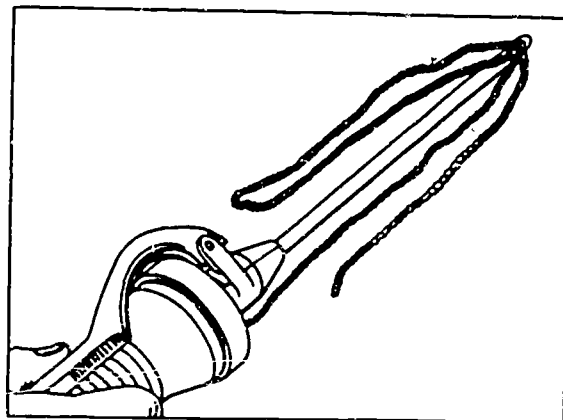

246

(9) After threading the needle retract the needle to 2 inches and dip the needle and thread 1/2 inch into the bonding compound. Squeeze the clamp lever tightly and insert the needle into the puncture, following the direction of the puncture. Push the needle at least 2 inches into the tire. Then release the pressure on the clamp lever and pull out on the tool until another 2 inches of the needle is exposed. To reduce the possibility of bending or breaking the needle, there should never be more than 2 inches of the needle exposed between the needle holder and the tire.

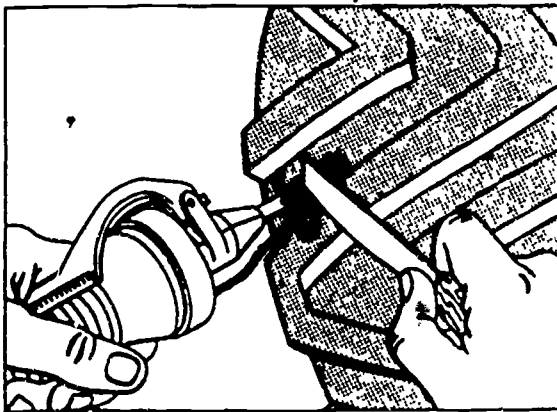
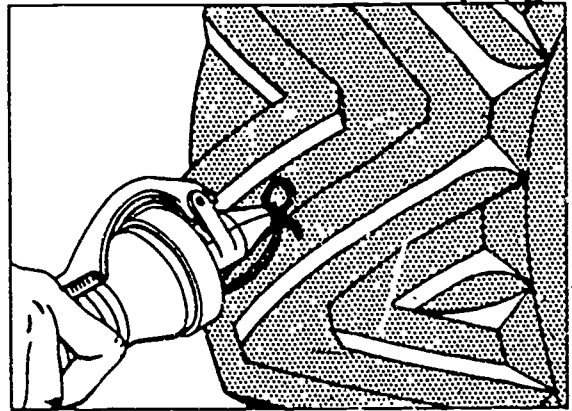

(10) Continue to push the needle and repair material into the puncture, 2 inches at a time, until the end of the material is 1/2 inch from the outside surface of the tire. Then squeeze the clamp lever and, with a steady pull, withdraw the needle so the needle holder is 2 inches from the tire. Release the lever and slide the toolholder on the needle to the tire. Squeeze the lever and withdraw the needle 2 more inches. Continue to withdraw

the needle until the end of the needle is out of the tire 1/2 inch. Cut the repair material at the eye of the needle so the tool can be removed, leaving the material in the puncture.

(11) If the puncture is large enough so that the hole is not firmly packed with repair material, rethread the needle and inject more material using the same procedures just described. Inflate the tire to the proper pressure and test the repair with the leak detector solution. If the solution bubbles, insert more repair material. When the leak is stopped, trim the repair material so it extends 1/4 inch from the tire.

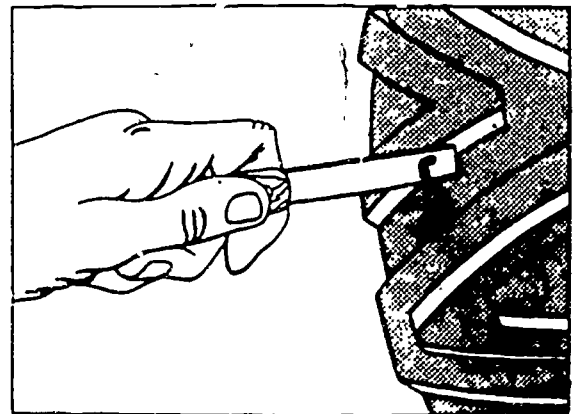

247
 13. TUBE REPAIR. To repair a tube it is necessary to first remove the tube from the tire. Care should be taken to insure that the object that caused the damage to the tube is removed from the tire. Either a hot or cold patch may be used to cover the area of the puncture in the tube and prevent escape of the air. On a tube made of synthetic rubber, the cold patch should only be used as a temporary emergency repair. Patches on tubes are only good for repairing small holes or tears and should not be used on injuries longer than $3/4$ of an inch.

a. The hot patch is a strip of gum on a metal pan that is made in several sizes. A white protective cloth covers the gum patch until the patch is applied to a tube. On the side opposite the gum, the hot patch contains a block of fuel. When this fuel is ignited and burned during application of the patch, the heat serves to bond the patch to the tube. The hot patch is applied in accordance with the instructions in the accompanying illustration. If the tube is made of synthetic rubber, the injury is filled with rubber that is included with the hot patch.

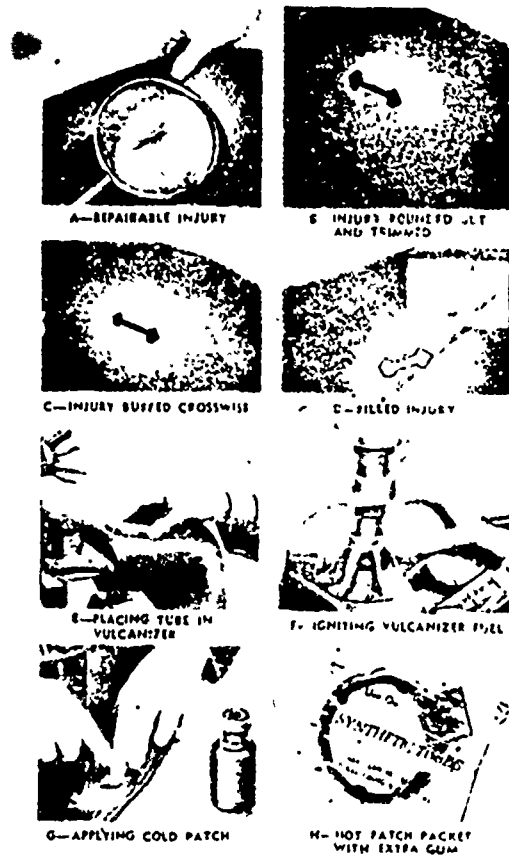

Repair of inner tubes.

b. Cold patches consist of strips of rubber protected by a cloth cover on one side. A package of cold patches normally will have an assortment of various sizes of ready-made patches, a larger strip or roll of patching material that may be cut to the desired size and shape, and a tube of rubber cement. Also, the package will have, usually on the cover, a rough surface for buffing the damaged tube during repair. When a cold patch is to be applied, the area around the puncture or tear in the tube is cleaned and buffed the same as for the hot patch. The cement is applied to the buffed area as specified by the directions on the package, and the patch applied after the protective covering has been removed. The side of the patch that held the protective cover is placed face down on the area and rolled with the edge of the package while laying on a hard flat surface.

c. Rubber covered valves that are used on smaller tires may be replaced using the hot patch method. Study steps A through F in the accompanying illustration. Notice that a special type fuel pan with a hole in the center is used to apply heat to the replacement valve.



A—REMOVING DAMAGED STEM

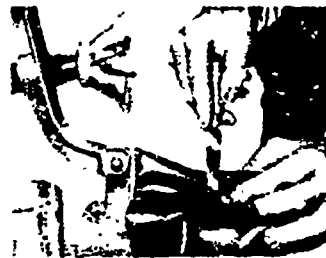

B—ENLARGING VALVE HOLE



C—BUFFING AREA FOR NEW VALVE



D—REMOVING PROTECTIVE COVERING FROM REPLACEMENT VALVE

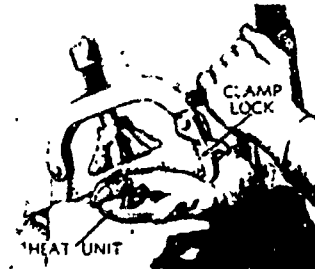

E—PLACING VALVE AND HEAT UNIT IN VULCANIZER

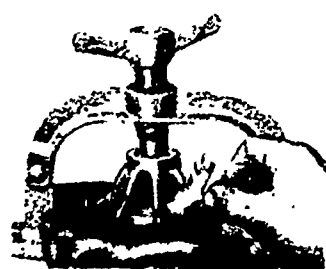

F—LIGHTING FUEL

Rubber valve-stem repairs.

249
d. The valve stem repair tool can be used to repair slightly damaged valve threads. For example, the die on the tool can be used to straighten up or chase the outside threads on the valve stem, as seen in the accompanying illustration. The tap can also be used to chase the threads on the inside of the valve stem. This tool, plus the many other tools described in this lesson, will make tire maintenance much easier for the mechanic.

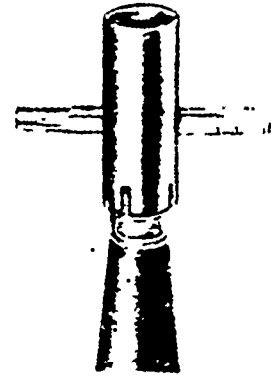

CHASING THREADS
ON VALVE STEM

SECTION V. CONCLUSION

14. SUMMARY.

a. Tools needed to remove and replace wheel and tire assemblies are issued with, and stored on, the vehicle so the operator can remove and install wheels any time it is necessary. The mechanic may also use the same tools to exchange wheels on the vehicle; however, he has a lot more tools available for his use, not only to speed up the exchange of wheels on the vehicle, but also to enable him to make minor repairs on tires and tubes.

b. When doing scheduled maintenance service on a vehicle, the mechanic will inspect the condition of the tires and wheels. He must be able to tell if the tires should be removed for repair or replacement or if they should be rotated. He must also be able to spot wear patterns that point to possible problems in areas such as the suspension, brakes, and steering and improper tire pressures.

c. Drop-center wheels are used on passenger cars and many small trucks. This enables the tire to be removed or replaced on the wheel by placing the tire bead in the drop center on one side while prying the bead over the rim on the opposite side. A retaining ring must be removed from one side of a large truck wheel before the tire can be removed or replaced. When inflating truck tires, BEWARE OF THE RETAINING RING!

d. A puncture in either a tubeless tire or a tube can be repaired with a hot patch. In either case the tire is removed from the wheel. A cold patch can be used in some tubes but is not recommended for use on a tube made of synthetic rubber. A puncture in a tubeless tire may also be sealed by injecting a string-like repair material through the hole with an injector tool made for this purpose.

250
15. PRACTICE TASKS. The following appendix contains a list of tasks associated with the maintenance of wheeled vehicle tires. They are representative of the tasks you will be required to perform as a wheeled vehicle mechanic. Perform all the tasks listed. Be sure you are under the supervision of an officer, NCO, or specialist who is qualified in the MOS when you practice the tasks. If you find you are having difficulty in certain tasks, restudy the appropriate training material and practice the tasks until you become proficient in each one.

257
EXERCISE

96. You have been instructed to remove and repair a leaking tire mounted on a 2-1/2-ton truck. Which tools that can be used for the task are carried on the truck?
- Pneumatic tire demounter
 - Impact wrench and socket
 - Lug wrench and jack
97. What type of mud and snow tire is used on tactical wheeled vehicles?
- Directional
 - Nondirectional
 - Commercial
98. What size wheel, in inches, is used with an 8.25X20 tire?
- 8
 - 8.25
 - 20
99. Adding more plies to a tire will
- reduce tread wear.
 - improve the ride.
 - increase the strength.
100. Commercial tires should be retreaded when the tread is worn down to
- 1/32 inch.
 - 1/16 inch.
 - 1/8 inch.
101. What is indicated by the red dot on the sidewall of a tire?
- Balance mark
 - Type of rubber
 - Tread design
102. When inspecting the tires on a vehicle, a tape measure is used to determine the
- tread wear.
 - circumference of the tire.
 - diameter of the tire.

- 252
103. When installing dual rear wheels on a truck, the valve stems of each set of duals should be located
- 90° apart.
 - 180° apart.
 - in the same position.
104. The outside lug nut on military dual wheels is threaded onto the
- mounting studs.
 - axle shaft.
 - inside wheel nut.
105. A fishing tool is used to
- check for breaks in the tire carcass.
 - locate leaks in a punctured tube.
 - pull the valve stem through the hole in the wheel rim.
106. What should be done to the beads that refuse to seat on a flat rim as the tire is inflated?
- Lubricate beads with grease
 - Coat beads with soap
 - Compress tread to expand beads
107. What is an advantage of directional-type treads on tires?
- Increased tread life
 - Self-cleaning action
 - Easier steering
108. What item is used when applying a hot patch to an inner tube?
- Roughing tool
 - Vulcanizing tool
 - Injector tool
109. Which type of vehicle usually has a rib-type tread on the front wheels?
- Farm tractor
 - Commercial sedan
 - Cargo truck

253

110. When rotating tires on the 1/4-ton truck M151, the spare is moved to the
- a. left front.
 - b. right rear.
 - c. right front.
111. How does the organizational motor pool obtain a tubeless tire repair kit?
- a. Included in the No 1 common tool set
 - b. Included in the No 2 common tool set
 - c. On an as-required basis
112. The air compressors available in organizational maintenance sets are powered by
- a. gasoline engines.
 - b. electric motors.
 - c. diesel engines.
113. Nondirectional mud and snow tires should be removed and retreaded when the
- a. fabric is exposed.
 - b. center of the tire is worn smooth.
 - c. depth of the tread is 1/8 inch.
114. A front-end alignment on a wheeled vehicle shows the wheels are toed-out. Where will the treads show wear due to this type misalignment?
- a. Inside edge
 - b. Outside edge
 - c. Center
115. Excessive but even wear on both edges of the tire tread is usually the result of
- a. improper braking.
 - b. incorrect steering alignment.
 - c. under inflation.

116. Which task should be done with the tool in the accompanying illustration?
- Install a tube-type tire valve core
 - Restore wheel lug nut threads
 - Remove tubeless tire valves

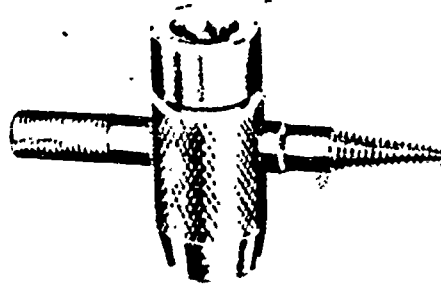

117. Which method is recommended to break the tire beads away from a drop-center wheel rim?
- Drive on to the sidewall with another vehicle and force the sidewall away from the rim
 - Hit the sidewall with a smooth-faced sledge hammer and drive it away from the rim
 - Place a jack between the sidewall and a vehicle bumper and force the sidewall down
118. Which tools or equipment are included in the organizational tool set No 1?
- Twelve-ton hydraulic jack
 - Twenty-foot steel tape measure
 - Fifteen-CFM air compressor
119. Which size tire can be removed from the wheel using the pneumatic tire demounter?
- 7:00X15
 - 8:25X20
 - 18:00X22

255

120. What type rim is depicted in the accompanying illustration?

- a. Safety
- b. Drop-center
- c. Semidrop-center

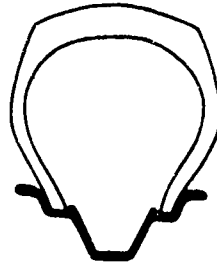

258

APPENDIX

PRACTICE TASK LIST

Practice Objective After practicing the following tasks you will be able to:

- 1. Inspect wheeled vehicle tires to determine their serviceable condition.
- 2. Replace tires on both drop-center and military-type wheels.
- 3. Rotate tires and wheels.
- 4. Repair an inner tube.

Practice Tasks.

1. Make an inspection of the tires on some of the wheeled vehicles in your unit. Look for the following conditions:

- a. Make sure that the tires are of the proper size for that vehicle. You can find this information in the appropriate technical manual.
- b. Examine the tires for any damage that would render the tires unserviceable.
- c. Check the tread wear on each tire and see if the duals are properly matched.
- d. Determine if the vehicle should have the tires rotated.
- e. Inspect the condition of the valve stems and the amount of tire pressure, including the spare.

2. Remove and install, or help remove and install, a tire on both a drop-center and a military-type wheel. Make sure you inspect the conditions of the inside of the tire while it is removed. You should also make sure that the wheel and tube are in a serviceable condition while the tire is removed.

257

3. Select a vehicle that is due for rotation of tires. It could be one of the vehicles you inspected. Make sure you rotate the tires according to the rotation plan for that specific vehicle. Don't guess on the rotation plan or sequence.

4. Find out if there is an inner tube in your unit that needs repairing. If so, using the information gained in this lesson, patch the tube so that it is in a serviceable condition.

6-56

270

258

EXERCISE RESPONSE LIST

**ORDNANCE SUBCOURSE 63B206
WHEELED VEHICLE DRIVE LINES, AXLES,
AND SUSPENSION SYSTEMS**

SEPTEMBER 1975

**DEPARTMENT OF ARMY WIDE TRAINING SUPPORT
US ARMY ORDNANCE CENTER AND SCHOOL
ABERDEEN PROVING GROUND, MARYLAND**

I M P O R T A N T: READ AND POST

Change 1 to Exercise Response List
28 January 1976

Ordnance Subcourse 63B206
Wheeled Vehicle Drive Lines,
Axles, and Suspension Systems
September 1975

Page 2, Response Number 142. Change to read:

Para 2b

Page 2, Response Number 154. Change to read:

Para 2d

Page 2, Change to be made. Add response number 164:

164 Para 7c

Page 3, Response Number 200. Change to read:

Para 4b

Page 5, Response Number 256. Change to read:

Para 4f

Page 5, Response Number 260. Change to read:

Para 6c

Page 5, Response Number 273. Change to read:

Para 10

Page 5, Response Number 276. Change to read:

Para 4d

Page 6, Response Number 307. Change to read:

Para 4b

Page 8, Response Number 363. Change to read:

Para 2d

I M P O R T A N T: READ AND POST

260

I M P O R T A N T: READ AND POST

Change 1 to Exercise Response List (Continued)
28 January 1976

Ordnance Subcourse 63B206
Wheeled Vehicle Drive Lines,
Axles, and Suspension Systems
September 1975

Page 9, Response Number 404. Change to read:

Para 4a

Page 12, Response Number 510. Change to read:

Para 4d

Page 12, Response Number 512. Change to read:

CORRECT. The special studs are threaded on the mounting studs, while the outer nuts are threaded on to the special studs. Remember, the special studs must be tight before the outer nuts are installed.

Page 12, Response Number 537. Change to read:

Para 4f

Page 14, Response Number 591. Change to read:

Para 5b

Page 16, Response Number 643. Change to read:

Para 5b

Page 16, Response Number 664. Change to read:

Para 2b

Page 16, Response Number 666. Change to read:

Para 4a

Page 17, Response Number 682. Change to read:

Para 6c

I M P O R T A N T: READ AND POST

Page 2 of 2

273

261

RESPONSE
NUMBER

RESPONSE*

- 100 Para 3
- 101 Para 2
- 103 Para 6
- 104 Para 2
- 106 Para 3
- 108 Para 10b
- 109 Para 4
- 110 CORRECT. These angles must be the same when conventional universal joints are used in order to eliminate the speed fluctuations.
- 112 CORRECT. All Army tactical wheeled vehicles use universal joints in the drive train that have either roller or needle bearings. Most civilian vehicles also use roller or needle bearings.
- 113 Para 4c
- 115 Para 10c
- 116 Para 4
- 117 Para 5
- 118 CORRECT. If the tire is retreaded sooner, usable rubber is wasted. On the other hand, if we wait until the tread is worn down to the fabric, the tire carcass will be too weak for retreading.
- 119 Para 6
- 121 CORRECT. Using this equipment on this size tire and wheel makes tire demounting much easier.
- 122 Para 6e
- 124 CORRECT. Both of these gears usually have teeth that are spiral bevel, which means the teeth are curved.
- 127 CORRECT. All tactical wheeled vehicles are equipped with nondirectional mud and snow tires.
- 129 CORRECT. These units generally have a seal between them and the final drive lubricant.

*If your response is not listed CORRECT, refer to the indicated paragraph for the proper answer.

262

- 131 CORRECT. We measure the circumference of the tire with a tape measure. It is important that the tires on a vehicle have the same circumference so that they will roll the same distance on each revolution.
- 133 Para 4e
- 134 CORRECT. The shock absorber passes through the front spring and is attached to a bracket on the lower suspension arm.
- 136 Para 3
- 138 CORRECT. The bar is designed to be twisted in one direction only: If it is twisted in the wrong direction it will break.
- 140 Para 4
- 141 Para 6
- 142 Para 4c
- 143 CORRECT. A threaded cap is used. The cap not only secures the seal in its proper position, it helps to keep the dust out.
- 145 CORRECT. The word "laminated" means made up of, or composed of, layers.
- 147 CORRECT. The shackle swings on the pivot to allow the spring to lengthen or shorten as it flexes.
- 149 CORRECT. The inside edge of the tire will be forced to slide as well as roll if the wheels are toed-out, and the inside of the tread will wear rapidly.
- 150 CORRECT. You do not have the responsibility for this type of repair. This work should be done at a higher category of maintenance.
- 152 CORRECT. The inside wheel will slow down and the outside wheel will speed up. The speed changes between the wheels are taken care of by the differential gears.
- 154 Para 3
- 156 Para 2
- 159 Para 2
- 161 Para 7
- 166 Para 4a
- 167 Para 2c
- 170 CORRECT. The rubber insulators used at the ends of the shock absorbers are also called grommets.
- 172 Para 5a

- 173 Para 5
- 175 Para 6i
- 177 Para 5d
- 178 CORRECT. Use a fine stone to smooth the bearing surface. A rough stone may scratch the surface and cause more damage.
- 179 Para 2
- 181 Para 3
- 183 CORRECT. This is due to a small metal bead on the rim which helps hold the tire in place if it loses its air.
- 184 Para 3a
- 186 Para 6d
- 188 Para 4
- 190 CORRECT. With it, pressure is applied to the hot patch as it is bonded to the tube.
- 191 CORRECT. The front suspension and drive on this truck is also called a swing axle. This type of axle is used on many European cars and on some American cars.
- 192 Para 5
- 193 Para 4
- 194 Para 3
- 195 Para 7
- 197 Para 6
- 199 CORRECT. The tube should be inserted in the tire so that the valve stem lines up with the red dot to balance the entire tire and tube assembly.
- 200 Para 4h
- 202 Para 6
- 204 Para 4
- 205 CORRECT. The head of the spring center bolt usually fits into a hole in the spring seat on the axle to help hold the axle in alignment.
- 206 CORRECT. This type spring is the most commonly used on trucks and passenger cars that use leaf-type springs.
- 207 Para 4

264

- 209 Para 6f
- 210 CORRECT. In fact, the ability of the spring ends to slide back and forth on these plates makes it a variable rate spring.
- 212 CORRECT. This is the diameter of the wheel without the tire and tube. 8.25 indicates the distance across the side walls of the tire when it is mounted on the rim and inflated.
- 213 CORRECT. This gear is attached to the differential case assembly. The pinion gear is the input gear and it drives the ring gear, except when the vehicle is coasting. Then the drive is reversed.
- 215 CORRECT. Toe-in is increased by bringing the wheels closer together at the front. To do this, the tie rod, which is mounted at the rear of the wheels, must be lengthened.
- 218 Para 3
- 220 Para 2g
- 222 CORRECT. When properly mounted, this type of tire is self-cleaning, because the "chevron" design tends to throw the mud out of the grooves. With the grooves free of mud, traction is improved.
- 223 Para 2
- 224 Para 10b
- 225 CORRECT. This component fits inside the front coiled spring and must be removed before the spring can be removed.
- 227 CORRECT. The inner ends of all axle shafts on these vehicles are splined to, and driven by, the differential side gears.
- 228 Para 7
- 231 CORRECT. The U-joint yokes at both ends of the M151 propeller shafts are welded to the shaft, so there can be no slip joints. The slip joint is actually on the U-joint companion flanges on the transfer case output shafts.
- 233 Para 2c and 4a
- 235 Para 3
- 236 Para 4c
- 238 Para 10c
- 239 CORRECT. The chains at each end of the gage must just touch the floor, or be the same distance from the floor, for the gage to be parallel with the axle. On any vehicle be sure the gage is properly positioned before you check the toe-in.

- 241 CORRECT. The ball-and-trunnion type has a pair of grooves in the flange body which permit the trunnion to move back and forth as the propeller shaft lengthens or shortens.
- 242 Para 4b
- 243 CORRECT. The greater the angle through which the conventional U-joint operates, the greater the speed fluctuations.
- 245 Para 4b
- 247 Para 5
- 248 Para 9
- 250 Para 6i
- 253 CORRECT. A zipper is used to close the boot after it is placed on the axle. To keep the zipper from loosening, it must be locked with wire. A sealant cement is used to make the boot leakproof.
- 256 Para 4d
- 259 CORRECT. The steering knuckle pin is probably better known by this name. Its purpose is to provide a pivot for the wheels on the axle.
- 260 Para 6g
- 262 Para 6k
- 264 CORRECT. The spider gears would be walking around the slow side gear.
- 266 Para 1
- 268 CORRECT. The U-type shackle is threaded at both ends to mate with the internal threads of the spring's shackle bushing.
- 271 Para 6i
- 273 Para 3
- 274 Para 3a
- 276 Para 6c
- 277 CORRECT. The same bolts that secure the spindle flange to the steering knuckle also secure the brake backing plate to the knuckle.
- 278 CORRECT. We want the transmission in gear and the propeller shaft connected when checking for a broken axle shaft.
- 279 Para 6
- 281 Para 11



266
282

- 284 Para 4
- 286 Para 4
- 288 CORRECT. The drive axles can swing up and down as the wheels go over the bumps. The final drive and differential are mounted in a separate gearcase, while the axle shafts, which are standard propeller shafts, are exposed.
- 289 Para 7
- 290 CORRECT. If the shaft is dented or bent its balance will be upset. When the shaft is unbalanced it usually vibrates and causes a noticeable noise. The vibrations and noise will increase as the vehicle's speed is increased.
- 292 Para 3
- 293 Para 5a
- 295 Para 5
- 296 CORRECT. If one wheel loses traction it will spin. Since that wheel can rotate on the side gear of the opposite axle, the wheel on the opposite side does not turn. If one wheel loses traction, the vehicle will not move.
- 298 Para 3
- 299 Para 3c
- 300 CORRECT. If possible, use a heavy vehicle for this operation as a light vehicle will raise rather than the sidewall go down.
- 301 Para 5b
- 304 Para 4
- 306 Para 3
- 307 Para 4h
- 309 Para 3
- 311 Para 7
- 313 CORRECT. We used a caliper first to measure the overall height of the joint under load and then the overall height without the load.
- 316 Para 3h
- 318 CORRECT. Short valves are difficult to hold in the opening in the rim while the tire is forced into position. The fishing tool makes it easy to hold the valve.

- 320 Para 8
- 323 Para 2c
- 324 Para 6
- 326 CORRECT. When a gear ratio is shown, the revolutions made by the driving gear are always indicated first. In this question the ratio is 45:10 or 4.5:1.
- 328 Para 6d
- 329 Para 8
- 330 Para 9
- 332 Para 5
- 333 CORRECT. We should listen for any unusual noises that may be coming from the axle assemblies. Before the road test, however, check for leaking gaskets and loose mounting bolts.
- 335 Para 6
- 336 Para 6
- 338 CORRECT. Some valve caps are also designed to do the same job.
- 339 CORRECT. With the plumb bob we can accurately locate on the floor the points of reference needed to measure frame alinement.
- 341 CORRECT. Most modern vehicles use the banjo-type axle housing which requires less disassembly work to inspect the differential gearing.
- 342 Para 7
- 344 CORRECT. They are used to adjust the caster and camber of the front wheels. This is a very exacting adjustment, so be sure to put the shims back on the same lower control arm mounting bolts.
- 347 Para 8
- 349 Para 3a
- 350 Para 2
- 352 CORRECT. The brake backing plate must be removed, so it is necessary to disconnect the hydraulic hose that delivers the hydraulic fluid to the wheel cylinder.
- 355 CORRECT. The rib-type tread makes it easier to steer. Such a tread will last on this type vehicle because it is a low-speed vehicle and has no brakes on the front wheels.
- 356 Para 3a

268

- 358 Para 5
- 360 CORRECT. Loose U-bolts will allow the spring to shift on the axle. Such shifting usually shears off the head of the spring center bolt.
- 362 Para 2
- 363 Para 3
- 365 CORRECT. The end of the bolt is peened (mushroomed like a rivet) by pounding on it with the round end of a ball peen hammer. With the end of the bolt thus enlarged, the nut cannot work loose on the threads.
- 367 CORRECT. As a passenger in a car or truck, you get the violent bump during spring rebound, not during compression.
- 369 CORRECT. The joint is called constant velocity because its input and output speeds do not fluctuate as a conventional universal joint does.
- 371 CORRECT. The spring seat bearings used on the M35-series trucks are interchangeable with the wheel bearings. The adjusting nuts are also the same, so the same wrench can be used to turn the nuts on both the spring seat bearings and wheel bearings.
- 372 Para 6
- 374 Para 2
- 375 Para 4a
- 376 Para 3
- 378 Para 6b
- 379 CORRECT. This adjustment is critical because it affects the steering, braking, bearing life, and tire wear. Be sure you adjust the bearings according to the specifications given on any vehicle.
- 381 Para 4
- 382 Para 4c
- 384 CORRECT. This type power works very well on this type of equipment, and it is more mobile and less expensive than some of the other available sources of power.
- 385 Para 9a
- 387 Para 3
- 389 Para 3
- 390 CORRECT. A dead axle delivers no power to the wheels. Such an axle provides the mounts for the wheels, supports part of the weight, and helps maintain alignment. A dead axle on a truck is usually a solid steel I-beam.

- 391 Para 6
- 392 Para 4c
- 393 CORRECT. The individual coils do not rub against each other, so there is no friction. This type of spring continues to compress and rebound after the vehicle has passed over the bump, unless its action is controlled by a shock absorber.
- 394 Para 4d
- 396 Para 4
- 397 CORRECT. Always be sure you have the right specs when adjusting toe-in. Too much or too little toe-in can ruin a set of front tires in a hurry. Accuracy is the word when setting the toe-in.
- 400 Para 3
- 402 Para 3
- 403 Para 3h
- 404 Para 10
- 405 Para 4b
- 407 Para 3
- 408 CORRECT. Grease, automotive and artillery (GAA), is prescribed, but regular wheel bearing grease is satisfactory if GAA is not available.
- 409 Para 3
- 410 Para 5b
- 412 Para 7
- 414 Para 13
- 415 Para 7c
- 416 Para 4
- 417 CORRECT. The flap protects that part of the inner tube that is not enclosed in the tire (the part next to the rim).
- 419 Para 5a
- 420 Para 5
- 421 Para 3
- 422 Para 3e
- 423 Para 5



270

- 425 Para 3
- 426 Para 6b
- 427 Para 3
- 429 Para 4
- 431 Para 6i
- 432 Para 1
- 434 Para 2e
- 437 Para 2b
- 439 Para 8
- 440 Para 6
- 442 Para 4
- 444 Para 2g
- 446 CORRECT. The rear wheels should follow directly behind the front wheels, or at equal distances on either side of the front wheels, on a level, straight road.
- 447 Para 6f
- 448 Para 9
- 451 Para 5
- 452 CORRECT. The ring gear gets its name from the fact that its center is open - like a ring. Some of them are bevel gears with curved teeth, and they are called spiral bevel gears.
- 454 CORRECT. These studs are large ones because they are subjected to a lot of twisting stresses. They must be tightened to 350-400 lb-ft of torque so that there will be no danger of their working loose.
- 457 Para 3a
- 459 Para 6g
- 460 CORRECT. This bolt has the high yield strength needed to resist the stress imposed on a vehicle frame.
- 462 Para 6
- 463 CORRECT. These bolts have 12 points on their heads instead of the usual six. To remove or replace the bolts, a 12-point socket wrench is needed.

- 465 Para 4
- 468 Para 8
- 470 Para 10
- 471 Para 4h
- 474 Para 3
- 477 Para 3
- 480 Para 11
- 482 Para 2c
- 483 Para 4
- 485 CORRECT. These gears are located inside the differential and have splines to mate with the splines on the axle shafts.
- 486 Para 4
- 488 Para 6i
- 490 CORRECT. Tactical vehicles used by the military must be able to travel through swamps, sand, and most other types of adverse terrain. The live front axle provides the extra traction needed for this type of operations.
- 491 Para 2
- 492 Para 4b
- 493 CORRECT. The drive flange is splined to the axle and bolted to the hub. Thus, the torque supplied by the axle is transmitted to the hub to turn the wheels.
- 496 Para 4b
- 497 Para 9
- 498 CORRECT. The drum, of course, must turn with the wheel so it can slow it down when the brakes are applied. Many smaller vehicles use the lug bolts to help secure the drum to the hub.
- 500 Para 4
- 501 CORRECT. The greatest strain is on the outer surface of the shaft. Because the strain is on the outer surface, tubular shafts are used in most installations.

272

- 504 Para 6
- 505 Para 7
- 507 CORRECT. It acts as a lubricant and is used instead of grease because grease will damage rubber.
- 508 Para 3e
- 510 Para 6c
- 512 CORRECT. The inside nuts are threaded on the mounting studs, while the outer nuts are threaded on the inside nuts. Remember, the inner nuts must be tight before the outer wheel and nuts are installed.
- 513 Para 1
- 516 CORRECT. In fact, the clips are often called rebound clips because they keep the leaves together during spring rebound.
- 518 CORRECT. Your shop has the necessary tools and equipment needed in performing this measurement and adjustment.
- 520 Para 7
- 521 Para 6
- 522 Para 3
- 523 Para 2b
- 524 CORRECT. This is true unless it is on the front axle assembly. The constant velocity joint makes things a little different on this axle.
- 526 Para 2 and 4
- 527 Para 4
- 529 Para 6
- 531 Para 3
- 533 CORRECT. Three bolts and nuts are used. When installing these bolts and nuts, remember that they must be tightened to specifications with a torque wrench.
- 535 Para 6
- 536 Para 2
- 537 Para 4d
- 539 Para 4b

- 541 CORRECT. The full-floating axle shaft does not support the vehicle weight nor does it absorb the side thrust. The vehicle weight and most of the wheel side thrust are taken by the axle housing.
- 543 Para 3
- 545 Para 4
- 547 CORRECT. When a blind spline, which is normally twice as wide as the other splines, is used, it is impossible to assemble the slip joint in more than one position.
- 549 Para 6h
- 551 CORRECT. When the tread is worn to this point, the tire is unsafe and should be retreaded.
- 553 Para 3
- 555 CORRECT. Both the compression and rebound pistons in this type of shock absorber are moved by cams.
- 556 Para 6d
- 557 Para 5
- 559 CORRECT. If the spring is weak, it loses its arch and flattens out. As it flattens it becomes longer and forces the shackle back.
- 561 Para 4
- 562 Para 5
- 563 CORRECT. The other possible answers this question may be done, but visually inspecting the axle assembly is always the first step in the maintenance ladder.
- 565 CORRECT. The trunnion shaft is also called a spring seat cross-shaft or a bogie axle. Regardless of its name, the spring seat bearings are mounted on it and are held in place by an adjusting nut and a locknut.
- 567 CORRECT. The slight (5°) taper on each bead seat provides a squeeze force between the rim and the tire to prevent slippage of the tire beads on the rim.
- 569 CORRECT. Because some of the tactical vehicles use tubeless tires, some motor pools will need this kit. If your unit needs one, it is available.
- 570 Para 3
- 572 Para 8
- 573 Para 1
- 575 Para 2

274

- 577 CORRECT. The lower the axle, the lower the body of the vehicle. The vehicle's center of gravity is lowered any time the load is lowered.
- 578 Para 7
- 579 Para 7
- 580 Para 3
- 581 Para 4h
- 582 Para 4
- 584 CORRECT. The seal in the outer end of the axle housing would be damaged if the axle shaft slides across it as it enters the housing. Be sure to support the axle shaft so it will not damage the seal when it is installed.
- 587 CORRECT. Increasing the number of plies increases the load-carrying capacity of the tire. However, the ride will be much worse because the tire will be stiffer and will not flex easily.
- 590 CORRECT. Unitized means made as one, and, in this case, the frame members and body are welded together.
- 591 Para 8
- 594 Para 2
- 595 CORRECT. The flexing springs cause the axles to move up and down. As the axles move, the distance between them and the transfer case changes. To compensate for these changes, a slip joint is used on the propeller shaft.
- 597 Para 4e
- 599 CORRECT. You will need this equipment when working on heavy wheeled vehicles.
- 600 Para 6e
- 601 Para 5a
- 603 Para 5d
- 605 CORRECT. The tools needed to remove the wheels and tires are on each vehicle. Other tools needed for tire work are found in the organizational maintenance set.
- 607 CORRECT. When the valve stems are 180° apart they are exactly opposite each other. This makes it easier to locate the valves during blackout conditions.

- 608 CORRECT. On large military trucks the lug nuts tighten toward the front, which means that the lug bolts and nuts have right-hand threads on the right-hand side and left-hand threads on the left side of the vehicle.
- 610 Para 6d
- 611 Para 5a
- 612 CORRECT. Snapping is another name for spring retainer. Tab locks are commonly used to lock wheel bearing adjusting nuts in place, and C-washers are used to secure brakeshoes on their pivot pins. Neither of these devices is made of spring steel, however, and they are not normally used to secure U-joint bearings.
- 614 Para 5b
- 615 Para 6
- 617 CORRECT. The CV-joint is housed in the steering knuckle. The CV-joint and knuckle can pivot on the outer ends of the axle housing in order to steer the vehicle.
- 619 Para 5b
- 621 CORRECT. The figure 7.50 indicates the tire's approximate width, in inches, when the tire is mounted on the wheel and properly inflated.
- 623 CORRECT. The center of the tire will buckle inward if the tires have too little air, leaving the edges to support the load.
- 624 Para 6
- 627 CORRECT. On almost any drive or propeller shaft with a slip joint, the slip joint goes toward the source of the power. In this case, the source is the differential.
- 628 CORRECT. The Tracta joint is a male and female mechanical joint with no balls for the yokes to pivot on. The male and female yokes and slots are in sliding contact with each other.
- 629 CORRECT. The lifting eye, with its locknut, is illustrated in a figure in the lesson. The eyes at each of the four wheels are the lifting points on the vehicle when it is being airlifted in the field.
- 630 Para 6
- 631 Para 2
- 634 Para 2c
- 635 CORRECT. The yokes on the driven half of the universal joint speed up twice and slow down twice during each revolution. How much they speed up and slow down depends on the angle of drive between the driving and driven shafts.

276
636

CORRECT. When ball and trunnion joints are used, no slip joint, as such, is needed because the balls on their trunnions can move back and forth to perform the function of a slip joint. To keep the shaft centered, however, compensating springs are used.

637 Para 5a

638 CORRECT. The spring seats are mounted on tapered roller bearings. These bearings allow the spring to pivot and maintain equal pressure on the driving axles even when one wheel rises as it passes over the bumps on the road.

639 CORRECT. The vent valve is located in the top of the differential case. This drive has swing axles, so there is no right or left axle housing.

640 Para 3

642 Para 7

643 Para 8

644 Para 6

647 Para 4d

648 CORRECT. The telescoping, direct-action shock absorber is commonly called an airplane type. In fact, they are extensively used in airplanes.

651 CORRECT. The entire front suspension and drive assembly, which includes the crossmember, is secured to the frame rails by eight bolts, four on each frame rail.

654 CORRECT. By placing the jack stands under the frame rails at the point where the rails are welded to the body, you get good support and plenty of room to work.

657 Para 2

659 Para 13

661 Para 7

662 Para 5

664 Para 4c

665 Para 6h

666 Para 10

667 Para 4

669 CORRECT. The wheel and tire removed from the right front is then mounted on the spare.

672 Para 3

674 Para 3

677 Para 3

679 Para 3

682 Para 6g

684 CORRECT. The spring seat bearings are preloaded to 60-75 lb-ft torque because they are subjected to severe radial and thrust loads.

685 Para 7

687 CORRECT. This pattern is always followed on this vehicle when rotating the tires and wheels in order to equalize the wear of all of the tires, including the spare.

688 Para 5

690 Para 3

691 Para 3

693 Para 6g

694 Para 9

696 CORRECT. The assembled spring is under tension. If it is not clamped in a vise it will fly apart when the center bolt is removed.

699 CORRECT. The vise is clamped around the inner shaft when the CV-joint is checked for wear. Don't forget to use wooden blocks or soft metal protectors in the vise to avoid damage to the shaft.

ANSWER SHEET

FOR STUDENT USE ONLY - DO NOT RETURN

	a	b	c		a	b	c		a	b	c		a	b	c
1.	104	501	536	41.	437	523	333	81.	246	405	460	121.	625	346	515
2.	223	667	586	42.	349	639	274	82.	380	440	824	122.	484	286	399
3.	421	306	243	43.	277	394	647	83.	600	366	122	123.	217	688	436
4.	241	483	527	44.	539	496	699	84.	233	526	339	124.	334	603	139
5.	376	186	612	45.	113	408	382	85.	886	282	271	125.	893	388	291
6.	690	110	427	46.	522	387	289	86.	176	684	488	126.	111	660	331
7.	562	290	420	47.	191	642	412	87.	434	180	676	127.	633	282	479
8.	630	197	463	48.	368	662	263	88.	661	363	184	128.	216	436	828
9.	579	143	681	49.	500	379	416	89.	226	474	672	129.	411	198	671
10.	647	686	342	50.	116	483	204	90.	400	136	362	130.	868	189	388
11.	289	578	231	51.	164	418	533	91.	371	536	202	131.	388	687	276
12.	626	489	236	52.	629	186	630	92.	613	288	446	132.	144	467	666
13.	429	386	636	53.	311	506	498	93.	106	664	643	133.	478	502	123
14.	108	112	629	54.	167	239	323	94.	644	262	464	134.	602	268	460
15.	118	336	178	55.	304	442	227	95.	387	618	181	135.	229	303	696
16.	610	278	462	56.	631	369	680	96.	188	374	806	136.	188	441	306
17.	238	382	524	57.	677	208	426	97.	667	127	332	137.	472	680	126
18.	161	489	362	58.	389	402	147	98.	410	619	212	138.	389	167	576
19.	521	381	389	59.	316	638	468	99.	247	461	687	139.	534	389	244
20.	628	378	426	60.	184	583	288	100.	328	661	186	140.	676	221	401
21.	486	124	682	61.	383	679	477	101.	189	391	614	141.	287	689	806
22.	641	482	242	62.	284	367	109	102.	683	131	489	142.	384	686	189
23.	326	133	687	63.	287	546	646	103.	431	807	269	143.	641	297	486
24.	283	486	637	64.	422	138	688	104.	281	468	612	144.	163	689	366
25.	248	339	288	65.	616	684	417	105.	881	288	318	145.	646	322	287
26.	152	295	423	66.	146	487	218	106.	116	667	236	146.	236	449	614
27.	286	681	643	67.	689	286	376	107.	681	222	419	147.	418	139	689
28.	673	389	432	68.	621	177	683	108.	414	189	689	148.	688	386	186
29.	537	213	266	69.	488	688	339	109.	386	611	172	149.	284	604	406
30.	182	284	117	70.	134	487	684	110.	667	439	329	150.	424	188	363
31.	681	471	341	71.	386	448	179	111.	149	381	689	151.	646	219	646
32.	279	617	324	72.	209	686	307	112.	384	667	183	152.	128	683	264
33.	681	677	282	73.	674	184	616	113.	610	118	686	153.	321	483	676
34.	289	679	286	74.	667	289	682	114.	149	447	208	154.	171	364	620
35.	347	672	129	75.	228	688	161	115.	482	336	623	155.	663	237	484
36.	166	684	278	76.	372	141	688	116.	338	686	404	156.	436	662	146
37.	179	683	481	77.	649	686	219	117.	108	224	309	157.	689	102	337
38.	486	684	188	78.	444	229	313	118.	688	684	142	158.	310	632	270
39.	216	634	482	79.	688	689	173	119.	388	121	649	159.	214	476	671
40.	467	627	366	80.	109	344	631	120.	183	479	273	160.	678	162	346
161.	428	613	114												
162.	201	552	443												
163.	609	373	689												
164.	189	481	239												
165.	367	272	564												
166.	686	386	174												
167.	343	181	686												
168.	129	519	496												
169.	626	246	314												
170.	487	662	293												
171.	286	433	649												
172.	618	166	361												
173.	473	668	249												
174.	211	586	489												
175.	182	361	681												
176.	388	486	686												
177.	636	266	106												
178.	446	187	646												
179.	163	642	312												
180.	234	666	466												
181.	679	283	569												
182.	392	439	146												
183.	574	317	249												
184.	186	346	684												
185.	326	663	281												
186.	622	179	464												
187.	662	208	618												
188.	208	617	327												
189.	686	413	107												
190.	377	673	132												
191.	136	319	461												
192.	683	186	379												
193.	494	261	626												
194.	644	488	232												
195.	267	639	649												
196.	668	263	466												
197.	316	169	632												
198.	137	611	349												
199.	688	383	289												
200.	478	689	126												

US ARMY ORDNANCE CENTER AND SCHOOL
CORRESPONDENCE/OJT COURSE

279



EXAMINATION VERSION I

Ordnance Subcourse No 63B206 . . . Wheeled Vehicle Drive Lines, Axles,
and Suspension Systems

Credit Hours One

Objective To test the student's overall
knowledge of the material covered
in this subcourse.

Suggestions Before starting this examination,
it is suggested that you review all
lessons studied in this subcourse.

Texts All study texts used in this
subcourse.

Materials Required None

(Do not send these pages in—use the answer sheet provided for recording
and mailing your solution.)

Requirement (35 Questions)—Weight 100—All items are weighted equally.

MULTIPLE CHOICE

(See instructions on answer sheet provided)

1. When installing dual wheels, the wheel disk holes are alined to
 - a. allow the flow of air for cooling.
 - b. maintain proper wheel balance.
 - c. distribute the load on the wheel bearings.
 - d. permit locking the wheels together.

63B206, E-1
September 1975

280

2. One or more torque rods must be disconnected to remove which component from a 2-1/2-ton truck M35A1?
 - a. Front axle
 - b. Rear spring
 - c. Rear axle
 - d. Front spring

3. What special tool is needed to adjust the wheel bearings of a 1/4-ton truck M151?
 - a. Torque wrench
 - b. Wheel bearing nut adjusting wrench
 - c. Spanner wrench
 - d. Deep well socket wrench

4. A shackle is installed on a leaf-type spring to
 - a. increase the spring's strength.
 - b. prevent excessive bouncing.
 - c. permit changes in spring length.
 - d. hold the axle in alignment.

5. Which part must be removed from the M151 truck when replacing a differential side gear seal?
 - a. Final drive assembly
 - b. Universal joint flange
 - c. Wheel drive shaft
 - d. Brake backing plate

6. A sheared off spring center bolt is usually the result of
 - a. a bent frame.
 - b. loose lug bolts.
 - c. a bent axle.
 - d. loose U-bolts.

7. If a rivet is found to be missing when inspecting a truck frame, what action should be taken at the organizational maintenance level?
 - a. Install a grade 5 bolt of the proper size
 - b. Install a new rivet
 - c. Spot-weld the area around the rivet hole
 - d. Send the vehicle to support maintenance

63B206, E-2

- 281
8. A constant velocity universal joint is used with which type of shaft?
 - a. Propeller
 - b. Rear axle
 - c. Winch
 - d. Front axle

 9. What secures the front axle of the 2-1/2-ton truck to the springs?
 - a. Spring center bolts
 - b. U-bolts
 - c. Rebound clips
 - d. Spring hanger

 10. Which type of final drive gearing permits the vehicle body to be located at the lowest possible center of gravity?
 - a. Spur bevel
 - b. Hypoid
 - c. Spiral bevel
 - d. Worm

 11. Which step should be taken first when removing the tire from a drop-center type wheel?
 - a. Draw the outside bead over the edge of the rim
 - b. Remove the inner tube from the tire
 - c. Position the beads in the center of the rim
 - d. Slide a tire iron between the bead and the rim

 12. What is the proper procedure for adjusting the front-wheel bearings on a 2-1/2-ton truck M35A2?
 - a. Torque the adjusting nut to 150 lb-ft
 - b. Turn the adjusting nut until all play is removed
 - c. Tighten the adjusting nut until grease is forced out of the outer bearing
 - d. Turn the adjusting nut until the wheel binds, and then back off 1/8 turn of the nut

63B206, E-3

282

13. On the M151 truck, the coil spring insulator is installed in the
- body.
 - crossmember.
 - lower control arm.
 - upper control arm.
14. What is used on a tire bead and wheel rim to make mounting the tire easier?
- GAA grease
 - Soap solution
 - Brake fluid
 - Vaseline
15. What must be done BEFORE the front-wheel toe-in is measured on a 1/4-ton truck M151?
- Vehicle weight must be removed from tires
 - Steering gear must be properly adjusted
 - Wheel drive shafts must be removed
 - Wheel bearings must be properly adjusted
16. What type of fastener is used to secure the universal joint of the front wheel drive shaft to the differential drive flange of an M151 truck?
- Lock rings
 - Hex-head studs
 - Hollow head capscrews
 - U-bolts
17. During an inspection of a 2-1/2-ton truck you find that the right side of the front axle has slipped to the rear. Which component, if defective, can cause this problem?
- Kingpin
 - Steering knuckle
 - Spring center bolt
 - Backing plate flange

18. One of the troubleshooting tests performed on a 1/4-ton truck M151 consists of stretching a string across the front tires, even with the lower control arm pivots. What is determined by this test?
- If the vehicle leans to one side
 - If the toe-in is correct
 - If the wheels track
 - If the toe-out is too much
19. What statement about the shock absorbers of an M151 truck is true?
- They are interchangeable between front and rear
 - The front ones are interchangeable between right and left
 - They can be installed with either end up
 - The front ones are identified by the mounting eyes on each end
20. What wrench is used to tighten the bearing retaining nuts on the rear spring seat of a 2-1/2-ton truck M35A2?

a.

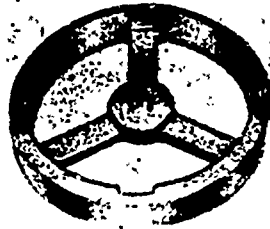

b.



c.

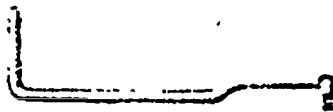

d.



21. Which parts change the strength of a suspension system by changing the effective length of the springs?
- Auxiliary springs
 - Trunnion axles
 - Spring shackles
 - Curved bearing plates

284

22. The amount of wear on the M151 truck lower ball joint can be checked with the use of a jack and a
- a. dial indicator.
 - b. pry bar.
 - c. caliper.
 - d. plumb bob.
23. The brake hydraulic system of a 2-1/2-ton truck must be bled after removing and installing which part?
- a. Axle assembly
 - b. Constant velocity joint
 - c. Axle oil seal
 - d. Steering knuckle boot
24. What is the minimum number of bead clips needed to mount one tire on a rim?
- a. 2
 - b. 6
 - c. 12
 - d. 18
25. Which is a suitable tool for removing the inner wheel bearing cup from the M151 truck?
- a. Brass drift
 - b. Puller screw
 - c. Pry bar
 - d. Sharp chisel
26. What is caused by too much air pressure in tires?
- a. Excessive wear in the center of the tire treads
 - b. Cracks in the sidewalls of the tires
 - c. Scuffing of tires on turns
 - d. Gouges on the outer edges of tires

285

27. When an inspection of a universal joint reveals that all parts are good except for a deep pit in the journal's bearing surface, which action should be taken?
- a. Replace the journal only
 - b. Replace the propeller shaft
 - c. Install a universal joint parts kit
 - d. Repair the journal
28. A special tool is required to remove the fasteners that secure the front propeller shaft to the differential of the older M151 trucks. What tool is made for this purpose?

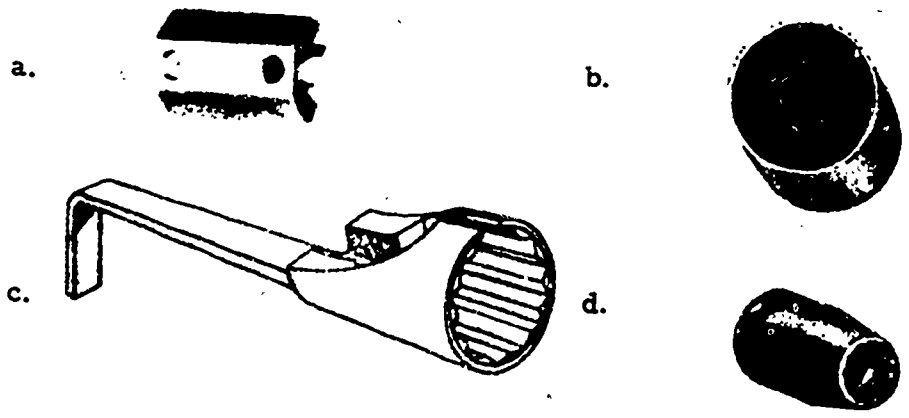

286
29.

After tires have worn to a certain point they can be recapped and used again. Some worn conditions make a tire unfit for recapping. Which tire is most suitable for recapping?

a.



b.



c.



d.



30. What is used to lubricate the injector tool needle when probing the puncture in a tubeless tire?

- a. Engine oil
- b. Bond component
- c. Soapy water
- d. General purpose grease

31. What is the first step in removing the front axle shaft from 2-1/2-ton truck M35A2?

- a. Place the transmission in gear
- b. Place the transmission in neutral
- c. Block the wheels so the vehicle can't roll
- d. Jack up the axle and support the frame with blocks or jack stands

63B206, E-8

- 287
32. Excessive wear on the inside edge of front tires indicates improper
- a. operation of the vehicle.
 - b. tire rotation procedures.
 - c. wheel balance.
 - d. steering adjustments.
33. What component identifies a ball-and-trunnion type universal joint?
- a. Snapping
 - b. Spider
 - c. Needle bearing
 - d. Dust boot
34. What component must be removed in order to remove a front spring from the 1/4-ton truck M151?
- a. Differential flange guard.
 - b. Upper control arm ball joint
 - c. Shock absorber
 - d. Tie rod end
35. When removing a front axle shaft from a 2-1/2-ton truck M35A2, it is not necessary to remove the
- a. brake line.
 - b. backing plate.
 - c. steering spindle.
 - d. outer bearing.