

DOCUMENT RESUME

ED 212 743

UD 022 102

AUTHOR Vigilante, Richard P.
TITLE Computer Systems for Urban School Administrators: A Guide for Decision Making. ERIC/CUE Urban Diversity Series, Number 78.
INSTITUTION Columbia Univ., New York, N.Y. Inst. for Urban and Minority Education.; ERIC Clearinghouse on Urban Education, New York, N.Y.
SPONS AGENCY National Inst. of Education (ED), Washington, D.C.
PUB DATE Nov 81
CONTRACT 400-77-0071
NOTE 38p.
AVAILABLE FROM ERIC Clearinghouse on Urban Education, Box 40, Teachers College, Columbia University, New York, NY 10027 (\$5.00).

EDRS PRICE MF01/PC02 Plus Postage.
DESCRIPTORS *Administrator Role; Computer Assisted Instruction; Computer Programs; *Computers; Computer Science; Databases; Data Processing; *Decision Making; *Educational Administration; Elementary Secondary Education; Information Needs; *Information Systems; *Management Systems; Urban Schools

ABSTRACT

This monograph introduces educational administrators at a variety of levels to the basic concepts and procedures in the successful implementation of educational computer systems. In the first section, the units and functions of the computer are defined, and the administrative, research, and instructional applications of educational computing are examined. The concepts and processes of management information systems are discussed in the second section, which includes a comparative analysis of data file and data base systems. Also examined are the definition, design, development, and operation phases of systems implementation. The final section examines the nature and role of data control, data confidentiality, and data administration; the responsibilities of the data base administrator are looked at in the light of existing laws which deal with both privacy and access to information. It is suggested that the effectiveness of an information system cannot be determined in isolation from the functional activities that it was designed to serve, and a process-oriented system with a high degree of flexibility will, in the long run, be more cost-efficient and effective than a static, product-oriented system. (JCD)

 * Reproductions supplied by EDRS are the best that can be made *
 * from the original document. *

ED212743

ERIC/CUE URBAN DIVERSITY SERIES
Number 78, September 1981

**COMPUTER SYSTEMS FOR
URBAN SCHOOL ADMINISTRATORS:
A GUIDE FOR DECISION MAKING**

By
Richard P. Vigilante, Ph.D.
Department of Educational Administration
Teachers College, Columbia University

**U.S. DEPARTMENT OF EDUCATION
NATIONAL INSTITUTE OF EDUCATION
EDUCATIONAL RESOURCES INFORMATION
CENTER (ERIC)**

This document has been reproduced as
received from the person or organization
originating it.

Minor changes have been made to improve
reproduction quality.

- Points of view or opinions stated in this document do not necessarily represent official NIE position or policy.

UD 022 102

ERIC CLEARINGHOUSE ON URBAN EDUCATION

Institute for Urban and Minority Education
Teachers College, Columbia University
New York, New York 10027

2

This publication is one of the ERIC/CUE Urban Diversity Series produced by the ERIC Clearinghouse on Urban Education under contract between the National Institute of Education, United States Department of Education and Teachers College, Columbia University. Additional copies will be available from:

ERIC Document Reproduction Service
P.O. Box 190
Arlington, Virginia 22210

Its ED identification number and full ordering instructions will be found in *Resources in Education*, the monthly ERIC abstract journal, or can be obtained by contacting ERIC/CUE.

Copies are also available from the ERIC Clearinghouse on Urban Education, Box 40, Teachers College, Columbia University, New York, New York 10027, for \$5.00 each.

This publication was prepared with the assistance of the National Institute of Education, U.S. Department of Education, under contract number 400-77-0071. The opinions expressed in this publication do not necessarily reflect the positions or policies of NIE or the Department of Education.

The National
Institute of
Education
U.S. Department
of Education
Washington, D.C. 20208



TABLE OF CONTENTS

I. Introduction	5
II. Educational Computing: A Crash Course	6
Computer Fundamentals	6
Educational Computer Applications	10
III. Management Information Systems	13
Information-System Concepts	13
Data Files and Data Bases	16
Information-Systems Implementation	22
IV. Computer-System Issues for Administrators	23
Data Control	24
Data Confidentiality	27
Data Administration	31
V. Conclusions	33
VI. References	34
VII. Appendix	35

I. INTRODUCTION

There is nothing more difficult to plan, more doubtful of success, nor more dangerous to manage than the creation of a new system. For the initiator has the enmity of all who would profit by the preservation of the old system and merely lukewarm defenders in those who would gain by the new one.

—Niccolo Machiavelli, *The Prince*, 1513

During the past decade, school districts have had to deal with a number of critical educational issues arising out of a dynamic social and political environment. Integration compliance, fiscal constraints, declining enrollments, and low achievement have all imposed great demands on the districts' decision-making capability. As a result, educational administrators have been faced repeatedly with the need for accurate, detailed and timely information for a variety of analyses, operations and reports. Such situations, which are becoming increasingly more frequent, call for both high levels of technical expertise and clear lines of organizational authority to provide the necessary information.

Computerized information systems can enable the school administrator to achieve many management objectives more effectively and efficiently than formerly possible and to achieve other objectives never before possible. But such systems also place a burden on the administrator who wishes to use them. The administrator must learn about and participate in the development of the system. Otherwise, the administrator may get the system that was asked for, but it may not be the system that was desired or that should have been asked for.

The purpose of this paper is to introduce educational administrators at a variety of levels—building supervisors, project directors, business managers, and district administrators—to the basic concepts and procedures necessary for the successful implementation of educational computer systems. The paper covers the various roles computers play today in elementary-secondary education, what computers are and how they work, the various phases in the creation of computerized information systems, and the major administrative issues inherent in systems development and utilization. Emphasis will be on *information*—how to gather it, maintain it, and protect it—over *systems*; consequently, those aspects of computer technology that are more properly the function of the analyst will not be discussed. The topics covered are based primarily on relevancy to the educational administrator as the ultimate user of an information system. In discussing these subjects, therefore, no attempt is made to present all aspects of a topic. Those issues which are important to the administrator are identified and explained.

II. EDUCATIONAL COMPUTING: A CRASH COURSE

The Latin word *computare* means "to compute." Therefore, any device that helps one compute—such as a slide rule, adding machine, or pocket electronic calculator—might technically be called a computer. However, today the word "computer" is almost always used to refer to an electronic, digital computer. Computers are basically tools for doing jobs better, and their advantages revolve around some rather fundamental matters such as speed of processing, accuracy, and access to data.

Computer Fundamentals

The features that distinguish an electronic computer from other computing devices are speed, internal memory, and automatic execution of a program stored in computer memory. The speed of an electronic computer is achieved by the use of electronic circuitry. The internal memory of a computer is used to store both data and instructions. A sequence of instructions (such as an entire payroll calculation) is carried out automatically, without human intervention. In contrast, a calculator requires human direction (by means of a keyboard) at each step in a computational routine.

There are two basic types of computers: analog and digital. An *analog computer* operates on data that vary continuously, such as voltage, pressure, and temperature. In contrast, a *digital computer* is basically a counting device that operates on discrete data or numbers. Since most educational data are in discrete form (either numerical or alphabetical), the digital computer is readily adaptable to both administrative and instructional data-processing applications.

All educational computer applications regardless of their size or complexity require a *computer system* for their operation. A computer system consists of the *hardware* and *software* through which the application is processed. As the name implies, hardware is physical equipment such as the mechanical, electronic, and magnetic units in a computer. Software is the set of computer programs that causes the computer to produce the desired results. The major functional components or units of a computer are shown in Figure 1. To understand the purpose of each of these units, one must know what operations a computer must perform in order to solve a problem.

Suppose a school administrator wished to compare the salaries of twenty teachers in a school and find the arithmetic mean. To accomplish this task manually, the following steps might be performed:

- Write the twenty annual teacher salaries in a column on a sheet of paper.
- Add the twenty salaries together to obtain their sum.
- Divide the sum by 20 to obtain the mean of the salaries.
- Record the answer or communicate it to someone else.

Now consider how a computer might accomplish the task, without any outside assistance or intervention during the calculations. First, there are two steps that would have to be performed by a human being:

—A set of instructions would have to be prepared to direct the computer to perform each step in the calculation. Such a set of instructions is called a *program*. The program must be prepared in a language or form that the computer can understand.

—The twenty salaries would have to be prepared or made available in a form suitable for entry into the computer (for example, they might be punched into cards).

To solve a problem on the computer, it is necessary to create a computer program and to prepare the input data. If such a program has been prepared to compute the arithmetic mean of twenty salaries, and this program has been stored in the computer, the program will direct the computer to perform the following steps:

- Read the twenty salaries into the computer.
- Compute the sum of the salaries.
- Divide the sum by 20.
- Write or display the result.

In this example, as in most computer applications, the computer must be able to *read* or *input* data, and it must be able to *write* or *output* results. It must have a *memory* to store program instructions as well as the data that are being processed. Since the computer is directed by a program, it must have a unit that interprets the program instructions and supervises their execution. These functions are performed by a *control unit*. Finally, the computer requires a unit that can perform additions, divisions, and other arithmetic operations. This unit is called an *arithmetic and logic unit*, since it can also perform logical operations. These various units and their functions are described in more detail

Figure 1. Components of a Computer

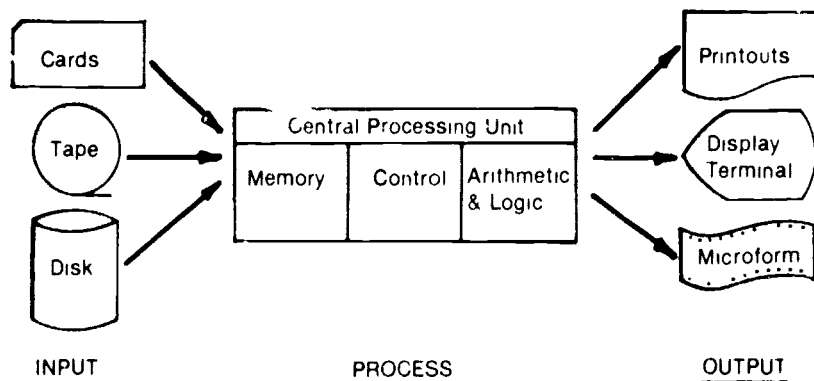

1. Central Processing Unit

In most computers, the memory, control unit, and arithmetic/logic unit are integrated into a single device called the *central processing unit*, or *CPU*, which is usually contained in a single cabinet. Modern electronics technology's continuous advances result in ever smaller, faster, and more reliable central processing units. This has made possible the development of tiny processing units contained on a single semiconductor chip called a *microprocessor*. Microprocessors perform many of the CPU functions in most computers, from the smallest *microcomputer* to the largest *mainframe* computer.

Memory Program instructions and required data are stored in the memory unit of the CPU. Data and instructions are kept in areas called *locations*; each location in the memory unit has an *address* so that data can be located. The capacity of main memory depends on the size of the computer, which can range from a few thousand locations in a small microcomputer to several million locations in a mainframe computer. Since memory is relatively expensive, it is often not feasible to store all of the data used in large processing applications in the CPU. Instead, less-expensive *mass* (or *secondary*) storage devices such as tape and disk drives are used for storing large data files.

Control Unit The control unit supervises all activities of the computer under the direction of a stored program. First, the control unit determines which instruction is to be executed next by the computer. The control unit then fetches this instruction from the memory and interprets the instruction, which is then executed by the other computer units. For example, the control unit may cause two numbers to be added by the arithmetic/logic unit. Other instructions may cause data to be read into the memory or to be displayed on a printer.

Arithmetic/Logic Unit The arithmetic/logic unit of the CPU performs arithmetic operations directed by the control unit. For example, an "add" instruction causes two numbers to be transferred to the arithmetic/logic unit. The addition is performed by this unit, and the result is then returned to the memory. In addition to the four basic arithmetic operations, the arithmetic/logic unit also performs logical operations. A typical logical operation involves comparing two numbers, then selecting one of two program paths depending on the result of the comparison.

2. Input/Output Units

Most educational data-processing applications require the preparation and input of certain amounts of data resulting from the various transactions that occur within the school district. These data must be converted to machine-readable form before they can be input into the computer. As a result, costs of input data preparation may represent a significant percentage of the total operating budget of a typical computer center. In addition, the number of data-processing jobs that can be handled daily is

often limited by input/output operations rather than by internal computer-processing speeds.

A larger number of devices and media are used for input and output of data. These may be categorized according to the type of medium used. For low input and output volumes, devices using paper media (punched cards and printed outputs) may be used. For fast but limited data entry and display, keyboard printers and video display terminals are often used. Magnetic media (magnetic tape, disk and diskette) provide very high speed input and output and are used in high-volume applications. Some of the more important input/output devices and their advantages and disadvantages are summarized in Table 1.

Table 1—Principal Input/Output Media and Devices

Media/Device	Advantages	Disadvantages
Card (Input)	Human readable Easy to change	Cumbersome and easily damaged Slow and expensive input
Tape (Input)	Faster input than cards Compact and inexpensive	Only machine readable Sequential data access
Disk (Input)	Faster input than tape Random data access	Expensive for limited data Requires tape back-up
Printer (Output)	Human readable Multiple copies	Slow output Space consuming
Video (Output)	Compact and cheap Interactive	Slow output Limited display size
Microform (Output) Includes both film and fiche	Very cheap and compact Very fast output	Needs reader/printer Needs careful indexing

3. Computer Software

Before educational problems can be solved on a computer, they must be stated in the form of a program, or concise set of instructions to the computer. In the early days of computing, it was necessary to state problems in a highly complex machine language that consisted of octal or hexadecimal number system codes. This was very difficult and tedious, and the number of successful applications was quite limited.

To overcome these problems, a body of computer programs and techniques called software has been developed. Software includes programming languages and translators, and computer operating systems. It also includes *application* programs that solve problems for a particular user. Supporting documents and training programs are often considered part of software.

Software systems greatly improve the efficiency of computer use. They promote man-computer interaction and reduce programming time and cost. They reduce the dependence of the computer on human action and judgment, thereby increasing productivity. To a large extent, the rapid increase in data-processing applications in recent years can be attributed to improved software systems.

A computer performs a given task by executing a series of instructions stored in its memory. These instructions are prepared (or coded) by a programmer who writes the instructions that are required for the described task. While relatively simple tasks can be written by a single programmer, many of the educational applications described in the following section require the development of a complex sequence of programs that represents the efforts of both technical individuals and the user.

Educational Computer Applications

Very few institutions and organizations today remain unaffected by computer technology. In the past decade there has been increasing interest on the part of educators in how they might realize some of the benefits that computers offer. Many schools and school districts already use computers to some extent; however, a great number have not yet explored the possibilities of what computers can do for them and their students.

The basic educational applications utilizing computers are shown in Figure 2. As the diagram illustrates, educational computing is divided into three parts: administration, research, and instruction.

Administrative applications As with almost every other organization of our day, the average school district has experienced an increase in the number and variety of accounting and record-keeping tasks. The large data-handling and fast data-processing capabilities of computers have found wide applicability in such areas of educational administration as student accounting (for generating attendance data, report cards, and student schedules), budget and finance (for line item or program budgeting, encumbrance accounting, and financial analyses), payroll and personnel (for producing paychecks, earnings statements, and employee profiles), and career guidance (for student access to occupational, educational, and financial aid data banks).

Research applications Research within a school district can run the gamut from basic statistical analyses of descriptive characteristics—registers, attendance, class size—to fairly sophisticated enrollment forecasts and evaluations of educational programs. Computers not only support such studies by providing statistical programs to analyze data, but they also make the data itself readily available through the creation and maintenance of detailed and longitudinal data files on students, personnel, programs, and facilities.

The more recent innovations in educational computing involve computers as a tool or subject of instruction. Instructional computing is a method of automating part of the teaching-learning process. The same storage and processing capabilities used in the more traditional computing applications are used here to store and present instructional material to a student. It is in this application that some questions and misconceptions arise about computers. For example, the idea that the

impersonal computer in some way will replace the teacher is sometimes heard. Actually, computer-assisted and computer-managed instruction properly integrated into the curriculum should help both the teacher and supervisor to be more effective. It can, for example, enable a teacher to

Figure 2. Computers in Education

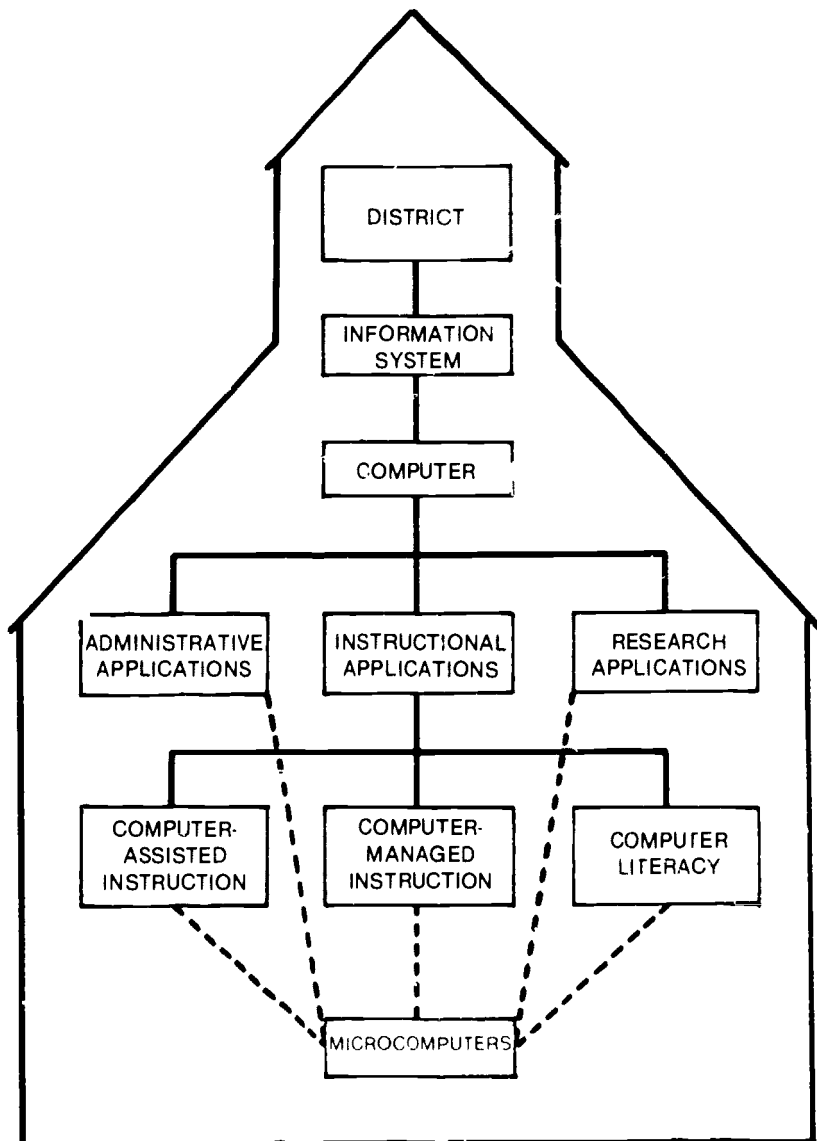

give a student specialized instruction that otherwise might not be available. A computer can permit the slow student to get additional instruction, and the fast student to progress at a speed closer to his or her capability.

Computer-assisted instruction (CAI) CAI uses the capabilities of the computer to provide individualized instruction by complementing other educational methods and materials such as lectures, textbooks, films, and television. The ability of CAI to analyze and feed back information on a student's progress makes it a sophisticated teaching tool. The computer evaluates student responses and adjusts the presentation of material accordingly. Many CAI programs call for branching to new levels when a student has reached adequate skills in a given subject or for remediation of material not assimilated by the student. CAI techniques include drill and practice (individual student drills with response-adjustment), tutorial (subject content presented in a dialogue mode), stimulation (user-computer interaction with models of real situations), and problem-solving (student solution of formulas and problems).

Computer-managed instruction (CMI) CMI employs the computer to support instructional activities linked to educational program objectives, to provide continuous measurement of student performance with criterion-referenced mastery tests, and to maintain longitudinal student records. At first, the development and use of CMI was largely motivated by the fact that CMI functions were less expensive to perform in the computer than were the instructional functions themselves (such as drill and practice). As computers become less expensive and more powerful, most large computer-based instructional systems will include CMI along with other instructional functions.

Computer literacy Increasingly, the computer itself, because of its widespread use in business, government and the professions, has become a subject of instruction. There are very few students in school today who will not, at some time in their careers, require some knowledge of computers and their operation. The impact of recent advances in information technology is expected to be felt in all aspects of society. Andrew Molnar of the National Science Foundation writes that in an information society "a computer literate populace is as important as energy or raw materials are to an industrial society" (Molnar 1978:35). He emphasizes that computers should be introduced into the curriculum from kindergarten to the university. Computer literacy programs can be offered at an awareness level (introduction to computer concepts, terminologies and applications), functional level (hands-on proficiency in basic computer operations and programming), and professional level (detailed technical, economic and organizational knowledge of computer systems) (Molnar 1978).

Microcomputers The continuing advances in the miniaturization of computer hardware resulted in the widespread availability just four years ago of the microcomputer. These small, personal computers typically in-

clude a relatively powerful microprocessor chip, some primary memory for data and program storage, a keyboard, and a cathode ray tube for data display. Often a microcomputer system includes secondary tape or diskette data storage capabilities, a slow printer and a telephone interconnect. Microcomputers will become increasingly important in education, ranging from the "home" computer costing about \$400 and used for initial student "hands-on" computer experience, to a complete professional microcomputer system costing over \$3,000 and used to support fairly complex administrative or instructional applications.

III. MANAGEMENT INFORMATION SYSTEMS

Data processing is a term that often connotes a room full of blinking computers, spinning tape reels, and purposeful technicians. While this may well be an accurate mental picture of what data processing represents in many instances, data processing does not necessarily include only the computer. *Data processing*, more generally and accurately defined, simply means the manipulation of data to achieve a desired result. Viewed from this perspective, computing is only one of many ways to manipulate data.

To provide an additional dimension to the term data processing, the word *system* can be added. A system is simply an organized way of doing something. Thus, a data-processing system is an organized way of manipulating data to achieve a desired result. When that desired result is information to be used in the management of organizations, the entity supporting this function can be called a *management information system*.

Information-System Concepts

Information can be thought of as the end result of some data manipulation activity. *Data* are facts—the raw materials from which information is made. Data are facts about people, places, things, and their activities. These unorganized facts, or raw data, are transformed by some process into an arranged, ordered and usable form known as information. In a stricter sense, data may consist of numbers and letters that can be restructured by an information system in a way that will increase their usefulness. The processing or restructuring of data into usable information may take place in many ways. However, raw data are not randomly manipulated and then formulated into usable information. Instead, data are manipulated according to a predetermined procedure to achieve a desired result.

Figure 3 shows the sequence of steps by which data become information in a management information system. *Original data* (1) are gathered on a written transaction form or input via a computer terminal and delivered to the computer center. *Data editing* (2) is performed by both

Figure 3. Components of an Information System

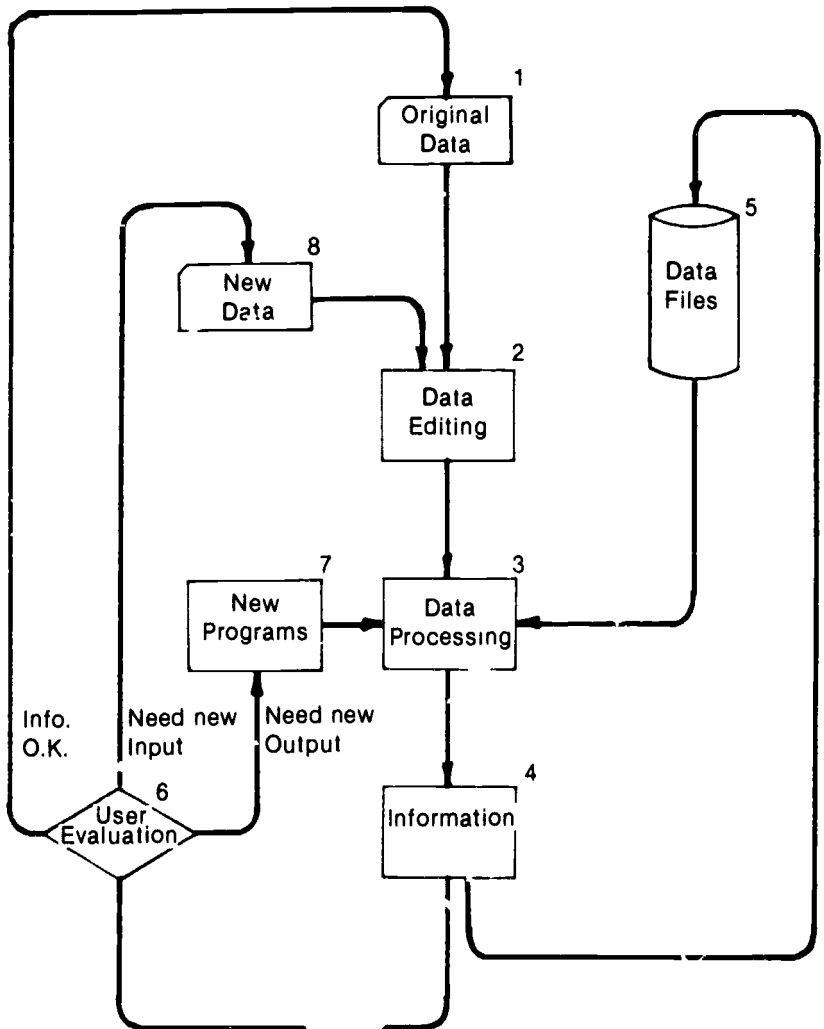

manual checks for completeness and basic accuracy and by computerized checks for total arithmetic accuracy and internal logic. *Data processing* (3) involves the manipulation of the data—sorting, classifying, computing—into the final desired and usable format. *Information* (4) consists of the various reports, terminal displays, and graphics that are given to the intended users within the organization.

It is often assumed, by both computer specialist and administrative user, that the generation of information in step 4 is the end of the process. But the very definition of information, data which have been transformed into something useful, belies this assumption. As with any system, information systems should change according to changing needs, circumstances and conditions. Such change requires the introduction of a formal feedback mechanism. Steps 5 through 8 in Figure 3 show how such feedback might affect an information system.

In addition to the various reports produced in step 4, it is likely that some of the information produced must be saved and utilized in the next processing cycle. A monthly payroll that must accumulate year-to-date salary and deductions for annual tax preparation is such an example. *Data files* (5) that consist of various information outputs are therefore a likely component in an information system. In each successive processing cycle, the new data collected in step 1 and edited in step 2 is joined in step 3 by cumulative data from previous processing cycles. The information generated in step 4 consists therefore of manipulations of both current and historical data.

A more significant feedback process, however, is shown in steps 6, 7, and 8. Users need to assess the utility of information that a system has produced for them. *User evaluation* (6) is a continuing process and begins with the production of the first report. If the user finds the generated data useful, then the system can complete subsequent operating cycles without change. At some point, however, the user will likely find the information to be less than originally desired (or presently required), and system changes will have to be made. *New programs* (7) will be needed if the processing manipulations or report formats have to be changed. While these changes will involve some expense and time, they are primarily the concern of the computer staff and user and need not affect the larger organization. *New data* (8) however will involve not only reprogramming, but also changes in the forms, procedures and edits used in the capture of data. Since collecting new data may likely involve the retraining of staff outside of the user's organizational unit, this type of system change will involve greater expense and time.

Modifying an information system to accommodate unanticipated, new or restated needs is frequently costly and sometimes impossible. Thus, an information system can become a constraint on decision-making because of its inflexibility. This rigidity can have serious effects. Information systems can, quite inadvertently, prevent needed information from coming to light because of the effort involved in trying to process or alter

data lodged within the system's files in a manner never envisioned by the system's designers. Given the likelihood for change at some point in an information system's lifetime, system flexibility becomes an important consideration.

Data Files and Data Bases

Administrators within many school districts are hard put to fully manage and use their educational data for reasons that are largely historical. Because of the rapid growth of computer technology, management of data has developed in a haphazard and laggard fashion over the years. A general approach to data organization has emerged only very recently; consequently, most educational information systems and their data files are highly specialized, and are designed for a specific operational use or for a specialized staff function.

As with most organized entities, data are composed in a hierarchy of levels, as shown in Figure 4. The most discrete level of data is the *character* (also called the *byte*) and consists of a single number, letter or special symbol that, by itself, conveys little or no meaning. One or more characters make up a *data element* (or *variable* or *field*) which represents specific and meaningful attributes such as a person's name, social security number, or sex. All of the data elements that pertain to an individual person, place or thing constitute a *record* (or *observation* or *case*). A group of records that are related by function, type or use compose a *file*. Common data files in education include payroll, personnel, student, and achievement files.

Figure 4. Hierarchical Levels of Data

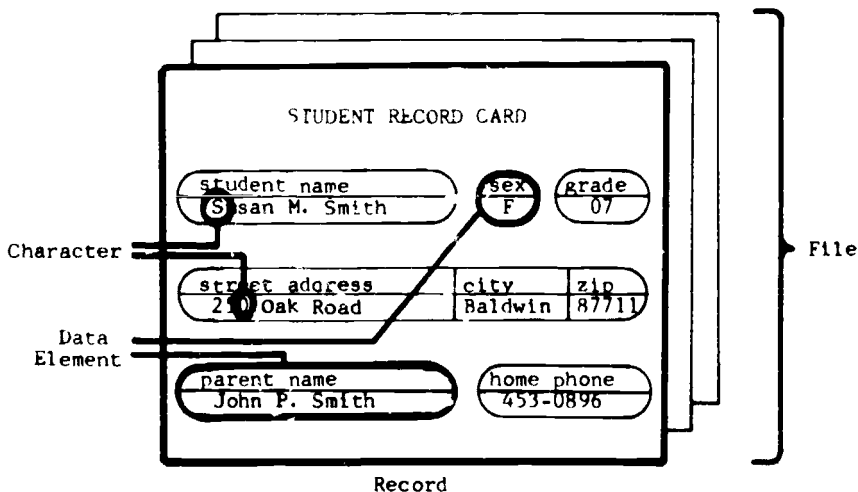

In the early days of school-district computerization, the limited memory and capabilities of the hardware and software in turn limited the scope of programming and the amount of data needed for any given application. In effect, this reinforced the practice of creating and maintaining separate files for each educational application. Although the later generations of computers had greatly increased power, many school districts still organized and coded their data along first-generation computer lines—that is, by specific files and programs.

Hence, the administration of data has continued to develop in fragmented fashion and at rather low organizational levels. This traditional approach to educational data processing used by most school systems involves collecting, editing, and coding data for specific computer systems, and consequently linking them more or less permanently and exclusively to these systems as well as to the district offices or units that create and maintain them. This type of data structure—separate data files feeding into specialized reporting systems—severely limits the managerial utility of these data (Hussain 1973:135-136).

Figure 5A shows an oversimplified and hypothetical model of two educational data systems—pupil attendance and pupil testing—that are structured along the traditional approach. The pupil attendance file consists of four separate data elements or characteristics on each pupil: school number (A), homeroom class code (B), student identification number (C), and student attendance during a marking period (D). The pupil testing file also contains four data elements per pupil: school number (A), class code (B), student number (C), and student test score (E). Notice that data elements A, B and C are common to both files.

The redundancy of data is obvious. In this simplified example, six out of eight (75 percent) of the data elements in the files are redundant. During the initial operation of data systems, redundancy does not cause much trouble. As soon as data elements must be changed or updated, however, redundancy can cause a great deal of unnecessary effort. A few simple class code changes, for example, would involve changing data element B on hundreds of individual student records. Given the plethora of separate data systems that many districts maintain, the process of updating all the redundant files in a systematic and synchronized fashion becomes exceedingly difficult and costly.

The traditional data structure also severely limits the ability of districts to combine and analyze data elements from separate data files. For example, Figure 5A shows that pupil attendance data (Element D) and pupil test scores (Element E) are contained in two different data files. If one wanted to analyze the statistical relationship between these two variables, it would be necessary to first perform pupil-by-pupil editing of each record and then pupil-by-pupil sorting and matching from each of the two files (while identifying and correcting all manner of data errors and coding inconsistencies in the process) in order to produce a new data

file containing data Elements A, B, C, D, and E. The time and effort required to do this often discourages requests for such analyses or leads to a manual computation of the data from printouts. As a result the school district's own data has become a frozen asset, a highly constrained resource, analogous to funds which may be used to purchase only one type of instructional supply (Lucas 1978:173-1976).

Today school administrators need access to information that can be generated only from properly structured, cross-functional data that incorporate data from the specialized applications and activities located throughout the district organizational hierarchy. Management requires that school administrators have common and consistent data that can be used in conjunction with flexible reporting systems to generate information on a broader and more comprehensive scale than the single, isolated applications files and systems.

The information needs of school administrators have given rise to the concept of a districtwide data base. The data base concept has two key aspects:

1. The data (e.g., student, payroll/personnel, budget/finance) that computer programs use are considered an independent resource in themselves, separate from the computer programs.
2. There is an optimal approach to managing and structuring the school district's data as a whole so that they constitute a resource available to the entire district for broad-ranging applications, especially on an *ad hoc* basis (Josephson 1975:106-107).

Figure 5a. Components of a Data Files System

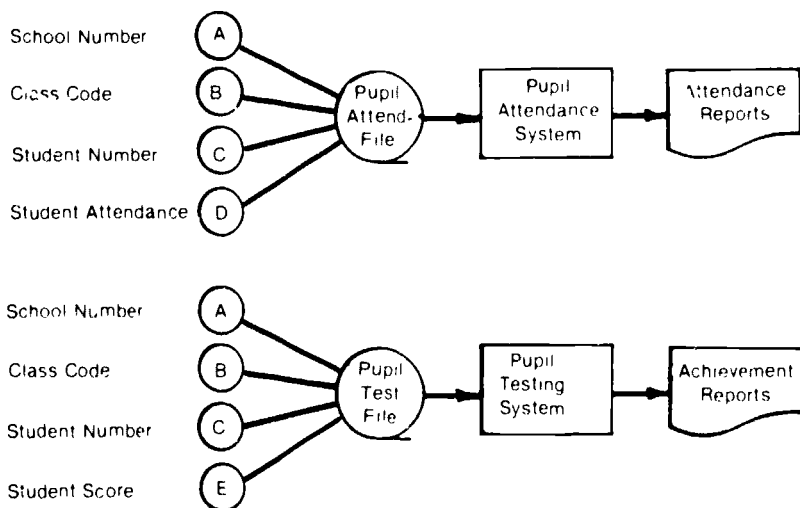

As shown in Figure 5B, the data-base concept hierarchically structures and combines the pupil attendance and testing data files into a common pool. Note that no files appear since the pool of data elements constitutes the general file for the school district (at least, for this example, pupil attendance and testing), and specific files are for the most part unnecessary. In the data-base approach, an interface called the data-base management system exists between the data and the various reporting systems for accessing the data elements and producing reports. The data base enables the district to organize and structure the data elements in a way which minimizes redundancy and inconsistencies and maximizes data accessibility.

The use of data-base management systems to maintain and access information will provide school administrators with the required degree of flexibility. In the class code change cited above, a data-base system would change only the affected B data elements and not the hundreds of student data records (data element C) that a data-file system would necessitate. The data base would automatically associate each class code change with all of their respective student records.

The creation of data bases requires a new position within the district organization: the data-base administrator. The data-base administrator is the custodian of the data and is responsible for its security and control (see sections below on data control and data confidentiality). The administrator maintains the overall view of the district's data, encourages standardization of data items, and determines what data structures and layouts will be best for the data users as a whole. Within a school district, the data-base administrator's job combines a rare mixture of technology and organizational politics (Martin 1976:6-7).

Figure 5b. Components of a Data-Base Management System

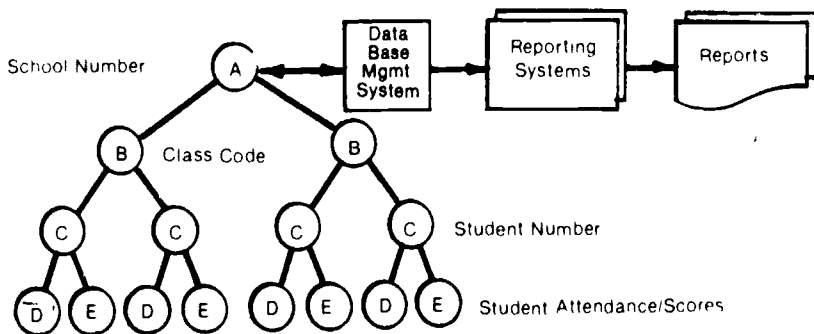
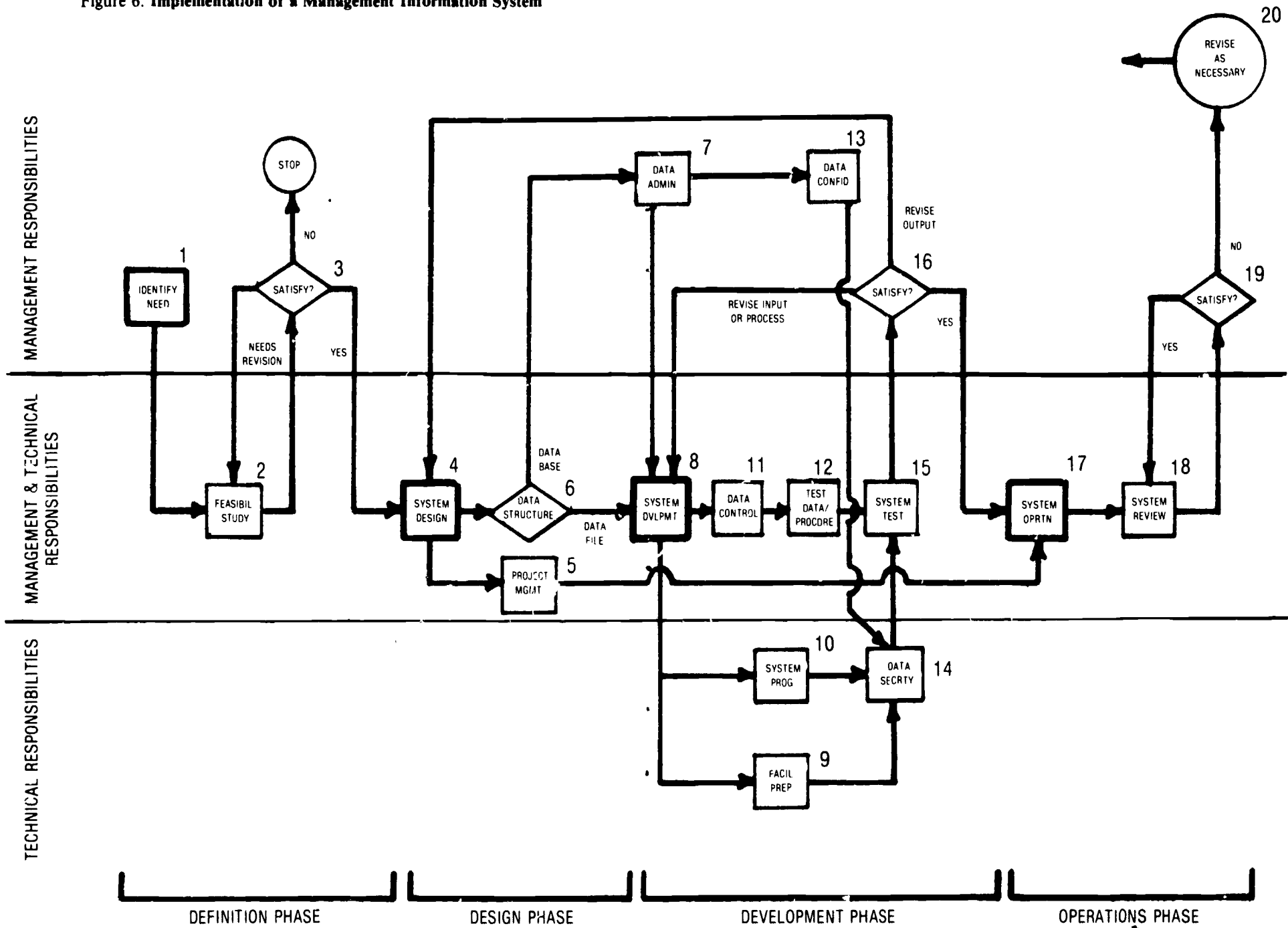

Figure 6. Implementation of a Management Information System



DEFINITION PHASE

DESIGN PHASE

DEVELOPMENT PHASE

OPERATIONS PHASE

Information-Systems Implementation

The process of developing even a modest educational information system is likely to involve the efforts of dozens of individuals over many months or even years. Both the complex nature of the task and the wide range of technical and administrative activities that must be coordinated make proper management of the total process the prerequisite for success. Only through the appropriate participation of the administrator can the promises of the computer staff and the expectations of the educational user be fully realized. While an even elementary discussion of the systems implementation process is far beyond the scope of this paper, an outline of the various steps involved may prove useful. Figure 6 shows the major steps in the implementation of a management information system. Each step is identified with a managerial, technical, or shared level of responsibility, and with one of the four phases—definition, design, development, or operations—that make up the overall implementation process.

Definition Phase This phase, and the entire implementation process, begins when the educational management *identifies the need* (1) for an information system due to a change in district goals, programs, structure or requirements. To ascertain whether and what kind of system would meet the anticipated information need, a *feasibility study* (2) is conducted by a team of administrators, educators, and technical specialists. The feasibility study identifies basic information objectives, policy issues, and resource constraints, and evaluates some alternative approaches to meeting the stated needs. The completed study is *evaluated* (3) by district management to determine whether the effort should be terminated, revised and restudied with different objectives or constraints, or deemed satisfactory. In the last case, a commitment is made to proceed to the *design phase* (4).

Design Phase This phase will transform the general technical and administrative parameters of the system identified by the feasibility study into specific input, processing, and output specifications. A formal *project management* (5) unit of both administrative and technical staff is established to assume direct operating responsibility for the system-implementation effort until it is declared *operational* (17). A major design consideration that will involve administrators is the type of *data structure* (6) the system is to utilize. A conventional data-file structure may not impose too many changes upon the district's organizational structure or procedures, but a data-base system may have a profound impact upon the *data-administration* (7) functions, as will be discussed in the next section of this paper. Completion of all system-design specifications leads to the complex system *development phase* (8).

Development Phase This phase involves many simultaneous efforts at all organizational levels of the district. On the technical level, the completed design specifications are used for *facilities preparation* (9)—select-

ing, contracting, preparing, and installing the necessary work space and electrical, computer, data-entry, and support equipment—and for *system programming* (10)—writing all of the computer programs and documentation for the system. During this period, selected administrative and technical staff should be formulating a *data control* (11) procedure and policy under which the system will operate (see section IV). A joint group of administrators and technicians will also prepare *test data and procedures* (12) and evaluate the system's programs and procedures. A group of management and policy personnel will establish the *data confidentiality* (13) policies that the system may necessitate (see section IV). Once formulated, these policies on data access are used by technical staff to develop *data security* (14) procedures and mechanisms. When all of these developmental activities have been completed, an integrated *system test* (15) is conducted to run the system under operational conditions, either on a partial basis or parallel to the existing system. The system test provides both technical and managerial staff with a clear indication of how well the new hardware, software, procedures, and organizational staff work together. Following a few months of system testing, a formal management *evaluation* (16) is made to determine user satisfaction with the system. At this point, any need to revise input, process, or output parameters are identified and acted upon. If user expectations are met, the system is declared *operational* (17) and turned over by the project management staff to the appropriate district organizational units.

Operations Phase Once placed in operation, information systems should undergo a periodic *system review* (18) to determine if user needs in the context of a dynamic educational environment, are still being met. The users *evaluate* (19) the system and either recertify its adequacy or implement steps with the appropriate technical staff to *revise as necessary* (20). Depending upon the circumstances, such revisions can be relatively minor or involve reinstitution of the implementation process in the development, design, or even definition phase.

The preceding has been a brief discussion of the information-systems implementation process. A more detailed analysis can be found in the following references: Hussain 1973:173-341; and Lucas 1978:219-278. The following section will investigate those aspects of the implementation process that necessitate direct participation and decision making by educational administrators.

IV. COMPUTER-SYSTEM ISSUES FOR ADMINISTRATORS

The flow of educational data is the administrative lifeblood of school districts. This data flow is a continuous record of the status of many pertinent factors that affect the successful operation of a district. A major responsibility for school managers is the development of mechanisms for the administration, control, and dissemination of critical information from this flood of data which will assist more effective decision making.

Information management is, or more properly should be, such a mechanism. In this section, a number of issues which inherently affect the successful implementation of management information systems are examined.

Data Control

The primary function of management information systems is to provide accurate, timely and comprehensive educational information in a fashion that minimizes the cost and burden to data respondents in school districts. Essential to the management and control of this information is close coordination of the collection of data required by federal, state, and district educational offices. A plethora of survey forms that have never been reviewed and approved through a common data-control procedure are described in information-systems terminology as being fragmented or nonintegrated. To cope with this phenomenon, integrated information systems require structured or orderly data collection procedures which identify and approve all relevant data acquisition activities according to established criteria.

During the late 1970s, both the federal agencies and a number of state education departments created procedures for coordinating the collection of educational data. Excessive government paperwork which cost school districts time and money and could have been better spent on educating students prompted Congress to create the Federal Education Data Acquisition Council (FEDAC). FEDAC is responsible for coordinating the activities of all federal agencies that collect educational data and ensuring that the data are collected as efficiently as possible. The intent is to reduce the federally imposed burden of paperwork by eliminating excessive detail and redundancy in information requests.

The procedures employed by FEDAC were described as follows in a National Center for Education Statistics report:

To carry out its purpose, FEDAC annually prepares the Federal education data acquisition plan and inventory. The plan identifies Federal instruments used to request education information from 10 or more persons. It includes questionnaires, telephone and personal interviews, guides and any other types of forms used for grant applications, research and evaluation studies, statistical surveys, financial and performance reports, and other management reports. FEDAC prepares the plan by coordinating requests proposed by Federal agencies and reviewing them for redundancy, costs, overall burden and the use of standard terminology and definitions (1980:3).

A review of the data-collection procedures used by the federal and various state educational agencies has identified a basic data-collection model that should be of great use to school district administrators. The following is a description of this model's procedures as they might be established for a school district. The procedural flow of the model is shown in Figure 7.

Figure 7. District Data Collection Approval Process

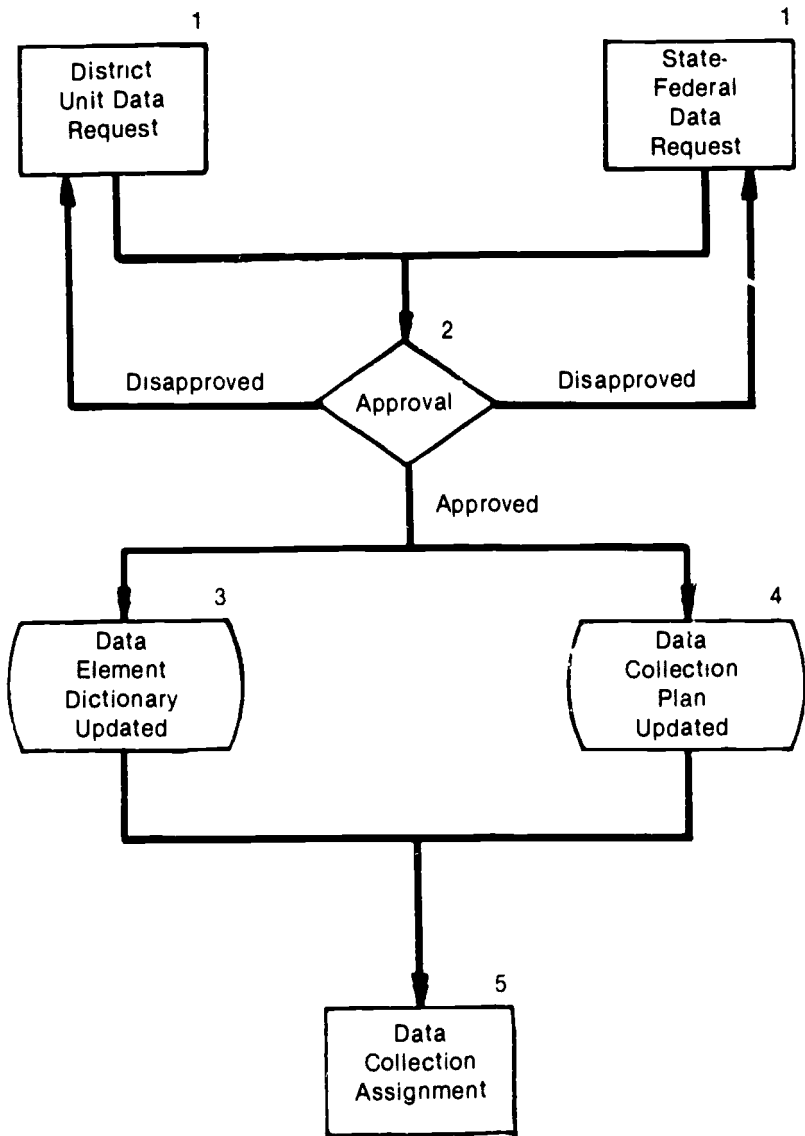

Data-Request Submission All requests to collect data by district offices, and by city, state, or federal agencies are submitted to the district's data-base administrator. School district offices must prepare a Data Review and Approval Document providing information concerning the justification for and pertinent details (e.g., respondents, frequency, data elements, completion time) of the data-collection activity. State and federal agencies must provide notification of prior approval by the appropriate authority (e.g., United States Office of Management and Budget, FEDAC, state education department).

Data-Request Review The district's data-base administrator will evaluate student data requests using criteria for review and approval that fall within two major categories: (1) Justification, and (2) Technical Analysis. In special circumstances, data requests not based directly on law or regulation may be authorized on an emergency basis when such data are critical to the school district's operations and when delay would seriously jeopardize mandated activities. Based upon the evaluation, a data request will be either disapproved, conditionally approved (upon completing required modifications), or approved.

Data-Element Dictionary Updated When a data-collection activity is approved, the Data-Element Dictionary will be updated by the data-base administrator to include new data elements and an identification of the new user of existing data elements. The dictionary defines the characteristics of data elements available within the school district and is used to build a common data base and provide detailed descriptions of each item of relevant data to permit retrieval. There would be an annual review of the dictionary to determine if data elements should be deleted or modified to show changes in current usage. The dictionary would be distributed throughout the school district to allow all users ready selection of data elements that have been defined and to inform users of where a specific data element can be located at the district office.

Annual Data-Collection Plan Updated After a data-collection activity has been approved, the district's school and offices should have advance knowledge of when they can expect to receive the survey in question. That advance notice is one of the primary reasons for the data-base administrator's creation and continual updating of an Annual Data-Collection Plan. The plan is a publication of the approved data-collection activities planned for implementation during a given school year. It would list by month the justification for, and the types of, data survey forms that would collect the data. The plan would be distributed in the spring prior to the school year in question and would be updated during the school year by addendum notices.

Data-Collection Assignment The data-base administrator would review all approved data-collection activities, and, through a feasibility analysis, assign the data-gathering activity to the appropriate district unit. This assignment determination would be based on the degree of potential interface between the data instruments and the data base.

Where necessary, the feasibility analysis would define from the data user's viewpoint the requirements of the data-collection activity by information flow, output documents, input data, and data processing.

The result of a uniform and mandated set of data-collection procedures is a management information system that can provide for one-time collection of data, easy retrieval of stored data, and ready access to existing data. In order to be effective, however, these procedures must be authorized by policies established by the district superintendent and the school board. The establishment of the following policies regarding data-collection procedures would therefore be necessary:

1. No instruments shall be authorized and used to collect data from schools, districts units, or offices unless they follow the Standard Data-Collection Procedures of the school district and are approved by the data-base administrator.
2. No office or unit within the school district shall collect or authorize collection of data directly from schools unless they coordinate their needs with the data-base administrator.
3. No state or federal agency or their contractors shall collect data directly from schools without having first routed their request through the data-base administrator.
4. No school or district office shall be required to complete a data-collection form prepared by a city, state or federal agency that has not been reviewed and approved by the data-base administrator.

When the data-base administrator approves a data-collection activity, a control number and date of expiration would be assigned to the data form(s). The data-base administrator would then provide a standard letter of authorization that must be attached to the actual data form(s). This, coupled with the Annual Data-Collection Plan, would ensure the adherence to item 4 in the above policy statement and would provide school and district personnel with an appropriate authorization check.

Data Confidentiality

The successful development and implementation of student and personnel information systems will raise a host of policy and technical issues concerning the confidentiality and security of the personal information thus collected and maintained. Computerized data files may be more difficult to access than manual files—or at least the number of people with the ability to access such files is fewer. However, once computerized files are penetrated, a greater quantity of data can be obtained in a shorter time period with less effort. Even where access is stringently controlled, legitimate copies of information extracted from a computer system compound the problems of protection and confidentiality.

Safeguarding personal information protected by statute or by policies of confidentiality and privacy is an integral part of information management. Unauthorized disclosure or use of personal and privileged information can be seriously detrimental to respondents. Adequate

safeguards are necessary to protect these interests as well as to ensure cooperation in the accurate and timely flow of student and staff information to support educational operations. Although legal or administrative safeguards may exist, it is the responsibility of the school district to ensure that adequate procedures and physical measures are implemented. Measures must address unauthorized or inadvertent disclosure, and the destruction, diversion, or alteration of confidential data.

Protective measures must enable the authorized exchange of student and staff information with other agencies outside the school district. Such exchange is essential to meet the data requirements of state and federal programs and to minimize the duplication of efforts imposed on respondents. However, inadequate protection from either gaining or exchanging agencies can impede the transfer as well as the collection of needed personal information.

When considering student information systems, the confidentiality of the student data collected and maintained by the school district determines not only what information may be withheld from public disclosure but also the extent to which that information may or may not be shared with other agencies. Accordingly, familiarity with relevant confidentiality laws in formulating student information policies is essential. Confidentiality of student information is most affected at present by two laws: The Family Educational Rights and Privacy Act (1976) and the Freedom of Information Act (1974).

Family Educational Rights and Privacy Act This Act, commonly referred to as the "Buckley Amendment," deals only with educational records and defines, more precisely than has ever been done in the past, who may or may not see them. On the one hand, the law guarantees parents access to student records; on the other hand, it takes from the schools the privilege of indiscriminate disclosure. Basically, the law sets forth these main requirements for school districts:

- allows all parents, even those not having custody of their children, access to each educational record that a school district keeps on their child
- establishes a district policy on how parents can go about seeing specific records
- seeks parental permission in writing before disclosing any personally identifiable information on a child to individuals or organizations other than professional personnel employed in the district.

In order to understand the requirements governing a district's disclosure policy, it is necessary to consider the meaning of the phrase, "personally identifiable information." Federal regulations define it to mean information that contains one of the following: the name of the student, his or her parent, or another member of the family; the address of the student; any number (such as an identification number) that would make it possible to trace a student's identity; a list of personal characteristics or codes that would enable someone to identify the stu-

dent; and any other information establishing a student's identity. School districts may release data about a student without obtaining a parent's written permission as long as no one can recognize which student the information describes. But if the information in any way identifies a particular student, then the disclosure falls under the jurisdiction of the Family Educational Rights and Privacy Act.

There are, however, certain circumstances under which school districts may disclose "personally identifiable information" without obtaining parental permission. One important circumstance involves data which the regulations loosely refer to as directory information. Personally identifiable information such as a student's name, sex and address may be released by a district without a parent's written consent as long as the district has included in its policy statement a description of the kinds of data it has designated as directory information.

Freedom of Information Act This Act, unlike the Family Educational Rights and Privacy Act, imposes no limitations on information disclosure. On the contrary, it requires the disclosure of government-held information except for certain exempted categories. Of the nine exemptions to the Act, the one of most relevance to student information confidentiality concerns records or data which, if disclosed, would constitute an unwarranted invasion of personal privacy. An unwarranted invasion of personal privacy is defined by the Act to include, but not be limited to the following:

- disclosure of employment, medical, or credit histories or personal references of applicants for employment
- disclosure of items involving the medical or personal records of a client or patient in a medical facility
- sale or release of lists of names and addresses if such lists would be used for commercial or fund-raising purposes
- disclosure of information of a personal nature when disclosure would result in economic or personal hardship to the subject party and such information is not relevant to the work of the agency requesting or maintaining it
- disclosure of information of a personal nature reported in confidence to an agency and not relevant to the ordinary work of such agency.

An unwarranted invasion of personal privacy does not justify the denial of access to records:

- when identifying details are deleted
- when the person to whom a record pertains consents in writing to disclosure
- when upon presenting reasonable proof of identity, a person seeks access to records pertaining to himself.

There is a presumption in favor of public disclosure, clearly expressed in both state and federal versions of the Freedom of Information Act (FOIA) and fully supported by the courts. Thus, unless there is a specific

FOIA exemption for the data, or school district policy specifically requires that the information be kept confidential, student information maintained by a school district should be available for dissemination.

In view of the broad range of information likely to be supported by a student data base and the unique problems of privacy and security posed by the information's computerization, a thorough review and revision of existing school-district regulations and policies, and the establishment of new and appropriate standards of confidentiality and access are matters of high priority. In analyzing the body of student information to be maintained by a data-base system, the superintendent and school board should establish a formal mechanism to formulate and reexamine present and future standards of student data confidentiality based on the following criteria.

1. The public interest which can be served by student data disclosure:
 - by helping the school district to fulfill its functions and accomplish its objectives
 - by providing information to the public as required by law
 - by facilitating intergovernmental sharing of data and reducing duplication of effort
2. The potential harm which can arise in both public and private interests through the release of student information:
 - by adversely affecting the collection of the quality of such data in the future due to a lack of confidentiality guarantees
 - by constituting a clearly unwarranted invasion of privacy.
3. The alternatives to full disclosure that could protect both private and public interests as, for example, the removing of identifying characteristics or codes prior to the public release of student data or limited dissemination to other agencies rather than full public disclosure.

As the issues arising out of the utilization of an expanding student data base will undoubtedly be of a continuing and ever-present nature, the criteria proposed above should be implemented by a standing, student-information policy committee. This committee, chaired by the data-base administrator and including representatives of the district's teachers, principals, and office administrators, would meet on a regular basis. The following responsibilities regarding the implementation and utilization of computerized student information should belong to such a committee:

1. Revise current regulations and policies, promulgate and implement new regulations and policies governing computerized student information, and base policies on the principles established in existing law and along guidelines which allow the broadest, most feasible dissemination of public information while providing the necessary safeguards to ensure the protection of the rights and privacy of students and parents.
2. Inform student information sources and information respondents, whenever new student data are collected, of the school district's

legal authority and technical ability to guarantee confidentiality; the specific data that will be safeguarded; and the extent, if any, to which data disclosures will be made (e.g., what data will be designated as directory information).

3. Determine the appropriate organizational levels of staff access (superintendent, principal, counselor, teacher, and aide) to the various kinds of information in the student data base and establish guidelines encompassing the management and technical safeguards for computerized student information.
4. Review and evaluate on an individual basis all requests by outside parties, organizations, institutions or governmental agencies for access to and utilization of any portion of the student data base for any informational, statistical, survey, or research purpose not already prohibited by existing policy, regulation or statute.

Data Administration

One final information-management issue that must be addressed by school administrators is the location of the data-processing function within the district's organizational hierarchy. The most appropriate location will depend in part on the size of the central administrative office, the number and kind of educational applications to be computerized, and the importance attached to management information by the chief

Figure 8. Alternative Data Processing (DP) Department Locations

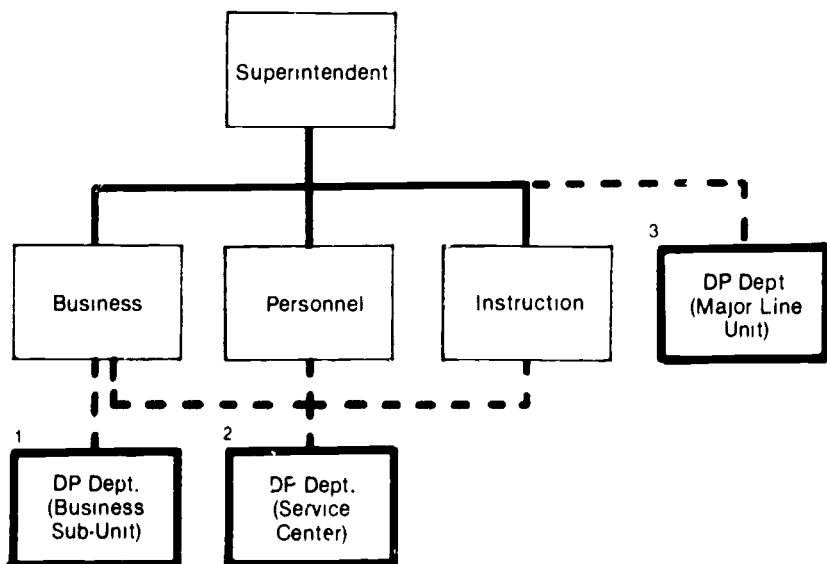

district administrators. As shown in Figure 3, there are three possible locations for a district's data processing unit (Sanders and Birkin 1980:245-247).

DP (Data Processing) as a Business Sub-Unit The small memory, slow speed, and complex programming of the Garvy computers limited the first computer applications to relatively simple and straightforward tasks such as payrolls and accounting statements. Since most of these early applications were of a financial nature, the computer and its staff were most often placed under the control of the district's business administrator. Even as the computer operation grew to service non-business functions such as personnel and instruction, the organizational location remained unchanged. Experience in many school districts, however, identified a number of serious disadvantages with this business-area location. Since the computer staff reported to the business administrator, the data processing needs of the non-business functions were often given lower priority than business applications, despite perhaps the greater importance of non-business functions to the district. Also, many of the computer staff were likely to have backgrounds and orientations that clearly favored the business side of the district's operations.

DP as a Service Center In an effort to avoid a particular functional bias in setting data-processing priorities, some districts have located their computer facility as a "service center" not directly responsible to any single district office. Each district activity is provided with appropriate access to the computer and priority for its systems within a given overall district policy and within the limitations of the computer staff and facility. While the service-center concept appears sound, it usually suffers from a lack of coherent direction by virtue of its ambiguous position on the periphery of the main district organization. The DP manager, therefore, has little organizational status or authority, and the development of new application systems often proceeds along a fragmented, "free-for-all" approach.

DP as a Major Line Unit Given the general lack of satisfaction with the two previous DP organizational locations and an increasing awareness on the part of educational administrators that management information has become a basic function of the district, some school districts have established their computer centers as independent departments equal in organizational rank to such traditional line-management operations as business, personnel and instruction. Such a placement provides the DP director with the organizational status to determine broad information-management policies for the district, and the ability to work directly with the chief district administrators. This, in turn, will make possible both the development of integrated data-base management systems and the resolution of data-control and confidentiality issues.

V. CONCLUSIONS

Many educational administrators still view a computerized information system as a product with precise and unchanging input, processing, and output specifications. Users are asked to specify their information needs and a system is designed and delivered around these requirements. Experience has shown, however, that information systems developed through this conventional approach frequently have failed to meet the high expectations of their users. Educators do not appear to be capable of completely specifying their information needs *a priori*. As situations change and new needs emerge, as they invariably will, demands for information must change.

The alternative conception of an information system advocated in this paper is one of process: an ongoing and integrated set of activities for acquiring data and producing information. This view differs from the product view in that the specifications for input data, processing operations, and output report formats are not frozen at any time. In the process-oriented system, all of these system components are expected to change continually.

Certain functional requirements that follow from this process view should be incorporated into the design of the information system. Since school administrators cannot specify their complete information needs, the system's data should be stored within a disaggregated but integrated data base so that future needs to use the data in ways not initially anticipated can be met. Furthermore, the data-handling capacity of the system should be large enough so that any information required to support future management needs can be stored.

In considering the costs of educational information systems, the services provided by the system should not be separated from the functional activities it would support. The costs of developing a process-oriented system having a high degree of flexibility are necessarily higher than those for a fixed product-oriented system. The temptation to reduce development costs of a system at the expense of flexibility is always strong. However, failure to resist that temptation totally defeats the purposes of an effective information system.

In the end, it must be remembered that an educational information system, by itself, has no reason for existence. Therefore, the costs of its development cannot be the measure of its effectiveness. The value of an information system cannot be determined in isolation from the functional activities that it was designed to serve. True measures of effectiveness—those related to educational and administrative objectives—can only be defined and evaluated for the management activities themselves.

VI. REFERENCES

- Family Educational Rights and Privacy Act
1976 U.S. Code. Title 20, Chapter 1232-G.
- Frates, Jeffrey, and Moldrup, William.
1980 *Introduction to the Computer*. Englewood Cliffs, NJ:
Prentice-Hall.
- Freedom of Information Act
1974 U.S. Code. Title 5, Chapter 552.
- Hussain, Khateeb M.
1973 *Development of Information Systems for Education*.
Englewood Cliffs, NJ: Prentice-Hall.
- Josephson, Ben, Jr., et al.
1975 *The Comprehensive Instructional Management System*. New
York: Riverside Research Institute.
- Lucas, Henry C., Jr.
1978 *Information Systems Concepts for Management*. New York:
McGraw-Hill.
- Martin, James
1976 *Principles of Data-Base Management* Englewood Cliffs, NJ:
Prentice-Hall.
- Molnar, Andrew R.
1978 "The New Great Crisis in American Education: Computer
Literacy." *The Journal* 5:35-39.
- National Center for Education Statistics, Washington, D.C.
1980 *The Condition of Education, 1980 Edition*. Annual Report.
U.S. Government Printing Office.
- Sanders, Donald H. and Birkin, Stanley J.
1980 *Computers and Management in a Changing Society*. New
York: McGraw-Hill.

VII. APPENDIX: EDUCATIONAL COMPUTING RESOURCES

The following is a highly selective list of educational computing associations, organizations, periodicals and books that might be of interest to school administrators.

Associations and Organizations

Association For Computing Machinery (ACM)

1133 Avenue of the Americas
New York, NY 10036
(212) 265-6300

ACM is a professional computer association which includes a number of educational special-interest groups: Computers and Society, Computer Science Education, Computer Use in Education, and the ACM Elementary and Secondary Schools Subcommittee.

Association for Educational Data Systems (AEDS)

1201 16th Street, N.W.
Washington, D.C. 20036
(202) 833-4100

AEDS is a professional association for teachers, administrators, and computer specialists at the elementary, secondary, and postsecondary levels. AEDS focuses on both administrative and instructional computing and has a number of statewide affiliates.

Association for the Development of Computer-Based Instructional Systems (ADCIS)

Computer Center
Western Washington University
Bellingham, WA 98225
(206) 676-2860

ADCIS consists of a number of special interest groups and emphasizes close user-vendor communication to improve the development and use of computer-based education

Educational Products Information Exchange (EPIE Institute)

P.O. Box 620
Stony Brook, NY 11790
(516) 246-8664

EPIE is an educational computing consumer advocacy and testing organization that evaluates computer software packages and disseminates its findings among members.

Lawrence Hall of Science

University of California

Berkeley, CA 94720

(415) 642-3167

The Hall of Science's Computer Education Project runs computer literacy workshops and produces related instructional material for teachers and students, both at the Hall and at Bay Area schools.

Microcomputer Resource Center

Teachers College, Columbia University

New York, NY 10027

(212) 678-3740

The Center provides educators with access to its microcomputers and library and conducts a number of on-campus and off-campus seminars and workshops in computer-based instruction.

Microcomputer Software and Information for Teachers (Micro SIFT)

Northwest Regional Educational Laboratory

710 2nd Avenue, S.W.

Portland, OR 97204

(503) 248-6874

The U.S. National Institute of Education funded Micro SIFT as a clearinghouse for assembling, evaluating, and disseminating reviews of microcomputer software at the elementary-secondary level.

Minnesota Educational Computing Consortium (MECC)

2520 Broadway Drive

St. Paul, MN 55113

(612) 376-1101

MECC is the coordinating agency for educational computing services for the Minnesota public schools; MECC provides a wide range of software products, workshops and in-service training, and publications.

Periodicals

Classroom Computer News

P.O. Box 266

Cambridge, MA 02138

Bimonthly. Emphasizes use of microcomputers in schools and general educational computer applications.

Creative Computing

P.O. Box 789-M

Morristown, NJ 07960

Monthly. Contains articles and reviews on microcomputer hardware and software for many applications.

Educational Technology

140 Sylvan Avenue

Englewood Cliffs, NJ 07632

Monthly. Covers computer, audio-visual, video, and related technologies in instruction.

Electronic Learning

902 Sylvan Avenue

Englewood Cliffs, NJ 07632

Monthly. During the school year, focuses on use of new interactive technologies in learning environments.

Interface Age

16704 Marquardt Avenue

Cerritos, CA 90701

Monthly. Provides articles and reviews on microcomputing for business and home applications.

Personal Computing

50 Essex Street

Rochelle Park, NJ 07662

Monthly. Covers the business and professional applications of microcomputing.

Popular Computing

P.O. Box 307

Martinsville, NJ 08836

Monthly. Articles and reviews on microcomputer hardware and software, especially for personal use.

T.H.E. Journal

P.O. Box 992

Acton, MA 01720

Monthly. Deals with computer, videotape, videodisk, and audio-visual technologies which affect education.

Books

- Billings, Karen, and Moursund, David. *Are You Computer Literate?* Beaverton, OR: Dilithium Press, 1979.
- Covey, H. Dominic, and McAlister, Niel H. *Computer Consciousness*. Reading, MA: Addison-Wesley, 1979.
- Davis, William S., and McCormack, Allison. *The Information Age*. Reading, MA: Addison-Wesley, 1979.
- Doerr, Christine. *Microcomputers and the 3R's*. Rochelle Park, NJ: Hayden Book Co., 1979.
- Evans, Christopher. *The Micro Millennium*. New York: Viking Press, 1979.
- Hussain, Khateeb M. *Development of Information Systems for Education*. Englewood Cliffs, NJ: Prentice-Hall, 1973.
- Lucas, Henry C., Jr. *Information Systems Concepts for Management*. New York: McGraw-Hill, 1978.
- Martin, James. *An End-User's Guide to Data Base*. Englewood Cliffs, NJ: Prentice-Hall, 1981.
- Poirot, James L. *Computers and Education*. Manchaca, TX: Sterling Swift, 1980.
- U.S. House Committee on Science and Technology, Washington, D.C. *Information Technology in Education*. Hearing Transcript number 134, April, 1980. Washington, D.C.: U.S. Government Printing Office, 1980.