

DOCUMENT RESUME

ED 211 687

CE 030 918

AUTHOR Bhola, H. S.
TITLE The Theory of the Mass Literacy Campaign.
PUB DATE Feb 82
NOTE 9p.; Paper presented at the Annual Henry Lester Smith Conference on Research in Education (7th, Bloomington, IN, February 1-2, 1982).

EDRS PRICE MF01/PC01 Plus Postage.
DESCRIPTORS Adult Basic Education; *Adult Literacy; *Developing Nations; Educational Needs; Educational Planning; Foreign Countries; *Literacy Education; *Models; Policy Formation; Political Influences; Program Design; *Program Development; Public Policy
IDENTIFIERS *Literacy Campaigns

ABSTRACT

After an analysis of eight mass literacy campaigns (USSR 1919-39; Vietnam, 1945-77; China, 1950-58; Cuba, 1961; Burma, 1960-1981; Brazil, 1967-80; Tanzania, 1971-81; and Somalia, 1973-75), a campaign strategy for a mass literacy campaign is proposed. A potentially successful mass literacy campaign has to be both an educational and a political event. A useful theory of the mass literacy campaign must, therefore, include the two dimensions of ideology and technology. Ideology will determine the possibility of the articulation and sustenance of the political will to achieve universal literacy--a necessary condition for a successful campaign. The prevailing ideology of the society will also determine the organizational and technological choices that can be made in the planning and implementation of the campaign. The technology of the mass literacy campaign must deal with three sets of considerations: creating organizational structures; determining dissemination of information about the campaign as well as its curricular content, target audience, and methods and materials to be used; and motivation of the people through mobilization. A model for planning and implementation of a mass literacy campaign would include the following elements: mating of ideas of politicians, development theorists and literacy workers; articulation of the political will; sustenance of the political will; temporary institutionalization of the first policy initiative; development of a comprehensive policy-making and -legitimizing organ; study and diagnosis of pre-conditions; evaluation; implementation of programs; and preparation and implementation of post-literacy programs. (KC)

 * Reproductions supplied by EDRS are the best that can be made *
 * from the original document. *

The document has been reproduced as received from the person or organization originating it. Minor changes have been made to improve reproduction quality.

Points of view or opinions stated in this document do not necessarily represent official NIE position or policy.

H. S. Bholā

TO THE EDUCATIONAL RESOURCES INFORMATION CENTER (ERIC)."

THE THEORY OF THE MASS LITERACY CAMPAIGN¹

By H. S. Bholā²

The campaign strategy (being organized large-scale series of activities, intensely focussed on a set of objectives to be achieved within some pre-determined period of time) is no more the language of soldiering alone. It is already a part of the language of politics³ as well as of the language of development.⁴

Eight mass literacy campaigns (a special category of educational/developmental campaigns) were analyzed by the author as part of a study conducted for Unesco in behalf of the International Council of Adult Education.⁵ The literacy campaigns covered in this study were USSR (1919-39), Vietnam (1945-77), China (1950-58), Cuba (1961), Burma (1960s-1980s), Brazil (1967-80), Tanzania (1971-81), and Somalia (1973-75).

On the basis of the analyses of the campaigns included in the Unesco/ICAE study (and an examination of other educational/developmental campaigns recently conducted in various parts of the world), it is possible to propose a theory of the mass literacy campaign. We suggest that a potentially successful mass literacy campaign has to be, at the same time, an educational and a political event. A useful theory of the mass literacy campaign must, therefore, include the two dimensions of ideology and technology.

The prevailing ideology of a society will, first, determine if universal adult literacy is indeed considered central to the achievement of overall national developmental goals. Thus, ideology will determine the possibility of the articulation and sustenance of the "political

ED211687

8180918

will" to achieve universal literacy -- a necessary condition for a successful literacy campaign. At an other level, the prevailing ideology of the society will reflect a particular "political culture" which, in turn, will determine the organizational-mobilizational and the technological choices that can or cannot be made in the planning and implementation of the mass literacy campaign.

The other dimension of the theory of the mass literacy campaign is technological. Political will is prior, but technology is the great enabler in the planning and implementation of successful mass literacy campaigns.⁶ The technology of the mass literacy campaign must deal with three sets of considerations:

1. Structural/Organizational

Organizational structures must be created that can plan, mobilize for, implement, and evaluate the mass literacy campaign.

2. Curricular/Informational

Decisions must be made regarding the dissemination of information about the campaign as well as in regard to its curricular content, language(s) of literacy, and methods and materials to be used.

3. Motivational/Interactional

People must be motivated through mobilization because motivations are seldom spontaneous. Provisions must be made for the people to come together to learn, discuss, interact, internalize and to act on their decisions.

The graphic on the next page presents a general model for the planning and implementation of a mass literacy campaign. In the notes below, numbers for paragraphs match with the numbers in the graphic model.

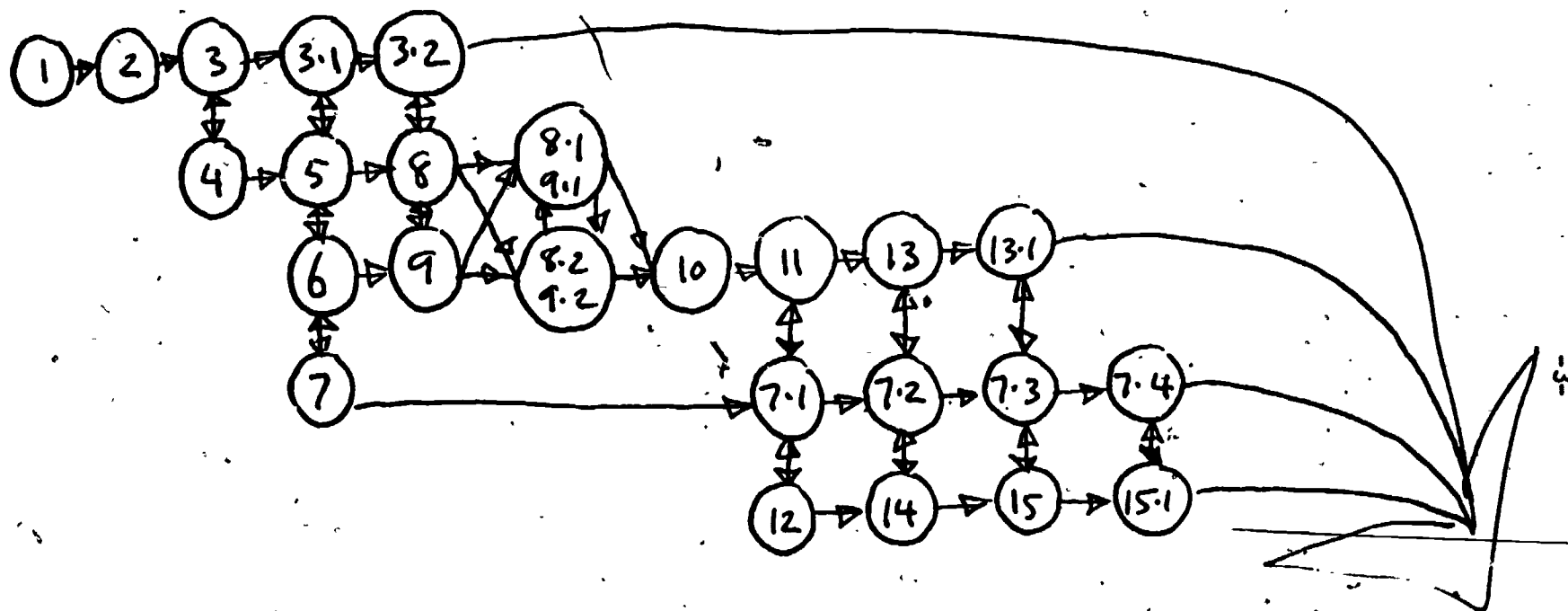

Figure -1. A general model for the planning and implementation of a mass literacy campaign.

4

5

1. Mating of ideas of politicians, development theorists and literacy workers. The existence of a revolutionary condition, the fervor generated by newly-won independence or a change of government are specially conducive to the mating of ideas leading to declarations of mass literacy campaigns. However, these are not the only historical conditions under which the need for universal literacy will emerge. Important cultural and moral resources will be found to exist in all societies.
2. Articulation of the political will. The processes of building consensus for the articulation of the political will differ from society to society. Such articulation is, however, a necessary condition for a successful literacy campaign.
3. Sustenance of the political will. (Also 3.1 and 3.2) Once articulated, the political will will need to be sustained.
4. Temporary institutionalization of the first policy initiative. This institutionalization must occur at the highest level of government -- above individual departments, bureaus and ministries. The association of "the leader" with such institutionalization will help considerably.
5. Development of a comprehensive policy making and legitimizing organ. The first temporary institutionalization must be followed by more comprehensive institution-building. Once again institutionalization must be trans-departmental.
6. Study and diagnosis of pre-conditions. This should be done not to make a "Go/No Go" decision, but to understand the existing conditions to promote implementation. Such a study could also be used as a strategy for mobilization.

7. Evaluation. (Also 7.1, 7.2, 7.3, and 7.4) Evaluation must begin with the study of the context and then cover process evaluation, product evaluation and impact evaluation.
8. Mobilization of the state resources. This will have to be done in two parts: (1) establishment of technical structures; and (2) establishment of administrative structures. (See 8.1 and 8.2)
9. Mobilization of non-governmental resources. A mass literacy campaign need not be organized solely by the state. Voluntary action may play an important part. In such a situation, the voluntary sector must also mobilize to be able to make needed technical inputs and to deliver required services. (See 9.1 and 9.2)
10. Establishment of structures of mass participation. Participation of the people will not come about unless structures for such participation are provided. This may require the assistance of mass organizations; and where none exist, new mass organizations may have to be promoted.
11. Pre-operational field preparation. Such preparations must be made closest to the field of action. A national perspective and thrust must, however, be provided to guard against fragmentation of action. Time for this activity must be provided as part of the planning process.
12. Planning for post-literacy programs. Planning for the post-literacy programs must begin as soon as activities for literacy promotion begin on the ground.
13. Implementation of pedagogical and developmental actions. (Also 13.1) Connections must be made between learning and developmental actions in the economic, social and political aspects.

14. Preparation of post-literacy curriculum, materials and delivery systems. Such programs must cover both newly-literates (coming out of

literacy classes) and those already literate living in the community.

15. Implementation of post-literacy programs. (Also 15.1) Here again the relationship between learning and developmental actions should be clear and articulated.⁷

A discussion of the campaign strategy for literacy promotion is today more than an academic interest. Literacy has been considered a human right and has been included by many developing countries as one need among the basic human needs. Unesco has called it the "priority of priorities" for the 1980s. Out there in the real world, there are some 815 million adult illiterates, most of them in the Third World. As the Udaipur Declaration⁸ pointed out:

The magnitude of illiteracy in many countries calls for a massive effort. In order to imbue the fight against illiteracy with the needed sense of urgency, to create the appropriate climate of opinion and to make the mobilization of the necessary resources possible, time-bound campaigns with specific targets and intensified action would be an appropriate strategy in these countries.

The theory and the model presented here may make a small contribution to the realization of this hope.

REFERENCES AND NOTES

1. This short paper was prepared for the Seventh Annual Henry Lester Smith Conference on Research in Education held at Indiana University, Bloomington, Indiana during February 1-2, 1982.
2. H. S. Bhola is professor of education (in the departments of instructional systems technology; and historical, philosophical and comparative studies in education), Indiana University at Bloomington.
3. Some of us are perhaps familiar with the many published analyses of Presidential campaigns in U.S.A. Theodore H. White, Making of the President Nineteen Seventy-Two, Atheneum, 1973 is but one example of an analysis of a political campaign. There have also been attempts to understand the technology of political campaigning. See for example, Edward Schwartzman, Campaigning Craftsmanship: A Professional Guide to Campaigning for Elective Office, Universe, 1973.
4. See for instance D. Crowley and M. Colclough, The People and the Plan: The Report on Botswana's Educational Project on the Five-Year Development Plan, University of Botswana, Lesotho and Swaziland, Gaborone, 1974; Budd Hall, Tanzania's Health Campaign, Clearinghouse of Development Communication, Washington, D.C., 1978; and Ronald Rice and William Paisley (Eds.), Public Communication Campaigns, Sage, 1981. Educational campaigns have been organized in recent years in many countries, among them, Algeria, Canada, India, Iraq, Honduras, Mozambique, etc., etc.
5. H. S. Bhola, Campaigning for Literacy: A Critical Analysis of Some Selected Literacy Campaigns of the 20th Century, with a Memorandum to Decision Makers. A report to Unesco, Paris, 1981. The Report will be published by Unesco in English, French, Spanish and Arabic during 1982. A pre-publication copy of the report has been placed in the Indiana University Libraries. Chapter III of this report was published as "Why Literacy Can't Wait: Issues for the 1980s" in Convergence (An International Journal of Adult Education), XIV(1):6-23, 1981.
6. Our analysis of successful mass literacy campaigns suggests that no set of conditions is too adverse and severe to launch a mass literacy campaign. If political will exists, the campaign itself will solve the problems it lays bare. Innovative solutions are created as peoples and their governments are challenged to promote universal literacy.
7. A more detailed discussion of this general model may be found in Chapter XII of the report cited in (5) above. See the chapter entitled, "Planning, Implementing and Evaluating Literacy Campaigns: A Memorandum to Decision Makers."
8. The Udaipur Declaration was unanimously adopted by the "International Seminar on Campaigning for Literacy" held in Udaipur, India during January 4-11, 1982. The Seminar was attended by teams from 17 countries of Asia, Africa and Latin America. The Unesco/ICAE report, Campaigning for Literacy by H. S. Bhola was the basic discussion document and the author of the report served as the Technical Director of the seminar.