

DOCUMENT RESUME

ED 211 684

CE 030 912

AUTHOR Coyle, John, A., Jr.
TITLE Aviation Electrician's Mate 3 & 2. Rate Training Manual and Nonresident Career Course.
INSTITUTION Naval Education and Training Program Development Center, Pensacola, Fla.
REPORT NO NAVEDTRA-10348-E
PUB DATE 81
NOTE 557p.; Photographs will not reproduce well.

EDRS PRICE MF02/PC23 Plus Postage.
DESCRIPTORS Aviation Mechanics; *Aviation Technology; Aviation Vocabulary; Course Content; Electrical Occupations; *Electrical Systems; Electricians; Electricity; Electronic Control; *Electronic Technicians; Engines; Independent Study; Inservice Education; *Instrumentation; Learning Modules; *Military Training; Physics; Postsecondary Education; Programed Instructional Materials

ABSTRACT

This Rate Training Manual and Nonresident Career Course (RTM/NRCC) form a self-study package that will enable Aviation Electrician's (AE) Mates to help themselves fulfill the requirements of their rating. Designed for individual study and not formal classroom instruction, the RTM provides subject matter that relates directly to the occupational standards for the AE3 and AE2. Topics covered in the course include Navy publications and supplies; elementary physics; electrical maintenance and troubleshooting; aircraft electrical power systems; aircraft electrical and associated systems; instruments; and compass, inertial navigation, automatic flight control, and stabilization systems. A glossary and list of symbols are also included in the package. The NRCC provides the usual method for satisfying the requirements for the RTM. The set of assignments in the NRCC includes learning objectives and supporting items designed to lead students through the RTM. The occupational standards used as minimum guidelines in the preparation of the manual are found in the "Manual of Navy Enlisted Manpower and Personnel Classifications and Occupational Standards." (KC)

 * Reproductions supplied by EDRS are the best that can be made *
 * from the original document. *

FD211684

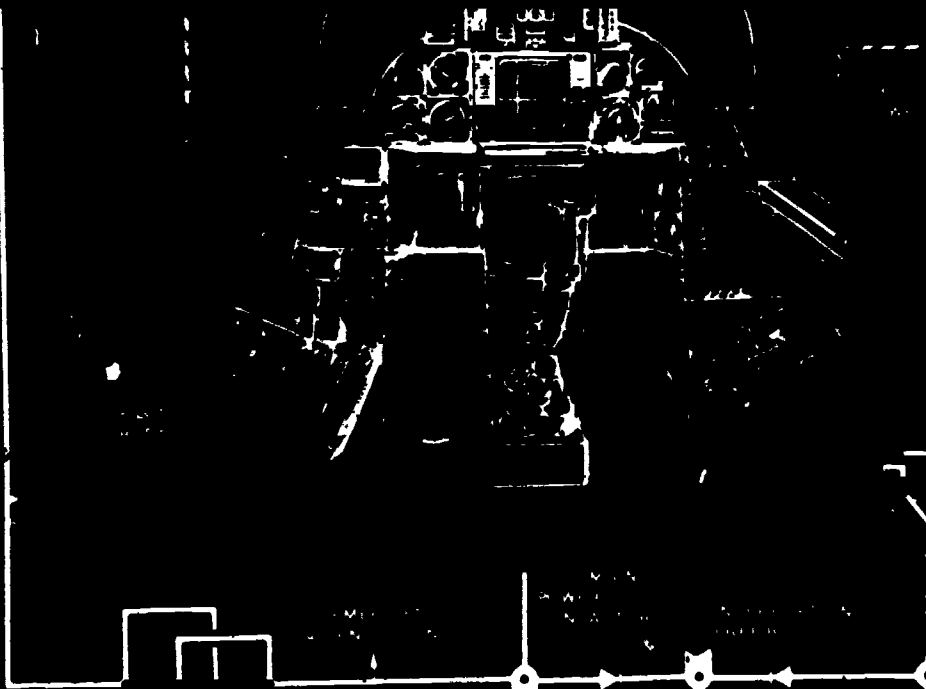

AVIATION

ELECTRICIAN'S MATE 3 &

NAVAL EDUCATION AND TRAINING COMMAND
BASIC TRAINING MANUAL AND NONRESIDENT CAREER

NAVEDTRA 10348-E

2-30912

ERIC
Full Text Provided by ERIC

ED211684

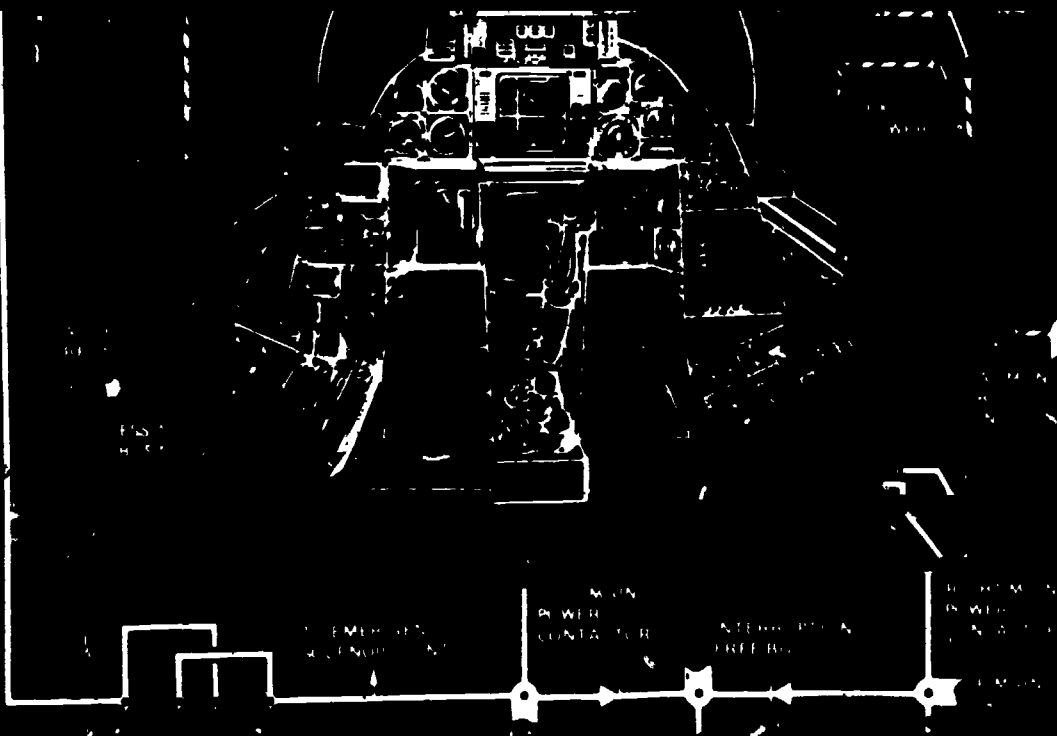

AVIATION

ELECTRICIAN'S MATE 3 & 2

CE

NAVAL EDUCATION AND TRAINING COMMAND
RATE TRAINING MANUAL AND NONRESIDENT CAREER COURSE

NAVEDTRA 10348-E

U.S. DEPARTMENT OF EDUCATION
NATIONAL INSTITUTE OF EDUCATION
EDUCATIONAL RESOURCES INFORMATION
CENTER (ERIC)

- ✓ This document has been reproduced as received from the person or organization originating it.
- ✓ Minor changes have been made to improve reproduction quality.
- Points of view or opinions stated in this document do not necessarily represent official NIE position or policy.

030912

Although the words "he", "him", and "his", are used sparingly in this manual to enhance communication, they are not intended to be gender driven nor to affront or discriminate against anyone reading *Aviation Electrician's Mate 3 & 2*, NAVEDTRA 10348-E.

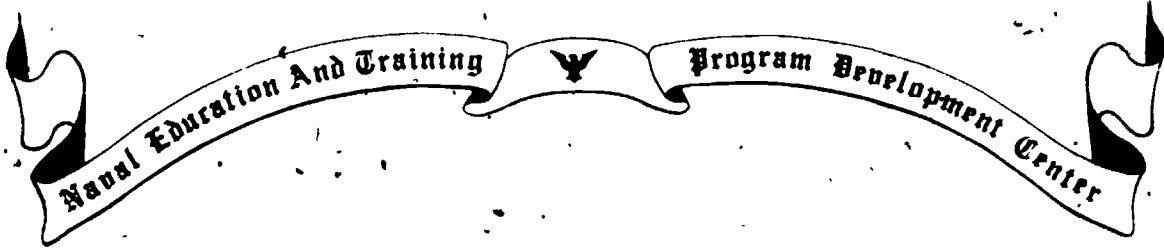

AVIATION ELECTRICIAN'S MATE 3 & 2

NAVEDTRA 10348-E

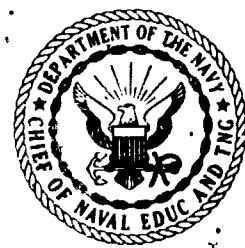

*1981 Edition Prepared by
AECS John A. Coyle Jr.*

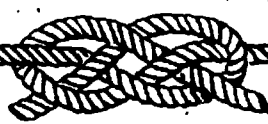

PREFACE

This Rate Training Manual and Nonresident Career Course (RTM/NRCC) form a self-study package that will enable ambitious Aviation Electrician's Mates to help themselves fulfill the requirements of their rating.

Designed for individual study and not formal classroom instruction, the RTM provides subject matter that relates directly to the occupational standards for the AE3 and AE2. The NRCC provides the usual method for satisfying the requirements for completing the RTM. The set of assignments in the NRCC includes learning objectives and supporting items designed to lead students through the RTM. The occupational standards used as minimum guidelines in the preparation of this manual are to be found in the *Manual of Navy Enlisted Manpower and Personnel Classifications and Occupational Standards*, NAVPERS 18068-D.

This Rate Training Manual was prepared by the Naval Education and Training Program Development Center, Pensacola, Florida, for the Chief of Naval Education and Training. Technical review of the manuscript was provided by personnel at NATTC, NAS Memphis, Millington, Tennessee and personnel at Naval Aviation Logistics Center, Patuxent River, Maryland.

1981 Edition

Stock Ordering No.
0502-LP-051-7415

Published by
NAVAL EDUCATION AND TRAINING PROGRAM
DEVELOPMENT CENTER

UNITED STATES
GOVERNMENT PRINTING OFFICE
WASHINGTON, D.C.: 1981

THE UNITED STATES NAVY

GUARDIAN OF OUR COUNTRY

The United States Navy is responsible for maintaining control of the sea and is a ready force on watch at home and overseas, capable of strong action to preserve the peace or of instant offensive action to win in war.

It is upon the maintenance of this control that our country's glorious future depends; the United States Navy exists to make it so.

WE SERVE WITH HONOR

Tradition, valor, and victory are the Navy's heritage from the past. To these may be added dedication, discipline, and vigilance as the watchwords of the present and the future.

At home or on distant stations we serve with pride, confident in the respect of our country, our shipmates, and our families.

Our responsibilities sober us; our adversities strengthen us.

Service to God and Country is our special privilege. We serve with honor.

THE FUTURE OF THE NAVY

The Navy will always employ new weapons, new techniques, and greater power to protect and defend the United States on the sea, under the sea, and in the air.

Now and in the future, control of the sea gives the United States her greatest advantage for the maintenance of peace and for victory in war.

Mobility, surprise, dispersal, and offensive power are the keynotes of the new Navy. The roots of the Navy lie in a strong belief in the future, in continued dedication to our tasks, and in reflection on our heritage from the past.

Never have our opportunities and our responsibilities been greater.

CONTENTS

CHAPTER	Page
1. Publications and Supply	1-1
2. Elementary Physics	2-1
3. Electrical Maintenance and Troubleshooting	3-1
4. Aircraft Electrical Power Systems	4-1
5. Aircraft Electrical and Associated Systems	5-1
6. Instruments	6-1
7. Compass, Inertial Navigation, Automatic Flight Control and Stabilization Systems	7-1
APPENDIX	
I. Glossary	AI-1
II. Symbols	AII-1
INDEX	I-1
Nonresident Career Course follows Index	

CHAPTER 1

PUBLICATIONS AND SUPPLY

PUBLICATIONS

Naval publications are important sources of information for guiding personnel of the naval aeronautic organization. Generally, these publications fall into two broad groups—those dealing with operational and administrative matters, and those dealing with technical and material matters.

AERONAUTICAL PUBLICATIONS

Publications dealing primarily with the operation and maintenance of aircraft and related equipment within the Naval Establishment originate from the Naval Air Systems Command (NAVAIRSYSCOM frequently referred to as NAVAIR) and are issued by authority of the Commander, Naval Air Systems Command.

Publications concerned mainly with the training of flight personnel and air operations emanate from the Office of the Deputy Chief of Naval Operations (AIR).

The Naval Air Technical Services Facility (NATSF) functions as the sponsor of both types of publications and controls the initial distribution, distribution lists, printing, and retention of reproducible copy.

The Forms and Publications Supply Office functions as inventory manager for residual stocks of both types of publications, including the supporting distribution systems and numerical cataloging.

The basic sources of technical aeronautic information are the technical manuals, issued by

NAVAIR. Letter publications usually supplement the information contained in aeronautic technical manuals.

Aviation Electricians at the E-4 and E-5 levels are primarily concerned with technical publications; therefore, this discussion is directed mainly toward them. However, it includes some coverage of general and administrative type publications of importance to all naval personnel.

Good technical manuals are vital to the maintenance of modern weapons systems. Our Navy's combat readiness depends, to an increasing degree, on the information and knowledge possessed by maintenance personnel. If these persons are to maintain increasingly complex weapons systems incorporating the latest devices and systems, they must be able to obtain the required information from technical manuals.

The Department of Defense, the Department of the Navy, and the Naval Air Systems Command are working together to improve the standardization and quality of aeronautic maintenance manuals. The purpose of the following discussion is to present some detailed information concerning the contents and uses of these manuals.

Maintenance Information Automated Retrieval System (MIARS)

As a means of improving updated manual availability and reducing stowage space, NAVAIR is in the process of placing numerous maintenance and illustrated parts breakdown manuals on 16 mm microfilm. The microfilm is stored in 4-inch (10.2 cm) square cartridges similar to 8-track recording tapes. (Fig. 1-1)

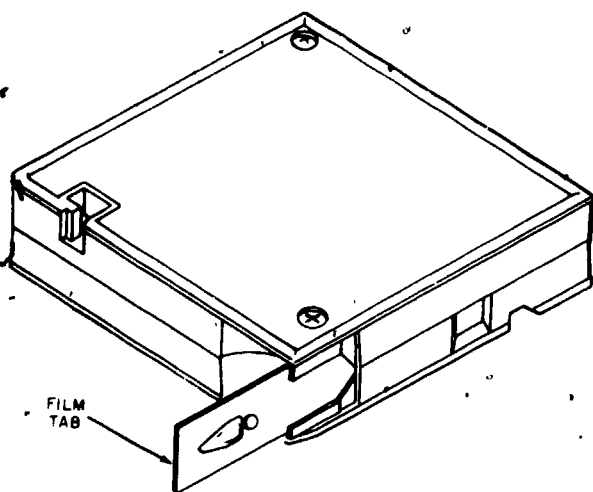

208.273

Figure 1-1.—MIARS film cartridge.

Each cartridge has the capability of containing 2,700 pages of information. A label on the cartridge indicates the number of the manual(s) enclosed. It is intended that MIARS cartridges be issued to organizations in lieu of printed material. Organizations will be provided with a number of automatic-reader printers and portable readers as shown in figure 1-2 and 1-3 to enable use of the microfilm. The automatic reader-printer will print a copy of the page projected on the reader screen at a readable size. The portable reader will only project the microfilm to a readable size. The number of automatic reader-printers and portable readers allowed will depend on the size and mission of the organization.

Microfiche

Microfiche is a film negative card (fiche). Fiche cards are used for many purposes throughout the Navy wherever microfilming may be used to reduce amounts of paper documents. (Figure 1-4). Each fiche card of this deck is approximately 5.75 by 4 inches (14.6 by 10.2 cm) and has a capacity of 270 pages of microfilmed data.

The fiche is divided into frame-grids of 15 rows (A through O down the side) and 18

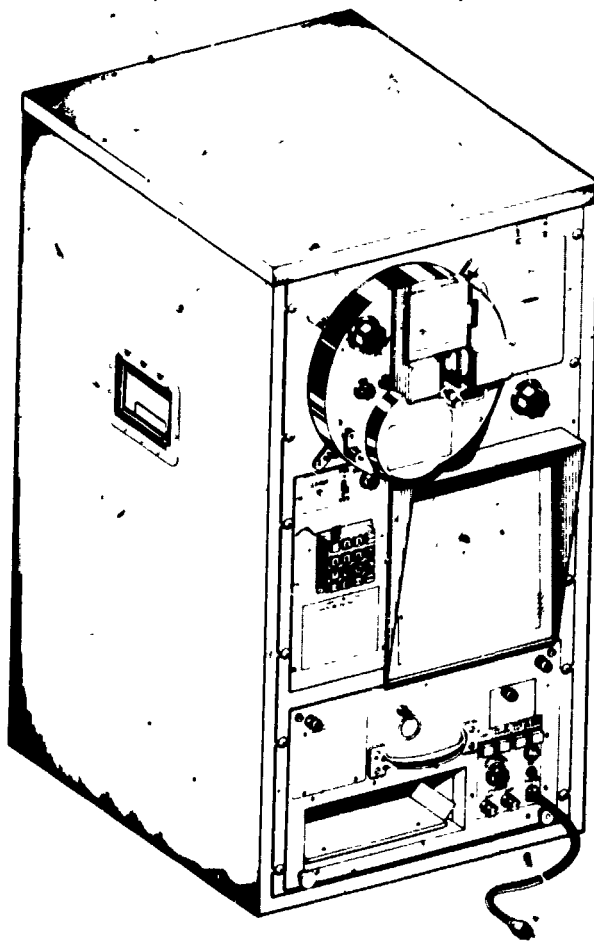

216.239

Figure 1-2.—Automatic reader printer.

columns (1 through 18 across the top). The lower right entry (0-18 or 18-0) is a table of contents for the fiche and lists the first entry of each frame-grid.

The eye-readable (without projection) information across the top of the fiche lists the following: the first entry on the first frame-grid (NA-A 5.17), the title of the publication (NAVSUP 2002), the information contained on the fiche (Form/Pub/Hull No.), the revision date of the card (May 1975), and the number of the card within the deck (02).

Fiche cards are used in conjunction with a viewer which projects the frame-grid selected on the viewer screen at a readable size.

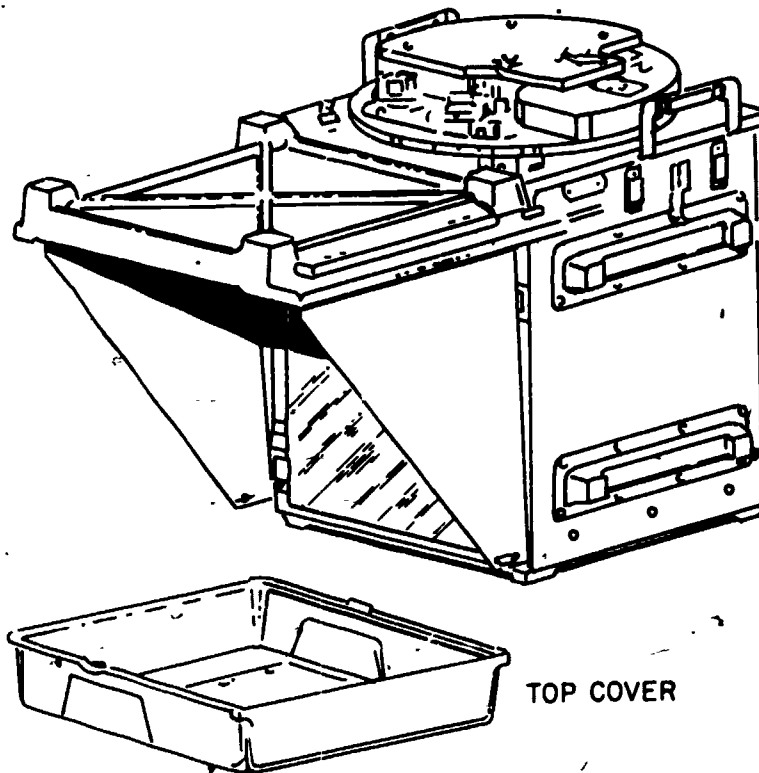

Figure 1-3.—Portable reader.

Aeronautic publications originated by NAVAIR and distributed by NATSF may be found in the Naval Aeronautic Publications Index (NAPI). The index consists of the following six parts:

1. NAVSUP Publication 2002, Navy Stock List of Publications and Forms.
2. NAVAIR 00-500A, Equipment Application List.
3. NAVAIR 00-500B, Aircraft Application List.
4. NAVAIR 00-500C, Directives Application List by Aircraft Configuration.
5. NAVAIR 00-500M, Microfilm Cross Reference Index.

6. NAVAIR 01-700, Airborne Weapons/Stores, Conventional/Nuclear, Check Lists/Stores Reliability Cards/Manual.

NAVSUP Publication 2002, Navy Stock List of Publications and Forms

This is the primary index for all Navy technical manuals and forms. It is compiled and controlled by the Naval Publications and Forms Center, Philadelphia, Pa. under the direction of the Naval Supply Systems Command. The index is issued quarterly (February, May, August and November), based on information updates provided by the individual systems commands. It is the only index authorized for placing orders for Navy technical manuals and forms.

Detailed instructions for use of this index are provided in a printed pamphlet titled

AVIATION ELECTRICIAN'S MATE 3 & 2

NA-01-S3AAA - 4	1	0801-LP-227-2560	S-3A Aircraft, Introduction, Numerical and Reference Designation Indexes, Organizational Maintenance IPB	12/15/75
NA-01-S3AAA - 4	2	0801-LP-227-3020	S-3A Aircraft, Airframe Group System, Organizational Maintenance IPB (Includes Change 1)	10/01/74
NA-01-S3AAA - 4	3	0801-LP-227-3520	S-3A Aircraft, Landing System, Organizational Maintenance IPB (Includes Change 1)	10/01/74
NA-01-S3AAA - 4	4	0801-LP-221-8520	S-3A Aircraft, Hydraulic System, Organizational Maint IPB	10/01/74
NA-01-S3AAA - 4	5	0801-LP-227-4020	S-3A Aircraft, Fuel and Inflight Refueling System, Organizational Maintenance IPB (Includes Change 1)	10/01/74
NA-01-S3AAA - 4	6	0801-LP-227-4520	S-3A Aircraft, Propulsion System and Engine Buildup, Organizational Maintenance IPB	10/01/74
NA-01-S3AAA - 4	7	0801-LP-227-5020	S-3A Aircraft, Environmental Control System, Organizational Maintenance IPB (Includes Change 1)	10/01/74
NA-01-S3AAA - 4	8	0801-LP-227-5520	S-3A Aircraft, Escape and Survival Systems, Organizational Maintenance IPB	10/01/74
NA-01-S3AAA - 4	9	0801-LP-227-6020	S-3A Aircraft, Flight-Control System, Organizational Maint IPB (Includes Change 1)	10/01/74
NA-01-S3AAA - 4	10	0801-LP-226-7520	S-3A Aircraft, Wing and Fin Fold Systems, Organizational Maint W/IPB (Includes Change 1)	10/01/74
NA-01-S3AAA - 4	11	0801-LP-227-6520	S-3A Aircraft, Power Distribution Electrical Power and Lighting, Organizational Maintenance IPB	10/01/74
NA-01-S3AAA - 4	12	0801-LP-221-9030	S-3A Aircraft, General Purpose Digital Computer, Organizational Maint. IPB	10/01/74
NA-01-S3AAA - 4	13	0801-LP-221-9520	S-3A Aircraft, Avionic Systems - Data Processing and Control Acoustic Processing Armament and Stores Control, Organizational Maint IPB	10/01/74
NA-01-S3AAA - 4	14	0801-LP-226-8020	S-3A Aircraft, Avionic Systems - Nonacoustic Sensors, Electronic Countermeasures, Navigation, Automatic Flight Control and Communications, Organizational Maint- IPB (Includes Change 1)	10/01/74

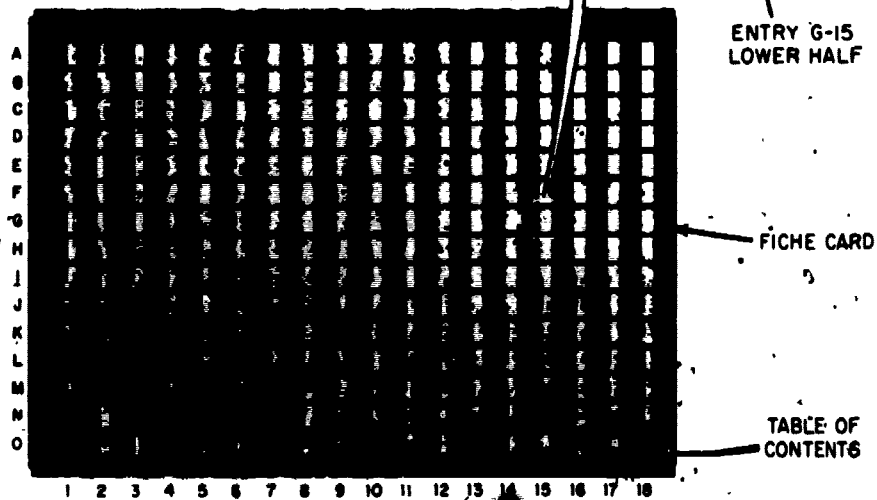

220.580

Figure 1-4.—Microfiche card example.

Chapter 1—PUBLICATIONS AND SUPPLY

“Introduction to Navy Stock List of Publications and Forms”. The index itself is produced in microfiche only. Each new addition to the microfiche supersedes the previous addition in its entirety. It is composed of three sections as follows:

1. Section I is an alphanumeric listing of form numbers, publication numbers, hull numbers and electronic model numbers. It lists all Cog OI and II publication numbers and form numbers in ascending alphanumeric sequence, cross referenced to a basic stock number with

title/nomenclature and revision date. (Refer to figure 1-5.)

2. Section II is an alphabetic listing of publications and forms by title/nomenclature. It lists all Cog OI and II publications and forms by title/nomenclature, cross referenced to a basic stock number, with form, publication number and revision date. (Refer to figure 1-6.)

3. Section III is a numeric listing (in stock number sequence) of Cog OI and II stock numbers, publications, forms and NAVAIRSYS-COM technical directives. It includes all of the

FORM/PUB NO.	STOCK NUMBER	TITLE/NOMENCLATURE	REV. DATE
NA 03-25GG 1	0803-LP-490-3500	Valve Control Dual Brake P/N 23410-3 (STERER) Acft. Maint.	02/15/70
NA 03-25GR 3	0803-LP-499-8410	Actuator, Arresting Hook Life (Grumman Aerospace) Intermediate/Depot Maintenance w/IPB	11/15/72
NA 03-25GR 6	0803-LP-499-8600	Superseded by S/N 0803-LP-499-8610	
NA 03-24GR 10	0803-LP-499-8700	Swivel Wheel Brake Torsion (Grumman Aerospace) Intermediate Maint. w/IPB	11/15/72
NA 03-25GR 25	0803-LP-498-3500	Superseded by S/N 0803-LP-498-3510	

Figure 1-5.—Example of NAVSUP Pub 2002, Section I.

TITLE/NOMENCLATURE	FORM/PUB NO.	REV. DATE	STOCK NUMBER
Generator, Tachometer(GE) Ovhl. Instrs. w/PB	NA 05-5J-14	05/15/53	0805-LP-006-8000
Generator, Tachometer(GE) Ovhl. Instrs. w/PB	NA-05-5J-504	03/15/55	0805-LP-008-3500
Generator, Tachometer (GE) Ovhl. Instrs. w/PB	NA 05-5J-509	10/15/54	0805-LP-008-5000
Generator, Tachometer (Heintz) IPB	NA 05-5K-506	07/01/61	0805-LP-009-2500
Generator, Tachometer (Heintz) Ovhl. Instrs.	NA 05-5K-505	07/01/61	0805-LP-009-1500

Figure 1-6.—Example of NAVSUP Pub 2002, Section II.

AVIATION ELECTRICIAN'S MATE 3 & 2

technical data related to the items listed, that is required for requisitioning purposes (refer to figure 1-7). The NAVAIRSYSCOM technical directives listed in this section are located on a separate fiche, immediately following the last fiche reflecting stock numbers for publications and forms.

NAVAIR 00-500 Series Indices

This index series is prepared and issued under the direction and authority of the Commander, Naval Air Systems Command. There is no relationship or connection between this series and the NAVSUP Pub 2002. The NA 00-500 documents have been developed to provide a direct relationship between the NAVAIR technical manual inventory and fleet operational requirements and weapon systems maintenance, rather than to supply and issue control.

NAVAER 00-500A, Equipment Applicability List

This index consists of a detailed cross reference of NAVAIR cognizant aircraft components and equipment to their associated publications. All listings are arranged alphanumerically and sequenced by model, type or part number (refer to figure 1-8). This document is prepared and released annually in November of each year. To assure current

information, cumulative supplements are issued quarterly in February, May and August. Further detailed instructions and explanations of applicable columns are outlined in the introduction section of volume I to this index.

NAVAIR 00-500B, Aircraft Application List

This index consists of listings of technical manuals as they apply to a specific aircraft weapons system. All listings are arranged alphanumerically by NAVAIR technical manual number with Maintenance Information Automated Retrieval System (MIARS) cartridge numbers (if applicable) (refer to figure 1-9). This document is prepared and released annually in January of each year.

NAVAIR 00-500C, Directives Application List

This index consists of listings of the active NAVAIRSYSCOM technical directives as they apply to a specific aircraft series. All listings are arranged numerically by Technical Directive (TD) code. This document is prepared and released semiannually for each aircraft series. Further detailed instructions and explanations of columns are outlined in the introduction of each section.

STOCK NUMBER	PUBLICATION NO.	TITLE/NOMENCLATURE	R/D	B/C	MCC	UI	PS	RR
0805-LP-127-5510	NA-05-55N-58	Indicator, Exhaust Pressure, Ovhl Instrs w/IPB	03/15/73	B		EA		DV
0816-LP-074-8500	NA-16-30AFQ94-5	Radar Set AN/APQ-94 for Radar Tuner AN/APQ-94-7.(Magnavox Supp to Oper Instrs.	09/15/64	B		EA	C	
0816-LP-196-7020	NA-16-30USC13-21	Communication Systems AN/USC-13#- V#7 and AN/USC-13#V#8, Organizational and Intermediate Maint. Instrs. Vol. 1	04/15/73	B		EA	S	

Figure 1-7.—Example of NAVSUP Pub 2002, Section III.

Chapter 1—PUBLICATIONS AND SUPPLY

1 NOV 1977		NAVAIR 00-500A NAVAL AERONAUTIC PART NUMBER TECHNICAL MANUAL INDEX				VOLUME 1	
MODEL / TYPE / PART NO.	VENDOR	NOMENCLATURE TECH DATA NO.	NEXT HIGHER ASSEMBLY TYPE TECH DATA STK NO	SUPPL REMARKS SC MF CARTRGE NO.	SUPPL PART NO. DATA MF CRTGE STK NO.		
A	10849	FLASHER UNIT 1137-0618-1	03 ONLY-ON-FILM	U	A6,21	0894-LP-006-0210	
A	19500	PIRE DETECTION SYS 03-456A-1	03 0803-LP-390-9010	U		- - -	
A	19707	ANTENNAE 18-45-840 18-45-841	03 0816-LP-155-1500 04 0816-LP-155-2000	U U		- - -	
A	27266	OSCILLOSCOPE 17-20VA-07	23 0817-LP-093-7500	U	EQUAL TO	93-54A	- - -
A	87332	COMPENSATOR 05-20NB-517	10 0805-LP-042-6500	U		- - -	
A INDICATOR	27266	INDICATOR 17-20VA-12	23 0817-LP-104-1540	U		- - -	
A-424G	87424	ALTITUDE CYRO 05-45CFA-11	99 - - -			- - -	
A-844G2	76301	ROCKET MOTOR A/F MFL AND/OR IPB	- - -		EQUAL TO	842450845	- - -
A-844G3	76301	ROCKET MOTOR A/F MFL AND/OR IPB	- - -		EQUAL TO	842450847	- - -
			0819-LP-059-1500	U		- - -	
			0819-LP-059-2000	U		- - -	

Figure 1-8.—Example of NAVAIR 00-500A, Equipment Applicability List.

NAVAIR 00-500M, Microfilm Cartridge Cross Reference

This index consists of a cross reference of technical manuals to microfilm cartridges and microfilm cartridges to technical manuals. It is arranged in three parts.

Parts I and II are covered in NAVAIR 00-500M.1. Part I, which is a cross reference of technical manuals to microfilm cartridge numbers with their current dates, is arranged alphanumerically by the NAVAIR technical manual number. Part II, which is a listing of MIARS cartridge numbers and their latest film date, is arranged in cartridge number sequence.

Part III is covered in NAVAIR 00-500M.2. Part III, which is a cross reference listing of microfilm cartridge numbers to NAVAIR technical manual number, is arranged in cartridge number sequence within the aircraft series.

NAVAIR 00-500M.1 is prepared and issued quarterly with cumulative monthly supplements. NAVAIR 00-500M.2 is prepared and issued semiannually. These documents are companion handbooks and should be used in conjunction with one another. Further detailed instructions for these documents are outlined in the introduction section to NAVAIR 00-500M.1.

NAVAIR 01-700, Airborne Weapons/Stores, Conventional/Nuclear, Check Lists/Stores Reliability Cards/Manual

This index is designed to provide using activities with a guide to insure that all existing changes have been incorporated in check lists and manuals on hand and that these manuals are the most recent available. It is arranged in two sections. Section I, which is arranged in aircraft sequence, cross references aircraft identification with airborne weapons descriptions, NAVAIR

AVIATION ELECTRICIAN'S MATE 3 & 2

JANUARY 1978	NAVAIR 00-500B PART I NAVAL AERONAUTICAL PUBLICATIONS INDEX AIRCRAFT APPLICATION LIST		ATTACK SERIES
A-48			
TECHNICAL MANUAL NO. CARTRIDGE NO.	TECHNICAL MANUAL NO. CARTRIDGE NO.	TECHNICAL MANUAL NO. CARTRIDGE NO.	
00-ALLIANCE LISTS	C1-AIRCRAFT	U3-ACCESSORIES	
00-250RT-1	C1-40AVC-2-4	44.31	03-508-8
00-80R-14	C1-40AVC-2-4-1	44.31	U3-508-9
00-900C-2	C1-40AVC-2-4-2	GEN. 3	03-10-313
	C1-40AVC-2-5	44.10	U3-10-833
C1-AIRCRAFT	C1-40AVC-2-6	44.10	03-10886-571
01-1a-8	C1-40AVC-2-6-1	44.7(C)	03-10888-572
U1-1a-20	C1-40AVC-2-7	44.11	03-10888-784
01-19MG-2	C1-40AVC-2-7-1	44.11	U3-10888-510
01-19MG-2-1	C1-40AVC-2-7-2	44.11	03-10888-511
01-19MG-1	C1-40AVC-2-7-3	44.7(C)	03-10889-117
01-40AV-0	C1-40AVC-2-8	44.11	03-10889-529
01-40AV-1T	C1-40AVC-2-9	44.11	03-10889-535
01-40AV-1TA	C1-40AVC-3	44.14	03-10890-8
U1-40AV-1TA	C1-40AVC-4-1	44.14	03-10890-518
01-40AV-0-02	C1-40AVC-4-2	44.14	03-10891-18
01-40AV-0	C1-40AVC-4-3	44.14	03-10891-19
01-40AV-75	C1-40AVC-4-4	44.14	03-10891-2
01-40AV-75-1A1	C1-40AVC-4-5	44.14	03-10891-26
01-40AV-75-1A2	C1-40AVC-4-6	44.15	03-10891-27
01-40AV-75-1A1U	C1-40AVC-4-7	44.15	03-10891-28
01-40AV-75-2	C1-40AVC-4-8	44.15	03-10891-29
01-40AV-75-2-1	C1-40AVC-4-9	44.15	03-10891-30
01-40AV-75-2-2	C1-40AVC-4-10	44.7(C)	03-10891-4
01-40AV-75-2-3	C1-40AVC-0		03-10891-5
01-40AV-75-2-4	C1-40AVC-0-1		03-10891-1
01-40AV-75-3	C1-40AVC-0-2		03-10891-2
01-40AV-75-3-1	C1-40AVC-0-3		03-10891-3
01-40AV-75-3-2	C1-40AVC-0-4		03-10891-4
01-40AV-75-3-3	C1-40AVD-1F		03-10891-5
01-40AV-75-3-4	C1-40AVD-2-4-2	44.1A	03-10891-6
01-40AV-75-3-5	U3-ACCESSORIES		03-10891-7
01-40AV-75-3-6			03-10891-8
			03-10891-9
			03-10891-10
			03-10891-11
			03-10891-12
			03-10891-13

Figure 1-9.—Example of NAVAIR 00-500B, Aircraft Application List.

numbers, issue dates and applicable changes and dates. Section II consists of a cross reference of NAVAIR technical manual numbers to their associated national stock numbers. This document is prepared by the Naval Weapons, Evaluation Facility, Albuquerque, New Mexico and is released quarterly (January, April, July and October).

MANUAL IDENTIFICATION

Control numbers are assigned to manuals for the purpose of identification. The numerical and alphabetical combination of a NAVAIR technical manual number is used to identify the basic equipment category, main groups within the category, specific item of equipment, type of usage, type or model designation and specific type of manual.

The NAVAIR manual number consists of a prefix and a combination of numbers or

numbers and letters divided into three parts and separated by a dash. Additional numbers may be added to designate multiple volumes of a manual. The manual prefix, i.e., NAVAIR, identifies the command responsible for developing and maintaining the manual. The three parts which make up the remaining portions of the number are as follows:

Part I of the publication number is a two digit number (in some cases, two digits and a letter) that designates the general subject classification or major category of the manual, i.e., 01 for airframes, 02 for power plant, 03 for accessories, etc. (Refer to Table 1-1.)

Part II of the publication number consists of numbers and/or numbers and letters which identify either the basic aircraft model, manufacturer of specific aircraft and engine or the specific class, group or subcategory of the manual. (Refer to Table 1-2.)

Chapter 1 - PUBLICATIONS AND SUPPLY

Table 1-1.-Subject Categories and code numbers for aeronautic manuals

General	00
Allowance lists	00-350
Training publications (aviation)	00-80
Aircraft	01
Powerplants	02
Accessories	03
Hardware and rubber	04
Instruments	05
Fuels, lubricants, and gases	06
Dopes and paints	07
Ground servicing and automotive equipment	08, 19 & 20
Photography	10
Armament	11
Fuel and oil handling equipment	12
Parachute and personal equipment	13
Standard preservation and packaging instructions	15
Electronics	08 & 16
Machinery, tools, and test equipment	17 & 18
Chemical equipment	24
Instructional equipment and training aids	09 & 28
Meteorology (aerology)	50
Ships installations	51

Table 1-2.-Manual codes for part II

Aircraft manual number codes	
General	-1
Douglas	-40
Chance Vought (LTV)	-45
Lockheed	-75
Grumann	-85

Aircraft manual letter codes

AA, AAA	A-7A/B
AA, AAE, AE	A-7E
AV, AVA	A-4A/B
AV, AVB	A-4C/L
AV, AVC, AVE	A-4E/F
PA, PAA	P-3A/B
PA, PAC	P-3C

NOTE: Complete letter codes vary from manual to manual. Only the first two letters are significant as to aircraft type.

Part III of the publications suffix number, may or may not have identifiable numerical significance within the airframe, missile and power plants series. The number usually identifies a particular type of manual, i.e., NAVAIR 01-XXXX-1 (-1 NATOPS), NAVAIR 01-XXXX-2 (-2 maintenance), NAVAIR 01-XXXX-3 (-3 structural repair) and NAVAIR 01-XXXX-4 (-4 IPB). Additional numbers may be added to indicate system grouping breakout by volume or subsystem grouping by subvolume, i.e., NA01-XXXX-2-2. The second -2 indicates the second volume of the maintenance series which is usually grouped by system. If the number assignment is NAVAIR 01-XXXX-2-2.3,

the .3 indicates a subvolume or subsystem within a grouping. Refer to figure 1-10(C) for specific examples of the above. However, this system does not hold true in all cases. In many technical manual number assignments, the suffix numbers are assigned in numerical sequence for identification only and have no significant meaning.

Security Classification

Safeguarding of Classified Technical Manuals. All technical manuals must conform with Federal Security Regulations. The NAVAIR technical manuals described in this

AVIATION ELECTRICIAN'S MATE 3 & 2

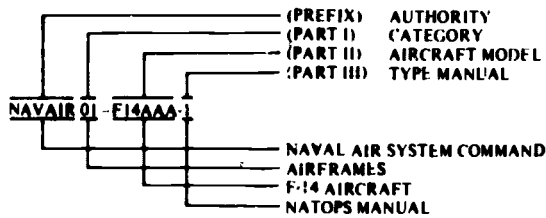

(A)

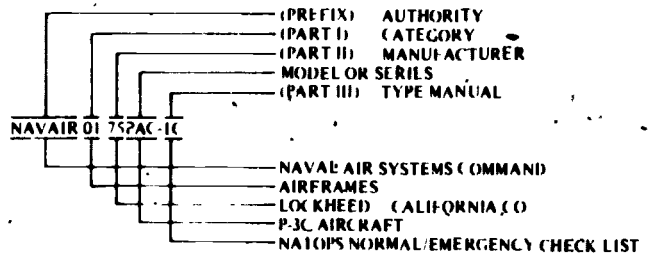

(B)

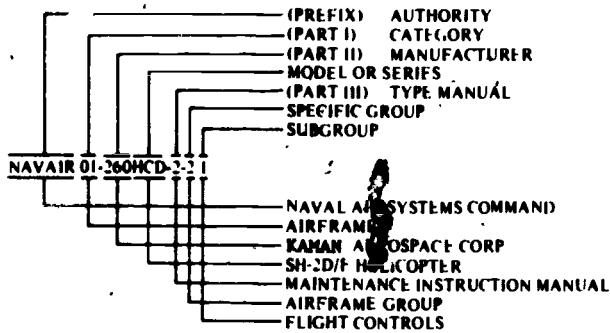

(C)

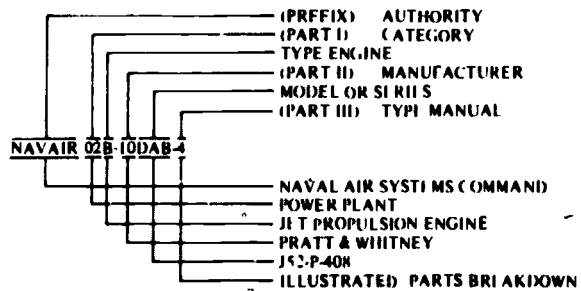

(D)

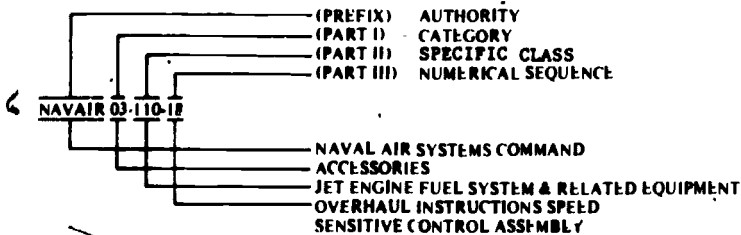

(E)

Figure 1-10.—Specific Examples of Number Assignments.

chapter are published as unclassified, confidential, secret or top secret. Classified manuals are appropriately marked and identified and must be safeguarded in accordance with the requirements of the current OPNAVINST 5510.1, Navy Security Manual for Classified Information.

Microfilming of Classified Technical Manuals. Manuals bearing the security classification of secret or higher will not be reproduced in microfilm media.

Classified. Titled Technical Manuals. The security classification of each classified technical manual is indicated in the Physical Security (PS) column of the NAVSUP 2002 stock number list. Unclassified manual titles are carried on the nomenclature, form/pub/hull and stock number microfiche cards. When the title of the manual is classified, nomenclature is omitted and the word "classified" is substituted for the actual title.

NOTE: Classifications appearing on the printed manuals, or NAVSUP 2002 listings, apply only to the information contained in the manual and not to the security classification of the equipment covered. Changes in classification of manuals are reflected as rapidly as possible after such action is approved.

Aircraft Manuals (01 Series)

Aircraft manuals are published for each aircraft model in naval use. The manuals for a particular aircraft model consist of a series of individual publications, each dealing with a definite phase of the overall operation or maintenance program. As indicated in the previous discussion, the manuals are in the NA 01- (Series), and manuals pertaining to a particular model may be identified by an alphanumeric designator immediately following the 01- (Fig. 1-10(A)).

There are several different types of aircraft technical manuals. Some of these manuals are of extreme importance to AE maintenance personnel in the performance of their normal routine duties. These types are discussed in some detail in this chapter. Manuals of other types are

of limited importance to AE personnel and are discussed only briefly.

The NAVAIR 01-1 (Series) manuals do not apply to specific aircraft, but present some aspect of construction, operation, maintenance, repair, or inspection applicable to many models of aircraft. Some important examples of this type manual are NAVAIR 01-1A-505 (Installation Practices; Aircraft Electric and Electronics Wiring); and NAVAIR 01-1A-509 (Aircraft Weapons Systems Cleaning and Corrosion Control).

Aircraft Electrical and Electronic Wire Installation Manual

Technical Manual, Installation Practices, Aircraft Electric and Electronic Wiring, NAVAIR 01-1A-505, is the basic source for most of the recommended practices and techniques to be used for installing, repairing, and maintaining aircraft electric wiring. The information contained in this manual was obtained from the country's leading airframe manufacturers, airline operators, and overhaul activities. Long experience has shown that certain jobs or operations are best accomplished by using certain materials and techniques. AEs should be thoroughly familiar with these, because they are the means by which they actually apply theoretical training.

There is usually a considerable gap between learning electrical theory and then actually working as an AE. The installation manual goes a long way toward bridging this gap. It gives specific details of exactly how to do a great number of small operations. A few of these are soldering, splicing, lacing and tying, safety wiring, and working with conduit. Clear illustrations help make this manual easily understandable. Verbal instructions are kept to a minimum. The AE should find this manual a valuable aid in everyday work. If this publication is not available in the work center, ask the leading petty officer to obtain it.

Aircraft Weapons Systems Cleaning And Corrosion Control

Cleaning and Control Manual, NAVAIR 01-1A-509 establishes requirements for

Intermediate and Organizational Levels of maintenance afloat and ashore. Included are general instructions, procedures, and information for cleaning and corrosion control of naval aircraft and associated equipment. Where specified by contractual requirements, naval aircraft cleaning or corrosion control rework may be accomplished using this manual as a reference guide.

NOTE: In the event of a conflict between this manual and a corrosion control and cleaning manual for a specific aircraft model, the instructions contained in this manual pertaining to aircraft cleaning, corrosion removal, materials, methods, and subsequent finishes shall take precedence.

Technical Manual List

Under the new technical manual system for late model aircraft, an additional volume has been added. This is the "zero" volume. For the S-3A aircraft, the publication number is NA 01-S3AAA-0, and is titled, Technical Manual List. The purpose of this volume is to provide information concerning the availability and applicability of technical manuals for the maintenance of the particular aircraft model.

This manual is arranged in four sections. Section I is the introduction, which provides general information and defines the purpose, arrangement, and use of the manual.

Section II lists all known publications applicable to the aircraft model. The publications are listed in alphanumerical sequence by publication number.

Section III provides a list of systems, subsystems, and components applicable to the specific aircraft model. These items are listed in alphanumerical order by type/part number with the available publications applicable for all three levels of maintenance listed by publication number. All publications listed in this section are also listed in publication number sequence with title in Section II.

Section IV lists Ground Support Equipment (GSE), by part number, applicable to the

specific aircraft model. The applicable publications are listed for each item of equipment. These publications are also listed in Section II.

Whenever the term "Not Required" is used in any column, for any particular level of maintenance, in either Section III or IV, it means that a manual is not required for that level of maintenance and no future requirement is anticipated. Whenever the term "Not Available" is used in any column, for any particular level of maintenance, in either Section III or IV, it means that a manual is required for that level of maintenance, but is not yet available.

As indicated, this volume is very important to maintenance personnel. To determine if publication information is required for an aircraft component or item of GSE, it may be found in the alphanumerical listings in Sections III and IV, respectively. The associated manuals are listed for each level of maintenance.

NATOPS Flight Manual

The NATOPS (Naval Air Training and Operating Procedures Standardization) Flight Manual contains complete operating instructions for the aircraft and its operational equipment. Emergency operation instructions as well as normal instructions are provided. For a given model aircraft, the complete flight manual usually comprises the standard NATOPS manual, pocket checklist, and classified supplements. Although this series is of primary interest to the pilot and aircrew, much of the information is of general interest to all personnel concerned in any manner with that aircraft. For example, sections are devoted to the functional operation of the electrical/instrument systems.

Manuals of this series are identified by the number 1 in Part III of the publications number. (Refer to fig. 1-10(A) and 1-10(B).)

Maintenance Instructions Manual (MIM)

The number 2 in Part II of the publication number identifies this type manual. Refer to fig. 1-10(C). The MIM comprises a variable number of individual publications, each dealing with some portion of the overall maintenance effort

for the applicable model aircraft. It contains all the essential information required by aircraft maintenance personnel for service and maintenance of the complete aircraft. It includes the data necessary for troubleshooting and maintaining the powerplant, accessories, and all other systems and components of the aircraft.

Before attempting any task on an aircraft, the MIM for that particular model aircraft should be consulted. Proper use of this manual may prevent possible damage and save much time. Recommended maintenance methods provide procedures which can be accomplished by the appropriate level maintenance activity. Also included is a Quality Assurance Summary. This summary indicates the minimum quality control inspection requirements for each maintenance task.

In the past, these manuals were issued as a single complete unit. They were arranged so the pertinent sections could be removed and kept available in the applicable work center. At present, the separate sections of these manuals are issued as separate publications under individual identifying numbers. This facilitates procurement, storage, filing, and use of specific parts of the manual by maintenance personnel.

With the introduction of manuals for late model aircraft, such as the F-14 and S-3, the format for MIMs has changed somewhat.

Under the older format, a volume contains several sections. The number of sections in each volume may differ from one model aircraft to another and from one volume to another. In some cases, organizational maintenance is covered in one section and intermediate maintenance is covered in another. In other cases, this is accomplished through the issuance of two separate volumes.

Sections I and II of all volumes are usually similar in format. Section I is an introduction to the volume. It provides a general description of the manual, including the scope of coverage, format, and arrangement of the included information. It contains listings of applicable publications and technical directives required by maintenance activities pertaining to the specific model aircraft or equipment covered in the manual.

Section II contains a physical description of the equipment or systems covered in the

volume. For example, in a volume pertaining to the Powerplant and Related Systems for the A-7E aircraft, Section II contains descriptions and operating instructions for the powerplant and the related systems.

In some volumes, a section is devoted to any ground support and special equipment required for the maintenance of the systems covered. In other volumes, this information may be provided in the section pertaining to a specific system. As stated previously, the remaining number of sections may differ. In all cases, however, these sections contain the maintenance information for the included systems.

The MIMs are sectionalized into work packages (WPs), and subordinate work packages (SWPs), if necessary, to provide smaller informational units. WPs and SWPs are identified by a five-digit number, with the first three digits representing the WP number, and the last two representing the SWP number. (NOTE: The two digits that identify the SWP are usually printed in smaller size type than the three digits that identify the WP.)

Figure 1-11 is an example of Page A of a testing and troubleshooting MIM. It contains the numerical index of the effective WPs and SWPs in the volume. WP 001 00 contains an alphabetical listing of all WPs/SWPs in the volume. WP 002 00 is the introduction to the volume. The introduction pages of all subsequent WPs/SWPs contain information as to which aircraft serial numbers the WPs/SWPs apply. Also included is information on reference material, technical directives, and ground support equipment applicable and/or required to perform the work covered in the particular WP or SWP.

Reference is made within each WP and SWP to other WPs and SWPs, in the same or other manuals, as necessary to facilitate maintenance without repeating the same procedures in various WPs and SWPs.

Classified maintenance information is not included in the regular volumes of the MIMs. Essential classified information is contained in separate volumes or supplements and are classified appropriately. These classified volumes are bound in red covers in order that they may be identified readily. These volumes must be handled in accordance with the Department of

AVIATION ELECTRICIAN'S MATE 3 & 2

WP/SWP Number	Title	Change Number
Page A	Numerical Index of Effective Work Packages	0
001 00	Alphabetical Index	0
002 00	Introduction	0
003 00	Propulsion Systems	0
004 00	Cockpit Arrangement—Propulsion System	0
005 00	Powerplant (Engine) System	0
006 00	Engine Indicating Groups	0
007 00	Engine Oil System	0
008 00	Engine Fuel and Mach Lever Actuator Systems	0
008 01	Engine Fuel System	Q
008 02	Mach Lever Actuator System	0
009 00	Afterburner Fuel and Exhaust Nozzle Control System	0
010 00	Engine Compressor Bleed Systems	0
011 00	Throttle Control System	0
012 00	Starting and Ignition System	0
013 00	Air Inlet Control System	0
013 01	AICS Ramp Stow Circuit	0
013 02	Air Inlet Control System Testing	0
013 03	Air Inlet Control System Troubleshooting	0
014 00	Engine Anti-Ice and Ice Detection System	0
015 00	Oil Cooler Ejector System	Q
016 00	Fire Detection and Warning System	0

Figure 1-11.—Example of WP/SWP numbering.

the Navy Information Security Program Regulations, OPNAV Instruction 5510.1 (Series).

MIMs make extensive use of illustrations, as do many other technical manuals and publications. AEs use these illustrations in nearly every phase of their work—the location and identification of units and components, troubleshooting, circuit tracing, installation, calibration and adjustment, testing, operation, and evaluation. They also use these illustrations in the study of operating principles of circuits and equipments.

No one particular type illustration is suitable for all applications; therefore, many types are required, several of which are discussed in the following paragraphs. Each type has its own advantages and disadvantages, and may be

combined as necessary to produce the desired results.

PICTORIAL.—Pictorial illustrations normally indicate physical appearance. They may present details concerning the location, size, construction, physical relationships of size and location, or parts arrangement. They appear throughout manuals of all types and are useful for locating and identifying systems, equipments, components, or parts. They are used in connection with installation, inspection, servicing, operation, adjustment, calibration, troubleshooting, and repair functions. A typical pictorial is shown in figure 1-12.

Pictorial illustrations may be accurately detailed representations, or they may be merely generalized indications, depending on their

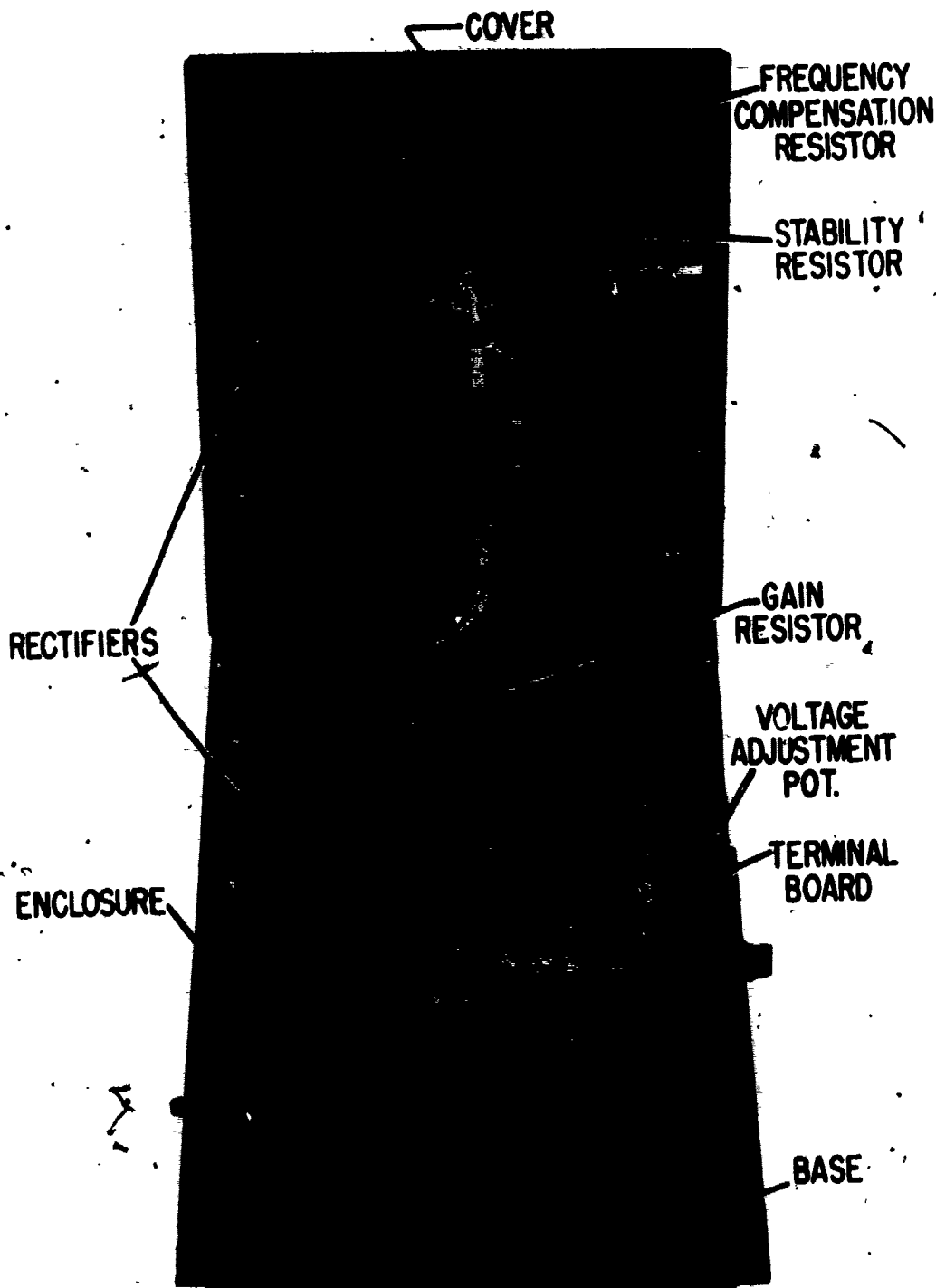

207.101

Figure 1-12.—Pictorial view of magnetic amplifier regulator.

purpose. They may be photographs, halftone or shaded sketches, or line drawings.

CUTAWAY VIEW.—A cutaway view is an illustration used to show some detail of construction which would be extremely difficult or impossible to show by conventional pictorial views. It is often used in connection with discussions of physical construction and the operation of mechanical devices. It is frequently used in assembly diagrams and in construction details. A cutaway view of a jet engine igniter is shown in figure 1-13.

LOCATION AND DIMENSION DIAGRAMS.—Location diagrams are used to show physical position relationships, and may or may not be sufficiently detailed to show physical appearance. They are primarily useful for familiarization, and are commonly used in Flight Manuals, in the General Information and Servicing section of the MIMs in the Illustrated Parts Breakdown Manual (IPB), and in the Operation and Maintenance Instructions for equipments. A typical location diagram is shown in figure 1-14.

Dimension diagrams denote physical size and distance. They are useful in planning the layout of bench stations, making equipment installations, or packing materials for reshipment. They are frequently used in the general information sections of technical manuals, and in those sections devoted to familiarization, installation, and shipment. They are also frequently found in change type technical directives. In figure 1-15, the dimensions of a lamp are shown.

Location and dimension diagrams may be combined with other type illustrations, thus providing additional details without increasing the number of illustrations.

EXPLODED VIEWS.—These diagrams, as the name implies, provide details of construction which are useful in assembling parts into a unit. They are also useful in explaining the operation of mechanical or electromechanical devices. A typical exploded view is shown in figure 1-16.

SYMBOLS.—Diagrams of electrical circuits use symbols to indicate circuit components and,

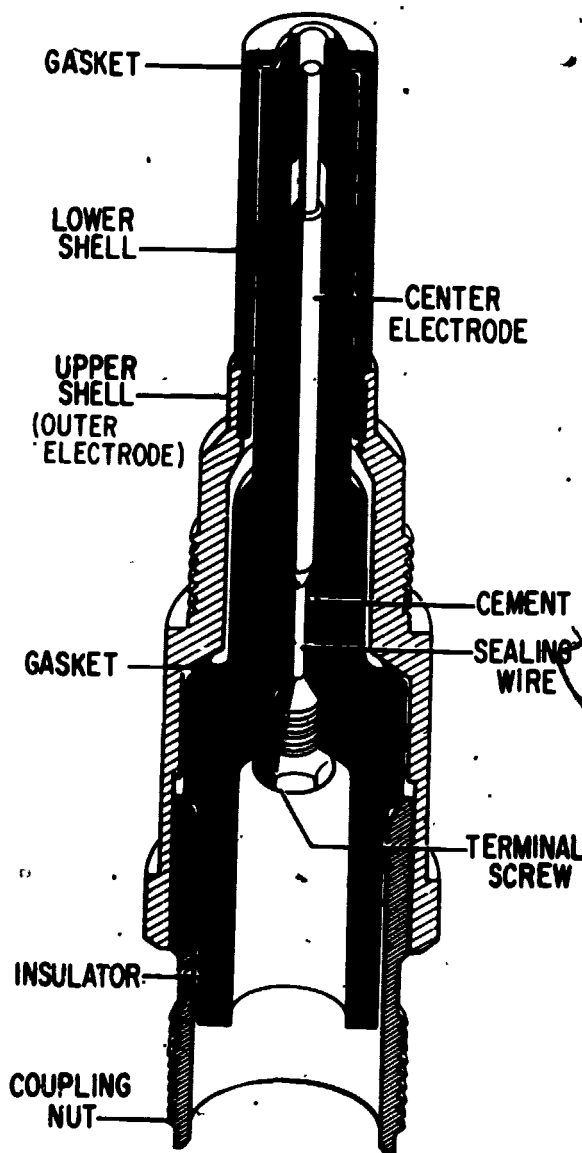

207.215

Figure 1-13.—Cutaway view of a jet igniter plug.

in some cases, composite assemblies within a system. In order to make maximum use of diagrams it is essential to recognize the symbols and to understand their meanings and limitations. A complete listing is given in a publication titled Graphical Symbols for Electrical and Electronics Diagrams (Including Reference Designation Class Designation Letters) which

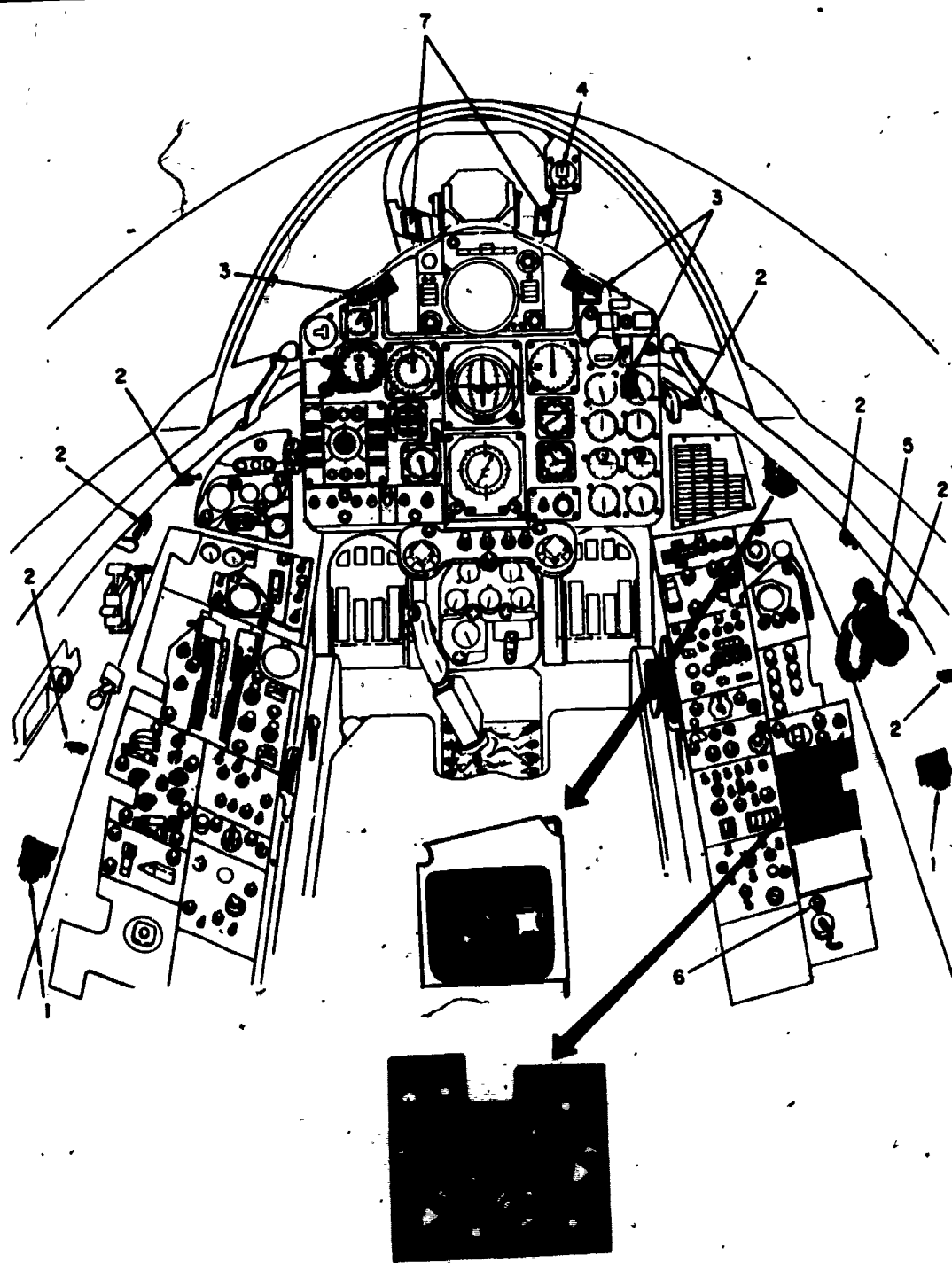

- 1. White floodlights.
- 2. Red floodlights.
- 3. Instrument emerg. floods.
- 4. Standby compass light.

- 5. Utility spotlight and floodlight.
- 6. Spare lamp container.
- 7. Angle of attack indexer lights.

Figure 1-14.—Location diagram of interior lights.

207.84

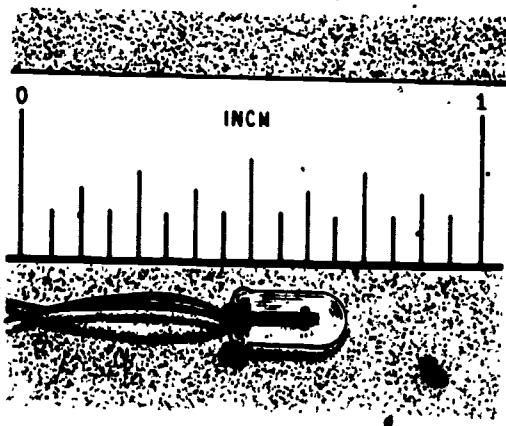

207.85

Figure 1-15.—Dimension diagram of "Grain of Wheat" lamp.

was adopted for mandatory use by the Department of Defense.

Manufacturers of equipment may use other than standard symbols in special situations only if a key is readily available. Many times symbols or reference designators are identified in the front of the manual.

BLOCK DIAGRAMS.—Block diagrams are used to present a generalized explanation of overall functional operation, and do not show

physical shape, size, or location. They range from very simple to very complex; depending on the type equipment, the quantity and quality of details to be covered, and the purpose for which the information is included. They are found in nearly all manuals dealing with basic or detailed theory of operation, whether of relatively simple subassemblies or of very large and complex systems. The more complex the equipment, the more probable the need for block diagrams. Figure 1-17 illustrates a typical block diagram.

Many block diagrams are used in connection with electromechanical devices, as well as with electrical or mechanical systems. Proper use of this type diagram helps increase understanding of functional relationships and operation.

SIGNAL FLOW DIAGRAMS.—One special type of block diagram is called the signal flow diagram, or signal flow chart. It is usually used in connection with overall operation of complicated systems such as aircraft power generating, regulating, and distribution systems; air data computers; inertial navigation systems; automatic flight control systems; etc. It includes all features normally associated with block diagrams; and in addition, it includes considerable detail regarding signal paths, signal waveshape, timing sequence and relationships, magnitudes of potentials or signals, frequencies,

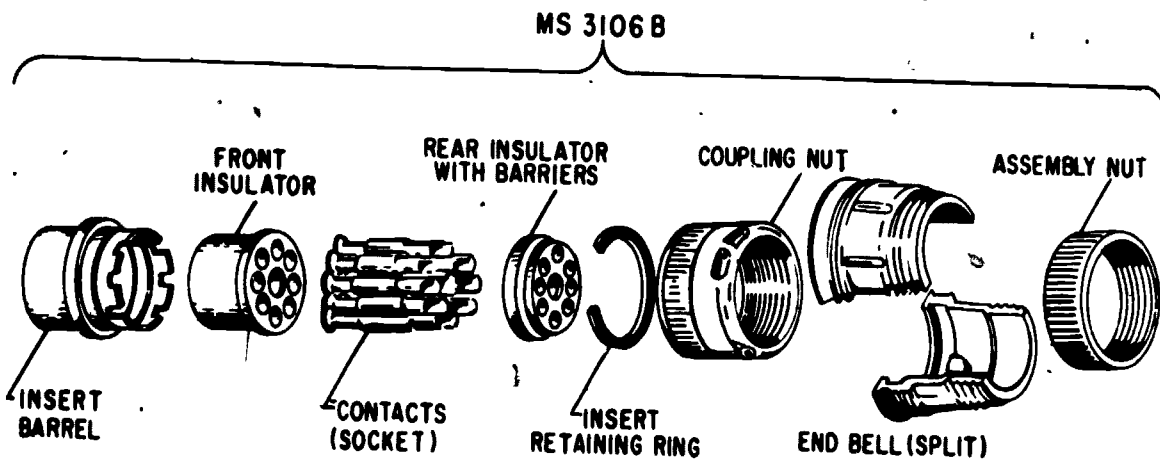
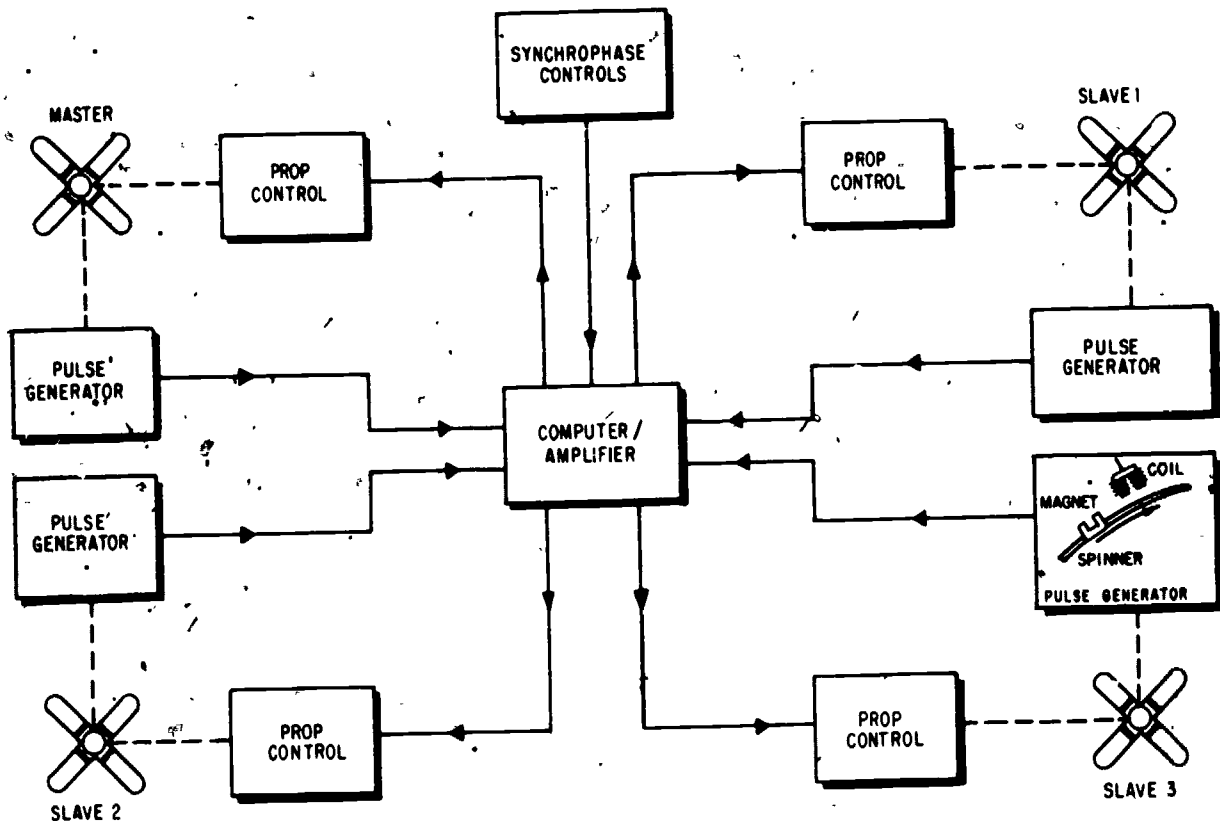

Figure 1-16.—Exploded view of split-shell connector.

207.59



207.57

Figure 1-17.—Synchrophaser system block diagram.

etc. A typical signal flow diagram is shown in figure 1-18.

SCHEMATIC DIAGRAMS.—The major purpose of the schematic diagram is to establish the electrical operation of a particular system. It is not drawn to scale and shows none of the actual construction details of the system, such as the physical location within the aircraft, physical layout of the components, or physical appearance of components. Graphic symbols are used to represent the components. A complete schematic diagram shows all components of all units, including circuit breakers, fuses, switches, relays, controls, sensing elements, terminal boards, junction blocks, connection plugs and jacks, and interconnection wiring.

In large or complex equipments, a complete schematic drawing may be too large for practical

use. For this reason, most technical manuals present partial or simplified schematics for individual circuits or units. A typical schematic diagram is shown in figure 1-19.

Simplified schematics normally omit parts and connections which are not essential to understanding circuit operation. In studying or troubleshooting equipment, AEs may find it helpful to make their own simplified drawings. In these cases they should include only those items that contribute to the purpose of the drawing, but they should take care to include all such items. In using the schematic drawings throughout this course (and those in technical manuals, textbooks, and other publications), many techniques for simplifying schematics will become apparent. Special attention should be paid to those techniques found useful by the

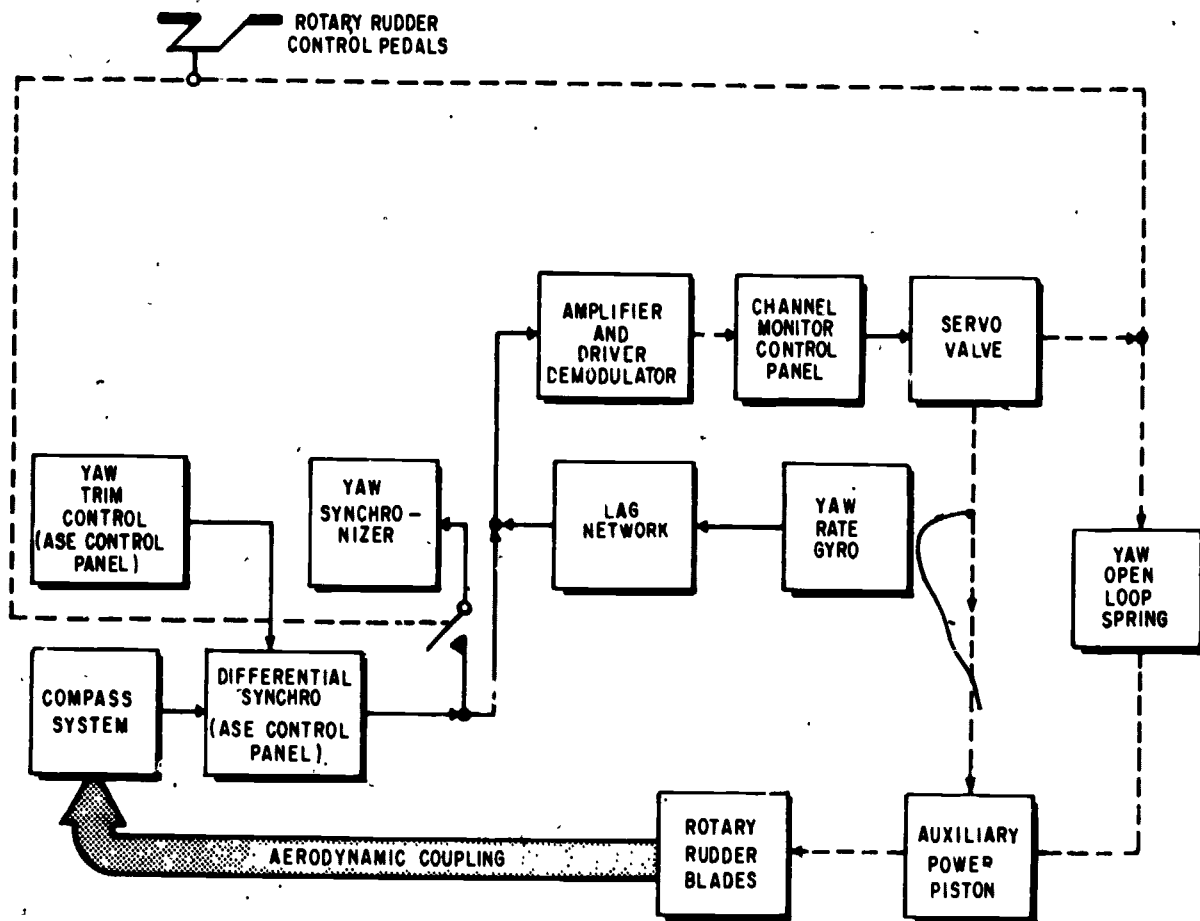

Figure 1-18.—Signal flow diagram ASE yaw channel.

207.229

individual maintenance person. They can be extremely important tools.

Simplified schematic diagrams often have some portions of the system shown in block diagram form to help understand the required inputs and outputs from the schematic. Also, block diagrams sometimes have a partial schematic inserted when it would clarify the purpose or operation of the block.

Schematic diagrams often indicate a mechanical linkage between components by use of a dashed line between those components (such as between separate contacts of a relay or switch, between potentiometers adjusted

simultaneously, between a servomotor and a synchro control transformer, etc.). However, this does not always indicate if the motion is rotational or translational, nor if it is by direct connection, gears, cams, etc., and so is still schematic in nature.

ELECTROMECHANICAL DRAWINGS.—Electromechanical devices such as synchros, gyros, accelerometers, etc., are quite common in avionics systems. For a complete understanding of these units, neither an electrical drawing nor a mechanical drawing would be adequate—and confusion could result from the use of two drawings. Therefore, a combination type drawing using some aspects of each is used.

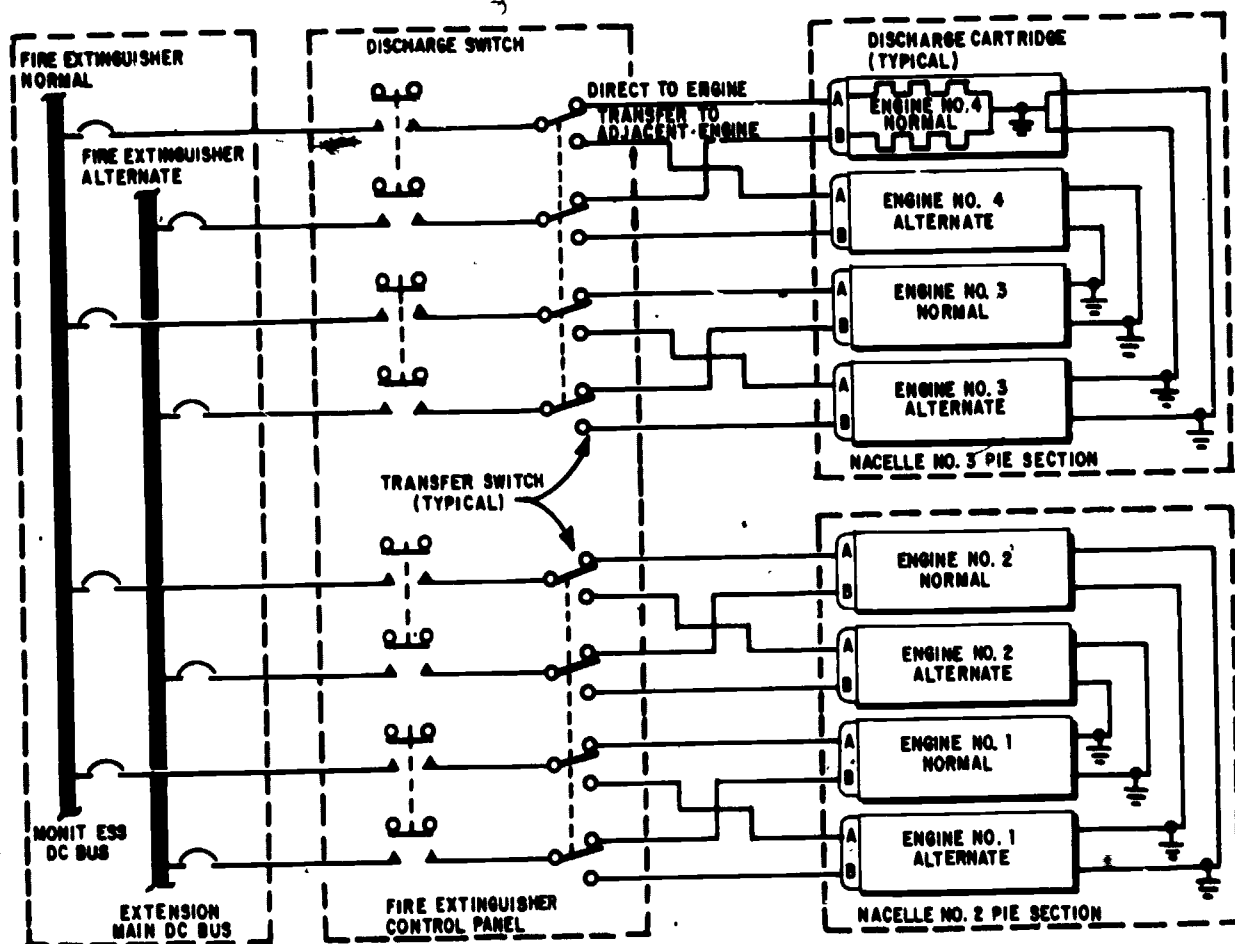

207.278

Figure 1-19.—Engine fire extinguishing circuit schematic.

These drawings are usually simplified both electrically and mechanically, and only those items essential to the operation are indicated on the drawing. A typical electromechanical drawing is shown in figure 1-20.

PARTS PLACEMENT DIAGRAMS.—These diagrams show the physical layout of the unit or portion thereof, and all component parts and tie points are shown. Each indicated part is identified, thus facilitating the use of the IPB to determine values and other data. (The values of resistors, capacitors and other components are normally not indicated.) They resemble the line drawing type of pictorial illustrations mentioned earlier, with additional information added. A

typical parts placement diagram is shown in figure 1-21.

When the wiring connecting the components is shown, they are sometimes referred to as **CHASSIS WIRING DIAGRAMS** (or as **CIRCUIT BOARD WIRING DIAGRAMS**, as suits the unit). They then become very valuable tools when troubleshooting or replacing components, because some sealed components such as relays, transformers, and multicontact switches do not have their terminals numbered on the case. (The terminals are identified only by their physical location on the case.) Some diagrams, especially for complex chassis or circuit boards, also identify each wire between components or tie points, either by color or the reference part

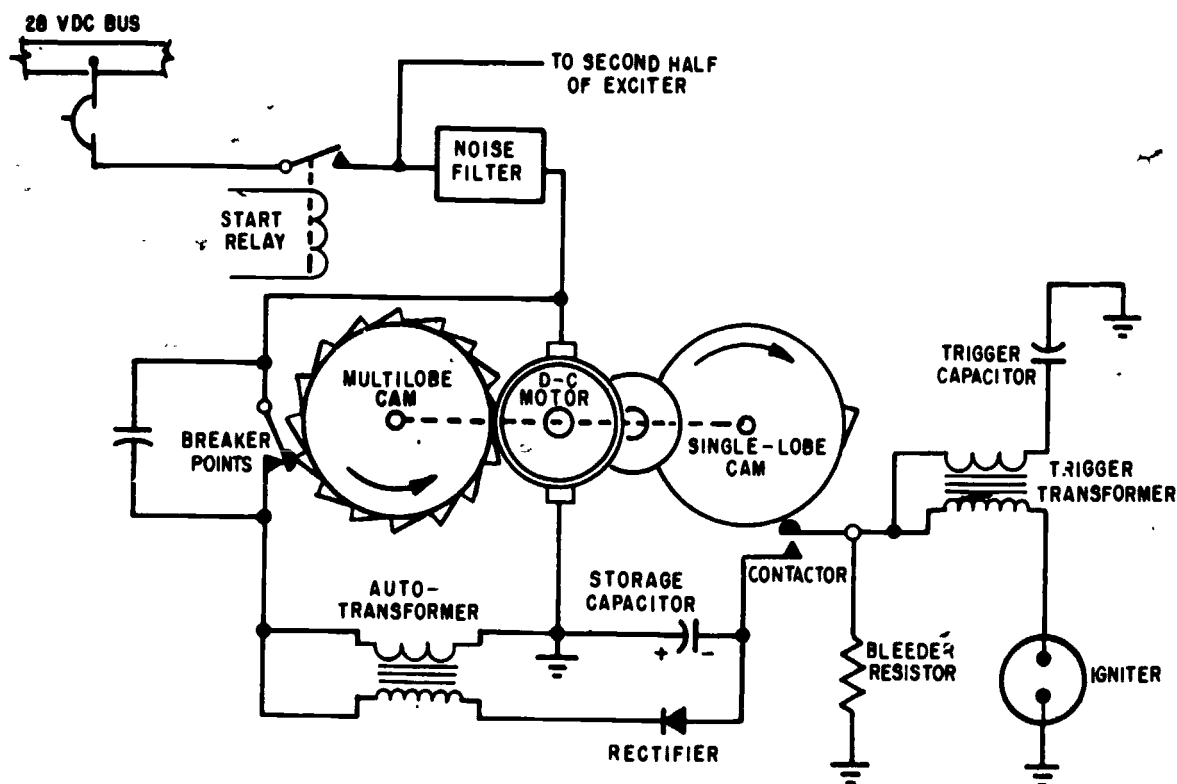

Figure 1-20.—Functional schematic of capacitor discharge system.

207.217

designation number and specific terminal to which connection is made, or both.

INTERCONNECTION DIAGRAMS.—These diagrams show in detail how each wire is routed between units of a system. Each segment of the complete run is shown, along with its identification number, as well as each plug or terminal strip used. Actual positioning is not indicated, and sometimes wire bundles are represented by single lines with the separate wires entering at an angle to indicate the direction to follow to locate the other end of the wire. Some diagrams use wire callouts in lieu of actual wiring—the callout indicating where to find the other end of the wire. The meaning of the callouts is explained on the first sheet of a set of such diagrams. A typical interconnection diagram is shown in figure 1-22.

ISOMETRIC DIAGRAMS.—Diagrams of major circuits generally include an isometric shadow outline of the aircraft showing the location of items of equipment involved and the routing of interconnecting cables. A typical isometric diagram is shown in figure 1-23. A cable, regardless of the number of conductors, is represented on an isometric diagram by a single line, and no attempt is made to show the connections in junction boxes or at components. An isometric drawing thus shows at a glance a rough picture of the entire system's layout. Isometric wiring diagrams of lighting and power circuits are usually used to indicate only the main supply cables, feeders, and their associated equipment.

CABLE CONSTRUCTION DIAGRAMS.—Cable construction diagrams present details concerning the fabrication and construction of

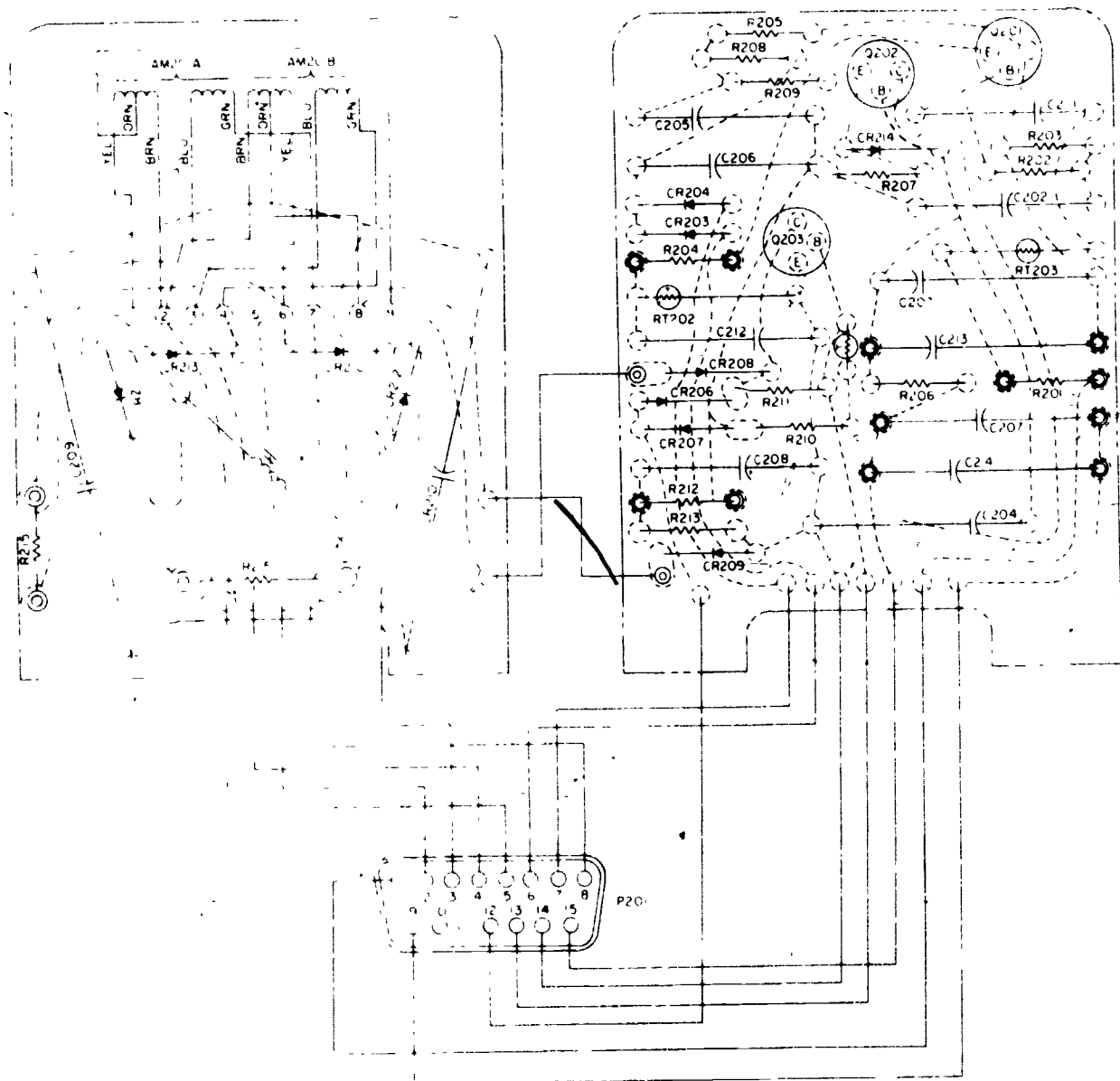

207.7

Figure 1-21.—Sample parts placement diagram.

cables. These details usually include designation of the type connectors or terminals, the identification of wires for each terminal, potting requirements, length of wires, lacing or sleeving specifications, and any other specifications or special considerations involved. A typical cable construction diagram is shown in figure 1-24.

Illustrated Parts Breakdown (IPB)

The Illustrated Parts Breakdown (IPB) normally consists of several individual volumes; one for each functional element of the aircraft, and one volume which is the Master Parts Index. The Master Parts Index is identified by a 4 in

AVIATION ELECTRICIAN'S MATE 3 & 2

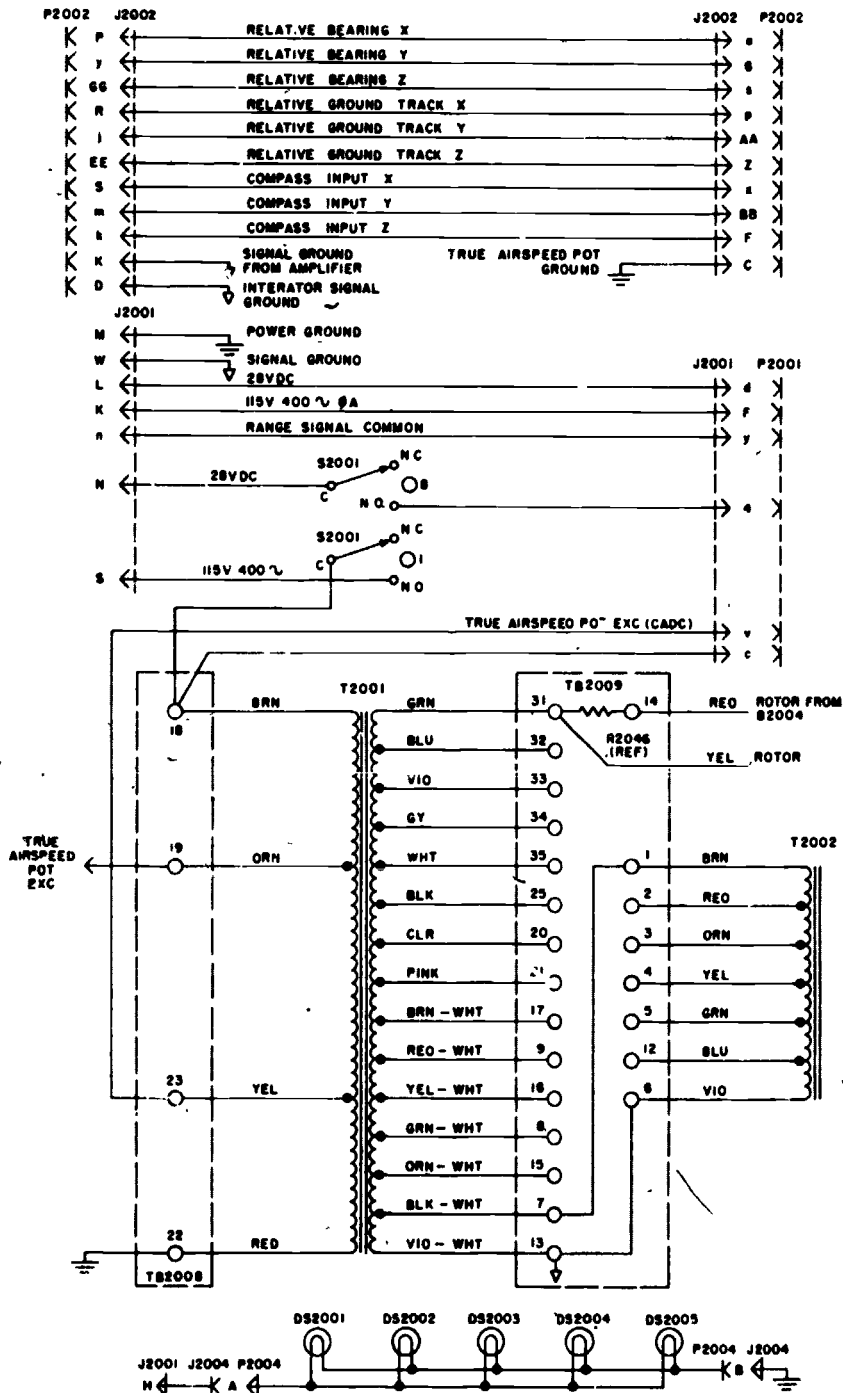
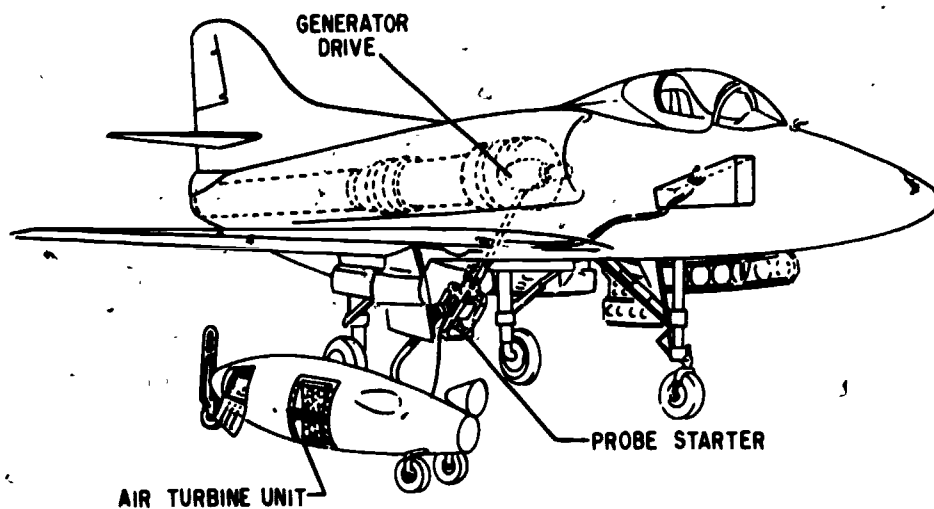

Figure 1-22.—Sample interconnection diagram.

207.8



207.143

Figure 1-23.—Isometric drawing portable probe starting.

Part III of the publications number. (Refer to fig. 1-10(D).) For example, the Master Parts Index for the F-14A aircraft is NA 01-F14AAA-4 and the IPB volume for the propulsion system is NA 01-F14AAA-4-6.

The IPB is useful in the procurement, requisitioning, storing, issuing, and identification of parts. In addition, it can be used to determine the exact part or item required for replacement in a repair situation.

The separation of the IPB into its separate volumes does not necessarily follow the same order as the MIM breakdown; however, the type information available is consistent for nearly all IPBs. In order to derive maximum benefit from maintenance functions, certain records and reports must be compiled. Some of these reports and records require details concerning parts that have failed or that have been replaced for any reason. These details are available from the IPB. The procedures for locating the information depend on what is known about the part and what data is required, as shown in the following discussion:

1. When the part number is not known, determine the function and application of the

part. Turn to the Table of Contents of the IPB Volume containing the affected equipment or system and select the title that seems most appropriate. Note the illustration page number. Turn to the page indicated, and locate the desired part on the illustration. From the illustration, obtain the index (callout) number assigned to the part. Refer to the accompanying description for specific information regarding the part.

2. When only the part number is known, refer to the Numerical Index. Locate the part number and note the figure and index number assigned to the part. Turn to the figure indicated, and locate the referenced index number. If a pictorial representation of the part or its location is desired, refer to the same index number on the accompanying illustration.

3. When only the reference designation number is known, refer to the Reference Designation Index. Locate the reference designation number and note the figure index number and the part number assigned. Turn to the figure indicated and locate the index number. If a pictorial representation of the part or its location is desired, refer to the index number shown on the accompanying illustration.

AVIATION ELECTRICIAN'S MATE 3 & 2

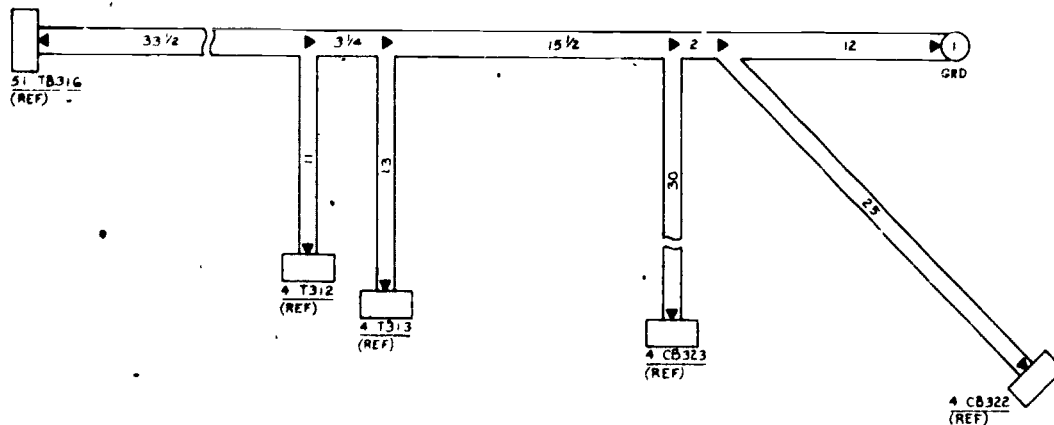

PARTS LIST

QTY	PART NAME	PART NUMBER
8	TERMINAL	MS25036-12
8	TERMINAL	MS25036-57
12	TERMINAL	MS25036-3
12	TERMINAL	5M33-1B-8 (76301)

WIRE TABLE

WIRE NO	WIRE CODE	LG	TERMINATION	TERM CODE	TERMINATION	TERM CODE
P1A10	167	48	4-TB312 (+)	38	51-TB316 (6)	37
P1B10		48	4-TB312 (+)		(6)	
P3B10		40	4-TB313 (+)		(3)	
P3C10		40	4-TB313 (+)		51-TB316 (3)	
P10A10N		39	4-TB312 (-)		GROUND 1	
P10B10N		39	4-TB312 (-)			
P11A10N		56	4-TB313 (-)			
P11B10N		56	4-TB313 (-)	38	GROUND 1	37
X1G18A			4-CB322 (T1)	80	4-TB301 (2)	09
X2G18B			4-CB322 (T2)		(4)	
X3G18C			4-CB322 (T3)		(6)	
X18D18A			4-CB323 (T1)		(14)	
X19D18B			4-CB323 (T2)		(16)	
X20D18C			4-CB323 (T3)		4-T301 (17)	
X173A18A			4-CB322 (L1)		4-T312 (A)	
X174A18B			4-CB322 (L2)		4-T312 (B)	
X175A18C			4-CB322 (L3)		4-T312 (C)	
X176A18A			4-CB323 (L1)		4-T313 (A)	
X177A18B			4-CB323 (L2)		4-T313 (B)	
X178A18C	167		4-CB323 (L3)	80	4-T313 (C)	09

207.9

Figure 1-24.—Sample cable construction diagram.

Work Unit Code (WUC) Manual

Work Unit Code (WUC) manuals are provided for each model aircraft. These manuals are identified by a -8 as Part III of the publication number. For example, NA 01-F14AAA-8 is the WUC manual for the F-14 aircraft. There is also a Work Unit Code Manual provided for ground support equipment.

Maintenance data must be recorded in such a manner that it will be adaptable to accounting machine processing. Therefore, much of the information that maintenance personnel enter

on maintenance forms must be in the form of codes. These maintenance forms are processed through a key punch operation, and the information contained thereon is punched into accounting machine cards. These cards are then processed to produce reports for use in the management and improvement of the maintenance, material, supply, and equipment design function. It is therefore important that all coded information entered on the maintenance forms be accurate and clearly written so that key punch machine operators can read and enter the information correctly on the punched cards.

Chapter 1—PUBLICATIONS AND SUPPLY

The reports produced are significant and useful only if the codes are carefully selected and accurate.

Most of the codes required are listed and defined in OPNAV Instruction 4790.2 (Series), The Naval Aviation Maintenance Program. However, work unit codes may vary from one model aircraft to another; therefore, these codes are provided in the WUC manuals. In addition, most of the other codes commonly used by maintenance personnel are included. The manual is issued in pocket size for the convenience of the worker. Brief descriptions of these codes are presented in the following paragraphs:

Work Unit Code—A five- or seven-character numeric or alphabetic numeric code which normally identifies the system, subsystem, assembly, component, etc., on which maintenance is being performed. The first two characters are standardized for all aircraft, but the remaining characters may vary to fit individual aircraft models. The sixth and seventh characters, when used, identify repairable subassemblies of major components.

Malfunction Description Code—This code consists of three numeric characters and is used to describe equipment malfunction. Conditional malfunction codes are those which describe a malfunction caused by battle damage, improper maintenance/handling, improper operation of associated equipment, etc. In the WUC manual, conditional codes are indicated by an asterisk (*) preceding the code. The malfunction description codes are listed in both alphabetical and numerical sequence in the WUC manual.

When Discovered Code—This code consists of one alphabetic character which indicates when the need for maintenance action was discovered.

Action Taken Code—This code consists of one numeric or alphabetic character and indicates what maintenance action was taken on the item identified by the work unit code.

Support Action Code—This code is a three-character numeric code used to identify routine, repetitive maintenance actions of a nonrepair type; for example, aircraft fueling, cleaning, inspection, etc.

Type Maintenance Code—This code consists of one alphabetic character and is used to describe the type of work being accomplished.

Type Equipment Code—This code consists of four characters and is used to identify complete end item or category of equipment being worked on.

Examples of these codes are used on the maintenance forms described later in this chapter.

Periodic Maintenance Information Cards (PMICs)

The PMICs are a published set of 5 x 8 cards that pertain to specific aircraft models; that is, there is a separate set of PMICs for the F-4, the A-7, the S-3, etc. A -6 in Part II of the publication number (01 series manuals) identifies the PMIC. For example, the publication number of the PMICs for the F-14A aircraft is NA 01-F14AAA-6.

The PMICs contain lists of certain items or components, installed on the aircraft, that have an approved mandatory replacement interval. For example, the PMIC for the F-14A aircraft might list the starter assembly to be replaced at 1,000 hour intervals, the generator at 2,000 hour intervals, etc. The components listed in a particular aircraft's PMIC must be replaced at the designated interval regardless of the condition of the component. Of course, if the component fails prior to the established interval, it is replaced with a serviceable one.

The PMICs indicate whether there are any special records or logs to be maintained on the components designated as having an established replacement interval.

The PMICs contain maintenance tables that list those references which have been incorporated in the periodic maintenance requirements publications since the last routine change or revision.

Also included in the PMIC is the Maintenance Requirements Card (MRC) index which lists by system those requirements to be performed by the operating activity. The left column indicates the maintenance requirements card number on which the requirement is listed

and the right column lists a brief description of the requirement.

Maintenance Requirements Cards (MRCs)

The term Maintenance Requirements Cards (MRCs) was mentioned previously. These cards are applicable to aircraft and support equipment. Either MRCs and CERRCs (Complete Engine Repair Requirements Cards) are applicable to engines. These cards have the same publication numbering system as the technical manuals. For example, the Phased Maintenance Requirements Cards for the F-4B Aircraft is NA 01-245FDD-6-3 and the Complete Engine Repair Requirements Cards for the TF-41-A-2 Engine is NA 02B-5EA-6-4.

MRCs are 5 x 8 cards that provide detailed step-by-step instructions required for the efficient performance of certain maintenance tasks. Each MRC contains the tasks relating to a particular system, subsystem, area, or component and provides a logical sequence for the accomplishment of these tasks. The MRCs identify the recommended rating/Military Occupational Specialty (MOS), performance interval, and the work/zone area involved. A listing is provided which identifies ground support equipment, consumables, replacement parts, and assistance requirements for task performance. Illustrations, clearances, tolerances, charts, part numbers, and other pertinent information are included where necessary.

The MRCs do not include instructions for repair and adjustment/calibration, or means of correcting defective conditions. The applicable technical manuals should be consulted for these instructions.

A Sequence Control Chart or Card is used in conjunction with the applicable MRCs. These Charts/Cards are graphic sequential work displays prepared to insure orderly planning and timely performance of aircraft and engine maintenance requirements.

Complete Engine Repair Requirements Cards (CERRCs) are provided, if applicable, in separate decks for each engine type/model. Each deck also contains a Sequence Control Chart/Card. CERRCs contain necessary

procedures required to process an engine through a complete repair cycle. The requirements are arranged in logical sequence and each card includes such details as maintenance requirements, illustrations, tolerances, charts, and/or part numbers.

Like other aircraft, engine, and equipment technical publications, MRCs and CERRCs are listed in NAVSUP Publication 2002 and, as appropriate, in NAVAIR 00-500A and NAVAIR 00-500B.

Accessories Manuals (03 Series)

The 03 series manuals (fig. 1-10(E)) cover all types of accessories. An accessory is defined as any item of equipment which is required for operation of the aircraft and which cannot be considered an integral part of the airframe or engine.

The manufacturer of each item of equipment (valves, pumps, fuel controls, etc.) is required to provide adequate instructions for the operation of the item and for the maintenance of it throughout its service life. Accessories Manuals therefore contain descriptive data; detailed instructions for installation, operation, inspection, maintenance, and overhaul; and an illustrated parts breakdown. All accessories manuals available for issue are listed in numerical order (by publication number) in the NAVSUP Publication 2002. They are also listed in NAVAIR 00-500A, but in alphanumeric order according to part number. In NAVAIR 00-500B, Accessories Manuals are listed under the aircraft in which the accessory is installed.

Accessories Manuals are used to supplement information in aircraft Maintenance Instructions Manuals. For example, when the Maintenance Instructions Manual does not provide instructions for repairing a particular item, reference should be made to the applicable Accessories Manual.

To determine what manuals are available for a particular accessory, proceed as follows:

If the model, type, or part number is known, use the NAVAIR 00-500A and locate the item in the alphanumeric listing. All manuals applicable to that particular item of equipment

will be listed by code number, publication number, and stock number. Using these numbers, the complete title of the available manuals may be found in the NAVSUP Publication 2002.

Support Equipment Manuals (17 and 19 Series)

Although Aviation Support Equipment Technicians (AS) perform maintenance on support equipment, AE and other aviation maintenance ratings must operate this equipment; therefore, operating instructions should be available.

The 17 and 19 series of aeronautic technical publications cover most types of support equipment. The manufacturer of each item of support equipment is required to furnish adequate instructions for operating the equipment and maintaining it throughout its service life. Like aircraft Maintenance Instructions Manuals, these publications prepared by the manufacturer are issued under the authority of the Naval Air Systems Command.

Support equipment manuals are stocked and listed in the same manner as the technical manuals discussed previously.

General Aircraft Manuals

The following manuals do not come under NAVAIR 01-1 or 03 Series but are described here because of their importance to the AE Rate.

AVIONIC CLEANING AND CORROSION PREVENTION CONTROL.—The primary purpose of NAVAIR 16-1-540 manual is to establish avionic corrosion control requirements and procedures for Intermediate and Organizational Maintenance Activities afloat and ashore. Included is the required information for understanding the types of corrosion that most affect naval avionic systems and instructions, procedures and information for cleaning, treating and preserving the avionics systems.

NOTE: In this manual, the definition of the term "avionic systems" includes any device that uses electrical power. The term "avionic

technician" includes the Aviation Electrician, Aviation Electronic Technician, Aviation Fire Control Technician, Aviation Ordnanceman, and Aviation Anti-Submarine Warfare Technician.

NAVAL AIRCRAFT STORAGE BATTERIES.—Until a few years ago, the Navy used only lead-acid storage batteries as a reserve source of DC power for aircraft applications. However, nickel-cadmium and silver-zinc storage batteries have recently been adapted to aircraft because of their superior performance and other advantages over lead-acid batteries. The use of these new battery types has placed greater demands on the skill of battery servicing personnel since care and maintenance differs considerably from that for the lead-acid battery.

The NAVAIR 17-15BAD-1 handbook provides battery servicing personnel with the required information for understanding the care and maintenance of lead-acid, nickel-cadmium, and silver-zinc aircraft storage batteries. (This handbook includes cell replacement procedures for the latter two types.)

Updating Manuals

In an effort to provide maintenance activities with the latest and most accurate information possible, NAVAIRSYSCOM has instituted a program of continuous review and frequent revision of technical publications. The degree of urgency of updating publications depends upon the type of information involved and the frequency of reference to the affected publications. In any event, technical data change and revision material should not be allowed to accumulate at any point.

As stated previously, activities receive copies of applicable revisions and changes automatically through the proper submission of the Naval Aeronautic Publications Automatic Distribution Requirements Tables, NAVAIR 00-25DRT-1. The different methods of updating technical manuals are discussed in the following paragraphs.

CHANGES.—Changes are issued when only parts of the existing manuals are affected. The changed pages replace the correspondingly numbered pages, which must be removed and

AVIATION ELECTRICIAN'S MATE 3 & 2

discarded. If a change contains additional material that cannot be fully included on a replacement page, additional pages are issued and inserted between or after the affected pages. Pages added between pages are assigned the preceding page number plus capital letter suffixes in consecutive order. Pages added after affected pages continue in numerical order.

Changes may, at times, include "pen and ink" instructions in which only a few words of a manual page require correction, and the printing of a completely new page is not warranted.

FORMAL CHANGES.—A formal change is defined as an alteration in a portion of a manual already in existence, which is not large enough to justify the issuance of a revision. The formal change may be issued as replacement, addition, or deletion of pages. The changed pages and backup pages are prepared to be collated into the manual without disrupting the sequence of the manual. Formal changes are prepared to include new models of equipment or to add new procedures, and change existing equipment or procedures which do not constitute an emergency situation. Manuals of eight pages or less, or which do not include a title page, are not changed but replaced by a revision.

RAPID ACTION CHANGES.—Rapid Action Changes (RACs) are manual changes used to expedite inclusion of essential and urgent operation and maintenance information in technical manuals. RACs are used to distribute urgent and essential data when it constitutes a direct hazardous effect to personnel, impairment to safety of flight, aircraft grounding, mission capability, equipment or property damage, and maintenance capability, including that for high value and repairable items. RACs are not normally issued to correct training, format, grammar, typing errors, and similar nonprocedural information. RACs are distributed in two formats, Type I and Type II.

Type I—A message change issued to cover urgent changes requiring immediate dissemination.

Type II—A page insert change ready for printing within 30 days after definition of the

requirement. Type II RACs are never issued for microfilm, only manuals.

REVISIONS.—A revision is a complete new edition of an existing manual. It replaces the original or preceding issue and includes any existing changes. A revision will be prepared when determined necessary by the Naval Air Technical Services Facility (NATSF) for additions, deletions, or other changes in information.

Revisions are prepared in the same manner as basic manuals. All previously modified page, graph, figure, and change symbols are eliminated. Change symbols are used in a revision to identify new or altered material from the previous edition of the manual.

Manuals which are furnished on microfilm in a MIARS cartridge are updated (either by changes or revisions) by the issuance of an updated cartridge which supersedes the previous issue of the cartridge. The table of contents reflects the date of the latest revision/change to the technical manuals in the cartridge. The outdated cartridges are returned to NATSF.

Incorporation of Change Material.—When making a pen-and-ink change to any official publication or directive, be sure to record the source of the corrected material or the authority for the change. In this manner, subsequent users of the document will know the change is official, and also where to look for additional details. Eliminating the confusion which results from too much information, some of which may be incorrect, will make the document much more valuable as a tool for maintenance.

When making a substitute page type change to a manual, be sure to double check that all instructions forwarded with the change copy are complied with. These instructions normally include the removal of certain pages and substitution of other pages in their place. Be sure that all canceled pages are removed and disposed of in the proper manner, and all pages not canceled are retained in their proper sequence.

Reporting of Errors in Manuals.—As a part of the program to improve the quality and accuracy of the technical manuals,

NAVAIRSYSCOM has a program for encouraging users to report errors and discrepancies. This reporting program provides a simplified procedure for reporting technical publication deficiencies. Publication deficiencies include but are not limited to printing/grammatical errors, omissions, and microfilm deficiencies such as film density and legibility. Technical publications include Work Unit Code Manuals, MIMs, and Technical Manuals. Deficiencies in Instructions, Notices, and NATOPS publications are not reported under this program.

All routine technical publication deficiencies are to be reported by the use of OPNAV Form 4790/66, Technical Publications Deficiency Report. The deficiencies and recommendations should be described on the form. The original of the completed form is sent to NATSF with a copy to the Cognizant Field Activity (CFA). (NOTE: The Cognizant Field Activity is an activity that has been delegated the authority and assigned the responsibility to perform specific engineering functions.)

Since NATSF acts as the central manager for all technical publications, this activity maintains a record of all technical manual deficiencies reported and acknowledges receipt of each deficiency report to the originator. In addition, NATSF coordinates with CFA/Contractor to ensure each deficiency is corrected and provides followup on each deficiency report to ensure corrective action is accomplished. Many of the changes and revisions to technical manuals are originated in this manner.

For technical publication deficiencies that affect Maintenance Requirements Cards, a copy of the deficiency report should be sent by the reporting activity to the Naval Aviation Logistics Center (NALC), Patuxent River, Maryland.

All technical publication deficiencies that meet the criteria for safety messages shall be submitted in the prescribed message format. OPNAV 4790.2 (Series), Naval Aviation Maintenance Program, should be consulted for information concerning the format and content of the message and also the reporting form OPNAV 4790/66.

DIRECTIVES

There are two broad categories of letter type publications. One category pertains to information of a technical nature and includes Bulletins and Changes. This category is referred to as Technical Directives. The other category pertains to policy and administration procedures. Instructions and Notices are used to disseminate this type of information. These different forms of letter type publications are discussed in the following paragraphs.

Technical Directives

The Technical Directive (TD) System has been established for the control and issue of all technical directives. This system standardizes the method of issuance for such directives and the authorized means for directing the accomplishment and recording of modifications and one-time inspections to equipment procured by and for the NAVAIRSYSCOM. The TD system is an important element in the programs designed to maintain equipment in a safe and current state of operational and material readiness.

This system provides for two types of technical directives. The types are determined by the method of dissemination. The two types are formal letter type and message type directives. Such directives contain instructions or information of a technical nature. The accomplishment of a technical directive often necessitates a change or revision to the applicable technical manual. Technical directives are issued in the form of Changes, or in the case of special circumstances, by Interim Changes or Bulletins.

A formal technical directive is issued as a Change, or as an Amendment or Revision thereto, and, as stated previously, is disseminated by letter. Formal technical directives are used to direct the accomplishment and recording of modifications to aircraft, engines, support equipment, and related equipment, and are comprised of changes and amendments and/or revisions thereto.

An Interim technical directive is a document issued as a Change, or as an amendment or revision thereto, and, in order to ensure prompt

delivery to the concerned activities, is disseminated by message. The Interim TD is reserved for those instances to correct a safety or operational condition whenever it is considered too important to risk the time involved for the issuance of a formal directive. Interim Changes are superseded by a formal change directive which will have the same number as the Interim directive.

A Change is a document containing instructions and information which directs the accomplishment and recording of a material change, a repositioning, a modification, or an alteration in the characteristics of the equipment to which it applies. A Change is issued to direct that parts be added, removed, or changed from the existing configuration, or that parts or material be altered, relocated, or repositioned.

A Change may be issued in parts to accomplish specific stages of a total directed action, or to accomplish action on different configurations of affected equipment.

A Bulletin is a message type directive, comprised of instructions and information, which directs a one-time inspection to determine whether a given condition exists, and specifies what action is to be taken if the condition is found. It may contain instructions for corrective action using approved repair procedures, provided no change in material or configuration is involved.

UPDATING TDs.—Sometimes it is found that a Change or Bulletin is not the complete answer to a problem, and it is necessary to amend or revise an outstanding directive. An Amendment is a document comprised of information which clarifies, corrects, adds to, deletes from, makes minor changes in requirements to, or cancels an existing technical directive. It is only a supplement to the existing directive and not a complete directive in itself. A maximum of three Amendments may be applied to the TD, each in effect until rescinded or superseded by a Revision. Amendments may not be used to cancel another Amendment.

A Revision is a completely new edition of an existing directive. It supersedes the original

directive or Revision and all existing Amendments.

Rescission is the process by which TDs are removed from active files after all requirements have been incorporated. Final rescission action is directed in the TD index, NAVSUP Publication 2002. All activities maintaining active technical libraries should maintain the TDs on file until they are deleted from the TD index, NAVSUP 2002.

Cancellation of a technical directive is the process whereby the TD is removed from the active files when it is determined that the previously issued TD is not to be incorporated. Cancellation is directed by the issuance of an Amendment to the TD. The cancellation explicitly states the required configuration of each article initially specified for modification; for example, whether installed modifications are to remain installed or are to be removed, etc.

TD TITLES AND NUMBERING.—There are many title subjects of Changes and Bulletins. A few example titles are as follows:

- Power Plant (PPC, PPB)
- Airframe (AFC, AFB)
- Accessory (AYC, AYB)
- Support Equipment (SEC, SEB)
- Propeller (PRC, PRB)
- General Power Plant Bulletin (GPPB)

EXAMPLES:

- TF41 Power Plant Change No. 64
- Support Equipment Change No. 1299
- A-7 Interim Airframe Change No. 487
- F-14 Airframe Bulletin No. 74

If the technical directive involves safety of flight, the word "SAFETY" will appear immediately following the title and number.

Changes and Bulletins are numbered consecutively in accordance with their subject title. For example, TF41 Power Plant Change No. 64 is the 64th Power Plant Change issued concerning the TF41 engine. This numbering system has been in effect for some time, and most technical directives are cataloged under this system.

The numbers assigned to Changes and Bulletins are provided by the Technical Directives Control Center, which is located at the Naval Air Technical Services Facility, Philadelphia. Changes or Bulletins that have been amended will have their basic number followed by the words "Amendment 1," "Amendment 2," etc. A revised directive will have the basic directive number followed with the words "Rev. A," "Rev. B," etc., as appropriate, to denote the first, second, etc., revision to that basic directive.

The Changes and Bulletins are automatically distributed to all concerned activities. All TDs are issued by NAVAIR or NATSF, except in cases where the time delay in obtaining approval is unacceptable. In such cases, the controlling custodians are authorized to issue Interim TDs to preclude unacceptable risks to personnel or equipment. Changes and Bulletins are generally based on Contractor Service Bulletins, other letters of recommendation, or proposed modifications from field activities.

TD Categories

Technical directives are assigned a "category" in accordance with the importance and urgency of accomplishing the work involved. A category of Immediate, Urgent, Routine, or Record Purpose is assigned each technical directive.

The category Immediate Action is assigned to directives which are issued to correct safety conditions, the uncorrected existence of which would probably result in fatal or serious injury to personnel or extensive damage or destruction of property. These directives are identified by a border of black Xs broken at the top center of the page by the words IMMEDIATE ACTION.

The category Urgent Action is assigned to directives which are used to correct safety conditions which, if uncorrected, could result in personnel injury or property damage. These directives are identified by the words URGENT ACTION at the top of the first page and a border of black diagonals around the cover page.

Routine Action directives are those concerned with equipment or procedural deficiencies of a material-mechanical, operational, or tactical in nature--of which the

uncorrected existence could constitute a hazard. They are identified by the words ROUTINE ACTION printed at the top of the cover page.

The category Record Purpose is used when a modification has been completely incorporated by the contractor or inhouse activity in all accepted equipment, and when retrofit is not required of repairables in the Navy's possession. They are identified by the words RECORD PURPOSE printed in black capital letters at the top of the first page.

Instructions And Notices

Information pertaining to action of a continuing nature is contained in Instructions. An Instruction has permanent reference value and remains in effect until the originator supersedes or cancels it. Notices contain information pertaining to action of a one-time nature. A Notice does not have permanent reference value and contains provisions for its own cancellation.

For purposes of identification and accurate filing, all instructions and notices can be recognized by the originator's authorized abbreviation; the type of release (whether an Instruction or Notice); a subject classification number; and, in the case of Instructions only, a consecutive number. (Because of their temporary nature, the consecutive number is not assigned to Notices.) This information is assigned by the originator and is placed on each page of the release.

The manner of numbering and identifying these directives can be better understood by considering a typical identifier:

SECNAV	INST	5215.1A
(a)	(b)	(c) (d)

(a) The authorized abbreviation of the originator of the directive.

(b) The type of release (in this case an Instruction).

(c) The subject number of the directive (obtained from the Table of Subject Classification Numbers).

(d) The consecutive number (found only on Instructions). An originator would assign consecutive numbers to those consecutive

instructions with the same subject classification number. In the example above, the subject classification number 5215 concerns "Issuance Systems." If the originator, SECNAV, issued additional Instructions dealing with issuance systems, they would be assigned the numbers 5215.2, 5215.3, 5215.4, etc. The letter A indicates that this is the first revision of the same basic directive.

Subject classification numbers are listed in the Table of Subject Classification Numbers found in SECNAV Instruction 5210.11 (Series). This table contains a numerical and alphabetical listing of numbers with their related subjects, and has reference value when information or instructions of a particular nature are desired. This Instruction contains all necessary information concerning the use and procedures of the Naval Directives System.

Periodicals

Many periodicals of interest to the AE are published and issued by naval activities. A few of the most important are discussed in the following paragraphs.

APPROACH.—Approach, The Naval Aviation Safety Review, NAVAIR-00-75-510, is published monthly by the U.S. Naval Safety Center. It is distributed to naval aeronautical organizations on the basis of one copy for each ten personnel assigned. It presents the most accurate information currently available on the subject of aviation accident prevention. It is an unofficial publication, and its contents are not to be considered as regulations, orders, or directives. It should, however, be read each month by all aviation personnel.

NAVAL AVIATION NEWS.—Naval Aviation News is published monthly by the Chief of Naval Operations and the Naval Air Systems Command. Its purpose is to disseminate information on aircraft, aviation training and operations, and other aeronautical matters.

This publication should be read each month by all naval aviation personnel.

ALL HANDS.—All Hands is issued monthly by the office of the Chief of Information, for

the information and interest of the naval service as a whole. It is not an official publication in the sense of constituting authority for action based on information contained therein, nor is it a statement of official policy. However, it is an important publication in that it contains information vital to naval personnel.

Distribution of All Hands is automatic to each activity, and is based on one copy for each six personnel assigned. It should be read every month by all personnel.

MAINTENANCE CROSSFEED.—Maintenance Crossfeed is an "Official Use Only" publication issued monthly by the Naval Safety Center. Each Crossfeed is in the form of a letter to aviation activities.

Due to the designation "Official Use Only," the Crossfeeds are not available for general distribution through an activity. Crossfeeds often contain information extracted from Aircraft Accident Reports (AARs), incidents and ground accident reports, Medical Officer's Reports (MORs), and special investigations of aircraft mishaps. Since these reports must be designated "Official Use Only," the Crossfeeds must be designated likewise.

Maintenance Crossfeeds are prepared in sections according to subject matter. The sections are titled Maintenance Management, Airframes, Armament, Avionics, Ground Support, Powerplants, and Life Support Equipment. The AE, of course, is most concerned with the section titled Avionics. From time to time, this section, and others, contains information of critical importance to AEs in the performance of their duties.

The unit's aviation safety officer will generally pass Crossfeed information on to those with an obvious need to know and will followup to see that it is used. However, each applicable Crossfeed should be checked for pertinent information by the AE. For those who understand the need for special handling of the information contained in Crossfeed and for those interested enough in the information and their jobs to ask for it, these publications can provide a wealth of useful and timely information.

MECH.—Mech is published quarterly by the U.S. Naval Safety Center and is distributed to naval aeronautical organizations on the basis of one copy per ten persons assigned. It presents the most accurate information available on maintenance-caused mishap prevention and general aviation ground safety. The contents are informational and should not be considered as regulations, orders, or directives.

The Mech carries the Safety Center's motto, which is "Our product is safety, our process is education, and our profit is measured in the preservation of lives and equipment and increased mission readiness."

SUPPLY

One of the duties of an AE involves the identification of aeronautical material. Required material must be identified prior to submitting a requisition. If a request document is submitted with incorrect information, the wrong material may be received or the request may be rejected for lack of identification. Much confusion and unnecessary labor, expense, and waiting result when orders do not correctly identify the material required.

MATERIAL IDENTIFICATION

As part of the aviation maintenance team, you will work closely with the aviation storekeepers in keeping aircraft in an "up" status. In order to obtain replacement parts as rapidly as possible, you must know how to determine the source of supply for different items. For example, you may waste many hours looking for a source, only to find out that the required item is to be manufactured within the local activity. Also, it is important to know the correct stock numbers and cognizance symbols used to requisition items from supply.

The cataloging system developed by the Department of Defense is such that it identifies with one name and stock number any item of supply that is carried in any or all government agencies. In the procurement of material it is normally necessary to identify your material requirement in the medium understandable to the supply system.

National Stock Numbers

Prior to 1952 each of the services had its own numbering system for identifying, cataloging, stocking, and issuing items of military supply. It is not unheard of that one service would be negotiating on the open market for an item that was held in surplus by another service under its own stock number. This confusion resulted in the passage in 1952 of the Defense Cataloging Standardization Act.

The implementation of this Act has resulted in a reduction of item duplication between the services by providing for one National Stock Number (NSN) for each item, regardless of the use of the item or the using activity.

CODED NATIONAL STOCK NUMBER.—The national stock number consists of a 13-digit number. The Aviation Supply Office uses national stock numbers with prefixes composed of one, two, or three symbols, and suffixes composed of four characters which may be all letters or a combination of letters and numbers. When the prefixes and suffixes are used, the national stock number becomes a coded national stock number. A coded national stock number and its breakdown are shown in figure 1-25.

If a one-symbol prefix is used, it designates the command or office having control or cognizance of a particular item. Listed below are some of the more common cognizance symbols, together with the type material controlled and the name of the cognizant command or office.

SYMBOL	COGNIZANT ACTIVITY	MATERIAL CONTROLLED
2R	Aviation Supply Office	Aeronautical material
2V	Naval Air Systems Command	Major aeronautical equipment
1I	Navy Supply Depot, Philadelphia	Forms
0I	Navy Supply Depot, Philadelphia	Publications

Many variations of coded stock numbers will be encountered in field maintenance work.

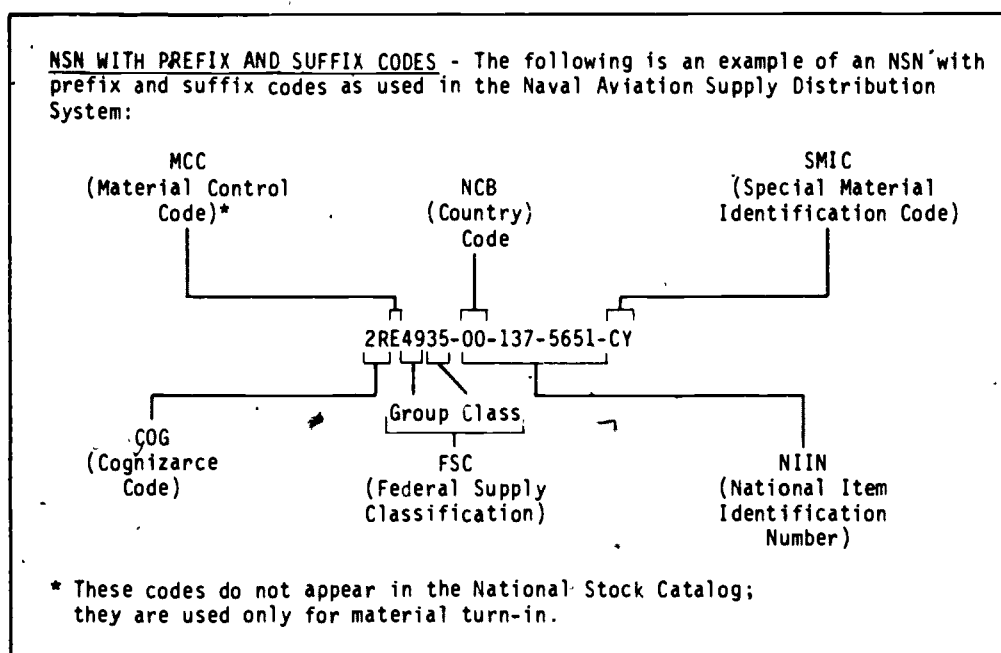

221.85

Figure 1-25.—Breakdown of a coded National Stock Number.

These variations indicate material management responsibilities for the item; flag certain items as recoverable, consumable, high value, etc.; and identify the condition of the material if it is not ready for issue. Some of the more common codes that an AE is likely to encounter include the following:

2RH—a recoverable aeronautical component of high value.

2RHF—a recoverable aeronautical component of high value that is not ready for issue.

Because the variety of codes is so extensive and the trend to single service management of items has caused so many changes in recent years, a list of codes that might be prefixed or suffixed to a stock number would not be appropriate for this manual. The primary things to keep in mind are that the basic stock number, consisting of three groups of numerals, identifies the item from a technical point of view and that

the other codes identify material management characteristics.

With the advent of the single manager concept, many items formally carried in the individual Navy Stock Lists are cataloged in the Federal Supply Catalog for General Supplies. The complete catalog consists of many sections and is arranged by federal supply classification class.

Material Identification Aids

There may be times when a part or some technical material is needed and the stock number is unknown. At other times some material may be on hand and its identity is not positively known. There are many ways in which material may be identified and knowledge of these methods is very helpful in speeding up the completion of a maintenance task. Certain data may be available which does not identify an item but may lead to positive identification. An aircraft part has a part number. The part number

may be looked up in the IPB and identified by nomenclature and often by the stock number. If the stock number is not furnished in the IPB, it may be found by referring to the Cross-Reference Section C0006 of the Navy Stock List of ASO.

Some equipments have attached nameplates which provide such information as the manufacturer's name, make or model number, serial number, size, voltage, phase, etc. Identification data taken from the nameplate of the old part can be very helpful in procuring a replacement.

When only the description of the item is known, the best source for identification is the descriptive sections of the various Navy Stock Lists.

Various publications used in identifying material are described in the following paragraphs. (Some of the following publications have been discussed earlier in this chapter, but for the sake of continuity, they will be mentioned again.)

NAVSUP Publication 2002, The Navy Stock List of Publications and Forms, should be used as a guide when you are requisitioning publications and forms. NAVSUP 2002 is issued quarterly (February/May/August/November) in microfiche form only (no paper publication copy is available) and each quarterly edition supersedes the previous one in its entirety. This stock list is supplemented by and should be used in conjunction with NAVAIR 00-500A, Equipment and Subject Applicability List, and NAVAIR 00-500B, Aircraft Application List. These lists serve as handy references to publications that should assist you in the identification of material.

ILLUSTRATED PARTS BREAKDOWN (IPB) lists are probably the most important tool for the identification of aeronautical material. As a Petty Officer, you should be familiar with them. Due to the importance attached to them as a material identification source, they are discussed briefly in the following paragraphs.

IPBs are compiled by the manufacturer for each aircraft model in naval use. IPBs, as discussed here, encompass IPBs for aircraft, aircraft engines, and for individual accessories and components.

Although slight variations in format exist among the various IPBs, each normally includes the following major sections:

1. Table of contents, Section I. This section shows the breakdown of the catalog into sections and furnishes a cross-reference between the various assemblies and figures where they are illustrated. This section also cross-references assemblies and pages where they are broken down into subassemblies and parts.

2. Introduction, Section II. This section includes general information and instructions for using the publication. Because variations between IPBs do exist, this section should be referred to prior to using an IPB with which you are not thoroughly familiar.

3. Group assembly parts lists, Section III. This section is the main text of the publication. It consists of a series of illustrations and parts lists in which all parts of the aircraft/engine/equipment are shown in assembly breakdown order. The illustrations and parts lists are keyed to each other by means of figure and index numbers. Each assembly included in the parts lists is followed immediately by its component parts properly indented to show their relationship to the assembly. The group assembly parts lists is subdivided into groups such as wing group, tail group, and fuselage.

4. Numerical index, Section IV. This section lists all parts in alphanumerical order, and each part is cross-referenced to the figure and index number where it is illustrated. This list also shows the official source, maintenance and recoverability (SM&R) codes of each part listed in the applicable IPB. Uniform SM&R codes are used to identify the source of spares, repair parts and items of support equipment, and the levels of maintenance authorized to maintain, repair, overhaul, or condemn all equipment. An objective of such coding is to control, by applying maintenance and supply experience and judgment, the range of parts procured to support new equipments. Another objective of SM&R coding is to expedite the maintenance, repair, and overhaul of aeronautical equipments by providing maintenance and supply personnel with the necessary information relative to the source of

supply and, where applicable, the maintenance implications and recoverability status of items.

Uniform SM&R codes shall be used, to the maximum degree practicable, in all commodity areas where provisioning is practiced and shall be applicable to:

- All new equipments being provisioned.
- All equipments being reprovisioned.

Equipments modified or added by approved Engineering Change Proposal (ECP) actions.

The uniform code format is composed of four parts consisting of a two position Source Code, a two position Maintenance Code, a one position Recoverability Code, and a one position Service Option code. See figure 1-26.

Source codes are entered in the first and second positions of the uniform format and indicate the source for acquiring the item for replacement purposes, i.e., procured, stocked, manufactured, or assembled.

The Maintenance Code entered in the third position indicates the lowest maintenance level authorized to remove/replace and use the item.

The Maintenance Code entered in the fourth position indicates whether the item is to be repaired and identifies the lowest maintenance level with the capability to perform complete repair (i.e. maintenance functions authorized at this level to return an item to a serviceable condition).

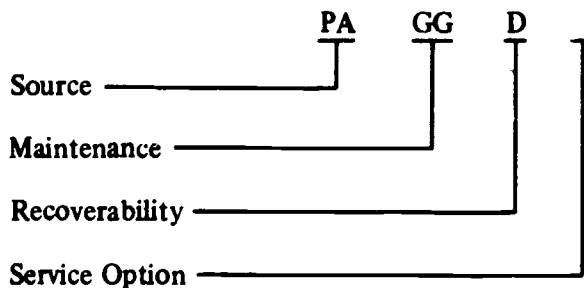

Figure 1-26.—Breakdown of a Source Maintenance and Recoverability (SM&R) code.

Recoverability Code entered in the fifth position of the uniform format indicates the desired disposition of the support item.

Service Option Codes are special codes used to further define certain conditions not covered by the uniform codes. This Code is reserved for internal management purposes of each service. Codes to be used in this position will be coordinated by Commander, Naval Supply Systems Command.

Further information on Source, Maintenance and Recoverability codes may be obtained from NAVSUP Instruction 4423.14 (Series).

ALLOWANCE REQUIREMENT REGISTERS

This title is inclusive of publications identified as Allowance Requirement Registers and initial outfitting lists.

Aeronautical Allowance Lists are prepared by the Naval Air Systems Command or by activities as designated and directed by this command. These lists include the following:

1. The equipment and material (both consumable and nonconsumable) necessary to outfit and maintain units of the aeronautical organization in a condition of material readiness.
2. Substantially all items used with sufficient frequency to justify their issuance to all activities maintaining aircraft or equipment for which the lists are designed.
3. Information concerning stock number, nomenclature, interchangeability, and supersedures.
4. A set of detailed instructions for the application and utilization of the publication.
5. A table of logistic data showing the total weight and cube of all material contained in the lists.

In the final analysis, Allowance Requirement Registers are lists of equipment and material determined from usage data and provisioning conferences to be necessary to place and maintain aeronautical activities in a position of optimum material readiness.

Allowance requirement registers are published by the Aviation Supply Office quarterly in microfiche form. A paper copy forward, under the publication title ARR-100, is provided with each microfiche set. The forward to the ARR-100 contains instructions for use of the microfiche and the column headings for columns seven through seventeen of the microfiche.

Outfitting Lists are publications which indicate the range and quantities of maintenance spare parts considered necessary to support various aeronautical end items. This material is provided to vessels or activities and is firm only at the time of initial outfitting. Increases and decreases in both range and/or quantities of material are based on the experience (usage data) of each activity concerned. Each series list is designed to support an aircraft, electronic equipment, or some other aeronautical end item. The allowances of material are established for various end items for a 90-day period. Not all items capable of replacement by a maintenance activity are listed, only those that are expected to be used at least once in a 90-day period.

Types And Identification

Allowance requirement registers are identified within ASO publication number ARR-100 to each individual weapon system by the publication number ASO-00-35Q series. The forward to the ARR-100 provides a cross reference from Allowance Requirement to weapon system and vice versa.

SECTION B, AIRCRAFT MAINTENANCE PARTS.—Section B lists airframe, engine, and accessories maintenance parts peculiar to each type of aircraft. A separate section B is issued for each model of aircraft. Quantities of items included in this section are the amounts estimated to be required for a given period of time (normally 90 days). Quantities of items appearing in section B are firm allowances for outfitting only, and are used as a guide for replenishment until such time that sufficient

usage data are available for determining requirements.

SECTION BN, AIRCRAFT ENGINE MAINTENANCE PARTS.—Section BN lists maintenance parts required for the maintenance and build-up of aircraft engines.

SECTION BR, TARGET AIRCRAFT, DRONE HELICOPTER, AND GUIDED MISSILE MAINTENANCE PARTS.—Section BR lists maintenance parts (airframe, engine, accessories, and electronics) required for support of the above mentioned vehicles. It is prepared in lieu of a separate section B list for airframe, engine, and accessories, and a section R list for electronics parts due to limited installation of electronic equipment.

SECTION G, GENERAL SUPPORT EQUIPMENT FOR ALL TYPES, CLASSES, AND MODELS OF AIRCRAFT.—Section G lists the quantities of handtools, handling, and servicing equipment, and material which are made available for maintenance support of aircraft as may be assigned or supported.

SECTION R, AERONAUTICAL ELECTRONIC MATERIAL LIST.—Section R comprises allowance lists of electronic equipment and material required for the test and maintenance of aeronautical electronic/armament equipments within the Naval Establishment.

SECTION T, SPECIAL MAINTENANCE SUPPORT EQUIPMENT.—Section T is applicable to Navy and Marine Aeronautical maintenance activities and lists the allowances of special support equipment required for maintenance support of assigned aircraft. A separate section T allowance is published for each aircraft manufacturer.

SECTION X, AERONAUTICAL ELECTRICAL MATERIAL LIST.—Section X comprises Allowance Requirement Registers of electrical equipment and material required for test and maintenance of aeronautical electrical equipments within the Naval Establishment.

CHAPTER 2

ELEMENTARY PHYSICS

The Aviation Electrician is associated with some very complex machines and equipment. The AE is expected to understand, operate, service, and maintain these machines and equipment, and to instruct new personnel so that they can also perform these functions. No matter how complex a machine or item of equipment is, its action can be satisfactorily explained as an application of a few basic principles of physics. In order to understand, maintain, and repair the equipment and machinery necessary to the operation of the aircraft of the fleet, an understanding of these basic principles is essential. There can be no question that the electrician who possesses this understanding is better equipped to meet the demands of the AE rating.

Physics is devoted to finding and defining problems, as well as to searching for their solutions. It not only teaches a person to be curious about the physical world, but also provides a means of satisfying that curiosity. The distinction between physics and other sciences cannot be well defined, because the principles of physics also pertain to the other sciences. Physics is a basic branch of science and deals with matter, motion, force, and energy. It deals with the phenomena which arise because matter moves, exerts force, and possesses energy. It is the foundation for the laws governing these phenomena, as expressed in the study of mechanics, hydraulics, magnetism, electricity, heat, light, sound and nuclear physics. It is closely associated with chemistry and depends heavily upon mathematics for many of its theories and explanations.

MEASUREMENTS

A good understanding of measurements is particularly important to the Aviation

Electrician in that much of the AE's professional responsibility will be concerned with some type of measurement. The instruments with which the AE will work include not only meters to measure voltage, current, and resistance, but also aircraft-installed measuring devices such as altimeters, airspeed indicators, position indicators, etc.

In any study of physics, it soon becomes obvious that specific words and terms have specific meanings which must be mastered from the very start. Without an understanding of the exact meaning of the term, there can be no real understanding of the principles involved in the use of that term. Once the term is correctly understood, however, many principles may be discussed briefly to illustrate or to emphasize the particular aspects of interest. The first part of this chapter is devoted to definitions of some physical terms and a brief general discussion of certain principles of vital interest to all personnel.

In order to evaluate results, it is often essential to know how much, how far, how many, how often, or in what direction. As scientific investigations become more complex, measurements must become more accurate, and new methods must be developed to measure new things.

Measurements may be classified into three broad categories—magnitude, direction, and time. These categories are broken down into several types, each with its own standard units. Measurements of direction and time have become fairly well standardized and have comparatively few subdivisions. Magnitude, on the other hand, is an extremely complex category with many classes and subdivisions involved.

AVIATION ELECTRICIAN'S MATE 3 & 2

Table 2-1.—Frequently used units of measurement

English system	Metric system	General
acre	angstrom	ELECTRICAL
Btu (British thermal unit)	bar	ampere
bushel	calorie	coulomb
dram	dyne	decibel
foot	erg	farad
gallon	gram	henry
hertz	hectare	ohm
horsepower	hertz	volt
hour	hour	watt
inch	joule	LIGHT
knot	liter	candle
mil	meter	candela
mile	metric ton (1,000 kg)	lambert
minute	micron	lumen
ounce	minute	MAGNETIC
peck	newton	gauss
pint	quintal	gilbert
pound	second	maxwell
quart	stere	rél
second		
slug		
ton (short, 2,000 lb long, 2,240 lb)		
yard		

The unit of measurement is just as important as the number which precedes it, and both are necessary to give an accurate description.

Two widely used sets of measurement units are the metric and the English. The metric units are most often used to express scientific observations where the basic unit of distance is the meter, of mass is the kilogram, and of time is the second. This is called the meter-kilogram-second system, or the mks system. Another widely used metric system uses the centimeter for units of distance, the gram for units of mass, and the second for units of time, and so is called the centimeter-gram-second system, or cgs system. The English system uses the foot for distance, the pound for mass, and the second for time, and so is called the foot-pound-second system, or fps system. See table 2-1 for other units.

METRIC UNITS OF LENGTH

Metric units of length are based on the standard meter which was first intended to be one ten-millionth part of the distance between the earth's Equator and one of the poles. Although more recent measurements show this distance to be close to 10,000,880 meters, the original length of the meter is still accepted as standard.

When large distances are measured it is customary to use the kilometer, which is 1,000 meters; 1 kilometer (km) = 1,000 meters (m). For smaller measurements the meter is divided into smaller units. One meter equals 100 centimeters (1 m = 100 cm) and 1 centimeter equals 10 millimeters (1 cm = 10 mm), so 1 meter equals 1,000 millimeters (1 m = 1,000 mm).

The micron is still smaller, and is used in referring to the size of a particle of foreign matter that may pass through a screen or filter in a hydraulic system. The micron is one-thousandth of a millimeter or one-millionth of a meter, the millimicron is one-thousandth of a micron, and the micromicron is one-thousandth of a millimicron or one millionth of a micron.

ENGLISH UNITS OF LENGTH

The common units of the English system of distance measurement are inches, feet, yards, and miles, where 1 foot equals 12 inches (1 ft = 12 in.), 1 yard equals 3 feet (1 yd = 3 ft = 36 in.) and 1 mile equals 1,760 yards (1 mile = 1,760 yd = 5,280 ft = 63,360 in.). The nautical mile is 6,076.115 feet. The mil is 1/1,000 inch.

In 1866 the United States, by an act of Congress, defined the yard to be 3,600/3,937 part of a standard meter, or in decimal form approximately 0.9144 meter. Thus, other conversions between the systems may be found by proper multiplication or division. Some approximate conversions are listed in table 2-2.

VOLUME

Volume is the amount of space enclosed within the bounding surfaces of a body. To determine the volume of a regularly shaped body, three measurements of length are required—

$$\text{Volume} = \text{length} \times \text{width} \times \text{depth (height)}$$

$$V = lwh$$

Volume is said to have dimensions of length cubed because it is the product of three length measurements. The unit of volume is a cube having edges of unit length. (See fig. 2-1.)

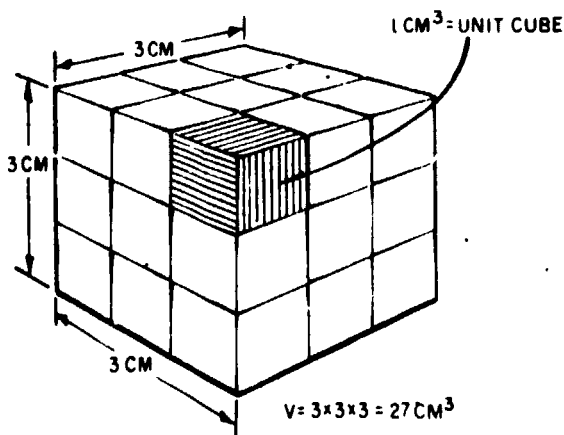

243.4

Figure 2-1.—Volume measurement.

Table 2-2.—Conversion factors for units of length

	km	m	cm	mm	in.	ft	yd	mile
1 km =	1	1,000	100,000	1×10^6	39,370	3,280.83	1,093.61	0.621369
1 m =	0.001	1	100	1,000	39.37	3.28083	1.09361	6.214×10^{-4}
1 cm =	1×10^{-5}	0.01	1	10	0.3937	0.032808	1.094×10^{-2}	6.214×10^{-5}
1 mm =	1×10^{-6}	1×10^{-3}	0.1	1	0.03937	3.28×10^{-3}	1.094×10^{-3}	6.214×10^{-7}
1 in. =	2.54×10^{-5}	2.54 $\times 10^{-2}$	2.54	25.4	1	0.08333	0.02777	1.58×10^{-5}
1 ft =	3.048×10^{-4}	0.3048	30.48	304.8	12	1	0.33333	1.89×10^{-4}
1 yd =	9.144×10^{-4}	0.9144	91.44	914.4	36	3	1	5.68×10^{-4}
1 mile =	1.60934	1,609.34	160,934	1,609,340	63,360	5,280	1,760	1

NOTE: When a number is multiplied by a power of ten, the decimal point is moved the number of places represented by the power. A negative power moves the decimal point to the left; a positive power moves it to the right. Thus, $84 \times 10^{-2} = .84$, and $84 \times 10^2 = 8,400$. Simply stated, a power of ten merely moves the decimal point left or right.

24

50

A great deal of ingenuity is often needed to measure the volume of irregularly shaped bodies. Sometimes it is practical to divide a body into a series of regularly shaped parts and then apply the rule that the total volume is equal to the sum of the volumes of all individual parts. Figure 2-2 demonstrates another method of measuring the volume of small irregular bodies. The volume of water displaced by a body submerged in water is equal to the volume of the body.

A somewhat similar consideration is possible for floating bodies. A floating body displaces its own weight of liquid. This may be proved by filling a container to the brim with liquid, then gently lowering the body to the surface of the liquid and catching the liquid that flows over the brim. Weighing the liquid displaced and the original body will prove the truth of the statement.

UNITS OF MASS, WEIGHT, AND FORCE

The measure of the quantity of matter which a body contains is called mass. The mass of a body does not change. It may be compressed to a smaller volume, or expanded by the application of heat, but the quantity of matter remains the same.

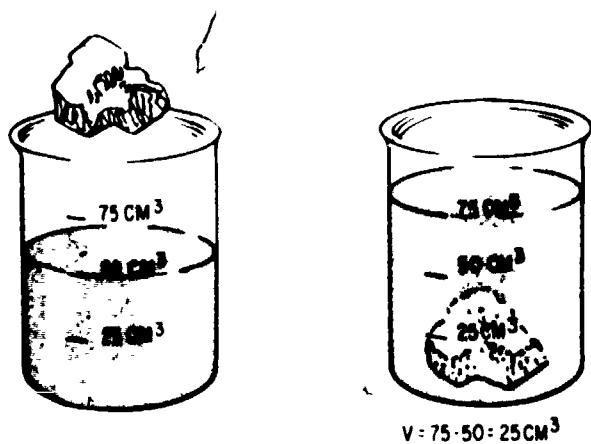

243.5

Figure 2-2.—Measuring the volume of an irregular object.

Originally, the metric unit of mass was based on the gram (gm) being equal to the mass of 1 cubic centimeter of pure water at a temperature of 4° Celsius, and for practical purposes this is essentially correct. The U.S. Bureau of Standards has two blocks of platinum which are identical to the standard kilogram (1,000 gm) block of platinum preserved at the International Bureau of Weights and Measures near Paris. The standard pound (lb) is the mass equal to 0.4536 kilograms, or 453.6 grams, at sea level.

The mass of a body is constant no matter where the body is located. Its weight, however, is the force with which it is attracted toward the earth, and becomes less as the body is moved away from the earth's surface.

In addition to grams, kilograms, and pounds being used as units of mass, these same units are also used to describe the weight of a body by comparing the body's weight to the weight of a standard mass unit. Unless otherwise specified, when an object is described as having a weight of 1 pound, it means the object has the same pull of gravity that a mass of 1 pound would have near the earth's sea level. At sea level, the numerical values of weight and mass of a given object are equal when expressed in the same units.

It is interesting to note that spring weighing machines are not legal for trade in most states of the U.S. A spring scale registers the force necessary to overcome the pull which gravitational force exerts on the object being weighed. This gravitational force varies with the altitude of the object on the earth. A balancing scale, usually called a BALANCE, measures mass rather than weight, although the dial is marked in pounds. On a balance, the object to be weighed is compared with a standard unit of mass. The variation due to altitude is canceled because it affects both the standard unit and the object to be weighed. Therefore, the standard mass serves as an accurate unit of measure for all locations on the surface of the earth.

The slug may be used as the unit of mass. This is the mass which weighs 32 pounds at sea level. Its relationship to pounds weight or pounds force and the advantage of its use will be discussed in more detail later in this chapter. Also to be discussed are the metric force units of

dynes and newtons. At this point, however, it can be said that at sea level a mass of 1 gram (gm) exerts a downward force of 980 dynes due to gravity, and that 1 kilogram (kg) exerts a downward force of 9.8 newtons. Since 1 kg = 1,000 gm, a kilogram exerts a force of 1,000 X 980 dynes or 980,000 dynes, which is equal to 9.8 newtons. Thus 1 newton = 100,000 dynes.

To relate the newton to the English system, 1 newton equals 0.2247 pound force, or 1 pound force equals 4.448 newtons. Also, the mass unit of 1 slug equals the mass of approximately 14.6 kilograms, so 1 kilogram of mass is approximately 0.0686 slug.

Conversion between weight units of the metric system is simple since it is only a matter of moving the decimal point: 1,000 milligrams (mg) = 1 gm; 1,000 gm = 1 kg; and 1,000 kg = 1 metric ton. The English system requires more effort, since the pound is divided into 16 ounces, and the ounce into 16 drams. The "short ton" is 2,000 pounds, while the "long ton" is 2,240 pounds. The metric ton is fairly close to the long ton, converting to 2,205 pounds.

DERIVED UNITS

Units based on combinations of two or three fundamental units can always be expressed as some combination of these units. The watt (unit of power) could be written as joules (unit of work) per second. The joule in turn could be expressed as newtons (force) times meters (distance) and the watt then becomes newton-meters per second. Likewise, the unit of horsepower could be expressed in foot-pounds per second. Although there are conversion factors between derived units of the English system and the metric system, fundamental units of the two systems are not combined. For instance, if force is given in pounds and distance in meters, one or the other must be changed before combining them to get work units.

Speed and Velocity

One example of a derived unit is the knot, a unit of speed. This unit combines the nautical mile as the unit of distance and the hour as the

unit of time, and is derived by dividing the distance traveled by the time required. Thus, if an aircraft traveled at a constant rate for 6 minutes (0.1 hr) and moved a distance of 30 nautical miles, its speed would be 30/0.1 or 300 knots. The rate of travel (speed) may also be used to solve for distance traveled when time is known. If the above aircraft traveled 250 knots for 3 hours, it would move 750 nautical miles. Likewise, the time required for moving a certain distance may be determined when the speed is known. A distance of 360 nautical miles traveled at 240 knots would require 360/240 = 1.5 hours, or 1 hour 30 minutes.

Very often speed is expressed with two fundamental units such as miles per hour, kilometers per hour, or feet, inches, meters or centimeters per minute or per second. Conversion is a matter of replacement of one unit by its equivalent in another unit. For example, a speed of 60 miles per hour (60 mph) may be converted to feet per second by replacing the mile with 5,280 feet and the hour with 3,600 seconds. Thus a speed of 60 mph = $\frac{60 \times 5,280}{3,600 \text{ sec}}$ = 88 feet per second.

Table 2-3 gives the conversion factors between meters per second, feet per second, kilometers per hour, miles per hour, and knots.

The terms "speed" and "velocity" are sometimes used as having the same meaning. However, velocity is a vector quantity—that is, it is speed in a given direction. Thus, a car may move around a circular path with a constant speed while its velocity is continuously changing. When a body moves with constant speed along a straight line whose direction is specified, it is customary to speak of its velocity (which is numerically equal to its speed). Moving along a curved path or along a straight path with no reference being made to direction, it is proper to speak of its speed.

Work and Energy

Units of work and energy, also derived units, are the product of the units of force and distance. In the cgs system, the erg is the work done by a force of 1 dyne acting through a

Chapter 2—ELEMENTARY PHYSICS

Table 2-3.—Conversion factors for speed and velocity

Speed	m/sec	ft/sec	km/hr	mi/hr	knots
1 m/sec =	1	3.281	3.6	2.24	1.94
1 ft/sec =	0.3048	1	1.0973	0.6818	0.5921
1 km/hr =	0.27778	0.9113	1	0.6214	0.5396
1 mi/hr =	0.44704	1.4667	1.6093	1	0.8684
1 knot =	0.5148	1.689	1.853	1.152	1

distance of 1 centimeter. The joule is the unit of work in the mks system where 1 newton acts through a distance of 1 meter. Since 1 newton equals 100,000 dynes and 1 meter equals 100 centimeters, then the joule is equal to 10,000,000 ergs.

In the English system the unit foot-pound is defined as the work done in lifting 1 pound a distance of 1 foot against the force of gravity. Thus the work done in lifting an object of 5 pounds vertically 4 feet is $5 \text{ lb} \times 4 \text{ ft} = 20$ foot-pounds. (Do not confuse this foot-pound with the one used to measure torque.) Since 1 pound force equals 4.448 newtons, and 1 foot equals 0.3048 meter, then 1 foot-pound is approximately 1.356 joules.

The calorie is the heat energy required to raise the temperature of 1 gram of water 1° Celsius. The Btu (British thermal unit) is the heat energy required to raise the temperature of 1 pound of water 1° Fahrenheit, and is equivalent to 252 calories (and, incidentally, to 777.8 foot-pounds of mechanical energy).

Power

All units of power include measurements of force, distance, and time, because power equals work (which is force times distance) divided by time. The watt is the unit of power frequently used with electrical units, but is also the rate of doing 1 joule of work in 1 second. Thus, if a

force of 5 newtons acts through a distance of 12 meters in 3 seconds, the power required is $P = \frac{5 \times 12}{3} = 20$ watts. If the same work is to be done in 2 seconds, 30 watts will be required.

The horsepower is a larger unit of power and is equal to 550 foot-pounds per second, or 746 watts; therefore, 1 foot-pound per second is $746/550$ watts, or about 1.356 watts.

TEMPERATURE

If an object is hot to the touch, it is said to have a "high" temperature. If it is cold to the touch, it has a "low" temperature. In other words, temperature is used as a measure of the hotness or coldness of an object being described. However, hotness and coldness are only relative. For example, on a cold day, metals seem colder to the touch than nonmetals because they conduct heat away from the body more rapidly. Also, upon leaving a warm room the outside air seems cooler than it really is. Going from the outside cold into the warm room, the room seems warmer than it really is. In other words, the temperature a person feels depends upon the state of their body.

Temperature Conversion

There are many systems of temperature measurement; it is frequently necessary to

convert from one to the other. The four most common scales in use today are the Fahrenheit (F), Celsius (C), Rankine (R), and Kelvin (K). The Celsius scale was formerly known as the centigrade scale, but was renamed to Celsius scale in recognition of Anders Celsius, the Swedish astronomer who devised it.

FAHRENHEIT SCALE.—The most familiar scale to most Americans is the Fahrenheit scale which was established so that its zero point approximates the temperature produced by mixing equal quantities by weight of snow and common salt.

Under standard atmospheric pressure, the boiling point of water is 212 degrees above zero and the freezing point 32 degrees above zero. Each degree represents an equal division, and there are 180 such divisions between freezing and boiling.

CELSIUS SCALE.—This scale uses the freezing point and boiling point of water under standard atmospheric pressure as fixed points of 0 and 100, respectively, with 100 equal divisions between. These 100 divisions represent the same difference in temperature as 180 divisions of the Fahrenheit scale. This ratio of 100/180 reduces to 5/9, which means a change of 1°F is equal to a change of 5/9°C. A change of 5° on the Celsius scale, therefore, is equal to a change of 9° on the Fahrenheit scale. Because 0 on the Celsius scale corresponds to 32° on the Fahrenheit scale, a difference in reference points exists between the two scales. (See fig. 2-3.)

To convert from the Fahrenheit scale to the Celsius scale, subtract the 32° difference and multiply the result by 5/9. As an example, convert 68° Fahrenheit to Celsius--

$$\frac{5}{9}(68 - 32) = \frac{5}{9} \times 36 = 20^{\circ}\text{C}$$

To convert Celsius to Fahrenheit, the reverse procedure is necessary. First multiply the reading on the Celsius thermometer by 9/5 and then add 32 to the result--

$$\frac{9}{5}(20) + 32 = 36 + 32 = 68^{\circ}\text{F}$$

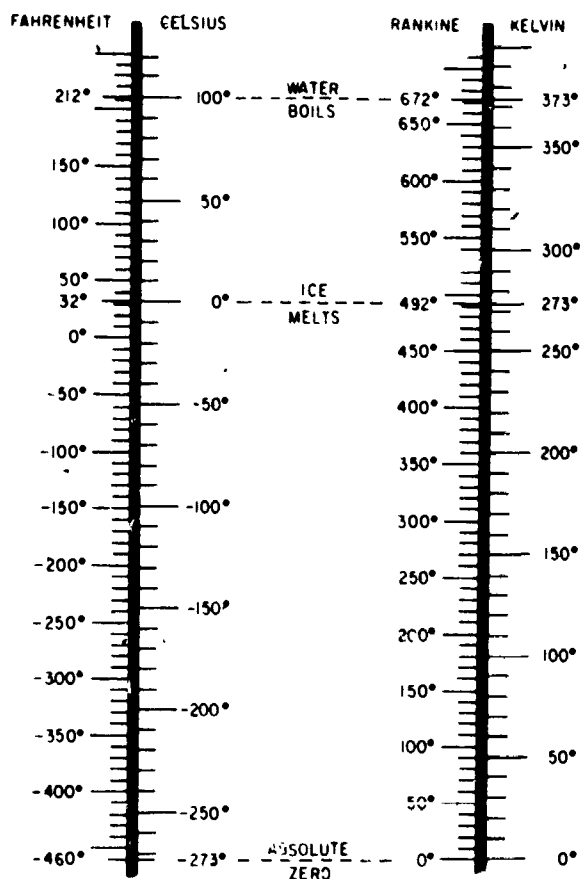

243.15

Figure 2-3.—Comparison of the four common temperature scales.

One way to remember when to use 9/5 and when to use 5/9 is to keep in mind that the Fahrenheit scale has smaller divisions than the Celsius scale. In going from Celsius to Fahrenheit, multiply by the ratio that is larger; in going from Fahrenheit to Celsius, use the smaller ratio.

Another method of temperature conversion which uses these same ratios is based on the fact that the Fahrenheit and Celsius scales both register the same temperature at -40°; that is, -40°F equals -40°C. This method of conversion, sometimes called the "40 rule," proceeds as follows:

1. Add 40 to the temperature which is to be converted. Do this whether the given temperature is Fahrenheit or Celsius.

2. Multiply by 9/5 when changing Celsius to Fahrenheit; by 5/9 when changing Fahrenheit to Celsius.

3. Subtract 40 from the result of step 2. This is the answer.

As an example to show how the 40 rule is used, convert 100°C to the equivalent Fahrenheit temperature:

$$\begin{aligned} 100 + 40 &= 140 \\ 140 \times 9/5 &= 252 \\ 252 - 40 &= 212 \end{aligned}$$

Therefore, 100°C = 212°F. Remember that the multiplying ratio for converting F to C is 5/9, rather 9/5. Also remember to always ADD 40 first, then multiply, then SUBTRACT 40, regardless of the direction of the conversion.

It is important that all electricians be able to read thermometers and to convert from one scale to the other. In some types of electrical equipment, thermometers are provided as a check on operating temperatures. Thermometers are also used to check the temperature of a charging battery. Aircraft-installed outside air temperature gages normally indicate in degrees Celsius and it may be necessary to convert to degrees Fahrenheit to calibrate fuel quantity systems or perform other maintenance.

KELVIN SCALE.—Also known as the absolute scale, the Kelvin scale has as its zero point the temperature which has been indicated by experiments with hydrogen as the point where all molecular motion would cease and no additional heat could be extracted from the substance. Theoretically, this is referred to as absolute zero temperature. This point is -273.16°C, but -273°C is used for most calculations as shown on figure 2-3. The spacing between degrees is the same as for the Celsius scale, and so conversion to Kelvin temperature is made by adding 273 to the Celsius temperature.

RANKINE SCALE.—This scale has the same spacing between degrees as the Fahrenheit scale, but has its zero corresponding to 0°K (absolute zero). This is calculated to be -459.69°F, but -460°F is usually used. To convert Fahrenheit to

Rankine, add 460 to the Fahrenheit temperature.

Since Rankine and Kelvin both have the same zero point, conversion between the two scales requires no addition or subtraction. Rankine temperature is equal to 9/5 times Kelvin temperature, and Kelvin temperature is equal to 5/9 times Rankine temperature.

Formulas may be derived for converting between Fahrenheit and Kelvin and between Celsius and Rankine from the information already given, but since they are less frequently needed are not included here.

Thermometers

The measurement of temperature is known as THERMOMETRY. Many modern thermometers used liquids in sealed containers. Water was the first liquid used, but because it freezes at 0°C it could not measure temperatures below that point. After much experimentation, scientists decided that the best liquids to use in the construction of thermometers are alcohol and mercury because of the low freezing points of these liquids.

LIQUID THERMOMETERS.—The construction of the common laboratory thermometer gives some idea as to the meaning of a change of 1° in temperature. A bulb is blown at one end of a piece of glass tubing of small bore. The tube and bulb are then filled with the liquid to be used. The temperature of both the liquid and the tube during this process are kept at a point higher than the thermometer will reach in normal usage. The glass tube is then sealed and the thermometer is allowed to cool. During the cooling process, the liquid falls away from the top of the tube and creates a vacuum within the thermometer.

For marking, the thermometer is placed in melting ice. The height of the liquid column is marked as the 0°C point. Next, the thermometer is placed in steam at a pressure of 76 centimeters of mercury and a mark is made at that point to which the liquid inside rises. That is the boiling point, or the 100°C mark. The space between these two marks is then divided into 100 equal parts. These spacings are known as DEGREES.

It is this type of thermometer that is used almost exclusively in laboratory work and in testing electrical equipment, and is known as the Celsius thermometer which was mentioned earlier.

SOLID THERMOMETERS.—Because the range of all liquid thermometers is extremely limited, other methods of thermometry are necessary. Most liquids freeze at temperatures between 0° and -200° Celsius. At the upper end of the temperature range where high heat levels are encountered, the use of liquid thermometers is limited by the high vapor pressures of those liquids. Among the most widely used types of thermometers, other than the standard liquid thermometers, are the resistance thermometer and the thermocouple.

The **RESISTANCE THERMOMETER** makes use of the fact that the electrical resistance of metals changes as the temperature changes. This type thermometer is usually constructed of platinum wire wound on a mica form and enclosed in a thin-walled silver tube. It is extremely accurate from the lowest temperature to the melting point of the unit.

The **THERMOCOUPLE** shown in figure 2-4 is essentially an electric circuit. Its operation is based on the principle that when two unlike metals are joined and the junction is at a different temperature from the remainder of the circuit, an electromotive force is produced. This electromotive force can be measured with great accuracy by a galvanometer. Thermocouples can be located wherever measurement of the temperature is important, and wires run to a

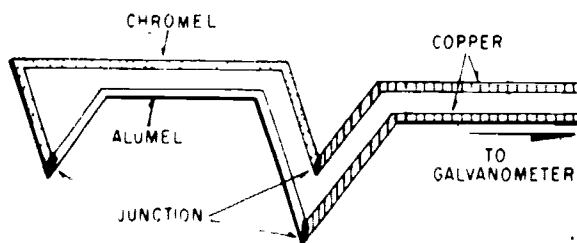

243.6

Figure 2-4.—Thermocouple.

galvanometer located at any convenient point. By means of a rotary selector switch, one galvanometer can read the temperatures of thermocouples at any of a number of widely separated points. Also several thermocouples can be connected in parallel to supply an average voltage to an indicator, as is done with jet engine temperature indicating systems.

The principle of the compound bar (fig. 2-5) is also used in thermometers. The bar may be in the shape of a spiral, or perhaps a helix, so that within a given enclosure a greater length of the compound bar may be used, thereby increasing the movement of the free end per degree of temperature change. Also, the indicating pointer may be joined to the moving end of the compound bar by means of distance-multiplying linkage to make the thermometer easier to read. Often this linkage is arranged to give circular movement to the pointer.

SOUND

The methods used to produce, transmit, detect or measure sound are not as important to the AE as they are to many other ratings which deal directly with those facets of sound. The AE, however, working on and around aircraft and other noise generating devices, must always be aware of the personal hazards associated with sound. Chapter 3 of this manual includes a discussion of these safety hazards, and in this

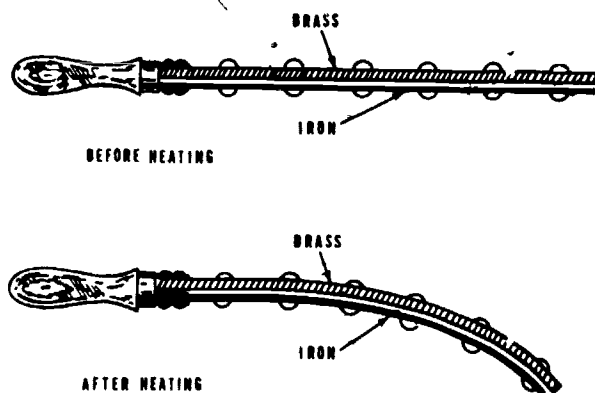

243.18

Figure 2-5.—Compound bar.

chapter only the definitions associated with the measurement of sound will be discussed.

Measurement of Sound

The range of sound that the human ear can detect varies with the individual. The normal range extends from about 20 to 20,000 vibrations per second.

The human ear is a nonlinear unit that functions on a logarithmic basis.

If the ear is tested with tones of any one frequency, the threshold of audibility is reached when intensity is reduced to a sufficiently low level so that auditory sensation ceases. On the other hand, the threshold of feeling is reached when intensity is increased to a sufficiently high level so that the sound produces the sensation of feeling and becomes painful. If this procedure is performed over a wide frequency range, the data can be used to plot two curves—one for the lower limit of audibility and the other for the maximum auditory response (fig. 2-6). Below the lower curve, the sound is too faint to be audible. Above the upper curve, the sensation is one of feeling rather than of hearing; that is, the sensation of sound is masked by that of pain. The area between the two curves shows the pressure ranges for auditory response at various frequencies. Note that the scales of frequency

and pressure are nonlinear. An advance of one horizontal space doubles the frequency, and an advance of one vertical space multiplies the pressure by ten.

SOUND UNITS.—The loudness of sound is not measured by the same type of scale used to measure length. Units of sound measurement are used that vary nonlinearly with the amplitude of the sound variations. These units are the bel and decibel, which refer to the difference between sounds of unequal intensity or sound levels. The decibel, which is one-tenth of a bel, is the minimum change of sound level perceptible to the human ear. Hence, the decibel merely describes the ratio of two sound levels. A sound for which the power is 10 times as great as that of another sound level differs in power level by 1 bel, or 10 decibels; thus, 5 decibels may represent almost any volume of sound, depending on the intensity of the reference level or the sound level on which the ratio is based.

INTENSITY LEVEL.—An arbitrary zero reference level is used to accurately describe the loudness of various sounds. This zero reference level is the sound produced by 10^{-16} watts per square centimeter of surface area facing the source. This level approximates the least sound perceptible to the ear and is usually called the threshold of audibility. Thus, the sensation experienced by the ear when subjected to a noise of 40 decibels above the reference level would be 10,000 times as great as when subjected to a sound that is barely perceptible.

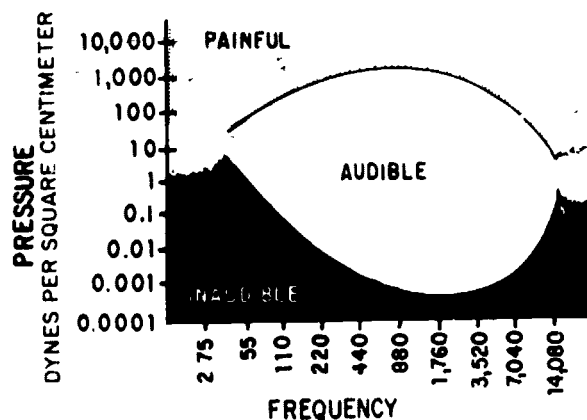

228.43

Figure 2-6.—Field of audibility.

STRUCTURE OF MATTER

All matter is composed of atoms, and these atoms, are, in turn, composed of smaller subatomic particles. The subatomic particles of major interest in elementary physics are the electron, the proton, and the neutron. They may be considered electrical in nature, with the proton representing a positive charge, the electron representing a negative charge, and the neutron being neutral (neither positive nor negative). Although in general the composition of matter follows a consistent pattern for all

atoms, the detailed arrangement of subatomic particles is different for each distinct substance. It is the combination and arrangement of the subatomic particles which imparts distinguishing chemical and physical characteristics to a substance.

The protons and the neutrons of an atom are closely packed together in a nucleus (core), with the electrons revolving around the nucleus (fig. 2-7). Atoms are normally considered to be electrically neutral—that is, they normally contain an equal number of electrons and protons—but this condition does not actually prevail under all circumstances. Atoms which contain an equal number of electrons and protons are called balanced atoms; those with an excess or a deficiency of electrons are called "ions."

The proton and the neutron have approximately the same mass, which is

approximately 1,836 times the mass of an electron. In any atom, nearly all the mass is contained in the nucleus. It may be assumed that under normal conditions any change in the composition of the atom would involve a change in the number or arrangement of the electrons. This assumption is generally correct—the most notable exception being in the field of nuclear physics, or nucleonics. In chemistry and in general physics (including electricity and electronics), it is the electron complement that is of major concern.

ELEMENTS

The word element denotes any one of about 100 natural substances, such as iron, which comprise the basic substance of all matter. Two or more elements may combine chemically to form a compound; any combination which does not result in a chemical reaction between the different elements is called a mixture.

The atom is the smallest unit that exhibits the distinguishing characteristics of an element. An atom of any one element differs from an atom of any other element in the number of protons in the nucleus. All atoms of a given element contain the same number of protons. Thus, it may be seen that the number of protons in the nucleus determines the type of matter.

The various elements are frequently tabulated according to the number of protons. The number of protons in the nucleus of the atom is referred to as the atomic number of the element.

Nucleus

The study of the nucleus of the atom is known as nucleonics or nuclear physics, and is the subject of extensive modern investigation. Experiments on nuclei usually involve the bombardment of the nucleus of an atom, using various types of nuclear particles. By this method the composition of the nucleus is changed, usually resulting in the release of energy. The change to the nucleus may occur as an increase or a decrease in the number of protons and/or neutrons.

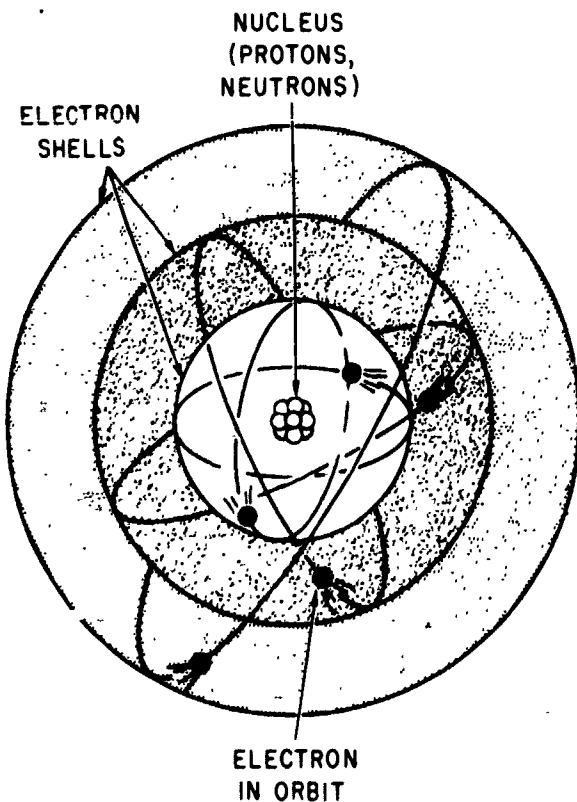

207.15

Figure 2-7.—An atom.

If the number of protons is changed, the atom becomes an atom of a different element. This process, called "transmutation," is the process sought by the alchemists of the middle ages in their attempts to change various metals into gold. Scientists of that period believed transmutation could be accomplished by chemical means—hence the impetus given to the development of chemistry.

If, on the other hand, only the number of neutrons in the nucleus is changed, the atom remains an atom of the same element. Although all the atoms of any particular element have the same number of protons (atomic number), atoms of certain elements may contain various numbers of neutrons. Hydrogen, the sole exception to the rule that all atoms are composed of three kinds of subatomic particles, normally contains a single proton and a single electron—and no neutrons. However, some hydrogen atoms do contain a neutron. Such atoms (although they are atoms of hydrogen) are known as deuterium, or "heavy hydrogen." They are called "heavy" because the addition of the neutron has approximately doubled the weight of the atom. Deuterium figured prominently in the research which led to the development of nuclear energy and the atomic bomb. The atomic weight of an atom is an indication of the total number of protons and neutrons in the atomic nucleus.

Atoms of an element which have atomic weights which differ from other atoms of that element are called isotopes. Nearly all elements have several isotopes; some are very common, and some are very rare. A few of the isotopes occur naturally. Most of those produced by nuclear bombardment are radioactive or have unstable nuclei. These unstable isotopes undergo a spontaneous nuclear bombardment which eventually results in either a new element or a different isotope of the same element. The rate of spontaneous radioactive decay is measured by "half-life" which is the time required for one-half the atoms of a sample of radioactive material to change (by spontaneous radioactive decay) into a different substance. Uranium, after a few billion years and several substance changes, becomes lead.

Electron Shells

The physical and chemical characteristics of an element are determined by the number and distribution of electrons in the atoms of that element. The electrons are arranged in successive groups of electron shells of rotation around the nucleus; each shell can contain no more than a specific number of electrons. An INERT element (that is, one of the few gas elements which do not combine chemically with any other element) is a substance in which the outer electron shell of each atom is completely filled. All other elements are active, and one or more electrons are missing from the outer shell. An atom with only one or two electrons in its outer shell can be made to give up those electrons; an atom whose outer shell needs only one or two electrons to be completely filled can accept electrons from another element which has one or two "extras."

The concept of "needed" or "extra" electrons arises from the basic fact that all atoms have a tendency toward completion (filling) of the outer shell. An atom whose outer shell has only two electrons may have to collect six additional ones (no easy task, from an energy standpoint) in order to have the eight required for that shell to be full. A much easier way to achieve the same objective is to give up the two electrons in the outer shell and let the full shell next to it serve as the new outer shell. In chemical terminology, this concept is called valence and is the prime determining factor in predicting chemical combinations.

COMPOUNDS AND MIXTURES

Under certain conditions, two or more elements can be brought together in such a way that they unite chemically to form a COMPOUND. The resulting substance may differ widely from any of its component elements; for example, ordinary drinking water is formed by the chemical union of two gases—hydrogen and oxygen. When a compound is produced, two or more atoms of the combining elements join chemically to form the MOLECULE that is typical of the new compound. The molecule is the smallest unit

that exhibits the distinguishing characteristics of a compound.

The combination of sodium and chlorine to form the chemical compound sodium chloride (common table salt) is a typical example of the formation of molecules. Sodium is a highly caustic poisonous metal containing eleven electrons; its outer shell consists of a single electron, which may be considered "extra" (a valence of +1). Chlorine, a highly poisonous gas with seventeen electrons, "lacks" a single electron (has a valence of -1) to fill its outer shell. When the atom of sodium gives up its extra electron, it becomes a positively charged ion. (It has lost a unit of negative charge.) The chlorine, having taken on this extra unit of negative charge (electron) to fill its outer shell, becomes a negative ion. Since opposite electric charges attract, the ions stick together to form a molecule of the compound sodium chloride.

The attracting force which holds the ions together in the molecular form is known as the "valence bond," a term which is frequently encountered in the study of transistors.

Note that in the chemical combination, there has been no change in the nucleus of either atom; the only change has occurred in the distribution of electrons between the outer shells of the atoms. Also note that the total number of electrons has not changed, although there has been a slight redistribution. Therefore, the molecule is electrically neutral, and has no resultant electrical charge.

Not all chemical combinations of atoms are on a one-for-one basis. In the case of drinking water, two atoms of hydrogen (valence of +1) are required to combine with a single atom of oxygen (valence of -2) to form a single molecule of water. Some of the more complex chemical compounds consist of many elements with various numbers of atoms of each. All molecules, like all atoms, are normally considered to be electrically neutral. There are some exceptions to this rule, however, with specific cases of interest being the chemical activity in batteries.

Elements or compounds may be physically combined without necessarily undergoing any chemical change. Grains of finely powdered iron

and sulfur stirred and shaken together retain their own identity as iron or sulfur. Salt dissolved in water is not a compound; it is merely salt dissolved in water. Each chemical substance retains its chemical identity, even though it may undergo a physical change. This is the typical characteristic of a MIXTURE.

STATES OF MATTER

In their natural condition, forms of matter are classified and grouped in many different ways. One such classification is in accordance with their natural state—solid, liquid, or gas. This classification is important because of the common characteristics possessed by substances in one group which distinguish them from substances in the other groups. However, the usefulness of the classification is limited by the fact that most substances can be made to assume any of the three forms.

In all matter, the molecules are assumed to be in constant motion, and it is the extent of this motion that determines the state of matter. The moving molecular particles in all matter possess kinetic energy of motion. The total of this kinetic energy is considered to be the equivalent of the quantity of heat in a sample of the substance. When heat is added, the energy level is increased, and molecular agitation (motion) is increased. When heat is removed, the energy level decreases, and molecular agitation diminishes.

In solids, motion of the molecules is greatly restricted by the rigidity of the crystalline structure of the material. In liquids, molecular motion is somewhat less restricted, and the substance as a whole is permitted to "flow." In gases, molecular motion is almost entirely random—the molecules are free to move in any direction and are almost constantly in collision both among themselves and with the surfaces of the container.

This topic and some of its more important implications are discussed in detail under the heading "Heat" in a later section of this chapter.

Solids

The outstanding characteristic of a solid is the tendency to retain its size and shape. Any

change in these values requires an exchange of energy. The common properties of a solid are cohesion and adhesion, tensile strength, ductility, malleability, hardness, brittleness, and elasticity. Ductility is a measure of the ease with which the material can be drawn into a wire. Malleability refers to the ability of some materials to assume a new shape when pounded. Hardness and brittleness are self-explanatory terms. The remaining properties are discussed in more detail in the following paragraphs.

COHESION AND ADHESION.—Cohesion is the molecular attraction between like particles throughout a body, or the force that holds any substance or body together. Adhesion is the molecular attraction existing between surfaces of bodies in contact, or the force which causes unlike materials to stick together.

Cohesion and adhesion are possessed by different materials in widely varying degrees. In general, solid bodies are highly cohesive but only slightly adhesive. Fluids (liquids and gases), on the other hand, are usually quite highly adhesive but only slightly cohesive. Generally a material having one of these properties to a high degree will possess the other property to a relatively low degree.

TENSILE STRENGTH.—The cohesion between the molecules of a solid explains the property called tensile strength. This is a measure of the resistance of a solid from being pulled apart. Steel possesses this property to a high degree; and is thus very useful in structural work. When a break does occur, the pieces of the solid cannot be stuck back because merely pressing them together does not bring the molecules into close enough contact to restore the molecular force of cohesion. However, melting the edges of the break (welding) allows the molecules on both sides of the break to flow together, thus bringing them once again into the close contact required for cohesion.

ELASTICITY.—If a substance will spring back to its original form after being deformed, it has the property of elasticity. This property is desirable in materials to be used as springs. Airspeed indicators and altimeters are examples of instruments that depend on the elasticity of certain types of metal to provide critical information to the pilot of an aircraft.

Elasticity of compression is exhibited to some degree by all solids, liquids, and gases; the closeness of the molecules in solids and liquids makes them hard to compress, but gases are easily compressed because the molecules are farther apart.

Liquids

The outstanding characteristic of a liquid is its tendency to retain its own volume while assuming the shape of its container; thus a liquid is considered almost completely flexible and highly fluid.

Liquids are practically incompressible; applied pressure is transmitted through them instantaneously, equally, and undiminished to all points on the enclosing surfaces. Hydraulic apparatus can be used to increase or to decrease input forces, thus providing an action similar to that of mechanical advantage in mechanical systems. Because of these properties, hydraulic servomechanisms have advantages as well as disadvantages and limitations when compared with other systems.

The fluidity of hydraulic liquids permits the component parts of the system to be placed conveniently at widely separated points when necessary. Hydraulic power units can transmit energy around corners and bends without the use of complicated gears and levers. They operate with a minimum of slack and friction, which are often excessive in mechanical linkages. Uniform action is obtained without vibration, and the operation of the system remains largely unaffected by variations in load. The accumulator (which provides the necessary pressurization of a hydraulic system to furnish practically instantaneous response) can be pressurized during periods of nonaction, thus eliminating the "buildup time" characteristic of electric servos.

However, the hydraulic hoses which transmit the fluid from unit to unit are bulky and heavy compared to electric wiring. Many of the hydraulic fluids in common usage are messy and constitute safety hazards. They contribute to the danger of slipping, they cause deterioration of the insulation on electric wiring, they

conduct electricity and thus increase the hazards of short circuiting, and some are flammable.

Gases

The most notable characteristic of a gas is the tendency to assume not only the shape but also the volume of its container, and the definite relationship that exists between the volume, pressure, and temperature of a confined gas.

The ability of a gas to assume the shape and volume of its container is the result of its extremely active molecular particles, which are free to move in any direction. Cohesion between molecules of a gas is extremely small, so the molecules tend to separate and distribute themselves uniformly throughout the volume of the container. In an unpressurized container of liquid, pressure is exerted on the bottom and the sides of the container up to the level of the liquid. In a container of gas, however, the pressure is also exerted against the top surface, and the pressure is equal at all points on the enclosing surfaces.

The relationship of volume, pressure, and temperature of a confined gas are explained by Boyle's law, Charles' law, and the general law for gases.

Many laboratory experiments based on these laws make use of the ideas of "standard pressure" and "standard temperature." These are not natural standards, but are standard values selected for convenience in laboratory usage. Standard values are generally used at the beginning of an experiment, or when a temperature or a pressure is to be held constant. Standard temperature is 0°C, the temperature at which pure ice melts. Standard pressure is the pressure exerted by a column of mercury 760 millimeters high. In many practical uses these standards must be changed to other systems of measurement.

All calculations based on the laws of gases make use of "absolute" temperature and pressure. These topics require a somewhat more detailed explanation.

GAS PRESSURE.—Gage pressure may be indicated in either of two ways—absolute

pressure or gage pressure. Since the pressure of an absolute vacuum is zero, any pressure measured with respect to this reference is referred to as "absolute pressure." In the present discussion, this value represents the actual pressure exerted by the confined gas.

At sea level the average atmospheric pressure is approximately 14.7 pounds per square inch (psi). This pressure would, in a mercurial barometer, support a column of mercury 760 millimeters in height. Thus, normal atmospheric pressure is the standard pressure mentioned previously.

However, the actual pressure at sea level varies considerably; and the pressure at any given altitude may differ from that at sea level. Therefore, it is necessary to take into consideration the actual atmospheric pressure when converting absolute pressure to gage pressure (or vice versa).

When a pressure is expressed as the difference between its absolute value and that of the local atmospheric pressure, the measurement is designated "gage" pressure, and is usually expressed in "pounds per square inch gage" (psig). Gage pressure may be converted to absolute pressure by adding the local atmospheric pressure to the gage pressure.

ABSOLUTE ZERO.—Absolute zero, one of the fundamental constants of physics, is usually expressed in terms of the Celsius scale. Its most predominant use is in the study of the kinetic theory of gases. In accordance with the kinetic theory, if the heat energy of a given gas sample could be progressively reduced, some temperature should be reached at which the motions of the molecules would cease entirely. If accurately determined, this temperature could then be taken as a natural reference, or a true "absolute zero" value.

BOYLE'S LAW.—The English scientist Robert Boyle was among the first to study what he called the "springiness of air." By direct measurement he discovered that when the temperature of an enclosed sample of gas was kept constant and the pressure doubled, the volume was reduced to half the former value; as the applied pressure was decreased, the resulting

volume increased. From these observations, he concluded that for a constant temperature the product of the volume and pressure of an enclosed gas remains constant. Boyle's law is normally stated: "The volume of an enclosed dry gas varies inversely with its pressure, provided the temperature remains constant."

In equation form, this relationship may be expressed either

$$V_1 P_1 = V_2 P_2, \text{ or}$$

$$\frac{V_1}{V_2} = \frac{P_2}{P_1}$$

where V_1 and P_1 are the original volume and pressure, and V_2 and P_2 are the revised volume and pressure.

Although not strictly considered an enclosed gas, the air pressure sensed by the pressure altimeter will illustrate the use of Boyle's law. The altimeter contains a bellows which is sealed at a constant pressure, usually sea level pressure, and is called an aneroid. As the aircraft increases altitude the pressure outside of the aneroid decreases, which allows the volume of air inside the aneroid to expand (increase the distance between molecules), which increases the volume of the fixed mass of air. As the volume increases, the pressure inside the aneroid decreases until it equals the pressure outside the aneroid. (Thus, referring to Boyle's law, as the volume increases, the pressure decreases.) The expansion of the aneroid is measured and, through a series of gears, is calibrated to indicate an increase in altitude.

CHARLES' LAW.—The French scientist Jacques Charles provided much of the foundation for the modern kinetic theory of gases. He found that all gases expand and contract in direct proportion to the change in the absolute temperature, provided the pressure is held constant. Expressed in equation form, this part of the law may be expressed

$$V_1 T_2 = V_2 T_1, \text{ or}$$

$$\frac{V_1}{T_1} = \frac{V_2}{T_2}$$

where V_1 and V_2 refer to the original and final volumes, and T_1 and T_2 indicate the corresponding absolute temperatures.

Since any change in the temperature of a gas causes a corresponding change in volume, it is reasonable to expect that if a given sample of a gas were heated while confined within a given volume, the pressure should increase. By actual experiment, it was found that the increase in pressure was approximately 1/273 of the 0°C pressure for each 1°C increase. Because of this fact, it is normal practice to state this relationship in terms of absolute temperature. In equation form this part of the law becomes

$$P_1 T_2 = P_2 T_1, \text{ or}$$

$$\frac{P_1}{T_1} = \frac{P_2}{T_2}$$

In words, this equation states that with a constant volume, the absolute pressure of a gas varies directly with the absolute temperature.

The principles of Charles' law may be illustrated by studying the problems incurred in trying to measure a quantity of aircraft fuel. Some of the very early aircraft had the fuel tank outside the windscreen directly in front of the pilot. Measuring the volume was simple—a rod with a cork or float was inserted inside the tank. When the tank was full, the rod protruded high above the tank, and as the volume decreased the rod disappeared into the tank. By knowing the inside dimensions of the tank, the pilot knew the approximate volume of fuel remaining.

Obviously this method of measuring fuel is unrealistic in our modern aircraft. The energy developed by an engine is determined by the mass of the fuel it uses rather than by the volume, and more fuel can go into the same volume of space on a cold day than on a hot day. A single gallon of JP-4 jet fuel under standard day conditions—15°C (59°F) and 29.92 in./Hg (14.7 lbs/sq in.) at sea level—will weigh approximately 6.5 pounds. If the temperature of the fuel increases to approximately 50°C (122°F), one gallon of JP-4 will weigh approximately 6.3 pounds. This 0.2 pound does not disappear, but because the molecules become more active and the space

between the molecules increases, the same mass of fuel occupies more than one gallon of space. Thus, referring to Charles' law, if the temperature increases, the volume must also increase to contain the same amount of mass.

The importance of this variation in the weight of fuel becomes apparent when one considers large quantities such as 10,000 gallons which may be used in large transport or patrol aircraft. Expansion and contraction can cause the aircraft's fuel to vary in weight by 2,000 pounds (a ton of fuel) or more. In an extremely cold climate, it can cause the aircraft to exceed its maximum gross weight. In an extremely warm climate, the reduced tank capacity may cause critically reduced range. The methods used to measure fuel quantity and to compensate for nonstandard conditions are discussed in chapter 6 of this manual.

GENERAL GAS LAW.—The facts concerning gases discussed in the preceding sections are summed up and illustrated in figure 2-8. Boyle's law is expressed in (A) of the figure, while the effects of temperature changes on pressure and volume (Charles' law) are illustrated in (B) and (C), respectively.

By combining Boyle's and Charles' laws, a single expression can be derived which states all the information contained in both. This

expression is called the **GENERAL GAS EQUATION**, a very useful form of which is given by the following equation. (NOTE: the capital P and T signify absolute pressure and temperature, respectively.)

$$\frac{P_1 V_1}{T_1} = \frac{P_2 V_2}{T_2}$$

It can be seen by examination of figure 2-8 that the three equations are special cases of the general equation. Thus, if the temperature remains constant, T_1 equals T_2 and both can be eliminated from the general formula, which then reduces to the form shown in (A). When the volume remains constant, V_1 equals V_2 , thereby reducing the general equation to the form given in (B). Similarly, P_1 is equated to P_2 for constant pressure, and the equation then takes the form given in (C).

It should be understood that the general gas law applies only when one of the three measurements remains constant. When a gas is compressed, the work of compression is done upon the gas. Work energy is converted to heat energy in the gas so that dynamical heating of the gas takes place. Experiments have shown that when air at 0°C is compressed in a nonconducting cylinder to half its original

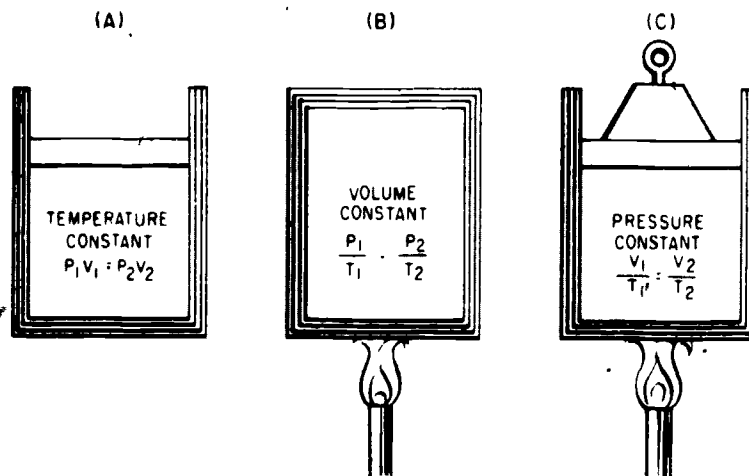

Figure 2-8.—The general gas law.

volume, its rise in temperature is 90°C , and when compressed to one-tenth, its rise is 429°C .

The general gas law applies with exactness only to "ideal" gases in which the molecules are assumed to be perfectly elastic. However, it describes the behavior of actual gases with sufficient accuracy for most practical purposes.

MATTER AND ENERGY

MATTER, as already discussed may be defined basically as "anything that occupies space and has weight or mass." Matter may be changed or combined by various methods—physical, chemical, or nuclear. Matter has many properties; properties possessed by all forms of matter are called general properties, while those properties possessed only by certain classes of matter are referred to as special properties.

ENERGY may be defined basically as "the capacity for doing work." It may be classified in many ways; but for this discussion, energy will be classified as mechanical, chemical, radiant, heat, light, sound, electrical, or magnetic. Energy is constantly being exchanged from one object to another and from one form to another.

Law of Conservation

Matter may be converted from one form to another with no change in the total amount of matter. Energy may also be changed in form with no resultant change in the total quantity of energy. In addition, a third statement has been added within the past half century: "Although the total amount of matter and energy remains constant, matter can be converted into energy or energy into matter." This statement is known as the law of conservation for energy and matter.

The destruction of matter creates energy, and creation of matter requires expenditure of energy. From this observation it may be implied that a given quantity of matter is the equivalent of some amount of energy. In common usage it is usually stated that matter "possesses" energy. For example, aviation gasoline contains energy to produce heat to make an engine run.

General Properties of Matter

Matter, in all forms, possesses certain properties. In the basic definition it has been stated that matter occupies space and has mass. Those two ideas contain most, if not all, of the general properties of matter.

SPACE.—The amount of space occupied by, or enclosed within, the bounding surfaces of a body is called volume. In the study of physics, this concept must be somewhat modified in order to be completely accurate. Matter may appear as a solid, as a liquid, or as a gas—each having special properties. In a later section of this chapter it will be shown that for even a specific substance the volume may vary with changes in circumstances. It will also be shown that liquids and solids tend to retain their volume when physically moved from one container to another, while gases tend to assume the volume of the container.

In order to clarify our concept of "occupying space," we must deal with minute particles of matter, which are in turn composed of still smaller particles separated from each other by empty space which contains no matter. This idea is used to explain two general properties of matter—impenetrability and porosity.

Two objects cannot occupy the same space at the same time; this is known as the "impenetrability of matter." The actual space occupied by the individual subatomic particles cannot be occupied by any other matter. The impenetrability of matter may, at first glance, seem invalid when a cup of salt is poured into a cup of water—the result is considerably less than two cups of salt water. However, matter has an additional general property called "porosity" which explains this apparent loss of volume: The water simply occupies space between particles of salt. Porosity is present in all material—but to an extremely wide range of degree. Generally, gases are extremely porous, liquids only slightly so; solids vary over a wide range, from the sponge to the steel ball.

INERTIA.—Every object tends to maintain a uniform state of motion. A body at rest never

starts to move by itself; a body in motion will maintain its speed and direction unless it is caused to change. In order to cause a body to deviate from its condition of uniform motion, a push or a pull must be exerted on it. This requirement is due to that general property of all matter known as INERTIA.

The greater the tendency of a body to maintain uniform motion, the greater its inertia. The quantitative measure of inertia is the MASS of the body.

ACCELERATION.—Any change in the state of motion of a body is known as acceleration, and the cause which produces it is called an accelerating force. Acceleration is the rate of change in the motion of a body, and may represent either an increase or a decrease in speed and/or a change in direction of motion.

The amount of acceleration is stated as the change of velocity divided by the time required to make the change. For example, if a car traveling 15 mph increases its speed to 45 mph in 4 seconds, the 30 mph increase divided by 4 seconds gives 7.5 miles per hour per second as its acceleration. By converting the 30 mph to 44 feet per second, the acceleration could be expressed as 11 feet per second per second, or as 11 ft/s^2 .

FORCE.—Force is the action on a body which tends to change the state of motion of the body acted upon. A force may tend to move a body at rest; it may tend to increase or decrease the speed of a moving body; or it may tend to change the body's direction of motion. The application of a force to a body does not necessarily result in a change in the state of motion; it may only TEND to cause such a change.

A force is any push or pull which acts on a body. Water in a can exerts a force on the sides and bottom of the can. A tug exerts a push or a pull (force) on a barge. A man leaning against a bulkhead exerts a force on the bulkhead.

In the above examples, a physical object is exerting the force and is in direct contact with the body upon which the force is being exerted. Forces of this type are called contact forces. There are other forces which act through empty

space without contact—in some cases with even seeming to have any mass associated with them. The force of gravity exerted on a body by the earth—known as the weight of the body—is an example of a force that acts on a body through empty space and without contact. Such a force is known as an action-at-a-distance force. Electric and magnetic forces are other examples of these action-at-a-distance forces. The space through which these action-at-a-distance forces are effective is called a force field.

Force is a VECTOR quantity; that is, it has both direction and magnitude. A force is completely described when its magnitude, direction, and point of application are given. In a force vector diagram, the starting point of the line represents the point of application of the force.

Any given body, at any given time, is subjected to many forces. In many cases, all these forces may be combined into a single RESULTANT force, which may then be used to determine the total effect on the body.

Each body of matter in the universe attracts every other body with a force which is proportional to the mass of the bodies and inverse to the square of the distance between them. This force is called the UNIVERSAL FORCE OF GRAVITATIONAL ATTRACTION. Since every body exerts this force on every other body, when considering the forces acting on a single body, it is an almost universal practice to resolve all gravitational forces into a single resultant. At or near the surface of the earth, this becomes a fairly simple process—due to its extremely large mass, the earth exerts such a large gravitational attraction that it is entirely practical to ignore all other such attractions, and merely use the earth's gravitational attraction as the resultant.

Although gravitational attraction is exerted by each body on the other, in those cases where there is a great difference in the mass of two bodies, it is usually more convenient to consider the force as being exerted by the larger mass on the smaller mass. Thus, it is commonly stated that the earth exerts a gravitational force of attraction on a body. The gravitational attraction exerted by the earth on a body is called GRAVITY.

The gravitational force exerted by the earth on a body is called the **WEIGHT** of that body, and is expressed in force units. In the English system, force is expressed in pounds. If a body is attracted by a gravitational force of 160 pounds, the body is said to weigh 160 pounds. The gravitational force between two bodies decreases as the distance between them increases; therefore, a body weighs less a mile above the surface of the ocean than it weighs at sea level, it weighs more a mile below sea level.

Density and Specific Gravity

The **DENSITY** of a substance is its weight per unit volume. A cubic foot of water weighs 62.4 pounds; the density of water is 62.4 pounds per cubic foot. (In the metric system the density of water is 1 gram per cubic centimeter.)

The **SPECIFIC GRAVITY (S.G.)** of a substance is the ratio of the density of the substance to the density of water—

$$\text{S.G.} = \frac{\text{weight of substance}}{\text{weight of equal volume of water}}$$

Specific gravity is not expressed in units but as a pure number. For example, if a substance has a specific gravity of 4, 1 cubic foot of the substance weighs 4 times as much as a cubic foot of water—62.4 times 4 or 249.6 pounds. In metric units, 1 cubic centimeter of a substance with a specific gravity of 4 weighs 1 times 4 or 4 grams. (Note that in the metric system of units, the specific gravity of a substance has the same numerical value as its density.)

Specific gravity and density are independent of the size of the sample under consideration, and depend only upon the substance of which the sample is made. See table 2-4 for values of specific gravity for various substances.

The Aviation Electrician frequently works with equipment and systems in which the principles of density and specific gravity are involved. For instance, the state of charge of the lead acid battery may be determined by measuring the specific gravity of the electrolyte. If the specific gravity of the electrolyte is between 1.24 and 1.3 times the specific gravity of water, then the battery is normally considered to be charged.

Table 2-4.—Values of specific gravity

Substance	Specific gravity
Platinum	21.3
Gold	19.3
Mercury	13.6
Lead	11.3
Silver	10.5
Copper	8.9
Brass	8.6
Iron	7.8
Steel	7.8
Aluminum	2.7
Sulphuric acid	1.83
Water	1.00
Ice	0.92
Ethyl alcohol	0.81
JP-4 jet fuel	0.75

Density and pressure must be considered when discussing altimetry and airspeed. Although very light, air has weight and is affected by gravity. By its weight, air exerts pressure on everything it touches. Since air is a gas, its pressure is exerted in all directions. Air pressure at a given altitude is determined by the weight of the air pressing down from above.

The weight and compression of the atmosphere cause the molecules to be closer together and more numerous per unit volume at the bottom of the atmosphere, or where it rests upon the earth's surface. This means that the air at the bottom of the atmosphere is more dense than it is at higher altitudes. Air pressure at sea level on an average day will support a column of mercury 29.92 inches high as shown by the mercurial barometer in figure 2-9.

By definition, atmospheric pressure is a force per unit area, and force is equal to mass multiplied by acceleration. There is a change of pressure whenever either the mass or the acceleration of the molecules within the atmosphere are changed. Although altitude exerts the dominant control,

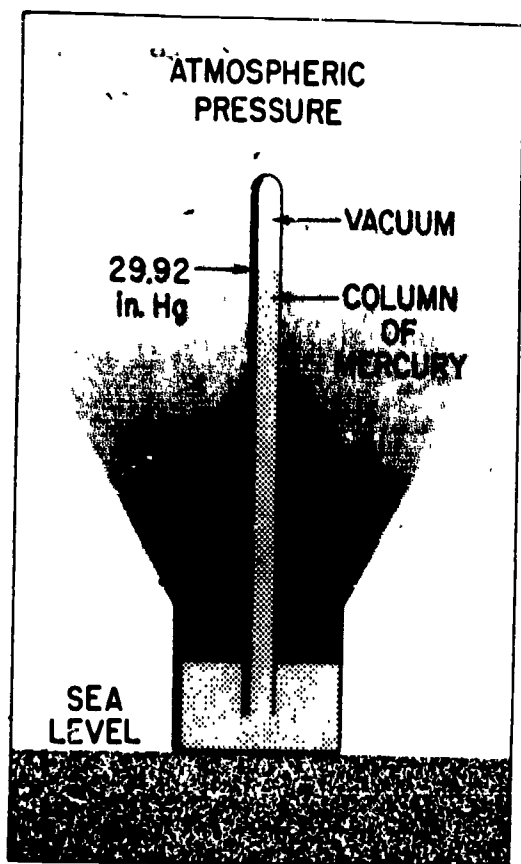

Figure 2-9.—Mercurial barometer.

207.16

temperature and moisture alter pressure at any given altitude. Figure 2-10 shows the standard pressure and temperature at given altitudes.

Conditions, are, however, very seldom "standard" for either temperature or pressure, which makes it necessary to make corrections in order to find density altitude or true airspeed. Let us consider an airfield that is under the influence of a low-pressure climatic condition where the temperature is very hot. Together, these two conditions may reduce the density of the air to such an extent that the performance of an aircraft engine is affected and takeoff capability is marginal, especially for a helicopter. The density of air also directly affects resistance to the movement of an aircraft through the air, and thus the true airspeed of the aircraft.

Pressure and Total Force

Pressure and force, while closely related topics, are not the same thing. A weight of 10 pounds resting on a table exerts a force of 10 pounds. However, the shape of the weight must be taken into consideration to determine the effect of the weight. If the weight consists of a thin sheet of steel resting on a flat surface, the effect would be quite different if the same sheet of steel were resting on a sharp corner.

Pressure is concerned with the distribution of a force with respect to the area over which that force is distributed. Pressure is defined as the force per unit of area, or $P = F/A$. A flat pan of water with a bottom area of 24 square inches and a total weight of 72 pounds exerts a total force of 72 pounds, or a pressure of $72/24$ or 3 pounds per square inch, on the flat table. If the pan is balanced on a block with a surface area of 1 square inch, the pressure is $72/1$ or 72 pounds per square inch. An aluminum pan with a thin bottom is suitable for use on a flat surface, but may be damaged if placed on the small block.

This concept explains why a sharp knife cuts with less resistance than a dull one. The smaller area of the sharp edge concentrates the applied force (increases the pressure) and penetrates with greater ease. For hydraulic application, the relationship between pressure and force is the basic principle of operation. In enclosed liquids under pressure, the applied pressure is transmitted equally to every point on the surfaces of the enclosing container, and therefore the force on a given surface is dependent on the area.

MECHANICS

Mechanics is that branch of physics which deals primarily with the ideas of force, mass, and motion and is usually considered the fundamental branch of physics. Many of its principles and ideas may be seen, measured, and tested. Since all other branches of physics are also concerned (to some extent at least) with force, mass, and motion, a thorough understanding of this section will aid in the understanding of later sections of this chapter.

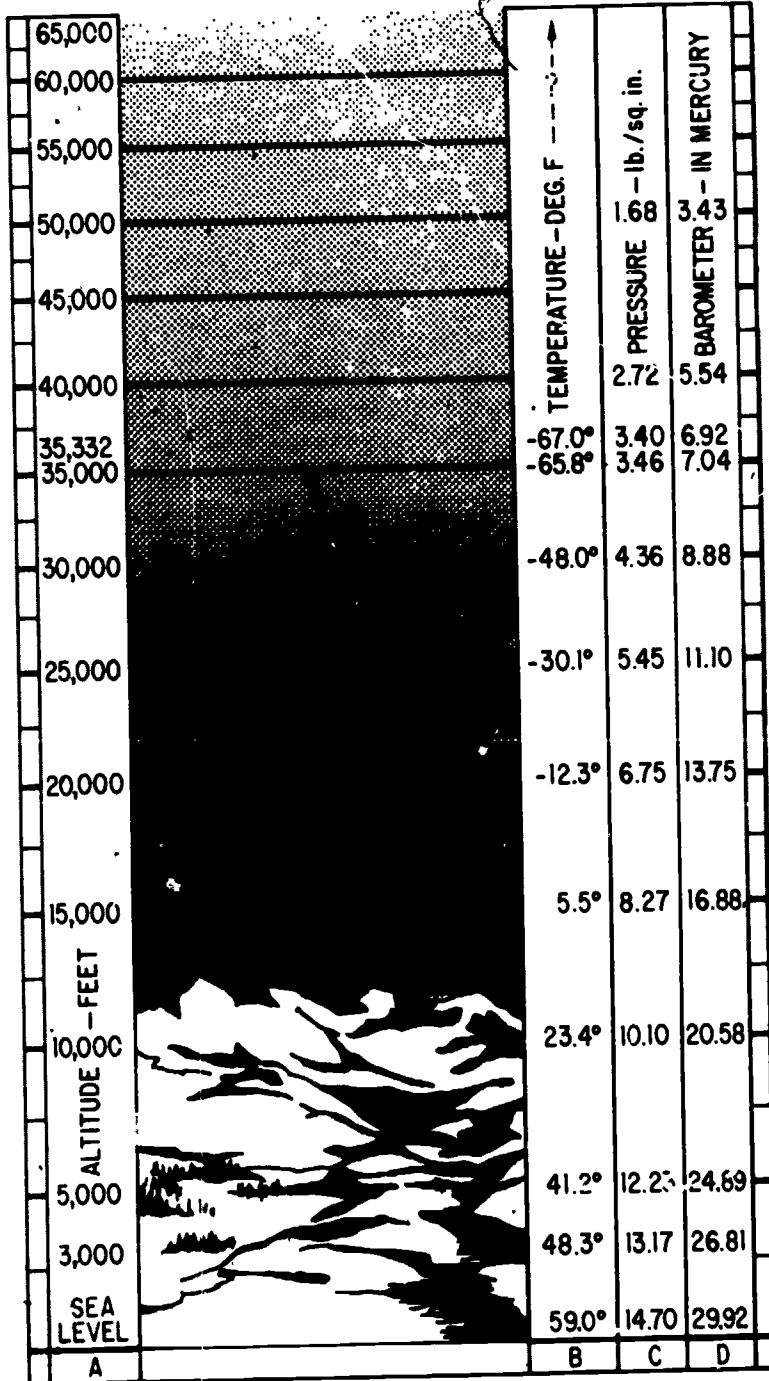

Figure 2-10.—The standard atmosphere.

201.38

FORCE, MASS, AND MOTION

Each particle in a body is acted upon by gravitational force. However, in every body there is one point at which a single force, equal to the gravitational force and directed upward, would sustain the body in a condition of rest. This point is known as the **CENTER OF GRAVITY**, and represents the point at which the entire mass of the body appears to be concentrated. The gravitational effect is measured from the center of gravity. In symmetrical objects of uniform mass, this is the geometrical center. In the case of the earth, the center of gravity is near the center of the earth.

When considering the motion of a body, it is usually convenient to describe the path followed by the center of gravity. The natural tendency of a moving body is to move in a manner so that the center of gravity travels in a straight line. Movement of this type is called **LINEAR motion**.

Some moving bodies, however, do not move in a straight line but describe an arc or a circular path. Circular motion falls into two general classes—rotation and revolution.

Since objects come in many different shapes, in order to discuss rotary and revolutionary motion it becomes necessary to consider the location of the center of gravity with respect to the body. Refer to figure 2-11 for the following discussion.

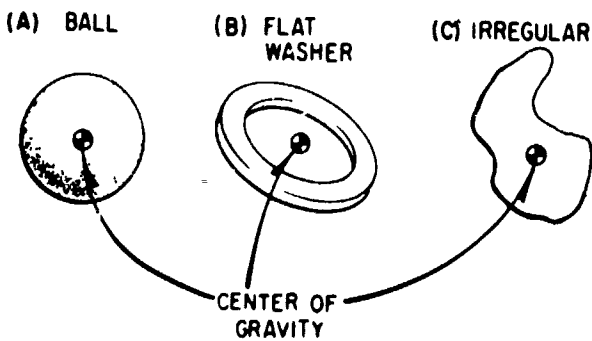

243.53

Figure 2-11.—Center of gravity in various bodies.

In (A), the center of gravity of a ball coincides with the physical center of the ball. However, in the flat washer (B), the center of gravity does not coincide with any part of the object, but is located at the center of the hollow space inside the ring. In irregularly shaped bodies, the center of gravity may be difficult to locate exactly.

If the body is completely free to rotate, the center of rotation coincides with the center of gravity. On the other hand, the body may be restricted in such a manner that rotation is about some point other than the center of gravity. In this event, the center of gravity revolves around the center of rotation. These conditions are illustrated in figure 2-12.

In general usage, the gyro rotor (A) is said to **ROTATE** about its axis, and the ball (B) is said to **REVOLVE** about a point at the center of its path.

Masses in Motion

MOTION may be defined as the "act or process of changing place or position." The "state of motion" refers to the amount and the type of motion possessed by a body at some definite instant (or during some interval) of time. A body at rest is not changing in place or position; it is said to have zero motion or to be motionless.

The natural tendency of any body at rest is to remain at rest. A moving body tends to

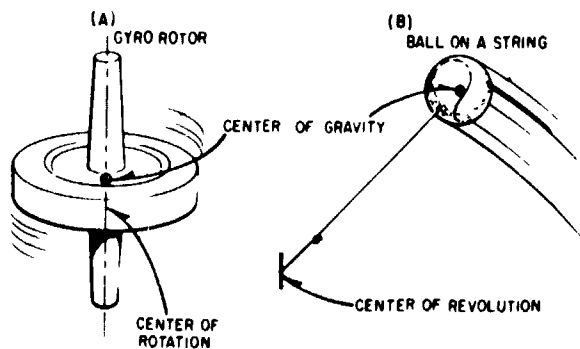

243.54

Figure 2-12.—Center of gravity as center of rotation.

continue moving in a straight line with no change in speed or direction, and a body which obeys this natural tendency is said to be in uniform motion.

Any change in the speed or direction of motion of a body is known as acceleration and requires the application of some force. Acceleration of a body is directly proportional to the force causing that acceleration; acceleration depends also upon the mass of the body acted upon. The greater mass of a lead ball makes it harder to move than a wood ball of the same diameter. The wood ball moves farther with the same push.

These observations point to a connection between force, mass, and acceleration, and indicate that the acceleration of a body is directly proportional to the force exerted on that body and inversely proportional to the mass of that body. In mathematical form, this relationship may be expressed as

$$a = \frac{F}{m}$$

or, as it is more commonly stated: Force is equal to the product of the mass and acceleration ($F = ma$).

Acceleration Due to Gravity

The small letter g used in formulas for solving for weight when mass is known ($W = mg$), represents the acceleration of a body in free fall, neglecting any friction. This can happen only in a vacuum. At sea level near the Equator, g has the approximate value of 32 ft/sec^2 . Transposing the formula $W = mg$ to solve for m , the absolute units of mass of a body may be determined when its weight is known. Thus, when Newton's Second Law of Motion—force = mass times acceleration—is used to find the force necessary to give a one-ton weight an acceleration of 8 ft/sec^2 , if $\frac{W}{g}$ is substituted for mass, then force = $\frac{2,000 \text{ lb}}{32 \text{ ft/sec}^2} \times 8 \text{ ft/sec}^2 = 500 \text{ pounds}$.

The slug is a mass which would be accelerated 1 ft/sec^2 by a force of 1 pound. Since any mass falling freely under the pull of gravity has an acceleration of 32 ft/sec^2 , this acceleration imparted to 1 slug could only be caused by a force of 32 pounds. In other words, a slug of mass weighs 32 pounds.

Example: A wagon weighing 160 pounds (5 slugs) stands at rest on a level surface. Neglecting friction, what acceleration will be given by a force of 20 pounds?

$$a = \frac{F}{m} = \frac{20 \text{ lb}}{5 \text{ slugs}} = 4 \text{ ft/sec}^2$$

The advantage of using absolute units for mass is more apparent when considering bodies in motion far removed from the earth where the pull of gravity is greatly reduced. The 5-slug wagon would experience the same acceleration when acted on by the given force, even though its weight be greatly reduced.

In the metric system the newton is the force which causes a mass of 1 kg to be accelerated 1 m/sec^2 . Since $g = 9.8 \text{ m/sec}^2$, a 1-kg mass exerts a force of 9.8 newtons due to gravity. A newton is equal to 0.224 lb.

The dyne is the force which causes a mass of 1 gm to be accelerated 1 cm/sec^2 , so a 1-gm mass exerts a force of 980 dynes due to gravity.

If the accelerating force is applied to the center of gravity in such a manner as to accelerate the body with no rotation, it is called a TRANSLATIONAL force. A force applied in such a manner as to cause the body to rotate about a point is called a TORQUE force.

Laws of Motion

Among the most important discoveries in theoretical physics are the three fundamental laws of motion attributed to Newton. Although some of these laws have been used in explanations of various topics earlier in this chapter, they are restated and consolidated at this point to clarify and summarize much of the discussion regarding mechanical physics. This restatement and consolidation are also used to

introduce additional aspects involving the application of basic mechanical principles.

1. Every body tends to maintain a state of uniform motion unless a force is applied to change the speed or direction of motion.
2. The acceleration of a body is directly proportional to the magnitude of the applied force and inversely proportional to the mass of the body; acceleration is in the direction of the applied force.
3. For every force applied to a body, the body exerts an equal force in the opposite direction.

Momentum

Every moving body tends to maintain uniform motion. Quantitative measurement of this tendency is proportional to the mass of the body, and also to its velocity. (Momentum = mass X velocity.) This explains why heavy objects in motion at a given speed are harder to stop than lighter objects, and also why it is easier to stop a given body moving at low speed than it is to stop the same body moving at high speed.

WORK, POWER, AND ENERGY

As defined earlier, energy is the capacity for doing work. In mechanical physics, WORK involves the idea of a mass in motion, and is usually regarded as the product of the applied force and the distance through which the mass is moved (work = force X distance). Thus, if a man raises a weight of 100 pounds to a height of 10 feet he accomplishes 1,000 foot-pounds of work. The amount of work accomplished is the same regardless of the time involved. However, the RATE of doing the work may vary greatly.

The rate of doing work (called POWER) is defined as the work accomplished per unit of time (power = work/time). In the example cited above, if the work is accomplished in 10 seconds, power is being expended at the rate of 100 foot-pounds per second; if it takes 5 minutes (300 seconds), the rate is approximately 3.3 foot-pounds per second.

In the English system of measurements, the unit of mechanical power is called the HORSEPOWER and is the equivalent of 33,000 foot-pounds per minute, or 550 foot-pounds per second. Since energy is readily convertible from one form to another, the work and power measurements based on the conversion of energy must also be readily convertible. As an example, the electrical unit of power is the watt. Electrical energy may be converted into mechanical energy; therefore, electrical power must be convertible into mechanical power. One horsepower is the mechanical equivalent of 746 watts of electrical power, and is capable of doing the same amount of work in the same time.

The accomplishment of work always involves a change in the type of energy, but does not change the total quantity of energy. Thus, energy applied to an object may produce work, changing the composition of the energy possessed by the object.

Potential Energy

A body is said to have potential energy if by virtue of its position or its state it is able to do work. A wound clock spring and a cylinder of compressed gas both possess potential energy since they can do work in returning to their uncompressed condition. Also, a weight raised above the earth has potential energy since it can do work in returning to the ground. Thus, potential energy results when work has been done against a restoring force. The water in a reservoir above a hydroelectric plant has potential energy regardless of whether the water was placed there by work applied via a pump or by the work done by the sun to lift it from the sea and place it in the reservoir in the form of rain.

Kinetic Energy

The ability of a body to do work by virtue of its MOTION is called its kinetic energy. A rotating wheel on a machine has kinetic energy of rotation. A car moving along the highway has kinetic energy of translation.

For a given mass m , moving in a straight line with a velocity v , the kinetic energy is determined by

$$\text{Kinetic energy} = \frac{1}{2}mv^2$$

}	in ergs when	{	m is in grams
			v is in cm per sec
}	in ft-lbs when	{	m is in slugs
			v is in ft per sec

Example: The kinetic energy of a 3,200-lb car which is traveling at 30 miles per hour can be found by expressing the 3,200 lb as 100 slugs and the 30 mph as 44 feet per second. Inserting these values into the formula gives kinetic energy $\frac{1}{2} \times 100 \times 44 \times 44 = 96,800$ foot-pounds of energy. This amount of kinetic energy is the result of 96,800 foot-pounds of work (plus that to overcome friction) having been applied to the car to get it traveling at the rate of 44 feet per second. This same amount of energy could do the work of lifting the 3,200 pounds vertically a distance of 30.25 feet, and so could have been potential energy if the car had been at rest on an incline and then allowed to coast to a point which is vertically 30.25 feet below its starting point (again neglecting friction).

Efficiency

Provided there is no change in the quantity of matter, energy is convertible with no gain or loss. However, the energy resulting from a given action may not be in the desired form—it may not even be usable in its resultant form. In all branches of physics, this concept is known as EFFICIENCY.

The energy expended is always greater than the energy recovered. An automobile in motion possesses a quantity of kinetic energy dependent on its mass and velocity. In order to stop the car, this energy must be converted into potential energy. When the car comes to rest, its potential energy is considerably less than the kinetic

energy it possessed while in motion. The difference, or the "energy lost" is converted into heat by the brakes. The heat serves no useful purpose, so the recovered energy is less than the expended energy—the system is less than 100 percent efficient in converting kinetic to potential energy.

The term efficiency is normally used in connection with work and power considerations to denote the ratio of the input to the output work, power, or energy. It is always expressed as a decimal or as a percent less than unity.

Friction

In mechanical physics, the most common cause for the loss of efficiency is FRICTION. Whenever one object is slid or rolled over another, irregularities in the contacting surfaces interlock and cause an opposition to the force being exerted. Even rubbing two smooth pieces of ice together produces friction, although of a much smaller magnitude than in the case of two rough stones. Friction also exists in the contact of air with all exposed parts of an aircraft in flight.

When a nail is struck with a hammer, the energy of the hammer is transferred to the nail, and the nail is driven into a board. The depth of penetration depends on the momentum of the hammer, the size and shape of the nail, and the hardness of the wood. The larger or duller the nail and the harder the wood, the greater the friction, and therefore the lower the efficiency and less depth of penetration—but the greater the heating of the nail.

Friction is always present in moving machinery, and accounts in part for the fact that the useful work accomplished by the machine is never as great as the energy applied. Work accomplished in overcoming friction is usually not recoverable. Friction can be minimized by decreasing the number of contacting points, by making the contacting areas as small and as smooth as possible, by the use of bearings, or by the use of lubricants.

There are two kinds of friction—sliding and rolling, with rolling friction usually of lower magnitude. Therefore, most machines are constructed so that rolling friction is present rather than sliding friction. The ball bearing and

the roller bearing are used to convert sliding friction to rolling friction. A third type, the common (or friction) bearing, utilizes lubricants applied to surfaces which have been made as smooth as possible. Many new types of machines utilize self-lubricating bearings to minimize friction and thus maximize efficiency.

Mechanical Advantage

The concept of mechanical advantage has proven to be one of the great discoveries of science. It permits an increase in force or distance and represents the basic principle involved in levers, block and tackle systems, screws, hydraulic mechanisms, and other work saving devices. However, in the true sense, these devices do not save work, they merely enable humans to accomplish tasks which might otherwise be beyond their capability. For example, a human would normally be considered incapable of lifting the rear end of a truck in order to change a tire; but with a jack, a block and tackle, or a lever, the job can be made comparatively easy.

Mechanical advantage is usually considered with respect to work. Work represents the application of a force through a distance in order to move an object through a distance. Thus, it may be seen that there are two forces involved, each with an appropriate distance. This is illustrated by the simple lever in figure 2-13.

Assuming perfect efficiency, the work input ($F_1 D_1$) is equal to the work output ($F_2 D_2$).

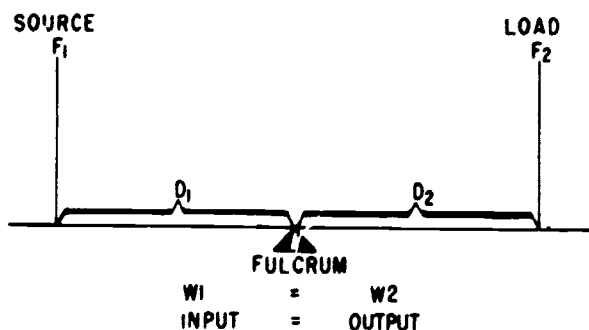

Figure 2-13.—Mechanical advantage.

243.55

Assuming equal distances D_1 and D_2 , a force of 10 pounds must be applied at the source in order to counteract a weight of 10 pounds at the load. By moving the fulcrum nearer the load, less force is required to balance the same load. This is a mechanical advantage of force. If the force is applied in such a manner as to raise the load 1 foot, the source must be moved through a distance greater than 1 foot. Thus, mechanical advantage of force represents a mechanical disadvantage of distance. By moving the fulcrum nearer the source, these conditions are reversed.

Since the input work equals the output work (assuming no losses), the mechanical advantage may be stated as a ratio of the force or of the distances. In actual situations, friction results in energy loss and decreased efficiency, thereby requiring an even greater input to accomplish the same work.

REVOLVING BODIES

Revolving bodies represent masses in motion; therefore, they possess all the characteristics (and obey all the laws) associated with moving bodies. In addition, since they possess a specific type of motion, they have special properties and factors which must be taken into consideration.

Revolving bodies travel in a constantly changing direction, so they must be constantly subjected to an accelerating force. Momentum tends to produce linear motion, but this is prevented by application of a force which restrains the object. This restraining force prevents the object from continuing in a straight line, and is known as CENTRIPETAL force. According to Newton's third law of motion, the centripetal force must be opposed by an equal force which tends to produce linear motion. This second force is known as CENTRIFUGAL force. The two forces, their relationships, and their effects are illustrated in figure 2-14.

The various forces involved in revolving bodies may be illustrated by use of a ball and string. A slip knot is tied in the center of a 10-foot length of twine so as to shorten the line to 5 feet; a rubber ball is attached to one end of the string. Holding the other end of the line,

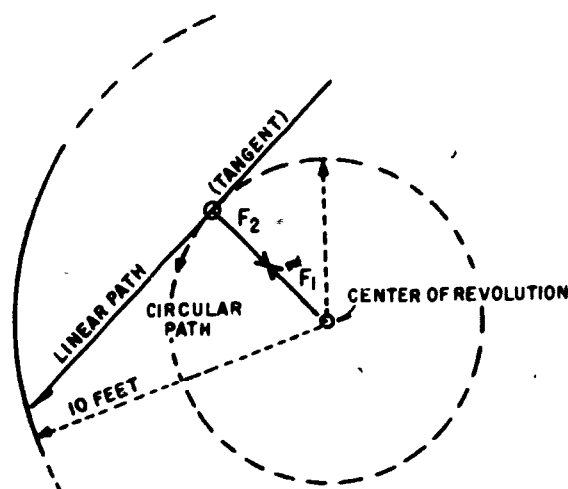

F_1 = CENTRIFUGAL FORCE
 F_2 = CENTRIPETAL FORCE

243.56

Figure 2-14.—Forces on revolving bodies.

whirl the ball slowly in a circle. Note that the ball exerts a force against the hand (through the string); and that in order to restrain the ball in its circular path, the hand must exert a force (through the string) on the ball. As the ball is revolved at higher speed, the forces increase, and the ball continues in a circular path. As the rotational velocity of the ball is gradually increased, note the increasing forces.

At some rotational speed, the forces involved become great enough to overcome inertial friction, and the knot slips. At this time, allow the velocity of the rotation to stabilize (stop increasing in rotational velocity, but not slowing down; either), so that the existing conditions may be analyzed. When the knot slips, the ball is temporarily unrestrained and is free to assume linear motion in the direction of travel at that instant (tangent to the circle at the instantaneous position). The ball travels in a straight line until the string reaches its full length; during this time, no force is exerted on or by the hand. As soon as all the slack is taken up, there is a sharp jerk—an accelerating force is exerted in order to change the direction of motion from its linear path into a circular

rotation. The ball again assumes rotational motion, but with an increase in radius.

The ball does not make as many revolutions in the same time (rotational velocity is decreased), but it does maintain its former linear velocity. (The kinetic energy and the momentum of the ball have not changed.) Since the change in direction is less abrupt with a large radius than with a small one, less accelerating force is required, and the hand will feel less force. If the ball is then accelerated to the same rotational velocity as immediately prior to the slipping of the knot, the linear velocity of the ball becomes much greater than before; the centripetal and centrifugal forces are much greater, also.

In this example, it has been assumed that the hand is fixed at a point which represents the center of rotation. This assumption, while somewhat erroneous, does not affect the general conclusions. For practical purposes, the two forces are equal at all points along the string at any given time, and the magnitude of each force is equal at all points along the string.

In summarizing the conclusions reached by the above example and explanation, consider the following relationship:

$$\text{force} = \frac{\text{mass} \times \text{velocity}^2}{\text{radius}}$$

where velocity represents the linear velocity of the ball. This emphasizes that the centripetal and the centrifugal forces are equal in magnitude and opposite in direction. Each force is directly proportional to the mass of the body and inversely proportional to the radius of rotation. Each force is also proportional to the square of the velocity.

In revolving or rotating bodies, all particles of the matter which are not on the axis of rotation are subjected to the forces just described. The statement is true whether the motion is through a complete circle, or merely around a curve. An automobile tends to take curves on two wheels—the sharper the curve (smaller radius) or the higher the velocity, the greater the tendency to skid.

HEAT

Heat represents a form of energy; therefore, it must be readily exchangeable with, or convertible into, other forms of energy. When a piece of lead is struck a sharp blow with a hammer, part of the kinetic energy of the hammer is converted into heat. (See fig. 2-15.) In the core of a transformer, electrical and magnetic energy are exchanged, but due to hysteresis and eddy currents, some of the energy is lost as heat. These are some examples of the unwanted conversions, but there are many instances when the production of heat is desirable. Many devices are used almost exclusively to produce heat.

Regardless of how or why it is produced, heat possesses certain characteristics which make it important to the AE. A knowledge of the nature and behavior of heat may prove helpful in understanding the operation of some types of avionics equipment, or in determining the cause of nonoperation or faulty operation of others.

NATURE OF HEAT

There are several theories regarding the nature of heat, none of which satisfactorily explain all the characteristics and properties exhibited by heat. The two theories most

commonly included in discussions regarding the nature of heat are the kinetic theory and the radiant energy theory.

In the kinetic theory, it is assumed that the quantity of heat contained by a body is represented by the total kinetic energy possessed by the molecules of the body.

The radiation theory treats radio waves, heat, and light as the same general form of energy, differing primarily in frequency. Heat is considered as a form of electromagnetic energy involving a specific band of frequencies falling between the radio spectrum and light.

A common method used to produce heat energy is the burning process. Burning is a chemical process in which the fuel unites with oxygen, and a flame is usually produced. The amount of heat liberated per unit mass or per unit volume during complete burning is known as the heat of combustion of a substance. By experiment, scientists have found that each fuel produces a given amount of heat per unit quantity burned.

TRANSFER OF HEAT

There are three methods of heat transfer—conduction, convection, and radiation. In addition to these, a phenomenon called absorption is related to the radiation method.

Conduction

The metal handle of a hot pot may burn the hand; a plastic or wooden handle, however, remains relatively cool even though it is in direct contact with the pot. This phenomenon is due to a property of matter known as thermal conductivity. All materials conduct heat—some very readily, some to an almost negligible extent. When heat is applied to a body, the molecules at the point of application become violently agitated, strike the molecules next to them, and cause increased agitation. The process continues until the heat energy is distributed evenly throughout the material. Aluminum and copper are used for cooking pots because they conduct heat very readily to the food being cooked. Wood and plastic are used as handles because they are very poor conductors of heat.

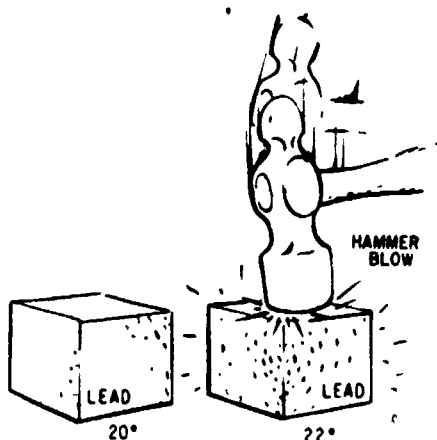

243.6

Figure 2-15.—Generation of heat.

As a general rule metals are the best conductors of heat, although some metals are considerably better than others.

Figure 2-16 shows an example of the different rates of conduction of various metals. Four rods of different metals have several wax rings hanging on them. One flame is used to simultaneously heat one end of each rod. The rings drop off from the copper rod first, then from the aluminum rod, then from the nickel rod, and last from the iron rod. This example shows that among the four metals used, copper is the best conductor of heat and iron is the poorest.

Among solids, there is an extreme range of thermal conductivity. In the original example, the metal handle transmits heat from the pot to the hand, with the possibility of burns. The wooden or plastic handle does not conduct heat very well, so the hand is given some protection. Materials that are extremely poor conductors are called "insulators" and are used to reduce heat transfer. Some examples are the wood handle of soldering irons, the finely spun glass or rock wool insulation in houses, or the asbestos tape or ribbon wrapping used on steam pipes.

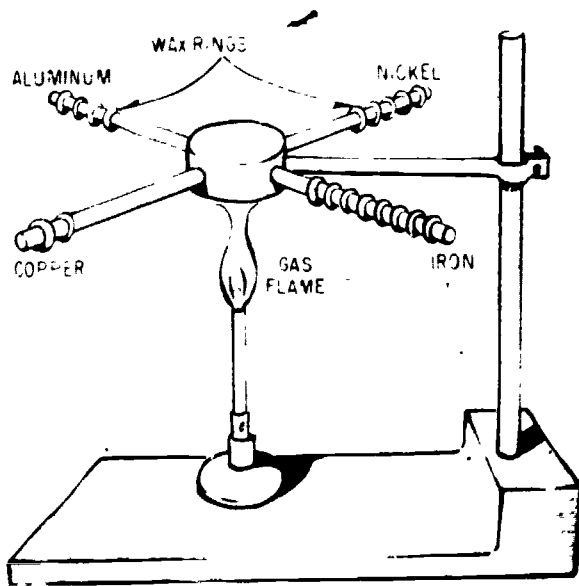

243.7

Figure 2-16.—Various metals conduct heat at different rates

WARNING.—Inhalation of asbestos fibers can produce severe lung damage in the form of disabling or fatal fibrosis of the lungs. Asbestosis means fibrosis of the lungs due to inhaled asbestos fibers. The use of the term "asbestosis" in a generic sense for all asbestos-associated disorders including pleural plaques is imprecise and confusing. Asbestos has also been found to be a casual factor in the development of carcinoma of the lung and malignant mesothelioma, as well as cancer of the gastro-intestinal track. A long latency period of 2-40 years between first exposure to asbestos and the appearance of a malignancy is frequently noted. For more information, refer to OPNAVINST 6260.0(Series).

CONDUCTION IN FLUIDS.—Liquids are generally poorer conductors than metals. In figure 2-17, note that the ice in the bottom of the test tube has not yet melted, although the water at the top is boiling. Water is such a poor conductor that the rate of heating of the water at the top of the tube is not sufficient to cause rapid melting of the ice at the bottom.

Since thermal conduction is a process by which molecular energy is passed on by actual

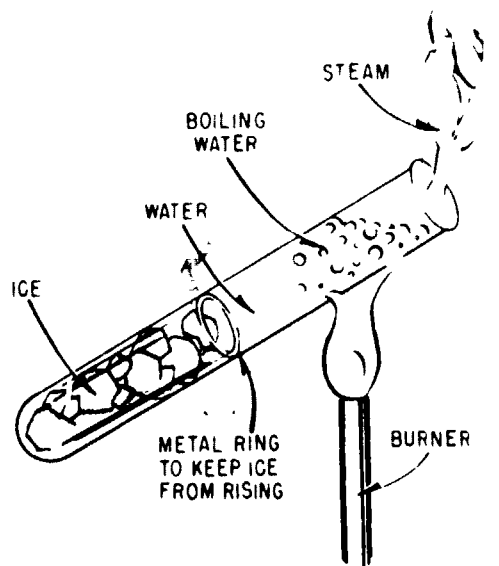

243.8

Figure 2-17.—Water is a poor conductor of heat.

contact, gases are generally even poorer conductors than liquids because the molecules are farther apart and molecular contact is not so pronounced. A double-pane window with an airspace between the panes is a fair insulator.

Convection

Convection is the process in which heat is transferred by movement of a hot fluid. For example, an electron tube gets hotter and hotter until the air surrounding it begins to move. The motion of the air is upward because heated air expands in volume and is forced upward by the denser cool air surrounding it. The upward motion of the heated air carries the heat away from the hot tube by convection. Transfer of heat by convection may be hastened by using a ventilating fan to move the air surrounding a hot object. The rate of cooling of a hot vacuum tube can also be increased by providing copper fins to conduct heat away from the hot tube. The fins provide large surfaces against which cool air can be blown.

A convection process may take place in a liquid as well as in a gas. One example is a transformer in an oil bath. The hot oil is less dense (has less weight per unit volume) and rises, while the cool oil falls, is heated, and rises in turn.

When the circulation of gas or liquid is not rapid enough to remove sufficient heat, fans, or pumps may be used to accelerate the motion of the cooling material. In some installations, pumps are used to circulate water or oil to help cool large equipment. In airborne installations electric fans and blowers are used to aid convection.

Radiation

Conduction and convection cannot wholly account for some of the phenomena that are associated with heat transfer. For example, heating through convection cannot occur in front of an open fire because the air currents are moving toward the fire. It cannot occur through conduction because the conductivity of the air is very low, and the cooler currents of air moving

toward the fire would more than overcome the transfer of heat outward. Therefore, heat must travel across space by some means other than conduction and convection.

The existence of another process of heat transfer is still more evident when the heat from the sun is considered. Since conduction and convection take place only through molecular contact within some medium, heat from the sun must reach the earth by some other method. (Outer space is an almost perfect vacuum.) Radiation is the name given to this third method by which heat travels from one place to another.

The term radiation refers to the continual emission of energy from the surface of all bodies. This energy is known as radiant energy. It is in the form of electromagnetic waves and is identical in nature with light waves, radio waves, and X-rays, except for a difference in frequency. Sunlight is a form of radiant heat energy which travels great distances through cold, empty space to reach the earth. These electromagnetic heat waves are absorbed when they come in contact with nontransparent bodies. The net result is that the motion of the molecules in the body is increased, as indicated by an increase in the temperature of the body.

The differences in conduction, convection, and radiation are as follows:

1. Although conduction and convection are extremely slow, radiation takes place with the speed of light. This fact is evident at the time of an eclipse of the sun when the shutting off of the heat from the sun takes place at the same time as the shutting off of the light.

2. Radiant heat may pass through a medium without heating it. For example, the plants inside a greenhouse may be much warmer than the glass through which the sun's rays pass.

3. Although conducted or convected heat may travel in roundabout routes, radiant heat always travels in a straight line. Thus, radiant heat can be stopped with a screen placed between the source of heat and the body to be protected.

Absorption

The sun, a fire, and an electric light bulb all radiate energy, but a body need not glow to give

off heat. A kettle of hot water or a hot soldering iron radiates heat. If the surface is polished or light in color, less heat is radiated. Bodies which do not reflect are good radiators and good absorbers, and bodies that reflect are poor radiators and poor absorbers. This is the reason white clothing is worn in the summer. A practical example of the control of heat is the Thermos bottle. The flask itself is made of two walls of "silvered" glass with a vacuum between them. The vacuum prevents the loss of heat by conduction and convection and the "silver" coating reduces the loss of heat by radiation.

The silver-colored paint on the "radiators" in heating systems is used only for decoration and decreases the efficiency of heat transfer. The most effective color for heat transfer is dull black; dull black is the ideal absorber and also the best radiator.

THERMAL EXPANSION

Nearly all substances expand or increase in size when their temperature increases. Railroad tracks are laid with small gaps between the sections to prevent buckling when the temperature increases in summer. Concrete pavement has strips of soft material inserted at intervals to prevent buckling when the sun heats the roadway. A steel building or bridge is put together with red-hot rivets so that when the rivets cool they will shrink and the separate pieces will be pulled together very tightly. A fuel tank that has been filled in the cool of early morning will overflow in the heat of the afternoon.

As a substance is expanded by heat, the weight per unit volume decreases. This is because the weight of the substance remains the same while the volume is increased by the application of heat. Thus the density decreases with an increase in temperature.

Experiments show that for a given change in temperature, the change in length or volume is different for each substance. For example, a given change in temperature causes copper to expand nearly twice as much as glass of the same size and shape. For this reason, the connecting wires into an electronic tube cannot be made of

copper but must be made of a metal that expands at the same rate as glass. If the metal did not expand at the same rate as the glass, the vacuum in the tube would be broken by air leaking past the wires in the glass stem. If the metal expanded at a greater rate than the glass, the glass would be broken. Through research, a material (Kovar) was developed that adheres to the glass and the metal pins of the tube, has a certain degree of elasticity, and the same expansion coefficient as glass.

The amount that a unit length of any substance expands for a 1° rise in temperature is known as the coefficient of linear expansion for that substance.

Coefficients of Expansion

To estimate the expansion of any object, such as a steel rail, it is necessary to know three things about it—its length, the rise in temperature to which it is subjected, and its rate of coefficient of expansion. The amount of expansion is expressed by the following equation:

$$\text{expansion} = \text{coefficient} \times \text{length} \times \text{rise in temperature}$$

or

$$e = kl(t_2 - t_1)$$

In this equation, the letter k represents the coefficient of expansion for the particular substance. In some instances, the Greek letter α (alpha) is used to indicate the coefficient of linear expansion.

PROBLEM: If a steel rod measures exactly 9 feet at 21°C, what is its length at 55°C? (The coefficient of linear expansion for steel is 11×10^{-6} .) If the equation $e = kl(t_2 - t_1)$ is used, then

$$e = (11 \times 10^{-6}) \times 9(55 - 21)$$

$$e = 0.000011 \times 9 \times 34$$

$$e = 0.003366$$

This amount, when added to the original length of the rod, makes the rod 9.003366 feet long. Since the temperature has increased, the rod is longer by the amount of e . If the temperature had been lowered, the rod would have become shorter by a corresponding amount.

The increase in the length of the rod is relatively small; but if the rod were placed where it could not expand freely, there would be a tremendous force exerted due to thermal expansion. Thus, thermal expansion must be taken into consideration when designing ships, buildings, and all forms of machinery.

Table 2-5 is a list of the coefficients of approximate linear expansion of some substances per degree C.

A practical application for the differences in the coefficients of linear expansion is the thermostat. This instrument comprises two strips of dissimilar metal fastened together. When the temperature changes, a bending takes place due to unequal expansion of the metals. (See fig. 2-5.) Thermostats are used in overload relays for motors, in temperature sensitive switches, and in electric ovens. (See fig. 2-18.)

The coefficient of surface or area expansion is approximately twice the coefficient of linear expansion. The coefficient of volume expansion

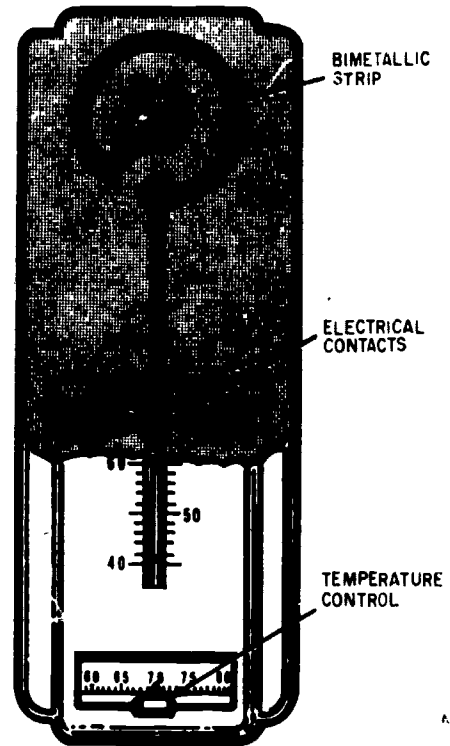

243.19

Figure 2-18.—Thermostat.

Table 25.—Expansion of coefficients

Substance	Coefficient of linear expansion
Aluminum	24×10^{-6}
Brass	19×10^{-6}
Copper	17×10^{-6}
Glass	$4 \text{ to } 9 \times 10^{-6}$
Kovar	$4 \text{ to } 9 \times 10^{-6}$
Lead	28×10^{-6}
Iron, steel	11×10^{-6}
Quartz	0.4×10^{-6}
Zinc	26×10^{-6}

is approximately three times the coefficient of linear expansion. It is interesting to note that in a plate containing a hole, the area of the hole expands at the same rate as the surrounding material. In the case of a volume enclosed by a thin solid wall, the volume expands at the same rate as would a solid body of the material of which the walls are made.

MEASUREMENT OF HEAT

A unit of heat must be defined as the heat necessary to produce some agreed-on standard of change. There are three such units in common use.

1. One British thermal unit (Btu) is the quantity of heat necessary to raise the temperature of 1 pound of water 1°F .

2. One gram-calorie (small calorie) is the quantity of heat necessary to raise 1 gram of water 1°C .

3. One kilogram-calorie (large calorie) is the quantity of heat necessary to raise 1 kilogram of water 1°C. (One kilogram-calorie equals 1,000 gram calories.)

The gram-calorie and small calorie is much more widely used than the kilogram-calorie or large calorie. The large calorie is used in relation to food energy and for measuring comparatively large amounts of heat. Throughout this discussion, unless otherwise stated, the term calorie means gram-calorie. For purposes of conversion, one Btu equals 252 gram-calories or 0.252 kilogram-calories.

The terms "quantity of heat" and "temperature" are frequently misused. The distinction between them should be understood clearly. For example, suppose that two identical pans, containing different amounts of water of the same temperature, are placed over identical gas burner flames for the same length of time. At the end of that time, the smaller amount of water will have reached a higher temperature. Equal amounts of heat have been supplied, but the increases in temperatures are not equal. As another example, suppose that the water in both pans is at the same temperature, say 80°F, and both are to be heated to the boiling point. It is obvious that more heat must be supplied to the larger amount of water. The temperature rises are the same for both pans, but the quantities of heat necessary are different.

Mechanical Equivalent

Mechanical energy is usually expressed in ergs, joules, or foot-pounds. Energy in the form of heat is expressed in calories or in Btu. In a precise experiment in which electric energy is converted into heat in a resistance wire immersed in water, the results show that 4.186 joules equals 1 gram-calorie, or that 778 foot-pounds equals 1 Btu. The following equation is used when converting from the English system to the metric system:

$$1 \text{ Btu} = 252 \text{ calories}$$

Specific Heat

One important way in which substances differ from one another is that they require

different quantities of heat to produce the same temperature change in a given mass of substance. The thermal capacity of a substance is the calories of heat needed, per gram mass, to increase the temperature 1°C. The specific heat of a substance is the ratio of its thermal capacity to the thermal capacity of water at 15°C. Specific heat is expressed as a number which, because it is a ratio, has no units and applies to both the English and the metric systems.

Water has a high thermal heat capacity. Large bodies of water on the earth keep the air and the surface of the earth at a fairly constant temperature. A great quantity of heat gain or loss is required to change the temperature of a large lake or river. Therefore, when the temperature of the air falls below that of such bodies of water, they give off large quantities of heat to the air. This process keeps the atmospheric temperature at the surface of the earth from changing very rapidly.

Table 2-6 gives the specific heats of several common substances listed in descending order.

Table 2-6.—Specific heats of some common substances

Hydrogen (at constant pressure)	3.409
Water at 4° C	1.0049
Water at 15° C	1.0000
Water at 30° C	0.9971
Ice at 0° C	0.502
Steam at 100° C	0.421
Air (at constant pressure)	0.237
Aluminum	0.217
Glass	0.160
Iron	0.114
Copper	0.093
Brass, zinc	0.092
Silver	0.057
Tin	0.056
Mercury	0.033
Gold, lead	0.031

To find the heat required to raise the temperature of a substance, multiply its mass by the rise in temperature times its specific heat.

Example: It takes 1,000 Btu to raise the temperature of 100 pounds of water 10°F, but only 31 Btu to raise 100 pounds of lead 10°F.

CHANGE OF STATE

A thermometer placed in melting snow behaves in a strange manner. The temperature of the snow rises slowly until it reaches 0°C. Provided that the mixture is stirred constantly, it remains at that point until all the snow has changed to water; when all the snow has melted, the temperature again begins to rise. A definite amount of heat is required to change the snow to water at the SAME temperature. This heat is required to change the water from crystal form to liquid form.

Heat of Fusion

Eight gram-calories of heat are required to change 1 gram of ice at 0°C to water at 0°C, and this is called the HEAT OF FUSION of water. The heat used while the ice is melting represents the work done to produce the change of state. Since 80 calories are required to change a gram of ice to water at 0°C, when a gram of water is frozen it gives up 80 calories. This is illustrated in figure 2-19

Many substances behave very much like water. At a given pressure, they have a definite heat of fusion and an exact melting point. There are many materials, however, which do not change from a liquid to a solid state at one temperature. Molasses, for example, gets thicker and thicker as the temperature decreases but there is no exact temperature at which the change of state occurs. Wax, celluloid, and glass are other substances which do not change from a liquid to a solid state at any particular temperature. In fact, measurements of the glass thickness at the bottom of windows in ancient cathedrals tend to indicate that the glass is still flowing at an extremely slow rate. Most types of solder used in avionics maintenance also tend to become mushy before melting.

CHANGE FROM SOLID/LIQUID AT CONSTANT TEMPERATURE

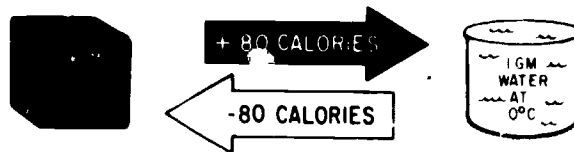

CHANGE OF TEMPERATURE WITHOUT CHANGE OF STATE

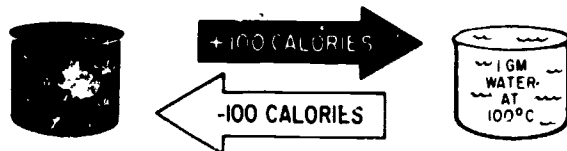

CHANGE FROM LIQUID/VAPOR AT CONSTANT TEMPERATURE



243.13

Figure 2-19.—Thermal history of 1 gram of water.

Heat of Vaporization

Damp clothing dries more rapidly under a hot flatiron than under a cold one. A pool of water evaporates more rapidly in the sun than in the shade. Thus, it may be concluded that heat has something to do with evaporation. The process of changing a liquid to a vapor is similar to that which occurs when a solid melts.

If a given quantity of water is heated until it evaporates—that is, changes to a gas (vapor)—a much greater amount of heat is used than that which is necessary to raise the same amount of water from the freezing point to the boiling point. For example, 540 calories are required to change 1 gram of water to vapor at a temperature of 100°C, while only 100 calories were required to change the temperature from the freezing point to the boiling point. The amount of heat necessary to change boiling water to vapor is called the HEAT OF VAPORIZATION of water. Over five times as much heat is required to change a given amount

of water to vapor than to raise the same amount of water from the freezing to the boiling point.

BOILING.—When water is heated, some vapor forms before the boiling point is reached. The change from water to vapor occurs as follows: As the water molecules take up more and more energy from the heating source, their kinetic energy increases. The motion resulting from the high kinetic energy of the water molecules causes a pressure which is called the vapor pressure. As the velocity of the molecules increases, the vapor pressure increases. At sea level, atmospheric pressure is normally 29.92 inches of mercury. The boiling point of a liquid is that temperature at which the vapor pressure equals the external or atmospheric pressure. At normal atmospheric pressure at sea level, the boiling point of water is 100°C .

While the water is below the boiling point, a number of molecules acquire enough kinetic energy to break away from the liquid state into a vapor. For this reason some evaporation slowly takes place below the boiling point. At the boiling point, large numbers of molecules have enough energy to change from liquid to vapor, and evaporation takes place much more rapidly.

If the molecules of water are changing to water vapor in an open space, the air currents carry them away quickly. In a closed container, they rapidly become crowded and some of them return to liquid as a result of collisions. When as many molecules are returning to the liquid state as are leaving it, the vapor is said to be saturated. Experiments have shown that saturated vapor in a closed container exerts a pressure and has a given density at every temperature.

CHAPTER 3

ELECTRICAL MAINTENANCE AND TROUBLESHOOTING

The majority of electrical equipment and systems that are maintained by Aviation Electricians do not always operate in the manner in which they were designed to operate. If they did, there would be no need for the AE, but systems are subject to failure, instruments need calibration, and components need adjustment. A general maintenance plan is necessary to ensure that this work is accomplished. The maintenance plan is outlined in the NAMP (Naval Aviation Maintenance Program, OPNAVINST 4790.2 (Series)) which encompasses all facets of naval aircraft maintenance. This training manual is devoted to the maintenance technique, tools, equipment used, and the safety aspects pertaining to the maintenance of naval aircraft.

Maintenance performed on aircraft equipment falls into two broad categories: (1) actions taken to reduce or eliminate failure and prolong the useful life of the equipment, and (2) actions taken when a part or component has failed and the equipment is out of service. Therefore, all maintenance can be grouped under the headings of preventive maintenance and corrective maintenance.

In maintenance work of any kind, knowledge and skills of two fundamental kinds must be used. Electricians must have specific information which applies to the particular equipment which they may be called upon to repair or to keep in good condition, and they must possess certain general skills and knowledge which apply to many kinds of equipment and types of work assignments.

The specific information required consists of special procedures and processes, and detailed

step-by-step directions approved by proper authority for a particular piece of equipment. This information is found in publications or checklists under the cognizance of the Naval Air Systems Command, type commanders, and other authorities.

General maintenance skills and procedures are based on knowledge which is not contained in equipment manuals. These skills must be learned from schools, during on-the-job training, and from training manuals such as this one.

SAFETY

In the performance of normal duties, the AE is exposed to many potentially dangerous conditions and situations. Training manuals, sets of rules or regulations, or even a listing of hazards cannot make working conditions safe. Common sense and careful adherence to established rules and regulations can produce an accident-free naval career. Attainment of this goal requires that the AE must be aware of all potential sources of danger, must remain constantly alert to these dangers, and must take the proper precautions and practice the basic rules of safety.

When working with electrical equipment there is one rule that must be strongly stressed—SAFETY FIRST. Whether you are working in the shop, on the line, or during a flight, you should follow prescribed safety procedures. You must be aware of the many dangers that are associated with the electrician's work. Among the possible hazards of this work

are electrical fires and harmful gases; gases are sometimes generated by faulty electrical and electronic devices. One of the most common dangers that you will encounter is that of high voltages that are present in much equipment. Also, when working on or near aircraft, there is the possibility of falling from the aircraft, of being burned by a jet blast, of losing your balance, or of being struck by propeller or helicopter rotor blades.

Because of these dangers, the electrician should regard the formation of safe and intelligent work habits as being equal in importance to the development of a knowledge of electrical equipment. One primary objective should be to become a safety specialist, trained in recognizing and correcting dangerous conditions, and in avoiding unsafe acts.

Most accidents which occur in noncombat operations can be prevented if the full cooperation of personnel is gained and vigilance is exercised to eliminate unsafe acts. Each individual concerned should strictly observe all safety precautions applicable to work or duty.

GENERAL PRECAUTIONS

Because of the possibility of injury to personnel, the danger of fire, and possible damage to material, all repair and maintenance work on both electronic and electrical equipment should be performed only by duly authorized and assigned persons.

When any electrical equipment is to be overhauled or repaired, the main supply switches or cutout switches in each circuit from which power could possibly be fed should be secured to the open position and tagged. The tag should read, "This circuit was ordered open for repairs and shall not be closed except by direct order of . . ." (usually the person directly in charge of the repairs). After the work has been completed, authorization to remove the tag (or tags) should be given by the person whose name appears on the tag.

The covers of fuse boxes and junction boxes should be kept securely closed except when

work is being performed. Safety devices such as interlocks, overload relays, and fuses should never be altered or disconnected except for replacements. Safety or protective devices should never be changed or modified in any way without specific authorization.

Fuses should be removed and replaced only after the circuit has been deenergized. When a fuse blows, it should be replaced only with a fuse of the same current rating. When possible, the circuit should be carefully checked before making the replacement since the burned-out fuse is often the result of circuit fault.

When working around electrical equipment, move slowly. Maintain good balance and do not lunge after falling tools. Do not work on electrical equipment if you are mentally or physically exhausted. Do not touch energized electrical equipment when standing on metal, damp, or other well grounded surfaces. Do not handle energized electrical equipment when you are wet or perspiring heavily. **DO NOT TAKE UNNECESSARY RISKS.**

Some of the general safety precautions are as follows:

1. Each individual concerned should **REPORT ANY UNSAFE CONDITION**, or any equipment or material which is considered to be unsafe, to the immediate supervisor.

2. Each individual concerned should **WARN OTHERS** believed to be endangered by known hazards or by failure to observe safety precautions.

3. Each individual concerned should **WEAR or USE PROTECTIVE CLOTHING or EQUIPMENT** of the type approved for the safe performance of work or duty.

4. All personnel should **REPORT** to their supervisors **ANY INJURY** or evidence of impaired health occurring in the course of work or duty.

5. All personnel should **EXERCISE**, in the event of any unforeseen hazardous occurrence, such **REASONABLE CAUTION** as is appropriate to the situation.

The safety precautions which apply to the work and duty of Aviation Electrician's Mates include those pertaining to working in and around aircraft, in the electric or battery shop, precautions against electric shock and electric burns, and those which concern the proper use of handtools and small power tools. In addition to these, it is also necessary that the electrician know the authorized methods for dealing with fires of electric origin, for treating burns, and for giving artificial respiration to persons suffering from electric shock.

Rate Training Manuals, *Airman*, NAVEDTRA 10307 (Series), and *Standard First Aid Training Course*, NAVEDTRA 10081 (Series), contain safety information with which you should be familiar. It is recommended that you acquaint yourself with the sections of *Airman* that deal with safety as it relates to naval aviation. The *Standard First Aid Training Course* is designed as a basic reference in the field of first aid. Since all naval personnel are required to possess a knowledge of the principles of first aid, you should become familiar with this training manual.

The Department of the Navy has issued NAVMAT P5100 (Series), Safety Precautions for Shore Activities, and OPNAV Instruction 5100.19 (Series) Navy Safety Precautions for Forces Afloat. The manuals include a great variety of operations and functions in the Navy, and therefore are basic and general in nature. Activities may use these manuals as a basis for establishing specific safety instructions suited to their particular equipment, weapons system, or locality.

PRECAUTIONS REGARDING AIRCRAFT

Hazards on the flight line are of paramount consideration to the AE because any type of moving machinery is dangerous; therefore, the AE must be doubly alert when working around aircraft whose engines are operating. When working with propeller type aircraft, the first general precaution that you must observe is **BEWARE OF PROPELLERS**. The propellers on

engines that are operating are hard to see, and you should develop a habit of staying clear of the propeller area at all times. These precautions also apply to rotors when in the vicinity of helicopters.

Jet aircraft present basically the same type of problem in that the AE should stay clear of the intake and exhaust. Due to the tremendous suction of the intake, the area around the aircraft must be kept clear of loose equipment and debris.

The maintenance instructions manual for each type of aircraft has an illustration such as that shown in figure 3-1 for the A-7 aircraft. These illustrations should be studied for each aircraft in your operating area. Instructions have been promulgated which require the anti-collision light to be operating whenever the engine or engines are operating. This is intended to give an additional warning to beware of propellers, rotors, or jet intakes and exhausts.

Noise Hazards

Continuous and intermittent exposure to loud noises, such as those created by jet and propeller-driven aircraft, marine engines, and industrial-type activities, may result in hearing loss. This loss may be temporary, disappearing after a period of nonexposure, or it may be permanent because of irreversible injury to the inner ear. Susceptibility to hearing impairment due to noise varies greatly among individuals. Loss of sensitivity occurs first in the higher frequencies in the 4000-6000 Hertz range. Individuals may sustain quite extensive impairment before the important speech range (500-3000 Hertz) is appreciably affected, and long before they become aware of any difficulty in hearing speech.

When working around aircraft it is imperative that some type of ear protection be used. Jet aircraft, especially, produce high-volume noise, usually at a high frequency, which tends to deteriorate hearing at a rapid rate. Maintenance manuals normally have a

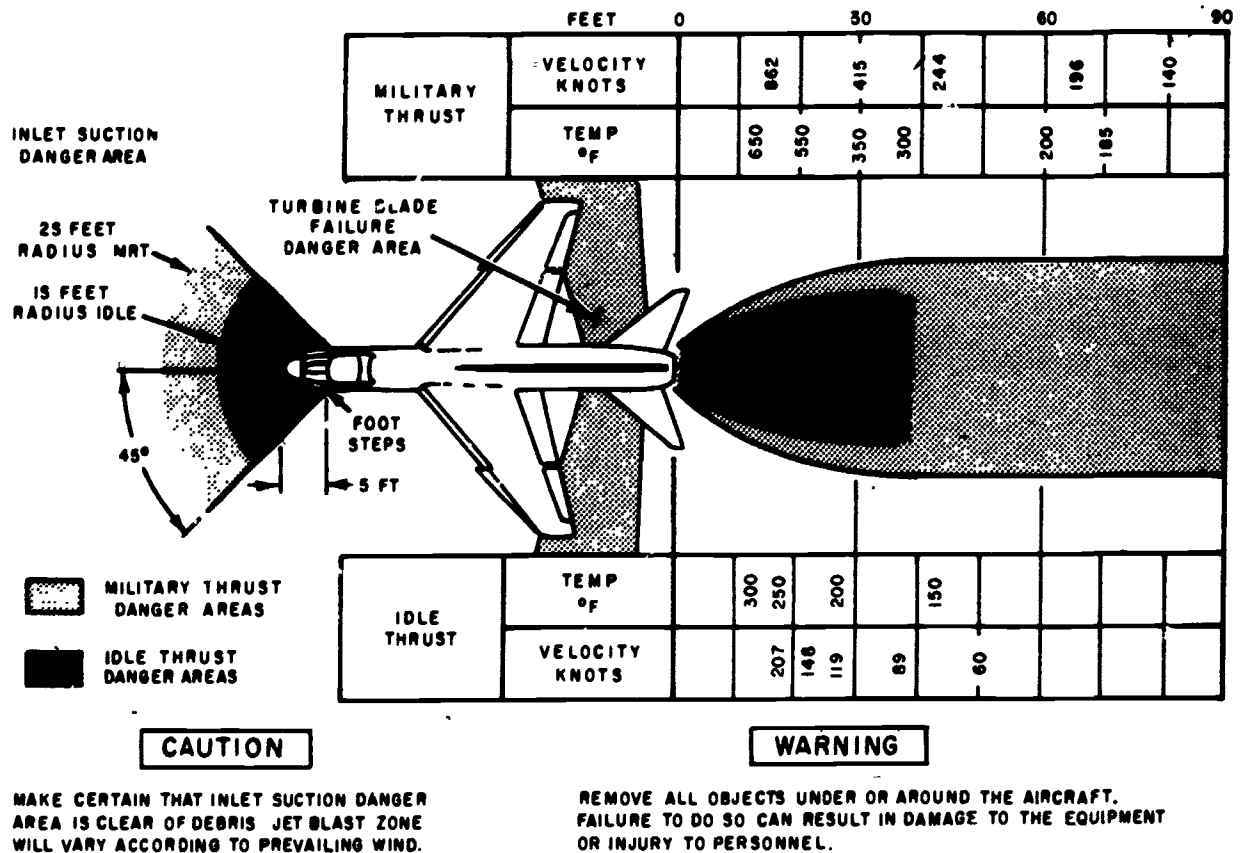

Figure 3-1.—Intake, exhaust, and turbine blade failure danger area.

207.2

diagram similar to that shown in figure 3-2 to identify noise hazard areas. Table 3-1 gives the maximum time limits for exposure with and without ear protection so as not to incur permanent ear damage.

Table 3-1.—Range of noise levels that may cause permanent ear damage

DB level	No protection	With ear protection
100	2 Hours	
110	1/2 Hour	
120	5 Minutes	4 Hours
130	0 Seconds	1 Hour
140	0 Seconds	5 Minutes

There are several types of ear protection devices, but those used most commonly by the Navy today are rubber earplugs and sound attenuators (Mickey Mouse ears). Check the fit of the ear protectors by pressing earplugs with the forefinger and ear muffs with the palms. If they fit correctly, no amount of pressure will cut down on the amount of sound that is still getting through. Sometimes pressing will increase the sound because the hearing protector is being deformed and is allowing some sound to get through; ignore such increases. To afford the best ear protection, both earplugs and Mickey Mouse ears may be worn at the same time. Also, voices will be heard much easier when the background noise is blocked. Plain cotton is useless in attenuating sound.

Whenever ear protectors are worn, it is extremely hard to determine if a particular jet

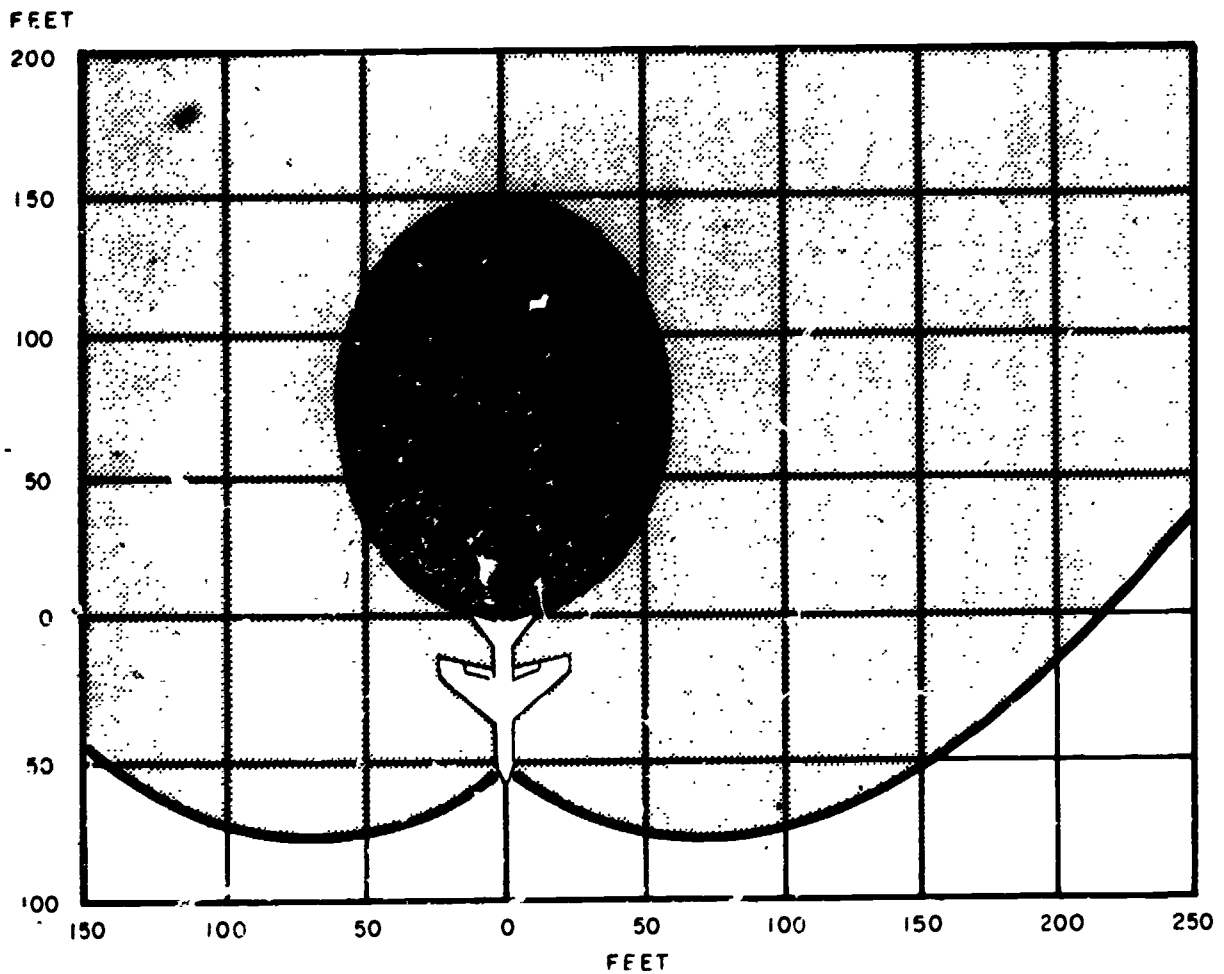

 MILITARY THRUST - 140 DB AND ABOVE. DANGEROUS EVEN WITH EAR PROTECTION. LIMIT EXPOSURE TO ABSOLUTE MINIMUM. IDLE THRUST - 95 DB AND ABOVE. EAR PROTECTION REQUIRED.

 MILITARY THRUST - 120 DB TO 140 DB. EAR PROTECTION REQUIRED. USE CAUTION IN EXPOSURE TIME.

 MILITARY THRUST - 90 TO 120 DB EAR PROTECTION REQUIRED.

207.5

Figure 3-2. - Noise hazard area for A-7 aircraft.

89

on the line or flight deck is being turned up, and audible warnings cannot be heard. It is, therefore, relatively easy to walk into the blast zone of an aircraft, therefore extreme caution must be used. Your eyes are your greatest safety factor—keep them moving to keep yourself aware of surrounding conditions.

Flight Deck Safety

The best thing to remember about the flight deck of an aircraft carrier during flight operations is to stay away unless you are **REQUIRED** to be there.

The flight deck of an aircraft carrier during flight quarters is inherently a highly dangerous area. This deck, combined with the hangar deck, magazines, and shops, provide the equivalent operating facilities of a large airfield. The hazards associated with aircraft operations are focused, however, into a relatively small area. Therefore, exposure of personnel to potential dangers is greater.

The more common flight deck hazards present during flight operations are listed below:

1. Jet blast and prop wash
2. Jet intakes
3. Rotating propellers, helo blades, and tail rotors
4. High wind and blowing particles
5. High noise level
6. Pitching and rolling deck
7. Catapults, arresting gear, and tie-down chains
8. Aircraft fueling and LOX handling
9. Moving yellow equipment
10. Ordnance loading/unloading
11. Potential aircraft crash area

For the reasons outlined above, personnel required to be present on the flight deck of carriers (or helo platforms of nonaviation ships) must be thoroughly trained and equipped to perform their duties.

For those people who **HAVE** to be there, a uniform is prescribed and must be worn at all

times. The complete flight deck uniform includes the following as a minimum:

1. **Helmet**—has a hard shell and goggles. The color of the helmet and jersey combination identifies the person's job responsibility; e.g., green helmet and green jersey with black stripe and squadron insignia for an AE maintenance person.
2. **Life vest**—in a seven-month cruise, an average of eight people will fall or be blown from a carrier into the water.
3. **Light and whistle**—a person in the water is very difficult to see even under the best of conditions. These items are paramount for rescue and survival.
4. **Jersey with long sleeves**—sleeves and pant legs should never be rolled up. In the event of fire, your clothing can provide enough protection to save your life.
5. **Gloves**—provide protection against fire, and can reduce the chance of being cut by sharp objects.
6. **Hard toe safety shoes**—foot protection is as important as hand protection.

All safety precautions regarding aircraft are doubly important on a flight deck because of the limited space in which all operations must be conducted. Figure 3-1 indicates the danger areas of an A-7 aircraft jet intake and exhaust. When several aircraft are turning up on a flight deck it is extremely difficult to remain clear of these areas. Even though the maintenance of aircraft is a team effort, while on the flight deck each person must be self-responsible for safety.

FOD

FOD, which is the abbreviation for Foreign Object Damage, is a kind of catchall term which refers not only to the damage caused by a foreign object, but also to any object that has the potential to cause damage. A loose nut or bolt is FOD because it has the potential of being drawn into a jet intake possibly destroying a multimillion-dollar engine, or of being propelled at high speeds through the air to cause injury or damage to nearby personnel or equipment.

Another area where FOD is particularly hazardous is that of loose objects in the aircraft. A wrench or screwdriver left in an aircraft performing aerobatics or conducting carrier takeoffs and landings could cause electrical short circuits, controls to be jammed, or bodily injury to crewmembers.

The following paragraphs are taken from the Naval Aviation Maintenance Program (NAMP), 4790.2 (Series) and are printed to demonstrate Naval Aviation's deep concern regarding Foreign Object Damage.

The ingestion of foreign objects and debris is a continuing problem that currently accounts for the largest percentage of premature removal of gas turbine engines from naval aircraft. Furthermore, these removals consume excessive maintenance man-hours, impose unscheduled workloads on supporting activities, and create an unwarranted shortage of engines and spare engine parts on the supply system, the composite of which drastically reduces training capability and fleet operational readiness. It is also significant that the majority of gas turbine engines undergoing depot rework exhibit some degree of FOD.

Most FOD can be attributed to three general causes: poor housekeeping, poor maintenance practices, and everyday carelessness. The present and upward trend of engine rejection due to FOD is excessive and, in the interest of economy and operational readiness, cannot be tolerated. The requirement to reduce this waste is, therefore, mandatory. It is a command responsibility.

The following safety precautions in regards to FOD should be adhered to when working on or around aircraft:

1. Account for each nut, bolt, washer, piece of safety wire, etc.
2. Prior to completing any work, account for each tool used in the repair work.
3. Remove loose objects from pockets prior to beginning work.
4. Do not wear loose clothing which can be drawn into aircraft engine (white hat, ball cap, etc.).

5. Remove loose objects from all rolling stock and support equipment utilized in the vicinity.

6. Pick up debris and any loose objects and deposit them in FOD prevention containers or elsewhere, as appropriate.

Tool Control Program (TCP)

Aircraft accidents and incidents attributable to tools being left in aircraft after maintenance work has been performed are major problems. To reduce the potential for tool FOD related mishaps, this program provides the mechanic/technician a means to rapidly account for all tools after completing a maintenance task on an aircraft or its related equipment.

The TCP is based on the instant inventory concept. Basically the program provides internally configured, silhouetted tool containers, when applicable, so that all tools have individual locations to highlight a missing tool.

All tools will be color coded and etched to denote the work center, organization, and tool container it belongs to. All containers will be marked to identify work center, work package, maintenance level, and organization on the exterior. If possible, the container will contain a silhouette of each tool in its proper place. On containers where silhouetting is not feasible, a note with the inventory and drawing of the container outline will be included. Either system enables the work center supervisor or inspector to quickly ensure that all tools have been retrieved after a maintenance action.

The most significant benefit of this program is the lives and equipment that are saved by eliminating tool-FOD-caused accidents. Additional desirable benefits are: reduced initial outfitting and tool replacement costs; reduced tool pilferage; reduced man-hours required to complete each maintenance task; and insurance that proper tools are available for specific maintenance tasks.

Safety In Flight

In the air the pilot in command of the aircraft is responsible for the safe and orderly

conduct of the flight. When the electrician wishes to operate electrical equipment or to make any unusual repairs on the equipment, permission from the pilot must be requested before proceeding. When making in-flight repairs, special precaution must be taken to prevent being knocked into a live circuit because of turbulent air.

PRECAUTIONS REGARDING PERSONNEL AND MATERIALS

Insofar as is practicable, repair work on energized circuits should not be undertaken. When repairs on operating equipment must be made because of emergency conditions, or when such repairs are considered to be essential, the work should be done only by experienced personnel, and if possible, under the supervision of the senior petty officer of the electrical shop. Every known safety precaution should be carefully observed. Ample light for good illumination should be provided, and the worker should be insulated from ground with some suitable nonconducting material such as several layers of dry canvas, dry wood, or a rubber mat of approved construction.

Helpers should be stationed near the main switch or the circuit breaker so that the equipment can be deenergized immediately in case of emergency, and the worker rescued. An individual qualified in first aid for electrical shock should stand by during the entire period of the repair.

High-Voltage Precautions

Personnel should never work alone near high-voltage equipment. Tools and equipment containing metal parts should not be used in any area within four feet of high-voltage circuits or any wiring having exposed surfaces. The handles of all metal tools, such as pliers and cutters, should be covered with rubber insulating tape; however, the use of plastic or cambric sleeving or of friction tape alone for this purpose is prohibited.

Before touching a capacitor which is connected to a deenergized circuit, or which is disconnected entirely, short-circuit the terminals

to make sure that the capacitor is completely discharged. Grounded shorting prods should be permanently attached to workbenches where electrical devices are regularly serviced.

Do not work on any type of electrical apparatus with wet hands or while wearing wet clothing, and do not wear loose or flapping clothing. The use of thin-soled shoes with metal plates or hobnails is prohibited. Safety shoes with nonconducting soles should be worn if available. Flammable articles, such as celluloid cap visors, should not be worn.

When working on electrical or electronic apparatus, you should first remove all rings, wristwatches, bracelets, and similar metal items. Care should be taken that the clothing does not contain exposed zippers, metal buttons, or any type of metal fastener.

Warning signs and suitable guards should be provided to prevent personnel from coming into accidental contact with high voltages.

Low-Voltage Precautions

Most people never realize the dangers of low-voltage electric shock. These hazards are ever present, and it is surprising how dangerous they can be. Defective handtools and improper usage can be corrected, but some hazards will always exist. An awareness of their existence seems to be the answer. In general, beware of any voltage greater than 15 volts.

DEGREE OF SHOCK.—The amount of current that may pass through the body without causing damage depends on the individual, the type, path, and length of contact time.

Body resistance varies from about 1,000 to 500,000 ohms for unbroken, dry skin. Resistance is lowered by moisture and is highest with dry skin. Breaks, cuts, or burns may lower body resistance to 300 ohms. Electric shock may cause burns of varying degree, cessation of breathing and unconsciousness, ventricular fibrillation (a tendency of the heart to beat at the same rate as the input electrical frequency), or cardiac arrest and death. A 60-Hertz

alternating current passed through the chest cavity generally has the following effect:

1. At about 1 milliamperes (0.001 ampere) the shock will be felt.
2. At about 10 milliamperes (0.01 ampere) the shock is severe enough to paralyze muscles, and a person may be unable to release the conductor.
3. At about 100 milliamperes (0.1 ampere) the shock is usually fatal if it lasts for 1 second or more. **IT IS IMPORTANT TO REMEMBER THAT, FUNDAMENTALLY, CURRENT, RATHER THAN VOLTAGE, IS THE CRITERION OF SHOCK INTENSITY.**

When a person is rendered unconscious by a current passing through the body, it is impossible to tell how much current caused the unconsciousness. Artificial respiration must be applied immediately if breathing has stopped.

FIRST AID FOR ELECTRIC SHOCK.—Electric shock is a jarring, shaking sensation resulting from contact with electric circuits or from the effects of lighting. The victim usually feels like a sudden blow has been received; if the voltage and resulting current is sufficiently high, the victim may become unconscious. Severe burns may appear on the skin at the place of contact; muscular spasm may occur, causing the victim to clasp the apparatus or wire which caused the shock and be unable to turn it loose.

The following procedure is recommended for rescue and care of shock victims:

1. Remove the victim from electrical contact at once. Do not endanger yourself. This can be accomplished by: throwing the switch if it is nearby; cutting the cable or wires to the apparatus, using an axe with a wooden handle while taking care to protect your eyes from the flash when the wires are severed, using a dry stick, rope, belt, coat, blanket, or any other nonconductor of electricity, to drag or push the victim to safety.
2. Determine whether the victim is breathing. Keep the person lying down in a comfortable position and loosen the clothing about the neck, chest, and abdomen for easy

breathing. Protect from exposure to cold, and watch closely.

3. Keep victim from moving about. In this condition, the heart is very weak, and any sudden muscular effort or activity on the part of the patient may result in heart failure.

4. Do not give stimulants or opiates. Send for a medical doctor at once, and do not leave the patient until adequate medical care is available.

5. If the victim is not breathing, apply artificial respiration without delay, even though the patient may appear to be lifeless. Do not stop artificial respiration until the victim revives or authority pronounces the victim is beyond help.

For complete coverage on administering artificial respiration and treating burns, refer to *Standard First Aid Training Course, NAVEDTRA 10081 (Series)*.

Electrical Fires

In case of electrical fires, the following steps should be taken:

1. Deenergize the circuit that caused the fire.
2. Call the fire department if the fire is in a hangar or a shop (aboard ship call the OOD).
3. Control or extinguish the fire, using the correct type of fire extinguisher.

For combating electrical fires, use a CO₂ (carbon dioxide) fire extinguisher and direct it toward the base of the flame. Application of water to electrical fires is dangerous; likewise, foam type fire extinguishers should not be used since the foam is electrically conductive.

Liquid Oxygen

Many naval aircraft are equipped with liquid oxygen systems. As an AE, you may be called upon to work on or around these systems. Liquid oxygen is very dangerous; therefore, applicable safety precautions must be rigidly observed.

The main dangers of liquid oxygen are the extremely low temperature of the liquid, its expansion ratio, and the supporting of violent combustion. The liquid is nontoxic, but will freeze (burn) the skin severely upon contact.

Extreme caution should be taken not to touch equipment containing liquid oxygen, unless gloves are worn. Without gloves, skin will immediately stick to metal surfaces.

A greater danger than freezing is the combustion-supporting potential of oxygen. When liquid oxygen is used, it is possible to build up high concentrations of oxygen quickly. Many materials such as cloth, wood, grease, oil, paint, or tar burn violently when saturated with oxygen, provided an ignition source is supplied. A static electric discharge or spark can serve as an igniter. Once an oxygen fire is started it is virtually impossible to extinguish until the oxygen supply is cut off.

An added danger exists if a combustible material is saturated with oxygen at low temperatures. Many materials, especially hydrocarbons, tar, etc., will burn with explosive violence when so saturated and then subjected to very mild shock or impact.

Extreme care must be taken not to splash or spill liquid oxygen onto clothing. Mixed with cloth, an ideal and deadly situation for a fire exists—a fire that cannot be extinguished.

Liquid oxygen by itself will not burn, but mixing with the smallest amount of nearly any material will cause the liquid to boil and splash violently, and combustion is possible. If splashed out of a container, it will scatter widely upon contact with the ground.

Some of the general safety precautions of concern to the AE are as follows:

1. Oxygen should never be used in place of compressed air.
2. Never allow smoking, sparks, or open flames in the vicinity of liquid oxygen or gaseous oxygen equipment.
3. Never store volatile or flammable material near oxygen storage tanks or vent lines.
4. Keep combustible materials, especially oil and grease, away from possible contact with oxygen.

5. Do not get liquid oxygen on articles of clothing—it renders the material highly flammable. If liquid oxygen accidentally penetrates the clothing, remove the clothing immediately. If liquid or gaseous oxygen saturates the clothing, but does not penetrate to the skin, move immediately but slowly out of the compartment and allow the clothing to become well aired out.

Volatile Liquids

Because of the danger of igniting fumes by sparks, volatile liquids, such as insulating varnish, lacquer, turpentine, and kerosene are dangerous when used near electrical equipment which is operating. When these liquids are used in compartments containing nonoperating equipment, be sure that there is sufficient ventilation to avoid an accumulation of fumes, and that all fumes are cleared before the equipment is energized.

Neither alcohol nor gasoline should ever be used for cleaning. Use the approved cleaning agent, Dry Cleaning Solvent, Federal Specification PD-680.

The fire hazards encountered in the handling of hydrocarbon products (all present-day aviation fuels are hydrocarbons) are related to the flashpoint. Products which give off flammable vapors at or below 80°F, such as gasoline, solvents, and most crude oils, are the most hazardous of all petroleum products to handle. Certain petroleum products may be slightly less hazardous to handle, such as kerosene, light and heavy fuels, and lubricating oils which have a flashpoint above 80°F.

The vapors of petroleum, gasoline, and other petroleum products cause drowsiness when inhaled. Petroleum vapors in a concentration of 0.1 percent can cause dizziness to the extent of inability to walk straight after 4 minutes of exposure. Longer exposure and/or greater concentration may cause unconsciousness or death.

The first symptoms of exposure to toxic (poisonous) vapors are headaches, nausea, and dizziness. If such symptoms are noted, they should be taken as a warning of the presence of dangerous amounts of vapors in the air.

Recovery from these early symptoms is usually prompt after removal to fresh air. However, if people are overcome by vapors, they should receive immediate medical attention. First aid consists of the prevention of chilling, and of artificial respiration if breathing has stopped.

Gasoline may cause skin irritation if allowed to remain in contact with the skin, particularly under soaked clothing or gloves. Clothing or shoes through which gasoline has soaked should be removed at once. Gasoline should be washed from the skin with soap and water. Repeated contact with gasoline removes the protective oils from the skin and causes drying, roughening, chapping, and cracking, and in some cases infection which may become serious. While the clothes are being removed, an arc caused by static electricity is enough to cause the fuel to ignite. For this reason, fuel soaked clothes should be removed in a running shower.

If a person swallows gasoline, first aid should be given immediately. Give the victim large amounts of water or milk and four tablespoons of vegetable oil if available. DO NOT induce vomiting. Medical attention must be sought immediately.

JP-4 fuel, although having some of the characteristics of gasoline, is by no means the same substance. Due to some of the different characteristics, such as lower vapor pressure and high aromatic content (having compounds added to increase the performance number), this fuel must be handled very carefully.

JP-5 is a kerosene type fuel. It has a vapor pressure close to 0 psi. Since its tendency to vaporize is lower than the more volatile grades, the vapor-air mixture above its liquid surface is too lean to be ignited until the surface of the liquid reaches 140°F. This fuel must also be handled very carefully.

Precautions must be taken to prevent personnel from breathing fumes from any fuel and to prevent fuel from coming in contact with the skin, especially if the skin has abrasions, pimples, or sores.

Compressed Air

Compressed air, when misused, can be extremely dangerous. Injuries can occur through

failure of the hose or fittings, causing the hose to whip dangerously and possibly propelling parts of the fittings through the air; through the blowing around of dust and small particles which constitute an eye hazard; through the introduction of air pressure into one of the body cavities, either accidentally or through horseplay. Air under pressure will pass through clothing and may cause agonizing internal injury or even death by introducing a strong airstream into body tissue, usually through an existing cut or scratch. Air can actually rupture cell tissues and cause severe wounds through injection of minute foreign bodies into the skin due to impurities which almost always exist in a shop's air line. Falls can result from tripping over air lines which are thoughtlessly left lying on the floor.

Compressed air should be considered a special tool, and is not to be used as a substitute for a brush to clean machines, clothing, or your person. Any form of horseplay should be prohibited, with severe penalties for violation of the rule. In those cases where an air hose is essential for blowing out fixtures and jigs, eye protection must be provided and the pressure maintained at a maximum of 30 psi. It is also desirable to place screens around work to confine the blown particles.

The National Safety Council has published the following general safety rules for working with compressed air.

1. Use only sound, strong hose with secure couplings and connections.
2. Be sure that there are not sharp points on metal hose parts.
3. Close control valve in portable pneumatic tools before turning on air.
4. Before changing one pneumatic tool for another, turn off air at the control valve. Never kink hose to stop airflow.
5. Wear suitable goggles, mask, protective clothing, or safety devices.
6. Never use air to blow dust chips from work clothing, or from work benches.
7. Never point the hose at anyone. Practical jokes with compressed air have caused painful deaths.
8. When using compressed air, see that no nearby workers are in line of airflow.

PRECAUTIONS REGARDING TOOLS

As a general precaution, be sure that all tools used conform to Navy standards as to quality and type, and use them only for the purposes for which they were intended. All tools in active use should be maintained in good repair, and all damaged or nonworking tools should be turned-in.

Use only straight, undamaged, and properly sharpened drills. Tighten the drill securely in the chuck, using the key provided; never tighten with wrenches or pliers. It is important that the drill be set straight and true in the chuck. The work should be firmly clamped and, if of metal, a center punch should be used to score the material before the drilling operation is started.

When using a portable power drill, grasp it firmly during the operation to prevent it from bucking or breaking loose and causing injury to yourself or damage to the tool.

One of the primary duties of the AE is to become proficient in the use of handtools and to be able to select the proper hardware in any maintenance task. The proper use of handtools and materials improves the quality of maintenance and reduces the possibility of new failures.

Carelessness is the greatest menace in any shop, and is always the fault of a human; a machine alone cannot inflict injury. Lack of attention is the cause of most accidents in electrical and electronics shops today. It should be remembered that all moving machinery is potentially dangerous. It is unsafe to lean against any machine that is in motion, or that may be started in motion by anyone else. Treat a machine with businesslike respect and there is no need to fear it. Do not start a machine until its operation has been fully explained by a competent instructor.

The following two basic safety precautions may be used to summarize this idea, and they must be emphasized strongly:

1. Use the proper tool for its own peculiar function, and use it in the proper manner. A toolbox will often reflect the personal habits of its owner; that is, if an individual is sloppy, the tools also are often in need of care; and if the

individual is neat, the tools and toolbox are also neat and well cared for.

2. Maintain all tools in proper working order and in a safe condition. Sharpen or replace dulled cutting tools, replace broken or defective tools, and protect tools from damage while in use or in stowage.

When performing any function requiring the use of tools and/or materials, arrange them so that they are easily accessible but are not in a position to interfere with the work. This arrangement increases efficiency as well as safety.

Tools should be cleaned, inspected, and accounted for after the job has been completed. Return all tools to their proper stowage place. If a tool becomes worn, damaged, or broken, report it to the work center supervisor.

Nonmagnetic Tools

Tools made of nonmagnetic materials are available through normal supply channels. They are used for performing specific maintenance function on certain classes of equipment or components. These tools are normally made of beryllium-copper or plastic, are not as rugged as steel tools, and are much more easily damaged. Restricting their use to the purpose for which they were intended will prolong their useful life and increase their usefulness when required.

Nonmagnetic tools should always be used in the vicinity of compasses and other components containing permanent magnets. Magnetic susceptible tools could become magnetized and transfer this magnetic condition to undesirable places.

Good general maintenance practice involves wiping the tools before use and again after use. This is especially advisable in the case of nonmagnetic tools. A lint-free cloth dampened with an approved cleaning solvent may be used for this purpose.

Insulated Tools

Safety considerations require use of insulated tools. Many types of tools are available in insulated form directly through supply channels at little or no additional cost. These

tools should be obtained and used whenever available. However, many types of insulated tools are not readily available or are available only at considerable added expense. If essential, these tools should be procured locally, or conventional tools may be modified. Insulated sleeving may be put on the handles of pliers and wrenches and on the shanks of screwdrivers. Tools modified in this manner should be used only for low-voltage circuits because of the limitations of the insulating materials. For higher voltage uses, special insulating handles are available for many of the common types of tools.

In some instances, it is necessary to use tools (such as fuse pullers) which are made of insulating material, rather than merely having an insulating handle. In these instances, the tools should be requisitioned through normal supply channels, if possible. If they are not available through normal supply channels, they may be purchased on the open market.

Power Tools

In your work as an Aviation Electrician's Mate, you will most likely be required to use a few pieces of shop machinery, such as a power grinder or drill press. In addition to the general precautions on the use of tools, there are a few other precautions which should be observed when working with machinery. The most important ones are:

1. Never operate a machine with a guard or cover removed.
2. Never operate mechanical or powered equipment unless you are thoroughly familiar with the controls. When in doubt, consult the appropriate instruction or ask someone who knows.
3. Always make sure that everyone is clear before starting or operating mechanical equipment.
4. Never try to clear jammed machinery without first cutting off the source of power.
5. When hoisting heavy machinery or equipment by a chain fall, always keep everyone

clear, and guide the hoist with lines attached to the equipment.

6. Never plug in electric machinery without ensuring that the source voltage is the same as that called for on the nameplate of the machine.

PORTABLE POWER TOOLS.—All portable power tools should be carefully inspected to see that they are clean, well-oiled, and in a proper state of repair before being used. The switches should operate normally, and the cords should be clean and free of defects. The casings of all electrically driven tools should be grounded. Sparking portable electric tools should not be used in any place where flammable vapors, gases, liquids, or exposed explosives are present.

Be sure that power cords do not come in contact with sharp objects. The cords should not be allowed to kink, nor be left where they might be run over. They should not be allowed to come in contact with oil, grease, hot surfaces, or chemicals, and when damage, should be replaced instead of being patched with tape. When unplugging power tools from receptacles, grasp the plug, not the cord.

Soldering Iron

The soldering iron is potentially a fire hazard and a source of burns. Always assume that a soldering iron is hot; never rest the iron anywhere but on a metal surface or rack provided for that purpose. Keep the iron holder in the open to minimize the danger of fire from accumulated heat. Do not shake the iron to dispose of excess solder—a drop of hot solder may strike someone, or strike the equipment and cause a short circuit. Hold small soldering jobs with pliers or clamps.

When cleaning the iron, place the cleaning rag on a suitable surface and wipe the iron across it—do not hold the rag in the hand. Disconnect the iron when leaving the work, even for a short time—the delay may be longer than planned.

Grounding

A poor safety ground, or one that is wired incorrectly, is more dangerous than no ground at all. The poor ground is dangerous because it does not offer full protection, while the user is

lulled into a false sense of security. The incorrectly wired ground is a hazard because one of the line wires and the safety ground are transposed, making the shell of the tool "hot" the instant the plug is connected. Thus the unwary user is trapped, unless by pure chance the safety ground is connected to the grounded side of the line on a single-phase grounded system or no grounds are present on an ungrounded system. In this instance the user again goes blithely along using the tool until he encounters a receptacle which has its wires transposed or a ground appears on the system.

Because there is no absolutely foolproof method of ensuring that all tools are safely grounded (and because of the tendency of the average sailor to ignore the use of grounding wire), the old method of using a separate external grounding wire has been discontinued. Instead, a 3-wire, standard, color-coded cord with a polarized plug and a ground pin is required. In this manner, the safety ground is made a part of the connecting cord and plug. Since the polarized plug can be connected only to a mating receptacle, the user has no choice but to use the safety ground.

All new tools, properly connected, use the green wire as the safety ground. This wire is attached to the metal case of the tool at one end and to the polarized grounding pin in the connector at the other end. It normally carries no current, and is used only when the tool insulation fails, in which case it short circuits the electricity around the user to ground and protects him from shock. The green lead must never be mixed with the black or white leads which are the true current-carrying conductors.

Check the resistance of the grounding system with a low reading ohmmeter to be certain that the ground is adequate between the case of the tool and the polarized grounding pin. If the resistance indicates greater than 0.1 ohm, use a separate ground strap.

Some old installations are not equipped with receptacles that will accept the grounding plug. In this event, use one of the following methods:

1. Use an adapter fitting.
2. Use the old type plug and bring the green ground wire out separately.
3. Connect an independent safety groundline.

When using the adapter, be sure to connect the ground lead extension to a good ground. Do not use the center screw which holds the cover plate on the receptacle. Where the separate safety ground leads are externally connected to a ground, be certain to first connect the ground and then plug in the tool. Likewise, when disconnecting the tool, first remove the line plug and then disconnect the safety ground. The safety ground is always connected first and removed last.

PLANNED MAINTENANCE SYSTEM (PMS)

The PMS is a program for formally ensuring that aeronautical equipment is maintained through its life cycle by controlling degradation resulting from time, operational cycles, utilization, or climatic exposure of the equipment. Many separate but interrelated functions and tasks are combined to make up the maintenance workload in support of aircraft and aeronautical equipment. The limited time available for the performance of maintenance does not allow these tasks to be considered, planned, and performed on an individual basis. They must be combined and sequenced properly if the overall job is to be accomplished efficiently. The best possible use of time, manpower, materials, and funds is mandatory if the maximum potential equipment availability and utilization is to be realized. The PMS, when properly conducted, ensures that all aeronautical equipment receives the necessary maintenance throughout its life cycle.

SCHEDULED MAINTENANCE

Maintenance performed to prevent the likelihood of future troubles or malfunctions is usually referred to as preventive or scheduled maintenance.

Aircraft Inspections

Operating aircraft are subject to a variety of stresses, strains, vibrations, and detrimental environments. If not inspected regularly, the aircraft would soon become inoperable.

Maintenance, such as correcting of discrepancies and timely lubricating, is performed in conjunction with inspections and enables the aircraft to be flown safely until the next inspection is due.

Types of inspections which are performed by activities responsible for the maintenance of naval aircraft are as follows:

1. **Acceptance Inspection.** A minimum acceptance inspection consists of an inventory of installed material and loose gear, configuration verification, functional test of appropriate emergency systems, and a thorough daily inspection. Accepting activities may elect to increase the depth of inspection if the aircraft conditions warrant.

2. **Daily Inspection.** Daily Inspection is provided to inspect for defects to a greater depth than the Turnaround or Preflight Inspections. The Daily Inspection is valid for a period of 72 hours, provided that no flight occurs during this period and no maintenance other than servicing has been performed. Aircraft may be flown for 24 hours without another Daily Inspection. This 24 hour period begins with the first launch following accomplishment of the Daily Inspection. In no case is a Daily Inspection valid for more than 72 hours.

3. **Turnaround.** This inspection is conducted between flights to ensure the integrity of the aircraft for flight, verify proper servicing, and to detect degradation that may have occurred during the previous flight. The turnaround inspection may be considered valid for a period of 24 hours provided that no flight and no maintenance other than servicing occurs during this period. The accomplishment of the daily inspection does not satisfy the turnaround requirements. On aircraft which are furnished turnaround inspection requirements, the preflight and postflight do not apply.

NOTE: In the event that maintenance, other than servicing, must be performed after the accomplishment of the daily, preflight, or turnaround inspection, maintenance control shall determine if a complete daily inspection or portion thereof is required.

4. **Phased Inspection.** The phased maintenance concept divides the total scheduled maintenance requirements into small packages (phases) of approximately the same work content that are accomplished sequentially at specified intervals. Completion of all required phases at their specified interval completes the phased inspection cycle. The cycle is repetitive for the service life of the aircraft and is not interrupted during Standard Depot Level Maintenance (SDLM).

5. **Conditional Inspection.** A conditional inspection is an inspection that depends upon occurrence of certain circumstances or conditions, or a maintenance action with a prescribed interval other than the preflight, postflight, daily, or calendar/phased inspection cycle.

6. **Special inspection**—an inspection with a prescribed interval other than turnaround, daily, or calendar as specified in the inspection requirements for the aircraft—e.g., every 7 days, 28 days, etc.

7. **Transfer inspection**—an inspection performed at the time a reporting custodian is relieved of responsibility for the aircraft. It includes an inventory of all equipment, verification of configuration, and a daily inspection.

Periodic maintenance requirements for every model aircraft are promulgated by the Naval Air Systems Command. With every activity using the inspection criteria prescribed for their assigned models, it follows that any given aircraft model is subject to a standardized program of periodic maintenance wherever it is being operated.

Standardization of periodic maintenance procedures is accomplished by the use of Periodic Maintenance Information Cards (PMICs), various sets of Maintenance Requirements Cards (MRCs), the Sequence Control Chart (SCC), and related forms and reports.

Lubrication

Lubrication of electrical equipment consists of lubricating the mechanical parts associated

with the equipment. Equipment which may need periodic lubrication, such as unsealed bearings, gear trains, linkages, etc., should be lubricated as directed by the equipment's Maintenance Instructions Manual. The specification number of a lubricant should be strictly complied with, because the viscosity of a lubricant changes with a change in operating temperature. High operating temperatures cause lubricants to become thin, while low operating temperatures cause lubricants to thicken or harden; therefore, the lubricant used for a particular job will depend on the operating characteristics and temperature. Particular attention should be paid to equipment lubrication in aircraft that are flown at high altitudes. The proper lubricant must be used so that it will not harden and cause a physical overload on drive motors and shafts, and an electrical overload on the circuits involved.

CORROSION CONTROL

In modern aircraft, the need for corrosion control has become a major concern. Corrosion is something that destroys equipment and is active 24 hours a day. It is of the utmost importance that its causes be understood in order to combat corrosion.

Most of the metals used today have been refined from natural ores found in the earth's surfaces. These metals are extracted from the ore and are used in various combinations to form alloys with distinct properties. Some of these properties are: lightweight, strength, and resistance to extreme temperatures. These refined metals have a tendency to return to their natural state, but proper corrosion control will prevent this action from taking place.

Corrosion-Control Program

All activities responsible for maintenance of naval aircraft shall establish corrosion-control programs as required by OPNAVINST 4790.2 (Series). The type of program established depends upon the conditions or environments to which the aircraft may be exposed. At sea, where conditions are most severe, aircraft are exposed to salt spray, shipstack gases, and

aircraft-engine exhaust. Accordingly, a continuing effort by all hands is mandatory as a day-to-day requirement to prevent corrosion before it starts.

It is much simpler and more efficient to protect equipment from corrosion than it is to correct corrosion damage. The basic philosophy of an effective corrosion control program must be to clean it, treat it, and reprotect it at once.

It is important to remember that no matter how adverse conditions are in regard to corrosion control, a course of action is available that, if taken, will produce rewarding results. In addition materials used shall be those covered and controlled by Federal or military specifications, preferably those authorized specifically for use on aircraft. Many materials used for less critical applications may lack the properties considered necessary for application to aircraft. Commercial and proprietary preparations may not have been checked under aeronautical conditions and may be harmful to naval aircraft.

To properly implement and maintain a positive corrosion control program the AE must be familiar with the following technical manuals: Aircraft Weapons System Cleaning and Corrosion Control, NAVAIR 01-1A-509 and Avionic Cleaning and Prevention/Control, NAVAIR 16-1-540.

NOTE: In the event of a conflict between NAVAIR 01-1A-509 and the corrosion control and cleaning manual for a specific aircraft model, the instructions contained in NAVAIR 01-1A-509 shall take precedence.

UNSCHEDULED MAINTENANCE

Unscheduled maintenance can be defined as those repair actions that are performed at no set intervals. Discrepancies that are noted prior to, during, and after flight by pilots, crewmembers, and maintenance personnel will fall into this category.

Visual Checks

Equipment should be checked visually for loose leads, improper connections, damaged or

broken components, etc., prior to applying power to the equipment. This applies particularly to new equipment which has been preserved or stored for long periods of time, and equipment which has been exposed to the weather. A close visual inspection should also be conducted on O-rings, gaskets, and other type seals when the equipment under check is a pressurized component. This visual inspection will often reveal discrepancies that may be corrected at that time with a minimum amount of labor and parts. Such discrepancies, if left uncorrected, might result in a major maintenance problem.

TROUBLESHOOTING TECHNIQUES

Some of the AE's time is spent troubleshooting the equipment in squadron aircraft. The AE maintains a great number of components and systems, many of which are quite complex and difficult to troubleshoot. However, the most difficult troubleshooting job usually becomes much simpler if it is first broken down into the following steps:

1. Analyze the symptom.
2. Detect and isolate the trouble.
3. Correct the trouble and test the work.

ANALYSIS OF TROUBLE

The AE cannot hope to work effectively on a system or component which is not understood. The first step is to understand what a system is supposed to do, then how it does this. Once these questions are answered, the very nature of the trouble will usually suggest an answer as to what is wrong. An understanding of a particular system may be obtained by referring to the pertinent Maintenance Instructions Manual. These manuals may answer the questions you might ask about a particular aircraft. They are most useful aids in analyzing troubles. These manuals explain what an entire system does, what each component does, the location of the components, and other useful information. Once the AE has used the manual to thoroughly analyze a particular system, an idea of what is

wrong will usually present itself when a description of the trouble is given.

Another excellent aid in analyzing a trouble is to check past records of the malfunctioning system or component. Check to see if maintenance has been performed previously on the same system or component and, if so, what repairs were made, which components were replaced, and what troubleshooting has been accomplished. Check for interrelated discrepancies; e.g., if an engine instrument is malfunctioning, a recent engine change may point to a particular connector plug that might have been left off or loose. Try not to duplicate work that has already been performed.

Two steps in analyzing troubles are (1) determining what a system is supposed to do, and (2) determining the most likely cause for the trouble.

DETECTION OF FAULTS

Visible condition of system components is usually the first thing to check in any process of troubleshooting. If certain parts are obviously not in proper condition, correct these faults before going any further. Such conditions include equipment being burned, loose from mounting, disconnected, dented, or any other obviously improper condition.

If there is nothing visibly wrong with a component, the next logical step is to see if it is receiving power. Again, there is need of the Maintenance Instructions Manual. It will indicate which pin in a connector is used for power input to the connector. The manual will also show which circuit breakers must be closed and which switches to use for testing. They are shown on the electrical schematics in the Maintenance Instructions Manual. If there is power to the component and it still does not work, then the obvious fault is with the component itself.

If there is no power reaching the component, assume temporarily that the component is all right, and start checking the power supply. The best place to start the check is at the bus which supplies the power. Consult the manual to locate successive points along a wire at which to make power checks. The first and most important step is to check the

condition of fuses and circuit breakers. Sometimes a circuit protector will open as a result of transient conditions such as momentary voltage surge. Reset or replace the circuit protector and apply power—if the protector again opens, secure the power because this indicates a circuit malfunction, and power should not be reapplied until the malfunction is corrected. If a short, ground, or overload condition is not indicated, continue to take power readings at the checkpoints. The most common faults which interrupt power through a circuit are broken wiring, loose terminal or plug connections, faulty relays, and faulty switches. Be alert for these conditions when checking the successive points along a circuit. If, as mentioned earlier, there is evidence of a short circuit or overload, secure the power and prepare to start continuity and resistance checks.

Continuity and Resistance Checks

The process of fault detection often leads beyond visual inspection and power checks. The voltmeter will indicate if a power circuit is delivering power to the proper place, but will rarely identify the nature of a trouble when it exists. A better instrument for identifying trouble is the ohmmeter. With the ohmmeter, the exact trouble can be determined. When properly used, it will indicate opens, shorts, grounds, or wrong values of resistance. By frequent reference to a schematic, any circuit or component can be traced, piece by piece and wire by wire, until the trouble is completely isolated. Wiring, control switches, relays, and other such isolated components are relatively easy to check since their individual circuitry is usually simple. It is quite a different story when checking a complex component with internal wiring and parts that form a maze of branches and interconnected paths.

When checking a particular component, refer to its Operation and Service Instruction Manual. This manual contains information on the specific piece of equipment, and lists the proper resistance readings between connector pins.

In addition to the various types of testing meters, there are various bench-test installations. These are used when a component is removed from the aircraft and taken into the shop, or

sent to the intermediate maintenance activity for operational tests. In a typical installation, there is a complete and fully operational system with the components grouped closely together. This enables the troubleshooter to remove any unit and replace it with one the AE wants to test. In this manner, the unit's performance can be checked under conditions that are almost identical to those in the aircraft.

This method of trouble detection is especially useful when the trouble is not completely clear; that is, when the unit is functioning to some extent, but does not measure up to minimum standards. These test installations are highly specialized and only specific tests can be performed on specific components. Much of the AE's troubleshooting is performed with a meter and a schematic, and the use of technical knowledge.

Nonelectric Components

The information that has been given so far has dealt only with fault detection in systems using electric power. There is, however, a group of systems and components which do not use electricity. This group includes such items as mechanical instruments, direct reading gages, and mechanisms closely associated with electrical equipment. Such mechanisms are switch actuators, mounting assemblies, mechanical linkages, and any type of hardware that is part of an electrical system. This equipment is not checked with a volt-ohmmeter but the three basic rules for troubleshooting remain the same—analyze, detect, and correct.

CORRECTION OF FAULTS

Detailed instructions on how to correct any specific fault would involve writing a training course on the one subject. Many faults may occur, and for each fault a corrective action must be performed. There are general rules which apply to practically all such corrective actions. In some cases, the correction of a fault involves more time and labor than detecting it. For this reason it is a good idea to keep these general rules in mind so that the time and workload can be minimized.

First, study the job and think through each step to be performed. Form a plan of attack, and at the same time decide which tools are needed. In addition to handtools, equipment such as extension lights and cooling blowers should be considered; they are well worth the extra time it takes to obtain them, especially on a prolonged job. The Maintenance Instructions Manual lists the special tools needed, and also describes the best way to gain access to some certain unit or area; that is, some component may be mounted at an obscure location in the aircraft so that it may be approached only through a certain inspection plate or from a certain direction. Another source of valuable information is someone who has performed that particular job before. This person can usually offer some very good pointers.

The troubleshooter should also plan methods of dealing with special conditions which will be encountered during a job. Some of these are excessive hydraulic oil drainage from disconnected lines; dangling and unprotected power cables; high-pressure air lines; and the handling of very heavy components such as starters and generators.

Gas or liquid lines may be drained or bled off, and heavy objects should be handled with special care. (NOTE: Only Aviation Structural Mechanics (AMEs) will work on oxygen lines.) If exposed power cables are unavoidably left loose, some means should be used to avoid their shorting out. This may be accomplished by covering them with a temporary insulating shield and by placing a warning sign on the main power switch in the cockpit and on the external power receptacle. Another very good precautionary measure, where applicable, is to disconnect the aircraft battery. In this case, a sign should be placed in the cockpit stating that the battery is disconnected. All of the safety measures mentioned here should be completed before work is started.

The procedures used in actually doing the work are determined by the nature of the job. The job can be classed as either repair or replacement. The quality of any job performed is determined by how well all the smaller operations are performed. This refers to such

operations as soldering, replacement of connecting devices, safety wiring, and use of tools.

Good techniques should be learned and practiced. An excellent way to learn them is by doing the work under the supervision of an experienced AE. Installation Practices for Aircraft Electric and Electronic Wiring, NAVAIR 01-1A-505, is an excellent reference. It sets forth the accepted way of performing a great number of practical operations, and is well illustrated.

Replacements

In many cases the replacement of a part is obviously the correct thing to do, as in the case of burned-out fuses, lamps, and resistors, or broken instruments. However, replacement of parts should never be used as a method of troubleshooting. Each year, thousands of dollars worth of instruments and "black boxes" are returned to overhaul activities with labels stating that they are faulty. When these are tested by the overhaul activity, many are found to be in good working order.

This practice is wasteful and very expensive, and reflects badly on the quality of a unit's maintenance program. This refers, of course, to replacing suspected parts without establishing proof that they are actually faulty. In the same category of poor maintenance, is the replacement of an entire unit when only a small component is at fault. A typical example of such a case is the replacement of an entire compass amplifier when there is only a single faulty fuse. The troubleshooter should remember that he/she is often working with equipment that is both expensive and in short supply. For this reason, decisions to replace equipment should be made only after thorough tests have shown it to be faulty.

The procedures to follow in the replacement and testing of equipment are found in the Maintenance Instructions Manual (MIMs) under the headings Removal, Installation, and Testing. Each heading will be discussed in detail.

REMOVAL.—Removal of equipment should be done in such a way that no further damage is caused to it or to nearby structures. Particular

attention should be given to keeping small parts from being lost or misplaced. They may be easily replaced with new ones, but small items that are lost in the aircraft constitute a very real hazard if they are not found. This refers to nuts, bolts, washers, small tools, and safety-wire clippings. FOD can be a killer.

If the new part cannot be installed immediately, remove all tools and parts from the aircraft during the waiting period. They are too easily forgotten if left in the aircraft. (This precaution applies to any unfinished job in which a waiting period is involved.) Once the part to be replaced is removed from the aircraft, notice should be placed in the cockpit. This is to prevent such occurrences as fuel pumps being turned on when fuel lines are opened, or power being applied to loose cables.

INSTALLATION. Many of the rules for removal apply also to installation. However, there are a few things which apply almost exclusively to installing new equipment. Some units are put into special condition for shipping. This is something to watch for, because it often means that sealing plugs, locking devices, and other special equipment must be removed from the component before installing it. If adjustments are to be made on new equipment, investigate the possibility of doing it before the installation is completed.

For example, the matching of a position transmitter to the position indicator in the cockpit often can be easily accomplished with only the electric wiring connected to the actuator. After calibration, mechanical mounting is completed. Again, the best guide for making adjustments to any system is the Maintenance Instructions Manual. In the final installation, particular care should be taken to ensure that (1) all mounting hardware is in place and properly tightened, and (2) all cables and lines are securely connected to the proper points.

TESTING.—The entire process of detecting and correcting a fault will mean nothing unless it is determined that the system operates properly. To determine this, the final step of the job is to test the equipment. This test is usually of an

operational nature. Where possible, simply operate the new component to see that it is doing its job properly and within the time requirement. When a final check has shown that the job is completed, it is important to pass this word quickly to those concerned because the aircraft is officially "down" until the proper people are notified.

USE OF BASIC TEST EQUIPMENT

CAUTION. Several rules are set forth below and are intended as a guide to follow when making the tests described in this section.

1. Always connect an ammeter in series, never in parallel.
2. Always connect a voltmeter in parallel—never in series.
3. Never connect an ohmmeter to an energized circuit.
4. On test meters, select the highest range first, then switch to lower ranges as needed.
5. When using an ohmmeter, select a scale that will result in a near midscale reading, since midscale is where the meter is calibrated for greatest accuracy.
6. Do not leave the selector switch of a multimeter in a resistance position when the meter is not in use, because the leads may short together and discharge the internal battery. There is less chance of damaging the meter if it is left on a high ac volts setting, or in the "off" position if it has one. Meters that have an off position dampen the swing of the needle by connecting the meter movement as a generator. This prevents the needle from swinging wildly when the meter is moved.
7. View the meter from directly in front to eliminate parallax error.
8. Observe polarity when measuring dc voltage or current.
9. Do not place meters in the presence of strong magnetic fields.
10. Never attempt to measure the resistance of a meter or a circuit with a meter in it, as the high current required for ohmmeter operation may damage the meter. This also applies to circuits with low-filament-current tubes, and to some types of semiconductors.

11. When measuring high resistance, be careful not to touch the test lead tips or the circuit, as body resistance will shunt the circuit and cause an erroneous reading.

12. Connect the ground lead of the meter first when making voltage measurements. Work with one hand whenever possible.

CONTINUITY TEST

Open circuits are those in which the flow of current is prevented by a broken wire, open switch, or by any other means which prevents the flow of current. The test used to check for opens or to see if the circuit is complete or continuous is called continuity testing.

An ohmmeter which contains its own batteries is excellent for a continuity test. When necessary, a continuity tester can readily be made from a flashlight. Normally, continuity tests are performed in circuits where the resistance is very low such as the resistance of a copper conductor. An open circuit is indicated by a very high or infinite resistance. Such a condition would exist in an open conductor.

The diagram in figure 3-3 shows a continuity test of a cable. Note that both connectors are disconnected and the ohmmeter is in series with

the conductor under test. The power must be off. Checking conductors A, B, and C, the current from the ohmmeter will flow through plug No. 2, through the conductor, and through plug No. 1. From this plug it will pass through the jumper to the chassis which is "grounded" to the aircraft's structure. The structure will serve as the return path to the chassis of unit 2, completing the circuit to the ohmmeter. The ohmmeter will indicate a low resistance for conductors A, B, C.

Checking conductor D will reveal an open, and the ohmmeter will indicate infinite resistance because current cannot flow. Where conditions are such that the aircraft structure cannot be used as the return path, one of the other conductors may be used. For example, to check conductor C, a jumper is connected from pin C to pin A of plug 1, and the ohmmeter leads are connected to pins C and A of plug 2. This technique, by the process of elimination, will also reveal the open in the circuit.

GROUNDING CIRCUIT TEST

Grounded circuits are caused by some conducting part of the circuit making contact

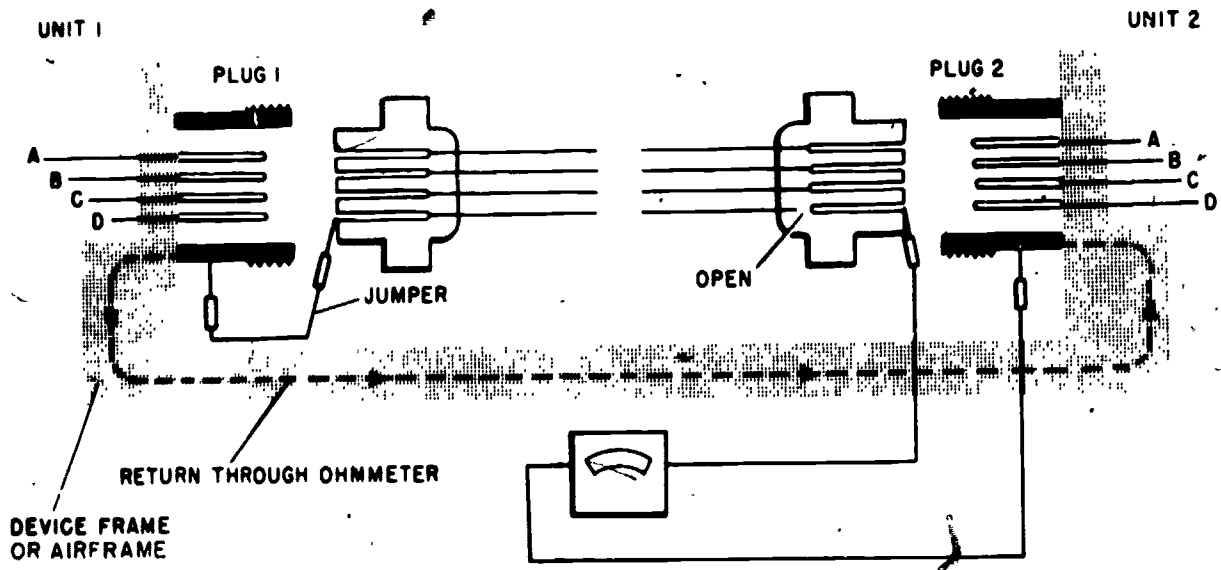

243.325

Figure 3-3.—Continuity test

either with the metallic framework of the aircraft or with another metal object that is grounded. Grounds may have many causes, the most common of which is the fraying of insulation from a wire, allowing the bare wire to come in contact with the metal ground.

Grounds are usually indicated by blown fuses or tripped circuit breakers. Blown fuses or tripped circuit breakers, however, may also result from a short other than ground. Then too, a high resistance ground may be troublesome but may not cause sufficient current to rupture the fuse or open the circuit breaker.

In testing for grounds, the ohmmeter or some other continuity tester may be used. By measuring the resistance to ground at any point in a circuit, it is possible to determine if the point is grounded. By considering figure 1-3, one possible means of testing a cable for grounds can be seen. If the jumper is removed from pin D of plug 1, a test for grounds is made for each conductor of the cable. This is accomplished by connecting one meter lead to ground and the other to each of the pins of one of the plugs. A low resistance will indicate that a pin is grounded. Both plugs must be removed from their units for this test; if only one plug is removed, a false indication is possible, for a conductor may be grounded through the unit.

SHORT TEST

A short circuit, other than a grounded one, is one where two conductors accidentally touch each other directly or through another conducting element. Two conductors with frayed insulation may touch and cause a short. Too much solder on the pin of a connector may short to the adjacent pin. In a short circuit, sufficient current may flow to blow a fuse or open a circuit breaker. However, it is entirely possible to have a short between two cables carrying signals; such a short may not be indicated by a blown fuse.

As when checking for a ground, the device used for checking for a short is the ohmmeter. By measuring the resistance between two conductors, a short between them may be detected by a low resistance reading. In figure 3-3, by removing the jumper and disconnecting

both plugs, a short test may be made. This is performed by measuring the resistance between the two suspected conductors.

Shorts are not reserved for cables, they occur in many components, such as transformers, motor windings, capacitors, etc. The major test method for testing such components is to make a resistance measurement and compare the indicated resistance with the resistance given on schematics or in maintenance manuals. Comparison could also be made with measurements from identical operating equipment.

VOLTAGE TEST

Since voltage tests must be made with power applied, prescribed safety precautions must be followed to prevent injury to personnel and damage to the equipment.

The AE will find in maintenance work that the voltage test is of utmost importance. It is used not only in isolating malfunctions to major components, but also in the maintenance of subassemblies, units, and circuits. Before checking a circuit voltage, a check of the power source voltage should be made to be sure that the normal voltage is being impressed across the circuit.

AMMETER

The ammeter used for routine maintenance of electrical/instrument equipment is normally specified by the Service Instruction Manual for the equipment. Since the ammeter has to be connected in series with the current path, circuits requiring frequent current readings or adjustments normally provide current jacks for use with a plug-in meter. Some equipment has a meter installed as part of the equipment, with a meter switch to provide the necessary ranges.

OHMMETER

The Navy does not normally supply its maintenance facilities with an instrument consisting solely of an ohmmeter. The

ohmmeter is incorporated with the voltmeter to form a multimeter. Therefore, the choice of ohmmeter should be determined by the resistance ranges available in the various multimeters. Small multimeters have a high range of $R \times 100$; larger multimeters, such as the AN/PSM-4, have a high range of $R \times 10,000$. VTVM TS-505A/D has a high range of $R \times 1,000,000$ and should be used where high values of resistance must be measured. When it is necessary to have high accuracy in the measurement of resistance, it is necessary to use a balanced-bridge instrument.

WHEATSTONE BRIDGE

Resistance measurements made by the ohmmeter method are not always sufficiently accurate. This inaccuracy is caused by an error in meter movement and in the reading of the meter. Therefore another device that is widely used for precise resistance measurements is the Wheatstone bridge. A bridge circuit is shown in figure 3-4.

In this circuit R_1 , R_2 , and R_3 are resistors of known values, and R_x is the resistance to be measured. In most bridges, R_1 and R_2 are adjusted in ratios of 1 to 1, 10 to 1, 100 to 1, etc., and R_3 is adjusted in small steps. When measuring the resistance of R_x , R_3 is adjusted

until the galvanometer reads zero. When the galvanometer reads zero, points A and B are at the same potential. This also means that the voltage drop across R_1 is equal to the voltage drop across R_2 . Similarly the voltage drop across R_x must be equal to the voltage drop across R_3 . From this we can see that the ratio of the resistor values allow us to find the value of R_x . The formula for finding the value of unknown resistor R_x , using a Wheatstone bridge, is

$$\frac{R_x}{R_1} = \frac{R_3}{R_2}$$

or

$$R_x = \frac{R_1 \times R_3}{R_2}$$

The dials on the adjustment panel of a Wheatstone bridge indicate values R_1 , R_2 , and R_3 .

DC VOLTMETER

The selection of a dc voltmeter is normally based on the sensitivity of the meter movement and its effect on the circuit being tested. Meter sensitivity is discussed in *Navy Electricity and Electronics Training Series (NEETS)*.

A multimeter having low sensitivity may be used for quick, rough readings where approximations are adequate. When a high degree of accuracy is desired, a meter having high sensitivity is required. Such a meter has wide application in the maintenance of medium- and high-impedance electronic circuits found in aviation electrical/instrument systems.

A vacuum tube voltmeter, because of its high input impedance, is the ideal instrument for measuring low voltage in oscillators, automatic gain control, automatic frequency control, and other electronic circuits sensitive to loading. When measuring voltages in excess of 500 volts, a multimeter having a sensitivity of 20,000 ohms per volt has an input impedance comparable to most vacuum tube voltmeters. This can be proven by comparing input impedances of the two types of meters. The input impedance of most vacuum tube voltmeters is between 3 and

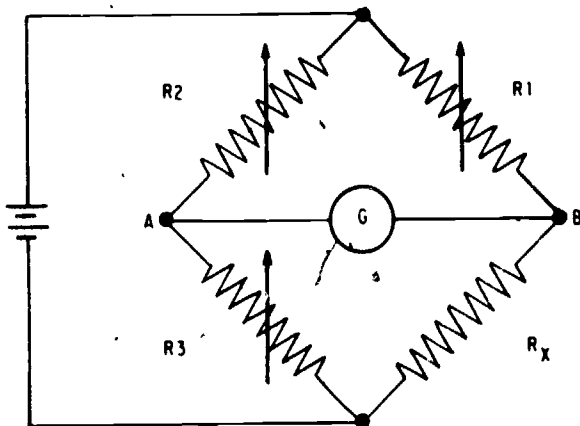

Figure 3-4.—Bridge circuit.

207.236

10 megohms. A 20,000-ohm-per-volt meter when reading a voltage of 500 volts, has an input impedance of $500 \times 20,000$ or 10 megohms. Therefore, on the 500-volt scale a multimeter of this sensitivity has an input impedance at least equal to the vacuum tube voltmeter. For voltage readings over 500 volts, a 20,000-ohms-per-volt multimeter offers an input impedance higher than the vacuum tube voltmeter.

Any multirange voltmeter, though its sensitivity may not exceed 1,000 ohms per volt, can be used to obtain fairly reliable readings in a dc circuit. If the impedance of the circuit being tested is not known, a comparison of two voltage readings, one on the lowest usable range and the other on the next higher range will indicate if the meter is having a loading effect on the circuit. If the two readings are approximately the same, the meter is not causing appreciable voltage variations, and the higher readings may be accepted as the true voltage. If the two readings differ considerably, the true voltage may be found by the following formula:

$$E = \frac{E_2 \cdot E_1}{\frac{E_1 R}{E_2} - 1} + E_2$$

where

E is the true voltage

E_1 is the lower of the two voltage readings

E_2 is the higher of the two voltage readings

R is the ratio of the higher voltage range to the lower voltage range

To illustrate the application of the correction formula, the following conditions are assumed:

1. A reading of 22 volts was obtained between two terminals with the meter on the 0-30 volt scale

2. A reading of 82 volts was obtained from the same terminals when the meter was switched to the 0-300 volt scale

The true voltage may be found as follows:

$$E = \frac{82 \cdot 22}{\frac{22 \times 10}{82} - 1} + 82$$

$$E = 117.7 \text{ volts}$$

MULTIMETER

The multimeter combines a voltmeter, ammeter, and ohmmeter in one unit. It includes all the necessary switches, jacks, and additional devices arranged in a compact, portable case utilizing one meter movement. Figure 3-5 illustrates a schematic diagram of a typical multimeter circuit. The permanent-magnet, moving-coil meter mechanism is direct-current responding only. To adapt this mechanism for measuring alternating current and voltages, a rectifier or a thermal converter for RF (radio frequency) voltages must be used to convert the alternating current to direct current.

At this point it is important to consider how the calibration of the meter is affected by the use of a rectifier. Waveforms of various shapes have different average and effective values. Since this type of meter mechanism responds only to the average value, the shape of the waveform must be taken into consideration when the meter is calibrated for effective value. Thus, the meter reading is correct only on waveforms for which the meter was originally calibrated. In this respect, the instrument has a definite limitation because waveforms may vary considerably in conventional circuits. For example, the sine-wave voltage response of a half-wave rectifier is 32 percent of maximum for the average value, and 50 percent for the effective value. The full-wave rectifier response is 64 and 71 percent, respectively. In the design of the meter, these values are taken into consideration, and the scales are plotted to read in effective units when calibrated against an accurate standard.

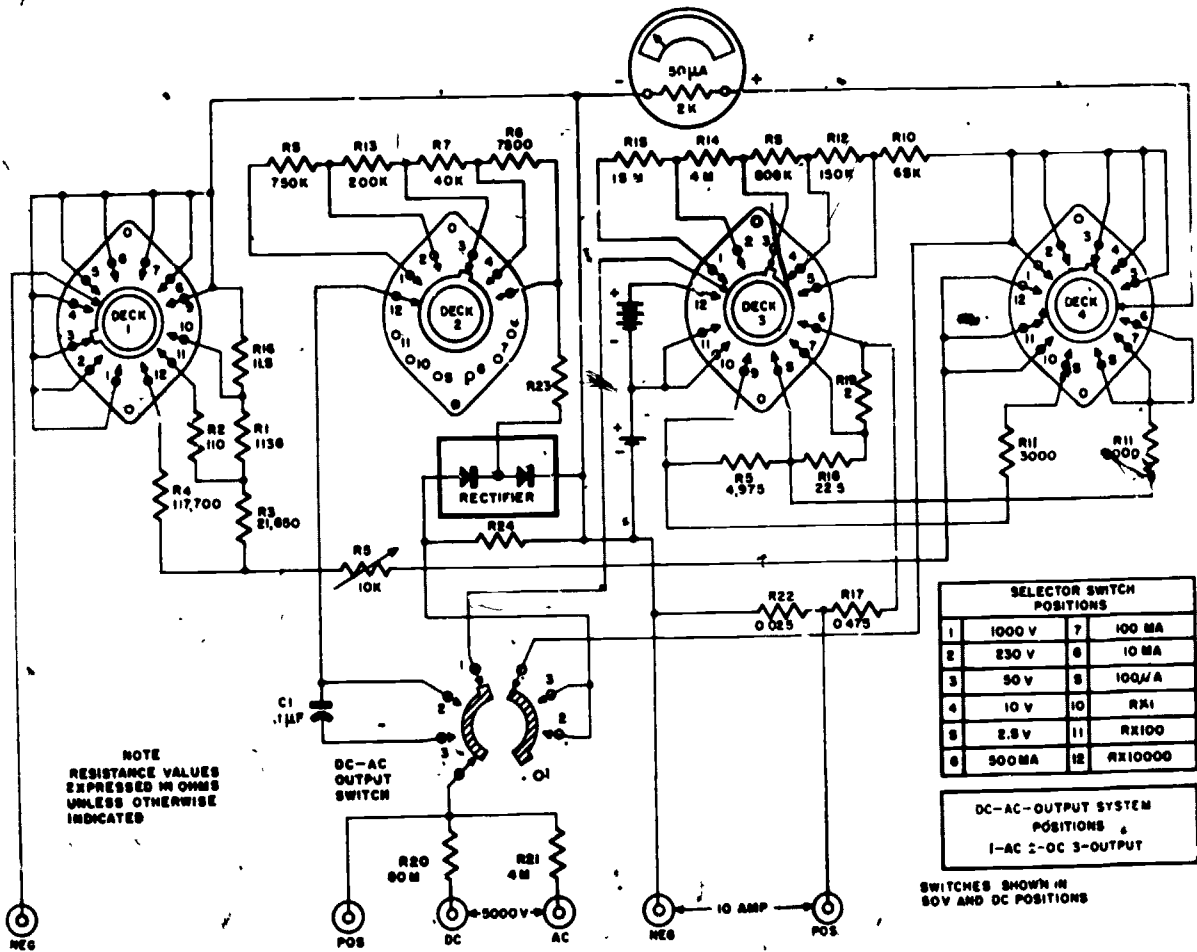

207.237

Figure 3-5.—Schematic diagram of a typical multimeter.

VACUUM TUBE VOLTMETER

The ordinary voltmeter has several disadvantages that make it practically useless for measuring voltages in high-impedance circuits. For example, suppose that the plate voltage of a pentode amplifier is to be measured. (See fig. 3-6.) When the meter is connected between the plate and cathode of the electron tube, the meter resistance, R_m , is placed in parallel with the effective plate resistance, R_{eff} , thereby lowering the effective plate resistance. The effective plate resistance is in series with the plate-load resistor, R_L , and this series circuit appears to the supply voltage, E_{bb} , as a voltage divider.

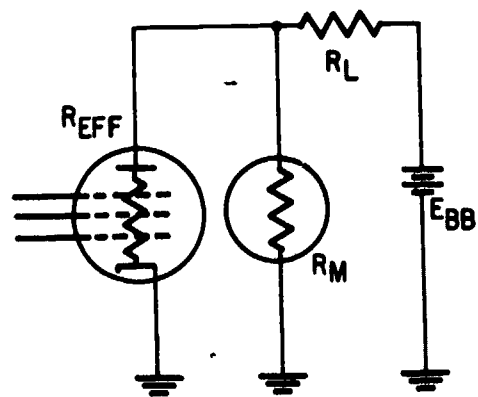

207.238

Figure 3-6.—Shunting effect of meter resistance.

Since the overall resistance is lowered, the current through R_L increases, the voltage drop across R_L also increases, and the voltage drop across R_{eff} decreases. The result is an incorrect indication of plate voltage.

Before the voltmeter is connected, the plate current is determined by the effective resistance of the plate circuit, the plate-load resistor, and the plate voltage. If the tube has an effective resistance of 100,000 ohms, R_L is 100,000 ohms, and the plate power supply is constant at 200 volts, then the plate current is $200\text{v}/200,000$ ohms, or 0.001 ampere. The plate voltage (plate to cathode) is $0.001 \times 100,000$, or 100 volts.

Assume that the voltmeter used to measure the plate voltage of the tube has a sensitivity of 1,000 ohms per volt and that the selected meter range is from 0 to 250 volts. The meter then has a resistance of 250,000 ohms. This resistance in parallel with the tube resistance of 100,000 ohms produces an effective resistance of 71,400 ohms in series with the plate-load resistor. The total resistance across the B supply is therefore 171,000 ohms instead of the 200,000 ohms before the meter was applied, and the current through the plate-load resistor is $200 \text{ v}/171,400$ ohms, or 0.00117 ampere.

Across the plate-load resistor, the voltage drop is $0.00117 \times 100,000$ or 117 volts, and the plate-to-cathode voltage on the tube is 200-117, or 83 volts when the meter is connected. Thus, an error of 17 volts (17 percent in this case) results. The lower the sensitivity of the meter, the greater this error will be.

A meter having a sensitivity of 20,000 ohms per volt and a 250-volt maximum scale reading would introduce an error of about 1 percent. However, in circuits where very high impedances are encountered, such as in grid circuits of electron tubes, even a meter of 20,000-ohms-per-volt sensitivity would impose too much of a load on the circuit.

Another limitation of the nonelectronic voltmeter is the shunting effect of the metallic-oxide rectifier used in the ac measuring section of the meter. Due to the large

capacitance of the rectifier plates this shunting effect becomes more pronounced as measured frequencies go up. As pointed out previously, the metallic-oxide rectifier is limited to frequencies up to 20,000 Hz.

This shunting effect may be greatly reduced by replacing the metallic-oxide rectifier with an electron tube rectifier. The rectified and filtered output of the diode is then applied to an amplifier tube that drives the meter. Such a device is called a vacuum tube voltmeter, usually abbreviated VTVM. Figure 3-7 shows a schematic diagram of a VTVM.

The input impedance of a VTVM is large, and therefore the current drawn from the circuit whose voltage is being measured is small, and in most cases negligible. This enables the AE to measure a voltage in a high-impedance circuit without danger of excessively loading the circuit and introducing errors in the reading. Table 3-2 shows the relative circuit loading effect of a nonelectronic voltmeter as compared with that of an electronic voltmeter.

MEGGER

A megger is an instrument that applies a high voltage to the component under test and measures the current leakage of the insulation. Thus a capacitor or insulated cable can be checked for leakage under much higher voltages than an ohmmeter is capable of supplying. It consists of a hand-driven, dc generator and an indicating meter. The name megger is derived from the fact that it measures resistances of many megohms.

There are various resistance ratings of meggers with full scale values as low as 5 megohms, and as high as 10,000 megohms. The first scale marking below infinity represents the highest value for which the instrument can be accurately used. Thus, if the pointer goes to infinity when making a test, it means only that the resistance is higher than the range of the set.

There are also various voltage ratings of meggers (100, 500, 750, 1,000, 2,500, etc.). The most common type is the one with a 500-volt

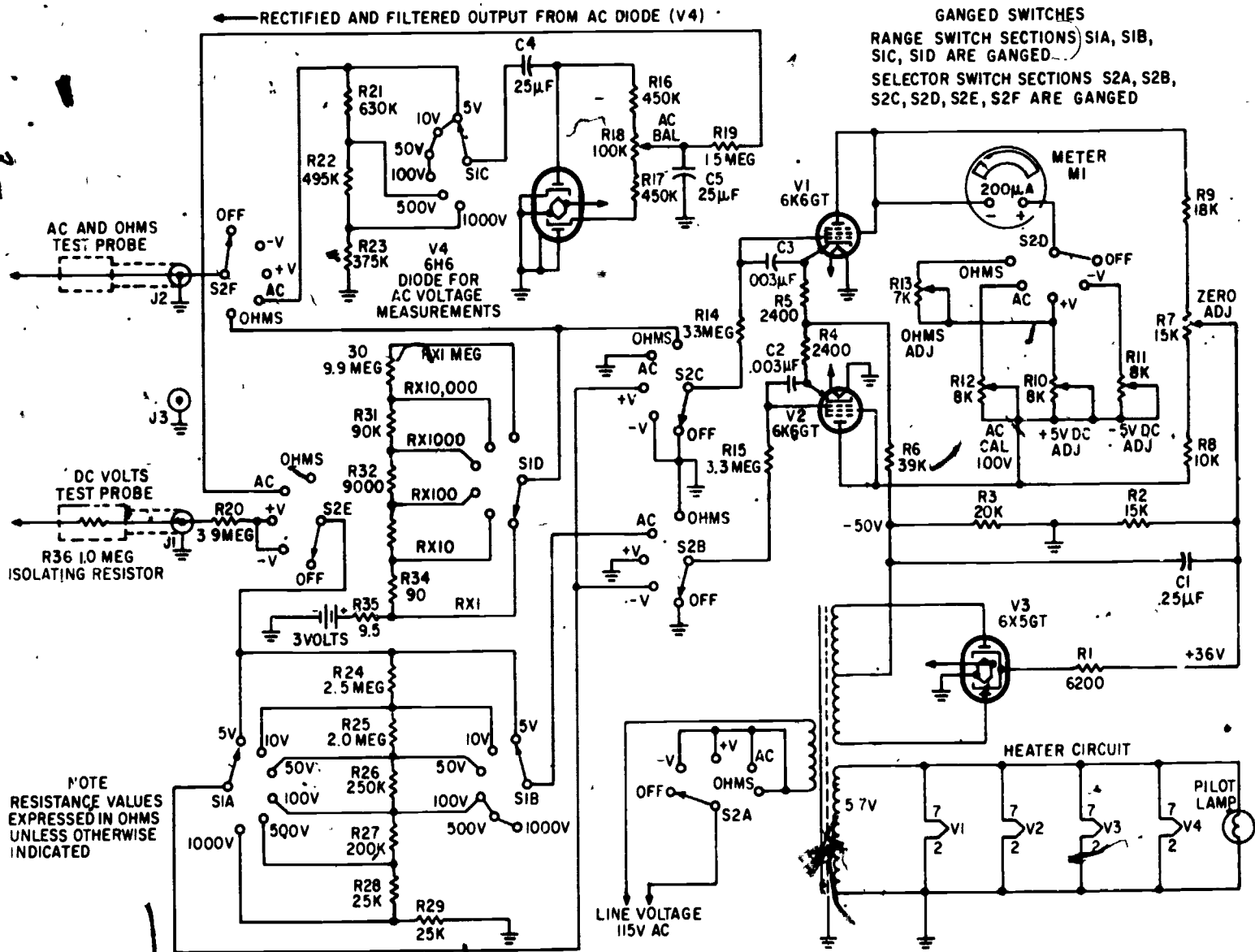

Figure 3-7.—Schematic diagram of a VTVM.

207.239

AVIATION ELECTRICIAN'S MATE 3 & 2

Table 3-2.—Circuit loading effect-VTVM vs. nonelectronic voltmeter

Range (volts)	Input resistance		Circuit loading effect
	VTVM	Nonelectronic voltmeter*	
5	10 megohm	0.1 megohm	Nonelectronic voltmeter 100 times that of VTVM.
10	10 megohm	0.2 megohm	Nonelectronic voltmeter 50 times that of VTVM.
50	10 megohm	1.0 megohm	Nonelectronic voltmeter 10 times that of VTVM.
100	10 megohm	2.0 megohm	Nonelectronic voltmeter 5 times that of VTVM.
500	10 megohm	10.0 megohm	Nonelectronic voltmeter same as as that of VTVM.
1,000	10 megohm	20.0 megohm	Nonelectronic voltmeter one-half that of VTVM.

*Nonelectronic voltmeter = 20,000-ohm-per-volt type.

rating. This voltage rating refers to the maximum output voltage of the megger. The output voltage is dependent upon the turning speed of the crank and armature. When the megger's armature rotation reaches a predetermined speed, a slip clutch maintains the armature at a constant speed. The voltage rating is important, for the application of too high a voltage to even a good component will cause a breakdown. Therefore, the AE must not use a megger to test a circuit or component whose breakdown voltage is below the voltage produced by the megger.

Meggers are used to test the insulation resistance of conductors in which shorting or breaking down under high voltage is suspected. In some situations, meggers are used in the prevention of unnecessary breakdowns by maintaining a record of insulation resistance of power and high voltage cables, motor and generator windings, and transmission lines. These records will reflect fluctuations in resistance and aid in determining when the components should be replaced to prevent a breakdown.

Meggers are used for testing capacitors whose peak voltages are not below the output of the megger. They are also used for testing for high resistance grounds or leakage on such devices as antennas and insulators.

Precautions to be followed in the use of the megger are:

1. When making a megger test the equipment must not be energized.
2. Observe all rules for safety in preparing equipment for test and in testing, especially when testing installed high voltage apparatus.
3. Use well-insulated test leads, especially when using high range meggers. After the leads are connected to the instrument and before connecting them to the component to be tested, operate the megger and make sure there is no leak between the leads. The reading should be infinity. Make certain the leads are not disconnected or broken by touching the test ends of the leads together while turning the crank slowly. The reading should be zero.
4. When using high voltage meggers, take proper precautions against electric shock. There

is a sufficient amount of capacitance in most electrical equipment to "store up" sufficient energy from the megger generator to give a very disagreeable and even dangerous electric shock. The megger has a high protective resistance and its open circuit voltage is not as dangerous, but care should be exercised.

5. In order to avoid the danger of receiving a shock, equipment having considerable capacitance should be discharged before and after making megger tests. This can be accomplished by grounding or short circuiting the terminals of the equipment under test.

OSCILLOSCOPE

An oscilloscope is a versatile instrument used in viewing wave shapes of voltages or currents, it is capable of giving information concerning frequency values, phase differences, and voltage amplitudes. It is also used to trace signals through electronic circuits to localize sources of distortion and to isolate troubles to particular stages.

The majority of oscilloscopes used for test and other measurements contain a basic presentation unit (screen) and accessory units such as amplifiers, synchronizing circuits, time-delay circuits, and sweep oscillators. These circuits are used to display a stationary pattern on the cathode-ray tube. The sensitivity of an oscilloscope should be adequate for the smallest signals to have sufficient amplitude to be displayed on the screen.

The cathode-ray tube, the oscilloscope, and their operation are discussed in detail in *NEETS*.

TIME-DOMAIN REFLECTOMETRY

Time-domain reflectometry (TDR) is a measurement concept beginning to be widely used in the analysis of wideband systems. The art of determining the characteristics of electrical lines by observation of reflected waveforms is not new. For many years power-transmission engineers have located discontinuities in power-transmission systems by sending out a pulse and monitoring the

reflections. Discontinuity is defined as any abnormal resistance or impedance that interferes with normal signal flow.

TDR is particularly useful in analyzing coaxial cables such as those used in fuel or oxygen quantity indicating systems. The amplitude of the reflected signal corresponds directly to the impedance of the discontinuity, and the distance to the discontinuity can be determined by measuring the time required for the pulse to travel down the line to the reflecting impedance and back to the monitoring oscilloscope.

The TDR analysis consists of the insertion of a step or pulse of energy into a system and the subsequent observation, at the point of insertion, of the energy reflected by the system. Several arrangements are possible, but the following procedure is used with the newer, specialized reflectometers. (See fig. 3-8.) A fast (or incident) step is developed in the pulse generator. This step then passes through a TEE connector and is sent into the system under test. The sampling oscilloscope is also attached to the TEE connector, and the incident step, along with the reflected waveform, are displayed on the CRT. Analysis of the magnitude, duration, and shape of the reflected waveform indicates the type of impedance variation in the system under test.

PHASE ANGLE VOLTMETER

The overall accuracy of many electronic components is determined by measuring phase

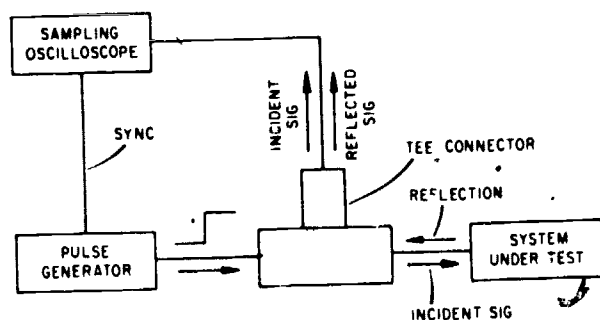

229.21

Figure 3-8.—Typical time domain reflectometer.

angles in computing transformers, computing amplifiers, and resolver systems. In the past, one of the most common methods used for measuring phase shift or phase angles between signals was observing patterns on an oscilloscope. With this method, it was hard to determine small angles, and difficult to translate various points into angles and sines of angles. The most limiting factor in using oscilloscope patterns developed when one of the signals contained harmonic distortion or noise.

In any complex waveform containing a fundamental frequency and harmonics, measuring phase shifts presents problems. In most applications, interest lies in the phase relationship of the fundamental frequencies, regardless of any harmonics which may be present. One of the requirements of a phase measuring device is to measure the phase difference between two discrete frequencies, regardless of the phase and amplitude of other components of the waveform.

The basic block diagram of a phase angle voltmeter is shown in figure 3-9. There are two inputs—the signal and the reference. Both channels contain filters which pass only the fundamental frequency. Harmonics are highly attenuated. Each channel has a variable amplitude control and amplifiers to increase the variety of signals that can be checked.

A calibrated phase shifter is inserted into the reference channel; that channel signal can be phase shifted to correspond to the other channel. This is detected in the phase detector and observed on the meter.

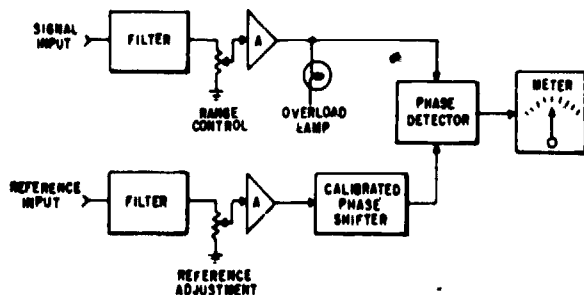

208.231

Figure 3-9.--Phase angle voltmeter, Block diagram.

The calibrated phase shifter is made up to a switch (whose position corresponds to the 0° , 90° , 180° , and 270° phase shift) and a potentiometer (whose dial is calibrated from 0° to 90°). The total phase shift is made up of the sum of the two readings.

The phase detector is a balanced diode bridge type demodulator. Its output is proportional to the signal amplitude times the cosine of the angle of phase difference between the signal input and the reference input.

If the reference input is phase shifted until it is in phase or 180° out of phase with the signal input, the output from the phase detector is proportional to the signal input amplitude (the cosine of the angle is unity). If the reference input is phase shifted until it is 90° out of phase with the signal input, the phase detector output is zero (the cosine of the angle is zero).

The point at which the two signals are in phase or 180° out of phase is the point of maximum deflection on the meter. The difference between the in-phase and the 180° out-of-phase points is in the direction in which the needle swings—not the distance it swings. As the point of maximum deflection is approached, the rate of change of the meter reading decreases because the cosine has a small rate of change near 0° . This makes it difficult to read the exact point of maximum deflection.

Because the cosine has a maximum rate of change as it approaches 90° and thus gives a better indication on the meter, most commercial voltmeters are set to determine the point at which the signals are 90° out of phase—"quadrature." When the voltmeter is set for this point, there must be some way of converting the phase shifter reading so that it shows the correct amount of phase shift rather than 90° more or less than the actual amount. Some confusion exists in this area because different manufacturers have different methods of determining the signal quadrant. Manufacturers also differ on whether the final reading is a leading or a lagging phase shift. This means the electrician must be familiar with as many types of phase angle voltmeters as the Navy has in the field. It cannot be assumed that the method used to determine phase angle on one type of meter can be used on another; nor

can it be assumed that, because one meter gives a leading angle between signal and reference waveforms, another manufacturer's meter also gives leading phase shift.

DIFFERENTIAL VOLTMETER

The differential voltmeter is a reliable precision item of test equipment. Its general function is to compare an unknown voltage with an internal reference voltage, and to indicate the difference in their values.

The differential voltmeter 803D/AD can be used as an electronic voltmeter, as a precision potentiometer, and as a megohmmeter. It can also be used to measure the excursions of a voltage about a reference value. Ease of operation, inherent protection from any accidental overload, and high reliability of readings are additional advantages of the instrument. It is accurate enough for precision work in calibration laboratories, yet rugged enough for general shop use.

AIRCRAFT WIRE AND CABLES

An important part of aircraft electrical maintenance is determining the correct wire or cable for a given job. For purposes of electric installations, a wire is described as a stranded conductor, covered with an insulating material. The term cable, as used in aircraft electrical installation, includes the following: two or more insulated conductors contained in the same jacket (multiconductor cable); two or more insulated conductors twisted together; one or more insulated conductors covered with a metallic braided shield (shielded cable); a single insulated center conductor with a metallic braided outer conductor (RF cable). See Fig. 3-10.

WIRE REPLACEMENT

For wire replacement work, the aircraft's Maintenance Instructions Manual should first be consulted since it normally lists the wire used in a given aircraft. When this information cannot

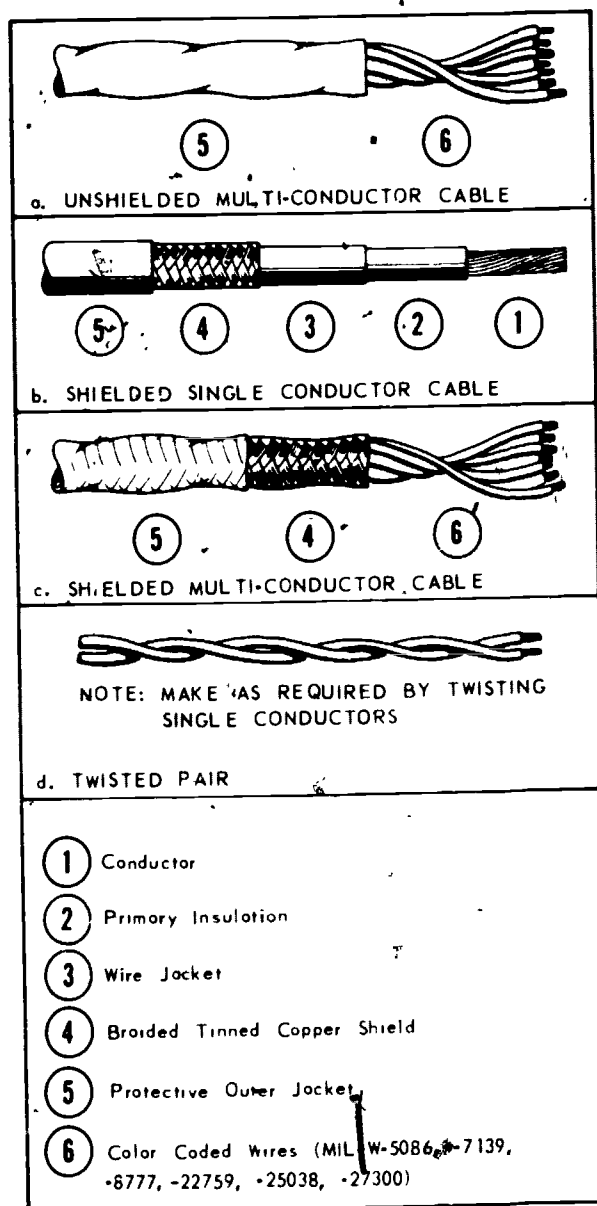

Figure 3-10.—Cables commonly used in aircraft.

be obtained from the manual, the AE must select the correct size and type of wire needed. The factors used in determining correct wire size are explained in *NEETS* and *Installation Practices for Aircraft Electric and Electronic Wiring, NAVAIR 01-1A-505*. The procedures specified in the latter publication are mandatory for the maintenance of naval aircraft; therefore,

AVIATION ELECTRICIAN'S MATE 3 & 2

it is important that the AE becomes familiar with this publication.

The information given in these two publications plus that given in Military Specification MIL-W-5088 (Series) should enable the AE to make the correct selection. The data necessary to determine the correct wire for a given application may be summarized as follows:

1. Current drawn by the load.
2. Length of wire required to go from the source to the load.

3. Allowable voltage drop between the source or point of voltage regulation and the load.

4. The maximum voltage that is applied to the wire.

5. The approximate ambient air temperature where the wire is installed.

6. Whether the conductor is a stranded wire in free air or one of a group of wires in a bundle or in a conduit.

Table 3-3 shows the current-carrying capacity of copper and aluminum wires and cables.

Table 3-3.—Current carrying capacity of wires and cables

Wire or cable size (American Wire Gage)		Continuous-duty current—amperes	
Aluminum	Copper	Single wire in free air	Wires and Cables in conduit or bundles
	22	5
	20	11	7.5
	18	16	10
	16	22	13
	14	32	17
	12	41	23
	10	55	33
	8	73	46
	6	101	60
	4	135	80
	2	181	100
	1	211	125
	0	245	150
	00	283	175
	000	328	200
	0000	380	225
8	60	36
6	83	50
4	108	66
2	152	82
1	174	105
0	202	123
00	235	145
000	266	162
0000	303	190



Wire Selection and Characteristics

After the wire size has been determined, the characteristics of its insulation should be considered. The following descriptions of the various military specifications will help in selecting the correctly insulated wire for a specific need. These military specification numbers are given on the reel, spool, or shipping container.

MIL-S-5086 (Series) single conductor copper wire (600 volts) is general-purpose wire and is the one most commonly used in aircraft wiring systems. It consists of a stranded copper conductor with insulation that is resistant to abrasion, moisture, and aircraft engine oils, and also partially resistant to flame and fungus. The voltage rating of the insulation is 600 volts maximum. Temperature limits are conductor temperature rating 220°F and ambient temperature rating 135°F.

MIL-W-7072 (Series) aluminum single conductor wire (600 Volts) is made up of stranded aluminum conductors and is covered with an insulation that has the same properties as that on MIL-W-5086 (Series) wire. Aluminum wire has 1.6 times the resistivity of copper, but is only 1/3 as heavy. Temperature limits are conductor temperature rating 220°F and ambient temperature rating 150°F. This wire may be used only in NAVAIR approved applications.

MIL-W-22759/2B single conductor, high temperature wire (600 volts) is stranded insulated nickel coated copper wire, designed for continuous operation with the conductor's total temperature as high as 400°F and ambient temperature rating 310°F. Its insulation is designed to assure short-time emergency operation of electrical circuits in the event of fire, and to be resistant to abrasion, fuel oils, and moisture as encountered in aircraft. The strands of this wire are coated with pure silver.

MIL-C-7078 (Series) shielded single and multiconductor cable (600 volts) is available in two types. Type I is shielded and contains from 1 to 7 stranded conductors, each of which conforms to the conductor requirements described in MIL-W-5086 (Series). Type II has a

nylon jacket over the shield. With the exception of the shield, the insulation characteristics of this wire are identical to those for wires manufactured in accordance with MIL-W-5086 (Series).

MIL-C-25038 (Series) fire alarm detector wire (125 volts) is a type of stranded wire designed for use in fire detection systems in aircraft engines. It is highly resistant to flame due to its insulation of asbestos or glass braid. Insulation is rated at 125 volts, and will not break down at temperatures up to 650°F. It has relatively poor abrasion, moisture, and fuel oil resistance. Generally, fuel oils and moisture are not present where this type of wire is used.

MIL-C-3702 (Series) ignition, high-tension, single-conductor cable is a stranded, high-tension, insulated ignition cable for the ignition systems of internal combustion engines for aircraft, automotive vehicles, and marine service.

Aluminum Wire Properties

The use of aluminum wire in aircraft has been well established. Therefore, it is appropriate to review some of the unusual properties of aluminum.

Aluminum is unusual in that it forms an electrically resistant oxide film on all of its surfaces; it has an inherent property known as "creep" which makes proper installation of a terminal extremely critical. Creep is the tendency of aluminum to actually flow away from the point where pressure is applied. Aluminum is softer than copper, and reacts chemically when placed in direct contact with copper.

The electrically resistant aluminum oxide film is always present and must be either penetrated or removed in order to guarantee a satisfactory electrical connection. A specified compound is used to remove this film. Initially, tin-plated terminals and splices are supplied so that no oxide film is present. If the terminals have become dirty due to storage or excessive handling, they should be cleaned by wiping with a soft cloth. Never use a wire brush or any

abrasive method to clean a tinned aluminum surface.

One of the troublesome problems resulting from the use of aluminum wire is that caused by dissimilar metals. This problem occurs frequently when aluminum and copper are placed side by side. As soon as moisture accumulates between the two metals, an electrical differential exists which produces a "battery effect." This effect results in greater corrosion.

To reduce the undesirable effects caused by aluminum's softness, creep, and oxide film forming, these techniques should be followed:

1. Select the proper size of wire and terminals/splices. AL or ALUM is stamped on terminals and splices for use with aluminum wire.
2. Select the proper handtool when crimping.

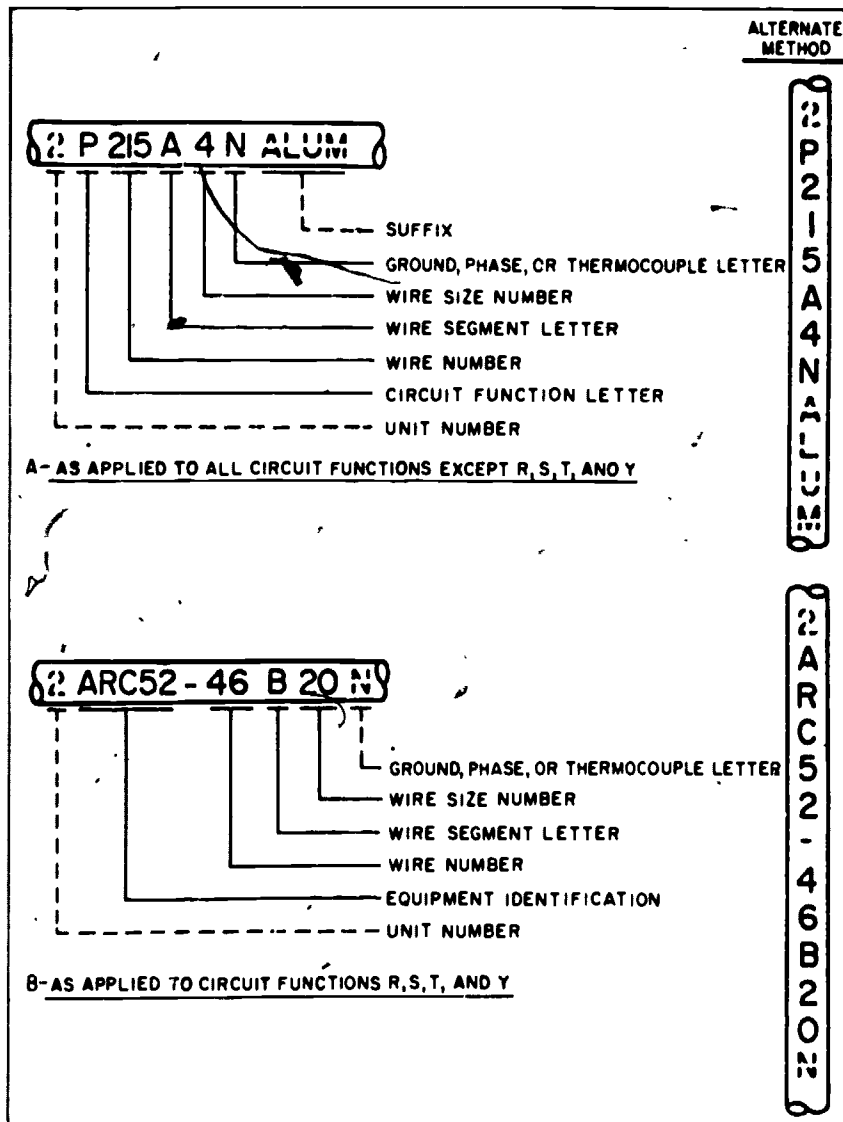

Figure 3-11.—Examples of wire identification coding.

207.393

3. Handle the aluminum wire carefully and use the proper assembly procedure when preparing it for an electrical connection.

4. Thoroughly clean any terminals used.

5. Be careful not to scrape or nick the wire when stripping.

CAUTION: Never cut aluminum wire with tools which have reciprocating motion, such as a hack saw. Reciprocating cutting action "work hardens" aluminum. This will lead to broken and torn strands.

WIRE IDENTIFICATION

The wire identification code for wires and cables having function letters "R", "S", "T", and "Y" is assigned by the equipment contractor as follows. The wire identification code is obtained by using that portion of the military type designation (AN nomenclature) following the slash (/) but excluding the hyphen and any suffix letters. The block of wire numbers for each equipment shall start with 1 and continue for as many numbers as are needed to identify all wires. For example, wires of the AN/APS-45 would be identified APS45-1A20-APS45-975C22, those of the AN/ARC-52A would be ARC52-1A22-ARC52-9C22, and the MX-94 would be the MX-94-1A20, etc. For equipment which a type designation (AN nomenclature) will not be assigned, such as commercial equipment, a block of numbers is obtained from the procuring activity.

Wire Marking

The identification code may be stamped on wires either horizontally or vertically, as shown in figure 3-11. The preferred method of identification is to stamp the identification marking directly on the wire or cable with a hot foil stamping machine. Use this method wherever possible. If the wire insulation or outer covering will not stamp easily, lengths of insulating tubing (sleeves) are stamped with the identification marking and installed on the wire

or cable. The following types of wire are usually identified by means of sleeves:

1. Unjacketed shielded wire
2. Thermocouple wires
3. Multiconductor cable
4. High temperature wire with insulation difficult to mark (such as asbestos, TFE, fiberglass, etc.)

CAUTION: Do not use metallic markers or bands for identification. Do not use any method of marking that will damage or deform the wire or cable.

Use sleeves only if wire cannot be marked directly. With care, some wires previously thought to be unsuitable for direct marking can be stamped with a standard marking machine using special foils.

Whatever method of marking is used be sure marking is legible, and that color of stamping contrasts with the wire insulation or sleeve. Use black stamping for light colored backgrounds. Use white on dark colored backgrounds. Make sure that markings are dry so they do not smear. Stamp wires and cables at intervals of not more than 15 inches along their entire lengths. (See figure 3-12.) In addition, stamp wires within

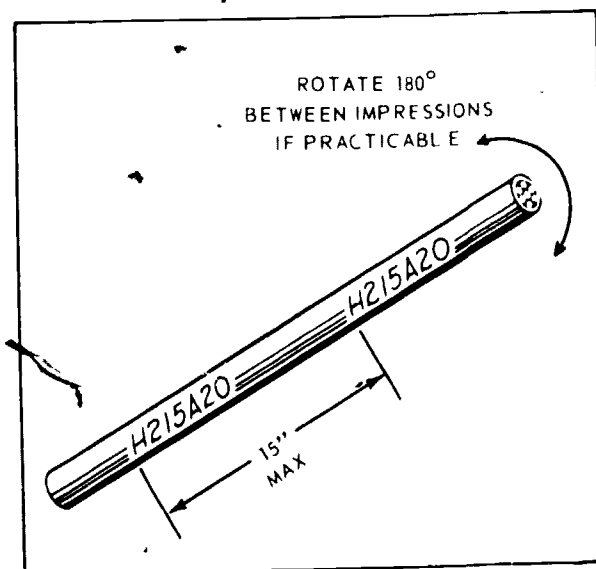

Figure 3-12—Spacing of identification stamping on wire and cable.

three inches of each junction (except permanent splices), and at each terminating point. Stamp wires which are three to seven inches long in the center. Wires less than three inches long need not be stamped.

Sleeving also is used to help protect connections against accidental shorting and moisture, and to lengthen the arc-over path between contacts. Insulating sleeves should not be used when connections or connectors are to be moisture-proofed by potting. It should not be used on connectors that are provided with a sealing grommet which covers the soldered connection.

Sleeving, commonly called spaghetti, has many applications in naval aviation. Some of the more common applications are for covering soldered connections, open bus bars, and permanent splices.

For general-purpose wiring, flexible vinyl sleeving, either clear or opaque, should be used. For high-temperature applications (160°F to 400°F), use silicone rubber or Fiberglass. Where resistance to synthetic hydraulic fluids or other solvents is necessary use nylon sleeving, either clear or opaque, for best results.

Wiring and Cable Identification Codes

To make maintenance easier, each of the connecting wires installed in an aircraft is marked with a combination of letters and numbers which identify the wire, the circuit to which it belongs, its gage size, and other information necessary to relate the wire to a wiring diagram. This marking is called the cable identification code. Identification of each wire is coded by a combination of letters and numbers imprinted on the wire at prescribed intervals along its entire run. The accompanying discussion explains the code used in aircraft wiring. Complete details are to be found in the latest revision of Wiring, Aircraft, Selection and Installation, MIL-W-5088.

NOTE: Stranded conductor wire is used for flexibility in installation and service. Wire sizes approximate American Wire Gage (AWG), but vary sufficiently so that it is improper to refer to aircraft wire as "AWG".

The basic wire identification code used for all circuits except those having the circuit function letters R, S, T, or Y is as follows, see fig. 3-11, reading from left to right.

1. Unit number: Where two or more identical items of equipment are installed in the same aircraft, the unit numbers "1", "2", "3", "4", etc., may be prefixed to differentiate between wires and cables when it is desired that the equipment have the same basic cable identification. To facilitate interchangeability requirements, identical wiring located in left and right wings, nacelles, and major interchangeable structural assemblies may have identical cable identification and the unit number is not required. The unit number for circuit functions "R", "S", "T", and "Y", are used only where duplicate complete equipment are installed, and do not apply to duplicate components within a single complete equipment such as duplicate indicators or control boxes.

2. Circuit function letter (except R, S, T, and Y). The circuit function letter is used to identify the circuit function specified in table 3-4. Where a wire or cable is used for more than one circuit function, the circuit function letter of that circuit which is functionally predominant applies. When functional predominance is questionable, the circuit function letter for the wire or cable having the lowest wire number is used.

3. Wire number: The wire number consisting of one or more digits is used to differentiate between wires in a circuit. A different number shall be used for wire not having a common terminal or connection, as follows:

a. Wires with the same circuit function having a common terminal connection or junction have the same wire number but different segment letters.

b. Numbers 2,000 to 4,999, inclusive, are reserved for use by the procuring activity to identify wires installed by service modifications, except for those wires with circuit function letters of R, S, T, and Y.

Chapter 3 - ELECTRICAL MAINTENANCE AND TROUBLESHOOTING

Table 3-4.—Wiring circuit function code

Circuit function letter	Circuits
A	Armament
B	Photographic
C	Control surface
D	Instrument
E	Engine instrument
F	Flight instrument
G	Landing gear, wing folding
H	Heating, ventilating, and de-icing
I	Ignition
K	Engine control
L	Lighting
M	Miscellaneous
P	D-c power Wiring in the d-c power or power control system is identified by the circuit function letter P.
Q	Fuel and oil
R	Radio (navigation and communication) RN—Navigation RP—Special systems RZ—Interphone, headphone
S	Radar SA—Altimeter SN—Navigation SQ—Bombing SR—Recorder SS—Search
T	Special electronic TE—Countermeasures TN—Navigation TR—Receivers TX—Television transmitters TZ—Bombing devices
V	D-c power and d-c control wires for a-c systems are identified by the circuit function letter V.
W	Warning and emergency
X	A-c power Wiring in the a-c power system is identified by the circuit function letter X.
Y	Armament special systems

c. Beginning with the lowest number, a number is assigned to each wire in numerical sequence, insofar as practicable.

4. Wire segment letter: A wire segment is a conductor between two terminals or connections. The wire segment letter is used to differentiate between conductor segments in a particular circuit. A different letter is used for wire segments having a common terminal or connection. Wire segments are lettered in alphabetical sequence. The letter "A" identifies the first segment of each circuit starting at the power source. If a circuit contains only one wire segment, the wire segment is marked "A". The letters "I" and "O" are not used as segment letters. Double letters "AA", "AB", "AC", etc., are used when more than 24 segments are required. Two permanently spliced wires do not require separate segment letters if the splice is used for modification or repair.

5. Wire size number: The wire size number is used to identify the size of the wire or cable. For coaxial cables and thermocouple wires, the wire size number is not included. For thermocouple wires, a dash (-) is used in lieu of the wire size number.

6. Ground, phase, or thermocouple letter(s).

a. Ground cable letter "N" is used as a suffix to the wire identification code to identify any wire or cable that completes the circuit to the ground network. Such wires and cables shall be capable of being connected to the ground network of aircraft electrical systems without causing malfunctioning of any circuit. For critical and sensitive electronic systems which have interconnecting "ground" leads, but only one segment actually grounded to structure, only the segment actually grounded to structure is identified with the "N" suffix.

b. Phase letter "A", "B", or "C" shall be used as a suffix on the wire identification code to identify the phase or wires that is in the three-phase power distribution wiring of AC systems. The phase sequence shall be "A-B-C".

c. Phase letter "V" shall be used as a suffix on the cable identification code to identify the ungrounded wire or cable that is in a single-phase system.

d. For thermocouple wire, the following suffixes shall be used as applicable:

CHROM—Chromel CONS—Constantan

ALML—Almuel COP—Copper

IRON—Iron

7. Suffix (when required). When aluminum wire is used, ALMUNINUM or ALUM shall be added to the identification code.

CABLE STRIPPING AND HEAT SHRINKABLE TUBING

Nearly all wire and cable used as electrical conductors are covered with some type of insulation. In order to make electrical connections with the wire, a part of this insulation must be removed, leaving the end of the wire bare. To facilitate the removal of this insulation, use a wire and cable stripping tool similar to the one shown in figure 3-13.

Although several variations of this basic tool are available, the most efficient and effective is the type illustrated. Its operations is extremely simple—insert the end of the wire in the proper direction to the depth, to be stripped, position the wire so that it rests in the proper groove for that size wire, and squeeze. The tool functions in three steps as follows:

1. The cable gripping jaws close, clamping the insulated wire firmly in place. The wire must be inserted so that the jaws clamp the main section of the wire rather than the end to be stripped.

2. The insulation cutting jaws close, cutting the insulation. If the wire is not inserted in a groove, the conductor will also be cut. If the wire is positioned into too small a groove, some of the strands will be severed. If the groove is too large, the insulation will not be completely severed. Inserted properly into the correct groove, the insulation will be cut neatly and completely, and the wire will not be damaged.

3. The two sets of jaws separate, removing the clipped insulation from the end of the wire.

Heat-shrinkable tubing is a plastic like tubing (similar to insulation sleeving) that will shrink to a smaller diameter when proper heat is applied. The tubing is applied by placing a section of it over the joint, terminal, or part to be covered and is then heated with a heat gun, oven, or other appropriate heat source.

When the tubing reaches a specific temperature ("shrink temperature," a value which depends upon the type of tubing), it will quickly shrink around the object, forming a snug jacket over it. In addition to being an insulator, the shrinkable tubing aids in strain relief and in waterproofing.

MAINTENANCE OF MOTORS

Since most motors are installed in sections of the aircraft not accessible during flight, the first indication of motor trouble in many instances is complete failure.

Most problems with motors can be located during scheduled maintenance. Ensure that the motor is mounted securely. Inspect the mechanical linkage for proper alignment and security. The electrical connection to the motor should be secure and clean. Check for signs of corrosion. Make sure that proper voltage is supplied.

The exposed portion of windings should be inspected for evidence of overheating. If the insulation on the windings or leads is cracked and brittle, replace the motor. Connect the motor to the proper voltage supply for the final check. If, when the motor is operating, an odor of burned insulation is evident, or if smoke or excessive noise is observed, the motor should be replaced.

When dismantling a motor, the bearings should be removed carefully, wiped clean, and wrapped in clean oil paper until needed during reassembly.

In the inspection of ball bearings, the assembly is slowly rotated. Bearings showing pronounced stickiness or bumpy operation should be replaced. During inspection of bearing assemblies, check for the presence of cracks, pitted surfaces, and any physical damage present in bearing elements.

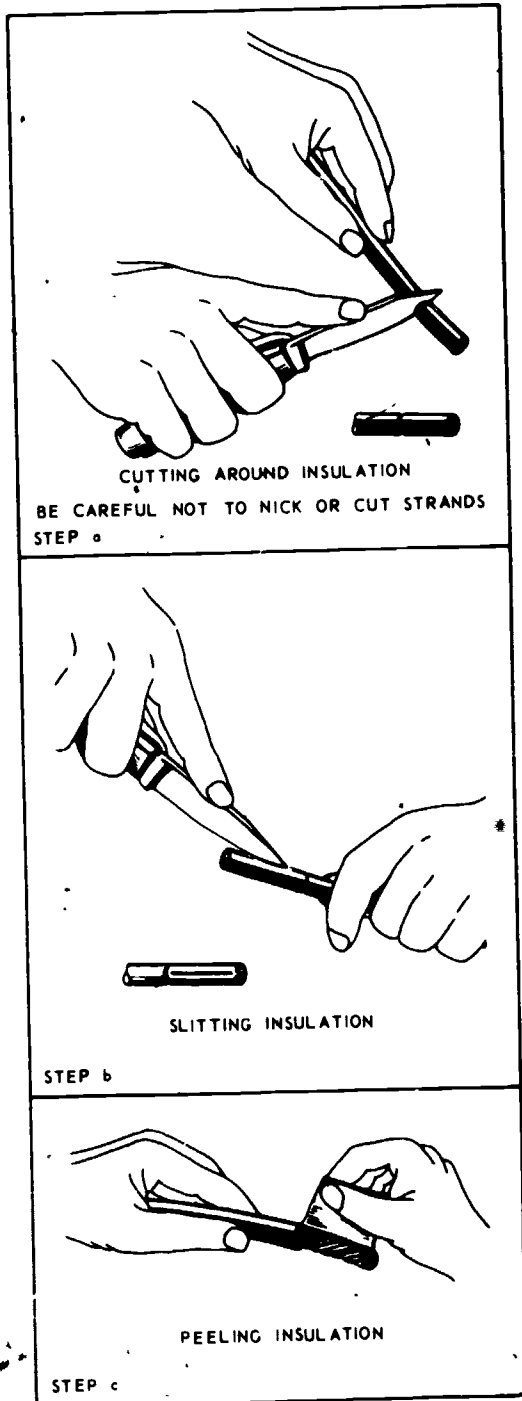
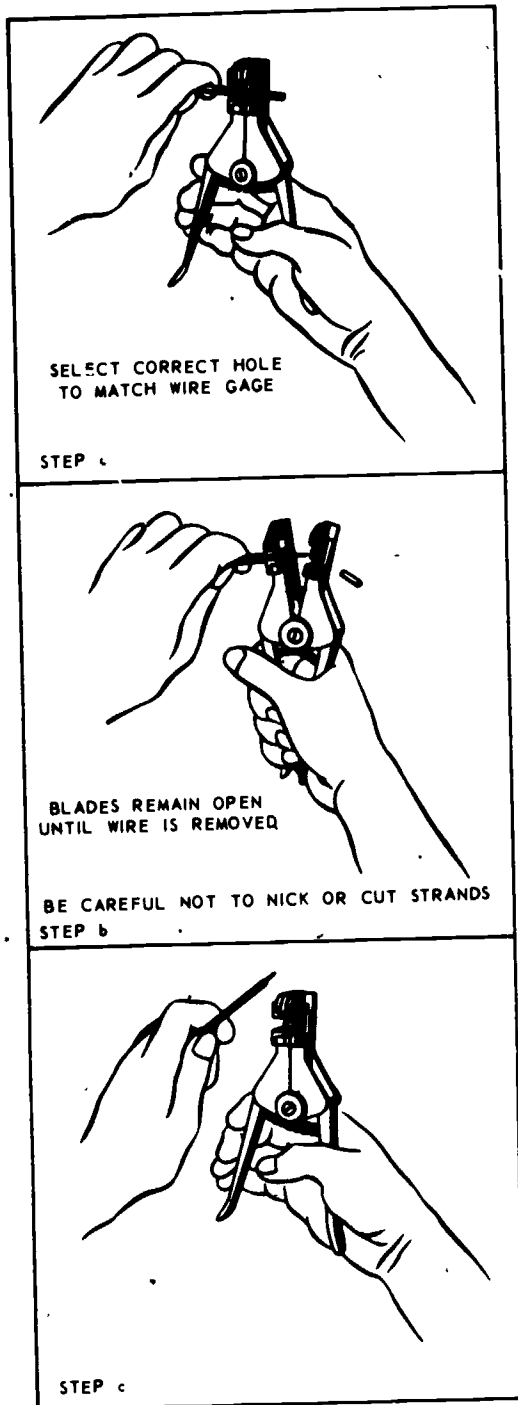

Figure 3-13.—Wire stripping methods.

Antifriction bearings may be either of the ball or the roller types, both of which are widely used in rotating electrical equipment. Many modern electrical motors are equipped with sealed bearing assemblies. The maintenance of these bearings is very easy since they are prelubricated and require almost no attention during the normal life of the motor in which they are installed. When cleaning motors with sealed bearings, never immerse the sealed bearings in the cleaning solvent. To do so will remove some of the prepacked lubricant.

As a guide to proper maintenance of ball or roller bearings in rotary equipment, the detailed recommendations of the manufacturer as given in the Service Instruction Manual should always be followed. As an example of a general maintenance procedure, consider the following directions, which are taken from a manufacturer's instructions pertaining to a small motor containing standard ball bearings.

The bearings used in this motor normally are replaced with new bearings whenever abnormal conditions occur. However, in the event that replacements are not available, the bearings may be cleaned and relubricated as follows.

1. Wipe the outside of the bearings clean, using a clean cloth.
2. Wash the bearing thoroughly in a dry-cleaning solution.
3. Blow with compressed air until the assembly is dry. Care should be taken not to rotate the bearings while washing or drying.
4. Relubricate by packing the bearing full with the lubricant recommended by the manufacturer.
5. With a clean wooden stick, dig out any grease that can be removed from between the balls on both sides of the bearing assembly. This will leave the bearing about 25 percent full of lubricant, which is the maximum that should be used.

Corrosion control, as discussed earlier in this chapter is particularly important for rotating machinery and includes the following functions:

1. An adequate cleaning program.
2. Thorough periodic lubrication.

3. Detailed inspection for corrosion and failure of protective systems.
4. Prompt treatment of corrosion and touch-up of damaged paint areas.

An effective program of protection starts with a positive and continuous cleaning schedule. There is no single cleaning agent or process that will clean all types of parts. A cleaning agent that will clean one set of parts will not clean another, or it may attack the alloys or metal comprising the other set. Therefore, different cleaning agents are necessary, and selection of these agents will vary for different surfaces and equipment. The choice of cleaning agents and the correct process can generally be satisfactorily made by considering the following points.

1. Composition of the part.
2. Nature of the surface of the part.
3. Complexity of construction.
4. Type of contaminations to be removed.
5. Degrees of cleanliness required.

In addition to approved drycleaning solvents, trichlorethylene and inhibited methyl chloroform can be used when cleaning electrical and electronic equipment. Inhibited methyl chloroform (trichloroethane), even though nonflammable and less toxic than some formerly used solvents, does present some hazards to personnel and insulation. (See NAVSHIPS Technical Manual, Chapter 9600.)

Methyl chloroform is somewhat severe on insulation which deteriorates proportionally to the amount of time exposed to the solvent. After 5 minutes, methyl chloroform will noticeably soften varnishes and reduce dielectric strength and abrasion resistance. A continuous immersion of 1 hour will completely destroy the properties of most insulating materials and varnishes used in armatures, field coils, and similarly constructed electrical components. Glass melamine and laminated phenolics, however, are only slightly affected by such immersion.

Methyl chloroform itself is nonflammable, but after 90 percent evaporation, the residue contains a high percentage of the flammable

inhibitor. When the solvent has been allowed to evaporate from containers, the flammability of the residue should be recognized.

Special precautions when using methyl chloroform are:

1. Avoid prolonged or repeated breathing of vapor or contact with the skin. Do not take internally.

2. Prevent contact with open flame, because highly toxic phosgene may be formed.

3. Immerse electrical equipment less than 5 minutes, because prolonged immersion will destroy the properties of most insulating materials.

WARNING: When using cleaning solvents, take precaution to avoid burning the skin or inhaling the fumes. Use solvents in a well-ventilated room only.

4. The solvent should first be tested on a portion of the item to be sure it will not remove, blister, or otherwise damage the material.

5. Do not use on oxygen equipment—the inhibiting agent is flammable.

6. Do not use on hot equipment—the accelerated evaporation will increase the toxic hazard.

7. Use with adequate ventilation.

On dc motors, the condition of the commutator should be determined. Grease or dirt on the commutator causes arcing at the brushes which results in abnormal pitting and wear. The commutator should be cleaned with the recommended solvent; in some cases, the solvent may do a satisfactory job and it may be necessary to use an abrasive. One that is recommended is No. 0000 sandpaper. If the commutator is found to be burned or pitted either completely or in any localized area, turn in the motor for overhaul. Brushes should be replaced if they are chipped, cracked, or too short. The amount of wear allowable varies with different motors. In no case should the brush be allowed to wear down to the brush holder. Brushes should slide freely in their holders and if any do not, clean the holders and brushes. If

this does not help, replace the brushes. When brushes are removed but are not replaced with new ones, mark them so they can be returned to their original holders; otherwise they may require contouring to ensure good commutator contact.

Due to the simple construction of ac motors, very little actual maintenance is required. An inspection of the motor for proper security of mounting and proper alignment of the mechanical drive end is necessary. Check all connections for proper voltage, security, and absence of corrosion. A simple continuity check of the fields is usually sufficient in checking for shorts, opens, or grounds.

Most ac motors are prelubricated at the time of manufacture and are equipped with sealed bearings. The bearings require a visual inspection only. If they are found to be damaged, turn in the motor for overhaul. Before reassembling, wipe the rotor and stator clean; this can be accomplished by using a lint-free cloth that has been dampened with the recommended cleaning solvent. As a final check, conduct a preinstallation operational check of the motor, using the proper voltage and phase connections.

PRINTED CIRCUITS

The trend toward replaceable units has lead to several new methods of construction of electronic equipment, an example of which is the printed circuit. This type circuit is designed for speed and economy of maintenance, as well as saving of space and weight.

CIRCUIT CONSTRUCTION

One method of manufacturing a printed circuit is the "photoetching" process. A plastic or phenolic sheet with a thin layer of copper coating may be used. The copper coating is covered with a light-sensitive enamel, and a template of the circuit that will ultimately appear on the plastic sheet is placed over it. The entire sheet is then exposed to light. The area of the copper that is exposed reacts to the light. This area is then removed by an etching process. The exposure of the printed circuit is similar to

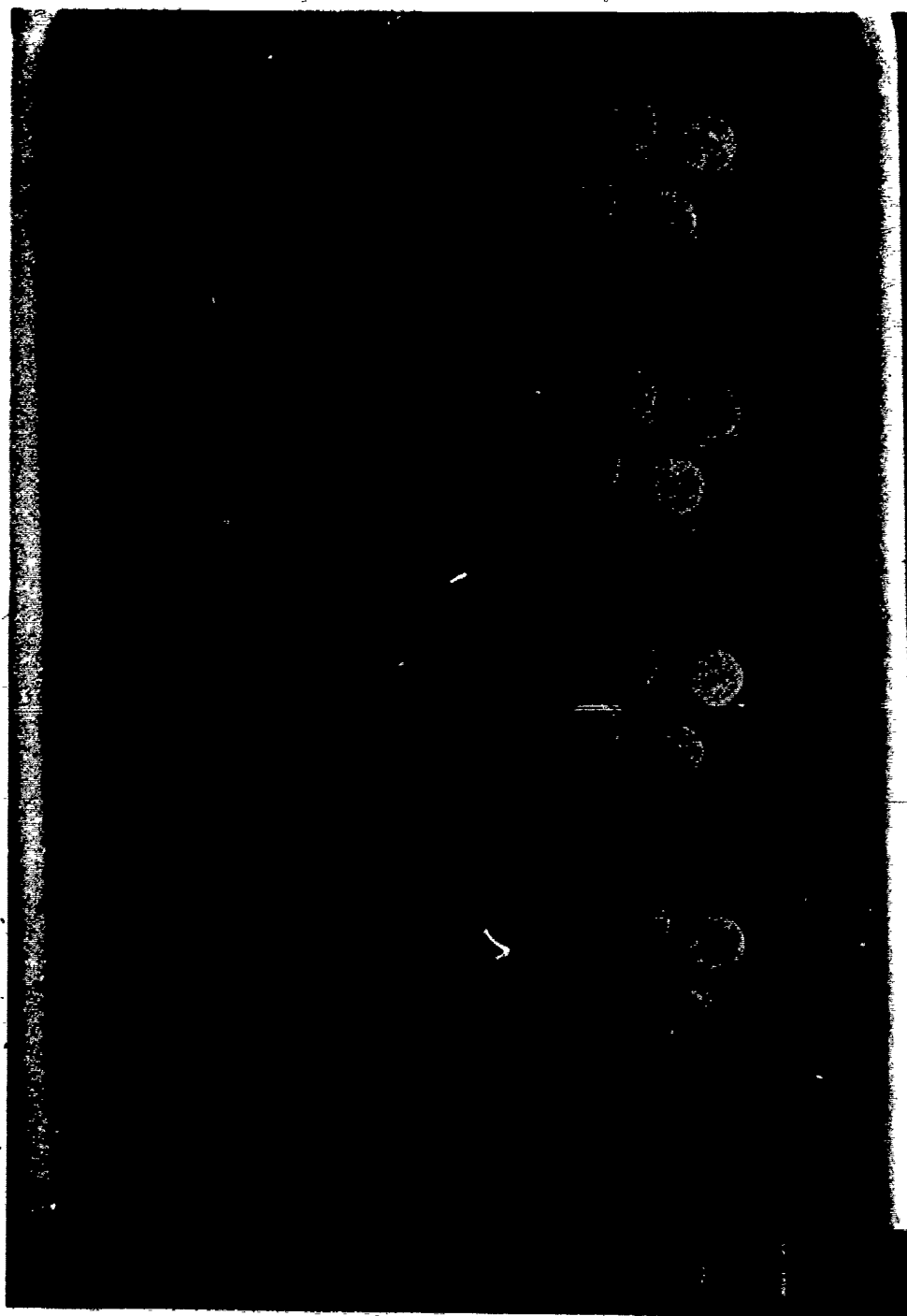

Figure 3-14.—Electronic module construction.

207.233

3-42

127

a photographic exposure. The enamel on the unexposed circuit protects the copper from the etching bath that removes the exposed copper. After the etching bath, the enamel is removed from the printed circuit. This leaves the surfaces in a condition for soldering parts and connections.

Some manufacturers use machinery to mount standard parts like capacitors, resistors, and transistors—further speeding manufacture. Circuits thus produced operate as well as conventional circuits and are as easily repaired.

Figure 3-14 shows an improved type of construction, from the troubleshooter's standpoint, consisting of a removable subassembly of the type called "modules." These modules are readily removable and have numerous internal and external test points to facilitate troubleshooting. The modules are built of standard parts that are easily replaceable. Most test racks have plug-in extensions that permit any module to be raised, making all parts accessible for checking and repairing. The module is not expendable but can easily be repaired, since all parts are of conventional design. Miniature and subminiature parts are so common in today's electronic equipment that they are considered to be conventional.

PRINTED CIRCUIT MAINTENANCE

Although troubleshooting procedures for printed circuits are similar to those for conventional circuits, repair of printed circuits requires considerably more skill and patience.

In accordance with OPNAV INST 4790.2 (Series), only those AIMDs which have been certified as having the capability are allowed to perform microminiature circuit repair. Activity certification is acknowledgement that the AIMD has individually certified (qualified) technicians assigned and NAVAIR approved, operable repair equipment available, and does not include any specific authorization to repair.

Initial repair technician certification will be granted only upon successful completion of the appropriate NAMTD course or an equivalent contractor training course approved and provided by NAVAIR.

Recertification of each individual is required periodically to assure continued quality of performance.

MODULES AND POTTED COMPONENTS

The following established definitions will be helpful in understanding the terms involved. A module is defined as a unit of standard of measurement—a fixed dimension. A modular assembly has outline dimensions which are multiples of a module. Equipment which consists of replaceable assemblies (any type tubes, transistors, etc.) is said to be of unitized construction. Modular construction, then, is a type of unitized construction consisting predominately of modular assemblies.

The sketches in figure 3-15 show two possible arrangements of modular construction. Note that the blocks can be arranged in more than one way to approximately the same dimensions.

The original concept of many modular assemblies was that they should not be maintained in the field. The intention was to replace the assembly and ship it back to some repair facility. As assemblies became more complex, the point was soon reached where the extensive supply system required for the replacement concept was too costly. A lot of equipment built during this initial stage was potted with some secret ingredient to discourage maintenance personnel from tampering with the insides of a black box. When the Navy reassessed this concept, realizing that the fleet must maintain everything it could, most of the equipment manufacturers began to make

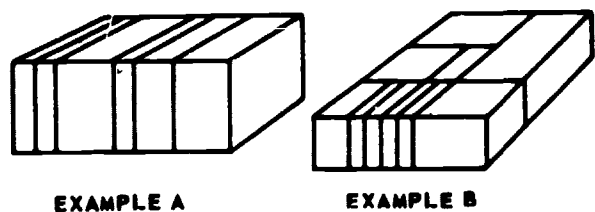

Figure 3-15.—Two examples of modular construction.

207.253

components accessible. However, many electricians are still convinced that modular assemblies are impossible to repair. This conviction may stem from a lack of experience in working with the printed circuits and the other components in modular assemblies. While it is true that special tools and techniques are required, it is also true that satisfactory repairs can be made to any printed circuit by using just a little care and common sense. Actually, with a little experience, repairs can be made as easily as in conventional assemblies—often more easily because of improved accessibility.

Repair of this type of assembly is the same as that required of all circuit board assemblies.

GROUND SUPPORT EQUIPMENT

Ground support equipment (GSE) includes all equipment required on the ground to keep aeronautical systems operational in their intended environment. GSE may be categorized as common (general purpose), where the equipment may be used in support of two or more components or systems, and peculiar (special purpose), where the support equipment is designed especially for a particular component or system and is not compatible with other systems. Items not considered to be GSE are:

1. Powered and nonpowered handtools.
2. Housekeeping items.
3. Office furniture and equipment required as indirect support.
4. Common production tools and tooling such as lathes, drills, grinders, etc.
5. Items used only by the contractor.
6. Personal equipment (headsets, microphones, etc.).

The electrical power requirements for starting and servicing modern aircraft are extremely high; even in aircraft equipped with batteries, and with the batteries fully charged, their capacity is not sufficient to withstand the heavy load of starting an aircraft engine or the power drain of prolonged operational ground checks.

The Navy has expended enormous amounts of time and money in the engineering of

powerplants which are used for starting aircraft engines and for furnishing power for electrical and electronic circuits when performing operational ground checks.

NOTE

Batteries are not to be used to start aircraft reciprocating engines except in an extreme emergency. The purpose of an aircraft battery is to operate specific instruments and radios in case of a loss of aircraft generator power.

Increasing numbers of aircraft are being manufactured that do not have an internal source of electrical power unless the engines are operating. This presents problems in performing maintenance where electrical power is required. Even on aircraft where batteries are installed, use of the battery to perform maintenance is prohibited so that the pilot will have a fully charged battery should he need it in an emergency. Running the aircraft engines to provide electrical power for maintenance purposes is also poor practice because of the danger of turning propellers, jet intake and exhaust blast, or the expense of operating high powered engines for long periods when only electrical power is required. To facilitate maintenance and to provide instrumentation necessary to monitor engine performance during starts, an external source of electrical power is necessary.

MOBILE ELECTRICAL POWERPLANTS

Although the AE is not responsible for the upkeep and maintenance of Mobile Electric Powerplants (MEPP), you must have a basic knowledge of their capacity and operation. On all of the mobile electric powerplants described in this chapter, the ac frequency is automatically controlled by a governor that controls the speed of the powerplant. The voltage is controlled by a voltage regulator. If the powerplant does not regulate to the proper speed (frequency), it must be serviced by the Ground Support Equipment work center.

Chapter 3—ELECTRICAL MAINTENANCE AND TROUBLESHOOTING

There are many and varied types of electric powerplants available; some are designed for universal use, while others can be used only on specific aircraft. The AE, therefore, should consult the Maintenance Instruction Manual for the recommended powerplant for the type aircraft being worked on. In the following discussions, no attempt is made to cover all MEPP that the AE may encounter.

OPNAV 4790.2 (Series) has established the Ground Support Equipment Operator/Organizational Maintenance Program. This program emphasizes and formalizes the responsibilities and procedures required in connection with the operation of GSE equipments.

During recent years, the improper use of GSE has resulted in far too many ground handling accidents, excessive repair and replacement costs amounting to millions of dollars annually and reduced operational readiness. Investigation has shown the major reasons for improper use of this equipment to be lack of effective training for the individuals who operate and maintain the equipment and the

lack of effective supervision and leadership by the officers, petty officers/non-commissioned officers directly responsible for such operation and maintenance at the various activities.

NOTE

A GSE operator's license OPNAV Form 4790/102 is required of all personnel who operate GSE regardless of rate or rating.

It is emphasized that the GSE Training Program is intended to teach GSE equipment operation and organizational level maintenance only. This training does not qualify the individual to operate equipment on the aircraft.

NC-2A

The NC-2A (fig. 3-16) is a self-propelled diesel-engine-powered unit. It is front-axle driven, steered by the two rear wheels, and

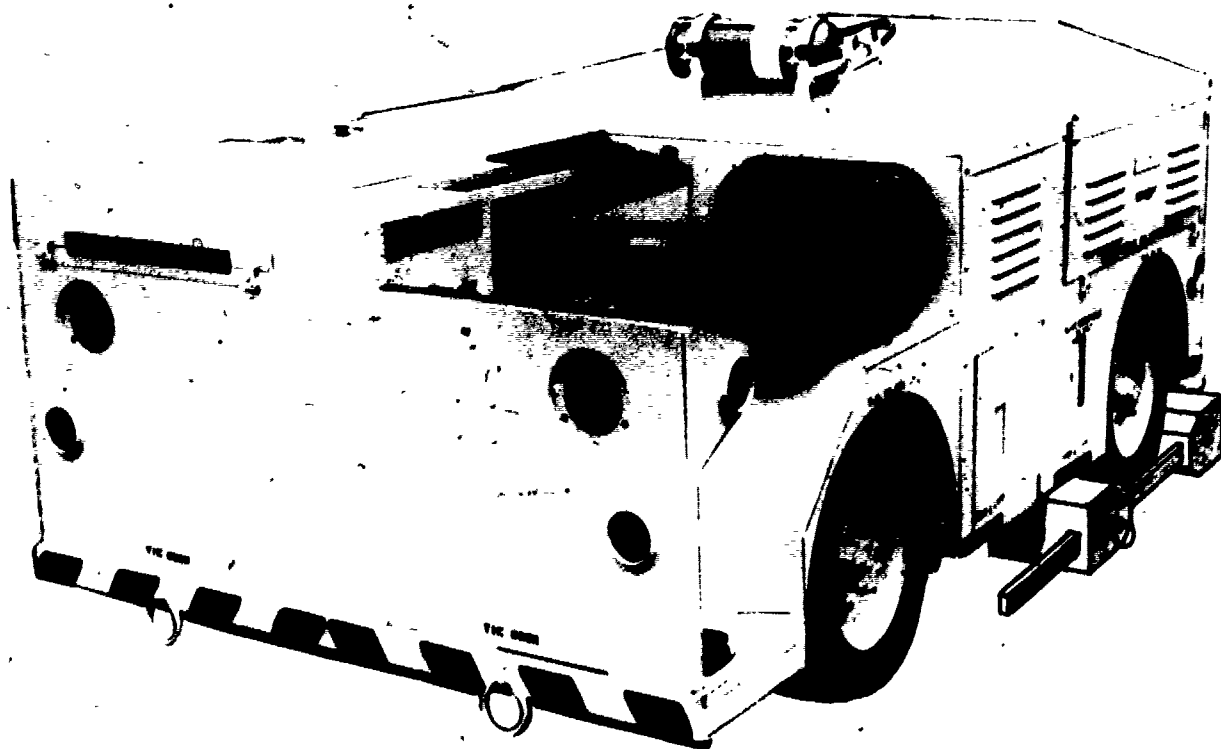

Figure 3-16.—MEPP NC-2A.

225.156

readily maneuverable in congested areas. The front axle is driven by a 28-volt dc, reversible, variable-speed motor, capable of propelling the unit up to 14 mph on level terrain, and has a turning radius of approximately 11 feet.

The primary source of power is a 3-cylinder, water-cooled diesel engine which drives the ac and dc generators through a speed increasing transmission. All controls, both propulsion and electrical power, are available to the operator on three panels located in the front and to the right of the operator's seat.

The powerplant is designed for air transport and is provided with two tiedown rings each on the front and the rear bumpers. Forklift channels are located between the front and rear axles, providing safe lifting points for the unit.

NC-7C

The NC-7C is powered by a V-8 gasoline engine, contains two dc generators, an ac generator, a control console for control of the engine and both electrical power systems, and a propulsion system for moving the powerplant under its own power (fig. 3-17). Access doors are provided for the control console, engine compartment, battery compartment, cable storage compartment, and tool compartment. A hand operated control unit is provided on the tow bar for controlling the unit during self-propelling operations. A fire extinguisher readily accessible for emergency use is mounted near the tow bar.

CAUTION

Do not move the powerplant by means of the self-contained propulsion mechanism while supplying power to an aircraft. Under no condition is the powerplant to be used for towing other equipment.

The self-propelling feature should be used only when moving from one aircraft to another or from the line to the hangar if the distance is not too great. For greater distances, the unit must be towed—maximum towing speed is 10 mph.

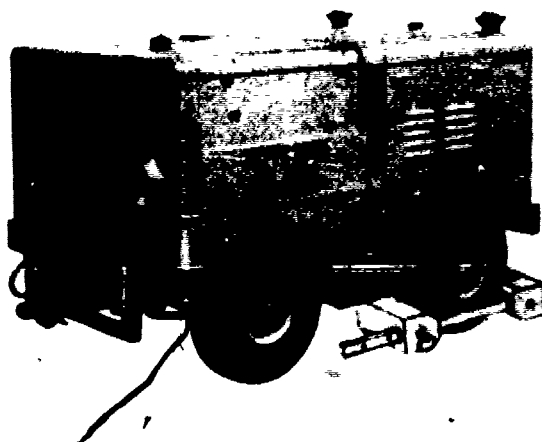
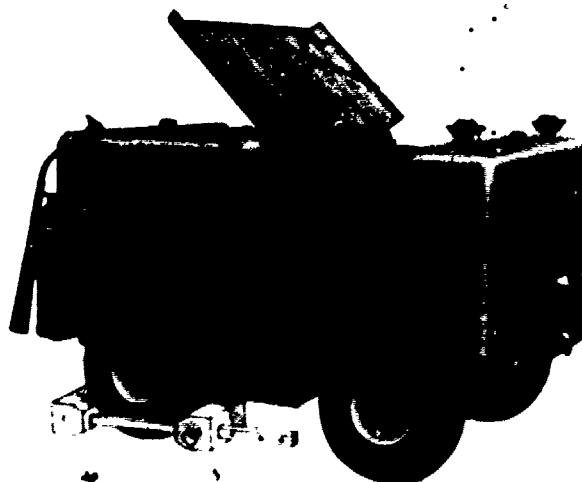

225.132

Figure 3-17.—MEPP NC-7C.

NC-8A

The NC-8A (fig. 3-18) is a mobile, self-propelled unit used for servicing and starting rotary and fixed wing aircraft. It is powered by a 4-cylinder, two-stroke-cycle, diesel engine controlled by an electro-hydraulic governor.

This unit has one dual-purpose generator, capable of supplying both ac and dc power simultaneously. It consists of a dc generator and a synchronous alternator enclosed in one housing. The mainshaft is connected to the engine by a driving disk which drives the ac generator rotating field and the dc generator rotating armature. Field excitation for the

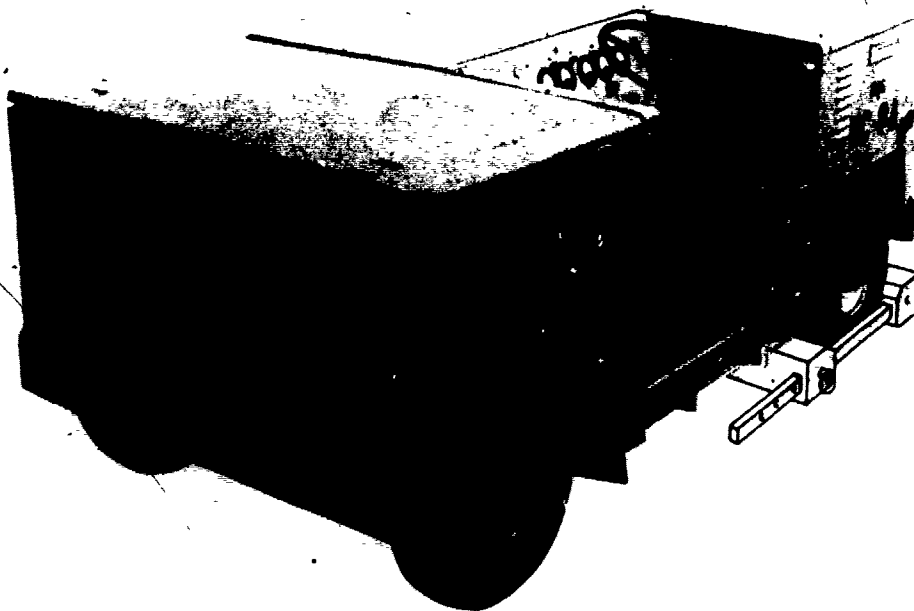

225.134

Figure 3-18.—MEPP NC-8A.

generator is supplied by the vehicle battery. The generator is cooled by two internal fans mounted on the mainshaft.

All engine controls and instruments are located directly in front of the operator, controls and instruments for the generator are located to the operator's right.

Vehicle propulsion power is provided by a 28-volt, direct-current, reversible, variable-speed motor. The motor is connected to the rear wheels via an automotive type differential, and speed is controlled by a conventional foot-operated accelerator pedal. The direction of travel is controlled by a switch mounted on the instrument/control panel.

NOTE: A special feature of the NC-8A serves as a reminder of the necessity for continual alertness in monitoring the actions of inexperienced personnel. This feature is labeled NC-8A Support Equipment Change No. 2436, and is designed to prevent the NC-8A from being

driven unless the power cables are properly stowed on the cable reels and the cable heads are plugged into dummy receptacles. The change was issued in response to numerous incidents in which maintenance or line crew personnel tried to tow an aircraft using the mobile electric powerplant with the power cables acting as the tow bar.

NC-10B

The NC-10B (Fig. 3-19) is a diesel-engine-driven unit designed for shipboard or shore station use. This unit supplies 90-kva, 120/208-volt, 3-phase, 400-Hz power for servicing, starting, and maintaining helicopters and jet aircraft. A portion of the electrical power generated is rectified to supply 28 volts dc at 750 amperes (1,000 amperes intermittent) for aircraft starting.

The powerplant is enclosed in a steel housing, fabricated in two sections which are

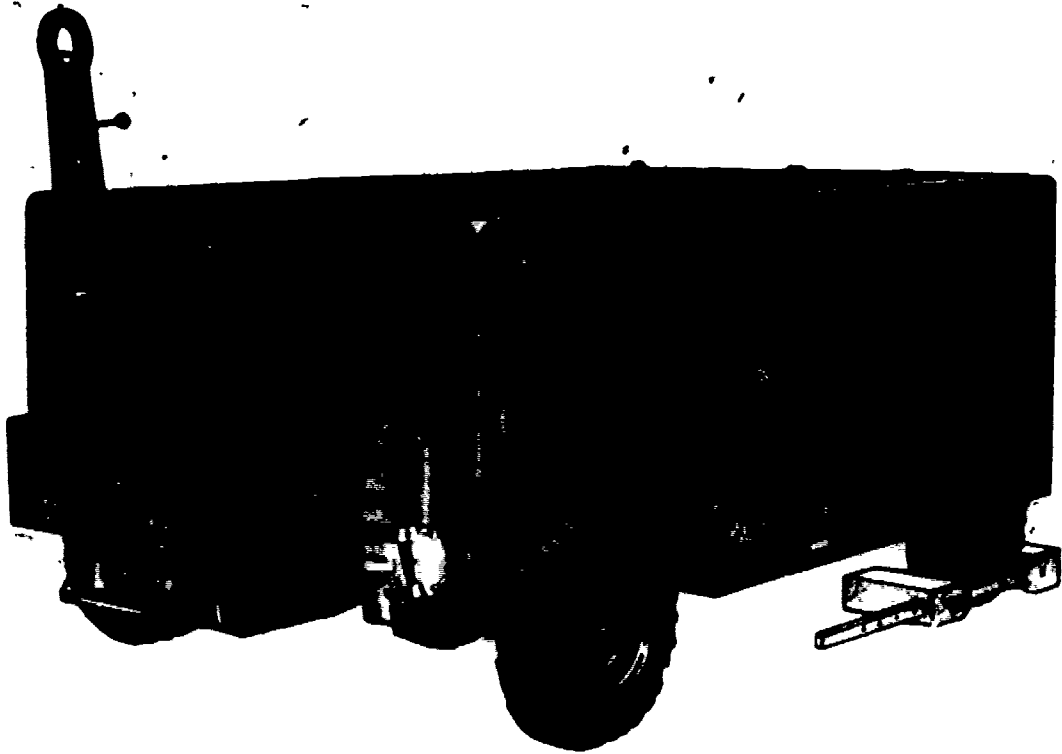

Figure 3-19.—MEPP NC-10B.

225.137A

easily removed for servicing the unit. Operating components are mounted on a 4-wheel trailer which is equipped with mechanical type internal expanding wheel brakes. The brakes may be set by hand lever, and are set automatically when the tow bar is in the vertical position.

Double hinged doors provide access to the control panel, starting components, and three output power cables.

The plant's electrical system is protected from overload by output circuit contactors, circuit breakers, overvoltage and undervoltage relays, overfrequency and underfrequency relays, thermal overload relays, and fuses.

This unit is self-propelled, for movement between aircraft on the line, by two hydraulic wheel motors. The operator's control is located on the towbar. Hydraulic pressure is supplied by

the hydraulic system which also provides pressure to operate the engine starter and the electrohydraulic governor's actuator system.

Power generation, both dc and ac, is controlled by the operator from the control panel located at the right front of the unit. The control panel contains three functional groups of instruments—the ac controls, the dc controls, and the engine controls.

NC-12A

The NC-12A (fig. 3-20) is a fully enclosed, diesel-engine-driven, dual output powerplant. It provides a 120/208-volt, 3-phase, 400-Hz, 125-kva output, or 87.5-kva ac power simultaneously with a 750-ampere, 28-volt dc output. A dc output of 950 amperes can be

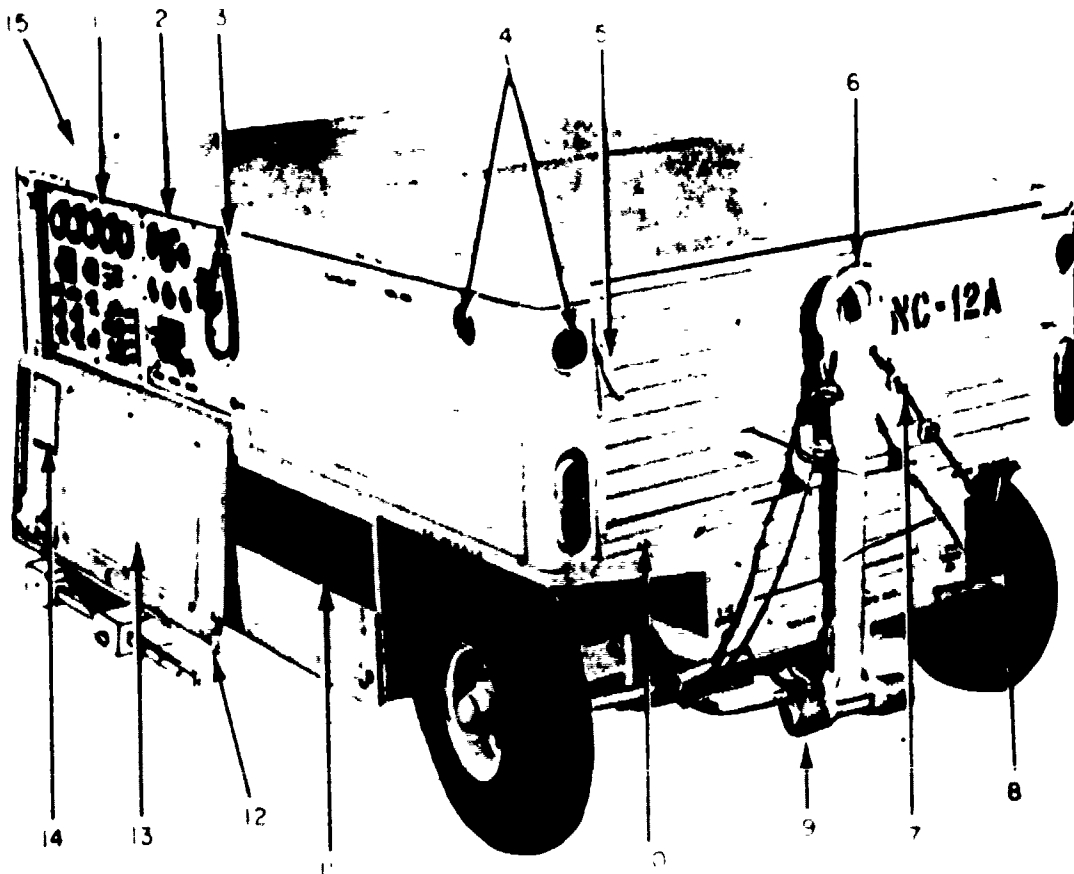

- | | |
|---|---|
| <ol style="list-style-type: none"> 1. Electrical control panel. 2. Engine control panel. 3. Chain strap. 4. Safety reflectors. 5. Manual shutter control lever. 6. Tow bar. 7. Safety cable. | <ol style="list-style-type: none"> 8. Parking brake lever. 9. Tow bar return springs. 10. Automatic shutters. 11. Output cable storage. 12. Control panels access door. 13. Schematic diagram encapsulation. 14. Lubrication diagram encapsulation. 15. Floodlight mounting location. |
|---|---|

225.139

Figure 3-20.—MEPP NC-12A.

obtained intermittently when only the dc power is being used.

The generator assembly consists of two brushless ac generators and two brushless exciters, mounted on a common shaft and directly coupled to the engine. The NC-12A provides a dc output by rectifying the output of

one of the generators. The generator outputs are separately controlled—one by the ac regulator, and the other by the dc regulator.

The powerplant and its components are mounted on a 4-wheel trailer equipped with mechanical rear wheel brakes which are actuated by a hand lever, or by the spring-loaded tow bar.

These units are not equipped with self-propelling features, and must be towed.

RCPT-105

The RCPT-105 (fig. 3-21) is a gas-turbine-driven aircraft ground service unit, mounted in a low-silhouette, self-propelled trailer. The low silhouette design and the self-propulsion system enable the unit to be maneuvered in congested aircraft parking areas. It is completely self-contained—provides compressed air for starting the main engine, ac and dc electrical power for operation of aircraft components, and conditioned air for aircraft compartment cooling and pressure suit ventilation. All controls and instruments for the unit are grouped, by system, on one panel located at the right rear of the unit.

Propulsion System

The RCPT-105 is provided with a self-propulsion mechanism for use in moving the unit over distances not to exceed 2,000 feet on a smooth, level surface. For greater distances, the

unit must be towed. Power to operate the 28-volt dc reversible drive motor, located on the rear axle, is provided by the unit's batteries. The operator controls are located on the towbar, and a time delay relay is used to keep the brakes applied for 4 seconds after the unit is stopped—this delay ensures that the unit is completely stopped before changing direction of travel.

MOBILE MOTOR-GENERATOR SETS

Mobile motor-generator sets (MMGs) perform the same function as the mobile electric powerplants, but they are not self-contained and require an external source of electrical power for operation. The MMGs are primarily used in hangars on shore stations, or on the hangar decks of aircraft carriers where the running of an internal combustion engine would be objectionable, and where external power is readily available.

MMG-2

The MMG-2 (fig. 3-22) is physically quite small and very compact. It is a trailer mounted

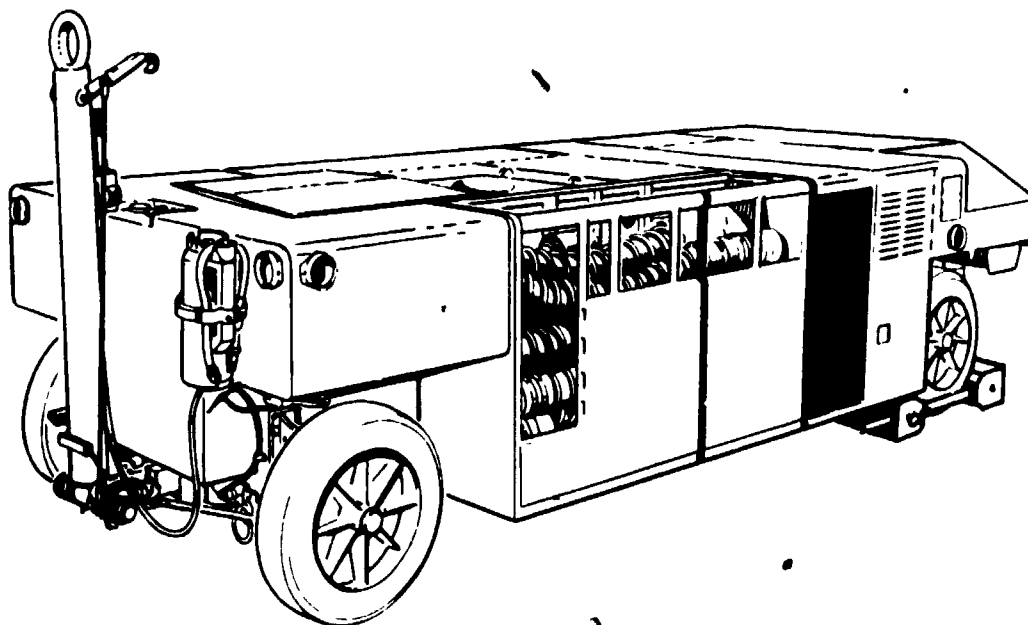
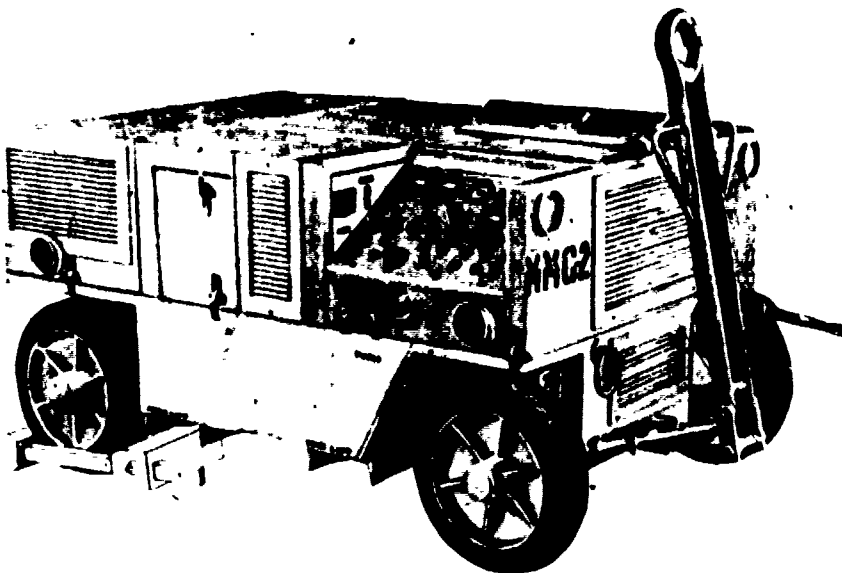

Figure 3-21.—RCPT-105.

225.141



207.153

Figure 3-22.—MMG-2.

electric motor-driven generator set used to provide 120/208-volt, 400-Hz, ac power, and 28-volt dc power for use in ground maintenance, calibration, and support for all fighter/interceptor type aircraft equipment.

MMG-RX400

The RX-400 (fig. 3-23) provides 120/208-volt, 3-phase, 400-Hz ac power, and 28-volt dc power for use in ground maintenance,

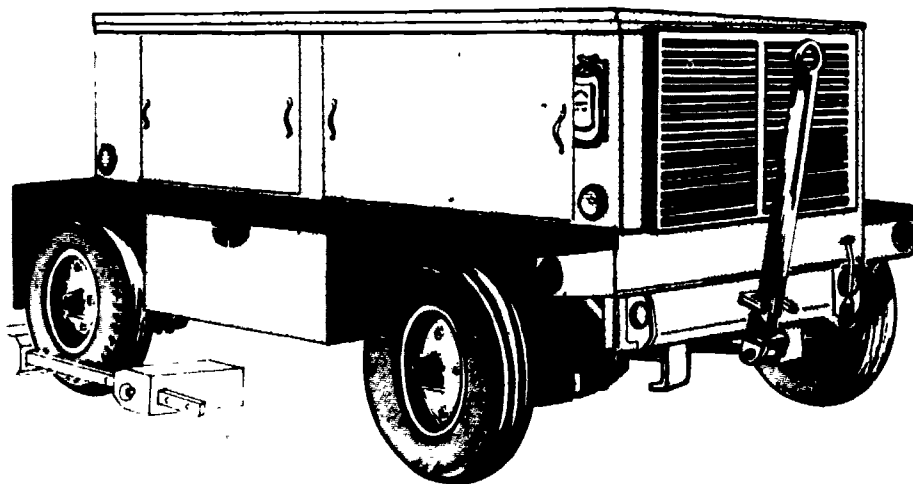

207.154

Figure 3-23.—MMG RX-400.

calibration, and support of aircraft equipment. The motor generator power supply contains two output channels. Channel 1 provides 60-kva, 120-volt ac line-to-neutral, 208-volt ac line-to-line. Channel 2 provides 60-kva, 120-volt ac line-to-neutral, 208-volt ac line-to-line, or 28-volt dc at a maximum dc load of 2,000 amperes—either ac or dc, but not both at the same time.

DECKEDGE POWER

The primary function of the deckedge electrical power system installed on aircraft carriers is to provide a readily accessible source of servicing and starting power to aircraft at almost all locations on the carrier's flight and hangar decks.

The 28-volt dc is supplied by motor-generators, or rectified ac from remote ac generators.

The 400-Hz, 3-phase ac servicing voltage is usually supplied by these ac generators through stepdown transformers. Figure 3-24 shows a

diagram of an electrical system which may be found on a modern carrier. The deckedge power may be supplied by service outlets at the edge of the flight deck or from recesses in the flight deck. All systems have standard remote control switches, service outlet boxes, and portable cables. Figure 3-25 shows a typical deckedge installation.

The dc service outlet box contains two male plugs. One is rectangular in shape and the other is oval. The rectangular plug provides servicing power and the oval provides starting power for aircraft with electrical starters.

The aircraft is equipped with an oval-shaped plug for applying dc servicing power and a rectangular-shaped 6-pin plug for applying 3-phase, 400-Hz, ac servicing power. Power is applied to the aircraft by connecting the portable cables between the deckedge and aircraft plugs. To obtain dc servicing power, the oval end of the portable cable is connected to the oval plug in the aircraft, and the rectangular end is connected to the dc service power box rectangular plug.

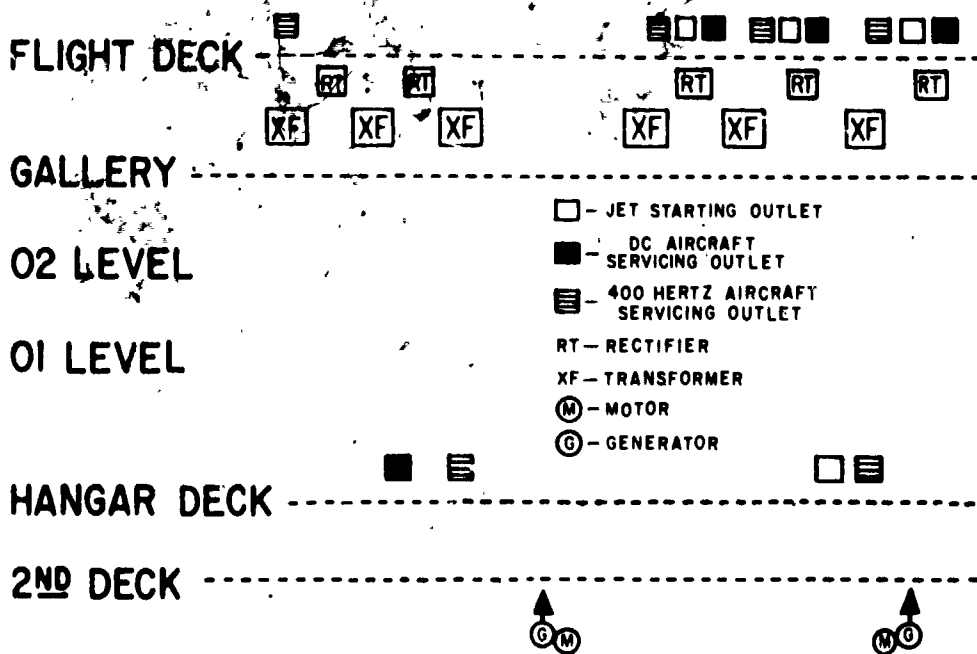
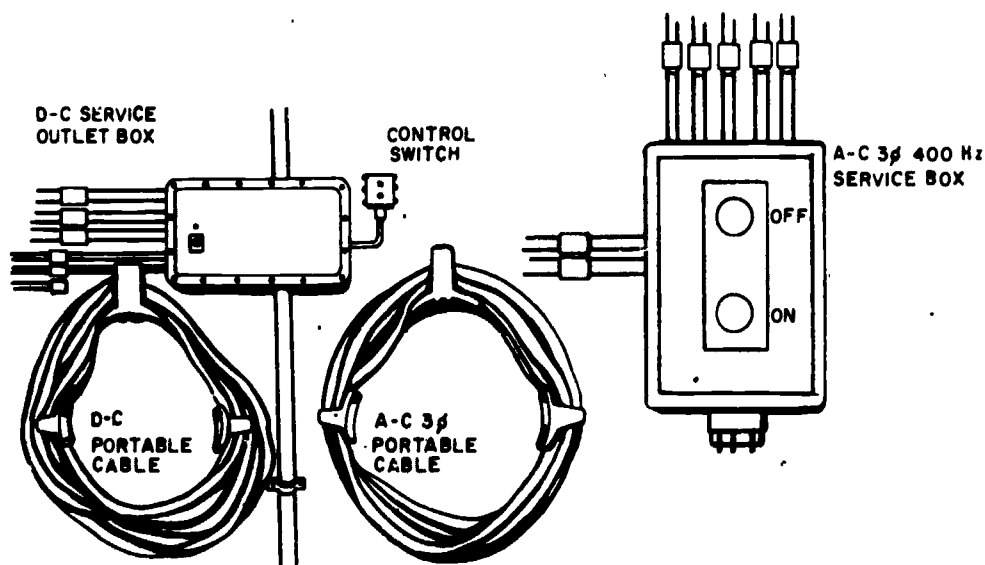

Figure 3-24.—Deckedge electrical system.



207.162

Figure 3-25.—Typical deckedge installation.

To obtain 3-phase, 400-Hz, ac service power, the portable cable with the 6-pin rectangular shaped plugs is connected to the aircraft and the deckedge ac service power box. The ends of this portable cable are interchangeable.

The ac service power is usually provided at the same station as the dc power. The cable and plugs are the same type as those used on the NC-8A and NC-2A mobile powerplants. The cable is usually permanently attached to the service outlet box. Although its plugs are rectangular, there is no danger of connecting them to the dc service box rectangular receptacle as the size and number of pins are not the same.

Care should be exercised when connecting external power cables to the aircraft. The cables are heavy, and damage to the aircraft may result if there is not sufficient slack in the cables.

TEST EQUIPMENT

The following items of ground support equipment may be classified as either common

or peculiar. In some cases test equipment may be peculiar to a specific system but that system may be installed in several different types of aircraft.

Test equipment may further be identified by where it is to be used. Line test equipment used on the aircraft to determine a system operational readiness and to isolate malfunctions to a particular component. This type equipment will normally be painted yellow to distinguish it from the equipment installed in the aircraft.

Bench test equipment is that equipment normally used in the shop to isolate malfunctions to a particular module, subassembly, or to the exact resistor, capacitor, etc. Occasionally, line test equipment may be used in conjunction with bench test equipment to perform complete checks of a component. Whenever test equipment is used, adherence to the Maintenance Instructions Manual or other operating instructions supplied for the specific test equipment, aircraft, and system is paramount. Never try to troubleshoot equipment from memory, use of test equipment instructions and the references for equipments being tested will prevent false findings, damage to test equipment and systems, and loss of time.

**MA-2 AIRCRAFT ELECTRICAL
POWER TEST SET.**

A generator test stand is designed to subject the generator, voltage regulator, and reverse-current relay to as many of the aircraft operating conditions as possible.

A test stand must be capable of driving a generator in excess of its maximum rated rpm to provide an "overspeed check." It must also have ample driving power to provide an overload test of the generator. A suitable test stand must also have an easy speed change mechanism and maximum power within all speed ranges.

The test stand must provide adequate cooling for the generator. A separate blower is usually installed for this purpose. A gate valve is employed in the air line to control the pressure. Some generators, although they have a built-in fan, require blast cooling.

A test panel or load box is required with the generator drive unit. A dc test panel is made up of a bank of resistors (for loading the generator), a voltmeter, and an ammeter with suitable ranges and shunts. A main line switch is incorporated so that all the load may be removed with one switch. Large carbon pile rheostats can be used as a load, but the adjustment tends to "creep" and requires constant attention.

Control of generator voltage can be achieved with a manually operated field rheostat, but it is standard practice to use a dependable voltage regulator.

Many test stands are driven by constant speed ac drive motors using split-pulley variable-speed changers. These motors should always be started and stopped at low drivehead rpm with no load on the generator. Heavy currents flow in drive motors whenever they are started with a heavy load, or when they are overloaded or stalled. Such currents result in blown fuses, open circuit breakers, and burned-out motors.

Under emergency conditions, a test panel may be improvised using landing lights, motor alternators, or motors requiring considerable current to provide a load bank. Resistors make the best load, they can be wound on ceramic

tubes or made self-supporting, it is important to avoid exceeding the ampere rating of the resistance wire being used. Ordinary aircraft ammeters, voltmeters, and switches can be mounted conveniently on the improvised panel.

The test set assembly shown in figure 3-26 is used to perform complete test and check out of all aircraft power generation system ac and dc components, both air-cooled and oil-cooled, and constant-speed-driven generator packages. The test set is of modular construction consisting of four major assemblies, the variable speed drive assembly, the control console, the load bank, and the oil supply system. The test set allows the four major assemblies to be assembled as one unit or separated to permit operation in a confined area.

The test set variable speed drive assembly is capable of producing 55 horsepower loads at speeds between 2,000 and 11,000 rpm. Speed regulation is better than ± 1 percent in this speed range. Speed is controllable between 55 and 11,000 rpm. The upper frame of the variable speed drive houses the drive motor reversing switch, the main input power circuit breaker, the line radio noise filters, the unit-under-test cooling air blower, and the trolley and hoist assembly. The output shaft speed of the gear box is controlled by the speed control panel on the control console.

The control console may be wall mounted, floor mounted, or mounted on the test set assembly. The control console provides the means of programming and monitoring the test function remotely from the other subassemblies of the test set. The operating controls and instruments are grouped for ease of operation and monitoring. A stowaway type shelf extending the full length of the control console provides operator work space. A card file drawer, convenience power outlets, and covered terminals are located on the left-hand end of the control console. The panels contain dead front switches and controls, and all power exceeding 125 volts ac is contained within enclosures for operator safety. The control console consists of a variable-speed drive panel, an ac metering panel, a dc metering panel, a load bank control

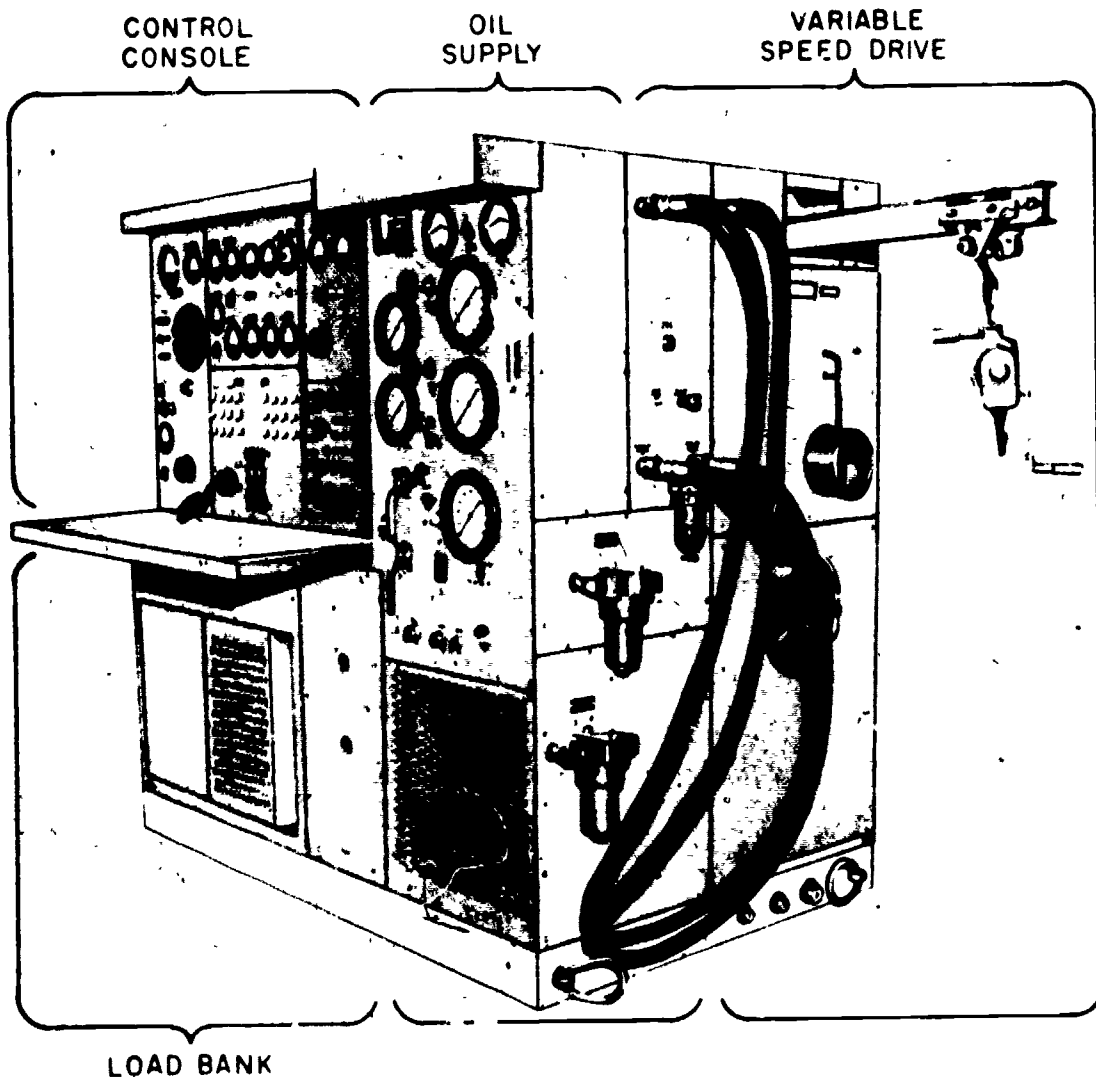

Figure 3-26 —MA-2 aircraft electrical power test set.

207.245

panel, and a terminal panel. The control console is totally enclosed by louvered panels, solid panels, and metering panels to protect the operator.

The load bank provides for the loading of ac generators, inverters, dc generators, transformer-rectifiers, and frequency converters. Resistive loads are applied by switches located on the control console. The load bank houses the resistive elements, both ac and dc, along with the necessary load switching relays,

temperature sensors, and a self-contained forced-air cooling system. It is limited to selecting and applying adjustable resistive ac balanced loads from 1 to 30 kw (0-10 kw per phase), or 0 to 500 ampere dc loads.

SEMICONDUCTOR TESTING

Since semiconductors have replaced vacuum tubes, the testing of semiconductors has become increasingly vital. Two basic types of equipment

are discussed in this section. They are the in-circuit transistor tester, represented by the TS-1100/U, and the transistor curve tracer (Tektronix 575).

In-Circuit Transistor Tester

Test Set, Transistor TS-1100/U (Fig. 3-27) is designed to measure the beta parameter of a transistor when the transistor is connected in a circuit, and to measure beta and I_{c0} parameters with the transistor removed from the circuit.

The characteristics of the test set are:

1. Range of beta 10 to infinity (∞) in a single band.
2. Leakage current measurements: 0 to 50 microamperes.
3. Temperature range: 0°C to +50°C.
4. Power supply: Battery operated.

The equipment contains two separate battery power supplies, one provides the power for the internal circuits, and the other furnishes the bias voltage required for the transistor under test. Either mercury type or zinc-carbon batteries may be used for operation of the test set.

Low impedance techniques are used for measurement in order to isolate the transistor under test from the surrounding circuitry. The measurement accuracy of the tester is within ± 20 percent provided that the loading of the emitter-base diode or the collector-base diode is not below 500 ohms, and the loading between the collector and the emitter is not below 500 ohms. If the emitter-base load contains a diode, the series impedance should not fall below 7,000 ohms to maintain this accuracy.

The range of beta that can be measured is between 10 and infinity. A beta of infinity corresponds to zero microamperes on the readout meter scale. A transistor having a beta below 10 causes the pointer of the meter on the tester to move off the scale. Because of the nonlinear characteristic of the meter scale, which causes crowding at the high end, the readout accuracy for betas above 100 is impaired.

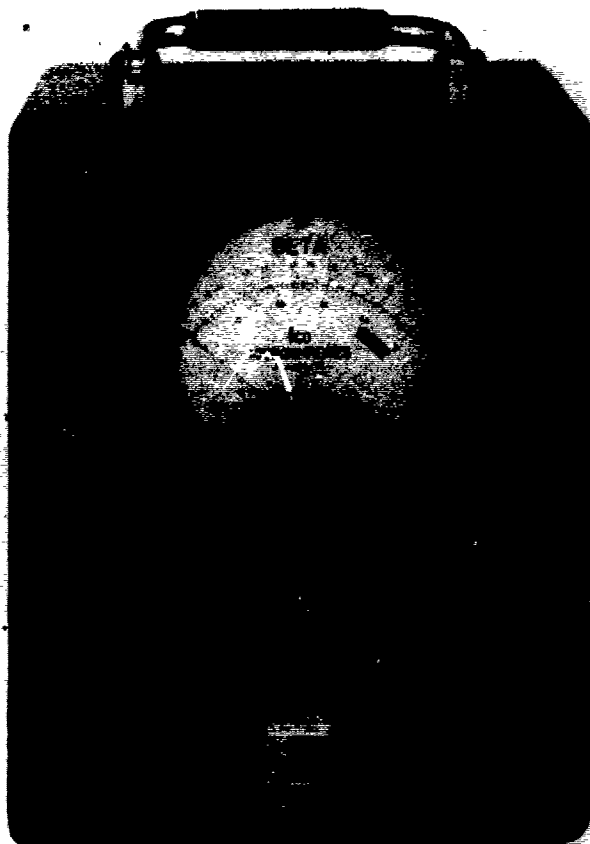

162.121

Figure 3-27.—Test Set, Transistor TS-1100/U.

The following items, as seen on the front panel (fig. 3-27), are incorporated in the test set:

1. POWER switch (labeled ON-OFF): Turns the internal power source on or off.
2. PNP-NPN (transistor select) switch: Selects proper collector bias polarity for the type transistor under test.
3. BETA switch: Permits readout of beta.
4. BIAS SELECT switch: Used to set proper collector bias voltages (nominally 3, 6, or 12 volts). Also checks the condition of the internal battery when in test position.
5. REDLINE SET control: Adjusts the amplitude of the test signal.
6. SHORT switch (labeled CB, CE, BE): Enables measurement of a short circuit or a low

impedance in the collector-base (CB), collector-emitter (CE), or base-emitter (BE) circuits.

7. I_{co} switch: Enables readout of transistor leakage.

8. SHORT indicator: The indicator lamp will light when a short circuit or low impedance exists in either the transistor under test or in the surrounding circuitry. If the lamp lights, this indicates a load of less than 500 ohms.

9. TEMPERATURE indicator: The indicator lamp will light when the ambient temperature surrounding the equipment exceeds $+50^{\circ}\text{C}$. This indicates that the equipment is operating in an environment beyond that for which it has been designed, and that measurement inaccuracies will arise.

10. METER: Indicates magnitude of beta; indicates magnitude of I_{co} ; and indicates the condition of the internal battery. (The battery is good when the meter needle moves under the green band on the dial.)

11. PROBE connector: For connecting the cables (furnished with the test set) to the transistor to be tested.

12. TRANSISTOR socket (labeled E-B-C): Enables direct connection between the test set and the transistor to be tested.

13. BATTERY DISCONNECT switch (upper left corner of panel—not labeled): Disconnects the internal battery when the front cover is snapped in place.

For proper procedure in operating the test set, refer the Technical Manual for Test Set Transistor TS-1100/U, NAVSHIPS 93277.

FUNCTIONAL DESCRIPTION

The block diagram (fig. 3-28) consists essentially of a reference oscillator, a tuned amplifier, and a variable bias supply. The oscillator is used to generate a test signal, the tuned amplifier is used to measure the second harmonic component of the current of the transistor under test, and the bias circuit furnishes the appropriate voltages to the transistor under test.

The reference signal source is a Hartley oscillator operating at 1125 Hz. The transistor

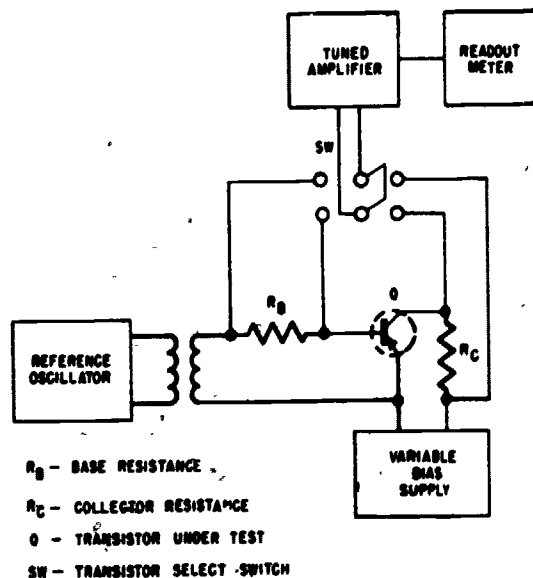

124.223

Figure 3-28.—TS-1100/U, block diagram.

under test is biased for approximately class B operation. Thus, the transistor conducts only when the input signal level exceeds the work function of the emitter-base diode. The input signal is adjusted until the average collector current is 1 milliampere. The current passes through the collector load resistor, and a voltage is developed across it. The signal is first coupled through a high gain, narrowband amplifier, having a center frequency of 2250 Hz, and then through a dc microammeter. The amplifier gain has been adjusted so that the red line on the meter face corresponds to an average collector current of 1 milliampere.

The bandpass amplifier and meter are then switched across the base load resistor, and the meter then reads the magnitude of the average beta directly for a given transistor. Since the collector current is held constant for all transistors under test, the base current is inversely proportional to beta.

Transistor Curve Tracer (Tektroniz 575)

The transistor curve tracer is employed to plot or trace characteristic curves of transistors and other semiconductor devices. (Refer to figure 3-29.) There are two methods of plotting

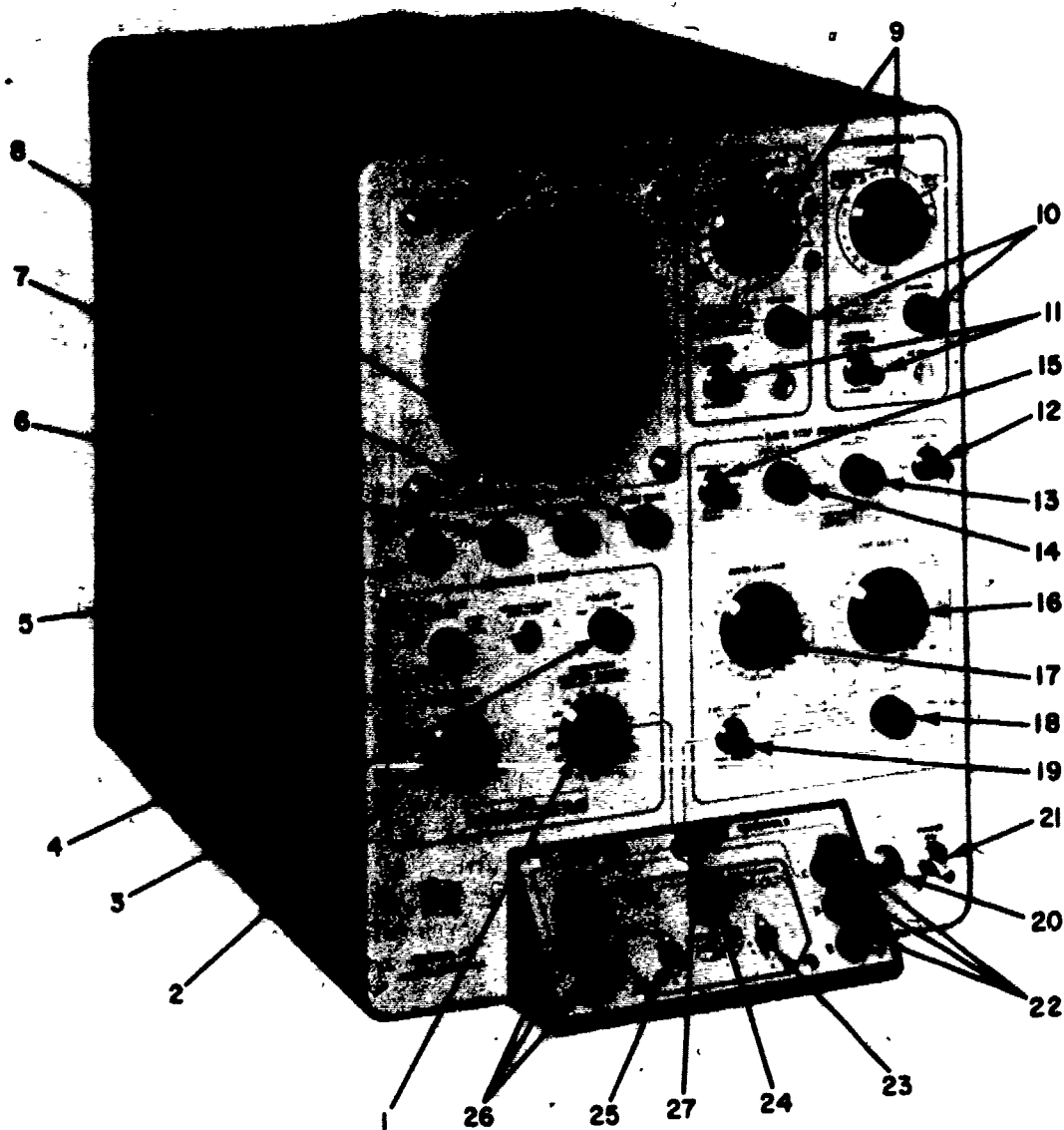

- 1. Disipation limiting resistor.
- 2. Peak volt control.
- 3. Polarity switch.
- 4. Peak volts range.
- 5. Focus control.
- 6. Intensity control.
- 7. Astigmatism control.
- 8. Beam Illumination.
- 9. Vertical/horizontal select.

- 10. Display position.
- 11. Amplifier calibration.
- 12. Steps/sec selector.
- 13. Polarity switch.
- 14. Steps/family.
- 15. Repetitive/single family.
- 16. Step selector.
- 17. Series resistor.
- 18. Step zero.

- 19. Zero current/voltage.
- 20. Indicator lamp.
- 21. Power ON-OFF.
- 22. Binding posts B.
- 23. Socket B.
- 24. Configuration switch.
- 25. Socket A.
- 26. Binding posts A.
- 27. Comparison switch.

Figure 3-29.—Transistor Curve Tracer (Tektronix 575).

151.274

the characteristic curves of a transistor—one is to apply dc voltages and take measurements point-by-point; the other is to use changing voltages and display the curve on an oscilloscope as in the 575.

There are several advantages in the use of the second method. To begin with, it is faster and more accurate than the point-by-point method. The point-by-point method may allow small irregularities in the characteristics to go undetected. Since heat is a major factor in transistor operation, errors caused by heat are reduced because the periods of applied power are shorter. Another definite advantage is that permanent records of the curves traced out on the oscilloscope may be easily produced at a reasonable cost by the use of photographic equipment. The peak voltage can be varied in two ranges, from 0 to 20 volts and from 1 to 200 volts. The polarity of the sweep voltage can be reversed in order to check both PNP- and NPN-type transistors (item 3). A variable amount of resistance can be placed between the collector sweep supply and the transistor under test in order to limit the maximum amount of collector dissipation (item 1).

BASE SWEEP GENERATOR.—The sweep generator develops currents and voltages which change value in stairstep fashion in synchronization with the collector sweep voltage (items 12, 16, 17, and 18). The output of the generator can be reversed in polarity and can be connected to either the base or the emitter of the transistor under test (item 13). The number of steps can be varied from 4 to 12 according to the type of display desired (item 14).

DISPLAY FUNCTION.—The display function includes the three major functional blocks remaining—the vertical and horizontal amplifiers, and the cathode-ray tube. (The operation of a cathode-ray tube is given in *NEETS*, an oscilloscope was discussed previously in this chapter.

The horizontal and vertical amplifiers of the cathode-ray tube can be driven by several different inputs, depending upon what characteristics are of interest (item 9). The horizontal amplifier can select any of four

inputs and display one of them on the horizontal axis. The four inputs are base volts, collector volts, base current or base-source volts, and external.

This equipment is provided with a self-calibration test. The operator can quickly be reassured of the accuracy of the test set by use of this built-in calibration check.

The following paragraphs describe briefly how the 575 works, and outline a method for determining dial settings for transistors found in the fleet.

An illustration of the front panel of the equipment is shown in figure 3-29. As can be seen, the controls are grouped into five blocks, with a test connector panel at the base of the test set. In addition to the block arrangement, the panel is also color coded to simplify the operation. The collector currents and voltages are referenced by the sections of the panel etched in red; the sections etched in blue refer to the base currents and voltages. An exception to this color code is when a common base transistor configuration is being tested, at which time the blue is in reference to the emitter.

In the description of the five functional divisions that follows, refer to figure 3-29 for the item numbers listed, and to figure 3-30 for the functional block diagram.

The collector sweep circuit supplies the transistor under test with a collector voltage which is the output of a full-wave rectifier without any filtering. The 60-Hz line voltage is supplied to the full-wave rectifier and the output of the rectifier is 120-Hz pulses. The output waveform varies from zero volts to some peak value which can be controlled from the front panel (items 2 and 4). In the base volts positions, the horizontal amplifier is connected to the base of the transistor under test. In the collector volt position, the horizontal amplifier is connected to the collector of the transistor under test. Both of these inputs have several positions so that the scaling factor can be changed. The base-current or base-source volts position connects the output of the base step generator into the horizontal amplifier. The external position connects the horizontal

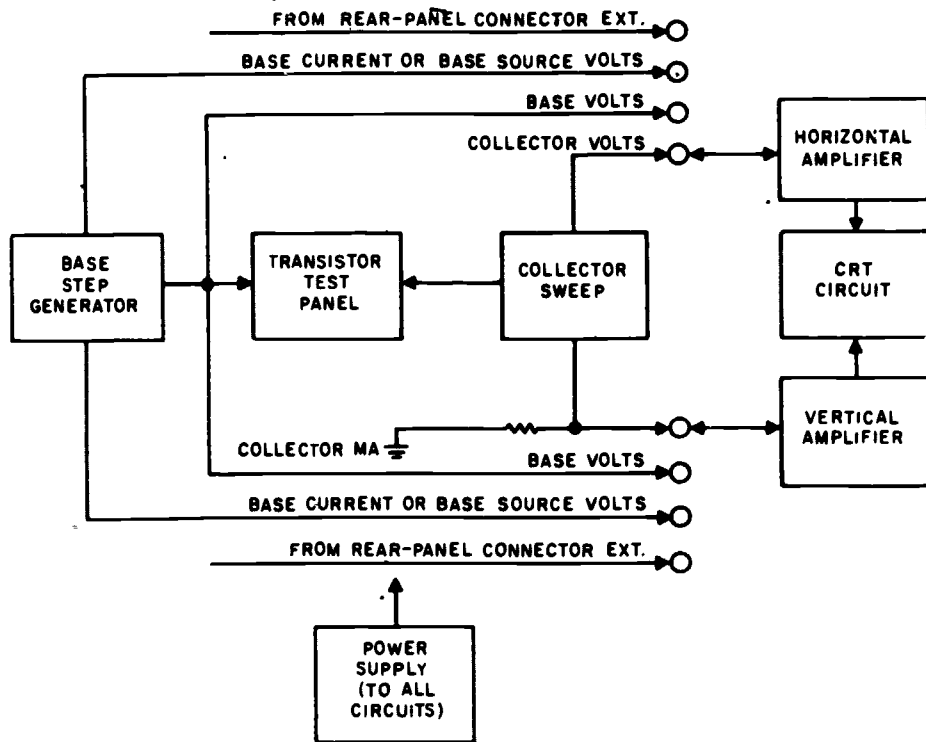

189.56

Figure 3-30.—Transistor curve tracer, block diagram.

amplifier to two coax connectors on the rear of the instrument.

The vertical amplifier can also select from four different inputs—collector MA, base volts, base current or base-source volts, and external. Base volts, base current or base-source volts, and external positions are the same as described for the horizontal amplifier, but in the collector MA position, the vertical axis displays a plot collector current.

Interpreting the display, as the collector voltage changes from zero to some peak value and back to zero again, the step generator output remains at some specific level and then changes to some new level for the next collector voltage cycle. The collector voltage is swept at a rate of 120 Hz, and the step generator changes steps or level after every cycle (in the 240 steps per second, the step generator changes at both

the zero point). Figure 3-31 is a plot of collector sweep voltage and base step generator current. It should be noted that the collector sweep makes a complete excursion while the base remains at some steady value. As the next collector sweep starts, the base current is changed to the next value of current selected by the dials on the front of the instrument; and again the base

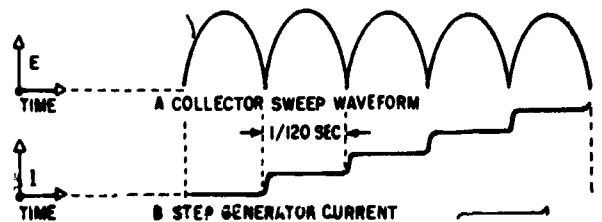

189.57

Figure 3-31.—Waveforms of collector sweep versus step generator current.

current remains steady while the collector voltage is varied.

As previously mentioned, the waveforms of figure 3-31 can be reversed by switches on the front panel in order to check either PNP or NPN.

Figure 3-32 is a plot of collector voltage and collector current for given values of base current for an NPN transistor. For this type of transistor, it is conventional to have the lower left-hand corner represent zero collector voltage and current. In this graph, it was arbitrarily decided that each division to the right on the horizontal axis would represent a collector voltage change of one volt positive. Thus, a collector voltage swing of zero volts to 10 volts can be indicated. The vertical axis is a plot of collector current varying from zero milliamperes to 10 milliamperes in 1 milliamperere steps. The lines on the graph represent different values of base current; in this case, each line represents a change of 0.01 milliamperere. If this graph had been for a PNP rather than for an NPN, the upper right-hand corner would have represented zero collector voltage and zero collector current. The divisions to the left would have represented

negative collector voltage, and the divisions downward from the top would have indicated the amount of negative current. This would have made the family of curves appear as shown in figure 3-33.

These curves are known as the static collector characteristics for a common emitter configuration, or output characteristics curve. Curves can be developed for common base and common collector also, but normally the information is available for the common emitter mode. Using this configuration, it is easier to check the transistor. To thoroughly describe how a transistor is going to work in a circuit, it is necessary to know the input characteristic curve as well as the output curve. The input characteristic curve is developed by plotting base current on the horizontal axis, and base to emitter voltage (V_{BE}) on the vertical axis at various values of collector to emitter voltage (V_{CE}). Although it is necessary for the design engineer to know the input characteristic curve when designing a circuit, the output characteristic curve will normally give the operator enough information to allow the person to evaluate a transistor.

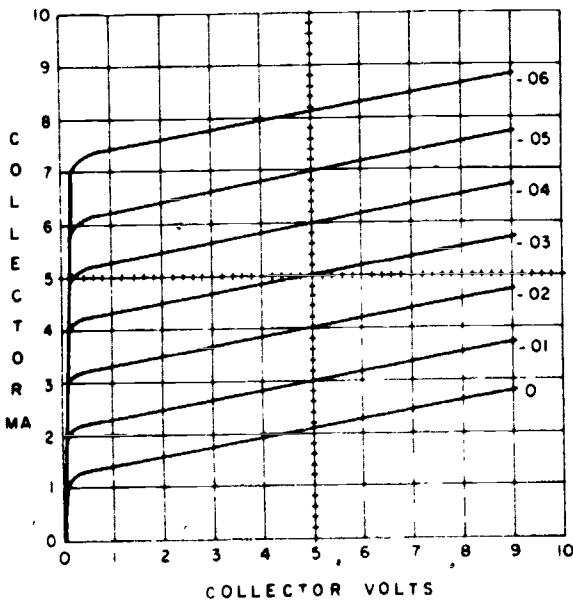

189.58

Figure 3-32.—Typical NPN collector curves.

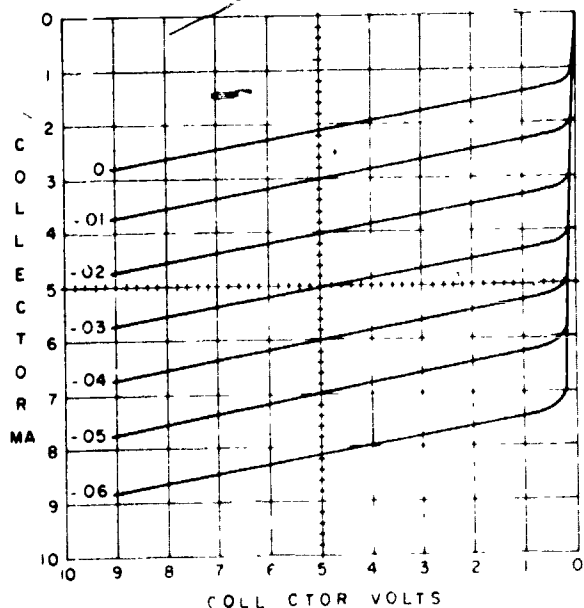

189.59

Figure 3-33.—Typical PNP collector curves.

MEASURING BETA (h_{fe}).—One means of measuring the quality of a transistor is the beta (β) or current gain in the common emitter configuration. Mathematically, beta is represented by the formula

$$\beta = \frac{\Delta i_c}{\Delta i_b}$$

where V_{CE} is constant. Beta is also called the forward current transfer ratio and represented by the symbol h_{fe} . To determine the beta from the output characteristics, measure the change in collector current between two values of base current at some constant collector voltage; for instance in figure 3-32, to determine the beta at a collector voltage of 5 volts, measure the change in collector current between the base current curves of 0.02 ma and 0.03 ma. In this example, the change in collector current measure 1 ma, so that the beta is equal to the change in collector current divided by the change in base current, or

$$\frac{1 \times 10^{-3}}{0.01 \times 10^{-3}} = 100$$

MEASURING I_{CO} .—Another characteristic of a transistor is the I_{CO} , also called I_{CBO} . This is the collector current when the collector is biased in the reverse direction (high resistance, normal connection) with respect to the base, and the emitter is open-circuited. The I_{CO} of a transistor is highly temperature-dependent, and the measurement made with the curve tracer will be valid at the ambient temperature only; but it is still significant. The method used to measure the I_{CO} is shown schematically in figure 3-34. Notice the emitter is not connected.

The display of the curve tracer when measuring I_{CO} is shown in figure 3-35. The vertical axis indicates collector current, just as it did when beta was being measured; but now the vertical amplifier is adjusted to afford maximum gain so that the small amount of current causes a noticeable deflection. The horizontal axis is still calibrated to show collector voltage.

The electrician must know the beta and I_{CO} of a transistor in order to tell whether or not the one being tested is good. Since no manual

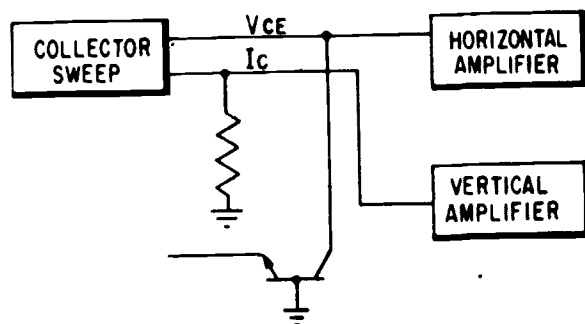

189.60

Figure 3-34.—Connections for checking I_{CO} (I_{CBO}).

describing the characteristics of various transistors is provided with the curve tracer, it is necessary to obtain this information from a specification sheet supplied by the manufacturer.

The collector voltage (V_{CE}) and collector current (I_C) provide the starting points from which to determine the curve tracer settings; for instance, if the V_{CE} is 5 volts, the horizontal amplifier would be set to COLLECT or VOLTS.

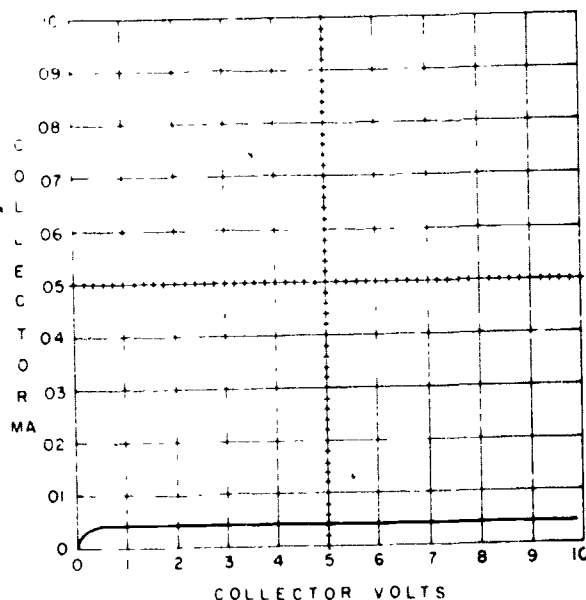

189.61

Figure 3-35.—Typical display of I_{CO} (I_{CBO}).

1 volt per division. This would place the 5-volt position in the middle of the display, and if the I_C is 1 ma, the vertical amplifier would be set to COLLECT or MA, 0.2 MA per division. This would place the 1-ma position in the middle of the display. The collector sweep can be determined from these settings, since the horizontal amplifier is set to 1 volt per division. The collector voltage varies a total of 10 volts, so the PEAK VOLTS RANGE is in the 0 - 20 position and the PEAK VOLTS control is set at 10. To determine the setting for the DISSIPATION LIMITING RESISTOR, obtain the maximum collector dissipation from the column in the technical section labeled MAX COLL DISS. This, in conjunction with the setting of the PEAK VOLTS control, can be plotted on the chart on top of the curve tracer to obtain the correct setting of the limiting resistor.

The step generator is set up in the following manner. The switch labeled REPETITIVE-OFF-SINGLE FAMILY is set to REPETITIVE, and the control labeled STEPS/FAMILY is set counterclockwise. This gives four steps per family, which is usually sufficient; but if more are desired, set STEPS/FAMILY to any value. The switch labeled POLARITY has a chart under it showing the correct position for NPN and PNP. Use the portion of the chart pertaining to grounded emitter-type circuits. The switch labeled STEPS/SEC can be in either of the two 120 positions or in the 240. The only difference in the two 120 positions is that at one of them the step generator changes level when the collector is at zero volts, and at the other position, the step generator changes level when the collector is at the maximum voltage. In the 240 position, the step generator changes level at both the zero collector voltage and at the maximum point. The step selector can be set by starting at the smallest change per step (0.001 ma) and increasing the size of the step until the display has the necessary separation between the values of base current to determine beta. In the alternative procedure, the beta listed in the technical section can be divided into the amount of collector current and the result used as the setting of the step selector. If there is not enough separation between the lines

representing the base current to accurately determine the beta, increase the amount of each base step until a good display is obtained.

To check the I_{CO} of the transistor, disconnect the emitter and change the current per division setting on the vertical amplifier to the most sensitive position (0.01 ma). Set the step zero very accurately, as described in NA 16-45-107, which is the Service Instruction Manual and Operating Instruction Manual for the curve tracer. After setting the step zero, note the difference between the step zero and the present position of the trace; this is an indication of the I_{CO} . The I_{CO} of the transistor is listed in the technical section, in the column MAX I_{CBO} at MAX V_{CB} , which describes the I_{CO} at MAX V_{CB} , which describes the I_{CO} at BV_{CBO} —the breakdown voltage, collector-to-base with emitter open.

By measuring beta and I_{CO} a fair picture of the condition of a transistor is presented.

There is one thing that should be mentioned in connection with the curve tracer—matching of transistors. Some Navy equipments have matched pairs of transistors, but unless the specifications are checked, it cannot be automatically assumed that betas of the transistors are matched. Sometimes the betas are matched, sometimes they are not; many times several characteristics are matched.

JET IGNITION SYSTEM TESTER

This ignition tester is used to detect and isolate faults in the jet engine ignition system. The tester can be used in making the following checks:

1. Operational check of the ignition system from the engine through the ignition unit to the spark plug.
2. Operational check of the spark plugs.
3. Check of the ignition unit output in sparks per second.
4. Power input to the ignition unit.

The panel of the ignition system tester is shown in figure 3-36.

Procedures for the use of the tester can be found in the tester's Operation and Service

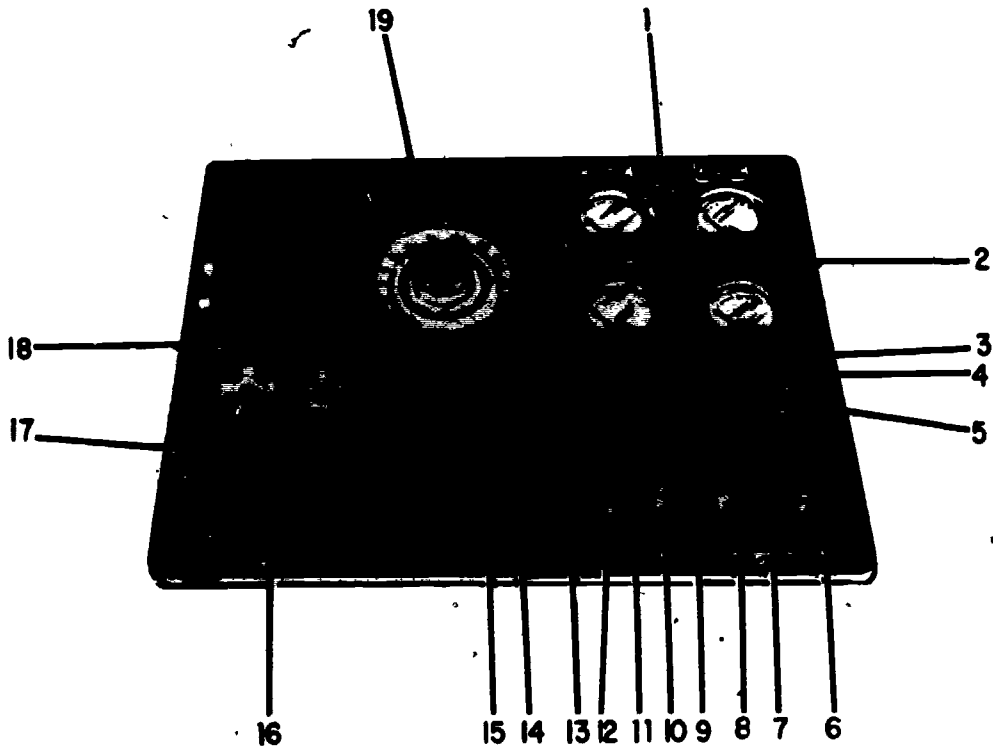

1. A-c and d-c voltmeters (M3 and M4).
2. A-c and d-c ammeters (M1 and M2).
3. Main ignition primary-secondary selector switch (S1).
4. Main ignition energy level switch (S2).
5. A/B ignition test on-off switch (S3).
6. High-voltage spark plug test switch (S7).
7. High-voltage spark plug test light (I5).
8. Low-voltage spark plug test switch (S8).
9. Low-voltage spark plug test light (I4).
10. Spark rate counter power on-off switch (S8).
11. Spark rate counter power indicator light (I3).
12. Spark rate counter timer power on-off switch (S9).
13. A/B ignition switch test light (I2).
14. Spark rate counter timer start switch (S10).
15. Nozzle unlock switch test light (I1).
16. Spark rate counter.
17. Spark rate counter reset knob.
18. High-voltage (P1) and low-voltage (P2) slave spark plugs.
19. Spark rate counter timer.

207.225

Figure 3-36.—Jet Ignition System Test Panel.

Instruction Manual, and in the Maintenance Instructions Manual for the engine ignition system to be maintained.

TACHOMETER INDICATOR-GENERATOR TEST SET TTU-27/E

The TTU-27/E provides complete facilities for testing the following:

1. Tachometer indicator of the percent type and the rpm type.
2. Four-pole reciprocating engine tachometer generators.

3. Two-pole jet engine tachometer generators.

Tachometer indicators can be tested for starting voltage and calibration accuracy; tachometer generators can be tested for starting voltage, calibration accuracy, speed, and output voltage under load conditions. Tachometer generators and indicators can be tested either on or off the aircraft.

Figure 3-37 shows a TTU-27/E tester. All the operating controls, switches, and indicators required for the tester are mounted on the panel assembly. The two-speed test pad accommodates

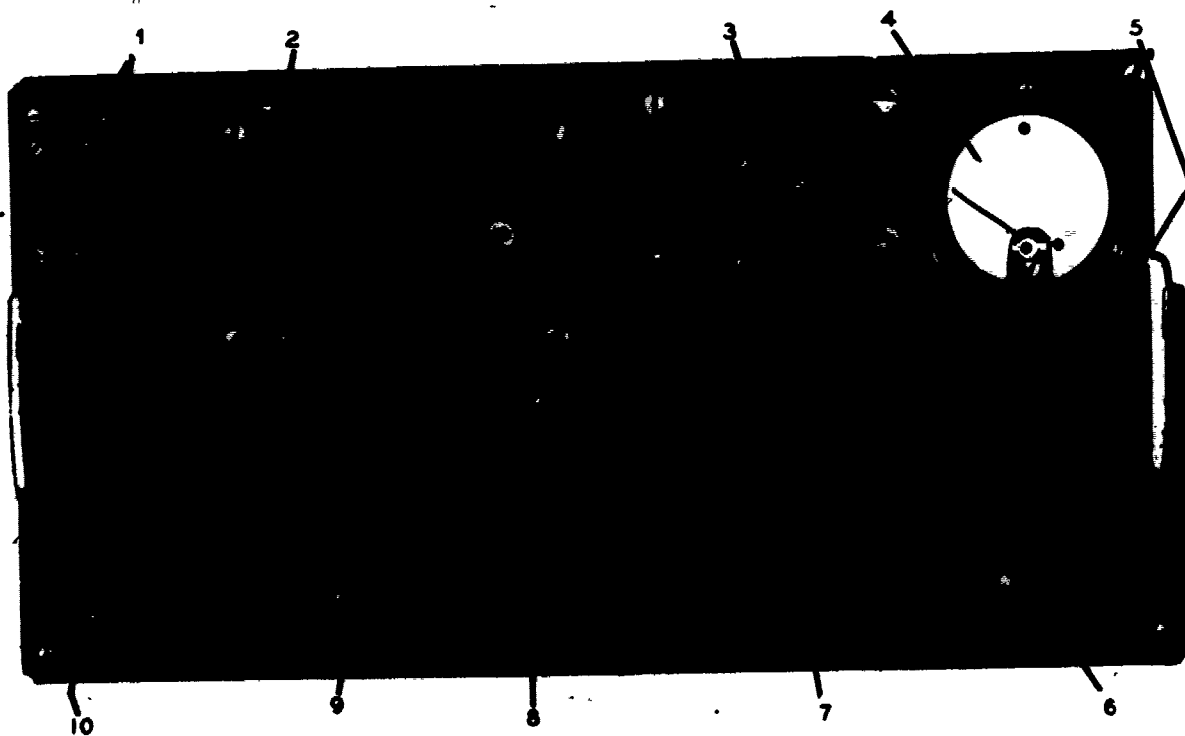

1. TEST GEN. INPUT and MAST. GEN. OUTPUT.
2. TWO-SPEED TEST PAD.
3. LOAD IN OHMS.
4. GENERATOR OUTPUT VOLTAGE meter.
5. MAST. GEN. OUTPUT control

6. VOLTMETER SEL. switch.
7. RPM indicator.
8. Test set ON-OFF.
9. Speed control.
10. Generator selector.

207.274

Figure 3-37.—Tachometer Indicator-Generator Test Set TTU-27/E.

either two-pole or four-pole tachometer generators for testing. The RPM counter indicator provides a precision readout of tachometer generator speed with scales of RPM X 2, RPM X 1, and PERCENT RPM.

The tester is powered by 115-volt, 400 Hz ac.

NOTE: Do not attempt to operate the tachometer tester until the ground connection of the power lead has been made.

The drive assembly consists of a gearbox and a master tachometer generator. The gearbox drives the two-speed test pad which is used for mounting the tachometer generator under test. A variable dc drive motor is used for controlling the drive speed of the gearbox, and thus controls the speed at which the master tachometer and the tachometer generator under test are driven.

The RPM indicator assembly is part of the precision speed indicator, and consists of a 2-phase servomotor which drives an inline digital type display. The counter ranges are from 0 to 10,000, from 0 to 5,000 and from 1 to 119.4, for the respective scales. The components of the RPM indicator are enclosed within a metal container which is solder-sealed to prevent dirt from entering.

When performing a check of aircraft engine speed, a "T" adapter is used to break into the cable harness at the aircraft tachometer indicator or generator. By using the three-wire cable assembly provided with the tester and connecting the "T" adapter to the TEST GEN INPUT, the RPM indicator provides an accurate measurement of engine speed. When the tester is used in this manner, the drive should not be operated.

Indicator calibration can be checked by the master tachometer generator. The indicator rpm or percent rpm indication is compared to the reading on the RPM indicator of the tachometer tester.

For additional information on the operation and service instruction of the TTU-27/E tester, refer to NAVWEPS 17-15CM-2.

JET CALIBRATION (JETCAL) ANALYZER

Of the many factors affecting jet engine life, efficiency, and safe operation, two of the most

important are exhaust gas temperature and engine speed. Excess exhaust gas temperature of a few degrees reduces turbine blade life as much as 50 percent. Excess exhaust gas temperature resulting from excess engine speed can cause premature engine failure. Either of these conditions makes engine operation extremely dangerous. Low exhaust gas temperature reduces jet engine efficiency and thrust. The JETCAL analyzer is used to detect and prevent these conditions.

Indications of fuel system trouble, tailpipe temperature, and rpm can be more accurately checked with the JETCAL analyzer than with the gages in the aircraft cockpit. With proper utilization of the JETCAL analyzer, malfunctions in these systems can be detected.

The JETCAL analyzer (fig. 3-38) is a rugged portable instrument, fabricated of aluminum, stainless steel, and plastic. The major components of the analyzer are the thermocouples, RPM and EGT indicators, resistance and insulation check circuits, and the overheat detection system test circuits.

On the EGT system functional test and the thermocouple and harness checks the JETCAL analyzer has an accuracy of plus or minus 4°C at the test temperature, which is usually the maximum operating temperature of the jet engine. Maximum engine operating temperatures are found in the applicable Maintenance Instructions Manual (MIMs).

The first test to be performed is a functional test of the EGT system. This test is made by heating the engine thermocouples in the tail cone of the engine to test temperature. This heat is supplied by heater probes through the necessary cables connected to the JETCAL analyzer. To measure the temperature of the heater probes, thermocouples are embedded in the probes. The temperature of the heater probes is read on the JETCAL potentiometer while the temperature of the aircraft thermocouples is read on the aircraft EGT indicator. The readings are then compared for accuracy.

The junction box that is supplied with the JETCAL set is wired in parallel, therefore it is not necessary to have heater probes connected

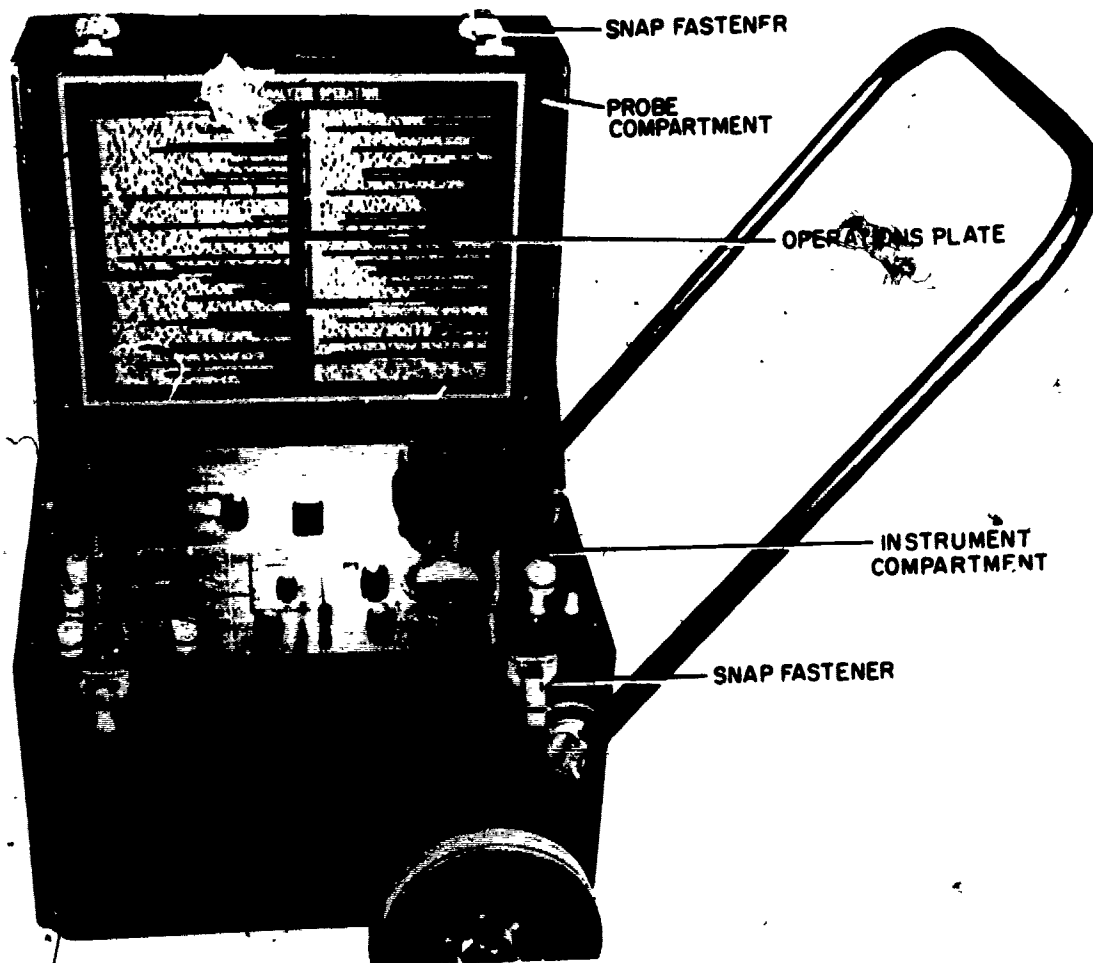

207.282

Figure 3-38.—Jetcal analyzer.

to all the outlets of the junction box when making a check. On engines that have a balancing type thermocouple system, the balancing thermocouple must be removed from the circuit, the remaining thermocouples can then be checked individually or together. The balancing thermocouple is checked, using a single probe, the output of the balancing thermocouple is read on the JETCAL potentiometer and compared to the heater probe thermocouple reading. The JETCAL is used for nozzle scheduling because exhaust gas temperature is extremely critical in engine operation. During temperature adjustments, all

temperature readings must be made on the JETCAL potentiometer. This is necessary because engine temperature must be accurately read to ensure the operator that the engine is operating at optimum engine conditions. When the engine is to be checked and exhaust gas temperature adjusted, a switch box can be installed in the EGT circuit at the beginning of the test, the switch box is used to switch the cockpit indicator into the circuit or to switch the temperature indication of the engine thermocouple and harness to the JETCAL potentiometer. However, temperature readings from the engine thermocouple and harness can

also be read on the JETCAL analyzer by making the necessary connections.

Incorporated in the analyzer is the TAKCAL unit (rpm indicator) check circuit, the purpose of which is to read engine speed with an accuracy of ± 0.1 percent during engine operation. An additional use of the TAKCAL unit check circuit is to troubleshoot the aircraft's tachometer system. After the exhaust gas temperature and engine speed systems have been tested for accuracy and any malfunctions corrected, the operator may use selected portions of the JETCAL analyzer circuits to establish the proper relationship between exhaust gas temperature and engine speed.

The JETCAL analyzer requires a power supply of 95 to 135 volts, 50 to 400 Hertz, and will operate in temperatures from minus 55°C to plus 70°C . A 95- to 135-volt ac power supply must be used for the TAKCAL unit check and the thermocouple check. All other operations can be performed by using emergency batteries when an external power supply is not available. The batteries are actuated by a pushbutton switch. When the switch is released, the batteries are out of the circuit. However, the switch can be depressed when using ac without damage to the batteries. To preserve the life of the emergency batteries, use an external ac power supply whenever possible.

The JETCAL analyzer has eleven primary and separate functions. They are:

1. To functionally check the entire jet aircraft exhaust gas temperature system for error without running the engine or disconnecting the wiring.
2. To check individual thermocouples before placing them in the aircraft.
3. To check each engine thermocouple for continuity.
4. To check the thermocouples and harness for accuracy of output.
5. To check the resistance of the EGT circuit, without the EGT indicator, to assure allowable limits.
6. To check the insulation of the EGT circuit for shorts or grounds.

7. To check the EGT indicators.

8. To check engine thermocouples and harness on the engine with the engine removed from the aircraft.

9. To read engine rpm to an accuracy of ± 0.1 percent during engine runup.

10. To use the rpm check (TAKCAL) and potentiometer to establish the proper relationship between exhaust gas temperature and engine speed on the engine runup during tabbing. (Tabbing is the procedure followed to adjust fixed or variable exhaust gas tail cone areas during normal checks of the aircraft, approximately every 30 to 50 hours.)

11. To check aircraft fire detector, overheat detector, and wing anti-icer systems by using tempcal probes.

For the proper procedure of checking and adjusting the variable nozzle system of a particular aircraft, refer to the Maintenance Instructions Manual for that aircraft. Detailed instructions for adjusting the EGT with the JETCAL analyzer can be obtained from the applicable Maintenance Instructions Manual.

PRESSURE-TEMPERATURE TEST SET, TTU-205B/E

This Tester (fig. 3-39) is used to provide regulated pitot and static pressure for evaluating performance characteristics of aircraft pneumatic instruments, air data systems, and other auxiliary equipment. The Tester is also used to conduct dynamic tests, quantitative calibration tests, pneumatic-system leak tests, and total temperature probe tests.

The test set is a single, compact assembly comprising a control panel and components assembly, and a combination carrying case with a removable cover. All of the controls, indicators, switches, electrical and pneumatic connectors are mounted on the front panel of the test set. All of the components are mounted on the underside of the control panel, which makes the subassemblies and components easily accessible when the panel is removed from its carrying case. The test set simulates airspeed and

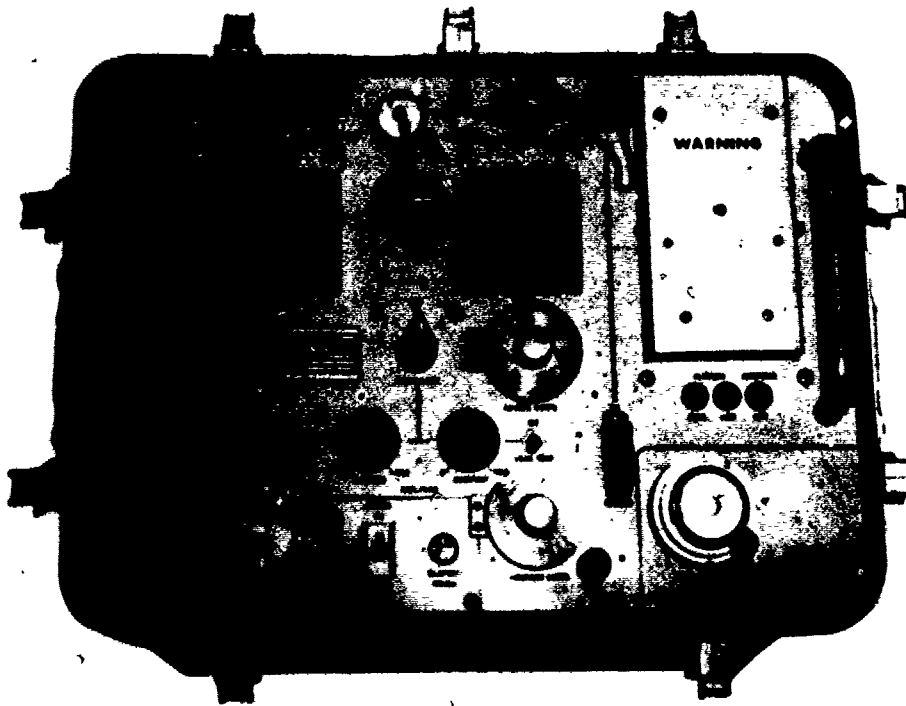

Figure 3-39.—Test Set, Type TTU-205C/E.

207.392

altitude information which is displayed on the front panel. See Table 3-5 for test set particulars.

The test set has the following capabilities;

a. Performs overall system checks on the following equipment, either installed in or removed from the aircraft:

Pneumatic Systems

Air Data Systems

Flight Instruments

Pneumatic Ancillary Equipment

b. Provides simulated total temperature for the USAF MA-1 Probe, which is a platinum resistance sensing element whose resistance is 50.0 ohms at 0°C.

c. Connects directly into aircraft's pneumatic system to measure and control static pressure (P_s) and pitot pressure (P_T) that is required for the pneumatic instruments on the aircraft.

d. Accepts electrical power from an external source.

e. Incorporates safety features that prevent damage to test set and the Unit under test.

CAUTION: The power requirements for this Tester are 115 volts single phase and 400 Hz. For on-bench or hangar use, ensure that the correct frequency of 400 Hz. is available. The tester will not work on 115 volts, 60 Hz. power.

CAPACITIVE-TYPE LIQUID QUANTITY TEST SET TF-20

Many types of capacitive fuel quantity testers are used in naval aviation. All operate on the same basic principle—that of a variable capacitor. Since it is impractical to describe all of the various testers, only the TF-20 is discussed. It will test most of the capacitive fuel

AVIATION ELECTRICIAN'S MATE 3 & 2

Table 3-5.—Pressure-temperature test set, TTU-205C/E

Power Requirements:	
AC Input	115 volts, 400 Hz., Single phase
Power Consumption	350 VA (approx.)
Weight	97 pounds
Dimensions:	
Length	22.85 inches
Width	17.23 inches
Height	13.25 inches
Volume	3.0 Cubic feet
Range:	
Altitude	-1500 to +80,000 feet (approx. 31.5 to 0.82" Hg A)
Airspeed	50 to 1000 knots (approx. 0.12 to 73.55" Hg diff.)
Static Load Range	5 to 250 cubic inches
Pitot Load Range	5 to 100 cubic inches
Slew Rate:	
Altitude	0 to 35,000 feet/minute
Airspeed	0 to 700 knots/minute
Static Test Fixture Vacuum	More than 4 psi below ambient
Temperature Simulation	30.0 to 129.9 ohms (approx. -99 to +430°C)
Pressure Modulation:	
Frequency	0.05, 0.25 and, 0.50 Hz
Amplitude	Variable

quantity systems that are now in use on naval aircraft.

The Model TF-20 Liquid Quantity Test Set (fig. 3-40) contains circuitry which makes the tester capable of:

1. Measuring tank unit probe capacitance.
2. Measuring tank unit insulation resistance.

3. Simulating the total capacitance of a probe for checking the aircraft fuel quantity indicator.

4. Calibrating the test set capacitance indicator dial and the megohmmeter scales

Tests can be performed with the fuel-gaging system either installed in the aircraft or removed from the aircraft. The test set includes a transit case, a shock mounted instrument case, and a set

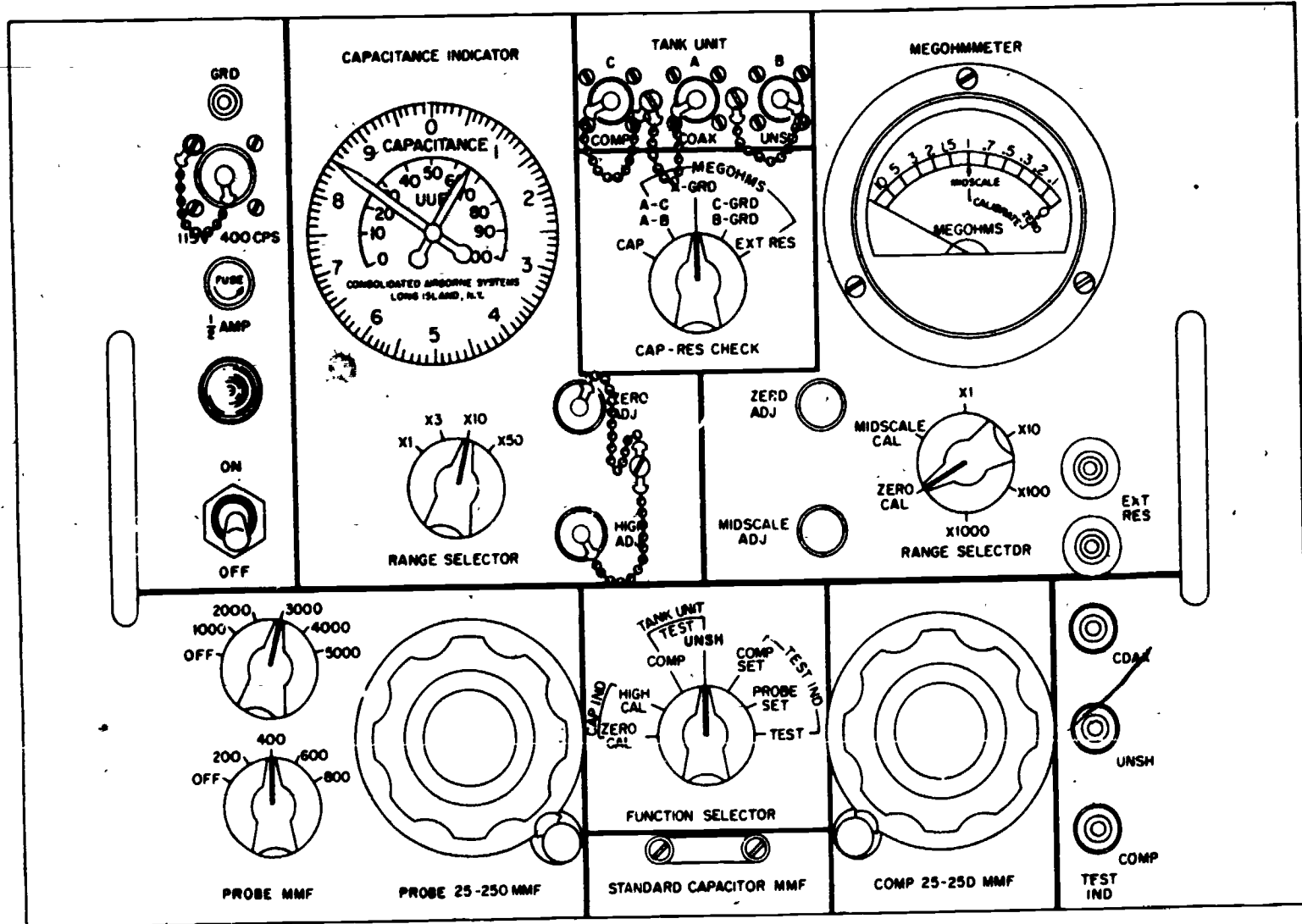

3-71

Figure 3-40.—TF-20 Liquid Quantity Test Set.

207.298

of adapter cables. Circuitry is provided for measuring capacitance, for measuring dc resistance, and for simulating the capacitance of compensated and uncompensated type fuel tank probes. The instruments operate with 115-volt, 400-Hz power.

The capacitance indicator (containing a servomotor, gear train, and rebalance potentiometer) and the megohmmeter indicator are hermetically sealed. To prevent electrical leakage, teflon insulators are employed at points where the megger section assembly is secured to the chassis. The ZERO ADJ and MIDSCALE ADJ variable resistors are secured to the panel through teflon washers and bushings. Teflon-insulated wire is used throughout the megger section assembly. The reference capacitor assemblies in the capacitance-measuring circuit are hermetically sealed after adjustment at the factory. All transformers are potted and use glass headers for minimum electrical leakage. A binding post is provided at the upper left area of the front panel for the purpose of establishing a reference ground potential.

All operating controls are mounted on the front panel as shown in figure 3-40. Three BNC type receptacles, at the top center of the panel designated COMP, COAX, and UNSH provide a means of connecting the tester to the tank unit probe under test. A pair of binding posts at the right center of the front panel, designated EXT RES, permits connecting the tester to a source of unknown high external resistances. These binding posts are used when it is not feasible to connect the tester to the TANK UNIT receptacles with the accessory cables supplied. Another set of three BNC type receptacles, designated COAX, UNSH, and COMP, are provided at the bottom right area of the panel. These three receptacles provide a means of connecting the tester to the aircraft fuel-quantity-gage indicator with the accessory cable supplied.

All adjustment controls required for self-calibration of the tester are accessible on the front panel. The ZERO ADJ and HIGH ADJ controls (to the right of the capacitance RANGE SELECTOR) provide a means of setting zero and the high end of the scale on the CAPACITANCE indicator. The ZERO ADJ and MIDSCALE ADJ controls (to the left of the

megohmmeter RANGE SELECTOR) are used for adjusting the MEGOHMS indicator so that its pointer will position at zero and at midscale. These four adjustments are provided with covers so that the calibrating controls will not be inadvertently disturbed when the test set is being used.

In any case, adherence to instructions in the applicable Maintenance Instructions Manual for the system being tested is mandatory.

ANGLE-OF-ATTACK TEST SET AN/PSM-17A

The purpose of this test set is to provide for tests, adjustments, calibration, simulation, and monitoring of the angle-of-attack indicating system installed in naval jet aircraft. The test set also provides facilities for testing the aircraft approach lights, cockpit index lights, and the stall warning system.

The test set (fig. 3-41) consists of a control panel enclosed in a case with the necessary cables and components to interconnect and test the angle-of-attack system and associated components without their removal from the aircraft.

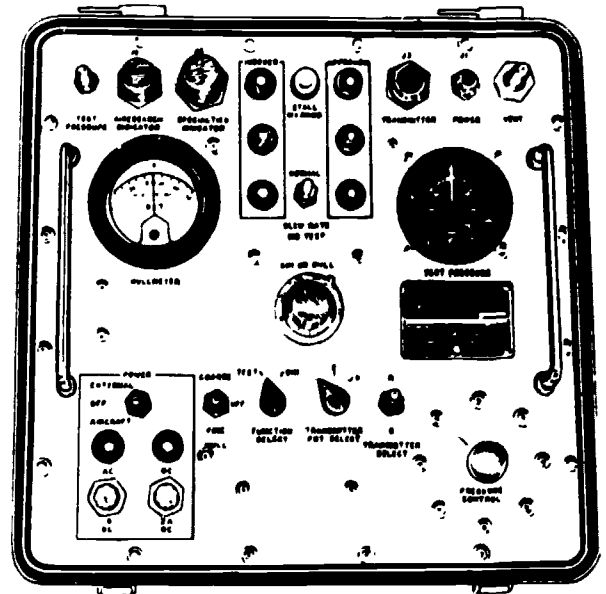

207.309

Figure 3-41.—Angle-of-attack test set.

The control panel contains a microammeter, a differential pressure gage, a potentiometer control, a bellows assembly, indicator lamps, electrical connectors, and various toggle and rotary switches to select and control circuits within the test set.

A ratiometer system comprises the largest portion of the test set. This system consists of the nullmeter, the SIM OR NULL potentiometer control and the NULL switch. Operation of the system enables the angle-of-attack transmitter to be tested by placing switches in various positions and using the potentiometer dial to simulate known inputs to the indicators.

A pressure system, consisting of a differential pressure gage, test pressure connector, bellows assembly, pressure control, and surge chamber (test set case) is used to dynamically test the angle-of-attack transmitters.

By positioning the control on the bellows assembly, an air pressure or vacuum is transmitted through a hose to parts in the

angle-of-attack transmitter probe. This slight pressure causes the probe to rotate. Thus, the pressure system of the test set is used to simulate conditions corresponding to various angles of attack of the aircraft.

A series of indicator lamps (three indexer, three approach, and a stall warning) are installed on the test set control panel and are used to simulate the action of the aircraft indexer and approach lights and the stall warning vibrator. Two additional lamps are used to indicate when ac and dc power is being supplied to the test set.

The power requirements for the test set are 28 volts dc and 110-120 volts, 400 Hz, single phase ac.

ATTITUDE-HEADING REFERENCE SYSTEM ANALYZER AN/ASM-78

The AN/ASM-78 analyzer (fig. 3-42) is used to test several compass systems used in naval aircraft. The analyzer is to be used on the

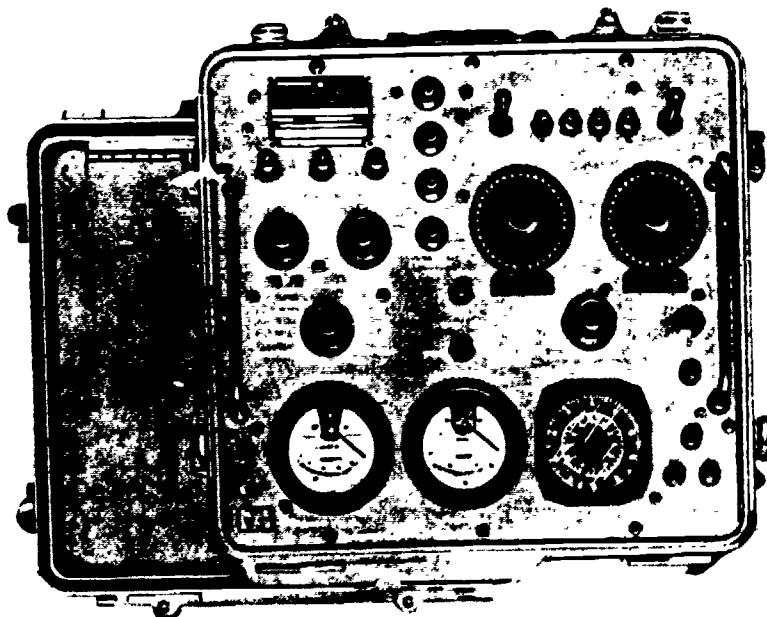

Figure 3-42.—AN/ASM-78 attitude-heading reference system analyzer.

207.310

aircraft, and through the use of test cables is inserted in the system in series between the sensors and the indicators. Controls and indicators on the test set provide the capability of testing and monitoring such system components as the displacement gyro, power supply, compass adapter, etc. Simulators on the test set provide for monitoring inputs to the compass and attitude indicators.

Capability of the analyzer is limited to locating a malfunctioning component (compass adapter, displacement gyro, etc.) or an electrical wiring problem. Component repair is then accomplished in accordance with instructions for repair of the component in question.

When using the analyzer, the interconnecting cables are connected to the aircraft through test receptacles mounted in the aircraft. When the test set is connected, many of its circuits are in series between the appropriate sensor and the indicator. When the test set is not connected, shorting plugs must be connected to these receptacles so that the circuit is completed for proper operation of the system.

**AIR-CONDITIONING TEST SET
AN/PSM-21A**

The PSM-21A (fig. 3-43) is used for flight line checkout and troubleshooting of electrical components in the cabin, pressure suit, and equipment air-conditioning systems. To accomplish checkout of these systems external electrical power must be applied to the aircraft.

Checkout of the system under test involves simulation of sensor and limiter inputs by the test set. External test equipment may be

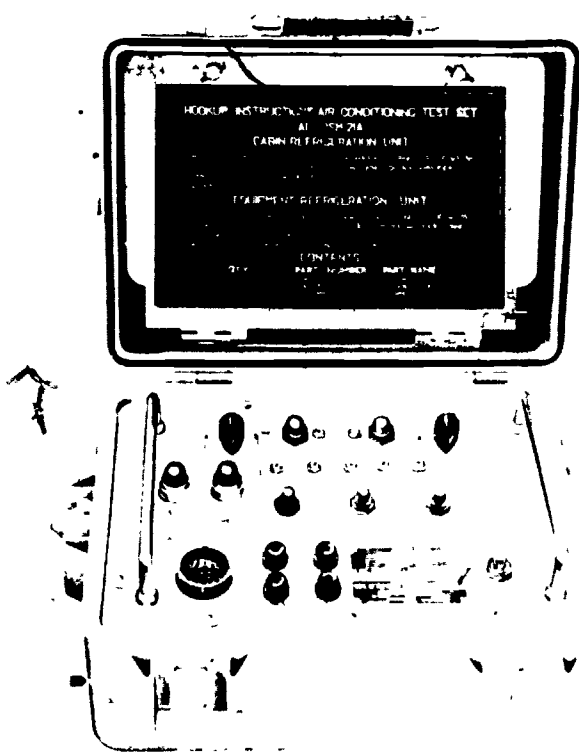

207.311

Figure 3-43.—Air-conditioning Test Set AN/PSM-21A.

connected to test points on the test set to measure resistance, voltage, or waveforms to determine if system operation is correct. System operation may also be determined by visual monitoring. For example, with a known electrical input into the air conditioning system, air conditioning valves should move to a known position.

CHAPTER 4

AIRCRAFT ELECTRICAL POWER SYSTEMS

AIRCRAFT ELECTRICAL POWER SOURCES

One of the first uses of electrical power in aircraft occurred in 1915 when a standard shipboard radio set with a battery power supply was first installed in an aircraft. By the beginning of World War I, it had been determined that airborne radio was practical and installations were made in aircraft, using 45-volt dry cell batteries and 6-volt storage batteries.

Energy for the operation of electrically operated equipment in aircraft is supplied by either dc generators or ac generators. A generator is a machine that converts mechanical energy into electrical energy by electromagnetic induction. A generator that produces alternating current (ac) energy is sometimes called an alternator. In most cases, however, as in this text, an alternator will be referred to as an ac generator. A generator that produces direct-current energy is called a dc generator. The major difference between an ac generator and a dc generator is the method by which the electrical energy is collected and applied to the external circuit. For a detailed discussion of generator theory refer to the *Navy Electricity and Electronics Training Series (NEETS)*.

The dc generator is still used as the source of electrical energy in some Naval aircraft. Dc generators driven by the aircraft engine(s) supply electrical energy for the operation of all dc equipment in the electrical system and energy for charging the aircraft battery when installed. Ac power is supplied by the use of inverters on these aircraft. On most modern high performance jet aircraft, patrol aircraft, and helicopters, electrical energy is supplied by ac

generators. Dc power for these aircraft is obtained by using transformer-rectifier (TR) units.

DC GENERATORS

Generators used in naval aircraft differ somewhat in design because they are built by various manufacturers. All, however, have the same general construction and operate similarly. Figure 4-1 shows a dc generator used on a typical Navy aircraft.

The most common aircraft dc generator is the 28-volt shunt type machine, that is, the field windings are connected in parallel with the armature. High-output generators also employ commutating poles (interpoles) and compensating windings. These are employed to minimize brush sparking and communication interference by counteracting the self-induced emf in the coil undergoing commutation and by opposing field distortion due to armature reaction. The magnetic field from these windings

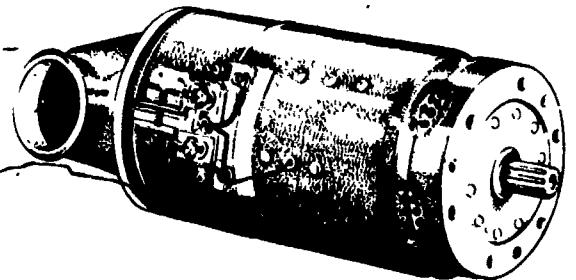

207.104

Figure 4-1.—Typical dc generator.

does not add to that produced by the shunt-field winding for producing output voltage, thus, these generators are not classified as compound generators.

Current Range

Shunt generators for aircraft are designed for a wide range of current capacities. Generators used on basic type training aircraft and light observation and reconnaissance aircraft, which have a minimum of electrical equipment, sometimes use generators rated as low as 50 amperes. Some types of aircraft contain so much electrical equipment that they require more than one generator in order to supply enough current for the load. It is not uncommon to find two or more shunt generators mounted on one aircraft.

The use of more than one generator on an aircraft provides a safety factor. Should one generator become inoperative the electrical system will still have a source of generator power. In the multigenerator aircraft the normal electrical demands are such that the generators are loaded considerably below their maximum capacity. This allows near-normal operation in the event one of the generators fails since the others can absorb the load and still not be overloaded.

Speed Range

Aircraft generators are designed to operate within two different speed ranges. The speed range is that range of speed in which a generator must be operated in order to obtain rated generator output; that is, rated voltage at all values of load current with the current range of the generator. The low-speed range is approximately 2,000 to 4,500 rpm and the high-speed range is approximately 3,000 to 8,000 rpm. Either end of these ranges may vary slightly, depending on the design of a particular generator. Some generators are designed to operate at an upper speed range as high as 10,000 rpm.

AC GENERATORS

The use of the ac power system has resulted in better design and utilization of equipment. Typical electronic equipment, powered from dc power, may have an inverter as an integral component for supplying ac power and a dynamotor for supplying higher voltage dc power. These components are very heavy for their relative power outputs as well as being sources of unreliability and increased maintenance. The same ac powered electronic equipment could obtain various ac voltages and dc power by the use of simple transformers and transformer-rectifiers, respectively. These components are light-weight, simple, reliable devices. For the past several years, nearly all the new aircraft designs have included ac primary power systems.

As total aircraft power requirements continue to grow, and as the majority of aircraft equipment is converted to ac power, it can be seen that the predominant power system for naval aircraft is 3-phase, 120/208-volt, ac. The factors which determine the frequency of the voltage produced by a generator are the number of magnetic poles in the machine and the rate of rotor rotation. With the number of poles a fixed quantity, constant frequency requires constant rotor speed.

The 120/208-volt, 400-hertz, ac power system has many advantages over the 28-volt dc system. Due to higher voltage and a 4-wire (ground neutral) system, the current carried in each wire is only a fraction of that required for the same power in a 28-volt dc system. This permits the use of much smaller aircraft wiring with a great saving in weight. The ac generator itself, especially in the larger sizes, and many of the system control and protection components are lighter. While 12 kilowatts appears to be the practical limit to the size of a dc generator that can be successfully mounted on an aircraft engine, up to 75-kilovolt-ampere ac generators are now found on some naval aircraft. Service difficulties, such as high altitude commutation problems and brush wear, are greatly reduced in ac generators. Most types of ac generators now in use completely eliminate brushes.

Types of AC Generator

The many types of ac generators used on Naval aircraft range in size from the relatively tiny tachometer instrument generator up to the 75,000 volt-ampere generators. Regardless of weight, shape or rating, practically all of these generators have the following characteristics in common:

1. The ac output is taken from a set of stationary windings (stator).
2. The ac generator field (rotor) is a rotating magnetic field with fixed polarity.
3. Where voltage control is used, it is accomplished by controlling the strength of the rotating magnetic field.
4. The frequency of the output voltage is controlled by regulating the speed of rotation of the rotating magnetic field.

Present military specifications require that the basic aircraft ac power system produce voltage with a value of 120 and 208 volts. A 3-phase generator is actually three separate power sources enclosed in one housing (fig. 4-2 (A)). In order to produce the required 120/208-volt output, external connections must be made to form a wye as shown in figure 4-2 (B). Each output winding will produce 120 volts as measured from n to a, b, or c. If two separate phase voltages are measured together (a to b, a to c, or b to c) then the voltage output will be 1.73 times the single-phase voltage (208 volts).

In the 4-wire grounded neutral, wye connected system, as applied to aircraft, the neutral wire is connected to the frame of the aircraft, which in this case constitutes ground. The 3-phase wires are then connected to buses from which power is taken to supply the various loads. Those loads operated line-to-neutral are connected between one of the buses and the aircraft frame. Those operated line-to-line are connected between two of the buses.

The line-to-line voltage found in a 3-phase, wye-connected system is the vector sum of the voltages generated by two separate phase

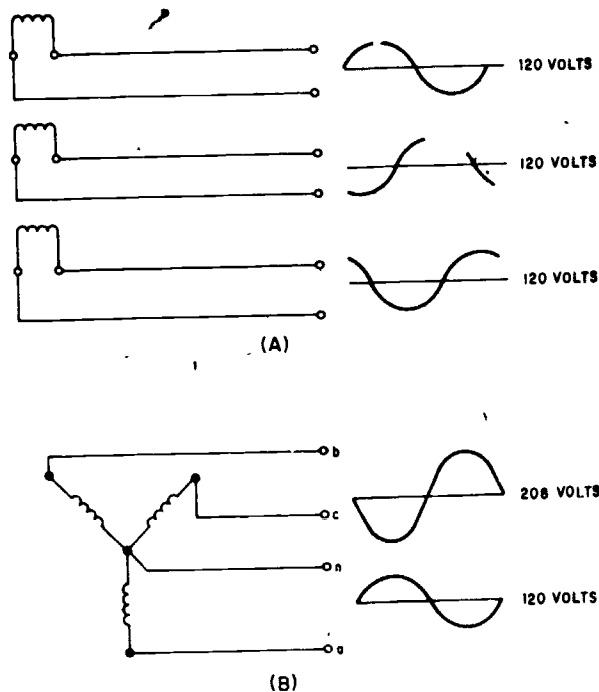

207.27

Figure 4-2.—Three-phase ac generator output.

windings. Because a phase difference of 120 degrees exists between the two generated voltages, they reach their peak amplitudes at different times and consequently must be added vectorially, not directly.

BRUSH TYPE.—Figure 4-3 shows a brush-type 3-phase ac generator. This ac generator is an engine-driven, wide speed range, variable-frequency power supply. It provides 30-kilovolt-amperes (kva) of 3-phase power at 120/208 volts, 400/800 hertz at a 90 percent minimum lagging power factor, when rotated from 4,000 to 8,000 rpm.

Figure 4-4 shows the internal wiring of this ac generator. It contains a separate dc generator called an exciter. The exciter output is controlled by an external voltage regulator which varies the resistance in series with the exciter shunt field winding. The exciter output is also routed through sliprings to the ac generator field windings. The magnitude of the dc voltage passing through the field windings

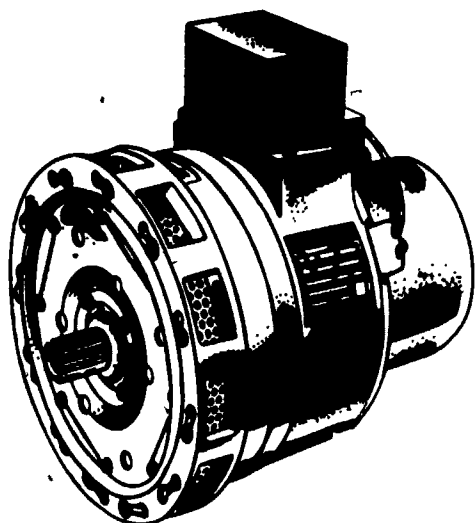

207.122

Figure 4-3.—Brush-type 3-phase generator.

The collector rings, exciter armature, rotating field, and a fan are mounted on the same shaft which is supported between two bearings. This shaft is driven by a flexible drive spindle which mates directly in the engine-drive spline. A friction damper is incorporated to damp twisting oscillations, thereby reducing spline wear and preventing spindle breakage. The fan provides ventilating air while the aircraft is on the ground and there is no ram air pressure. This gives sufficient cooling for the generator to deliver power at a 25 percent rated load (maximum) continuously.

The stationary member of the generator is made up of the ac armature and the dc exciter field. Both ac and exciter terminal boards are mounted so that they are easily accessible. All brush rigging is located on the generator and is protected with a brush cover. Slotted-hole type mounting provides for ease in attaching to the engine pad. Capacitors connected between the exciter armature terminals and ground suppress radio noise.

determines the strength of the magnetic field and thus the voltage of the ac generator.

Figure 4-5 is a disassembled view of the main assembly of an ac generator. It shows those items which are of importance to AE personnel.

The ac generator rotating field has 12 poles with adjacent poles being of opposite polarity.

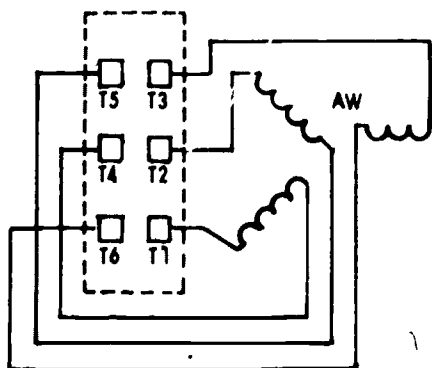

- SFW - EXCITER SHUNT FIELD WINDING.
- AW - AC GENERATOR ARMATURE WINDING.
- FW - AC GENERATOR FIELD WINDING.
- SW - EXCITER SERIES WINDING.

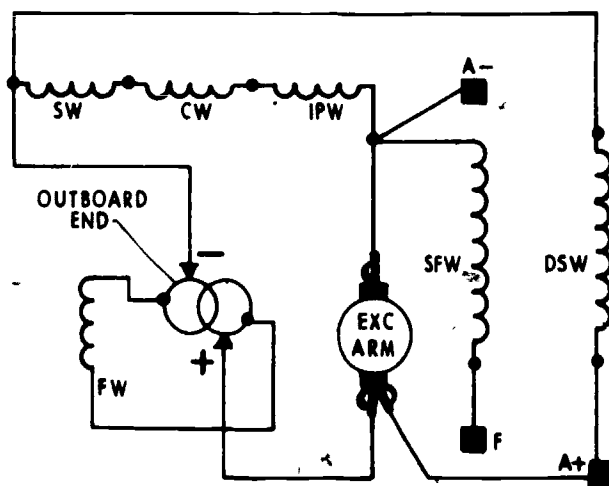

- CW - EXCITER COMPENSATING WINDING.
- IPW - EXCITER INTERPOLE WINDING.
- DSW - EXCITER DIFFERENTIAL SHUNT WINDING.

207.124

Figure 4-4.—Internal wiring diagram of brush-type ac generator.

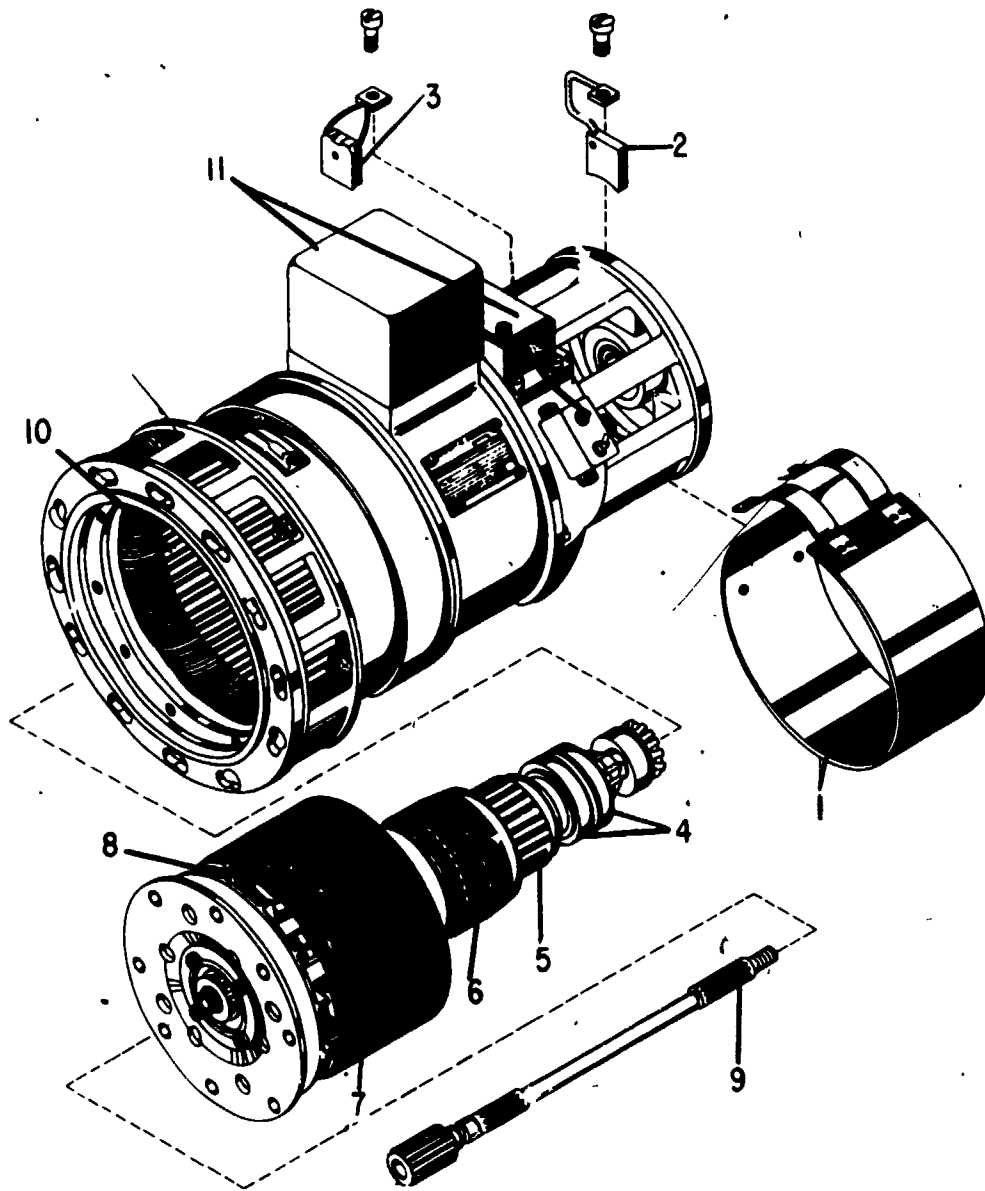

207.123

Figure 4-5.—Disassembled aircraft brush-type ac generator.

One cycle per revolution is produced by each pair of poles; thus, 6 cycles are produced per revolution. The output frequency of the generator varies in direct proportion to the engine drive speed. A generator operating at 6,000 rpm is operating at 100 revolutions per second or at 600 hertz.

BRUSHLESS TYPE.—Most aircraft are using a new concept in voltage generation. This concept eliminates the need for brushes in the ac generator. The advantage of a brushless generator over a brush type is its increased reliability and a greater operating time between overhaul, principally because there are no

brushes or sliprings to wear and contaminate the segments as in a brush-type generator. Figure 4-6 is a disassembled view of the main assembly of a brushless generator. It shows those items which are of importance to AE personnel.

The brushless generator shown in figure 4-6 is a salient 8-pole, 6,000 rpm ac generator with a 12-pole ac exciter and a three-phase, half-wave diode rectifier assembly mounted to rotate with the exciter armature and main alternator field assembly. The exciter rotor consists of a hollow frame assembly with the main ac field mounted on the inside of the assembly and connected to a common drive shaft. A single-phase permanent magnet generator (PMG), assembled with the exciter rotor, furnishes control voltage and power for the voltage regulator. Three rectifiers are mounted on the exciter rotor and connected to the exciter armature windings. The engine reduction gearing is protected from possible damage, if the generator should seize, by a shear pin action that is incorporated in the generator stub

shaft. A cooling air fan mounted at the drive end of the generator provides an airflow around the rotor and stator windings and also through the hollow shaft (on which all rotating components are mounted) to provide a flow of air to the drive and bearings.

Some aircraft have generators that are cooled by oil. The oil enters the generator through an inlet port and leaves through an exit port located in the mounting flange of the generator. As the oil passes through the generator, it absorbs the heat from the rotor and stator. At the same time, it cools the rotating seals and lubricates and cools the bearings. Aircraft engine oil is used for cooling the generator and also for operating the constant speed drive.

As the generator starts to rotate, (fig. 4-7) the permanent magnet generator (PMG) starts supplying single-phase ac voltage to the voltage regulator and other protective circuits. The PMG power is rectified and supplied to the exciter

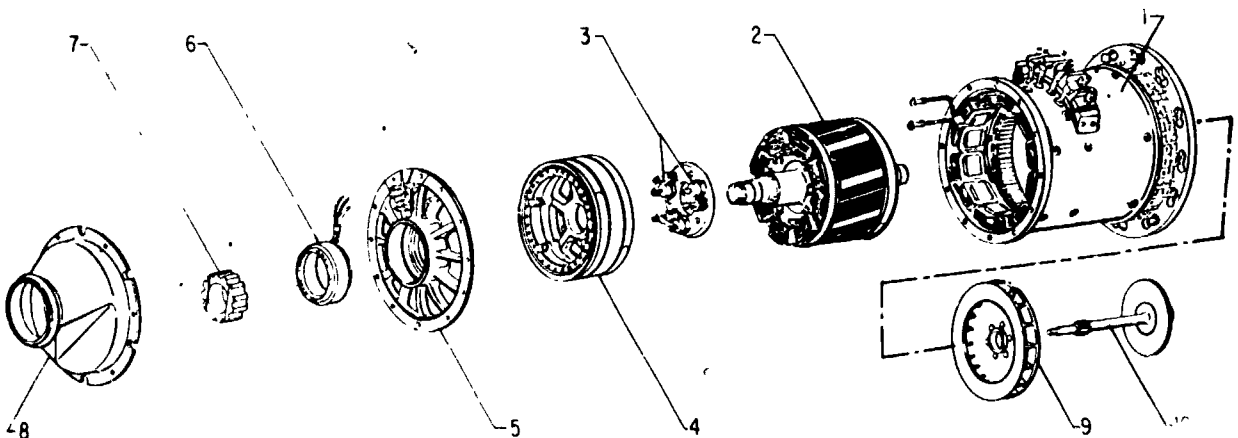

1. Stator assembly.

2. Rotor and shaft.

3. Rotating diode assembly.

4. Exciter rotor.

5. End bell.

6. PM generator stator.

7. Permanent magnetic rotor core.

8. Generator to air duct adapter.

9. Fan assembly.

10. Drive shaft assembly.

Figure 4-6.—Disassembled brushless ac generator.

207.126

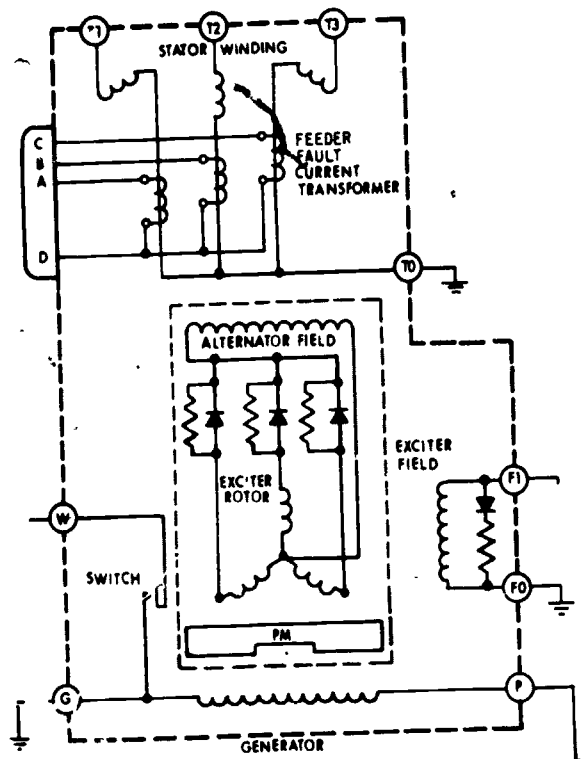

207.126
Figure 4-7.—Sectional schematic of a brushless ac generator.

field, and the resulting electromagnetic field, built up by the excitation current flowing in the exciter stator, induces current flow in the rotating 3-phase exciter rotor. This current is half-wave rectified by the shaft-mounted rotating rectifiers, and the resultant direct current is applied to the rotating field winding of the 3-phase ac generator. The rotating electromagnetic field induces an ac voltage in each leg of the 3-phase, wye-connected output winding of the generator stator. Voltage regulation is accomplished by varying the strength of the exciter stationary field. By using an integral ac exciter, the necessity for brushes within the generator is removed and minimization of radio noise is accomplished by the absence of brushes.

Protection against the shorting of any feeder line between the generator and the bus it powers

(called feeder fault) is provided by two 3-phase differential transformers. One transformer is mounted on the generator as shown in figure 4-7, and its coils sense the current flow through each of the legs that connect the ground side of the generator stator to ground. The other transformer is located at the main bus and senses current flow through the three feeder lines. Should a short occur in the feeder line, a difference in current flow between the two transformers will be detected by a sensing circuit and remove the generator from the line.

A generator mechanical failure warning device is incorporated in the generator. It consists of a soft copper strip embedded in and insulated from the generator stator assembly. Should a bearing begin to fail, increased bearing clearance allows the rotor to rub against the stator, thus wiping the copper strip across the insulation and completing a warning light circuit to ground.

Prime Movers

The device, such as an aircraft engine, that provides the driving force for a generator, is called the prime mover. Early attempts were made to control the rotor speed of ac generators by the use of variable-pitch propellers or slipping clutches. Due to the unsuitability of these early methods, most ac generator power was of variable frequency; that is, it was generated by an ac generator directly driven by a reciprocating engine. This usually gave approximately a 2 to 1 speed range from maximum engine power to minimum cruise, and the engine gear ratio was chosen to give power from 400 to 800 Hertz. However, ground idle speed of the engine was usually considerably below that required to obtain 400 hertz, and no usable power could be taken from these generators on the ground.

It became apparent that great weight savings and vastly improved performance could be effected in utilization of equipment if power could be supplied at an essentially constant frequency. As the total power requirements grew, the point was reached, from a weight and performance standpoint, where it was more

advantageous to furnish the ac power at a constant frequency. The constant frequency is obtained by a hydromechanical constant-speed drive which converts the variable engine speed to a constant speed output to drive the generator. A constant speed can also be obtained by the use of an air or gas turbine generator drive or by the constant rpm of a turboprop engine. The air or gas turbine may obtain its air supply by using bleed air from the jet engine compressor or from a separate compressor.

The hydromechanical drive will hold the frequency steady within a few Hertz of the desired 400, and load and fault transients are held approximately within a 380- to 420-Hertz range. Air or gas turbine drives are somewhat smoother in operation and hold steady-state frequencies within ± 10 Hertz.

The constant-speed characteristic of the turboprop engine ensures good frequency stability of the ac generator output. Frequency stability is maintained within very close limits through control of engine speed by the propeller synchrophaser system which holds the rpm constant and the ac generator frequency to 400 ± 0.8 Hertz. Should the synchrophaser fail, the propeller-governing mechanical-hydraulic system will hold the generator frequency to 400 ± 4 Hertz.

INVERTERS

On Navy aircraft that rely on dc generators as the primary source of electrical power, ac electrical power is supplied through the use of devices called inverters. Inverters are also used as an emergency source for ac power when normal ac power has failed. An example of this type backup system is found in the A/F-18 aircraft. The standby attitude indicator is normally powered by the right 115V ac bus. If the aircraft's generators fail to supply power to this bus the standby attitude indicator is then powered by an inverter.

Because of such a wide variety in the types and makes of inverters that are installed on aircraft, it is impractical to describe all of them in this manual.

The present standard is the 120-volt, 3-phase, 4-wire, 400 Hertz ac system. The 4-wire system is advantageous over the 3-wire system because it allows a greater choice of single-phase circuits, balancing of the phase loads is improved, it is less vulnerable to power failure, and better frequency and voltage control is obtained. For detailed information about a particular inverter, refer to the manuals on that inverter.

Inverters operate on the same electrical principles as dc motors and ac generators. These principles are discussed in *Navy Electricity and Electronics Training Series (NEETS)*.

In most inverters the dc armature and the ac generating field windings are wound on the same rotor shaft, while the dc motor field and generator output (armature) windings are wound on the stator. A control box is attached to many inverters and contains the necessary devices to control the inverter's operation. These devices consist of the operating relays, voltage regulator and rectifier, filtering units, and smaller circuit components.

The dc motor of most aircraft inverters is essentially a shunt-wound motor. High starting currents and low rate of acceleration (due to low torque at starting) are characteristic of shunt-wound machines. To avoid the effects of these undesirable characteristics on other portions of the aircraft's dc system, the larger inverters employ a series starting winding. When the machine approaches its normal rated speed, relays disconnect the series starting winding and connect the dc input directly to the dc motor armature and the shunt winding. The machine then operates as a shunt-wound motor which has desirable constant-speed characteristics. In some machines, small compensating and commutating pole windings are used in series with the motor armature, but these windings have no effect on the shunt-motor action.

The dc motor converts electrical energy into mechanical energy to drive the generator. The dc load current drawn by the motor depends on the ac load on the generator. The motor speed can be controlled by a speed governor or by pulsating direct current through the field windings. The pulsating direct current is accomplished by a solid state ON-OFF switching circuit. The speed of a dc motor is inversely

proportional to the strength of the field. Therefore, as the motor tends to speed up, a greater current is allowed to flow in the shunt windings, thus reducing the speed. As the motor speed tends to fall below its normal value, less current flows in the shunt-field windings, and the motor speeds up.

The generator ac voltage is proportional to the speed of the rotor and the strength of the generator rotor field flux. The controlled frequency of the ac output is usually fixed at 400 Hz. This frequency is a function of the number of poles in the generator field and the speed of the motor. The number of independent voltages, or phases, in the output is determined by the number of sets of windings on the stator of the generator. In some inverters both 3-phase and single-phase outputs are obtained from the same machine; others are equipped to supply only one type of output—either single-phase or 3-phase. A typical inverter is shown in figure 4-8.

The output voltage rating of aircraft inverters may vary, depending on the type of aircraft in which the inverter is installed and the equipment which it supplies. For example, a number of inverters may be installed in the same aircraft. One may be designed to supply

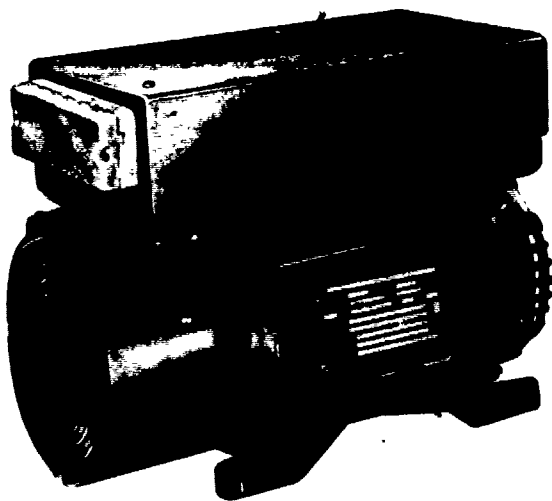

207.132

Figure 4-8.—Typical aircraft inverter.

120-volt, 3-phase alternating current to an essential bus during emergencies. Another may be used continuously to supply 120-volt, single-phase ac power, while still another may be used to furnish 120/208-volt, 3-phase power to a specified bus or equipment.

The output voltage of the machine is usually maintained at an almost constant value by controlling the dc excitation current in the rotor field of the generator. Variation in the output level of the inverter determines the strength of the dc rotating field. The theory of voltage generation and regulation is discussed in *Navy Electricity and Electronics Training Series (NEETS)*.

Instrument Type Inverter

A cutaway view of an instrument inverter used on several types of aircraft is shown in figure 4-9. Inverters of this type do not produce as high an output as the type just discussed and are smaller in size. Refer to figure 4-9 (cutaway view) and figure 4-10 (wiring diagram) when studying the operation of this inverter. Each major component of the inverter is discussed.

MOTOR.—The motor is a compound wound, direct current type; that is, it has one set of field coils connected in parallel with the armature, and one set of field coils connected in series with the armature. The series field develops a high starting torque in order to rapidly bring the motor up to normal operating speed, and the shunt field provides a means of good speed regulation.

The direct current divides into two branches. One branch passes through the motor shunt-field coils and a speed governor assembly; the other passes through the series-field coils, a commutator assembly, and armature coils to ground. The current through the shunt and series coils and the armature coils sets up magnetomotive forces which produce a torque in the armature, causing it to rotate.

Motor speed, which determines the ac output frequency, is controlled by a resistor in series with the shunt field at ground potential. The resistor is cut in or shorted out of the shunt-field circuit by contacts of the speed

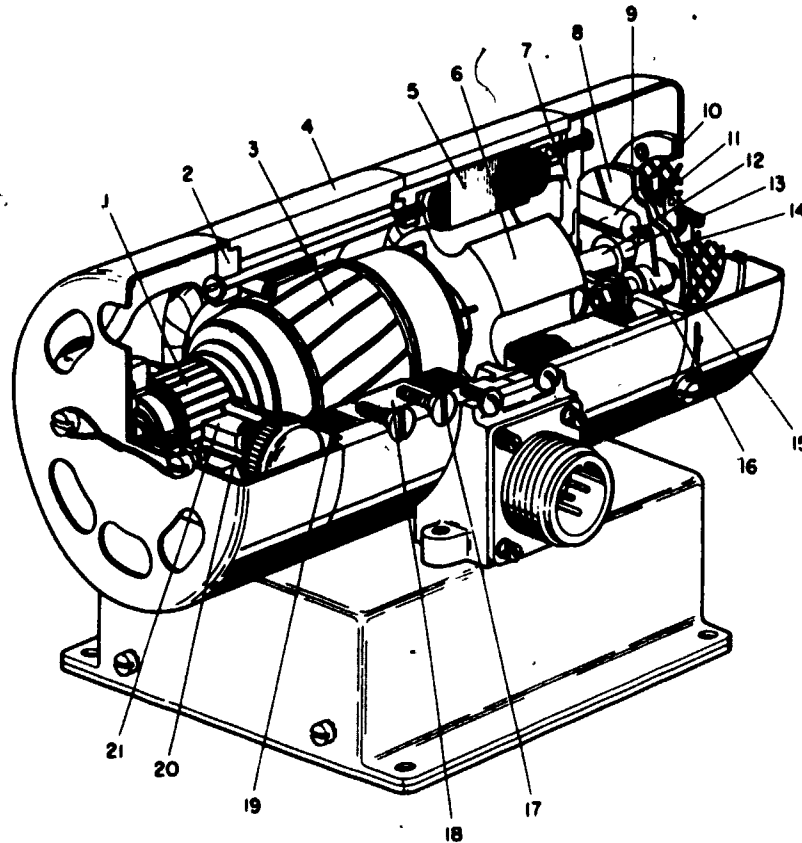

- | | |
|---------------------|------------------------------|
| 1. Commutator | 12. Shaft. |
| 2. Bearing bracket. | 13. Bushing. |
| 3. Armature. | 14. Speed governor. |
| 4. Housing. | 15. Brushes. |
| 5. Stator core. | 16. Brush holder. |
| 6. Rotor. | 17. Screws |
| 7. Bearing bracket. | 18. Pole shoe. |
| 8. Sliprings. | 19. Field coil. |
| 9. Insulator disk. | 20. Commutator brush holder. |
| 10. Capacitor. | 21. Commutator brush. |
| 11. Contacts. | |

207.135

Figure 4-9.—Cutaway view of an E1616-2 inverter.

governor assembly mounted on the generator end of the shaft.

FIELD COILS.—The field coil assembly consists of two field coils. Each is placed around a laminated pole shoe which is secured by two screws to the inside of the steel cylindrical

housing, forming the magnetic circuit. The series and the shunt windings are wrapped together in the same coil.

MOTOR ARMATURE.—The motor armature consists of a core, windings, insulation, and the commutator mounted on the shaft. The

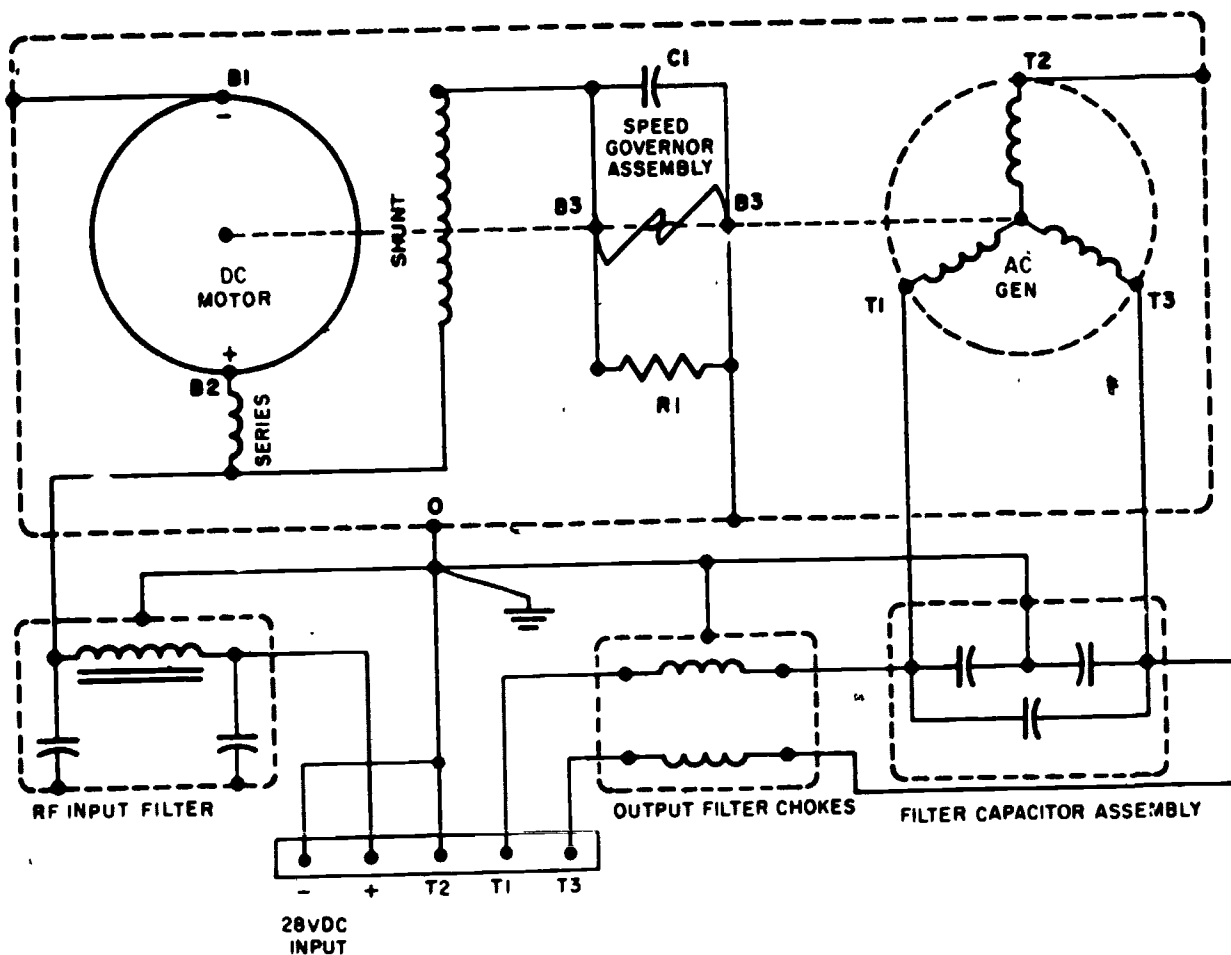

207.136

Figure 4-10.—Inverter E1616-2 internal wiring diagram.

core is made up of a stack of slotted iron laminations held tightly together and anchored to the shaft. The armature winding consists of coils wound in the slots of the core. The ends of the coils are connected to the commutator segments. The shaft rotates in two greasepacked ball bearings.

SPEED GOVERNOR.—The speed governor assembly (fig. 4-9) consists of two sliprings, an insulator disk, and two contacts. Each of the sliprings is a semicircular copper disk. They are both attached to the insulator disk, but do not contact each other. The insulator disk insulates the two sliprings from each other and also from

the metal bushing which contacts the shaft. Two brushes contact the sliprings. One of the brush holders is grounded. The other brush holder is insulated from the ground. The shunt field is connected to the ungrounded brush holder. The ungrounded brush holder is connected through a brush and a slipring to one of the contacts. The other contact is grounded through the opposite slipring and brush. A resistor is connected across the sliprings, in parallel with the contacts of figure 4-10.

Resistance in series with the shunt-field circuit decreases magnetic field strength and increases motor speed. Decreased resistance in the shunt-field circuit lowers motor speed. The

position of the governor contacts with respect to each other determines the path of the shunt-field current and the strength of the magnetic field at any instant. The path may be either through the resistor or through the governor contacts and sliprings, the latter path having a relatively low resistance compared to the resistor. By this means resistance is either added to the shunt-field circuit or removed from it, and the motor speed is controlled.

When the spring-mounted contacts of the governor are closed, shunt-field current flows from one slipring to the other and the resistor is shorted out. The governor contacts open and close by centrifugal action. At rest, the contacts are in a closed position and the resistor is shorted out to result in full field strength and large starting torque when line voltage is applied to the motor. Motor acceleration is rapid, and when rotation begins, the contacts tend to open but do not actually separate until 5,000 to 7,000 rpm speed has been reached. The outer spring is weaker than the inner spring. When speed exceeds 5,000 to 7,000 rpm the outer spring is forced away from the inner by centrifugal action, causing the contacts to open and remove the short on the resistor.

The field current is thereby reduced and the magnetic flux weakened, resulting in armature speed acceleration and creation of additional centrifugal force on the springs. The contact on the inner spring is forced toward the contact on the outer spring by the increased speed. Movement of the latter is limited by the preadjusted screw top. At approximately 12,000 rpm the contact on the inner spring touches the contact on the outer spring, thus again shorting out the resistor, strengthening the field and tending to reduce the motor speed. The speed does not, however drop noticeably within the specified input voltage limits because the action is repeated rapidly to give a high degree of speed stability and minimum hunting effect. Figure 4-11 illustrates the action of the governor contact.

GENERATOR.—The generator consists of a 4-pole permanent magnet rotor (Fig. 4-9, #6) rotating within a 3-phase stator.

The permanent magnet creates a fixed magnetic flux in the stator core when it is at

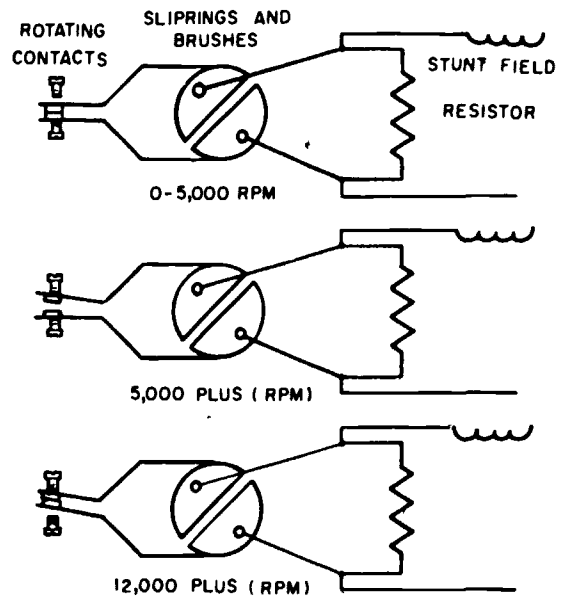

207.137

Figure 4-11.—Action of governor contacts for controlling motor speed.

rest. When the armature revolves, causing the rotor to revolve, the magnetic flux also rotates at the same rate, and cuts the conductors of the stator winding, inducing voltage in it. In a 2-pole generator, the induced voltage causes current to flow in one direction for one-half revolution of the rotor and in the opposite direction for the other half of the revolution, thus completing one cycle. In the generator of this inverter, which has 4 poles, the induced voltage changes the direction of flow four times, completing two ac cycles per revolution. The frequency of the inverter generator voltage is determined by the speed at which the rotor magnet rotates.

The generator stator coils are 3-phase, Y-connected. They consist of three groups of coils connected 120 electrical and mechanical degrees apart. Therefore, three separate voltages are brought out through two leads, plus the stator frame, which is used as the third and grounded lead.

FILTERS.—There are five filters in the inverter; a capacitor (C1, fig. 4-10), across the

speed governor brushes, a capacitor assembly, a filter assembly, and two RF chokes in the filter box. Capacitor C1 suppresses electrical disturbances created by the "make and break" action of the governor contacts. The RF chokes and the capacitor assembly suppress RF disturbances originating in the inverter from the ac output circuits. The capacitor assembly also functions as a power factor corrector to adjust the output voltage to the required value. The input filter assembly consists of two capacitors and a choke. It prevents RF disturbances which may exist in the dc input line from entering the inverter, and also prevents RF disturbances created by the inverter operation from being transmitted to the dc input line.

OPERATION.—Operation of the inverter is entirely automatic. There is no starting switch, load switch, fuse or circuit breaker, or other disconnecting device included in the inverter. Such auxiliaries are usually part of the equipment with which the inverter operates, or are included in the power control and distribution circuits. Voltage control is accomplished by maintaining a constant load.

TRANSFORMERS

A transformer, by itself, cannot be considered a true electrical power source. A true electrical power source must be capable of producing electrical energy from some other type of energy, such as chemical or mechanical. However, the transformer does take electrical energy in the form of an ac voltage and converts it to a different usable ac voltage. The construction and theory of operation of transformers are covered in *Navy Electricity and Electronics Training Series (NEETS)*.

Transformer-Rectifier

Ac powered equipment has been proven to be far more efficient than the larger, heavier dc powered equipment, so the dc generator has

been virtually replaced by the ac generator; therefore, a source of dc power must be provided for such functions as lighting and for control of ac powered equipment. The most common device now used to provide the necessary dc voltage is the transformer-rectifier (TR).

Transformer-rectifiers employ no moving parts, other than a cooling fan, which provides high reliability and ruggedness unmatched by most other avionics equipment. A separate voltage regulator is not required so long as the ac input voltage can be maintained within reasonable limits. Current capability is generally high and is largely dependent on the cooling provided.

Figure 4-12 shows an electrical schematic of a typical transformer-rectifier. It requires 120/208-volt, 3-phase, 4-wire input at 400 Hertz. It has an output capability of 200 amperes at 25.5 to 29.5 volts.

The input ac voltage is applied through pins B, F, and I, through a radiofrequency (RF) filter which is used to reduce noise interference to other avionics equipment in the aircraft, to the wye-connected primary of a stepdown power transformer. The ac output of the wye delta-connected secondaries is rectified by diodes CR1 through CR12, sent through interphase transformer T2, and then through a filter network consisting of L2, C4, and C5 to the load. Interphase transformer T2 has an adjustable center tap which may be set to balance the two delta transformers for equal current output. The filter network reduces the 4800-Hertz ripple voltage to nearly straight-line dc voltage.

Fan motor B1 is connected in parallel with the power transformer primary. This fan motor is highly essential to proper operation and provides the only moving parts of the transformer-rectifier. A thermostat (S1) is provided to detect excessively high temperatures and, in conjunction with external circuits, can turn on an overheat warning light, automatically disconnect the input, or perform both functions.

Autotransformer

The autotransformer is similar in most respects to an ordinary transformer except that

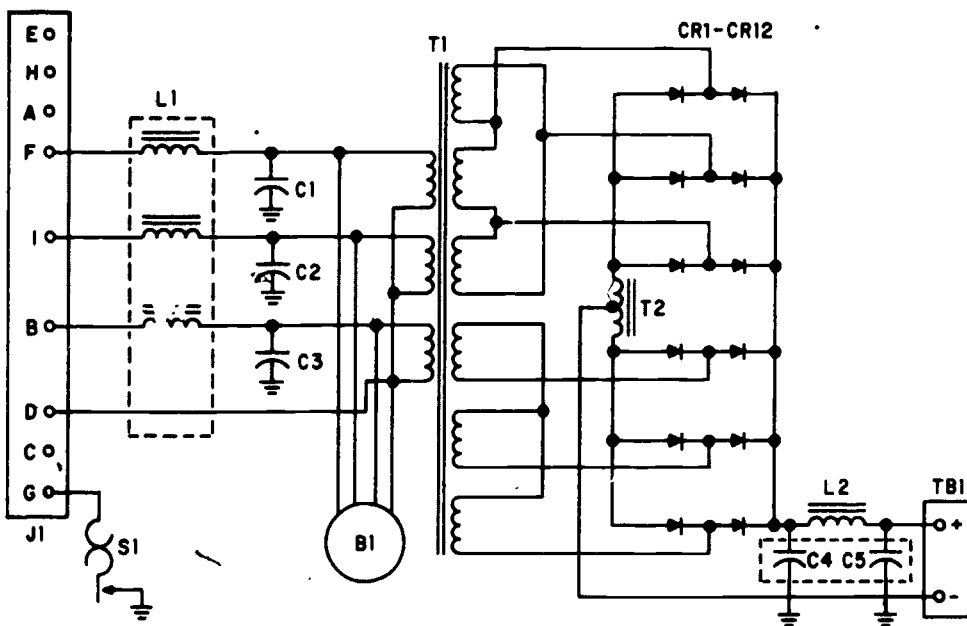

207.28

Figure 4-12.—Schematic diagram of a typical transformer-rectifier.

it has only one winding which is common to both primary and secondary. Within the limits of its application, it offers savings in both size and cost over conventional units. These savings are greatest when the turns ratio is less than 2 to 1 (either step-up or step-down), and diminish to insignificance when the turns ratio increases beyond about 8 or 10. A feature which is sometimes objectionable is that there is no isolation between primary and secondary positions of the circuit. For this reason it is not employed to step down a very high voltage as there is danger that the secondary may be subjected to the high primary voltage,

Referring to figure 4-13, a saving in wire results from the fact that both the source current and the secondary current flow through the load. The secondary winding is connected in a direction so as to add to the current flowing through the primary. Current is generally the governing factor in determining the size of a conductor. The maximum current necessary through any conductor in this autotransformer is 5 amperes to supply a 10-ampere load. Therefore, the transformer can be smaller than a

regular transformer where the secondary must supply the full 10-ampere load. The autotransformer has a disadvantage, however, in that the secondary is not isolated from the source voltage as is the secondary of a regular transformer. The turns ratio and other details of

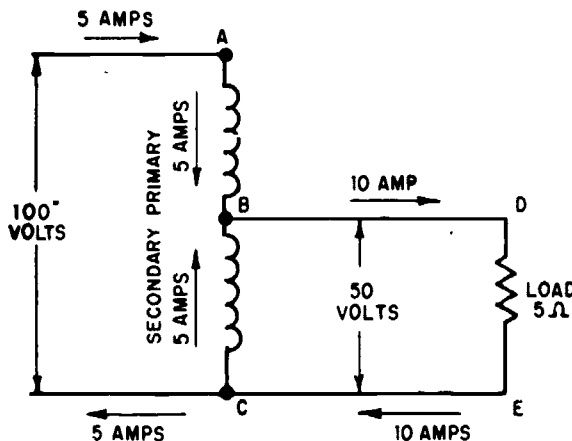

207.195

Figure 4-13.—2:1 ratio autotransformer.

the circuit are determined in the same manner as for conventional transformers.

The circuit in figure 4-13 shows an autotransformer with a turns ratio of 2-to-1 stepdown, the tap at point B dividing the winding into two equal parts. With a load of 5 ohms, connected as shown, the load current is computed by the formula $I = E/R$ or $50/5 = 10$ amperes. The power in the load therefore equals EI (50×10) or 500 watts. As in a regular transformer, this power comes from the primary by means of the magnetic field and, disregarding losses, the primary must take 500 watts from the line. The primary current would therefore be P/E ($500/100$) or 5 amperes. Only the difference between these two currents, which is 5 amperes, flows in the common portion C to B, as indicated by the arrow. Thus, when the turns ratio is 2:1 (either step-up or stepdown), the current in both sections of the winding is the same, and the cost and weight of an entire winding are saved.

The autotransformer in figure 4-14 has a turns ratio of 1.33:1 connected to a load which draws 20 amperes. This represents a secondary power of $EI = (90 \times 20)$ or 1,800 watts. The primary current, neglecting losses, equals P/E ($1,800/120$) or 15 amperes. As in the previous problem, the current in that portion of the winding from B to C which is common to both circuits is the difference between the primary

and secondary line currents, or 5 amperes. The saving here is obvious. A conventional transformer of the same characteristics would require a 120-volt 15-ampere primary and a separate 90-volt 20-ampere secondary. Here all that is required is a 30-volt 15-ampere winding in series with a 90-volt 5-ampere winding, provided, of course, that the application at hand permits the use of an autotransformer. Thus, a 0.45 kva autotransformer will supply this 1.8 kva load.

There are many interesting uses of autotransformers. An autotransformer with a continuous variable tap is marketed under the name VARIAC, and is used for many purposes where a continuous control from zero to full (or even above) line voltage is required. The core in this case is made in the form of a ring (toroid), and the winding is usually in the form of a single layer covering almost the entire surface. A control shaft carries an arm and a brush which makes contact with each turn of the winding as the shaft is rotated. Thus, the setting of the shaft determines the turns ratio. One end of the winding goes to both line and load, and the other end goes to the line. The brush is connected to the other side of the load. If it is desired to obtain voltages in excess of line voltage, such as to compensate for abnormally low line voltage, the primary is connected to a tap approximately 10 percent down from the end of the winding. This provides secondary control from zero to full line voltage, even though the actual line voltage is as much as 10 percent below normal.

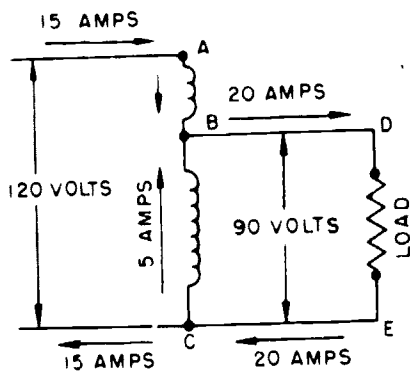

207.196

Figure 4-14.—1.33:1 ratio autotransformer.

Instrument Transformers

It is usually not practicable to connect meters directly to high-voltage and high-current ac circuits. Therefore, meters are coupled to these circuits by means of instrument transformers. These transformers are divided into two general types—the current and the potential. These devices permit the use of standard low-voltage meters for all high-voltage or high-current ac circuits, and at the same time protect the operating personnel from the

Table 4-1.—Electrical requirements for an inertial navigation system

D-c	A-c
+45 V transistor bias	26 V, 400 hertz
-45 V transistor bias	140 V, 400 hertz, 3 phase
+28 V unfiltered and unregulated	90 V, 375 hertz, 3 phase
+28 V transistor bias	12.6 V, 400 hertz
+28 V unregulated, relay excitation	6.3 V, 400 hertz
+20 V transistor bias	
+10 V reference	
-10 V reference	

high-voltage circuits. Transformers are covered in detail in *Navy Electricity and Electronics Training Series (NEETS)*.

ELECTRONIC POWER SUPPLIES

In high performance aircraft, avionics systems have been developed so that the pilot may communicate, navigate or fire missiles. Other systems have been designed to ease the pilot's workload, such as radar and autopilot (AFCS) systems. Each of these systems requires precision voltage inputs for proper operation.

For instance, an inertial navigation system may require the voltages shown in table 4-1. The voltages required by an AFCS in the same aircraft may be seen in table 4-2.

It then becomes obvious that one simple electrical power source will not provide all of the needed power for the 20 or 30 different avionics systems in each type aircraft.

Each avionics system will normally have its own power supply. Figure 4-15 shows the power supply for a typical autopilot system. The electrical power input requirement is 120/208 volts, 3-phase, 4-wire, 400-hertz and produces the voltages listed in table 4-2. The majority of the output voltages are produced by three autotransformers shown in figure 4-16 as T4, T5, and T6. The autotransformers are manufactured with taps from each transformer winding at the proper position to produce the required voltage. Under fairly constant load conditions, no further voltage regulation is necessary.

DC voltages may be produced by full wave rectifiers as shown in figure 4-17. Each pair of

Table 4-2.—Electrical requirements for a typical transistorized autopilot system

Phase A	Phase B	Phase C	DC
120 VAC	120 VAC	120 VAC	28 V filtered
45 VAC	26 VAC	15 VAC	28 V unfiltered
26 VAC	15 VAC	10 VAC	
19 VAC			
15 VAC			
7 VAC			

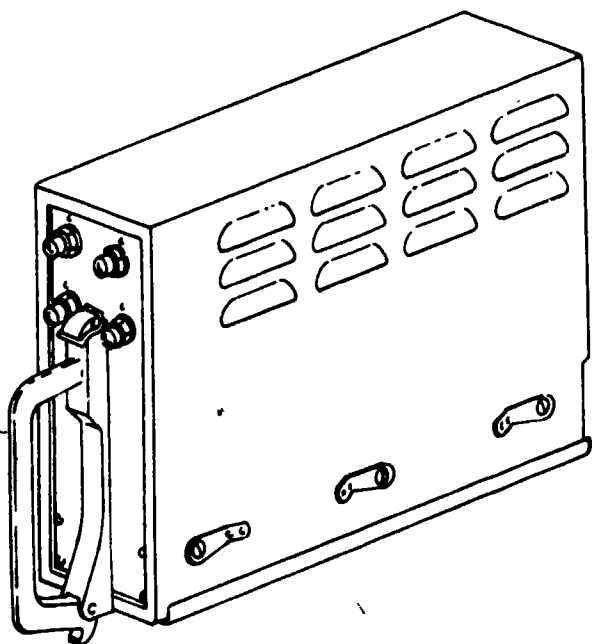

207.29

Figure 4-15.—Typical electronic power supply.

rectifiers (either CR7 and CR10, or CR8 and CR9) will conduct during alternate half cycles of the ac input from the secondary of stepdown transformer T7. The unfiltered dc is then used to operate lights and relays for internal operation of the system, and is also fed to a filter network. The filtered dc is used to supply transistor bias to the electronic amplifiers in the autopilot system.

The circuit shown in figure 4-18 may be used to develop precision dc voltages. Diode CR1 is a zener diode which will develop a constant dc voltage at the input of amplifier A1, regardless of fluctuations in the input voltage. If the dc input voltage at the top of R1 increases, CR1 will conduct harder and the excess voltage will be dropped across R1. If the voltage decreases, CR1 will conduct less and less voltage will be dropped across R1, maintaining the voltage at the anode of CR1 at a constant, precision potential.

Considering no current flow through R2, then the same potential will be present at the

input of amplifier A1 as is on the anode of CR1. The gain of amplifier A1 is controlled by feedback voltage through R3 and R4. If the combined resistance values of R3 and R4 are the same as the resistance of R2, then the output voltage will be at the same potential as that on the anode of CR1. Variable resistor R4 may be used to fine tune the output voltage to the desired level. Isolation amplifier A1 prevents changes in the load current from being felt at the zener diode.

There are many methods of providing precision voltages, both dc and ac, by the use of either transistors or electron tubes, and frequencies of ac voltages may be changed. Several of these methods are discussed in *Basic Electronics, Vol. 1, NAVPERS 10087 (Series)*.

EMERGENCY POWER SOURCES

Naval aircraft are provided with a means of back-up (emergency) electrical power in the event that primary sources of electrical power fail. Some of the various ways used to supply this emergency power are; aircraft storage batteries, hydraulic-motor driven generators, and ram air driven turbine generators. Each of these systems will be discussed in the following paragraphs.

Batteries

The function of the aircraft storage battery is to provide an emergency source of electrical power for operating the electrical systems of an aircraft. The battery also functions in such a manner that it reduces the commutator ripple produced on aircraft equipped with dc generators. During normal aircraft operation, either the ac generator and the transformer-rectifier combination, or the dc generator supplies the primary source of electrical energy and maintains the battery in a charged state. The battery supplies power to the aircraft only when the generating systems are unable to supply sufficient power.

Since the battery may be the emergency power source for the aircraft, extreme care must

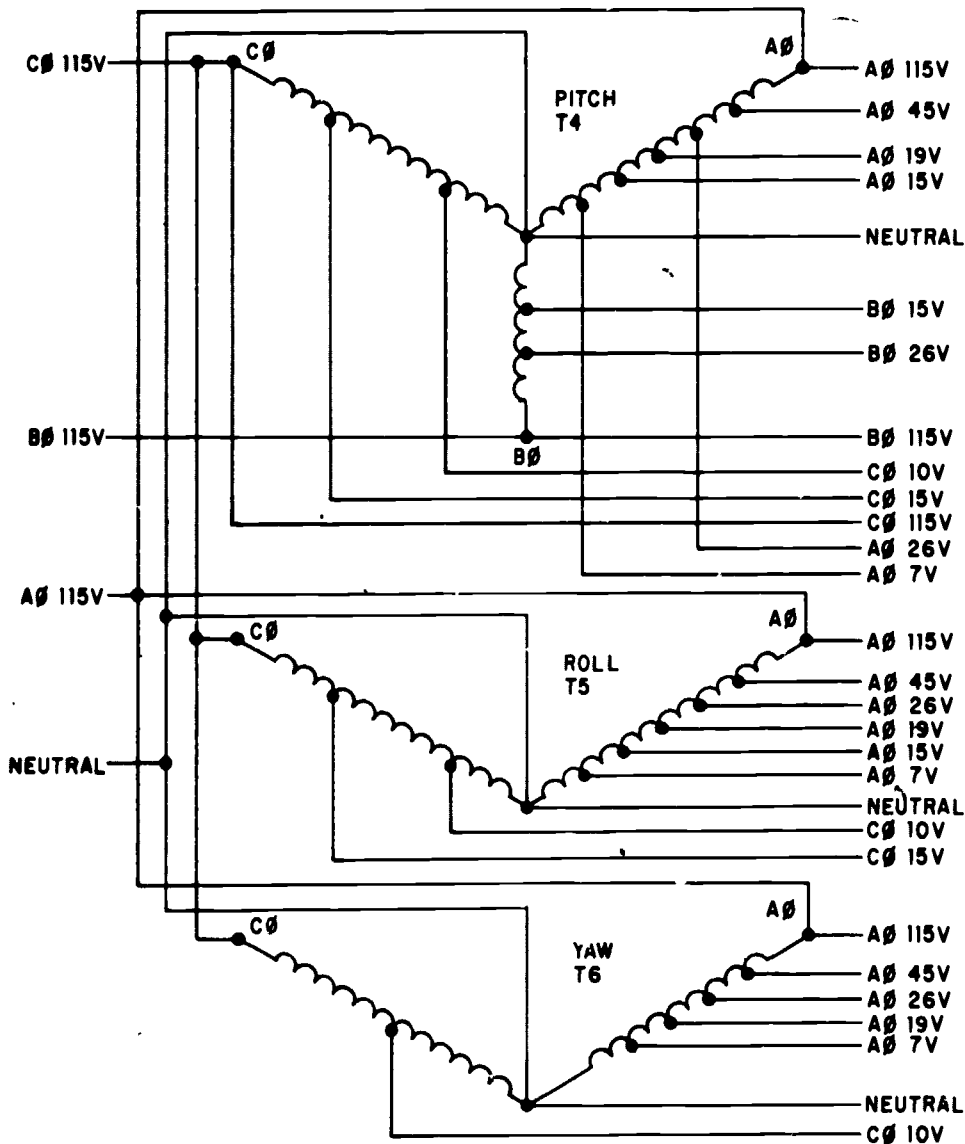

Figure 4-16.—Developing ac voltages for the autopilot.

207.30

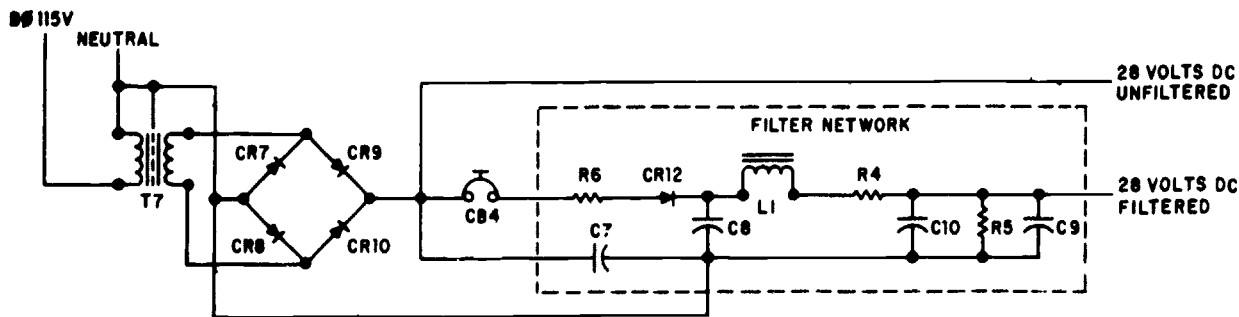
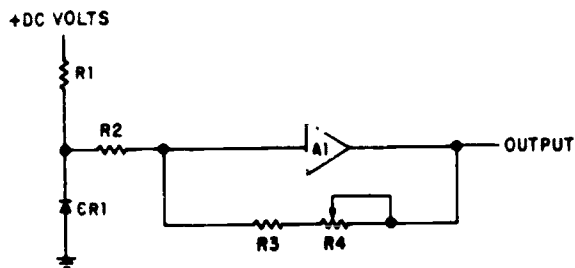

Figure 4-17.—Full wave rectifier and filter network.

207.31



207.32

Figure 4-18.—Precision dc voltage developer.

be taken to see that every precaution is taken to maintain the battery in perfect condition. Therefore, the battery should never be used for starting engines or servicing equipment if another source of power is available. Such unnecessary usage tends to shorten the life of the battery and keeps it in poor condition to meet emergency operation requirements. The service life of the aircraft battery depends a great deal upon the frequency and quality of care it is given. Batteries that are abused or that receive careless treatment and servicing generally have their service life ended prematurely.

The most common aircraft batteries in use today are lead-acid, nickel-cadmium, and silver-zinc batteries. The basic principles of all three types of batteries are covered in detail in the *Navy Electricity and Electronics Training Series (NEETS)*. Another reference that the AE should be well acquainted with is *Naval Aircraft Storage Batteries, NAVAIR 17-15BAD-1*.

COLOR CODING OF BATTERIES.—All acid batteries must, by NAVAIR requirements, be furnished in pink cases and all alkaline batteries in blue cases, to avoid the mistaken identity of acid and alkaline batteries which may lead to their contamination by using the wrong electrolyte when servicing. Indiscriminate use of the same tools on both types of batteries is a principal cause of contamination so the tools should also be painted these colors to assure that they will be used on only one type of battery.

Electrolyte used in lead-acid batteries is a strong solution of sulphuric acid and distilled

water. Anything associated with the lead-acid battery should never come in contact with the alkaline electrolyte or the battery. Even acid fumes can damage the hardware of the nickel-cadmium or silver-zinc batteries. The AE should be particularly careful when using hydrometers or syringes.

Tools and equipment used on lead-acid batteries can be neutralized by rinsing in clean water, preferably hot water, then immersing in a solution of ammonia or sodium bicarbonate (baking soda), followed by an additional rinse with clear tap or distilled water. Vinegar, or a boric acid solution may be used as a neutralizing agent for tools contaminated with potassium hydroxide (alkaline) solution. Also, water should be used freely to rinse the tools after neutralization.

A battery that is no longer fit for service in aircraft but is to be used for other purposes must be painted bright yellow and stenciled:

**DO NOT INSTALL IN AIRCRAFT
FOR GROUND USE ONLY**

These batteries may only be used on testing devices, battery carts, or other ground equipment.

QUICK-DISCONNECT UNIT.—To make installation and removal of the battery quicker and easier, most batteries use a quick-disconnect unit to connect the power leads to the battery. This unit consists of a plug, which is attached to the end of the battery leads in the aircraft, and a receptacle, which is mounted on the terminal side of the battery. (See fig. 4-19.) The receptacle covers the battery terminal posts and prevents accidental shorting during installation and removal. The plug consists of a socket with a keyway to prevent reverse installation of the wires and a handwheel having a coarse-pitch thread. The advantages of this unit are:

1. Only a few turns are required on the turnwheel to lock the connector in place.
2. No safety wire is required.
3. Accidental reversal of the leads is prevented.

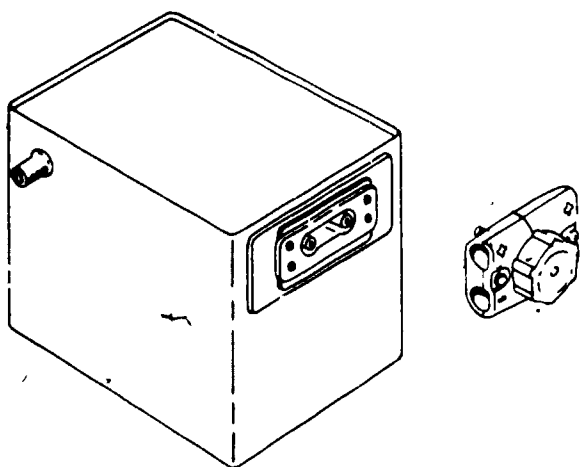

207.18

Figure 4-19.—Typical aircraft storage battery with quick-disconnect unit.

4. In an emergency the battery may be disconnected in minimum time.
5. Both leads are connected or disconnected simultaneously.

BATTERY VENT SYSTEM.—Wet-cell batteries, in general, emit some type of gas when being charged or discharged. This is especially true of lead-acid batteries and, to a lesser degree, the nickel-cadmium and silver-zinc batteries. For this reason a vent is provided, usually in the filler plug, for each cell to vent gas and moisture to the top of the battery. If allowed to stand on the top of the battery, the moisture could cause shorting of the cells and corrosion of the battery and external parts. Ventilation is provided by openings at each end of the battery which can be used for venting or draining.

In a vent system (fig. 4-20), the void above the cells and beneath the sealed cover is subjected to differential pressure areas on the skin of the aircraft through the vent nozzles level with the top of the cells on opposing sides of the battery container. As the battery is mounted in the aircraft, the higher of the two vent nozzles is connected to a rising vent tube which is exposed to a positive pressure area on the skin of the aircraft. This provides definite

pressure on the battery in flight and acts as a chimney or flue for the light hydrogen gas when the aircraft is at rest. The lower of the two vent nozzles connects to a tube which is exposed to a negative pressure area on the skin of the aircraft.

When a battery drain sump is used, the negative pressure tube from the battery is connected to a glass jar sump and extends into the jar approximately 1 inch. The exhaust tube from the sump jar is cut at a 30° angle; extends into the sump jar approximately one-third its depth, and routed to the skin surface of the aircraft. The sump jar normally contains a felt pad and, in the case of the lead-acid battery, will be moistened with a concentrated solution of sodium bicarbonate for neutralizing gases and excess battery solution.

When a sump jar is not used, the negative pressure tube is connected to the nozzle of the battery which is lower when the aircraft is in a taxiing position, and is located in such a manner that battery acid may escape without injury to the aircraft.

Refer to the Maintenance Instructions Manual of the aircraft for specific directions concerning the maintenance of the particular vent-sump system that is used.

AC/DC Hydraulic Motor Driven Generators

This emergency power source consists of the following components. A hydraulically driven ac/dc generator, a motor-generator control unit, and a control solenoid.

The motor-generator provides 115/200-volt ac and 28-volt dc power to essential electrical circuits if normal power fails. This type of emergency generator is usually rated at a much lower KVA rating than the primary generator(s). Hence, only a limited number of circuits can be energized when the emergency generator is being used.

GENERATOR.—The brushless generator consists of the following components: a stationary permanent generator, an exciter alternator (mounted on the rotor assembly), a stationary ac output winding, a stationary dc

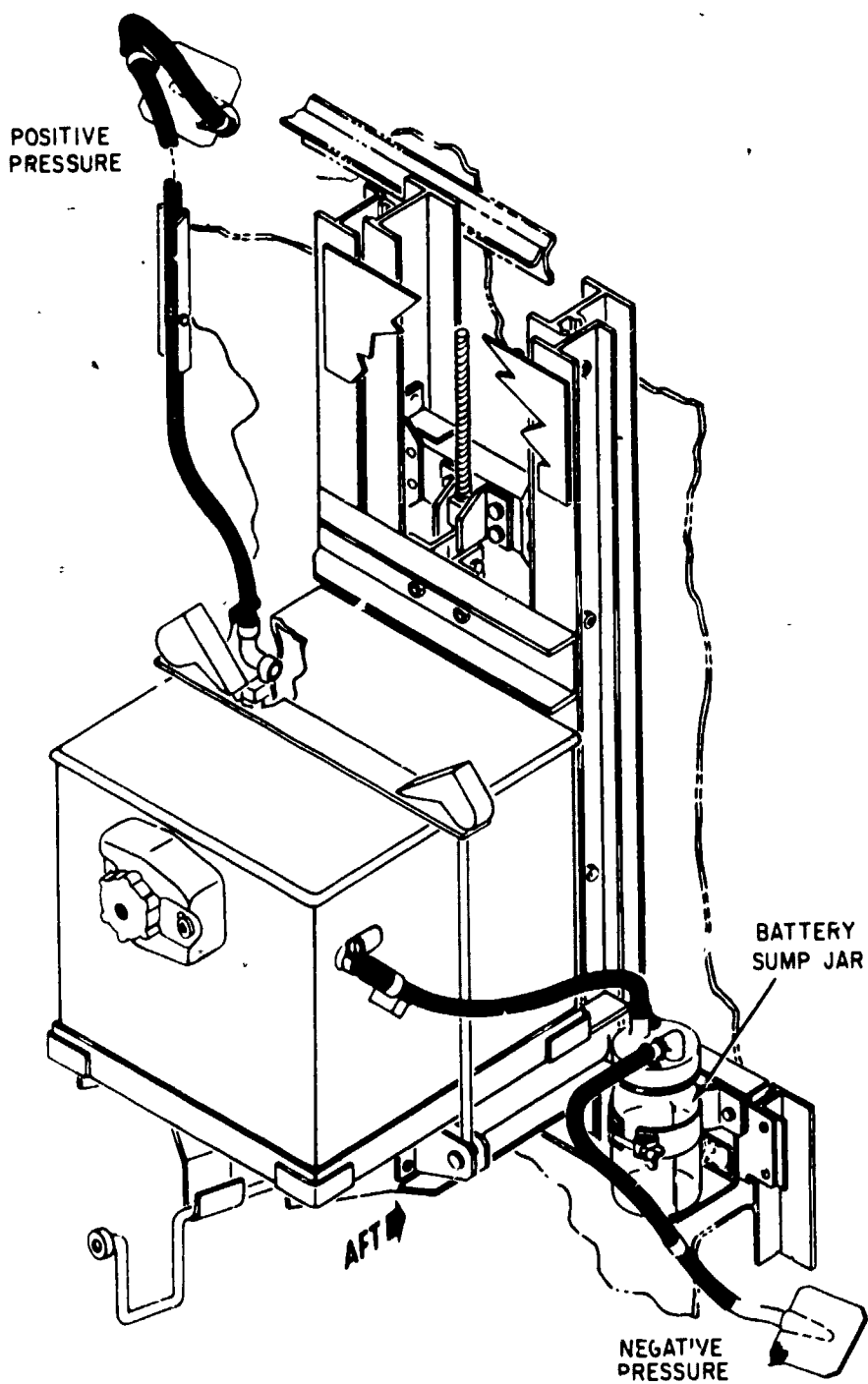

207.19

Figure 4-20.—Battery vent system.

output winding, a rotating rectifier assembly, and a permanent magnet with a dc output rectifier section. As the rotor turns (hydraulic motor running), the permanent magnet induces power into the permanent magnet generator. This power is used for control and regulation and to energize the four essential power transfer relays. Regulated and rectified permanent magnet generator output power is routed to a stationary control field within the motor-generator and, through the motion of the rotor assembly, is induced into the windings of the exciter alternator. This power is rectified and, in turn, induced into the output ac winding and the dc winding. The ac output is monitored

by the motor-generator control, which adjusts the regulation to maintain the output ac voltage at 115 volts per phase $\pm 1.5\%$ during the time that the hydraulic motor is operating under full system pressure (3,000-psi combined hydraulic power system pressure). The dc output from the stationary rectifier section is directly routed to the dc transfer relay contacts for distribution to the essential dc buses.

The hydraulic motor converts 3,000-psi hydraulic pressure to constant-speed rotation driving the generator at a constant speed (see figure 4-21) maintaining generator-output frequency at 400 Hz.

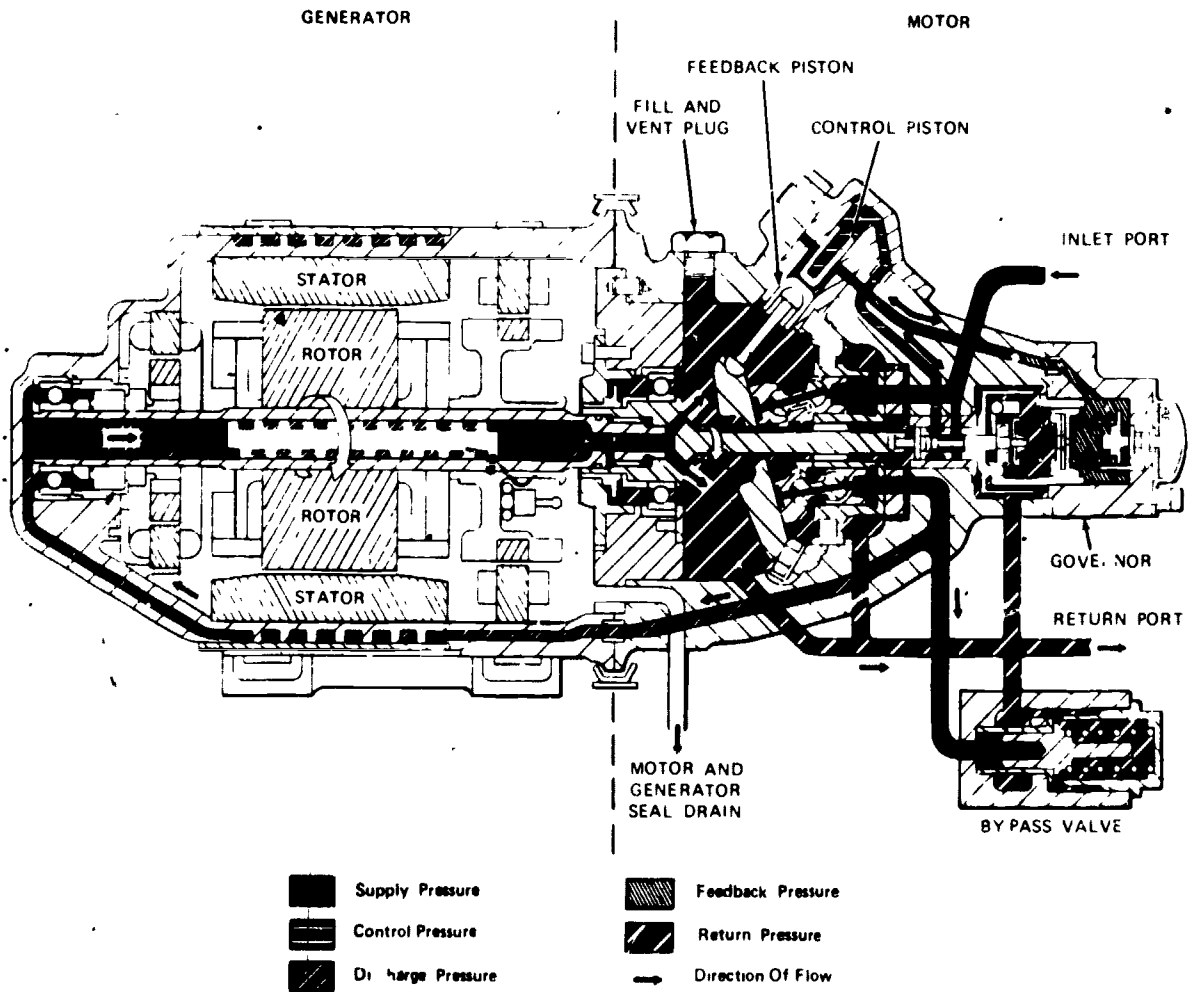

Figure 4-21.—Motor-generator.

The motor-generator is cooled by hydraulic fluid from the same source that drives the hydraulic motor.

MOTOR-GENERATOR CONTROL.—The motor-generator control provides voltage regulation for, and detection of, motor-generator output.

When the motor-generator is operating, permanent magnet generator power is routed to the rectifier section of the motor-generator control, where this three-phase ac is rectified to a dc signal. The dc signal, used for motor-generator control panel power and relay control power, is routed to the voltage regulator section of the motor-generator control. The voltage regulator supplies field excitation to the motor-generator and monitors the output voltage, adjusting the field to maintain an output of 115 volts \pm 1.5% per phase.

Monitoring and protective circuits in the motor-generator control prevent out-of-tolerance power from being connected to that portion of the essential bus system where out-of-tolerance power would be detrimental to equipment.

MOTOR-GENERATOR SOLENOID CONTROL VALVE.—The motor-generator solenoid control valve (Fig. 4-22) controls operation of the emergency electrical power system. The valve is electrically actuated to the shutoff position with primary electrical power. When primary electrical power fails the valve becomes deenergized and opens, routing hydraulic system pressure to the hydraulic motor, which drives the generator. The entire operation is completely automatic upon primary electrical power failure.

Ram Air Turbine Generator

Many jet aircraft are equipped with ram-air emergency generators. These provide emergency electrical power in the event of main electrical power failure. Different types of emergency power generating systems have been developed, and the manner in which they are installed depends upon the type of aircraft.

In a typical installation, the emergency electrical power is provided by a power package which, when used, is extended into the airstream. This occurs when the pilot operates a lever which, through a linkage, pneumatically, or

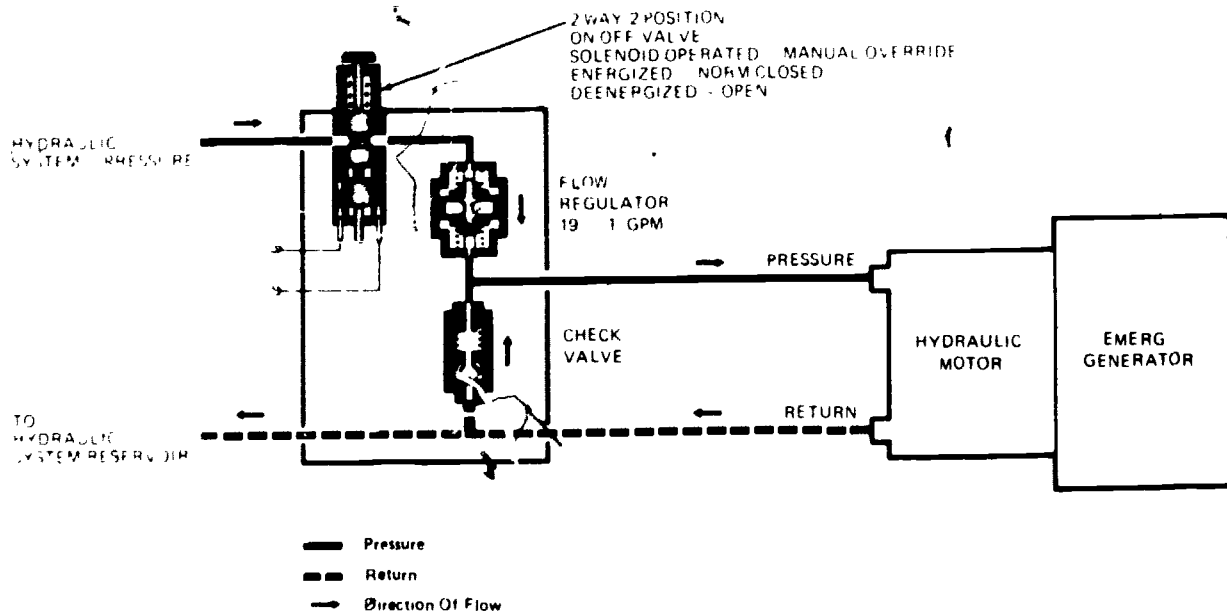

Figure 4-22.—Motor-generator solenoid control valve.

by a spring arrangement, causes the power package to protrude. The ram-air of flight, which is caused by the aircraft moving through the atmosphere, provides the turning power for the turbine which in turn rotates the generator's armature.

The systems are constructed so that the emergency generator will not be placed on the bus until its armature is up to speed. This is controlled in different ways; for example, on the A-7 aircraft the pilot places the generator on the bus by throwing a switch. In the F-4 aircraft the emergency generator is automatically placed on the bus by an air-pressure actuated switch. This switch connects the output of the emergency generator to the solenoid of a relay which

energizes when the generator is up to speed. When the relay energizes, it connects the generator to the bus. The aircraft must have an airspeed of at least 190 knots to activate the air pressure switch.

A typical 3-phase emergency generator is shown in figure 4-23(A). This generator has a capacity of 3 kva, a voltage output of 120/208 volts at 400 ± 20 Hertz, and the output windings are wye connected. The frequency of the output voltage is maintained by automatic positioning of the variable-pitch blades (fig. 4-23 (B)) and speed regulating section of the ram-air turbine.

Ground testing of some types of emergency generators may be performed while the

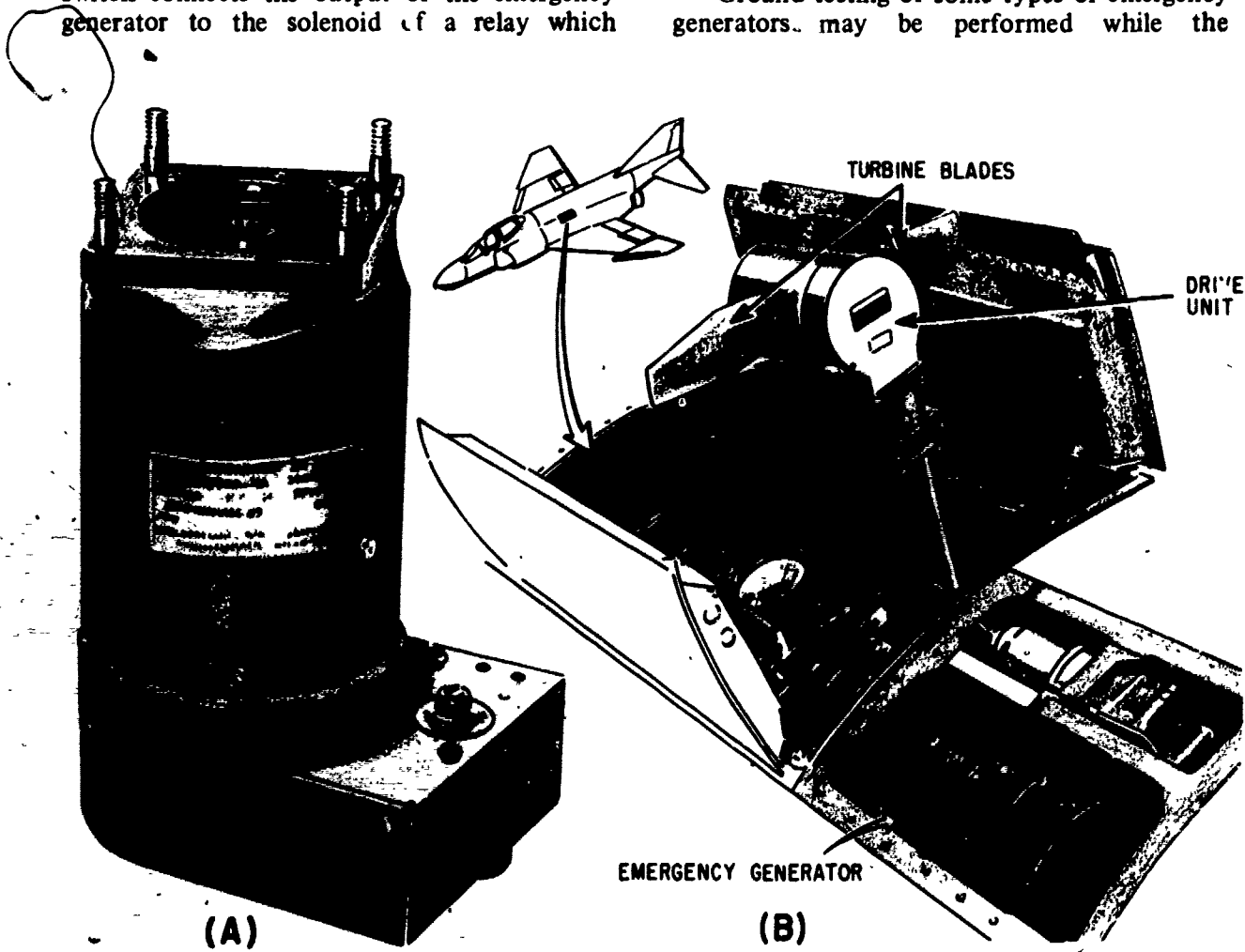

Figure 4-23.—(A) Emergency generator; (B) typical emergency generator installation.

207.127

generator is mounted on the aircraft. When this is done, compressed air from a gas-turbine compressor is funneled into the turbine blades to drive the generator.

AUXILIARY POWER UNITS (APU)

Some aircraft are equipped with auxiliary power units (APU). These may be installed at different locations on different aircraft. They are used to furnish electrical power when engine-driven generators are not operating, when external power is not available, or when the engine-driven generator fails. The power output from the APU provides a constant voltage at a constant frequency, which is advantageous since the APU is not dependent on aircraft engine rpm.

Some of these units use a gasoline engine to drive the generator, while others use a gas turbine. The gas turbine type also provides compressed air to start engines, using the pneumatic starting system, and for air conditioning, thereby making the aircraft independent of the need of ground power units to carry out its mission. There are many types

and configurations of gas turbine units; however, because of their similarity in construction and operation, only one is described in the following paragraphs.

GTCP95 Unit

This gas turbine powerplant unit (hereafter referred to as APU) is capable of furnishing electrical power, starting air, and air to heat or cool the interior of the aircraft while on the ground by providing a fresh air supply for the aircycle cooling systems. (See fig. 4-24.) The gas turbine engine of the APU is a self-contained power source which requires only the aircraft battery and fuel for starting. Shaft power at the main output drive pad is used to drive a generator. Pneumatic power is available as clean, compressed air at the output end of the engine bleed load control and air shutoff valve located at the rear right of the engine. The engine is basically composed of two main sections and four main systems. The two main sections include an accessory assembly located at the front of the engine, and a compressor and turbine assembly located at the rear. The four main systems consist of an electrical system, a

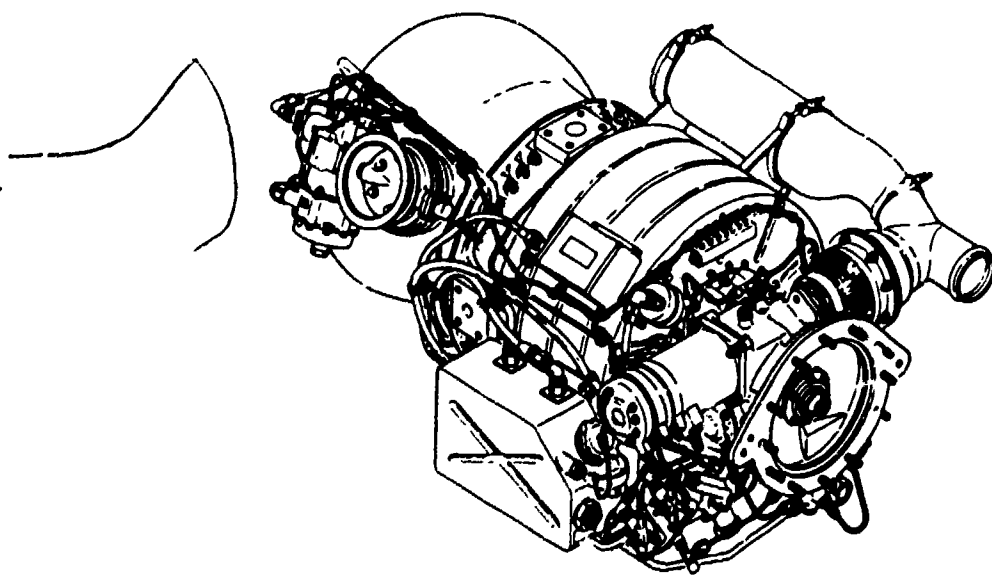
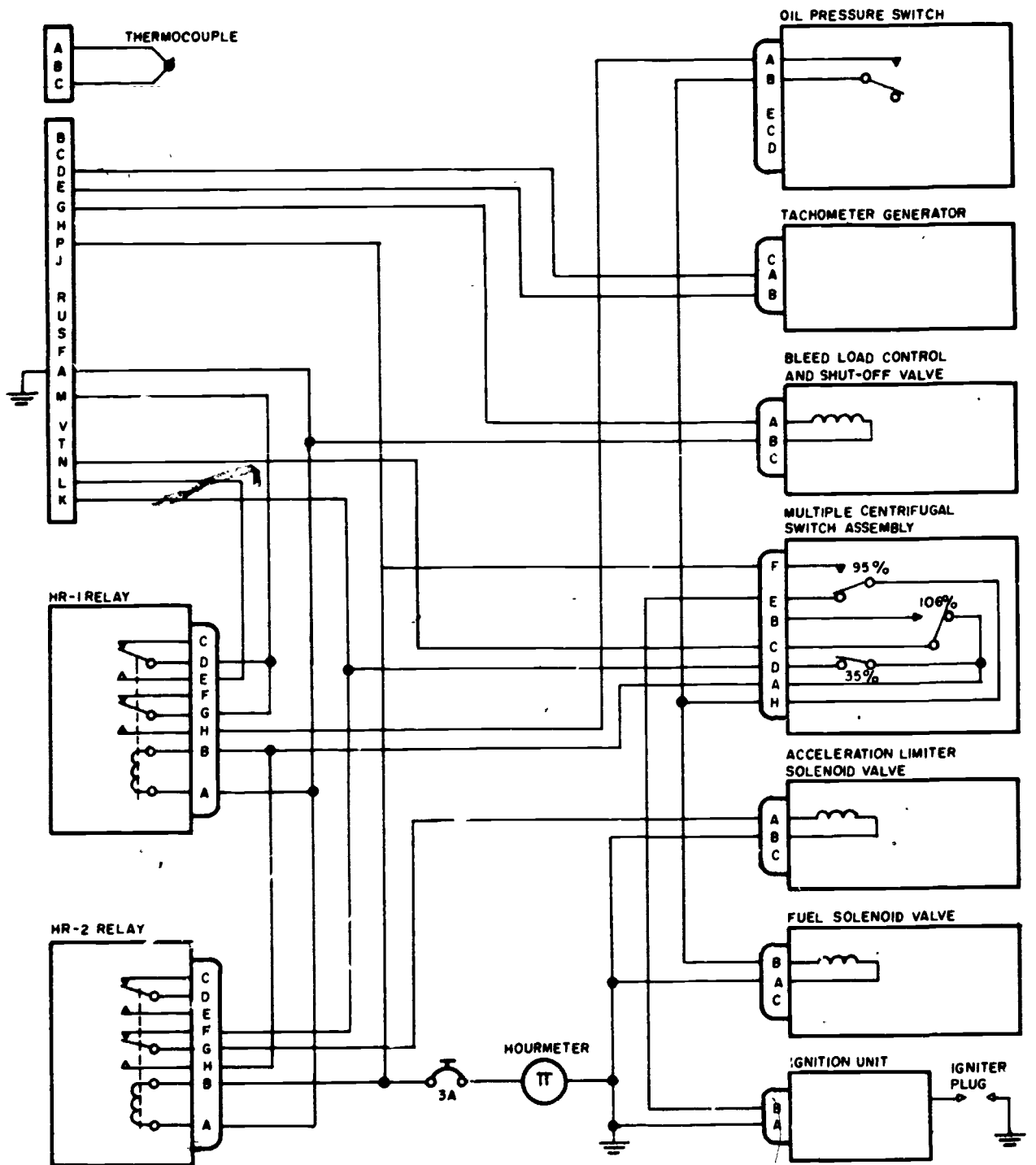

Figure 4-24.--Gas turbine powerplant unit (GTCP-95).

207.156



207.159

Figure 4-25.—GTCP-95-2 gas turbine engine electrical schematic.

fuel control system, a bleed air system, and a lubrication system.

The engine develops power by compressing ambient air with a two-stage centrifugal compressor. Compressed air, mixed with fuel and ignited, drives a radial inward flow turbine wheel. The rotating shaft of the turbine wheel drives the compressor, the accessories, and the output shaft for the ac generator. Pneumatic power is obtained by bleeding air from the compressor before it is mixed with fuel.

Gas Turbine Engine Electrical System

The electrical system (fig. 4-25) provides automatic actuation in proper sequence of the various circuits that control fuel supply, ignition, engine starting, acceleration, fuel flow, and monitoring. The electrical system consists of

the following main components: holding relays, oil pressure switch, multiple centrifugal switch assembly, time totalizing meter (hourmeter), and harness assembly.

The ignition portion consists of an exciter and ignition plug controlled by the multiple centrifugal switch. Ignition is only required during starting and is automatically cut at approximately 95 percent engine rpm.

The switches and controls required for starting, stopping, monitoring, and loading circuits are located in the aircraft. These components include a master start-stop switch and a start relay. A pad is provided on the oil pump assembly housing for mounting the tachometer-generator.

CENTRIFUGAL SPEED SEQUENCE SWITCH.—This component (fig. 4-26) controls the sequence of operation of various electrical

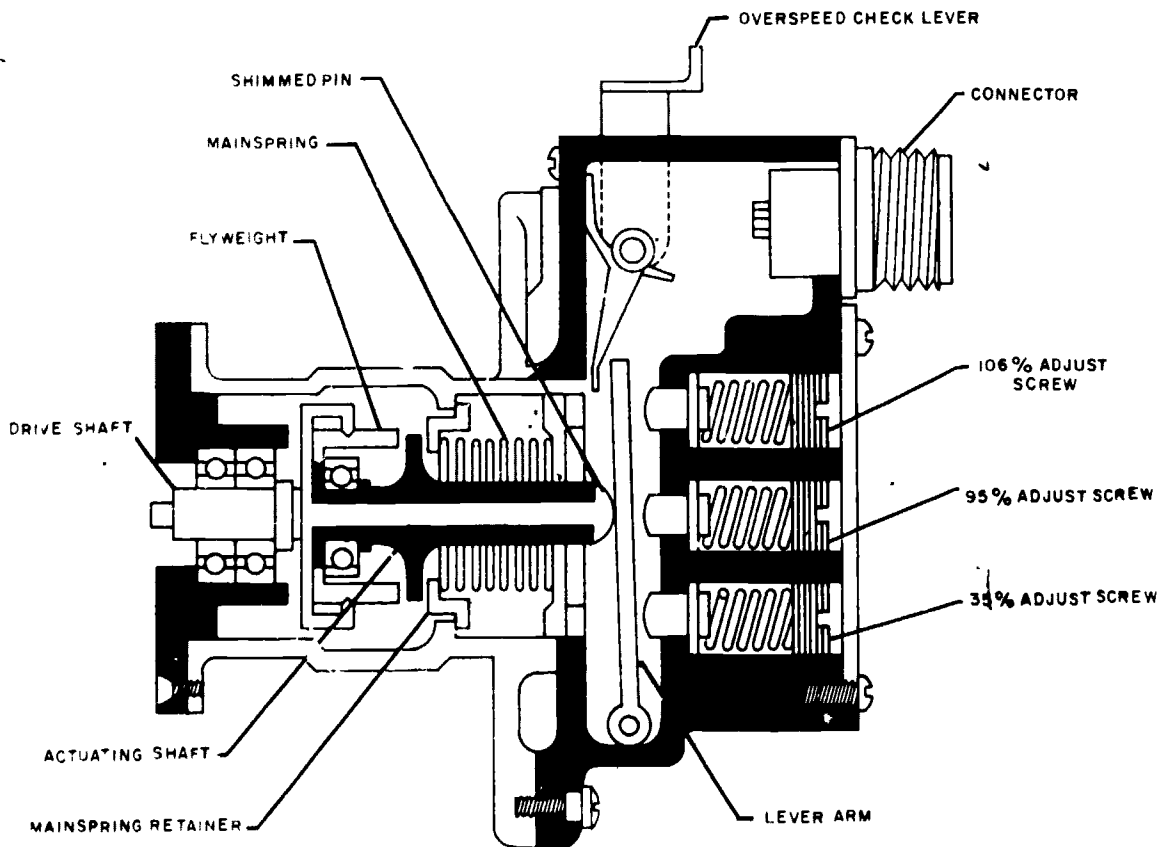

Figure 4-26.—Centrifugal switch assembly.

207.160

components. It is driven by the accessory drive idler gear shaft. The input drive shaft turns a knife-edged fulcrum (flyweight support) and a pair of flyweights pivot on the knife edges. Each flyweight has a toe which lies under the outer race of a ball bearing on the actuating shaft. As the centrifugal switch is turned, centrifugal force causes the flyweights to pivot on the knife edges, moving the actuating shaft to the right against the lever arm. The three electrical switches, shown in figure 4-25 are actuated at 35 percent, 95 percent and 106 percent of turbine speed by the lever arm. Fine adjustment of these switches can be accomplished by applying spring tension to the lever arm with the three adjustment screws shown in figure 4-26. The functions of the switches are:

1. 35 percent—turns off starter motor.
2. 95 percent—arms load control circuits, starts hourmeter, turns off ignition.
3. 106 percent—stops unit (overspeed protection).

As the input shaft is rotated, the flyweights (acted upon by centrifugal force) move outward, forcing the actuating shaft to move the lever arm, actuating the switches. Since the lowest percent speed adjustment spring acts on the lever arm during the actuating of all switches, a change in its setting will also affect the setting of the 95 percent and 106 percent switches. A drift in setting of the 106 percent switch will affect only the 106 percent switch.

Generally, checking an overspeed switch in a gas turbine requires that the unit be operated above its governed speed. However, the multiple centrifugal switch assembly on the engine incorporates a lever, which extends from the switch housing, that can be manually positioned to actuate the three switches. The lever is spring loaded in order not to interfere during normal operation. When the lever is manually actuated, it rotates on a pivot, forcing the centrifugal switch lever arm to actuate the switches. This check may be performed with the unit operating or stopped. Actuation of the switch will cut off the fuel flow to the combustor and stop the unit.

STARTER MOTOR.—The starter provides the initial power for rotating the components of the gas turbine to self-sustaining speeds. It rotates the compressor to a speed high enough for correct airflow for combustion, and continues to assist the unit to accelerate after light-off to prevent excessive turbine temperature at low speeds.

The starter motor is rated approximately 1.5 hp at 14 volts at 5,000 rpm. The starter has a duty cycle of 1 minute ON and 4 minutes OFF.

The starter motor armature shaft is splined and pinned to the clutch assembly. The starter clutch assembly performs two functions. As a friction clutch, it prevents excessive torque between the starter and accessory drive gears to protect both. As an overrunning clutch, it provides the means of automatically engaging the starter with the gear train for starting, and automatically disengaging it when the unit has reached a condition allowing it to accelerate and run without assistance.

The friction clutch section provides overtorque protection. The assembly is set to slip at approximately 135- to 145-pound-inches of torque. Due to the inertia the engine offers when the starter motor pawls first engage with the gearbox ratchet, the overrunning clutch flange and splined clutch plates tend to remain stationary while the motor, the clutch housing, and the keyed clutch plates rotate. Slippage occurs until engine and starter speeds have increased enough to develop less than the specified torque value.

The starter is normally deenergized by the centrifugal switch at 35 percent. If the switch does not cut out at this speed, the starter may fail from overheating, or it may fail mechanically from overspeed. If the overrunning clutch does not disengage properly, mechanical overspeed failure of the starter will result.

EXTERNAL POWER SOURCES

To provide ground crews with electrical power for servicing, fueling, and performing of maintenance actions, naval aircraft are designed to accept electrical power from an external source.

Aside from fuel costs and the wear and tear on engines, it is unsafe and highly impractical to turn-up aircraft parked in the hangar or hangar bay of a carrier. Chapter 3 of this manual describes the deck edge power system and the various types of mobile power units used to provide external power.

Design features built into the aircraft itself make it impossible to have both the aircraft generator voltage and external power voltage applied to the buses at the same time.

To protect the aircraft, monitoring circuits are utilized to ensure that the voltage, frequency, and phasing of external power are correct before the aircraft will accept power from an external source. These monitoring circuits are also an integral part of the aircraft's electrical system; they operate in principle like that of the supervisory panel discussed later in this chapter.

CONTROLS AND CIRCUIT PROTECTION

The first part of this chapter dealt with the various devices used to provide electrical power in naval aircraft. This section deals with methods of regulating the output voltages of dc and ac generators. To understand how voltages are regulated, the AE must be familiar with the principles of ac and dc power generation. These principles are covered in detail in the *Navy Electricity and Electronics Training Series (NEETS)*. Before continuing with this chapter, it is strongly recommended that you review the above text.

Two methods of voltage regulation have become popular in recent years. The most common method in use in power generating systems today is to vary the current to an exciter winding (sometimes called field winding) in the generator. This, in turn, changes the magnitude of the magnetic field, thereby changing the voltage output of the generator. This method can be used on both dc and ac generators.

The second method of voltage regulation is to maintain a constant load on the generator. This method permits the use of a permanent

magnet on the generator rotor in place of exciter windings, and thereby simplifies generator construction. This type of regulation must, however, be utilized with systems which supply fairly constant loads, and will generally be limited in capacity. For instance, an inverter or an electronic power supply may use this type of voltage regulation. The regulator varies the resistance of a parallel resistor so that total resistance remains constant regardless of the load resistance. This type regulator can also be used with both ac and dc power sources.

DC GENERATOR CONTROL

A simple ohm's law analysis of dc controls will illustrate the problems encountered in dc generating systems (fig. 4-27). Each of the boxes marked "load" represents some type of electrical load such as a lighting system, relays, electrical heaters, or a complete system such as an autopilot or air conditioning system. As shown, with switches S-1 through S-6 open, the only load on the generator is the voltage regulator. The voltage regulator controls a small current to the exciter field winding, the resultant magnetic field is small, and because the generator output conductors cut only a few lines of flux the current flow is small and the voltage is maintained at the preset level.

When loads are added in parallel with the voltage regulator by closing switches S-1 through S-6, the total resistance goes down. By looking at ohm's law, $E = IR$, it can be seen that if the resistance goes down and the current remains the same, the voltage must go down. It is therefore necessary to increase the current flow to keep the voltage constant, and this is accomplished by the voltage regulator which senses an undervoltage and causes an increase in the current flow to the exciter winding.

If only a small load is applied to the generator at any one time, such as only S-1 being closed, the voltage regulator has no particular problem maintaining the voltage constant. However, in modern aircraft where there are hundreds of these loads being used at various times, causing large current fluctuations, the regulator must react almost instantaneously in order to maintain the voltage at the desired level.

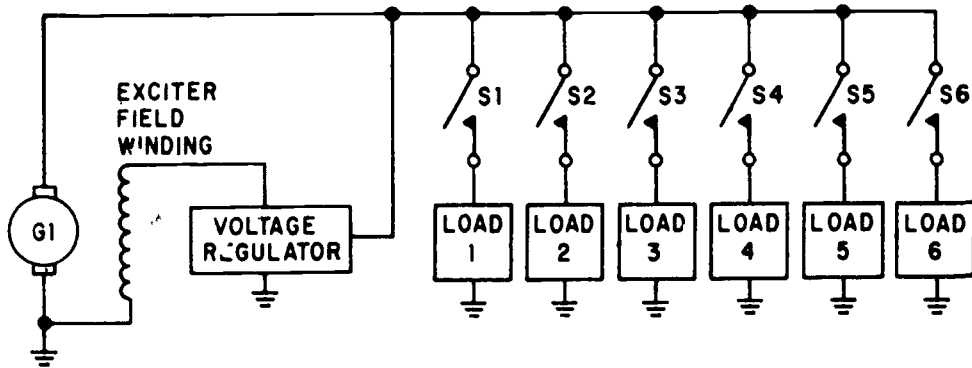

207.33

Figure 4-27.—Simplified dc generator voltage control.

AC GENERATOR CONTROL

In an ac generator an alternating voltage is induced into the armature windings when magnetic fields of alternating polarity are passed across these windings. The amount of voltage induced into the ac generator windings depends mainly on three things: the number of turns of conductor per winding, the speed at which the magnetic field passes across the winding (generator rpm), and the strength of the magnetic field. Any of these three could conceivably be used to control the amount of voltage induced into the ac generator windings.

The number of turns per winding and the number of windings are determined when the generator is manufactured and cannot readily be changed. The frequency of the output voltage is therefore dependent wholly on the speed of the generator when the generator is operating. The output voltage may then be controlled by the strength of the magnetic field. In some cases, however, such as the tachometer generator, a permanent magnet field is provided and the generator load is maintained at a constant value.

In today's aircraft, electrical and electronic equipment are designed to operate at exact frequencies and voltages. Systems exposed to extreme overvoltages or off-frequencies not only may be destroyed themselves, but may compound a failure into an emergency by

starting a fire. Ac generator control systems, then, must also contain circuits to protect against underfrequency and overfrequency, undervoltage and overvoltage, and improper phase sequence.

Voltage Control

The generators in figure 4-28 (A) and (B) use an electromagnetic field rather than a permanent magnet type field. (NOTE: Permanent magnets are used in the exciter circuits of some brushless generators.) The strength of this electromagnetic field may be varied by changing the amount of current flowing through the field. This is accomplished by varying the amount of voltage applied across the field. By varying the dc output voltage from the exciter armature, the ac generator field strength is also varied. Thus, the magnitude of the generated ac voltage depends directly on the value of the exciter input. This relationship allows a relatively large ac voltage to be controlled by a much smaller dc voltage. On the brushless generator, the rotating 3-phase rectifiers change the ac output of the exciter to dc which is fed to the main ac generator rotating field, thus eliminating the use of brushes.

As previously stated, effective control of the generated voltage can be maintained by controlling the strength of the magnetic field through which the conductors are moving. The strength of the magnetic field is controlled by a voltage regulator. The current which generates

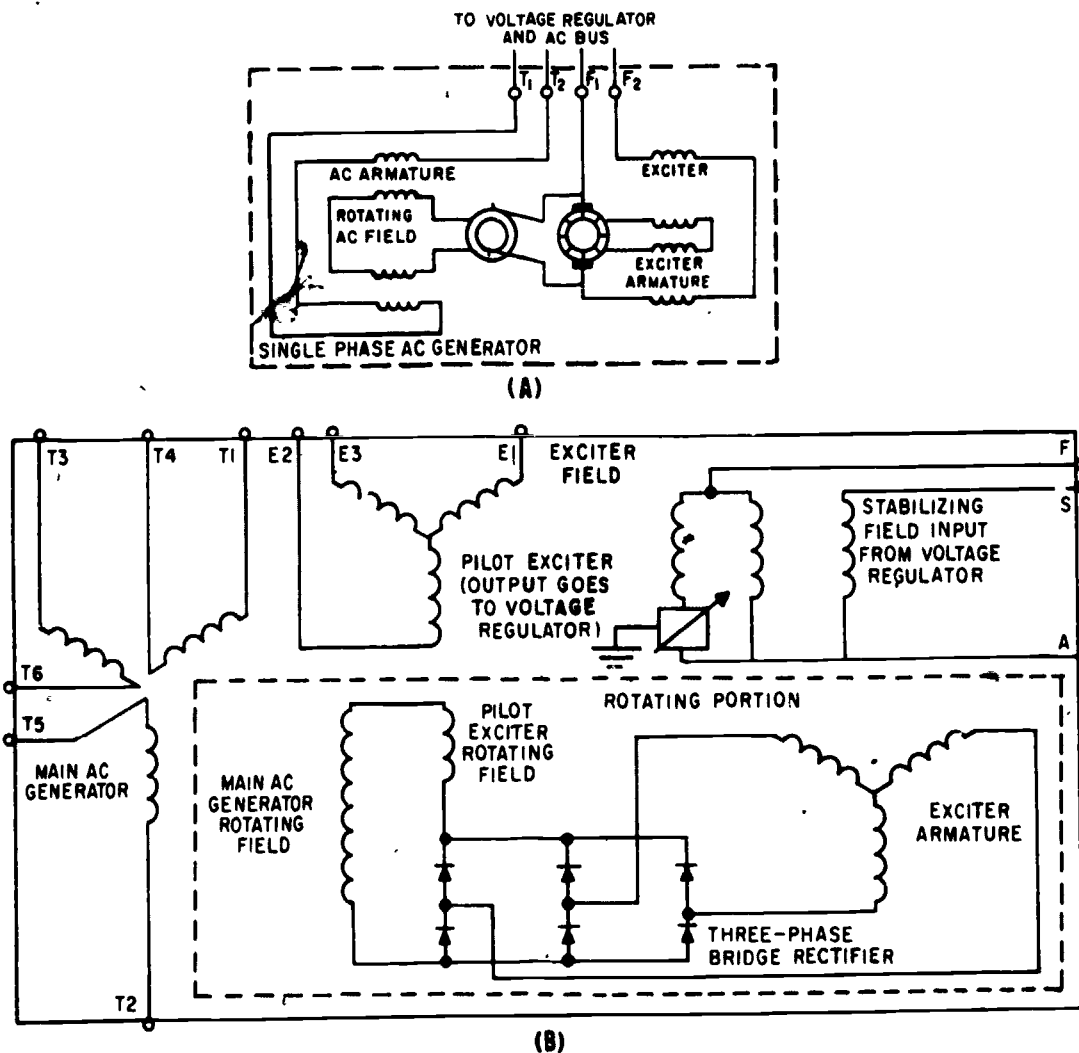

Figure 4-28.—AC generators. (A) Brush type; (B) brushless type.

207.178

this magnetic field, called the excitation current, is supplied either by an auxiliary dc generator (called the exciter) or by a rotating 3-phase rectified ac exciter generator. The exciter is usually mounted on the same shaft as the ac generator to make it an integral part of the machine.

The present military specification for aircraft ac generators states that they should be self-supporting. To meet this requirement, dc exciter units are integrated into the ac generators.

The chief advantage of these exciter units is that each generator has its own independent source of excitation, and no dependence is placed upon any external source of electric power. In a multigenerator installation, failure of the excitation source for one machine does not render the complete system inoperative as would be the case in a common external excitation system. Furthermore, with these exciters it is not necessary to transmit excitation power any distance in the aircraft, thus reducing the chances of losing excitation due to open or short circuited wiring.

In contrast to dc generators, the magnetic field coils in most aircraft ac generators are rotated, and the ac voltage is induced into the stationary windings.

One type of voltage regulator which has no mechanical moving parts (except the exciter control relay) is the solid state regulator. Before going into this system, review semiconductor devices in *Basic Electronics, Vol 1, NAVPERS 10087 (Series)*.

The ac output of the generator is fed to the voltage regulator where it is compared to a reference voltage, and the difference is applied to the control amplifier section of the regulator. (See fig. 4-29.) If the output is too low, field strength of the ac exciter is increased by the

circuitry in the regulator. If the output is too high, the field strength is reduced.

The power supply for the bridge circuit is CR1, which provides full-wave rectification of the 3-phase output from transformer T1. The dc output voltages of CR1 are proportional to the average phase voltages. Power is supplied from the negative anode of CR1 through point B, R2, point C, Zener diode CR5, point D, and to parallel connected V1 and R1. Tap off point C of the bridge is located between resistor R2 and the Zener diode. In the other leg of the reference bridge, resistors R9, R7 and temperature compensating resistor RT1 are connected in series with V1 and R1 through

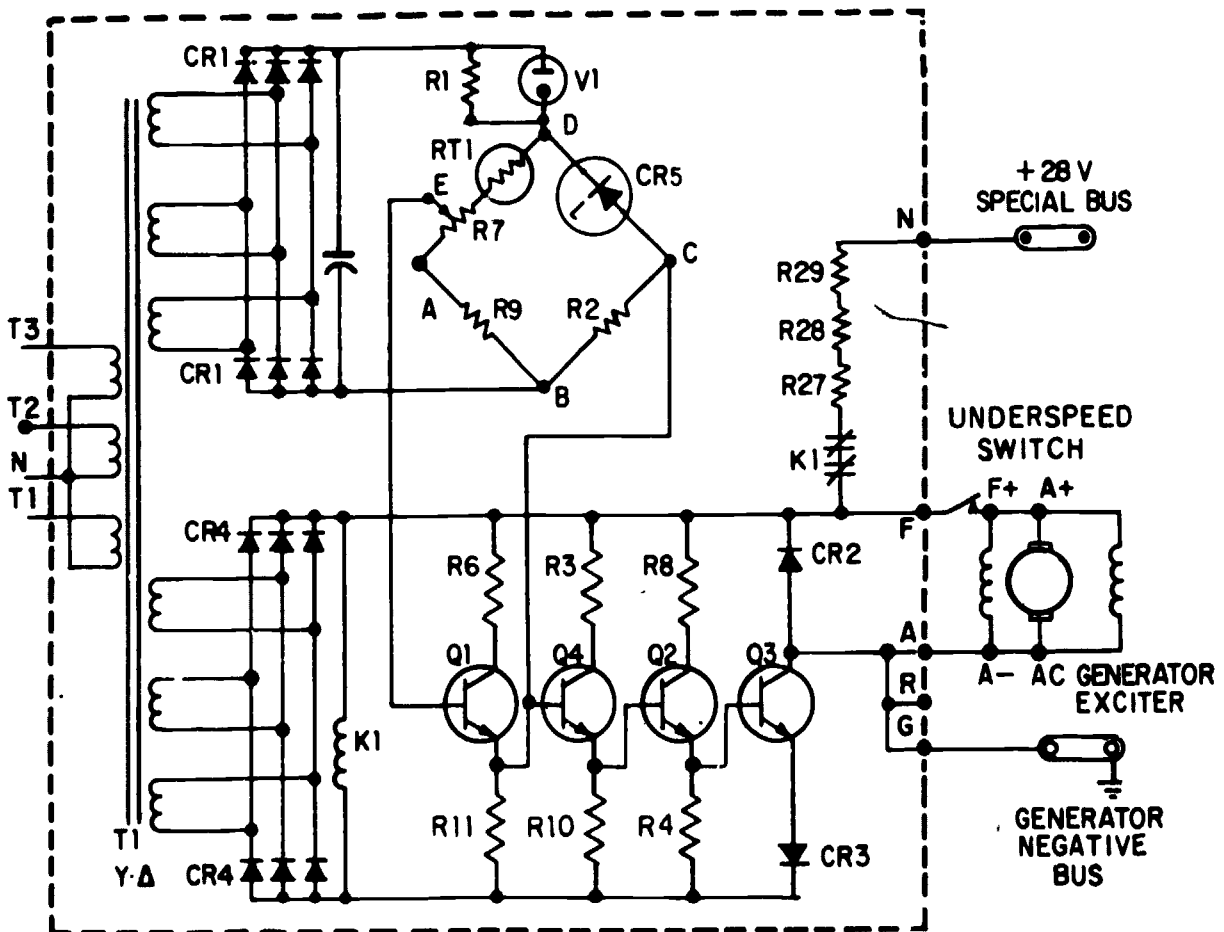

Figure 4-29.—Solid state voltage regulator.

207.187

points B, A, and D. The output of this leg of the bridge is at point E.

As voltage changes occur, for example if the generator voltage decreases, the voltage across R1 and V1 (once V1 starts conducting) will remain constant, leaving the total voltage change occurring across the bridge. Since the voltage across the Zener diode remains constant (once it starts conducting) the total voltage change occurring in that leg of the bridge is across resistor R2. In the other leg of the bridge, the voltage change across the resistors will be proportional to their resistance values.

Therefore, the voltage change across R2 is greater than the voltage change at point E. If the generator output voltage were to drop, point C would be negative with respect to point E. Conversely, if the generator voltage output were to increase, the polarity of the voltage between the two points would be reversed.

The bridge output, taken between points C and E, is connected between the emitter and the base of transistor Q1. With the generator output voltage low, the voltage from the bridge is negative to the emitter and positive to the base. This is a forward bias signal to the transistor and the emitter to collector current therefore increases. With the increase of current, the voltage across emitter resistor R11 increases. This, in turn, applies a positive signal to the base of transistor Q4, increasing its emitter to collector current and increasing the voltage drop across emitter resistor R10.

This gives a positive bias on the base of Q2, which increases its emitter to collector current and increases the voltage drop across its emitter resistor, R4. This positive signal controls output transistor Q3. The positive signal on the base of Q3 increases the emitter to collector current.

The control field of the exciter generator is in the collector circuit. Increasing the output of the exciter generator increases the field strength of the ac generator, and this increases the generator output.

To prevent exciting the generator when the frequency is at a low value, there is an underspeed switch located near the F+ terminal. When the generator reaches a suitable operating

frequency, the switch closes and allows the generator to be excited.

Resistors R27, R28, and R29 are connected in series with the normally closed contacts of relay K1. The coil of relay K1 is connected across the power supply (CR4) for the transistor amplifier. When the generator is started, electrical energy is supplied from the 28-volt dc bus to the exciter generator field to "flash the field" for initial excitation. When the field of the exciter generator has been energized, the ac generator starts to produce and, as its output voltage increases, relay K1 is energized, opening the "field flash" circuit.

Another type of solid state voltage regulator (fig. 4-30) operates by sensing the voltage existing on the lines, amplifying the changes in this signal, and varying the average current supplied to the field winding of the integral exciter. The voltage regulator consists of a sensing circuit with input rectifiers, a temperature compensated Zener diode reference, an error detecting bridge, and a three-stage transistor amplifier. The output of the bridge circuit is a voltage inversely proportional to the difference between the generator voltage and the regulator set voltage and is referred to as the error signal.

The output of the 3-phase ac generator is supplied through transformer T1 in the regulator to provide isolation from the generator and to deliver correct utilization voltages. The output of the transformer is then passed through the full-wave bridge rectifier (CR1) to obtain a direct-current voltage to supply the comparison circuit. The output of the rectifier is proportional to the average of the three line voltages and is applied to the voltage reference and error detecting bridge. This voltage is then compared to the constant voltage present across the Zener diode (CR5), and a means of telling whether the generator is too high or too low is achieved. Potentiometer R7 permits adjustment to the desired voltage. The glow tube (V1) serves to increase the sensitivity of the voltage reference and error detecting bridge. Thermistor RT1 provides temperature compensation in the comparison circuit to offset the effects of changes in the other elements of the circuit

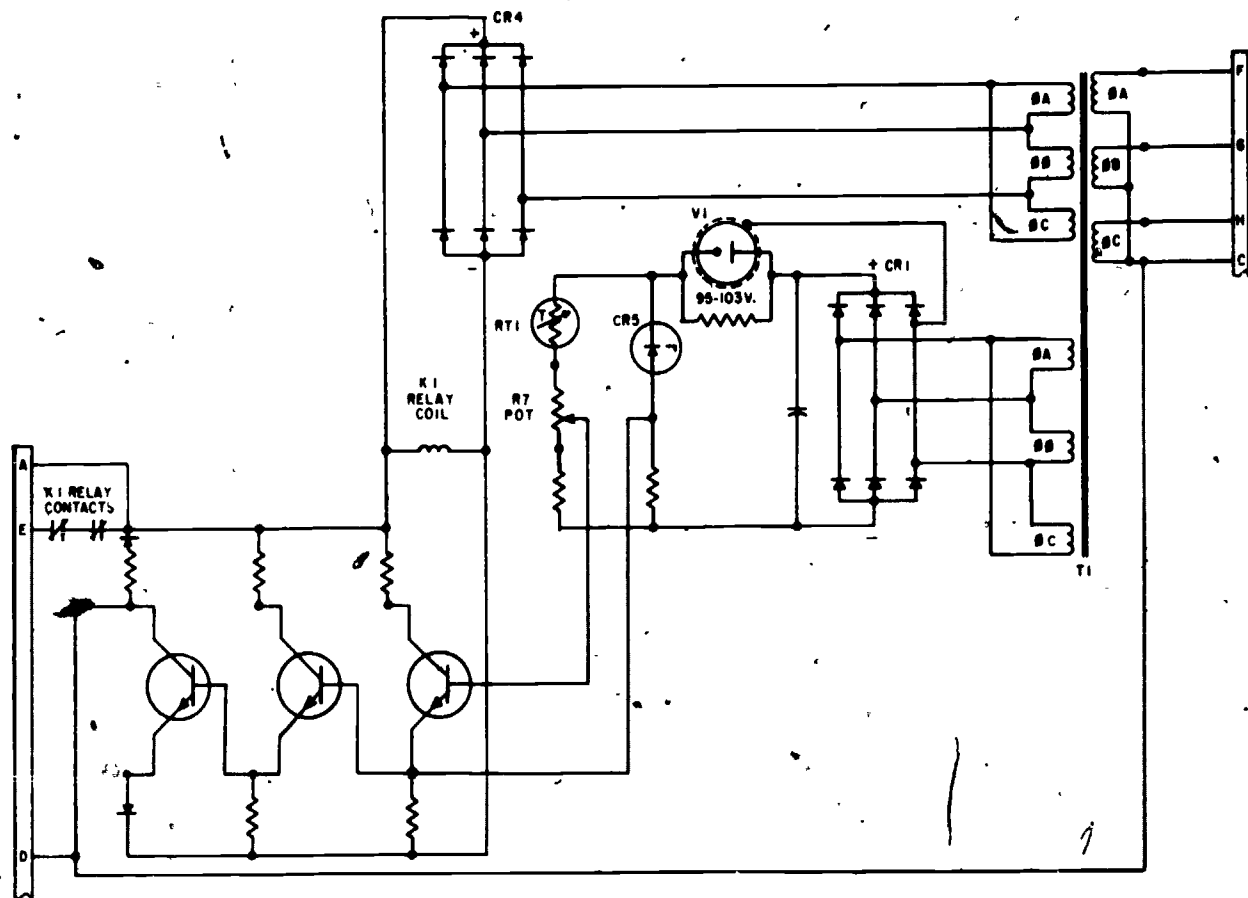

Figure 4-30.—Solid state voltage regulator schematic.

207.188

resulting from temperature variations so that a nearly constant voltage is held.

The output voltage of the error detecting bridge has a sawtooth wave shape due to the ripple resulting from the semifiltered 3-phase rectifier supply: This sawtooth voltage is applied to the input of the first stage of the three-stage transistor amplifier, and with the second and third stages being overdriven, an essentially square wave output is obtained. The effect of the error detecting bridge output is to modulate the width of the pulses that are being passed through the amplifier so that the output current to the exciter field is varied by varying the width of the square wave impulses.

Figure 4-31 shows a pulse width modulation diagram. As the voltage tends to rise, as shown by the dotted back-to-back sawtooth, the square wave pulse to the exciter field is OFF longer than it is ON. This causes the output of the ac generator to decrease. The decrease in voltage causes the back-to-back sawtooth to drop to its normal value shown by the solid waveform, causing about equal ON and OFF times of the square wave pulse to the exciter field. Therefore, the output of the ac generator is controlled by varying the ON and OFF excitation to the exciter field.

The power for operating the three-stage transistor amplifier is supplied through the full-wave bridge rectifier (CR4) from

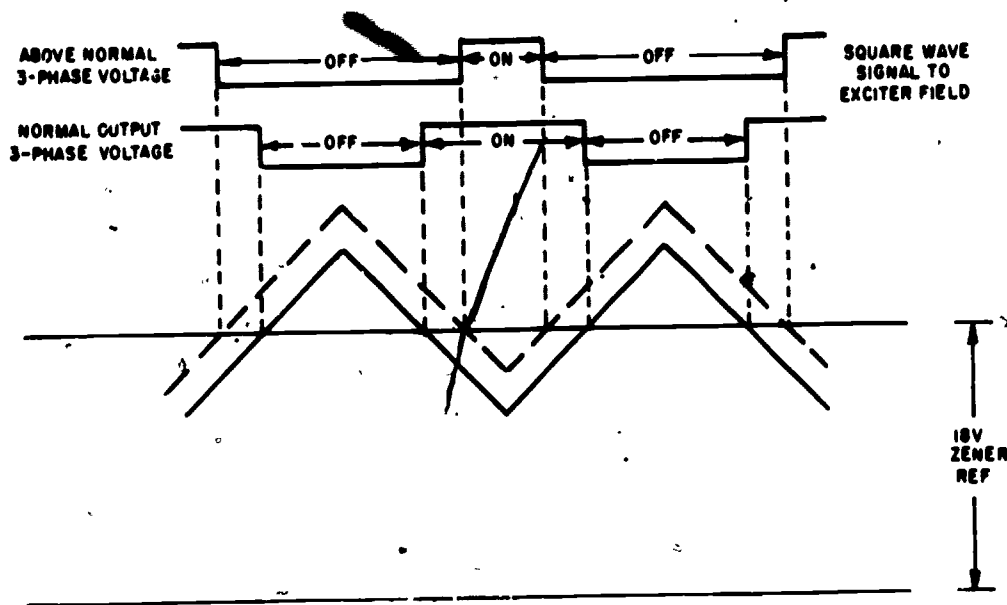

207.189

Figure 4-3 Width modulation diagram.

transformer T1 (fig. 4-30). Obtaining the amplifier power in this manner requires special consideration since there are times when excitation is required and no voltage is available to supply the amplifier. Such conditions exist during initial buildup of system voltage from rest, and during 3-phase short circuit on the generator. A control relay (K1) connected across the full-wave bridge rectifier (CR4) overcomes these obstacles since, with the relay deenergized, its contacts provide permanent-magnet generator voltage to the exciter field. When the generator voltage is approximately 90 volts line to line, the voltage across CR4 is sufficient for the control relay (K1) to energize, removing the self-excited field circuit, and the exciter field is then supplied from the voltage regulator. No feedback network or stabilizing transformers are necessary in this voltage regulator due to the absence of phase shift and the fast response characteristics of the transistor type amplifier.

Frequency Control

Because the number of poles (i.e., the number of magnetic fields) must be fixed by the

manufacturer when he builds the generator, the only means of fine tuning the output to the exact frequency is by controlling the RPM of the rotor. Constant speed drive units (CSDs) are generally used for controlling generator rotor RPM. CSDs are mechanically operated either with hydraulic power, pneumatic power or from the accessory drive section of an engine. CSDs are maintained by the AM or the AD rating.

CIRCUIT PROTECTION

Protection must be provided to both the generator and the equipment and systems that the generator powers in the event of a malfunction. This protection is usually supplied by circuits designed to sense certain types of malfunctions, and is used to energize relays which either warn the pilot of the malfunction or disconnect the generator. The circuit protection needed and the methods used to control the malfunctions are dependent upon the type of aircraft and the design of the equipment. For instance, a single piloted aircraft may necessitate that all malfunctions be detected and corrected automatically, whereas a multipiloted aircraft generating system may only

warn the flight crew of a problem and corrective action be left to the discretion of the pilot in command. Also, some types of malfunctions may be unique to certain types of generating systems.

Voltage regulation and circuit protection for both the operating generator and the equipment it powers is sometimes provided in one component called a supervisory panel. This device will provide the same functions as several components in older power generating systems. A schematic diagram of a typical supervisory panel is shown in Figure 4-32.^c

The supervisory panel will provide voltage regulation at 120/208 volts ac and the generator will be attached to some type of constant speed drive that will provide frequency control at 400 ± 35 Hz. The supervisory panel further provides relays and other associated circuitry to disconnect the generator from the load if any of the following conditions occur:

1. Underfrequency.
2. Overfrequency.
3. Undervoltage.
4. Overvoltage.
5. Feeder fault. (A condition where the current leaving the generator does not pass through the load. Protection against feeder fault is not necessary in generating systems where feeder fault is not likely to occur.)

Underfrequency and Overfrequency Control

The output of the PMG is 39 volts at 600 Hz when the generator is "on speed." The voltage and frequency are sampled by the voltage reference bridge and the frequency sensitive bridge. The band pass filter is tuned to 600 Hz (called its resonant frequency) so that its minimum resistance and maximum current flow occur at exactly 600 Hz. At this frequency the outputs of the bridge networks are equal and opposite, and the under/over frequency sensor senses an "on frequency" condition and energizes the under/over frequency relay (K1). (See fig. 4-32.) Current through contacts 4 and 6 of energized relay K1 allows the generator

control relay (K2) to energize if the frequency remains within tolerance for at least 3 seconds.

If the PMG frequency changes from the desired 600 Hz, the band pass resistance increases and the output of the circuits unbalance. The under/over frequency sensor senses the unbalance and causes K1 to deenergize and immediately cuts off SCR-1. K2 will then deenergize and disconnect any input to the exciter stator coils and reduce the generator output voltage to zero.

Contacts 1 and 2 or K1 change the frequency tolerance from 600 ± 42 Hz to 600 ± 53 Hz by adding resistance to the voltage reference bridge circuit when K1 is energized. This prevents the relay from chattering when the generator is operating at or very near its tolerance limit.

Voltage Control

Voltage regulation is accomplished by changing the ac voltage produced by the permanent magnet generator (PMG) to a dc voltage and controlling its amplitude through the use of a voltage regulating circuit. The voltage regulator senses all three phases of the generator output, and if the average of these voltages is low, the regulator increases the dc voltage to the exciter stator coils in the generator until the output voltage is at the desired level. If the output voltage is high, the voltage regulator decreases its output to the exciter stator coils until the voltage is within tolerance.

The 3-phase output voltage is controlled to 120 ± 2 volts through a wide range of loads from 1 to 120 kva for short periods of time. The load on any one phase may be up to one-third more than on the other two phases and the voltage will not vary more than about 5 volts between the phases. It will take about 1.7 amperes of current through the exciter stator coils to produce the desired magnetic field to generate a 60-kva load at 120/208 volts.

UNDervoltage.—The undervoltage sensing and control circuit makes generator output available to the power distribution system when the voltage rises to 105 volts

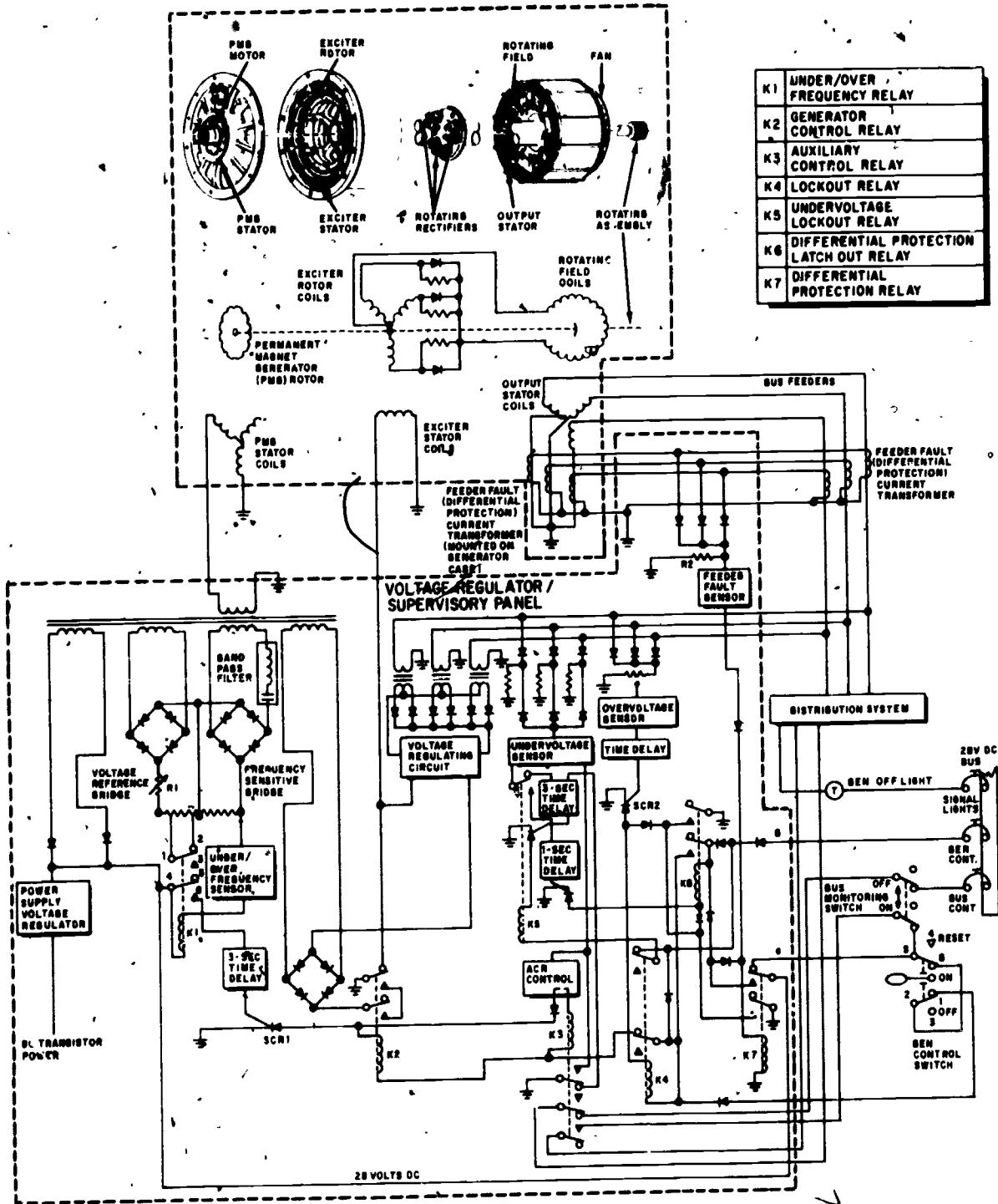

Figure 4-32.—Generator control system with voltage regulator/supervisory panel.

207.34

during initial generator buildup but does not deenergize and reduce generator output to zero until one or more phases fall below 90 volts. The undervoltage sensor monitors generator output and, in conjunction with K1, energizes the auxiliary control relay (K3) to connect the generator output to the power distribution system.

When K3 is energized, its contacts arm a timing circuit that will act automatically when one or more phases are reduced to 90 volts. The timing cycle duration is divided electronically into a 3-second period and a 1-second period in that sequence. The two are additive and the total time involved before an undervoltage trip occurs is approximately 4 seconds. The delay circuitry is intended primarily to allow time for corrective measures to occur—circuit breakers or current limiters to open—and remove the cause of the undervoltage.

If the cause of the undervoltage is removed and the voltage rises to at least 105 volts before the initial time delay lapses, the generator continues to supply the bus and the lapsed increment is canceled—the full 4-second delay is reinstated. However, after a 4-second delay, the differential protection latch out relay (K6) energizes, which energizes the lock out relay (K4), which removes power from K3 and K2.

An undervoltage could be caused by an excessive load on the generator (a short circuit in a system that has a defective circuit breaker or fuse). This condition, if allowed to continue, could cause a fire or destroy the generator. Therefore, both K6 and K4 are provided with holding circuits to maintain them energized even when the undervoltage condition is corrected. In order to check if the undervoltage has in fact been corrected, the GEN CONTROL SWITCH must be placed in the off position, the GEN CONT circuit breaker pulled and reset, and the GEN CONTROL SWITCH returned to the on position.

OVERVOLTAGE.—An overvoltage sensor will sense when the line voltage rises above 129 volts and will start a time delay. When initiated, the delay will time out for a period of time proportional to the amount of overvoltage—a voltage of 130 volts on a single phase may cause

a delay of 3 to 4 seconds, whereas a large overvoltage on all three phases may only last for a few milliseconds. When the delay has completed timing, it will trigger SCR2 into conduction and allow K4 to energize.

An overvoltage may occur from either a malfunctioning voltage regulator or from a large load (several loads) being removed from the generator (the voltage regulator has insufficient time to react). That is, it is possible for an overvoltage to occur during normal operation of the generating system. K4, by supplying its own holding circuit, will prevent the generator from supplying power to the load again until the GEN CONTROL SWITCH is placed either to the reset or the off position and then back to on again. This will prevent a generating system with a malfunctioning voltage regulator from cycling on and off.

Feeder Fault System

If a short were to occur between the generator and the distribution system, where there are no protective devices such as circuit breakers and fuses, a fire could occur before adequate troubleshooting could be accomplished and the proper action taken. To protect against this possibility, a circuit was designed as shown in figure 4-32.

Current transformers are placed on each side of each armature (output) winding of the generator. One set of current transformers (on the grounded side of each armature winding) is placed as close to the armature windings as possible. The other set is placed as close to the distribution system (and its protective devices) as possible. The transformers are then connected in such a manner that the voltages produced by the current transformers cancel each other out. The input to the feeder fault sensor would then be nearly zero. If at any time while the generator is operating there is a short to ground or from phase to phase, a voltage will be developed across R2 and cause the feeder fault sensor to energize the differential protection relay (K7). K7 will then act to energize K6, K6 will energize K4, and K4 will deenergize K2 and K3. Since K7 is held energized by its own contacts directly from PMG voltage, the system

cannot be reset until PMG voltage is removed by stopping the generator.

PARALLEL OPERATION

Two or more ac generators may be operated in parallel with each generator sharing the same load, but certain precautions must be taken before connecting them to the same bus. Paralleling is a complicated procedure, and all currently operating aircraft utilizing multi-ac generator systems use the split bus system. That is, each generator supplies specific systems and equipment, and in the event of a malfunction a generator may be switched to supply the load of a failed generator. The basic principles of parallel operation of ac generators are given in *Navy Electricity and Electronics Training Series (NEETS)* and will not be covered in this manual.

POWER IN AC CIRCUITS

In a dc circuit, power is computed by the equation, $P = EI$; that is, watts equals volts times amperes. Thus, if 1 ampere flows in a circuit at a pressure of 200 volts, the power is 200 watts. The product of the volts and the amperes is the TRUE POWER in a dc circuit.

In an ac circuit, a voltmeter indicates the effective voltage and ammeter indicates the effective current. The product of these two readings is called the APPARENT POWER. Only when the ac circuit is made up of pure resistance is the apparent power equal to the true power. When the impedance of the circuit is either inductive or capacitive, the current and voltage are not exactly in phase, and the true power is less than the apparent power. The true power may be obtained by a wattmeter reading. The ratio of the true power to the apparent power is called the POWER FACTOR, and is equal to true power divided by apparent power.

It is desirable that equipment utilizing ac power have as near a unity power-factor load as practicable. This improves the efficiency of power distribution by reducing the line current and I^2R losses. Most ac loads in an aircraft are somewhat inductive, resulting in a lagging power factor. Power-factor correction may be

accomplished by connecting a capacitor of the proper capacitance in parallel with the circuit. The connection should be made as close to the inductive load as possible.

The nonenergy component of the current in the inductive branch is 180° out of phase with the capacitive current. These currents circulate between the capacitor and inductive load and do not enter the line. The vector sum of capacitor current and total inductive load current is equal to line current. The line current is now in phase with the applied voltage to the parallel combination of the inductive load and the capacitor. This reduction in line current reduces line loss and increases the efficiency of transmission.

Additional information on power factor and power-factor correction may be found in *Navy Electricity and Electronics Training Series (NEETS)* under the heading "Power and Power Factor."

POWER DISTRIBUTION

To this point, various sources that provide electrical power to operate aircraft electrical equipment and systems have been discussed. Now a system must be discussed which connects the electrical power source to the equipment. Each manufacturer must develop a system that will meet the needs of his particular aircraft design. A system of priorities is established so that in the event of a malfunction, certain critical equipment may still be operable. For instance, if a power lead normally used to start an engine were to short out during flight, it would certainly be inappropriate to sacrifice all electrical power, especially power to such things as lighting during night flights, navigation equipment, flight instruments, and other essential equipment. Therefore, systems of like priority are grouped on a common line called a bus.

Each aircraft has a group of buses normally identified by the priority of the equipment it powers. (Some older aircraft with limited electrical equipment may have one bus labeled "electrical bus".) For instance, a flight essential bus may power emergency lighting, critical flight and engine instruments, and/or an emergency

radio. Less important but critical equipment may be powered from an essential bus, and normal systems used to complete the assigned mission or provide crew comfort may be placed on the main bus. The input to a bus may be either dc or ac and the output from the bus will usually be protected by a protective device such as a circuit breaker, fuse, or current limiter. A 3-phase ac bus will have three separate common lines, one for each phase, as shown in figure 4-33. The three phases may be drawn only as one line on some schematics.

GROUNDED SYSTEMS

The term grounded system means that one leg of the system is connected to a common conductor, such as the earth, the skin of the aircraft, or to a structural member of the aircraft. When the grounded leg of the circuit is connected to a good electrical conductor, this conductor may serve as one leg of the circuit; thus, no separate conductor is needed for this leg of the circuit.

Figure 4-34 shows a simple grounded system. Even though the grounds are shown at different points, the potentials at these points are essentially the same since they are connected to a common conductor.

Any wire that completes the circuit to the ground network for an equipment is designated

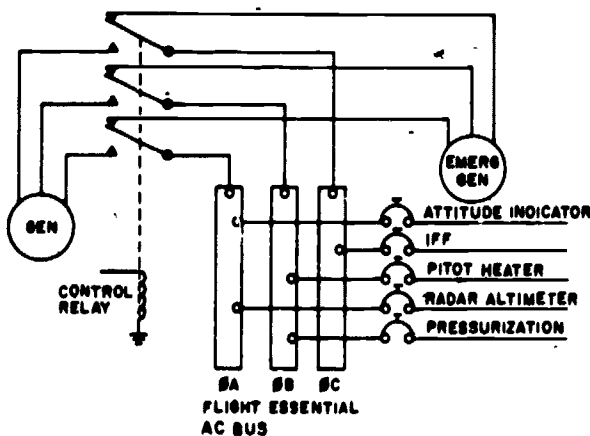

Figure 4-33.—Three-phase ac bus.

207.35

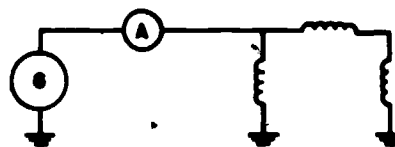

Figure 4-34.—Grounded system.

207.190

with the letter N. Any wire so designated may come in contact with ground at any point without causing malfunction of the equipment.

Grounding is accomplished in 3-wire systems by grounding one of the phases, usually the B-phase in aircraft. In 4-wire systems the neutral is grounded. Care must be taken to insure that the same phase is grounded in all equipment. Figure 4-35 shows the grounding of 3-phase systems.

The grounded type circuit is advantageous over the ungrounded circuit since it reduces overall weight by using fewer conductors. This results in a reduction in cost and space requirements. Other advantages are that troubleshooting is simplified to some extent and the impedance of the ground return path is lower than that of a run conductor. The disadvantages of a grounded system are that short circuits will result when a bare spot on any ungrounded conductor of the system touches ground, and where circuits of different potentials and frequencies are using a common

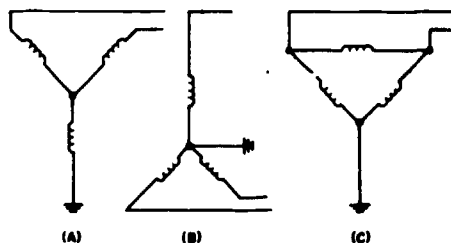

Figure 4-35.—Grounded 3-phase systems. (A) Grounded 3-wire wye; (B) grounded 4-wire wye; (C) grounded delta.

207.191

ground, there is the possibility of one circuit feeding into another. This trouble is prominent in electronic circuits.

UNGROUNDING SYSTEMS

The term ungrounded system means that the circuit is in no way connected to ground; thus, all conductors are run from the power source to the loads. Circuits of this type are often referred to as being above ground. The ungrounded system has the following advantages: It prevents one circuit from feeding into another; no malfunction of equipment will occur should one conductor become accidentally grounded; and the circuits are completely insulated from each other. The system has the disadvantage of adding more weight because it requires more conductors than the grounded system. This results in added cost and space requirements.

Both the grounded and ungrounded systems have their specific usage in modern aircraft. The grounded system utilizes the skin of the aircraft for one side of the line. The ungrounded system is completely isolated. The type of system to be used depends upon the factors required of the circuit.

SINGLE-PHASE AND POLYPHASE SYSTEMS

Single-phase systems are of simple design and construction and are utilized where relatively low power is required. Polyphase systems are more complicated in construction and design, and are used where high power is required. These systems provide a "smoother" source of power.

Single-phase power may be obtained from polyphase systems, but when this is done, care must be taken to keep the load on the polyphase system balanced.

CHAPTER 5

AIRCRAFT ELECTRICAL AND ASSOCIATED SYSTEMS

AIRCRAFT LIGHTING SYSTEMS

Primarily, the lighting system in an aircraft serves two purposes—to provide specialized light sources outside the aircraft and to illuminate the interior. Lights on the exterior provide illumination at night for navigation and such other operations as signaling, landing, anticollision, and formation flying. The interior lighting provides illumination for instruments, equipment, cockpits, cabins, and other sections occupied by the crew. In addition, certain lights are used to indicate to the pilot and crew if the electrical, electronic, and mechanical systems are operating normally or if a malfunction has occurred. They are also used to indicate the position of the landing gear, bomb bay doors, sonobuoy exit doors, etc.

Various types and sizes of light assemblies are used on present-day naval aircraft. The selection of a particular assembly is governed by the nature of the lighting that is needed. Generally speaking, a light assembly consists of a housing (fixture), a lamp, and a lens.

DESCRIPTION AND TYPES OF LAMPS

Aircraft lamps are devices that are used as sources of artificial light. The incandescent light is the most common and uses an electrical source to heat a filament until it is white hot. Normally, the source voltage will be 26 to 28 volts ac or dc; some lighting systems utilize lower voltage lamps and use stepdown transformers to supply 3 to 6 volts to the lamps. The lower operating voltage allows the lamp filament to be somewhat larger and thus helps to reduce lamp failure due to vibrations.

When a lamp is replaced, the replacement must be the same as the original lamp, or an approved alternate. Spare lamps that are carried in the aircraft should be shock-mounted; otherwise, they are apt to fail earlier than the lamps in use since cold filaments are normally more subject to fatigue failure than hot ones. Make sure the glass bulb of the lamp is clear and free from grease and dirt. To help keep bulbs clean, avoid touching the glass bulb with bare hands if possible.

The parts of a lamp are the bulb, filament, and base. Incandescent lamps vary chiefly in electrical rating, base type, bulb shape, and bulb finish.

The electrical rating is usually expressed as combinations of volt, watts, amperes, and candlepower. (Candlepower is the luminous intensity expressed in candles and used to specify the strength of a light source.) The lamp rating is marked on either the base or the bulb of the lamp. In the case of small lamps, the electrical rating is usually replaced by an identifying number. This number is usually the same as the Military Specification (MS) dash number and is stamped on the base.

The base types vary as to size, number of electrical contacts, and the method of securing in a socket. The most common bases are the single or double contact bayonet (push in and turn) type. These are desirable for aircraft use since they lock in the socket and do not become loose because of vibration. The single contact is used in single-wire systems. In this system one side of the lamp filament is soldered to the base and the other to the contact. The double contact is used where the single-wire system is not practicable. In this system the filament is

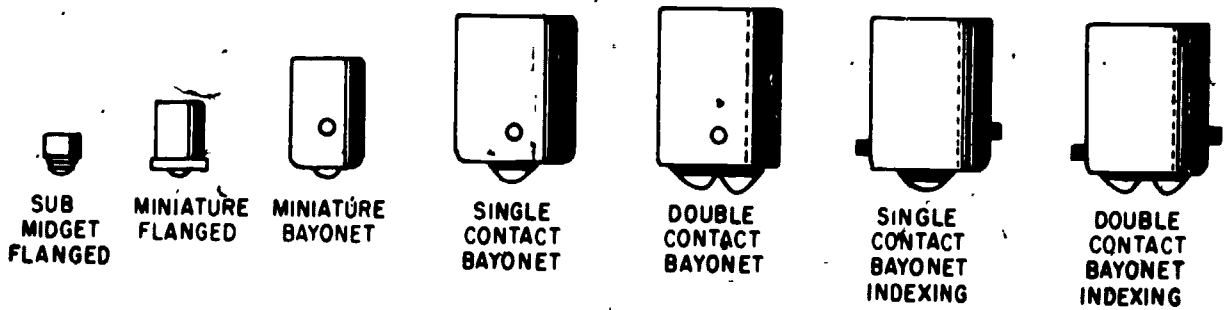

Figure 5-1.—Lamp bases.

207.40

connected to the contacts and does not make an electrical connection to the base unless dual filaments are employed, in which case a common contact is made to the base. The single and double contact type lamps cannot be used interchangeably.

Some bases are of the screw type, but they find limited use because they loosen easily. Figure 5-1 shows some of the popular types and sizes of lamp bases used in aircraft.

Some lamps are provided with an indexing type base having offset index pins. (See fig. 5-1.) The purpose of this index type base is to assure that the lamp is seated in the socket so that the light shines in the proper direction.

Some lamps do not have a base and are intended to be soldered directly onto a circuit-board or permanently embedded in control box panels. These lamps are usually carefully tested and selected so they will last the life of the

aircraft. One such lamp, the "grain of wheat" lamp, is shown in figure 5-2.

Bulb shapes are designated by the combination of a letter and numeral. The letter designation indicates the shape of the bulb in accordance with a code, and the number is a measure of the approximate maximum diameter of the bulb in eighths of an inch. The shapes of the more common glass envelopes are:

- G Globular
- GG Grimes Globular
- S Straight
- T Tubular
- PAR Parabolic Alum. Reflector
- R Reflector

For example, a bulb designated as T-6 has a tubular shape and a diameter of six-eighths inch. A variety of sizes and shapes of glass envelopes can be found in the Defense Logistics Agency (DLA) Identification List available through the local supply support center. Figure 5-3 shows some common bulb shapes.

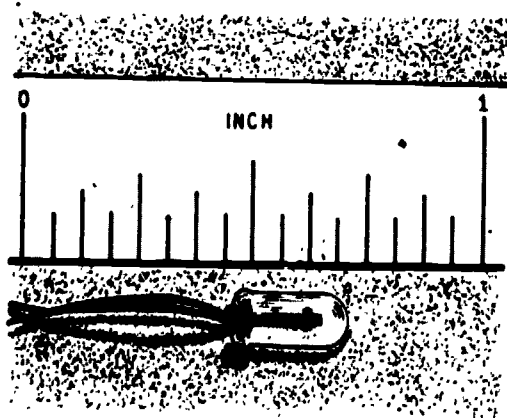

Figure 5-2.—"Grain of wheat" lamp.

207.85

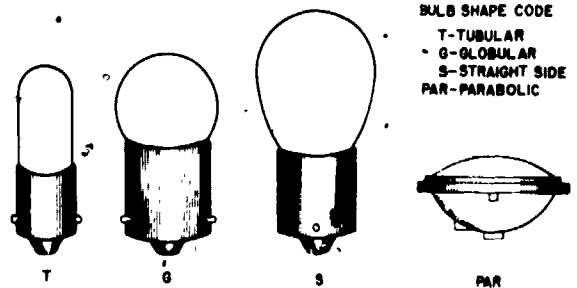

Figure 5-3.—Common bulb shapes.

207.79

The majority of aviation lamps are either clear glass or inside frosted. For particular applications, however, bulbs may be partially frosted to cut down emission of light in a particular direction, or they may be partially silvered to prevent emission in specified directions and to concentrate the light in other directions. Some applications call for colored bulbs; for example, in instrument illumination and safety lights. Bulb finish is indicated by letters preceding the MS dash number--R for red, SB for silvered bowl. If no letter is present, the lamp is clear glass or frosted. Colored lighting can be provided by using clear lamps that are covered with colored lenses.

There are many special purpose lamps used in naval aircraft. Three of the most common are:

1. The parabolic, sealed beam landing and taxi light. (The sealed beam type lamp is also used in signal lights.)
2. The midget flange type lights which are used in instrument panels and control boxes.
3. Lamps having two filaments in parallel to provide fast signaling (smaller filaments heat and cool faster) are used in fuselage and signal lights.

EXTERIOR LIGHTING

Numerous types of lights are used in fulfilling the exterior lighting requirements of naval aircraft. The principal types of exterior lights are the navigation or position lights, anticollision lights, landing lights, signaling lights, and formation lights.

Figure 5-4 shows the components used in the exterior lighting system of a carrier type aircraft. This figure shows the lights that are common to most naval aircraft, but it does not show every type light that may be found on different aircraft. The lighting requirements vary from one aircraft to another, depending upon the aircraft type.

Navigation Lights

These lights are mounted on the aircraft to attract visual attention to its position and heading at night. A standard minimum set of

navigation lights, meeting Federal Aviation Administration requirements for light distribution and intensity, is required on all military heavier-than-air aircraft.

The standard minimum set of navigation lights for night operations consists of:

1. One red light on the tip of the left wing.
2. One green light on the tip of the right wing.
3. One white light on the tail, located so as to be visible over a wide angle from the rear.

These navigation lights will be positioned on a stationary surface to the extreme left, right, and aft on helicopters (fig. 5-5). In some aircraft configurations navigation lights will only burn steady, while in other configurations they may be made to burn steady or to flash approximately 80 flashes per minute.

Fuselage Lights

Fuselage signal lights are mounted on the fuselage of the aircraft as a part of the navigation lighting system, and provide a method of visual signaling. When installed, two fuselage lights are necessary, one on the top and one on the bottom of the aircraft. In cases where it is not practicable to install the light on the bottom, as in the case of a seaplane or of a radome obstruction, two lights are installed—one on either side and as near the bottom as feasible. Fuselage lights may be made to burn steady or flash at a constant rate. Some aircraft also incorporate manual keying of lights for signaling, as shown on the control box in figure 5-4.

Anticollision Lights

Anticollision beacon lights are required by the Federal Aviation Agency to be installed on all aircraft. Their primary purpose is flight safety, during daylight hours as well as night.

One type anticollision light consists of two 40-watt reflector type lights and a red lens assembly. The bulb assembly is rotated by an ac

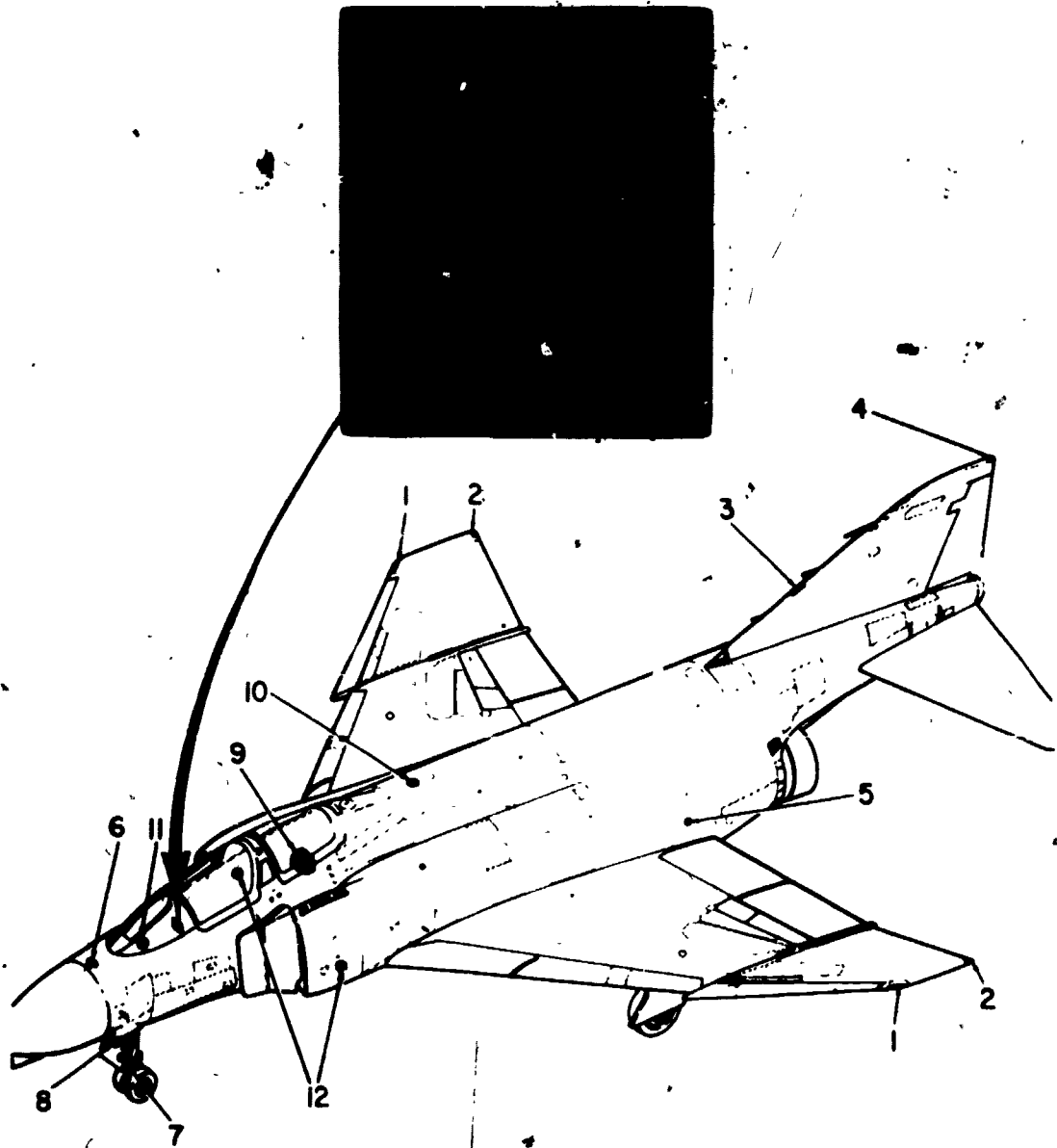

- 1. Wingtip position lights.
- 2. Join-up lights.
- 3. Anticollision light.
- 4. Tail light.
- 5. Angle-of-roll light.
- 6. Flasher.

- 7. Approach lights.
- 8. Taxi light.
- 9. Exterior lights relay panel.
- 10. Upper fuselage light.
- 11. IFR probe light.
- 12. Lower fuselage lights.

Figure 5-4.—Exterior lighting.

207.81

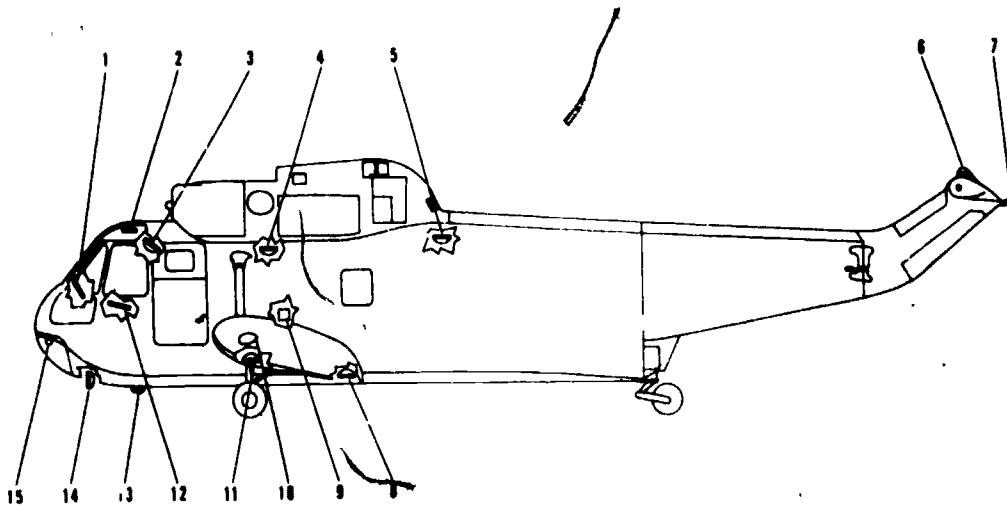

207.88

Figure 5-5.—Typical helicopter lighting.

or dc motor causing 80 to 90 flashes per minute to occur. Electric power to the bulbs is provided by sliprings. On another type of anticollision light, the bulb is stationary and flashing is accomplished by motor-driven reflectors, which are contained in the light assembly. Some aircraft are now utilizing strobe lights to provide anticollision warning to other aircraft. This system provides intensity of 3000 to 3500 candle-power white light for day and 150 to 200 candle-power red for night, each at 60 flashes per minute.

On those aircraft equipped with inflight fueling tanker capabilities, provisions have been made in the external lighting system to turn off the lower anticollision light during delivery of fuel to another aircraft. Tanker aircraft use a bluish-green lens over their anticollision lights so that they can be readily identified by other aircraft in need of fuel.

Landing Lights

Landing lights are extremely powerful and are used to illuminate the landing strip. Multiengine aircraft usually have a landing light mounted on each wing. Single-engine aircraft use only one landing light, which is normally mounted on the port wing.

Landing lights are usually of the retractable type and are actuated by split-field series dc motors or ac induction motors. (See fig. 5-6.) The lights are of the sealed-beam type and are rated at 28 volts, 600 watts. The 28-volts ac is obtained from an autotransformer located within each light assembly. In the retracted position, movable lights are flush with the undersurface of the wing. Some aircraft have provisions for installing a landing light in the nosewheel fairing door, while other aircraft may utilize a fixed type landing light which is mounted in the leading edge of the wing.

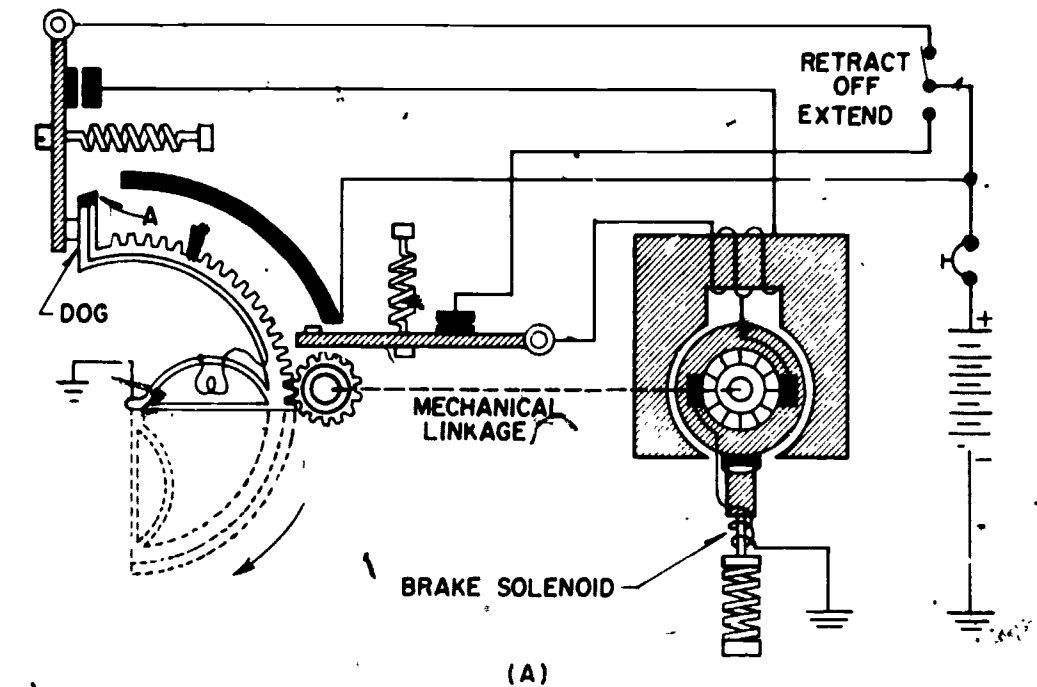

(A)

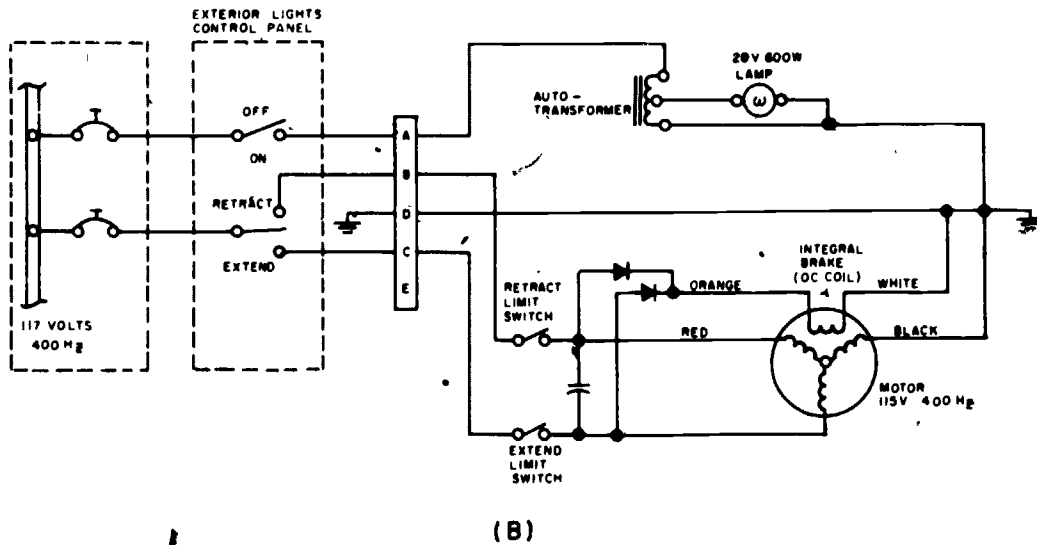

(B)

Figure 5-6.—Retractable landing lights.

207.82

By reference to figure 5-6 (A), the principle of operation of a typical retractable landing light may be examined. The landing light switch on the pilot's lighting panel controls the landing light motor. When the switch is positioned to

either EXTEND or RETRACT, power is applied simultaneously to the magnetic brake (which releases the brake) and the drive motor. Limit switches open the motor circuit when the light has reached its limit of travel either in the

extended or retracted position. This light is stopped in any position between its travel limits by turning the switch off. When the power to the motor is turned off, either by a limit switch or the manual switch, the light is held at that particular position by the gear train.

The lamp is automatically lighted by means of sliding contact A after the light has traveled downward about 10 degrees, and will remain lighted until the lamp again reaches the 10-degree position when traveling in the upward direction. The lamp will remain lighted in any extended position past the 10-degree position regardless of power application to the control motor. This arrangement provides the pilot with a means of adjusting the angle of the light beam to suit his particular needs. A switch is often provided to turn the lamp off while the light is extended, as shown in figure 5-6 (B).

Landing light assemblies are so designed that the maximum extended position can be varied and set for each particular aircraft installation by means of a simple adjustment. The light is set at the factory to open to an extended position of 73 degrees, plus or minus 3 degrees, from the retracted position. The light assembly, however, is capable of being extended to variable positions ranging from 50 degrees to 85 degrees from the fully retracted position.

When ground testing landing lights, caution should be exercised to prevent possible damage to the lamp from overheating or extending it against ground support equipment. Never look directly at an illuminated landing light as it can cause permanent eye damage.

Approach Lights

Approach light systems are provided on carrier type aircraft to provide the pilot and landing safety officer (LSO) with a positive indication of a safe or unsafe landing configuration. All shipboard naval aircraft have approach lights mounted to be clearly visible to the LSO. Installations of the approach lights vary with aircraft; older aircraft have them mounted in the leading edge of the port wing.

Modern jet aircraft such as the F-4 and A-7 have the approach lights mounted on the nose

landing gear door. A typical approach light installation for the F-4 is illustrated in figure 5-4. Most jet aircraft are equipped with a three-lamp approach light connected to the angle-of-attack indicator. The approach lights are controlled by cam actuated switches in the angle-of-attack indicator. The lights operate when the landing gear is completely down, when the aircraft is off the gear, and when the arresting gear is extended.

There are three lights in the approach-light assembly, colored red, amber, and green. When the red light is on, it indicates that the angle of attack of the aircraft is low. When the green light is on, it indicates that the angle of attack of the aircraft is high. When the amber light is on, the angle of attack is optimum for the landing approach.

Working in conjunction with the approach lights are the cockpit angle-of-attack indexer lights (refer to Chapter 6, Figure 6-21) which present angle-of-attack information to the pilot. They are usually mounted in the cockpit on either side of the windshield so that they are clearly visible to the pilot but do not obstruct his vision.

The indexer lights are energized by cam operated switches in the angle-of-attack indicator. At very low angles of attack, an inverted V (colored red) is illuminated and warns the pilot to increase his angle of attack. At slightly low angles of attack, both the inverted V and circular symbol (doughnut) are illuminated. At optimum angles of attack the doughnut (colored amber) is illuminated. At slightly high angles of attack, both the V and doughnut are illuminated. At very high angles of attack, a V symbol (colored green) is illuminated, warning the pilot to decrease his angle of attack. The indexer information corresponds with the approach lights assembly information displayed to the LSO.

Steady burning of the approach lights indicates to the LSO (1) the angle of attack of the aircraft, (2) the landing gear is down and locked, and (3) the arresting gear is fully extended. A limit switch in the arresting gear circuit is actuated when an unsafe condition exists, causing the lights to flash. The approach lights will not illuminate unless the landing gear

is down and locked and the weight is off of the gear.

An arresting gear (tailhook) override switch is provided for carrier landing practice at airfields. The override switch is the momentary ON type; when placed in the ON position, the arresting gear switch bypass relay is energized. When the switch is placed in the ON position, the approach lights operate only in conjunction with landing gear since the arresting gear is not used. When power is removed from the circuit, it reverts automatically to its normal condition (arresting gear switch not bypassed). For example, in most aircraft types the circuit is restored to normal by lowering the arresting gear, by turning off the battery, generator switch, or by removing the external power. The angle-of-attack system is discussed in detail in chapter 6 of this manual.

Formation Lights

Formation lights are used on certain naval aircraft for night formation flying. In a typical formation light installation, a wingtip formation light is installed within the upper and lower surfaces of the aft section of each wingtip. Translucent diffusing windows are installed flush with the wingtip surface above and below each light. The right-hand (starboard) light covers are green and the left-hand (port) light covers are red. The lamp assembly is bracketed to a cover plate within the lower wingtip surface, and is accessible when the cover plate is removed.

Fuselage formation lights are installed in box assemblies on each side of the fuselage. Each is equipped with a plastic window for light emission; access to the lamp is obtained by removing the box cover. These lights are connected in parallel with the wingtip formation lights, thus they are illuminated simultaneously and are controlled from the same switches.

Manufacturers of different types of aircraft sometime identify lights having the same purpose as formation lights by another name such as join-up lights or strip lights.

Taxi Lights

Taxi lights are used before or after flight to aid the pilot in maneuvering. On aircraft having

a nosewheel, the taxi light assembly is usually located on the movable strut so that the light will turn with the wheel. It is always installed so as to afford maximum visibility for the pilot and copilot. (See fig. 5-4 for a typical taxi light installation.)

In-flight Refueling Probe Light

Most modern high performance naval aircraft flights are limited due to fuel capacity. To increase range and flight time, in-flight refueling became necessary both night and day. Most naval shipboard aircraft have provisions for in-flight refueling. During night refueling, it became necessary to install in-flight refueling (IFR) probe lights. The IFR probe light is installed on the fuselage forward of the IFR probe. The light lens is usually red in color and is used during night in-flight refueling operations to illuminate the refueling probe and drogue from the refueling aircraft. Figure 5-4 shows a typical IFR probe light installation.

Angle-of-Roll Light

The low swept wing design of the F-4 prevents the landing signal officer from observing the right wingtip light during a normal carrier approach. Therefore, a green angle-of-roll light is installed on the left side of the fuselage just above the trailing edge of the wing. This light is illuminated during carrier approaches and field mirror landing practice only and is designed to serve as a roll reference for the landing officer until such time that the right wingtip is visible. (See fig. 5-4.)

Hover Lights and Spotlights

In helicopter installations, hover lights are used to illuminate the area directly beneath the aircraft (fig. 5-5). These can be used for several different purposes, including landing or search and rescue.

A spotlight can be mounted in the nose of a helicopter such as that shown in figure 5-5 and can be extended or retracted as necessary. It is controlled by an ON, OFF, RETRACT switch on the forward end of the pilot's control stick,

and a spring-loaded four-way thumb switch marked EXTEND, RETRACT, LEFT, RIGHT. It can rotate through 360° of azimuth.

INTERIOR LIGHTING

Interior lighting of naval aircraft is accomplished through the use of various types of lights and lighting systems. Almost all of these may be included under one of the following types:

1. Instrument lighting.
2. Cockpit lighting.
3. Cabin and passageway lighting.
4. Indicator lights.

An important consideration in connection with interior lighting of aircraft is the fact that undue eyestrain must be prevented. The eyes are slow to make adjustments to changing light intensities, and this action can cause fatigue or eyestrain. Aircraft lighting is engineered to produce as little discomfort as possible, and you as the person who maintains the lights should be certain that the specifications as to fixtures and lamps to be used are followed when making replacements. The AE will insure that the following general considerations are observed in connection with the interior lighting of aircraft:

1. Use lenses to diffuse light that lies within the pilot's field of vision.
2. Eliminate all bright spots of light, direct sources of light, and reflections.
3. Use sparingly any surface that reflects light, such as chromium or nickel.
4. Utilize quick-change lighting fixtures so that lamps may be changed rapidly.

Instrument Lights

The first use of artificial light in aircraft was for the illumination of instruments. Operation of modern aircraft is more dependent upon the various instruments than ever before, and because of this, instrument lighting becomes more important. Different methods of instrument lighting are used, and the decision as

to the one best method would be difficult. No matter what system of lighting is used, one common requirement is that the light must not be visible outside the aircraft.

One method of lighting that was very desirable since it produced no objectionable reflections was known as indirect (mask) lighting. The lamps were set in the instrument panel and the panel was covered with a reflector (mask) which had openings in it for observing the instruments. The light was reflected back and forth until it became diffused and in so doing flooded the entire panel. Even though this system produced satisfactory lighting it is impractical today because of space and weight requirements.

Another method of instrument lighting (commonly called post lighting) is accomplished by installation of specially adapted shields in front of the instruments. Small lamps in small red filtered sockets are installed in the front surface of the cover shields which cast the light down and onto the instruments. These shields are cut out over the instrument for vision and are flanged in such a way as to direct the lights properly for illumination of the dial. Red light is used in naval aircraft since it has been found to be the most satisfactory of all colors that will allow the eyes to adjust from an illuminated surface to a dark night environment.

The intensity of light is often controlled by means of a rheostat in the lighting circuit. This is illustrated in figure 5-7. The rheostat is a

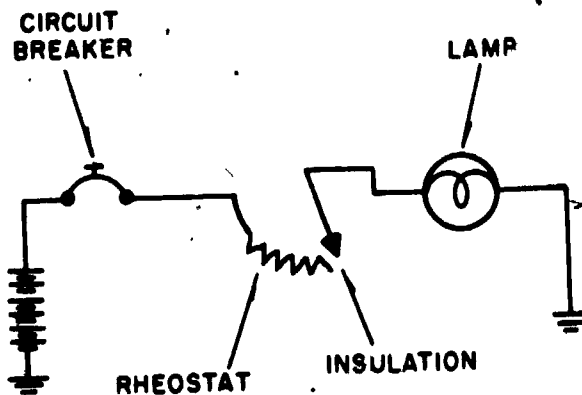

Figure 5-7.—Rheostat switch.

207.83

variable resistor used to limit the amount of current through the circuit. When the pivoting arm reaches the high resistance end of the rheostat, it slips off the contact surface, thereby breaking the circuit. This arrangement is sometimes called a rheostat switch.

A typical aircraft instrument lighting system is shown in figure 5-8. The lighting equipment consists of edge-lighted control panels, individual lights for the instruments on the instrument panel, and red floodlights for overall lighting. The brilliance of the individual instruments lights and the red floodlights is controlled by rheostats located on the interior lights control panel. The edge-lighted panels provide diffused lighting for the control and indicator panels.

Instruments which have a light source as an integral part of the instrument are in use, and it is expected that all instruments will soon be integrally lighted. Since the use of individual lights for instruments is compatible with the "integrally lighted" instruments, they may be intermixed.

Edge-lighted control and indicator panels such as shown in figure 5-8 have a nongloss, black background with white lettering for maximum ease of reading. The lighting is accomplished by small lamp assemblies which are mounted so as to diffuse light through the plastic panels. These lamps are fitted with red filters to eliminate glare. All lamp assemblies in the edge-lighted panels are powered from the essential bus. Bulb replacement is relatively simple since all that is required is to unscrew the top cap from the assembly, pull the bulb from the cap, replace the bulb, and reassemble the unit.

Most of the instrument lights consist of panel lights and instrument integral lights used to illuminate the instruments. All instrument lights receive their power from the essential bus through circuit breakers, or from autotransformers through fuses. Overall light intensity is controlled by the COCKPIT LIGHTS control panel (fig. 5-8). The INSTR PANEL lights control is a variable intensity control for the instrument lights. As the control is rotated

from the OFF position in a clockwise direction, the intensity of the instrument lights increases.

The CONSOLE panel lights control is a variable intensity control for the console panel edge lights. As the control is rotated clockwise, the intensity of the console edge lights increases. Also as soon as the control is rotated to the OFF position, a switch within the control is actuated, removing power from the dim contact of the console flood switch. Therefore, the console red floodlights will operate in dim only when the console panel lights control is in a position other than OFF.

The CONSOLE FLOODS switch is a three-position switch—BRT, DIM, and MED—for selecting intensity of console floodlights. Selection of the BRT or MED position energizes the lights regardless of the position of the console panel lights control. The floodlights will remain off when the CONSOLE FLOODS switch is in the DIM position and are illuminated when the CONSOLE panel lights control is rotated from the OFF position. The WHITE FLOOD switch has two positions—OFF and ON. Placing the switch to ON energizes the white floodlights. The NORMAL WARNING LIGHTS switch has two positions—NORMAL and TEST—and is spring loaded to the NORMAL position. Placing the switch in the momentary contact TEST position illuminates all of the warning lights in the pilot's cockpit.

The INSTR PANEL EMERG FLOOD switch (fig. 5-8) has three positions—OFF, DIM, and BRT. The switch is used to illuminate the red floodlights above the main instrument panel in an emergency when the normal instrument lights are malfunctioning.

In some aircraft, tiny "grain of wheat" lamps are permanently embedded in the control-box panels. Having been aged and carefully selected for output and reliability, the lamps should last for the lifetime of the aircraft.

Lamps to be embedded in the plastic panels are first aged at their rated voltage for 10 hours. This process eliminated much of the problem of early lamp failure. To insure a nearly standard value of illumination, lamps whose light emission falls under, or goes over, a certain candle-power rating are also excluded.

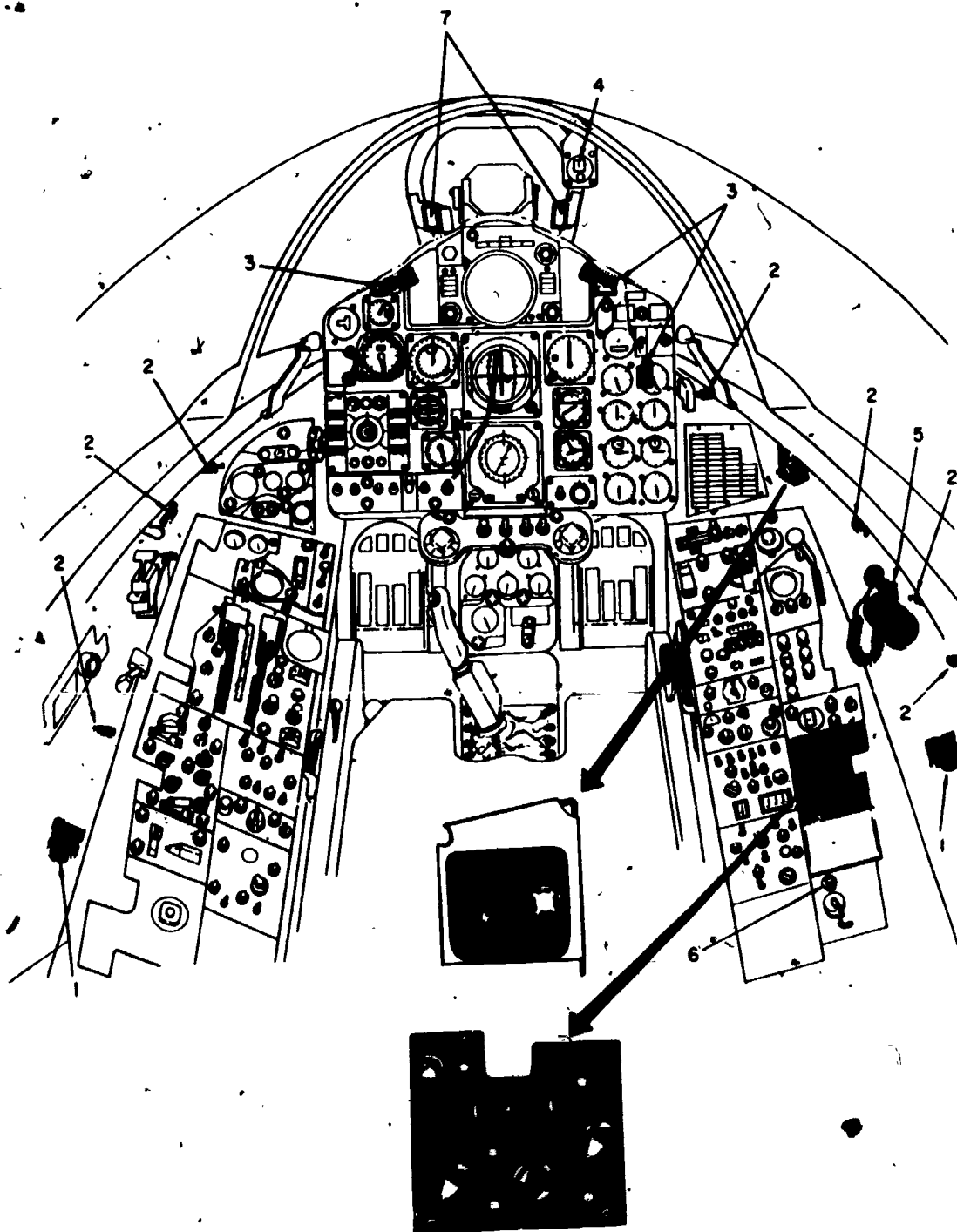

- 1. White floodlights.
- 2. Red floodlights.
- 3. Instrument emerg. floods.
- 4. Standby compass light.

- 5. Utility spotlight and floodlight.
- 6. Spare lamp container.
- 7. Angle of attack indexer lights.

Figure 5-8.—Interior lighting.

207.84

Cavities are machined in the back of the panel to accommodate the panel connector and lamps, and shallow trenches are cut to route the lamp leads to the panel connector. The connector, lamps, and leads are then potted into the back of the panel with a clear plastic potting material. Normally, the lamps are in parallel, and failure of one lamp will not appreciably degrade the panel lighting. The main advantages of embedded lamps are long life, ruggedness, resistance to aircraft vibrations, and better illumination.

Cockpit Lights

The term cockpit lighting is rather broad in its coverage. Its meaning varies, depending on the type aircraft being described. In fighter type aircraft, it may be thought of as the interior lighting which consists mainly of individually lighted instruments and switches, lighted control panels, and necessary floodlights. In the larger aircraft, cockpit lighting includes the various lights that are required for the crew to perform its duties. It includes the interior lighting just mentioned as well as many other special lighting assemblies.

A much used lighting device is the small incandescent spotlight known as a utility light assembly. These assemblies, installed at crew stations, are mounted in a position where they provide illumination of the equipment which the crewmember uses during flight. The light from the lamp assembly can be focused in either a small spot or in a wide beam, and minimized in amount by a red filter. Figure 5-9 shows one type light in which an ON-OFF switch and an intensity control rheostat controls the operation of the light assembly. These lights are sometimes equipped with a small momentary-contact switch which, when pressed, causes the light to burn with full intensity regardless of the setting of the rheostat.

Cockpit extension light assemblies are used to provide crewmembers with an extension light for reading maps or illuminating small areas. These assemblies consist of a connecting cord, switch, and lamp housing assembly. The light may be removed from its mounting and used as

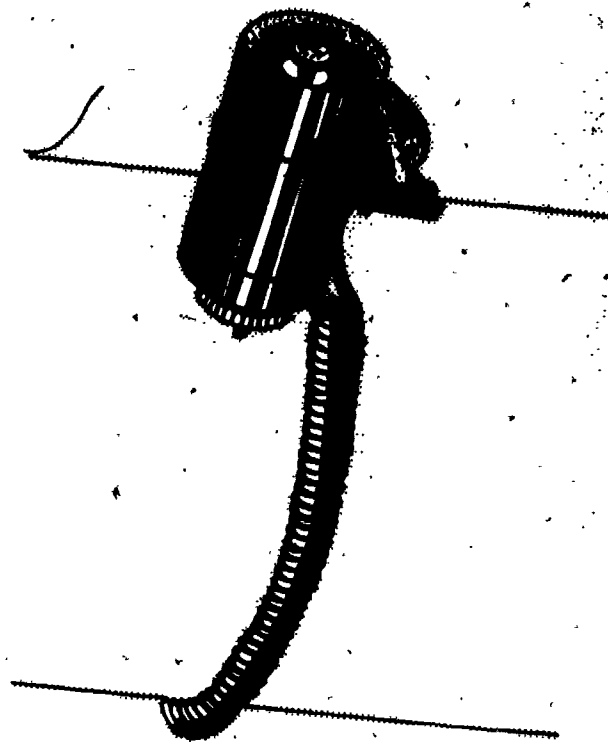

207.86

Figure 5-9.—Cockpit utility light.

an extension light. By adjusting the assembly, it is possible to change the size of the beam of light.

Indicator Lights

To provide a means for obtaining information pertaining to the operating status of the aircraft and its equipment, various indicator (warning, caution, and advisory) lights are installed. These lights are used for various purposes, such as indicating the position of the landing gear, arresting hook, wings, and bomb bay doors. They can also indicate low oil pressure, equipment overtemperature, generator failure, and numerous other data.

Indicator lights are constructed in various shapes and sizes, dependent upon the particular

job they are designed to perform. They are installed in the aircraft in such places as to be easily noticed when they are glowing. It is important that bulb replacement can be made quickly and easily since some of the lights relay vital information that concerns the safety of flight. Whenever practical, the fixtures are constructed so that the bulbs may be replaced in flight without the use of tools. Most warning lights are so designed that a push-to-test feature or a test switch enables you to determine if the bulb is good. The test switch energizes various test relays which, in turn, either provide power or a ground circuit for energizing the lights; thus the condition of the bulb may be checked without actuating the equipment.

The legend type lights indicating specific functions on the lens surface are more prominent on late model aircraft. (See fig. 5-10.) The warning lights are red and are provided to warn the crew of a dangerous malfunction or unsafe operating condition which requires immediate corrective action. The caution lights are yellow and are provided to alert the crew to a minor malfunction or impending dangerous condition requiring attention but not necessarily immediate corrective action. The advisory lights are green and are provided to indicate to the

crew a safe or normal configuration, condition of performance, or for attracting attention for routing purposes.

These indicator lights must be bright enough to be seen during daylight operation but not so bright at night as to cause undue eyestrain. Brilliance control is obtained by connecting resistors in the lighting circuit, by placing dimmer caps on the lights, by special adaption of edge lighting, and by special type lenses in which dimming can be obtained by twisting the lens.

An example of the use of indicator lights is the system used to indicate high oil temperature. A thermostatic switch located in the oil return line closes when a temperature above normal is reached. This usually provides a path to ground lighting the "OIL HOT" light. The light is extinguished only when the oil cools to normal temperature by actions of the pilot or crew, or after the aircraft lands and the malfunction is repaired by the maintenance crew.

Another application of the use of an indicator light is the landing gear unlocked warning light. For example, in some aircraft, a red light in the translucent handle of the landing gear control lever glows when the gear is not locked in either the up or down position.

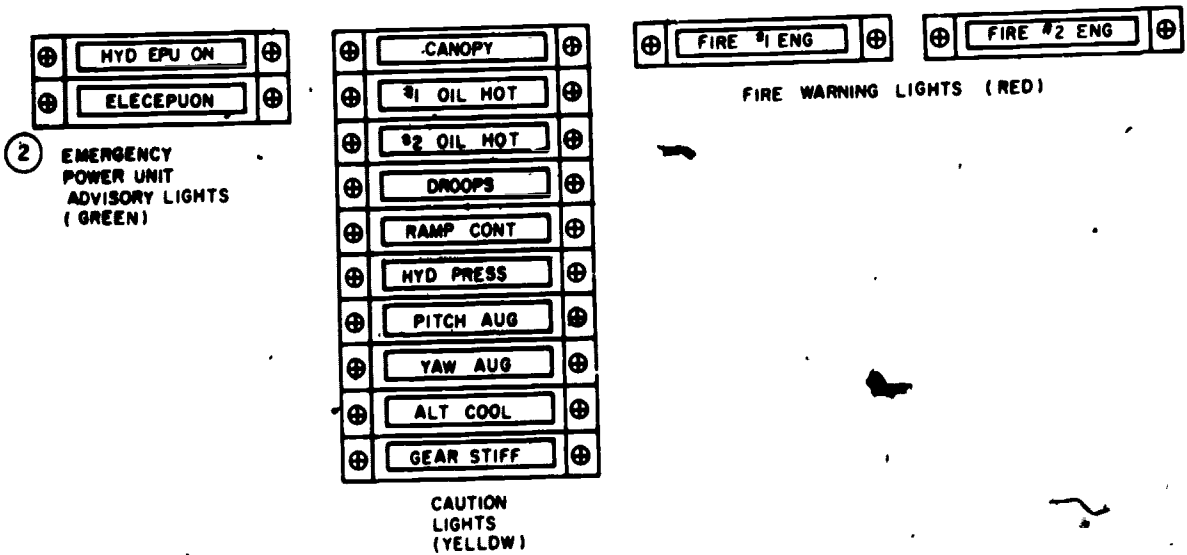

Figure 5-10.—Legend type lights.

AIRCRAFT ELECTRICAL HARDWARE

Items of hardware used when installing electrical equipment in aircraft are specified in the applicable Maintenance Instructions Manual. In all instances the proper parts should be used; if substitution becomes necessary, care must be taken that the substitute item is satisfactory in all respects.

It is not always desirable to use the same mounting parts that were removed from the installation. Prior to reinstalling the same items, an inspection must be made to insure that the parts are of the type specified, and are not defective or damaged. It must also be determined that instructions do not forbid their reuse. Then, and only then, may the removed parts be reinstalled.

General information regarding such mounting parts as screws, nuts, bolts, washers, and consumable components such as switches, relays, circuit breakers, and fuses, etc., is included in various Navy Training Manuals. Aircraft Structural Hardware for Aircraft Repair, NavAir 01-1A-8, and Installation Practices for Aircraft Electric and Electronic Wiring, NavAir 01-1A-505, are valuable sources for detailed information.

If the mounting parts specified by the applicable Illustrated Parts Breakdown cannot be obtained, a temporary installation may be made using suitable substitute parts, but these parts should be replaced with the proper items as soon as they can be obtained. When making part substitutions, special consideration must be given to:

1. **Corrosion.** The chemical or metallic composition of the part must be such that its use does not contribute appreciably to the danger of corrosion.

2. **Strength.** The strength of the substitute part must be the same, or greater than the one prescribed. (When determining the strength, consideration should be given to the tensile, compression, and/or shear strength, as applicable to the specific use.)

3. **Size.** Substitute nuts, bolts, and screws should be the same as the prescribed item. In all

cases, washers must have the same inner diameter as the prescribed item, but a different outer diameter or thickness may sometimes be permitted.

4. **Length.** Substitute screws or bolts must have a length which is sufficient for the particular installation, but must not be so long that they are in the path of any moving part. They must not be in contact with other aircraft items such as electrical wiring, hydraulic lines, etc.

5. **Magnetic properties.** Specific areas of the aircraft (for example, vicinity of such items as the magnetic compass, magnetic anomaly detection equipment, radio direction finder, or gyros) should not be changed in a manner that may cause the magnetic fields of the area to become distorted. In these areas, any substitute part must possess the same magnetic properties and characteristics as the one prescribed.

6. **Style.** Most items of mounting hardware are available in various styles. It is usually easy to find screws and bolts which are identical in all respects except for the type head. These parts are usually to be preferred as substitutes, provided they possess all required special features.

7. **Special features.** If a bolt is to be torqued to a given value, a torque wrench which is usable with that type part and which has the proper torque range must be available. If lockwiring is required, the part must have suitable provisions.

8. **Lubrication or coating.** If specific instructions call for lubrication or coating of the parts, they must be followed for the substitute part as well as for the prescribed part. If no lubrication is permitted, the substitute part is not to be lubricated.

Always check with the work center supervisor before making any substitution.

SHOCK MOUNTS

The protection of electrical and electronic equipment from the effects of vibration is a major problem in aircraft. Almost all amplifiers, instrument panels, and other fragile parts are usually protected by shock mounting. Shock

mounts are sometimes referred to as vibration insulators. The failure of many systems can be traced to faulty shock mounts. The AE should be constantly aware of the importance of shock mounting. A good maintenance practice to follow is to check shock mounts periodically, and when found to be defective ensure that they are replaced before the equipment becomes damaged.

Figure 5-11 (A) and (B) shows two types of shock mounts used in naval aircraft. Part (A) of the figure shows mounts that can be replaced individually. Each mount has a rod which extends into the vibration eliminating material. This type of mount may be replaced by drilling out the rivets in the mounting base and riveting the replacement in position. It is important that the replacement be of the same size and type as

the mount that is being replaced. The weight of the unit to be protected determines the type mount that will be used. If a mount designed for a heavier unit is used, it will not "give" to protect the unit. If a mount designed for a lighter unit is used, it can easily pull away from the base and cause the unit to be damaged.

The shock mount unit shown in figure 5-11 (B) is designed for a particular unit of equipment. This type of mount must be replaced as a unit. The vibration insulators are made of hollow rubber and locked into place when manufactured. These must be checked for cracks or splits. If one is damaged, the complete shock mount unit should be replaced.

Shock absorbing materials commonly used in shock mounts are usually electrical insulators. In order to prevent static charge buildup, each

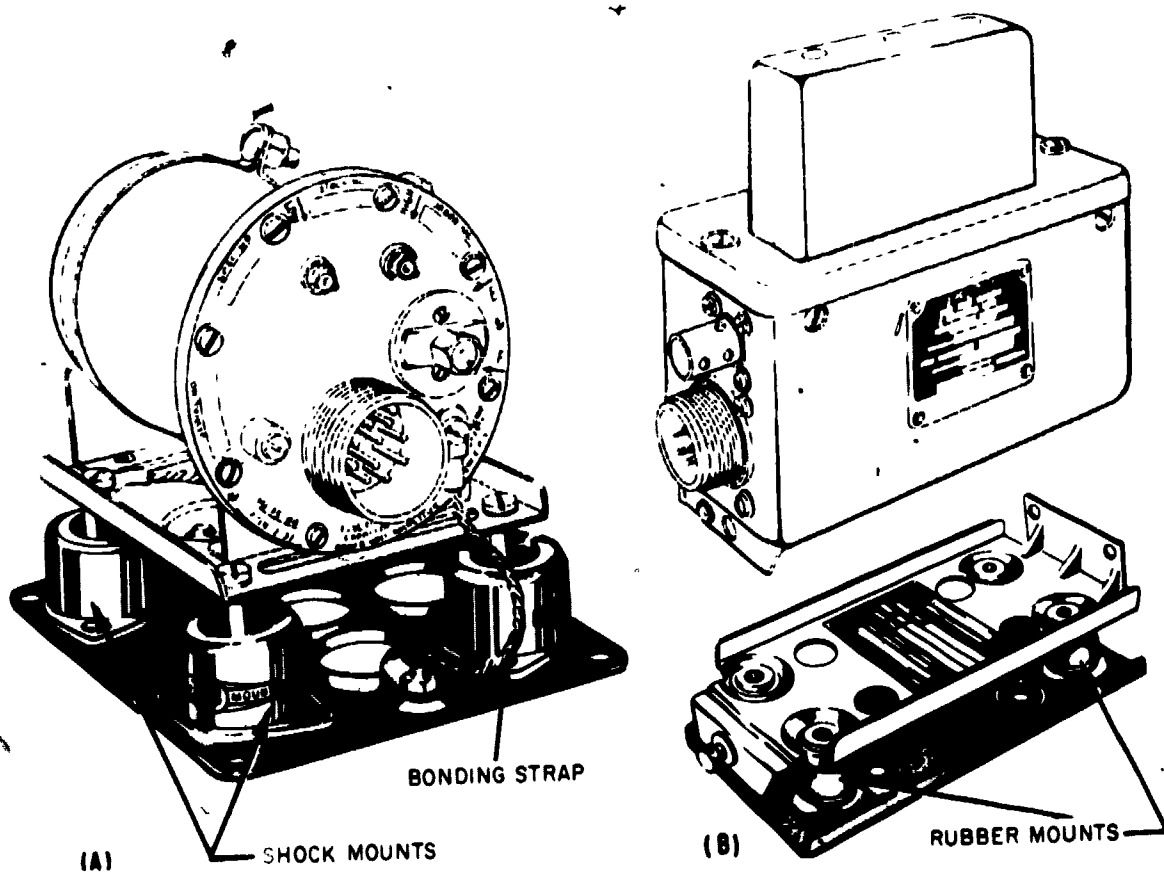

Figure 5-11.—Typical shock mounts.

207.71

electronic or electrical unit mounted in this manner must be electrically bonded to a structural member of the aircraft. (See fig. 5-11 (A).) An inspection of the bonding strap should also be included when inspecting the shock mounts, and defective or ineffective bonding straps should be replaced or repaired.

ELECTRICAL CONNECTORS

In the discussion which follows, the word "connector" is used in a general sense. It applies equally well to connectors designated by "AN" numbers and those designated by "MS" numbers. AN numbers were formerly used for all supply items cataloged jointly by the Army and Navy. Many items, especially those of older design, continue to carry the AN designator, even though the supply system is shifting over to MS (Military Specification) numbers.

Connectors are devices attached to the ends of cables and sets of wires to make them easier to connect and disconnect. Connectors consist of two portions—The fixed portion, called the receptacle, and the movable portion, called the plug. Plug assemblies may be straight or angled (usually 90°), and receptacle assemblies may be the wall-mounted, box-mounted, or integral-mounted types. MS specification numbers and letters identify the type, style, and arrangement of a connector.

Electrical connectors are designed to provide detachable coupling between major components of electrical and electronic equipment. These connectors are constructed to withstand the extreme operating conditions imposed by airborne service. They must make and hold electrical contact without excessive voltage drop despite extreme vibration, rapid shifts in temperature, and great changes in altitude.

These connectors vary widely in design and application. The two assemblies are held firmly together by a coupling nut or ring, and each assembly consists of an aluminum shell containing an insulating insert which holds the current-carrying contacts. The plug is usually attached to a cable end and is the part of the connector on which the coupling nut is

mounted. The receptacle is the half of the connector to which the plug is connected and is usually mounted on a part of the equipment.

There are wide variations in shell type, design, size, layout of contacts, and style of insert.

In late model naval aircraft, connectors with crimp type contacts are widely used. Maintenance on this type of contact is greatly facilitated by the fact that it can be removed from the connector. If the connector is damaged, all of the contacts may be removed and the connector replaced; if a connector pin is damaged, it may be removed and replaced. This serves as a considerable advantage over the solder type connector both in convenience and time savings. Special tools required for removal and insertion of crimped contacts are discussed in Installation Practices, Aircraft Electric and Electronic Wiring, NAVAIR 01-1A-505.

Some common types of subminiature connectors are shown in figure 5-12. They are used on instruments, switches, transformers, amplifiers, relays, etc.

FABRICATION OF CABLES

Occasionally the AE must fabricate a cable using connectors. The type of connector to be used is specified in the Maintenance Instructions Manual for the particular aircraft. The following is an outline of the procedure for fabricating a cable:

1. Disassemble the connector to allow access to the terminals, and devise a means of holding the connector so that both hands are free.
2. Cut cables to the correct length.
3. Strip the wire end with a wire stripper or knife. If a knife is used, avoid cutting or nicking the wire strands. Tin the bare wire end.
4. Run the wires through the connector assembly and coupling nuts.
5. See that all surfaces are clean.
6. Flow rosin-core solder into the connector terminals.
7. Hold the tip of the soldering iron against the terminal, and as the solder melts, push the wire into the cavity. Hold the wire steady while the solder cools.

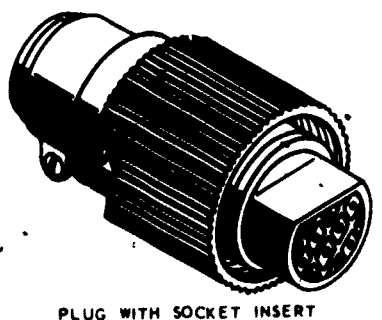

PLUG WITH SOCKET INSERT

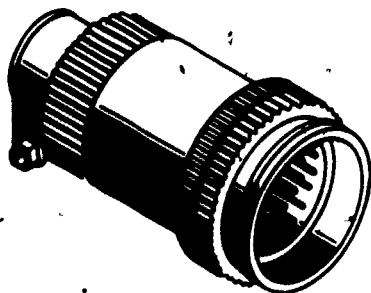

PLUG WITH PIN INSERT

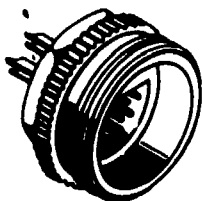

RECEPTACLE WITH PIN INSERT

Figure 5-12.—Subminiature connectors.

Care should be taken to avoid injuring the connector insulation with the soldering iron. When soldering the connector, follow a prearranged sequence. The recommended sequence is to start from the bottom connection and work from left to right, moving up a row at a time. (See Fig. 5-13.) After soldering the connections, the shields, if used, are soldered to a common terminal or ferrule. The cable is then laced and the connector reassembled and moistureproofed if necessary.

Fabricating instructions are contained in NAVAIR 01-1A-505, Handbook of Installation Practices for Aircraft Electric and Electronic Wiring.

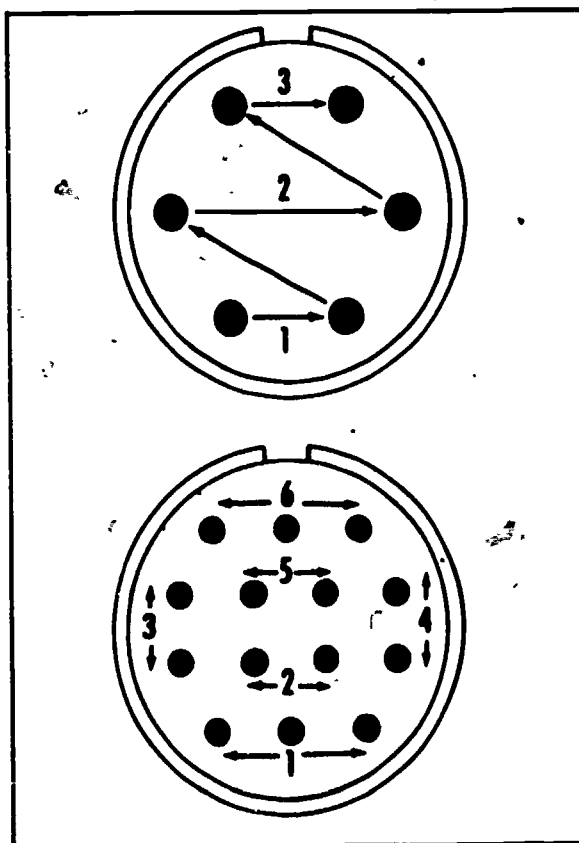

Figure 5-13.—Connector Soldering Sequence.

207.62

MOISTUREPROOFING

Present Navy practice is to use potted connectors (moistureproof or environment-proof connectors). All jet and carrier type aircraft have potted connectors. On other aircraft, moistureproofing sealant is applied to electrical connectors in areas where a probability of failure exists. All connectors located in wheel wells, wing fold areas, engine areas, engine nacelles, or cockpit decks are considered to have a high probability of failure and are sealed. In addition, all connectors which interconnect equipment that is essential to flight and/or basic navigation of the aircraft are also moistureproofed.

Moistureproofing reduces failure of electrical connectors by reinforcing the wires at the

connectors against failure caused by vibration and lateral pressure, both of which fatigue the wires at the solder cup. The sealing compound also protects electrical connectors from corrosion and contamination by excluding metallic particles, water moisture, and aircraft liquids. As a result of the connector's improved dielectric characteristics, the possibility of arc-over between pins is reduced.

TERMINAL BLOCKS

Terminal blocks are made from an insulating material which supports and insulates a series of terminals from each other as well as from ground. They provide a means of installing terminals within junction boxes and distribution panels.

Two methods of attaching cable terminals to terminal blocks are illustrated in figure 5-14. In (A) of the figure a standard non-locking nut is used. In this method installation, the use of a

lockwasher is necessary. The preferred method is shown in (B) of the figure. An anchor nut, or self-locking nut, is used and the lockwasher is omitted. The use of anchor nuts is especially desirable in areas of high vibration. In both installations, it is required that a flat washer be employed as shown in the drawing.

Each terminal board in the aircraft electrical system is identified by the letters TB followed by a number which is the number of the individual board. Each stud on the terminal board is identified by a number adjacent to it, with the lowest number in the series at the end nearest the terminal board identification number. The identification number may be marked on the aircraft structure to which the terminal board is attached, or may be on an identification strip cemented to the structure, under the terminal board. When a terminal board is replaced, do not remove the identification marking unless it has been damaged. In that case, replace the identification marking exactly as in the original, in accordance with the applicable wiring diagram.

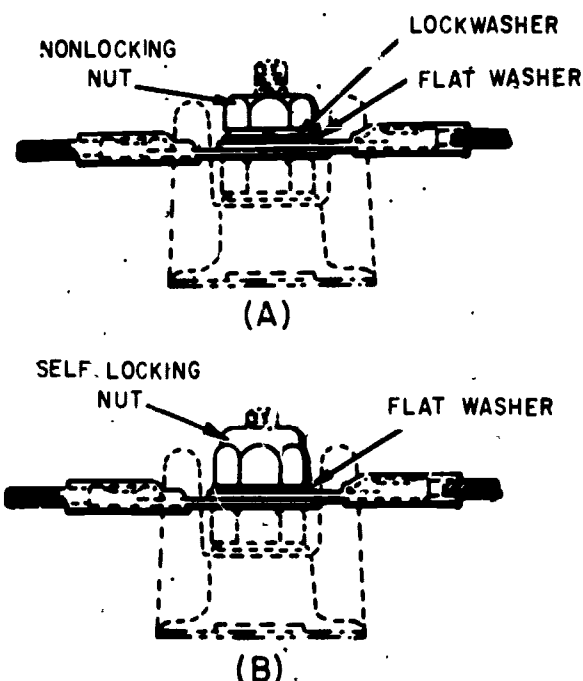

JUNCTION BOXES

Junction boxes are installed to accommodate electrical terminals or other equipment. Individual junction boxes are named according to their function, location, or equipment with which they are associated. Examples are camera junction box, lower main junction box, and forward right inboard junction box. Junction boxes are provided with a drain hole (except boxes labeled "vaportight") located at the lowest point so that water, oil, condensate, or other liquids will not be trapped.

Figure 5-15 shows a representative junction box for housing and protecting a number of terminal blocks.

When installing a junction box, insure that screw or bolt heads are inside the box. Do not install attaching hardware so that the threaded part of the screw or bolt protrudes inside the junction box, as the sharp thread edges will damage wire insulation.

207.77

Figure 5-14.—Installation of cable terminals on terminal block.

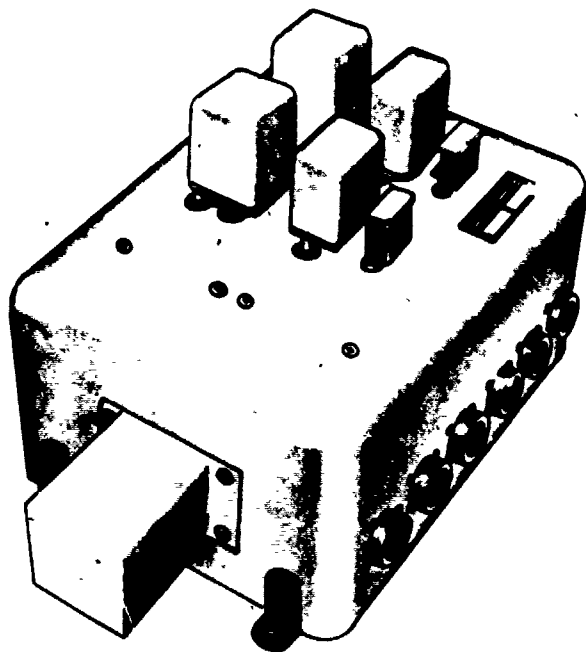

Figure 5-15.—Aircraft junction box.

207.43

SUPPORT CLAMPS

Clamps are used to provide support for conduit and open wiring, and to serve as lacing on open wiring. They are usually supplied with a rubber cushion or are of all plastic construction. When used with shielded conduit, the clamps are of the bonded type (fig. 5-16 (A)); that is, provision is made for electrical contact between the clamp and conduit. Unbonded clips are used for the support of open wiring. (Bonding is discussed later in this chapter.)

Long runs of cable between panels are supported either by a strap type clamp (fig. 5-16 (B)), or by an AN 742 clamp (fig. 5-16 (C)). The preferred method of supporting cables for all types of runs is with AN 742 clamps. MS 25281D plastic clamps may be used where the maximum temperature does not exceed 250°F. When the strap type clamp is used, precautions

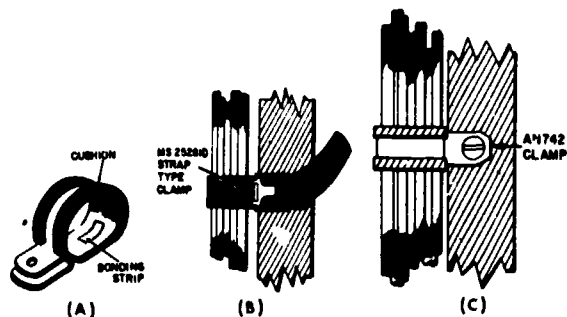

207.69

Figure 5-16.—Cable clamps.

must be exercised to insure that they will hold the cable firmly away from lines, surface control cables, pulleys, and all movable parts of the aircraft. These clamps should be used only as a temporary measure, and should be replaced with a permanent type installation as soon as possible.

When cables pass through lightening holes, the installation should conform to the examples shown in figure 5-17. In each case, the cable is held firmly by an AN 472 cable clamp. The cable should be routed well in the clear of the edges of the lightening hole to avoid any possibility of chafing the insulation. If any wire is closer than one-fourth inch to the edge of the lightening hole, a grommet (a rubber cushion) is used to protect the wires.

Wire bundles should also be protected from:

1. High temperature.
2. Battery acid fumes, spray, or spillage.

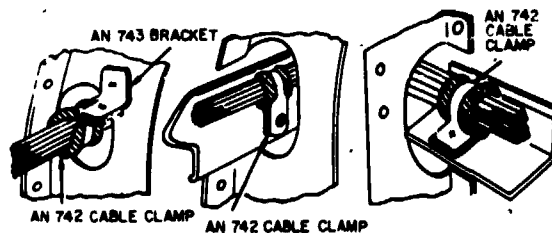

207.70

Figure 5-17.—Routing cables through lightening holes.

3. Solvents or fluids.
4. Abrasion in wheel wells where exposed to rocks, ice, or mud.
5. Damage due to personnel using the wire bundle as handholds or footsteps.
6. Damage due to shifting cargo.

Never support any wire or wire bundle from a plumbing line carrying flammable fluids or oxygen; clamps may be used on these lines only to insure separation of the wire bundle from the plumbing line. Whenever possible, route wires and bundles parallel with or at right angles to the stringers or ribs of the area involved, as shown in figure 5-18.

Do not install single wires or wire bundles with excessive slack. Slack between support points such as cable clamps should normally not exceed one-half inch. This is the maximum that it should be possible to deflect the wire with moderate hand force. This slack may be exceeded if the wire bundle is thin and the clamps are far apart, but the slack must never be so great that the wire bundle can touch any surface. Allow a sufficient amount of slack near each end for any or all of the following:

1. To permit ease of maintenance.
2. To allow replacement of terminals at least twice.

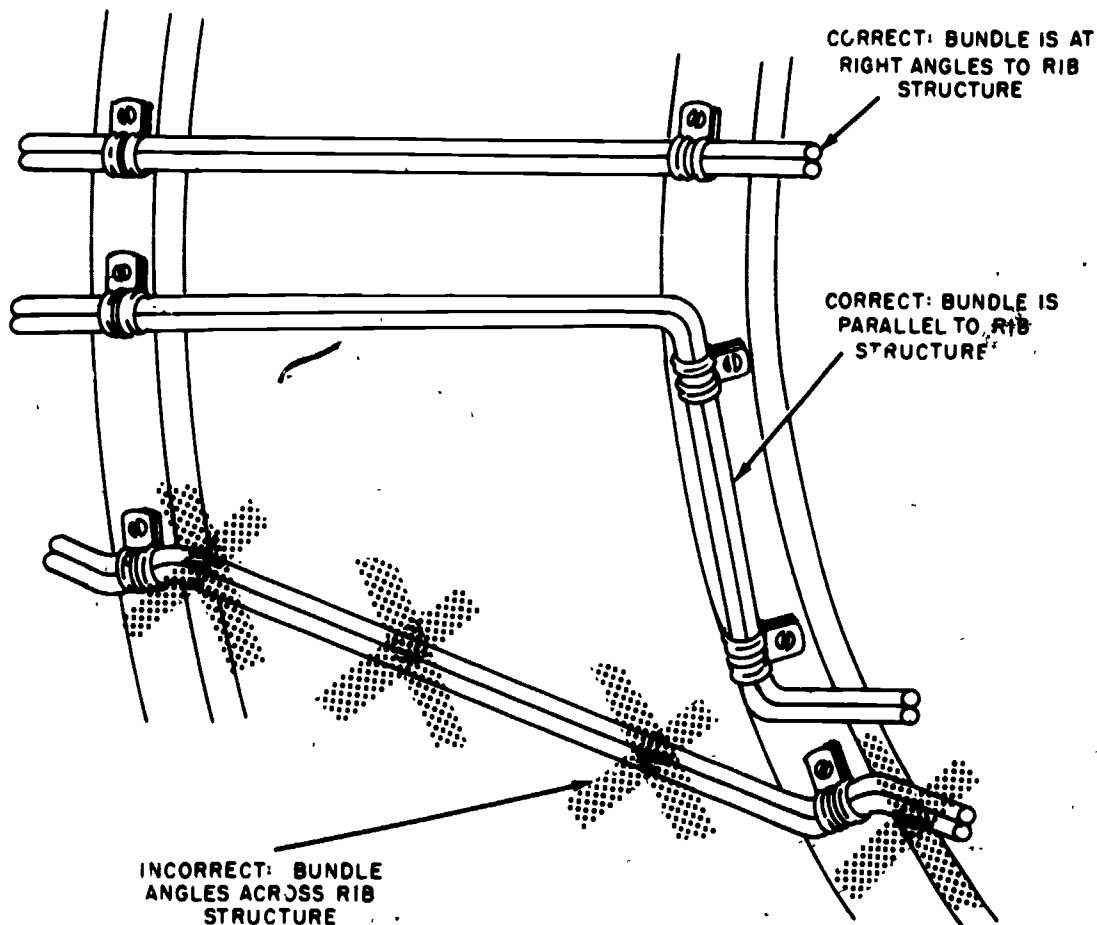

Figure 5-18.—Routing cables.

207.45

3. To prevent mechanical strain on the wires, cables, junctions, and supports.
4. To permit free movement of shock and vibration mounted equipment.
5. To permit shifting of installed equipment for purposes of maintenance.

CONDUIT AND FITTINGS

In many aircraft the use of conduit is eliminated to a marked degree. This is advantageous in that it saves weight and insures the wide separation of cables; this separation makes the electrical system less vulnerable to gunfire. However, some current aircraft, especially those with limited space for wire routing, utilize conduit.

Conduit is made in two basic types—flexible and rigid. Its chief functions are to act as radio shielding and as a support and protection for wires.

Conduit fittings are used for attaching either flexible or rigid conduit to junction boxes and other equipment, and usually include ferrules and coupling nuts. Various forms of both are used along with special designs of locknuts, box connectors, and coupling adapters.

Couplings are made in straight or angular designs to fit all needs. Ferrules are really bushings or flanges applied to the ends of the conduit to obtain greater strength and to support the coupling nuts. They are either crimped or swaged on by the use of crimping or swaging tools.

SAFETY WIRE

There are three types of safety wire:

1. Lock wire is a heavy twisted double-strand wire used to secure parts against inadvertent opening in all areas of high vibration such as an aircraft's compartment. Electric connectors are lock-wired in high-vibration areas

which are normally inaccessible for periodic maintenance and inspection.

2. Shear wire is a lighter, single-strand wire used to secure parts which may be subject to periodic disconnection, maintenance and inspection, or for parts which must be quickly removed.

3. Seal wire is a thin, easily breakable wire used as a seal on fire extinguishing systems, oxygen regulators and other emergency devices which must be quickly released for use, and to indicate whether these devices have been used or tampered with.

BONDING AND BONDING DEVICES

A bond is any fixed union existing between two metallic objects that results in electrical conductivity between them. Such a union results from either physical contact between conductive surfaces of the objects or from the addition of a firm electrical connection between them. Aircraft electrical bonding is the process of obtaining the necessary electrical conductivity between metallic parts of the aircraft, and between the aircraft structure and installed equipments. An isolated conducting part or object is one that is physically separated by intervening insulation from the aircraft structure and from other conductors which are bonded to the structure.

A bonding connector provides the necessary electrical conductivity between metallic parts in an aircraft not in sufficient electrical contact. Bonding jumpers and bonding clamps are examples of bonding connectors.

Purpose

Clouds may become highly charged, as is evidenced by lightning. An aircraft can also become highly charged while in flight. If the aircraft is improperly bonded, all metal parts will not have the same amount of charge. A difference of potential will then exist between various metal surfaces. Neutralization of the charges flowing in paths of variable resistance, due to such causes as intermittent contact caused from vibration or the movement of the

control surface, will produce electrical disturbances (noise) in the radio receiver. If the resistance between isolated metal surfaces is great enough, charges can accumulate until the potential difference becomes high enough to cause a spark. In addition to creating radio interference, this also constitutes a fire hazard. In the case of lightning striking the aircraft, a good conducting path is necessary for the heavy current in order to minimize severe arcs and sparks which would damage the aircraft and possibly injure its occupants.

The aircraft structure is also the ground for the radio. For the radio to function properly, a proper balance must be maintained between the aircraft structure and the radio antenna. This means the surface area of the ground must be constant. Control surfaces, for example, may at times become partially insulated from the remaining structure due to a film of lubricant on the hinges. This would affect radio operation if the condition were not taken care of by bonding. Bonding also provides the necessary low-resistance return path for single-wire electrical systems.

The reasons for bonding may be summed up as follows:

1. To minimize radio and radar interferences by equalizing static charges that accumulate.
2. To eliminate a fire hazard by preventing static charges from accumulating between two isolated members and creating a spark.
3. To minimize lightning damage to the aircraft and its occupants.
4. To provide the proper "ground" for proper functioning of the aircraft radio.
5. To provide a low-resistance return path for single-wire electrical systems.
6. To provide a means of bringing the entire aircraft to the earth's potential and keeping it that way while it is grounded to the earth.

Parts Requiring Bonding

The trend in current naval aircraft is to keep the number of bonding jumpers to a minimum. As a consequence, the jumpers used are very important and must be replaced whenever necessary to keep them in good condition. A partial listing of the parts of an aircraft that must be bonded includes:

1. Control surfaces. Each control surface should have at least two bonding jumpers. This does not apply to trim tabs.

2. Engine mounts. At least four bonding jumpers should be connected across each engine mount support to provide a current path between the engine mount and aircraft structure.

3. Engine cowling. At least four symmetrically placed bonding jumpers should be used to bond the engine ring cowling to the engine across the rubber mounts at the front end of the cowling.

4. Equipment mounts. Bonding jumpers should be placed across shock mounts used to support electrical and radio equipment and the instrument panel.

Methods and Materials

Bonding connections should be installed so that vibration, expansion or contraction, or relative movement incident to normal service use will not break the bonding connections nor loosen them to such an extent that the resistance will vary during the movement.

Since a primary objective for bonding is to provide an electrical path of low dc resistance and low RF impedance, it is important that the jumper be a good conductor of ample size for the current-carrying capacity, have low resistance, and be as short as possible. Parts should be bonded directly to the basic aircraft structure rather than through other bonded parts insofar as practical. Bonding jumpers should be installed so as not to interfere in any

way with the operation of movable components of the aircraft. (See fig. 5-19.)

Contact of dissimilar metals in the presence of an electrolyte, such as salt water, produces an electric action (battery action) which causes a pitting in one of the metals. The intensity of this electric action varies with the kinds of metals. Bonding frequently necessitates the direct contact of dissimilar metals. In such cases the metals used are of the kind that will produce minimum corrosion. The connections are also made so that if corrosion does occur, it will be in replaceable elements, such as jumpers, washers, or separators, rather than in the bonded or bonding members.

Self-tapping screws should not be used for bonding purposes, nor should jumpers be compression-fastened through plywood or other nonmetallic material. When performing a bonding operation, the contact surfaces should be cleaned of insulating finishes or surface films before assembling, and then the completed assembly refinished with a suitable protective finish.

Consult Installation Practices for Aircraft Electric and Electronic Wiring, NavAir 01-1A-505, for detailed information dealing with bonding.

CABLE LACING AND TYING

Wire groups and bundles are laced or tied to provide ease of installation, maintenance, and inspection. The purpose of lacing or tying is to keep all cables neatly secured in groups and to avoid possible damage from chafing against equipment or interference with equipment operation.

Tying is the securing together of a group or bundle of wires by means of individual pieces of cord tied around the group or bundle at regular intervals. Lacing is the securing together of a group or bundle of wires inside enclosures by means of a continuous piece of cord forming loops (half hitches) at regular intervals around the group or bundle.

Cotton, nylon, or Fiberglas cord is used for tying or lacing. The cotton cord must be waxed to make it moisture and fungus resisting.

SLEEVING

Sleeving, commonly called spaghetti, has many applications in naval aviation. Some of the more common applications are for covering soldered connections, open bus bars, and permanent splices.

For general-purpose wiring, flexible vinyl sleeving, either clear or opaque, should be used. For high-temperature applications (160°F to 400°F), use silicone rubber or Fiberglas. Where resistance to synthetic hydraulic fluids or other solvents is necessary, use nylon sleeving, either clear or opaque, for best results.

Sleeving is used to help protect connections against accidental shorting and moisture, and to lengthen the arc-over path between contacts. Insulating sleeves should not be used when connections or connectors are to be moisture-proofed by potting. Also, it should not be used on some connectors that are provided with a sealing grommet which covers the soldered connection.

Bus bars are usually enclosed in panels or junction boxes to protect them against

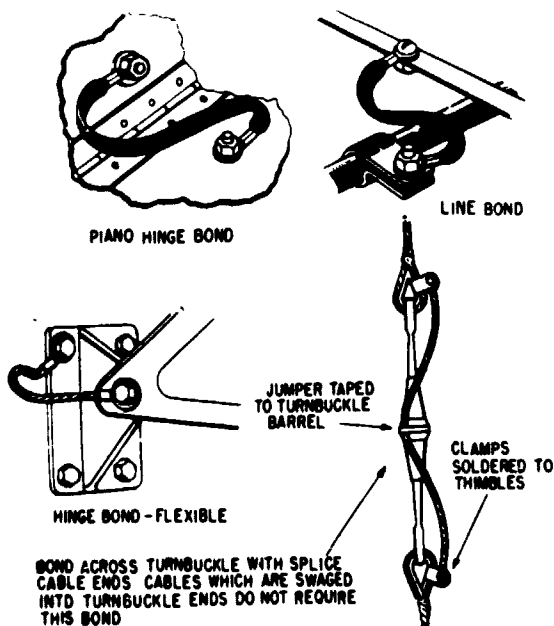

28.39

Figure 5-19.—Bonding methods.

accidental shorting. If the bus bars are not enclosed, it may be desirable to use some protective coating. The sleeving can be used by slitting a piece of vinyl tubing and wrapping it around the bar after all connections have been made. Care should be taken to select tubing

which has a large enough diameter to permit a generous overlap when it is tied in place. (See fig. 5-20 (A).)

A wire with damaged insulation may be temporarily protected by using a sleeve of flexible tubing 1 1/2 times the outside diameter

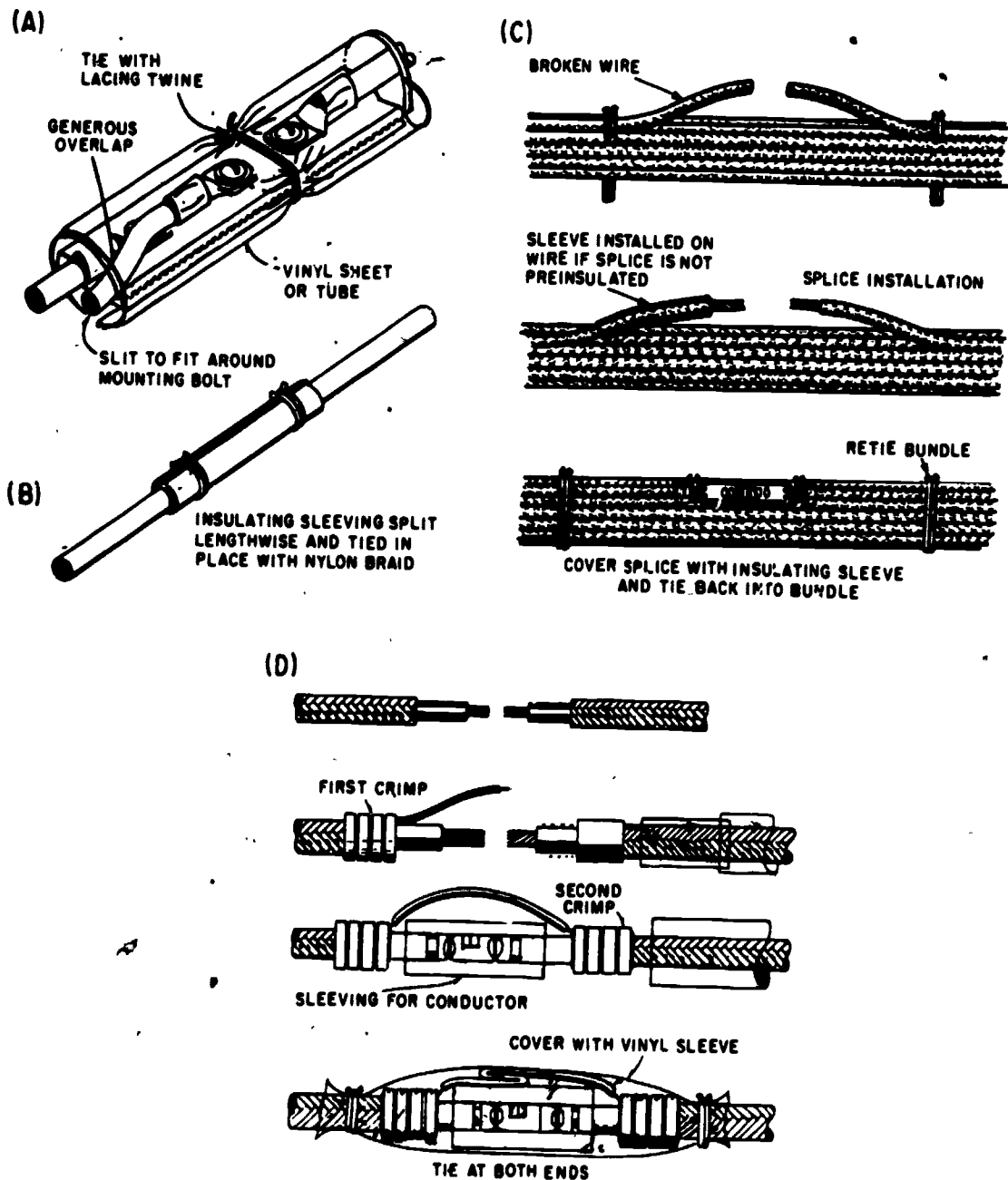

Figure 5-20.—Typical uses of sleeving.

of the wire. The length should be at least 2 inches longer than the damaged portion of the insulation. Split the sleeve lengthwise and wrap it around the wire at the damaged section, and then tie with nylon braid at each end and at 1-inch intervals over the entire length. (See fig. 5-20 (B).) Since the replacement of damaged wire, by use of permanent splices if necessary, is the only satisfactory repair, the procedure just described should be performed only in case of emergency.

To cover a permanent splice, as shown in figure 5-20 (C), the sleeving is slipped on the wire before the splicing operation. After the splice is completed, it is moved to cover the finished splice and then tied at each end with nylon braid.

A slightly different arrangement is used for the repair of shielded wire. In this application note that two pieces of sleeving are used, one for the braid and one for the wire itself. This is shown in figure 5-20 (D).

HEAT-SHRINKABLE TUBING

Heat-shrinkable tubing is plasticlike tubing (similar to insulation sleeving) that will shrink to a smaller diameter when proper heat is applied. The tubing is applied by placing a section of it over the joint, terminal, or part to be covered and is then heated with a heat gun, oven, or other appropriate heat source. When the tubing reaches a specific temperature ("shrink temperature," a value which depends upon the type of tubing), it will quickly shrink around the object, forming a snug jacket over it. In addition to being an insulator, the shrinkable tubing aids as a strain relief and waterproofing. Figure 5-21 shows the sleeving that has been placed on a disconnect and a switch terminal before and after it was heated. This type of insulation will eventually replace the sleeving discussed previously and is being used on modern aircraft.

AIRCRAFT POWERPLANT SYSTEMS

Each aircraft, with the exception of gliders, requires a mechanism to propel it through the

air. The powerplant and its associated controls are maintained by personnel in the Aviation Machinist's Mate rating. There are, however, several electrical systems, such as starting, ignition, fire warning, fire extinguishing, anti-icing, fuel, and oil, and indicating systems which support the powerplant, that AEs must maintain. Indicating systems that produce visual displays of powerplant operation are covered in chapter 6 of this manual.

STARTING EQUIPMENT

Jet engine starters must be capable of providing both high starting torque to initially overcome the large amount of weight of the engine rotor, and high speed to increase rotor rpm until the rotor is self sustaining. The following paragraphs describe the various starting systems used on turbojet, turboprop, and turbofan engines.

Turbine Impingement Starting

On naval aircraft such as the F-4 the jet engines are started by means of low-pressure air directed onto the second-stage turbine rotor buckets (turbine impingement starting). (See fig. 5-22.) Impingement starting may be accomplished by directing jets of compressed air into blades in either the compressor or turbine section of a gas turbine engine. The number of air outlets and the air pressure required for impingement starts vary as the size, weight, and design parameters of the engine to be started vary. The impingement type starting discussed in this chapter is the starting system of an F-4 aircraft, and is not the impingement starting system used by all manufacturers.

Starting air is supplied by an external starting unit and is controlled by an air shutoff valve in the external air supply unit. The shutoff valve is electrically controlled by the applicable engine starter switch through the start relay. The starting air is delivered through a flexible hose to the starting manifold connection. The air is then



Coaxial Cable Connector Sleeving for Moisture Proofing and Strain Relief



Tough, semi-rigid heat-shrinkable tubing provides strain relief by transferring the flexing stress from the wire insulation directly to the connector pin, terminal or component body. The stress on the bare conductor joint is thus relieved and the connection made reliable.

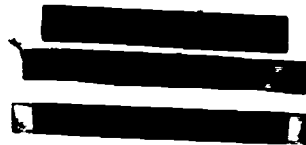

Bussbar Insulation.



Terminal Insulation.

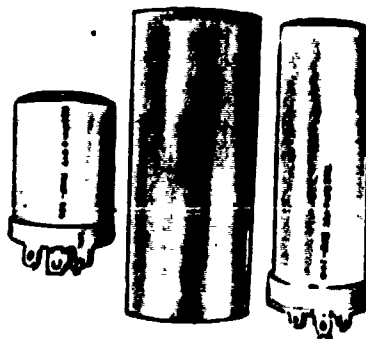

Clear Sleeving for Insulation. Identification and inspection are not hindered.



Insulation, Color Coding and Identification.

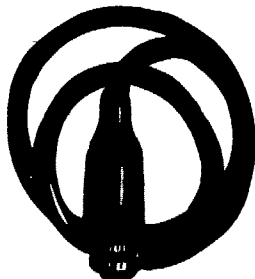

Harness Jacket and Connector Boot. Both shrink to provide tight covering for wire bundle and moisture proofing and strain relief for connector terminals without potting.

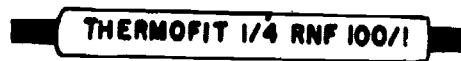

Disconnect Insulation and Marking.

Figure 5-21.—Typical uses of heat shrinkable tubing.

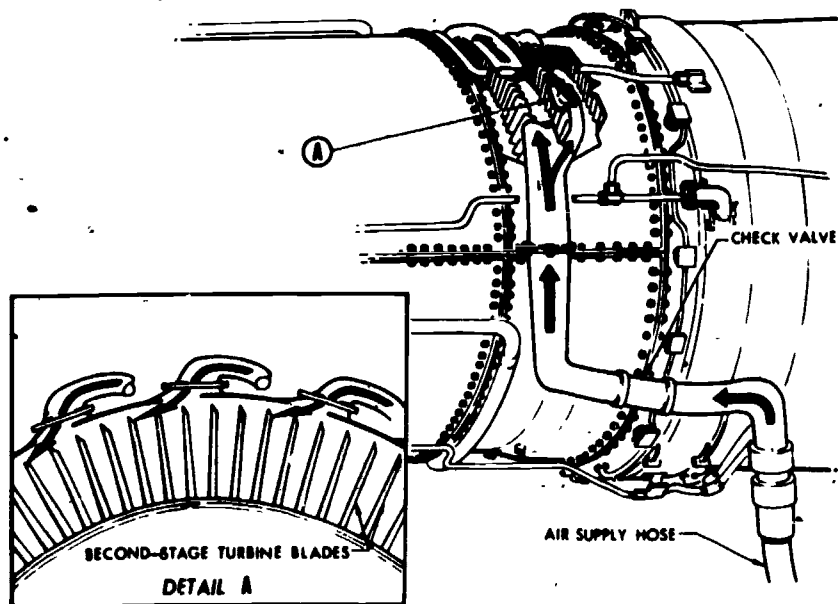

Figure 5-22.—Turbine impingement starting.

207.144

ducted through the impingement manifold and directed onto the second-stage turbine blades at seven points at the top of the turbine casing.

A check valve in the starting manifold prevents loss of gases after the engine is started. The external starting unit electrical connector must be plugged into the receptacle corresponding to the engine being started. In addition to the air supply, external electrical power must be applied to aircraft before the engines can be started. The function of the turbine impingement starting system is to start and sustain engine rotation at a speed at which the fuel-air mixture is satisfactory for light-off, and also to assist the engine to increase rpm until it is self-sustaining.

Air from the external source is routed to the quick-disconnect fitting and from there to the left or right selector valve. These valves will distribute air to either the left or right engine, depending upon the position of the cockpit selector switch (fig. 5-23). The engine manifold assembly distributes the starting air to the impingement nozzles which direct the air against

the second-stage turbine blades of the engine turbine wheel.

The impingement starting system flow-schematic is shown in figure 5-23. With the cockpit switch in the left engine start position, the energized solenoid on the left selector valve plunger positions the free floating ball to allow the inner cylinder to vent to the downstream side of the selector valve. Air pressure cannot move the piston against the piston spring because of a greater area on the lower portion of the exposed piston face. With the solenoid energized, the inside of the selector valve piston becomes evacuated and the starting air supply will act on the outside of the piston causing the piston to move to the open position, thereby permitting an air supply to move toward the left engine nozzles. With the right solenoid deenergized, air pressure flows past the free floating ball into the inner cylinder. The air pressure is equalized on both sides of the piston and the valve remains closed. (NOTE: With the cockpit switch in the OFF position, both valves will remain closed. Therefore, even with starting air and electrical power supplied, neither engine

AVIATION ELECTRICIAN'S MATE 3 & 2

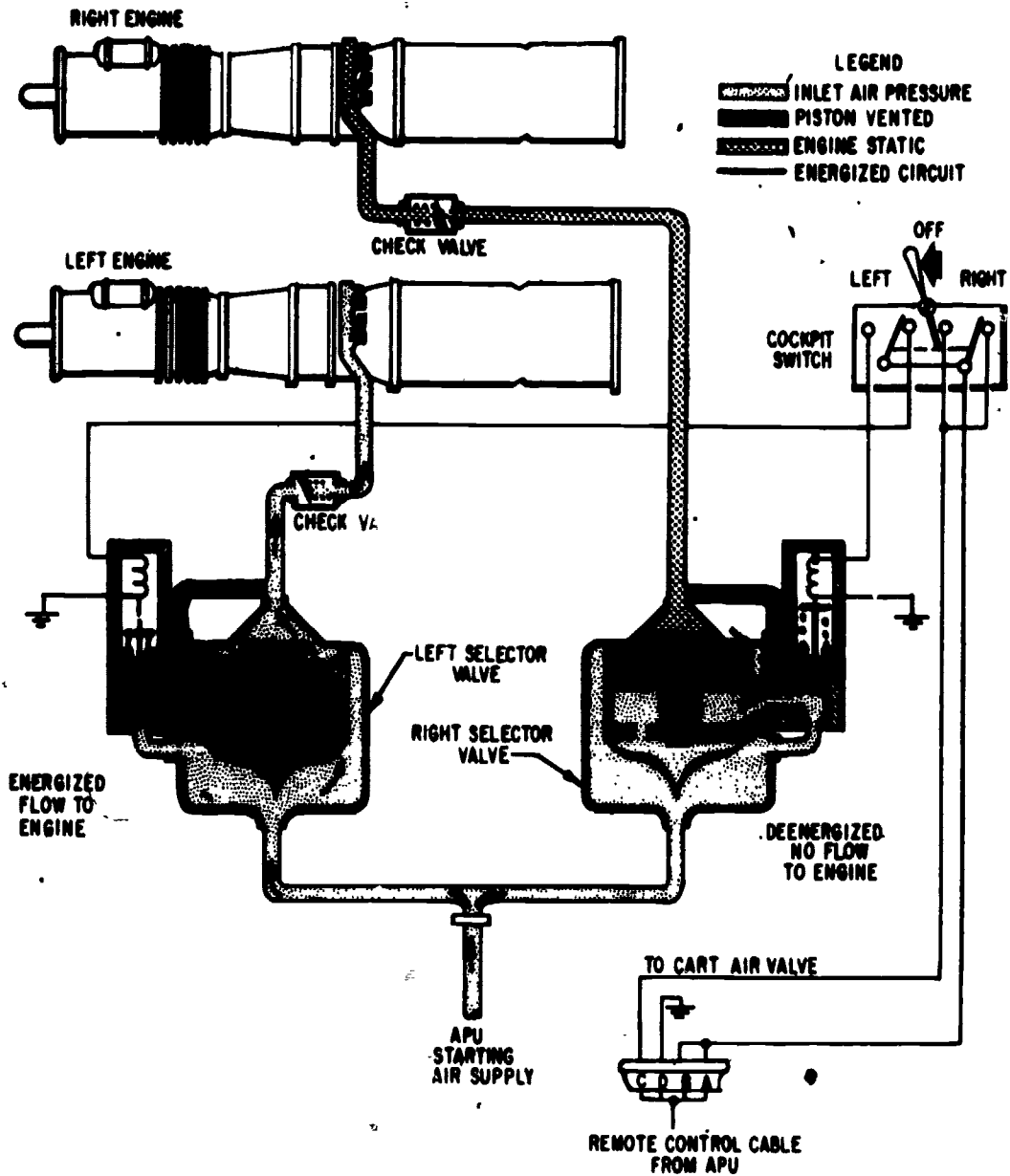

207.145

Figure 5-23.—Impingement starting system flow schematic.

will start until the cockpit switch is in the left or right position.)

Both in air turbine starting and turbine impingement starting, an external gas turbine compressor is used for the air source to supply air for turning over the engine for starting. These

units have different air supply requirements; therefore, when starting an engine with turbine impingement starting, make sure a gas turbine compressor with a suitable high airflow rating is used. Prior to starting a jet engine, the recommended airflow requirements in the

applicable Maintenance Instructions Manual should be consulted.

Constant Speed Drive/Starter

Another type of starting system is utilized on the A-6 Intruder aircraft. This system utilizes the Constant Speed Drive/Starter (CSD/S) that provides for three separate modes of operation:

1. Main engine starting.
2. Constant speed drive system for a main generator to maintain frequency control regardless of engine rpm or generator loads.
3. Auxiliary and emergency operation of a main generator from a turbine motor and reduction gear drive when the main engine is shut down.

Air for starting or emergency/auxiliary operation of the generator can be supplied from the other engine or from an external source.

The CSD/S unit (fig. 5-24) is made up of two sections and is mounted to the engine input drive shaft through a generator. The turbine motor section contains an axial flow turbine wheel and variable area nozzle that directs air and controls the speed of the turbine wheel

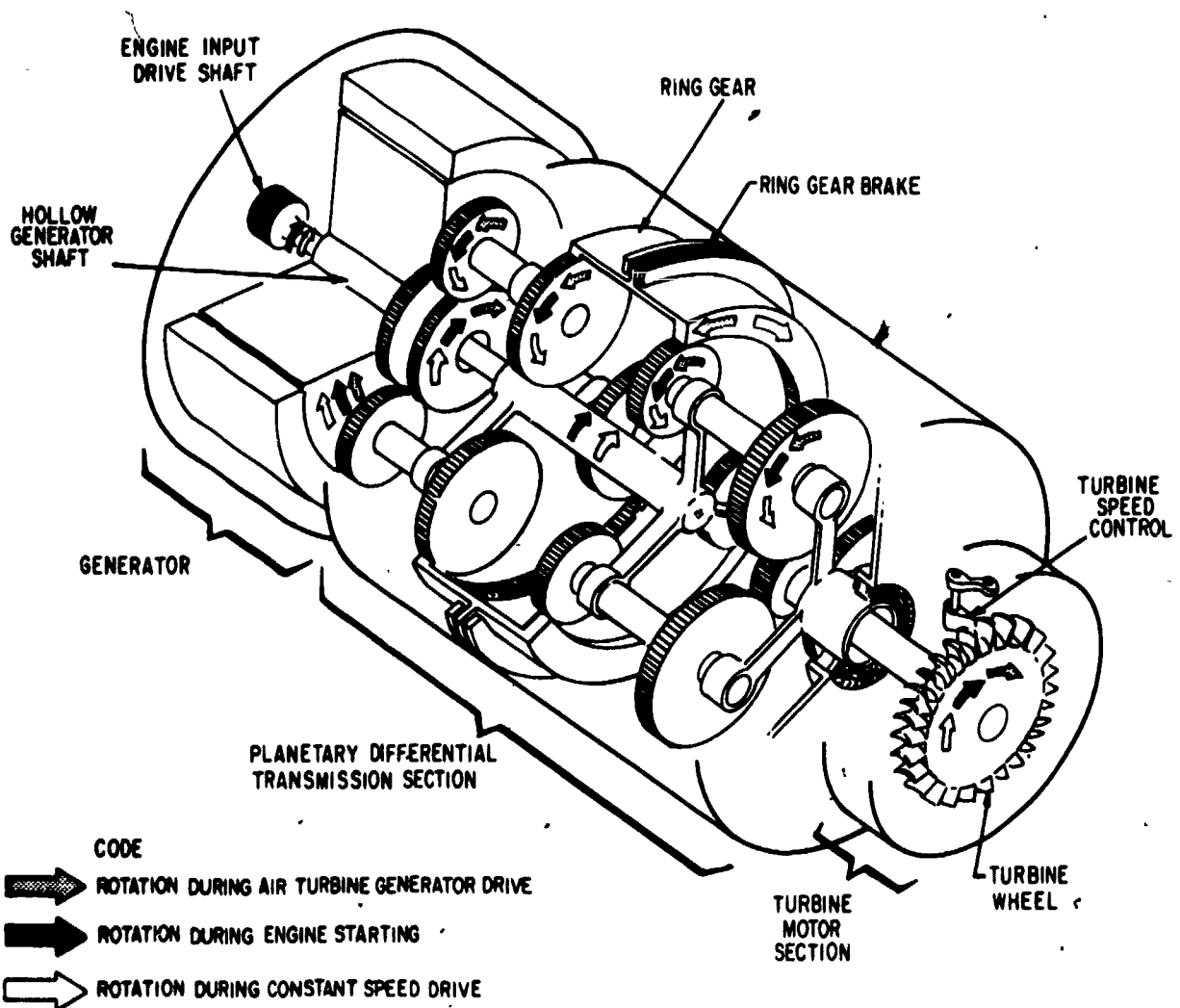
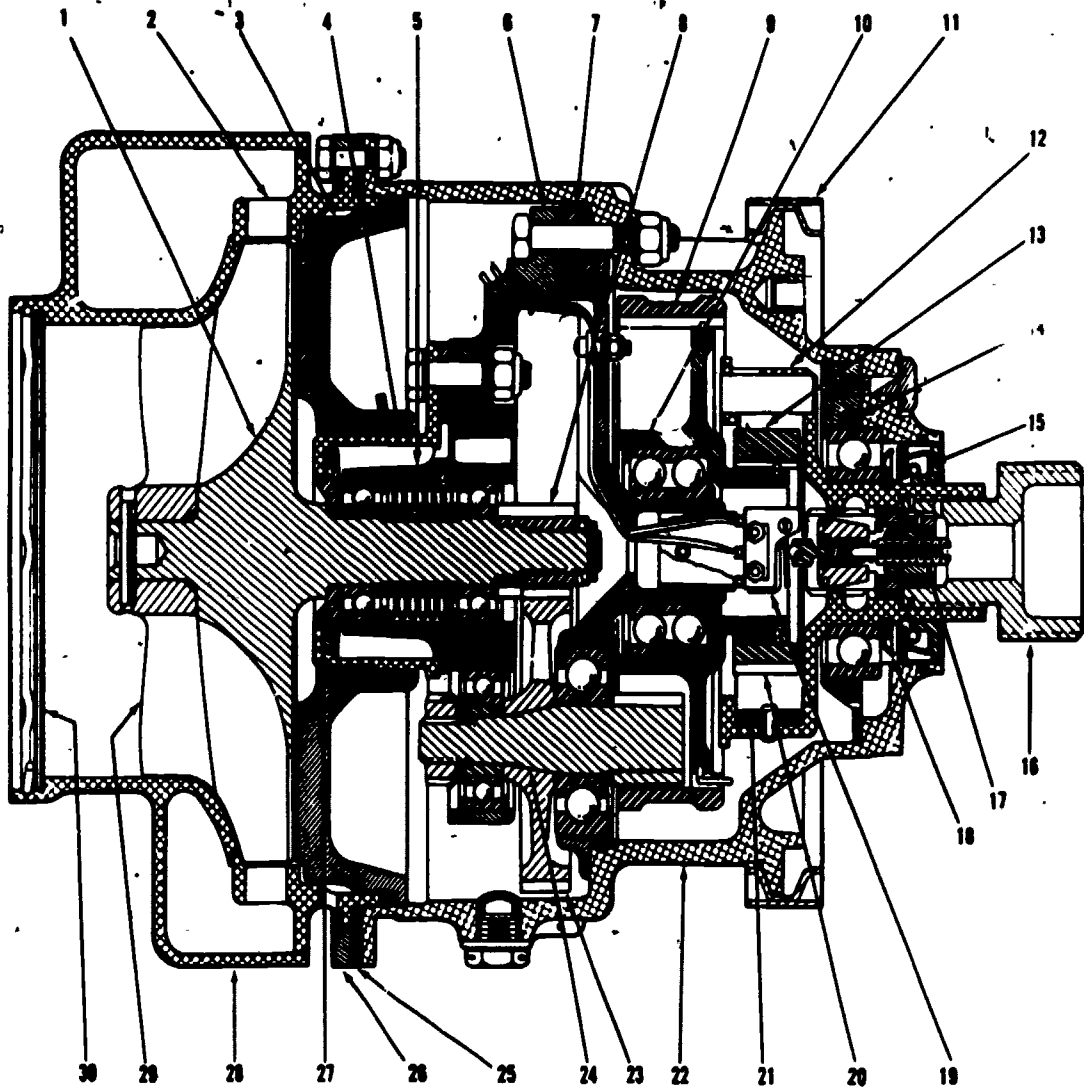

Figure 5-24.—Constant speed drive/starter.

207.55



- 1. Turbine wheel assembly.
- 2. Scroll nozzle.
- 3. Air barrier seal.
- 4. Oil seal.
- 5. Bearing carrier.
- 6. Turbine end gear carrier.
- 7. Output end gear carrier.
- 8. Pinion gear.
- 9. Internal ring gear.
- 10. External hub gear.
- 11. Quick-attach-detach coupling assembly.

- 12. Drive shaft.
- 13. Drive jaw.
- 14. Bearing retainer assembly.
- 15. Shaft seal.
- 16. Output shaft.
- 17. Overspeed control assembly.
- 18. Oil baffle.
- 19. Switch assembly.
- 20. Drive pawl.

- 21. Pawl spring assembly.
- 22. Gear housing assembly.
- 23. Reduction gear.
- 24. Reduction shaft.
- 25. Heat barrier.
- 26. Scroll flange.
- 27. Wheel slinger.
- 28. Scroll assembly.
- 29. Wheel exducer.
- 30. Screen assembly.

Figure 5-25.—Air turbine starter.

203.129

blades. The planetary differential transmission section is a variable gear assembly with infinite gear ratios.

In the start mode of operation, the turbine wheel is driven by an external air source. Through gear reduction in the transmission section, the high speed of the turbine is converted to high torque and delivered to the engine input drive shaft through the hollow core of the generator rotor.

After the engine has acquired a self-sustaining speed, the ring brake releases and allows the system to change to the constant speed drive mode. In this mode, electro-mechanical, pneumatic, and pneumatic-hydraulic components act to vary the gear ratio of the planetary differential transmission to maintain an output of 8,000 rpm from the engine input drive shaft.

In the event it becomes necessary to shut down an engine, air flow can be directed from the remaining operating engine to the CSD/S, placing the system in the air turbine motor generator drive mode of operation. In this mode, power to drive the generator is developed entirely from the turbine drive wheel, and the engine is disconnected from the generator and turbine by the planetary differential transmission section.

Air Turbine Starter

The air turbine starter is a lightweight unit designed to start turbojet, turboprop, and turbofan engines when supplied with compressed air. The unit consists primarily of a scroll assembly, rotating assembly, reduction gear system, overrunning clutch assembly, and output shaft. An overspeed switch mechanism is used to limit maximum rotational speed. Compressed air, supplied to the scroll inlet, is directed to the turbine wheel by the nozzle in the scroll assembly. The reduction gear system transforms the high speed and low torque of the turbine wheel to low speed and high torque at the output shaft. When the desired starter rotational speed is reached, the flyweights in the governor assembly will throw out and open the limit switch. This section sends a signal which

shuts off the supply air. At a higher, predetermined rotational speed, the overrunning clutch assembly disengages the output shaft from the rotating assembly.

A source of compressed air is supplied to the shutoff valve inlet duct to drive the starter. The starter is a turbine air motor equipped with a radial inward-flow turbine wheel assembly, reduction gearing, splined output shaft, and a quick-detaching coupling assembly. The complete assembly is mounted within one scroll assembly and gear housing (See fig. 5-25.)

OPERATING PRINCIPLES.—The air turbine starter converts energy from compressed air to shaft power, which is delivered to a splined output shaft at speed and torque values for starting certain aircraft engines.

Initial control of the air shutoff valve is made by means of a normally open, momentarily closed, start switch and a relay box. See figure 5-26. After the start switch is pressed, the sequence of operation of the valve and starter is automatic. A normally closed, momentarily open, stop switch provides a means of manually stopping the starter when motoring an engine without fuel or in emergencies.

When the external start switch is held momentarily closed, a double-pole, single-throw, holding relay in the relay box is actuated, completing electrical circuits to the air shutoff valve and the starter. When the external start switch is released, the holding relay receives a positive potential through the normally closed external stop switch and a negative potential through the closed overspeed control provided within the starter. The relay continues to hold until the positive potential is broken by actuating the normally closed external stop switch or until the negative potential is broken by actuating the closed overspeed control in the starter.

When high-pressure air is applied to the inlet of the normally closed regulating valve and the holding relay is actuated through the start switch, the regulating valve opens, admitting compressed air to the starter. The compressed air is regulated to specified conditions by action of the control mechanism of the valve. This

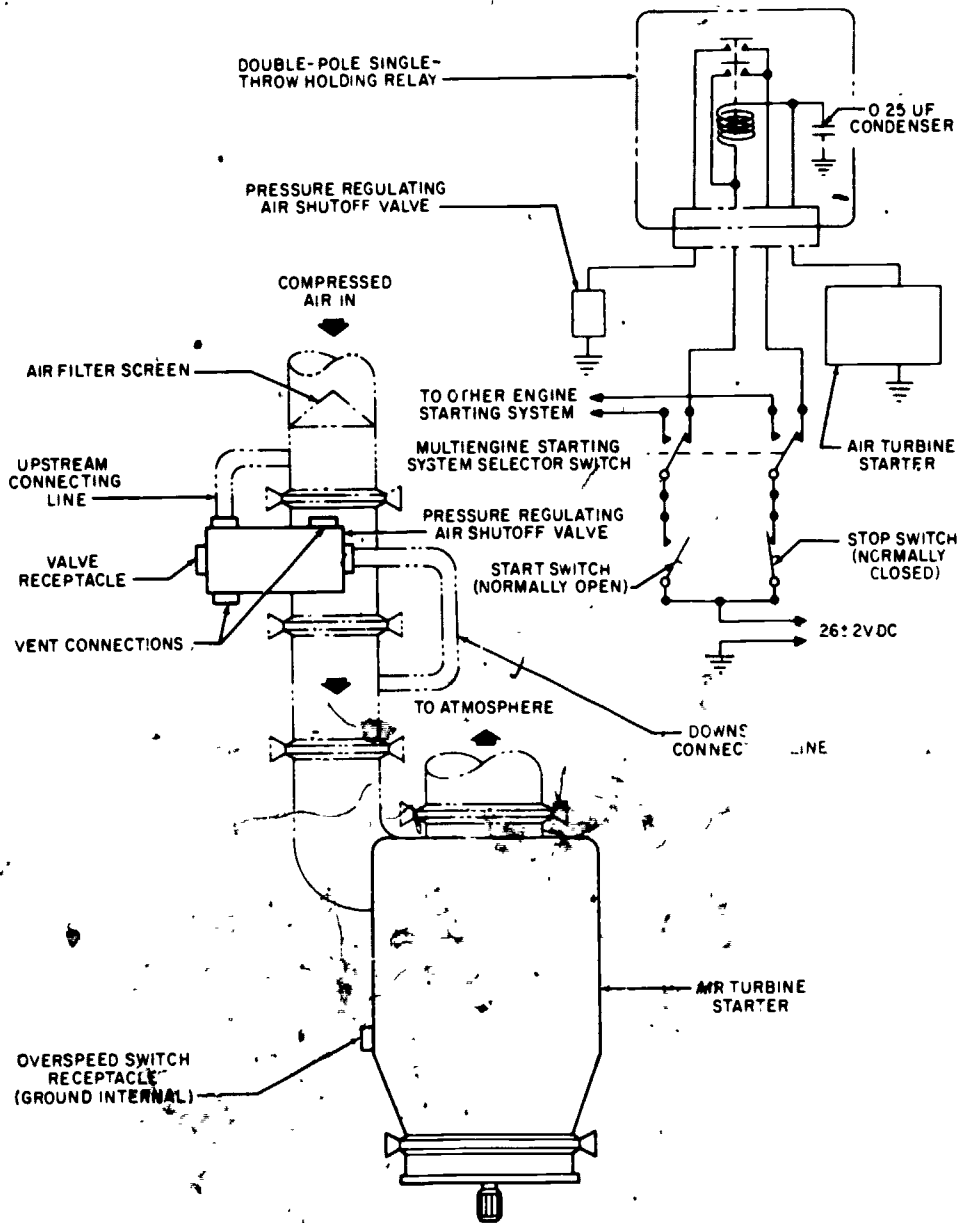

203.130

Figure 5-26.—Air turbine starting system diagram.

senses upstream and downstream conditions and positions the valve butterfly to supply desired flow.

The compressed air enters the inlet port of the starter and is expanded as it flows radially inward through the nozzle vanes and is directed

against the blades of the turbine wheel to rotate the turbine wheel. The high-speed, low-torque output of the turbine wheel is converted to low-speed, high-torque output by the reduction gear system, which transmits power to the drive shaft. The drive shaft is driven by means of

spring-loaded pawls which fit into ratchet teeth in a drive jaw.

As supply air is permitted to enter the inlet port of the starter through the air shutoff valve, the turbine wheel rotates and transmits a torque to the drive jaw through reduction gearing. This torque is transmitted to the drive shaft through the splined drive shaft. When the speed of the aircraft engine exceeds that of the starter drive shaft, the speed of the starter output shaft (which is directly connected to the engine drive) also exceeds that of the drive jaw. When this condition occurs, the pawls begin to ratchet. When the output shaft (driven by the aircraft engine) attains sufficient speed, centrifugal force disengages the pawls completely from the drive jaw, disengaging the starter from the aircraft engine. When the starter reaches cutoff speed, the internal overspeed control is actuated. Actuation of the overspeed control breaks the electrical circuit to the holding relay in the external relay box, thus closing the regulating air shutoff valve butterfly and preventing supply air from entering the starter.

NOTE: If the aircraft engine shaft speed does not exceed the speed of the starter driving mechanism by the time the starter cutoff speed is reached, the cutout switch is actuated, automatically shutting down the starter.

A starting operation is initiated by momentarily closing the start switch to energize the regulating valve circuit. Sequence of the regulating valve and start operation then becomes automatic and is continued until engine light-off occurs and the engine overspeeds the starter driving mechanism or until output shaft speed reaches the calibrated cutoff point. In either of these conditions, disengagement of the starter from the engine or interruption of the supply air to the starter is automatic. Starter operation is also discontinued by momentarily opening the stop switch, which shuts down the regulating valve, interrupting the supply air to the starter.

NOTE: During operation of the starter, personnel should stand clear of the plane of rotation of the high-speed rotating turbine wheel. Only qualified ADs should be allowed to install and service the unit and its control valve.

IGNITION SYSTEMS

Three things are necessary to cause a fire—a combustible material (such as aircraft fuel), oxygen, and heat. A fire will not start without all three, and when any of the three is removed the fire will cease. All internal combustion engines use fire to produce mechanical energy, and the piston type engine uses the higher degree of fire—an explosion.

Heat is the element of fire that is produced by ignition systems. In a piston (reciprocating) type aircraft engine, heat is produced at a spark plug. A high voltage is applied to the electrodes of the spark plug at the exact instant when the fuel-to-air mixture is proper and the piston is in the proper position. The arc produced by the spark plug ignites the mixture and causes an explosion which forces the piston to move and the propeller to turn.

The ignition system must be capable of producing 10,000 to 25,000 volts and delivering it to the proper cylinder at the exact time when it is needed.

The gas turbine (jet) engine also produces its energy through the use of fire; however, its operation is considerably different from the piston type. Rather than a series of independent explosions, a jet engine produces a continuous burning fire. Ignition is necessary only during the engine start cycle to initially start the fire burning. Since no explosion takes place, exact timing of the spark is unimportant.

Electronic ignition systems are used to provide internal combustion for turboprop, turboprop, and turbojet engines. Unlike reciprocating engine systems, timing is not a factor in turbine-power ignition systems. All that is needed is a series of sparks of sufficient intensity to cause combustion.

A voltage of sufficient amplitude to produce a spark is developed by a device called an exciter. The exciter unit contains a capacitor or capacitors to develop the voltage and current necessary to supply a spark plug (called an igniter). The resultant spark is of great heat intensity, capable not only of igniting abnormal fuel mixtures but also of burning away any foreign deposits on the plug electrodes. The exciter is a dual unit and produces sparks at each of two igniter plugs.

The igniter plugs are, in general, similar to the spark plugs used on reciprocating engines except for such changes as are necessitated by the higher energies, voltages, and temperatures encountered in jet operation. In general, the igniter plug is larger, more open in construction, and is set to a much wider gap than the spark plugs of familiar design. Figure 5-27 shows a typical jet igniter plug.

Control of jet ignition systems is usually accomplished through relays or switches that are

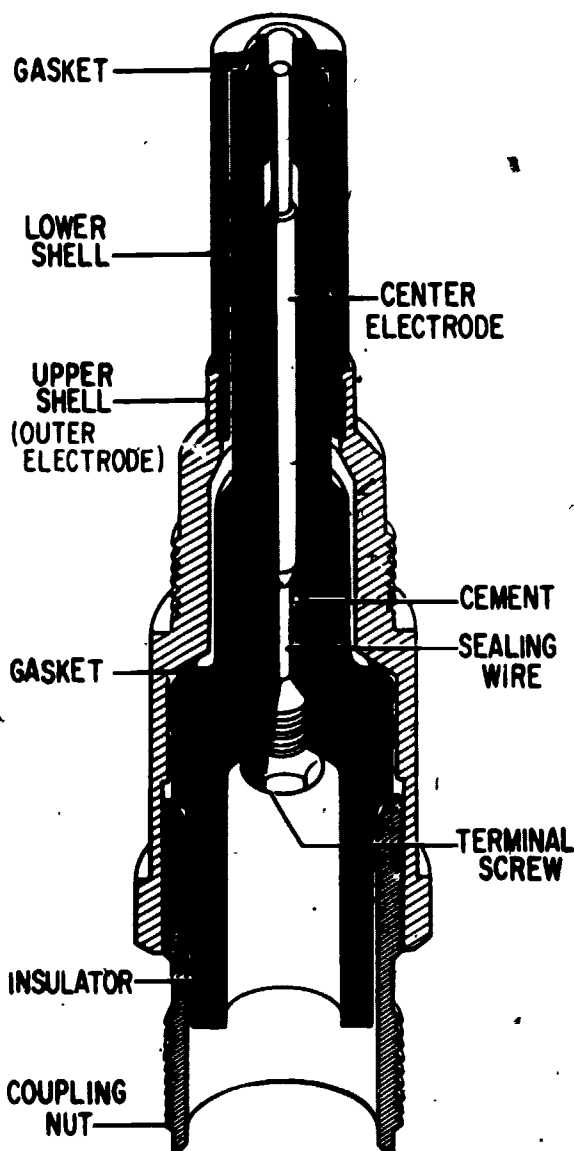

207.215

Figure 5-27.--Cross section view of a jet igniter plug.

operated automatically during the engine start cycle. Fuel or oil pressure switches or centrifugal speed switches are used to energize a relay to initiate ignition. Ignition is discontinued by actuation of centrifugal switch at a speed somewhere between 45% and 65% of rated engine speed.

Capacitor-Discharge Ignition System

This ignition system has three major components: one ignition exciter and two lead assemblies. The exciter unit is hermetically sealed, which affords permanent protection to the internal components from moisture, foreign matter, inadvertent maladjustments, pressure changes, and adverse operating conditions of all kinds. This type of construction eliminates the possibility of flashover at high altitude due to pressure change, and insures positive radio noise shielding. The complete system, including leads and connectors, is designed to insure adequate shielding against leakage of high frequency voltage which would interfere with radio reception of the aircraft. It is designed to supply energy to two surface type spark igniters.

Figure 5-28 is a functional schematic of the system; refer to this figure when studying the theory of operation.

The ignition system derives its input power from the low-voltage dc power supply of the aircraft electrical system. Its function is to produce high energy, capacitance type sparks at the spark igniters in the engine.

Input power from the low-voltage supply is connected through a noise filter to a dc motor which drives a multilobe cam to actuate two breakers, and a single-lobe cam which actuates two contactors. One breaker and one contactor are associated with each side of the system. The two sides are identical, and the following description applies to either side.

When the breaker is closed by the multilobe cam (as shown), input current flows through the primary winding of the autotransformer, establishing a magnetic field. The breaker is then opened, the flow of current stops, and the collapse of field induces about 1,000 volts in the secondary. This voltage causes a pulse of current to flow into the storage capacitor through a rectifier which limits the flow to a single direction. Thus, each time the breaker opens,

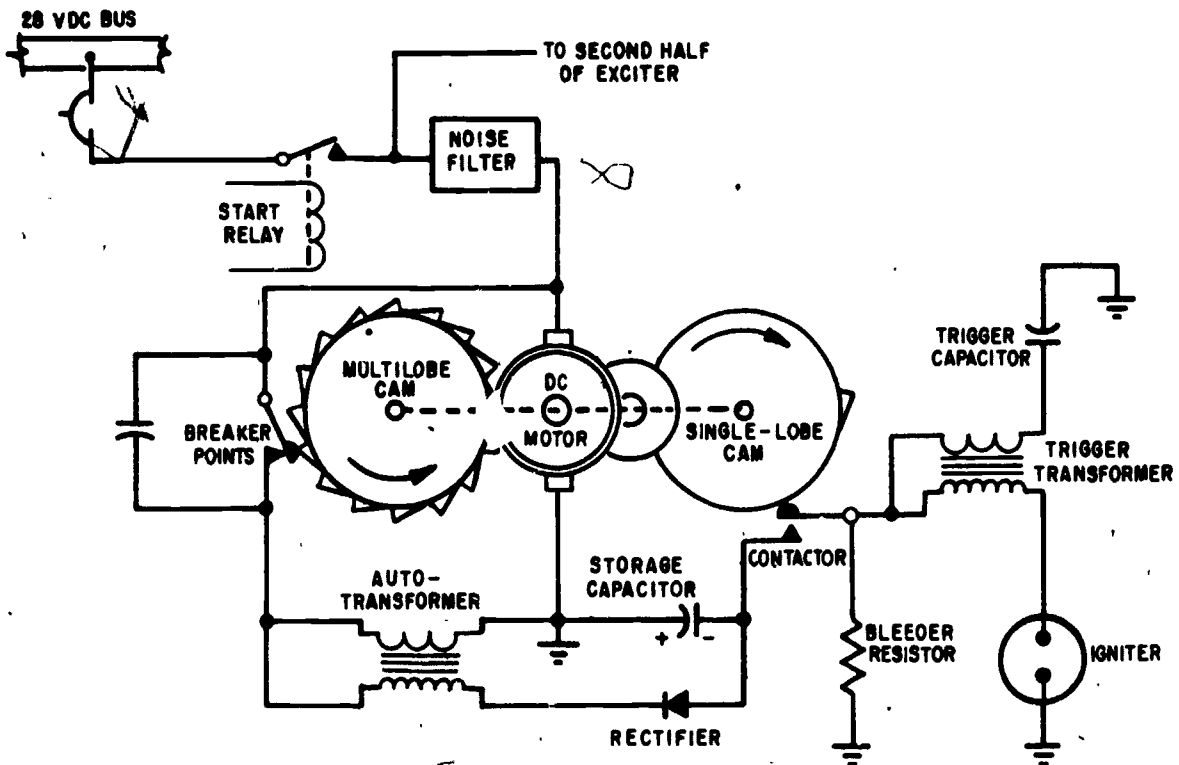

Figure 5-28.—Functional schematic of capacitor-discharge system.

207.217

the capacitor receives a charge of electricity, and the action of the rectifier prevents any loss of this charge. When 34 such pulses have accumulated a charge on the capacitor, the contactor is closed by mechanical action of the single-lobe cam, then the capacitor discharges its stored energy through a triggering transformer, and the energy is dissipated at the igniter. The triggering transformer increases the output voltage of the ignition unit and thus insures reliability of the system.

The spark rate at the igniter will vary in proportion to the voltage of the dc power supply, which affects the speed of the motor. However, since both cams are geared to the same shaft, the storage capacitor always accumulates its store of energy from the same number of pulses before discharge.

CAUTION: Due to the high voltage and amperage of this system, extreme caution should be used around the equipment.

Electronic Ignition System

With the development of modern, powerful jet engines for the Navy's first line aircraft, the demand for a reliable, maintenance-free ignition system has become more acute. No attempt is made in this chapter to cover all of the systems utilized, however, the system discussed is representative of most modern systems. This system has an advantage over the capacitor-discharge system in that it contains no moving parts and has no breaker points or contactors that can become pitted or burned.

The engine ignition system, illustrated in figure 5-29 provides the necessary electrical energy and control for initiating engine combustion during aircraft armament firing, during starting, and for automatic reignition in case of engine flameout.

ENGINE IGNITION EXCITER.—The exciter is a dual-circuit and dual-output unit that supplies a high-voltage, high-energy electrical

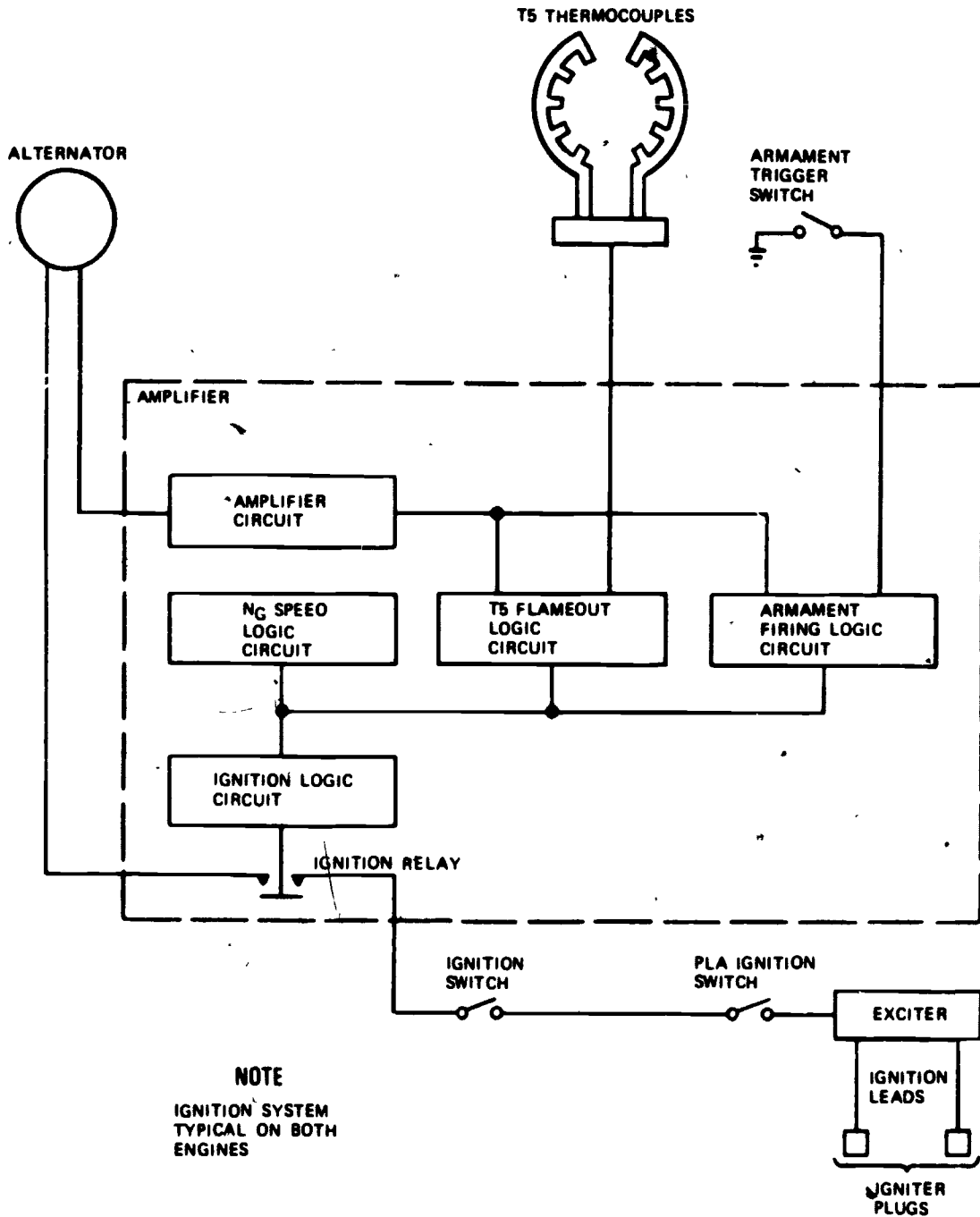

NOTE
IGNITION SYSTEM
TYPICAL ON BOTH
ENGINES

Figure 5-29.—Jet engine ignition system.

288.7

current for ignition. The exciter consists of a radio frequency interference filter and two power, rectifier, storage, and output elements. The exciter is mounted on the forward part of the compressor section of the engine.

ENGINE CONTROL AMPLIFIER.—The amplifier is the electronic control center of the engine. It controls the function of the ignition system as well as other engine operational functions. The amplifier is located on the

compressor section aft of the engine front frame.

ENGINE IGNITION LEADS AND IGNITER PLUGS.—The ignition leads are high-tension cables which transmit electrical current from the exciter to the igniter plugs. The igniter plugs are located in the combustion chamber housing.

ENGINE ALTERNATOR STATOR.—The alternator is an engine-driven single-phase, ac electrical-output unit mounted on the engine accessory gearbox. It supplies the engine with electrical power independently of the aircraft electrical system. It contains three sets of windings. Two windings supply electrical power to the ignition exciter and the third supplies electrical power to the control amplifier.

IGNITION OPERATION.—With the ignition switch ON, the engine cranking for starting, and the throttle advanced to the 10-degree power lever angle (PLA) position, current flows from the alternator stator to power the control amplifier. (See fig. 5-29.) Simultaneously, the PLA ignition switch in the fuel control closes. The gas generator (Ng) speed logic circuit will close the ignition relay to provide ignition whenever the Ng is within the 10 to 48 percent Ng range. With the relay closed, a circuit is completed from the alternator stator ignition windings, through the ignition exciter, to the igniter plugs. Current flows from the alternator, through the control amplifier, to the ignition exciter. At the ignition exciter, current is intensified and discharged as a high-voltage output, which is conducted through the igniter cables to the igniters. Current crossing the gaps in the igniters produces a continuous high-intensity spark to ignite the fuel mixture in the combustion chamber. When engine speed reaches 8,500 rpm Ng and interturbine temperature (ITT) reaches operating range, a signal from the T5 temperature detectors is transmitted through the T5 circuit to the control amplifier logic circuit. The control amplifier ignition relay opens and ignition is terminated. Combustion then continues as a self-sustaining process.

Ignition is automatically reactivated when either a flameout occurs or when aircraft armament is fired. When T5 temperature drops in excess of 800°F (427°C) from T5 selected by PLA, a signal transmitted from the T5 detectors causes the control amplifier T5 flameout logic to close the amplifier igniter relay. This activates ignition system operation. Ignition continues until engine operating temperature is again attained and the 800°F temperature error signal is cancelled, causing the control amplifier to terminate ignition operation.

To prevent flameout from armament gas ingested by the engine, an armament-firing protection circuit is incorporated in the aircraft wiring. When the aircraft armament is fired, the armament-firing logic circuit in the control amplifier is activated by a signal from the armament trigger switch. The amplifier logic then causes ignition operation to be activated. Ignition operation is terminated after a 1-second time delay in the amplifier logic following release of the armament firing trigger.

ANTI-ICING AND DEICING SYSTEMS

Naval aircraft are designed to fly in any type of weather. When there is sufficient moisture in the air and freezing temperatures are encountered, the power plant must be protected against ice buildup. The electrical systems designed for this purpose may be divided into two categories, anti-icing and deicing. Anti-icing systems must be capable of preventing ice from forming, whereas deicing systems act to remove ice that has already accumulated.

Guide Vane Anti-Icing System

The guide vanes of a turbine powered engine are used to direct the flow of inlet air into the compressor section. The air is coldest at this point and is most subject to icing. The biggest problem resulting from ice forming at this point is the blockage of inlet air which causes air starvation and thus engine failure. Consideration should also be given to the possibility of inducting chunks of ice into the engine;

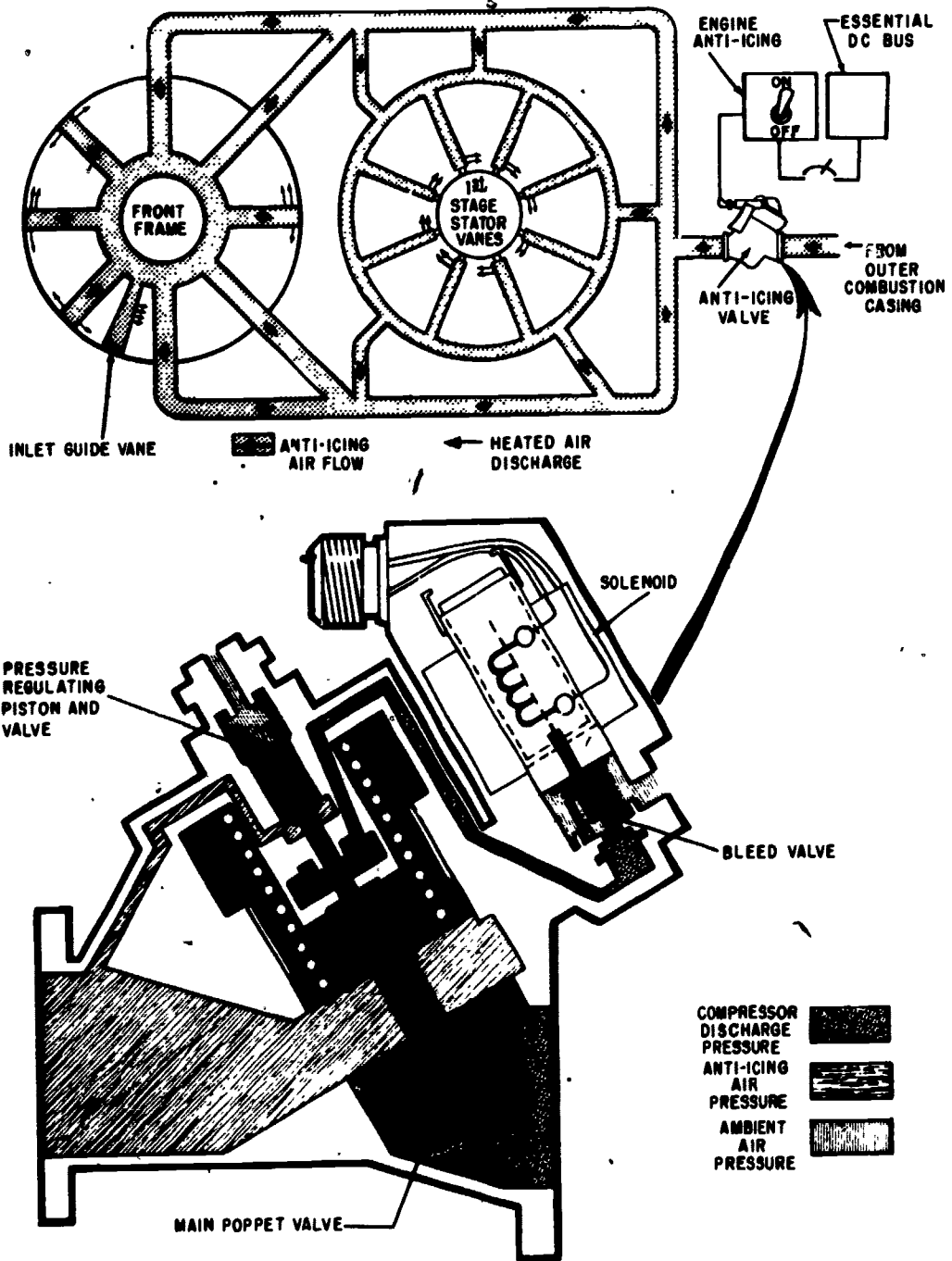

Figure 5-30.—Jet engine anti-icing system.

207.265

therefore, the system should be turned on at the first indication of or prior to entering any icing condition. Icing will not normally occur in supersonic flight because heat caused by the friction of the aircraft passing through the air is sufficient to prevent ice from forming.

Many types of anti-icing systems are in use today; all systems use heated air from the engine to perform the anti-icing function. The use of heated air causes engine power loss; consequently, anti-icing will be used only when necessary. In some aircraft a reversible electric motor is used to open and close an air valve to supply the needed air. In other aircraft an electrical solenoid is used to cause a pneumatic valve to be positioned to allow regulated heated air into the engine anti-ice system.

Where the mission of the aircraft dictates that it be routinely flown in adverse weather conditions, a failsafe system may be utilized. In this system, the solenoid actuated air valve is electrically actuated closed. If the switch is turned on, or if electrical power is lost, the valve is spring-loaded to the open position. Some systems anti-ice the complete inlet duct, while in other systems only the guide vanes are anti-iced.

Because of the variety of engine anti-icing systems in use today, only a system representative of several systems designed for Navy aircraft is discussed. (See fig. 5-30.) Note that the electrical portion of the circuit serves only to turn the system on or off.

The anti-icing valve is a solenoid-operated bleed valve. With no electrical input to the solenoid, the bleed valve is closed and there is no anti-icing airflow through the anti-icing valve. When the engine is operating with the valve solenoid deenergized, the main poppet will remain in the closed position. When the solenoid is energized, the solenoid valve is unseated and permits air pressure within the main poppet to escape through the overboard vent.

With pressure decreasing in the poppet valve body, the inlet pressure on the face of the main poppet overcomes spring tension and raises the valve from its seat. This permits the high pressure air to be discharged through the outlet of the valve to the anti-icing manifold on the engine. Discharge air from the anti-icing valve is

regulated to a preset pressure by the regulating piston and spring.

Propeller Deicing System

One method of preventing an excessive accumulation of ice on propeller blades of reciprocating engines is through the use of electric heaters. Figure 5-31 is a simplified schematic diagram of a system for a two engine aircraft.

The propeller deicing system consists of a three-position, two-speed selector switch (propeller deicer switch) and an indicator light, both mounted in the cockpit; a two-speed timer; and two propeller deicer relays (one for each propeller). Also, included (for each propeller) are the brush pad bracket assembly, mounted on the engine nose section; the slipring assembly, which is the aft portion of the propeller assembly, and a neoprene rubber heating element and connector for each blade. The blade heaters are protected by abrasion strips. The deicing system is designed to operate at either a slow cycle of 40-75 seconds on, 120-225 seconds off; or a fast cycle of 17-22 seconds on, 51-66 seconds off. Positioning of the switch to FAST or SLOW should be determined according to the icing conditions encountered.

Setting the selector switch to either SLOW or FAST permits dc power from the essential bus to energize the deicer timer motor and turn on the indicator light. Resistances in the timer determine the speed of the timer motor. The motor, through reduction gears, causes the cams on the camshaft to rotate, positioning the cam switches alternately between the right and left contacts. Current flows through these contacts to cycle their respective propeller deicer relays. With the relays being energized alternately, current from the 3-phase generator ac buses, through the 3-phase propeller deicer circuit breakers, flows to the carbon brushes of the propeller brush pad bracket assemblies. These carbon brushes contact the copper sliprings of the propellers and transmit ac power to the sliprings which transfers the power to the blade heating elements. Placing the selector switch in the OFF position stops propeller deicing operation and the indicator light goes out.

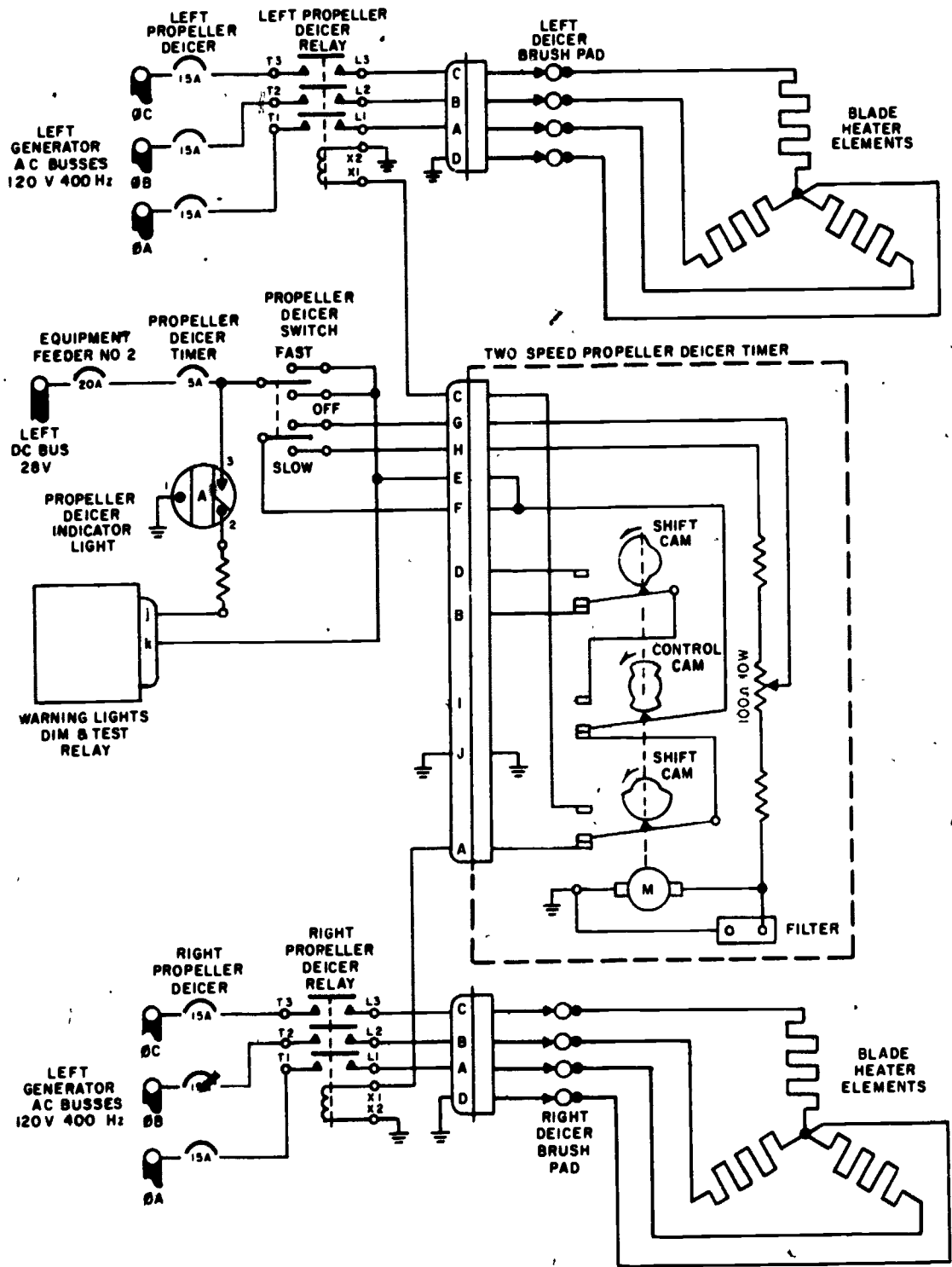

207.266

Figure 5-31.—Electrical deicing for a propeller system.

The propeller deicer timer is a two-speed, automatically controlled timer which regulates, in cycles, the time duration and sequence of electrical impulses to the propeller blade heating elements. The unit is contained in a moisture proof, airtight case and is mounted where it is isolated from extremes of temperature and vibration. The deicer timer consists of a fractional horsepower, constant speed, dc motor incorporating a reduction gear, a camshaft with three cams, three cam switches, two fixed resistors, and a variable resistor. A filter is also included to minimize radio interference.

Operationally, with the propeller deicer switch set to FAST, direct current flows from the left dc bus, through the propeller deicer circuit breaker and switch, through pins E, F, and G of the connector plug, to the timer. This current follows two paths in the timer. One path, from pins E and F which are connected in the timer, directs the current flow to the control cam switch, while the other, from pin G, directs the flow through the variable resistor and one fixed resistor to the timer motor, the filter, and to ground. The adjustment of the variable resistor determines the speed of the motor. The motor, through the 3,000 to 1 reduction gear, rotates the camshaft and cams. Two single-lobed shift cams and a single two-lobed control cam are secured to the camshaft. They are positioned on the camshaft so that the two single-lobed shift cams are on either side of the two-lobed control cam. As the control cam is rotated by the motor, it alternately makes and breaks its right and left cam switch contacts. This permits the flow of current to the shift cam switches. As the current flows to the other shift cam switch, rotation of the single-lobed cam makes and breaks the shift cam switch contacts, thus cycling first the right and then the left propeller deicer relays.

With the propeller deicer switch set to SLOW, the operation is identical to the fast cycle with the one exception, that direct current enters the timer through a different pin (pin H) in the plug and flows through the two fixed resistors and the variable resistor to the motor, the filter, and to ground. (Dc power to the control cam switch is through the same pins as

for the fast cycle.) Because of the increase in resistance, the motor operates at a slower speed. Thus, with the motor speed reduced, rotation of the camshaft, through the reduction gear, is slowed and the timer now functions at the slower cycle.

Several aircraft have an anti-icing and deicing system which prevents the formation of ice (anti-icing) on the forward portion of the propeller spinner, and removes any ice formation (deicing) from the blades and cuffs, aft portion of the spinner, and spinner islands. This system operates similar to the system described previously except that the anti-icing elements are heated continuously and the deicing elements are cycled by a timer when the system is turned on. Figure 5-32 shows the location of the heating elements. The system usually contains a safety feature for testing the propellers on the ground. This feature provides a low voltage to the heating elements which prevents damage to the prop from overheating.

FIRE WARNING AND EXTINGUISHING SYSTEMS

Some turbine engines operate at temperatures in excess of 1,000°C, and fuel and oil lines may be routed within a few inches of these extreme temperatures, therefore the engine area must be monitored closely to ensure

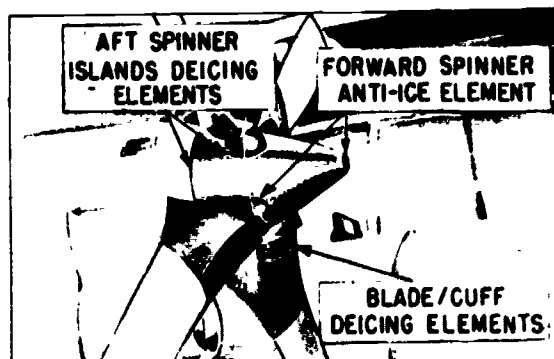

207.267

Figure 5-32.—Propeller heating elements.

that corrective action is taken immediately when an abnormal condition occurs.

Precision work must be performed when maintaining fire warning systems to insure unquestionable reliability. A fire that goes undetected may cost the lives of the aircrew and possibly millions of dollars in aircraft and equipment.

In multiengine aircraft, a fire warning usually dictates that the engine be shut down and, if the fire can be extinguished, that the aircraft be landed as soon as possible. The very least that can happen in the event of an erroneous fire warning is that the aircraft will abort its assigned mission.

Warning System

The engine fire detector system is an electrical system for detecting the presence of fire, or dangerously high temperatures, in the vicinity of the engine(s). The system for each engine consists basically of several sensing elements, a control unit, a test relay, a signal lamp, and a test switch. The detector utilizes a continuous strip of temperature-sensing elements in order to cover fully the paths of airflow in the engine compartment. Identical engine fire warning systems are installed in multiengine aircraft, one for each engine.

The electrical schematic for a fire warning system representative of systems used in modern Navy aircraft is shown in figure 5-33. The system is of the continuous-element, resetting type, and the sensing element consists of two parallel conductors separated by a semiconductor. The outer conductor is at ground potential, and the center conductor is attached to the input of an amplifier in the fire detector control unit. The semiconductor portion of the element has an inverse temperature coefficient; as the temperature increases, the resistance of the sensing element decreases.

The fire detector control unit continuously monitors the electrical resistance of the fire detector system's sensing element. The control

unit activates a fire warning light, and in some units an audible warning is also given, when:

1. The resistance of the sensing element decreases to the predetermined level (established by the fire alarm setting) due to an increase in temperature.
2. The sensing element resistance decreases at a predetermined rate due to the rate of temperature increase in the sensing element.

SHORT DISCRIMINATOR CIRCUIT.—

Until recently, there were no provisions incorporated into fire detection systems that eliminated erroneous warning indications caused by short circuits. In the past, flights have been aborted and crewmen have actually ejected because a fire warning light illuminated in flight due to a short circuit in the system.

Present day aircraft fire warning systems have a built in discriminator circuit that can differentiate between an actual overtemp (fire) and a short circuit somewhere in the system. If there is a short in this system, the fire warning light will NOT illuminate.

The following paragraphs describe a dual jet engine, aircraft's fire warning system. Both systems are identical in the manner in which they operate and are similar in operation to those used on other Navy aircraft.

The following paragraphs pertain to the left system. Electrical power from the L FIRE DET circuit breaker is supplied to the left fire detector and sensing element circuit through pin A of the detector control unit. (See fig. 5-33.) The left fire sensing element loop, which is connected to pins L and C of the detector control unit, completes the sensing circuit through normally closed contacts of the deenergized relay K1. At normal temperatures, the sensing element resistance is high, reverse-biasing diode CR1 and allowing current through resistor R2 to turn transistor Q1 on. This shunts base current from transistor Q2, turning transistor Q2 off, and allows current to flow into the base of transistor Q3, turning transistor Q3 on and transistor Q4 off. Transistors Q3 and Q4 are relay-driving transistors. With transistor Q3 turned on, relay

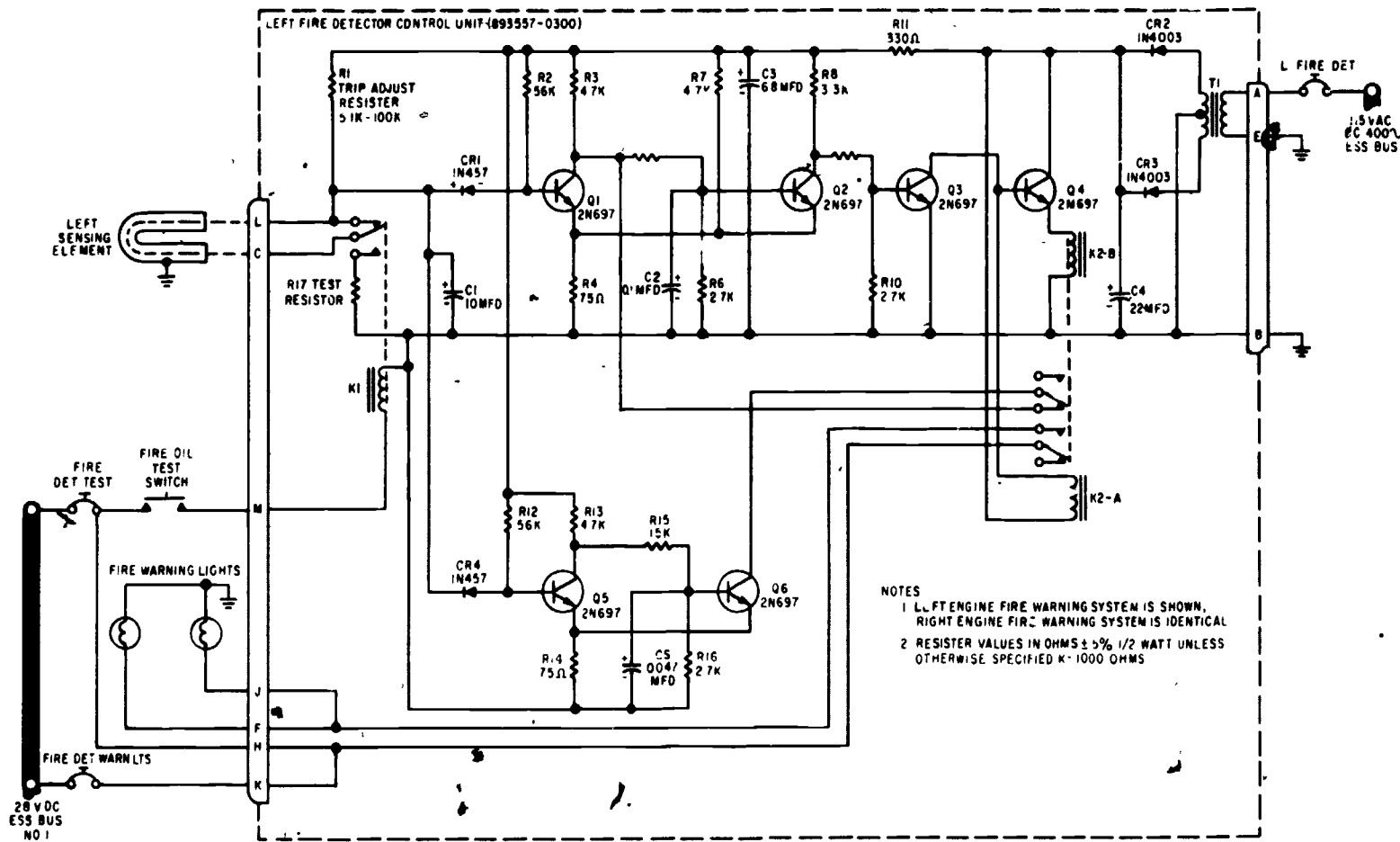

Figure 5-33.—Typical engine fire warning circuit schematic.

207.394

coil K2A is energized, opens K2 relay contracts, deenergizes the warning circuit, and turns out the L FIRE warning indicator lights. Under normal temperature conditions, relay coil K2A is energized.

When the temperature rises, the sensing element resistance decreases, shunting the current from resistor R2 through diode CR1, turning transistor Q1 off. This switches transistor Q2 on, transistor Q3 off, and transistor Q4 on. With transistor Q4 on, relay coil K2B is energized, while deenergizing relay coil K2A and transferring (switching) contacts of relay K2. The warning circuit is now energized. Then, 28V dc from the FIRE DET WARN circuit breaker powers the the warning circuit through pin K of the detector and turns on the L FIRE warning indicator lights. If the temperature drops, the warning circuit is deenergized, causing the fire warning indicator lights to go out.

Transistors Q5 and Q6 make up the short discriminator circuit. Its principle of operation is based on the rate of change of sensor resistance. In a fire, the resistance rate of change is slow. In an electrical short condition, the resistance rate drops abruptly. The two timing circuits, made up of resistors R5 and R6 and capacitor C2, and resistors R15 and R16 and capacitor C5, are preset so that a slow change of sensor resistance will allow transistor Q1 to switch transistor Q2 before transistor Q5 switches transistor Q6. A fast change of sensor resistance will allow transistor Q5 to switch transistor Q6 before transistor Q1 switches transistor Q2. If transistor Q6 is switched first, transistor Q2 is prevented from switching, thereby holding the rest of the circuits in the deenergized (no alarm) condition. If transistor Q2 switches first, the energized contacts of relay K2B removes transistor Q6 from the discriminator circuit.

Extinguishing System

The fire extinguishing system provided on many aircraft to control fires within the engines and nacelles is an electrically controlled HRD (high rate discharge) fire extinguishing system. Normally, the AE will not be required to service the HRD system except for the electrical circuits.

A welded steel sphere container, approximately 9 inches in diameter and cadmium plated for corrosion prevention, contains the extinguishing agent. (See fig. 5-34). Each container is filled with bromotrifluoromethane, and pressurized with nitrogen. Bromotrifluoromethane (CF_3Br in liquid form) is nontoxic and classed as a nonpoison; however, it is very volatile, not easily detected by odor, can be harmful, and should be handled with care. Do not permit it to come in contact with the skin; frostbite or low temperature burns may result.

The liquid is changed to a gaseous state by vaporization as it leaves the system and displaces the oxygen in the compartment, thereby rendering the air incapable of supporting combustion.

Each container is equipped with two valve assemblies for discharging the agent. Each valve

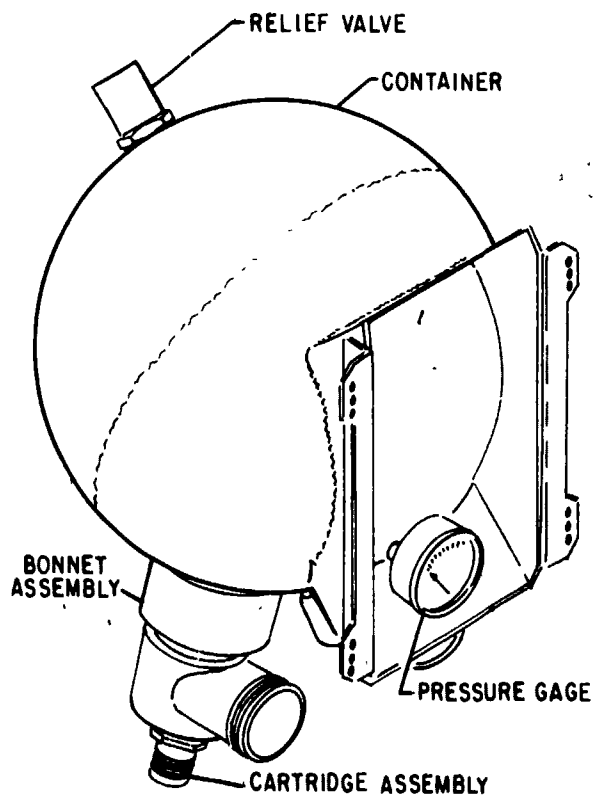

207.277

Figure 5-34.—Container and dual valve assembly.

assembly contains a high temperature electrically controlled cartridge. When a fire extinguishing discharge switch is actuated to complete a circuit (fig. 5-35), the cartridge is electrically fired to allow its slug to rupture the frangible disk in the neck of the container and allows the nitrogen pressure to force the extinguishing agent to be expelled from the container.

FUEL TRANSFER SYSTEM

The primary function of the fuel transfer system is to provide a continuous flow of fuel to

the aircraft engine(s) at the required flow rate and pressure under all operating conditions. In the past, these systems consisted mostly of electrical components such as, electric boost pumps, fuel level sensing devices (thermistors), and electrically controlled valves. Later aircraft are more mechanically orientated and the use of electrical components has been greatly curtailed.

Regardless of the type system used, the AE must be thoroughly familiar with the principal of operation of the transfer system because of its tie-in with the fuel quantity system.

The following is a brief description of the fuel transfer system used on the A7 aircraft. Refer to figure 5-36. The major electrical

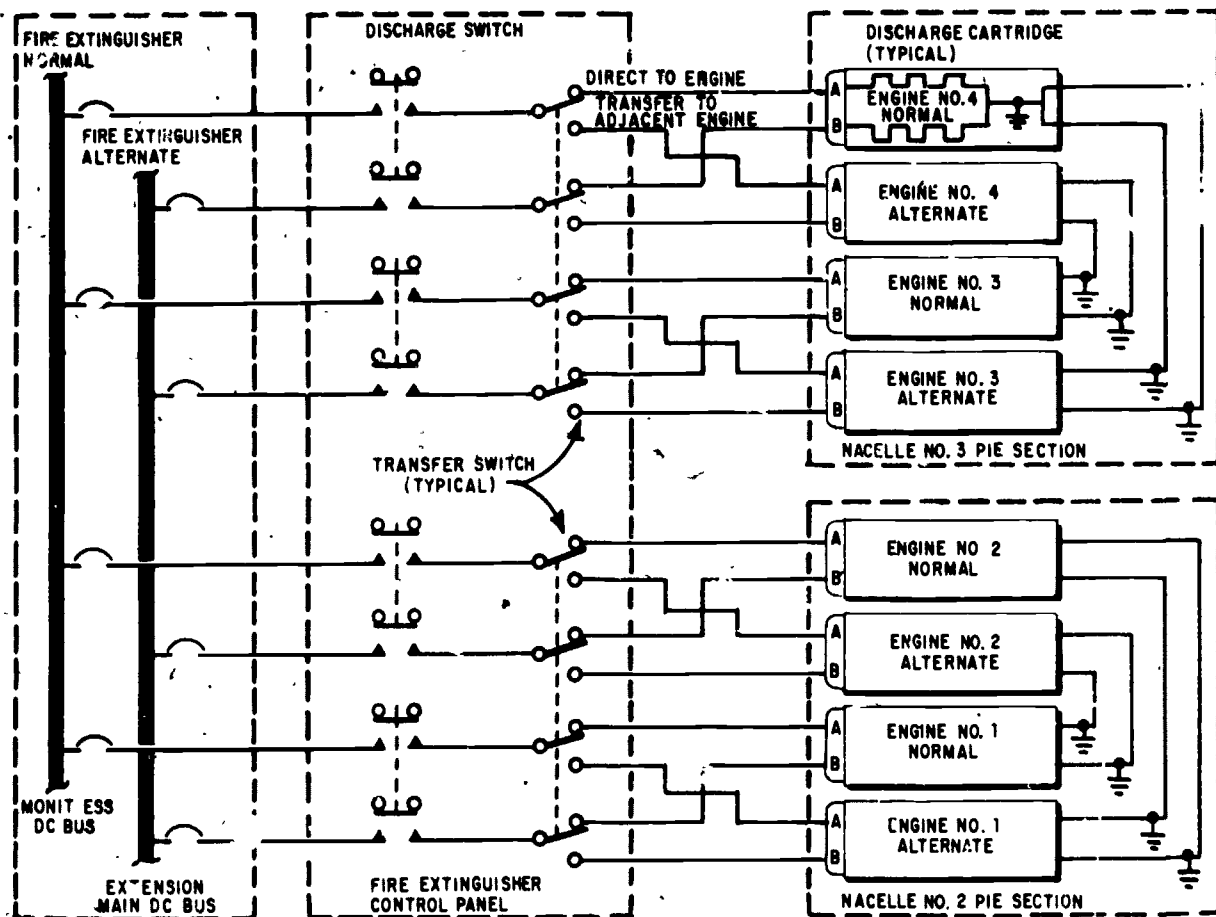
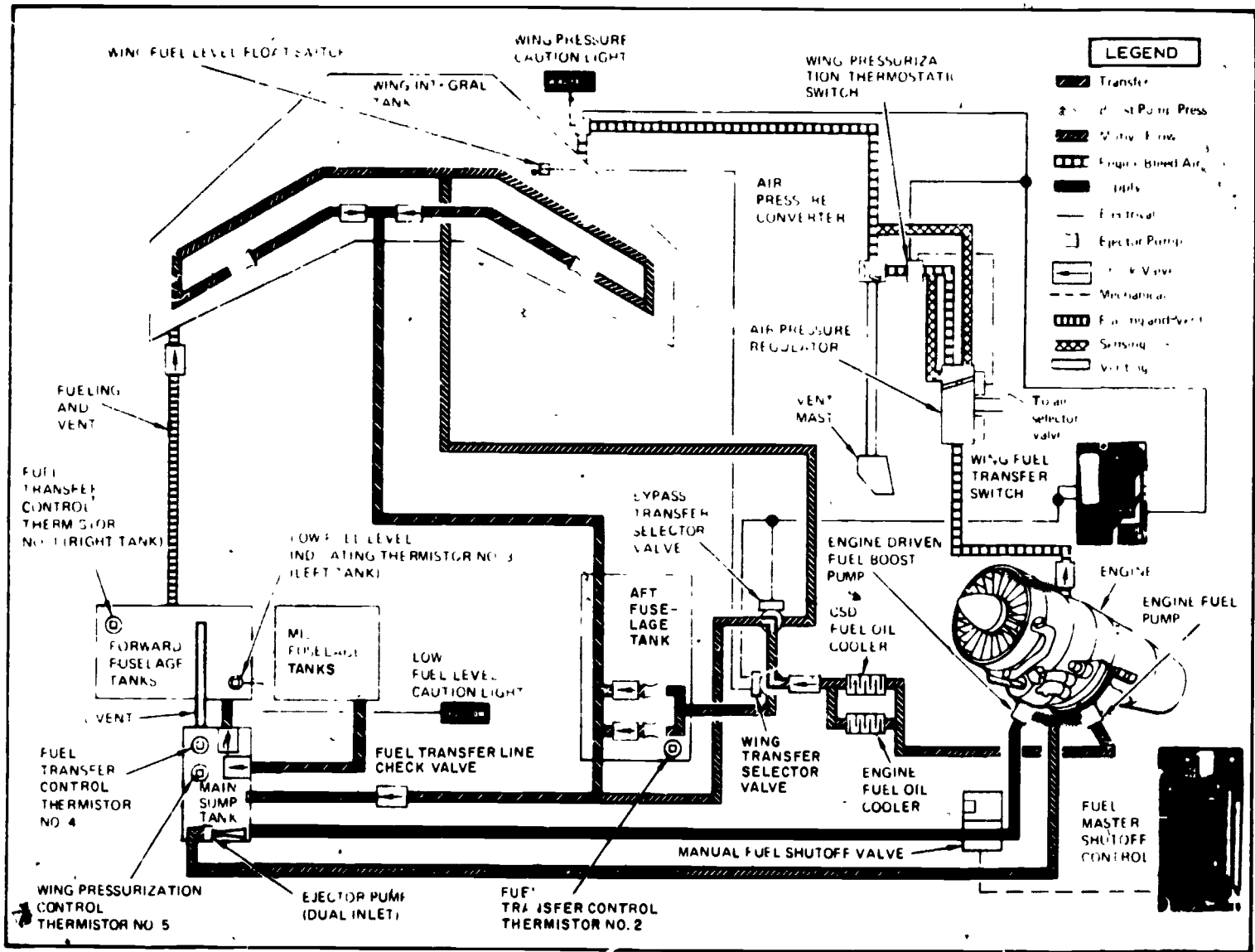

Figure 5-35.—Engine fire extinguishing circuit schematic.

207.278



546

Figure 5-36.—Internal fuel feed and transfer schematic diagram.

components are five thermistors and two motor driven transfer selector valves.

A thermistor is a temperature sensitive resistor with a negative coefficient. Covered with fuel, the thermistor has a high resistance. Uncovered, the surrounding temperature is higher and the thermistor's resistance is lower. Making the thermistor one leg of a bridge circuit provides for a method of monitoring the amount of fuel that is in a fuel tank.

The five thermistors in the system are located near or at the bottom of different fuel

cells throughout the aircraft. (Fig. 5-37.) Thermistors 1, 2, and 5 are used for controlling the transfer of fuel from one cell to another. Thermistor No. 3 is used in conjunction with the fuel low level warning light. Thermistor No. 4 is used to control wing tank pressurization.

The above system is fully automatic. The pilot selects AUTO with the fuel transfer switch (Fig. 5-38) and no other action is required on the pilot's part. If the AUTO mode of operation develops a malfunction, the pilot can select EMER with the transfer switch and regulated

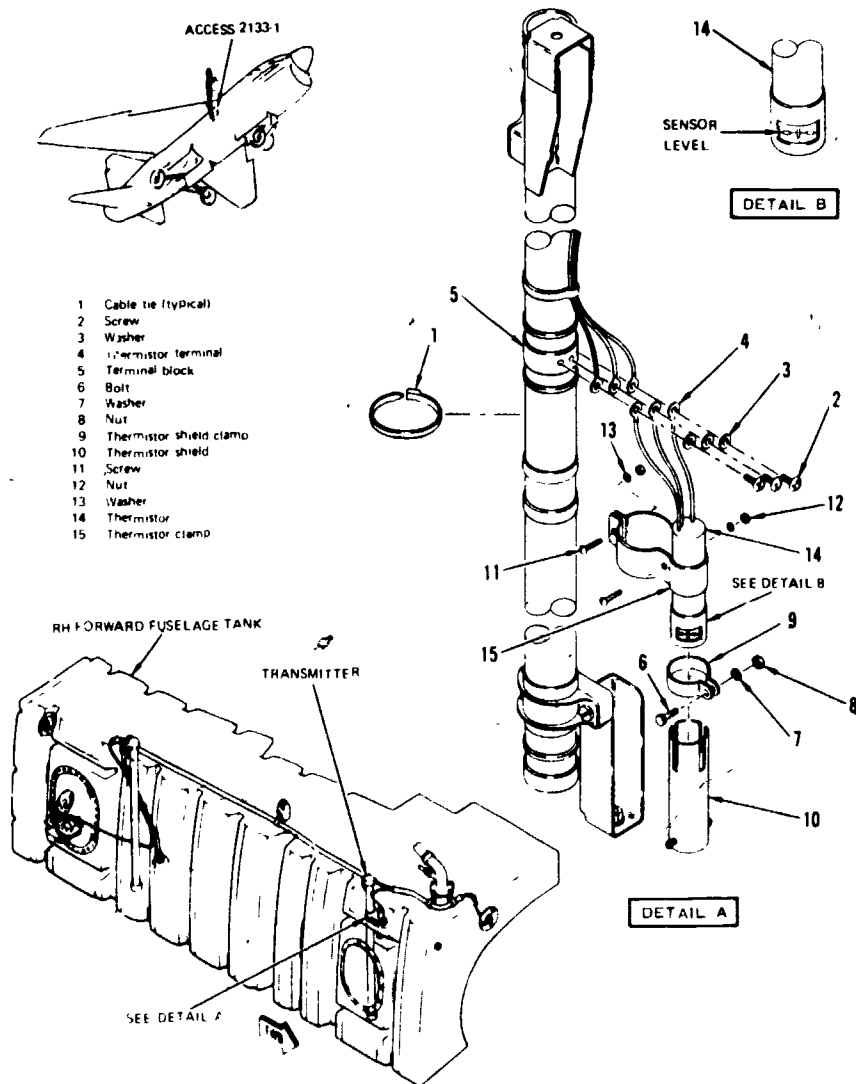

Figure 5-37.—Fuel quantity transmitter with fuel level sensing thermistor attached.

INDEX NO.	CONTROL/INDICATOR	FUNCTION
1	WING FUEL TRANSFER SWITCH (WING TRANS)	<p>AUTO - COMPLETES CIRCUIT WHICH ALLOWS FUEL TRANSFER SELECTOR VALVES TO PROVIDE AUTOMATIC TRANSFER OF FUEL FROM THE WING AND FUSELAGE TANKS.</p> <p>EMER - OPENS AIR PRESSURE REGULATOR TO PROVIDE REGULATED ENGINE BLEED AIR TO PRESSURIZE WING TANK FOR EMERGENCY TRANSFER OF WING FUEL TO SUMP TANK.</p> <p>OFF - ALLOWS ACTUATION OF ONLY THE WING TRANSFER SELECTOR VALVE TO PROVIDE EJECTOR PUMP MOTIVE FLOW TO THE AFT AND SUMP TANKS ONLY, RETAINING WING TANK FUEL</p>

Figure 5-38.—Main and transfer fuel system controls.

207.397

engine bleed air is routed to the wing tank and fuel is forced out by pressurization.

The A7 has the capabilities of being an inflight tanker. Placing the fuel transfer switch in the OFF position isolates the wing tank and the fuel in it from the main sump tank. This fuel can then be transferred through the refueling store to another aircraft.

OIL DILUTION AND DIVERTER SYSTEM

The purpose of an oil dilution system is to inject gasoline from the fuel lines into the engine

oil system of a reciprocating engine. Oil dilution is used whenever a cold weather start is expected. It is accomplished prior to stopping the aircraft engine. Oil dilution thins the oil that is left in the engine and greatly reduces the cranking torque of the next engine start.

Figure 5-39 is the electrical schematic of an oil dilution circuit.

This system is a manually controlled electrical circuit. The oil dilution control switch, located in the cockpit, is of the momentary-on type. When the control switch is held in the OIL DILUTION position the solenoid of the oil

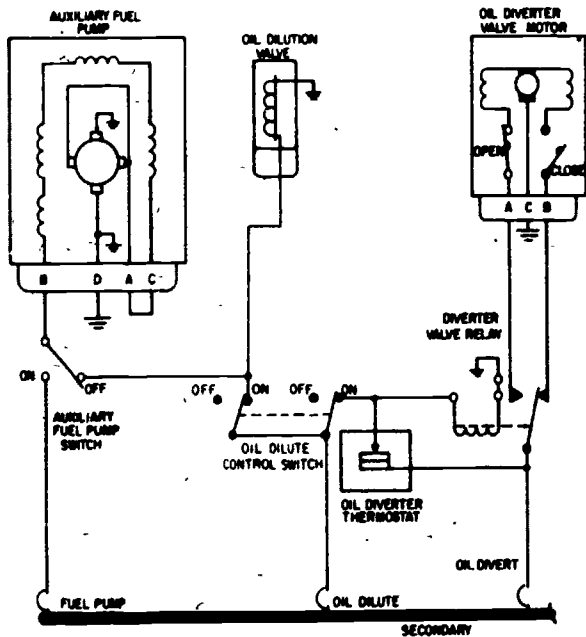

207.279

Figure 5-39.—Oil dilution and diverter circuit.

dilution valve is energized. Also, the auxiliary fuel pump will start automatically if it is not already operating. This pump supplies the pressure that is needed to force the gasoline into the oil system.

The control switch also energizes the diverter valve relay, causing the oil diverter valve motor to open the diverter valve. Fuel flows through the oil dilution valve to the oil system, and the diverter valve directs the oil into the warmup compartment of the supply tank. The action of the diverter valve permits dilution of only the oil in the warmup compartment of the supply tank.

Oil returning from the engine flows through the diverter valve either to the warmup compartment or to the main compartment of the tank. The diverter motor is connected with the diverter valve control circuit; internal limit switches open the circuit when the motor reaches its extreme limits of travel.

When the temperature of the oil in the tank sump drops below 130°F, the thermostats contacts close, energizing the diverter valve relay

to complete the circuit to the diverter valve motor; the motor closes the valve port to the tank's main compartment so that oil flows to the warmup compartment. When oil temperature in the tank sump rises above 130°F, the thermostat contacts open and the diverter valve relay deenergizes. This completes the circuit to the other side of the motor to close the valve port to the warmup compartment so that oil is directed into the main compartment. Automatic control of the circuit is relinquished by the thermostat when the oil dilution system is in operation; the oil dilution circuit, when energized, bypasses the thermostat and energizes the oil diverter relay, thus completing the circuit to the valve motor to divert all oil, regardless of temperature, to the tank warmup compartment.

OIL TEMPERATURE CONTROL SYSTEM

The cooling capacity of the oil cooler system in an aircraft is dependent upon the amount of air that is allowed to pass through the cooler. The airflow is controlled by an oil cooler door which varies the opening of the oil cooler air exit duct under the control of the oil cooler door actuator. (See fig. 5-40.)

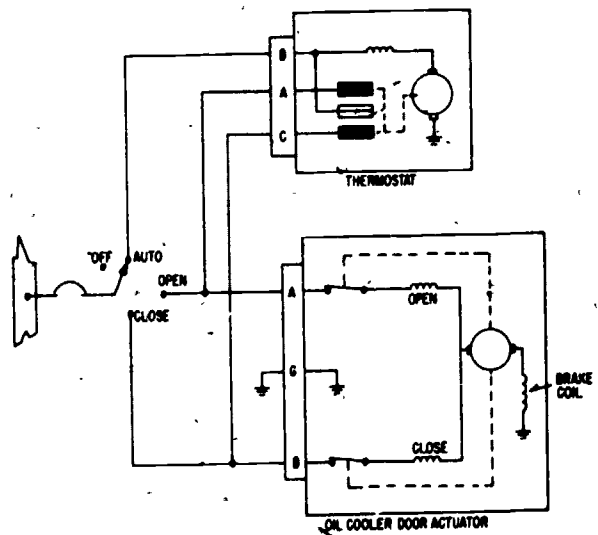

207.280

Figure 5-40.—Oil temperature control circuit.

The door is operated by a split-field, reversible dc motor which includes a magnetic brake to stop the motor quickly when the limits of travel are reached.

The control switch is of the four-position type, with OPEN, CLOSE, AUTOMATIC, and OFF positions. In the OPEN or CLOSE position, electrical power is directed to the actuator motor and opens or closes the oil cooler door completely. When the switch is placed in the AUTOMATIC position, the actuator is controlled by a thermostat.

The thermostatic control unit is mounted in the oil return line. The unit contains two floating contact arms and a central contact arm that is actuated by a bimetallic coil immersed in the oil of the return line. One of the floating contacts is in the "door open" circuit and the other is in the "door closed" circuit. The two arms rest on a cam which is constantly rotated by a small motor. Thus, the floating contacts are constantly vibrating toward the central contact.

If the oil temperature rises above normal, the thermostatic element causes the central contact to move toward the "door open" contact so that as the contact vibrates it intermittently closes the "door open" circuit. As the actuator is intermittently energized, the door is slowly opened until the oil temperature returns to normal, at which time the central contact moves back to a neutral position.

If the oil temperature falls below normal, the central contact is moved in the opposite direction, causing the door to close. To prevent excessive hunting of the system a tolerance is maintained by adjustment of the cam on the floating contact.

In an extreme case, where the oil temperature rises high above the normal value, the central contact will lift the floating contact clear of the cam, completing a continuous circuit. The door will then move to the full open position where a limit switch in the actuator will break the circuit.

In figure 5-41 another type of engine oil temperature regulator is shown. This regulator employs a mercury-filled thermostat and relays to automatically control the position of the engine oil cooler doors.

When the engine temperature is low and more heat is required, the two relays are

energized and complete a path for current to close the oil cooler door. As the temperature increases, the thermostat completes a path to ground, bypassing the relay coils and deenergizing them. Power is then routed through the contact of one of the relays to the open coil of the actuator, causing the oil cooler door to open and reduce engine temperature.

ENGINE TEMPERATURE CONTROL SYSTEMS

On most reciprocating engines, the cylinder head temperature (CHT) is controlled by operating the engine cowl flaps. This, in turn, controls the amount of airflow over the cylinders in much the same manner as the oil temperature control systems explained above.

In turbine powered engines, control of the turbine temperature is an entirely different matter. In general, engine temperature can be used as a measure of power, and temperature is a product of the fuel consumed. In most turbine powered aircraft, then, the desired power is selected by the pilot through a mechanically operated fuel control. As the power increases, so does the temperature. In turbojet aircraft this will also cause an increase in engine speed. The only electrical circuits required are those to indicate temperature and speed.

In turboprop aircraft, however, where the engine runs at a constant speed, it is desirable to have a fine tuning system to control engine temperature. This system is called a temperature datum system and performs three functions:

1. Limits the engine starting temperature to a preset value.
2. Provides a safety temperature limit when the engine is below normal operating speed or below normal operating power setting.
3. Provides temperature control at the normal operating speed and normal power settings.

Temperature Datum Valve

The temperature datum valve controls the amount of fuel going to the engine, and is placed

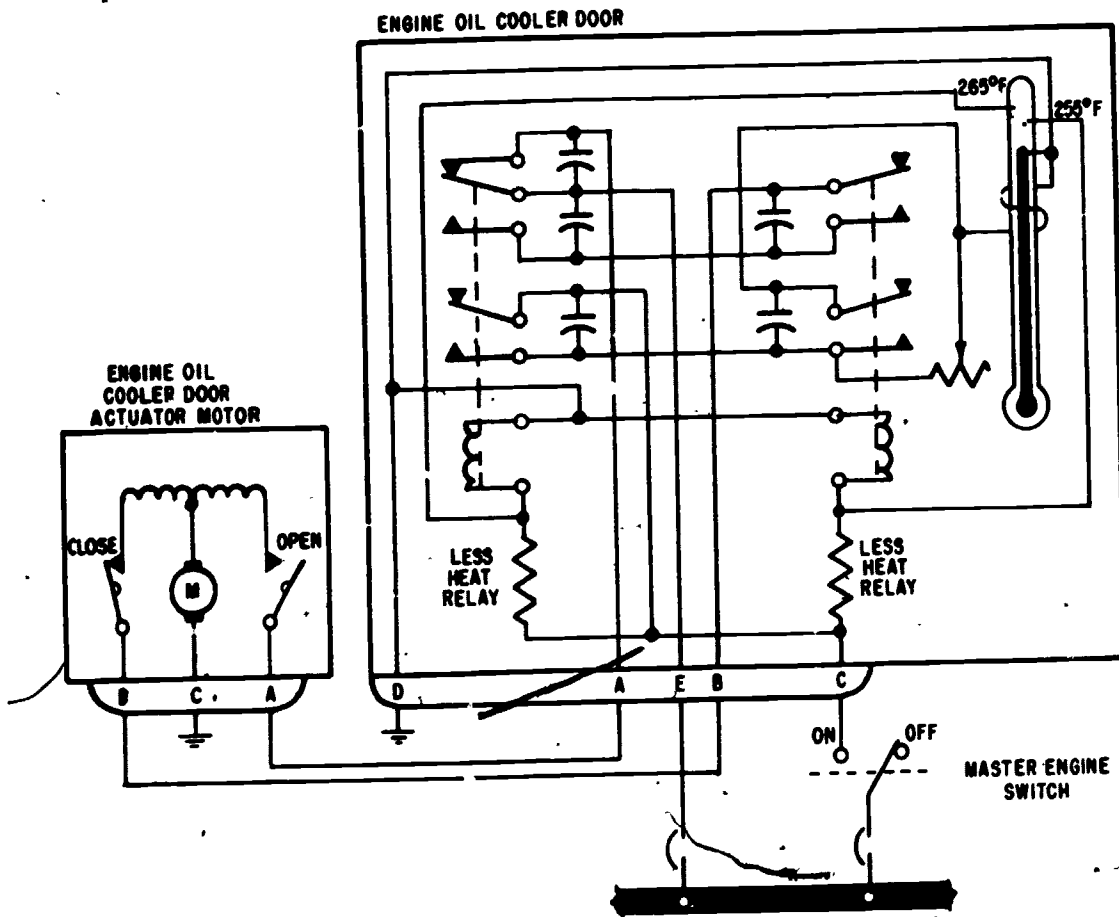

207.281

Figure 5-41.—Automatic oil temperature control circuit.

in the fuel line between the mechanical fuel control and the engine. The fuel control is scheduled to deliver to the temperature datum valve 120% of the fuel required by the engine. The valve then selects, by electrical inputs from a temperature datum control, the exact amount of fuel necessary for proper operation of the engine. It has the capability of supplying the engine with the full 100% of fuel supplied by the fuel control, or to supply only 50%.

Temperature Datum Control

The temperature datum control receives electrical inputs from: a speed sense control;

thermocouples which are located at the turbine inlet of the engine; an engine coordinator; and a temperature datum control switch located in the cockpit. (See fig. 5-42.)

The temperature datum control switch, when placed in the NULL position, causes a solenoid in the temperature datum valve to operate so that the valve supplies 100% of fuel control fuel to the engine and 20% back to the fuel control. In the AUTO position of the switch, the temperature datum control positions the valve to supply the proper amount of fuel to the engine.

The speed sensitive control has centrifugally mounted switches for relaying to the

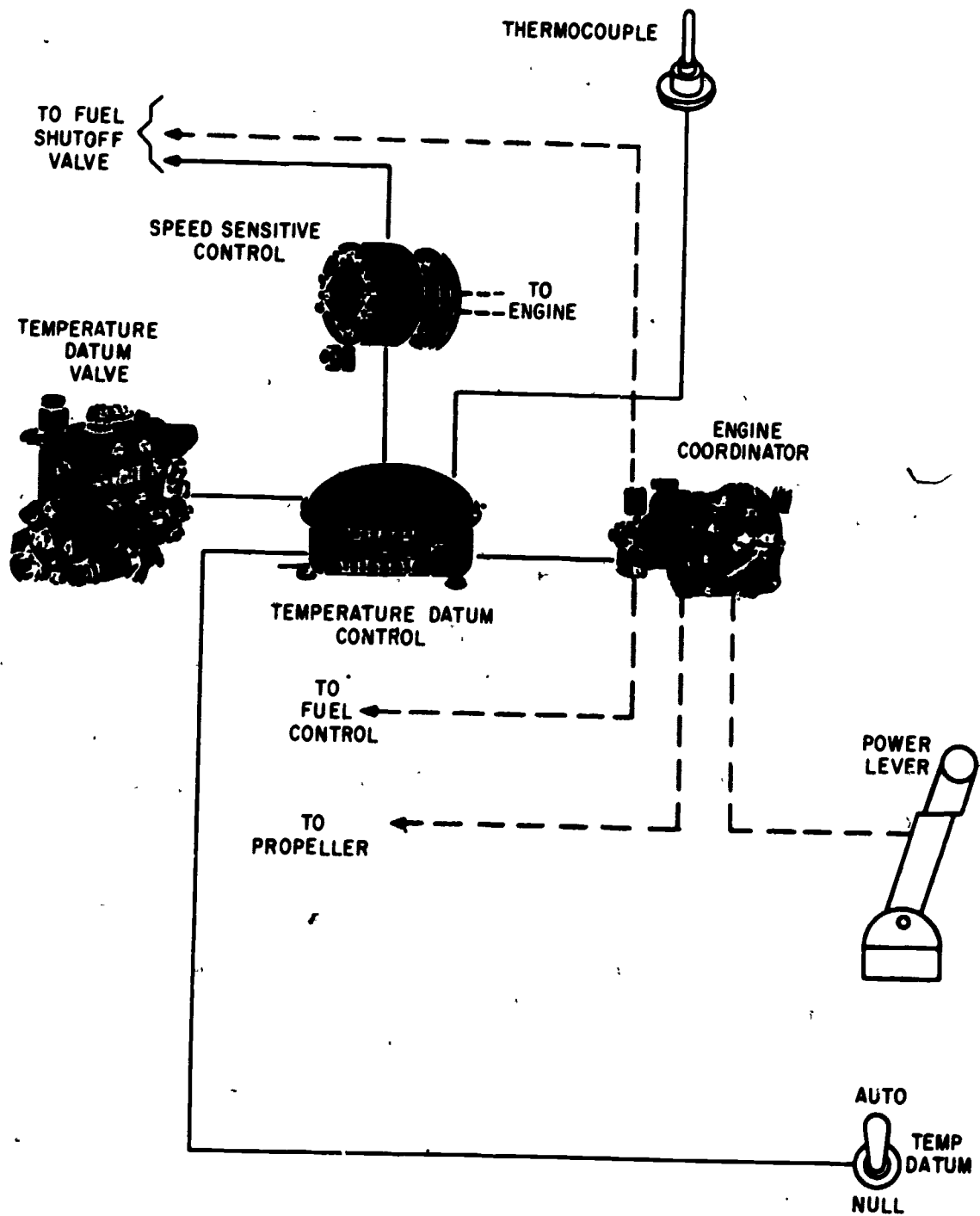

Figure 5-42.—Temperature datum system.

207.56

temperature datum control the engine's speed. If engine speed is below 94%, the limiting temperature can be set to approximately 830°C to prevent excessive turbine inlet temperature during start and acceleration. Temperature limiting is accomplished by sensing the temperature at the thermocouples and comparing it with the maximum temperature present into the temperature datum control. If the temperature exceeds this maximum value, a motor in the temperature datum valve operates and causes less fuel to be routed to the engine and more fuel to be routed back to the fuel control.

The engine coordinator is positioned by the power lever (throttle) from 0° to 90°. When the engine speed is above 94% and the engine coordinator is set to less than 66°, temperature is limited to 1,077°C maximum by automatic positioning of the motor in the temperature datum valve.

When the engine speed is above 94% and the engine coordinator is between 66° and 90°, a potentiometer in the coordinator identifies the exact engine temperature desired by the pilot (movement of the power lever). This desired temperature is compared with the actual temperature sensed at the thermocouples, and if there is more than 1.9°C difference, the temperature datum valve will be repositioned to add or take away fuel.

The temperature datum control has temperature adjustments to allow for varying engine configurations and capabilities.

PROPELLER SYNCHROPHASING SYSTEM

In propeller driven aircraft, if the propellers are allowed to turn at different speeds a kind of throbbing vibration is set up which causes constant irritation to the flight crew, and over a period of time can cause structural failure of the aircraft. In early aircraft, synchronizing the propellers was accomplished manually by listening to the tone changes. Later, an instrument called a synchroscope (fig. 5-43) was used to monitor the difference in engine speeds, and it is still used in some aircraft today.

The instrument consists of a small electric motor which receives electrical energy from the tachometer generators of both engines that are

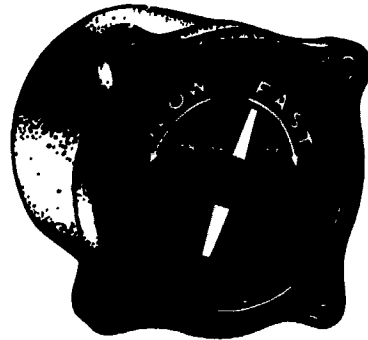

207.383

Figure 5-43.—Synchroscope indicator.

to be synchronized. If both engines—and thus both tachometer generators—are rotating at exactly the same speed, the synchroscope motor does not turn. A double-ended pointer on the dial of the instrument indicates which engine is turning faster than the other.

If one engine is turning faster than the other, its tachometer generator will turn the synchroscope motor in one direction. If the speed of the other engine becomes faster than the first, then its tachometer generator will gain control and the synchroscope motor will reverse itself and rotate in the opposite direction.

In a synchroscope system it is necessary to designate one engine of the aircraft as the master engine if the synchroscope indications are to have any meaning. The dial readings—with left-hand rotation of the pointer indicating “slow” and right-hand rotation indicating “fast”—would then refer to the operation of the second engine in relation to the speed of the master engine.

The synchroscope does not lend itself well to use in aircraft with more than two engines, and with the advent of the turbine powered constant speed engine a more accurate method of synchronization was desirable. This is accomplished in some naval aircraft through the use of synchrophasing systems.

A block diagram of a synchrophasing system used with the T56 engine is shown in figure 5-44. When an engine is running the propeller is stabilized at 100% rpm by a hydromechanical governor. Fine tuning to stabilize all propellers at exactly the same speed is accomplished by monitoring each engine's

pulse generator. The slave propellers are then caused to rotate at the same speed as the master propeller by automatic repositioning of the hydromechanical propeller governor in the slave propellers to conform to the master pulse generator. Since this signal is routed directly to the propeller and no action is required by the flight crew, synchronizing is accomplished rapidly and accurately.

A pulse generator consists of a permanent magnet attached to the rotating propeller and a coil attached to a stationary component of the propeller. As the propeller rotates, a single pulse is transmitted from the propeller each time the magnet passes the coil. By counting the pulses per minute the exact rpm can be sensed and by detecting the exact time between pulses the exact position of any blade on any propeller at any instant of time can be determined. This information is compared and used to reposition the hydromechanical governor on the propeller so that the number one blade of each slave

propeller is an exact number of degrees leading or lagging the number one blade of the master propeller.

Synchronizing, then, is causing all propellers to rotate at the same speed; the more precise procedure of positioning the propeller blades to an exact position is called synchronizing.

APPROACH POWER COMPENSATOR SYSTEM

The approach power compensator (APC) system automatically controls engine power to maintain optimum angle of attack during landing approaches. This permits the pilot to direct most of his attention toward flying the approach. During an APC approach in light to moderate turbulence, the set can maintain airspeed within a range of ± 4 knots.

Major components of the system are a control panel, accelerometer, computer, control

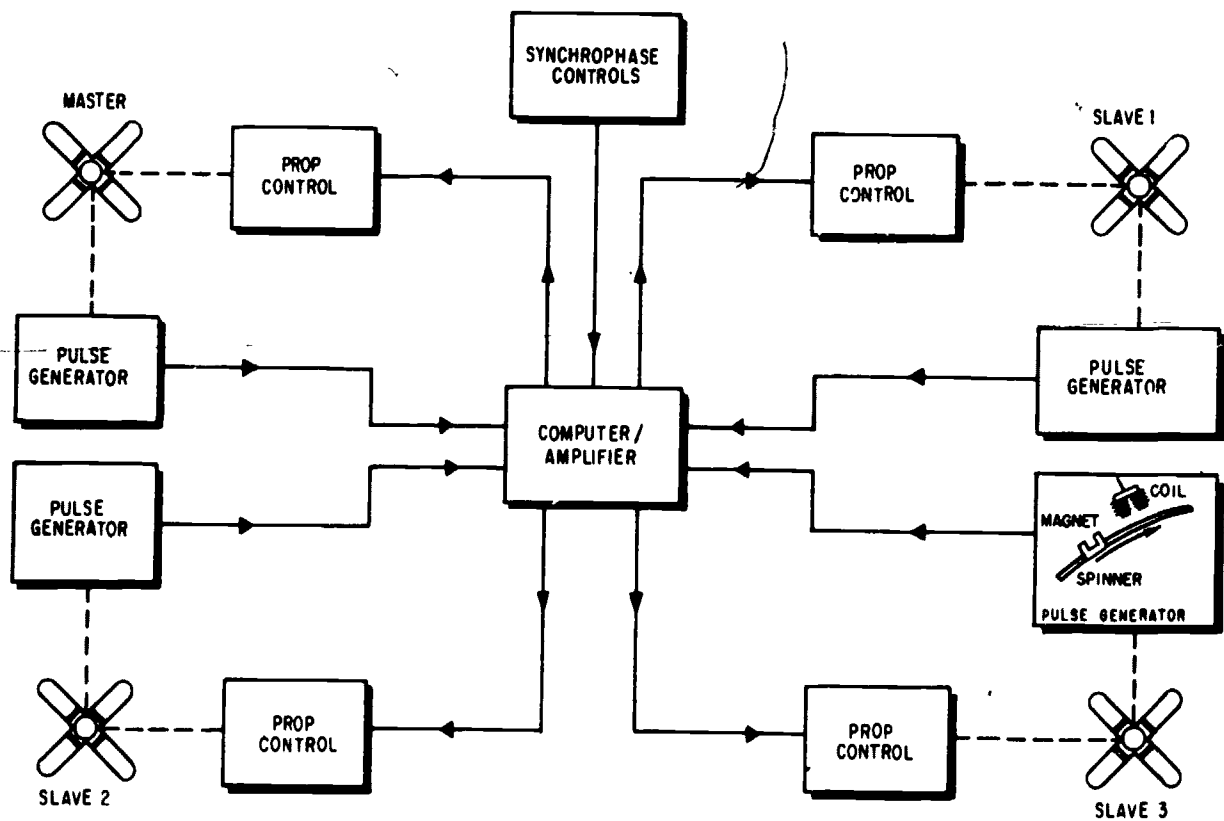

Figure 5-44.—Synchronophaser system block diagram.

207.57

amplifier, a potentiometer to detect changes in elevator position, and a rotary actuator which moves the throttle linkage. The aircraft angle-of-attack transducer supplies angle-of-attack signals to the computer. A compression switch on the landing gear is used to break the APC circuit upon touchdown. (See fig. 5-45.)

Operation

With the landing gear down and weight off the gear, the set is energized by placing the engage switch to ON. The engage switch is held magnetically in this position until the aircraft touches down, the system is manually overridden with the throttle, or the engage switch is manually returned to OFF. The set will also disengage automatically if either the

override switch or the compression switch should fail.

With the set engaged, the accelerometer, angle-of-attack transducer, and the ambient temperature selector switch supply information to the computer, and the APC computer also receives elevator position signals from a potentiometer mounted in the control valve linkage of the elevator actuator. When normal acceleration is one G and the angle-of-attack is optimum for a landing approach, the computer sends no corrective signal and the throttle position does not change. Deviations from these values are interpreted by the computer as either offsetting each other or as requiring a change of power setting. If a power change is required, the computer sends an electrical signal to the rotary actuator through the control amplifier. The

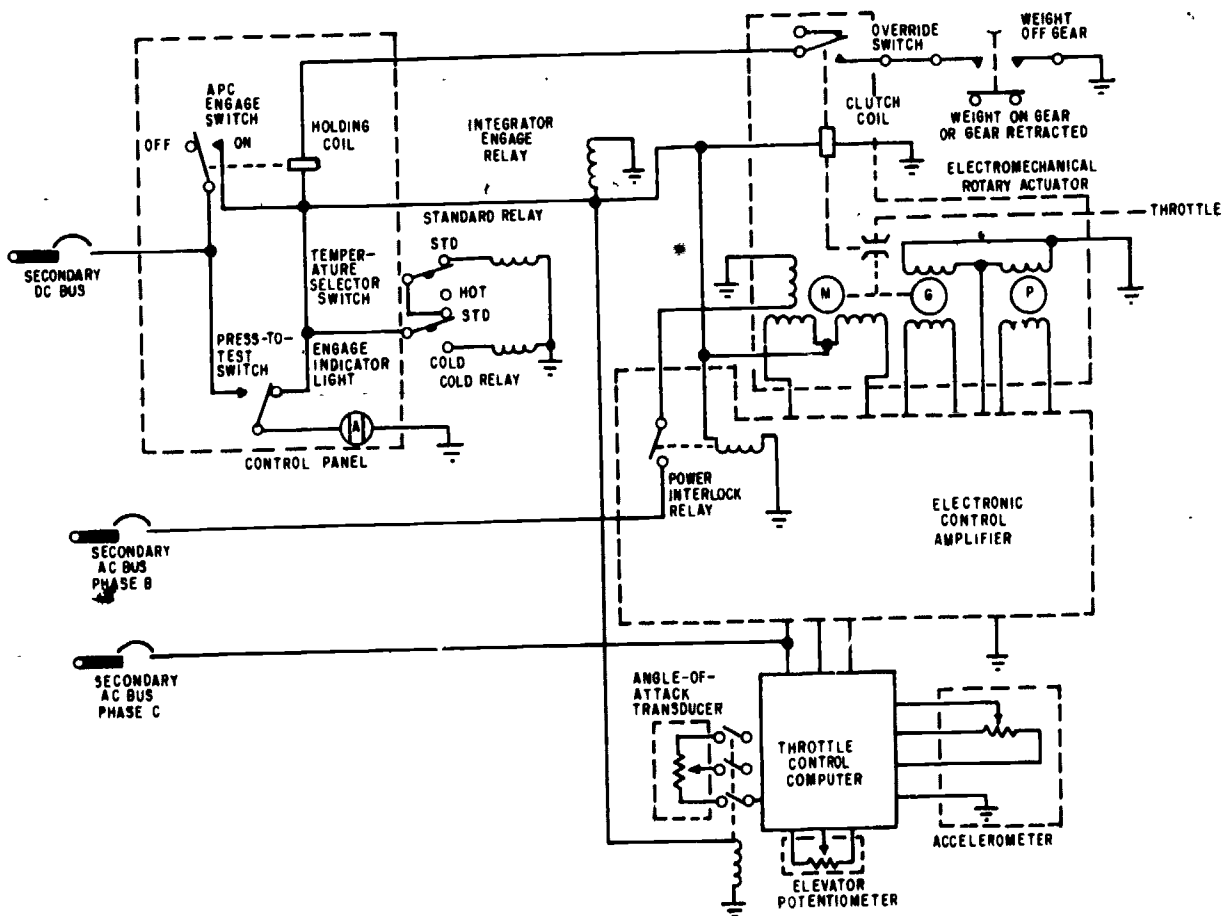

Figure 5-45.—Approach power compensator simplified schematic.

5-55
258

rotary actuator motor then drives the engine control linkage to accomplish the required power change. The system is capable of driving the throttle linkage at speeds up to 25° per second. The APC can vary the engine rpm from that obtained at full throttle to 67% rpm at temperatures above 0°F, or to 58% rpm at temperatures below 0°F.

Since engine performance varies with ambient air temperature, the set incorporates a three-position temperature switch to compensate for this effect. At low ambient air temperatures the thrust change per degree of throttle movement is greater than at high ambient air temperatures. When the APC temperature switch is placed in COLD, the APC operates with an approximate 15% reduction in gains from those obtained with the switch in STD. Conversely, with the temperature switch in HOT the APC operates with an approximate 11% increase in gains from STD. The end result is that APC performance is essentially the same regardless of ambient air temperature when the following temperature settings are made: COLD below 4°C (40°F), STD from 4°C to 27°C (80°F), and HOT above 27°C.

VARIABLE INLET DUCT RAMP SYSTEM

High speed aircraft are usually operated at predetermined Mach numbers instead of specific airspeeds. Mach number is the ratio of the speed of an object to the speed of sound in the same medium and at the same temperature. Sonic velocity and Mach number vary with air temperature, therefore, at standard day conditions the airspeed which corresponds to a given Mach number will vary with changes in altitude.

In the case of aircraft which are designed to fly at speed of Mach 2.0 and greater, the air velocities which are encountered at the inlet duct are much higher than the engine can efficiently use. The velocity of the air at the inlet duct entrance must therefore be decreased prior to entering the engine.

In some aircraft this is accomplished through a variable inlet duct ramp. That is, by moving

part of the surface attached to the leading edge of the engine inlet duct, the supersonic shock waves can be positioned to allow only subsonic air to enter the duct. Through wind tunnel tests it can be determined the exact ramp position necessary at any particular speed.

Figure 5-46 shows a block diagram of the variable inlet duct ramp system used in the F-4 aircraft. The central air data computer (discussed in chapter 6 of this manual) senses the exact speed of the aircraft and develops a signal proportional to the exact ramp angle necessary. This signal is amplified and displaces a hydraulic servo valve to cause a hydraulic actuator to move the ramp. Attached to the ramp is a feedback potentiometer which, when the ramp is properly positioned, zeros the output of the amplifier. The servo valve then returns to zero and the actuator stops. Any change in speed or temperature will cause the ramp to again move to maintain the shock wave at the exact position for the proper flow of intake air.

AIRCRAFT ELECTROHYDRAULIC AND PNEUMATIC SYSTEMS

The word "hydraulics" is based on the Greek word for water, and originally meant the study of physical behavior of water at rest and in motion. Today the meaning has been expanded to include the physical behavior of all liquids, including hydraulic fluid.

Hydraulics is the science pertaining to liquid pressure and flow. In its application to aircraft, hydraulics is the action of liquids, forced under pressure through tubing and orifices, to operate various mechanisms.

The AE's primary concern in working with hydraulics is to control the flow of fluid. This may be accomplished by a solenoid to simply turn on or shut off a flow of fluid, or to change flow direction; in some cases electrical devices may be used to schedule a precise amount of fluid flow. In any case, it is necessary for the AE to understand the characteristics of liquids. First, a liquid has no definite shape, but conforms to the shape of its container. This characteristic enables liquids to flow freely.

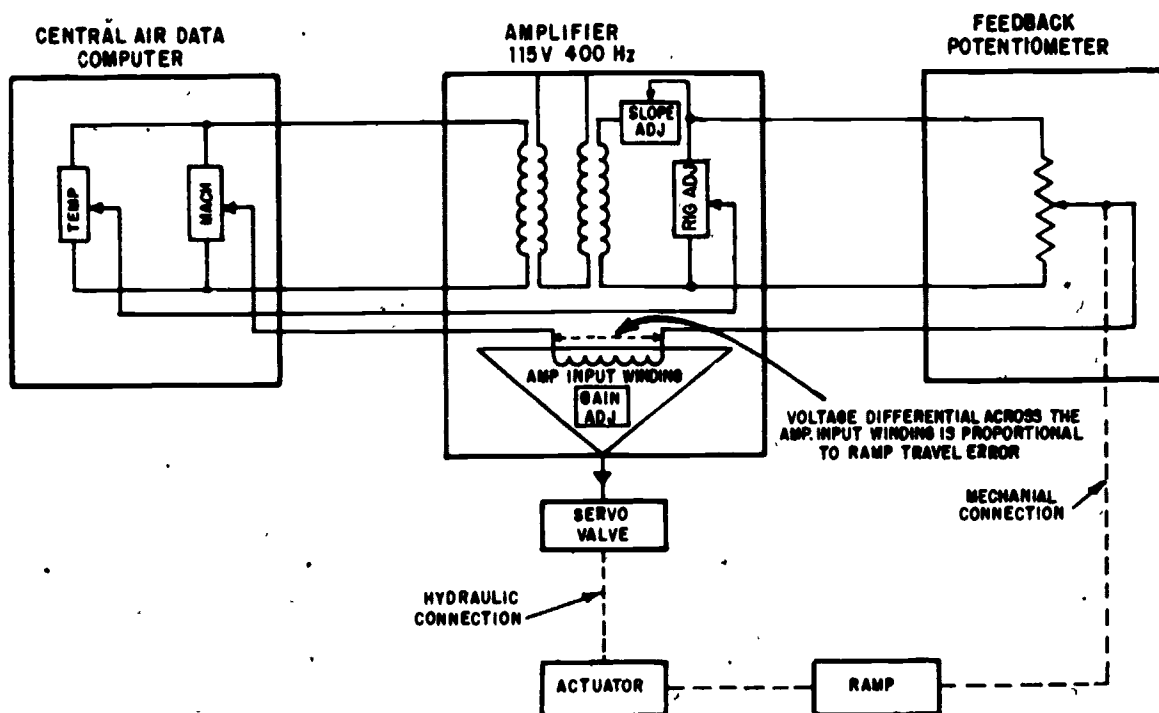

207.84

Figure 5-46.—Variable inlet duct ramp system block diagram.

When sufficient liquid is forced into a system, the liquid completely fills all the lines and chambers open to it.

Another important characteristic is that a liquid can be only slightly compressed. In some applications of hydraulics, where extremely close tolerances are required, the compressibility of liquids must be considered in the design of the system. However, in dealing with the hydraulic systems of aircraft, liquids are considered to be incompressible.

The third characteristic of liquid is its ability to transmit pressure. This is based on Pascal's law which states: "Pressure applied to an enclosed or confined fluid is transferred equally in all directions without loss and acts with equal force on equal surfaces."

The physics of fluids and basic hydraulic principles are covered in the publication, *Fluid Power*, NAVPERS 16193 Series. The first two chapters of *Fluid Power* should be studied in conjunction with this chapter.

Although some aircraft manufacturers make greater use of hydraulics than others, the hydraulic system of the average modern aircraft performs many functions. Among the units commonly operated by hydraulics are: landing gear, wing flaps, speed brakes, wing folding mechanisms, flight control surfaces, canopy, bomb bay doors, wheel brakes, and arresting gear.

BASIC HYDRAULIC SYSTEM

All hydraulic systems are essentially the same, regardless of their function. Hydraulics is used on the farm, in industry, aboard ship, and many other places as well as in aircraft. Regardless of its application, each hydraulic system has a minimum of four components—reservoir, pump, selector valve, actuating unit—plus lines through which the

fluid is transmitted. Figure 5-47 illustrates a basic hydraulic system, showing these four essential components and their relationship within the system.

The reservoir is provided to store a supply of fluid for operation of the system. It replenishes the fluid of the system when needed, provides room for thermal expansion, and normally provides a means for bleeding air from the system.

The pump is provided to create a flow of fluid. The pump in this system is hand operated; however, aircraft systems are equipped with engine-driven or electric-motor-driven pumps. There are two types used in naval aircraft, the piston and gear type. One aircraft may incorporate both types due to the requirements of the various hydraulic systems.

The purpose of the selector valve is to direct the flow of fluid. These valves are actuated either manually or by solenoids; they may be operated directly, or they may be operated indirectly with the use of mechanical linkage.

The purpose of the actuating unit is to convert fluid pressure into useful work. The actuating unit may be an actuating cylinder or a

hydraulic motor. An actuating cylinder converts fluid pressure into useful work by linear/reciprocating-mechanical motion, while a motor converts fluid pressure into useful work by rotary-mechanical motion.

In figure 5-47 the flow of hydraulic fluid can be traced readily from the reservoir through the pump to the selector valve. With the selector valve in the #1 position, the flow of fluid created by the pump is through the valve to the right-hand end of the actuating cylinder. Fluid pressure then forces the piston to the left; at the same time, the fluid which is on the left of the piston is forced out, up through the selector valve, and back to the reservoir through the return line. When the selector valve is moved to the #2 position, the fluid from the pump then flows to the left side of the actuating cylinder, thus reversing the process. Movement of the piston can be stopped at any time simply by moving the selector valve to neutral. In this position, all four ports are closed and pressure is trapped in both working lines.

This basic system is one from which any hydraulic system can be derived. Additions may be made to it for the purpose of providing additional sources of power, operating additional cylinders, making operation more automatic, or increasing the reliability; but these additions are all made on the framework of the basic hydraulic system diagrammed in figure 5-47.

ELECTROHYDRAULIC SYSTEMS

There are basically two types of electrically controlled, hydraulically operated components—selector valves to start, stop, or change the direction of a fluid flow, similar to a switch in an electrical circuit, and control valves to schedule an exact amount of fluid flow, much like a potentiometer controls current flow. Each of these components is manufactured in varying degrees of complexity, dependent upon its intended use, and each manufacturer uses his own identification for his components, such as transfer valve, engagement valve, servo valve, etc.

Aircraft hydraulic systems normally operate at a pressure of 3,000 psi; therefore, each component must be capable of operating at this pressure. All applicable safety precautions should be observed when working with high pressure hydraulic or pneumatic systems.

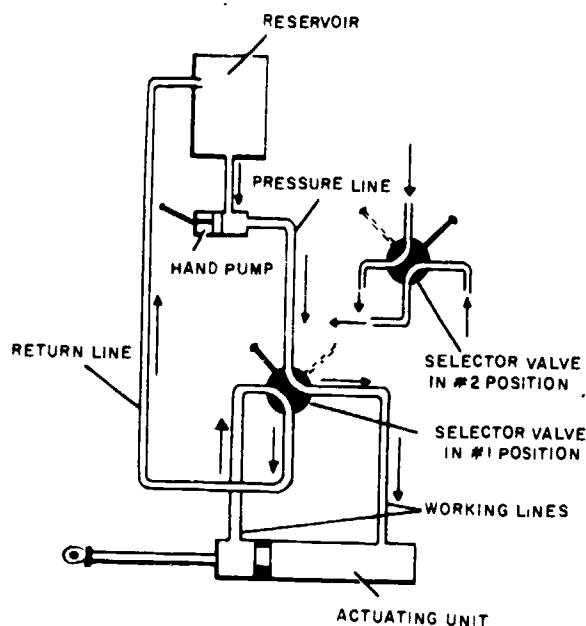

207.65

Figure 5-47.—Basic hydraulic system, hand-operated pump.

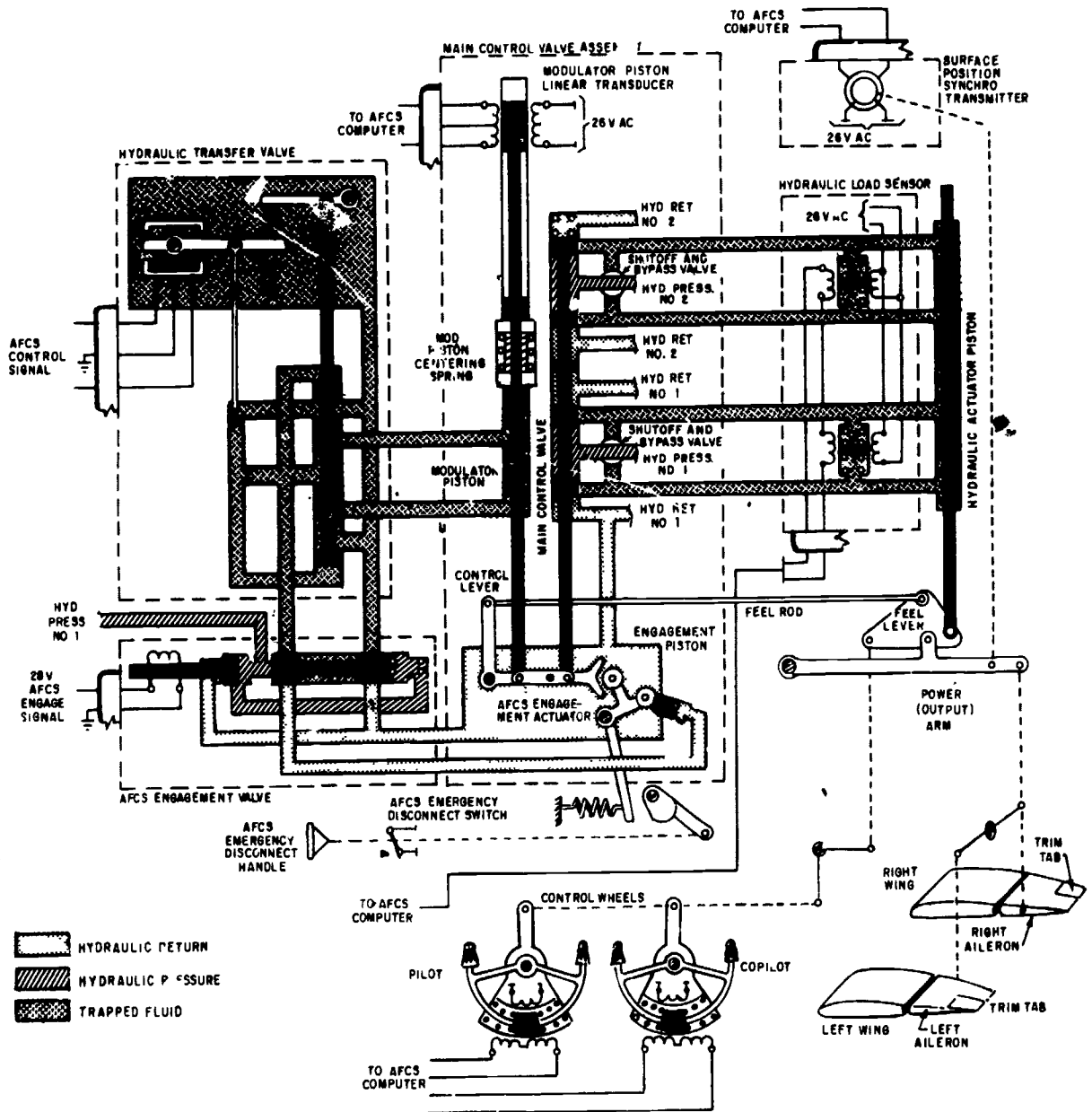

207.66

Figure 5-48.—Hydraulic surface control booster with no mechanical input and AFCS disengaged.

Hydraulic Surface Control Booster System

The hydraulic surface control booster system contains both selector and control components, as shown in figures 5-48 and 5-49.

The automatic flight control system (AFCS) engagement valve is a selector, which either applies pressure to or removes pressure from the AFCS portion of the booster. The hydraulic transfer valve is used to control the direction and amount of fluid to the booster.

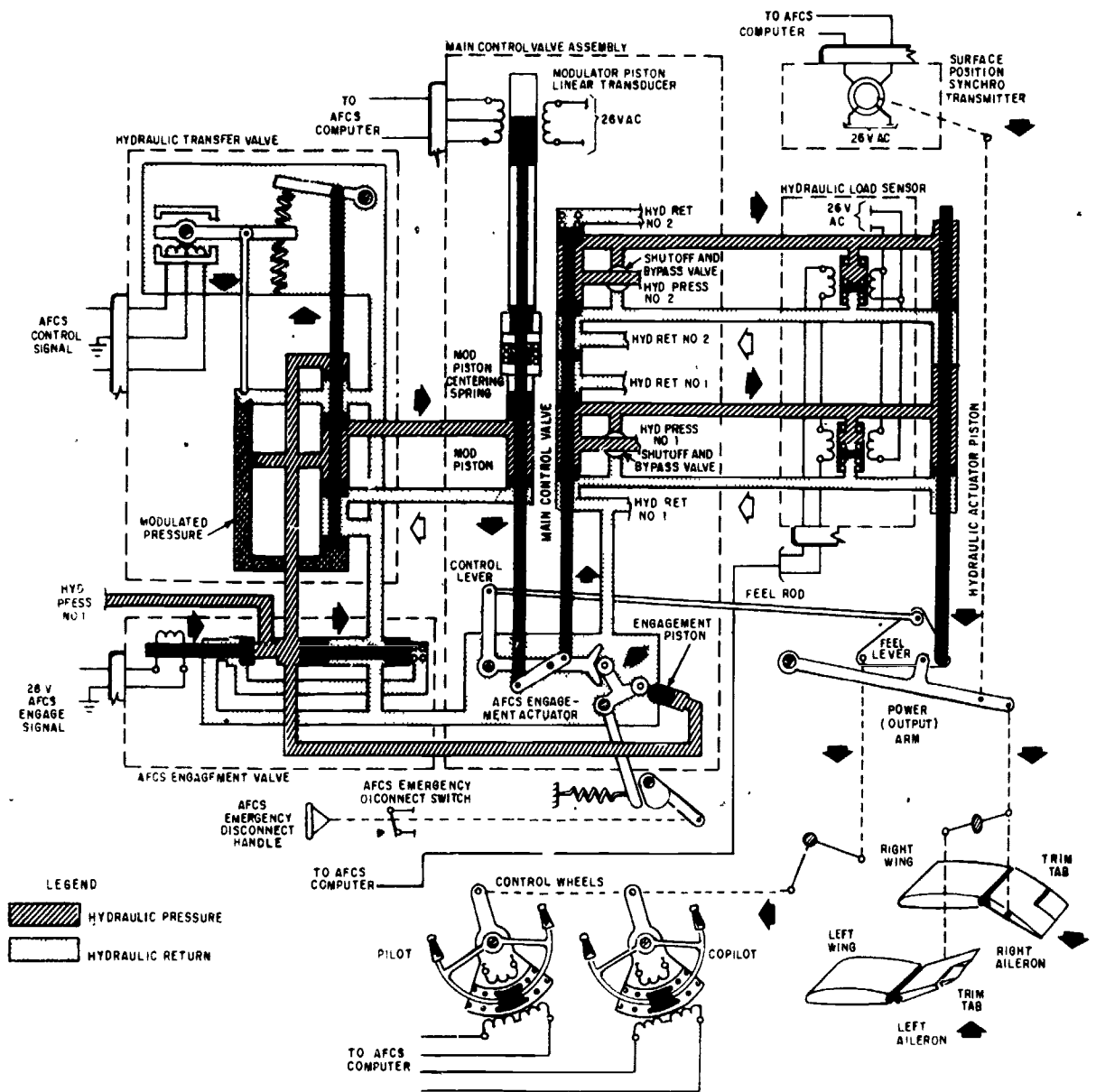

207.67

Figure 5-49.—Hydraulic surface control booster with no mechanical input and AFCS engaged.

AFCS ENGAGEMENT VALVE.—The AFCS engagement valve shown in figure 5-48 is in the disengaged or relaxed position. No voltage is supplied to the coil and 3,000-psi hydraulic pressure pushes the solenoid piston to the left, allowing the hydraulic fluid to flow to the right side of the spring-loaded piston. With the same

pressure on either side, the spring-loaded piston moves to the left, preventing any further flow in the system.

When AFCS is engaged (fig. 5-49), a 28-volt dc signal is supplied to the solenoid coil to drive its piston to the right. This action relieves hydraulic pressure from the right side of the

spring-loaded piston and pressure on the left side causes the piston to move right and compress the spring. Hydraulic pressure is then supplied to the other AFCS components of the boost system.

HYDRAULIC TRANSFER VALVE.—With AFCS engaged a dc control signal is supplied from the AFCS computer. In the static state (zero signal), dc flow through the transfer valve coils is equal, and the plunger mechanism is held in the centered position (with the aid of the centering springs).

Hydraulic pressure from the engagement valve is supplied to the top land on the hydraulic transfer valve piston. Fluid is also allowed to flow through a small orifice to the bottom land of the same piston. Pressure to the bottom of the piston is regulated by controlling the amount of fluid leaving the modulated pressure chamber. If the pressure in the chamber is 1,500 psi and one drop of fluid is allowed to leave the chamber for every drop of fluid that enters, the pressure remains constant. To increase pressure, an unbalanced dc voltage on the coil causes the plunger to block the return orifice for an instant so that more fluid enters the chamber than departs. Conversely, an unbalanced dc signal from the AFCS computer that causes the plunger to rise for an instant lowers pressure in the chamber.

With zero input signal from the AFCS computer, the transfer valve piston is in the centered position, as shown in figure 5-48 that is, the 3,000 psi acting on the smaller surface area at the upper land of the piston and the modulated pressure acting on the larger area of the lower surface of the piston are balanced and keep the piston centered.

With an electrical signal input as shown in figure 5-49 a higher pressure in the modulated chamber causes the piston to raise, allowing fluid to flow to another component of the boost system. The larger the electrical signal input, the more pressure difference on the piston and the more fluid allowed to flow.

BOOSTER SYSTEM OPERATION.—The booster operates in two separate modes—manual

and AFCS. In the manual mode, control surface deflection desired by the pilot is initiated by a lateral movement of the control wheel (fig. 5-48). This small movement of the control wheel is transmitted through the feel lever and feel rod to the control lever. The control lever is free to move about its pivot, and the modulating piston is held in place by a centering spring. Movement of the control lever displaces the main control valve to port fluid from two separate hydraulic systems to the hydraulic actuator piston. (The main control valve and hydraulic actuator work identically, whether in manual or AFCS modes.)

When the hydraulic actuator piston moves, both the feel lever and the power arm move to position the control surface and the control wheel to the position selected by the pilot. The more pressure applied to the control wheel, the faster the control surface moves. The direction in which pressure is applied determines the direction of control surface movement.

If there is no pressure applied to either control wheel, the main control valve is centered, as in figure 5-48, and trapped fluid holds the hydraulic actuator piston in its last position.

The dual shutoff and bypass valves can be operated from the flight station in the event of loss of hydraulic pressure or a malfunction in the boost system. Operation of the valves shuts off hydraulic pressure to the hydraulic actuating piston and opens both working lines to each other. This prevents a hydraulic lock in the actuator piston and allows the control surface to be moved without the aid of the boost system.

Trapped hydraulic pressure in the modulator piston aids the mod piston centering spring in holding the piston centered. This allows positive control of the main control valve by the control lever.

When AFCS is engaged, the engagement valve ports hydraulic fluid to the hydraulic transfer valve and to the engagement piston. Movement of the engagement piston locks the control lever in its centered position and prevents mechanical inputs from the control wheels. This piston can, however, be overpowered by approximately 15 pounds of force on the control wheel if necessary in an emergency.

Electrical inputs from the AFCS computer are changed to hydraulic fluid pressures in the hydraulic transfer valve and are used to control the modulator piston. The modulator piston changes the hydraulic pressure into linear mechanical motion which repositions the main control valve. Movement of the main control valve ports hydraulic fluid to the hydraulic actuator piston to position the control surface and control wheel in the manner previously described.

Electrical devices are attached to the booster to provide information inputs to the AFCS. The modulator piston linear transducer tells the AFCS the rate of movement of the control surface, and the surface position synchro transmitter provides the AFCS with position information. Automatic flight control system operation is discussed in chapter 7 of this manual.

Landing Gear System

Most naval aircraft are equipped with hydraulically actuated, electrically controlled retractable landing gear. Locking the the landing gear in either the retracted or extended position is normally accomplished automatically. Figure 5-50 is the electrical schematic of the landing gear control circuit of a patrol type naval aircraft.

CIRCUIT OPERATION.—The landing gear circuit incorporates an electrical, solenoid-operated selector valve to control hydraulic actuation of the landing gear. Current is supplied to the landing gear selector valve through two SPDT switches. These switches are actuated by a cam on the landing gear control lever, permitting current to flow to either the up or down coil of the valve, depending on the position of the control lever. The landing gear control circuit also incorporates electrical control for emergency extension of the nose gear with emergency hydraulic system power. A center-off switch (SPDT type) provides control of a double solenoid-actuated hydraulic selector valve. The center-off position of the switch is the normal position during operation of the landing gear with the main hydraulic system. The down

position selects emergency hydraulic system power for nose gear extension. The bypass position is used only during retraction of the nose gear with main hydraulic power after it has once been extended by emergency hydraulic power, and at any other time when it is desired to release emergency system hydraulic pressure.

ADDITIONAL CIRCUITS.—In some aircraft the landing gear control circuit also controls the supply of power to the propeller-reversing circuit (through left and right main torque-link switches), to the stores release circuit (through left main torque-link switch) and to the bomb-bay door control circuit (through nose gear down sense switch). The left main gear torque-link switch supplies power to energize the landing gear lever locking solenoid. The weight of the aircraft must be removed from the landing gear shock strut before the landing gear control lever may be moved away from the wheels down position. The solenoid will be deenergized by the up sense switch of the left main gear after the gear retracts; this switch energizes a relay whose normally closed contacts are in series with the solenoid circuit. The left and right main gear torque-link switches (parallel connected) are wired in series with the power to the throttle lever-locking solenoid to prevent the throttles from being placed in reverse propeller range until one of the torque-link switches is actuated (by aircraft weight compressing one or both main landing gear strut oleos). The left main landing gear torque-link switches (series connected) also open the stores release circuit so that inadvertent release of wing station external stores is prevented when the weight of the aircraft has compressed the shock strut oleo.

A solenoid is installed under the pilot's console to mechanically prevent movement of the landing gear control lever from the wheels down position when the weight of the aircraft is on the gear. When the weight of the aircraft is on the landing gear, this solenoid is deenergized (the left main gear torque-link switches are open), allowing the solenoid armature pin to protrude outboard. This position of the solenoid armature pin mechanically prevents movement of the landing gear control lever from the wheels down position to prevent retraction of the

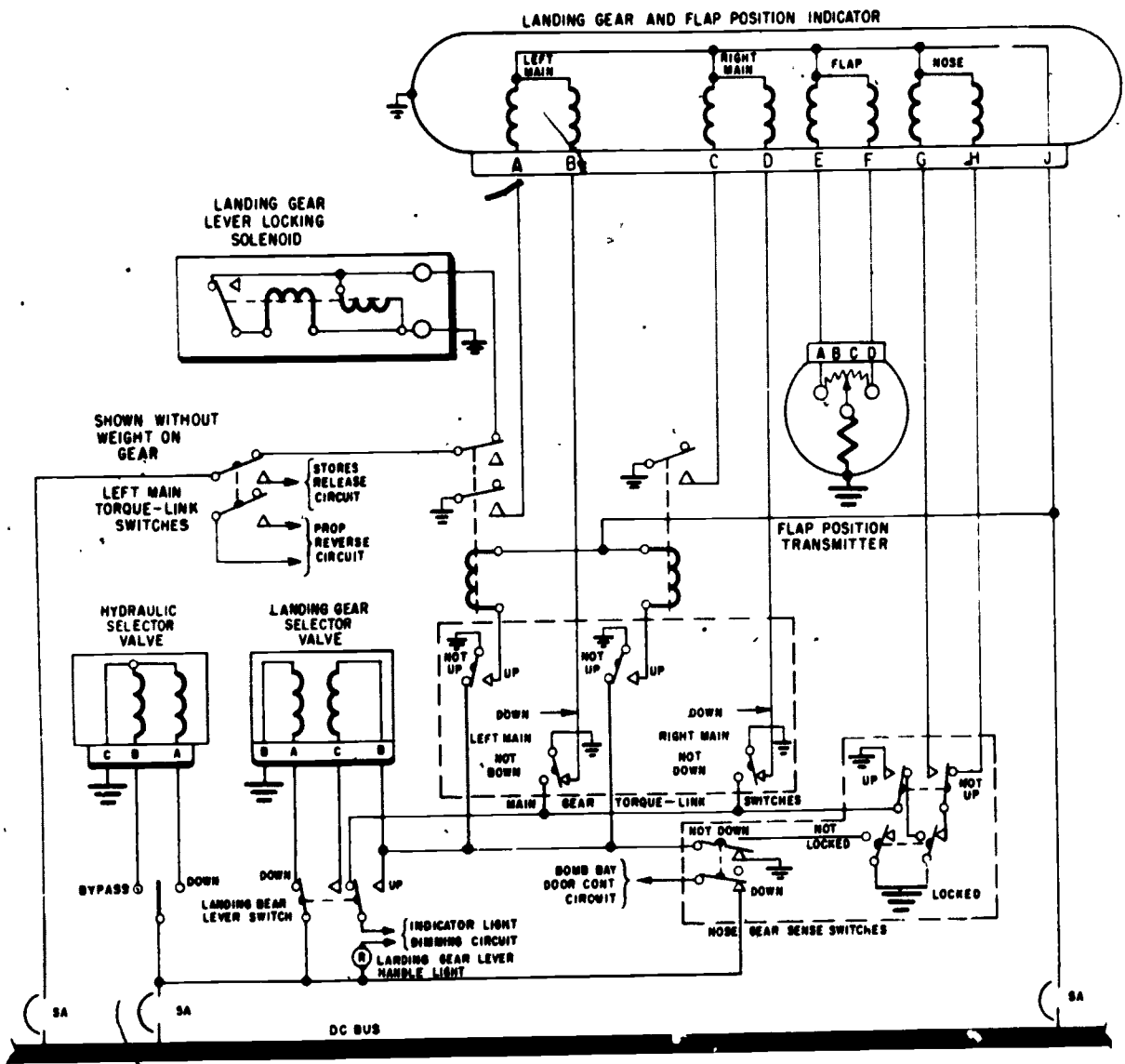

207.273

Figure 5-50.—Landing gear control circuit.

landing gear when the aircraft is on the ground. The solenoid armature pin may be depressed manually for emergency or test procedures to allow movement of the control lever.

That portion of the bomb-bay door-control circuit which is provided power through the nose gear down sense switch is used to switch power for illuminating the bomb-bay "doors-open" warning light when the bomb-bay

doors are opened with the alternate bomb-bay door switch and emergency hydraulic system power.

Arresting Gear System

The arresting gear system is used to halt the aircraft during carrier landings and emergency field arrestments. The primary component of



5-64

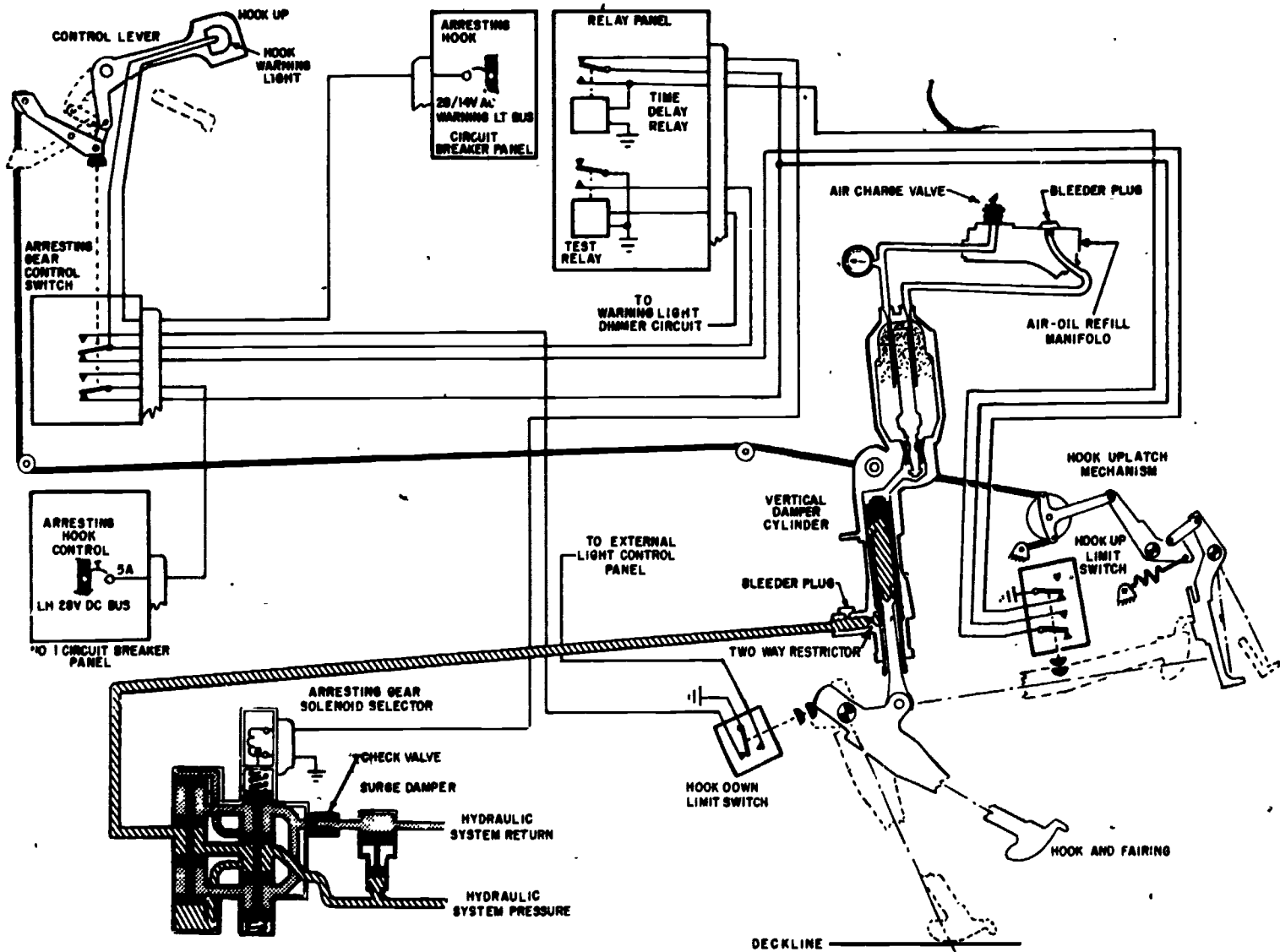

267

Figure 5-51.—Arresting gear control and indicating system.

207.68

268

AVIATION ELECTRICIAN'S MATE 3 & 2

the system is the arresting hook on the underside of the aft fuselage. The hook is pivoted at the forward end allowing up, down, and sideways motion and engages a runway or cross deck pendant when in the down position. Raising and lowering the hook is controlled by a lever in the cockpit (fig. 5-51). The lever electrically energizes a hydraulically actuated vertical damper cylinder for hook retraction and trips an uplatch mechanism through mechanical linkage for lowering the hook. Hook motion from deck impact forces is dampened by two horizontal dampers and one vertical damper. Two centering spring assemblies maintain the hook in the center position.

EXTENSION.—The arresting hook is extended by moving the control handle in the forward cockpit from the up to the down position. This removes tension from the cable and allows the uplatch mechanism to deflect to the opposite extreme of travel (aft). The arresting hook is then free to extend by action of the vertical damper cylinder and its own weight. At the same time, a switch in the control handle is actuated, deenergizing both the arresting hook relay and the selector valve solenoid, thus permitting fluid from the vertical damper cylinder to return. Return line high pressure surges, caused by hook extension, are reduced by the surge damper to prevent damage to other subsystems.

RETRACTION.—Moving the cockpit lever from the down to the up position puts tension back onto the cable, moving the uplatch mechanism forward ready to receive the arresting hook and latch it in the retracted position. At the same time the lever is moved up, a switch in the lever mechanism is actuated, allowing current to pass through the deenergized arresting hook relay to energize the solenoid of the selector valve. Hydraulic pressure is then directed to the vertical damper cylinder to raise the hook. When the hook reaches the retracted position, it actuates the up limit switch which completes the circuit to energize the arresting hook relay which, in turn, breaks the circuit to the selector valve solenoid and stops the flow of hydraulic fluid to the vertical damper. The arresting hook relay has a 1.1 second time delay

to assure that the hook is up and locked before hydraulic pressure is removed.

Nosewheel Steering System

The nosewheel steering system (fig. 5-52) is an electrically controlled, hydraulically operated system that provides a nonlinear relationship between the rudder pedals and the angular position of the nosewheel. The system provides the pilot with adequate directional control of the aircraft during ground operation. The system consists of a hydraulic steer-damper unit, a solenoid-operated shutoff valve, a command potentiometer, a steering amplifier, a steering feedback potentiometer, and an electrical control system. Electrical power to the system can be controlled through either of the ground safety switches on the left or right main landing gear, the landing gear handle switch, a pushbutton switch on the pilot's stick grip, and the rudder pedals.

The steering system is alined for steering operation when electrical circuitry to the steering system is energized. At such time, the solenoid operated hydraulic shutoff valve is opened to supply fluid to the steering actuator. Simultaneously, all related circuitry for controlling the steering servo valve is activated. The electrical section of the steering system is essentially a bridge circuit. One side of the bridge circuit is completed through the command potentiometer; the opposite side is completed through the feedback potentiometer. Output of each potentiometer is supplied to the steering system amplifier. Amplifier output currents are mixed in the coils of the hydromechanical servo valve, and the net signal actuates the servo valve that, in turn, causes nosewheel steering action.

During operation, the nosewheel steering system attempts to maintain symmetry of the electrical bridge circuit. The circuit is symmetrical when equal voltages are supplied to the amplifier from both potentiometers and the servo valve is at a null position. The bridge circuit becomes unbalanced whenever a turn request is initiated by repositioning of the command potentiometer wiper. When the bridge circuit is unbalanced, it is reflected as a current

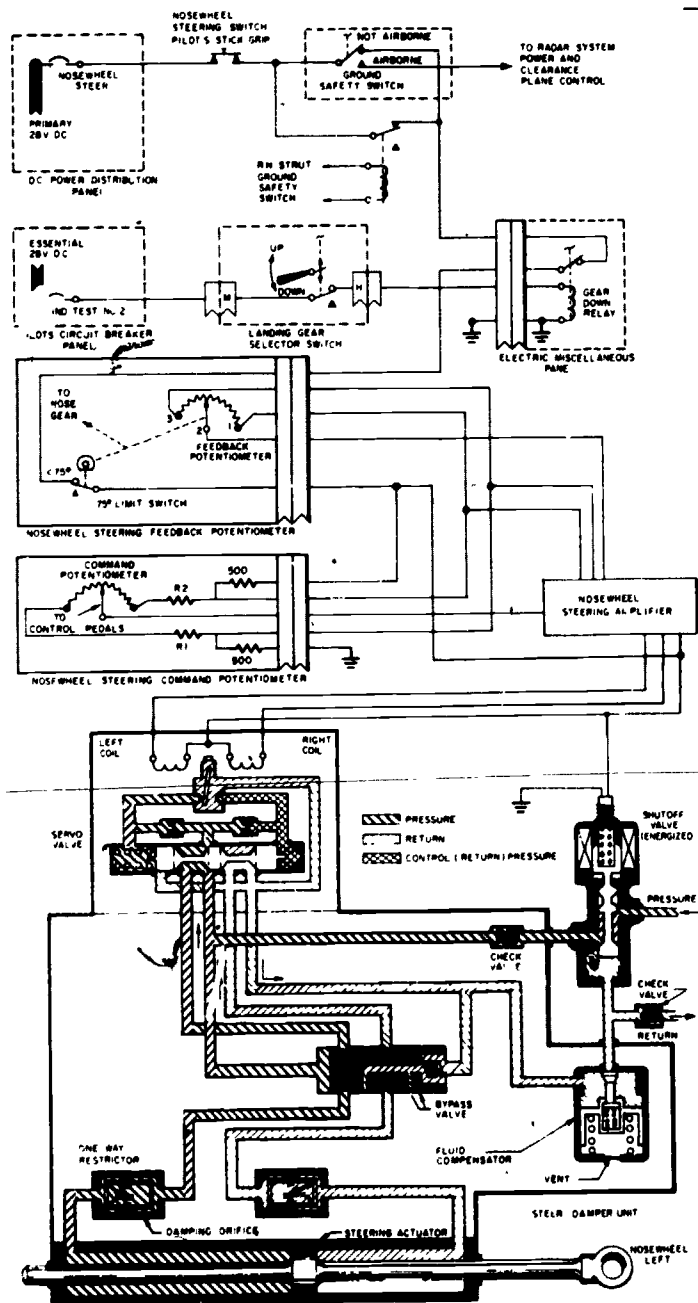

207.299

Figure 5-52.—Nosewheel steering system.

differential in the windings of the servo valve torque motor; thus, movement of the servo valve spool causes hydraulic pressure to be ported to the appropriate side of the actuator piston to cause the nosewheel to turn.

STEER-DAMPER UNIT.—The steer-damper unit is an electrically controlled, hydraulically operated package mounted on the nose gear strut assembly. The unit provides both the steering of the nosewheel and the shimmy

damping effect required. The package consists of a check valve, a servo valve, a bypass valve, two unidirectional restrictors, the steering actuator, and a fluid compensator.

The check valve prevents reverse flow from the unit to the shutoff valve. The servo valve controls the actuator position by controlling fluid flow to and from the actuator in response to signal variations from the amplifier. The bypass valve closes off the interconnecting passages between both ends of the actuator whenever hydraulic pressure is available to the unit. This permits the actuator to act as a steering unit instead of a damping unit. The unidirectional restrictors provide a restricted reverse flow to dampen nosewheel shimmy. The steering actuator is a balanced piston type hydraulic actuator which provides the force to turn the nosewheel and, in conjunction with the restrictors, provides the shimmy damper action. The fluid compensator is located in the return passage in the unit and traps a quantity of fluid at 40 to 100 psi. The compensator supplies fluid to the actuator through the bypass valve and the restrictor when the unit is being used as a shimmy damper and extra fluid is required to prevent cavitation of the actuator. Since the compensator traps fluid in the actuator, it incorporates thermal relief provisions to prevent excessive pressure buildup within the steer-damper unit.

STEERING SHUTOFF VALVE.—The steering shutoff valve is a three-way, two-position, normally closed, solenoid-operated valve. The valve controls hydraulic system pressure to the steer-damper unit. When the valve is deenergized, fluid flow is cut off from the steer-damper unit. When the valve is energized (during normal steering or arrested landings), pressure is directed to the check valve, bypass valve, and servo valve in the steer-damper unit.

STEERING COMMAND POTENTIOMETER.—The steering system uses a rotary type pedal position (command) potentiometer. This potentiometer is mechanically linked to, and driven by, the rudder pedals. It is constructed to provide a

nonlinear steering response. The potentiometer sends a signal to the nose gear steering amplifier to indicate the degree and direction of turn commanded by the pilot. Moving the potentiometer, with the steering system operating, unbalances a bridge circuit causing the steering amplifier to send a signal to the servo valve to turn the nosewheel.

STEERING FEEDBACK POTENTIOMETER.—The steering feedback potentiometer assembly consists of a potentiometer that is attached to and driven by the drive arm on the nose gear spindle. As the nose gear moves in response to the pilot's command, the feedback potentiometer feeds back a signal to the steering amplifier. When the signal from the feedback potentiometer matches the signal from the command potentiometer, the amplifier output causes the servo valve to neutralize and stop movement of the nosewheel. The feedback potentiometer assembly contains a swivel disconnect switch which opens when the nosewheel turns 75° to 80° either side of straight ahead, electrically deenergizing the circuit to prevent reverse steering or damage to the aircraft.

STEERING SYSTEM AMPLIFIER.—The steering amplifier is a small transistorized differential amplifier. The amplifier is used to detect the differential positions of the command potentiometer and the steering feedback potentiometer. Any difference in signals received results in a signal being sent to the servo valve to port hydraulic pressure to the steering actuator. This causes the nosewheel to turn and the steering feedback potentiometer to move. When the feedback potentiometer signal matches the command potentiometer signal, the amplifier causes the servo valve to be neutralized and the nosewheel to cease turning. In addition, the amplifier contains a circuit that provides a centering signal which holds the nosewheel in the straight-ahead position during an arrested landing.

OPERATION.—When the nosewheel steering switch button is depressed (fig. 5-52), power is supplied to the electrical control system and the solenoid-operated shutoff valve. As the valve

opens, hydraulic pressure is directed to the servo valve on the steer-damper unit. Signals are sent to the amplifier from the command potentiometer and from the feedback potentiometer on the steering linkage. If these signals are equal, the amplifier signals the servo valve to stay in the neutral position. If the nosewheel (and consequently the feedback potentiometer) does not correspond to the position of the rudder pedals (and command potentiometer), the signals sent to the amplifier are different, and this causes the amplifier to send a signal to the servo valve.

The signal sent to the servo valve causes the valve to be moved to port pressure to the steering actuator in the steer-damper unit. The hydraulic pressure causes the actuator to move the nosewheel (and the feedback potentiometer) to a position corresponding to the rudder pedal position (command potentiometer). When the nosewheel reaches a position corresponding to the pedal position, the signals to the amplifier are equal and the amplifier signals the servo valve to a neutral position. When the servo valve goes to the neutral position (with the steering system energized and hydraulic pressure available) both the pressure and return passages to the steering actuator are blocked off and the actuator is hydraulically locked in position. The steering actuator will remain locked in position until the servo valve is signaled to turn the wheel or hydraulic and/or electrical power is removed from the system. Whenever the steering system is not being used, the steer-damper unit performs the functions of a shimmy damper. Shimmy damping is performed by trapping hydraulic fluid on both sides of the steering actuator piston and forcing this fluid from one side of the actuator to the other side through the restrictor.

Catapulting System

The catapulting system (fig. 5-53) provides catapult handling and attachment capabilities for carrier operations. The system consists of a catapult launch bar, a launch bar actuating cylinder and gimbal, swivel joints, a cockpit controlled selector valve, leaf centering spring, leaf retracting springs, and a catapult tension bar socket. The launch bar is swivel mounted on the

forward side of the nose gear outer cylinder and may be extended and retracted during taxiing. The launch bar is automatically retracted after catapulting. A launch bar warning light on the main instrument panel comes on any time the launch bar control switch is in EXTEND, the selector valve is in bar extend position (solenoid A energized), the launch bar is not up and locked with weight off the landing gear, or the launch bar control switch is in RETRACT and the launch bar actuator is not up and locked. Accessories for the catapulting system include a tension bar and a catapult holdback bar. The catapult tension bar socket is mounted on the nose gear axle beam and provides for attachment of the tension bar for tensioning the aircraft prior to catapulting.

OPERATION.—Placing the launch bar control switch in EXTEND completes a power circuit through the weight-on-gear position of the weight-on-gear switch, applying 28 volts dc to the launch bar selector valve extend solenoid (solenoid A). A power circuit is also completed through closed contacts of the launch bar valve position switch to apply 28 volts dc to the launch bar warning light, which comes on and remains on as long as the switch is in EXTEND. When the selector valve actuates to direct hydraulic pressure to extend the launch bar actuator, a plunger on the end of the valve mechanically actuates the launch bar valve position switch. The actuated switch completes a parallel circuit to the warning light. If the control switch is placed in OFF, with weight on the landing gear, the warning light should go off. If the control switch is placed in RETRACT, the warning light should come on until the launch bar is up and locked. If the light remains on, the selector valve has failed to cycle from the bar extend position, and pressure is still on the extend side of the launch bar actuator.

The hydraulic pressure applied to the launch bar actuator unlocks locking fingers inside the actuator and extends the actuator to lower the launch bar. As the locking fingers unlock, they close the contacts of the launch bar up-lock switch mounted inside the actuator. After catapulting, the weight-on-gear switch is actuated to the weight-off position. This applies

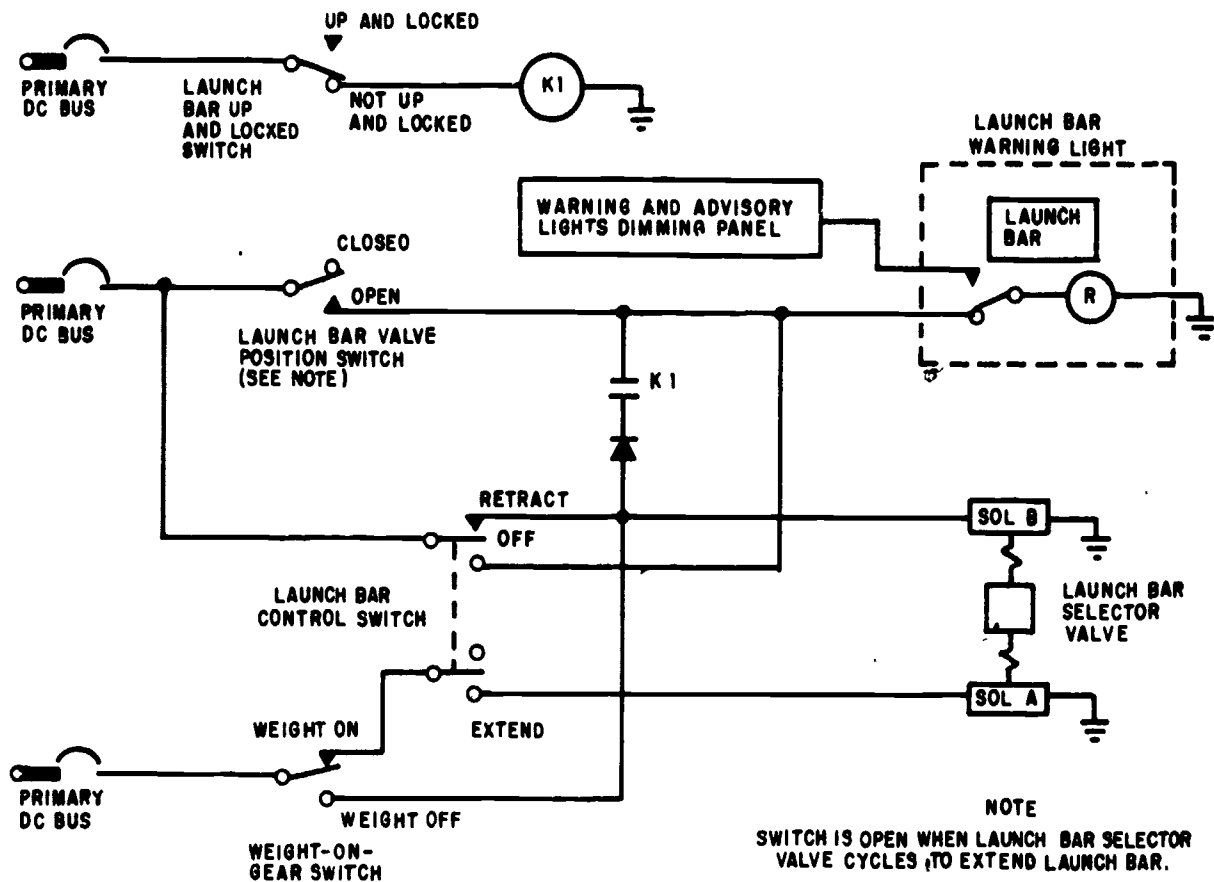

Figure 5-53.—Catapulting system control and indicating system.

207.72

28 volts dc to the launch bar selector valve retract solenoid (solenoid B) and to the launch bar warning light through the energized contacts of relay K1. K1 is energized until the launch bar is up and locked. Application of 28 volts to the launch bar selector valve retract solenoid provides automatic hydraulic retraction and locking of the launch bar after catapulting. The launch bar actuating cylinder, locking in the fully retracted position, deenergizes K1 thereby turning off the launch bar warning light. The approach light circuit is completed through deenergized relay K1, giving an additional indication that the launch bar is up and locked.

To retract the launch bar hydraulically, the launch bar control switch is placed and held in

RETRACT. This completes a power circuit to apply 28 volts dc to the launch bar selector valve retract solenoid (solenoid B). The energized selector valve directs hydraulic pressure to retract the launch bar. The control switch returns to OFF when released, deenergizing the selector valve.

Speed Brake System

Speed brakes are hinged moveable control surfaces used for reducing the speed of aircraft. Some manufacturers refer to them as DIVE BRAKES, others call them DIVE FLAPS. On some aircraft they are hinged to the sides or bottom of the fuselage, on others they are attached to the wings. Regardless of their

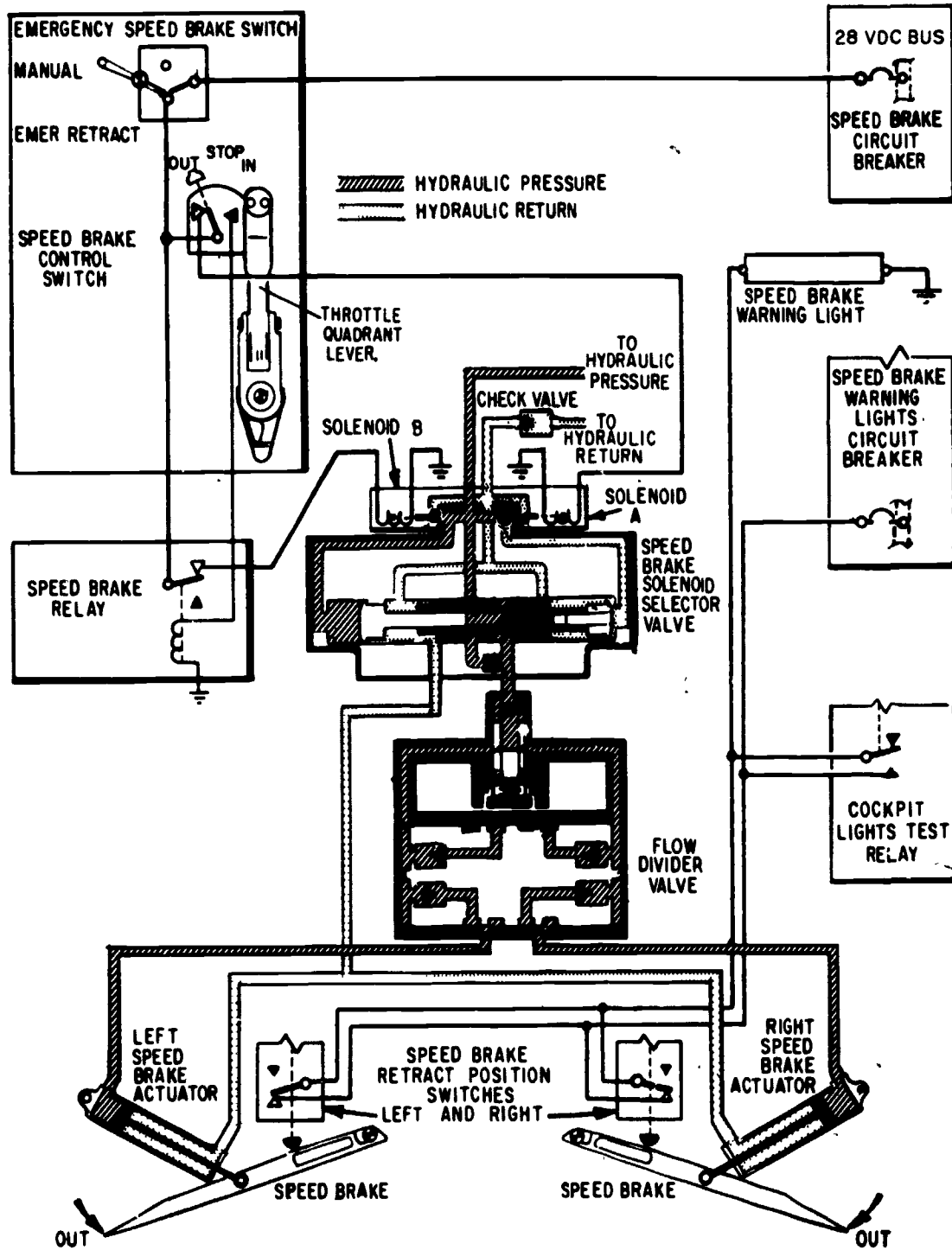

Figure 5-54.—Speed brake system.

207.295

5-70.

location, speed brakes serve the same purpose on all aircraft on which they are used. Their primary purpose is to keep the speed from building up too high in dives. They are also used in slowing down the speed of the aircraft preparatory to landing. Speed brakes are electrically controlled, hydraulically operated. Fig. 5-54 depicts a typical speed brake system.

EXTENSION.—The speed brakes are extended by placing the speed brake control switch (located on the throttle lever grip) to the OUT position. The OUT position is a momentary-contact position, the switch being spring-loaded to return to STOP when released. Holding the control switch in the OUT position energizes both selector valve solenoids (solenoids A and B), connecting hydraulic pressure to the extend side of the actuators and connecting the return to the retract side of the actuators. Any desired position of the brakes may be attained and is held by a "hydraulic lock" within the selector valve. The speed brake out warning light illuminates when either the left or right speed brake is not fully retracted. The warning light circuit is completed through either the left or right speed brake retract position switch.

NOTE Figure 5-54 shows the speed brake control switch being held in the OUT position, thus allowing hydraulic pressure to be ported to the extend side of the speed brake actuators, forcing the speed brakes to the extend position.

RETRACTION. In normal operation, the speed brakes are retracted by moving the speed brake control switch to the IN position. This deenergizes solenoid A by removing the power to the solenoid and energizes the speed brake relay. The action of the speed brake relay removes the power from solenoid B.

With both selector valve solenoids deenergized, the selector valve permits pressure flow to the retract side of the speed brake and return flow from the extend side to the hydraulic return. The speed brake warning light goes out when both speed brakes are fully retracted.

EMERGENCY RETRACTION.—The speed brakes can be retracted by placing the

emergency speed brake switch in the EMER-RETRACT position. This switch deenergizes solenoids A and B of the selector valve (normal solenoid positions for retracting the speed brakes) by connecting both the extend and retract sides of the speed brake actuators to the system return. Thus, hydraulic pressure is removed and the speed brakes are forced shut by the airstream. This action is necessary only if the speed brake relay does not energize when the speed brake control switch is placed in the IN position. If an electrical failure (e.g., popped circuit breaker) occurs with the speed brakes extended, retraction is the same as if the emergency retract switch had been actuated.

Canopy System

As previously stated, solenoid valves are used in many applications in naval aircraft. The hydraulic system shown in figure 5-55 (canopy system for A6 aircraft) is another illustration of an electrohydraulic system employing a solenoid selector valve. The canopy selector valve is a four-way, two-position spool valve, which is actuated either electrically or manually.

The canopy system consists of a sliding canopy mounted over the cockpit area and the components required for normal operation and emergency jettison of the canopy. The entire system is hydraulically operated with the exception of the electrical canopy jettison device. Hydraulic power for operation of the canopy is furnished by either the combined hydraulic system or the hand pump system.

When the canopy switch is in the CLOSE position, a circuit is completed from the 28-volt dc bus through the control circuit breaker to a terminal on the isolation switch. Current flows from the terminal, through the closed contacts of the canopy switch, to solenoid 2 of the canopy selector valve; the selector valve then energizes to the close position, and hydraulic pressure from either the combined hydraulic system or the hand pump system flows through the selector valve into the canopy close line. Pressure delivered through a flow regulator to the rod end of the canopy actuating cylinder causes the piston and rod to retract and close the canopy.

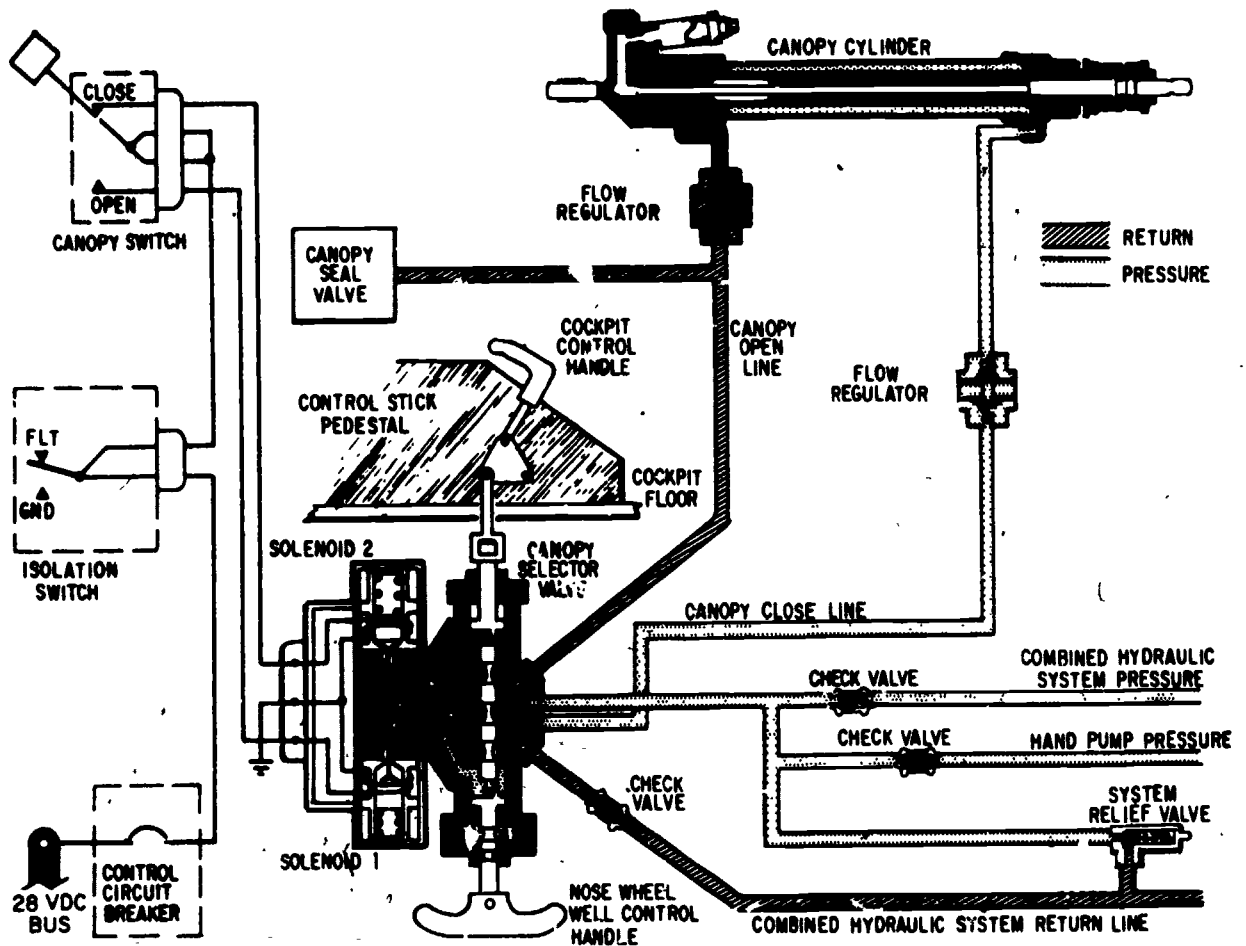

207.296

Figure 5-F5.—Canopy system.

When the canopy switch is in the OPEN position, a circuit is completed from the 28-volt dc bus through the control circuit breaker, the isolation switch terminal, the opposite contacts of the canopy switch, to solenoid 1 of the canopy selector valve. The selector valve energizes to the open position, reversing the sequence of pressure and return flow. Hydraulic pressure flows through the canopy open line to the canopy seal valve and hydraulically trips the seal valve, dumping the air pressure in the canopy seal and allowing the seal to deflate. Pressure in the canopy open line continues its flow through a flow regulator to the backhead end of the cylinder, causing the cylinder to extend, opening the canopy. Hydraulic fluid in

the opposite end of the cylinder is released through the canopy close line to the selector valve, across the valve, and into the return flow line of the combined hydraulic system. Fluid is then returned to the main reservoir of the system.

For canopy jettison, (fig. 5-56), a firing circuit is initiated by the emergency canopy jettison switch in the cockpit, or by either of the two emergency outside jettison switches. Closing any of the three switches completes the circuit direct to the electrically fired canopy jettison cartridge on the backhead end of the canopy cylinder. The cartridge discharges through the canopy cylinder, causing the canopy to be jettisoned.

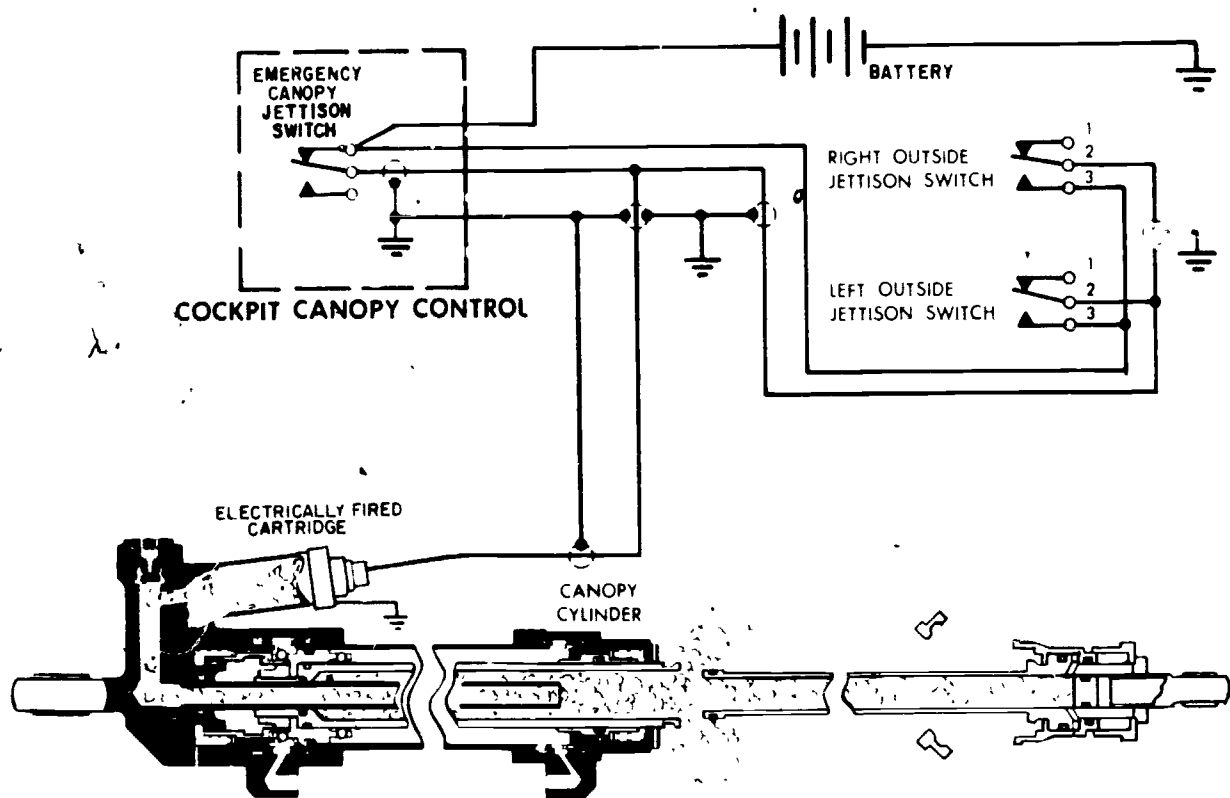

207.297

Figure 5-56.—Canopy jettison.

PNEUMATIC POWER SYSTEM

The pneumatic power system supplies compressed air for various normal and emergency pneumatically actuated systems. The compressed air is stored in storage cylinders in the actuating systems until required by actuation of the system. These cylinders and the power system manifold are initially charged with compressed air or nitrogen from an external source via a single air charge valve. In flight, the air compressor replaces the pressure and volume lost through leakage, thermal contraction, and actuating system operation.

The air compressor is supplied with supercharged air from the engine bleed air system. This insures an adequate supply of air to the compressor at all altitudes.

The air compressor may be driven by an electric motor or by a hydraulic motor. The system described in this chapter is hydraulically driven. (See fig. 5-57.)

System Operation

The aircraft hydraulic system provides power to operate the hydraulic-motor-driven air compressor. The air compressor hydraulic actuating system consists of a solenoid-operated selector valve, flow regulator, hydraulic motor, and motor bypass line check valve. When energized, the selector valve allows the system to be pressurized and run the hydraulic motor; when deenergized the valve blocks off hydraulic pressure, stopping the motor. The flow regulator, compensating for the varying hydraulic system flow and pressures, meters the flow of fluid to the hydraulic motor to prevent

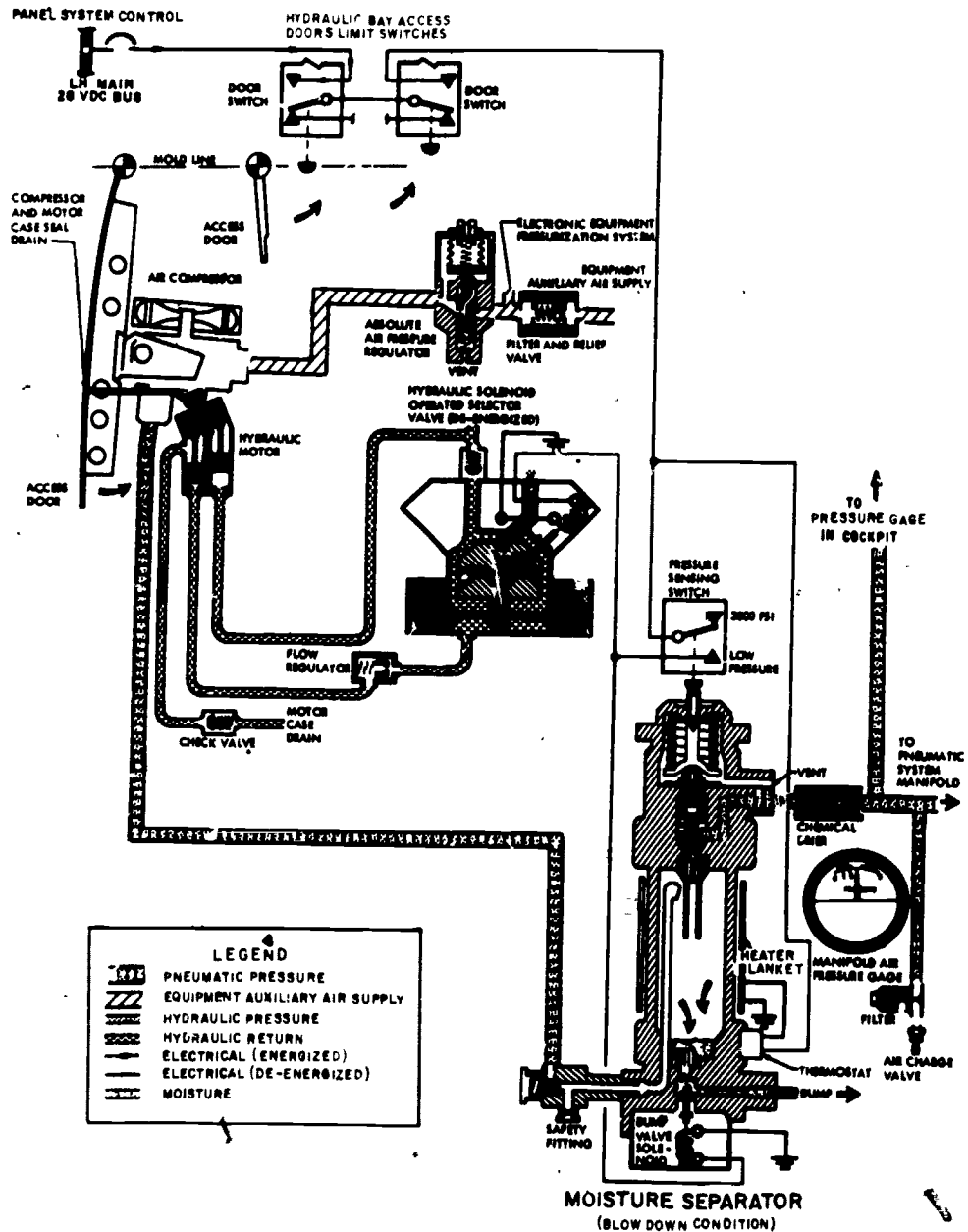

Figure 5-77.—Pneumatic system.

207.300

excessive speed variation and/or overspeeding of the compressor. A check valve in the motor bypass line prevents system return line pressure from entering the motor and stalling it.

The air compressor is the pneumatic system's pressurizing air source. The compressor is activated or deactivated by the manifold

pressure sensing switch which is an integral part of the moisture separator assembly.

The moisture separator assembly is the pneumatic system's pressure sensor-regulator and relief valve. The manifold pressure switch governs the operation of the air compressor. When the manifold pressure drops below 2,750

psi the pressure sensing switch closes, energizing the separator's moisture dump valve and the hydraulic selector valve, activating the air compressor. When the manifold pressure builds up to 3,150 psi the pressure sensing switch opens, deenergizing the hydraulic selector valve to deactivate the air compressor and dump valve. The deactivated dump valve vents overboard any moisture accumulated in the separator. The separator is equipped with a thermostat and heating element. The thermostatically controlled wrap-around blanket type heating element prevents freezing of moisture within the reservoir in low-temperature atmospheric conditions.

The safety fitting, installed at the inlet port of the moisture separator, protects the separator from internal explosions due to hot carbon particles or flames that may be emitted from the air compressor.

A chemical drier further reduces the moisture content of the air emerging from the moisture separator.

An air charge valve provides the entire pneumatic system with a single external ground servicing point. An air pressure gage, located near the air charge valve, is used in servicing the pneumatic system. This gage indicates the manifold pressure.

An air filter in the ground air charge line prevents the entry of particle impurities into the system from the ground servicing power source.

AIRCRAFT ENVIRONMENTAL SYSTEMS

The proper operation of today's aircraft requires maintaining a proper environment not only for personnel but also for certain types of equipment on board. Similarities exist in the electronic equipment used to control these systems and the components used within these systems.

The environmental systems on most aircraft include cockpit/cabin air conditioning and pressurization, equipment cooling, windshield anti-icing and defogging, and equipment pressurization systems. On some aircraft

equipment, cooling is provided by teeing off with ducting from the cockpit/cabin system, other aircraft will utilize a separate system for cooling equipment. These systems are not usually the exclusive responsibility of the AE, but rather are the responsibility of other ratings with the AE assisting in their maintenance.

TERMS AND DEFINITIONS

The system which maintains cabin air temperatures to meet the requirements for pilot efficiency is the air-conditioning system. The sources of heat which make cabin air conditioning necessary are:

1. Ram air temperature.
2. Engine heat.
3. Solar heat.
4. Electrical heat.
5. Body heat of personnel.

Ram air temperature is the frictional temperature increase created by ram compression on the skin surface of an aircraft. This factor becomes serious only at extreme airspeeds. For example, if an aircraft were flying at 45,000 feet and at a speed of 1,200 mph, the ram air temperature would be about 2,000°F on some parts of the aircraft. This extreme temperature plus the heat from other sources would cause cabin temperature to rise to about 190°F. The maximum temperature that a crewman can endure and still maintain top physical and mental efficiency is about 80°F. Prolonged exposure to a temperature greater than 80°F will seriously impair his mental and physical abilities. Furthermore, under low-speed operating conditions at low temperature, cabin heating may be required.

It is necessary to become familiar with some terms and definitions in order to understand the operating principles of air-conditioning systems. (NOTE: Some of the terms were discussed in chapter 2, Elementary Physics. Although they are briefly defined in this chapter, a review of

chapter 2 will be beneficial.) Terms and definitions relative to temperature control are:

1. Absolute temperature—Temperature measured along a scale which has zero value at that point where there is no molecular motion (-273.1°C or -459.6°F).

2. Adiabatic—A word meaning no transfer of heat. The adiabatic process is one in which no heat is transferred between the working substance and any outside source.

3. Ambient temperature—The temperature in the area immediately surrounding the object under discussion.

4. Ram air temperature rise—The increase in temperature created by the ram compression on the surface of an object traveling at high speed through the atmosphere. The rate of increase is proportional to the square of the speed of the object.

5. Temperature scales:

a. Celsius (C)—A scale on which 0° represents the freezing point of water, and 100° is equivalent to the boiling point of water at sea level.

b. Fahrenheit (F)—A scale on which 32° represents the freezing point of water, and 212° is equivalent to the boiling point of water at sea level.

TEMPERATURE CONTROL

Hot, high-pressure air comes from a compressor, such as a supercharger, or the compressor section of a jet engine. The temperature of the bleed air delivered to the pressurizing and air-conditioning system is 300° to 800°F . The pressure of this air is from 75 to 250 psi. The temperature of this air being delivered to the cabin must be reduced to the point where crewmember efficiency is not impaired.

Most current aircraft require cabin or cockpit air pressure and temperature control because of the extreme speeds and altitudes at which they operate. The cabin air-conditioning and pressurization system supplies conditioned air for heating and cooling the cockpit and crew spaces. This air also provides cabin

pressurization to maintain the crewmembers in a safe, comfortable environment. In addition to cabin air conditioning, some aircraft equipment and equipment compartments require air conditioning to prevent heat buildup and consequent damage to the equipment.

NOTE: The term air conditioning as used in this manual can mean either heating or cooling, so each use of the term must be considered in the context in which it appears.

The majority of the air-conditioning systems installed in modern aircraft utilize air turbine refrigerating units to supply cooled air. These are called air cycle systems. One model aircraft, the E-2, utilizes a compressed gas cooling system for cooling of electronic equipment and electronic compartments; the refrigerating unit is quite similar in operation to a common household refrigerator. Systems utilizing this refrigeration principle are called vapor cycle systems.

ENVIRONMENTAL SYSTEM COMPONENTS

AEs must have a working knowledge of how all of the system components function; they must also be thoroughly familiar with the circuitry controlling these components.

Primary Heat Exchanger

The primary heat exchanger (located in the air-conditioning unit) is the first stage of cooling for the hot bleed air coming from the engine. (See fig. 5-28.) The heat exchanger is similar to an automobile radiator in that the hot air travels through metal cores in the same manner as water travels through an automobile radiator core. Also, cold ram air passes over the primary heat exchanger core in much the same manner as air is pulled through the automobile radiator by the fan; this is called air-to-air cooling. The flow route of the cold ram air is determined by the ambient air shutoff valve. With the valve in the closed position, the cold ram air is directed through the primary heat exchanger, thereby allowing maximum cooling of the hot air passing through the primary heat exchanger core; with

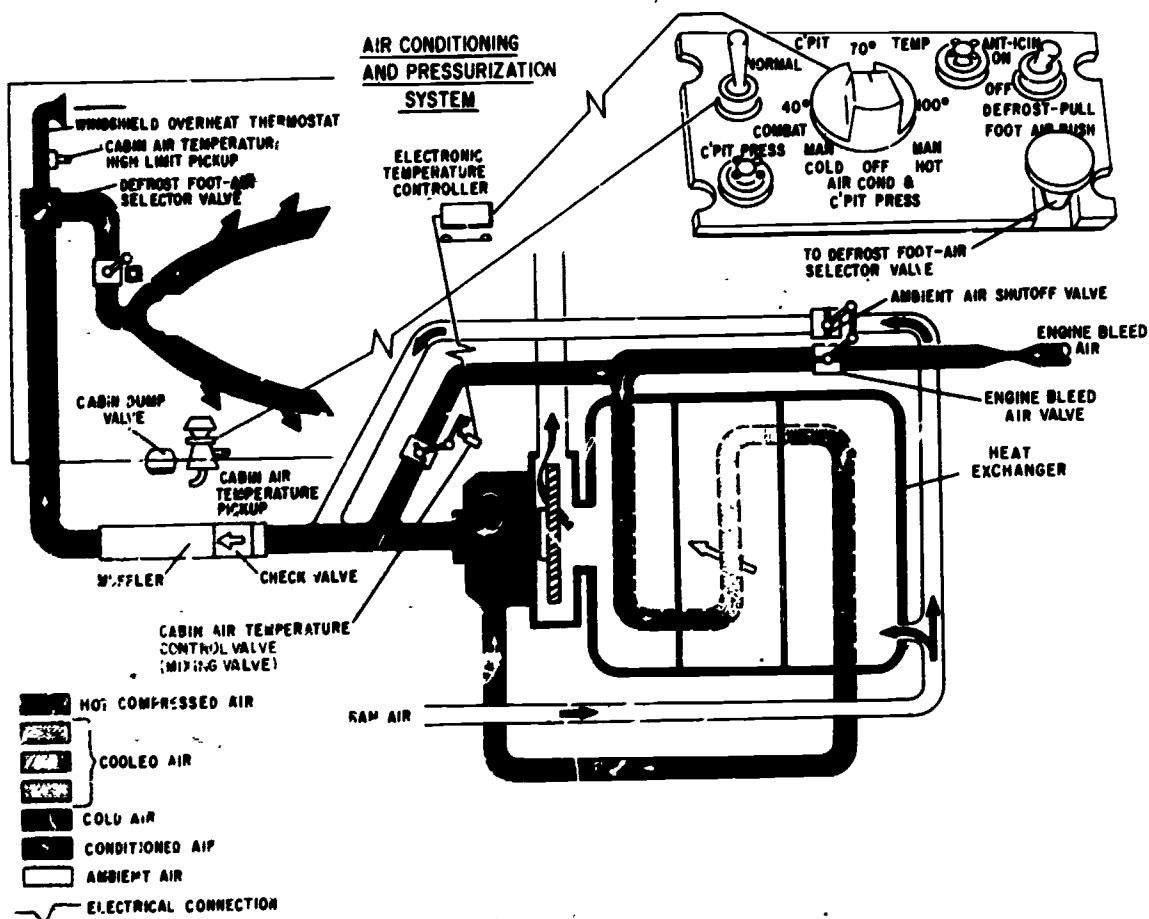

207.255

Figure 5-58.—Cabin pressurization and air-conditioning system.

the ambient air shutoff valve open, there is no air-to-air cooling because the ram air bypasses the heat exchanger and is routed directly to the cabin. Note that the engine bleed air valve is geared to the ambient air shutoff valve so that when the ambient air shutoff valve is open the bleed air valve is closed.

The position of the mixing valve (cabin air temperature control valve) is controlled by an electric motor. This motor is controlled either manually or automatically. In the manual mode, the pilot has direct control of the mixing valve through the temperature control switch; in the automatic mode, the mixing valve is controlled by a bridge and amplifier circuit. This automatic system has control of the mixing valve when the

cockpit air temperature switch is placed in any position between 40° and 100°.

In some installations where the air coming from the primary heat exchanger is not cooled sufficiently, a second heat exchanger is required to increase the efficiency of refrigeration; such units are called secondary heat exchangers.

Secondary Heat Exchanger

The secondary heat exchanger is the next stage for cooling the warm air that leaves the primary heat exchanger. Figure 12-2 shows an aircraft refrigeration unit. This unit is a typical secondary heat exchanger.

Some installations use more than one secondary heat exchanger. These secondary exchangers also operate on the principle of air-to-air cooling. The final stage of cooling will always employ the adiabatic process in which no heat is transferred to or from a working substance. That is, the final cooling of cabin air is accomplished by means of rapid expansion, rather than by exchange of heat.

The warm air from the primary heat exchanger enters the cabin air inlet (fig. 5-59). The inlet air passes through metal cores just as it did in the primary heat exchanger. At the same time, cooling air flows over the metal cores and again cools the cabin air by the air-to-air process. As the cooled cabin air leaves the cores, it is routed into an expansion turbine section. The cooling turbine utilizes the principle of cooling-by-expansion; rapid expansion causes cool air to become still cooler. The cooling-air discharge impeller, driven by the expansion turbine, boosts the flow of cooling air through the heat exchanger, thus increasing the efficiency of the refrigeration unit.

The Aviation Structural Mechanic (E) is responsible for the maintenance and installation

of heat exchangers, turbines, ducting, and various mechanical valves. The Aviation Electrician is required to troubleshoot and maintain the electrical controlling features of the pressurization and air-conditioning system; however, the importance of the AE and AME working together must be realized.

Mixing Valve

The mixing valve is enclosed in an aluminum alloy housing and is actuated by an electric motor. This valve is a modulating type and serves as a means of proportioning the hot engine bleed air to the refrigerated air from the heat exchanger (fig. 5-58). Its operation depends on a butterfly valve connected to the motor by a mechanical gear assembly (fig. 5-60).

The motor that actuates the mixing valve is a split-field, dc type motor, equipped with a magnetic brake. Contacts inside the motor housing break the circuit to the motor when the actuator is either in the fully opened or fully

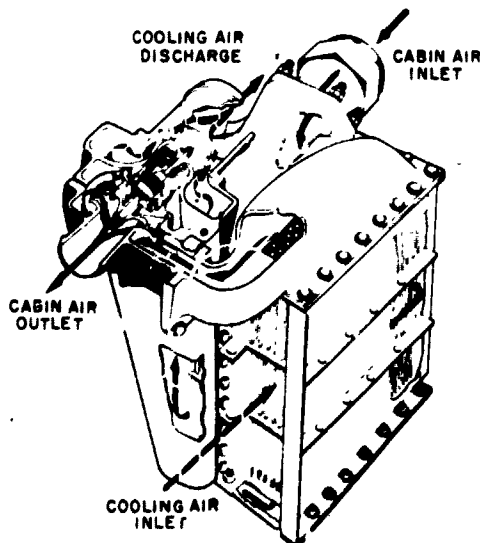

207.256

Figure 5-59.—Typical aircraft refrigeration unit.

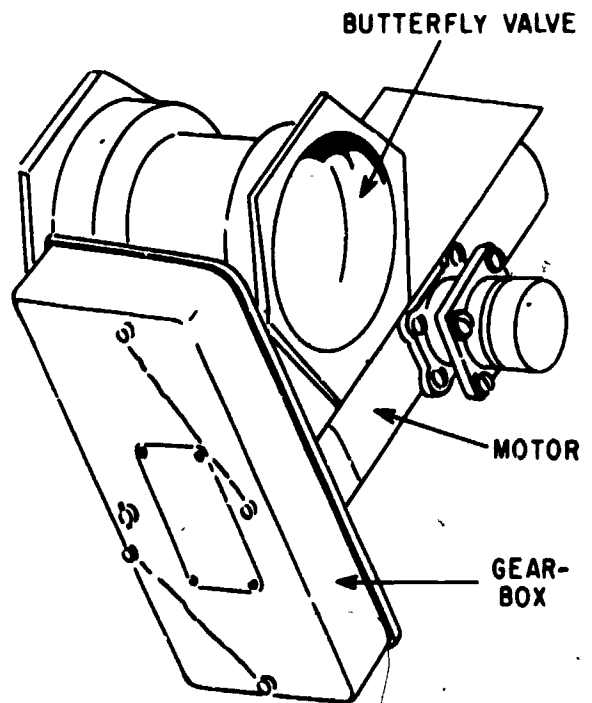

207.257

Figure 5-60.—Mixing valve.

closed position. The reason for this is to prevent overloading the motor.

The mixing valve is operated according to the demands of the cabin temperature control unit which keeps the temperature of the air delivered to the cabin within specified limits.

In some installations, the mixing valve may be identified by other names; for example, cabin air temperature control valve, bypass valve, modulating valve, or proportioning valve. All of these perform the same function and operate on the same principle.

ELECTRONIC CABIN TEMPERATURE CONTROL SYSTEM

Operation of the electronic temperature control system is based primarily on the balanced bridge circuit principle. When any the "legs" of the bridge change resistance due to a temperature change, the bridge circuit becomes unbalanced. An electronic regulator receives an electrical signal as a result of this unbalance and amplifies this signal to control the mixing valve actuator.

In a typical application of the electronic temperature control system, three units are utilized:

1. The electronic regulator.
2. The manual temperature selector.
3. The cockpit temperature pickup unit (thermistor).

Figure 5-61 shows a simplified schematic diagram of an electronic temperature control system. Figure 5-62 shows a cutaway of the thermistor temperature pickup unit.

Cockpit Temperature Pickup Unit

The cockpit temperature pickup unit (temperature sensing unit) is a resistor (thermistor) that is highly sensitive to temperature changes and is usually located in the cockpit or cockpit air supply duct. As the temperature of the air supply changes, the resistance value of the pickup unit also changes, thus causing the voltage drop across the pickup

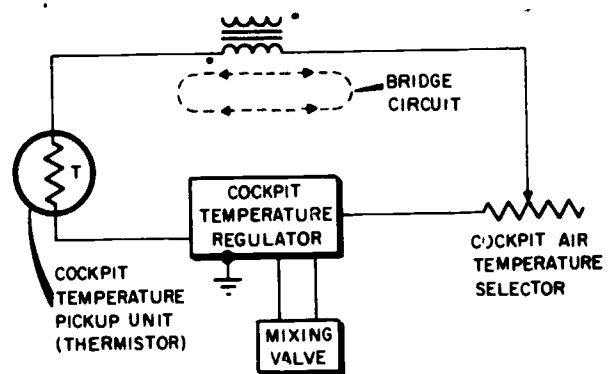

207.258

Figure 5-61.—Electronic air temperature control system (simplified).

to change. This thermistor has a negative temperature coefficient; therefore as the temperature of the resistance bulb increases, the resistance of the bulb decreases. This is shown in the graph in figure 5-63.

Cockpit Air Temperature Selector

The air temperature selector (fig. 5-61) is a rheostat located in the cockpit and controlled by the pilot. It permits selective temperature control by setting the effective control point of the temperature pickup unit. The rheostat

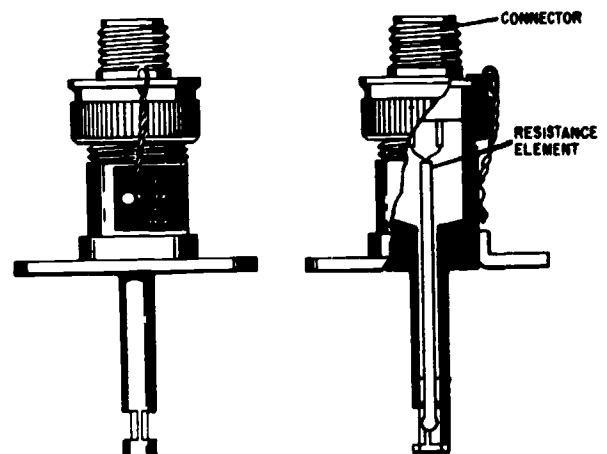

207.259

Figure 5-62.—Temperature pickup unit.

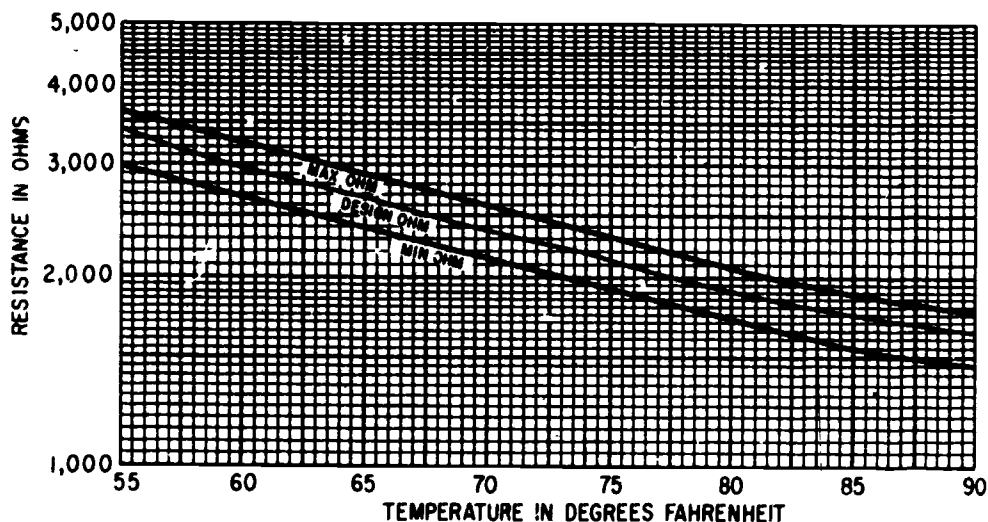

Figure 5-63.—Resistance-temperature graph.

207.260

causes the pickup unit to demand a specific temperature of the supply air

Cockpit Air Temperature Control Regulator

The cockpit temperature regulator, in conjunction with the temperature selector rheostat and the temperature pickup unit, automatically maintains the air entering the cockpit at a preselected temperature. The regulator is an electronic device with a temperature regulating range which, depending upon the installation requirement, may extend from as low as 32°F to as high as 117°F.

The output of the regulator controls the position of the butterfly in the mixing valve (fig. 5-60), thus controlling the temperature of the inlet air to the cockpit.

Figure 5-64 shows an electrical schematic of a typical air temperature control system. In a typical system, there is one switch located in the cockpit to select the mode of temperature control. This switch has three stationary positions—OFF, MAN HOT, and MAN COLD—and a variable position between 40° and 100°. In the OFF position, the temperature

control system is inoperative. With the switch in the 40° to 100° range, the temperature control system is in the automatic mode. With the switch in either the MAN HOT or MAN COLD position, the temperature control system is in the manual mode.

1. OFF position—With the temperature switch in the OFF position, the pilot has no control of the air temperature. The air may become very cold, because the ambient air shutoff valve is open and the engine bleed air valve is closed.

2. MANUAL position—In the manual mode, the pilot can change the position of the butterfly valve by selecting MAN HOT or MAN COLD. This sends direct current to the hot-field or cold-field winding of the actuator. When the pilot uses this mode, he should return the control switch to the automatic range after the system begins delivering the desired rapid change of temperature. Long periods of rapid temperature change are not usually needed.

3. AUTOMATIC position—In the automatic mode, the control switch positions the rheostat in the bridge circuit between 40°F and 100°F, allowing the mixing valve motor to be controlled by the regulator

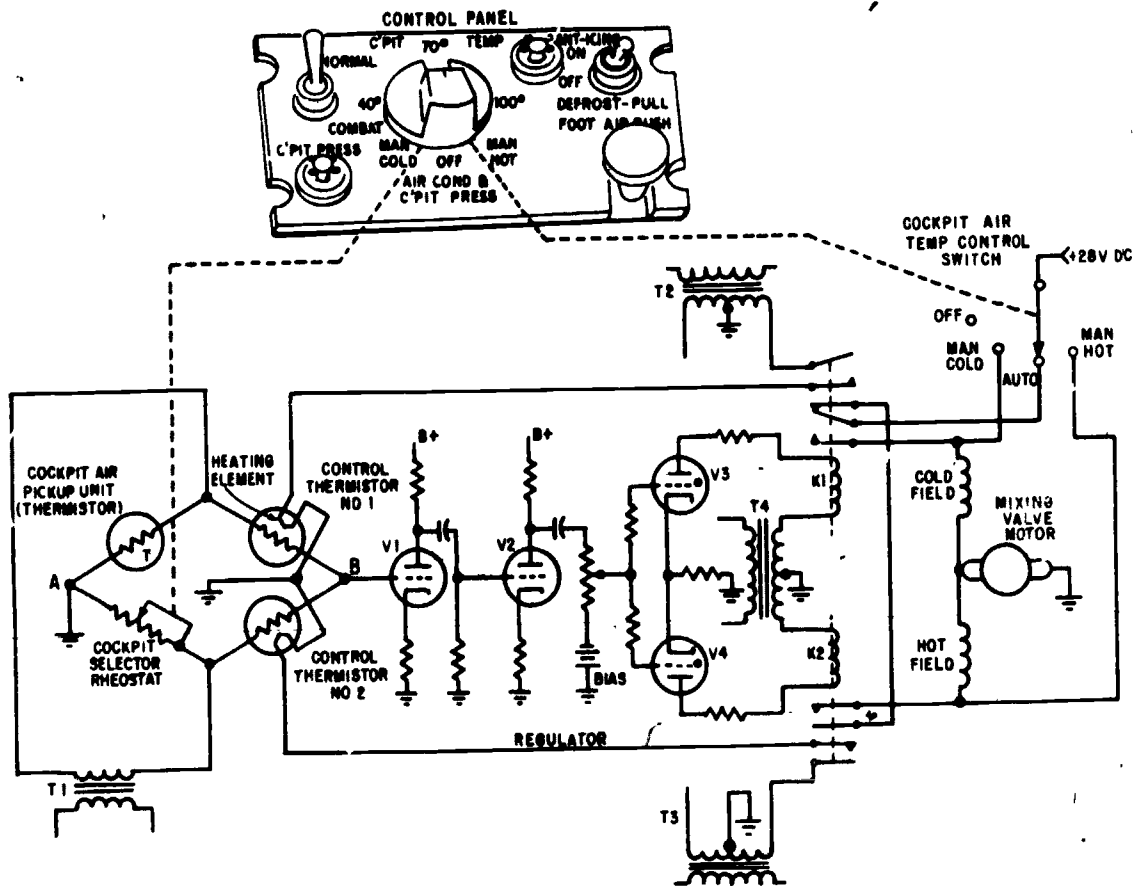

207.261

Figure 5-64.—Air temperature control system (simplified).

Electronic Temperature Control Regulator

The cockpit selector rheostat and the cockpit air pickup unit (thermistor) determine the direction and amount of rotation of the mixing valve motor. This function is controlled in the cabin air temperature regulator. The cockpit selector rheostat and the cockpit air pickup unit (fig. 5-64) are connected into a bridge circuit which includes two thermistors that are located in the regulator.

The bridge circuit is energized by an ac source (T1). If the resistance of the pickup unit and the selector rheostat were equal, then points A and B would have no potential difference.

Note that points A and B are the signal reference points for V1 (grid and cathode). If the air temperature increases, the resistance of the pickup unit decreases, since the flow of the air passes over the pickup unit. This decrease in resistance of the pickup unit causes the voltage developed across the pickup unit to decrease, resulting in a potential difference between points A and B.

This signal, which is impressed on the grid of V1, goes through two stages of voltage amplification (V1 and V2). The amplified signal is applied to the grids of the two thyatron tubes (V3 and V4). The thyatron tubes are used for signal phase detection. If the signal on the grid of V3 is in phase with the signal on the plate, V3

will conduct, causing current to flow through the coil of relay K1, closing its contacts.

One set of contacts completes a circuit for direct current flow to the cold-field coil of the mixing valve motor. This directs more hot air into the refrigeration outlet duct, thereby cooling the cockpit air. At the same time, the remaining set of contacts of K1 completes a source of ac power (T2) to the heating element of thermistor No. 1 of the bridge circuit, causing the resistance of thermistor No. 1 to decrease. (Remember that a thermistor's resistance decreases as the temperature rises.) The resultant change in the voltage drop across thermistor No. 1 results in a balanced bridge across points A and B. This, in turn, causes relay K1 to become deenergized, stopping the rotation of the mixing valve motor.

At this point, heater voltage is removed from thermistor No. 1 and it cools, again unbalancing the bridge. This causes the mixing valve motor to drive farther towards the cool position, allowing still more refrigerated air to enter the cabin. Cycling continues until the drops in voltage across the cockpit pickup unit and the cockpit selector rheostat are equal.

Had the cabin air temperature been colder than the selected setting, the bridge would have become unbalanced in the opposite direction. This would have caused relay K2 in the regulator to become energized, thus energizing the hot-field coil of the mixing valve motor.

The bridge may also be unbalanced by another method. This is accomplished by repositioning the cockpit selector rheostat. Again the mixing valve moves to regulate the temperature of the air until the bridge is rebalanced.

EQUIPMENT COOLING

Various avionics packages aboard some current naval aircraft generate heat in quantities that would be detrimental to equipment operation if cooling facilities were not incorporated.

Air Cycle System

One method of cooling is accomplished by the air cycle system (discussed earlier in this

chapter). The same air used for cabin air conditioning is ducted through appropriate valves to various electronic compartments and avionics equipment.

Vapor Cycle System

Another cooling system utilized for avionics equipment is the vapor cycle system, such as employed on the E-2 Hawkeye aircraft. A typical vapor cycle system flow schematic is shown in figure 5-65.

Vapor cycle systems make use of the scientific fact that a liquid can be vaporized at any temperature by changing the pressure above it. Water, at sea level barometric pressure of 14.7 psi, will boil if its temperature is raised to 212°F. The same water in a closed tank under a pressure of 90 psi will not boil at less than 320°F. If the pressure were reduced to 0.95 psia by a vacuum pump the water would boil at 100°F. If the pressure were reduced further, the water would boil at a still lower temperature; for instance, at 0.12 psia, boiling of water would occur at 40°F. Water can be made to boil at any temperature if the pressure corresponding to the desired boiling temperature can be maintained.

Liquids that will boil at low temperatures are the most desirable for use as refrigerants. Comparatively large quantities of heat are absorbed when liquids are evaporated, that is, changed to a vapor. For this reason, refrigerant 12 is used in most vapor cycle refrigeration units, whether in aircraft or in home air conditioners and refrigerators.

If liquid refrigerant 12 were poured into an open container surrounded by standard sea level pressure, it would boil at any temperature above -22°F. There would be a continuous flow of heat from the warm surrounding air through the walls of the container to the boiling refrigerant. Moisture from the air would condense and freeze on the exterior of the container.

Elaborate electrical circuits are used in the vapor cycle system for control and for coordination of the cooling system with other aircraft systems. It should be remembered that, although the ducting and similar hardware are responsibilities of the AME, these units should

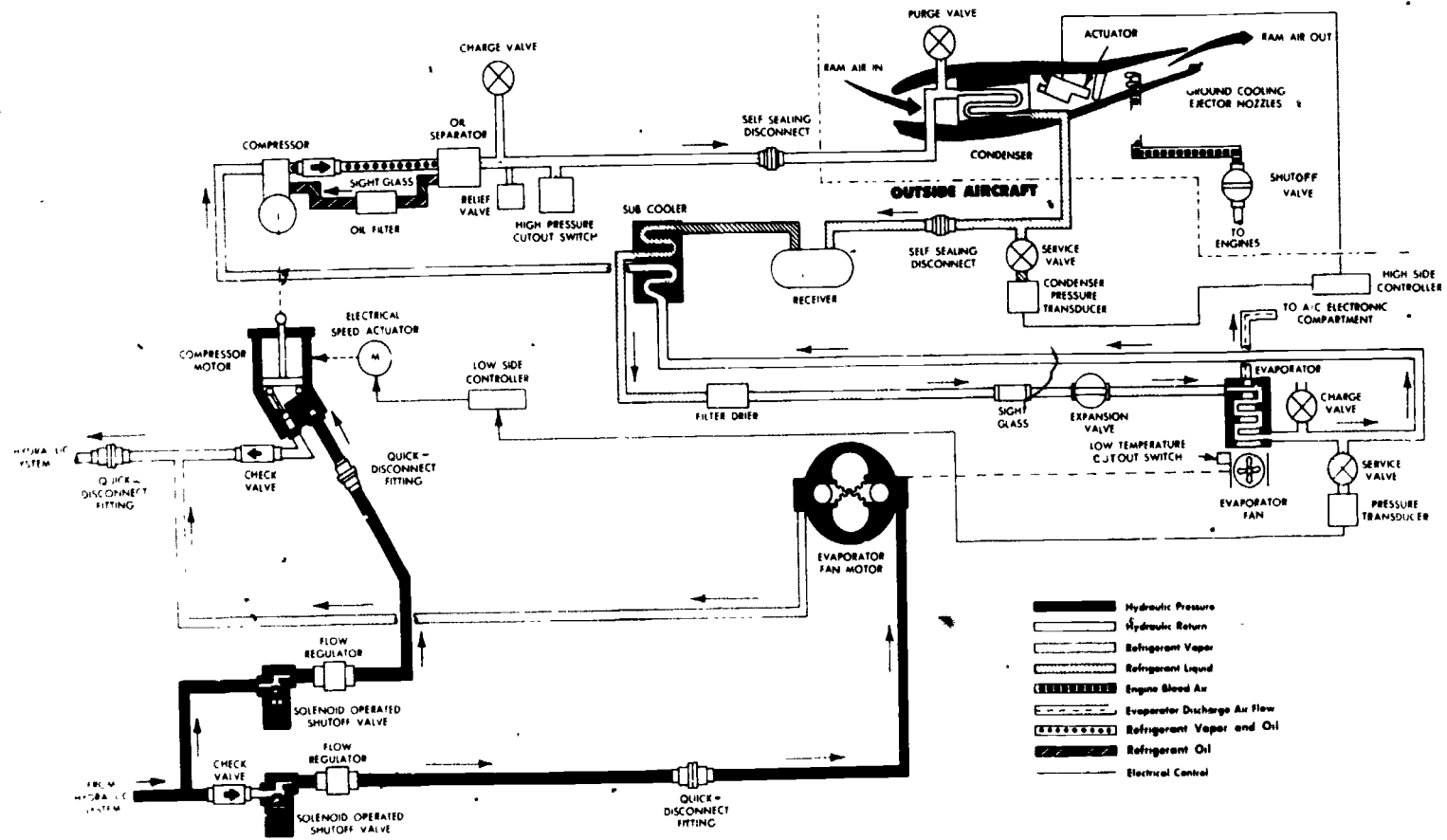

Figure 5-65.—Vapor cycle system flow schematic.

207.262

257

also be checked by the AE for damage. Once again, the importance of teamwork between the AE and the AME is emphasized.

PRESSURIZATION

Atmospheric pressure at sea level is approximately 14.7 psi. Cockpit pressure is maintained as near as is practical to sea level pressure. As altitude increases, the atmospheric pressure decreases; current aircraft sometime travel at altitudes where the atmospheric pressure is only 1 psi. If an unprotected pilot were exposed to this near-vacuum air pressure, he would be seriously injured or killed. It is mandatory that all aircraft having an operating altitude where such exposure could occur must be equipped with pressurizing equipment.

Terms and Definitions

There are terms and definitions with which the AE should become familiar in order to understand the discussion of pressurization. Some of these are

1. Absolute pressure—Pressure measured along a scale which has zero value at a complete vacuum.
2. Aircraft altitude—Altitude above sea level in the standard atmosphere. (pressure altitude).
3. Ambient pressure—The pressure in the area immediately surrounding the object under discussion.
4. Atmospheric pressure—The weight of gases in the atmosphere sufficient to hold up a column of mercury 760 millimeters high (29.92 inches). At sea level this pressure is 14.7 psi and decreases with altitude in a logarithmic progression.
5. Cabin altitude—Used to express cabin pressure in terms of equivalent altitude above sea level.
6. Differential pressure—The difference in pressure between the pressure acting on one side of a wall and the pressure acting on the other side of the wall. In aircraft pressurization systems, it is the difference between cabin pressure and local atmospheric pressure.

7. Gage pressure—A measure of the pressure in a vessel, container, or line, as compared to ambient pressure.

There are five basic requirements for cabin pressurizing and air-conditioning systems.

1. A pressurized area of the aircraft, usually the cockpit or cabin, designed to withstand the specified pressure differential.
2. An adequate source of compressed air.
3. A means of controlling the cabin pressure by regulating the outflow of air from the cabin.
4. A means of dumping all regulated air from the cabin, and provisions for obtaining fresh air.
5. A means of conditioning (in most cases cooling) the compressed air before it enters the cabin (discussed previously in this chapter).

The design of the cabin to withstand the pressure differential and hold leakage of air within the limits of the pressurization system is primarily an airframe engineering and manufacturing problem. An adequate air supply is provided by a separate air compressor or air from the compressor section of the aircraft's jet engine. Control of the outflow of air from the cabin is provided by the cabin pressure regulator. Rapid expulsion of air that may be contaminated is accomplished through the cabin dump valve. This is operated by an electrical switch. Simultaneously, fresh ram air may be brought into the cabin through the ambient air shutoff valve.

In addition to the components just discussed, various valves, controls, and allied units are necessary to complete a cabin pressurization system. When auxiliary systems such as windshield anti-icing, canopy defrosting, pressurized canopy sealing, pressurized fuel tanks, and pressurized hydraulic tanks are required, additional shutoff valves and control units are necessary.

Figure 5-58 shows a diagram of a pressurization and air-conditioning system. The exact details of this system are peculiar to only one model of aircraft, but the general concept is similar to that found in the majority of naval aircraft.

Additional Valves

If the cockpit air becomes contaminated, or if the pressurization system fails, the temperature control switch should be turned to the OFF position. This opens the ambient air shut off valve, thus depressurizing the cockpit and clearing it of contaminated air; it also closes the engine bleed air valve. Refer to figure 5-58 for the location of these valves in a typical pressurizing and heating system.

ANTI-ICING AND DEICING EQUIPMENTS

The anti-ice and defrost system on some aircraft that employ the air-conditioning and pressurization system described in this chapter use the air cycle systems as a source of air. The anti-ice and defrost equipment consists of the windshield anti-ice system and the windshield defrost system. Each receives its hot air supply from the same manifold. The anti-icing switch is located on the pilot's temperature control panel (Refer to fig. 5-58.)

A windshield overheat thermostat and a shutoff valve in the windshield defrosting duct operate together (in a typical system) to prevent overheating of the windshield. The thermostat opens the valve automatically when the temperature becomes too high, this diverts the hot defrosting air to the air-conditioning outlet at the floor of the cockpit until the temperature is reduced. Windshield overheating occurs only in the event of failure of the cabin air temperature-high limit pickup.

A manual control is provided on the pilot's control panel for directing the greater portion of air to either the windshield or the cockpit floor. (See fig. 5-58.) The positions of this control knob, labeled DEFROST-PULL and FOOT AIR-PUSH, provide mechanical setting of a flapper valve in the windshield defrosting duct.

Windshield Anti-Icing and Defogging System

An electrical anti-icing and defogging system is provided for the windshield panels in current naval aircraft. The panels are constructed of two

pieces of semitempered plate glass laminated with a vinyl plastic core. The core acts as a safety device to prevent shattering in the event of collision with birds when it is in the heated condition. The resistance heating element for anti-icing and defogging consists of a transparent, electrically conductive film, evenly distributed over the inner surface of the outer pane of glass. In addition, the system includes the following:

1. A windshield wire terminal box, located between the windshield panels.
2. A temperature sensing element embedded in each panel.
3. Two windshield autotransformers and a heat control relay.
4. A dual windshield control unit.
5. A windshield heat control toggle switch located in the cockpit.

A typical system as used in the E-1B aircraft is depicted in figure 5-66.

The system is powered from the ac buses through the windshield heat control circuit breakers. When the windshield heat control switch is set to HIGH, 115-volt, 400-Hertz is supplied to the left and right amplifiers in the dual windshield control unit through one set of contacts on the windshield heat control switch. The windshield heat control relay is then energized, thereby applying two phases of ac power at 200-volts, 400-Hertz to the windshield heat autotransformers. These transformers provide 218-volt ac power to the windshield heating current bus bars through the dual windshield control unit relays. The sensing element in each windshield has a POSITIVE temperature coefficient of resistance and forms one leg of a bridge circuit. (Some systems use a thermistor, which has a negative temperature coefficient, for a sensing element to control windshield temperature.)

When the windshield temperature is above calibrated value, the sensing element will have a higher resistance value than that needed to balance the bridge. This decreases the flow of current through the amplifiers, and the relays of the control unit are deenergized. As the

5-86

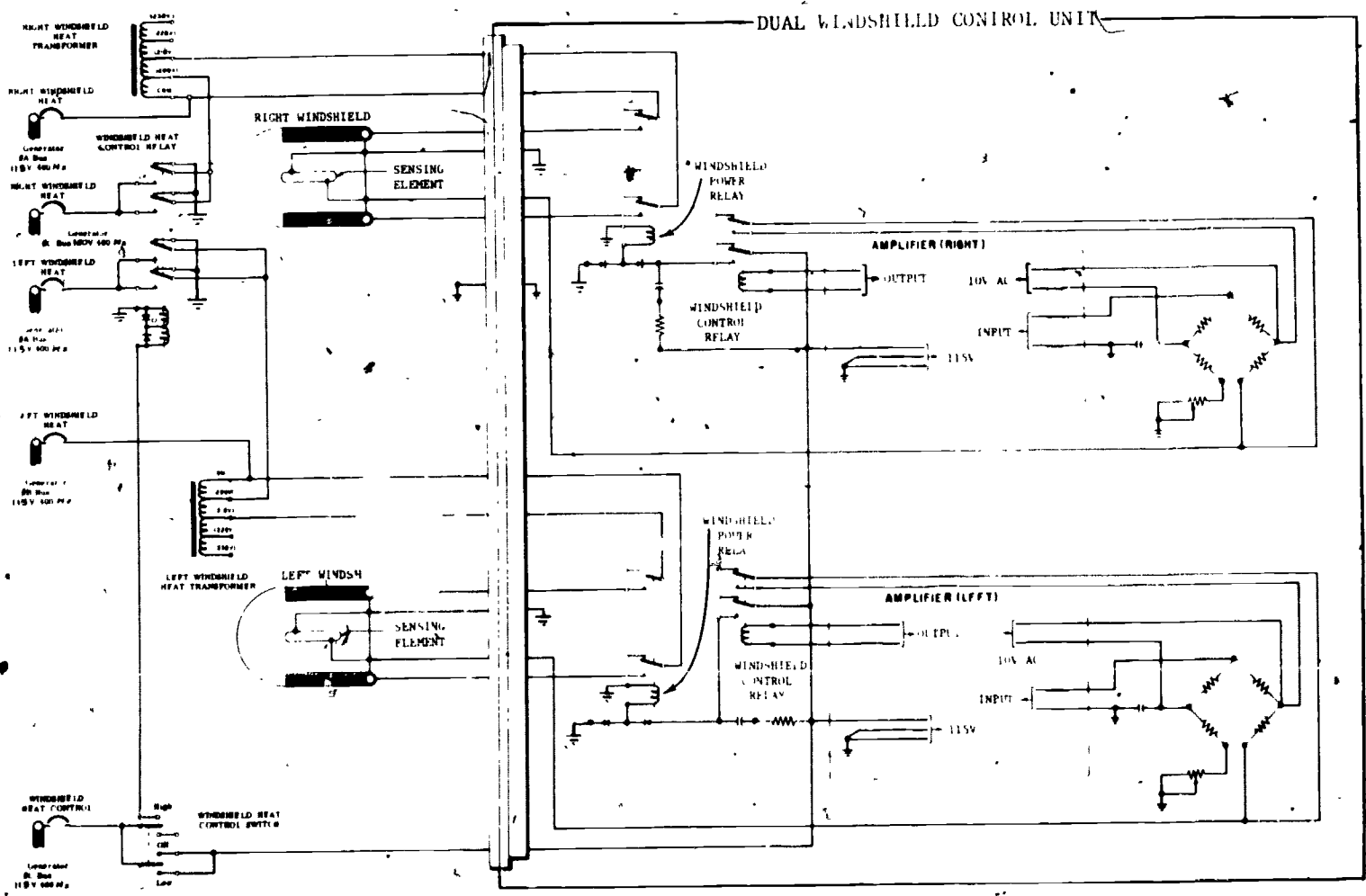

Figure 5-86.—Windshield anti-icing and defogging system.

207.268

291

292

temperature of the windshield drops, the resistance value of the sensing element also drops, and the current through the amplifiers will again reach sufficient magnitude to operate the relays in the control unit, thus energizing the windshield heaters.

When the windshield heat control switch is set to LOW, 115-volt, 400-Hertz alternating current is supplied to the left and right amplifiers in the dual windshield control unit from the windshield heat autotransformers. In this condition, the transformers provide 121-volt ac power to the windshield heating current bus bars through the dual windshield power relays. The sensing elements in the windshield operate in the same manner as described for high heat operation to maintain proper windshield temperature control. The units are calibrated to maintain windshield temperature between 40°C and 49°C (105°F to 120°F).

Wind and Tail Anti-Icing

Some aircraft are equipped with a thermal anti-icing system that is designed to prevent the formation of ice on the leading edge of the wing panels and tail surfaces by heating the leading edges with hot air. The hot air is supplied by a combustion heater installed in the wings and tail section, or by utilizing hot compressed air from the compressor section of a jet engine. Fuel for the anti-icer heaters is obtained by electrically operated pumps. The amount of fuel delivered by the pump is determined by the demands of the heater. In some aircraft, heater demands are determined automatically through the use of thermostats. Fuel flow and airflow may be controlled by various types and combinations of solenoid-operated valves.

Wing and Tail Deicing

Some aircraft are equipped with air-inflated, rubber deicer boots on the leading edges of wing and tail surfaces. Air pressure or vacuum is

alternately applied to these boots and cracks off any ice that has formed. Once the ice has cracked, the force of the airstream peels it back and carries it away. Pressure for inflating the air cells in the deicer boots is normally supplied by engine-driven pumps. Air pressure or vacuum is alternately applied either by the use of motor-driven rotary distribution valves or by the combination of an electronic timer and solenoid distributor valves.

Empennage Deicing

The P-3 empennage deicing system combines both anti-icing and deicing for the vertical and horizontal stabilizers. The system uses electrical power to prevent or remove the accumulation of ice. Electrical heating elements are built into the leading edges and surfaces of the empennage. The system is ac powered and dc controlled. Anti-icing is accomplished by parting strips in the leading edge of each stabilizer. The parting strips are constantly heated once the system is actuated. Deicing is accomplished by 20 cyclic heated areas. During normal operation, each of the cyclic areas is heated for 8 seconds and not heated for 168 seconds. The system is protected by overheat sensors and a thermal sensitive relay. Any time an overheat is sensed, power is shut off automatically to prevent damage to the metal structure.

Pitot Tube Anti-Icing

In order to prevent the formation of ice over the opening in the pitot tube, a built-in electric heating element is provided. A switch is provided on the pilot's console for controlling power to the heaters; power is taken from either the ac or the dc bus. Caution should be exercised when ground checking the pitot tube since the heater must not be operated for long periods unless the aircraft is in flight, and the danger of ground personnel accidentally being burned also exists.

CHAPTER 6

INSTRUMENTS

When the first aircraft came into existence, the main objective was to launch the aircraft and keep it airborne as long as possible. At first, it was not possible to keep the aircraft in the air for longer than a few minutes. However, as better engines and aircraft structures were developed, the aircraft could remain aloft for a considerable length of time. Along with these improvements came the need for instruments. The first aircraft instruments were fuel and oil pressure instruments to warn of engine trouble so that the aircraft could land before the engine failed. Later, when the aircraft was able to fly over considerable distances, weather became a problem. This led to the development of instruments that helped to fly through snowstorms, thunderstorms, and other bad weather conditions. And so, as the need for various instruments became apparent, the development of aircraft instruments progressed.

Instruments that were used in aircraft a few years ago were reasonably simple as compared with those in current aircraft. The jet aircraft has brought many complex problems to instrument engineering.

Instrumentation is basically the science of measurement. Measurements that must be made in all aircraft are those that relate to position, direction, speed, altitude, engine condition, fuel on board, fuel consumption, and many others. In addition, jet aircraft instrumentation must indicate Mach number, angle of attack, tailpipe temperature, etc.

There are two ways of grouping aircraft instruments—by their operating principles and by the job they perform. Instrument operating principles include gyroscopic, pressure or temperature sensing, magnetism, electrical

energy, or combinations of any of these. This chapter deals with indicators and indicating systems in relation to the job they perform—flight, engine, and equipment instruments. Flight instruments discussed in this chapter are those instruments that provide aircraft performance information to the pilot. These instruments include the airspeed, altimeter, vertical speed, attitude, turn and bank, and angle-of-attack indicators or indicating systems. Along with the heading indicator, these instruments provide primary flight reference to the pilot even though he is unable to see outside the aircraft. The heading indicator is a flight instrument and will be discussed in the chapter on inertial navigation systems.

FLIGHT INSTRUMENT SYSTEMS

In order to maintain instruments properly, AEs must be well versed in the basic principles of the flight instrument systems. In addition, they must understand the electrical and electronic principles involved in aircraft instruments. Much of this information is available in the basic Rate Training Manuals contained in the AE section of *Bibliography for Advancement Study*, NAVEDTRA 10052 (Series).

PITOT-STATIC SYSTEM

The pitot-static system in an aircraft includes some of the instruments that operate on the principle of the barometer. It consists of a pitot-static tube and three indicators, all

connected with pipelines that carry air. The three indicators are airspeed, altimeter, and vertical speed indicator (VSI).

The airspeed indicator indicates the speed of the aircraft through the air; the altimeter indicates the altitude; and the VSI indicates how fast the aircraft is climbing or descending. They all operate on air that is taken in from outside the aircraft during flight.

Pitot stands for impact pressure, which is the pressure of the outside air against the aircraft flying through it. The tube, or line that goes from the pitot chamber of the pitot tube to the airspeed indicator merely applies the pressure of this outside air to the airspeed indicator. The airspeed indicator is calibrated so that various air pressures cause different readings on the dial. In other words, the airspeed indicator interprets air pressure from the pitot tube in terms of airspeed in knots.

The pitot tube is mounted on the outside of the aircraft at a point where the air is least likely to be turbulent, and points in a forward direction parallel to the aircraft's line of flight. One general type of airspeed tube is designed for mounting on a streamlined mast extending below the nose of the fuselage. Another type is designed for installation on a boom extending forward of the leading edge of the wing. Although there is a slight difference in their construction, they operate identically.

Static means stationary or not changing. The static part of the pitot-static system (fig. 6-1) also introduces outside air, but at its normal outside atmospheric pressure as though the aircraft were standing still in the air. The static line applies this outside air to the altimeter, the vertical speed indicator and the airspeed indicator.

Altimeter

An altimeter is an instrument that measures pressure and is calibrated in feet of altitude. In order for the AE to understand the operation of an altimeter, it is necessary for him to have an understanding of altitude. It is also necessary to remember that even though the altimeter indicates in feet it is actually measuring pressure.

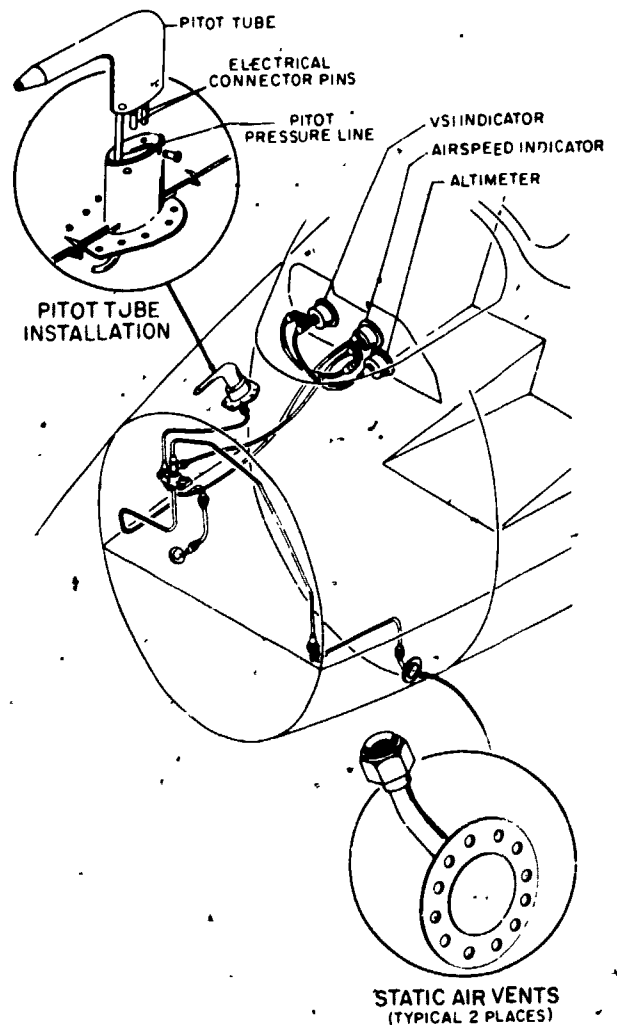

207.355

Figure 6-1.—Pitot-static system.

The word altitude by itself is vague and must be further defined if it is to have meaning. The term altitude includes altitude above mean sea level (MSL) or above ground level (AGL), pressure altitude, indicated altitude, density altitude, and elevation.

MEAN SEA LEVEL.—Since approximately 80 percent of the earth's surface is covered with water, it would seem natural that this level would be used as an altitude reference point. Because of tides and the fact that the earth is

not perfectly round, the pull of gravity is not the same at sea level all over the world. Therefore, an average (or mean) value has been determined and defines as that point where gravity acting on the atmosphere above the earth's surface produces a pressure of 14.70 lbs per sq in. This pressure supports a column of mercury in a barometer to a height of 29.92 inches. All other altitudes are then measured from this reference point and compared with a specified temperature; this is the basis for what is called standard atmosphere. See fig. 2-10 in chapter 2. Altitude read from an altimeter is in reference to MSL.

ELEVATION AND TRUE ALTITUDE.—

Elevation is the height of a land mass above mean sea level, and is measured with precision instruments far more accurate than the standard aircraft altimeter. Elevation information may be found printed on charts or painted on a hangar near an aircraft ramp or taxi area.

True altitude is the actual number of feet above mean sea level if the altitude could be measured using a ruler or yardstick. In standard day conditions pressure altitude and true altitude are the same.

ABSOLUTE ALTITUDE.—Absolute altitude simply means the distance between the aircraft and the terrain over which it is flying. This altitude is referred to as altitude above ground level (AGL). AGL is generally useless information to the pilot because of variations in the terrain, unless flying near the ground such as in a takeoff or landing pattern. AGL can be found by subtracting the elevation of the terrain beneath the aircraft from the altitude read on the altimeter (MSL). An instrument called a radar altimeter indicates actual altitude above the terrain; this indication is called radar altitude.

PRESSURE ALTITUDE. It is not possible to have a ruler extending from an aircraft and reaching to sea level that is calibrated to measure altitude; however, an accurate method of measuring altitude is to sense the air pressure and compare it to known values of standard air pressure at specific, measured altitudes. When

referring to an altitude read from a properly calibrated altimeter referenced to 29.92 inches of mercury (Hg), it is called "pressure altitude".

Referring again to figure 2-10, if a pressure altimeter senses a pressure of 6.75 lb/sq in. with the altimeter set to sea level barometric pressure of 29.92 in. Hg, the altimeter will indicate 20,000 feet. This does not mean that the aircraft is exactly 20,000 feet above mean sea level, but rather that the aircraft is in a mass of air which exerts a pressure equivalent to the pressure exerted at an altitude of 20,000 feet on a standard day. This, then, is "pressure altitude," not true altitude.

INDICATED AND CALIBRATED ALTITUDE.—Unfortunately, standard atmospheric conditions very seldom exist; atmospheric conditions and barometric pressure can vary considerably. A pressure change of one-hundredth (0.01) of an inch of mercury represents approximately a nine-foot change in altitude at sea level, and barometric pressure changes between 29.50 and 30.50 are not uncommon (a pressure change representing approximately 923 feet). Indicated altitude is the uncorrected reading of a barometric altimeter, whereas calibrated altitude is the indicated altitude corrected for inherent and installation errors of the altimeter instrument. On an altimeter without such errors, indicated altitude and calibrated altitude are identical, and that is the condition assumed in the remainder of this discussion.

When flying below 18,000 feet, the aircraft altimeter must be set to the altimeter setting (barometric pressure corrected to sea level) of a selected ground station within 100 miles of the aircraft. Altitude read from an altimeter set to local barometric pressure is said to be indicated altitude. The accuracy of this method is limited in that it is dependent upon the assumption of a standard lapse rate. That is, for a given number of feet of altitude, an exact change in pressure occurs; this very seldom happens, and thus limits the accuracy of the altimeter. Above 18,000 feet, all altimeters are set to 29.92 (pressure altitude) so that even though the altimeter does not indicate accurate distance above MSL, as long as all aircraft are set to the same barometric

pressure vertical separation between aircraft can be controlled.

DENSITY ALTITUDE.—A very important factor in determining the performance of an aircraft or engine is the density of the air. The denser the air, the more horsepower the engine can produce, the more resistance to the aircraft in flying through the air, and the more lift the airfoils can produce. Air density is affected by pressure, temperature, and moisture content, and is measured in weight per unit volume, e.g., pounds per cubic foot. However, a more convenient measurement of air density for the pilot is density altitude, which is the altitude assigned to a given density in the standard atmosphere.

Density altitude is not indicated on an instrument, and is usually either taken from a table or computed by comparing pressure altitude and temperature. Although moisture content also affects air density, most computations for aircraft performance consider its effect to be negligible.

Figure 6-2 illustrates the different types of altitude. At Navy Memphis, the field elevation is 322 feet and the altimeter should read 322 feet when properly set to the local altimeter setting (in this case 29.67). If the altimeter were set to 29.92 (standard day pressure at sea level), the altimeter would read approximately 550 feet. The density altitude (density of the air) is such that the aircraft and engine perform the same as if they were at a standard day altitude of 1,180

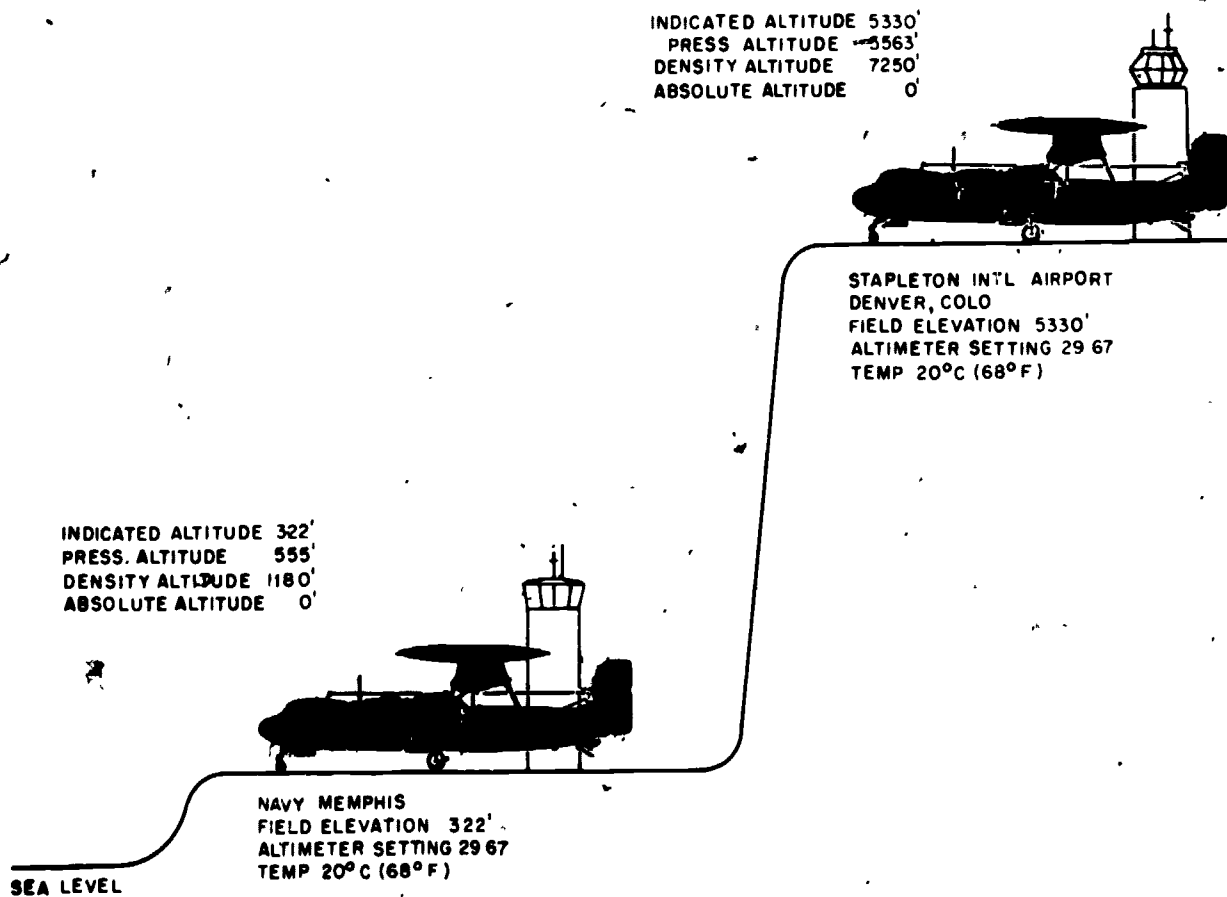

Figure 6-2.—Different types of altitude.

feet; i.e., the distances required for takeoff and landing are longer for higher density altitudes (higher temperatures). The absolute altitude (AGL) for the aircraft at Memphis is zero feet because the aircraft is touching the surface.

Another example of altitude is shown in figure 6-2 for Stapleton International Airport in Denver, Colorado. Notice that the difference between pressure altitude and indicated altitude remains the same as at Memphis, but at the same temperature the density altitude is much greater at Denver.

Air Data Computer System

The performance of an aircraft and its effectiveness as a weapon depend greatly on its surroundings; therefore the pilot of today's high-performance aircraft must constantly keep track of conditions around him. To aid the pilot, various environmental factors are measured by conventional measuring devices, and these measurements are displayed on indicators in the cockpit. The pilot is then able, on the basis of these indicator readings, to compensate as necessary for changing flight conditions.

In some cases, however, the pilot need not make corrections himself; corrections are made automatically through electrical or electromechanical servomechanisms, based on data supplied by the air data computer (ADC).

The supersonic speeds and higher altitudes attained by today's aircraft have outgated the more conventional flight data systems. The need for accuracy and quicker response, complicated by the more complex avionics equipment carried, means that more equipments require more data than ever before. So an ADC has become necessary.

The computer derives the outputs shown in figure 6-3 from indicated static pressure (P_{si}), total pressure (P_t), total temperature (T_t), and direction of local airflow (α_t). The multiple output of the ADC eliminates duplicate computations and components which would be needed to meet the requirements of the various individual systems in the aircraft. To measure the input parameters and convert them to usable electrical signals, the following sensors are used:

1. Static pressure pickup.
2. Pitot pressure pickup.
3. Temperature probe.

Sensing and computing functions of the ADC are expressed in terms commonly used to describe the speed and atmospheric pressure surrounding an aircraft in flight. These terms are defined as follows:

True (corrected) static pressure, P_s : Static pressure is the atmospheric pressure of the undisturbed air through which the aircraft is flying. This pressure is a function of altitude or distance above ground (barometric pressure); the common reference is MSL.

Indicated static pressure, P_{si} : Indicated static pressure is taken at a selected point or points on the surface of the aircraft, but must be corrected for the local pressure field (position error) of the selected point in order to give true static pressure.

Impact pressure, Q_c : Impact pressure is the incremental increase in pressure due to flight velocity; that is, the difference between total and static pressure ($Q_c = P_t - P_s$).

Total pressure, P_t : Total pressure is the air pressure at the leading surfaces of the aircraft in flight; that is, the sum of the impact and static pressure ($P_t = P_s + Q_c$).

Mach number (M): Mach number is the speed of an aircraft in relation to the speed of sound in the atmosphere through which the aircraft is flying. For example, an aircraft flying at a speed of Mach 1.0 is moving at the same speed at which sound would travel through air at the same conditions of temperature and pressure.

$$M = \frac{V_t}{a}$$

where V_t (true velocity) is true airspeed, and a is speed of sound.

True airspeed, V_t : True airspeed is the actual speed of the aircraft with respect to the air surrounding the aircraft in flight.

DESCRIPTION.—The Air Data computer uses inputs from the aircraft pitot-static system and from a total temperature probe to develop electrical outputs which represent altitude, Mach number, and true airspeed. The system consists of an Air Data Computer, a total temperature probe and the true airspeed indicator. The Air

AIR DATA COMPUTER SYSTEM

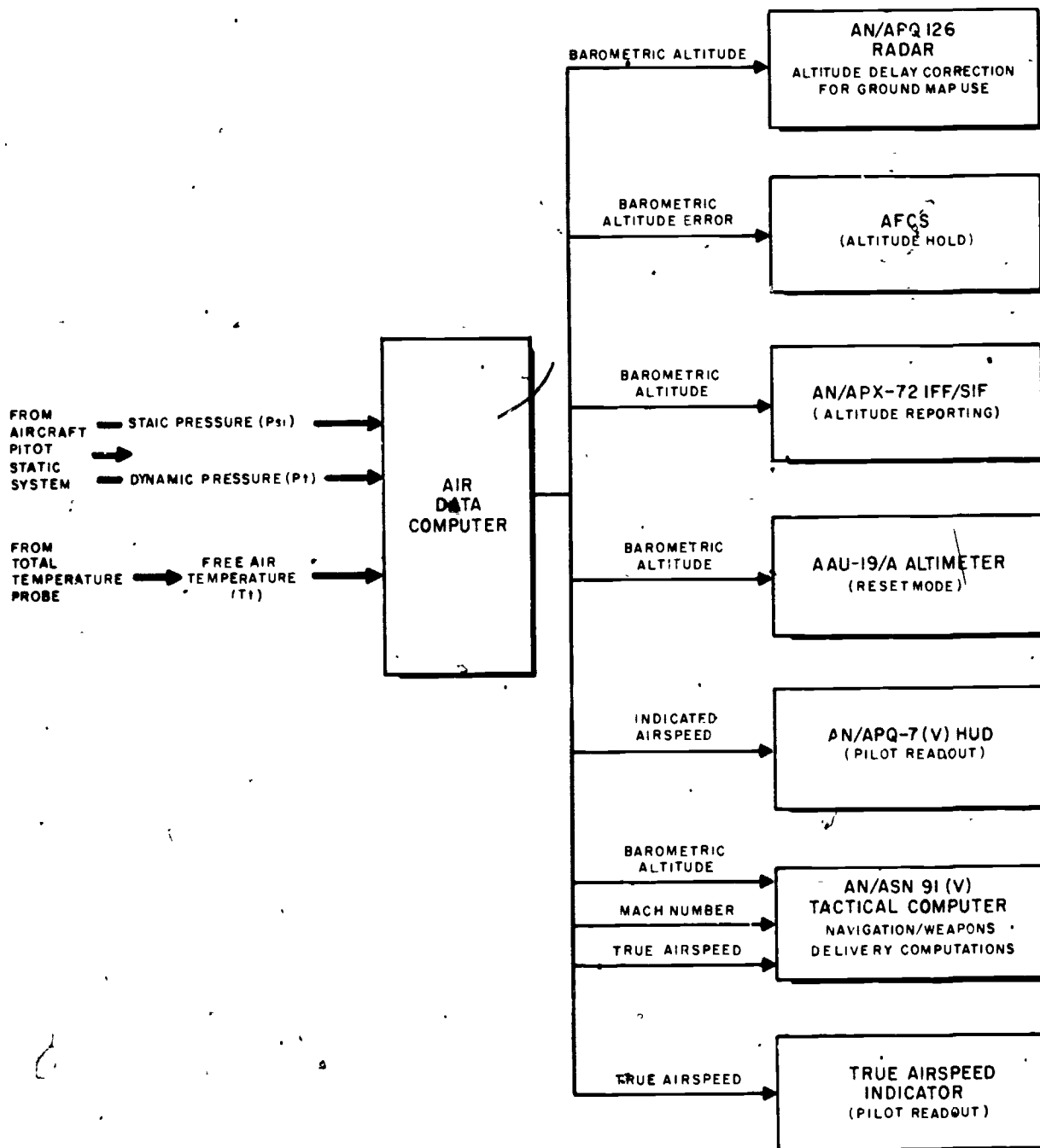

207.384

Figure 6-3.—ADC system; inputs and outputs.

Data Computer contains three replaceable modules and a power supply unit which converts primary ac bus power into the voltages necessary for system operation. Each module contains a miniature motor, gear train, and potentiometers to develop the applicable outputs. The total temperature probe, provides free airstream temperature to the Air Data Computer.

An ADC advisory light is included on the advisory light panel. The light comes on to indicate a failure of Mach, airspeed, or altitude function of the ADC. When the light is on, the Tactical Computer rejects inputs from the ADC.

OPERATION.—The altitude module converts static pressure into an electrical signal which is combined with a Mach effects signal from the Mach module. The resultant signal, which represents barometric altitude, is supplied to the radar, the Tactical Computer, and the AFCS, when operating in altitude hold.

An altitude signal is sent to the transponder for the altitude reporting mode and to the AAU-19/A altimeter to give the pilot a readout of the reported altitude.

The Mach module converts pitot and static pressure into an electrical signal. The resultant signal is transmitted to the Tactical Computer, to the HUD as IAS, to the altitude module for Mach compensation of static pressure, and to the true airspeed module.

The true airspeed module converts the Mach number input which is combined with a temperature signal from the total temperature probe into true airspeed signals for the Tactical Computer and the true airspeed indicator.

AUTOMATIC ALTITUDE SYSTEM

Serious problems of vertical separation, terrain clearance, and collision avoidance created by the astonishing increase in air traffic since 1950 have necessitated the development of improved air traffic control techniques by the use of altitude-coded transponders for automatic altitude and position reporting.

In the past, the air traffic control system utilized radar to present azimuth and distance information to the controller on a horizontal radarscope. Aircraft identification was accomplished primarily by (1) voice radio, (2)

the use of position reports over definite fixes, (3) the making of identifying turns of the aircraft to headings requested by the controller, or (4) by a beacon identification signal. Altitude information was given over the voice radio. At the conclusion of this information-gathering process, the information was recorded on a flight strip by the controller and updated by him as required. When the aircraft moved into another controller's area, the handoff of the aircraft and the associated information was basically a manual process. Although the system was ordinarily adequate, it could become cumbersome during heavy traffic.

Automatic altitude reporting equipment that provides continuous automatic identification of aircraft on the ground controller's radarscope has been developed. This equipment, eliminates many of the manual steps required in the old air traffic control system. An air data computer corrects static pressure errors and provides synchro-driven altitude information to the pilot's altimeter. It also provides altitude in digital form to the aircraft transponder in high-performance aircraft. In low-performance aircraft the equipment provides a direct readout of altitude to the pilot and digital altitude information to the aircraft transponder. The digital information is then transmitted to the ground interrogator and presented on the radarscope in alphanumeric form.

Operation of the system is as follows: An interrogation pulse group is transmitted from the interrogator-transmitter unit through a directional interrogator antenna assembly. The pulse group triggers an airborne transponder, causing a multiple pulse reply group to be transmitted. The transponder transmission is received by the ground interrogator-receiver, processed through a computer, and then displayed in alphanumeric form on the controller's radar screen. The length of the round-trip transit time determines the range of the replying aircraft, the mean direction of the main beam of the interrogator antenna during the reply determines the azimuth, and the encoded signal from the transponder provides, via Mode C, the aircraft's altitude in 100-foot increments.

As illustrated in figure 6-4 the modernized, semiautomated air traffic control system

includes the following improvements over the past system:

1. It automatically provides the air traffic controller with a radar presentation, identified in three dimensions, of every properly equipped aircraft within his control area.

2. As a result of the three-dimensional presentation, it greatly reduces the necessity for using voice radio, eases the workload of the air traffic controller, and thus increases air traffic control efficiency.

3. A transponder signal reinforces the radar signal normally seen on the radarscope and subsequently makes the signal stronger and much less susceptible to atmospheric interference.

4. The beacon system altitude reporting feature may reduce vertical separation in the higher flight levels.

5. Its continuous updating of aircraft altitude records in 100-foot increments permits more accurate traffic control when aircraft are changing altitude rapidly, as they do in terminal areas.

The AIMS Program

The AIMS Program, implemented by the Department of Defense to satisfy two requirements, derives its name from the following acronym:

- ATCRBS (Air Traffic Control Radar Beacon System)
- IFF (Identification Friend or Foe)
- MARK XII Identification System
- Systems (reflecting the many AIMS configurations)

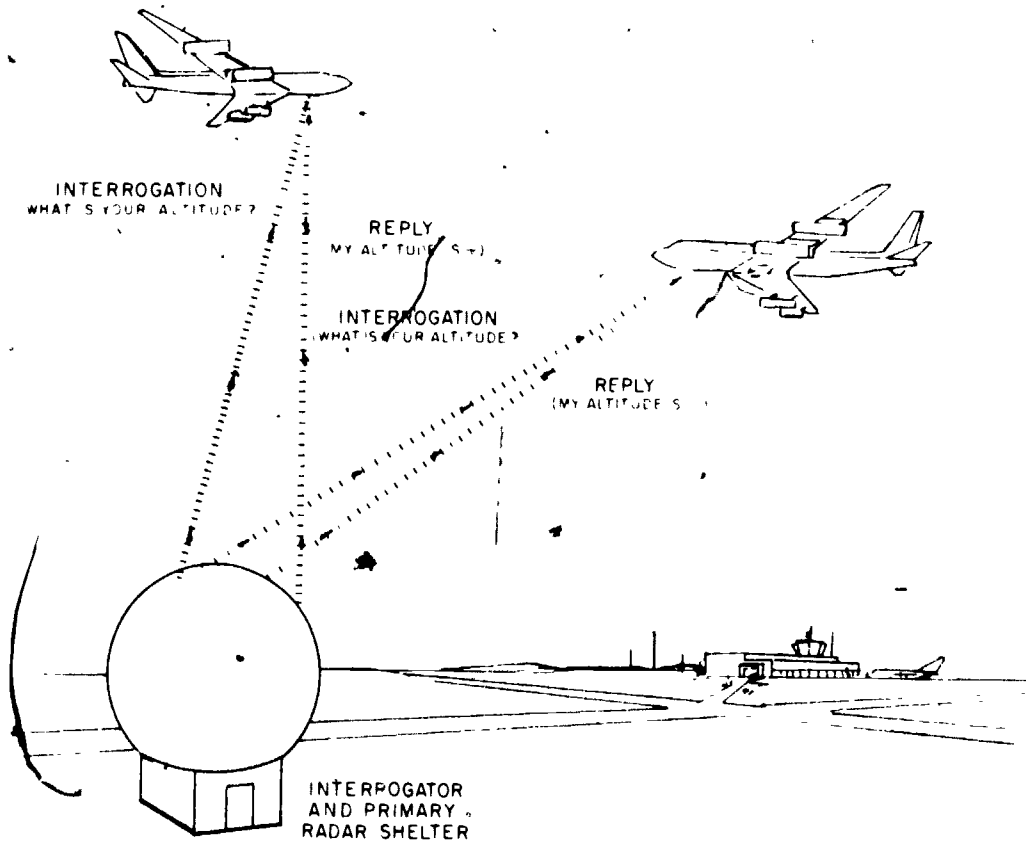

Figure 6-4.—The Automatic-Altitude Reporting System.

207.385

The primary objective, the improvement of air traffic control within the United States, necessitated DOD participation in the first phase of an FAA plan to upgrade peacetime operational use of the airspace. The plan includes the provision of additional identification and altitude signals to ground air traffic control stations, and results in a major improvement in military air traffic control. The secondary objective is to classify equipment configurations and capabilities.

The AIMS system consists of transponders, interrogators, computers, servoed altimeters, altimeter-encoders, control panels, and associated equipment. Interrogators are included in most AIMS-equipped ground and surface sites, in tactical ground and surface systems, and in certain special-task airborne vehicles. To avoid misreadings and the friction problems associated with current aircraft altimeters, all altimetry displays are of the counter-drum-pointer type.

Concurrent with the Department of Defense decision to implement the AIMS system, the following tolerances were established:

1. Maximum difference between the pilot's and ground displays, ± 125 feet.
2. Maximum difference between the pilot's display and true altitude, ± 250 feet.

Tolerances during takeoff, instrument approach, and landing remain in accordance with existing military/FAA standards.

Static Pressure Errors

The total altimeter system accuracy limitation of ± 250 feet imposed the problem of eliminating, correcting, or compensating for virtually all of the errors of the system. To achieve the greatest accuracy, each type of aircraft must be treated separately to determine what corrections its pressure system will require within its flight envelope. Slow, low-flying aircraft with small or negligible measured static-pressure defects require only an instrument to transform a static-pressure input into a digital electrical output of pressure altitude.

High-performance subsonic aircraft have substantial position errors which require an

instrument to compensate or correct for the static-pressure error, as a function of Mach number. The pressure error, in order to be compensated for, must be known and be repeatable in aircraft of the same type. Since repeatability is a problem when flush static ports are used, the ports are generally replaced with a pitot-static tube.

High-performance, supersonic aircraft also require an instrument capable of compensating for pressure error as a function of Mach number. Because of the greater magnitude of errors encountered over a wider range of altitude and speed, the instrumentation used in this type of high-altitude aircraft is necessarily more complex than that required for subsonic aircraft.

Errors produced in the measurement and transmission of true pressure altitude can be divided into three groups: errors in measured altitude, altitude transmission, and instruments (transducer or computer and digitizer).

Errors in measured static pressure are a result of the following variables: design of the pressure pickup, location of the pressure pickup on the aircraft, the Mach number, the angle of attack, and the aircraft configuration. The static pressure sensor can be either a flush fuselage vent or a static pressure L-shaped tube. In the case of a flush vent, even the slightest surface irregularity or structure in the vicinity of the vent may substantially deflect the perpendicular flow of air past the vent. In the case of static pressure tubes, concern must be given to such variables as the shape of the tube, the orifice configuration, and the type of structural support. In either case, there will be a local pressure surrounding the pressure-sensing vent which will differ from the free stream pressure.

Altitude errors are introduced by pressure lag, system leaks, and instrument errors. Lag can cause errors of hundreds of feet, depending upon the rate of pressure change and the system volume. In level flight or during very low rates of ascent and descent (500 to 600 ft/min) the errors are small and almost negligible. Errors produced by system leaks can be significant if the leak is located in a pressurized area of the aircraft.

Instrument errors are the result of friction, hysteresis, temperature, acceleration, and design limitations. The overall accuracy of the

instrument depends upon the range of the instrument and complexity of the mechanism.

Equipment Requirements

Today all Naval aircraft are capable of automatic altitude reporting. In most of the high-performance aircraft containing an Air Data Computer (ADC), the ADC has been modified to have the capability of automatic altitude reporting and to provide an output for the AAU-19/A servoed altimeter. An AAU-21A Altimeter-Encoder will be installed in slower, low-flying aircraft that do not require an ADC. The signal is based on the standard atmospheric pressure of 29.92 inches of mercury.

Air Data Requirements

The basic functions of the air data computer in the Air Traffic Control Radar Beacon System (ATCRBS) are the correction of the sensed static pressure and the provision of appropriate outputs of altitude which are usable in two forms: a digital output in 100-foot increments for wire transmission to transponders and an analog synchro output for providing pressure

altitude information to an AAU-19/A Servoed Altimeter. Failure monitoring is also included. The general requirements for the type CPU-46/A and the CPU-66/A are listed in table 6-1.

The air data computers generally consist of a pressure-sensing means, a computing mechanism, an error signal generator, a servo loop, and output devices to provide signals for both altitude indication and altitude reporting. The unit computes corrected pressure altitude from the inputs of indicated static pressure, total pressure, and information on the aircraft static pressure error, which is stored in the computer on a two-dimensional cam. The cam is readily replaceable in the event that a change is necessary or if the unit is to be calibrated for another type of aircraft.

The system (figure 6-5) operates in the following manner. A small step change in static pressure causes the aneroid capsule to deflect and rotate the rocking shaft assembly. The rotation causes the "Geneva" sector and locking disk to rotate the microsyn rotor from its null position. Alternately, a correction for static pressure defect can rotate the microsyn rotor. In

Table 6-1.—Computer Requirements

	CPU-46/A COMPUTER	CPU-66/A COMPUTER
RANGE	80,000 FT	50,000 FT
TOLERANCE	±20 FT OR ±0.2% OF ALTITUDE	±25 FT OR ±0.25% OF ALTITUDE
STATIC PRESSURE CORRECTION	0.2 TO 2.5 MACH AT ALL ALTITUDES	0.2 TO 0.95 MACH AT ALL ALTITUDES
INPUTS	STATIC PRESSURE TOTAL PRESSURE	STATIC PRESSURE TOTAL PRESSURE
OUTPUTS	TRUE ALTITUDE 1. SIGNAL TO TRANSPONDER ENCODED IN 100-FOOT INCRE- MENTS. 2. SYNCHRO SIGNAL USED TO DRIVE ALTIMETER INDICATOR.	TRUE ALTITUDE 1. SIGNAL TO TRANSPONDER ENCODED IN 100-FOOT INCRE- MENTS. 2. SYNCHRO SIGNAL USED TO DRIVE ALTIMETER INDICATOR.

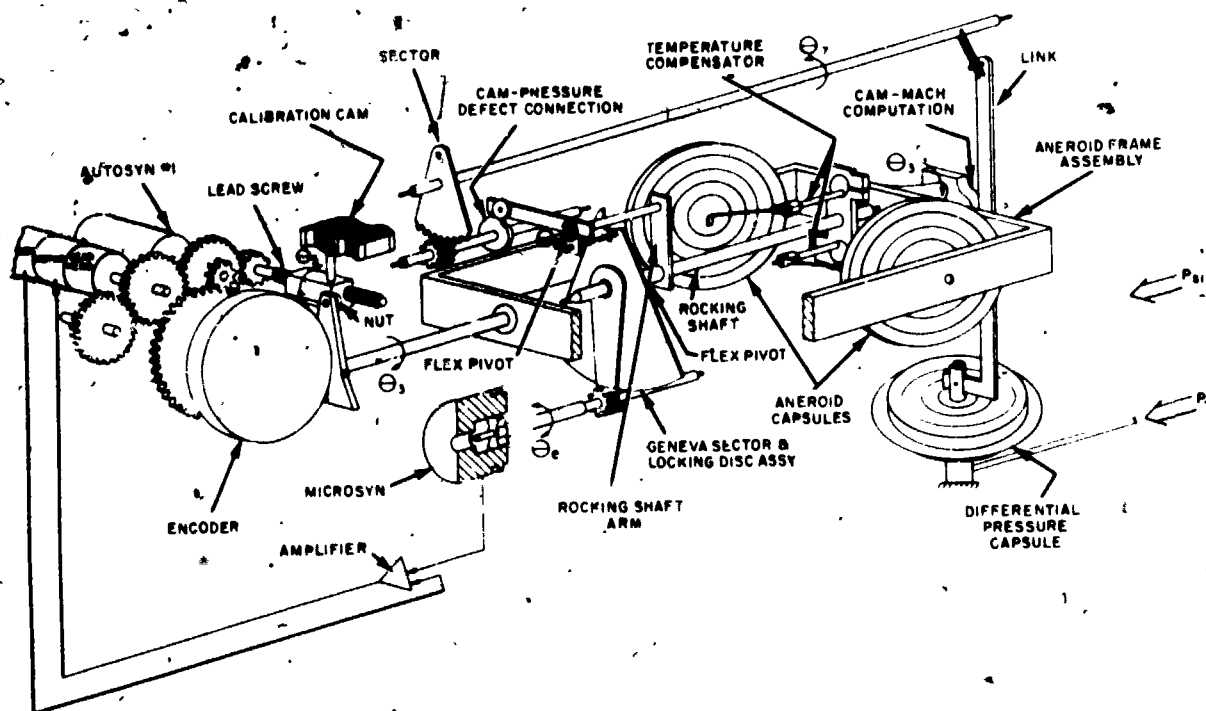

Figure 6-5.—CPU-65/A Computer Components.

207.389

either case, the error voltage generated is amplified and directed to the two-phase servomotor. This drives the output devices, lead screw, and frame until the microsyn is again in a null position. Thus, the angular rotation of the frame caused by the aneroid capsule displacement provides a change in the synchro and encoder outputs.

CPU-46/A SUPERSONIC ALTITUDE COMPUTER.—The CPU-46/A Altitude Computer (figure 6-6) is designed for use in high-performance supersonic aircraft with operational limitations of 80,000 feet altitude and Mach 2.5. It consists of pressure sensors, a computing system, an electronic package, and output devices packaged into one unit with dimensions of 5.5 x 6.5 x 9.8 inches. The unit receives pressure from the aircraft pitot-static system and requires a 115V, 400-Hz power source. It provides altitude information which is

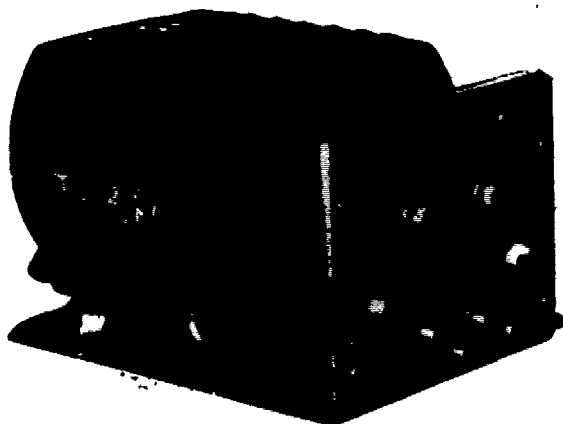
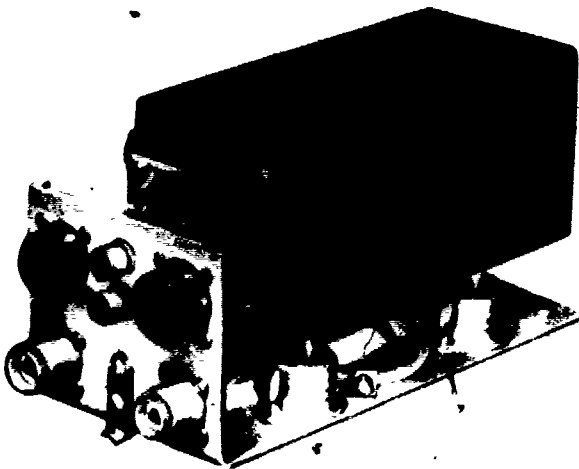

Figure 6-6.—CPU-46/A Supersonic Altitude Computer.

207.386



207.387

Figure 6-7.—CPU-66/A Subsonic Altitude Computer.

corrected for static pressure error in the form of:

1. Two separate analog signals for positioning the remote AAU-19/A Altimeters.

2. An encoded binary signal to the airborne transponder for altitude reporting in accordance with the Air Traffic Control Radar Beacon System. The output of the encoder must agree with the output to the AAU-19/A to within ± 20 feet. A mechanical cam is used to compensate for static-pressure position error. Corrected pressure altitude is thus computed and provided as output signals.

In case of computer failure, the AAU-19/A Altimeter automatically reverts to a pneumatic standby mode, and the altitude reporting encoder is deactivated. A standby flag appears on the AAU-19/A display to advise the pilot of the failure.

CPU-66/A SUBSONIC ALTITUDE COMPUTER.—The CPU-66/A Altitude Computer (figure 6-7) is designed for use to 50,000 feet and at speeds to 0.95 Mach. Its operation is similar to that of the CPU-46/A.

The ADCs have been modified to have the same altitude output capabilities as the CPU-46/A or the CPU-66/A, depending on the



AAU-19/A

AAU-21/A

AAU-24/A

Figure 6-8.—AAU-19/A, AAU-21/A, and AAU-24/A Altimeters.

207.388

speed and altitude capabilities of the aircraft in which they are used.

Altimetry

The three altimeters that have been developed for the automatic altitude reporting system are the AAU-19/A, AAU-21/A, and AAU-24/A (figure 6-8).

SERVOED BAROMETER ALTIMETER AAU-19/A.—The counter-drum-pointer servoed barometric altimeter (figure 6-9) consists of a pressure altimeter combined with an ac-powered servomechanism. Altitude is displayed in digital form by a 10,000 foot counter, a 1000-foot counter and a 100-foot drum. Also, a single pointer indicates hundreds of feet on a circular scale. A barometric pressure setting (baroset)

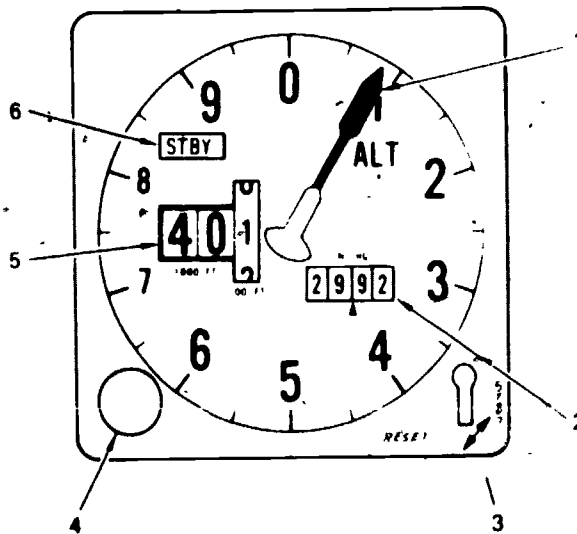

INDEX	CONTROL/INDICATOR	FUNCTION
1	Altimeter pointer	Indicates less than thousand-foot scale altitude in 50-foot increments
2	Barometric scale	Displays altimeter setting in inches of mercury
3	RESET/STBY selector	RESET—Altimeter is operated electrically through the AACS STBY—Altimeter is operated barometrically through the pitot/static system
4	Barometric pressure set knob	Sets barometric pressure in inches of mercury on barometric scale
5	Altitude counter-drum	Indicates altitude in thousands of feet and hundreds of feet
6	STBY warning flag	STBY flag denotes mode of altimeter operation: In/view (STBY)—operating barometrically Out-of-view—operating electrically through AACS

Figure 6-9.—AAU-19/A Altimeter.

knob is used to insert the local pressure in inches of Hg. The baroset knob has no effect on the digital output (Mode C) of the ADC, which is always referenced to 29.92 in. Hg. The altimeter has a servoed mode and a pressure mode of operation, controlled by a spring-loaded, self-centering mode switch, placarded RESET and STBY. In the servoed mode, the altimeter displays altitude, corrected for position error, from the synchro output of the Air Data Computer. In the standby mode, the altimeter receives static pressure directly from the static system (uncorrected for position error) and operates as a standard pressure altimeter.

The servoed mode is selected by positioning the mode switch to RESET for approximately three seconds, provided that ac power is on. During standby operation, a red STBY flag appears on the dial face. The altimeter will automatically switch to standby operation if electrical power is interrupted or if there is a system failure in the altimeter or altitude computer. Standby operation can also be selected by placing the mode switch to STBY.

An ac-powered internal vibrator is automatically energized in the standby mode to minimize friction in the display mechanism.

When the local barometric pressure is set, the altimeter should agree within 75 feet at field elevation in both modes, and the servoed or standby readings should agree within 75 feet.

AAU-21/A. -The AAU-21/A Altimeter is intended for use in low/slow aircraft. It has a counter-drum-pointer display similar in appearance to the AAU-19/A. The altimeter contains a servo-driven encoder which provides an altitude signal to the aircraft transponder for transmission to a ground station.

AAU-24/A. -The AAU-24/A altimeter contains a precision pressure sensing device, counter and pointer drive mechanisms and a combination counter-drum and pointer for altitude display. The counter displays two digits indicating multiples of 10,000 feet and 1000 feet respectively and moves intermittently. The drum indicates multiples of 100 feet and moves

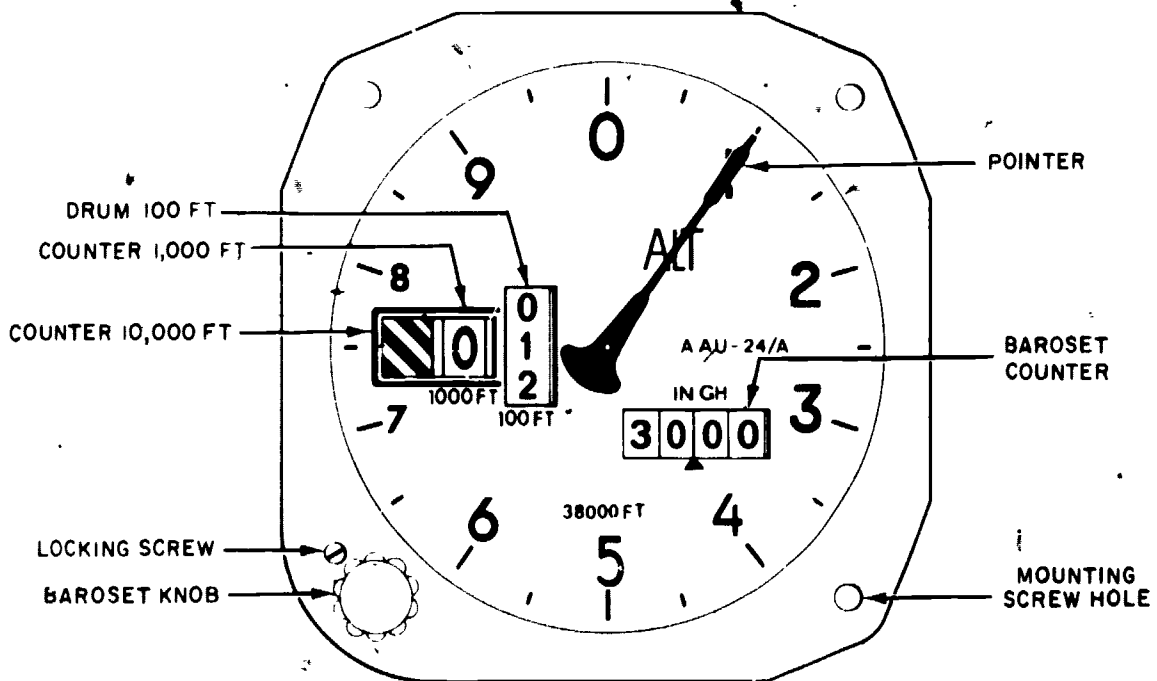

Figure 6-10.—AAU-24/A Altimeter Dial Face.

continuously. The pointer travels one revolution for each increment of 1000 feet altitude. The pointer scale is marked from 0 to 9, each step representing an increment of 100 feet. Each 100 foot step is subdivided into two increments of 50 feet each. Refer to figure 6-10. The barometric setting (baroset) knob, located at the lower left corner of the bezel, protrudes a maximum of 0.73 inches in front of the bezel. The baroset knob is used in conjunction with a four-digit counter, designated IN HG, to set the altitude indication in accordance with the prevailing barometric pressure. Adjustment is provided over a range of 28 to 31 inches of mercury. Adjacent to the baroset knob is a locking screw. This screw is used only during calibration procedures to enable the barometric pressure (IN HG) indication to be aligned with altitude indication. Two sets of internal lights, one red and one white, are provided for dial lighting. Each set consists of four lights. Power input for each lighting circuit is applied via the electrical connector. Controls for dial lighting

are external to the altimeter. To overcome the effects of stop and jump friction in the altimeter mechanisms, an internal electrically-operated mechanical vibrator is built into the altimeter. Power input for the vibrator is applied via the electrical connector. On-off control for the vibrator is external to the altimeter.

The block diagram (figure 6-11) illustrates the operation of the altimeter.

Outside air pressure from the aircraft static pressure system is applied to the altimeter case. Two evacuated pressure-sensing element assemblies within the case expand as the case pressure decreases with increasing altitude. Expansion or contraction of each element transmits movement to a rocker shaft assembly via a link-arm configuration. Pivots for the rocker shaft assemblies are coupled to a temperature compensating ring that modifies the movement of the rocker shafts to compensate for temperature changes. A differential gear

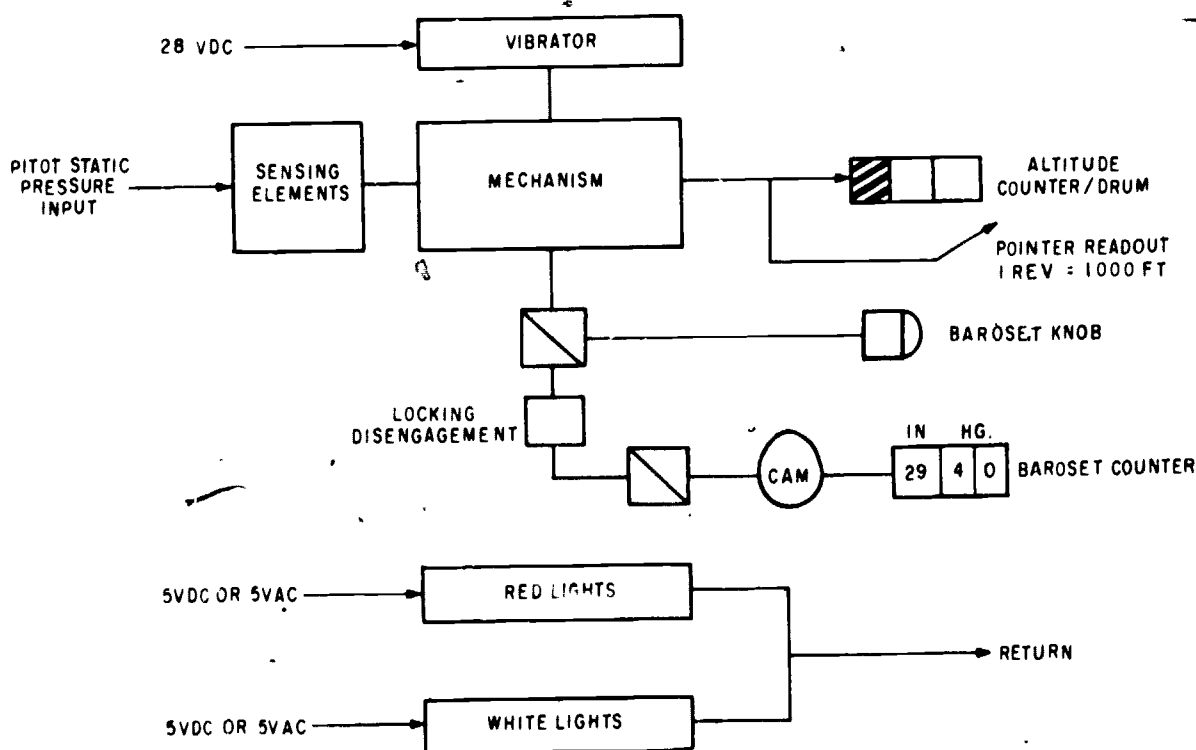

Figure 6-11.—Altimeter Block Diagram.

assembly, coupled by segment gears to the rocker shafts, provides an output movement proportional to the average expansion or contraction of the two sensing element assemblies.

The output gear of the differential gear assembly drives a gear train mechanism that actuates a counter-drum assembly and a pointer assembly that traverses the instrument dial. The counter-drum provides a numerical readout of altitude. The position of the pointer provides greater accuracy of readout.

The baro set knob is coupled via a barometric setting shaft to two spur gears that run on an idler shaft. One spur gear is meshed to a gear that drives the barometric counter. The other spur gear is meshed with the gear train mechanism that provides altitude indication. Thus the pressure indicated by the barometric counter is tied to a particular indication of altitude. To permit calibration of this relationship of pressure and altitude, a device is provided to disengage the barometric counter gear train mechanism from the baro set knob. During normal operation of the altimeter the device is locked, by means of a locking screw, in a position such that both spur gears on the idler shaft are actuated by the baro set knob. For the purpose of calibration, the locking screw may be slackened and moved towards the edge of the bezel. This enables the baro set knob to be withdrawn by a small amount away from the bezel. The knob is then disengaged from one spur gear so that turning the knob actuates only the altitude indication.

The vast increases in the speed and volume of air traffic brought about the necessity for a more efficient, automated Air Traffic Control System. The ATCRBS, which automatically provides the controller with a three-dimensional identified presentation, is a step toward the solution of the problems of vertical separation, terrain clearance, and collision avoidance. Automatic altitude reporting relieves both the pilot and the ground controller of much radio work and provides a continuous monitoring of the altitude of every properly equipped aircraft.

This will result in increased efficiency in the Air Traffic Control System and provide the pilot with a more accurate altimetry system. Altimetry equipment in the past had errors of approximately 0.8 percent of altitude. AIMS equipment reduces the errors to approximately 0.35 percent of altitude.

Airspeed Indicators

Readings from an airspeed indicator are useful in a number of ways. Its readings are important in estimating groundspeed and in determining throttle settings for the most efficient flying speed. It also provides a basis for calculating the best climbing and gliding angles. It warns when diving speed approaches the safety limits of the aircraft's structure. And, since airspeed increases when the nose drops and decreases in a climb, the indicator is an excellent check on whether level flight is being maintained. Figure 6-12 shows a cutaway view of a typical airspeed indicator.

An airspeed indicator has a cylindrical airtight case which is connected to the static line from the pitot-static tube. Inside the case is a small aneroid diaphragm that is made of phosphor bronze or beryllium copper. The diaphragm, which is very sensitive to changes in pressure, is connected to the impact pressure (pitot) line so that air from the pitot tube can enter the diaphragm. This side of the diaphragm is fastened to the case and is rigid. The needle or pointer is connected through a series of levers and gears to the free side of the diaphragm.

The airspeed indicator is a differential pressure instrument. That is, it measures the difference between the pressure in the impact pressure line and the pressure in the static pressure line. The two pressures are equal when the aircraft is stationary on the ground. However, movement through the air causes the pressure in the impact line to become greater than the pressure in the static line. The diaphragm, being connected directly to the impact pressure line, expands because of this increase in impact pressure. The expansion or contraction of the diaphragm is transmitted by a

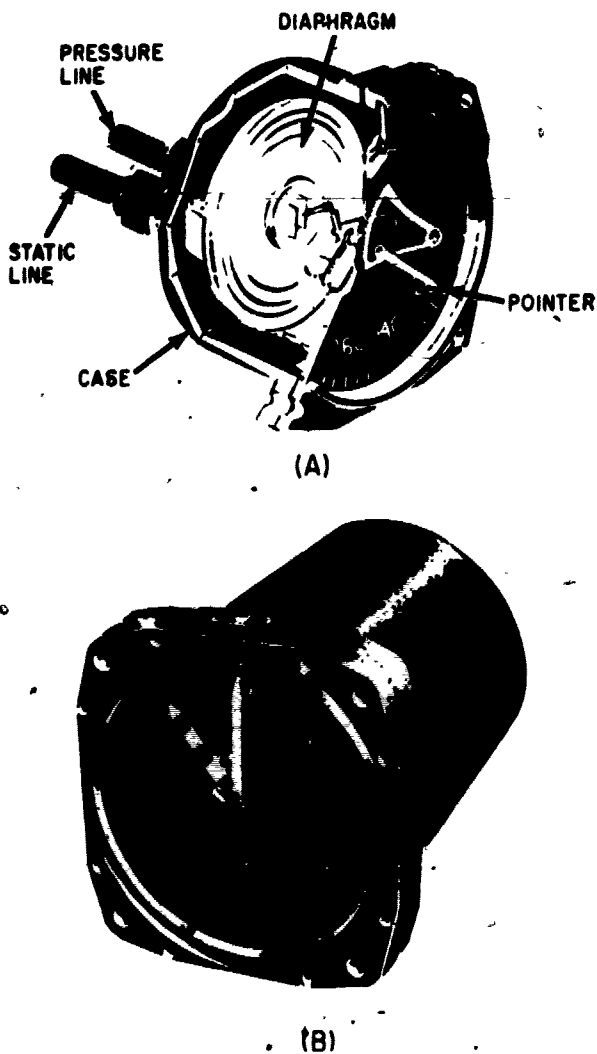

207.358
 Figure 6-12.—(A) Airspeed indicator; (B) maximum allowable airspeed indicator.

series of levers and gears to the face of the instrument to regulate the position of the needle. The needle indicates the pressure differential in mph or knots. (All speeds and distances are based on nautical miles.)

MAXIMUM ALLOWABLE AIRSPEED INDICATOR.—Figure 6-12(B) shows the face of a maximum allowable airspeed indicator. The dial face is calibrated in knots from 50 to 450, with an expanded scale below 200 knots. The

dial has an indicating pointer and a maximum safe airspeed pointer. The maximum safe airspeed pointer varies from its initial setting as the maximum safe airspeed varies due to the static pressure changes at different altitudes.

In the interest of obtaining accurate readings from an airspeed indicator, it should be remembered that errors are usually the result of installation conditions or of poor adjustments on the instrument.

No matter how carefully the location is chosen for placing the pitot-static tube on the aircraft, it is almost impossible to keep it free from all air disturbances set up by the aircraft structure. Actually, the differential pressure developed in the pitot-static system is slightly different from what it would be if conditions were theoretically perfect. Allowances must be made for this "installation error" when reading the indicator. Errors may also be caused by temperature changes in the instrument or by imperfect scaling of the indicator dial with respect to the air-speed-differential pressure relationship. Rather simple adjustments can be made in the instrument mechanism itself to correct the tendency of the instrument to read fast or slow.

MACH NUMBER INDICATORS.—In some instances the speed of an aircraft is expressed in terms of Mach numbers rather than in mph or in knots. The Mach number of any moving body is the ratio of its speed to the speed of sound in the surrounding medium (local speed). For example, if an aircraft is flying at a speed equal to one-half the local speed of sound, it is said to be flying at Mach 0.5. If it moves at twice the local speed of sound, its speed is then Mach 2. (The term Mach number is derived from the name of an Austrian physicist, Ernest Mach, who was a pioneer in the field of aerodynamics.)

Figure 6-13 shows the front view of a typical airspeed and Mach number indicator. The instrument consists of altitude and airspeed mechanisms, incorporated in a single housing. It provides the pilot with a simplified presentation of both indicated airspeed and Mach number. Both indications are read from the same pointer. The pointer indicates airspeed at low speeds, and

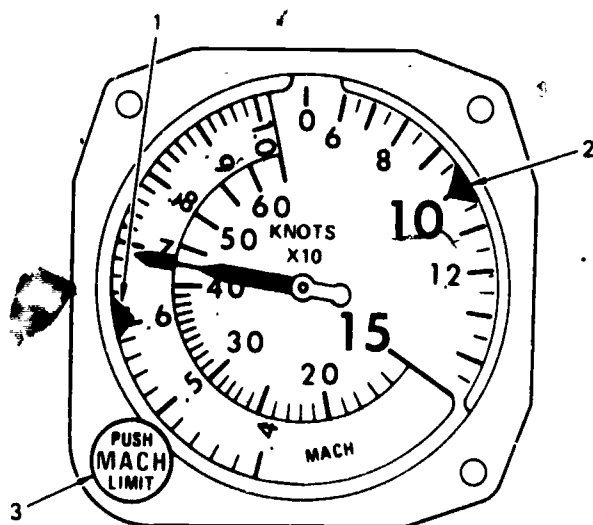

INDEX	CONTROL/INDICATOR	FUNCTION
1	Mach index	Provides a reference mark along the mach scale
2	Airspeed index	Provides a reference mark along the airspeed scale
3	MACH PUSH LIMIT knob	<p>When pressed and rotated it causes the mach index to move along the mach scale from 0.4 to 2.0 mach. When rotated (not pressed) it causes the airspeed index to move along the airspeed scale from 0 to 150 knots</p> <div style="text-align: center;"> <p>CAUTION</p> <p>To set mach limit, turn knob counterclockwise only.</p> </div>

Figure 6-13.—Airspeed/Mach Indicator.

both indicated airspeed and Mach number at high speeds. The pointer is moved by pitot pressure on a diaphragm, and the Mach number dial is controlled by an aneroid diaphragm which reacts to static pressure changes due to altitude

changes. Figure 6-14 is a mechanical schematic of an airspeed and Mach indicator.

The range of the instrument is 80 to 650 knots indicated airspeed, and from 0.5 to 2.0 Mach number, with a calibrated operating limit

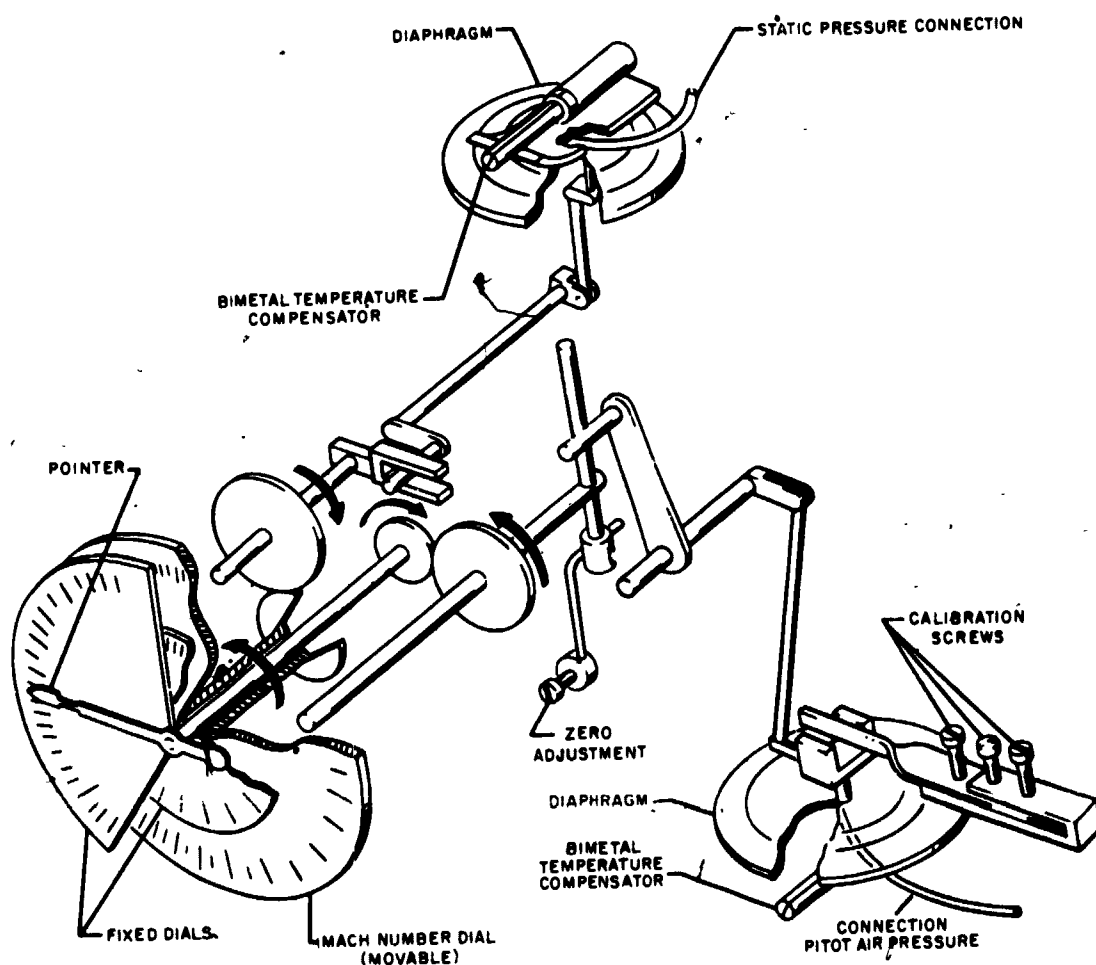

207.360

Figure 6-14.—Airspeed/Mach number indicator mechanical schematic.

of 50,000 feet of altitude. The upper range of the movable, Mach dial is masked by the stationary airspeed dial at low altitudes. The stationary airspeed dial is graduated in knots. The instrument incorporates a landing speed index and a Mach number setting index. Both indexes can be set manually by a knob located on the lower lefthand corner of the instrument. The landing speed index can be set over a range of 80 to 150 knots, and is operated with the knob in its normal position. The Mach number index can be set over the entire Mach range and is operated by depressing the knob and turning it.

VERTICAL SPEED INDICATORS (VSI).—A vertical speed indicator indicates the

rate at which an aircraft is climbing or descending. It is of primary importance for flying at night, through fog or clouds, or whenever the horizon is obscured. Another use is to determine if the maximum rate of climb is being obtained during performance tests or in actual service.

The rate of altitude change, as shown on a climb indicator dial, is positive in a climb and negative in a dive or glide. The dial pointer, as shown in figure 6-15, moves in either direction from the zero point, depending on whether the aircraft is going up or down. In level flight the pointer remains at zero.

The vertical speed indicator is contained within a sealed case and connected to the static

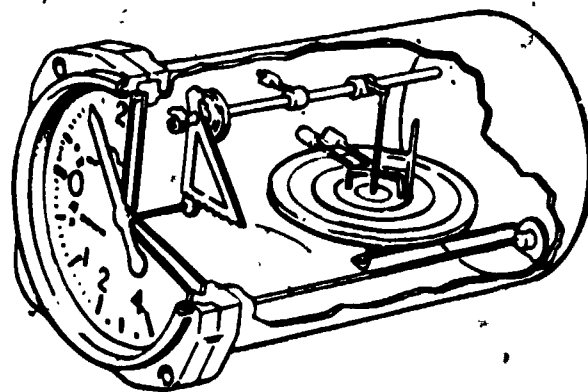
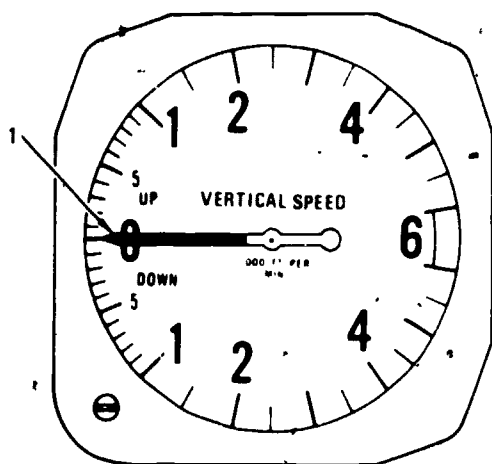

207.74

Figure 6-16.—Mechanical schematic of a VSI.

INDEX	INDICATOR	FUNCTION
1	VSI POINTER	DISPLAYS VERTICAL VELOCITY IN FEET PER MINUTE

Figure 6-15.—Vertical Speed Indicator (VSI).

pressure line through a calibrated leak. As shown in figure 6-16, changing pressures expand or contract a diaphragm which is connected to the indicating needle through gears and levers. The instrument automatically compensates for changes in temperature. Although the vertical speed indicator operates from the static pressure source, it is a differential pressure instrument. The differential pressure is established between the instantaneous static pressure in the diaphragm and the static pressure trapped within the case.

When the pressures are equalized in level flight, the needle reads zero. As static pressure in the diaphragm changes during entry to a climb or descent, the needle immediately shows a change of vertical speed. However, until the differential pressure stabilizes at a definite ratio, rate indications are not reliable. Because of the restriction in airflow through the calibrated leak, a 6- to 9-second lag is required for the pressures to equalize or stabilize.

The VSI is equipped with a zero adjustment on the front of the case which can be used while

the aircraft is on the ground to return the pointer to zero. Tap the instrument lightly to remove friction effects when making this adjustment.

ANGLE-OF-ATTACK (AOA)

The angle-of-attack indicating system detects the local angle of attack of the aircraft from a point on the side of the fuselage and furnishes reference information for the control and actuation of other units and systems in the aircraft. Signals are provided to operate an angle-of-attack indicator (figure 6-17) located on the pilot's instrument panel, where a continuous visual indication of the local angle of attack is displayed. A typical angle-of-attack system provides electrical signals for the operation of a rudder pedal shaker which warns the pilot of an impending stall when the aircraft is approaching the critical stall angle of attack. Electrical switches are actuated at the angle-of-attack indicator at various preset angles of attack that energize colored lights in the approach light system and an approach index light in the cockpit. These lights, completely automatic, furnish the Landing Signal Officer and the pilot with an accurate indication of approach angle of attack during landing. An angle-of-sideslip system (consisting of an airstream direction detector and an angle-of-attack and angle-of-sideslip compensator) is installed on some aircraft. The outputs from these are used for controlled rocket firing.



DIAL ADJUSTMENT SCREW
(A)

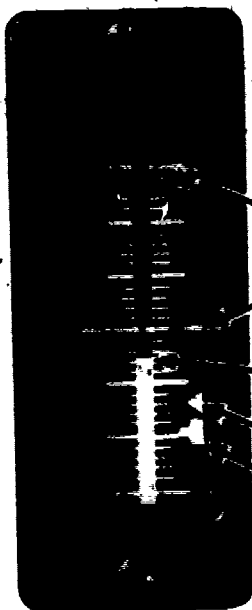

ANGLE-OF-ATTACK
INDICATOR
(B)

207.375
Figure 6-17.—AOA indicators; (A) Radial; (B) vertical scale.

The angle-of-attack indicating system consists of an airstream direction detector transmitter (fig. 6-18) and an indicator. The airstream direction detector contains the sensing element which measures local airflow direction relative to the true angle of attack by determining the angular difference between local airflow and the fuselage reference plane. The sensing element operates in conjunction with a

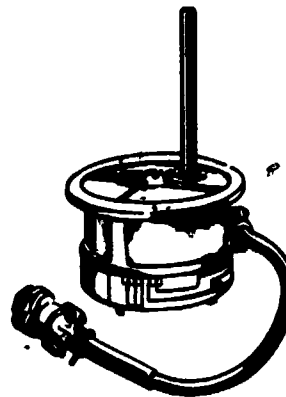

207.375.1
Figure 6-18.—AOA transmitter.

servodriven balanced bridge circuit which converts probe positions into electrical signals.

The operation of the angle-of-attack indicating system is based on detection of differential pressure at a point where the airstream is flowing in a direction that is not parallel to the true angle of attack of the aircraft. This differential pressure is caused by changes in airflow around the probe unit. The probe extends through the skin of the aircraft into the airstream.

The exposed end of the probe contains two parallel slots which detect the differential airflow pressure (fig. 6-19). Air from the slots passes through two separate air passages to separate compartments in a paddle chamber. Any differential pressure, caused by misalignment of the probe with respect to the direction of airflow, causes the paddles to rotate. The moving paddles rotate the probe, through mechanical linkage, until the pressure differential is zero. This occurs when the slots are symmetrical with the airstream direction.

Two potentiometer wipers, rotating with the probe, provide signals for remote indications. Probe position, or rotation, is converted into an electrical signal by one of the potentiometers which is the transmitter component of a self-balancing bridge circuit. When the angle of attack of the aircraft is changed and, subsequently, the position of the transmitter potentiometer is altered, an error voltage exists

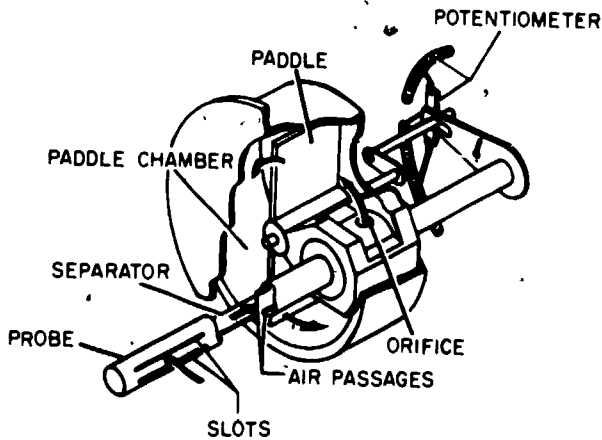

207.376
 Figure 6-19.—Mechanical schematic of airstream direction detector.

between the transmitter potentiometer and the receiver potentiometer in the indicator.

Current flows through a sensitive polarized relay to rotate a servomotor located in the indicator. The servomotor drives a receiver potentiometer in the direction required to reduce the voltage and restore the circuit to a null or electrically balanced condition. The polarity of the error voltage determines the resultant direction of rotation of the servomotor. The indicating pointer is attached to, and moves with, the receiver potentiometer wiper arm to indicate on the dial the relative angle of attack.

The adjustable cams (switches) which control the approach light, approach indexer, and stall warning are shown in figure 6-20.

The cams are actuated as the indicator responds, the relationship of the indicator to the lights and stall warning are shown in figure 6-21. The angle-of-attack indexer on the pilot's glare shield has two arrows and a circle illuminated by colored lamps to provide approach information. The relay operated contacts in the angle-of-attack indicator also control the angle-of-attack indexer. The upper arrow is for high angle of attack (green), the lower arrow is for low angle of attack (red), and the circle is for

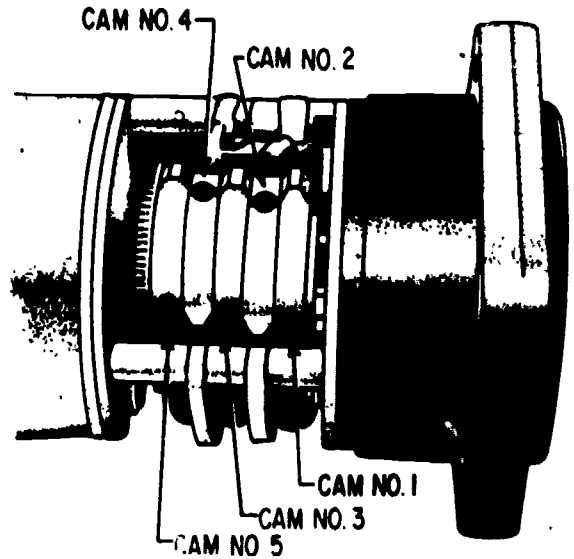

207.377
 Figure 6-20.—Angle-of-attack indicator cams.

optimum angle-of-attack (amber). When both an arrow and a circle appear, an intermediate position is indicated.

The indexer lights function only when the landing gear is down. A flasher unit causes the indexer lights to pulse when the arresting hook is up with the HOOK BY-PASS switch in the CARRIER position.

Stall Warning System

Stall warning indicators are installed on many aircraft to warn the pilot of an impending aerodynamic stall. Early stall warning indicators were pneumatically controlled devices which activated either warning horns or flashing lights. In later years, however, it was learned that a stall is directly related to angle of attack, regardless of airspeed, powersetting, or aircraft loading. The stall warning devices of most aircraft now in the fleet are activated at a specified angle of attack through cams located in the angle-of-attack indicator. The cam-driven switch activates a vibrator motor connected to either a rudder pedal or the control stick.

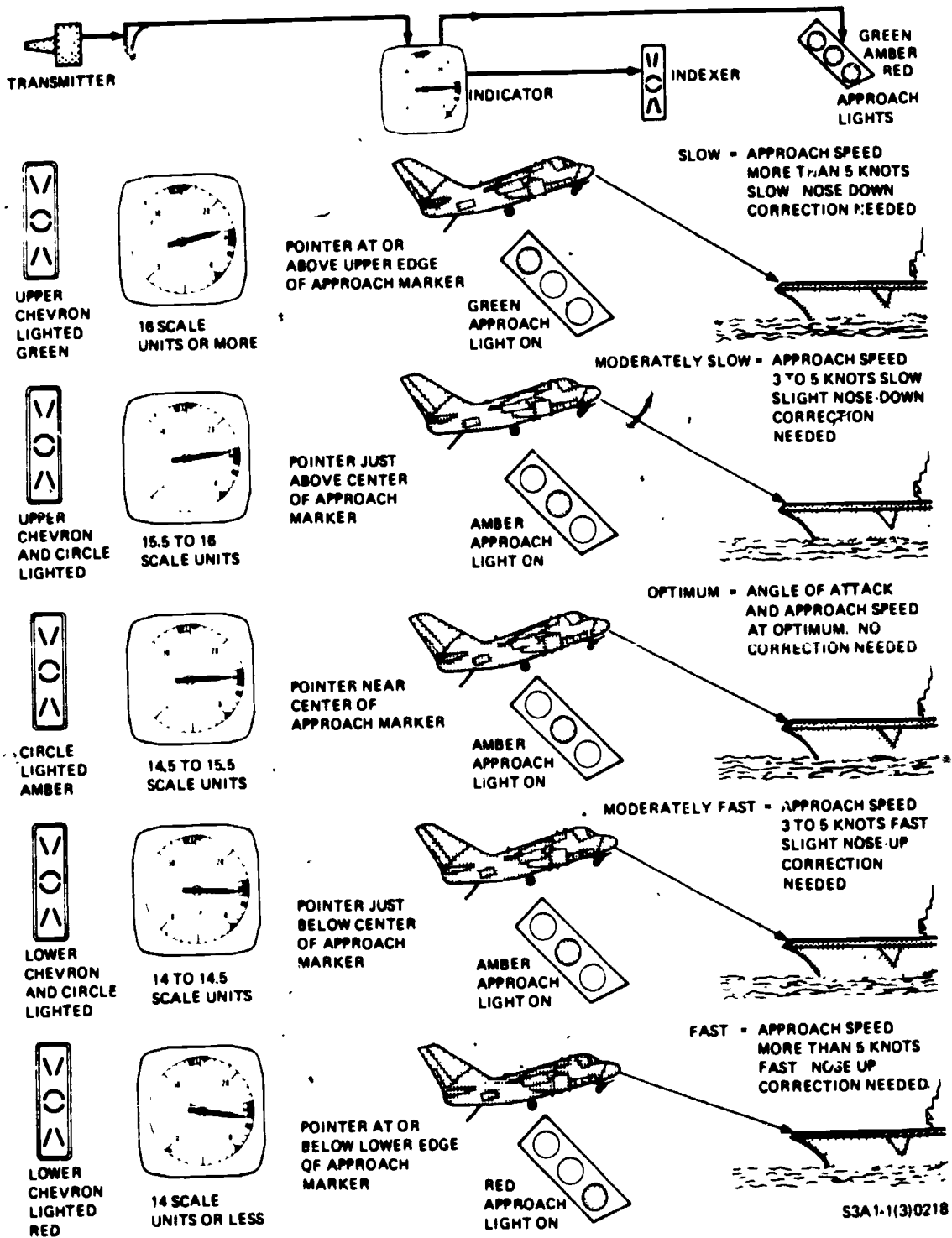

Figure 6-21.-Angle-of-attack (AOA) indications.

207.390

GYROSCOPIC INSTRUMENTS

Early aircraft were flown by visually aligning the aircraft with the horizon; when visibility was poor, it was impossible to fly the aircraft safely. The need for flight instruments to correct this condition caused the development of gyroscopic instruments. The gyroscopic properties of a spinning wheel have made precision instrument flying, precise navigation, and pinpoint bombing practical and reliable. Some of the instruments which depend on a spinning wheel for their operation are the turn-and-bank indicator, directional gyro, gyro horizon, AFCS, drift meter, gyrostabilized fluxgate compass, and the inertial navigation system.

A gyroscope is a spinning wheel or rotor which is universally mounted; that is, mounted so it can assume any position in space. Any spinning object exhibits gyroscopic properties. However, a wheel designed and mounted to utilize these properties is called a gyroscope. The two important design characteristics of an instrument gyro are (1) great weight for small size (high density), and (2) rotation at high speeds with low friction bearings. The mountings of the gyro wheels are called gimbals; they may be circular rings, rectangular frames, or, in flight instruments, a part of the instrument case itself. A simple gyroscope is illustrated in figure 6-22.

The two general types of mountings for gyros are the free or universal mounting and the restricted or semirigid mounting. The type mounting used depends on the purpose for which the gyro is to be utilized.

A gyro can have different degrees of freedom, depending on the number of gimbals in which it is supported, and the way in which the gimbals are arranged. The term "degrees of freedom," as used here, must not be confused with an angular value as degrees of a circle. The term as used with gyros is an indication of the number of directions in which the rotor is free to move. (Some authorities consider the spin of the rotor as one degree of freedom, but most do not.)

A gyro enclosed in one gimbal, such as the one shown in figure 6-22, has only one degree of

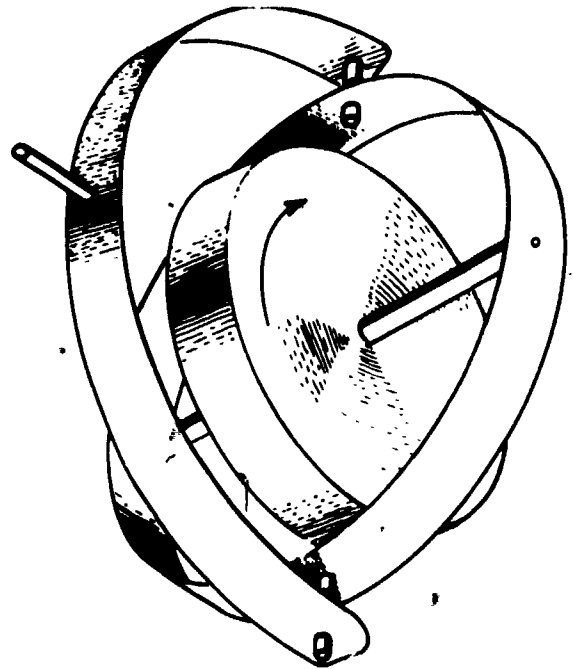

207.304

Figure 6-22.—Simple gyroscope.

freedom. This is a freedom of movement back and forth at a right angle to the axis of spin. When this gyro is mounted in an aircraft, with its spin axis parallel to the direction of travel and capable of swinging from left to right, it has one degree of freedom. The gyro has no other freedom of movement. Therefore, if the aircraft should nose up or down, the geometric plane containing the gyro spin axis would move exactly as the aircraft does in these directions. However, if the aircraft should turn right or left, the gyro would not change its position, since it has a degree of freedom in these directions.

A gyro mounted in two gimbals normally has two degrees of freedom. Such a gyro can assume and maintain any attitude in space. For illustrative purposes, consider a rubber ball in a bucket of water. Even though the ball is supported by the water, it is not restricted as to attitude by the water, and can lie with its spin axis pointed in any direction. Such is the case with a two-degree-of-freedom gyro (often called a free gyro).

This means that if the base surface turns around the outer gimbal axis, or around the inner gimbal axis, the gyro spin axis remains fixed. In other words, the gimbaling system isolates the rotor from the base rotation. The universally mounted gyro is an example of this type. Restricted or semirigidly mounted gyros are those mounted so that one of the planes of freedom is held fixed in relation to the base.

Practical applications of the gyro are based upon two fundamental properties of gyroscopic action: (1) rigidity in space, and (2) precession.

Newton's first law of motion states: "A body at rest will remain at rest, or if in motion will continue in motion in a straight line, unless acted upon by an outside force." An example of this law is the rotor in a universally mounted gyro. When the wheel is spinning, it has the ability to remain in its original plane of rotation regardless of how the base is moved. This is shown in figure 6-23. The gyroscope holds its position relative to space, even though the earth turns around once every 24 hours.

The factors which determine how much rigidity a spinning wheel has are found in

Newton's second law of motion which states: "The deflection of a moving body is directly proportional to the deflective force applied and is inversely proportional to its mass and speed." To obtain as much rigidity as possible in the rotor, it is given great weight for size, and rotated at high speeds. To keep the deflective force at a minimum, the rotor shaft is mounted in bearings which are as frictionless as possible. The basic flight instruments which utilize the gyroscopic property of rigidity for their principle of operation are the gyro horizon, the directional gyro, and any gyro-stabilized compass system; consequently, their rotors must be freely or universally mounted.

Precession is the resultant action of deflection of a spinning wheel when a deflective force is applied to its rim. When a deflective force is applied to the rim of a rotating wheel, the resultant force is 90° ahead of the direction of rotation and in the direction of the applied force. This is illustrated in figure 6-24. The rate at which the wheel precesses is inversely proportional to the speed of the rotor and directly proportional to the deflective force. The force with which a wheel precesses is the same as the deflective force applied (minus the friction in the gimbal ring, pivots, and bearings). If too great a deflective force is applied for the amount of rigidity in the wheel, the wheel precesses and topples over at the same time.

Any spinning mass exhibits the gyroscopic properties of rigidity in space and precession. The rigidity of a spinning rotor is directly proportional to the weight of the rotor and its speed, and inversely proportional to the deflective force. For a complete understanding of gyros and gyro fundamentals the AE should refer to *Servos, Synchros and Gyros, Module 15, Navy Electricity and Electronics Training Series (NEETS)*.

Attitude Indicator

A pilot determines aircraft attitude by referring to the horizon if and when he can see it. Often enough, however, the horizon is not visible. When it is dark, or when there are obstructions to visibility such as overcast,

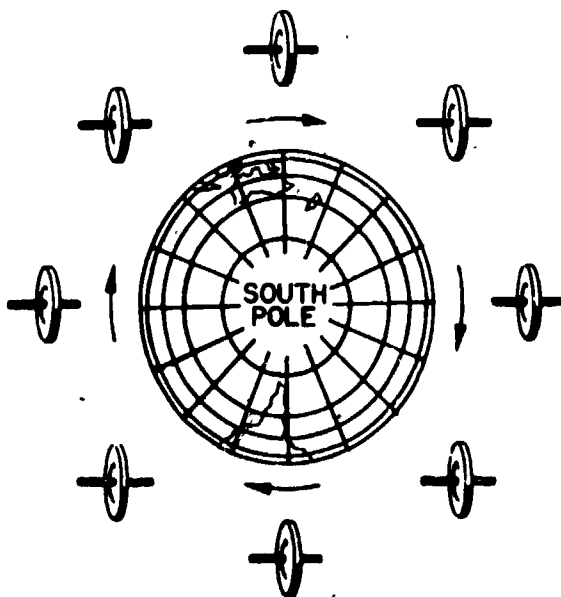

207.305

Figure 6-23.—Action of a freely mounted gyroscope.

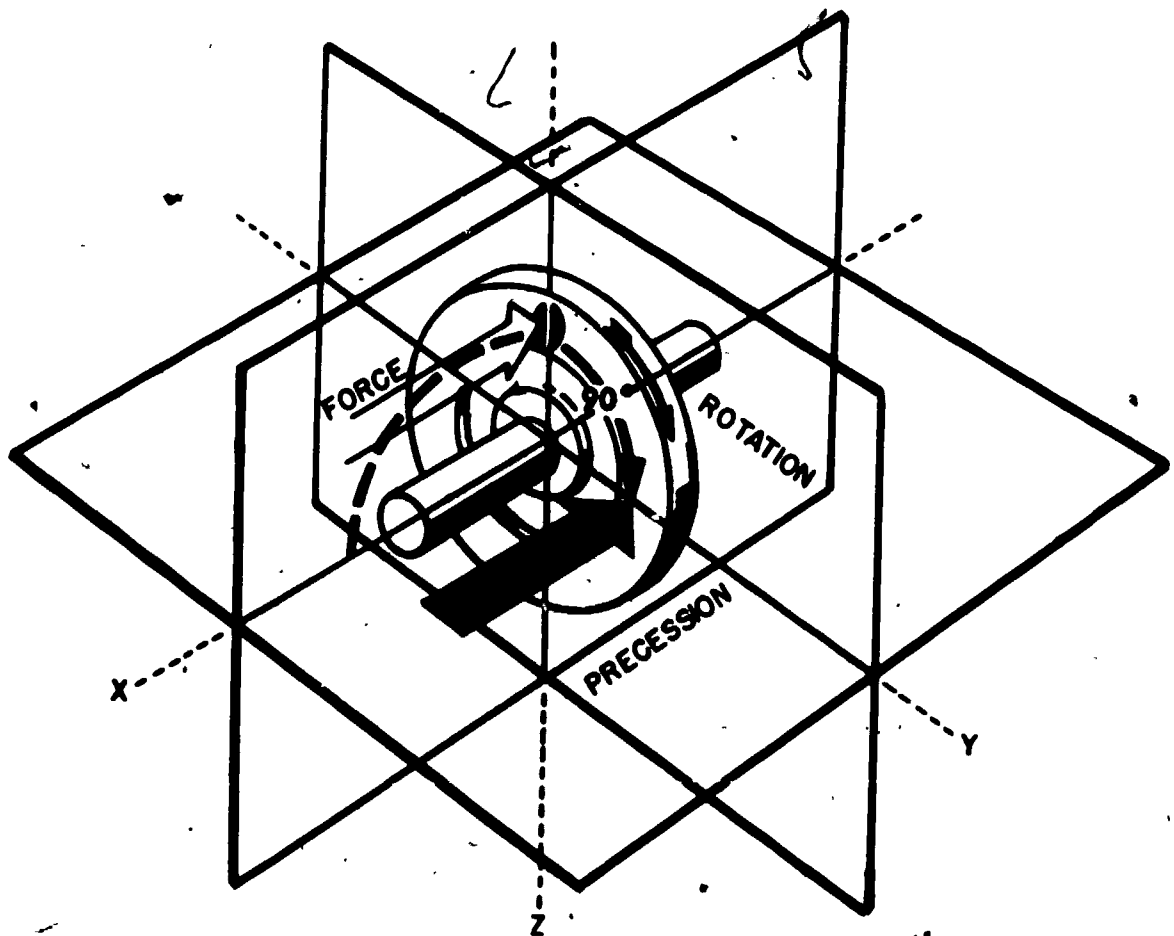

Figure 6-24.—Precession resulting from deflective force.

207.306

smoke, or dust, he cannot use the earth's horizon as a reference. When this condition exists, he refers to an instrument called the attitude indicator. This instrument is also called by other names, such as vertical gyro indicator (VGI), artificial horizon, or gyro horizon. From these instruments the pilot learns the relative position of the aircraft with reference to the earth's horizon.

The attitude indicator gyro rotor revolves with its spin axis in a vertical position (with respect to the earth's surface). This vertical position is rigidly maintained as the aircraft pitches and rolls about the space-rigid gyro. (See fig. 6-25.) The case of the gyro is rigidly

attached to the aircraft, therefore, any movement of the aircraft is identically duplicated by the case. The case is free to revolve around the stable gyro because of the mounting of the gyro motor in gimbals. It follows, therefore, that the aircraft itself actually revolves around the rotor and is the complementing factor in establishing the indications of the instrument.

Although attitude indicators may be different in size and appearance they all have the same basic components and present the same basic information. There will always be a miniature aircraft on the face of the indicator which represents the nose (pitch) and wing

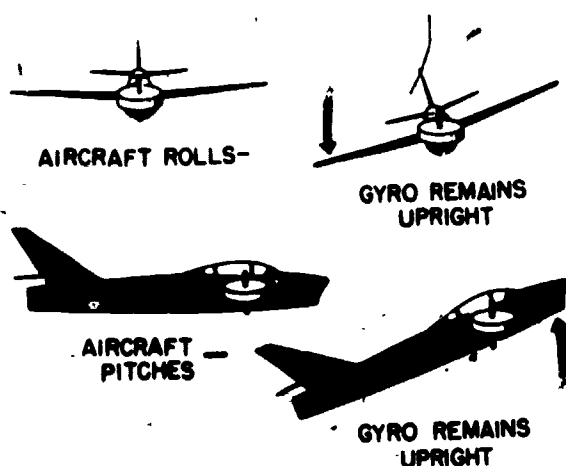

207.307
Figure 6-25.—Aircraft reference and gyro stability.

(bank) attitude of the aircraft in respect to the earth's horizon, as shown in figure 6-26. There will be a bank pointer on the face of the indicator which indicates the degree of bank (in 10° increments up to 30° , then 30° increments to 90°). The sphere will always be shaded light on the upper half and dark on the lower half to show the difference between sky and ground. Calibration marks on the sphere will indicate degrees of pitch (5° or 10° increments). Each indicator will also have a pitch trim adjustment so that the horizon may be centered as necessary by the pilot.

Some attitude indicators have the gyro self-contained, however, most modern indicators utilize pitch and roll information from other systems such as the inertial system or the attitude heading reference system. These systems are far more accurate and reliable because they can be made larger since their size is not limited by the confined space of an instrument panel. Electrical signals from the remote gyro are transmitted via synchros and amplified in the indicator to drive servomotors and position the indicator sphere exactly as the vertical gyro is positioned in the gyro case. In the newer attitude indicators, the sphere is gimbal-mounted and capable of 360° rotation. In contrast, the older gyros were limited to approximately 60° to 70° of pitch and 100° to

110° of roll. Some aircraft incorporate an all attitude indicator (fig. 6-27) which, in addition to pitch and roll, also indicates azimuth (compass information) along the horizon bar and turn and bank information on the bottom. An even more sophisticated instrument called a "flight director" displays all of the above information and, in addition, radio navigation information, all on one instrument.

Turn and Bank Indicator

The turn-and-bank indicator (fig. 6-28) also called the turn-and-slip, or the needle-ball indicator is used to indicate the lateral attitude of an aircraft in straight flight, and to provide a reference for the proper executions of a coordinated bank and turn. It indicates when the aircraft is flying on a straight course, and also indicates the direction and rate of a turn. It was one of the first modern instruments to be used for controlling an aircraft without visual reference to the ground or horizon.

The indicator is a combination of two instruments, a ball and a turn pointer. The ball part of the instrument is actuated by natural forces, while the turn pointer depends on the gyroscopic property of precession for its indications. The gyro of the turn indicator may be driven by vacuum or it may be electrically operated.

BALL.—The ball portion of a turn-and-bank indicator (fig. 6-28) consists of a sealed, curved, glass tube containing water-white kerosene and a black or white agate or common steel ball bearing which is free to move inside the tube. The fluid provides a damping action and insures smooth and easy movement of the ball. The tube is curved so that when it is held in a horizontal position, the ball has a natural tendency to seek the lowest point, which is the center. A small projection on the left end of the tube contains a bubble of air which allows for expansion of the fluid during changes in temperature. Two markings or wires are located around the center of the glass tube. They serve as reference markers to indicate the correct



15° RIGHT TURN
10° NOSE UP

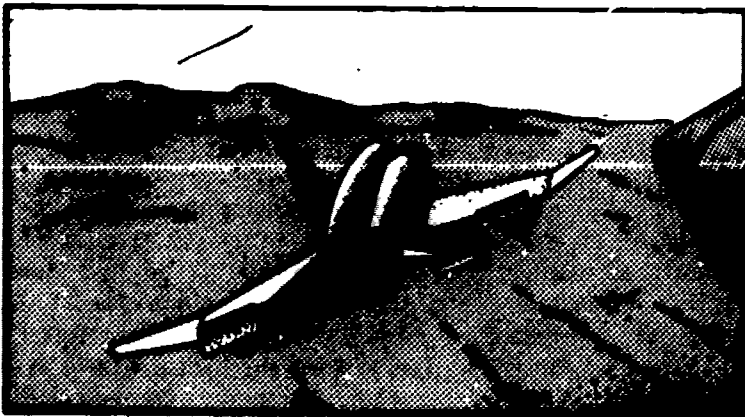

30° LEFT TURN
6° NOSE DOWN

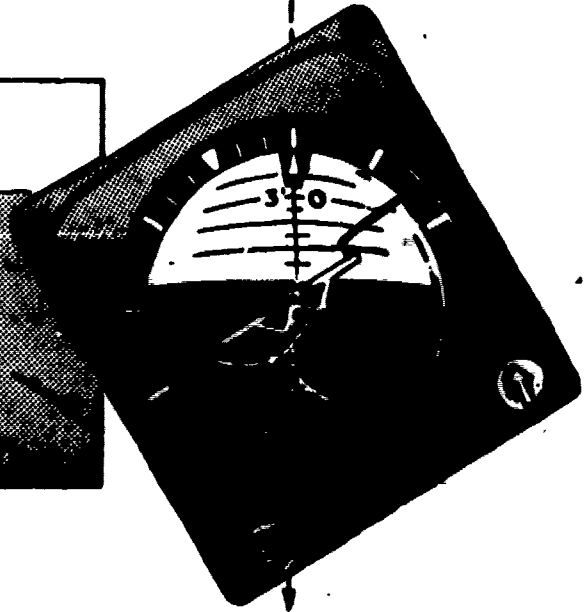

**GYRO REMAINS CONSTANTLY UPRIGHT
DURING MANEUVERS; AIRCRAFT
REVOLVES AND PITCHES
AROUND AND ABOUT THE GYRO.**

207.75

Figure 6-28.—Roll and pitch indications on the attitude indicator.

position of the ball in the tube. The plate to which the tube is fastened and the references are usually painted with luminous paint.

The only force acting on the ball during straight flight (no turning) with the wings level is

gravity. The ball seeks its lowest point and stays within the reference marks. In a turn, centrifugal force also acts on the ball in a horizontal plane opposite to the direction of the turn.

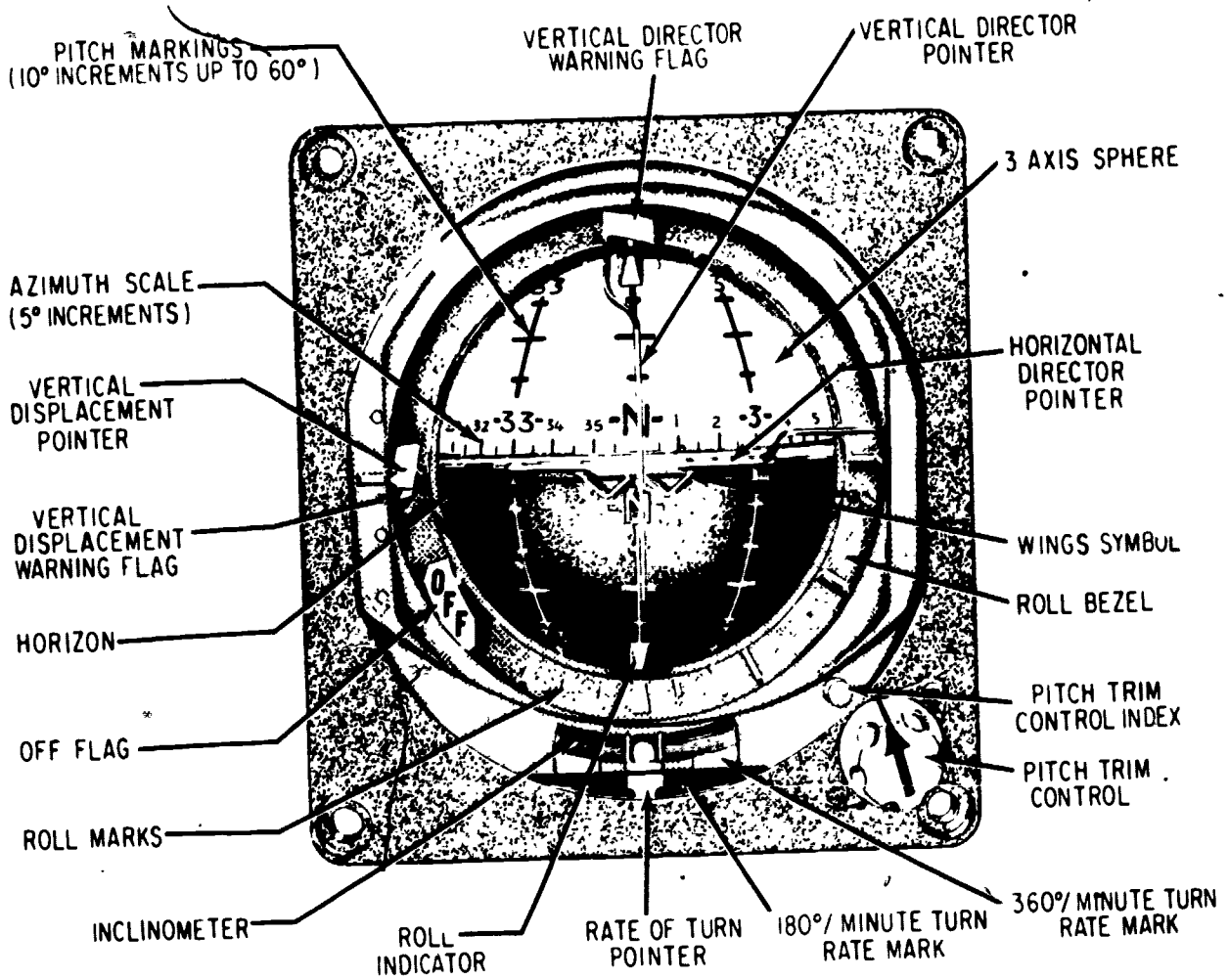

207.76

Figure 6-27.—All attitude indicator.

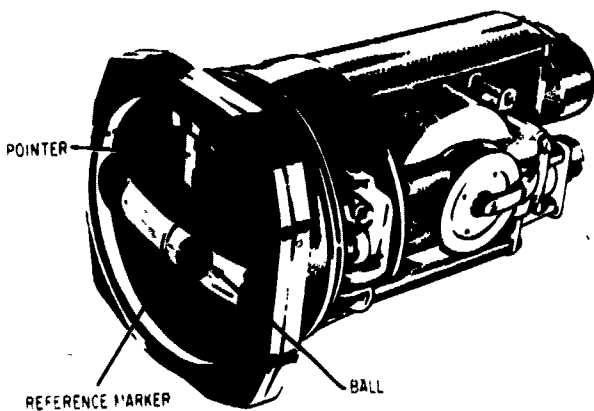

207.247

Figure 6-28.—Turn-and-bank indicator.

The ball assumes a position between the reference markers when the resultant of centrifugal force and gravity acts directly opposite to a point midway between the reference markers. When the forces acting on the ball become unbalanced, the ball moves away from the center of the tube.

In a skid, the rate of turn is too great for the angle of bank, and the excessive centrifugal force causes the ball to move to the outside of the turn. The resultant of centrifugal force and gravity is not opposite the midpoint between the reference markers; consequently, the ball moves in the direction of the force, which is toward the outside of the turn. Returning the ball to center

(coordinated turn) calls for increasing the bank or decreasing the rate of turn, or a combination of both.

In a slip, the rate of turn is too slow for the angle of bank, and the resultant of centrifugal force and gravity causes the ball to move to the inside of the turn. Returning the ball to center (coordinated turn) requires decreasing the bank or increasing the rate of turn, or a combination of both.

The ball instrument is actually a "balance" indicator, because it indicates the relationship between the angle of bank and the rate of turn. It enables the pilot to know when the aircraft has the correct rate of turn for its angle of bank.

TURN POINTER.—The turn pointer is actuated by a gyro. The gimbal ring encircles the gyro in a horizontal plane and is pivoted fore and aft in the instrument case.

The major components of the turn portion of a turn-and-bank indicator are:

1. A frame assembly that is used as a means of assembling the instrument.
2. A motor assembly consisting basically of the stator, rotor, and motor bearings. The electrical motor serves as the gyro for the turn indicator.
3. A plate assembly that is used for mounting the electrical receptacle, pivot assembly, a choke coil and capacitors for eliminating radio interference, and the power supply of transistorized indicators.
4. A damping unit that is used to absorb vibrations and prevent excessive oscillations of the needle. The unit consists of a piston and cylinder mechanism, and the amount of damping may be controlled by adjustment screws.
5. An indicating assembly composed of a dial and pointer.
6. The cover assembly.

The gyro is carefully balanced and rotates about the lateral axis of the aircraft in a frame that pivots about the longitudinal axis. When mounted in this way, the gyro responds only to

motion around a vertical axis, being unaffected by rolling or pitching.

The turn indicator takes advantage of one of the fundamental principles of gyroscopes known as precession. Precession, as already explained, is a gyroscope's natural reaction 90° in the direction of rotation from an applied force. It is visible as resistance of the spinning gyro to a change in direction when a force is applied. As a result, when the aircraft makes a turn, the gyro position remains constant, but the frame in which the gyro is suspended dips to the side opposite the direction of turn. However, because of the design of the linkage between the gyro frame and the pointer, the pointer indicates correctly the direction of turn and the pointer displacement is proportional to the rate of turn of the aircraft. If the pointer remains on center, it indicates that the aircraft is flying straight. If it moves off center, it indicates that the aircraft is turning in the direction of the pointer deflection.

The turn needle indicates the rate (number of degrees per minute) at which the aircraft is turning.

By observing the turn-and-bank indicator, the pilot may check for coordination and balance in straight flight and in turns. If this instrument is cross-checked against the airspeed indicator, the relation between the lateral axis of the aircraft and the horizon (angle of bank) may be determined. For any given airspeed, there is a definite angle of bank necessary to maintain a coordinated turn at a given rate.

MISCELLANEOUS FLIGHT INSTRUMENTS

Several other indicators are useful to the pilot for control of his aircraft. These indicators are not useful at all times, but come into play under special flight conditions. (Refer to fig. 6-29.)

Accelerometer Indicators

The accelerometer furnishes an indication of the load on the structure of the aircraft in terms

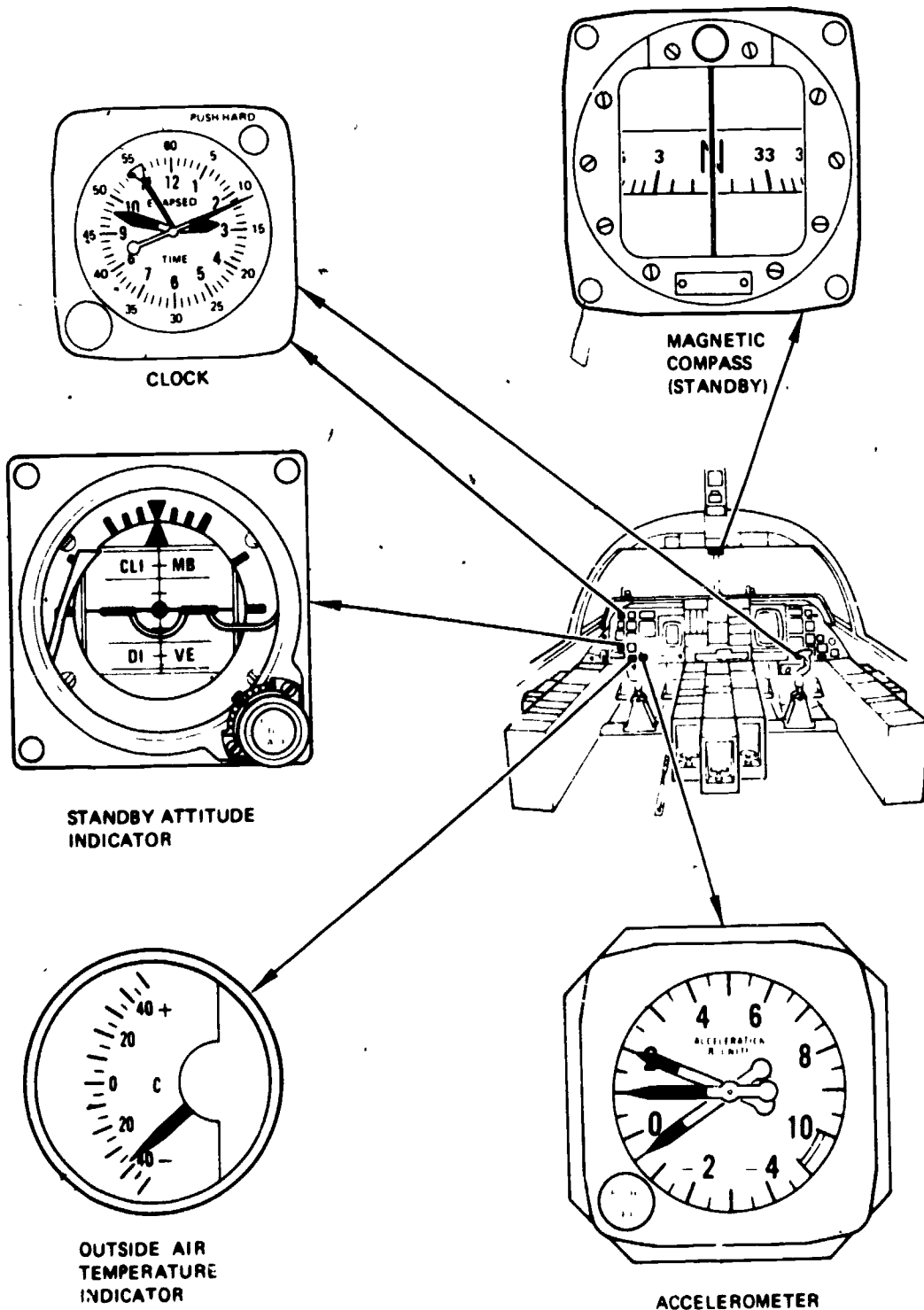

Figure 6-29.—Miscellaneous Flight Instruments.

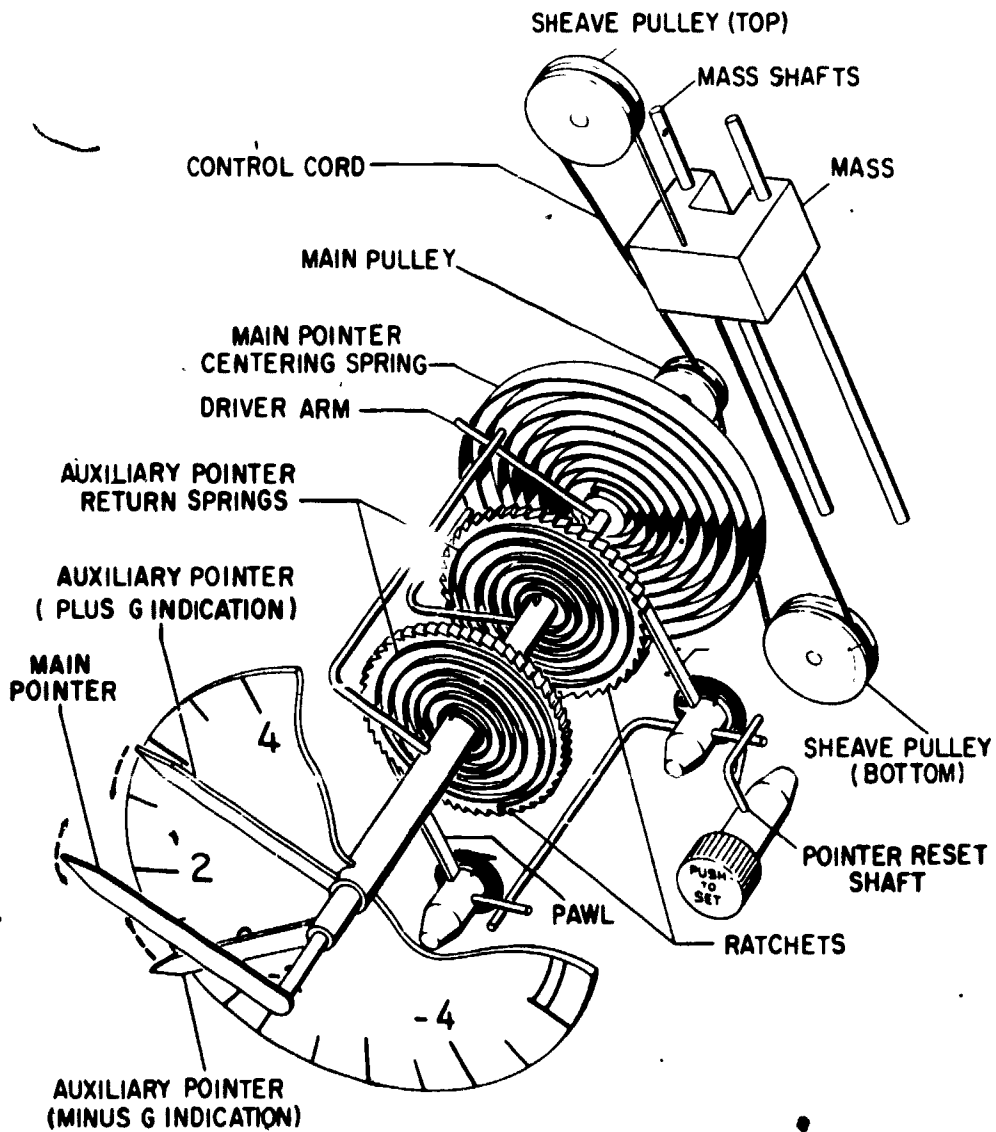

Figure 6-30.—Accelerometer mechanical schematic.

207.352

of gravitation (g) units. It presents information which enables maneuvering within the aircraft's operational limits. The pilot must limit the maneuvers of the aircraft so that various combinations of acceleration, airspeed, gross weight, and altitude remain within specified values, thereby eliminating the possibility of damage to the aircraft as a result of excessive stresses.

The forces sensed by the accelerometer act along the vertical axis of the aircraft. The main hand moves clockwise as the aircraft accelerates upward; it moves counterclockwise as the aircraft accelerates downward.

The indications shown by the accelerometer are in g units. The main indicating hand turns to +1g whenever the lift of the aircraft wing is exactly equal to the weight of the aircraft. Such

a condition prevails in level flight. The hand turns to +3g when the lift is three times the weight; and to minus readings when the forces acting on the aircraft surfaces cause the aircraft to accelerate downward.

The accelerometer operates independently of all other aircraft instruments and installations. The activating element of the mechanism is a mass that is movable in a vertical direction on a pair of shafts (fig. 6-30). Vertical movement of the mass is damped by the action of a spiral-wound main spring. The force of the mass is transmitted by means of a string and pulley system to the main spring and main shaft, and from there to the plus and minus assemblies on which are mounted the hand assemblies. Changes in vertical acceleration cause movement of the mass on the shafts, which is translated into turning motion of the main shaft. The turning motion pivots the indicating hands around the dial a distance equivalent to the value in g units of the upward or downward acceleration of the aircraft.

The accelerometer operates on the principle that a body in motion tends to remain in motion, and a body at rest tends to remain at rest unless acted upon by an external force. During level flight, or when the aircraft is in a constant rate of climb or descent, no forces act on the mass to displace it from a position about midway between the top and bottom of the mass shafts. Consequently the accelerometer pulley system performs no work and the indicating hands remain stationary at +1g. When the aircraft changes from level flight or changes its rate of climb or descent, forces act on the mass, causing it to move either above or below its midway position. These movements cause the accelerometer indicating hands to change their position. When the aircraft goes nose down, the hands move to the minus section of the dial; when the nose goes up, they move to the plus section.

The main hand continuously indicates changes in loading. The two other hands on the accelerometer indicate the highest plus acceleration and highest minus acceleration of the aircraft during any maneuver. These readings are maintained through the use of a ratchet mechanism. A knob in the lower left of the

instrument face provides a means for resetting the maximum- and minimum-reading hands to normal at any time. Thus, the accelerometer may retain an indication of the highest plus and minus accelerations during a particular phase of a flight or during a series of flights.

COUNTING ACCELEROMETER.—The counting accelerometer (fig. 6-31), although not a flight instrument and installed remote from the cockpit, duplicates the information indicated by the accelerometer just discussed. The counting accelerometer system indicates and records the maximum accelerations of the aircraft during a flight. The system records the number of times the preset airframe gravitational loads are equaled or exceeded.

The system consists of a sensor and an indicator. The sensor consists of a movable mass that changes the positions of a contact bar. As the contact bar moves across successive contacts, a signal is generated which operates relays in the indicator. Signals from the sensor activate one or more of the four indicator counters.

The accelerometer indicator has four counter windows from which readings can be taken when the aircraft is on the ground. The counting accelerometer system is operated by 28 volts d.c. from the secondary bus through the up and locked contacts of the main gear up switch.

The location of the indicator and sensor vary with different aircraft configurations.

Clocks

The standard Navy clock is a 12 hour, elapsed time stem wound clock with an 8 day movement. This type clock is mounted in the cockpit for use by the pilot or copilot, but may be located for use by other crewmembers as well. The pull-to-set winding stem is at the lower left of the dial. The dial is marked with sixty divisions which may be read as minutes or seconds as appropriate. The face has standard minute and hour hands, a sweep second hand, and an elapsed time minute hand. The elapsed time minute hand may be started, stopped, and reset to zero by pressing a single button at the upper right of the dial.

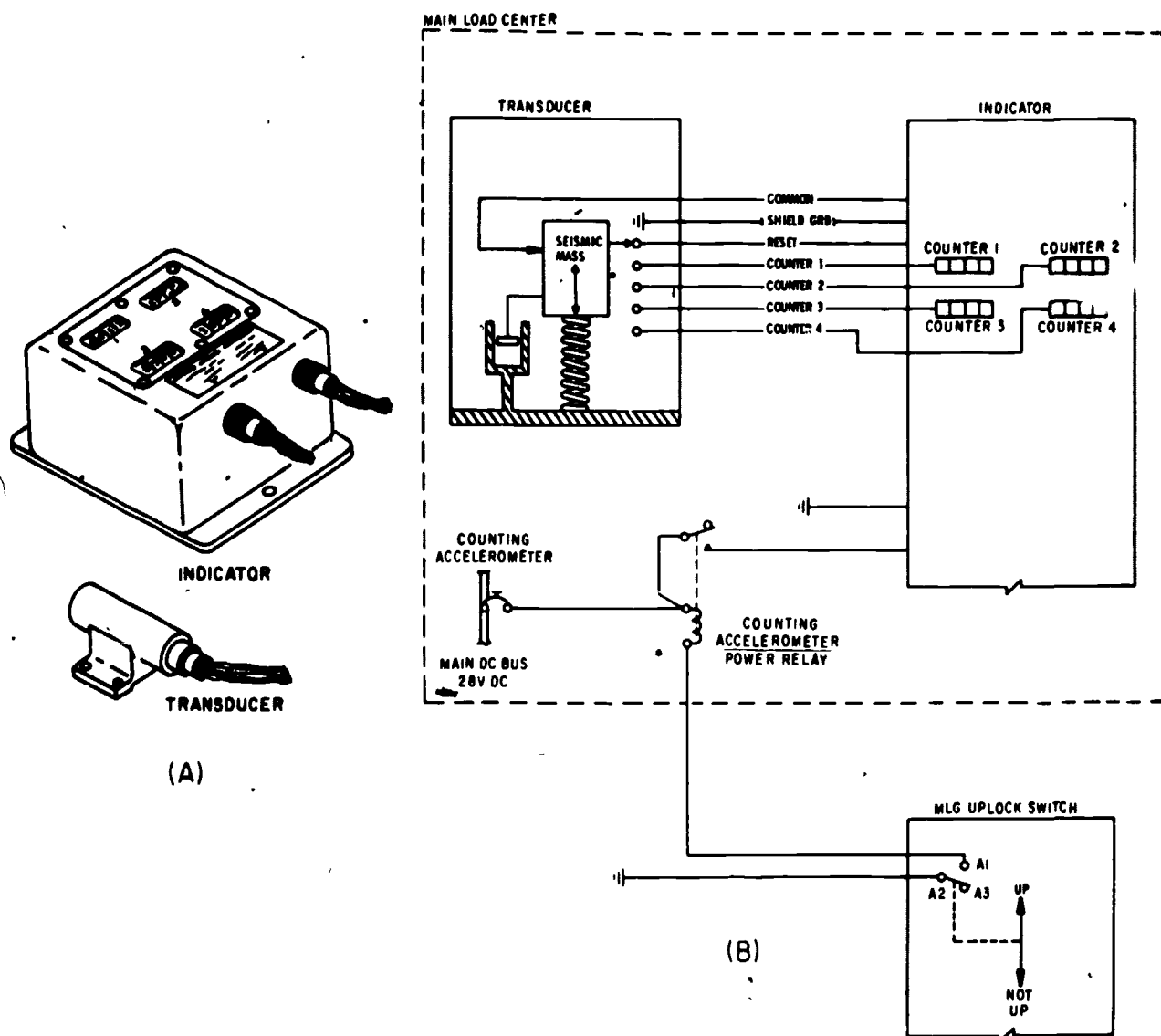

207.353

Figure 6-31.—(A) Counting accelerometer group; (B) counting accelerometer group schematic.

Direct-Reading Compasses

During the early days of aviation, direction of flight was determined within the aircraft chiefly by direct-reading magnetic compasses. Today the direct-reading magnetic compass still finds use as a standby compass. Direct-reading magnetic compasses used in Navy aircraft are mounted on the instrument panel for use by the pilot, and can be read like the dial of a gage.

A nonmagnetic metal bowl, filled with liquid, contains a compass indicating "card" which provides the means of reading compass indications. The card is mounted on a float assembly and is actually a disk with numbers painted on its edge. A set of small magnetized bars or needles is fastened to this card. The card-magnet assembly is suspended on a jeweled pivot which allows the magnets to align themselves freely with the north-south

component of the earth's magnetic field. The compass card and a fixed position reference marker called the lubber's line are visible through a glass window on the side of the bowl.

An expansion chamber is built into the compass to provide for expansion and contraction of the liquid, caused by altitude and temperature changes. The purpose of the liquid is to dampen—or slow down—the oscillation of the card. This oscillation is caused by vibration and changes in the aircraft heading. If suspended in air, the card would keep swinging back and forth and be difficult to read. The liquid also buoys up the float assembly, thereby reducing the weight and friction on the pivot bearing.

Instrument-panel compasses for naval aircraft are available with cards marked in steps of either 2° or 5°. Such a compass indicates continuously without electrical or information inputs. The approximate heading of the aircraft may be read by looking at the card in reference to the lubber's line through the bowl window.

Standby Attitude Indicator

The standby attitude indicator (refer to fig. 6-29) located on the pilot instrument panel, consists of a miniature aircraft symbol, a bank angle dial, a bank index, and a two-colored drum background with a horizon line dividing the two.

The color white is used to depict the top (or sky half) and grey is used to depict ground. The indicator roll index is graduated in 10-degree increments to 30 degrees, with graduation marks at 60 and 90 degrees. The indicator is capable of displaying 360 degrees of roll, 92 degrees of climb, and 79 degrees of dive. The gyro is powered electrically. Due to the high spin rate of the gyro, the indicator displays accurate pitch and roll data for approximately 9 minutes after electrical failure. The attitude indicator incorporates a pitch trim knob to position the miniature aircraft symbol above or below the horizon reference line. The pitch trim knob is also used to cage the gyro. When the pitch trim knob is pulled out, the gyro will cage. If the knob is rotated clockwise while extended it will lock in the extended position. The attitude indicator also incorporates an OFF flag. The flag will appear if electrical power to the indicator is

interrupted or if the gyro is caged with the pitch trim knob.

Outside Air Temperature Indicator

An indicator displaying uncorrected outside air temperature is installed on the pilot instrument panel. A bulb, powered by the primary dc bus, consisting of a temperature sensitive resistor exposed to the slipstream measures the change in temperature of the air in the form of changing resistance. This change in resistance is displayed on the outside air temperature indicator. The indicator dial is graduated in degrees centigrade from +50 to -50.

ENGINE INSTRUMENT SYSTEMS

Engine instruments provide indications which include tail pipe temperature, oil and fuel pressure, engine rpm, oil temperature, and fuel flow rate. It is essential that the pilot be aware of engine operation at all times. If oil pressure falls below the normal operating limit or if tail pipe temperature becomes excessively high, the engine instruments provide these indications.

TACHOMETER SYSTEMS

The tachometer indicator is an instrument for indicating the speed of the crankshaft of a reciprocating engine and the speed of the main rotor assembly of a gas turbine (jet) engine.

The dials of tachometer indicators that are used with reciprocating engines are calibrated in revolutions per minute (rpm); those used with jet engines are calibrated in percentage of rpms being used, based on the takeoff rpm as shown in figure 6-32.

A number of various types and sizes of generators and indicators are used in the tachometer system of naval aircraft. Generally speaking, all operate on the same basic principle. In presenting information on tachometer systems, a typical generator and a typical indicator are described. It is not practical to describe all of the generators and indicators in a training manual such as this; for detailed

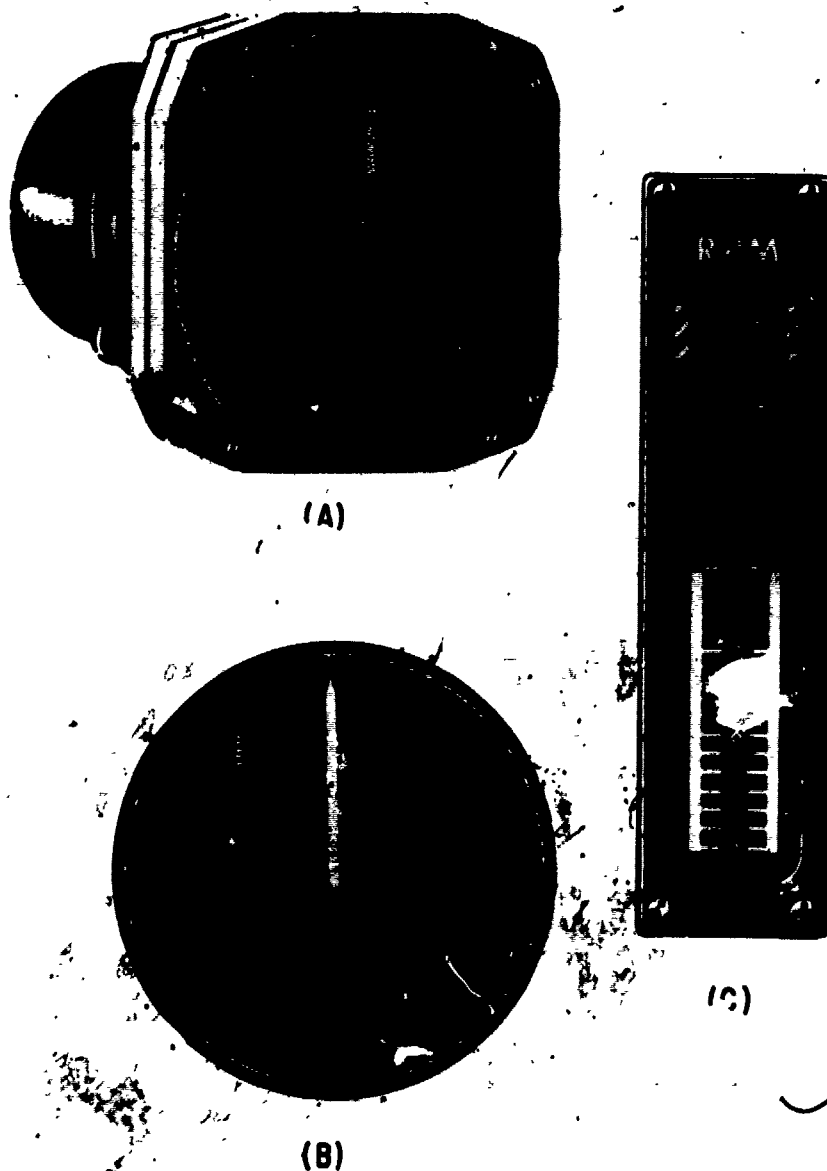

Figure 6-32.—Tachometer indicators. (A) Reciprocating engine; (B) jet engine (radial) (C) jet engine (vertical scale).

207.366

information on a particular system refer to the manufacturer's manuals.

The tachometer system described consists essentially of an ac generator coupled to the aircraft engine and an indicator consisting of a magnetic-drag element mounted on the instrument panel. The generator transmits electric power to a synchronous motor, which is

a part of the indicator. The frequency of this power is proportional to the engine speed. By applying the magnetic-drag principle to the indicating element, an accurate indication of engine speed is obtained. The problem of changes in generator output voltage is eliminated by the generator and synchronous-motor combination which constitutes a

frequency-sensitive system for transmitting an indication of engine speed to the indicator with absolute accuracy.

For many installations, it is desirable to transmit a single engine-speed indication to two different stations in the aircraft. The frequency-sensitive system is ideal for this application since there is no change in indication when a second indicator is connected in parallel with the first. Synchronous-motor operation in each indicator is dependent only upon the availability of sufficient power in the generator to operate both indicator motors.

Tachometer Generator

Tachometer generator units are small and compact (about 4 inches by 6 inches). The generator is constructed with an end shield designed so that the generator can be attached to a flat plate on the engine frame, or reduction gearbox, with four bolts.

Figure 6-33 shows a cutaway view of a tachometer generator. The generator consists essentially of a permanent-magnet rotor (1) driven by the engine, and a stator (8) in which 3-phase power is developed as the rotor turns.

The armature of the generator consists of a magnetized rotor which has been cast directly

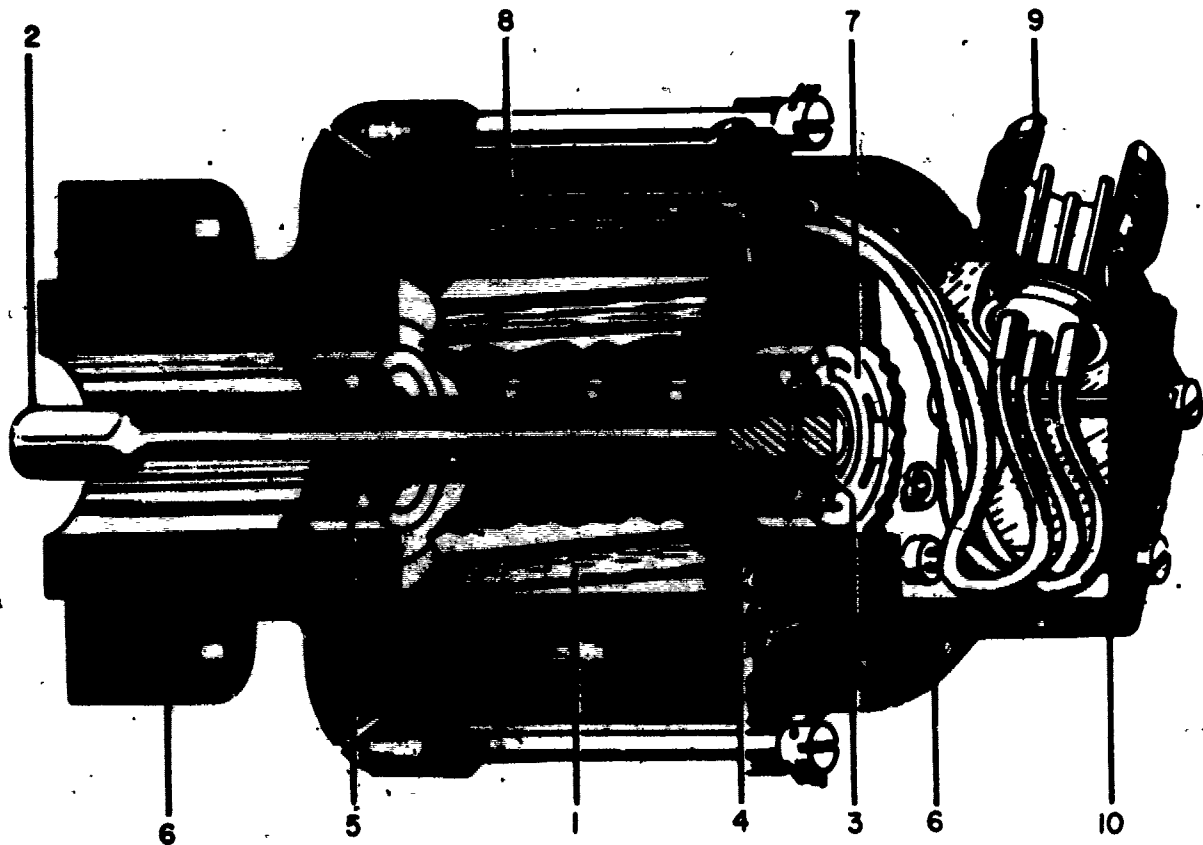

- | | | | | |
|---------------|-------------------|-------------------|----------------------|-------------------|
| 1. Rotor. | 3. Pin. | 5. Ball bearings. | 7. Adjusting spring. | 9. Receptacle. |
| 2. Drive key. | 4. Oil-seal ring. | 6. End shields. | 8. Stator. | 10. Junction box. |

207.367

Figure 6-33.—Cutaway view of a tachometer generator.

onto the generator shaft. The generator may be of either two- or four-pole construction. The two- and four-pole rotors are identical in appearance and construction, and differ only in that the two-pole rotor is magnetized north and south diametrically across the rotor, while the four-pole rotor is magnetized alternately north and south at each of the four pole faces.

The key (2) which drives the rotor is a long slender shaft having sufficient flexibility to prevent failure under the torsional oscillations originating in the aircraft drive shaft, as well as to accommodate small misalignments between the generator and its mounting surfaces. This key is inserted into the hollow rotor shaft and is secured in place by means of a pin (3) at the end opposite the drive end. An oil-seal ring (4) is placed inside the hollow shaft and over this key to prevent leakage of oil into the generator through the hollow shaft. The shaft runs in two ball bearings (5) set in stainless steel inserts which are cast directly into the generator end shields (6). An adjusting spring (7) is set at the receptacle end of the shaft to maintain the proper amount of end play.

The stator consists of a steel ring into which a laminated core of ferromagnetic material is

placed. A 3-phase winding is inserted around this core and, in properly insulated from it. The winding is adapted for two- or four-pole construction, depending on the generator in which it is used. The two end shields are made of diecast aluminum alloy, and serve to support the generator stator and rotor. Connections are made to the 3-phase stator by means of a receptacle (9) which is attached to the junction box (10) of the generator. The generator and indicator are connected electrically with a cable having mating plugs that fit into the receptacles on both the units.

Tachometer Indicators

Tachometer indicators are usually mounted on the instrument panel in the cockpit. They are relatively small in size. These units vary as to type, depending on the particular installation; some are single-element and others are dual-element. The operating principles of the two types are basically the same.

Figure 6-34 shows a cutaway view of a single-element tachometer (radial) indicator. The unit consists essentially of two parts—a

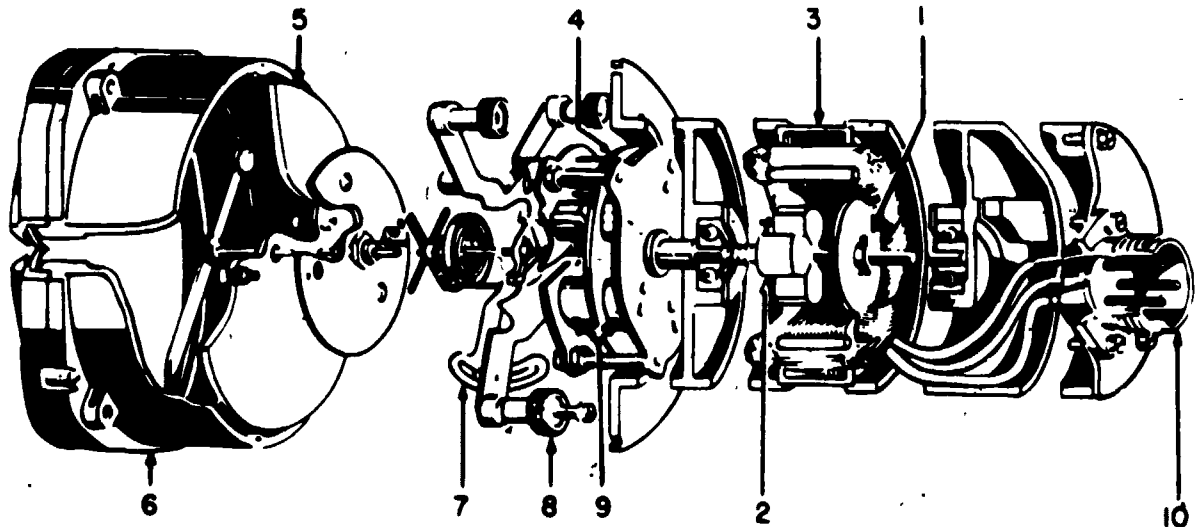

- | | | | | |
|---------------------|---------------|--------------------|-------------------|-----------------------|
| 1. Hysteresis disk. | 3. Motor. | 5. Scale plate. | 7. Adjusting arm. | 9. Magnet assemblies. |
| 2. Rotor. | 4. Drag disk. | 6. Cover assembly. | 8. Adjusting nut. | 10. Receptacle. |

Figure 6-34.—Cutaway view of a tachometer indicator (radial).

207.372

synchronous motor, which runs in synchronism with the tachometer generator; and an indicating element, which is driven by the motor through a magnetic-drag coupling. The indicating element indicates the speed of the synchronous motor and, therefore, the speed of the aircraft engine.

The synchronous motor (3) consists of a 3-phase stator winding which is inserted in, and insulated from, a laminated circular core. Within the circular core is a shaft to which the rotating parts are attached. A hysteresis disk (1) is secured to the shaft by a cotter pin. A permanent magnet rotor (2) is free to move on the shaft, and is restrained from longitudinal motion at one end by the hysteresis disk, and at the other end by a spring which is secured to the shaft for the purpose of transmitting torque from the rotor to the shaft. Ball bearings are inserted in the motor end shields to support the shaft. These end shields also serve to locate the stator so that all parts of the motor will maintain their proper position with respect to each other.

The armature of the synchronous motor consists mainly of the permanent magnet and the hysteresis disk. The purpose of the permanent-magnet material is to provide starting and running torque at low speeds when the magnitude of flux is low. This purpose of the hysteresis disk is to provide starting torque at high speed when the magnitude of flux is great but where the permanent magnet, by itself, will not pull into step. At the higher speeds, the hysteresis disk moves the rotor up to near synchronism and then the permanent magnet pulls it into exact synchronism.

One end of the motor shaft extends through the front end shield and supports the drag-magnet assembly (9). The drag-magnet assembly, which is driven by the synchronous motor, consists of two plates to which small permanent magnets are attached. The magnets are arranged to concentrate the flux near the outside edge of the drag disk in order to obtain maximum torque with minimum weight. Between the two plates carrying the magnets is a disk (4) of conducting material. This material is an alloy having a low temperature coefficient so that its resistance is not greatly affected by temperature changes. As the magnet assembly

spins around the disk of conducting material, torque is produced on the disk.

The drag disk is connected to the lower end of the shaft of the indicator assembly. When the disk rotates, the indicator pointer moves to indicate the speed of the aircraft engine. The indicating element is supported by three posts on which adjusting nuts (8) are placed for leveling the assembly as required. Further positioning is obtained by the adjusting arm (7).

The scale plate (5) is calibrated either in rpm or percent and indicates the speed of the engine. The cover assembly (6) serves as a protective container for the mechanism. Electrical connection to the tachometer generator is provided by the receptacle (10) located at the rear of the indicator.

Dual Indicators

With the increasing requirement for more instruments for efficient flight, the combination of several instruments in one has become very common. The dual tachometer is an example of this combining of instruments and is used on some multiengine aircraft.

The dual tachometer consists of two synchronous-motor-magnetic-drag tachometer indicators housed in a single case. The indicators show simultaneously on a single dial the speeds of rotation of the engines. One tachometer indicator is used for each pair of engines on the aircraft.

In multiengine aircraft the tachometer generator located on the engine may be used to generate the synchronizing voltage used by the propeller synchronizing system. This causes automatic pitch adjustment of each propeller so that all the engines are running at the same speed, thereby minimizing vibration in the aircraft. If one engine tends to speed up, the output frequency of its tachometer generator increases. This increased frequency causes the automatic mechanism in the propeller hub to increase the pitch of the blades. The blades then take bigger "slices" of air and increase the load on the engine, causing it to slow down. This automatic operation is continuous so that there is no actual fluctuation of the engine speed.

Vertical Scale Indicators

On some models of naval aircraft vertical scale indicators are employed. In preference to radial dial indicators, a vertical scale is used to indicate engine performance data such as fuel flow, engine speed, exhaust gas temperature, and accelerometer readings. Vertical scale indicators are compact, light in weight, and easily read.

Basically, all vertical scale indicators consist of a vertical tape that is actuated by an amplifier, motor, gears, and sprockets.

For the purpose of discussing vertical scale indicating systems, the systems utilized on the F-14 will be used. These systems (fig. 6-35) would be basically the same when used on other aircraft with possible changes in nomenclature due to the various aircraft and engine manufacturers.

The engine indicating groups consist of cockpit indicators and associated sensing devices required to monitor left and right engine performance. Dual indicators display percentage of engine N_2 rotor speed (RPM indicator), turbine inlet temperature (TIT indicator), and engine fuel rate-of-flow (FF indicator). Individual indicators display engine power trim (PT indicator) and N_1 overspeed caution (L or R N_1 OVSP caution indicator light).

TACHOMETER INDICATOR.—The electrical tachometer (RPM) indicator, on the pilot left knee panel, displays percentage of engine N_2 rotor speed on two vertical scales, one each for the left and right engine. The indicator scales are linear from 0 to 6, and from 6 to 11 multiplied by 10 to obtain percent of RPM. Upper left and right limit range markers and OFF failure flags appear between the 10.4 and 11 points of the scales. Absence of the OFF failure indications confirms that indicator channels are powered. The indicator receives variable-frequency signals proportional to N_2 compressor speed from each engine tachometer generator. The signals are applied to solid-state circuitry to produce a proportional drive signal for a servomotor. The servomotor drives gears and sprockets to position a tape on the indicator

face, indicating percentage of engine N_2 rotational speed. When the test selector switch on the MASTER TEST panel is used to test the indicators, a self-test circuit in the indicators is disconnected from the tachometer-generator input circuits and connected to an appropriate test signal within the two indicator channels. The channel circuitry processes the test signal and drives the indicator tapes to indicate 80 percent of RPM.

N_1 , N_2 TACHOMETER GENERATORS.—The N_1 and N_2 tachometer generators are identical two-phase alternator types, which supply electrical signals directly proportional to engine-compressor rotational speed. The N_1 tachometer generator for the left and right engine is driven by the N_1 low-pressure compressor rotor. Single-phase from the generator go to the engine rotor overspeed detector. The signals represent N_1 compressor revolutions per minute (RPM). The N_2 tachometer generator is driven by the N_2 high-pressure compressor through the engine accessory gearbox. Signals from this generator go directly to Electrical Tachometer Indicator (RPM indicator), at the pilot station, where percentage of N_2 rotor speed is displayed.

ENGINE ROTOR OVERSPEED DETECTOR.—The engine rotor overspeed detector receives electrical signals from left and right N_1 tachometer generator. The detector consists of three solid-state circuit boards; a crystal oscillator (clock) board and two identical gated counter boards, one for each engine. The detector receives an approximate 0 to 33-volt, 0 to 70-Hz signal from each N_1 tachometer generator. In the detector, the voltage is clipped to a constant 5 volts. The normal frequency signal is reshaped and processed through the counter circuit to establish a signal period. The clock establishes a reference period for each counter. The counters measure the period for their respective tachometer generator signal and compares tachometer generator signal period with the established clock reference period. If the incoming generator signal period is sensed to be shorter than the clock reference period, the counter energizes a switching relay, which completes a circuit to power its respective

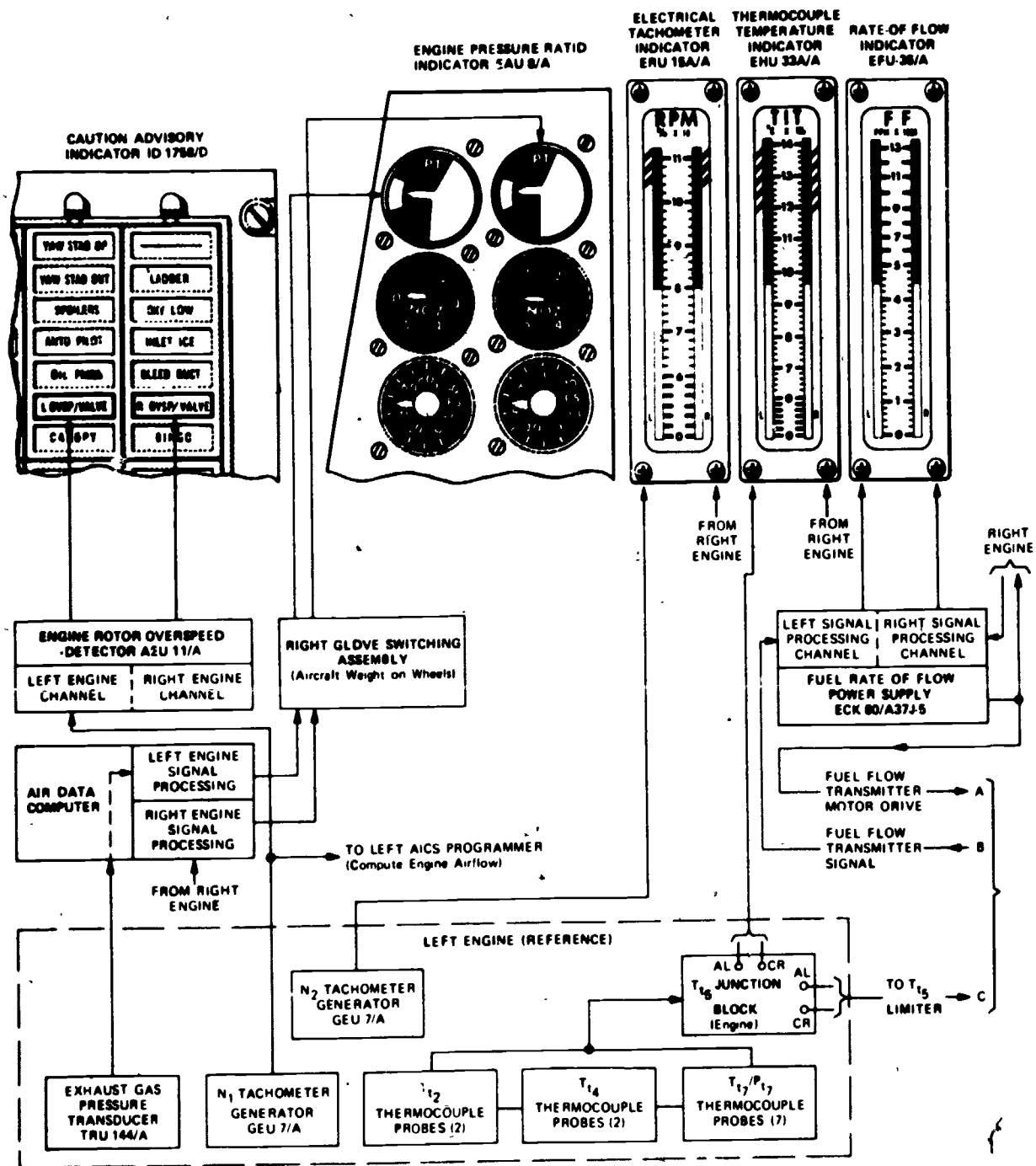

Figure 6-35.—F-14 Engine Instrument indicating group.

207.391

caution indicator light on the pilot CAUTION ADVISORY indicator.

TEMPERATURE INDICATING SYSTEMS

To properly monitor the operation of an aircraft engine, various temperature indications must be known. Some of the more important indications include the temperatures of the engine oil, carburetor mixture, carburetor air, free air, engine cylinders, heater ducts, and exhaust systems of jet engines. Various types of thermometers such as the bimetal and resistance types, are used to collect and present this information.

The main parts of resistance thermometers used on naval aircraft are:

1. The indicating instrument.
2. The temperature-sensitive element (resistance bulb).
3. The connecting wires leading from the bulb.

The indicator dials of resistance type thermometers are calibrated in accordance with the range of temperature to be measured. Figure 6-36 shows a resistance thermometer indicator. The indicators are self-compensating, allowing for the changes in cockpit temperatures.



207.323

Figure 6-36.—Indicator of a resistance thermometer.

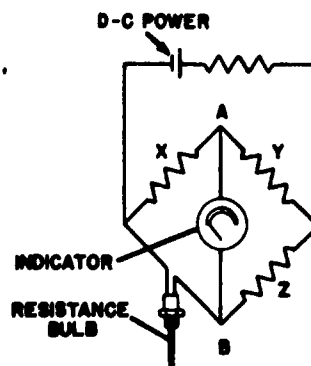

207.324

Figure 6-37.—Wheatstone bridge thermometer.

Wheatstone Bridge System

A schematic diagram of a Wheatstone bridge thermometer circuit is shown in figure 6-37. The resistance bulb element is one of the sides of the Wheatstone bridge circuit. The other three sides are resistors that are contained in the indicating meter. Voltage is applied to the circuit from the d-c power supply in the aircraft.

When the temperature bulb is exposed to a temperature of 0°C, its resistance is 100 ohms. The resistance of arms X, Y, and Z are also 100 ohms each. At this temperature, therefore, the Wheatstone bridge is balanced. This means that the resistance of X and Y added together equals the resistance of the bulb and Z. Therefore, the same amount of current flows in both sides of this parallel circuit. Since all four sides are equal in resistance, half of the applied voltage is dropped across side X and also across the bulb. The voltages at points A and B are, therefore, equal. Since these voltages are equal, the voltage from A to B is zero. Therefore, the indicator reads zero. It is important to note that if there is an open in the voltage supply circuit, the galvanometer will also read zero.

When the temperature of the bulb increases, its resistance also increases. This unbalances the bridge circuit and causes the needle to be deflected to the right. When the temperature of the bulb decreases, its resistance decreases. Again the bridge circuit is unbalanced, but this

time it causes the needle to be deflected to the left.

The galvanometer has been calibrated so that the amount of deflection either to the right or to the left causes the needle to point to the number of the meter scale that corresponds to the temperature at the resistance bulb, wherever it may be located.

This instrument requires a constant and steady supply of dc voltage, since the bridge imbalance is directly affected by fluctuations in the total bridge current. Unless the bulb is damaged by excessive heat, it will give accurate service indefinitely. If it is damaged by too much heat, it should be replaced. When a thermometer will not operate properly, check carefully for loose wiring connections before replacing the bulb.

Ratiometer System

The ratiometer type of temperature indicator uses two coils in a balanced circuit instead of resistors as in the Wheatstone bridge type. In some instruments, these coils are designed to turn between the poles of a permanent magnet. In other instruments of this type, a small permanent magnet rotor turns between stationary coils. Ratiometer circuits vary in design, but the principle of operation is very much the same for all.

A simplified circuit of the type with the permanent magnet rotor is illustrated in figure 6-38. The two coils are fixed in the instrument, and the indicator needle is fastened to the permanent magnet rotor. The position of the needle is determined by how the small permanent magnet aligns itself with the resultant flux of the two coils.

For an understanding of how the circuit operates, trace the current through the circuit. Starting at ground, current flows up through the bulb, centering potentiometer R5, and R6 to point D. Current through the left leg of the bridge is from ground through R1 to point A; from point A through the lower part of the expansion and contraction potentiometer R2; and from pin 2 of R2 through R4 to point D. Here the currents of the two legs combine and flow through R7 to the positive 28 volts.

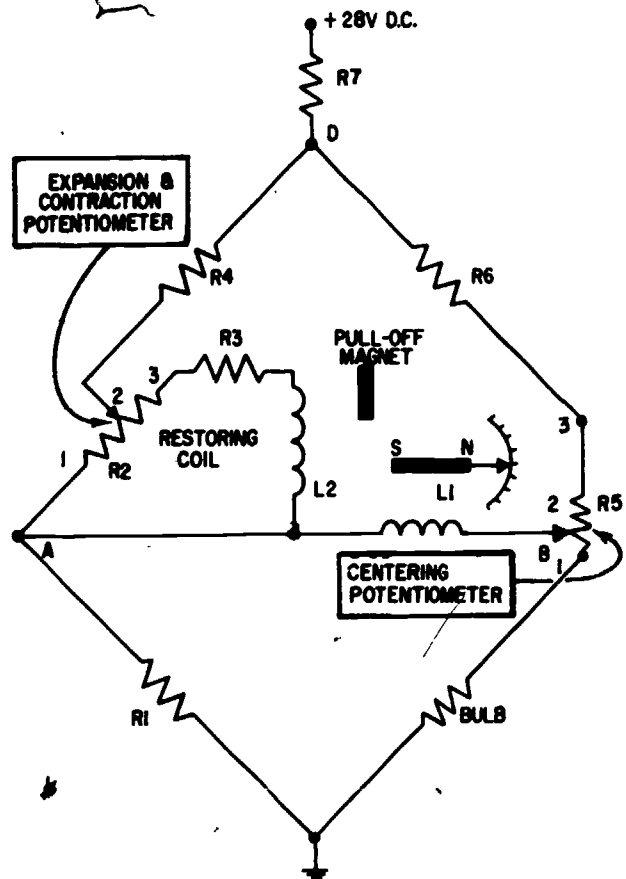

207 331

Figure 6-38.—Ratiometer type temperature indicator.

It should be noted that restoring coil L2, resistor R3, and the upper part of potentiometer R2 form a parallel path for current flow from point A to pin 2 of R2. Deflection coil L1 is connected between points A and B; therefore any difference in potential between these two points will cause current to flow through L1.

The ratiometer type temperature indicator utilizes a fixed permanent magnet to pull the pointer to an off position when the indicator is not operating. Thus, current through restoring coil L2 must compensate for the pull-off magnet when the indicator is operating. Variations in the resistance of the bulb, due to temperature changes, cause a change in voltage at point B and a resulting change in current through deflection coil L1.

Thermocouple System

Thermocouple temperature indicators are used to indicate the temperature of the engine cylinders, the air temperatures in the heater duct of anti-icing systems, and the exhaust system of jet engines.

A thermocouple is a junction or connection of two unlike metals; such a circuit has two junctions. If one of the junctions is heated to a higher temperature than the other, an electromotive force is produced in the circuit. By including a galvanometer in the circuit, this electromotive force can be measured. The hotter the high-temperature junction (hot junction) becomes, the greater the electromotive force produced. By calibrating the galvanometer dial in degrees of temperature, it becomes a thermometer. The galvanometer contains the "cold" junction.

The thermocouple thermometer systems used in naval aircraft consist of a galvanometer type indicator, a thermocouple or thermocouples, and thermocouple leads. Some thermocouples are made up of a strip of copper and a strip of constantan that are pressed tightly together. Constantan is an alloy of copper and nickel. Other thermocouples are made up of a strip of iron and a strip of constantan, or a strip of chromel and a strip of alumel. Iron-constantan is used mostly in radial engine aircraft; chromel-alumel is used with jet aircraft.

The "hot" junction of the thermocouple varies in shape depending on its application. Two common types are shown in figure 6-39 the gasket type and the rivet type. In the gasket type, the rings of two dissimilar metals are pressed together to form a spark plug gasket. Each lead that makes a connection back to the galvanometer must be made of the same metal as the part of the thermocouple to which it is connected. For example, a copper wire is connected to the copper ring and a constantan wire is connected to the constantan ring. The rivet type thermocouple is shown installed in the cylinder walls. Here again, the same metal is used in the lead as in the part of the thermocouple to which it is connected. Thermocouple leads are critical in makeup and length, because the galvanometers are calibrated for a specific set of leads in the circuits.

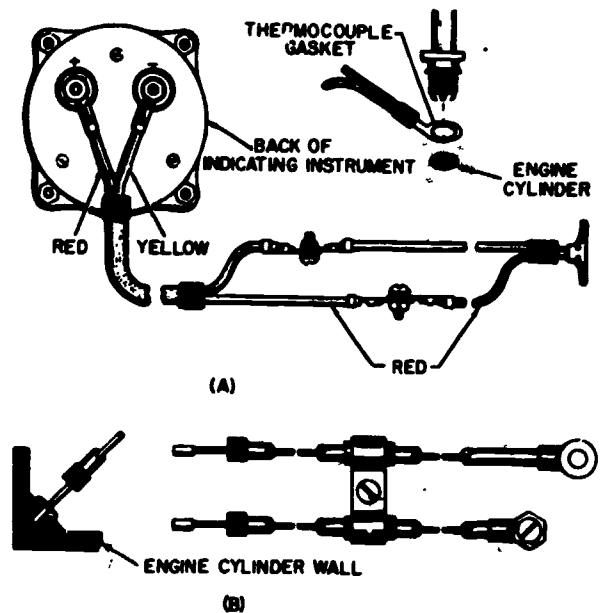

207.332

Figure 6-39.—Thermocouples. (A) Gasket type; (B) rivet type.

TURBINE INLET TEMPERATURE (TIT) INDICATOR SYSTEM.—Aircraft such as the P-3 utilize an engine turbine inlet temperature indicator system to provide a visual indication in the flight station of the temperature of gases entering the turbine. The temperature of each engine turbine inlet is measured by 18 dual-unit thermocouples installed in the turbine inlet casing. One set of these dual thermocouples is paralleled and transmits signals through a harness and aircraft wiring to an indicator. The other set of thermocouples is also paralleled and provides signals to the temperature datum control. Each circuit is electrically independent and provides dual system dependability. (See fig. 6-40.)

All parts of the engine temperature measurement system are made of chromel and alumel material, including welds. Special wiring and wire identification are installed in the aircraft from the thermocouple harness terminal block to the indicator. Plugs in the thermocouple circuits are also special type. The thermocouple harness mounts on the turbine

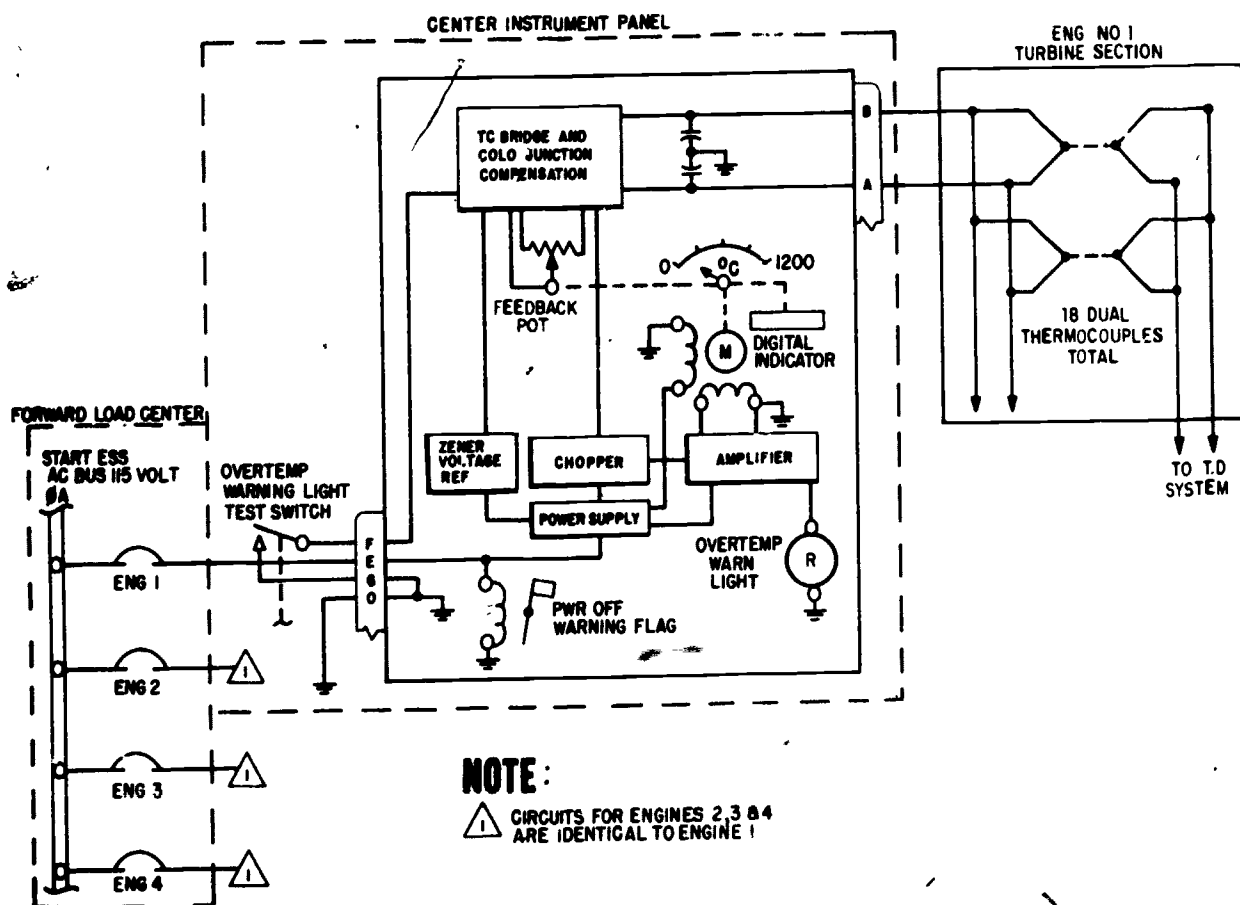

207.347

Figure 6-40.—Turbine inlet temperature indicator system.

unit aft of the thermocouple. The harness includes separate leads for each of the 18 thermocouples, and maintains two electrically separate circuits. The harness is enclosed in a rigid metal, channel type housing and cover. The leads and terminals project through holes in the front side of the housing wall. Electrical signals from the 18 dual junction thermocouples are averaged within the harness.

The thermocouple assemblies are installed on pads provided around the turbine inlet case. Each thermocouple incorporates two electrically independent junctions within a sampling type probe. Alumel terminal studs are identified by AL and chromel terminal studs by CR stamped adjacent to the studs.

Since the average voltage of the thermocouples at the thermocouple terminal blocks represents the turbine inlet temperature, it is necessary that no interference with the signal take place while the signal is transmitted to the indicator. Therefore, the wiring from the thermocouple terminal block to the indicator is routed through the harness. Harness wiring is routed separately from other interference-producing wiring.

The indicator contains a bridge circuit with cold junction compensation, a 2-phase motor to drive the pointer, and a feedback potentiometer. Also included in the indicator is a Zener voltage reference circuit, a chopper circuit, an amplifier, power supply, a power off flag, and an overtemp warning light.

Output of the bridge circuit is fed to the chopper circuit so as not to load the bridge circuit. The chopper output is fed to the amplifier. Output of the amplifier feeds the variable field of a 2-phase motor which positions the indicator main pointer and the digital indicator. The motor also drives the feedback potentiometer to provide a nulling signal relative to the temperature signal to stop the drive motor when correct pointer position is reached.

The Zener diode circuit provides a closely regulated reference voltage in the bridge to avoid error caused by voltage variation from the indicator power supply. The indicator power supply provides power to the Zener circuit, the chopper, the amplifier, the power off warning flag, and the fixed field of the 2-phase motor.

The over-temperature warning light in the indicator comes on when the turbine inlet temperature (TIT) is at $1,082^{\circ}\text{C}$. At this point a switch in the indicator is closed to energize the warning light. One test switch installed external to the indicators enables the crew to test all of the indicator over-temperature warning lights at the same time. When the test switch is operated to the test position, an over-temperature signal is simulated in each indicator's temperature control bridge circuit.

When power to an indicator is interrupted, a red warning flag at the indicator becomes visible, the indicator pointers maintain their position, and the over-temperature warning light becomes inoperative.

The indicator scale is calibrated in degrees C from 0 to 12 (times 100°C). The digital indicator is calibrated from 0° to $1,200^{\circ}\text{C}$ in 2° increments.

Another aircraft using the thermocouple principle for indicating engine turbine inlet temperatures is the F-14. Each engine has 10 thermocouple probes, distributed at three stations on the engine for measuring and averaging engine turbine inlet temperature. There are three types of thermocouple probes: compressor inlet temperature (T_{12}), compressor discharge temperature (T_{14}), and exhaust gas temperature thermocouple-pressure (T_{17} - P_{17}). Each thermocouple probe has one or more alumel-chromel junctions. When the junctions are heated, a reaction between the dissimilar

metals generates a dc voltage. A thermocouple harness connects the thermocouples in parallel to provide an average heat signal from each station.

The thermocouple temperature indicator (see fig. 6-35) on the pilot's left knee panel, displays turbine inlet gas temperature on two vertical scales, one for each engine. The scales are linear from 0 to 6; segmented in tens, from 6 to 14 and multiplied by 100°C when read. OFF failure flags appear at the upper left and right of the indicator to indicate loss of signal input, or electrical power.

Internally, the indicator has two channels, one for each engine. The channels basically consist of a cold junction compensator, rebalance potentiometer, chopper, servo-amplifier, servomotor, and gear train. Thermocouple signal voltage from the engines is applied to the cold junction compensator in each channel. The compensator provides corrective voltages to counteract the effect of secondary thermocouple junctions in the indicator when alumel and chromel leads connect to copper ones. A stable voltage is fed to the cold junction compensator and rebalance potentiometer.

The feedback of the potentiometer and output of the compensator are fed to the chopper, where the inputs are compared. The chopper provides a 400-Hz error signal to the servosystem. The chopper output (signals relative to temperature change and potentiometer versus compensator difference) goes to the servoamplifier, where the signals are modified to drive the servomotor. The shaft of the motor is coupled to the rebalance potentiometer and indicator tape through the gear train.

As the motor is driven by the amplified error, the rebalance potentiometer is driven in a direction that reduces this error signal and nulls the condition. The tape indicates temperature, on the front scale of the indicator, relative to thermocouple output. A test circuit in the indicator when supplied with 28 volts dc, energizes a relay, disconnects thermocouple input, and substitutes a test signal of specific value to be processed and to drive the indicator tape.

EXHAUST GAS TEMPERATURE INDICATING SYSTEM.—The exhaust gas temperature (EGT) indicating systems provide a visual temperature indication in the pilot's cockpit of the engine exhaust gases as they leave the turbine unit. A typical exhaust gas temperature indicating system used on the F-4B is discussed.

Two separate but identical exhaust gas temperature indicating systems, one for each engine, are utilized in this aircraft. Each system consists of 12 dual thermocouples located on the engine turbine frame, a combination indicator and transistorized amplifier located on the pilot's main instrument panel, and the interconnecting chromel and alumel leads. Power for the indicator-amplifier is supplied from the essential 115 v ac bus. (See fig. 6-41.)

Both exhaust gas temperature indicators are located on the pilot's main instrument panel and provide a visual indication of the engine exhaust temperatures. Each instrument is a hermetically sealed unit and contains a single receptacle for a mating plug electrical connection. The instrument scale ranges from 0° to 1,200°, with a vernier dial in the upper right corner of the instrument face. A power off warning flag is located in the lower portion of the dial.

Internally, the indicator contains a simulated thermocouple cold junction with compensating resistors, a reference voltage source, dc to ac modulator, a transistor power output stage, miniature ac servomotor, and the power off warning flags. The temperature indicators contain range markings on the instrument faces.

The thermocouples convert engine exhaust gas temperature into millivolts. The voltage produced by the thermocouples is transmitted directly to the indicator-amplifier by the chromel and alumel leads. The voltage is amplified and used to drive a small servomotor, which in turn drives the indicator pointer. The thermocouple harness is made up of two halves, each containing six dual loop thermocouples. The assembled halves make up two independent thermocouple systems, each consisting of 12 thermocouples connected in parallel. The harness is mounted to the turbine frame aft of the turbine : or.

FUEL FLOW SYSTEMS

Fuel flow indicating systems provide a continuous indication of the rate that fuel is being delivered to the engine in pounds per

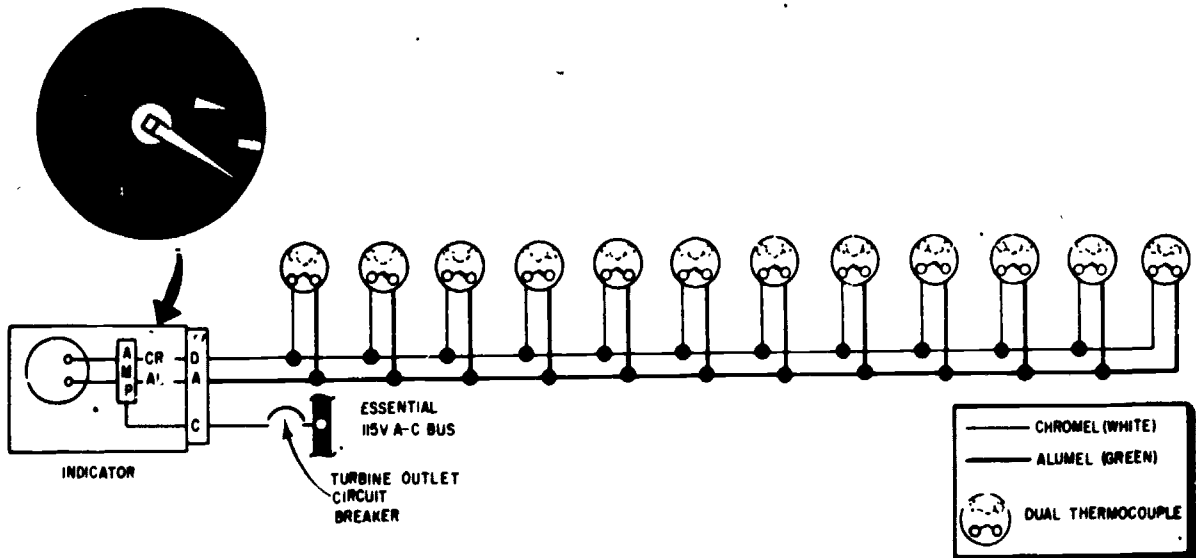

207.349

Figure 6-41.—Exhaust gas temperature indicating system.

hour. The indicator in some systems also indicates the amount of fuel remaining in the tanks. A typical flowmeter consists of two units—a transmitter and an indicator. The measurements are transmitted electrically to the panel-mounted indicator. Thus use of electrical transmission eliminates the need for a direct fuel-filled line from the engine to the instrument panel, and possibilities of fire hazard and mechanical failures are greatly minimized.

The fuel flowmeter system is quite similar to other synchro systems discussed in *Navy Electricity and Electronics Training Series Course (NETS)*. The discussion that follows is based on an understanding of the operation of a basic synchro system. A typical fuel flow indicating system is described in order to acquaint the AE with flowmeters in general. However, the AE should always refer to the manuals for the particular type system that is being maintained.

Figure 6-42 shows a cutaway view of a fuel flow transmitter. It is a two-in-one unit, being made up of a fuel-measuring mechanism (or meter) and a synchro transmitter. These parts can be separated from one another for maintenance purposes, but are joined together as a single assembly for installation.

The fuel enters the inlet port of the transmitter and is directed against the vane (1), causing the vane to swing. The spiral fuel chamber is designed so that the distance between the vane and the chamber wall becomes increasingly larger as the rate of flow increases. A calibrated hairspring (2) retards the motion of the vane. When the force exerted by the hairspring on the vane is equal to the force exerted by the fuel on the vane, motion of the vane ceases.

The rotor shaft of the synchro transmitter (3) is linked to a bar magnet (4). Attached to the vane shaft is a ring magnet (5); the ring magnet moves as the vane shaft moves. The transmitter mounting frame is located between the bar magnet and the ring magnet, forming a liquid-tight seal between the fuel-metering section of the mechanism and the synchro. However, the bar magnet will move in unison with the ring magnet because the two magnets are magnetically coupled, the south pole of the

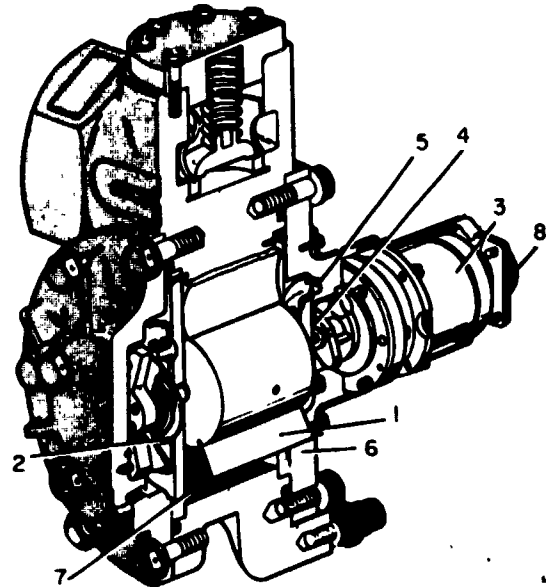

- | | |
|-------------------------|--------------------------------|
| 1. Vane. | 5. Ring magnet assembly. |
| 2. Hairspring. | 6. Transmitter mounting frame. |
| 3. Synchro transmitter. | 7. Fuel chamber. |
| 4. Bar magnet assembly. | 8. Electrical connector. |

207.338

Figure 6-42.—Cutaway view of a fuel flow transmitter.

ring magnet being opposite the north pole of the bar magnet. Movement of the vane, caused by the flow of fuel, is transmitted by the two magnets to the synchro rotor, resulting in a corresponding movement of the rotor. Therefore, the relative position of the synchro rotor, with respect to the stator, is determined by the angular displacement of the vane in relation to the housing of the fuel chamber.

The fuel flow transmitter is equipped with a relief valve which automatically opens and bypasses the instrument whenever the fuel flow exceeds the capacity of the instrument—as it may during takeoff, for example. At such time, only part of the fuel flows through the metering portion. As soon as the pressure across the instrument falls below the value at which the

relief valve is set, the valve closes and the flowmeter again operates normally. The transmitter unit is located in the fuel line between the fuel pump and the carburetor or fuel nozzle.

The fuel flowmeter indicator, located on the instrument panel, is a remote indicating instrument. It consists of a synchro receiver, a step-up gear train, a magnetic drag cup, and a calibrated spring. When fuel flows through the fuel flow transmitter, an electrical signal is sent to the indicator receiver. This causes the synchro rotor to assume a position in accordance with the signal that is coming from the transmitter. Thus, the indicator pointer indicates the rate of fuel flow.

Figure 6-43(A) shows the face of the single flow indicator. To determine the amount of fuel being consumed per hour, multiply the scale reading by 1,000. A schematic diagram of the single fuel flow indicator is shown in figure 6-44.

The F-14 system will be used as an example for discussion of a fuel flow system, other aircraft fuel flow systems would be similar.

The fuel flow transmitter consists of a synchronous motor, drum assembly, impeller assembly, spiral spring, and pickup coils in a housing with fuel inlet and outlet attachment flanges. The drum and impeller assemblies have two miniature permanent magnets, 180° apart. The motor is driven at a constant 120 RPM; a shaft connects it to the drum assembly.

The impeller assembly rotates over the motor-drum shaft and is mechanically coupled to the drum with the spiral spring. The pickup coils, one for each assembly, are in line with the drum and impeller assembly magnets. As the motor rotates the drum, the impeller also rotates. When there is no fuel flow, the magnets of the drum and impeller assemblies are aligned. As they pass their respective coil, simultaneous output signals are generated.

As fuel flow starts and increases through the transmitter housing it is forced through straightening vanes which eliminate swirling motion of fuel. The fuel then passes through straight drilled passages of the rotating impeller. As fuel flow increases through the impeller, a proportional drag factor, or resistance to rotation, is imposed on the impeller assembly, causing the spring to deflect; this equalizes loading. The impeller magnets are then deflected out of alignment to produce a later signal than that of the drum magnets and coil. Thus, increased time span between signals of the rotating assemblies becomes relative to increased fuel flow.

The fuel rate-of-flow power supply consists of a power transformer and power supply, two signal-conditioning channels, and a motor driver. The transformer receives 115 volts ac, 400-Hz, and feeds the power supply, which provides low dc voltage to operate the motor driven logic and signal-conditioning channels for the left and right engine systems. Using a stepping signal to drive control logic, the motor driver controls positive and negative 8-Hz dc signals between phases of both fuel rate-of-flow transmitter motors.

The signal-conditioning channel for each engine system, receives pulses from the coils of its transmitter. A pulse shaper, for each channel, converts the time between transmitter drum and impeller coil pulses into a rectangular pulsewidth signal. This converted signal is processed by an averaging filter to provide a low ripple dc signal as an input to the rate-of-flow (FF) indicator. The magnitude (0 to 5 volts dc) of this signal is proportional to flow rate. A test circuit permits testing the power supply. A tap off motor phases A and B from the motor driver routes an 8-Hz signal through an external test switch to

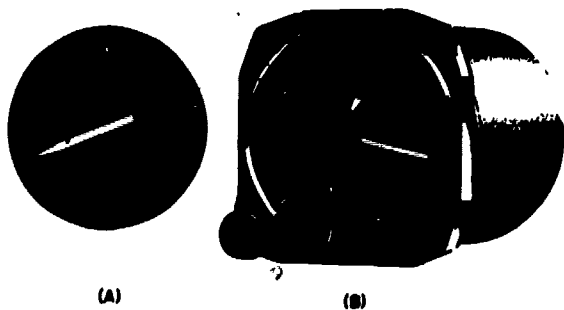

207.339

Figure 6-43.—(A) Fuel flow indicator; (B) fuel flow totalizing indicator.

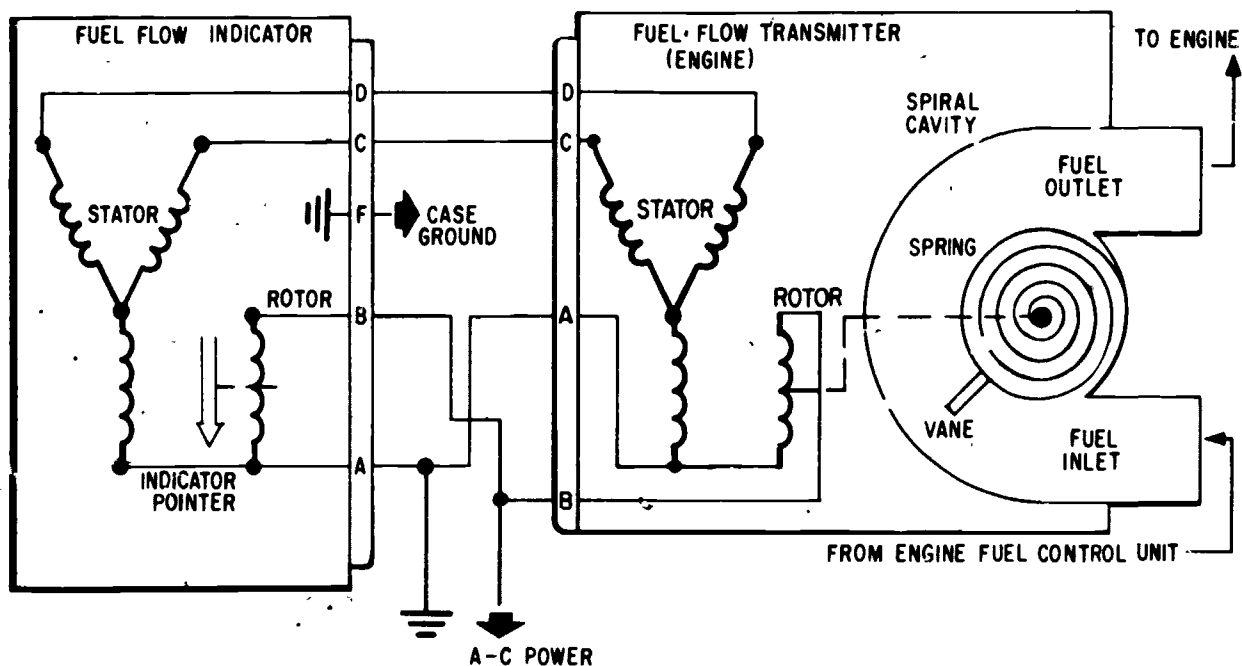

207.3

Figure 6-44.—Single fuel flow indicating system.

the signal-conditioning channels for processing. The results of the processed signal are displayed on the indicator.

The rate-of-flow (FF) indicator, a vertical scale indicator on the pilot's left knee panel, displays rate of fuel flow for each engine, on parallel scales; the scales are graduated from 0 to 13. The scale reading, multiplied by 1,000, indicates the rate (pounds per hour) at which fuel is being consumed by the engine. Loss of power, or signal, to the indicator is indicated by upper left and right OFF failure flags. The indicator has two separate channels, one for each engine. The channels include a control transformer servoamplifier, servomotor, gears, and sprockets. The indicator channels are powered by 115 volt ac for signal processing. An input of 0 to 5 volts dc from the fuel rate-of-flow power supply produces an output from the control transformer rotor winding to the servoamplifier.

The servoamplifier modifies the signal to proper impedance and power level to drive the

channel servomotor. Shaft rotation is phased in a direction such that when coupled back to the control transformer rotor shaft, the rotation tends to reduce transformer output voltage. When the output is nulled, the motor, gear train, and sprockets that move the tape come to rest at a fuel flow scale rate equivalent to the input signal.

When the test selector switch on the MASTER TEST panel is used to test the indicators, a self-test circuit in the indicators disconnects the fuel-rate-of-flow transmitter input circuits and connected to an appropriate test signal within the two indicator channels. The channel circuitry processes the test signal and drives the indicator tapes to indicate 4,200 to 4,400 pounds per hour.

Fuel Flow Totalizing Systems

Figure 6-43(B) shows the indicator of a fuel flow totalizing system. The pointer of this instrument usually indicates the combined rate

of fuel flow into two or more engines. However, it also gives a true indication if only one engine is being operated. A continuous reading of the pounds of fuel remaining in the aircraft fuel cells appears in the small window. The fuel cells, when full, contain a certain number of pounds of fuel. The fuel quantity indicator indicates how many pounds. Before starting the engines, this total amount of fuel in the aircraft is set on the pounds-fuel-remaining indicator. This is done with the reset knob on the front of the instrument. As soon as the engines are started and begin consuming fuel, the fuel flow pointer indicates how fast the fuel is being used. The fuel remaining indicator starts counting backward toward zero, thus giving a continuous reading of the pounds of fuel remaining in the cells. Numbers rotate past the window in a manner quite similar to that of the mileage indicator of an automobile speedometer.

The entire fuel flow totalizing system consists of two or more fuel flow transmitters—an amplifier and an indicator.

The fuel flow transmitters are almost identical to those already discussed in the single system. In the fuel flow totalizing system, the transmitters are connected electrically so that their combined signals are fed as one into the fuel flow amplifier.

The fuel flow amplifier is an electronic device which supplies power of the proper magnitude and phasing to drive the indicator. The speed at which the indicator motor is driven depends on the transmitter signal fed into the amplifier.

The fuel flow totalizer indicator contains a 2-phase variable speed induction motor. This motor is always driven in one direction only, but at varying speeds. As the rate of fuel consumption by the engines increases, more and more power is fed to the indicator motor. This causes the speed of the motor to be proportional to the rate of fuel consumption. The motor turns a magnetic drum-and-cup linkage (similar to the hysteresis cup in the tachometer indicator) which causes a pointer deflection proportional to the motor speed, and thus proportional also to the rate of fuel consumption. At the same time, another linkage

employing a friction clutch drives the pounds-fuel-remaining indicator. This clutch is disengaged by the reset knob when the knob is used to set a reading on the pounds-fuel-remaining indicator.

OIL PRESSURE SYSTEM

Oil pressure instruments indicate that oil is or is not circulating under proper pressure. Oil pressure drops warn of impending engine failure due to lack of oil, oil pump failure, or broken lines. Oil pressure may be indicated on an engine gage unit which consists of three separate gages housed in a single case—oil pressure, fuel pressure, and oil temperature. Such an engine gage unit is shown in figure 6-45. The gage has a Bourdon tube mechanism which is one of the most practical methods of measuring fluid under pressure. (See fig. 6-46.) The instrument's oil pressure range is from 0 to 200 psi, and its scale is marked in graduations of 10 psi. There is a single connection on the back of the case leading directly into the Bourdon tube.

Reciprocating aircraft engines are equipped with engine-driven oil pumps. Whenever the engine is running, oil is forced through the engine under pressure. This pressure is controlled by a pressure relief valve which can

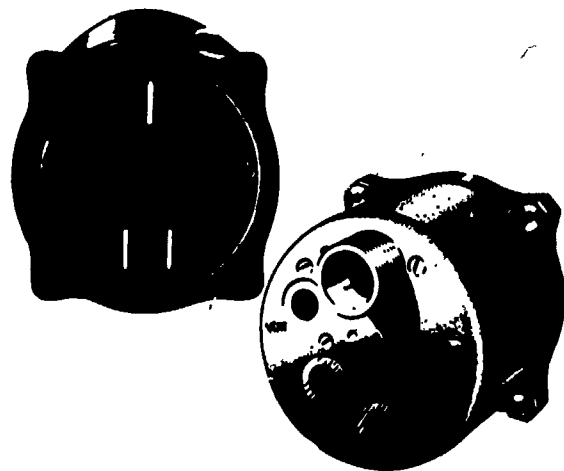

207.334

Figure 6-45.—Engine gage unit.

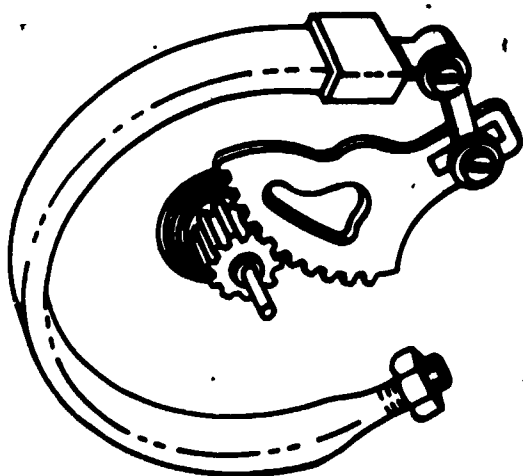

207.333

Figure 6-46.—Bourdon tube pressure gage.

be set for the recommended pressure of the specific engine. The pressure gage is connected into the system at a point between the relief valve and the engine.

At the point where an oil pressure gage is connected into the system, there is a restriction in the line. This restriction prevents the surging action of the oil pump from damaging the gage, keeps the gage pointer from oscillating violently through wide ranges, and makes it possible to read the gage accurately. Because of this and the sluggishness of cold oil, the gage may fail to indicate any pressure immediately after the engine is started in cold weather; however, if the system is working properly, this condition will shortly correct itself.

In some aircraft the oil pressure gage is a separate instrument, this type is shown in figure 6-47. This instrument also operates on the Bourdon tube principle.

Another method of measuring oil under pressure is the synchro system. This type oil pressure system used on some aircraft is essentially a method of measuring engine oil pressure directly, and transmitting the measurements electrically from the point of measurement to the synchro indicator on the instrument panel. The use of electrical transmission of measurement in the synchro

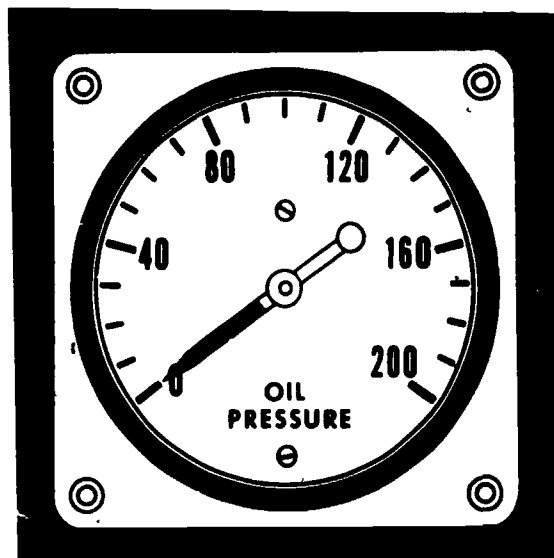

207.335

Figure 6-47.—Bourdon tube oil pressure instrument.

system eliminates the need for direct pressure lines from the engine to the instrument panel, and reduces the possibility of fire, loss of oil or fuel, and mechanical difficulties.

The system is composed of synchro indicator and transmitter. The synchro transmitter consists of a permanent magnet moving within a stator. The stator is a circular core of magnetic material wrapped with a single, continuous toroidal winding which is divided into three sections by taps. Voltages in each of the sections vary with the position of the permanent magnet. As the magnet is moved, the ratio between the three signal voltages varies accordingly.

See figure 6-48. When the transmitter and indicator are connected in parallel and excited by the same fundamental source, the signal voltages in corresponding sections of the two stators are equal and balanced as long as the magnets are in the same relative positions. However, if the transmitter magnet is moved to a new position, the voltages in the three sections of the transmitter are no longer the same as the voltages in the corresponding sections of the indicator. Because of this imbalance, current

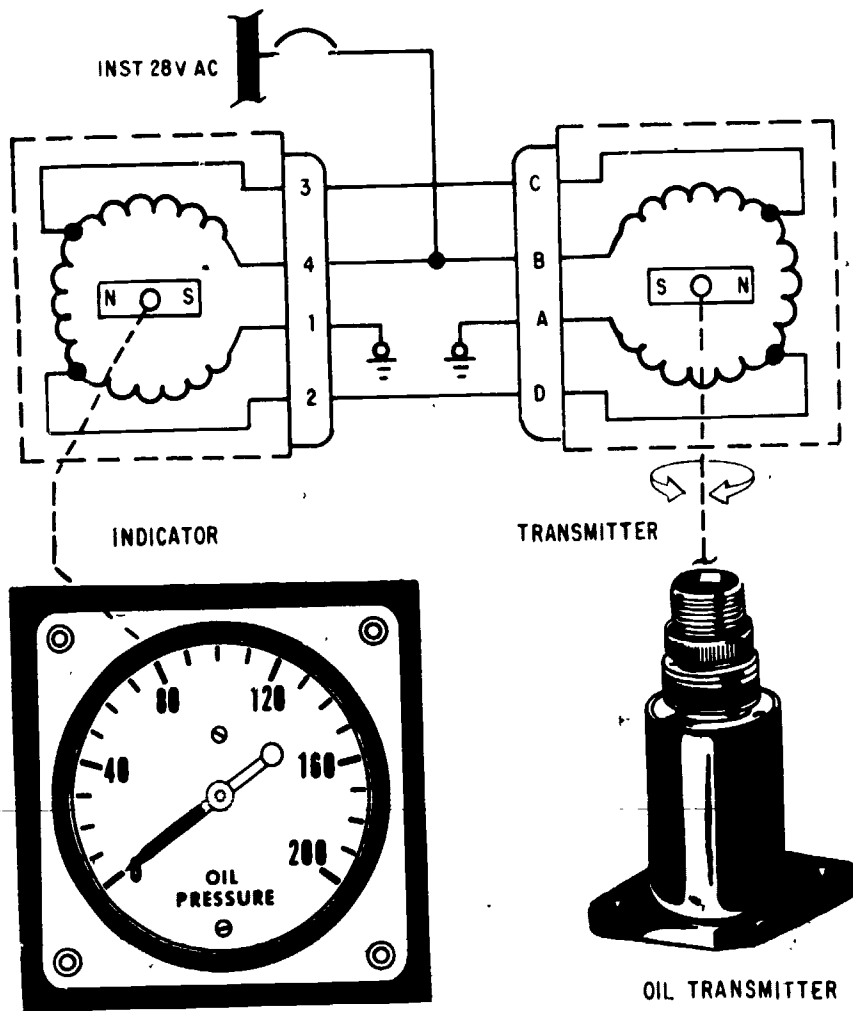

Figure 6-48.—Schematic of a synchro oil pressure indicating system.

207.336

flows between the two units. This circulating current sets up additional magnetic lines of force in each stator. As a result, a magnetic force is set up between the stator and the magnet of each unit. Since the indicator magnet is free to turn, it moves to a position corresponding to the position of the transmitter magnet. The indicator magnet is connected to the indicator pointer by a shaft to provide the visual indication.

The electrical leads between the transmitter and the indicator may be any reasonable length without noticeable effect on the indication.

FUEL PRESSURE SYSTEM

The fuel pressure gage provides a check on the operation of the fuel pump and fuel pressure relief valve, and indicates whether or not fuel is being supplied steadily to the carburetor under the correct operation pressure. In order for the engines to have a full range of power at all altitudes, the gages must be checked often to insure that the fuel pressure is correct. The fuel pressure gage operates on the same principle as the oil pressure gage.

Fuel pressure indicators may also be conveniently located in the cockpit by means of synchro systems. This type of system is the same for both fuel and oil pressure indications; however, the oil system transmitter is not interchangeable with the fuel system transmitter.

The synchro system shown in figure 6-49 is for indicating fuel pressure. A change in fuel pressure introduced into the synchro transmitter causes an electrical signal to be transmitted through the interconnecting wiring to the synchro receiver. This signal causes the receiver rotor and the indicator pointer to move a distance proportional to the amount of pressure exerted by the fuel.

Note that in figure 6-49, the transmitter is vented to the atmosphere. This allows the transmitter to accurately measure the differential between pump pressure and atmospheric pressure.

OIL TEMPERATURE SYSTEM

Two types of oil temperature gages are available for use in the engine gage unit. One

unit consists of an electrical resistance type oil thermometer, supplied with electrical current by the aircraft dc power system. The other unit, the capillary oil thermometer, is a vapor pressure type thermometer consisting of a bulb connected by a capillary tube to a Bourdon tube, and a multiplying mechanism connected to a pointer which indicates on a dial the temperature of the oil.

EXHAUST NOZZLE INDICATING SYSTEM

The exhaust nozzle position indicating system (such as that used in the F-4B) provides a visual indication in the pilot's cockpit of the engine variable exhaust nozzle position. This in turn provides a measure of percentage of afterburning, since constant temperatures are held throughout the afterburner range.

Separate but identical nozzle position indicating systems are used for each engine. Each system consists of a transmitter potentiometer in the nozzle area control unit, an indicator on the pilot's main instrument panel,

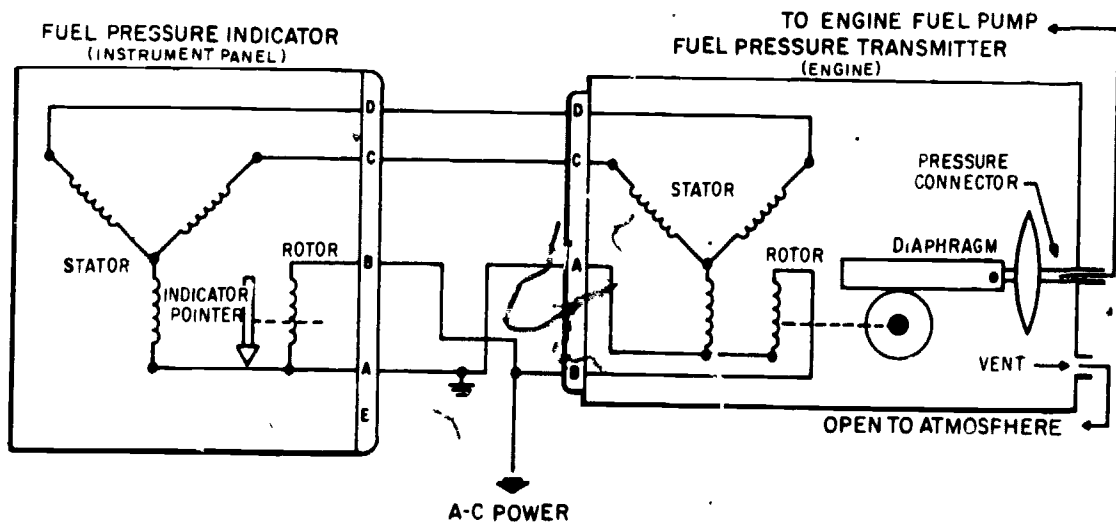

Figure 6-49.—Fuel pressure synchro system.

207.337

6-54

347

and the interconnecting wiring. Power for the system is supplied from the essential 28v dc bus.

Each indicator is a hermetically sealed unit containing a single receptacle for a mating plug electrical connection. The instrument scale ranges from OPEN to CLOSE, with markings at the 1/4, 1/2, and 3/4 positions (fig. 6-50).

The transmitter potentiometer consists of a resistance winding on which is located a movable brush. This brush is attached to a linkage within the nozzle area control and moves in relation to the variable exhaust nozzle. Current supplied to the resistance winding is picked up by the movable brush, and varies according to the location of the brush. This signal current is then carried to one of the indicator field coils.

The indicator contains two field coils and a rotor. The polarized rotor is mounted on a free-moving shaft located in the center of the magnetic field created by the two coils. One of the coils is connected to the transmitter potentiometer in the nozzle area control; the other is supplied with a constant current to give smooth indicator operation. The rotor aligns itself with the magnetic field which varies in accordance with the signal received from the potentiometer. A pointer mounted on the rotor

shaft indicates the position of the rotor in relation to nozzle position.

TORQUEMETER SYSTEMS

The electric torque meter system used on turboprop aircraft measures the torque (horsepower) produced by the engine at the extension shaft. Each system consists of a transmitter (which is part of the engine extension shaft), a phase detector, and an indicator (fig. 6-51). The system measures the torsional deflection (twist) of the extension shaft as it transmits power from the engine power section to the propeller. This deflection is detected by magnetic pickups and measured electronically. The indicator registers the amount of deflection in terms of inch-pounds of torque.

The extension shaft of the engine consists of two concentric shafts. The inner shaft is the power transmitting shaft. The outer shaft is attached to the inner shaft at the rear end. Toothed flanges on the front end of each shaft rotate in the field of magnetic pickups. When the engine is running, the teeth on the flange of the driving (inner) shaft are displaced in relation to the teeth on the flange of the outer reference shaft. The displacement between the shafts is proportional to the torque load on the driving shaft. This displacement causes a phase

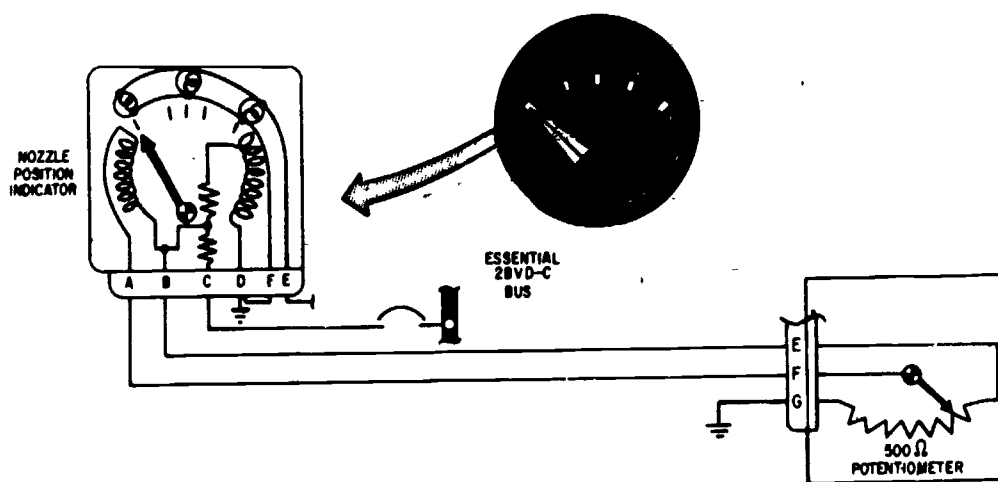
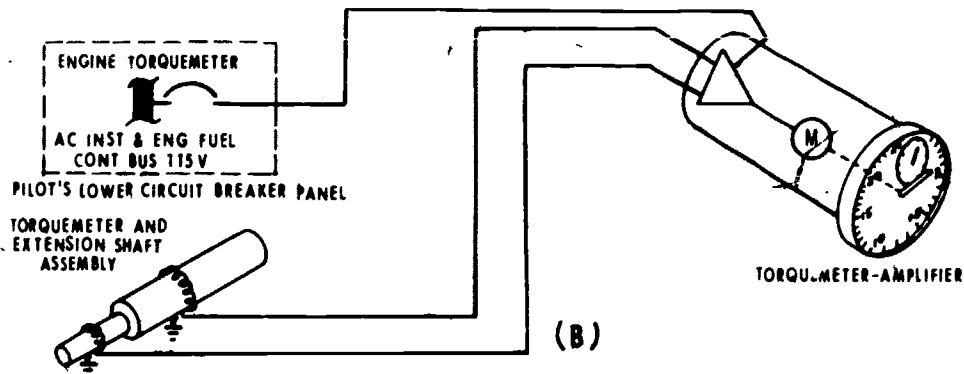
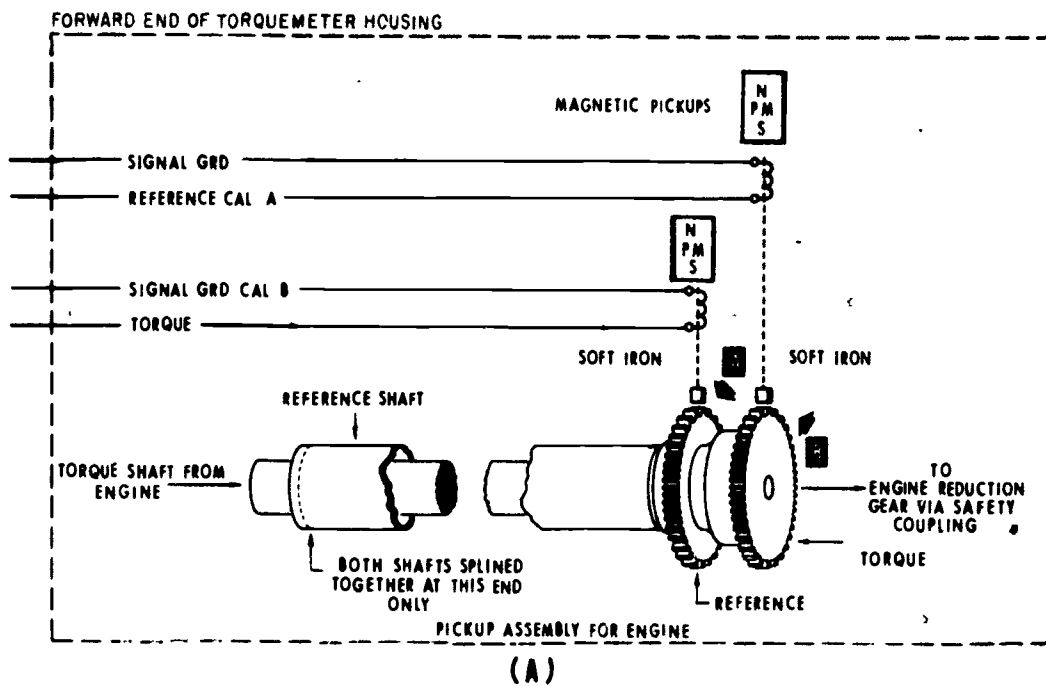

Figure 6-50.—Exhaust nozzle position indicating system.

207.374



207.350

Figure 6-51.—Torquemeter system. (A) Pickup assembly; (B) indicating system.

displacement between the pickup signals. The phase angle of the resultant signal is linearly proportional to the shaft deflection. The phase detector and amplifier located within the indicator converts the signal to current. The current is directed to a servomotor which drives the indicator pointers. The servomotor also drives the rotor of a synchro control transformer in the indicator to balance the synchro system when the pointer registers the measured torque.

MISCELLANEOUS INSTRUMENT SYSTEMS

There is another group of instruments found on most Navy aircraft which does not come under the category of flight instruments or engine instruments. It is a group usually referred to as miscellaneous instruments. This group partially consists of instrumentation for such

systems as: fuel, hydraulics, flap and gear positions and cabin pressure.

CAPACITIVE TYPE FUEL QUANTITY INDICATING SYSTEM

The capacitive type fuel quantity gage system is an electronic fuel measuring device that accurately determines the weight (not gallons) of the fuel in the tanks of an aircraft. The main units of the system are an indicator, a tank probe, a bridge unit, and an amplifier. In some systems the bridge unit and amplifier are one unit mounted in the same box. Later systems have been designed with the bridge and a transistorized amplifier built into the indicator, the complete unit being sealed within the instrument case.

Fuel Quantity Indicator

The indicator, (figure 6-52) is a hermetically sealed, self-balancing, motor-driven instrument containing a motor, pointer assembly, transistorized amplifier, bridge circuit, and adjustment potentiometers. As the quantity of fuel in the tank changes, the capacitance value of the tank probe changes proportionately. The tank probe is one arm of a capacitance bridge circuit. The change of capacitance of the probe unbalances the bridge circuit of the amplifier power unit, causing an error voltage. The error voltage is amplified and fed to the motor which drives the pointer mechanism and the rebalancing potentiometers to restore the bridge to a balanced condition. The direction of change in the capacitance of the probe unit determines the phase of the error voltage; the phase determines the direction of motor rotation and, therefore, the direction of pointer movement.

Tank Probe

A tank probe and a simplified version of a tank circuit is shown in figures 6-53 and 6-54. The capacitance of a capacitor depends upon three factors—the area of the plates (A), the distance between the plates (d), and the

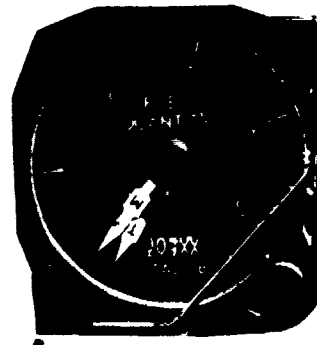

(A)

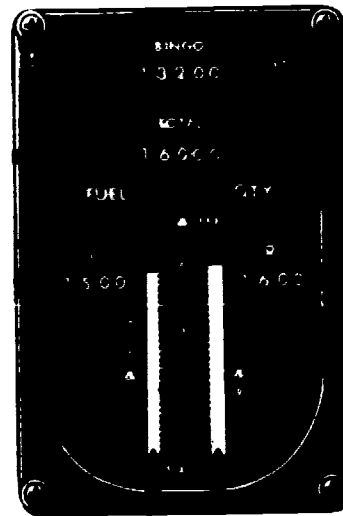

(B)

Figure 6-52.—Fuel Quantity Indicator. (A) Radial; (B) vertical scale.

dielectric constant (K) of the material between the plates ($C = \frac{KA}{d}$). The only variable factor in the tank probe is the dielectric of the material between the plates. When the tank is full, the dielectric material is all fuel. Its dielectric constant is about 2.07 at 0°C , compared to a dielectric constant of 1 for air. When the tank is half full, there is air between the upper half of the plates and fuel between the lower half. Therefore, the capacitor has less capacitance

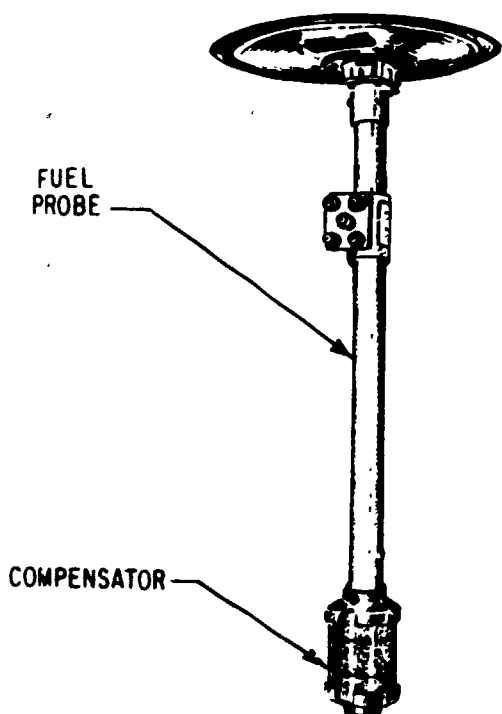

207.379
Figure 6-53.—Fuel Quantity Transmitter.

than it had when the tank was full. When the tank is empty, there is only air between the plates, and capacitance is still less. Any change in fuel quantity between full and empty produces a corresponding change in capacitance.

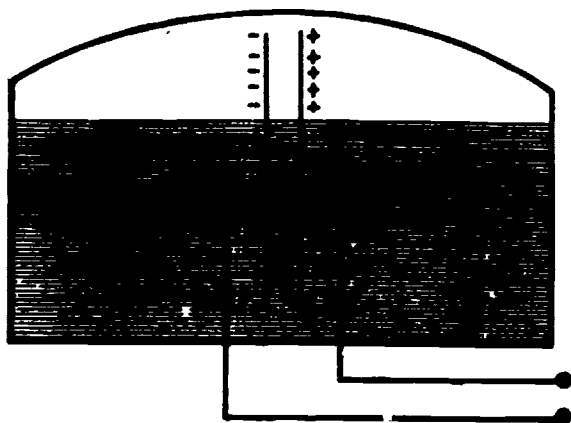

207.380
Figure 6-54.—Simplified tank circuit.

System Operation

A simplified capacitance bridge circuit is illustrated in figure 6-55. The fuel tank capacitor and a fixed reference capacitor are connected in series across a transformer secondary winding. A voltmeter is connected from the exact center of the transformer winding to a point between the two capacitors. If the two capacitances are equal, the voltage drops across them will be equal, and the voltage between the centertap and point P will be zero. As the fuel quantity increases, the capacitance of the tank unit increases, causing more current to flow in the tank unit leg of the bridge circuit. This causes a voltage to exist across the voltmeter, in phase with the voltage applied to the transformer. As the quantity of fuel in the tank decreases, there is a smaller flow of current in the tank unit leg of the bridge. The voltage across the voltmeter is now out of phase with the voltage applied to the transformer.

In an actual capacitive type fuel gage, the input to a two-stage amplifier is connected in place of the voltmeter. It amplifies the signal resulting from an imbalance in the bridge circuit. The output of the amplifier energizes a winding of the 2-phase indicator motor. The other motor winding, called the line phase winding, is constantly energized by the same voltage that is

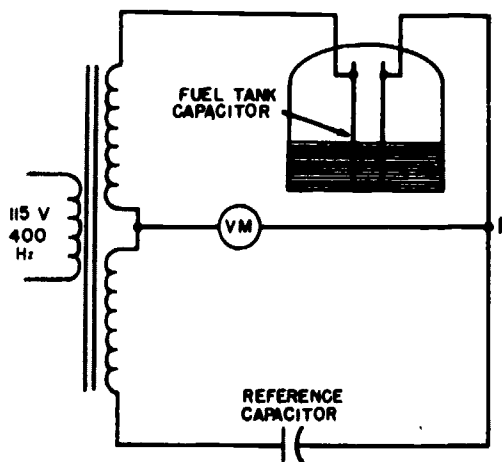

207.301
Figure 6-55.—Simplified capacitance bridge circuit.

applied to the transformer in the bridge circuit, but its phase is shifted 90° by a series capacitor. As a result, the indicator motor is phase sensitive; that is, it will operate in either direction, depending on whether the tank unit capacitance is increasing or decreasing.

(See figure 6-56.) As the tank unit capacitance increases or decreases because of a change in fuel quantity, it is necessary that the bridge circuit be maintained at a balanced condition so that the indicator motor will not continue to change the position of the indicating needle. This is accomplished by balancing potentiometer R128 which is connected across part of the transformer secondary. The indicator

motor drives this potentiometer wiper in the direction necessary to maintain continuous balance in the bridge.

The circuit shown in figure 6-56 is a self-balancing bridge circuit. An empty-calibrating potentiometer and a full-calibrating potentiometer are connected across portions of the transformer secondary winding. These potentiometers may be adjusted so that the bridge voltage balances over the empty-to-full capacitance range of a specific system.

A test switch (not shown) is used to unbalance the bridge circuit momentarily when checking the operation of the system. When the

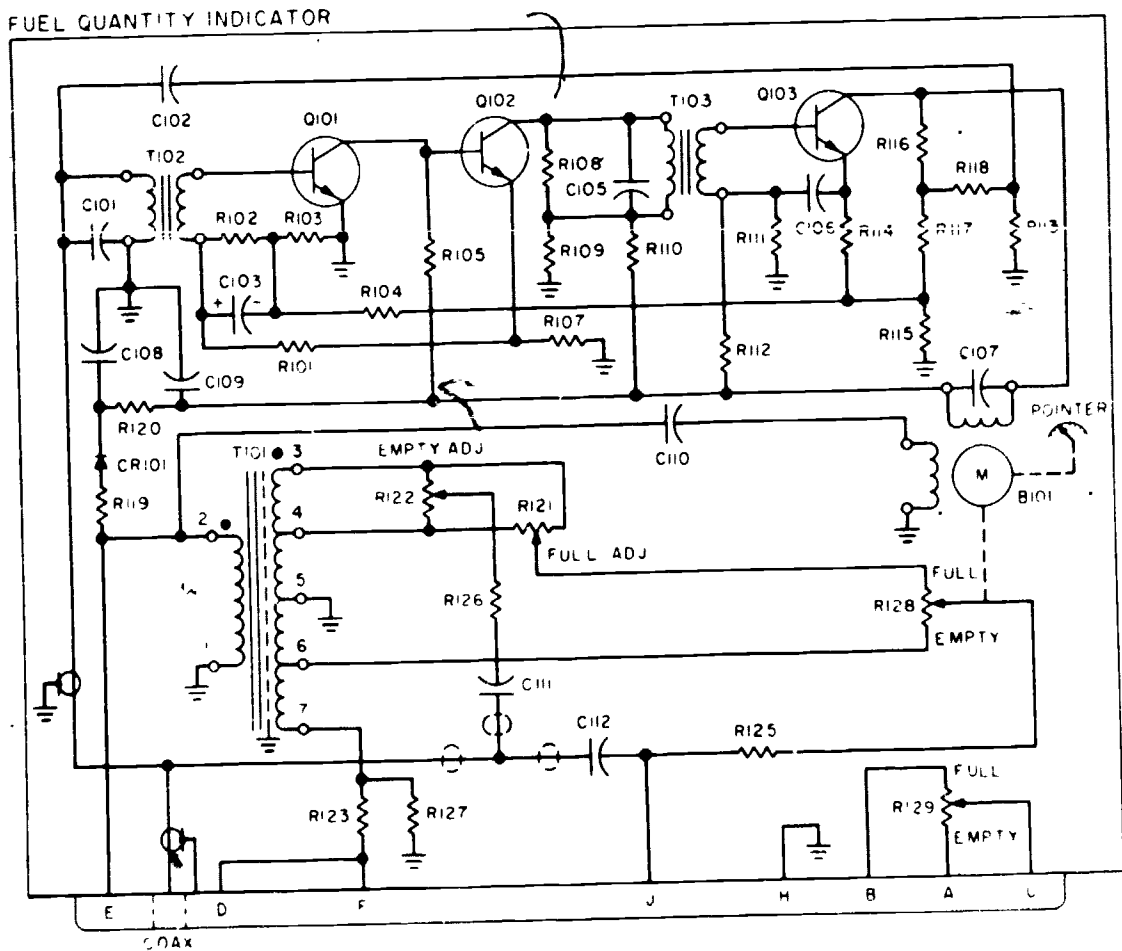

Figure 6-56.—Fuel Quantity indicator schematic.

207.322

switch is closed, pin F is grounded, unbalancing the circuit. As a result, the indicator drives toward the empty end of the dial. Opening the switch should restore the bridge to balance and return the indicator pointer to its original position. This proves that the system is operating correctly.

In some installations where the indicator shows the contents of only one tank, and where the tank is fairly symmetrical, one unit is sufficient. However, for increased accuracy in peculiarly shaped fuel tanks, two or more tank units are connected in parallel to minimize the effects of changes in aircraft attitude and sloshing of fuel in the tanks. Due to the varying design characteristics of the fuel cells in Naval Aircraft, the necessity of accurately measuring fuel level changes for different depths and contours requires tank units with special designs.

The tank units used in a typical capacitance fuel quantity measuring system are categorized as **NON-CHARACTERIZED AND CHARACTERIZED.** (See figure 6-57.)

NON-CHARACTERIZED tank units are variable capacitors, vertically mounted in the fuel cell. As the fuel level changes, the capacitance of the tank unit changes. This change in capacitance is uniform throughout the entire length of the tank unit.

CHARACTERIZED tank units are similar in construction and mounting to the non-characterized tank units. As the fuel level changes, the capacitance of the tank unit changes. This change in capacitance is **NOT** uniform throughout the entire length of the tank unit.

Since neither electrode of the tank unit is grounded, and since one of the leads between the tank unit and amplifier is shielded, the capacitance to ground does not enter into the circuit. Therefore, the length of the tank unit leads does not affect the accuracy of the system.

FUEL CHARACTERISTICS.—The characteristics of fuel are such that the dielectric constant and density will deviate due to temperature change, or due to the variable factor in the composition of the fuel. The

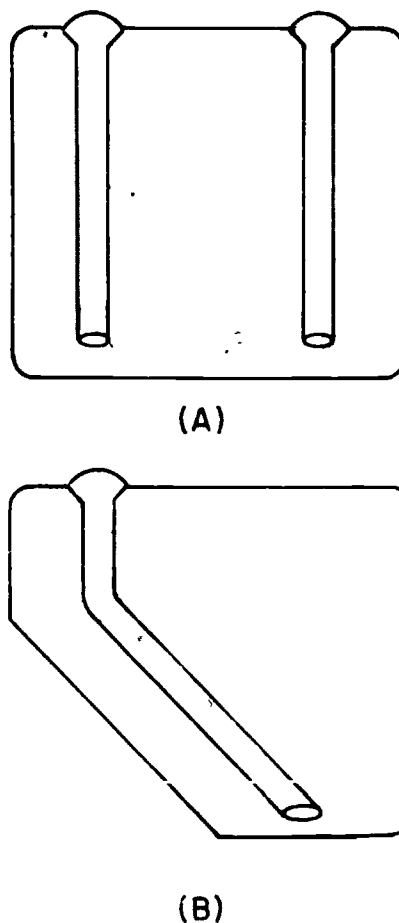

Figure 6-57.—Fuel Quantity tank units. (A) NONCHARACTERIZED; (B) CHARACTERIZED.

weight by volume of aircraft fuel depends upon its density, which, in turn, depends upon its temperature. As the temperature of the fuel goes down, the density increases; and as the temperature of the fuel goes up, the density decreases. Any change in the dielectric constant or density of the fuel will affect the movement of the indicator pointer accordingly. For example, assume that the indicating system is at balance with the tank unit immersed to a given depth in a fuel having the density and dielectric constant of the fuel for which the system is calibrated. The indicator pointer will then reflect the correct amount of fuel in terms of pounds. Now, if the tanks were drained and then refilled to the same level with a fuel having a

greater density and higher dielectric constant, the pointer would indicate a greater weight. The new reading would be correct only if the effect of the changes in density and dielectric constant were proportional. However, it is known that the effect of the increase in dielectric constant is generally greater than the effect of the increase in density, resulting in an incorrect indication. This error is minimized (compensated for) by varying the capacitance of the reference capacitor in the leg of the bridge opposite the immersed tank unit.

COMPENSATION.—The reference capacitor is varied by connecting a compensator unit in parallel with it. The compensator, like the tank probe, is a variable capacitor. However, the compensator mounts at the lowest level of fuel so that it is completely immersed until the tank is almost dry. Thus, its capacitance is dependent on the dielectric content of the fuel rather than the quantity. The compensator connects into the common reference leg for both phases of the bridge circuit so that it is part of the reference capacitance. Since a change in the dielectric constant of the fuel affects both the tank probe and the compensator capacitance, the resultant current change in the tank probe leg of the bridge is counteracted by a similar change in the reference leg of the circuit.

There are various capacitor type fuel quantity systems that operate on the principle just described. Indicators, tank probes, and power units may differ as to shape, size, and specifications from system to system, so always consult the manufacturer's manuals for specific information on a particular system.

HYDRAULIC PRESSURE INDICATORS

In most naval aircraft the hydraulic system operates the landing gear, flaps, speed brakes, bomb bay doors, and certain other units. Aircraft hydraulic pressure gages are designed to indicate either the pressure of the complete system or the pressure of an individual unit in the system. A typical direct reading gage contains a Bourdon tube and a gear-and-pinion mechanism by which the tube's motion is amplified and transferred to the pointer. The

position of the pointer on the calibrated dial indicates the pressure in pounds per square inch.

The pumps which supply pressure for the operation of an aircraft's hydraulic units are driven either by the aircraft engine or by a separate electric motor, or by both. Some installations employ a pressure tank or "accumulator" to maintain a reserve of fluid under hydraulic pressure at all times. In such cases the pressure gage registers continuously. With other installations, however, operating pressure is built up only when needed, and pressure registers on the gage only during these periods.

The pressures of hydraulic systems vary for different models of aircraft. In older pressure systems the gages registered from 0 to 2,000 psi. In general, pressure ranges are increasing with the later models of aircraft. Some aircraft have systems with pressure ranges as high as 4,000 psi. The trend is away from the direct reading pressure gage and towards the synchro (electric) type.

Figure 6-58 (A) shows the hydraulic pressure indicator of a late model naval aircraft. This aircraft is equipped with three hydraulic systems. The indicating system provides a continuous pressure indication of the No. 1 and No. 2 flight control systems and the utility hydraulic system. The indicating system consists of three remote pressure transmitters, one located in each of the system lines, a hydraulic pressure selector switch and a dual pointer indicator, both located on the pilot's instrument panel. The system is powered by 26-volt, 400-hertz, single-phase alternating current from the 26-volt, single-phase bus.

Pressure Transmitter

A pressure transmitter of the Bourdon tube type is located in each hydraulic pressure system line. Expansion and contraction of the Bourdon tube is transmitted by mechanical linkage to the rotor of the transmitter synchro. The pressure transmitter synchro transmits an electrical signal through interconnecting wiring to the receiving synchro within the indicator. The receiving synchro's rotor is mechanically linked to the

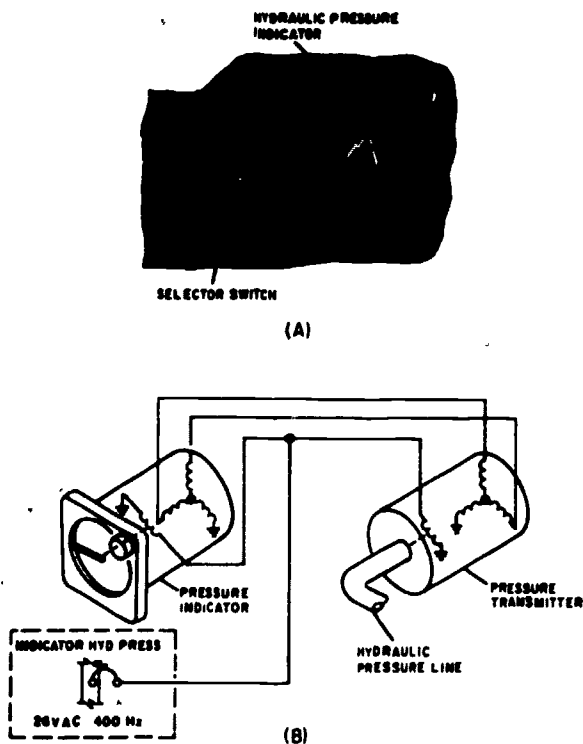

207.346

Figure 6-58.—(A) Hydraulic pressure indicator; (B) hydraulic pressure indicating schematic.

indicator pointer. The pressure indicator contains two synchros mechanically attached to two separate pointers. When the HYD PRESS SELECTOR switch is in the No. 1 & No. 2 FLT CONT position, the pointers indicate the pressure in each system independent of each other. When the HYD PRESS SELECTOR switch is in the UTILITY position, the synchros are connected in electrical parallel and the pointers act as one. An arrangement such as this is desirable since it saves instrument panel space.

PNEUMATIC PRESSURE SYSTEMS

The cabin pressure altitude indicator (fig. 6-59) is a sensitive altimeter used to measure the cabin pressure. The instrument contains a sensitive diaphragm which expands or contracts with changes in cabin pressure. The altitude

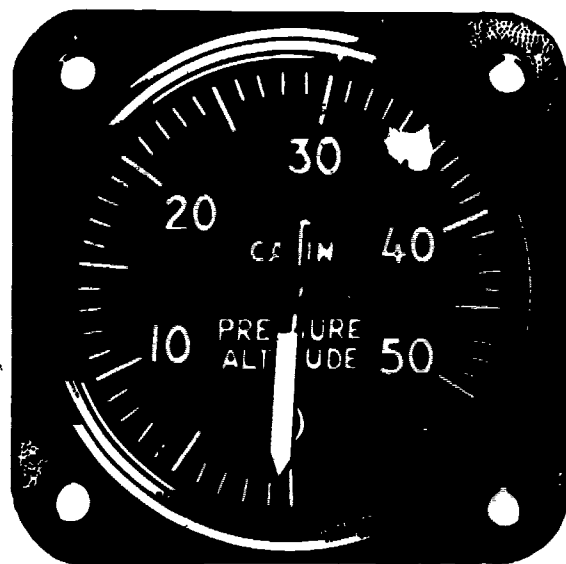

207.348

Figure 6-59.—Cabin pressure altitude indicator.

equivalent of cabin pressure is indicated on the dial in increments of 1,000 feet within the range from 0 to 50,000 feet. An opening in the back of the case permits sensing of the cabin pressure. The instrument may be used to reflect pressure suit altitude rather than cabin altitude when a pressure suit is worn.

CAUTION: The cabin pressure altitude indicator should be removed if the aircraft is to undergo a cabin pressurization test on the ground. Failure to remove the indicator will result in damage to the instrument due to excessive pressure.

POSITION INDICATING SYSTEM (D-C SYNCHRO SYSTEM)

A dc synchro system is a method of indicating a remote mechanical condition. Specifically, these systems are used to show the movement and position of wing flaps, cowl flaps, oil cooler doors, or similar moveable parts of the aircraft.

The system consists of a transmitter, an indicator, and connecting wires. A dc voltage

from the aircraft's electrical power system supplies the required voltage to operate the system. The transmitter part of the system is mechanically connected to the movable device that is actually supplying the positioning data. The indicator repeats this information on a properly calibrated scale in the indicator on the instrument panel. A complete three-wire system is illustrated in figure 6-60.

Transmitter

The transmitter of the three-wire system consists of a continuous circular toroidal resistance winding on which two diametrically opposite brushes touch the winding continuously. These brushes apply d.c. to the winding and rotate with the movement of the aircraft part to which they are mechanically attached.

Indicator

The indicating element used in the three-wire system consists essentially of an annular core, a permanent magnet rotor, a damping cylinder, and three field coils. The leads between the coils are connected to the three taps of the transmitter winding. As

voltages at the transmitter taps are varied through brush rotation, so is the distribution of current in the indicator coils, causing the resulting magnetic field of the three coils to position the permanent magnet rotor attached to the pointer.

A damping effect is provided by a copper cylinder. The induced eddy currents in this cylinder oppose movement of the rotor and thus reduce the tendency of the pointer to oscillate.

Landing Gear

An example of a position indicating system is a wheel position indicator. The system consists of three back-mounted indicators, controlled through a series of limit switches in the landing gear control circuit. The wheel instrument (fig. 6-61 (A)) gives a ready indication of the landing gear position. Three positions painted on a drum which moves above an axis are indicated. One portion of the drum has a landing gear wheel symbol; the center has a diagonal barber pole (black and yellow warning lines); and the other portion has the word UP. The miniature wheel indicates that the wheel is down and locked; the UP, that the wheel is up and locked; and the barberpole, that the wheel is somewhere between up and down, or not locked in position.

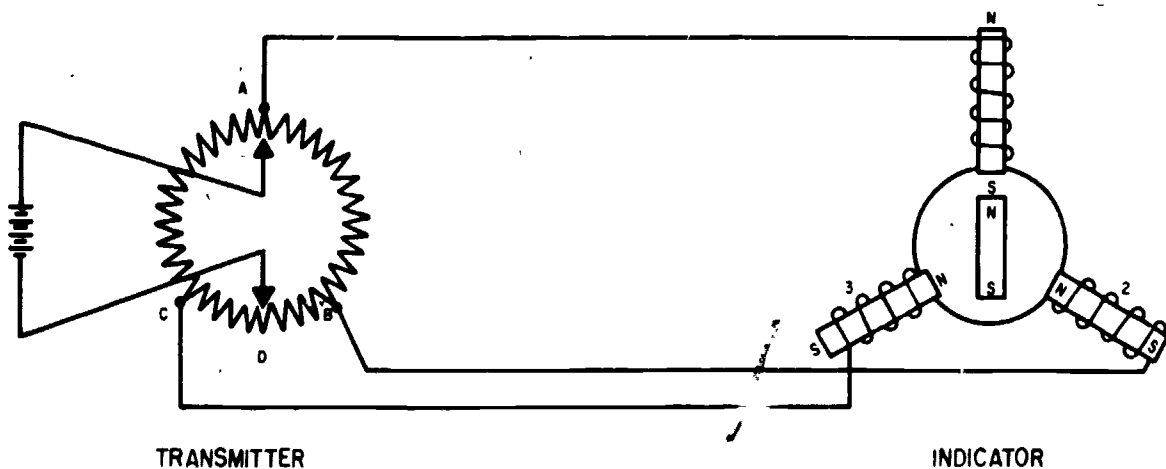
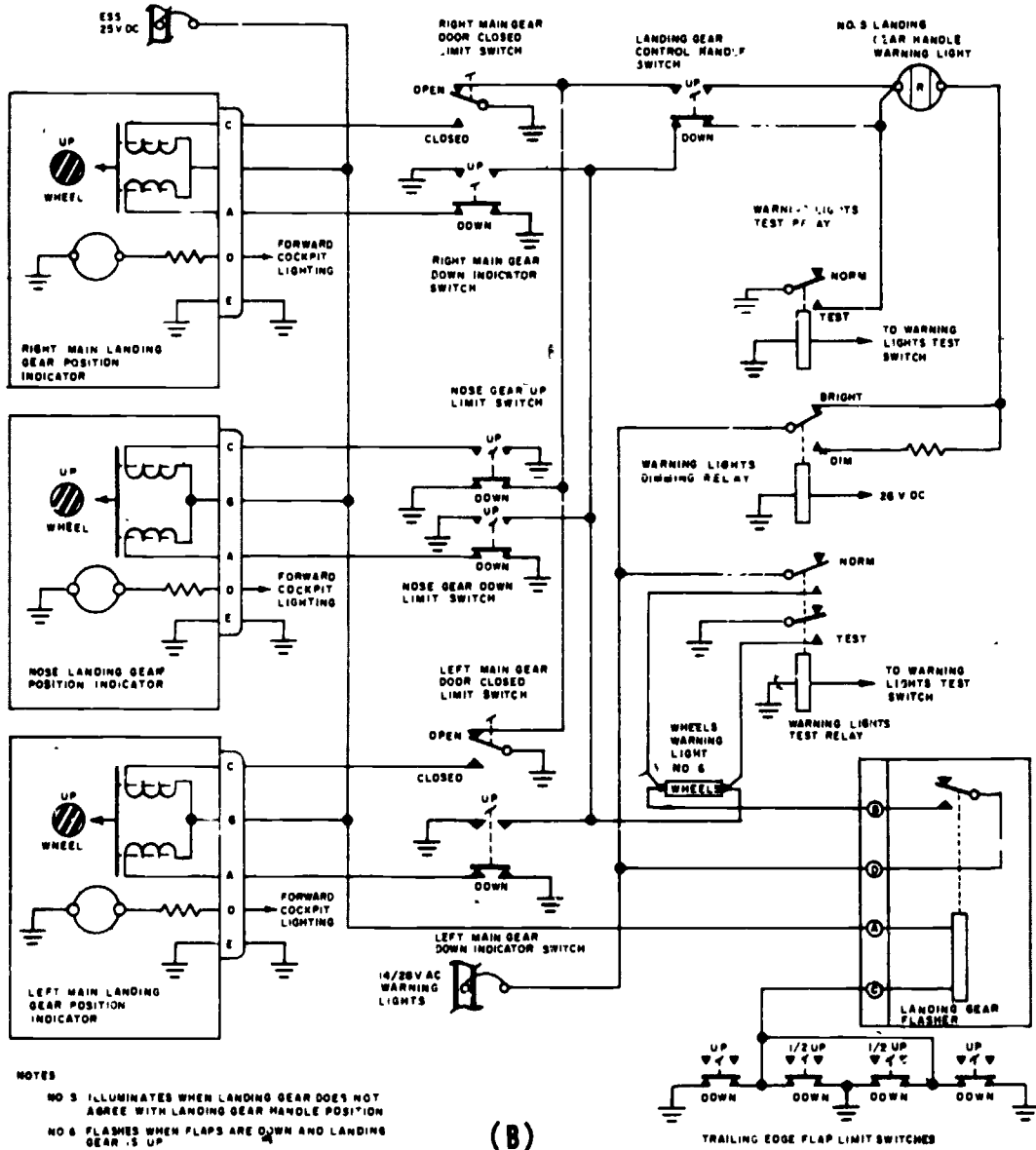
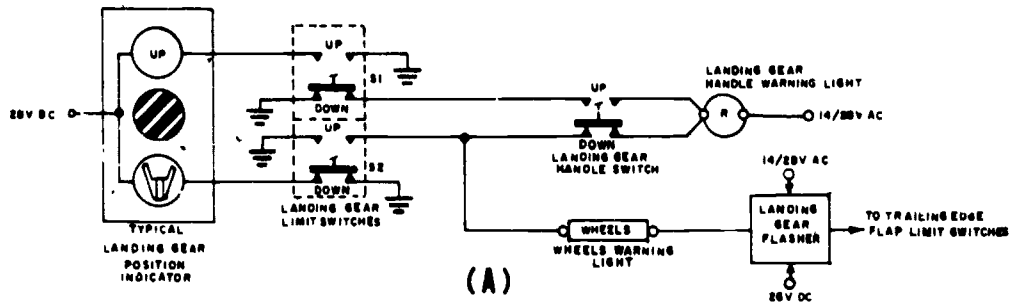

Figure 6-60.—Three-wire d-c synchro system.

207.370



NOTES
 NO 5 ILLUMINATES WHEN LANDING GEAR DOES NOT AGREE WITH LANDING GEAR HANDLE POSITION
 NO 6 FLASHES WHEN FLAPS ARE DOWN AND LANDING GEAR IS UP

207.371

Figure 6-61.—Landing gear position indicating system (A) Typical; (B) system schematic.

The position indicator is actuated by the landing gear limit switches installed in the wheel wells of the aircraft. When the movable contact of S1 (fig. 6-61 (A)) is actuated to the up position by the landing gear, the indicator shows that the wheel is up and locked. Similarly when the movable contact of S2 is moved to the down position by the landing gear, the pilot sees the miniature landing wheel, which means that the wheel is down and locked. Each switch is connected to a solenoid in the indicator. As the solenoids are energized, the indicator element moves to reveal the position of the aircraft landing gear. When the landing gear is in transition (any position between up and down and locked), both the uplock and downlock switches are released, opening both circuits to the corresponding indicator and causing the black and yellow barber pole to be displayed and the warning light in the landing gear handle to illuminate.

Figure 6-61 (B) shows a schematic for a complete aircraft system.

Flaps

The position of the flaps on aircraft can be indicated in a similar manner as the landing gear. These indicators show UP, 1/2, DN, and barber

pole, and are energized by limit switches. (See fig. 6-62).

Other aircraft indicate the position of the flaps using the d-c synchro system of remote indication which consists essentially of a transmitter and an indicator. (See fig. 6-63). A change in flap position moves the transmitter rotor, and a similar rotor movement occurs in the indicator on the instrument panel. A pointer attached to the indicator rotor indicates the amount of travel of the flaps in percent of full extension. The transmitter is mounted on the flap drive control unit and is driven by the control actuating mechanism.

Integrated Position Indicator

In many jet aircraft, the position indicators for various systems are sometimes combined into one instrument called the integrated position indicator (IPI). A typical IPI is shown in figure 6-64; this one is taken from the A6A Intruder, all-weather attack aircraft.

The IPI is shown in four different configurations—power off, transient, clean, and dirty. Power off and transient are self explanatory; clean is a term used to describe an aircraft when all of its gear are up or in and the profile of the aircraft is as free of parasitic drag

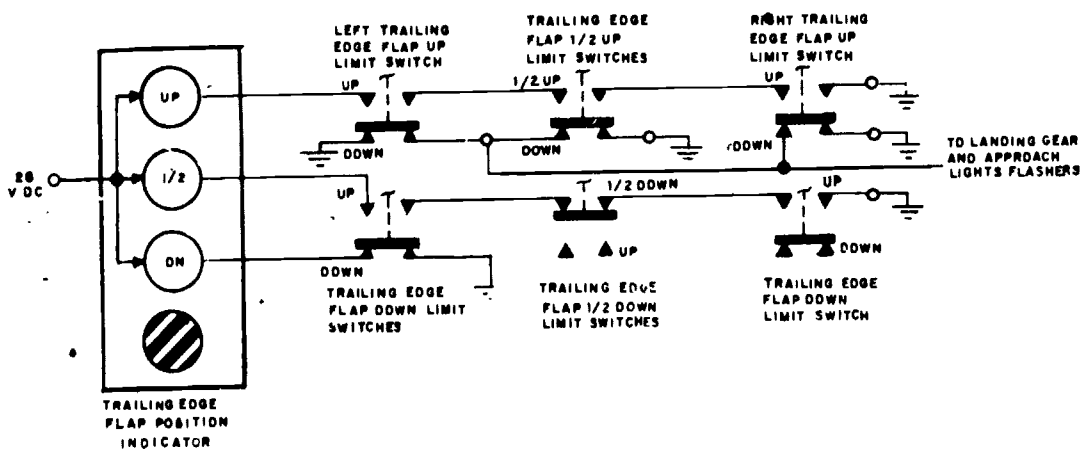

Figure 6-62.—Flap position indicating system.

207.372

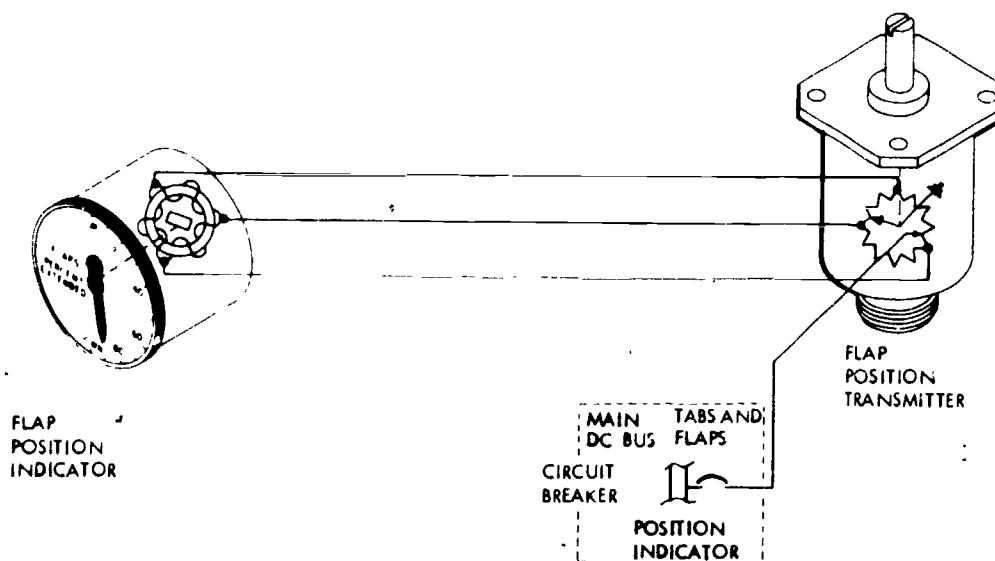

Figure 6-63.—DC synchro flap position indicating system.

207.373

as possible, dirty indicates just the opposite—that units are protruding out or down, and that resulting drags are to be expected. These four illustrations are not the only aircraft configurations possible; most of the individual systems (stabilizer, flaps, speed brakes, etc.) are capable of independent action, and not all of them function simultaneously as depicted in the figure.

As may be seen in (A) and (B), a transitional period (such as the time from initiating a gear-down selection until the time when the wheels are actually down and locked) will appear the same as power off—"barber poles."

For specific operation and exact position indications of these instruments, reference should be made to the Maintenance Instructions Manual for the specific aircraft. There are many possible sets of indications. Briefly, however, slats are usually positioned in conjunction with flap movements, the stabilizer gives indications of pitch trim control (nose up, nose down); and speed brakes, which are normally used for reducing airspeed, are either in or out, with no midposition

INSTRUMENT SYSTEM MAINTENANCE

Maintaining the many aircraft instruments and their associated equipments calls for a wide variety of skills. The importance of checking, inspecting, and maintaining these instruments must be emphasized—the aircraft cannot perform properly unless the instruments are presenting reliable information.

The accuracy imposed on the instruments used in high-speed aircraft requires assurance that such instruments are giving correct indications. The need for preventive maintenance is exemplified by the accuracy required of such instruments as percent type tachometers, tailpipe temperature indicators, gyro attitude indicators, and by fuel quantity and fuel flow systems. The existence of excessive errors in such instrument systems has a direct relation to flight safety and to efficient aircraft performance. It cannot be assumed that borderline instrument errors are acceptable for the successful operation of aircraft. This is of particular importance with high-speed aircraft.

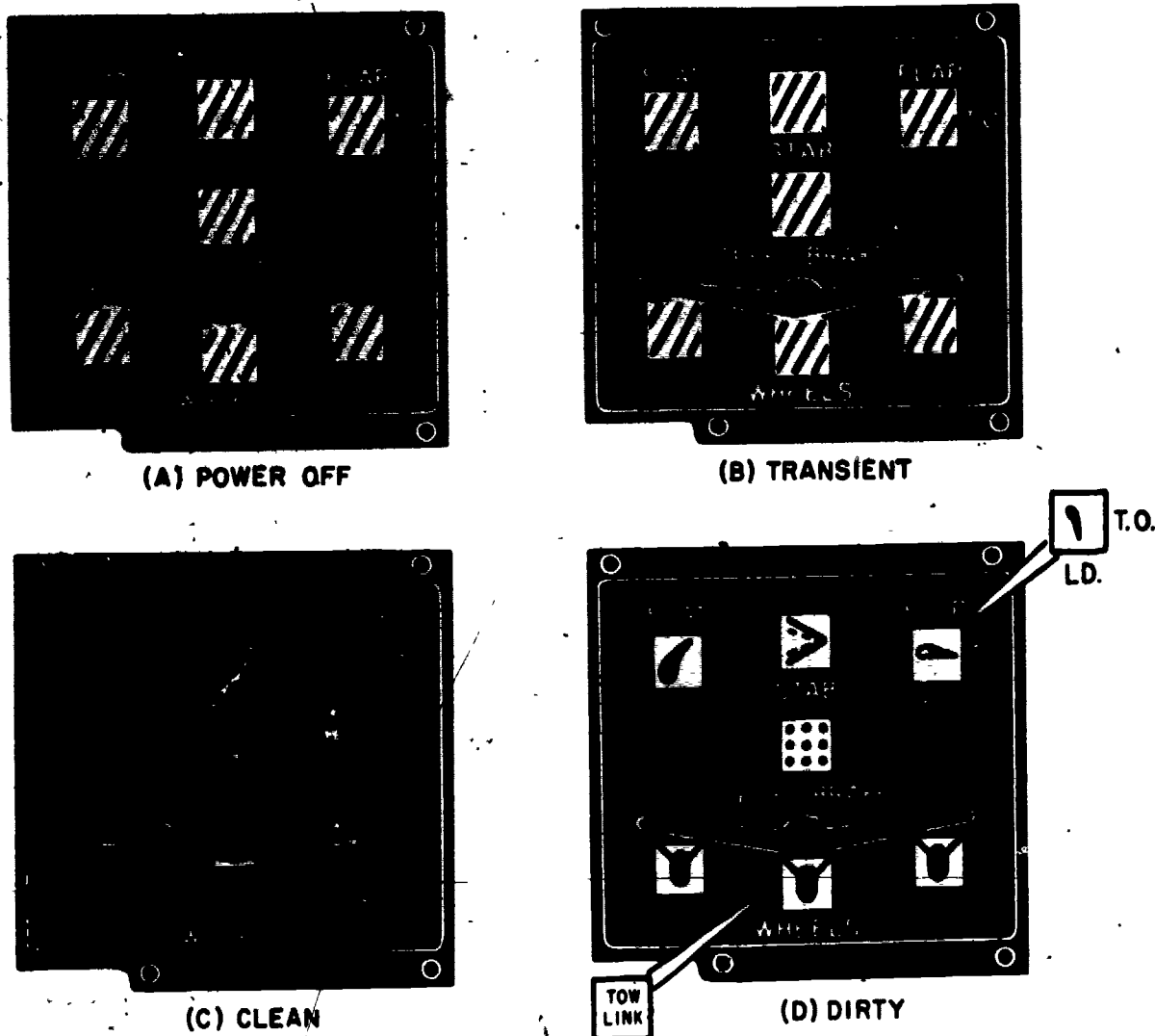

Figure 6-84.—Integrated Position Indicator (IPI).

207.133

Assurance of correct aircraft instrument indication can be attained only by periodic functional testing. Instrument testing requires time, and advantage must be taken of each inspection check to accomplish instrument operational and functional tests. The AE should become thoroughly acquainted with the operation and use of aircraft instruments and associated maintenance tools and test equipment. Without this knowledge and skill it would not be possible to perform the tasks assigned to the AE rating.

GENERAL MAINTENANCE

CASES.—Instruments, regardless of type, are encased in one of four different kinds of cases: the one- or two-piece phenolic composition cases, the nonmagnetic all-metal case, or the metallic-shielded case. The cases are made in several different sizes and provide for simplified maintenance and removal. Special instruments that contain mechanisms too large for adaption to a standard case must be provided with specially designed cases.

Instruments are easily mounted on the panel by a locking device molded into the instrument flange assembly, by spring locknuts or a mounting clamp. Instruments that use a mounting clamp are easily removed by unscrewing the tension screw normally located at the lower right corner of the instrument. The tension screw does not have to be removed to release the tension on the clamp assembly.

For pressure connections, nonstructural tubing is attached to the case proper by a standard-thread brass insert molded into the rear of the case.

Markings and Graduation

Numerals and indicating pointers are coated with luminous paint which is applied only at authorized instruments shops. Markings are applied to the glass instrument face covers to aid flight personnel in confining operation within the prescribed ranges of the equipment.

The markings usually consist of a white arc applied to the outer edges of the instrument glass or over the calibration on the dial face, and indicate the normal operating range. A red mark is used to show that the limit has been reached and should not be exceeded.

WARNING: An index marking of white paint not over one-sixteenth inch wide by three-sixteenths inch long is placed at the bottom center of all instruments color-marked for operating ranges. This index mark is made at the point between the glass and the case in order to show whether or not the glass cover moves at any time after the ranges have been marked. The proper range markings for the instruments used in aircraft may be obtained from the flight manual (NATOPS) on the particular aircraft.

Panels

Instrument panels are usually made from sheet aluminum alloy of sufficient strength to

resist flexing. The panel is nonmagnetic and is painted a dull black to eliminate glare and reflection. Some panels are constructed in two layers so that the instrument faces are flush with the rear panel when they are mounted. The front panel is a reflector panel mounted over the rear panel with sufficient clearance to supply indirect lighting effect. The indirect lighting system is not standard for all aircraft; some aircraft are equipped with spotlights, edge lighting, or a combination of these, while some instruments have their own lighting system internally.

Instrument panels are shock-mounted to absorb low-frequency, high-amplitude shocks. Square-plated type absorbers are used in sets of two, each secured to separate brackets. They should be inspected periodically for deterioration—if the rubber is found to be cracked, the pair should be replaced.

Among the instrument maintenance duties of the Aviation Electrician are certain inspections which are conducted at regular intervals. A daily inspection includes the following items:

1. Pointers are checked for excessive errors. Some indicators should show existing atmospheric pressure, existing temperatures, etc. Others should indicate zero.
2. Instruments are checked for loose or cracked cover glasses. Pitot-static instruments must be replaced if damaged.
3. Instrument lights are checked for proper operation.
4. Caging and setting knobs are checked for freedom of movement and correct operation.
5. Any irregularity reported by a pilot must be carefully investigated.

When performing a phase/calendar inspection, the following checks are made:

1. All the instruments and their dependent units for security of mounting.

2. Instrument cases, lines, and connections for leaks.

3. Dial markings and pointers for dull or marred luminous paint.

4. Operation and limitation markings for correctness and condition.

5. Instrument and electrical bonding for contact and condition of bonding.

6. Shock mountings for condition of rubber and security of attachment.

7. All lines and tubing behind the instrument panel for freedom of motion, that they are properly clamped or taped to avoid chafing, and for freedom from moisture, crimps, etc.

After the engine has been started, the instrument pointers should be checked for oscillation, and readings should be checked for consistency with engine requirements and speeds. In the case of multiengine aircraft, the instruments for the various engines, should be checked against each other, and any inconsistency should be investigated since it is probably indicative of a faulty engine, component, or instrument.

After careful diagnosis of a particular trouble has been completed, and if the instrument has been determined to be faulty, it should be removed immediately and turned in to the supply activity along with the reasons for its removal. The following precautions should be remembered when removing and installing instruments.

1. They must be handled carefully at all times. Additional damage may result if the instrument is abused.

2. The location of an indicator must not be changed.

3. Do not force the mounting screws. If the screw is cross-threaded, replace it. Do not draw

the screws up too tight against the panel--the case may be distorted sufficiently to affect the operation of the instrument, crack the case, or break off the mounting lugs.

4. When removing or installing tubing of a pressure-operated instrument, use a backup wrench to avoid twisting the tubing or fitting. Do not exert undue force while tightening the connection.

5. All electrical plugs are installed hand tight.

6. Before connecting an electrical plug to an instrument, check the plug for bent or broken pins.

7. Cap the open electrical receptacles, plugs, and hose connections to prevent foreign material from entering the instrument or system.

Lubrication

Generally, instruments require little or no lubrication in the field. The shafts and bearings or instruments are lubricated before assembly and no further lubrication should be required until the instrument is sent to a Naval Air Rework Facility for overhaul. Overhaul operations for aircraft instruments are performed by specially trained personnel only.

Aircraft Plumbing

Rigid and flexible tubing are used extensively in aircraft. These tubes are manufactured in many different sizes; sizing is usually determined by outside diameter and ranges from 1/8 inch to 2 inches. The amount of pressure that a tube can safely withstand is determined by the type of material and the wall thickness. When replacing or repairing tubing use caution to insure that the proper type is used. Detailed information on tubing and tubing repairs may be found in Aircraft Structural Hardware, NAVAIR 01-1A-8.

RIGID TUBING.—Rigid metal tubes are widely used in aircraft for fuel, oil, coolant, oxygen, instrument, hydraulic and vent lines. Tubing of copper, corrosion-resistant steel (stainless steel), and aluminum alloy is used. The basic tube material may be identified by either visual inspection or, as in the case of aluminum alloys, the actual alloy designation may be stamped on the surface of the tubing.

While it is difficult to generalize as to the specific material application, copper has been replaced as a general-purpose material by aluminum alloys, because of their lighter weight workability, and resistance to corrosion and fatigue.

Tube fittings are required when connecting tubes together or when connecting a tube to an instrument. These are made from aluminum alloy, steel, or copper base alloys. The shape of the fitting is determined by the particular installation—some are straight, while others are made at various angles. Fittings are secured to the tubes by a beaded or flared joint. The beaded or upset joint is used in low-pressure lines such as those found in vacuum, deicer, and oil systems where rubber hose fittings are utilized. Flared joints are used on all high-pressure and some low-pressure lines. Metal fittings are always used. Grip dies and flaring or beading tools are required in forming flared and beaded joints. When working rigid tubing, consult the manuals on the beading and flaring tools for instructions on the proper use of the tools.

Damaged piping and lines should be replaced with new parts. When repairing tubing, the length removed will be determined by the location and extent of the damage and the most convenient location for tool manipulation. To prevent damage by a misfit and to insure a leak-proof system, be sure to use the correct size and proper type of coupling and fitting.

There is a tendency to overtighten tubing nuts to insure that high-pressure fluid will not escape. Such overtightening may severely damage or completely cut off the tube flare. If, upon the removal of a tube, a flare is found to retain less than 50 percent of its original wall thickness, it should be rejected.

In bending tubing, care must be exercised to prevent collapsing the tube at the bend. Bending is best accomplished by using the bending tool.

When making bends for fluid tubing, be certain that you use the proper bending radius. These specifications are given in NW 01-1A-8.

Rigid Line Identification.—Each rigid line in the aircraft is identified by bands of paint or strips of tape around the line near each fitting. These identifying markers are applied at least once in each compartment. Various other information is also applied to the lines.

Identification tapes are applied to all lines less than 4 inches in diameter except cold lines, hot lines, lines in oily environment, and lines in engine compartments where there is a possibility of the tape being drawn into the engine intake. In these cases, and all others where tapes should not be used, painted identification is applied to the lines.

Identification tape codes indicate the function, contents, hazards, direction of flow, and pressure in the fluid line. These tapes are applied in accordance with MIL-STD-1247. This standard was issued in order to standardize rigid line identification throughout the Department of Defense (figure 6-65).

The function of a line is identified by use of a tape, approximately 1 inch wide, upon which word(s), color(s), and geometric symbols are printed. Functional identification markings, as provided in MIL-STD-1247, are the subject of international standardization agreement. Three-fourths of the total width on the left side of the tape has a code color or colors which indicate one function only per color or colors. The function of the line is printed in English across the colored portion of the tape, but even a non-English-speaking person can troubleshoot or maintain the aircraft if he knows the color code. The right-hand one-fourth of the functional identification tape contains a geometric symbol which is different for every function. This is to insure that all electricians who may be colorblind, whether English speaking or not, may positively identify the line function by means of the geometric design rather than by the color(s) or word(s). Figure 6-66 is a listing, in tabular form, of functions

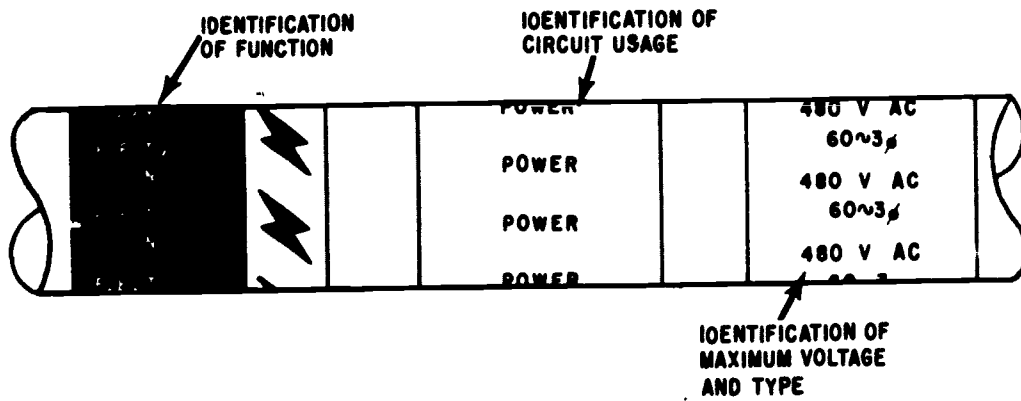

Figure 6-65.—Electrical line identification application.

207.234

FUNCTION	COLOR	SYMBOL
Fuel	Red	◆
Rocket Oxidizer	Green, Gray	☾
Rocket Fuel	Red, Gray	◆☾
Water Injection	Red, Gray, Red	∇
Lubrication	Yellow	⋮
Hydraulic	Blue, Yellow	●
Solvent	Blue, Brown	≡
Pneumatic	Orange, Blue	∞
Instrument air	Orange, Gray	⚡
Coolant	Blue	~
Breathing Oxygen	Green	■
Air Conditioning	Brown, Gray	⋯
Monopropellant	Yellow, Orange	T
Fire Protection	Brown	◇
De-Icing	Gray	▲
Rocket Catalyst	Yellow, Green	
Compressed gas	Orange	▱
Electrical Conduit	Brown, Orange	⚡
Inerting	Orange, Green	++

Figure 6-66.—Functional identification tape data.

207.235

and their associated identification media as used on the tapes.

The identification-of-hazards tape shows the hazard associated with the contents of the line. Tapes used to show hazards are approximately 1/2-inch wide, with the abbreviation of the hazard contained in the line printed across the tape. There are four general classes of hazards found in connection with fluid lines. These hazards are outlined in the following paragraphs.

Flammable Material (FLAM). The hazard marking "FLAM" is used to identify all materials known ordinarily as flammables or combustibles.

Toxic and Poisonous Materials (TOXIC). A line identified by the word "TOXIC" contains materials which are extremely hazardous to life or health.

Anesthetics and Harmful Materials (AAHM). All materials productive of anesthetic vapors and all liquid chemicals and compounds hazardous to life and property, but not normally productive of dangerous quantities of fumes or vapors, are in this category.

Physically Dangerous Materials (PHDAN). A line which carries material which is not dangerous within itself, but which is asphyxiating in confined areas or which is generally handled in a dangerous physical state of pressure or temperature, is identified by the marking "PHDAN."

Table 6-2 lists some of the fluids with which the AE may be required to work and the hazards associated with each.

FLEXIBLE TUBING (HOSE).—Flexible hose assemblies, which consist of lengths of hose that are coupled with threaded end fittings, may be divided into two major groups—high pressure and low pressure, according to their application.

The specifications of a flexible hose may be obtained by interpreting the identification code that is printed on the hose. This identification, which is a series of dots and dashes, gives the

hose size, temperature range, and date of manufacture in quarter of year and year. Refer to NAVAIR 01-1A-8 for a detailed discussion of flexible hose identification.

High-pressure flexible hose cannot be made up at the organizational level; it must be ordered through regular supply channels. The reason for this is that this hose must be subjected to high-pressure tests. Squadrons are not allowed to make such tests.

The parts that make up a low-pressure flexible hose may be ordered through supply and the hose made up locally. Fittings from a damaged hose may be reused provided they meet the required specifications.

Hose should be installed so that it will not be subjected to twisting under any condition of operation. This type installation lessens the tendency for connecting fittings to loosen. When replacing hose in hydraulic, fuel, oil, alcohol, and pneumatic systems, the hose installed must duplicate the hose removed as to length, outside diameter, inside diameter, material, type, and shape (except on directed modifications).

If a bend is required when installing hose in fluid systems, the radius must not be smaller

Table 6-2.—Hazards associated with various fluids

Contents	Hazard
Air (under pressure)	PHDAN
Alcohol	FLAM
Carbon dioxide	PHDAN
Freon	PHDAN
Gaseous oxygen	PHDAN
Liquid nitrogen	PHDAN
Liquid oxygen	PHDAN
LPG (liquid petroleum gas)	FLAM
Nitrogen gas	PHDAN
Oils and greases	FLAM
JP-4	FLAM
Trichlorethylene	AAHM

than the minimum specified in NAVAIR 01-1A-8. This publication shows the minimum bend radii for flexible hose. When practical it is desirable to use a radius that is larger than the specified minimum.

When hose is installed through holes in brackets, and when supporting clips are used there must be no reduction in the diameter of the hose. If these conditions are present, the flow is reduced and damage to the hose may occur.

Hose must be supported at least every 24 inches. Closer supports are desired when practical. The support of a flexible line should be such that it will never tend to cause deflection of the rigid connecting lines under any possible relative motion that may occur. Flexible hose between two rigid connections may have excessive motion restrained where necessary, but should never be rigidly supported.

Chafing may be avoided by using suitable bulkhead type grommets or cushioned clips.

Protect hose installations from excessive temperature, such as exhaust blasts, supercharger ducts, and the like, either by shrouding or relocation. Use of flame-resistant hose is preferred forward of the firewall and is directed by NAVAIR instructions on certain aircraft.

Where hose connections are made to an engine or to engine-mounted accessories, the hose must be installed so that 1-1/2 inches of slack, or an adequate bend is provided between the last point of support and the attachment to the engine or accessory. This prevents the possibility of the hose being pulled off the nipple due to engine movement. Whenever possible, hose should be installed so that all markings on the hose are visible.

All hoses are manufactured from materials subject to deterioration by exposure to heat, sunlight, excessive moisture, and ozone. Accordingly, hose should be stowed in a cool dry place and away from electrical equipment. Age limits of shelf items based on the

manufacturer's code can be obtained from the current accessory bulletins. Hose must be stowed in straight lengths to prevent it becoming set in a curved position. Peeling or flaking of the hose cover, or exposure of the braid reinforcement to the elements, is cause for replacement of the hose.

PITOT-STATIC INSTRUMENT MAINTENANCE

Maintenance of the pitot-static system consists primarily of checking for integrity of the lines, and for the presence of water and miscellaneous obstructions. A pressure check is of the utmost importance as any slight leak will result in erroneous indications of the instruments during flight. The pitot heater should also be checked for proper operation by monitoring a voltage drop when the heat is turned on, or by checking the pitot tube for the presence of heat.

CAUTION: Do not touch the pitot tube with your bare hand when heat is applied—the extreme heat may cause the skin to adhere to the surface.

The following procedure is outlined for water and debris removal from the pitot-static system.

1. Disconnect all altimeters, airspeed and rate-of-climb indicators, and any other instruments or systems that derive information from the pitot-static system. Disconnect the lines from pitot or pitot-static tubes.
2. Remove all drain caps in the system. (Refer to the Maintenance Instructions Manual for location.)
3. Circulate a stream of clean, dry, filtered air at medium pressure through the complete system and into each static vent, being careful not to include the cabin pressurization system static vent. Be certain that air is flowing from the exit end of each line.
4. Inspect all static vents and the pitot tube water removal drain holes for damage and

evidence of foreign matter and obstructions. Check all low points in the lines for possible cracks due to icing in the lines.

5. Replace and secure all system drain caps.
6. Reconnect all instruments. For proper installation refer to the Maintenance Instructions Manual. Tighten connections properly, avoiding kinking or bending the lines.
7. Using a field test set or other approved tester, thoroughly check the system for proper operation and leaks. While the pitot-static system is relatively simple when compared to more complex systems, its maintenance should not be considered a minor task.

INSTRUMENT TESTING

Operation of most aircraft instruments is entirely automatic. Once installed, the units require no further maintenance or servicing other than routine and periodic inspections. If malfunctioning of a system or an instrument occurs, it is first necessary to localize the source of trouble. A systematic troubleshooting procedure, including the possible service troubles and their remedies, should be developed for each type of instrument. Much of this information may be found in pertinent aeronautical publications and in the Maintenance Instructions Manual for specific aircraft, and the Service Instruction Manual for specific instruments.

An instrument reported as functioning improperly, or otherwise suspected of being unserviceable, must first be checked to determine whether the instrument or the installation is at fault. Usually troubles fall into three groups: trouble in the power supply; trouble in the unit; or trouble in the connections to units, either electrical or mechanical. If the installation is faulty, it can be corrected by line maintenance. If the instrument is the cause of the trouble, in most cases it must be removed and replaced with a serviceable unit. The defective unit will be sent to a qualified

instrument overhaul depot for detailed inspection, overhaul, and repair.

Only authorized instrument shops are allowed to open instrument cases and make repairs or adjustments. Maintenance that the AE may perform on the small panel instruments, many of which are hermetically sealed, will be limited to flight-line performance checks and replacement of defective units. These sealed units can be repaired only at Naval Air Rework Facilities.

Portable Field Test Sets

When making ground tests of electrical instruments, an external power supply should be connected to the aircraft's external connections. The battery should not be used in conducting ground tests of equipment.

Ground testing is performed with portable field test sets such as the TTU-205B/E (used on altimeters, airspeed indicators, etc.) and the TTU-27/E tachometer tester. These and several other test sets are discussed in Chapter 3.

Always use a precision voltmeter to check instrument power. Many of the electrical instruments may be checked by using a test indicator to determine whether the trouble lies in the unit or in its electrical connections. For example, synchro indicators may be checked by using a synchro test indicator.

TROUBLESHOOTING

The manuals that the AE will use in connection with instrument maintenance contain troubleshooting charts. These charts help the AE to determine what is wrong with an instrument system and are designed primarily for maintenance personnel. The troubleshooting chart for the particular instrument should be consulted as soon as the nature of the trouble is known—it gives a listing of the common troubles, probable causes, and remedies.

Efficient troubleshooting calls for an orderly systematic plan of attack and a good

understanding of the theory of operation of the equipment. A visual inspection should be made first; this will frequently pinpoint the trouble. When making this inspection, look for discolored or burned wires, discolored or burned terminal boards, corroded switch contacts, broken or frayed wires, loose connector plugs, and loose mechanical assemblies.

Tables 6-3 and 6-4 are typical troubleshooting charts.

INTERCHANGEABILITY OF INSTRUMENTS

Extreme care must be exercised in the substitution of aircraft instruments. The

Illustrated Parts Breakdown Manual for the type aircraft should be checked for the correct type of instrument. This manual lists the part number of the instrument.

Should the exact replacement for an inoperative instrument not be available, substitution of an interchangeable instrument may prevent undue delay in returning an aircraft to service. Aviation supply items bearing the same stock numbers are operationally interchangeable regardless of the manufacturer or the manufacturer's part number. An instrument which has been assigned a stock number has at least one distinctive feature which has made it advisable to identify it individually. Normally, one instrument will not be

Table 6-3.—Troubleshooting chart—airspeed indicator

Trouble	Probable cause	Remedy
Pointer does not move.	Pitot pressure connection not connected properly to line from pitot tube. Pitot or static pressure line clogged. Defective indicator mechanism.	Check tubing and connections for leaks. Disconnect pitot and static pressure lines from all instruments. Drain at lowest point of each tube line. Blow through tubing to remove obstructions. Replace indicator.
Inaccurate readings.	Leak in tubing from pitot or static pressure fittings. Leak in indicator case. Defective indicator.	Check lines to external fittings for leaks. Replace indicator. Replace indicator.
Pointer does not set on zero when airplane is on ground.	Defective indicator.	Replace indicator.
Pointer oscillates.	Leak in tubing from pitot or static pressure fittings. Leak in indicator case. Leak in rate of climb indicator or altimeter installations. Moisture in pitot lines.	Disconnect lines from indicator. Check lines for leaks. Replace indicator. Check lines for leaks. If instrument is at fault, replace instrument. Drain moisture from lines.

AVIATION ELECTRICIAN'S MATE 3 & 2

Table 6-4.—Troubleshooting chart-fuel flow indicating system

Trouble	Probable cause	Remedy
Sluggish pointer operation.	No power on one rotor. Defective indicator.	Check connections. Replace indicator.
Pointer 180° degrees in error.	No power on one rotor.	Check connections.
Pointer swings in limited arc at top of indicator.	Transmitter ground lead open. Reversed power leads.	Check connection to pin A of transmitter.
Pointer swings in limited arc at bottom of indicator.	Indicator ground lead open.	Interchange power leads Check connection to pin A of indicator.
Pointer swings at side of indicator dial, audible squeal from instrument.	Short or reversed connection between power and stator leads.	Check for short. Interchange power leads.
Pointer swings at side of indicator dial, no audible squeal.	Open stator lead.	Replace lead.
Pointer rotates in reverse direction.	Reversed stator leads.	Interchange stator leads.
Slight movement of pointer.	Defective indicator. Defective transmitter. Clogged or dirty fuel or pressure lines to transmitter.	Replace indicator. Replace transmitter. Clean lines.
Pointer spins.	Power lead reversals, power and stator leads shorted or reversed or making intermittent contact. Defective indicator.	Check for continuity and shorts. If wiring is correct, replace indicator. Replace indicator.
Low fuel indication.	Defective indicator. Trouble in engine fuel regulation system or fuel system.	Replace indicator Refer to fuel system.

substituted for another; however, in an emergency it may be necessary. Before substitution is made, the instrument should be properly identified in the Aviation Supply Catalog which pertains to instruments, or some other publication such as the Maintenance Instructions Manual or other manuals.

EMERGENCY PROTECTIVE TREATMENT

Aircraft instruments that have been submerged in water must, as soon as practicable

after immersion, be given treatment to minimize corrosion of parts. Refer to NAVAIR 16-1-540, Avionic Cleaning and Corrosion Preventive Control Manual for the correct procedures.

Many of the components of instrument systems, such as amplifiers, transformers, and capacitors, are given a protective treatment to inhibit the growth of fungus.

This treatment consist of coating the components with a special type fungus-resistant varnish or lacquer. The operation is usually performed by the manufacturer or at a Naval Air Rework Facility. Some maintenance activities may be required to do this job. Since the varnish

and lacquer are poisonous, this is a dangerous operation and requires special equipment and specially trained personnel.

SHIPPING AND HANDLING

Instruments in need of repair should be handled with the same care that is exercised in handling new instruments, in order that additional damage due to improper handling may be avoided. In order to prevent damage in handling and stowage, all instruments, insofar as practicable, are stored and transported in individual metal containers and well packed cartons. Care should be taken in packing inoperative instruments to ensure that no additional damage will result during shipment. Individual cartons are packed for shipment in strong wooden boxes, except where the means of shipment, such as by air, prohibits such packing.

Instruments which have a locking mechanism should be placed in the locked position prior to shipment. Refer to the manufacturer's instructions for detailed information regarding the locking of a particular instrument.

Cleaning

All aircraft instruments, after being removed from the aircraft and before shipping to supply, should be cleaned externally. If such instruments are fluid transmitters or pressure

indicators, such as fuel flow transmitters and Bourdon type instruments, they should be drained to ensure that no fluid remains inside the instrument.

Extreme care should be exercised to prevent contamination of instruments with perspiration. Thoroughly dry the instrument before wrapping with moistureproof material.

Containers

All instruments and accessories when received from supply are in containers. Two types are used—nonmetallic and metallic.

The nonmetallic container is usually constructed of a high-grade cardboard. It will not withstand the rough treatment that the metallic type container can endure; however, if they are not abused, they afford adequate protection for the instrument.

The metallic type is constructed of a heavy gage metal and is equipped with a lid that is secured to the can with a snapping fastener. This type may be opened and closed without any damage to the container.

Both the nonmetallic and metallic containers and the packing material therein should not be damaged or thrown away after the instrument has been removed. Provisions should be made for retaining this material in the electric shop since it may be used for returning equipment to supply. Many of these containers are labeled "REUSABLE CONTAINER—DO NOT DESTROY."

CHAPTER 7

COMPASS, INERTIAL NAVIGATION, AUTOMATIC FLIGHT CONTROL AND STABILIZATION SYSTEMS

The material in this chapter pertains to terms and definitions used in aircraft navigation systems, the aircraft compass system and Inertial Navigation System (INS) and the calibration of these two systems; Automatic Flight Control Systems (AFCS); and Automatic Stabilization Systems (ASE).

The manner in which the electrical signals are detected, amplified and delivered to various indicators and/or equipment in these systems is highly sophisticated. Therefore, a thorough knowledge of *Module 15, Navy Electricity and Electronics Training Series*, titled *Principles of Synchros, Servos, and Gyros* is necessary in understanding the contents of this chapter.

NAVIGATION TERMS AND DEFINITIONS

Any purposeful movement in the universe involves an intention to proceed to a definite point, and navigation is the business of proceeding in such a manner as to arrive at that point. AIR NAVIGATION is defined, formally, as the process of directing the movement of an aircraft from one point to another. The function of air navigation is primarily to determine the direction necessary to accomplish the intended flight, locate positions, and measure distance and time as means to that end.

POSITION

Position is a point defined by stated or implied coordinates. This term is frequently qualified by such adjectives as "estimated," "dead reckoning," "no wind," etc. But however qualified, the word "position" always refers to some place which can be identified. One of the basic problems of the navigator is that of "fixing

his position," because unless he knows where he is, he frequently cannot know how to direct the movement of his craft to its intended destination.

DIRECTION

Direction is the position of one point in space relative to another, without reference to the distance between them. Direction may be either three-dimensional or two-dimensional, the horizontal being the usual plane of the latter. For example, the direction of San Francisco from New York is approximately west (two-dimensional); while the direction of an aircraft from an observer on the ground may be west and 20° above the horizontal (three-dimensional). Direction is not itself an angle (e.g., the direction east) but it is often measured in terms of its angular distance from a reference direction.

COURSE

Course is the intended horizontal direction of travel. Suppose, for example, that the direction of NAS Jacksonville from NAS Pensacola is east—the intended direction of flight. Because of wind conditions aloft; the aircraft might not be headed straight toward Jacksonville, but somewhat to one side. No matter how the aircraft is headed, the course (the intended direction) is still east.

HEADING

Heading is the horizontal direction in which an aircraft is pointed. The example given above shows the distinction between course and heading. Heading is the actual orientation of the

longitudinal axis of the aircraft at any instant while course is the direction of travel intended. True heading uses the direction of the geographic north pole as the reference. Magnetic heading uses the direction of the earth's magnetic field at that location as the reference, and thus differs from true heading by the amount of variation at that location. Compass heading differs from magnetic heading by the amount of deviation, and from true heading by the amount of compass error (deviation \pm variation). Variation and deviation are explained later in this chapter.

BEARING

Bearing is the horizontal direction of one terrestrial point from another. Bearings are usually expressed in terms of either of two reference directions, (a) true north, and (b) the direction in which the aircraft is pointed. If true north is the reference direction, the bearing is called a true bearing. If the reference direction is the heading of the aircraft, the bearing is called a relative bearing.

If a bearing is obtained by radio it is called a radio bearing; if visually, a visual bearing. Thus, the direction between two objects on (or near) the surface of the earth can be described concisely by saying, "The (radio, visual) bearing of A from B is X° (relative, true)."

DISTANCE

Distance is the separation between two points and is measured by the length of a line joining them. This seems understandable enough, but suppose that the two points are on opposite sides of a baseball. How is the line to be drawn? Does it run through the center of the ball, or around the surface? If the latter, what path does it follow? It is clear that the term "distance" as used in navigation must be qualified to indicate how the distance is to be measured. The shortest distance on the earth's surface from NAS San Diego to Sydney, Australia, is 6,530 miles, but via Honolulu and Guam, a frequently used route, it is 8,602 miles. And, of course, the length of a chosen line could be expressed in various units, as miles, kilometers, or yards

TIME

Time has many definitions, but those used in navigation consist mainly of two; (a) the hour of the day, and (b) an elapsed interval. The first is used to designate a definite instant, as "Takeoff time is 0215". The second definition is used to designate an interval, as "Time of flight, 2 hours 15 minutes".

POLES

The earth's geographic poles are the extremities of the earth's axis of rotation. Consider figure 7-1, in which P_n , E, P_s , W represents the surface of the earth at sea level, and P_nP_s is the axis of rotation, being in the plane of the paper. The earth's rotation is such that all points in the hemisphere P_nWP_s approach the reader, while those in the opposite hemisphere recede from the reader. The extremities of the axis, points P_n and P_s , are the north and south poles, respectively. A man on the surface of the earth and facing in the direction of rotation, has the north pole on his left, east in front of him, the south pole on his right and west behind him.

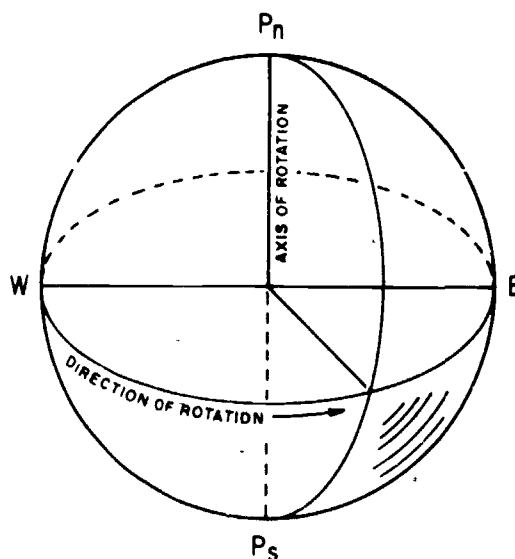

207.226
Figure 7-1.—Schematic representation of earth showing axis of rotation and equator.

The earth has some of the properties of a bar magnet, and the magnetic poles are the regions near the ends of the magnet where the highest concentration of magnetic lines of force exist. However, the earth's magnetic poles are not at the geographic poles, nor are they antipodal to each other.

GREAT CIRCLES AND SMALL CIRCLES

The intersection of a sphere and a plane is a circle; a great circle if the plane passes through the center of the sphere, and a small circle if it does not.

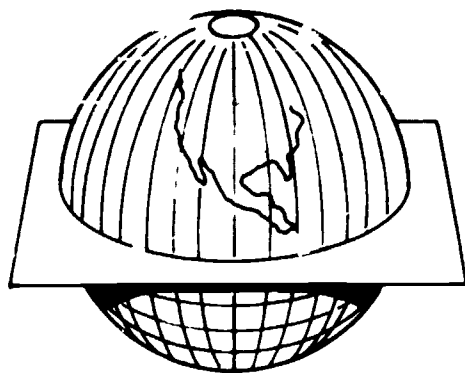

207.80

Figure 7-2.—The equator is a great circle whose plane is perpendicular to the polar axis.

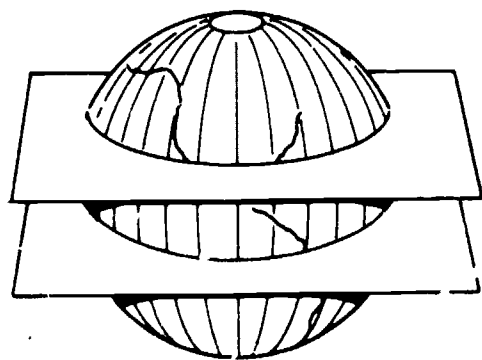

207.89

Figure 7-3.—The plane of a parallel is parallel to the equator.

PARALLELS AND MERIDIANS

As indicated in figure 7-2; the earth's equator is a great circle. If a second plane (fig. 7-3) is passed through the earth parallel to the equator, the intersection of this plane and the surface of the earth is a small circle. Small circles need not have planes which are perpendicular to the polar axis, but if they ARE perpendicular, then all points on the small circle are equidistant from the equator; that is, the circles are parallel to the equator. Such small circles, together with the equator, are called PARALLELS and provide one component of a system of geographical coordinates.

Now suppose that planes are passed through the earth's poles, as in figure 7-4. Such planes contain the axis, and since they also contain the

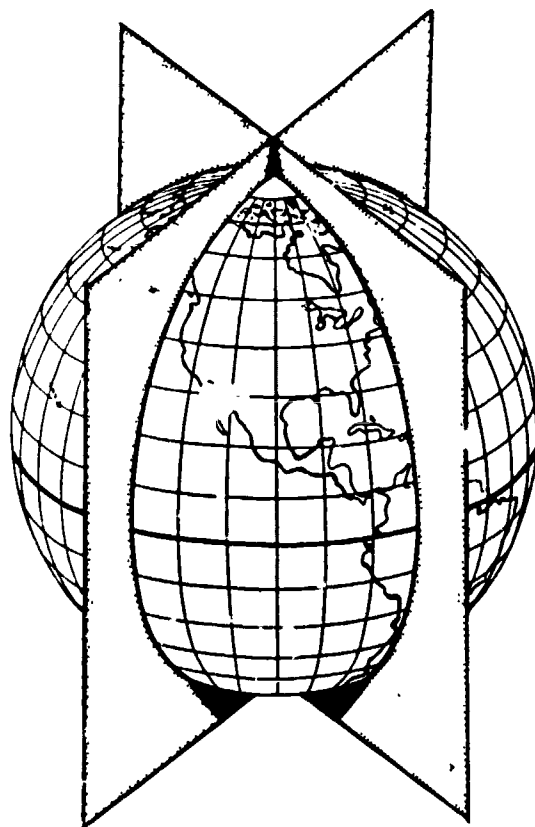

207.91

Figure 7-4.—Great circles through the poles form meridians.

center, they form great circles at the surface. Great circles through the poles of the earth are called MERIDIANS. All meridians are perpendicular to the equator. Meridians form the second component of a system of geographical coordinates commonly used by navigators.

LATITUDE AND LONGITUDE

Any point on earth can be identified by the intersection of a parallel and a meridian, just as it is possible to designate an address as "at the corner of Fourteenth Street and Seventh Avenue", if some unambiguous method is used for identifying the parallels and meridians.

For measurement purposes, the circumference of a circle is divided into 360 units called degrees, and the same unit (the degree) is used to measure an angle. In figure 7-5 circumference $QP_nQ'P$, represents a meridian, and QQ' , represents the equator whose plane passes through the axis of rotation. Let M be some position north of the equator on a meridian. The number of degrees in arc QM is the measure of angle QOM . If arc QM is 30° ,

then angle QOM is 30° . In other words, a central angle is measured by its subtended arc.

Let MM' be the plane of a small circle parallel to QQ' , the equator. Then arc QM measures the distance of any point on MM' from the equator. In other words, the whole parallel MM' can be described by saying that it is 30° , north of the equator. Similarly, any point on NN' can be said to be 45° south of the equator. The angular distance of a position north or south of the equator is called the position's latitude. Latitude is measured northward or southward through 90° and labeled N or S to indicate the direction of measurement. Latitude may be expressed in terms of the angle at the center, QOM in figure 7-5, or what is numerically the same, in terms of meridional arc QM . Latitude, then, is the north-south geographical coordinate.

The east-west geographical coordinate is called longitude, which is defined as (1) an arc of the equator or a parallel, (2) the angle at the pole, or (3) the angle at the center, between the planes of the prime meridian and the meridian of a point on earth, measured eastward or westward from the prime meridian through 180° , and labeled E or W to indicate the direction of measurement.

Just as latitude is measured from a standard great circle (the equator), so is it necessary to adopt a standard great circle, a meridian, as the origin of longitude measurements. The standard meridian is called the prime meridian. By international agreement in 1884, the meridian adopted as the prime meridian of 0° longitude is the one on which the Greenwich Observatory was then located, near London, England.

Figure 7-6 represents the earth with QQ' the equator, its plane passing through the center, O . G is the position of Greenwich and M is a position in north latitude west of Greenwich. P_nM' and P_nG' are portions of the meridians through M and G intersecting the equator at M' and G' . The longitude of M is (1) the arc of the equator $G'M'$, (2) angle GP_nM formed by the meridional planes through G and M , and (3) the angle $G'OM'$ formed at the center between G' and M' . Each of these expressions should be

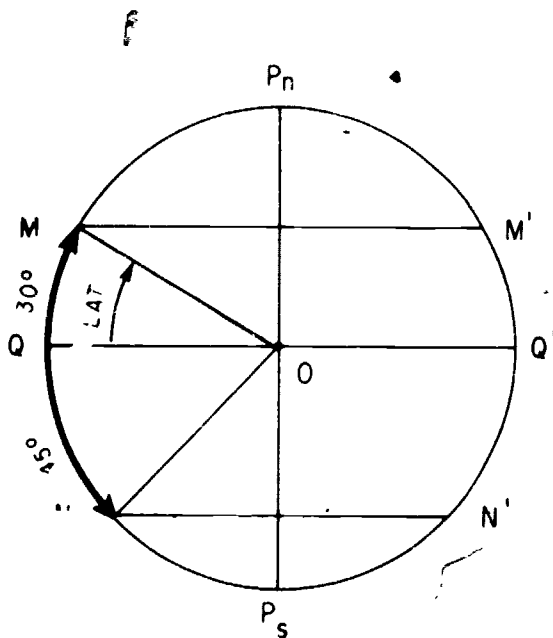

207.92

Figure 7-5.—Latitude of M is angle QOM or arc QM .

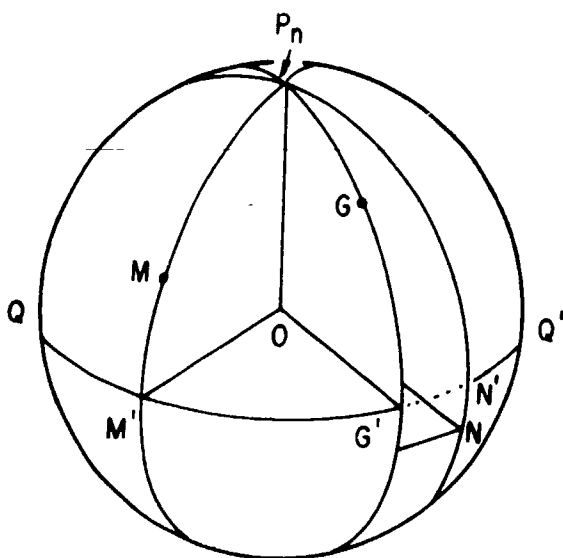

207.93

Figure 7-6.—Longitude is measured between meridians.

recognized as measuring the same coordinate, longitude.

The longitude of a position is further described as being east or west of Greenwich. In figure 7-6, the longitude of M is west; the longitude of N is east. It should be apparent from the figure that longitude east or west cannot exceed 180° .

A degree may be subdivided into smaller units as in the decimal system. However, the more common method of subdivision is to divide each degree into (1) 60 minutes ($'$) of 60 seconds ($''$) each, extending each second to as many decimal places as desired, or (2) into 60 minutes and tenths of minutes.

To convert minutes into decimals of degrees, or to convert seconds into decimals of minutes, divide by 6. Thus: $15^\circ 30' = 15.5^\circ$, and $15^\circ 30' 24'' = 15^\circ 30.4'$.

VARIATION

As was stated under the definitions of poles, the earth's true (geographic) poles and its magnetic poles are not at the same location.

Also, the location of the magnetic poles even changes slightly over the years. In 1960, the north magnetic pole was located at latitude 74.9° N and longitude 101.0° W, approximately. The southern pole was at latitude 67.1° S and longitude 142.7° E, approximately. Thus, a given line on the surface of the earth may be a different direction relative to the true north pole from that relative to the magnetic north pole. In addition, the lines of magnetic force are not in general straight lines because of irregular iron deposits near the earth's surface. Since a compass needle aligns itself with the lines of force at its location, it may not point to either true north or magnetic north. The locations on the earth where the compass does point to true north, when connected together, form an irregular line called the agonic line. At other locations, the angle between the direction of true north and the direction of the earth's magnetic field (not necessarily the same as the direction of the earth's magnetic pole) is called the variation at that location. This same angle is also often called the "angle of declination." Variation (or declination) is labeled east or west, respectively, of true north. (See figures 7-7 and

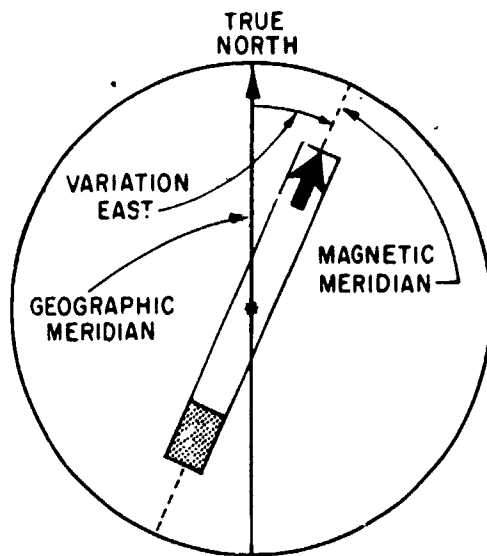

207.95

Figure 7-7.—Easterly magnetic variation.

7-8.) Lines connecting locations having the same variation are called isogonic lines.

DEVIATION

Deviation is the error in a magnetic compass caused by nearby magnetic influences, such as those related to magnetic material in the structure of the aircraft and to electrical circuits. These magnetic forces deflect a compass needle from its normal alignment with the earth's magnetic field. The amounts of such deflections are expressed in degrees, and are labeled east or west as the compass points east or west, respectively, of the earth's magnetic lines of force. Deviation varies with the heading of the aircraft. One reason for this is shown in figure 7-9.

Suppose, for example, that the net result of all magnetic forces inherent in an aircraft can be represented by an arrowhead in the longitudinal axis of the aircraft and aft of the compass. If the aircraft is headed toward magnetic north, the magnetic forces (arrowhead) attract the south-seeking end of the compass needle but do

not change the needle's direction because the inherent magnetism has the same polarity as the earth's field. Suppose, now, that the aircraft heads east magnetic. The aircraft's magnetic forces now repel the north end of the compass needle and attract the south end, causing easterly deviation. The figure also shows that the deviation when headed south is zero and when headed west is westerly. Deviation can be reduced by changing the position of small compensating magnets provided in the compass case for this purpose. However, it is usually not possible to remove all the deviation on all headings. The residual deviation must be determined for each compass installation and recorded on a deviation card which shows the actual deviation on various headings or, more frequently, the compass headings for various magnetic headings. This is accomplished by a process known as compass swinging and is covered later on in the chapter under the heading of compass calibration.

COMPASS ERROR

Both variation and deviation are expressed in degrees, and the net result of both is called compass error. If variation and deviation have the same name (east or west), they are added to obtain compass error. If they have different names, the smaller is subtracted from the larger and the difference given the name of the larger. (See fig. 7-10.) Occasionally, variation and deviation are labeled (+) if east, and (-) if west. In this case compass error is the algebraic sum of the two.

Example 1.

Given: Variation 7° west, deviation 2° west.

Required: Compass error.

Solution: 7° W + 2° W = 9° west. To make good a true course of 135°, this particular aircraft over this particular spot on the earth's surface would have to fly a compass heading of 144°.

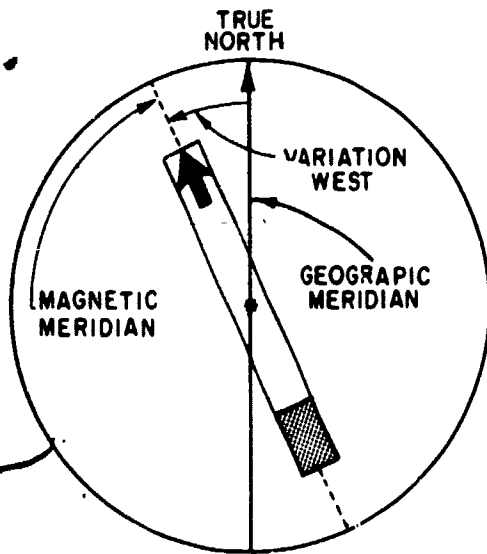

207.96

Figure 7-8.—Westerly magnetic variation.

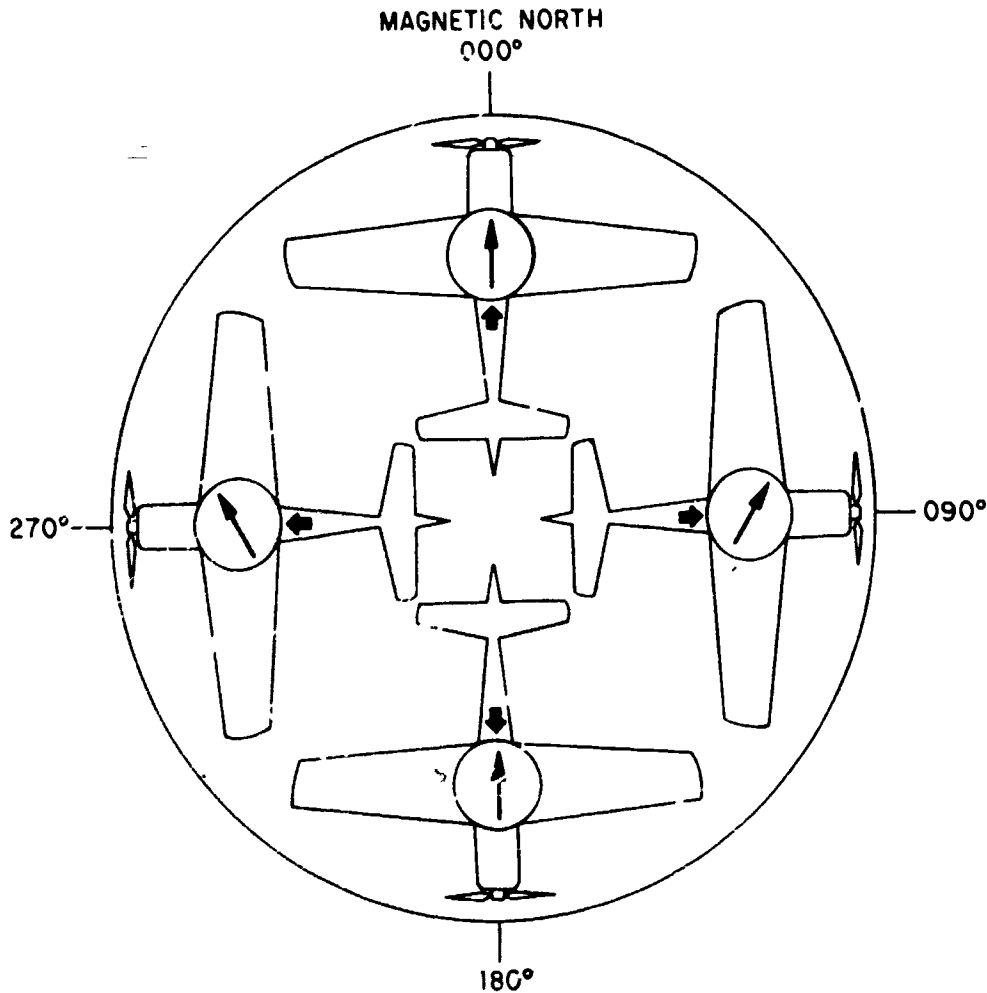

207.97

Figure 7-8.—Deviation changes with heading.

Example 2.

Given: Variation $(-)$ 2° , deviation $(+)$ 5°

Required: Compass error.

Solution: $(-)$ $2^{\circ} + 5^{\circ} = (+)$ 3° .

MAGNETIC DIP

At the magnetic poles, the direction of the earth's magnetic field is vertical (perpendicular to the earth's surface), and along the aclinic line (sometimes called the magnetic equator),

roughly half way between the poles, the field's direction is horizontal (parallel to the earth's surface). The difference between the direction of the earth's field and the horizontal at any location is called magnetic dip, and varies from very small angles near the equator to very large angles near the poles. The angles can be measured by a dip needle, which is a magnetic needle free to turn about a horizontal axis. At San Francisco the dip angle is about 62° . A line connecting all locations having equal dip angles is called an isoclinic line.

The total intensity of the magnetic field is along the dip angle, but it may be shown as two

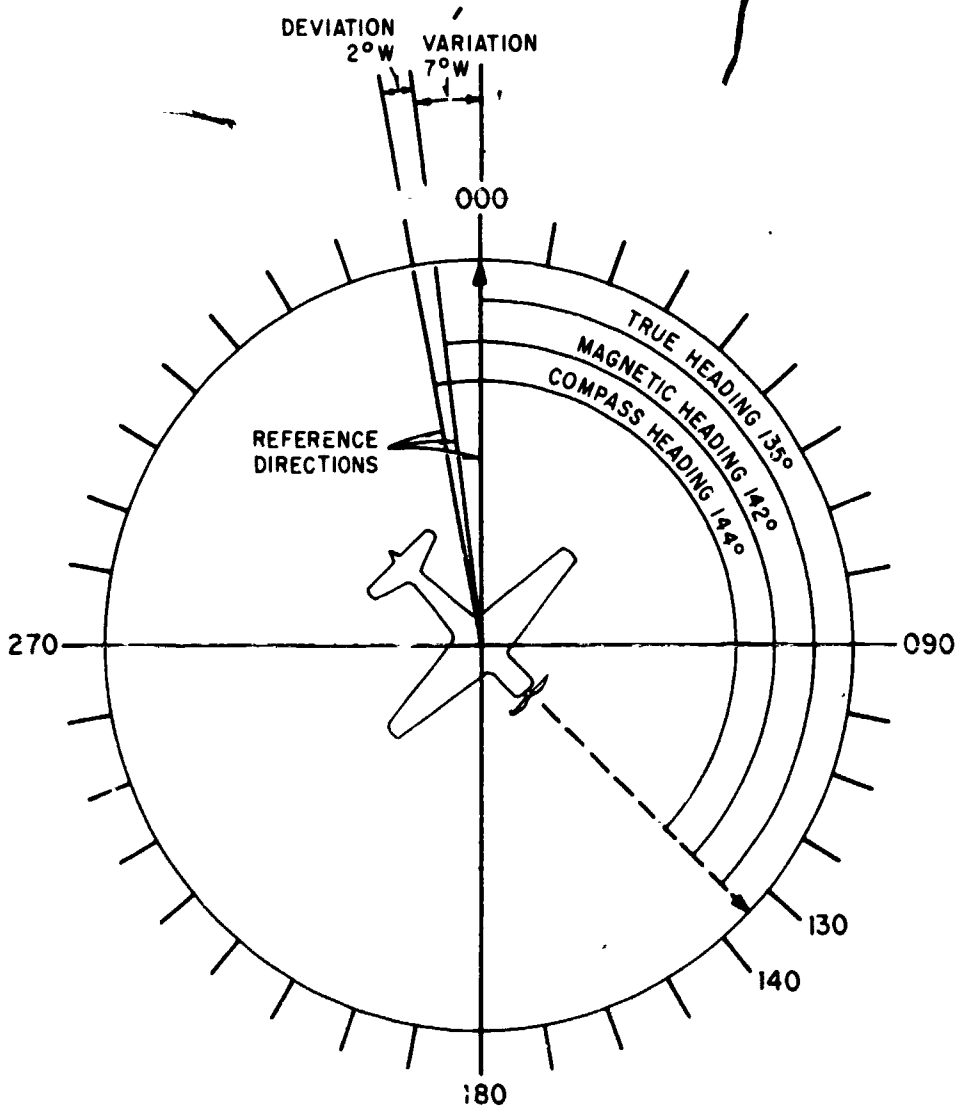

Figure 7-10.—Effect of compass error.

207.88

components—vertical and horizontal. (See figure 7-11.)

Only the horizontal component is effective as a directive force for a magnetic compass, and loses its effectiveness near the magnetic poles because of the weak horizontal component there. The vertical component also causes errors in a magnetic compass during aircraft maneuvers which cause the compass card to tilt to the east or west. If an aircraft heading east increases its speed, or when headed west decreases its speed,

or turns east from a north or south heading, the floating compass card will tilt, with the east side sinking and the west side rising. The vertical component of the earth's field will then cause the compass card to rotate to the east when in the northern hemisphere and to the west when in the southern hemisphere. The amount of error is zero at the aclinic line and increases toward the magnetic poles. It should be apparent that precise turns are difficult by reference to such a compass.

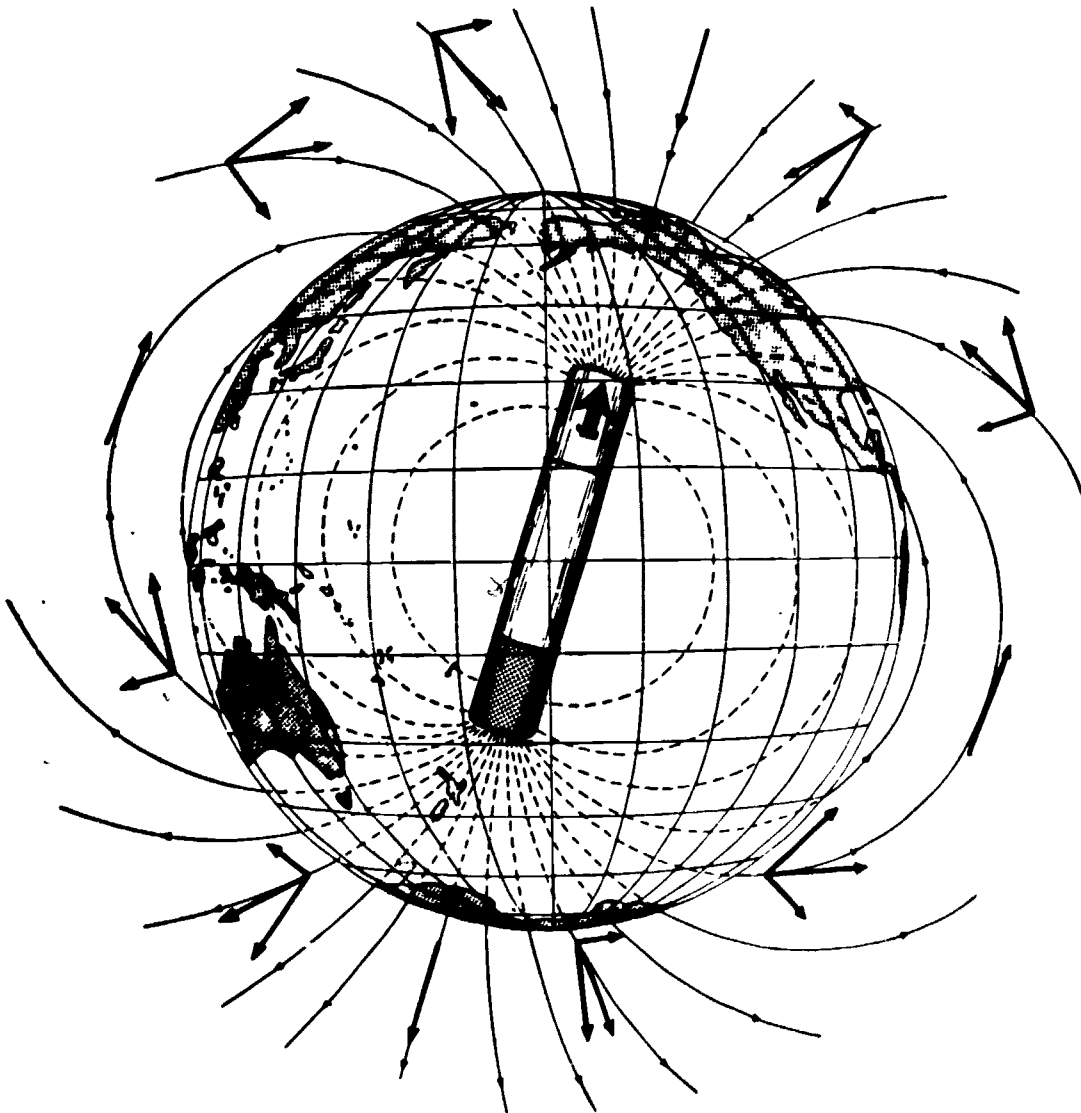

207.99

Figure 7-11.—The earth's magnetism.

PILOTAGE

Pilotage is the directing of aircraft from point to point by visual or radar observation of landmarks either previously known or recognized from a chart. It is somewhat similar to making a trip by automobile where the highway is the course taken and the towns along the way are the check points. This method has obvious limitations if the flight is made over

large bodies of water or poorly charted areas, and if made using only visual observations, darkness, rain, or fog further limits its use. Therefore, whenever possible, pilotage is used in conjunction with other methods of navigation.

DEAD RECKONING

Dead reckoning is the process of determining position deduced from the record of previously

known position, course, speed, and time traveled. To be accurate, every change of course and speed during the flight must be considered, whether the changes are made by the pilot or by movement of the air mass (wind) through which the aircraft is flying.

RADAR NAVIGATION

Modern radar can be a valuable aid to navigation. Some radars present a maplike display of the terrain below and around the aircraft on the screen of a cathode-ray tube. This allows pilotage to be extended beyond some of the limitations of visual observations.

Radar transponders are devices which are normally inoperative until interrogated or triggered into action by a suitable signal from another radar transmitter. They then transmit their own signal which is received by the interrogating radar. These are used both for fixed navigational aids, such as radar beacon stations, and for airborne IFF (identification friend or foe) systems.

Doppler radar can detect and indicate actual ground speed and drift of an aircraft regardless of wind speed or direction.

Radar altimeters give the actual distance from the aircraft to the surface below, whether it be a body of water or land masses far above sea level.

RADIO NAVIGATION

Radio navigational aids vary from a fairly simple direction finding receiver, which indicates the relative bearing of any radio station within its distance and frequency range, to complex systems using special transmitting stations which make it possible to fix the position of an aircraft with considerable accuracy. The usable range varies according to its intended use, and also with weather and ionospheric conditions. Beacon stations associated with an instrument landing system (ILS) are usually of low power, whereas Long Range Air Navigation (LORAN)

stations have a range extending to 1,400 miles under favorable conditions. The airborne portions of radio and radar systems are maintained by Aviation Electronics Technicians.

CELESTIAL NAVIGATION

Celestial navigation is the method of fixing the position of the aircraft relative to celestial bodies. Since the earth is constantly revolving, an accurate time device is necessary. A sextant may be used to measure the angle of the celestial bodies with respect to the horizon. In marine navigation the visible horizon is used as a reference, and in air navigation an artificial horizon is generally used. Also the navigator needs an almanac to determine the celestial equator system coordinates at the time of observation.

The usual method of establishing a line of position from celestial observation consists of (1) observation, (2) coordinate conversion, and (3) plotting. The navigator tries, whenever possible, to select three bodies approximately 120° apart in azimuth. This not only results in lines of position which cross cleanly, but tends to minimize the effects of a constant error in the observations.

INERTIAL NAVIGATION

Inertial Navigation Systems (INS) are dead reckoning devices which are completely self-contained within the vehicle and are independent of their operating environment, such as wind, visibility, or aircraft attitude. They do not radiate or receive RF energy; therefore, they are impervious to countermeasures. They make use of the physical laws of motion that Newton described three centuries ago. Of course, the starting position must be entered into the system, and when known positions are available, the system may be corrected or updated if an error exists.

Another input to the system is from acceleration detectors which measure the rate of change of motion of the aircraft. The first integral of acceleration is velocity; that is, when acceleration is integrated in respect to time, the

Chapter 7—COMPASS, INERTIAL NAVIGATION, AUTOMATIC FLIGHT CONTROL AND STABILIZATION SYSTEMS

result is velocity. In a simplified case, if a body was started from rest and was constantly accelerated at the rate of 8 feet per second per second for 11 seconds, the velocity at the end of this time would be 88 feet per second (60 miles per hour). However, in actual practice, acceleration is not always this constant, and the integration of acceleration is the process of summing all minute acceleration-time increments over a given period of time.

By integrating velocity with respect to time, the result is displacement (distance); therefore, the second integral of acceleration is displacement. Since the inertial navigator's purpose is to keep track of position and not the total distance traveled, it integrates all values of acceleration (positive and negative) detected over the time involved.

If the earth were flat and the vehicle traveled only on the earth's surface, a two-axes inertial navigation system could plot the position using two accelerometers—one sensitive along the x-axis (E-W) and the other sensitive along the y-axis (N-S). The important point to note about detecting acceleration of a body is that each accelerometer detects only the component of the resultant acceleration along its sensitive axis. They have no way of telling whether the detected velocity change is due to a speed change or a direction change or both; nor does it matter what forces cause the velocity change. Neither can the accelerometer distinguish between the acceleration of the vehicle and the pull of gravity. Therefore, if the accelerometer is tilted off level its output will include a component of gravity as well as vehicle acceleration. To obtain the correct vehicle acceleration in the horizontal plane, it is necessary to hold the sensitive axis of the accelerometer perpendicular to the gravitational field.

Of course the earth is not flat, and not exactly round either. Its radius at the poles is less than its radius at the equator. It also spins about its polar axis. A spinning gyro mounted in gimbals tends to maintain a fixed direction in relation to space rather than to any point on the earth. Consider a gyro at the equator with its spin vector direction east, toward the morning sun. After 6 hours of earth rotation, the spin vector would be up in relation to the earth's surface; after 12 hours it would be west; after 18

hours it would be down; and after 24 hours east again. Also, consider a spinning gyro with its spin axis parallel with the earth's axis of rotation—at the equator it is parallel with the earth's surface, but as it is moved to the north pole it becomes vertical to the earth's surface. All of these things must be taken into account and corrected for. So, to navigate on the earth requires a highly complex inertial system, each component of which is capable of extreme accuracy.

A four-gimbal platform is mounted so that regardless of what maneuvers are made by the aircraft the platform retains the original orientation, thus serving as a level mount for the accelerometers. The stable element contains two identical floated, two-degree-of-freedom gyros, mounted with their spin axes horizontal and at right angles to each other. By utilizing the gyroscopic principle of precession as the aircraft flies over the rotating earth, it is possible to apply a continuous torque to the appropriate axes, thereby reorienting the gyros to maintain the stable element horizontal to the earth's surface and pointed north. An electronic analog computer is used to develop the signals necessary to properly torque the gyros. The corrections for earth rate depend on the aircraft's position on the earth's surface.

As many as three accelerometers can be used. Two are horizontal with one sensitive to north-south acceleration and the other sensitive to east-west acceleration. In some installations a third accelerometer is mounted to determine vertical acceleration. The gravity component is subtracted from the output of the vertical accelerometer by the computer. A more detailed description of an INS follows later in the chapter.

AIRCRAFT COMPASS SYSTEMS

Countless navigational devices and methods have been invented and devised. In the present era, with its supersonic speeds, accurate determination of direction has become increasingly important. An error of only a few degrees in a space of minutes will carry the modern aviator many miles off his course.

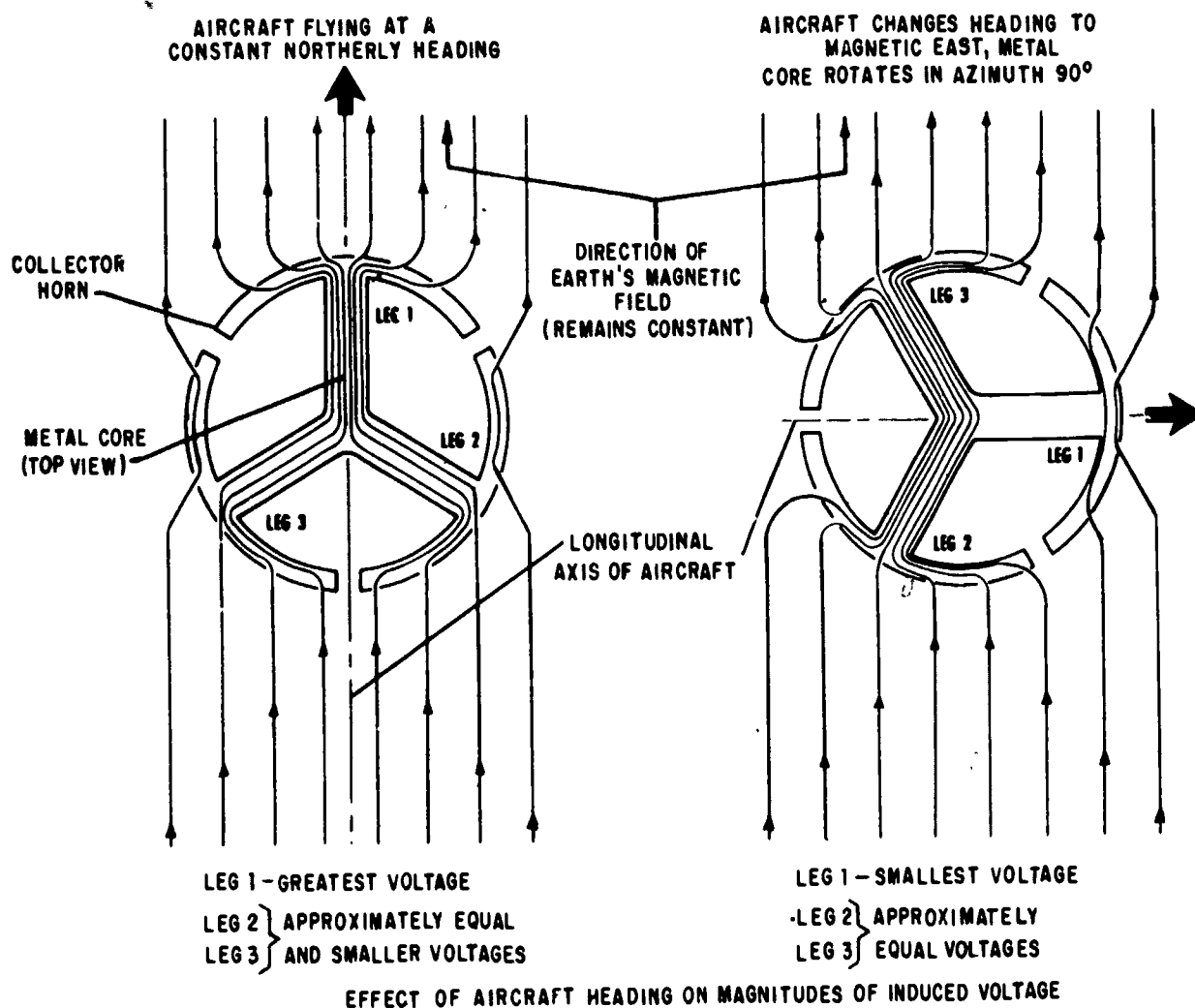

207.100

Figure 7-12.—Flux valve heading changes.

During the early days of aviation, direction of flight was determined within the aircraft chiefly by direct-reading magnetic compasses. Today the direct-reading magnetic compass still finds use as a standby compass should the more sophisticated compass systems fail.

COMPASS SYSTEM SENSORS AND INDICATORS

In chapter 6 the heading indicator was mentioned as a flight instrument, this

instrument is part of the primary heading reference system. The heading indicator receives electrical/electronic signals from various components in the system and displays to the pilot the aircraft's heading in degrees. This compass system should not be confused with the standby compass system (wet compass) covered in chapter 6.

Sophisticated navigation systems and weapons delivery systems require aircraft heading information in electrical signal form which can be applied to computers, indicators,

Chapter 7—COMPASS, INERTIAL NAVIGATION,
AUTOMATIC FLIGHT CONTROL AND STABILIZATION SYSTEMS

and other components, in addition to the visual indication of aircraft heading provided for the pilot. Also, by using these signals, indicators can include aircraft heading along with other information in a single instrument.

Compass Transmitter

The compass transmitter, called a flux valve, detects the direction of the flux lines of the magnetic field of the earth and electrically transmits this information to a servo loop. The transmitter is only a few inches in height, and can be installed within the wing or tail of the aircraft where magnetic disturbances are lowest. It consists of a hermetically sealed hemispherical bowl containing a pendulous sensing element mounted in a damping fluid. A universal mounting permits the sensing element up to 30 degrees of freedom in roll and pitch, while prohibiting rotation about the vertical axis.

The laminated metal core of the sensing element is a good conductor of magnetic lines of force. It is shaped like a three-spoked wheel with the rim split between the spokes as shown in figure 7-12. The earth's magnetic lines of force will be concentrated in these legs because they offer low reluctance to the flux, and the amount of flux in any one leg is proportional to the angular position of the leg relative to the earth's magnetic lines of flux. The signal pickup coils

are wound around these legs, one for each leg, and so are positioned 120 degrees apart in a horizontal plane. The coils are electrically connected in a wye configuration.

Around the hub of the core, corresponding to the axle of a wheel, is wound the exciter coil to which is applied 400-Hz ac power. This coil is called the primary and the signal pickup coils the secondary, but the core and windings are designed so there is no transformer action between the coils. The primary winding and its applied voltage are only for the purpose of producing a magnetic field and thus changing the reluctance of the core. When the 400-Hz ac is applied to the primary coil the current generates a magnetic field in the core, driving it to saturation at the peak of each positive and each negative portion of the cycle. Figure 7-13 shows the side view of the center hub and one leg of the sensing element.

When the 400-Hz voltage is at zero, the reluctance of the core is low, and a maximum number of the earth's magnetic flux lines are concentrated in the core. As the sine wave builds up toward maximum the reluctance increases, making the core less attractive to the earth's magnetic flux lines and they move out, cutting through the secondary coil and inducing a voltage in it. Refer to figure 7-14. The movement of flux lines increases until point Y on the 400-Hz sine wave and then the movement

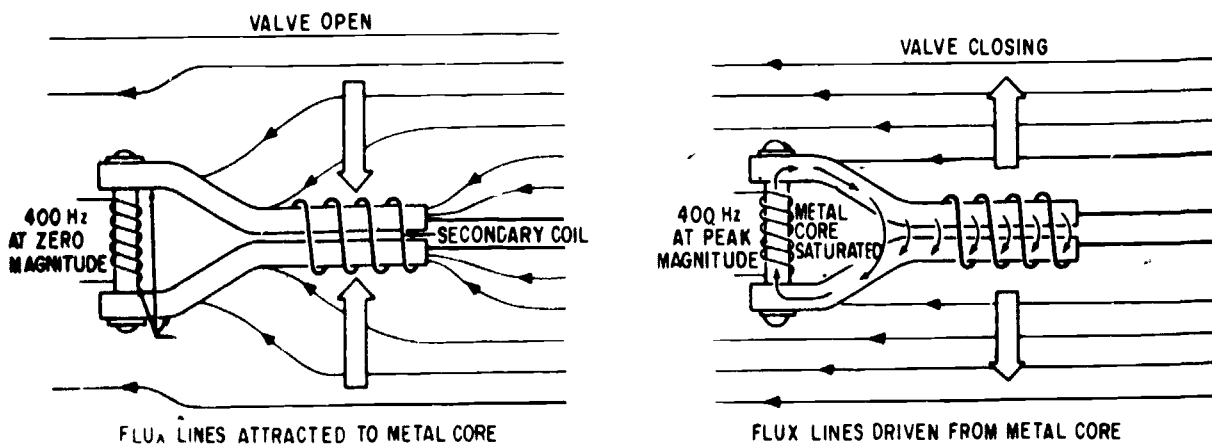
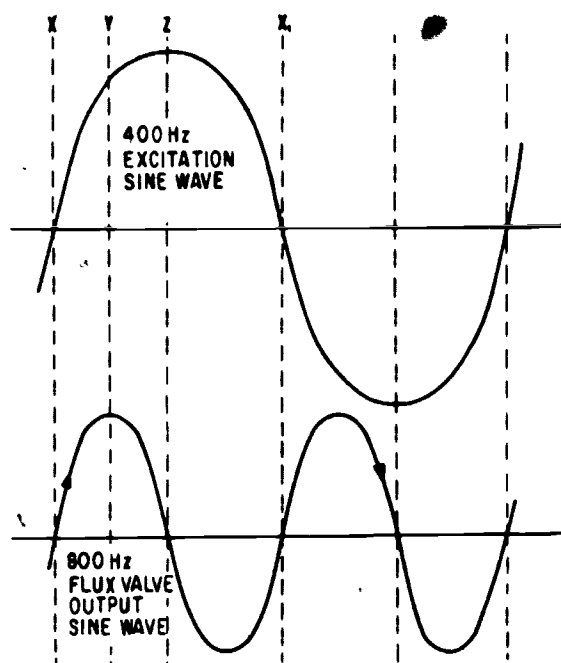

Figure 7-13.—Magnetic flux line movement.

207.101



207.103

Figure 7-14.—Flux valve sine waves.

tapers off and stops moving at point Z. At this time no voltage is induced into the secondary winding. As the primary sine wave starts dropping toward X_1 , the reluctance of the core decreases, and the core attracts more and more of the earth's flux lines which cut through the secondary coil in the opposite direction and induce a voltage of the opposite polarity. When the primary sine wave reaches X_1 , the maximum number of the earth's flux lines are again concentrated in the core, but are not moving, so the induced voltage in the secondary coils is zero.

The same action takes place during the negative half of the 400-Hz excitation current, and the resulting output of the flux valve is an 800-Hz signal. The voltages of each of the three secondary coils pass through zero at the same instant, but their polarity and amplitude depend on the heading of the aircraft. They vary in the same fashion as the output of a synchro generator, and may be used to drive an 800-Hz synchro system. The original 400-Hz excitation is effectively cancelled by the special

construction of the metal core and windings, because lines of flux produced by the primary coil induce cancelling voltages in the secondary coils.

Attached to the top of the compass transmitter is a compensator assembly (fig. 7-15) consisting primarily of two sets of two small permanent bar magnets. The relative azimuth position of each set can be changed by rotating a screw, on the outside of the unit, which positions the magnets by means of a gear train. One adjusting screw adjusts for north-south compensation, and the other screw adjusts for east-west compensation.

Two wiring symbols for the flux valve are shown in figure 7-16. To distinguish them from synchro units, the words "compass transmitter" or "flux valve" are usually included in the drawing.

Displacement Gyroscope Assembly

The displacement gyroscope assembly consists of a vertical gyro and a directional gyro mounted in a common outer roll gimbal. See figure 7-17. The vertical gyro provides pitch and

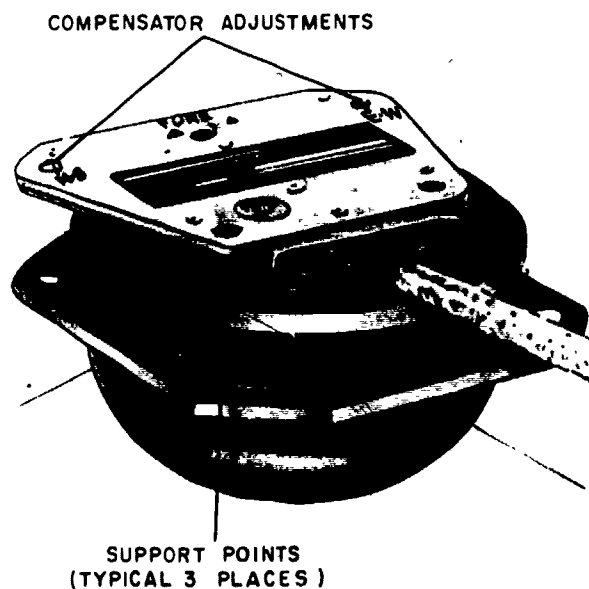

207.105

Figure 7-15.—Compass transmitter and compensator.

Chapter 7—COMPASS, INERTIAL NAVIGATION,
AUTOMATIC FLIGHT CONTROL AND STABILIZATION SYSTEMS

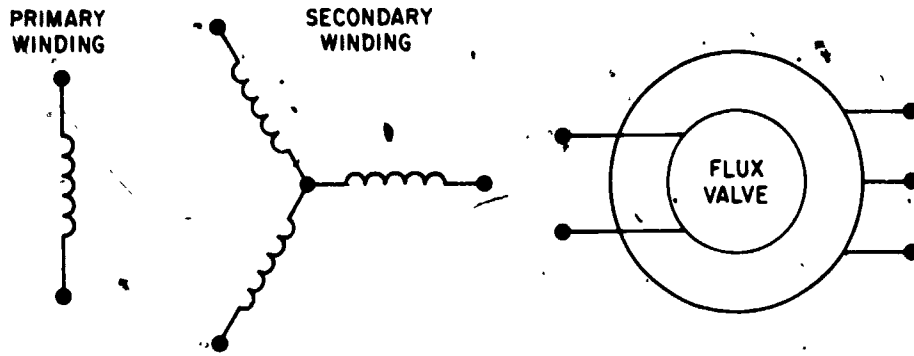

207.106

Figure 7-16.—Compass transmitter schematic and functional symbols.

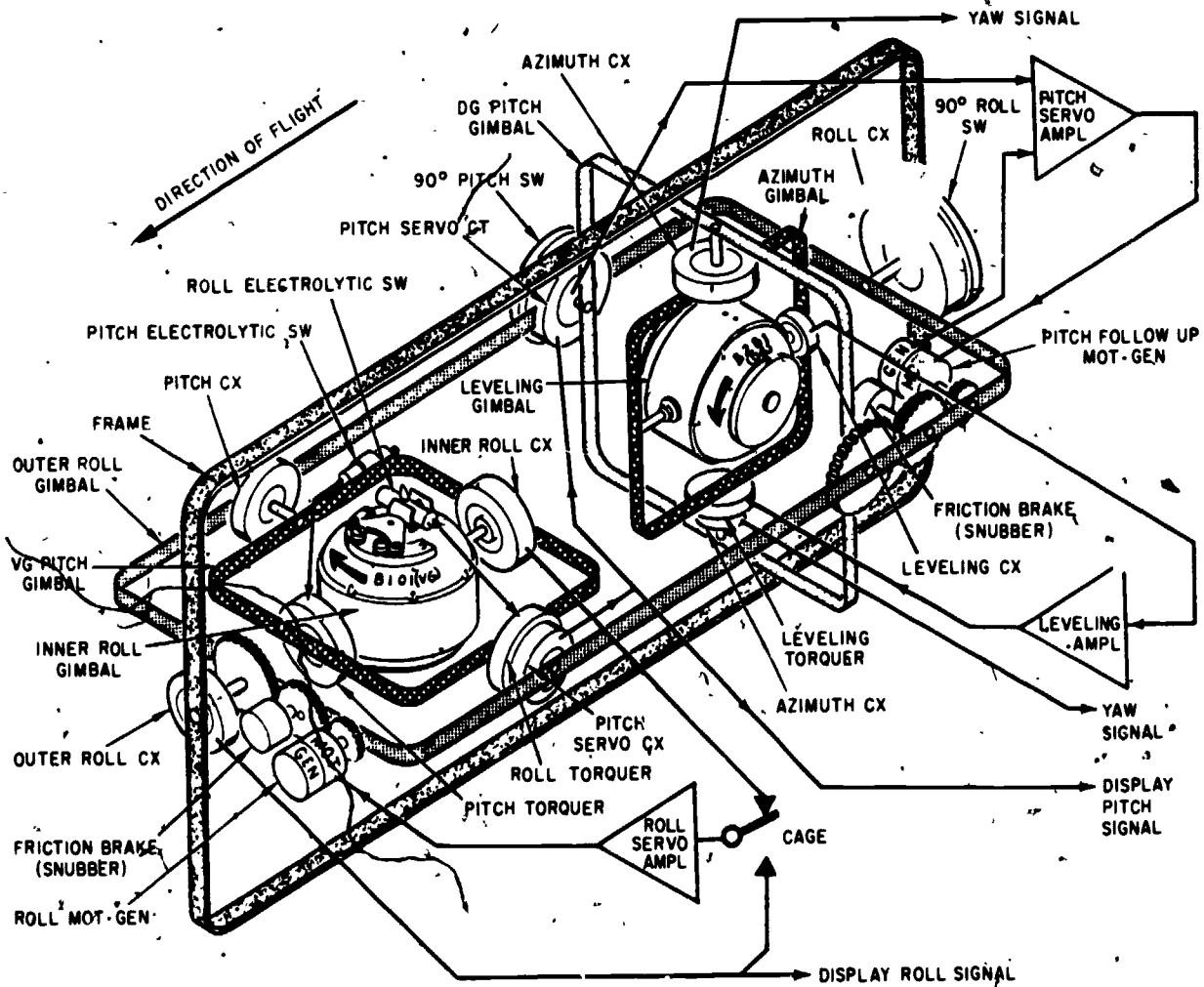

Figure 7-17.—Typical displacement gyro and servo loops.

207.115

roll signals and the directional gyro provides heading (azimuth) signals. Erection and leveling servo loops erect and maintain the spin axis of the vertical gyro gravity-vertical, and the directional gyro spin axis parallel to the earth. Roll, pitch, and azimuth control transmitters convert aircraft attitude into electrical signals.

VERTICAL GYROSCOPE OPERATION.—The vertical gyro consists of gyro spin motor B101 (which is the inner roll gimbal), vertical gyro pitch gimbal, outer roll gimbal, and the frame. The frame is mounted to the assembly case and follows all aircraft maneuvers. The outer roll gimbal, mounted in the frame, may rotate 360° about the roll axis but follows the aircraft in pitch and yaw.

The vertical gyro pitch gimbal, mounted in the outer roll gimbal, may rotate 360° about the pitch axis but follows the outer roll gimbal movements in roll and yaw. The gyro spin motor may rotate $\pm 85^\circ$ in roll, but follows the vertical gyro pitch gimbal in pitch and yaw. Mechanical stops (not shown) limit the movement of the inner roll gimbal to prevent alignment of B101's spin axis to the vertical gyro pitch gimbal axis. Such an alignment would cause the vertical gyro pitch gimbal to spin about its pitch axis (gimbal lock).

Leveling.—At power application, a friction brake (snubber) releases the outer roll gimbal from the frame. The gyro spin motor starts and electrolytic switches sense unlevel conditions in pitch and roll. The output of the electrolytic switches activates the torquers. The gyro reacts to the applied torque and precesses until the electrolytic switches are level. The inner roll control transmitter, mounted between the vertical gyro pitch gimbal and the inner roll gimbal, applies signals to the roll servo amplifier to drive the roll motor-generator, which in turn drives the outer roll gimbal to the level of the inner roll gimbal.

Pitch Sensing.—As the aircraft pitches, the outer roll gimbal follows, but the vertical gyro pitch gimbal remains level. The pitch servo control transmitter detects the pitch attitude and applies pitch signals to the indicators and other aircraft systems. The pitch control

transmitter applies pitch signals to the Automatic Flight Control System (AFCS) control amplifier and to the Angle Bomb Release Computer.

Roll Sensing.—As the aircraft rolls, B101 remains level but the vertical gyro pitch gimbal has rolled (with the outer roll gimbal). The inner roll control transmitter senses the difference and causes the roll amplifier to drive the roll motor-generator until the outer roll gimbal is level with B101. The outer roll control transmitter (on front end of frame) detects and applies roll signals to indicators and other systems. The roll control transmitter (on aft end of frame) applies roll signals to the AFCS control amplifier.

DIRECTIONAL GYROSCOPE OPERATION.—The directional gyro consists of gyro spin motor B201 (which includes a leveling gimbal), an azimuth gimbal, and a directional gyro pitch gimbal. The directional gyro pitch gimbal, mounted in the outer roll gimbal, may move 360° about the pitch axis but follows the outer roll gimbal in roll and yaw. The azimuth gimbal mounted in the directional gyro pitch gimbal, may move 360° about the yaw axis, but follows the directional gyro pitch gimbal in pitch and roll. B201, mounted in the azimuth gimbal, is limited to $\pm 85^\circ$ by mechanical stops (not shown) to prevent gimbal lock.

Leveling.—The leveling control transmitter output is applied to the leveling amplifier which drives the leveling torquer. When the leveling torquer moves the azimuth gimbal, B201 precesses until the leveling control transmitter senses a level condition. The directional gyro pitch gimbal is servoed to the vertical gyro pitch gimbal and maintained perpendicular to the surface of the earth. The output of the pitch servo control transmitter, through the pitch servo control transformer, is amplified and drives the pitch followup motor-generator to position the directional gyro pitch gimbal.

Azimuth Sensing.—The azimuth gimbal may settle at any random position in yaw. The only forces acting on the gimbal are gyro rigidity, apparent (earth rate) precession, and the leveling torquer. Azimuth sensing in the directional gyro mode of operation is reliable only if the correct

heading is initially set into the system with the SET HDG control. Two azimuth control transmitters sense any movement of the directional gyro pitch gimbal about the azimuth gimbal. The yaw signal of one azimuth control transmitter is applied to the attitude indicator, and the yaw signal of the other azimuth control transmitter is processed in the compass adapter-compensator and applied to other aircraft systems.

Switching Rate Gyroscope (SRG)

The switching rate gyroscope contains a gyro motor and associated turn-switching circuitry. It actuates relays which cut out roll erection and directional gyro slaving whenever the aircraft turn rate exceeds a specified limit (15° per minute in most units) for a specified time. This switching action (1) reduces vertical gyro errors caused by turn-acceleration forces acting upon the gravity-sensitive erection switches, and (2) minimizes azimuth slaving errors which occur when the pendulously suspended magnetic detector (flux valve) in the remote compass transmitter swings too far from vertical. Most models of the SRG are hermetically sealed and filled with dry helium gas. The gyro is positioned so that aircraft movements about the yaw axis apply forces to the spin axis, causing the gyro to precess. The gyro spin axis is forced to change position a proportional number of degrees dependent upon the rate of turn of the aircraft about the yaw axis. The precession, in conjunction with an associated transistor circuit, controls the operation of a relay. Damping is used to prevent continued closing and opening of the relay for slight yaw deviations or oscillations and on short-duration turns. For example, switching may occur after 30 seconds at 15° per minute, 20 seconds at 20° per minute, 8 seconds at 45° per minute, or 3 seconds at 180° per minute. Switching returns to normal 20 seconds or more after a turn. Return-to-normal time is 30 seconds after a 180° per minute turn that has lasted for at least 15 seconds.

Rate Gyroscope Transmitter (RGT)

The rate gyroscope transmitter—which should not be confused with the switching rate

gyroscope—provides a dc signal that is proportional to the rate of displacement about the vertical axis of the aircraft. This output is applied to the rate-of-turn pointer on the attitude indicator. When the aircraft yaws, it produces an immediate indication, whereas the switching rate gyroscope is, as the name implies, a switching device.

Horizontal Situation Indicator (HSI)

Aircraft, such as the F-4 and P-3, utilize the horizontal situation indicator to provide the pilot with a visual indication of the navigational situation of the aircraft. The horizontal situation indicator (fig. 7-18) is installed on the pilot's main instrument panel.

It provides a visual presentation of the horizontal or plan view of the aircraft with

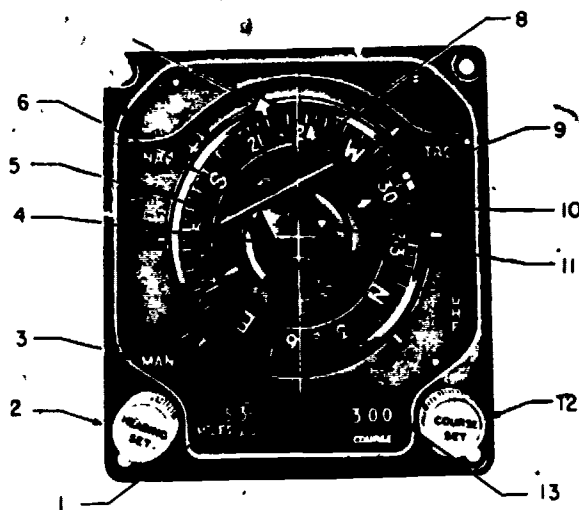

- | | |
|----------------------------|----------------------------|
| 1. Distance counter. | 7. Bearing pointer. |
| 2. Heading set knob. | 8. Lubber line. |
| 3. Mode light. | 9. Command heading marker. |
| 4. Aircraft symbol (fixed) | 10. Course pointer. |
| 5. Course deviation bar | 11. To-from pointer. |
| 6. Compass card | 12. Course set knob. |
| | 13. Course counter. |

207.116

Figure 7-18.—Horizontal situation indicator.

respect to the navigation situation. It also provides an integrated display of navigation data from various sources and presents this data to the pilot in a symbolic-pictorial display for quick and easy assimilation. The center portion of the display contains an azimuth or compass card (6), which displays aircraft magnetic heading when read against the top of the lubber line (8), and against which the bearing pointer (7), course pointer (10), and command heading marker (9) may be read.

The bearing pointer (outer pointer, shown at 220°) provides pictorial bearing information to a ground electronic station, or to a base or target (as computed by the Navigational Computer Set). The course pointer (inside compass card, at 300°) indicates the selected course to a ground electronic station, or aircraft magnetic ground track. The course deviation bar (5) (center segment of this pointer) indicates the aircraft's deviation from a selected course, as shown pictorially with respect to the stationary miniature aircraft symbol (4), at the center of the display.

A to-from pointer (11) (just above the aircraft symbol) shows whether or not the selected course leads to or from a ground electronic station. A command heading marker (9) just outside the compass card (shown at 300°) indicates the command magnetic heading and, by its angular displacement from the lubber line, the heading error angle. The course pointer and the command heading marker may be set either manually by means of the COURSE SET (12), and HEADING SET (2) knobs, respectively, or remotely by external signals to the HSI course command and heading command servos. The selected course to a ground electronic station or aircraft magnetic ground track is also indicated on the course counter (13) at the lower right of the display, while a distance counter (1) at the lower left indicates the distance in nautical miles to the ground electronic station, or to the base or target (as computed by the Navigational Computer Set).

There are four mode-of-operation lights (3) (TAC, UHF, MAN, NAV) shown around the display. These are illuminated internally to indicate the selected operating modes. The unilluminated words remain practically invisible. The instrument is integrally lighted.

For detailed operation of the horizontal situation indicator system, refer to the applicable Maintenance Instructions Manual.

Bearing-Distance-Heading Indicator (BDHI)

This instrument may be used with various navigation systems, and provides information according to the mode selected. Some aircraft may have more than one BDHI, with separate select switches for each instrument. The distance counter numerals may be in a vertical row or horizontal, as the ID-663A/U shown in figure 7-19.

The lubber index is a fixed reference mark at the top of the instrument face. The compass card (read under the lubber index) indicates the aircraft heading (either true or magnetic, depending on the mode used). Two pointers, a single bar and a double bar, can indicate (1) bearing to a ground electronic station, (2) bearing to destination (either base or target), (3) aircraft ground track, (4) aircraft drift angle, or (5) heading error. The available combinations of these indications are limited by the BDHI select switch used in a given aircraft configuration.

Electrical inputs for the compass card and pointers come from synchro transmitters located in other equipment. In the ID-663A/U, the compass card and both pointers are positioned by synchro torque receivers. In the ID-663B/U and ID-663B/V, torque receivers position both pointers, and they contain a synchro control transformer, a transistor error signal amplifier, and a two-phase servo-motor to position the compass card. The ID-663C/U has the compass card and both pointers positioned by the control transformer-amplifier-servo-motor method.

The distance counter may display distance to base, target, or ground electronic station, depending on the mode selected. It consists of three synchro torque receivers to position the units, tens, and hundreds numerals, plus a "1,000" flag to place the numeral 1 preceding the hundreds numeral which enables the counter to display distance up to 1,999 nautical miles.

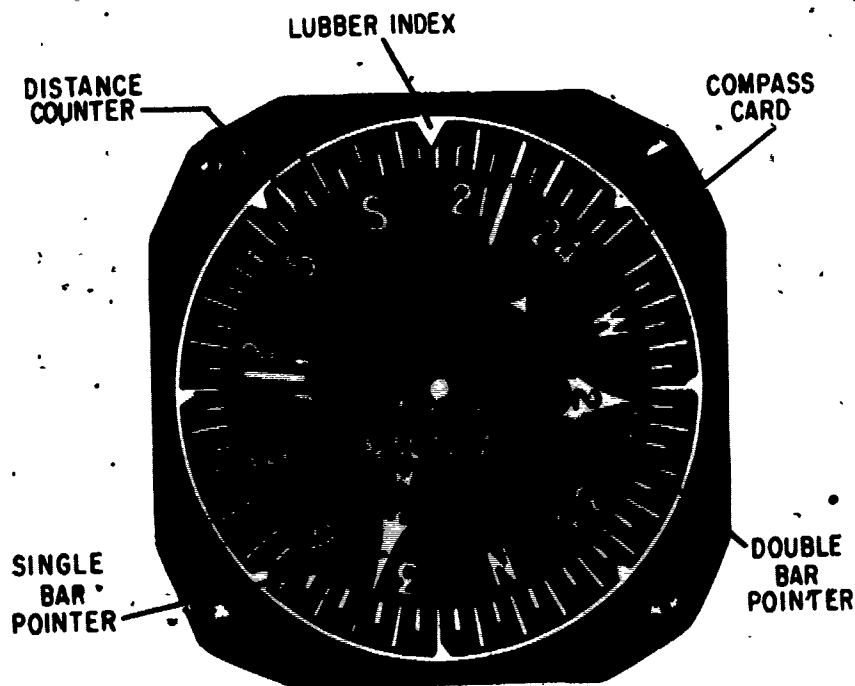

207.117

Figure 7-19.—Bearing-distance-heading indicator.

An "OFF" flag covers the distance counter, when distance information is not provided. The ID-663B/V has the "1,000" flag and the OFF flag positioned by separate coils, whereas the ID-663A/U, ID-663B/U, and ID-663C/U have a meter type movement which, when deenergized, shows OFF. Partial rotation moves the OFF flag out of view, and full rotation brings the "1,000" flag into view.

All Attitude Indicator

Aircraft heading information is also displayed on the attitude indicator in some aircraft. The ID-694/AJB-3 All Attitude Indicator, ID-811/AJB-3A Attitude Director Indicator, and ID-1144/AJB-7 Attitude Indicator are examples of this, and figure 6-27 in chapter 6 shows the azimuth markings on the sphere of one such indicator. The sphere is gimbal mounted and servo driven which provides for 360-degree rotation about the roll, pitch, and azimuth axes.

MA-1 COMPASS SYSTEM

The MA-1 compass system combines the most desirable features of the directional gyroscope and the magnetic compass to give an accurate, reliable, and continuous azimuth heading. The component items of the system consist of a controller, a directional gyroscope, and an amplifier. In addition, a compass transmitter (flux valve) and a course indicator are used with the system, but not supplied as part of the system. Also, a deviation-compensating adapter is available as auxiliary equipment. The system may be operated either as a compass-controlled gyro system or as a low-drift free gyro system. The drift rate is 4° per hour or less during free gyro unit operation.

Detailed information of the MA-1 system is contained in NAVAIR 05-15D-501, the handbooks of operation and service instructions. The MA-1 system is manufactured by two different companies and the components are,

therefore, somewhat different in their physical appearance and electrical operation. However, the basic theory of operation and operating modes are essentially the same, and only one version will be discussed.

Compass Controller

The MA-1 compass system is wired so that it is on when aircraft power is present and the circuit breakers are closed. The controller has a power failure indicator flag to show when no power is applied. The controller is used to select either free or slaved method of operation, to set the latitude of the present location, for initial alinement of the system each time it is turned on, and to correct it during flight. A SYNC IND meter on the front of the controller is a zero-center meter which provides visual synchronization indication of the relationship between the required magnetically-slaved position and the present gyro-reference position. The indicator shows the direction and, through a limited range, the amount of correction to be made by use of the set heading control. The meter does not function when the system is in the free mode of operation.

SLAVED-FREE SELECTION.—The slaved position of the switch causes the system to operate as a magnetically-slaved-gyro system with the gyro reference servo-positioned to align with a heading determined by signals from the flux valve. The free position causes the system to operate from a heading reference maintained by the stability inherent in a free gyroscope.

LATITUDE SETTING.—This control sets the amount of compensation voltage required for canceling the apparent drift due to the earth's rotation. This is not in use during SLAVED operation. A single dial (LAT. CONT.) has settings from 90° north to 90° south.

SYNCHRONIZING PROCEDURE.—When the directional gyro comes up to speed its spin axis may be in any direction, and thus the direction indicator also. In the slaved mode, information from the flux valve causes the gyro to precess until the two are together, but this is a slow process (about 2° per minute) because it

is not desired that the system respond to the continuous rapid fluctuations of the flux valve, but only to the average direction changes. In locations where magnetic information is not reliable the system must be set to correspond to a known direction such as a runway or a line between known landmarks. A three-position rotary SET. HDG. switch provides normal operation in the center position, and when placed in the "L" or "R" position a higher voltage is connected to the azimuth torquers which precess the gyro at a much higher rate than normal, and continues to do so as long as the switch is not in center position. When in the slaved mode, the switch is positioned to "L" or "R" until the SYNC IND needle is centered, and then returned to the middle position. When in the free mode, the heading indicator is viewed to align the system with a known direction. A switch cuts out the automatic flight control system (AFCS) (if it is receiving heading information from the MA-1 system) while the heading is being set.

Directional Gyroscope

The directional gyro acts as a stabilizing element when the MA-1 compass system is in slaved operation using the earth's magnetic lines of force as a heading reference. In free operation, the latitude-compensated gyro acts as the heading reference. The gyro units are hermetically sealed with dry gas at a pressure of one atmosphere. The directional gyro is mounted within the amplifier case.

LEVELING.—For the most accurate results, the spin axis of the gyro should be level with respect to the earth's surface. Gimbal suspension consists of an inner gimbal and an outer gimbal arranged so that the gyro is universally mounted. Windings of the leveling torquer receive voltage from the leveling amplifier. The gyro has a leveling synchro control transmitter to provide input to the amplifier. When the gyro motor spin axis tilts about the horizontal axis, an ac voltage is induced in the synchro control transmitter. The magnitude of the induced voltage is a function of the angle of tilt, and the phase is a function of the direction of tilt. This voltage is applied to the leveling amplifier.

AZIMUTH INFORMATION.—The gyro unit has two azimuth synchro transmitters (one for AFCS and one for azimuth indicators) plus a slaving synchro control transformer, which are all positioned with the spin axis of the gyro.

Amplifier

The main components of the amplifier are the chassis assembly, a leveling amplifier, a slaving amplifier, a transformer board assembly, and the directional gyro. The transformer board assembly contains magnetic amplifiers and also provides for required operating and reference voltages.

The leveling amplifier receives its input from the leveling synchro control transmitter in the gyro unit, and its output supplies the two-phase leveling torquer motor.

In SLAVED operation, the flux valve signals go to the slaving control transformer which is positioned with the spin axis of the gyro. The error signal is amplified by the slaving amplifier (which uses some components on the transformer board assembly) and supplies the two-phase slaving torquer motor until the gyro has precessed to alignment with the magnetic heading.

In the FREE mode, the slaving torquer motor receives its control winding voltage from the wiper arm of the latitude compensation potentiometer on the controller panel. The two ends of this potentiometer are supplied from the secondary winding of a centertapped transformer, the centertap being at zero signal reference. With the arm at the center position of the potentiometer there is no output; movement of the arm in one direction from center provides an output of a given phase; movement of the arm in the opposite direction from center provides an output 180° out of phase with the signal for the first movement. This reversal of phase with knob direction provides for the required opposite direction of latitude compensation in north and south hemispheres.

When the SET HDG switch on the controller panel is moved off center, normal slaving or latitude compensation voltages are switched out. Higher voltages are applied to the slaving torquer motor for fast synchronization (slewing or fast slaving). The phase relation of the voltage to the

fixed phase winding of the slaving torquer motor depends on the "L" or "R" position of the SET HDG switch.

AJB-7 COMPASS SYSTEM

The complete AN/AJB-7 is an Attitude Reference Bombing Computer Set (ARBCS), and performs the functions of an all-attitude flight reference system plus a correlated LABS (low altitude bombing system) bomb release system. This section will discuss the all-attitude flight reference system which provides a continuous display of aircraft attitude through 360° in pitch, roll, and azimuth.

More details of the AN/AJB-7 system are contained in NAVAIR 05-35KAB-16 (maintenance instructions). The following is mainly concerning the compass system.

In addition to the following components which are part of the basic system, the flux valve (compass transmitter), remote attitude indicator, and standby attitude indicator are used with the system. The block diagram in figure 7-20 shows these as well as some other components and how they are connected to complete the system.

Amplifier-Power Supply

The amplifier-power supply fulfills the necessary servo amplifier and power requirements for proper gyroscope erection and operation. It incorporates both plug-in and wired-in modules.

Attitude Indicator

A three-axes sphere indicates aircraft pitch, roll, and heading. It also performs specialized indicating functions by use of flags and pointers. (Refer to the all-attitude indicator in chapter 6.)

Compass Adapter-Compensator

This unit obtains heading information from the compass transmitter and the displacement gyroscope assembly, processes the signals

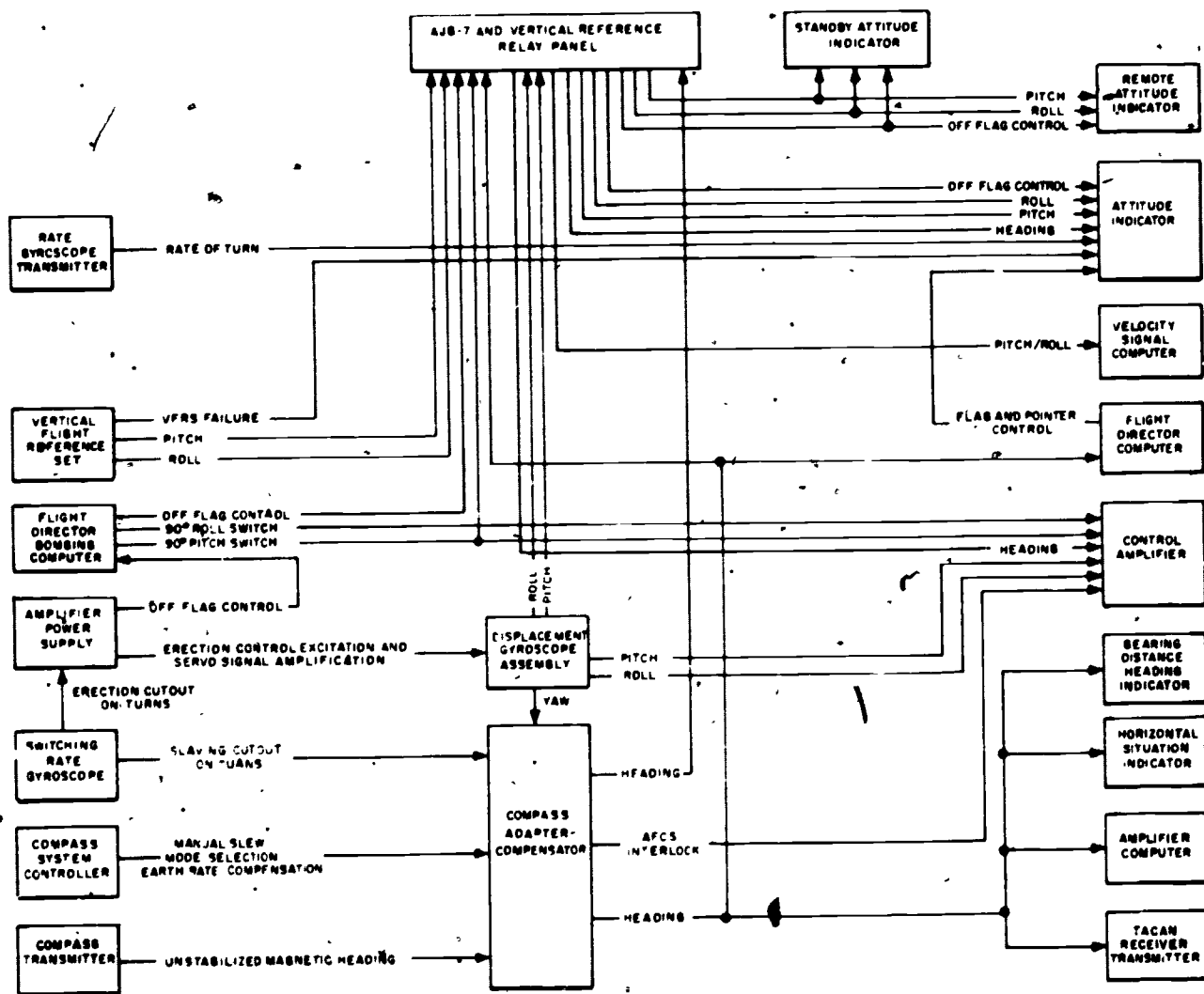

207.118

Figure 7-20.—Block diagram of the all-attitude reference system.

according to the azimuth mode selected by the compass system controller, and provides heading output to the attitude indicator and other aircraft systems.

Displacement Gyroscope Assembly

The AJB-7 system uses a displacement gyroscope somewhat similar to that shown in figure 7-17 to develop signals representative of aircraft attitude through 360° of roll, pitch, and yaw.

Switching Rate Gyro

On aircraft turns of 15° per minute or more, the switching rate gyro operates relays which cut out erection and slaving of the displacement gyroscope assembly. The faster the turn, the quicker the relays operate: 30 seconds at 15° per minute; 20 seconds at 20° per minute; 8 seconds at 45° per minute; 4 seconds at 180° per minute. About 15 seconds after the turn is completed normal erection and slaving resume.

Compass System Controller

This control panel provides the switches and controls for operation of the azimuth system and the selection between primary and standby sources of pitch and roll signals to the attitude indicator and missile control system. It contains a SYNC IND meter, a PRIM-STBY switch, a N-S hemisphere switch (which is screwdriver positioned), a mode switch (COMP-DG-SLAVED-SYNC), and a slew control (SETHDG).

See figure 7-21. PRIM selects vertical flight reference set and STBY selects ARBCS. (The standby attitude indicator and the remote attitude indicator always display ARBCS pitch and roll signals regardless of switch position.)

The mode switch (COMP-DG-SLAVED-SYNC) selects azimuth system mode of operation. COMP (compass) mode is an emergency mode used when the directional gyro signals are not reliable, and provides a source of magnetic heading information. When the switch is placed to COMP: (1) the AFCS disengages and cannot be reengaged since magnetic signals are too unstable for use in the automatic flight control system; (2) the attitude indicator displays magnetic heading in PRIM or gyro

heading signals in STBY; (3) the HSI and BDHI display magnetic heading.

The DG (directional gyro) mode is used in latitudes of 70° or more, in areas where the magnetic field is appreciably distorted, or when the flux valve malfunctions. If DG is selected in PRIM, the attitude indicator (AI) displays vertical flight reference system (VFRS) pitch and roll, but directional gyroscope assembly (DGA) heading. The BDHI and HSI also display DGA heading. If DG is selected in STBY, DGA pitch, roll, and yaw signals are applied to the AI, and DGA yaw is applied to the HSI and BDHI. To insure correct DG mode heading display, the following actions must be taken: (1) correct heading must be set into the system by pressing and turning the SET HDG control until indicators display actual aircraft heading; (2) the N-S switch must be placed to local hemisphere; (3) the LAT control must be set to local latitude and readjusted for each 5° latitude change.

The SLAVED mode is the mode used under most normal conditions. The flux valve magnetic heading signals are stabilized by the gyro. Synchronization between the gyro and flux valve signals is always in effect in the slaved mode. The SYNC IND meter on the controller

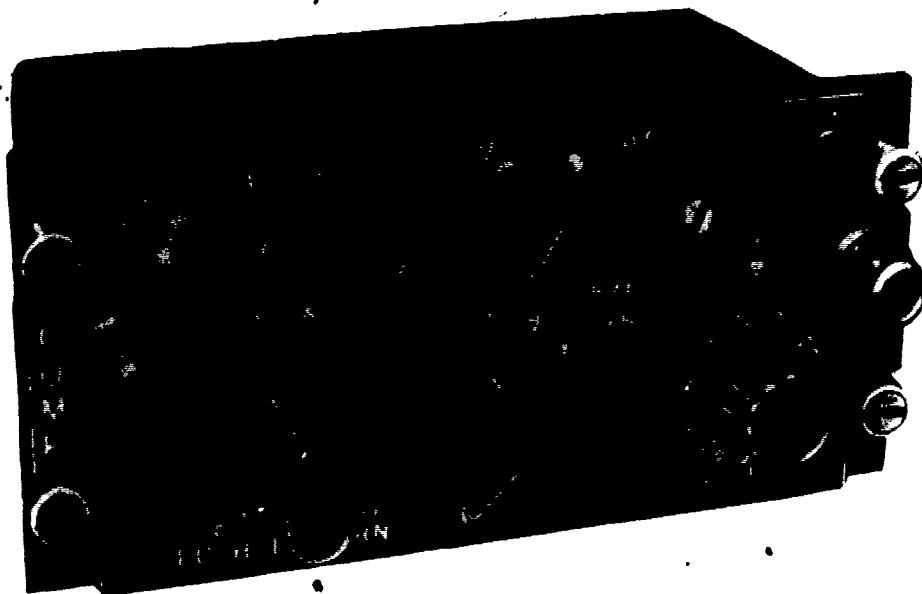

Figure 7-21.—Compass system controller.

207.120

normally remains centered but will + or - if an error signal is present in the compass servo loop. Normal sync of 2° per minute provides satisfactory results for most applications; however, after severe aircraft maneuvers, a faster sync rate is desired (50° per second). Fast sync may be initiated manually or automatically as follows: (1) the cycle started with slaved mode selected; (2) mode switch moved to SLAVED from another mode; (3) selection of STBY with slaved mode selected; (4) momentary selection of SYNC (the switch is spring-loaded to return to SLAVED). When fast sync is activated either manually or automatically, the following actions occur a relay and a speed changer clutch coil energize and remain energized as long as the output of the slaving and correction amplifier is equivalent to an error of 2° or more; the relay cuts out the AFCS and the clutch coil shifts to high speed (50° per second) synchronization; when the error decreases to less than 2°, the clutch coil deenergizes and normal slaving is resumed; and the AFCS cutout relay deenergizes and AFCS may then be reengaged.

INERTIAL NAVIGATION SYSTEM

The following paragraphs describe a heading reference system found on the latest model high-speed aircraft and some patrol type aircraft. The Inertial Navigation System (INS) is usually maintained by the Aviation Fire Control Technician rating (AQ). Some squadrons utilize a concept called an Integrated Weapons Team (IWT) which is composed of the four Avionics/Armament division (work center 200) ratings, AQ, AO, AT and AE. Regardless of who maintains the INS, you as an AE must be familiar with the theory and operating principles of such a system.

There are two methods of navigation. One is position fixing by measuring position relative to some known object. The most common example is celestial navigation. Loran is another example of navigation by periodic position fixes. The other method, dead reckoning, measures speed and heading and, using these measurements, computes position change from an initial position fix. The most common example of this form of navigation is the ship navigator's

position plot. One of the oldest automatic navigation systems is the dead reckoning analyzer, which takes its speed from the ship's log and its heading from the ship's gyrocompass to compute latitude and longitude. A more accurate automatic dead reckoning device is the Doppler radar navigator.

Navigation systems which require a continuous record of position normally use both methods; that is, since it is not always convenient to establish position continuously by a direct fix, they dead reckon between position fixes. However, the error in dead reckoning, as a percentage of the distance traveled, commonly reaches 2 to 5 percent. Thus, as the distance traveled between fixes increases, as in the case of high speed aircraft, the accuracy of dead reckoning must be increased if a small absolute position error is to be maintained.

The inertial navigation system is a dead reckoning system with very good accuracy. Instead of measuring speed directly, the system derives it from measurements of the vehicle's accelerations. Two accelerometers are used; one accelerometer is pointed north, and the other is pointed east. The first integral with respect to time of these accelerations gives the north and east changes in velocity, and the second integral with respect to time gives the north and east position changes. Of course, the vehicle's initial velocity and initial position must be inserted for accurate navigation.

The accelerometer can be made to measure acceleration very accurately; however, it cannot distinguish between accelerations of the vehicle and the effect of gravity. This difficulty can be eliminated by keeping the sensitive axis of the accelerometer perpendicular to the gravity vector at all times. To accomplish this, the accelerometers are mounted on a three-axis, gyro-stabilized platform.

The platform (fig. 7-22) is attached to the vehicle through a gimbal system which permits it to take any orientation with respect to the vehicle. Three gyros are mounted on the platform with their input or sensitive axes in three mutually perpendicular directions. The gyros have the property of sensing angular rates about their input axes. A sensed rate causes the gyro to precess around its output axis, providing an electrical output from the gyro which is

Chapter 7—COMPASS, INERTIAL NAVIGATION,
AUTOMATIC FLIGHT CONTROL AND STABILIZATION SYSTEMS

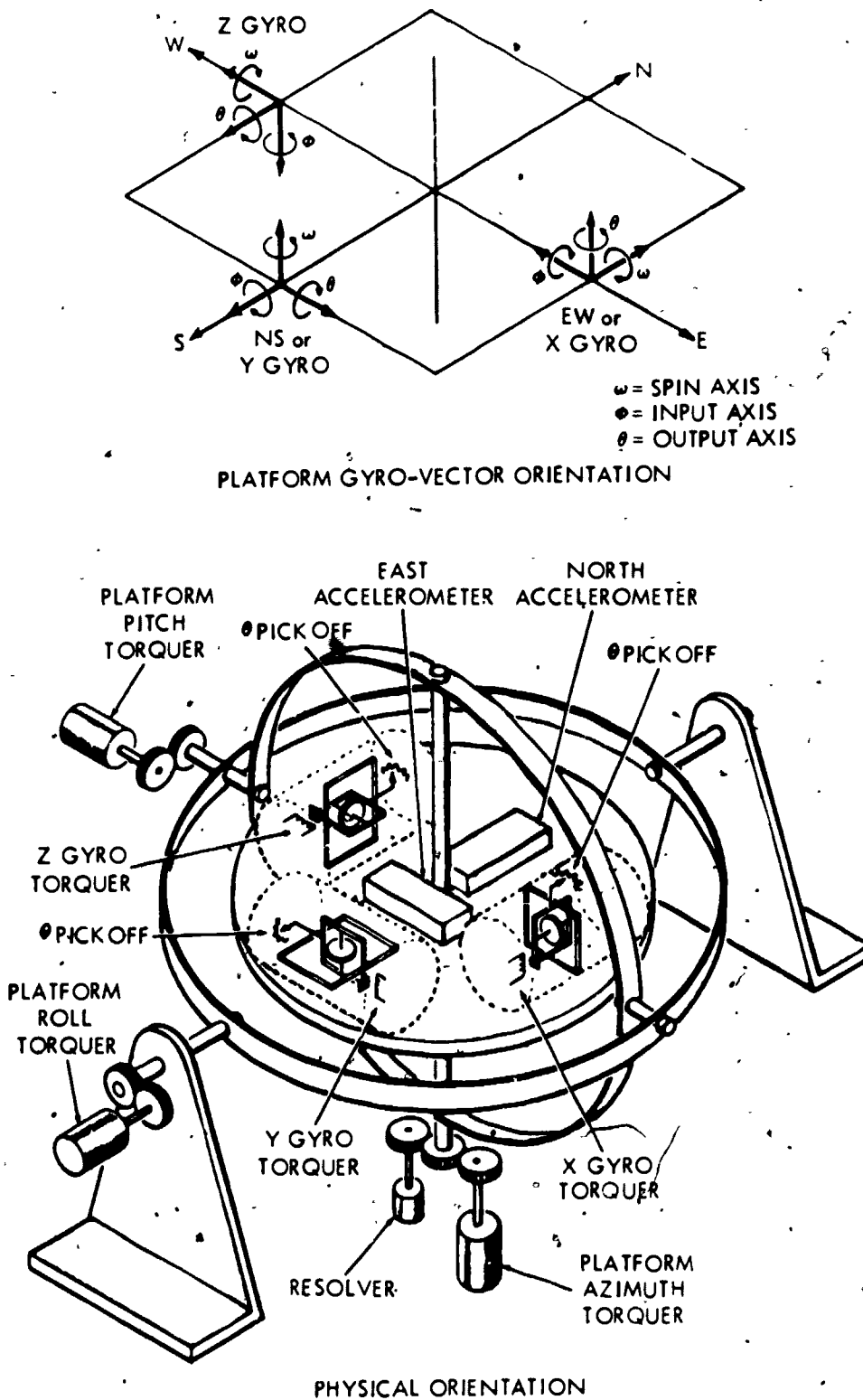

Figure 7-22.—Platform control components and gyro vector orientation.

223-179

amplified and used to drive a platform control torquer to null out the sensed rate. Thus, if the vehicle rotates about any of its three axes, the platform tends to rotate; and the rotation rate is sensed by the gyros. The resulting gyro output causes the platform to be driven in the opposite direction, thus keeping the platform space stabilized while the vehicle rotates around it. Mounting the accelerometers on this platform preserves their orientation independent of the vehicle's rotation. The gyros shown in figure 7-22 are the single-degree-of-freedom type.

Since the integral of angular rate with respect to time is an angle, the platform is commonly described as an integrator. The angle through which the platform moves relative to the vehicle is equal to the negative integral of the vehicle's angular rate.

There is one rotation of the vehicle that should be taken into account in orienting the accelerometers. This rotation arises from motion over the earth. (Refer to fig. 7-23.) The vehicle moves from point A to point B. In doing so, it rotates through an angle θ so that it remains level, or perpendicular to gravity. If the platform does not rotate, it will take position shown at B; and the accelerometers will sense gravity. It is

now apparent that the platform must be more than space stabilized; it must be stabilized with relation to the earth, and it will take more than just the output of the gyros controlling the platform torquers to do this.

Since the platform integrates the input rates, an artificial input equal to the negative of the vehicle's angular rate would keep it level. The vehicle's true angular rate ω_T , in radians per hour, while the vehicle is traveling over the earth, is V_T/R , where V_T is its true linear velocity, and R is the radius of the earth. This artificial signal would be applied to the gyro torquer, which will cause the gyro to move a few degrees around its output θ axis and produce a signal from its θ pickoff even though the input ϕ axis senses no angular rate. By torquing the gyro with $-V_c/R$, where V_c is the computed value of V_T , the gyro θ pickoff output will cause the platform to rotate through an angle relative to the horizontal equal to the integral of $(V_T - V_c)/R$ (which actually would be an error angle). If V_c equals V_T , there will be no error due to the vehicle's rotation while it is traveling over the earth, and the platform will stay horizontal at all times. Since the computed input results from Schuler tuning, the basic principles of Schuler tuning are described below and should be thoroughly understood before proceeding.

In order to comprehend what is happening during the tuning process a brief review of some facts on accelerometers, accelerations and mass is necessary. There are two types of forces that can cause a body to move—acceleration forces and field forces. It is important to note that an accelerometer cannot distinguish between these two forces. Newton's second law of motion describes acceleration force thus: If a body is acted upon by a force, the product of the acceleration (a) and the mass (m) of the body is proportional to the force (f); ($f = ma$). The most common field force is gravity. This force is represented by the formula ($f = mg$). The term (g) represents gravitational acceleration, 32.17 ft per sec per sec—the acceleration with which a body falls freely toward the earth's surface, neglecting air friction.

It should be understood that the accelerometer will provide no output while it is

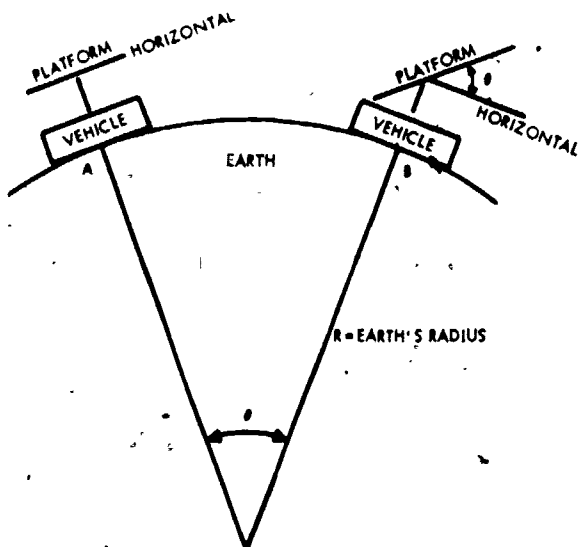

273.180

Figure 7-23.—Vehicle motion in relation to space stabilized platform.

Chapter 7—COMPASS, INERTIAL NAVIGATION, AUTOMATIC FLIGHT CONTROL AND STABILIZATION SYSTEMS

moving at a constant velocity and its sensitive axis is perfectly horizontal. But if the sensitive axis should become misaligned, gravitational acceleration will result in a force which displaces the mass and causes the accelerometer to give an erroneous indication of the vehicles acceleration.

SCHULER TUNING

Schuler tuning is used in most inertial navigation systems. It maintains the stable platform in an orientation perpendicular to the earth's gravity. It also reduces the long term errors, described later, resulting from certain imperfections in the instruments.

To understand why Schuler tuning was developed and how it operates, consider first some of the problems involved in maintaining a stable platform perpendicular to the earth's gravity. For simplicity at this point, consider the earth to be spherical, but nonrotating. A stable platform bearing an accelerometer is shown with respect to the earth in figure 7-24. If the platform is stationary but tilted, as shown in fig. 7-24(A), gravitational acceleration will cause the mass in the accelerometer to move to the left and produce an output ($g \sin \theta$) simulating acceleration to the right. The platform can be

leveled automatically if the accelerometer output drives the motor M (fig. 7-24(B)), which rotates the platform through a gear train. The motor turns until the output from the accelerometer is zero, when the platform angle θ is also zero.

Now assume that the platform is uniformly accelerated to the right. The mass in the accelerometer will again move to the left; and the output of the accelerometer, after amplification, will drive the platform away from the true level position to a new position where there is zero motor voltage. The action of the accelerometer is exactly the same as that of a pendulum; if accelerated along the earth's surface, they both give an erroneous indication of the vertical.

Professor Schuler of the University of Göttingen solved this problem, in principle, in the nineteenth century. He considered the case of a pendulum mounted on a moving body, as shown in figure 7-24(C). The vehicle has a pendulum of mass (m) hanging from a pivot. When the vehicle is accelerated, the pendulum lags by an angle ϕ , as shown. In figure 7-24(D), a longer pendulum is used. For any given acceleration, the angle of lag ϕ_2 is less than ϕ_1 in figure 7-24(C). If the pendulum is made longer and longer, the angle of lag becomes less and less. If the pendulum could have its bob at the center of the earth, the angle of lag would be zero and the bob would not move. This is Schuler tuning.

Such a pendulum would have to have an effective length equal to the radius of the earth, approximately 4,000 miles, and a period of 84.4 minutes.

The formula for the period of a pendulum is

$$T = 2\pi \sqrt{\frac{l}{g}}$$

where

T = period in seconds

l = length in feet

g = 32.17 ft per sec per sec

A pendulum with a period of 84.4 minutes can be simulated with electromechanical

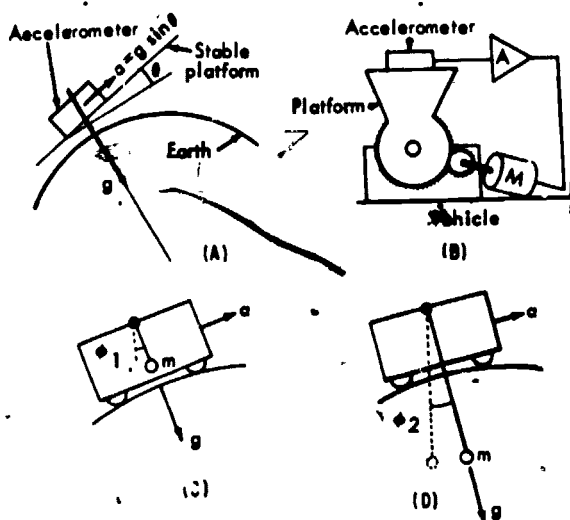

223.181

Figure 7-24.—Basic ideas of Schuler tuning.

elements. Taking the output of the accelerometer and integrating it twice before it actually controls the platform provides, essentially, a Schuler-tuned platform. This is shown in figure 7-25. To prove that this loop has an 84.4-minute period and is therefore Schuler tuned, tilt the platform very slightly and observe the following events:

An accelerometer mounted on a platform yields a signal proportional to the tilt angle of the platform (assuming that there is no linear motion of the platform). The output of the accelerometer is

$$e = g \sin \theta$$

For very small angles, the sine of the angle is very nearly equal to the angle in radians; therefore,

$$e = g\theta$$

The angle θ through which the platform moves to correct the tilt is proportional to the double integral of the accelerometer's output,

$$\theta = -k \iint g\theta \, dt \, dt$$

where

$$k = \text{constant}$$

Differentiating both sides of this equation twice yields the differential equation

$$\frac{d^2\theta}{dt^2} + k\theta = 0$$

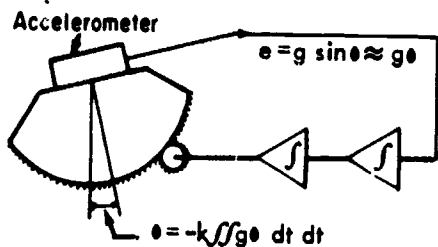

223.182

Figure 7-25 - A Schuler-tuned platform.

A solution to the differential equation is

$$\theta = A \sin(\sqrt{kg}t)$$

where

$$A = \text{constant}$$

Since a sine function is involved, the platform is evidently going to oscillate because it was disturbed—this oscillation is very slow. To find the frequency or period of the sine function let

$$\sqrt{kg} = \omega$$

and the following are known relationships

$$\omega = 2\pi F = \frac{2\pi}{T}$$

Therefore

$$T = \frac{2\pi}{\omega} = \frac{2\pi}{\sqrt{kg}}$$

or

$$T = 2\pi \sqrt{\frac{l}{kg}}$$

Now, if we let $k = 1/R$, where $R = 4,000$ miles (the radius of the earth), the period T will be equal to 84.4 minutes.

The platform will actually be moved very slowly in a direction to correct the slight erroneous tilt, but it will overshoot and move back. The Schuler loop, therefore, is oscillatory. Once disturbed, the platform continues to oscillate about the vertical like an undamped pendulum. The associated oscillations are called Schuler oscillations. However, proper initialization and accurate components keep these oscillations very small. In fact, some of the inaccuracies which would normally result in large errors after a long period of time are averaged out by the oscillations and result in very little long term error.

Unlike the usual pendulum system, the Schuler-tuned system is not disturbed by the vehicle's accelerations. Recall that the second integral of acceleration is distance traveled; therefore, as shown in figure 7-25, the amount the platform rotates, θ , as the vehicle moves

Chapter 7—COMPASS, INERTIAL NAVIGATION, AUTOMATIC FLIGHT CONTROL AND STABILIZATION SYSTEMS

over the earth is directly proportional to the distance traveled. Consequently, the platform rotates just enough to remain perpendicular to the earth's gravity as the vehicle moves over the earth. In other words, it acts as if it were a pendulum with its bob at the center of the earth.

SCHULER LOOP

Figure 7-26 contains both a functional and a mathematical diagram of a Schuler loop. For simplicity, only the north loop is shown. Two such loops, one for north and the other for east, are required for an inertial system. The

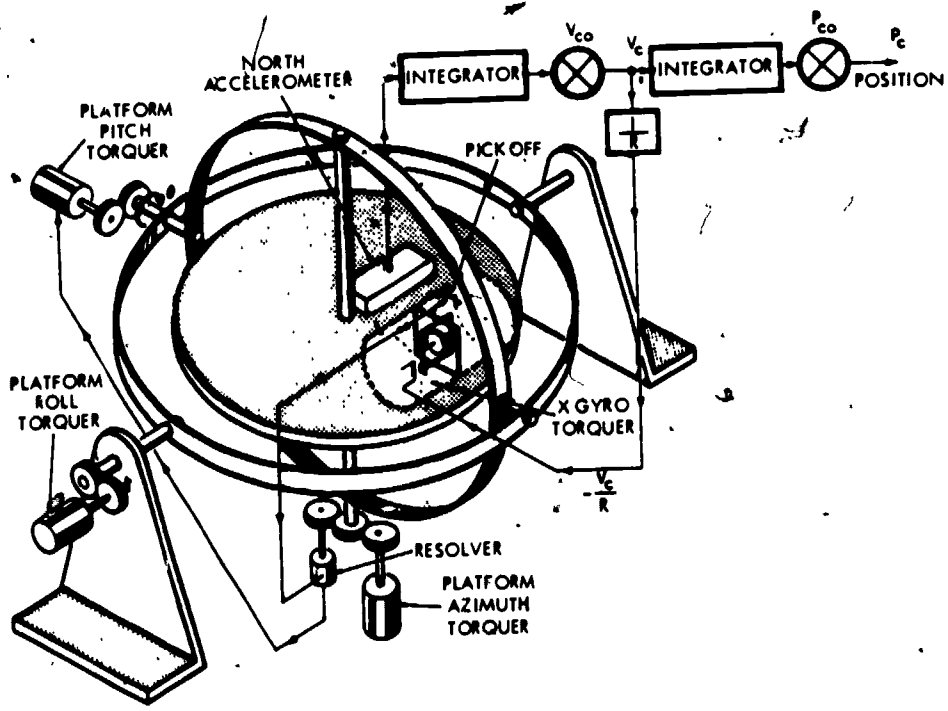
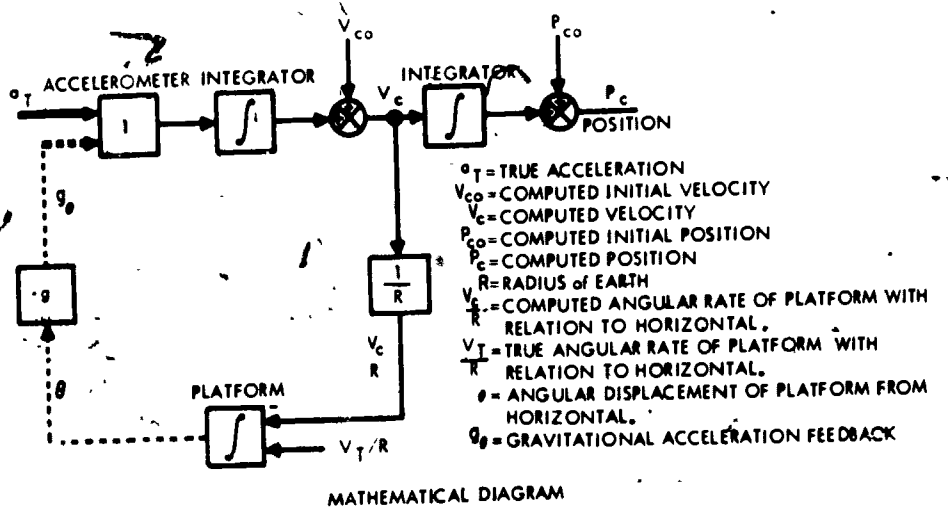

Figure 7-26.—The north Schuler loop, functional diagram.

223.183

accelerometer in the north loop senses north-south accelerations; however, the gyro in the north loop senses east-west angular rates—the vehicle's angular movements around the east-west axis. (See fig. 7-22.)

By convention, the accelerometers and gyros are named according to the direction of their input axes; and the inertial or Schuler loop takes the name of its accelerometer. The north loop contains the north accelerometer and X (east) gyro, while the east loop contains the east accelerometer and Y (north) gyro.

Refer to figure 7-26. True acceleration is a_T due to the vehicle's acceleration. An acceleration, $g\theta$, called gravity feedback, is also sensed by the accelerometer when the platform is not perfectly level. It is actually gravitational acceleration g (32.17 ft per sec per sec) times the very small tilt angle θ (probably in milliradians).

It has previously been stated, that the platform could be maintained level by torquing it with a signal proportional to $-V_c/R$. Figure 7-26 shows how this is done. The integrated accelerometer output, V_c , is multiplied by $1/R$ to obtain a signal proportional to $-V_c/R$. This signal torques the X (east) gyro to cause it to precess and provide a θ pickoff output through the azimuth resolver to the platform pitch torquer. This, in turn, causes the platform to be torqued through an angle proportional to the distance traveled. In other words, the platform actually integrates the computed angular rate $-V_c/R$ to produce an angle.

V_{co} and P_{co} are both inputs to the system, but only V_{co} has any effect on the Schuler loop. For this explanation, V_{co} was assumed to be zero. Another input (not shown in figure 7-26) that is sensed by the gyro input ϕ axis, is caused by normal flight and combat maneuvers; that is, the angular rate of such maneuvers is sensed by the gyro, causing it to precess and to provide an output through the azimuth resolver to the pitch torquer. The platform torquer responds to these signals, keeping the platform level.

The gyro input ϕ axis also senses V_T/R , which is the vehicle's true angular rate due to the vehicle remaining horizontal as it moves over the earth. V_c/R must be equal to V_T/R ; if it is not, the platform will not remain level. The

sources and effects of such errors are described later.

CORRECTION TERMS

This explanation of inertial navigation has glossed over several important correction terms by assuming a spherical, nonrotating earth. A basic understanding of system operation can be attained without considering these terms. Nevertheless, they are essential for system accuracy and are briefly described.

Correction for Altitude and Earth's Radius

It has been stated that the stable platform is kept level by rotating the platform at the rate V_c/R . This would be acceptable if the earth were a sphere and the vehicle stayed at the surface of the earth. Since neither of these conditions is met completely, the value of R must be modified to allow for the ellipticity of the earth and for the vehicle's altitude. The new rate of platform rotation required to compensate for these deviations is V_c/R_1 , where R_1 is the correct instantaneous earth radius. In other words, the $1/R$ term in figure 7-26 is computed continuously as the vehicle's altitude and latitude change. The instantaneous value $1/R_1$ can be expressed by the series formula:

$$\frac{1}{R_1} = \frac{1}{R_p} \left[1 - \frac{e \cos L_1}{R_p} \cdot \frac{h}{R_p} \right]$$

where R_p is the earth's radius at the pole, e is the correction for the ellipticity of the earth, L_1 is the instantaneous latitude, and h is the vehicle's altitude.

Coriolis Correction

Accelerometers actually measure acceleration with respect to inertial space. Up to this point, a nonrotating earth has been assumed; therefore, acceleration due to the earth's rotation has been ignored. The difference

Chapter 7—COMPASS, INERTIAL NAVIGATION, AUTOMATIC FLIGHT CONTROL AND STABILIZATION SYSTEMS

between the accelerations measured in a vehicle moving over a nonrotating earth and the accelerations measured in the same vehicle moving over a rotating earth is called Coriolis acceleration. Coriolis acceleration occurs because a straight path with respect to the earth becomes a curved path in space when the earth rotates. A curved path can be achieved only by an acceleration force acting at right angles to the flightpath, and the accelerometer detects this acceleration. Since the magnitude is a function of the vehicle's instantaneous latitude and the earth's rotation, it is continuously computed and subtracted from the accelerometer output.

Correction for Earth's Rotation

Another correction due to the earth's rotation is required. Since the platform gyros sense rates about the three input axes, they will sense the earth's rotation. The earth's rotation is constant; thus, the compensation rate about each axis is a function of the vehicle's position. A correction rate for each axis is continuously computed and added to V_c/R_i . The resultant signal torques the appropriate gyros to maintain the platform level as the vehicle moves over the rotating earth.

ERRORS IN NAVIGATION

For completeness, more mathematics will be used in the description of system errors; however, system errors can be understood without a thorough knowledge of the mathematics used. The sources of the errors will be described first, and then the major system error due to each source will be considered.

Sources of Errors

Errors in the initial conditions affect the accuracy of the system. There are four initial conditions that must be set before the system can navigate accurately. Two are initial conditions for computation—the initial position, P_{co} , and the initial velocity, V_{co} . Their associated errors are initial position error,

$(E)P_{co}$, and initial velocity error $(E)V_{co}$. The other two are platform initial conditions. Since the platform must be perfectly level, there is probable initial tilt error, θ_0 , in each axis; and since the platform must have one axis pointed exactly north and the other east, there is a probable initial alignment error ψ_0 to north.

There are two major component errors—accelerometer bias, Δa , and gyro drift rate, \dot{m} . They are caused by mechanical imperfections of the components. Accelerometer bias is an erroneous output from the accelerometer when the platform is perfectly level and the vehicle is not accelerating. Gyro drift is an output from the gyro θ pickoff which was not caused by the rotation of the earth or by any movement of the vehicle over the earth's surface. Gyro drift is the more important of the two.

Effect of Errors

The error in the computed velocity, $(E)V_c$, can be computed for each of the errors mentioned above. The equations which give the $(E)V_c$ for each error individually are included, and are plotted in figure 7-27. They were

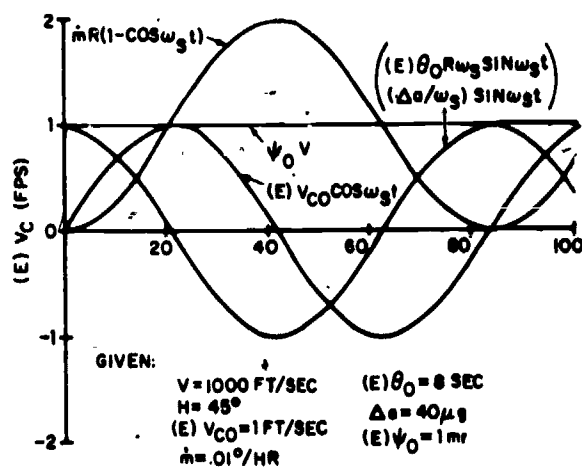

223.184

Figure 7-27.—System velocity errors as a function of time (minutes).

derived by using differential equations, and their derivation is considerably beyond the scope of this course. Error in computed velocity, $(E)V_c$, due to an error in initial velocity, $(E)V_{c0}$, is

$$(E)V_c = (E)V_{c0} \cos \omega_s t$$

where

$$\omega_s = \sqrt{\frac{g}{R}}$$

Error in computed velocity due to gyro drift rate \dot{m} is

$$(E)V_c = \dot{m} R (1 - \cos \omega_s t)$$

Error in computed velocity due to initial platform tilt error θ_0 is

$$(E)V_c = \theta_0 R \omega_s \sin \omega_s t$$

Error in computed velocity due to accelerometer bias Δ_a is

$$(E)V_c = (\Delta_a / \omega_s) \sin \omega_s t$$

Error in computed velocity due to true vehicular acceleration a_T is

$$(E)V_c = a_T (0)$$

The last equation was also derived using differential equations and is important because it shows there is no velocity error due to vehicular acceleration. All the errors are due to erroneous initial conditions and to component errors. Since the two loops are identical, the errors are the same for the north and east Schular loops.

Figure 7-28 shows that the velocity error due to an initial platform alignment error, ψ_0 , is the error in resolving the vehicle's velocity, V , through the angle $H - \psi_0$ instead of H . The velocity errors are different in the north and east directions and are functions of the heading H .

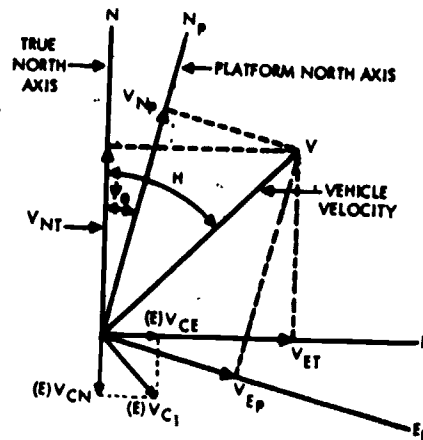

223.165

Figure 7-28.—Effect of platform alignment.

Assuming ψ_0 to be a very small angle, the velocity errors are

$$(E)V_{cN} = V_{NT} - V_{NP} = \psi_0 V \sin H$$

$$(E)V_{cE} = V_{ET} - V_{EP} = \psi_0 V \cos H$$

where

$(E)V_{cN}$ and $(E)V_{cE}$ equal computed north and east velocities.

V_{NT} and V_{ET} equal true north and east velocities.

V_{NP} and V_{EP} equal platform north and east velocities.

These two equations can be combined into an error, $(E)V_{c1}$, which is perpendicular to V . That is,

$$(E)V_{c1} = \sqrt{(E)V_{cN}^2 + (E)V_{cE}^2}$$

$$(E)V_{c1} = \psi_0 V$$

This equation, plotted in figure 7-27, becomes a straight line at 1 fps. That is, since vehicle velocity is given at 1,000 fps and ψ_0 is given as 1 milliradian, $1000 \times .001 = 1$ fps.

The computed position error, $(E)P_c$, can be found for each type of error by integrating the velocity error equation. These errors are plotted

Chapter 7—COMPASS, INERTIAL NAVIGATION, AUTOMATIC FLIGHT CONTROL AND STABILIZATION SYSTEMS

in figure 7-29. However, $(E)P_c$, due to initial position error $(E)P_{c0}$, is equal to the initial position error; that is,

$$(E)P_c = (E)P_{c0}$$

and $(E)P_{c0}$ is assumed to be zero in figure 7-29. All other fixed values in figure 7-29 are the same as those given in figure 7-27. As plotted in figure 7-29, an error in computed position $(E)P_c$ due to an error in initial velocity is

$$(E)P_c = \left[(E)V_{c0}/\omega_s \right] \sin \omega_s t$$

Error in computed position due to a gyro drift rate \dot{m} is

$$(E)P_c = \dot{m}R \left[t - \left(\frac{1}{\omega_s} \right) \sin \omega_s t \right]$$

Error in computed position due to platform tilt error θ_0 is

$$(E)P_c = \theta_0 R [1 - \cos \omega_s t]$$

Error in computed position due to accelerometer bias Δ_a is

$$(E)P_c = (\Delta_a/\omega_s^2) [1 - \cos \omega_s t]$$

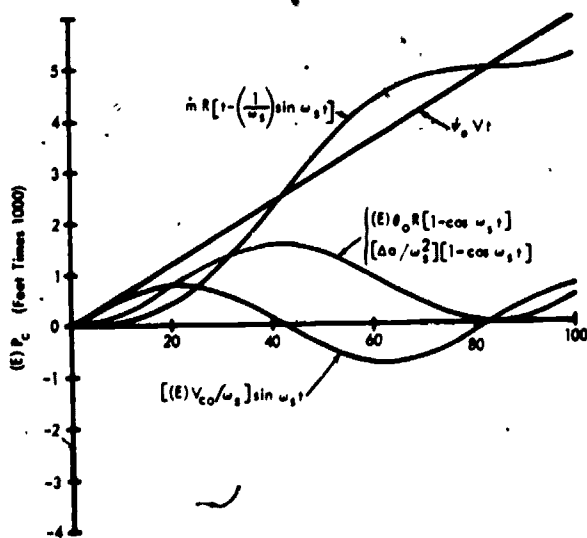

223.186

Figure 7-29.—Systems position errors as a function of time (minutes).

The computed north position error $(E)P_{cN}$ due to a platform initial alignment error is

$$(E)P_{cN} = \psi_0 (V \sin H)t$$

and, the computed east position error $(E)P_{cE}$ due to ψ_0 is

$$(E)P_{cE} = -\psi_0 (V \cos H)t$$

Combining these two errors produces an error perpendicular to the path traveled, $(E)P_{c1}$ where

$$(E)P_{c1} = \psi_0 V t$$

The first five position error equations are both north and east errors, independent of the vehicle's heading; that is, each equation applies to both the north and east Schuler loops. The next two equations are north and east errors, because they are functions of heading. The first five equations and the last equation are plotted in figure 7-29.

Figures 7-27 and 7-29 clearly illustrate one of the major advantages of inertial navigation. Of all the sources of velocity error, only two result in position errors that increase with time—platform initial azimuth alignment error ψ_0 and gyro drift rate \dot{m} . Gyro development has reduced drift rates to approximately 0.01° per hour, whereas a platform initial azimuth misalignment of about 2 milliradians is practical.

INITIALIZATION OF INERTIAL NAVIGATION SYSTEMS

The introduction into the system of aircraft with inertial navigation systems creates a whole new set of problems in operation, maintenance, and deck handling. One of the maintenance problems encountered with the inertial navigation system is system initialization.

The following is a description of the techniques and problems involving leveling and aligning inertial navigation systems. Such problems range from the most simple case to the one which is of primary concern to Navy aircraft; that is the problem of initialization on board an aircraft carrier. While leveling and aligning are related and, in some cases, dependent upon each other, they are treated

separately at the beginning to simplify the discussion.

Before continuing, some of the terms used frequently are defined briefly:

Leveling—the process of bringing the stable platform to a position where the accelerometers do not sense any gravity components.

Aligning—the process of bringing the sensitive axes of the platform into a known position in azimuth.

Initialization—the process of bringing the inertial system to a set of initial conditions from which it can proceed with the navigation process. This includes leveling, aligning, setting of initial velocity and initial position, and all additional computations required to start the navigation. In the following discussion, the term will be used to mean leveling and alignment, but keep in mind that these other initial conditions are implied. They receive less emphasis because they are easily accomplished in the computer.

Slaving—the process of torquing the system gimbals to a position defined by some reference which is external to the system.

Gyrocompassing—the process of self alignment whereby the system achieves azimuth orientation from its own sensors, in the manner similar to a conventional gyrocompass.

The effects of tilt error and azimuth error at the beginning of navigation were examined previously, and a plot of system position errors as a function of time for several values of these initial condition errors was shown in figure 7-29. It is evident from an examination of these curves and from reading the description of the errors, that failure to achieve the proper initial conditions is disastrous to navigational accuracy.

The initialization technique which most of us would first consider is probably one of slaving. The platform gimbals could be rotated to position defined by some external reference in the same manner as a gun mount is slaved to the stable element of a ship. This method is useful and can be applied to our problem; however, the accuracies we require cause it to be a more critical operation than gun mount

stabilization. In addition, while it is quite simple in concept, slaving is more complicated in terms of additional equipment required.

In self initialization no external directional references are used. The system orients itself by means of computations performed on the outputs of its own sensors—gyros and accelerometers. This method is less complicated in terms of external equipment, but more complicated in concept. The following paragraphs are devoted primarily to a description of self-initialization techniques and the problems and errors associated with these techniques.

Slaving in a Stationary Location

The most simple environment for the initialization of an inertial system is a known, fixed position on the earth. All initial conditions, including level and azimuth, could be available from external sources. A typical example of this environment is a missile launching site. Here, level and azimuth information can be transferred to the platform by optical and electrical transfer methods. These methods require installation of equipment to mechanize this transfer and are best suited to the missile launching situation.

Self Initialization in a Stationary Location

Still simple, but not so well suited to external slaving, is the environment of a known, stationary position not sufficiently fixed to permit installation of slaving equipment. An example of this environment is an aircraft which aligns at any of a number of stationary positions in or about the hangar and flight apron. This discussion is started with self initialization for systems in this environment, from which it can be expanded to encompass the more complex environment of an aircraft carrier. An additional simplification will be introduced here by discussing leveling separately from alignment. Within certain limits, leveling can be accomplished independent of azimuth alignment; and it can be seen later, in the discussion of gyrocompassing, that it is desirable to level the platform before attempting to gyrocompass.

Chapter 7—COMPASS, INERTIAL NAVIGATION, AUTOMATIC FLIGHT CONTROL AND STABILIZATION SYSTEMS

Briefly review the sensors and connections available on the inertia platform. It contains the accelerometers, which sense acceleration and consequently gravity; gyros, which sense angular rates; a gyro-torquing coil, as part of each of the three gyros on the platform, to torque each gyro individually; and gimbal-torquing motors to torque the platform. The gyro-servo combination is capable of accepting electrical inputs from external sources to torque the platform.

An electrical signal applied to the gyro torquer will cause the gyro to produce an output signal to the platform-torquing servomotor which, in turn, causes the platform to rotate continuously until that signal is removed. All self-initialization schemes make use of this characteristic of the gyro-servo combination. They all operate on some modification of the basic acceleration-leveling scheme, which is described first.

ACCELERATION LEVELING.—In its most simple form, leveling is accomplished by taking the electrical output of the accelerometer and applying it to the gyro torquer. As long as the platform is not level, the accelerometer has an output due to the force of gravity. When this accelerometer output is sent to the gyro torquer, it causes the platform to rotate and thus reduce the signal from the accelerometer. When the accelerometer is leveled, it no longer has an output. Thus, the gyro no longer has an input, and the platform remains in this leveled position.

The speed with which this mechanization can level the platform is a function of the gain of the amplifier. Higher gains will cause the platform to torque more rapidly. However, due to the presence of noise in the output of the accelerometer, there are certain limitations to the amount of gain which can be used. If the gain is very high, the platform will respond rapidly to small variations in the output of the accelerometer. A theoretical acceleration-leveling arrangement is shown in figure 7-30.

Figure 7-31 is a mathematical schematic diagram of this theoretical arrangement. All electrical connections are indicated by solid lines and all physical inputs by dotted lines. For example, the gyro output is a physical quantity; i.e., the angle between the platform and the

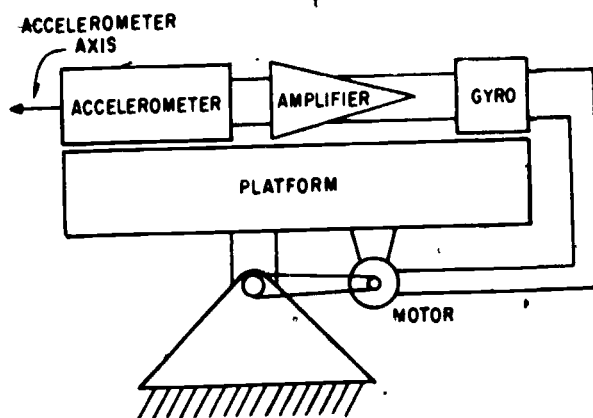

223.187

Figure 7-30.—Functional diagram of acceleration leveling.

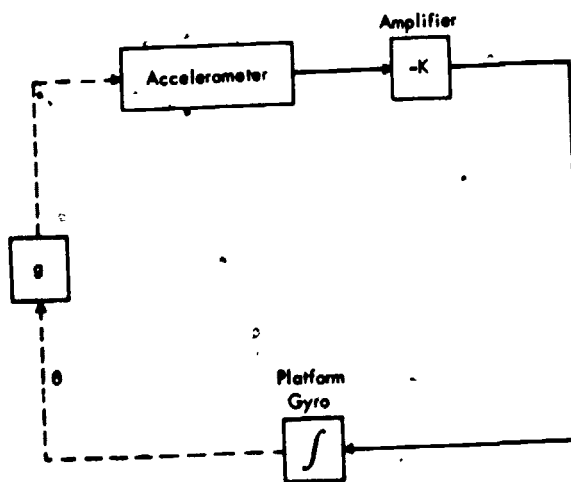

223.188

Figure 7-31.—Mathematical diagram of acceleration leveling or first order leveling.

horizontal. When this angle is not zero, it causes gravity to be coupled into the accelerometer input, as indicated by the block labeled g . This physical input to the accelerometer box causes an electrical output from the accelerometer, which is amplified ($-K$ is the amplifier gain) and used to torque the gyro. Thus we have the closed loop system. When the platform is level, there is no gravity coupling to the accelerometer; and the loop is in a steady state.

SECOND ORDER LEVELING.—As previously explained, the navigational function of the platform requires the acceleration be integrated to obtain velocity before it is fed to the gyro torquer. It would be desirable to maintain this configuration for the leveling loop so there would be a minimum of changes between the leveling system and the navigating system. (See fig. 7-26.)

It would seem that this loop would also level the platform, since the accelerometer output is applied to the gyro torquer through the integrator. Unfortunately, this is not exactly true. The nature of the Schuler loop causes it to act as an undamped pendulum which never reaches a level condition, but continues to oscillate about that position. Another drawback to leveling in this manner is the sluggish nature of this loop, due to the very low gains. The basic period of this loop is 84 minutes—primarily due to the low gain of $1/R$. Since the purpose here is to establish a vertical, and not to navigate, this term is no longer required to be $1/R$, but can take on any value desired. In this case, it is desirable to make it large in order to level the platform rapidly. Having altered the sluggish nature of the platform, it is changed to act like a dampened pendulum by feeding the integrator output to the accelerometer input. This causes the oscillating platform to come to rest in a level position. The mathematical diagram of this arrangement is shown in figure 7-32. The gain $-K2$ is larger than $1/R$. The diagram shows, too, that the initial tilt error θ_0 also causes the accelerometer to sense gravity and that the platform tilts until its output θ cancels θ_0 . At that time the accelerometer will be level.

GYROCOMPASSING.—Before gyrocompassing is described, the rate measuring capability of a gyro should be clarified. The gyro detects rates about its input axis. The platform gyro-vector orientation is shown in figure 7-22. If the axis of the rotation is not parallel to the gyro input axis, the gyro will not sense the entire rate but only some portion of it which is proportional to the angle between the rate rotation axis and the gyro input axis. This can be easily represented by using vectors to describe the rates. A vector representation of a rate will be directed along the axis of rotation,

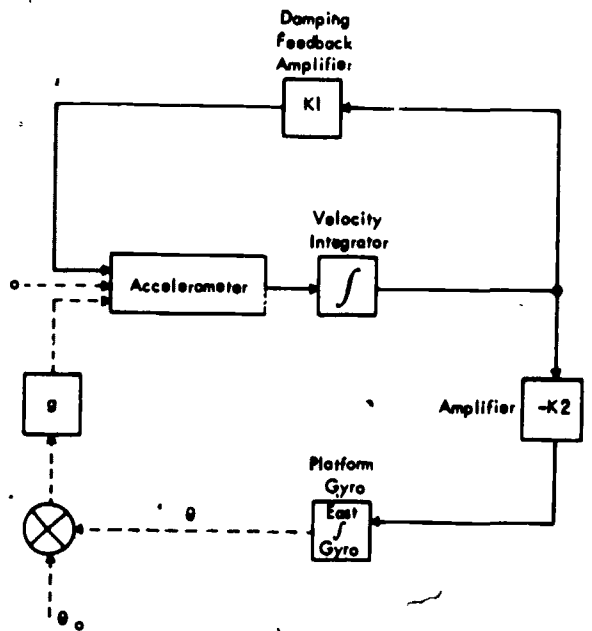

223.189

Figure 7-32.—Second order leveling loop.

with its length proportional to the rate and its direction according to the right-hand rule, which is similar to the one used in describing magnetic fields about a wire. If the right hand is wrapped around the axis with the fingers indicating the direction of rotation, the thumb points in the direction of the rate vector. Rate components of this vector along other axes at angles to the rotation axis will be equal to the rate times the cosine of the angle between the axes. Figure 7-33 shows how this works for the earth-rate component in the horizontal plane. This shows that a gyro with its input axis in the horizontal plane and pointed north will sense a rate equal to earth-rate times the cosine of latitude; that is, when the north gyro is at the equator, it senses the entire earth rotation rate; but when it is at the north pole, it senses none.

With this concept in mind, a discussion of azimuth alignment by a method known as gyrocompassing should follow. It is so called because the basic technique is exactly the same as the one used in a conventional ship's gyrocompass. The vector relationship for

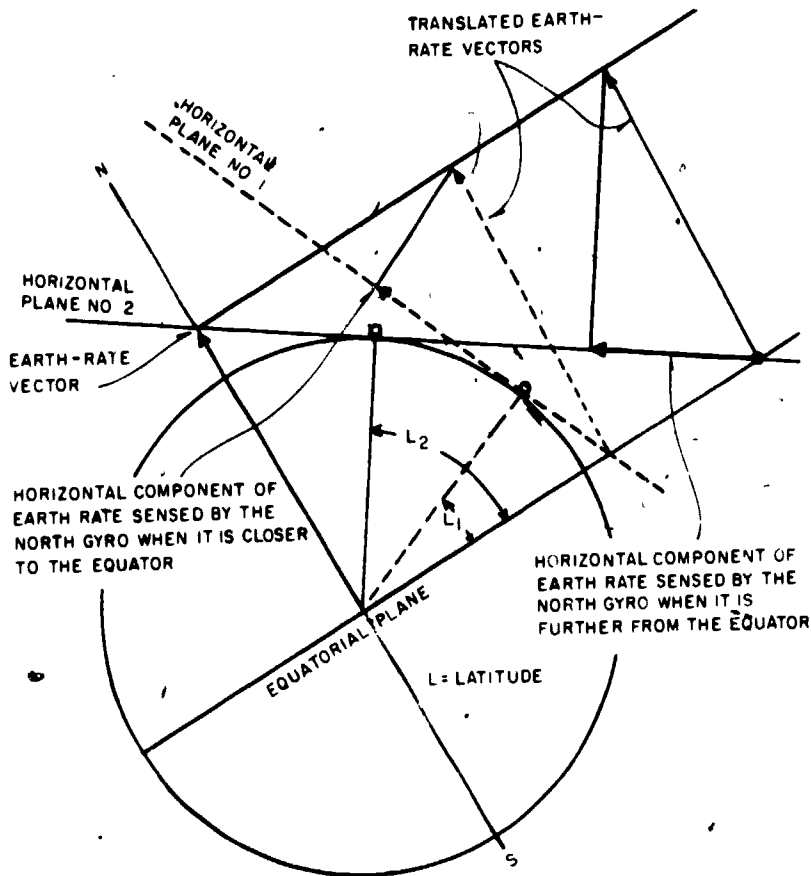

223.190

Figure 7-33.—Horizontal component of earth rate.

earth-rate in the horizontal plane was shown in figure 7-33. Now examine figure 7-34, which is a top view of the horizontal plane. The coordinate axes labeled X and Y are the principal axes of a platform misaligned from north by an angle ψ . Each of these axes is the sensitive axes of a gyro: Y is the north gyro and X is the east gyro. (As mentioned previously, the north gyro has its input axis running north-south and would sense the east-west rotation of the earth.) First simplify the earth-rate vector by letting $\Omega_{IE} \cos L = \Omega_N$. Then, resolving it into the X and Y axes gives the two components shown, $\Omega_N \cos \psi$ along the north gyro axis and $-\Omega_N \sin \psi$ along the east gyro axis. It is desired to rotate the platform in azimuth until ψ is zero. At that time the two components will be Ω_N along the north gyro axis and zero along the east

gyro axis. This is a situation made to order for a servomechanism approach. The east gyro is an error sensor which detects zero error when the platform is in the desired position. Practically all the necessary components are in the second order leveling loop. If the second order leveling loop is not oriented with the east gyro axis pointed exactly east, this gyro will pickup an earth-rate component. For the leveling loop to reach a steady state, this gyro input must be canceled.

The gyrocompassing feature is added to the second order leveling loop in figure 7-35. The integrated acceleration does not reach zero, but rather a value equal and opposite to the earth-rate input to the gyro. This value can be used as the error signal for azimuth alignment. The signal is amplified with a gain of -K3, and

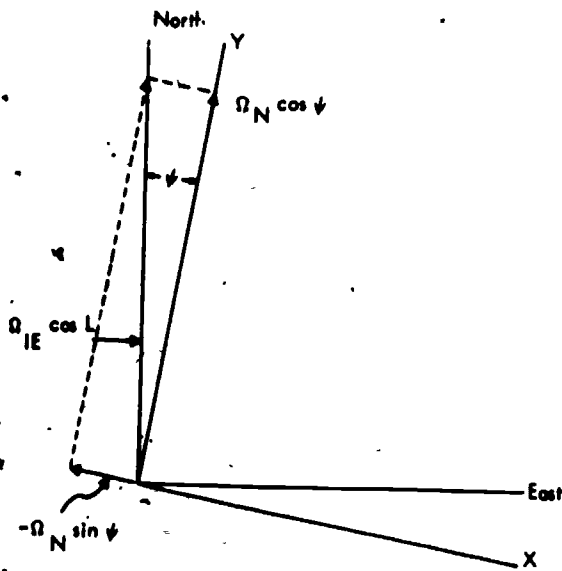

223.191

Figure 7-34.—Components of earth rate in the horizontal plane.

directly east and the platform is level. The azimuth gyro is represented as an integrator with an output of platform azimuth error ψ . Remembering that the sine of a small angle is approximately equal to the angle in radians, the earth-rate input to the east gyro can be simplified; it is shown as $\Omega_N \psi$. When the loop reaches steady state, the east gyro has zero input because ψ is equal to zero; the azimuth gyro has no input because the indicated input to -K3 is zero. In addition, the platform is level because there is no signal feedback through K1.

Initialization on a Moving Base

At this point there is an established system which aligns satisfactorily in a stationary environment. Now go back to the simple first order leveling loop (fig. 7-31) and examine its performance on an accelerating base such as an aircraft carrier.

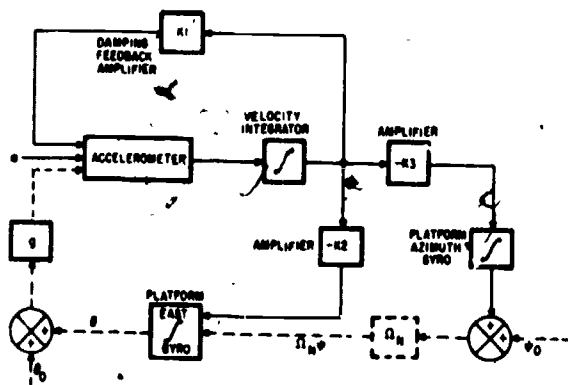

223.192

Figure 7-35.—Gyrocompassing loop.

used to torque the azimuth gyro and, consequently, the platform; that is the azimuth gimbal torquer moves through an angle ψ until it cancels out the initial alignment error angle ψ_0 . As the east gyro axis becomes perpendicular to the earth-rate vector, the output of the velocity integrator drops to zero; and the platform stops torquing when the east gyro axis is pointed

ACCELERATION LEVELING.—Leveling was accomplished by nulling the accelerometer output. If the platform is on a vehicle which is accelerating (an aircraft carrier in a turn), there will be an input to the accelerometer in addition to the gravity terms caused by tilt. These will cause outputs, which look like tilts, at the level position of the accelerometer; that is, an acceleration of 0.001 g will look like a tilt of 3.44 minutes of arc. The simple acceleration leveling scheme will rotate the platform until the accelerometer has zero output, whether these outputs are from tilts on accelerations of the base. The 0.001-g input mentioned will cause a tilt error of 3.44 minutes of arc. An aircraft carrier in a turn of 0.5 degree per second at 25 knots is accelerating at a rate of 0.11 g toward the center of the turn. It can be seen that this causes an intolerable tilt error. One way to eliminate this problem is to introduce a term which compensates for the acceleration. This would require some independent device to measure the acceleration. The achievement of an external measure of acceleration without the use of another inertial system presents so many problems that first order leveling on the moving base is abandoned, since there are easier ways to solve the problem.

SECOND ORDER LEVELING.—The second order leveling loop also provides leveling problems during accelerations. The velocity integrator output changes during accelerations and disturbs the platform level through the $K1$ feedback. In addition, the aircraft carrier's velocity over the earth introduces rate inputs to the gyros which cause steady state platform tilts. The tilts associated with these effects are too large for satisfactory platform initialization and must be removed by some form of compensation. Both of the disturbing errors are velocities; therefore, they can be compensated for by introducing velocity from an external source, such as the ship's electromagnetic log (EM log).

The ship's EM log is a speed measuring device which makes use of Lenz's law to measure the speed of the ship. Lenz's law defines the nature of electric currents generated in conductors moving in magnetic fields. In the case of the EM log, a sensor called the sword is lowered into the water. As sea water (which is a conductor) flows around the sword, a current is induced in the sea water. This current causes a secondary magnetic field which distorts the primary field of the log. Measurement of the field distortion gives an indication of the ship's speed through the water.

The log has two major sources of error: First, it measures only speed through the water; consequently it ignores any ship velocity due to ocean currents; and second, it measures only the local longitudinal component of velocity. As the ship slips sideways in a turn, the alterations in local flow at the log cause it to have errors on the order of 2 to 3 knots.

The reference velocity is introduced as shown in figure 7-36, that is, it cancels the steady state value of platform velocity at the velocity integrator output so that the feedback through $K1$ and the feed forward through $-K2$ are nearly zero in a steady state. The rate due to the aircraft carrier's velocity over the earth is computed and used to compensate the level gyros. Neglecting errors in reference velocity, the system levels as accurately as a second order loop at a stationary location.

Examine the effects of errors in the reference velocity. There are two major types of error, and they cause two very different

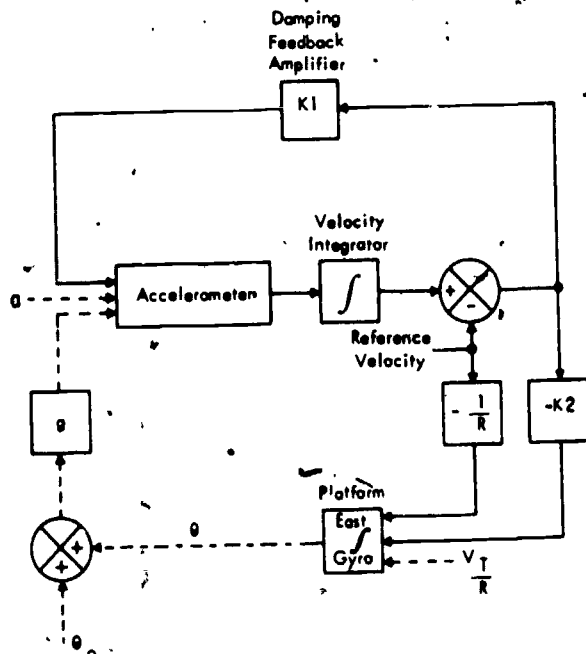

223.193

Figure 7-36.—Second order leveling loop with reference velocity.

problems. The constant error, which is due to ocean current and EM log bias, causes a steady state tilt error just as a gyro drift rate does. This error would not substantially change the gains used in leveling at sea. The other source of reference velocity error is the transient and oscillatory error in the EM log. The most troublesome error in the log is the inaccuracy of its output during a turn. The errors thus introduced to the platform cause it to take up transient tilts with peak values much larger than the steady state errors. Even if the ship is not in a turn, there is continuous oscillatory "noise" on the EM log due to slight wander of the ship about its straight course and to the ship's pitch and roll motion. In order to minimize the transient excursions of level, the gains must be made lower. Making gains lower has the detrimental effect of lengthening the time required to remove initial errors. The gain selection then becomes a compromise between fast elimination of erroneous initial conditions and attenuation of transient errors. This defines

Chapter 7—COMPASS, INERTIAL NAVIGATION, AUTOMATIC FLIGHT CONTROL AND STABILIZATION SYSTEMS

values. Even with these low gains, large turns at the end of alignment can cause intolerably large errors in azimuth.

INERTIAL SOURCE OF REFERENCE VELOCITY.—One method of solving this problem lies in the use of another aligned inertial system to supply the reference velocity to the aligning system. The problem with the EM log was two-fold: It did not measure all velocities (ship motion), and it was in error during turns. The inertial reference source does not have these drawbacks. It measures all velocities at the point where it is mounted, and it has no errors which are a function of turns. The worst problem of the inertial system is long term bias errors due to platform drift and initial alignment errors. If the inertial system is aligned at sea, it will have a bias error equal to EM log bias in its velocity output. However, the errors due to long term biases are small compared to the transient errors; and the accuracy of inertial systems on a short term basis makes these transient errors small. In this respect, the inertial source of velocity holds forth promise of shortening alignment times, but gyrocompassing is still limited in the sea environment because this environment is inherently noisier and requires lower gains to attenuate the noise. At present, the limited factor in the use of inertial reference sources in the distribution of correct reference velocity to points remote from the reference location. Pitch, roll, and yaw motions cause remote parts of the ship to have sizable velocities with respect to the reference location. To realize the full value of an inertial source, these relative velocities must be computed and added to the reference system output velocities. The accuracy with which this can be done limits the maximum gains which can be used.

ROUGH LEVELING.—The sea environment adds one more problem to the alignment process. Since platform tilt enters the gyrocompass loop as part of the apparent azimuth alignment error, any initial tilt at the start of gyrocompassing will result in an azimuth response. In fact, the loop is quite sensitive to this tilt, with a peak azimuth transient error reaching as high as 20 times the initial tilt error. At sea, where sea motion causes the vehicle to

be oscillating about the vertical, it is difficult to initialize the level accurately. It may be off 3° or 4° , causing a peak azimuth transient of 60° to 80° . One way to avoid this problem is to level roughly with the second order loop before starting the gyrocompass torquing. In 2 or 3 minutes the platform can be leveled to less than 10 to 20 minutes-of-arc error. Subsequent gyrocompassing is then easier because of the elimination of the large transient.

Now review the requirements and problems of shipboard initialization. The accelerations of the ship create inputs to both accelerometers and gyros which prevent the techniques of stationary leveling from working properly. These accelerations must be compensated by the introduction of a reference velocity. The EM log is a fairly good source of reference velocity, but it has its largest error during turns—which is also the time of highest acceleration. To reduce these errors, system gains must be made low, resulting in long alignment times. Reference velocity from an inertial system has better characteristics and will permit shorter alignments; however, the sea environment is always a difficult environment for gyrocompassing; and there are practical limits to short alignment even with inertial source of reference velocity. Alignment times of 5 minutes and less will require more exotic methods than gyrocompassing.

COMPASS CALIBRATION

As stated earlier in this chapter, variation and deviation will effect the accuracy of a magnetic compass. Variation is a natural phenomenon whose magnetic strength varies in intensity throughout the world. Variation is marked on navigation maps and is corrected for by the pilot as he flies the aircraft. Deviation can be considered man-made and caused by the magnetic fields of such aircraft components as engines, electric equipment, landing gear struts and flight control surfaces and their control cables. The effects of deviation can be kept to the very minimum by a process called compass swinging.

The AE must be completely familiar with the two methods of compass swinging. These two methods are the MC-2 compass calibration set and the use of a compass rose. For a

gyro-stabilized compass or Inertial Navigation system the MC-2 is considered the primary means of swinging. Deviation in a wet or standby compass is corrected for on a compass rose.

The following paragraphs describe the compass rose and the MC-2 calibration set.

Compass Rose

Aircraft magnetic compasses (wet or standby) are equipped with devices called compensators which provide a means of compensating for deviation errors. The AE cannot eliminate all errors, but can reduce them to a minimum by a process called swinging.

Swinging the compass consists of compensating the N-S and E-W headings, then setting the aircraft on every 15 or 30 degrees on the compass rose and noting the difference between the aircraft heading and the indicated heading. The compensators are then adjusted to reduce this difference or deviation to a minimum.

Compensators are of two types. One is known as the universal screw type, and consists of an assembly having a group of small compensating magnets permanently installed in it. Adjustments to change the compensating effect of the assembly are made by means of two adjusting screws, one for north-south compensation, the other for east-west. The other type of compensator employs small, loose magnets which are placed in special chambers on the compass as needed. One such chamber is placed so that its magnets make east-west corrections; the other (at right angles to the east-west chamber) corrects north-south deviation. Compensation is done only on the cardinal headings on standby compasses, but on all other compass systems in naval aircraft, compensation is made at 15-degree increments.

Before starting the swinging operation, make certain that all magnetic equipment is secured in the position it will occupy in normal flight. Also be sure that no one near the aircraft compasses during swinging operations has any magnetic materials on their person. Magnetic materials include tools, pocketknives, mechanical pencils, wristwatches, dog tags, bracelets, eyeglasses, jewelry, officer caps, badges, etc. Remember,

too, that a nonmagnetic screwdriver must be used in adjusting universal compensator screws.

The actual swinging of a compass may be accomplished in one of several ways; however, the AE is chiefly interested in ground swings. Ground swinging is usually performed with the aircraft at rest on a compass rose, as shown in figure 7-38.

Most air stations are equipped with a compass rose, which is much like an oversized card from a navigation compass. The directions shown by it are magnetic directions, and the "north" arrow points toward the earth's magnetic pole. A compass rose may also have a line showing true north.

Jacks, lifts, hoists, or any dolly needed to perform the ground swinging job should preferably be made of nonmagnetic material. However, this is not always possible. Devices used in the swinging process must be tested for their effects on the compasses by moving them about the aircraft in a circle with the normal separation distance between the device and the instruments. Devices causing more than one-quarter degree change in the compass reading should not be used.

Trucks, automobiles, railroad cars, and other aircraft contain magnetic metals and should not be within the swinging area where they will have magnetic effect on the compasses of the aircraft being adjusted. Be sure that the compass is in good condition. Examine the compass for clear liquid and proper level. Check to see that the card assembly is level and turns freely when the aircraft's tail is in a level flying position.

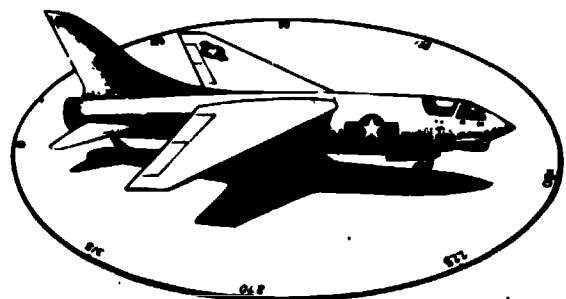

207.302
Figure 7-38.—Compass rose, with aircraft on south heading.

Chapter 7—COMPASS, INERTIAL NAVIGATION, AUTOMATIC FLIGHT CONTROL AND STABILIZATION SYSTEMS

Set the compensator so that it has no effect on the main compass magnets. With a loose-magnet compensator this is accomplished by removing all loose magnets from their chambers. Universal screw type compensators are set for zero effect by turning both adjusting screws until the dots on the screws are matched with the dots on the compensator case.

The aircraft is then placed directly on a south magnetic heading over the compass rose, with the tail in a level flying position. The engine(s) should be turning, and as many pieces of avionics equipment as possible turned on will create as many stray magnetic fields as possible and simulate the condition of the aircraft in flight. Note the compass reading and make record of it. From this reading, it is simply a matter of algebraic subtraction (or subtraction of numbers having plus and minus signs) to determine the deviation on the south heading. The deviation is the algebraic difference between the magnetic heading and the compass reading. Deviation is the error in a magnetic compass caused by electromagnetic disturbances in the aircraft.

Following this, the aircraft is placed on a west heading. Again note the compass reading and determine the deviation or difference between the magnetic heading and what the compass reads. The next heading to which the aircraft should be turned is magnetic north. After taking the compass reading on this heading and determining the deviation, subtract algebraically the south heading deviation from the north heading deviation and divide the remainder by two.

For example, if the compass reads $175\ 1/2^\circ$ while on the south heading (180°) record this as a deviation of $+4\ 1/2^\circ$ ($180^\circ - 175\ 1/2^\circ$). If the compass reading is too low, the deviation is plus; if the reading is too high, the deviation is minus.

Suppose that on the north (000°) heading the compass reads $006\ 1/2^\circ$. Such a reading is $6\ 1/2^\circ$ too high and would be recorded as a deviation of $-6\ 1/2^\circ$ ($000^\circ - 006\ 1/2^\circ$).

The next job is to determine the coefficient of north-south deviation by subtracting, algebraically, the deviation on the south heading

from the deviation on the north heading and dividing the remainder by two.

$$\frac{(-6\ 1/2^\circ) - (4\ 1/2^\circ)}{2} = \frac{-11^\circ}{2} = -5\ 1/2^\circ$$

The aircraft is still on the north heading and the compass reads $006\ 1/2^\circ$. Since the coefficient of the north-south deviation is $-5\ 1/2^\circ$, the north-south compensator must be adjusted by this amount, and the compass reading on the north heading will now be 001° . This adjustment also corrects the south deviation by the same amount (but in the opposite sense), so that on a south heading the compass will now read 181° . The coefficient of north-south deviation, which is $-5\ 1/2^\circ$ in this case, is called coefficient "C."

If the compensator is the loose-magnet type, the adjustment for north-south deviation is made by inserting the necessary number of magnets into the lateral (athwartship) chamber of the compensator. If the compass has a universal compensator, the adjustment is made by turning the north-south (N-S) compensator screw.

The next step is to determine the east-west deviation. The aircraft must be turned so that its heading is magnetic east, according to the compass rose, and record the compass reading on that heading. Now determine the coefficient of east-west deviation, otherwise known as coefficient "B."

Assume, for example, that the compass reads 276° when the aircraft was on the west (270°) heading, and reads exactly 90° on the east (90°) heading. Coefficient "B" is found by algebraically subtracting the deviation on west (-6°) from the deviation on east (0°) and by dividing by two.

$$\frac{(0^\circ) - (-6^\circ)}{2} = \frac{+6^\circ}{2} = +3^\circ$$

While the aircraft is on the east heading, adjust the east-west (E-W) compensator to add 3° to the compass reading. This reading becomes 93° on the east heading, and the compass would read 273° on the west heading. The adjustment is made by turning the E-W screw on a universal compensator, or by adding the necessary magnets in the longitudinal (fore-and-aft) chamber if the compass compensator is of the

AVIATION ELECTRICIAN'S MATE 3 & 2

loose-magnet type. Leaving the aircraft on an east magnetic heading, next compute an overall deviation correction based on what is called coefficient "A." This coefficient is equal to the algebraic sum of the compass deviations on all four cardinal headings (north, east, south, and west), divided by four.

$$\frac{(-6 \frac{1}{2}^\circ) + (0^\circ) + (4 \frac{1}{2}^\circ) + (-6^\circ)}{4} = \frac{(-8^\circ)}{4} = -2^\circ$$

Instrument panel compasses must be compensated for coefficient "A" if it amounts to 2° or more in either direction. When making this correction, leave the magnetic compensators alone. Compensation for coefficient "A" is accomplished by moving the instrument in its mounting.

Compensation of panel mounted compasses for coefficient "A" can be accomplished either by a slight realignment of the whole instrument panel, or by turning the compass a little with relation to the front of the panel and placing washers or spacers under its mounting screws.

After compensation is completed, the aircraft must be swung again on at least eight equally spaced headings (for example, 0°, 45°, 90°, 135°, 180°, 225°, 270°, and 315°), and the compass readings recorded for each heading on a compass correction card. An illustration of a compass correction card is shown in figure 7-39.

The small, right-hand portion of the compass correction card is intended to be detached and mounted in the aircraft. It is thus available for ready reference, telling the pilot or navigator the comparative compass headings and magnetic

COMPENSATING SWING			RESIDUAL SWING		
	ACTUAL HEAD (M)	AIRCRAFT COMP	DEV'N	ACTUAL HEAD (M)	AIRCRAFT COMP.
N 000	000	006½	-6½	000	001
				045	045
E 090	090	090	0	090	093
				135	135
S 180	180	175½	+4½	180	181
				225	225
W 270	270	276	-6	270	273
				315	315
	(1)	(2)	(1) - (2)	(3)	(4)

IF SWINGING COMPASS USED AHEAD OF AIRCRAFT ADD OR SUBTRACT 180 DEGREES

COEFF C. $\frac{N-S}{2} = \frac{(-6 \frac{1}{2}^\circ) - (4 \frac{1}{2}^\circ)}{2} = -\frac{11^\circ}{2} = -5 \frac{1}{2}^\circ$

COEFF B. $\frac{E-W}{2} = \frac{(0^\circ) - (-6^\circ)}{2} = \frac{+6^\circ}{2} = +3^\circ$

COEFF A. $\frac{N+E+S+W}{4} = \frac{(-6 \frac{1}{2}^\circ) + (0^\circ) + (4 \frac{1}{2}^\circ) + (-6^\circ)}{4} = -2^\circ$

BU # 191357 SER # 9548-353 SWUNG 7-23-74		AIRCRAFT COMPASS BY <i>Beaton</i>	
TO FLY	STEER	TO FLY	STEER
N	001	180	181
015	016	195	196
030	030½	210	210
045	045	225	225
060	061	240	240½
075	078	255	256½
090	093	270	273
105	107	285	286½
120	121	300	300½
135	135	315	315
150	150	330	330
165	165½	345	346

Figure 7-39.—Compass correction card.

7-44
111

Chapter 7—COMPASS, INERTIAL NAVIGATION,
AUTOMATIC FLIGHT CONTROL AND STABILIZATION SYSTEMS

headings. The larger portion of the card should be turned over to maintenance control for insertion into the aircraft logbook.

**MC-2 Magnetic Compass
Calibrator Set**

Components of the MC-2 (fig. 7-40) provide a controlled magnetic field (simulated earth's magnetic field) about the aircraft transmitter (flux valve) to calibrate accurately the aircraft compass system. Use of the MC-2 requires only that the aircraft be accurately placed on a north-south line, and the need for rotating the aircraft on a compass rose is eliminated. The

compass calibrator provides electrical heading inputs from 0 to 345 degrees in 15-degree increments with an accuracy of 0.1 degree.

The compass calibrator also has the capability of surveying an area for magnetic uniformity and providing the necessary data for layout and marking of a compass swing site.

The compass calibrator consists of four major components—the control console, the magnetic field monitor, the remote transmitter turntable, and the field tester. Various cable assemblies, reels, racks, tripods, and some special alignment equipment are included with the set.

The control console contains the controls, indicators, and electronic components that allow

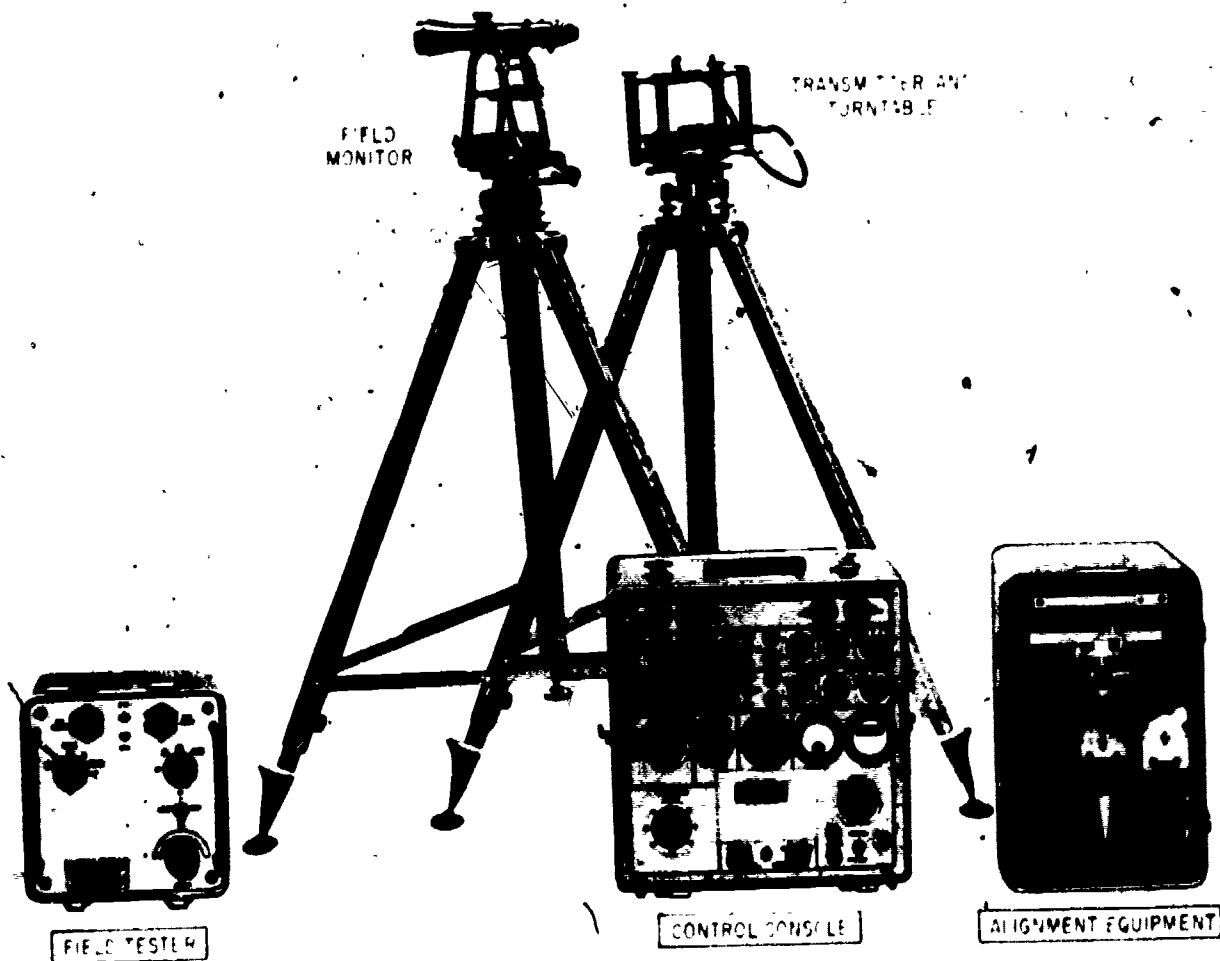

Figure 7-40.—MC-2 magnetic compass calibrator set.

207.246

the compass calibrator set to operate. It accepts 115 volts, 400 Hz at a maximum of one ampere and changes this electrical power into ac and dc voltages required by the set.

The magnetic field monitor is an engineer's transit that has been modified to operate as a component of the compass calibrator set. The modification consists of installing a magnetic sensing element in place of the magnetic compass. The monitor is made of nonferrous and nonmagnetic materials, and has a telescope, a horizontal circular scale with an adjustable vernier azimuth scale, levels, and leveling adjustment screws. The telescope is 22-power with an interior focusing optical system, and rotates 180 degrees in a vertical plane.

The remote transmitter turntable is also an engineer-type transit with the compass, vertical circle, and telescope removed. Also included with the turntable is a transmitter mounting bracket and a rain hood.

The field tester is a portable metal-encased tester consisting of a test panel, a shield can assembly, and a magnetic azimuth reference detector. All connectors, controls, switches, and electronic parts are mounted on the test panel. The shield can assembly contains a valve assembly within two magnetic shield cans. The magnetic azimuth reference detector consists of a 6-power telescope with azimuth adjustment and a flux valve assembly mounted to a triangular support plate. The valve assembly has an attaching cable assembly.

The alignment equipment consists of a telescope, two plate assemblies, shaft coupling, quick connector, plumb bob and adapter, screwdrivers, magnifier, wrenches, and sunshade. Parts used are dependent upon the aircraft and transmitter under calibration. The telescope is a fixed-focus type, 8-power, with 360-degree azimuth rotation. A drum dial fine-adjusts azimuth, and an azimuth lock prevents unwanted rotation.

The compass calibrator set is used to conduct an area magnetic survey to determine the magnitude and direction of the earth's magnetic field at a proposed aircraft swing site, and to conduct the actual compass swing. Normally, the AE will be concerned only with the actual compass swing. The control console provides controlled dc currents for the

transmitter, and the monitor detects the magnitude and direction of the earth's magnetic field and supplies this information to the control console. The alignment equipment is used with the turntable to optically align the compass system transmitter (flux valve).

A review of the flux valve will be helpful in the following discussion.

In an electrical compass swing, a dc magnetic field is generated in the transmitter and varied in magnitude and direction so that, in combination with the horizontal component of the earth's field, an equivalent earth's field is simulated in the transmitter at a desired heading. Errors in the compass system are measured as the difference between the magnetic heading of the aircraft as shown by the aircraft compass indicator, and the magnetic heading of the simulated earth's field as shown by the setting of the HEADING SELECTOR switch on the control console.

Controlled dc currents are applied to the secondary coils of the transmitter to generate an electromagnetic field (electrical swing). A current is applied to leg A coil of the transmitter (fig. 7-41) to generate a field aligned to leg A. In the electrical swing this field is used to provide the north-south component of the simulated earth's field. A dc current is also applied through leg B and C coils to generate two fields, each aligned to its respective coil. These fields are so oriented that north-south components of these two fields cancel, leaving one east-west component. By reversing the direction of the current flow, the east-west component is rotated 180 degrees.

The procedures for an electrical compass swing using the magnetic compass calibrator set are:

1. Set up the turntable over the spot where the remote compass transmitter will be located when the aircraft is positioned on the "north" line.
2. Remove the remote compass transmitter (flux valve) from the aircraft and mount the transmitter on the turntable.
3. Determine the alignment of the transmitter to magnetic north and its electrical calibration to the ambient magnetic field. Calibrate the N-S and E-W adjustments on the transmitter.

Chapter 7—COMPASS, INERTIAL NAVIGATION,
AUTOMATIC FLIGHT CONTROL AND STABILIZATION SYSTEMS

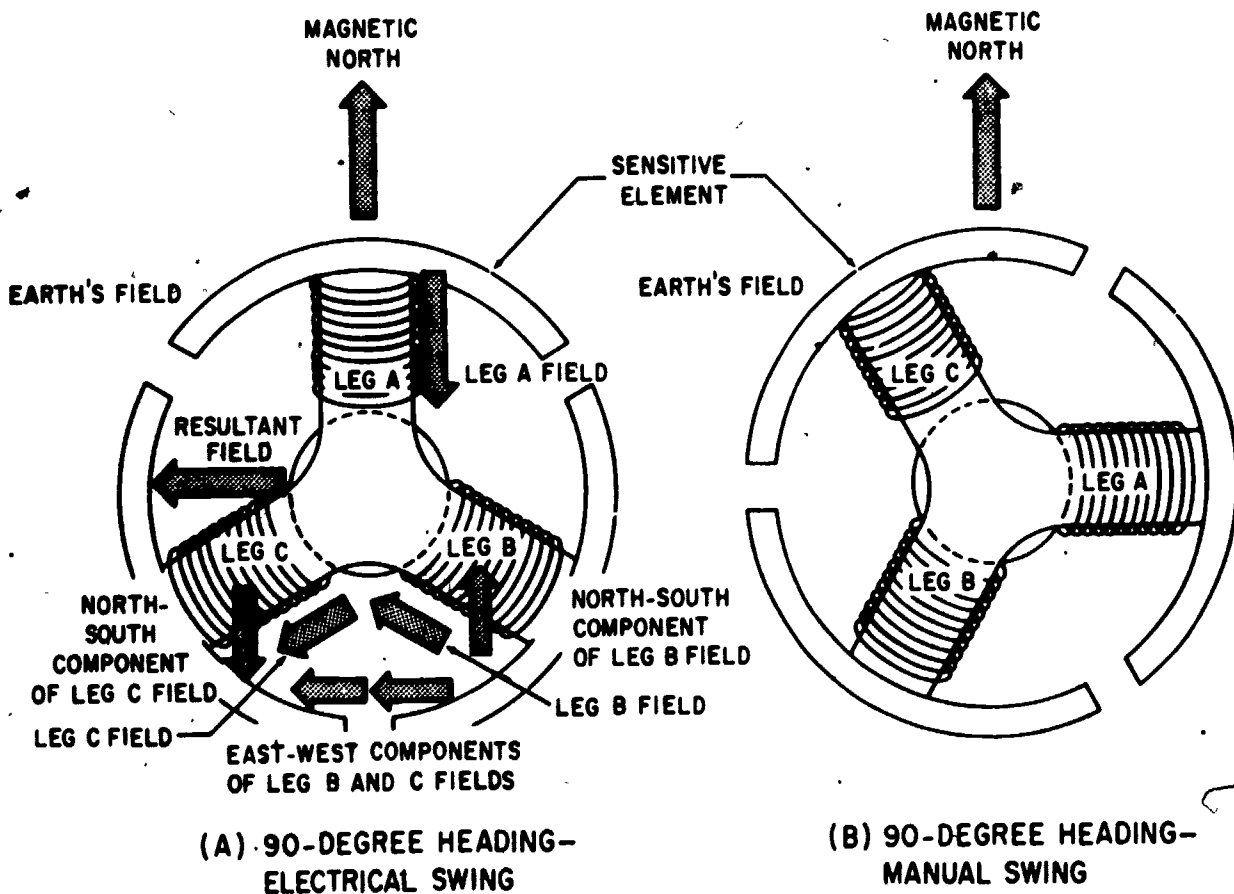

207.251

Figure 7-41.—Electrical swing and manual swing at a 90-degree heading.

4. Mount the necessary optical alignment equipment to the remote compass transmitter and align the telescope to a predetermined target one-half mile or more away.

5. Tow the aircraft into position exactly on the north line by using plumb bobs or some other accurate method.

6. Compute the optical alignment correction, insert the correction into the optical alignment scope, and replace the compass transmitter in the aircraft (sighting on the same target used in (4) above).

7. With the transmitter fastened down, reconnect the leads.

8. Using the appropriate adapter cables, connect the compass calibrator set into the compass system.

The aircraft magnetic headings are set in with the heading selector on the control console, and the errors are recorded as the difference between the indicated heading and that set in with the heading selector. Calibrate the compass system components to within 0.1 degree of the heading selector position.

Detailed information on compass swinging is given in Military Standards, MIL-STD-765A. Consult this specification for additional information in connection with swinging, compensating, and calibrating compasses.

AUTOMATIC FLIGHT CONTROL AND STABILIZATION SYSTEMS

A previous chapter of this manual discussed indicating systems and instruments which supply the pilot with information concerning the

performance of the aircraft. The pilot must be able to see and interpret each of these indicators, then react to obtain the desired performance. In high performance aircraft, and especially in single piloted aircraft, other flight duties may require much of the pilot's time. Navigation, communication, radar, and operation of other special equipment could be severely limited if the pilot were required to focus his attention consistently on the physical manipulation of the controls.

In high performance aircraft capable of supersonic flight, the speed of the aircraft is such that the pilot's normal response time is far too slow. By the time the pilot sees and interprets an indicator to mean that a control force is necessary, the aircraft may have already progressed to a position where it is out of control.

Automatic flight control and stabilization systems have been designed to ease the pilot's workload and to provide aircraft stability at all speeds. By causing information to flow directly to a flight control computer rather than to an indicator, the time required to initiate control movement is lessened to nearly zero (increased stability). The system also provides command controls by which the computer can also control the aircraft in nearly any desired flight condition—straight and level flight, turning flight, climbs, and descents. In some aircraft, the automatic flight control system is capable of flying the aircraft to radio navigation aids, correcting for winds and making pilot-unaided landings.

In newer aircraft, the terms automatic flight control system (AFCS), or automatic stabilization equipment (ASE), are used instead of the older term automatic pilot, or the shortened version, autopilot. A reliable AFCS is necessary because pilots have duties other than moving the flight controls; however, regardless of how sophisticated the AFCS computer may be, the reasoning power of the pilot cannot be duplicated.

PRINCIPLES OF FLIGHT

To sufficiently understand flight control systems it is necessary to study the effects that the various controls have on the aircraft. A basic introduction to the principles of flight and flight

controls is presented in *Airman*, NAVEDTRA 10307 (Series), and should be reviewed before proceeding with this chapter.

An airfoil is any part of an aircraft designed to produce lift. Obviously a wing is the primary airfoil on an aircraft, but propeller blades, tail surfaces and even the fuselage itself are important airfoils. The design of an airfoil is determined by the job it is to do, but all airfoils have the basic elements shown in figure 7-42. In general, an airfoil consists of two nearly parallel surfaces, one of which is more rounded than the other. As air passes over these two surfaces, the air passing over the rounded surface has farther to travel than the air passing over the flat surface. However, two particles of air leaving the leading edge of the airfoil at the same instant, one passing over the rounded surface and one passing over the flat surface, arrive at the trailing edge at the same time. Therefore, it can be seen that air passing over the rounded surface travels at a higher velocity than air passing over the flat surface.

Bernoulli's theory concerning the behavior of fluids $E = V \cdot P$ explains how pressure is changed and lift is produced. In this case E stands for the total energy produced by the airfoil passing through the air, V is velocity energy, and P is pressure energy. An airfoil passing through air at a velocity of 50 feet per second and exerting a pressure of 10 pounds per square inch on the flat surface produces a total energy of 500 foot pounds per square inch per second.

$$E = V \cdot P = 50 \cdot 10 = 500$$

If the velocity of the airflow over the rounded surface is increased to 60 feet per second and the total energy remains unchanged, the pressure then becomes 8.33 foot pounds per square inch per second on the rounded surface.

$$P = \frac{E}{V} = \frac{500}{60} = 8.33$$

The difference in the pressure between the rounded surface and the flat surface of the airfoil is called lift.

In actual practice, the flat surface is not perfectly flat and causes some decreased pressure which may be called negative lift. This negative lift, however, is more than compensated for by the creation of a high pressure on the flat

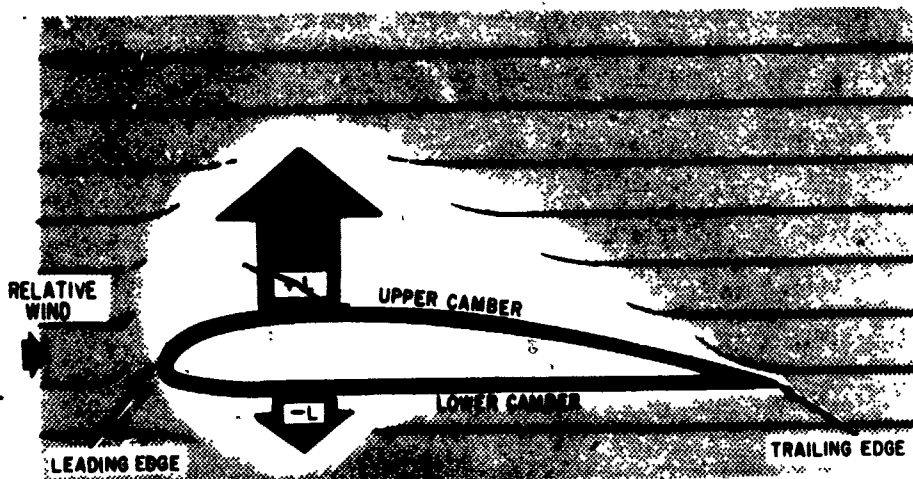

207.138

Figure 7-42.—An airfoil.

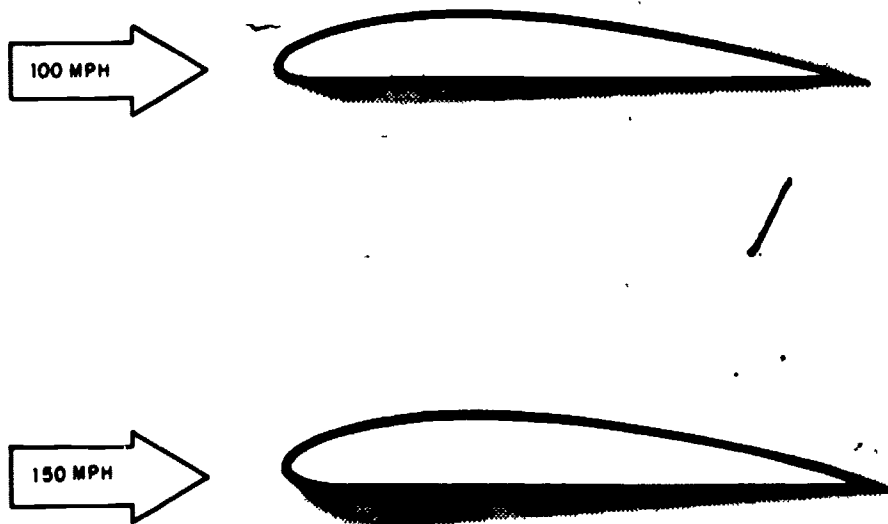

207.140

Figure 7-43.—Lift increases as velocity increases.

surface caused by the air packed beneath the airfoil (called dynamic lift), and the true measure of lift remains the difference in pressure between the rounded and flat portion of the airfoil.

Increased lift is the result of a larger pressure difference between the surfaces and can be produced in two ways—by increasing the forward movement of the airfoil through the air (fig. 7-43), and by changing the angle-of-attack.

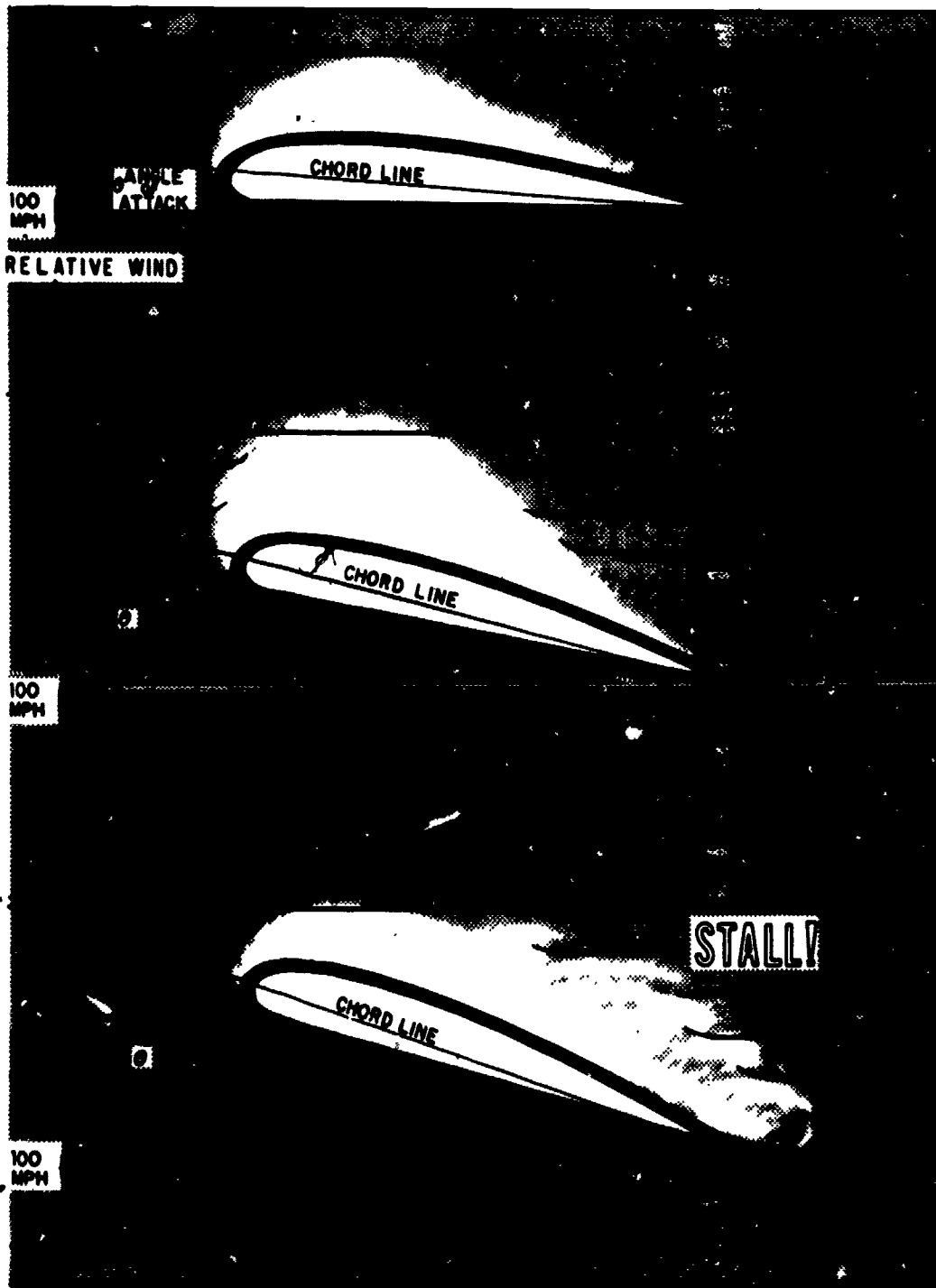

Figure 7-44.—Constant velocity vs. increasing angle-of-attack.

207.141

7-50
420

Chapter 7—COMPASS, INERTIAL NAVIGATION, AUTOMATIC FLIGHT CONTROL AND STABILIZATION SYSTEMS

Angle-of-attack can be defined as the acute angle between the chord line of an airfoil and its direction of motion relative to the air. The chord of an airfoil is an imaginary straight line drawn from the leading edge to the trailing edge of the airfoil (7-44). As the angle-of-attack increases, the air strikes the leading edge closer to the flat portion of the airfoil. The distance air must flow over the rounded portion becomes even greater in relation to that flowing over the flat portion, a larger pressure difference occurs, and more lift is developed.

When the angle-of-attack is increased too much, airflow over the rounded portion of the

airfoil separates from the surface and becomes turbulent. This turbulence causes the pressure on both surfaces to become nearly equal, and the airfoil is said to stall.

When lift is produced, a secondary effect called drag is also produced. Drag produced by a lifting surface or airfoil is called induced drag. Induced drag develops in direct proportion to lift—when lift increases, induced drag also increases. At a given speed and angle-of-attack, a thick airfoil produces more lift and drag than does a thin airfoil (fig. 7-45). It follows, then, that large subsonic aircraft must have thick

THIN LEADING EDGE
THIN AIRFOIL
LOW LIFT
LOW DRAG



THICK LEADING EDGE
THICK AIRFOIL
HIGH LIFT
HIGH DRAG



HIGH ANGLE OF ATTACK
HIGH LIFT
HIGH DRAG

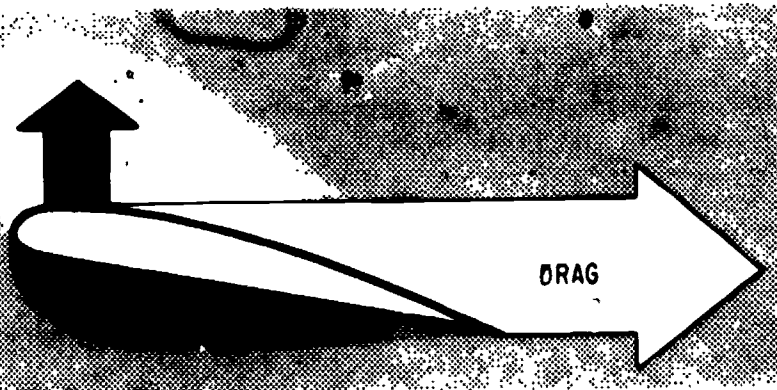

207.146

Figure 7-45.—Induced drag.

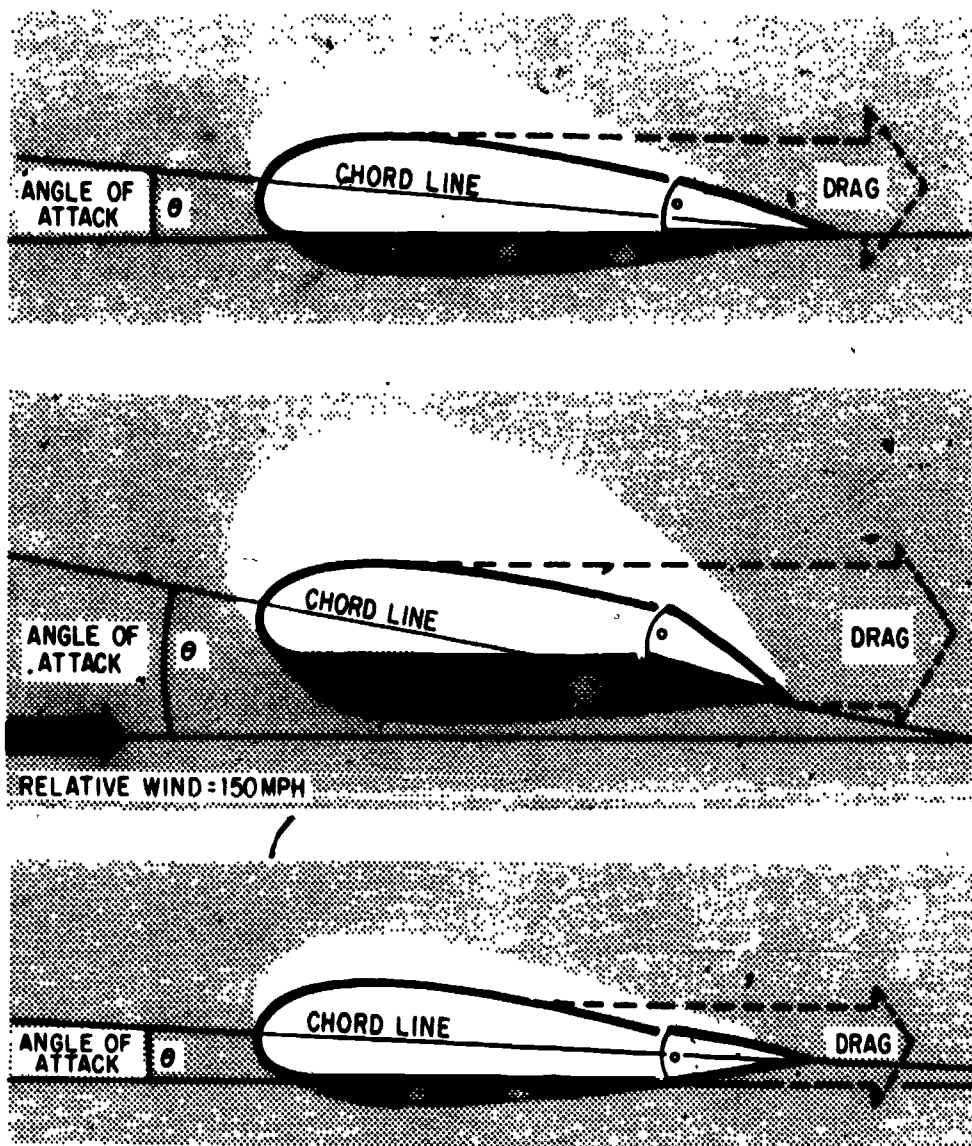

207,147

Figure 7-46.—Lift and drag change proportionately with the shape of the airfoil.

wings to produce a great amount of lift at slow speeds, and supersonic aircraft must have very thin wings to decrease drag at high speeds.

Many airfoils have devices attached to them to increase or decrease lift in various flight conditions or attitudes. These devices may be attached to the leading edge, trailing edge, rounded surface, or flat surface. If the trailing edge is attached by a hinge, and controls are

provided to move the trailing edge, lift can be controlled by changing the angle-of-attack (fig. 7-46). When the trailing edge is forced into the higher pressure air on the flat side of the airfoil, the angle-of-attack is effectively increased, causing more lift and drag. Conversely, if the trailing edge is moved into the low-pressure side of the airfoil the angle-of-attack is decreased, and lift and drag are decreased accordingly.

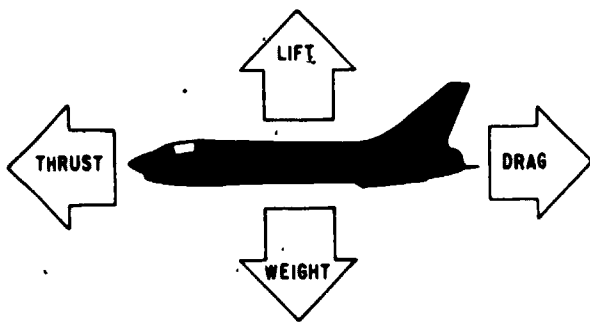

207.148

Figure 7-47.—Forces on an aircraft.

Each aircraft in flight has certain forces acting upon it, as shown in figure 7-47. In order to sustain flight at a constant altitude, the total lift of all airfoils must be equal to the weight of the aircraft. Changes in altitude are accomplished by changing the total lift—if the aircraft weighs 10,000 pounds, 10,001 pounds of lift causes the aircraft to climb, and 9,999 pounds of lift allows the aircraft to descend.

Flight at constant airspeed is accomplished when the forces of thrust and drag are equal. When one force is greater than the other, the aircraft accelerates or decelerates.

To turn, the aircraft is placed in a bank angle, as shown in figure 7-48. The lift developed by the airfoils can then be broken down into components of horizontal and vertical lift. The horizontal component of lift is used to pull the aircraft around in the turn. The vertical component of lift must be equal and opposite to gravity in order for the aircraft to remain at a constant altitude. (Note that total lift must necessarily be increased to prevent a loss in altitude.)

When centrifugal force equals horizontal lift, the aircraft is in a constant-rate turn. If a faster rate of turn is desired, horizontal lift can be increased by increasing the bank angle. When all lift is vertical to gravity, any turning motion is called a skid.

Fixed Wing Aircraft

A fixed wing aircraft, as compared to a rotary wing helicopter, is one in which the main lifting surface remains stationary with respect to the rest of the aircraft. This classification also

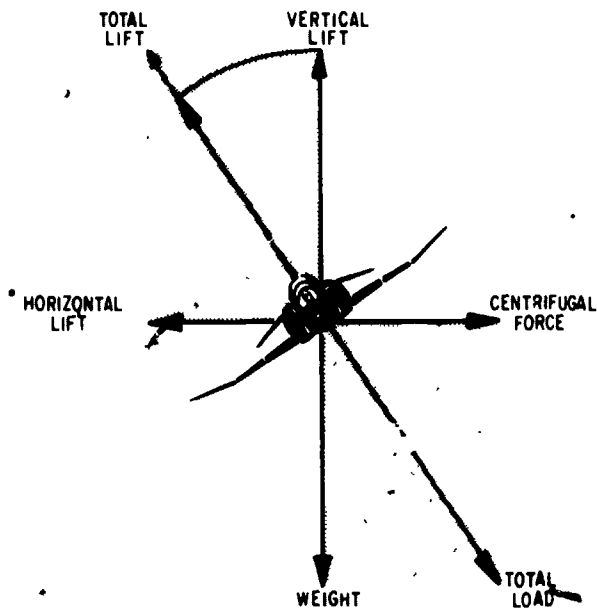

207.157

Figure 7-48.—Forces in a turn.

includes such aircraft designs as the swing wing design of the F-14. Fixed wing aircraft are equipped with certain fixed surfaces or airfoils—wings, vertical and horizontal stabilizers—which are designed to provide stability (fig. 7-44). In addition, it has movable airfoils—ailerons, elevators, and a rudder—which permit the pilot to control the aircraft.

Movement about the lateral axis of the aircraft (the axis that extends from wing to wing through the center of gravity) is called pitch and is controlled by the elevators. If a nose-up attitude is desired, an aft motion is applied on the cockpit control (stick or yoke) to cause the elevator to move up, thereby creating a downward force on the horizontal stabilizer. Rotation about the lateral axis then causes the nose to rise. Conversely, if the nose of the aircraft is to be lowered, a forward motion is applied on the cockpit control to cause the elevator to lower, thus creating an upward force on the horizontal stabilizer. Rotation about the lateral axis then causes the nose to lower.

Movement of the aircraft about the longitudinal axis (from nose to tail) is called bank or roll and is controlled by ailerons. The ailerons are mechanically connected to each other, but move in opposite directions. To cause

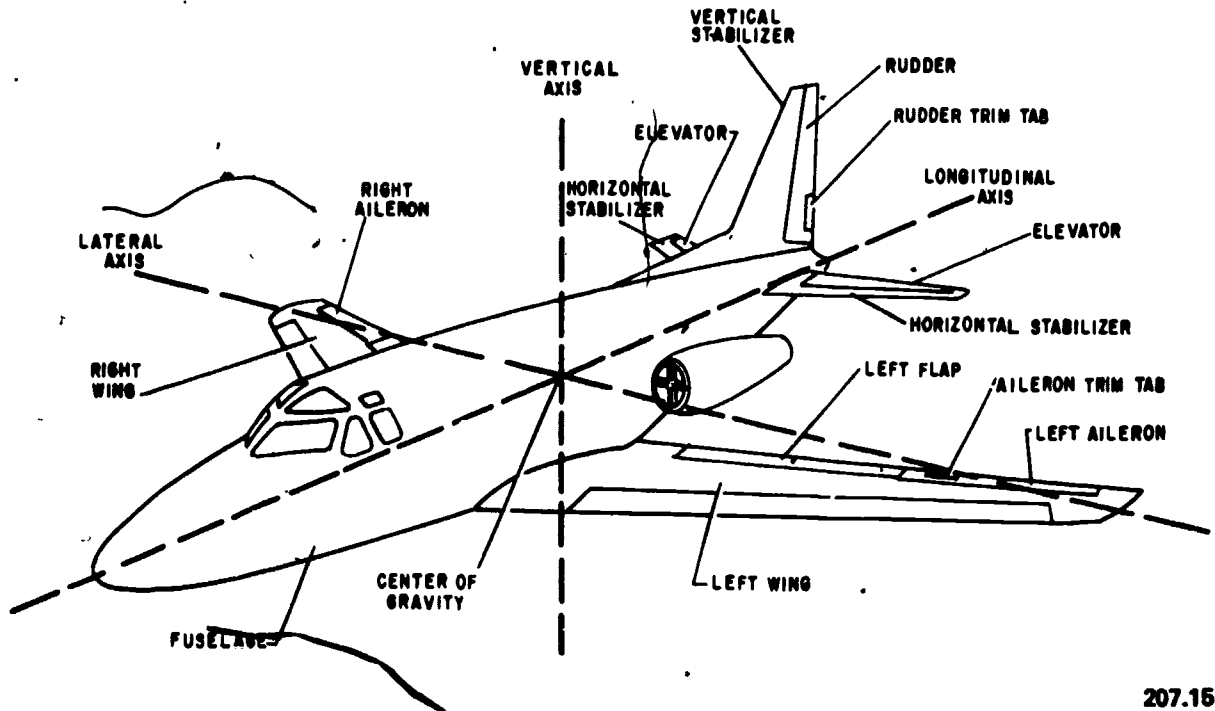

Figure 7-49.—Fixed wing aircraft controls.

207.158

the aircraft to enter a left bank, the angle-of-attack of a portion of the right wing must be increased by lowering the aileron to increase the lift on that wing, and the aileron on the left wing is raised to decrease the lift on that wing. The aircraft then rotates about its longitudinal axis until the ailerons are neutralized in some angle of bank, and the aircraft remains in that bank angle until the ailerons are again moved.

Refer again to figure 7-48. Whenever the aircraft is in a bank, lift developed by the wings is displaced from the vertical position. If lift is not increased, the vertical component of lift is insufficient to maintain the aircraft at a constant altitude. To prevent a loss in altitude, a change in pitch attitude to increase the angle-of-attack of the wings is the method usually used. A few degrees of bank angle requires an imperceptibly small pitch change, whereas a 90° bank in level flight (no altitude change) is theoretically impossible because of the absence of vertical lift. As the bank angle is changed, coordination between ailerons and elevators is necessary to prevent a loss in altitude.

To return to level flight, lift is increased on the left wing by lowering its aileron into the higher pressure area beneath the airfoil, and reduced on the right wing by raising its aileron into the lower pressure area at the top of the airfoil. As the wings become level, the ailerons are again neutralized.

Movement about the vertical axis is called yaw, and is generally undesirable in an aircraft. Any tendency of the aircraft to yaw is corrected by using the rudder; the rudder is NOT used to turn the aircraft (change heading).

When the ailerons are displaced into the airstream, the aircraft has a tendency to yaw. In banking an aircraft to the right, more lift and drag are produced on the left wing, and less lift and drag are produced on the right wing. Even though the intention is to turn to the right by going into a right bank, the initial tendency is for the nose of the aircraft to go to the left because of the increased drag on the left wing and decreased drag on the right wing. This is called adverse yaw, and is compensated for by displacing the rudder in the same direction as

Chapter 7—COMPASS, INERTIAL NAVIGATION, AUTOMATIC FLIGHT CONTROL AND STABILIZATION SYSTEMS

the intended turn whenever the ailerons are displaced from neutral.

If an aircraft in a turn tends to slip into the inside of the turn or skid to the outside of the turn, this is also called yaw and must be compensated for by use of the rudder. Many other things may cause yaw, such as the engines on one wing of a multiengine aircraft producing more power than the engines on the other wing.

It can be seen, then, that whenever a fixed wing aircraft is placed in a bank angle, coordination between all three controls—aileron, elevator, and rudder—is necessary.

Control of elevators, ailerons, and rudders is accomplished by the pilot through the use of a control stick and rudder pedals (fig. 7-50). To operate the ailerons, the control stick is moved right or left in the direction of the intended turn. Aft force on the control stick raises the elevator and causes the nose to pitch up; forward pressure on the control stick lowers the elevator and causes the nose to pitch down. Rudder pedals are operated by the feet—pressure on either rudder pedal causes rudder deflection in that direction.

Weight distribution in an aircraft varies for many reasons—for instance, fuel may be used faster from one wing tank than from the other, allowing that wing to become lighter, and in large aircraft where crewmembers or passengers may walk around, the balance point (called center of gravity) is shifted whenever someone changes position in the aircraft. As fuel is used, the gross weight of the aircraft is reduced and the angle-of-attack of the wings must be reduced to lessen lift and prevent a gain in altitude.

These unbalanced flight conditions must be compensated for by use of control pressures. Several methods are used to reduce these control pressures and to ease the pilot's workload, the most common being the trim tab. Figure 7-49 shows only rudder and aileron trim tabs; trim tabs on the elevators on this particular aircraft are undesirable because they produce excessive drag. Another method of elevator trim, involving linkage pressure, is also used.

When a force must be exerted on the cockpit control, the pilot can use the trim control to relieve that force. For instance, when it is necessary to hold left rudder pressure to prevent yaw movement to the right, the rudder trim tab

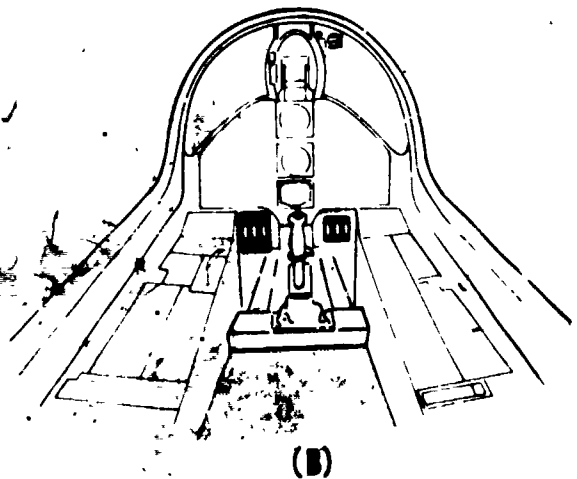
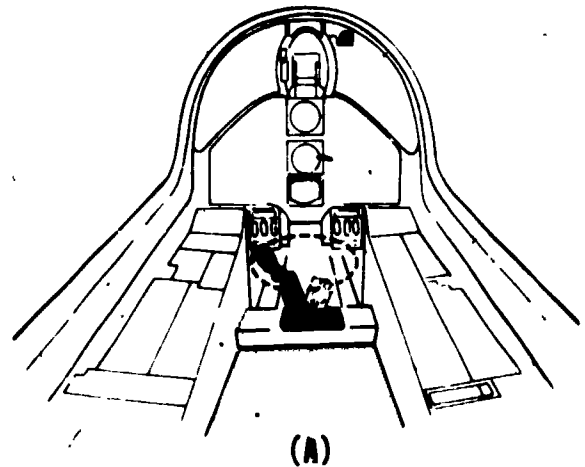

207.166

Figure 7-50.—Flight controls. (A) Elevator and aileron; (B) Rudder.

is moved to the right. The airflow on the right side of the vertical stabilizer strikes the trim tab and moves the complete rudder a little to the left. Since the required rudder pressure is then being supplied by the trim tab, it is no longer necessary for the pilot to hold pressure on the rudder pedals.

Rotary Wing Aircraft

An aircraft that derives its main lifting force from a horizontally driven propeller device

(rotor) is called a rotary wing aircraft. The most common rotary wing aircraft is called a helicopter. There must be relative motion between an airfoil and an airmass, so the major advantage of a rotary wing aircraft is its ability to maintain zero or very low speeds while the wings (rotors) are still creating lift.

Forces acting on a rotary wing aircraft are identical to those acting on a fixed wing aircraft (fig. 7-47). The rotary wing aircraft must also be controlled about the vertical, longitudinal, and lateral axes in figure 7-49.

In the conventional helicopter, the main rotor and tail rotor are both engine driven. The more recent models of the turbine powered helicopters utilize the constant speed rotor; however, some older helicopters using reciprocal type engines may still use variable rpm rotors. Keeping in mind the earlier discussion on airfoils, lift can be increased by either increasing the speed of the airfoil through the air, or by increasing the angle-of-attack (in this case called blade pitch) of the airfoil. When speed of the rotors is constant, complete control of the aircraft is maintained by varying the pitch of the rotor blades.

Helicopter flight controls are shown in figure 7-51. The pilot operates collective control with the left hand, cyclic control with the right hand, and rudder control with the feet. Movements of the collective and cyclic controls are directed to the main rotor. Operation of the rudder control changes the blade angle of the tail rotor.

In helicopter flight except hovering flight, the altitude, bank, and directional control is provided by the main rotor through use of the collective and cyclic cockpit controls. The tail rotor is used to prevent the main body of the helicopter from spinning (yawing) from the torque of the main rotor, and to prevent yaw in much the same way as the fixed wing aircraft rudder.

Collective control is used to maintain or change altitude. Movement of the collective control causes an equal change in pitch (angle-of-attack) of all main rotor blades, and, through a mechanical mixer, automatically changes tail rotor pitch to compensate for increase or decrease in main rotor torque. Since the rotor blades are somewhat flexible, the more collective applied, the more an action called

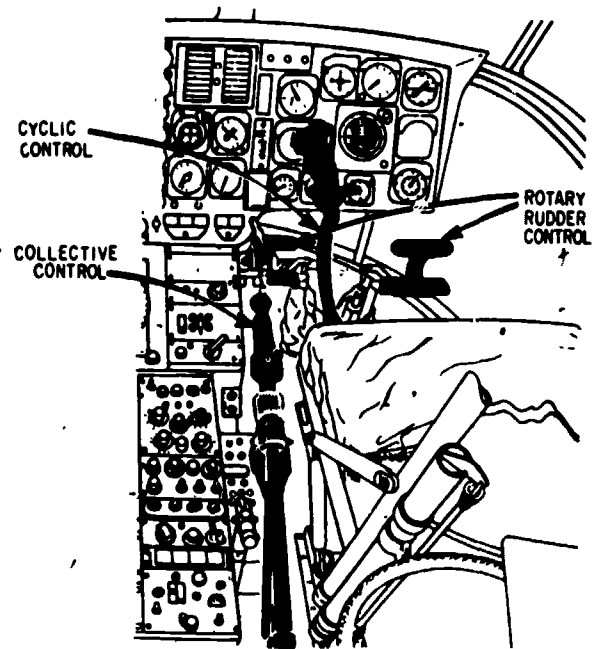

207.167
Figure 7-51.—Helicopter flight controls.

coning takes place—the rotating blades take the shape of a cone, as shown in figure 7-52. The coning angle is determined by the speed and pitch of the blade tips. With a constant pitch, the faster the rotor blades turn, the more horizontal the blades become because of centrifugal force. As the blade pitch increases, lift also increases, and the coning angle increases because of the load on the blades.

In hovering flight, pitch and roll, which create forward and sideward motion,

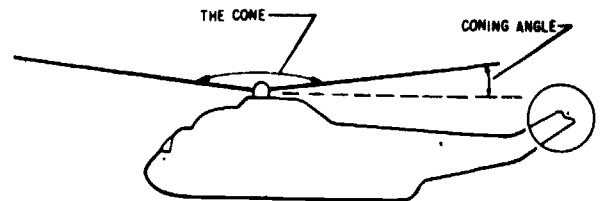

207.168
Figure 7-52.—Coning angle increases as load increases.

Chapter 7—COMPASS, INERTIAL NAVIGATION,
AUTOMATIC FLIGHT CONTROL AND STABILIZATION SYSTEMS

respectively, are controlled by the cyclic stick, altitude is controlled by the collective; and heading is controlled by the rudder pedals.

Pitch and directional control of the helicopter is accomplished through use of the

cyclic stick. When pressure is applied to the cyclic stick, each blade is controlled to a specific pitch angle as it passes a certain point in its rotation (fig. 7-53). To accomplish forward flight, the blade pitch is greatest as it passes the

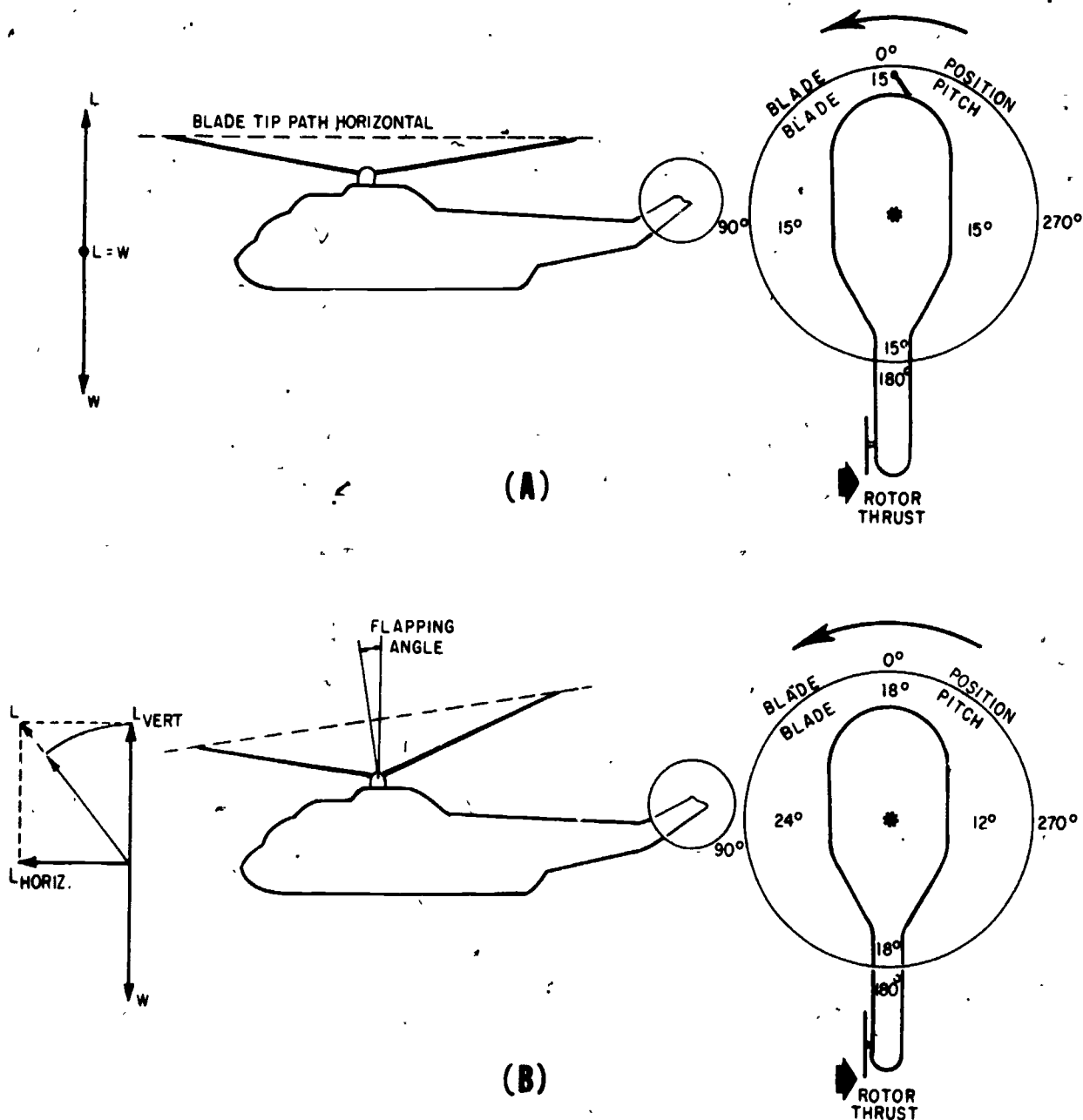

Figure 7-53.—Flapping angle creates horizontal lift. (A) Hovering flight; (B) Forward flight.

207.173

90° position, least at the 270° position, and equal at the 0° and 180° positions. (To turn the aircraft, lateral motion of the cyclic stick causes blade pitch to be greatest at 0° and 180°, and least at 90° and 270°.) Since the blades form a spinning mass, the gyroscopic principle of precession occurs 90° in the direction of rotation from where the lifting force is applied. The coning angle remains the same but the cone tilts, (called flapping angle) in the direction of the desired flight path. Lift can again be broken down into its vertical and horizontal components. As shown in (B) of the figure, to maintain altitude vertical lift must be increased until it is equal to gravity. With the cone at a flapping angle, the helicopter accelerates in the desired direction until drag is equal to horizontal lift.

To accelerate the helicopter in a forward direction, the cyclic control stick is moved forward, and a corresponding increase in collective is necessary to maintain altitude. As the collective is increased, torque on the main rotor blade is increased and the helicopter tends to rotate in the direction opposite of rotor blade rotation (nose right). A mechanical mixer automatically changes the pitch of the tail rotor to overcome the right turning tendency (skid).

Turning of the helicopter (changing heading) is accomplished by placing the cyclic control stick to the right or left. Flapping action of the main rotor blades causes the cone to tilt in the direction of the desired turn. As in the fixed wing aircraft, coordination must be maintained in a turn through use of the rudder pedals to prevent skid or slip. Also, the collective must be adjusted to prevent a loss in altitude. In hovering flight, turn is accomplished through use of the rudder pedals only, thus producing a skid.

AUTOMATIC FLIGHT CONTROL SYSTEMS (AFCS)

In the human body, signals to move us from place to place are originated by our five senses as they reference outside conditions. These signals are processed in the brain, then transmitted through the nerves to the muscles, and the body does its required movement by muscle power. Similarly, most automatic flight control systems (AFCS) have their component parts divided into

three major groups—sensors (information inputs), amplifier/computer, and output units.

The sensors are the units which originate the signals as they are acted upon by outside references. The sensors only sense change in directions and do not have sufficient power to make corrections.

The "brains" for the AFCS are the amplifiers and computers. They receive the weak signals from the sensors, which in most cases are synchros, and determine how much and in what direction correction is necessary. The synchro signals are usually in millivolts, but the strength needed is in volts, so the amplifier amplifies the weak signal to a workable voltage. The value of the weak signal produced by a synchro depends on the amount of rotor displacement in respect to the stator from the null position. The direction of correction needed is determined by the direction of rotor displacement from the stator. Most amplifiers have at least two stages of voltage amplification—one stage of phase discrimination, and an amplifier where power amplification takes place. Other types of amplifiers control the voltage to control valves in hydraulic servos.

The "muscles" of the AFCS is a hydraulic booster package. There is a booster package for each control surface—rudder, aileron, and elevator. The boosters are also used to assist the pilot in manual control of the aircraft.

Summing up the major groups, the sensors send a small signal to the amplifier/computer when a displacement occurs: the amplifier/computer amplifies the weak signal to a workable voltage and sends it to the output unit; the output unit changes the electrical energy to mechanical displacement and moves the control surfaces by an amount commanded by the sensor signal.

Signal Generator Pickoff (Synchro)

The principle of operation of a signal generator pickoff is illustrated in figure 7-54. The pickoff consists of a stator and rotor. The stator is ring-shaped and has four poles, with a

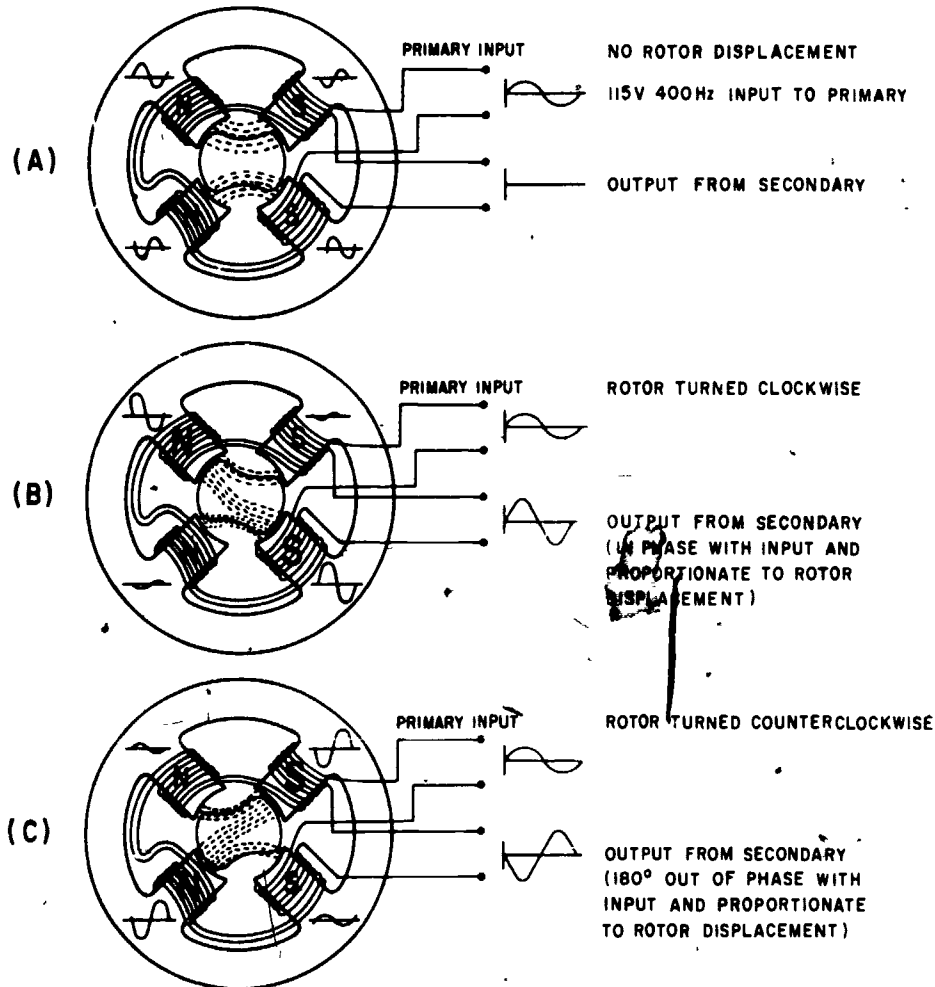

207.174

Figure 7-54.—Signal generator pickoff operation.

primary and secondary winding on each of the poles. The rotor has no windings, but serves to change the reluctance of the flux paths between the stator poles. The primary and secondary windings are connected in such a way that the voltages induced into the secondaries are of opposite polarity on adjacent poles (indicated by the voltage curves beside the poles), but are of the same polarity on opposite poles.

The voltage output of the secondary is zero if the rotor is in its neutral position, as in (A) of the figure. Repositioning the rotor as in (B) or (C) results in a stronger magnetic field on a single pair of poles, and a voltage output on the

secondary winding. Amplitude of the output voltage is proportional to the amount of rotor displacement—the greater the displacement, the greater the amplitude. Polarity of the output voltage is determined by the direction of rotor movement and will be either in phase with the input voltage, or 180° out of phase with it.

Synchros can be constructed to produce an accurate voltage vs. angle signal, effective through 360° of rotation. *Principles of Synchros, Servos, and Gyros, Module 15, NEETS*, discusses various types of synchros used in modern automatic flight control systems.

Gyros

For a basic understanding of gyroscopic principles, refer to *Principles of Synchros, Servos, and Gyros, Module 15, NEETS*.

VERTICAL GYRO.—The vertical gyroscope (gyro) (fig. 7-55) is an electrically driven gyro that provides pitch and bank attitude references

for the AFCS. It can also provide pitch and bank attitude references for servoed indicators and other systems of the aircraft. It has sufficient signal load capacity to sustain several systems at the same time.

The vertical gyro is a two-degree-of-freedom gyro. This gyro is termed the vertical gyro because it is continuously erected with its spin axis vertical to the surface of the earth. The spin

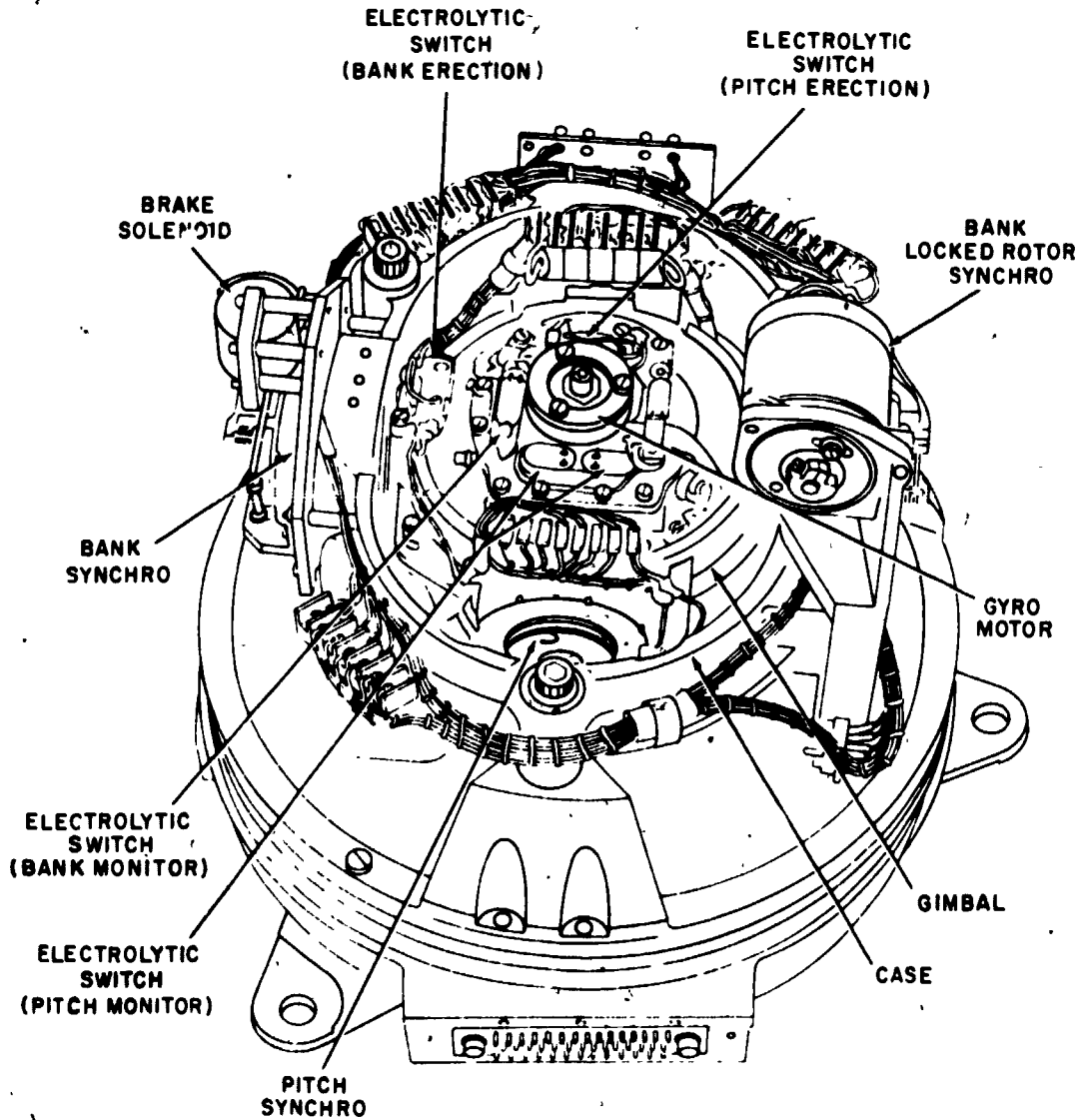

Figure 7-55.—Vertical gyro components.

207.176

Chapter 7—COMPASS, INERTIAL NAVIGATION,
AUTOMATIC FLIGHT CONTROL AND STABILIZATION SYSTEMS

axis provides a vertical reference from which the bank angle and pitch angle of the aircraft are measured, because it is characteristic of a gyro to resist any force attempting to move it. The gyro is isolated from its housing (and the aircraft) by roll and pitch gimbals. Thus, the aircraft can bank or pitch while the gyro remains vertical because of gyroscopic action. (See fig. 7-56.) A pitch synchro mounted on the pitch pivot of the vertical gyro continuously senses the relative pitch angle between the gyro and the aircraft. Similarly, a bank synchro mounted on the bank pivot of the vertical gyro continuously

senses the relative bank angle between the gyro and the aircraft.

The gyro motor rotates at a speed of approximately 20,000 rpm. A solenoid-operated friction brake prevents nutation and tumbling when the gyro motor is idle and during the initial starting torque. The gyro motor operates from single-phase, 115-volt, 400-Hz power, and is a split-phase, capacitor type. The gyro is operative through 85° in pitch and 360° in bank.

Synchros are the sensors that are mounted on the gyro to detect motion between the gyro,

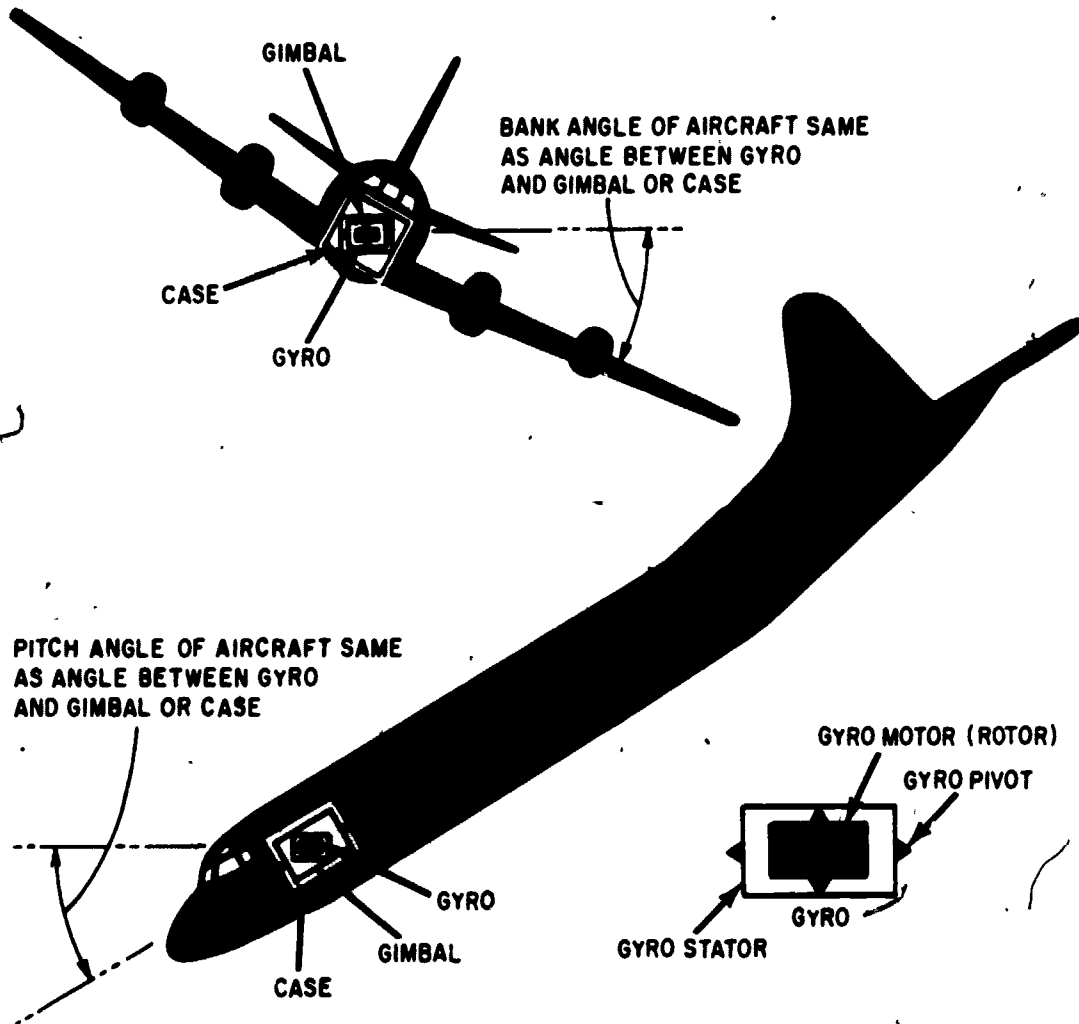

Figure 7-56.—Vertical gyro pitch and roll reference.

207.177

the gyro gimbal, and the gyro case. A synchro generates a weak signal when its rotor is displaced from its stator. The pitch synchro is mounted with its rotor on the gyro pivot and its stator on the gyro gimbal. Thus, the synchro measures the displacement angle between the gyro and the gimbal. This is the pitch displacement angle from the vertical reference. The bank synchro is mounted with its rotor on the gyro gimbal pivot and its stator on the gyro case. Thus, the synchro measures the displacement angle between the gimbal and the case. This is the bank displacement angle from the vertical reference.

As the pitch attitude of the aircraft changes, the gyro case and gimbal turn about the gyro rotor. The pitch synchro rotor is held rigid in space by the gyro, so voltages are generated in the pitch synchro in proportion to the pitch angle of the aircraft with respect to the surface of the earth. During changes in pitch attitude, the bank synchro remains at null since the gyro gimbal is not free to rotate with respect to the case in pitch, and therefore tilts with the case.

As the bank attitude of the aircraft changes, the bank synchro stator (mounted on the case) turns about the bank synchro rotor (mounted on the gimbal pivot). The gimbal is held rigid in space by the gyro because it is not free to rotate with respect to the gyro in bank. Thus, the bank synchro generates voltages which are proportional to the bank angle between the aircraft and the surface of the earth.

When the aircraft yaws, the case, the gimbal, and the gyro stator turn about the rotating gyro motor. This has no significant effect upon the relative positions between the gyro and the gimbal and between the gyro and the case. As a result, no pitch and bank synchro output voltages are generated in response to changes in yaw.

RATE SWITCHING GYRO.—The rate switching gyro is used to monitor the rate of movement about an aircraft axis. In automatic flight control systems it is used to monitor the rate of turn of the aircraft. When the turn rate exceeds a certain limit, usually 15 degrees per minute, a switch is actuated and provides a 28-volt signal to some other component of the system. This gyro's operation is similar to the

rate switching gyro discussed earlier in this chapter.

RATE CONTROL GYRO.—Rate control gyros are used to monitor the rate of movement of an aircraft about its vertical, lateral, or longitudinal axis. They provide synchro signal outputs representing yaw rate, pitch rate, or roll rate. These units are sometimes very similar in appearance to the rate switching gyro, but provide entirely different information to the system. Two or more gyros may be installed in the same case.

Output rotation of the rate gyros illustrated in figure 7-57 is measured by a synchro whose rotor is mounted on the gyro pivot shaft and whose stator is mounted on the gyro case. Since rotation of the gyro about its pivot (constrained by calibrating springs) is proportional to the rate of change in attitude of the aircraft, the synchro signal represents this rate. To measure the rate of movement of the aircraft about the pitch and yaw axes, the yaw and pitch rate gyros are mounted so that their input axes are parallel to the yaw and pitch axes of the aircraft.

If, for example, the aircraft yaws in flight with pitch attitude still unchanged (fig. 7-57 (A)), the yaw rate gyro turns about its input axis with the motion of the aircraft, and the resulting torque produces an output rotation which is measured by the synchro. The output voltage of the synchro is then proportional to the yaw of the aircraft. However, since the spin axis of the pitch rate gyro is vertical, rotation of the aircraft merely turns the pitch rate gyro stator with respect to the spinning gyro rotor and no output results.

If the aircraft pitches in flight (fig. 7-57 (B)), the pitch rate gyro turns about its input axis with the motion of the aircraft, and the resulting torque produces an output rotation which is measured by the synchro. However, the yaw rate gyro is merely turned about its spin axis. If the aircraft rolls in flight (fig. 7-57 (C)), the pitch and yaw rate gyros are turned by their calibrating springs along with the aircraft. However, the resulting torque produced at the input axis has no effect because the gyros are not free to rotate about this axis. Thus, the synchros in the pitch and yaw rate gyros produce no voltage for the roll condition.

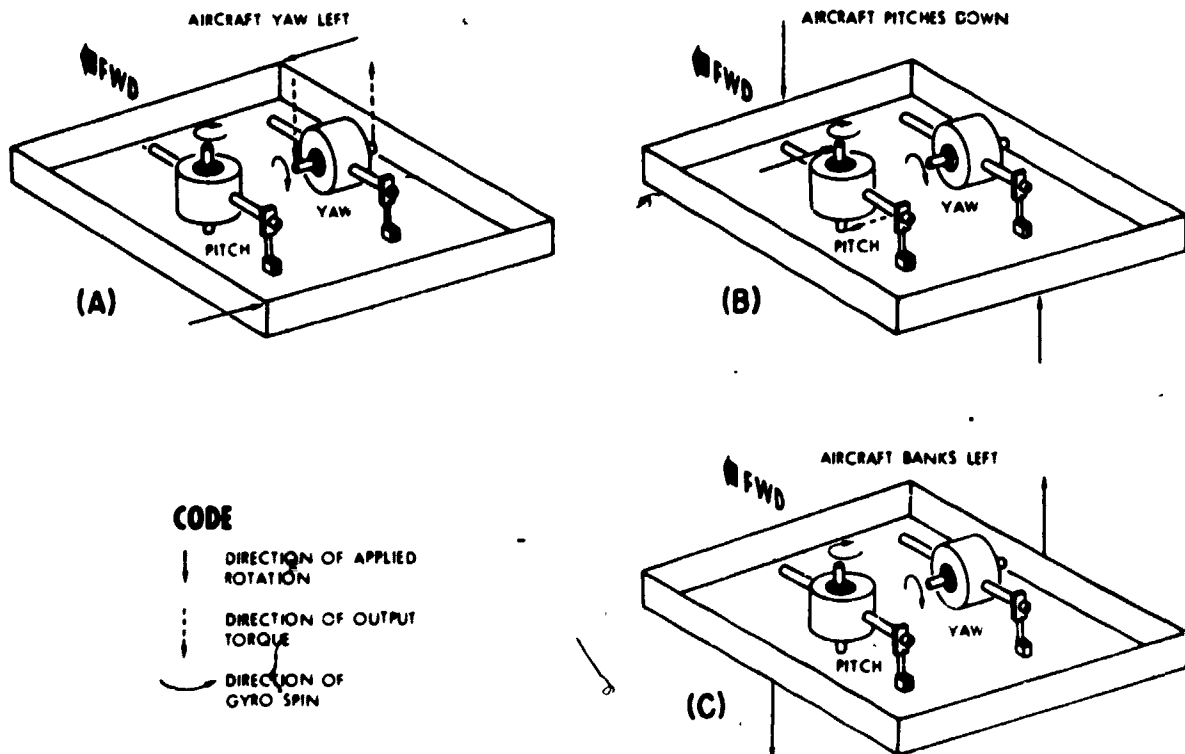

207.185

Figure 7-57.—Yaw and pitch rate control gyros.

Compass Information

Compass information for the AFCS will normally be supplied by the aircraft compass system or the inertial navigation system (INS) which were discussed earlier in this chapter. At least one type of compass information is developed for the AFCS.

The compass system/INS incorporates a gear train to which several synchros are attached. The gear train is driven by a motor generator unit to align with the heading of the aircraft, and one of the synchros provides an electrical output to the heading indicator for information to the pilot. One synchro rotor is attached to the gear train through a clutch and is designated the clutched heading synchro. When the AFCS is not engaged, the clutch remains deenergized and the rotor is spring loaded to an electrical null condition.

When the pilot engages the AFCS, the clutch engages so that the engaged heading establishes the reference heading for the system. If the aircraft drifts off heading, the gear train drives against the spring tension on the rotor so that an electrical signal is sent to the aileron channel, much like the signal generator pickoff operation discussed in reference to figure 7-54. Limiters in the AFCS prevent the bank angle from becoming excessive when large heading errors are detected.

Another type of compass information is derived from the heading indicator in the cockpit. The pilot selects a desired heading on the face of the indicator. The difference between the selected heading and the actual heading becomes an error signal to the AFCS and causes the aircraft to turn to the desired heading.

Compass information may also be supplied by a radio navigation aid. If the pilot desires to

fly to a selected ground station, a signal may be developed in the radio receiver to produce the desired ground track directly to the station.

Air Data Information

Changes in the speed of an aircraft also vary the effectiveness of the control surfaces. At a given altitude, slow speeds require more control surface movement than high speeds, if the same amount of maneuvering is to be accomplished.

The pilot maintains (or changes) the altitude by reference to the altimeter. The AFCS may also be used to maintain a constant altitude, and thus must have an altitude reference. Altitude data for the AFCS is supplied by an air data sensor or the air data computer (ADC).

AIRSPEED.—To compensate for changes in airspeed, control surface signals are modified by a gain control unit. This unit makes use of the difference between the pressure created by the flight of the aircraft (ram pressure), and the pressure outside the aircraft caused by barometric pressure alone (static pressure). Figure 7-58 shows a mechanical schematic of the gain control unit. It can be seen in the schematic that as airspeed increases (ram air pressure increases), the bellows causes the spring to become more compressed. This allows the armature to move each potentiometer's sliding arm to modify the control surface signals an amount representative of the change in airspeed of the aircraft.

When airspeed decreases, the armature moves to the right, selecting a different amplifier

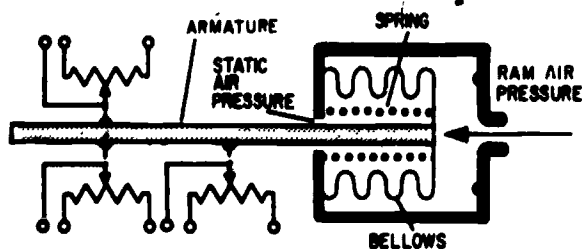

207.186

Figure 7-58.—Mechanical schematic of a gain control unit.

gain. The opposite occurs for increases in airspeed.

ALTITUDE.—To maintain the aircraft at a fixed altitude, AFCS systems include an altitude control feature. The altitude controller consists of an aneroid, a mechanism for transmitting and magnifying the motion of the aneroid, a solenoid operated clutch, a synchro transmitter, and a centering device for returning the synchro transmitter rotor to the null or no-signal position. In place of an altitude controller, signals from the ADC are used.

Figure 7-59 (A) shows a three-quarter view of a barometric altitude control. The outside appearance of various controls of this type varies, depending upon the manufacturer; however, the working parts are similar. (B) of the figure shows the internal parts of a barometric altitude control, and (C) shows a simplified mechanical schematic.

The aneroid consists of two diaphragms sealed internally at standard (sea level) barometric pressure. The two diaphragms are connected in tandem on a single pushrod, and mounted in an airtight case ((B) of the figure). The case is connected by a tube to a source of static air pressure. The diaphragm pushrod is mechanically connected to one of the clutch plates through a linkage consisting of a lever, a pivoted shaft to which a sector gear is attached, and a pinion gear.

Any departure of the aircraft from the barometric pressure altitude at which the altitude control switch is set produces movement of the aneroid diaphragms. This motion is transmitted through the linkage to displace the rotor of the synchro transmitter, resulting in generation of a signal in the synchro transmitter stator. This signal is applied to the elevator channel to produce elevator control for returning the aircraft to the pressure altitude indicated by the aneroid. When the aircraft reaches the correct altitude, the synchro transmitter signal becomes zero and elevator control is again maintained through normal AFCS operation.

When the altitude control switch is turned off, the magnetic clutch and the centering device

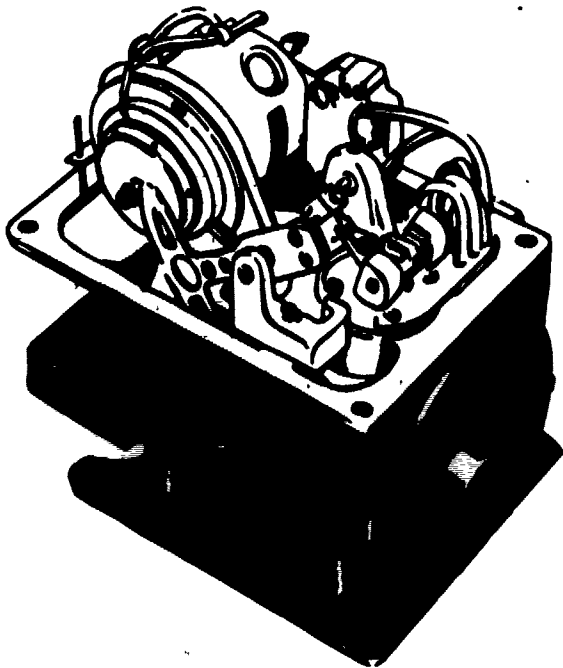

(A)

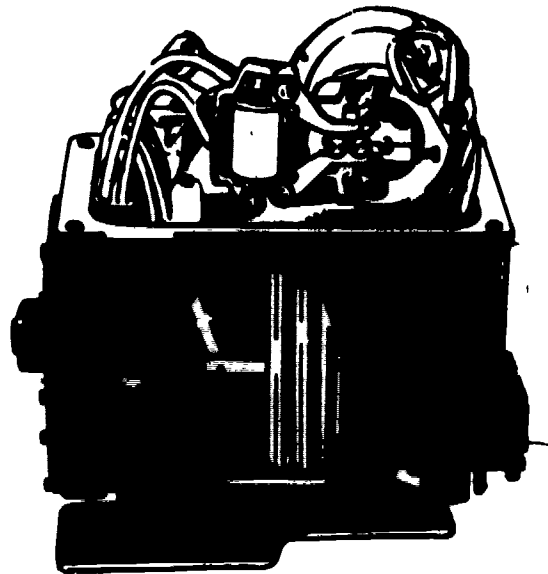

(B)

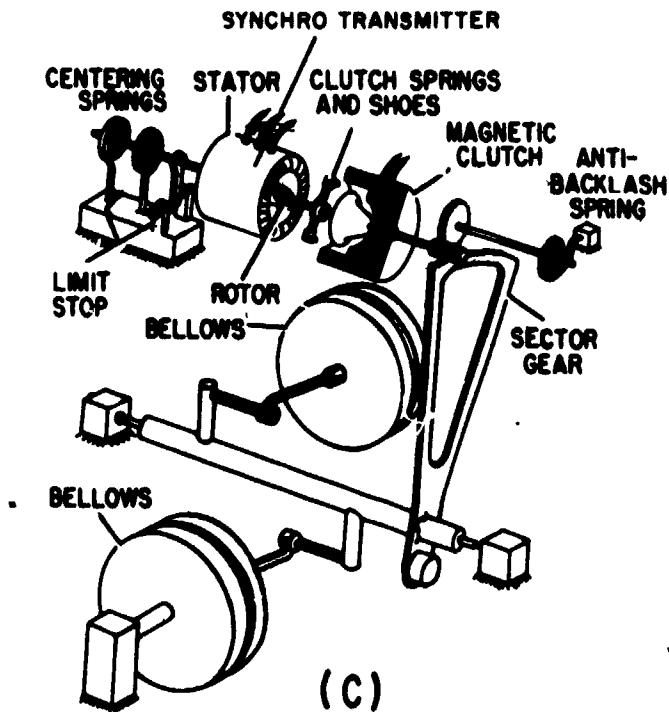

(C)

207.192

Figure 7-59.—(A) Barometric altitude control; (B) Internal parts; (C) Simplified schematic.

actuating coil are deenergized. This opens the clutch to disengage the synchro transmitter rotor from the aneroid mechanism and, at the same time, the centering yoke, by spring action, closes on the synchro transmitter rotor shaft lever to return the rotor to the null or no-signal position.

In this way, the synchro transmitter rotor is always held at the no-signal position whenever the altitude control is not selected, and since the clutch is disengaged, the aneroid is free to move. Therefore, the altitude control may be engaged at any time. Regardless of the position of the aneroid, the altitude that it senses is the one used as the reference for maintenance of constant altitude when the altitude control is turned on. It is not necessary to wait for synchronization or alignment.

Flap Position Information

When the flaps are lowered on some aircraft, the increased lift developed by the flaps causes the aircraft to gain altitude (normally called ballooning). Ballooning is undesirable and must be counteracted by using nosedown pressure on the cockpit control. When the AFCS is engaged and the flaps are lowered, automatic nosedown force is applied to the elevator. Flap position is detected by the use of a flap position transmitter.

The flap position transmitter consists of two synchro transmitters driven from a single input shaft. (See fig. 7-60.) When the shaft is linked to the flap hinge, the synchro transmitters supply flap position information to the elevator control channel of the AFCS and to an external flap position indicator.

Coordination Input

In some aircraft, a dynamic vertical sensor detects lateral accelerations of the aircraft; that is, slip or skid. The sensor supplies a signal to position the rudder to correct the slip or skid, hence to coordinate the turn. The signal is proportional to the amount the aircraft deviates from the vertical axis of the aircraft. Some

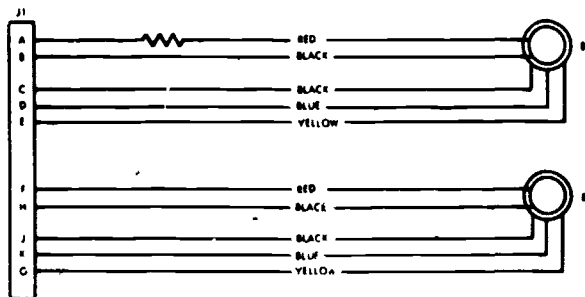
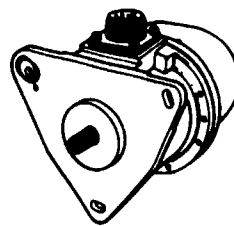

207.193

Figure 7-60.—Flap position transmitter and schematic.

aircraft may use a horizontally mounted accelerometer aligned with the lateral axis of the aircraft to provide the same information. Only the dynamic vertical sensor will be discussed.

Basically, the unit consists of a viscous-damped pendulum, mechanically connected to the rotor shaft of a transmitter synchro. The cutaway view of the sensor (fig. 7-61) shows the mechanism assembly which includes a synchro transmitter with a pendulum and vane assembly attached to the rotor. The vane moves in an oil-filled chamber. The damping effect of the fluid gives a long term sensing characteristic that makes the unit relatively insensitive to transient oscillations. The damping chamber also limits displacement of the pendulum to 10° either side of the center position.

A pin in the housing fits into a slot in the mechanism shell. This positions the mechanism to give proper alignment of the synchro rotor with the fore-aft axis of the aircraft when installed.

The sensor functions in the same manner as the ball in a turn-and-bank indicator. The ball

Chapter 7—COMPASS, INERTIAL NAVIGATION,
AUTOMATIC FLIGHT CONTROL AND STABILIZATION SYSTEMS

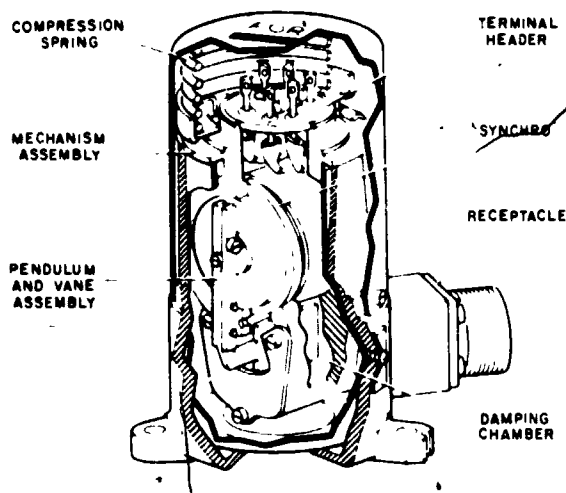

207.194

Figure 7-61.—Cutaway view of a dynamic vertical sensor.

gives a visual indication of slip or skid resulting from lateral acceleration, and the sensor provides a signal output of this condition. A diagram of the forces acting on the aircraft in a turn is shown in figure 7-62. In a coordinated turn, the vertical and lateral forces resolve into a vector perpendicular to the span of the aircraft. The aircraft is turning with the two forces in balance. The ball in the turn-and-bank indicator is centered and the pendulum in the sensor gives a null output.

When the aircraft bank angle is too large for the turn rate, the balance is upset as shown in (B). The ball moves away from the center toward the inside of the turn, and the pendulum moves the synchro rotor from the center null position. The rotor displacement produces a signal with magnitude proportional to the displacement angle and signal polarity corresponding to the direction of displacement. The unbalanced condition results from a sideways accelerating force, causing the aircraft to slip toward the inside of the turn.

When the aircraft is insufficiently banked for the turn, an acceleration acts toward the outside of the turn as shown in (C). The ball in the turn and bank indicator moves from the center, and

the pendulum in the dynamic vertical sensor is displaced from null in the direction corresponding to the ball. This gives a signal whose polarity is opposite to that of the signal when the aircraft was in a slip. The signal is fed to the rudder control channel for right or left rudder to coordinate the turn. Since the pendulum is unaffected by transients, the rudder adjustment is on a comparatively long-term basis.

Electronic Components

The electronic components are what make automatic flight control systems work. The control panel allows the pilot to program the AFCS so that the aircraft will perform any desired maneuver within the capability of the system. Originally, AFCS systems were very limited in that they supplied only one-channel operation to the ailerons to keep the wings level. Newer aircraft receive inputs from other aircraft systems. Radar and barometric altimeter signals are coupled to the AFCS in order to maintain the aircraft at a constant altitude. Also, signals from data link systems are used on some aircraft in order to fly the aircraft during approaches and landings. Some fighters have the fire control system tied in so that the aircraft can be flown automatically to an enemy aircraft. Fighterbombers with a weapons control system tie-in can be flown automatically to the target and have their weapons released at the proper time; long range patrol aircraft have their ASW systems tied into their AFCS. The automatic flight control system operates the rudder, the elevator, and the ailerons through the use of various sensors and electrically controlled hydraulic servos. Prior to engagement, the AFCS is synchronized with the flight control surfaces to prevent sudden or violent maneuvers upon engagement.

The system senses deviation from the reference flight condition and causes the aileron control to maintain either a reference bank angle or a heading, the elevator control to maintain either a reference pitch angle or an altitude, and

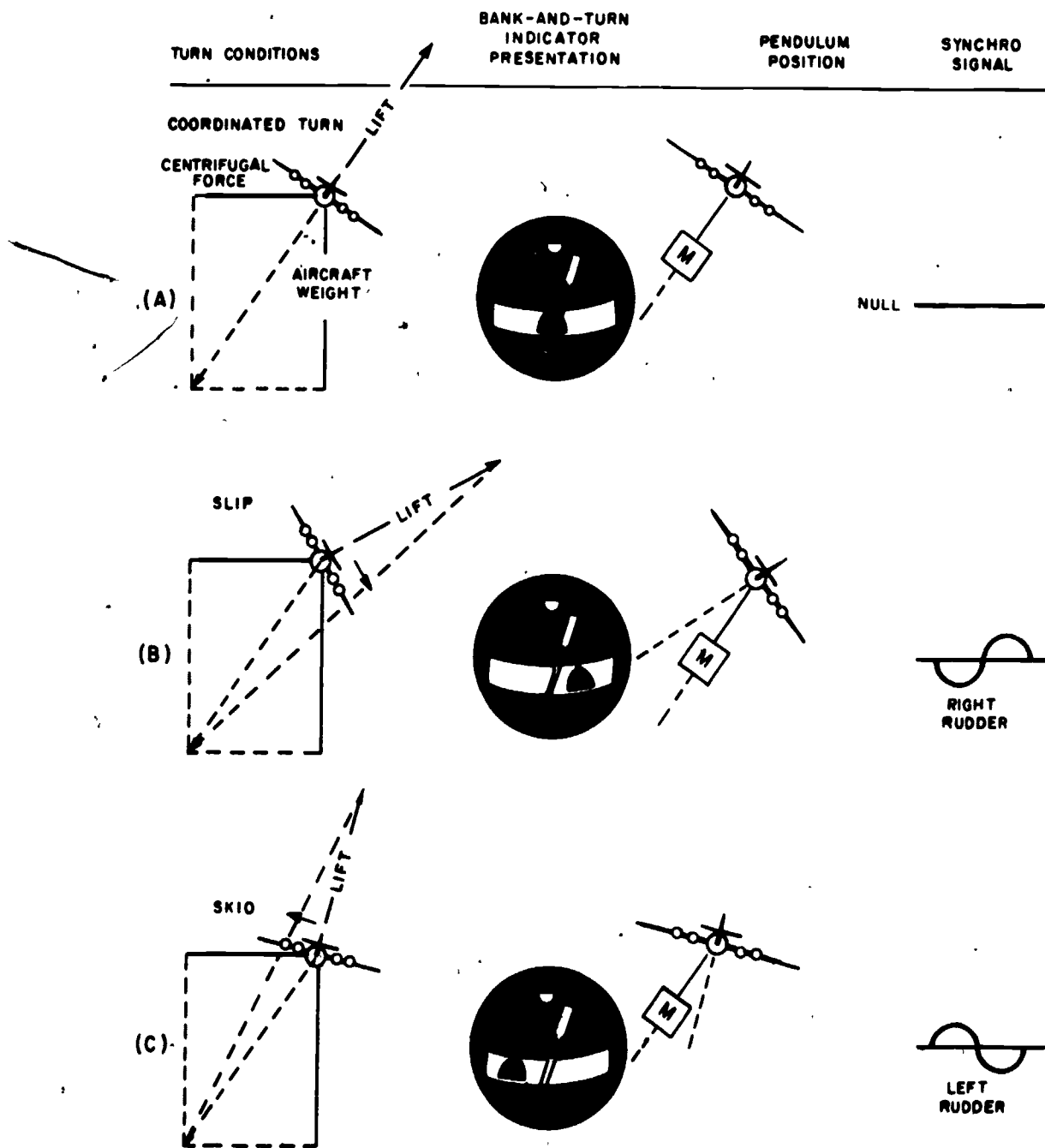

Figure 7-62.—Dynamic sensor pendulum positions. (A) Coordinated turn; (B) Slip; (C) Skid.

207.197

the rudder control to coordinate turns and provide automatic yaw damping.

A typical AFCS control panel shown in figure 7-63 allows the pilot to select the systems desired for automatic control.

CONTROL STICK STEERING.—Control stick steering or control wheel steering is used on some aircraft to control the aircraft electronically through the AFCS, using the regular control stick or control wheel. On

Chapter 7—COMPASS, INERTIAL NAVIGATION,
AUTOMATIC FLIGHT CONTROL AND STABILIZATION SYSTEMS

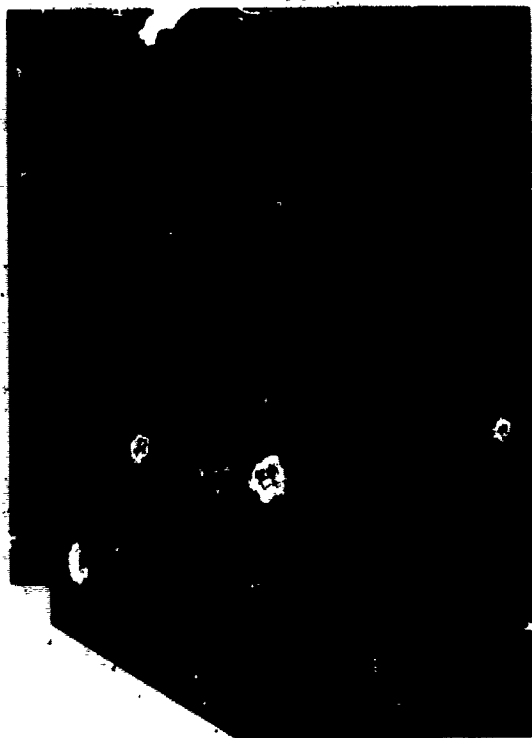

207.397

Figure 7-63.—Typical AFCS control panel.

fighters, the signals are generated in a unit such as the one labeled "motional pickup transducer" shown in figure 7-64.

If the control stick is moved to the left or right, the roll force switch, due to pressure on the stick, momentarily disengages the roll channel of the AFCS, and the pilot controls the roll attitude of the aircraft through regular stick control. When stick pressure is released, the force switch opens and allows roll AFCS to reengage. If the bank angle is above a given angle (for example, 5°), the bank angle is maintained. If the bank angle is below the given angle, the AFCS automatically returns to wings level.

The pitch force switches are closed when a fore or aft pressure is placed on the control stick; this momentarily disengages the AFCS. At the same time, the stick pressure causes a signal to be coupled through the E-pickoff transformer that is labeled "force sensor" in the figure. The signal is coupled to the AFCS pitch channel which makes the aircraft climb or dive, depending upon the direction (fore or aft) of the stick pressure.

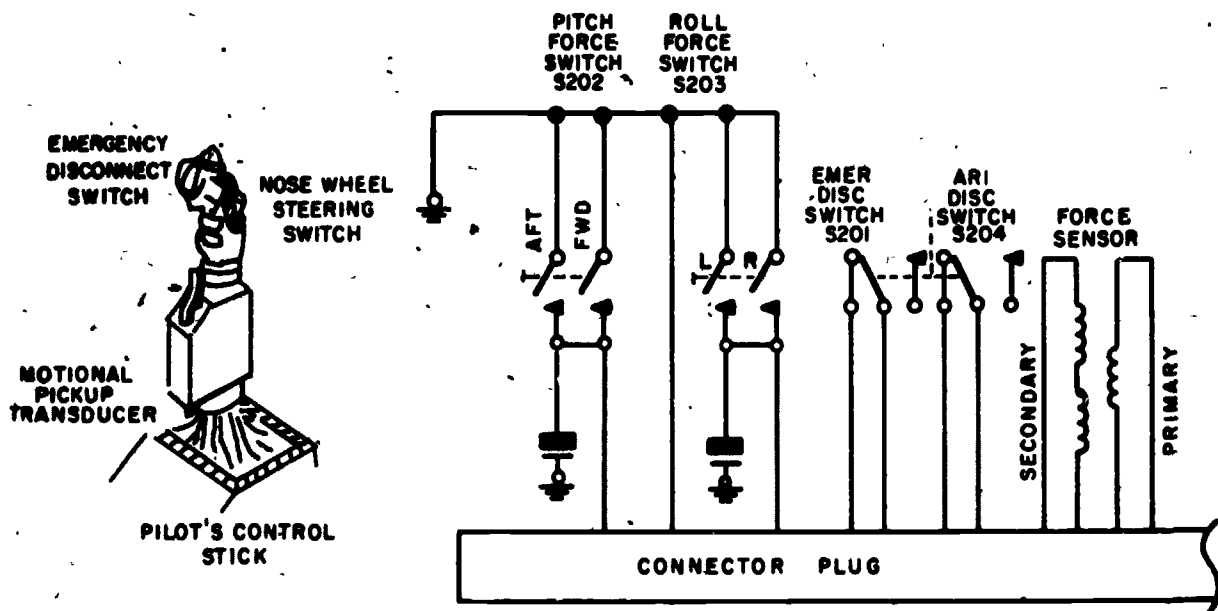

207.200

Figure 7-64.—Control stick steering components.

AMPLIFIER AND COMPUTER.—The amplifier and the computer modify the combined signals supplied by various sensors and command controls in order to develop output signals to control the aircraft's ailerons, rudder, and elevators. By means of this control, the aircraft is automatically held at a reference attitude, heading, and altitude, or is maneuvered in a coordinated manner in response to roll and pitch controller settings on the control panel.

Analog computations performed by the computer are accomplished by servomechanisms consisting of electromechanical computer cards and electronic amplifier cards mounted in the amplifier/computer. In addition, a transformer board and a resistor board provide the summing networks which combine the various signals supplied to and generated within the unit. Also included is an interlocking relay arrangement which performs most of the switching control in the automatic flight control system.

Along with the sensors which originate weak signals, the amplifier which strengthens the signals, and the computer which combines the several signals into a control surface command, some device must be used to convert the small electrical signal voltage into a power capable of moving the control surface. Originally, this was accomplished by an amplifier and an electric motor, but due to the force and quick response needed on modern aircraft, these electric motors are being replaced by electrically controlled hydraulic servo actuators.

The outputs from the amplifier/computer can also be used to give indications of AFCS operation. In some aircraft, an additional output may be used to provide automatic trim of the controls, which lessens the pilot's workload even more.

ELECTROHYDRAULIC SERVO ACTUATORS.—Electrohydraulic servo actuators (hydraulic booster packages) are discussed in chapter 5 of this manual. Many types of boosters are used in today's aircraft, but in each, the booster has at least two modes of operation.

The first mode is the manual mode, and its primary purpose is to aid the pilot in manually

positioning the control surfaces. Control surfaces on large aircraft are much too large to move unaided, and on smaller high-speed aircraft the high air forces make it nearly impossible to move the controls unaided. In the manual mode of operation, the hydraulic booster package is connected between the pilot's control stick and the control surface, and provides hydraulic assistance to the pilot in much the same manner that power steering aids the driver of a car or truck.

Mode two of the hydraulic booster package provides for operation of the control surface through the use of electrical input signals from the AFCS. In this mode, the booster package connects the AFCS to the control surface and provides the muscle to move the surface. Electrical signals are also provided back to the amplifier and computer by devices attached to the booster. (See fig. 7-65.)

The surface position transmitter sends the AFCS a signal representing the amount and direction of control surface displacement from the streamline position. This signal acts as a followup to prevent overshoot of the controls and serves to return the control surface to the trimmed condition as the original signal returns to zero.

The modulating piston is displaced only when the control surface is in motion. The position of the modulating piston is monitored, and the rate of movement of the control surface is sensed. Thus, a signal is generated to dampen control surface movement.

So that the pilot may properly trim the aircraft before AFCS disengagement, some aircraft utilize hydraulic load sensors to determine the amount of pressure being applied to a control surface. If the aircraft is not properly trimmed and the control pressure is relieved suddenly, the control surface moves rapidly, causing a disengagement bump.

Some aircraft utilize both manual and AFCS modes simultaneously to provide aircraft stabilization from the AFCS while the pilot manually controls the aircraft. All flight control systems have a method of disconnecting the booster package so that manual operation of the control surfaces is available in the event of booster malfunction or failure of the hydraulic system.

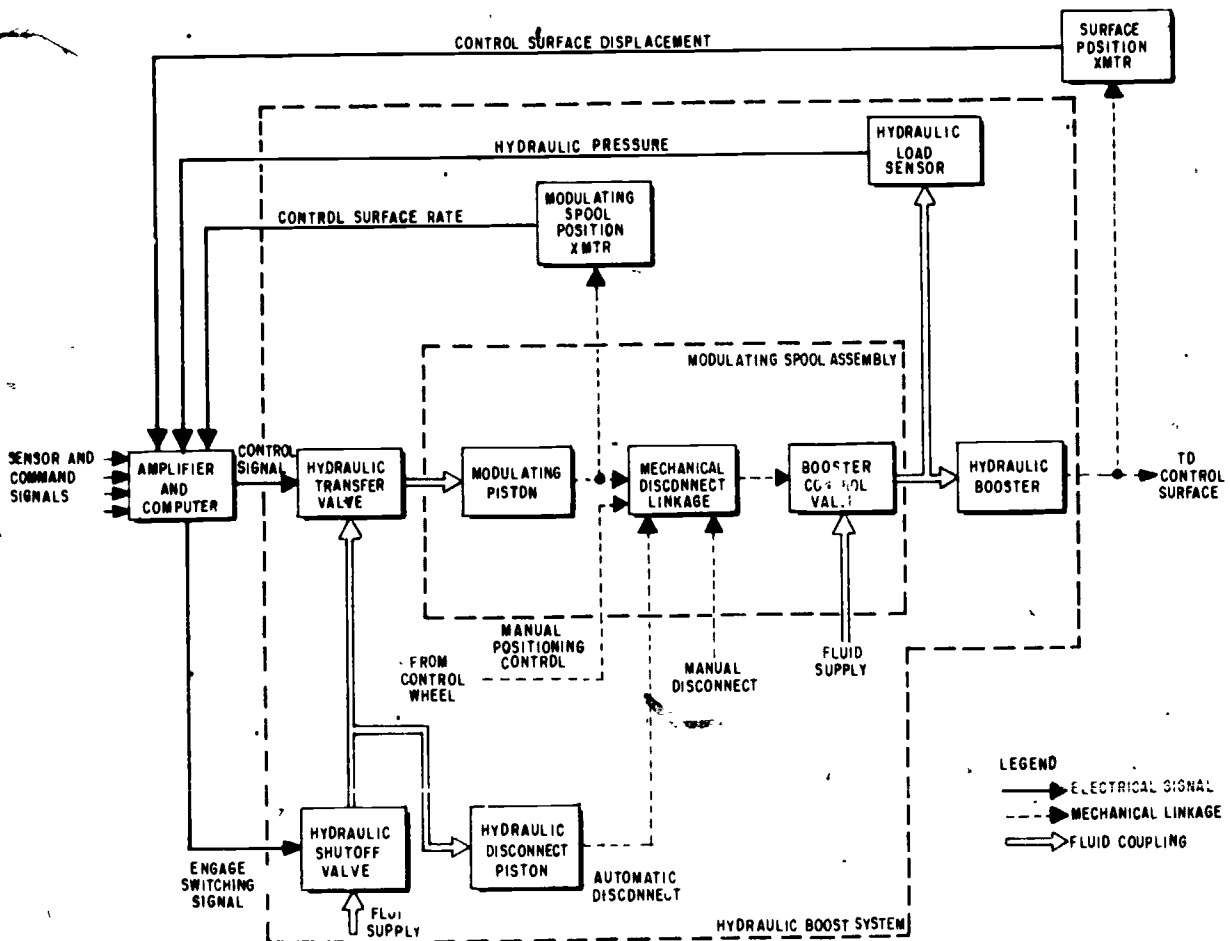

207.201

Figure 7-65.—Hydraulic booster block diagram.

THREE-AXES TRIM INDICATOR.—The three-axes trim indicator used on some aircraft serves as a visual monitor of the trim condition of each aircraft control axis. It consists of separate meter movements, one for each control axis, and a fourth for the elevator trim flag (fig. 7-66 (A)). On the instrument face, there is a white painted bar for each control channel. Each bar is moved from between its index marks when dc flows in the related coil shown in (B). Direction of displacement from the center index and the amount of displacement are determined by the polarity and amplitude, respectively, of the input dc voltage.

When the AFCS control channel associated with any of the three axes is not engaged, the

input to the meter movement is provided by a dc signal produced by the amplifier and computer. When the indicator bar is centered or floating about center, it indicates that the channel is synchronized. An offcenter indication informs the pilot that the channel is not synchronized. This condition can cause an undesirable transient maneuver upon engagement of the AFCS.

Upon engagement of any AFCS control channel, the input to its meter movement is switched to indicate hydraulic load. In figure 7-66 (C) the trim channel is engaged and the meter reflects hydraulic load. An ac signal from the hydraulic load sensor is amplified and converted to dc by a trim indicator amplifier

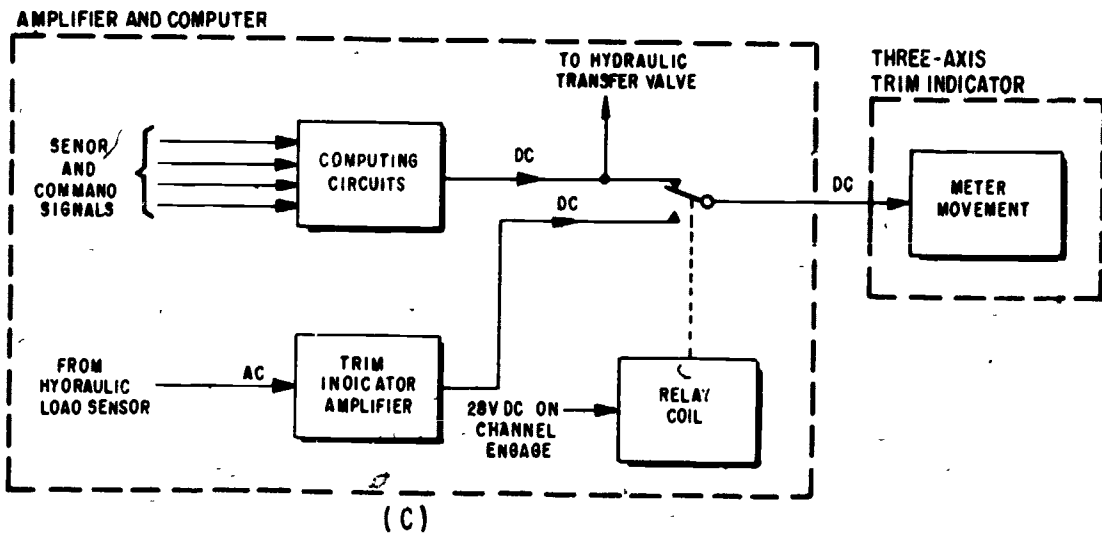
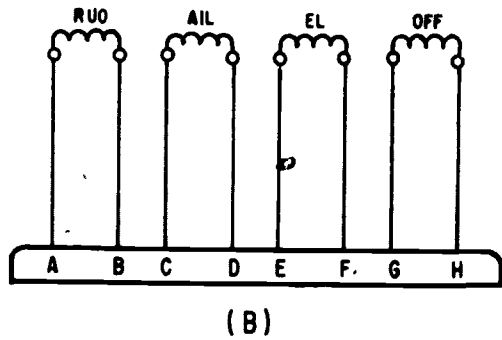
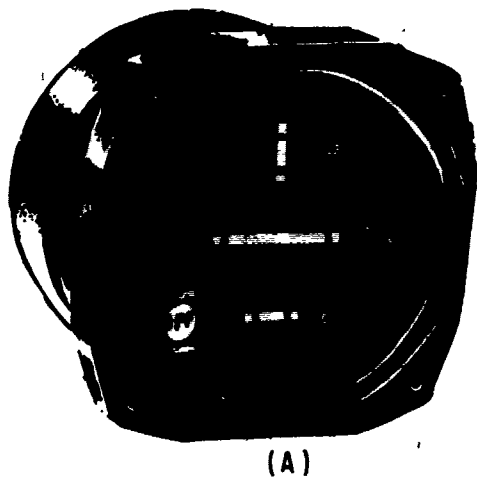

Figure 7-66.—Three-axes system. (A) Indicator; (B) Indicator schematic; (C) System schematic.

207.202

and applied to the meter movement. Sustained displacement of the bar indicates that the hydraulic displacement boost system is experiencing a constant load resulting from an out-of-trim condition. The pilot corrects this condition by manually trimming the aircraft; in some systems trim is accomplished automatically.

Disengagement of the AFCS when there is large displacement of a bar on the indicator

produces an undesirable transient maneuver. When a trim servo-clutch is not engaged, the trim indicator displays a yellow flag with the word OFF printed on it. The flag is retracted by its meter movement when the autotrim clutch becomes engaged.

TRIM SERVOS.—Some automatic flight control systems incorporate automatic trimming. Whenever a signal is present in the control channel there is an unbalance in fluid

Chapter 7—COMPASS, INERTIAL NAVIGATION,
AUTOMATIC FLIGHT CONTROL AND STABILIZATION SYSTEMS

pressure at the input to the hydraulic booster. This unbalance is sensed by the hydraulic load sensor (fig. 7-67) and the output of the hydraulic sensor is amplified and used to drive a trim servo motor. The engagement clutch is engaged whenever the AFCS is engaged and the automatic trim system is functioning properly. The slip clutch allows the pilot to override the automatic trim in case of a malfunction. Autotrim is most often used in the pitch channel, but can be used for yaw and roll as well.

AFCS Modes

The following is a brief description of the various modes available in a typical automatic flight control system. These modes are selected by the pilot through use of the AFCS control panel, moving the control stick, or through the use of knobs on the face of some instruments.

Due to the complexity and variance in circuitry, no specific mode will be diagrammed. However, most of the following modes can be found on naval aircraft.

CONTROL STICK STEERING/CONTROL WHEEL STEERING.—This mode has been mentioned previously in this chapter. Use of this mode enables the pilot to manually (moving the stick/wheel) change the attitude of the aircraft with the AFCS engaged without causing disengagement. After achieving the new attitude the pilot releases the stick/wheel and the AFCS will then resume control of the aircraft.

ALTITUDE HOLD.—With altitude mode engaged, the aircraft will maintain the altitude that existed at the time of engagement. If the aircraft is climbing or diving at the time of engagement, it will return to the altitude that

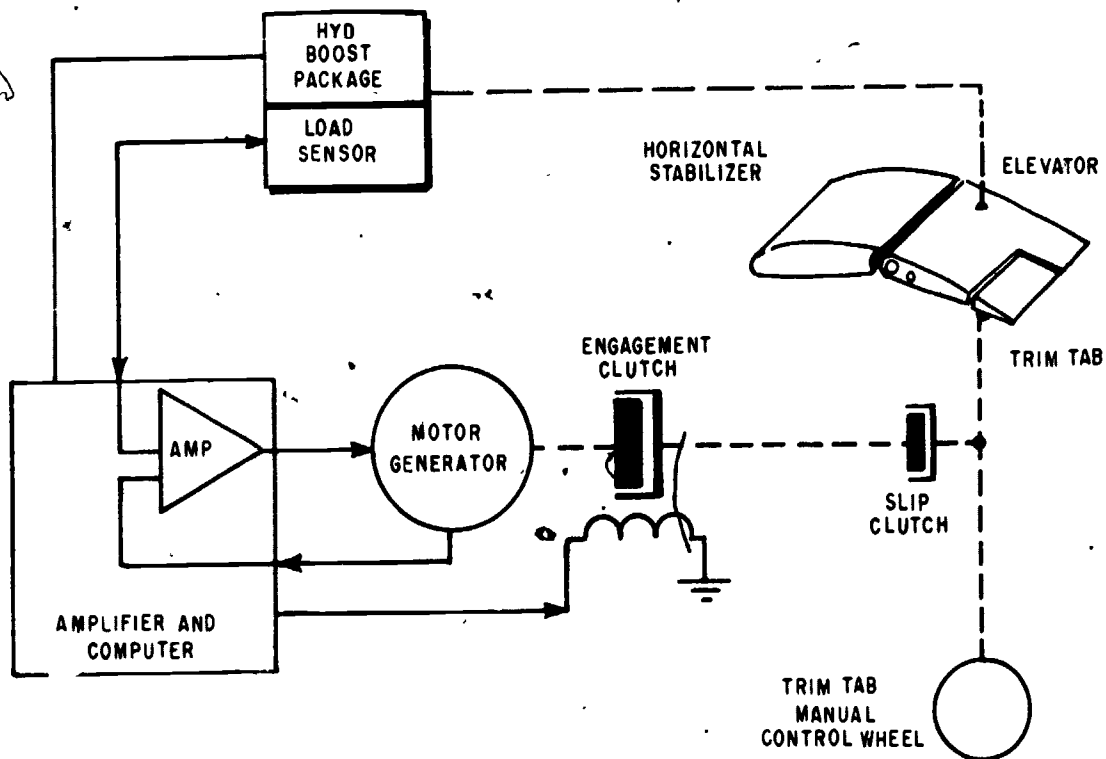

Figure 7-67.—Automatic pitch trim block diagram.

207.203

existed at the time of engagement. Control signals for this mode are received from the ADC.

ATTITUDE HOLD.—With attitude hold mode engaged, aircraft attitude at the time of engagement is maintained in pitch and roll. This particular mode is governed by the actual degrees of bank or pitch that the aircraft is in. For example, a typical attitude hold mode will disengage when the aircraft exceeds $\pm 60^\circ$ in pitch or $\pm 70^\circ$ in roll.

HEADING HOLD.—With heading hold engaged, the aircraft heading existing at the time of engagement is maintained. In other words if the pilot is flying a heading of 180° and engages heading hold, the aircraft will maintain the heading of 180° .

HEADING SELECT.—In this mode the aircraft will automatically turn to a course selected by the pilot on the Horizontal Situation Indicator (HSI). Upon engagement, the aircraft will assume a fixed maximum roll and turn to the selected heading.

MACH HOLD.—The mach hold function maintains the mach number existing at the time of mach hold engagement. In this mode a signal from the air data computer commands a pitch-up or pitch-down whenever the airspeed is above or below selected mach number.

AUTOMATIC CARRIER LANDING SYSTEM (ACLS).—In this mode the pilot is able to make a "hands-off" carrier landing. The aircraft follows command signals generated by the Data Link receiver.

GROUND CONTROL BOMBING.—Similar to ACLS, the aircraft will follow command signals from personnel on the ground.

STABILITY AUGMENTATION MODE(S).—The stability augmentation mode provides improved control of the aircraft by automatically damping oscillations about the pitch, roll, and yaw axes. In some high speed aircraft, STAB AUG is considered so critical to safe flight that the STAB AUG engagement switch is connected in series with all other

modes of the AFCS. This arrangement ensures that STAB AUG will be engaged before any other mode of the AFCS is engaged.

AUTOMATIC STABILIZATION EQUIPMENT (ASE) AND COUPLER SYSTEM

The following description is of an automatic stabilization equipment and coupler system as installed in the SH-3 helicopter. The SH-3 is powered by two turbine engines which drive a single constant-speed rotary wing having five variable pitch blades and an antitorque rotary rudder. Pitch of the rotary wing blades is controlled by the rotary wing flight control system which is connected to the blades through a swashplate assembly. The swashplate assembly consists of an upper (rotating) swashplate which is driven by the rotary wing hub, and a lower (stationary) swashplate which is secured to the main gear box.

Both swashplates are mounted on a ball-ring and socket assembly. This assembly keeps the swashplates parallel at all times but allows them to be tilted, raised, or lowered simultaneously by hydraulic components of the rotary wing flight control system which connect to arms on the stationary swashplate. Cyclic or collective pitch changes introduced at the stationary swashplate are transmitted to the blades by the pitch change linkage on the rotating swashplate.

Control motions from the collective pitch lever for vertical control, from the cyclic stick for attitude control and from the rudder pedals for yaw, are combined in a mixing unit in the ASE control compartment. Control action is assisted by two hydraulically operated flight control servosystems. The ASE is connected to one of the hydraulic systems by servo valves. The servo valves require only small amounts of control power to operate the hydraulic system and are characterized by very-low-threshold levels and very-high-frequency response.

The ASE input into the hydraulic system has limited authority and is in parallel with the pilot's flight controls. This arrangement provides a fail-safe situation in that an electronic failure of any sort can put in only a relatively small portion of control authority. The ASE may be engaged constantly, with stability corrections

Chapter 7—COMPASS, INERTIAL NAVIGATION, AUTOMATIC FLIGHT CONTROL AND STABILIZATION SYSTEMS

being introduced into the flight control system in such a manner that the pilot maintains complete control of the helicopter through normal use of the flight controls. When ASE and barometric altitude are engaged, roll, pitch, yaw, and altitude are stabilized by differential input signals without the need of an override force by the pilot.

The integrated coupler system consists of an altitude (collective) coupler section and a cyclic coupler section. The altitude section of the coupler receives Doppler vertical velocity signals and signals from a low altitude radar altimeter to maintain the helicopter at a constant altitude in the RAD ALT mode. In the CABLE ALT mode, the coupler receives Doppler vertical velocity inputs from cable pickoffs which indicate the length of sonar cable payed out and the depth of the sonar transducer. The VERT ACCEL position is used as an alternate for the other two modes in rough air or high sea states.

The cyclic coupler receives an input from the Doppler radar representing ground speed, and a separate input from a set of accelerometers. In the CABLE ANGLE mode, the cyclic coupler uses cable angle pickoffs to maintain a vertical sonar cable. The basic ASE system is applicable to several helicopters; however, the coupler system is unique to the SH-3 helicopter.

The automatic stabilization equipment and coupler system have five modes of operation:

1. Attitude and directional stabilization;
2. Barometric altitude retention.
3. Automatic cruise and hover (through signals received from the radar Doppler, including the capability of setting ground speed, drift, and altitude below 200 feet).
4. Automatic approach to a hover (through signals received from the radar Doppler).
5. Automatic hover (through signals received from the cable angle and hydrostatic height detectors).

ASE Control Panel

The ASE control panel (fig. 7-68) is mounted on the cockpit console between the pilot and copilot. The three pushbuttons on the top row marked ASE, BAR ALT, and CPLR,



207.211

Figure 7-68.—ASE control panel.

and the HOVER TRIM pushbutton on the bottom of the panel have built-in lamps that illuminate when their respective mode is engaged. When the ASE button is pressed, the pitch, roll, and yaw channels operate to improve pitch, roll, and heading stability. ASE is disengaged by a button marked AUTO STAB REL on the pilot's or copilot's cyclic stick grip.

The BAR ALT button is depressed to engage the barometric altitude controller, and the BAR OFF button is depressed to disengage. When the barometric altitude control is engaged, it can be disengaged momentarily by a switch labeled BAR REL on the pilot's or copilot's collective pitch stick to make a change in altitude.

When the CPLR button is depressed, engagement of the coupler and the barometric altitude control is indicated by light in the CPLR and BAR ALT buttons. Engagement of the coupler is possible any time ASE is engaged.

There are two three-position switches on the ASE control panel—the CYC CPLR switch and the altitude coupler toggle switch. The CYC CPLR switch on the upper left corner has three

positions marked DOPP, OFF, and CABLE ANGLE. The DOPP position should be selected during cruise flight when the coupler is engaged. The DOPP position also enables the DRIFT and SPEED controls on the control panel, and allows hover trim engagement. The CABLE ANGLE position is used to maintain a vertical cable for sonar operation. The OFF position makes it possible to disable the cyclic coupler even though the altitude coupler is operating.

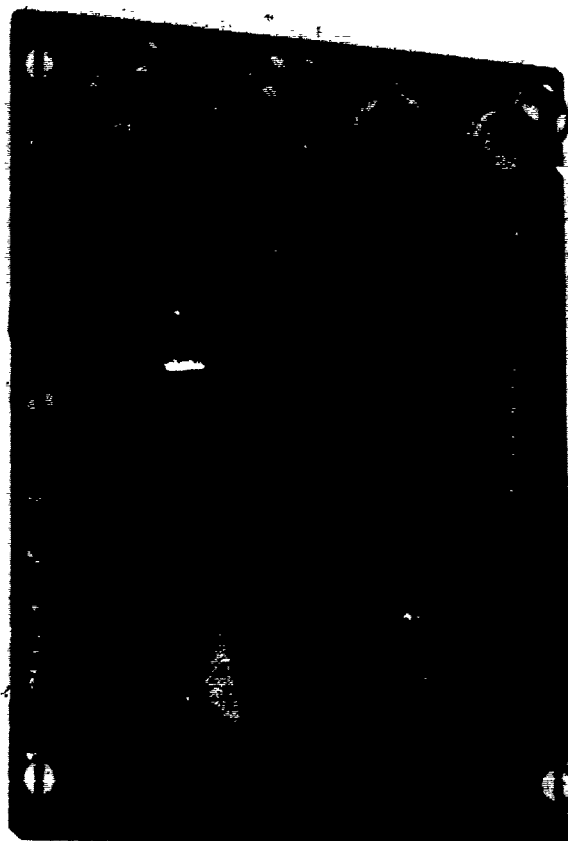

207.214

Figure 7-69.—Channel monitor panel.

The altitude coupler toggle switch in the upper right corner of the panel is labeled RDR ALT, VERT ACCEL, and CABLE ALT. The RDR ALT position transfers the altitude error signals to the radar mode. A specific radar altitude (actual distance above the terrain or water) can be selected on the ALTITUDE control at the lower right corner of the control panel. The RDR ALT position can be used in cruising flight or when initiating automatic approach to a hover. The VERT ACCEL position is used to achieve an automatic approach to a stabilized hover should the pilot desire an alternate to RAD ALT in a high sea state condition prior to engaging CABLE ALT. The CABLE ALT position allows an antisubmarine warfare sensing device (sonar) to be submerged a fixed depth in water by the use of sensors which measure the amount of cable payed out and the depth of the sonar.

The pushbutton marked HOVER TRIM ENG can be engaged only when the CYC CPLR switch is in DOPP position. When engaged, it transfers approximately 11 knots of control from the pilot to the crewman at the hoist position for positioning the helicopter during hoisting operations. Disengagement is accomplished by the CPLR REL switch on the collective pitch level, or by the CYC CPLR switch being placed first to OFF then back to DOPP.

Channel Monitor Panel

The channel monitor panel (fig. 7-69) is mounted within easy reach of the pilot. It contains an ON-OFF toggle switch for each ASE channel so that one malfunctioning channel may be disabled without losing the entire ASE system.

There is one guarded toggle switch for each channel, marked HARDOVER, to provide for testing the ASE system during preflights and for use in maintenance. There is also a meter selector for selecting inputs to the hover indicator and a switch to provide vertical gyro ASE inputs from either of two sources. Monitoring of the four channels can be viewed on the cockpit hover indicator when appropriate switch positions are selected.

PITCH CHANNEL.—Automatic pitch attitude stabilization is maintained continuously after ASE is engaged. The vertical gyro produces a signal proportionate to displacement of the helicopter fuselage from the horizon. (See fig. 7-70.) This displacement signal is also sent through a rate network to produce a signal that

Chapter 7—COMPASS, INERTIAL NAVIGATION,
AUTOMATIC FLIGHT CONTROL AND STABILIZATION SYSTEMS

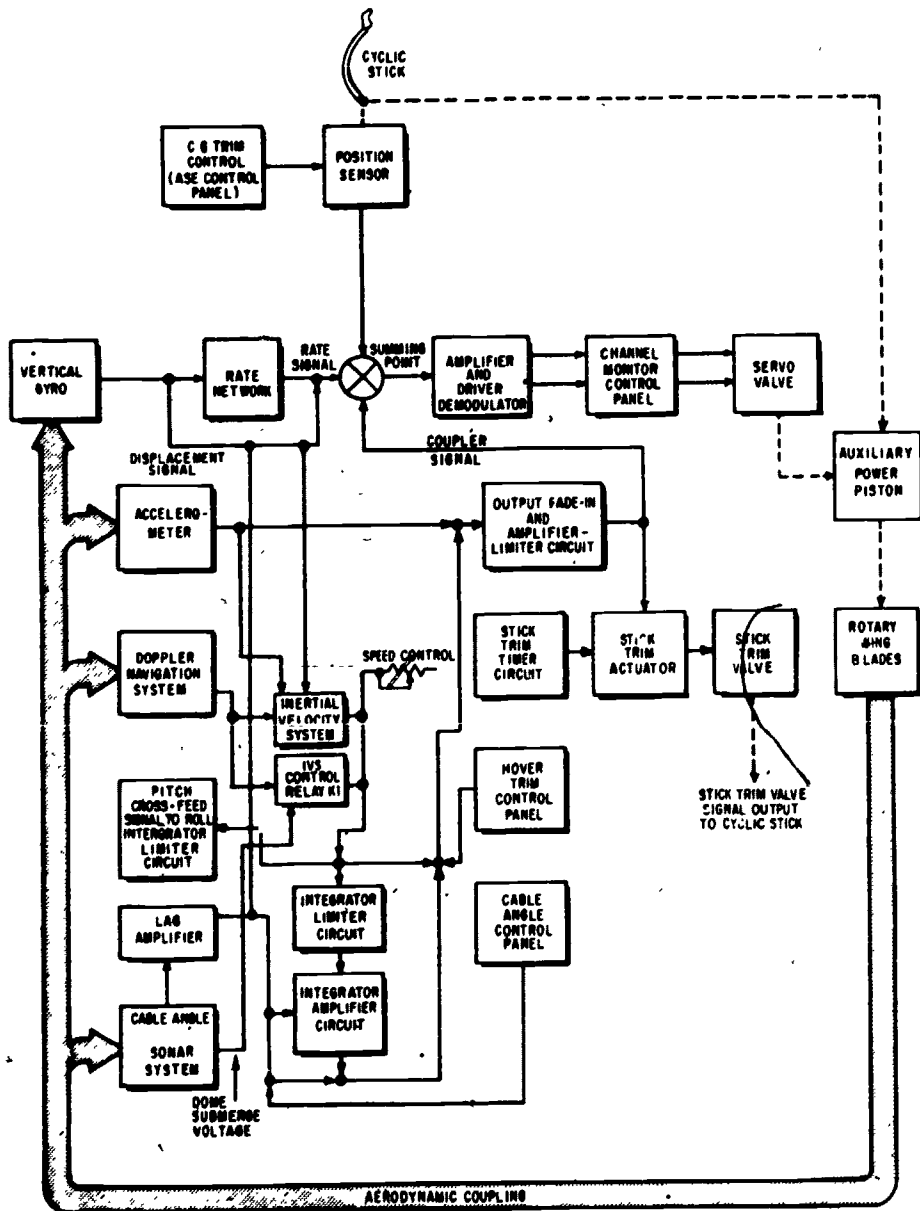

207.219

Figure 7-70.—ASE/coupler pitch channel.

is equivalent to the rate of change of pitch attitude. The displacement and rate signals are both developed in a direction to cause the rotor blades to produce lift and return the fuselage to the desired attitude.

A combination of CG (center of gravity) trim and cyclic stick position serves to provide

the reference attitude. In a balanced state, the vertical gyro displacement and rate signals are equal and opposite to the CG trim/position sensor signal at the summing point, and no movement is commanded. If the pitch attitude changes without the cyclic stick being moved, the vertical gyro senses the movement and

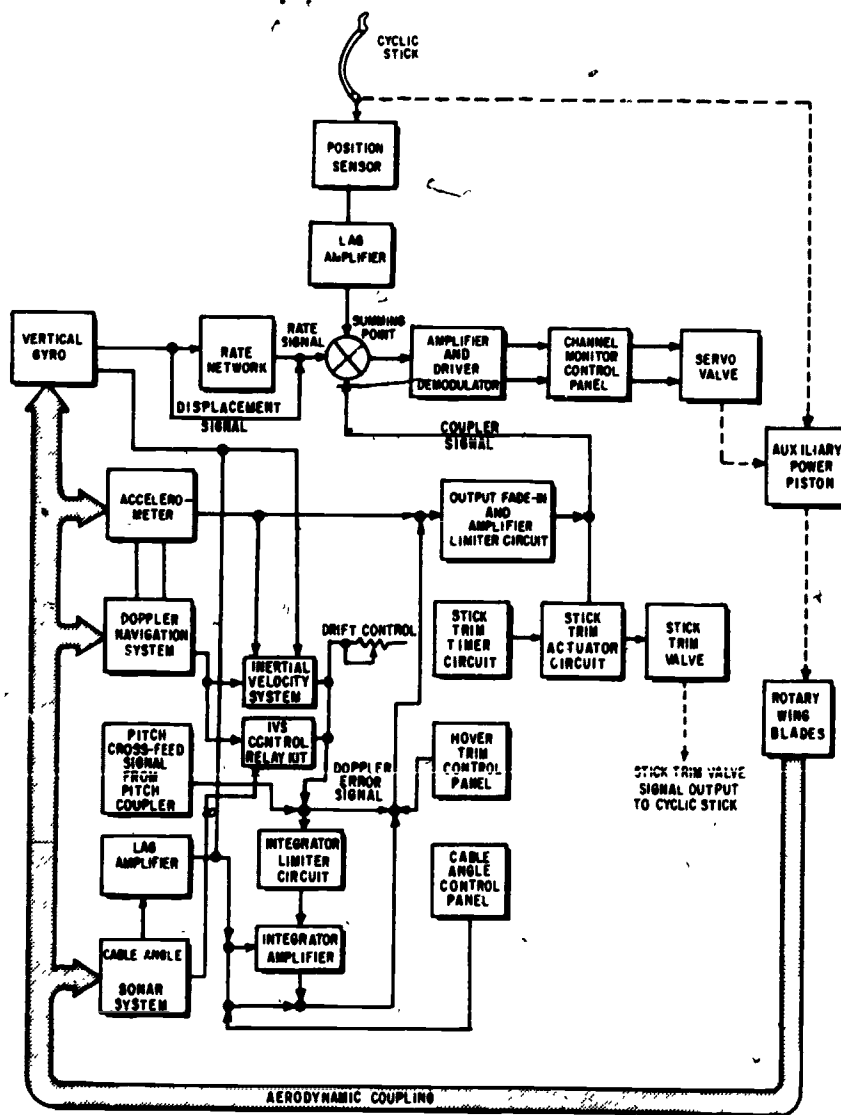

Figure 7-71.—ASE/coupler roll channel.

207.227

causes the aircraft to return to its original pitch attitude. If the pilot desires to change the pitch attitude, the cyclic stick is moved forward or aft, producing an error signal at the summing point. As the helicopter changes attitude to correspond with the cyclic stick position, the vertical gyro pitch displacement signal increases until the two signals are equal and opposite again. This becomes the new pitch reference attitude.

During CPLR operation in the DOPP mode, Doppler ground speed is compared with the speed selected on the ASE control panel. Any difference between the actual ground speed and the selected ground speed produces an error signal and causes the helicopter to change speed until the two voltages balance. An accelerometer monitoring a change in speed produces a rate signal to oppose any change in speed and prevents large rapid changes in pitch attitude.

Chapter 7—COMPASS, INERTIAL NAVIGATION, AUTOMATIC FLIGHT CONTROL AND STABILIZATION SYSTEMS

The hover trim control panel allows the hoist operator to provide small attitude changes in hovering flight.

The integrator circuits monitor any steady-state error signal that may exist because of the difference between Doppler speed and selected speed (could be caused by head or tail winds). The larger the output of the integrator the more correction is made until the Doppler speed equals selected speed.

In the cable angle mode, pitch attitude from the vertical gyro is compared with the cable angle (in respect to the deck of the helicopter) to maintain the sonar cable vertical to the earth's surface regardless of aircraft attitude. The cable angle error signal is processed in a similar manner as the Doppler error signal.

An inertial velocity system (IVS) circuit becomes operational in the cable angle mode when the IVS control relay is energized by a dome submerge voltage from the sonar system. The voltage is developed when the sonar transducer is submerged to a depth below 11 feet. When the IVS circuit is operational, outputs from the accelerometer and the vertical gyro are combined with the Doppler velocity signal to produce a very accurate inertially derived signal.

The output of the coupler is also fed to a stick trim actuator circuit. If the coupler output reaches a certain level, a solenoid of the pitch stick trim valve is excited to automatically reposition the cyclic stick, thereby extending pitch channel authority.

ROLL CHANNEL.—Roll channel operation is similar to pitch channel operation. (See fig. 7-71.) In basic ASE, the position sensor is lagged by an amplifier before being added to or subtracted from the rate-plus-displacement signal. In the Doppler mode, the pilot input is the DRIFT control on the ASE control panel. Roll signals are otherwise processed in the same manner as are the pitch signals.

COLLECTIVE CHANNEL.—After ASE is engaged, the collective channel is engaged by the BAR ALT engage button to stabilize helicopter altitude. Part of the altitude error signal is fed to the collective coupler integrator during BAR

ALT operation. (See fig. 7-72.) If the altitude control error signal is steady-state (due to variables such as fuel, load, weather, etc.), a signal is developed to compensate for this steady-state error and to improve engaged altitude retention. When the BAR ALT REL button is pressed, the integrator cancels any remaining compensating signal.

As the servo valve corrects the altitude error signal through the auxiliary power piston and rotary wing blades, the altitude error signal diminishes. When the helicopter returns to the engaged altitude, the altitude control output error signal returns to null. However, as the servo valve corrects the altitude error signal, it places the collective servosystem in an open-loop condition.

The open-loop spring, in conjunction with a balance spring, supports the weight of the collective stick and linkage so that the stick remains in a desired position with little or no external force applied to hold the stick. The open-loop spring also allows the barometric altitude control to make larger than 10 percent correction over a period of time. The pilot may override open-loop operation by applying an opposing force on the collective stick. As the altitude error signal diminishes, the position sensor signal returns the collective pitch control stick to the engaged altitude position. While BAR ALT is engaged, the pilot applies collective and depresses the BAR REL button on the collective stick grip momentarily to change altitude. The collective clutch nulls the output of the position sensor and the barometric altitude input while the BAR REL button is depressed.

During collective coupler operation with radar altitude mode engaged, the coupler seeks and retains the altitude selected on the control panel. Any difference between radar altitude and the selected altitude produces an error voltage which causes the total lift developed by the rotor blades to change and seek the selected altitude. The radar altitude error signal is also fed to the integrator amplifier circuit, providing a signal to compensate for a steady-state error signal input. The compensating signal is added to the other portion of the radar altitude error signal, and the combined signal is coupled to an output fade-in circuit.

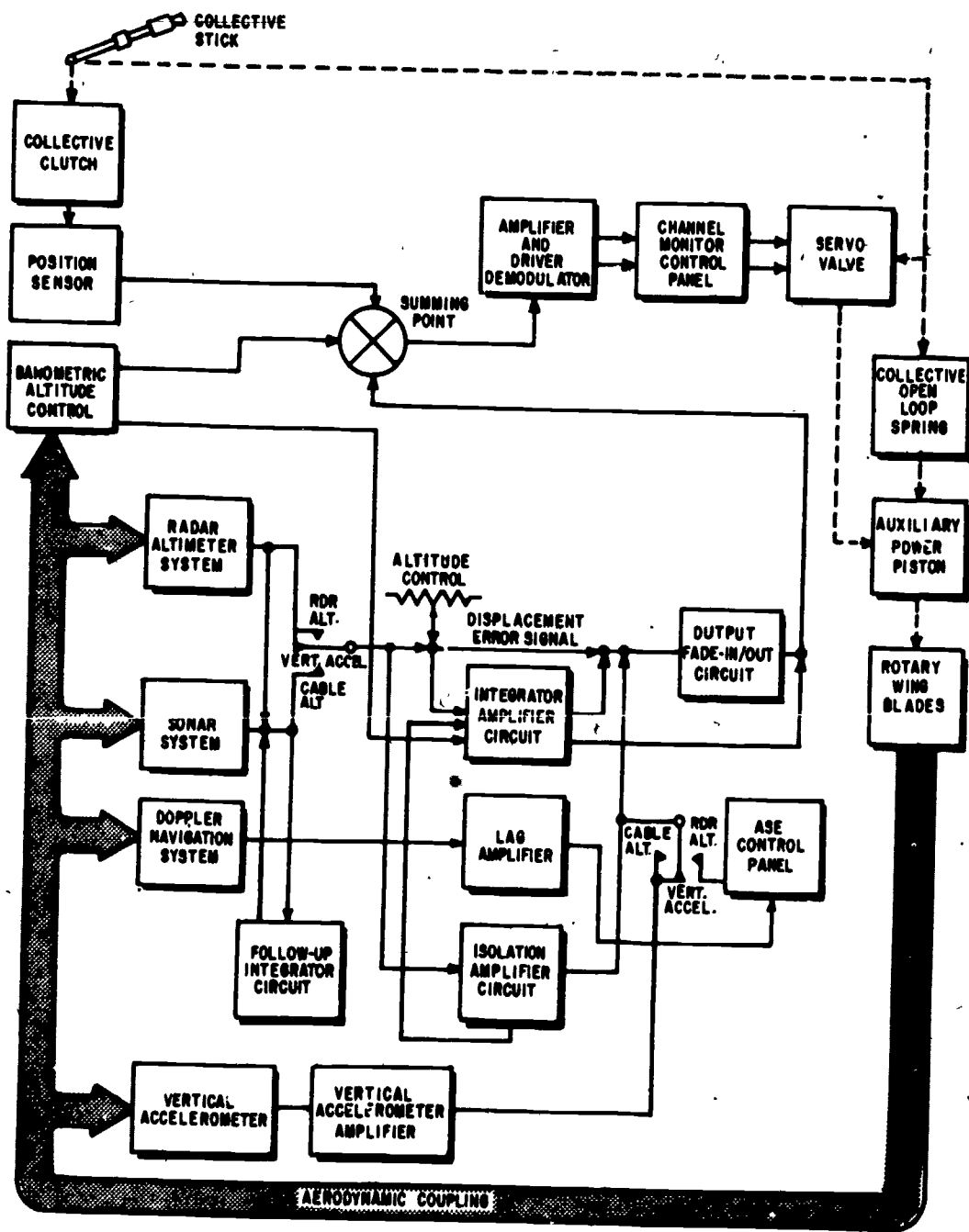

Figure 7-72.—ASE/coupler collective channel.

207.228

The radar navigation set produces a signal (vertical velocity) proportional to the rate of change in altitude. This rate signal is lagged approximately 1 second in the lag amplifier, routed through the ASE control panel, and

coupled to the output fade-in circuit. The coupler altitude error signal is coupled to the collective ASE amplifier and processed in a similar manner as the basic ASE altitude error signal.

Chapter 7—COMPASS, INERTIAL NAVIGATION, AUTOMATIC FLIGHT CONTROL AND STABILIZATION SYSTEMS

In the cable altitude mode, the cable altitude output signal is compared to the radar altitude output signal, and any difference is fed to the followup integrator circuit. The followup output signal is fed back to the cable altitude input to correct the cable altitude signal. The corrected cable altitude input signal is summed with the ALTITUDE control, and the resultant signal is coupled through the isolation amplifier to the fade-in circuit. The isolation amplifier output is summed with the vertical accelerometer signal, and the resultant is combined with the integrator amplifier output.

When operating in the collective coupler vertical accelerometer mode, the cable signal is disconnected and only the vertical accelerometer

and radar altitude signals are applied to the output fade-in/out circuit. During collective coupler operation, accidental momentary disengagement of the altitude control is prevented by a diode in the ASE control panel which makes the momentary BAR REL button ineffective.

YAW CHANNEL.—While ASE is engaged, the yaw channel stabilizes the heading of the helicopter. The compass system feeds a heading signal to a differential synchro in the ASE control panel. (See fig. 7-73) The physical position of the differential synchro is controlled by the ASE control panel YAW TRIM control. The output of the differential synchro is

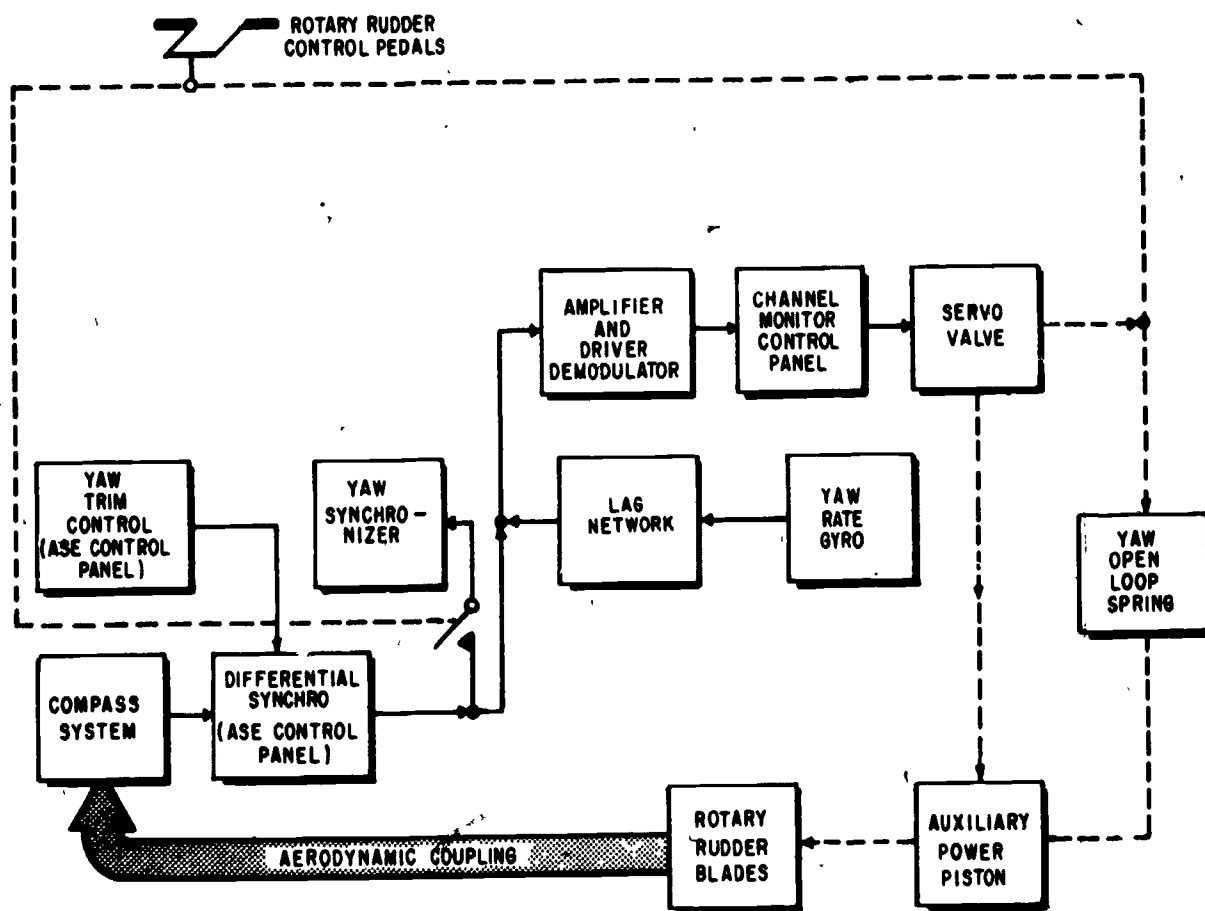

Figure 7-73.—ASE yaw channel.

207.229

coupled to the yaw synchronizer module. Depending on the mode of the yaw channel, the signal becomes a synchronizing signal or a heading error signal. During the synchronizing mode (manual turns using cyclic stick and rudder pedals), heading signals are nulled out and no error signal is coupled to the yaw ASE amplifier. When the yaw channel is operating, heading error signals are added to a rate signal developed by the yaw rate gyro. The resultant signal is routed through the channel monitor control panel as differential current flow to provide outputs to excite the yaw servo valve; the signal is also coupled to the hover indicators.

As the servo valve corrects the heading error signal through the auxiliary power piston and rotary rudder blades, the heading error signal diminishes. When the helicopter returns to its reference heading, the compass system output signals return to their original value. As the servo valve corrects large heading error signals, it places the yaw servosystem in an open-loop condition. The open-loop condition enables the yaw channel to make larger heading corrections if necessary. The pilot may override the open-loop operation by applying an opposing force on the pedals.

If the pilot uses the pedals to turn manually while ASE is engaged, an artificial force is felt which reduces the tendency to overcontrol. The yaw rate gyro produces a signal proportional to the turning rate of the helicopter. This rate signal is eventually coupled to the servo valve and places the yaw servosystem in an open-loop condition, opposite to the turn direction.

METER SELECTOR (HOVER INDICATOR).—The hover indicator contains scale increment marks across the center vertical and horizontal axes, and along the vertical (left side) and bottom of the dial face. (See fig. 7-74.) Two movable bars coincide with the center vertical and horizontal axes scale marks on the dial, and in a hover, intersect at a small circle masked on the face. There are two arrowhead type pointers—one on the left side of the indicator which moves vertically up or down, coinciding with the vertical scale, and the other at the bottom of the indicator which moves horizontally left or right coinciding with the horizontal scale.

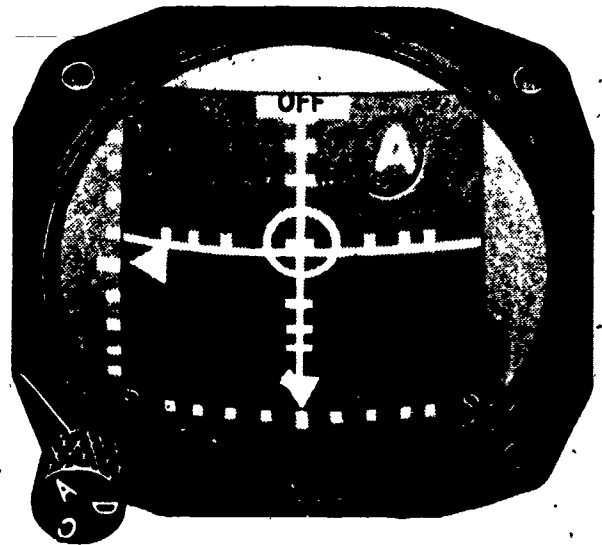

207.216

Figure 7-74.—Hover indicator.

A mode selector switch is on the lower left edge of the hover indicator case with marked positions A, C, and D. A mode selector window on the dial face of the indicator operates in conjunction with the mode selector switch and displays one of the letters A, C, or D to indicate the mode of operation.

Operation in the A mode connects the hover indicator to ASE. With the meter selector on the channel monitor panel in ASE position, the hover indicator operates as a null indicator, including the input to the ASE servo valves. The hover indicator horizontal bar is used to monitor the pitch channel; the vertical bar, the roll channel; the vertical point, the altitude channel; and the horizontal pointer, the yaw channel.

Operation in the D mode connects the hover indicator to the Doppler radar. The horizontal bar indicates forward or rearward velocities, and the vertical bar indicates left or right drift. Each increment on the hover indicator horizontal and vertical scales indicates ten knots ground speed, with a maximum indication of 40 knots. The vertical pointer indicates vertical velocity, with each increment equal to 250 feet per minute.

Chapter 7—COMPASS, INERTIAL NAVIGATION, AUTOMATIC FLIGHT CONTROL AND STABILIZATION SYSTEM

Full-scale deflection is equal to 1,000 feet per minute up or 1,000 feet per minute down. To indicate forward flight, the horizontal bar moves downward. To indicate drift, the vertical bar moves in a direction opposite to the direction of drift; therefore, the pilot flies into the bar for correction.

Operation in the C mode connects the hover indicator to the cable pickoff potentiometers mounted on the sonar hoist assembly. The horizontal and vertical bars of the indicator then represent cable angle, with each increment equal to about 2.5 degrees of cable angle. The vertical

pointer shows sonar depth as an error signal. The null position represents the selected sonar search altitude, and each increment above and below the null point represents 10 feet of error.

In both C and D modes the yaw pointer is disconnected and should not move. An OFF flag on the upper dial face of the hover indicator is used in all three modes of operation. In the A mode, the flag disappears when the ASE is engaged. In the D mode, the flag disappears when the Doppl signal is reliable. In the C mode, the flag disappears, when the sonar equipment is turned on.

APPENDIX I

GLOSSARY

ACCESS TIME.—In computers, the time interval between the calling for information from a computer unit and the instant that such information is delivered.

ADDER.—An electronic circuit capable of providing the sum of two numbers entered therein.

AGONIC.—An imaginary line of the earth's surface passing through points where the magnetic declination is 0° ; that is, points where the compass points to true north.

AMBIENT CONDITIONS.—Physical conditions of the immediate environment; may pertain to temperature, humidity, pressure, etc.

AMMETER.—An instrument for measuring the amount of electron flow in amperes.

AMPERE.—The basic unit of electrical current.

AMPERE-TURN.—The magnetizing force produced by a current of one ampere flowing through a coil of one turn.

AMPLIDYNE.—A rotary magnetic or dynamoelectric amplifier used in servomechanism and control applications.

AMPLIFICATION.—The process of increasing the strength (current, power, or voltage) of a signal.

AMPLIFIER.—A device used to increase the signal voltage, current, or power, generally

composed of solid state circuitry called a stage. It may contain several stages in order to obtain a desired gain.

AMPLITUDE.—The maximum instantaneous value of an alternating voltage or current, measured in either the positive or negative direction.

ANALOG COMPUTER.—A type of computer which provides a continuous solution of a mathematical problem with continuously changing inputs. Inputs and outputs are represented by physical quantities that may be easily generated or controlled.

AND GATE.—A logic circuit having multiple inputs and a single output, so designed that the output is energized when (and only when) every input is in the prescribed signal state.

ARC.—A flash caused by an electric current ionizing a gas or vapor.

ARMATURE.—The rotating part of an electric motor or generator. The moving part of a relay or vibrator.

ATTENUATOR.—A network of resistors used to reduce voltage, current, or power delivered to a load.

AUTOTRANSFORMER.—A transformer in which the primary and secondary are connected together in one winding.

AVB.—Avionic Bulletin.

AVC.—Avionic Change.

BATTERY.—Two or more primary or secondary cells connected together electrically. The term does not apply to a single cell.

BIAS.—In vacuum tubes, the difference of potential between the control grid and the cathode; in transistors, the difference of potential between the base and emitter and between the base and collector; in magnetic amplifiers; the level of flux density in the core under no-signal conditions.

BREAKER POINTS.—Metal contacts that open and close a circuit at timed intervals.

BRIDGE CIRCUIT.—The electrical bridge circuit is a term referring to any one of a variety of electric circuit networks, one branch of which, the "bridge" proper, connects two points of equal potential and hence carries no current when the circuit is properly adjusted or balanced.

BRUSH.—The conducting material, usually a block of carbon bearing against the commutator or sliprings through which the current flows in or out.

BUS BAR.—A primary power distribution point connected to the main power source.

CAGING (GYRO).—The act of holding a gyro so that it cannot precess or change its attitude with respect to the body containing it.

CAPACITOR.—Two electrodes or sets of electrodes in the form of plates, separated from each other by an insulating material called the dielectric.

CHOKER COIL.—A coil of low ohmic resistance and high impedance to alternating current.

CIRCUIT.—The complete path of an electric current.

CIRCUIT BREAKER.—An electromagnetic or thermal device that opens a circuit when the current in the circuit exceeds a predetermined amount. Circuit breakers can be reset.

CIRCULAR MIL.—An area equal to that of a circle with a diameter of 0.001 inch. It is used for measuring the cross section of wires.

COAXIAL CABLE.—A transmission line consisting of two conductors concentric with and insulated from each other.

COMMUTATOR.—The copper segments on the armature of a motor or generator. It is cylindrical in shape and is used to pass power into or from the brushes. It is a switching device.

COMPARATOR.—A circuit which compares two signals or values, and indicates agreement or variance between them.

COMPUTER.—A mechanism or device that performs mathematical operations. (See also Analog computer and Digital computer.)

CONDUCTANCE.—The ability of a material to conduct or carry an electric current. It is the reciprocal of the resistance of the material, and is expressed in mhos.

CONDUCTIVITY.—The ease with which a substance transmits electricity.

CONDUCTOR.—Any material suitable for carrying electric current.

CORE.—A magnetic material that affords an easy path for magnetic flux lines in a coil.

COUNTER EMF.—Counter electromotive force; an emf induced in a coil or armature that opposes the applied voltage.

COUNTING CIRCUIT.—A circuit which receives uniform pulses representing units to be counted and produces a voltage in proportion to their frequency.

CURRENT LIMITER.—A protective device similar to a fuse, usually used in high amperage circuits.

CYCLE.—One complete positive and one complete negative alternation of a current or voltage.

Appendix I—GLOSSARY

DEGREES OF FREEDOM (GYRO).—A term applied to gyros to describe the number of variable angles required to specify the position of the rotor spin axis relative to the case.

DIELECTRIC.—An insulator; a term that refers to the insulating material between the plates of a capacitor.

DIGITAL COMPUTER.—A type of computer in which quantities are represented in numerical form and which is generally made to solve complex mathematical problems by use of the fundamental processes of addition, subtraction, multiplication, and division. Its accuracy is limited only by the number of significant figures provided.

DIODE.—Vacuum tube—a two element tube that contains a cathode and plate; semiconductor—a material of either germanium or silicon that is manufactured to allow current to flow in only one direction. Diodes are used as rectifiers and detectors.

DIRECT CURRENT.—An electric current that flows in one direction only.

DOPPLER EFFECT.—An apparent change in the frequency of a sound wave or electro-magnetic wave reaching a receiver when there is relative motion between the source and the receiver.

EDDY CURRENT.—Induced circulating currents in a conducting material that are caused by a varying magnetic field.

EFFICIENCY.—The ratio of output power to input power, generally expressed as a percentage.

ELECTROLYSIS.—A type of corrosion (chemical, decomposition) caused by current flow resulting from contact of dissimilar metals.

ELECTROLYTE.—A solution of a substance which is capable of conducting electricity. An electrolyte may be in the form of either a liquid or a paste.

ELECTROMAGNET.—A magnet made by passing current through a coil of wire wound on a soft iron core.

ELECTROMOTIVE FORCE (emf).—The force that produces an electric current in a circuit.

ELECTRON.—A negatively charged particle of matter.

ENERGY.—The ability or capacity to do work.

E-TRANSFORMER.—A magnetic device with an E configuration, used as an error detector.

FARAD.—The unit of capacitance.

FEEDBACK.—A transfer of energy from the output circuit of a device back to its input.

FIELD.—The space containing electric or magnetic lines of force.

FIELD WINDING.—The coil used to provide the magnetizing force in motors and generators.

FLUX FIELD.—All electric or magnetic lines of force in a given region.

FREE ELECTRONS.—Electrons which are loosely held and consequently tend to move at random among the atoms of the material.

FREE GYRO.—A gyro so gimballed that it assume and maintain any attitude in space. Free gyro has two-degrees of freedom; torque cannot be applied to the rotor of a truly free gyro.

FREQUENCY.—The number of complete cycles per second existing in any form of wave motion; such as the number of cycles per second of an alternating current.

FULL ADDER.—An adder circuit which can complete the adding procedure involving the carry process, as distinguished from the half adder which is not capable of accepting a previous carry.

FULL-WAVE RECTIFIER CIRCUIT.—A circuit which utilizes both the positive and the negative alternations of an alternating current to produce a direct current.

FUSE.—A protective device inserted in series with a circuit. It contains a metal that will melt or break when current is increased beyond a specific value for a definite period of time.

GAIN.—The ratio of the output power, voltage, or current to the input power, voltage, or current, respectively.

GALVANOMETER.—An instrument used to measure small dc currents.

GENERATOR.—A machine that converts mechanical energy into electrical energy.

GIMBAL.—A frame in which the gyro wheel spins and which allows the gyro wheel to have certain freedom of movement. It permits the gyro rotor to incline freely and retain that position when the support is tipped or repositioned.

GROUND.—A metallic connection with the earth to establish ground potential. Also, a common return to a point of zero potential.

GROUND SUPPORT EQUIPMENT (GSE).—All the equipment on the ground needed to support aircraft in a state of readiness for flight.

GYROSCOPES.—A wheel or disk so mounted as to spin rapidly about one axis and be free to move about one or both of the two axes mutually perpendicular to the axis of spin.

HALF ADDER.—A partial adding circuit which is not capable of accepting a previous carry. It must be combined with another half adder and a circuit capable of performing the carry function to form a full adder.

HERO.—Hazardous electromagnetic radiation to ordnance.

HERTZ.—A unit of frequency equal to one cycle per second.

HMI.—~~Handbook~~ Maintenance Instructions.

HORSEPOWER.—The English unit of power, equal to work done at the rate of 550 footpounds per second. Equal to 746 watts of electrical power.

HYSTERESIS.—A lagging of the magnetic flux in a magnetic material behind the magnetizing force which is producing it.

Hz.—Cycles per second.

IMPEDANCE.—The total opposition offered to the flow of an alternating current. It may consist of any combination of resistance, inductive reactance, and capacitive reactance.

INDUCTANCE.—The property of a circuit which tends to oppose a change in the existing current.

INDUCTION.—The act or process of producing voltage by the relative motion of a magnetic field across a conductor.

INDUCTIVE REACTANCE.—The opposition to the flow of alternating or pulsating current caused by the inductance of a circuit. It is measured in ohms.

INPHASE.—Applied to the condition that exists when two waves of the same frequency pass through their maximum and minimum values of like polarity at the same instant.

INTEGRATOR.—A computing device used for summing up an infinite number of minute quantities.

INVERSELY.—Inverted or reversed in position or relationship.

ISOGONIC LINE.—An imaginary line drawn through points on the earth's surface where the magnetic variation is equal.

Appendix I—GLOSSARY

JOULE.—A unit of energy or work. A joule of energy is liberated by one ampere flowing for one second through a resistance of one ohm.

KNEE (OF A CURVE).—An abrupt change in direction between two fairly straight segments of a curve.

LAG.—The amount one wave is behind another in time; expressed in electrical degrees.

LAMINATED CORE.—A core built up from thin sheets of metal and used in transformers and relays.

LEAD.—The opposite of LAG. Also, a wire or connection.

LINE OF FORCE.—A line in an electric or magnetic field that shows the direction of the force.

LOAD.—The power that is being delivered by any power producing device. The equipment that uses the power from the power producing device.

LOGIC CIRCUITS.—Digital computer circuits used to store information signals and/or to perform logical operations on those signals.

MAGNETIC AMPLIFIER.—A saturable reactor type device that is used in a circuit to amplify or control.

MAGNETIC CIRCUIT.—The complete path of magnetic lines of force.

MAGNETIC FIELD.—The space in which a magnetic force exists.

MAGNETIC FLUX.—The total number of lines of force issuing from a pole of a magnet.

MAGNETIZE.—To convert a material into a magnet by causing the molecules to rearrange.

MAGNETO.—A generator which produces alternating current and has a permanent magnet as its field.

MEGGER.—A test instrument used to measure insulation resistance and other high resistances. It is a portable hand operated dc generator used as an ohmmeter.

MEGOHM.—A million ohms.

MIARS.—Maintenance Information Automated Retrieval System. A system utilizing an Automatic Reader-Printer/Automatic Reader which provides a projected display of maintenance manuals from 16-mm microfilm in cartridges.

MICRO.—A prefix meaning one-millionth.

MICROFICHE.—A film negative card (fiche) developed for many purposes throughout the Navy wherever microfilming is used to reduce amounts of paper documents.

MICROMETER.—A unit of length equal to 10^{-6} meter. Formerly a micron.

MICRON.—See micrometer.

MILLI.—A prefix meaning one-thousandth.

MILLIAMMETER.—An ammeter that measures current in thousandths of an ampere.

MOTOR-GENERATOR.—A motor and a generator with a common shaft used to convert line voltages to other voltages or frequencies.

MUTUAL INDUCTANCE.—A circuit property existing when the relative position of two inductors causes the magnetic lines of force from one to link with the turns of the other.

NAMP.—The Naval Aviation Maintenance Program.

NANOMETER.—A unit of length equal to 10^{-9} meter. Formerly millimicron.

NEGATIVE CHARGE.—The electrical charge carried by a body which has an excess of electrons.

NEUTRON.—A particle having the weight of a proton but carrying no electric charge. It is located in the nucleus of an atom.

NOT CIRCUIT.—In computers, a circuit in which the output signal does not have the same polarity as the input signal. A phase inverter.

NUCLEUS.—The central part of an atom that is mainly comprised of protons and neutrons. It is the part of the atom that has the most mass.

NULL.—A point or position where a variable-strength signal is at its minimum value (or zero).

OHM.—The unit of electrical resistance.

OHMMETER.—An instrument for directly measuring resistance in ohms.

OR GATE.—A logic circuit having multiple inputs and a single output, so designed that the output is energized when any one or more of the inputs are in the prescribed signal state.

OVERLOAD.—A load greater than the rated load of an electrical device.

PARAMETERS.—In electronics, the design or operating characteristics of a circuit or device.

PERMALLOY.—An alloy of nickel and iron having an abnormally high magnetic permeability.

PERMEABILITY.—A measure of the ease with which magnetic lines of force can flow through a material as compared to air.

PICKOFF.—In gyros, a sensing device which measures the angle of the spin axis with respect to its reference, and provides an error signal which indicates the direction and (in most cases) the magnitude of the displacement.

PHASE DIFFERENCE.—The time in electrical degree by which one wave leads or lags another.

POLARITY.—The character of having magnetic poles, or electric charges.

POLE.—The section of a magnet where the flux lines are concentrated; also where they enter and leave the magnet. An electrode of a battery.

POLYPHASE.—A circuit that utilizes more than one phase of alternating current.

POSITIVE CHARGE.—The electrical charge carried by a body which has become deficient in electrons.

POTENTIAL.—The amount of charge held by a body as compared to another point or body. Usually measured in volts.

POTENTIOMETER.—A variable voltage divider; a resistor which has a variable contact arm so that any portion of the potential applied between its ends may be selected.

POWER.—The rate of doing work or the rate of expending energy. The unit of electrical power is the watt.

POWER FACTOR.—The ratio of the actual power of an alternating or pulsating current, as measured by a wattmeter, to the apparent power, as indicated by ammeter and voltmeter readings. The power factor of an inductor, capacitor, or insulator is an expression of their losses.

PRECESSION.—The reaction of a gyro to an applied torque, which causes the gyro to tilt itself at right angles to the direction of the applied torque in such a manner that the direction of spin of the gyro rotor will be in the same direction as the applied torque.

PROGRAM.—In computers, a complete set of "word" instructions indicating the sequential order which the computer must follow in solving a particular problem.

PRIME MOVER.—The source of mechanical power used to drive the rotor of a generator.

PROTON.—A positively charged particle in the nucleus of an atom.

RADIAN.—In a circle, the angle included within an arc equal to the radius of the circle. A complete circle contains 2π radians. One radian equals 57.3 degrees and one degree equals 0.01745 radian.

RATE GYRO.—A gyro with one degree of freedom which has an elastic restraint, with or without a damper, and whose output will be proportional to the rate of the applied torque.

RATIO.—The value obtained by dividing one number by another, indicating their relative proportions.

REACTANCE.—The opposition offered to the flow of an alternating current by the inductance, capacitance, or both, in any circuit.

RECTIFIERS.—Devices used to change alternating current to unidirectional current. These may be vacuum tubes, semiconductors such as germanium and silicon, and dry-disk rectifiers such as selenium and copper-oxide.

RELAY.—An electromechanical switching device that can be used as a remote control.

RELUCTANCE.—A measure of the opposition that a material offers to magnetic lines of force.

RESISTANCE.—The opposition to the flow of current caused by the nature and physical dimensions of a conductor.

RESISTOR.—A circuit element whose chief characteristic is resistance; used to oppose the flow of current.

RETENTIVITY.—The measure of the ability of a material to hold its magnetism.

RHEOSTAT.—A variable resistor.

RIGIDITY.—In gyros, the characteristics of a spinning body that causes it to oppose all attempts to tilt it away from the axis in which it is spinning.

SATURABLE REACTOR.—A control device that uses a small dc current to control a large ac current by controlling core flux density.

SATURATION.—The condition existing in any circuit when an increase in the driving signal produces no further change in the resultant effect.

SELF-INDUCTION.—The process by which a circuit induces an e.m.f. into itself by its own magnetic field.

SERIES-WOUND.—A motor or generator in which the armature is wired in series with the field winding.

SERVO.—A device used to convert a small movement into one of greater movement or force.

SERVOMECHANISM.—A closed-loop system that produces a force to position an object in accordance with the information that originates at the input.

SOLENOID.—An electromagnetic coil that contains a movable plunger.

SPACE CHARGE.—The cloud of electrons existing in the space between the cathode and plate in a vacuum tube, formed by the electrons emitted from the cathode in excess of those immediately attracted to the plate.

SPECIFIC GRAVITY.—The ratio between the density of a substance and that of pure water at a given temperature.

SYNCHROSCOPE.—An instrument used to indicate a difference in frequency between two ac sources.

SYNCHRO SYSTEM.—An electrical system that gives remote indications or control by means of self-synchronizing motors.

TACHOMETER.—An instrument for indicating revolutions per minute.

TERTIARY WINDING.—A third winding on a transformer or magnetic amplifier that is used as a second control winding.

THERMISTOR.—A resistor that is used to compensate for temperature variations in a circuit.

THERMOCOUPLE.—A junction of two dissimilar metals that produces a voltage when heated.

TORQUE.—The turning effort or twist which a shaft sustains when transmitting power.

TRANSFORMER.—A device composed of two or more coils, linked by magnetic lines of force, used to transfer energy from one circuit to another.

TRANSMISSION LINES.—Any conductor or system of conductors used to carry electrical energy from its source to a load. -

TUMBLE (GYRO).—To subject a gyro to a torque so that it presents a precession violent enough to cause the gyro rotor to spin end over end.

VAR.—Abbreviation for volt-ampere reactive.

VECTOR.—A line used to represent both direction and magnitude.

VOLT.—The unit of electrical potential.

VOLTMETER.—An instrument designed to measure a difference in electrical potential, in volts.

WATT.—The unit of electrical power.

WATTMETER.—An instrument for measuring electrical power in watts.

APPENDIX II SYMBOLS

RESISTORS

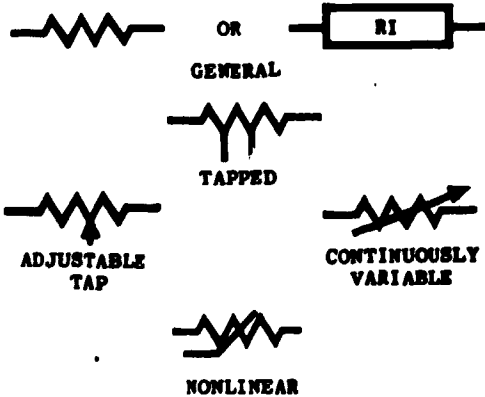

INDUCTIVE COMPONENTS

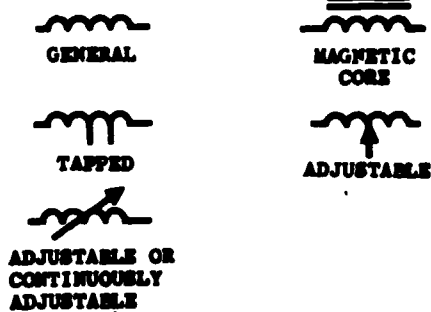

SATURABLE-CORE REACTOR

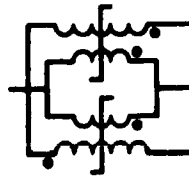

(POWER WINDINGS ARE DRAWN WITH THREE SCALLOPS OR LOOPS, CONTROL WINDINGS WITH FIVE. AN INCREASE OF CURRENT ENTERING THE END OF THE CONTROL WINDING MARKED WITH A DOT CAUSES AN INCREASE IN THE POWER OUTPUT.)

CAPACITORS

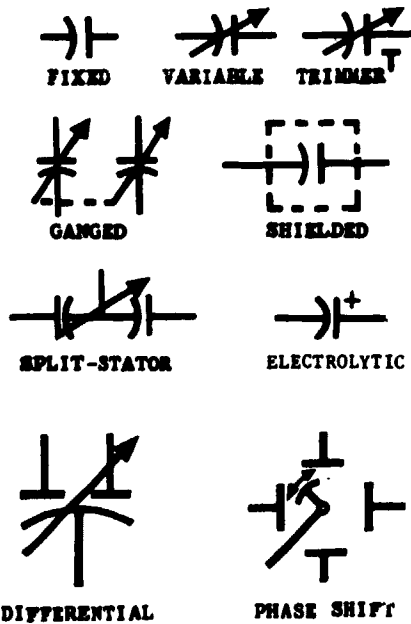

(WHEN CAPACITOR ELECTRODE IDENTIFICATION IS NECESSARY, THE CURVED ELEMENT SHALL REPRESENT THE OUTSIDE ELECTRODE IN FIXED PAPER-DIELECTRIC AND CERAMIC-DIELECTRIC CAPACITORS, THE MOVING ELEMENT IN VARIABLE AND ADJUSTABLE CAPACITORS, AND THE LOW POTENTIAL ELEMENT IN FEED-THROUGH CAPACITORS.)

TRANSFORMERS

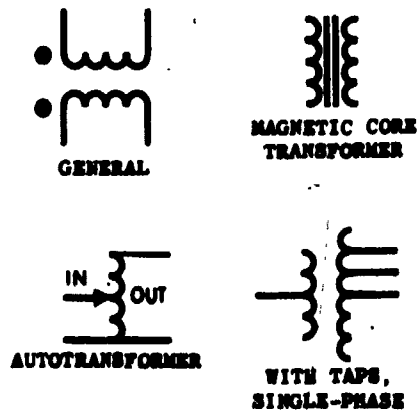

(A DOT, REPRESENTING INSTANTANEOUS POLARITY, MAY BE PLACED NEAR ONE END OF EACH COIL OR WINDING SYMBOL.)

INDICATOR LAMPS

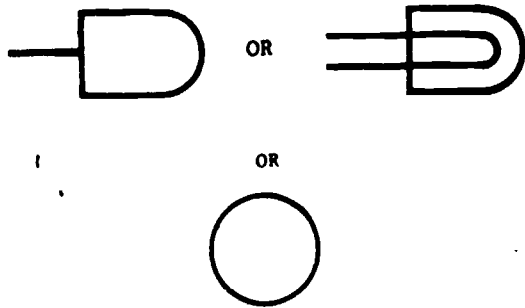

MAY HAVE APPLICABLE IDENTIFICATION FOR CIRCUIT USAGE OR COLOR.

PATH, TRANSMISSION

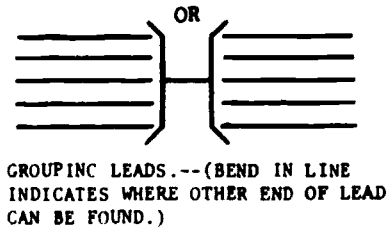
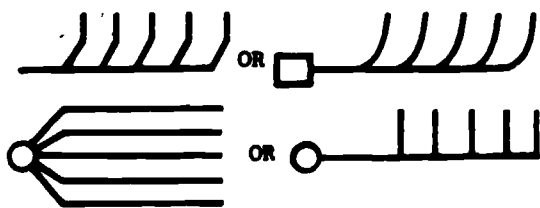
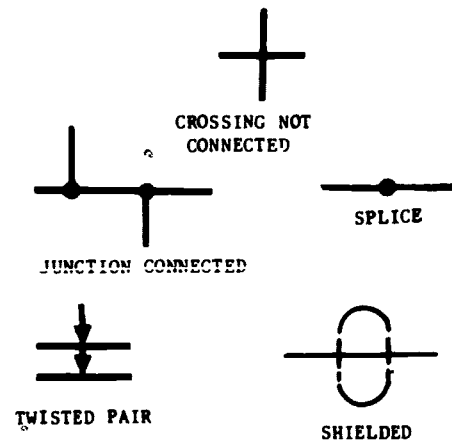

DISCONNECTING DEVICES

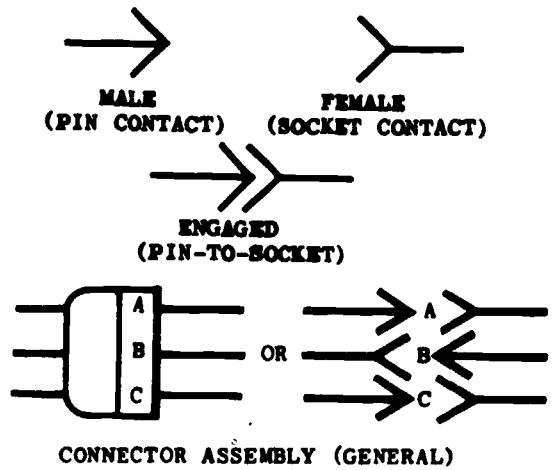

CIRCUIT RETURNS

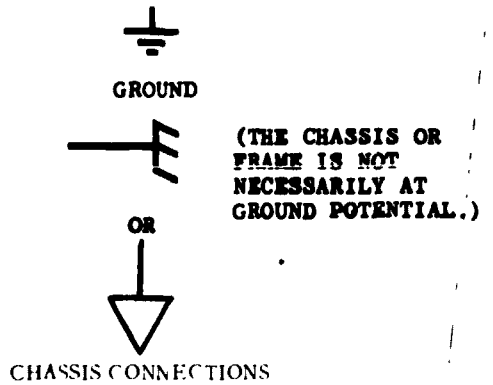

SWITCHES

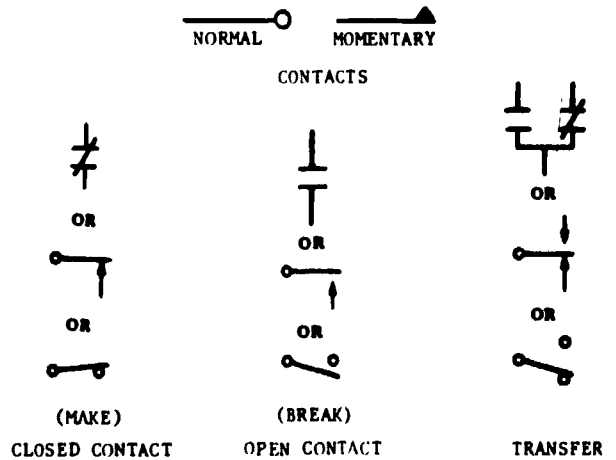

Appendix II—SYMBOLS

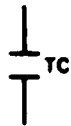

OR



TIME CLOSING (TC) OR TIME-DELAY CLOSING (TDC)



MAKE-BEFORE-BREAK

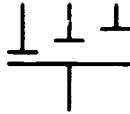

OR

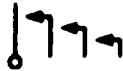

TIME SEQUENTIAL CLOSING

PUSHBUTTON, MOMENTARY OR SPRING-RETURN SWITCHES



CIRCUIT CLOSING (MAKE)



CIRCUIT OPENING (BREAK)



TWO-CIRCUIT

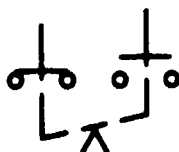

TWO-CIRCUIT, MAINTAINED OR NOT SPRING-RETURN

SELECTOR OR MULTIPosition SWITCHES

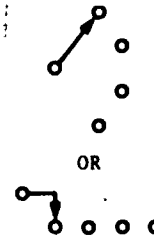

OR

BREAK-BEFORE-MAKE, NONSHORTING (NONBRIDGING), DURING CONTACT TRANSFER

THE POSITION IN WHICH THE SWITCH IS SHOWN MAY BE INDICATED BY A NOTE OR DESIGNATION OF SWITCH POSITION.

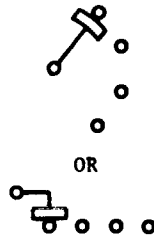

OR

MAKE-BEFORE-BREAK, SHORTING (BRIDGING) DURING CONTACT TRANSFER

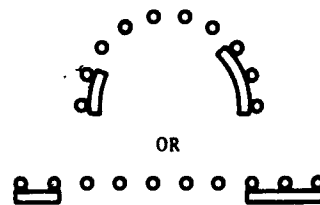

OR

SEGMENTAL CONTACT

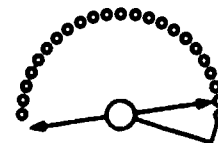

22-POINT SELECTOR SWITCH

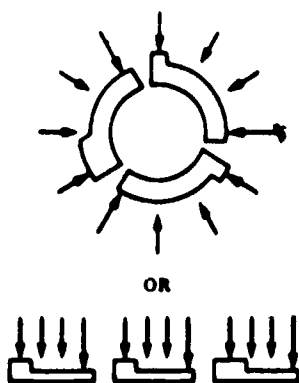

ROTARY (SECTION-, DECK-, OR WAFER-TYPE) SWITCH.

VIEWED FROM END OPPOSITE CONTROL KNOB OR ACTUATOR UNLESS OTHERWISE INDICATED. FOR MORE THAN ONE SECTION, THE FIRST SECTION IS THE ONE NEAREST CONTROL KNOB OR ACTUATOR. WHEN CONTACTS ARE ON BOTH SIDES, FRONT CONTACTS ARE NEAREST CONTROL KNOB.

TEMPERATURE-ACTUATED SWITCHES

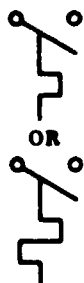

THERMOSTAT

CLOSES ON RISING TEMPERATURE

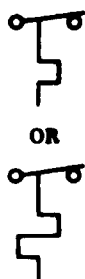

OPENS ON RISING TEMPERATURE

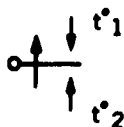

TRANSFER, WITH INTENDED CENTRAL-OFF (NEUTRAL) POSITION

(THE t° SYMBOL WILL BE SHOWN OR BE REPLACED BY DATA GIVING THE NOMINAL OR SPECIFIC OPERATING TEMPERATURE OF THE DEVICE.)

(IF CLARIFICATION OF DIRECTION OF CONTACT OPERATION IS NEEDED, A DIRECTIONAL ARROW MAY BE ADDED. THE ARROWHEAD WILL POINT IN THE DIRECTION OF RISING TEMPERATURE OPERATION. A DIRECTIONAL ARROW WILL ALWAYS BE SHOWN FOR CENTRAL-OFF (NEUTRAL) POSITION DEVICES.)

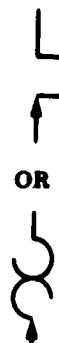

FLASHER SELF-INTERRUPTING SWITCH

LIMIT SWITCHES, DIRECTLY ACTUATED, SPRING RETURN



NORMALLY OPEN



NORMALLY OPEN-HELD CLOSED



NORMALLY CLOSED



NORMALLY CLOSED--HELD OPEN

BATTERIES



ONE CELL MULTICELL TAPPED MULTICELL

(LONG LINE IS ALWAYS POSITIVE)

Appendix II—SYMBOLS

CIRCUIT PROTECTORS



FUSE



PUSH PULL OR PUSH



GANGED

CIRCUIT BREAKERS

THERMAL ELEMENTS

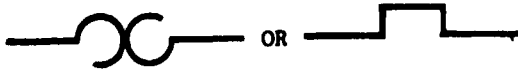

THERMAL RELAY WITH NORMALLY CLOSED CONTACT.

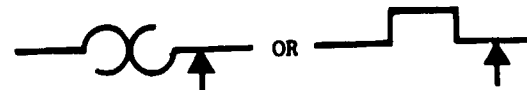
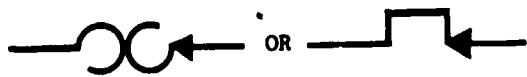

FLASHER; THERMAL CUTOUT



GENERAL



LINEAR



NONLINEAR

THERMISTORS



TEMPERATURE-MEASURING THERMOCOUPLE (DISSIMILAR METAL DEVICE)

SEMICONDUCTOR DEVICES



ELECTRON FLOW IS AGAINST THE ARROW.



OR



UNIDIRECTIONAL DIODE; VOLTAGE REGULATOR



OR



BIDIRECTIONAL DIODE

TRANSISTORS

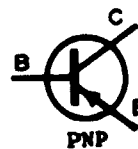

PNP

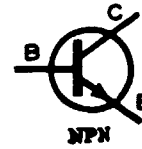

NPN

ROTATING MACHINES



MOTOR AC



MOTOR DC



GENERATOR DC



GENERATOR AC

TYPES OF WINDINGS



SERIES

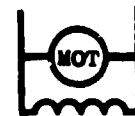

SHUNT



SEPARATELY EXCITED



DYNAMOTOR

AVIATION ELECTRICIAN'S MATE 3 & 2

WINDING SYMBOLS

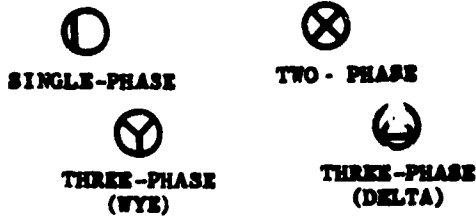

CLUTCH/BRAKE

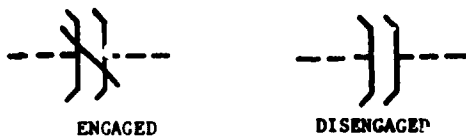

METERS



A	AMMETER
AH	AMPERE-HOUR METER
CRO	OSCILLOSCOPE
DB	DB (DECIBEL) METER AUDIO LEVEL/ETER
DBM	DBM (DECIBELS REFERRED TO 1 MILLIWATT) METER
F	FREQUENCY METER
μA OR	
UA	MICROAMMETER
MA	MILLIAMMETER
OHM	OHMMETER
PF	POWER FACTOR METER
PH	PHASEMETER
PI	POSITION INDICATOR
REC	RECORDING METER
SY	SYNCHROSCOPE
t°	TEMPERATURE METER
T	TOTAL TIME METER ELAPSED TIME METER
V	VOLTMETER
VA	VOLT-AMMETER
VAR	VARMETER
W	WATTMETER
WH	WATTHOUR METER

SYNCHROS



CDX	CONTROL-DIFFERENTIAL TRANSMITTER
CT	CONTROL TRANSFORMER
CX	CONTROL TRANSMITTER
TDR	TORQUE-DIFFERENTIAL RECEIVER
TDX	TORQUE-DIFFERENTIAL TRANSMITTER
TR	TORQUE RECEIVER
TX	TORQUE TRANSMITTER
RS	RESOLVER

(IF THE OUTER WINDING IS ROTATABLE IN BEARINGS, THE SUFFIX B SHALL BE ADDED TO THE ABOVE LETTER COMBINATIONS.)

(COMPLETE SYMBOLS MAY ALSO BE FORMED BY USING A WINDING SYMBOL.)

AMPLIFIERS



OPERATIONAL



SUMMING AMPLIFIER

(4 INPUTS AND 1 OUTPUT SHOWN)

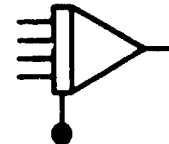

INTEGRATOR (AMPLIFIER)

(4 INPUTS AND 1 OUTPUT SHOWN)



ELECTRONIC MULTIPLIER



ELECTRONIC DIVIDER

Appendix II—SYMBOLS

AMPLIFIERS CONT.



BDC BRIDGING
 BST BOOSTER
 CMP COMPRESSION
 DC DIRECT-CURRENT
 EXP EXPANSION
 LIM LIMITING
 MON MONITORING
 PGM PROGRAM
 PRE PRELIMINARY
 PWR POWER
 TRQ TORQUE



MAGNETIC AMPLIFIER

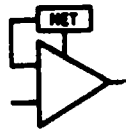

AMPLIFIER WITH EXTERNAL FEEDBACK PATH

LOGIC FUNCTIONS

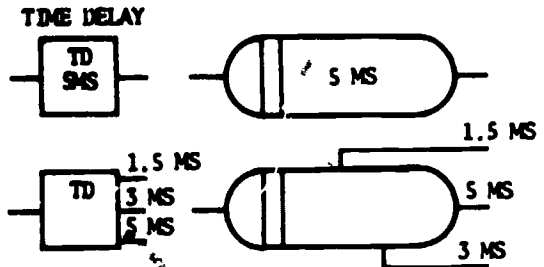
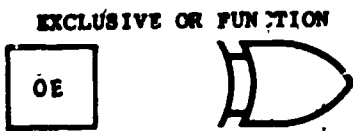
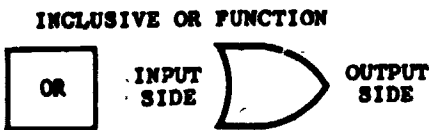
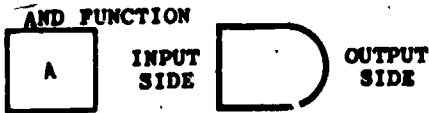

FLIP-FLOPS

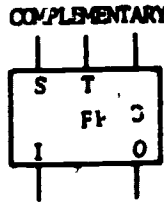
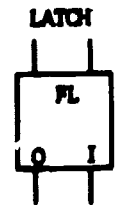

S-SET

T-TRIGGER

C-CLEAR

INDEX

A

Ac generators, 4-2 to 4-8
Accelerometer indicators, 6-30 to 6-33
Accessories manuals (O3 series), 1-18 to 1-29
Aeronautical publications, 1-1 to 1-8
AFSC codes, 7-73 to 7-74
AIMS program, the, 6-8 to 6-9
Air data computer system, 6-5 to 6-7
Air-conditioning test set AN/PSM-21A, 3-74
Aircraft compass systems, 7-1 to 7-24
Aircraft electrical and associated systems, 5-1 to 5-87
 aircraft electrical hardware, 5-14 to 5-25
 bonding and bonding devices, 5-21 to 5-23
 cable lacing and tying, 5-23
 conduit and fittings, 5-21
 electrical connectors, 5-16
 fabrication of cables, 5-16 to 5-17
 heat-shrinkable tubing, 5-25
 junction boxes, 5-18
 moistureproofing, 5-17 to 5-18
 safety wire, 5-21
 shock mounts, 5-14 to 5-16
 sleeving, 5-23 to 5-25
 support clamps, 5-19 to 5-21
 terminal blocks, 5-18
 aircraft electromagnetic and pneumatic systems, 5-56 to 5-75
 arresting gear system, 5-63 to 5-65
 basic hydraulic system, 5-57 to 5-58
 canopy system, 5-71 to 5-73
 catapulting system, 5-68 to 5-69
 electrohydraulic systems, 5-58 to 5-73

Aircraft electrical and associated systems— Continued

 aircraft electromagnetic and pneumatic systems—Continued
 landing gear system, 5-62 to 5-63
 nosewheel steering system, 5-65 to 5-68
 pneumatic power system, 5-73 to 5-75
 speed brake system, 5-69 to 5-71
 aircraft environmental systems, 5-75 to 5-87
 anti-icing and deicing equipments, 5-85 to 5-87
 components, 5-76 to 5-79
 electronic cabin temperature control system, 5-79 to 5-82
 equipment cooling, 5-82 to 5-84
 pressurization, 5-84 to 5-85
 temperature control, 5-76
 terms and definitions, 5-75 to 5-76
 aircraft lighting systems, 5-1 to 5-14
 description and types of lamps, 5-1 to 5-3
 exterior lighting, 5-3 to 5-9
 interior lighting, 5-9 to 5-14
 aircraft powerplant systems, 5-25 to 5-56
 anti-icing and deicing systems, 5-37 to 5-41
 approach power compensator system, 5-54 to 5-56
 engine temperature control system, 5-50 to 5-53
 fire warning and extinguishing systems, 5-41 to 5-45
 fuel transfer system, 5-45 to 5-48
 ignition systems, 5-33 to 5-37
 oil dilution and diverter system, 5-48 to 5-49

Aircraft electrical and associated systems—
Continued

- aircraft powerplant systems—Continued
 - oil temperature control system, 5-49 to 5-50
 - propeller synchrophasing system, 5-53 to 5-54
 - starting equipment, 5-25 to 5-33
 - variable inlet duct ramp system, 5-56

Aircraft electrical power systems, 4-1 to 4-41

- aircraft electrical power sources, 4-1 to 4-29
 - ac generators, 4-2 to 4-8
 - auxiliary power units (APU), 4-25 to 4-28
 - batteries, 4-17 to 4-20
 - dc generators, 4-1 to 4-2
 - electronic power supplies, 4-16 to 4-17
 - emergency power sources, 4-17 to 4-25
 - external power sources, 4-28 to 4-29
 - inverters, 4-8 to 4-13
 - prime movers, 4-7 to 4-8
 - transformers, 4-13 to 4-16
- controls and circuit protection, 4-29 to 4-41
 - ac generator control, 4-30 to 4-35
 - circuit protection, 4-35 to 4-39
 - dc generator control, 4-29
 - feeder fault system, 4-38 to 4-39
 - grounded systems, 4-40 to 4-41
 - parallel operation, 4-39
 - power distribution, 4-39 to 4-40
 - power in ac circuits, 4-39
 - single-phase and polyphase systems, 4-41
 - ungrounded systems, 4-41

Aircraft inspections, PMS, 3-14

Aircraft manuals (O1 series), 1-11

Aircraft wire and cables, 3-31 to 3-38

- cable stripping and heat shrinkable tubing, 3-38
- wire identification, 3-35 to 3-38
- wire replacement, 3-31 to 3-35

Airspeed indicators, 6-16 to 6-20

AJB-7 compass system, 7-21 to 7-24

Allowance requirement registers, 1-38 to 1-39

- Altimeter, 6-2 to 6-5
- Ammeter, 3-22
- Angle-of-attack (AOA), 6-20 to 6-24
- Angle-of-attack test set AN/PSM-17A, 3-72
- Anti-icing and deicing systems, 5-37 to 5-11
- Approach power compensator system, 5-54 to 5-56
- ASE control panel, 7-75 to 7-76
- Attitude-heading reference system analyzer AN/ASM-78, 3-73
- Attitude indicator, 6-25 to 6-27
- Automatic altitude system, 6-7 to 6-20
- Automatic flight control and stabilization systems, 7-47 to 7-83
- Auxiliary power units (APU), 4-25 to 4-28

B

- Basic hydraulic system, 5-57 to 5-58
- Basic test equipment, 3-20 to 3-31
 - ammeter, 3-22
 - continuity test, 3-21
 - dc voltmeter, 3-23
 - grounded circuit test, 3-21
 - megger, 3-26 to 3-29
 - multimeter, 3-24
 - ohmmeter, 3-22
 - oscilloscope, 3-29
 - phase angle voltmeter, 3-29 to 3-31
 - short test, 3-22
 - time-domain reflectometry, 3-29
 - vacuum tube voltmeter, 3-25
 - voltage test, 3-22
 - Wheatstone bridge, 3-23
- Batteries, 4-17 to 4-20
- BDHI (bearing-distance-heading indicator), 7-18 to 7-19
- Bodies, revolving, 2-28 to 2-30
- Bonding and bonding devices, 5-21 to 5-23

C

- Cable stripping and heat shrinkable tubing, aircraft, 3-38
- Cables, fabrication of, 5-16 to 5-17
- Calibration, compass, 7-41 to 7-47
- Capacitive-type liquid quantity test set TF-20, 3-69 to 3-72

INDEX

- Circuit construction, printed circuits, 3-41
- Circuit protection, 4-35 to 4-39
- Clamps, support, 5-19 to 5-21
- Clocks, 6-33 to 6-34
- Compass, inertial navigation, automatic flight control and stabilization systems, 7-1 to 7-83
 - aircraft compass systems, 7-11 to 7-24
 - AJB-7 compass system, 7-21 to 7-24
 - all attitude indicator, 7-19
 - bearing-distance-heading indicator (BDHI), 7-18 to 7-19
 - compass system sensors and indicators, 7-12 to 7-19
 - compass transmitter, 7-13 to 7-14
 - displacement gyroscope assembly, 7-14 to 7-17
 - horizontal situation indicator (HSI), 7-17 to 7-18
 - MA-1 compass system, 7-19 to 7-21
 - rate gyroscope transmitter (RGT), 7-17
 - switching rate gyroscope (SRG), 7-17
 - automatic flight control and stabilization systems, 7-47 to 7-83
 - AFCS modes, 7-73 to 7-74
 - air data information, 7-64 to 7-66
 - ASE control panel, 7-75 to 7-76
 - automatic flight control systems (AFCS), 7-58 to 7-74
 - automatic stabilization equipment (ASE) and coupler system, 7-74 to 7-83
 - channel monitor panel, 7-76 to 7-83
 - compass information, 7-63 to 7-64
 - coordination input, 7-66 to 7-67
 - electronic components, 7-67 to 7-73
 - fixed wing aircraft, 7-53 to 7-55
 - flap position information, 7-66
 - gyros, 7-60 to 7-63
 - principles of flight, 7-48 to 7-58
 - rotary wing aircraft, 7-55 to 7-58
 - signal generator pickoff (synchro), 7-58 to 7-60
- Compass, inertial navigation, automatic flight control and stabilization systems—Continued
 - inertial navigation system, 7-24 to 7-47
 - compass calibration, 7-41 to 7-47
 - compass rose, 7-42 to 7-45
 - correction terms, 7-30 to 7-31
 - errors in navigation, 7-31 to 7-33
 - initialization of inertial navigation systems, 7-33 to 7-41
 - MC-2 magnetic compass calibration set, 7-45 to 7-47
 - Schuler loop, 7-29 to 7-30
 - Schuler tuning, 7-27 to 7-29
 - navigation terms and definitions, 7-1 to 7-11
 - bearing, 7-2
 - celestial navigation, 7-10
 - compass error, 7-6 to 7-7
 - course, 7-1
 - dead reckoning, 7-9 to 7-10
 - deviation, 7-6
 - direction, 7-1
 - distance, 7-2
 - great circles and small circles, 7-3
 - heading, 7-1 to 7-2
 - inertial navigation, 7-10 to 7-11
 - latitude and longitude, 7-4 to 7-5
 - magnetic dip, 7-7 to 7-9
 - parallels and meridians, 7-3 to 7-4
 - pilotage, 7-9
 - poles, 7-2 to 7-3
 - position, 7-1
 - radar navigation, 7-10
 - radio navigation, 7-10
 - time, 7-2
 - variation, 7-5 to 7-6
 - Compass rose, 7-42 to 7-45
 - Compasses, direct-reading, 6-34 to 6-35
 - Compounds and mixtures, 2-13 to 2-14
 - Compressed air, safety, 3-11
 - Conduit and fittings, 5-21
 - Connectors, electrical, 5-16
 - Continuity test, 3-21
 - Controls and circuit protection, 4-29 to 4-41
 - Cooling, equipment, 5-82 to 5-84
 - Corrector terms, 7-30 to 7-31
 - Corrosion control, PMS, 3-16

AVIATION ELECTRICIAN'S MATE 3 & 2

D

Dc generators, 4-1 to 4-2
Dc voltmeter, 3-23
Deckedge power, GSE, 3-52 to 3-53
Direct-reading compasses, 6-34 to 6-35
Directives, 1-31 to 1-33

E

Electrical fires, safety, 3-9
Electrical hardware, aircraft, 5-14 to 5-25
Electrical maintenance and troubleshooting,
3-1 to 3-74
 aircraft wire and cables, 3-31 to 3-38
 cable stripping and heat shrink-
 able tubing, 3-38
 wire identification, 3-35 to 3-38
 wire replacement, 3-31 to 3-35
 ground support equipment, 3-44 to 3-53
 deckedge power, 3-52 to 3-53
 mobile electrical powerplants,
 3-44 to 3-50
 mobile motor-generator sets,
 3-50 to 3-52
 RCPT-105, 3-50 to 3-52
 maintenance of motors, 3-38 to 3-41
Planned Maintenance Systems (PMS),
3-14 to 3-17
 corrosion control, 3-16
 scheduled maintenance, 3-14 to
 3-16
 unscheduled maintenance, 3-16 to
 3-17
printed circuits, 3-41 to 3-44
 circuit construction, 3-41
 maintenance, 3-43
 modules and potted components,
 3-43 to 3-44
safety, 3-1 to 3-14
 general precautions, 3-2
 precautions regarding aircraft,
 3-3 to 3-8
 precautions regarding personnel
 and materials, 3-8 to 3-11
 precautions regarding tools, 3-12
 to 3-14

Electrical maintenance and troubleshooting— Continued

test equipment, 3-53 to 3-74
 air-conditioning test set
 AN/PSM-21A, 3-74
 angle-of-attack test set
 AN/PSM-17A, 3-72
 attitude-heading reference system
 analyzer AN/ASM-78, 3-73
 capacitive-type liquid quantity
 test set TF-20, 3-69 to 3-72
 function description, 3-57 to 3-63
 jet calibration (JETCAL) analyzer,
 3-66 to 3-68
 jet ignition system tester, 3-63
 to 3-65
 MA-2 aircraft electrical power
 test set, 3-54
 pressure-temperature test set
 TTU-205B/E, 3-68
 semiconductor testing, 3-55
 tachometer indicator-generator
 test set TTU-27/E, 3-65
troubleshooting techniques, 3-17 to 3-20
 analysis of trouble, 3-17
 correction of faults, 3-18
 detection of faults, 3-17 to 3-18
 use of basic test equipment, 3-20 to 3-31
 ammeter, 3-22
 continuity test, 3-21
 dc voltmeter, 3-23
 grounded circuit test, 3-21
 megger, 3-26 to 3-29
 multimeter, 3-24
 ohmmeter, 3-22
 oscilloscope, 3-29
 phase angle voltmeter, 3-29 to 3-31
 short test, 3-22
 time-domain reflectometry, 3-29
 vacuum tube voltmeter, 3-25
 voltage test, 3-22
 Wheatstone bridge, 3-23
Electrical power sources, aircraft, 4-1 to 4-29
Electrohydraulic systems, 5-58 to 5-73
Electromagnetic and pneumatic systems, 5-56
to 5-75
Elementary physics, 2-1 to 2-37
 heat, 2-30 to 2-37
 change of state, 2-36 to 2-37
 measurement of, 2-34 to 2-36
 nature of, 2-30

INDEX

Elementary physics—Continued

heat—Continued

thermal expansion, 2-33 to 2-34

transfer of, 2-30 to 2-33

measurements, 2-1 to 2-11

derived units, 2-6 to 2-7

English units of length, 2-3

metric units of length, 2-3

sound, 2-10 to 2-11

temperature, 2-7 to 2-10

units of mass, weight, and force,
2-5 to 2-6,

volume, 2-3 to 2-5

mechanics, 2-22 to 2-30

force, mass, and motion, 2-24
to 2-26

revolving bodies, 2-28 to 2-30

work, power, and energy, 2-26 to
2-28

structure of matter, 2-11 to 2-22

compounds and mixtures, 2-13 to
2-14

element, 2-12 to 2-13

matter and energy, 2-19 to 2-22

states of matter, 2-14 to 2-19

Emergency power sources, 4-17 to 4-25

Engine instrument systems, 6-35 to 6-56

Environmental systems, 5-75 to 5-87

Errors in navigation, 7-31 to 7-33

Exhaust nozzle indicating system, 6-54 to 6-55

Exterior lighting, 5-3 to 5-9

External power sources, 4-28 to 4-29

F

Feeder fault system, 4-38 to 4-39

Fire warning and extinguishing systems, 5-41 to 5-45

Flight deck safety, 3-6

Flight instrument systems, 6-1 to 6-35

Flight instruments, miscellaneous, 6-30 to 6-35

Flight, safety in, 3-7 to 3-8

FOD, safety, 3-6

Force, mass, and motion, 2-24 to 2-26

Fuel flow systems, 6-47 to 6-51

Fuel pressure system, 6-53 to 6-54

Fuel quantity indicator, 6-57

Fuel transfer system, 5-45 to 5-48

G

Generator control, 4-29 to 4-35

ac, 4-30 to 4-35

dc, 4-29

Glossary, AI-1 to AI-8

Ground support equipment, 3-44 to 3-53

deckedge power, 3-52 to 3-53

mobile electrical powerplants, 3-44 to 3-50

NC-2A, 3-45

NC-7A, 3-46

NC-8A, 3-46

NC-10B, 3-47

NC-12A, 3-48 to 3-50

mobile motor-generator sets, 3-50 to 3-52

MMG-2, 3-50

MMG-RX400, 3-51 to 3-52

RCPT-105, 3-50

propulsion system, 3-50

Grounded circuit test, 3-21

Grounded systems, 4-40 to 4-41

Grounding, safety, 3-13 to 3-14

Gyroscopic instruments, 6-24 to 6-30

H

Heat, 2-30 to 2-37

High-voltage precautions, 3-8

HSI (horizontal situation indicator), 7-17 to 7-18

Hydraulic pressure indicators, 6-61 to 6-62

I

Ignition systems, 5-33 to 5-37

Illustrated parts breakdown (IPB), 1-23 to 1-25

Indicators and sensors, compass system, 7-12 to 7-19

Inertial navigation, automatic flight control, compass and stabilization systems, 7-1 to 7-83

Initialization of inertial navigation systems, 7-33 to 7-41

Instructions and notices, 1-33 to 1-34

Instruments, 6-1 to 6-77

engine instrument systems, 6-35 to 6-56
 exhaust nozzle indicating system,
 6-54 to 6-55
 fuel flow systems, 6-47 to 6-51
 fuel pressure system, 6-53 to 6-54
 oil pressure system, 6-51 to 6-53
 oil temperature system, 6-54
 ratiometer system, 6-43 to 6-44
 tachometer systems, 6-35 to 6-42
 temperature indicating systems,
 6-42 to 6-47
 thermocouple system, 6-44 to 6-47
 torquemeter systems, 6-55 to 6-56
 Wheatstone bridge system, 6-42 to
 6-43

flight instrument systems, 6-1 to 6-35
 accelerometer indicators, 6-30 to
 6-33
 AIMS program, the, 6-8 to 6-9
 air data computer system, 6-5 to
 6-7
 airspeed indicators, 6-16 to 6-20
 altimeter, 6-2 to 6-5
 angle-of-attack (AOA), 6-20 to
 6-24
 attitude indicator, 6-25 to 6-27
 automatic altitude system, 6-7 to
 6-20
 clocks, 6-33 to 6-34
 compasses, direct-reading, 6-34 to
 6-35
 gyroscopic instruments, 6-24 to
 6-30
 miscellaneous flight instruments,
 6-30 to 6-35
 outside air temperature indicator,
 6-35

pitot-static system, 6-1 to 6-7
 stall warning system, 6-22 to 6-24
 standby attitude indicator, 6-35
 turn and bank indicator, 6-27 to
 6-30

instrument system maintenance, 6-66 to
 6-77

emergency protective treatment,
 6-76 to 6-77
 general maintenance, 6-67 to 6-73
 instrument testing, 6-74
 interchangeability of instruments,
 6-75 to 6-76

Instruments—Continued

instrument system maintenance—
 Continued

pitot-static instrument mainten-
 ance, 6-73 to 6-74
 shipping and handling, 6-77
 troubleshooting, 6-74 to 6-75
 miscellaneous instrument systems, 6-56 to
 6-66
 capacitive type fuel quantity
 indicating system, 6-57 to 6-61
 flaps, 6-65
 fuel quantity indicator, 6-57
 hydraulic pressure indicators, 6-61
 to 6-62
 integrated position indicator, 6-65
 to 6-66
 landing gear, 6-63 to 6-65
 pneumatic pressure systems, 6-62
 position indicating system (dc
 synchro system), 6-62 to 6-66
 tank probe, 6-57 to 6-58

Insulated tools, safety, 3-12

Interior lighting, 5-9 to 5-14

Inverters, 4-8 to 4-13

J

Jet ignition system tester, 3-63 to 3-65

JETCAL, jet calibration analyzer, 3-66 to
 3-68

Junction boxes, 5-18

L

Lighting systems, aircraft, 5-1 to 5-14

Liquid oxygen, safety, 3-9 to 3-10

Low-voltage precautions, 3-8 to 3-9

Lubrication, PMS, 3-15 to 3-16

M

MA-1 compass system, 7-19 to 7-21

MA-2 aircraft electrical power test set, 3-54

INDEX

Maintenance information automated retrieval system (MIARS), 1-1 to 1-2
Maintenance instructions manual (MIM), 1-12 to 1-23
Maintenance, instrument system, 6-66 to 6-77
Maintenance of motors, 3-38 to 3-41
Maintenance, printed circuits, 3-43
Maintenance requirements cards (MRCs), 1-28
Manual identification, 1-8 to 1-31
Mass, motion, and force, 2-24 to 2-26
Material identification, 1-35 to 1-38
Matter, states of, 2-14 to 2-19
 gases, 2-16 to 2-19
 liquids, 2-15 to 2-16
 solids, 2-14 to 2-15
MC-2 magnetic compass calibration set, 7-45 to 7-47
Measurements, 2-1 to 2-11
Megger, 3-26 to 3-29
Metric units of length, 2-3
Microfiche, 1-2 to 1-3
Miscellaneous instrument systems, 6-56 to 6-66
Miscellaneous flight instruments, 6-30 to 6-35
Mixtures and compounds, 2-13 to 2-14
Mobile electrical powerplants, 3-44 to 3-50
Mobile motor-generator sets, GSE, 3-50 to 3-52
Modules and potted components, printed circuits, 3-43 to 3-44
Moistureproofing, 5-17 to 5-18
Multimeter, 3-24

N

NATOPS flight manual, 1-12
NAVAER 00-500A, 1-6
NAVAIR 00-500, 1-6
NAVAIR 00-500B, 1-6
NAVAIR 00-500C, 1-6
NAVAIR 00-500M, 1-7
NAVAIR 01-700, 1-7 to 1-8
Navigation terms and definitions, 7-1 to 7-11
NAVSUP publication 2002, 1-3 to 1-6
Noise hazards, safety, 3-3 to 3-6
Nonmagnetic tools, safety, 3-12
Notices and instructions, 1-33 to 1-34

O

Ohmmeter, 3-22
Oil pressure system, 6-51 to 6-53
Oil temperature system, 6-54
Oscilloscope, 3-29
Outside air temperature indicator, 6-35

P

Parallel operation, 4-39
Periodic maintenance information cards (PMICs), 1-27 to 1-28
Periodicals, 1-34 to 1-35
Phase angle voltmeter, 3-29 to 3-31
Physics, elementary, 2-1 to 2-37
Pitot-static system, 6-1 to 6-7
PMS, Planned Maintenance System, 3-14 to 3-17
 corrosion control, 3-16
 scheduled maintenance, 3-14 to 3-16
 aircraft inspections, 3-14
 lubrication, 3-15 to 3-16
 unscheduled maintenance, 3-16 to 3-17
 visual checks, 3-16 to 3-17
Pneumatic and electromagnetic systems, 5-56 to 5-75
Pneumatic pressure systems, 6-62
Polyphase and single-phase systems, 4-41
Power distribution, 4-39 to 4-40
Power, energy, and work, 2-26 to 2-28
Power supplies, electronic, 4-16 to 4-17
Power tools, safety, 3-13
Powerplant systems, 5-25 to 5-56
Pressure-temperature test set, TTU-205 B/E, 3-68
Prime movers, 4-7 to 4-8
Principles of flight, 7-48 to 7-58
 fixed wing aircraft, 7-53 to 7-55
 rotary wing aircraft, 7-55 to 7-58
Printed circuits, 3-41 to 3-44
 circuit construction, 3-41
 maintenance, 3-43
 modules and potted components, 3-43 to 3-44

AVIATION ELECTRICIAN'S MATE 3 & 2

Publications and supply, 1-1 to 1-39
publications, 1-1 to 1-35
 accessories manuals (03 series),
 1-28 to 1-29
 aeronautical publications, 1-1 to 1-8
 aircraft manuals (01 series), 1-11
 directives, 1-31 to 1-35
 general aircraft manuals, 1-29
 illustrated parts breakdown (IPB),
 1-23 to 1-26
 instructions and notices, 1-33 to
 1-34
 maintenance information automated
 retrieval system (MIARS),
 1-1 to 1-2
 maintenance instructions manual
 (MIM), 1-12 to 1-23
 maintenance requirements cards
 (MRCs), 1-28
 manual identification, 1-8 to 1-31
 microfiche, 1-2 to 1-3
 NATOPS flight manual, 1-12
 NAVAER 00-500A, 1-6
 NAVAIR 00-500, 1-6
 NAVAIR 00-500B, 1-6
 NAVAIR 00-500C, 1-6
 NAVAIR 00-500M, 1-7
 NAVAIR 01-700, 1-7 to 1-8
 NAVSUP publication 2002, 1-3 to
 1-6
 periodic maintenance information
 cards (PMICs), 1-27 to 1-28
 periodicals, 1-34 to 1-35
 security classification, 1-9 to 1-11
 support equipment manuals (17 and
 19 series), 1-29
 TD categories, 1-33
 technical directives, 1-31 to 1-33
 technical manual list, 1-12
 updating manuals, 1-29 to 1-31
 work unit code (WUC) manual, 1-26
 to 1-27
supply, 1-35 to 1-39
 allowance requirement registers,
 1-38 to 1-39
 material identification, 1-35 to 1-38
 material identification aids, 1-36
 to 1-38
 types and identification, 1-39

R

Ratiometer system, 6-43 to 6-44
 RCPT-105, GSE, 3-50
 RGT (rate gyroscope transmitter), 7-17

S

Safety, electrical maintenance and trouble-
shooting, 3-1 to 3-14
 general precautions, 3-2
 precautions regarding aircraft, 3-3 to
 3-8
 precautions regarding personnel and
 materials, 3-8 to 3-11
 precautions regarding tools, 3-12 to 3-14
 Safety wire, 5-21
 Schuler loop, 7-29 to 7-30
 Schuler tuning, 7-27 to 7-29
 Security classification, 1-9 to 1-11
 Semiconductor testing, 3-55 to 3-57
 Sensors and indicators, compass system,
 7-12 to 7-19
 Shock mounts, 5-14 to 5-16
 Short test, 3-22
 Single-phase and polyphase systems, 4-41
 Sleeving, 5-23 to 5-25
 Soldering iron, safety, 3-13
 Sound, 2-10 to 2-11
 SRG (switching rate gyroscope), 7-17
 Stall warning system, 6-22 to 6-24
 Standby attitude indicator, 6-35
 Supply and publications, 1-1 to 1-39
 Support equipment manuals (17 and 19 series),
 1-29
 Symbols, AII-1 to AII-7

T

Tachometer indicator-generator test set
 TTU-27/E, 3-65
 Tachometer systems, 6-35 to 6-42
 Tank probe, 6-57 to 6-58
 TCP, Tool Control Program, safety, 3-7
 Technical directives, 1-31 to 1-33
 Technical manual list, 1-12

INDEX

- Temperature, 2-7 to 2-10
Temperature control, 5-76
Temperature indicating systems, 6-42 to 6-47
Terminal blocks, 5-18
Test equipment, GSE, 3-53 to 3-74
 air-conditioning test set AN/PSM-21A, 3-74
 angle-of-attack test set AN/PSM-17A, 3-72
 attitude-heading reference system analyzer AN/ASM-78, 3-73
 capacitive-type liquid quantity test set TF-20, 3-69 to 3-72
 functional description, 3-57 to 3-63
 transistor curve tracer (Tektronix 575), 3-57 to 3-63
 jet calibration (JETCAL) analyzer, 3-66 to 3-68
 jet ignition system tester, 3-63 to 3-65
 MA-2 aircraft electrical power test set, 3-54
 pressure-temperature test set, TTU-205B/E; 3-68
 semiconductor testing, 3-55 to 3-57
 in-circuit transistor tester, 3-56 to 3-57
 tachometer indicator-generator test set TTU-27/E, 3-65
Testing, instrument, 6-74
Thermal expansion, 2-33 to 2-34
Thermocouple system, 6-44 to 6-47
Time-domain reflectometry, 3-29
Tools, precautions regarding, 3-12 to 3-14
 grounding, 3-13 to 3-14
 insulated, 3-12
 nonmagnetic, 3-12
 power, 3-13
 soldering iron, 3-13
Torquemeter systems, 6-55 to 6-56
Transformers, 4-13 to 4-16
Troubleshooting, instrument, 6-74 to 6-75
 Troubleshooting techniques, 3-17 to 3-20
 analysis of trouble, 3-17
 correction of faults, 3-18 to 3-20
 replacements, 3-19 to 3-20
 detection of faults, 3-17 to 3-18
 continuity and resistance checks, 3-18
 nonelectric components, 3-18
Turn and bank indicator, 6-27 to 6-30
- U
- Ungrounded systems, 4-41
Units, derived, 2-6 to 2-7
- V
- Vacuum tube voltmeter, 3-25
Volatile liquids, safety, 3-10 to 3-11
Voltage test, 3-22
Volume, 2-3 to 2-5
- W
- Wheatstone bridge, 3-23
Wheatstone bridge systems, 6-42 to 6-43
Wire identification, 3-35 to 3-38
 wire marking, 3-35
 wiring and cable identification codes, 3-36 to 3-38
Wire replacement, aircraft, 3-31 to 3-35
 aluminum wire properties, 3-33 to 3-35
 selection and characteristics, 3-33
Work, power, and energy, 2-26 to 2-28
Work unit code (WUC) manual, 1-26 to 1-27

AVIATION ELECTRICIAN'S MATE 3&2

NAVEDTRA 10348-E

Prepared by the Naval Education and Training Program Development Center, Pensacola, Florida

Your NRCC contains a set of assignments and perforated answer sheets. The Rate Training Manual, Aviation Electrician's Mate 3 & 2, NAVEDTRA 10348-E, is your textbook for the NRCC. If an errata sheet comes with the NRCC, make all indicated changes or corrections. Do not change or correct the textbook or assignments in any other way.

designated to grade it. The graded answer sheet will not be returned to you.

If you are completing this NRCC to become eligible to take the fleetwide advancement examination, follow a schedule that will enable you to complete all assignments in time. Your schedule should call for the completion of at least one assignment per month.

HOW TO COMPLETE THIS COURSE SUCCESSFULLY

Study the textbook pages given at the beginning of each assignment before trying to answer the items. Pay attention to tables and illustrations as they contain a lot of information. Making your own drawings can help you understand the subject matter. Also, read the learning objectives that precede the sets of items. The learning objectives and items are based on the subject matter or study material in the textbook. The objectives tell you what you should be able to do by studying assigned textual material and answering the items.

At this point you should be ready to answer the items in the assignment. Read each item carefully. Select the BEST ANSWER for each item, consulting your textbook when necessary. Be sure to select the BEST ANSWER from the subject matter in the textbook. You may discuss difficult points in the course with others. However, the answer you select must be your own. Remove a perforated answer sheet from the back of this text, write in the proper assignment number, and enter your answer for each item.

Your NRCC will be administered by your command or, in the case of small commands, by the Naval Education and Training Program Development Center. No matter who administers your course you can complete it successfully by earning a 3.2 for each assignment. The unit breakdown of the course, if any, is shown later under Naval Reserve Retirement Credit.

WHEN YOUR COURSE IS ADMINISTERED BY LOCAL COMMAND

As soon as you have finished an assignment, submit the completed answer sheet to the officer

Although you complete the course successfully, the Naval Education and Training Program Development Center will not issue you a letter of satisfactory completion. Your command will make an entry in your service record, giving you credit for your work.

WHEN YOUR COURSE IS ADMINISTERED BY THE NAVAL EDUCATION AND TRAINING PROGRAM DEVELOPMENT CENTER

After finishing an assignment, go on to the next. Retain each completed answer sheet until you finish all the assignments in a unit (or in the course if it is not divided into units). Using the envelopes provided, mail your completed answer sheets to the Naval Education and Training Program Development Center where they will be graded and the score recorded. Make sure all blanks at the top of each answer sheet are filled in. Unless you furnish all the information required, it will be impossible to give you credit for your work. The graded answer sheets will not be returned.

The Naval Education and Training Program Development Center will issue a letter of satisfactory completion to certify successful completion of the course (or a creditable unit of the course). To receive a course-completion letter, follow the directions given on the course-completion form in the back of this NRCC.

You may keep the textbook and assignments for this course. Return them only in the event you disenroll from the course or otherwise fail to complete the course. Directions for returning the textbook and assignments are given on the book-return form in the back of this NRCC.

PREPARING FOR YOUR ADVANCEMENT EXAMINATION

Your examination for advancement is based on the Occupational Standards for your rating as found in the MANUAL OF NAVY ENLISTED MANPOWER AND PERSONNEL CLASSIFICATIONS AND OCCUPATIONAL STANDARDS (NAVPERS 18068). These Occupational Standards define the minimum tasks required of your rating. The sources of questions in your advancement examination are listed in the BIBLIOGRAPHY FOR ADVANCEMENT STUDY (NAVEDTRA 10052). For your convenience, the Occupational Standards and the sources of questions for your rating are combined in a single pamphlet for the series of examinations for each year. These OCCUPATIONAL STANDARDS AND BIBLIOGRAPHY SHEETS (called Bib Sheets), are available from your ESO. Since your textbook and NRCC are among the sources listed in the bibliography, be sure to study both as you take the course. The qualifications for your rating may have changed since your course and textbook were printed, so refer to the latest edition of the Bib Sheets.

NAVAL RESERVE RETIREMENT CREDIT

This course is evaluated at 12 Naval Reserve retirement points. Upon satisfactory completion of assignments 1 through 9 these points will be creditable to personnel eligible to receive them under current directives governing retirement of Naval Reserve personnel.

COURSE OBJECTIVE

The basic objective of this course (RTM/NRCC package) is to help you meet the professional (technical) standards for the Aviation Electrician's Mate 3 & 2. You will demonstrate your understanding of the course material by correctly answering questions in the following subject areas: aeronautical publications and supply; elementary physics; electrical maintenance and troubleshooting; safety procedures and practices; test equipment; ground support equipment; aircraft electrical power systems; aircraft electrical and associated systems; flight, engine, and miscellaneous instrument systems; compass, inertial navigation, automatic flight control, and stabilization systems.

While working on this Nonresident Career Course, you may refer freely to the text. You may seek advice and instruction from others on problems arising in the course, but the solutions submitted must be the result of your own work and decisions. You are prohibited from referring to or copying the solutions of others, or giving completed solutions to anyone else taking the same course.

Naval courses may include a variety of questions -- multiple-choice, true-false, matching, etc. The questions are not grouped by type; regardless of type, they are presented in the same general sequence as the textbook material upon which they are based. This presentation is designed to preserve continuity of thought, permitting step-by-step development of ideas. Some courses use many types of questions, others only a few. The student can readily identify the type of each question (and the action required) through inspection of the samples given below.

MULTIPLE-CHOICE QUESTIONS

Each question contains several alternatives, one of which provides the best answer to the question. Select the best alternative, and blacken the appropriate box on the answer sheet.

SAMPLE

- s-1. The first person to be appointed Secretary of Defense under the National Security Act of 1947 was
1. George Marshall
 2. James Forrestal
 3. Chester Nimitz
 4. William Halsey

Indicate in this way on the answer sheet:

	1	2	3	4	
s-1	<input type="checkbox"/>	<input checked="" type="checkbox"/>	<input type="checkbox"/>	<input type="checkbox"/>	---

TRUE-FALSE QUESTIONS

Mark each statement true or false as indicated below. If any part of the statement is false the statement is to be considered false. Make the decision, and blacken the appropriate box on the answer sheet.

SAMPLE

- s-2. Any naval officer is authorized to correspond officially with any systems command of the Department of the Navy without his commanding officer's endorsement.

Indicate in this way on the answer sheet:

	1	2	3	4	
s-2	<input checked="" type="checkbox"/>	<input checked="" type="checkbox"/>	<input type="checkbox"/>	<input type="checkbox"/>	---

MATCHING QUESTIONS

Each set of questions consists of two columns, each listing words, phrases or sentences. The task is to select the item in column B which is the best match for the item in column A that is being considered. Items in column B may be used once, more than once, or not at all. Specific instructions are given with each set of questions. Select the numbers identifying the answers and blacken the appropriate boxes on the answer sheet.

SAMPLE

In questions s-3 through s-6, match the name of the shipboard officer in column A by selecting from column B the name of the department in which the officer functions.

A

B

Indicate in this way on the answer sheet:

- | | |
|------------------------------|---------------------------|
| s-3. Damage Control Assisart | 1. Operations Department |
| s-4. CIC Officer | 2. Engineering Department |
| s-5. Disbursing Officer | 3. Supply Department |
| s-6. Communications Officer | |

	1	2	3	4	
s-3	<input type="checkbox"/>	<input checked="" type="checkbox"/>	<input type="checkbox"/>	<input type="checkbox"/>	---
s-4	<input checked="" type="checkbox"/>	<input type="checkbox"/>	<input type="checkbox"/>	<input type="checkbox"/>	---
s-5	<input type="checkbox"/>	<input type="checkbox"/>	<input checked="" type="checkbox"/>	<input type="checkbox"/>	---
s-6	<input checked="" type="checkbox"/>	<input type="checkbox"/>	<input type="checkbox"/>	<input type="checkbox"/>	---

Assignment 1

Publications and Supply; Elementary Physics

Text: Pages 1-1 through 2-9

In this course you will demonstrate that learning has taken place by correctly answering training items. The mere physical act of indicating a choice on an answer sheet is not in itself important; it is the mental achievement, in whatever form it may take, prior to the physical act that is important and toward which course learning objectives are directed. The selection of the correct choice for a course training item indicates that you have fulfilled, at least in part, the stated objective(s).

The accomplishment of certain objectives, for example, a physical act such as drafting a memo, cannot readily be determined by means of objective type course items; however, you can demonstrate by means of answers to training items that you have acquired the requisite knowledge to perform the physical act. The accomplishment of certain other learning objectives, for example, the mental acts of comparing, recognizing, evaluating, choosing, selecting, etc., may be readily demonstrated in a course by indicating the correct answers to training items.

The comprehensive objective for this course has already been given. It states the purpose of the course in terms of what you will be able to do as you complete the course.

The detailed objectives in each assignment state what you should accomplish as you progress through the course. They may appear singly or in clusters of closely related objectives, as appropriate; they are followed by items which will enable you to indicate your accomplishment.

All objectives in this course are learning objectives and items are teaching items. They point out important things, they assist in learning, and they should enable you to do a better job for the Navy.

This self-study course is only one part of the total Navy training program; by its very nature it can take you only part of the way to your training goal. Practical experience, schools, selected reading, and the desire to accomplish are also necessary to round out a fully meaningful training program.

Learning Objective: Identify Navy aeronautic publications including their source, contents, numbering and status.

- 1-1. Aeronautic publications containing technical information designed to guide personnel in the maintenance of naval aircraft originate in what organization?
1. Naval Air Systems Command
 2. Chief of Naval Operations (Air)
 3. Forms and Publications Supply Office
 4. Naval Air Technical Services Facility
- 1-2. The printing and distribution of publications dealing with aircraft maintenance and flight crew training is controlled by what organization?
1. Office of DCNO (Air)
 2. Naval Air Systems Command
 3. Naval Air Technical Services Facility
 4. Forms and Publications Supply Office

- 1-3. What is the total number of pages a MIARS cartridge is capable of containing?
1. 1000
 2. 2700
 3. 3500
 4. 4700
- 1-4. As they become available to the fleet, aeronautical manuals and technical directives will be listed in which of the following publications?
1. NAVSUP Publication 2002
 2. NAVAIR 00-500M
 3. Navy-Air Force Publications Instructions
 4. Armed Forces Publications Index
- 1-5. What part of the Naval Aeronautic Publications Index (NAPI) is titled Equipment Applicability List?
1. NAVAIR 00-500
 2. NAVAIR 00-500A
 3. NAVAIR 00-500B
 4. NAVAIR 00-500C

- 1-6. In NAVAIR 00-500B, the aviation electrician will find a listing of technical manuals relating to
1. aircraft weapon systems only
 2. aircraft engines only
 3. aircraft engine accessories only
 4. aircraft weapons, engines, and engine accessories
- 1-7. Which of the following publications should be used to cross-index a technical manual to a specific microfilm cartridge?
1. 00-500A
 2. 00-500B
 3. 00-500C
 4. 00-500M
- 1-8. The NAVAIR manual number is divided into how many parts?
1. 1
 2. 2
 3. 3
 4. 4
- Refer to Table 1-1 and the publication number NA 01-45ABC-2-5 in answering items 9 through 11.
- 1-9. What is the subject category of this publication?
1. General
 2. Armament
 3. Aircraft
 4. Photograph
- 1-10. What part of the number identifies the aircraft manufacturer?
1. ABC
 2. 2
 3. 5
 4. 45
- 1-11. What part of the number identifies the publication as a Maintenance Instructions Manual?
1. 01
 2. 2
 3. 5
 4. ABC
- 1-12. For information on the safeguarding of classified manuals, you should consult which of the following publications?
1. OPNAVINST 4790.2 (Series)
 2. OPNAVINST 5510.1 (Series)
 3. NAVEDTRA 10348 (Series)
 4. NAVEDTRA 10307 (Series)
- 1-13. Manuals with which of the following classifications will NOT be reproduced on microfilm?
1. Confidential
 2. Secret only
 3. Top secret only
 4. Secret and top secret
- 1-14. Basic information for maintaining aircraft electrical wiring is found in which of the following publications?
1. NAVAIR 01-1A-505
 2. NAVAIR 01-1A 509
 3. NAVAIR 16-1-540
 4. NAVAIR 17-15BAD-1
- 1-15. Which of the following volumes contains information concerning the availability and applicability of technical maintenance manuals for the S-3A aircraft?
1. NA-S3AAA-0
 2. NA-S3AAA-1
 3. NA-S3AAA-2
 4. NA-S3AAA-3
- 1-16. Before attempting to perform any maintenance task on an aircraft, you should consult which of the following publications?
1. NATOPS manual
 2. Maintenance Instructions Manual (MIM)
 3. Illustrated Parts Breakdown (IPB)
 4. Equipment Applicability List
- 1-17. The MIMs for newer type aircraft may be sectionalized into how many work packages?
1. 5
 2. 2
 3. 3
 4. 4
-
- Learning Objective: Recognize contents and uses of various types of diagrams associated with aircraft electrical systems and equipment.
-
- 1-18. Which of the following illustrations normally indicates physical appearance and may show details regarding size, construction, arrangement, and location of parts?
1. Assembly diagram
 2. Block diagram
 3. Simplified schematic diagram
 4. Pictorial illustration
- 1-19. What type of diagram is useful in re-assembling a unit you have taken apart?
1. Exploded view diagram
 2. Dimension diagram
 3. Interconnection diagram
 4. Symbolic diagram

- 1-20. Which of the following types of diagrams is used to present a generalized explanation of the overall function of an operating system, disregarding the system's physical size, shape, or location?
1. Assembly diagram
 2. Block diagram
 3. Isometric diagram
 4. Simplified schematic diagram
- 1-21. The major purpose of the schematic diagram is to
1. show all the wiring in an aircraft on a single diagram
 2. show the electrical functioning of a particular system without regard to construction details
 3. establish the position of electrical equipment in a specific aircraft
 4. present detailed circuitry information on all electrical and electronic systems
- 1-22. How are mechanical linkages between parts on a simplified schematic diagram shown?
1. By dashed lines
 2. By solid lines
 3. By drawings of the mechanical linkages
 4. By dotted lines.
- 1-23. Which of the following types of diagrams show in detail how each wire is routed between units of a system?
1. Parts placement
 2. Schematic
 3. Signal flow
 4. Interconnection
- 1-24. On an isometric wiring diagram, a five-conductor cable appears as
1. one line
 2. five lines
 3. a section of tubing
 4. one line in a section of tubing

Learning Objective: Indicate the use and purposes of aeronautic publications:

- 1-25. The publication number NA 01-F14AAA-4 identifies what type of manual?
1. Operating Instruction Manual
 2. Maintenance Instructions Manual
 3. Service Instruction Manual
 4. Illustrated Parts Breakdown

- 1-26. Which of the following manuals should be used for the requisitioning and identification of aircraft parts?
1. NATOPS
 2. MIM
 3. IPB
 4. PMIC

- 1-27. Work Unit Code (WUC) manuals are identified by what number in Part III of the publication number?
1. -2
 2. -4
 3. -6
 4. -8

- 1-28. When used, the sixth and seventh characters of a WUC number identify what?
1. The type aircraft
 2. The location of the component
 3. Repairable subassemblies
 4. Whether the part is consumable or not

- 1-29. Which of the following characters would be used for a "When Discovered Code?"
1. A
 2. 2
 3. A2
 4. 799

- 1-30. To find the mandatory replacement interval for an aircraft's generator, you should refer to which of the following references?
1. MIM
 2. IPB
 3. WUC
 4. PMIC

- 1-31. Maintenance Requirement Cards (MRCs) do NOT include which of the following information?
1. Calibration procedures
 2. Work/zone area involved
 3. Performance interval
 4. Recommended rating

- 1-32. When the MIM does not include instructions for repairing a particular item, reference should be made to which of the following publications?
1. Illustrated Parts Breakdown
 2. Support equipment manual
 3. Accessories manual
 4. Periodic Maintenance Information Card

- 1-33. Avionic cleaning and corrosion prevention control requirements can be found in which of the following manuals?
1. NA 01-45AVA-4
 2. NA 01-1A-505
 3. NA 16-1-540
 4. NA 17-15BAD-1

Learning Objective: Identify directives pertaining to naval aviation and the methods used to distribute them.

- 1-34. What type of publication would be used to make an alteration to a portion of an existing manual?
1. A technical note
 2. A technical order
 3. A formal change
 4. A revision

- 1-35. What type of Rapid Action Change (RAC) would be issued for an urgent change to a technical manual?
1. Type I
 2. Type II
 3. Type III
 4. Type IV

- 1-36. An outdated MIARS cartridge must be returned to which of the following commands?
1. NAVAIR
 2. NATSF
 3. Forms and Publications Supply Office
 4. CNO (AIR)

- 1-37. The Technical Publications Deficiencies Reports (TPDRs) are used to report deficiencies in which of the following publications?
1. WUC manuals only
 2. MIMs only
 3. Technical manuals only
 4. WUC manuals, MIMS and technical manuals

- 1-38. In what format(s) should formal technical directives be issued?
1. Changes only
 2. Amendments and recissions
 3. Revisions and recissions
 4. Changes, amendments and revisions

- 1-39. Instructions and information directing a one-time inspection on an aircraft to determine whether a given condition exists should be issued in which of the following formats?
1. Change
 2. Bulletin
 3. Revision
 4. Amendment

- 1-40. What symbols appear in the border of IMMEDIATE ACTION directives?
1. Red Xs
 2. Black Xs
 3. Red diagonals
 4. Black diagonals

- 1-41. What information appears in the number identifier of an instruction but not in that of a Notice?
1. Type of release
 2. Consecutive number
 3. Subject classification number
 4. Originator's authorized abbreviation

- 1-42. What publication(s) is/are consulted to determine the subject classification number to assign to an instruction?
1. Navy Stock List of Forms and Publications, NAVSUP 2002
 2. List of Specifications and Standards, NAVWEPS 00-25-544
 3. SECNAV Instruction 52.0.11
 4. All of the above publications are required to assemble the various parts of the number

Learning Objective: Identify publications relating to aviation maintenance, identify the parts of a National Stock Number and recognize features of the Source Maintenance and Recoverability (SM&R) Code and the sections of an allowance requirement register.

- 1-43. Which of the following periodicals contains information extracted from aircraft accident reports, incidents, ground accident reports and is for Official Use Only?
1. Approach
 2. All Hands
 3. Naval Aviation News
 4. Maintenance Crossfeed

1-44. Which of the following publications gives accurate information on aviation related, maintenance-caused mishap prevention?

1. All Hands
2. Approach
3. Naval Aviation News
4. MECH

1-45. The National Stock Number consists of how many digits?

1. 7
2. 9
3. 11
4. 13

1-46. What part of the coded stock number 2VC 6420-00-174-4542-CY identifies the material as being under the control of Naval Air Systems Command?

1. CY
2. VC
3. 174
4. 2V

1-47. How often is NAVSUP 2002 issued?

1. Monthly
2. Quarterly
3. Semiannually
4. Annually

1-48. The SM&R code does NCT provide which of the following information?

1. Whether the part is ordered through supply or can be manufactured locally
2. The lowest maintenance level authorized to replace the item
3. The rating primarily responsible for repairing the item
4. The disposition required for a part that has been removed

1-49. Which positions of the SM&R code identify the lowest maintenance level authorized to remove and replace an item and to perform complete repair on the item?

1. One and two
2. Two and three
3. Three and four
4. Four and five

1-50. What section of the Allowance Requirement Registers pertains to handtools?

1. B
2. T
3. G
4. R

Learning Objective: Indicate the extent to which AEs utilize the principles of elementary physics; identify measurement systems and the relationship of the measuring units within the systems; and recognize terms associated with the measuring units.

1-51. Why should an AE understand the basic physical laws?

1. To help in doing a better job of maintaining and repairing equipment
2. To help in understanding the operation of the pertinent equipment
3. To gain knowledge which can be used in instructing new personnel in handling complex machines
4. For all of the above reasons

1-52. What unit of measurement is common to both the English system and the metric system?

1. Distance
2. Force
3. Mass
4. Time

1-53. The base for metric units of length is the

1. angstrom
2. micrometer
3. meter
4. kilometer

1-54. Refer to table 2-2. To convert meters to millimeters, the decimal point is moved to the

1. right, 6 places
2. left, 9 places
3. right, 3 places
4. left, 6 places

Learning Objective: Identify the following terms and their units of measurement: volume, mass, weight, force, speed; velocity, work, energy, power and derived units.

1-55. The quantity of matter a body contains is measured by its

1. volume
2. weight
3. mass
4. density

- 1-56. If a merchant on a mountain used spring-type scales for weighing a pound of beans to be placed in a bag, which of the following statements would be correct
1. The spring balance would be displaced the same amount by the pull of gravity as if the beans were weighed at the foot of the mountain
 2. The number of beans would be the same as if weighed at the foot of the mountain
 3. The bag would receive fewer beans than if weighed at the foot of the mountain
 4. The bag would receive more beans than if weighed at the foot of the mountain.
- 1-57. A standard mass, when used as a checking device for a balancing scale, serves as an accurate unit of measure at any position on earth because
1. the mass of a standard weight does not change with altitude, therefore its weight does not change with altitude
 2. acceleration of the standard mass due to gravity remains the same at any altitude on the earth's surface
 3. gravity affects both the standard mass and an object being weighed in proportional amounts
 4. the standard mass is manufactured to weigh exactly the weight necessary to overcome gravity
- 1-58. Dynes and newtons are used in the metric system as units of
1. work
 2. force
 3. pressure
 4. mass
- 1-59. To solve for the joules of work done by a force of 10 newtons acting through a distance of 30 feet, it is first necessary to
1. convert the 30 feet to meters
 2. convert the 10 newtons to watts
 3. know the time involved
 4. multiply 10 newtons by 30 feet
- 1-60. The knot is a derived unit which combines the unit of distance with the unit of
1. power
 2. work
 3. time
 4. acceleration
- 1-61. The term velocity may be used in place of speed only if the
1. unit of measurement is distance per second for a given length of time
 2. unit of measurement is distance per hour for a given length of time
 3. motion of the body is in a circular path following a given arc
 4. motion of the body is in a straight path in a given direction
- 1-62. The heat energy required to raise the temperature of 8 pounds of water 5°F is
1. 40 calories
 2. 40 Btu
 3. 252 calories
 4. 777.8 foot-pounds
- 1-63. The mechanical equivalent of 10 Btu of heat energy is
1. 1,356 foot-pounds
 2. 2,520 foot-pounds
 3. 7,460 foot-pounds
 4. 7,778 foot-pounds
- 1-64. All units of power involve measurements of
1. force, distance, and time
 2. mass, velocity, and time
 3. work and distance
 4. mass and distance
-
- Learning Objective: Identify characteristics applicable to the measurement of temperature, including temperature measurement scales and thermometers, and solve problems relative to temperature conversion.
-
- 1-65. If various objects are placed in a cold room until the temperature of each stabilizes, the ones which will conduct body heat fastest and seem coldest to the touch will be those composed of
1. rubber
 2. glass
 3. metal
 4. clay
- 1-66. Assume that the normal human body temperature is 98.6°F. On a Celsius thermometer, what reading would be considered normal?
1. 37.0°C
 2. 40.0°C
 3. 58.6°C
 4. 66.6°C

1-67. On a day when the temperature increases from 20°F to 45°F , how many degrees of increase would a Celsius thermometer indicate?

1. 13.88°C
2. 25.00°C
3. 27.76°C
4. 29.00°C

1-68. When a thermometer registers 30°C , what is the Fahrenheit temperature?

1. 54°F
2. 62°F
3. 75°F
4. 86°F

1-69. Using the "40 rule", the Fahrenheit temperature which corresponds to a Celsius temperature of 160° is

1. 32°F
2. 80°F
3. 160°F
4. 320°F

1-70. When a thermometer indicates a temperature of -22°F , what is the corresponding Celsius temperature?

1. -30°C
2. -10°C
3. 10°C
4. 18°C

In items 1-71 through 1-74, select from the temperature measurement scale which is associated with each temperature indication listed in column A.

	<u>A. Temperature Indications</u>	<u>B. Scales</u>
1-71	Indicates absolute zero point at 273°C	1. Kelvin
1-72	Indicates the boiling point of water at 212°F	2. Celsius
1-73	Indicates absolute zero at -460°F	3. Fahrenheit
1-74	Indicates the freezing point of water at 0°C	4. Rankine

Assignment 2

Elementary Physics

Text: Pages 2-9 through 2-29

Learning Objective (Continued):
Identify characteristics applicable to the measurement of temperature, including temperature measurement scales and thermometers, and solve problems relative to temperature conversion.

- 2-1. Water is not suitable for use in most modern thermometers because
 1. it does not expand or contract
 2. it expands and contracts
 3. its freezing point is too high
 4. its reaction to pressure changes is negative
- 2-2. The zero point on a Celsius thermometer coincides with the temperature of
 1. frost
 2. dry snow
 3. solid ice
 4. melting ice
- 2-3. The boiling point on a Celsius thermometer indicates the temperature of
 1. water just as it begins to boil
 2. water immediately before it boils
 3. steam under a pressure of 76 cm of mercury
 4. steam under a pressure of 100 cm of mercury
- 2-4. The resistance element used in the construction of resistance thermometers is normally fabricated with
 1. copper wire
 2. silver wire
 3. mercury
 4. platinum wire
- 2-5. The temperature measuring device which produces an electromotive force is a
 1. calorimeter
 2. galvanometer
 3. thermocouple
 4. resistor

Learning Objective: Recognize the human ear's reaction to sound and how sound reacts under given conditions.

- 2-6. Which statement is correct regarding the human ear's reaction to sound?
 1. It responds to sound on a linear scale
 2. It responds to sound on a logarithmic scale
 3. It responds to all sounds having sufficient pressure level
 4. It responds to all sounds between 55 and 14,000 vibrations per second if the pressure level is 1 dyne/cm² or higher

Refer to figure 2-6 in answering items 2-7 and 2-8.
- 2-7. The figure shows that a sound with a frequency of 7,040 vibrations per second and a pressure of 800 dynes/cm² is inaudible for which of the following reasons?
 1. The sound has exceeded the combinations of frequency and pressure for audibility and lies in the painful area
 2. The pressure is too high at that frequency
 3. Both 1 and 2 above
 4. The frequency is too low at that pressure
- 2-8. Which of the following statements is correct concerning a sound wave having a frequency of 220 vibrations per second at a pressure of 0.001 dyne/cm²?
 1. The sound is inaudible because the frequency is too low
 2. The sound is inaudible because the pressure is too low
 3. The sound will become audible if either pressure or frequency is sufficiently increased
 4. All of the above are correct

- 2-9. The minimum change in sound level that the human ear can detect is
1. 0.1 decibel
 2. 1 decibel
 3. 1 bel
 4. 10 bels

Learning Objective: Identify the particles which constitute matter and their relationship to each other in elements, compounds, and mixtures.

- 2-10. The phenomena associated with the atom are due to the presence of which of the following groups of principal subatomic particles?

1. Electron, proton, shell
2. Electron, neutron, nucleus
3. Electron, proton, nucleus
4. Electron, proton, neutron

- 2-11. The mass, and consequently the weight, of an atom is contained almost entirely in the

1. nucleus
2. protons
3. neutrons
4. electrons

- 2-12. Which of the following statements best describes a compound?

1. It is a chemical combination of two or more elements
2. It is a mixture of two or more elements
3. It is a combination of two or more elements that does not result in a chemical reaction
4. It is a combination of atoms of the same element but which have a different atomic weight

- 2-13. When an atom of one element has been changed into an atom of another element, it has undergone the process of

1. transference
2. transmutation
3. isotopic mutation
4. nuclear transference

- 2-14. Under some conditions, what element contains a neutron but under other conditions does not contain a neutron?

1. Gold
2. Deuterium
3. Hydrogen
4. Peroxide

- 2-15. The combined numbers of what two particles indicate the atomic weight of an atom?

1. Proton and nucleus
2. Proton and neutron
3. Proton and electron
4. Electron and nucleus

- 2-16. The term which refers to atoms of an element which have a different number of neutrons from other atoms of that same element and result in a different atomic weight is

1. isotope
2. hydrogen
3. deuterium
4. heavy hydrogen

Refer to figure 2A in answering items 2-17 and 2-18. (NOTE: The opposite of inert is active, meaning a tendency to combine with other elements.)

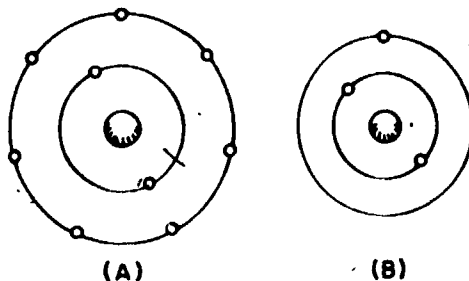

Figure 2A.--Elemental atom; with orbital electrons.

- 2-17. What chemical property is determined by the number of electrons in the outer shells of atom A and atom B?

1. A is active, B is inert
2. A is inert, B is active
3. Both are active
4. Both are inert

- 2-18. When placed adjacent to each other, atoms A and B will

1. attract each other since both are positively charged
2. repel each other since both are negatively charged
3. combine to form a compound
4. combine to form a mixture

- 2-19. How many electrons are there in the first three shells of an atom if those shells are completely filled?

1. 9
2. 28
3. 36
4. 72

- 2-20. In matter, the relative sizes of the particles are such that the
1. atom is the smallest unit of a compound, and the molecule is the smallest unit of an element
 2. atom is the smallest particle of a molecule, and the proton is the smallest particle of the atom
 3. molecule is the smallest unit of a substance, and the proton is the largest negatively charged particle of the atom
 4. molecule is the smallest unit of a compound, and the atom is the smallest unit of an element

- 2-21. Which phrase is most descriptive of an ion?
1. An electron which has been involved in secondary emission
 2. An atom which has the same number of protons and electrons
 3. An electron which is in motion between the cathode and the plate of a diode
 4. An atom which has gained or lost an electron

- 2-22. An atom becomes a negative ion when it
1. loses a proton from its nucleus
 2. gains a proton in its nucleus
 3. gains an electron in its outer shell
 4. loses an electron from its outer shell

Learning Objective: Identify the natural states of matter and the physical characteristics of each state.

- 2-23. Which of the following substances represent the natural states of matter?
1. Solids and gases
 2. Gases and liquids
 3. Liquids and solids
 4. Gases, liquids, and solids

- 2-24. The molecules of which substances are assumed to be constantly in motion?
1. Gases and liquids
 2. Liquids and solids
 3. Solids and gases
 4. Gases, liquids, and solids

- 2-25. Oil from a crankcase clings to a metal dipstick because of the oil's
1. ductility
 2. cohesion
 3. adhesion
 4. elasticity

- 2-26. Steel cannot be pulled apart easily because
1. its molecules exert a slight cohesive force between themselves
 2. cohesion and adhesion between the crystals serve to bond them together
 3. its molecules exert a great molecular force that resists separation
 4. a tremendous adhesive force between its molecules causes them to cling together

- 2-27. Which of the following groups of substances possess the property of elasticity?
1. Liquids, solids, and gases
 2. Solids and gases
 3. Gases and liquids
 4. Liquids and solids

- 2-28. Which of the following statements concerning liquids contains an error?
1. The utilization of hydraulic machinery permits liquids to be used to increase or decrease input forces
 2. Energy is transmitted through liquids practically instantaneously and equally in all directions with little or no loss in power
 3. Being completely flexible, liquids can easily transmit energy around bends, thereby making remote location of servos possible
 4. Liquids provide an excellent mechanical advantage because of their fluidity and compressible nature

Learning Objective: Identify characteristics of gases, and solve problems involving factors of pressure, volume, and temperature using Boyle's, Charles', and the general gas laws.

- 2-29. The laws of gases assume that gas molecules possess which of the following properties?
1. Constant motion
 2. Freedom to move in any direction
 3. Exertion of equal pressure at all points on enclosing surfaces
 4. All of the above

- 2-30. On a standard day to obtain an absolute pressure of 37.6 psi at sea level you would
1. add 76 psi to a gage pressure of -38.4 psi
 2. subtract 14.7 psi from gage pressure
 3. subtract 14.7 psi from a gage pressure of 52.3 psi
 4. add 14.7 psi to a gage pressure of 22.9 psi

- 2-31. According to the kinetic theory, which statement is correct concerning absolute zero?
1. It is the temperature at which no heat remains in a gas, but not the lowest temperature obtainable
 2. It has been attained only once, at which time the absolute zero point of 273.16°C was determined
 3. It is the temperature at which it is believed that all molecular activity in a substance ceases
 4. It is the temperature to which liquids, solids, and gases can be reduced and at which most molecular activity ceases

- 2-32. Use Boyle's law to solve the following problem. A gas is confined in 30 cubic feet of space, with an absolute pressure of 50 psi. If the volume is changed so that the pressure is increased to an absolute value of 100 psi, what is the new volume in cubic feet?
1. 13.4
 2. 15
 3. 19.4
 4. 60

- 2-33. Use Charles' law to solve the following problem. If the volume of a gas is 400 cubic feet at a temperature of 10°C, what will the volume be in cubic feet when the temperature is 60°C? (Change T to absolute values.)
1. 470.67
 2. 476.70
 3. 2,400
 4. 4,200

- 2-34. The energy developed in an aircraft engine is determined by the fuel's
1. mass
 2. weight
 3. volume
 4. temperature

- 2-35. The general gas equation used in the study of gases is a combination of which of the following gas laws?
1. Charles and Boyle
 2. Charles and Kelvin
 3. Boyle and Fahrenheit
 4. Boyle, Charles, and Kelvin

- 2-36. A tank containing 700 cubic inches of air has a gage pressure of 30 pounds when the temperature is 10°C. When the temperature rises to 35°C, gage pressure in pounds will be
1. 30.3
 2. 32.7
 3. 33.9
 4. 39.3

Learning Objective: Recognize the properties of matter and energy, including basic laws, related terms, and the solving of associated problems.

In answering items 2-37 through 2-39, select from column B a physical description that applies to each of the substances listed in column A.

A. Substance	B. Descriptions
2-37. Helium	1. Has a definite volume but no definite shape
2-38. Coal	2. Has neither a definite volume nor shape
2-39. Water	3. Has a definite volume and a definite shape
	4. Has definite shape but no definite volume

- 2-40. Which of the following statements defines impenetrability?
1. The ability of like molecules to attract each other
 2. The property of matter to occupy a space exclusively
 3. The ability of unlike molecules to attract each other
 4. The total amount of matter in an object

Learning Objective: Recognize the properties of matter and energy, including basic laws, related terms, and solve associated problems.

- 2-41. The reluctance of a body to change its speed, direction, or resting position is known as
1. weight
 2. density
 3. inertia
 4. cohesion
- 2-42. A resting body remains motionless until an external force acts upon it because
1. a body at rest possesses inertia
 2. all bodies possess a tendency to resist the pull of gravity
 3. its weight downward is greater than the upward force of the platform on which it rests
 4. when resting, its mass is maximum and the body is reluctant to impart any portion of its mass to motion energy
- 2-43. What is the quantitative measure of inertia called?
1. Mass
 2. Weight
 3. Density
 4. Acceleration due to gravity
- 2-44. Acceleration does NOT occur in which of the following circumstances?
1. A car traveling at 50 miles-per-hour turns a curve
 2. A car travels in one direction at 50 miles-per-hour for two minutes
 3. A car starts from stop and reaches 60 miles-per-hour in eighteen seconds
 4. A car slows from 60 miles-per-hour to 45 miles-per-hour in twelve seconds
- 2-45. The force of attraction exerted by the earth on a body is named
1. acceleration
 2. velocity
 3. gravity
 4. inertia
- 2-46. The space through which action-at-a-distance force acts is called
1. weight
 2. gravity
 3. a force field
 4. a force space
- 2-47. The description of a force is complete with an indication of
1. its point of application only
 2. its direction and magnitude only
 3. its direction and magnitude and its point of application
 4. its magnitude, direction, and use
- 2-48. The weight of a body at any altitude is determined by calculating the
1. sum of its mass and its acceleration due to gravity
 2. force on the body exerted by gravity at that altitude
 3. gravitational pull on it minus the associated frictional forces
 4. gravitational pull between one cubic inch of the body and the earth's surface
- 2-49. The specific gravity of a substance may be calculated by
1. dividing the volume of the substance by its weight
 2. dividing the weight of the substance by the weight of an equal volume of water
 3. dividing the volume of the substance by the volume of an equal weight of water
 4. taking the reciprocal of its density
- 2-50. A substance having a specific gravity of 5.5 weighs how many pounds per cubic foot?
1. 249.6
 2. 342.0
 3. 343.2
 4. 374.4
- 2-51. Refer to table 2-4. Which of the following terms is descriptive of a pound of lead when compared to a pound of iron?
1. More dense
 2. Less dense
 3. Lower specific gravity
 4. The same density
- 2-52. Which of the following statements relative to air in the atmosphere is NOT correct?
1. The molecules of air are closer together at the bottom of the atmosphere
 2. The weight of air pressing down from above determines air pressure at a given altitude
 3. Air exerts pressure in a downward direction only
 4. Air is more dense on the earth's surface than at an altitude of 1,000 feet

- 2-53. Refer to table 2-4. A bar of lead 9 feet long and 4 inches square (1 cubic foot) is placed on a flat surface in a horizontal position. What pressure in pounds per square inch does it exert on the surface?
1. 0.408
 2. 1.632
 3. 3.264
 4. 6.528

Learning Objective: Indicate the principles of gravity and acceleration in mechanics as related to force, mass, and motion, and solve associated problems.

- 2-54. Where is the approximate location of the center of gravity of the earth?
1. Along the Equator
 2. Near the center of the earth
 3. At the point where the 0° meridian intersects the Equator
 4. At the junction of the Equator and the international date line
- 2-55. Refer to figure 2-12. Which statement most accurately describes the two aspects of circular motion?
1. Rotation and revolution both describe the motion of a body around a fixed point; however, rotation is involved with smaller bodies
 2. Rotation and revolution both describe the motion of a body around an axis; however, revolution is involved with larger bodies
 3. Revolution describes the motion of a body around its axis, while rotation describes the motion of a body around an exterior point
 4. Rotation describes the motion of a body around its axis, while revolution describes the motion of a body around an exterior point
- 2-56. In the study of masses in motion, the term acceleration describes a
1. body that is moving
 2. body at rest or moving
 3. condition commonly called velocity
 4. change in a body's speed or direction of travel

- 2-57. In the formula $F = ma$, if "a" is zero, as in the case of a vehicle traveling at a constant speed in a given direction, force is
1. zero
 2. changing
 3. infinite
 4. impossible to determine unless the speed is known
- 2-58. Neglecting friction, what acceleration, will be given a wagon weighing 320 pounds (10 slugs) by an applied force of 30 pounds?
1. 3 ft/sec²
 2. 5 ft/sec²
 3. 10 ft/sec²
 4. 15 ft/sec²
- 2-59. A force which is applied to the center of gravity of a body and causes the body to accelerate but not to rotate is called a
1. torque
 2. translational force
 3. centrifugal force
 4. centripetal force

Learning Objective: Identify the relationships of work, power, and energy in solving associated problems, and recognize the need to consider friction and efficiency in calculating mechanical advantage.

- 2-60. Which statement is correct concerning work done by a person who lifts a 50-pound weight a distance of 4 feet and holds it there for 1 minute?
1. No work is done because the person does not move
 2. Work is done both in lifting the weight and in holding it motionless
 3. Work is done in lifting the weight, but not in holding it motionless
 4. No work is done because there is no translational force present
- 2-61. A pump lifts 1,000 gallons of a liquid which weighs 8 pounds per gallon through a vertical distance of 125 feet. In foot-pounds, what is the amount of work done?
1. 1,000
 2. 1,250
 3. 1,000,000
 4. 1,250,000

- 2-62. An elevator lifts an aircraft weighing 30 tons a distance of 25 feet in 6 seconds. What is the approximate horsepower developed?
1. 330
 2. 454
 3. 554
 4. 745

In answering items 2-63 and 2-64, assume that the water system of a naval installation requires the expenditure of 2,000,000,000 foot-pounds of energy during a 24-hour period.

- 2-63. Assuming 100% efficiency, how many watts of electrical power are used to produce the mechanical power expended by the pumps?
1. 15,699.93
 2. 31,399.14
 3. 94,197.42
 4. 165,599.70

- 2-64. If the pumps are only 50% efficient, how many watts of electrical energy are required?
1. 31,399.14
 2. 62,798.28
 3. 188,394.84
 4. 331,199.40

- 2-65. An automobile whose mass is 100 slugs is moving at 12 feet per second. What is its kinetic energy? (The unit of kinetic energy is the foot-pound.)
1. 600 foot-pounds
 2. 3,600 foot-pounds
 3. 7,200 foot-pounds
 4. 14,400 foot-pounds

- 2-66. Which of the following is an example of friction?
1. The action of skates against ice
 2. The use of a parachute by a landing aircraft
 3. The contact of an airborne aircraft with the air
 4. Each of the above

- 2-67. Refer to figure 2-13. How much force must be applied at the source of a lever to raise a load of 100 pounds if D1 is 10 feet and D2 is 2 feet?
1. 20 lb
 2. 50 lb
 3. 80 lb
 4. 100 lb

Learning Objective: Identify centripetal and centrifugal forces and their relationship to revolving bodies.

- 2-68. Centripetal and centrifugal are terms used to denote equal and opposite forces in relation to
1. bodies moving with zero acceleration
 2. revolving bodies
 3. stationary bodies
 4. bodies moving with acceleration

- 2-69. Refer to figure 2-14. During the time that the ball is in a circular path, the force which prevents the ball from traveling in a linear path is
1. momentum
 2. centrifugal force
 3. centripetal force
 4. either centripetal force or centrifugal force, depending upon the length of the circle's radius

- 2-70. In a given circular path, as rotational speed increases how do the centripetal and centrifugal forces vary?
1. Both increase
 2. Both decrease
 3. Centripetal increases and centrifugal decreases
 4. Centripetal decreases and centrifugal increases

- 2-71. Which of the following statements about centripetal and centrifugal forces is correct as shown by the force formula given in your textbook concerning rotational motion?
1. The forces involved are inversely proportional to mass and velocity, and are directly proportional to radius
 2. The forces involved are directly proportional to mass, and are independent of radius
 3. The smaller the radius or the greater the mass, the smaller are the forces involved
 4. The smaller the radius or the greater the mass, the larger are the forces involved

Assignment 3

Elementary Physics; Electrical Maintenance and Troubleshooting

Text: Pages 2-30 through 3-16

Learning Objective: Identify the nature and properties of heat, and the kinetic and radiant energy theories used to explain the nature of heat.

- 3-1. The theory of radiation of energy treats radio waves, heat, and light as belonging to the same general form of energy, and their principal difference is one of
1. phase
 2. polarity
 3. frequency
 4. magnitude
- 3-2. Gases are poorer conductors of heat than most solids because
1. gas molecules expend their energy in striking each other
 2. the molecules in gases travel slower than those in solids
 3. gas molecules do not absorb as much heat as those in solids
 4. the molecules in gases are more loosely packed than those in solids
- 3-3. Transfer of heat by convection involves,
1. electromagnetic wave motion
 2. smooth, light-colored surfaces
 3. heating a substance that moves when heated
 4. adjacent molecules transferring heat by collision
- 3-4. An object which is cooled by the use of surrounding fins employs the heat transfer processes named
1. absorption and convection
 2. absorption and conduction
 3. conduction and radiation
 4. conduction and convection
- 3-5. The term that identifies heat energy transfer which occurs in the form of electromagnetic waves, and which is almost identical to the same action in the transfer of light, is
1. radiation
 2. absorption
 3. conduction
 4. convection
- 3-6. Characteristics of the heat transfer principle of radiation reveal that radiant heat acts in which of the following ways?
1. Moves at the speed of light
 2. Always travels in a straight line
 3. May pass through a medium without heating it
 4. All of the above ways

In answering items 3-7 through 3-9, select from column B the term which is most closely related to each definition listed in column A.

	<u>A. Definitions</u>	<u>B. Terms</u>
3-7	Heat transference by molecular collision	1. Conduction 2. Convection
3-8	Motion of the cooling medium occurring without mechanical motion being applied	3. Radiation 4. Absorption
3-9	Heat transference closely resembling radio wave propagation	

- 3-10. The surface which is most effective in radiating heat is a
1. dull black surface
 2. polished black surface
 3. dull silver-colored surface
 4. polished silver-colored surface

Learning Objective: Indicate expansion characteristics of substances relative to temperature.

- 3-11. Copper cannot be employed in conjunction with the stem or base of a vacuum tube because
1. copper and glass have the same rate of expansion
 2. copper and glass do not have the same rate of expansion
 3. copper has a positive coefficient of expansion while glass has a negative coefficient of expansion
 4. copper has a negative coefficient of expansion while glass has a positive coefficient of expansion
- 3-12. A steel tape is exactly 100 feet long when its temperature is 20°C . If its temperature is increased to 38°C , what will its length be?
1. 100.0198 ft
 2. 100.1988 ft
 3. 101.0019 ft
 4. 101.0198 ft
- 3-13. Which of the following temperature measuring devices utilizes the differences in coefficients of expansion of dissimilar metals?
1. Thermostat
 2. Thermometer
 3. Thermograph
 4. Thermocouple
- 3-14. A steel plate 1 foot square and 1 inch thick has a 1/2-inch diameter hole through its center. What happens to the hole as the plate is heated?
1. It becomes larger
 2. It becomes smaller
 3. It remains the same size
 4. It becomes either larger or smaller, depending on the amount of heat applied
- 3-15. The number of British thermal units required to raise the temperature of two pounds of water from its freezing point (32°F) to its boiling point (212°F) is
1. 180
 2. 212
 3. 244
 4. 360
- 3-16. An action producing 1,764 calories of heat energy requires how many foot-pounds of mechanical energy?
1. 3,112
 2. 3,890
 3. 4,668
 4. 5,446
- 3-17. Refer to table 2-6. If equal amounts of heat are applied to equal masses of the following materials, which material will have the greatest increase in temperature?
1. Copper
 2. Glass
 3. Silver
 4. Water
- 3-18. The amount of heat required to change a unit mass of a substance from a solid state to a liquid state with no change in temperature is known as the heat of
1. condensation
 2. combustion
 3. fusion
 4. vaporization
- 3-19. Refer to figure 2-19. How much heat is required to convert 12 grams of ice at 0°C to steam at 100°C ?
1. 6,480 calories
 2. 7,240 calories
 3. 7,680 calories
 4. 8,640 calories
- 3-20. The amount of heat required to change liquid into a vapor is known as the heat of
1. condensation
 2. fusion
 3. vaporization
 4. combustion

Learning Objective: Identify phenomena and terminology related to heat and heat measuring methods, and perform calculations using relevant formulas.

- 3-21. Water will boil at a temperature lower than 212°F on top of Mt. Everest because
1. the heat of vaporization increases as altitude is increased
 2. molecules of water absorb heat faster under a condition of decreased atmospheric pressure
 3. the atmospheric pressure is less than at sea level, and water boils when the vapor pressure and atmospheric pressure are equal
 4. the atmospheric pressure is greater than at sea level, and the increased external pressure will equal the vapor pressure at a lower temperature

- 3-22. In heating a liquid, when the number of molecules returning to the liquid state is equal to the number changing from the liquid to gaseous state, the condition is known as
1. saturated vapor
 2. condensation
 3. equal vaporization
 4. equilibrium

Learning Objective: Identify the categories of aircraft maintenance and the publications that outline the aircraft maintenance plan; recognize factors relevant to safety and first aid while working around aircraft.

- 3-23. What manual outlines the maintenance plan for naval aircraft?
1. NAVEDTRA 10348-E
 2. NAVAIR 01-1A-509
 3. NAVAIR 16-1-540
 4. OPNAVINST 4790.2(Series)
- 3-24. All maintenance performed on naval aircraft can be grouped under which of the following categories?
1. Preventive only
 2. Corrective only
 3. Preventive and corrective
 4. Fix in place
- 3-25. An accident-free naval career can best be achieved by accomplishing which of the following actions?
1. By constantly reading the technical manuals
 2. By reading all Navy rules and regulations
 3. By making a list of all potential work hazards
 4. By taking a common sense approach towards safety

- 3-26. If electrical equipment is to be repaired, what should be done before the actual work is begun?
1. The buses for the associated circuits should be removed
 2. The main supply switches should be shorted out
 3. The main power switches should be secured open and properly tagged
 4. An individual should be stationed nearby with a fire extinguisher

- 3-27. Which of the following personnel share in the responsibility for reporting unsafe working conditions?
1. Every individual who is aware such conditions exist, regardless of their rate or position
 2. Safety inspectors and quality assurance inspectors
 3. Shop supervisors and quality assurance inspectors
 4. Shop supervisors and shop safety petty officers

- 3-28. Which of the following publication(s) provides information pertaining to first aid treatment for electrical shock?
1. Airman, NAVPERS 10307
 2. Standard First Aid Training Course, NAVPERS 10081
 3. Both 1 and 2 above
 4. Aviation Electrician's Mate 3 & 2, NAVPERS 10348-E

- 3-29. Which of the following information is NOT found in NAVMAT P-5100(Series), Safety Precautions for Shore Activities?
1. Basic information which can be readily adapted for shipboard activities
 2. Basic and general information which can be used for many operations and functions in the Navy
 3. Basic information which can be used in establishing specific safety instructions for an activity's particular equipment or weapons system
 4. Specific safety instructions which can be used in any locality

- 3-30. When working on or around reciprocating engine aircraft, which of the following areas is considered the most dangerous?
1. Intakes and exhaust ducts
 2. Propeller areas
 3. Areas that contain loose equipment and debris
 4. Ejection seat areas

- 3-31. When an aircraft engine is operating on the flight line, the anticollision light on that aircraft is turned on to warn personnel of propellers, rotors and
1. aircraft refueling in progress
 2. ordnance loading in progress
 3. liquid oxygen converters being filled
 4. jet intakes and exhausts
- 3-32. Loss of sensitivity in hearing first occurs in which of the following frequency ranges?
1. 500 - 3,000 Hertz
 2. 4,000 - 6,000 Hertz
 3. 7,000 - 8,000 Hertz
 4. 7,500 - 9,000 Hertz
- 3-33. Refer to figure 3-2. When you are at a position 50 feet to the rear and 100 feet to the right of an A-7 aircraft, ear protection is required because you are within what decibel range?
1. 90 dB to 120 dB
 2. 120 dB to 140 dB
 3. 140 dB to 160 dB
 4. 160 dB and above
- 3-34. When working on the flight deck during flight operations, which of the following senses will greatly increase your safety?
1. Hearing
 2. Sight
 3. Smell
 4. Touch
- 3-35. Which of the following statements relative to flight deck safety is INCORRECT?
1. Sleeves and pant legs of flight deck uniforms should never be rolled up
 2. Life vests should be worn during flight deck operations in the event the crewman is blown overboard
 3. Personnel participating in flight deck operations are not required to wear the flight deck uniforms
 4. Gloves and hard toe safety shoes should be worn to minimize the chances of injury

Learning Objective: Identify AE flight deck clothing and the precautionary measures to be exercised by the AE in the work environment to prevent personal injury and foreign object damage to aircraft; recognize the appropriate fire extinguisher to be used on electrical fires.

- 3-36. During flight operations on an aircraft carrier, AE maintenance personnel are identified by the wearing of which of the following clothing?
1. A blue helmet and blue jersey with white stripe and squadron insignia
 2. A green helmet and blue jersey with black stripe and squadron insignia
 3. A yellow helmet and yellow jersey with black stripe and squadron insignia
 4. An orange helmet and orange jersey with yellow stripe and squadron insignia
- 3-37. During work on the flight deck, which of the following persons is most responsible for your safety?
1. Flight deck chief
 2. Air boss
 3. Maintenance officer
 4. Yourself
- 3-38. If a loose bolt is drawn into the jet engine intake which of the following results would probably occur?
1. Electrical circuits would be shorted
 2. The engine would be destroyed
 3. The flight controls would jam
 4. All of the above
- 3-39. Which of the following practices is NOT recommended for minimizing foreign object damage (FOD) to aircraft?
1. Picking up debris and any loose objects in the hangar or on the flight line
 2. Removing loose objects from pockets prior to beginning work
 3. Wearing loose clothing articles on the flight line
 4. Replacing dust covers when work is completed

3-40. The most significant aspect of leaving small parts or tools adrift in an aircraft is that

1. they must be replaced from stock
2. the AE shop will have less parts or tools with which to work
3. the aircraft's logbook must reflect such losses
4. they constitute a hazard to crewmen and equipment

3-41. When working on high voltage circuits or around wiring having exposed surfaces, tools and equipment having metal parts must be kept at a minimum of how many feet from the work area.

1. 5
2. 2
3. 3
4. 4

3-42. You should exercise caution when working with voltages above

1. 6 v
2. 10 v
3. 12 v
4. 15 v

3-43. The intensity of electrical shock is determined by which of the following electrical properties?

1. Current
2. Voltage
3. Electromagnetic force
4. Impedance

3-44. Normally, the primary reason why a person should be requested to rest after receiving an electrical shock is that the

1. heart is temporarily weakened
2. muscles have been damaged
3. nerves have been damaged
4. brain is impaired

3-45. When fighting an electrical fire, the AE should use a fire extinguisher containing which of the following elements?

1. Foam
2. Soda and Water
3. Carbon dioxide (CO₂)
4. Water (H₂O)

Learning Objective: Identify proper methods of handling volatile materials and compressed air, dangers associated with them, and some appropriate first aid measures concerning volatile materials; recognize safety practices to be followed when using tools and equipment.

3-46. Liquid oxygen must be handled with extreme caution to prevent spilling on clothing, wood, grease, etc. Such items when oxygen-saturated may be ignited by which of the following sources?

1. Sparks from any source
2. Static electricity discharge
3. Open flame
4. Each of the above

3-47. Which of the following material(s) is hazardous when it comes in contact with liquid oxygen?

1. Oil only
2. Grease only
3. Both 1 and 2 above
4. Air

3-48. Which of the following actions should be taken by a person who has swallowed gasoline?

1. Swallow three glasses of salt water to induce vomiting
2. Drink large amounts of milk or water and take four tablespoons of vegetable oil if available
3. Take two aspirins and two glasses of water
4. Swallow a solution of bicarbonate of soda and water

3-49. Which of the following statements concerning compressed air is INCORRECT?

1. It can inject minute foreign bodies into the skin
2. It can rupture cell tissue and cause severe wounds
3. It can pass through clothing and may cause fatal internal injuries
4. It is not harmful to the person because once released from the hose the air loses its pressure

- 3-50. When using compressed air to blow out fixtures and jigs, what maximum pressure should be maintained?
1. 10 psi
 2. 20 psi
 3. 30 psi
 4. 40 psi
- 3-51. To tighten a drill bit firmly in the drill, which of the following devices should be used?
1. Adjustable wrench
 2. Pliers
 3. Chuck key
 4. Straight slot screwdriver
- 3-52. Accidents in electrical and electronics work centers are mostly caused by which of the following potential hazards?
1. Moving machinery
 2. Improper grounding
 3. Carelessness
 4. Exposed electrical fixtures
- 3-53. A worn, damaged, or broken tool should be reported immediately to which of the following personnel?
1. Crew leader
 2. Work center supervisor
 3. Division officer
 4. Material control officer
- 3-54. Screwdrivers used in electrical work should have which of the following features?
1. Nonconducting handle
 2. Conducting handle
 3. Grounded handle
 4. Bronze shaft
- 3-55. If the cord on an electrical power tool is damaged, what action should be taken?
1. Coat the cord with flux and cover with rubber tape
 2. Shorten the cord to remove the damaged portion
 3. Repair the damaged section with insulating tape
 4. Replace the cord
- 3-56. When using the soldering iron, which of the following practices should NOT be followed?
1. Providing ventilation for the iron while on its rest rack
 2. Holding small soldering jobs with pliers or clamps
 3. Wiping excess solder from the iron with a hand-held rag
 4. Disconnect the iron during temporary absences from the area
- 3-57. While using an electric drill, you experience an electrical shock. Which of the following conditions would most likely cause this?
1. Voltage source too high
 2. Voltage source too low
 3. Incorrectly grounded drill
 4. Drill overloaded
- 3-58. Why has the polarized three-wire plug replaced the two-wire plug in many installations?
1. To provide a grounding system that is as nearly fool-proof as possible
 2. To provide a choice of grounding-pin selection for local installations
 3. To make it unnecessary to observe color-code wire connections in electrical equipment
 4. To assure that the black wire in a receptacle will be attached to the case of the plugged-in equipment
- 3-59. What color is the safety ground wire for electrical tools?
1. Black
 2. White
 3. Green
 4. Red
- 3-60. The safest method of applying voltage from an old two-wire receptacle to a power tool which has the newer three-wire system is to use an adapter which has an external ground wire and
1. bend the external ground wire out of the way and tape the exposed terminal
 2. connect the external ground wire to a good ground before plugging in the tool
 3. use a strap to connect the external ground wire of the adapter to the case of the tool
 4. connect the external ground wire to the center screw of the receptacle plate before plugging in the tool
- 3-61. Which of the following programs ensures that aeronautical equipment is maintained through its life cycle?
1. TCP
 2. FOD
 3. PMS
 4. IMRL

Learning Objective: Identify the criteria for, and the types of aircraft inspections. Recognize the importance of using recommended lubricants on an aircraft.

Learning Objective: Identify the primary source of information for aircraft corrosion control treatment, the basic philosophy of the corrosion control program and corrosion effects on refined metals.

- 3-62. An aircraft equipment inventory is required when which of the following inspections is performed?
1. Acceptance inspection.
 2. Daily inspection
 3. Calendar inspection
 4. Phase inspection

- 3-68. Corrosion affects refined metals in a manner which causes them to
1. become hard and brittle
 2. tend to return to their natural state
 3. alloy with adjacent environmental elements
 4. tend to evaporate into the atmosphere

In items 3-63 through 3-66 select from column B the type of inspection identified by the information in column A.

	<u>A. Information</u>	<u>B. Inspections</u>
3-63.	An inspection divided into small packages accomplished at a prescribed interval	<ol style="list-style-type: none"> 1. Daily 2. Phased 3. Turnaround 4. Conditional
3-64.	An inspection that is conducted between flights	
3-65.	An inspection required as the result of a hard landing	
3-66.	An inspection required prior to the first flight of the day	

- 3-69. Which of the following actions is NOT considered a part of the basic philosophy of an effective corrosion control program?
1. cleaning
 2. treating
 3. reprotecting
 4. replacing

- 3-70. When working on a specific aircraft, which of the following manuals shall take precedence for conducting corrosion treatment?
1. NA 01-1A-509
 2. NA 16-1-540
 3. The aircraft's corrosion manual
 4. OPNAVINST 4790.2 (Series)

- 3-67. It is important to use the lubricants specified in the applicable aircraft Maintenance Instructions Manual because
1. temperature changes affect the viscosity of a lubricant
 2. lubricants become thin when subjected to low temperatures
 3. increased altitude causes lubricants to become thin
 4. the aircraft manufacturer has the right to specify their own lubricant

Assignment 4

Electrical Maintenance and Troubleshooting

Text: Pages 3-17 through 3-74

Learning Objective: Identify procedures for troubleshooting and repairing equipment; recognize test equipment components, functions, operation and use in troubleshooting.

- 4-1. The first major step to take when troubleshooting an aircraft's electrical system is to analyze the trouble. The Maintenance Instructions Manual is valuable during this step because it provides which of the following guides?
1. Explains the function of the system
 2. Points out the location of each part in the system
 3. Describes the job of each component of the system
 4. Each of the above
- 4-2. When troubleshooting aircraft systems or components, why should past records be checked?
1. To determine how the systems or components operate
 2. To see if previous or interrelated maintenance was performed on the same systems or components
 3. To determine the location of the components in the system
 4. To determine which test equipment to use
- 4-3. What is the first check that is usually made in troubleshooting an electrical device that is not receiving power?
1. Check the fuses
 2. Check the power supply
 3. Check for loose connector pins
 4. Check for visible indications of trouble
- 4-4. Which of the following meters is the most useful when troubleshooting an open circuit?
1. Voltmeter
 2. Ammeter
 3. Ohmmeter
 4. Wattmeter
- 4-5. After planning the job of correcting an electrical power failure on an aircraft, the AE assembled the necessary tools and equipment, and performed the following steps:
- A. Disconnected the aircraft battery
 - B. Removed a section of oxygen line to give access to an electrical power connector
 - C. Disconnected the connector
 - D. Replaced a corroded pin in the connector
 - E. Reassembled the connector and oxygen line, and reconnected the battery
- What error was committed and why was it wrong?
1. The battery was disconnected; the main circuit protector should have been disconnected instead
 2. The connector was repaired in the aircraft; it should have been repaired in the shop
 3. The oxygen line was removed and replaced; this should have been done so by an Aviation Structural Mechanic E
 4. One pin on the connector was replaced; the complete connector should have been replaced instead
- 4-6. Before replacing a major component in an aircraft, the AE should determine that
1. the component to be replaced is defective
 2. the intended replacement is not a substitute component
 3. replacement of the component will not require a test flight
 4. the appropriate work center has been assigned the task

- 4-7. When making adjustments to any system, which of the following manuals should be consulted?
1. MIMS
 2. IPB
 3. NAVSUP 2002
 4. NATOPS
- 4-8. Which of the following statements is correct regarding how an ammeter is connected into a circuit?
1. It is in parallel with the circuit
 2. It is in series-parallel with the circuit
 3. Both 1 and 2 are correct
 4. It is in series with the circuit
- 4-9. The selector switch on a multimeter, not being used, should be placed in the OFF or what other position?
1. High resistance position
 2. High dc volts position
 3. High ac volts position
 4. Low resistance position
- 4-10. A grounded circuit is most likely caused by which of the following conditions?
1. A blown fuse
 2. A tripped circuit breaker
 3. Frayed insulation on wiring
 4. Loose terminal lugs
- 4-11. Which of the following conditions could be the cause of a short circuit?
1. A blown fuse
 2. A faulty circuit breaker
 3. A loose plug-in connection
 4. Frayed insulation
- 4-12. What is the first step you should take before checking a circuit's voltage?
1. Check the power source for proper voltage
 2. Check for tripped circuit breakers
 3. Pull the proper circuit breakers or fuses to prevent damage to the meter
 4. Disconnect the load to prevent a drain on the power source
- 4-13. For precise resistance measurements you should use which of the following instruments?
1. Ohmmeter
 2. Megger
 3. Wheatstone bridge
 4. Multimeter
- 4-14. A multimeter consists of which of the following meters in one unit?
1. Voltmeter, frequency meter, ohmmeter
 2. Frequency meter, ammeter, voltmeter
 3. Ammeter, voltmeter, ohmmeter
 4. Frequency meter, ohmmeter, ammeter
- 4-15. A permanent-magnet, moving-coil meter mechanism can be adapted to measure alternating current and voltage when used with which of the following devices?
1. Transformers
 2. Transponders
 3. Rectifiers
 4. Reactors
- 4-16. A voltmeter with low sensitivity should NOT be used to measure which of the following types of circuits?
1. Low impedance
 2. High impedance
 3. Low inductance
 4. High inductance
- 4-17. A megger is prevented from exceeding its rated output voltage by the action of
1. the breakdown of the insulation being tested
 2. a slip clutch
 3. a voltage regulator
 4. a diode limiter
- 4-18. When testing for high resistance grounds or leakage, what meter should be used?
1. VTVM
 2. Ammeter
 3. Multimeter
 4. Megger
- 4-19. Which of the following values CANNOT be measured with an oscilloscope?
1. Impedance
 2. Frequency
 3. Voltage amplitude
 4. Phase differences
- 4-20. What term is used to define abnormal resistance or impedance interference with normal signal flow?
1. Distortion
 2. Discontinuity
 3. Reflectometry
 4. Reduction

- 4-21. Which of the following instruments is particularly useful in troubleshooting fuel quantity coaxial cables?
1. VTVM
 2. Time domain reflectometer
 3. Wheatstone bridge
 4. Ammeter
- 4-22. The output of the phase detector in a phase angle voltmeter is proportional to the signal amplitude multiplied by the
1. sine of the angle of phase difference
 2. cosine of the angle of phase difference
 3. tangent of the angle of phase difference
 4. cotangent of the angle of phase difference
- 4-23. Maximum deflection of the phase angle voltmeter occurs when the phase relationship between the two signals is
1. 0° or 90°
 2. 0° or 180°
 3. 90° or 120°
 4. 90° or 180°
- 4-24. A precision voltmeter that compares an unknown voltage with an internal reference voltage is a
1. phase angle voltmeter
 2. time domain reflectometer
 3. differential voltmeter
 4. VTVM
-
- Learning Objective: Recognize facts pertinent to aircraft wiring, including selection, installation, and identify maintenance procedures for electrical motors.
-
- 4-25. To be classified as a cable, a single conductor must have which of the following characteristics?
1. Insulated and have a metallic covering
 2. Insulated and designed for carrying RF energy
 3. Covered by a metal shield and designed for carrying RF energy
 4. At least a 00 wire size
- 4-26. If you must replace an electrical wire in an aircraft, what publication should you first consult to determine the correct size and type of wire to be used?
1. The Maintenance Instructions Manual for the aircraft involved
 2. Basic Electricity, NAVEDTRA 10348 (Series)
 3. Military Specifications MIL-W-5088 (Series)
 4. Installation Practices for Aircraft Electric and Electronic Wiring, NAVREP 01-1A-505
- 4-27. Which of the following types of insulated wire is most frequently used in aircraft electrical systems?
1. Stranded copper conductor rated at 600 V
 2. Stranded aluminum conductor rated at 600 V
 3. Solid copper conductor rated at 150 V
 4. Solid aluminum conductor rated at 150 V
- 4-28. Aluminum has a tendency to flow away from the point where pressure is applied. This tendency is known by what term?
1. Keying
 2. Crystallization
 3. Creep
 4. Feed-through
- 4-29. When stamping wires or cables, the distance between markings shall not exceed
1. 3 inches
 2. 6 inches
 3. 15 inches
 4. 24 inches
- 4-30. Which of the following information is NOT given in the wire identification code?
1. Circuit function
 2. Wire size
 3. Wire segment
 4. Wire resistance
- 4-31. Which of the following letters should NOT be used to identify a wire segment?
1. E
 2. O
 3. X
 4. Z

- 4-32. Relative to wiring identification, which of the following letters is used to designate a ground wire?
1. A
 2. B
 3. C
 4. N
- 4-33. The use of sealed antifriction bearing assemblies greatly simplifies the maintenance of motors because
1. the entire motor can be submerged in cleaning solvent without disassembly
 2. the bearings require no cleaning or lubrication except during major aircraft inspections
 3. the bearings require little or no attention
 4. they are easily disassembled
- 4-34. You are using methyl chloroform to clean electrical equipment. How long should the equipment be allowed to stay in the solution?
1. Less than 5 minutes
 2. 5 to 15 minutes
 3. 15 to 30 minutes
 4. 30 to 60 minutes
- 4-35. During motor disassembly, why should the brushes be marked for eventual return to their original holders?
1. To restore the original spring tension on the brushes
 2. To ensure correct fit of the brushes on the commutator
 3. To ensure the brushes do not bind in the holders
 4. To provide proper fit of the hold-down springs

Learning Objectives: Recognize construction methods and relevant factors pertaining to printed circuit boards; identify capabilities, functions and characteristics of ground support equipment.

- 4-36. When a printed circuit is manufactured by the photoetching process, what portions of the plastic or phenolic sheet are actually photographically exposed?
1. All areas covered by the light-sensitive enamel
 2. Only areas where circuit components, such as resistors, are attached
 3. Only areas that are later removed
 4. Only areas that act as wires

- 4-37. During the etching process in which copper is removed, the unexposed copper surfaces are protected by
1. enamel
 2. solder
 3. the printed circuit overlay
 4. the exposed-copper smear
- 4-38. Once certified for microminiature repair, a person need not be recertified ever.
- 4-39. Which of the following items are ground support equipment?
1. Lathes
 2. Electric drills
 3. Headsets
 4. Aircraft starting units
- 4-40. The ac frequency output of mobile electric powerplants is controlled by which of the following components?
1. A voltage regulator
 2. Current transformers
 3. A supervisory panel
 4. A speed governor
- 4-41. Personnel who operate GSE equipment should be familiar with the ground support equipment operator/organizational maintenance program. Which of the following manuals contains this program?
1. Aircraft MIMS
 2. NATOPS
 3. OPNAVINST 4790.2 (Series)
 4. NA 01-IX-505
- 4-42. The hand operated control on the tow bar of the NC-7C is used for which of the following purposes?
1. Starting the unit
 2. Control of voltage output
 3. Directional control during self-propelled operation
 4. Control of frequency output
- 4-43. What is the maximum towing speed for the NC-7C powerplant?
1. 10 mph
 2. 20 mph
 3. 30 mph
 4. 40 mph
- 4-44. What type of engine/motor propels the NC-8A powerplant?
1. 4-cylinder diesel engine
 2. Variable speed electric motor
 3. V-8 gasoline engine
 4. Hydraulic motor

- 4-45. The dc output of the NC-12A powerplant is obtained from which of the following components?
1. Dc generator
 2. Rectifier
 3. Two 24 volt batteries
 4. Transformer
- 4-46. To obtain compressed air for jet engine starting, which of the following CSE units must be used?
1. NC-2A
 2. NC-8A
 3. RCPT-105
 4. RX-400
- 4-47. Mobile motor-generator sets (MMGs) are primarily used in which of the following areas?
1. On flight lines
 2. On flight decks
 3. In hangars/hangar decks
 4. On small ships
- 4-48. Alternating current service receptacles on the aircraft are (a) what shape and (b) contain how many pins?
1. (a) rectangular, (b) 3 pins
 2. (a) rectangular, (b) 6 pins
 3. (a) oval, (b) 3 pins
 4. (a) oval, (b) 6 pins
-
- Learning Objective: Identify the capabilities, functions and operating characteristics of aircraft test equipment, and recognize the appropriate test sets for the systems to be checked.
-
- 4-49. What color is line test equipment normally painted?
1. Yellow
 2. Red
 3. White
 4. Orange
- 4-50. Which of the following statements is NOT correct with regard to the troubleshooting of aircraft electrical equipment?
1. Troubleshooting should be done from memory in order to save time
 2. Line test equipment may be used in conjunction with shop test equipment
 3. Instructions in Maintenance Instructions Manuals for the equipment must be followed
 4. Line test equipment is used to isolate malfunctions to a specific component
- 4-51. The MA-2 test assembly is modular and consists of how many major assemblies?
1. 1
 2. 2
 3. 3
 4. 4
- 4-52. The load bank of the MA-2 test assembly is capable of supplying dc loads within what range?
1. 0-1500 A
 2. 0-1000 A
 3. 0-750 A
 4. 0-500 A
- 4-53. The TS-100/U transistor test set will measure beta that approaches infinity, but is most accurate at which of the following measurements?
1. Below 9
 2. Those that do not exceed 10
 3. Those that do not exceed 100
 4. Between 100 and infinity
- 4-54. On the TS 1100/U transistor test set, the temperature indicator lamp when illuminated, indicates
1. that excessive current is flowing in the transistor under test
 2. a too-low free-air temperature for readings to be reliable
 3. a too-high free-air temperature for readings to be reliable
 4. current flow is too low for an accurate check of the transistor
- 4-55. The Hartley oscillator in the TS-1100/U operates at what frequency?
1. 400 Hz
 2. 850 Hz
 3. 1125 Hz
 4. 1500 Hz
- 4-56. Which of the following statements is correct concerning the two methods of plotting transistor characteristic curves?
1. The point-to-point method is the more accurate method
 2. The point-to-point method is the faster method
 3. Permanent photographic records may be efficiently made when the point-to-point method is used
 4. The oscilloscope display method will show any irregularities in the characteristic curves

- 4-57. The curve tracer's display function is composed of the
1. base step generator and the collector sweep circuit
 2. cathode ray tube, the collector sweep circuit and the step generator
 3. vertical and horizontal amplifiers and the base step generator
 4. vertical and horizontal amplifiers and the cathode ray tube

- 4-58. What should the AE do after obtaining an erroneous display if it is suspected that test equipment may be inaccurate?
1. Return the test equipment for recalibration
 2. Replace the transistor with one known to be good, then recheck
 3. Do both 1 and 2 above
 4. Check the tester with its self-checking feature

Items 59 and 60 pertain to the TTU-27E tachometer indicator generator test set.

- 4-59. The test set can be used to test which of the following components?
1. Two-pole and four-pole tachometer generators for speed and output voltage under load
 2. Tachometer indicators of the rpm type for calibration accuracy
 3. Tachometer indicators of the percent type for starting voltage
 4. Each of the above

- 4-60. After the tachometer generator to be tested is mounted on the tester, what component will control the speed at which it is driven?
1. The master tachometer generator
 2. A variable dc drive motor in the test set
 3. The two-speed test pad
 4. The gear box drive

Items 61, 62 and 63 pertain to the jet calibration analyzer (jetcal).

- 4-61. During maintenance checks, exhaust gas temperature and engine speed are checked with the jetcal analyzer rather than with the cockpit instruments because the jetcal readings are more accurate.

- 4-62. When performing a functional ground test of the EGT system, heat for the thermocouples is provided by
1. heater probes
 2. exhaust gas
 3. the jetcal potentiometer
 4. the aircraft heating and air-conditioning system

- 4-63. An external ac power supply is required to supply electrical power to a jetcal analyzer that is being used to check
1. engine speed
 2. the EGT circuit for shorts or grounds
 3. the EGT indicators
 4. the resistance of the EGT circuit

- 4-64. Which of the following test sets is used to check out the aircraft's pitot-static system?
1. TF-20
 2. TTU-205 B/E
 3. TTU-27/E
 4. AN/PSM-17A

- 4-65. The power requirement(s) for the TTU-205 B/E test set is/are
1. 28 vdc
 2. 28 vdc; 115 vac, single phase, 400 Hz
 3. 115 vac; single phase, 400 Hz
 4. 115 vac; three phase, 400 Hz

- 4-66. The TF-20 capacitor-type liquid quantity test set can be used to perform which of the following functions?
1. Measure tank unit probe capacitance and insulation resistance
 2. Simulate tank unit probe capacitance
 3. Calibrate the test set's megohmmeter and capacitance indicator scales
 4. All of the above

- 4-67. What is the purpose of the binding posts on the upper left corner of the TF-20 test set panel?
1. They permit measuring the dc resistance of the fuel probe
 2. They establish a reference ground potential
 3. They provide a convenient point for measuring internal capacitance between fuel probe and aircraft
 4. They ensure proper tester connection when accessory cables cannot be used

4-68. When using the AN/PSM-17A to dynamically test the transmitter of an angle-of-attack system, what type energy is fed to the transmitter probe?

1. Hydraulic
2. Vacuum or air pressure
3. Mechanical
4. Electrical

4-69. The AN/ASM-78 attitude heading reference system analyzer can be used to perform which of the following functions?

1. Monitor inputs to compass system components
2. Locate electrical wiring problems
3. Both 1 and 2 above
4. Bypass malfunctioning components

Assignment 5

Aircraft Electrical Power Sources; Aircraft Electrical and Associated Systems

Text: Pages 4-1 through 5-7

Learning Objective: Identify ac and dc power sources for an aircraft, and recognize construction features and characteristics of ac and dc generators.

- 5-1. An ac generator is also known by what other name?
1. Autosyn
 2. Converter
 3. Alternator
 4. Magnetron
- 5-2. Which of the following statements is correct regarding the operation of electrical systems on aircraft?
1. Aircraft with dc primary systems obtain ac power from transformer-rectifier units
 2. Aircraft with ac primary systems obtain dc power from inverter units
 3. Aircraft with dc primary systems obtain ac power from inverter units
 4. Aircraft with primary ac systems do not have requirements for dc power
- 5-3. Compensating windings and interpoles are used in aircraft dc generators in order to
1. decrease the effect of self-induced voltage
 2. establish a neutral commutating plane
 3. stabilize output voltage
 4. increase output voltage
- 5-4. Why are the generators on multigenerator aircraft loaded considerably below their maximum capacity?
1. To ensure that voltage regulation does not present or cause a problem
 2. To ensure that the remaining generator(s) can furnish more power if one generator fails
 3. To prevent overheating and to reduce the cooling mechanism's size
 4. To prevent power surges in the system
- 5-5. Which of the following statements describes an advantage of the ac power system over the dc power system?
1. The ac generator and the control and protection components are lighter
 2. Current is transmitted at a lower level
 3. Smaller wires are used
 4. Each of the above describes an advantage
- 5-6. The frequency of an ac generator is determined by which of the following factors?
1. The field strength and the rpm of the rotor
 2. The number of poles and the rpm of the rotor
 3. The number of conductors and the field strength
 4. The number of conductors and the rpm of the rotor
- 5-7. Which of the following characteristics may be considered common to all ac generators?
1. The output frequency is controlled by regulating the speed of rotation of the rotating magnetic field
 2. Voltage control is accomplished by controlling the strength of the rotating magnetic field
 3. The output is taken from stationary windings
 4. Each of the above
- 5-8. Refer to figure 4-2. The power generated by a 120/208-volt ac generator is normally distributed by a
1. 3-wire, wye-connected system
 2. 3-wire, delta-connected system
 3. 4-wire, wye-connected, common-neutral system
 4. 4-wire, delta-connected, common-neutral system

- 5-9. Relevant to a 4-wire grounded neutral system on an aircraft, which of the following statements is correct?
1. Wye-wound generators neutral is connected to the airframe for ground
 2. Wye wound generators A or B phase may be connected to the airframe for ground
 3. Wye-wound generators A or C phase may be connected to the airframe for ground
 4. Wye-wound generators any phase may be connected to the airframe for ground

- 5-10. The brushless type aircraft generator is superior to the brush type because it has which of the following advantages?
1. It generates no radio noise and is maintenance free
 2. It can be operated longer between overhaul periods and is more reliable
 3. It requires less regulation
 4. Each of the above

Learning Objective: Recognize the advantages and disadvantages of the 3- and 4-wire inverter systems, identify the construction features of the inverter and their purpose, and recognize inverter controlling components and their function, purpose, and capabilities.

- 5-11. In comparison to a 3-wire inverter power system, a 4-wire, 120-volt, 3-phase, 400-Hz power system provides for
1. automatic distribution so that equal power is maintained in each phase
 2. automatic distribution so that equal current and voltage are maintained in each phase
 3. improved load balancing per phase
 4. current flow stoppage when the loads are unbalanced

- 5-12. What is the purpose of the series starting winding used in some inverters?
1. To provide high starting torque
 2. To increase starting current
 3. To limit frequency buildup
 4. To improve frequency stability

- 5-13. The number of phases in the output of an inverter is determined by the number of
1. independent voltages in the input
 2. sets of windings on the stator
 3. sets of windings on the rotor
 4. poles in the generator field

- 5-14. The output voltage of an inverter is maintained at the correct level by controlling the
1. dc field current of the generator
 2. dc voltage input to the motor
 3. speed of the motor
 4. ac field current of the generator

- 5-15. The speed control governor controls inverter motor speed by
1. switching a series resistor in and out of the shunt winding circuit of the dc motor
 2. switching a series capacitor in and out of the series winding circuit of the dc motor
 3. varying the resistance of a carbon pile in series with the shunt winding of the dc motor
 4. varying the capacitance of a capacitor in series with the shunt winding circuit of the dc motor

- 5-16. Maximum field strength and acceleration of the inverter are achieved when
1. motor speed is 7,000 rpm
 2. the slipping contacts are open
 3. the slipping contacts are closed
 4. the shunt field is placed in series with a resistor

- 5-17. The inverter speed control governor maintains the armature at its operating speed of approximately
1. 5,000 rpm
 2. 7,000 rpm
 3. 12,000 rpm
 4. 18,000 rpm plus or minus 5,000 rpm

- 5-18. The source of magnetic flux for the ac generator section of the inverter is a
1. permanent magnet
 2. coil wound on the rotor
 3. coil wound on the stator
 4. series resistor

- 5-19. In order for the frequency of the inverter generator voltage to be constant, which of the following conditions must exist?
1. The motor armature current must be held constant
 2. The motor armature current must be varied
 3. The motor field current must be held constant
 4. The motor must maintain the generator section at a constant rpm

- 5-20. What is the primary function of C1 in figure 4-10?
1. To correct the output power factor
 2. To smooth out ripple in the dc supply
 3. To filter electrical noise generated by the speed control contacts.
 4. To prevent RF disturbances in the dc supply from entering the inverter

Learning Objective: Identify components used in avionic power supplies, and recognize operating characteristics of the components.

- 5-21. Which of the following statements relative to characteristics of a typical transformer-rectifier is NOT correct?
1. It is usually cooled by a cooling fan
 2. It always requires separate voltage regulators
 3. It requires radio frequency filters to reduce noise interference in avionic equipment
 4. It is highly reliable and rugged
- 5-22. The thermostat in a transformer-rectifier unit can be utilized to perform which of the following functions when overheat occurs in the unit?
1. Lighting of the overheat warning light.
 2. Removal of the input ac voltage
 3. Both 1 and 2 above
 4. Disengagement of the overrunning clutch
- 5-23. Autotransformers are normally utilized in circuits where a very high voltage must be stepped down to a relatively low voltage.
- 5-24. Assume that an autotransformer similar to that in figure 4-14 has a 120-volt input, a turns ratio of 3 to 1 stepdown, and a load current of 15 amperes. The power in the load circuit in watts is
1. 240 W
 2. 480 W
 3. 600 W
 4. 1,800 W
- 5-25. A Variac transformer is used to provide which of the following functions?
1. Maximum transfer of power to the load
 2. Continuous control of line voltage
 3. Control of ten percent of line voltage
 4. Voltage adjustment, regulation, and compensation

- 5-26. Modern aircraft are required to have several electronic power supply systems for which of the following reasons?
1. To isolate the systems from one another
 2. To facilitate changes within the systems.
 3. Because one power supply cannot supply the needed power for all systems
 4. For all of the above reasons

- 5-27. Refer to figure 4-17. When a positive potential is applied from the secondary of transformer T7 to the junction between CR7 and CR9, which combination of rectifiers will conduct?
1. CR7 and CR8
 2. CR7 and CR10
 3. CR8 and CR9
 4. CR9 and CR10

- 5-28. Refer to figure 4-18. If the input voltage increases, which of the following events will occur?
1. The voltage drop across R2 will decrease
 2. The input voltage to amplifier A1 will decrease
 3. The voltage drop across R1 will increase
 4. The feedback voltage across R3 and R4 to the input of amplifier A1 will increase

Learning Objective: Recognize types and construction features of batteries used in Navy aircraft, and identify battery system components and their functions.

- 5-29. Which of the following actions will have a tendency to shorten the life of an aircraft battery?
1. The use of sulphuric acid in a lead acid battery
 2. The use of distilled water in a lead acid battery
 3. Frequent engine starts on the battery
 4. Frequent use of the hydrometer during battery checks

- 5-30. What method is used to identify aircraft acid batteries from alkaline batteries?
1. Acid batteries are in a hard rubber case, alkaline in a plastic case
 2. Acid batteries are in a plastic case, alkaline in a hard rubber case
 3. Acid batteries are in a blue case, alkaline in a pink case
 4. Acid batteries are in a pink case, alkaline in a blue case
- 5-31. What is the disposition of aircraft batteries that are no longer fit for service in aircraft, but can be used in other equipment?
1. They are formally surveyed by the shop having custody and placed back in the supply system
 2. They are returned to the station battery shop for modification
 3. They are sent to the nearest Naval Air Rework Facility (NARF) for repair
 4. They are painted yellow, appropriately stenciled, and used on ground support equipment
- 5-32. What type of battery installation connection is used on most aircraft?
1. Solder connection
 2. Taper pin connector
 3. Quick-disconnect unit
 4. Threaded terminal
- 5-33. Which of the following statements pertaining to aircraft battery connections is correct?
1. The connectors must be safety wired
 2. The connectors may be connected or disconnected individually
 3. The connectors are locked in place with several turns of the wheel on the plug
 4. Reversal of leads is possible by connecting the power plug improperly
- 5-34. What is the purpose of a sump jar when used in the battery vent system?
1. To neutralize gases and excess battery solution
 2. To act as an electrolyte reservoir
 3. To prevent battery overcharging
 4. To prevent electrolyte spillage
- 5-35. Power for turning the ram-air turbine generator armature is obtained from
1. the aircraft engine
 2. a hydraulic drive unit
 3. a manual cranking assembly
 4. a ram-air driven turbine
- 5-36. The output of a ram-air turbine generator is kept at the desired frequency by
1. connecting it to a fixed load
 2. holding the aircraft at a stated speed
 3. the action of the voltage regulator
 4. the action of the variable-pitch blades and speed regulator section
- 5-37. Airborne APUs are particularly useful in large aircraft because they
1. replace malfunctioning generators automatically
 2. provide constant or variable frequency output
 3. depend on aircraft engines for their source of power
 4. make the aircraft independent of ground power sources
- Items 5-38 through 5-45 relate to the GTCP95 powerplant.
- 5-38. The APU is capable of providing which of the following aircraft inputs?
1. Air for ground operation of aircraft air-cycle cooling systems
 2. Starting air for aircraft engines
 3. Aircraft electrical power
 4. All of the above
- 5-39. What are the four main systems of the gas turbine engine?
1. Electrical, fuel control, bleed air, and lubrication
 2. Turbine, compressor, accessories, and electrical
 3. Accessory, turbine, bleed air, and electrical
 4. Turbine, electrical, bleed air, and main output drive
- 5-40. What portion of the compressor and turbine assembly supplies bleed air for pneumatic power?
1. Turbine
 2. Turbine wheel
 3. Compressor
 4. Turbine plenum

Learning Objective: Recognize emergency and auxiliary electrical power sources used on aircraft and their purpose; identify the functions and characteristics of emergency and auxiliary power unit components.

- 5-41. Which of the following statements is correct concerning the operation of the ignition system?
1. A continuous spark ignition is required during run time
 2. The high-energy current source is obtained by discharging a booster coil into the storage capacitors
 3. Ignition is only required during starting and is automatically cutoff at approximately 95 percent engine rpm
 4. The high voltage required to fire the ignition plug is obtained by discharging the capacitors through a step-down transformer
- 5-42. The three centrifugal speed sequence switches in the APU are adjusted to operate at what percentages of turbine speed?
1. 30, 60, 90
 2. 35, 95, 106
 3. 35, 95, 110
 4. 50, 75, 100
- 5-43. What is the function of the 35 percent switch?
1. Acts as a safety device
 2. Permits the use of bleed air
 3. Deenergizes the starter
 4. Each of the above are
- 5-44. Which of the following statements is INCORRECT concerning the overspeed switch?
1. It can be checked manually with the turbine either operating or stopped
 2. A lever extends from the switch housing that can be used to manually actuate the switch
 3. The turbine must be operating above its governed speed in order to check it for proper operation
 4. When the turbine exceeds 106 percent of engine rpm, it actuates and cuts off the fuel flow to the engine
- 5-45. The starter clutch assembly performs which of the following functions?
1. Prevents excessive heat build up between the starter and accessory drive gears
 2. Automatically engages and disengages the starter with the gear train
 3. Protects the starter from overspeed in case the 35 percent switch fails
 4. Automatically engages the engine compressor and turbine sections

Learning Objective:
Recognize the purpose and means of controlling voltage and frequency in a generator circuit, and identify components and functions of a solid state voltage regulator/supervisory panel.

- 5-46. The most common method of voltage regulation in ac and dc generators is to vary the
1. current in the field winding
 2. current in the shunt winding
 3. resistance of the load
 4. resistance of a parallel resistor
- 5-47. Refer to figure 4-27 and assume that switches S1 and S2 are closed. Closing switch S3 causes the total resistance of the load to
1. fluctuate erratically
 2. increase only
 3. decrease only
 4. increase, then decrease
- 5-48. The amplitude of the output voltage of an ac generator may be controlled by which of the following methods?
1. Varying the generator rpm
 2. Changing the rectifier connections
 3. Varying the strength of the magnetic field
 4. Tapping off a varying number of turns per winding
- 5-49. Refer to figure 4-28(B). The exciter's variable ac output is changed to dc by which of the following components?
1. Exciter rotating field coil
 2. Voltage regulator
 3. Bridge rectifier
 4. Main generator rotating field coil
- 5-50. The action of the voltage regulator in controlling the strength of the generator's magnetic field results in a controlled output
1. voltage
 2. current
 3. frequency
 4. phase angle

- 5-51. The magnitude of the control voltage applied to the control amplifier of the solid state regulator represents the
1. excitation voltage of the ac generator
 2. sum of the generator's excitation and output voltages
 3. difference between the generator's ac output voltage and a reference voltage
 4. difference between the generator's dc excitation voltage and a reference voltage
- 5-52. Refer to figure 4-29. Assume a decrease in generator voltage. The voltage change appears across
1. all components of the bridge except CR5, but greater across R2 than across any of the other resistors
 2. all components of the bridge, but greater across R2 than across any of the other components
 3. all components of the bridge except CR5, in equal amounts
 4. R2, R7, and R9, but greater across R2 than across R7 and R9
- Refer to figure 4-29 in answering items 5-53 and 5-54.
- 5-53. A decrease in generator output voltage causes an increase in emitter-collector current in all four transistors, producing which of the following results?
1. Exciter gen output increases, ac gen field strength decreases, and gen output increases
 2. Exciter gen output increases, ac gen field strength increases, and gen output increases
 3. Exciter gen output decreases, ac gen field strength decreases, and gen output decreases.
 4. Exciter gen output increases, ac gen field strength increases, and gen output decreases
- 5-54. The exciter generator field is excited with a field-flash voltage from the special +28-volt bus when
1. K1 energizes
 2. the underspeed switch closes
 3. Q1 receives a voltage-change indication
 4. the generator's armature begins to rotate
- 5-55. Refer to figure 4-30. Although potentiometer R7 sets the bridge at the desired operating point, the reference voltage which determines if changes occur in the generator's output voltage is developed across
1. V1
 2. RT1
 3. CR5
 4. CR1
- 5-56. In figure 4-30, what is the purpose of K1?
1. To provide for exciter shunt field excitation
 2. To protect the transistors from generator overvoltage
 3. To prevent exciter excitation prior to the generator's achieving a 90-volt output
 4. To provide for exciter shunt field excitation from an external source during initial voltage buildup
- 5-57. The supervisory panel accomplishes which of the following functions?
1. Frequency regulation and circuit protection for the generator and its associated equipment
 2. Only circuit protection for the generator and its associated equipment
 3. Only voltage regulation for the generator and its associated equipment
 4. Voltage regulation and circuit protection for the generator and its associated equipment
- 5-58. The supervisory panel will disconnect the generator from the load under which of the following conditions?
1. Underfrequency and undervoltage only
 2. Underfrequency, undervoltage and overvoltage only
 3. Feeder fault, undervoltage and overfrequency only
 4. Feeder fault, underfrequency and overfrequency, and undervoltage and overvoltage
- 5-59. In a supervisory panel, voltage regulation is accomplished by controlling which of the following functions?
1. Amplitude of the dc voltage to the generator-exciter stator coils
 2. Polarity of the dc voltage to the generator-exciter stator coils
 3. Frequency of the ac voltage to the generator-exciter stator coils
 4. Amplitude of the ac voltage to the generator-exciter stator coils

- 5-60. Refer to figure 4-32. What component(s) protect(s) the circuit from an overvoltage and undervoltage condition?
1. Voltage sensors
 2. Monitoring switch
 3. K-I relay
 4. K-7 relay

Learning Objective: Identify methods used to control ac circuits; recognize differences between 3- and 4-wire electrical systems.

- 5-61. In an ac circuit, the ac load is slightly inductive. To improve the power factor of the load in this circuit, how should the capacitor be connected?

1. In parallel with the circuit
2. In series with the circuit's inductor only
3. In parallel with the circuit's resistor only
4. In series with the circuit

- 5-62. Using a capacitor to bring the power factor of an ac circuit to unity results in

1. an increase in the power furnished by the source
2. an increase in the voltage developed across the resistance
3. reduced line current
4. increased line current

- 5-63. In a 4-wire grounded system, the N wire (common return) is accidentally placed in contact with a ground. What effect, if any, will this have on the operation of the circuit?

1. None
2. It will cause one circuit to feed into another
3. It will cause the circuit to operate intermittently
4. It will provide a short circuit path, and the circuit will draw abnormally high current

- 5-64. In a grounded 3-wire system, how is grounding usually accomplished?

1. By grounding the B-phase
2. By grounding the neutral wire only
3. By grounding the B-phase and neutral wire
4. By grounding the C- and B-phases

- 5-65. Which of the following is an advantage that an ungrounded electrical system has over a grounded system?
1. The system is easier to troubleshoot
 2. Cost, weight, and space are minimized
 3. One circuit may feed into another
 4. Circuits are insulated from each other

- 5-66. A single-phase voltage regulating system is characterized by being of
1. complex design for use in low-power requirements
 2. simple design for use in high-power requirements
 3. simple design for use in low-power requirements
 4. complex design for use in high-power requirements

Learning Objective: Identify the construction, principles of operation and the use of various types of aircraft lighting and lighting systems.

- 5-67. That portion of an aircraft incandescent lamp most easily damaged by vibration is the

1. base
2. bulb
3. filament
4. contact bayonet

- 5-68. Screw-type lamp bases are seldom used in aircraft because they

1. are difficult to install
2. loosen in the socket too easily
3. are impractical for double-base lamps
4. are impractical for dual-filament lamps

- 5-69. What is the purpose of offsetting the index pins on some lamp bases?

1. To provide firm holding in the socket
2. To provide good electrical contact to the socket
3. To assure that the light will shine in the proper direction
4. To assure that a double-contact bulb will be installed in a double-contact socket

- 5-70. What is the purpose of two parallel filaments in a special purpose lamp?

1. To provide a softer light
2. To provide a brighter light
3. To provide stronger filament support
4. To provide for faster signaling

- 5-71. What organization establishes the minimum standards concerning the number, color, location, and intensity of exterior lights on naval aircraft?
1. Federal Aviation Administration
 2. Naval Air Systems Command
 3. Chief of Naval Operations
 4. Federation of Aircraft Manufacturers
- 5-72. Electric power is supplied to the bulb assembly of a rotating anticollision light through which of the following components?
1. A step-up transformer
 2. A rotary transformer
 3. A commutator
 4. Sliprings
- 5-73. Aircraft landing lights are factory-set to open to an extended position of
1. $10^\circ \pm 3^\circ$
 2. $50^\circ \pm 3^\circ$
 3. $73^\circ \pm 3^\circ$
 4. $85^\circ \pm 3^\circ$
- 5-74. On carrier-type aircraft, approach lights are designed to operate under which of the following conditions?
1. Aircraft flying and the landing gear down only
 2. Aircraft standing still with the tail hook extended
 3. Aircraft flying, landing gear down, and the tail hook extended
 4. Aircraft approaching the carrier with the tail hook extended
- 5-75. During a carrier landing, the aircraft's amber approach light is illuminated. This informs the LSO that the aircraft's angle of attack is
1. zero
 2. optimum
 3. low
 4. high

Assignment 6

Aircraft Electrical and Associated Systems

Text: Pages 5-7 through 5-67

Learning Objective: Identify the principles of operation and use of various types of aircraft lighting and lighting systems; and recognize maintenance aspects of lighting components and systems.

- 6-1. In reference to the index lights, an inverted V indicates to the pilot that the angle of attack is
1. slightly low
 2. slightly high
 3. very high
 4. very low
- 6-2. What is the function of the arresting hook override switch?
1. It activates a light showing the landing signal officer that the arresting hook is extended for landing
 2. It allows the approach lights to signal that the aircraft is unprepared to land
 3. It allows the approach lights to function while the arresting hook is up
 4. It shows the pilot the position of the arresting hook
- 6-3. The fuselage formation lights are connected in parallel with and controlled by the same switches as what other lights?
1. Fuselage signal lights only
 2. Wingtip formation lights only
 3. Fuselage signal and wingtip formation lights
 4. Fuselage signal, wingtip formation, and navigation lights
- 6-4. What is the purpose of the in-flight refueling probe light?
1. To illuminate the drogue of the refueling aircraft only
 2. To illuminate the probe of the aircraft being fueled only
 3. To illuminate the probe of the aircraft being fueled and the drogue of the refueling aircraft
 4. To indicate fuel flow and stoppage of fuel flow into the aircraft being fueled
- 6-5. When a search light is mounted in the nose of a helicopter, it will have how many degrees of azimuth travel?
1. 90°
 2. 180°
 3. 270°
 4. 360°
- 6-6. When replacing aircraft interior lamps or light covers, the AE should be aware that replacements should meet the same specifications as the originally installed units for which of the following reasons?
1. Fire hazards can be easily created in lighting fixture alterations
 2. The aircraft's power circuitry will be unbalanced if substitute lighting is used
 3. Original specifications were based on scientific considerations of necessity and crew comfort
 4. Each of the above
- 6-7. What color of light has been found to be the most satisfactory in allowing the eyes to adjust from an illuminated surface to a night environment?
1. Yellow
 2. Red
 3. Green
 4. White

- 6-8. What process is used to age "grain of wheat" type instrument lamps prior to installation in the instrument panels?
1. They are operated at their rated voltage for a period of 10 hours
 2. They are operated at twice their rated voltage for a period of 5 hours
 3. They are operated at one-half their rated voltage for a period of 20 hours
 4. They are operated at their rated voltage plus 25 percent for a period of 10 hours
- 6-9. What are the advantages of the "grain of wheat" type instrument lamps over the other type lamps used in instrument systems?
1. Longer life only
 2. More rugged only
 3. Better illumination only
 4. Longer life, more rugged, and better illumination
- 6-10. What lighting feature is provided on aircraft to aid a crewmember in doing detailed chart reading?
1. Red floodlights
 2. White floodlights
 3. Extension lights
 4. Momentary-contact switches to bypass the rheostats on floodlights
- 6-11. Which of the following statements is correct regarding the push-to-test feature on warning lights?
1. It provides a means for checking the system's circuits only
 2. It provides a means for checking the condition of the warning light bulb only
 3. It provides a means for checking the system's circuits and the condition of the warning light bulb
 4. It provides a means for momentarily activating all equipments and circuits in the respective system
- 6-12. The single pointer on the AAU/19A altimeter displays altitude in increments of
1. 10 feet
 2. 100 feet
 3. 1,000 feet
 4. 10,000 feet
- 6-13. Prior to reusing the same items of mounting hardware, what must be determined about the items?
1. They exceed the specifications for their intended use
 2. They are essentially the same size and shape of the specified items
 3. Their reuse is not prohibited by existing directives
 4. They are not damaged and exceed the specifications of the items required by the IPB
- 6-14. If a temporary installation is made using suitable substitute parts, when should these parts be replaced?
1. During the next periodic inspection only
 2. During the time the aircraft is at the NAVAIRREWORKFAC only
 3. As soon as the parts become defective
 4. As soon as the required parts are obtained
- 6-15. Which of the following considerations should you observe when substituting mounting parts?
1. Color
 2. Availability
 3. Magnetic properties
 4. Accessibility
- 6-16. Refer to figure 5-11. Which of the following statements is correct concerning replacement of the shock mounts?
1. None of the shock mounts can be replaced
 2. Those shown in both (A) and (B) can be replaced, but all four must be replaced simultaneously
 3. Those shown in (B) can be individually replaced, and those shown in (A) cannot be replaced
 4. Those shown in (A) can be individually replaced, and those shown in (B) cannot be replaced

Learning Objective: Recognize uses and characteristics of aircraft electrical and mechanical hardware, including connector identification and potting, cable lacing and tying, and the use of sleeving and heat shrinkable tubing.

- 6-17. Refer to figure 5-11 (B). One vibration insulator is cracked. What corrective action should be taken?
1. Replace the complete shock mount assembly
 2. Replace the cracked vibration insulator
 3. Replace the cracked part
 4. Replace all vibration insulators
- 6-18. Moistureproofing of electrical connectors is accomplished for which of the following reasons?
1. To reinforce the connector
 2. To reduce the possibility of connector cracking
 3. To improve the connector's dielectric characteristics
 4. To protect the connector for future reuse
- 6-19. The preferred method of attaching cable terminals to terminal blocks requires the use of which of the following items of hardware?
1. An anchor nut and a lockwasher
 2. An anchor nut and a flat washer
 3. A standard nut and a lockwasher
 4. A standard nut and a flat washer
- 6-20. Shielded conduit should be supported with what type of clamp?
1. AN 742 clamp
 2. Strap clamp
 3. Bonded clamp
 4. Nonbonded clamp
- 6-21. Which of the following types of clamp is preferred for supporting long runs of cable between panels?
1. Strap clamp
 2. Plastic clamp
 3. Bonded clamp
 4. AN 742 clamp
- 6-22. When installing a cable through a lightening hole, you should use a grommet (rubber cushion) if the cable's distance from the edge of the hole is less than
1. one-quarter inch
 2. three-eighths inch
 3. one-half inch
 4. five-eighths inch
- 6-23. In addition to supporting and protecting electrical wires, what other advantage does conduit offer?
1. Protects against heat radiation
 2. Provides for radio shielding
 3. Provides for bullet deflection
 4. Gives support to adjacent cables
- 6-24. Which of the following types of wire should be used to safety-wire an oxygen regulator?
1. Seal wire
 2. Lock wire
 3. Shear wire
 4. Soft-steel wire
- 6-25. Which of the following conditions could exist as a result of an improper bonded aircraft?
1. Increased likelihood of fire and a noisy radio receiver
 2. Increased likelihood of lightning strikes
 3. The likelihood of lightning strikes would be decreased
 4. All electrical equipment on the aircraft would fail to operate
- 6-26. A primary objective for bonding is to provide an electrical path of
1. high dc resistance and high RF impedance
 2. low dc resistance and high RF impedance
 3. high dc resistance and low RF impedance
 4. low dc resistance and low RF impedance
- 6-27. How should cord be utilized to secure a new wiring installation in which runs of cable pass through free space, enclosed junction boxes, and open panels?
1. Tie the runs in free space and open panels; lace those in enclosed junction boxes
 2. Lace the runs in free space and open panels; tie those in enclosed junction boxes
 3. Tie the runs in free space; lace those in open panels and enclosed junction boxes
 4. Tie the runs in open panels, enclosed junction boxes and free space

6-28. Which of the following statements best describes the method of installing heat-shrinkable tubing?

1. A section of the tubing is placed over the part to be covered and then heated to its "shrink temperature" which causes it to quickly shrink around the object
2. A section of the tubing is heated until it expands, fitted over the part to be covered, and then cooled until it shrinks around the object
3. A section of the tubing is refrigerated and caused to expand, after which it is fitted over the area to be covered and heated to room temperature to cause shrinkage
4. A section of the tubing is placed over the part to be covered and then subjected to a chemical solution to cause shrinkage

Learning Objective: Recognize components of the engine start and ignition system and their functions; identify the properties required to produce fire.

6-29. Jet engine starters must have which of the following capabilities?

1. Low starting torque and low speed
2. High starting torque and high speed
3. Low starting torque and high speed
4. High starting torque and low speed

6-30. Refer to figure 5-23. What is the function of the check valve in the starting manifold of the impingement starting system?

1. To control the pressure of the starting air system
2. To close the selector valve when proper engine rpm is reached only
3. To prevent loss of gases after the engine starts only
4. To perform the operations listed in both 2 and 3 above

6-31. Refer to figure 5-24. What two sections make up the constant speed drive/starter unit?

1. A turbine motor and a planetary differential transmission
2. A turbine motor and a generator
3. A generator and a planetary differential transmission
4. A generator/turbine motor and a planetary differential transmission

6-32. An output of 8,000 rpm from the engine input shaft is maintained by what constant speed drive unit mode of operation?

1. Air turbine motor generator drive mode only
2. Start mode only
3. Start and air turbine motor generator drive mode
4. Constant speed drive mode

6-33. Which of the following properties must be present to cause a fire?

1. Oxygen and a combustible material only
2. Oxygen and heat only
3. Heat and a combustible material only
4. Heat, oxygen, and a combustible material

6-34. Which of the following statements relative to the operation of aircraft ignition systems is INCORRECT?

1. The spark plug produces the heat for combustion in the cylinders of reciprocating engines
2. The reciprocating engine ignition system delivers 10,000 to 25,000 volts to each cylinder
3. The fuel in jet engines is ignited upon starting, and continuous burning is sustained
4. The exact timing for delivering spark in jet engines is critical for each rotor revolution

6-35. What component in the electronic ignition system develops the voltage to produce a spark?

1. The transformer
2. The exciter
3. The dynamotor
4. The booster coil

Learning Objective: Recognize the operational features of anti-icing and deicing systems, and identify operating characteristics of engine fire warning and extinguishing systems.

6-36. Refer to figure 5-30. Anti-icing air is fed to the engine when the solenoid is energized. Energizing the solenoid causes the pressure in the anti-icing valve to

1. decrease in the poppet valve body
2. increase in the poppet valve body
3. increase on the face of the main poppet
4. decrease on the face of the main poppet

6-37. The timing cycle for propeller deicers is such that, for any slow-cycle operation, current is supplied to the heating elements for approximately what time period?

1. One minute
2. One and one-half minutes
3. Two minutes
4. Three minutes

6-38. The propeller deicer motor is changed from fast speed to slow speed by which of the following actions?

1. Switching a filter into the motor circuit
2. Bypassing the variable resistor with two fixed resistors
3. Adjusting the variable resistor to provide maximum resistance
4. Switching an additional fixed resistor in series with the variable resistor

6-39. A fire warning light will illuminate at which of the following times?

1. When the control unit does not monitor resistance changes
2. When resistance of a sensing element does not change with a change in engine compartment temperature
3. When resistance of the sensing element decreases to a predetermined level, or at a predetermined rate
4. When resistance of the sensing element increases to a predetermined level, or at a predetermined rate

6-40. What is the purpose of the discriminator circuit in a fire warning system?

1. To determine if there is an opening somewhere in the system and, if so, turn on the warning light
2. To determine if there is a short in the system and, if so, turn on the warning light
3. To prevent the warning light from coming on when an open occurs in the circuit
4. To prevent the warning light from coming on when a short circuit occurs in the system

6-41. Which of the following statements best describes the means by which CF3Br extinguishes an aircraft engine fire?

1. It forms a blanket around the engine's air passages, thereby smothering the fire
2. It cools the burning area to an extremely low temperature, thereby extinguishing the fire
3. It uses the oxygen in the compartment at a rapid rate, thereby rendering the air incapable of supporting combustion
4. It displaces the oxygen in the engine nacelle, thereby rendering the air incapable of supporting combustion

Learning Objective: Identify operational aspects of an aircraft fuel quantity and transfer system; recognize the operational features and characteristics of engine oil and temperature systems.

6-42. Which of the following statements defines a thermistor?

1. It is a temperature sensitive resistor with a positive coefficient
2. It is a temperature sensitive resistor with a negative coefficient
3. It is a density monitoring capacitor with negative and positive coefficients
4. It is a density monitoring resistor with a positive coefficient

6-43. When the fuel transfer switch in the A7 aircraft fuel system is switched to the OFF position, what happens to the fuel in the wing tank?

1. It is automatically routed to the sump tank to be used for inflight refueling
2. It is force fed to the sump tank by differential air pressure for use in the refueler aircraft
3. It is isolated from the sump tank and used for inflight refueling
4. It is fed to the sump tank by gravity to be used for inflight refueling

- 6-44. Oil dilution is a means by which oil in a reciprocating engine is thinned by
1. mixing lightweight oil with the regular engine oil
 2. maintaining engine oil above a specified temperature
 3. injecting gasoline into the engine oil system
 4. circulating hot water around the cylinder sleeves
- 6-45. What controls the oil cooler door position when the oil cooler switch is in "automatic" mode?
1. A thermistor
 2. A thermostat
 3. A magnetic brake.
 4. A solenoid valve
- 6-46. In turbine powered aircraft, what relationship, if any, exists between engine power and turbine temperature?
1. They are directly proportional
 2. They are inversely proportional
 3. They tend to cancel each other
 4. None
- Items 6-47 through 6-50 pertain to aircraft equipped with temperature datum systems.
- 6-47. The temperature datum control valve is located in which of the following positions?
1. Between the fuel tank and the fuel control
 2. Between the fuel control and the engine
 3. Between the turbine temperature thermocouples and the fuel control
 4. Between elements in the turbine inlet temperature system
- 6-48. What percent of the required engine fuel does the fuel control deliver to the temperature datum valve?
1. 50%
 2. 75%
 3. 100%
 4. 120%
- 6-49. When the engine speed is greater than 94% and the engine coordinator is set to less than 66°C, the engine temperature is limited to a maximum of
1. 730°C
 2. 830°C
 3. 1,050°C
 4. 1,077°C
- 6-50. When the engine speed is above 94% and the engine coordinator setting is above 66°C, repositioning of the temperature datum valve, when required, will be determined by the
1. temperature sensed at the thermocouples
 2. temperature set on the engine coordinator's potentiometer
 3. difference between the temperature set on the engine coordinator's potentiometer and the temperature sensed at the thermocouples
 4. difference between ambient temperature and the temperature sensed at the thermocouples

Learning Objective: Recognize considerations and features of a propeller synchrophasing system; identify functions and operational characteristics of the approach power compensating system and the variable inlet duct ramp system.

- 6-51. What is the purpose of the modulator piston linear transducer in the Automatic Flight Control System (AFCS)?
1. To send rate signals to the AFCS computer
 2. To send position signals to the AFCS computer
 3. To reposition the modulator piston
 4. To detect hydraulic failures
- 6-52. If aircraft propellers are allowed to turn at different speeds in flight, the result will be
1. crew irritation only
 2. aircraft structural failure only
 3. crew irritation and aircraft structural failure
 4. mechanical failure of the aircraft engines
- 6-53. Relative to a propeller synchronizing system, which of the following statements about the synchroscope is NOT correct?
1. It has a small electric motor which operates on electrical energy received from the engine's tachometer generators
 2. It indicates the speed of the second engine in relation to the master engine
 3. It operates efficiently with more than two engines
 4. It allows the electrical energy from the tachometer generator of the faster turning engine to gain control of the synchroscope motor

6-54. Relative to the pulse generator in a propeller synchronizing system, what information can be determined from the pulses generated in one minute by each propeller?

1. The exact rpm
2. The exact position of any blade on the propeller
3. Both 1 and 2 above
4. The cutting angle of each blade on the propeller

6-55. Which of the following is a function of the approach power compensator system?

1. It positions the aircraft control surfaces automatically during landing approaches
2. It provides sudden surges of fuel for additional altitude when required
3. It controls the engine power automatically during landing approaches
4. It maintains the airspeed of the aircraft in moderate turbulence within a range of 10 knots

6-56. Relative to the approach power compensator system, what component or aircraft system provides information about the aircraft's approach angle to the computer?

1. Pitot-static system
2. Static system
3. Angle of attack indicator
4. Angle of attack transducer

6-57. Which of the following statements relative to operating characteristics of the approach power compensator system is NOT correct?

1. The computer provides no corrective signal to reposition the throttle as long as the acceleration is one G and the angle-of-attack is optimum for landing approaches
2. The system is capable of operating in three ambient temperature ranges to control engine performance
3. The rotary actuator motor positions the engine control linkage after receiving a corrective signal from the computer
4. The system can drive the throttle linkage at speeds up to 42° per second

6-58. At supersonic speeds greater than Mach 2, the function of the variable inlet duct ramp system is to allow

1. only supersonic air to enter the inlet duct
2. only subsonic air to enter the engine
3. both subsonic and supersonic air to enter the inlet duct
4. supersonic air to increase in velocity before entering the engine

6-59. Refer to figure 5-46. What is the signal chain sequence for repositioning the inlet duct ramp system?

1. Central data computer → hydraulic actuator → hydraulic servo valve → amplifier → inlet duct ramp
2. Central data computer → hydraulic servo valve → amplifier → hydraulic actuator → inlet duct ramp
3. Central data computer → amplifier → hydraulic servo valve → hydraulic actuator → inlet duct ramp
4. Central data computer → amplifier inlet duct ramp → hydraulic servo valve → hydraulic actuator

Learning Objective: Identify the components and their function in a hydraulic system, and recognize the AE's role in maintaining hydraulic systems.

6-60. Relative to aircraft hydraulic systems, the AE maintains circuits that control fluid

1. viscosity
2. flow
3. shape
4. pressure

6-61. All hydraulic systems contain a minimum of what four components?

1. Pump, selector valve, actuator, reservoir
2. Pump, pressure regulator, switch, reservoir
3. Selector valve, filter, pump, actuator
4. Selector valve, actuator, pressure lines, return lines

6-62. Which of the following components directs fluid flow in a hydraulic system?

1. Reservoir
2. Pump
3. Selector valve
4. Actuating unit

Learning Objective: Recognize functions, operating principles and procedures relative to components in landing gear control circuits, arresting gear control and nosewheel steering systems.

- 6-63. Which of the following functions is common to both left and right main gear torque-link switches?
1. Preventing the throttles from being placed in reverse propeller range while airborne
 2. Furnishing power for the landing gear control lever locking solenoid
 3. Disabling wing station external stores circuits
 4. Energizing the bomb bay door control circuit

6-64. Refer to figure 5-50. What prevents the landing gear control lever from being placed in the wheels up position when the weight of the aircraft is on the landing gear?

1. A manually operated solenoid
2. An electrically operated but deenergized solenoid
3. The safety switch in the right main gear torque-link switch housing
4. An electrically operated solenoid that energizes when the aircraft lands

Refer to figure 5-51 in answering items 6-65 and 6-66.

6-65. Retraction of the arresting hook is electrically controlled and hydraulically actuated, but extension of the hook is accomplished by use of

1. hydraulic power only
2. electrical power only
3. electrical or hydraulic power
4. mechanical means

6-66. The purpose of the time delay relay in the relay panel is to

1. dampen hydraulic pressure surges when the system is first energized
2. ensure that the arresting hook is fully up and locked before hydraulic pressure is removed
3. prevent the arresting hook from dropping if the handle is inadvertently moved to the down position
4. ensure that the arresting hook is completely down before hydraulic pressure is applied

In items 6-67 through 6-70, select from column B the function that is performed by each steer-damper unit component listed in column A.

<u>A. Components</u>	<u>B. Functions</u>
6-67. Steering shutoff valve	1. Controls hydraulic pressure to the steer-damper unit
6-68. Servo valve	2. Permits restricted hydraulic fluid flow to the bypass valve to dampen shimmy
6-69. Unidirectional restrictor	3. Controls the flow of fluid to the actuator
6-70. Fluid compensator	4. Prevents system pressure from becoming excessive

In answering items 6-71 through 6-73 concerning the electrical units in the steering system, select from column B the function of each component listed in column A.

<u>A. Components</u>	<u>B. Functions</u>
6-71. Command potentiometer	1. Provides nosewheel position information to the indicator
6-72. Steering amplifier	2. Feeds a signal to the steering amplifier as the nosewheel is moved
6-73. Steering feedback potentiometer	3. Provides a non-linear steering response as it is varied mechanically by the rudder pedals
	4. Receives the turn signal ordered by the rudder pedals from the command potentiometer

Assignment 7

Aircraft Electrical and Associated Systems; Instruments.

Text: Pages 5-68 through 6-27

Learning Objective: Recognize principles of operation of aircraft catapulting, speed brake and canopy systems; identify functions of pneumatic power system components.

- 7-1. Refer to figure 5-53: The catapulting system's launch bar warning light illuminates when which of the following conditions exists?
1. The launch bar is up and locked with weight off the landing gear
 2. The launch bar is up and locked with weight on the landing gear
 3. Solenoid B is energized
 4. Solenoid A is energized
- 7-2. Which of the following statements concerning the speed brake control switch is correct?
1. Speed brake extension will stop when the switch is released from the OUT position
 2. Speed brake retraction will stop when the switch is momentarily held in the IN position
 3. The degree of extension or retraction may be controlled by the degree of movement of the switch lever to or from the STOP position
 4. Momentary contact in either the IN or OUT position causes the speed brake to move fully to the indicated position
- 7-3. Refer to figure 5-54. In order to retract the speed brakes, the speed brake control switch is moved to the IN position, causing solenoid A and solenoid B to be
1. energized only
 2. deenergized only
 3. energized and deenergized, respectively
 4. deenergized and energized, respectively
- Items 7-4 through 7-6 pertain to the canopy system of an A6 aircraft.
- 7-4. Which of the following statements best describes the operational principle of the canopy selector valve?
1. It is hydraulically or electrically actuated, manually operated
 2. It is manually or hydraulically actuated, manually operated
 3. It is hydraulically or manually actuated, electrically operated
 4. It is manually or electrically actuated, hydraulically operated
- 7-5. To close the canopy, which of the following conditions must exist?
1. Control circuit breaker closed, canopy switch closed, solenoid 1 energized
 2. Control circuit breaker closed, canopy switch open, solenoid 2 deenergized
 3. Control circuit breaker closed, canopy switch closed, solenoid 2 energized
 4. Control circuit breaker open, canopy switch closed, solenoid 1 energized
- 7-6. To open the canopy, which of the following conditions must exist?
1. Control circuit breaker closed, canopy switch open, solenoid 1 energized
 2. Control circuit breaker open, canopy switch open, solenoid 1 energized
 3. Control circuit breaker closed, canopy switch closed, solenoid 2 energized
 4. Control circuit breaker open, canopy switch open, solenoid 1 deenergized

In items 7-7 through 7-10, select from column B the pneumatic power system component that performs each function listed in column A.

A. Functions	B. Components
7-7. Ensure the fluid to the hydraulic motor is not surging	1. Pressure sensing switch
7-8. Simultaneously passes voltage to the hydraulic selector valve and dump valve	2. Flow regulator
7-9. Protects the motor against reverse fluid pressure	3. Dump valve
7-10. Enables accumulated moisture to escape from the air system	4. Check valve

Learning Objective: Recognize terms, definitions and principles of operation of aircraft air conditioning and pressurization systems; identify components in these systems and their function.

- 7-11. Although all the following conditions create a demand for cabin air conditioning in aircraft flying at extreme airspeeds, which of the following is the principal cause of cabin temperatures rising above the level at which the crew can maintain top physical and mental efficiency?
1. Engine heat
 2. Solar heat
 3. Body temperature
 4. Ram-air friction
- 7-12. What is the temperature that is measured from a point at which there is no molecular motion called?
1. Standard temperature
 2. Absolute temperature
 3. Critical temperature
 4. Ambient temperature
- 7-13. Which of the following temperature equations is correct?
1. $100^{\circ}\text{C} = 212^{\circ}\text{F}$
 2. $32^{\circ}\text{C} = 212^{\circ}\text{F}$
 3. $32^{\circ}\text{F} = 100^{\circ}\text{C}$
 4. $0^{\circ}\text{F} = 32^{\circ}\text{C}$

7-14. The hot high-pressure air delivered to the pressurizing and air-conditioning system of a jet aircraft comes from what source?

1. Engine compressor
2. Secondary heat exchanger
3. Primary heat exchanger
4. Ram air

Refer to figure 5-58 in answering items 7-15 and 7-16.

- 7-15. In the air conditioning system of a jet aircraft, what method is used to cool the air in the primary heat exchanger?
1. Expanding and contracting freon in the heat exchanger core
 2. Circulating ram air through the heat exchanger core
 3. Passing engine bleed air over the heat exchanger core
 4. Passing ram air over the heat exchanger core
- 7-16. The final stage of cooling hot bleed air is one in which no heat is transferred to or from a working substance. This is known as the
1. ambient process
 2. absolute process
 3. adiabatic process
 4. differential process
- 7-17. When the air-conditioning system in a jet aircraft is operating normally, cabin air moving through the secondary heat exchanger passes directly to which of the following components?
1. Cockpit outlet valves
 2. Mixing valve
 3. Expansion turbine
 4. Modulating valve
- 7-18. To prevent overloading of the mixing valve motor, contacts located inside the motor housing will break the circuit to the motor when the valve actuator is in what position?
1. Half open
 2. Fully open only
 3. Fully closed only
 4. Either fully open or fully closed
- 7-19. In a normally operating electronic temperature control system, an unbalance of the bridge circuit results from
1. a voltage change across a leg element, with leg temperature constant
 2. a current change through a leg element, with leg voltage constant
 3. a temperature change of a leg element
 4. an electrical signal from the mixing valve motor

- 7-20. The cockpit temperature pickup unit demands supply air of a specific temperature in accordance with the adjustments of a
1. potentiometer
 2. thermocouple
 3. thermistor
 4. rheostat

Refer to figure 5-64 in answering items 7-21 and 7-22.

- 7-21. After the desired temperature has been reached in a manual mode, the temperature-control switch should be placed in which setting?
1. MANUAL COLD, if the previous setting was MANUAL HOT
 2. MANUAL HOT, if the previous setting was MANUAL COLD
 3. AUTOMATIC
 4. OFF

- 7-22. What tubes are used for signal phase detection?

1. V1 and V2
2. V1 and V3
3. V2 and V4
4. V3 and V4

- 7-23. Which of the following phrases best describes the characteristic of Freon-12 that makes it desirable for use in aircraft refrigeration units?

1. High boiling point
2. Low boiling point
3. Low stability
4. High stability

- 7-24. What term is applied to the pressure in an area immediately surrounding the object under discussion?

1. Absolute pressure
2. Atmospheric pressure
3. Ambient pressure
4. Differential pressure

- 7-25. In an aircraft with a pressurized cabin, the difference between cabin pressure and atmospheric pressure is known as

1. differential pressure
2. absolute pressure
3. ambient pressure
4. gage pressure

- 7-26. Rapid expulsion of contaminated air in a pressurized aircraft is accomplished by activating which of the following components?

1. Cabin pressure regulator
2. Ambient air shutoff valve
3. Bleed air valve
4. Cabin dump valve

Learning Objective: Recognize the principles of operation of anti-ice, deice and defrost systems; identify components in the systems and their function.

- 7-27. Windshield overheating is prevented by the combined actions of a shutoff valve and

1. a thermostat
2. a dump valve
3. a thermistor
4. an electronic temperature controller

- 7-28. Division of air between the windshield and the cockpit floor is determined through the positioning of a

1. rheostat
2. thermistor
3. manual control knob
4. toggle switch

- 7-29. Where is the heating element for windshield anti-icing and defogging located?

1. On the outer surfaces of both glasses
2. On the outer surface of the outer glass
3. Between the outer glass and the vinyl plastic core
4. Between the inner glass and the vinyl plastic core

- 7-30. What is the method used to deice the empennage of P-3 type aircraft?

1. A dc-powered, ac-controlled electrical anti-icing system provides constant heating of the empennage surfaces
2. Hot air from the turbo-prop engines is circulated through the tail structure
3. The leading edges of the vertical and horizontal stabilizers are electrically heated
4. Heat is routed from inside the aircraft's fuselage into the vertical and horizontal stabilizers by electrically controlled valves

Learning Objective: Identify aircraft flight instruments and their source of power; recognize altitude terms and how they are determined.

- 7-31. Which of the following instruments are considered flight instruments?
1. A turn and bank indicator and an altimeter
 2. A turn and bank indicator and an air-speed indicator
 3. An airspeed indicator and an altimeter
 4. A turn and bank indicator, an airspeed indicator and an altimeter

- 7-32. The altimeter is part of what aircraft system?
1. Compass
 2. Navigation
 3. Pitot-static
 4. Radio

- 7-33. In a pitot-static system, the word pitot represents what type of pressure?
1. Stationary
 2. Ambient
 3. Impact
 4. Barometric

- 7-34. Which of the following is a meaning for the term altitude?
1. Elevation
 2. Distance above mean sea level (MSL)
 3. Distance above ground level (AGL)
 4. Both of the above

- 7-35. That point where gravity acting on the atmosphere above the earth's surface produces a pressure of 14.70 pounds per square inch and supports a column of mercury to a height of 29.92 inches is referred to as
1. absolute altitude
 2. true altitude
 3. pressure altitude
 4. mean sea level

- 7-36. An altitude reading obtained from a properly calibrated altimeter referenced to 29.92 inches of mercury is called
1. true altitude
 2. absolute altitude
 3. pressure altitude
 4. indicated altitude

- 7-37. At sea level a barometric change of 0.03 inch will produce a change in the altimeter reading of how many feet?
1. 9
 2. 18
 3. 27
 4. 36

- 7-38. For the pilot to obtain the best performance of the aircraft engine, it is important that which of the following altitudes is known?
1. True
 2. Density
 3. Indicated
 4. Calibrated

In items 7-39 through 7-41, select from column B the definition of each type pressure listed in column A.

	A. Pressures	B. Definitions
7-39.	True static pressure	1. Atmospheric pressure of the undisturbed air
7-40.	Total pressure	2. Pressure taken at a select point on the aircraft that is corrected for local field pressure
7-41.	Impact pressure	3. The air pressure at the leading surfaces of the aircraft in flight
		4. The incremental increase in pressure created as a result of aircraft velocity

Learning Objective: Recognize air data computer (ADC) output information; identify components in the automatic altitude reporting system, their functions and relationship to other aircraft systems.

- 7-42. The air data computer supplies which of the following data?
1. Vertical airspeed, true airspeed, and Mach number
 2. Altitude, Mach number, and true airspeed
 3. Outside air temperature, altitude, and vertical airspeed
 4. Altitude, outside air temperature, and vertical airspeed

7-43. In the automatic altitude system, position and altitude reporting is accomplished by which of the following components?

1. Tachometer generators
2. Flashing beacons
3. Transponders
4. Transformers

7-44. In an automatic altitude reporting system, the transponder provides the aircraft's altitude in increments of

1. 50 feet
2. 100 feet
3. 150 feet
4. 250 feet

7-45. The semi-automatic air traffic control system presentation displays how many dimensions?

1. One
2. Two
3. Three
4. Four

7-46. Which of the following is the primary reason for the development of the AIM system?

1. Shorter intervals in carrier landings were needed
2. Improvement in air traffic control within the United States was needed
3. A reduction in the number of aircraft in the air at any one time was needed
4. Improvements in radar maintenance were needed

7-47. What is the maximum difference between the pilot's and the ground display altitudes allowed in the AIM system?

1. ± 50 feet
2. ± 125 feet
3. ± 250 feet
4. ± 350 feet

7-48. Most naval high performance aircraft utilize which of the following altimeters as part of the AIM system?

1. AAU/18A
2. AAU/19A
3. AAU/21A
4. AAU/24A

7-49. The CPU-46/A altitude computer has an operational limit of

1. 25,000 feet; Mach 8
2. 25,000 feet; Mach 2.5
3. 80,000 feet; Mach 2.5
4. 80,000 feet; Mach 8

7-50. When the CPU-46A altitude computer fails, which of the following conditions will exist regarding the AAU-19A altimeter and the altitude reporting encoder?

1. The altimeter automatically reverts to pneumatic standby mode and the altitude reporting encoder is deactivated
2. The altimeter becomes inoperative and must be switched to standby mode; the altitude reporting encoder will continue to function
3. The altimeter and the altitude reporting encoder become inoperative
4. The altimeter is inoperative; the altitude reporting encoder continues to function

7-51. The AAU/19A operates as a standard pressure altimeter when in which of the following modes?

1. Rest
2. Servoed
3. Baroset
4. Standby

7-52. Which of the following components are used to overcome the effects of stop and jump friction in the AAU-24/A altimeter?

1. Servos
2. Synchros
3. Transponders
4. Vibrators

7-53. What is used in the AAU-24A altimeter to drive the barometric counter when the baroset knob is turned?

1. Counter-drum assembly
2. Spur gear
3. Magnetic coupler
4. Aneroid assembly

Learning Objective: Recognize the purpose and terminology of air pressure measuring instruments, the different conditions/factors that affect their operation, and the effects these conditions/factors produce.

7-54. In computing airspeed, the airspeed indicator utilizes which of the following pressures?

1. Static pressure only
2. Impact pressure only
3. The sum of the impact and static pressures
4. The difference between the impact and static pressures

- 7-55. The accuracy of airspeed indicator readings may be affected by which of the following conditions?
1. Temperature changes in the instrument
 2. Air turbulence around the pitot tube
 3. Poor scaling of the indicator dial
 4. Each of the above
- 7-56. Assume that an aircraft's Mach indicator showed 0.5 when the airspeed indicator showed 300 knots. If the speed were doubled to an airspeed of 600 knots, which statement would be true regarding Mach indication and aircraft speed?
1. The aircraft is at the speed of sound, and indicating Mach 0.25
 2. The aircraft is at the speed of sound, and indicating Mach 1
 3. The aircraft is at one-half the speed of sound, and indicating Mach 1
 4. The aircraft is at one-fourth the speed of sound, and indicating Mach 0.025

- 7-57. When the aircraft is in level flight, what will the pointer on the VSI indicate?
1. +1
 2. 0
 3. -1
 4. Aircraft speed

- 7-58. In a VSI indicator, the pointer is driven by
1. the difference between diaphragm and case pressures
 2. the difference between pitot and static pressures
 3. a pneumatic driven motor
 4. a calibrated leak

Learning Objective: Recognize a use of an angle-of-sideslip system, and indicate the operation of an angle-of-attack indicating system.

- 7-59. When utilized on Navy aircraft, the angle-of-sideslip system is used in which of the following systems?
1. Gunfiring
 2. Bombing
 3. Rocket firing
 4. Crosswind landing
- 7-60. The angle-of-attack indicating system operates by detecting
1. earth field variation
 2. airflow differential pressure
 3. altitude/speed pressure gradient
 4. airflow/altitude change rate

- 7-61. When the angle-of-attack of an aircraft is changed, which of the following actions in the self-balancing bridge circuit of the angle-of-attack system?
1. An error voltage will exist between the transmitter potentiometer and the receiver potentiometer
 2. A servomotor will drive the receiver potentiometer to return the bridge circuit to null
 3. Both 1 and 2 above
 4. A servomotor will drive the transmitter potentiometer to return the bridge circuit to null

- 7-62. Illumination of the red arrow in the pilot's angle-of-attack (AOA) indexer signifies which of the following conditions exists?
1. The aircraft is nose low
 2. The aircraft is nose high
 3. The aircraft is at optimum AOA
 4. There has been a failure in the system

- 7-63. The stall warning system on most naval aircraft reacts to inputs from which of the following systems?
1. Pitot-static
 2. Angle-of-attack
 3. Air data computer
 4. Automatic altitude

Learning Objective: Recognize the characteristics, parts, and operating principles of gyroscopic instruments.

- 7-64. Which of the following groups of general characteristics is most desirable for an instrument gyroscope?
1. Light weight, small size, and low speed of rotation
 2. Light weight, small size, and high speed of rotation
 3. Heavy weight, large size, and high speed of rotation
 4. Heavy weight, small size, and high speed of rotation
- 7-65. In order for a gyro to maintain any attitude in space, it requires a mounting that permits 2 degrees of freedom. What total number of gimbals would be required for such a gyro?
1. 1
 2. 2
 3. 3
 4. 4

- 7-66. What are the two fundamental properties for gyroscopic action?
1. Stability and rigidity in space
 2. Precession and centrifugal force
 3. Stability and centrifugal force
 4. Rigidity in space and precession
- 7-67. Assume that a spinning gyroscope precesses when subjected to a deflective force. What will make this gyroscope precess at a faster rate?
1. A decrease in the speed of the rotor
 2. An increase in the force applied
 3. Either 1 or 2 above
 4. An increase in the speed of the rotor
- 7-68. In order to indicate the attitude of an aircraft with respect to the horizon, an artificial horizon is constructed with a miniature aircraft fixed to the case so that the
1. case revolves about a gyro
 2. case and gyro spin axis are both free to move with respect to the aircraft
 3. gyro spin axis is revolved about its case
 4. gyro and case are held stationary and the needles are free to move
- 7-69. The sphere in the attitude indicator may be centered by a control on the face of the indicator to correct the indicator for which of the following flight attitudes?
1. Yaw
 2. Roll
 3. Pitch
 4. Each of the above
- 7-70. In a turn-and-bank indicator, the ball's position is determined by which of the following factors?
1. Natural forces
 2. Gyroscopic precession
 3. Earth's magnetic lines of force
 4. Electrical tilting of the plate on which the tube is mounted

Assignment 8

Instruments; Compass, Inertial Navigation, Automatic Flight Control and Stabilization Systems.

Text: Pages 6-28 through 7-5

Learning Objective: Identify the purpose and principles of operation of turn-and-bank indicator, accelerometer, direct reading compass, and the stand by attitude indicator; recognize the characteristics of a standard Navy aircraft clock.

- 8-1. Gravity and centrifugal force position the ball in a turn-and-bank indicator. In a flight-coordinated turn, what position in the tube will the ball be in?
1. In the center
 2. Toward the end nearest the center of the turn
 3. Either 2 or 3 above, depending upon the direction of turn
 4. Toward the end opposite the center of the turn
- 8-2. Relevant to a turn-and-bank indicator, when the aircraft is in a turn, the frame in which the gyro is suspended moves to the side opposite the direction of turn. However, the pointer of the indicator moves in the direction of turn because
1. centrifugal force and gyro precession are in opposition to each other
 2. gravity is greater than centrifugal force in any aircraft attitude other than straight-and-level flight
 3. the pointer is connected to the frame in a manner which causes the two to move in opposite directions
 4. the centrifugal force applied to the pointer is in the direction opposite to the centrifugal force applied to the frame
- 8-3. What instrument is most useful to the pilot in eliminating the possibility of damage to the aircraft as a result of excessive stresses?
1. Turn pointer
 2. Accelerometer
 3. Slip indicator
 4. Vertical gyro indicator
- 8-4. What is the reading on the accelerometer of an aircraft weighing 40,000 pounds and traveling in straight-and-level flight?
1. -1 g
 2. 0 g
 3. +1 g
 4. +2 g
- 8-5. What will be the reading on the accelerometer in an aircraft weighing 10,000 pounds having a lift equal to 20,000 pounds?
1. -2 g
 2. 0 g
 3. +1 g
 4. +2 g
- 8-6. The principle of accelerometer action involves a
1. body that flexes a diaphragm in response to pressure changes
 2. body that moves in response to aircraft maneuvering
 3. tuning fork whose frequency varies in proportion to airframe stress
 4. timing clock whose speed varies in proportion to airframe stress
- 8-7. What type of movement does the standard Navy aircraft clock have?
1. 12 hour, 8 day
 2. 24 hour, 8 day
 3. 12 hour, 12 day
 4. 24 hour, 12 day
- 8-8. Why is the bowl of an aircraft direct reading compass filled with fluid?
1. To keep the surface of the compass card smooth
 2. To slow the movement of the compass card
 3. To compensate for pressure changes
 4. To magnify the compass card

- 8-9. What is the purpose of the lubber line on the direct reading compass?
1. To reduce card oscillation
 2. To lock the card into position
 3. To serve as a reference mark when reading the card
 4. To enable the compass to be utilized as a standby unit

- 8-10. The standby attitude indicator is capable of displaying a maximum of how many degrees of roll?
1. 79°
 2. 92°
 3. 180°
 4. 360°

Learning Objective: Identify the components, purpose and operating principles of engine tachometers and temperature systems.

- 8-11. A jet engine's tachometer is referenced to a percentage of what rpm?
1. Starting rpm
 2. Cruising rpm
 3. Takeoff rpm
 4. The maximum engine rpm possible

- 8-12. The indicator of a tachometer system is designed to respond to changes in
1. frequency
 2. current
 3. voltage polarity
 4. voltage amplitude

- 8-13. The principal difference between a 2-pole and a 4-pole tachometer generator is the manner in which
1. their outputs are fed to the indicator
 2. they are mounted on the engine
 3. their stators are constructed
 4. their rotors are magnetized

● Refer to figure 6-3 in answering items 8-14 through 8-16.

- 8-14. At high speeds, the armature of the synchronous motor is brought into synchronism by the action of which of the following components?
1. Hysteresis disc only
 2. Hysteresis disc and the permanent magnet
 3. Drag disc only
 4. Hysteresis and drag discs

- 8-15. What is the purpose of concentrating the flux near the outside edge of the drag disc?

1. To provide the maximum torque/weight ratio
2. To stabilize the armature rotational speed
3. To eliminate the effects of temperature changes
4. To minimize the amount of friction encountered by the armature

- 8-16. Linkage between the plates and the drag disc of the drag-magnet assembly is provided by

1. the hysteresis disc
2. a cotter pin
3. a magnetic field
4. a direct mechanical coupling

- 8-17. A multiengine aircraft uses a tachometer generator to furnish the synchronizing voltage for the operation of the propeller automatic pitch adjustment. When an engine tends to speed up, the result is that tachometer generator frequency

1. increases, causing propeller blade pitch to increase
2. increases, causing propeller blade pitch to decrease
3. decreases, causing propeller blade pitch to increase
4. decreases, causing propeller blade pitch to decrease

- 8-18. Vertical scale instruments have which of the following characteristics?

1. Small size and light weight
2. Light weight and easy to maintain
3. Compact and easy to read
4. Compact and easy to maintain

- 8-19. When testing a vertical scale indicating system, activating the test selector switch causes the indicator to read what percent of rpm?

1. 40%
2. 60%
3. 80%
4. 100%

● Refer to figure 6-37 in answering items 8-20 and 8-21.

- 8-20. When the galvanometer in the Wheatstone bridge thermometer indicates zero, which of the following circuit conditions exist?
1. Bulb current and the current through resistor Y are equal
 2. The sum of the voltage drops across X and Z equals the sum of the voltage across the bulb and Y
 3. The combined resistance of X plus Y equals the resistance of Z plus the bulb resistance
 4. Each of the above
- 8-21. Which of the following quantities is indicated on the meter scale?"
1. Resistance of X
 2. Voltage between A and B
 3. Temperature at the bulb
 4. Current flow between A and B
- 8-22. Refer to figure 6-38. In normal operation, an unbalance in the ratiometer bridge circuit is caused by a change of resistance in which of the following components?
1. R1
 2. Centering potentiometer
 3. Thermometer bulb
 4. R2
- 8-23. Thermocouple indicators operate on which of the following principles?
1. Dissimilar-metal junctions produce an electromotive force when heated
 2. Changes in temperature causes changes in junction adhesion, producing an electromotive force
 3. Changes in temperature cause changes in junction size, producing an electromotive force
 4. Different metals bend at different rates when heated, producing an electromotive force
- 8-24. On the P-3 aircraft, how many dual-unit thermocouples are mounted in each engine turbine inlet casing?
1. 12
 2. 18
 3. 24
 4. 36
- 8-25. Why is it necessary to route engine turbine inlet thermocouple wiring through a separate harness to the EGT indicator?
1. To shield the thermocouple from heat
 2. To concentrate heat on the thermocouples
 3. To protect the bridge circuit of the cold junction compensator
 4. To prevent outside signals from changing the average voltage produced by the thermocouples
- 8-26. Thermocouples in an engine exhaust system convert exhaust gas temperature into which of the following units of measurement?
1. Millivolts
 2. Milliampere
 3. Milliwatts
 4. Milliohms
-
- Learning Objective: With respect to engine instruments, recognize purposes, components, and operating principles of fuel flowmeters, synchro oil pressure systems, exhaust nozzle indicating systems, vertical scale indicators, and torque meter systems.
-
- Refer to figure 6-42 in answering items 8-27 and 8-28.
- 8-27. In the fuel flow transmitter, upon what component is the incoming fuel directed?
1. Ring magnet assembly
 2. Hairspring
 3. Synchro transmitter
 4. Vane
- 8-28. What force moves component 4 of the fuel flow transmitter?
1. Rotation of component 3
 2. Mechanical force of component 2
 3. Magnetic force of component 5
 4. Electrical power from component 8
- 8-29. When input fuel pressure to the fuel flow transmitter becomes excessively high, the instrument is bypassed by the action of what transmitter component?
1. Check valve
 2. Baffle valve
 3. Relief valve
 4. Intake valve
- 8-30. The fuel flow transmitter converts fuel flow into an electrical signal which represents the rate of fuel flow in pounds per hour, and transmits this signal to what component in the system?
1. Transmitter synchro receiver
 2. Fuel control regulator
 3. Synchro receiver in the fuel flow indicator
 4. Bypass valve solenoid in the fuel control regulator

Learning Objective: Recognize the operating characteristics of the capacitor-type fuel quantity system.

- 8-31. What component in the fuel flow transmitter eliminates the swirling motion of the incoming fuel?
1. Spiral springs
 2. Straightening vanes
 3. Rotating impeller
 4. Drum magnets
- 8-32. Refer to figure 6-43(B). What quantity of fuel remains in the fuel cells?
1. 99 pounds
 2. 999 pounds
 3. 9,990 pounds
 4. 99,000 pounds
- 8-33. In the fuel flow indicator, what part causes the pointer to deflect in proportion to the fuel being consumed?
1. The friction clutch on the motor shaft
 2. The magnetic drum and cup linkage
 3. The mechanical gear train
 4. The direct coupling of motor to shaft
- 8-34. In a synchro oil pressure system, the movement of the indicator needle is dependent upon which of the following factors?
1. Oil pressure in the engine
 2. Sensing the action of the oil pressure transmitter
 3. Voltages set up in the synchro stators
 4. Each of the above
- 8-35. Refer to figure 6-50. Movement of the transmitter potentiometer will result in which of the following actions?
1. Removal of the 28 volts from one of the coils in the indicator
 2. Removal of the 28 volts from both coils in the indicator
 3. Movement of the nozzle position indicator to the OFF position
 4. Application of a signal to the nozzle position indicator
- 8-36. The torquemeter system operates on the principle that engine loading will create a
1. measurable change in engine rpm
 2. measurable coupling change between the splines of two shafts
 3. shaft twist which is detected by magnetic pickups and measured electronically
 4. shaft twist which causes two magnets to measure the distance from two toothed flanges
- 8-37. The capacitor-type fuel quantity gage indicates fuel quantity in the tank in what units of measurement?
1. Gallons
 2. Pounds
 3. Cubic inches
 4. Percentages
- 8-38. Refer to figure 6-54. The capacitance of the fuel gage capacitor depends upon which of the following factors?
1. The area of the plates
 2. The distance between the plates
 3. The type of dielectric
 4. Each of the above
- 8-39. Refer to figure 6-55. Which of the following conditions exist in the circuit as fuel quantity is increased?
1. Tank unit capacitance increases, tank unit leg current decreases, and transformer voltage and voltage across the voltmeter are in phase
 2. Tank unit capacitance decreases, tank unit leg current increases, and transformer voltage and voltage across the voltmeter are in phase
 3. Tank unit capacitance decreases, tank unit leg current decreases, and transformer voltage and voltage across the voltmeter are out of phase
 4. Tank unit capacitance decreases, tank unit leg current increases, and transformer voltage and voltage across the voltmeter are out of phase
- 8-40. A comparison of which of the following characteristics of two voltages determines the fuel quantity indicator motor's direction of rotation?
1. Polarity
 2. Phase
 3. Amplitude
 4. Frequency
- 8-41. Refer to figure 6-56. As the fuel level varies, the balance of the bridge is maintained by the automatic adjustment of what resistor?
1. R121
 2. R122
 3. R128
 4. R129

- 8-42. Two or more fuel tank units, connected in parallel, minimize the effects of which of the following conditions?
1. A decrease in fuel
 2. An increase in fuel
 3. Variations in aircraft altitude
 4. Irregularities in fuel tank shape

- 8-43. Dielectric constant and density of fuel will deviate due to which of the following conditions?
1. Altitude and temperature of the fuel
 2. Altitude and composition of the fuel
 3. Composition of the fuel and shape of the fuel tank
 4. Temperature of the fuel and shape of the fuel tank

- 8-44. In a capacitive type fuel quantity system, what is the circuit relationship between the reference capacitor and the compensator unit?
1. In parallel with each other
 2. In series with each other
 3. Electrically isolated from each other
 4. Coupled together by transformer action

Learning Objective: Identify the unit of measurement on aircraft hydraulic pressure indicators, the instrument to be removed for cabin pressurization checks, and the functions of a dc position indicating system.

- 8-45. What unit of measurement is indicated by hydraulic pressure indicators on most naval aircraft?
1. Pounds per square inch
 2. Pounds per square foot
 3. Pounds per second
 4. Pounds per minute

- 8-46. Which of the following instruments should be removed from the aircraft prior to a cabin pressurization test on the ground?
1. VSI
 2. Airspeed indicator
 3. Cabin pressure altimeter
 4. Turn and bank indicator

- 8-47. In a dc position indicating system, what is the purpose of the copper cylinder in the indicator?
1. To aid the magnetic field
 2. To maintain equal coil spacing
 3. To dampen pointer oscillation
 4. To position the transmitter brushes

- 8-48. In aircraft equipped with the landing gear lighted handle feature, which of the following conditions will exist when the gear handle is illuminated?
1. The circuits controlled by the uplock and downlock switches will be open
 2. The landing gear will not be locked in either the up or the down position
 3. The black and yellow warning lines on the position indicator will be visible
 4. All of the above

Learning Objective: Identify instrument maintenance procedures; instrument markings and their purpose; recognize the daily inspection criteria for aircraft instruments.

- 8-49. Which of the following procedures is recommended for ensuring the accuracy of aircraft instruments?
1. Replace them at regular intervals
 2. Periodically subject them to functional tests
 3. Replace them rather than adjust them
 4. Periodically readjust the adjustable mechanisms

- 8-50. What does a red mark on an instrument glass indicate?
1. The normal operating range
 2. Glass slippage
 3. A critical airspeed
 4. A maximum limit

- 8-51. What is the purpose of the white index mark painted at the bottom center of all instruments color-marked for operating ranges?
1. To be used when setting the pointer at zero reference
 2. To designate the 6-o'clock position of the indicator for mounting purposes
 3. To be used as a guide for mounting the lighting masks
 4. To show whether or not the glass cover has moved after operating ranges have been marked

- 8-52. A check on which of the following items should be accomplished during a daily inspection of an aircraft's instrument panel?
1. Proper operation of caging and setting knobs
 2. Loose or cracked cover glass
 3. Proper operation of lights
 4. Each of the above

- 8-53. Which of the following statements relative to the lubrication of aircraft instruments is correct?
1. Lubrication is limited to that required by the bearings
 2. Squadron personnel rarely lubricate any part of the instruments
 3. Lubrication is performed by AMs under the direction of AEs
 4. Lubrication is limited to that required by the shafts

Learning Objective: Identify construction features and installation practices for rigid and flexible tubing, including the application and meaning of identification markings, and indicate the source of information for aircraft tubing repair.

- 8-54. Detailed information on aircraft tubing and tubing repair may be found in which of the following publications?

1. NAVEDTRA 10348-E
2. NAVEDTRA 10349-D
3. NAVAIR 16-1-540
4. NAVAIR 01-1A-8

- 8-55. Rigid tubing in modern aircraft may be made from which of the following metals?

1. Copper
2. Aluminum alloy
3. Corrosion-resistant steel
4. Each of the above

- 8-56. Where are identification markings located on rigid tubing in naval aircraft?

1. Near the fittings and in each compartment
2. Midway between each pair of fittings
3. Not more than one inch from and on both sides of each fitting
4. On the fittings

- 8-57. When identification tape is used on rigid tubing in military aircraft, the function of the tubing is identified by the
1. wording on a 3/4-inch wide tape
 2. color, wording, and symbols on a 1-inch wide tape
 3. color of a 1/2-inch wide tape
 4. color and wording on a 1-inch wide tape

- 8-58. Refer to table 6-2. Of the following groupings, which one consists of materials all classified as physically dangerous and would have PHDAN printed on the identifying tape on the lines which carry them?

1. Carbon dioxide, liquid nitrogen, nitrogen gas, JP-4 fuel
2. Carbon dioxide, liquid nitrogen, liquid oxygen, alcohol
3. Carbon dioxide, gaseous oxygen, nitrogen gas, Freon
4. Carbon dioxide, liquid nitrogen, gaseous oxygen, liquid petroleum gas

- 8-59. The specifications of flexible tubing installed in naval aircraft are identified by

1. the type of fittings used
2. a code of dots-and-dashes printed on the tubing
3. colored tape bands applied to the tubing
4. color-coded bands of paint printed on the tubing

- 8-60. Which of the following statements concerning replacement of high- and low-pressure flexible hoses is correct?

1. Low-pressure may be fabricated locally and high-pressure must be obtained through supply
2. Both must be obtained through supply
3. High-pressure may be fabricated locally and low-pressure must be obtained through supply
4. Both may be fabricated locally

- 8-61. To prevent flexible hose from being pulled loose from the engine due to engine movement, which of the following precautions must be taken when the hose is installed?

1. Cushioned clips must be used to hold the hose
2. Supports must be mounted not less than 24 inches apart
3. Slack must be allowed between the last hose support and the connection to the engine
4. The hose must be properly shrouded

Learning Objective: Identify the organization that repairs sealed instruments the precautions to be taken when substituting aircraft instruments, and the disposition of instrument shipping containers.

8-62. Hermetically sealed instruments may be repaired by personnel in which of the following organizations?

1. Naval air rework facilities
2. Intermediate maintenance activities
3. Squadrons
4. Each of the above

8-63. Refer to table 6-4 in your textbook. The pointer on the fuel flow indicator swings to the side of the dial and a squeal is heard from the instrument. Which of the following conditions could cause this malfunction?

1. A short in the system
2. Power leads reversed to the stator
3. Both 1 and 2 above
4. An open stator lead

8-64. When it is necessary to substitute one aircraft instrument for another, which of the following precautions should be taken?

1. Insure that the instrument has the same stock number only
2. Insure that the instrument has the same manufacturer's part number only
3. Insure that the instrument has the same manufacturer's part number and stock number
4. Insure that the instrument is made by the same manufacturer

8-65. What should be the disposition of containers in which instruments are received?

1. The containers should be returned to supply
2. The containers should be routed to salvage for final disposition
3. The containers should be destroyed or plainly labeled NOT FOR REUSE FOR INSTRUMENTS
4. The containers should be retained for future use in packaging instruments

Learning Objective: Recognize facts about air navigation, and identify associated terms and their meanings.

8-66. Which of the following statements is INCORRECT concerning use of air navigation?

1. It is used in measuring distance and time
2. It is used in measuring aircraft attitude
3. It is used to determine the aircraft's position
4. It is used to determine the direction an aircraft must fly to reach its destination

In answering items 8-67 through 8-70, select from column B the definition for each term listed in column A.

A. Terms	B. Definitions
8-67. Course	1. The intended horizontal direction of travel
8-68. Heading	2. The horizontal direction of one terrestrial point from another
8-69. Bearing	3. The horizontal direction in which an aircraft is pointed
8-70. Distance	4. The separation between two points measured in some scalar quantity

8-71. Planes that pass through the earth perpendicular to the earth's rotational axis, and that intersect with the earth's surface to form circles, are called

1. parallels
2. perpendiculars
3. meridians
4. prime meridians

8-72. What is the location of a point designated as latitude 37° S and longitude 83° E?

1. 37° south of Greenwich, England, and 83° east of the Equator
2. 83° east and 37° south of Greenwich, England
3. 83° east of Greenwich, England, and 37° south of the Equator
4. 37° south and 83° east of the Equator

8-73. Convert the coordinates latitude 47.75° N and longitude 131.45° E from decimal form to degree of minutes/seconds form.

1. latitude 47° 60' 4" N and longitude 131° 45' E, respectively
2. latitude 42° 36' N and longitude 48° 55' E, respectively
3. latitude 47° 45' N and longitude 131° 27' E, respectively
4. latitude 48° 15' N and longitude 131° 75' E, respectively

Assignment 9

Compass, Inertial Navigation, Automatic Flight Control and Stabilization Systems.

Text: Pages 7-5 through 7-83

Learning Objective: Recognize facts about air navigation, identify associated terms and their meanings, and solve for compass error.

In answering items 9-1 through 9-3, select from column B the definition of each of the terms listed in column A.

<u>A. Terms</u>	<u>B. Definitions</u>
9-1. Variation	1. An irregular line connecting points on a map of the earth, indicating where a compass points to true north
9-2. Agonic line	2. An irregular line connecting points on a map of the earth, indicating where there is the same variation from true north
9-3. Isogonic line	3. The angular difference between the directions of true north and magnetic north at a particular location
	4. The angular difference between the direction of the earth's magnetic field and the compass reading due to nearby magnetic influences

- 9-4. If variation is 6° west and deviation is 1° west, the compass error is equal to
1. $-6^\circ + 1^\circ = 5^\circ$ east
 2. $-6^\circ - 1^\circ = 7^\circ$ east
 3. $6^\circ + 1^\circ = 7^\circ$ west
 4. $6^\circ - 1^\circ = 5^\circ$ west

- 9-5. If variation is $(-)^3^\circ$ and deviation is $(+)^4^\circ$, the compass error is equal to
1. $(-)^3^\circ + (+)^4^\circ = (+)^1^\circ$ or 1° east
 2. $(-)^3^\circ - (+)^4^\circ = (-)^7^\circ$ or 7° east
 3. $(-)^3^\circ + (+)^4^\circ = (+)^1^\circ$ or 1° west
 4. $(-)^3^\circ - (+)^4^\circ = (-)^7^\circ$ or 7° west.
- 9-6. The difference between the direction of the earth's magnetic field and the horizontal at any location on the earth's surface is called
1. magnetic dip
 2. magnetic variation
 3. surface variation
 4. surface deviation
- 9-7. On a map, a line that connects all places having equal dip angles is called an
1. agonic line
 2. aclinic line
 3. isobaric line
 4. isoclinic line
- 9-8. If the navigator of an aircraft plots the present position by using aircraft speed and course, the aircraft's last known position, elapsed time, and any changes in speed and course since the last known position, what type of navigation is the navigator using?
1. Pilotage
 2. Mapping
 3. Inertial
 4. Dead reckoning
- 9-9. Accelerometers in inertial navigation equipment are mounted on a platform that remains perpendicular at all times to the earth's gravitational field in order that the accelerometers will
1. sense gravity changes only
 2. sense vehicle accelerations only
 3. sense gravity changes and vehicle accelerations
 4. function without being damaged

Learning Objective: Recognize functions and operating principles of components used in various types of aircraft compasses and indicators, and identify information that the indicators provide.

Items 9-10 through 9-12 relate to a compass system that provides aircraft heading information in electrical signal form.

9-10. In the compass system, what unit senses the direction of the flux lines of the earth's magnetic field?

1. The direct-reading compass.
2. The magnetic amplifier
3. The gyro amplifier
4. The flux valve

9-11. A displacement gyro assembly provides which of the following electrical signals?

1. Azimuth and pitch only
2. Pitch and roll only
3. Roll and azimuth only
4. Azimuth, pitch, and roll

9-12. When power is first applied to a typical displacement gyro assembly, which components in the assembly sense the earth's gravity and initiate signals for leveling the vertical gyro?

1. Pendulums
2. Electrolytic switches
3. Vertical accelerometers
4. Micro switches

Items 9-13 through 9-15 relate to vertical gyroscope operation.

9-16. The directional gyro pitch gimbal is maintained perpendicular to the surface of the earth by a motor-generator which is driven by the amplified output of

1. a generator damped by a pendulum-type weight
2. micro switches
3. the vertical gyro's pitch servo control transmitter
4. electrolytic switches mounted on the directional gyro's pitch gimbal

9-17. When does the switching rate gyroscope actuate relays that cut out roll erection and directional gyro slaving?

1. When the aircraft makes a 7° bank
2. When the aircraft makes a 20° turn in two minutes
3. When the aircraft turns at a rate of 1° per second
4. When the aircraft turns at a rate of 1° per minute

9-18. The horizontal situation indicator in an aircraft will provide which of the following items of information?

1. The selected course to an electronic ground station
2. The aircraft's deviation from a selected course
3. The pictorial bearing and the distance in nautical miles to an electronic ground station
4. Each of the above

9-19. Electrical inputs to the bearing-distance-heading indicator are coupled from synchro transmitters in

1. the compass card
2. a torque receiver
3. other electronic equipment
4. an electronic ground station

In answering items 9-13 through 9-15, select from column B the control transmitter that initiates each of the signals listed in column A.

A. Signals	B. Control Transmitters
9-13. Roll signals to the AFCS control amplifier	1. Outer roll control transmitter
9-14. Roll signals to the indicators	2. Pitch control transmitter
9-15. Pitch signals to the indicators	3. Roll control transmitter
	4. Pitch servo control transmitter

Learning Objective: Relative to the MA-1 compass system, recognize operating features, procedures, and principles, and indicate drift and precession rates associated with the system.

9-20. The MA-1 compass system provides an accurate, reliable, and continuous azimuth heading by using a combination best features of the

1. attitude gyroscope and yaw accelerometer
2. directional gyroscope and attitude gyroscope
3. magnetic compass and directional gyroscope
4. yaw accelerometer and magnetic compass

- 9-21. When operating as a free gyro, the MA-1 compass system has a drift rate of
1. 1° per minute or less
 2. 1° per hour or less
 3. 4° per minute or less
 4. 4° per hour or less

- 9-22. Which of the following statements is correct concerning the MA-1 compass system operating in the slaved mode?
1. The signals from the flux valve servo position the gyro's spin axis
 2. The gyro is slaved in such a way that its spin axis is always aligned perpendicular to the direction of flight
 3. The flux valve is slaved to align with the gyro's spin axis
 4. The gyro's spin axis is positioned so that it is always pointed in the direction of flight

- 9-23. From what component does the slaving torquer motor directly receive its signals for torque change when the MA-1 compass system is operating in (a) SLAVED mode and (b) FREE mode?
1. (a) Gyro spin axis synchro,
(b) slaving amplifier
 2. (a) Slaving amplifier,
(b) slaving amplifier
 3. (a) Slaving amplifier,
(b) latitude compensation potentiometer wiper arm
 4. (a) Accelerometers,
(b) latitude compensation potentiometer wiper arm

Items 9-24 through 9-27, pertain to the AJB-7 compass system and controller.

- 9-24. Refer to figure 7-20. Besides the components that are part of the basic AJB-7 compass system, what other aircraft components are used with the system?
1. Flux valve, directional gyro, and horizontal situation indicator
 2. Compass transmitter, standby attitude indicator, and remote attitude indicator
 3. Directional gyro, amplifier-power supply, and compass adapter-compensator
 4. Compass adapter-compensator and compass transmitter

In answering items 9-25 through 9-27, select from column B the circumstance for using each of the modes listed in column A.

	A. Modes	B. Circumstances
9-25.	SLAVED	1. Used in areas where the earth's magnetic field is appreciably distorted
9-26.	SYNC	
9-27.	COMP	2. Used in normal conditions 3. Used when the directional gyro signals are not reliable 4. Used after severe aircraft maneuvers

Learning Objective: Identify the theory of operation and operating principles of an Inertial Navigation System; recognize the various methods of navigation, and identify terms associated with navigation.

Items 9-28 through 9-37, pertain to an inertial navigation system using Schuler tuning.

- 9-28. An inertial navigation system must contain a minimum of
1. one differentiator
 2. two accelerometers
 3. three integrators
 4. four gyroscopes
- 9-29. What accelerometer and gyro combinations make up the north and east Schuler loops, respectively?
1. Vertical accelerometer and north gyro; vertical accelerometer and east gyro
 2. North accelerometer and east gyro; east accelerometer and north gyro
 3. North accelerometer and north gyro; east accelerometer and east gyro
 4. East accelerometer and north gyro; north accelerometer and east gyro
- 9-30. Which symbol represents the only input signal which has an effect on the Schuler loop in an inertial navigation system?
1. P_c
 2. P_c^-
 3. V_c
 4. V_{co}

- 9-31. Which of the following conditions does NOT result in an error in computed velocity?
1. Vehicular acceleration
 2. Accelerometer bias
 3. Gyro drift
 4. Initial platform tilt

Learning Objective: Identify compensation and calibration procedures for aircraft magnetic compasses, and compute related coefficients of deviation.

In items 9-32 through 9-34, select from column B the process applicable to each term listed in column A.

	A. Terms	B. Processes
9-32.	Aligning	1. Torquing the system's gimbals to a position as defined by an external reference
9-33.	Leveling	2. Achieving alignment in azimuth by means of sensors
9-34.	Slaving	3. Moving the platform's sensitive axes to a known azimuth position 4. Moving the stable platform to such a position that the accelerometers do not sense gravity components

- 9-35. Which of the following terms correctly describes a functioning Schuler loop?
1. Undamped pendulum
 2. Damped pendulum
 3. Level platform
 4. Oscillating platform

- 9-36. When leveling procedures are being carried out aboard a carrier, an intolerable tilt error will be introduced if the carrier is making a turn of one-half degree per second at a maximum speed of
1. 10 knots
 2. 15 knots
 3. 20 knots
 4. 25 knots

- 9-37. At midlatitudes, what is the approximate azimuth error in the reference velocity in a gyrocompassing loop?
1. 1 degree for each 4 knots of north reference error
 2. 4 degrees for each knot of north reference error
 3. 1 minute for each 4 knots of north reference error
 4. 4 minutes for each knot of north reference error

- 9-38. During a process known as swinging, compensators of a magnetic compass are adjusted for the purpose of
1. reducing deviation error
 2. dampening compass oscillations
 3. correcting for variation error
 4. determining an area of small magnetic disturbance
- 9-39. A pulley system used to move an aircraft during a ground swinging operation causes the compass to deviate $1\ 1/2^\circ$. This deviation exceeds the maximum permissible deviation by
1. 1°
 2. $1/2^\circ$
 3. $3/4^\circ$
 4. $1\ 1/4^\circ$
- 9-40. The error in a magnetic compass that is termed deviation error results from
1. inaccuracies in compass system manufacture
 2. inherent lag in the compass indicator
 3. electromagnetic disturbances in the aircraft
 4. the earth's geographic and magnetic poles being separated

● In answering items 9-41 through 9-43, assume that you are swinging the compass of an aircraft and note the following readings:

North: 005°
 South: $175\ 1/2^\circ$
 East: $093\ 1/2^\circ$
 West: $269\ 1/2^\circ$

- 9-41. What is the coefficient C of the north-south deviation in the preceding information?
1. $-4\ 3/4^\circ$
 2. -2°
 3. $1/2^\circ$
 4. $3\ 1/4^\circ$
- 9-42. What is the coefficient B of the east-west deviation in the preceding information?
1. -4°
 2. -2°
 3. $1\ 1/2^\circ$
 4. 2°

9-43. What is the coefficient A of the deviations in the preceding information?

1. $-7/8^\circ$
2. -2°
3. $1/2^\circ$
4. $1\ 1/8^\circ$

9-44. Compensations for coefficient B and C deviations in a direct reading compass are made by moving the compensator magnets, but excessive coefficient A deviations are corrected by

1. moving the compass to another location in the aircraft
2. turning the compass in its mounting
3. tilting the compass correction card
4. rotating the compass platform

Items 9-45 through 9-47 relate to the use of the MC-2 magnetic compass calibrator set to calibrate an aircraft's compass.

9-45. Use of the calibrator set to calibrate an aircraft compass system eliminates the necessity of

1. accurately placing the aircraft on a north-south line
2. rotating the aircraft on a compass rose
3. installing the compass in the aircraft in order to accomplish the calibration
4. providing the electrical heading input of 0 to 345 degrees

9-46. The accuracy of the electrical heading inputs provided by this calibrator set is

1. 0.02°
2. 0.1°
3. 0.25°
4. 0.5°

9-47. Errors in the compass system are measured as the difference between the aircraft's magnetic heading as indicated on the aircraft compass, and the magnetic heading of

1. the earth's field
2. a simulated earth's field
3. a modified earth's field
4. true Geographic North

Learning Objective: Identify the purpose of an automatic flight control system; recognize the theory and factors involved in fixed wing and rotary wing flight.

9-48. The purpose of an automatic flight control system (AFCS) is to

1. eliminate the need for pilots
2. provide information to sensors
3. reduce the pilot's workload in controlling the aircraft
4. increase aerodynamic loading of the flight control surfaces

9-49. Which of the following aircraft components are examples of airfoils?

1. Fuselages only
2. Propellers only
3. Wings and fuselages
4. Fuselages, propellers, and wings

9-50. An airfoil produces lift by

1. decreasing drag
2. decreasing the angle of attack
3. creating high pressure on the rounded surface
4. creating low pressure on the rounded surface

9-51. A moveable device attached to the trailing edge of an airfoil will increase lift by

1. increasing airspeed
2. increasing the angle-of-attack
3. decreasing the angle-of-attack
4. decreasing drag

9-52. Aft motion on the cockpit control stick of a fixed-wing aircraft causes the

1. nose of the aircraft to move down
2. elevators to move up
3. elevators to move down
4. ailerons to move down

9-53. What aileron control is necessary to return an aircraft to laterally level flight from a right bank?

1. The left aileron must go down and the right aileron must go up
2. Both ailerons must go up
3. The left aileron must go up and the right aileron must go down
4. Both ailerons must go down

9-54. Movement of the nose in the opposite direction of an intended turn, caused by aileron drag, is known as

1. adverse yaw
2. skid
3. ballooning
4. slip

9-55. What controls must be coordinated when banking an aircraft?

1. Elevators and ailerons only
2. Rudder and ailerons only
3. Elevators and rudder only
4. Rudder, ailerons, and elevators

- 9-56. To compensate for an aircraft's right yaw condition, the pilot should take which of the following actions?
1. Push left rudder pedal and hold
 2. Push right rudder pedal and hold
 3. Move rudder trim tab to the left
 4. Move rudder trim tab to the right

Learning Objective: Indicate an advantage of a helicopter over fixed-wing aircraft, and recognize the principle of operation of the rotary wing aircraft flight controls.

- 9-57. The major advantage of a helicopter over a fixed-wing aircraft is its ability to
1. fly at low altitudes
 2. fly at zero or very low airspeeds
 3. make sharp turns
 4. climb at high rates of speed
- 9-58. Operation of the cyclic control causes a change in pitch angle in the
1. rudder
 2. ailerons
 3. tail rotor blades
 4. main rotor blades
- 9-59. In hovering flight only, helicopter heading is controlled by the
1. cyclic stick only
 2. collective stick only
 3. cyclic and collective sticks
 4. rudder pedals

Learning Objective: Identify the function, characteristics, and operational features of mechanical and electrical components of an automatic flight-control system (AFCS).

- 9-60. The function of the amplifiers and computers in the automatic flight control system is to
1. sense conditions that require correction
 2. provide a reference for standard conditions
 3. produce a reference for nonstandard conditions
 4. determine the magnitude and direction of correction needed

- 9-61. Pitch and bank reference information is furnished the automatic flight control system by a/an
1. amplifier/computer
 2. vertical gyro
 3. rate control gyro
 4. compass transmitter
- 9-62. The term vertical gyro implies that the
1. gyro's spin axis is continuously erected vertical to the surface of the earth
 2. output represents movement about the vertical axis
 3. output represents movement along the vertical axis
 4. gyro's spin axis is continuously erected parallel to the vertical axis of the aircraft

- 9-63. Heading information for the automatic flight control system is received from the
1. aircraft compass system/inertial navigation system
 2. vertical gyro
 3. standby (wet) compass
 4. amplifier/computer

- 9-64. What component of the automatic flight control system corrects the amount of control surface deflection due to changes in airspeed?
1. An airspeed cutout switch
 2. An automatic trim tab
 3. An airspeed gain control unit
 4. A barometric altitude gain control unit

- 9-65. Why is the elevator channel in the AFCS fed a nosedown signal when the flaps are lowered?
1. To maintain current airspeed until the power control reacts to the increase in drag
 2. To prevent the aircraft from gaining airspeed
 3. To prevent the aircraft from gaining altitude
 4. To balloon the aircraft

Learning Objective: Recognize the purpose and capabilities of the automatic flight control system and the automatic stabilization system; identify operational features of the AFCS and ASE control panels.

- 9-66. The purpose of mode one operation of the hydraulic booster package is to
1. connect the AFCS to the control surfaces
 2. provide operation of the control surfaces through the use of electrical input signals
 3. provide hydraulic assistance to the pilot in moving the control surfaces
 4. allow the pilot to control the aircraft through the AFCS
- 9-67. The component of the hydraulic booster package that supplies rate-of-movement information to the AFCS is the
1. modulating piston
 2. hydraulic transfer valve
 3. surface position transmitter
 4. hydraulic load sensor
- 9-68. When the AFCS is engaged in an aircraft using a three-axes trim indicator, what is indicated if the aileron channel indicator bar remains off center?
1. The aileron channel is inoperative
 2. The aileron channel needs synchronizing
 3. The aileron channel is unreliable
 4. The aileron channel is functioning normal
- 9-69. When the Heading Select mode is engaged in the automatic flight control system, changes in aircraft heading are obtained by
1. turning the latitude knob on the compass controller
 2. turning the heading set knob on the HSI
 3. engaging the control stick steering control wheel steering mode
 4. engaging the heading hold mode
- 9-70. In high-speed aircraft, which of the following AFCS modes is considered most critical to safe flight?
1. ALTITUDE HOLD
 2. ATTITUDE HOLD
 3. HEADING HOLD
 4. STABILITY AUGMENTATION
- 9-71. The automatic stabilization equipment and coupler system has what total number of modes of operation?
1. 5
 2. 6
 3. 3
 4. 4
- 9-72. What is the purpose of the four guarded toggle switches on the ASE channel monitor panel?
1. To select the inputs to the hover indicator
 2. To perform preflight testing and maintenance
 3. To conduct inflight maintenance
 4. To disconnect malfunctioning channels
- 9-73. When ASE only is engaged, the reference attitude for the pitch channel is provided by the
1. CG trim and collective stick position
 2. barometric altitude and cyclic stick position
 3. CG trim and cyclic stick position
 4. collective and cyclic stick position
- 9-74. When the ASE is in the DOPP mode of coupler operation, the pitch channel reference signal is equal to the difference between what two quantities?
1. Set speed on the control panel and the actual speed
 2. Set altitude on the control panel and the actual altitude
 3. Set speed on the control panel and the actual altitude
 4. Set drift on the control panel and the actual drift
- 9-75. When ASE is engaged, the yaw channel compass and trim signals are synchronized during
1. automatic turns initiated by the yaw rate gyro and yaw trim
 2. automatic turns initiated by the yaw trim and drift control
 3. manual turns initiated by the drift control an yaw rate gyro
 4. manual turns using cyclic stick and rudder pedals

COURSE DISENROLLMENT

All study materials must be returned. On disenrolling, fill out only the upper part of this page and attach it to the inside front cover of the textbook for this course. Mail your study materials to the Naval Education and Training Program Development Center.

PRINT CLEARLY

NAVEDTRA NUMBER		COURSE TITLE	
10348-E		NRCC AVIATION ELECTRICIAN'S MATE 3 & 2	
Name	Last	First	Middle
Rank/Rate	Designator		Social Security Number

COURSE COMPLETION

Letters of satisfactory completion are issued only to personnel whose courses are administered by the Naval Education and Training Program Development Center. On completing the course, fill out the lower part of this page and enclose it with your last set of answer sheet. Be sure mailing addresses are complete. Mail to the Naval Education and Training Program Development Center.

PRINT CLEARLY

NAVEDTRA NUMBER		COURSE TITLE	
10348-E		NRCC AVIATION ELECTRICIAN'S MATE 3 & 2	
Name			
ZIP CODE			

MY SERVICE RECORD IS HELD BY:

Activity	
Address	ZIP CODE
Signature of enrollee	

A FINAL QUESTION: What did you think of this course? Of the text material used with the course? Comments and recommendations received from enrollees have been a major source of course improvement. You and your command are urged to submit your constructive criticisms and your recommendations. This tear-out form letter is provided for your convenience. Typewrite if possible, but legible handwriting is acceptable.

Date _____

From: _____
(RANK, RATE, CIVILIAN)

ZIP CODE _____

To: Naval Education and Training Program Development Center (PD 7)
Pensacola, Florida 32509

Subj: Aviation Electrician's Mate 3 & 2, NAVEDTRA 10348-E

1. The following comments are hereby submitted:

(Fold along dotted line and staple or tape)

(Fold along dotted line and staple or tape)

DEPARTMENT OF THE NAVY
NAVAL EDUCATION AND TRAINING PROGRAM
DEVELOPMENT CENTER (PD 7)
PENSACOLA, FLORIDA 32509

OFFICIAL BUSINESS
PENALTY FOR PRIVATE USE, \$300

POSTAGE AND FEES PAID
NAVY DEPARTMENT
DoD-316



NAVAL EDUCATION AND TRAINING PROGRAM DEVELOPMENT CENTER
BUILDING 2435 (PD 7)
PENSACOLA, FLORIDA 32509

548

PRINT OR TYPE

ATION ELECTRICIAN'S MATE 3 & 2
NAVEDTRA 10348-E

NAME _____ ADDRESS _____
Last First Middle Street/Ship/Unit/Division, etc.

RANK/RATE _____ SOC. SEC. NO. _____ DESIGNATOR _____ ASSIGNMENT NO _____
City of PPO State Zip

USN USNR ACTIVE INACTIVE OTHER (Specify) _____ DATE MAILED _____

SCORE

	1	2	3	4	
1	<input type="checkbox"/>	<input type="checkbox"/>	<input type="checkbox"/>	<input type="checkbox"/>	-----
2	<input type="checkbox"/>	<input type="checkbox"/>	<input type="checkbox"/>	<input type="checkbox"/>	-----
3	<input type="checkbox"/>	<input type="checkbox"/>	<input type="checkbox"/>	<input type="checkbox"/>	-----
4	<input type="checkbox"/>	<input type="checkbox"/>	<input type="checkbox"/>	<input type="checkbox"/>	-----
5	<input type="checkbox"/>	<input type="checkbox"/>	<input type="checkbox"/>	<input type="checkbox"/>	-----
6	<input type="checkbox"/>	<input type="checkbox"/>	<input type="checkbox"/>	<input type="checkbox"/>	-----
7	<input type="checkbox"/>	<input type="checkbox"/>	<input type="checkbox"/>	<input type="checkbox"/>	-----
8	<input type="checkbox"/>	<input type="checkbox"/>	<input type="checkbox"/>	<input type="checkbox"/>	-----
9	<input type="checkbox"/>	<input type="checkbox"/>	<input type="checkbox"/>	<input type="checkbox"/>	-----
10	<input type="checkbox"/>	<input type="checkbox"/>	<input type="checkbox"/>	<input type="checkbox"/>	-----
11	<input type="checkbox"/>	<input type="checkbox"/>	<input type="checkbox"/>	<input type="checkbox"/>	-----
12	<input type="checkbox"/>	<input type="checkbox"/>	<input type="checkbox"/>	<input type="checkbox"/>	-----
13	<input type="checkbox"/>	<input type="checkbox"/>	<input type="checkbox"/>	<input type="checkbox"/>	-----
14	<input type="checkbox"/>	<input type="checkbox"/>	<input type="checkbox"/>	<input type="checkbox"/>	-----
15	<input type="checkbox"/>	<input type="checkbox"/>	<input type="checkbox"/>	<input type="checkbox"/>	-----
16	<input type="checkbox"/>	<input type="checkbox"/>	<input type="checkbox"/>	<input type="checkbox"/>	-----
17	<input type="checkbox"/>	<input type="checkbox"/>	<input type="checkbox"/>	<input type="checkbox"/>	-----
18	<input type="checkbox"/>	<input type="checkbox"/>	<input type="checkbox"/>	<input type="checkbox"/>	-----
19	<input type="checkbox"/>	<input type="checkbox"/>	<input type="checkbox"/>	<input type="checkbox"/>	-----
20	<input type="checkbox"/>	<input type="checkbox"/>	<input type="checkbox"/>	<input type="checkbox"/>	-----
21	<input type="checkbox"/>	<input type="checkbox"/>	<input type="checkbox"/>	<input type="checkbox"/>	-----
22	<input type="checkbox"/>	<input type="checkbox"/>	<input type="checkbox"/>	<input type="checkbox"/>	-----
23	<input type="checkbox"/>	<input type="checkbox"/>	<input type="checkbox"/>	<input type="checkbox"/>	-----
24	<input type="checkbox"/>	<input type="checkbox"/>	<input type="checkbox"/>	<input type="checkbox"/>	-----
25	<input type="checkbox"/>	<input type="checkbox"/>	<input type="checkbox"/>	<input type="checkbox"/>	-----

	1	2	3	4	
26	<input type="checkbox"/>	<input type="checkbox"/>	<input type="checkbox"/>	<input type="checkbox"/>	-----
27	<input type="checkbox"/>	<input type="checkbox"/>	<input type="checkbox"/>	<input type="checkbox"/>	-----
28	<input type="checkbox"/>	<input type="checkbox"/>	<input type="checkbox"/>	<input type="checkbox"/>	-----
29	<input type="checkbox"/>	<input type="checkbox"/>	<input type="checkbox"/>	<input type="checkbox"/>	-----
30	<input type="checkbox"/>	<input type="checkbox"/>	<input type="checkbox"/>	<input type="checkbox"/>	-----
31	<input type="checkbox"/>	<input type="checkbox"/>	<input type="checkbox"/>	<input type="checkbox"/>	-----
32	<input type="checkbox"/>	<input type="checkbox"/>	<input type="checkbox"/>	<input type="checkbox"/>	-----
33	<input type="checkbox"/>	<input type="checkbox"/>	<input type="checkbox"/>	<input type="checkbox"/>	-----
34	<input type="checkbox"/>	<input type="checkbox"/>	<input type="checkbox"/>	<input type="checkbox"/>	-----
35	<input type="checkbox"/>	<input type="checkbox"/>	<input type="checkbox"/>	<input type="checkbox"/>	-----
36	<input type="checkbox"/>	<input type="checkbox"/>	<input type="checkbox"/>	<input type="checkbox"/>	-----
37	<input type="checkbox"/>	<input type="checkbox"/>	<input type="checkbox"/>	<input type="checkbox"/>	-----
38	<input type="checkbox"/>	<input type="checkbox"/>	<input type="checkbox"/>	<input type="checkbox"/>	-----
39	<input type="checkbox"/>	<input type="checkbox"/>	<input type="checkbox"/>	<input type="checkbox"/>	-----
40	<input type="checkbox"/>	<input type="checkbox"/>	<input type="checkbox"/>	<input type="checkbox"/>	-----
41	<input type="checkbox"/>	<input type="checkbox"/>	<input type="checkbox"/>	<input type="checkbox"/>	-----
42	<input type="checkbox"/>	<input type="checkbox"/>	<input type="checkbox"/>	<input type="checkbox"/>	-----
43	<input type="checkbox"/>	<input type="checkbox"/>	<input type="checkbox"/>	<input type="checkbox"/>	-----
44	<input type="checkbox"/>	<input type="checkbox"/>	<input type="checkbox"/>	<input type="checkbox"/>	-----
45	<input type="checkbox"/>	<input type="checkbox"/>	<input type="checkbox"/>	<input type="checkbox"/>	-----
46	<input type="checkbox"/>	<input type="checkbox"/>	<input type="checkbox"/>	<input type="checkbox"/>	-----
47	<input type="checkbox"/>	<input type="checkbox"/>	<input type="checkbox"/>	<input type="checkbox"/>	-----
48	<input type="checkbox"/>	<input type="checkbox"/>	<input type="checkbox"/>	<input type="checkbox"/>	-----
49	<input type="checkbox"/>	<input type="checkbox"/>	<input type="checkbox"/>	<input type="checkbox"/>	-----
50	<input type="checkbox"/>	<input type="checkbox"/>	<input type="checkbox"/>	<input type="checkbox"/>	-----

	1	2	3	4	
51	<input type="checkbox"/>	<input type="checkbox"/>	<input type="checkbox"/>	<input type="checkbox"/>	-----
52	<input type="checkbox"/>	<input type="checkbox"/>	<input type="checkbox"/>	<input type="checkbox"/>	-----
53	<input type="checkbox"/>	<input type="checkbox"/>	<input type="checkbox"/>	<input type="checkbox"/>	-----
54	<input type="checkbox"/>	<input type="checkbox"/>	<input type="checkbox"/>	<input type="checkbox"/>	-----
55	<input type="checkbox"/>	<input type="checkbox"/>	<input type="checkbox"/>	<input type="checkbox"/>	-----
56	<input type="checkbox"/>	<input type="checkbox"/>	<input type="checkbox"/>	<input type="checkbox"/>	-----
57	<input type="checkbox"/>	<input type="checkbox"/>	<input type="checkbox"/>	<input type="checkbox"/>	-----
58	<input type="checkbox"/>	<input type="checkbox"/>	<input type="checkbox"/>	<input type="checkbox"/>	-----
59	<input type="checkbox"/>	<input type="checkbox"/>	<input type="checkbox"/>	<input type="checkbox"/>	-----
60	<input type="checkbox"/>	<input type="checkbox"/>	<input type="checkbox"/>	<input type="checkbox"/>	-----
61	<input type="checkbox"/>	<input type="checkbox"/>	<input type="checkbox"/>	<input type="checkbox"/>	-----
62	<input type="checkbox"/>	<input type="checkbox"/>	<input type="checkbox"/>	<input type="checkbox"/>	-----
63	<input type="checkbox"/>	<input type="checkbox"/>	<input type="checkbox"/>	<input type="checkbox"/>	-----
64	<input type="checkbox"/>	<input type="checkbox"/>	<input type="checkbox"/>	<input type="checkbox"/>	-----
65	<input type="checkbox"/>	<input type="checkbox"/>	<input type="checkbox"/>	<input type="checkbox"/>	-----
66	<input type="checkbox"/>	<input type="checkbox"/>	<input type="checkbox"/>	<input type="checkbox"/>	-----
67	<input type="checkbox"/>	<input type="checkbox"/>	<input type="checkbox"/>	<input type="checkbox"/>	-----
68	<input type="checkbox"/>	<input type="checkbox"/>	<input type="checkbox"/>	<input type="checkbox"/>	-----
69	<input type="checkbox"/>	<input type="checkbox"/>	<input type="checkbox"/>	<input type="checkbox"/>	-----
70	<input type="checkbox"/>	<input type="checkbox"/>	<input type="checkbox"/>	<input type="checkbox"/>	-----
71	<input type="checkbox"/>	<input type="checkbox"/>	<input type="checkbox"/>	<input type="checkbox"/>	-----
72	<input type="checkbox"/>	<input type="checkbox"/>	<input type="checkbox"/>	<input type="checkbox"/>	-----
73	<input type="checkbox"/>	<input type="checkbox"/>	<input type="checkbox"/>	<input type="checkbox"/>	-----
74	<input type="checkbox"/>	<input type="checkbox"/>	<input type="checkbox"/>	<input type="checkbox"/>	-----
75	<input type="checkbox"/>	<input type="checkbox"/>	<input type="checkbox"/>	<input type="checkbox"/>	-----

PRINT OR TYPE

NAME _____ ADDRESS _____
Last First Middle Street/Ship/Unit/Division, etc.

City or FPO State Zip

RANK/RATE _____ SOC. SEC. NO. _____ DESIGNATOR _____ ASSIGNMENT NO _____

USN USNR ACTIVE INACTIVE OTHER (Specify) _____ DATE MAILED _____

SCORE

	1	2	3	4
1	<input type="checkbox"/>	<input type="checkbox"/>	<input type="checkbox"/>	<input type="checkbox"/>
2	<input type="checkbox"/>	<input type="checkbox"/>	<input type="checkbox"/>	<input type="checkbox"/>
3	<input type="checkbox"/>	<input type="checkbox"/>	<input type="checkbox"/>	<input type="checkbox"/>
4	<input type="checkbox"/>	<input type="checkbox"/>	<input type="checkbox"/>	<input type="checkbox"/>
5	<input type="checkbox"/>	<input type="checkbox"/>	<input type="checkbox"/>	<input type="checkbox"/>
6	<input type="checkbox"/>	<input type="checkbox"/>	<input type="checkbox"/>	<input type="checkbox"/>
7	<input type="checkbox"/>	<input type="checkbox"/>	<input type="checkbox"/>	<input type="checkbox"/>
8	<input type="checkbox"/>	<input type="checkbox"/>	<input type="checkbox"/>	<input type="checkbox"/>
9	<input type="checkbox"/>	<input type="checkbox"/>	<input type="checkbox"/>	<input type="checkbox"/>
10	<input type="checkbox"/>	<input type="checkbox"/>	<input type="checkbox"/>	<input type="checkbox"/>
11	<input type="checkbox"/>	<input type="checkbox"/>	<input type="checkbox"/>	<input type="checkbox"/>
12	<input type="checkbox"/>	<input type="checkbox"/>	<input type="checkbox"/>	<input type="checkbox"/>
13	<input type="checkbox"/>	<input type="checkbox"/>	<input type="checkbox"/>	<input type="checkbox"/>
14	<input type="checkbox"/>	<input type="checkbox"/>	<input type="checkbox"/>	<input type="checkbox"/>
15	<input type="checkbox"/>	<input type="checkbox"/>	<input type="checkbox"/>	<input type="checkbox"/>
16	<input type="checkbox"/>	<input type="checkbox"/>	<input type="checkbox"/>	<input type="checkbox"/>
17	<input type="checkbox"/>	<input type="checkbox"/>	<input type="checkbox"/>	<input type="checkbox"/>
18	<input type="checkbox"/>	<input type="checkbox"/>	<input type="checkbox"/>	<input type="checkbox"/>
19	<input type="checkbox"/>	<input type="checkbox"/>	<input type="checkbox"/>	<input type="checkbox"/>
20	<input type="checkbox"/>	<input type="checkbox"/>	<input type="checkbox"/>	<input type="checkbox"/>
21	<input type="checkbox"/>	<input type="checkbox"/>	<input type="checkbox"/>	<input type="checkbox"/>
22	<input type="checkbox"/>	<input type="checkbox"/>	<input type="checkbox"/>	<input type="checkbox"/>
23	<input type="checkbox"/>	<input type="checkbox"/>	<input type="checkbox"/>	<input type="checkbox"/>
24	<input type="checkbox"/>	<input type="checkbox"/>	<input type="checkbox"/>	<input type="checkbox"/>
25	<input type="checkbox"/>	<input type="checkbox"/>	<input type="checkbox"/>	<input type="checkbox"/>

	1	2	3	4
26	<input type="checkbox"/>	<input type="checkbox"/>	<input type="checkbox"/>	<input type="checkbox"/>
27	<input type="checkbox"/>	<input type="checkbox"/>	<input type="checkbox"/>	<input type="checkbox"/>
28	<input type="checkbox"/>	<input type="checkbox"/>	<input type="checkbox"/>	<input type="checkbox"/>
29	<input type="checkbox"/>	<input type="checkbox"/>	<input type="checkbox"/>	<input type="checkbox"/>
30	<input type="checkbox"/>	<input type="checkbox"/>	<input type="checkbox"/>	<input type="checkbox"/>
31	<input type="checkbox"/>	<input type="checkbox"/>	<input type="checkbox"/>	<input type="checkbox"/>
32	<input type="checkbox"/>	<input type="checkbox"/>	<input type="checkbox"/>	<input type="checkbox"/>
33	<input type="checkbox"/>	<input type="checkbox"/>	<input type="checkbox"/>	<input type="checkbox"/>
34	<input type="checkbox"/>	<input type="checkbox"/>	<input type="checkbox"/>	<input type="checkbox"/>
35	<input type="checkbox"/>	<input type="checkbox"/>	<input type="checkbox"/>	<input type="checkbox"/>
36	<input type="checkbox"/>	<input type="checkbox"/>	<input type="checkbox"/>	<input type="checkbox"/>
37	<input type="checkbox"/>	<input type="checkbox"/>	<input type="checkbox"/>	<input type="checkbox"/>
38	<input type="checkbox"/>	<input type="checkbox"/>	<input type="checkbox"/>	<input type="checkbox"/>
39	<input type="checkbox"/>	<input type="checkbox"/>	<input type="checkbox"/>	<input type="checkbox"/>
40	<input type="checkbox"/>	<input type="checkbox"/>	<input type="checkbox"/>	<input type="checkbox"/>
41	<input type="checkbox"/>	<input type="checkbox"/>	<input type="checkbox"/>	<input type="checkbox"/>
42	<input type="checkbox"/>	<input type="checkbox"/>	<input type="checkbox"/>	<input type="checkbox"/>
43	<input type="checkbox"/>	<input type="checkbox"/>	<input type="checkbox"/>	<input type="checkbox"/>
44	<input type="checkbox"/>	<input type="checkbox"/>	<input type="checkbox"/>	<input type="checkbox"/>
45	<input type="checkbox"/>	<input type="checkbox"/>	<input type="checkbox"/>	<input type="checkbox"/>
46	<input type="checkbox"/>	<input type="checkbox"/>	<input type="checkbox"/>	<input type="checkbox"/>
47	<input type="checkbox"/>	<input type="checkbox"/>	<input type="checkbox"/>	<input type="checkbox"/>
48	<input type="checkbox"/>	<input type="checkbox"/>	<input type="checkbox"/>	<input type="checkbox"/>
49	<input type="checkbox"/>	<input type="checkbox"/>	<input type="checkbox"/>	<input type="checkbox"/>
50	<input type="checkbox"/>	<input type="checkbox"/>	<input type="checkbox"/>	<input type="checkbox"/>

	1	2	3	4
51	<input type="checkbox"/>	<input type="checkbox"/>	<input type="checkbox"/>	<input type="checkbox"/>
52	<input type="checkbox"/>	<input type="checkbox"/>	<input type="checkbox"/>	<input type="checkbox"/>
53	<input type="checkbox"/>	<input type="checkbox"/>	<input type="checkbox"/>	<input type="checkbox"/>
54	<input type="checkbox"/>	<input type="checkbox"/>	<input type="checkbox"/>	<input type="checkbox"/>
55	<input type="checkbox"/>	<input type="checkbox"/>	<input type="checkbox"/>	<input type="checkbox"/>
56	<input type="checkbox"/>	<input type="checkbox"/>	<input type="checkbox"/>	<input type="checkbox"/>
57	<input type="checkbox"/>	<input type="checkbox"/>	<input type="checkbox"/>	<input type="checkbox"/>
58	<input type="checkbox"/>	<input type="checkbox"/>	<input type="checkbox"/>	<input type="checkbox"/>
59	<input type="checkbox"/>	<input type="checkbox"/>	<input type="checkbox"/>	<input type="checkbox"/>
60	<input type="checkbox"/>	<input type="checkbox"/>	<input type="checkbox"/>	<input type="checkbox"/>
61	<input type="checkbox"/>	<input type="checkbox"/>	<input type="checkbox"/>	<input type="checkbox"/>
62	<input type="checkbox"/>	<input type="checkbox"/>	<input type="checkbox"/>	<input type="checkbox"/>
63	<input type="checkbox"/>	<input type="checkbox"/>	<input type="checkbox"/>	<input type="checkbox"/>
64	<input type="checkbox"/>	<input type="checkbox"/>	<input type="checkbox"/>	<input type="checkbox"/>
65	<input type="checkbox"/>	<input type="checkbox"/>	<input type="checkbox"/>	<input type="checkbox"/>
66	<input type="checkbox"/>	<input type="checkbox"/>	<input type="checkbox"/>	<input type="checkbox"/>
67	<input type="checkbox"/>	<input type="checkbox"/>	<input type="checkbox"/>	<input type="checkbox"/>
68	<input type="checkbox"/>	<input type="checkbox"/>	<input type="checkbox"/>	<input type="checkbox"/>
69	<input type="checkbox"/>	<input type="checkbox"/>	<input type="checkbox"/>	<input type="checkbox"/>
70	<input type="checkbox"/>	<input type="checkbox"/>	<input type="checkbox"/>	<input type="checkbox"/>
71	<input type="checkbox"/>	<input type="checkbox"/>	<input type="checkbox"/>	<input type="checkbox"/>
72	<input type="checkbox"/>	<input type="checkbox"/>	<input type="checkbox"/>	<input type="checkbox"/>
73	<input type="checkbox"/>	<input type="checkbox"/>	<input type="checkbox"/>	<input type="checkbox"/>
74	<input type="checkbox"/>	<input type="checkbox"/>	<input type="checkbox"/>	<input type="checkbox"/>
75	<input type="checkbox"/>	<input type="checkbox"/>	<input type="checkbox"/>	<input type="checkbox"/>

PRINT OR TYPE

AVIATION FLECTRICIAN'S MATE 3 & 2
NAVEDTRA 10348-E

NAME _____ ADDRESS _____
Last First Middle Street/Ship/Unit/Division, etc.

RANK/RATE _____ SOC. SEC. NO. _____ DESIGNATOR _____ ASSIGNMENT NO. _____
City or PPO State Zip

USN USNR ACTIVE INACTIVE OTHER (Specify) _____ DATE MAILED _____

SCORE

	1	2	3	4
1	<input type="checkbox"/>	<input type="checkbox"/>	<input type="checkbox"/>	<input type="checkbox"/>
2	<input type="checkbox"/>	<input type="checkbox"/>	<input type="checkbox"/>	<input type="checkbox"/>
3	<input type="checkbox"/>	<input type="checkbox"/>	<input type="checkbox"/>	<input type="checkbox"/>
4	<input type="checkbox"/>	<input type="checkbox"/>	<input type="checkbox"/>	<input type="checkbox"/>
5	<input type="checkbox"/>	<input type="checkbox"/>	<input type="checkbox"/>	<input type="checkbox"/>
6	<input type="checkbox"/>	<input type="checkbox"/>	<input type="checkbox"/>	<input type="checkbox"/>
7	<input type="checkbox"/>	<input type="checkbox"/>	<input type="checkbox"/>	<input type="checkbox"/>
8	<input type="checkbox"/>	<input type="checkbox"/>	<input type="checkbox"/>	<input type="checkbox"/>
9	<input type="checkbox"/>	<input type="checkbox"/>	<input type="checkbox"/>	<input type="checkbox"/>
10	<input type="checkbox"/>	<input type="checkbox"/>	<input type="checkbox"/>	<input type="checkbox"/>
11	<input type="checkbox"/>	<input type="checkbox"/>	<input type="checkbox"/>	<input type="checkbox"/>
12	<input type="checkbox"/>	<input type="checkbox"/>	<input type="checkbox"/>	<input type="checkbox"/>
13	<input type="checkbox"/>	<input type="checkbox"/>	<input type="checkbox"/>	<input type="checkbox"/>
14	<input type="checkbox"/>	<input type="checkbox"/>	<input type="checkbox"/>	<input type="checkbox"/>
15	<input type="checkbox"/>	<input type="checkbox"/>	<input type="checkbox"/>	<input type="checkbox"/>
16	<input type="checkbox"/>	<input type="checkbox"/>	<input type="checkbox"/>	<input type="checkbox"/>
17	<input type="checkbox"/>	<input type="checkbox"/>	<input type="checkbox"/>	<input type="checkbox"/>
18	<input type="checkbox"/>	<input type="checkbox"/>	<input type="checkbox"/>	<input type="checkbox"/>
19	<input type="checkbox"/>	<input type="checkbox"/>	<input type="checkbox"/>	<input type="checkbox"/>
20	<input type="checkbox"/>	<input type="checkbox"/>	<input type="checkbox"/>	<input type="checkbox"/>
21	<input type="checkbox"/>	<input type="checkbox"/>	<input type="checkbox"/>	<input type="checkbox"/>
22	<input type="checkbox"/>	<input type="checkbox"/>	<input type="checkbox"/>	<input type="checkbox"/>
23	<input type="checkbox"/>	<input type="checkbox"/>	<input type="checkbox"/>	<input type="checkbox"/>
24	<input type="checkbox"/>	<input type="checkbox"/>	<input type="checkbox"/>	<input type="checkbox"/>
25	<input type="checkbox"/>	<input type="checkbox"/>	<input type="checkbox"/>	<input type="checkbox"/>

	1	2	3	4
26	<input type="checkbox"/>	<input type="checkbox"/>	<input type="checkbox"/>	<input type="checkbox"/>
27	<input type="checkbox"/>	<input type="checkbox"/>	<input type="checkbox"/>	<input type="checkbox"/>
28	<input type="checkbox"/>	<input type="checkbox"/>	<input type="checkbox"/>	<input type="checkbox"/>
29	<input type="checkbox"/>	<input type="checkbox"/>	<input type="checkbox"/>	<input type="checkbox"/>
30	<input type="checkbox"/>	<input type="checkbox"/>	<input type="checkbox"/>	<input type="checkbox"/>
31	<input type="checkbox"/>	<input type="checkbox"/>	<input type="checkbox"/>	<input type="checkbox"/>
32	<input type="checkbox"/>	<input type="checkbox"/>	<input type="checkbox"/>	<input type="checkbox"/>
33	<input type="checkbox"/>	<input type="checkbox"/>	<input type="checkbox"/>	<input type="checkbox"/>
34	<input type="checkbox"/>	<input type="checkbox"/>	<input type="checkbox"/>	<input type="checkbox"/>
35	<input type="checkbox"/>	<input type="checkbox"/>	<input type="checkbox"/>	<input type="checkbox"/>
36	<input type="checkbox"/>	<input type="checkbox"/>	<input type="checkbox"/>	<input type="checkbox"/>
37	<input type="checkbox"/>	<input type="checkbox"/>	<input type="checkbox"/>	<input type="checkbox"/>
38	<input type="checkbox"/>	<input type="checkbox"/>	<input type="checkbox"/>	<input type="checkbox"/>
39	<input type="checkbox"/>	<input type="checkbox"/>	<input type="checkbox"/>	<input type="checkbox"/>
40	<input type="checkbox"/>	<input type="checkbox"/>	<input type="checkbox"/>	<input type="checkbox"/>
41	<input type="checkbox"/>	<input type="checkbox"/>	<input type="checkbox"/>	<input type="checkbox"/>
42	<input type="checkbox"/>	<input type="checkbox"/>	<input type="checkbox"/>	<input type="checkbox"/>
43	<input type="checkbox"/>	<input type="checkbox"/>	<input type="checkbox"/>	<input type="checkbox"/>
44	<input type="checkbox"/>	<input type="checkbox"/>	<input type="checkbox"/>	<input type="checkbox"/>
45	<input type="checkbox"/>	<input type="checkbox"/>	<input type="checkbox"/>	<input type="checkbox"/>
46	<input type="checkbox"/>	<input type="checkbox"/>	<input type="checkbox"/>	<input type="checkbox"/>
47	<input type="checkbox"/>	<input type="checkbox"/>	<input type="checkbox"/>	<input type="checkbox"/>
48	<input type="checkbox"/>	<input type="checkbox"/>	<input type="checkbox"/>	<input type="checkbox"/>
49	<input type="checkbox"/>	<input type="checkbox"/>	<input type="checkbox"/>	<input type="checkbox"/>
50	<input type="checkbox"/>	<input type="checkbox"/>	<input type="checkbox"/>	<input type="checkbox"/>

	1	2	3	4
51	<input type="checkbox"/>	<input type="checkbox"/>	<input type="checkbox"/>	<input type="checkbox"/>
52	<input type="checkbox"/>	<input type="checkbox"/>	<input type="checkbox"/>	<input type="checkbox"/>
53	<input type="checkbox"/>	<input type="checkbox"/>	<input type="checkbox"/>	<input type="checkbox"/>
54	<input type="checkbox"/>	<input type="checkbox"/>	<input type="checkbox"/>	<input type="checkbox"/>
55	<input type="checkbox"/>	<input type="checkbox"/>	<input type="checkbox"/>	<input type="checkbox"/>
56	<input type="checkbox"/>	<input type="checkbox"/>	<input type="checkbox"/>	<input type="checkbox"/>
57	<input type="checkbox"/>	<input type="checkbox"/>	<input type="checkbox"/>	<input type="checkbox"/>
58	<input type="checkbox"/>	<input type="checkbox"/>	<input type="checkbox"/>	<input type="checkbox"/>
59	<input type="checkbox"/>	<input type="checkbox"/>	<input type="checkbox"/>	<input type="checkbox"/>
60	<input type="checkbox"/>	<input type="checkbox"/>	<input type="checkbox"/>	<input type="checkbox"/>
61	<input type="checkbox"/>	<input type="checkbox"/>	<input type="checkbox"/>	<input type="checkbox"/>
62	<input type="checkbox"/>	<input type="checkbox"/>	<input type="checkbox"/>	<input type="checkbox"/>
63	<input type="checkbox"/>	<input type="checkbox"/>	<input type="checkbox"/>	<input type="checkbox"/>
64	<input type="checkbox"/>	<input type="checkbox"/>	<input type="checkbox"/>	<input type="checkbox"/>
65	<input type="checkbox"/>	<input type="checkbox"/>	<input type="checkbox"/>	<input type="checkbox"/>
66	<input type="checkbox"/>	<input type="checkbox"/>	<input type="checkbox"/>	<input type="checkbox"/>
67	<input type="checkbox"/>	<input type="checkbox"/>	<input type="checkbox"/>	<input type="checkbox"/>
68	<input type="checkbox"/>	<input type="checkbox"/>	<input type="checkbox"/>	<input type="checkbox"/>
69	<input type="checkbox"/>	<input type="checkbox"/>	<input type="checkbox"/>	<input type="checkbox"/>
70	<input type="checkbox"/>	<input type="checkbox"/>	<input type="checkbox"/>	<input type="checkbox"/>
71	<input type="checkbox"/>	<input type="checkbox"/>	<input type="checkbox"/>	<input type="checkbox"/>
72	<input type="checkbox"/>	<input type="checkbox"/>	<input type="checkbox"/>	<input type="checkbox"/>
73	<input type="checkbox"/>	<input type="checkbox"/>	<input type="checkbox"/>	<input type="checkbox"/>
74	<input type="checkbox"/>	<input type="checkbox"/>	<input type="checkbox"/>	<input type="checkbox"/>
75	<input type="checkbox"/>	<input type="checkbox"/>	<input type="checkbox"/>	<input type="checkbox"/>



PRINT OR TYPE

AVIATION ELECTRICIAN'S MATE 3 & 2
NAVEDTRA 10348-E

NAME _____ ADDRESS _____
Last First Middle Street/Ship/Unit/Division, etc.

City or FPO State Zip

RANK/RATE _____ SOC. SEC. NO. _____ DESIGNATOR _____ ASSIGNMENT NO _____

USN USNR ACTIVE INACTIVE OTHER (Specify) _____ DATE MAILED _____

SCORE

	1	2	3	4	
	T	F			
1	<input type="checkbox"/>	<input type="checkbox"/>	<input type="checkbox"/>	<input type="checkbox"/>	-----
2	<input type="checkbox"/>	<input type="checkbox"/>	<input type="checkbox"/>	<input type="checkbox"/>	-----
3	<input type="checkbox"/>	<input type="checkbox"/>	<input type="checkbox"/>	<input type="checkbox"/>	-----
4	<input type="checkbox"/>	<input type="checkbox"/>	<input type="checkbox"/>	<input type="checkbox"/>	-----
5	<input type="checkbox"/>	<input type="checkbox"/>	<input type="checkbox"/>	<input type="checkbox"/>	-----
6	<input type="checkbox"/>	<input type="checkbox"/>	<input type="checkbox"/>	<input type="checkbox"/>	-----
7	<input type="checkbox"/>	<input type="checkbox"/>	<input type="checkbox"/>	<input type="checkbox"/>	-----
8	<input type="checkbox"/>	<input type="checkbox"/>	<input type="checkbox"/>	<input type="checkbox"/>	-----
9	<input type="checkbox"/>	<input type="checkbox"/>	<input type="checkbox"/>	<input type="checkbox"/>	-----
10	<input type="checkbox"/>	<input type="checkbox"/>	<input type="checkbox"/>	<input type="checkbox"/>	-----
11	<input type="checkbox"/>	<input type="checkbox"/>	<input type="checkbox"/>	<input type="checkbox"/>	-----
12	<input type="checkbox"/>	<input type="checkbox"/>	<input type="checkbox"/>	<input type="checkbox"/>	-----
13	<input type="checkbox"/>	<input type="checkbox"/>	<input type="checkbox"/>	<input type="checkbox"/>	-----
14	<input type="checkbox"/>	<input type="checkbox"/>	<input type="checkbox"/>	<input type="checkbox"/>	-----
15	<input type="checkbox"/>	<input type="checkbox"/>	<input type="checkbox"/>	<input type="checkbox"/>	-----
16	<input type="checkbox"/>	<input type="checkbox"/>	<input type="checkbox"/>	<input type="checkbox"/>	-----
17	<input type="checkbox"/>	<input type="checkbox"/>	<input type="checkbox"/>	<input type="checkbox"/>	-----
18	<input type="checkbox"/>	<input type="checkbox"/>	<input type="checkbox"/>	<input type="checkbox"/>	-----
19	<input type="checkbox"/>	<input type="checkbox"/>	<input type="checkbox"/>	<input type="checkbox"/>	-----
20	<input type="checkbox"/>	<input type="checkbox"/>	<input type="checkbox"/>	<input type="checkbox"/>	-----
21	<input type="checkbox"/>	<input type="checkbox"/>	<input type="checkbox"/>	<input type="checkbox"/>	-----
22	<input type="checkbox"/>	<input type="checkbox"/>	<input type="checkbox"/>	<input type="checkbox"/>	-----
23	<input type="checkbox"/>	<input type="checkbox"/>	<input type="checkbox"/>	<input type="checkbox"/>	-----
24	<input type="checkbox"/>	<input type="checkbox"/>	<input type="checkbox"/>	<input type="checkbox"/>	-----
25	<input type="checkbox"/>	<input type="checkbox"/>	<input type="checkbox"/>	<input type="checkbox"/>	-----

	1	2	3	4	
	T	F			
26	<input type="checkbox"/>	<input type="checkbox"/>	<input type="checkbox"/>	<input type="checkbox"/>	-----
27	<input type="checkbox"/>	<input type="checkbox"/>	<input type="checkbox"/>	<input type="checkbox"/>	-----
28	<input type="checkbox"/>	<input type="checkbox"/>	<input type="checkbox"/>	<input type="checkbox"/>	-----
29	<input type="checkbox"/>	<input type="checkbox"/>	<input type="checkbox"/>	<input type="checkbox"/>	-----
30	<input type="checkbox"/>	<input type="checkbox"/>	<input type="checkbox"/>	<input type="checkbox"/>	-----
31	<input type="checkbox"/>	<input type="checkbox"/>	<input type="checkbox"/>	<input type="checkbox"/>	-----
32	<input type="checkbox"/>	<input type="checkbox"/>	<input type="checkbox"/>	<input type="checkbox"/>	-----
33	<input type="checkbox"/>	<input type="checkbox"/>	<input type="checkbox"/>	<input type="checkbox"/>	-----
34	<input type="checkbox"/>	<input type="checkbox"/>	<input type="checkbox"/>	<input type="checkbox"/>	-----
35	<input type="checkbox"/>	<input type="checkbox"/>	<input type="checkbox"/>	<input type="checkbox"/>	-----
36	<input type="checkbox"/>	<input type="checkbox"/>	<input type="checkbox"/>	<input type="checkbox"/>	-----
37	<input type="checkbox"/>	<input type="checkbox"/>	<input type="checkbox"/>	<input type="checkbox"/>	-----
38	<input type="checkbox"/>	<input type="checkbox"/>	<input type="checkbox"/>	<input type="checkbox"/>	-----
39	<input type="checkbox"/>	<input type="checkbox"/>	<input type="checkbox"/>	<input type="checkbox"/>	-----
40	<input type="checkbox"/>	<input type="checkbox"/>	<input type="checkbox"/>	<input type="checkbox"/>	-----
41	<input type="checkbox"/>	<input type="checkbox"/>	<input type="checkbox"/>	<input type="checkbox"/>	-----
42	<input type="checkbox"/>	<input type="checkbox"/>	<input type="checkbox"/>	<input type="checkbox"/>	-----
43	<input type="checkbox"/>	<input type="checkbox"/>	<input type="checkbox"/>	<input type="checkbox"/>	-----
44	<input type="checkbox"/>	<input type="checkbox"/>	<input type="checkbox"/>	<input type="checkbox"/>	-----
45	<input type="checkbox"/>	<input type="checkbox"/>	<input type="checkbox"/>	<input type="checkbox"/>	-----
46	<input type="checkbox"/>	<input type="checkbox"/>	<input type="checkbox"/>	<input type="checkbox"/>	-----
47	<input type="checkbox"/>	<input type="checkbox"/>	<input type="checkbox"/>	<input type="checkbox"/>	-----
48	<input type="checkbox"/>	<input type="checkbox"/>	<input type="checkbox"/>	<input type="checkbox"/>	-----
49	<input type="checkbox"/>	<input type="checkbox"/>	<input type="checkbox"/>	<input type="checkbox"/>	-----
50	<input type="checkbox"/>	<input type="checkbox"/>	<input type="checkbox"/>	<input type="checkbox"/>	-----

	1	2	3	4	
	T	F			
51	<input type="checkbox"/>	<input type="checkbox"/>	<input type="checkbox"/>	<input type="checkbox"/>	-----
52	<input type="checkbox"/>	<input type="checkbox"/>	<input type="checkbox"/>	<input type="checkbox"/>	-----
53	<input type="checkbox"/>	<input type="checkbox"/>	<input type="checkbox"/>	<input type="checkbox"/>	-----
54	<input type="checkbox"/>	<input type="checkbox"/>	<input type="checkbox"/>	<input type="checkbox"/>	-----
55	<input type="checkbox"/>	<input type="checkbox"/>	<input type="checkbox"/>	<input type="checkbox"/>	-----
56	<input type="checkbox"/>	<input type="checkbox"/>	<input type="checkbox"/>	<input type="checkbox"/>	-----
57	<input type="checkbox"/>	<input type="checkbox"/>	<input type="checkbox"/>	<input type="checkbox"/>	-----
58	<input type="checkbox"/>	<input type="checkbox"/>	<input type="checkbox"/>	<input type="checkbox"/>	-----
59	<input type="checkbox"/>	<input type="checkbox"/>	<input type="checkbox"/>	<input type="checkbox"/>	-----
60	<input type="checkbox"/>	<input type="checkbox"/>	<input type="checkbox"/>	<input type="checkbox"/>	-----
61	<input type="checkbox"/>	<input type="checkbox"/>	<input type="checkbox"/>	<input type="checkbox"/>	-----
62	<input type="checkbox"/>	<input type="checkbox"/>	<input type="checkbox"/>	<input type="checkbox"/>	-----
63	<input type="checkbox"/>	<input type="checkbox"/>	<input type="checkbox"/>	<input type="checkbox"/>	-----
64	<input type="checkbox"/>	<input type="checkbox"/>	<input type="checkbox"/>	<input type="checkbox"/>	-----
65	<input type="checkbox"/>	<input type="checkbox"/>	<input type="checkbox"/>	<input type="checkbox"/>	-----
66	<input type="checkbox"/>	<input type="checkbox"/>	<input type="checkbox"/>	<input type="checkbox"/>	-----
67	<input type="checkbox"/>	<input type="checkbox"/>	<input type="checkbox"/>	<input type="checkbox"/>	-----
68	<input type="checkbox"/>	<input type="checkbox"/>	<input type="checkbox"/>	<input type="checkbox"/>	-----
69	<input type="checkbox"/>	<input type="checkbox"/>	<input type="checkbox"/>	<input type="checkbox"/>	-----
70	<input type="checkbox"/>	<input type="checkbox"/>	<input type="checkbox"/>	<input type="checkbox"/>	-----
71	<input type="checkbox"/>	<input type="checkbox"/>	<input type="checkbox"/>	<input type="checkbox"/>	-----
72	<input type="checkbox"/>	<input type="checkbox"/>	<input type="checkbox"/>	<input type="checkbox"/>	-----
73	<input type="checkbox"/>	<input type="checkbox"/>	<input type="checkbox"/>	<input type="checkbox"/>	-----
74	<input type="checkbox"/>	<input type="checkbox"/>	<input type="checkbox"/>	<input type="checkbox"/>	-----
75	<input type="checkbox"/>	<input type="checkbox"/>	<input type="checkbox"/>	<input type="checkbox"/>	-----

PRINT OR TYPE

AVIATION ELECTRICIAN'S MATE 3 & 2
NAVEDTRA 10348-E

NAME _____ ADDRESS _____
Last First Middle Street/Ship/Unit/Division, etc.

RANK/RATE _____ SOC. SEC. NO. _____ DESIGNATOR _____ ASSIGNMENT NO _____
City or PFO State Zip

USN USNR ACTIVE INACTIVE OTHER (Specify) _____ DATE MAILED _____

SCORE

	1	2	3	4	
1	<input type="checkbox"/>	<input type="checkbox"/>	<input type="checkbox"/>	<input type="checkbox"/>	-----
2	<input type="checkbox"/>	<input type="checkbox"/>	<input type="checkbox"/>	<input type="checkbox"/>	-----
3	<input type="checkbox"/>	<input type="checkbox"/>	<input type="checkbox"/>	<input type="checkbox"/>	-----
4	<input type="checkbox"/>	<input type="checkbox"/>	<input type="checkbox"/>	<input type="checkbox"/>	-----
5	<input type="checkbox"/>	<input type="checkbox"/>	<input type="checkbox"/>	<input type="checkbox"/>	-----
6	<input type="checkbox"/>	<input type="checkbox"/>	<input type="checkbox"/>	<input type="checkbox"/>	-----
7	<input type="checkbox"/>	<input type="checkbox"/>	<input type="checkbox"/>	<input type="checkbox"/>	-----
8	<input type="checkbox"/>	<input type="checkbox"/>	<input type="checkbox"/>	<input type="checkbox"/>	-----
9	<input type="checkbox"/>	<input type="checkbox"/>	<input type="checkbox"/>	<input type="checkbox"/>	-----
10	<input type="checkbox"/>	<input type="checkbox"/>	<input type="checkbox"/>	<input type="checkbox"/>	-----
11	<input type="checkbox"/>	<input type="checkbox"/>	<input type="checkbox"/>	<input type="checkbox"/>	-----
12	<input type="checkbox"/>	<input type="checkbox"/>	<input type="checkbox"/>	<input type="checkbox"/>	-----
13	<input type="checkbox"/>	<input type="checkbox"/>	<input type="checkbox"/>	<input type="checkbox"/>	-----
14	<input type="checkbox"/>	<input type="checkbox"/>	<input type="checkbox"/>	<input type="checkbox"/>	-----
15	<input type="checkbox"/>	<input type="checkbox"/>	<input type="checkbox"/>	<input type="checkbox"/>	-----
16	<input type="checkbox"/>	<input type="checkbox"/>	<input type="checkbox"/>	<input type="checkbox"/>	-----
17	<input type="checkbox"/>	<input type="checkbox"/>	<input type="checkbox"/>	<input type="checkbox"/>	-----
18	<input type="checkbox"/>	<input type="checkbox"/>	<input type="checkbox"/>	<input type="checkbox"/>	-----
19	<input type="checkbox"/>	<input type="checkbox"/>	<input type="checkbox"/>	<input type="checkbox"/>	-----
20	<input type="checkbox"/>	<input type="checkbox"/>	<input type="checkbox"/>	<input type="checkbox"/>	-----
21	<input type="checkbox"/>	<input type="checkbox"/>	<input type="checkbox"/>	<input type="checkbox"/>	-----
22	<input type="checkbox"/>	<input type="checkbox"/>	<input type="checkbox"/>	<input type="checkbox"/>	-----
23	<input type="checkbox"/>	<input type="checkbox"/>	<input type="checkbox"/>	<input type="checkbox"/>	-----
24	<input type="checkbox"/>	<input type="checkbox"/>	<input type="checkbox"/>	<input type="checkbox"/>	-----
25	<input type="checkbox"/>	<input type="checkbox"/>	<input type="checkbox"/>	<input type="checkbox"/>	-----

	1	2	3	4	
26	<input type="checkbox"/>	<input type="checkbox"/>	<input type="checkbox"/>	<input type="checkbox"/>	-----
27	<input type="checkbox"/>	<input type="checkbox"/>	<input type="checkbox"/>	<input type="checkbox"/>	-----
28	<input type="checkbox"/>	<input type="checkbox"/>	<input type="checkbox"/>	<input type="checkbox"/>	-----
29	<input type="checkbox"/>	<input type="checkbox"/>	<input type="checkbox"/>	<input type="checkbox"/>	-----
30	<input type="checkbox"/>	<input type="checkbox"/>	<input type="checkbox"/>	<input type="checkbox"/>	-----
31	<input type="checkbox"/>	<input type="checkbox"/>	<input type="checkbox"/>	<input type="checkbox"/>	-----
32	<input type="checkbox"/>	<input type="checkbox"/>	<input type="checkbox"/>	<input type="checkbox"/>	-----
33	<input type="checkbox"/>	<input type="checkbox"/>	<input type="checkbox"/>	<input type="checkbox"/>	-----
34	<input type="checkbox"/>	<input type="checkbox"/>	<input type="checkbox"/>	<input type="checkbox"/>	-----
35	<input type="checkbox"/>	<input type="checkbox"/>	<input type="checkbox"/>	<input type="checkbox"/>	-----
36	<input type="checkbox"/>	<input type="checkbox"/>	<input type="checkbox"/>	<input type="checkbox"/>	-----
37	<input type="checkbox"/>	<input type="checkbox"/>	<input type="checkbox"/>	<input type="checkbox"/>	-----
38	<input type="checkbox"/>	<input type="checkbox"/>	<input type="checkbox"/>	<input type="checkbox"/>	-----
39	<input type="checkbox"/>	<input type="checkbox"/>	<input type="checkbox"/>	<input type="checkbox"/>	-----
40	<input type="checkbox"/>	<input type="checkbox"/>	<input type="checkbox"/>	<input type="checkbox"/>	-----
41	<input type="checkbox"/>	<input type="checkbox"/>	<input type="checkbox"/>	<input type="checkbox"/>	-----
42	<input type="checkbox"/>	<input type="checkbox"/>	<input type="checkbox"/>	<input type="checkbox"/>	-----
43	<input type="checkbox"/>	<input type="checkbox"/>	<input type="checkbox"/>	<input type="checkbox"/>	-----
44	<input type="checkbox"/>	<input type="checkbox"/>	<input type="checkbox"/>	<input type="checkbox"/>	-----
45	<input type="checkbox"/>	<input type="checkbox"/>	<input type="checkbox"/>	<input type="checkbox"/>	-----
46	<input type="checkbox"/>	<input type="checkbox"/>	<input type="checkbox"/>	<input type="checkbox"/>	-----
47	<input type="checkbox"/>	<input type="checkbox"/>	<input type="checkbox"/>	<input type="checkbox"/>	-----
48	<input type="checkbox"/>	<input type="checkbox"/>	<input type="checkbox"/>	<input type="checkbox"/>	-----
49	<input type="checkbox"/>	<input type="checkbox"/>	<input type="checkbox"/>	<input type="checkbox"/>	-----
50	<input type="checkbox"/>	<input type="checkbox"/>	<input type="checkbox"/>	<input type="checkbox"/>	-----

	1	2	3	4	
51	<input type="checkbox"/>	<input type="checkbox"/>	<input type="checkbox"/>	<input type="checkbox"/>	-----
52	<input type="checkbox"/>	<input type="checkbox"/>	<input type="checkbox"/>	<input type="checkbox"/>	-----
53	<input type="checkbox"/>	<input type="checkbox"/>	<input type="checkbox"/>	<input type="checkbox"/>	-----
54	<input type="checkbox"/>	<input type="checkbox"/>	<input type="checkbox"/>	<input type="checkbox"/>	-----
55	<input type="checkbox"/>	<input type="checkbox"/>	<input type="checkbox"/>	<input type="checkbox"/>	-----
56	<input type="checkbox"/>	<input type="checkbox"/>	<input type="checkbox"/>	<input type="checkbox"/>	-----
57	<input type="checkbox"/>	<input type="checkbox"/>	<input type="checkbox"/>	<input type="checkbox"/>	-----
58	<input type="checkbox"/>	<input type="checkbox"/>	<input type="checkbox"/>	<input type="checkbox"/>	-----
59	<input type="checkbox"/>	<input type="checkbox"/>	<input type="checkbox"/>	<input type="checkbox"/>	-----
60	<input type="checkbox"/>	<input type="checkbox"/>	<input type="checkbox"/>	<input type="checkbox"/>	-----
61	<input type="checkbox"/>	<input type="checkbox"/>	<input type="checkbox"/>	<input type="checkbox"/>	-----
62	<input type="checkbox"/>	<input type="checkbox"/>	<input type="checkbox"/>	<input type="checkbox"/>	-----
63	<input type="checkbox"/>	<input type="checkbox"/>	<input type="checkbox"/>	<input type="checkbox"/>	-----
64	<input type="checkbox"/>	<input type="checkbox"/>	<input type="checkbox"/>	<input type="checkbox"/>	-----
65	<input type="checkbox"/>	<input type="checkbox"/>	<input type="checkbox"/>	<input type="checkbox"/>	-----
66	<input type="checkbox"/>	<input type="checkbox"/>	<input type="checkbox"/>	<input type="checkbox"/>	-----
67	<input type="checkbox"/>	<input type="checkbox"/>	<input type="checkbox"/>	<input type="checkbox"/>	-----
68	<input type="checkbox"/>	<input type="checkbox"/>	<input type="checkbox"/>	<input type="checkbox"/>	-----
69	<input type="checkbox"/>	<input type="checkbox"/>	<input type="checkbox"/>	<input type="checkbox"/>	-----
70	<input type="checkbox"/>	<input type="checkbox"/>	<input type="checkbox"/>	<input type="checkbox"/>	-----
71	<input type="checkbox"/>	<input type="checkbox"/>	<input type="checkbox"/>	<input type="checkbox"/>	-----
72	<input type="checkbox"/>	<input type="checkbox"/>	<input type="checkbox"/>	<input type="checkbox"/>	-----
73	<input type="checkbox"/>	<input type="checkbox"/>	<input type="checkbox"/>	<input type="checkbox"/>	-----
74	<input type="checkbox"/>	<input type="checkbox"/>	<input type="checkbox"/>	<input type="checkbox"/>	-----
75	<input type="checkbox"/>	<input type="checkbox"/>	<input type="checkbox"/>	<input type="checkbox"/>	-----



PRINT OR TYPE

AVIATION ELECTRICIAN'S MATE 3 & 2
NAVEDTRA 10348-E

NAME _____ ADDRESS _____
Last First Middle Street/Ship/Unit/Division, etc.

RANK/RATE _____ SOC. SEC. NO. _____ DESIGNATOR _____ ASSIGNMENT NO. _____
City or PFO State Zip

USN USNR ACTIVE INACTIVE OTHER (Specify) _____ DATE MAILED _____

SCORE

	1	2	3	4	
1	<input type="checkbox"/>	<input type="checkbox"/>	<input type="checkbox"/>	<input type="checkbox"/>	-----
2	<input type="checkbox"/>	<input type="checkbox"/>	<input type="checkbox"/>	<input type="checkbox"/>	-----
3	<input type="checkbox"/>	<input type="checkbox"/>	<input type="checkbox"/>	<input type="checkbox"/>	-----
4	<input type="checkbox"/>	<input type="checkbox"/>	<input type="checkbox"/>	<input type="checkbox"/>	-----
5	<input type="checkbox"/>	<input type="checkbox"/>	<input type="checkbox"/>	<input type="checkbox"/>	-----
6	<input type="checkbox"/>	<input type="checkbox"/>	<input type="checkbox"/>	<input type="checkbox"/>	-----
7	<input type="checkbox"/>	<input type="checkbox"/>	<input type="checkbox"/>	<input type="checkbox"/>	-----
8	<input type="checkbox"/>	<input type="checkbox"/>	<input type="checkbox"/>	<input type="checkbox"/>	-----
9	<input type="checkbox"/>	<input type="checkbox"/>	<input type="checkbox"/>	<input type="checkbox"/>	-----
10	<input type="checkbox"/>	<input type="checkbox"/>	<input type="checkbox"/>	<input type="checkbox"/>	-----
11	<input type="checkbox"/>	<input type="checkbox"/>	<input type="checkbox"/>	<input type="checkbox"/>	-----
12	<input type="checkbox"/>	<input type="checkbox"/>	<input type="checkbox"/>	<input type="checkbox"/>	-----
13	<input type="checkbox"/>	<input type="checkbox"/>	<input type="checkbox"/>	<input type="checkbox"/>	-----
14	<input type="checkbox"/>	<input type="checkbox"/>	<input type="checkbox"/>	<input type="checkbox"/>	-----
15	<input type="checkbox"/>	<input type="checkbox"/>	<input type="checkbox"/>	<input type="checkbox"/>	-----
16	<input type="checkbox"/>	<input type="checkbox"/>	<input type="checkbox"/>	<input type="checkbox"/>	-----
17	<input type="checkbox"/>	<input type="checkbox"/>	<input type="checkbox"/>	<input type="checkbox"/>	-----
18	<input type="checkbox"/>	<input type="checkbox"/>	<input type="checkbox"/>	<input type="checkbox"/>	-----
19	<input type="checkbox"/>	<input type="checkbox"/>	<input type="checkbox"/>	<input type="checkbox"/>	-----
20	<input type="checkbox"/>	<input type="checkbox"/>	<input type="checkbox"/>	<input type="checkbox"/>	-----
21	<input type="checkbox"/>	<input type="checkbox"/>	<input type="checkbox"/>	<input type="checkbox"/>	-----
22	<input type="checkbox"/>	<input type="checkbox"/>	<input type="checkbox"/>	<input type="checkbox"/>	-----
23	<input type="checkbox"/>	<input type="checkbox"/>	<input type="checkbox"/>	<input type="checkbox"/>	-----
24	<input type="checkbox"/>	<input type="checkbox"/>	<input type="checkbox"/>	<input type="checkbox"/>	-----
25	<input type="checkbox"/>	<input type="checkbox"/>	<input type="checkbox"/>	<input type="checkbox"/>	-----

	1	2	3	4	
26	<input type="checkbox"/>	<input type="checkbox"/>	<input type="checkbox"/>	<input type="checkbox"/>	-----
27	<input type="checkbox"/>	<input type="checkbox"/>	<input type="checkbox"/>	<input type="checkbox"/>	-----
28	<input type="checkbox"/>	<input type="checkbox"/>	<input type="checkbox"/>	<input type="checkbox"/>	-----
29	<input type="checkbox"/>	<input type="checkbox"/>	<input type="checkbox"/>	<input type="checkbox"/>	-----
30	<input type="checkbox"/>	<input type="checkbox"/>	<input type="checkbox"/>	<input type="checkbox"/>	-----
31	<input type="checkbox"/>	<input type="checkbox"/>	<input type="checkbox"/>	<input type="checkbox"/>	-----
32	<input type="checkbox"/>	<input checked="" type="checkbox"/>	<input type="checkbox"/>	<input type="checkbox"/>	-----
33	<input type="checkbox"/>	<input type="checkbox"/>	<input type="checkbox"/>	<input type="checkbox"/>	-----
34	<input type="checkbox"/>	<input type="checkbox"/>	<input type="checkbox"/>	<input type="checkbox"/>	-----
35	<input type="checkbox"/>	<input type="checkbox"/>	<input type="checkbox"/>	<input type="checkbox"/>	-----
36	<input type="checkbox"/>	<input type="checkbox"/>	<input type="checkbox"/>	<input type="checkbox"/>	-----
37	<input type="checkbox"/>	<input type="checkbox"/>	<input type="checkbox"/>	<input type="checkbox"/>	-----
38	<input type="checkbox"/>	<input type="checkbox"/>	<input type="checkbox"/>	<input type="checkbox"/>	-----
39	<input type="checkbox"/>	<input type="checkbox"/>	<input type="checkbox"/>	<input type="checkbox"/>	-----
40	<input type="checkbox"/>	<input type="checkbox"/>	<input type="checkbox"/>	<input type="checkbox"/>	-----
41	<input type="checkbox"/>	<input type="checkbox"/>	<input type="checkbox"/>	<input type="checkbox"/>	-----
42	<input type="checkbox"/>	<input type="checkbox"/>	<input type="checkbox"/>	<input type="checkbox"/>	-----
43	<input type="checkbox"/>	<input type="checkbox"/>	<input type="checkbox"/>	<input type="checkbox"/>	-----
44	<input type="checkbox"/>	<input type="checkbox"/>	<input type="checkbox"/>	<input type="checkbox"/>	-----
45	<input type="checkbox"/>	<input type="checkbox"/>	<input type="checkbox"/>	<input type="checkbox"/>	-----
46	<input type="checkbox"/>	<input type="checkbox"/>	<input type="checkbox"/>	<input type="checkbox"/>	-----
47	<input type="checkbox"/>	<input type="checkbox"/>	<input type="checkbox"/>	<input type="checkbox"/>	-----
48	<input type="checkbox"/>	<input type="checkbox"/>	<input type="checkbox"/>	<input type="checkbox"/>	-----
49	<input type="checkbox"/>	<input type="checkbox"/>	<input type="checkbox"/>	<input type="checkbox"/>	-----
50	<input type="checkbox"/>	<input type="checkbox"/>	<input type="checkbox"/>	<input type="checkbox"/>	-----

	1	2	3	4	
51	<input type="checkbox"/>	<input type="checkbox"/>	<input type="checkbox"/>	<input type="checkbox"/>	-----
52	<input type="checkbox"/>	<input type="checkbox"/>	<input type="checkbox"/>	<input type="checkbox"/>	-----
53	<input type="checkbox"/>	<input type="checkbox"/>	<input type="checkbox"/>	<input type="checkbox"/>	-----
54	<input type="checkbox"/>	<input type="checkbox"/>	<input type="checkbox"/>	<input type="checkbox"/>	-----
55	<input type="checkbox"/>	<input type="checkbox"/>	<input type="checkbox"/>	<input type="checkbox"/>	-----
56	<input type="checkbox"/>	<input type="checkbox"/>	<input type="checkbox"/>	<input type="checkbox"/>	-----
57	<input type="checkbox"/>	<input type="checkbox"/>	<input type="checkbox"/>	<input type="checkbox"/>	-----
58	<input type="checkbox"/>	<input type="checkbox"/>	<input type="checkbox"/>	<input type="checkbox"/>	-----
59	<input type="checkbox"/>	<input type="checkbox"/>	<input type="checkbox"/>	<input type="checkbox"/>	-----
60	<input type="checkbox"/>	<input type="checkbox"/>	<input type="checkbox"/>	<input type="checkbox"/>	-----
61	<input type="checkbox"/>	<input type="checkbox"/>	<input type="checkbox"/>	<input type="checkbox"/>	-----
62	<input type="checkbox"/>	<input type="checkbox"/>	<input type="checkbox"/>	<input type="checkbox"/>	-----
63	<input type="checkbox"/>	<input type="checkbox"/>	<input type="checkbox"/>	<input type="checkbox"/>	-----
64	<input type="checkbox"/>	<input type="checkbox"/>	<input type="checkbox"/>	<input type="checkbox"/>	-----
65	<input type="checkbox"/>	<input type="checkbox"/>	<input type="checkbox"/>	<input type="checkbox"/>	-----
66	<input type="checkbox"/>	<input type="checkbox"/>	<input type="checkbox"/>	<input type="checkbox"/>	-----
67	<input type="checkbox"/>	<input type="checkbox"/>	<input type="checkbox"/>	<input type="checkbox"/>	-----
68	<input type="checkbox"/>	<input type="checkbox"/>	<input type="checkbox"/>	<input type="checkbox"/>	-----
69	<input type="checkbox"/>	<input type="checkbox"/>	<input type="checkbox"/>	<input type="checkbox"/>	-----
70	<input type="checkbox"/>	<input type="checkbox"/>	<input type="checkbox"/>	<input type="checkbox"/>	-----
71	<input type="checkbox"/>	<input type="checkbox"/>	<input type="checkbox"/>	<input type="checkbox"/>	-----
72	<input type="checkbox"/>	<input type="checkbox"/>	<input type="checkbox"/>	<input type="checkbox"/>	-----
73	<input type="checkbox"/>	<input type="checkbox"/>	<input type="checkbox"/>	<input type="checkbox"/>	-----
74	<input type="checkbox"/>	<input type="checkbox"/>	<input type="checkbox"/>	<input type="checkbox"/>	-----
75	<input type="checkbox"/>	<input type="checkbox"/>	<input type="checkbox"/>	<input type="checkbox"/>	-----

PRINT OR TYPE

AVIATION ELECTRICIAN'S MATE 3 & 2
NAVEDTRA 10348-E

NAME _____ ADDRESS _____
Last First Middle Street/Ship/Unit/Division, etc.

RANK/RATE _____ SOC. SEC. NO. _____ DESIGNATOR _____ ASSIGNMENT NO. _____
City or PPO State Zip

USN USNR ACTIVE INACTIVE OTHER (Specify) _____ DATE MAILED _____

SCORE

	1	2	3	4	
1	<input type="checkbox"/>	<input type="checkbox"/>	<input type="checkbox"/>	<input type="checkbox"/>	-----
2	<input type="checkbox"/>	<input type="checkbox"/>	<input type="checkbox"/>	<input type="checkbox"/>	-----
3	<input type="checkbox"/>	<input type="checkbox"/>	<input type="checkbox"/>	<input type="checkbox"/>	-----
4	<input type="checkbox"/>	<input type="checkbox"/>	<input type="checkbox"/>	<input type="checkbox"/>	-----
5	<input type="checkbox"/>	<input type="checkbox"/>	<input type="checkbox"/>	<input type="checkbox"/>	-----
6	<input type="checkbox"/>	<input type="checkbox"/>	<input type="checkbox"/>	<input type="checkbox"/>	-----
7	<input type="checkbox"/>	<input type="checkbox"/>	<input type="checkbox"/>	<input type="checkbox"/>	-----
8	<input type="checkbox"/>	<input type="checkbox"/>	<input type="checkbox"/>	<input type="checkbox"/>	-----
9	<input type="checkbox"/>	<input type="checkbox"/>	<input type="checkbox"/>	<input type="checkbox"/>	-----
10	<input type="checkbox"/>	<input type="checkbox"/>	<input type="checkbox"/>	<input type="checkbox"/>	-----
11	<input type="checkbox"/>	<input type="checkbox"/>	<input type="checkbox"/>	<input type="checkbox"/>	-----
12	<input type="checkbox"/>	<input type="checkbox"/>	<input type="checkbox"/>	<input type="checkbox"/>	-----
13	<input type="checkbox"/>	<input type="checkbox"/>	<input type="checkbox"/>	<input type="checkbox"/>	-----
14	<input type="checkbox"/>	<input type="checkbox"/>	<input type="checkbox"/>	<input type="checkbox"/>	-----
15	<input type="checkbox"/>	<input type="checkbox"/>	<input type="checkbox"/>	<input type="checkbox"/>	-----
16	<input type="checkbox"/>	<input type="checkbox"/>	<input type="checkbox"/>	<input type="checkbox"/>	-----
17	<input type="checkbox"/>	<input type="checkbox"/>	<input type="checkbox"/>	<input type="checkbox"/>	-----
18	<input type="checkbox"/>	<input type="checkbox"/>	<input type="checkbox"/>	<input type="checkbox"/>	-----
19	<input type="checkbox"/>	<input type="checkbox"/>	<input type="checkbox"/>	<input type="checkbox"/>	-----
20	<input type="checkbox"/>	<input type="checkbox"/>	<input type="checkbox"/>	<input type="checkbox"/>	-----
21	<input type="checkbox"/>	<input type="checkbox"/>	<input type="checkbox"/>	<input type="checkbox"/>	-----
22	<input type="checkbox"/>	<input type="checkbox"/>	<input type="checkbox"/>	<input type="checkbox"/>	-----
23	<input type="checkbox"/>	<input type="checkbox"/>	<input type="checkbox"/>	<input type="checkbox"/>	-----
24	<input type="checkbox"/>	<input type="checkbox"/>	<input type="checkbox"/>	<input type="checkbox"/>	-----
25	<input type="checkbox"/>	<input type="checkbox"/>	<input type="checkbox"/>	<input type="checkbox"/>	-----

	1	2	3	4	
26	<input type="checkbox"/>	<input type="checkbox"/>	<input type="checkbox"/>	<input type="checkbox"/>	-----
27	<input type="checkbox"/>	<input type="checkbox"/>	<input type="checkbox"/>	<input type="checkbox"/>	-----
28	<input type="checkbox"/>	<input type="checkbox"/>	<input type="checkbox"/>	<input type="checkbox"/>	-----
29	<input type="checkbox"/>	<input type="checkbox"/>	<input type="checkbox"/>	<input type="checkbox"/>	-----
30	<input type="checkbox"/>	<input type="checkbox"/>	<input type="checkbox"/>	<input type="checkbox"/>	-----
31	<input type="checkbox"/>	<input type="checkbox"/>	<input type="checkbox"/>	<input type="checkbox"/>	-----
32	<input type="checkbox"/>	<input type="checkbox"/>	<input type="checkbox"/>	<input type="checkbox"/>	-----
33	<input type="checkbox"/>	<input type="checkbox"/>	<input type="checkbox"/>	<input type="checkbox"/>	-----
34	<input type="checkbox"/>	<input type="checkbox"/>	<input type="checkbox"/>	<input type="checkbox"/>	-----
35	<input type="checkbox"/>	<input type="checkbox"/>	<input type="checkbox"/>	<input type="checkbox"/>	-----
36	<input type="checkbox"/>	<input type="checkbox"/>	<input type="checkbox"/>	<input type="checkbox"/>	-----
37	<input type="checkbox"/>	<input type="checkbox"/>	<input type="checkbox"/>	<input type="checkbox"/>	-----
38	<input type="checkbox"/>	<input type="checkbox"/>	<input type="checkbox"/>	<input type="checkbox"/>	-----
39	<input type="checkbox"/>	<input type="checkbox"/>	<input type="checkbox"/>	<input type="checkbox"/>	-----
40	<input type="checkbox"/>	<input type="checkbox"/>	<input type="checkbox"/>	<input type="checkbox"/>	-----
41	<input type="checkbox"/>	<input type="checkbox"/>	<input type="checkbox"/>	<input type="checkbox"/>	-----
42	<input type="checkbox"/>	<input type="checkbox"/>	<input type="checkbox"/>	<input type="checkbox"/>	-----
43	<input type="checkbox"/>	<input type="checkbox"/>	<input type="checkbox"/>	<input type="checkbox"/>	-----
44	<input type="checkbox"/>	<input type="checkbox"/>	<input type="checkbox"/>	<input type="checkbox"/>	-----
45	<input type="checkbox"/>	<input type="checkbox"/>	<input type="checkbox"/>	<input type="checkbox"/>	-----
46	<input type="checkbox"/>	<input type="checkbox"/>	<input type="checkbox"/>	<input type="checkbox"/>	-----
47	<input type="checkbox"/>	<input type="checkbox"/>	<input type="checkbox"/>	<input type="checkbox"/>	-----
48	<input type="checkbox"/>	<input type="checkbox"/>	<input type="checkbox"/>	<input type="checkbox"/>	-----
49	<input type="checkbox"/>	<input type="checkbox"/>	<input type="checkbox"/>	<input type="checkbox"/>	-----
50	<input type="checkbox"/>	<input type="checkbox"/>	<input type="checkbox"/>	<input type="checkbox"/>	-----

	1	2	3	4	
51	<input type="checkbox"/>	<input type="checkbox"/>	<input type="checkbox"/>	<input type="checkbox"/>	-----
52	<input type="checkbox"/>	<input type="checkbox"/>	<input type="checkbox"/>	<input type="checkbox"/>	-----
53	<input type="checkbox"/>	<input type="checkbox"/>	<input type="checkbox"/>	<input type="checkbox"/>	-----
54	<input type="checkbox"/>	<input type="checkbox"/>	<input type="checkbox"/>	<input type="checkbox"/>	-----
55	<input type="checkbox"/>	<input type="checkbox"/>	<input type="checkbox"/>	<input type="checkbox"/>	-----
56	<input type="checkbox"/>	<input type="checkbox"/>	<input type="checkbox"/>	<input type="checkbox"/>	-----
57	<input type="checkbox"/>	<input type="checkbox"/>	<input type="checkbox"/>	<input type="checkbox"/>	-----
58	<input type="checkbox"/>	<input type="checkbox"/>	<input type="checkbox"/>	<input type="checkbox"/>	-----
59	<input type="checkbox"/>	<input type="checkbox"/>	<input type="checkbox"/>	<input type="checkbox"/>	-----
60	<input type="checkbox"/>	<input type="checkbox"/>	<input type="checkbox"/>	<input type="checkbox"/>	-----
61	<input type="checkbox"/>	<input type="checkbox"/>	<input type="checkbox"/>	<input type="checkbox"/>	-----
62	<input type="checkbox"/>	<input type="checkbox"/>	<input type="checkbox"/>	<input type="checkbox"/>	-----
63	<input type="checkbox"/>	<input type="checkbox"/>	<input type="checkbox"/>	<input type="checkbox"/>	-----
64	<input type="checkbox"/>	<input type="checkbox"/>	<input type="checkbox"/>	<input type="checkbox"/>	-----
65	<input type="checkbox"/>	<input type="checkbox"/>	<input type="checkbox"/>	<input type="checkbox"/>	-----
66	<input type="checkbox"/>	<input type="checkbox"/>	<input type="checkbox"/>	<input type="checkbox"/>	-----
67	<input type="checkbox"/>	<input type="checkbox"/>	<input type="checkbox"/>	<input type="checkbox"/>	-----
68	<input type="checkbox"/>	<input type="checkbox"/>	<input type="checkbox"/>	<input type="checkbox"/>	-----
69	<input type="checkbox"/>	<input type="checkbox"/>	<input type="checkbox"/>	<input type="checkbox"/>	-----
70	<input type="checkbox"/>	<input type="checkbox"/>	<input type="checkbox"/>	<input type="checkbox"/>	-----
71	<input type="checkbox"/>	<input type="checkbox"/>	<input type="checkbox"/>	<input type="checkbox"/>	-----
72	<input type="checkbox"/>	<input type="checkbox"/>	<input type="checkbox"/>	<input type="checkbox"/>	-----
73	<input type="checkbox"/>	<input type="checkbox"/>	<input type="checkbox"/>	<input type="checkbox"/>	-----
74	<input type="checkbox"/>	<input type="checkbox"/>	<input type="checkbox"/>	<input type="checkbox"/>	-----
75	<input type="checkbox"/>	<input type="checkbox"/>	<input type="checkbox"/>	<input type="checkbox"/>	-----

PRINT OR TYPE

NAME _____ ADDRESS _____
Last First Middle Street/Ship/Unit/Division, etc.

RANK/RATE _____ SOC. SEC. NO. _____ DESIGNATOR _____ ASSIGNMENT NO _____
City or PFO State Zip

USN USNR ACTIVE INACTIVE OTHER (Specify) _____ DATE MAILED _____

SCORE

	1	2	3	4
1	<input type="checkbox"/>	<input type="checkbox"/>	<input type="checkbox"/>	<input type="checkbox"/>
2	<input type="checkbox"/>	<input type="checkbox"/>	<input type="checkbox"/>	<input type="checkbox"/>
3	<input type="checkbox"/>	<input type="checkbox"/>	<input type="checkbox"/>	<input type="checkbox"/>
4	<input type="checkbox"/>	<input type="checkbox"/>	<input type="checkbox"/>	<input type="checkbox"/>
5	<input type="checkbox"/>	<input type="checkbox"/>	<input type="checkbox"/>	<input type="checkbox"/>
6	<input type="checkbox"/>	<input type="checkbox"/>	<input type="checkbox"/>	<input type="checkbox"/>
7	<input type="checkbox"/>	<input type="checkbox"/>	<input type="checkbox"/>	<input type="checkbox"/>
8	<input type="checkbox"/>	<input type="checkbox"/>	<input type="checkbox"/>	<input type="checkbox"/>
9	<input type="checkbox"/>	<input type="checkbox"/>	<input type="checkbox"/>	<input type="checkbox"/>
10	<input type="checkbox"/>	<input type="checkbox"/>	<input type="checkbox"/>	<input type="checkbox"/>
11	<input type="checkbox"/>	<input type="checkbox"/>	<input type="checkbox"/>	<input type="checkbox"/>
12	<input type="checkbox"/>	<input type="checkbox"/>	<input type="checkbox"/>	<input type="checkbox"/>
13	<input type="checkbox"/>	<input type="checkbox"/>	<input type="checkbox"/>	<input type="checkbox"/>
14	<input type="checkbox"/>	<input type="checkbox"/>	<input type="checkbox"/>	<input type="checkbox"/>
15	<input type="checkbox"/>	<input type="checkbox"/>	<input type="checkbox"/>	<input type="checkbox"/>
16	<input type="checkbox"/>	<input type="checkbox"/>	<input type="checkbox"/>	<input type="checkbox"/>
17	<input type="checkbox"/>	<input type="checkbox"/>	<input type="checkbox"/>	<input type="checkbox"/>
18	<input type="checkbox"/>	<input type="checkbox"/>	<input type="checkbox"/>	<input type="checkbox"/>
19	<input type="checkbox"/>	<input type="checkbox"/>	<input type="checkbox"/>	<input type="checkbox"/>
20	<input type="checkbox"/>	<input type="checkbox"/>	<input type="checkbox"/>	<input type="checkbox"/>
21	<input type="checkbox"/>	<input type="checkbox"/>	<input type="checkbox"/>	<input type="checkbox"/>
22	<input type="checkbox"/>	<input type="checkbox"/>	<input type="checkbox"/>	<input type="checkbox"/>
23	<input type="checkbox"/>	<input type="checkbox"/>	<input type="checkbox"/>	<input type="checkbox"/>
24	<input type="checkbox"/>	<input type="checkbox"/>	<input type="checkbox"/>	<input type="checkbox"/>
25	<input type="checkbox"/>	<input type="checkbox"/>	<input type="checkbox"/>	<input type="checkbox"/>

	1	2	3	4
26	<input type="checkbox"/>	<input type="checkbox"/>	<input type="checkbox"/>	<input type="checkbox"/>
27	<input type="checkbox"/>	<input type="checkbox"/>	<input type="checkbox"/>	<input type="checkbox"/>
28	<input type="checkbox"/>	<input type="checkbox"/>	<input type="checkbox"/>	<input type="checkbox"/>
29	<input type="checkbox"/>	<input type="checkbox"/>	<input type="checkbox"/>	<input type="checkbox"/>
30	<input type="checkbox"/>	<input type="checkbox"/>	<input type="checkbox"/>	<input type="checkbox"/>
31	<input type="checkbox"/>	<input type="checkbox"/>	<input type="checkbox"/>	<input type="checkbox"/>
32	<input type="checkbox"/>	<input type="checkbox"/>	<input type="checkbox"/>	<input type="checkbox"/>
33	<input type="checkbox"/>	<input type="checkbox"/>	<input type="checkbox"/>	<input type="checkbox"/>
34	<input type="checkbox"/>	<input type="checkbox"/>	<input type="checkbox"/>	<input type="checkbox"/>
35	<input type="checkbox"/>	<input type="checkbox"/>	<input type="checkbox"/>	<input type="checkbox"/>
36	<input type="checkbox"/>	<input type="checkbox"/>	<input type="checkbox"/>	<input type="checkbox"/>
37	<input type="checkbox"/>	<input type="checkbox"/>	<input type="checkbox"/>	<input type="checkbox"/>
38	<input type="checkbox"/>	<input type="checkbox"/>	<input type="checkbox"/>	<input type="checkbox"/>
39	<input type="checkbox"/>	<input type="checkbox"/>	<input type="checkbox"/>	<input type="checkbox"/>
40	<input type="checkbox"/>	<input type="checkbox"/>	<input type="checkbox"/>	<input type="checkbox"/>
41	<input type="checkbox"/>	<input type="checkbox"/>	<input type="checkbox"/>	<input type="checkbox"/>
42	<input type="checkbox"/>	<input type="checkbox"/>	<input type="checkbox"/>	<input type="checkbox"/>
43	<input type="checkbox"/>	<input type="checkbox"/>	<input type="checkbox"/>	<input type="checkbox"/>
44	<input type="checkbox"/>	<input type="checkbox"/>	<input type="checkbox"/>	<input type="checkbox"/>
45	<input type="checkbox"/>	<input type="checkbox"/>	<input type="checkbox"/>	<input type="checkbox"/>
46	<input type="checkbox"/>	<input type="checkbox"/>	<input type="checkbox"/>	<input type="checkbox"/>
47	<input type="checkbox"/>	<input type="checkbox"/>	<input type="checkbox"/>	<input type="checkbox"/>
48	<input type="checkbox"/>	<input type="checkbox"/>	<input type="checkbox"/>	<input type="checkbox"/>
49	<input type="checkbox"/>	<input type="checkbox"/>	<input type="checkbox"/>	<input type="checkbox"/>
50	<input type="checkbox"/>	<input type="checkbox"/>	<input type="checkbox"/>	<input type="checkbox"/>

	1	2	3	4
51	<input type="checkbox"/>	<input type="checkbox"/>	<input type="checkbox"/>	<input type="checkbox"/>
52	<input type="checkbox"/>	<input type="checkbox"/>	<input type="checkbox"/>	<input type="checkbox"/>
53	<input type="checkbox"/>	<input type="checkbox"/>	<input type="checkbox"/>	<input type="checkbox"/>
54	<input type="checkbox"/>	<input type="checkbox"/>	<input type="checkbox"/>	<input type="checkbox"/>
55	<input type="checkbox"/>	<input type="checkbox"/>	<input type="checkbox"/>	<input type="checkbox"/>
56	<input type="checkbox"/>	<input type="checkbox"/>	<input type="checkbox"/>	<input type="checkbox"/>
57	<input type="checkbox"/>	<input type="checkbox"/>	<input type="checkbox"/>	<input type="checkbox"/>
58	<input type="checkbox"/>	<input type="checkbox"/>	<input type="checkbox"/>	<input type="checkbox"/>
59	<input type="checkbox"/>	<input type="checkbox"/>	<input type="checkbox"/>	<input type="checkbox"/>
60	<input type="checkbox"/>	<input type="checkbox"/>	<input type="checkbox"/>	<input type="checkbox"/>
61	<input type="checkbox"/>	<input type="checkbox"/>	<input type="checkbox"/>	<input type="checkbox"/>
62	<input type="checkbox"/>	<input type="checkbox"/>	<input type="checkbox"/>	<input type="checkbox"/>
63	<input type="checkbox"/>	<input type="checkbox"/>	<input type="checkbox"/>	<input type="checkbox"/>
64	<input type="checkbox"/>	<input type="checkbox"/>	<input type="checkbox"/>	<input type="checkbox"/>
65	<input type="checkbox"/>	<input type="checkbox"/>	<input type="checkbox"/>	<input type="checkbox"/>
66	<input type="checkbox"/>	<input type="checkbox"/>	<input type="checkbox"/>	<input type="checkbox"/>
67	<input type="checkbox"/>	<input type="checkbox"/>	<input type="checkbox"/>	<input type="checkbox"/>
68	<input type="checkbox"/>	<input type="checkbox"/>	<input type="checkbox"/>	<input type="checkbox"/>
69	<input type="checkbox"/>	<input type="checkbox"/>	<input type="checkbox"/>	<input type="checkbox"/>
70	<input type="checkbox"/>	<input type="checkbox"/>	<input type="checkbox"/>	<input type="checkbox"/>
71	<input type="checkbox"/>	<input type="checkbox"/>	<input type="checkbox"/>	<input type="checkbox"/>
72	<input type="checkbox"/>	<input type="checkbox"/>	<input type="checkbox"/>	<input type="checkbox"/>
73	<input type="checkbox"/>	<input type="checkbox"/>	<input type="checkbox"/>	<input type="checkbox"/>
74	<input type="checkbox"/>	<input type="checkbox"/>	<input type="checkbox"/>	<input type="checkbox"/>
75	<input type="checkbox"/>	<input type="checkbox"/>	<input type="checkbox"/>	<input type="checkbox"/>

PRINT OR TYPE

NAME _____ ADDRESS _____
Last First Middle Street/Ship/Unit/Division, etc.

RANK/RATE _____ SOC. SEC. NO. _____ DESIGNATOR _____ ASSIGNMENT NO. _____
City or FPO State Zip

USN USNR ACTIVE INACTIVE OTHER (Specify) _____ DATE MAILED _____

SCORE

	1	2	3	4	
1	<input type="checkbox"/>	<input type="checkbox"/>	<input type="checkbox"/>	<input type="checkbox"/>	-----
2	<input type="checkbox"/>	<input type="checkbox"/>	<input type="checkbox"/>	<input type="checkbox"/>	-----
3	<input type="checkbox"/>	<input type="checkbox"/>	<input type="checkbox"/>	<input type="checkbox"/>	-----
4	<input type="checkbox"/>	<input type="checkbox"/>	<input type="checkbox"/>	<input type="checkbox"/>	-----
5	<input type="checkbox"/>	<input type="checkbox"/>	<input type="checkbox"/>	<input type="checkbox"/>	-----
6	<input type="checkbox"/>	<input type="checkbox"/>	<input type="checkbox"/>	<input type="checkbox"/>	-----
7	<input type="checkbox"/>	<input type="checkbox"/>	<input type="checkbox"/>	<input type="checkbox"/>	-----
8	<input type="checkbox"/>	<input type="checkbox"/>	<input type="checkbox"/>	<input type="checkbox"/>	-----
9	<input type="checkbox"/>	<input type="checkbox"/>	<input type="checkbox"/>	<input type="checkbox"/>	-----
10	<input type="checkbox"/>	<input type="checkbox"/>	<input type="checkbox"/>	<input type="checkbox"/>	-----
11	<input type="checkbox"/>	<input type="checkbox"/>	<input type="checkbox"/>	<input type="checkbox"/>	-----
12	<input type="checkbox"/>	<input type="checkbox"/>	<input type="checkbox"/>	<input type="checkbox"/>	-----
13	<input type="checkbox"/>	<input type="checkbox"/>	<input type="checkbox"/>	<input type="checkbox"/>	-----
14	<input type="checkbox"/>	<input type="checkbox"/>	<input type="checkbox"/>	<input type="checkbox"/>	-----
15	<input type="checkbox"/>	<input type="checkbox"/>	<input type="checkbox"/>	<input type="checkbox"/>	-----
16	<input type="checkbox"/>	<input type="checkbox"/>	<input type="checkbox"/>	<input type="checkbox"/>	-----
17	<input type="checkbox"/>	<input type="checkbox"/>	<input type="checkbox"/>	<input type="checkbox"/>	-----
18	<input type="checkbox"/>	<input type="checkbox"/>	<input type="checkbox"/>	<input type="checkbox"/>	-----
19	<input type="checkbox"/>	<input type="checkbox"/>	<input type="checkbox"/>	<input type="checkbox"/>	-----
20	<input type="checkbox"/>	<input type="checkbox"/>	<input type="checkbox"/>	<input type="checkbox"/>	-----
21	<input type="checkbox"/>	<input type="checkbox"/>	<input type="checkbox"/>	<input type="checkbox"/>	-----
22	<input type="checkbox"/>	<input type="checkbox"/>	<input type="checkbox"/>	<input type="checkbox"/>	-----
23	<input type="checkbox"/>	<input type="checkbox"/>	<input type="checkbox"/>	<input type="checkbox"/>	-----
24	<input type="checkbox"/>	<input type="checkbox"/>	<input type="checkbox"/>	<input type="checkbox"/>	-----
25	<input type="checkbox"/>	<input type="checkbox"/>	<input type="checkbox"/>	<input type="checkbox"/>	-----

	1	2	3	4	
26	<input type="checkbox"/>	<input type="checkbox"/>	<input type="checkbox"/>	<input type="checkbox"/>	-----
27	<input type="checkbox"/>	<input type="checkbox"/>	<input type="checkbox"/>	<input type="checkbox"/>	-----
28	<input type="checkbox"/>	<input type="checkbox"/>	<input type="checkbox"/>	<input type="checkbox"/>	-----
29	<input type="checkbox"/>	<input type="checkbox"/>	<input type="checkbox"/>	<input type="checkbox"/>	-----
30	<input type="checkbox"/>	<input type="checkbox"/>	<input type="checkbox"/>	<input type="checkbox"/>	-----
31	<input type="checkbox"/>	<input type="checkbox"/>	<input type="checkbox"/>	<input type="checkbox"/>	-----
32	<input type="checkbox"/>	<input type="checkbox"/>	<input type="checkbox"/>	<input type="checkbox"/>	-----
33	<input type="checkbox"/>	<input type="checkbox"/>	<input type="checkbox"/>	<input type="checkbox"/>	-----
34	<input type="checkbox"/>	<input type="checkbox"/>	<input type="checkbox"/>	<input type="checkbox"/>	-----
35	<input type="checkbox"/>	<input type="checkbox"/>	<input type="checkbox"/>	<input type="checkbox"/>	-----
36	<input type="checkbox"/>	<input type="checkbox"/>	<input type="checkbox"/>	<input type="checkbox"/>	-----
37	<input type="checkbox"/>	<input type="checkbox"/>	<input type="checkbox"/>	<input type="checkbox"/>	-----
38	<input type="checkbox"/>	<input type="checkbox"/>	<input type="checkbox"/>	<input type="checkbox"/>	-----
39	<input type="checkbox"/>	<input type="checkbox"/>	<input type="checkbox"/>	<input type="checkbox"/>	-----
40	<input type="checkbox"/>	<input type="checkbox"/>	<input type="checkbox"/>	<input type="checkbox"/>	-----
41	<input type="checkbox"/>	<input type="checkbox"/>	<input type="checkbox"/>	<input type="checkbox"/>	-----
42	<input type="checkbox"/>	<input type="checkbox"/>	<input type="checkbox"/>	<input type="checkbox"/>	-----
43	<input type="checkbox"/>	<input type="checkbox"/>	<input type="checkbox"/>	<input type="checkbox"/>	-----
44	<input type="checkbox"/>	<input type="checkbox"/>	<input type="checkbox"/>	<input type="checkbox"/>	-----
45	<input type="checkbox"/>	<input type="checkbox"/>	<input type="checkbox"/>	<input type="checkbox"/>	-----
46	<input type="checkbox"/>	<input type="checkbox"/>	<input type="checkbox"/>	<input type="checkbox"/>	-----
47	<input type="checkbox"/>	<input type="checkbox"/>	<input type="checkbox"/>	<input type="checkbox"/>	-----
48	<input type="checkbox"/>	<input type="checkbox"/>	<input type="checkbox"/>	<input type="checkbox"/>	-----
49	<input type="checkbox"/>	<input type="checkbox"/>	<input type="checkbox"/>	<input type="checkbox"/>	-----
50	<input type="checkbox"/>	<input type="checkbox"/>	<input type="checkbox"/>	<input type="checkbox"/>	-----

	1	2	3	4	
51	<input type="checkbox"/>	<input type="checkbox"/>	<input type="checkbox"/>	<input type="checkbox"/>	-----
52	<input type="checkbox"/>	<input type="checkbox"/>	<input type="checkbox"/>	<input type="checkbox"/>	-----
53	<input type="checkbox"/>	<input type="checkbox"/>	<input type="checkbox"/>	<input type="checkbox"/>	-----
54	<input type="checkbox"/>	<input type="checkbox"/>	<input type="checkbox"/>	<input type="checkbox"/>	-----
55	<input type="checkbox"/>	<input type="checkbox"/>	<input type="checkbox"/>	<input type="checkbox"/>	-----
56	<input type="checkbox"/>	<input type="checkbox"/>	<input type="checkbox"/>	<input type="checkbox"/>	-----
57	<input type="checkbox"/>	<input type="checkbox"/>	<input type="checkbox"/>	<input type="checkbox"/>	-----
58	<input type="checkbox"/>	<input type="checkbox"/>	<input type="checkbox"/>	<input type="checkbox"/>	-----
59	<input type="checkbox"/>	<input type="checkbox"/>	<input type="checkbox"/>	<input type="checkbox"/>	-----
60	<input type="checkbox"/>	<input type="checkbox"/>	<input type="checkbox"/>	<input type="checkbox"/>	-----
61	<input type="checkbox"/>	<input type="checkbox"/>	<input type="checkbox"/>	<input type="checkbox"/>	-----
62	<input type="checkbox"/>	<input type="checkbox"/>	<input type="checkbox"/>	<input type="checkbox"/>	-----
63	<input type="checkbox"/>	<input type="checkbox"/>	<input type="checkbox"/>	<input type="checkbox"/>	-----
64	<input type="checkbox"/>	<input type="checkbox"/>	<input type="checkbox"/>	<input type="checkbox"/>	-----
65	<input type="checkbox"/>	<input type="checkbox"/>	<input type="checkbox"/>	<input type="checkbox"/>	-----
66	<input type="checkbox"/>	<input type="checkbox"/>	<input type="checkbox"/>	<input type="checkbox"/>	-----
67	<input type="checkbox"/>	<input type="checkbox"/>	<input type="checkbox"/>	<input type="checkbox"/>	-----
68	<input type="checkbox"/>	<input type="checkbox"/>	<input type="checkbox"/>	<input type="checkbox"/>	-----
69	<input type="checkbox"/>	<input type="checkbox"/>	<input type="checkbox"/>	<input type="checkbox"/>	-----
70	<input type="checkbox"/>	<input type="checkbox"/>	<input type="checkbox"/>	<input type="checkbox"/>	-----
71	<input type="checkbox"/>	<input type="checkbox"/>	<input type="checkbox"/>	<input type="checkbox"/>	-----
72	<input type="checkbox"/>	<input type="checkbox"/>	<input type="checkbox"/>	<input type="checkbox"/>	-----
73	<input type="checkbox"/>	<input type="checkbox"/>	<input type="checkbox"/>	<input type="checkbox"/>	-----
74	<input type="checkbox"/>	<input type="checkbox"/>	<input type="checkbox"/>	<input type="checkbox"/>	-----
75	<input type="checkbox"/>	<input type="checkbox"/>	<input type="checkbox"/>	<input type="checkbox"/>	-----