

DOCUMENT RESUME

ED 211 388

SE C36 099

AUTHOR Fraser, Mollie; And Others
 TITLE Energy Conservation Activity Guide, Grades 9-12. Bulletin 1602.
 INSTITUTION Louisiana State Dept. of Education, Baton Rouge. Div. of Academic Programs.; Louisiana State Dept. of Natural Resources, Baton Rouge.
 PUB DATE Jan 81
 NOTE 469p.; Contains occasional light and broken type.

EDRS PRICE MF01/PC19 Plus Postage.
 DESCRIPTORS *Conservation Education; *Energy; *Energy Conservation; Environmental Education; High Schools; *Interdisciplinary Approach; Learning Activities; Natural Resources; Nuclear Energy; *Science Activities; Science Education; Secondary Education; *Secondary School Science; Solar Radiation
 IDENTIFIERS. Alternative Energy Sources; *Energy Education

ABSTRACT

As an interdisciplinary, non-sequential teaching guide, this publication was developed to increase awareness and understanding of the energy situation and to encourage individuals to become energy conservationists. Sections provide background information for the teacher followed by a variety of student activities using different subject areas for grades 9-12 (art, language arts, social studies, music, mathematics, science). Some of the topics included are energy in Louisiana; energy demand; energy development in Louisiana; sources of energy; solar, nuclear, and geothermal energy; fossil fuels; wind; biomass; solid waste; gasohol; conservation; and energy futures. Each activity identifies the subject area(s), objectives, materials, and procedures. A glossary, listing of free and inexpensive materials, and bibliography are provided. (Author/DC).

 * Reproductions supplied by EDRS are the best that can be made *
 * from the original document. *

State of Louisiana



ENERGY CONSERVATION PUBLICATION FOR

U.S. DEPARTMENT OF EDUCATION
NATIONAL INSTITUTE OF EDUCATION

LOUISIANA SCHOOLS

PERMISSION TO REPRODUCE THIS
MATERIAL HAS BEEN GRANTED BY

S. Ebarb

TO THE EDUCATIONAL RESOURCES
INFORMATION CENTER (ERIC)

GRADES 9-12

DEPARTMENT OF NATURAL RESOURCES

DIVISION OF RESEARCH AND DEVELOPMENT

This public document was published at an annual cost of \$4.54 per copy by the Division of Administration, Administrative Services, P.O. Box 44095, Baton Rouge, Louisiana 70804 to promulgate the State Energy Conservation Plan developed under P.L. 94-385 under special exception by Division of Administration. This material was printed in accordance with the standards for printing by state agencies established pursuant to R.S. 43:31.

January 1981

7 rules to help conserve fuel in schools

- 1 Lower thermostat settings to "sweater comfort" heating.
- 2 Avoid blocking heating vents or air return grills with furniture or drapes.
- 3 Control room temperatures with thermostats, not by opening windows.
- 4 Use limited number of outside doors—keep doors closed when not in use.
- 5 Reduce fresh air ventilation to the minimum required by state and local codes.
- 6 Turn off unused lights and electrical equipment
- 7 Establish a program of preventive maintenance for heating, water heating and food service equipment.

COOPERATION CONSERVES ENERGY!

DEPARTMENT OF PUBLIC EDUCATION
STATE OF LOUISIANA

BULLETIN 1602
JANUARY 1981

ENERGY CONSERVATION ACTIVITY GUIDE

Issued by
Division of Academic Programs

J. KELLY NIX
State Superintendent

TABLE OF CONTENTS

	<u>Page</u>
ACKNOWLEDGMENTS	i
DISCLAIMER	ii
MEMBERS OF ENERGY CURRICULUM WRITING TEAM	iii
SPECIAL THANKS	iv
HOW TO USE THIS GUIDE	vii
RATIONALE	viii
ENERGY IN LOUISIANA	ix
ENERGY BACKGROUND	1
THE DEMAND FOR ENERGY	10
HISTORICAL SKETCH OF ENERGY DEVELOPMENT IN LOUISIANA	16
WHERE DOES THE ENERGY WE USE COME FROM?	17
WHAT IS ENERGY?	23
ENERGY ACTIVITIES	32
SOLAR ENERGY	57
SOLAR ENERGY ACTIVITIES	64
NUCLEAR ENERGY	100
NUCLEAR ENERGY ACTIVITIES	119
FOSSIL FUELS	150
FOSSIL FUEL ACTIVITIES	156
NEW AND UNUSUAL ENERGY RESOURCES	201
GEOHERMAL ENERGY	213
GEOHERMAL ENERGY ACTIVITIES	224
WIND ENERGY	228
WIND ENERGY ACTIVITIES	231
BIOMASS	247
BIOMASS ACTIVITIES	249

	<u>Page</u>
COMPOSITION OF MUNICIPAL SOLID WASTE	256
SOLID WASTE ACTIVITIES	259
GASOHOL--THE AMERICAN RENEWABLE ENERGY?	273
GASOHOL ACTIVITIES	277
ENERGY CONSERVATION	298
ENERGY CONSERVATION ACTIVITIES	302
ENERGY FUTURES	411
GLOSSARY	412
FREE/INEXPENSIVE RESOURCES	421
BIBLIOGRAPHY	430

ACKNOWLEDGMENTS

This publication represents the cooperative efforts of personnel in the Bureau of Secondary Education and the Bureau of Curriculum, Inservice, and Staff Development in the Division of Academic Programs, Louisiana State Department of Education. Special recognition goes to Mr. Donald McGehee, Science Supervisor, who served as chairman in the development of the guide. Special commendation goes also to members of the writing team who worked diligently to make this publication a reality.

Robert W. Gaston

Robert W. Gaston, Ed.D.
Assistant Superintendent
Division of Academic Programs

E. Ray Reech

E. Ray Reech
Executive Director of Instruction

Gerald W. Cobb

Gerald Cobb, Ed.D., Director
Bureau of Secondary Education

Helen Brown

Helen Brown, Ed.D., Director
Bureau of Curriculum, Inservice,
and Staff Development

DISCLAIMER

The contents of this manual are offered as guidance. Neither the Louisiana Department of Natural Resources, nor any of its employees, nor any of its contractors, subcontractors, or their employees, and all technical sources referenced in this manual make any warranty or representation, express or implied, with respect to the accuracy, completeness, or usefulness of the information contained in this report. We also do not guarantee that the use of any information, apparatus, method or process disclosed in this report will not infringe privately owned rights; or assume any liabilities with respect to the use of, or for damages resulting from the use of any information, apparatus, method, or process disclosed in this report. This report does not reflect official views or policy of the above-mentioned institutions. Mention of trade names or commercial products does not constitute endorsement or recommendation for use.

MEMBERS OF ENERGY CURRICULUM WRITING TEAM

Mrs. Mollie Fraser
J.D. Meisler Junior High School
3800 Cleary Avenue
Metairie, Louisiana 70002

Ms. Marvalyn F. Henderson
Southwood High School
9000 Walker Road
Shreveport, Louisiana 71108

Ms. Debra Murphy
John Ehret High School
4300 Patriot Street
Marrero, Louisiana 70072

Mrs. Bernadette Morris
Istrouma Senior High School
3730 Winbourne Avenue
Baton Rouge, Louisiana 70805

Mr. Fred Z. Shirley
Baton Rouge Magnet School
2825 Government Street
Baton Rouge, Louisiana 70806

Mr. D.C. Green
Westlake High School
1000 Garden Drive
Westlake, Louisiana 70669

The Science Section of the State Department of Education would like to acknowledge Dr. Burton Voss, University of Michigan, and Mrs. Essie Beck, Jefferson Parish School System, for their assistance in editing the contents of this guide. Particular appreciation is expressed to Dr. Jerry Miller, Louisiana Tech University, and Mr. Louis Nicolosi, Social Studies Supervisor, State Department of Education, for their valuable input and guidance. A special thanks is also given to Mrs. Gert Landry, secretary, Science Section, and Mrs. JoAnn Brian, secretary, Division of Research and Development, for the typing of this document.

STATE OF LOUISIANA
DEPARTMENT OF EDUCATION



J. KELLY NIX
State Superintendent

P. O. Box 44064
Baton Rouge, La.
70804

Dear Educators:

Conservation is presently the only real alternative we have to the energy problems that confront us. No longer can we rely on the efforts of business, industry, and government to solve this complex problem. An effort by all sections of society is necessary in order to maintain our present standards of living.

Educators have the unique opportunity to help instill conservation awareness in our society, since they are involved with the education of our young people. Given the proper guidance and instruction, these students will mature to become energy conscious decision-makers of tomorrow.

The information and activities contained in this guide will better equip children to include conservation as a part of their daily lives. This can happen if we make energy conservation an integral part of the total curriculum.

This guide is designed as a resource reference so that each school can design its own conservation awareness program. The personnel from the State Department of Education will be happy to assist you with your program in any way they can.

Sincerely,

A handwritten signature in cursive script that reads "J. Kelly Nix".

J. KELLY NIX

JKN:dmg

State of Louisiana



DAVID C. TREEN
GOVERNOR

DEPARTMENT OF NATURAL RESOURCES

FRANK A. ASHBY, JR.
SECRETARY

Dear Teachers:

The responsibilities of today's teachers have gone beyond giving our children basic knowledge in the traditional curriculum studies. You are now faced with preparing our future citizens with information that will affect the quality of life in America for generations to come.

Perhaps the most important areas in education--for both students and the general public--are energy production, energy use and energy conservation. It was with the idea of providing our teachers with the information available that this curriculum guide has been developed.

I sincerely hope that you and your students will benefit from this guide, and that it will give our country's future adults the knowledge they will need to keep the standards of living our country has enjoyed.

Sincerely,

FRANK A. ASHBY, JR.
Secretary

FAA/DCD/pam

HOW TO USE THIS GUIDE

The activities and information in this curriculum guide can be organized into an intensive unit or can be used individually in ongoing discussion and exploration. These materials are meant to span grades 9-12, allowing the individual teacher to select those activities that best suit the subject area and specific needs of the students. Sections within the guide provide background material for the teacher followed by student activities in various curricula: art, language arts, social studies, music, mathematics, and various science courses. Activities may be adapted for use in diversified areas. They are intended to be a starting point of investigation for both teacher and student into the very pressing issue of energy and all of its implications. The bibliography and resource materials section provide additional sources for teachers to investigate this complex subject.

This energy publication has been developed to increase awareness and understanding of the energy situation and to encourage each individual to become an energy conservationist. The material has been designed with an interdisciplinary, non-sequential approach and an attempt has been made to provide a flexible document which may be altered to fit local needs.

RATIONALE

Of all the environmental problems we face, the energy problem--how to provide enough energy to keep America running without further polluting it--is perhaps the greatest. The need for conserving energy will affect each of us in how we live, work, travel, and play.

To educators the energy crisis is an opportunity for further service to society. It reflects a set of problems that demand changes in attitudes--values, lifestyles, and methods of building construction that will require many years to achieve. If energy conservation is properly taught, it can bring to the forefront the moral and ethical values that have taken second place in so many of our lives. Unless the students today learn problem-solving strategies in their formative years, the future is bleak.

Louisiana is one of the most dynamic, fastest-growing states in the nation. It contains some of the richest deposits of oil and natural gas in the country. It is our desire that our state continue to be a leader in the energy field by implementing a successful energy conservation program.

The energy crisis can be the most effective teaching aid of the decade. It can serve as a motivating device by addressing issues most fundamental to students such as where they live, how they get to school, where they will work after they graduate.

Therefore, it is to this end that this guide has been developed: to provide teachers and students with the means to learn about energy and how to conserve it.

ENERGY IN LOUISIANA

Louisiana has always enjoyed an enviable position among her sister states in the production of energy. And, in 1980, that place of esteem remains intact; the state ranks first in the nation in the production of natural gas and second in oil production.

Louisiana is not only the birthplace of offshore drilling, but also dominates that scene. Except for gas used by the city of New Orleans, all of the oil and gas produced off the shores of Louisiana is shipped out of state; and 50 percent of oil and gas produced within the state is shipped also. The remaining products are processed by petroleum refining complexes in the state, the third largest refining district in the country. There are thirty refineries in Louisiana capable of processing 2.5 million barrels of oil a day. One of these complexes is the second largest in the United States and is the most diversified refinery in the world, for it can produce a wide variety of petrochemical products. Even though the production of oil peaked in 1971 and has been slowly declining, the discovery in the Tuscaloosa Sands, mainly in East Baton Rouge, West Baton Rouge, and Pointe Coupee parishes, has boosted the production in Louisiana. This find is projected to be the largest oil and natural gas discovery in this country.

Louisiana's nation-leading gas production is estimated to be 7.2 trillion cubic feet of natural gas per year. It is further estimated that the state has the potential for 45 trillion cubic feet of natural gas reserves.

Louisiana's role in oil conservation is as important as it is in production. For instance, five of the six sites selected for the Strategic Petroleum Reserve are located in Louisiana. The specific sites, the amounts stored as of February 1980, and the capacities of these state-based storage areas are indicated below.

<u>SITE</u>	<u>Amount Stored</u> (million barrels)	<u>Capacity</u> (million barrels)
1. Bayou Choctaw (Iberville Parish)	28.7	36.0
2. Sulphur Mines (Calcasieu Parish)	0.6	22.0
3. West Hackberry (Cameron Parish)	30.7	50.6
4. Weeks Island (Iberia Parish)	N/A	75.0
5. St. James Terminal (St. James Parish)	N/A	N/A

The target of 750 million barrels of oil reserves is scheduled for full implementation by 1985. This implementation will involve not only the previously stated sites, but also sites under construction at Cote Blanche and Napoleonville, each with 30 million barrel capacities.

These Strategic Petroleum Reserve projects ensure America a valuable energy supply in the event of a future crisis in oil production and/or attainment.

In an effort to take a port to the large supertankers delivering crude oil from abroad, the Louisiana Offshore Oil Port, known as LOOP, will begin operation by mid-year, 1981. This, the nation's first deepwater port capable of directly unloading crude oil from supertankers, is expected to reduce greatly crude oil transportation costs because of the remarkable economies of scale engineered into these large vessels. Coming from Saudi Arabia, Nigeria, Kuwait, Egypt, Qatar, Abu Dhabi, Algeria, Oman, Libya and the North Sea, oil for the LOOP Deepwater Port is expected to come from approximately 330 ships to the facility in its first year of full operation.

The entire LOOP system will include 19 miles of offshore pipelines and 28 miles of pipeline through the marshland between the shoreline and the Clovelly Salt Dome, where crude oil will be temporarily stored.

The first stage facilities have a design capacity of 1.4 million barrels of throughput per day. (There are 42 gallons to a barrel.) Approximately one-half will be piped to refineries in the Midwest.

LOOP is a corporation owned by a group of oil companies: Ashland Oil, Inc.; Marathon Pipe Line Company; Murphy Oil Corporation; Shell Oil Company; and Texaco, Inc.

Unlike salt cavity oil storage in other parts of the world and in this country, the Clovelly Salt Dome Storage Terminal will be used for "working" storage. Oil from the various cavities will be pumped in and out on almost a daily basis, just as is done with a traditional above-ground tank farm at a refinery.

Typically, oil leaving the Clovelly Salt Dome will head northwest through the 48-inch diameter LOCAP pipeline, which will connect the dome storage cavities with the St. James terminus of CAPLINE, a crude oil pipeline serving the Midwest. From there the oil will either be piped to refineries in Louisiana or sent up the CAPLINE system. Because of CAPLINE and adjacent crude oil pipelines, when in operation the LOOP Deepwater Port will be connected with over 25 percent of the nation's refinery capacity.

The Louisiana Department of Wildlife and Fisheries is engaged in an ongoing environmental monitoring program of all LOOP activities. It will measure the environmental effect of the operations and any oil spills if they occur.

In August 1977, LOOP became the first organization to accept federal license requirements for building a deepwater port. Although other possible deepwater ports are planned for the United States, the LOOP project is the only one under construction. Total cost of the completed project is expected to exceed \$600 million.

In addition to these clearly marked places of distinction, Louisiana is also a leader in the pioneering and developing of solar energy. For instance, there are hot water heating systems located on the campuses of Louisiana State University in Baton Rouge and Loyola University in New Orleans. Moreover, there are extensive solar energy projects at Fort Polk, including a solar-heated and cooled apartment complex, and a dining facility and hospital which employ a solar heating system as do several individual homes across southern Louisiana.

Although Louisiana has no potential for the development of energy powered by the wind, a coal-fired electric generating plant in St. James Parish is scheduled for operation by Louisiana Power and Light by 1988. The coal for this facility will be floated down the Mississippi River from St. Louis, Missouri. Furthermore, lignite coal deposits discovered in DeSoto Parish make possible another avenue of coal-produced energy for the state.

With a commercial operation date of March 1983, Louisiana Power and Light expects the nuclear power plant under construction at Taft to aid greatly the struggle for America to regain its energy independence. Called Waterford Unit 3, the facility at Taft is projected for fuel loading by October 1982. Similarly, Gulf States Utilities has scheduled April of 1984 as the projected date of commercial operation for its nuclear station, River Bend, located in West Feliciana Parish. These two giant energy-generating facilities will enable Louisiana to join other states as a leader in nuclear power.

With some service stations in Louisiana already pumping gasohol as a viable alternative to the gasoline shortage, the Great Western Sugar Company of Reserve has announced plans to build a \$350 million plant for production of alcohol to be blended into gasohol by Louisiana refineries. Using yellow corn as its basic raw material, this plant will allow Louisiana to compete with Midwestern states in the production of gasohol.

Finally, various other methods of energy production are in both operating and experimental stages in the state. Some companies in Louisiana are obtaining energy by recycling steam or hot water created in one section of the plant whose processing is done and using it to produce heat for the plant or for fuel.

In conclusion, due to its rich supply of natural resources and the intense desire of its citizenry to excel, Louisiana continues to occupy an esteemed position in the areas of energy production and conservation.

ENERGY BACKGROUND

From earliest history, human beings have sought to minimize their labor through the use of tools. Early hunters used tools to kill animals, and thereby stretched their own biological energy, derived from sunlight in the form of food, to get more energy from the bison and mammoth.

The most vital discovery during the stone age was how to make fire.

During the later Neolithic period, humans used stone tools for agriculture and were able to produce renewable crops. The first stable communities began to develop, and various forms of housing were built. These primitive dwellings were designed to meet the climatic needs of the area in which they were located. Thus communities could flourish, since the population did not have to migrate with the seasons to escape unfavorable weather conditions.

Further technological progress brought the ability to mine metals and use fire to forge them into tools and weapons. First came copper, then bronze, which is a mixture of copper and tin. Following the Copper and Bronze Ages came the Iron Age, which may have begun in Africa or the Orient about 2400 years ago.

Before the time of the Greek and Roman civilization, the only significant energy sources were natural ones. The power of falling water was used in basic industry, agriculture and grinding grain. The power of the wind was used for ships, and fire from the burning of wood was the major energy source for industry. Much of the mining and mechanization in early cultures--and

certainly in Greece and Rome--was for the purpose of improving weapons for war.

The major source of energy in both Greece and Rome was the energy of human bodies--particularly slaves. From the Greek and Roman era to the beginning of the Industrial Revolution, sophisticated tools were developed, but they were powered by humans or animals. Yet the idea of a heat engine--a device that would use heat to do work--had been envisioned as early as 75 A.D. by the Greek inventor Hero. He made a toy which would spin as steam was expelled through vents.

Toolmaking and architecture were the primary developments between the fall of the Roman Empire and the last few years of the 17th century. Many significant inventions were developed during this time. This was the time of Leonardo da Vinci, but the application of his mechanical discoveries was limited by the absence of energy sources. Technical advances during this time included the printing press and the mechanical clock.

These years in European history were an era of great intellectual and scientific advancement. This was the dawn of Galileo's physics, Kepler's astronomy, and the mathematics and philosophy of Spinoza, Descartes, and Newton. Some of the great laws of nature were conceived. The spirit of the era was discovery--of the world and of applied science.

But to bring about the era of modern technology, an engine was necessary that could use an energy source and produce useful work. The water mills and windmills were limited to specific sites, and there was no way known to transport their energy to where it was needed. By the end of the 17th century this engine

appeared. In 1698, Englishman Thomas Savery obtained a patent for a machine which used fire to boil water, generating steam in a boiler for use in draining water from mines. His steam engine pump was soon improved upon and these engines made possible the deep mining of coal, which had previously been hampered because of the buildup of underground water in the mines.

Englishman James Watt patented a vastly improved engine in 1782, and by this time the steam engine had become the forerunner of mechanized civilization. They were used for pumping water and supplying power to textile mills, rolling mills, and flour mills. A later breakthrough came with the development of engines that could use high pressure steam, making the engines much more efficient. With Robert Fulton's successful operation of the steamboat Clermont on the Hudson River in 1807, and Richard Trevithick's use of a steam locomotive to transport coal in Wales, the modern era of mechanized transportation began.

Little was actually understood about the theory of these engines until the rise of the science of thermodynamics. When these scientific principles came to be understood, bigger and better engines could be built.

Up until the second half of the 19th century, the United States' energy sources were primarily muscle power of humans and animals, along with wind, wood, and falling water. Ninety percent of the fuel burned in 1850 was wood. Coal accounted for only 10 percent, despite the presence of plenty of coal and the technology to use it. The extensive cutting of forests in the east raised the price of wood and increased the distance that it had to be transported to the growing cities. So the demand

for coal sky-rocketed until in 1885 coal surpassed wood as the dominant fuel. In 1885, coal was used to fuel the railroads, to make coke for the steel industry, to power miscellaneous industries, and to provide residential fuel. Coal was to remain the dominant fuel well into the 20th century.

During the 1800s, pressure increased for better and cheaper lighting methods. The various oils burned to produce light were expensive, explosive, or otherwise unsatisfactory. England had developed a coal gas pipeline network for lighting, but the scattered population and undeveloped coal industry in the United States made such a network generally impractical. Finally, an Englishman devised a method of producing oil from coal, which he called coal oil or kerosine. By the late 1850s, there were many kerosine plants in the Eastern U.S. Then some people began to notice a resemblance between the kerosine and the largely useless "rock oil" that came out of springs and wells in western Pennsylvania. In 1857, a Yale chemistry professor hired by a group of Pennsylvania entrepreneurs called the Pennsylvania Rock Oil Company, gave his report on some of this oil. He concluded that some "very valuable products" might be manufactured from it. Drilling, rather than digging, turned out to be the best way of getting to the oil, and so in September 1859, in Titusville, Pennsylvania, oil was struck at a depth of 69 feet. This was not the first oil well in history--the potential value of oil had been recognized centuries before. But it was only in the Western industrial world of the time that science, technology, and society all came together at a point necessary for oil to be exploited

as the concentrated fuel that would eventually replace coal.

The crude oil was made mostly into kerosine. Some of the other products were lubricants, necessary for increasing mechanization, and fuel oil, whose use grew as it began to replace coal for firing boilers for steam generation.

The use of steam for railroads and ships was a great step for transportation, but coal was too bulky and inefficient for use in any smaller scale vehicles. What was needed was a smaller engine. In 1870, inventors began testing an engine using gasoline in a compressed air-gas mixture. Up until this time, gasoline had been a generally useless by-product of kerosine refining. In 1887, a gasoline-fueled engine was adapted to vehicles and the first Benz automobile was patented. This engine was the forerunner of all internal combustion engines in operation today. By 1900, many automobiles had been built in the United States, most of them steam-driven or electrically powered. But the increasing availability of both fuel and lubricants for gasoline-powered automobiles speeded their development. They were light, maneuverable, fast, and competitive in cost. In 1900, the Oldsmobile switched from steam to gasoline, and three years later, Henry Ford introduced his gasoline-powered automobile. His mass-production techniques revolutionized industry.

A milestone in energy history occurred in 1879 with Thomas A. Edison's electric light. Edison himself, however, saw his own greatest achievement not as the light itself, but as the world's first electrical power-generating and distribution system. In 1882, he supervised the building of this system to

light 1200 lamps in a one-half square mile area in New York City. Edison's generating station consisted of four boilers which produced steam to power six generators.

Electricity made it possible to deliver energy to distant sites cheaply and cleanly. It essentially put the steam engine at the disposal of every home, business, and industry in America and much of the Western world.

Shortly after Edison's station began to generate electricity, water wheels began generating the nation's first hydroelectric power in Appleton, Wisconsin.

As electricity became more widely available, the number of electrical devices grew dramatically. Work that was previously done by muscle power could now be done by the new "labor-saving devices," and mechanization of the home was underway.

The latter half of the 19th century also saw a series of inventions which led to farm mechanization. These inventions included the reaper, the harvester, and the twine binder. Such inventions were necessary to develop the agricultural base to support the high-energy society that was rapidly evolving.

Energy use in the United States grew dramatically in the first decades of the 20th century. The number of automobiles increased at a remarkable pace--from 8,000 in 1900, to 194,000 in 1908, to more than 8 million in 1920. Electrical power generation increased at an amazing pace--by 1917, electric consumption was more than seven times what it had been in 1900. Factories had found electric power especially suited to the concept of the assembly line, and the number of electric motors soared. Electricity

thus made practical the mass production of appliances, which were themselves electrically powered.

Total energy use in the United States grew much more slowly after World War I, and the shift toward oil continued. Oil overtook coal as the dominant fuel just after World War II, and has continued to claim an increasing share of the market. This shift to oil was brought about by the growing use of the automobile, and the switch from coal to fuel oil for residential heating and powering trains. Gasoline's share of the petroleum market increased very quickly. Two other uses of fuel also increased sharply during the years from the 30's to the 50s -- aviation and farm equipment. The major petroleum product being produced was thus changing from kerosine to fuel oil to gasoline to accommodate the changing patterns in consumption. There was also a large increase in the use of asphalt, another petroleum product, to pave roads.

Geographic areas of oil production were also changing from Pennsylvania and neighboring Ohio and West Virginia, to California and Oklahoma, and then to Texas and Louisiana.

Natural gas, which is often found in conjunction with oil, was mostly wasted until the late 1920s when it became technologically feasible to lay the pipeline to transport it. Natural gas was clean-burning, convenient, and cheap, and it thus became the nation's primary household fuel by 1960. Gas also found use in industry, and for electrical power generation.

After World War I, as the number of electrical appliances multiplied, growth in electrical consumption accelerated, although overall energy growth was slower. From the beginning of World War I, total electric power demand has been doubling every 10 years.

In the 1920s and 1930s, coal was the fuel for about two-thirds of the electric power generated; with hydroelectric power providing the rest. The shift to oil and natural gas had changed this ratio significantly; by 1970, coal had dropped to about 45 percent; hydroelectric power provided 17 percent; natural gas accounted for almost 25 percent; oil, about 12 percent; and a newcomer to the fuel scene, nuclear power, provided about 1 percent.

At the beginning of the 20th century, scientists were investigating the rays given off by radium. In 1905, Albert Einstein demonstrated mathematically the relationship between mass and energy, although it was decades before this theory could be proved. On December 2, 1942, a group of scientists headed by Dr. Enrico Fermi gathered under a squash court at the University of Chicago, where the first controlled nuclear reaction occurred. Scientists have since been working to safely harness that tremendous nuclear energy for the generation of electricity. The nation's first prototype nuclear power plant was built at Shippingport, Pennsylvania, in 1957.

In the years since World War II, energy consuming technology has appeared everywhere. During this period, a huge fleet of passenger airplanes has developed; there has been an automobile "population explosion." Air conditioning, central heating, television, clothes washers and dryers are generally thought of as necessities, not luxuries. A mechanized agricultural industry uses tremendous amounts of energy. The various engines that perform America's work produced 7.5 times the number of horsepower in

1971 as they did in 1940, while the number of people in the country increased by only 54 percent. Even with the slowing population growth, more and more energy is being used.

Our country now has a fossil fuel economy. We use these fuels not only to produce energy, but also as a basic raw material for plastics, pesticides, and synthetic organic chemicals. Everyone alive today was born years after this fossil fuel epoch began, and we have tended to act as if we expect it to go on forever. But Dr. M. K. Hubbert of the U.S. Geological Survey estimates that in a period of only 1300 years from beginning to end, humans will have consumed the world's entire available supply of fossil fuels.

Thus the world today is on the brink of transition from the fossil fuel age to some future energy era. As we have seen from this discussion of energy history, humans have moved from one fuel epoch to another, not because the old source was depleted, but because something better had been found to take its place. Discovery of the new preceded depletion of the old. People did not run out of muscle or wind or animals, they simply found something better. But this time there must be a change to some other energy form, and in the meantime, until the transition is made, we must conserve the fossil fuel resources we have by cutting down wasteful uses and increasing the efficiency of what we do need to use.

THE DEMAND FOR ENERGY

WORLD ENERGY CONSUMPTION

Energy, the ability to do work, is the basic building block of civilization. People's use of energy once came only from their own muscles. Later humans learned to use fire to keep warm and cook food. Then they learned to use the energy of the wind in sailboats and windmills, the energy of falling water in waterwheels, and the energy of animals to work for them. Today we use a great variety of energy resources, and in doing so, we are able to control many of the events which affect our lives, and thus raise our standard of living.

A country's standard of living is directly related to its use of energy. The per capita energy consumption for a country is the total energy consumption of that country divided by its population, and is thus the average amount of energy used by each person in the country. The United States leads the world in both energy consumption and standard of living. In fact, with only about 6 percent of the world's population, the United States accounts for about one-third of the world's energy consumption. Other industrialized countries of the world follow the U.S. in energy consumption, while the developing countries show the smallest energy consumption, corresponding to lower standards of living.

Thus, it appears that in order for the developing countries of the world to raise their standard of living through increased food production, improved sanitary conditions and increased availability of manufactured products, they must increase their per capita energy consumption. It also appears that a continued high per capita consumption of energy will be necessary to maintain the high standard of living that the United States and other countries enjoy. This increasing demand for energy by the world's population is one of the reasons for the current energy shortage and the increasing cost of energy.

In addition to an increasing per capita consumption of energy, we must consider the world's increasing population. At the beginning of the Christian era, there were 200 million to 300 million people in the world. It took about 1600 years for the population to double to 500 million. The population doubled again to one billion by 1825, in the next 225 years; during this time the first industrial revolution, based on steam power, started, allowing the world to support a larger population. By 1930, world population had doubled again to two billion in only 105 years. During this time, the second industrial revolution, based primarily upon the development and use of electrical power, took place.

In the 45 years since 1930, the population has doubled again to four billion. During this period, medical advances have increased life spans, causing even greater population increases. Some forecasters predict that the world population may well double again

before the year 2000.

Most of this gain will take place in the underdeveloped regions of the world. Thus, these countries have an especially hard task. Since they have so many more people, they must increase their energy consumption by a tremendous amount to increase per capita consumption.

The effect of growing per capita consumption and rapidly expanding population has been a great increase in world energy consumption, which illustrates the rise in energy demands including some predictions for the future. The demand rises so fast that it goes off the top of most graphs by the year 2000.

A standard measure of energy is the British Thermal Unit (BTU), which you have probably heard in descriptions of the capacity of heaters or air conditioners. A Q is a billion billion BTUs of energy--that is, a one followed by 18 zeroes. It can also be written 10^{18} BTU. One Q is an astonishingly large amount of energy. To put it into perspective, the total world consumption of energy in 1970 was 0.2Q, while the U.S. consumption was 0.07Q.

Most energy is obtained from the three major fossil fuels: coal, oil and natural gas. These materials, deposited on the earth hundreds of millions of years ago represent the fossil remains of ancient forests and peat swamps. The use of fossil fuels increased rapidly, starting with coal about 800 years ago, followed by oil and gas at the beginning of this century. For the last hundred years or so, fossil fuels have accounted for most of the world's energy consumption. Coal, oil and natural gas will be supplemented in the future by petroleum products from sources such as oil shale and tar sands. Fossil fuel use is leveling off, and, within a hundred years, is expected to begin a rapid decrease. This decrease will be caused by the fact that the world's fossil fuel supply, which is not replaceable, is being used up rapidly. Other energy sources must be found to fill in the gap between world energy needs and dwindling fossil fuel supplies.

Prior to 1850, most of the world's energy was supplied by the three W's--wind, wood and water. These are still used today, but even expanding their use could not make up the difference between worldwide needs and the available supply of fossil fuel. This is the reason for the increased emphasis on research into other energy sources.

ENERGY CONSUMPTION IN THE UNITED STATES

Covering 400 years for the United States, Figure 4 shown on the following page gives a more detailed breakdown of the various energy sources consumed in the past 175 years, along with a possible future breakdown. This figure shows that oil and gas from both domestic and foreign sources will probably be consumed by the middle of the next century. The large resources from tar

Figure 4
 U.S. ENERGY CONSUMPTION AND FUEL RESOURCES
 Past and Future

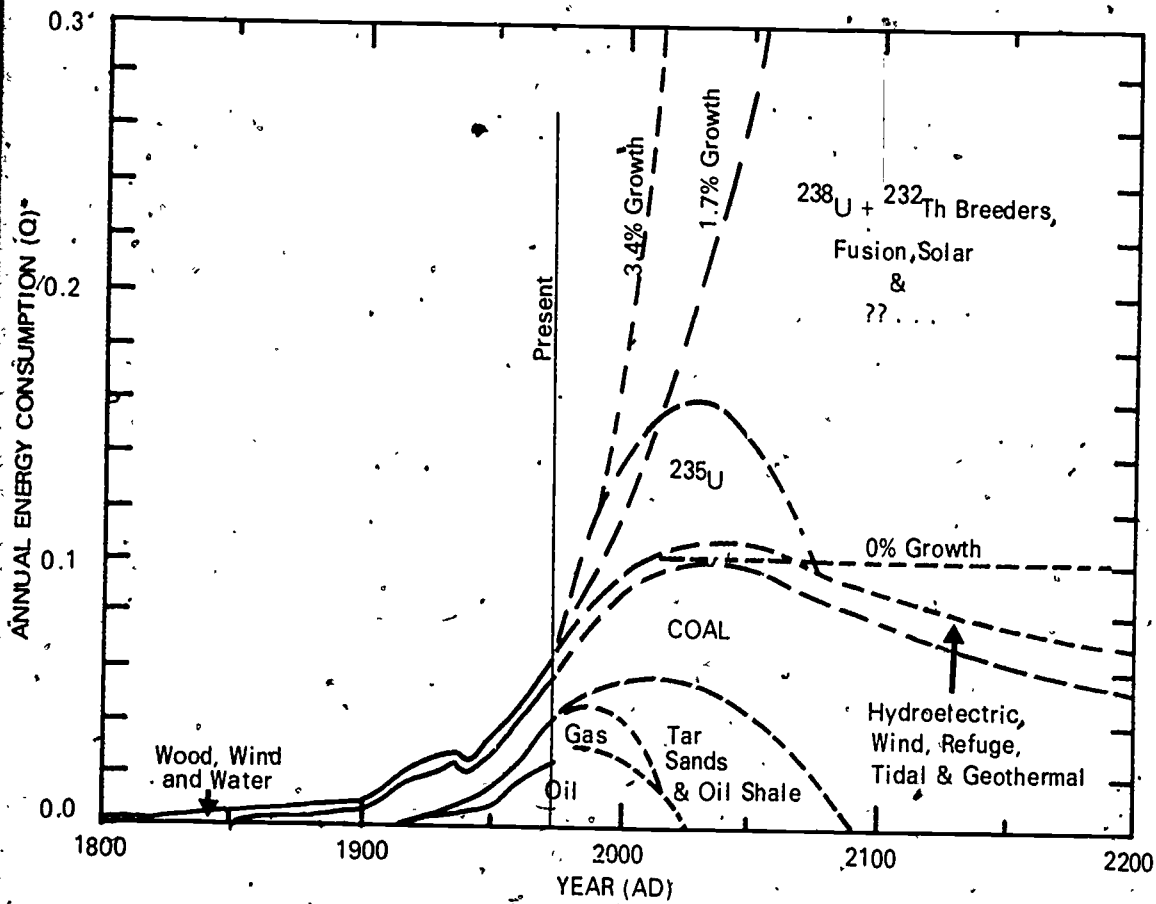

* $1Q = 10^{18}$ BTU

sands and oil shale, which are just becoming economical to use, will probably be consumed by the end of the next century.

Coal is the one fossil fuel which will last us for several centuries. Fortunately, this country has much of the world's known coal reserves. The area labeled "coal" on Figure 4 also represents the increasing use of coal to produce gas and oil. That part of the figure representing wood, wind and water in the past is expanded to include the predicted future use of tidal and geothermal power and the combustion of agricultural waste and other refuse as energy sources. This figure shows the recent introduction of uranium-235 in nuclear reactors for the production of electricity. Note that this source of energy cannot be used indefinitely--the economical supply of uranium-235 will eventually run out. In the future, if public acceptance is possible, will come the use of uranium-238 and thorium-232 in breeder reactors, which produce more fuel than they consume. These breeder reactors, along with solar energy and fusion reactors, will probably be our major energy sources in future centuries. There may even be some completely new energy sources, undreamed of today.

The need for energy sources will, of course, depend on how fast the demand for energy grows. Figure 4 shows the demands that three possible growth rates would make. Energy consumption has increased an average of 3.4 percent each year between 1950 and 1970. The steepest line on Figure 4 represents a continuation of this growth rate. All possible energy sources would have to be developed as rapidly as possible to environmental consequences. The horizontal line projects the reaching of zero energy growth by the year 2000. Since the population will still be increasing, this approach would probably result in a gradual lowering of the average standard of living. Even this level of energy use cannot be long maintained by our traditional energy resources. More efficient consumption of the energy being produced would help stretch our previous energy resources. The possibility of energy use increasing at its present rate, but with more efficient use, is represented by the 1.7 percent growth rate line.

ECONOMIC IMPACT OF THE ENERGY SHORTAGE

Abundant energy at a reasonable cost is basic to an industrialized country like the United States. When this energy is not available, or when its cost rises greatly, the impact is felt by all of us. For example, the petroleum shortages of 1973 and 1974 had effects far beyond the long lines at the gas pumps. Oil shortages have also helped to slow our economic growth and have been a major factor in the continuing inflation.

The energy pinch is felt in many ways. For example, the price of electricity has increased significantly for the first time in years, and people are buying smaller cars as fuel economy becomes increasingly important.

The shortage of energy sources, coupled with concern over environmental pollution, has caused severe problems for electrical generating plants and other industries. They are forced to search for energy substitutes and to pay greatly increased prices for fuel.

Petroleum products are the basic ingredient in many man-made products, such as fertilizer, synthetic fibers, plastics, synthetic rubber, detergents and paints. In the future, food will probably join the list. With such products in short supply, we should perhaps consider whether such manufacturing uses rate a higher priority than simply burning the petroleum products as fuel.

In the short term, considerable energy savings can be realized through conservation and careful energy management. However, in the long run we must develop new energy resources and restructure our energy demands, since the availability and cost of energy have a dramatic impact on our lives.

THE DEMAND FOR ELECTRICAL ENERGY

Perhaps you have some feeling now for the complex energy problems facing us today. We will now narrow our discussion to only one important aspect of the energy picture: electrical power generation and its environmental impact. The reason for our concentration in this area is that electrical power generation is predicted to be the fastest growing area of energy use. In 1947, about 13 percent of the fuel used in this country was used to produce electricity. By 1970, this figure had increased to 25 percent. By the year 2000, it is predicted that between 40 and 50 percent of the fuel used will be consumed in the production of electricity. In the next century, most of the energy we consume will probably be in the form of electricity.

A number of factors contribute to the increased use of electricity over other energy forms. First, shortages and increased costs of gas and oil will lead to more use of coal and uranium-235. These two fuels are most suited to the production of electricity. Secondly, the burning of fuel to produce electricity at a few large installations should make for better pollution control. Pollution control is extremely difficult when millions of homes, factories and cars consume gas and oil for heating, cooling, or power. These two factors will lead to the increasing use of electricity, probably including the widespread use of electric automobiles and public transportation.

Electrical consumption is also growing because of new consumer products and industrial processes demanded by the American public to maintain an ever-increasing standard of living. Do members of your family own more electrical appliances than they did five years ago? Chances are good that they do, and this use of electricity in the home represents only part of an individual's per capita consumption of electricity. Much more electricity is

expended to manufacture the goods and services required to maintain the desired standard of living. Most of the items which Americans take for granted, such as plastics, aluminum and glass, require the use of electrical energy in their manufacture. In fact, the nation has become so dependent on electrical power and other forms of mechanical energy that human muscle now accounts for less than one percent of the work done in factories.

In addition to these increasing demands for electricity, significant amounts will soon be required for cleaning up the environment by such uses as recycling of wastes and sewage treatment.

Table 1 shows how the electricity consumed in the United States is divided among various segments of the economy.

TABLE I

Consumption of Electricity in the United States:

Use	Percentage (U.S. Average)
Residential	32%
Commercial	22%
Industrial	42%
Other Uses	4%

HISTORICAL SKETCH OF ENERGY DEVELOPMENT IN LOUISIANA

- 1870 - Accidental discovery of natural gas at an artesian well drilling site in Shreveport; used for illumination at an ice plant.
- 1901 - Oil first brought in in commercial quantities at the Heywood well near Jennings.
- 1906 - Legislature passed the first state oil and gas conservation laws.
- 1908 - The first natural gas pipeline was laid in Louisiana, bringing gas from the Caddo field to Shreveport.
- 1909 - The new refinery in Baton Rouge went on stream. This is the Exxon refinery of today which is among the largest oil refineries on the North American continent.
- 1910 - The first over-water drilling in America occurred on Caddo Lake near Shreveport.
- 1938 - First production in open water of the Gulf of Mexico.
- 1947 - The first oil well out of sight of land, was brought in in the Gulf of Mexico about 45 miles south of Morgan City, marking the birth of the offshore oil and gas industry.
- 1968 - Louisiana's known reserves of natural gas peaked.
- 1970 - Louisiana's known reserves of crude oil peaked.
- 1970 - Louisiana becomes the nation's largest natural gas producing state.
- 1978 - Significant discoveries of natural gas north of Baton Rouge in the Tuscaloosa Sands, 3 miles below the earth's surface.

WHERE DOES THE ENERGY WE USE COME FROM?

There are five primary sources of energy that are naturally available to us on earth: solar, chemical, nuclear, geothermal, and tidal energy. Two of these, the chemical energy of fossil fuels and nuclear energy, are stored or potential forms of energy. The other three--solar, geothermal, and tidal energy--are kinetic forms of energy; that is forms which are active and always in motion. While we can use the energy in the stored sources of energy whenever we choose, we can use the kinetic forms only when nature makes them available to us; for example, sunlight is only available during daylight hours. In the sections that follow we will briefly discuss each of the primary sources.

SOLAR ENERGY: Solar energy is a kinetic form of energy.

It is more precisely called radiant energy, much of which is observable as visible light. A major portion of the sunlight which approaches earth is reflected by the atmosphere back into space. Although only roughly half of the solar energy reaches the ground, half is still a tremendous amount. If all the solar energy reaching the ground could be stored for 48 minutes, it could provide as much energy as was used worldwide in 1970.

A very small part (1/5000) of this energy interacts with plants and fuels in the photosynthesis process. Solar energy, thus, is indirectly the source of the food energy on which we depend. It is also the source of the chemical energy which was stored hundreds of millions of years ago in the plant life of the swampy jungles of the earth. We are using stored solar energy when we burn the fossil fuels: coal, oil, and natural gas.

The sun's radiant energy also heats the land and the oceans and thus provides the energy for the great air and ocean currents--the winds and waves. Historically, wind and water currents were early sources of energy and were harnessed by windmills, sailboats, and waterwheels. With increases in the world's population and the rise of cities, however, these sources became inadequate. Today we get some of our energy from these wind and water currents in a different manner. Some of the sun's energy evaporates water from lakes and oceans. The water rises and is carried in the winds. If the water falls on the mountains, we get some of the energy for our use by letting the mountain-fed streams and rivers turn the turbines of hydroelectric plants to produce electricity.

Most of the solar energy reaching the ground is unused by man. It is available during the daylight hours throughout the world in varying amounts. However, since it is a kinetic form of energy, it must be used immediately or it must be converted into some potential form of energy for later use. Presently, sunlight is being used as the sole source of heat for a few homes. However, collection and storage of solar energy for later transportation and use is still difficult. In particular, we have not perfected practical and economical methods of collecting solar energy and converting it into electricity. Since the lifetime of the sun is many billions of years, for all practical purposes this energy source will always be with us. It is a continuous source of energy which does not need to be renewed.

FOSSIL FUELS: The most important form of stored energy is

the chemical potential energy of the fossil fuels: coal, oil, and natural gas. As we have said, this energy was originally solar energy hundreds of millions of years ago. Coal began to be formed when the huge mosses and ferns of the Paleozoic swamps died and fell into the mud. They were acted on by anaerobic bacteria (bacteria which do not need oxygen) and then by pressure and heat as they were buried under tons of sediment and converted to the almost pure carbon of coal. When the carbon atom is burned (oxidized), it releases this stored energy.

Petroleum and natural gas were formed in a similar manner. Some of the plant and animal life sank to the bottom of the great sea beds and went through a different chemical transformation under pressure and heat to form the "hydrocarbons," the complicated molecules of hydrogen and carbon characteristic of petroleum. Their stored energy is also released by burning.

Fossil fuels are used extensively because they are relatively easy to find, collect, store, and transport. Coal, oil, and natural gas resources can be located through geological surveys. Once discovered, the fuels can be removed from the ground by mining or drilling and transported by pipes, truck, rail, etc., to any destination. Although the formation of fossil fuels is continuing, the process is very slow. It would take another 300 million years or so to produce an amount equal to that which has been built up so far. Since our energy use is much more rapid than this, we are likely to use up all of our fossil fuels. For this reason, fossil fuels are called nonrenewable sources of energy.

NUCLEAR ENERGY: A form of potential energy which is of

growing importance is that stored in nuclei, the tiny, dense cores of atoms. Nuclei are made up of the elementary particles--protons and neutrons. It is by rearranging these particles that nuclear energy is stored and released. There are two important examples of this: the fission reaction and the fusion reaction. In the fission reaction, the heavy nucleus, or center, of an atom such as uranium is split into two lighter ones. In this process, mass is converted into energy and it is this energy we obtain from the hot interior of a nuclear reactor.

The fusion reaction involves very light nuclei. It is the same reaction which is the source of the sun's energy. In a typical example, four hydrogen nuclei, by a complicated series of reactions, combine to form the heavier helium nucleus (two protons and two neutrons). Again, some of the mass has been converted to energy.

Nuclear energy becomes available to us in the nuclear reactor of an electric power plant. The energy of the nuclear reaction heats water, for example, and converts it to steam. This turns a turbine which produces electricity much as a river is used in a hydroelectric power plant. The electricity is then transmitted to our homes through wires. The major fuel for the fission reaction in nuclear reactors is uranium 235; it is available in limited quantities throughout the world.

Like the fossil fuels, the nuclear fuels are also presently nonrenewable. However, if all of the many technical and safety problems of a new type of reactor called the breeder reactor can be overcome, nuclear fuels will be much more plentiful. The breeder reactor, while it uses up some nuclear fuel to produce

electricity, produces a by-product which can be reused as a nuclear fuel to produce more electricity.

GEOHERMAL ENERGY: The earth's interior is molten rock, or "magma" as the geologists call it. There is a tremendous amount of energy in the earth. Although heat energy is an active or kinetic form of energy, the heat of the earth is effectively stored and insulated by the solid, thin crust on which we live. We are not sure how the energy got there. It may have been stored in the molten blob of original earth, or it may have come from the impact of countless chunks of matter pulled to it by the earth's gravity. We are fairly certain that the radioactivity of some of the material in the earth keeps it hot. There seems to be enough uranium, radium, and other naturally radioactive material in the earth's interior to produce that relatively small amount of heat needed to make up for that lost through the surface. In this sense, geothermal energy does not need to be renewed and is essentially a continuous source.

The geological conditions which produce geothermal energy restrict this energy source to a few geographic areas. Where available, it is inexpensive, clean, and has few adverse environmental effects. It is available to us in those regions where the magma is close to the surface and the energy can leak out from the core through cracks in the crust. Volcanoes, geysers and hot springs are visible evidence of geothermal reservoirs, but more sophisticated techniques will soon allow us to find others not evident on the earth's surface. If available as hot water or steam, geothermal energy can be used to heat buildings. Some

500 homes and offices in Klamath Falls, Oregon, are heated by hot water drawn from a hot spring running under the town. The only large-scale use of it is in the Geysers in California where dry steam--steam so hot there are no water droplets in it--is piped to steam turbines and used to generate electricity.

TIDAL ENERGY: The last of the big five, tidal energy, is probably of least importance for our use. The source of this energy is the kinetic energy stored in the rotation of the earth-moon system. Like geothermal energy, it is another example of the successful temporary storage of energy in the kinetic form. It is continuous and does not need to be renewed. This energy is converted to motion of the oceans through the gravitational attraction of the moon on the oceans' contents. Ocean water is pulled toward the moon on the near side (and bulges in the other direction on the far side). To use this tidal energy, the up and down (in and out) motion of the water must be used to turn a turbine and produce electricity. This electricity can then be carried by wires to homes and offices.

Tidal generation of electricity is only practical where geologic peculiarities cause high tides. The first tidal dam and generator were built in the Rance estuary on France's Brittany coast where tides rise and fall an average of 26 feet.

There has also been some interest in building a tidal conversion facility at Passamaquoddy Bay on the far northern coast of Maine, but it does not yet appear commercially usable. We do not expect much contribution to our total supply of energy from this form.

WHAT IS ENERGY?

Definition

Energy is the capacity to do work. Work is force times distance. Thus, energy is the ability to apply a force, causing an object to move some distance. In order for something to move, e.g., a door held closed by a spring, a force (push or pull) must be applied in the appropriate direction. Thus, work (force x distance) is done on the door to open it. It is said, then, that energy is given to and stored in the door spring. When the door is released, the energy stored in the spring is released, causing enough force to be applied to the door to close it. In other words, the spring does work on the door.

Kinds of Energy

Energy in the form of motion, heat, or light is called kinetic energy. The energy stored in bread, gasoline, or batteries, in the nucleus of the uranium atom, or in any of its other clever hiding places, is potential energy. Kinetic energy is energy in transit, energy on the move. We use it in this form. Potential energy is stored energy and it is in this form that we dig it from mines, pump it from wells, ship it, and stockpile it. The whole story of energy is found in the description of these two forms, and in the conversion between them.

To use energy it must be in the kinetic form. We use energy because we want to do something to matter: move it, illuminate it, or warm it. A moving car has kinetic energy. The electrons flowing through the toaster's heating element and the photons of

light coming to us from the sun have their energy in kinetic form.

We store energy in the potential form. It is, of course, possible to store kinetic energy; the flywheel of an engine stores kinetic energy in its rotating mass, and kinetic energy is stored in the rotation of the moon about the earth. We can also store heat energy in thermos bottles. Light energy is almost impossible to store. Kinetic energy storage, however, is quite different from potential energy storage. It is temporary; we trap or insulate kinetic energy: it is a caged tiger ready to run free.

Forms of Energy

Energy is found in many forms and may, in fact, be transformed in many cases, as is indicated by the arrows in the diagram.

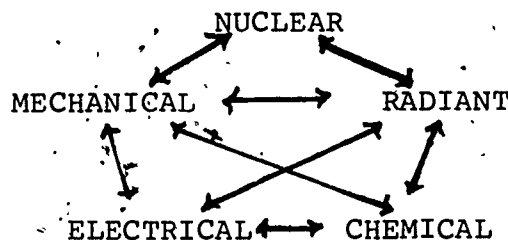

The many varied forms of energy can become confusing, hence to facilitate communication, the scientist generally thinks of energy as being in one of the following forms:

Mechanical --the energy of motion; falling, rolling or sliding bodies, sound, etc.

Electrical --the energy composed of electrons, either the push or pull between bodies that are electrically charged and/or have a magnetic field about them; or the changes which result from the movement of electrons (friction, etc.).

~~Radiant~~ --the energy of wave phenomena resulting from the acceleration of a charged particle: x-ray, heat, light, etc.

~~Chemical~~--The energy released or used up during an interaction between the electrons of various atoms (in chemical reactions): corrosion, fire, explosion, biological, etc.

Nuclear --The energy released or used up during alterations within the nucleus of atoms: fission, fusion, transmutation.

Energy, regardless of its form, may or may not be active at any one time; therefore, each of the foregoing forms may be divided into potential (stationary) or kinetic (moving) energy.

Energy Transformation

When one state or form of energy is derived from another, we have energy-to-energy conversions; these are happening all the time around us (and even inside us). The one important thing to remember is that you get only as much out of energy-to-energy conversion as you put into it; only the forms or states of energy are changed when energy is converted from one form to another. There is no such thing as getting something for nothing.

Of all energy conversions occurring all the time, only a very few will result in work useful to man. We increase the number of conversions that generate useful energy through converters called machines, which transform energy of one form, the fuel, into energy of another form, the product. An automobile engine converts, by burning, the fuel gasoline into the mechanical energy of motion. Our own bodies convert food into movement, heat, and all life processes. The excess heat and sound generated by an automobile engine are mostly waste energy, not useful to our purpose of moving from place to place.

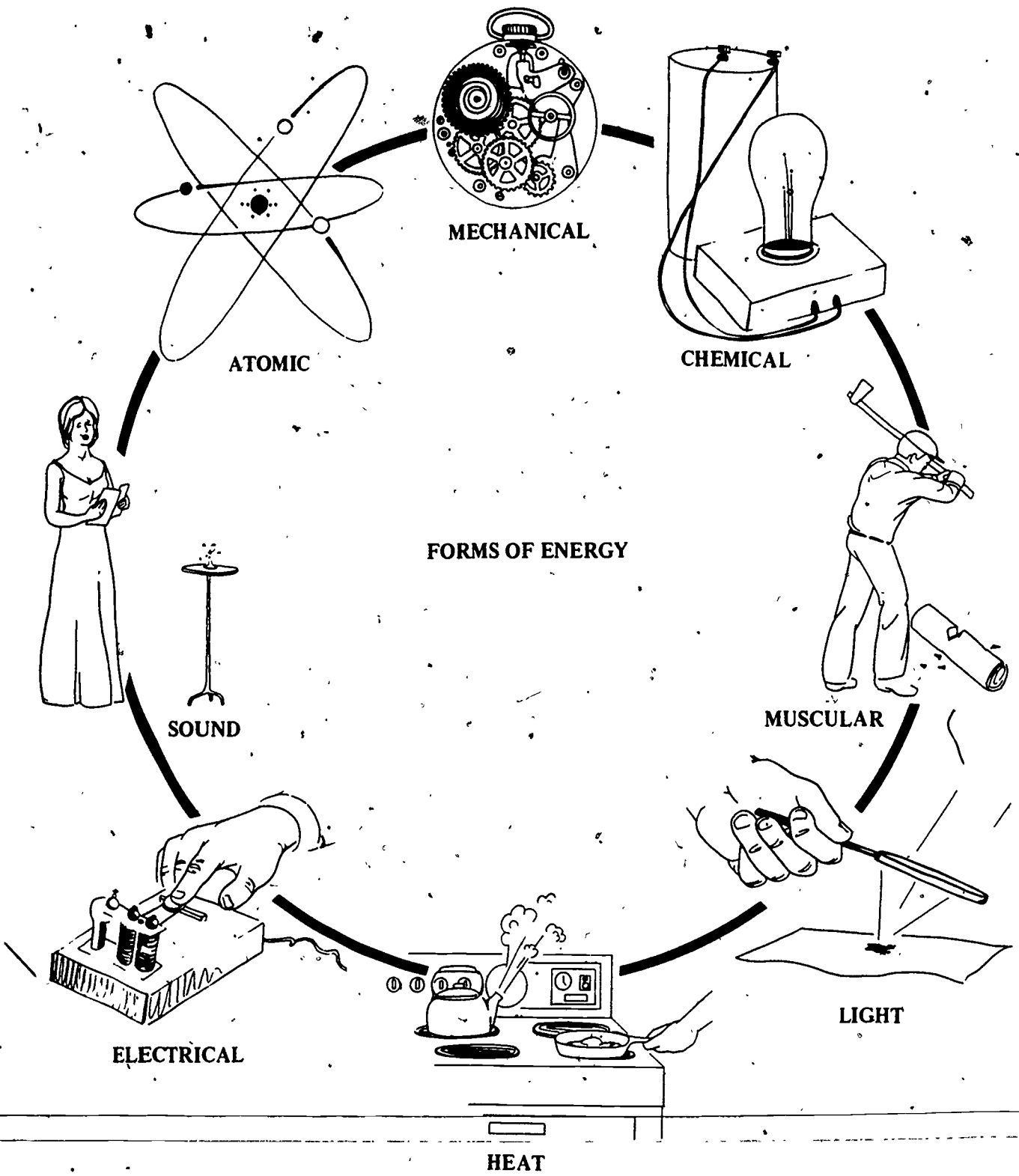

Sources of Energy

There are five primary sources of energy that are naturally available to us on earth: solar, chemical, nuclear, tidal, and geothermal. Two of these, the chemical energy of fossil fuels and nuclear energy, are stored or potential forms of energy. The others--solar, tidal and geothermal energy--are kinetic forms of energy; that is, forms which are active and always in motion. While we can use the energy in the stored sources of energy whenever we choose, we can use the kinetic forms only when nature makes them available to us; for example, sunlight is only available during daylight hours.

In the sections that follow we will briefly discuss each of the primary sources, as well as some energy sources which are in experimental stages at this time, such as wind power and power from organic wastes.

Energy is measured in BTUs. The following charts show energy source equivalents, where energy comes from, how it is used, and projections for the year 2000.

Energy Transformations

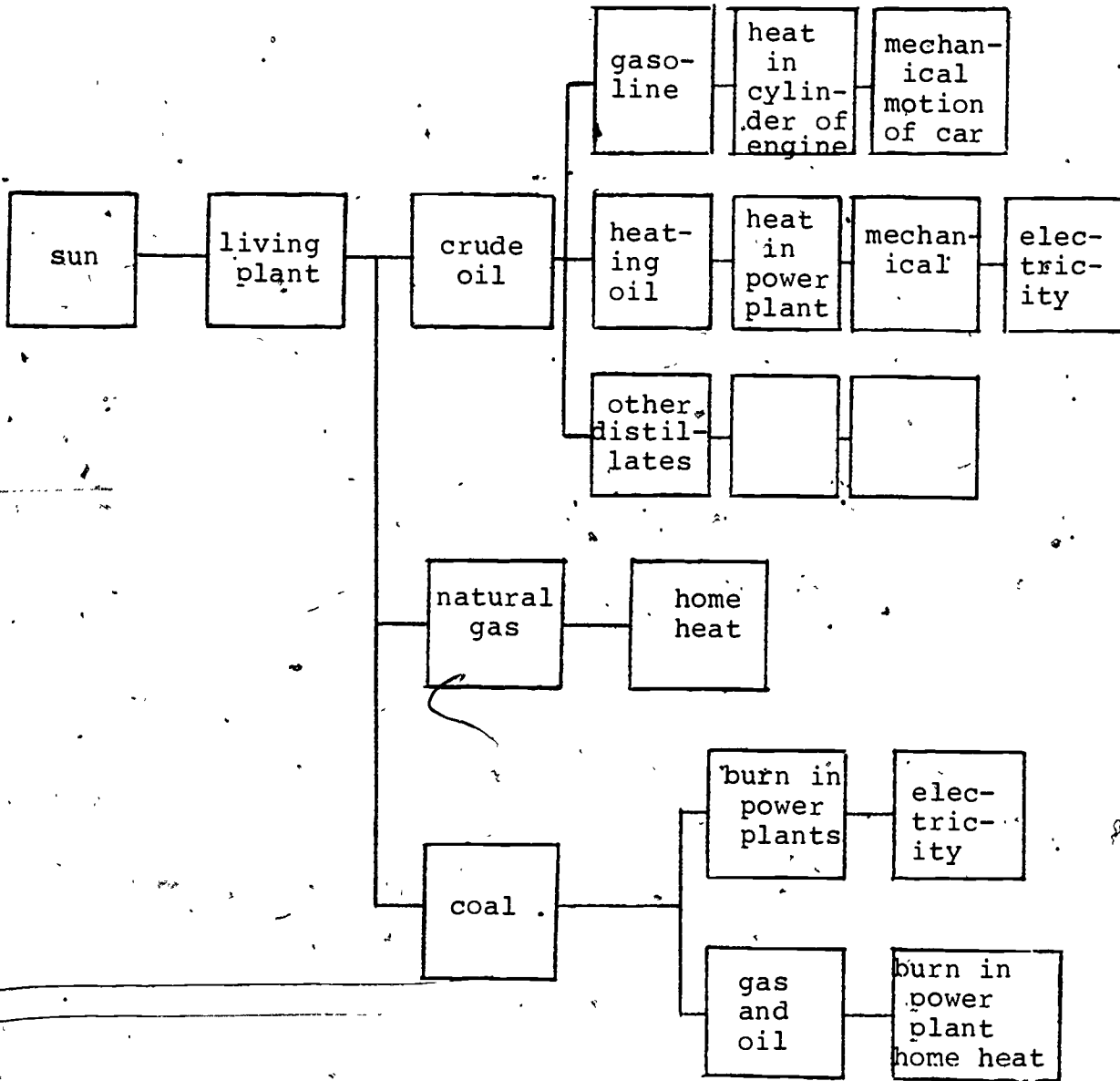

Energy Transformation

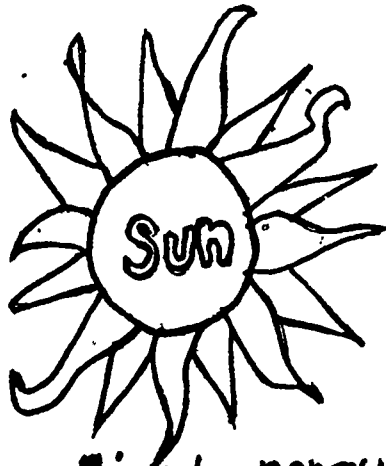

Light energy



coal
Chemical energy

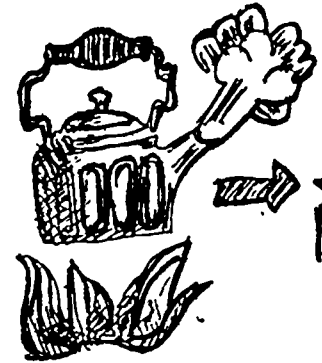

fire
Heat energy

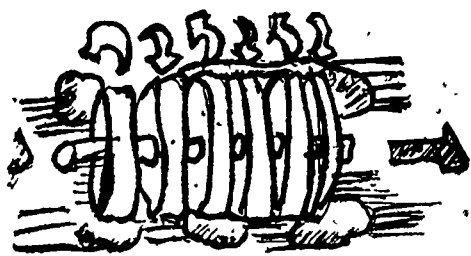

turbine
Mechanical energy

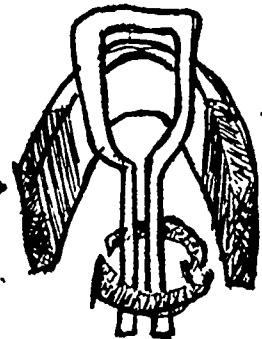
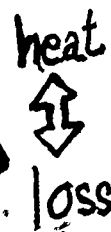

Electrical generation
Electrical energy

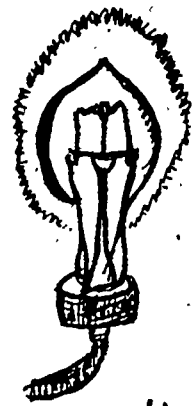
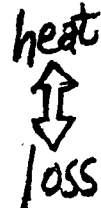

Light bulb
Heat and Light energy

ENERGY SOURCE EQUIVALENTSCOMMON MEASUREBTUs

Oil	Barrel*	5,800,000
Natural gas	Cubic feet	1,032
Coal	Short ton	24,000,000 or 28,000,000
Nuclear fuel (such as Uranium 235)	Pound	360,000,000

*1 barrel of oil equals 42 gallons of oil.

Where Our Energy Comes From (Trillions of BTU)

<u>ENERGY SOURCE</u>	<u>1971</u>	<u>1975</u>	<u>1980</u>	<u>1985</u>	<u>2000</u>
Coal	12,560 (18.0%)	13,825 (17%)	16,140 (17%)	21,470 (18%)	31,360 (16%)
Oil	30,492 (44.0%)	35,090 (44%)	42,190 (44%)	50,700 (43%)	77,380 (37%)
Natural gas	22,734 (44.0%)	25,220 (31%)	26,980 (28%)	28,390 (24%)	33,980 (18%)
Nuclear	405 (0.6%)	2,560 (7%)	6,720 (7%)	11,750 (10%)	49,230 (26%)
Hydropower	<u>2,789</u> (4.4%)	<u>3,560</u> (5%)	<u>3,990</u> (4%)	<u>4,320</u> (5%)	<u>5,950</u> (3%)
TOTAL	68,989	80,265	96,020	116,630	191,900

Where Our Energy Goes (Trillions of BTU)

<u>ENERGY SOURCE</u>	<u>1971</u>	<u>1975</u>	<u>1980</u>	<u>1985</u>	<u>2000</u>
Household and commercial	14,281 (21%)	15,935 (20%)	17,500 (18%)	18,960 (16%)	21,920 (11%)
Industrial	20,294 (29%)	22,850 (28%)	24,840 (26%)	27,520 (24%)	39,300 (21%)
Transportation	16,971 (25%)	19,070 (24%)	22,840 (24%)	27,090 (23%)	42,610 (22%)
Electrical generation	17,443 (25%)	22,410 (28%)	29,970 (31%)	40,390 (35%)	80,380 (42%)
Synthetic gas			870 (1%)	2,670 (2%)	7,690 (4%)
TOTAL	68,989	80,265	96,020	116,630	191,900

TITLE: POTENTIAL-KINETIC ENERGY

AREA: Science

OBJECTIVE: To investigate potential and kinetic energy considerations in moving a rolling cart along a flat table surface.

MATERIALS: Rubber band, cart, spring scale

ACTIVITY: Hook one end of the rubber band to the cart and the other end to the spring scale. Stretch the rubber band by pulling on it with a force of 150 grams. Hold the cart to keep it from moving. Then release the cart and allow it to roll along the table. Where did the cart get the energy to move? What form of energy does the rubber band have in its stretched condition? Again, repeat the above experiment, this time measuring the distances (in cm) that the cart moved when forces of 50 g., 100 g., 150 g., 200 g. and 250 g. were applied to the stretched rubber band. What effect did the increased force have on the speed and movement of the cart? Describe the behavior in terms of kinetic and potential energy.

Teacher Notes: The cart received its energy for movement from the stretched rubber band (potential energy). However, work was previously done in stretching the rubber band (as kinetic energy) to create the necessary potential energy source.

Complete the following chart for the last part of this activity:

Force	50 g.	100 g.	150 g.	200 g.	250 g.
Distance					

Prepare a graph correlating force (g) with distance (cm). What relationship is suggested by the curve of the graph?

TITLE: ENERGY CONVERSION

AREA: Science

OBJECTIVE: To review the Second Law of Thermodynamics by means of an energy anacrostic.

MATERIALS: Listed in activity

ACTIVITY: You Can't Win for Losing

Activity: An Energy Anacrostic

Use: "Filler" during a learning plateau; review; day before vacation, a "gimmick."

Timing: After the energy unit!

"You can't win for losing" is an everyday statement of an important phenomenon in nature--so important that this statement has the status of a LAW. To find the formal and "official" name of this law, work out the anacrostic.

And then:

1. Look up this LAW in some appropriate reference. Which one? That's your problem, but you might try your notes on energy production.
2. Copy this LAW onto a sheet of paper and show by giving examples (be specific, please) that you understand what it means.
3. Do you believe that the title of this exercise is appropriate? Why? Why not? Be specific--that means EXAMPLES. Prove your whys and why not.
4. What do you think of this as another possible title?

"There is no such thing as a free lunch."

-Barry Commoner

Attach your material from this activity to the completed anacrostic and turn everything in at the end of the period.

YOU CAN'T WIN FOR LOSING

S <u>1</u>	E <u>2</u>	C <u>3</u>	O <u>4</u>	N <u>5</u>	D <u>6</u>	L <u>7</u>	A <u>8</u>	W <u>9</u>	O <u>10</u>	F <u>11</u>			
T <u>12</u>	H <u>13</u>	E <u>14</u>	R <u>15</u>	M <u>16</u>	O <u>17</u>	D <u>18</u>	Y <u>19</u>	N <u>20</u>	A <u>21</u>	M <u>22</u>	I <u>23</u>	C <u>24</u>	S <u>25</u>

- | | | | | | | |
|--|----------------|----------------|----------------|----------------|----------------|----------------|
| 1. The ability to do work | E
<u>2</u> | N
<u>20</u> | E
<u>14</u> | R
<u>13</u> | G
<u>8</u> | Y
<u>25</u> |
| 2. A commonly used fossil fuel | C
<u>3</u> | O
<u>10</u> | A
<u>21</u> | L
<u>7</u> | | |
| 3. Power source for the atom | N
<u>5</u> | U
<u>24</u> | C
<u>24</u> | L
<u>21</u> | E
<u>8</u> | A
<u>21</u> |
| 4. Useful energy in the home | E
<u>2</u> | L
<u>13</u> | E
<u>14</u> | C
<u>21</u> | T
<u>22</u> | R
<u>23</u> |
| | | | | | | I
<u>23</u> |
| | | | | | | T
<u>12</u> |
| | | | | | | Y
<u>19</u> |
| 5. Class of materials which are burned | F
<u>11</u> | U
<u>20</u> | E
<u>14</u> | L
<u>7</u> | S
<u>25</u> | |
| 6. This changes to steam in power production | W
<u>9</u> | A
<u>8</u> | T
<u>21</u> | E
<u>2</u> | R
<u>23</u> | |
| 7. The Arabs have this energy source | O
<u>4</u> | I
<u>13</u> | L
<u>14</u> | | | |
| 8. This is too much! Heat pollution | T
<u>12</u> | H
<u>13</u> | E
<u>14</u> | R
<u>15</u> | M
<u>16</u> | A
<u>21</u> |
| | | | | | | L
<u>7</u> |
| 9. An old, old fuel is described this way | F
<u>11</u> | O
<u>17</u> | S
<u>25</u> | S
<u>21</u> | I
<u>8</u> | L
<u>24</u> |
| 10. These are checking stations (one type) | M
<u>22</u> | O
<u>10</u> | N
<u>5</u> | I
<u>23</u> | T
<u>22</u> | O
<u>10</u> |
| | | | | | | R
<u>24</u> |
| 11. This fella made an engine a long, long time ago (steam type) | W
<u>9</u> | A
<u>8</u> | T
<u>21</u> | T
<u>22</u> | | |
| 12. This is the cover for the fuel in the nuclear reactor | C
<u>3</u> | L
<u>13</u> | A
<u>21</u> | D
<u>6</u> | D
<u>18</u> | I
<u>23</u> |
| | | | | | | N
<u>5</u> |
| | | | | | | G
<u>25</u> |

TITLE: ENERGY TRANSFER

AREA: Science

OBJECTIVE: To demonstrate the transfer of energy from a food chain to the environment.

MATERIALS: Environmental Pollution (Prentice-Hall)

Others listed in activity

ACTIVITY: After studying food chains and food webs and the flow of energy through the environment, the following demonstration of gas production by anaerobic organisms may be demonstrated. A small-mouthed glass is filled with two to three inches of a mixture of muck from the bottom of a stagnant pond and oatmeal pabulum in a 5:1 ratio respectively. A thin layer of sand is spread over this and the entire mixture is moistened. The jar is capped with a one-holed stopper and a piece of tubing is connected from the jar to a gas collection apparatus. The gas is then analyzed several days later. Then students should correlate the production of gas in this fashion to the production of natural gas which they use in their homes.

Gas Collection Apparatus

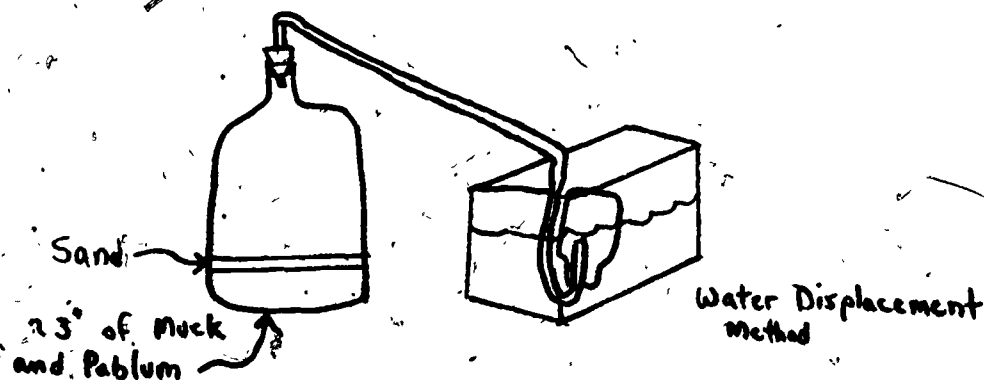

TITLE: ENERGY FLOW THROUGH A FOOD CHAIN

AREA: Science, Home Economics

OBJECTIVE: To help students understand how energy from food is used, transferred, and lost.

MATERIALS: Listed in activity

ACTIVITY: Discuss with students such terms as: food chain, producer, consumer, decomposer, respiration, biomass, trophic level, food pyramid, metabolism, and Calorie. Students should know why chemical energy available in life processes is constantly decreasing through the food chain.

Specifically, students should:

1. Be able to construct a simple food chain and describe how energy is passed along it.
2. Know the extent to which green plants absorb the sun's energy.
3. Know that most energy used in life processes of the plant is expended in respiration.
4. Know the Calories contained in some of the more common foods.
5. Know how energy is dissipated to maintain body metabolism.
6. Understand how energy is lost as it is passed along each trophic level.
7. Know how man, through the agricultural processing of foods, loses or wastes significant amounts of energy.

CONTACT ORGANIZATIONS:

Local Agricultural Extension Service; Home Economics or Agriculture departments at nearby colleges or universities.

REFERENCES:

See biology and ecology textbooks in school library.

TITLE: ENERGY FLOW IN MANUFACTURING

AREA: Language Arts, Speech

OBJECTIVE: To help students gain an understanding of how energy is used to produce and operate individual pieces of merchandise.

MATERIALS: Listed in activity

ACTIVITY: Each student should select an item he/she has recently purchased or would like to purchase, then develop a research paper, essay, or oral presentation about it (including visual aids for emphasis) based on the following questions:

1. What were the original sources of energy used to make the object?
2. What types of energy were needed or transformed in manufacturing the item?
3. What raw materials were used in manufacturing the object?
4. Tracing the energy used to manufacture the object all the way back to its ultimate source:
 - a. How much energy does it take to make the object?
 - b. How much energy does it take to operate the object?
5. How durable is the object and what happens to it when it is no longer operational? Can it be recycled?

TITLE: SOLAR ENERGY CONVERSION

AREA: Science

OBJECTIVE: To demonstrate the use of solar energy conversion.

MATERIALS: Umbrella, aluminum foil, beaker, thermometer

- ACTIVITY:
1. Students can build a makeshift solar reflector by using an old umbrella and aluminum foil. Remove the handle of the umbrella and then line the inside with foil. This solar reflector can be used to heat water by focusing it at the sun and then concentrating the energy on a beaker of water.
 2. Using a thermometer, take temperature readings.
 3. Discuss questions:
 - a. How hot does the water temperature get?
 - b. How long will water remain this hot?
 - c. Do you get the same results on a cloudy day? When the reflector is not pointed directly toward the sun?
 - d. Try heating other things in your solar reflector.
 - e. Could the solar reflector have any applications in your everyday life?
 4. The teacher can guide the students into a discussion of the potential use of solar energy to produce steam to run turbines, to heat homes, and to cook foods. A study of weather conditions and geographic locations suitable to the use of solar energy could be researched.
 5. Define and discuss evaporation, condensation, and distillation.
 6. How is the water cycle related to hydropower? Why is hydropower considered a form of solar energy?
 7. How can a solar still be put to practical use?

TITLE: CONVERSION OF PLANTS TO COAL

AREA: Biology

OBJECTIVE: To study the conversion of plant materials into coal.

MATERIALS: Ferns, slides or diagrams of tree ferns, sand, peat moss, coal, 10-gallon aquarium, slides or charts of geologic time.

- ACTIVITY:
1. Distribute samples of ferns, peat moss, and coal to the students. Show students geologic time charts and describe the physical condition of the earth during the coal-forming process.
 2. Fill a 10-gallon aquarium with tap water. Add enough peat moss to make a 1" layer. Allow one week to elapse. What is the condition of the water now? (Include pH, odor, turbidity, decomposition of peat moss, etc.) Have any changes occurred in the peat moss? Suggest reasons for the changes or explain why changes did not occur.

Sift moderately fine sand over the peat moss to a depth of 1". After the sand settles, add an equal depth of peat moss. Repeat the process for as long as desired or until several successive layers have formed. Is coal still being formed naturally today? Explain.
 3. Students should then go to the library and research the formation of coal, the types of coal, and the locations of coal deposits in this state.
 4. Using topographical maps, locate the coal-producing areas in the United States. Find cross sections of the area and locate a coal vein. Would the cost of extracting the coal be feasible and practical?

TITLE: ENERGY CONVERSION

AREA: Science

OBJECTIVE: To show how chemical energy may be transferred to heat energy,

MATERIALS: Large tin can, small vial or test tube, thermometer, plaster of Paris, cardboard for insulation

ACTIVITY: Mix the plaster of Paris and pour it in the large tin can. Immediately place the vial containing water and thermometer into the semiliquid plaster of Paris. Record the temperature at the beginning of the activity and a final reading when the plaster of Paris has hardened. Discuss the range of temperature change. What caused the temperature change?

Use a measured mass of water and calculate calories of energy released. Calories released are equal to the change in temperature \times the mass of the water.

Alter the amount of plaster of Paris and graph curves of change in amount of plaster vs temperature change.

Use a constant amount of plaster and change the amount of water to alter the concentration; graph and discuss the results.

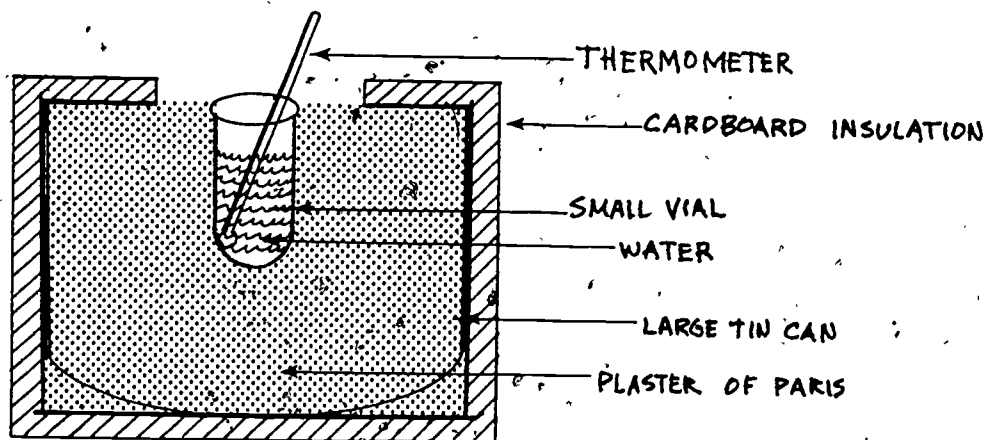

TITLE: CONVERSION OF ENERGY
AREA: Science, Home Economics

OBJECTIVE: To study the conversion of food energy to heat energy and to calculate the approximate food energy value in calories.

MATERIALS: Wire stand, 50 ml beaker, 40 ml tap water (equals 40 grams), thermometer, potholder or tongs, straight pins, large cork stopper, aluminum foil, miniature marshmallows (stale ones work better), peanuts, scales, alcohol burner or Bunsen burner

- ACTIVITY:
1. Measure an amount of marshmallows equal to the weight of one peanut. Mount the peanut and marshmallows on separate straight pins.
 2. Set up an experiment with the peanut as shown in diagram. Cover cork with aluminum foil. Put books or cardboard under the cork so that the peanut will be 2 cm from the beaker. Cover the top of the books or cardboard with aluminum foil for safety.
 3. Measure 40 ml of tap water and add to beaker. Measure the temperature of the water and record on Table I under Starting Temperature.
 4. Holding the cork with tongs, start the peanut burning using an alcohol burner, Bunsen burner, or matches. Quickly and carefully, place the cork with the burning peanut under the beaker of water.
 5. When the peanut stops burning, measure the new temperature of the water in the beaker and record it under Final Temperature.
 6. Repeat this procedure two more times. Use 40 ml of fresh tap water each time. Then calculate the average gain in water temperature.
 7. Using the marshmallows, repeat steps 3 through 6 and record the temperatures on Table II.

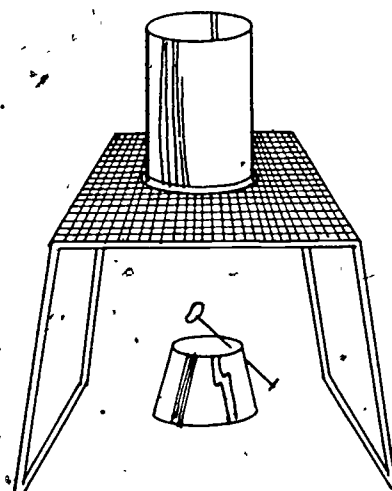

8. Calculate the amount of energy in the peanuts and marshmallows.

Calories = grams of water x change in temperature
(°C)

(A calorie is a unit of energy; the amount of energy needed to raise the temperature of 1 gram of water 1°C. A "diet" Calorie is a kilocalorie (1,000 calories) and should be written with a capital "C" to distinguish it from the smaller unit.)

9. Compare the results of the experiment and discuss:
- Did you measure all of the food energy released?
 - Why is the energy value of peanuts and marshmallows so different?
 - How did the energy get into the food?
 - Compare and contrast food and petroleum.

TABLE I - PEANUTS

Trial No.	No. of Peanuts	Mass of Water (grams)	Starting Temp. (°C)	Final Temp. (°C)	Change in Temp. (°C)
1	1	40			
2	1	40			
3	1	40			
Average Temperature Change _____					

TABLE II - MARSHMALLOWS

Trial No.	No. of Marshmallows	Mass of H ₂ O	Starting Temp. (°C)	Final Temp. (°C)	Change in Temp. (°C)
1		40			
2		40			
3		40			
Average Temperature Change _____					

TITLE: BODY HEAT CALCULATION

AREA: Science

OBJECTIVE: To calculate the heat generated by the bodies in a classroom.

MATERIALS: None

- ACTIVITY:
1. The average student produces 250 BTU/hour sitting at his/her desk. A class of 30 students in a classroom 24' x 35' x 8' would produce how much heat?
 2. A BTU is required to raise the temperature of 1' of air 1° F. How warm would the classroom be in one hour if the outside temperature is 32° F and no other heat source is used? Assume complete transfer of heat to air. Assume also that the classroom temperature is 32° F at the start of the hour.
 3. The statement was made by one author that a room of students would remain comfortable even if the temperature outside is below freezing. Do you agree with this statement? Show calculations to back your decision.

OPTIONAL ACTIVITIES:

1. Devise a method for measuring heat generated by a group or a single student. (Tip: Try a smaller place than a classroom.)
2. How much energy would be necessary to raise the temperature of your classroom 10° F? How many students would be required to produce this much heat in one hour?
3. What would be the effect of jackets or other insulative clothing on the heating of the room?
4. Convert the values given in this activity to metric units.

1 BTU = 0.25 kilocalorie (or Calorie)

TITLE: POTENTIAL ENERGY

AREA: Science

OBJECTIVE: To measure a person's potential as an energy source.

MATERIALS: Hand-cranked generator; three or more light bulbs (15-watt, 30-watt, 60-watt), insulated wire; light bulb socket, watch with second hand

- ACTIVITY:
1. Use the generator to light a 15-watt light bulb. What effect does varying the speed of the generator have on the brightness of the light? By counting the number of turns per minute, determine the rate of turning needed for maximum light and minimum light.
 2. Change the size of the bulb. Repeat #1 with 30- and 60-watt bulbs. What was the effect? Graph number of turns per minute vs wattage of bulb.
 3. How long can a student keep the 15-watt bulb burning brightly? Measure time in seconds. How much power was produced?

Power = power x time

Energy = wattage of bulb x number of seconds

Energy = _____ joules

Energy unit: joule Power unit: watt

1 joule of energy is 1 watt of power used for 1 second.

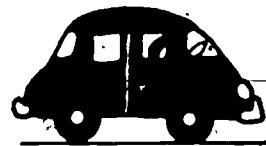

TITLE: ENERGY CONVERSION

AREA: Science

OBJECTIVE: To describe the energy conversions that take place in an automobile and to give examples of energy conversion using everyday processes around them.

MATERIALS: Listed in activity

ACTIVITY: After the brief introduction to the topic of energy, distribute the Fact Sheet to students and allow sufficient time for in-class reading of the material. The Fact Sheet might well be read aloud in class. Pause frequently to explain and bring out important functions of energy conversion.

You may sum up by having students use the terms from the lesson orally in filling in the blanks of the auto story, which you may ditto for paper and pencil work, or read aloud, pausing at appropriate times to have students fill in the energy form.

Naming the Energy Form

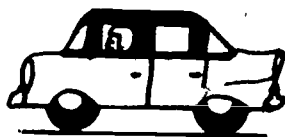

When a fuel such as gasoline is ignited, the 1 energy is converted to 2 energy. This 3 energy is converted to 4 energy of the pistons in the engine, which causes the rotation of the flywheel. Some of the 5 energy is then used to turn the generator to convert 6 energy to 7 energy. Some of the 8 energy is converted to 9 energy for the headlights, and 10 energy in the cigarette lighter.

An alternate summing up may be accomplished by having students identify energy by what it does. Prepare a series of statements similar to these, or have students invent statements of their own.

When you clap your hands, you change muscular energy to (motion) and to (sound)

When you are talking, you change (mechanical) energy to (sound).

When striking a match, you convert (chemical) energy to (heat) and to (light).

Have students use the information found in the Fact Sheet to help trace light energy in the automobile back to its energy origin. Ditto class copies of the pictured auto and energy tracing blocks to be filled in.

The blocks should read:

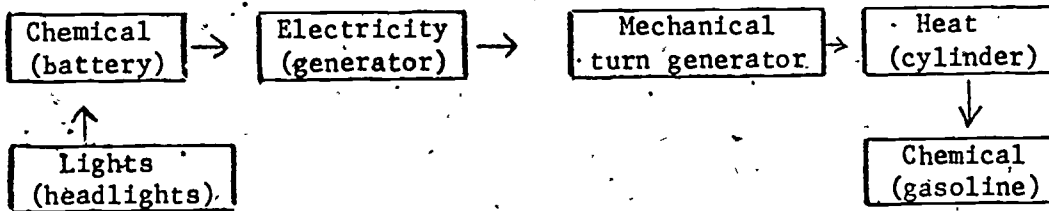

To broaden the concept of energy conversion, have the students complete the matrix, "Examples of Energy Conversion."

References:

NSTA. Interdisciplinary Student/Teacher Materials in Energy, the Environment, and the Economy, 1977.

Teacher Notes:

One very important property of energy is that almost any form of energy can be converted into almost any other form. Changes in energy are most useful when controlled. Mastery of energy has been the key to technological progress. Unwise use of energy might be the key to mankind's destruction.

The automobile, being familiar to all, is a good example of a way in which changes in energy have been controlled and used.

Answers to Auto Story

- 1 - chemical
- 2 - heat
- 3 - heat
- 4 - mechanical
- 5 - mechanical
- 6 - mechanical
- 7 - electrical
- 8 - electrical
- 9 - light
- 10 - heat

Energy Conversion: A Fact Sheet

What is energy? The first step in trying to define energy is to set up two categories: energy in the form of motion, heat, or light is called kinetic energy; energy that is stored in food, gasoline, the nucleus of atoms and batteries is called potential energy. Kinetic energy is energy on the move. Potential energy is stored energy and it is in this form that we dig it from mines and pump it from wells. To use energy, it must be in the kinetic form.

We use energy because we want to do something to matter; move it, illuminate it, or warm it. We usually store energy in the potential form but it is possible to store energy in the kinetic form, too. This form of storage, however, is quite different from potential storage, it is temporary; we trap or insulate kinetic energy. Examples of kinetic energy being stored are the flywheel of an engine and heat energy in a thermos bottle. Potential energy storage is more permanent. It is accomplished by changes in the structure of matter. A simple way to store energy is to lift something away from the earth. (Energy is stored when water is pumped to the top of a water tower, then converted to kinetic energy when it is allowed to run through pipes.)

Energy constantly changes forms. It can be potential stored in coal and when the coal burns at a power plant it changes to the kinetic form, the heat of steam. When steam is allowed to strike the blades of a turbine, some of the heat energy becomes the kinetic energy of motion (mechanical) of the engine. The turbine turns an electric generator and some of the energy becomes electric energy. Electric energy is also changed in form when it is used.

These changes of forms are governed by strict laws; the first of these is called the First Law of Thermodynamics, which states that energy can neither be created nor destroyed. The Second Law of Thermodynamics states that in any conversion of energy from one form to another some of it becomes unavailable for use. This is mainly because some of it becomes heat and it is not possible to convert all of a given amount of heat energy completely back to another form. This unusable heat energy leaks away and gradually warms up the universe.

It is possible to convert all of a certain amount of mechanical energy to heat by, for instance, putting on the brakes of a car. It is possible to convert all the chemical energy of coal into heat by burning it. These conversions cannot go to completion in the other direction, only a limited amount of heat energy is convertible back to other forms. There are many forms of energy but before most energy can be used to do work it first needs to be changed into mechanical energy.

Tracing Energy Conversion in an Automobile

Directions: Take an automobile trip backwards by tracing the light energy in an automobile back to its original source. Fill in each numbered block with the name of the appropriate energy form: heat, light, chemical, etc., and with what part of the car makes this conversion possible. The first space has been filled in to help you.

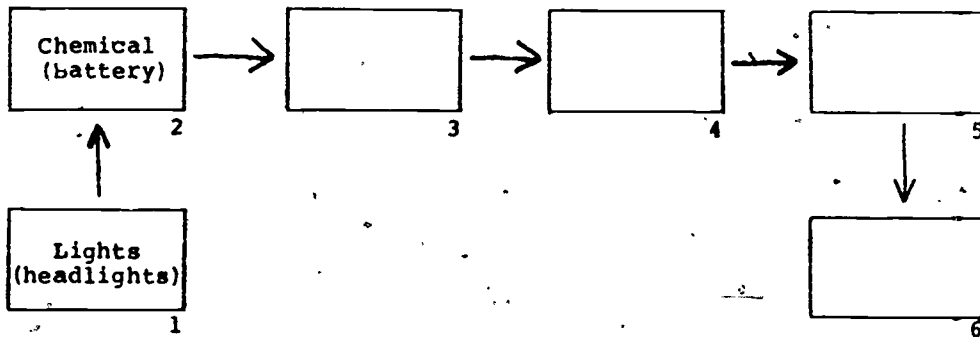
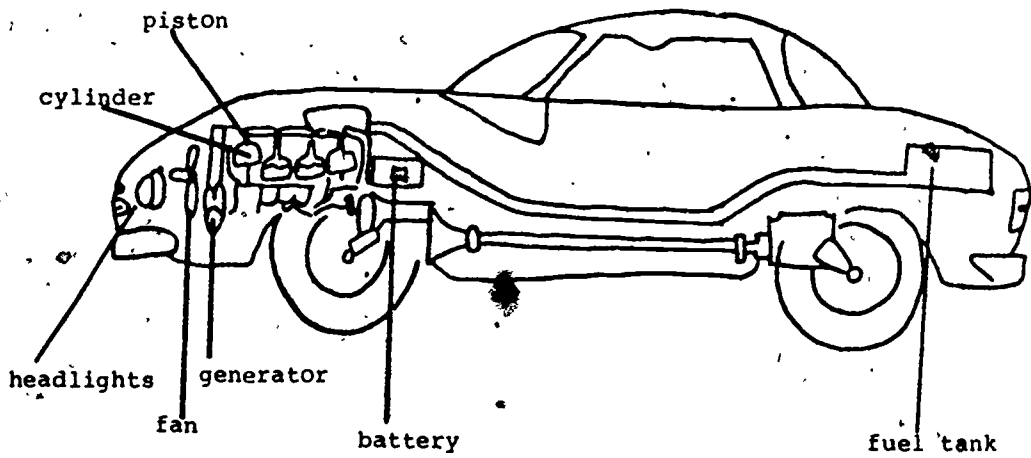

Examples of Energy Conversion

Directions: Write in each box examples of one form of energy being converted into another form. Begin with the vertical column on the left.

Example - Heat is converted into a light energy in a light bulb so write light bulb in the box formed by the intersection of the two energy forms.

	HEAT	LIGHT	SOUND	MECHANICAL (Movement)	CHEMICAL	ELECTRIC	NUCLEAR
HEAT	/						
LIGHT		/					
SOUND			/				
MECHANICAL (Movement)				/			
CHEMICAL					/		
ELECTRIC						/	
NUCLEAR							/

50

70

71

TITLE: EFFICIENCY

AREA: Science, Vo-Tech, Mathematics, Language Arts, Art, Social Studies

OBJECTIVE: To discover the relationship between the efficiency of people and machines.

MATERIALS: Listed in activity

ACTIVITY: Ask the class to describe an efficient person. (One who gets work done with an apparent minimum of effort, or wasted energy.)

Discuss whether the same definition of efficiency would apply to a machine. (Yes; the efficiency of a machine is the ratio of work done to the energy used to do the work.)

Find out how efficiency is determined. (Divide work done by energy used and multiply by 100 = % efficiency.)

What is lost that determines efficiency? (heat)

Ask the students to rate the following energy conversion processes in terms of their efficiency from highest to lowest. (These are in the correct order; be sure to give them to the students in a different order.)

electric generator - 95%	steam power plant - 40%
dry cell battery - 90%	diesel engine - 35%
large electric motor - 90%	automobile engine - 25%
storage battery - 75%	fluorescent lamp - 20%
small electric motor - 65%	steam locomotive - 10%
steam turbine - 50%	incandescent light bulb - 2%

Compare our major uses of energy with the efficiency ratings; for example, 1/4 of our energy is used in producing electricity in plants with an efficiency of 30% or less.

Compare use and efficiency for transportation.

Ask: Why are engines so inefficient? (Many moving parts, plus burning fuel = a lot of heat loss.)

Investigate how the efficiency of automobiles expressed in miles per gallon has been increased in recent years. (Lighter cars, high compression; could be increased more except for use of air conditioning.)

Ask: "What helps to keep automobile efficiency low?" (Automatic transmissions, power brakes, air conditioning.)

Deliver a two-minute sermon on the evils of inefficiency.

Draw a picture of an inefficient, low-energy transportation system. (Hiker, Himalayan porters, etc.)

Describe your efficient transportation.

Compare the efficiency of automobiles and airplanes in moving 100 people from Atlanta to New Orleans. (According to one of the major airlines, a Boeing 727 uses approximately 1860 gallons of fuel per hour. It is approximately 1 hour's flying time from New Orleans to Atlanta. The 727 would use approximately 1860 gallons of fuel from New Orleans to Atlanta. If automobiles average 16 miles per gallon and the distance from New Orleans to Atlanta is 448 miles, it would take 28 gallons of fuel for an automobile to go from New Orleans to Atlanta. At the average of 2 persons per automobile, at the above rate how many gallons would it take for 100 persons in 50 cars? Calculate the amount of gallons required to take 100 persons in a 727 and by automobile, varying numbers of passengers per automobile.) Make up your own problems and do calculations using the following data.

Type of Plane	Number of Gallons	Passenger Limits
Boeing 727	1860 per hour 31 per min.	137
DC-10	2730 per hour 45 per min.	327

Even without the above data, it is more energy efficient to fly on a regularly scheduled airliner. Why? (Planes will be flying anyway.)

Make the same comparisons for trains and trucks used to move freight. (Trains use 1/4 the amount of energy to move the same amount of freight.)

What other factors might be considered in deciding how to move freight? (Perishable cargo, etc.)

What other factors increase overall efficiency of trains as compared to automobiles? (Trains use energy to move their cargo; most energy used in cars is used to move the vehicle, not the cargo.)

Add new energy words to the class energy vocabulary list.

TITLE: HEAT PUMPS

AREA: Science, Industrial Arts, Vocational-Technical, History

OBJECTIVE: To discover the relationships involved in heat transfer to and from the natural environment.

MATERIALS: Listed in activity

ACTIVITY: Introducing the lesson:

1. Say: "At last we have a device which seems to defy the laws of thermodynamics. It produces more energy as heat than is contained in the fuel used to operate it - the heat pump."
2. Ask: How could heat pumps benefit the energy conservation effort in the State of Louisiana?
3. Collect information on heat pumps for heating and air conditioning from local stores.

Developing the lesson:

1. Investigate the operation of a heat pump. (Operates on the same principle as a refrigerator - alternate evaporation and condensation of a heat transfer agent, Freon, ammonia, etc., to take heat energy from a colder area (inside refrigerator) and pump it into a hotter area (kitchen), but, unlike refrigerators, the heat pump can be reversed to provide heat instead of removing it.)
2. Investigate the heat given off by a refrigerator. Feel the coils under or behind the unit.
3. Ask: Is the heat given off by a refrigerator wasted? (It is not only wasted, but is released into a kitchen from which it may have to be removed by air conditioning.)
4. Ask: What is the source of the heat required for the evaporation of the heat transfer agent? (Outside air)
5. Compare the heating and cooling cycles of the heat pumps. (In summer, heat needed for evaporation of heat transfer agent is taken from inside the house. This evaporation cools the coils and surrounding air. This cooled air is then blown into the room by a fan = air conditioning. In winter, the cycle is reversed. Heat is drawn from the

outside air, further cooling it. When blown into a room during the condensation stage, the heat warms the room, or supplements the regular room heating.)

Extending the lesson:

1. Investigate the development of heat pumps by pioneer inventors Sadi Carnot, Rudolf Clausius, and Lord Kelvin.
2. Find out why heat pumps are not more widely used. (No effort by electric utility companies, manufacturers, or retail stores to inform the public of their usefulness and energy conservation value. There were also operational problems with earlier models. Heat pumps are now being promoted as energy conservers.)
3. Ask: Why should utility companies be expected to promote a device that saves electricity?
4. Investigate why heat pumps work more efficiently in Louisiana than in the northern U.S. (Freezing temperatures form frost on outside coils, reducing pump efficiency.)
5. Investigate the differences between water to air heat pumps and air to air heat pumps, and the advantages or disadvantages of each type.

TITLE: . COMPARING ENERGY PRODUCTION AND CONSUMPTION

AREA: Science, Social Studies

OBJECTIVE: To familiarize students with and enable them to read charts on energy to compare the data.

MATERIALS: Charts, pens, handouts

ACTIVITY: Using charts on production and consumption, ask the children:

1. What conclusions do you draw concerning production and consumption of the following energy sources: (a) oil, (b) coal, (c) natural gas, (d) hydro, (e) nuclear.
2. What is the effect of consuming more energy than we produce?
3. What is the economic effect of this?
4. What is the significance of the data on coal and natural gas?

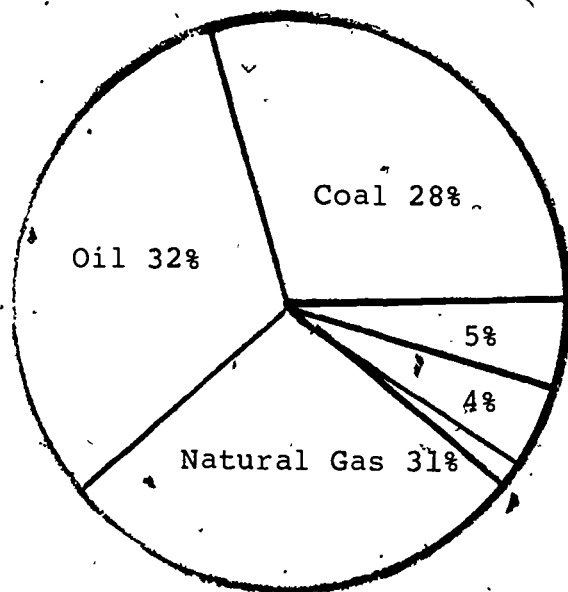

1979 PRODUCTION

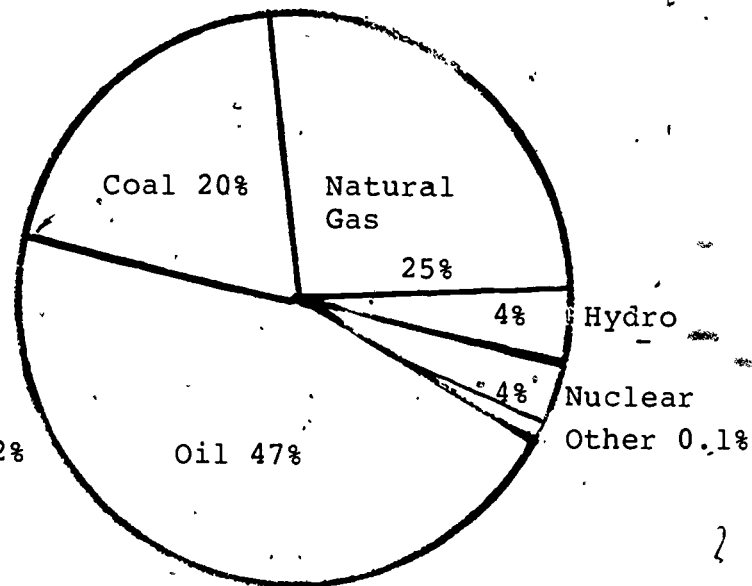

1979 CONSUMPTION

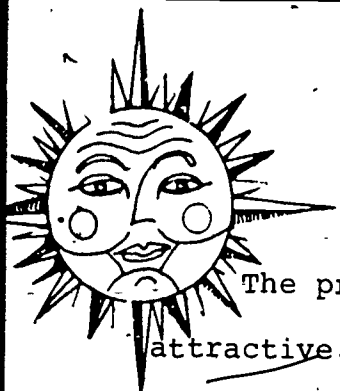

SOLAR ENERGY

The prospect of harnessing the sun's energy is enormously attractive. The reasons are understandable: sunlight is ubiquitous and inexhaustible, sunlight is safe and non-polluting, and sunlight is free.

The concept is far from new. As long ago as 1872, a large solar still produced fresh water in Chile. In 1913 a 50-hp solar steam engine was built near Cairo, Egypt. In the 1920s and 30s solar-powered water heaters were used in more than 25,000 homes in Florida, Arizona and California, until cheap, abundant natural gas made them obsolete.

The sun, like the other visible stars, is a giant thermonuclear furnace which converts matter into energy. Every second nearly 5 million tons of the sun's mass is converted into energy, producing power corresponding to nearly 4×10^{26} watts. The earth receives only a small portion of this, but its share still corresponds to 180×10^{15} watts, which is about 30,000 times as large as the world's total average power consumption. Even though about one-third of this energy is reflected back out into space (mainly by clouds) and only half actually reaches the earth's surface, the total amount of solar energy constitutes a vast and largely untapped resource. The two main problems in using it are that it is not very intense (large collection areas are needed) and it is not available much of the time.

Most of the energy resources used by the human race are really solar energy in converted forms. Sunlight is essential to the photosynthetic processes required for plant growth and

is thus the energy source of food and wood fuel. The sunlight of ages past was the source of the chemical energy of the fossil fuels--coal, oil and gas. The ultimate source of wind energy is the sun's heat, which drives the circulation of the atmosphere. Hydro-energy of water power and hydroelectric installations also come from the sun, whose heat evaporates water which then condenses when cooled and eventually flows downhill to the ocean. Energy resources that are not derived directly from solar energy are nuclear, geothermal and tidal energy; the latter is partially solar, but mainly lunar energy.

Several methods of using solar energy are being used or tested today, and others are on the drawing board.

Solar heating systems make use of the heat that results from absorption of sunlight. The heat can be collected by flat-plate collectors and used to heat (or cool) water or air for such purposes as domestic hot water heating, space heating or air conditioning. The storage of the heat for use when the sun is down or on cloudy days is a major part of such a system. One collection-storage system, the solar pond, can store summer heat for winter use, but most other systems can store heat for no more than a few days. Solar thermal energy can also be used to produce electricity at large "solar farms" in desert areas or at seaside thermal-energy-conversion plants.

Sunlight can be converted directly into electricity by photovoltaic devices such as silicon or cadmium sulfide "solar cells." These operate in direct sunlight and do not involve the conversion of solar energy into heat before conversion into electricity.

In addition to the "active" methods of using solar energy

with the aid of equipment such as collectors, there are "passive" systems which involve proper design of buildings to take advantage of sunlight directly. Examples of "passive" systems are large south-facing windows, roof overhangs to keep out direct sun in summer, and walls and floors of heavy construction to store excess solar heat for later use. Home design with good insulation and passive systems can greatly reduce winter heating needs.

The simplest method of using solar energy to conserve fossil fuels is to collect solar heat to heat homes or hot water for domestic use. Solar thermal energy can also be used for cooling (air conditioning).

The basic collector being tested or sold in the U.S. today is a flat-plate collector consisting of a black absorber, a heat transfer fluid to carry the heat to the place of use, a cover plate of glass or plastic, and insulation. Such a collector works best in direct sunlight but can also collect heat on cloudy or hazy days from diffuse sunlight.

The absorber of the collector is painted black to increase the amount of solar energy absorbed. Certain selective coatings have been developed which are transparent to visible light (and thus let the sunlight pass through) but opaque to infrared radiation (and thus decrease the heat losses due to radiation from the absorber).

The cover plate is usually glass, which admits sunlight (or most of the sunlight) while preventing convection losses from the inside of the collector. Some heat loss from conduction occurs through the glass; thick glass or several panes of glass will

reduce such heat loss. In colder climates the use of several layers of glass more than compensates for the reduction in sunlight passing through the glass layers. The heat transfer fluid may be either gas or liquid, and both types of collectors are available. The most common fluids are air and water.

A solar collector can collect heat only during the day, so it must be used together with a storage system if it is to meet a substantial portion of the energy needs of the building. Air systems generally have a large storage tank consisting of rocks about the size of a baseball, although other storage systems involving salts can also be used. Glauber's salt, a hydrated sodium sulfate, has been tested because its melting point of 90°F. is very useful. Heat coming into the salt storage melts some of the salt, while heat removal freezes some of the liquid salt; in either case the temperature remains at 90°F. Water or other liquid systems usually store energy in a tank of the liquid.

The solar heat collected can be used for space heat during the winter and for heating hot water for domestic use. Solar hot water heaters have been used for many years in Florida and other southern states as well as in foreign countries such as Japan. The technology for solar hot water heating is simple and often very economical. Solar heat can also be used for air conditioning, using absorption type air conditioners; this use has the advantage that the days the cooling is most needed are usually the days of ample solar energy.

Several different designs for solar electric plants are being studied. The heat could be collected in any of several ways, such as by flat-plate collectors similar to those used for home

heating. Since steam-electric plants are more efficient when they have high temperatures, it would be better to use concentrators to secure high temperatures. The most promising method, however, is the central receiver concept. In such a system hundreds of mirrors would be placed on a large expanse of ground to reflect sunlight onto a collector at the top of a high tower the mirrors positioned to reflect the sunlight directly to the tower. The absorbing fluid at the central receiver would serve as the working substance for the electric plant. The University of Houston has designed such a system using a square mile of reflecting mirrors and a 1500-foot tower. The plant will produce 500 megawatts, equivalent to a large conventional plant that might occupy a similar amount of land.

The photovoltaic technology for generating electricity directly from sunlight was invented at the Bell Laboratories in the 1950s and is commonly referred to by the term "solar cell." The most common solar cells are specially treated single crystals of the semiconductor silicon, which can convert solar radiation directly into electric power with an efficiency of about 10 percent. The incident light energy separates electrons from the atoms in the solar cell and produces a voltage.

Solar cells have proved very useful and convenient for producing electricity in remote areas, as on satellites, but their cost has inhibited their use by electric utilities or homeowners. Solar cells capable of producing one kilowatt of power cost hundreds of thousands of dollars until very recently, when concerted efforts have been made to reduce their costs by finding new and more efficient ways of manufacturing them. Currently their price

is tens of thousands of dollars per kilowatt, which makes them tens of times as expensive as other methods of generating electricity. However, semiconductor technology has made great advances in recent years (best illustrated by the great price reductions of pocket electronic calculators) and there is hope that solar cells will be competitive in the 1980s.

Low-cost solar cells could revolutionize the electric industry. A homeowner could use solar cells on an area roughly the area of a house roof to meet the home's electric requirements. The major problem is likely to be a battery system to store electric energy for use when the sun is not shining; battery systems are presently rather expensive. The promise of photovoltaic technology had led to a \$30 million investment by Mobil Corporation in Tyco Laboratories, which has been researching a particularly promising approach to manufacturing silicon solar cells inexpensively.

Silicon cells are not the only possibility. Other materials such as cadmium sulfide are also being studied. In addition, since the cells are expensive it is often cheaper to build reflectors which concentrate sunlight from a large area onto the cells than to build large cells. Improved technologies for concentrating sunlight can thus help solar cell technology.

In addition to small scale uses of solar cells, it might be possible to cover large areas of land (e.g., desert areas) with solar cells to generate electricity. Another idea that has been developed by Peter Glaser is to build large solar cell arrays in space, where they can be facing the sun continuously. The collected electric power would be beamed to earth in the form of

microwaves, which can then be reconverted to electricity. U.S. electric power needs could be met by several dozen large (13-square-mile) photovoltaic collectors of this sort. Such satellite collectors would probably be very expensive to construct, and large land areas would be needed to collect the microwave power sent to the earth's surface.

"How feasible is it to use solar heating in a home at this time? Commercially available solar collectors are approximately \$10/square foot, and a home solar heating system that would provide both heat and hot water runs about \$10,000 to \$15,000. The payback time for this system would be in the range of 15 to 20 years.* As fuel costs rise, the payback time could be shorter. A system for providing only hot water ranges in price from \$500 to \$2000, depending on the type of system, and the payback period for this would be 3 to 5 years. Systems can be retrofitted onto houses that are already built, but results are usually more satisfactory when they are incorporated into new houses." (Hodges and Neff, 1976.)

* Varies with the geographic location, the system, and the initial cost.

TITLE: LIGHT

AREA: Science

OBJECTIVE: To discover the relationship between the light of the sun and how people see it.

MATERIALS: Listed in activity

- ACTIVITY:
1. Ask: What is light? (A form of the radiant energy of the sun, measured in wave lengths)
 2. Have the students describe the light of the sun.
 3. Ask: What does it mean to you? (Write their answers on the chalkboard - brightness, shade, blending of colors, etc.)
 4. Investigate the use of lenses and other optical glassware to study light through the ages.
 5. Focus lights covered with red, blue, and green lenses or cellophane on the top of a white cue ball or egg. Describe the colors you see. (Spectrum)
 6. Now focus the lights on a large sheet of white paper lying flat on the floor so that the colors overlap in the center. Note the color white where the red, blue, and green light overlap. Ask: What is white? (Sum of all colors)
 7. Note where only two colors overlap. Describe the color you see. (Red-green overlap = yellow light; red-blue overlap = magenta light; blue-green overlap = cyan)
 8. Try to produce the same colors, using artists paints. Do you get the same colors when you mix pigments? (No)
 9. Look through a prism to see the colors of the spectrum.
 10. Ask: How else might we see the spectrum? (Rainbow or looking through a drop of water)
 11. Investigate the bending of light as it passes through a lens or water. (Look at half of a friend's face through a glass of water. What happened to the light? (Different colors bent by different amounts and so they spread out to show their colors.)

Extending the lesson:

1. What is the color green we see? (Green pigment which absorbs all the colors of white light except green)
2. What is black? (Pigment which absorbs all white light)
3. What is white? (Pigment which reflects light and absorbs none or very little color at all)
4. Investigate the reverse colors of a photographic negative.
5. Add to the class energy vocabulary list.

TITLE: SOLAR OVEN

AREA: Science, Social Studies, Industrial Arts

OBJECTIVE: To demonstrate the construction and the use of a solar oven

MATERIALS: A 30-square inch piece of sheet metal painted on one side with flat black paint; 1-5/6 square yard of 2 to 4 inch styrofoam or a wood frame; 1-5/6 yard of 1 inch fiberglass insulation, glass cover for the front of oven; oven thermometer; thermometer to check water temperature.

ACTIVITY: After a few simple experiments to show the heating power of the sun, involve the students in constructing a solar-radiation oven. Students should dry apples, heat water and bake cup cakes in the solar oven.

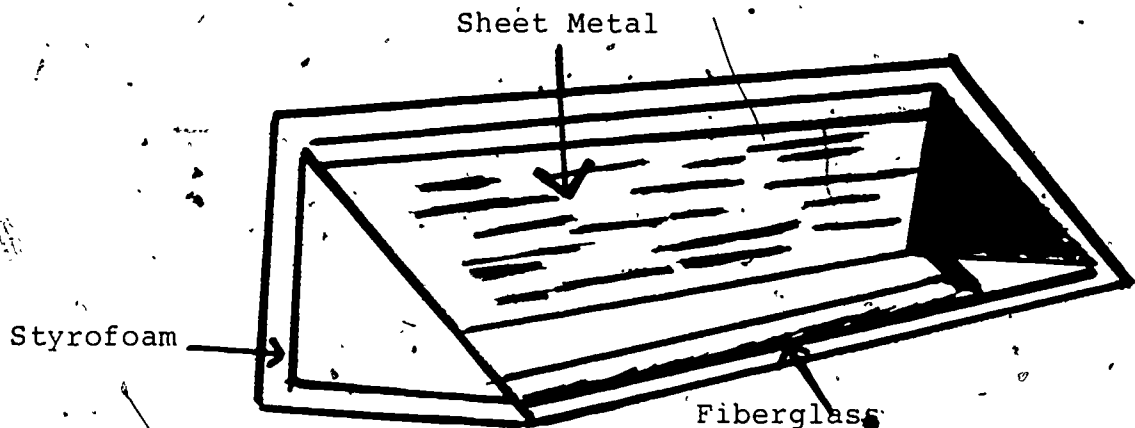

TITLE: TRAPPING SOLAR ENERGY

AREA: Science

OBJECTIVE: To demonstrate the most efficient means of trapping solar energy.

MATERIALS: Six test tubes with one-hole stoppers to fit; six thermometers, one sheet each of black, blue, red, white and green colored paper; aluminum foil

ACTIVITY: Fill each test tube with water. Place stopper on test tube and insert the thermometer into the hole in the stopper. Behind each of the test tubes place a sheet of colored paper and a piece of aluminum foil.

Record the initial water temperature. After five minutes of sunlight exposure, read the temperature of the water again and record. Repeat this procedure for thirty minutes. What can be said about the color background and the temperature change?

Repeat the experiment, this time wrapping each test tube completely in the colored paper. Are there any differences observable from the first set of data? Explain any such differences.

Can you see any application of this experiment to the use of solar energy in the home? Explain.

TITLE: SEA THERMAL POWER

AREA: Science, Social Studies, History

OBJECTIVE: To discover the relationship between ocean temperature gradients and heat engines.

MATERIALS: Listed in activity

ACTIVITY: Introducing the lesson:

Every person in the South knows about the warm Gulf Stream which flows north along the east coast of Florida. Ask the students if there is any way that the heat energy of the Gulf Stream could be used. (Yes, the ocean is a natural heat engine which could produce electricity if its energy could be captured.)

In solar power proposals, collectors of solar heat are often too expensive to make the project economically feasible. Ask: What is the solar heat collected in the Gulf of Mexico? (The sea itself collects the heat--free.)

Developing the lesson:

Find out how a heat engine works. (Heat engine placed between a high temperature source (the ocean surface) and a low temperature source (deep water in ocean). Heat flows from hot to cold through the heat engine, which converts it to work for electric power production.)

Ask: Why is the Gulf Stream a good location for use of a heat engine to produce electric power? (There is a year-round difference of about 40 degrees between the surface and water 1000 feet below the surface. No seasonal or daily variations.)

Investigate the research of the French scientist Georges Claude and his development of a sea thermal steam turbine in Cuba in the 1920s.

Describe the operation of the Claude power plant in Cuba. (A vacuum pump brought warm surface water to a boil by reducing pressure. Steam was used in a turbine to produce electric power.)

Why were larger plants not built when they were so successful? (They could not compete economically with plants using newly-developed oil resources.)

Investigate efforts by the French government to build a sea thermal power plant.

Read in Clark's "Energy for Survival" about the proposals of the Andersons of York, Pennsylvania and Dr. William Heronemus of the University of Massachusetts to use sea thermal power plants to produce electricity or hydrogen for fuel.

Extending the lesson:

Some areas of Louisiana are short of fresh water. Investigate the dual use of a sea thermal power plant to desalinate sea water.

Describe the advantages of an underwater ocean power plant. (No storm problems)

How would such a system work in polar regions? (Even the cold ocean can be a heat source, like the inside of a refrigerator can give off heat, as long as there is colder air around to act as a heat sink for the plant's condensers.)

Investigate the possible effects on marine life of a sea thermal power plant in the Gulf Stream. (Cold water brought up from bottom would be beneficial to marine life. The greatest concentrations of marine life in the world are in areas where currents bring nutrient-rich cold water to the surface.)

Investigate how electricity produced could be used to produce hydrogen for a hydrogen-based energy economy. (Instead of sending electricity ashore, it would be used to make hydrogen by electrolysis of water. This hydrogen could be transported in existing gas pipelines to local fuel cell plants to make electricity.)

Ask: Why don't we build it?

Add to the class energy word list.

TITLE: SOLAR COLLECTOR

AREA: Science

OBJECTIVE: To demonstrate the construction and use of a solar collector.

MATERIALS: Listed in activity

ACTIVITY: Each of the following are outlines for suggested student projects in solar power. The outlines are intended to serve as starting points only and are not to be taken as a set of step-by-step instructions on how to build or design solar collectors.

1. Construction of a simple solar collector:

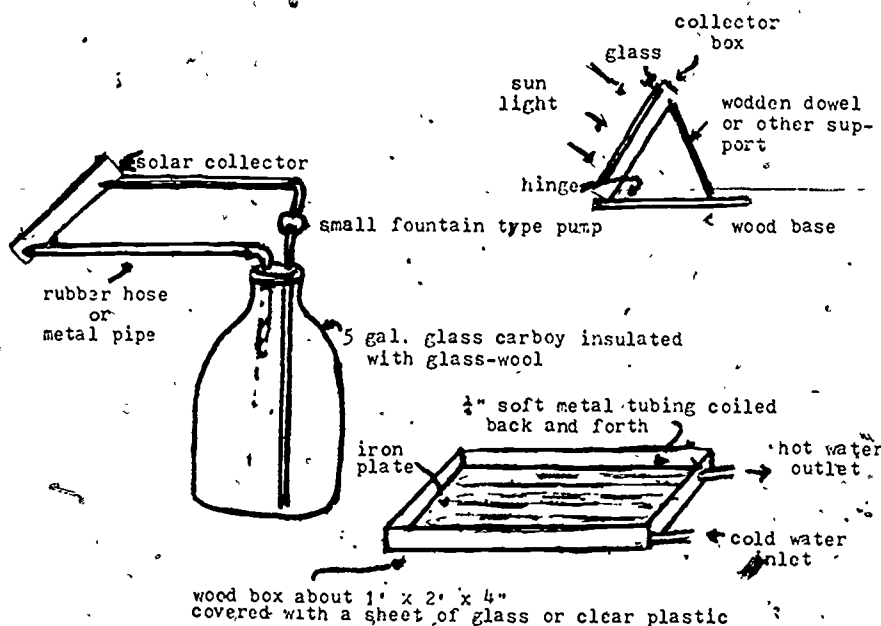

Construct wooden box, place iron plate with tubing secured on surface inside, paint flat black, cover with glass and place on roof.

Water lines running from roof to classroom should be insulated. Soft rubber sheathing used by air-conditioner contractors should be ideal.

Pump should have a small flow rate but develop enough pressure to push water up to roof. Depending on climate, anti-freeze may be added to prevent bursting pipes in winter.

Recirculate water during daylight only and take temperature readings several times per day over a period of a few weeks. Determine maximum temperature reading.

2. Prepare three essentially identical collector systems and vary the tilt referenced to horizontal. Set one collector so measure of angle is equal to latitude above equator. Vary the other collectors and determine the most efficient placement for your geographic location.
3. Use three identical collector systems set at optimum angle. Connect the three heat reservoirs in series with each other. Determine if placing the collectors in series or parallel will be more efficient. Propose an explanation for your results.
4. To get more realistic results, place a load on your system by drawing off a small quantity of the hot water and make it up with cold. A flow rate of about .1 total volume per hour would be a reasonable load. Determine power rating of system by measuring flow rate and average temperature change. If possible collect data over several months.
5. To make the system more efficient, design and install a control device to detect the temperature increase in the collector and interconnect with the pump. The system should circulate water when there is a heat gain in the coil and shut off when not.
6. If small experimental system begins to operate effectively, design a larger model using a discarded hot water heater as the tank. Try to use the hot water produced for as many useful purposes as possible. Some examples are: hot water for washing glassware, design a heat exchange and use the heat to warm aquariums, use the heat to warm animal rooms, plant rooms, or greenhouses.

TITLE: SOLAR STILL

AREA: Science

OBJECTIVE: To use a solar still to demonstrate the water cycle and hydropower.

MATERIALS: Three plastic containers or buckets (about one liter volume); plastic to cover and overlap container; string or tape to bind the plastic as a cover on the container; three weights or stones; three tumblers or small tin cans that will fit inside the container

- ACTIVITY:
1. Put water into the container to a depth of approximately 3 cm and a tumbler in the center of the container.
 2. Place the overlapping plastic on the container and bind it to the sides of the container, making it airtight.
 3. Place a weight or stone on top of the plastic causing it to sag so that the plastic is barely above the tumbler.
 4. Place the container in the sun for a considerable time. Observe that the water evaporates and condenses on the plastic as droplets which run into the glass in a continuous process.
 5. Repeat the experiment, using three solar stills with the same size containers and collectors. Set up one as before with plain water. In the second still, put brine or salt water in the container. In the third still, put green lawn clippings or chopped leaves in the container. Place the three solar stills in the sun for the same amount of time. Examine and compare the contents of the three collectors.
 6. Define and discuss evaporation, condensation, and distillation.
 7. How is what happened in the solar stills similar to the water cycle in nature? How is the water cycle related to hydropower? Why is hydropower considered a form of solar energy?
 8. How can a solar still be put to practical use?

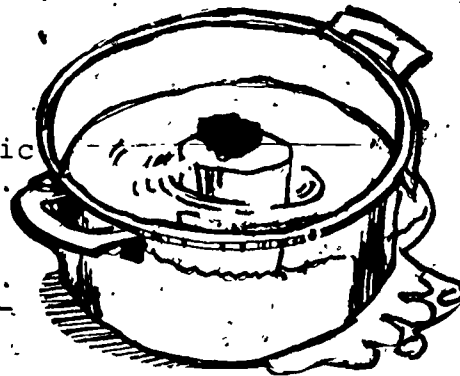

TITLE: TRACKING THE SUN BY COMPUTER
AREA: Science, Astronomy, Computer Science

OBJECTIVE: To find the altitude and azimuth of the sun for any date, location and time; to find the right ascension and declination of the sun for any date, location and time; and by use of the computer visually to display a diagram of the sun's position for any date, location and time.

MATERIALS: A computer terminal; sun-position computer program (included in activity)

Background Information

This computer program was devised by high school students to find answers to their questions about the sun's apparent movements. A knowledge of mathematics, computer science and astronomy was necessary to devise this program. This knowledge then had to be integrated into a scientific tool. This tool could then be used in solving solar energy problems.

The students who devised this program know that the effectiveness of a solar powered device depends on its alignment to the sun. If a collector is properly aligned its effectiveness could be greatly increased. Therefore they wanted to find the sun's exact position. They knew that this position could easily be found by looking in the nautical ephemeris, but in devising a computer program many valuable lessons were learned.

This program can be used as an end in itself or as a stimulus toward the development of more solar information programs.

Hints on Gathering Materials

Whenever devising a computer program decide if it serves a purpose and is applicable to the needs of the unit being studied.

A flow chart from which this program was developed is available from the Solar Energy Education Project, c/o Bureau of Science Education, State Education Department, Albany, New York 12234.

Suggested Time Allotment

If the program is to be used as an informational gathering tool it could be completed in five minutes.

If the program is to be used as a stimulus to the development of further programs the time allotment could be several weeks.

Suggested Approach

- The program must be entered into the school's own data storage system and therefore a program list has been supplied. The program is written in Hewlett-Packard Basic 2000 Level F.
- Before beginning, students should be adequately instructed in the method of getting this program on the computer and told to follow carefully all instructions, given by the program.

Typical Results

- See next page

Precautions

- The computer must be programmed exactly according to the accompanying program.

Modifications

- The program may be modified to include additional astronomical motions.

Evaluation

- NONE

QUESTIONS

1. How could this information about the sun be used in the placement of solar collectors?
2. What are the astronomical changes that take place to cause the variations in the sun's path?
3. What effect does the sun's changing position have on the effectiveness of a solar collector?

GOING FURTHER

- Additional information programs about the sun could be developed, such as: a) A program to compute the duration of sunlight on a given day at a given latitude. b) A program to compute the effectiveness of a collector in a fixed position, as the sun moves along its daily path, and during the sun's change in position during the year.

RUN
SUN

THIS PROGRAM WILL ALLOW YOU TO CALCULATE THE RIGHT
ASCENSION, DECLINATION, ALTITUDE, AND AZIMUTH OF THE SUN
ON A GIVEN DATE

THE AZIMUTH OF THE SUN RUNS FROM 0 DEGREES AT THE SOUTH
TO 90 DEGREES AT THE EAST TO 180 DEGREES AT THE NORTH
TO 270 DEGREES AT THE WEST

WHAT IS YOUR LATITUDE IN DEGREES(+ FOR NORTH, - FOR SOUTH)?40

WHAT IS YOUR LONGITUDE IN DEGREES(+ FOR WEST, - FOR EAST)?72

TO FIND THE DESIRED INFORMATION	*	INPUT
IN THIS TIME ZONE	*	THIS
*****		*****
GREENWICH MEAN TIME	*	GREENWICH
EASTERN STANDARD TIME	*	EST
CENTRAL STANDARD TIME	*	CST
MOUNTAIN STANDARD TIME	*	MST
PACIFIC STANDARD TIME	*	PST

WHAT IS YOUR TIME ZONE?EST

INPUT THE DATA IN THE FOLLOWING FORM
INPUT THE MONTH(1-12), A COMMA, THE DAY(1-31),
A COMMA, AND THE YEAR(ALL 4 DIGITS)?6,22,1992

INPUT THE TIME OF DAY IN THE FOLLOWING FORM
INPUT THE TIME ON THE INTERNATIONAL CLOCK (0-24)
THE TIME MUST BE INPUT IN DECIMAL FORM?5.25

THE DECLINATION OF THE SUN IS 23 DEGREES
THE RIGHT ASCENSION OF THE SUN IS 6.3 HOURS
THE ALTITUDE IS 15 DEGREES
THE AZIMUTH IS 108 DEGREES

ZENITH

* * * * *

(S)

Q
* I *
* I *
* *
* *
* *

I	I	I	I	I	I
I	I	I	I	I	I
NE	E	S		W	NW

LIST
SUN

COMPUTER PROGRAM

```
1000 REM ****PROGRAMED BY MICHAEL D. ANGLE ****
1010 REM **** WRITTEN IN HEWLETT-PACKARD BASIC 2000 LEVEL F ****
1020 PRINT "THIS PROGRAM WILL ALLOW YOU TO CALCULATE THE RIGHT"
1030 PRINT "ASCENSION, DECLINATION, ALTITUDE, AND AZIMUTH OF THE SUN"
1040 PRINT "ON A GIVEN DATE"
1050 PRINT "THE AZIMUTH OF THE SUN RUNS FROM 0 DEGREES AT THE SOUTH"
1060 PRINT "TO 90 DEGREES AT THE EAST TO 180 DEGREES AT THE NORTH"
1070 PRINT "TO 270 DEGREES AT THE WEST"
1080 PRINT
1090 DIM A$(9),F$(1),T$(9)
1100 LET A=.91706
1110 LET Z=.217202
1120 LET Z1=.57.2958
1130 LET Z2=.817453
1140 LET P1=3.14159
1150 PRINT "WHAT IS YOUR LATITUDE IN DEGREES(+ FOR NORTH, -FOR SOUTH)";
1160 INPUT L1
1170 LET L1=L1*Z2
1180 PRINT
1190 PRINT "WHAT IS YOUR LONGITUDE IN DEGREES(+ FOR WEST, - FOR EAST)";
1200 INPUT L2
1210 LET L2=L2/15
1220 PRINT
1230 PRINT "TO FIND THE DESIRED INFORMATITON * INPUT"
1240 PRINT "IN THIS TIME ZONE * THIS"
1250 PRINT "*****"
1260 PRINT "GREENWICH MEAN TIME * GREENWICH"
1270 PRINT "EASTERN STANDARD TIME * EST"
1280 PRINT "CENTRAL STANDARD TIME * CST"
1290 PRINT "MOUNTAIN STANDARD TIME * MST"
1300 PRINT "PACIFIC STANDARD TIME * PST"
1310 PRINT
1320 PRINT "WHAT IS YOUR TIME ZONE";
1330 INPUT T$
1340 PRINT
1350 PRINT "INPUT THE DATE IN THE FOLLOWING FORM"
1360 PRINT "INPUT THE MONTH(1-12), A COMMA, THE DAY(1-31),"
1370 PRINT "A COMMA, AND THE YEAR(ALL 4 DIGITS)";
1380 INPUT D1.D2.Y8
1390 PRINT
1400 PRINT "INPUT THE TIME OF DAY IN THE FOLLOWING FORM"
1410 PRINT "INPUT THE TIME ON THE INTERNATIONAL CLOCK(0-24)"
1420 PRINT "THE TIME MUST BE INPUT IN DECIMAL FORM";
1430 INPUT T1
1440 PRINT LIN(2)
1450 RESTORE 2350
1460 PEAD A9,B9
1470 IF A9#D1 THEN 1460
1480 IF (Y8/4)#(INT(Y8/4)) THEN 1510
1490 IF D1 <= 2 THEN 1510
1500 LET B9=(B9+1)
1510 LET A3=Z*B9+D2
1520 RESTORE 2390
```

```

2120 IF Y#U THEN 2140
2130 PRINT TAB(X-1)"(S)";
2140 READ F1,F$
2150 IF F$="5" THEN 2200
2160 PRINT TAB(F1);
2170 IF (F1+1) >= (X-1) AND (F1+1) <= (X+1) AND Y=U THEN 2140
2180 PRINT F$;
2190 GOTO 2140
2200 PRINT
2210 NEXT U
2220 FOR U1=1 TO 71
2230 PRINT "*";
2240 NEXT U1
2250 PRINT " I"TAB(11)"I"TAB(35)"I"TAB(59)"I"TAB(69)"I"
2260 PRINT " I"TAB(11)"I"TAB(35)"I"TAB(59)"I"TAB(69)"I"
2270 IF L1<0 THEN 2300
2280 PRINT " NE"TAB(11)"E"TAB(35)"S"TAB(59)"W"TAB(68)"NW"
2290 STOP
2300 PRINT " SW"TAB(11)"W"TAB(35)"N"TAB(59)"E"TAB(68)"SE"
2310 STOP
2320 PRINT " ";
2330 GOTO 2140
2340 REM **** DAYS FROM MAR. 21 DATA ****
2350 DATA 1,-80,2,-49,3,-21,4,11,5,41,6,72,7,102,8,133
2360 DATA 9,164,10,194,11,225,12,255
2370 REM **** TIME ZONE, MERIDIAN DATA ****
2380 DATA "GREENWICH",0
2390 DATA "EST",5,"CST",6,"MST",7,"PST",8
2400 REM **** PICTURE PRINTOUT DATA ****
2410 DATA 28,"*",35,"*",42,"*",0,"5"
2420 DATA 22,"*",48,"*",0,"5",0,"5"
2430 DATA 16,"*",54,"*",0,"5",0,"5",0,"5"
2440 DATA 9,"*",61,"*",0,"5",0,"5",0,"5"
2450 DATA 5,"*",65,"*",0,"5",0,"5",0,"5"
2460 DATA 3,"*",67,"*",0,"5",0,"5",0,"5",0,"5"
2470 DATA 1,"*",35,"*",69,"*",0,"5"
2480 DATA 34,"*",35,"I",36,"*",0,"5"
2490 DATA 33,"*",35,"I",37,"*",0,"5"
2500 DATA 34,"*",36,"*",0,"5"
2510 DATA 0,"*",33,"*",37,"*",70,"*",0,"5"
2520 END

```

PROGRAM ADDENDUM

TRACKING THE SUN BY COMPUTER

The following changes for some of the foregoing program instructions are made to assist you in putting this exercise on your system.

The changes may have to be initiated because of the lack of standardization among BASIC compilers. Any changes suggested conform to the so-called Dartmouth Basic which is as close to being a standard as exists. Instructions for which no comments have been made are common to all BASIC compilers.

TABLE OF SUGGESTED CHANGES

1. <u>Statement #(s)</u>	<u>Item</u>
1090	DIM Statement

Comment: String variables are handled by two different methods depending on the compiler.

- a. As in this program, by defining the number of characters in the string variable.

Example: DIM A\$(9) - - -

A\$ is a string variable 9 alphanumeric characters long.

- b. By setting up an array (table) of a specified number of elements or locations.

Example: DIM A\$(9) - - - will create a string variable array A\$ of 9 locations of a set length depending on the compiler.

If your system does not handle strings by method (a.) above exclude this statement from the program.

2. <u>Statement #(s)</u>	<u>Item</u>
1260	PRINT

Comment: If your system uses method (a.) as described immediately above, it is suggested that the following three changes be made in the program listing. (If your system uses Method (b.) ignore these changes.)

1090 DIM A\$(3),F\$(1),T\$(3)
1260 PRINT "Greenwich Mean Time *GRE"
2380 DATA "GRE",0

TITLE: PRODUCTION OF BIOMASS

AREA: Science

OBJECTIVE: To learn the role of solar energy in producing biomass.

MATERIALS: Potting soil; flowerpots; lima bean and pea seeds; scale for weighing

ACTIVITY I.



1. Involve two or three groups of students in a project to determine the gain in weight (mass) that occurs when a plant is grown from a seed.
2. Weigh carefully the amount of dry potting soil necessary to fill a flowerpot. Moisten the soil and plant a small seed such as a lima bean or pea which has been weighed carefully by the teacher. Record the weight on a chart which will be used for the entire class. Have the chart up in the room for the students to see.
3. Place the flowerpot on a windowsill in the classroom where it will receive available sunlight, water as needed, and permit to grow for several weeks. Each group may keep an observation sheet showing the day-to-day progress of the seed. The time and date may also be recorded.
4. Remove the plant and as many roots of the plant as possible from the soil being careful to save the soil since all soil used in the project should be dried and reweighed to ascertain the loss, if any, from the original starting material.
5. Dry the plant and roots thoroughly and weigh. Record the dry weight on the class chart.
6. Discuss questions:
 - a. How does the weight of the plant grown compare to the weight of the original seed?
 - b. How does the weight of the plant compare with the change of weight in the soil?
 - c. From where did the gain in weight come?
 - d. How important was sunlight in this experiment?
 - e. Could the dried plant be burned to produce energy?
 - f. From where did that energy come?

ACTIVITY II.

1. The astronauts used solar energy as a primary source of energy in the Skylab. The energy is provided by a conversion of the sun's energy to electric energy. This source has been suggested as an energy substitute for gasoline to provide power to run cars. What are some of the problems which would occur if cars used solar energy? How could these problems be solved?

ACTIVITY III.

1. Have the students design a car or a house utilizing solar energy as the main source of power. Is it technically possible? Economically feasible?

ACTIVITY IV.

1. As a class project, build a fully-functioning windmill and show the variety of uses the source of energy can provide and determine the limitations of the windmill.

ACTIVITY V.

1. Among the few renewable energy resources is wood; however, abuse could quickly make it nonrenewable. To prevent a total loss of wood both as an energy source and for building, public policy has required that national forests be harvested so that the forests can be renewed. People have not always followed this policy. Have students attempt to discover which ancient and modern civilizations lost their forest resources. Discuss how the renewal of forest resources either helps or hinders individuals and societies.

ACTIVITY VI.

1. Have the students investigate all possibilities of getting energy from the oceans. Describe the limitations and advantages of Ocean Thermal Energy Conversion (OTEC), tidal power, and wave power as sources of energy.

ACTIVITY VII.

1. Have the students research the history of the fossil fuels from their original discovery; through the early means of recovery; changes in technology which caused changes in the mining, refining, and transporting of the fossil fuels; changes in demand and technology which increased the demand for fuel; changing status of workers; etc.

TITLE: A SOLAR FARM

AREA: Science, Mathematics, Art, Social Studies, Language Arts

OBJECTIVE: To discover the relationship between direct solar energy and people's use of it.

MATERIALS: Listed in activity

- ACTIVITY:
1. Ask the students to suggest words that describe a farm. Write them in columns on the chalkboard as fast as you hear them. Make it a game to go faster than they do.
 2. Read in the Meinel Book, "Power For The People," or in the NSTA Source Book about the Meinel proposal to build a huge solar "farm" in the southwestern U.S.
 3. Investigate the cycle for capturing the sun's energy and using it. (Trap solar radiation in collectors; pump heat to a central power plant; generate steam; and produce electricity with steam turbines.)
 4. Describe the "rows" on the farm. (Rows of solar collectors with mirrors to focus sunlight on black pipes filled with liquid sodium to carry the heat. The whole collector is enclosed in a transparent vacuum half cylinder.)
 5. Ask: "What is the crop?" (Heat - temperature as high as 1000 degrees Fahrenheit.)
 6. Ask: "What happens on cloudy days?" (Heated sodium flows to a storage tank which could hold heat for a few days and continue to generate electricity.)
 7. Investigate how much electricity could be produced on a solar farm. (A farm of 10,000 square miles, 100 miles on a side, could produce half of the nation's need for electricity in the year 2000 according to Meinel.)
 8. Ask: "Isn't that a lot of land to use?" (Yes, but in the southwestern U.S., 10,000 square miles is only a tiny fraction of the area of relatively unused desert.)
 9. How does the efficiency of a solar farm compare with the efficiency of a standard electric generating plant? (Both operate about 30% efficiency, but after the initial installation of the solar collecting equipment, fuel is free.)

Extending the lesson

1. Draw a picture or diagram of a solar farm.
2. Discuss this use of direct solar energy by people.
3. Ask: "What could a development like the solar farm proposed by the Meinel mean for the future?" (Cheap, plentiful electricity, although there would still be a great loss in transmission of electricity if all the solar farms for the U.S. were located in the southwestern U.S.)
4. Debate whether or not it would be feasible to set aside 10,000 square miles of Louisiana land to build a solar farm. (Would it be as good to use land for citrus farming?)
5. Start a class energy vocabulary list.
6. Write an argumentative essay, pro or con, on the feasibility of such a farm in Louisiana.
7. Construct a model of a solar farm.

TITLE: MOVING AIR

AREA: Science, Social Studies, History, English, Art, Music

OBJECTIVE: To discover the relationship between solar energy and moving air.

MATERIALS: Listed in activity

- ACTIVITY:
1. Complete the following sentence: Wind is.....
.....
 2. Write the words used by the students on the chalkboard as fast as you can, no matter how unlikely they may sound to you.
 3. From the class list of words, develop a list of opposite words which can be used to describe moving air. (For example, hot-cold; good-bad; fickle-steady; reliable-unpredictable; gentle-violent; etc.)
 4. Ask: "What do most of the words tell us about what wind is?" (Moving air)
 5. Investigate the atmosphere around the earth as a giant heat machine (engine) moved by solar radiation. (The rays of the sun, stronger near the Equator than in the polar regions, cause tropical air to warm and rise, while cooler polar air moves in to replace it.)
 6. Discuss the effect of the earth's rotation on this north-south flow of heated air. (Air moving to the north - a south wind - is deflected toward the east, = a SW wind; air moving to the south - a north wind - is deflected toward the west = a NE (trade) wind.)
 7. Ask: "What other factors influence the movement of air?" (Local atmospheric conditions - high and low pressure systems; obstructions, - mountains or high buildings; and type of surface - asphalt, land; or water, which influence local heating and cooling.)
 8. Discuss how a sea breeze follows this general pattern of uneven heating of the earth's surface. (Air over land heats and rises; colder air over water flows in to take its place.)

Extending the lesson

1. Investigate the historical importance of the wind as a source of energy for people's use.
(Moved ships; pumped water; milled grain; etc.)
2. Investigate the windmills invented by Marcellus Jacobs of Fort Myers, Florida to produce electricity with a wind generator.
3. Move like the kind of wind which represents each of the words used to describe it at the beginning of this lesson.
4. Draw a picture of your favorite wind, and a wind you are afraid of.
5. Ask: "How do airplanes use the wind?" (Take-off; landing; flight; jet stream; tail winds.)
6. Investigate how wind and other weather records are kept.
7. See the wind graphically on the TV satellite weather report each day.
8. Add to the class energy vocabulary list.
9. Create a sculpture which shows the effects of wind.
10. Sing songs which have wind and sun as themes - "Mariah" and "Sunshine" - etc.
11. Write original poems with the wind and/or sun as themes.
12. Do a slide presentation or photography display based around wind and/or sun and its/their effects.
13. Compose an original song based on themes of wind and/or sun.

- TITLE: SOLAR ELECTRICITY
- AREA: Science
- OBJECTIVE: To discover the relationship between the sun's energy and its use for power.
- MATERIALS: Listed in activity
- ACTIVITY:
1. Without the development of solar cells for power, the space vehicles and satellites could not have been operated. What are solar cells? (Tiny slices--wafers--of silicon, about $1\frac{1}{2}$ inches square and only a few thousandths of an inch thick.)
 2. Solar cells are called "photovoltaic cells." What does photovoltaic mean? (Photo = light; voltaic = electricity; named after Alessandro Volta.)
 3. How does a solar cell produce electricity? (The silicon wafer is coated with boron to produce a positive electric layer; this interacts with the negatively-charged silicon. When photons in sunlight strike the silicon cell, they are converted to electrons which flow to the boron layer, causing a flow of direct current (electricity)).
 4. Why are solar cells so expensive? (Skilled hand labor in growing and cutting silicon crystals; more energy used to manufacture cells than they can produce.)
 5. Ask: "Is there any hope for solar cells for use in power plants?" (Mass production of wafers from ribbons of silicon slices made in a machine looks promising.)
 6. Investigate proposals of Dr. Peter Glaser for development of solar power plants in space.
 7. Why are environmentalists concerned about the Glaser proposal? (Proposes to beam microwave electricity back to earth receiver; could act as a death ray.)

Extending the lesson

1. Investigate possible development of solar power plants on earth. (For the immediate future, it looks like a choice of nuclear and coal for fuel, until the various solar technologies can be made economically feasible.)

2. Ask: "Why would a solar cell power plant be more efficient in space?" (Could be positioned to receive sun's rays 24 hours a day; no loss of solar radiation by reflection from clouds and atmosphere.)

TITLE: A CLOTHES "POLE"

AREA: Science, Home Economics

OBJECTIVE: To discover the relationship between solar energy and the evaporation of water.

MATERIALS: Listed in activity

- ACTIVITY:
1. Survey the class to determine use of appliances for washing and drying clothes. Ask: How many of you are wearing clothes that were washed and dried without using any appliances?
 2. Determine what articles of clothing are most apt to be washed by hand and hung up to dry.
 3. Ask: "How many have an outdoor clothesline or dryer?"
 4. The U.S. Department of Energy estimates that the average owner of an electric clothes dryer uses 1000 kilowatt-hours of electric power per year. Calculate how many kilowatt-hours of electric power are used by the homes of class members, using the DOE's average rate.
 5. How much would this cost at \$4.00 per kilowatt-hour?
 6. From local weather records, determine the number of days on which clothes could have been dried outdoors in your community last year.
 7. How much energy could be saved if all the people in your community hung their clothes out to dry? (Number of homes times 1000 kilowatt-hours per year.)
 8. Conduct a "clothes pole" (poll) of your neighborhood to find out how many homes have dryers and how many have outdoor clotheslines.
 9. Ask: "Is there any evidence that the number of outside clotheslines is changing?"

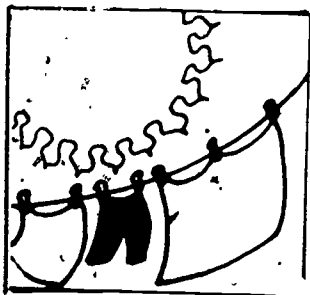

Extending the lesson

1. Survey radio and TV advertisements for detergents. How many emphasize the "clean, fresh smell of the outdoors" which is lost by using an electric or gas dryer?
2. Investigate why Monday was always washday.

3. Discuss the relationship between the increase in use of clothes dryers, air pollution, and urbanization.
4. Investigate the water pollution problems associated with the use of detergents.
5. Ask: "Should the use of clothes dryers be banned to save electricity or gas?" Discuss the pros and cons.
6. Ask: "Is there another appliance that your family would rather give up than your clothes dryer?"
7. List the appliances in the order in which the members of the class would give them up in the event of a serious energy shortage.

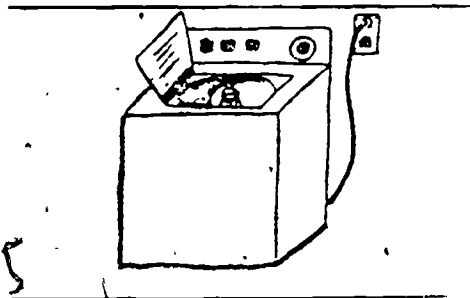
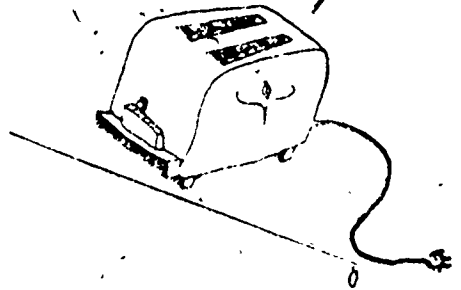
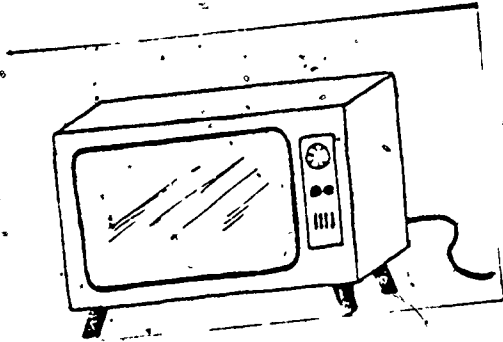

TITLE: - SOLAR ENERGY FOR POWER

AREA: Science, History

OBJECTIVE: To discover the relationship between energy and power.

MATERIALS: Listed in activity

- ACTIVITY:
1. The day before starting this lesson, ask each student to bring in a small mirror and a magnifying glass.
 2. Take the students outside to the school yard. Have them try to focus the rays of the sun on a small piece of paper placed on a sidewalk or other bare area. (Bring a small container of water to wet the area around the paper.) Students should have no trouble burning a hole in the paper. They have used solar energy to do the work.
 3. Next, set up a piece of paper vertically between the sun and the class. Ask the students to use their mirrors to focus the sun's rays on the piece of paper from their position. (They will have to move forward or backward to do this.)
 4. After they have focused their mirrors, have them try to focus on a central spot to burn a hole in the paper.
 5. Have each student measure and record the distance from the mirror to the paper. (Are they all the same distance?)
 6. According to the Greek historian Galen, the Greek scientist Archimedes used solar reflecting mirrors (bronze shields) to set fire to the Roman fleet besieging the City of Syracuse in 212 B.C. by focusing the sun's rays on their black sails. On the basis of their own experience, do the students think this was possible?
 7. Ask one of the students to investigate and report on the solar system engine built by the French scientist Augustin Mouchet in the 1860s.
 8. Do the same for the work of the Swedish-American John Ericson in the development of solar engines.
 9. Investigate the research of Frank Shuman in Pennsylvania and his development of the Sun Power Company in 1908.

10. Compare the operation of the Sun Furnace in the French Pyreñess (Felix Trombe) to the experience with mirrors the students had at the beginning of this lesson.
11. Investigate the use of solar power for desalting water.
12. Ask: "How did the discovery of oil in Pennsylvania affect the development of solar power?" (Oil was a much cheaper source of power, so research was almost halted until 1973.)
13. Ask: "How have the times made water desalinization important?" (Because of water shortages and pollution.)
14. Investigate how the solar power research of Dr. Robert Goddard led to his invention of the rocket engine.

- TITLE: BROTHER SUN
- AREA: History, Science, Language Arts, Music, Art
- OBJECTIVE: To discover the relationship between people and the sun throughout the ages.
- MATERIALS: Listed in activity
- ACTIVITY:
1. Read to the class the song to the sun written by St. Francis of Assisi in 1224:
Praise to you, my Master, for all your creatures,
Foremost for lordly Brother Sun
Who lights our daytime for us.
He is a beautiful thing who spreads for a great
splendor,
Of You Most High, he is the visible emblem.
 2. Ask: "Why have people through the ages felt such strong emotions when they contemplated the wonders of the sun?"
 3. Ask the students to comment on Henry Thoreau's comparison of daybreak and the rising of the sun with spiritual awakening.
 4. Write a new verse to the John Denver song "Sunshine."
 5. Find two or more authors who have written about sun power and compare their descriptions of the sun.
 6. Write a poem which expresses your feeling about the sun.
 7. Investigate Inca worship of the sun.
 8. Find pictures of the Inca temples to the sun "Father."
 9. Find "Sun Fathers" in other cultures.
 10. Investigate how the culture of the Sioux Indians looked beyond the power of the sun to the responsibility of people to use it wisely.
 11. Comment on how well we have heeded the advice of the Sioux.
 12. Investigate the device known as the "Camera Obscura," the dark room prototype of the camera.

13. Read the following passage from the Papago Indian ceremony to the sun:

In the east is the house of the sun.
Up over the top of his roof-beam
The sun climbs and journeys
Over the heads of us
Who make our journey below him.
I stretch my right hand sunward,
Then trace upon my body
The ritual sign.

(This ritual, called a "ciwiltkona," is performed by dancers who believe that they recharge themselves with the sun's energy as they circle a sand painting, of the sun.)

STAR POWER

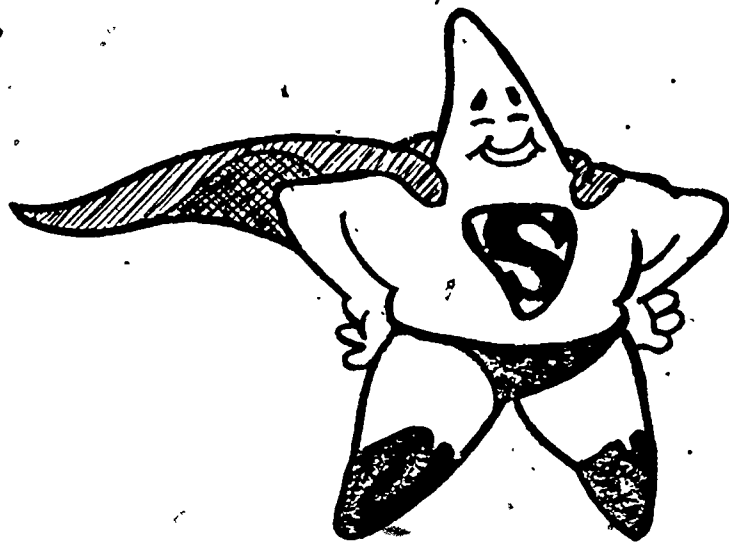

The sun's energy is used to do much work which we take for granted. The heating of the atmosphere by the sun results in temperature differences in the air, creating winds which are responsible for our weather and climate. The circulation of rain and water, known as the hydrologic cycle, is powered by solar energy. Visible light is used by plants to manufacture food on which all life, directly or indirectly, depends.

Solar energy is also increasingly being considered as an alternative source of energy for generating electricity, heating homes and water, and cooling. The energy of the sun is virtually limitless. It will last nearly as long as the sun shines.

But there are some interesting problems in converting solar energy into forms which people find useful. Solar energy is dilute and needs to be collected and concentrated. Solar collectors for a large capacity generating facility require a large collecting

area. Solar energy is also interrupted by clouds (unpredictable) and the daily rational cycle (predictable) of the earth. In order to ensure a dependable supply, the energy captured by collectors must be stored or supplemented by other energy back-up systems.

We already make use of solar energy in our homes. It enters through our windows and adds heat in both the summer and winter. The exclusive use of solar energy to heat homes is not economical at present, and most present-day systems require furnaces for supplemental heating in homes equipped with solar energy panels.

One of the things we need to do is better understand solar energy. What is it? What are the ways that it can be used both as an enhancer and as an extender of our present fuel systems?

In using solar energy there are three primary considerations: 1) the energy must be collected and concentrated, 2) the energy must be stored, and 3) the energy must be transferred and distributed.

One way to learn more about solar energy is from a solar heat collector. A solar collector is a sealed container with an integral dull black surface and a cover of glass or other transparent material. Solar heat collectors are very similar to greenhouses or closed cars on hot days in the way that they work.

Sunlight (short light wave radiation) passes easily through glass. It is converted into longwave radiation or heat. Because both the greenhouse and the car are closed to air circulation, little heat is lost through convection. In addition, glass is also not a good heat conductor of longwave radiation. Both the greenhouse and the car stay warm.

TITLE: COLLECTING STAR POWER

AREA: Science

OBJECTIVES: To form hypotheses regarding the collection of solar energy; to design experiments to test these hypotheses; to collect and analyze data from these experiments.

MATERIALS: Boxes of assorted sizes and shapes (shoe, cigar, shirt, etc.); flat paints; poster paper in assorted colors; window glass; clear plastic wrap; black plastic sheeting; candy and/or regular thermometers; glazing compound; modeling clay; graph paper; aluminum foil; scissors; fiberglass, vermiculite, mineral wool, cellulose insulation; wrapping and/or masking tape; corrugated cardboard; white glue; packaging materials of styrofoam beads or elbows; egg cartons; stones; gravel and sand. (CAUTION: WEAR GLOVES WHEN HANDLING FIBERGLASS AND MINERAL WOOL INSULATION.)

- ACTIVITY:
1. Student should read and discuss the accompanying handout on "Star Power," then do the following investigative activities.
 2. After you take the temperature inside an empty box, place the box in a sunny window. After the box has been there for a while take the temperature again. Share the temperature information with your class. Challenge your students to improve upon the design of the box. Be sure you have a variety of materials available for them to work with. Students are to do these things:
 - a. raise the temperature of the air inside the box;
 - b. retain the heat collected in the box;
 - c. construct an observation sheet and record measurements they take. They should record temperatures and times until the temperature stops rising in the box they construct. They should also be able to show that they were able to retain the heat collected.
 3. Have students paint the inside of the box with a flat black paint. After the paint is dry, a thermometer is placed in the box. Tape the thermometer down but be sure that it is located so that the temperature can be read.

If you do not have enough thermometers for the class, have students build a small door on one side of the solar heat collector so that the thermometer can be moved from one box to another.

Cut an opening so that the door can be shut after temperature reading is taken. A small tab of masking tape can be used as a handle for the door.

Students cover the box with a piece of glass or plastic type food covering. If they use glass, cover the edges with masking tape. If they use a box which has a cover, make a hole in it that is a little smaller than the top of the box. You can then mount the glass window over the opening with masking tape.

It is important to make the seal between the box and the covering as air tight as possible. Place the box in the sun so that the glass top faces the sun with a minimum of shadows inside the box.

4. Help your students construct an observation sheet. Some suggested measurements follow. Emphasize the importance of recording all pertinent observations.
 - a. Record the temperatures and times inside and outside the box until the temperature inside the box stops rising. Make a graph of temperature against time.
 - b. Take the box out of the sun. How fast does the temperature change?
 - c. Vary the angles of the box with the surface of the ground. Take measurements when the box is at the horizontal, at 30 degrees, at 45 degrees, at 60 degrees, and at 90 degrees.
 - d. Try to find out what time of day the differences between the inside and the outside temperature is the greatest.
 - e. Try the collector at different times throughout the year. Try the collector once each week for a month.

What are some of the variations in temperature that are observed?

5. Some student questions:

- a. In what way does the sun affect you?
- b. Which passes more easily through the transparent top of the heat collector - light or heat? On the basis of what you did how do you know?

- c. What is a solar heat collector? How do you know one when you see it?
- d. The sun is the answer to the energy crisis because of the huge reserves of sunlight. Do you agree or disagree? What are some of your reasons?

Some additional investigations

1. Try constructing a collector with two transparent covers. A bead of clay about the thickness of your finger can be used to separate the two pieces of glass. How much better is this collector than single covered collectors?
2. Insulate the collector. Fit it in a larger box and surround it with an insulating material. In what way(s) does this improve the collector?
3. Vary the colors used to paint the inside surface of the box and note the temperature differences. Which color works best? What are some reasons for this?
4. Compare different boxes and designs with each other. Which one is most efficient? Which gains the most heat? What are some reasons for this? Which loses heat most rapidly?
5. Try a solar heat collector in the winter time on the school playground or on any hard surface such as concrete. Take measurements and record. Now try the same experiment but with a small snow bank piled in front of the box. Does the box heat faster with or without the snow? Is the final temperature higher with or without the snow? What are some reasons for this?
6. Try different corrugated and textured surfaces in the box. Glue plastic packaging beads/elbows to the inside of the box and paint them. Compare temperature of collectors with pieces glued to corrugated surfaces and smooth surfaces. Glue rocks/sand inside the boxes and note temperature and heating differences.

TITLE: WHOSE SUN?

AREAS: Drama, Government, Civics

OBJECTIVE: To evaluate arguments regarding the infringement of others rights in the installation of solar collectors.

MATERIALS: Reference - "Conservation News " National Wildlife Federation. April 15, 1978

ACTIVITY: Recreate this courtroom drama in your classroom and see if your verdict is the same.

"An Albany, New York Supreme Court judge ruled that a local zoning ordinance could stop a New York couple from placing a solar heating unit in their front yard. The judge failed to yield to arguments that the couple had the right to try to conserve energy and choose the method they preferred for heating their home. His logic: suppose they had wanted to build a nuclear power plant on their front lawn. Instead, the adjudicator determined that the pair had created their own hardship by purchasing the \$4,000 solar heating unit and he upheld the Colonie Zoning Board's decision not to grant the necessary variance."

NUCLEAR ENERGY

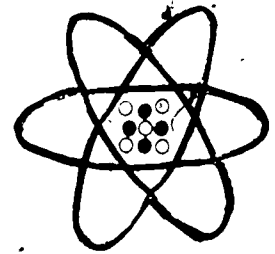

The beginnings of the nuclear age began with Roentgen's discovery of x-rays in 1896. Becquerel became interested and began his own experiments, and found that uranium emitted a spontaneous energy source of rays. The Curies found that radium emitted an even more intense radioactivity. Becquerel, the Curies, and Rutherford studied the rays given off by radioactive substances. They found three different kinds of emissions--alpha particles (heavy positive charges), beta particles (electrons), and gamma rays (energy rays). In 1905 Albert Einstein equated mass to energy by the following equation: $E = mc^2$, where E is energy, m is mass, and c is the velocity of light. This means that small amounts of mass could be converted to enormous amounts of energy. In 1932 Chadwick demonstrated the existence of an uncharged particle, the neutron. In 1934 Fermi used neutrons to bombard various elements. Usually the nucleus would capture the neutron, give off a beta particle, and thereby change to the next heavier element. When uranium was bombarded with neutrons, it too gave off a beta particle. Fermi believed that uranium was behaving as the other elements, but Hahn and Strassman, in repeating the experiment, found that instead of a heavier element being produced, two smaller elements were formed. The neutron had thus caused the uranium to split. Large amounts of energy accompanied the split, because the smaller

particles and other products were not quite as heavy as the original uranium plus neutron. The lost mass had been turned into energy according to Einstein's equation. Several free neutrons are also formed, which can go on to split other uranium atoms and thus cause a chain reaction.

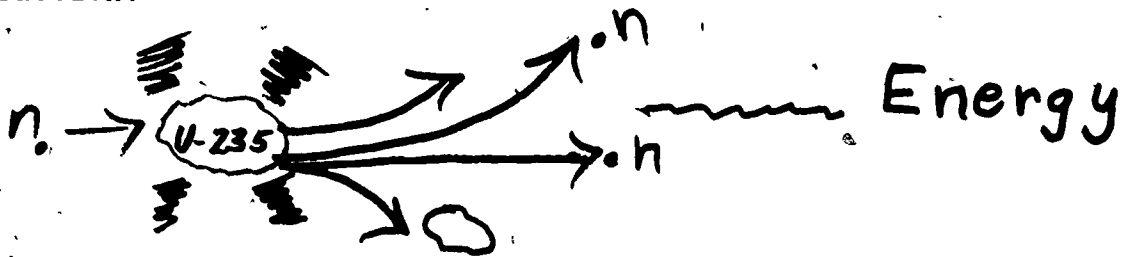

Uranium occurs in nature principally in two isotopes-- U-235 (less than 1%), and U-238 (99%). Of these two isotopes only U-235 will split (is fissionable).

In 1941, with the U.S. at war, President F.D. Roosevelt decided to commit the U.S. to construction of atomic weapons, using the large amount of energy produced in fission for bombs. The secret Manhattan project produced the first controlled chain reaction at the University of Chicago in 1942, and in 1945 the first nuclear bomb was set off in New Mexico. Three weeks later, nuclear bombs, the most terrible weapons ever used, annihilated Hiroshima and Nagasaki and ended World War II. Nuclear weapons produced not only a gigantic explosion, but also tremendous heat, and covered the entire area with dangerously radioactive materials.

Nuclear bombs use pure U-235, allowing the chain reaction to go on uncontrolled. The nuclear reactor, on the other hand, uses only a slightly enriched mixture of U-235 and U-238

(2%-4% U-235), with a controlled chain reaction.

A nuclear reactor has the following principal parts: 1) a core of atomic fuel, 2) a moderator, 3) a cooling system, 4) a control system.

A nuclear reactor must first have fuel, which is slightly enriched U-235, in the form of uranium oxide. This fuel is held in zirconium alloy tubes called assemblies, which are combined with a moderator such as water or graphite to make up the core of the reactor. The moderator's job is to slow down the fast-moving neutrons, thus making collisions more probable.

There are control rods of some neutron absorbing materials such as boron, which can be inserted between the fuel assemblies to regulate the power level of the reactor. When they are fully inserted into the core, they absorb so many neutrons that the chain reaction will be stopped.

A circulating fluid such as water or gas is used in the reactor both as a coolant and as a means for transporting heat to the boilers for steam production.

Surrounding the reactor are several shields. The reflector shield is meant to reflect back into the core neutrons that might otherwise leak away. In addition, there will be shielding to protect operating personnel from radiation, and the entire reactor will be surrounded by a large concrete and steel structure, meant to contain radiation and thus protect the environment.

The disposal of nuclear wastes is a problem that has not been adequately solved. The wastes are the decay products of the nuclear reactions, and are removed periodically with the

insertion of new fuel. The wastes now total 600,000 gallons in the U.S. This amount will, of course, become greater in years to come if the number of nuclear plants increases. The wastes remain radioactive for as long as thousands of years, and must be carefully guarded during this period. At present, only temporary storage tanks are being used. In the future, it is hoped that the wastes can be reprocessed, with useful components being removed, and the remainder of the wastes being stored in some permanent facility. Several methods being considered for this permanent disposal of wastes are: burying them in polar caps, burying them in salt formations, sending them in rockets to orbit and eventually crash into the sun, burial in the ocean in such a way that the wastes will be carried into the earth's core by movements of the earth's plates.

The breeder reactor takes advantage of the fact that U-238 can capture neutrons to produce Pu-239.



U-238 is the most abundant isotope in nature and, for the most part, is left-over material in ordinary reactors. Since Pu-239 is a fissionable material, it can be used as a fuel. Only a small amount of fuel (U-235 or Pu-239) is needed to operate the breeder, while extra fuel (Pu-239) is produced. Hence the term "breeder reactor" is used.

The use of the breeder reactor extends the life of our dwindling uranium supplies by many hundreds of years. There

are, however, some problems with the development of such reactors that have delayed their acceptance into wide usage. The principal problem is that of sabotage, since Pu can be made into a bomb.

One other topic that should be covered is the effect of radiation. Exposure to radiation, either from natural or man-made sources, can be harmful to living organisms in a number of ways. Effects of radiation on an organism are classified broadly as somatic effects (those occurring within the exposed organism) and genetic effects (those affecting descendants of the exposed organism). An individual who is exposed to a large whole body dose of radiation will suffer immediate illness and/or death. Most somatic effects, however, are the result of repeated, brief exposures and are manifested as higher incidences of cancers and leukemia.

Some radioactive isotopes, when ingested with food, have the capacity of concentrating themselves in certain parts of the body. Strontium-90, for example, concentrates in the bones, while cesium-137 concentrates in muscle tissue and iodine-131 concentrates in the thyroid. Because of this ability, certain radioisotopes do more damage than others. In addition, some radioactive isotopes tend to become concentrated in a food chain in such a way that animals which are on the end of the food chain receive larger doses.

Man is exposed to many sources of radiation. These include occupational sources, medical sources, fall-out from nuclear weapons tests, and natural background radiation that will vary from area to area. The additional exposure suffered

by the average person due to the siting of a nuclear power plant near his home is negligible. Only in the case of a highly improbable accident at a reactor or at a fuel processing plant would there be any chance of a harmful exposure of any segment of the public to radiation.

PRICE-ANDERSON ACT

When nuclear power began to emerge as a practical means of power generation, the U.S. Congress faced this question: what is the best method of providing for damages arising from a nuclear accident, even though such an event is extremely remote? The Price-Anderson Act evolved to answer that question. It requires a utility which operates a nuclear power plant to purchase the maximum amount of liability insurance it can obtain, currently \$110 million. The federal government provides additional insurance, up to a total of \$560 million, to pay the public for damages from a nuclear accident. Thus the government currently provides \$450 million in insurance. Each utility pays a premium to the government for Price-Anderson coverage.

The Price-Anderson Act relieves all parties of liabilities in the event that damage from a nuclear accident should exceed the \$560 million maximum. Critics of nuclear power are quick to point out this provision, and say that the maximum is not enough.

A private insurance pool provides insurance on nuclear facilities themselves. There is no government-backed coverage on nuclear facility property.

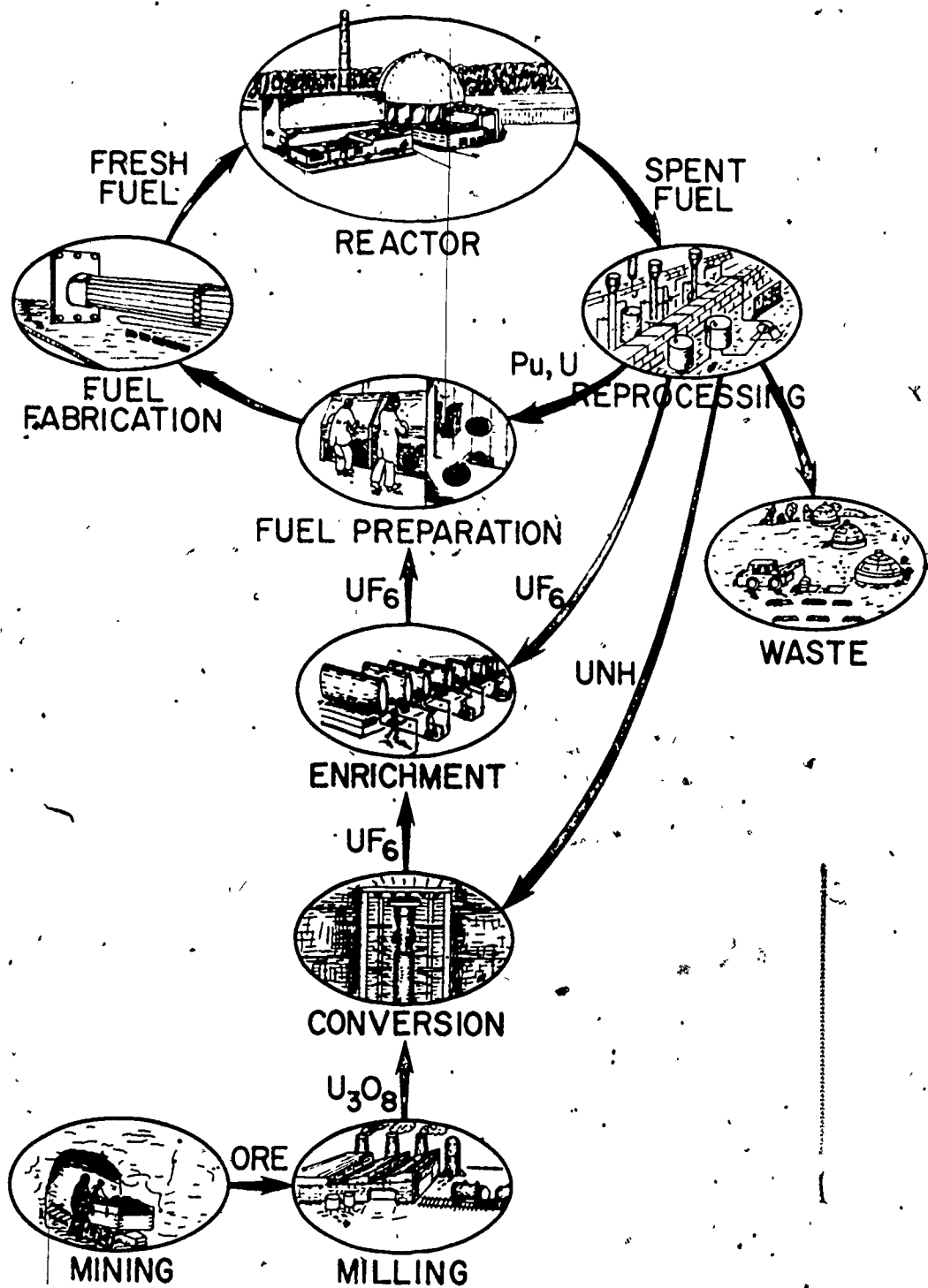

MAJOR STEPS IN NUCLEAR FUEL CYCLE

TYPES OF REACTORS

A fuel core and control rods plus circulating water, as coolant and moderator, are the basic components of an operating nuclear energy conversion device. Also required are ways to get this heated water to a heat engine, convert it to mechanical work, and turn a generator. It is in the accomplishment of this heat transfer that differentiation between various reactor types takes place. In this country, at the present time, all commercial reactors are thermal, or slow, neutron reactors. Light water-moderated, they use enriched uranium as fuel; that is, uranium in which the amount of U-235 has been enhanced by three to four times its natural abundance. There are two basic types now in use: the boiling water reactors, BWR, and the pressurized water reactors, PWR. Generically these are the light water reactors, LWR.

PWR: The pressurized water reactor contains, as the name suggests, water under very high pressure, as high as 2,000 pounds per square inch. There are, in fact, two separate water circulation systems, and it is the high-pressure system that is in contact with the reactor core. At such high pressures water does not boil at the normal 212°F and, therefore, it remains a liquid at the 600°F it reaches in the reactor core. This heat energy is then transferred through a "heat exchange" to the second circulating system of low pressure water in which it produces steam to drive the steam turbine.

From the turbine on, the operating machinery is basically the same as in a fossil fuel plant. In particular there is still need for a third water circulating system to condense the steam

back to water. In contrast to the first two systems, which are essentially closed, this last one is open and connected to a body of water or a cooling tower.

In the PWR it is easier to contain the radioactive materials that inevitably leak through the fuel rod cladding. The first pressurized system is completely separated from the other parts of the system and, in particular, from the turbine.

The PWR reactor was the first one to be put into commercial service, at the Shippingsport, Pennsylvania, plant in 1957.

It is also the type used in nuclear submarines.

BWR: The boiling water reactor has only one circulating water system in which the water is at lower pressure (about 1,000 pounds per square inch) and is allowed to boil. The steam generated by this boiling rises to the top of the core region and, after passing through steam separators and dryers, is piped directly to the turbo-generators.

Since the steam comes in contact with the fuel rods in the BWR, this reactor could release radioactive pollutants to the environment. There is always some leakage of fission products from the rods and some water-borne impurities made radioactive by the neutron flux in the core. It is thus important that the steam be tightly contained and not allowed to escape.

The first commercial BWR was installed at Commonwealth Edison's Dresden, Illinois, plant in 1960.

BREEDER REACTORS

The reactors we have discussed so far are classified as

"converters" and their major purpose is to convert the fissionable fuel--almost exclusively U-235--into energy. Although the energy these reactors produce, per ton of fuel, is quite impressive when compared with fossil fuel plants--less than 200 tons of uranium per year for a 1,000 Mw reactor as against 2 million tons of coal for a coal-fired plant of the same capacity, there are not many thousands of tons of uranium around. It was natural, from the beginning of the nuclear age, to look for other fissionable fuels.

What is required to make a nucleus fissionable by slow neutrons is a particular structure. It has to have, so to speak, a hole for a neutron to fall into so that the probability of neutron capture will be high and a sufficient amount of energy will be released. U-235 is the only naturally occurring nucleus which has that structure.

There are two artificial isotopes, U-233 and Pu-239, that can be created in neutron reactions. U-233 is produced by the neutron bombardment of Th-232 (thorium). Pu-239 is produced in the same way from U-238. Since thorium is actually a little more plentiful than uranium, and U-238 has been, so far, considered a waste material, the addition of these two elements promises to greatly extend the supply of fissionable fuels.

In order to "breed" fuel, to produce more fuel by these reactions than is used in the core, there must be more than two neutrons per fission available. One of these sustains the chain reaction and the other is used to convert U-238 or Th-232. The success of a breeder is measured by the breeding ratio, B.R.,

the ratio of the amount of fossil fuel produced to that used up. A second measure of importance is the "doubling time," the time it will take for a breeder reactor to produce enough fuel to run a second reactor.

There are two types of breeder reactors: the thermal breeder reactor, which uses slow neutrons, and the fast breeder, which uses more energetic neutrons. The thermal breeder works with Th-232 as fuel and the fast breeder with U-238. Most of the present research and development effort is going into the fast breeder.

PRESSURIZED WATER REACTOR

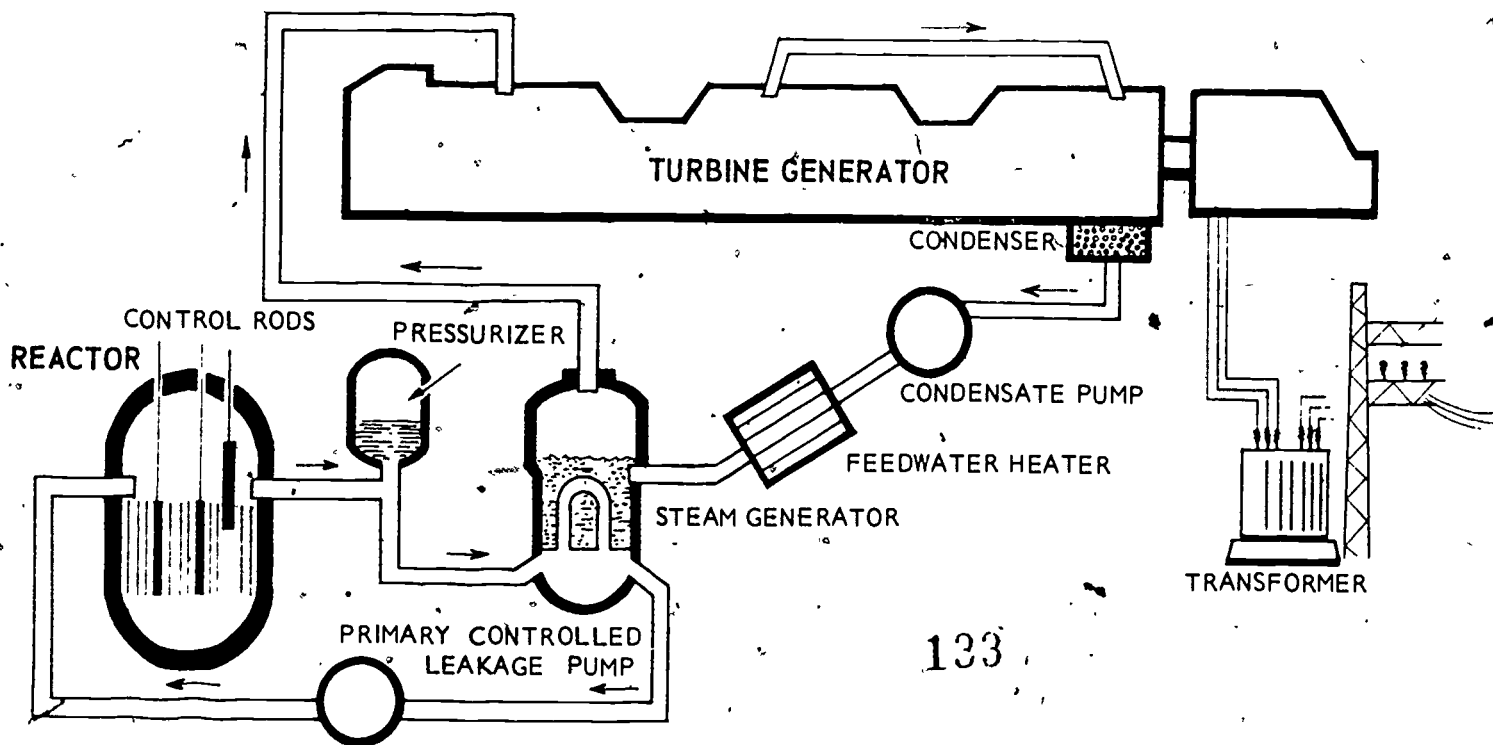

133

BOILING-WATER REACTOR

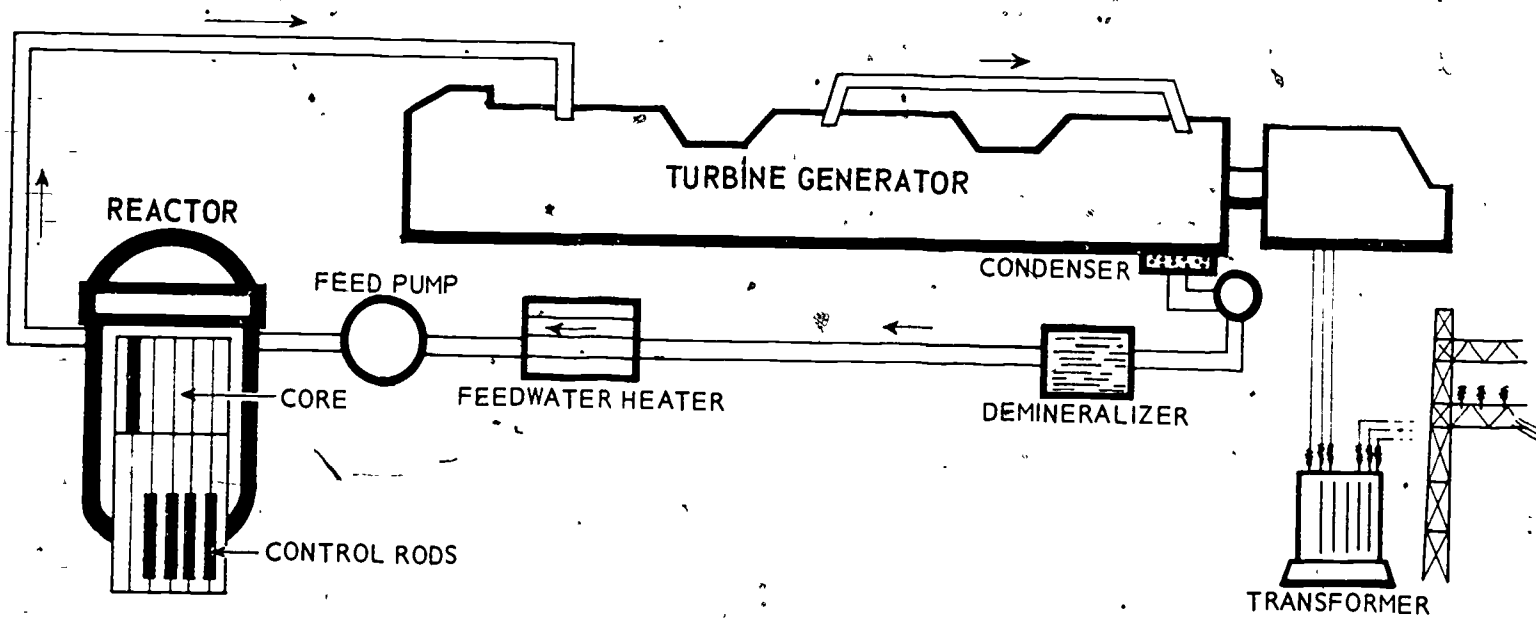

THREE MILE ISLAND NUCLEAR GENERATING STATION

ENVIRONMENTAL IMPACT OF ELECTRICAL POWER GENERATION: NUCLEAR AND FOSSIL

The transfer of heat from the reactor to the steam generators produces tremendous quantities of high-pressure steam. In the turbine building, the steam blasts against turbine blades, turning the huge turbines 1800 revolutions per minute (30 turns per second). The connecting shaft of the generator rotates a coil of wires within a magnet and electricity flows. Transformers in the substation step up the voltage for long distance transmission.

Having used up much of its energy in turning the turbines, the now low-pressure steam is condensed to liquid form and sent back to the steam generator for re-use. The water which cools the steam becomes warm and is sent to the cooling tower. Trickling down over what seems to be thousands of venetian blinds, a small percentage of the water evaporates, cooling the remainder. The purpose of the huge tower is to cause a draft which will aid in the evaporation and carry the heat high into the atmosphere where it dissipates. The cooled water can then be recycled to the condenser to cool more steam.

Three Mile Island Nuclear Generating Station

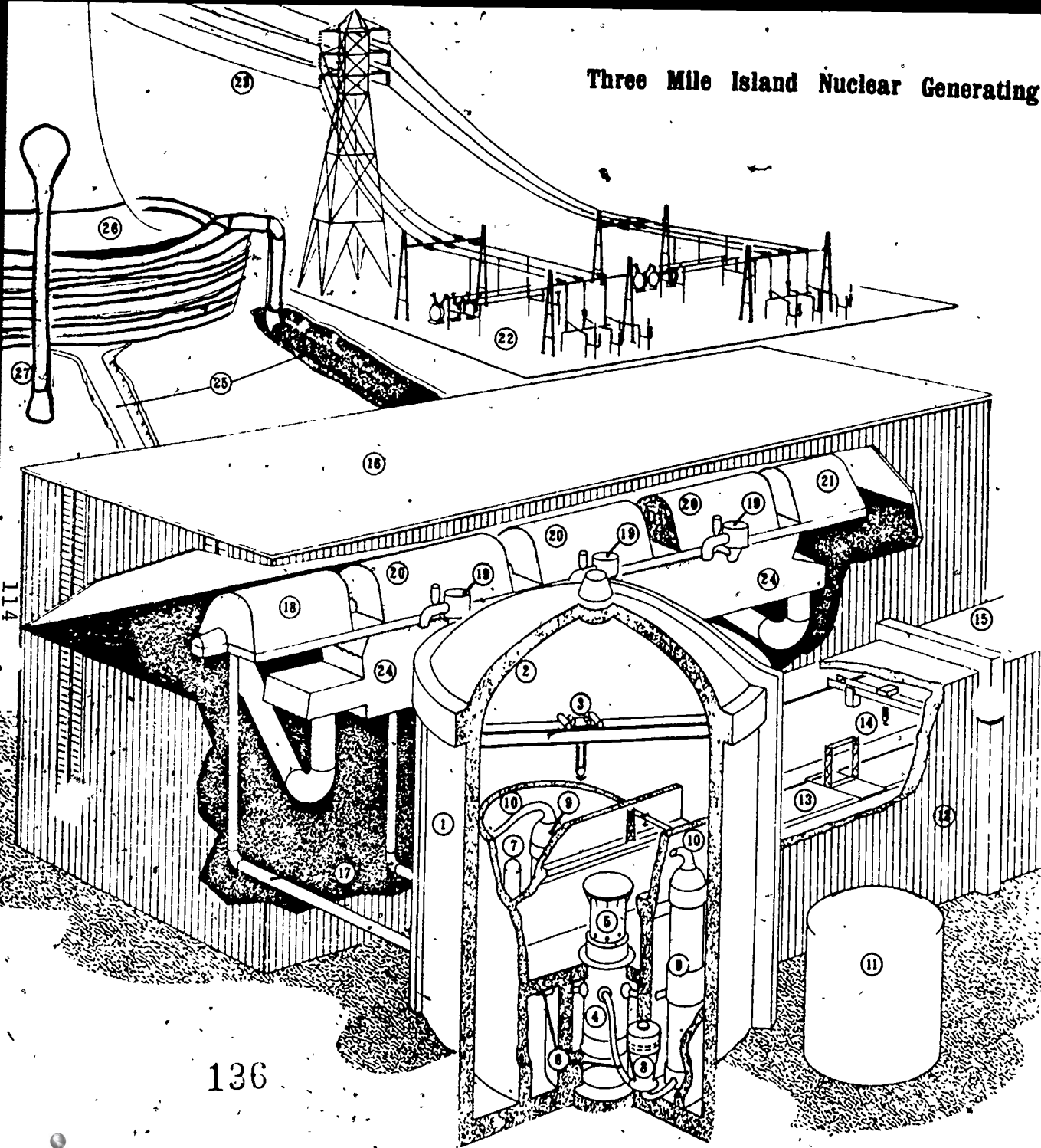

1. Containment Structure
2. Containment Enclosure Shell
3. Containment Building Crane
4. Reactor Vessel
5. Control Rod Machinery
6. Reactor Coolant Pipes
7. Pressurizer
8. Reactor Coolant Pump
9. Steam Generators
10. Main Steam Lines
11. Borated Water Tank
12. Fuel Handling Building
13. Spent Fuel Storage Pool
14. Fuel Manipulation Crane, Platform Bridge & Hoist
15. Fuel Shipping Area
16. Turbine Building
17. Main Steam Piping
18. High Pressure Turbine
19. Moisture Separator
20. Low Pressure Turbines
21. Electrical Generator
22. Electrical Substation
23. High Voltage Transmission Lines
24. Condenser
25. Cooling Water Loop
26. Cooling Tower
27. Watersphere (For Filtered Water and Fire Service).

LIQUID METAL FAST BREEDER REACTOR

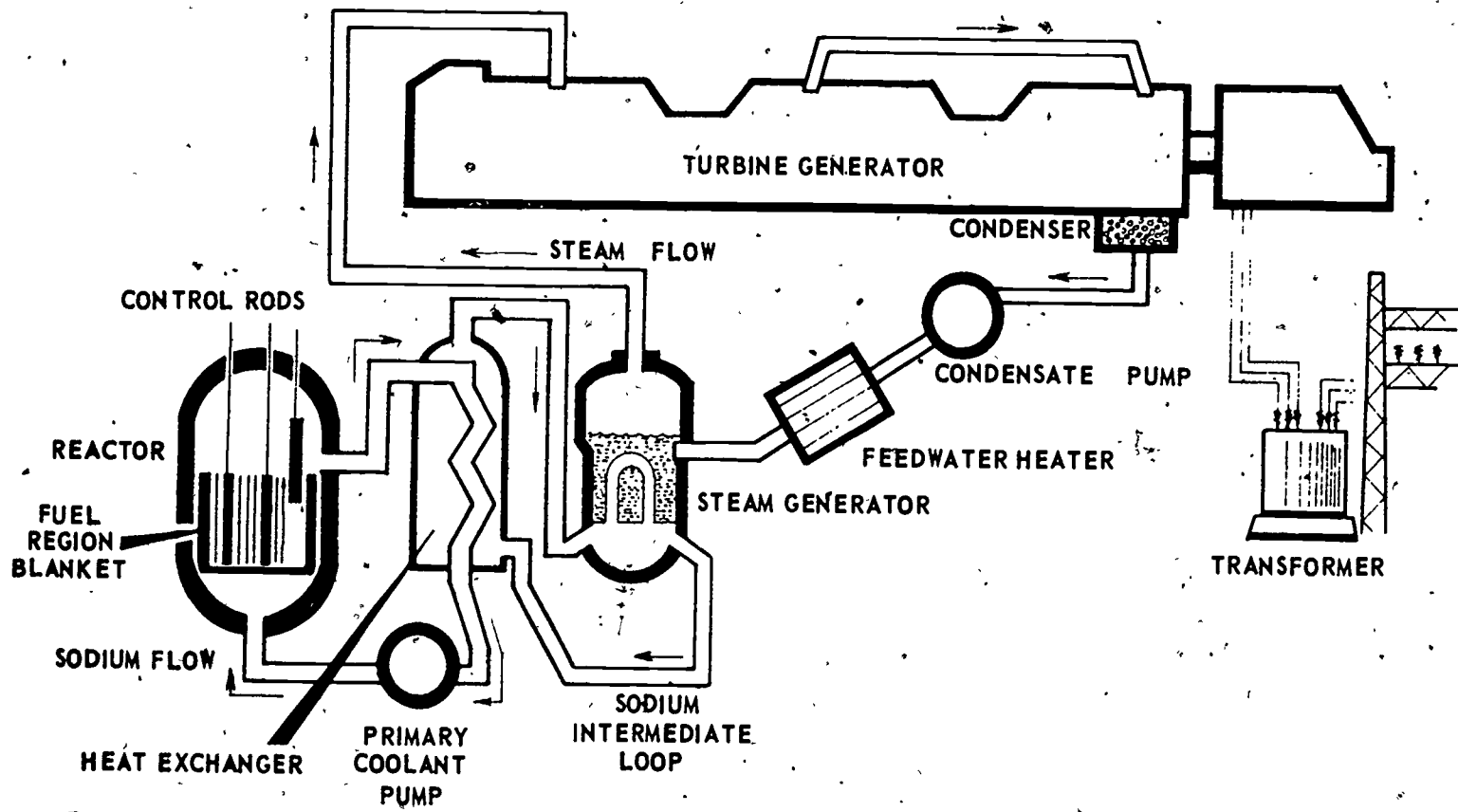

115

38

139

NUCLEAR FUSION

Nuclear fusion is the fusing of hydrogen ions at very high temperatures to form the heavier element helium. Mass is lost during this process and is changed into enormous quantities of energy by Einstein's formula, $E = mc^2$. This energy could then be used to produce electricity. The energy of the sun comes from this process where 40 billion tons of hydrogen are fused per minute.

Hydrogen occurs largely in nature as light hydrogen (H^1), heavy hydrogen or deuterium (H^2), and tritium that can be used in the controlled fusion reaction. The best source of deuterium is sea water, but tritium must be manufactured from lithium, since the amount of it found in nature is too small. Lithium is fairly abundant in the earth's crust, and sea water is abundant, so that there is sufficient fuel for fusion to last for hundreds of years. If the reaction can be made to occur using only deuterium, there will be sufficient fuel for thousands of years.

In addition to the abundance of fuel, fusion has other advantages. The radioactive by-products are much fewer in number than those of fission reactions. In addition, the reaction does not need to be controlled as does a fission reaction because there is no chain reaction involved.

However, there are stringent conditions that must be met before fusion can take place, and so far research has not completely provided these conditions. Temperatures near 100-million degrees must be reached at high enough density and for a long enough period of time for a reaction to occur.

Many technical problems must be overcome before any of these processes are workable, let alone being scaled up for commercial usage. At this point in time, more energy is being put into the reaction than is being produced. Optimists predict a break-through in the 1980s, but most scientists feel that success will be at least several decades in the future.

NUCLEAR FISSION

Composition/ Origin	Uranium and thorium ores
Location	Ores are found in Colorado Basin, Canada, South Africa, Zaire, India.
Extraction/ Conversion	Chemical processing concentrates ore; enrichment of desired isotopes by physical means, e.g., gaseous diffusion. In nuclear reaction, nuclei of heavy atoms of "fissionable" isotope are bombarded by neutrons causing nuclei to split, converting the matter to great quantities of heat. Fission of one atom releases neutrons causing a chain reaction, splitting other atoms in a controlled process. Turns water to steam to drive turbines and produce electricity.
Uses	100% electrical generation

SOURCE	HOW CONVERTED	COMMENT
Nuclear Fission (breeder reactor)	Uses U-235 as "starter" to bombard surrounding atoms of nonfissionable U-238 and convert it to Plutonium 239 which is fissionable, "creating" more starter.	Uses less scarce U-235 than present light-water reactors. Some plutonium is produced directly in light-water reactors; is cooled by liquid sodium (difficult to handle). Possibility of accident, especially during transportation of wastes, more of a concern with plutonium than with uranium. Technological difficulties.
Thermonuclear Fusion	Fusion of atoms of hydrogen to form heavier atoms of helium under extremely high temperatures (100 million degrees C) in a controlled reaction (as opposed to the uncontrolled fusion reaction of a hydrogen bomb.)	Hydrogen is very abundant. Ordinary seawater could be used as source of fuel. Very efficient reaction. Releases only small amounts of radioactivity. However, it is technologically very difficult to achieve a controlled reaction at present levels of technology and knowledge.

811

TITLE: THE NUCLEAR REACTOR

LEVEL: Science

OBJECTIVE: To develop an understanding of the nuclear reactor and its potential for producing electricity.

MATERIALS: Library and research skills and materials

ACTIVITY: The nuclear reactor is a device for the controlled fission of a fuel (uranium and thorium). Nuclear fission occurs when heavy atoms, on being struck in the right way by a subatomic particle called a neutron, split into two or more fragments and release energy in the process.

Have students conduct library research and contact organizations to learn about the operation of a nuclear reactor and its potential use in the future. Students should obtain answers to the following questions.

1. What are the components of the nuclear reactor system? How does the system operate?
2. How efficient is the nuclear power plant in comparison to the fossil-fueled plant?
3. Does nuclear energy compete economically with other forms of energy?
4. What are the most serious dangers involved in the production of nuclear energy?
5. What are the major kinds of safety systems built into the nuclear power plant?
6. What is the "emergency core cooling system" in a nuclear reactor? Explain.
7. How is radioactive waste transported, stored, and disposed of?
8. How do thermal discharges from the nuclear power plant affect the life cycles of aquatic plant and animal life?
9. Can we afford to bypass the construction of more nuclear power plants for cleaner and safer means of generating electric power? If so, what are the best alternatives to nuclear power?
10. What agency approves the licensing of a nuclear power plant?

11. How many nuclear power plants are now under construction in Louisiana? Where are these plants located? How many plants does Louisiana plan to build during the next 10 years? Where will these plants be located?
12. What criteria does Louisiana use to select sites for nuclear plants?
13. What is a nuclear park?
14. What is the Price-Anderson Act? Explain.
15. Where are known reserves of uranium located in the United States? In other countries? How long would uranium reserves in the United States last based upon present consumption rates? Could the breeder reactor greatly extend uranium supplies? If so, how? To what extent does the United States sell uranium to foreign countries? Why is this done? Does the United States import uranium?
16. What is a nuclear reprocessing plant and how does it function?

CONTACT ORGANIZATIONS:

1. Clinch River Breeder Reactor Plant Project, P.O. Box U, Oak Ridge, Tennessee 37830
2. Energy Research and Development Administration, 20 Massachusetts Avenue, NW, Washington, D.C. 20545
3. Nuclear Regulatory Commission, Washington, D.C. 20555
4. Tennessee Valley Authority, 400 Commerce Avenue, Knoxville, Tennessee 37902
5. East Tennessee Energy Group, 1538 Highland Avenue, Knoxville, Tennessee 37916
6. Tennessee Energy Office, Suite 250, Capitol Hill Building, 7th and Union, Nashville, Tennessee 37219
7. Tennessee Environmental Council, P.O. Box 1422, Nashville, Tennessee 37202
8. Tennessee Friends of the Earth, Box 12489, Nashville, Tennessee 37212

9. Tennessee Citizens for Wilderness Planning,
130 Tabor Road, Oak Ridge, Tennessee 37830
10. American Association for the Advancement of
Science, 1515 Massachusetts Avenue, NW,
Washington, D.C. 20036
11. American Nuclear Society, 244 East Ogden
Avenue, Hinsdale, Illinois 60521
12. Atomic Industrial Forum, Inc., 475 Park Avenue
South, New York, New York 10016
13. National Intervenors, 153 E. Street, SE,
Washington, D.C. 20003
14. Scientists' Institute for Public Information,
49 East 53rd Street, New York, New York 10022

FIELD TRIP SITES:

1. Little Gypsy Steam Generating Plant, Montz,
Louisiana
2. Louisiana Power & Light Waterford Steam Generating
Plant, Taft, Louisiana
3. Gulf States Utilities River Bend, St. Francisville,
Louisiana
4. Mississippi Power & Light Grand Gulf, Port Gibson,
Mississippi
5. Nine Mile Point Steam Generating Station, Westwego,
Louisiana.

TITLE: HOW MUCH URANIUM?

AREA: Science, Mathematics

OBJECTIVE: To calculate the amount of uranium available for light-water reactors and breeders.

MATERIALS: Library resources

ACTIVITY: Give the students the data contained in Tables 1 and 2.

1. Ask them to calculate the amount of U_3O_8 needed to keep the 1975 installed capacity operating until 2000, and 2030.
2. Can this U_3O_8 be obtained from the reserves?
3. How long can we keep the 1975 installed capacity operating if we use reserves, probable and possible resources (at \$30/lb.)?
4. How much U_3O_8 (cumulative) is required by the year 2000 for the mid-growth scenario?
5. Can this be obtained from the reserves?
6. How much cumulative U_3O_8 would be required to operate the installed 2000 capacity until the year 2030 in the mid-growth?
7. From what reserve or resource area must this come?
8. If conventional reactors use only about 1% of the energy in uranium and breeders use 50% of the energy, how long could the U.S. operate 510,000 MW on the quantities of uranium in the (a) reserves, (b) reserves and possible and probable resources (at \$30/lb.)?

Teacher Notes:

- ANSWERS:
1. 25 yrs. x 9.TT* 1 yr. = 225TT
 2. Yes
 3. Reserves + probable + possible =
640 + 1060 + 1270 = 2970 x TT
 4. 1,195 TT

**TT = Thousand tons

5. No
6. $1,195 \text{ TT} + 82 \text{ TT/yr.} \times 30 \text{ years} = 365 \text{ TT}$
7. Reserves + probable + possible + speculative + ?
8. 510,000 MW uses 82 TT/year for conventional
or 1.64 TT for breeder (assuming 50 times more efficient)
 - a. $\frac{640 \text{ TT}}{1.64 \text{ TT/yr.}} = 390 \text{ yrs.}$
 - b. $640 + 1060 + 1270 = 2970 \text{ TT}$
 $\frac{2970 \text{ TT}}{1.640 \text{ TT/yr.}} = 1811 \text{ yrs.}$

TABLE 1 U.S. URANIUM RESOURCES (THOUSAND TONS U_3O_8)

\$/LB U_3O_8 Cutoff Cost	Reserves	Potential			Total
		Probable	Possible	Speculative	
10	270	440	420	145	1,275
15	430	655	675	290	2,050
30	640	1,060	1,270	590	3,560
By-product from copper and phosphate production 1975-2000	140				3,700

Source: Statistical Data of the Uranium Industry - 1976, ERDA, Grand Junction, Colorado. January 1, 1976.

TABLE 2 ANNUAL AND CUMULATIVE U_3O_8 REQUIREMENTS UNITED STATES 1975-2000 (ERDA MID Scenario)

	1975	1980	1985	1990	2000
Installed Capacity	39,000MW	67,000MW	145,000MW	250,000MW	510,000MW
U_3O_8 Requirements, Annual (Thousand Tons)	9	19	36	55	82
U_3O_8 Requirements, Cumulative (Thousand Tons)	9	73	220	455	1,195

Source: 1975: Edward J. Hanrahan, Energy Research and Development Administration, Demand for Uranium and Separative Work, Atomic Industrial Forum Fuel Cycle Conference, 1976, Phoenix, Arizona.

1980-2000: Edward J. Hanrahan, Richard H. Williamson, and Robert H. Brown, World Requirements and Supply of Uranium, September 14, 1976, AIF International Conference on Uranium, Geneva, Switzerland.

- TITLE: A LOT FOR A LITTLE
- AREA: Science
- OBJECTIVE: To describe the various kinds of nuclear reactors and the ways in which both U-235 and U-238 can be used as energy sources.
- MATERIALS: Library, research skills and materials
- ACTIVITY:
1. Review the reaction for the light-water (converter) reactors. Describe the reactants and the products.
 2. Compare and contrast the two types of converters (PWR and BWR).
 3. Distinguish between this reaction and that of the breeder reactor. Have students list advantages and disadvantages of each process.
 4. Have students propose solutions as to what to do with nuclear wastes.

Teacher Notes:

Reference: National Science Teachers Association. Energy-Environment Sourcebook, 1975.

TITLE: THE ECONOMICS OF NUCLEAR VS. COAL-FIRED PLANTS

AREA: Science, Mathematics

OBJECTIVE: To calculate the cost factors of nuclear versus coal electrical generation and explore how changes in the current costs will affect the future comparative costs of these two energy sources.

MATERIALS: Pencil

ACTIVITY: The following questions are exercises in calculating electrical generation costs:

1. In 1976 dollars, a nuclear power plant costs \$667/KW to build.
 - a. What is the cost of a 1,000 MW plant?
 - b. If the plant has a 60% capacity factor, how many KWH will be generated in one year from a 1,000 MW plant?
 - c. If there is 13% capital charge rate, what is the capital charge/KWH in mills? KWH?
2. A coal power plant with scrubbers costs \$555/KW to build. Given the same 60% capacity factor and a 13% capital charge rate, what is the capital charge/KWH?
3. Which plant is cheaper per KWH to construct?
4. If U_3O_8 costs \$30/lb and a 1,000 MW plant operating @ 60% capacity uses 200 tons/yr., what is the cost of nuclear fuel in mills/KWH?
5. If coal costs $\$1.08/10^6$ BTU* and a 1,000 MW plant operating @ 60% requires 48.66×10^{12} BTU, what is the cost of fuel in mills/KWH?
6. Which plant costs less to fuel?

*Based on a cost of \$17.00/ton and $15/74 \times 10^6$ BTU/ton.

7. Better cost figures for coal and nuclear are obtained by adding operations and maintenance for both fuel treatment for nuclear and transportation for coal: Cost mills/KWH:

	<u>Nuclear</u>	<u>Coal with Scrubber</u>
Operations & Maintenance	2.0	2.8
Fuel		2.0
Conversion to U_{235}	.1	
Enrichment	2.0	
Fabrication	0.4	
Spent fuel, storage, disposal	0.4	
		Transportation

Add in the values obtained for capital charges and fuel costs and compare the costs of nuclear versus coal.

8. The future cost of nuclear versus coal. Calculate what will happen to cost of electrical production with the following changes:
- The cost of nuclear plant construction increases to \$2667/KW when coal goes to \$1665/KW.
 - The cost of U_{235} increases to \$100/lb. and coal to \$2.16/10⁶ BTU.
 - a + b
 - Suppose that five years from now, the cost/KWH of all costs of nuclear and coal have doubled. How expensive can U_{235} become and still keep nuclear competitive with coal?

Teacher Notes:

ANSWERS:

$$\begin{aligned}
 \text{1a. } & 1\text{MW} = 1,000 \text{ KW} \\
 & \text{Cost} = \$667 \times 1000 \times 1000 = \\
 & \quad \$667,000,000 \\
 \text{1b. } & 365 \text{ days} \times .24 \text{ hrs.} \times 1000 \text{ MW} \times \\
 & \quad 1000 \times .60 = 5265 \times 10^6 \text{ KWH/yr.} \\
 \text{1c. } & \$667 \times 10^6 \times .13 = \$86.71 \times 10^6 \text{ yr.} \\
 & \frac{\$86.71 \times 10^6 \text{ yr.}}{5256 \times 10^6 \text{ KWH/yr.}} = \$.0165/\text{KWH} \\
 & = 16.5 \text{ mills/KWH}
 \end{aligned}$$

$$2. \quad \$555 \times 10^6 \times .13 = \$72.15 \times 10^6 \text{ yr.}$$

$$\frac{\$72.15 \times 10^6 \text{ yr.}}{5256 \times 10^6 \text{ KWH/yr.}} = 13.7 \text{ mills/KWH}$$

3. Coal with scrubber

$$4. \quad \$30/\text{lb.} \times 200 \text{ tons} \times 2000 \text{ lbs./ton} =$$

$$\quad \quad \quad \$12 \times 10^6 \text{ yr.}$$

$$\frac{\$12 \times 10^6 \text{ yr.}}{5256 \times 10^6 \text{ KWH/yr.}} = \$.0023/\text{KWH}$$

$$= 2.3 \text{ mills/KWH}$$

$$5. \quad \$1.08/10^6 \text{ BUT} \times 48.66 \times 10^{12} \text{ BTU/yr.} =$$

$$\quad \quad \quad \$52.56 \times 10^6 \text{ yr.}$$

$$\frac{\$52.56}{5256 \times 10^6 \text{ KWH}} = \$.010/\text{KWH}$$

$$= 10 \text{ mills/KWH}$$

6. Nuclear

7. Nuclear total = 23.7 mills/KWH
Coal total = 28.5 mills/KWH

$$8a. \quad \frac{\text{Nuclear increase } \$2668}{\$667} = 4x$$

$$\text{Capital charge} = 16.5 \times 4 = 66$$

$$\text{increase} = 49.5$$

$$\text{New total cost} = 49.5 \times 23.7 = \underline{73.2} \text{ mills/KWH}$$

Coal

$$1665/\$555 = 3x$$

$$\text{Capital} = 13.7 \times 3 = 41.1 \text{ mills/KWH}$$

$$\text{increase} = 27.4$$

$$\text{Total coal} = 28.5 + 27.4 = 55.9 \text{ mills/KWH}$$

$$8b. \quad \frac{\text{Nuclear } \$100}{\$30} = 3.33x$$

$$U_{38} = 2.3 \text{ mills/KWH} \times 3.33 = 77$$

$$\text{increase} = 5.4$$

$$\text{Nuclear} = 23.7 + 5.4 = 29.1 \text{ mills/KWH}$$

$$\text{Coal } 2.16/1.08 = 2x$$

$$\text{Coal} - 10.00 \text{ mills/KWH} \times 2 = 20.00$$

$$\text{increase} = 10.00$$

$$\text{New coal} = 28.5 + 10 = 38.5 \text{ mills/KWH}$$

8c. Nuclear -

$$23.7 + 5.4 + 49.5 = 78.6 \text{ mills/KWH}$$

Coal -

$$28.5 + 10 + 27.4 = 65.9 \text{ mills/KWH}$$

8d. Nuclear cost - $U_3O_8 = 21.4$

$$\text{doubled} = 43.4 \text{ mills/KWH}$$

$$\text{If coal doubles} = 57.0 \text{ mills/KWH}$$

$$\text{To be competitive } U_3O_8 = 57.0 - 42.4 = 15.6 \text{ mills/KWH or less.}$$

$$\$0.0156/\text{KWH} \times 5256 \times 10^6 \text{ KWH} = \$81.99 \times 10^6 \text{ yr.}$$

A plant uses 4×10^5 lbs./yr.

$$\text{Cost: } \frac{\$81.99 \times 10^6}{4 \times 10^5 \text{ lbs.}} = \$205/\text{lb.}$$

U_3O_8 can cost up to \$205/lb.

155

Supplementary Activities

Using the information on the map below, locate and try to name the nuclear power plants near Louisiana. Is this a heavily concentrated region? Why is this so?

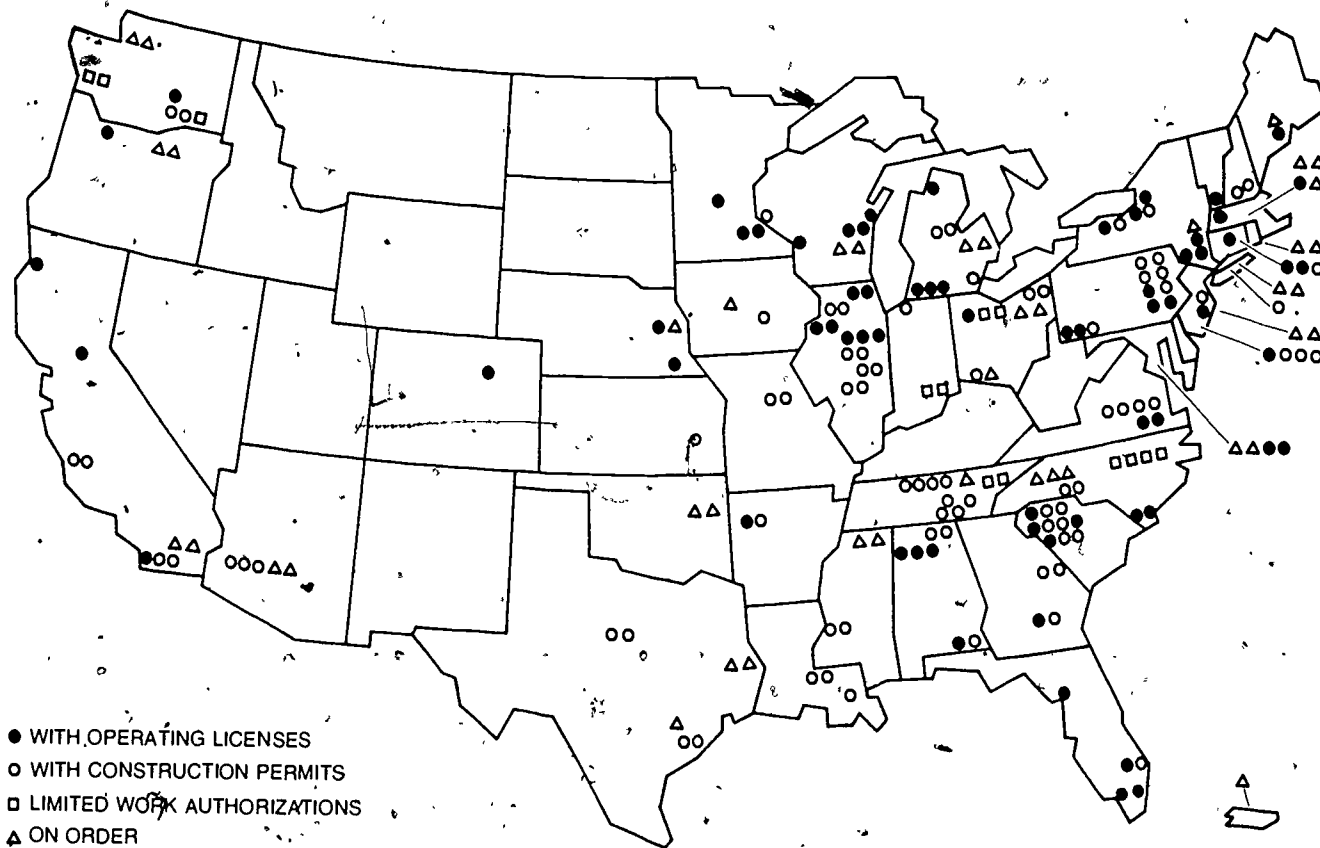

Nuclear power plants operable, under construction or proposed at the beginning of 1978

130

156

157

- TITLE:** BIOLOGICAL AND ECOLOGICAL EFFECTS OF RADIATION
- AREA:** Science, Mathematics
- OBJECTIVE:** To calculate the amount of radiation in his/her own environment.
- MATERIALS:** Library, research skills
- ACTIVITY:**
1. Review radiation effects as discussed in the introduction to this unit on nuclear energy.
 2. Discuss the four kinds of nuclear radiation as depicted in the accompanying master.
 3. Using the accompanying student activity sheet, have each student compute his own radiation dosage.
 4. Plan a class discussion or assign a written composition on the following questions:
 - a. How large a part does radiation from a nuclear power plant play in your radiation dosage?
 - b. If you were going to be a nuclear engineer and work in a nuclear plant, how would you adjust your lifestyle so as to keep your dosage about 200 mrem?
 - c. If three nuclear power plants were to be built in Louisiana, where would you place them to minimize radiation dosage for all Louisianians?
 - d. Is the radiation from a nuclear power plant harmful?
 - e. What are some ways in which people working in radiation areas, such as x-ray technicians, nuclear engineers, and radiation biologists, protect themselves from radiation exposure?
 - f. What are some of the important uses of radiation in agriculture?

Teacher Notes:

- ANSWERS: 4a. Very small
- 4b. Build your house out of wood. Avoid unnecessary x-rays, etc.

- 4c. As far apart as possible.
- 4d. The nuclear proponent would probably say that the amount of radiation from a plant is so small compared to background or other man-made radiation that it is negligible. The nuclear opponent would counter by saying that any additional radiation is harmful--even very small quantities.
- 4e. Shields, remote handling, cleanliness, dosimeters (film badges).
- 4f. Control of insects through sterilization of males, causing mutations in plants, preserving food, stimulating plant growth, as a tracer in physiology studies.

Note:

Several excellent films are available regarding the effects of radiation on the environment. Teachers should contact the vendors of free loan films listed in free and inexpensive resources to obtain information.

TITLE: COMPUTE YOUR OWN RADIATION DOSAGE

AREA: Science, Mathematics, Health

OBJECTIVE: To compute radiation dosage

MATERIALS: Listed in activity

ACTIVITY: We live in a radioactive world. Radiation is all about us and is part of our natural environment. By filling out this form, you will get an idea of the amount you are exposed to every year.

	Common Source of Radiation	Your Annual Inventory
WHERE YOU LIVE	Location: Cosmic radiation at sea level Add 1 for every 100 feet of elevation Typical elevations: Pittsburgh 1200; Minneapolis 815; Atlanta 1050; Las Vegas 2000; Denver 5280; St. Louis 455; Salt Lake City 4400; Dallas 435; Bangor 20; Spokane 1890; Chicago 595. (Coastal cities are assumed to be zero, or sea level).	40
	House construction (1/4 time factor): Wood 35, Concrete 45; Brick 45, Stone 50.	—
	Ground: (1/4 time factor) - U.S. Average	15
WHAT YOU EAT, DRINK & BREATHE	Water, Food, and Air: U.S. Average	25
HOW YOU LIVE	Jet Airplanes: Number of 6000-mile flights _____ x 4	—
	Television viewing: Black and white: Number of hours per day _____ x 1 Color: Number of hours per day _____ x 2	—
	X-ray diagnosis and treatment: Chest x-ray _____ x 100-200 Gastrointestinal tract x-ray _____ x 2000 Dental x-ray _____ x 20	—
	Compare your annual dose to the U.S. Annual Average of 225	Sub Total ___mrem
HOW CLOSE YOU LIVE TO A NUCLEAR PLANT	At site boundary: Annual average number of hours per day _____ x 0.2	—
	One mile away: Annual average number of hours per day _____ x 0.02	—
	Five miles away: Annual average number of hours per day _____ x 0.002	—
	Over 5 miles away: _____ None	—
		Total ___mrem

One mrem per year is equal to: Moving to an elevation 100 feet higher
Increasing your diet by 4%
Watching one additional hour of black and white TV per day
Taking a 4-5 day vacation in the Sierra Nevada Mountains.

TITLE: DETECTING RADIATION

AREA: Science

OBJECTIVE: To measure the intensity of radiation, the effect of air on beta particles and gamma rays, and the absorption of radiation.

MATERIALS: Scalar counter, gamma sources, beta sources, lead sheets, paper and aluminum sheets, Coleman lantern mantle, sand from weighted tape dispenser, dial from clock painted with luminous paint.

ACTIVITY: I. TEST. To determine if the scalar counter is working properly. Be certain that the high voltage is turned off. Too much damage will ruin the GM tube. All radiation is to be recorded in counts per minute. The counter will count the radiation and time your experiment for you. The timer will measure to the .01 of a minute; therefore, when the timer reads 100, a minute has elapsed. In the test the electricity will be registered. You should get 60 counts per second. If you allow the counter to run for one minute, what should the counter read?

_____ c/m

II. BACKGROUND. Background radiation is the radiation about you. This radiation is natural from both the earth itself and outer space. Naturally man has increased this level with atmospheric testing of bombs. Since this number will be used to correct your readings, you should take at least three readings and average the numbers.

III. INTENSITY OF RADIATION. To measure the radiation being given off by different radioactive sources, place the sources where you can get maximum count. Place the sources at the same distance from the tube each time. All sources will emit beta particles and gamma rays. You will test a Coleman lantern mantle which has Th-232. Its half-life is 1.4×10^{10} years. After the mantle has burned, it is still radioactive. The mantle emits alpha and beta particles. The government does not regulate this radiation to which you are exposed.

IV. EFFECT OF AIR ON BETA PARTICLES AND GAMMA RAYS. To determine the effect of air on beta particles and gamma rays, place the radioactive source 10 cm from the window. Determine the count. Repeat at intervals of 5 cm up to 60 cm. Perform once for a strong gamma source and once for a strong beta source. Graph this data. The time should be on the X-axis since it

changes at regular intervals. The counts should be on the Y-axis since it changes at irregular intervals. Put both the gamma and beta on the same graph; put a color key on the graph.

V. ABSORPTIVE EFFECT. To determine the absorption of radiation by various solids, begin with a single sheet of paper; progress to the aluminum and then to the lead.

See following pages for data sheets.

162

DATA SHEETS

Background Radiation

_____ c/m

_____ c/m

_____ c/m

_____ c/m average background

Intensity of Radiation

Material Used	Type of Radiation	Count	Corrected Count

136

163

164

Effect of Air

Distance	Source	Count	Corrected Count	Source	Count	Corrected Count

137

165

166

Absorptive Effect

Radiation	Material	Count	Corrected Count

138

167

168

TITLE: RADIOACTIVITY OF AIR

AREA: Science, Mathematics

OBJECTIVE: To measure the amount of radioactivity in a collected air sample.

MATERIALS: Vacuum cleaner, Geiger counter, means of measuring air flow

ACTIVITY: Entire class will take information from a single demonstration following the procedure below. Fill in the data sheet provided with the experiment, do all the calculations and complete the questions at the end of the experiment.

The apparatus needed for this experiment will include a vacuum cleaner, Geiger counter and a means of measuring the air flow. (Note: students are to be involved in figuring out this technique.) The yield of a Geiger counter equals the counts per minute divided by the disintegrations per minute. For most Geiger counters it is approximately 4%. Additional information needed: One Currie equals 3.7×10^{10} dps.

DATA TABLE

Rate of air flow _____ cu.ft/min.

Time air flow started..... _____ hrs.

Time air flow ended..... _____ hrs.

Volume of air used (computed)..... _____ cu. ft.

Counts per min. (computed)..... _____ cpm

 Beginning time..... _____ hrs.

 Ending time..... _____ hrs.

 Total count..... _____ minus background

Disintegrations per sec. (computed)..... _____ dps.

 (_____ cpm _____ yield) * 60

Change dps. to Micro Curries..... _____ uCi

 (one Ci equals 3.7×10^{10} dps.)

Concentration of Micro Curries/cu. ft... _____ uCi/cu.ft.

Concentration of Micro Curries/ml..... _____ uCi/ml

Accepted Value (EPA)..... _____ uCi/ml

Reference: Vollmer, Gerald W. Environmental Chemistry in Secondary School, 1974. Carey, Walter. Experiment on Radioactivity at Stone Laboratory. Activity suggested by Kenneth McCall, Science Teacher, Portsmouth High School, Portsmouth, Ohio.

TITLE: HALF-LIFE OF RADIOACTIVE ELEMENT

AREA: Science, Mathematics

OBJECTIVE: To plot a graph illustrating the half-life of a radioactive element (represented by pennies).

MATERIALS: Box, 100 pennies, graph paper (for each two students)

ACTIVITY: Place 100 pennies "heads-up" in a box. Close the box and shake it in all directions for several seconds. Now open the box and look at the pennies. The pennies that are laying "heads-up" represent radioactive atoms and those laying "tails-up" represent decomposed atoms.

Remove the "decomposed" pennies. Record the number of pennies remaining in the box (radioactive).

Repeat this several times and record the number of pennies remaining after each shake. Repeat this procedure until all pennies have been removed.

Using the scales on the theoretical graph below, plot the results. The amount of time it takes to shake the box and have one-half of the pennies "decay" is equivalent to the half-life of the pennies.

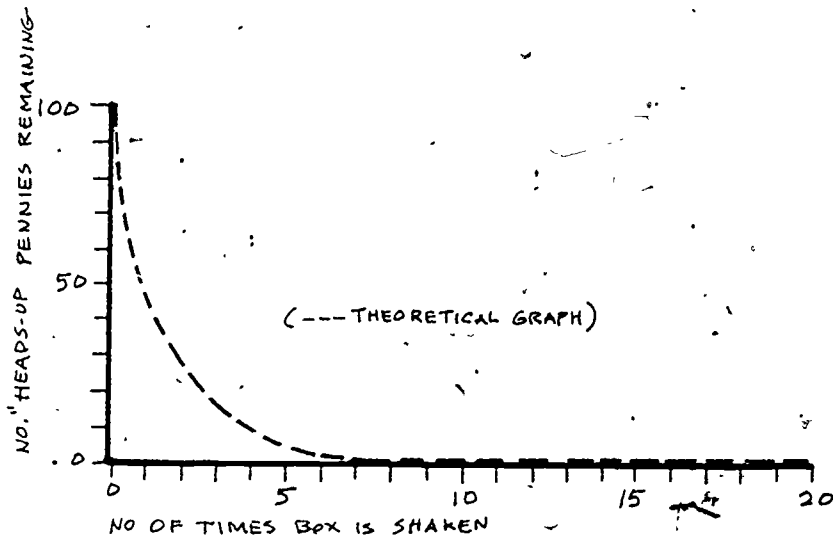

Collect and plot on a graph the data from each pair of students in the class. Compare the class graph to graphs for each pair of students and the theoretical graph of half-life (above).

Optional Activities

Plot on semi-log graph paper and/or plot logarithms of the number of pennies remaining each time vs. times shaken.

Find the equation for the line. Compare with the basic equation for decay.

Teacher Notes:

Students should shake the box for the same number of seconds and in the same manner each time. If a coin is leaning against the side of the box, it should be flipped over without being looked at.

171

TITLE: SMALL + SMALL = BIG + BIG

AREA: Science

OBJECTIVE: To diagram the fusion process and evaluate the state of technological progress in utilizing fusion as an alternative energy source.

MATERIALS: Listed in activity

ACTIVITY: Review atomic structure to include a discussion of isotopes. Focus on the isotopes of hydrogen: ordinary hydrogen, deuterium, tritium.

A. The energy from deuterium

1. If 1 g of deuterium releases 340 million BTU's, how much is released from one ton of deuterium?
2. If coal releases 25 million BTU's/ton, how does it compare with deuterium?
3. If the world uses 300×10^{15} BTU's/year, how many tons of deuterium would be required to supply that demand?
4. How many pounds of water would be required?
5. If the world's energy use remains constant and there are 10×10^{12} tons of deuterium available, how long would the deuterium last?
6. If the world's energy use doubled, how long would the deuterium last?

B. Fusion Reactions.

Ask the students to propose possible products for the following reactions:

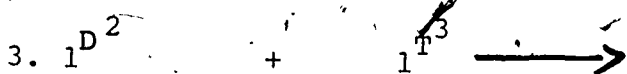
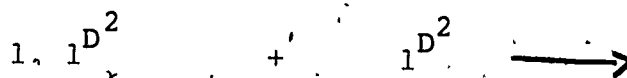

C. To Make the Reaction Work

Charge two pith balls with like charges and bring them together. Students should note how like charges repel one another—just as the positively charged D^+ of T^+ nuclei do.

How then are we to combine those nuclei to produce energy?

Ask the students to propose techniques, then discuss actual methods. (See Teacher Notes)

D. The Status of Fusion Reactors

Discuss with the students the problems of bringing nuclear fusion onto line. Emphasize the time and money that will be required to make fusion reactors a reality.

Teacher Notes:

ANSWERS

A. Deuterium is rare. It combines with oxygen to make the laboratory curiosity "heavy water." In a natural sample of water, only one molecule in 6500 is of that variety. In other words, in 60,000 pounds of water, there is only about 1 pound of deuterium. But water is enormously abundant and the earth's oceans, rivers, and lakes contain ten-trillion tons of deuterium. The world's total "recoverable" resources of coal are estimated to be only 6 to 8 million tons. In a fusion reaction between deuterium nuclei, the total amount of energy released is 340-million BTU's per gram of deuterium or about 1.5 quadrillion (1.5×10^{15}) BTU's per ton. In contrast, coal releases at most 25 million (25×10^6) BTU's per ton when burned. Thus each ton of deuterium could produce 60 million times more energy than a ton of coal.

The energy content of all this deuterium is difficult to comprehend. The total energy the world uses in one year could be obtained from 200 tons of it. Even if the world consumed twice the annual amount of energy it now does, the deuterium supply would last about 50 billion years--which is longer than we can be sure the world will last. The use of deuterium as a fuel is the most attractive fusion possibility.

B. In a fusion reaction two small nuclei (${}_1^2\text{D}$, ${}_1^3\text{T}$ or ${}_2^3\text{He}$) combine to produce a larger atom, an atomic particle, and energy.

1. ${}_2^3\text{He} + \text{N} \quad + 3.2 \text{ Me V}$
2. ${}_1^3\text{T} + \text{P} \quad + 4.0 \text{ Me V}$
3. ${}_2^4\text{He} + \text{N} \quad + 17.6 \text{ Me V}$
4. ${}_2^4\text{He} + {}_1^1\text{H} \quad + 18.3 \text{ Me V}$

Me V = millions of electron volts

1 Me V = 23 M BTU/g

C. How can the nuclei in reactions 1 to 4 be made to combine?

The problem is fairly simple to state. The reacting particles must be given enough energy to collide in spite of the electrical force trying to shove them apart. In a simple analogy, they must roll up over a hill before they can crash down together into the deep valley and give up energy.

Fusion reactions do occur in the sun and in hydrogen bombs. In those cases, energy is supplied in the form of heat. If a mixture of deuterium and tritium (D and T) can be held together and brought to a temperature of 50 to 100 million degrees Celsius (C), the fusion reaction will take place. The ignition temperature--as this reacting temperature is called--is about 500 million C for D + D mixture. Since the ignition temperature for D + T mixtures is lower, the experiments now underway concentrate on this reaction.

The enormous temperatures which are needed greatly limit confinement techniques. Ordinary vessels--bottles, cans, and tanks--cannot be used. The reacting particles must be suspended in a vacuum, free of any matter which could conduct their heat away. We know of two ways to accomplish this, magnetic confinement and inertial confinement.

In magnetic confinement, the deuterium-tritium mixture is given enough energy so that the electrons are stripped from the nuclei, forming a "plasma" of charged electrons and nuclei. This plasma can be controlled by

a magnetic field much in the same way that a beam of electrons is controlled in a television tube. Several different experimental approaches using magnetic confinement are described below.

In inertial confinement, a solid target, (a droplet or sphere) of deuterium and tritium is heated extremely rapidly so that it reaches the ignition temperature for fusion before it can expand and reduce its density. Bombardment of a small sphere of deuterium from all sides with a high powered laser is one method which may achieve this.

- D. Given the current status of fusion and the scientific and engineering problems which must be solved before the "scientific feasibility" of fusion can be demonstrated, it may seem premature to spend time considering what a commercial power producing plant would look like.

The production of fusion fuels, because of the enormous amounts of energy they contain, should cause little disruption of the environment. Removing one hydrogen atom in 6500 from the ocean will have no measurable effect on it and the amount of lithium needed is equally miniscule when compared to projected needs of coal or even uranium.

The fusion reaction would be, it appears, as environmentally benign as any technology except solar energy.

The fusion reaction, relying on abundant deuterium for fuel, could provide humankind with energy for millions, perhaps billions, of years and at modest cost to the environment. Unfortunately, in spite of almost 30 years of scientific and engineering labor, and a billion or so dollars spent in the U.S., we have not yet produced a self-sustaining, controlled reaction.

TITLE: NUCLEAR SCIENCE CAREERS

AREA: Science, Social Studies, Language Arts

OBJECTIVE: To identify career opportunities and educational requirements in the field of nuclear science.

MATERIALS: Listed in activity

ACTIVITY: A. The students will write for information related to career opportunities in nuclear science. To assure response to requests, attach stamped, self-addressed envelopes:

1. Society of Nuclear Medical Technologists
P. O. Box 284
Arlington Heights, Illinois 60006
2. National Science Foundation
1800 G. Street, NW
Washington, D.C. 20550
3. The American Society of Radiologic Technologists
645 North Michigan Avenue
Room 620
Chicago, Illinois 60617
4. Careers (Career Publication)
Box 135
Largo, Florida 33540
5. Nation Center for Information on Careers
in Education
1607 New Hampshire Avenue, NW
Washington, D.C. 20007

B. After students receive the information, they will identify the career which interests them most. They will list in order the educational and other preparatory needs to meet the requirements.

Optional Activities:

1. Make chart of careers and their descriptions.
2. Assemble career titles into bingo game.
3. Make bulletin board of collage depicting careers.
4. Guest speaker

- TITLE:** NUCLEAR ENERGY - VALUE CLARIFICATION
- AREA:** Science, Social Studies, Language Arts
- OBJECTIVE:** To examine the factors involved in site selection for a nuclear generating plant and the impact on the environment and the community.
- MATERIALS:** Library, resource materials
- ACTIVITY:** A. Organize the class so as to hold a simulated public hearing by the Louisiana Public Service Commission on a proposal by the Electric Company to build a new energy-producing plant in your community.

The following simulated situation can be adapted for a specific community to provide ideas for the background.

A new industry has chosen this area to build a new plant that will employ 500 people. The new industry has taken an option to purchase land along the main highway where it borders a tributary to a body of water (river or lake).

The Electric Company finds that they will need a new plant to supply the additional electrical energy for this plant and the increased smaller needs in this area. Its present plants are running at full capacity. They have chosen a site for the new plant which is adjacent to the one the new industry has selected. The Electric Company has decided to use nuclear energy to fuel the new plant. The factors considered by the Electric Company during plant site evaluation are: water supply, geology and subsurface, seismology, meteorology, proximity to transmission grid, demography, land usage and availability, labor supply (construction), impact on local aquatic and terrestrial environment, local economic impact, and ability to be licensed.

The environmental groups in the area have joined forces to point out some of the effects on the environment that the new electrical energy generating plant will probably produce.

The Public Service Commission has decided to hold a public hearing in the community to gather information to assist it in reaching a decision whether or not to grant permission for the Electric Company to build the new plant.

- B. One suggested organizational pattern for a class might be:
1. One group of three students to represent a team to present the Electric Company's position.
 - a. An engineer to present the background of why the company needs to build the plant.
 - b. Another engineer to present why the company has chosen the specific site.
 - c. A third engineer to bring out the positive side of the benefits to the community such as:
 - . Construction jobs while the plant is being built.
 - . Permanent jobs while the plant is in operation.
 - . Economic benefits to the community: payroll which will be spent in the community and property taxes.
 2. Another group of three students to represent a team to present the environmental group's position.
 - a. One to discuss water usage (pollution, industrial waste, a need for additional water supply).
 - b. One to discuss air pollution (need for smokestack controls, references to air pollution index).
 - c. One to discuss land usage (any history of flooding that might be pertinent, loss of farmland).
 3. One person to act as presiding officer.
 4. Five students to act as members of the Public Service Commission.
 5. One student(s) to act as a reporter for the local newspaper.
 6. Remainder of the class to act as public citizens attending the hearing with questions and comments ready when requested.

- C. One possible format for the hearing might be:
1. Allot 15 minutes (5 minutes to each member of a team) for presentation of the Electric Company's position.
 2. Allot 15 minutes (5 minutes to each member of a team) for presentation of the environmental group's position.
 3. Allot 5 minutes for the environmental group to cross-examine and rebut the Electric Company's position.
 4. Allot 5 minutes for the Electric Company's team to cross-examine and rebut the environmental group's position.
 5. Allot 5 minutes for questions and comments from the public citizens.
- D. At the conclusion of the hearing, the Commission Members should vote on the question. Then the entire class should evaluate the activity, discussing the questions raised, pros and cons, etc. Perhaps parallels might be drawn which include actual situations.

ENERGY

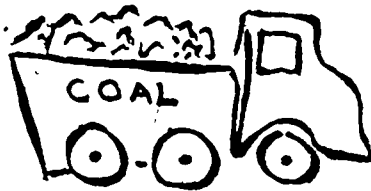
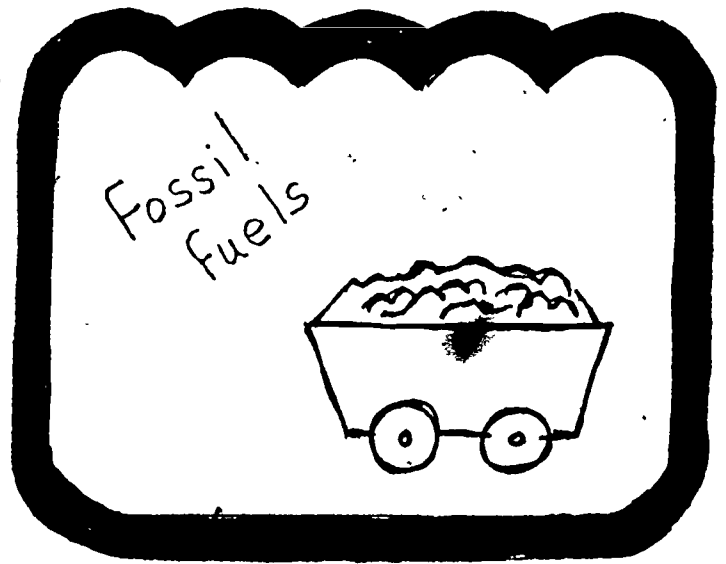

COAL:

COAL constitutes 89% of all fossil fuel reserves in the United States. It is undoubtedly a major fuel source of the future. There are some problems, however, in the use of our coal reserves. The sulfur content and other combustion residue of our coal make it difficult to meet environmental regulations. There are processes to remove the sulfur before burning the coal, but they are quite costly at present.

The environmental problems surrounding coal also include mining techniques. Strip mining, where the top layer of earth, the overburden, is removed to expose the coal area, is an increasingly controversial problem. Great and expensive efforts have been made to reclaim the earth for later use. However, all of the environmental precautions greatly add to the total cost of our most abundant fossil fuel reserves.

Today's students are likely to be unfamiliar with the use of coal as an energy supplier, but only 45 years ago coal was the most widely used energy source in the world. In 1947, coal supplied as much as 50% of

America's energy needs while in 1971, it supplied under 18% of the total. Development of petroleum and natural gas reserves dealt a severe blow to the coal industry and relegated coal to a poor third place in the energy race. With the present energy problems, however, the picture is likely to change again.

Estimates of present coal reserves and how long these reserves will last vary widely, depending upon who is providing the figures. The Geological Survey estimates that there are about 217 billion tons of identified, economically recoverable reserves of coal. (USGS, 1974) The total amount of known coal is actually much higher since there are known to be 1300 billion tons that cannot be recovered economically using present technology. This figure includes the 50% of the coal in most underground mines which is left to support the roof. There are then about 1.5 trillion tons of identified coal in the United States. (USGS, 1974)

How long will this coal last us? This question can only have a qualified answer. Energy experts have given estimates of from 200 to 500 years, but any estimate depends on how the coal is to be used and on the rate of coal consumption. If the consumption of coal continues at its present rate and if the coal is used directly in power generating stations, our reserves could last 300 years or more. It is more likely, however, that the rate of coal consumption will increase and that some part of the coal reserves will be used in gasification or liquefaction plants, which are themselves energy consuming. This will result in the shortening of the lifetime of these reserves. Louisiana historically has used little coal because of the abundance of wood and natural gas. Production of lignite is beginning in northwest Louisiana.

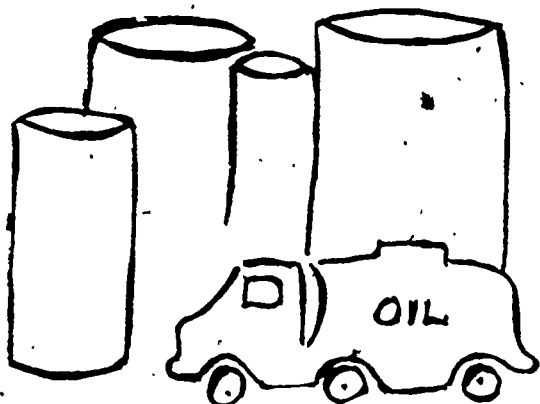

CRUDE OIL:

CRUDE OIL supplies more than half of the nation's energy needs. It is the basis from which many everyday items are produced, as well as the actual source of heating fuels, gasoline, lubricating oils and asphalts. At present, it is the foundation of much of the world's economy.

Crude oil is found in many countries throughout the world, but major reserves are located in the Western Hemisphere, Middle East and North Africa. A major problem arises when a country uses more petroleum than it produces and has to import oil from



another country. It becomes dependent on imports and subject to price increases or embargoes--as the United States experienced in 1973 and 1974 and since.

It is important to distinguish between "reserves" and "resources." Estimated proven reserves: identified by geological and engineering data as recoverable in future years from known reservoirs using present economic and operating conditions. Resources: undiscovered deposits probably economically producible, and presently known supplies that are uneconomic at today's prices. U.S. reserves will be sufficient for about 10 years (at present rate of consumption) and predicted resources are good for no more than 50 years.

After oil is found by exploratory drilling, it is pumped from its location deep within the earth's surface under sedimentary layers of sand and stone. Once the oil is pumped from the ground it is transported by pipeline or tanker to the refinery.

At the refinery the crude oil is processed into various groups of like characteristics. The three major processes at the refinery are separation, cracking, and treatment. For separation, the oil is heated to a high temperature. Oils separate into different vapors which are then cooled and collected in their liquid state. To increase the yield of high quality fuels, some of the separated components undergo cracking. This is a process in which hydrocarbon molecules are broken down, at high temperatures and pressures, often with the use of a catalyst, into smaller molecules.

After separation and cracking, the resulting products are often treated to reduce undesirable odors, or to improve combustion residues. Oil is usually treated to remove sulfur, which causes wear in equipment and pollutes the atmosphere.

Through experimentation with more efficient refining processes, scientists discovered petrochemicals. The gaseous by-products of the refining operations have given the world a major industry and over 3,000 different chemicals. Petrochemicals are the basis

for products such as synthetic rubber, plastics, detergents, dry cleaning fluids, antifreeze, aspirin, food preservatives, insulation and clothing.

Because we are increasing our imports of oil, the transportation of oil in tankers is becoming a bigger and bigger business. And the ships used to transport the oil are become bigger and bigger also. The "super tankers" of today are as long as three football fields, end to end, including end zones. Unfortunately ships occasionally have accidents and may spill part or all of their cargo into the sea. When a super tanker has an oil spill, the results can be devastating, as the accident in March of 1978 off the coast of Normandy, which spilled 120 million tons of oil. Oil kills birds and aquatic life and is a real environmental threat. As oil imports rise all over the world, oil spills become more probable.

Much of Louisiana's oil comes from Louisiana but a great deal is imported for production in more than 30 refineries.

Our world revolves around the use of fuels refined from crude oil: gasoline, aviation and jet fuels, kerosine, diesel fuels, heavy oils, lubricants and greases. The shortage and misuse of these products has given us the energy crisis, the solution of which begins with conservation and research into alternative energy sources.

OIL SHALE:

OIL SHALE is a rock containing a material that yields oil when it is crushed and heated. One ton of rock will produce about 25 gallons of oil. Most oil shale deposits are in the west. The rock must be mined, either by deep mining or surface mining. Extracting the oil takes large amounts of water--three barrels to every one barrel of oil processed. One of the big problems is the disposal of the spent rock after the oil is extracted. Vegetation will not grow on the used shale without a moderate amount of rain--scarce in many parts of the West. Without vegetation some animals may lose their homes and natural food supply. Rain water passing through this rock will possibly pick up pollutants and carry them to larger bodies of water if there is no vegetation. In addition, oil shale processing contributes to air pollution if not controlled.

NATURAL GAS:

NATURAL GAS and oil are found deep within our earth's surface in deposits of accumulated organic materials millions of years old. The NATURAL GAS, because it is lighter, is stored in the upper layers of the porous rock, with oil or salt water deposits below.

At first natural gas was considered a nuisance when its presence accompanied the discovery of oil; it was allowed to burn off. This practice is still going on at many of the oil wells in

the Middle East. It was soon discovered that natural gas is a very clean, efficient, and low cost fuel. Pipelines were built to carry it, and by 1958 it surpassed coal as our number two fuel.

Natural gas, today's most coveted fuel, is tapped from wells and pressurized within the pipeline in which it is transported. The gas is then moved to the scrubbers, where it is cleaned and dried before going to the pumping station. Natural gas is transported in the pipeline under 100 pounds of pressure per square inch, necessitating the placement of pumping stations every 200 miles.

Louisiana is the leading natural gas producing state in the nation. Much of the gas produced in the state goes elsewhere.

In the United States, natural gas is transported through 900,000 miles of pipeline to its many and varied customers. It cooks our food, heats our homes, processes many everyday products, and generates our electricity. It is an invisible, odorless gas to which a chemical odor is added for safety's sake, and and it has become our most exploited fossil fuel.

Natural gas can be flashcooled to -260° , at which temperature it becomes a liquid which may be stored in insulated tanks for future use. Its volume is condensed 600 times so the liquid natural gas (LNG) can be easily stored to supply peak demand during our cold winters. The entire operation of importing gas must include facilities for liquifying the gas at the source country, special ships for transporting, unloading facilities at the receiving country, and facilities for changing the liquid back to gas. The processes are considered somewhat dangerous. For example, when a ship unloads LNG, every other ship is cleared from its vicinity. Near Lake Charles the Trunkline LNG Gas company has under construction an unloading facility in an area away from concentrated population. From here gas will travel to distribution centers.

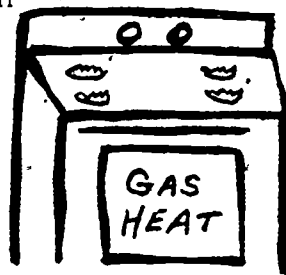

Natural gas is in short supply. Since the early part of this century the price of natural gas has been kept low by government regulation, causing natural gas to be widely used. The low cost created a heavy demand for gas. As demand increased, it out-paced new discoveries and reduced the known proven reserves. Because supply has not been able to meet demand, curtailments have occurred during periods of peak energy use.

Natural gas reserves peaked in 1967, and have been

going down since. Even the additions of the Alaskan deposits cannot reverse this trend because new reserves have just not kept pace with our increased usage. In 20 years at present rates, proven reserves will be gone. Resources may last for 30-50 years.

TITLE: FORMATION OF FOSSIL FUELS.

AREA: Science

OBJECTIVE: The student will investigate how fossil fuels are formed.

MATERIALS: Ferns, sand, peat, coal, 10-gallon aquarium, slides or charts of geologic time scale

- ACTIVITY:
- A. Have students examine samples of ferns, peat and coal. Show the students geologic time charts and describe the physical condition of the earth during the coal forming processes. Then stimulate the conditions in the aquarium.
 - B. Fill the aquarium with tap water. Add enough peat moss to make a one-inch layer. Allow one week to elapse. What is the condition of the water? Include such things as pH, odor, turbidity, decomposition of peat, etc. Have any changes occurred in the peat? Suggest reasons for the changes, or explain why changes did not occur.
 - C. Sift moderately fine sand over the peat to a depth of one inch. After the sand settles, add an equal depth of peat. Repeat the process for as long as desired, or until several successive layers have formed. Is coal being formed today naturally?

TITLE: GEOGRAPHIC LOCATION OF FOSSIL FUELS

AREA: Science, Social Studies, English

OBJECTIVE: The student will locate geographically our world-wide energy resources of fossil fuels.

MATERIALS: World map, library literature, colored pins

ACTIVITY: Energy resources, such as oil, coal, and natural gas, are located in different geographic regions of the world. Have students research the known energy resources, their location and the geographic characteristics that indicate a possible fossil fuel reserve. On a map of the world, have the students locate these energy resources using different colored pins for each fuel.

Once the energy resources have been located, have the students decide which countries have the most fuel reserves and which countries have the greatest demand for those energy fuels. Discuss what problems result in this supply/demand imbalance.

TITLE: LOCATION OF COAL BEDS

AREA: Science, Social Studies

OBJECTIVE: The student will locate coal beds on topographical maps.

MATERIALS: Topographical maps

ACTIVITY: Many minerals such as coal and limestone occur in distinct layers called beds. These beds usually cover many square kilometers (sq. mi.) and usually are tilted or bent downward in one direction. Once strip mining has started at several points on a single bed of mineral, it is easy to plot the outline of the bed and predict its mass and volume from a topographical map.

• First: Have student teams make a topographical cross section of an area which has several strip mines scattered across it. This is accomplished by drawing a straight line across a topographical map then plotting on graph paper each of the contour lines that touch the straight line.

Second: Have the students mark on the completed cross sectional plots the locations of each strip mine that touches the line drawn on the map. Since coal (and other minerals) occur in beds, the students can sketch the location of the hidden coal bed by connecting the elevations of the strip-mined area.

Third: The amount of tilt (dip or strike) in the bed can be readily determined by examination of the graphed data.

Fourth: If the mined area is located close to the school, the approximate volume of coal present in the bed can be estimated. Measure the bed's thickness at road cuts on the mine high walls. Next, multiply the surface area of the bed times its thickness times the specific gravity of the coal.

Teacher Notes:

The teacher must check the map carefully in advance of this exercise to make sure only one mineral is being strip-mined in the map area being studied. Otherwise the students will usually unknowingly plot both mine systems on one paper and get a set of data they cannot interpret.

The finished cross sectional diagram should look like the one shown below.

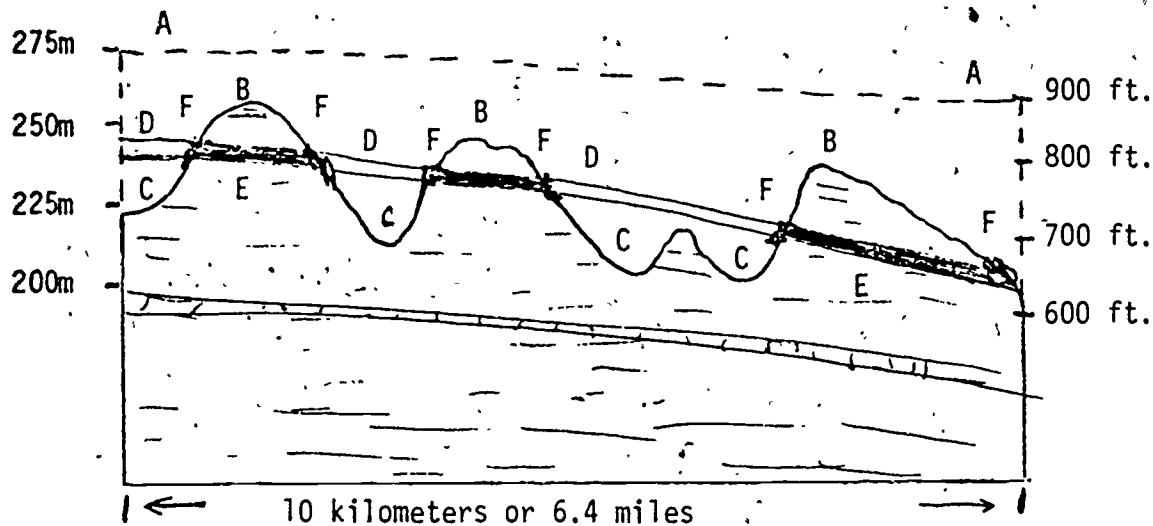

- LEGENT:
- A. Land surface before erosion started
 - B. Present hilltops
 - C. Present valleys
 - D. Coal bed removed by erosion
 - E. Remaining coal bed
 - F. Strip-mined areas

COAL FIELDS OF THE UNITED STATES
(FROM UNITED STATES GEOLOGICAL SURVEY)

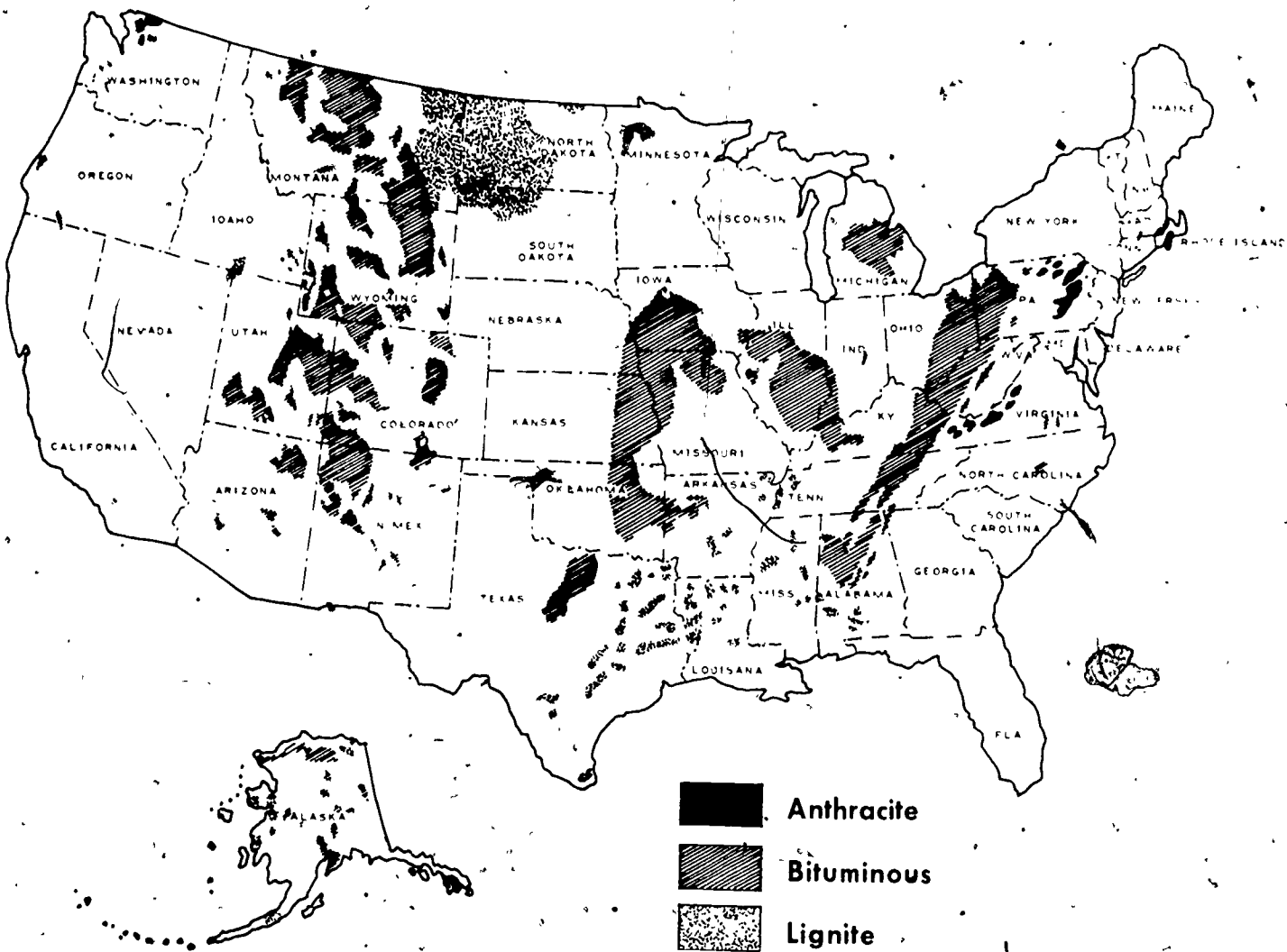

TITLE: OBSERVATION OF THE DIFFERENT TYPES OF COAL

AREA: Science

OBJECTIVE: The student will observe the difference between the types of coal.

MATERIALS: Small sample of peat, lignite, bituminous coal, anthracite coal, crucible tongs, Bunsen burner, hard lens

ACTIVITY: Examine the samples carefully, using a hard lens if necessary. Answer the following questions:

1. Which sample looks most like plants?
2. Which sample looks least like plants?
3. Arrange the samples in order of hardness.
4. Arrange the samples in order of luster.
5. Which sample looks like it has the most carbon in it?
6. Which sample looks like it has very little carbon in it?

Hold each sample with the crucible tongs and light it with the Bunsen burner. Note how long each takes to ignite. Also note any odors or smoke, and how rapidly each burns.

TITLE: EFFECTS OF GASES EMITTED FROM THE BURNING OF COAL IN A CLOSED AQUATIC ECOSYSTEM

AREA: Science

OBJECTIVE: The student will determine the effects of gases emitted from the burning of coal in a closed aquatic ecosystem.

MATERIALS: Elodea, Guppies, aquarium sand, glass tubing, rubber tubing and stoppers, two one-gallon jars

ACTIVITY: Into two one-gallon jars add two inches of aquarium gravel. Add water to the top of the vertical column. Add several strands of Anacharis (Elodea sp.). These may be floating or rooted in the gravel. Let the aquaria set for one week. Introduce a male and female Guppy. Feed the Guppies for several days and then seal the jars with paraffin-coated lids. (The Guppies should be fed several times a day.) One jar lid should have a hole large enough to admit a glass tube. Put one gram of finely ground coal with a known sulfur content into a .22 x 180mm test tube. Plug with a one-hole rubber stopper. Insert a short section of glass tubing through the stopper. Place a long (25cm) glass tube through the hole in the lid of one jar. Connect the glass tubes with an aquarium hose. Burn the coal using an external flame. As the coal burns down, be careful that water is not drawn back into the test tube--this could cause the glass to break. Repeat the process daily or weekly for several weeks. Have students record any changes which occur in the two jars. Make sure the jars are kept near each other, under the same conditions, and out of direct sunlight.

What effect does the burning of coal have on this closed aquatic ecosystem? How does this system compare to the biosphere? Does the burning of coal have any potential effect on the aquatic portion of the biosphere? Compare and contrast the effects of burning coal on an aquatic ecosystem and a terrestrial ecosystem.

KFY

1. Aquarium gravel
2. Elodea
3. Water level
4. Sealed lid
5. Fish (guppies)
6. Coal
7. Glass delivery tube

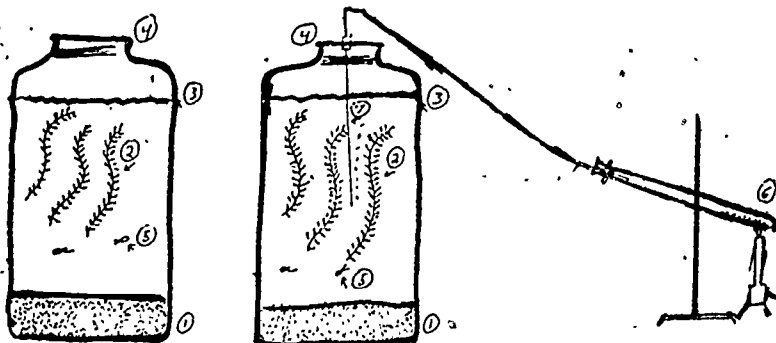

*The activity should be terminated if it becomes obvious that the fish are being adversely affected.

TITLE: SULFUR DIOXIDE EMISSIONS FROM THE BURNING OF FOSSIL FUELS

AREA: Science

OBJECTIVE: The student will study the harmful effects of sulfur dioxide emissions from the burning of fossil fuels.

MATERIALS: Soft coal, pure sulfur, red and blue litmus, green leaf, zinc, colored cloth, red apple peel, containers, water

- ACTIVITY:
1. Ignite some soft coal (high sulfur content if possible) and have students note the odor (using the correct technique). What are the possible gases given off during this reaction? In the hood ignite a piece of pure sulfur, note the odor, collect the gas given off and pass through containers that have the following: red and blue litmus, green leaf, piece of zinc, small piece of colored cloth, and a piece of red apple peel. Be sure and close containers as soon as gas is added. Have students record their results.
 2. Add 10 ml. of water to each container and shake. Again, have students record their results.

3. DISCUSS THE FOLLOWING REACTIONS WITH STUDENTS

When sulfur burns in the air you have the following reaction: $S + O_2 \rightarrow SO_2$.

The sulfur dioxide produced from this reaction added to water yields sulfurous acid.

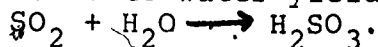

Sulfur dioxide when mixed with oxygen of the air in the presence of sunlight will yield sulfur trioxide. $2SO_2 + O_2 \rightarrow 2SO_3$.

Sulfur trioxide in the presence of water yields sulfuric acid. $SO_3 + H_2O \rightarrow H_2SO_4$.

4. QUESTIONS

1. Are the bleaching effects due to the dry sulfur dioxide or the sulfurous acid?
2. Why does the paint often peel and blacken on houses located near factories that burn sulfur-containing fuels?

3. For what purpose is powdered sulfur sometimes used on rosebushes?
4. How many useful and essential uses can you list for sulfur and its related compounds?

TITLE: EFFECTS OF GASES EMITTED FROM THE BURNING OF COAL
IN A CLOSED TERRESTRIAL ECOSYSTEM

AREA: Science

OBJECTIVE: The student will determine the effects of gases emitted from the burning of coal in a closed terrestrial ecosystem.

MATERIALS: Sand, potting soil, coal, two species of plants (two of each), test tube, 22 x 180mm glass tubing, hypodermic needle, two one-gallon clear glass jars with wide mouths and lids

ACTIVITY: Into two one-gallon jars, add pea gravel to a depth of one inch. Make sure the soil is free from fungi, add a minimum of 1-1/2 inches of soil. Plant two species of a succulent variety in each jar. Make sure specimens in the two jars are as similar in size and vigor as possible. Drill a hole in the lid and insert a thin rubber diaphragm such as the plugs used in blood-clotting vacuum tubes. As an added protection against unwanted contaminants, use a paraffin seal between the lid and the jar. Add sufficient water to moisten the soil. Screw the lids on and place in indirect sunlight. (Direct sunlight will cook the plants.) Keep both jars together and allow the jars to reach equilibrium.

Finally, grind one gram of high sulfur coal (or coal used in your area). Place the coal in a large test tube. Insert a small glass tube into a one-hole stopper. Connect the rubber tubing to the protruding glass tube. Then insert the entire apparatus into the end of the test tube. To the end of the rubber tubing attach a hypodermic needle of sufficient size and length. Insert the needle into the diaphragm, making sure the opening is not blocked.

Heat the test tube containing the coal until all the coal has burned.

Observe the growth rates of the plants in each jar. Daily measurements should be taken. The gases from the coal should be administered daily for two weeks.

What effects did the burning of the coal have on the closed ecosystem? Explain.

How does this closed ecosystem compare with our biosphere?

Based on the data collected on this experiment, what do you think could be some of the possible effects of burning coal in our atmosphere?

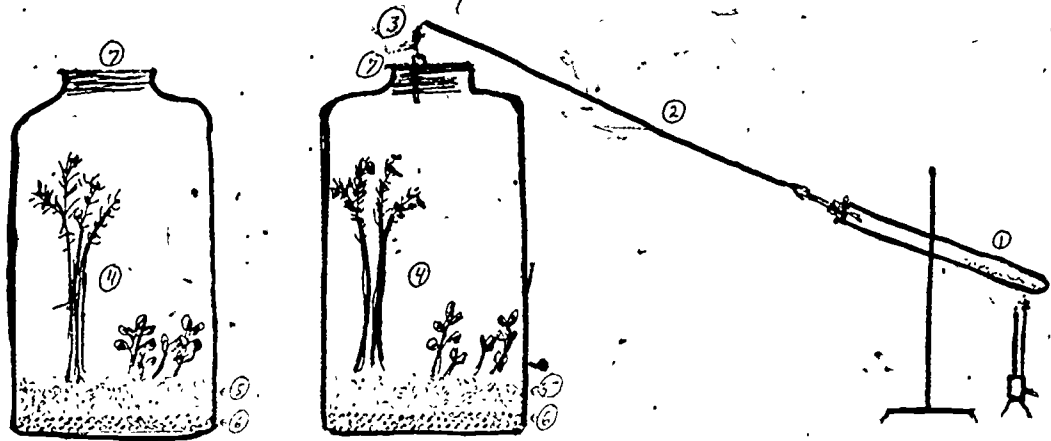

KEY

1. Test tube containing finely ground coal
2. Rubber tubing
3. Hypodermic needle through rubber diaphragm
4. Succulent plants
5. Disease-free potting soil
6. Pea gravel
7. Sealed jar lids

- TITLE: A SECOND COAL AGE?
- AREA: Science, Social Studies; History, Art
- OBJECTIVE: To discover the relationship between energy supplies and the lives of people.
- MATERIALS: Piece of coal, pen, paper
- ACTIVITY:
1. Investigate the advantages of coal in terms of:
 - a. abundance (we have enough for centuries)
 - b. accessibility (we know where it is and how to get it; no costly exploration is needed)
 - c. cost (half the price of oil per unit of energy)
 - d. uses (a very versatile fuel and can be converted to oil or gas)
 2. Investigate the disadvantages of use of coal as a fuel. (High sulfur content = air pollution, acid rain; mining hazards; environmental hazards - acid wastes; difficulty of reclamation of strip-mined lands.)
 3. Discuss industry and governmental recommendations that environmental restrictions on mining and burning coal be removed to increase production, at least until technology can be developed to remove sulfur and eliminate acid wastes.
 4. Ask: "What is coal?" (Request samples from local utility.)
 5. Investigate stages in the formation of coal. (Peat, lignite, bituminous, anthracite.)
 6. Investigate the location of the world's coal reserves.
 7. Investigate the productivity of a coal miner. (10-15 tons per day but dropping rapidly during recent years.)
 8. Find out how coal is used in your area and how it is transported.
 9. Ask: What is a "captive mine?" (A mine owned by a utility company to guarantee future supplies of coal.)

10. Calculate the amount of coal it would take to supply your energy needs and the energy needs of your school. (One pound of coal = one kilowatt hour of electric power.)
11. Draw a picture of your home and school in the "Second Coal Age."
12. Describe your life if all the environmental effects of using coal are eliminated. (Plenty of energy but very expensive.)
13. Investigate regulations to increase mine safety.
14. Add to the class energy vocabulary list.

TITLE: DESTRUCTIVE DISTILLATION OF FUELS

AREA: Science

OBJECTIVE: The student will become aware of products formed by destructive distillation of fuels.

MATERIALS: 100 mm pyrex ignition test tube, glass jet tube, red and blue litmus paper, lead acetate paper, sawdust or wood shavings, powdered soft coal

ACTIVITY: Set up apparatus as shown below. Fill the ignition tube about 2/3 full of sawdust, excelsior, or small bits of wood. Heat the tube gently at first and slowly increase the size of the flame until the tube is being heated strongly. Test the escaping gas for hydrogen sulfide by holding a strip of moistened lead acetate paper in it for a few seconds. Bring a flame to the gas escaping through the jet. Note the appearance and odor of the liquid formed in the bottom of the condenser. Test the condensate with red and blue litmus. When there is no further evidence of action, stop heating the tube and allow the apparatus to cool. Remove the contents of the tube and examine the product.

Clean the ignition tube used as well as you can without using water, and fill it about half full of crushed soft coal. Replace the condenser and tubes with a clean set and heat the coal as you did the wood. Test the escaping gas with lead acetate paper. Test this gas with litmus paper also.

Bring a burning match to the gas escaping from the jet. Heat the tube until gas is no longer given off. Note the appearance and odor of the liquid formed in the bottom of the condenser. Test the liquid with red and blue litmus paper. When the tube has cooled, remove the contents and examine the product.

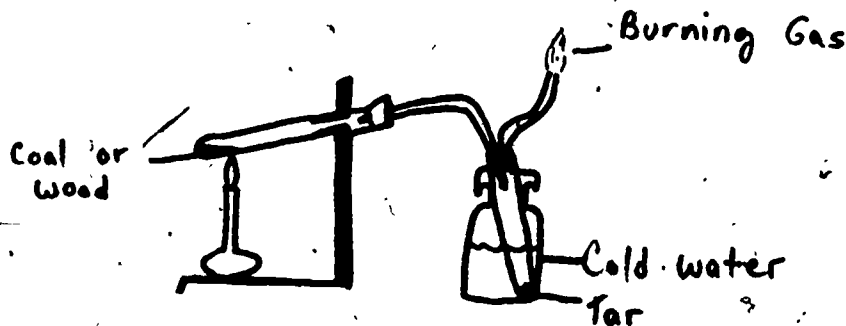

TITLE: HEAT CONTENT OF FUEL GASES

AREA: Science, Mathematics

OBJECTIVE: The student will determine the heat content of fuel gases experimentally.

MATERIALS: Methane, Bunsen burner, propane, propane torch, water filled jug, rubber hose, asbestos furnace paper, two liter pans

ACTIVITY: Fuels such as natural gas and propane have a definite quantity of chemically bound energy that can be converted into a definite corresponding amount of heat energy. This exercise can be used to determine how much energy natural gas, propane, or an alcohol has. It can also determine whether or not yellow flames produce as much heat as blue flames.

Use water displacement to determine the number of seconds needed to pass exactly one liter of methane through a Bunsen burner or to pass one liter of propane through a propane torch.

System one: Place the burner inside a large, inverted, water-filled jug. Measure the number of seconds needed for enough gas to pass through the burner to empty the water from the jug.

System two: Remove the barrel from the burner and use a rubber hose to transfer the gas to an inverted, water-filled jug. Measure the number of seconds needed for enough gas to pass through the burner to empty the water from the jug.

For either system, divide the jug's volume in liters into the number of seconds of elapsed time to obtain the time needed for one liter of flow. The calculations needed for the Boyle's Law, Charles Law and water's vapor pressure may be included at this point for advanced classes.

Construct calorimeters by covering the top and sides of two liter pans with several layers of damp asbestos furnace paper. Cut the asbestos so that it extends about 20 cm below the bottom of the pans. Set the pans aside and allow the asbestos to dry, then mount the pans on ring stands so that the asbestos skirt reaches down to about 10 cm above the table top.

To operate the calorimeter, add 1,000 grams of cool water to the pan. Next, light the burner and set it inside the asbestos skirt under the pan for the number of seconds it takes for 1.0 liters of gas to pass through it. Record the maximum temperature reached by the water in the pan.

The calculation for the heat content of the gas is:

$$\text{Kilocalories/liter of gas} = \frac{[(\text{kg water}) + (0.22) (\text{Kg aluminum pan})] \times (\text{temp rise } ^\circ\text{C})}{1.0}$$

This experiment should be repeated using two or more different fuels with the burner adjusted each time to burn with a hot blue flame. Then it should be repeated again with the burner's air supply reduced so that the fuels burn with a cool yellow flame.

TITLE: REMOVAL OF SOLID PARTICLES FROM GASEOUS EMISSION OF FOSSIL FUEL POWER PLANTS

AREA: Science

OBJECTIVE: To demonstrate the principle involved in removing solid particles from the gaseous emissions of fossil fuel power plants.

MATERIALS: 500 ml graduated cylinder, metal ring stand rod, one-hole rubber stopper, copper wire, induction coil, D.C. power source, glass tubing, millipore hand vacuum assembly, rubber tubing, cigarette

ACTIVITY: Electric precipitators are now widely used to prevent particulate wastes (fly ash) from being released to the atmosphere through smokestacks. Charged particles, ranging in size from 0.1 microns to more than 200 microns, are attracted to electrodes of opposite charge. In this way as much as 99.9% of the particulate emissions can be removed from the gaseous effluent.

Assemble the apparatus as shown in the figure and light the cigarette. Introduce smoke into the bottom of the graduated cylinder by depressing the plunger in the millipore hand vacuum assembly. When the smoke has diffused to the top of the cylinder, connect the induction coil and switch on the power. Observe the effects of the electric charge on the smoke particles in the cylinder.

Repeat the above procedure using different sources of smoke (e.g. camphor, incense, ammonium chloride). Also introduce the smoke from these various sources at different rates and observe the outcome.

DISCUSSION

Does the efficiency of the model electrostatic precipitator vary noticeably when the nature of the smoke or the rate of smoke production is altered? In addition to fossil fuel power plants, name some industries where this device might be used. Are there any industries in your community that have electrostatic precipitators in their smokestacks? If so, find out their cost of installation and their efficiency in removing particulate matter. What are

some of the environmental consequences that might be expected if electrostatic precipitators are not used in a heavily industrialized area?

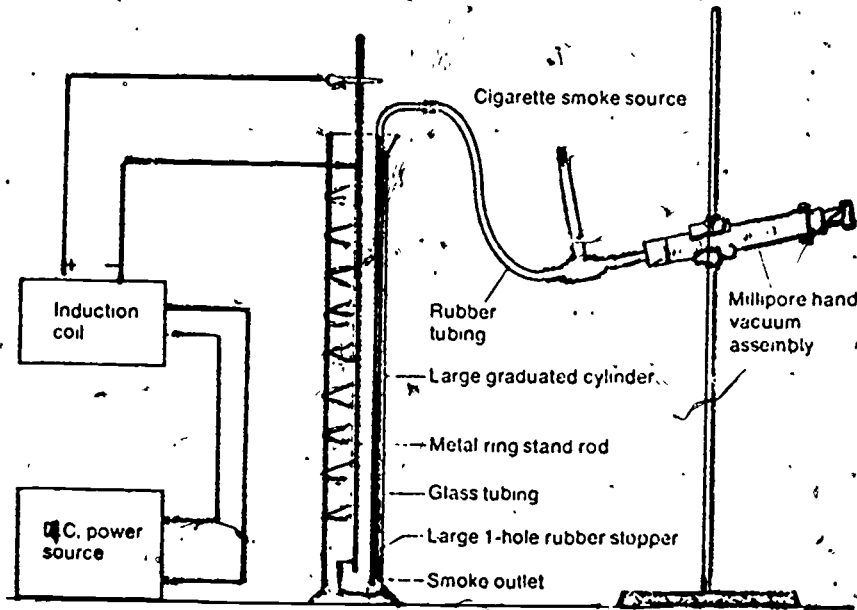

Model of an electrostatic precipitator

TITLE: ENERGY AND MAN'S ENVIRONMENT.

AREA: Science, Social Studies

OBJECTIVE: Given the opportunity to complete a depletion of fossil fuel reserves, the student will be able to consider its effects on other elements of a quality life.

MATERIALS: Various lengths of scrap yarn, macrame, cord or string; blank sheets of paper; felt-tip markers or crayons

ACTIVITY: Explain to students that on April 20, 1977, President Carter, in his energy address, made several references to "quality of life." What is meant by phrases such as "quality of life," "high standards of living," and the "good life?" On a chalkboard or overhead projector write "ELEMENTS OF THE GOOD LIFE," and ask students to brainstorm those aspects--products, services, necessities--which appear to be vital to our way of life. Examples are: transportation system, food, petrochemicals, fossil fuels, communications, aesthetics, electrical appliances, housing, laws, sanitary services, industry and countless others.

Refine and consolidate items on the master list until the total equals the number of students in your class. Assign each student to play the "role" of a particular good life element, using the blank sheet of paper to make a "name tag." Make one for yourself which reads "Government."

Instruct students to stand and arrange themselves in a circle, using lengths of yarn to connect themselves to other elements of the good life on which they depend. After a few minutes, a web of interdependencies will emerge. Or course, nearly all elements are subject to governmental control and, if you are standing in the middle of the circle, you will become hopelessly entangled--much to the delight of your students.

When the completeness of the web becomes apparent, simulate a production crisis of the fossil fuels (or just oil and natural gas) by asking those students to carefully remove their strings from other elements which depend upon them. The result is a frightening simplification of the web.

FURTHER DISCUSSION

In the same way that ecosystems face potential collapse due to removal of components, so does the

web of good life elements when the fossil fuels are removed. Discuss the fact that the strength of our social system which depends on many apparently distinct elements is maintained by diversity, weakened by simplification and almost totally dependent on the fossil fuels.

- TITLE:** SYNTHETICS
- AREA:** Science, Home Economics, Social Studies
- OBJECTIVE:** To discover the relationship between synthetic materials and the oil chemicals and energy used to make them.
- MATERIALS:** None
- ACTIVITY:**
1. Ask: If you took off all the clothes you are wearing which were made from synthetic materials or fibers, what would you be wearing? (Possibly not much more than part of a pair of sneakers and a smile.)
 2. Make a class list of the synthetics being worn.
 3. Ask: "Do we live in an age of synthetics?"
 4. Investigate the use of crude oil by the petrochemical industry. (Use about 5% of oil supply to produce the chemicals needed for the manufacture of synthetics.)
 5. Take a class field trip to a shopping mall to survey the store windows for synthetic products. (Do not go into any of the stores.)
 6. At the end of the field trip, make a list of the synthetic products seen by members of the class.
 7. Divide the class list of synthetic products into the following categories, those which:
 - a. make life easier
 - b. make life more comfortable
 - c. make life more enjoyable
 - d. make life more wasteful
 - e. make life more efficient
 8. Determine how many stores would have things to sell if there were no synthetic products.
 9. Investigate the substitutes for these and other natural products--wood, leather, cotton, wool, oil.

FURTHER DISCUSSION:

1. Check your own list of synthetic possessions.

2. Discuss how synthetic products have changed the form and amount of packaging by industries (use the yellow pages to get a list of industries affected).
3. Discuss the pros and cons of modern packaging.
4. For each item on the class list of synthetic products, determine the natural materials that were replaced and the effects on the industries that market the natural materials. (Effect of nylon on cotton, for example.)
5. Synthetics have replaced natural materials in many manufacturing processes. Investigate the effects of this replacement on people and sections of the nation. (For example, effect on the South of changes in textile manufacturing.)
6. Make a mural showing life before the invention of synthetic products.
7. Devise a synthetics-energy conservation program for:
 - a. yourself
 - b. your school
 - c. your home
 - d. your community.
8. Ask: "Should we save the 5% of crude oil used by the petrochemical industry?" (Consider your discussion in relation to the number of stores dependent on synthetics.)
9. Add to the class energy vocabulary list.

- TITLE: OBITUARY TO A "GAS GUZZLER"
- AREA: Social Studies, English
- OBJECTIVE: To discover the relationship between energy supplies and automobile engine efficiency.
- MATERIALS: Pen and paper
- ACTIVITY:
1. Read this to your class: A television news story stated that "An association of owners of Rolls-Royce automobiles is lobbying for special consideration for their gasoline needs in the event of a gasoline shortage. Their reason: they are unique, and their five mile-per-gallon 'gas guzzlers' are an important element of the good life of America and should be maintained." The owners also expressed their willingness to pay a penalty tax of \$500 to \$1000 to offset their high use of energy.
 2. Ask: "Do you think the large, luxury car owners have a valid argument?"
 3. Discuss the pros and cons of their case.
 4. Ask: "Do you believe a penalty of \$500-\$1000 would make up for their excessive use of gasoline? (Their cars cost up to \$75,000.)"
 5. Check with your local big-car dealer to determine any changes in their automobiles since the oil crisis of 1973 in:
 - a. weight of automobiles,
 - b. gasoline efficiency in miles-per-gallon
 - c. sales volume
 - d. advertising (efficiency vs. luxury)
 6. Survey small-car dealers to determine any change in the number of big-car owners who have traded in their "gas guzzlers" for a small automobile.
 7. Investigate the availability of diesel engine automobiles.
 8. Write an obituary to a "gas guzzler."
 9. Design an epitaph to a "gas guzzler."
 10. Ask: "What will take the place of the large luxury car in the dreams of people?"
 11. Write a poem on the new dream.

12. Write a class skit showing the last owner of a "gas guzzler" trying to buy gasoline.
13. Have the class observe a moment of silence for the last "gas guzzler."
14. Compare the worst "gas guzzling" automobile with a yacht or private airplane.
15. Ask: "Is a compact car saving gas driving down a highway, as its bumper sticker says?"
16. Play a game filling in the blank with one or two word endings. Student with most words wins. (For example: An automobile is saving energy when it is _____ (parked, tuned-up, coasting, turned off, etc.))
17. Add to the class energy vocabulary list.

TITLE: OFFSHORE OIL

AREA: Science, Geography, Social Studies, History, Art

OBJECTIVE: To discover the relationship between crude oil supplies and the search for oil "offshore."

MATERIALS: Library, pen and paper

- ACTIVITY:
1. Man has drilled deep into the earth of the continental U.S. Now there is increasing discussion and controversy about offshore oil. Ask: What is offshore oil? (Oil in the continental shelf in relatively shallow water.)
 2. Examine a map which shows the location of the continental shelf along the coasts of the U.S.
 3. Find pictures of offshore drilling platforms, during construction and in operation.
 4. Ask: "If there is plenty of oil left as the oil companies say, why are they drilling in the hostile environments of the offshore wells?" (North Sea, Arctic, etc.)
 5. Look on a map of the Channel Islands off the California coast, scene of recent offshore exploration and drilling.
 6. Investigate the dangers of drilling in this area. (Wells are located in a major earthquake zone - the San Andreas fault.)
 7. Investigate the oil well "blowout" which polluted the beaches of Corpus Christi, Texas in 1979.
 8. Locate the Baltimore Canyon area off the Atlantic coast. Then read about recent attempts to find oil and gas there.
 9. Investigate the procedures for obtaining a lease from the U.S. Department of the Interior for drilling rights in areas of the continental shelf.
 10. Investigate the problems of constructing drilling platforms in deep and stormy offshore areas.
 11. Describe the world when there is no more oil to be found.
 12. Read oil company reports and advertisements to find evidence of aesthetic or environmental concern (or lack of it).

13. Read about the great oil spill at a Chevron platform in the Gulf of Mexico in 1970 and the Mexican well in 1979.
14. In an oil company advertisement, comedian Bob Hope drives a golf ball off an offshore platform. Draw a picture of yourself using a platform to do your favorite thing.
15. Draw a mural to show the process of offshore drilling.
16. Investigate the effects of drilling platforms on marine life. (Act as artificial reefs; generally thought to be favorable to marine life, although there is some concern about possible long-term effects of spilled oil and other chemicals.)
17. Discuss whether oil companies would be drilling offshore in the Arctic if there were plenty of domestic supplies which needed only financial incentive (profit) for development.
18. Add to the class energy word list.

- TITLE:** OIL FROM ROCKS
- AREA:** Science, Geography, Social Studies, Art.
- OBJECTIVE:** To discover the relationship between energy forms and the natural forces which caused their formation.
- MATERIALS:** Pictures, library
- ACTIVITY:**
1. Ask: "Did you ever hear of oil that is not a liquid?" (There are two solid forms--oil shale and tar sands.)
 2. Collect pictures showing the process of recovery of oil from oil shale rocks.
 3. Locate on a map of the U.S. the Green River Formation where Utah, Wyoming, and Colorado meet along the Green River, a tributary of the Colorado River.
 4. Find out how oil was bound into the rocks. (Caught in clay sediments which were turned into shale by heat and pressure.)
 5. Describe the oil in shale. (Called kerogen, a gas-like material which melts at 450-600 degrees Centigrade, releasing vapors that can be converted to shale oil.)
 6. Ask: "How much oil is there in the Green River Formation?" (Two trillion barrels, many times the amount of all the easily available oil in the U.S.)
 7. Investigate the processes, and the energy required for recovery of oil:
 - a. above ground (energy for mining, crushing heating, waste disposal).
 - b. in situ (in place in the rocks; heating rock, oil recovery, waste).
 8. Investigate the recovery problems with each method. (Above ground - rock has to be mined, crushed, heated, then waste removed. Rocks expand when heated, so amount of waste material is greater than original rock; in situ - rock has to be broken up by pressure, chemical explosives, or a nuclear explosion, then heated to release oil.)

9. Investigate the environmental problems.
(Vast quantities of water required - could seriously affect already over-committed flow of the Colorado River; waste rock areas impossible to revegetate without water, if at all; area will become a barren wasteland, devoid of wildlife.)
10. Investigate the sale and leasing of oil shale lands by the U.S. Department of the Interior.
11. Ask: "Why should the government sell lands containing trillions of barrels of oil to oil companies for a few dollars an acre?" (That's what the laws for mining require.)
12. Discuss the pros and cons of encouraging the development of our oil shale reserves. (Need versus problems.)
13. Ask: "Should we destroy a beautiful section of our western mountains so we can continue our oil-spending and energy-wasting spree?"
14. What are the alternatives?
15. Investigate plans to recover a similar type of oil from the Athabasca Tar Sands in Canada.
16. Draw a picture of yourself around a campfire lined with oil shale rocks.
17. Add to the class energy vocabulary list.

TITLE:

PETROCHEMICALS

AREA:

Consumer Education, Physical Sciences, Social Studies

OBJECTIVE:

The student should be able to: (1) list some manufactured items for which fossil fuels serve as raw materials and (2) describe the "petrochemical crisis" in terms of the "energy crisis."

MATERIALS:

Pen, paper

ACTIVITY:

1. Students may make a list of those things for which fossil fuels are used. Discuss the difference between using fossil fuel as an energy source to power a process (such as transportation) and its use as a raw material in the manufactured item (such as tires).
2. Using this list and the extensive listing on the next page, have students speculate how our life styles may be forced to change as the abundance of fossil fuels dwindles.

BESIDES GAS FOR YOUR CAR AND HEAT FOR YOUR HOME, CAN YOU NAME A FEW OTHER THINGS OIL IS USED FOR? HERE'S HELP:

Credit cards	Pacifiers	Ring binders	Fertilizers
Eyelashes	Dresses	Tote bags	Hair coloring
Aspirin	Cassettes	Dishwashing liquids	Knitting yarn
Permanent-press clothes	Track shoes	Unbreakable dishes	Toilet seats
Oxygen masks	Dominoes	Toothbrushes	Towel bars
Golf balls	Fences	Extension cords	Denture adhesive
Ink	Luggage	First-aid kits	Frisbees
Lighter fluid	Kitchen counter tops	Notebooks	Hair rollers
Heart valves	Antifreeze	Combs	Light fixtures
Hair spray	Protractors	Watchbands	Movie film
Crayons	Earphones	Darts	Panties
Steering wheels	Flashlights	Toothpaste	Fishing boots
Disposable diapers	Whistles	Flea collars	Candles
Food wraps	Motorcycle helmets	Tents	Hairbrushes
Laxatives	Carpet sweepers	Plastic varnish	Water pipes
Parachutes	Antibiotics	Foot pads	Guitar picks
Trash cans	Checkers	Refrigerants	Switch plates
Telephones	Chess boards	Rugs	Shower curtains
Enamel	Shower doors	Nightgowns	Sponges
Wall coverings	Soap dishes	Sandals	Beach balls
Transparent tape	Yardsticks	Hair curlers	Sunglasses
Acrylic paints	Slip covers	Lamps	Bird houses
Antiseptics	Shoes	Lipstick	Bathinettes
Vacuum bottles	Paddles	Ice cube trays	Stuffed animals
Shoe trees	Decoys	Visors	Soft contact lenses
Safety flares	Volley balls	Swimming pool liners	Dice
Overcoats	Tobacco pouches	Electric blankets	Thermal blankets
Upholstery	Sleeping bags	Ear plugs	Drinking straws
Ping-pong paddles	Pencils	Digital clocks	Hand lotion
Bubble bath	Electrician's tape	Draperies	Shampoo
Purses	Smocks	Life jackets	Shaving cream
Bookends	Tennis balls	Audio tape	Aquariums
Uniforms	Tires	Car battery cases	Afghans
Phonographs	Tablecloths	Insect repellent	Car mats
Hearing aids	Measuring cups	Hockey pucks	Dog leashes
Welcome mats	Rulers	Ice buckets	Trash bags

TITLE: PUT THE HORSE BACK IN HORSEPOWER AND
MAN BACK IN MANPOWER

AREA: U.S. History, Agriculture, Civics

OBJECTIVE: Students should be able to: (1) interpret graphs and tables, (2) identify the cause(s) that lead to substituting one resource for another, and (3) analyze the effect(s) of resource substitutions upon the rate and amount of energy use.

MATERIALS: Slide Tables I-III

ACTIVITY: A good way to begin this lesson is to provide an opportunity for your students to brainstorm for examples of some of the resources needed today to produce a crop. Choose corn as a starter. Brainstorming, of course, offers the free exchange of ideas with all suggestions entertained. Later you can suggest that the students may want to revise the list of suggestions. Some ideas are: human labor, animal labor, machinery (tractors, harvesters, etc.), fertilizer, gasoline, LP Gas (propane), electricity, buildings. The list can go on and on.

You may wish to go over the meaning of the term resource if students have difficulty getting started. (A resource refers to available means; a new or reserved source of supply or support.)

Move the lesson forward by asking: How have resources changed since, say, George Washington's day? How have they changed since 1910? Which resources had wider use in 1910 than today? Would the use of gasoline, fertilizer, insecticides, and machinery be greater today than in 1910? When might you see more people working on farms-- today or in 1910?

To have students consider factual changes, rather than merely speculative ones, distribute copies of Table I. Explain that the information refers to selected resources used on American farms. Each year's data is expressed in percentages of the use of a resource in 1910. In other words, the use of farm machinery in 1970 is shown as 505%. Another way of saying the same thing is that in 1970, machinery was used 5.05 times its use in 1910.

After developing an understanding of the substitution of machines and agricultural chemicals for human labor and animals in American agriculture, the next question for your students to consider is why did this happen?

To advance thinking, ask for student ideas in another brainstorming session. Suggestions could include:

1. Machines are cheaper.
2. Machines can produce more.
3. Machines can be fairly easy to handle, maintain, and are dependable.

It should become clear that a farmer will logically try to produce the most crops at the lowest cost, in order to make the most profit.

What information would be needed to prove or disprove the hypothesis that machines are better?

- A. To show changes in costs, have the students look at Table II. (Here data are presented as percentages of their 1950 level.)

Note: The questions should show the relation between the decline in farm labor and the increase in wages. Also, the small increases in fertilizer costs can be seen as contributing to its increased usage. The rapid increase in farm real estate prices are considered a possible factor in keeping land use down.

- B. To look at changes in farm productivity, have students look at Table III. Here, depending upon the background of the students, the teacher may wish to discuss the concept of productivity. (The measure of output (production) per unit of input, meaning resource.) You can illustrate productivity by the following example:

A farmer has a herd of dairy cows, and with the help of three farm hands, obtains 100 gallons of milk per day by milking the cows by hand. If he replaces the extra men with a milking machine, and does not increase his time spent milking, production increases by 20%. This is a change in productivity since output (milk production) divided by input (labor) went from $100/4$ to $120/1$ or from 25 to 120, a 380% increase.

In Table III, this is shown as "Farm Output Per Hour of Farm Labor." A more complete measure of productivity would include, however, the cost of all resources used in the production of milk. If, by replacing the three extra farm hands with the milking machine, the costs of milking go from \$40 to \$60, then the output divided by total

costs went from 100/40 to 120/60 or from 2.5 to 2--a decrease of 20%. In Table III this more complete measure of productivity is labeled "Farm Output Per Unit of Total Input." Both measures of productivity are expressed as percentages of 1910 costs.

The last questions should help the students see that productivity has increased as a result of the substitution of machines and chemicals for labor and animals. Since the costs of these new resources are relatively high, output per unit of total inputs has increased at a lower rate than output per man-hour.

Finally, the student should be aware of the effect that resource substitution in agriculture has had on energy use. You might wish to present the idea of energy use with the following introduction and questions.

Since we are becoming increasingly more aware of the scarcity of our energy resources, it is important to see how energy use in agriculture is related to the energy shortages today. Remembering that energy is a component of all resources used in agriculture (for instance, fertilizers are produced from natural gas, pesticides use petroleum and, of course, farm machinery uses gasoline).

1. What change do you feel has taken place in energy in U.S. farming?
2. What have been the causes for the change in energy use?
3. If from 1940 to 1970 farm production in the U.S. has increased by 60%, do you think that energy use has increased at a greater, lesser, or same rate as production? (Energy use from 1940 to 1970 increased by 34%, 5 times greater than the increase in production.)
4. What resources used in modern American farming consume the greatest amounts of energy? (Fuel for machinery and fertilizer.)

Teacher Notes:

The main purpose of this lesson is to present your students with information concerning the substitution of machines and agriculture chemicals for animals and human power in American agriculture since 1910. The learning activities involve the student in inter-

preparing graphs and tables that show how American farming has become increasingly energy-intensive. The lesson can best fit into existing U.S. history courses, particularly in segments where students investigate the changing nature of the American economy and society in the 20th Century. It can also apply to issues under consideration in Economics, and Problems of Democracy (Civics) courses.

Answers to Student Questions (Table I)

1. Each decade has seen a rapid rise in machinery use, chemical fertilizers, and a decline in the use of human and animal labor.
2. Decreased: Use of human labor
 Use of animal labor

Increased: Power and machinery

Stayed About the Same: Value of Real Estate
3. If we lump them all together, the answer would be in the decades 1940 through 1960. Separately, the answers read:

Labor 1940-1960
Animal 1940-1960
Fertilizer 1950-1960.
4. Mechanical power and machinery
5. Animal manure, chemical fertilizer.

Answers to Student Questions (Table II)

1. Decreased: None

Increased: Farm wage rates
 Farm real estate
 Farm machinery

Stayed About the Same: Fertilizer costs
2. Farm real-estate
3. Among the possible responses there is a relation between the decline in farm labor and the increase in wages. Also, the small increase in fertilizer costs can be seen as contributing to its increased use. The rapid increase in farm real estate prices may be a factor in keeping land use down.

Answers to Student Questions (Table III)

1. Farm productivity as measured in units of input has steadily increased since 1910.
2. Decade from 1950-1960.
3. Huge increase in the use of power machinery and fertilizer are among the most important.
4. Productivity has increased as a result of the substitution of machines and chemicals for human labor. Since the cost of these new resources is relatively high, output per unit of total input has increased at a lower rate than output per man hour.

Reference: National Science Teachers Association, 1976.

STUDENT QUESTIONS

TABLE I

1. How do the figures support your thinking about changing resource use on the farm?
2. Which resources have declined in use? Which have increased? Which have stayed about the same?
3. In which decades did animal, fertilizer, and labor use change the most?
4. As the use of farm labor, horses and mules has declined, what resources have taken their place?
5. What was the major source of fertilizer on 1910 farms? What has taken its place?

TABLE II

1. Which prices have increased, decreased, or stayed about the same?
2. Which prices have increased the most?
3. How have the increases in the costs of farm resources affected their use?

TABLE III

1. How has farm productivity changed since 1910?
2. During which decade has productivity changed the most?
3. What are possible causes for this change in productivity?
4. Why has farm output per unit of total input changed by a lesser degree than output per hour of farm labor?

TABLE I
Quantities of Selected Farm Inputs

Year	Labor	Horses and Mules	Value of Farm Real Estate ₁	Use of Mechanical Power and Machinery	Tons of Fertilizer And Other Agricultural Chemicals ₂
1910	100	100	100	100	100
1920	107	102	98	160	133
1930	102	78	99	200	183
1940	92	59	100	210	233
1950	68	31	101	415	500
1960	46	14	96	475	833
1970	29	NDA	95	505	1830
1975	27	NDA	92	530	2262

192

1 - Includes service buildings and improvements on land.

2 - Includes fertilizer, lime and pesticides.

NDA -No Data Available

Source: U.S. Department of Agriculture

TABLE II
 Prices of Selected Farm Resources
 (All quotations are on Adjusted Dollars)

Year	Farm Wage Rates	Farm Real Estate	Farm Machinery	Fertilizer
1950	100	100	100	100
1955	121	131	113	108
1960	148	171	138	106
1965	171	214	154	106
1970	255	286	194	103

Source: U.S. Department of Agriculture

193

TABLE III
Farm Productivity

Year	Farm Output Per Unit of Total Input	Farm Output Per Hour of Farm Labor
1910	100	
1920	100	
1930	107	100
1940	128	124
1950	139	200
1960	172	382
1970	187	653
1975	206	806

Source: U.S. Department of Agriculture

TITLE: IMPORTANCE OF FOSSIL FUELS AS CHEMICAL RAW MATERIALS

AREA: Science

OBJECTIVE: To understand the importance of petroleum and natural gas as chemical raw materials.

MATERIALS: Library, bulletin board material

ACTIVITY: 1. Have two or three students do encyclopedic research to ascertain the tremendous number of products being made today that use petroleum and/or natural gas as a basic natural resource material. The list which could be illustrated in an effective bulletin board display would include such things as lacquer, varnish, paint thinner, soap, mineral oil, salves, ointments, candles, detergents, waxes, asphalt, pitch, rubber, plastics, synthetic fibers, explosives, fertilizers, and many, many other important industrial chemicals. Have the other students do a report on the list.

It has been indicated that petroleum and natural gas are so critically important as "chemical stock" for the future that it is a very serious mistake to use these substances simply as fuel.

2. Have the students who did the research suggested above to lead a class discussion focused on the above idea. What responsibility, if any, does the present generation have for future ones in using these substances simply as fuel?
3. If we reduce the use of petroleum and natural gas for fuel, what substitutes might be or are available? What other actions are possible?

TITLE: DETERMINING PRIORITIES: ALTERNATIVE METHODS OF GENERATING ELECTRICITY

AREA: Science

OBJECTIVE: The student will develop an understanding of the many factors involved in determining priorities for funding.

MATERIALS: All materials used in this unit

ACTIVITY: Have students study the listing given below of alternative methods of electric power generation. After considering existing or available technologies and the economic, social, and environmental costs and benefits (advantages/disadvantages) of each method, they should then rank the items in order of their importance for receiving research and development funds. Students should be able to defend their rankings.

Rank Items According to Importance:
(1=Most Important; 11=Least Important)

- ___ Hydroelectric
- ___ Oil
- ___ Nuclear
- ___ Refuse (resource energy)
- ___ Coal
- ___ Wind
- ___ Nuclear (fusion)
- ___ Ocean (tides, currents)
- ___ Natural Gas
- ___ Solar
- ___ Geothermal

TITLE: HOW LONG MIGHT OUR OIL AND NATURAL GAS LAST?

AREA: Science, Social Studies, English, Mathematics

OBJECTIVE: Students will discover the limits of the supplies of oil and natural gas.

MATERIALS: Activity sheets

ACTIVITY: Students will complete the activity "How Long Might Our Oil and Natural Gas Last" which follows:

HOW LONG MIGHT OUR OIL AND NATURAL GAS LAST?

Both liquid petroleum, which is more commonly called oil, and natural gas are fossil fuels. Like coal, they were formed by the chemical changes of ancient plants and animals over millions of years and were trapped in rock layers of the earth.

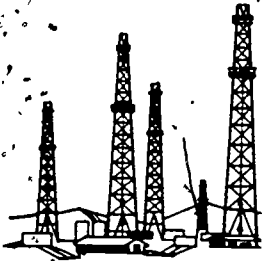

Gasoline that runs our cars, trucks, and planes is made from petroleum. So are paints, insecticides, fertilizers, and many other manufactured products. Natural gas is a clean-burning fuel that heats many of our homes, cooks our food, and serves industry. Together, oil and natural gas supply 76 percent of our total energy needs.

Read the following items; then see if you can determine how long our oil and natural gas resources might last.

Item #1: During 1975, the United States produced from oil wells about 3 billion barrels of oil (a barrel holds 42 gallons).

Item #2: The Federal Energy Administration estimates that our proved oil reserves in the U.S. (those known to exist and to be recoverable) are 38 billion barrels.

Item #3: Many geologists figure that it is fairly certain that an additional 27 billion barrels of oil reserves exist.

If this amount of oil still in the ground were all we had, and if we did not increase or decrease our production each year, in about how many years would the U.S. run out of domestically produced oil? (Add #2 and #3, and divide by #1.)

(#2) 38 billion barrels

+ (#3) 27 billion barrels

65 billion barrels

÷ (#1) 3 billion barrels

21+ number of years

Item #4: The highest estimate is as much as 127 billion barrels of additional domestic oil still undiscovered.

If Item #4 is true, and if we do not increase or decrease our production, how many years might our possible total oil resources last?

On the back of this sheet, add #2, #3, and #4 and divide by #1. Put the number of years in this space.)

64 number of years

In the same way, determine how long our natural gas resources might last.

Item #5: During 1975, the U.S. produced for use about 20 trillion cubic feet of natural gas.

Item #6: Our proved reserves at the end of 1974 were 240 trillion cubic feet.

Item #7: Fairly certain reserves of natural gas are about 202 trillion cubic feet.

If this amount of domestic natural gas was all the supply we had, it would last about how many years? (Add #6 and #7, and divide by #5. Put the answer in this space.)

22+ number of years

Item #8: The highest estimate of undiscovered natural gas resources is 655 trillion cubic feet.

If this amount is true, about how many years might our supply of natural gas last? (Add #6, #7, and #8, and divide by #5. Put answer in this space.)

55 number of years

BUT...the United States is now using each year almost double the oil that it produces from its own reserves. Where does this additional oil come from? We buy it from other countries.

What could happen if our usage continues to increase each year? We will have to buy more or run out sooner.

What if oil and natural gas usage increases in other countries? Competition for supplies will increase. Prices will rise.

At what time in your life could the U.S. run out of oil and natural gas?

- TITLE:** ECONOMIC ISSUES AND THE ENERGY CRISIS
- AREA:** Economics, Free Enterprise, Consumer Economics
- OBJECTIVE:** The student will be able to describe the effects of the energy crisis on economic systems.
- MATERIALS:** Current newspapers, news magazines
- ACTIVITY:** The American public is fearful of the power of large companies and higher prices. The people are deeply concerned that huge oil, gas and electric companies will amass excessive profits while the suffering customers pay dearly. The government is therefore under pressure to regulate prices in order to protect the consumer.

On the other hand, when goods and services are not rationed by their prices in a free market, shortages and inconvenience may be expected since something-- if only waiting in long lines--must always regulate consumption to keep it exactly equal to production.

When are government controls necessary or appropriate and when is the free market the only satisfactory mechanism for regulating the price of a commodity? This and other fundamental economic issues involved in the energy crisis are illustrated in the following topics for discussion.

1. Are shortages the result of lower or of higher prices? Examine the statement below by controversial economist Milton Friedman:

"Economists may not know much. But we do know one thing very well: how to produce shortages and surpluses. Do you want to produce a shortage of any product? Simply have government fix and enforce a legal maximum price on the product which is less than the price that would otherwise prevail...Do you want to produce a surplus of any product? Simply have government fix and enforce a legal minimum price above the price that would otherwise prevail."

Do you agree with this statement? Is it borne out by our experience with oil and natural gas?

2. What effect has the energy crisis had on our day-to-day cost of living? Some perspective may be gained by making a comparison of prices over the past few years on certain items which require large amounts of energy to produce. Such examples as fertilizers and steel will be helpful. What has happened to the cost of transporting goods and materials?

3. Break your class into groups, each of which will study a company in one of the following areas: petroleum, natural gas, and electric power. In each case have the students find out whether the prices for the companies' products are set by the free market or by a governmental regulatory authority. Local representatives of these companies will be helpful in supplying your students with information.
4. How high a price would Americans be willing to pay for oil and gasoline in order to eliminate their dependence on foreign supplies?
5. Some people are now saying that the oil embargo of 1973 was a blessing in disguise. Discuss with your class how this might be true.

INTRODUCTION

NEW AND UNUSUAL ENERGY RESOURCES

Three hundred years ago coal wasn't a resource, but a rock. A hundred years ago oil was a sticky nuisance, not a resource. Forty years ago uranium wasn't a resource. Coal, oil, and uranium became resources because the mind of man figured out a way to use them beneficially. There is only one real resource in the world: the world of man....

--Ben Wattenberg. The Real America

Today the United States has more energy available than any other country, not because we have more resources (we don't), but because we know how to use what we have effectively. Thanks to research workers, we have had fuels for energy in the past. We now count on them to use their imagination and skill to create new resources or develop old ones in a new variety of ways for more and better energy before traditional energy sources run out. Emphasis must be on renewable resources instead of non-renewable ones.

Energy from Organic and Municipal Waste

Like the caveman, researchers look first to plants. They hope to produce fast-growing plants that will produce useful by-products after converting waste organic matter into clean fuels or other energy products. By direct photosynthesis, scientists hope to produce hydrogen for fuel. The hydrogen producers will then reproduce themselves or be useable as fertilizer or other valuable products. One study at Texas A & M is using anaerobic (without oxygen) bacteria from marine and bacterial cultures to break down agricultural wastes such as chicken manure and cotton gin waste to produce hydrogen.

Hydrogen is expected to be an ecologically attractive, broadly useable, easily stored and transported fuel of the future. It is thought the anaerobic nonsulphur photosynthetic bacteria, Rhodospirillum rubrum, and the anaerobic sulfur photosynthetic bacterium, Chromatium vinosum, when grown on organic waste, can produce large amounts of low-cost hydrogen.

The Texas A & M study used chicken manure and cotton gin waste. These materials were collected, boiling water was poured over the waste, and the liquid was filtered with a vacuum pump. The marine mud was placed in a one-liter column with 2-4 cm. layer of meat scraps and marine mud at the base, covered with 1 gram of CaCO_3 and CaSO_4 , and topped with more marine mud and seawater. In the presence of light, good colonies of Chromatium vinosum developed in about 10 days.

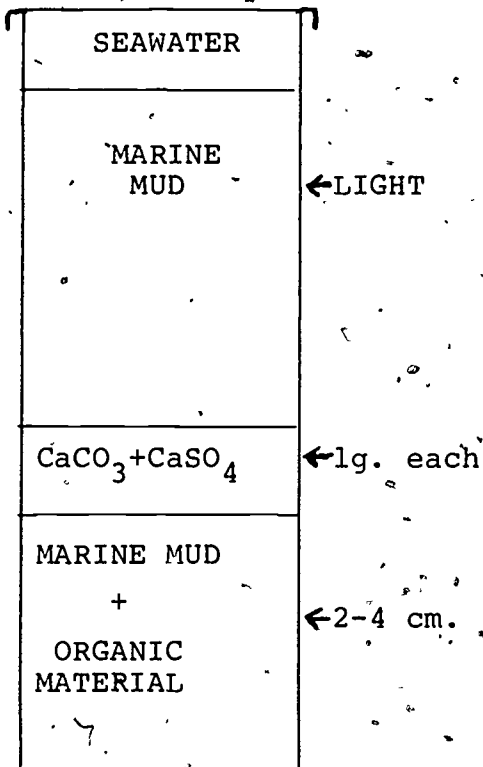

Once the colonies had developed, they were shifted to the filtered liquid media described above. Cultures of the Rhodospirillum rubrum were also added to other samples of liquid medium. These were placed in a warm bath (30 degrees C.) under Tungsten light. The gas collected was measured by Warburg manometers. In the A & M experiment, it has been found that when the bacteria is growing well, ammonia inhibits the enzyme that produces hydrogen; when the bacteria ceases to grow well, it produces hydrogen.

Bacteria are being isolated for use in methane production from organic and municipal waste. Animals are natural methane producers. A cow has the bacteria, methanum bacterium rumenium, in her rumen fluid. It has been said that "10 cows burp enough gas in a year to provide for all the space heating, water heating and cooling requirements for a small house." Now we do not recommend burp bags for cows, but we do know that the bacteria from their rumen, after waste has been broken down by other bacteria, can be used to make methane from feed and hog lot wastes-- enough perhaps to generate on-site electricity for feed graining and home heating for the individual farmer with fertilizer as a by-product.

Forest residues have already produced significant energy to run sawmills and pulping processes. During World War II, France's liquid fuel supply consisted of methanol manufactured from wood feedstock.

Other biomass (agricultural wastes and energy crops) may be produced from Eucalyptus, sycamore, fast-growing sea kelp, sugar cane, sunflowers, water hyacinth, Sudangrass, and sorghum.

Municipal waste disposal problems are reaching crisis proportions. Unlike agricultural wastes which are very homogeneous, municipal solid waste is very unhomogeneous and requires sophisticated separation methods for practical recovery. Conversion of material to fuel may be accomplished in the following ways:

END PRODUCTS OF ORGANIC DECAY.

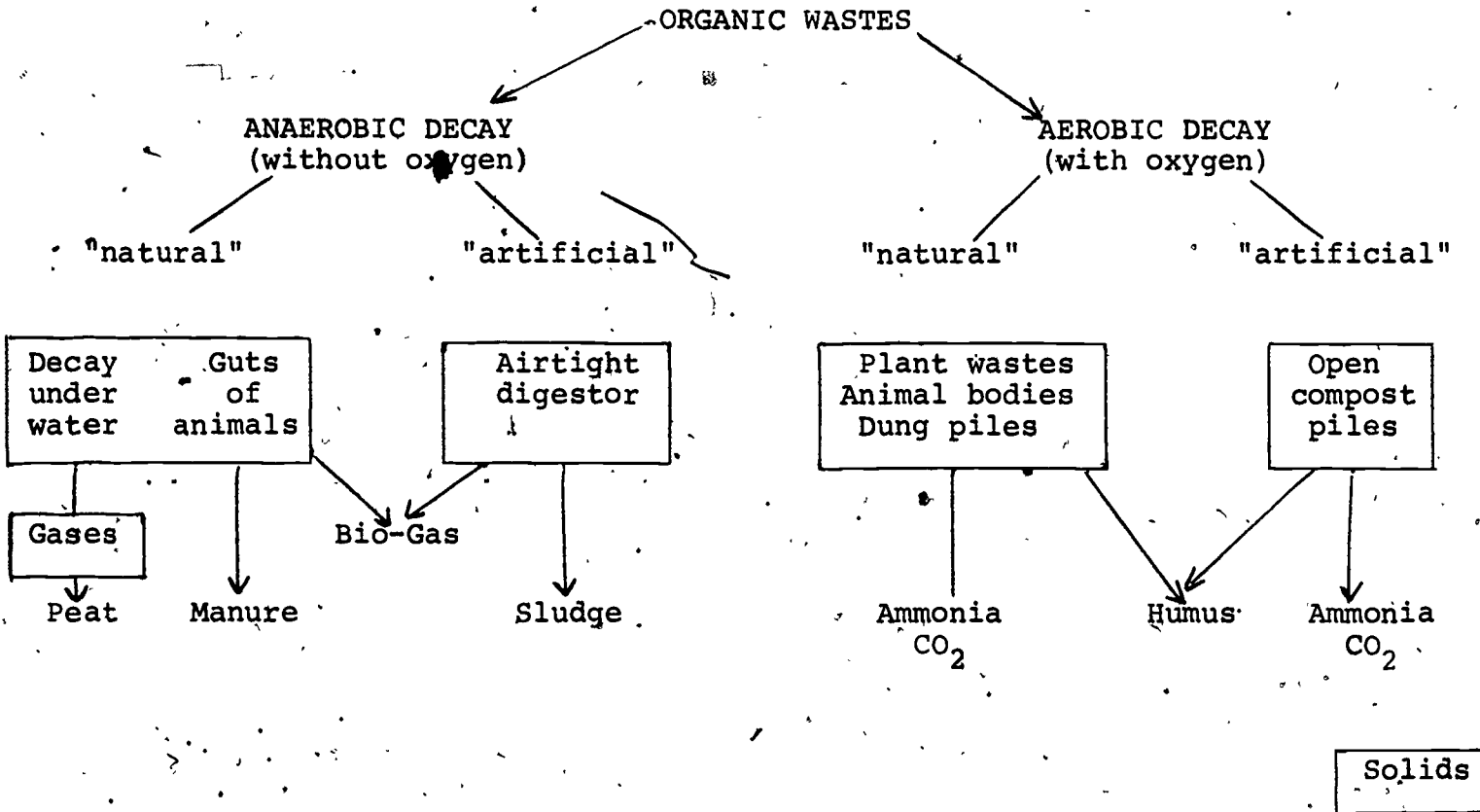

From: Carol Hopping Stoner
Producing Your Own Power

SOLAR FUELS

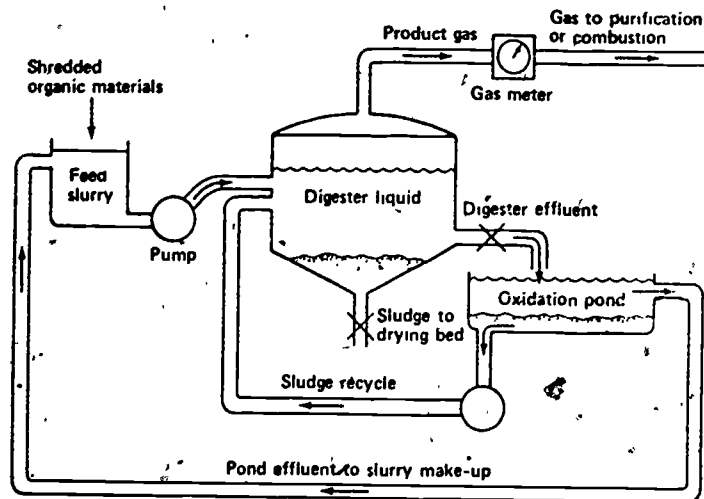
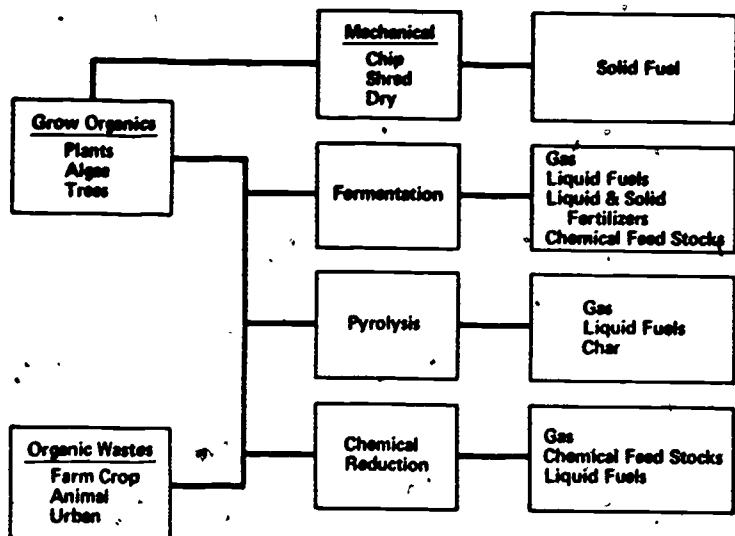

Concept of a unit for continuous conversion of organic material to methane by anaerobic fermentation (without oxygen). (From ERDA booklet, Eaton: Solar Energy.)

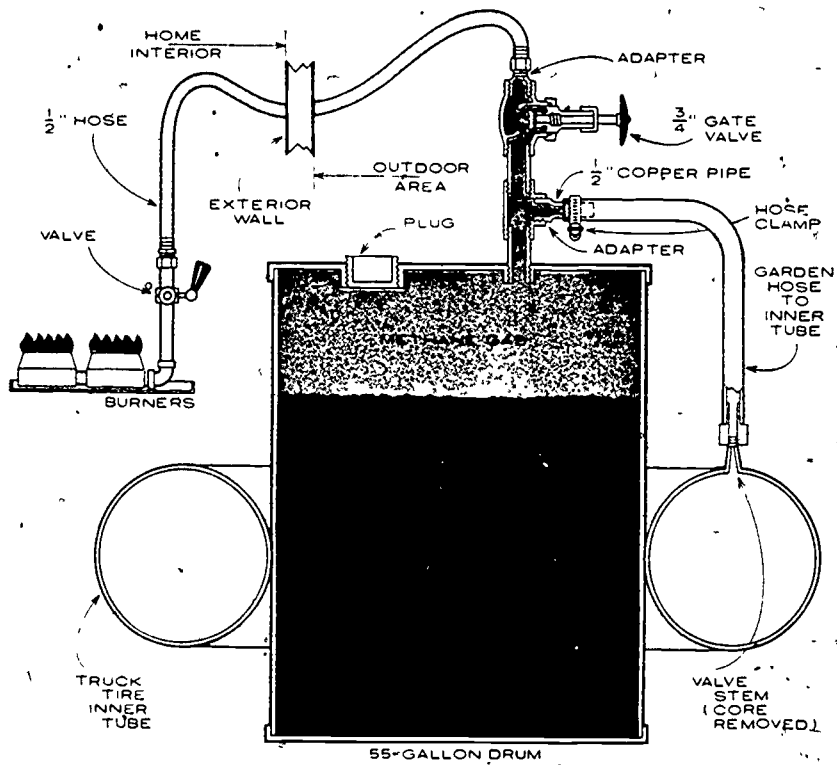

DESIGN FOR A HOMEMADE MANURE-POWERED GENERATOR
 (Popular Science, December 1975, p. 95)

1. Burning shredded trash with coal to heat water. This makes steam to generate electricity.
2. Converting solid waste to a fuel-like gas or oil-like liquid to produce electricity or other forms of energy.

Two types of organic waste digesters are used to speed the decay. The first is a batch-load digester which is filled, sealed, and emptied when the raw material has stopped producing gas. The second is a continuous

load digester, fed a little raw material regularly so gas and fertilizer are produced continuously. Each load progresses down the length of the digester to a point where methane bacteria are active. Gas rises to the surface and can be removed to be burned directly for heat and light, stored for future use, or compressed to power heat engines.

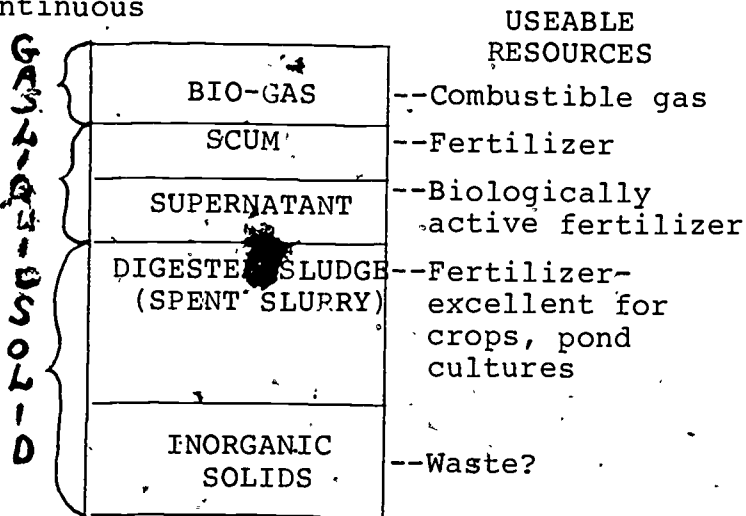

ORGANIC WASTE DIGESTER
(Stoner, Carol. Producing Your Own Power, p. 139.)

The basic conversion processes involved in energy farming may be classified as biological (fermentation and enzyme hydrolysis), thermochemical (pyrolysis and catalytic gasification), combustion, and advanced processes (biophotolysis--the direct photosynthetic production of hydrogen). Fermentation could produce methane and alcohol; combustion and thermochemical processes could produce methanol; and pyrolytic conversion of urban solid waste to produce BTU gaseous fuels and oils.

The problems involved in setting up energy farms may include: competition for land with food and fiber crops, cost of conversion facilities, legal, political, and security problems inherent in ocean-based farms, and desalination of water for possible use of present nonarable land.

Harnessing the Wind

Interest in aviation led to the development of more powerful and efficient windmills based on the aerodynamics of airplane propellers. By 1950, the United States had over 6 million windmills. Some are still in use, although most were displaced by electricity. Now windmills are again under study for improved production of electricity. The energy available will depend upon windspeed, which will limit the areas of efficient use. Factors affecting windspeed include geographical location, height above

ground, topography, and weather fluctuations. Tower heights must be aesthetic. Rotor designs must withstand at least 125 mph winds. The West Texas area around Amarillo, Texas is one of the most feasible areas of the United States. It has wind-speeds of more than 10 mph, 80% of the year.

Studies are being made involving the size of sweep areas, number and shape of propellers, and possible storage of the direct current produced.

At the turn of the century, the United States had the most graceful and efficient sailing ships ever built--the clipper ships; they lost out to competition from the powerful iron-hulled steam ships. Now, Germany has developed a full-scale 17,000 ton modern clipper ship with stainless steel sails and hydraulically turned masts. It is said to take only 5% as much fuel as a similar conventional ship.

Water Power from Tides and Ocean

Engineers have suggested using the rise and fall of tides to provide usable energy. When the difference between tides is at least 18 feet, water may be trapped behind dams as the tides come in, then used to turn water wheels and machinery as the tide goes out. One such tidal power plant was designed for Passamaquoddy, Maine. This is located on the Bay of Fundy on Canada's east coast where 50-foot tides occur. Another suggestion has been to install giant undersea windmill-like machines beneath the current of the Gulf Stream off the eastern coast of the United States. Electricity would be produced and transmitted by long cables to the mainland.

Plans are underway for anchoring floating power plants in the Gulf Stream and other ocean areas to vaporize fluids by exposing them to the warm temperatures of the upper layers of the oceans. The resulting steam-like vapors would turn turbine-generators, producing electricity. Suggested operating locations are at 200-foot depths.

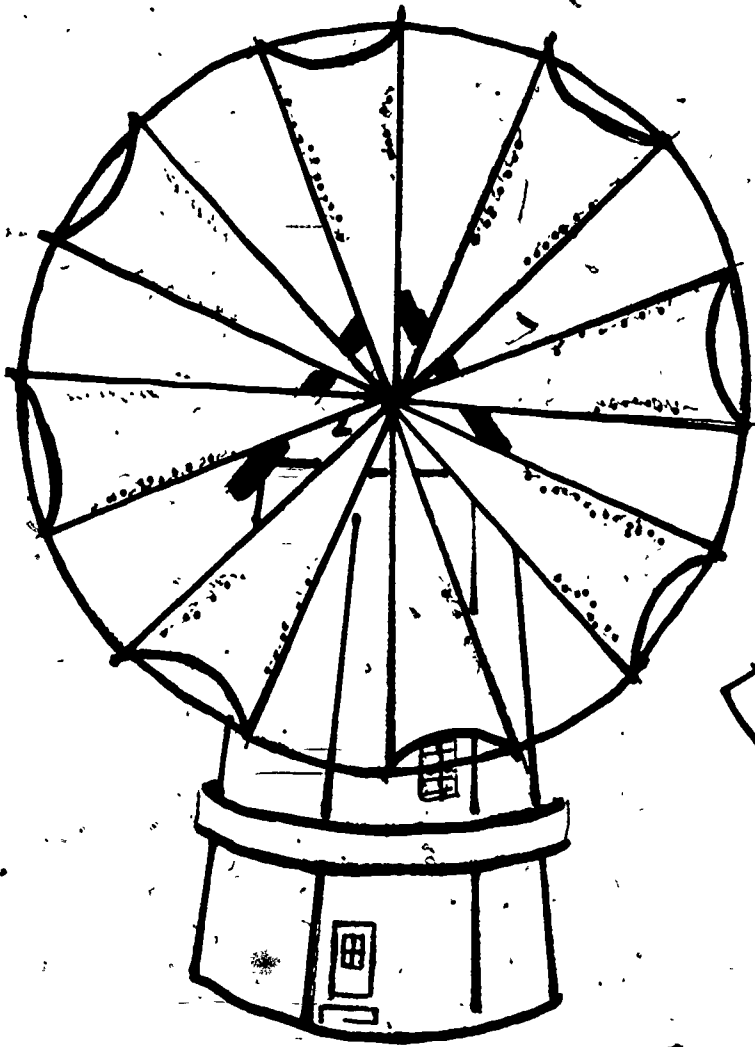

EARLY 18th CENTURY DUTCH
PLANE-VANE WINDMILL

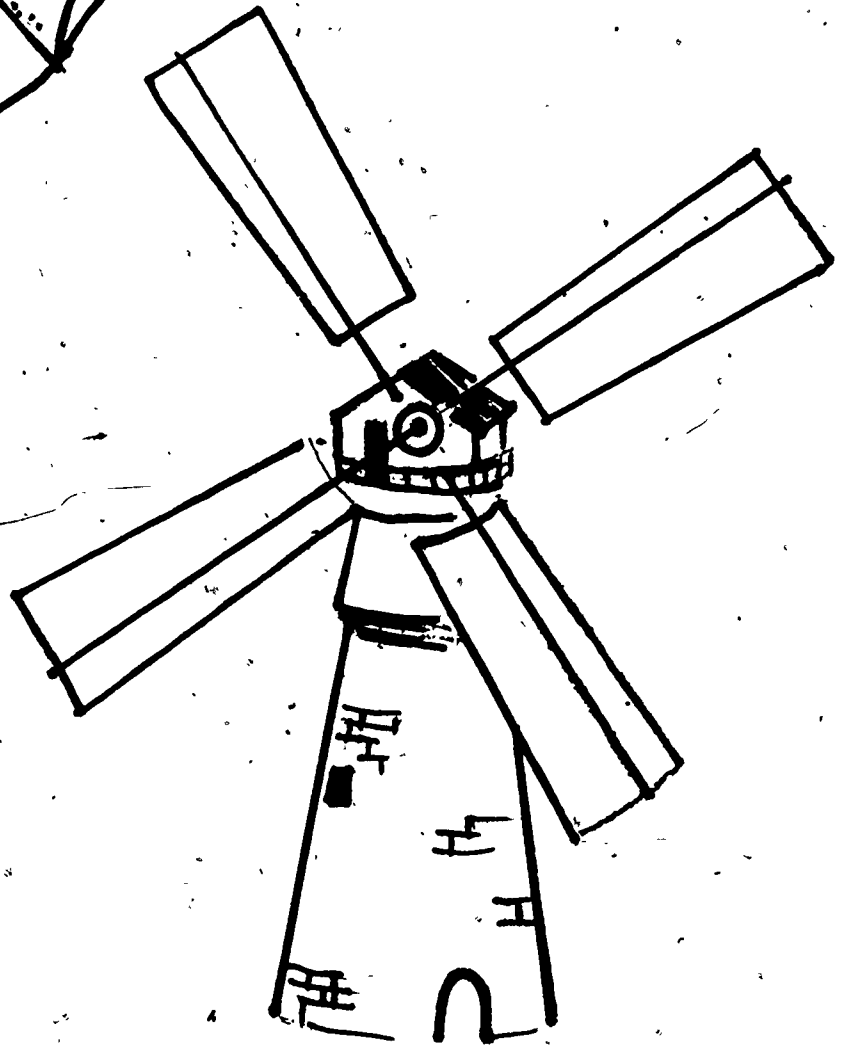

LA COUR WINDMILL

EARLY AMERICAN WINDMILL

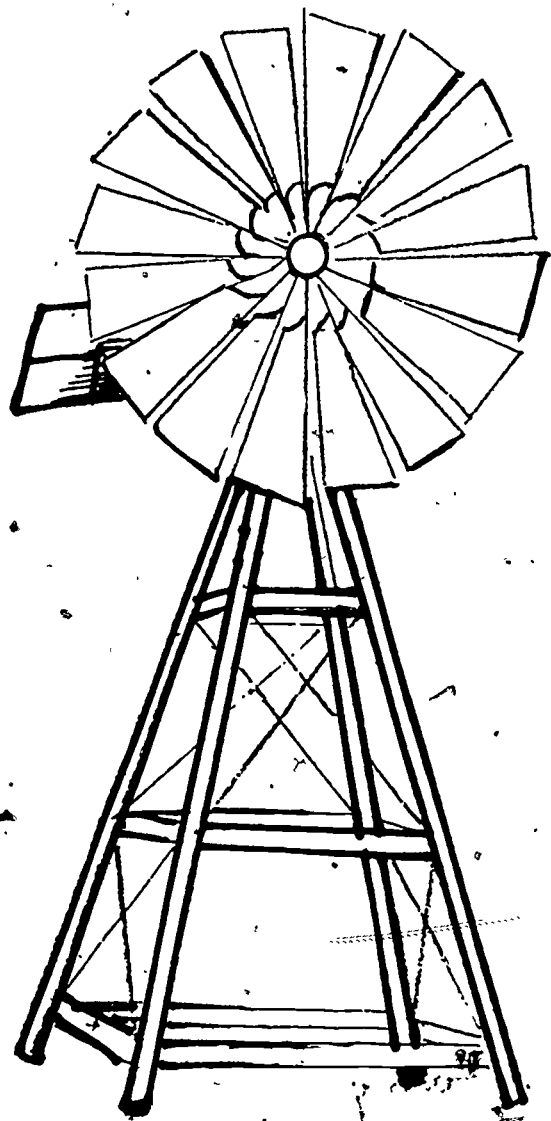

THREE-BLADED TURBINE
GEDSEN, DENMARK

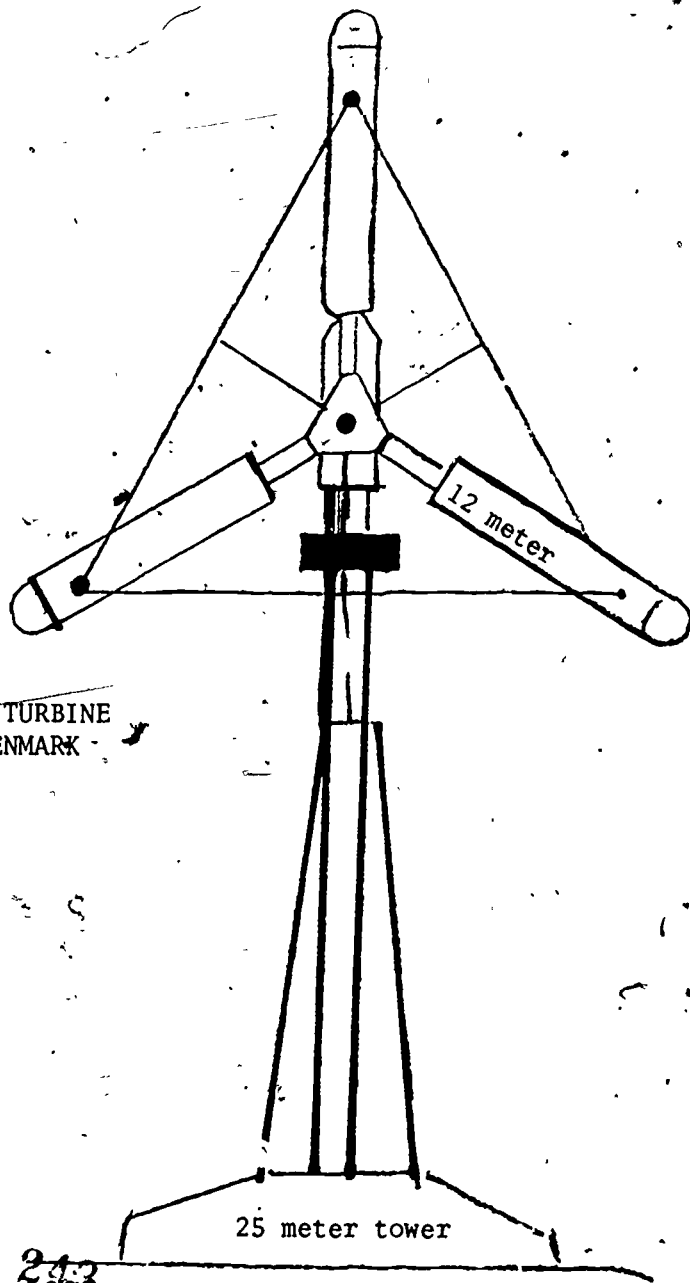

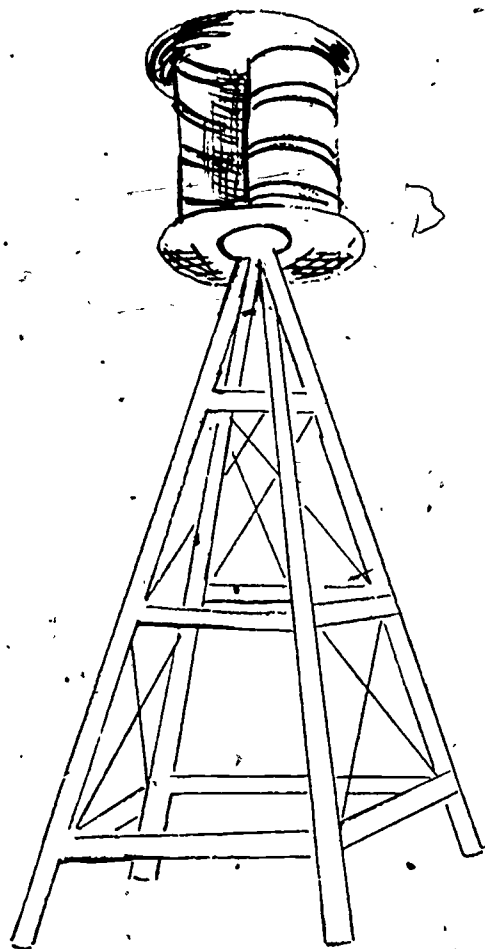

SAVONIS ROTOR WINDMILL

TWO WINDMILLS INDEPENDENT OF
WIND DIRECTION

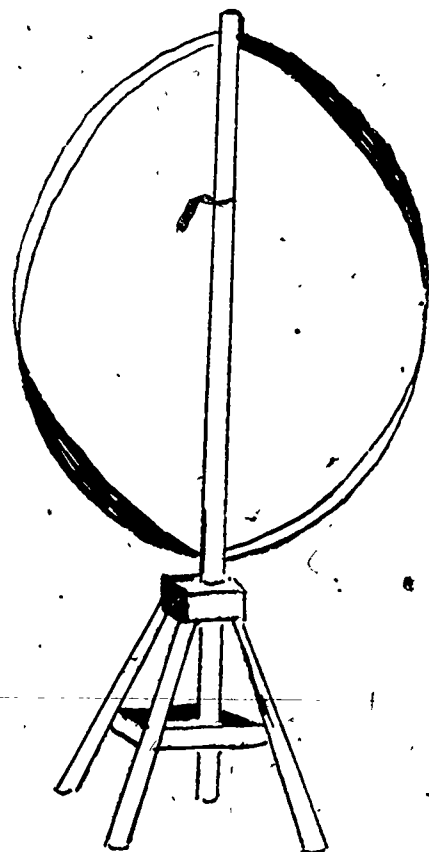

DARRIEUS VERTICAL-AXIS
WINDMILL

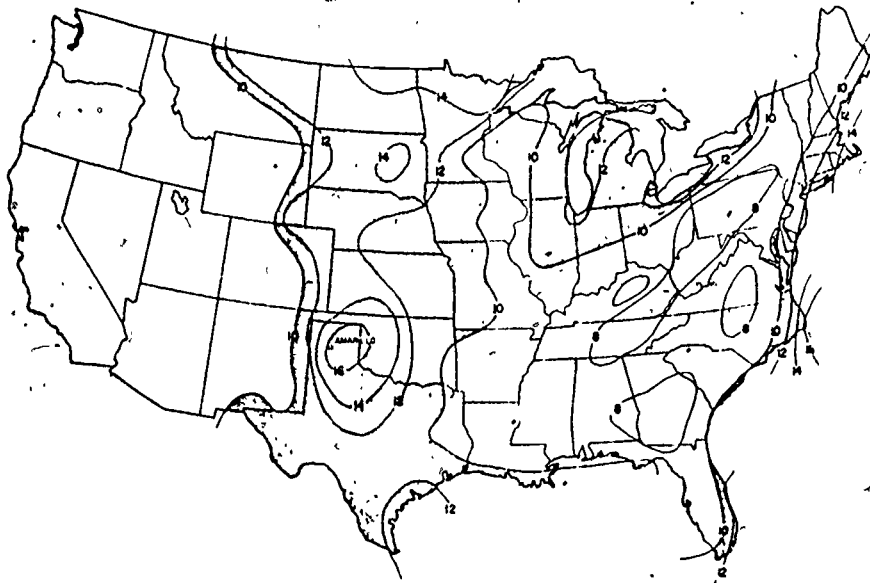

Contour lines of average hourly windspeed obtained by Thomas adjusted to 100 ft above ground³

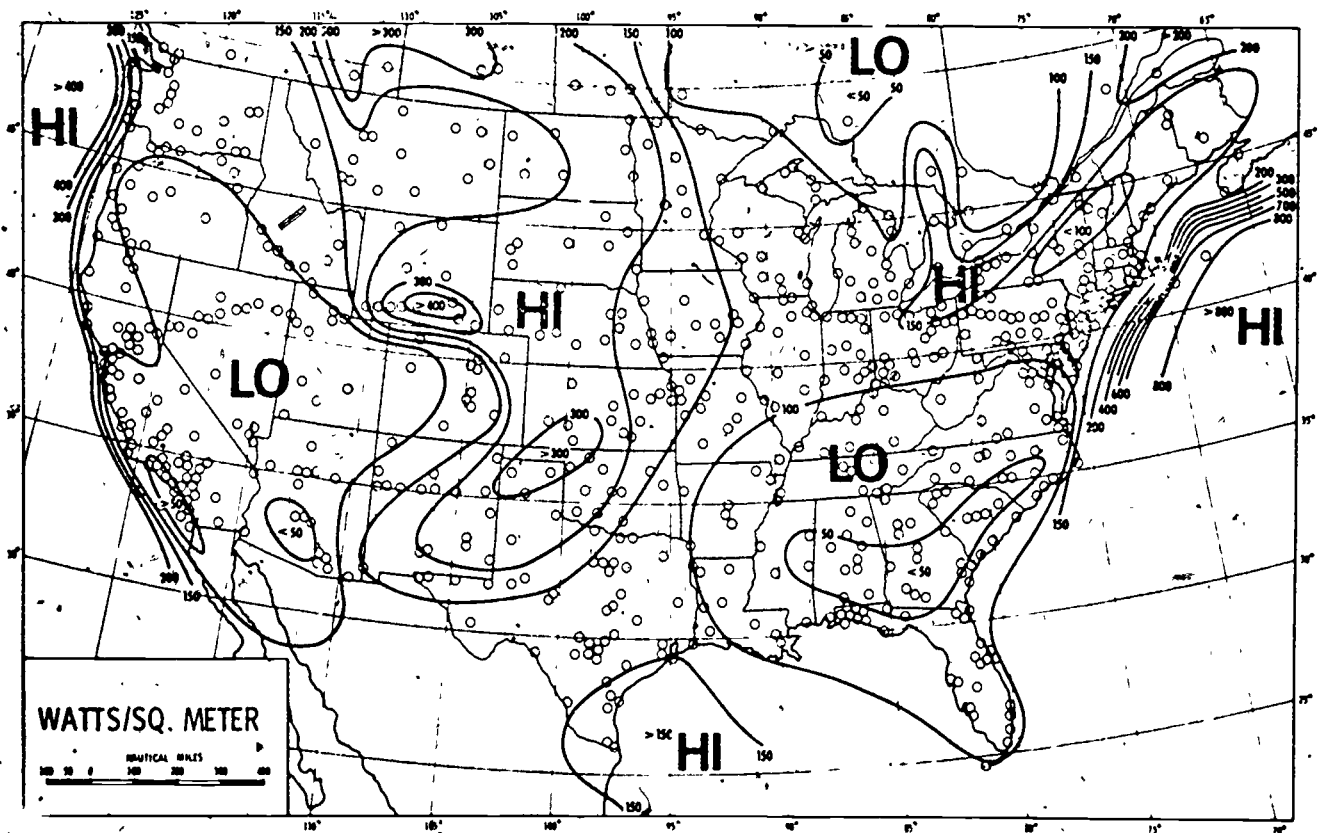

Annual average of available wind power.

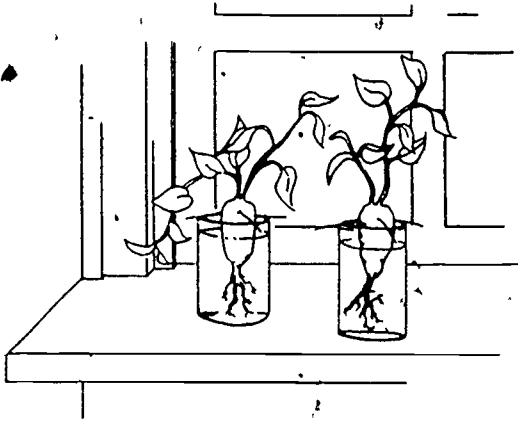

Sunlight shining on leaves helps make the food a plant needs to grow.

The energy in oil, coal and natural gas is believed to come from plants and animals that years ago lived in the sunlight.

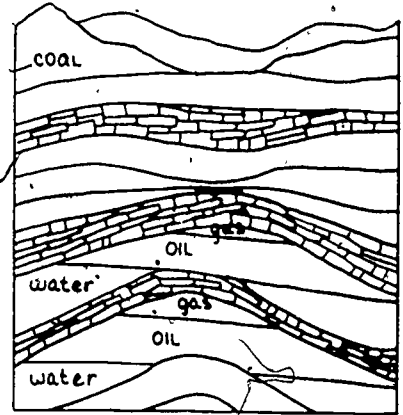

Energy from the sun produces electric energy in solar cells. Electricity from solar cells can power telephone systems.

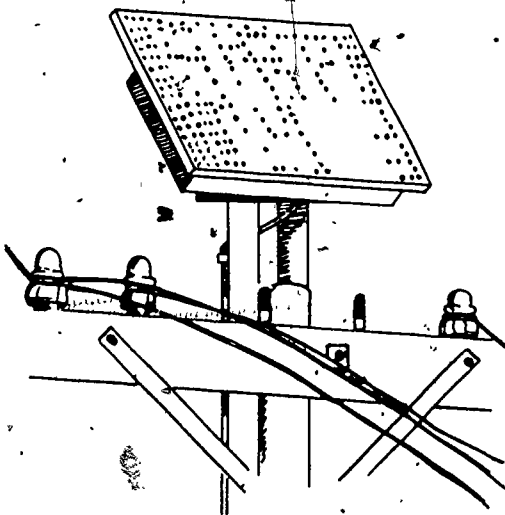

The heat of the sun causes the air to move.

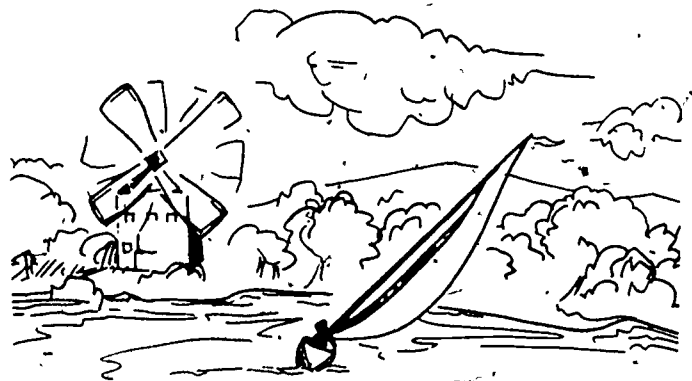

INTRODUCTION

GEOHERMAL ENERGY



The quantity of heat stored within the center of the earth is called geothermal energy. The decay of small amounts of radioactive elements produces the heat. At a depth of approximately twenty-five miles the earth is molten and the temperature is about 1,100 degrees C. As yet, we do not know how to drill holes deep enough to extract this energy. Fortunately, there are areas where the energy is closer to the surface. These areas are identified by surface geysers, hot springs, and volcanoes.

Geothermal energy was first utilized some seventy years ago in Italy. Today we find geothermal energy being produced in California, Italy, New Mexico, Russia, and Iceland, where all the island's electric power is derived from geothermal sources.

It has been estimated by the Department of the Interior (the Hickel Report) that a well-funded research and development program could result in 132,000 megawatts by 1985 and 395,000 megawatts by the year 2000. This represents 16 to 25 percent of the anticipated total electrical energy generating capacity in the coming years. Dr. Thomas O. Fitz, Deputy Geothermal Coordinator for the U. S. Department of the Interior, disputes this. Dr. Fitz says that the Hickel report was based on the known reserves rather than what we could use after collecting and transmitting losses were deducted. According to his calculations, by the year 1985 we will be able to generate 4,000 megawatts or 0.2% of our needs and by the year 2000 we would have 40,000 megawatts or 1.5% of our needs. Another worker, Donald E. White, has also made estimates and from areas he studied he maintains that the world's potential geothermal power is about a third larger than the present hydroelectric power capacity, or about 20 percent the total installed electric power capacity of the United States. Hence, while geothermal energy is capable of sustaining a large amount of small power plants in a limited number of localities, it still represents only a small fraction of the world's total energy requirements, and this is for only a limited period of time.

Types of Geothermal Energy Production

Dry Steam

Such geothermal systems are fairly infrequent and are thought to contain both water and saturated steam, the steam being the substance which controls the pressure. When a well is drilled, the pressure is decreased and the heat contained in the rocks dries and superheats the steam as much as 50 degrees C. Between 50,000 and 200,000 pounds of steam per hour is the normal range for a commercial well. The steam is trapped in pipes and conducted to a power station, where it is used to turn a turbine which in turn generates electricity.

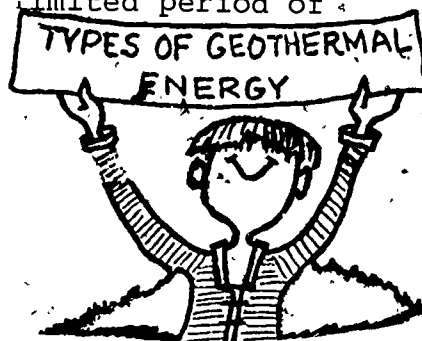

The Geysers, California, produces 180 megawatts of electricity. Valles Caldera, New Mexico, and Matsukawa, Japan, are also examples of dry steam fields. The geothermal plant in Lardello, Italy, was built about 1913 and is also dry steam powered. Now farms, orchards and vineyards cover much of the land surface around the site.

Condensed Steam

Water in this type of system picks up heat from a concentrated heat source and moves up in the system. When this hot water reaches the surface it is usually observable as hot springs or geysers. When the energy is tapped by a well about 15-25% of the fluid "flashes" to steam due to the pressure released. The temperatures can reach 266 degrees C and have pressures between 50 and 150 pounds per square inch at the surface. The steam is used to turn turbines while the water is either discharged at the surface or in some cases injected back into the ground.

The following areas use this type of geothermal well: Wairekei, New Zealand; Otaka, Japan; Cerro Prieto, Mexico; and Pathe, Mexico.

Water-Surface Injection

Hot dry rocks overlying a concentrated heat source such as a magnum chamber may provide a source of geothermal energy if water is injected from the surface. Gravity will carry the water down, and in passing through the hot rocks it will absorb the heat, which causes it to expand, carrying it back up to the surface.

An experimental geothermal plant of this sort has been constructed in the Jemez Mountains of northern New Mexico by the Los Alamos Scientific Laboratory (LASL). They have drilled 2,600 feet or 1/2 mile into the rock at one edge of a volcanic crater. The pressure of the water being forced down into this hot impermeable rock causes the rock to crack, forming a one dimensional fissure. LASL has found that as they recycle the water through the system, it is not necessary to add more. This probably means that the cracks leak very little water and are not getting larger with time. Another possible source for this type of well is near Marysville, Montana.

In order to be profitable, a crack must be large enough to yield heat for about ten years. Some people in this field have suggested drilling at a slant which is perpendicular to the expected orientation of the fractures and then making a series of parallel vertical cracks along this single well line, possibly as often as every 30 meters.

The following is a possible diagram of this type of geothermal well:

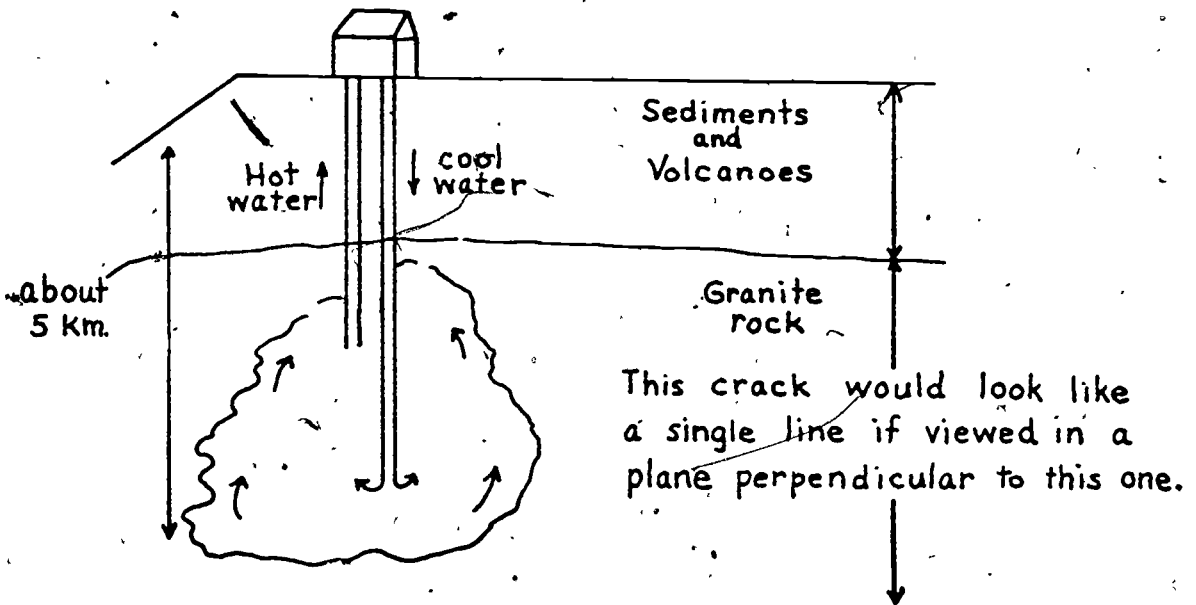

ENVIRONMENTAL CONSIDERATIONS OF GEOTHERMAL ENERGY

Advantages

1. Geothermal power cycle is self-contained.
2. Needs no outside support to maintain it, so strikes by railroads, natural catastrophes, etc., would not put it out of commission.
3. Natural phenomenon which is reliable.
4. Dry steam geothermal wells produce their own cooling water by condensing their steam, therefore do not need extra water.
5. Does not involve political implications of Foreign intervention.
6. This is relatively inexpensive: 1/2¢ per kwh. (Pacific Gas and Electric, The Geysers.)
7. Hot water geothermal systems will bring into use waters which are presently below economic drilling depths--may improve quality of currently usable waters.

Disadvantages

1. Many fractures will need to be made in areas without naturally occurring steam or water. (See water injection.)
2. There have been recent earth tremors in Colorado due to re-injection of water.
3. Plants are "dirty, noisy, unsightly, malodorous and possibly dangerous." (Newsweek, February 19, 1973, page 72.)
4. Steam contains hydrogen sulphide.
5. Other minerals present in waters can poison fish and other forms of life in streams and rivers after steam condenses.
6. Areas which produce energy by brine method may have such a large mineral content that turbines and wells get clogged.
7. A Mexican steam field had about 12.5 cm subsidence; also New Zealand.

Forbes, January 15, 1973, Vol. 111, #2, "The Great Land Rush of '73."

Newsweek, February 19, 1973, page 72.

Power Generation Alternatives, Seattle City Light, 1972 2nd Ed., page 17.

QUESTIONS ON GEOTHERMAL ENERGY

1. What are the three types of geothermal plants?
2. Do people who think geothermal energy is the answer to our energy dilemma probably believe in the Hickel Report or Dr. Fitz's views? Explain.
3. Can you think of a better way to extract geothermal energy from the earth? (Better than the ones already presented.)
4. What might happen by drilling holes in the earth's crust?
5. Why do you think most geothermal sites are located in the western United States?
6. Is geothermal energy polluting? List advantages and disadvantages.
7. Where does geothermal energy come from?
8. Is geothermal energy renewable?

ANSWERS TO GEOTHERMAL QUESTIONS

(For Teacher's Use Only)

1. The three types of geothermal plants are: dry steam, condensed steam, and water-surface injection.
2. The Hickel Report makes one believe that geothermal energy is the answer to our energy dilemma. Hickel's facts and figures lead one to believe that geothermal energy is much more abundant than other workers have estimated.
3. One possible way to improve collection of geothermal energy would be to pump nonpolluting liquid in a pipe through the heat source in the earth and to use the hot returning vapors to generate electricity. This is similar to the operation of a refrigerator. Note: This is environmentally better but economically not very good, since pumps, nonpolluting liquids, etc., add expenses to plant operation and construction.
4. Earthquakes, volcanoes might occur from drilling holes in the earth's crust.
5. The western U. S. is where faults in the earth's crust predominate. It is because of these faults or "cracks" that geothermal energy can be collected.
6. Listed on previous page.
7. Decay of small amounts of radioactive elements releases geothermal energy.
8. Yes, geothermal energy is renewable as long as radioactive elements are present and decaying.

Location of Geothermal Resources in the U.S.

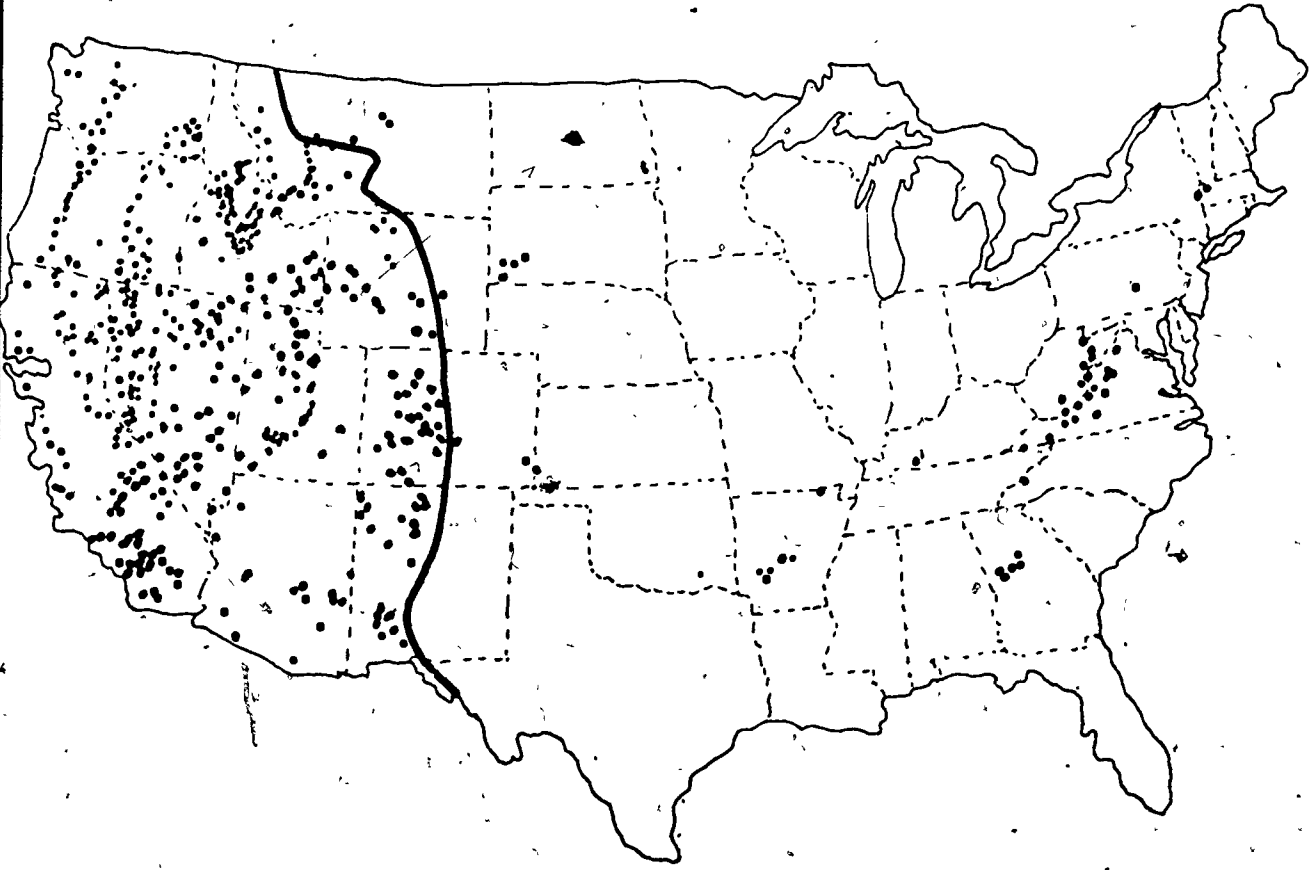

Data from "Project Independence Report," Federal Energy Administration, November 1974.

• Areas of Promise

GEOHERMAL ENERGY

What is Geothermal Energy?

Geothermal energy is created by the natural heat of the earth. When the heat from the molten inner core of the earth meets the underground water, hot water or steam results. When this water or steam pushes through the surface of the earth, it creates either a hot water spring or a geyser (see Diagram 1).

People have used hot water springs as health baths for centuries, but only in the 1900s have natural steam and hot water been used for heating homes. In 1904 geothermal energy was first used in Italy to provide electricity. Hungary and Iceland started piping natural steam and hot water directly into homes in the 1930s. Finally, by the 1960s, New Zealand, Japan, and the United States started to build small power plants that used geothermal steam to generate electricity. Presently geothermal energy accounts for 0.1 percent of the world's electric power. The largest United States field, California's The Geysers, provides about 500 megawatts* of electric power.

DIAGRAM 1

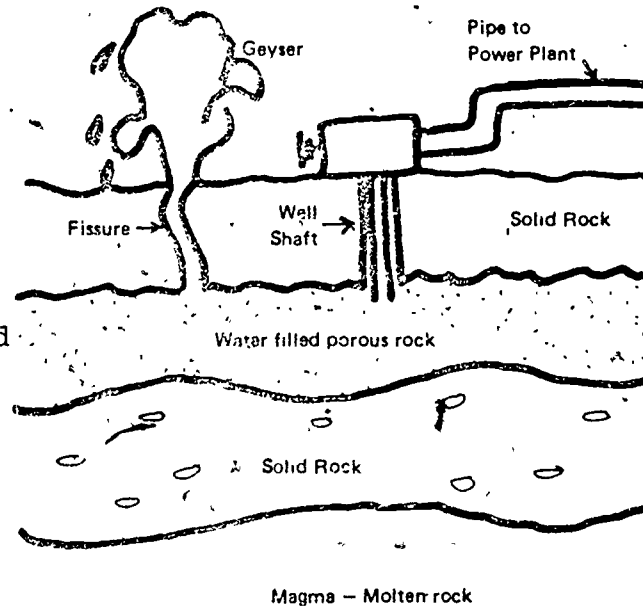
Tapping and Using Geothermal Energy

Geysers indicate that in the surrounding area hot underground water and steam are near the earth's surface. Once the geysers have been located, a geologist, a scientist who studies the earth and its outer layer, investigates the size, volume, and temperature of the geothermal system. If conditions are favorable, a well is dug near a geyser and the steam is channeled through large pipes to its destination (see Diagram 2, next page). This natural steam may be piped directly to homes or to a nearby electric plant.

When natural steam is piped directly to a home, it fills hot water radiators and provides heat. More often today it is piped to an electric plant and is used directly to turn the turbines and generate electric power. Then this electric power is

*A watt is a measure of electric power: the rate at which electric energy is produced. A megawatt is one million watts. For reference, a typical football or baseball stadium uses about a megawatt of electric power for night lighting.

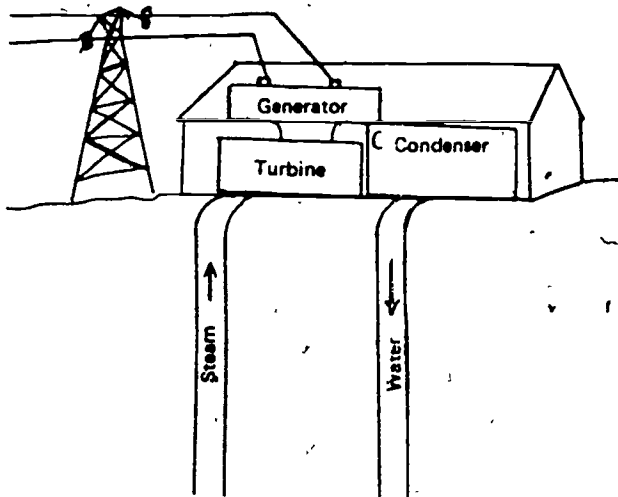

transmitted through wires into individual homes. Inside a home, electric power can heat either by using an electric hot-air furnace or by using electric space heaters. Electric power can cool by using individual air conditioners or a centrally located forced cool air system.

How Much Geothermal Energy Is There?

At the present time geothermal energy provides 0.1 percent of our electric power and only isolated examples of direct steam power for homes. It is limited to those areas where geysers exist. In the United States, most of these areas are located in the Western states. Geothermal springs are located in Idaho, Nevada, Colorado, New Mexico, Oregon, Wyoming, Utah, and Montana (see map of Geothermal Regions, next page). The more thorough study now under way will, no doubt, locate many more sources not visible on the land's surface.

Steam is not easily transported long distances, therefore, geothermal-electric power plants are located on the geothermal sites. Relatively small, they service only the local area. The Geysers Plant in California provides half of San Francisco's electricity.

How Much Does It Cost?

One of the most attractive qualities of geothermal energy is its low cost. The initial cost of locating reservoirs of natural steam is fairly expensive, but natural steam itself is very inexpensive when compared to nuclear and fossil fuels. Natural dry steam (steam without any water droplets) is available at about \$0.70 per million British Thermal Units (BTU)*. If steam is piped directly to individual homes, the average cost of heating with dry natural steam would be about \$92 per year.

When dry natural steam is used to create electric power, it is also less expensive than nuclear or fossil fuels. An estimated cost for geothermal electric heat for the average American home would be about \$200 per year (see Table, Regional Cost of Geothermal Electric Energy, on next page).

* 1 BTU = one-fourth of a Calorie.

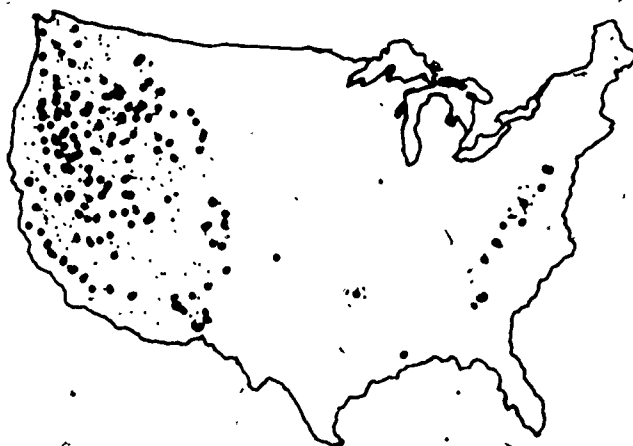

This is about one-third the cost of oil-generated electric heat and one-half the cost of nuclear-electric heat. So the relatively low cost of geothermal-electric heat makes it a desirable alternative for heating and cooling homes where it is available.

How Does It Affect Our Environment?

The use of geothermal energy can have adverse effects on the surrounding land area and on the people and animals who live there. Most geysers and hot water springs are present in scenic areas with unique landscapes. Yellowstone National Park is one area where geysers, such as Old Faithful, are located. People often object to "spoiling" these landscapes with geothermal wells. Tapping geothermal energy would require the construction of roads, ponds, wells, large above-ground pipes, and an electric power plant. In addition, geothermal wells require a ventilating system to prevent the loss of the well due to condensation. Noise from an unmuffled well has been compared to a jet plane on takeoff. When the steam and fluids of a geothermal reservoir are removed, the ground may subside, or sink, a little. In residential areas this would create problems. One solution to this is to pump the used water and fluids back into the earth after they have been used.

Geothermal energy also affects the water and air. Poisonous or highly salty geothermal fluids can pollute streams, ponds, and ground water. In addition, the heat added to the water can be fatal to marine life. Certain gases, such as ammonia and carbon dioxide, which are released from the wells, can cause serious air pollution in the local areas. These pollutants will have to be controlled at the well.

Although people, wildlife, and marine life are affected in various ways by geothermal energy, it does not create as many problems as fossil and nuclear fuels. Geothermal energy can be used directly and does not require processing plants for fuels. It does not require major land disturbances, such as mining, when extracting the fuel. It also does not create as many problems with waste disposal as do the fossil fuels. It produces a basically clean heat. For these reasons it is considered a desirable source of energy where it is available.

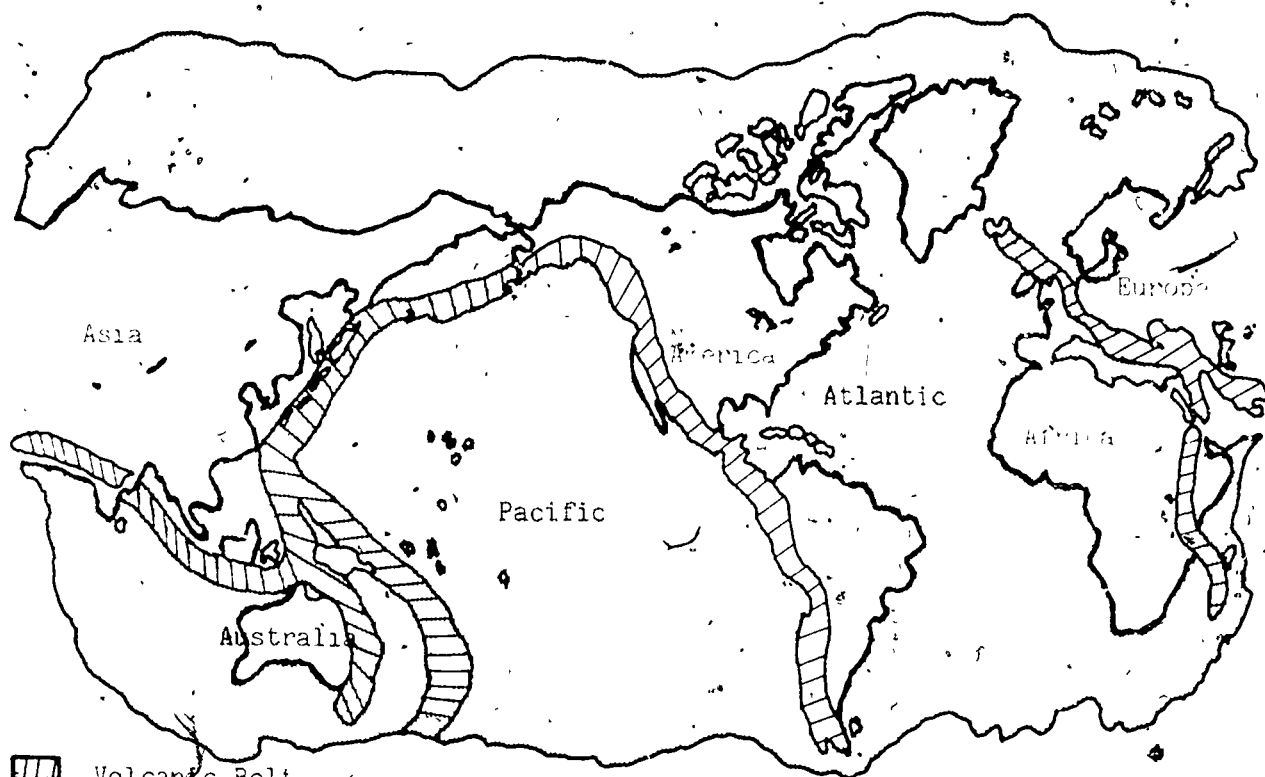

 Volcanic Belt

Volcanoes are found mostly near the oceans.

257

TITLE: Geothermal Energy: Dilemmas and Problems

AREA: Earth Science, Social Science

OBJECTIVE: The student will be able to discuss the various problems and dilemmas related to geothermal energy.

MATERIALS:

1. Handout information on geothermal energy
2. Questions on geothermal energy
3. Map, "Location of Geothermal Resources in the U. S."

ACTIVITY:

1. The student should read the information on geothermal energy.
2. Have a class discussion on geothermal energy handout information. (Use questions on handout as a guide.)
3. Use the map, "Location of Geothermal Resources in the U. S.," as a discussion of local geology and geography of the areas with potential geothermal resources.

TITLE: UNDERSTANDING GEOTHERMAL ENERGY

AREA: Science, Social Studies, English

OBJECTIVE: The student will be able to answer vital questions pertaining to geothermal energy, after being exposed to lecture, handouts, and map study.

MATERIALS: Handout
Map

ACTIVITY: Students answer the following questions:

1. What is geothermal energy?
2. What are geothermal reservoirs?
3. Name three kinds of energy found in geothermal areas.
4. How are the following projects providing energy?
 - a. Geysers fields of Northern California
 - b. Imperial Valley
5. Name two advantages in using geothermal energy.
6. List two problems with geothermal energy.
7. Why can't geothermal energy be used nationwide?

TITLE: POTENTIAL OF GEOTHERMAL ENERGY

AREA: Social Studies, English

OBJECTIVE: The student will understand why there is high heat flow in some areas but not in others, thereby affecting geothermal energy potential.

MATERIALS: World map

- ACTIVITY:
1. Using a map of the world, identify all the locations where geothermal activity might be used as a potential source of energy. Evaluate whether it would be practical to use each of those sources to produce energy.
 2. Debate the aesthetic qualities that should be considered for the use of a geothermal source for energy.
 3. Research the Geyserville geothermal electric energy production activity.
 4. Write to the Klamath Falls, Oregon, Chamber of Commerce or to Oregon Institute of Technology, Klamath Falls, Oregon, to secure information which shows how geothermal power is used in this city.

TITLE: GEOTHERMAL POWER

AREA: Social Studies, Science, English, Art

OBJECTIVE: The student will be able to:

1. Define the term "geothermal."
2. Sketch a cross section of the earth.
3. Explain why the temperature rises as we go deeper into the earth.
4. Determine the possible sites for commercial production of geothermal energy.
5. List and explain the advantages and disadvantages of the use of geothermal energy.

MATERIALS: Books from school library
Clay
World map
Graph paper

- ACTIVITY:**
1. Make a report which explains geothermal energy.
 2. Make a clay model representing a cross section of the earth.
 3. Make a line graph to show the relationship between depth and temperature.
 4. Construct a geyser to show that the earth is hotter internally than on the surface.
 5. Locate the "hot zones" of the earth on a world map.
 6. Write a report on the Yellowstone National Park.
 7. Write a report on Mt. St. Helen, Washington.

INTRODUCTION

WIND ENERGY



Wind is caused by the uneven heating of the atmosphere by the sun. Like the air over a hot stove, air heated by the sun expands and rises. Cooler surface air then flows in to take the heated air's place. This process is called circulation. Two kinds of circulation produce wind: 1) widespread general circulation extending around the earth, and 2) smaller secondary circulation. Winds that occur only in one place are called local winds.

General circulation occurs over large sections of the earth's surface. It produces prevailing winds. Near the equator, heated air rises to about 60,000 feet. Surface air moving in to replace the rising air produces two belts of prevailing winds. These belts lie between the equator and about 30 degrees north and south latitude. The winds there are called trade winds because sailors once relied on them in sailing trading ships.

Secondary circulation is the motion of air around relatively small regions of high and low pressure in the atmosphere. These regions form within the larger general circulation. Air flows toward low-pressure regions called lows or cyclones. Air flows away from high-pressure regions called highs or anticyclones. As in the general circulation, air moving toward the equator moves in a generally westerly direction and air moving away from the equator moves in an easterly direction. As a result, secondary circulation in the Northern Hemisphere is clockwise around a high and counterclockwise around a low. These directions are reversed in the Southern Hemisphere.

Secondary circulations move with the prevailing winds. As they pass a given spot on the earth, the wind direction changes. For example, a low moving eastward across Chicago produces winds that shift from southwest to northwest.

Local winds arise only in specific areas on the earth. Local winds that result from the heating of land during summer and the cooling of land during winter are called monsoons. They blow from the ocean during summer and toward the ocean during winter. Monsoons control the climate in Asia, producing wet summers and dry winters. A warm, dry, local wind that blows down the side of a mountain is called a chinook in the western United States and a foehn in Europe.

Wind Driven Generators

Modern wind-driven generators extract energy from the wind and convert it into electricity. A complete wind-driven system consists of: 1) a tower to support the wind generator, 2) the propeller and hub system, 3) the tail vane, 4) devices regulating

generator voltage, 5) a storage system to store power for use during windless days, and 6) an inverter which converts the stored direct current (D. C.) into regulated alternating current (A. C.), if it is required.

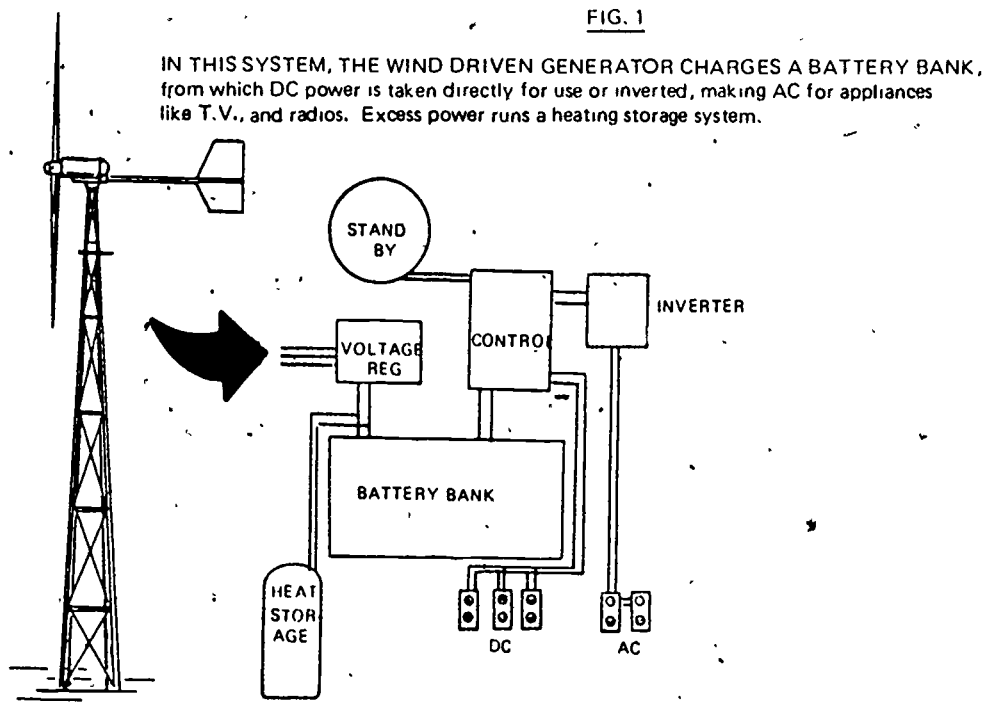

Wind pressure turns vanes or propellers attached to a shaft. The revolving shaft, through connections to various gears and mechanical or hydraulic couplings, spins the rotor of a generator. The generator creates an electric current which could be used directly or stored in battery banks.

The power output of a wind machine depends both on wind velocity (or speed) and on the diameter of the blades. For maximum power, a wind machine should have the longest blades possible (about 100 ft. is the maximum now) and should be located in the strongest winds. The height of the wind machine is another important factor because there is greater wind speed and constancy at higher altitudes than at the earth's surface. The expense of building a tower also increases with its height, however, in that most present designs call for a tower between 100 and 150 feet high.

There are a number of U. S. sites where large amounts of wind energy are available: the Great Plains, the eastern foothills of the Rocky Mountains, the Texas Gulf Coast, the Green and White Mountains of New England, the continental shelf of the northeastern United States, and the Aleutian Islands off the coast of California. Among the schemes for using wind power is construction of a grid of wind machines at half mile or mile intervals throughout the Great Plains area. Such a system could produce 190,000 Mw of installed electrical capacity, roughly half of the U. S. total in 1971. Also proposed is an offshore scheme in which the winds would be used to electrolyze water into hydrogen and oxygen. The

hydrogen could then be piped to shore or brought in by refrigerated tankers.

Small-scale schemes may also continue to prove promising. A ten-foot rotor could provide enough energy for an all-electric single family home in many parts of the U. S. Another option, too, would be to tie into, or remain tied into the existing utility line, switching to central-station power when the local generator is down or inadequate. Modern "homesteaders" are still finding wind power an economical alternative to having the nearest power company run lines out to their remote areas, and a number of companies are now producing wind electric generators designed for home use.

For all its antiquity, wind machine design is a new challenge to American engineers and several exotic designs have already appeared. Among these are the "Sailwing" (developed at Princeton and scheduled for production by Grumman Corporation) whose blade deforms in the wind and is therefore self-orienting. A prototype is already in operation in India. Also under development are several vertical axis designs which are not dependent on wind direction.

There are a number of advantages of wind power. There is no fuel cost. In addition, wind power is continuously regenerated in the atmosphere under the influence of radiant energy from the sun, and thus is a self-renewing source of power, does not release pollutants/poisons to the environment, and conserves nonrenewable resources. However, there are a number of factors which limit its immediate use. The initial cost of building the machine is high. A storage system for days of no wind can be expensive. Depending on location of the windmill, care must be taken for high winds, low temperature (ice forming on blades), and structural dynamics between the tower and the revolving blades. Wind variability also affects the output frequency of the generation. Since standard U. S. power networks require constant frequency (60 cycles per second) and alternating current (AC), some means for regulating the frequency is needed. While constant-speed drives or converters are available, they add to the expense. Finally, a major drawback is land use. Although a single machine does not occupy much space, a giant grid of them complete with power lines would have aesthetic drawbacks, but wind harvesting should be compatible with other uses of the land, such as pasturage and farming.

TITLE: PRINCIPLES OF WIND POWER

AREA: Science, Mathematics

OBJECTIVE: The student should be able to:

1. Read a simple line graph.
2. Compare two graphs with wind speed data and propeller size.
3. Calculate the value of K in the formula, $P=KV^3D^2$.

MATERIALS: Student activity sheets
Overhead projector (optional)

ACTIVITY: During course of lecture-discussion using overhead projector, students can do the worksheets.

235

PRINCIPLES OF WIND POWER

The power available from the wind is a measure of how much and how fast the wind energy is being made available to the windmill propeller. The amount of energy is proportional to the kinetic energy of the wind ($KE = 1/2mv^2$), and to the area swept out by the moving propeller normal to the wind ($A = \pi d^2/4$, where d = diameter). The speed at which the wind energy is being made available to the propeller is proportional to the wind speed. The power available from the wind is then proportional to the product of these three terms:

$$P \propto (1/2mv^2) \cdot \frac{(\pi d^2)}{4} \cdot v$$

From which: $P \propto v^3 d^2$.

The mass of the wind is usually considered constant because of density of the air does not vary appreciably over the operating ranges of temperature, pressures, and humidity.

The relationship given above, written in equation form ($P = kv^3 d^2$) is investigated in the accompanying worksheet. Note that this equation gives the power available from the wind and not really the power output of the wind machine as suggested in the worksheet. How the actual output of a wind machine follows the power available from the wind is a complicated function of the total system design and operation. The discussion that follows attempts to hit upon the main ideas involved.

A windmill propeller is designed differently than an airplane propeller. An airplane propeller is designed with a pitched surface so that it screws itself into the air as a result of its rotation. A windmill propeller is designed like the wings of an airplane so that wind blowing past it causes a differential in pressure on its two surfaces and results in a turning force. Aerodynamic analysis has shown that the theoretical maximum efficiency of an open air wind machine is 59.26%. This value is only for the conversion of the wind power to rotational mechanical power exclusive of frictional losses in bearings and assuming 100% propeller efficiency. For the purpose of electrical power production, a well designed windplant can capture about 35% of the wind power available to it. These additional losses are due to gearbox and mechanical drive inefficiencies, electrical generator inefficiencies, control and storage device inefficiencies, and its operating characteristics.

The operating characteristics of a large electricity producing wind machine is depicted in the graph following. Note that the available wind power is proportional to the wind speed cubed. Because of friction, a windmill propeller will not begin to turn until the wind speed reaches a cut-in speed V_{ci} . This is typically of the order of 6-8 mph. From the cut-in speed up to the machine's

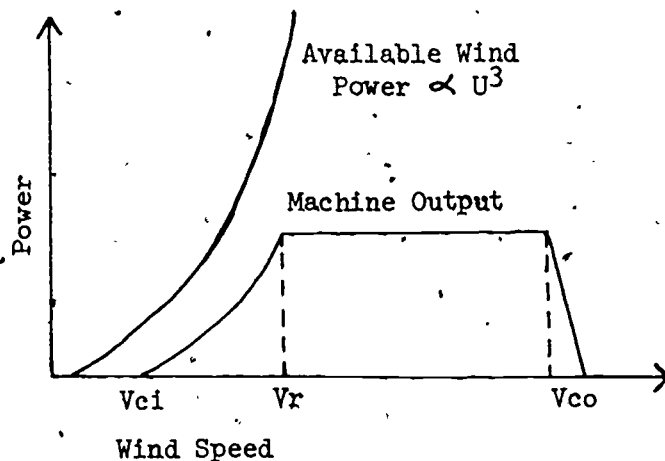

rated speed V_r , the machine output follows the power available curve. The difference is due to overall system inefficiencies. A machine's rated speed is typically 10-18 mph. From the machine's rated speed up to a cut out speed V_{co} (typically 50 mph), the machine's rated speed is kept constant. This constraint is due to the necessity for constant generator speed (to maintain constant voltage and frequency output). The spilling of the surplus power may seem very wasteful, but it is not as bad as it may seem at first glance. While it is true that the greater the wind speed, the greater the surplus power to be spilled, it is also true that the percent of the time a particular high speed occurs is a type of inverse function of the speed. In other words, high wind gusts being of short time duration, require a large power spilling but only for a short time; hence, not much energy is lost. The operating range of an electricity producing wind machine is considered to be from V_r to V_{co} . The numerical values of V_r and V_{co} are determined by a complex analysis of weather and wind speed distribution data for the proposed site and the specifications of all of the components of the wind machine system.

237

TITLE: WIND MACHINE--AN INTRODUCTION

AREA: Science, Industrial Arts, Art

- OBJECTIVE:
1. Students can name the major working parts of a windmill and give purpose of each.
 2. Students can identify by name different types of wind machines.

MATERIALS: Drawings of several types of wind machines

- ACTIVITY:
1. Identify the major parts of a windmill and describe the purpose of each.
 - a. main power blade
 - b. tail fan
 - c. power shaft
 - d. gears
 - e. movable top (cap)
 2. Given drawings of several types of wind machines, identify them by matching the letter corresponding to the picture to the name of the machine.

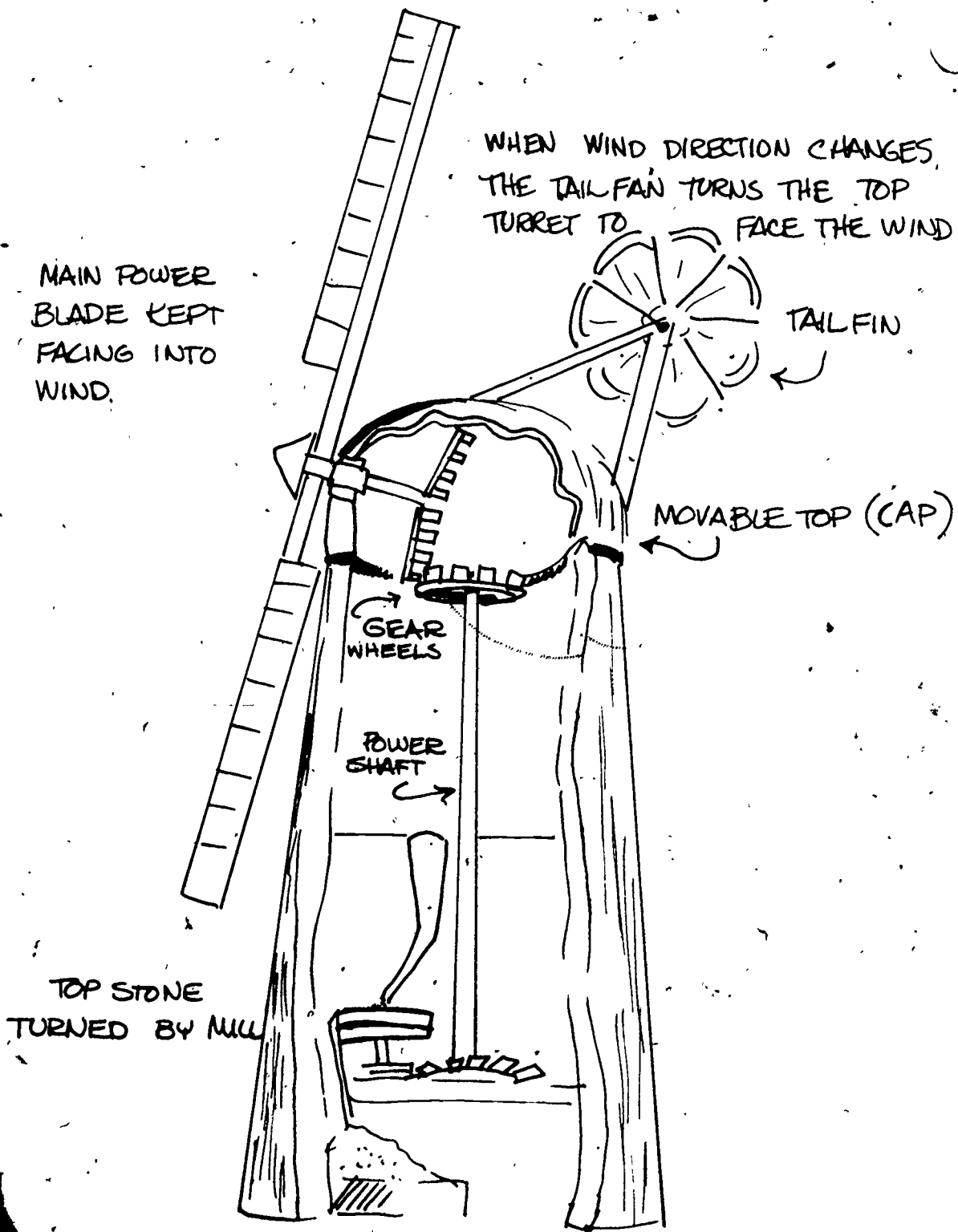

DUTCH MILL GRINDING GRAIN

259

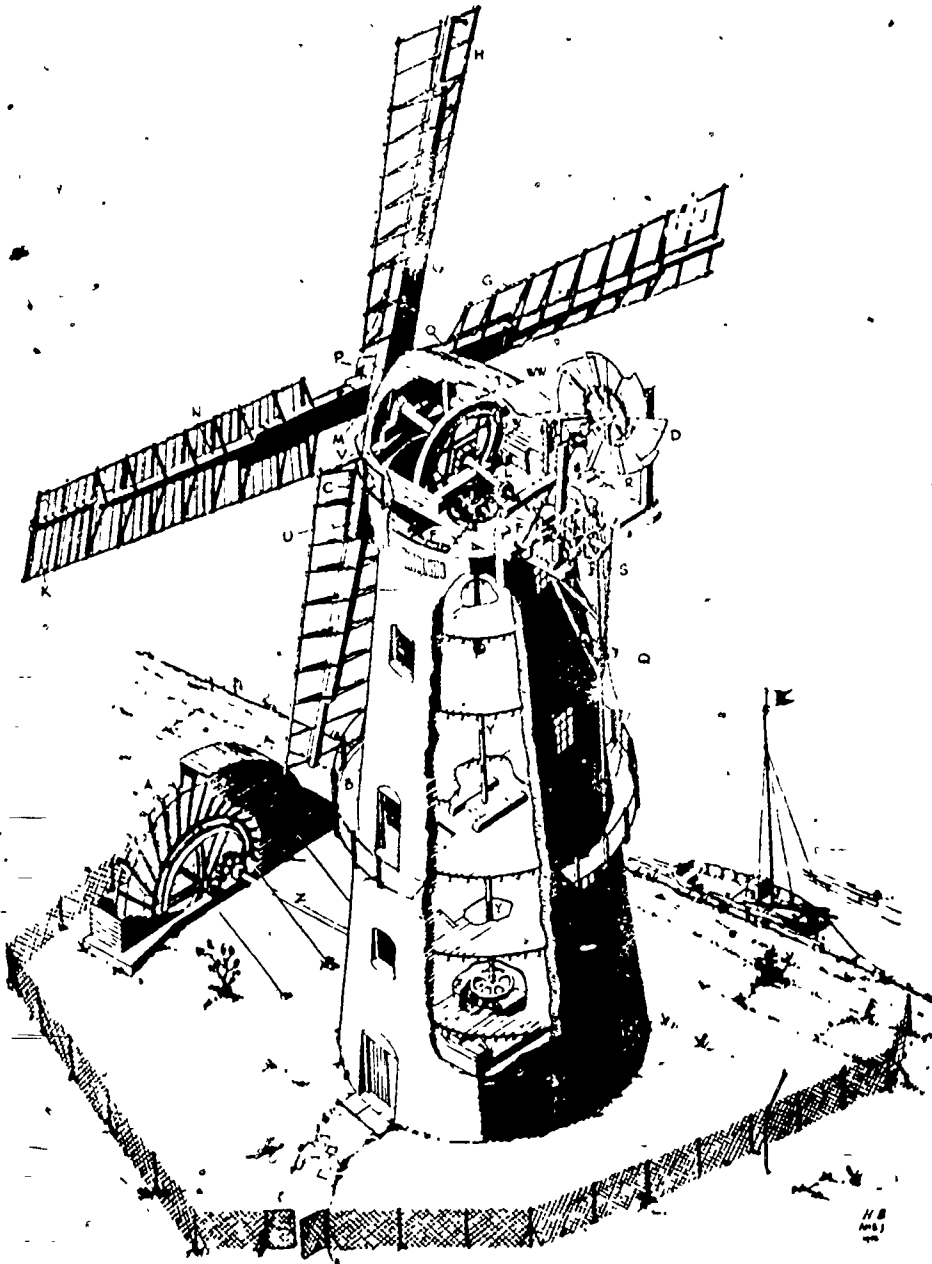

ISOMETRIC DRAWING OF HIGH MILL, BERNEY ARMS, NORFOLK

A, Scoop wheel. B, Stage. C, Gallery. D, Lantail. E, Fan drive. F, Curb. G, Hemlath. H, Whip. J, Bay. K, Shutter. L, Windshaft. M, Poll end. N, Stock. O, Clamps. P, Front striking gear. Q, Striking chain. R, Fan stage. S, Chain guide. T, Cap. U, Sheer. W, Brake wheel. WW, Brake. X, Wallower. Y, Upright shaft. Z, Scoop wheel driving shaft.

Freese, Stanley. Windmills and Millwrighting. Cambridge University Press, London, 1957.

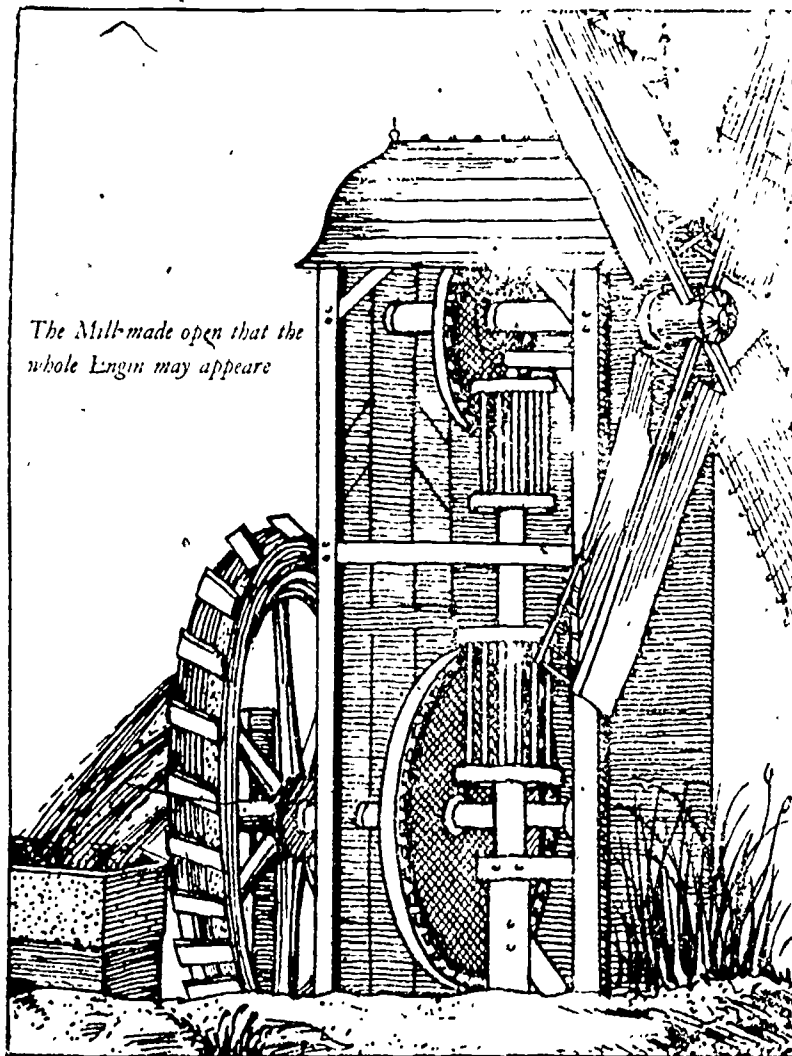

*The Mill-made open that the
whole Engin may appeare*

An early fixed windmill (from the 1652 reprint of Walter Blith's
England's Improvement).

The windmill is a Couris thing
Completely built by art of man,
To grind the corn for man and beast
That they alike may have a feast.

The mill she is built of wood, iron, and stone,
Therefore she cannot go aloan
Therefore to make the mill to go,
The wind from some part she must blow.

The motison of the mill is swift,
The miller must be very thrift
To jump about and get things ready,
Or else the mill will soon run empty.

Some lines found in a Sussex windmill by M. A. Lower.

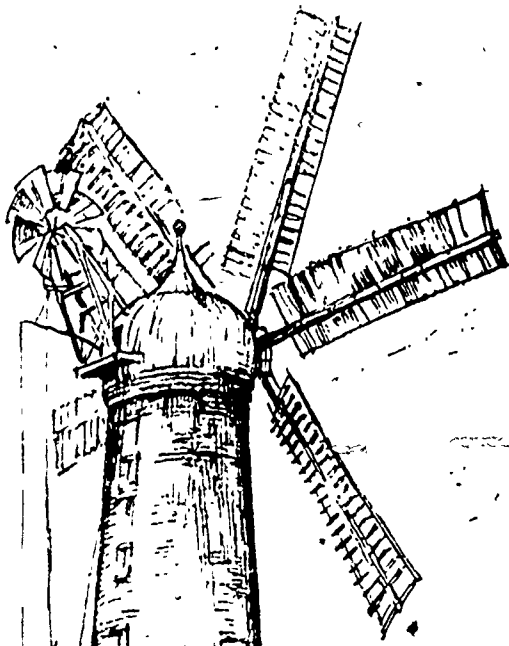

TRADER MILL, SIBSEY

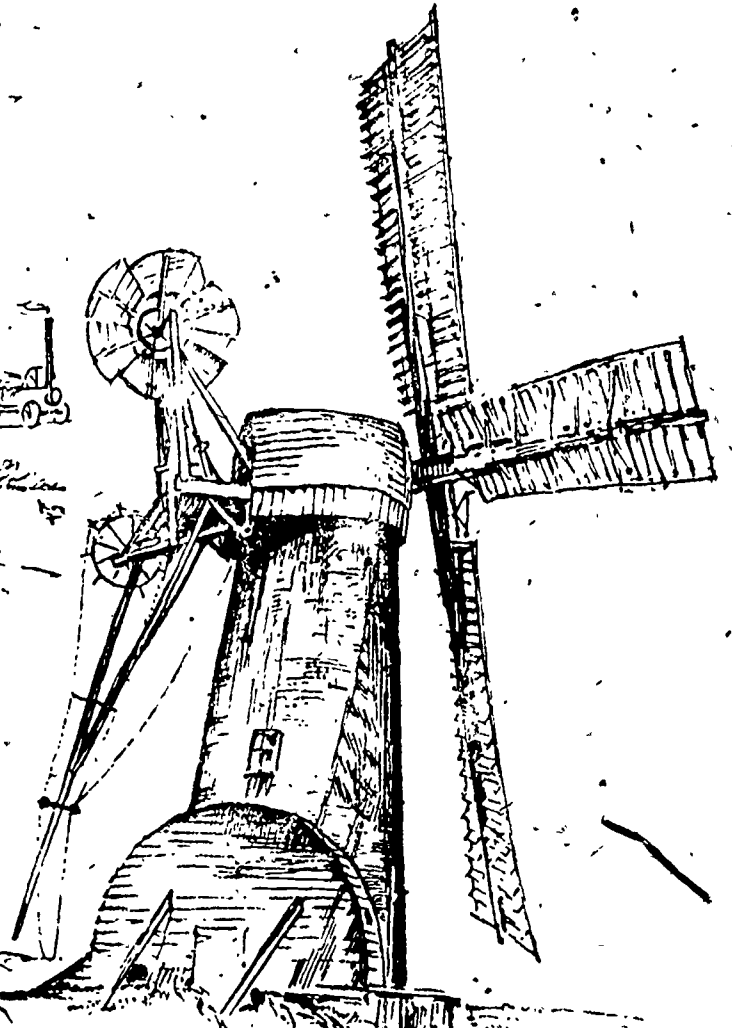

ASHITREE FARM MILL

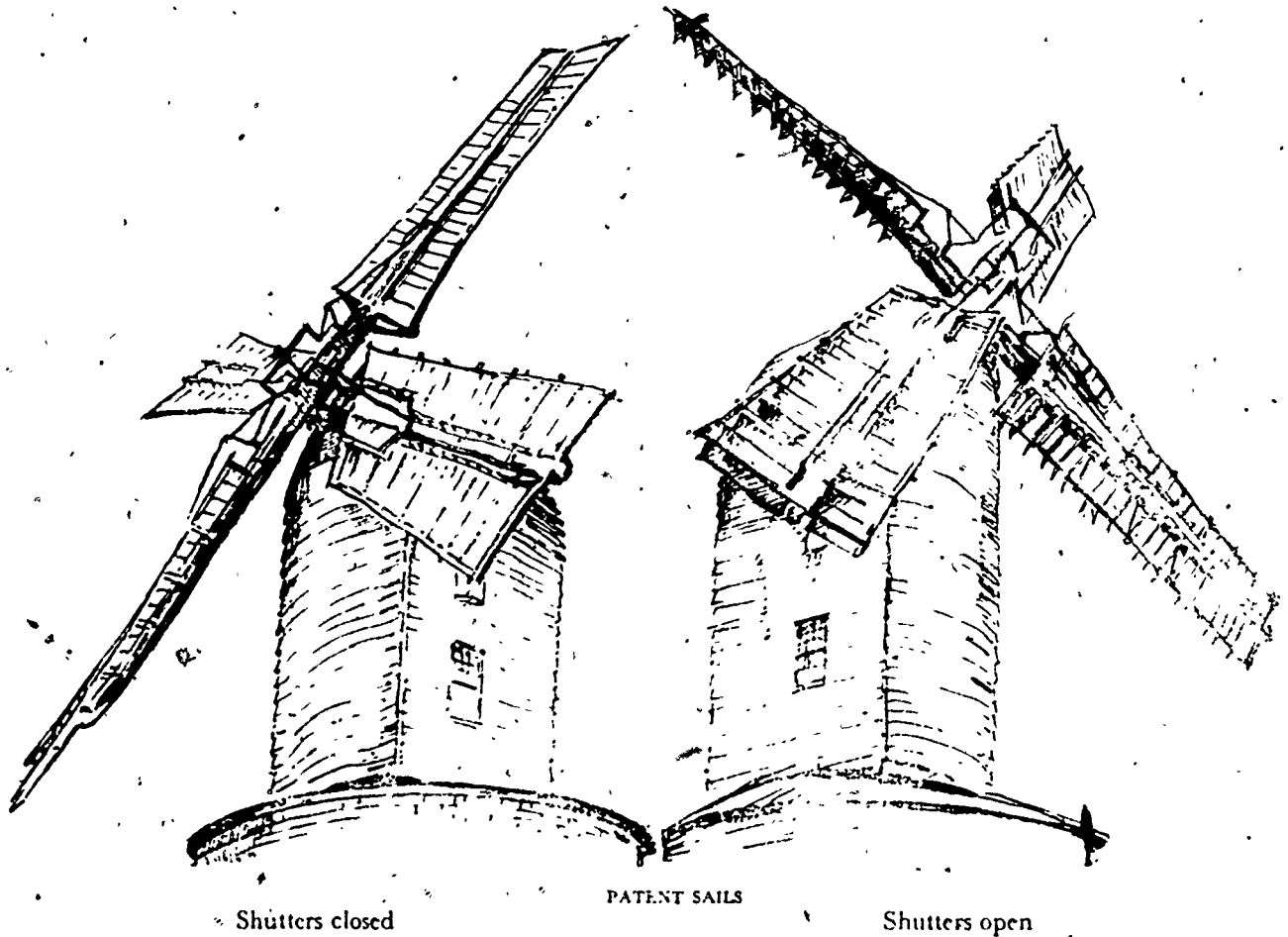
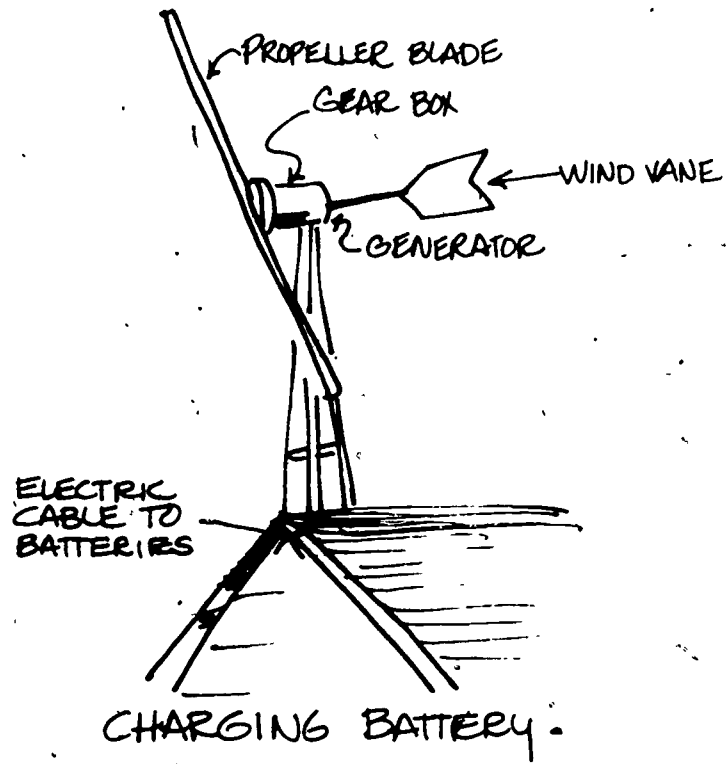

WINDMILLS

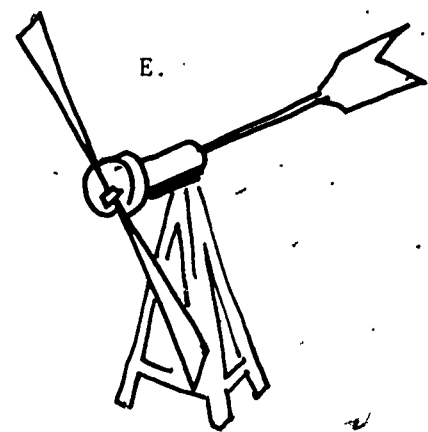
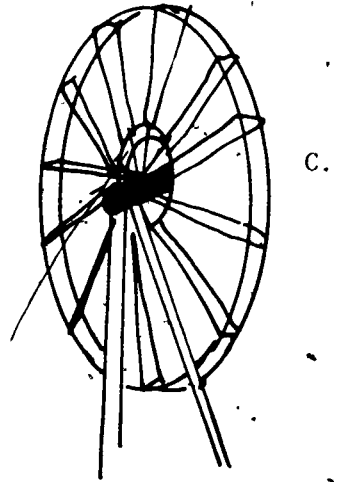
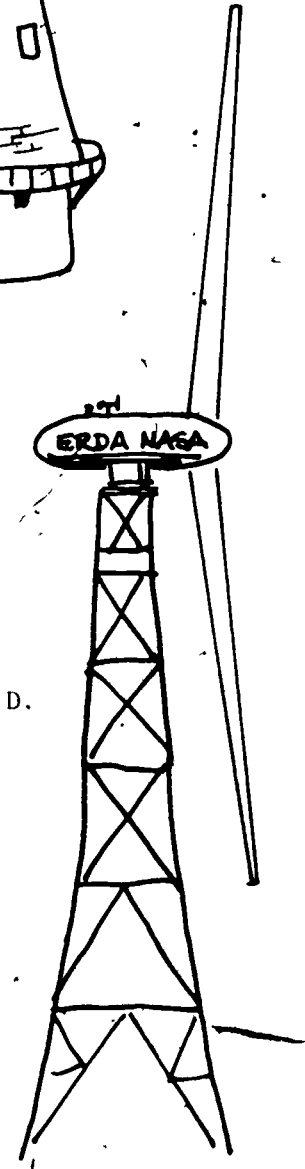
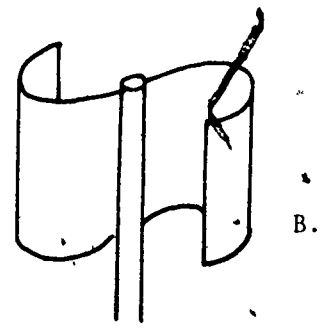
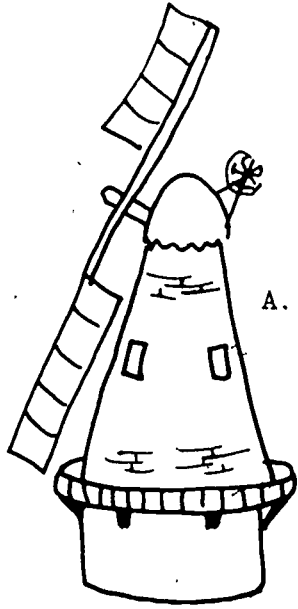

1. Wind Spoke Turbine (C)
2. Battery Charger (E)
3. Model Zero (D)
4. Savonius Rotor (B)
5. English Windmill (A)

274

THE EFFECT OF WIND SPEED AND ROTOR SIZE

Objective

Student will demonstrate the effect on energy produced by wind generators due to different wind speeds and rotor designs.

Discussion

Power increases as the cube of the wind velocity. Example 1: the power in a 20 mph wind is 8 times greater than in a 10 mph wind. Example 2: Chicago wind speed is a constant 11.2 mph, while Minneapolis averages 11.2 mph, but one-half day at 8.2 mph, and the other one-half day at 14.2 mph. During the windier half day, Minneapolis would have available as much power as Chicago during the whole day.

$$\left(\frac{14.2}{11.2}\right)^3 = 1.2678, 1.2678^3 = 2.0$$

Rotor size has the effect that power from the wind goes up with the square of the rotor diameter. By doubling the diameter of a rotor, four times the power is produced. Thus, it would take four 100-foot rotors to equal the power of one 200-foot one.

An increase in the number of blades will provide an increased torque at low speeds. This concept is used for water pumping. Fewer blades provide more energy for their cost. In small wind machines with blades 20 to 40 feet in diameter, three blades are probably best in terms of cost and balance. In larger wind turbines, two blades are better.

Variable pitch blades are one answer to the problem of different wind speeds. Another possibility which is cheaper is to have different generators or gearboxes for use in different sites.

TITLE: WINDMILL POWER OUTPUT IN WATTS

AREA: Science, Math, Social Studies

OBJECTIVE: Students will investigate how the power output of a typical small wind powered electric generator depends on both wind speed and propeller diameter.

MATERIALS: Student activity sheet

ACTIVITY: 1. On a grid provided by the instructor, the students will plot the power output as a function of propeller diameter for wind speeds of 10 mph and 20 mph.

Students answer questions related to Grid I.

2. On grids provided, plot the power output as a function of wind speed for propeller diameters of 10 ft. and 20 ft.

Students answer questions related to Grid II.

3. Show the relationship between the power output of the windmill to windspeed and propeller diameter according to provided equation.

Students answer questions related to data Table III.

STUDENT ACTIVITY SHEET

Name _____

Date _____

In this activity you will investigate how the power output of a typical small wind powered electric generator depends on both wind speed and propeller diameter.

The following is the table of data you will be working with:

WINDMILL POWER OUTPUT IN WATTS	Propeller Diameter in Feet	Wind Velocity in mph					
		5	10	15	20	25	30
	2	0.6	5	16	38	73	130
	4	2	19	64	150	300	520
	6	5	42	140	340	660	1150
	8	10	75	260	610	1180	2020
	10	15	120	400	950	1840	3180
	12	21	170	540	1360	2660	4600
	14	29	230	735	1850	3620	6250
	16	40	300	1040	2440	4740	8150
	18	51	375	1320	3060	6000	10350
	20	60	475	1600	3600	7360	12760
	22	73	580	1940	4350	8900	15420
	24	86	685	2300	5180	10650	18380

On the grids provided below plot the power output as a function of propeller diameter for wind speeds of 10 mph and 20 mph.

Grid I:

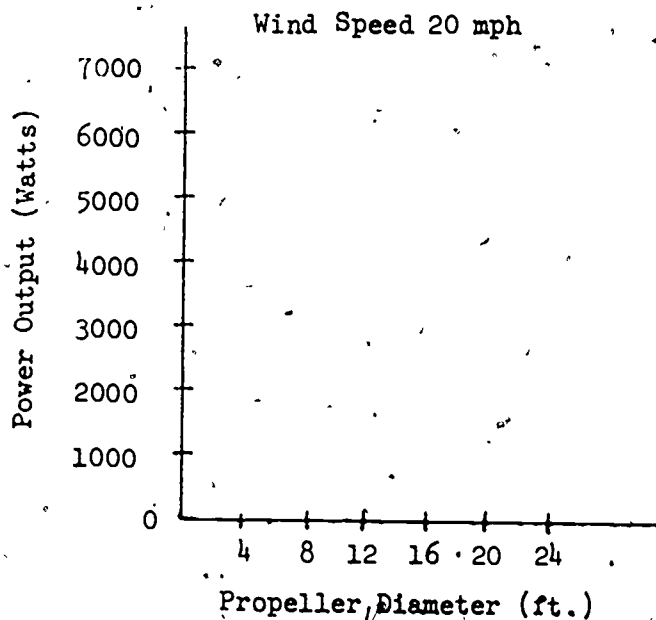
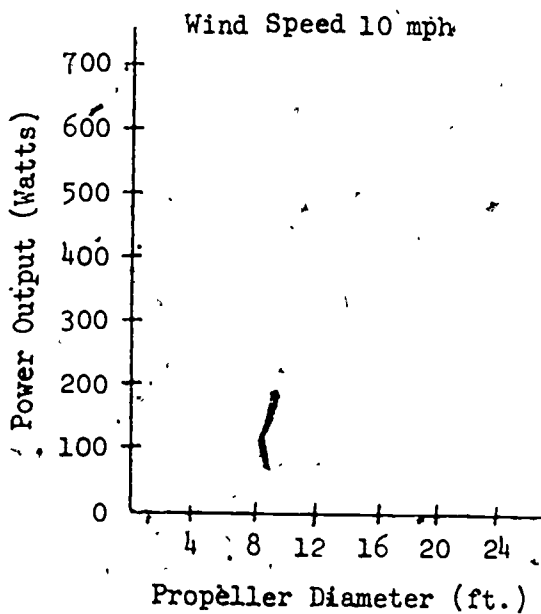

Questions:

1. How do the general shapes of the two graphs compare? _____

2. For a given wind speed, how is the power output related to the propeller diameter? _____

3. Try to write a formula which can be used to calculate the power output for various propeller diameters at a wind speed of 10 mph. _____

4. Ignoring other considerations, which would produce more power (or would they be the same): two windmills with 10 ft. propellers or one windmill with a 20 ft. propeller? _____

Grid II:

On the grids provided below plot the power output as a function of wind speed for propeller diameters of 10 ft. and 20 ft.

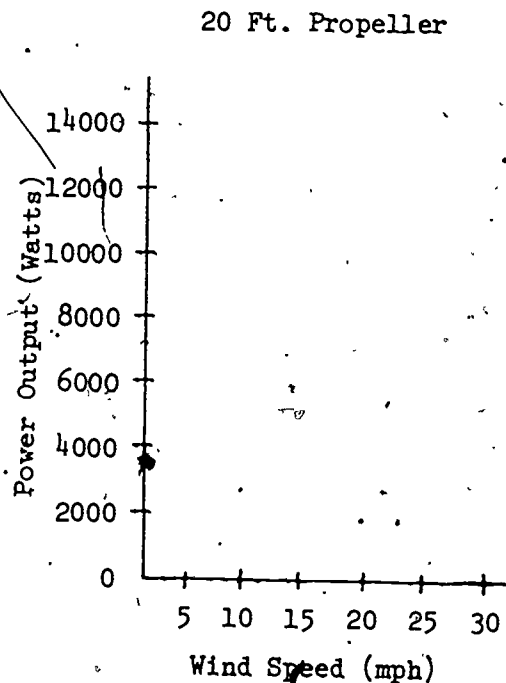
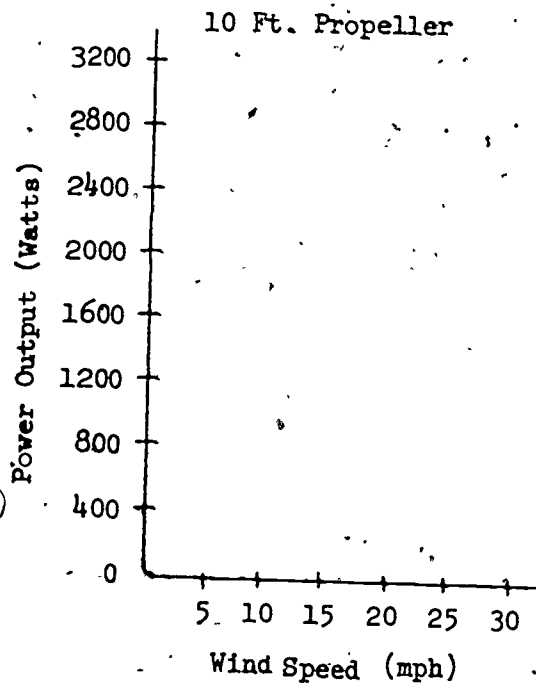

Questions:

5. How do the general shapes of the two graphs compare? _____

6. For a given propeller diameter, how is the power output related to the windspeed? _____

7. Try to write a formula to calculate the power output for various windspeeds with a propeller diameter of 10 ft.

Table III:

For the table of data given, the power output of the windmill can be related to windspeed and propeller diameter according to the following equation:

$$P = kv^3 d^2 \text{ where}$$

P = power output (watts)
v = wind speed (mph)
d = propeller diameter (ft.)
k = constant of proportionality

Using the data in the table, calculate the value of k of the following conditions:

$$\begin{aligned} v &= 10 \text{ mph} \\ d &= .10 \text{ ft.} \\ k &= 0.0012 \end{aligned}$$

$$\begin{aligned} v &= 20 \text{ mph} \\ d &= 20 \text{ ft.} \\ k &= 0.001125 \end{aligned}$$

Questions:

8. The table of data gives 60 different wind speed and propeller diameter combinations from which 60 values of k could be calculated. How would you expect these 60 values of k to compare with each other? _____

9. What design and operating features (other than propeller diameter and wind speed) do you think determine the value of k? _____

The following activity is designed for class discussion.

10. List some pros and cons for the following statement:

For a given power requirement, a single large windmill is "better" than several small ones.

Pros

Cons

11. How valid would you say the following statement is: For wind powered generators, "the more wind, the better it is."

BIOMASS

Biomass is the term for organic material other than fossil fuels. Plant or animal matter has stored chemical energy by virtue of the process of photo (or chemical) synthesis of protoplasm. Only 0.1% of the incident solar energy is converted to biomass and only 2% of the biomass produced is ever used. Half, or 1%, becomes food and feed, the other 1% is used for fuel and fiber. It is hoped that through improved processing and new technology as much as 40 times as much solar energy (4%) can be utilized.

Though it is a tiny fraction of the sun's energy, biomass has in the past provided humanity with 98% of the energy used. About 100 years ago, 90% of the energy in the U. S. came from biomass (including wood and that biomass which became our fossil fuels). Today it still supplies 75%. In developing nations 2/3 of their energy comes from wood, agricultural residue and dry animal wastes. Often, improved combustion methods make more efficient use of these renewable, inexpensive and readily available fuels.

To appreciate the energy supplied by biomass one needs to look at the efficiencies of biomass systems. First, 99% of the incident solar energy is lost to the green plants by reflection and evaporation. Of the 1% absorbed energy about 75% is converted to biomass and is available as food for herbivores. About

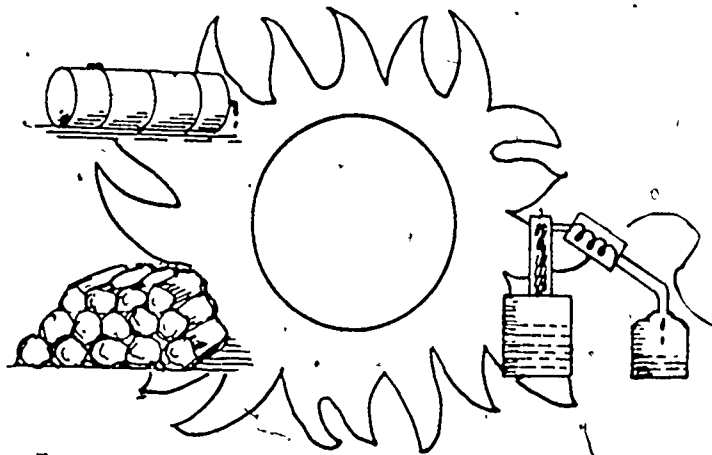

BIOMASS PRODUCTION AND CONVERSION

half is actually consumed. The result is that only 0.5% of the solar energy falling on a field is eaten and passed down the chain. Once eaten, 10% of the energy is utilized to form meat protein. The following schematic shows the efficiency of plants in capturing radiant energy and the losses as it is used in food.

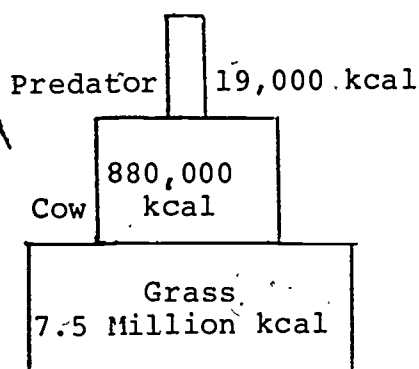

PYRAMID OF ENERGY

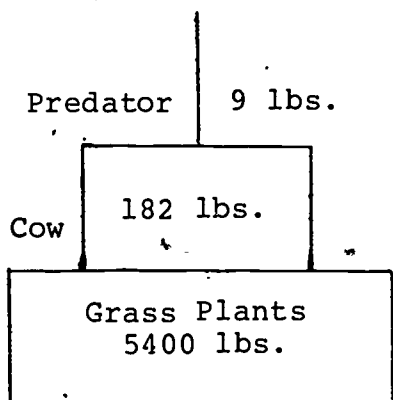

PYRAMID OF BIOMASS

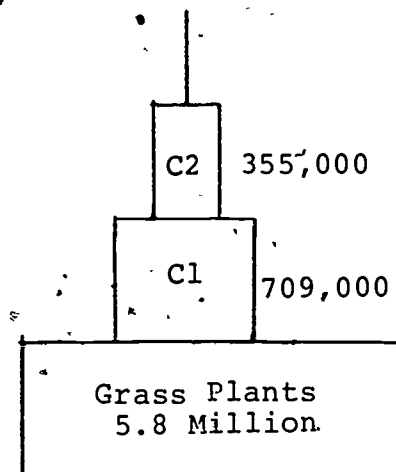

PYRAMID OF NUMBERS

Three kinds of ecological pyramids based on the food chain of a 1 acre field of grass over 1 year. Pyramids of energy and biomass are from grass/cow ecosystem described in text. Pyramid of numbers is from data presented by Odum 1971 (Ref. 8), where: C-1=primary consumers (herbivorous invertebrates); C-2=secondary consumers (carnivorous spiders and insects).

Even at these low efficiencies enormous amounts of energy are available. To convert biomass into units of energy so as to compare it with other fuel sources, it is estimated that one gram dry weight of organic matter is equivalent to 4-5 Kcalories or 1400-1750 Kcalories/per pound, which is 5500-6900 BTU per pound. When larger masses are converted, one metric ton is the equivalent of 1.25 barrels of oil, 1200 cubic feet of gas, or 750 pounds of coal. The table on the following page provides the energy available in a wide range of materials in the biomass--both the readily replaceable and the long range replaceable.

We need to know how much of this energy is actually extracted by various conversion processes. What would be the sense of selecting a less efficient process, assuming all other factors are the same? To give information on the efficiencies of certain biological and mechanical systems, refer to the table immediately following the "Energy Values..." table.

In the U. S., the Biomass Program has two separate approaches. One aims at increasing the recovery of resources from urban, municipal and industrial wastes. The other concentrates on the development of sources of biomass energy as yet relatively untapped. These areas include land and fresh water "Energy Farms" along with a promising source called Ocean Energy Farming or Aquaculture. In both, plants are grown for their use as biomass sources of more useful forms of energy.

TITLE: BIOMASS AS A SOURCE OF ENERGY

AREA: English, Social Studies, Science

OBJECTIVE: The student will be able to determine the role of biomass as an energy source.

MATERIALS: Handout

- ACTIVITY:
1. After reading the handout material, students should answer the following questions:
 1. What is biomass?
 2. List 10 kinds or forms of biomass.
 3. What percentage of energy is currently provided by biomass?
 4. How is biomass converted into units of energy?
 5. What are the two separate approaches to the Biomass Program in the U. N.?
 2. Sponsor a field trip to a recycling plant; report on findings.

ENERGY VALUES OF VARIOUS FOSSIL FUELS AND BIOFUELS

	SOLID	LIQUID	GAS
	kcal/g	BTU/lb	BTU/gal
			BTU/ft
FOSSIL FUELS			
COAL —			
bituminous	9.2	13,100	
anthracite	8.9	12,700	
lignite	4.7	6,700	
COAL COKE	9.1	13,000	
CRUDE OIL		18,600	138,000
FUEL OIL		18,800	148,600
KEROSINE		19,810	135,100
GASOLINE		20,250	124,000
LP GAS		21,700	95,000
COAL GAS			450-500
NATURAL GAS		21,500	75,250
(Methane)			1,050
PROPANE		21,650	92,000
BUTANE		21,250	102,000
			2,200-2,600
			2,900-3,400
BIOFUELS			
CARBOHYDRATES			
sugar	3.7-4.0	5,300	
starch/cellulose	4.2	5,800	
lignin	6.0	8,300	
PROTEIN			
grain/legume	5.7-6.0	8,050	
vegetable/fruit	5.0-5.2	7,025	
animal/dairy	5.6-5.9	7,850	
FATS			
animal	9.5	13,100	
vegetable oil	9.3	12,800	
MICRO-ALGAE	5.0-6.5	9,500	
WOOD			
oak, beech	4.1	5,650	
pine	4.5	6,200	
all woods	4.2	5,790	
BRIQUETS	8.1	11,500	
ALCOHOL			
methanol		8,600	67,000
ethanol		12,000	95,000
BIOGAS			
(60% CH ₄)			600-650
METHANE		21,500	75,250
MISC. "WASTES"			
municipal or-			
ganic refuse	2.8-3.5	4,000-5,000	
raw sludge	2.7-5.3	3,700-7,300	
digested sludge	2.7-5.0	3,800-6,900	
paper	5.5	7,600	
glass	5.6	7,700	
leaves	5.2	7,100	
dry plant.	5.6	8,000	
MISC. ANIMALS			
insect	5.4		
earthworm	4.6		
mammal	5.2		

EFFICIENCIES OF SOLAR ENERGY CONVERSION SYSTEMS:

COMPARING THE BIOLOGICAL WITH THE MECHANICAL

		Efficiency		
		Of Process	To Heat	To Electricity
I. BASIC PHYSICAL CONVERSIONS				
A.	Steam → Mechanical Energy	10-30		
B.	Mechanical → Electrical			80
C.	Steam → Electrical			AxB= 8.25
II. SOLAR - MECHANICAL CONVERSIONS				
A.	Low Temperature Solar			
	Solar energy → hot water		20	
B.	High Temperature Solar			
1.	Solar heaters, cookers, reflectors		50-80	
2.	Solar reflector → steam		40-60	
3.	"I-C" above			8.25
4.	Solar → steam → electricity			3-15
C.	Solar → Electricity (Photocells)			
1.	Cadmium sulfide			5
2.	Silicon			12
D.	Wind			
1.	Wind → mechanical	44		
2.	"I-B" above			80
3.	Wind → mechanical → electrical			35
III. SOLAR - BIOLOGICAL CONVERSIONS				
A.	Food Chains			
1.	Solar energy → plant chemical energy	0.3-3.0		
2.	Plant energy → herbivore energy	5-10		
3.	Herbivore → carnivore energy	5-15		
B.	Wood			
1.	Solar energy → forest wood	0.5-3.0		
2.	Wood → heat (steam)		60-80	
3.	"I-C" above			8.25
4.	Solar → steam → electrical			.04-.8

C. Biogas (Digestion)

- | | | |
|---|--------|--------|
| 1. Solar → plant | .3-3.0 | |
| 2. Biomass → biogas* | 40-70 | |
| 3. Biogas → heat | | 75 |
| 4. Biogas → heat → mechanical | 25-40 | |
| 5. "I-B" above | | .80 |
| 6. Organic waste → electricity (via biogas) | | .02-.5 |

D. Alcohol (Distillation)

- | | | |
|-----------------------------|----|--|
| 1. Fruits, grains → ethanol | 75 | |
| 2. Wood → ethanol | 65 | |
| 3. Biomass waste → methanol | 55 | |

*Not including process heat.

Each year the U. S. produces over 880×10^6 dry tons of organic wastes which is equivalent to 10×10^6 BTU per metric ton or 90 (a Q is 10^{15} BTU) of energy total. Most of this waste is in the forms of manure and paper. With today's collection and processing methods about 16% can be reclaimed. The processes used to convert the biomass and/or organic wastes are: 1) direct combustion, 2) pyrolysis, and 3) anaerobic digestion.

Direct Combustion in utility boilers can yield 4000 to 5000 BTU per pound as an additive to coal. It can replace as much as 10% of the coal presently used. This is now practiced in the Merrimac Plant near St. Louis, Missouri. At a rate of 21% mix of waste with 77% coal a combustion efficiency of 98% results. In this way waste is turned into cheap electricity.

Pyrolysis is the burning of organic wastes in the absence of air at 200 degrees C - 900 degrees C and STP*. The results are oil and gas which can then be burned as fuel. For each metric ton processed the oil produced yields 4.8×10^6 BTU, an efficiency of 16%. The gas produced yields 5.5×10^6 BTU per metric ton processed, for an efficiency of 55%.

Anaerobic digestion is a biological process which converts the carbon fraction of the biomass to other compounds, releasing the trapped energy. This is the "Small Technology" process used in developing nations and on some small farms in the U. S.

There are two stages to this digestion. First stage--complex organic materials are acted upon by acidogenic (acid forming) bacteria to form fatty acids, glycerol, sugar compounds which are in turn acted on by enzymes to form lower alcohols, acetic acid and carbon dioxide. The second stage is the one in which methanogenic bacteria act on the waste to form methane (CH_4) and CO_2 . This second stage can be accomplished by means of a "Lower Technology Conversion" or mesophylic phase which occurs in a digester or air free pot at 30 degrees - 40 degrees C and yields methane gas after about 30 days. It can also occur under "High Technology Conversion" at 60 degrees C and produce methane after 2 or 3 days. The heating value of methane is about 500 - 800 BTU/ft³. This type of small digester operation could supply the cooking fuel for a family of 6 - 8 people.

Ocean Energy Farming is being studied off the coast of San Diego, California, under the sponsorship of ERDA and the U. S. Navy. They are growing kelp as the biomass and have had very favorable yields. An idea of the energy available from an acre of grain or woodlot can be obtained from the following figure.

*STP = Standard Temperature and Pressure.

The use of biomass to supply some of our energy needs not only takes into account the vast plant resources of the earth but also aids us in reducing the problems associated with disposal of waste. Digested organic wastes provide combustible gas and valuable fertilizer. Urban wastes help fuel electric generating plants and cut down on the need for land fill. Pollution of ground and ocean water by organic wastes is eased and small farms can be made less dependent on imported fuel. Recycling is an automatic part of the use of urban wastes as fuel and the drain on resources can be alleviated. None of these processes is terribly difficult to engineer and the end result of none is harsh on the environment. Biomass is a practical way to recover some of the incident solar energy.

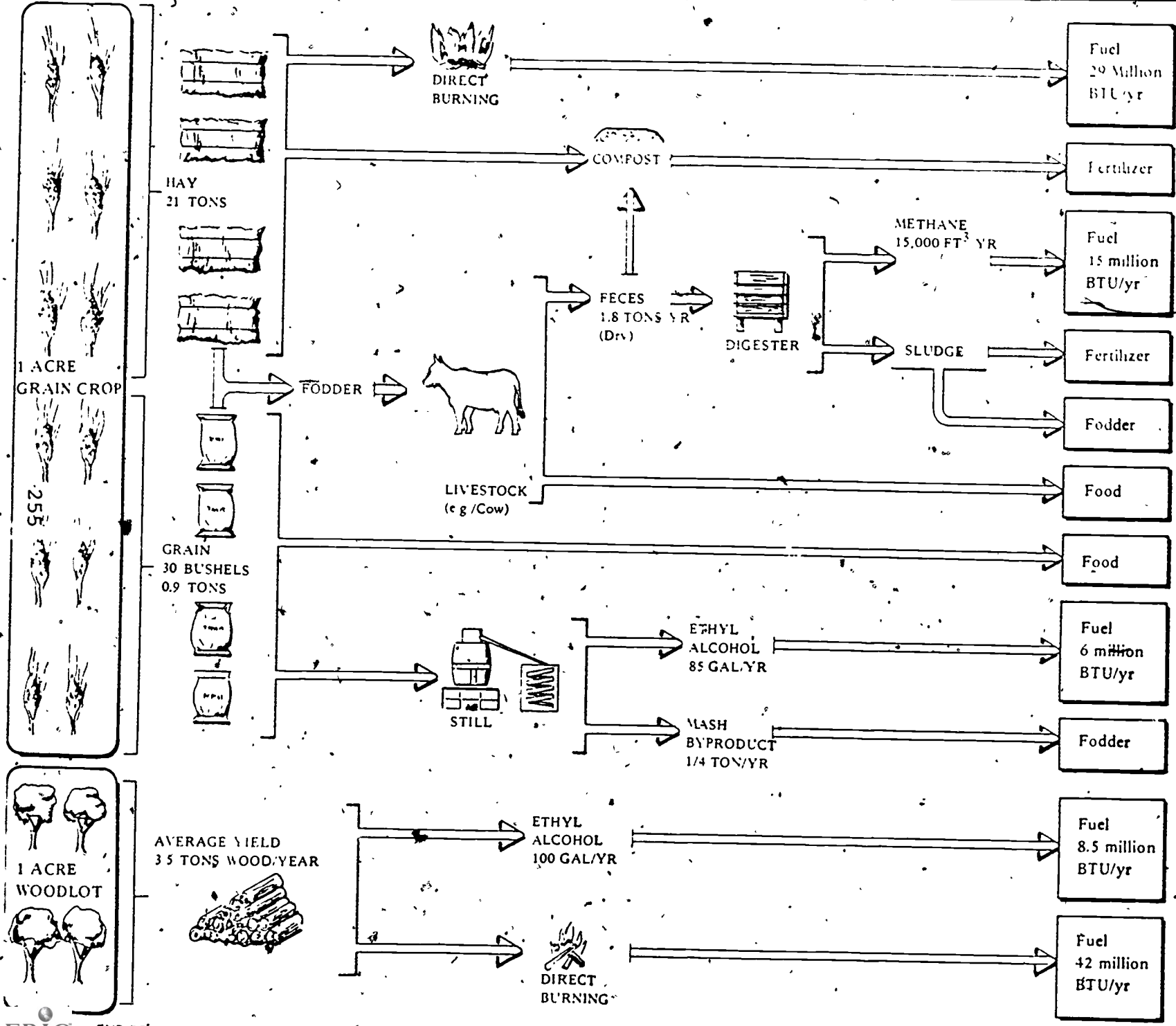

END PRODUCTS AND ROUGH ENERGY EQUIVALENTS OF VARIOUS BIOMASS CONVERSIONS FROM A 1 ACRE GRAIN FIELD AND WOODLOT.

INTRODUCTION

COMPOSITION OF MUNICIPAL SOLID WASTE

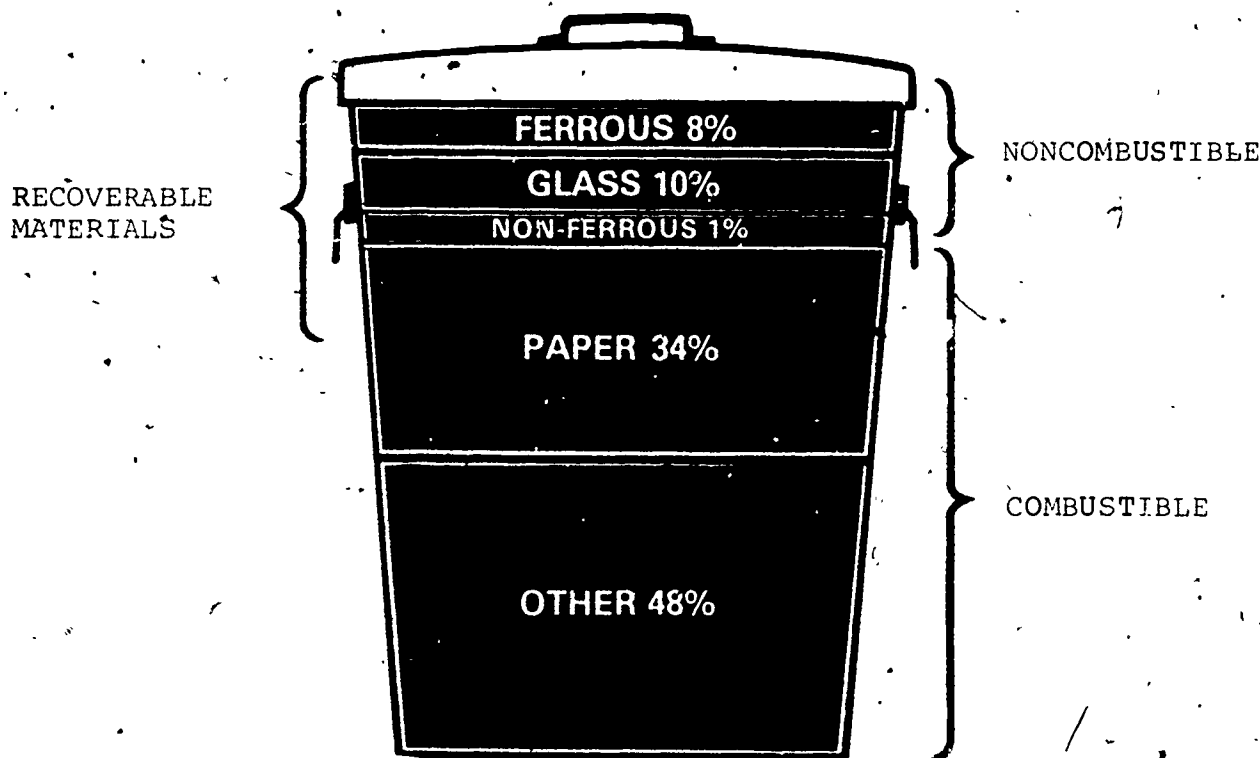

Waste to Watts

Resource recovery is garbage.

It is an idea that has caught the fancy of the American public.

The concept of making garbage into energy and saving valuable materials intrigues our nation's problem solvers.

The realities of reclaiming resources and energy from garbage are one of the problems that daily confront some members of Region V, U. S. EPA's waste management team members.

"During last winter's energy crunch," says Karl Klepitsch, Chief of Region V's Waste Management Branch, "people were burning oil and coal that was dirtier than their garbage."

Garbage is a valuable resource for America, says Klepitsch. Yet EPA data reveal that by 1985, America will throw away almost 200 million tons of trash a year.

Today, roughly 70 to 80 percent of urban waste is combustible. **solution** would be to burn it for its BTU content, suggested

Klepitsch. Each person disposes daily 3.5 pounds of refuse which has the energy value of 1.5 pounds of coal.

In 1973, the United States could have saved the equivalent of approximately 200 million barrels of oil if it had been able to reuse the 135 million tons of garbage generated across the nation.

In addition, 12 million tons of steel, one million tons of aluminum and 200,000 tons of copper were thrown away in 1973, because the great majority of garbage was not reused.

Resource recovery can be a significant element in a community's own solid waste management program. Congress formally recognized this concept when it passed the Resource Conservation and Recovery Act of 1976 last fall. Besides calling for the closure of all open dumps in the country and the development of the statewide solid waste and hazardous-waste plans, RCRA promotes the development of resource recovery systems wherever economically feasible. Specifically programs for technical and financial assistance are authorized.

As the "Chief of Recycling and Reuse" in Region V, Klepitsch assembles technical assistance teams to help communities in evaluating resource recovery alternatives.

EPA staffers stressed that these teams cannot replace a community's staff or consultants they might hire, but they would be able to provide objective oversight of technical and financial plans which a community is considering.

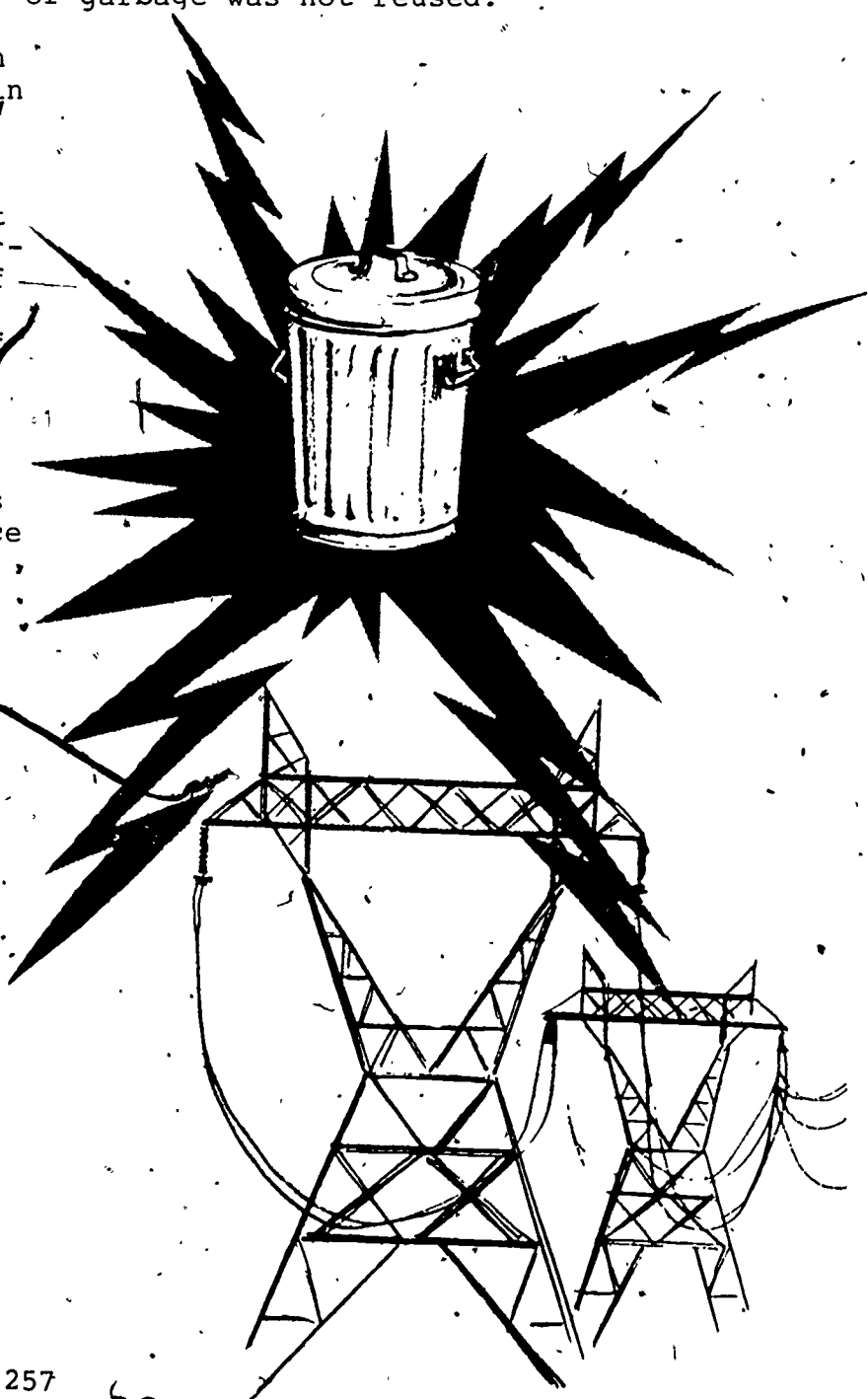

"We do not have sufficient resources to replace consultants," said James Chambers of Region V's Waste Management Team, "but we can provide communities with procurement and technical assistance."

TITLE: TRASH AND GARBAGE: AN ALTERNATIVE SOURCE OF ENERGY

AREA: Social Studies, English, Science

OBJECTIVE: The student will be able to:

1. Define the terms "generate" and "incinerator."
2. Identify those waste materials which release the greatest amount of heat.
3. Explain the operation and use of municipal steam generating incinerators.

MATERIALS: School library
Trash at home and/or school

- ACTIVITY:
1. Students may write a report on new incinerators designed to operate steam engines.
 2. Students may examine trash at home and/or school and classify the trash according to tin, plastics, P. V. C. plastics, paper, and garbage.
 3. Students may divide the items up into what is suitable and what is not suitable for a steam-raising incinerator.
 4. Students may write a report on steam generated incinerators in Europe, Chicago, and Montreal.
 5. Students may visit municipal incinerating plants to view the operation.

Flow plan of Montreal incinerator

Burns garbage-produces steam

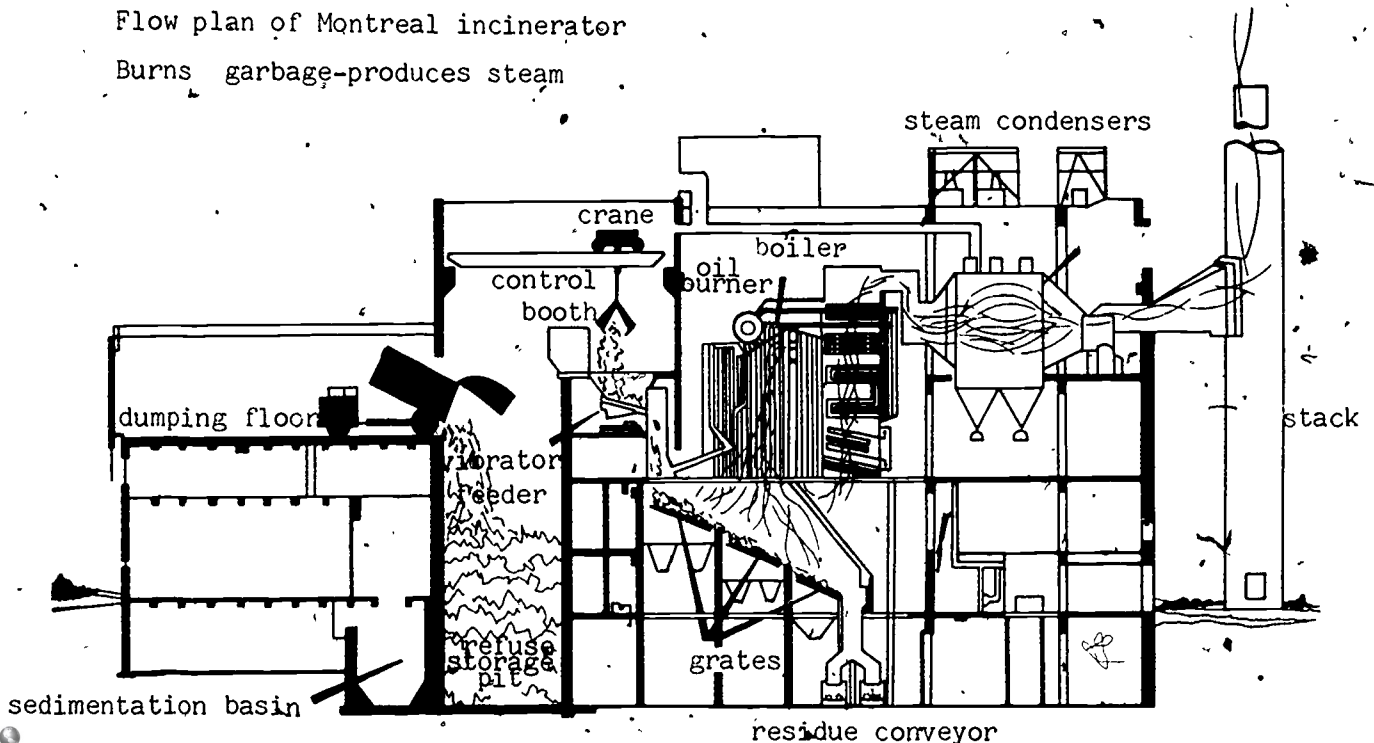

TITLE: GARBAGE POWER

AREA: Science, Social Studies, Industrial Arts

OBJECTIVE: The student will discover the relationship between energy and matter in organic materials.

MATERIALS: Library literature
Local industrial literature

- ACTIVITY:
1. Investigate the formation of methane. Why is it called natural gas? (organic wastes--dead materials--are fermented by anaerobic bacteria--grow in the absence of oxygen--to form methane and carbon dioxide)
 2. Ask: "Why cannot people use this age-old natural method to dispose of their organic wastes?" (too many people and mountains of waste)
 3. Find out how much waste is generated in your community.
 4. Read about the work of Dr. Ram Bux Singh in designing and construction of "Biogas" plants in India.
 5. Investigate problems of using sewage effluent from a community in a biogas plant. (too much water, which reduces efficiency of the digester)
 6. Discuss how use of cow manure from cattle feed lots in biogas plants could reduce water pollution and waste of a valuable resource. (Kaplan project in Bartow, Florida)
 7. Investigate whether or not your community sewage disposal system uses an anaerobic bacteria process. If so, is the methane produced used to power the plant?
 8. Investigate the supply problems of a biogas plant. (major problem is transportation of wastes to the biogas plant)
 9. Consider the environmental costs of using animal manure for biogas production. (loss of valuable soil conditioner and fertilizer)

TITLE: ENERGY IN THE WASTE BASKET

AREA: Science, Math

OBJECTIVE: The student will be able to evaluate the volume and contents of solid waste and realize its energy potential.

MATERIALS: Garbage
Bags for sorting

- ACTIVITY;
1. Have the students save their garbage for one week. It would be best if they sorted it as it is saved, i. e., one bag each for paper, plastics, metals, organic, and glass.
 2. In class, have the students determine the following:
 - a. Which type of solid waste that was collected weighed most?
 - b. Which type weighed least?
 - c. Figure what percentage of the total amount of solid waste each constitutes:

<u>TOTAL WEIGHT</u>	=	<u>WEIGHT</u>	=	<u>PERCENTAGE</u>
Plastics	=			
Paper	=			
Organic	=			
Metal	=			
Glass	=			

3. If you were going into the recycling business, which of the substances would you choose to recycle? Why?
4. For what could the organic solid waste be used?
5. Assuming that all the metal is of a ferrous type, how long would it take for you to accumulate one ton? (In reality only a very small percentage of most cans is tin. About 98% of a "tin" can is steel. The amount of tin depends upon the corrosiveness of contents.) Industries will pay about \$20 each ton of ferrous metal. Is it worth your effort to recycle this metal? Explain.
6. Find the amount (weight) of aluminum that would be collected per month. Is the aluminum worth recycling?
7. The average amount of garbage per person each day in the United States is 2.27 kg. How did your family's total compare with this average?

8. Add the whole class's data together. How did the whole class compare with this average? The class could graph their data as follows:

frequency

garbage, kg.

297

TITLE: MEASURING ANAEROBIC RESPIRATION ON YEAST

AREA: Science

OBJECTIVE: Students will observe the effects of anaerobic (respiration) fermentation using yeast.

MATERIALS: Yeast
Two vacuum bottles
Glass tubing
Glycerin or soap solution
Stoppers or corks
25% molasses solution
Beaker of limewater
Thermometers
Data charts
Data guide

Activity sheets

ACTIVITY: 1. Assemble the two sets of apparatus as depicted in the drawing following:

CAUTION: Be sure to lubricate the thermometers and the glass tubing with the glycerin or soap solution before inserting them into the stoppers or corks. Point the thermometers away from your hands and body as you insert them. Be sure not to force the thermometers or glass tubes into the stoppers or corks, they break easily and cause injury.

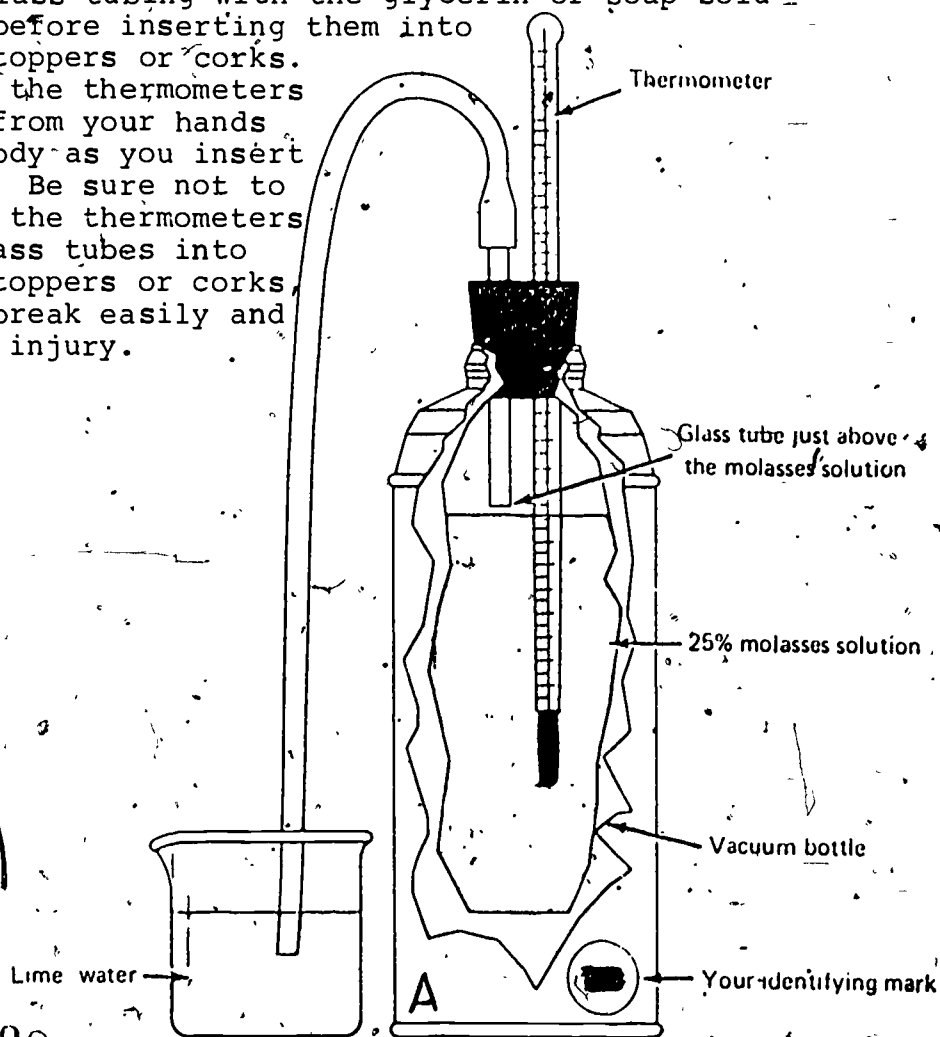

2. Label the vacuum bottles A and B. Fill them with the molasses solution to a level which is very close to the open end of the glass tube which leads to the tubing to the beaker of limewater. Add the 1/4 package of dry yeast to bottle B and gently stir the mixture to suspend the yeast throughout the solution. Place the stoppers securely into the openings of both vacuum bottles. Place the rubber tubing which is attached to the glass tubing in each bottle into each of the two beakers which contain about 200 ml of limewater. Be sure the open end of the rubber tubing is below the surface of the limewater.
3. Pour the remaining limewater (about 100 ml) into the third beaker. Gently exhale through the drinking straw so that the exhaled gases will bubble through the limewater solution. Record any changes which take place in the limewater solution.
4. Observe the change in the appearance of the limewater and the temperature of the molasses solutions in each vacuum bottle at the beginning of this activity and at five minute intervals for the first hour. Observe the appearance of the limewater and the temperature readings as often as possible for the next 24 to 48 hours.

Record the temperatures and appearance of the limewater observed for each bottle and the time elapsed between each reading onto the data chart provided on the next page. (Extend the data chart if necessary to enter all readings.)

In which bottle did a chemical change occur, if any?

5. After collecting all the data, remove the stoppers from both bottles. Note the distinctly different odors which come from each bottle.

Using the data from both bottles, plot the temperature changes as a function of time on the graph grid provided on the next page. Plot the data for both bottles on the same grid to provide a comparison at a glance. Label the line plot for each bottle.

	BOTTLE A		BOTTLE B	
	° C	Limewater, Appearance	° C	Limewater Appearance
Time started:				
Elapsed time:				
"				
"				
"				
"				
"				
"				
"				
"				
"				
"				
"				
"				
"				
"				

Temperature

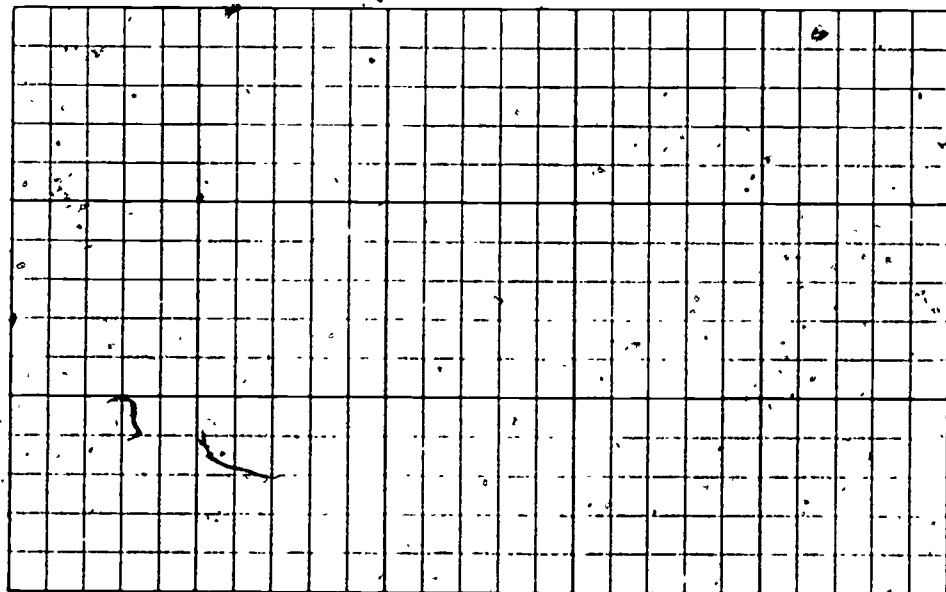

Time

265300

In which bottle did a chemical change occur, if any? On what evidence do you base your reply to this question?

Why is this section of yeast considered anaerobic, even though oxygen was present?

From which bottle was a gas produced--if at all? What is produced in both?

If a gas was produced, can you give a tentative identification of it and on what do you base this tentative identification?

In what ways does anaerobic digestion or fermentation resemble respiration?

TITLE: FERMENTATION

AREA: Science

OBJECTIVE: The student should be able to:

1. Measure a change in temperature through time in the fermenting process.
2. Observe the production of CO_2 from the fermenting system.
3. Detect, through identifying an odor, the formation of alcohol from the fermenting slurry.
4. List the raw materials necessary for fermentation and the products.
5. Construct a time vs. temperature curve to demonstrate the exothermic nature of the system.
6. Apply the information gleaned from this exercise to the process of generating heat energy directly for fuel and gas needed for photosynthesis.
7. Devise exercises for the anaerobic digestion of organic wastes.

LECTURE:

Aerobic respiration is much more efficient than anaerobic. It has been estimated that about 60% of the total energy in the glucose molecule is released from the process of aerobic respiration as opposed to about 3.2% from the anaerobic process. The purpose of this exercise is to demonstrate the release of photochemical energy from organic molecules. The source of molasses, the sugar cane plant, should be recognized as one of the more efficient solar users of the green plants in the U. S. as can be determined in the following narrative and table.

Plants are simply unable to use most of the sunlight available to them. On land, from 70-80% of the incident light is reflected or absorbed by physical things other than plants. We can get an idea of what happens to the remaining light energy from an elegant study done on an acre of corn during a 100 day growing season. The study showed that 44.4% of the light received by plants was used to evaporate the 15 inches of rainfall received during the season: 54% was converted directly to heat and lost by convection and radiation, and the minute quantity remaining (1.6%) was actually converted into the tissues of the corn plants. About 33% of this gross productivity was used in respiration leaving 1.2% of the available light energy as corn biomass.

Energy Budget of an Acre of Corn During One
Growing Season (100 days). 76.6% of the
Solar Energy Assimilated is Put into Biomass.

	Glucose (lbs)	kcal (million)	Solar Efficiency
INCIDENT SOLAR ENERGY		2.043	
PRODUCTIVITY			
Net (N)	3040	25.3	1.2%
Respiration	<u>910</u>	<u>7.7</u>	<u>0.4%</u>
Gross (G)	3970	33	1.6%
Production efficiency = N/G			76.6%

Photosynthetic Efficiency of Various Plants, Crops
and Ecosystems

	% of Gross Productivity	% of Net Productivity
EXPERIMENTAL		
LABORATORY		
Algae (Chlorella)	20-35	
Dim light experiments	15-20	
FIELD		
Chlorella silt ponds	30	
Sewage ponds	2.8	
CULTIVATED CROPS		
PEAK OF SEASON		
Sugar beets, Europe	7.7	5.1
Sugar cane, Hawaii	7.6	4.8
Irrigated corn, Israel	6.8	3.2
DURING SEASON		
Sugar beets, Europe	2.2	
Rice, Japan		2.2
Sugar cane, Java		1.9
Corn, US	1.6	1.3
Water hyacinth	1.5	
Tropical forest plantation	0.7	
ECOSYSTEMS		
Annual desert plants (peak)	6.7	
Tropical rain forest	3.5	
Freshwater springs, Florida	2.7	
Polluted bay, Texas	2.5	
Coral reef	2.4	
Beech forest, Europe	2.2	1.5
Scots pine, Europe		2.4
Oak forest, US	2.0	9.1
Perennial herb, grass		1.0
Cattail marsh	0.6	
Lake, Wisconsin	0.4	
Brookside community	0.3	
BIOMES		
Open ocean	0.09	
Arctic tundra	0.08	
Desert	0.05	
BIOSPHERE		
Land		0.4
Sea		0.2

Sources: Energy Primer, Portola Institute, 1974.

MATERIALS: Student activity sheets
 2 thermos vacuum bottles, approximately 0.5 liter
 2 two-holed rubber stoppers or corks to fit the opening of the vacuum bottles
 2 glass tubing, 6 mm diameter x 8 cm long
 2 thermometer, 20 degrees C to 120 degrees C (1 degree C graduation)
 2 rubber or plastic tubing, 25-30 cm long (to fit on glass tubing)
 3 250 ml beakers
 500 ml 25% molasses solution (75% water)
 Glass-marking wax pencil
 1/4 package of dry yeast
 2 drinking straws
 Glycerine or soap solution
 Stirring rod, about 20 cm long
 2 500 ml beakers

ACTIVITY: This activity should follow the introduction of the production of energy from anaerobic digesters.

The students' discussion of this area should include the materials which are fed to the digester; the design of the apparatus; the delivery system to the digester; the availability of the raw materials; the time, temperature and mixture materials used in the digester; the products expected and the amount/unit of input materials; the usefulness of the various products; the systems for evacuating the gases, liquids, and solids from the digester; the desirability of the products; the safety precautions needed for the system; the delivery system for the products; the space required for the system and its location on the property; the number of people/size of unit served by the system; economics of the system; need for the system. There should be many more including the social acceptance of the system in various locales.

The conversion factors of 3413 BTU = 1 Kwh = 3600 Joules and 1HP = 0.7455 KW should be supplied to the students to compute the energy input/output/efficiency of the system. Remember that a digester system of the low-tech conversion requires about 30 days to effectively produce methane with 3 pairs and a high-technology system requires 2 to 3 days. Methane has a heating value of 500-800 BTU/ft³.

This activity will produce CO₂ and alcohol. The change in the limewater will demonstrate the CO₂ production (Ca(OH)₂ + CO₂ → CaCO₃ + H₂O). The distinctive odor of fermenting yeast has been used to deduce the formation of alcohol (ethanol).

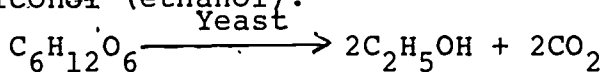

It is possible that someone in the class may have experienced this odor emanating from a bakery.

It may serve to demonstrate a fact that alcohol is combustible, if you ignite a small quantity of alcohol either prior to or following the exercise. This should further enforce the concept of energy from the anaerobic (respiration) digestion of sugars.

Notes to the Teacher

The fermentation process will proceed at a slow rate after the apparatus has been set up, increase and then level off. In order to collect data on temperature change and any change in the limewater solution, students should return to the lab room or wherever the set up is kept to make observations as often as possible for 48 hours. The first set of data will be collected in lab at 5-minute intervals to give the students a feeling for the direction in which the processes will go.

CAUTION: Be sure to instruct the students to lubricate the thermometers and glass tubing with glycerine or soap solution before they insert them into the openings in the stoppers or corks. Also, they should be very careful not to force them either in or out of the stoppers or corks because they break very easily. They should also take precautions when inserting or removing them that if broken the possibility of pushing the tubing into their person does not exist.

Sample Responses

1. The limewater becomes cloudy.
2. Bottle A = no temperature change.
Bottle B = slight increase in temperature after about 45 minutes, then a more marked increase to a point of plateau after about 48 hours-- depending on the amount of molasses and yeast used.

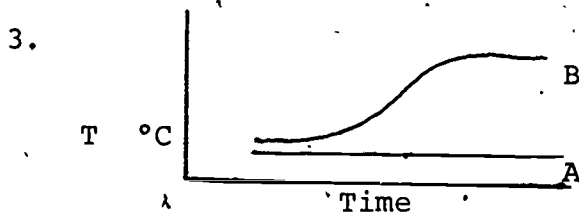

4. Bottle B.
5. Change in temperature, change in limewater appearance and change in odor of the solution.
6. The reaction eventually takes place in the absence of oxygen.

7. Bottle B.
8. CO_2 . The limewater became cloudy, which is one test for the presence of CO_2 .
9. The same gas, CO_2 , is released, heat is produced in both reactions; they are chemical reactions which occur at about 37. degrees C.

Extension Activities

Burn grass, nuts, oil, alcohol to determine the change in temperature of water and BTU/gm weight.

Substitute a beaker of an algae mixture for the limewater to note the probable "bloom" effect.

Construct other tests or apparatus set ups for culturing anaerobes.

Report on various types of anaerobic digesters.

Conduct a feasibility study on the appropriateness of this technology for the small unit (6 person family), the intermediate sized unit (large kennel or small livestock house) and the large scale unit (municipality or village) using the following information and tables: 1 lb of volatile solids (VS = 5 - 7 ft³ methane).

	Wet Raw Manure			Total Solids		Volatiles		Livestock Unit
	lb/day	ton/yr	gal/day	lb/day	ton/yr	lb/day	Unit	
Bovine								
Dairy Cow	1600	132	23	18	16.6	3.1	13.8	100 350
	1300	107	19.5	15	13.5	2.5	11.2	250 300
Dairy Heifer	1000	85	15.5	12.2	9.2	1.7	7.5	150 200
Beef Feeder	1000	60	11	7.5	6.9	1.3	5.9	150
Beef Stocker	500	45	8.2	5.2	5.8	1.0	4.8	120
Horse								
Large	1000	45	8.2	6.7	9.4	1.7	7.5	180 200
Medium	850	36	6.6	5.4	7.0		5.5	120 150
Pony		15.4			3.0		2.4	50 70
Swine								
Hog Breeder	500	25	4.6	3	2.2	0.4	1.6	40
Hog Feeder	200	13	2.4	2.2	1.2	0.22	1.0	25
	100	6.5	1.2	1.1	0.6	0.11	0.5	13
Wiener	15	1.0	0.2		0.1			
Sheep								
Feeder	100	4	0.7	0.8	1.0	0.18	0.8	20
Lamb	30	1.5	0.3		0.4		0.2	5
Fowl								
Geese, Turkey	15	6	220 lb	2 qt	15	55 lb	.10	2.5
Ducks	6	4	250 lb	15 qt	10	37 lb	.07	1.8
Broiler Chicken	4	3	110 lb	1 qt	0.7	26 lb	.05	1.3
Laying Hen	4	.2	75 lb	1 qt	0.5	18 lb	.04	1.0
	Portion	Amount	% 15	15/day	VS	VS/day		Livestock Unit
Humans	Urine	2 pt., 2.2 lb	6%	13	75%	.10		6
(150 lbs)	Feces	0.5 lb	27%	14	92%	.13		
	Total	2.7 lb	11%	27	81%	.25		

TABLE I MANURE PRODUCTION OF VARIOUS LIVESTOCK AND HUMANS. "Livestock Unit" = VS production relative to laying hens

*Bulk density of raw manure = 34 ft³/ton or 60 lb/ft³, or 8 lb/gal with no flushing water.

USE	FT ³	RATE
Lighting	2.5	per mantle per hour
Cooking	8 - 16	per hour per 2-4 burner
	12 - 15	per person per day
Incubator	.5 - .7	ft ³ per hour per ft ³ incubator
Gas Refrigerator	1.2	ft ³ per hour per ft ³ refrigerator
Gasoline Engine*		
CH ₄	11	per brake horsepower per hour
Bio Gas	16	per brake horsepower per hour
For Gasoline		
CH ₄	135 - 160	per gallon
Bio-Gas	180 - 250	per gallon
For Diesel Oil		
CH ₄	150 - 188	per gallon
Bio-Gas	200 - 278	per gallon

*25% efficiency

TABLE II USES FOR METHANE Consumption of methane and bio-gas for different uses.

INTRODUCTION

GASOHOL--THE AMERICAN RENEWABLE ENERGY?

As talk of gas shortages grows and lines at gas stations lengthen, the gasohol bandwagon is attracting ever more adherents--from farmers to legislators to President Ronald Reagan. There now are more than 500 U. S. service stations that sell gasohol, and the Department of Energy estimates that consumption could reach 75 to 100 million gallons this year. Many government offices have switched to gasohol, and strong efforts are underway in Congress and in state legislatures--including Louisiana--to encourage gasohol use and accelerate its commercialization.

Gasohol has a patriotic appeal: It is heralded as a product of the American farm, and not of unreliable foreign oil fields. Actually, only 10% of each gallon of gasohol comes from the farm. Gasohol is one part biomass-derived alcohol blended with nine parts gasoline (although blends of 20% alcohol can be used in most cars, and with minor modifications, even more). Still, biomass fuels offer interesting possibilities for integrating farm and energy policies to the benefit of both areas. The farm could become a significant producer of domestic energy, perhaps enabling us to reduce our dependence on foreign oil, and the farmer would have a new market for his crop.

Many farmers feel that becoming energy as well as food producers may offer them a much-needed market diversity and a solution to the surpluses that depress prices and keep farmland idle. It has been proposed that the subsidy now paid to farmers for diverting a certain percentage of their acreage away from production be shifted to the distiller to bring the price of his alcohol down to a competitive level. (Prices for biomass alcohol are now around \$1.20/gallon--much higher than regular gasoline.) The farmers' land that would otherwise have been idle would instead be producing a money crop. A gasohol market could also protect the farmer from nature's whims since crops which are spoiled for human consumption or are otherwise of subpar quality will often produce perfectly good ethanol.

Corn is the only crop presently grown in the U. S. with a scale of production large enough to make a significant impact on biomass alcohol. It is sometimes argued that large-scale conversion of corn into fuel would cause food shortage. According to Lipinsky, however, the present corn biomass system could theoretically permit production of 2-4 billion gallons of ethanol while obtaining the same quantity and quality of end-use products, and without increasing the land area devoted to corn or the yield per acre. That amount would allow 18-35% of all motor fuel consumed annually in the U. S. to be gasohol (at 1978 consumption levels). The idea is to manufacture ethanol and a protein-rich stillage from some of the grain now used to feed ruminant animals. Production of corn stover (stalks, cobs, husks, and leaves of the

plant--harvested at a rate that does not endanger the soil) could provide ample replacement for the corn grain now fed to cattle.

A more serious charge against conversion of corn into ethanol is that its production requires high energy inputs--particularly in the form of fertilizer derived from fossil fuels. Corn has a high energy yield per acre, but it also has a very low ratio of energy output to input. The exact net energy outcome of corn to alcohol conversion is still a subject of debate, but if heavy fertilizer use is required, biomass conversion to alcohol may not represent a large net energy gain.

In Louisiana the attention surrounding gasohol centers on sugar cane. Farmers, faced with low sugar cane prices, see conversion of part of their crop to fuel as an opportunity to create an additional market. Already, plans have been announced to construct several gasohol plants, although some of them may import crops from out of state. The actual impact of sugar cane conversion on the Louisiana gasoline supply situation will be small, even if all sugar cane produced were converted, but the gasohol market could be a needed shot-in-the-arm for the sugar cane industry.

Commercial interest has centered on biomass conversion to alcohol because it can be mixed directly with and sold alongside regular gasoline. Research at Louisiana State University, however, is beginning to indicate that perhaps alcohol may not be the best fuel choice. Its liquid nature that makes alcohol convenient to use presents problems in the conversion process. Separating it from the fermented sugar solution is difficult and entails a high energy cost. It is much easier to separate a gas, like methane, from the liquid solution. L. S. U. Chemical Engineering professor Clayton D. Callihan has been looking at the fermentation of cellulose, the primary building block material of plants, into methane. According to Callihan, it makes little difference in energy recovery potential whether one ferments cellulose to methane or sucrose (in the form of extracted cane juice) to alcohol, but the cost of producing methane is substantially less than producing alcohol. In addition, one is able to use the entire sugar cane plant and not just the cane juice.

The objection to converting biomass to methane is basically that methane is a gaseous fuel, whereas our current shortage is primarily in liquid fuels. However, along the cellulose to methane conversion pathway intermediate products are generated that have a potential to be used as liquid fuels. Preliminary experiments might be cheaply produced with simple equipment; farmers might even make their own acids if they can be used as fuels.

The Farmer As Energy Producer

When the farmers went to Washington, they stopped by the Department of Energy. A five-member panel--representing small and medium, owned and leased, irrigated and non-irrigated farms--told a group of consumer representatives their varied reasons for

wanting 90% parity prices. They also talked about energy.

"We grow it," one panel member pointed out. "Everything you grow on a farm contains usable energy." The irony for the farmer is that fuels, and fossil-fuel-based fertilizers, constitute 1/4 to 1/2 of his operating costs. But putting his own crop energy to work may not be far off.

A farm is essentially a gigantic solar collector, storing solar energy as biomass. Farm crops, and farm residues as well, can be turned into useful fuels. Alcohol can be distilled from grain, sugar beets, potatoes, distressed crops, etc., with a high-protein by-product useful for food or feed. Methane (the major component in natural gas) is available from processes that "digest" animal wastes and/or crop residues. Compacted cellulose waste pellets can be used as solid fuel. All of these biomass fuels--alcohol, methane, and cellulose for direct combustion--are made from carbon-dioxide-absorbing plant matter, so burning them does not increase the CO₂ in the atmosphere.

Alcohol, methane, and pellets are already reducing energy expenses for some farmers, if not yet making them energy independent. On-site digesters can provide gas for cooking and heating. Stationary farm engines (like those that run irrigation pumps and feed grinders) can be converted to run on alcohol, alcohol/gasoline blends, or methane. Work is underway in adapting diesel engines, which power most mobile farm equipment, to run on diesel/alcohol or alcohol/vegetable oil blends.

Off the farm, the market for alcohol is growing. Though 100% alcohol fuel cannot compete pricewise with gasoline, millions of gallons of gasohol (90% gasoline/10% agriculturally-derived alcohol) have been sold in the Midwest, Virginia, and other states. Since the National Energy Act (NEA) exempts gasohol from the 4¢/gallon excise tax, a gasohol dealer has a 40¢ incentive for every gallon of alcohol he buys. And the user gets a more efficient, cleaner-burning (alcohol reduces the need for octane-boosters) fuel.

Alcohol fuels supporters want to see agriculture reidentified as energy production, not just food production. Becoming energy producers, many farmers feel, may offer them the market diversity they have needed and a solution to "overproduction," the surpluses that depress prices and keep farmland idle. Federal legislation on the books would allow farmers to use their set-aside acreage to grow energy crops. The Department of Agriculture will decide this fall whether to initiate the program in 1980.

The Bureau of Alcohol, Tobacco, and Firearms (ATF), which licenses stills, is drafting legislation that would streamline the licensing procedure for alcohol fuel producers. The Bureau has been granting "experimental" licenses to farmers to allow them to produce their own fuels and roughly 400 applications have already been received this year. (Applications for licenses can

be made through the ATF's Regional Regulatory Administrators in New York City, Philadelphia, Atlanta, Cincinnati, Chicago, Dallas, and San Francisco.)

Support for alcohol fuels is growing. Several states have gasohol fuels commissions to encourage gasohol use. The National Gasohol Commission, Inc., was established as a clearing-house for information on alcohol fuels policy, production, and legislation. (For more information write the Commission at 521 South 14th Street, Suite 5, Lincoln, Nebraska 68508.) And members of the National Alcohol Fuels Commission, authorized by Congress to recommend near-term policy with respect to alcohol fuels, are being appointed this spring.

A Department of Energy-wide Alcohol Fuels Policy Review Group solicited comment on the economics, supply, production, and end use of alcohol fuels like ethanol, methanol, and gasohol. Their report, which is due out soon, will make policy recommendations and suggest DOE initiatives in support of alcohol fuels.



TITLE: LOUISIANA'S POTENTIAL AS AN ETHANOL PRODUCER

AREA: Social Studies, English, Science

OBJECTIVE: The student will be able to give reasons for Louisiana's potential as an ethanol producer.

MATERIALS: Outline maps
Paper
Pen
Handouts

ACTIVITY: After reading the attached handout information, the student will answer the following questions:

1. List the unique characteristics of Louisiana which make it an ideal location for the production of gasohol.
2. What trends have led Louisiana to a critical consideration of alternative sources of energy?
3. Why is the Louisiana sugar cane industry considered a threatened industry?
4. On an outline map of Louisiana, locate 10 of the state's existing sugar mills.
5. Devise a comparative chart which analyzes the advantages and disadvantages of using sugar and of using corn in the production of ethanol.

LOUISIANA'S POTENTIAL AS AN ETHANOL PRODUCER

Louisiana's Unique Combination of Characteristics Point Toward Ethanol-Production

Discussions of alcohol fuel and gasohol invariably end with the statement, "If any place can do it, Louisiana can!" The basis for this assertion is Louisiana's unique combination of characteristics as an energy provider, a sugar cane producer, a port state and a leader in energy transportation and transformation.

Since the late 1800s Louisiana has produced oil and gas for the nation, second only to her sister state Texas in production volume. Twentieth century America has looked to Louisiana for the energy necessary to support its energy intensive standard of living. It was in 1909, in Baton Rouge, that the largest capacity petroleum refinery in the United States began processing crude oil. It was the following year that the first long distance pipeline supplied oil to the refinery from Caddo Parish. Since those early days Louisiana has set the pace technologically and provided skill, innovation and expertise as well as energy to the nation and the world.

However, by definition, Louisiana's nonrenewable energy sources are finite. The state's oil reserves peaked in 1970 and have begun an inevitable decline.

While Louisiana's "conventional," nonrenewable sources of energy are rapidly being depleted, the nation whose energy needs Louisiana long helped supply continues to consume ever greater amounts of energy. Predictions show energy consumption in the U. S. to be increasing at an annual average rate of 2.2 percent per year. These opposing trends have led the United States to dangerous dependency on foreign energy and have led Louisiana to a critical consideration of alternative sources of energy.

A factor leading to the consideration of ethanol production is Louisiana's sugar cane industry. This state's sugar cane farmers supply 42 percent of the nation's mainland domestic cane production. In fact, only four states in the United States produce sugar cane which is an extremely efficient bio-converter of solar energy.

Cultivated in Louisiana since the late 1700s, the amount of cane produced in the state has steadily increased over the last 50 years with 1977 production at 7,695,000 tons. In spite of the increase, the Louisiana sugar cane industry is considered a threatened industry, continually faced with the pressure of low world sugar price. Longer growing seasons and lower production costs give foreign cane producers a decided economic advantage over their counterparts in Louisiana. As a matter of agricultural policy, Louisiana would strive to provide all possible markets for her sugar cane producers. The potential of ethanol production is therefore very attractive to the state.

A related advantage Louisiana provides for ethanol production is the existing sugar mills, 34 of which were operating within the state in 1976. These mills reduce cane to sugar juice suitable for fermentation. Further, Louisiana has long supplied the world with sugar related engineering expertise. Numerous engineering firms and machine shops have provided technical assistance on sugar engineering problems the world over. Such technological familiarity can only expedite the development of an efficient ethanol fuel industry in Louisiana.

Louisiana's Corn As An Ethanol Feedstock

In 1978 Louisiana produced 2,773,000 bushels of corn from 65,000 acres. The cash value of the crop was estimated at \$1,930,000.

Acreage in corn production in Louisiana has steadily decreased over the last 15 years. Note, however, that production yields per acre have increased so that actual grain production has not declined as dramatically as has the acreage planted. Economic pressures from alternative crops, particularly the recent success of soybeans, have tended to shift farmers out of corn cultivation in Louisiana.

Corn, considered an excellent feedstock for ethanol production, is being used to manufacture ethanol for gasohol in the Midwest today. It is preferred by producers because it is plentiful and has a high starch (complex carbohydrate) content which results in an alcohol yield of 2.57 gallons per bushel of corn.

Another attractive aspect of corn to ethanol is the valuable by-product commonly called Distiller's Dried Grain (DDG). The DDG is an accepted animal feed and also serves to alleviate what would otherwise be a serious waste disposal problem. Another positive aspect is that corn may be easily stored for later use.

Katzen and Associates' report to the Department of Energy, "Grain Motor Fuel Alcohol, Technical and Economic Assessment Study," was based on a proposed corn to ethanol plant located in central Illinois. The study determined that the economic costs and energy requirements of a corn oil by-product system were too high to justify such an addition to the ethanol facility. The report recommended that ethanol facilities for gasohol purposes be limited to the production of ethanol with DDG as the single by-product.

Corn stover (husks, stalks and leaves) has been suggested as a boiler fuel, but because of its low fuel quality, the Katzen study showed that use of the stover raised the price of the ethanol product over what it would have been had coal been used.

In comparing the relative merits of corn and sweet sorghum as ethanol feedstocks, the Katzen report points out that sweet sorghum may not be stored, as its sugar deteriorates. On the other

hand, corn's starch content requires a conversion step to fermentable sugar, not required of the sweet sorghum.

A 50 percent corn, 50 percent sweet sorghum ethanol facility was investigated by the Katzen report. The operating cost of such a plant was found to be 32 percent higher than for a 100 percent corn base case facility. Contributing factors were the higher fixed charges related to higher investment costs, the higher cost of sweet sorghum relative to corn and a reduction in the value of the stillage by-product credit (sweet sorghum stillage is of a lesser quality and quantity than corn stillage).

Robert Guillory of Eunice, President of Louisiana Gasohol, Inc., announced a January 1980 groundbreaking for a plant that the St. Mary Parish Port Harbor and Terminal District intends to issue revenue bonds with which to finance the facility.

Governor Edwin Edwards and representatives of Caldwell Sugar Co-Op, Inc., of Thibodaux and Independence Energy Company, Inc., of New York announced construction of an ethanol plant adjacent to the Caldwell Sugar Co-Op, Inc., sugar mill in Thibodaux. The plant will be designed "to produce between 100 and 200 million gallons of gasohol a year."

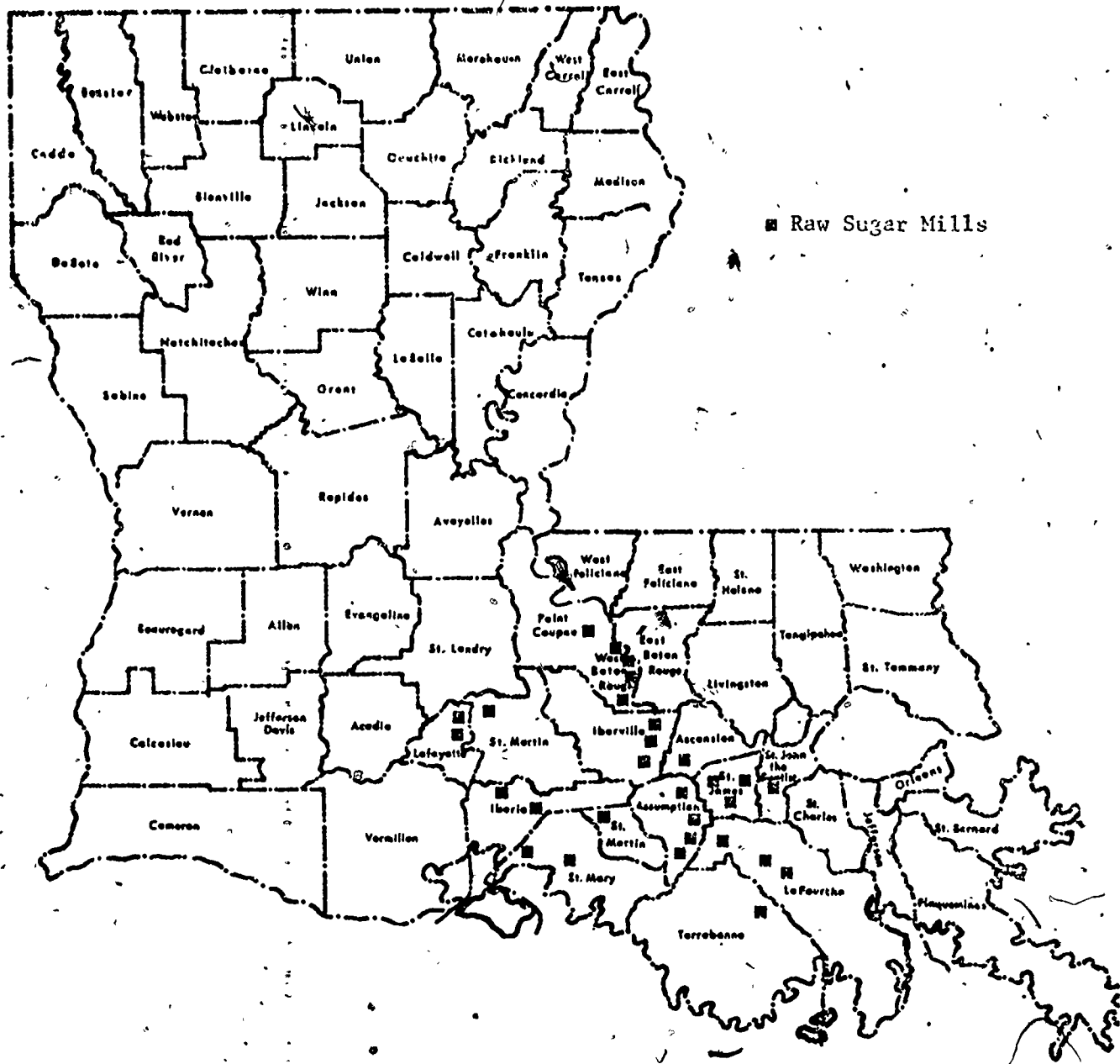

Location of 34 Louisiana Raw Sugar Mills

From: Pricing Methods for Raw Sugar in Louisiana, Edward Jordan, Ewell Roy, Department of Agricultural Economics Research Report No. 538, LSU, Baton Rouge, Louisiana, 1978, p. 3.

CORN ACREAGE PLANTED IN LOUISIANA
1964 - 1978

Source: L. Fielder and S. Guy; Agricultural Statistics for Louisiana, 1964-1977; Department Agricultural Economics (DAE) Research Report No. 541; LSU, Baton Rouge, Louisiana, 1978; and L. Fielder and B. Nelson; Agricultural Statistics and Prices for Louisiana, 1975-1978, DAE Research Report No. 554, 1979.

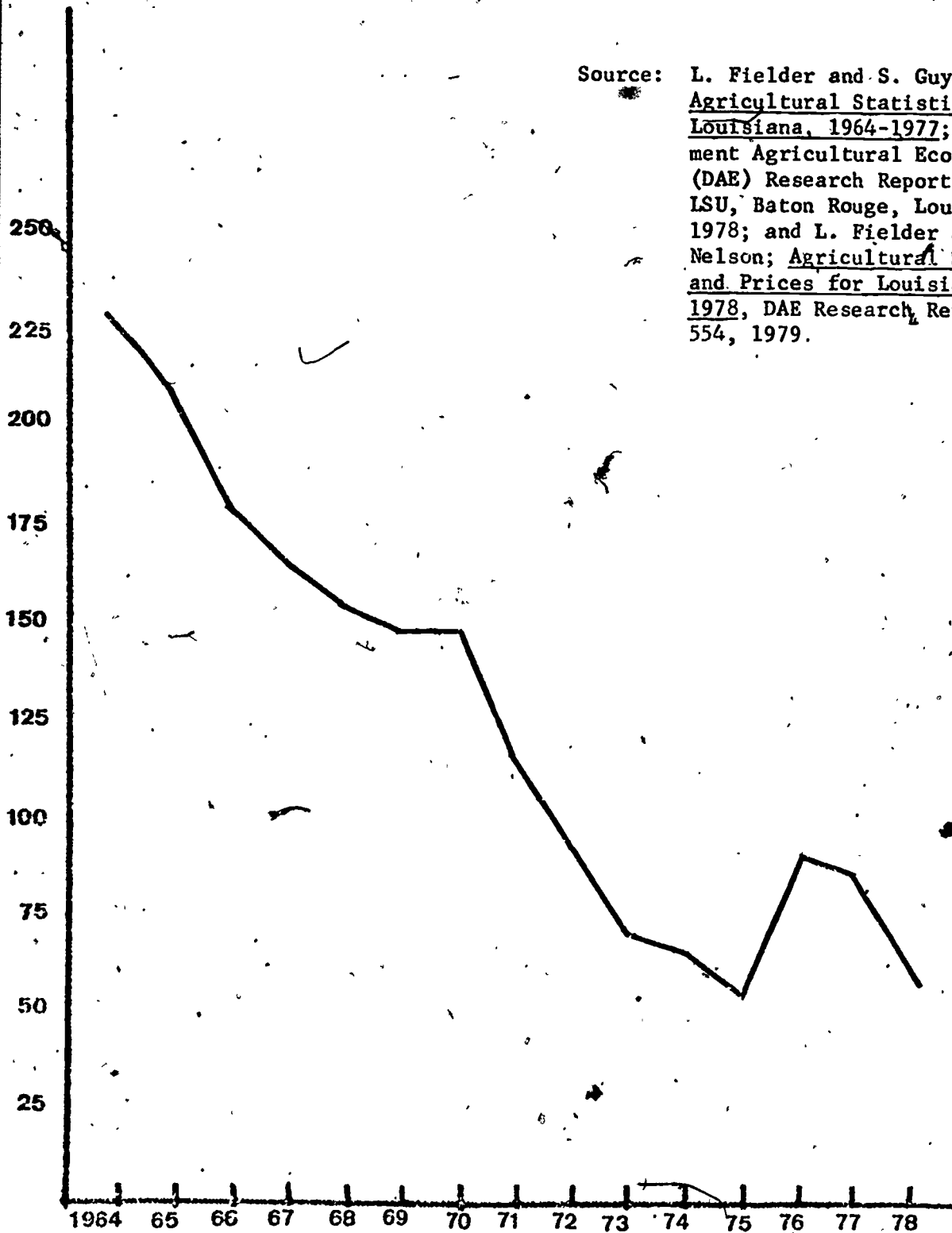

TITLE: GASOHOL--A POSSIBLE ALTERNATIVE ENERGY RESOURCE

AREA: Science, Social Studies

OBJECTIVE: To familiarize students with gasohol.

MATERIALS: Handout
Pen
Paper

ACTIVITY: Answer the following questions from handout, "Applications for Ethanol Produced in Louisiana."

1. What are some possible uses of Louisiana's ethanol? What appears to be the best short-term market for it?
2. "Gasohol" has come to mean a blend of what?
3. What are two advantages to mixing ethanol with gasoline? It also frees the refineries to do what?
4. What did Bell Telephone's preliminary test on the use of gasohol reveal?
5. What three technical benefits did the Department of Energy (DOE) note?
6. No tests to date on gasohol have indicated a necessity to do what?
7. In addition to the general public, what group of people support the use of gasohol?
8. Specifically, what group in Louisiana supports its use?

APPLICATIONS FOR ETHANOL PRODUCED IN LOUISIANA

Gasohol appears to be the most feasible short-term use of Louisiana's ethanol. As such a detailed discussion of gasohol follows. Other possible short-term applications are gas turbines and use in the petrochemical industry. Gas turbines are presently providing power for electrical power generating stations, oil and gas pipeline pumping stations and jet aircraft engines. The last use is not practical for ethanol, since its lower BTU ratio makes it too bulky for aircraft use. The turbines of electrical power generation or pipeline pumping stations are both feasible as ethanol facilities. One of the factors recommending the use of ethanol for electrical power plants is that the utility sector is already closely regulated by the government. Therefore, a government plant embracing ethanol as a source of energy for electrical power plants might be easily implemented. The Powerplant and Industrial Fuel Use Act of 1978, which limits the use of natural gas for production of electricity, is also a factor. On the other hand, ethanol contains only about 65 percent of the energy, on a volume basis, of conventional liquid gas turbine fuels so that almost twice as much alcohol must be burned for equal power output. Use of biomass ethanol in the petrochemical industry is technically feasible but other factors are discouraging. Forecasters see limited market growth for the industry which is presently overproducing.

Therefore, the short-term market for ethanol in Louisiana appears to be gasohol.

Gasohol For Spark Ignition Engine Use

Gasohol's history as a motor fuel was recited earlier, tracing its use from the earliest engines to the present. Today "gasohol" has come to mean a blend of 10 percent ethanol and 90 percent gasoline. The United States Department of Energy reports that there were over 800 outlets retailing gasohol in 28 states in June of 1979. In November of 1978 there were only three plants producing biomass-based ethanol for gasohol: Archer Daniels Midland of Illinois; Milbrew, Inc., of Wisconsin; and Grain Processors of Iowa. By May 1979, these three plants were producing approximately 150,000 gallons of ethanol per day, which would in turn produce 1.5 million gallons per day of gasohol. During 1979 other plants had begun entering the industry.

High consumer preference for gasohol is behind the surge in demand. The DOE finds consumer demand to be based primarily on three factors: (a) driver-perceived improved drivability, (b) consumer preference for renewable fuel, and (c) lower selling price than high octane gasolines. In an Iowa state marketing test, gasohol outsold gasoline 3.9 to 1.

The marketing of gasohol has been mainly by independent retailers who simply convert existing pumps to gasohol pumps and either mix the blend themselves or buy from a wholesaler who has done the mixing. At present, retailers are selling gasohol because it has a higher octane rating than does "regular" unleaded. Retailers like the advertising value of a new fuel, and they may garner an adequate profit from gasohol.

Ethanol is both a gasoline extender and an octane improver. Assuming a positive energy balance in ethanol production process, the 10 percent in the gasohol blend provides more gasoline to the market. The octane improver characteristic is important because the octane improvers currently permitted on the market, TBA (tertiary butyl alcohol) and MTBE (methyl tertiary butyl ether); are produced from petroleum and, thus, aggravate our dependency on nonrenewable fuels.

Further, DOE points out that ethanol as an octane enhancer reduces the amount of "reforming" of oil to gasoline and so frees the refineries to produce more lower octane gasoline. "This increased capacity represents not oil savings per se, but rather the ability to shift production to gasoline from other petroleum products such as distillates."

Further testing of gasohol's fuel economy is needed in order to gather scientific data. Such tests must employ standardized engines and fuels. It is promising, however, that in the inexact yet extensive tests to date problems with gasohol's use have not arisen. For example, Bell Telephone Company's preliminary test results using gasohol show a 3.03 percent increase in mileage, while most tests show equal or better mileage with gasohol.

RELATIVE ENERGY CONTENT OF GASOLINE AND ALCOHOL FUELS

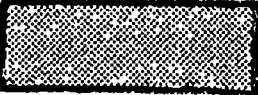
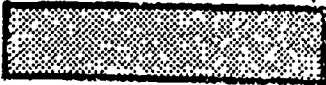
<u>Fuel</u>	<u>Energy Content (Btu/Gallon)</u>	<u>Relative Miles/ Gallon of Fuel Used</u>
Gasoline	124,000	
Methanol	64,800	
Ethanol	84,600	

From: Biomass-Based Alcohol Fuels: The Near Term Potential for Use with Gasoline, Mitre Corporation, Metrek Division, McLean, Virginia; 1978, p. 10.

There is no technical basis for expecting mileage improvements since ethanol has a lower energy content (i. e., lower BTU value) than does gasoline. Researchers believe that the improvements in fuel economy and efficiency are attributable to alcohol's ability to "lean" the gasohol mixture to be combusted, thus improving fuel characteristics for that particular engine.

DOE notes three technical benefits with regard to gasohol: (a) improved octane value, (b) reduced hydrocarbon and carbon monoxide emissions, and (c) general interchangeability in unmodified engines. The possible technical problems listed by DOE are: phase separation, vapor lock, and reduced drivability. "These problems seem to be amenable to solution using technology currently at hand."

Consumers have claimed improved drivability and less knocking as attributes of gasohol. The octane value of a fuel measures the anti-knock qualities of that fuel, and is related to the compression ratio of the engine. The higher the engine compression ratio, the higher the octane gasoline is required to operate the engine efficiently. Engines with low compression ratios reap no added benefit by using the highest octane fuel available. The octane rating of a fuel is usually measured as an average of the research octane number and the motor octane number as seen in the table below:

GASOLINE/GASOHOL OCTANE SPECIFICATIONS

	Current Octane Numbers ¹		
	Ron	Mon	(R+M)/2
Unleaded Regular	92.3	84.0	88.2
Unleaded Premium			
Leaded Regular	93.4	86.0	89.7
Leaded Premium	98.9	81.5	95.2
Gasohol			90.2 ²

¹EPA estimates. See DOE/EIA Analysis Memorandum, 1980 Motor Gasoline Supply and Demand, December 8, 1978, page 30.

²Based on average octane boost quality of 2 numbers (R + M)/2 for 190+ proof ethanol when blended with current unleaded regular gasolines.

Up to 40-50 percent of new cars suffer engine knock when using regular unleaded gasoline. Gasohol's added octane value may help make the operation of these vehicles more efficient.

None of the tests run to date on gasohol performance have altered or modified the test automobile engines. This supports the contention that no changes in existing engines are necessary in order to use gasohol.

The type and degree of emissions from engines fueled with gasohol is a matter of environmental concern. There are five main types of combustion emissions: carbon monoxides, hydrocarbons, nitrogen oxides, sulfur oxides, as well as particulates and smoke. Sulfur oxides and the particulates and smoke are not considered as significant as the other three types and, so, are not regulated by the U. S. Environmental Protection Agency as are the first three.

The 1970's and sharply rising oil prices brought a groundswell of public support for efforts to lessen the United States' dependency on foreign sources of energy. Further, support for the American farmer has led to a renewed interest in alcohol fuel. By 1979, gasohol was being sold at 800 retail outlets in 28 states, and old time moonshiners are being called in as "alcohol consultants."

TITLE: STEPS INVOLVED IN PRODUCTION OF ETHANOL

AREA: Science (Specifically chemistry)

OBJECTIVE: To become familiar with steps involved in ethanol production.

MATERIALS: See specific laboratory experiments.

ACTIVITY: The exact procedures for the following suggested activities can be found in almost any chemistry laboratory book.

1. Fermentation
2. Destructive Distillation of Wood (IPS suggested)
3. Fractional Distillation (IPS suggested)

ETHANOL PRODUCTION POSSIBILITIES IN LOUISIANA

Basic Existing Technologies

Ethanol may be produced from renewable resources using the simplest of technologies. What is done is to release the energy stored in plants by the photosynthetic process and transform it to a form of energy which may be utilized by machines.

Two steps are involved--fermentation and distillation. For fermentation carbohydrates must be broken down to simple sugars, a step accomplished by enzymes. Yeast is then mixed with the glucose and the yeast secretes enzymes which convert the glucose to ethanol and carbon dioxide:

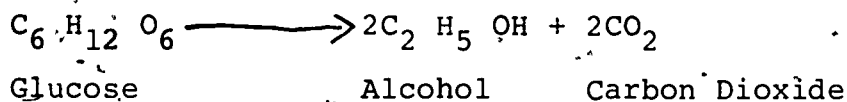

Distillation then removes the alcohol by boiling off the vapors and collecting the purified alcohol. Since the boiling point of alcohol and the water in the aqueous stillage are so close, a number of boiling steps are required to yield a relatively pure alcohol. This process is called fractional distillation. In order to purify the alcohol completely an azeotropic benzene distillation step is required. It has been argued that spirit alcohol (less than 199 proof) may be used for gasohol purposes but threats of phase separation, vapor lock and other mechanical difficulties dictate the production of anhydrous, 199 proof (99.5 percent pure) alcohol or neat alcohol which is 200 proof (or 100 percent pure).

Using this basic technology ethanol may be derived from sugar crops, starch crops, even cellulosic material. The low price of cellulosic feedstocks must be balanced against the high price of processing. Such processing costs will hopefully decline as a cellulosic fermentation technology is perfected. Fermentation of starch crops is attractive because of the well established technology; however, starch feedstocks tend to be expensive and have questionable energy balances. Sugar crops are the most efficient bioconverters and storers of solar energy but the limited availability of sugar juice makes them unlikely candidates for solving the nation's fuel crisis. Further, sugar crops present storage difficulties.

The first step in processing cane for ethanol is the milling of the stalks, which may be done in the traditional manner just as it is for refined sugar.

Because of the short harvest season for Louisiana cane the mills lie idle the greatest part of the year. Harvest in Louisiana is generally about a 90-day period stretching from late

September to mid-December. This is in strong contrast to the year-round Brazilian sugar cane harvest. The obvious solution of storing the sugar cane for later milling is untenable because the sugar deteriorates rapidly after the cane is harvested.

Proposals for extending the season have been made, chief among them the integration of other crops. Sweet sorghum, with a possible maximum season of 180 days, is under close scrutiny particularly because it may be milled by existing sugar cane mills. Other sources of starch or cellulose would require additional processing equipment.

After the cane is milled the next major step is fermentation. F. C. Schaeffer in the Battelle report, "Sugar As A Source Of Fuels," has detailed a model sugar cane to ethanol plant. The plant would produce 12,636,000 gallons of ethanol per year at capital cost of \$59,500,000. The daily capacity would be 9,000 short tons of cane producing 140,400 gallons of ethanol. These figures represent a yield of 15.6 gallons of ethanol per ton of cane.

After the sugar juice is extracted (which may be done in existing sugar mills) it is concentrated to a 20 percent sugar solution in preparation for fermentation. The 20 percent sugar concentration is necessary to assure a 10 percent ethanol concentration at the outset of the distillation process. By using a high concentration of yeast the Schaeffer model cuts fermentation time to 18 hours.

The distillation of alcohol out of the aqueous stillage takes place in the stripping-rectifying distillation columns. The resulting 95.5 proof alcohol is transformed to absolute or 200 proof ethanol in a benzene azeotrope reaction in the azeotropic distillation column.

The remaining stillage is concentrated by evaporation and dried for storage. The Schaeffer model notes that the spent yeast could be added to the stillage at this point which would improve the quality of the DDG processed.

The bagasse (the discarded cane stalk) is burned to provide the total power requirement of the facility. This is done without bringing any trash (leaves and remains from harvesting) in from the fields. The model supposes that the utilization of trash could provide excess electrical energy generation.

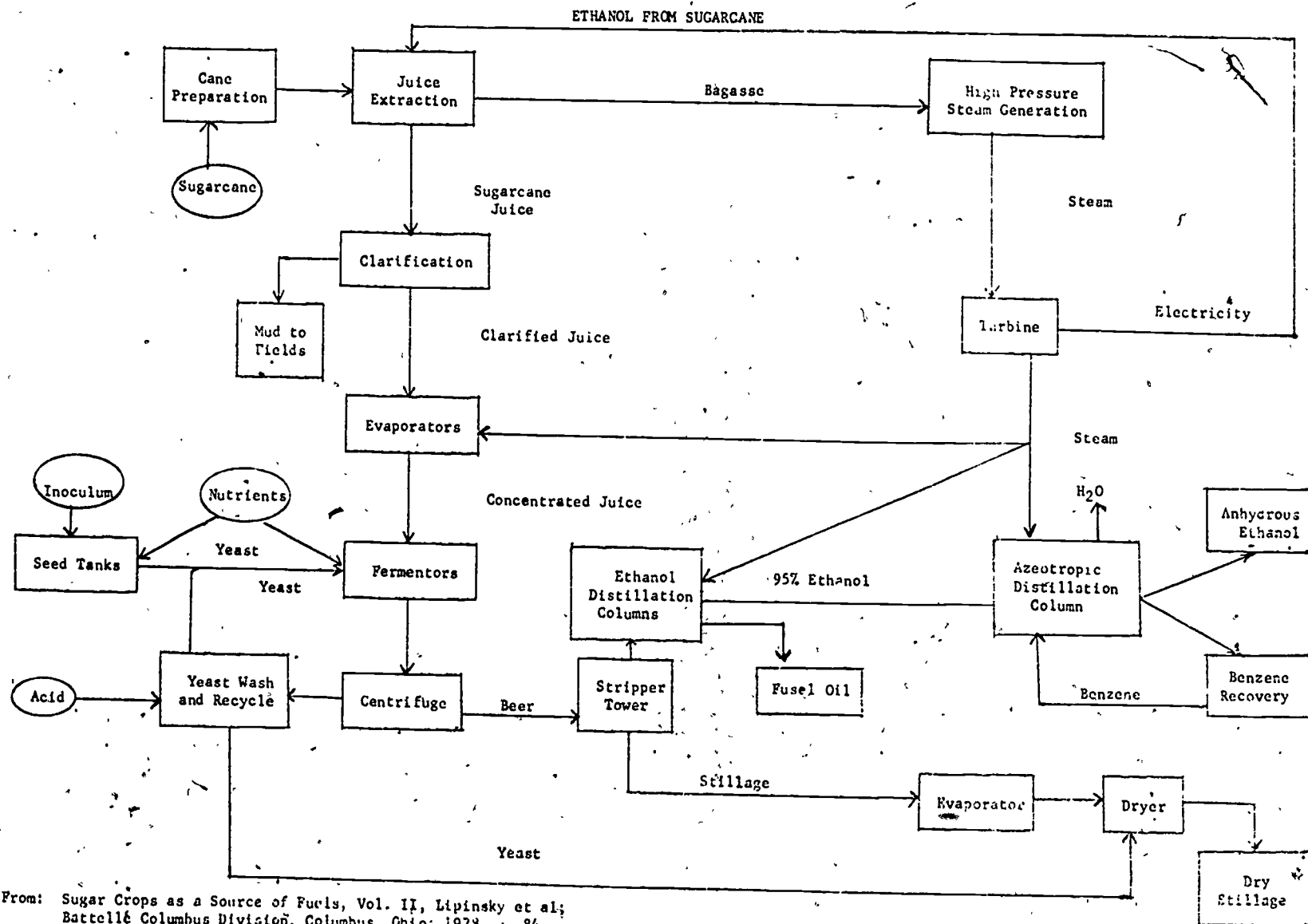

From: Sugar Crops as a Source of Fuels, Vol. II, Lipinsky et al;
Battellé Columbus Division, Columbus, Ohio; 1978, p. 84.

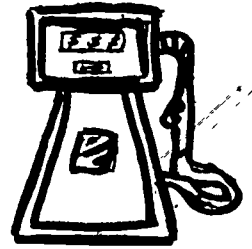

TITLE: THE PROS AND CONS OF GASOHOL

AREA: Social Studies, Science, English

OBJECTIVE: The student will be able to identify the various advantages and disadvantages of gasohol.

MATERIALS: Handouts
Transparencies
Library literature
Research literature

- ACTIVITY:
1. Students should do library research on the availability of materials on gasohol.
 2. Use the attached bibliography to write to sources which can provide additional information on gasohol.
 3. Divide students into two groups in order to list and explain the advantages and disadvantages of gasohol; debate the "pros and cons of gasohol."
 4. Have two students with identical make and model cars engage in a test drive of the same distance, one using gasoline and one using gasohol, and report back to the class on the number of miles traveled per gallon. Thus, the class will be able to make a mental comparative analysis of the test drive.

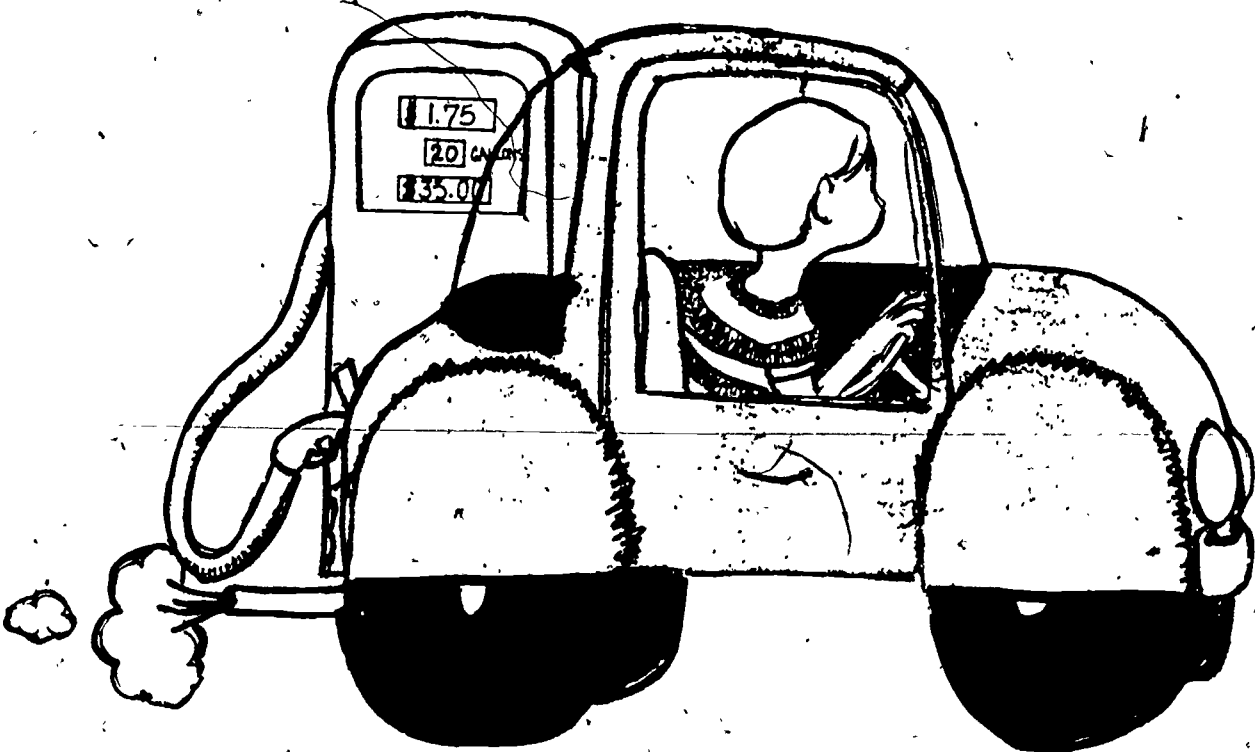

"Agricultural, Forestry and Rural Energy Act of 1979", Congressional Record - Senate, September 19, 1979; and comments by Senator Herman Talmadge, Washington.

Anderson, Jack; "Gasohol: Hope for Small Farmers or Big Boys"; Sunday Advocate, Baton Rouge, October 28, 1979.

Baird, Woody; "Moonshiners Back to Make Gasohol"; Morning Advocate, Baton Rouge, September 27, 1979.

Battelle Columbus Laboratories (E. S. Lipinsky, S. Kresovich, T. A. McClure, D. R. Jackson, W. T. Lawhon, A. A. Kalyoncu, E. L. Daniels); Sugar Crops as a Source of Fuels, Volume I: Agricultural Research, for U. S. Department of Energy; Columbus, 1978.

----- (E. S. Lipinsky, H. S. Birkett, J. A. Polack, J. E. Atchison, S. Kresovich, T. A. McClure, W. T. Lawhon); Sugar Crops as a Source of Fuels, Volume II: Processing and Conversion Research, for U. S. Department of Energy; Columbus, 1978.

Beck, Melinda and Holly Morris; "The Energy War: Brew It Yourself", Newsweek; New York, October 1, 1979.

Beckers, Thomas and Robert Weaver; An Economic Atlas, Louisiana's Renewable Resources in an Era of Higher Cost Energy; for the Louisiana Department of Natural Resources; Baton Rouge, 1978.

Bernard, M., III; "Environmental Planning and Assessment for Highway Vehicle Use of Alcohol Fuels"; Alcohol Fuels Technology, Third International Symposium, Volume III; Asilomar, 1979.

Bradshaw, Jim; "Tomorrow's Energy"; Acadiana Profile; Lafayette, Volume 7, No. 5; September/October 1979.

Bruschke, H.; "Direct Processing of Sugarcane into Ethanol"; International Symposium on Alcohol Fuel Technology, Methanol and Ethanol, English Translation published by U. S. Department of Energy; Washington, 1978.

Callihan, Clayton D. and Wilson Gautreaux; "Why Not Make Our Future Energy Cheap?" authors' manuscript, Baton Rouge, 1979.

Campbell, Joe R.; "Estimated Costs In Producing Sugar Cane In Louisiana For 1978 For An Efficient 500 Acre Sugar Cane Farm", author's manuscript, Baton Rouge, 1978.

----- "Estimated Costs In Producing Sugar Cane In Louisiana For 1979 For An Efficient 500 Acre Sugar Cane Farm", author's manuscript, Baton Rouge, 1979.

----- "Returns, Costs and Profits For Large Scale Sugar Cane Farms In Louisiana 1974-1976 Crop Years", Department of Agricultural Economics Research Report No. 550; Louisiana State University, Baton Rouge, 1979.

-----"Returns Costs and Profits For Raw Sugar Mills In Louisiana, 1974-1976 Grinding Seasons", Department of Agricultural Economics Research Report No. 551; Louisiana State University, Baton Rouge, 1979.

Cervinka, V. and D. Mason; "Alcohol Fuels and Agricultural Systems", Alcohol Fuels Technology, Third International Symposium, Volume III; Asilomar, 1979.

de Carvalho, Jr., A. V., V. Yang, and W. N. Milfont; "Energetics and Economics of Fuel Alcohols in Brazil", International Symposium on Alcohol Fuel Technology, Methanol and Ethanol. English Translation published by U. S. Department of Energy, Washington, 1978.

Duffy, Joan I., "Can 'Rum With a Kick' Save Louisiana Sugar Industry?" Sunday Advocate; Baton Rouge, May 27, 1979.

Ecklund, E.; "Legal and Regulatory Influences on Alcohol Fuels Use in the United States"; Alcohol Fuels Technology, Third International Symposium, Volume II; Asilomar, 1979.

Edwards, Edwin W., Comments upon taping of "Good Morning, America" segment; Baton Rouge, April 6, 1979.

Energy Management, Commerce Clearing House, Inc.; Chicago, 1979.

Energy Tax Act of 1978, Public Law 95-618.

Ergebart, W.; "Basic Data on Continuous Alcoholic Fermentation of Sugar Solutions and of Mashers from Starch Containing Raw Materials", International Symposium on Alcohol Fuel Technology, Methanol and Ethanol. English translation by the U. S. Department of Energy, Washington, 1978.

"Ethyl Alcohol Plant Planned For Thibodaux", Morning Advocate; Baton Rouge, November 1, 1979.

Fielder, Lonnie and Berger Nelson, Agricultural Statistics and Prices for Louisiana, 1975-1978, Department of Agricultural Economics Research Report No. 554; Louisiana State University, Baton Rouge, 1979.

Fielder, Lonnie and Sam Guy, Agricultural Statistics for Louisiana, 1964-1977, Department of Agricultural Economics Research Report No. 541; Louisiana State University, Baton Rouge, 1978.

Food and Agriculture Act of 1977; Public Law 95-113, 1977.

"Funds to Back Gasohol in Louisiana Reported", Morning Advocate; Baton Rouge, August 27, 1979.

"Gasohol Plant Set For Louisa About January", Morning Advocate; Baton Rouge, October 17, 1979.

"Gasohol Program Approved", Morning Advocate; Baton Rouge, September 19, 1979.

"Government to Sell Surplus Cane Sugar", Morning Advocate; Baton Rouge, HANDOUT
September 8, 1979.

Grainey, M., "Alcohol Fuel Technology and The National Energy Act"; Alcohol
Fuels Technology, Third International Symposium, Volume I; Asilomar,
1979.

Gulf South Research Institute, Economic Analysis of The Gulf Intracoastal
Waterway, Louisiana Section, for the Ozarks Regional Commission;
Baton Rouge, 1978.

Hagey, G.; A. J. Parker, Jr.; T. J. Timbario; D. L. Raley; "Methanol and
Ethanol Fuels - Environmental, Health and Safety Issues"; International
Symposium on Alcohol Fuel Technology, Methanol and Ethanol. English
translation published by the U. S. Department of Energy, Washington,
1978.

Harrist, Ron, "Kudzu Vine May Become Fuel Source", Sunday Advocate, Baton
Rouge, October 7, 1979.

Huffman, Donald, "Energy and Agriculture", Louisiana Rural Economist,
Department of Agricultural Economics and Agribusiness; Louisiana
State University, Baton Rouge, Volume 41, No. 3, 1979.

Humbert, Roger, "The Growing of Sugarcane for Energy"; Alcohol Fuels
Technology, Third International Symposium, Volume I; Asilomar, 1979.

Irvine, J. E.; 'Farming For Food or Fuel', "Cane Planter", The Sugar Journal;
New Orleans, May 1979.

Jones, J., P. Barkholder, D. Bomberger, C. Clark, R. Dickenson, et al;
SRI International, "A Comparative Economic Analysis of Alcohol Fuels
Production Options", Alcohol Fuels Technology, Third International
Symposium, Volume II; Asilomar, 1979.

Jones, Mark, John Netterville, David Johnson, James Wood; Chemistry, Man
and Society, W. B. Saunders Co.; Philadelphia, 1972.

Jordan, Edward and Ewell Roy, Pricing Methods For Raw Sugar In Louisiana,
Department of Agricultural Economics Research Report No. 538;
Louisiana State University, Baton Rouge, 1978.

Raphael Katzen and Associates, Grain Motor Fuel Alcohol, Technical and
Economic Assessment Study, for the U. S. Department of Energy;
Cincinnati, 1979.

Kendall, Don, "Record Corn Crop Forecast", Sunday Advocate; Baton Rouge,
September 16, 1979.

Litterman, Mary, Vernon Eidman and Harold Jensen; Economics of Gasohol,
Economic Report ER 78-10, Department of Agricultural and Applied
Economics; University of Minnesota; St. Paul, 1978.

-----Economics of Dieselhol - A Supplement to Economics of Gasohol, ER 78-10,
Department of Agricultural and Applied Economics; University of Minnesota,
St. Paul, 1979.

- Louisiana Board of Commerce and Industry, A Position Paper of the Special Task Force on Industry Inducements and Incentives, Baton Rouge, 1978.
- Louisiana Office of Conservation, Production Audit Section, "Refineries Filing Form, R-3"; Baton Rouge, 1978.
- "Petroleum Activity Report, August 1979", Baton Rouge, 1979.
- Martin, John and Warren Leonard, Principles of Field Crop Production, 2d ed., MacMillan Company, New York, 1967.
- McCaslin, John (ed.), International Petroleum Encyclopedia, The Petroleum Publishing Co., Tulsa, 1978.
- Arthur G. McKee and Company, Preliminary Engineering and Cost Analysis of Purdue/Tsao Cellulose Hydrolysis (Solvent) Process, for the U. S. Department of Energy; Chicago, 1978.
- Metrek Division of Mitre Corporation, Biomass-Based Alcohol Fuels: The Near-Term Potential for Use with Gasoline, for the U. S. Department of Energy; McLean, 1978.
- Comparative Economic Assessment of Ethanol from Biomass, for the U. S. Department of Energy; McLean, 1978.
- Mid-Continent Oil and Gas Association, "Louisiana Oil and Gas Facts", 17th ed., Baton Rouge, 1979.
- "Monroe Investors Plan Gasohol Products Plant", State-Times, Baton Rouge, August 22, 1979.
- Moran, Wilda, "Gasohol to be Produced from Iberia Sugarcane", Daily Iberian, New Iberia, April 18, 1979.
- Mueller Associates, Inc. (A. Parker, T. Timbario, J. Mulloney); Ethanol From Municipal Cellulosic Wastes; Alcohol Fuels Technology, Third International Symposium, Volume II; Asilomar, 1979.
- Status of Alcohol Fuels Utilization Technology for Highway Transportation, for the U. S. Department of Energy; Baltimore, 1978.
- Powerplant and Industrial Fuel Use Act of 1978, Public Law 95-620.
- "Revenuer: Moonshiners Becoming Gasohol 'Consultants'", State-Times, Baton Rouge, September 26, 1979.
- Ricaud, Ray and Joe R. Campbell, "Preliminary Estimate of Costs in Producing Sweet Sorghum Under Farm Conditions in Louisiana Based on Available Research Data", authors' manuscript, Reference No. JRC:11f 082279, Baton Rouge, 1979.
- Roy, Ewell, "The Brazilian Sugarcane-to-Alcohol Program", Louisiana Rural Economist, Department of Agricultural Economics and Agribusiness; Louisiana State University, Volume 41, No. 3, Baton Rouge, 1979.

- Rudolph, K.; W. Tentscher; R. P. Owsianowski; "Direct Production of Ethanol from Sugarcane", International Symposium on Alcohol Fuel Technology, Methanol and Ethanol. English translation published by the U. S. Department of Energy; Washington, 1978.
- Scheller, W., "The Production of Ethanol by the Fermentation of Grain", International Symposium on Alcohol Fuel Technology, Methanol and Ethanol. English translation published by the U. S. Department of Energy; Washington, 1978.
- "The Production of Grain Alcohol and Electric Power with Cogeneration of Steam"; Alcohol Fuels Technology, Third International Symposium; Asilomar, 1979.
- "Senate Bill to Promote Biomass Fuel", Morning Advocate, Baton Rouge, September 20, 1979.
- Sinclair, Ward, "House Ready To Fight Annual Sugar Battle (Analysis)", Morning Advocate, Baton Rouge, October 18, 1979.
- Sklar, S., "Alcohol Fuels: The Most Often Asked Questions"; Alcohol Fuels Technology, Third International Symposium, Volume III; Asilomar, 1979.
- Sokkappa, B. G., "Congressional Concerns About Alcohol Fuels--A Technical Advisor's Perspective"; Alcohol Fuels Technology, Third International Symposium, Volume III; Asilomar, 1979.
- U. S. Department of Agriculture, "Gasohol From Grain - The Economic Issues", prepared for The Task Force on Physical Resources, Committee on the Budget, U. S. House of Representatives; Washington, 1978.
- U. S. Department of Energy, Decision and Order, American Agri-Fuels Corporation (DEE-2179), Washington, 1979.
- Decision and Order, Fannon Petroleum Services, Inc. (DEE-3884), Washington, 1979.
- Energy Information Administration, Energy Supply and Demand In the Mid Term: 1985, 1990, and 1995, Washington, 1979.
- The Report of the Alcohol Fuels Policy Review, Washington, 1979.
- U. S. Senate, The Economic Feasibility of Gasohol, Hearings before the Subcommittee on Agricultural Research and General Legislation of the Committee on Agriculture, Nutrition and Forestry; held in Indianapolis, 1977.
- University of Santa Clara, University of Miami and E. Ecklund; Comparative Automotive Engine Operation When Fueled With Ethanol and Methanol, for the U. S. Department of Energy; Washington, 1978.
- Yang, V. and S. Trindade; "Brazil's Gasohol Program", Chemical Engineering Progress, New York, 1979.

ENERGY CONSERVATION

Until recent years, energy was cheap and abundant in the United States and there seemed no need for conservation. But matters have changed drastically, particularly since the Near East embargo on oil exports. Conservation of energy resources, which means making the best and wisest use of these resources, was forced on the American public. We are urged to conserve gasoline, natural gas, fuel oil and electricity.

Increases in the price of these products have helped promote conservation, and there have been some short-term savings in energy. Obvious measures, such as cutting down on display lighting, lowering thermostat settings in winter and reducing drying, have helped cut energy use.

We can consider two major thrusts in the area of energy conservation. One is the research and development programs being carried out by government agencies, utilities, and industries in an effort to make better use of energy resources. The other is the awareness that each of us as consumers should have of ways in which we can conserve energy.

A major example of research in conservation technology is that being carried out through the National Conservation Research, Development and Demonstration Programs funded through ERDA. Some of the aims of these programs are as follows: improving reliability and cutting energy losses in electrical distribution systems; developing methods for energy storage; assisting industry in becoming more efficient in their use of energy; developing uses for waste heat; developing economically feasible methods of decreasing energy loss from existing buildings; developing improved design for new buildings to reduce energy consumption; disseminating information on the energy efficiency of appliances; and encouraging industry to develop more energy-efficient products.

There are many things we can do in our homes each day to reduce the use of energy. Heating and cooling systems are the greatest energy users in our homes. There are many ways to save on energy in this area. The first is adequate insulation. Since the greatest amount of heat loss or gain is usually through the roof, proper attic insulation is a must. So is insulation in outside walls and in floors covering unheated areas. Weatherstripping, caulking and storm doors and windows also help to keep heat loss at a minimum in winter. During winter, a maximum daytime temperature of 68 degrees is recommended. This should be several degrees lower at night and when you are away for a while. During the summer, 78 degrees is a comfortable temperature. Since high humidity makes us feel warmer, a humidifier in the winter and a dehumidifier in the summer may help save energy in the long run. In the winter, the air from an electric clothes dryer can be vented into the house to add warmth and moisture. The proper use of lined or insulated drapes can help control a home's temperature. On sunny winter days, they should be opened to let the sun help warm the house.

Otherwise, they should be closed in winter. On sunny summer days, the drapes should be closed to keep the sun out. If possible, unused rooms of a home should not be heated or cooled. Air conditioner and heater vents or outlets should not be obstructed by furniture or drapes. Heating and cooling equipment should be kept clean and properly adjusted to operate more efficiently.

Heating water usually consumes the second largest amount of energy in our homes. There are several ways to reduce energy requirements in this area. In buying a water heater, choose one with high efficiency and good insulation. Get only the size needed, since too large a tank wastes energy. Try to place the water heater as near as possible to the major areas of hot water use to minimize heat loss in the pipes. Do not set the thermostat higher than necessary and use hot water only when necessary for laundry and dishwashing--cool or warm water can often be substituted. Eliminate leaks in faucets, particularly hot water leaks.

Proper use of home appliances can further cut energy use. For example, open and close refrigerator and freezer doors only when necessary. Use smaller burner and smaller oven in the kitchen range whenever possible. Wash only full loads in dishwashers and clothes washers. It may be possible to eliminate the drying cycle on the dishwasher by simply opening the door when the wash cycle is finished and letting the hot dishes air dry. Save energy by always turning off lights when leaving a room, even if only for a few minutes. Use fluorescent lamps wherever possible, since they use much less energy than incandescent bulbs for the same amount of light.

As we have seen, electricity cannot be efficiently stored, but must be generated as needed. Thus, utilities must be equipped to generate enough electricity to meet peak demands, even though much of the equipment is not needed at other times. So, it is helpful to use electrical power when demand is low. The peak times are between 5 p.m. and 8 p.m. in winter and between 1 p.m. and 5 p.m. in the summer. There is even talk of charging less for electricity used during nonpeak hours, as is now the case with long-distance phone calls.

Various consumer groups have calculated that home consumption of energy could be reduced by 15 percent by common-sense avoidance of waste.

AN ENERGY CONSERVATION ETHIC

Some sort of ethic stands behind every moral principle. Historically, Americans have believed in a "Work Ethic"--work as hard as possible, produce as much as possible, be as comfortable as possible, and be as successful as possible in terms of income and acquisitions. As a result of this productivity, our society has become increasingly prosperous and we have grown with little concern for future generations.

In the past, energy and technology increased worker productivity and provided an outlet for improved disposable income (longer vacations, more expensive cars, added convenience at home). As a result, American society has become increasingly energy-intensive and wasteful. Now that American energy supplies are dwindling, it is essential that some behavioral changes occur in our society.

In order to slow the exponential energy demand growth rate which may limit energy options available to future generations, citizens must adopt an Energy Conservation Ethic. Such an ethic not only can induce cost-saving responses, but can also productively change the American way of living. Teachers have the opportunity to make clear to teenagers that such an ethic is based on a realistic comprehension that so many of the raw materials on which current living standards rely will not be available much longer.

It goes without saying that conservation measures cannot be effected without some action by the consumers; such measures may not only alter the "comfort" citizens derive from conservation but also their "freedom" to consume. As observed in the Scientists' Statement on Energy Policy: "One man's conservation may be another man's loss of job. Conservation, the first time around, can trim off the fat, but the second time will cut deeply."

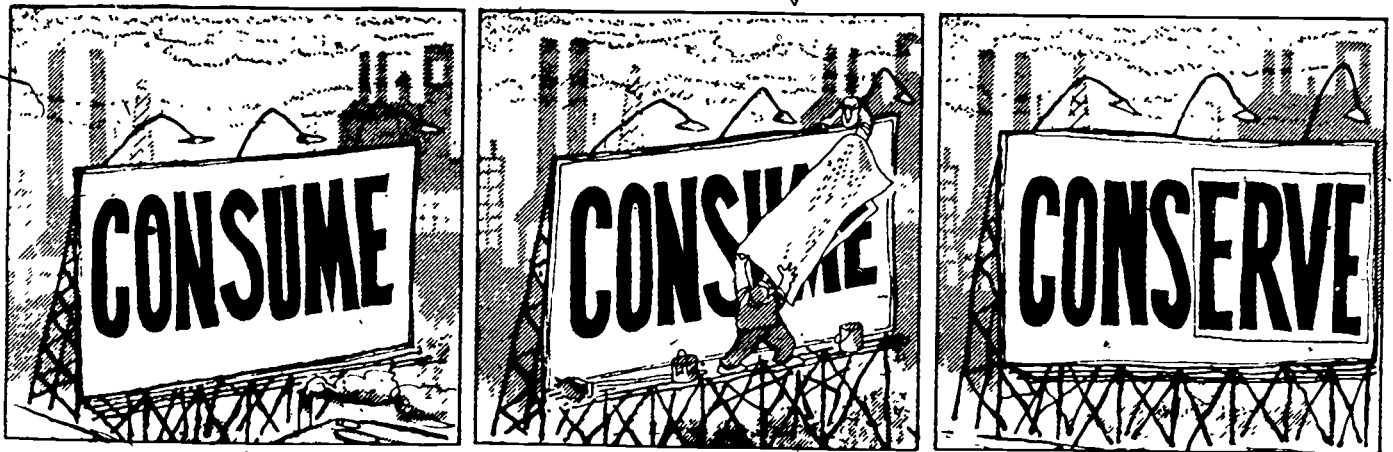

THE GOOD OLD DAYS?

Interview someone who is old enough to remember what life was like before the days of great usage of oil and natural gas. Ask him/her the questions that follow and others that you think of yourself.

1. What kind of lights did you use in your home? _____
How was it heated? _____
2. What fabrics were clothes made of? _____
Was clothing harder or easier to take care of? _____
3. What sort of washing machine did you have? _____
4. What kind of stove (and what kind of fuel) did your family use for cooking? _____
5. Did you have a refrigerator? _____
How did you keep your food fresh? _____
6. How was food packaged when it came from the store? _____
What did milk come in? _____
Was your milk delivered? _____ How? _____
7. What sort of soap did you use? _____
Did it clean as well as the cleaners we have now? _____
8. How was the water heated for bathing and laundry? _____
9. Did your family have a car? _____ If not, how did you travel? _____
How did you get to school? _____
10. Did you have a radio? _____ What did it look like? _____
Did you go to the movies? _____
What kind of entertainment did you enjoy? _____

Think up as many questions of your own as you can. Ask them during the interview.

In what ways is life for you more enjoyable now that we have electricity, plastics, detergents, and other oil and natural gas products?

In what ways did you like the "good old days" better?

TITLE: ENERGY EDUCATION/CONSERVATION EXAMINATION

AREA: Science, Social Studies

OBJECTIVE: To help measure the general awareness level of students in the area of energy and its conservation.

MATERIALS: Energy Education/Conservation Examination, Answer Sheet

ACTIVITY: Have students answer the questions in the Energy Education/Conservation Examination prepared for this activity. The examination can be given as a pre-test and administered later (after a study of energy) as a post-test. It could also be used with school administrators, teachers, or parents. An answer sheet form to be used for responses and a key for the answers are on the following pages.

ENERGY EDUCATION/CONSERVATION EXAMINATION

Directions: Please do not write on the examination. On the answer sheet provided, circle True (T) or False (F) as it pertains to each statement on the examination.

1. Coal is the most widely used fuel in the U.S. for generating electricity.
2. "R-value" is a measure of the resistance to heat flow through a material.
3. At this time, the use of solar cooling for buildings, wind energy conversion, and electricity from photovoltaics (solar cells) is both technologically practical and economical.
4. The technology for converting fuels such as coal, oil, and uranium to electricity is firmly established.
5. The population of the United States doubles about every 45 years and the demand for electricity doubles about every 10 years.
6. The breeder reactor will probably be used widely in the late 1980's.
7. The light water reactors will be used widely, continuing beyond the time the breeder reactor becomes a commercial reality.
8. The eastern part of the U.S. has more coal with lower sulfur content than the western states.
9. Open refrigerators or freezers in supermarkets waste energy.
10. A fuel cell converts gas directly into electricity.
11. Widespread conversion of urban refuse into fuels could supply approximately 25 percent of our total annual energy consumption.
12. Pumped storage systems are a common means of storing large amounts of energy.
13. At this time, the use of solar heating and hot water systems is technically practical and economical.
14. Solar radiation is a source of non-polluting energy but cannot be described as "free" because of the expense required in capturing the sun's energy in one manner or another.
15. Effective energy conservation programs will give us the needed time to find and develop new reserves and technologies to meet our growing energy needs.

16. It is not technically possible today to collect energy in space and transmit it to earth by microwave.
17. A significant portion of the total weight of organic waste is water, which cannot be used to produce energy.
18. The most efficient method of extracting energy from tides is to use dams and sluice gates across bays or estuaries where tidal heat can be used to run hydraulic turbines.
19. The first step toward reducing energy demand is to identify and eliminate areas where energy is being wasted.
20. Charts of average wind velocities for the entire United States are now available for use in determining optimum locations for wind turbine generators.
21. The problem with using wind to supply our energy needs is that it is unpredictable and unsteady.
22. The main reason we have wasted so much energy in the past has been because the price has been low.
23. There are very few problems associated with the development of geothermal energy.
24. The largest coal reserves in the western U.S. are found in Idaho.
25. If all coal from reserves in the U.S. were mined and made available, there would be enough to last us for several hundred years if used at the present rate of consumption.
26. The cost of transporting coal can often equal the cost of mining.
27. The costs of reclaiming strip-mined areas and installing pollution abatement equipment must be passed on to the consumer.
28. Oil is the cleanest burning of the fossil fuels and is, therefore, in great demand.
29. The Federal Power Commission regulates the transport and sale of natural gas in interstate commerce.
30. The most significant variable affecting fuel consumption in an automobile is its weight.
31. Urban refuse has approximately twice the heating value of coal.
32. Radial tires permit up to six percent better gas mileage than standard tires.

33. Fusion energy will probably not be available until about the year 2000, if at all.
34. Glass and metals make up about 33 percent of urban refuse.
35. Nuclear fission is caused by the splitting of a nucleus of an atom into two approximately equal fragments whose combined mass is less than the original nucleus.
36. The fission energy from one ounce of uranium fuel pellets is equivalent to the chemical energy of 100 tons of coal.
37. Uranium-238 can be used to produce energy when transformed into plutonium through neutron bombardment.
38. When spent fuel elements are removed from a power reactor, they are no longer radioactive.
39. If a reservoir has little or no storage capacity, it has limited value for producing energy.
40. The "Price-Anderson Act" provides for the insuring and indemnifying of nuclear power plants.
41. Siting and licensing requirements for all reactors are governed by the regulations set forth by the Federal Energy Administration (FEA).
42. A breeder reactor makes it possible to utilize up to 60 percent of the heat energy content of uranium ore, while water-cooled reactors utilize approximately one or two percent.
43. The breeder reactor could greatly extend the length of time present uranium reserves would last.
44. The potential value of fusion power lies in the virtually inexhaustible supply of inexpensive fuel which can be extracted from water.
45. The most favorable sites for large solar power installations appear to be in the southwest.
46. Some scientists believe the earth's atmosphere is increasing in temperature due to an increasing level of carbon dioxide from pollution.
47. Fluorescent lights are less efficient than incandescent.
48. Frost-free refrigerators and/or freezers use 50 percent more energy than manual units.
49. A house without ceiling or wall insulation will cost at least twice as much to heat as one properly insulated.

50. The south side of a building gets more sun than the north side.
51. Good insulation in houses is only important in the winter.
52. The best location for the thermostat is on the coldest wall.
53. The energy used to drive a car initially came from the sun via green plants.
54. A solid state color TV set consumes about 33 percent more energy than a black and white solid state set.
55. An insulation material having an R-value of 10 is better than one having an R-value of 18.
56. Fully insulating a home can cut the electric bill by about 50 percent.
57. The heat lost through the house is primarily through the ceiling.
58. Covering a window or wall air conditioner in the winter does not help conserve energy.
59. Operating fuel heaters in an airtight room could lead to the consumption of all the oxygen in the air and could cause suffocation.
60. Lowering the thermostat from 72° to 68° and leaving it there during winter months can result in a 20 percent reduction in your heating bill.
61. Setting back the thermostat at night can result in significant savings of energy and money.
62. It is best to use the central heating system and the fireplace at the same time.
63. An air conditioner cools and removes moisture from the air.
64. With more efficient production techniques in industry, over 30 percent of energy used now could be saved.
65. In the Tennessee Valley region, the water heater accounts for about 50 percent of the electric bill.
66. The United States has only about six percent of the world's population, but over 45 percent of the world's cars.

67. In the United States we now consume roughly 17 to 18 million barrels of oil a day, and at a five percent rate of increase, this is almost a million barrels a day additional requirement per year.
68. Large quantities of low sulfur coal can still be mined at a reasonable cost without the associated risks of deep mining.
69. Five years lead time is required to get a nuclear plant operating in the United States.
70. High-compression engines develop more power and are more efficient than low-compression engines, but they have a greater tendency to knock and consequently require gasoline of higher octane.
71. The anti-knock quality of a gasoline is usually expressed in terms of octane.
72. The lower the air or engine temperature, the greater the octane requirement.
73. The use of lead components has been the most economical way to increase the octane in gasoline.
74. Octane is the sole criterion of a quality gasoline.
75. Natural gas reserves are rapidly declining in the United States.
76. The liquid metal fast breeder reactor uses sodium as the reactor coolant and uranium-238 as the fertile material which is converted to plutonium as the reactor is operated.
77. A one-inch cube of uranium contains enough energy to supply a six-room house with electricity and heat for 1,000 years.
78. The breeder reactor would consume more fuel than it produces.
79. Thermal discharges can greatly affect life cycles of aquatic organisms.
80. The EPA regulates the amount of radiation permitted to be discharged from a nuclear reactor.
81. To date, in the United States, there has been no radioactive release from commercial nuclear reactors which has exceeded recommended population exposure guides.
82. Nuclear reactor vessels are enclosed in huge concrete and metal containers which, along with many automatic safety features, are designed to prevent leakage of radiation.
83. Higher fuel prices have been the primary reason for energy conservation to date.

84. Serious accidents have occurred in past shipment and storage of radioactive waste.
85. Hearings are held for license application in an area where a nuclear plant is proposed and the public, along with state and local authorities, can attend and testify.
86. The electric range uses less electricity than the clothes dryer, window air conditioner and dishwasher combined.
87. Studies have shown that the average bath requires 10 gallons of water, whereas the average shower requires about twice that much.
88. Solar energy is responsible for producing fossil fuels.
89. A British thermal unit (BTU) is the amount of heat required to raise the temperature of a pound of water 1° F.
90. The Louisiana Public Service Commission sets electric rates for local power distributors.
91. Radioactive wastes have been safely disposed of in salt beds.
92. The Middle East countries possess about 80 percent of the world's oil reserves.
93. The U.S. was self-sufficient in energy until about 1950, but since then has deteriorated.
94. Mercury vapor lamps are more efficient and produce more light with less energy than incandescent street lights.
95. Ceiling insulation should be at least six to ten inches thick.
96. Almost 20 percent of all the energy consumed in the U.S. is used in our households.
97. A 40-watt fluorescent tube provides more light than three 60-watt incandescent bulbs.
98. Automobiles consume about 14 percent of all the energy used in the U.S.
99. The amount of material needed to do a good insulating job in your home depends on the type of material used.
100. The U.S. uses more energy per capita than any other nation in the world.

ENERGY EDUCATION/CONSERVATION EXAMINATION
Answer Sheet

1.	T	F	21.	T	F	41.	T	F	61.	T	F	81.	T	F
2.	T	F	22.	T	F	42.	T	F	62.	T	F	82.	T	F
3.	T	F	23.	T	F	43.	T	F	63.	T	F	83.	T	F
4.	T	F	24.	T	F	44.	T	F	64.	T	F	84.	T	F
5.	T	F	25.	T	F	45.	T	F	65.	T	F	85.	T	F
6.	T	F	26.	T	F	46.	T	F	66.	T	F	86.	T	F
7.	T	F	27.	T	F	47.	T	F	67.	T	F	87.	T	F
8.	T	F	28.	T	F	48.	T	F	68.	T	F	88.	T	F
9.	T	F	29.	T	F	49.	T	F	69.	T	F	89.	T	F
10.	T	F	30.	T	F	50.	T	F	70.	T	F	90.	T	F
11.	T	F	31.	T	F	51.	T	F	71.	T	F	91.	T	F
12.	T	F	32.	T	F	52.	T	F	72.	T	F	92.	T	F
13.	T	F	33.	T	F	53.	T	F	73.	T	F	93.	T	F
14.	T	F	34.	T	F	54.	T	F	74.	T	F	94.	T	F
15.	T	F	35.	T	F	55.	T	F	75.	T	F	95.	T	F
16.	T	F	36.	T	F	56.	T	F	76.	T	F	96.	T	F
17.	T	F	37.	T	F	57.	T	F	77.	T	F	97.	T	F
18.	T	F	38.	T	F	58.	T	F	78.	T	F	98.	T	F
19.	T	F	39.	T	F	59.	T	F	79.	T	F	99.	T	F
20.	T	F	40.	T	F	60.	T	F	80.	T	F	100.	T	F

ENERGY EDUCATION/CONSERVATION EXAMINATION
Answer Key

1.	T	21.	T	41.	F	61.	T	81.	T
2.	T	22.	T	42.	T	62.	F	82.	T
3.	F	23.	F	43.	T	63.	T	83.	F
4.	T	24.	F	44.	T	64.	T	84.	F
5.	T	25.	T	45.	T	65.	F	85.	T
6.	F	26.	T	46.	T	66.	T	86.	F
7.	T	27.	T	47.	F	67.	T	87.	F
8.	F	28.	F	48.	T	68.	T	88.	T
9.	T	29.	T	49.	T	69.	F	89.	T
10.	F	30.	T	50.	T	70.	T	90.	F
11.	F	31.	F	51.	F	71.	T	91.	T
12.	T	32.	T	52.	F	72.	F	92.	F
13.	T	33.	T	53.	T	73.	T	93.	T
14.	T	34.	F	54.	T	74.	F	94.	T
15.	T	35.	T	55.	F	75.	T	95.	T
16.	F	36.	T	56.	T	76.	T	96.	T
17.	T	37.	T	57.	T	77.	T	97.	T
18.	T	38.	F	58.	F	78.	F	98.	T
19.	T	39.	T	59.	T	79.	T	99.	T
20.	T	40.	T	60.	T	80.	F	100.	T

346

ENERGY EDUCATION/CONSERVATION EXAMINATION

PERSONAL INFORMATION

DATE _____

NAME (optional): _____ URBAN _____ RURAL _____

ORGANIZATIONS: _____ SEX: _____ M _____ F _____

AGE: _____ Under 18 RACE: _____ White OCCUPATION: _____ Student
 _____ 19-25 _____ Black _____ Teacher
 _____ 26-35 _____ Other _____ Other
 _____ 36-50
 _____ 51-65
 _____ over 65

CIRCLE HIGHEST GRADE LEVEL COMPLETED IN SCHOOL/COLLEGE:

0-6 7 8 9 10 11 12 13 14 15 16 17+

-ENERGY CONSERVATION QUIZ

(OR RESEARCH)

What Is Your E. Q.? (Energy Quotient)

1. Why are our major fuels called fossil fuels?
2. What are the three principal fossil fuels?
3. Name three nonfossil sources of energy.
4. Of the nonrenewable fuels, which is most abundant?
5. Give examples of how the study of energy can be related to science, mathematics, social studies, literature, art, music.
6. What are the basic causes of the energy problem?
7. What are positive features of the energy shortage?
8. What two categories combined take over half of the average American family's energy budget?
9. What is the primary use of transportation energy in our country?
10. Why is electricity called secondary energy?
11. In what two ways does electrical power waste energy?
12. How were substantial quantities of natural gas reserves wasted?
13. What options do we have to meet energy demand?
14. How is energy defined in physics?
15. What are the two states of energy?
16. What two kinds of energy transformations take place in the sun which man has learned how to duplicate?
17. The three types of energy conversion processes are mechanical (physical), chemical, and nuclear (atomic).
 - (a) In which of these processes is waste heat generated?
 - (b) Which is the primary process responsible for all the energy we have?
 - (c) Which process takes place in a storage battery?

18. What unit is used commonly to measure potential or kinetic energy?
19. How is efficiency of the energy process defined?
20. What are the advantages and disadvantages of electricity?
21. When a substance is heated, it increases the movement of atoms; therefore, heat is really what kind of energy?
22. Uranium, green plants, coal, natural gas, sunlight, fuel oil, oil shale, and hydropower are sources of energy.
 - (a) Which of these sources are renewable or continuous?
 - (b) Which of these sources are nonrenewable or exhaustible?
23. What generalizations can be made about fossil fuels?
24. Which of the fossil fuels is most abundant in Louisiana?
25. What invention gave the impetus to supplant wood with coal?
26. What are some advantages in using oil or gas over coal?
27. Which fossil fuel is the principal one not being completely utilized in the United States?
28. What energy conversion process may ultimately create the biggest new market for coal?
29. What are possible sources of energy for the future?
30. What change took place in November, 1970, that gave us cause to worry about our future oil supply?
31. What is the goal of Project Independence?
32. Name three technology advancements being made in the energy field.
33. What are the three advantages of recycling?
34. What are problems in total recycling of throwaway materials?
35. What ways does the concern for natural environment figure in the energy problem?
36. What factors will encourage the development of new energy resources?
37. What is the energy conservation ethic?
38. How can the energy conservation ethic be practiced in schools?

39. What are some conservation measures which may be practiced in the home and community?
40. How can local, state and national government assist in the conservation of energy?

350

ANSWERS TO E.Q. QUESTIONS

1. Because they are derived from animal and vegetable remains that collected at the bottom of ancient seas and swamps more than three hundred million years ago.
2. Petroleum, natural gas, coal.
3. Sun, wind, falling water, tides, plants, animals, muscles.
4. Coal
5. The correlation of the study of energy to science and mathematics is obvious. Social studies trace the advancement of societies in relationship to energy use. Literature tells of the lives of people involved in the development of energy. The basic energy source, the sun, is frequently the theme of much music and art.
6. (1) The fossil fuels in the earth now are, for practical purposes, all that we will ever have. This dilemma is at the heart of man's current energy problems. (2) The demand for energy is ever increasing.
7. As a nation, we are realizing the need to move toward self-sufficiency, and technology is being challenged to discover new energy sources and conversion processes.
8. The automobile and space heating.
9. Over half of the transportation energy in our country is consumed by automobiles, which are used primarily to carry people rather than goods.
10. Because it requires conversion of a primary energy source such as coal, petroleum, nuclear fission, or hydropower for its generation.
11. The turbines which generate electricity are less than 50 percent efficient, and a substantial amount is lost through transmission along power lines.
12. By being burned off at the heads of oil wells before it was learned that gas could be used profitably.
13. In meeting our energy demand, we can either import more fuel or reduce our consumption. Other options are intensified exploration for new reserves, more efficient ways of recovering fuel resources, and discovery of new sources and conversion processes.
14. Energy is the ability to perform work.
15. Kinetic and potential.

16. Fission and fusion.
17. (a) All three.
(b) Nuclear
(c) Chemical
18. The British Thermal Unit (BTU).
19. The ratio of useful product to the total amount of energy input or output.
20. Electricity is clean, available instantly, and easily transmitted. However, both the generation and transmission of electricity involve some waste energy.
21. Heat is a kind of kinetic energy.
22. (a) Sunlight, green plants, and hydropower.
(b) Uranium, coal, natural gas, fuel oil and oil shale.
23. Fossil fuels are found primarily within the earth and all are storable and transportable. They have nonfuel uses and require altering the landscape for their use. All are burned, producing heat to perform work. All are nonrenewable.
24. Oil and natural gas.
25. Steam engine.
26. Oil and gas are cleaner, easier to handle than coal solids, more versatile, and less polluting.
27. Coal.
28. Gasification.
29. Hydropower, solar radiation, winds, tides and geothermal sources.
30. In November, 1970, the rate at which we were finding domestic oil reserves failed, for the first time, to exceed the rate at which we were consuming oil.
31. National energy self-sufficiency by 1985.
32. Technological advancements are being made in the areas of (1) harvesting energy resources without as high an environmental cost, (2) recycling to prolong the life of dwindling resources, (3) harnessing energy of renewable sources such as wind, sun, and tides.
33. Recycling (1) extends the life of products, (2) cuts consumption of natural resources, (3) reduces litter.

34. Problems in total recycling of throwaway materials are finding markets for the sorted scrap, costs of collecting and transporting it, and energy consumption of machines which sort and process it.
35. Present major extraction and conversion processes exact environmental cost by releasing pollutants and causing damage to the land and bodies of water.
36. Higher fuel prices to furnish an incentive for exploration and development of new sources of energy and conversion methods.
37. An acceptance of the fact that resources, in particular our fossil fuel resources, are finite and therefore precious, to be used wisely.
38. Maintaining lower temperatures and using electricity, paper supplies and other energy consuming materials carefully.
39. Turning off lights and appliances when not in use, keeping thermostats down, buying appliances which are efficient, providing adequate insulation.
40. Providing efficient mass transit, promoting nearby recreational attractions, enforcing lower speed limits, encouraging community planning to decrease commuting distances, enacting standards for more energy efficient cars and appliances, stimulating technological advances in the discovery and development of new sources of energy and means of conversion.

TITLE: VALUES CLARIFICATION ON ENERGY

AREA: Multidisciplinary

OBJECTIVE: To provide a means for students to examine their values and beliefs about energy.

MATERIALS: Energy Opinionnaire

ACTIVITY: Students should complete the Energy Opinionnaire. For each statement they should list as many reasons as possible to substantiate their opinion. Students should be asked to defend their positions.

Those opinionnaire items which elicit the most obvious differences of opinion or strong value judgments could be expanded into debate topics. Items 7, 11, 12 and 16 are examples.

ENERGY OPINIONNAIRE

Name _____ Date _____

Class _____ Teacher _____

Directions: Please cross out the word or phrase within the parentheses which least indicates your opinion. Be prepared to defend your opinion or belief.

I believe that:

1. The energy resources in the United States (are, are not) controlled by monopolies.
2. There (is, is not) a shortage of oil in our country.
3. We (should, should not) generate more energy by nuclear and fossil fuels.
4. Solar energy technology for generating electricity (is, is not) well established at this time.
5. Government funds (should, should not) be used to develop the railroads and barge traffic.
6. If fuel prices were to decline, consumption (would, would not) greatly increase.
7. American lifestyles (are, are not) wasteful of energy.
8. Manufacturers (should, should not) be forced to reveal the energy costs of their products.
9. Nonreturnable and disposable containers (should, should not) be discontinued.
10. Rising energy costs (have, do not have) a direct, personal impact on everyone.
11. Everyone (should, should not) observe reduced speed limits to conserve energy.
12. The use of energy (is, is not) a moral problem involving stewardship of resources.
13. The government (should, should not) restrict the size of cars.
14. The cost of pollution control (should, should not) be included in the individual customer's bill.
15. An individual (can, cannot) have an impact on energy consumption.

16. Individuals (will, will not) conserve energy if they realize there is a problem.
17. We (should, should not) develop energy resources regardless of environmental costs.
18. All demands for energy (will, will not) be met in the year 2000.
19. People (are, are not) born greedy and selfish in respect to use of natural resources.
20. Strict federal laws (will, will not) be the major factor in energy consumption.
21. Nuclear power (is, is not) too dangerous to be used in producing electricity.
22. Our government (is, is not) being effective in solving our energy problems.
23. Everyone (should, should not) be required to pay for energy regardless of economic level.
24. The production of an adequate supply of energy (is, is not) a major problem in our country today.
25. The energy problem (is, is not) political rather than technological.
26. The average citizen (is, is not) getting honest information on energy problems and their solutions.
27. Energy production (should, should not) be controlled by government rather than private industry.
28. Alternative energy sources such as wind, geothermal, solar, and tidal power (are, are not) receiving adequate funds for their development.
29. Foreign countries (do, do not) have the right to charge any price they please for their natural resources.
30. My family (is, is not) doing an adequate job of conserving energy.

TITLE: ENERGY RELATED VALUE DECISION

AREA: Science, Social Studies

OBJECTIVE: To confront students with the problem of making energy-related value decisions.

MATERIALS: Case study

ACTIVITY: Students are arranged in groups of four. Each student is given a copy of the case study and several related questions. As a group they are to discuss the problems involved and try to come to a group decision.

CASE STUDY

Area: Along the Ohio River, in an area called the Big Bend.

Location: A 350-acre farm.

History: The people living in the area are direct descendants of a Southern plantation master, the original owner of the farm. The area was once a thriving plantation located along the banks of the river. Today, a single woman resides on the farm in question. She is the granddaughter of the original owner. The current owner cares little for the farming ways of life, but has a religious reverence for the land of her forefathers. Recently, she learned that less than 400 feet down on her land there is a four-foot seam of coal. In addition, natural gas has been found on her farm. She has agreed to allow the gas to be pumped out, but no gas has been removed to date. Not only that, but various individuals in the gas company have reputedly asked for secrecy concerning her wells.

Beyond this, a large electric company is considering buying her farm as a site for a nuclear power plant. In attempting to purchase the farm, the electric company claimed no knowledge of the coal seam. Currently, the owner does not want to sell. If she refuses, the state will condemn her land, buy it and sell it to the power company.

QUESTIONS

Does an individual have the right to refuse to sell his/her land? Does a power company

have a responsibility to be completely frank with potential land purchases? Should land be used for "national need" as opposed to "personal need"? If you were a power company president would you take the ancestral home from a 75-year-old widow? Should a power company own land on which it does not intend to build a plant?

TITLE: LIFESTYLE INDEX

AREA: Mathematics, Humanities, Science

OBJECTIVE: To aid the students in understanding their lifestyles in terms of energy requirements and to place their lifestyles in world perspective.

MATERIALS: Pen

ACTIVITY: The Lifestyle Index is designed to demonstrate how much energy an individual uses each year and how his standard of living compares with that of an average individual in other countries of the world.

The basic unit employed is the Energy Unit which is equivalent to about 10 kilowatt hours or exactly 34,300 British Thermal Units. (See following pages.)

Part I-A. HOUSEHOLD ENERGY EXPENDITURES
(Precise Method)

The most precise method of calculating household energy expenditures is to convert quantities of electricity and fuel used to Energy Units by applying the following conversion factors. If you have not retained bills for the past year, go directly to Part I-B and use the approximate method. If you do use this precise method, omit Part I-B (except for the section on Residential Building Materials) and omit the section on Preparing and Preserving in Part III (Foods and Beverages) and the section on Electronic Appliances--Part IV (Leisure Activities).

ELECTRICITY

Multiply total kilowatt hours used in the last 12 months by the conversion factor 0.368. _____

NATURAL GAS

Multiply total cubic feet used in the last 12 months by 0.038. _____

FUEL OIL

Multiply number of gallons used in the last 12 months by 4.5 _____

Divide total energy units by number of users in the household and enter total here and on page _____

Part I-B. HOUSEHOLD ENERGY EXPENDITURES
(Approximate Method)

HOME APPLIANCES

Values listed in brackets are average Energy Units used per item annually. Multiply by the number of items in the home. Appliances used in preparation and preserving of food will be figured in Part III (Foods and Beverages).

ELECTRIC APPLIANCES

clock	[6]	_____
floor polisher	[6]	_____
sewing machine	[4]	_____
vacuum cleaner	[17]	_____
air cleaner	[80]	_____
bed covering	[54]	_____
dehumidifier	[128]	_____

heating pad	[4]	_____
humidifier	[60]	_____
germicidal lamp	[52]	_____
hair dryer	[5]	_____
heat lamp (infrared)	[5]	_____
shaver	[0.7]	_____
toothbrush	[0.2]	_____
vibrator	[0.7]	_____
clothes dryer	[365]	_____
iron (hand)	[53]	_____
wash machine (automatic)	[38]	_____
wash machine (nonautomatic)	[28]	_____

				Elec- tric	Nat. Gas	Oil	Coal	Solar
water heater (standard)	[1555]	_____						
water heater (quick recovery)	[1770]	_____	Northeast	6480	5360	6380	---	
			Mid-Atlantic	5800	4800	5720	2210	
			East North Central	6030	4900	5940	2290	
GAS APPLIANCES			West North Central	5350	4440	5280	2040	
clothes dryer	[277]	_____	South Atlan- tic	4460	3700	4400	1700	
water heater	[1170]	_____	East South Central	4040	3330	3960	790	
		Subtotal _____	West South Central	2900	2400	2860	570	
HOME LIGHTING			Mountain	4910	4060	4840	1870	
Figures are for average annual use. If your household uses more or less, increase or de- crease accordingly.			Pacific	3800	3140	3740	1440	
Electric lighting	[268]	_____						
Ornamental gas lights	[668]	_____	COAL					
		Subtotal _____	Multiply tons of coal used in the last 12 months by 775.					
COOLING AND VENTILATION								
CENTRAL AIR CONDITIONING (electric)			WOOD					
New England	[755]	_____	Multiply cords used in last 12 months by 620.					
Mid-Atlantic	[957]	_____						
East North Central	[905]	_____						
West North Central	[905]	_____						
South Atlantic	[1510]	_____	Subtotal _____					
East South Central	[1560]	_____						
West South Central	[1710]	_____	RESIDENTIAL BUILDING MATERIALS AND GROUNDS					
Mountain	[1058]	_____	Total home construction energy (including mining, processing, fabrication, transportation, and sales) has been allotted over the average lifetime of the home be- fore major alterations are re- quired. A 25-year span has been chosen for amortization. If your residence was built in the last 25 years, add the following for building materials.					
Pacific	[1210]	_____	single dwelling	[844]				
CENTRAL AIR CONDITIONING (gas)	[1046]	_____	2-to 4-unit apartment	[642]				
COOLING AND VENTILATION (noncentral)			5-units or more apartment	[669]				
fan (attic)	[107]	_____	public housing	[700]				
fan (circulating)	[16]	_____						
fan (roll-away)	[51]	_____						
fan (window)	[58]	_____						
electric room air conditioner	[316]	_____						
		Subtotal _____						
SPACE HEATING								
ELECTRICITY, NATURAL GAS, OIL, AND SOLAR HEATING								
If you have not used the precise method of Part I-A, the following table will provide an estimate of space heating energy expenditure, depending on location and type of heating.								

ADDITIONS AND ALTERATIONS

Multiply dollars expended for this purpose during the past year by 1.1

Subtotal _____

LAWN AND GARDEN GASOLINE ENGINES

[50]

Subtotal _____

Add all subtotals in Part I-B and divide by number of users in household. Enter total here and on page 332.

Total _____

Part II: HOUSEHOLD MATERIALS AND PERSONAL ITEMS

It requires energy to produce all consumer products from house furnishings to cigarettes. Consumer items such as rugs and soap require energy at every step of processing. In calculating Energy Units, it is necessary to include raw materials, processing, freight, and merchandizing. Handcrafting such household materials as drapes does not result in energy savings, since an electric sewing machine probably uses more energy than if mass production methods were used.

HOUSEHOLD MATERIALS

The following Energy Units represent annual expenditures for manufacturing and merchandizing household items. Operating energy will be calculated in Part IV for radios, phonographs, and similar items. Energy units are calculated for the individual user. Make allowances if you are a heavy or light user.

- furniture [35]
- electric appliances [46]
- electronics equipment (radio, phonographs, etc.) [17]
- pottery, earthenware, china [5]

other household wares (cutlery, glassware, etc.)

[10]

rugs and floor coverings

[29]

other textile furnishings

[73]

tissues, paper towels, and other household

paper products

[25]

cleaners and soaps

[38]

Subtotal _____

PERSONAL ITEMS

Adjust, according to whether the individual is a light, normal, or heavy user.

WEARING APPAREL

The large expenditure in the case of women's apparel is due to larger dollar sales and larger energy expenditures of establishments selling such apparel.

men and boys [156]

women and girls [204]

MISCELLANEOUS

toiletries and

beauty aids [23]

health and

medical supplies [58]

tobacco products

(1.6 packs per day

for average cigarette smokers)

[86]

shoes, footwear

[27]

other leather

products (luggage, handbags, gloves)

[6]

photographic supplies

[6]

jewelry

[12]

costume jewelry

[9]

Subtotal _____

Add all subtotals in Part II and enter here and on page 332

Total _____

Part III. FOODS AND BEVERAGES

About 12 percent of America's energy is used to produce, transport, sell, and prepare foods. A large proportion of this is concentrated in meat products. If you do not eat meat, omit the meat category and add extra for vegetables. If you produce your own vegetables by hand and without fertilizer, do not include the 19 Energy Units for vegetables. Energy Units are calculated by apportioning food agricultural energy expenditures according to the dollar basis of the food categories in Reference 12 and making adjustments for imports and exports. Average yearly consumption per capita is given in parentheses.

PRODUCTION

meat:		
beef (114.8 lb/yr)		___
veal (2.2 lb/yr)		___
lamb and mutton (3.4 lb/yr)		___
pork (73.0 lb/yr)		___
chicken (42.9 lb/yr)		___
turkey (8.9 lb/yr)	[163]	___
dairy products (356.1 lb/yr)	[41]	___
eggs (318 eggs/yr)	[11]	___
vegetables and melons (excluding home gardens; 312 lb/yr)	[20]	___
fruits and nuts (132 lb/yr)	[14]	___
food grain (141 lb/yr)	[7]	___
sugar:		
refined (103 lb/yr)		___
corn syrup (22 lb/yr)	[9]	___
beverages (coffee, tea, cocoa; 18 lb/yr)	[8]	___
edible vegetable oils and animal fats and oils (53 lb/yr)	[17]	___
fish (17 lb/yr)	[11]	___
	Subtotal	___

TRANSPORTATION OF FOOD TO PROCESSING PLANT AND STORE

Omit if you grow your own produce or buy most of your food at a farm.

	[16]	___
Subtotal		___

PROCESSING

meat	[28]	___
dairy products	[24]	___
canned and frozen foods	[28]	___
grain products	[16]	___
bakery products	[13]	___
sugar	[21]	___
confectionery	[4]	___
miscellaneous foods	[32]	___
beverages	[24]	___
Subtotal		___

CONTAINERS

The following Energy Units are for one 12-ounce container used per day throughout the year. Adjust accordingly.

BEVERAGE CONTAINERS

refillable glass bottles	[24]	___
one-way glass bottles	[71]	___
bimetallic cans (steel and alumi- num)	[57]	___
aluminum cans	[96]	___
distilled beverages or wine	[3]	___
Subtotal		___

OTHER FOOD CONTAINERS

paper	[42]	___
steel (cans)	[17]	___
glass	[9]	___
aluminum	[6]	___
plastic	[7]	___
Subtotal		___

RETAILING AND WHOLESALING ENERGY EXPENDITURES

Calculated on the basis of grocery sales for various food items.

meat	[46]	___
dairy products	[18]	___

fish	[7]	___
produce	[26]	___
canned and frozen foods	[30]	___
grains and bakery products	[17]	___
sugar and confectionery products	[9]	___
beverages (nonalcoholic)	[13]	___
miscellaneous foods	[18]	___
alcoholic beverages	[31]	___
Subtotal		___

refrig-frzr, 14 cu. ft.	[418]	___
refrigerator-freezer, (frostless, 14 cu. ft.)	[673]	___
roaster	[75]	___
sandwich grill	[12]	___
toaster	[14]	___
trash compactor	[18]	___
waffle iron	[8]	___
waste disposer	[11]	___
GAS APPLIANCES		
outdoor gas grill	[100]	___
range (apartment)	[350]	___
range (single unit)	[389]	___
refrigerator	[509]	___

PET FOODS

Multiply the pounds of meat products consumed each week by 50 and the pounds of pet food cereal products by 12 to get the total Energy Units. Then divide this figure by the number of persons in the household who regard the pet as theirs.

Subtotal _____

Add Energy Units for electric and gas appliances and divide by number of users in household to get subtotal.

Subtotal _____

Add all subtotals in Part III and enter total here and on page 332.

Total _____

FOOD PREPARATION AND PRESERVING

If you calculated home fuels by the precise method in Part I-A, or if all your meals are eaten out, this section should be skipped.

ELECTRIC APPLIANCES

blender	[6]	___
broiler	[37]	___
carving knife	[3]	___
coffeemaker	[39]	___
deep fryer	[30]	___
dishwasher	[133]	___
egg cooker	[5]	___
freezer (15 cubic ft)	[440]	___
freezer (frostless, 15 cubic ft)	[648]	___
frying pan	[68]	___
hot plate	[33]	___
mixer	[4]	___
oven (microwave only)	[70]	___
range (self-cleaning)	[443]	___
range (regular)	[432]	___
refrigerator (12 cu. ft)	[268]	___
refrigerator (frostless, 12 cu. ft.)	[448]	___

Part IV. LEISURE ACTIVITIES

Estimates for leisure activities outside the home vary considerably with distance traveled, means of transportation, equipment used, and frequency of use.

ELECTRONIC APPLIANCES

Omit if you estimated electricity used by the precise method in Part I-A. Energy expenditures for materials have already been calculated under Household Materials in Part III. Figures are for operation only, computed on the basis of average electric use per item per year (4 hours daily for television, 6 hours weekly for stereo). Adjust accordingly.

radio	[31]	___
radio/record player	[40]	___
stereo	[14]	___
television		___
black & white (tube)	[129]	___
black & wh. (solid state)	[44]	___

color (tube) [243] _____
 color (solid state) [162] _____
 Subtotal _____

CULTURAL AND LITERARY RECREATION

LITERARY ACTIVITIES

newspapers [95] _____
 books [36] _____
 periodicals [15] _____
 use of type-writer (materials and operation) [1] _____
 Subtotal _____

CRAFTS

Activities such as designing, floral arranging, knitting, and sewing require less than 1 Energy Unit and have been omitted. For other activities, add Energy Units according to the following scales, adjusting figures for more intensive, normal, and less intensive use.

[1 to 10 Energy Units]

Painting, drawing, leatherwork, woodcarving, sculpturing, stamp collecting, coin collecting, collecting articles such as bottles.

[10 to 100 Energy Units]

Woodworking (with electric lathe), pottery work (with kiln), metalworking (with forge or oven), recording.

MISCELLANEOUS ACTIVITIES

visits to amusement parks [20] _____
 motion pictures (8-9 movies per year) [9] _____
 toys [14] _____
 musical instruments [8] _____

Subtotal _____

SPORTS

Outdoor spectator sports require very small amounts of energy (except for night baseball games and the like) and may be omitted. Some participative sports (jogging, hiking, and most field events) require only human energy. Others, such as baseball, football, other ball games, swimming (in unheated pools), surfing, canoeing, skating (on natural ice), fishing (without a motor boat), biking, sledding, and indoor gymnastics (yoga, karate, judo, acrobatics) require less than 1 Energy Unit and may also be omitted. For other participative sports, add Energy Units according to the following scales, adjusting figures for more intensive and less intensive use. Let your conscience be your guide.

[1 to 10 Energy Units]

Indoor basketball, volleyball, wrestling, boxing, squash, handball, outdoor tennis, go-carting, camping, small-boat sailing.

[10 to 100 Energy Units]

Tennis (on clay court), skiing, horseback riding, mountain climbing, caving, scuba diving.

[More than 100 Energy Units]

Bowling with automatic pins, indoor swimming (private), motor boating, water skiing, snowmobiling, fox hunting, field polo, deep-sea fishing, yachting, airplane flying, dune buggy riding.

Subtotal _____

Add all subtotals in Part IV and enter total here and on page 332.

Total _____

Part V. TRANSPORTATION

All forms of transportation considered below include a factor for associated costs (fuel refining and retailing, vehicle manufacture and maintenance, insurance, etc.) except for highway construction, which is included in Part VI under Public Services. Energy consumed in freighting is included in the consumer product or service and is thus not counted separately here.

NONBUSINESS TRAVEL

PRIVATE CAR

This is a major part of your lifestyle energy use and should be calculated as closely as possible. First, determine the number of non-business miles traveled each year by subtracting miles of business travel from annual car mileage. Divide by the average number of passengers. Then multiply this figure by the following number, depending on your car's miles per gallon (mpg).

8 mpg.	Multiply by	0.50	_____
14 mpg.	"	0.29	_____
20 mpg.	"	0.20	_____
25 mpg.	"	0.16	_____

MOTORCYCLE

Divide number of nonbusiness miles each year by average number of riders (if any) and multiply by the following number, depending on miles per gallon.

50 mpg.	Multiply by	0.08	_____
100 mpg.	"	0.04	_____
160 mpg.	"	0.025	_____

GAS, OIL, TIRES, MAINTENANCE, INSURANCE, PARKING

For private car or motorcycle, multiply Energy Units calculated directly above by 0.395. _____

VEHICLE CONSTRUCTION AND RETAILING

This assumes the life of your vehicle is average (about 8 years). Divide the weight of the vehicle by the number of users and multiply this figure by 0.154. _____

OTHER NONBUSINESS TRANSPORTATION

Multiply the number of miles traveled per year by the figures indicated.

train	0.094	_____
highway bus	0.042	_____
urban mass transit	0.14	_____
commercial aircraft	0.30	_____
modern cruise liner	0.48	_____
yacht	1.4	_____
bicycle	0.016	_____
Subtotal		_____

RIDING TO WORK

The multiplying factors here are larger than in the preceding section because they include associated costs, such as vehicle maintenance and construction.

PRIVATE CAR

First determine annual mileage by multiplying round trip in miles by workdays per year. Divide by the number of passengers and then multiply this figure by the following number, depending on the car's miles per gallon (mpg).

7 mpg.	Multiply by	0.80	_____
10 mpg.	"	0.56	_____
14 mpg.	"	0.40	_____
21 mpg.	"	0.27	_____
28 mpg.	"	0.20	_____

MOTORCYCLE

Divide miles per year by average number of riders (if any) and multiply by the following number, depending on miles per gallon.

50 mpg.	Multiply by	0.11	_____
100 mpg.	"	0.056	_____
160 mpg.	"	0.036	_____

BICYCLE
Multiply miles per year
by 0.016. _____

PUBLIC TRANSPORTATION
Multiply miles traveled per
year by the following number.
urban mass transit 0.14 _____
intercity train 0.094 _____
highway bus 0.042 _____
Subtotal _____

Add all subtotals in Part V and
enter here and on page 332.
Total _____

Part VI. SOCIAL AND COLLECTIVE
SERVICES.

PRIVATE SERVICES

In addition to the personal uses of
energy considered so far, certain so-
cial and collective uses must be
charged to the ultimate consumer on a
per capita basis. We may not attend
schools or use hospitals ourselves,
but it is necessary to expend energy
to keep them available. If you are
sure that certain services do not apply
to you (for instance, beauty parlors),
they may be omitted. Multiply by 2 for
heavy use; divide by 2 for light use.

LEGAL [43] _____

NONPROFIT (INCLUDING
RELIGIOUS) [56] _____

PERSONAL

laundries [18] _____
beauty parlors [8] _____
barber shops [3] _____
photographic
services [2] _____
shoe repair [1] _____
funeral services [5] _____

REPAIRS (NONAUTO) [13] _____

HOTELS AND LODGINGS [26] _____

BUSINESS SERVICES

advertising, sign
painting [32] _____
services to build-
ings [5] _____
business and con-
sulting [12] _____
credit [3] _____
duplicating, mail-
ing, steno [3] _____
commercial research
and testing [5] _____
detective services [2] _____
equipment rental [5] _____
trading stamps [3] _____
Subtotal _____

PUBLIC SERVICES

All citizens have access to
the following services and fa-
cilities. If all of them apply,
your subtotal should be 631.
The Energy Units listed apply to
both construction and operation.

hospitals (public
and private) [211] _____
education (public
and private) [80] _____
telephone service
(3 calls per day) [21] _____
other public utili-
ties [46] _____
highway construction
and maintenance [186] _____
conservation and
development of
resources [11] _____
sewer systems [17] _____
water systems [47] _____
trash collection [12] _____

Subtotal _____

GOVERNMENT SERVICES

Government services are major
users of energy. Since all are
benefited (or harmed) by these
services, the total energy ex-
pended must be divided among all
citizens. Reliable statistics
are available for federal energy
expenditures. That is not the
case for state and local govern-
ment services. They are

estimated here to be equivalent to the federal government's non-military energy expenditures in comparable areas.

FEDERAL GOVERNMENT

The major user of energy in the federal government is the military, with 603 Energy Units per capita annually. Total federal expenditure, printed as your subtotal, is 709 Energy Units.

Subtotal 709

STATE AND LOCAL GOVERNMENTS

Construction not previously included amounts to 27 Energy Units. Maintenance of fire and police departments, etc., accounts for another 100.

Subtotal 127

POSTAL SERVICES

Per capita energy expenditure for the average person (824 pieces sent or received each year--or about 16 per week) is 31 Energy Units. Adjust accordingly.

Subtotal _____

Add all subtotals in Part VI and enter total here and in the space below.

Total _____

Enter below the Energy Unit totals for each of the six parts of the Lifestyle Index as each is completed. Then find your grand total.

Part	Energy Units
I. Household Energy Expenditures (A. Precise Method; B. Approximate Method)	_____
II. Household Materials and Personal Items	_____
III. Foods and Beverages	_____
IV. Leisure Activities	_____
V. Transportation	_____
VI. Social and Collective Services	_____
GRAND TOTAL	=====

You should now compare your total annual expenditure of energy with that of the average U.S. citizen (10,000 Energy Units) and with those of citizens of other countries given in Table XI.

TABLE XI
ANNUAL ENERGY UNITS PER CAPITA IN SELECTED COUNTRIES

Afghanistan	23	Brazil	435	Congo	212
Albania	524	Burma	57	Costa Rica	378
Angola	130	Burundi	9	Cuba	949
Argentina	1490	Cameroon	82	Czechoslovakia	5590
Australia	4500	Canada	7870	Dahomey	30
Austria	2890	Chad	23	Denmark	4495
Bahamas	4285	Chile	1255	Ecuador	263
Barbados	975	China	473	Egypt	241
Bolivia	175	Colombia	559	El Salvador	171

Ethiopia	34	Kenya	145	Puerto Rico	3230
Finland	3655	Khmer Republic	20	Saudi Arabia	813
France	3314	Kuwait	8610	Singapore	1320
Gabon	874	Laos	71	Spain	1406
Germany	4412	Lebanon	709	Sweden	5140
Ghana	157	Liberia	313	Switzerland	3015
Greece	1240	Malagasy Republic	62	Tanzania	59
Greenland	3750	Mali	21	Turkey	436
Guatemala	196	Mexico	1072	Uganda	61
Guinea	85	Mozambique	148	U.S.S.R.	3825
Haiti	24	Morocco	171	United Kingdom	4650
Honduras	183	Nepal	8	United States	9500*
Hong Kong	862	Netherlands	4325	Uruguay	775
Iceland	3640	Nicaragua	324	Venezuela	2107
India	157	Niger	21	Yemen	11
Indonesia	106	Nigeria	50	Yugoslavia	1360
Iran	865	Norway	4400		
Ireland	2830	Pakistan	68		
Israel	2245	Panama	662		
Italy	2245	Paraguay	119		
Ivory Coast	238	Péru	519		
Jamaica	1068	Philippines	246		
Japan	2755	Poland	3690		
Jordan	260	Portugal	685		

WORLD AVERAGES

With United States 1630
Without United States 1167

*This represents the per capita U.S. energy expenditure for 1971. The figure for 1972 (latest year on which computations could be based) is 10,000 Energy Units.

Source: World Energy Supplies, Statistical Papers. Series J. No. 16, United Nations, New York, 1973 (converted into Energy Unit values by the author).

Source: (Adapted from)
Lifestyle Index
Contrasumers by Alfred J. Fritsch

TITLE: ORGANIZING A SCHOOL ENERGY CONTEST

AREA: Multidisciplinary

OBJECTIVE: To provide students with an opportunity to use their understanding of energy problems to communicate energy conservation practices to others.

ACTIVITY: Sponsoring an energy contest will afford students an excellent opportunity to apply their knowledge about the energy situation and need for conservation. There are numerous possibilities, including: poster, photography, or essay contests, speeches, and debates. You will want to consider the following when developing a plan for the contest:

1. What specific kind of contest will it be?
2. What energy topic (problems, concerns, technologies) will be included?
3. Who is eligible to enter? How may they enter?
4. What criteria apply to the specific contest (e.g., if photography, the size, color, and mounting of photographs)?
5. What prizes or awards (e.g., cash, savings bonds, certificates) will be offered?
6. Who will select winners? Students? A panel of community members? What criteria will be used to select judges?
7. When would the contest begin and end?
8. To whom are entries submitted? A program coordinator? A teacher? The chairman of the panel of judges?
9. How will publicity be handled?
10. What companies or organizations might sponsor the contest?
11. Will there be an awards ceremony (reception, assembly, or luncheon) to announce the winners?

CONTACT ORGANIZATIONS:

1. Contact your local utility or electric power distributor.
2. Federal Energy Administration, 12th and Pennsylvania Avenue, NW, Washington, D.C. 20461
3. Tennessee Energy Office, Suite 250, Capitol Hill Building, 7th and Union, Nashville, Tennessee 37219
4. Your school librarian.
5. Any local environmental society.

TITLE: SOURCES OF ENERGY INFORMATION

AREA: / Communications, Language Arts

OBJECTIVE: To assist students in identifying the best sources of energy information; where agencies are located.

MATERIALS: Listing of energy concerns

ACTIVITY: Students should prepare a comprehensive listing of energy concerns (including those listed in the APPENDIX: SELECTED SOURCES OF ENERGY INFORMATION) and request detailed information about their energy programs and services. Student teams should be organized so there is no needless duplication in contacting agencies. The material obtained in response to questions about programs should be written as class reports. In brief, the report should include an alphabetical listing of energy and conservation agencies (federal, state, local) including the complete address (include zip code) and a description of the programs or services available. The report should be made available to teachers, librarians, and students and its availability should be advertised in local newspapers.

CONTACT ORGANIZATIONS:

1. Your local utility or electric power distributor and Chamber of Commerce.
2. See APPENDIX: SELECTED SOURCES OF ENERGY INFORMATION

372

TITLE \ AN ENERGY RESOURCE CENTER

AREA: Science, Social Studies

OBJECTIVE: To provide students with an opportunity to work with energy education conservation information.

MATERIALS: Listed in activity

ACTIVITY: Have students begin an Energy Resource Center (ERC) for the school. Locate it in the library or a classroom. This project would require at least one semester--perhaps an entire school year. Some tasks would include:

1. Develop a vertical file system which contains timely information on such topics as energy production, energy consumption, environmental problems, energy economics, problems, alternate energy sources, and energy conservation measures.
2. Compile a bibliography of available school and community print and nonprint materials on energy.
3. Provide copies of a current listing of institutions and agencies which can provide information on energy.
4. Write to local, state, and federal agencies explaining the ERC and requesting assistance and material.
5. Compile a list of community leaders who can speak on energy topics.
6. Make energy information available to students, teachers, parents, and community members.
7. Prepare a work schedule for students who will assist in the center--perhaps with the school librarian as the supervisor.

CONTACT ORGANIZATIONS:

1. Tennessee Energy Office, Suite 250, Capitol Hill Building, 7th and Union, Nashville, Tennessee 37219.
2. Environment Center, The University of Tennessee, South Stadium, Knoxville, Tennessee 37916.
3. Federal Energy Administration, 12th and Pennsylvania Avenue, NW, Washington, D.C. 20461.
4. Energy Research and Development Administration, 20 Massachusetts Avenue, NW, Washington, D.C. 20545.

5. Oak Ridge National Laboratory, P.O. Box X,
Oak Ridge, Tennessee 37830.
6. Center for Energy Information, 340 East 51st
Street, New York, New York 10022.

TITLE: ENERGY CONSERVATION TASK FORCE

AREA: Social Studies, Science

OBJECTIVE: To extend the findings in this course of study beyond the classroom and to initiate a conservation advocacy program.

MATERIALS: Listed in activity

ACTIVITY: The impact of energy conservation is only as great as the number of people involved and actively seeking and practicing conservation. The more people you can convince, enlighten, or involve in energy conservation efforts, the more energy can be saved.

Set up an Energy Conservation Task Force to plan and execute a continuing effort to collect and provide energy conservation information. The information you have gathered and applied should be shared with others in the form of bulletin boards, displays, class discussions, PTA meetings, school newspaper articles, printed fliers, recycling drives, demonstrations, and sponsored speakers and films.

Suggestions for additional activities:

1. Have students write short papers on energy conservation which could be used in the school or local newspaper.
2. Develop a series of bulletin boards dealing with the everyday practical aspects of energy conservation. Depict, for example, Bath vs. Shower, Use of a Microwave Oven, Food-Chain, Riding in a Car vs. Walking, etc.
3. Investigate the school's consumption patterns and make recommendations to the administration. Investigate food service, surrounding vegetation, insulation, shades or drapes, thermostat settings, busing and athletics.
4. Give demonstrations on conserving energy when cooking, sewing, or ironing and how to select and check appliances for energy conservation.
5. The Energy Conservation Task Force could be organized into a regular school club.
6. Sponsor field trips to power plants, energy conservation activities such as an energy fair, 4-H and FHA activities dealing with energy and the planning office or chamber of commerce in your area.

- TITLE:** ENERGY DEMANDS OF INDUSTRY FROM THE BEGINNING OF INDUSTRIAL AGE
- AREA:** Social Studies, Science.
- OBJECTIVE:** To trace the beginning of the industrial age to the present energy crisis using an energy time line.
- MATERIALS:** Reference book (Energy History of the United States 1776-1976, U.S. Government Printing Office #0-201-751)
- ACTIVITY:**
1. Prepare an energy time line showing the forms of energy used throughout history.
 2. Research each form of energy on the time line. Identify the beginning of the industrial age and the events that led to its development. Include possible energy sources for the future.
 3. Make a slide presentation of the energy time line. Use a camera to make slides or use the following procedure:
 - a. Allow each student to find information about and draw one event from the time line (each picture to be drawn on uniform size paper).
 - b. Tape the completed pictures together in a vertical sequence and attach the top and bottom pictures to plain sheets of paper.
 - c. Make a "viewing screen" from a cardboard box by cutting a hole in one side of the box proportionate to the size of the student pictures.
 - d. Place dowels (made from discarded broom handle) at the top and bottom of "screen."
 - e. Tape the bottom of the vertical strip to the bottom dowel and roll the pictures by turning the dowel clockwise until the top sheet can be attached to the top dowel. The strip is now ready for showing.
 - f. Allow students to present the completed "filmstrip" as a summary of the activity.

378

TITLE: ENERGY USAGE TO PACKAGE CONSUMER GOODS

AREA: Social Studies

OBJECTIVE: To become more aware of energy used to package consumer goods.

MATERIALS: Chalkboard, paper, pencil

ACTIVITY: Develop on the chalkboard with input from the pupils a list of all the packaging materials that come into their homes during typical weekend shopping. The list will certainly contain paper, waxed paper, tin cans, glass, plastic, and possibly aluminum. Often two or more substances will be used to package a single product such as toothpaste.

Ask selected children to find out the natural resources and energy needed to produce various packaging materials. Ask an individual or small group of pupils to interview a supermarket manager to see if he believes that some of the materials sold in his store might be "overpackaged."

Discuss what, if anything, can be done to save energy in this aspect of our distribution system.

TITLE: ENERGY AND CLOTHING PRODUCTION

SUBJECT: Social Studies

OBJECTIVE: To identify sources of energy used to provide clothing.

MATERIALS: Library and research materials

- ACTIVITY:
1. Have each student make a list of clothing items being worn. Compile a master list. Find the labels and learn of what the items are made. List all kinds of fabrics and materials which are represented.
 2. Research each fabric or material and find of what it is made. Record what kind of energy is used in its production. Make an energy chain for each item, making one link per kind of energy used (sun-tractor-cotton-harvesting-processing-weaving-sewing).
 3. Value judgment:
 - a. Which materials require more energy in production?
 - b. Which should you wear to conserve energy?
 - c. List jobs involved in clothing production.
 4. Design of the future: What new jobs can you create to help with future clothing design, production, and recycling?

TITLE: ENERGY AND FOOD CONTAINERS

AREA: Mathematics, Science

OBJECTIVE: To compare energy used in making food containers with the energy of food packaged in the containers.

MATERIALS: Food containers

ACTIVITY: Ask students to bring to class a variety of empty food containers made of paper, glass, steel, aluminum, and plastic.

Using information available on the containers or their labels, generally expressed in calories per certain weight serving, calculate the energy available from the food in each container (one food or "large" Calorie equals 3.968 BTU).

Weigh each container and use the appropriate value from the table below to calculate the energy used to make the container.

Energy required to make food packaging material:

Paper:	20,400 BTU/lb	or	44.9 BTU/gm
Glass:	7,628 BTU/lb	or	16.8 BTU/gm
Steel:	14,795 BTU/lb	or	32.6 BTU/gm
Aluminum:	96,616 BTU/lb	or	217.2 BTU/gm
Plastic:	18,544 BTU/lb	or	40.8 BTU/gm

Compare the amounts of energy used to make containers from different packaging materials with the amounts of energy in the packaged food. Is the ratio better in large or "economy" sized packages rather than the smaller size? Which packaging material is most energy-efficient? What can be done to save energy in food packaging? Why isn't more being done to save energy in this aspect of our food distribution system? What, if anything, can be done by individual shoppers?

REFERENCE: Energy, Food and You--An Interdisciplinary Curriculum Guide for secondary schools including ideas and activities on global food problems, energy and resource use, the U.S. food system, and energy-efficient alternatives (first draft). Washington State Office of Public Instruction, Office of Environmental Education, Olympia, Washington 98501

TITLE: PROS AND CONS OF DEEP-MINING AND STRIP-MINING COAL

AREA: Social Studies, Language Arts

OBJECTIVE: To examine the advantages and disadvantages of deep-mining and strip-mining coal.

MATERIALS: Library and research materials

ACTIVITY: Select two or three people to debate for deep-mining and the same number to debate for strip-mining. Provide adequate time for the debaters to prepare their case by researching encyclopedias and other written sources of information, by interviewing science teachers, engineers, miners, or other knowledgeable persons.

Select a student timer and conduct the debate in formal style with each debater having time (3-5 minutes) for formal presentation and 1-2 minutes for rebuttal of arguments presented by the opposite side.

After the debate is concluded, ask class members to decide which side won. Ask the class also to indicate if they favor expanded deep-mining or strip-mining of coal to meet the U.S. goal of greatly increased coal production in the years ahead.

TITLE: FOOD CYCLE ENERGY STEPS

AREA: Home Economics, Social Studies

OBJECTIVE: To isolate energy consuming steps in the food system and to speculate as to the different ways in which energy could be saved.

MATERIALS: Pencil, paper

ACTIVITY: Twelve steps in a food system are listed below for a frozen vegetable. Which steps could be eliminated to save energy?

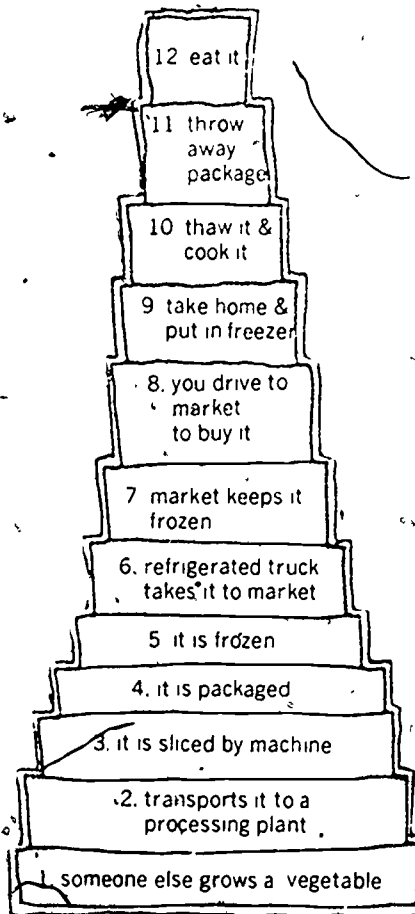

Construct the food chain steps for a canned soft drink and then make suggestions for steps which might be eliminated to save energy.

Suggestions: This type of visual representation makes a nice bulletin board display.

Possible Answers:

(a)

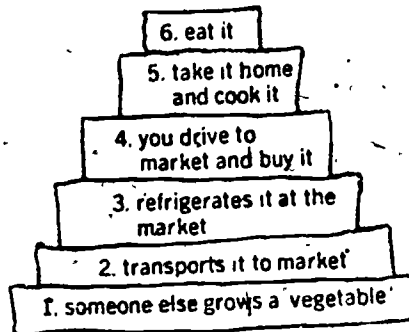

(b)

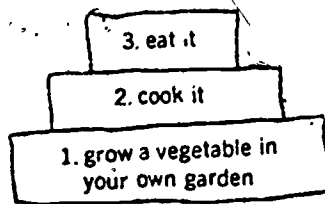

(c)

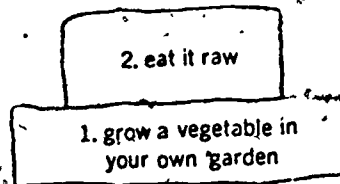

TITLE: PLANNING LAND USE

AREA: Science, Social Studies



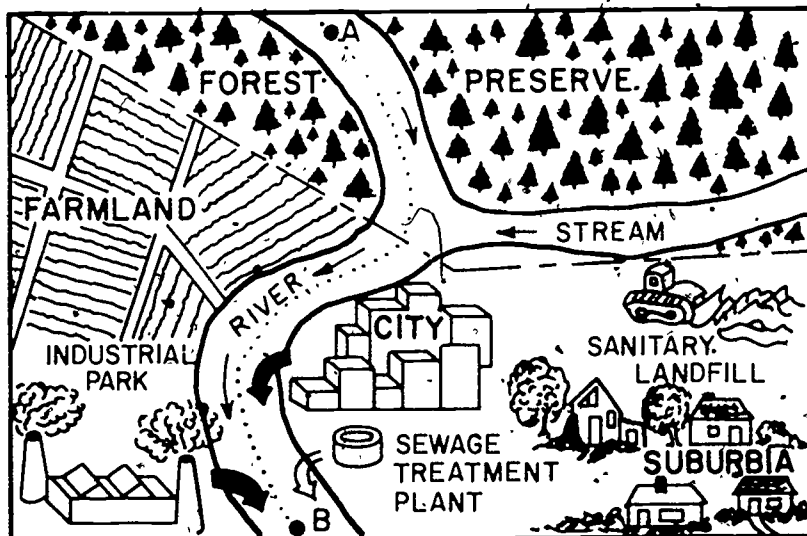

OBJECTIVE: To study good land use planning with respect to environmental and conservation principles.

MATERIALS: Map, questions provided

ACTIVITY: Good land use planning is an important aspect of environmental conservation and improvement. Conduct a class discussion on planning practices with the aid of the map and questions given below.



KEY

-  - waste discharge treated
-  - waste discharge untreated
-  - direction of water flow
-  - trees

0 10 20
kilometers

1. Does the map represent a well-planned area? Explain. What changes could be made to improve the area's environmental quality?
2. Which landscape region has probably been altered least by the activities of man? Explain.
3. What effect would a second industrial park have upon the environment?
4. Should people living here support legislation to rezone this land to allow for a second industrial park? Why or why not? Give some advantages and disadvantages.

5. Which graph best represents the probable quantity of bacteria (anaerobic) along line A-B in the river? Explain.

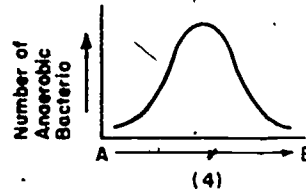
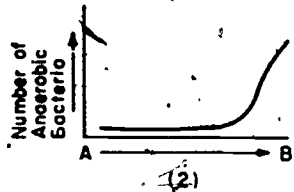
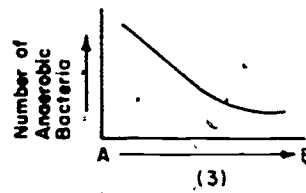
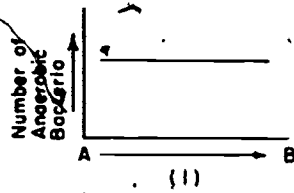

6. What causes the change in the bacterial count between points A and B? Who has the responsibility for monitoring and, if necessary, remedying the condition?



KEY:
 H = High Pollution
 L = Low Pollution

7. What are the principal causes of the air pollution? Who is responsible? What actions can the government agencies (and citizens) involved take to improve the quality of the air?

8. Compare the surface runoff rates of the four areas (forest preserve, suburban, city and farmland) during a 1-hour light rain. Arrange in order from most to least. Explain your reasoning.

(Environmental Understandings: [The limited nature of productive resources make it imperative that a society defines its economic objectives in terms of environmental reality.] [Natural resource policies come about as the result of interacting social processes: science and technology, government operations, private interests, and public attitudes.] [Soil, trees, and water are classified as renewable resources, but, because their renewal or revitalization requires a major investment in time and effort, they may be more realistically considered depletable resources.]

TITLE: POWER PLANT SITE SELECTION

AREA: Science, Social Studies

OBJECTIVE: To gain insight into the problems of selecting a power plant site.

MATERIALS: Topographical maps

ACTIVITY: Give students topographical maps of any area. The maps may be obtained from the State Department of Natural Resources or from a parish engineer. Tell students they are to choose a site in the area of the map for the possible location of a power generating plant.

Help students formulate a number of factors they must know before making a decision about the site. What are the advantages or disadvantages of the topography? What fuel is readily available? What is the population of the area? Is the population increasing or decreasing? What are the industrial demands for electricity? Is there a need for the plant? What fuel is available in the area? Cost of the fuel? Modes of transportation available? Can existing transmission lines be used? Will there be disposal problems in the area?

What are some of the other considerations that go into the selection of a site of a utility that relate to the plant itself? Will the plant size continue to serve the needs of the area over a period of time? What jobs will be displaced or created during plant construction? What are the pollutants of the plant? What are the laws of the area regarding the type of pollutants? Governmental laws? Can the plant system design meet the regulatory environmental laws? Cost?

Have the students write to their congressman for a copy of the Power Site Law in their state.

Ask a representative of the power company serving your area to talk to the students about sites for power plants.

The student will read each problem regarding site selection. Under the "jurisdiction" columns place one of the following codes to indicate which agency should

have jurisdiction for each problem.

- 0 = no jurisdiction
- 1 = primary (major) jurisdiction
- 2 = secondary (minor) jurisdiction
- C = coordinate with, as a means of information, but not as a policy determiner.

Give reasons for the choices. Include the economic, transportation, environmental and social factors.

PROBLEMS OF SITE SELECTION	JURISDICTION				
	Regional or local	State	Federal	Private	Other
INDUSTRIAL COMPLEX					
"HEAVY INDUSTRY"					
"LIGHT INDUSTRY"					
FOSSIL POWER PLANT					
NUCLEAR POWER PLANT					
MINERAL MINES					
OIL WELLS					
NEW CITY					
PORT					
STRIP MINES					
GRAVEL PIT					

TITLE: COMMUNITY ATTITUDES REGARDING ENERGY SHORTAGE

AREA: Social Studies, English

OBJECTIVE: To ascertain the reaction of the community to the energy situation.

MATERIALS: Cassette tape recorders

ACTIVITY: Select from the class two or three students who will, with the use of cassette tape recorder, interview people in the community to ascertain their reaction to the energy situation.

Involve the class in developing questions to be used by the students in the interviews and in deciding on the population to be interviewed.

Questions might include the following:

1. In your judgment, is there really an energy problem?
2. If there is a problem, whose fault is it?
3. If there is a problem, what can you do about it?
4. What, if anything, are you doing about it?

The sample of persons to be interviewed should represent a range of ages and occupations such as homemaker, student, store owner, service station operator, trucker, salesman, custodian, etc.

Urge the students who are doing the interviews to speak clearly and to urge those being interviewed to do the same since the recording is to be played to the entire class for their study-reaction.

As the recording is played to the class, ask students to determine how perceptions of the energy situation differ. Do these perceptions vary according to income level, age, or other criteria? Are there any agreements as to what could/should be done?

The activity might be concluded by asking each student to write a few paragraphs on what he/she has learned about community attitudes toward the energy problem.

TITLE: VARIATIONS IN ELECTRICITY DEMAND AT VARIOUS TIMES OF THE DAY

AREA: Science, Social Studies

OBJECTIVE: To examine the varying demand for electricity at different times of a day and the concept of time-of-day pricing.

MATERIALS: Pencil, paper

ACTIVITY: Ask three or four students to read their electric meters according to a definite pattern over a 24-28 hour period of time. A suggested pattern might be 6:00-8:00-10:00 a.m.-12:00 noon-2:00-4:00-6:00-8:00-10:00 p.m.

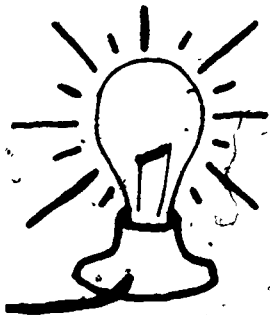

How many kilowatts of electricity are used during each two-hour block of time? Is the pattern of use consistent for each student's family? If not, can the discrepancies be explained?

Finally, engage the class in discussing the merits of time-of-day pricing. Such an arrangement (possible through special meters) would result in electricity costing more during periods of very heavy demand and less during periods of light demand such as from 10:00 p.m. to 6:00 a.m. How many families would (or could) change their pattern of using electricity to take advantage of such an arrangement?

BACKGROUND:

A factor that affects the price of electricity is heavy consumer use that results in "peak loads" on a generator station during relatively short periods of time. Home use tends to be heavy in the morning, late afternoon, and early evenings--little electricity is used between 11:00 p.m. and 6:00 a.m. in most homes.

Many factories operate only one or two shifts per day. Typically retail stores make heavy use of electricity only during daylight and early evening hours.

Weather also affects electrical use. Heavy air conditioner use on very hot summer afternoons results in very large demands for electrical power.

Since electricity cannot be stored, an electric power station must have available a much higher generation capacity than is usually required. Some units, generally the most inefficient, may be operated as little as 20 percent of the time. Since idle equipment is expensive, the reserve or unused capacity adds significantly to the cost of our electricity.

TITLE: U.S. CONSERVATION OF ENERGY
AREA: Social Studies
OBJECTIVE: To examine U.S. efforts to conserve energy.
MATERIALS: Pencil, paper
ACTIVITY: Review with the class the recommendations made by the President's Office of Emergency Preparedness in 1972.

Ask each student to discuss briefly in writing how he/she believes the United States has responded to these recommendations. Does the student have personal knowledge or belief that citizens have improved home insulation? Adopted more efficient air conditioning? Shifted freight traffic from highway to rail? Shifted passenger traffic from air to ground? Shifted urban passenger traffic from automobile to mass transit?

Involve students in converting their written answers to a five-point Likert scale of strongly agree, agree, neutral, disagree, strongly disagree and tabulate responses on the chalkboard. Discuss results.

What recommendations have received the most support from the American public in the past six years? Why? What, if anything, can be done to achieve the other recommendations more successfully?

BACKGROUND:

In 1972 (prior to the Arab oil embargo) the publication cited above identified six promising things that could be done to conserve energy. These were:

- Improve insulation in homes
- Adopt more efficient air conditioning
- Shift intercity freight traffic from highway to rail
- Shift intercity passenger traffic from air to ground
- Shift urban passenger traffic from automobile to mass transit
- Introduce more efficient industrial processes and equipment.

The energy program enacted by the U.S. Congress in 1978 and signed into law by President Carter, continued to stress the importance of conservation of energy.

TITLE: CITY GROWTH AND ENERGY USAGE

AREA: Social Studies, Language Arts

OBJECTIVE: To examine the relationship between growth of cities and increasing use of energy.

MATERIALS: Library, research materials, paper, pencil

ACTIVITY: Review with the class the fact that prior to James Watts' development of the steam engine, no city on earth had a population of one million people. Today several greater metropolitan areas have a population that exceeds 10 million. The World Almanac identifies more than 120 cities with a population greater than one million.

Cities use enormous amounts of energy. Food must be brought in, waste removed, workers commute from home to work, elevators lift objects, etc., etc.

Ask students to write a paper in which they explain how modern technology, powered by our present energy sources, has made possible the growth of cities.

The assignment might be used as an in-class without preparation activity to introduce the topic of city dependence on energy or it might be assigned as a major paper to be developed with use of out-of-class research.

TITLE: POLLUTION CONTROL AND PUBLIC UTILITIES
AREA: Science, Social Studies
OBJECTIVE: To examine the attitude of a public utility company toward mandated pollution control equipment.
MATERIALS: Listed in activity
ACTIVITY: Distribute to the class the following example quoted from the reference cited. Ask each student to read the material carefully and to decide whether he agrees or disagrees with the thrust of the article.

Ask for volunteers to debate in an informal way the validity of the arguments advanced. Open the debate to a general class discussion to ascertain how many agree with the utility position. Ask those who disagree to present sound arguments to justify their position.

A Case in Point

The Bruce Mansfield Plant being built by the Ohio Edison's subsidiary, Pennsylvania Power Company, in Shippingport, Pennsylvania, will cost about \$1.4 billion when completed. Almost 33 percent of that total cost will go for pollution control equipment, including an experimental sulfur removal and disposal system required to meet state and federal regulations.

It will require a massive "scrubber" system that uses lime and water to absorb the sulfur oxides from the gases resulting from the coal being burned in the plant's boilers.

It will require about 400 tons of lime per day for each of the three units of the plant--about 400,000 tons per year when the three units are operating.

It will require the largest earth and rockfill dam in the eastern United States to close the end of a valley six miles from the plant to create a disposal area for the waste slurry when it comes out of the scrubber system.

The dam and the disposal site alone will cost an estimated \$88 million.

Demand that legislation concerning the environment start with a scientific evaluation of the "pollution problem." And make sure that each request includes a consumer "economic impact" study as well as an "environmental impact" report.

Ask that "real" pollutants be identified clearly and that realistic methods be developed to measure them.

Require that all methods of abatement be accountable in terms of both benefits and costs.

Insist that reasonable degrees of perfection be arrived at. The cost of reaching "perfection" becomes more prohibitive the farther up the scale we attempt to go. The first 50 percent of pollutants can be removed at relatively low cost. But after the 90 percent level is reached, it often costs as much to achieve a further 5 percent than it did the first 50 percent! And absolute perfection, of course, is impossible.

TITLE: "PUBLIC HEARING"

AREA: Social Studies, Science, Consumer Education

OBJECTIVE: To simulate a "public hearing" which has been called to consider the threat to certain vital community services posed by the shortage of gasoline and heating oil.

MATERIALS: Imaginary comments provided, research and debate skills

ACTIVITY: Suggest that the class members simulate a "public hearing" which has been called to consider the threat to certain vital community services posed by the shortage of gasoline and heating oil. The hearing would provide a forum at which the causes and the specific effects of the crisis and measures to counteract the crisis may be considered. The people asked to participate from within and without the community include: (1) a Congressman, (2) a Senator, (3) a utilities spokesman, (4) an executive vice-president of an oil company, (5) a housewife, (6) a government economist, (7) an ecologist, and (8) a newspaper editor. A panel of advocates has an opportunity to cross-examine each witness as do people in the audience.

The student participants in this "public hearing" should have an opportunity to read the imaginary but fairly representative comments which follow, since what the public believes to be the reasons for an energy shortage is as important a factor as the actual reasons for the shortage.

"A high administration official said today that the Arab states' holding of oil could endanger this nation's security by severely limiting our military capability. He went on to say that the oil embargo amounted to blackmail, something that this country just won't stand for."

"A concerned housewife from the Midwest, whose husband has been laid off by an auto manufacturer, blames the Japanese and the Arabs for the current crisis. She says both countries have benefited greatly from trade with the United States, and now they are putting the squeeze on!"

"A noted economist from a major university in the East claims the government has known about a potential crisis for years but has ignored the problem."

"A member of Congress blames the Nixon administration for not coming up with a definitive National Energy Policy which would have averted the current crisis. The Administration blames Congress for not acting on bills that President Nixon sent to Capitol Hill for enactment into law."

"An editorial in a major metropolitan newspaper asserts that major oil companies in the United States, while achieving enormous profits for the last three years, have been in collusion with one another to hold back oil exploration and production. Not only are they not refining oil to capacity, but they are shipping domestic oil to foreign countries who are willing to pay the higher prices."

"A lobbyist for the American Petroleum Industry argues that environmentalists have contributed greatly to the energy crisis by blocking in-court necessary programs, such as the Alaskan pipelines, which would free up more energy resources for U.S. consumption. Environmental groups, on the other hand, say dependence on fossil fuels is excessive. What is needed, they say, is research into other forms of energy, such as solar and geothermal, and greater emphasis on recycling."

TITLE: ENERGY AND RECREATION

AREA: Social Studies, Language Arts

OBJECTIVE: To consider the desirability of reducing energy used for recreational purposes.

MATERIALS: Library

- ACTIVITY:
1. Review with the class the general idea that recreational activities consume tremendous amounts of energy in the United States. Involve the class in listing some of the biggest users such as night baseball games, the Indianapolis 500 automobile race, air-conditioned playing areas such as Superdome, Monday night football on TV, and others.
 2. Organize the class to simulate a Senate subcommittee charged with investigating the desirability of outlawing or drastically reducing high energy use recreational activities such as those cited above.
 3. Urge students to prepare and read short written statements in support of or in opposition to the idea under investigation. A "committee" of three to five students should be given the opportunity to question the witnesses after their presentations.
 4. After hearing all testimony the committee should prepare the recommendations it will submit to the Senate (entire class) on this issue. The report should include the major considerations that shaped the judgment of the committee.
 5. The committee report should be made available in written or oral form to the entire class which, after study and review, votes to accept or reject the subcommittee recommendations.

TITLE: ENERGY CONSERVATION

AREA: Mathematics

OBJECTIVE: To make students aware of energy scarcity by having them solve mathematical problems dealing with energy conservation.

MATERIALS: Listed in activity

ACTIVITY: Provide the class with the following problem for solution. A trucking company specializes in hauling goods from Albany to Buffalo, a distance of 280 miles. If the truck drivers are paid \$5.00 per hour, what percent increase in cost resulted from the change in the State speed limit from 65 miles per hour to 55 miles per hour (presuming, of course, that drivers adhere to the limits in both instances)?

Why was the speed limit lowered?

Who eventually absorbs the company's increased operating expenses? Explain.

Do you think that these increased costs are partially offset by greater fuel economies? Explain.

(Environmental Understandings: [Individuals should become well informed about the best ways to manage and conserve our energy supplies.] [The material welfare and aspirations of a culture largely determine the use and management of natural resources.]

Suggest the following problem to the class. Based upon emission control standards for cars manufactured since 1970, the carbon monoxide in exhaust fumes should not exceed 4 percent. A recent test of a 1972 auto indicated that 150,000 cubic centimeters of an exhaust sample contained 7,000 cubic centimeters of carbon monoxide. Using the principle of proportions, determine by how many cubic centimeters the carbon monoxide count must be reduced to meet the 4 percent requirement.

Have the standards for emission controls established by the Federal and state governments been realistic, manageable ones? Explain.

What have been the objections of auto manufacturers to these standards?

What effect have the emission devices had on gasoline consumption? Explain.

(Environmental Understandings: [Individuals tend to select short-term economic gains, often at the expense of greater long-term en-

vironmental benefits.] [Choices between essential needs and nonessential desires are often in conflict.]

Divide the class into three groups. Give each group the problem of planning a fenced-in garden having a specified length of fencing available, e.g., 120 yards. Give directions as follows:

Group I: Design a triangular-shaped garden with as large an area as possible.

Group II: Design a quadrilateral-shaped garden with as large an area as possible.

Group III: Design a pentagonal-shaped garden with as large an area as possible.

What triangle seems to have the largest area? What quadrilateral? What pentagon?

What would have to be done to obtain the largest possible area for the garden?

Discuss whether, or not gardens, building lots, construction sites, highways, etc., are planned or designed in a fashion which makes the most efficient use of available land.

What consideration, other than efficiency (economically speaking), must be part of our land-use planning?

(Environmental Understandings: [The nonrenewable resource base of mineral elements is considered finite and depletion can only be slowed by altered priorities, new demographic considerations, improved conservation practices, and vigorous recycling procedures.] [Any one of an environment's components, such as space, water, air, food, or energy, may become a limiting factor.])

Give the students the following problem. An apple orchard now has 30 trees per acre, and the average yield is 400 apples per tree. For each additional tree planted per acre, the average yield per tree is reduced by approximately 10 apples.

Write a function of x which represents the total yield of apples per acre if x represents the number of new trees planted per acre.

Graph the function.

Decide on the number of trees per acre which produces the maximum yield.

What implications does the above procedure have for efficient use of land and resources?

What is necessary in order for the above procedure to be applied?

(Environmental Understandings: [The nonrenewable resource base of mineral elements is considered finite and depletion can only be slowed by altered priorities, new demographic considerations, improved conservation practices, and vigorous recycling procedures.])

When searching for problems which involve logarithms, consider several environmentally-related topics. Some of these topics which are concerned with exponential functions are: population growth, bacterial growth, and radioactive disintegration. As an example, have students work with the population growth formula as used in the following problem:

$$p = p_0 \times \left(1 + \frac{a}{100}\right)^{ct}$$

p = new population

p_0 = original population

a = rate of population growth (constant)

c = factor of proportionality

t = time elapsed

If the population of the United States in 1970 was 210,000,000, (p_0), and the annual rate of population growth (a) is .62 percent, what will the expected population be in 1990? ($t = 20$ years.) (The factor of proportionality, (c) is 1/10.)

How long will it take for the population of the United States to double?

Graph the population growth of the United States from 1970 to 1990 using 5-year intervals.

Suggest events that might take place which would alter the appearance of the graph developed in answer to the preceding question.

Describe the appearance of the graph, which would reflect each of these events.

Estimate the current (1980) population of the United States.

In terms of environmental impact, how would you describe this rate of population growth (.62 percent)?

Obtain rates for other nations (in Europe, Africa, Asia, and Latin America) and compare them with the United States' rate. How soon will some of these nations experience a doubling of their populations?

(Environmental Understandings: [The demands of population growth coupled with man's tremendous waste of energy are responsible for some of our more serious environmental problems.] [Earth's resources and recycling system can support only a limited number of people; therefore, as populations increase and as resource supplies decrease, the freedom of the individual to use the resources as he wishes diminishes.])

The following problem could be included in any twelfth year course in which introductory calculus is presented. A truck has a minimum speed of 20 miles per hour in high gear. When traveling x miles per hour in high gear, the truck burns diesel fuel at the rate of $\frac{1}{300} \frac{2500}{x} + x$ gallons per mile.

The truck cannot be driven over 75 miles per hour. If diesel fuel costs 33 cents a gallon, find:

- The steady speed that will minimize the cost of fuel for a 500-mile trip.
- The steady speed that will minimize total cost of the trip if the driver is paid \$4.00 an hour.

Which of these two speeds decided on above would be the natural choice of trucking companies today? Explain.

Could the situation ever reverse itself? When and for what reasons?

(Environmental Understandings: [Individuals should become well informed about the best ways to manage and conserve our energy supplies.] [Raw materials and energy supplies are generally obtained from those resources available at least cost, with supply and demand determining their economic value.])

TITLE: RETAIL MERCHANTS AND ENERGY CONSERVATION

AREA: Social Studies

OBJECTIVE: To provide students with an insight into the response of local merchants on the need for energy conservation.

MATERIALS: Department Store Energy Audit

- ACTIVITY:
1. Students should use the Department Store Energy Audit Form developed for this activity to conduct a survey in a local department store. This should be done with permission and cooperation of the store manager or a person designated to work with the students. Information obtained from the survey should be used in preparing a recommended energy conservation plan for the department store. Students should be quite familiar with all items on the form and be equipped with quantitative information of interest to the store operator (e.g., effects of thermostat setback).
 2. Another activity would be to have students revise the attached form for use with public buildings, hospitals, grocery stores, or dairies. Interesting comparisons could be made between any two or more of these situations. Questions to consider would include:
 - a. Which one should receive highest priority in times of energy curtailment?
 - b. How much energy is required to keep a hospital functioning? What happens if power is cut off or curtailed? Which, if any, other community facilities face similar situations in case of emergency?

CONTACT ORGANIZATIONS:

1. Your local Chamber of Commerce may be able to help locate store managers who would cooperate in this activity.
2. U.S. Department of Commerce, 15th and E Streets, NW, Washington, D.C. 20230
3. Environment Center, The University of Tennessee, South Stadium Hall, Knoxville, Tennessee 37916.
4. Tennessee Energy Office, Suite 250, Capitol Hill Building, 7th and Union, Nashville, Tennessee 37219.

DEPARTMENT STORE ENERGY AUDIT FORM

STORE NAME: _____ DATE: _____

ADDRESS: _____

Student's Name: _____

Method(s) of Heating and Cooling: _____

Does the store own the building? Explain why it matters. _____

Are energy purchases (types and amounts of fuel used) controlled by the store operator/manager? Explain. _____

	yes	no	does not apply
1. Is thermostat setting for cooling 78° or higher?	_____	_____	_____
2. Is thermostat setting for heating 68° or lower?	_____	_____	1
3. Where possible, is outside air used to control temperature?	_____	_____	_____
4. Is the thermostat adjusted during non-selling hours?	_____	_____	_____
5. Are all heating/cooling systems regularly inspected?	_____	_____	_____
6. Are doorways and windows closed when heating/cooling equipment is operating?	_____	_____	_____
7. Is weatherstripping and caulking evident around doors and windows?	_____	_____	_____
8. Are display items (dishwashers, lamps, small appliances) turned on only by request and not left on?	_____	_____	_____
9. Is cleaning done during store hours? (After hours requires additional energy.)	_____	_____	_____

- | | yes | no | does
not
apply |
|--|-------|-------|----------------------|
| 10. Is lighting in sales areas adequate but not excessive? | _____ | _____ | _____ |
| 11. Is display lighting reduced to a minimum when the store is closed? | _____ | _____ | _____ |

Comments: _____

491

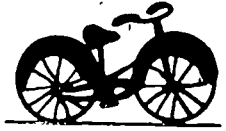

TITLE: COMMUNITY REDUCTION OF ENERGY USE

AREA: Social Studies

OBJECTIVE: To explore community reduction of energy use.

MATERIALS: Library and research materials

ACTIVITY: Review with the class the following description of Davis, California efforts to save energy. Discuss with the class the applicability of some of Davis' actions to their own towns or cities. Ask students as a homework assignment to get parental reaction to Davis' plan and write a short paper in which students discuss what parents think about such city planning activities.

One of the best comprehensive energy conservation programs is being run by Davis, California, a small city 12 miles outside Sacramento. The Davis' City Council convened a committee of architects, metrologists, planners, and citizens to survey energy use in the city and to make recommendations for reducing fuel consumed in space heating and cooling by 50 percent. The group drafted a new ordinance controlling building design elements such as window area and orientation (it requires that houses have limited window area on the north, west and east exposures), amount of insulation, building heat storage capacity and building orientation so as to make maximum use of natural heating and cooling. The final ordinance was accepted by the City Council. The changes have already reduced the city's electrical consumption by 10 percent and the natural gas consumption by 40 percent.

Davis' experience with its building ordinance prompted it to implement a broader energy conservation program; the city contracted a group called Living Systems to draft a comprehensive energy plan. The Living Systems plan, completed in June 1976, touches on land use, solar energy utilization, city procurement policies, and transportation. Maximum use of bicycles and walking is encouraged; the city of 35,000 residents now has 28,000 bicycles, seven-foot-wide bike lanes, and streets closed to automobiles. Zoning will be altered to make it possible for buildings to take best advantage of south-facing windows and thus optimize the effects of natural heating.

The plan calls for extensive planting of trees along streets and parking lots to create a natural cooling effect in summer. The city itself will switch to small

energy-saving vehicles for its fleet. The Davis plan will also guarantee "sun rights" in new residential developments so that owners of solar equipment need not fear that their systems will be shaded by neighboring buildings in the future. The city expects to reach its goal of 50 percent energy use reduction within 10 years. (Contact: Janice Jacobson, City of Davis, 218 F Street, Davis, California 95616, (916) 756-3740, Ext. 65.)

REFERENCE: A Survey of Model Programs: State and Local Solar/
Conservation Projects. Center for Renewable Resources,
1028 Connecticut Avenue, NW, Suite 1100, Washington,
D.C. 20036.

TITLE: DEVELOPMENT OF A TOWN'S ENERGY SOURCE

AREA: Social Studies, Science, English

OBJECTIVE: To develop an awareness of the problems surrounding the various types of energy-generating plants.

MATERIALS: Information on the advantages and disadvantages of the different energy-generating plants.

ACTIVITY: 1. Divide the class into four groups and pretend that they are going to develop a town beside a common stream. Their land is contiguous; they will generate their own energy.

Group 1 will set up a coal-fire generating plant
Group 2 will set up a gas-fire generating plant
Group 3 will set up a nuclear-generating plant
Group 4 will set up a hydro-generating plant.

2. Each group may oppose the erection of any other group's plant on the basis of pollutants, passage of fuel across their territory, or use/abuse of a common resource such as air or water.

3. The students must decide the best method of generating electricity, whether it should be a common source or several generators and which ones. If a common source is selected, whose land will it occupy and what compensation will be provided for the land use?

QUANTUM

TITLE: PLANET QUANTUM

AREA: Creative Writing

OBJECTIVE: To write a science fiction story about Planet Quantum incorporating energy concepts.

MATERIALS: Paper, pencil

ACTIVITY: The Story



The story takes place on a fictitious planet called "Quantum." The basic theme of the story is what happens when the production and distribution of energy resources on the planet are halted. Because of this, people adapt their behavior to conserve energy. This situation proves to be a learning experience for all and one to which we can relate.



The story opens with a view of the planet. Quantum is much like Earth in that many people are overconsuming energy. This overconsumption is causing problems for there is concern about unequal distribution and the diminishing availability of energy.

To deal with this situation the people of Quantum have elected representatives to make energy decisions that will affect everyone. There exists a satellite called the "Interdependence" which orbits Quantum and serves to regulate the production, use and distribution of energy resources. The satellite is computerized and without it, large-scale energy use would be impossible.

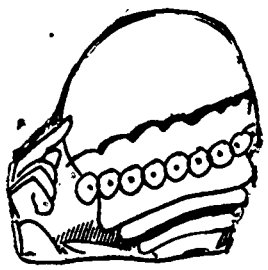

The elected energy specialists who control the Interdependence are introduced. Their title is QuEST which stands for Quantum Energy Saving Team. Their job is to set energy use and distribution priorities for the coming decade. The members of the QuEST are:

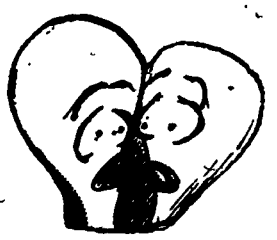

- 1) "Mega Watts" -- This character is a scientist with great energy expertise.
- 2) "Dr. Drat" -- This character is alienated and angry because of the way energy is currently being used and distributed.
- 3) "Omni" -- This character is the imager. Through Omni we can explore different ways to view energy and alternative conservation strategies.
- 4) "Dyad" -- This character is our decision-maker and compromiser. Dyad helps us to see the process of gathering evidence, considering alternatives and facilitating bargaining and compromise.
- 5) "Zbic" -- This character represents environmental and conservation concerns.

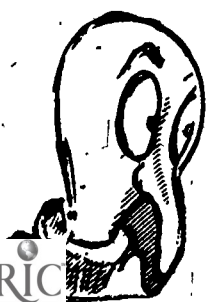



- 6) "The Incredible Bulk" -- This character represents overconsumption.

We see them meeting aboard the Interdependence. They realize that they are wasting energy by traveling to the Interdependence every time they wish to meet. They decide to go to a system of meeting via multi-media panels. This way they can communicate with each other without leaving their homes. QuEST continues to meet via multi-media panels and their differing views on energy priorities become evident.

Zoic reflects about the conditions which existed on Quantum before the QuEST and the "Interdependence." Omni imagines about all the different meanings of the concept of energy.

Meanwhile Dr. Drat becomes so frustrated that he decides to construct a plot to take over the control of the "Interdependence." He tricks the other members of the QuEST so that they will not be available when he re-computerizes the "Interdependence," redirecting energy resources from the overconsumers to those in need.

As fate would have it, just as he starts to alter the flow of energy resources, a series of human and natural disasters renders the "Interdependence" inoperable. We now see Quantum without large-scale energy resources.

At first there is chaos and panic. People are very dependent on energy and the crisis causes quite a shock. However, as time passes, people begin to cooperate and conserve. Their lifestyles change and eventually they realize that alternate forms of energy can be used to meet their needs.

The QuEST meets again. At first they comment that their condition is only temporary for eventually the "Interdependence" will be repaired. Very quickly they realize that even when it is repaired, if they return to their old energy habits, they will be right back where they started.

The story ends with the QuEST realizing that the people on Quantum have learned invaluable lessons about energy conservation from their crisis. They realize that the distribution and use of energy must be more equitable and efficient. Problems will always exist and solving them will not be easy. Everyone has learned a great deal, especially that conserving energy is a matter of changing people's energy habits.

1. Students could be asked to speculate about the nature of "Quantum" society as related to its dependence on energy. How is this society similar to our own? Ask students to write down examples of ways in which we depend on energy and discuss their ideas.
2. Have your students make two lists, one stating the benefits obtained from energy resources and the other disadvantages or negative results. Discuss the examples given in the cartoon book and those on their lists.
3. Help your students define the term "overconsumption." Alternative ideas could include the wasteful or overdependency on energy intensive appliances. What are some examples of overconsumption? Relate this idea to things with which they are familiar. What are examples of overconsumption in the classroom, school and community? Magazine advertisements often show examples of overconsumption. Students could make collages from these.
4. The satellite is called the "Interdependence." Have students define the concept and explain why the satellite is so named. Next ask the students to pick out examples of interdependence. How are the people mutually dependent on energy? How does the amount of energy available and the amount charged for its production affect the cost of energy to the consumer? Have your students ask their parents what it costs every month for electricity, gas and oil for their homes. Has the cost changed in the last year? What about the price of gas for the car? How have price changes affected their lifestyles?
5. The QuEST decides to meet via multi-media panels rather than travel to the "Interdependence." Do you think this actually saves energy? What are examples of using energy to save energy?
6. List on the board the names of the six main characters. What are the problems involved in making group decisions that affect others? Have your students imagine that they are members of the QuEST. Have several students role play a QuEST meeting. After they have role played, ask the class to identify aspects of group decision-making such as stating positions, the use of evidence, negotiation and compromise. What have they learned about group decision-making and the problems involved in establishing energy policy?

Relate this to the present situation in this country and the world. Why is it necessary to set energy priorities for the future now?

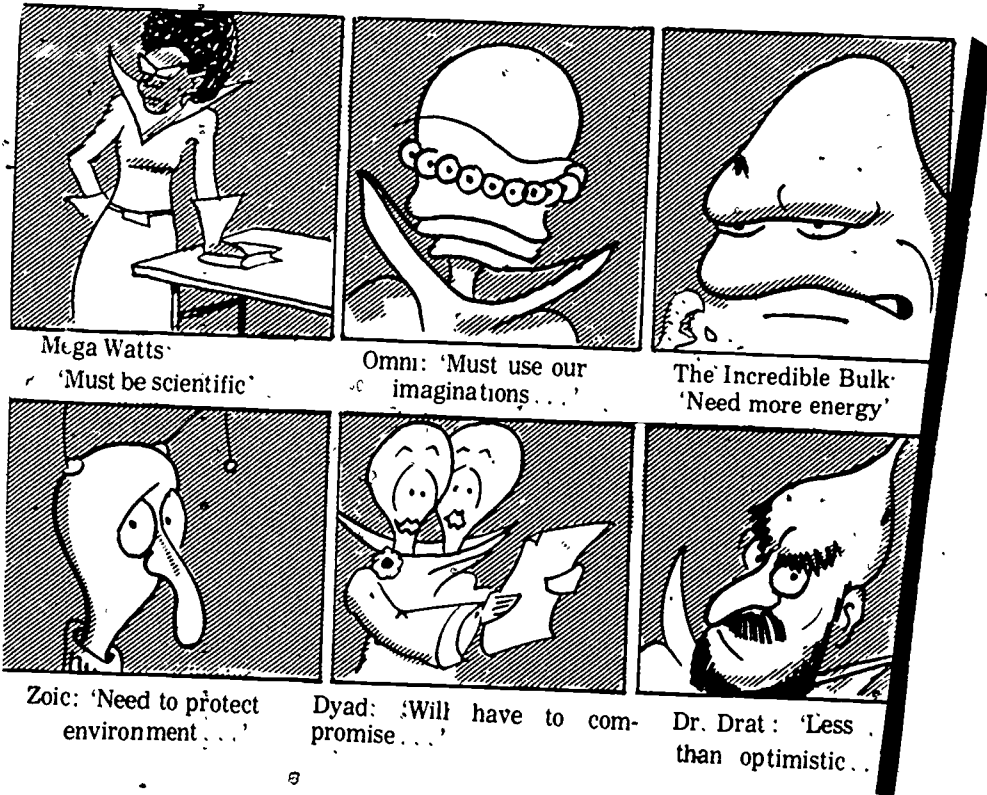

TITLE: CONSERVATION OF ENERGY AT HOME--LIGHT SOURCES

AREA: Social Studies, Science

OBJECTIVE: To compare incandescent and fluorescent bulbs for efficiency.

MATERIALS: Bulb package for incandescent and fluorescent bulbs

BACKGROUND: Wattage is the amount of energy required to operate a light bulb or other electrical device. The amount of light a bulb provides is indicated in lumens. Bulb packages should give not only the wattage required but also the lumens produced by the bulb.

ACTIVITY: 1. Using bulb packages, compare several incandescent and fluorescent bulbs for efficiency (lumens per watt).

For example: A 100-watt incandescent bulb may yield 1,750 lumens which gives the bulb an efficiency of 17.5 lumens per watt:

$$\frac{1,750 \text{ lumens}}{100 \text{ watts}} = 17.5 \text{ lumens per watt}$$

Determine the efficiency of the following bulbs, plus any others you may have:

- a. 100-watt fluorescent bulb
 - b. 40-watt fluorescent bulb
 - c. 100-watt incandescent bulb
 - d. 25-watt incandescent bulb
2. Which type of lighting is more efficient--incandescent or fluorescent?
 3. Is it more efficient to buy four 25-watt or one 100-watt incandescent bulb(s)?
 4. Discuss the comparative lifetimes of fluorescent and incandescent bulbs.
 5. Discuss the turning off and on of incandescent and fluorescent bulbs. (Fluorescent bulbs have a warm-up time; incandescent bulbs do not.)

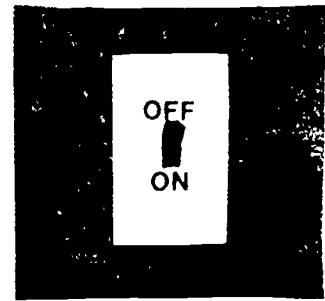

TITLE: ENERGY CONSERVATION AT HOME

AREA: Multi-disciplinary

OBJECTIVE: To help students gain an awareness of energy use and waste in the home.

ACTIVITY: Have students use the Energy Conservation Checklist For The Home prepared for this activity to determine where/why/how energy is wasted. Information gained from responses on the Checklist can be used by students to develop energy conservation suggestions for their parents. Students should encourage their families to implement the energy conservation measures and do their part to make it work. Following this experience, the class might discuss such questions as:

1. What are the most inexpensive ways to conserve energy in the home?
2. What are the most effective ways to conserve energy in the home?
3. Is it possible to still pay higher utility bills after implementing an effective energy conservation program at home? If so, why?
4. How do you read electricity and gas meters?

CONTACT ORGANIZATIONS:

1. Your local gas or electric utility, power distributor, and building supply house.
2. Tennessee Energy Office, Suite 250, Capitol Hill Building, 7th and Union, Nashville, Tennessee 37219.
3. Tennessee Valley Authority, 400 Commerce Avenue, Knoxville, Tennessee 37902.
4. Environment Center, The University of Tennessee, South Stadium Hall, Knoxville, Tennessee 37916.
5. See appendices for estimates of yearly consumption by common household appliances.

AN ENERGY CONSERVATION CHECKLIST FOR THE HOME

Name and Address
of Resident:

Name of Student:

Date:

USE THIS CHECKLIST TO DETERMINE WHERE/HOW/WHY ENERGY IS WASTED AT HOME. THE MORE CHECKED "YES," THE MORE ENERGY CONSERVATION MEASURES BEING USED.

	<u>YES</u>	<u>NO</u>
1. Are spaces around windows, doors, air conditioners, etc., properly caulked (sealed tightly)?	_____	_____
2. Are there storm windows and doors throughout the home?	_____	_____
3. Are windows tightly closed at all times during cold weather?	_____	_____
4. Are exterior doors closed quickly after use?	_____	_____
5. Are drapes and shades closed at night and on cloudy or windy days during the winter?	_____	_____
6. Are drapes insulated?	_____	_____
7. Are hot air ducts or radiators closed off in unused rooms or closets?	_____	_____
8. Are hot water pipes and air ducts insulated?	_____	_____
9. Is the air conditioner located on the shady side of the house?	_____	_____
10. Are drapes and furniture located so they do not interfere with air ducts, radiators, thermostats?	_____	_____
11. Are the walls insulated?	_____	_____

YES NO

- 12. Does the floor have 2 to 3 inches of insulation? _____
- 13. Does the attic have 6 to 8 inches of insulation? _____
- 14. Is an attic fan used in the summer? _____
- 15. Is the fireplace damper closed tightly when not in use? _____
- 16. Are heating and cooling filters clean? _____
- 17. Is the thermostat set at 68 degrees F or below during winter months? _____
- 18. Is the thermostat set at 78 degrees F during summer months? _____
- 19. Is the thermostat adjusted at night? _____
- 20. Do thermostats indicate accurately calibrated temperature settings? _____
- 21. Are lights turned off when not needed? _____
- 22. Is the TV, radio, or stereo turned off when not in use? _____
- 23. Are ovens and burners turned off immediately after use? _____
- 24. Is the oven used to bake more than one food at a time? _____
- 25. Is the refrigerator thermostat set at +40 degrees F? _____
- 26. Are gaskets around refrigerator and freezer doors tight? _____
- 27. Is the frost on the refrigerator and freezer less than 1/4-inch thick? _____
- 28. Is the water heater temperature setting between 120 degrees F and 140 degrees F? _____
- 29. Are all water faucets in good repair (not leaking)? _____
- 30. Do the residents take brief showers or use a small amount of water in the tub? _____

	<u>YES</u>	<u>NO</u>
31. Are clothes washed only when there is a full load?	_____	_____
32. When washing clothing, is cold or warm water used if possible?	_____	_____
33. Are dishes washed only when there is a full load?	_____	_____
34. Are evergreens properly located around the outside of the house to provide a break against cold winter wind and shade against the hot summer sun?	_____	_____
35. Are deciduous plants located on the south of the house to admit the winter sun and protect from the summer sun?	_____	_____
36. Is there a humidifier in the home?	_____	_____

TITLE: SHOWER VS. BATH

AREA: Health, Science

OBJECTIVE: To demonstrate that a short shower is more energy conserving than a bath, and that lengthy showers waste hot water and energy.

MATERIALS: Yardstick

ACTIVITY: If people took short showers instead of baths or lengthy showers, a lot of energy could be saved. It takes about an ounce of oil (or a cubic foot of gas, or 1/4 kilowatt-hour of electricity) to heat a gallon of water.

Compare the water used for a bath and a shower. Fill your bathtub (at the temperature and depth you like best) and measure the depth with a yardstick (when you are out of the water). Record the depth: _____ inches. At your next bathing time, take a shower (in the same tub). Keep the drain closed during your shower, but be careful not to overflow the tub. (Do not rush your shower; take your time!) This time record your bathing time as well as the water depth.

Beginning Time _____ Ending Time _____
Duration of Shower _____ Water Depth _____

If you took a short shower, it should have required only about half as much water as your bath.

Questions:

1. What bathing practice is more conservative for you?
2. What would be the energy impact of taking a 20-minute shower?
3. What are some other ways to conserve energy while bathing?

Suggestions:

1. If your shower was lengthy you may need to measure the depth, empty the tub and then finish your shower and measure again. Add the two depths.
2. Investigate the bathing practices of other members of your family. Who is most conservative?

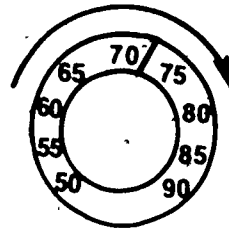

TITLE: THERMOSTAT SETBACK
AREA: Home Economics, Science

OBJECTIVE: To demonstrate the effect thermostat setback has on energy consumption.

MATERIALS: Central air or heat

ACTIVITY: You can investigate the effects of thermostat setback on the energy consumption at your residence. During the cooling season, thermostats should be set up to 78 degrees F to reduce the use of mechanical air conditioning and during the heating season, set down to 68 degrees F. The effect of these thermostat setbacks will vary from residence to residence, but should be significant.

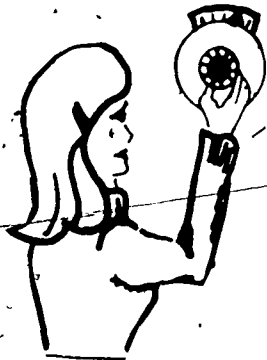

To test the impact of thermostat setback at your home, first determine the weekly consumption of energy prior to the setback. Read your gas, oil, or electric meter one week before the setback and read it a second time exactly seven days (to the hour) later.

For example:

First Reading

Meter Reading: 14276 kwh
Date: 9/8/76
Time: 8:00 a.m.

Second Reading

Meter Reading: 15101 kw
Date: 9/15/76
Time: 8:00 a.m.

The energy consumed by the example for the week was 925 kwh (15101 kwh-14276 kwh = 925 kwh)

Immediately after the second reading set back the thermostat 5 degrees F lower if heating and 5 degrees F if cooling. Then take a third meter reading exactly seven days later.

For example:

Third Reading

Meter Reading: 15897 kwh
Date: 9/22/76
Time: 8:00 a.m.

The energy consumed by the example home for the week with the set back is 796 kwh. To determine the possible savings, find the difference between the first week's consumption and the setback week's consumption.

Using the example home:

$$925 \text{ kwh} - 796 \text{ kwh} = 129 \text{ kwh}$$

Now try the test at your residence.

First Reading

Second Reading

Third Reading

Meter Reading: _____
Date: _____
Time: _____

Meter Reading: _____
Date: _____
Time: _____

Meter Reading: _____
Date: _____
Time: _____

First Week's consumption:

$$\frac{\text{meter reading 2}}{\text{meter reading 1}} = \text{consumption}$$

Setback week's consumption:

$$\frac{\text{meter reading 3}}{\text{meter reading 2}} = \text{consumption}$$

Savings

$$\frac{\text{First week's consumption}}{\text{Setback week's consumption}} = \text{savings}$$

Questions:

1. Why is it better to use a week's consumption for comparison rather than a day or an hour?
2. What could be possible reasons for finding no savings or possibly an increase in consumption during the week with the setback?
3. How much money could be saved in a year if you could realize the savings you found (if you found one) during the setback week?

Suggestions:

1. Do this investigation when mechanical heating or cooling is certain to be needed.
2. Make certain no one adjusts the thermostat during the two weeks of the investigation.

TITLE: SUN ORIENTATION/WIND ORIENTATION

AREA: Science

OBJECTIVE: To determine where the sun rises and sets in relation to your home and to determine local wind patterns.

MATERIALS: Compass, paper, Pencil

ACTIVITY: The way in which your home is oriented to the sun and wind affects the impact of the climate and the energy needed to maintain comfort. To understand this concept, it is helpful to determine the compass orientation of your home. First, think of your home as a box (usually a rectangular box) and view it from a bird's perspective. Given the directions of the compass on the circle below, locate your home in the center facing the appropriate direction. Use a compass to determine which direction each side of your home faces. It may not be directly N, S, E or W, but using the face of the compass and this circular representation you should be able to make a good estimation of the direction. Once the house is sketched on the circle, use your compass to locate the point at which the sun rises and sets.

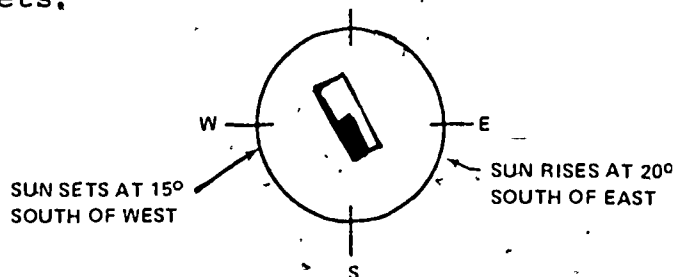

In the example above the house is rectangular and the living area (the family room/kitchen) is represented in black. You can see that the long axis of the house runs slightly W of North by slightly E of South. The points indicating the sunrise direction and sunset are marked. Conclusion: The family room area will receive the afternoon sun and be the "sun warmed" area. This could be beneficial or bad depending on the climate.

Use the circle on the following page to locate your house.
Instructions:

1. Draw in your house's orientation to the compass.
2. Draw in where the sun rises and sets.
3. Where are the living areas (den, family room, kitchen) of your house in relation to the compass? Blacken this area of the house.
4. Are the living areas exposed to morning or afternoon sun?

In addition to the sun, the winds also can be located on a similar drawing. Using the same example, we can illustrate the direction from which the winds affect the house. Information about winds can be found through observation or by inquiring at your local weather bureau, agricultural extension service, or news agencies. There may be slight differences within a local area due to hills or water.

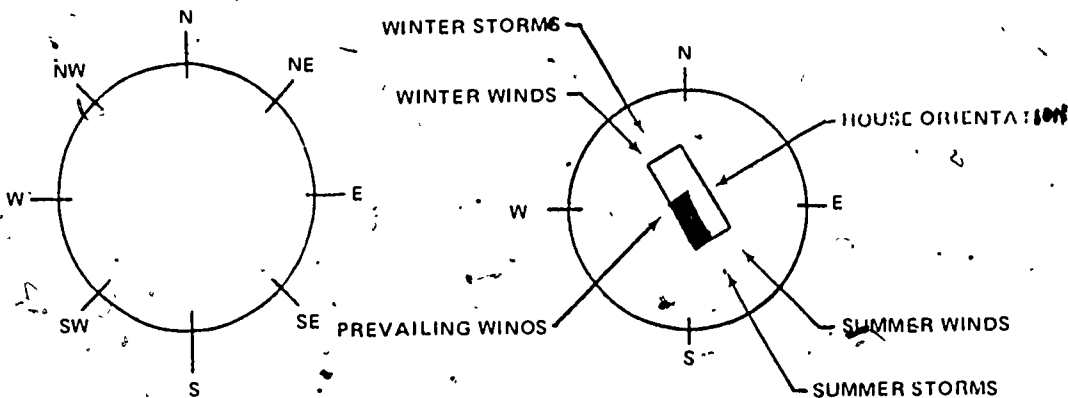

In the example, the living area is only exposed to prevailing winds and slightly to summer storm winds. The winter winds are from the NW, so this side of the example house should not have large window areas on the NW side if it is located in a temperate or cool climate zone.

Use the circle on the right to locate your house.
Instructions:

1. Locate house orientation.
2. Locate prevailing winds.
3. Locate summer winds and summer storms.
4. Locate winter winds and winter storms.
5. Which areas of your house are exposed to storm winds?
 To winter winds?

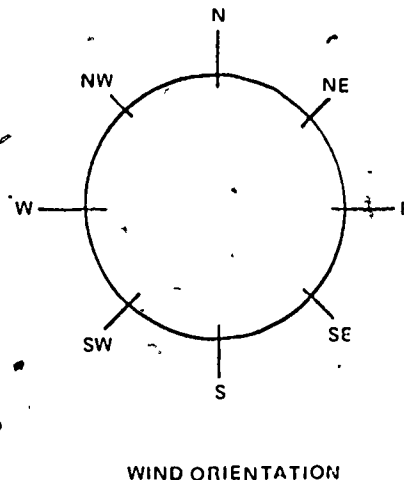

Question: Do you feel your house has a good or poor orientation to the sun and wind? Why?

Suggestion: The teacher may need to demonstrate how to use a compass. Locate the classroom on a circular grid.

TITLE: WINDOW AREA INVESTIGATION

AREA: Science, Home Economics, Drafting

OBJECTIVE: To determine the percentage of square footage of window area to total wall area and total floor area.

MATERIALS: Yardstick

ACTIVITY: Since glass has much less insulative value than a wall, it is wise to use as little glassed area (windows) as possible to conserve energy for cooling and heating. There are building code restrictions and guidelines for the amount of glassed area: 10 percent of the total square footage of floorspace for the home and less than 20 percent of the total square footage of the exterior wall are generally accepted standards for residences.

It is a simple arithmetic procedure to determine if your home or classroom meets these guidelines. First try the 10-percent-of-the-floor method. In the example below, we see the square footage of the room is 300 square feet.

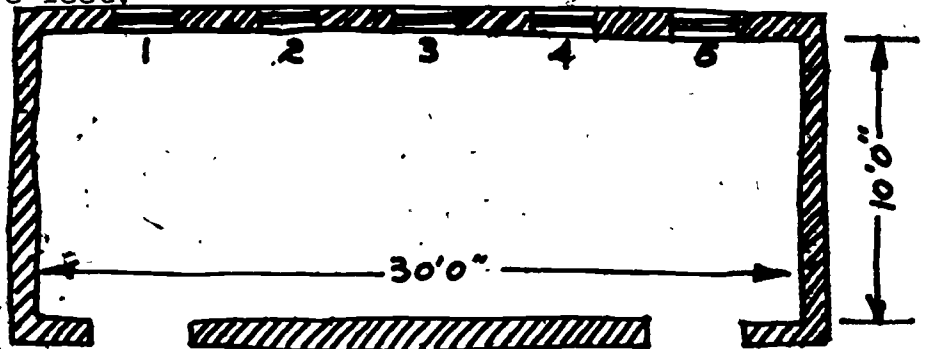

From the elevation, we see the total glassed area is 30 square feet.

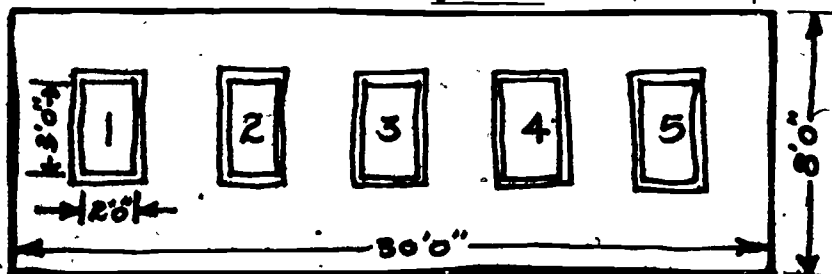

To determine the percentage of glassed area you simply divide:

$$\frac{30}{300} \text{ glassed area} = .10 \text{ or } 10\%$$

Now try the 20-percent-of-total-wall-area method. In the example, the total wall area is 240 sq. ft., since $8' \times 30' = 240 \text{ sq. ft.}$ The glassed area is 30 sq. ft. Therefore, the percentage of glassed area is:

$$\frac{30}{240} = .125 \text{ or } 12.5\%$$

Using either method, the glassed area is within the guidelines.

Now determine if your classroom or home meets the guidelines.

Method I: 10% of floor area

Total Floor Area _____ sq. ft.

Total Glassed Area _____ sq. ft.

$$\frac{\text{glassed area}}{\text{floor area}} = \frac{\quad}{\quad} = \frac{\quad}{\quad} \%$$

Method II: 20% of wall area

Total Wall Area _____ sq. ft.

Total Glassed Area _____ sq. ft.

$$\frac{\text{glassed area}}{\text{walled area}} = \frac{\quad}{\quad} = \frac{\quad}{\quad} \%$$

Suggestions:

1. Try both methods in the classroom before trying to tackle your home.
2. This makes a good group activity.
3. This activity may be used in conjunction with reading floorplans and measuring interior spaces.
4. Remember to measure only the glassed area of windows--not the frames, too.
5. Note that weather changes will also affect heating and cooling energy uses.

TITLE: HOT WATER AUDIT

AREA: Home Economics, Science

OBJECTIVE: To demonstrate a family's hot water consumption and possible conservation measures.

ACTIVITY: The major uses of hot water in the home are for bathing and laundry. Use the data sheet provided to estimate your family's hot water consumption for a week.

Task	Number of times/week	Multiplier (in gallons)	Quantity of Hot Water (in gallons)
laundry loads		15	
tub baths		25	
showers		20	
dishwasher loads		10	
washing dishes by hand		5	

Total--

Tally the number of times per week the task using hot water occurs. Then multiply the number of times by the multiplier provided. The multiplier is the average amount of hot water required for the task. The resulting value is the quantity of hot water consumed for the task. Then add the quantities for each task to arrive at an estimate of the hot water your family uses in one week. (The average household uses about 350 gallons of hot water per week.)

You can now approximate the energy required to supply this quantity of hot water.

$$\frac{\text{quantity of water}}{\text{gallons}} \times 2.45 \text{ watt-hours/gal.} = \text{watt-hour}$$

If you use _____ gallons per week, you use approximately 52 times that per year or _____ gallons.

Calculate the energy cost for a year's consumption:

$$\frac{\text{quantity of water}}{\text{gallons}} \times 2.45 \text{ watt-hours/gal.} = \text{watt-hours}$$

This is _____ kwh for one year (just move the decimal 3 places to the left.) Find out the rate in your area for electricity per kwh and determine the cost of one year's hot water consumption.

$$\frac{\text{yearly energy consumption for hot water}}{\text{kwh}} \times \frac{\text{cents}}{\text{rate kwh}} = \$ \underline{\hspace{2cm}}$$

How could you save money and energy for hot water at your house?

Some things to look for if your hot water consumption is high:

1. Check your water heater's thermostat--it should be set at 140 degrees F or less.
2. Check for leaks.
3. Are the hot water pipes insulated?
4. Is the water heater insulated?

Suggestions:

1. Students should bring in their tallies of frequencies from home and do the calculations as a class.
2. All of the figures and calculations in this activity are based on averages and estimates and do not indicate actual hot water use.

TITLE: ENERGY USAGE AT HOME

AREA: Multi-disciplinary

OBJECTIVE: To provide the awareness of energy usage in the home.

MATERIALS: Provided

ACTIVITY: Have the student check the correct box or write in the missing information in the spaces provided on energy usage at home.

1. I live in a private home apartment.
2. My family does receive does not receive an electric bill.
3. The number of persons living in my home or apartment is _____.
4. This includes _____ adults _____ children.
5. There are _____ persons living in my home or apartment who are home during the day.
6. The major appliances in my home or apartment include:

APPLIANCE	NUMBER (write "0" if you do not have the appliance)	NUMBER OF HOURS OF USE PER WEEK
Television set		
Radio		
Refrigerator		
Freezer (separate from refrigerator)		
Electric range		
Dishwasher		
Washing machine		
Electric clothes dryer		
Air conditioning unit (Number of hours in use during average SUMMER week)		
Electric heating system		

NOTE: There are 168 hours in one full week.

7. Family energy usage (kwh) during the period of the most recent electric bill:

_____ kwh x price per kwh _____ = monthly Bill _____

TITLE: EFFECTS OF PLANTS

AREA: Science, Social Studies, English

OBJECTIVE: To determine the effect vegetation has on energy consumption and comfort.

MATERIALS: The students' homes

ACTIVITY: Trees and plantings are often leveled in an area prior to residential development with little regard for their economic and esthetic values. The trees, shrubs, ground covers, vines and flowers temper the impact of sun and wind on the home. Vegetation can shield a home from unwanted sun and wind, but still admit desirable sun and breezes. Because of the angle of the sun and the effects of seasonal changes, most homes need protection from the sun during summer on the south, west, and east sides, and protection from wind during winter on the north side. Of course, there are regional variations. Investigate the N, S, E, and W sides of your home and determine if the vegetation is beneficial and where additional vegetation is needed. Make your comments in the space provided.

North Side:

Trees _____

Shrubs _____

Does the vegetation make a good wind shield?

South Side:

Trees _____

Shrubs _____

Ground cover _____

Vines _____

Does the vegetation make a good sun shade? Are most of the trees deciduous?

West Side:

Trees _____

Shrubs _____

Ground cover _____

Vines _____

East Side:

Trees _____

Shrubs _____

Ground cover _____

Vines _____

Have a landscape architect or nurseryman visit the class to discuss different types of vegetation and their effects on home heating and cooling needs.

Investigate the vegetation around the school and make recommendations to the school administration for additional plantings if they would be beneficial.

Have the students write an exposition about how vegetation or the lack of vegetation have an effect on energy consumption in their home.

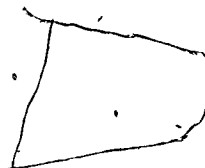

TITLE: AUTOMOBILE COMPARATIVE SHOPPING

AREA: Consumer Education

OBJECTIVE: To distinguish between transportation needs and transportation desires when purchasing automobiles considering economic and environmental factors.

MATERIALS: Automobile dealers, consumer and auto magazines, Blue Book

ACTIVITY: Discuss the relationship between each of the following pairs of factors:

- size and cost
- size and gas consumption
- options and gas consumption
- frequency of repair and options
- cost of maintenance and size

Are autos, whichever type one purchases, used efficiently? Explain, considering the efficacy of car pools and improved public transportation in light of the recent oil shortage.

Do dealers' statements on performance differ from test results as reported by consumer and trade magazines? Give details.

CONSUMER EDUCATION

What factors will be most important in helping you decide which car to buy?

Can we continue to justify the production of 10 million autos a year? Explain.

What environmental problems are created by the automobile? Which can be solved by diligent effort, and which may never be remedied?

(Environmental Understandings: Individuals should become well informed about the best ways to manage and conserve our energy supplies. Choices between essential needs and nonessential desires are often in conflict. The waste of natural resources can limit the options available to future generations.)

TITLE: GASOLINE RATIONING

AREA: Social Studies

OBJECTIVE: To become aware of problems associated with gasoline rationing in the United States.

MATERIALS: See activity.

ACTIVITY: Review with the class the U. S. experience with gasoline rationing. As a homework assignment, urge students to discuss with grandparents or other older persons their judgments about the effectiveness of the gasoline rationing system used during World War II.

Discuss as a class, or in small groups, the applicability of such a rationing system in the United States today. In the event that a very severe gasoline shortage predicted by some people actually develops is rationing inevitable? What other options are available?

BACKGROUND: When the U. S. rationed gasoline during World War II there were about 25 million automobiles on the road. In 1975 the country had registered, according to the World Almanac, more than 130 million vehicles.

A complex system that often led to black marketing and other efforts to bend the rules was created to ration gasoline "fairly." Car owners received "A," "B," "C," or "X" stickers that were pasted on the auto windshields. The "A" sticker entitled the car owner to a basic ration of four gallons a week which was later reduced to three gallons. The "B" sticker entitling the owner to extra gas was given to persons who could prove their cars were needed to get to work. The "C" sticker, and more gasoline, was given to workers such as physicians who could prove that extra gasoline was necessary in their job. The "X" sticker exempted a vehicle from rationing and was available to very few drivers.

Ration books and stamps accompanied stickers. Buying gasoline required stamps as well as money. The service-station operator was required by the Office of Price Administration to turn in stamps to account for all the gasoline he purchased and sold.

Speed limits were reduced to 35 miles per hour and a driver caught speeding could lose his gasoline ration.

During a period in 1943 when the gasoline "A" ration was three gallons per week, the Office of Price Administration banned all "pleasure driving." Essential

driving was defined by OPA to include "necessary" shopping, getting medical attention, attending funerals or church services, and meeting emergencies involving threats to life, health, or property.

While OPA reported good compliance by a large majority of motorists, a black market developed using counterfeit or stolen stamps. By the summer of 1944 several hundred black marketers had been convicted and several thousand drivers had their gasoline rations revoked for using illegal stamps.

TITLE: GOOD GASOLINE MILEAGE

AREA: Science, Driver Education

OBJECTIVE: To measure student ability to obtain good gasoline mileage.

MATERIALS: Quart of gasoline

ACTIVITY: It should be possible, at relatively small expense, to modify the fuel system of the school's driver education car so that mileage obtained from a quart of gasoline might be determined.

Near the end of the driver education program, each student in the class should be given the challenge of coaxing maximum mileage from the quart of gasoline allotted to him. Students should be interested in seeing how they rank when compared with others in the class. If it is possible to establish driving conditions that do not vary much, the instructor may wish to establish a minimum mileage figure as one of the conditions for passing the course.

This activity should emphasize to students the importance of factors that affect gasoline mileage such as motor tuning, tire pressure, rapid acceleration, excessive braking, and steady rate of driving.

TITLE: INDIVIDUAL GASOLINE SAVINGS

AREA: Math

OBJECTIVE: To investigate the importance of individual gasoline savings.

MATERIALS: Paper
Pencil

ACTIVITY: Share with your class the following information:

There are more than 100 million registered automobiles in the U. S. A typical car, with an average fuel economy of less than 13.7 miles-per-gallon, travels about 10,000 miles each year--and consumes well over 700 gallons of gasoline.

Altogether, these automobiles consume some 70 trillion gallons of gasoline each year--or about 14 percent of all the energy used in the United States, almost three-quarters of all gasoline used and 28 percent of all petroleum.

The importance of individual gasoline savings cannot be overemphasized. If, for example, the fuel consumption of the average car were reduced just 15 percent through fewer daily trips, better driving practices, and better maintenance, the nation's consumption of petroleum would fall by over 680,000 barrels per day, or about 4 percent of demand.

If every automobile consumed one less gallon of gasoline a week (an average of about 13 miles of driving), the nation would save about 5.2 billion gallons a year, or about 7 percent of the total passenger car demand for gasoline. Survey your students to ascertain the number of cars in each family.

Calculate the number of gallons of gasoline that could be saved by your students' families per year if each driver consumed one less gallon of gasoline per week.

Using the current cost of gasoline per gallon, calculate the amount of money that your class's families could save.

TITLE: GASOLINE USAGE BY AMERICAN MOTORISTS

AREA: Math

OBJECTIVE: To dramatize the enormous amount of gasoline used by American motorists.

MATERIALS: 42-gallon barrel
Pencil
Paper

ACTIVITY: Secure from the school custodian a 42-gallon barrel or have someone as an art project make a profile of a barrel to be displayed on a classroom wall. On the barrel or paper facsimile show the percent of oil used to make gasoline, jet fuel, and other products depicted on the drawing below.

Ask each child, as a homework assignment, to bring to class the actual mileage on the speedometers of their family car(s). Ask, also, that a parent estimate the average miles per gallon for the car(s). (If the mileage can't be estimated readily, use 15 mpg which is slightly better than the national average.)

Using the data brought to class, have each child calculate the number of gallons of gasoline that have been burned in his family car(s). How many barrels of crude oil were needed to produce that amount of gasoline? How many gallons of gasoline and barrels of oil have been used in the total class's family cars?

If every classroom in the school used gasoline at the same rate how much has been used by the entire school?

What, if anything, is being done by some families to curtail gasoline consumption?

WHERE THE OIL GOES

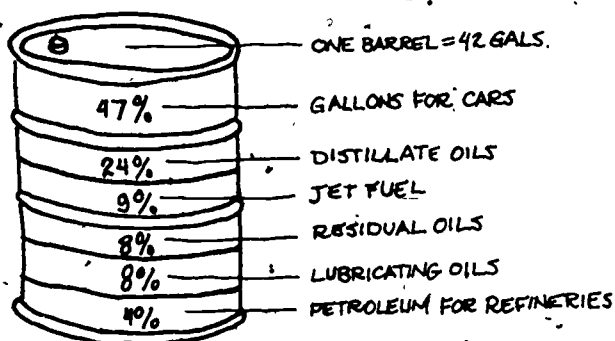

TITLE: TRUCKING AND 55 MPH

AREA: Social Studies

OBJECTIVE: To examine reasons why the trucking industry is opposed to the national 55 mph speed limit.

MATERIALS: Paper
Pencil

ACTIVITY: Review with the class the condition outlined briefly above which indicates that simple economics suggests that the 55 mph speed limit hurts truckers and the trucking industry.

Choose three members of the class to defend the truckers' position. Challenge the rest of the class to come up with all agreements they can to persuade the truckers that they should accept and obey the lower nationwide speed limit.

BACKGROUND: The opposition of interstate truck drivers to the 55 mph speed limit is well known. Equally well known is the fact that on some stretches of interstate highways, large tractor-trailers are driven at average speeds closer to 65 than to 55.

Many truckers are paid on the basis of miles driven in a 10-hour work period. The teamster rate in Columbus, Ohio in the fall of 1978 was quoted at 23.050 cents per mile. Thus, a higher highway speed that enables a trucker to travel an additional 100 miles per day results in an additional \$23 of wages earned. The additional fuel charge for the higher speed would, according to teamster officials, be less than half of the additional income.

TITLE: TRANSPORTATION AND ENERGY

AREA: Multidisciplinary

OBJECTIVE: To help students develop an understanding of energy consumption and conservation in the transportation sector.

MATERIALS: Provided

ACTIVITY: It is said that Americans travel farther and faster than any other people in the world. Transportation (fuel manufacturing and maintenance, highways) accounts for about 42 percent of our total energy budget in the United States. There is great potential for saving energy in the transportation sector.

Have students conduct research and contact organizations to learn more about conserving energy through transportation. As a result of their research, they should prepare a plan for themselves and their families. In conducting research, students should consider the following points:

1. Methods of making vehicles more energy-efficient.
2. Methods of saving energy in manufacturing and maintaining vehicles.
3. Methods of saving energy in road construction and maintenance.
4. Driving habits which result in energy conservation (e.g., fewer rapid accelerations, less quick braking).
5. Kinds of energy conservation legislation to mandate or encourage energy conservation through transportation (e.g., 55 m.p.h. speed limit, right-turn-on-red-after-stop).
6. Requirement of pollution control devices.
7. Advantages/disadvantages of radial tires, ignition-systems, streamlining designs, increasing passengers per vehicle, abandoning automatic transmissions.
8. Salvaging metals, etc., from junked vehicles.
9. Unnecessary trips or travel.
10. Ways to conserve energy while on vacation.
11. Growth, decline, advantages, and disadvantages of travel by walking, bicycle, automobile, bus, railroad, water, airplane.
12. Alternatives to individual transportation: car-pools, vanpools, mass transit.

CONTACT ORGANIZATIONS:

1. Energy Research and Development Administration, 20 Massachusetts Avenue, NW, Washington, D.C. 20545.
2. Environmental Protection Agency, 401 M Street, SW, Washington, D.C. 20460.

3. Federal Energy Administration, 12th and Pennsylvania Avenue, NW, Washington, D.C. 20461.
4. Tennessee Valley Authority, 400 Commerce Avenue, Knoxville, Tennessee 37902.
5. Department of Transportation, 400 Seventh Street, SW, Washington, D.C. 20590.
6. American Petroleum Institute, 1801 K Street, NW, Washington, D.C. 20006.
7. General Motors Corporation, General Motors Building, Room I-101, Detroit, Michigan 48202.
8. Transportation Research Center, South Stadium, The University of Tennessee, Knoxville, Tennessee 37916.

TITLE: TRANSPORTATION: CARPOOLING AT SCHOOL

AREA: Multidisciplinary

OBJECTIVE: To help students understand the savings which can be achieved by carpooling.

MATERIALS: Provided

ACTIVITY: Using the following information, have students figure the costs of commuting to and from school:

Car Size	Vehicle Cost Depreciated	Maintenance Accessories, Parts & Tires	Gas & Oil (Excluding Taxes)	Insurance	State and Federal Taxes	Total Cost (per mile)
Standard	4.5¢	3.7¢	5.5¢	1.7¢	1.6¢	= 17¢
Intermediate	4.2¢	3.4¢	5.3¢	1.6¢	1.5¢	= 16¢
Compact	2.9¢	2.7¢	4.7¢	1.5¢	1.2¢	= 13¢
Subcompact	2.3¢	2.5¢	3.8¢	1.5¢	0.9¢	= 11¢

Adapted from U. S. Department of Transportation-Federal Highway Administration Section.

EXAMPLE: How to figure your present commuting cost (Standard car-Ford LTD) traveling 30 miles round trip.

1. MULTIPLY (.17) x (30) = \$5.10
(Cost (Miles.
per per
mile) day)
2. ADD
Daily parking cost + 0.
3. TOTAL DAILY COST \$5.10
4. MULTIPLY DAILY COST
By number of
school days per month x 21
5. COST PER MONTH TO
DRIVE ALONE = \$107.10
- *6. DIVIDE BY NUMBER OF
PEOPLE IN CARPOOL ÷ 4

*IMPORTANT = For a successful carpool when the driver-owner does all the driving, fair share rates should be figured on paying riders only. The driver-owner should ride free.

7. NEW INDIVIDUAL COST
BY CARPOOLING = \$ 26.77

8. MONTHLY CARPOOL
SAVING (\$107.10
-26.77) = \$ 80.33

1. MULTIPLY $\frac{\text{Cost}}{\text{per mile}}$ X $\frac{\text{Miles}}{\text{per day}}$ = \$ _____

2. ADD
Daily parking cost _____

3. TOTAL DAILY COST = _____

4. MULTIPLY DAILY COST
By number of school
days per month X _____

5. COST PER MONTH TO
DRIVE ALONE = _____

6. DIVIDE BY NUMBER OF
PEOPLE IN CARPOOL \div _____

7. NEW INDIVIDUAL COST
BY CARPOOLING = _____

8. MONTHLY CARPOOL SAVING
(#5-#7) = _____

CONTACT ORGANIZATIONS:

1. Transportation Research Center, The University of Tennessee, South Stadium Hall, Knoxville, Tennessee 37916.
2. Tennessee Energy Office, Suite 250, Capitol Hill Building, 7th and Union, Nashville, Tennessee 37219.
3. U. S. Department of Transportation, 400 Seventh Street, SW, Washington, D.C. 20590.
4. Tennessee Department of Transportation, 817 Highway Building, Nashville, Tennessee 37219.

TITLE: LIFESTYLES VS. ENERGY COST

AREA: Social Studies, Language Arts

OBJECTIVE: To examine the relationships between lifestyles and energy costs.

MATERIALS: Use of the library

ACTIVITY: Review with the class the fact that gasoline sells for \$3.00 or more per gallon in many European countries such as Switzerland, Holland, Denmark, France, and Great Britain.

Divide the class into groups of three or four students. Ask each group to think about and develop a list of ways in which "lifestyles" in those countries with high gasoline costs is likely to be different from the ways people live in the U. S. A. where gasoline is cheaper than in any other highly industrialized country. Encourage the groups to think broadly beyond such obvious things as size of automobiles and number of superhighways. Types of family vacations, suburban sprawl, status of railroad passenger service, extent of air travel, use of recreational vehicles and many other elements of our lifestyle can be shown to be related to energy costs.

Ask each group, also, to make value judgments as to whether the lifestyle in high energy cost countries is worse or better than ours. Ask each group to state its conclusion on one or two specific examples and defend its position before the class.

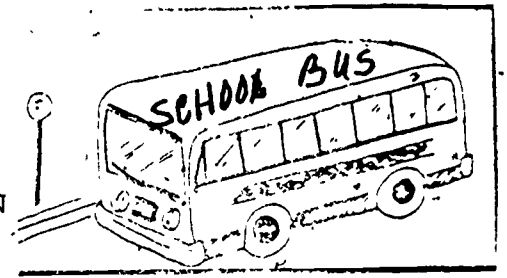

TITLE: THE STUDENT AND TRANSPORTATION

AREA: Science, Mathematics

OBJECTIVE: To determine the energy required to transport students to school.

MATERIALS: Provided

- ACTIVITY:
1. Review the students' general concepts in the natural production of fossil fuels. Direct the discussion to petroleum specifically. Have students determine what volume of crude oil is necessary for the production of a gallon of gasoline.
 2. Discuss with the students the need for transportation. Have students list the various modes of transportation. Direct student discussion to school bus transportation.
 3. Have a student call the school bus garage to find out the number of buses operating at the high school. Also find out the miles driven by the buses per day and the average number of miles per gallon. Calculate the number of gallons of gas consumed by the buses per year.
 4. Have several students count the number of student cars in the parking lot. Calculate the average number of miles driven by students to and from school.
 - a. Calculate the gallons of gas per student (annually) if all the students rode buses.
 - b. Calculate the gallons of gas per student (annually) including both gas consumed by buses and by student drivers.
 5. Students should then break up into small groups to determine the most efficient mode of transportation. They should discuss reasons why the most efficient method is or is not used.
 - a. If the most efficient consumption of fuel is not being used, what impact is this on local social standing and on environmental damage?
 - b. What suggestions do you have for more efficient use of this fossil fuel?
 - c. In the event of another fuel shortage, what could be done by students to conserve fuel?

TITLE: ENERGY SAVING VACATION SUGGESTIONS

AREA: Social Studies, Language Arts

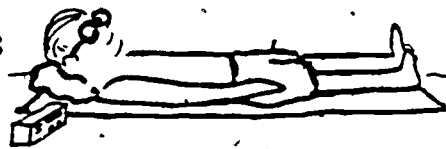

OBJECTIVE: To investigate energy saving vacation suggestions.

MATERIALS: Pencil
Paper

ACTIVITY: Ask students to write a summary report of their last family vacation. Where did they go? What did they see that they remember? What unusual activities were available at the vacation site? How many miles did they travel?

When some of these reports are read (possibly orally to the class), it will become apparent that some families traveled extensively during their two-or three-week vacation time.

Present to the class the following trips to save energy while taking vacations from the reference cited above.

Vacation at home this year.
Discover nearby attractions.

Choose a hotel or campground close to where you live. A nearby hotel or campground often can provide as complete and happy a change from routine as one that is hundreds of miles away.

Plan to stay in one place if you vacation away from home. "Hopping around" takes transportation energy.

Take a train or a bus instead of the family car. Save gasoline and relax.

Rediscover the pleasures of walking, hiking, and bicycling during your vacation. They're the most energy-conserving means of transportation and the healthiest for most people.

Save energy at home if you're going away. Remember to turn off lights, lower heating temperatures in winter, and turn off air-conditioning in summer.

Discuss the suggestions. Would it be possible to have a great vacation if a family followed one or more of the ideas? Which ones?

Finally ask that pupils review the suggestions with their parents. Ask each pupil to report briefly, in writing, parental reaction to the advice.

TITLE: WHAT DOES IT COST TO GET TO SCHOOL?

AREA: Multidisciplinary

OBJECTIVE: To examine the cost of bus transportation for students.

MATERIALS: Read activity section.

ACTIVITY: Students will need to obtain certain information about their bus route to do the activity. The information may be obtained by personal observations or by interviews with the bus driver. Students who do not ride a bus may be paired or grouped with students that do ride a bus for performing the calculations in this activity.

How much does your daily bus ride cost?

- a. What is the distance of your bus route? _____
- b. At 4 mpg, how much gasoline is used?
(# miles ÷ 4 mpg = # gallons) _____
- c. At \$.95/gallon, how much does the trip cost? (# gallons x \$.95 = cost) _____
- d. How many students ride your bus? _____
- e. How much does the trip cost per student? _____

How much time during your daily bus ride is the bus engine running while the bus is not moving (idling)?

- a. How many stops are there on your bus route? _____
- b. What is the total time that the bus is stopped during the trip? _____
- c. What is the average time per stop? _____
- d. What is the mpg while the bus is stopped? _____

How much does pupil transportation for your school cost?

- a. How many buses bring students to your school? _____
- b. If each bus uses as much gasoline as your bus (l.b.), how much gasoline is used by your school per day? _____
- c. At \$.95/gallon, how much does this gasoline cost the state each day? _____

If gasoline costs \$1.19/gallon and the state pupil transportation system uses 101,000 gallons each day:

- a. How much does it cost each day? _____
- b. How much does this cost for the school year of 180 days? _____

c. How much more would it cost for the school year if gasoline were \$1.50/gallon?

What other things besides idling time would increase the amount of gasoline used for pupil transportation?

What can you as a student riding the bus do to help save gasoline?

NOTE TO THE TEACHER:

For #2, you may want to have the student in your class who boards a particular bus first record the actual time for each stop on the route. Compare this actual time with the recommended time for each stop.

The fall, 1979 issue of The Energy Conserver contained a mini-lesson on transportation regarding private cars and carpooling. It also included a chart comparing different modes of travel which shows that buses are the most efficient of those considered. You may want to refer to that mini-lesson in conjunction with this one.

NATIONAL ENERGY EDUCATION DAY

President Carter signed a proclamation designating March 21, 1980 as National Energy Education Day. It marked the beginning of an ongoing one-year program to culminate on National Energy Education Day, March 20, 1981. The 96,000 schools across the nation will be asked to prepare for the 1981 observance by organizing committees in early September to plan for the March event.

444

Distances can be obtained from a city or county map, the car odometer, or by estimation (one city block is about one-eighth of a mile).

1. Using the completed data form, do you see possibilities for energy savings?
2. Are there trips by car of less than half a mile in distance?
3. Could several trips have been combined into one?
4. Could shopping be done on the way to or from work or school?
5. Could marketing have been done closer to home?
6. Could carpooling for shopping with neighbors be a possibility?
7. What recommendations would you make to your family for ways to conserve energy when marketing?

Suggestions:

Survey the students at large to determine how they travel from home to school and back. Discuss findings and recommendations in class.

ENERGY FUTURES

1. Solar energy will assist the energy pool by 1990, and about 10 percent of our energy needs will be filled by solar energy in the year 2000. Photovoltaic cells will be cheap enough to be affordable by the average homeowner in 1990. It is predicted that solar energy will fill 80 percent of our energy needs by the year 2200.
2. Synthetic fuels will provide little of our energy needs by 1990.
3. Nuclear power plants will help reduce the need for foreign oil by 1990. Nuclear power will peak by the year 2050 and solar will gradually take over as our major energy source. Fusion power could contribute significantly to the generation of electricity by the year 2030.
4. Fast breeder reactors could provide abundant energy for centuries. The U.S. Government has halted the development of breeder reactors. Other countries in the world are developing them and selling them to countries with few energy resources. It remains to be seen what the U.S. Government will do in the future.
5. There are ample supplies of coal. It is our most important energy source at present. Long-range predictions indicate it will provide about 20 percent of our energy needs in the year 2200.

The above are the important technical variables in the energy picture for the future. The other variables are human centered. The amount of energy conserved by human beings is dependent on their "energy ethic." Will people conserve gas by carpooling? Will the price of gasoline force many people to drive less? What will our relations with the OPEC countries be? How will developing countries expand into technologies utilizing more energy? Will population growth decrease in the world? These are people problems and they all have important imports on future energy use and reserves.

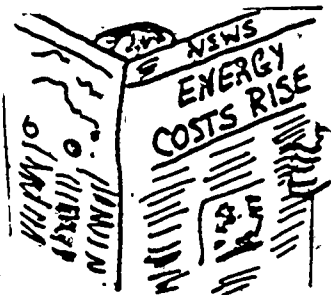

GLOSSARY

- alpha particle -the positively charged nucleus of a helium atom.
- ampere -a unit of measure for electric current, the charge flow per unit time. It is equivalent to a flow of approximately 6×10^{18} electrons per second.
- atom -the basic unit of all matter. It has a central core, with one or more electrically charged particles whirling around it.
- atomic number -the number of protons in the nucleus of an atom, and also its positive charge. Each chemical has its characteristic atomic number.
- atomic weight -the mass of an atom relative to other atoms. The unit of the scale is 1/12 the weight of the carbon-12 atom, or roughly the mass of one proton or one neutron.
- barrel -a liquid measure of oil, usually crude oil, equal to 42 gallons or about 306 pounds.
- bituminous coal -soft coal; it is high in carbonaceous and volatile matter.
- breeder reactor -a nuclear reactor that produces more fissionable fuel than it consumes.
- British Thermal Unit (BTU) -a unit of heat energy equal to the quantity of heat necessary to raise the temperature of one pound of water one degree Fahrenheit. It is equal to 1/4 of a Calorie.
- calorie -a unit of heat energy equal to the amount of heat that will raise the temperature of one kilogram of water 1° Centigrade.
- carbon dioxide -a compound of carbon and oxygen formed whenever carbon is burned.
- carbon monoxide -a compound of carbon and oxygen produced by the incomplete combustion of carbon. It is emitted by automobiles and is the major air pollutant on the basis of weight.
- celsius -the Centigrade temperature scale is sometimes known as the Celsius scale.

Centigrade	-a temperature scale in which the temperature of melting ice is set at 0°, the temperature of boiling water at 100°.
chemical energy	-energy stored in molecules, as in fossil fuels.
clean fuel	-usually means fuel in which there is very little sulfur.
coal	-a solid fuel, mostly carbon, formed from the fossils of plants living hundreds of millions of years ago.
coal gas	-the volatile, combustible gas driven from coal in coke-making.
coal gasification	-the conversion of coal to a gas suitable for use as a fuel.
coal liquification	-the conversion of coal into liquid hydrocarbons
coal tar	-a gummy, black substance produced as a by-product when coke is produced.
coke	-degassed coal, a porous, solid residue resulting from the incomplete combustion of coal.
combustion	-burning. Any very rapid chemical reaction in which heat and light are produced. Most familiar combustions are unions with oxygen.
conservation	-preservation from loss or waste. Finding the wisest possible use of nonrenewable, exhaustible energy sources.
conservation	-a process by which energy is converted from one form to another, such as radiant energy to heat or electric energy.
coolant	-anything pumped through a nuclear reactor to cool it or absorb the heat it produces. Common coolants are water, air, helium, and liquid sodium metal.
cracking	-processing that breaks down and rearranges the molecular structure of long hydrocarbon chains. It is used in the production of fuels such as gasoline from crude oil.

- critical mass -the smallest amount of nuclear fuel, like uranium, that will sustain a nuclear chain reaction of splitting atoms.
- crude oil -petroleum as it comes from the ground.
- demand -the rate at which electric energy is delivered to or by a system at a given instant or averaged over a period of time, expressed in kilowatts or other units.
- depletion allowance -a federal tax exemption for a portion of the net income received from producing a natural resource. The amount of the exemption is based on the perceived importance of the energy resource.
- deuterium -a hydrogen isotope, the nucleus of which contains one proton and one neutron.
- distillate oils -any fuel oil, gas oil, topped crude oil or other petroleum oil derived by refining or processing crude oil, which has a boiling range from 500°F to 1200°F.
- ecology -the science dealing with the relationship of all living things with each other and with their environment.
- efficiency -measures the amount of useful energy we get out, divided by the amount of energy we put into a machine; usually expressed as a percentage.
- electric current -a flow of charged particles, usually electrons.
- electricity -energy derived from electrons in motion.
- electrical energy -the energy associated with electric charges and their movements, and measured in watt hours or kilowatt hours.
- electron -an elementary particle with negative charge which circles the nucleus of an atom.
- energy -the ability to do work.
- environmental cost -all forms of energy extraction, conversion, and use exact a toll on our environment. The advantages of a particular energy use must be weighed against its effects on the environment.

environmental impact statement	-analytical statements that attempt to balance costs and benefits of projects from an environmental as well as economic point of view.
engine	-machine that converts fuel into energy and energy into power.
extraction	-retrieval of fossil fuels from the earth.
fermentation	-a process in which carbohydrates are changed to hydrocarbons by the action of microorganisms.
First Law of Thermodynamics	-states that energy can neither be created nor destroyed.
fission	-the splitting of a nucleus of one atom into two or more smaller atoms; fission often releases large quantities of energy.
fission products	-the smaller atoms formed when atoms fission or split.
force	-a push or a pull.
fossil fuels	-fuels derived from the fossil remains of organic materials; includes petroleum, natural gas, coal, oil shale and tar sands.
friction	-resistance to motion of two adjacent surfaces.
fuel	-anything converted from one form to another with release of energy to perform useful work.
fuel cell	-battery-like, portable electric generators producing current from the reaction of hydrogen and oxygen.
fusion	-the process of combining the nuclei of two light atoms to form a heavier atom; fusion can release great quantities of energy. The sun produces its energy by fusion.
gasoline	-a refined petroleum distillate composed primarily of light hydrocarbons. Most gasoline is produced by refining crude oil.
generator	-a device which produces electric energy from mechanical energy.
geothermal energy	-the heat energy in the earth's crust whose source is the earth's molten interior.

- geothermal steam -steam formed by underground water seeping through hot rocks deep beneath the earth's surface.
- greenhouse effect -the warming effect of carbon dioxide in the atmosphere.
- Gross National Product (GNP) -a measure of economic activity; the total market value of all goods and services produced in a country.
- half-life -the time in which half the atoms of a particular radioactive substance disintegrate to another nuclear form.
- heat -a form of kinetic energy that flows from one body to another because of the temperature difference between them.
- heavy water -water in which all hydrogen atoms have been replaced by deuterium.
- horsepower -a standard unit of power equal to 746 watts.
- hydrocarbon -an organic material found in nature that contains two elements, hydrogen and carbon.
- hydroelectric -using the force of falling water to turn the wheel of a turbine-generator to make electricity.
- hydropower -power produced by falling water.
- inertia -the resistance of an object to a change of state regarding its motion.
- ionization -removal of some or all electrons from an atom, leaving the atom with a positive charge, or the addition of one or more electrons, resulting in a negative charge.
- isotope -any or two or more species of atoms having the same number of protons in the nucleus but with differing numbers of neutrons.
- joule -a metric unit of work or energy; the energy produced by a force of one newton operating through a distance of one meter.
- kerosene -a mixture of hydrocarbons used as a fuel for jet engines and gas turbines.
- kilowatt -a unit that measures the rate at which energy is produced or used. One kilowatt equals 1000 watts.

kilowatt-hour -the basic unit of electrical energy. It equals one kilowatt of power applied for one hour.

kinetic energy -energy possessed by objects in motion.

Laws of Conservation of Energy -energy is neither created nor destroyed.

light -electromagnetic radiation that can affect the eye.

liquefied natural gas -natural gas that has been cooled to approximately -160°C , a temperature at which it is a liquid. The costs of storage and shipment are thus reduced.

machine -any system or object which, through any of a number of processes (burning, chemical reaction, atomic reactions), converts energy in one form (the fuel) into energy in another more used form (the product or output) plus some energy converted to a waste form.

magma -molten rock within the earth's interior.

matter -the substance of which a physical object is composed.

mechanical energy -one form of energy. It is observable as the motion of an object.

megawatt -a unit of power equal to 1000 kilowatts or 1 million watts..

moderator -material, such as water and graphite, used in a nuclear reactor to slow the speed of neutrons produced when atoms split.

molecule -atoms combined to form the smallest recognizable unit of a substance.

natural gas -gaseous fuel formed from the fossils of ancient plants and animals; often found with crude oil.

natural uranium -uranium as it is found in the ground; a mixture of two types of uranium atoms. Less than 1 percent of the atoms in natural uranium are the kind that will produce energy in a nuclear reactor.

neutron -a particle present in all atomic nuclei. Its mass is approximately that of a proton, but it has no electric charge. Neutrons are released in fission and fusion reactions.

nuclear energy -energy within the nucleus of the atom. It can be released by nuclear fission or fusion.

nuclear power -the energy produced by splitting atoms in a nuclear reactor.

nucleus -the extremely dense, positively charged core of an atom.

oil shale -rock formed by silt and mud settling to the bottom of ancient seas that contains a substance similar to crude oil.

organic -materials that once were living or are presently living.

OPEC -The Organization of Petroleum Exporting Countries. An organization of countries in the Middle East, North Africa and South America which aims at developing common oil-marketing policies.

open-pit mining -strip mining for coal.

particulates -the small soot and ash particles produced by burning.

petrochemicals -chemicals removed from crude oil at the refinery and used to make a wide range of products such as plastics, synthetic fibers, detergents, and drugs.

petroleum -an oily flammable liquid that occurs in many places in the upper strata of the earth; fractional distillation yields gasoline, diesel, lubricating oil and other products.

photosynthesis -the process by which green plants convert sunshine into chemicals.

plutonium -a heavy, man-made radioactive metal that can be used for fuel in a nuclear reactor.

potential energy -stored energy due to position or condition.

power -the rate at which work is performed or energy is expended, measured in watts or horsepower.

propane	-inflammable gas obtained from petroleum.
proton	-an elementary particle present in all atomic nuclei; it has a positive electric charge.
radioactivity	-the spontaneous decay or disintegration of an unstable atomic nucleus, usually accompanied by the emission of ionizing radiation.
radon	-a radioactive gas which is formed by the decay of uranium and other radioactive material
recoverable resource	-that portion of a resource expected to be recovered by present-day techniques and under present economic conditions. Includes geologically expected but unconfirmed resources as well as identified reserves.
reserve	-that portion of a resource that has been actually discovered and that is presently technically and economically extractable.
resource	-the total estimated amount of a mineral, fuel, or energy source, whether or not discovered or currently technologically or economically extractable.
Second Law of Thermodynamics	-the inevitable passage of some energy from a useful to a less useful form in any energy conversion.
solar cell	-a device which converts radiant energy directly into electric energy by the photovoltaic process.
solar collector	-a device for collecting solar energy and converting it into heat.
solar energy	-energy radiated directly from the sun.
strip mining	-a mining technique used when deposits of coal lie relative near the surface (less than 100 feet).
temperature	-the hotness or coldness of a substance; the temperature is proportional to the average kinetic energy of the atoms or molecules of a substance.
thermal energy	-heat energy
thermal pollution	-an increase in water or air temperature which disturbs the ecology of the area.

- thermodynamics -the science and study of the relationship between heat and mechanical work.
- thermonuclear reaction -a fusion reaction which is initiated by intense heating.
- tidal energy -energy derived from the rising and falling of ocean tides.
- transformation of energy -changes in energy state from potential to kinetic or kinetic to potential. Energy transformations are brought about by three types of processes: mechanical (physical), chemical, or nuclear.
- transmission -transportation of electrical energy from the point of generation to the point of use. Some energy loss is inevitable in transmission.
- turbine -a bladed, wheel-like device which converts the kinetic energy of a gas or liquid into the mechanical energy of a rotating shaft.
- waste -that which is not useful to one's purposes. Radioactive wastes produced in a nuclear power plant may stay radioactive for a long period of time.
- watt -the amount of power available from an electric current of 1 ampere at a potential of 1 volt.
- work -the conversion of energy which results in the movement of an object from one place to another in response to forces (mechanical, chemical, nuclear).
- x-ray -electromagnetic radiation with a very short wave length (about the diameter of an atom).

FREE/INEXPENSIVE RESOURCES

Department of Energy, Technical Information Center, Box 62, Oak Ridge, Tennessee 37830.

A. Curriculum Materials - free in single copies

1. *Interdisciplinary Student/Teacher Materials in Energy, the Environment, and the Economy - a set of instructional units prepared by NSTA. They include:

The Energy We Use	Grade 1
Community Workers and the Energy They Use	Grade 2
People, Places and Transportation	Grade 3
Energy Networks	Grade 4
The Study of Two Gulfs	Grade 6
Bringing Energy to the People: Ghana and the U.S.	Grades 6-7
The Mathematics of Energy	Grades 7-9
An Energy History of the United States	Grade 8
Energy, Engines and the Industrial Revolution	Grades 8-9
Agriculture, Energy, and Society	Grades 10-12
How a Bill Becomes a Law to Conserve Energy	Grades 9-11-12
Energy in the Global Marketplace	Grade 10
The New Westward Movement	Grade 11
The U.S. Energy Policy - Which Direction?	Grade 12
Energy for the Future	Grade 12

2. Energy Conservation in the Home: An Energy Education Conservation Curriculum Guide for Home Economics Teachers.
3. Award Winning Energy Education Activities for Elementary and Secondary Teachers.
4. Science Activities in Energy - a series of simple, concrete, revealing experiments for 4th, 5th, 6th grades.

Chemical Energy
Conservation
Electrical Energy
Solar Energy

5. Your Energy World - a program of spirit masters for intermediate grades. It consists of four units that take 3-5 periods each. A colorful two-sided wall poster is included.

Energy Overview

Transportation: The Energy Eater
Schools Can Conserve, Too
Energy Use in Homes and Stores

6. Energy History of the United States 1776-1976.
 A 3x4-foot color chart and user's manual.

B. Information Brochures - free in single copies

Coal in Our Energy Future	Nuclear Power Plant Safety
Creating Energy Choices for the Future	Plutonium in the Environment
Energy From the Winds	Safeguarding of Nuclear Materials
Energy Storage	Solar Energy
Energy Technology	Solar Energy for Heating and Cooling
Environment, Health and Safety	Superconducting Transmission of Electric Power
Fuel Cells: A New Kind of Power Plant	Tomorrow's Cars
Fusion	Waste Heat Recovery: More Power from Fuels
Geothermal Energy	Careers in Energy Industries
Heated Water From Power Plants	Energy in Focus: Basic Data (1977)
How Probable is a Nuclear Plant Accident?	Enhanced Recovery of Oil and Gas
Improving Advanced Underground Transmission of Electric Power	Nuclear Power in Space
I've Got a Question About Using Solar Energy	Ocean Thermal Energy Conversion
National Security	
New Energy-Saving Light Bulb	
Nuclear Energy	

C. *Fact Sheets - free in single copies

- | | |
|---------------------------------------|--|
| 1. Fuels From Plants - Bioconversion | 7. Solar Heating & Cooling |
| 2. Fuels From Wastes - Bioconversion | 8. Geothermal Energy |
| 3. Wind Power | 9. Energy Conservation - Homes |
| 4. Energy From the Sun - Photovoltaic | 10. Energy Conservation - Industry |
| 5. Energy From the Sun - Thermal | 11. Energy Conservation - Transportation |
| 6. Solar Sea Power | 12. Conventional Reactors |
| | 13. Breeder Reactors |

14. Nuclear Fusion
15. New Fuels From Coal
16. Energy Storage Technology
17. Alternative Energy Sources - Environment
18. Alternative Energy - Glossary
19. Alternative Energy Sources - Bibliography

D. Atomic Energy Booklets - free in single copies

Atomic Power Safety
Atoms in Agriculture
Fallout From Nuclear Tests
Genetic Effects of Radiation
Nondestructive Testing
Radioisotopes and Life Processes
Your Body and Radiation
The Atom and the Ocean

Delaware Energy Office, P. O. Box 1404, Dover, Delaware
 (1-800-282-8616) distribute copies of several publications including:

Annotated Bibliography of Energy Articles
Tips for Energy Savers (DOE)
Mickey Mouse and Goofy Explore Energy (Walt Disney)
How to Save Money by Insulating Your Home
Mickey Mouse and Goofy Explore Energy Conservation
Walt Disney

Exxon U.S.A., Public Affairs Department, P. O. Box 2780, Houston, Texas 77001. Energy Outlook 1977-1990.

Shell Answer Books, P. O. Box 61609, Houston, Texas 77208.

Gasoline Mileage Book
Rush Hour Book

League of Women Voters, 1730 M Street, Washington, D.C. 20036.
 Fifteen fact sheets on various energy forms available at a cost of \$1/set.

Ambiente Environmental Concerns, P. O. Box 13622, San Antonio, Texas 78213. Slash Your Energy Bills, an energy guide prepared especially for schools, filled with usable energy conservation methods. Cost \$1.35 each.

Worldwatch Institute, 1778 Mass. Ave., Washington, D.C. 20036
Publishes several papers (booklets) of a factual nature related to energy problems and trends. Cost is \$2 each.

The Other Energy Crisis: Firewood, 1975
Energy: The Case for Conservation, 1976
Nuclear Power: The Fifth Horseman, 1976
Energy: The Solar Prospect, 1977
Energy Development: Third World Options, 1977
The Solar Energy Timetable, 1979

Resource and Referral Service, the Center for Vocational Education, Ohio State University, 1960 Kenny Rd., Columbus, Ohio 43210.

Resources for School Energy Needs is a mini-list of organizations able to provide assistance to educators in products and services to reduce school energy consumption.

Teaching Aids, Mail Code 3705, Standard Oil Co., P. O. Box 5910-A, Chicago, Illinois 60680.

The Energy Crisis: What You Can Do About It and Living With Energy are two sets of spirit masters and teaching guides for the middle school grades.

Dow Chemical Company, Audio-Visual Dept., 2030 Dow Center, Midland, Michigan 48640.

Energy Crisis II is a set of slides that gives some explanations of the shortages of gas, oil and coal and the impact upon energy costs. Free loan.

American Gas Association, Film Service Library, 1515 Wilson Blvd., Arlington, VA 22209.

Fuel Cells is a filmstrip available free for permanent retention.

The National Coal Association, c/o Modern Talking Picture Service, 2323 New Hyde Park Rd., New Hyde Park, N.Y. 11040.

Coal: An American Asset is a filmstrip available free for permanent retention.

Union Carbide Corporation, Corporate Communication Dept., 4th floor, 270 Park Ave., N.Y., N.Y. 10017.

Petrified River - The Story of Uranium is a 25-page booklet, suitable for the secondary schools, telling how uranium was deposited. Free up to 25 copies.

Atlantic Industrial Forum, Publications Office, 1701 Wisconsin Ave., Washington, D.C. 20014. Informational pamphlets include:

How Nuclear Plants Work
Insuring Nuclear Risks
Savings With Nuclear Energy

Charles Edison Fund, 101 South Harrison St., East Orange, N.Y.
07018. A collection of booklets giving experiments
in energy.

Edison Experiments
Edison Inventions and Related Projects
Electrical and Chemical Experiments From Edison
Electrical Experiments You Can Do
Nuclear Experiments You Can Do
Selected Experiments and Projects From Edison
Thomas Alva Edison - His Fertile Mind Forged
Much of Our Country's Growth
Energy Conservation Experiments You Can Do
How To Build Five Useful Electrical Devices

Energy Challenge, Box 14306, Dayton, Ohio 45414.

The Energy Challenge is an activity program about
energy past, present, and future for secondary
schools. It contains 25 spirit masters.

Free Newsletters

Energy Education, published bimonthly by the National Science
Teachers Association, contains many timely items of
interest to persons concerned with energy education.
Write to NSTA, 1742 Connecticut Ave., N.W., Washington,
D.C. 20009.

American Gas Association Newsletter, published as a series of
Newsletters dealing with different issues in gas
production. Write to AGA, 1515 Wilson Blvd., Arlington,
VA 22209.

Energy Insider, published biweekly by the Department of Energy
has up-to-date information on energy technology.
Write Energy Insider, Department of Energy, Room 7203,
Washington, D.C. 20545.

Weekly Announcements, a compilation of news releases published
weekly by the Department of Energy.

Delaware Energy News, published monthly by the Delaware Energy
Office. Call 1-800-282-8616.

Publications Available at the Technical Information Center
P.O. Box 62, Oak Ridge, Tennessee 37830

ITEM NUMBER	TITLE
EDM-358	A Computer Program that Models Energy Usage In Buildings, DOE-2
EDM-331	A New Start: The National Energy Act
EDM-1128	A Partnership In Saving Energy
EDM-814	Annual Cycle Energy System Aces
EDM-327	Appropriate Technology. Small Grants Program
EDM-345	Be An Energy Miser In Your Home
EDM-019	Careers In Energy Industries
EDM-214	Citizens' Workshops On Energy And The Environment Handbook
EDM-330A	Como Ahorrar Gasolina... Y Dinero (How To Save Gasoline...and Money), Spanish
EDM-377	Consumers Resource Handbook
EDM-347	Dial For Dollars: Set Your Heat At 65 Degrees, Poster
EDM-1116	DOE Information Kit. The National Energy Act
EDM-1104	Don't Be Fuelish, Tips For Motorist, Poster
EDM-206	Emergency Handling Of Radiation Accident Cases: Ambulance-Rescue Squad
EDM-217	Emergency Handling Of Radiation Accident Cases: Firemen
EDM-208	Emergency Handling Of Radiation Accident Cases: Nurses
EDM-210	Emergency Handling Of Radiation Accident Cases: Police
EDM-211	Emergency Handling Of Radiation Accident Cases: Sheriffs
EDM-207	Emergency Handling Of Radiation Accident Cases: Hospital Administrators
EDM-1115	Energy And You
EDM-232	Energy And Your Environment
EDM-1071	Energy Education
EDM-812	Energy From The Winds
EDM-383	Energy Planner
EDM-144	Energy-Saving Checklist For Home Builders, Buyers, And Owners
EDM-353	Energy, DOE And You: Energy Use At DOE
EDM-354	Energy, DOE, And You: DOE Employees' Role In Energy Conservation
EDM-1084	Enhanced Recovery Of Oil And Gas
EDM-1118-2	Fact Sheet. Organization And Functions
EDM-362	Federal Assistance For Energy Inventors
EDM-078	Fossil Energy Oil
EDM-842	Fuel From Farms
EDM-1047	Fuels From Biomass
EDM-526	Geothermal Energy
EDM-050	Guide For The Submission Of Technical

ITEM
NUMBER

TITLE

EDM-338 He Will Thank You For Conserving Energy, Poster
 EDM-1050 Heat Pumps
 EDM-524 Heated Water From Power-Plants
 EDM-1150 Heating With Wood
 EDM-419 High Energy Physics; Big Machines To Look...
 EDM-375 Home Weatherization Charts
 EDM-1133 How To Comply W/The Energy Bldg. Temp. Res.
 EDM-1133A How To Comply W/The Energy Bldg. Temp. Res.- Spanish
 EDM-343 How To Get Better Mileage From Your Car, Poster
 EDM-1086 How To Improve The Efficiency Of Your Oil-Fired
 Furnace
 EDM-364 How To Keep Warm And Cut Your Fuel Bill
 EDM-330 How To Save Gasoline...And Money.
 EDM-1085 How To Understand Your Utility Bill
 EDM-1080 Hydrogen Fuel
 EDM-405 Improving Underground Trans Of Elec. Power
 EDM-351 Infrared--An Energy Tool. New Infrared Can Pinpoint
 Sources Of Heat Loss.
 EDM-080 Insulate Your Water Heater And Save Fuel.
 EDM-1112 Insulating Electric Water Heaters
 EDM-1052 Insulation
 EDM-1095 Integrated Appliances
 EDM-854 Introduction To Solar Heating & Cooling, Design
 And Sizing
 EDM-1097-A La Hormiga De La Energia (Energy Ant), Spanish
 EDM-355 Low Cost No Cost (W/Plastic Cap)
 EDM-356 Low Cost-No Cost, Energy Savers (W/Plastic Cap)
 EDM-409 Magnetic Fusion
 EDM-348 Making Energy Regulations, How The Public Gets
 Involved
 EDM-340 Model Code For Energy Conservation In New Building
 Construction
 EDM-1125 National Energy Plan II
 EDM-342 Not So Fast, Poster
 EDM-346 Not So Fast: Slow Down And Save Gas, Bumper Sticker
 EDM-504 Nuclear Power In Space
 EDM-075 Nuclear Power Plant Safety
 EDM-328 Office Of Small Business
 EDM-1108 Oven Curing: Energy Conservation And Emission Control
 In Coil Coating
 EDM-845 Passive Solar Heating
 EDM-407 Pep (Position-Electron Project)
 EDM-1045 Planning Future Electric Power Systems
 EDM-018 Professional Energy Careers
 EDM-123 Radiation Monitoring
 EDM-386 Saving Energy...Means Work
 EDM-1005 Selected Information Resources On Energy

ITEM NUMBER	TITLE
EDM-1110	She Will Thank You For Conserving Energy, Poster
EDM-824	Solar Electricity From Photovoltaic Conv.
EDM-821	Solar Electricity From Thermal Conversion
EDM-841	Solar Energy
EDM-859	Solar Energy Curriculum For Elem Schools
EDM-840	Solar Energy For Agriculture Industry
EDM-860	Solar Energy Project
EDM-865	Solar Energy Project. Activities. Biology
EDM-861	Solar Energy Project. Activities. General Solar Topics
EDM-817	Solar Energy-Conserv. For Home Heat-Cool
EDM-839	Solar Powered Irrigation Pump, The
EDM-848	Solar/Renewable Energy, Poster
EDM-503	Spent Fuel Storage Fact Book
EDM-360	Stop Wasting Energy
EDM-357	Stop Wasting Energy
EDM-857	Sun Power, Poster
EDM-404	Superconducting Trans. Of Electric Power
EDM-805	Survey Of Solar Energy Products And Services--May 1975
EDM-366	Take A Tip From Gasoline Alley: Poster
EDM-336	There Is An Alternative, Poster
EDM-337	They Will Thank You For Conserving Energy, Poster
EDM-337A	They Will Thank You For Conserving Energy - Spanish Poster
EDM-064	Tips For Energy Savers
EDM-065	Tips For Energy Savers - Spanish
EDM-1145	Turbine Power, Demonstration Project
EDM-334	Vanpool
EDM-335	Vanpool Implementation Handbook
EDM-384	Waste To Energy Program
EDM-818	Where To Find Information About Solar Energy
EDM-088	Winter Survival. A Consumer's Guide To Winter Preparedness
IB-003	Black Contributors To SCNS And Energy Tech
IB-1001	Energy Storage
IB-416	Inner Space: The Structure Of the Atom
IB-414	Nature's Invisible Rays
IB-1100	Oil
IB-412	Space Radiation
IB-019	Stamps Tell The Story Of Nuclear Energy
IB-303	The Atomic Fingerprint: Neutron Activation Analysis
IB-405	The Elusive Neutrino
IB-503	The First Reactor

ITEM
NUMBER

TITLE

EDM-089 Activities of The DOE In Energy Education
 EDM-1034 Agriculture, Energy, And Society. Grades 10, 11, 12
 EDM-1055 Award Winning Energy Education Activities
 EDM-1059 Bringing Energy To The People
 EDM-1030 Community Workers And The Energy They Use. Grade 2
 EDM-1049 Conservation. Science Activities In Energy
 EDM-1053 Electrical Energy. Science Activities In Energy
 EDM-1097 Energy Activities With Energy Ant
 EDM-1056 Energy And Transportation. Grade 3
 EDM-1132 Energy Education Workshop Handbook
 EDM-1062 Energy In The Global Marketplace. Grades 9, 10, 11
 EDM-1142 Energy Systems--Present, Future Extra-Terrestrials
 Grades 7, 8, 9, Science
 EDM-1061 Energy Transitions In U.S. History
 EDM-1032 Energy, Engines, And The Industrial Revolution,
 Grades 8, 9
 EDM-1140 Energy: What About The Future
 EDM-1139 Energy: What Can We Do Right Now
 EDM-1138 History Of Energy
 EDM-1033 How A Bill Becomes A Law To Conserve Energy
 EDM-1141 How We Make Energy Work
 EDM-1060 Mathematics in Energy. Grades 8-9
 EDM-1058 Networks: How Energy Links People, Goods And Services
 EDM-1054 Science Activities In Energy
 EDM-837 Science Activities In Energy: Solar Energy
 EDM-856 Science Activities in Energy: Solar Energy II
 EDM-855 Science Activities In Energy: Wind Energy
 EDM-1143 The Energy Dome, Social Studies Packet
 EDM-1144 The Energy Future Today, Social Studies
 EDM-1029 The Energy We Use. Grade 1
 EDM-1031 Transportation And The City. Grades 8 9
 EDM-1057. Two Energy Gulfs. Grades 6-7
 EDM-1064 U.S. Energy Policy--Which Direction? Grades 11-12
 EDM-1078 Western Coal: Boom Or Bust
 EDM-1137 What Is Energy
 EDM-1043-2 Fuels From Wastes (Bioconversion)
 EDM-1043-1 1. Fuels From Plants. Bioconversion
 EDM-1043-10. 10. Energy Conservation. Industry
 EDM-1043-11 11. Energy Conservation. Transportation
 EDM-1043-15 15. New Fuels From Coal
 EDM-1043-16 16. Energy Storage Technology
 EDM-1043-19 19. Alternative Energy Sources. A Bibliography
 EDM-1043-3 3. Wind Power
 EDM-1043-4 4. Electricity From The Sun I. Solar Photovoltaic Energy
 EDM-1043-5 5. Electricity From The Sun II. Solar Thermal
 Energy Conversion
 EDM-1043-6 6. Solar Sea Power. Ocean Thermal Energy Conversion
 EDM-1043-7 7. Solar Heating And Cooling
 EDM-1043-8 8. Geothermal Energy
 EDM-1043-9 9. Energy Conservation. Homes And Buildings

BIBLIOGRAPHY

- A Survey of Model Programs: State and Local Solar Conservation Projects. Center for Renewable Resources, 1028 Connecticut Avenue, N. W., Suite 1100, Washington, D.C. 20036.
- Alabama State Department of Education, resource materials.
- Center for Energy and Mineral Resources. ENCORE: Energy Conservation Resources for Education, Modules 1-19, 1976. Department of Industrial Education, Texas A & M University, College Station, Texas 77843.
- Coon, Herbert L. and Michele Y. Alexander, editors. Energy Activities for the Classroom, 1976. Eric/SMEAC, The Ohio State University, 1200 Chambers Road, Third Floor, Columbus, Ohio 43212.
- Energy and the Environment. Governor's Energy Office, State of Florida.
- Energy: A Teacher's Introduction to Energy and Energy Conservation. Ohio State Department of Education.
- Energy Crisis: A Teacher's Resource. New Jersey State Department of Education, New Jersey State Council for Environmental Education, and New Jersey Education Association.
- Energy, Food and You. Washington State Office of Public Instruction, Office of Environmental Education, Olympia, Washington 98501.
- Energy: Past, Present and Future, 1977. District of Columbia Public Schools.
- Energy Resources of Texas Curriculum Materials, Unit I: Energy from Start to Finish, 1976. Jay Earl Anderson, Jr., Bureau of Economical Geology, University of Texas at Austin, Austin, Texas 78712.
- Environmental Education: Strategies for Wise Use of Energy, 1974. North Carolina Department of Public Instruction, Division of Science Education, Raleigh, North Carolina 27611.
- Federal Energy Administration, resource materials.
- Harahan, Edward J., Energy Research and Development Administration, Demand for Uranium and Separative Work, Atomic Industrial Forum Fuel Cycle Conference, 1976, Phoenix, Arizona.
- Harahan, Edward J., Richard H. Williamson, and Robert H. Brown, World Requirements and Supply of Uranium, September 14, 1976, AIF International Conference on Uranium, Geneva, Switzerland.

Harnessing the Wind, Energy Conservation Resources for Education,
Department of Industrial Education, Texas A & M University,
College Station, Texas 77843.

Institute for Energy Research and W. Averill Harriman College for
Urban and Policy Sciences, Energy: Options for the Future
(Solar, Wind, and Biomass). State University of New York at
Stony Brook, Stony Brook, New York 11794.

Kentucky Department of Education, resource materials.

Louisiana State Department of Education, Conservation of Energy:
Teacher's Activity Guide, 1975. Louisiana State Department
of Education, Baton Rouge, Louisiana 70804.

Massachusetts Department of Education, Approaches to Energy Conser-
vation.

Ohio Department of Education, Energy: A Teacher's Introduction to
Energy and Energy Conservation, 1975. Batelle Center for
Improved Education, 505 King Avenue, Columbus, Ohio 43201.

Ohio Department of Education, Energy Conservation Teaching Resource
Units.

Pennsylvania Department of Education, The Environmental Impact of
Electrical Power Generation: Nuclear and Fossil.

Pennsylvania's Energy Curriculum for the Middle Grades.

Quantum Conserves (a comic book). Indiana Division of Curriculum,
Room 229, State House, Indianapolis, Indiana 46204.

Smith, Stephen M., editor. Energy-Environment Mini-Unit Guide, 1975.
National Science Teachers Association, 1742 Connecticut Avenue,
N. W., Washington, D.C. 20009.

South Carolina Department of Education, resource materials.

Tennessee Energy Office. Ideas and Activities for Teaching Energy
Conservation: Grades 7-12, 1977. The University of Tennessee
Environment Center, South Stadium Hall, Knoxville, Tennessee
37916.

The Journal of Energy Education, 1978.

The Potential of Energy Conservation. Executive Office of the Presi-
dent, Office of Emergency Preparedness, October, 1972.

Thinking About Energy. Secondary Studies Guide, State of Delaware.

Tips for Energy Savers, Federal Energy Administration, Washington, D.C. 20461, U. S. Government Printing Office, 1975, 0-586-806.

Tips for Energy Savers. Federal Energy Administration, Washington, D.C. 20461, publication FEA/D-77/212.

United States Department of Energy, resource materials.

University of New York, resource materials.

University of Tennessee Environment Center and College of Home Economics. Energy Conservation in the Home, 1977. University of Tennessee, Knoxville, Tennessee 37916.

Unusual Energy Sources! Energy Conservation Resources for Education, Department of Industrial Education, Texas A & M University, College Station, Texas 77843.

403

I THINK WE'VE ALL
LEARNED SOMETHING—
HOW TO CONSERVE!

