

DOCUMENT RESUME

ED 210 502

CE 030 774

TITLE Fundamentals of Energy Technology. Energy Technology Series.

INSTITUTION Center for Occupational Research and Development, Inc., Waco, Tex.; Technical Education Research Centre-Southwest, Waco, Tex.

SPONS AGENCY Office of Vocational and Adult Education (EI), Washington, D.C.

BUREAU NO 498AH80027

PUB DATE Sep 81

CONTRACT 300-78-0551

NOTE 290p.; For related documents see CE C30 771-789 and ED 190 746-761.

AVAILABLE FROM Center for Occupational Research and Development, 601 Lake Air Dr., Waco, TX 76710 (\$2.50 per module; \$17.50 for entire course.)

EDRS PRICE MF01 Plus Postage. PC Not Available from EDRS.

DESCRIPTORS Adult Education; Annotated Bibliographies; Behavioral Objectives; Course Descriptions; Courses; *Energy; *Energy Conservation; *Fuels; Glossaries; Laboratory Experiments; Learning Activities; Learning Modules; *Occupational Information; Pollution; Postsecondary Education; *Power Technology; Resource Materials; *Technical Education; Two Year Colleges

IDENTIFIERS Energy Audits; *Energy Consumption

ABSTRACT

This course in fundamentals of energy technology is one of 16 courses in the Energy Technology Series developed for an Energy Conservation-and-Use Technology curriculum. Intended for use in two-year postsecondary technical institutions to prepare technicians for employment, the courses are also useful in industry for updating employees in company-sponsored training programs. Comprised of seven modules, the course is designed as an overview of the entire energy field. It discusses energy fuels, production schemes, area of utilization, environmental considerations, and conservation/audit principles. Geared more to the seminar approach, the course also provides career visibility and rationale for including each course in the curriculum. Written by a technical expert and approved by industry representatives, each module contains the following elements: introduction, prerequisites, objectives, subject matter, exercises, laboratory materials, laboratory procedures (experiment section for hands-on portion), data tables (included in most basic courses to help students learn to collect or organize data), references, and glossary. Module titles are Energy Technology, Sources of Energy: I and II, Uses of Energy, Energy Analysis, and Energy and the Environment. The last module is an Energy Resource Guide that includes an annotated bibliography of print and non-print resources, explanation of the curriculum, examples of projects, and a glossary. (YLB)

ED210502

FUNDAMENTALS
OF
ENERGY TECHNOLOGY

CENTER FOR OCCUPATIONAL RESEARCH AND DEVELOPMENT

601 LAKE AIR DRIVE
WACO, TEXAS 76710

U.S. DEPARTMENT OF EDUCATION
NATIONAL INSTITUTE OF EDUCATION
EDUCATIONAL RESOURCES INFORMATION
CENTER (ERIC)

This document has been reproduced as
received from the person or organization
originating it.
Minor changes have been made to improve
reproduction quality.

• Points of view or opinions stated in this docu-
ment do not necessarily represent official NIE
position or policy.

"PERMISSION TO REPRODUCE THIS
MATERIAL IN MICROFICHE ONLY
HAS BEEN GRANTED BY

D. M. Hull

TO THE EDUCATIONAL RESOURCES
INFORMATION CENTER (ERIC)"

SEPT. '81

P R E F A C E

ABOUT ENERGY TECHNOLOGY MODULES

The modules were developed by TERC-SW for use in two-year postsecondary technical institutions to prepare technicians for employment and are useful in industry for updating employees in company-sponsored training programs. The principles, techniques and skills taught in the modules, based on tasks that energy technicians perform, were obtained from a nationwide advisory committee of employers of energy technicians. Each module was written by a technical expert and approved by representatives from industry.

Most modules contain the following elements:

- Introduction, which identifies the topic and often includes a rationale for studying the material.
- Prerequisites, which identify the material a student should be familiar with before studying the module.
- Objectives, which clearly identify what the student is expected to know for satisfactory module completion. The objectives, stated in terms of action-oriented behaviors, include such action words as operate, measure, calculate, identify and define, rather than words with many interpretations, such as know, understand, learn and appreciate.
- Subject Matter, which presents the background theory and techniques supportive to the objectives of the module. Subject matter is written with the technical student in mind.
- Exercises, which provide practical problems to which the student can apply this new knowledge.
- References, which are included as suggestions for supplementary reading/viewing for the student.
- Test, which measures the student's achievement of the pre-stated objectives.

ABOUT THE FUNDAMENTALS OF ENERGY TECHNOLOGY COURSE

The Fundamentals of Energy Technology course is designed as overview of the entire energy field; it discusses energy fuels, production schemes, areas of utilization, environmental consideration and conservation/audit principles. Most important for the student, this course provides career visibility and a logical rationale for including each course in the curriculum. This course should be taught to the student during the first quarter or semester of the curriculum. The instructor is encouraged to use the four modules as a framework in which films, speakers and numerous pamphlets can be inserted. Since this course is geared more to the seminar approach than the technical, "hands on" instructor, several of the module elements related to laboratory exercises are not included.

CONTENTS

Preface

Table of Contents

MODULE EF-01	Energy Technology
MODULE EF-02	Sources of Energy: I
MODULE EF-03	Sources of Energy: II
MODULE EF-04	Uses of Energy
MODULE EF-05	Energy Analysis
MODULE EF-06	Energy and the Environment
MODULE EF-07	Energy Resource Guide

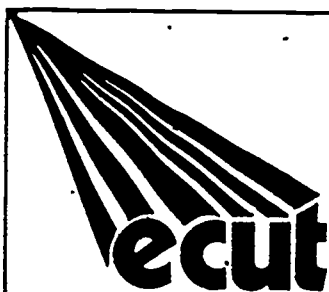

ENERGY TECHNOLOGY

CONSERVATION AND USE

FUNDAMENTALS OF ENERGY TECHNOLOGY

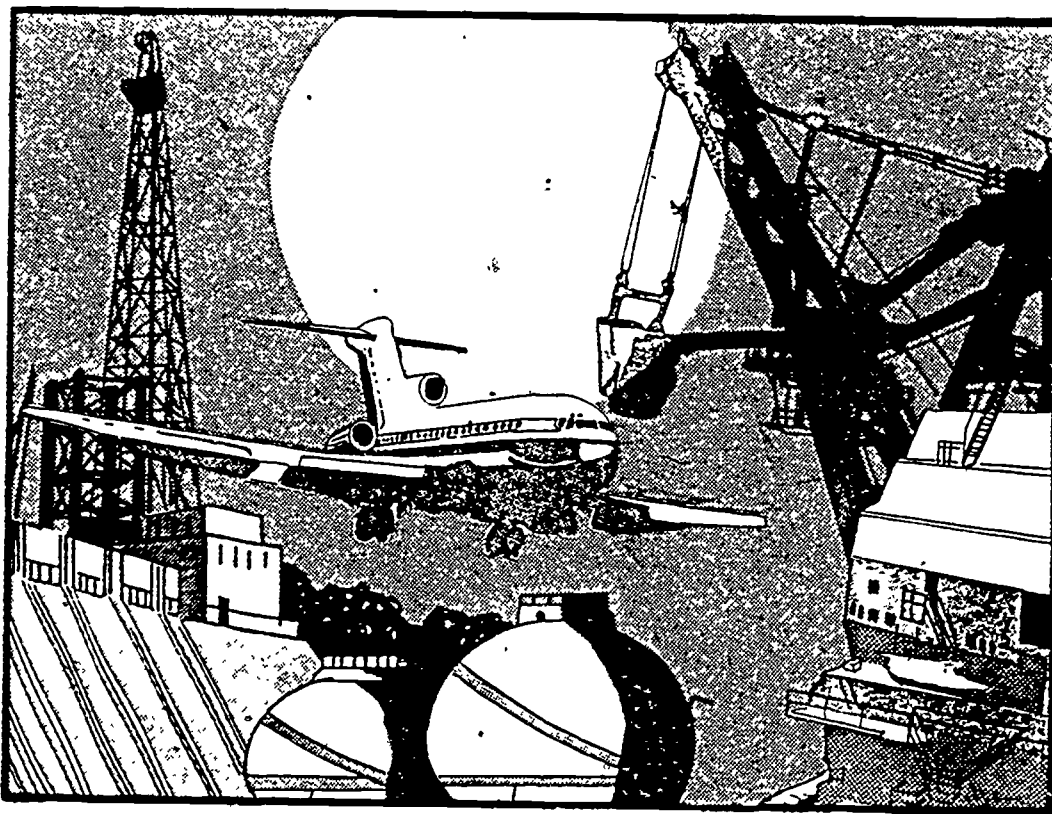

MODULE EF-01
ENERGY TECHNOLOGY



CENTER FOR OCCUPATIONAL RESEARCH AND DEVELOPMENT

INTRODUCTION

For want of a nail, the shoe was lost.
For want of a shoe, the horse was lost.
For want of a horse, the rider was lost.
For want of a rider, the battle was lost.
For want of a battle, the kingdom was lost -
And all for the want of a horseshoe nail.

Mother Goose

Energy is the missing nail in today's world economy. Right now, every effort is being made to either find that missing nail - or develop a substitute.

Although there is much talk about the so-called energy shortage, there really is no shortage of energy. There is, theoretically, enough energy in one copper penny to boil more than 30 million gallons of water.

The shortage is in the ability to convert matter efficiently and economically into useful energy. In the past, technology has been concerned primarily with the use of energy to power and produce new things. In the future, technology must also be concerned with the actual process of using - and conserving - energy more efficiently and wisely.

PREREQUISITES

None.

OBJECTIVES

Upon completion of this module, the student should be able to:

1. Define the following terms:
 - a. Energy.
 - b. Energy shortage.
 - c. Conservation Law.
 - d. Entropy Law.
 - e. Work.
 - f. Energy conservation.
 - g. Capital stock of U.S. economy.
 - h. The politics of energy.
 - i. Environmental ride.
 - j. Thermal pollution.
2. List the reasons that have contributed to the upward spiral in a demand for energy on both a national and an international basis.
3. List the three factors that have contributed to a total demand for energy.
4. Describe the past relationship between energy consumption and productivity and explain how this relationship is changing in the United States.
5. List the fossil fuels.
6. List the complaints of environmentalists about each of the fossil fuels, nuclear power, geothermal energy, solar energy, and hydropower energy production.
7. List the individuals or groups that have the power to take effective action about energy sources of the future.
8. List the four areas of energy management that can help conserve energy.

9. Explain the dichotomy in which the United States finds itself concerning the energy crisis.
10. List and describe the two areas through which the solution to the energy crisis may be achieved.

SUBJECT MATTER

WHAT IS ENERGY?

In texts of the last several decades, energy generally has been defined simply as the ability or capacity to do work. All functions of our environment require energy. However, this use of energy must be viewed in terms of the transformation of energy resources into various types of energy.

For instance, natural resources like uranium, coal, oil, and gas are transformed into heat, pressure, mechanical power, and electricity; hydropower and wind are also transformed into electricity.

The first law of thermodynamics, the Conservation Law, states that energy is not lost during such transformations. In other words, all the energy that ever was still exists.

What is lost is the ability to do work. The second law of thermodynamics, the Entropy Law, describes the transformation of work or heat into disorder, or entropy. Work is performed only when a force is exerted on a body while the body moves at the same time, and in such a way, that the force has a component in the direction of motion. Power is defined as the rate at which work is performed.

The available work provided by heat, pressure, mechanical energy, and electricity is utilized in the built environment (as opposed to the natural environment) to perform certain tasks. These tasks include the production of human comfort, the maintenance of set environmental conditions within structures, the provision of lighting and communications, the movement of people and goods, and the removal

of waste products. Each of these tasks requires work of a particular type and quality, but each task is presently provided with energy of many different types and often of a quality far in excess of need.

Energy conservation is defined as a planning process that emphasizes using all the available work content of energy resources. The available work content is called energy.

WHEN DID THE CRISIS START?

In the United States, a new attitude is rapidly emerging concerning the production and use of energy. Although various consequences of the so-called energy crisis have been predicted for decades, the public has not taken the problems seriously until the past few years.

Inflation, rising utility costs, rationing, and gas lines have combined to demonstrate just how dependent the American system is on energy. As a result, energy is one of the most popular topics of discussion - and one of the most controversial. It will continue to be.

Everyone is talking about energy: consumers, politicians, business persons, world leaders, and visitors to the local Laundromat. The increased cost of energy seems to be everyone's chief concern, rather than an overwhelming preoccupation about limited supplies. However, both concerns are equally valid.

Concern about energy-related topics is cross-cultural and international. And that concern, based on energy dependence, did not evolve out of nowhere.

WHAT IS THE HISTORY OF ENERGY?

Every civilization has something in its literature or history concerning energy. In Greek mythology, for example, Prometheus stole the fire of the gods to begin civilization. In the Bible, the beginning was light. Throughout the ages, civilization's progress has paralleled the development of new uses of energy.

Petroleum was first found and used from surface pools by early civilizations for warmth, cooking, medicines, and other purposes. The Chinese drilled for oil and gas more than 2,000 years ago. Obviously, energy has been here as long as the sun. Hopefully, energy sources will continue to be around for some time to come. However, the demand for energy has increased with each technological advance in an upward spiral that shows no sign of slowing.

WHAT ARE THE FACTORS AFFECTING DEMAND FOR ENERGY?

There are several factors that affect the total demand for energy: per capita energy consumption, population and the world distribution of energy sources. Both per capita energy consumption and population are increasing. Unfortunately, traditional energy sources are decreasing.

PER-CAPITA ENERGY CONSUMPTION

A human requires a certain amount of energy in the form of food each day in order to exist. As humans progressed from one state of civilization to another, their per capita

energy consumption increased. For example, prehistoric tribes needed only energy from food; whereas, early agricultural groups had to provide extra food energy for their animals. The most dramatic increases in energy consumption, however, have come in the past few hundred years with industrial development in many nations. The per capita energy consumption of various societies is illustrated in Figure 1. The number at the left of Figure 1 indicates the amount of energy individuals require in addition to food - energy for transportation, for example.

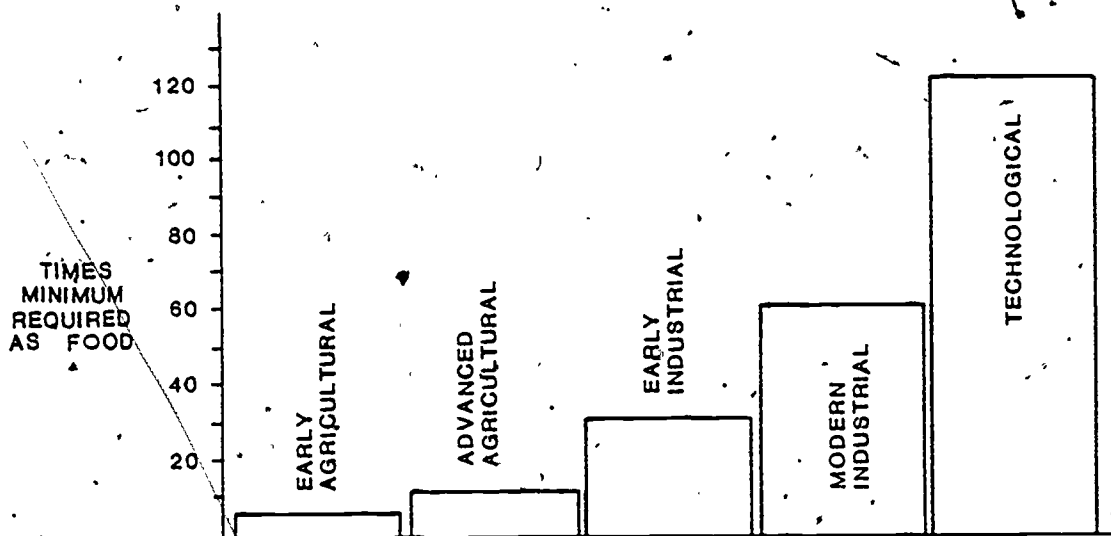

Figure 1. Per Capita Energy Consumption for Various Societies.

Although the populations of the earth are in various states of development, there is a tendency toward industrialization, and thereby, an increase in per capita energy consumption. To illustrate the extreme, the per capital consumption of energy from all sources in the United States is more than 100 times what is required as food.

POPULATION

At the time of the Roman Empire, the population of the world was approximately 150 million, with an annual increase of about 0.07%, or about 100,000 people. Due to a general increase in the quality of life throughout the centuries, both the actual population and the growth rate have increased. The world population is now about four billion, with an annual increase of 2%, or 80,000,000 people. Figure 2 illustrates the growth of world population.

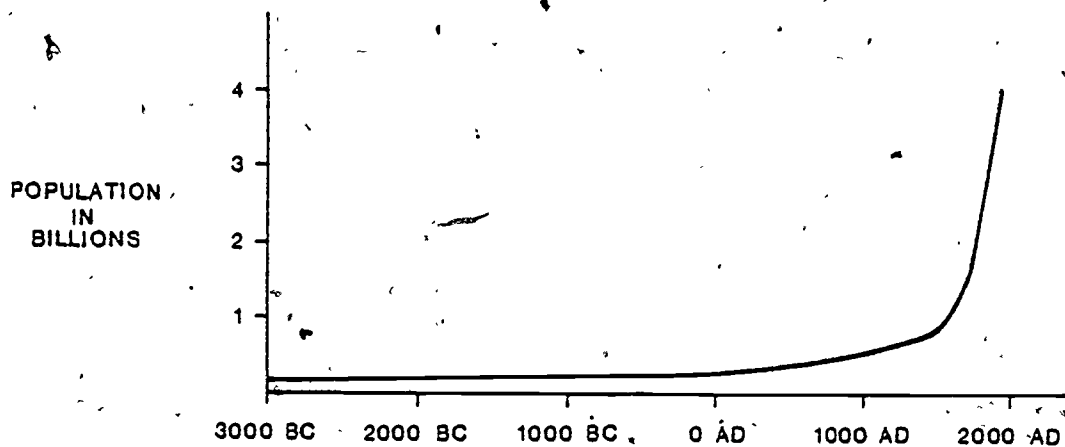

Figure 2. Growth of World Population.

As a result of increased population and per capita consumption of energy, the demand for energy is increasing at a rate of about 4% annually. This means that demand for energy — on a world scale — doubles about every 18 years. Example A illustrates how an increase in per capita consumption and population can combine to drastically increase total energy consumption.

Until only a short while ago, economists believed that energy input was proportional to productivity. In

other words, less energy input equaled less productivity.

However, from 1973 to 1978, United States industry reduced its energy use by 10% (about one quad*); productivity rose 12%.

EXAMPLE A: ENERGY CONSUMPTION.

Given: A country with a population of 10,000,000 in 1970 had a per capita energy consumption of 50,000 Btus per day. Assume that the population increases by 30% in 10 years and the per capita consumption increases 40% in the same time.

Find: The total energy consumption from 1970 to 1980.

Solution: Population in 1980 = 10,000,000 + 3,000,000
= 13,000,000 people.

Per capita in 1980 = 50,000 + 20,000
= 70,000 Btus.

Consumption in 1970 = 10,000,000 x 50,000
= 500,000,000,000 Btus/day.

Consumption in 1980 = 13,000,000 x 70,000
= 910,000,000,000 Btus/day.

During the 1940s and 1950s, consumption of energy in the United States increased by an average of 3.2% a year. During the 1960s, this increased to 4.3% annually.

*A quad is the unit of measurement economists use when talking about global supply and demand. Quad stands for a quadrillion (1,000,000,000,000,000) British thermal units (Btus) of energy.

Demand is presently growing at a rate of about 5% annually.

Increased demand has given America not only the highest per capita income in the world, but also the highest per capita energy consumption. Historical energy consumption of the United States is presented in Figure 3. Energy is measured in quadrillions of Btus (quads).

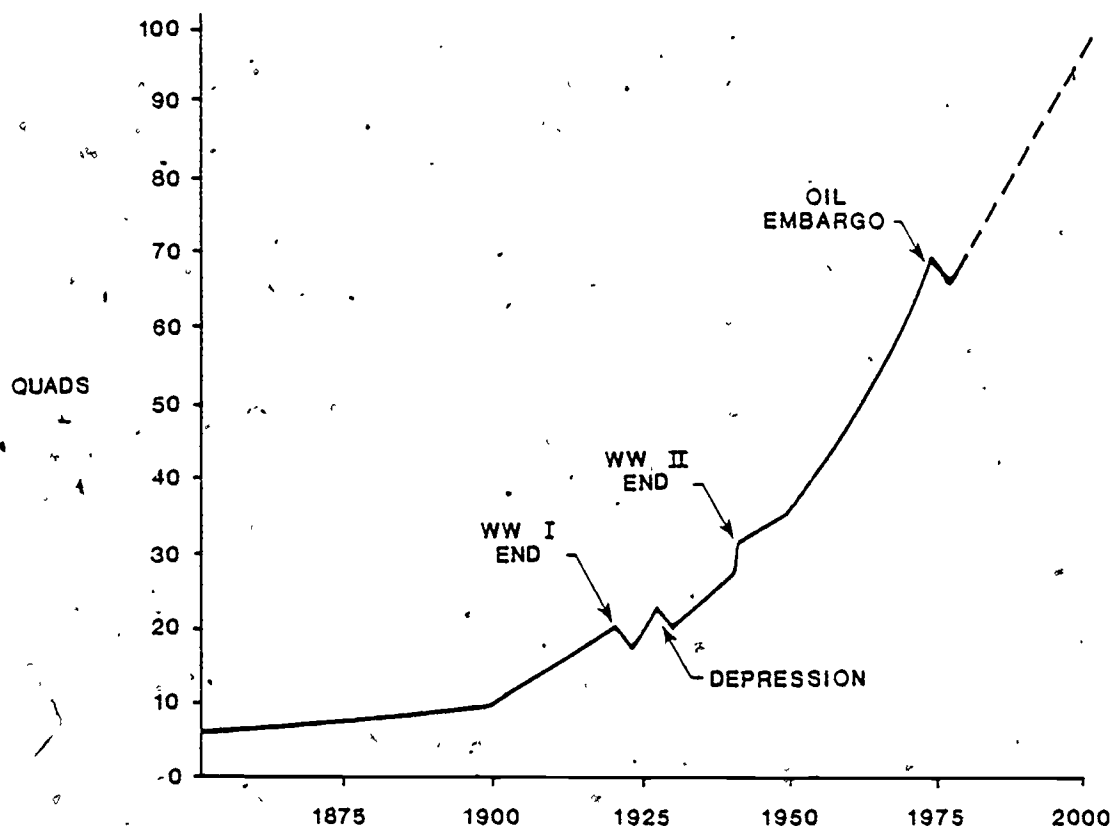

Figure 3. Historical Total Energy Consumption in the United States.

As a letter written to the New York Times recently expressed, "With less than 5% of the world's remaining reserves of proven crude oil, the United States now finds itself in the embarrassing position of owning almost 40%

of the world's passenger cars, and of consuming almost .60% of the world's gasoline."

WORLD DISTRIBUTION OF ENERGY SOURCES

More than 90% of the energy consumed comes from fossil fuels. These fuels are unevenly distributed over the earth so far as use and population are concerned. At one extreme is the United States, with 6% of the world population consuming over 30% of the energy. India, with about 35% of the world's population, consumes only 2% of the energy.

In the past, developed nations were able to obtain whatever energy sources were required rather easily from other nations. As more nations became industrialized and demand increased, the value of the limited fossil fuels became more evident.

Continued dependence on foreign supplies of energy will eventually lead to a redistribution of wealth and influence. The future of the United States - or any other nation - will depend upon its ability to effectively produce, use, and conserve energy. Dependence of the United States on imported oil is shown in Table 1.

TABLE 1. ENERGY IMPORTS INTO THE UNITED STATES.

Year	Percentage of Total Oil Consumed
1960	20
1970	25
1975	40
1977	50
1978	46
1979	45
1980 (projected)	45

HOW DOES ENERGY RELATE TO THE UNITED STATES ECONOMY?

United States energy investments will total \$650 billion (in 1975 dollars) over the next 10 years - if not more. Of this total, \$370 billion will go for oil and gas; \$250 billion for electricity; and \$23 billion for coal.

Roger Sant, former energy conservation chief for the Energy Research and Development Administration, projects another kind of energy investment: a new \$500 billion energy conservation industry. This industry would be capable of producing (by 1985) the equivalent of 17 million barrels per day of oil - a third of the needs of the United States. The key to this would be increasing the price of all energy to the level of cost of incremental additions to energy supply. The consumer is now paying \$3 per million Btus, Sant said, where the cost of marginal energy production (the kind that new supplies represent, whether from new technology or new exploration) is about \$5 per million Btus.

It takes a considerable period of time to adjust the capital stock of the economy without major disruption of the flow of goods and services to our standard of living. Productivity is still linked to energy consumption in many ways. Change must take place slowly.

For example, it was in 1975 that Congress mandated that the automobile industry would produce, on the average, more fuel-efficient automobiles and that, gradually, the efficiency would rise until in 1985 the average car being sold would obtain 27 1/2 miles per gallon.

At the time the legislation was passed, the average mileage being obtained by cars in the national fleet was approximately 13 1/2 miles per gallon. But by 1985, when the legislation takes full effect, the average of cars in the fleet will be approximately 20 miles per gallon. Consumer buying trends have had - and will have - an effect.

In any case, it will have taken a decade to increase fuel efficiency of automobiles by 50%. It is predicted that by 1992, the average of the fleet will be 27 1/2 miles per gallon. It will, thus, have taken better than 15 years to double the fuel efficiencies of automobiles. And similarly, with our entire capital stock, since investment is slow and time consuming, changes must be worked out gradually.

Gas currently provides a major contribution to United States energy supplies, accounting for approximately 26% of all energy consumed in the United States. Gas supplies over half of all residences and commercial establishments in the United States, serving over 44 million customers. Industry also depends very heavily on gas, which accounts for over 40% of all fuels consumed.

Moreover, the Nation has a large financial commitment to natural gas, with a total utility industry and consumer

equipment investment of over \$100 billion. Half of this investment is represented by over one million miles of underground gas pipeline and main throughout the United States. The gas utility industry alone has an annual payroll of more than \$3 billion and a total employment in excess of 200,000 people.

The breakdown of fuel consumption in the United States (summer of 1980) is approximately 46% oil, 26% gas, 19% coal, and 9% other sources. Sixty-three percent of the total energy consumed by the people of the United States is consumed by business and government agencies; 37% is consumed by individuals.

Of the top 10 industries in the United States, six are oil companies and two are automobile manufacturers.

Of the total available energy consumed by the American economy, almost half is lost each year in various conversions before it is finally put to some final purpose. Some way must be found to recapture some of the tremendous amount of energy lost in the generation-and-use process.

Like it or not, supplies are shrinking - at least temporarily. And serious economic repercussions are always associated with shortages of critical material. In a very real sense, the politics of energy will be the guiding force behind the path our nation - and other nations - travel for many generations to come.

WHAT FACTORS MUST BE CONSIDERED WHEN CHOOSING ENERGY SOURCES?

In the past, when necessary, technology has produced what was needed. Where should energy come from in the years immediately ahead? No traditional or alternate

energy supply sources offers a "free environmental ride." Each has its environmental costs.

FOSSIL FUELS

In the category of fossil fuels are petroleum, coal, tar sands, oil shale and natural gas.

Petroleum

The petroleum industry involves much more than gasoline. About one and one-half million people are directly employed in the industry. Another two million American are shareholders in just six large oil companies. Another 12 million Americans participate indirectly in these six large companies through mutual funds and similar investments. Millions more own interests in smaller companies within the industry or in related service companies.

Pipelines have come a long way since the first venture in 1865 in Pennsylvania. Technology has developed a superior refining industry. For example, in 1920, a refinery could extract only 11 gallons of gasoline and related products from a barrel of crude oil.

Today, the yield is 19 gallons of gasoline (on the average) from each 42-gallon barrel of oil. More than 3,000 chemicals are made from oil and gas to form the basis of the plastics industry, for detergents, fertilizers, fabrics, and rubber.

Environmentalists' complaints about oil are centered on offshore production. The most pervasive problems are (1)

damage to the coastal zone through poor siting on onshore holding facilities; (2) low-level chronic leaks from offshore oil facilities; and (3) occasional blowouts.

Coal

The problems with coal are familiar problems.

Coal industry expansion will require huge sums of capital, as much as \$25 billion at the extreme. The coal industry must have the high profits and cash flow required — plus an assured long-term market — before expansion of coal mining can meet spiraling energy needs.

Coal can be obtained from the earth in two ways: surface mining and underground mining. Surface mining involves upheaval of environmental surface, or land. Since most surface mining areas are remote from areas of use, transportation (itself a pollutant) is expensive. The major pollutant in coal is sulfur, and there are technological problems associated with making underground mining safe and economical.

Tar Sands

Tar sands are sandstone and limestone impregnated with heavy crude oil. The quality of the oil is poor and is contaminated with minerals that must be removed.

In addition, technology for underground mining will be expensive, and the cost competitiveness — compared to petroleum — is uncertain.

The environmental problems are similar to those associated with oil shale.

Oil Shale

Oil shale is a finely grained rock that contains material called kerogen.

Kerogen can be separated from the rock by heating it to about 900°F in a limited amount of oxygen, a process called retorting. The oil then must be refined to give synthetic oil and gas.

However, the amount of oil obtainable from shale varies, and there are technological problems and environmental concerns.

Oil shale rock expands about 20% and cannot be simply placed back in the ground. Scientists are now experimenting with revegetation of the "rock gardens," and there is concern over whether or not the plants that do grow will have toxic trace elements absorbed in the vascular systems. The large amounts of water required in the mining process are chemically bound with the waste minerals and cannot simply be recycled.

Natural Gas

Worldwide, natural gas production at projected increases can last only until approximately 2020 - another 40 years. During the 1970s, the cost of drilling and maintaining gas wells increased rapidly.

Although gas is a clean and efficient fuel for heating, and many valuable by-products are obtained during production, domestic supplies are limited and domestic production is decreasing rather rapidly.

The investment to deliver 16 trillion cubic feet of liquified natural gas, the lowest level that the Workshop on Alternative Energy Strategies foresees for the year 2000, would be \$70 billion (1975 dollars). Without long-term contracts and assurance of stability of supply and price at the wellhead, it is doubtful that the investment will be made.

Environmentalists worry about safety. Explosion of a gas tanker in a busy harbor would be a catastrophe, and is possibly more likely than a nuclear accident.

NUCLEAR

Environmentalists believe that nuclear power represents a premature development of a high technology that is too expensive socially. There is still no established system to permanently safeguard radioactive wastes. Experts are still divided over the safety of lightwater core cooling systems; and the world can ill afford the dangers that illegal diversion of fissile materials poses.

In any case, at the present time, little more than 3% of power for the United States' energy needs is coming from nuclear plants.

GEOHERMAL

The environmental problems stemming from the development of geothermal energy involve two questions: site compatibility and operational effects.

Moreover, other problems stem from the various phases of development, such as exploration, operation, and abandonment of the site after operations terminate.

Geothermal fluids are produced in the millions of gallons daily in a field that is operating. These fluids normally contain toxic substances like ammonia, arsenic, boron, and mercury. Water and air pollution are problematic, as is noise pollution (caused by high-pressure venting of escaping steam). The taking of fluids from under the ground can also cause sinking of the land surface.

SOLAR

Most energy sources depend on the sun. However, solar has come to mean renewable resources like wind, sunlight, water, and biomass conversion. (The latter category includes wood.) Some researchers feel that only direct solar offers no environmental hazards or inconvenience.

However, solar does have its enemies, who believe that solar energy converted directly to electricity or to commercially usable heat is potentially the most polluting and ecologically threatening form of commercial power being proposed.

Advocates of solar power point to an energy recovery factor of 5 to 10% with pride; those on the other side scoff at the recovery efficiency. The enemies of solar also point out that direct-conversion photovoltaic units will contain large tonnages of cadmium, dilicon, germanium, selenium, gallium, copper, arsenic, sulfur, and/or other conducting, semiconducting, and nonconducting materials of varying availability on world markets. Thermal-conversion

units will be made of thousands of tons of glass, plastics, and rubber, and will house uncommonly great volumes of ethylene glycol, liquid metals, Freon, and/or other heat movers.

HYDROPOWER

Water power, major sources of which are still underdeveloped, has an estimated potential of 10^6 megawatts. However, this energy source is available only in certain parts of the world.

Since all conversions of energy result in thermal pollution, this is also a problem with hydropower. However, if ways of converting thermal pollution (or waste heat) into additional usable energy were implemented, this liability might become an asset.

Sixteen percent of total electric power generated in the United States is derived from hydroelectric installations. Canada leads the world with 74.5% of its total energy generated from hydroelectric facilities.

Hydropower offers continuous, low-cost power production - except during droughts.

Maintenance costs are low, but there is a high initial cost for construction. Reservoirs are capable of storing large quantities of water and can provide some flood protection to downstream areas; however, flood protection can best be provided by an empty reservoir, and power production is best from a full reservoir. In any case, land that is suitable for agriculture is lost. In coastal areas, like Oregon and Washington, the construction of dams prohibits upstream migration of fish unless a fish ladder is provided. This is a major threat to the environment.

TIDAL POWER

The largest tidal plant in the world is the Rance Station, located near St. Malo, France. The plant took seven years to construct and has an average output of 65 Mw/hour - enough power for only 16,000 homes. In the United States, the only possible locations are the Passamaquoddy Bay region along the U.S./Canada border in Maine and the Cook Inlet region in Alaska. The site in Alaska does not have a sufficient population to warrant a plant in that area.

However, a plant built in the New England area would cost about a billion dollars - plus the cost of distributing the power. Environmentalists complain that there would be problems with area fish, mammals, and waterfowl. Even tidal power has its environmental costs.

WHO WILL MAKE THE DECISIONS ABOUT ENERGY?

The waste of plenty is
the resource of scarcity.

T. L. Peacock, Melincourt, Ch. 24.

Major decisions about energy sources of the future will revolve around governmental funding for research and development. However, the masses can make a difference. This difference will entail serious choices about energy.

Everyone will be able to select the energy source (fuels) for a residence; some will choose energy sources for the place of work, as well. In the future, these places may be one and the same.

However, it is in the area of energy conservation where individual decisions will have the most impact, for each person is capable of saving energy. Of course, the best motivation for saving energy is saving money; less energy consumed means less money spent.

Conservation decisions include transportation - choosing a car with more potential miles per gallon, riding a bicycle when possible, or using foot power and many other either/or debates. Conservation decisions will also require ingenuity - ways of using heretofore wasted materials to provide for the common energy good.

In other words, an emphasis must be placed on utilizing the available work content of all energy resources. It boils down to the old adage: Waste not, want not, is a law of nature. (John Platt, Economy, p. 22)

Basically, energy conservation can be accomplished through energy management in four areas: (1) energy awareness, which means simply being aware of turning energy burners off when not in use; (2) equipment and facility modification (utilizing engineering expertise to recover conversion losses or retrofitting existing structures); (3) maintenance programs, where existing equipment is kept in top energy-saving shape; and (4) through power factor correction at the point of use, which can be accomplished by following the suggestions of an energy technician.

One of the major energy education problems is that too many people are making broad generalizations or predictions about energy without giving all the variables.

Energy can be controlled. People cannot. But it is the people who will determine the direction that will be taken in the selection of energy sources. Energy has to become very personal.

Even so, this Nation's immediate energy shortages place the responsibility of each individual, corporation, institution, and association in an apparent dichotomy:

On the one hand, a reduction must be made in the appetite for energy so that there is less dependence on fossil fuels and oil imports, thereby becoming less vulnerable to pressures affecting national security.

At the same time, productivity, which has some correlation with the rate of energy consumption, must be maintained while using less traditional energy.

The solution to this dilemma involves a commitment in two areas.

First, the long-range goal must be to develop and utilize alternate sources of energy. This step will mean a shift from a civilization based heavily on a single source of energy to one based more securely on many. Ultimately, this means a civilization founded once more on self-sustaining, renewable - rather than exhaustible - energy sources.

Secondly, the individual's response to achieve immediate results must be to utilize available energy more efficiently - to audit consumption and search out and eliminate waste.

Both goals must be attained if there is to be more productivity, a high standard living, and the ability to do these things with less energy.

And the process involved in making these transitions is nothing short of a revolution - an energy revolution.

If the masses simply sit back and do nothing, like the grasshopper who fiddled while the ant worked, the future is going to be a long, cold, winter.

Individuals must commit themselves to the task of making wise energy decisions. For only through the making of wise choices can it be ensured that the world's children are

not left shivering in blackened snow.

For every evil under the sun,
There is a remedy, or there is none.
If there is one, seek till you find it;
If there be none, never mind it.

•Mother Goose

EXERCISES

1. As a futurist, write a paper describing, with documentation, an energy utopia in the year 2100 A.D.
2. Make a list of energy sources from which objects in the classroom were derived. Include equipment (or parts of equipment), furniture, clothing, and so forth.
3. Describe the socioeconomic factors in implementation of direct solar passive energy systems in new residential housing as these systems relate to financing, labor force, community services, power, and equipment. As to labor force, for example, if it were possible to use the sun's energy directly, what new jobs would be available and what former jobs would be reduced or eliminated?
4. Write a paper on what effect biomass energy production would have on the nation's agricultural community. In what ways could individual small-acreage farmers employ biomass techniques?
5. Enumerate several short-term national policy (energy) issues (between now and 1985) and indicate those relatively difficult to solve in the short term. Prioritize in decreasing order of difficulty.
6. Write a paper describing, with documentation, which energy source (or combination of sources) has the greatest potential and the least unfavorable environmental impact over the long term. Save the paper and write another on the same topic at the conclusion of this course. Compare the two.
7. As a consumer, survey the current automobile market to determine which new car is most economical if purchased now and kept for five years. In addition to initial purchase price, project financing, and known maintenance costs, as well as projected fuel costs. Debate the subject in class.

REFERENCES

"1978 Special Annual Issue -- '77-'78 A Look Back, A Look Forward." Energy. Stanford, CT: Business Communications, Inc., 1978.

Citizens' Advisory Committee on Environmental Quality.
Energy in Solid Waste -- A Citizen Guide to Saving.
Washington, D.C.: U.S. Government Printing Office,
1975.

Considine, Douglas M. ed. Energy Technology Handbook. New York: McGraw-Hill Publishing Co., 1977.

Fowler, John M. Energy and the Environment. New York: McGraw-Hill, 1975.

Hall, Peter. "Solar Energy: The Renewable Source."
Graduating Engineer. (Spring, 1980).

Hourmanesh, Mohsen. Natural Energy Sources and Passive Energy Systems in Architecture. Unpublished Dissertation.
College Station, Texas: Texas A & M University, 1979.

Miller, James N. "The Energy Crisis: There is an Easy Answer," Reader's Digest. (June, 1980).

Smith, Desmond. "What Is America's Secret Weapon in the Energy Crisis?" Panorama. (April, 1980).

The Mother Goose Book. Illustrated by Alice and Martin Provensen. New York: Random House, 1976.

Toffler, Alvin. The Third Wave. New York: William Morrow and Co., Inc., 1980.

Winston, Donald C. "There Goes the Sun." Newsweek. (December 3, 1979).

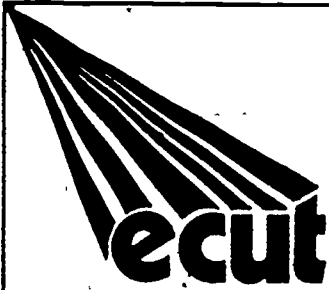

ENERGY TECHNOLOGY

CONSERVATION AND USE

FUNDAMENTALS OF ENERGY TECHNOLOGY

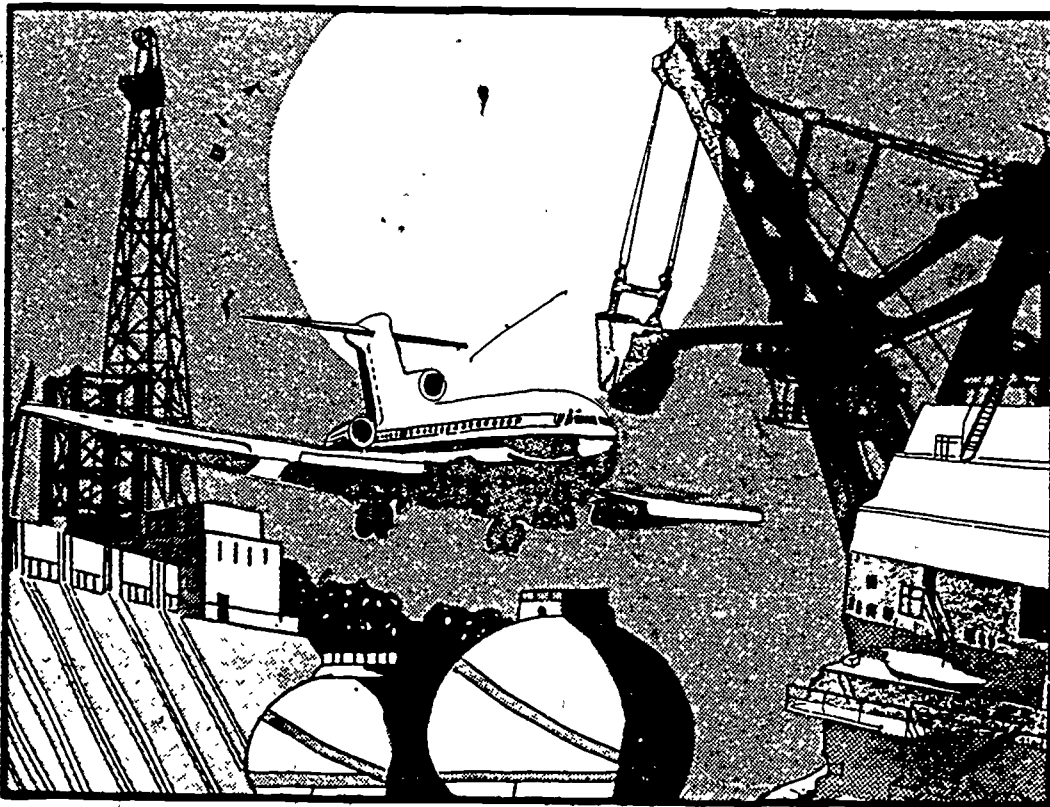

MODULE EF-02
SOURCES OF ENERGY I



CENTER FOR OCCUPATIONAL RESEARCH AND DEVELOPMENT

INTRODUCTION

This module presents an overview of the natural resources that have provided the world with most of its energy sources to the present.

These natural resources are wood and the fossil fuels: coal, petroleum and natural gas. Oil shale and tar sands may become more important sources of energy in the future.

Fossil fuels were formed from the decomposition process of plants and animals that lived many years ago. Solar energy was stored as chemical energy during the process of photosynthesis. This energy can be released during combustion and then converted to useful energy. Unfortunately, these fossil fuels are limited resources.

PREREQUISITES

The student should have completed Module EF-01, "Energy Technology."

OBJECTIVES

Upon completion of this module, the student should be able to:

1. Describe how each of the fossil fuels is formed.
2. Identify the primary components of each of the fossil fuels.
3. Discuss how each of the fossil fuels is obtained from the earth.
4. Identify the major areas of the world where each of the fossil fuels may be found.

5. Discuss the present and future conditions of each of the fossil fuels in terms of supply and demand.
6. Distinguish between present energy sources and future (or experimental) energy sources.
7. Discuss the present and future situations of each of the fossil fuels in terms of advantages and disadvantages.
8. Identify the following terms discussed in this module:
 - a. Lignite
 - b. Bituminous
 - c. Anthracite
 - d. Oil shale
 - e. Methane
 - f. Surface mining
 - g. Tar sands
 - h. Petroleum
 - i. Underground mining
 - j. Energy sources
 - k. Carboniferous Period

SUBJECT MATTER

SOURCES OF ENERGY: I

The history of the United States is a story of tremendous growth in all areas of human accomplishment. Vast supplies of available natural resources have provided the energy to achieve the highest standard of living in the world.

When one source of energy became scarce or expensive, there was always another to take its place. Only recently have there been serious problems with this rather short-term approach. The changing trend of energy sources in the United States is illustrated in Figure 1.

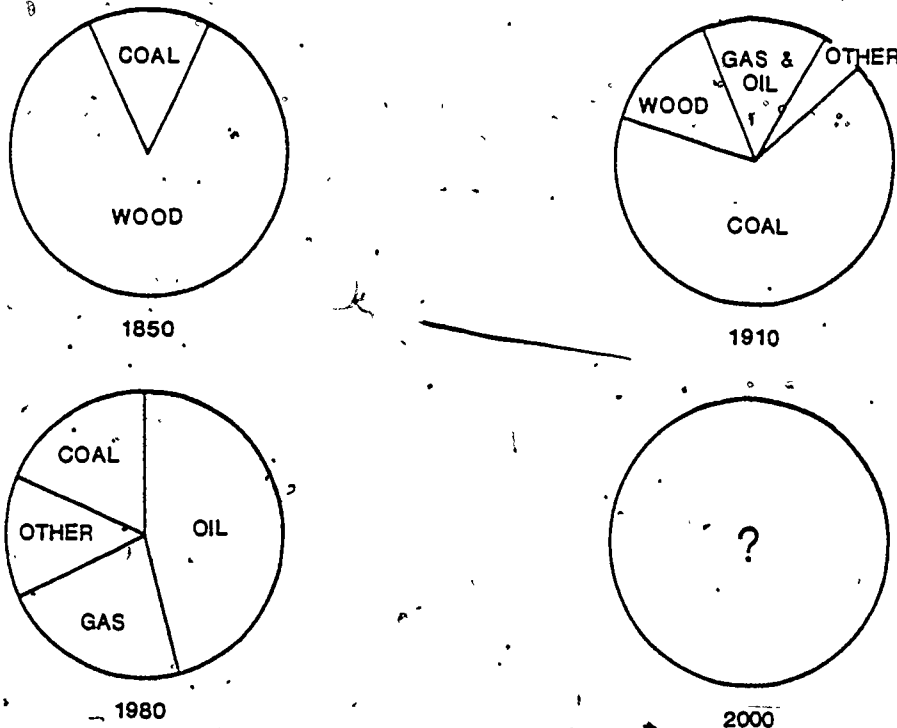

Figure 1. Historical Energy Sources for the United States.

WOOD

The earliest source of energy for mankind was probably wood. In fact, wood still provides most of the energy for warmth and cooking in poorer nations of the world. It is not surprising that the first visitors thought America to be a land of plenty. At that time, natural resources, like wood, with seemingly unlimited forests, appeared to be a cornucopia.

During the first few centuries of European influence in the Americas, wood was the major source of energy. In the 1700s and 1800s, the typical American home consumed approximately 16 cords of firewood a year. Since open fireplaces are inefficient, most of the energy was lost up the chimney. But since wood was so plentiful, this was of no concern.

Wood was also the major fuel for American industry during that time. It was used until the middle of the 1800s as the primary energy source for the railroads, river travel, mining operations, metal refining, and for manufacturing processes.

Today, wood is used in the United States mostly for recreational or aesthetic purposes, like outdoor grills or the psychological effects of an open fireplace. Although wood-burning stoves are becoming more popular, they present safety and pollution problems when used on a large scale. It is interesting to mention, however, that although the use of wood is presently not even 1% of the total energy consumption of the United States, contemporary wood use is more than half the total 1850 consumption.

The decreasing importance of wood as a fuel in the United States and the rising importance of the fossil fuels is illustrated in Table 1.

TABLE 1. SUMMARY OF ENERGY SOURCES IN THE UNITED STATES.

Year	Wood	Coal	Oil	Gas	Other
1850	90%	10%	0%	0%	0%
1860	83	17	0	0	0
1870	75	25	0	0	0
1880	58	40	2	0	0
1890	40	57	2	1	0
1900	22	71	3	2	2
1910	11	77	5	4	3
1920	9	71	11	5	4
1930	7	58	22	10	3
1940	5	50	29	12	4
1950	3	35	37	20	5
1960	0	23	43	51	3
1970	0	16	47	32	5
1980	0	19	46	26	9

COAL

Coal is the most abundant fossil fuel found in the United States. In 1980, it will supply about 19% of the total energy demand in the country. New technology will certainly result in a renewed importance of coal in the total energy picture.

THE NATURE AND DISTRIBUTION OF COAL

Although sometimes called minerals, coals are formed from the remains of plants and are, therefore, organic in

nature. Coals were formed 300 to 400 million years ago during the Carboniferous Period when the earth was hot and humid and plant formation was favorable.

During that time, thick forests and swamps covered much of the earth. As these plants died, they were covered by others; the ground became a thick layer of dead plants. As time passed, the partially-preserved plants were compressed to various degrees by other plants, dirt, gravel, and the advances and recessions of the oceans.

The type of material formed depended on the pressure and the time. Peat is formed quite easily. Peat is a spongy substance, much like decomposed wood. Although it is used as a fuel in some areas of the world, peat has more use in this country as a fertilizer.

The earliest type of coal formation, however, is usually called lignite. Lignite requires more time and pressure to be formed than peat. After a longer time, lignite can be converted into bituminous coal. Bituminous coal is sometimes called soft coal, since it can be broken easily. Extremely high pressures, continued for a long time, are needed to produce anthracite, or hard coal. A comparison of the major types of coal is given in Table 2.

TABLE 2. TYPES OF COAL:

Lignite

- soft and crumbles easily
- high in volatile oils; may undergo spontaneous combustion
- low carbon content and heat value
- burns with a very smoky flame

Table 2. Continued.

- high sulfur and ash content
- difficult to mine

Bituminous

- solid, but easily broken
- contains some volatile oils
- high carbon content and good heat value
- contains appreciable amounts of sulfur
- very easy to mine and readily available

Anthracite

- very hard and brilliant
- low in volatile oils
- high carbon content and excellent heat value
- low sulfur and ash content
- difficult to mine and relatively scarce
- burns with a clean blue flame

Coal is the most abundant energy resource in the United States. About 30% of the coal reserves of the world are located in this country. The Soviet Union has about 25%, China 15%, and Europe 10%. The worldwide distribution of estimated coal reserves is illustrated in Figure 2.

The reserves of coal in the United States are shown in Figure 3. The states of Montana, Illinois, and Wyoming combined have more than half the country's coal reserves. The states with most of the demonstrated reserves are listed in Table 3.



Figure 2. World Distribution of Coal Reserves.

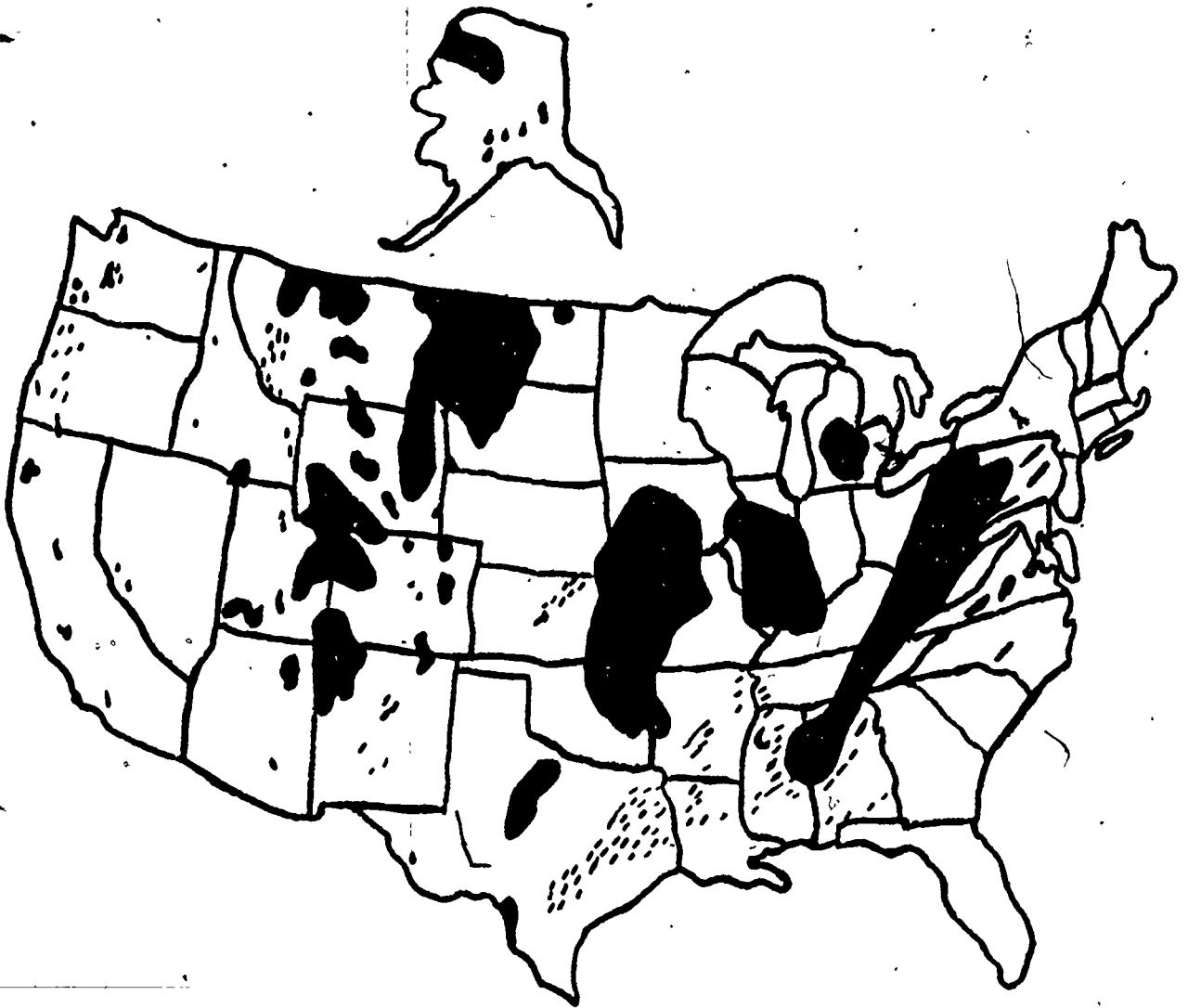

Figure 3. Distribution of Coal Reserves in the United States.

TABLE 3. DEMONSTRATED COAL RESERVES
IN THE UNITED STATES.

State	Billions of Tons
Montana	120.6
Illinois	68.0
Wyoming	55.4
West Virginia	38.6
Pennsylvania	30.8
Kentucky	26.0
Ohio	19.2
Colorado	16.3
Indiana	10.7
North Dakota	10.1
Utah	6.6
Alaska	6.2
Missouri	5.0
New Mexico	4.6
Virginia	4.3
Texas	3.2
Alabama	3.1
Iowa	2.2
Oklahoma	1.6
Washington	1.6
Maryland	1.0

DEVELOPMENT OF COAL

Although many early civilizations have used coal to some extent for centuries, it was not until the Industrial Revolution in England that coal became a heavily-used fuel.

For several centuries, England was the major producer of coal. Development and use of coal was delayed in the United States due to the availability of wood. When wood became scarce in the eastern part of the country and the efficiency of coal as a fuel was recognized, however, coal rapidly became the major source of energy for this country. The present major producers of coal in the world are listed in Table 4.

TABLE 4. MAJOR COAL PRODUCING COUNTRIES - 1976.

Country	Millions of Tons
Soviet Union	786
United States	685
China	532
East Germany	273
West Germany	247
Poland	241
Great Britain	137
Czechoslovakia	130
India	116
Australia	110

At first, coal was used primarily for railway and river transportation in steam engines. It was also realized very early that useful fuels of many kinds could be manufactured from coal. Kerosene, or coal gas, was made from coal in

the 1800s. This "town gas" (or "water gas") provided light and heat into the early 1900s.

More than half of the coal mined in this country is presently used for the production of electricity by public utilities. Coal-fired plants burn large amounts of coal to produce heat. The heat produces steam, which turns large turbines and generates electricity. The environmental effects of burning coal will be discussed in a later module.

Coal may be obtained from the earth in two ways: surface mining and underground mining. Surface mining is more productive but involves many associated cost problems. Most surface mines are located in the western United States where transportation to the more populated areas is very expensive. In fact, it is now cheaper for some coastal users of coal to purchase it from Australia than to transport the coal from Montana and Wyoming.

The major pollutant in coal is sulfur. Although western coal is low in sulfur, it is also low in energy content. Surface mining of coal also involves environmental problems, which will be discussed later.

There are many underground coal mines in the eastern United States. In addition to the higher sulfur content of eastern coals, there are many technological problems associated with making underground mining safe and economical. Table 5 lists the major coal-mining states.

In 1975, coal production of the United States was about 650 million tons. At this rate of use, known coal resources would last about 600 years. But electric utilities use enormous amounts of coal. In 1977, approximately 710 million tons were mined and three-fourths of the coal went into generating about half of the electricity needs of the country. In the last decade, about five billion tons of coal have been used by electric utilities.

TABLE 5. MAJOR COAL PRODUCING STATES - 1977.

State	Millions of Tons
Kentucky	143
West Virginia	95
Pennsylvania	83
Illinois	54
Ohio	46
Virginia	38
Wyoming	35
Montana	29
Indiana	28
Alabama	21
Texas	17
North Dakota	12
Colorado	12
Arizona	12
New Mexico	11
Tennessee	10

Although this represents a considerable increase over the previous decade, it may not be enough. Since the Arab oil embargo, the government has been trying to influence industry and utilities to use coal, rather than oil or natural gas. It is predicted that the annual consumption of coal will increase to a minimum of one billion tons by 1990, and perhaps to three billion tons by the year 2000.

At the present time, through research and development, an effort is being made to make more use of coal in this country. New thrust is also provided by the realization

that the end of the petroleum era is imminent. The required technologies for coal gasification (gas from coal), liquefaction (liquid fuels from coal), and for producing clean, high energy solid fuel from coal, have been demonstrated in laboratories and in small pilot plants. These synthetic fuels, however, are not presently economically competitive with oil and natural gas. Table 6 summarizes the future of coal in the United States.

TABLE 6. THE FUTURE OF COAL IN THE UNITED STATES.

Advantages

- Domestic sources of coal are vast.
- Coal can be used as a base for synthetic fuels.
- Technology is available for many new uses of coal.
- Advanced technology may reduce transportation costs.
- Smaller, more efficient plants are being developed.

Disadvantages

- Air pollution controls are expensive.
- Many environmental problems are associated with mining.
- Advanced technology is expensive.
- The feasibility of new fuels is uncertain.

PETROLEUM

Petroleum is the major source of energy for the United States at the present time. In 1980, petroleum will supply about 46% of the total energy demand of the country. It is a very versatile fuel. However, petroleum availability is limited in terms of new sources and world conditions.

THE NATURE AND DISTRIBUTION OF PETROLEUM

Petroleum was formed from the remains of tiny aquatic plants and animals in the sea. Over a period of time, these layers were mixed with mud and sand in layers of marine sediment. As time passed, marine sediment was mixed and trapped in deposits. Petroleum is a fossil fuel since it is derived from organic matter. However, petroleum is sometimes known as mineral oil, since it is found with mineral deposits.

Actually, petroleum is a mixture of many compounds. Although different crude oils have varying compositions, they may all be refined or separated into useful fractions. In one process, crude oil is vaporized and then allowed to cool. Components with lower boiling points liquify first and can be separated into common fractions. Gases are condensed and collected. The greases, waxes, and asphalt separate from what remains. A line diagram of a refinery fractionating tower is shown in Figure 4.

The various fractions obtained from petroleum have numerous applications. A summary of these products and their uses is given in Table 7. In addition to the fuel uses of petroleum, a large number of useful chemical and

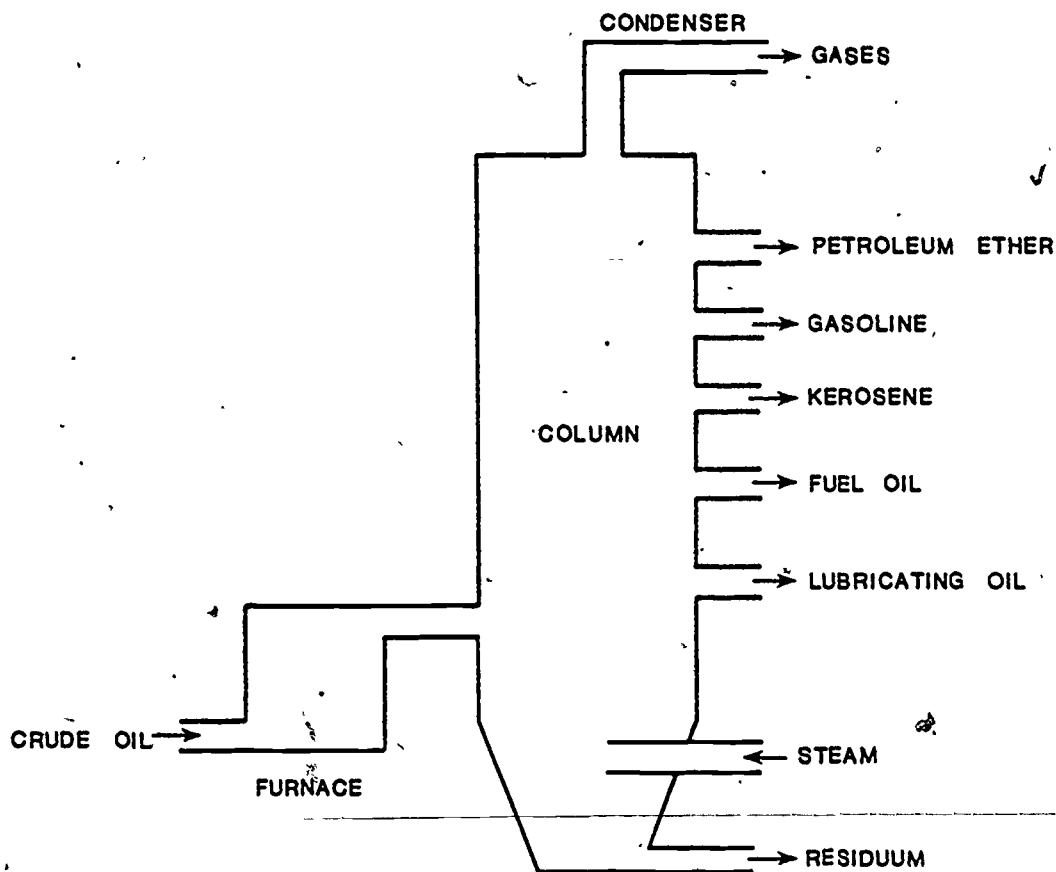

Figure 4. A Fractionating Tower for Petroleum Refining.

nonfuel substances are obtained. Some petrochemicals are base materials for synthetic rubber, drugs, plastics and fibers, detergents, and fertilizers.

There is much energy in a barrel of oil. One barrel of oil provides heat for an average home for a week in cold weather. One barrel of oil can transport passengers in a jetliner from Chicago to Washington. When considering energy on a larger scale, however, the amount of oil being required is staggering. For example, to run the city of

TABLE 7. COMMON FRACTION OF PETROLEUM.

Fraction	Uses
gases	liquid gas fuel
petroleum ether/naphtha	industrial solvent, lighter fluid
gasoline	motor fuel
kerosene	diesel fuel, jet fuel
fuel oil	heating oil, diesel fuel
lubricating oil	motor oil, lubrication oil
greases	lubrication, petroleum jelly
residuum	asphalt, tar, paraffin

Baltimore for just 10 minutes, 1,000 barrels of oil are required. On the other hand, the energy in 1,000,000 barrels of oil will supply the energy requirements of California for only eight hours. The supply of petroleum is simply not keeping up with increases in demand. In the United States, for example, domestic supplies of oil must be supplemented with petroleum imports.

The Middle East has about 53% of the petroleum reserves of the world. Africa has 16%, the Soviet Union 15%, and the United States has only 5%. Venezuela, Canada, Europe, and

Indonesia each have about 2%. Mexico, the Caribbean, and other South American countries have about 3%. The worldwide distribution of petroleum reserves is illustrated in Figure 5.



Figure 5. Worldwide Distribution of Estimated Oil Reserves.

THE DEVELOPMENT OF PETROLEUM

Petroleum was first found and used from surface pools by early civilizations for warmth, cooking, medicines, and many other purposes. Noah used pitch to caulk the ark. The ancient Egyptians used petroleum as a lubricant. Many ancient civilizations used tar during warfare. In Medieval Europe, surface oil was used for illumination.

Most petroleum, however, is trapped underground and is not evident from the surface. Although the ancient Chinese actually drilled for oil and gas more than 2,000 years ago, large scale production and use of oil can probably be traced to the first oil well drilled in the United States. The first oil well drilled in the United States was 70 feet deep, drilled in Pennsylvania in 1859. In a short time, a thriving industry was built in the area to refine the petroleum and transport it to consumers. As the demand for oil increased over the next 50 years, new fields were located in West Virginia, Colorado, Texas, California, Ohio, Illinois, Oklahoma, and Louisiana. Oil technology advanced so that the crude oil could be obtained from depths of down to four miles. The major oil-producing states are listed in Table 8.

The primary impetus to the use of petroleum was certainly the development of the internal combustion engine. Until that time, gasoline was considered a waste product. In 1900, 60% of the petroleum was used to produce kerosene. In 1975, 53% of the petroleum was used to produce gasoline and less than 1% went to produce kerosene. The relationship

TABLE 8. MAJOR OIL PRODUCING STATES - 1975.

State	Millions of Barrels
Texas	1,222
Louisiana	651
California	322
Oklahoma	163
Wyoming	136
New Mexico	95
Alaska	70
Kanasa	59
Mississippi	47
Utah	42
Colorado	38
Montana	33
Illinois	26
Michigan	24
North Dakota	20
Arkansas	16

of petroleum and industry is illustrated in Table 9. Of the top 10 industries in the United States, six are oil companies and two are automobile manufacturers.

By 1900, the United States exported about one-third of its oil and remained the leading oil producing country for most of this century. In the 1970s, however, oil production in this country dropped; demand increased. The Soviet Union and Saudi Arabia moved ahead in total oil production, and the United States imported almost half of its

TABLE 9. THE TOP TEN INDUSTRIES
IN THE UNITED STATES - 1980.

Company	Assets in Billions
Exxon	25.0
General Motors	19.5
Mobil Corporation	13.8
Ford Motor Company	13.1
Texaco	12.4
Standard Oil of California	10.0
Gulf Oil	7.6
IBM	14.6
General Electric	12.0
Standard Oil of Indiana	7.5

oil supply in 1979. Major oil-producing countries are listed in Table 10.

Future demand for petroleum is expected to increase. More machines, heat energy, and electric power are needed for industry, agriculture, transportation, and business operations to maintain the pace toward a higher standard of living for most of the world's population. Great quantities of petroleum will also continue to be required to produce lubricants and petrochemicals. Oil consumption in the United States may double by the end of the century. It is, therefore, evident that new sources of oil must be located, more efficient recovery of known deposits must be accomplished, and what oil is available must be used conservatively. Easy-to-find supplies of oil are decreasing.

TABLE 10. MAJOR OIL PRODUCING COUNTRIES —, 1976.

Country	Millions of Barrels
Soviet Union	3,793
Saudi Arabia	3,227
United States	2,970
Iran	2,153
Kuwait	873
Venezuela	838
Iraq	790
Nigeria	750
United Arab Emirates	710
Libya	698
China	618
Abu Dhabi	582
Indonesia	551
Canada	483
Algeria	384
Mexico	304
Qatar	178
Australia	156
Argentina	143
Oman	135
Malasia	132
Egypt	120
Dubai	115
Romania	106
Norway	102

Other options and alternatives must be investigated at the same time. Table 11 summarizes the future of petroleum in the United States.

TABLE 11. THE FUTURE OF PETROLEUM
IN THE UNITED STATES.

Advantages

- Petroleum is easily separated into many useful components.
- Petroleum is the base for most American industry.
- Cost is still low compared to many alternatives.

Disadvantages

- Domestic supplies are very limited.
- Imported oil is more expensive.
- Imported supplies are subject to world political situations.
- Eventually, world supplies will run out.

NATURAL GAS

Natural gas is efficient for heating and is relatively non-polluting. In 1980, it will supply about 26% of the total energy demand of the United States. The major disadvantage is that there is not enough natural gas.

THE NATURE AND DISTRIBUTION OF NATURAL GAS

The major component of natural gas is methane, a product in the decomposition of organic materials. Other gases present in minor amounts are ethane, propane and the butanes. Natural gas was formed during post geological ages and is usually found trapped beneath layers of rock (with petroleum deposits). Most natural gas has been found at depths of 1,000 to 18,000 feet, with over 60% found at depths greater than 15,000 feet.

Natural gas burns with a pale blue flame. When used in home heating, it is every efficient, since there is only one energy conversion involved. The efficiency of natural gas for heating purposes is usually greater than 60%; whereas, heating with electricity is less than 30%-efficient overall.

In 1976, the estimated reserve of natural gas in the United States was 228 trillion cubic feet. This estimate was 72 trillion cubic feet more than was estimated in 1945. Since that time, numerous reserves have been located in Alaska and offshore. Table 12 identifies the 23 states that have more than 200 billion cubic feet of natural gas in proven reserves. Note that the areas with large deposits of natural gas usually have petroleum, as well.

TABLE 12. MAJOR NATURAL GAS RESERVES - 1976.

State	Billions of Cubic Feet
Texas	71,040
Louisiana	61,310
Alaska	32,050
Oklahoma	13,080
Kansas	12,660
New Mexico	11,750
California	5,480
Wyoming	3,700
West Virginia	2,310
Arkansas	1,990
Colorado	1,890
Pennsylvania	1,680
Michigan	1,610
Ohio	1,350
Mississippi	1,210
Montana	930
Utah	920
Kentucky	810
Alabama	770
North Dakota	420
Illinois	380
Florida	270
New York	220

THE DEVELOPMENT OF NATURAL GAS

Natural gas is not a new fuel. Several early civilizations used natural gas for heat and light. In the early 1800s, a natural gas well 27 feet deep was drilled in Fredonia, New York. The gas was transported in hollow logs to the nearby town and used for lighting. Although recognized as a fuel, large amounts of natural gas were wasted during the production of petroleum. Due to problems of storage and shipping, it was sometimes easier to simply burn off the natural gas that was found with oil. In the early 1900s, it was estimated that 90% of the natural gas was burned off from the oil fields of Texas and Oklahoma.

Since that time, the use of natural gas has increased from about 5% of the total United States energy consumption in 1920 to a maximum of about 32% in 1970. This is primarily a result of the development of more effective methods of exploration, more efficient transmission lines, and extensive distribution systems. Although its percentage of the total decreased during the 1970s to 26% in 1980, natural gas continues to represent a very valuable source of energy.

A tested reservoir is an underground natural gas storehouse that is producing gas. By drilling a number of wells in various places, geologists and engineers can make an estimate of what lies below the surface. Rock and sand samples brought up by the equipment are studied, and the size of the reservoir can be estimated; this method has proven to be an excellent one.

During the 1970s, the cost of gas wells increased rapidly. Since drilling to greater depths means more expense, the average depth of drilling actually decreased; still, the

costs rose. In fact, some natural gas wells are still quite deep. The deepest well (in western Oklahoma) is six miles deep.

Raw gas from the wells must be purified before it can enter the pipeline system for distribution to homes and factories. In this processing, some valuable by-products are recovered. The natural gasoline obtained is mixed with gasoline from petroleum to improve the starting properties of engines in cold weather. Ethane is used as a raw material in making petrochemicals. Propane and butane are the familiar "bottle gas" and "tank gas" used in rural areas and for recreational vehicles.

Some gas fields also produce helium gas. Helium is used to inflate balloons and dirigibles, in welding (as a refrigerant for extremely low temperatures) and in atomic energy production.

Since production from existing domestic fields is declining, the difference must be made up in new discoveries, imports, and synthetic gas. Gas production on the North Slope of Alaska should begin in the mid-1980s. Imports from Canada and Mexico will also probably increase. A summary of the future of natural gas in the United States is given in Table 13.

TABLE 13. THE FUTURE OF NATURAL GAS
IN THE UNITED STATES.

Advantages

- Gas is a clean and efficient fuel for heating.
- Many valuable by-products are obtained during production.

Disadvantages

- Domestic supplies are limited.
- Domestic production is decreasing rapidly.
- Increased use of imports will be necessary.

OIL SHALE

Oil shale is a finely grained rock that contains organic material called kerogen. This solid material is also a fossil fuel that was formed at the bottom of prehistoric lakes and seas. Oil shale is frequently found in dolomite, calcite, quartz, and clay deposits. Over the ages, however, geological conditions were not severe enough to convert kerogen to natural crude oil. Kerogen may be separated from the rock by heating to about 900°F in a limited amount of oxygen. This process is called retorting. After cooling and purification, the dark brown viscous oil may be refined to give synthetic oil and gas.

The amount of oil obtainable from shale varies. Some deposits in the western part of the Soviet Union yield more than 60 gallons per ton of shale and can be burned directly. Shale in the western United States yields about 25 gallons

per ton; whereas, shale from Michigan averages about 15 gallons per ton.

The amount of recoverable shale oil in this country has been estimated to be greater than the proven reserves of crude oil. The region of most significance in the United States is the Green River Formation of Colorado, Utah, and Wyoming. Perhaps 600 billion barrels of oil could be recovered in the future, which would be about one-third of the 1,800 billion barrels in place at the site. However, this future development would be dependent upon the development of new technology to remove the oil.

In Michigan, there is a large deposit of low-grade oil shale. Gasification is considered the best method for retrieval of this resource. Although the approximate potential yield is 3,000 billion barrels of oil, many new methods must be developed for recovery to become feasible.

In addition to technological problems, there are several environmental concerns. Since oil shale rock expands by about 20% when processed to release the kerogen, it cannot simply be placed back in the ground if extracted by strip mining. The government has provided funds to scientists in Colorado to test various grasses, shrubs, and vascular plants in special research shale "rock gardens." Each garden will be covered with the crushed rocky wastes left from processing oil shale. Perhaps this will be a significant way to revegetate the lands disturbed by oil shale development.

In another study, ecologists will analyze plants grown on oil shale wastes to determine the amounts and types of trace elements absorbed in the vascular systems of the plants. Both these studies will provide information on potential effects of future oil shale development.

In addition, present techniques require large amounts of water - which is already scarce in the Green River Formation. This water cannot be recycled easily because it is chemically bound with the waste minerals. The disposal of this water presents a gigantic environmental problem by itself.

Although some proposals have been suggested for generating the oil at the site underground and associated air pollution could be controlled, the future is unclear. Table 14 summarizes the future of oil shale development.

TABLE 14. THE FUTURE OF OIL SHALE DEVELOPMENT
IN THE UNITED STATES.

Advantages

- Domestic and world resources are vast.
- Technology is presently being developed.

Disadvantages

- Technology will be expensive.
- Disposal problems are associated with processed shale rock.
- Large amounts of water are required.
- Air and water pollution problems are great.
- Cost competitiveness, compared to petroleum, is uncertain.

TAR SANDS

Tar sands, or oil sands, are sandstone and limestone reservoirs impregnated with a heavy crude oil. These deposits are usually found near the surface as large swamps of fine sand and clay with an asphalt-like tar known as bitumen. The oil is so dense that it cannot be obtained through a well by conventional drilling. These deposits may, however, be mined and heated to recover the oil. Another recovery method is to warm the oil in the ground with steam and then pump it out.

The most extensive deposit of tar sands in the world is located in the northeastern part of the Canadian province of Alberta. In South America, there are vast unexplored tar sand deposits. The largest deposit is probably in Venezuela, but other large formations are found in Brazil, Argentina, Columbia, Ecuador, and Peru.

Numerous smaller deposits of tar sands can be found in the United States. Many of these were quarried and sold as "asphalt rock" for paving material used in road construction during the early part of the 1900s. The largest deposits of tar sands in the United States are located in Utah. Minor deposits of tar sands are also found in Kentucky, Oklahoma, Kansas, Montana, Missouri, New Mexico, Wyoming, Alabama, Arkansas, Louisiana, and Texas.

Several projects are currently underway in Alberta to produce oil from tar sands. Although in the next several years considerable amounts of oil will be produced, there are many problems associated with the removal of oil from tar sands. Table 15 summarizes the future of tar sands.

TABLE 15. THE FUTURE OF TAR SANDS DEVELOPMENT.

Advantages

- World resources are vast.
- Technology is available for surface mining.

Disadvantages

- Technology for underground mining will be expensive.
- Quality of oil is poor.
- Oil is contaminated with minerals that must be removed.
- Environmental problems are similar to oil shale.
- Cost competitiveness, compared to petroleum, is uncertain.

EXERCISES

1. Identify the 50 states on a blank map of the United States.
2. Locate the top ten coal-producing nations on a world map. See Table 4.
3. Locate the top 25 oil-producing countries on a world map. See Table 10.
4. Locate the 13 OPEC nations on a world map. They are: Algeria, Ecuador, Gabon, Indonesia, Iran, Iraq, Kuwait, Libya, Nigeria, Qatar, Saudi Arabia, United Arab Emirates, and Venezuela.
5. Expand on the advantages and disadvantages listed for the fossil fuels discussed in this module by citing specific examples.
6. Start a collection of current news articles concerning the present and future of fossil fuels.
7. Construct a graph using the data in Table 1 to show the trends in energy use in the United States. Plot years on the horizontal axis and percentage of the total energy on the vertical axis. Extrapolate to the year 2000 to predict what the future might be like.

REFERENCES

Considine, Douglas M. Energy: Technology Handbook.

New York: McGraw-Hill Book Company, 1977.

Department of Energy. "Fact Sheet: Oil Shale Technology."

Information. Washington, DC: U.S. Government Printing Office, 1978.

Energy Outlook: 1977-1990. Exxon Company, January 1977.

Fowler, John M. FACTSHEET: New Fuels From Coal. Washington, DC: National Science Teachers Association, 1977.

Skinner, Brian J. "Energy: The Saga of the Fossil Fuels," Earth Resources. Englewood Cliffs, NJ: Prentice-Hall, 1968.

Stock, Robert W. "One Barrel of Oil," The New York Times Magazine. April 21, 1974.

U.S. Energy Research and Development Administration. Energy From Coal, ERDA 76-67. Washington, D.C.: U.S. Government Printing Office, 1976.

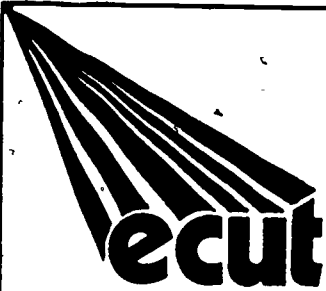

ENERGY TECHNOLOGY

CONSERVATION AND USE

FUNDAMENTALS OF ENERGY TECHNOLOGY

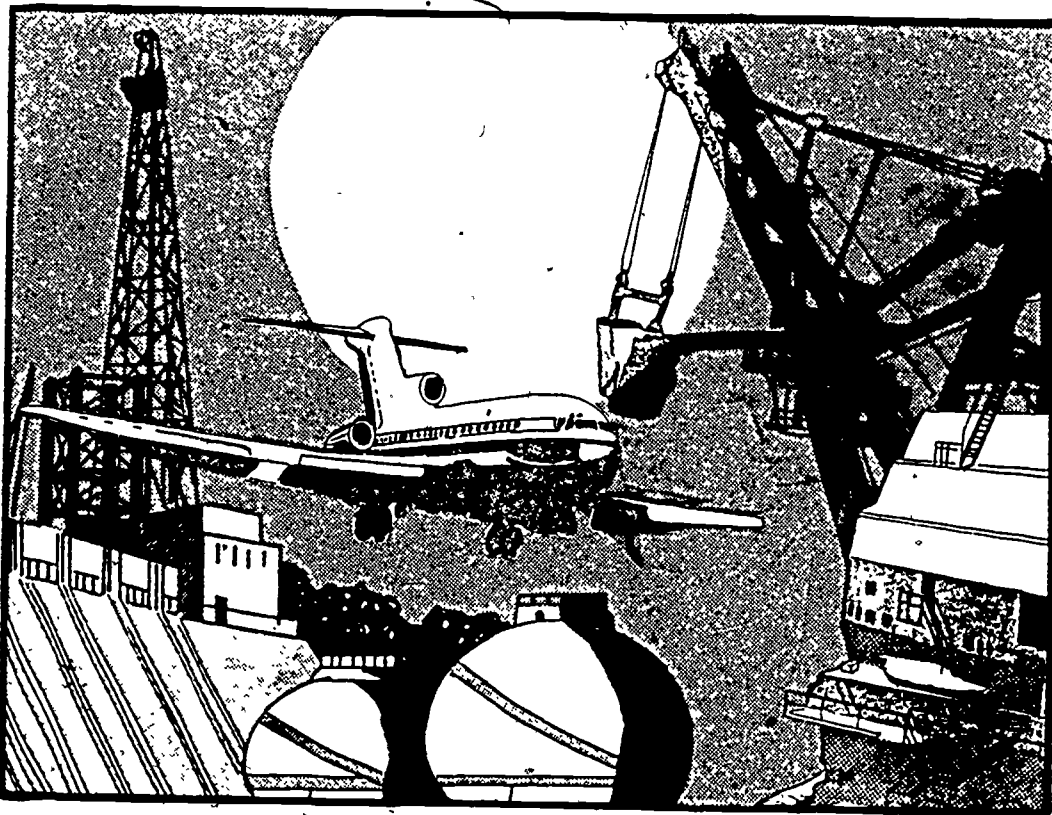

MODULE EF-03
SOURCES OF ENERGY II



CENTER FOR OCCUPATIONAL RESEARCH AND DEVELOPMENT

INTRODUCTION

This module presents an overview of the energy sources that are presently being developed or being considered for development as future energy alternatives to the fossil fuels. Although the fuels for nuclear fission are limited, the other methods discussed are either practically non-depletable or renewable.

There are many problems associated with these newer sources of energy. It is unlikely that any one source will be the single answer for the future. On the contrary, many of these new sources will combine to provide increasing amounts of energy to supplement fossil fuels during the next several decades.

PREREQUISITES

The student should have completed Module EF-02, "Energy Sources I."

OBJECTIVES

Upon completion of this module, the student should be able to:

1. Discuss the present and future conditions for each of the sources of energy presented in this module.
2. Discuss the advantages and disadvantages of each of the sources of energy presented in this module.
3. Discuss how each of the sources of energy presented in this module might be used to reduce dependence on fossil fuels.

4. Identify the following important terms:
- a. Nuclear fission
 - b. Neutron
 - c. Uranium-235
 - d. Light water
 - e. Heavy water
 - f. Boiling water reactor (BWR)
 - g. Pressurized water reactor (PWR)
 - h. High-temperature gas-cooled reactor (HTGR)
 - i. Helium
 - j. Fertile material
 - k. Liquid-metal fast breeder reactor
 - l. Gas-cooled breeder reactor
 - m. Molten-salt breeder reactor
 - n. Nuclear fusion
 - o. Plasma state
 - p. Magnetic containment
 - q. Inertial containment
 - r. Active solar system
 - s. Passive solar system
 - t. Ocean thermal energy
 - u. Aeolian energy
 - v. Geothermal energy
 - w. Hydrothermal reservoir
 - x. Geopressed reservoir
 - y. Hot-rock system
 - z. Hydroelectric power
 - aa. Tidal plant
 - bb. Biomass

SUBJECT MATTER

SOURCES OF ENERGY: II

Except for nuclear fuels, the sun is the original source of energy for the earth, either directly or as stored energy.

In terms of energy, everything goes back to the sun. Figure 1 illustrates that only a little of the total sunlight that reaches the earth is used to produce fossil fuels.

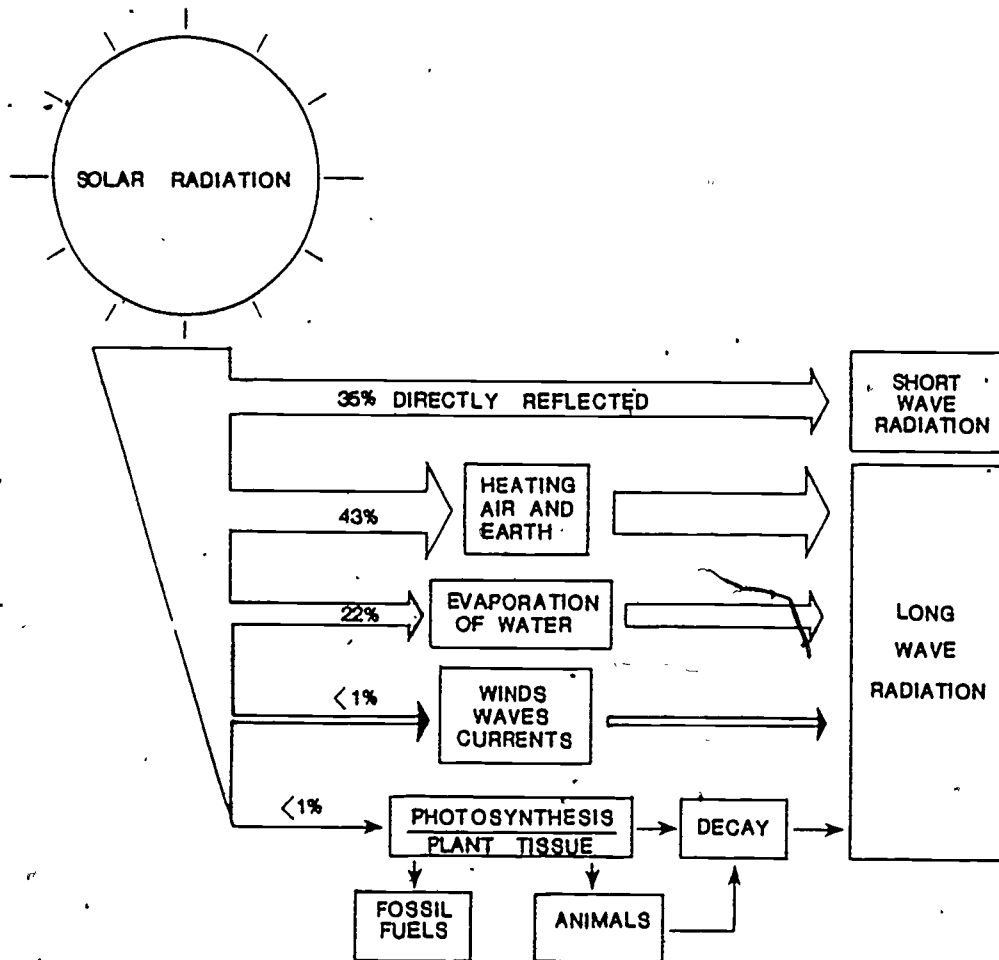

Figure 1. Distribution of Solar Radiation on the Earth.

As a result, the world is consuming these fuels approximately 50,000 times faster than fossil fuels are being produced. Although nuclear and the fossil fuels continue to be used, now is the time to investigate the other 99.999% of the energy that falls on the earth.

NUCLEAR ENERGY

Nuclear energy has become an important source of energy over the past decade. In 1980, nuclear energy will supply about 4% of the total energy demand for the United States. Most of this energy is used to produce electricity. Although there is considerable controversy concerning the continued use of presently existing nuclear plants, future technology promises many new ways to use nuclear energy.

NUCLEAR FISSION

In nuclear fission, the nucleus of a heavy atom is split into two or more fragments. Although the reaction starts by the absorption of a neutron, more neutrons are produced in the process. These neutrons can then cause more reactions to occur and a chain reaction is established.

Each fission is accompanied by the release of a tremendous amount of heat. The heat released may be converted to useful forms of energy. The fission process is illustrated in Figure 2.

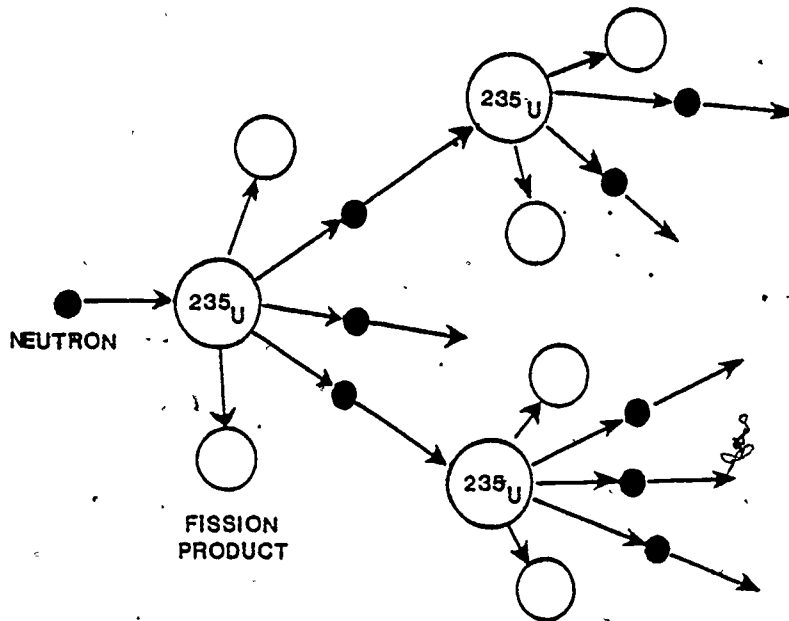

Figure 2. Nuclear Fission Reactions.

The fuel most commonly used for nuclear fission is uranium-235. Although this isotope of uranium occurs naturally, it is not found in its pure state. Natural uranium deposits are composed of about 99% uranium-238 and less than 1% uranium-235.

In order to be used in a nuclear reactor, uranium-235 must be concentrated or enriched to increase the content of fissionable material. This procedure is complicated and expensive. A synthetic element, plutonium-239, can also be used as a fuel. This isotope is made by reprocessing spent uranium fuels.

Most of the uranium in this country is found in the sedimentary rock formations of New Mexico and Wyoming. The uranium in the United States accounts for about 85% of the known domestic reserves.

FISSION REACTIONS

Although there are less nuclear plants in operation than were projected several years ago, there were 72 plants operating in 1979 - and 91 additional reactors in various states of construction. The technology necessary to control fission in nuclear reactors is well-established. In 1977, there were 65 reactors operating in the United States, supplying more than 12% of the electricity demand of the country. If this electricity were produced by oil, the amount of imported oil would have to be almost doubled.

Fuel is the only difference between nuclear power plants and conventional power plants. Conventional plants burn fossil fuel. Nuclear power plants burn uranium in the core of the reactor. The heat generated is converted to steam and then used to run a turbine and generate electricity.

Most of the reactors constructed are called thermal reactors. Selection of the coolant and moderator determines thermal reactor type. The coolant is used in the heat exchange process. The moderator is used to control the reaction of the fissionable fuel in the core. A majority of the reactors in the United States use water as both the coolant and moderator. In Canada, reactors are cooled and moderated by heavy water. Ordinary water is termed "light water."

There are two basic designs for light-water reactors: the boiling water reactor (BWR) and the pressurized water reactor (PWR). A boiling water reactor is pictured in Figure 3. Water is pumped through the reactor, which is at a temperature of about 600°F. Steam is formed at a pressure of about 1,400 psi and is used directly to drive the turbine. Figure 4 shows a pressurized water reactor. Water under a high pressure is pumped through the reactor and heated.

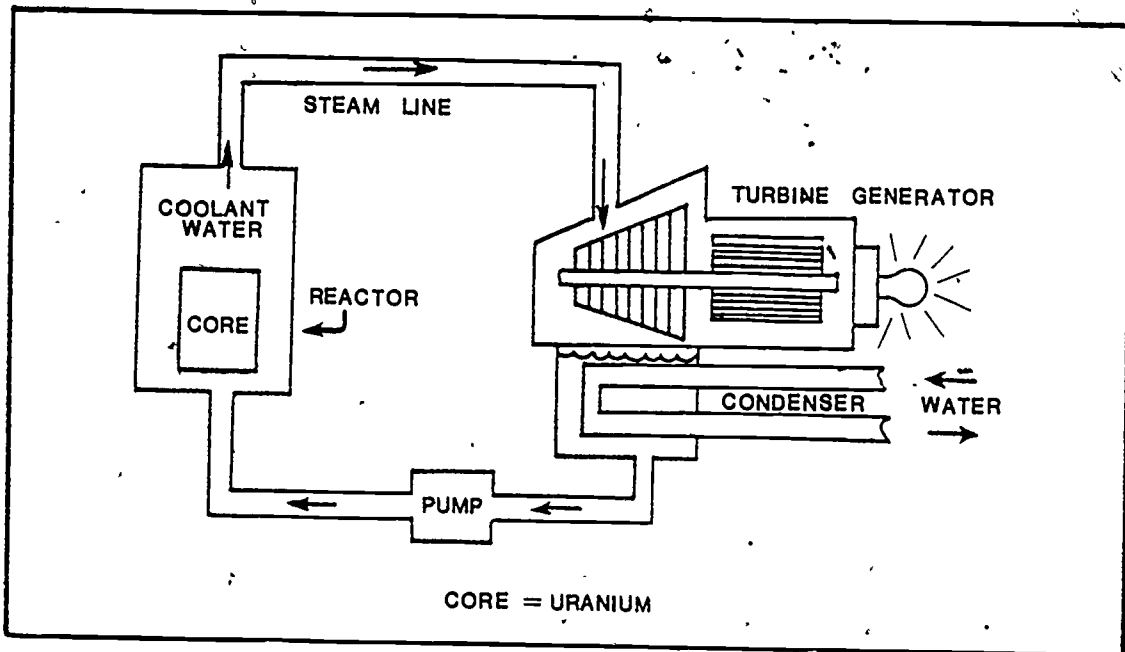

Figure 3. Boiling Water Reactor System (BWR).

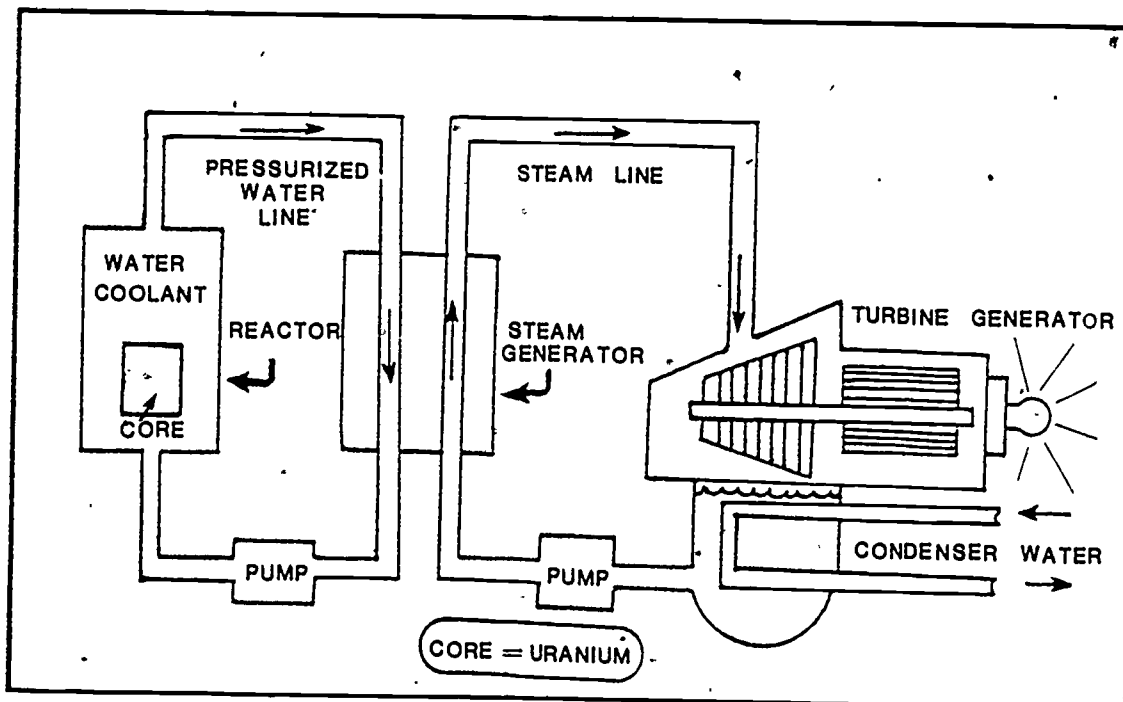

Figure 4. Pressurized Water Reactor System (PWR).

Heat obtained in the primary loop is removed in the steam generator. This steam drives the turbine.

Another type of reactor is the high-temperature gas-cooled reactor (HTGR). This reactor is diagrammed in Figure 5. Helium under pressure is the coolant that is pumped through the reactor. The uranium-thorium fuel used produces a higher temperature and the helium is heated to 1,400°F. The heat absorbed by the helium is then removed in the steam generator, forming steam to drive the turbine.

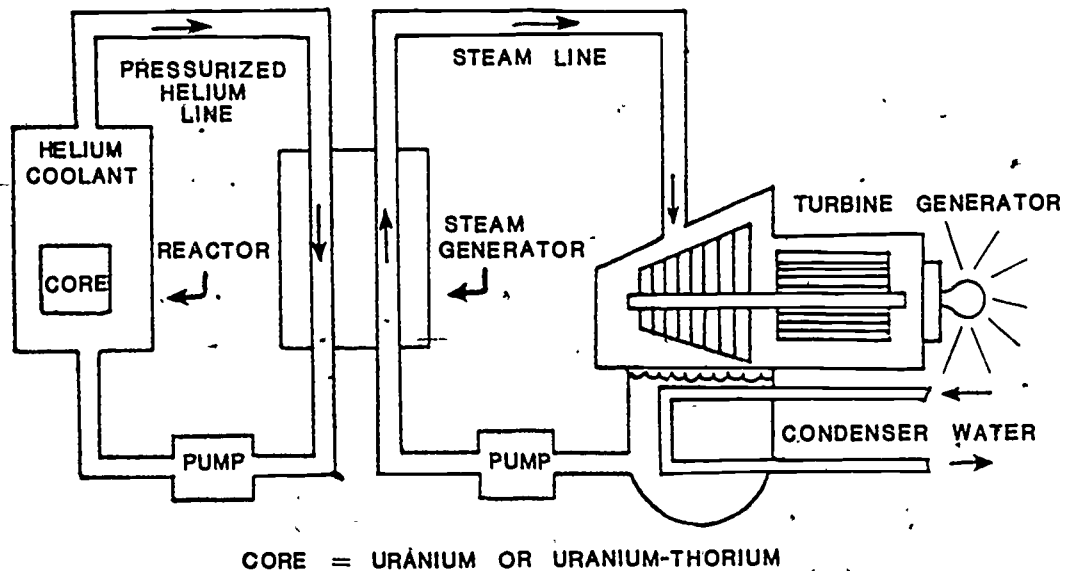

Figure 5. High-Temperature Gas-Cooled Reactor System (HTGR).

BREEDER REACTORS

Breeder reactors are similar in overall operation to fission reactors. During the reaction process, however, a nonfissionable substance (called a fertile material) is converted into a fissionable isotope. This means that more than one of the freed neutrons must be absorbed by an atom of fertile material for each neutron absorbed by an atom of fissionable material. If less than one new fissionable atom is produced, the amount of fuel decreases and the reactor is known as a converter or burner. Some reactors can produce some new fuel. These are known as advanced converters.

In a true breeder reactor, the average number of neutrons released in the fission of a single atom must be greater than two. One neutron is required to form another fissionable atom and one neutron is needed to carry on the chain reaction. - Any other neutrons can form extra fissionable atoms. Table 1 lists the average number of neutrons produced per neutron absorbed by different fissionable materials. Thermal neutrons are low-energy neutrons produced in thermal breeders. High-energy or fast neutrons are involved in fast breeder reactors.

TABLE 1. AVERAGE NUMBER OF NEUTRONS PRODUCED PER NEUTRON ABSORBED.

Fissionable Isotope	Neutrons Produced Per Thermal Neutron	Neutrons Produced Per Fast Neutron
^{233}U	2.3	2.3
^{235}U	2.1	2.1
^{239}Pu	1.9	2.4
^{241}Pu	2.1	2.7

Two factors are used to evaluate the possible performance of a breeder reactor. The breeding ratio is the ratio of new fissionable material produced to the fissionable material consumed. The doubling time is that time required for a breeder to produce enough new material to fuel a second reactor. The two basic breeder materials systems are shown in Table 2.

TABLE 2. MATERIALS USED AND PRODUCED IN BREEDER REACTORS:

Fissionable Material Used	Fertile Material Used	Fissionable Material Formed
^{239}Pu	^{238}U	^{239}Pu
^{233}U	^{232}Th	^{233}U

There are three types of breeder reactors: the liquid-metal fast breeder reactor (LMFBR), the gas-cooled breeder reactor (GCBR), and the molten-salt breeder reactor (MSBR). Both the GCBR and the MSBR use the uranium-thorium fuel cycle and are thermal breeders. The LMFBR is based on the plutonium-uranium cycle and has the highest priority of the breeder reactors:

A diagram of LMFBR is shown in Figure 6. Liquid sodium is pumped through the reactor and heated. In the heat exchanger, the hot liquid heats more sodium solution in the second loop. The sodium in the second loop then heats the water, forming steam that drives the turbine to generate

electricity. The major interest in the LMFBR is due to a breeding ratio that may be as high as 1.4 - with a doubling time of only 10 years.

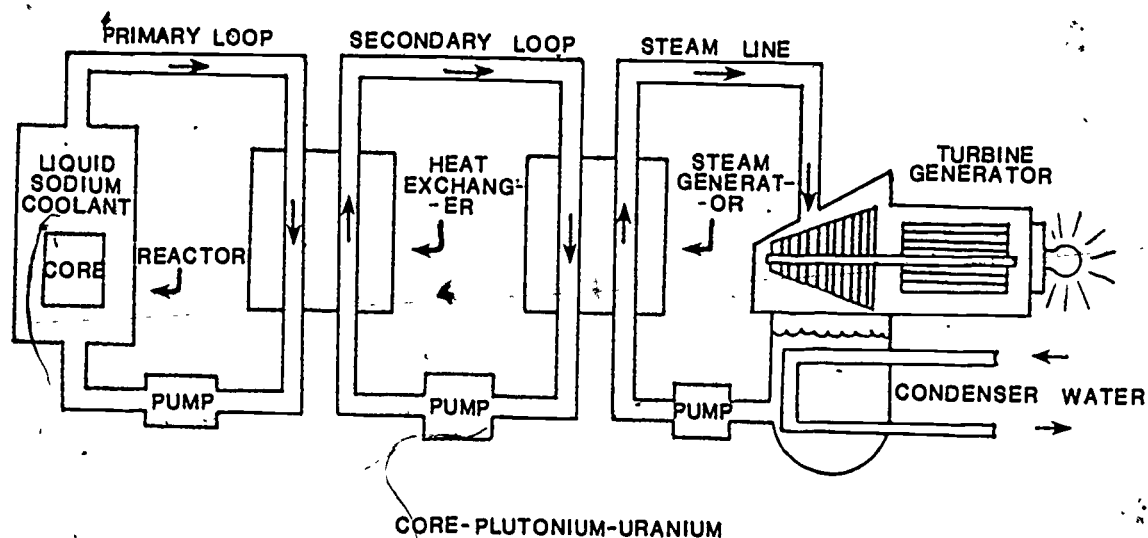

Figure 6. Liquid-Metal Fast Breeder Reactor System (LMFBR).

There are presently many problems associated with continued use and development of nuclear fission. The mishap at Three Mile Island in 1979 created widespread concern about nuclear power in general. Concerns over controlling large amounts of plutonium have resulted in delays in research and development of fast breeder reactors. Safe transportation and disposal of toxic radioactive waste is still uncertain. In addition, there may not be enough uranium to fuel the reactors that are presently under construction for very many years in the future. If breeder reactors are not developed, there may be many nuclear power plants idle for lack of fuel.

The future advantages and disadvantages of nuclear fission as an energy source in the United States are summarized in Table 3.

TABLE 3. THE FUTURE OF NUCLEAR FISSION IN THE UNITED STATES.

Advantages

- Technology is already developed for nuclear fission.
- Nuclear reactions produce tremendous amounts of energy.
- Nuclear energy is easily converted to electricity.
- Breeders may produce more sources of fuel.

Disadvantages

- Problems are associated with disposal of wastes.
- Breeder technology is falling behind other countries.
- There may be shortages of uranium fuel.
- Public confidence in nuclear energy is at a low point.
- Problems are associated with transportation of materials.

NUCLEAR FUSION

Nuclear fusion involves the combination of small atoms into larger ones. Tremendous amounts of energy are released in this process, even more than in nuclear fission. These reactions, however, can occur only in the plasma state - which is how matter exists at very high temperatures of hundred of millions of degrees. These reactions are like those that occur on stars or in nuclear explosions. Several possible fusion reactions are illustrated in Figure 7.

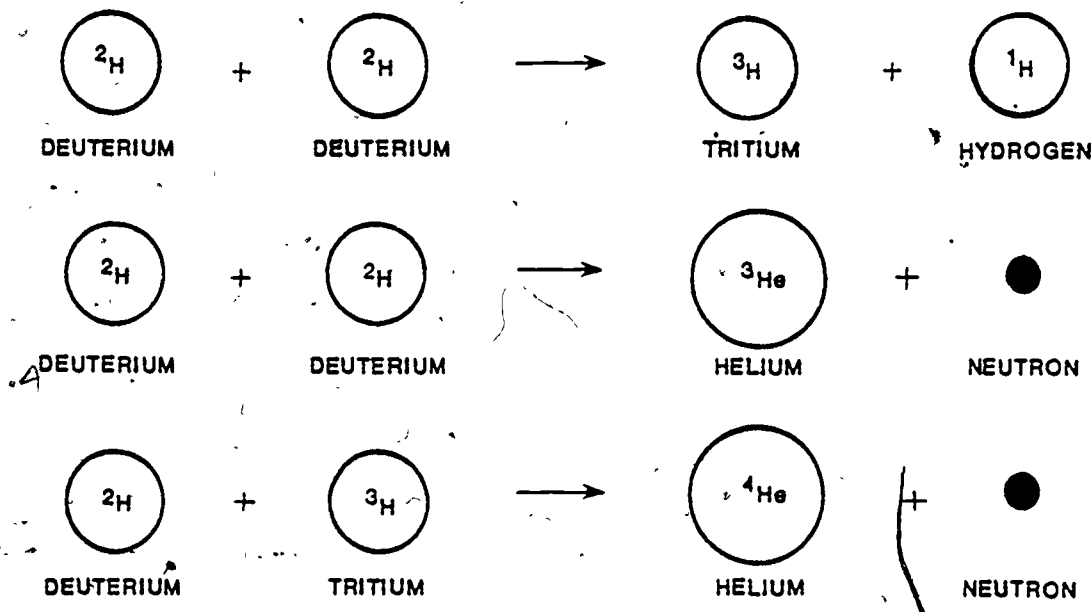

Figure 7. Fuel Systems for Nuclear Fusion.

Fusion uses fuels that are, for the most part, inexhaustible. There is enough deuterium in ocean water to provide energy for hundreds of billions of years. In addition, fusion reactors will not contain the huge amounts of radioactive materials characteristics of fission reactors.

Since no critical mass is involved, any malfunction would destroy the plasma and simply stop the reaction.

The feasibility of nuclear fusion was first scientifically indicated in the 1930s. To date, however, the only self-sustaining fusion reaction demonstrated has been the explosion of a hydrogen bomb. The main problem is that it is still not known if the process cost can be made economical.

Research has taken two approaches: magnetic containment and inertial containment of the plasma. In the first approach, the charged plasma is suspended in a large electromagnet. Maintaining these high temperatures necessary for any length of time is not yet possible. Future research and technology may result in huge installations that are practical only as the source of large amounts of electrical energy.

At the Los Alamos Scientific Laboratory, research is investigating inertial containment. High-energy laser beams are used to compress tiny fuel pellets to high densities and pressures.

The energy released in each explosion will be relatively small, perhaps the equivalent of a gallon of gasoline. But the process will be pulsed, with one small explosion following another. Recent projections for laser fusion are optimistic - if increased technology can continue to lower the cost of the process. This process is diagrammed in Figure 8.

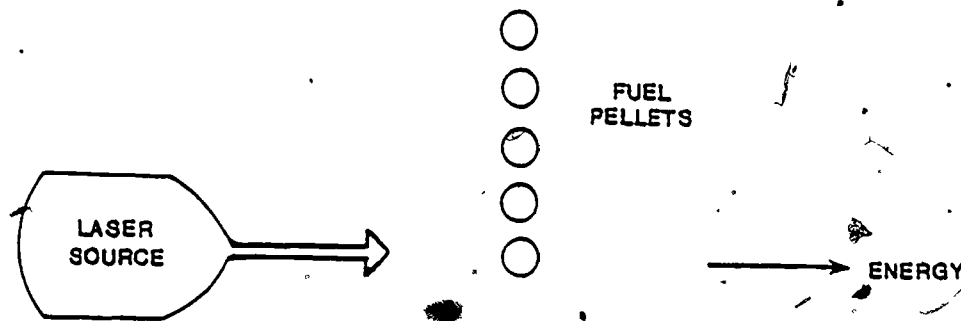

Figure 8. Laser Fusion.

There has been much government support for fusion research during the last two decades. The use of fusion for electrical power could be demonstrated by 1990 and the actual operation of large scale reactors by the year 2000. A summary of the future of nuclear fusion is given in Table 4.

TABLE 4. THE FUTURE OF NUCLEAR FUSION IN THE UNITED STATES.

<p><u>Advantages</u></p> <ul style="list-style-type: none"> • Nuclear fusion is the source of tremendous amounts of energy. • Fuel for nuclear fusion is virtually unlimited. • No radioactive wastes are produced. <p><u>Disadvantages</u></p> <ul style="list-style-type: none"> • Commercial feasibility is uncertain for the future.
--

SOLAR ENERGY

No source of energy is as clean, nondepletable, and attractive as solar energy. Use of solar energy requires no mining or drilling, produces no pollution or waste products, and is always possible to some degree everywhere.

Historically, solar energy has played a vital role in the growth of civilization. Up to the 20th century, for example, it was the wind that propelled most of the ocean vessels of the world. Until the 1940s, the wind provided water for tens of thousands of American homes. Solar clothes dryers continue to be popular in some areas. Ironically, low cost fossil fuels drove wind-generated water production out of business.

The use of solar energy in all its forms is certainly the most popular of the energy options for the future.

DIRECT SOLAR

At the present time, the best way to take advantage of direct sunlight is for home heating and cooling. The roof of an average home receives about six times the sunlight needed for these purposes. Efforts have been made in producing efficient solar space and water heating, and solar cooling systems.

Solar systems are termed either "active" or "passive." In an active solar house, energy is collected by solar collectors that are located on the roof. The heat energy is carried away by water or air and transferred to a large storage system. Energy is then circulated throughout the house when necessary by either a hot-water or hot-air system.

In a passive system, there is no circulation to a storage container. Houses using a passive solar system are generally found in the Sun Belt of the United States.

Figure 9 illustrates the feasibility of such systems in homes in the United States. The northern third of the country could use direct solar as a supplemental source of energy, but would require conventional systems for the majority of energy needs. The middle third of the country could use solar as a major source of energy, but would still require a conventional auxiliary system. Homes in the southern third of the United States could be powered almost completely by direct solar.

During the past decade, many projects have been undertaken to make efficient use of direct sunlight for home uses. At the University of Delaware, for example, work is being conducted on Solar One, an experimental solar-powered house. Solar One is a rooftop unit that combines a solar thermal collector for heating and cooling with solar photovoltaic devices for electricity. Approximately 90% of the household energy requirements can be met with this active solar system. This combination of collection and storage should produce an overall efficiency of about 60% conversion. The major disadvantage of such an efficient active solar system is cost. Installation of this active system would increase the cost of a home tremendously.

One of the major problems with direct solar is that it is rather dilute and it is difficult to make it economically feasible on a large scale. Although the total energy that falls on the upper atmosphere of the earth is gigantic, a third of it is reflected away. The actual amount to fall on a given portion of the earth is dependent upon the latitude, season, and local weather conditions.

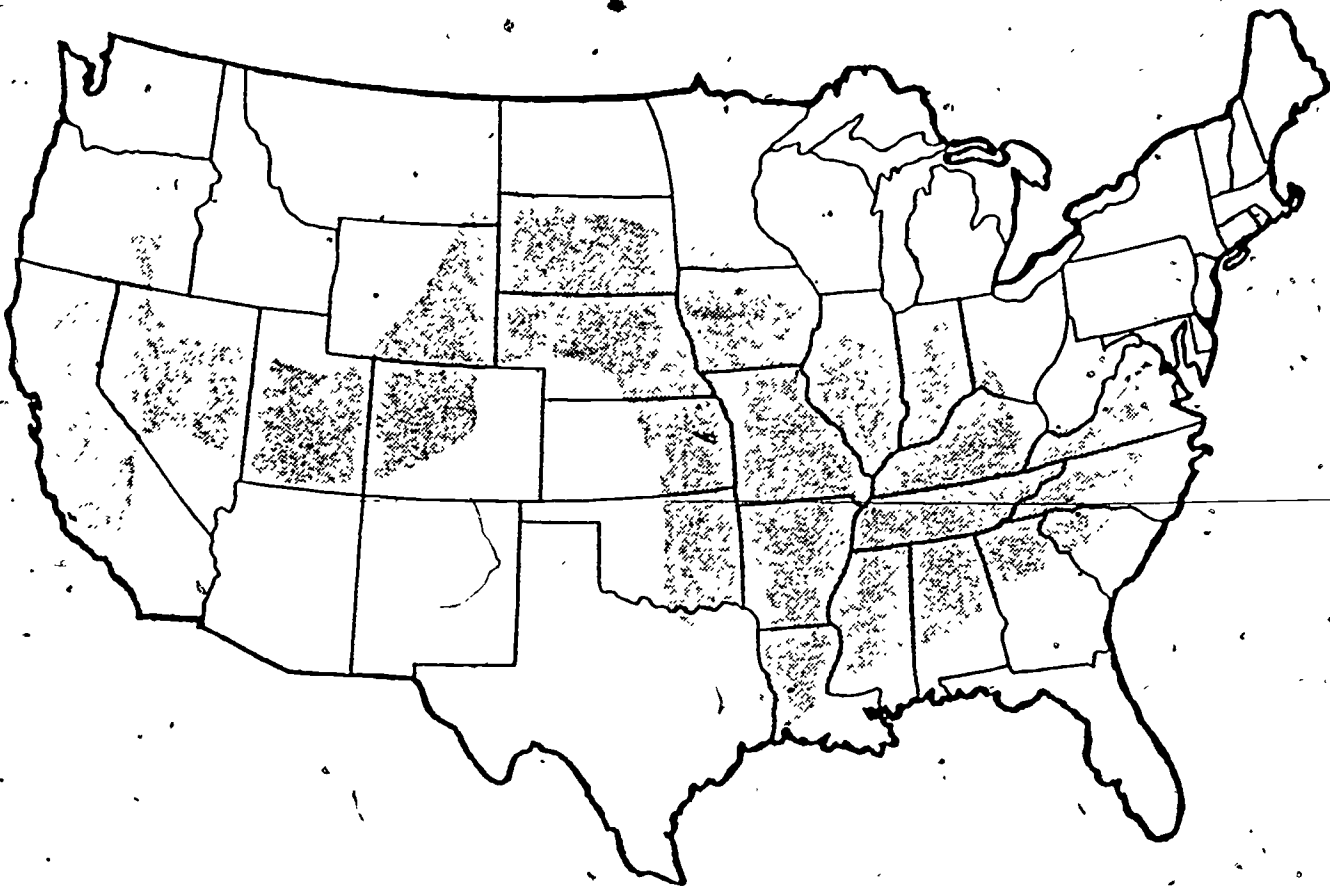

Figure 9. Zones of Direct Solar Use in the United States.

The average energy that falls on a square yard of the surface of the earth is just enough to power a 200-watt light bulb. Although this by itself is not very much energy, the possibilities add up when the total surface area of the world is considered. The average energy consumption of the United States is about one kilowatt per acre. Sunlight absorbed at ground level could theoretically supply about 800 kilowatts per acre.

SOLAR TECHNOLOGY.

A solar technology industry is rapidly developing in the United States. Solar cells are presently on the market for a wide variety of uses. Silicon photovoltaic cells have been employed in camera light meters and to generate electricity for spacecraft. Photoelectric cells are also used in communications and signaling equipment throughout the world.

Although the basic concepts are well-understood for many applications to solar energy, the development of the technology required is hindered by large production cost factors.

A more futuristic idea has been proposed by many others. Some projections have been worked out by the Arthur D. Little Corporation. A satellite with wing-like solar panels up to three miles long could be placed into orbit about 22,000 miles above the earth to collect energy from sunlight. This fixture would provide constant energy and would receive considerably more energy than a collection system based on the earth. The electric energy would then be converted to microwave radiation and beamed to earth where it would be collected

and reconverted. This satellite would be about 10,000 times larger than any previous satellite that has been placed in orbit. Although the costs for this new technology would certainly be staggering, many scientists predict that this is the only way that enough energy can be supplied for the earth in the next century.

OCEAN THERMAL

The largest collectors of solar energy are the oceans, which comprise 70% of the surface of the earth. Enormous quantities of solar energy are collected and stored in the oceans. Each year, the sun provides the earth with thousands of times as much energy as is consumed. It also melts the ice caps at the North and South Poles, creating deep, cold ocean currents that flow toward the equator beneath the warmer upper ocean layers. This temperature difference is the source of potential ocean thermal energy.

An excellent area for ocean thermal energy is located between the two tropics, Cancer and Capricorn, where 90% of the surface area is water. The surface temperature of the water there is around 80°F all year; deeper water is about 35°F. An ocean thermal energy converter plant could be located to work in this temperature differential of 50°. The potential energy stored in this area alone is phenomenal.

The Gulf Stream, for example, carries billions of cubic feet of seawater through the Gulf of Florida per second. In the Gulf Stream, ocean thermal units could be placed a mile or so apart. Operation at an efficiency of only 2% could produce more than 10 times the total consumption of electricity of the United States in 1980.

The technique of converting the thermal energy of the oceans into electrical energy is one that is understood in theory. However, due to inadequate technology, conversion of oceanic thermal energy is not yet fully developed. Warm water would be drawn into the system, where it would heat tubes containing a liquid with a low boiling point. Upon vaporization, the steam would drive a turbine generator. Cool water could then be pumped from the lower depths to condense the vapor and form the cyclical process. The system would work like a big refrigerator.

Government funds have provided for some of the preliminary research. Plans are now being formulated to construct demonstration power plants using ocean thermal as a source of energy. Future developments will depend upon increased government funds for research.

WIND

For years, power from the wind has been used to pump water for crop irrigation, to propel sailing ships across the oceans, and to turn millstones to grind flour from grain. About 2% of all the solar radiation that falls on the earth is converted to wind energy in the atmosphere.

This amount of energy alone would be enough to supply the United States with 10 times its consumption in 1980. If funding is provided for development of this source of energy, many predictions say that wind or aeolian energy could provide up to 10% of the energy demand of the United States in the year 2000.

The United States government has been interested in reviving aeolian energy programs. With government funding, NASA built an experimental wind turbine in Sandusky, Ohio. This and other similar projects will result in an increased emphasis of this type of energy source in the future.

Scientists have identified several sites where large amounts of aeolian energy are available: the Great Plains, the eastern foothills of the Rocky Mountains, the Texas Gulf Coast; the Green and White Mountains of New England, the continental shelf of the northeastern United States, and the Aleutian Islands. Scientists have also developed a plan for constructing a grid of wind machines at half-mile or mile intervals through the Great Plains area.

Such a system could theoretically produce a considerable amount of the domestic electricity used each year. An off-shore facility is also planned where wind could be used to electrolyze water into hydrogen and oxygen. Hydrogen then could be piped to shore or transported in refrigerated tankers.

Although large aeolian machines would perhaps be only five percent efficient, the source of energy is free. Because they do not produce by-products or residues, they are not especially troublesome. The largest drawback is land used. A giant grid system - complete with power lines - would have some aesthetic disadvantages. In addition, if a large scale system of aeolian machines were developed, there would be questions concerning the possible effects of the weather caused by the removal of large amounts of kinetic energy.

Wind power development has been slowed to date because of economic reasons. The cost of building wind power generating plants is considerably higher than conventional fossil

fuel or nuclear plants. In addition, wind power systems only operate part of the time, while others could operate all the time. However, since wind machines have low maintenance and no fuel costs, these devices could become more important energy sources in the future.

The future of the various types of solar energy (direct solar, ocean thermal, wind) is summarized in Table 5.

TABLE 5. THE FUTURE OF SOLAR, OCEAN THERMAL, AND WIND ENERGY.

Advantages

- This source of energy is free and essentially unlimited.
- Production of this energy is clean and non-polluting.
- Basic theories for use are developed.

Disadvantages

- The cost for large scale development is high.
- The efficiencies for use are low, but could be increased.
- The cost for initial installation is high.

GEOTHERMAL ENERGY

Geothermal energy, the natural subterranean heat of the earth, promises to be an important future source of energy. It is estimated to be a vast internal energy reserve. The challenge is to put this tremendous energy to work.

NATURE AND DISTRIBUTION OF GEOTHERMAL SOURCES

Far beneath the surface of the earth is molten rock. In some areas, this molten rock has worked its way near the surface. Underground water is then heated and hot springs result. Almost all of the known geothermal wells in the United States are located in California, Nevada, Oregon, Alaska, Idaho, Montana, New Mexico, Utah, Washington, and Texas. At present, the majority of knowledge of promising geothermal sites depends on the presence of geysers, hot springs, and volcanoes. As modern techniques develop, estimates of the size and location of these resources will certainly become more precise.

The most promising sources of geothermal wells are illustrated in Figure 10.

Geothermal reservoirs are found in the following usable forms: hydrothermal, geopressured, and dry-hot-rock reservoirs. Hydrothermal reservoirs are the most commonly used type with present technology. A vapor dominated (or dry steam) field, such as the Geysers, is the most commercially attractive, since the steam can be used to drive turbines. The hot water (or wet steam) fields are harder to work because of the mixture of steam and hot water, since the steam

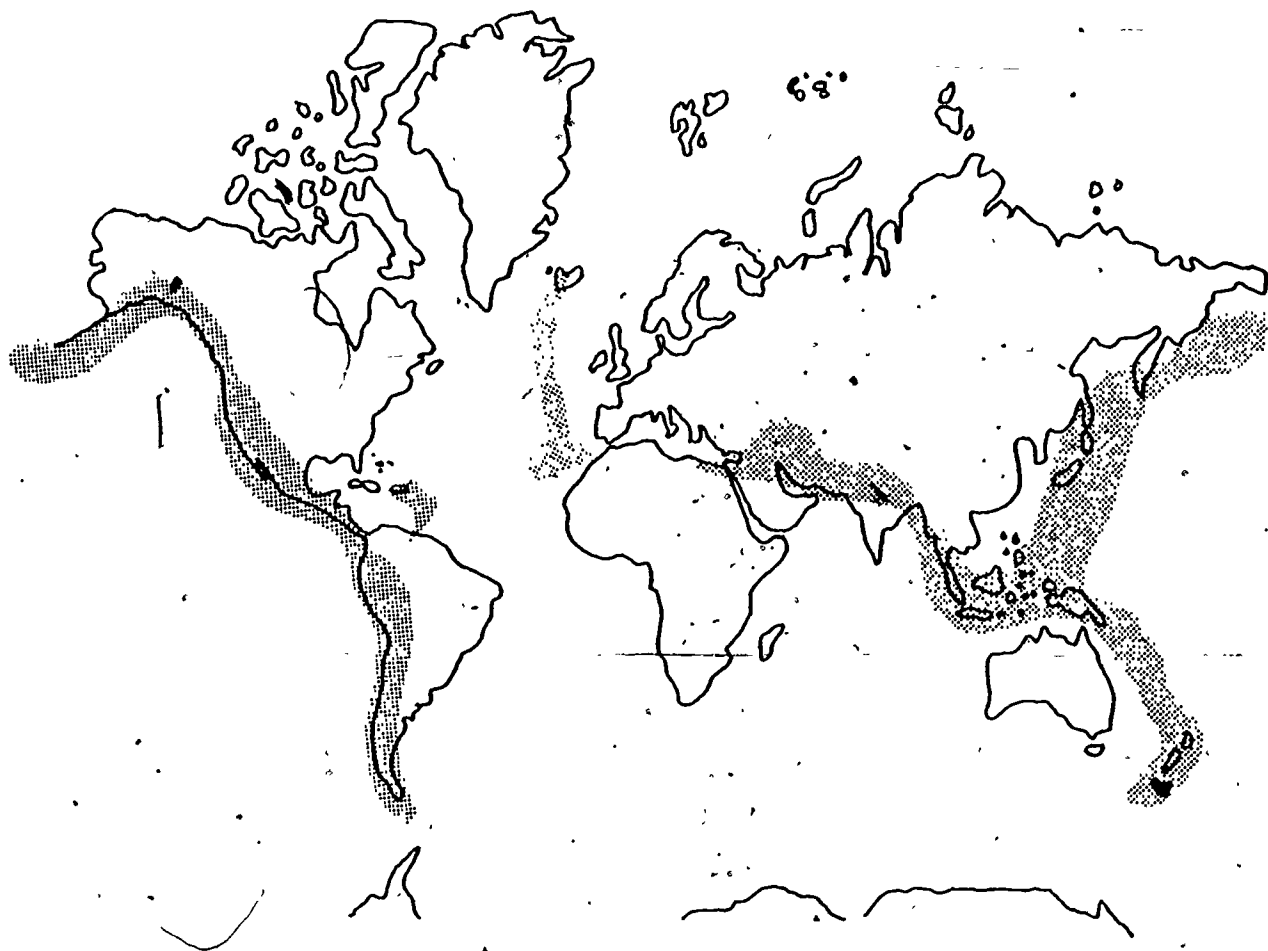

Figure 10. World Geothermal Belts.

must be clear of water for use in a turbine. Unfortunately, wet steam fields are twenty times more common than the dry steam fields.

Geopressured reservoirs are perhaps the least understood type of geothermal reservoirs. They are usually made up of porous sands containing water or brine at high temperature, or pressure-trapped beneath the earth. A large geopressured zone has been found along the Texas Gulf Coast and is thought to have a lot of energy potential. Such a deposit could provide hydraulic energy, as well as natural gas.

The hot-rock systems are potentially the largest and most widely-distributed resources. The normal temperature gradient is about $\pm 100^{\circ}\text{F}$ per mile. Since the usual power plants require steam of at least 400°F , the wells would have to be four to five miles deep. This is too deep for present techniques.

DEVELOPMENT OF GEOTHERMAL ENERGY

Two geothermal fields account for more than half of the total geothermal generating capacity of the world at the present time. One is a plant in Larderello, Italy. Several facilities are presently operating in California at the site of the Geysers near San Francisco. However, the combined capacity of these plants in the United States is less than the capacity of a good-sized coal or nuclear plant.

In Iceland, geothermal heat has been used for years to heat buildings. Geothermal provides most of the heat for the 100,000 people in Iceland's capital, Reykjavik. Several homes are heated in the same way in Oregon and Idaho.

There are several problems associated with development of geothermal plants. Clearing land and pumping massive amounts of water will certainly have some environmental disadvantages. These problems will probably be overcome in the future to allow this energy source to supplement the energy supply in the future. A summary of the future development of geothermal sources is presented in Table 6.

TABLE 6. THE FUTURE OF GEOTHERMAL ENERGY
IN THE UNITED STATES.

Advantages

- Supplies of geothermal are plentiful.
- Power plants are relatively inexpensive to build.
- There are no fuel costs.

Disadvantages

- Wastes that come to the surface must be disposed.
- The water cycle in the area may be disturbed.
- Efficiency is low.

HYDROPOWER

The potential energy difference in two water levels can also serve as a source of energy. This principle was recognized several thousands of years ago. Water wheels were used by many early civilizations for a variety of purposes. There are two possibilities for large scale use at the present: natural water courses and tides.

NATURAL WATER COURSES

Water flowing from a higher level to a lower level in a natural water course can generate electricity. The falling water may be used to turn a turbine generator for electricity or for mechanical power. A dam is built to store water in a reservoir where it can be released when needed. Although water power is theoretically a renewable energy source, the power plants themselves wear out; the reservoirs eventually fill up with silt.

A major advantage of a hydroelectric power plant is that it can be turned on and off quite easily. For this reason, hydroelectric power plants are important parts of the total electricity generating systems in the country. While it is difficult to moderate coal and nuclear plants, hydroelectric power plants can use energy generated to pump water back to a higher level. This reserve can then be used when the demand for electricity is high - during certain times of the day, or days of the week.

Good sites for building hydroelectric power plants are rather limited. Although capacity has doubled since 1950, hydroelectric power provided only 13% of the electricity for the United States in 1978.

The geographical distribution of hydroelectric power production in the United States is shown in Table 7.

TABLE 7. HYDROELECTRIC POWER DISTRIBUTION IN THE UNITED STATES.

Region	Percentage of US Total
Pacific	45.0%
Mountain	11.7
Middle Atlantic	10.5
South Atlantic	9.7
East South Central	9.3
West North Central	5.5
West South Central	4.0
New England	2.6
East North Central	1.5
Alaska and Hawaii	1.0

The leading hydroelectric power-producing countries in the world are: the United States, Canada, the Soviet Union, Japan, and France. Since there are many environmental problems associated with further hydroelectric power facilities in the United States, this source of energy will probably not be a major contributor to energy sources in this country. It will most certainly be a major source of energy to developing countries. The future advantages and disadvantages of hydroelectric power are summarized in Table 8.

TABLE 8. THE FUTURE OF HYDROELECTRIC POWER
IN THE UNITED STATES.

Advantages

- Electricity is produced inexpensively.
- No air pollution is present.
- Reservoir lakes can store large amounts of water.
- Reservoir lakes may benefit the environment.
- Fossil fuels are not consumed.

Disadvantages

- Initial construction costs are high.
- Reservoir lakes may damage the environment.
- Land suitable for agriculture may be lost.
- Droughts may curtail power production.

TIDES

Tides are the periodic rise and fall of the waters of the earth. They are caused by the gravitational effects of the sun and the moon on the oceans. The difference in water levels that results can also serve as a source of energy.

A power plant dam may be built across a narrow entrance to a bay, forming a reservoir between the power plant dam and the shore. As the waters rise and fall, a turbine is operated to generate electricity. Since there are two highs and two lows per day, energy can be extracted four times.

In order to generate power effectively, however, there must be an average difference of at least five feet between the depth of the water in the basin and the ocean floor. For efficiency purposes, the difference in the head or water depth should be greater than five feet.

There are presently two tidal plants in the world. The largest tidal plant in existence is the Rance Station near St. Malo, France. This plant uses the tides that flow into the English Channel on the French Side. The plant took seven years to construct and was finished in 1967. It would provide enough power for 16,000 homes in the United States. Another plant exists in the Soviet Union on the Ura River at the Barents Sea near Murmansk.

Although there are no tidal plants in the United States, the concept has been under investigation for several years. A study completed in 1977 found that there are only two areas sufficiently large enough for such a plant. They are the Passamaquoddy Bay region along the Canadian border in Maine, and the Cook Inlet region in Alaska.

It would not be feasible to build a plant in Alaska, since the Cook Inlet is located in a sparsely populated area and transportation costs would be high. On the other hand, a tidal plant in New England is a future possibility. The ideal location for a tidal plant would probably be in eastern Canada. The tides in the Bay of Fundy average over 40 feet at a time. The future of tidal power is summarized in Table 9.

TABLE 9. THE FUTURE OF TIDAL POWER.

Advantages

- No fuel is required.
- This causes minimum air and water pollution.
- Very little land is required.
- A long lifetime would be probable.
- New local industries might be developed.

Disadvantages

- Initial cost would be quite large.
- Fishing patterns would be disturbed.
- Corrosion and storm damage to facilities are probable.
- Distribution power to populated areas will be expensive.

NEW SOURCES

One way to satisfy the increasing demand for energy is to develop new sources of fuel. This is usually an extremely expensive alternative, however, since research and development costs are high. In addition, many of these alternatives are not popular.

SYNTHETIC FUELS

When faced with petroleum shortages during World War II, Germany demonstrated the feasibility of obtaining liquid and gaseous fuels on a large scale. In South Africa, where petroleum is scarce due to world political reasons, large plants are presently producing synthetic oil. When necessary, technology can produce what is needed. The Energy Security Act of 1980 provides \$20 billion in loan guarantees and incentives for industry to pursue synthetic fuels during the next decade. The total estimated cost of this synthetic fuel program (to reduce dependence upon foreign oil) is a staggering one trillion dollars.

BIOMASS

An indirect source of solar energy is biomass. Biomass is a general term for plant and animal waste. Since these energy sources are renewable, much use may be found for them in the future. A good example is the growing use of alcohol, which is produced through the fermentation of biomass and used to supplement petroleum-based fuels now used for transportation.

EXERCISES

1. Start a collection of current news articles concerning the present and future of the sources of energy discussed in this module.
2. Expand on the advantages and disadvantages listed for the energy sources discussed in this module by citing specific examples.
3. List the energy sources discussed in the module in order of future importance. Compare this list with others in the class.
4. Theoretically, two square miles of solar power could operate one million toasters. Although this statement is true, what would be some considerations on a large-scale use of solar power?
5. If you were President of the United States, for which of the energy sources discussed in the module would you favor spending for research and development? Compare this list with others in the class.

REFERENCES

- Barnea, Joseph. "Geothermal Power." Scientific American 225 (January 1972): 70-77.
- Chalmers, Bruce. "The Photovoltaic Generation of Electricity." Scientific American 235 (October 1976): 34-44.
- Cohen, Robert. "Ocean Thermal Energy Conversion." In Energy and Man: Technical and Social Aspects of Energy, Edited by M. Granger Morton. New York: IEEE Press, 1975.
- Considine, Douglas M. Energy: Technology Handbook. New York: McGraw-Hill Book Company, 1977.

Duffre, J.A. and Beckman, W.A. "Solar Heating and Cooling." Science 191 (January 16, 1976): 143-149.

Edison Electric Institute. You and Your Electric Company. EE 178-47. (New York).

Ellis, A.J. "Geothermal Systems and Power Development." American Scientist 63 (September/October 1975): 510-521.

"Energy From The Sea." Popular Science. May, June, July 1975.

Free, Jon F. "Solar Cells: When Will You Plug Into Electricity From Sunshine?" Popular Science 205 (December 1974): 52-55, 121-130.

Hamilton, R. "Can We Harness The Wind?" National Geographic 148 (December 1975): 812-829.

Henahan, John F. "Geothermal Energy - The Prospects Get Hotter." Popular Science 207 (November 1974): 96-99.

Inglis, David R. "Wind Power Now." Bulletin of the Atomic Scientists 31 (October 1975): 20-26.

Mitchell, III, W. and Turner, Stanley E. Breeder Reactors. United States Atomic Energy Commission, 1972.

Muffler, L.S.P. and White, D.E. "Geothermal Energy." The Science Teacher 39 (March 1972): 40-44.

Rosenblatt, A. "Energy Crisis Spurs Development of Photovoltaic Power Sources." Electronics 47 (April 4, 1974): 99-111.

Solar Energy for Earth. American Institute of Aeronautics and Astronautics, 1975.

See especially Chapter VII, "Photovoltaic Power."

"Wind Power: How New Technology is Harnessing an Age Old Energy Source." Popular Science 205 (July 1974): 54-59.

Zener, Clarence. "Solar Sea Power." Physics Today 26 (January 1973): 48-53.

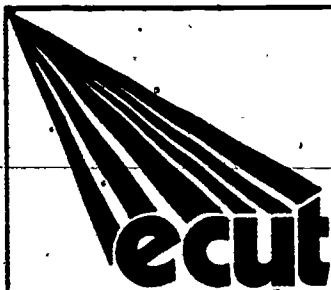

ENERGY TECHNOLOGY

CONSERVATION AND USE

FUNDAMENTALS OF ENERGY TECHNOLOGY

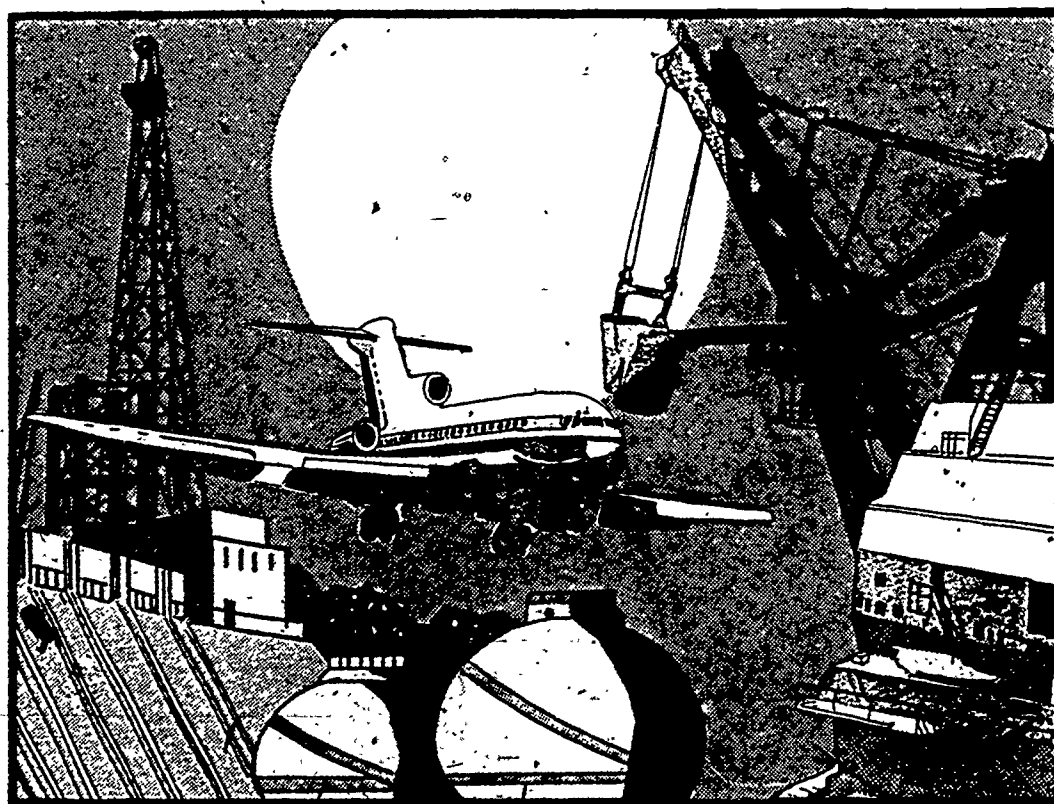

MODULE EF-04
USES OF ENERGY



CENTER FOR OCCUPATIONAL RESEARCH AND DEVELOPMENT

INTRODUCTION

The material contained in this module presents an overview of the primary systems that use energy. The energy consumed can be either an original energy source or electricity. Heating and cooling of air and water, transportation, illumination, and mechanical power are the leading actual energy uses in the United States. The increased demand for energy means that a re-evaluation of energy must occur.

Data presented in this module also provide some comparative information concerning efficiency ratings and conservation measures. If energy is to be conserved, these systems must use energy as efficiently as possible. Sometimes, this may be accomplished by the correct choice of system. Sometimes, this may be accomplished by individual decisions on use.

PREREQUISITES

The student should have completed Module EF-03, "Sources of Energy II."

OBJECTIVES

Upon completion of this module, the student should be able to:

1. List the four major sectors of energy use.
2. List the four major actual uses of energy.
3. Identify the various systems discussed in this module for heating and cooling, illumination, transportation, and industrial power.

4. Describe the general trends in the use and conservation of energy in the areas discussed in this module.
5. Discuss the meaning and consequences of load factors and demand charge to utilities and customers.
6. Discuss the general procedures and problems associated with the conversion of raw fuels into useful energy forms.
7. Identify the following important terms as discussed in this module:
 - a. Single zone system
 - b. Multizone system
 - c. Terminal reheat system
 - d. Variable air volume system
 - e. Constant volume system
 - f. Induction system
 - g. Dual duct system
 - h. Fan coil system
 - i. Self-contained systems
 - j. Gas/electric homes
 - k. All-electric homes
 - l. Thermostat
 - m. Energy Efficiency Ratio (EEF)
 - n. Climate zones
 - o. R-value
 - p. Insulation
 - q. Incandescent
 - r. Energy efficiency
 - s. Color rendition
 - t. Light intensity
 - u. Lumens
 - v. Fluorescent

- w. Mercury vapor
- x. Metal-halide
- y. High-pressure sodium
- z. Cogeneration
- aa. Recycling
- bb. Load factor
- cc. Demand charge

SUBJECT MATTER

USES OF ENERGY

The four major users of the original energy fuels consumed in the United States are the following: electrical, industrial, transportation, and residential/commercial. The various components of these sectors then convert the fuel into more useful forms of energy to power the American system.

Increased demand and cost have made it necessary for these sectors to re-evaluate energy-using systems in terms of efficiency and conservation. The portion of the original energy sources consumed by each of these sectors is illustrated in Figure 1.

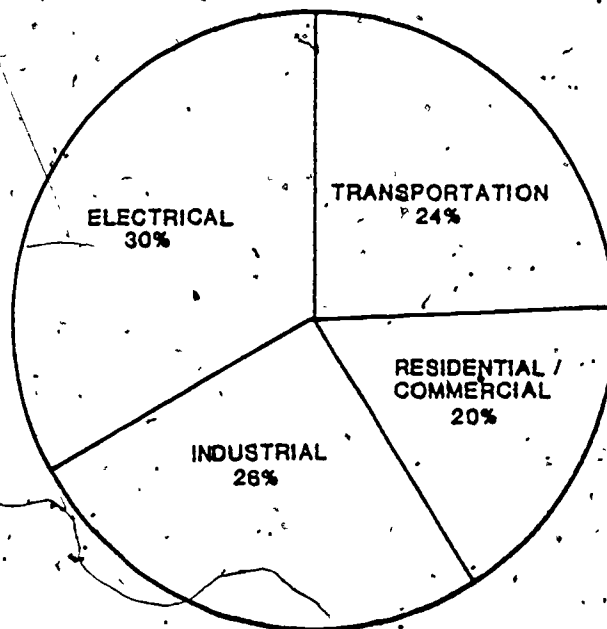

Figure 1. Major Original Energy Users in the United States - 1979.

ENERGY CONSUMPTION AND DISTRIBUTION

Oil, natural gas, coal, hydropower, geothermal, and nuclear are currently the major sources of power in the United States. The chart in Figure 2 illustrates the distribution of these energy sources. Numbers refer to percentage of the total energy consumption of the United States.

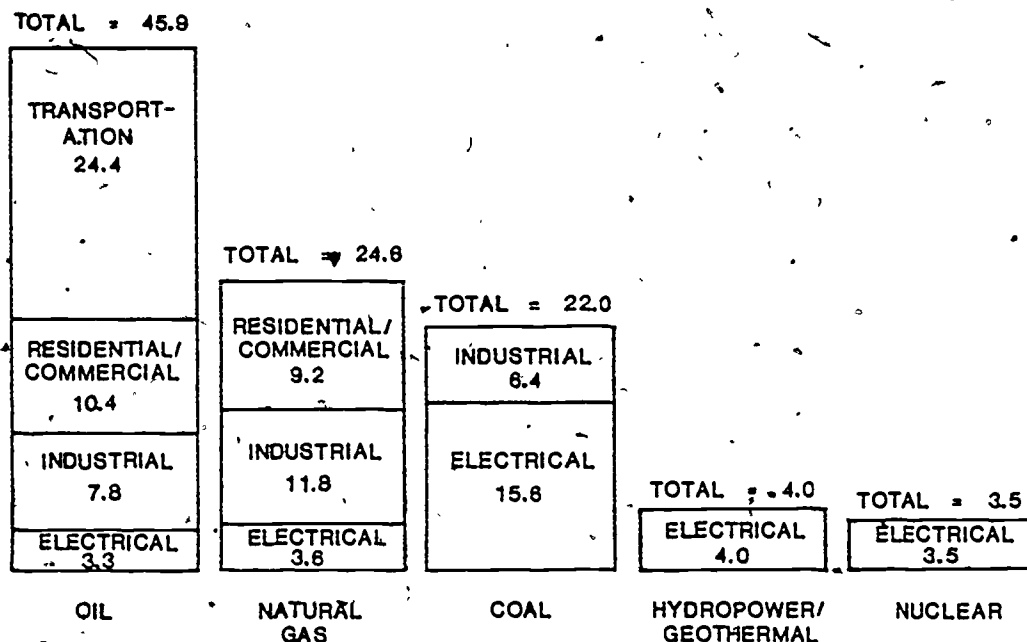

Figure 2. Distribution of Original Energy Sources in the United States - 1979.

Hydroelectric, geothermal, and solar power sources are projected to increase in importance in the future. The use of nuclear energy to generate electricity will also increase. These increases, however, will not be enough to make up for the increased total demand for energy over the next two decades. As a result, fossil fuels are expected to continue as

the major energy sources for the United States. However, coal will become a more important contributor to the total energy input, as oil and natural gas percentages decrease.

Heating and cooling, transportation, illumination, and mechanical power are the largest actual end-products of energy consumption. The chart in Figure 3 gives a more detailed breakdown of actual energy use.

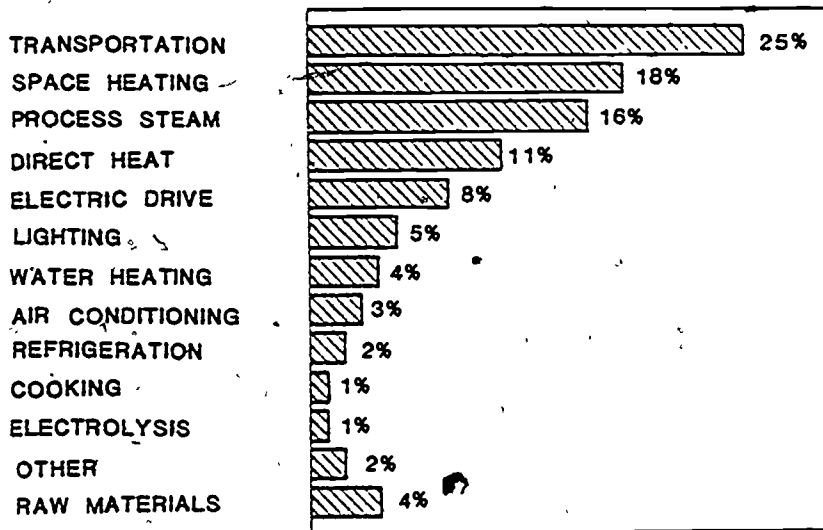

Figure 3. Distribution of Actual Energy Use in the United States.

Although about 63% of the total energy consumed in the United States is consumed by business and government agencies, a sizeable 37% is consumed by individual users. The distribution of personal energy use is shown in Figure 4.

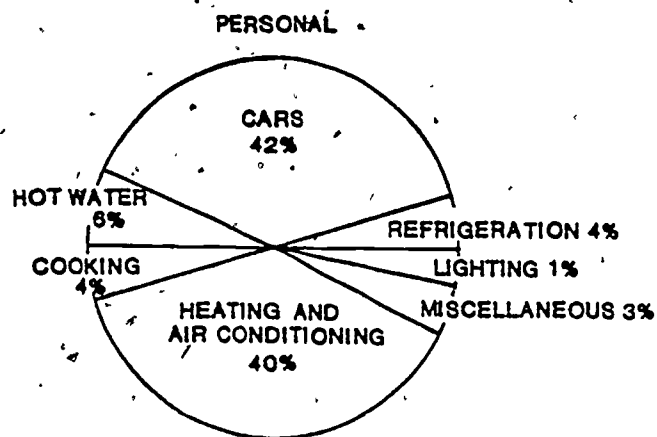

Figure 4. Distribution of Personal Energy Use in the United States.

HEATING AND COOLING

Space heating and cooling accounts for about 60% of the total residential and commercial energy consumption and for about 40% of the total personal energy consumption. Analysis of heating and cooling systems provides one of the best opportunities to save money.

HEATING AND COOLING SYSTEMS

The following discussion centers on heating and cooling systems.

Single Zone System

A zone is an area or group of areas in a building that experiences similar amounts of heat gain and heat loss. A single zone system is one that provides heating and cooling

to one zone that is controlled by the zone thermostat. The unit may be installed within - or remote from - the space it serves, either with or without air distribution ductwork.

Multizone System

A multizone system heats and cools several zones, each with a different load requirement, from a centralized unit. A thermostat in each zone controls dampers at the unit that mix the hot and cold air to meet the varying load requirements of the zone involved.

Terminal Reheat System

The terminal reheat system is a modification of a single zone system that provides a higher degree of temperature and humidity control. The central unit provides air at a given temperature to all zones served by the system. Secondary ~~terminal~~ heaters or coolers then adjust the air temperature to be compatible with the load requirements of the specific space involved. The high degree of control provided by this system requires an excessive amount of energy.

Variable Air Volume System

A variable air volume system provides heated or cooled air at a constant temperature to all zones served. Units located in each zone adjust the quantity of air reaching each zone, depending on the zone's load requirement.

Constant Volume System

Most constant volume systems either are part of another system or, serve to provide precise air supply at a constant volume. They are typically used in dual duct systems.

Induction System

An induction system is an air-handling unit that supplies heated or cooled primary air at high pressure to induction units located on the outside walls of each space served. The high pressure primary air is discharged within the unit through nozzles, inducing room air through a heating or cooling coil in the unit. The resultant mixture of primary air and induced air is discharged to the room at a temperature dependent on the load of the space involved.

Dual Duct System

The central unit of a dual duct system provides both heated and cooled air, each at a constant temperature. Each space is served by two ducts, one carrying hot air, the other carrying cold air. The ducts feed into a mixing box in each space. Dampers then mix the hot and cold air to achieve the air temperature required.

Fan Coil System

A fan coil usually consists of several fan coil units, each of which has a fan and a heating or cooling coil. These individual units can be located either in - or remote from - the space or zone being served.

Self-Contained Systems

A self-contained system is a roof-top unit, window unit, or through-the-wall unit.

APPLICATIONS

Application decisions begin with the selection of the heating/cooling system. Other decisions include the selection of the thermostat setting, efficiency ratings, type of insulation, maintenance efforts, and other steps.

Selection of Heating/Cooling System

There is no clear choice concerning heating and cooling systems. The relative cost and availability of natural gas and electricity, the prevailing weather conditions in specific areas, and individual building requirements must all be considered. A comparison of energy uses in gas/electric homes and all-electric homes is presented in Figure 5.

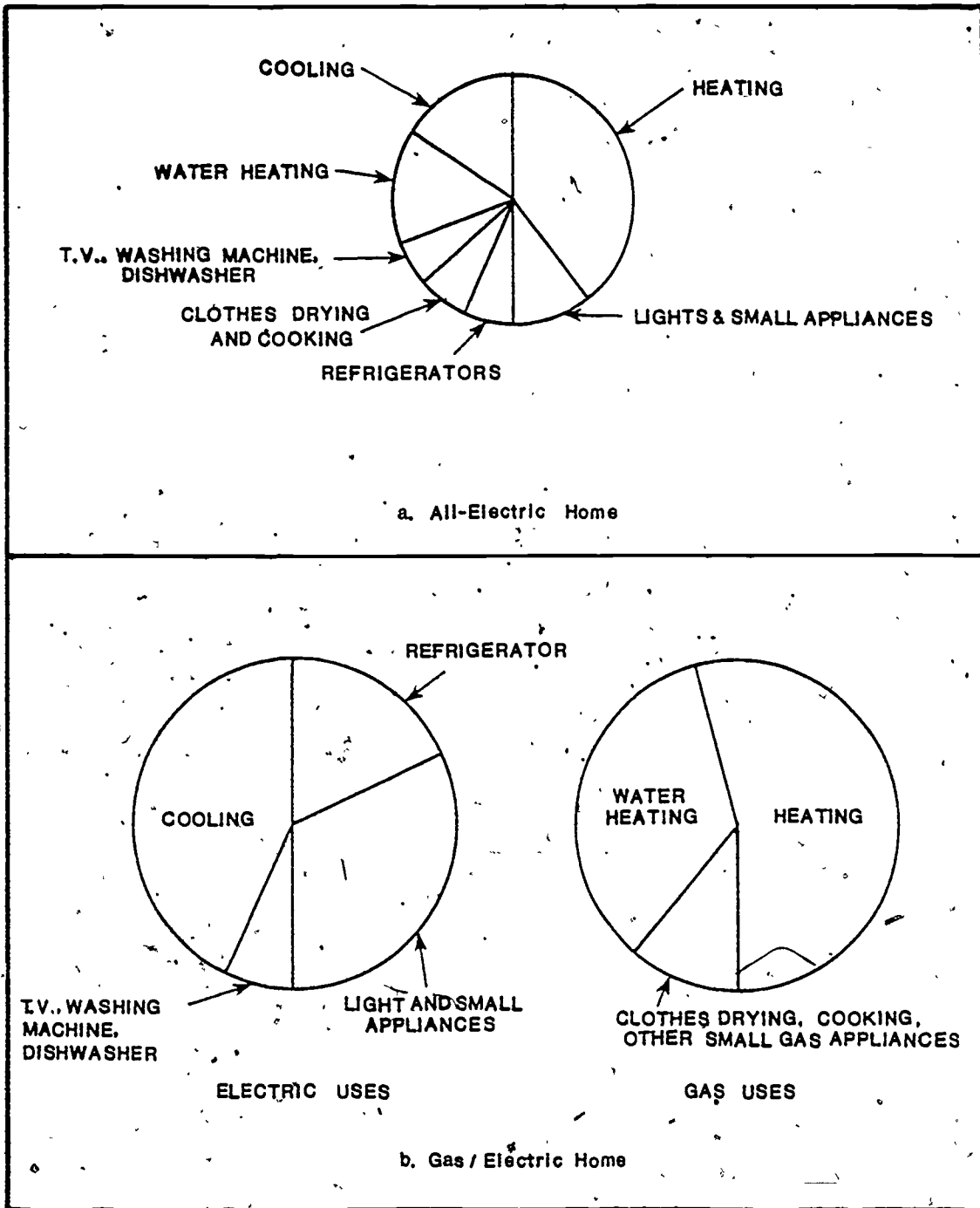

Figure 5. Energy Uses in Gas/Electric and All-Electric Homes.

Selection of Thermostat Setting

There is no ideal setting for either heating or cooling. A combination of temperature, humidity, air motion, and activity in a zone must be considered for maximum comfort. However, a difference in only one or two degrees of temperature does make a dramatic difference in energy consumption and cost. Figure 6 illustrates the thermostat settings for heating and cooling and the percentages of savings for each degree of change.

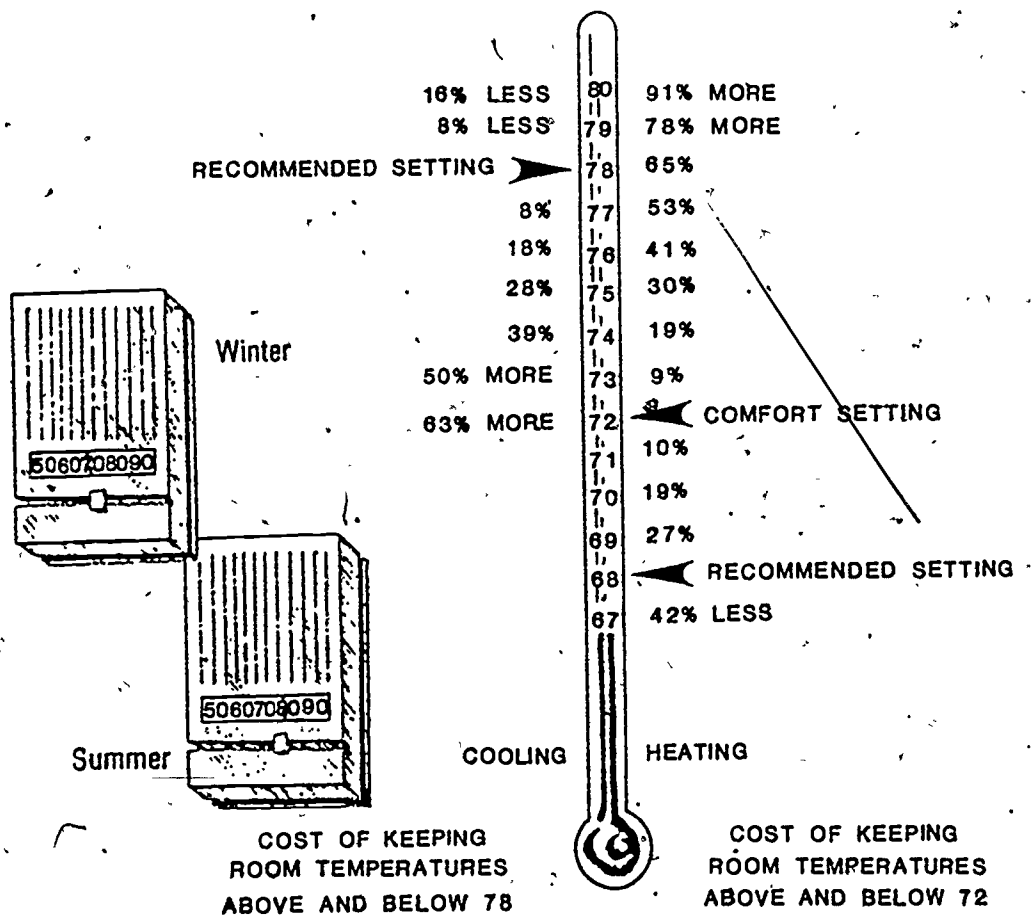

Figure 6. Thermostat Settings and Energy Consumption.

Consideration of Efficiency

Until recently, most Americans were not concerned about the efficiency of any energy-consuming systems. It was cheaper to buy less efficient systems and use more energy than to buy a more efficient system and use less energy.

For example, there are air conditioners on the market that operate on up to 30% less energy than other models. The more efficient an air conditioner, the higher its Energy Efficiency Ratio (EER). The EER is defined as the amount of heat one watt of electricity will recover from the air in one hour. The EER is determined by dividing the number of Btus required for cooling by the number of watts needed to produce cool air. An EER above 8.0 would be considered to be an excellent energy efficiency. Example A illustrates determination of EER.

EXAMPLE A. DETERMINATION OF ENERGY EFFICIENCY RATIO.

Given: A 36,000 Btu (three ton) air conditioner requires 6,000 watts to operate.

Find: The Energy Efficiency Ratio for this unit.

Solution:

$$\text{EER} = \frac{\text{Btu Output}}{\text{Watt Input}} = \frac{36,000 \text{ Btu}}{6,000 \text{ W}} = 6.0$$

Insulation

More than half of the homes in the United States are inadequately insulated. Large amounts of energy are, therefore, lost in both heating and cooling of these structures. The optimum amount of insulation recommended for a structure depends on the climate, the type of insulation material, and the structure itself. Figure 7 shows the climate zones for the United States.

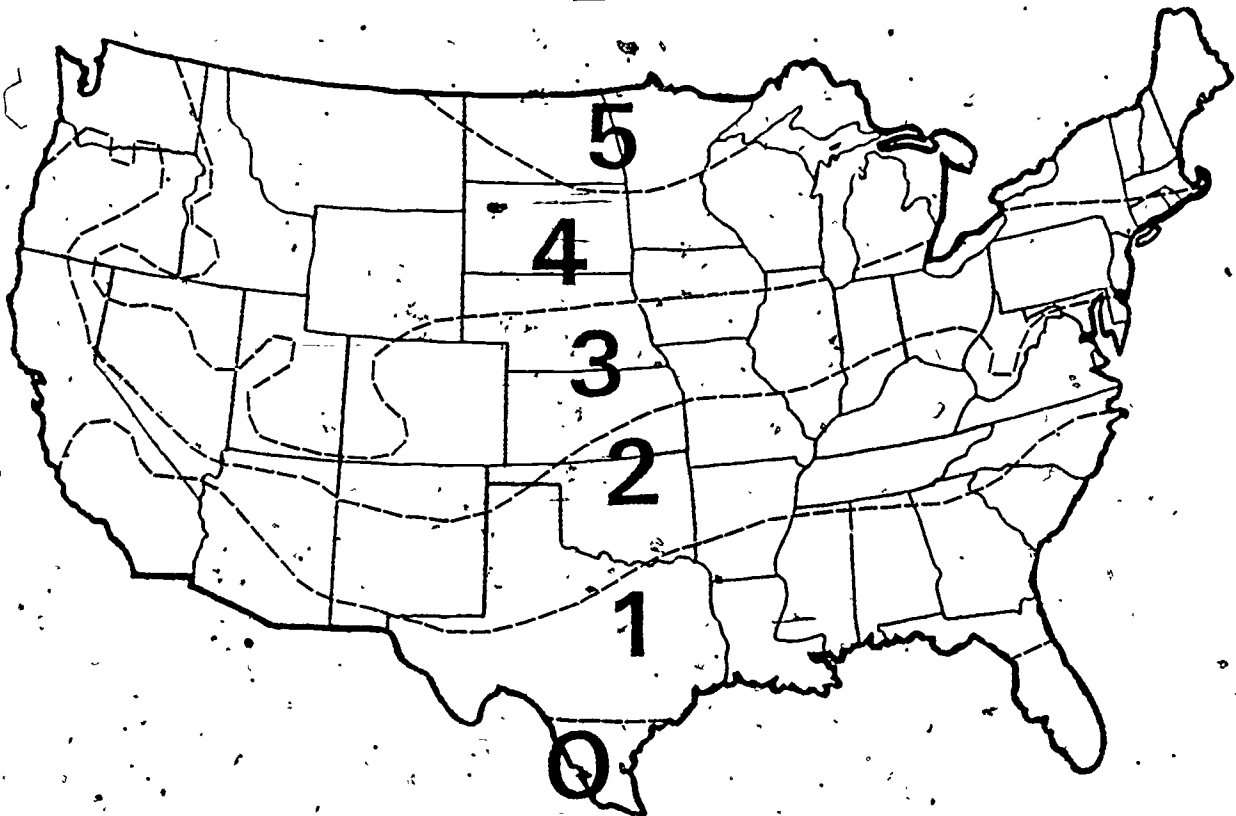

Figure 7. Climate Zones of the United States.

The effectiveness of various insulation materials is measured by their R-values. The higher the R-value, the greater is the resistance to the transfer of heat. Recommended R-values for home insulation are given in Table 1.

TABLE 1.. RECOMMENDED R-VALUES FOR CLIMATE ZONES.

Climate Zone	Attic Floors	Ceilings or Basements
1	R-26	R-11
2	R-26	R-13
3	R-30	R-19
4	R-33	R-22
5	R-38	R-22

The required thickness of various insulation materials is given in Table 2.

TABLE 2. INCHES OF INSULATION REQUIRED FOR R-VALUES.

R-Value	Glass Fiber Blanket	Rock Wool Blanket	Glass Fiber Fill	Rock Wool Fill
R-11	3½-4	3	5	4
R-13	4	4½	6	4½
R-19	6-6½	5½	8½	6½
R-22	6½	6	10	7½
R-26	8	8½	12	9
R-30	10	9	13½	10½
R-33	11	10	15	11½
R-38	12½	10½	17½	13½

Other Considerations

Efficient operation of the heating and cooling units provides the best opportunities for an individual to conserve energy. The efficiency of a home system depends upon a number of factors that an individual can easily control.

For instance, an individual can: check and clean filters; keep fireplace dampers closed when not in use; close off rooms when not in use; keep outside doors closed as much as possible; adjust the thermostat; add caulking and weather stripping to decrease energy loss; ventilate attics; install appropriate insulation; and plant trees and shrubs to provide appropriate shading and screening.

All of these operations will increase the efficiency of the heating/cooling system of a home or business.

ILLUMINATION

In the United States today, approximately 20% of all electricity generated is used for lighting homes and businesses. Perhaps up to 50% of that energy could be conserved with virtually no capital expense. Energy conservation in lighting can be achieved with little effort: sometimes it is as easy as flipping a switch. In addition, curbing energy use in lighting does not require a change in lifestyle or a substantial investment of funds.

ILLUMINATION SYSTEMS

Through decades of use, consumers have come to rely on the familiar incandescent bulb for all their lighting needs.

However, different tasks and situations require different lighting types and levels. Sometimes, it may be necessary to have high-powered outdoor security lights, but very dim night lights are better for many other purposes. A variety of light sources is available. Each has characteristics that make it suitable for various lighting situations.

Two considerations are important in choosing home lighting: energy efficiency and color rendition. Energy efficiency for all light sources is the measure of how much light is produced in relation to the amount of energy used. Light intensity is measured in lumens and energy per time period is measured in watts. The lumens-per-watt rating is similar to the miles-per-gallon rating of engine efficiency.

Some light sources convert electricity into light much more efficiently than others, and therefore can deliver more light for the same amount of electricity. The difference in

the amount of light provided per watt can have a dramatic impact on the amount of electricity required to light a home or office. The method of analysis of the efficiency of light sources is illustrated in Example B. The differences in the efficiencies of various light sources are shown in Figure 8.

EXAMPLE B. ANALYSIS OF LIGHT SOURCES.

Given: A 40-watt fluorescent tube delivers 66 lumens per watt. A 40-watt incandescent bulb deliver 12 lumens per watt.

Find: The efficiency of the fluorescent lighting compared to incandescent lighting in this situation.

Solution:

$$\text{Fluorescent Efficiency} = \frac{\text{Intensity}}{\text{Power}} = \frac{66 \text{ lumens}}{40 \text{ watts}} = 1.65 \frac{\text{lumens}}{\text{watts}}$$

$$\text{Incandescent Efficiency} = \frac{\text{Intensity}}{\text{Power}} = \frac{12 \text{ lumens}}{40 \text{ watts}} = 0.30 \frac{\text{lumens}}{\text{watts}}$$

Fluorescent lighting is, then, more than five times ($\frac{1.65}{0.30} = 5.5$) more efficient than incandescent lighting.

Although most home lighting is incandescent, most lighting used in business, industry, and government facilities is fluorescent. In terms of total operating costs, studies show that fluorescent lighting is nearly four times as efficient as incandescent lighting. The economic advantage increases

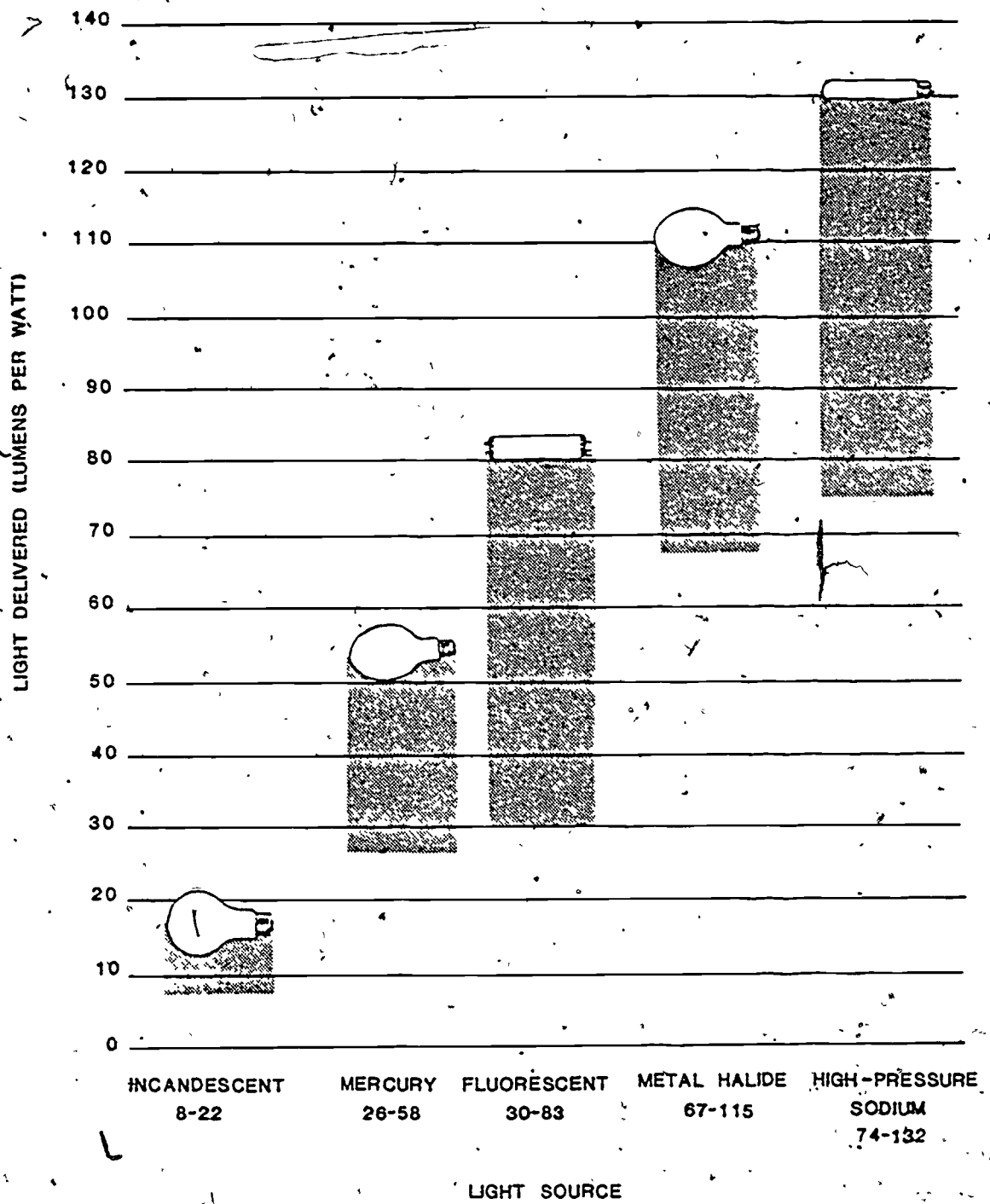

Figure 8. Efficiency of Various Light Sources.

when electricity rates rise and when lights must be operated for long periods of time. Fluorescent lighting generally costs more to install because of the greater cost of fixtures and lamps, but has two distinct economic advantages over incandescent in terms of operating costs. Most fluorescent tubes last about 12 times longer and operate on one-fourth to one-third less electricity.

Color rendition is the second factor to be considered when choosing a light source. Color is simply the effect of light waves bouncing off, or passing through, various objects. Therefore, the color of a given object is determined in part by the characteristics of the light source under which the object is viewed. Color rendition is a relative term in that it refers to the extent to which the perceived color of an object under a light source matches the perceived of that object under the familiar incandescent bulb. A good color rendition means a familiar appearance. Incandescent lamps accentuate warm tones (red, oranges, yellows). Fluorescent bulbs accentuate cool tones (blues, greens). Many home owners are reluctant to use fluorescent lighting because of these differences.

APPLICATIONS

Principles of energy conservation can be applied to lighting systems by the selection of light sources, reduction in light intensity, use of timers and dimmers, and utilization of natural light.

Selection of Light Sources

Selection of the best lighting source is a good place to start. The advantages of fluorescent over incandescent lamps have already been discussed. Relamping with lower-wattage slimline fluorescents has been estimated to reduce annual energy costs by as much as 17.5 watts for each lamp and ballast.

Various high-intensity discharge (HID) lamps, such as mercury vapor, metal-halide, and high-pressure sodium, are finding popularity in the commercial and industrial sectors because of efficiency and long life, as compared to incandescents.

Reduction of Intensity

Much of the lighting in American homes and businesses is too intense and unnecessary. More than twice as much energy is used for lighting in the United States as is used in many other countries for the same purposes. Although sufficient light must be used to prevent eye strain and accidents, providing the appropriate light for the activity performed (task illumination) is an easy way to save up to 50% of lighting costs.

Control of Lighting

Timing devices and lighting circuits controlled by dimmer switches can also contribute to conservation. Regular maintenance and cleaning of lamps and fixtures, light-painted

surfaces, and proper placement of light fixtures can increase actual light by as much as 20%.

Use of Natural Lighting

Natural lighting (passive solar) from windows and skylights can also be used for illumination. Solar mirror systems can be used for illumination, as well to heat space. However, the use of sunlight will only save energy as long as heat transmission is not increased. More money is spent to heat and cool space than for illumination.

TRANSPORTATION

The transportation sector accounts for almost one-quarter of the total annual energy consumption in the United States. It is also credited with being the most inefficient area of energy use.

Of all the energy consumed by the American economy in 1979, 24% was used in transportation. Almost all fuel is derived from petroleum. For example, gasoline is used for automobiles; diesel fuel for trucks; trains, and buses; kerosene, for airplanes. Conservation in the transportation area, therefore, has a direct effect on the dependence of the American economy on imported oil.

TRANSPORTATION SYSTEMS

The internal combustion engine, which dominates present transportation systems, is not very efficient. Only about 15% of the fuel energy is actually used to move vehicles. The automobile is the major user of this energy.

In many ways, the ideal engine for transportation would be electric. It is efficient, quiet, does not emit pollutants, and does not directly use oil-based fuels. Although the electric vehicle has a long history, and is marketed today, it presently does not compete with gasoline-powered vehicles. The major unsolved problem of the electric car is energy storage.

The common-lead acid storage battery is too heavy. It does not store enough energy per pound, cannot be discharged and recharged enough times, and is too expensive. In addition, existing battery systems must be replaced approximately every three years. Developing technologies, however, may make the electric car more economically feasible in the future.

There are numerous factors that influence the fuel economy of a motor vehicle. The most important factor is vehicle weight. Until the 1970's, there was a movement toward increasing size and weight, an increasing demand for air conditioning units, and a desire for automatic transmissions. Since that time, however, smaller cars with increased fuel economy have been more popular. The major consequence of improved fuel efficiency is that reliance on imported oil is decreased.

In spite of persistent rumors, there are no ultra-efficient new engines hidden in Detroit. Many small improvements will be seen in the future, such as the electronic ignitions and stratified charge engines that are already being marketed.

There are also longer-range improvements, such as a continuously variable transmission system that could improve fuel economy by as much as 26%.

Two new engines, the gas turbine and the stirling engine, are also receiving much attention. Both of these engines have the following important advantages: they can burn non-petroleum fuels like alcohol; they are more efficient and cleaner than gasoline or diesel engines; and they will not require emission controls. Research is also investigating such refinements as regenerative braking systems, which slow a vehicle by running the motor as a generator to recharge the battery.

Alternate fuel sources, such as synthetic fuels and alcohol, should provide some relief to the transportation problem. However, in the near future, petroleum will continue to be the main source of energy for transportation. As a result, the greatest savings in transportation will be realized when the existing systems are capable of moving people and materials more efficiently. The energy price paid for speed and convenience is illustrated in Table 3 and Table 4.

TABLE 3. ENERGY DATA FOR PASSENGER TRAFFIC — 1970.

Mode	Average Passenger Capacity	Average Load Factor	Btu Energy Cost Per Passenger Per Mile
Bicycle	1	100%	200
Walking	1	100	300
Intercity Bus	41	45	1,600
Subway/Trolley			2,300
Railroad Car	69	35	2,900
Automobile (highway)	5	48	3,500
Urban Bus	55	20	3,800
Airplane	106	50	8,400
Automobile (city)	5	28	8,500

TABLE 4. ENERGY DATA FOR FREIGHT TRAFFIC.

Mode	Btu Energy Cost Per Ton Per Mile
Waterway	680
Railroad	700
Oil Pipeline	1,850
Truck	2,800
Airplane	62,000

APPLICATIONS

Ways to apply conservation techniques to the transportation situation are through increased engine efficiency, carpooling, mass transit, and through personal conservation efforts in the use - or non-use - of the automobile.

Increased Engine Efficiency

The average engine efficiency of new cars has been increasing gradually from 15.6 miles per gallon in 1975, to 17.6 miles per gallon in 1976, to about 20 miles per gallon in 1979. An average of 27.5 miles per gallon is mandated by the government for all new cars produced in 1985.

Use of lighter materials, improved aerodynamic design, and more efficient drivetrains and engines will be required to meet this standard. Possibilities of advanced 40-50 miles per gallon cars in the 1990s are also being investigated.

Increased Load Factors

The load factor is the percentage of capacity carried by a car or other mode of transportation. Emphasis on carpooling could increase this factor considerably and, thereby, be an important source of energy conservation. However, since carpooling means a change in lifestyle efforts have met with limited success.

Mass Transit

Mass transit is the most energy-efficient form of transportation. Unfortunately, mass transit accounts for only a small part of total passenger travel. Although such systems are successful in densely-populated areas, mass transit cannot be used everywhere. New transit systems and improvements in older systems likely will have to be combined with penalties for automobile use before a shift to mass transit becomes an important part of the total picture.

Personal Conservation

The private automobile is the largest single energy-consuming unit in a typical household. Decisions made by large numbers of Americans can greatly affect the total energy supply of the country. Individuals can contribute to energy saving by: selection of the most energy-efficient model automobile available, careful driving habits, proper maintenance, and by simply driving less.

INDUSTRIAL POWER

The industrial sector is responsible for consumption of about one-quarter of the total energy sources and about one-third of the electricity produced. Since this sector uses the largest share of the energy, it is particularly sensitive to the relationship between Btus and dollars. As a result, industry is undergoing thorough energy conservation analysis on its own.

INDUSTRIAL POWER SYSTEMS

Although industry is a prime conservation target, it is also so diverse that broad conservation strategies are difficult to implement. Industry includes the steel industry with its coal-gulping blast furnaces, the energy-intensive plastics industry, but also the less energy-intensive garment industry. The electric utilities industry is the largest single user of primary energy sources.

Most of the energy consumed by industry is in the form of thermal energy as process steam and direct heat. The remainder of industry consumption is for electricity and for fossil fuels to use as raw materials for products. Electricity is used to provide mechanical work from motors, for refining processes, for heating and illumination.

The most rapidly-growing end-uses are for generation of electrical energy and raw materials. Since most of the energy is in thermal form, strongly directed conservation efforts toward insulation, heating efficiency and recovery, and recycling can result in tremendous energy savings. In addition, better energy management, illumination control, and thermostat lowering will be the major strategies industry can use to conserve energy.

APPLICATIONS

Conservation techniques that can be applied in the energy consumption of industry include installing energy-efficient industrial systems, through recycling, through increased energy efficiency of electricity generation, considering load factors, and utilization of control systems.

New Industrial Systems

Much wasted energy could be used for the production of electricity. Cogeneration, the simultaneous production of electric power or heat in industrial operations, is a powerful energy conservation method.

In addition, many industries have converted to different energy-using systems. For example, replacement of the open hearth furnace with the basic oxygen furnace at some iron and steel plants has saved up to two-thirds of the energy formerly consumed. The continuous casting process involved eliminates much of the heating and cooling required. In addition, modifications in the electrolytic cells used in aluminum refining could produce savings as large as 25%.

Recycling

With the high energy costs associated with aluminum, iron, copper, and paper manufacturing, a most important conservation strategy is recycling. This process would save tremendous amounts of energy in metal production, since mining operations would be eliminated. In addition, processing of recycled paper requires only about one-fourth of the energy required for virgin wood.

Increased Energy Efficiency of Electrical Generation

Conversion of original fuels to electricity is only about 30% efficient. The energy used to generate electricity

can be conserved by reducing electrical consumption, increasing the primary fuel conversion, or by increasing the efficiency of electrical use.

Consideration of Load Factors

A load factor is the ratio of average load to peak load in kilowatts of electricity. The greater the load factor, the less the per-unit cost of energy. There are seasonal, weekly, daily, and weekend/holiday peaks and valleys in utility energy loads. Utility companies encourage customers to smooth out demand for energy.

Since electricity must be generated at the instant it is required, the utilities must have reserve generating capacity to meet the highest peak demand on its lines during the instant of greatest load. Although peaks may last for only several hours during the course of a year, this leaves generating capacity that is unused and incapable of accruing revenue. This unused generating capacity must be paid for by demand charges.

The basic rate of electricity usage is determined by the utility companies and approved by the Public Utilities Commission. The cost to the customer is determined by the actual energy used, as measured by a meter. In addition, a demand charge is made to individual customers for the promise to supply sufficient energy for the peak demand of that customer. This charge is how the utility companies recover costs associated with investment in capacity and equipment to serve peak demand.

Utilization of Control Systems

Many companies have begun using computers to regulate energy use. This process essentially enables a company to more fully utilize its electricity by reducing peak demand for electricity and filling in when energy usage is normally low. Smaller microcomputer systems are also becoming popular for personal home use.

COMMUNICATIONS

By the next century, an even more interesting substitution of electricity into the transportation sector may take place. Video communication may replace business flights.

Face-to-face telecommunications may eventually replace physical meeting in many of the knowledge or information industries such as insurance, education, and government. The potential for energy savings is astronomical.

It is estimated, for instance, that a gallon of gasoline used in an automobile is equivalent in energy to about three days of continual telephone conversation.

EXERCISES

1. A new air conditioning system with a capacity of 20,000 Btus has a power rating of 2.2 kilowatts. The present system used has an EER of 8.0. Is the new system better?
2. A three-way light bulb has the following information listed on the package. Which is the most efficient way of producing light?

50-watt	580-lumen
100-watt	1640-lumen
150-watt	2220-lumen
3. What is the other major factor that must be considered in analysis of the most economical light bulb in the above problem?
4. List specific ways to save energy on transportation. Compare this list with others in the class.
5. Determine the EER of the air conditioning system found at home.
6. Determine the R-value of the insulation found at home.
7. Determine the mileage efficiency of the automobiles at home.

REFERENCES

"A Guide to Better Home Energy Management." Your Electric Light & Power Company.

Citizen's Workshop on Energy and the Environment Handbook.
Washington, DC: U.S. Department of Energy.

Creating Energy Choices for the Future. Washington, DC:
United States Energy Research and Development Administration.

Energy: Critical Choices Ahead. Washington, DC: U.S. Department of Commerce, Office of Energy Programs, 1975.

Energy Sourcebook for Educational Facilities. Council of Educational Facility Planners, International.

Energy You Can Bank On. Colorado Energy Conservation and Alternatives Center for Commerce and Industry.

"Factsheet." National Science Teacher Association.
Oak Ridge, TN: Department of Energy - Technical Information Center.

"Guidelines for Energy Conservation." Total Energy Management: A Practical Handbook on Energy Conservation and Management: Lighting. Washington, DC: U.S. Department of Energy.

Lighting. Washington, DC: U.S. Department of Energy.

"Our Energy Problems and Solutions." Malvern, PA: Energy Conservation Research.

Save Energy and Save \$. Austin, TX: Governor's Energy Advisory Council.

Simmons, Henry. "The Economics of America's Energy Future."
U.S. Energy Research and Development Administration.
Washington, DC: Office of Public Affairs.



ENERGY TECHNOLOGY

CONSERVATION AND USE

FUNDAMENTALS OF ENERGY TECHNOLOGY

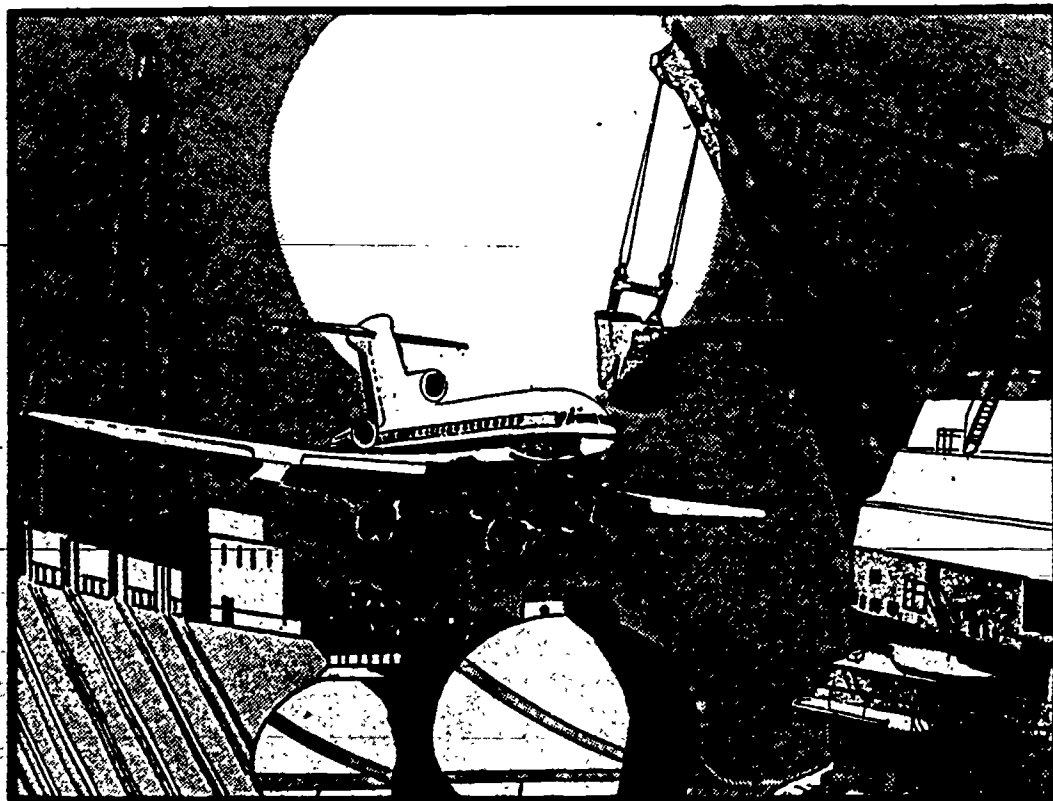

MODULE EF-05
ENERGY ANALYSIS



CENTER FOR OCCUPATIONAL RESEARCH AND DEVELOPMENT

INTRODUCTION

Energy conservation actually produces an additional source of energy: the energy that would normally be wasted. This module presents a discussion of how energy technology can help alleviate today's energy problems. The relationship of energy technology to conservation is discussed, and the general procedures for an energy audit are described.

Each section of this module is actually an introduction to further study in the field of energy technology.

PREREQUISITES

The student should have completed Module EF-04, "Uses of Energy."

OBJECTIVES

Upon completion of this module, the student should be able to:

1. Interconvert units of energy and power with the aid of the appropriate conversion factors.
2. List and describe two general approaches toward achieving energy conservation.
3. List and discuss five steps required in performing and reporting an energy audit.
4. Given the energy input and output, calculate energy loss and energy efficiency.
5. Given efficiencies of various conversion steps, calculate net energy efficiency of an operation.

6. Identify the following terms:

- a. Energy units
- b. British thermal units
- c. Quad
- d. Calorie (cal)
- e. Kilocalorie
- f. Joule
- g. Kilojoule
- h. Kilowatt-hour
- i. Energy
- j. Power
- k. Watt
- l. Kilowatt
- m. Horsepower
- n. Energy input
- o. Energy output
- p. Energy loss
- q. Net efficiency of energy use
- r. Energy audit
- s. Audit methods
- t. Economic analysis

SUBJECT MATTER

MEASUREMENT OF ENERGY

Any discussion of energy is usually accompanied by a variety of large numbers describing quantities of energy or power.

For example, in 1979, the United States consumed a total of 80,800,000,000,000,000, or 8.08×10^{15} , or 80.8 quadrillion Btus of energy.

Six point four billion barrels of oil were burned at a rate of more than 17 million barrels a day.

Approximately 680 million tons of coal were mined with about 500 million tons used for production of electricity.

And 19.8 trillion cubic feet of natural gas were consumed at a rate of almost 55 billion cubic feet per day — or more than 600,000 cubic feet per second.

Even larger numbers may be required in some cases.

For instance, the estimated power output of the sun is 3.47×10^{24} kilowatts, or 3.47 octillion kilowatts. Approximately 4.14×10^{17} watt-hours fall on the earth each day.

The wide range of energy quantities and power ratings is shown in Figure 1. Familiarity with energy units and power units is necessary for understanding and analyzing today's energy situation.

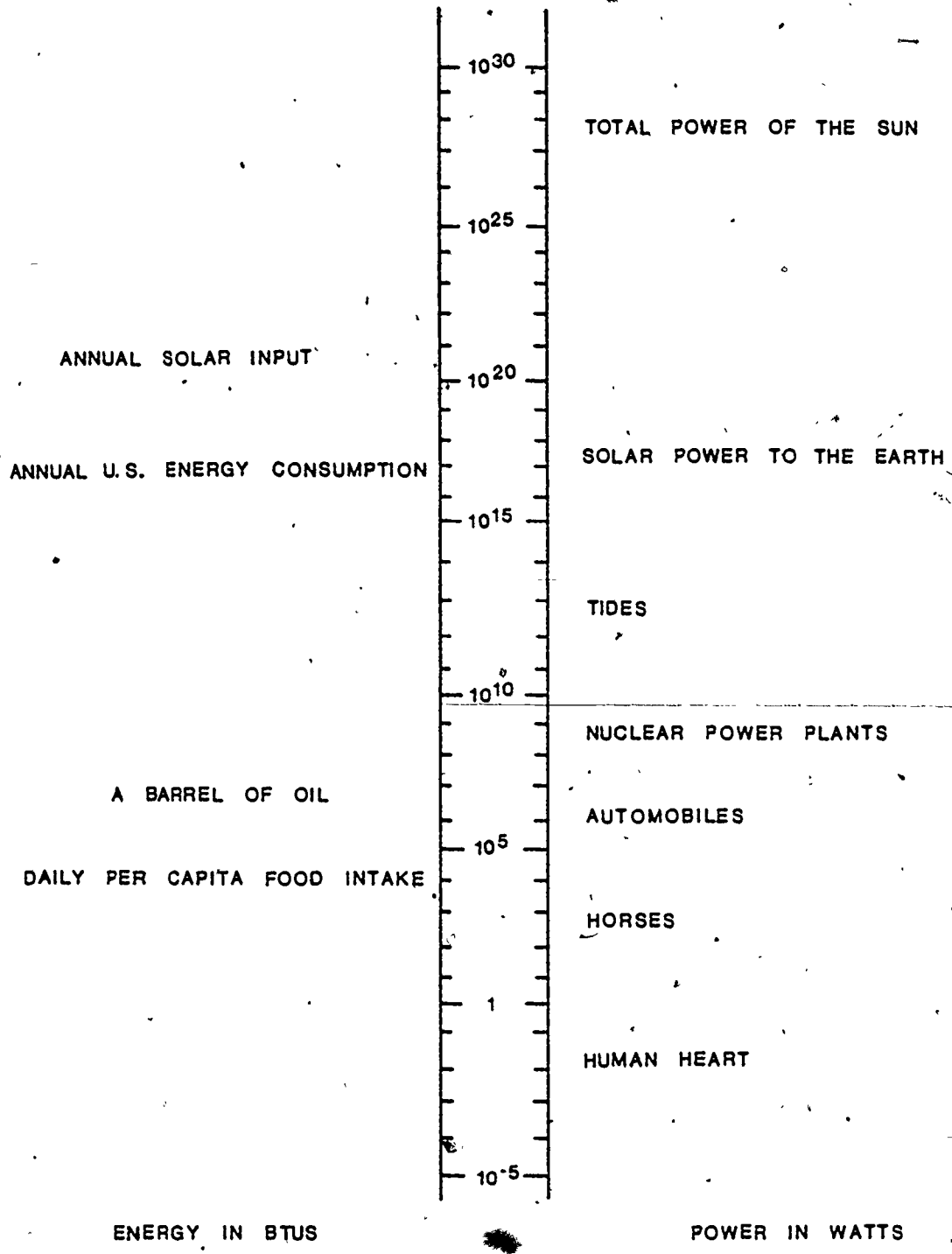

Figure 1. Ranges of Energy and Power.



ENERGY UNITS

Energy sources can be measured in many ways. For example, a quantity of petroleum can be measured in barrels or gallons; natural gas, in cubic feet; wood, in cords. However, the amount of usable energy varies from fuel to fuel, and even from sample to sample. That is, a barrel of Saudi Arabian crude oil may contain more or less energy than a barrel from Texas. A cord of oak provides more heat than a cord of pine. It is, therefore, convenient to measure energy sources in terms of available energy.

A comparison of the theoretical energy available from various sources in Btu equivalents is presented in Table 1. However, one must remember that conversion of one form of energy to another can never be 100% efficient. For example, it requires about 10,000 Btus of available fossil fuel to make one kilowatt-hour, which is equivalent to 3,413 Btus.

TABLE 1. AVERAGE BTU EQUIVALENTS OF COMMON ENERGY SOURCES.

Source	Quantity	Available Energy
Coal	Ton	26,000,000 Btus
Crude oil	Barrel	5,800,000 Btus
Liquid natural gas	Pound	21,000 Btus
Natural gas	Cubic foot	1,030 Btus
Electricity	Kilowatt-hour	3,413 Btus

Units commonly associated with energy measurement are reviewed below:

The Btu (British thermal unit) is a unit of energy in the English system. It is defined as the amount of heat required to raise the temperature of one pound of water one degree Fahrenheit.

The quad is a unit that is used when considering energy on a very large scale. It is equal to one quadrillion (1,000,000,000,000,000 or 10^{15} Btu).

The calorie (cal) is a common unit of heat energy in the metric system. It is defined as the amount of heat required to raise the temperature of one gram of water one degree Celsius.

The kilocalorie (kcal) is sometimes a more convenient unit. It is equivalent to 1,000 calories and is the heat required to raise the temperature of one kilogram of water by one degree Celsius. The food Calorie (Cal) is actually a kilocalorie.

The joule (J), kilojoule (kJ), and kilowatt-hour (kWh) are most commonly used to measure electrical energy.

A summary of the common relationships of the various common energy units is given in Table 2. Sample energy conversions are shown in Example A.

TABLE 2. ENERGY UNITS.

1 kilowatt-hour = 3,413 Btu = 860,000 calories = 3,600,000 joules.
1 Btu = 252 calories = 1,055 joules.
1 calorie = 4.186 joules.

EXAMPLE A: ENERGY CONVERSIONS.

Given: The total energy consumption of the United States in 1979 was approximately 80.8 quads.

Find: The energy consumed in the following units:

- a. Btus
- b. Equivalent barrels of oil
- c. Calories
- d. Kilowatt-hours

Solution:

a. $(80.8 \text{ quad}) \frac{(1 \times 10^{15} \text{ Btu})}{(1 \text{ quad})} = 8.08 \times 10^{16} \text{ Btus.}$

b. $(8.08 \times 10^{16} \text{ Btu}) \frac{(1 \text{ barrel of crude oil})}{(5.8 \times 10^6 \text{ Btu})} =$
 $1.39 \times 10^{10} \text{ barrels.}$

c. $(8.08 \times 10^{16} \text{ Btu}) \frac{(252 \text{ cal})}{(1 \text{ Btu})} =$
 $2.04 \times 10^{19} \text{ calories.}$

d. $(8.08 \times 10^{16} \text{ Btu}) \frac{(1 \text{ kilowatt-hour})}{(3,413 \text{ Btu})} =$
 $2.37 \times 10^{13} \text{ kilowatt-hours.}$

POWER UNITS

Power is the rate of energy flow. Power is defined as energy per unit time. It is important to remember that energy and power are not the same. The units commonly associated with power measurement are listed on the following page:

The watt (w) is the basic unit of power in the metric system. It corresponds to the passage of one joule of energy per second.

The kilowatt (kW) is the most commonly-used power unit. A kilowatt corresponds to the passage of 1,000 joules a kilojoule, per second.

In the English system, power is usually measured in more basic units like Btus per hour. An older term, horsepower (hp), is also sometimes used to measure power.

A summary of the common power units is given in Table 3. Sample conversions are presented in Example B.

TABLE 3. POWER UNITS.

1 horsepower = 746 watts = 0.746 kilowatts = 2,545 Btus/hour. 1 kilowatt = 1,000 watts = 3,410 Btus/hour.
--

EXAMPLE B: POWER CONVERSIONS.

Given:	A toaster has a power rating of 1.4 kilowatts.
Find:	The power rating in the following units: a. Watts b. Horsepower c. Btus/second

Example B. Continued.

Solution:

$$a. (1.4 \text{ kW}) \frac{(1,000 \text{ W})}{(1 \text{ kW})} = 1,400 \text{ watts.}$$

$$b. (1.14 \text{ kW}) \frac{(1 \text{ hp})}{(0.746 \text{ kW})} = 1.88 \text{ horsepower.}$$

$$c. (1.4 \text{ kW}) \frac{(3,410 \text{ Btu/hr})}{(1 \text{ kW})} \frac{(1 \text{ hr})}{(3,600 \text{ sec})} = 1.33 \text{ Btus/second.}$$

ENERGY CONSERVATION

The need for energy conservation on a national level is very apparent. Of the total available energy consumed by the American economy, almost half is lost each year in various conversions before it is finally put to some final purpose.

This enormous waste is illustrated in Figure 2. Of course, some loss is unavoidable, since no conversion of energy can be 100% efficient. But some way must be found to recapture some of the tremendous amount of energy lost in the generation-and-use processes.

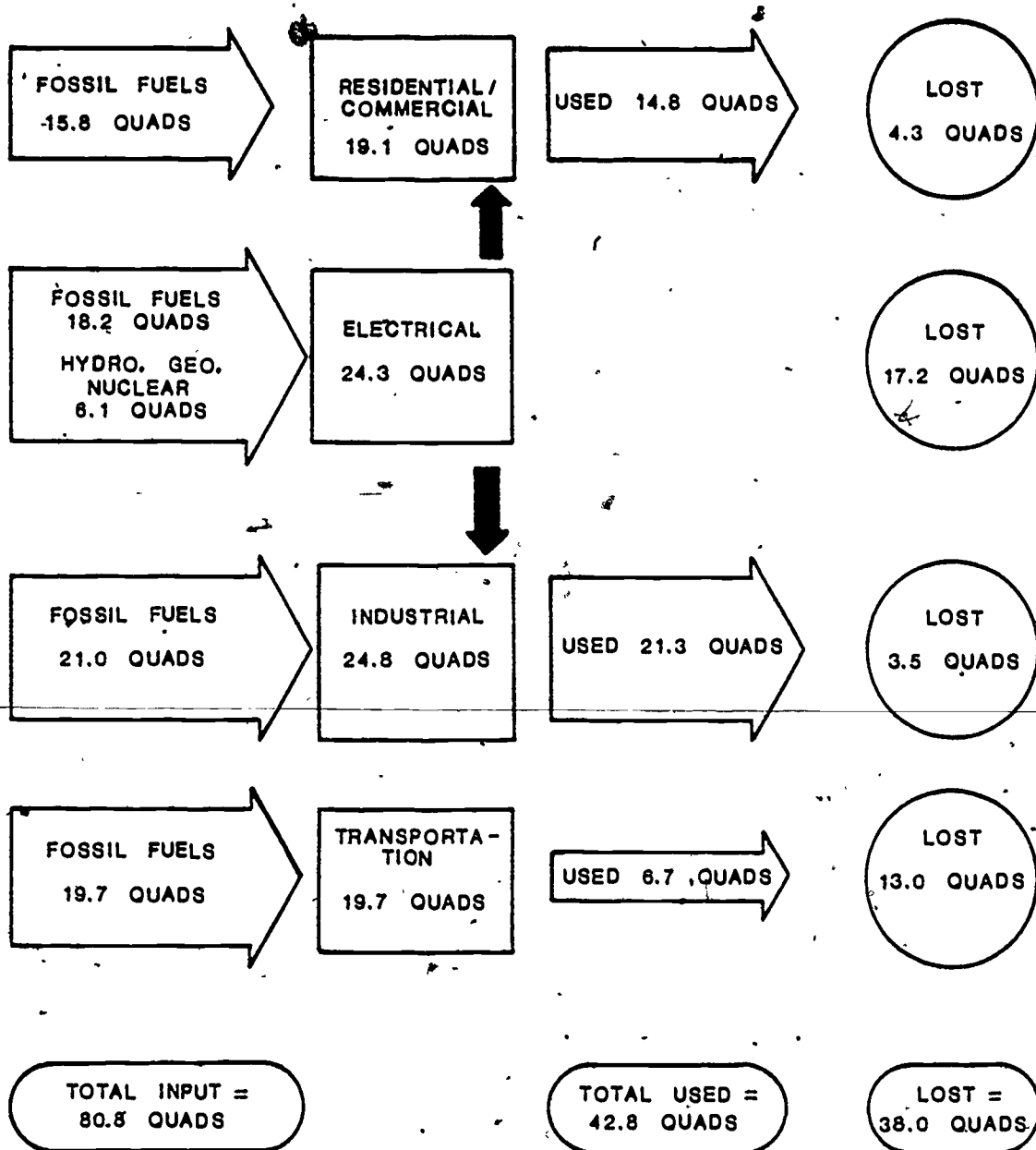

Figure 2. Total United States Energy Input and Output - 1979.

ENERGY SYSTEMS

All the energy that ever was still exists. The primary law of energy – the first law of thermodynamics – states that energy can neither be created nor destroyed.

Although energy can be converted from one form to another, energy is never really eliminated.

In an energy system, the difference in the energy input (E_{in}) and the energy output (E_{out}) is defined as the energy loss (E_{loss}) of a system. Although energy may also be stored in a system, the major relationship for energy conservation is given by Equation 1.

$$E_{loss} = E_{in} - E_{out} \quad \text{Equation 1}$$

Energy input is usually in the form of fossil fuel or electricity. Energy output is usually measured by useful work or products. However, energy lost exists somewhere, perhaps in the form of pollution or waste heat.

Energy efficiency (Eff) is a measure of the effectiveness of the system to convert energy sources to useful forms of energy. Energy efficiency is defined as the ratio of the energy output to energy input. This is given by Equation 2.

$$\text{Eff} = \frac{E_{out}}{E_{in}} \times 100 \quad \text{Equation 2}$$

Example C illustrates the relationships in these two equations.

EXAMPLE C: ENERGY EFFICIENCY.

Given: An air conditioning system consumes 23.4 kilowatt-hours, or 80,000 Btus, of electrical energy to cool a building one day in the summer. Measurements of the inlet air temperature, air flow rate, and relative humidity indicate that the air conditioning system removed 56,000 Btus of heat from the building.

Find: The energy efficiency and the energy loss of the system.

Solution: $E_{in} = 80,000 \text{ Btus.}$

$$E_{out} = 56,000 \text{ Btus.}$$

$$\text{Eff} = \frac{E_{out}}{E_{in}} \times 100 = \frac{56,000 \text{ Btu}}{80,000 \text{ Btu}} \times 100 = 70\%$$

$$E_{loss} = E_{in} - E_{out} = 80,000 - 56,000 = 24,000 \text{ Btus.}$$

The net efficiency of energy use is dependent on the number of steps required for conversion to a useful form. For example, the fossil fuels must be mined or extracted from the earth, then processed and transported to the user. Each step involves some energy cost and loss, as illustrated in

Example D. Some approximate efficiencies for various conversions are given in Table 4.

EXAMPLE D: NET EFFICIENCY OF ENERGY USE.

Given: The efficiencies for cutting, transporting, and burning wood in a stove are 66%, 98%, and 25%.

Find: The net efficiency of the energy using process.

Solution:

$$\begin{aligned}\text{Eff}(\text{net}) &= \text{Eff}(\text{cutting}) \times \text{Eff}(\text{transportation}) \times \text{Eff}(\text{burning}) \\ &= 0.66 \times 0.98 \times 0.25 = 0.16 = 16\%.\end{aligned}$$

TABLE 4. EFFICIENCIES OF ENERGY CONVERSIONS.

Source	Conversion	Efficiency
Coal	Mining	66%
	Processing	92%
	Transportation	98%
	Electricity	35%
Petroleum	Extraction	35%
	Refining	88%
	Transportation	92%
	Electricity	35%
	Oil Furnace	40%
	Internal Combustion Diesel Engine	9%
Natural Gas	Extraction	73%
	Processing	97%
	Transportation	95%
	Electricity	35%
	Natural Gas Furnace	50%
Uranium	Mining	95%
	Processing	57%
	Transportation	100%
	Electricity	35%
Wood	Cutting	66%
	Transportation	98%
	Woodburning Stove	25%
	Open Fireplace	8%

PRINCIPLES OF CONSERVATION

The traditional solution to an increased demand for energy was to increase the supply of energy. However, this option is becoming less economically feasible – or even possible. Conservation can increase the supply of useful energy and save original sources of energy. This is the option of the future.

Conservation is a result of any activity that saves energy. The mathematics of energy conservation is illustrated in Table 5.

TABLE 5. CONSEQUENCES OF ENERGY CONSERVATION.

Condition	E_{in}	E_{loss}	Eff	E_{out}
Decrease in Demand	↓	↓	Same	↓
Increase in Efficiency	↓	↓	↑	Same
Decrease in Demand + Increase in Efficiency	↓↓	↓	↑	↓
Increase in Demand + Increase in Efficiency	↓	↓↓	↑↑	↑

In the first case in Table 5, energy is conserved, since the decrease in demand for useful energy (E_{out}) means that less original energy (E_{in}) must be consumed. However, lowering demand alone means changing lifestyles and an overall decrease in the standard of living. This probably is the least popular of energy conservation methods.

Another way to conserve energy is to increase efficiency, as in the second case in Table 5. If demand remains the same, less energy will be consumed, since there is less loss.

Of course, the ideal conservation is a combination of decreased demand and increased efficiency. This results in energy savings from two factors.

This is illustrated in the fourth condition in Table 5. In order to save original energy sources (E_{in}) - and permit an increase in the output of useful energy (E_{out}) - the efficiency of a system (Eff) must reduce losses (E_{loss}) more than the increase in demand.

ENERGY AUDITS

An energy audit is a method to determine the efficiency of a system and devise ways to increase it and, thereby, reduce energy loss. An energy audit can be performed on a major industry, a production line operation, a single piece of equipment, or the home. An investigation is performed by skilled personnel to determine how energy is used and wasted. Conservation measures are then implemented to reduce energy consumption.

AUDIT METHODS

There are usually five steps in an energy audit procedure. The first three audit methods involve determination of energy loss. The others concern analysis for improvement of the system.

1. Measurement of energy consumed. The first step in an energy audit is to measure the energy consumed by the system (E_{in}). This may be accomplished by analysis of fuel and electric bills. The amount consumed is usually measured by a meter or some similar device.
2. Measurement of useful energy produced. The second step is to measure the energy that is considered useful (E_{out}). This could be in the form of products, heating and air conditioning, illumination, miles traveled, or electricity produced.
3. Determination of energy losses. If energy input and output can be determined, energy loss can be determined by use of Equation 1. Since it is difficult to ascertain the exact amounts of input and output of a large system and the individual energy consuming units contained in it, it is sometimes more convenient to concentrate on determining the losses directly. The importance of the audit process is to account for all losses in the system.
4. Corrective measures. After the losses in a system have been determined, it is necessary to devise methods to reduce these losses. This may be accomplished by modifying the building, repairing or replacing equipment, or changing production procedures. Some specific examples are shown in Table 6.

TABLE 6. EXAMPLES OF ENERGY LOSSES AND CORRECTIVE MEASURES.

LOSS	CORRECTIVE MEASURE(S)
<p><u>In Buildings</u></p> <p>Transmitted heat through windows ...</p> <p>Transmitted heat through ceilings ...</p> <p>Transmitted heat through walls ...</p> <p>Dirty (clogged) air filter ...</p> <p>Pipes and air ducts not insulated ...</p> <p><u>In Equipment</u></p> <p>Low Freon in air conditioner ...</p> <p>Low motor efficiency ...</p> <p>Poor gas mileage in automobile ...</p> <p>Poor boiler efficiency ...</p> <p><u>In Procedures</u></p> <p>Building cooled or heated beyond guidelines ...</p> <p>Waste heat from process vented outside ...</p> <p>Conveyor belts and machines running idle ...</p>	<p>Add storm windows, shades, drapes.</p> <p>Add insulation.</p> <p>Add insulation.</p> <p>Replace filter.</p> <p>Add insulation.</p> <p>Replace Freon.</p> <p>Replace brushes in armature.</p> <p>Operate at correct speed.</p> <p>Operate at rated horsepower.</p> <p>Tune engine.</p> <p>Inflate tires.</p> <p>Optimize combustion process.</p> <p>Increase insulate.</p> <p>Clean burners.</p> <p>Reset thermostat and prevent process to change.</p> <p>Recirculate waste heat to heat building or cycle through heat exchanger.</p> <p>Turn off equipment when not in use.</p>

5. Economic analysis. Each method for reducing loss must be analyzed in terms of cost. This requires a consideration of whether dollar savings from reducing energy consumption over an extended period of time are greater than the cost of making the change.

The actual results of an energy audit are illustrated in Example E.

EXAMPLE E: ENERGY AUDIT SAVINGS.

Given: An energy audit was performed on the air conditioning system in Example C. Measurement and observations revealed that losses were occurring in the air conditioning as a result of low Freon pressure, drive belt slippage between the motor and compressor, a dirty filter, and poorly-insulated air ducts. When these deficiencies were corrected, the air conditioner consumed the same amount of electricity, but removed 65,000 Btus of heat from the building.

Find: The reduction in energy loss and the new energy efficiency of the air conditioner.

Solution:

$$E_{in} = 80,000 \text{ Btus.}$$

$$E_{out} = 65,000 \text{ Btus.}$$

$$E_{loss} = E_{in} - E_{out} = 15,000 \text{ Btus.}$$

$$\begin{aligned} \text{Loss Reduction} &= \text{Original Loss} - \text{Final Loss} \\ &= 24,000 - 15,000 \\ &= 9,000 \text{ Btus.} \end{aligned}$$

$$\text{Eff} = \frac{65,000 \text{ Btus}}{80,000 \text{ Btus}} \times 100 = 81\%.$$

ECONOMIC ANALYSIS

Analysis of a project must be considered in terms of energy savings compared to the costs of the energy savings. The best way to perform the economic analysis is to convert energy sources into costs and then compare them to project costs. Saving money is the best initiative for energy savings.

A typical example of cost analysis is given in Example F.

EXAMPLE F: COST ANALYSIS.

Given: The installation of storm windows on a given home would cost \$7,000 and will save 25% in heating and air conditioning costs. The average bill for heating and air conditioning is \$100 per month.

Find: The savings per year and whether the project should be undertaken.

Solution:

Savings per year = $\$100 \times 12 \times 0.25 = \300 per year.

If the \$7,000 were deposited in the bank to draw interest at 6%, however, the annual interest would amount to over \$490. The project should not be implemented, since \$190 would be saved by not saving energy.

EXERCISES

1. The average consumption of food for a human is about 3,000 kilocalories per day. Calculate the energy in the following units:
 - a. Calories
 - b. Btus
 - c. Kilowatt-hours
 - d. Joules
2. A home heating unit can deliver 10,000 Btus per hour. Calculate the power rating of the following units:
 - a. Watts
 - b. Kilowatts
 - c. Horsepower
3. A building consumes energy according to the following data. Find the daily energy use in kilowatt-hours.

<u>Units</u>		<u>Rating</u>	<u>Time Period</u>
1	electric heater	10 kW	10 min/hr
20	light bulbs	100 W	6 p.m. - 9 p.m.
1	neon light	500 W	7 a.m. - 9 p.m.
1	water heater	12 kW	5 min/hr
1	computer system	600 W	8 a.m. - 6 p.m.
2	teletype machines	1 kW	9 a.m. - 4 p.m.

4. A fireplace burns wood with a total of 5,000 Btus in an evening. It provides 1,000 Btus of heat to the room. Determine the amount of energy lost and the efficiency of the fireplace.
5. Calculate the total energy produced in joules if a 600 kW system operates for 24 hours.
6. Make a table of equipment or appliances found in the home with the power ratings of each. Analyze which require the most energy.

7. A solar power plant could operate with four square miles of collectors at 100% efficiency. Calculate the area if the plant were only 20% efficient.
8. Using the data in Table 4, determine the net efficiency of the following conversions of energy:
 - a. Use of coal to provide electric lights
 - b. Use of uranium to provide electric lights
 - c. Use of petroleum to provide transportation

REFERENCES

- Cook, Earl. Man, Energy, Society. San Francisco: W.H. Freeman, 1976.
- Fowler, John M. Energy and the Environment. New York: McGraw-Hill, 1975.
- Miller, James N. "The Energy Crisis: There is an Easy Answer." Reader's Digest. June 1980.
- Reynolds, William C. Energy - From Nature to Man. New York: McGraw-Hill, 1974.
- Shepard, Marion L., Chaddock, Jack B., Cocks, Franklin H., and Harman, Charles M. Introduction to Energy Technology. Ann Arbor, MI: Ann Arbor Science, 1975.



ENERGY TECHNOLOGY

CONSERVATION AND USE

FUNDAMENTALS OF ENERGY TECHNOLOGY

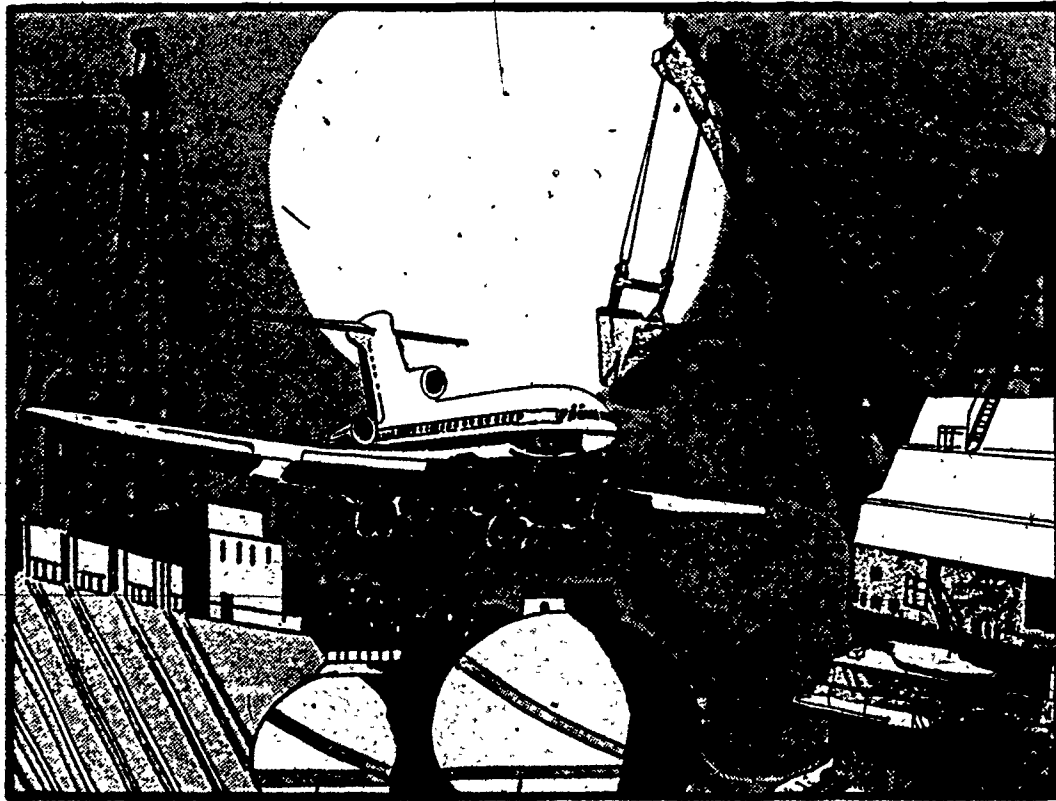

MODULE EF-06

ENERGY & THE ENVIRONMENT



CENTER FOR OCCUPATIONAL RESEARCH AND DEVELOPMENT

INTRODUCTION

This module presents an overview of energy as the binding force of the environment. Energy use produces waste heat and matter. Environmental problems related to air, water, and land pollution are discussed. Possible solutions are considered.

PREREQUISITES

The student should have completed Module EF-05, "Energy Analysis."

OBJECTIVES

Upon completion of this module, the student should be able to:

1. Give the five major biogeochemical cycles of nature.
2. Write a brief definition of the environment.
3. Discuss the major effects of energy use on the air, water, and land.
4. List the major air pollutants derived from energy use.
5. Discuss the major sources of water pollution.
6. Discuss the major sources of land pollution.
7. Identify the following terms as they are discussed in this module:
 - a. Biogeochemical cycles
 - b. Hydrological cycle (H_2O)
 - c. Carbon-oxygen cycle (CO_2-O_2)
 - d. Nitrogen cycle (N_2)
 - e. Sulfur cycle (S)

- f. Phosphorus cycle (P)
- g. Carbon monoxide (CO)
- h. Particulates
- i. Sulfur oxides
- j. Hydrocarbons
- k. Nitrogen oxides
- l. Carbon dioxide (CO₂)
- m. Thermal pollution
- n. Ecosystems
- o. Strip mining
- p. Underground mines
- q. Acid drainage
- r. Pipelines
- s. Reclamation
- t. Catalytic converters
- u. Nonregenerative processes
- v. Regenerative processes
- w. Scrubbers
- x. Cooling towers
- y. Nuclear wastes

SUBJECT MATTER

ENERGY AND THE ENVIRONMENT

The way energy is used is extremely important to survival and social development. The enormous use of energy by present society requires that tremendous amounts of fuel be extracted from the earth. Fuel extraction can cause major disruptions of the environment. These negative aspects of energy use must be considered in the quest to maintain a safe world.

THE ENVIRONMENT

For many years, most people were not aware that there was an environment - until it changed. Like energy, an environment can be altered, but it can never be destroyed. There will always be an environment. This environment may not, however, be the environment most beneficial to the future of mankind.

Most of the energy used until nuclear power was developed was derived from the effects of the sun. Solar energy is absorbed and stored in plants by photosynthesis and provides the energy found in food. The energy stored in fossil fuels is also indirectly derived from the sun. Solar energy provides the winds in the atmosphere, the tides of the oceans, and the rain that fills the rivers. Fuel is needed by everything that moves in society and, perhaps most importantly, by every living organism in the form of food. Energy is the resource necessary for all things on this planet.

Matter moves through cycles about the earth similar to energy. Since most of the matter cycles are related to living things, they are referred to as biogeochemical cycles. There are five of these, which are of great importance to life: the hydrological cycle (H_2O), the carbon-oxygen cycle (CO_2-O_2), the nitrogen cycle (N_2), the sulfur cycle (S), and the phosphorus cycle (P).

The most common and most-often-affected of these cycles is the hydrological cycle. Water covers more than 70% of the surface of the earth. The hydrological cycle contacts almost every square inch. Direct burning of large quantities of fossil fuels also directly affects the carbon-oxygen cycle. These are both pictured in Figure 1.

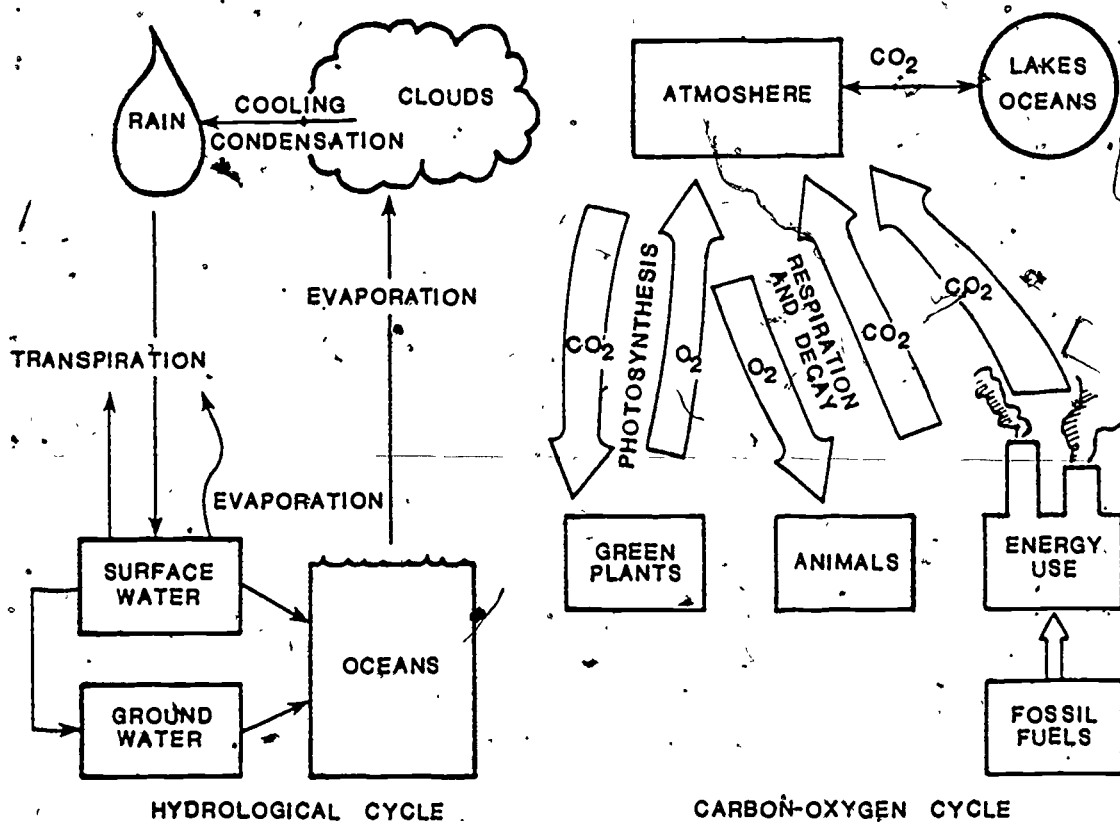

Figure 1. Hydrological Cycle and Carbon-Oxygen Cycle.

Other biogeochemical cycles are illustrated in Figure 2. Nitrogen composes about 78% of the atmosphere and is controlled by microorganisms, since nitrogen gas is inert

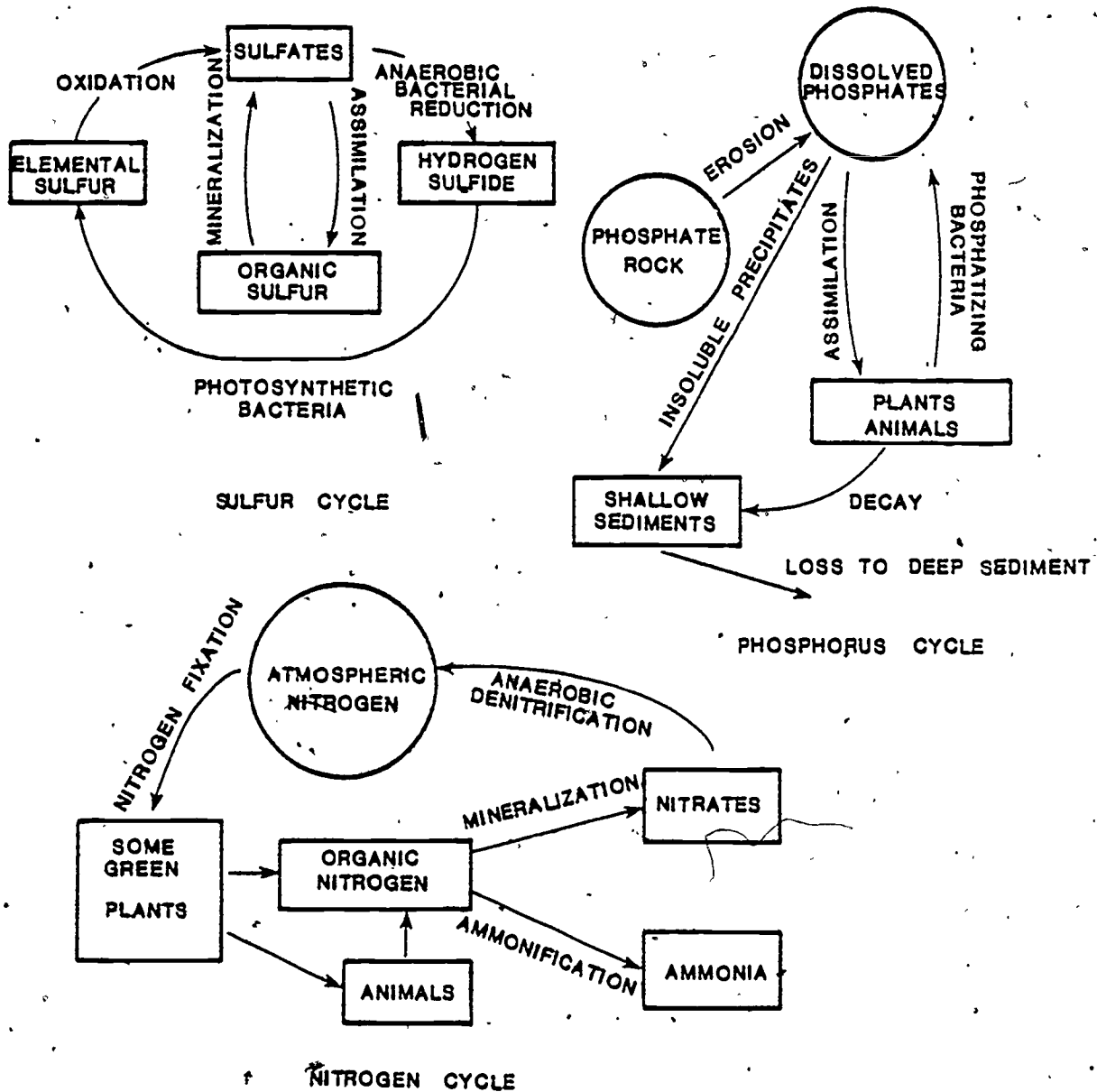

Figure 2. Sulfur, Nitrogen, and Phosphorus Biogeochemical Cycles.

to other forms of life. Although phosphorus is less common than nitrogen, it is a very important nutrient for living organisms. Sulfur is also an important element, since most coal reserves contain high sulfur levels.

Development of energy sources can affect these biogeochemical cycles by creating extra inputs or outputs. Since each cycle is important to the stability of an ecosystem, care must be taken to avoid major disruptions.

EFFECTS OF ENERGY USE ON THE ENVIRONMENT

Throughout the history of the United States, Americans have developed careless energy habits. Early settlers harvested — but rarely replanted. When the fossil fuels became more important, the same pattern was followed. The vast natural reserves of this country were developed and used with no plan for the future.

When population was low, there were no problems with waste disposal. Early settlers used most of their fireplace residues to make soap and fertilizer. Other wastes were carted some distance from home for free venting to the forest ecosystem. As the demand for energy increased, so did the weight of residues. Today, many urban areas are packed with people and the environment can no longer absorb these pollutants, residues, and wastes. The choice for the future is to breathe and drink it or to pay to remove it, prevent it, or clean it.

There are also other difficulties arising from energy production. The amount of land required for fuel production and energy conversion and distribution is a problem, and this will continue as long as the demand for energy use

continues. More than just the land is at stake. The attractiveness of the environment is also involved. Strip mining, power lines, and electric utilities are changing the environment as more energy use is required to keep pace with demand.

The United States has always been involved in resource exploration. Future exploration and exploitation could cause major environmental problems unless dealt with in an effective and timely manner. The energy/environmental issue has always been present in American society. Although sometimes reduced to an argument of progress against status quo, this controversy will continue to be an important factor in determining the pattern of energy use in the future. Any energy policies must consider the desire of most Americans for an increased economic and environmental standard of living.

Most of the concerns about energy and the environment revolve around specific pollutants that influence the bio-sphere. In this section, effects of energy use on the air, water, and land will be investigated.

EFFECTS OF ENERGY USE ON THE AIR

Approximately 85% of the air pollution in the United States is associated with the burning of fossil fuels. A survey performed by the National Air Pollution Control Administration (NAPCA) in 1968 identified energy conversion operations in motor vehicles and fossil fuel power plants as the major source of carbon monoxide, particulates, sulfur dioxide, hydrocarbons, and nitrogen oxides. These pollutants have the potential of impairing health, creating annoyance,

and causing property damage. The total emissions of these pollutants are indicated in Table 1.

TABLE 1. ESTIMATED NATIONWIDE EMISSIONS - 1968
(in millions of tons per year).

Source	Carbon monoxide	Partic- ulates	Sulfur oxides	Hydro- carbons	Nitrogen oxides	Total
Transportation	63.8	1.2	0.8	16.6	8.1	90.5
Fuel combustion in stationary sources	1.9	8.9	24.4	0.7	10.0	45.9
Industrial processes	9.7	7.5	7.3	4.6	0.2	29.3
Solid waste disposal	7.8	1.1	0.1	1.6	0.6	11.2
Forest fires, agri- cultural burning, coal waste fires	16.9	9.6	0.6	8.5	1.7	37.3
Total	100.1	28.3	33.2	32.0	20.6	214.2

Carbon Monoxide

Carbon monoxide (CO) is a poisonous gas produced by incomplete combustion of organic materials. The carbon monoxide formed can remain in the air for periods of one month to five years, depending on atmospheric conditions. High concentrations can build up unless CO is otherwise dispersed. The emission factors for carbon monoxide from uncontrolled sources at average operating conditions are given in Table 2.

TABLE 2. CARBON MONOXIDE EMISSION FACTORS.

Source	Average emissions per unit of fuel burned
<u>Coal</u>	
Household and commercial	10 lb/ton
Industry	2 lb/ton
Utility	1 lb/ton
<u>Fuel</u>	
Household	5 lb/1,000 gal
Commercial and industrial	0.2 lb/1,000 gal
Utility	0.04 lb/1,000 gal
<u>Natural Gas</u>	
Household and commercial	20 lb/million ft ³
Utility and industrial	0.4 lb/million ft ³
<u>Others</u>	
Gasoline-powered vehicle, urban 1970.	2,620 lb/1,000 gal
Diesel-powered bus and truck	225 lb/1,000 gal
Jumbo jet aircraft	28 lb/engine-flight

Carbon monoxide is a serious health hazard. It provides no prior warning, since carbon monoxide is colorless, odorless, and tasteless. When inhaled, carbon monoxide is quickly absorbed by the hemoglobin. As the hemoglobin becomes saturated with carbon monoxide, the blood decreases its ability to carry oxygen. Headache, nausea, unconsciousness, and death may occur quickly with continued exposure.

Particulates

The burning of coal in electric power plants accounts for about 64% of all particulate emission. Particulates may be defined as any matter, solid, or liquid in which individual particles are larger than a molecule but smaller than 0.5 millimeters.

The particulates released from the burning of coal are mostly in the form of fly ash, which is composed of carbon, silica, alumina, and iron oxide. Although oil has a much lower ash content than coal, it is also a source of particulate emission. Motor vehicles release particulate emissions of lead compounds, carbon, and metallic oxides.

Emission factors for particulates from uncontrolled sources are listed in Table 3. Notice that the actual emission from coal is dependent on the ash content of the fuel and the type of burning process. The average ash content of bituminous coal is 10%.

Fine particulate matter in the air has adverse effects on buildings, structural materials, and health. It may also have long-term effects on the thermal energy balance of the earth by reflecting some of the sunlight as it passes through the atmosphere.

A 1% increase in the cloud cover of the earth could reduce the average temperature of the earth by 1.4°F. An increase of 5% could lead to the return of an ice age. Volcanic eruptions are believed to account for most of the particulate contamination of the upper atmosphere and can certainly cause meteorological changes. Jet aircraft exhausts add water vapor and particulates to this portion of the atmosphere and can also contribute to varying weather conditions.

TABLE 3. PARTICULATE EMISSION FACTORS.

Source	Average emissions per unit of fuel burned
<u>Coal, Bituminous</u>	
General	16 A lb/ton
Dry bottom	17 A lb/ton
Wet bottom	13 A lb/ton
Cyclone	2 A lb/ton
Hand-fired equipment	20 lb/ton
<u>Residual Oil</u>	
Utility	8 lb/1,000 gal
Industrial and commercial	23 lb/1,000 gal
<u>Distillate Oil</u>	
Industrial and commercial	15 lb/1,000 gal
Household	10 lb/1,000 gal
<u>Natural Gas</u>	
Utility	15 lb/million ft ³
Industrial	18 lb/million ft ³
Household and commercial	19 lb/million ft ³
<u>Others</u>	
Gasoline-powered vehicle, urban 1970	8 lb/1,000 gal
Diesel-powered bus and truck	13 lb/1,000 gal
Jumbo jet aircraft	10 lb/engine-flight
NOTE: Where letter A is shown, multiply number given by the percent ash in coal.	

Sulfur Oxides

Sulfur dioxide (SO₂), and to a much lesser extent sulfur trioxide (SO₃), are also produced during combustion of fossil fuels. Most sulfur oxides originate from burning coal and oil. Emission factors for various uncontrolled sources are given in Table 4. Actual emission depends on the sulfur content of the fuel consumed. The average sulfur content of coal is approximately 2.5%; the average sulfur content of crude oil is about 0.3%.

TABLE 4. SULFUR DIOXIDE EMISSION FACTORS.

Source	Average emissions per unit of fuel burned
Coal	38 S lb/ton
Residual oil	157 S lb/1,000 gal
Distillate oil	142 S lb/1,000 gal
Natural gas	0.6 lb/million ft ³
Gasoline-powered vehicle, urban 1970	5 lb/1,000 gal
Diesel-powered bus and truck	27 lb/1,000 gal
Jumbo jet aircraft	2 lb/engine-flight

NOTE: S indicates percent sulfur in fuel.

Sulfur dioxide can cause corrosion, damage plant life, and cause or aggravate respiratory illness in humans. It is the major irritant in London-type smog. Many deaths have been attributed to sulfur dioxide in the past when this type of smog was more common. In addition, the sulfur oxides can react with water in the atmosphere and form sulfurous and sulfuric acids.

Hydrocarbons

Other pollutants to the atmosphere are hydrocarbons. These emissions are from evaporation of fuel from vehicles, fuel-handling operations, and unburned fuel in vehicle exhausts. Emission factors for various sources of hydrocarbons are listed in Table 5.

Many of the hydrocarbon compounds lost to the atmosphere are the lower boiling fractions of petroleum. However, some are products from incomplete combustion of fuel. A number of these compounds can react with other pollutants to form strong oxidizing agents that can cause corrosion of many materials. Some are also carcinogens.

TABLE 5. HYDROCARBON EMISSION FACTORS.

Source	Average emissions per unit of fuel burned
<u>Coal</u>	
Household and commercial	3 lb/ton
Industry	1 lb/ton
Utility	0.3 lb/ton
<u>Fuel Oil</u>	
Household	3 lb/1,000 gal
Industry and commercial	3 lb/1,000 gal
Utility	2 lb/1,000 gal
<u>Natural Gas</u>	
Household and commercial	8 lb/million ft ³
Utility and industry	40 lb/million ft ³
<u>Others</u>	
Gasoline-powered vehicle, urban 1970	330 lb/1,000 gal
Diesel-powered bus and truck	37 lb/1,000 gal
Jumbo jet aircraft	3 lb/engine-flight
Vehicle gas tank and carburetor	75 lb/1,000 gal
Filling of automobile tanks	12 lb/1,000 gal
Filling of service station tanks	12 lb/1,000 gal

Nitrogen Oxides

Nitrogen oxides are also emitted during the combustion of fossil fuels. Nitrogen dioxide (NO₂) is the most common

oxide of nitrogen classed as an air pollutant. It can react with oxygen in the air to produce ozone (O_3), a very strong oxidizing agent and air-pollutant. Table 6 shows average uncontrolled emission factors for nitrogen dioxide.

TABLE 6. EMISSION FACTORS FOR NITROGEN OXIDES.

Source	Average emissions per unit of fuel consumed
<u>Coal</u>	
Household and commercial	6 lb/ton
Industry	18 lb/ton
Utility	18 lb/ton
<u>Fuel Oil</u>	
Household and commercial	12 lb/1,000 gal
Industry	40 lb/1,000 gal
Utility	105 lb/1,000 gal
<u>Natural Gas</u>	
Household	50 lb/million ft ³
Commercial	100 lb/million ft ³
Industry	230 lb/million ft ³
Utility	390 lb/million ft ³
<u>Others</u>	
Gasoline-powered vehicle, urban 1970	183 lb/1,000 gal
Diesel-powered bus and truck	370 lb/1,000 gal
Jumbo jet aircraft	6 lb/engine-flight

Nitrogen dioxide and ozone are the major irritants of Los Angeles-type smog that is caused by heavy vehicular traffic. Both nitrogen dioxide and ozone are dangerous to life.

Carbon Dioxide

Another potentially troublesome product from burning any fossil fuel is carbon dioxide (CO₂). Although CO₂ occurs naturally in the atmosphere, the average concentration of carbon dioxide in air has increased about 10% in this country, due to increased use of fossil fuels.

Some scientists speculate that an increase in the atmosphere's carbon dioxide concentration will increase the ability of the atmosphere to retain solar energy and lead to a gradual warming of the earth. This is called the greenhouse effect. A slight increase in the average temperature of the earth would cause increased melting of the polar ice caps and flooding all over the world.

Other scientists disagree with this view, since the equilibrium capacity of the oceans may absorb any excess carbon dioxide. In addition, atmospheric dust has increased at about the same rate as carbon dioxide production. These dust particles would tend to block out some of the solar radiation hitting the earth.

However, in the future, increased carbon dioxide concentrations could become an important factor in changing the climate of the earth during the next century. Increasing levels of carbon dioxide and particulates puts the balance of nature in a precarious state.

EFFECTS OF ENERGY USE ON WATER

Water is an abundant resource. Water covers more of the surface of the earth than does land. Water is necessary for every form of life on the planet. Water is also used for the generation of electricity, for cooling nuclear reactors, and for many other energy-related applications.

The major impact energy use has on the waters of the earth is in the form of thermal pollution. Waste heat released to the water or air emerges in the hydrological cycle, where great quantities of water circulate to maintain the heat balance of the earth. Use of energy also results in direct water pollution and disturbance of natural ecosystems.

Thermal Pollution

Thermal pollution is produced when waste heat is released into the environment. Electric power generating plants release waste heat when electricity is produced. Automobiles release waste heat through exhaust and cooling systems.

Heat released in the Boston-Washington corridor equals 15% of the net solar radiation in summer and 50% in winter. The resulting urban heat island increases the temperature over the cities by as much as 15°F. Areas of high thermal pollution can cause significant meteorological changes.

The oxygen content and the temperature of water is critical for most aquatic life. Heated water released into an aquatic ecosystem lowers the dissolved oxygen of that system. Changes in the ecosystem are sure to follow lowering dissolved oxygen, since many forms of life cannot survive

in oxygen-depleted waters. Increasing water temperature can also increase the toxic effects of various pollutants and change the entire food chain.

Direct Water Pollution

The transportation of oil is also a source of tremendous pollution to the marine environment. The tankers used are so dangerous that insurance for them can seriously cut into profits. As a result, many tankers register under the flags of third world nations, which do not require the safety standards common to most international vessels.

Many oil tankers have broken apart or collided and caused oil spills in just about every part of the world. In 1969, approximately 0.1% of all the oil produced that year was released into the oceans. Offshore oil wells on floating platforms are also a source of direct water pollution.

Acid mine drainage, consisting of sulfuric acid and iron compounds formed by reaction of water and air with sulfur-containing minerals, contaminates local streams and rivers in coal mining areas. Both abandoned and active coal mines contribute to this form of water pollution.

Disturbance of Natural Ecosystems

Development of a hydroelectric dam not only changes the ecology of the river, it takes one natural ecosystem and creates two new smaller ones: the lake above the dam and the downstream river. These dams can adversely affect

aquatic life. Due to extensive use of hydroelectric power in the northwestern United States, elaborate and costly fish ladders had to be constructed so that salmon could reach their spawning grounds.

EFFECTS OF ENERGY USE ON THE LAND

Light energy from the sun produces many products such as food and wood, which are high-energy-containing sources. These energy sources ~~are not formed~~ rapidly, however, and cannot adequately supply all the energy needs of the world.

The fossil fuels and uranium are concentrated energy sources stored in limited quantities in the crust of the earth. In order to extract fossil fuels and uranium for use, the land must be disturbed in some way. The mining of these fuels — particularly coal — can cause major changes in the land. Transportation of fuels in pipelines can also lead to land pollution. In addition, the development of future energy sources must be considered in terms of development's effects on the land.

Mining

Although the use of coal has many environmental impacts, the most visible impact is certainly strip mining. In this procedure, the earth removed in one cut is usually dumped into the empty space left by the previous cut. In addition to disruption of the land surface, a major environmental impact from strip mining is the runoff of rainwater carrying silt, which can pollute and clog streams and prematurely fill reservoirs.

In contour mining, the earth is dumped downhill, destroying vegetation and property below, clogging streams, causing mud slides, and aggravating problems of runoff. Contour mining is often done in wilderness areas, which are even more difficult to restore than inhabited areas.

The total acreage of underground mines in the United States is equal to the surface area of Maryland and Delaware combined. Underground mines eventually settle and collapse, causing land slides. Disorganization of the rock strata during deep mining also upsets the water table. Water moving through the substratum carries toxic materials and eventually discharges toxic materials into open ecosystems. In coal mining, this is known as acid drainage. The acidity has increased so much in some Appalachian streams that fish and plant life cannot survive.

Fires in abandoned coal mines are difficult to control. These fires also burn for long periods of time. One coal mine fire in Ohio has been burning for almost 100 years. In addition, coal mining also produces large amounts of solid waste. This unusable waste contributes to soil erosion and produces water pollution problems.

Pipelines

About two-thirds of domestic crude oil and natural gas is transported through the over 200,000 miles of pipeline in the United States. Each year, hundreds of natural gas pipeline accidents are reported. The Alaskan pipeline carries petroleum 800 miles from the oil-rich North Slope of Valdez, Alaska, for tanker shipment to refineries. This pipeline is a constant threat to the wildlife and forests

of Alaska. It may also have already disrupted the migratory patterns of many birds.

Solar Collectors

Because it is so diffuse, solar energy requires large collecting surfaces to produce useful amounts of fuel or energy. A medium-sized power plant would require perhaps 5,000 acres of land with collecting mirrors covering half that surface. The shading for the solar collectors will change the environment by changing the surface absorption and evaporation, lowering surface temperature, and changing surface wind patterns. The change brought about by shading could be beneficial, since increased moisture retention would encourage vegetation.

POLLUTION CONTROL

All forms of energy conversion leave unwanted by-products such as heat, air pollution, scarred land, or contaminated water. Technology will not eliminate these negative aspects. That is, combustion will always produce nitrogen oxides and carbon monoxide; coal will always release sulfur; oil will always release hydrocarbons to the air. If nuclear energy becomes more important, there will be a new set of problems. The main objective of technology in this area is to minimize adverse effects on the environment. This can be accomplished by land reclamation, controlling devices, and safe handling of wastes.

RECLAMATION

Since natural reclamation of strip-mined land takes thousands of years, human restoration of the land is extremely important. Federal regulations require that strip-mined areas be reclaimed so that forests can grow again. This is a very expensive process for the coal mining industry.

All ecosystems can withstand moderate acid drainage through dilution or neutralization. Acid drainage can best be controlled by decoupling offending mines from their surroundings. This could be accomplished by diversion of water flow or mine sealing. The effluent could also be neutralized with synthetic compounds. Since cost of these procedures is high, they are not presently considered to be economically practical.

However, with the growing demand for coal, future surface mining can be expected to increase and affect large land areas. While reclamation is fairly straightforward in the eastern United States, where water is available to initiate quick growth of new plants, the scarcity of water in the arid western states is likely to make land reclamation much more difficult.

Strip mining areas are also under study as possible — solid waste disposal sites. Two problems can then result in a solution.

DEVICES AND EQUIPMENT

Although devices and equipment used to protect the environment from pollutants contribute very little to the overall national energy demand, they have contributed to an improved environment. Some of the more useful ones are discussed in this section.

Emission Controls for Automobiles

In 1979, over 100 million cars consumed about 15% of the total energy demand of the United States. The large amounts of fuel consumed by motor vehicles has made them a very significant source of pollution.

In the past decade, there has been a trend toward lighter cars with better fuel economy. This trend has resulted in fewer emissions. Increased use of emission controls has also improved air quality. Catalytic converters increase the oxidation process by converting more of the hydrocarbons and carbon monoxide to carbon dioxide and water. Future emission control device improvement could lead to better fuel economy.

Sulfur Oxide Controls for Power Plants

Nonregenerative and regenerative processes to remove sulfur oxides from power plant flue gases by scrubbing techniques are now being employed.

With the nonregenerative type of system, which employs a lime and limestone scrubbing process, the reaction product in the scrubbing slurry is discarded. With regenerative systems, which use either the ammonia or magnesia scrubbing process, the reaction product is converted to a useful end-product, and the scrubbing liquid is continually replenished by regenerated materials. The ammonia scrubbing liquid can be converted to fertilizers and the magnesia liquid can be used to form sulfuric acid.

More and more of these scrubbers are being installed in power plants. The small energy demands associated with control of sulfur oxide pollutants are a small price to pay for clean air. In addition, these devices allow the burning of high-sulfur containing coal, which is the most common type of coal.

Cooling Towers

Trading thermal pollution of water for thermal pollution of air is a common practice. Many utilities have elected to use cooling towers and ponds, rather than natural lakes and rivers.

Many power plants use either a wet or dry cooling tower. In a wet tower, cooling takes place by evaporation. These towers operate well in cool, dry climates. Since water is emitted into the atmosphere, fog conditions and local rain can take place.

A dry tower is basically a large radiator. The cooling water flows through finned tubes and is cooled by air passing over them. This type of tower is much more expensive to construct than a wet tower, but it has no water loss and no

adverse effects on the weather. Dry towers could be used to supply cooling for the western states, since water is recycled.

WASTES

Vast amounts of waste are also associated with energy demand and supply. Water, solid, and nuclear wastes are discussed in this section.

WASTEWATER

The amount of energy needed to treat wastewater depends on the degree of treatment needed and the process used. The energy is used for electricity to operate pumps, scrapers, compressors, chlorinators, and so forth.

Although the total energy required to recycle water is less than 1% of the total energy consumed, it certainly is a very important part of the relationship of energy use and the environment.

SOLID WASTES

Proper disposal of solid wastes is usually considered to be in the form of sanitary landfills. This process would also involve less than 1% of the total energy consumption of the United States. About four times as much energy could be generated from recovering energy from solid wastes than it takes to dispose of solid wastes.

NUCLEAR WASTES

The ultimate value of nuclear energy cannot be determined until the costs associated with safe disposal of nuclear wastes can be calculated. Most opponents to nuclear power do not fear the risk of accident as much as the environmental problems of nuclear waste. This nuclear waste must be stored in a permanently stable container, since nuclear wastes may be dangerous to life for hundreds of thousands of years.

Salt mines have been utilized for storage, since they are geologically stable formations. Reprocessing can recover some fuel for further nuclear reactions. Other problems with nuclear fuel and wastes are in transportation to and from the power plant. Although containers have been developed that can withstand collision with a railroad train, the problem of terrorism remains.

EXERCISES

1. If there is a nuclear power plant in the area, find the average emission of radioactivity and compare it to the background radiation of the area.
2. List the top three sources of air pollution for each of the following:
 - a. Carbon monoxide
 - b. Particulates
 - c. Sulfur oxides
 - d. Hydrocarbons
 - e. Nitrogen oxides
3. Prepare a list of common pollutants to the air, water, and land from home energy use.
4. Make a list of the environmental advantages and disadvantages of wood burning stoves.

REFERENCES

- Air Quality Criteria for Hydrocarbons. U.S. Dept. of HEW, NAPCA Publication No. AP-64. Washington, D.C.: U.S. Government Printing Office, 1970.
- Air Quality Criteria for Particulate Matter. U.S. Dept. of HEW, NAPCA Publication No. AP-51. Washington, D.C.: U.S. Government Printing Office, 1969.
- Air Quality Criteria for Sulfur Oxides. U.S. Dept. of HEW, NAPCA Publication No. AP-50. Washington, D.C.: U.S. Government Printing Office, 1969.
- Bartok, W. et al. Systems Study of Nitrogen Oxide Control Methods for Stationary Sources. 2 (November 1969).
- Bolin, B. "The Carbon Cycle." Scientific American. 223, 3, (September 1970).

- Brown, Theodore L. Energy and the Environment. Columbus, OH: Charles E. Merrill Publishing Co.; 1971.
- Compilation of Air Pollutant Emission Factors. Revised. U.S. Environmental Protection Agency, Office of Air Programs, Publication No. AP-42. Washington, D.C.: U.S. Government Printing Office, 1972.
- Considine, Douglas M. Energy Technology Handbook. New York: McGraw-Hill Book Co., 1977.
- Control Techniques for Particulate Air Pollutants. U.S. Dept. of HEW, NAPCA Publication No. AP-51. Washington, D.C.: U.S. Government Printing Office, 1969.
- Control Techniques for Sulfur Oxide Air Pollutants. U.S. Dept. of HEW, NAPCA Publication No. AP-52. Washington, D.C.: U.S. Government Printing Office, 1969.
- Dorf, R.C. Energy, Resources and Policy. Menlo Park, CA: Addison-Wesley Publishing Company, 1978.
- Environmental Quality. The First Annual Report of The Council on Environmental Quality. Washington, D.C.: U.S. Government Printing Office, 1970.
- Fowler, John M. Energy and the Environment. New York: McGraw-Hill, Inc., 1975.
- Garvey, Gerald. Energy, Ecology, Economy. New York: W.W. Norton & Co., Inc., 1972.
- Gordon, Howard and Meador, Roy. Perspectives On The Energy Crisis. Ann Arbor, MI: Ann Arbor Science Publishing, Inc., 1977.
- Haar, T.H. Vonder and Suomi, V.E. "Satellite Observations of the Earth's Radiation Budget." Science 163 (1969): 667-668.
- Hall, C.A.S. "Look What's Happening to Our Earth." Bulletin of Atomic Scientists (March 1975): 11-21.
- Hirst, E. "The Energy Cost of Pollution Control." Environment 14 (October 1973): 37-44.

- Kash, D. Our Energy Future. University of Oklahoma Press, 1977.
- Kissinger, H.A. "The Washington Energy Conference." Vital Speeches of the Day (March 1974): 322-325.
- Lapédes, Daniel N. et al. Encyclopedia of Energy. New York: McGraw-Hill, Inc., 1976.
- Martín, E.J. and Hill, R.D. Mine Drainage Research Program of the Federal Water Pollution Control Administration, Reprints of Papers presented before the Second Symposium on Coal Mine Drainage Research, Mellon Institute, May 14-15, 1968, Pittsburg, PA.
- Merriman, D. "Calcification of the Connecticut River, U.S.A." Transactions of the New York Academy of Sciences (January 1973): 59-65.
- Morris, D.N. (Rand Corporation) "Future Energy Demand and its Effect on the Environment," a report prepared for The National Science Foundation. September 1973, p. 27.
- Nationwide Inventory of Air Pollutant Emissions 1968. U.S. Dept. of HEW, NAPCA Publication No. AP-73. Washington, D.C.: U.S. Government Printing Office, 1970.
- Odum, Howard T. Environment, Power, and Society. New York: Wiley-Interscience, 1971.
- Olds, F.C. "Water Resources and Waste Heat." Power Engineering (June 1973): 26-33.
- Pfafflin, James R. and Ziegler, Edward N. Encyclopedia of Environmental Science and Engineering. Vol. 1. New York: Gordon and Breach Science Publishers, 1976.
- Rolfe, S.E. "Whatever Happened to Project Independence?" Saturday Review (January 1975): 25-28.
- Sansom, R.L. "The Automobile as a Social Machine," an address before the International Automobile Engineering Congress and Exposition, January 10, 1973. Detroit, MI.

Smith, J.W. Problems in Dealing with Oil Pollution on Sea and Land. Journal of the Institute of Petroleum 54, 539 (November 1968).

Smith, R. "Electrical Power Consumption for Municipal Wastewater Treatment." EPA-R2-73-281, July 1973.

Steinhart, Carole E. and Steinhart, John S. Energy: Sources, Use and Role in Human Affairs. North Scituate, MA: Duxbury Press, 1974.

Tennessee Valley Authority, "Sulfur Oxide Removal From Power Plant Stack Gas: Ammonia Scrubbing, Production of Ammonium Sulfate and Use as an Intermediate in Phosphate Fertilizer Manufacture." Final Report to Department of Health, Education, and Welfare's National Air Pollution Control Administration, 1970, p. 247.

Tennessee Valley Authority, "Sulfur Oxide Removal from Power Plant Stack Gas: Use of Limestone in Wet-Scrubbing Process." Final Report to Department of Health, Education, and Welfare's National Air Pollution Control Administration, 1969, p. 94.

Terry M. and Witt, P. Energy and Order. Friends of the Earth, San Francisco.

The Economy, Energy, and the Environment, a background study prepared for the use of the Joint Economic Committee, Congress of the United States, September 1970. Washington, D.C.: U.S. Government Printing Office, 1970.

Thring, M. "The Equations of Survival." New Scientist (March 1973): 482-485.

Train, R.F. Statement before the Subcommittee on Public Health and Environment, Committee on Interstate and Foreign Commerce, U.S. House of Representatives, December 3, 1973.

United States Environmental Protection Agency, Office of
Air and Water Programs, "A Report on Automobile Fuel
Economy." October, 1973.

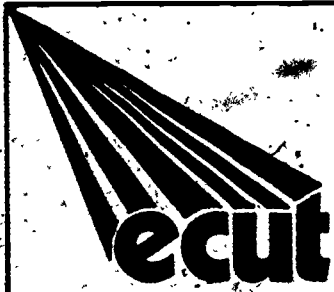

ENERGY TECHNOLOGY

CONSERVATION AND USE

FUNDAMENTALS OF ENERGY TECHNOLOGY

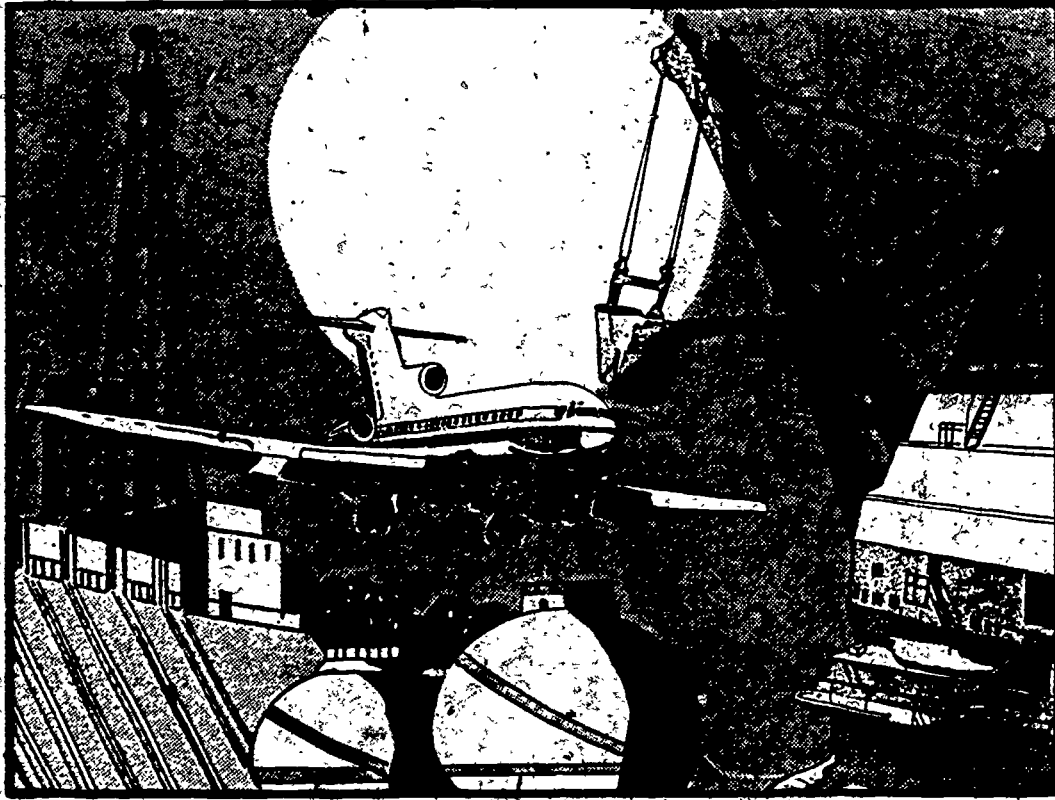

MODULE EF-07

ENERGY RESOURCE GUIDE



CENTER FOR OCCUPATIONAL RESEARCH AND DEVELOPMENT

PREFACE

Energy is a topic of discussion and concern for almost everyone. This is particularly true of utilities and corporations that have an interest in communicating data concerning energy sources, reserves, production, conversion, transportation and transmission, as well as energy distribution, utilization, and the energy/environmental interface. As a result, a wealth of information is available in the form of publications and films, many of which are free for the asking or free on loan.

The "Energy Resource Guide," Module EF-07 of the Fundamentals of Energy Technology course, presents a partial listing of communications on the subject of energy. This Guide is intended as a supplement to the references contained in each of the six previous modules.

In addition, the Guide contains a section that explains the Energy Conservation-and-Use Technician (ECUT) curriculum, a section that gives examples of various projects that might be undertaken by the class or the student individually, and a section that provides a glossary of energy terms.

The sections of the "Energy Resource Guide" are listed below:

Section I	Energy Conservation-and-Use Technician (ECUT)
Section II	Classroom Projects
Section III	Films
Section IV	Publications
Section V	Glossary

TABLE OF CONTENTS

	Page
Preface	iii
Table of Contents	iv
Energy Conservation-and-Use Technician (ECUT)	1
Classroom Projects	15
Films	21
Coal	23
Petroleum	27
Natural Gas	31
Nuclear	33
Solar	38
Geothermal	42
Oil Shale	44
Tar Sands	46
Miscellaneous Energy Subjects	47
General Energy Subjects	52
Publications	57
Coal	59
Petroleum	62
Natural Gas	66
Nuclear	68
Solar	71
Geothermal	76
Miscellaneous Energy Subjects	77
General Energy Subjects	86
Glossary of Energy Terms	89

SECTION I
ENERGY CONSERVATION-AND-USE TECHNICIAN
(ECUT)

ENERGY CONSERVATION-AND-USE TECHNICIAN (ECUT)

The equipment associated with energy production, conservation and utilization is typical of modern, complex equipment. It may consist of electric motors; heaters; lighting; electronic and pneumatic controls; mechanical drives and linkages; thermal systems for heating, drying, melting; or fusing; lubricants; optical, rf, or microwave systems and communication links; pneumatic and hydraulic drives; and, in some instances, involve nuclear radiation. To work with this type of equipment requires understanding of various technical disciplines and their inter-relationships. The graduates of ECUT programs will possess skills and knowledge to enable them to work in a wide variety of energy-related jobs and to continue to learn new skills as the dynamic field of energy continues to grow.

Prior to the design of the ECUT curriculum a survey was conducted to identify employers, types of jobs and projected demand for ECUT technicians. The employment opportunities for ECUTs can be grouped into four major areas of energy use and conservation.

1. Energy-Related Research and Development.

To develop new energy sources and to improve the acquisition and utilization of existing sources, a significant effort must be expended in research and development. The federal government is currently spending \$15 billion annually on research, development, and demonstration projects related to energy technology; and this expenditure is expected to increase significantly over the next 25-50 years. State and local governments, foundations, and private businesses are even exceeding the federal commitments in the

research and development areas. The specific areas of research such as solar, geothermal, nuclear fusion, electric automobiles, and so forth, are described in detail in Modules EF-02 and EF-03, "Sources of Energy" and EF-04 entitled "Uses of Energy."

- a. Employers: Research and development organizations within institutions, private industry, government, and the military.
- b. Job Descriptions: Under the direction of an engineer, physicist, chemist, or metallurgist, the technician will design, construct, and operate breadboards or laboratory experiments involving complex physical phenomena and equipment, perform tests and measurements on system performance, document results in reports and/or laboratory notebooks, and perform periodic maintenance and repair of equipment. Test data will often be acquired and reduced via interfaces with laboratory microcomputers. The technician will frequently supervise other workers.

2. Energy Production.

In a subsequent course entitled Energy Production Systems the student will learn about the operation and maintenance of plants, systems, and devices used to convert energy from the raw fuel state to usable heat, hot water, steam, electricity, or motion.

- a. Employers: Power plants, solar energy equipment manufacturers, installers and users; process plants that use high-temperature heat, steam, or hot water.
- b. Job Description: Develops, installs, operates, maintains, modifies, and repairs systems and devices used for the conversion of fuels and other resources into

useful energy. Systems may be furnaces or plants to produce hot water, steam, mechanical motion, or electric power. Typical systems, which include furnaces, electrical power plants, and solar heating systems, may be controlled manually, by semi-automated control panels, or by computers. The technician will frequently supervise other workers.

3. Energy Use.

To describe the technical areas and employers where it is necessary to use energy in a more effective and efficient manner is to literally encompass all facets of the home, building construction, maintenance, manufacturing, and transportation. Many of the job opportunities for ECUTs in this group may not even have the word "energy" in their title.

- a. Employers: Production line equipment maintenance; building and/or plant equipment maintenance; maintenance departments of hospitals, apartments, hotels/motels, office buildings, schools, churches, shopping centers, and restaurants.
- b. Job Description: Installs, operates, maintains, repairs, and modifies complex electromechanical, thermal, fluid, and optical systems used in production lines and for climate control and hot-water supply in hospitals, apartments, hotels/motels, office buildings, schools, churches, shopping centers, and restaurants. Frequently, this type of equipment will be automatically controlled with microcomputers. The technician will often supervise other workers.

4. Energy Conservation.

Energy audits, described earlier in this course, are performed by teams of energy specialists. Ideally, an energy audit team consists of an Engineer (team leader), five-to-eight energy technicians, and an economist. The team should be accompanied by at least one person who is thoroughly familiar with the facility, equipment, and/or operation. Technicians on the energy audit team are the key individuals responsible for performing the measurements described in Steps 1, 2, and 3 of the audit process. They must be thoroughly familiar with the use of electrical, mechanical, fluid, thermal, and optical instruments for the measurements. Technicians must also understand building construction and practices and codes, be able to read blueprints and schematics, understand the operation and maintenance of building and production equipment, and be able to communicate in writing and orally with each other, the engineer, and the economist about their findings.

a. Employers: Consulting engineers, energy audit firms, residential and commercial energy audit departments of public utility companies, municipal governments, architects, builders, and HVAC equipment manufacturer's representatives and sales outlets.

b. Job Description: The ECUT technician typically would work on a team lead by an engineer, performing the following activities: determine specifications for new-building construction, modifications and retrofits (equipment, structures and installation); use instruments and procedures in performing calculations which measure energy use and efficiency of components and systems (which may provide support to the building or activities within it); perform audits of energy use

and management, including economic cost-versus-benefits analyses; through written documents or oral presentations; recommend building retrofits and/or changes in equipment to achieve energy savings. The technician will frequently supervise other workers.

OTHER JOB TITLES

Because their technical training is so broad, ECUTs should also expect to find job opportunities in fields where the job titles may have little or no relationship to the energy field. Examples are the following:

- Technician
- System Technician
- Instrumentation-and-Control Technician
- Electromechanical Technician
- Plant Operator
- Control Room Operator
- Operating Engineer
- Laboratory Technician
- Building Maintenance Technician
- Energy Conservation Technician
- Energy Management Technician
- Production Equipment Technician
- Building Operating Equipment Technician
- Energy Audit Technician

The ECUT student should strongly consider part-time or summer employment to gain experience prior to graduation in one of the four major areas described earlier.

THE ECUT CURRICULUM

The designer/developer of the ECUT curriculum and instructional materials spent several months visiting prospective employers to determine the specific tasks performed and equipment used by their technicians. At the beginning of each instructional module in the remaining courses of the ECUT curriculum a series of performance based, learning objectives are listed. These objectives are based on the skills and knowledge required to perform in a job for ECUT employers. The model ECUT curriculum includes the courses shown in Table 1.

Schools in various sections of the country may modify the curriculum somewhat by adding some courses and dropping others depending on the particular needs of employers in the local area.

TABLE 1. ECUT CURRICULUM.

Unified Technical Concepts I, II, III	Fluid Power Systems
Chemistry for Energy Technicians I, II	Heating, Ventilating, and Air Conditioning
Fundamentals of Energy Technology	Electrical Power and Illumination Systems
Energy Economics	Electronic Devices and Systems
Energy Production Systems	Microcomputer Hardware
*Fundamentals of Electricity/Electronics	Instrumentation and Controls
Mechanical Devices and Systems	*Schematic and Blueprint Reading
Microcomputer Operations	Technical Communications
Electromechanical Devices	Energy Conservation
	Energy Audits
	*Codes and Regulations

*NOTE: Asterisk denotes courses not developed - only specified.

A technically broad-based curriculum such as the ECUT contains four types of courses which can be grouped accordingly:

- Support courses
- Principles courses
- Devices courses
- Systems courses

These groupings are shown graphically in Figure 1.

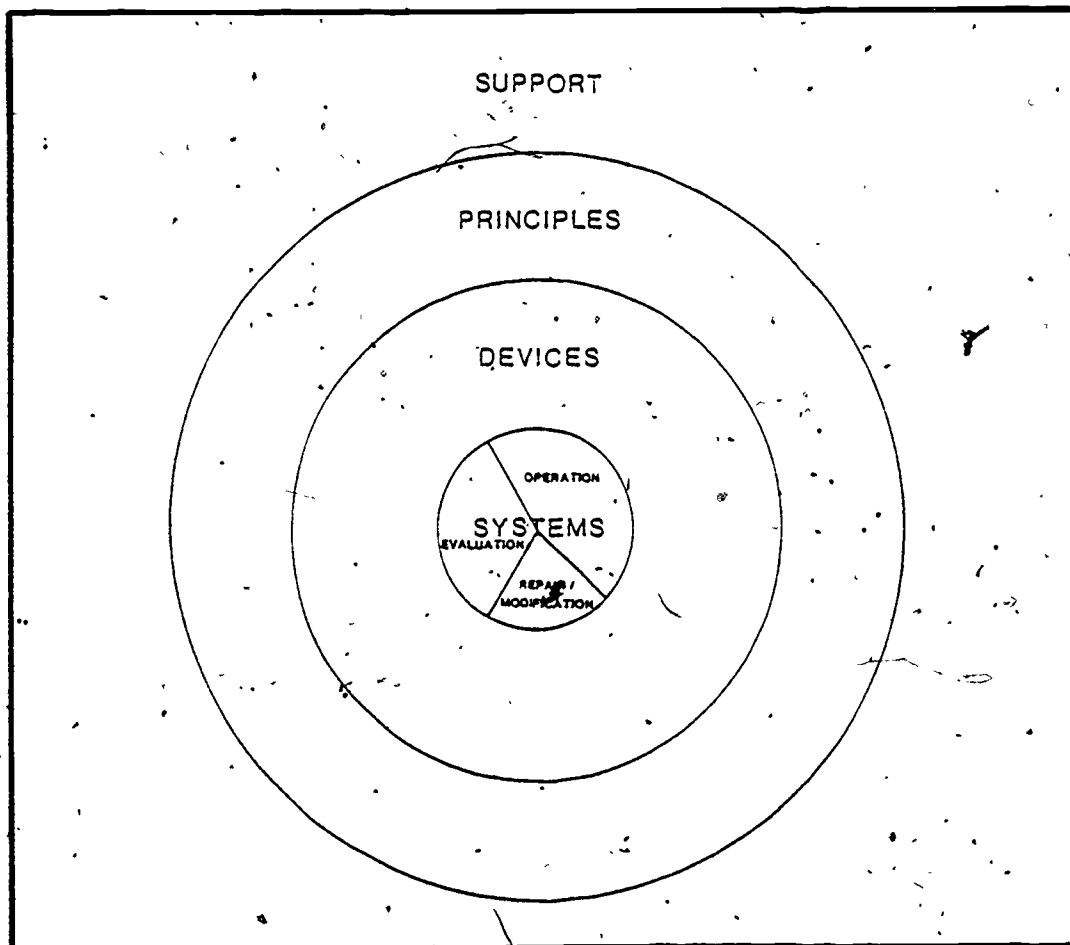

Figure 1. Four Major Groupings of Courses in a Systems-Technician Curriculum.

Several of the courses (and many module objectives) may appear to be only vaguely related to the job functions of an ECUT. Examples of such courses are math, microcomputers, communications, unified technical concepts (physics), and chemistry. These courses are often required to teach technical principles or provide supporting knowledge and skills for the systems and devices, which are more job specific.

Figures 2 - 5 illustrate the technical content and/or courses required for job performance in each of the four categories of ECUT technicians described earlier. As an example, study the sequence of content in Figure 5. The major job requirement is energy conservation related to building maintenance (shown in the bold block). One system included in building maintenance might be the hot water and steam supply system (located left of center). To understand, operate, and maintain this system requires knowledge and skills of devices such as boilers, pipes, valves, and pumps. An understanding of these devices requires knowledge of principles of heat transfer, mechanics and fluids, energy production systems, and unified technical concepts (physics). These principles can only be learned if one possesses skills in support courses such as chemistry and math. Careful study of each diagram (Figures 2 - 5) will enable the student to understand more clearly why the various courses are included in the ECUT curriculum.

Figure 6 graphically illustrates the role of each course in the ECUT curriculum, according to the four major groupings.

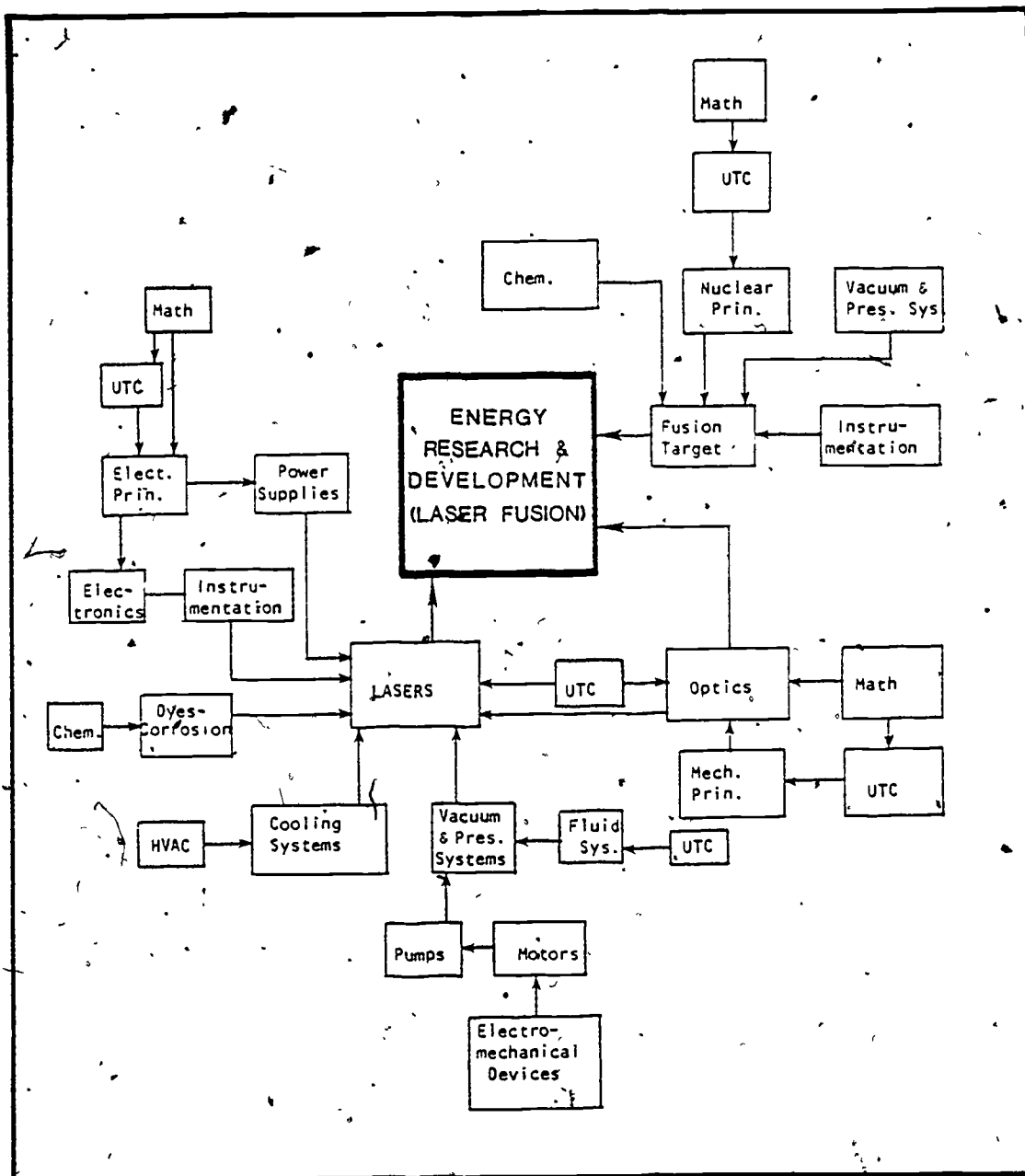

Figure 2. Technical Content/Courses for Energy Research and Development (Laser Fusion) Technician Job Requirements.

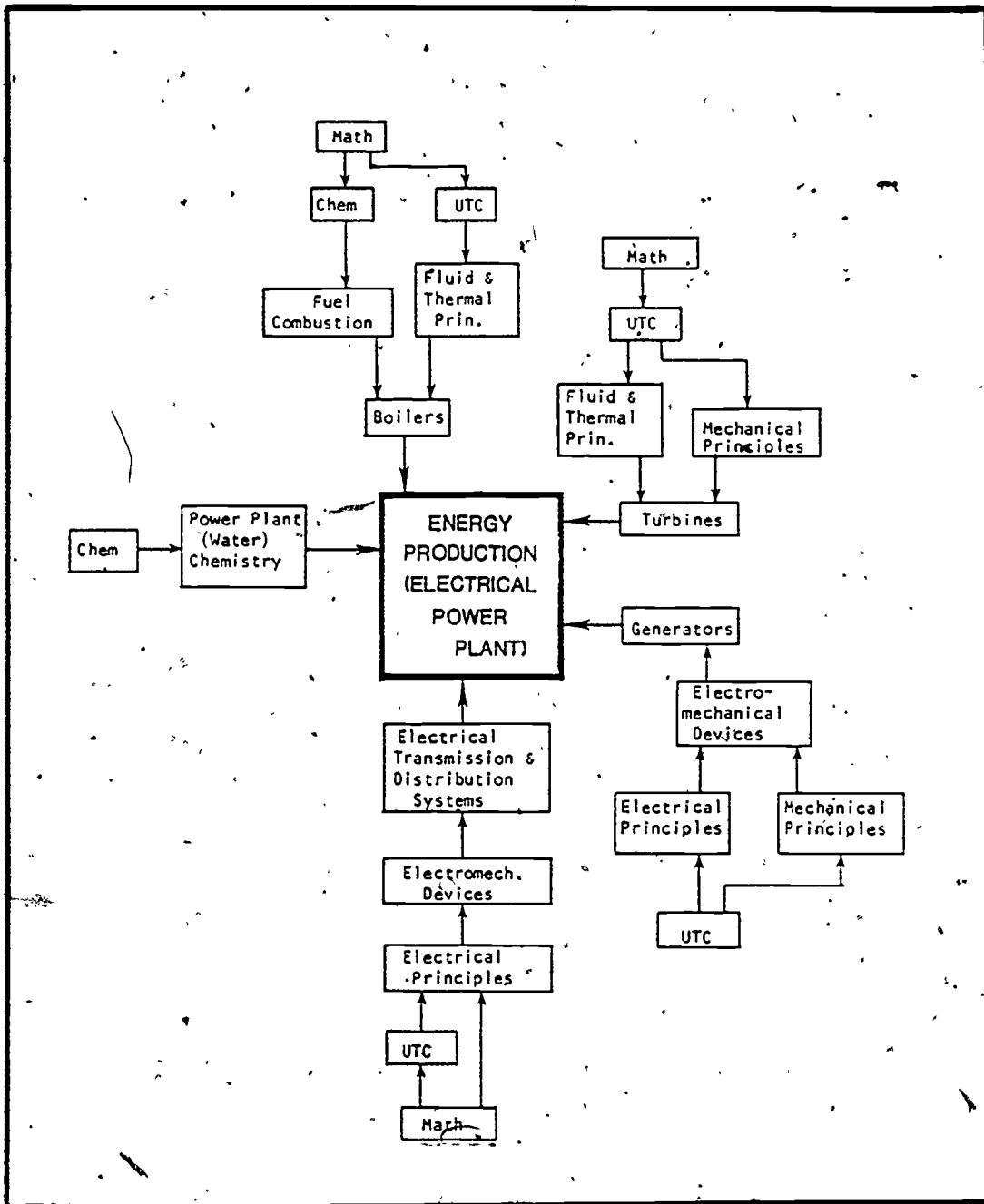

Figure 3. Technical Content/Courses for Energy Production (Electrical Power Plant) Job Requirements.

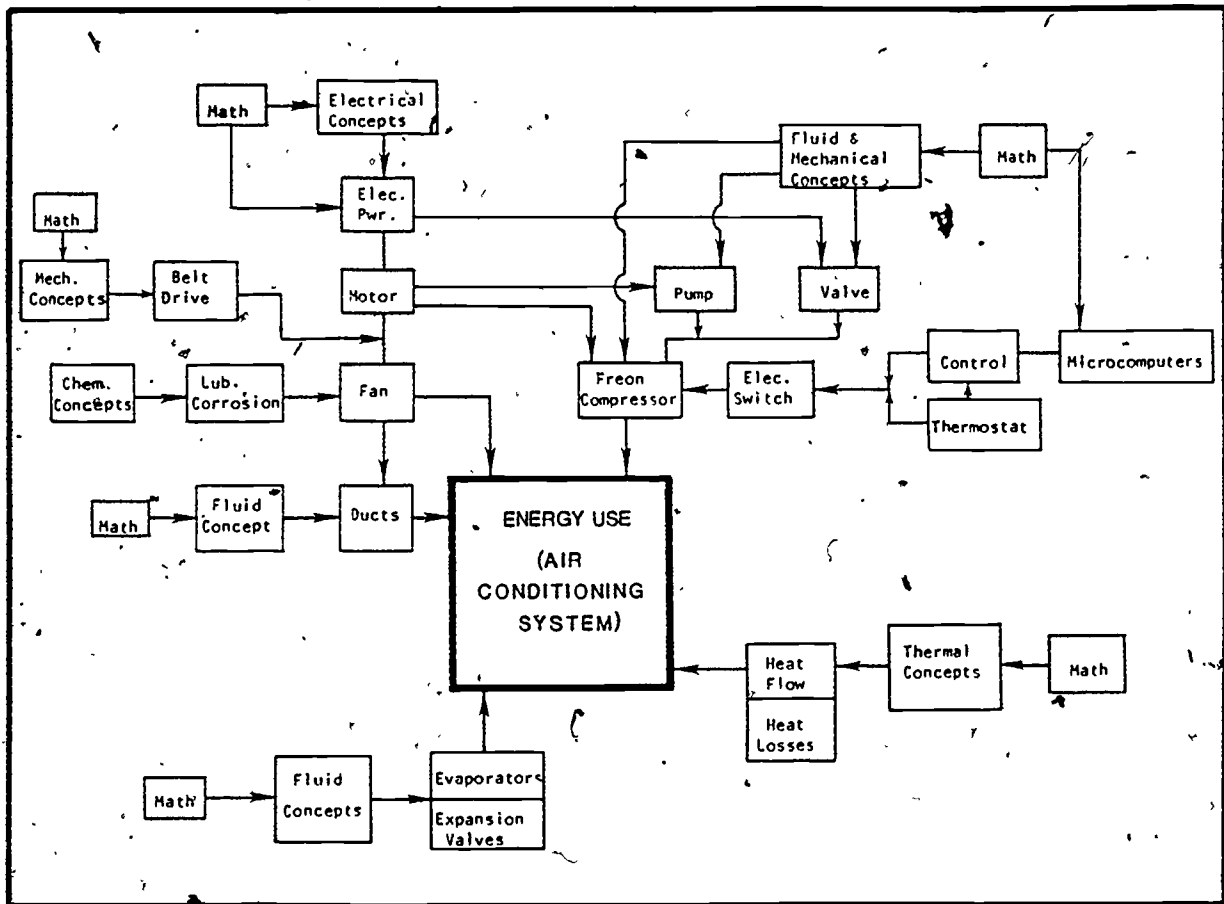

Figure 4. Technical Content/Courses for Energy Use (Air Conditioning System) Technician Job Requirements.

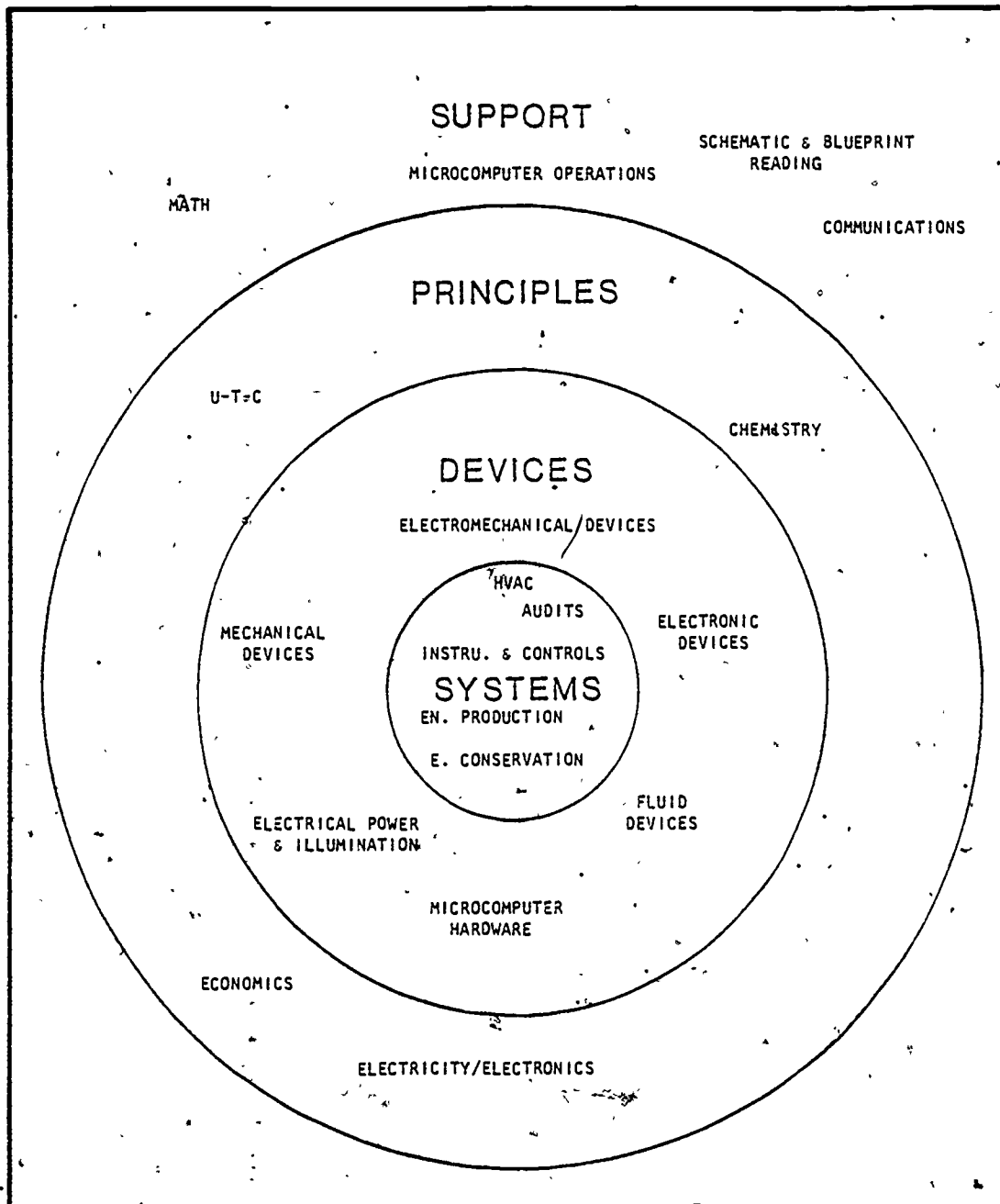

Figure 6. Four Major Groupings of Courses in the ECUT Curriculum.

- SECTION II
CLASSROOM PROJECTS

FIELD TRIPS

Arrangements may be made for a field trip to a local power plant. Most plants make provisions for accommodating tour groups and have the personnel available to make the tour worthwhile. A phone call or a personal visit is usually necessary to arrange the trip.

GUEST SPEAKERS

Guest speakers are readily available to talk to classes about energy. Some possible speakers and topics are outlined below.

1. Consumer Service Representatives: home energy economics, the utility industry, energy and the economy, energy conservation and management.
2. Building Contractor: energy conservation in buildings and homes, energy efficient structures.
3. Architectural Engineer: design of new buildings, environmental influences, energy conservation.
4. HVAC Engineer: design and construction of heating and cooling systems, energy conservation.
5. Energy Auditor: energy auditing practices, energy conservation, energy economics.

ENERGY MANAGEMENT GAME

The "Energy Management Game," A Biological Science Curriculum Study Game, is available from Hubbard Publishing Company, P.O. Box 104, Northbrook, Illinois 60042. This

game is for small groups of students but can be amended for larger classes. Each player is a power plant manager and makes game decisions concerning energy supply and demand. Discussions and group decisions are also involved in the simulation of economic factors and energy factors.

DEMONSTRATION

A very simple experiment can demonstrate the principles of energy use and consumption, as well as their effects on the environment. The materials required are the following: an ashtray, a pin, a matchbox, a test tube and holder, a small amount of water and a peanut.

Push the pin through the cover of the matchbox and place the peanut on the point. Place the matchbox cover and peanut in an ashtray. Pour a half inch of water into the test tube. Use a match to light the peanut and hold the test tube above the flame. This is illustrated in the diagram below.

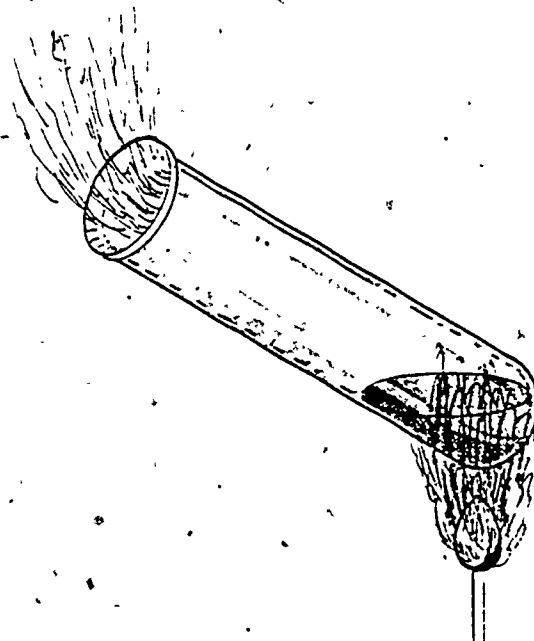
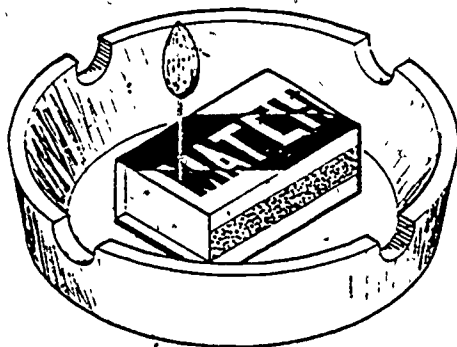

The objective of this experiment is to convert the chemical energy of the peanut into thermal energy and boil the water. Although the water is heated sufficiently, only a small fraction of the original chemical energy of the peanut is used. Most of the energy is wasted. Heat escapes into the air in the form of hot combustion gases. These gases contain air pollutants from unburned fuel. Incomplete combustion is also indicated by the deposits of carbon on the test tube. This layer decreases the rate of thermal energy transfer, lowering the efficiency further. Some of the peanut oil fails to burn and runs down the pin or drops into the ashtray. This is energy that could have been recovered but was not. After the peanut has burned, an ash remains. This ash represents another form of pollution that must be disposed of with minimum environmental impact.

DEMONSTRATION

The purpose of this demonstration is to determine which materials make the best insulators. The required materials are the following: a 100-W bulb in a ceramic socket, four thermometers, masking tape, and a cardboard box. A variety of insulating and noninsulating materials is also required, such as wood, aluminum foil, fiberglass, glass, various metal plates, paper, cardboard, heavy cloth, and so forth.

Prepare the box as shown below and then tape four insulating materials over the windows on the inside of the box. Tape a thermometer to the outside of each insulating material and record the before and after temperatures.

By leaving the light on for a standard amount of time, the qualities of the various insulating materials can be compared.

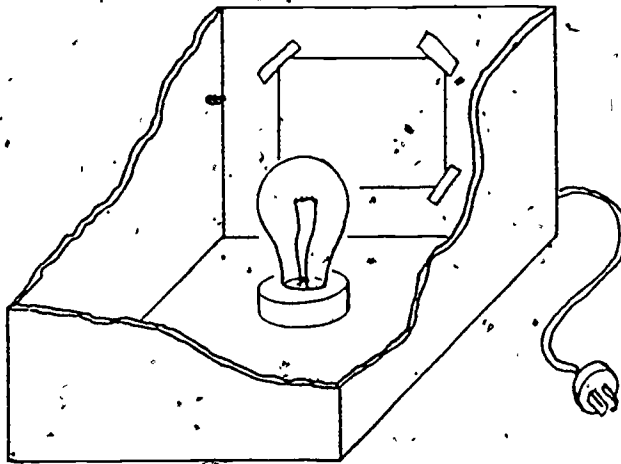
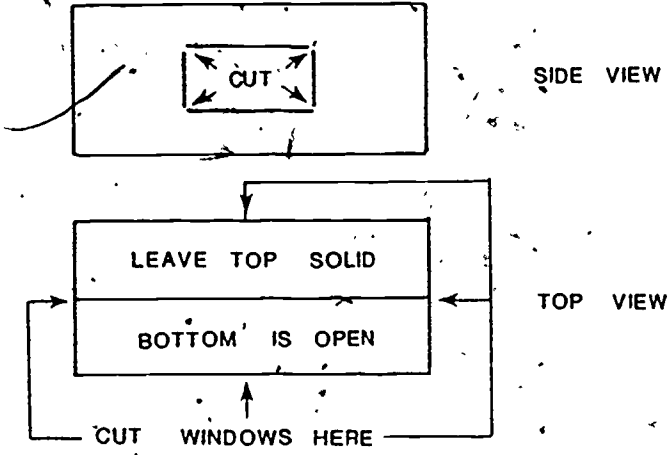

SECTION III

FILMS

COAL

Why Lignite? (22 minutes, 16 mm, sound and color)

Illustrates how lignite coal can be used to generate electricity with full concern for the environment, and to provide the electric energy needed in the future.

Texas Electric Service Co.
Attn: Educational Services
P. O. Box 970
Fort Worth, TX 76101

Free loan

Challenge at Glenrock (25 minutes, 16 mm, sound and color)

Reports how Pacific power and Light reclaims strip-mined coal lands. In addition, it shows how the land is shaped to erosion-resistant grades, stockpiled topsoil is applied and graded, straw mulch is added, and wheatgrass is planted. (1976)

Pacific Power and Light Co.
Public Service Bldg.
Portland, OR 97204
(503) 243-4830

Free Loan

Energy vs. Ecology: The Great Debate (27 1/2 minutes, 16 mm, sound and color)

The film shows how to mine coal and utilize its advantages ... and still leave a healthy environment. Shows surface mining and restoration to usable, productive, and ecologically sound condition. (1973).

Allis Chalmers Manufacturing Co.
Tractor Group
Milwaukee, WI 53201
(414) 475-2000

Purchase: \$125

Look What We've Done To This Land (21 minutes, 16 mm, sound and color)

Records Senate hearing on the problems involved in allowing huge coal-burning plants to be built at Four Corners (where Arizona, Utah, Colorado, and New Mexico meet). Rights of natural Americans are discussed since the coal is strip mined from Hopi and Navajo Indian lands. (1974)

Pyramid Films
P. O. Box 1048
Santa Monica, CA 90406
(213) 828-7577

Purchase: \$250

Rental: \$25

Videocassette: \$190

There's Coal in Them Thar Hills (20 minutes, 16 mm, sound and color)

The huge strip mining shovels that chewed up the green landscape of Kentucky are pointing their booms at the wide open spaces of Montana in search of clean energy. Moreley Safer of CBS News interviews ranchers and coal companies about the problems of wrestling land and the coal that lies under, it from reluctant Westerners. (1976)

Time-Life Multimedia
Distribution Center
100 Eisenhower Drive
Paramus, NJ 07652

Purchase: \$260

Rental: \$25

Videocassette: \$130

The Sleeping Giant - Coal (29 minutes, 16 mm, sound and color)

Explains the coal formation process and discusses the historical use of coal, dating back to 4,000 years ago. Reviews new coal technologies to produce synthetic fuels, along with the problems they present for the economy and ecology. (1975).

Educational Media Center
University of Colorado
Stadium Building
Boulder, CO 80309

Purchase: ~~\$333.~~

Rental: \$10/3 days.

Videocassette: \$230

Coal (27 minutes, 16 mm, sound and color)

The dilemma of Montana is the dilemma of many areas with coal resources. The economical way to mine coal in Montana is strip mining; but this means irretrievably changing large areas of the land. The mining companies say they will reclaim it, but the cost is high. On the other hand, extensive mining would give the state a source of new income which would provide better educational and health facilities. (1973)

Films, Inc.
5625 Hollywood Blvd.
Hollywood, CA 90028
(213) 466-5481

Purchase: \$355

Rental: \$30

Coal - Taking the Lumps Out (5 minutes)

Presents the research that is underway to convert coal to liquid or gaseous fuels at affordable prices. (1978)

Department of Energy
Film Library
P. O. Box 62
Oak Ridge, TN 37830

Black Diamonds - Green Pastures (15 minutes, 16 mm, color)

Examines latest research to improve land reclamation processes and technologies associated with strip-mining for coal. Department of Agriculture scientists are shown at work on problems of removing and replacing top-soil and growing green pastures on strip-mined land in semi-arid western states. Unfortunate strip-mining practices of the past are contrasted with what is done now to protect coal-rich lands. (1978)

Science and Education Administration
USDA
5142 South Building - USDA
Washington, DC 20250
Free loan

PETROLEUM

The Bottom of the Oil Barrel (34 minutes, 16 mm, sound and color)

Gives surveys of oil reserves, rates of depletion of each reserve, and projected dates when each will run dry. Suggests alternatives to current patterns of usage. (1974)

Time-Life Multimedia
Distribution Center
100 Eisenhower Drive
Paramus, NJ 07652
(201) 843-4545

Purchase: \$425

Rental: \$40

Videocassette \$215

Oil in the United States (37 minutes, 16 mm, sound and color)

Probes the "whys" of the problems in the production and distribution of oil. From the environmentalists who are concerned with refineries and the use of deep water ports to independent oil dealers who are forced to close because of lack of supply, the questions are numerous and complex. (1973)

Films, Inc.
5625 Hollywood Blvd.
Hollywood, CA 90028
(213) 466-5481

Purchase: \$445

Rental: \$38

Oil in the Middle East (20 minutes, 16 mm, color and sound)

Saudi Arabia, Iran, and Kuwait own more than half of the world's known oil reserves. The United States' position concerning these Middle Eastern nations is delicate. America has an emotional, if not a military, commitment to Israel; a deep economic interest in Arab oil; and a strategic interest in avoiding conflict with Russia in the Middle East. This film examines the ways in which the United States can reconcile these three elements, as well as the effect of the oil economy on various Middle Eastern nations as they find themselves in a new position of power. (1973)

Films, Inc.
5625 Hollywood Blvd.
Hollywood, CA 90028
(213) 466-5481

Purchase: \$275

Rental: \$20

The Oil Weapon (50 minutes, 16 mm, color and sound)

Presents an in-depth study of the far-reaching consequences of the oil trade situation. Provides an insight into the people of the Arab nations, their way of life and their goals, and the political power they hold over the rest of the world by virtue of their semi-monopoly on oil. (1975)

Films, Inc.
5625 Hollywood Blvd.
Hollywood, CA 90028
(213) 466-5481

Purchase: \$575

Rental: \$40

On Shore Planning for Offshore Oil (21 minutes, 16 mm,
color and sound)

Explores the physical, social, and economic effects
that offshore oil development has on those who live
and work in a Scottish coastal community. (1976)

Conservation Foundation
1717 Massachusetts Ave., NW
Washington, DC 20036
(202) 797-4300

Purchase: \$300

Rental: \$29

Unseen Journey (28 minutes, 16 mm, color and sound)

Shows how oil is brought to the surface on land and
offshore and is transported hundred of miles by "big-
inch" pipelines, barges, and tankers to feed distant
refineries.

Association Films, Inc.
866 Third Avenue
New York, NY 10022
(212) 935-4210

Free loan

Oil

A brief survey of the oil industry.

The Shell Film Library
1433 Sadlier Cir. W. Dr.
Indianapolis, IN 46239

Oil Well

The principles of drilling an exploration well, and how
a pattern of additional wells is used to appraise an oil
field and bring it into production.

The Shell Film Library
1433 Sadlier Cir. W. Dr.
Indianapolis, IN 46239

Refinery Processes

Description of some of the basic processes which take place inside an oil refinery.

The Shell Film Library
1433 Sadlier Cir. W. Dr.
Indianapolis, IN 46239

Reserved for Tomorrow (12 minutes, 16 mm)

An energy savings account? Yes. Steps taken to safeguard America from a foreign oil embargo involve the storage of millions of barrels of crude oil beneath the Louisiana-Texas Gulf Coast in underground salt domes. This film illustrates the problems and solutions of oil movement in the United States which signaled the creation of our nation's Strategic Petroleum Reserve. (1977)

Department of Energy
Film Library
P. O. Box 62
Oak Ridge, TN 37830
Free loan

NATURAL GAS

Natural Gas (17 minutes, 16 mm, sound and color)

Natural gas is a cheap, clean, and efficient fuel, which, today, heats half of all American homes and fuels half of all industrial production. However, gas is being consumed twice as fast as it is being discovered. (1973)

Films, Inc.
5625 Hollywood Blvd.
Hollywood, CA 90028
(213) 566-5481

Purchase: \$240

Rental: \$20

Nuclear Gas Stimulation: Tapping Our Natural Heritage

(29 minutes, 16 mm, color and sound)

Traces the historical use of natural gas, and explains that some reserves are accessible only through nuclear fracturing. Considers the potential dangers of this process in regard to society and the environment. (1975)

Educational Media Center
University of Colorado
Stadium Building
Boulder, CO 80309

Purchase: \$333

Rental: \$10/3 days

Videocassette: \$230

Focus on Energy (13 1/2 minutes, 16 mm, color and sound)

Reviews national energy needs. Emphasis is on natural gas. (1972)

American Gas Association
Film Librarian
1515 Wilson Blvd.
Arlington, VA 22209
(703) 524-2000

Free loan

LNG (Liquefied Natural Gas) Is On Its Way, (25 minutes, 16 mm, sound and color)

Explains how LNG is being brought from the Algerian Sahara to the energy-poor United States via the largest shipbuilding effort in peacetime history. (1976)

Modern Talking Picture Service
2323 New Hyde Park Road
New York, NY 11040
(212) 895-2237

Free loan

Natural Gas and Clean Air (27 minutes, 16 mm, sound and color)

Examines major types of air pollution and how use of natural gas can minimize or eliminate the most dangerous. (1970)

American Gas Association
Film Librarian
1515 Wilson Blvd.
Arlington, VA 22209
(703) 524-2000

Free loan

224

NUCLEAR

Energy: The Nuclear Alternative (20 minutes, 16 mm, color and sound)

Explores what fission power is, how it works, and the controversies that exist concerning safety and radioactive waste. (1974)

Churchill Films
662 N. Robertson Blvd.
Los Angeles, CA 90069
(213) 657-5110

Purchase: \$240

Rental: \$21/3 days

Energy: The Great Controversy (29 minutes, 16 mm, color and sound)

Questions the possibility of changing the image of nuclear power from a weapon to an energy producer. Discusses fission processes versus fusion technology, as well as reactors and their possible dangers. (1978)

Education Media Center
University of Colorado
Stadium Building
Boulder, CO 80309

Purchase: \$333

Rental: \$10/3 days

Videocassette: \$230

Fusion: The Energy Promise (56 minutes, 16 mm, color) and sound)

Nuclear fusion has numerous advantages over fission: it is more efficient and it results in no atomic wastes. The problems involved in making fusion economically feasible are examined. (From the "Nova" series.) (1976)

Time-Life Multimedia
Distribution Center
100 Eisenhower Drive
Paramus, NJ 07652
(201) 843-4545

Purchase: \$550

Rental: \$60

Videocassette: \$275

More Nuclear Power Stations (55 minutes, 16 mm, sound and color)

A rare glimpse into the workings of the present-day nuclear power industry, this film tracks the path of nuclear fuel from power station to reprocessing plant and then to waste storage. It also explains - simply and concisely - the function of nuclear power stations and the choices they now present. (From Denmark) (1976)

Green Mountain Post Films
Box 177
Montague, MA 01351

Rental: \$35

Purchase: \$625

The Need for Nuclear Energy: Our Energy Options (16 mm,
color and sound)

Reviews the U.S. energy picture through the year 2000 and presents a detailed analysis of the economics and availability of the various energy sources over the next thirty years, with particular emphasis on nuclear economics. (1975)

Atomic Industrial Forum, Inc.
7101 Wisconsin Ave.
Washington, DC 20014
(301) 654-9260

Purchase: \$150

Videocassette: \$100

Nuclear Energy: Power for Today and Tomorrow (28 minutes,
16 mm, color and sound)

Follows the development of nuclear power from the search for uranium, to the production process, to the installation of nuclear fuel in a reactor's core.

Modern Talking Picture Service
2323 New Hyde Park Road
New York, NY 11040
(212) 895-2237

Free loan

Nuclear Power in the U.S. (28 minutes, 16 mm, color and sound)

Describes the entire spectrum of nuclear power industry, including advanced reactor concepts such as the liquid-metal fast breeder, the high temperature gas-cooled reactor and others. (1971)

Department of Energy
Film Library
P.O. Box 62
Oak Ridge, TN 37830

Free loan

The Ultimate Energy (28 minutes, 16 mm, color and sound)

A visit to five thermonuclear fusion research laboratories to discuss the future of fusion power with several physicists who have dedicated their lives to the goal of imitating the sun in the laboratory. (1976)

Department of Energy
Film Library
P. O. Box 62
Oak Ridge, TN 37830
Free loan

On the Move (28 minutes)

Explains many aspects of packaging and shipping highly radioactive materials and shows the extreme safety designed in today's accident resistant packages. Actual torture tests are demonstrated. (1974)

Department of Energy
Film Library
P. O. Box 62
Oak Ridge, TN 37830
Free loan

Safety - Second to None (14 1/2 minutes)

As the watchdog over the nuclear power industry, the Government takes great care to see that plants are made extraordinarily safe, and that no short cuts are ever taken that might threaten the public health or safety. (1974)

Department of Energy
Film Library
P. O. Box 62
Oak Ridge, TN 37830
Free loan

The Silent Power (27 minutes)

A documentary on the peaceful uses of nuclear power in the United States space program. The film surveys the history, and it explores current work and developments for the future. We see the uses of nuclear energy in providing safe, reliable, long-life sources of electrical power for spacecraft and satellite systems. (1978)

Department of Energy

Film Library

P. O. Box 62

Oak Ridge, TN 37830

Free loan

SOLAR

Energy: Harnessing the Sun (19 minutes, 16 mm, color and sound)

Uses animated diagrams to explain various proposals for harnessing solar energy for the generation of electricity. (1974)

University of California Extension
Extension Media Center
Berkeley, CA 94720
(415) 642-0460

Rental: \$20

Solar Power: The Giver of Life (29 minutes, 16 mm, color and sound)

Traces the studies and setbacks in the technology of developing solar energy throughout early civilizations since the Middle Ages. Examines current and prospective solar technology and the impact of commercial installations on the environment. (1975)

Educational Media Center
University of Colorado
Stadium Building
Boulder, CO 80309

Purchase: \$333

Videocassette: \$230

Rental: \$10/3 days

Audio-cassette/35 mm filmstrip: \$15

Study Guide: \$2.50

230

38

Wind Power: The Great Revival (29 minutes, 16 mm, color and sound)

The history and current development of technologies to utilize the power of wind. (1975)

Educational Media Center
University of Colorado
Stadium Building
Boulder, CO 80309

Purchase: \$333

Rental: \$10/3 days

Videocassette: \$233

Audiocassette/35 mm filmstrip: \$15

Study Guide: \$2.50

Here Comes the Sun - (15 minutes, 16 mm, color and sound)

Solar energy systems (on roofs and on the ground) that are collectors and control centers for warming air and for warming water for swimming pools, dishwashers, and storage tanks. (1974)

Department of Energy
Film Library
P.O. Box 62
Oak Ridge, TN 37830

Free loan

Look To the Sun (12 1/2 minutes, 16 mm, color and sound)

Following an explanation of a flat plate collector, businesspersons, public officials, and a solar researcher suggest economic and efficient methods to design, finance, and build solar housing projects. (1977)

Department of Energy
Film Library
P. O. Box 62
Oak Ridge, TN 37830

Free loan

Putting the Sun to Work (5 minutes, 16 mm, color and sound)

Three leading solar experts explain current plans for harnessing sun power for homes and industry. (1974)

Department of Energy
Film Library
P. O. Box 62
Oak Ridge, TN 37830
Free loan

Solar Energy: To Capture the Power of Sun and Tide (21 minutes, 16 mm, color and sound)

Surveys present developments and future possibilities of solar and tidal energy. (1975)

Paramount Communications
5451 Maraton Street
Hollywood, CA 90038
(213) 463-0100
Purchase: \$330

The Sunbeam Solution (38 minutes, 16 mm, color and sound)

Examines solar energy and other untrapped energy resources to answer the following question: "What source of power can best transport man into the 21st century?" (1974)

Time-Life Multimedia
Distribution Center
100 Eisenhower Drive
Paramus, NJ 07652
(201) 843-4545
Purchase: \$425
Videocassette: \$215

The Sun: Its Power and Promise (24 minutes, 16 mm, color and sound)

Spectacular photography of the sun and lively animation combine to explore ways in which the sun's energy might be better used to help replace the ever-dwindling supplies of fossil fuels.

Encyclopedia Britannica
Educational Corporation
425 North Michigan Avenue
Chicago, IL 60611
(312) 321-6800

Purchase: \$320

Rental: Inquire

Sun Power for Farms (12 1/2 minutes, 16 mm, color and sound)

The potential of solar heating for agricultural production is enormous. This film shows how some of that potential is being realized through a series of research projects explained by the scientists themselves: a greenhouse heating system for nights and cloudy days, solar ponds of salt water for storing heat, rooftop solar collectors for warming poultry houses and milking parlors, and a system for drying and curing peanuts and corn. (1977)

Department of Energy
Film Library
P. O. Box 62
Oak Ridge, TN 37830
Free loan

GEOHERMAL

Geothermal Power: The Great Furnace (29 minutes, 16 mm, color and sound)

Briefly covers the historical use of geothermal energy, and reveals methods of discovering geothermal activity and of generating electrical power, using the geysers of California, New Zealand, and Mexico as examples. (1975)

Educational Media Center
University of Colorado
Stadium Building
Boulder, CO 80309

Purchase: \$333

Rental: \$10/3 days

Videocassette: \$230

Audiocassette/35 mm filmstrip: \$15

Study Guide: \$2.50

Geothermal: Nature's Boiler (7 minutes, 16 mm, color and sound)

Natural heat energy stored in and under the earth's crust can be put to work. Just as geysers now supply half the electricity for San Francisco's needs, these reservoirs may heat, cool, and light homes and factories across the country. (1977)

Department of Energy
Film Library
P. O. Box 62
Oak Ridge, TN 37830

Free loan

Geothermal Power (14 minutes, 16 mm, sound and color)

Heat from inside the earth may be one answer to the energy crisis. Generation of geothermal electric power demonstrates economic potentials of a new and practically unlimited source of energy. Explains geothermal power and methods used to harness this energy. (1974)

AV-ED Films
910 North Citrus Avenue
Hollywood, CA 90038
(213) 466-1344

Purchase: \$200

Rental: \$12/day; \$24/week

Power From the Earth (12 1/2 minutes, 16 mm, color and sound)

As viewers watch, eight scientists, engineers, and managers describe various aspects of obtaining thermal energy from the earth for the production of electrical power. (1974)

Department of Energy
Film Library
P. O. Box 62
Oak Ridge, TN 37830
Free loan

OIL SHALE

Oil Shale: The Rock That Burns (29 minutes, 16 mm, color and sound)

Although oil shale has been known as an energy source for 600 years, it has also been known as an expensive source to process. In addition, the ecological damage of mining it is yet to be determined. (1975)

Educational Media Center
University of Colorado
Stadium Building
Boulder, CO 80309

Purchase: \$333

Rental: \$10/3 days

Videocassette: \$230

Audiocassette/35 mm filmstrip: \$15

Study Guide: \$2.50

A Land for All Reasons (28 minutes, 16 mm, color and sound)

In Rifle, Colorado, people are worried about the energy crisis. Public lands surrounding Rifle hold enormous quantities of oil shale. The Federal government has leased portions of this land to oil companies who plan to extract, process, and refine the oil. This will not only mean construction of processing plants, but a large influx of workers into this rural area. The people of Rifle are concerned that the money the shale oil boom will add to the community may not be worth all the changes and problems that will come with it.

Associated Films, Inc.
866 Third Avenue
New York, NY 10022
(212) 935-4210

Free loan

Oil Shale (15 minutes, 16 mm, sound and color).

Film graphically depicts oil shale activities of Colony Development Operation (Atlantic Richfield Company, operator in research and potential of vast resources locked in shale) and addresses plans for this nation's first large-scale commercial oil shale facility.

Atlantic Richfield Co.
Public Affairs Division
1500 Security Life Building
Denver, CO 80202.

Free loan

TAR SANDS

Tar Sands: Future Fuel (27 minutes, 16 mm, color and sound)

Tar sands could prove to be the most expensive alternative source of energy, not only economically but ecologically as well. The technology of extracting oil products from tar sands is reviewed. (1975)

Educational Media Center
University of Colorado
Stadium Building
Boulder, CO 80309

Purchase: \$333

Rental: \$10/3 days

Videocassette: \$230

Study Guide: \$2.50

233

46

MISCELLANEOUS ENERGY SUBJECTS

Cooling Waters (26 minutes)

Shows the Federal Government's long-term concern over cooling-water systems of power plants that provide most of the urgently needed electricity. (1978)

Department of Energy
Film Library
P. O. Box 62
Oak Ridge, TN 37830
Free loan

No Turning Back (27 1/2 minutes)

This film visits some of the technicians involved in government studies at laboratories and sites across the country, such as arid land ecology, a tropical forest study, river ecosystems, industrial impact on natural waterways, and pollution patterns in layers of atmosphere. (1971)

Department of Energy
Film Library
P. O. Box 62
Oak Ridge, TN 37830
Free loan

A Sea We Cannot Sense (27 1/2 minutes)

Almost everything in nature can be seen or felt — wind, light, cold, texture — that is, everything except radiation. This is the sea that cannot be sensed. (1973)

Department of Energy
Film Library
P. O. Box 62
Oak Ridge, TN 37830
Free loan

Pedal Power (18 minutes, 16 mm, color)

Traces the history of pedal and treadle machines from the genius of Leonardo da Vinci to the present day. In the search for new energy sources, the strength in human legs is being rediscovered. Bicycle-powered machines are becoming popular again, and they can be seen at work on homesteads, in heart clinics, and in cottage industries - doing everything from grinding grain to ploughing a field. Pedal Power is offered as the supreme example of technology on a human scale. (1978)

Department of Energy
Film Library
P. O. Box 62
Oak Ridge, TN 37830
Purchase: \$240
Rental: \$28.50
(Also available on videocassette)

A Sense of Humus (28 minutes, 16 mm, color)

Conventional farming in North America consumes enormous amounts of scarce fossil fuels in the manufacture of chemical fertilizers, pesticides, and herbicides - as well as in the fuel tanks of modern agricultural machinery. This documentary about organic farming shows that food is being grown on a commercial scale without the use of petrochemicals. Organic farmers discuss their methods and beliefs. (1977)

Department of Energy
Film Library
P. O. Box 62
Oak Ridge, TN 37830
Purchase: \$375
Rental: \$38.50
(Also available on videocassette)

Transportation - The Way Ahead (7 3/4 minutes)

With gasoline in short supply, the Federal Government is looking at new energy sources for automobiles. (1977)

Department of Energy
Film Library
P. O. Box 62
Oak Ridge, TN 37830

Story in the Rocks

An introduction to paleontology.

The Shell Film Library
1433 Sadlier Cir. W. Drive
Indianapolis, IN 46239

The Fossil Story

Describes the science of deciphering age-old clues to help locate energy sources for the future.

The Shell Film Library
1433 Sadlier Cir. W. Drive
Indianapolis, IN 46239

Conservation - Investing in Tomorrow (6 1/2 minutes)

Presents some of the ways energy can be saved now: more efficient machines and industrial processes, improvements in the transmission of electric power, new autos, more energy efficient homes and buildings. (1977)

Department of Energy
Film Library
P. O. Box 62
Oak Ridge, TN 37830

Don't Cut Us Off (16 minutes, 16 mm, color)

Documents the activities of four communities to solve a common national problem: the high cost of energy as it affects the poor and elderly across the country. (1976)

Department of Energy
Film Library
P. O. Box 62
Oak Ridge, TN 37830

Free loan

John Denver on Conservation (4 minutes)

The internationally-known singing star, John Denver, appears in this short film, shot entirely on location in Colorado and California. The film showcases a portion of Mr. Denver's "Red Rock" outdoor concert coupled with a personal message from Denver on behalf of energy conservation. (1978)

Department of Energy
Film Library
P. O. Box 62
Oak Ridge, TN 37830

Running on Empty - The Fuel Economy Challenge (27 minutes)

Through citizen participation over a 90-mile road rally, the film illustrates various driving and fuel economy techniques. It shows how average drivers, driving average cars, can practice ways to achieve maximum savings in gasoline and money while traveling city streets, country roads, and major highways. (1978).

Department of Energy
Film Library
P. O. Box 62
Oak Ridge, TN 37830

242

Up the Power Curve (10 minutes)

Shows the practicality of energy conservation and the important role it plays in helping solve some of America's energy problems. The film also covers a wide range of energy saving ideas and the dollar savings to be achieved.

Department of Energy
Film Library
P. O. Box 62
Oak Ridge, TN 37830

Bill Loosely's Heat Pump (10 minutes, 16 mm, color)

Bill Loosely, an engineer living in snowbound Ontario heats his house by gathering warmth from the ground below the frost level and pumping it inside to heat Freon. The Freon is vaporized and fed into a heat-exchanger that yields hot air to heat the house. Loosely takes us into his home and explains the system, which has operated trouble-free since 1951. The ground heat pump is so efficient that it provides a return in heat six times greater than the energy required to run it. (1976)

Bullfrog Films
Oley, PA 19547

Rental: \$18.50

(Also available on videocassette)

GENERAL ENERGY SUBJECTS

Challenge of the Future (28 1/2 minutes)

A new age is beginning when energy will be more expensive and less abundant. Oil and gas, which have supplied three-quarters of the energy in this country, is fast becoming depleted. America and other nations face serious and increasing energy problems. This film's purpose is to look at the problems and to detail the options that are available. (Revised 1978)

Department of Energy
Film Library
P. O. Box 62
Oak Ridge, TN 37830

Energy Update (28 1/2 minutes)

With the President's energy message of April 19, 1977, as a backdrop, the film describes a number of situations in which people try to cope with energy problems and seek solutions now. The film touches on coal, solar, nuclear, and other energy sources.

Department of Energy
Film Library
P. O. Box 62
Oak Ridge, TN 37830

244
52.

Energy - The American Experience (28 1/2 minutes)

With the perspective over 200 years of history, the film shows the development of different forms of energy under the unique conditions of the "American Experience." Shown are the 60-year changing cycles of energy sources (from wood to coal to oil and gas) that have produced the steam and electrical energy that helped make the United States the industrial giant of the world. (Revised 1978)

Department of Energy
Film Library
P. O. Box 62
Oak Ridge, TN 37830

Energy - A Family Album (8 1/2 minutes)

A brief history of energy in America follows with some details of the Nation's plan to keep ahead of energy demands: alternate sources of fuel, geothermal power, solar power, and so forth. (1977)

Department of Energy
Film Library
P. O. Box 62
Oak Ridge, TN 37830

TIC - Index to Energy (5 1/2 minutes)

A visit to a computerized facility that gathers, abstracts, and catalogues technical reports and published scientific papers from around the world at the rate of approximately one million per year. (1977)

Department of Energy
Film Library
P. O. Box 62
Oak Ridge, TN 37830

Energy Carol (11 minutes, 16 mm)

Animated film based on Dickens' Christmas lesson where Ebenezer Scrooge is president of Zeus Energy Company. The motto of the company is: "if we didn't waste, we couldn't grow." Three spirits show Scrooge energy in the past, as it (energy) is today, and as it will be in the future when fossil fuels are depleted. One look at his splashily lit mausoleum after the power goes off convinces Scrooge that he must never waste energy again. This is a humorous film about things not so humorous.

National Film Board of Canada
1251 Avenue of the Americas
New York, NY 10020

Purchase: \$160

Rental: \$20

Videocassette: \$140

Preview available

A Play Half Written: The Energy Adventure (26 minutes, 16 mm)

Alexander Scourby hosts this film, which combines Beethoven's Ninth Symphony, the films of Buster Keaton, and the great steam colossus of the 1876 Centennial Exhibition to dramatize the link between energy and human achievement in the arts, in technology, and in our way of life. Energy sources of the past, present, and future are brought together. Nuclear power, Scourby points out, represents the newest available energy source that will allow continued development.

Atomic Industrial Forum
7101 Wisconsin Avenue
Washington, DC 20014

Purchase: \$125

216

54

Energy (20 minutes, 16 mm, color)

Illustrates how traditional sources of energy will be depleted in the near future. The promise of nuclear energy is short range, and its critics are numerous. A scientist explains how solar energy can serve the world through an orbiting satellite. Energy futurist, Dr. Peter Galsser, and lawyer-author, Robert Hallman, examine the problem. (1976)

Document Associates
211 E. 43rd Street
New York, NY 10017

Purchase: \$340

Rental: \$40/2 days

Energy: The Ultimate Problem? (10 minutes, 16 mm, color)

Can we reduce energy use? Is it too late to make the changes this would require? What are some of the alternative sources of energy? Experts, including a physical chemist, nuclear plant superintendent, utility manager, solar researcher, environmentalist, and social scientist, express different points of view throughout the film. (1976) (Teacher's Guide available)

Coronet Instructional Media
65 E. South Water St.
Chicago, IL 60601

(Also available on videocassette)

Energy: The Facts, The Fears, The Future (55 minutes,
16 mm, color)

Walter Cronkite and a team of CBS newsmen visit locations around the U.S.A. to assess the severity of the energy problem. They examine the facts regarding oil, natural gas, coal, and nuclear fusion; they survey the conservation measures being developed for automobiles, homes, and large buildings; and they assess the future impact of energy from fusion, solar, and geothermal sources. They conclude that a mixed, flexible strategy is needed in order to solve the energy crisis now. (1978) (Teacher's Guide available)

BFA Educational Media
2211 Michigan Avenue
Santa Monica, CA 90406

Purchase: \$650

Rental: \$55

213

56

SECTION IV
PUBLICATIONS

COAL

Coal News

Weekly newsletter of events of interest and importance to the bituminous coal industry.

National Coal Association
1130 17th Street, NW
Washington, DC 20036
(202) 628-4322

Purchase: \$50/yr

Coal Facts

Biennial multi-color book with tables, describing the modern bituminous coal industry and coal's importance to the U.S. economy.

National Coal Association
1130 17th Street, NW
Washington, DC 20036
(202) 628-4322

Purchase: \$5/issue

Coal and The Environment

A 12-page, illustrated booklet describing the latest developments in air pollution control, mine drainage, and the reclamation of surface-mined land.

National Coal Association
1130 17th Street, NW
Washington, DC 20036
(202) 628-4322

Coal and Research

A 12-page, illustrated booklet containing progress in converting coal into gaseous and liquid fuels, improving mine health and safety, controlling water and air pollution, developing a coal fuel cell, generating electricity from coal by magnetohydrodynamics, and studying improved methods of coal combustion.

National Coal Association
1130 17th Street, NW
Washington, DC 20036
(202) 628-4322

Map of Coal Areas in the U.S.

A 9" x 16" two-color folder showing deposits of bituminous coal, subbituminous coal, lignite, and anthracite. Reserve and production figures for individual states are included.

National Coal Association
1130 17th Street, NW
Washington, DC 20036
(202) 628-4322

Wall Charts

Two, 18" x 24", two-color wall charts with text and photographs: one describing surface and underground mining methods, the other outlining uses and transportation of coal.

National Coal Association
1130 17th Street, NW
Washington, DC 20036
(202) 628-4322

Coal - Answers to Your Questions (Publication No. 78-33)

Edison Electric Institute
New York, New York

Coal Mining

One of a series of pamphlets prepared by the technical staff of the Mining Enforcement and Safety Administration (MESA) to acquaint the reader with a specific area of mining. This pamphlet deals with coal, its origin, description, mining, processing, transportation, and use.

U.S. Department of the Interior
Mining Enforcement and Safety
Administration
Washington, DC

Coal

This booklet attempts to answer questions about coal and directs attention to what is being done to make coal more usable, more economic, and cleaner as a fuel of the future.

Edison Electric Institute
Washington, DC
(202) 862-3800

PETROLEUM

Gasoline Marketing - Structure, Facts, Demographics

(No. 801-15890)

A publication that provides an overview of the current patterns in which gasoline is distributed from the refinery gate to end users.

American Petroleum Institute
Publications and Distribution
Section
2101 L Street, NW
Washington, DC 20037
(202) 457-7160

Purchase: 50 cents

That Amazing Maze - A Refinery

A colorful brochure that describes the inside workings of a refinery converting crude oil to usable energy.

American Petroleum Institute
Publications and Distribution
Section
2101 L Street, NW
Washington, DC 20037
(202) 457-7160

Free

Movies About Oil

A catalog describing motion pictures of general interest about various phases of petroleum and the petroleum industry.

American Petroleum Institute
Publications and Distribution
Section
2101 L Street, NW
Washington, DC 20037
(202) 457-7160

Free

253

62

Facts About Oil

An illustrated booklet (lesson plan included) containing statistical data and information on the various phases of the petroleum industry, including origin, exploration, drilling, production, transportation, refining, marketing, supply and demand, uses, and general economics.

American Petroleum Institute
Publications and Distribution
Section
2101 L-Street, NW
Washington, DC 20037
(202) 457-7160

Purchase: 35 cents

Supplementary Energy Sources

A pamphlet describing coal, gas from coal, oil from coal, oil shale, tar sands, geothermal, nuclear, solar, tide and ocean, and wind.

American Petroleum Institute
Publications and Distribution
Section
2101 L Street, NW
Washington, DC 20037
(202) 457-7160

Free

The Trans Alaska Pipeline

A 15-page pamphlet describing the daily operations of the Alaska pipeline from its creation to completion.

Alyeska Pipeline Service Co.
1835 South Bragaw St.
Anchorage, Alaska 99504
(907) 278-1611

Free

Summary - Project Description of the Trans Alaska Pipeline System

A booklet that demonstrates how little the pipeline disturbed Alaska's countryside during construction and how it will operate without threat to the environment throughout its entire life.

Alyeska Pipeline Service Co.
1835 South Bragraw St.
Anchorage, AK 99504
(907) 278-1611

Free

The Story of Petroleum

This book explains the importance of petroleum and tells something about the men and women whose jobs must be linked together to produce oil. It also describes the role of the research scientists - the oil workers who work in laboratories and whose job it is to find methods of helping other oil workers do their jobs better, as well as to improve products and develop new ones from petroleum while protecting the environment.

Shell Oil Co.
One Shell Plaza
Houston, Texas 77002

The Story of Gasoline

This service publication of Ethyl Corporation is a reference book on the manufacture, characteristics, and uses of gasoline. A semi-technical treatment of each subject has been purposely chosen so that the book may serve as a training text on the one hand, or as a source of answers to the question of the motor-ing public on the other hand.

Ethyl Corporation
Petroleum Chemical Division

Energy Outlook 1977-1990

An 18-page booklet describing Exxon's assessment of the impact of governmental, economic, environment, and technical factors on energy supply and demand for the period 1977-1990.

Exxon Company, U.S.A.
Public Affairs Dept.
P. O. Box 2180
Houston, TX 77001.

NATURAL GAS

History of Natural Gas (No. N00430)

A comic book giving the story of gas industry past, present, and future.

American Gas Association
1515 Wilson Blvd.
Arlington, VA 22209
(703) 524-2000

Purchase: 1-4 copies, 6 cents each

Drilling on The Outer Continental Shelf (No. N00630-Vol. 4, No. 1)

A four-page newsletter printed in two colors. Notes the production from those areas of the outer continental shelf of the United States where drilling has been done, and the potential yet to be proved.

American Gas Association
1515 Wilson Blvd.
Arlington, VA 22209
(703) 524-2000

Purchase: 1-99 copies, 10 cents each

Energy Balance (No. N00645 - Vol. 6, No. 1)

A four-page newsletter printed in two colors. Discusses the energy balances that exist among the energy users and energy sources of society.

American Gas Association
1515 Wilson Blvd.
Arlington, VA 22209
(703) 524-2000

Purchase: 1-99 copies, 10 cents each

257

Natural Gas Energy and The Environment (No. N00650-Vol. 6,
No. 1)

A four-page newsletter, printed in two colors on the subject of the ecological implications of natural gas. Presents possible answers to two questions: (1) What are the ecological effects of burning fossil fuels for their heat energy; and (2) can we predict how long the deposits of fossil fuels will last at present and the projected rates of use?

American Gas Association
1515 Wilson Blvd.
Arlington, VA 22209
(703) 524-2000

Purchase: 1-99 copies, 10 cents each

The Energy Problem: Natural Gas

A 30-page paper (one in a series) on various aspects of the energy situation. It is useful on several counts, combining a good, concise summary of the present role of natural gas with interesting projection figures. Excellent charts and graphs suitable for classroom display are included... (1973)

Shell Oil Company
Public Affairs
P. O. Box 2463
Houston, TX 77001

NUCLEAR

Future Nuclear Usage

A series of pamphlets covering the following: insuring nuclear risks, how nuclear plants work, managing nuclear wastes, nuclear reactor safety, plutonium in perspective, protecting nuclear power plants, recycling nuclear fuel, shipping nuclear fuel, the savings with nuclear energy, and uranium-energy for the future.

Atomic Industrial Forum, Inc.
Public Affairs and Information
Program
7101 Wisconsin Avenue
Washington, DC 20014
(301) 654-9260

Free

In Time of Emergency

A citizen's handbook on nuclear attack and natural disasters.

Department of Defense
Office of Civil Defense
Washington, DC

Is Nuclear Power Safe?

This pamphlet contains the proceedings of one of a series of AEI Round Table discussions.

American Enterprise Institute
1150 Seventeenth St., NW
Washington, DC 20036

101 Atomic Terms and What They Mean

ESSO Research and Engineering
Company
P. O. Box 45
Linden, NJ

The Economics of Nuclear Power

Energy Research and Development
Administration
Office of Public Affairs
Washington, DC 20545

The Breeder Story

Atomic Industrial Forum Public Affairs Workshop Nuclear
Information Strategies: New Settings, New Approaches -
by Dr. John B. Yasinsky, Westinghouse Electric Corp.
Atomic Industrial Forum, Inc.

The Necessity of Fusion Power

W. H. Freeman & Company
660 Market St.
San Francisco, CA ~~94104~~

The Economics of Nuclear Power

An eight-page leaflet on the emerging role of nuclear
power in meeting our requirements for electricity.

Energy Research and Development
Office of Public Affairs
Washington, DC 20545

Atoms on the Move/Transporting Nuclear Material

Energy Research and Development
Office of Public Affairs
Washington, DC 20545

Nuclear Energy Resources

A geologic perspective.

U. S. Department of the Interior

Perspectives on the Development of Fusion Power by Magnetic Confinement 1977

A report of the Fusion Power Reactor Senior Review Committee.

Division of Magnetic Fusion
Energy
U.S. Department of Energy
Washington, DC 20545

Your Body and Radiation

U.S. Atomic Energy Commission

Atomic Power Safety

U.S. Atomic Energy Commission

Controlled Nuclear Fusion

U.S. Atomic Energy Commission

Radioactive Wastes

U.S. Atomic Energy Commission

The Nuclear Debate: A Call to Reason

A position paper on nuclear power. Rigorous examination of the present risks, costs, and impact of all electric power sources.

California Council for Environmental and Economic Balance
215 Market Street, Suite 930
San Francisco, CA 94105

Nuclear Industry

Atomic Industrial Forum
7101 Wisconsin Avenue
Washington, DC 20014

The Coming Age of Solar Energy

An interesting historical treatment of solar energy.

National Solar Heating and
Cooling Information Center
P.O. Box 1607
Rockville, MD 20850
(800) 523-2929

Purchase: \$7.95

Direct Use of the Sun's Energy

A publication that covers all aspects of solar energy
research and application.

National Solar Heating and
Cooling Information Center
P.O. Box 1607
Rockville, MD 20850
(800) 523-2929

Purchase: \$1.95

Applied Solar Energy: An Introduction

A basic textbook to the theory of solar energy, intended
for college students.

National Solar Heating and
Cooling Information Center
P.O. Box 1607
Rockville, MD 20850
(800) 523-2929

Purchase: \$17.95

Fact Sheets on Supplementary Energy Sources

1. "Wind Power"
2. "Electricity from the Sun, I" (Solar Photovoltaic Energy)
3. "Electricity from the Sun, II" (Solar Thermal Energy Conversion)

4. "Solar Sea Power" (Ocean Thermal Energy Conversion)

U.S. Department of Energy
Technical Information Center
Oak Ridge, TN 37830
(615) 576-5454
Free

Energy Pamphlets

1. "Solar Energy"
2. "Solar Powered Irrigation"
3. "I've Got A Question About Using Solar Energy"
4. "Solar Electricity from Thermal Conversion"

U.S. Department of Energy
Educational Programs Branch
20 Massachusetts Avenue, NW
Washington, DC 20545
(202) 376-4074

Free

A Citizen's Handbook on Solar Energy, 1977

An introduction to the economic and technical feasibility of solar energy. Discusses solar research. (92 pages)

Public Interest Research Group
P. O. Box 19312
Washington, DC 20036

Purchase: \$3.50 (individuals)
\$15 (institutions)

Note: This organization has an extensive list of related publications. Write for catalogue.

Solar Energy and Your Home

A booklet designed to answer some of the most frequently asked questions about how solar energy can be put to work at home.

U.S. Department of Housing
and Urban Development

7263

Solar Electricity From Photovoltaic Conversion

A pamphlet by DOE that lists the many advantages, convenience, versatility, safety, and (at least until recently) low cost of solar electricity.

Department of Energy
Office of Public Affairs
Washington, DC 20585

Solar Energy for Homes

A research project for the Electric Power Research Institute for the electric utility industry.

Electric Power Research Institute
Palo Alto, CA

Cogeneration Systems

Solar Turbines International
Operating Group for International
Harvester
San Diego, CA 92138

Solar Energy for Heating and Cooling

Department of Energy
Washington, DC

Facts

Solar Energy Research Institute
1536 Cole Blvd.
Golden, CO 80401

Solar Energy: Training Materials, Programs, and Manpower Needs

A bibliography of documents and journal articles from the NTIS, INSPEC, ENVIRONMENT, and ERIC Data Bases.

Center for Vocational Education
Ohio State University
Columbus, OH

Solar Heating and Cooling of Residential Buildings - Sizing, Installation, and Operation of Systems

This is a training course to develop the capability of practitioners in the home building industry to size, install and operate solar heating and cooling systems for residential buildings.

U. S. Department of Commerce

Solar Energy Task Force Report on Education and Training

This report summarizes data, information, and discussions stemming from the Task Force Workshop of September 12-13, 1978.

Solar Energy Research Institute
Golden, Colorado

Applied Solar Seminar Attracts a Crowd

Texas Energy

Solar Greenhouses Offer Many Benefits.

Texas Energy

Building the Solar Home

Reports preliminary, subjective finds from the first two cycles of demonstration projects. These are not the results of rigorous scientific studies, but represent experiences in the inferences drawn from a limited number of solar applications.

Department of Housing and
Urban Development
Washington, DC 20410

Cooperative Study Assessing the Need for Solar Technicians

Texas Energy and Mineral
Resources
Texas A & M University
College, Station, TX 77843

Solarwork

An update in the field of training solar workers. The purpose is to discuss the progress of solar training, to comment on new trends that affect the prospect for and nature of solar jobs, and to keep readers informed on solar-related educational and instructional materials.

Governor's Office of Appropriate
Technology
1530 Tenth Street
Sacramento, CA 95814

Solar Energy Information Locator

Prepared from the latest information available to the staff of the Solar Energy Information Data Bank.

Solar Energy Research Institute
1536 Cole Blvd.
Golden, CO 80401

The Job Creation Potential of Solar and Conservation:
A Critical Evaluation

A paper by Meg Schachter, consultant for DOE.

Department of Energy
Policy & Evaluation, Advanced
Energy Systems Policy Division

GEOTHERMAL

Geothermal Energy

A 10-page booklet explaining the harnessing of the natural heat of the earth.

Union Oil Company of California
Corporate Communications Dept.
Box 7600
Los Angeles, CA 90051
(213) 486-6815

Free

Geothermal Energy

A pamphlet describing how geothermal heat is tapped.

U.S. Department of Energy
Educational Programs Division
20 Massachusetts Ave., NW
Washington, DC 20454
(202) 376-4074

Free

Fact Sheets on Supplementary Energy Sources: Geothermal Energy

U.S. Department of Energy
Technical Information Center
P. O. Box 62
Oak Ridge, TN 37830
(615) 483-8611

Geothermal Energy: Prospects and Limitations

A three-page pamphlet which discusses the nature of geothermal energy, the environmental problems involved in its use, and its potential as a short-term alternative energy source.

The Sierra Club
105 Mills Tower
San Francisco, CA 94104

Purchase: 10 cents each

MISCELLANEOUS ENERGY SUBJECTS

Consumer Information Publications

1. "Gas Mileage Guide"
This guide gives fuel economy and other information that can help in the selection of a vehicle that meets transportation needs and, at the same time, is fuel efficient.
2. "Energy Saving Through Automatic Thermostat Controls"
Gives information concerning advantages of these timing devices, types available, and installation.
3. "Tips for Energy Savers"
Gives hints for conserving energy in household heating, cooling, and appliance use, in the workshop, and in family activities.

Consumer Information
Public Documents Distribution
Center
Pueblo, CO 81009
(303) 544-5277

Department of Commerce Publications (Conservation)

1. "Voluntary Industrial Energy Conservation Programs Report"
Issued quarterly, this publication reports on progress in energy conservation made by key energy-intensive industries.
2. "Energy Conservation Handbook"
3. "How to Start an Energy Management Program"
4. "Making the MOST of Your Energy Dollars"
5. "33 Money-Saving Ways to Conserve Energy in Your Business"

Department of Commerce
Washington, DC 20230
(202) 783-9200

Department of Energy Publications (Conservation)

1. "Energy Conservation in the Home"

A curriculum guide for teachers that contains an abundance of information on energy conservation.

2. "How to Save Money by Saving Energy"

3. "Selected DOE Publications"

4. "Understanding Your Utility Bill"

U.S. Department of Energy
ED Programs Division
20 Massachusetts Avenue, NW
Washington, DC 20545
(202) 376-4074

United States Energy Through the Year 2000

U.S. Department of the Interior
Superintendent of Documents
U.S. Government Printing Office
Washington, DC 20402

Energy Conservation Applications 1978

Daytona Beach Community College
P. O. Box 1111
Daytona Beach, Florida 32015

Conservation Task Force Report on Education and Training

U.S. Department of Energy
ED Programs Division
20 Massachusetts Avenue, NW
Washington, DC 20545
(202) 376-4074

Energy Conservation in New Building Design

Executive Summary (An Impact Assessment of ASHRAE Standard 90-75).

Federal Energy Administration
Conservation & Environment
Washington, DC 20461

Energy Conservation: How much is enough?

Reprint of an article.

Department of Commerce

Energy Conservation Grants

A program training manual for schools, hospitals, local governments, and public care institutions.

Texas Energy Management
Governor's Office of Energy
Resources
Austin, Texas

Retrofitting Existing Housing for Energy Conservation:
An Economic Analysis

This study is significant in that it provides a methodology for determining economically optimal levels of investment in energy conservation for reducing energy use in residential space heating and cooling.

Department of Commerce

The Systematic Energy Conservation Management Guide

Energy Management Division
American Management Association
135 West 50 Street
New York, NY 10020

Energy Conservation Workshop for Community College Leaders

This is a report on the results of a workshop on energy conservation for community college leaders.

Energy Research and Development Administration
Office of Public Affairs
Washington, DC 20545

Energy Conservation on Campus

This publication has been prepared for institutions of higher education by the Energy Task Force through Federal Energy Administration Contract No. CO-04-50247-00 with the Association of Physical Plant Administrators of Universities and Colleges. Its purpose is to assist colleges and universities and other non-profit institutions to mount and sustain effective management programs.

Federal Energy Administration
Washington, DC 20461

Department of Energy Publications (How to Save ...)

1. "How to Save Gasoline ... and Money"
Leaflet
2. "Tips for Energy Savers"
Booklet on how to save energy and money at home.
3. "How to Save Money by Insulating Your Home"
Department of Energy

The Complete Energy-Saving Home Improvement Guide

This book is designed to take the confusion and guesswork out of home energy conservation practices by showing how to save energy and money without sacrificing comfort.

Governor's Energy Office
80 Dean Street
Providence, RI 02903

A Guide to Reducing ... Energy Use Budget Costs

Federal Energy Administration

Making the Most of Your Energy Dollars in Home Heating & Cooling

The facts in this booklet are based on the findings and methods published earlier in an economic report, Retrofitting Existing Housing for Energy Conservation: An Economic Analysis.

U.S. Department of Commerce

How to Save Money by Saving Energy

Brochure.

U.S. Department of Commerce

Energy Conservation Handbook (For light industries and commercial buildings)

Brochure.

Office of Energy Programs
U.S. Department of Commerce
Washington, DC 20230

Tips for Energy Savers (In and Around the home, on the road, in the marketplace)

Brochure.

Federal Energy Administration

Energy Audit Procedures

Ohio Board of Regents
30 East Broad Street
36th Floor
Columbus, Ohio 43215

Washington Energy Auditor Training Manual (for schools, local government and public care facilities)

These materials are intended to provide the information and forms necessary for training Energy Auditors for the State of Washington.

Planergy, Inc.
901 W. Martin Luther King, Jr. Blvd.
Austin, TX 78701

Texas Energy Management

Planergy, Inc.
400 Madison St., #1303
Alexandria, VA 22314

Planergy, Inc.
901 W. Martin Luther King, Jr. Blvd.
Austin, TX 78701

Instructions for Energy Auditors (Volume I & II)

1. "Energy Audit Workbook for Bakeries"
2. "Energy Audit Workbook for Warehouses"
3. "Energy Audit Workbook for Bus Stations"
4. "Energy Audit Workbook for Restaurants"
5. "Energy Audit Workbook for Office Buildings"
6. "Energy Audit Workbook for Die Casting Plants"
7. "Energy Audit Workbook for Retail Stores"
8. "Energy Audit Workbook for Hotels and Motels"
9. "Energy Audit Workbook for Hospitals"
10. "Energy Audit Workbook for Schools"
11. "Energy Audit Workbook for Apartment Buildings"

U.S. Department of Energy

Energy Management: Trade Associations and the Economics of Energy

U.S. Department of Commerce

EPIC Energy Management Series

1. "Energy Management Guide for Light Industry and Commerce"
2. "Energy Management for Furnaces, Kilns, and Ovens"

Department of Commerce
Washington, DC

Energy Conservation Program Guide for Industry and Commerce

The EPIC is a guide to assist business and industry to establish an on-going conservation program. EPIC outlines the steps in an energy conservation program and suggests specific ways to reduce energy use in manufacturing and commercial businesses.

U.S. Department of Commerce

Waste Heat Management Guidebook

Sources of waste heat in industrial processes are reviewed, and an overview of off-the-shelf technology available for its use is given. Discussions of waste heat measurement technology and economics are included, as are 14 case studies of successful industrial waste-heat recovery installations.

U.S. Department of Commerce

Comparative Risk-Cost-Benefit Study of Alternative Sources of Electrical Energy

A compilation of normalized cost and impact data for current types of power plants and their supporting fuel cycles.

Office of Energy System Analysis
Division of Reactor Research
and Development
United States Atomic Energy
Commission
Washington, DC

Total Energy Management

TEM is an energy conservation approach based on the premise that to effect energy savings in buildings one must make the building's systems as efficient as possible.

U.S. Department of Commerce

Energy Management

A Magazine.

Industrial Publishing Co.
Division of Pittway Corp.
Cleveland, Ohio

Texas History: A Twenty-Five Year History

Texas Energy Advisory Council
7703 North Lamar
Austin, TX 78752

Texas Energy Report Number 24

Texas Energy Advisory Council
7703 North Lamar
Austin, TX 78752

NASA Nickel-Zinc Battery Technology: An Energy Boost for Electric Vehicles

National Aeronautics & Space
Administration
Lew Research Center
Cleveland, Ohio

Department of Energy Publications

1. "Gas Turbines for Efficient Power Generation"
2. "Enhanced Recover of Oil and Gas"
3. "Water Power: Use of a Renewable Resource"
4. "Flywheels: Storing Energy as Motion"

U.S. Department of Energy

Heat Pumps

DOE Technical Information
Center
P. O. Box 62
Oak Ridge, TN 37830

Industrial Heating

National Industrial Publishing
Co.
1610 Potomac Avenue
Pittsburgh, PA 15216
(412) 651-6191

Laser Fusion Program

Los Alamos Scientific Laboratory
P. O. Box 1663
Los Alamos, New Mexico 87545.

Energy in Solid Wastes

◆ A citizen's guide to saving.

Citizen's Advisory Committee
on Environmental Quality
1700 Pennsylvania Avenue, NW
Washington, DC 20006

GENERAL ENERGY SUBJECTS

Energy Report

A monthly publication.

National Energy Research
& Information Institute
1950 Third Street
LaVerne, CA 91750

United States ENERGY through the Year 2000

The mainstay of a modern industrial nation, such as the United States, is its ability to secure and use energy resources. This will continue to be important to the national economy. In order to properly plan for energy demand, it is necessary to assess and forecast the demand as accurately as possible - which is the purpose of this paper.

U.S. Department of Interior

Professional Energy Careers

This booklet gives a brief outline of the professional careers in the energy field.

Energy
P.O. Box 62
Oak Ridge, TN 37830

Creating Energy Choices for the Future

A summary of the national plan for energy research, development, and demonstration.

Energy Research and Development
Administration
Office of Public Affairs
Washington, DC 20545

World Energy Outlook

A background paper prepared by the Public Affairs
Department of Exxon Corporation.

Public Affairs Department
Exxon Corporation
1251 Avenue of the Americas
New York, NY 10020

Energy and Education Action Center

Brochure.

U.S. Department of Health,
Education & Welfare
Energy & Education Action
Center
Washington, DC 20202

Energy for Today and Tomorrow

Brochure.

Westinghouse Electric Corporation
Westinghouse Building
Gateway Center
Pittsburgh, PA 15222

The Energy Crisis

An eight-page pamphlet.

U.S. Energy Research & Development
Administration
Office of Public Affairs
Washington, DC 20545

The Energy Outlook for the 1980s

A study prepared for the use of the Subcommittee on
Economic Progress of the Joint Economic Committee Congress
of the United States.

U.S. Energy Research & Development
Administration
Office of Public Affairs
Washington, DC 20545

Energy & Power Journal
Magazine.

National Education Council
on Energy and Power
P. O. Box 618
Concord, MA 01742

Energy
Magazine:

Business Communications Co.,
Inc.
9 Viaduct Rd.
P. O. Box 2070C
Stamford, CT 06906

The Energy How You Fit in Puzzle

A one-time publication (magazine).

U.S. Department of Energy

Energy and the Way We Live

A calendar of issues:

U.S. Department of Energy

Information

Weekly announcements.

U.S. Department of Energy
Office of Public Affairs
Washington, DC 20461

Energy Insider

U.S. Department of Energy

Energy User News

A Fairchild Business Newspaper
7 East 12th Street
New York, NY 10003

SECTION V
GLOSSARY

Aeolian energy: Energy generated by wind power.

Acid drainage: The result of water moving through the substratum (during underground mining operations) and carrying toxic materials that eventually discharge into open ecosystems.

Active solar system: Energy is collected by solar collectors located on the roof of a building. Then, the heat energy is carried away by water or air and transferred to a large storage system to use later to circulate throughout the building when necessary.

All-electric homes: Homes supplied with energy from electricity alone.

Anthracite: A type of coal that is hard and brilliant. It is high in carbon content and has excellent heat value.

Audit methods: The first three of five usual steps in an energy audit procedure that involves determination of energy loss.

Biogeochemical cycles: The cycles in which matter that is related to living things moves about the earth.

Biomass: General term for plant and animal waste.

Biosphere: The life zone of the earth, including the lower part of the atmosphere, the hydrosphere, soil, and the lithosphere to a depth of about two kilometers.

Bituminous: A type of coal that is solid but easily broken. Its carbon content is high, its heat value is good, and it is very easy to mine.

Boiling water reactor (BWR): A light-water nuclear reactor in which water is pumped through the reactor (which is at a temperature of about 600°F) and steam is formed to drive the turbine.

British thermal units (Btu): The amount of heat energy required to raise the temperature of one pound of air-free water one degree Fahrenheit.

Calorie (cal): A common unit of heat energy in the metric system. It is the amount of heat required to raise the temperature of one gram of water one degree Celsius.

Capital stock of U.S. economy: The outstanding shares of a joint-stock company considered as an aggregate or the ownership element of a corporation divided into shares and represented by certificates as this definition applies to the nation.

Carbon dioxide: A gas that occurs naturally in the atmosphere yet is a potentially troublesome product emitted from the burning of fossil fuels.

Carboniferous period: A major period of geologic, coal-forming time, dated as approximately 300 million years.

Carbon monoxide (CO): A poisonous gas produced by incomplete combustion of organic materials. A pollutant.

Catalytic converters: An emission control device used in automobiles for increasing the oxidation process by converting more of the hydrocarbons and carbon monoxide to carbon dioxide and water.

Climate zones: A belt of the earth's surface within which the surface is generally homogeneous in some respect; an elemental region of a simple climatic classification.

Cogeneration: The simultaneous production of electric power or heat in industrial operations.

Color rendition: A consideration in choosing home lighting. It is a relative term in that it refers to the extent to which the perceived color of an object under a light source matches the perceived of that object under the incandescent bulb.

Conservation Law: The first law of thermodynamics which states that all the energy that ever was still exists.

Constant volume systems: Usually are part of another heating and cooling system or serve to provide precise air supply at a constant volume.

Cooling towers: A tower-like device used by power plants in which atmospheric air circulates and cools warm water, generally by direct contact (evaporation).

Demand charge: A charge made by utility companies to individual customers (electricity users) for the promise to supply sufficient energy for the peak demand of that customer. This charge is how utility companies recover costs associated with investment in capacity and equipment to serve peak demand.

Dual duct system: A system that has a central unit that provides both heated and cooled air, each at a constant temperature. Each space is served by two ducts, one carrying hot air, the other carrying cold air.

Economic analysis (cost analysis): Analysis of a project considered in terms of energy savings compared to the costs of the energy savings.

Ecosystems: A functional system which includes the organisms of a natural community together with their environment.

Energy: The ability or capacity to do work.

Energy audit: Method used to determine the efficiency of a system and devise ways to increase it and, thereby, reduce energy loss.

Energy conservation: A planning process that emphasizes the available work content of energy resources.

Energy efficiency: For light sources, it is the measure of how much light is produced in relation to the amount of energy used.

Energy Efficiency Ratio (EER): The amount of heat one watt of electricity will recover from the air in one hour.

Energy input (E_{in}): Amount of usable energy, usually in the form of fossil fuel or electricity.

Entropy Law: The transformation of work or heat into disorder, or entropy.

Energy loss (E_{loss}): The difference between energy input and energy output.

Energy output (E_{out}): Result of energy input, usually measured by useful work or products.

Energy shortage: Usually defined as depletion of energy resources. Actual shortage believed not to exist, but a result of inability to convert existing energy into usable forms.

Energy source: A source of energy, such as fossil fuels, wood, solar, nuclear, and so forth.

Energy units: Method of measuring energy sources in terms of available energy.

Environmental ride: The toll that an energy source takes on the complex of climatic, edaphic, and biotic factors that act upon an organism or an ecological community and ultimately determine its form and survival.

Fan coil system: A heating and cooling system that consists of several fan coil units, each of which has a fan and a heating or cooling coil.

Fertile material: A nonfissionable substance converted into a fissionable isotope during the reaction process in breeder reactors.

Fluorescent: A type of tubular discharge lamp in which ionization of mercury vapor produces radiation that activates the fluorescent coating on the inner surface of the glass. Used mainly in office buildings.

Gas-cooled breeder reactor: A type of breeder reactor that uses the uranium-thorium fuel cycle.

Gas/electric homes: Homes supplied with energy from both gas and electricity.

Geopressed reservoir: A type of geothermal reservoir usually made up of porous sands containing water or brine at high temperature or pressure-trapped beneath the earth.

Geothermal energy: Energy generated by the natural subterranean heat of the earth.

Heavy water: A compound of hydrogen and oxygen containing a higher proportion of the hydrogen isotope deuterium than does naturally occurring water.

Helium: A gaseous chemical element.

High-pressure sodium: A type of high-intensity discharge lamp. Used in commercial and industrial sectors because of efficiency and long life.

Horsepower (hp): A unit of power equal to 500 foot-pounds per second, approximately 745.7 watts.

Hot-rock system: A type of geothermal reservoir that would require wells to be four and five miles deep since the normal temperature gradient is about 100°F per mile. This is too deep for present techniques.

Hydroelectric power: Electricity or mechanical power from hydroelectric power plants that use the force of falling water to turn a turbine generator.

Hydrocarbons: Chemical compounds emitted from evaporation of fuel from vehicles, fuel-handling operations, and unburned fuel in vehicle exhausts. A pollutant.

Hydrothermal reservoir: The most commonly used type of geothermal reservoir in which steam is used to drive turbines.

Incandescent: As an electric lamp (bulb), it produces light when a metallic filament is heated white-hot in a vacuum by passing an electric current through the filament.

Induction system: An air-handling unit that supplies heated or cooled primary air at high pressure to induction units located on the outside walls of each space served.

Inertial containment: An approach to research with fusion as compared to magnetic containment.

Insulation: Material used in walls, ceilings, and floors to retard the passage of heat and sound.

Joule (J): A unit of energy equal to the work done by a force of magnitude of one newton when the point at which the force is applied is displaced one meter in the direction of the force.

Kilocalorie (kcal): A unit equivalent to 1,000 calories, it is the heat required to raise the temperature of one kilogram of water by one degree Celsius.

Kilojoule (kJ): A unit of energy equal to 1,000 joules.

Kilowatt: A commonly used power unit that corresponds to the passage of 1,000 joules a kilojoule, per second.

Kilowatt-hour (kWh): A unit of energy equal to 1,000 watt-hours (see watt).

Light intensity: Measured in lumens, it is the amount of light that is produced.

Light water: Ordinary water used as a coolant and moderator in nuclear reactors. Both hydrogen atoms in each molecule are of the isotope protium.

Lignite: A type of coal that is soft, crumbles easily, and is low in carbon content and heat value. It is difficult to mine.

Liquid-metal fast breeder reactor: The highest priority of breeder reactors. It uses the plutonium-uranium cycle.

Load factor: The ratio of average load to peak load in kilowatts of electricity.

Lumens: The unit of luminous flux, equal to the luminous flux emitted within a unit solid angle (one steradian) from a point source having a uniform intensity of one candela.

Magnetic containment: An approach to research with fusion in which the charged plasma is suspended in a large electromagnet.

- Mercury vapor: A high-intensity discharge lamp. Light is produced by an electric arc between two electrodes in an ionized mercury-vapor atmosphere; it gives off a bluish-green light rich in ultraviolet radiation.
- Metal-halide: A type of high-intensity discharge lamp. Used in commercial and industrial sectors because of efficiency and long life.
- Methane: A major component of natural gas. It is a product in the decomposition of organic materials.
- Molten-salt breeder reactor: A type of breeder reactor that uses the uranium-thorium fuel cycle.
- Multizone system: A heating and cooling system that heats and cools several zones, each with a different load requirement, from a centralized unit.
- Net efficiency of energy use: The effectiveness of converting energy sources to useful forms of energy. Highly dependent upon number of steps required for conversion.
- Neutron: An elementary particle which has approximately the same mass as the proton but lacks electric charge; and it is a constituent of all nuclei, having mass number greater than one.
- Nitrogen oxides: Gas that is emitted during combustion of fossil fuels. Nitrogen dioxide can react with oxygen in the air to produce ozone, and air-pollutant.
- Nonregenerative processes: A procedure to remove sulfur oxides from power plant flue gases by using a lime and limestone scrubbing process. The reaction product in the scrubbing slurry is discarded.
- Nuclear fission: The nucleus of a heavy atom is split into two or more fragments.
- Nuclear fusion: Combination of two light nuclei to form a heavier nucleus (and perhaps other reaction products) with release of some binding energy.
- Nuclear wastes: Liquid, solid, or gaseous waste resulting from production of reactor fuel materials, reactor operation, processing of irradiated reactor fuels, and so forth.

Ocean thermal energy: A potential source of energy created by a temperature difference that occurs when deep cold ocean currents flow toward the equator beneath the warmer upper ocean layers.

Oil Shale: A finely grained rock that contains organic material called kerogen.

Particulates: Any matter, solid, or liquid in which individual particles are larger than a molecule but smaller than 0.5 millimeters.

Passive solar system: Does not involve circulation to a storage container, as compare to an active solar system.

Petroleum: A fossil fuel formed from the remains of tiny aquatic plants and animals in the sea. It is a major source of energy.

Plasma state: How matter exists at very high temperatures of hundreds of millions of degrees. Nuclear fusion reactions can only occur in this state.

The politics of energy: The competition between competing interest groups or individuals for power and leadership in the area of having, getting, or maintaining resources that have the ability to do work.

Pollutants: Particles or substances that impair the purity of the environment.

Pressurized water reactor (PWR): A light-water nuclear reactor in which water under high pressure is pumped through the reactor and heated.

Quad: A unit used when considering energy on a very large scale. It is equal to one quadrillion (1,000,000,000,000,000 or 10^{15} Btu).

R-value: A measure of effectiveness of various insulation materials. The higher the R-value, the greater is the resistance to the transfer of heat.

Reclamation: Restoration of strip-mined land.

Recycling: Returning to an original condition or reuse of materials.

Regenerative process: A procedure to remove sulfur oxides from power plant flue gases by using either an ammonia or magnesia scrubbing process. The reaction product is converted to a useful end-product.

Scrubbers: Devices installed in power plants to remove sulfur oxides from power plant flue gases.

Self-contained systems: A roof-top unit, window unit, or through-the-wall unit.

Single-zone system: A heating and cooling system that provides both heating and cooling to one zone that is controlled by the zone thermostat.

Strip mining: Procedure for mining coal in which the earth is removed in one cut and dumped into the empty space left by the previous cut. It disrupts land surface and contributes to pollution and clogging of streams and reservoirs.

Sulfur oxides: Oxides of sulfur which are produced during combustion of fossil fuels. A pollutant.

Tar sands: Sandstone and limestone reservoirs impregnated with a heavy crude oil.

Terminal reheat system: A modification of a single zone system that provides a higher degree of temperature and humidity control.

Tidal plant: A power plant that uses the rise and fall of tidal waters to operate a turbine that generates electricity.

Thermal pollution: To contaminate through the production of heat. Occurs when waste heat is released into the environment.

Thermostat: A instrument that measures changes in temperature and directly or indirectly controls sources of heating and cooling to maintain a desired temperature.

Underground mines: Used in deep mining for coal.

Underground mining and surface mining: The two methods of mining coal. The composition, hardness, and regularity of the strata both overlying and underlying a coal bed are highly important in assessment of minability.

Uranium-235: Fuel most commonly used for nuclear fission.

Variable air volume system: A heating and cooling system that provides heated or cooled air at a constant temperature to all zones served. Units in each zone adjust the quantity of air reaching each zone.

Watt: The basic unit of power in the metric system that corresponds to the passage of one joule of energy per second (see joule).

Work: What happens when a force is exerted on a body while the body moves at the same time in such a way that the force has a component in the direction of motion.