

DOCUMENT RESUME

ED 210 471

CE C30 732

AUTHOR Countryman, Gene L.
TITLE Builder 3 & 2. Naval Education and Training Command
Rate Training Manual and Nonresident Career Course.
Revised.

INSTITUTION Naval Education and Training Program Development
Center, Pensacola, Fla.

REPORT NO NAVEDTRA-10648-G

PUB DATE 81

NOTE 798p.: Photographs will not reproduce well.

EDRS PRICE MF05/PC32 Plus Postage.

DESCRIPTORS Behavioral Objectives: Building Trades: *Cement
Industry: *Construction (Process): *Construction
Management: Correspondence Study: Finishing:
Flooring: Independent Study: Learning Activities:
*Masonry: Military Training: Painting (Industrial
Arts): Postsecondary Education: Roofing: Textbooks:
*Trade and Industrial Education: *Woodworking

IDENTIFIERS Navy

ABSTRACT

This Rate Training Manual (Textbook) and Nonresident Career Course form a correspondence, self-study package to provide information related to tasks assigned to Builders Third and Second Class. Focus is on constructing, maintaining, and repairing wooden, concrete, and masonry structures, concrete pavement, and waterfront and underwater structures: performing rough and finish carpentry: erecting or repairing waterfront structures, wooden and concrete bridges and trestles: fabricating and erecting forms: mixing, placing, and finishing concrete: laying and setting masonry: and painting or varnishing new and refinished surfaces. The 16 chapters in the text are Construction Administration: Drawings and Specifications: Woodworking Shop and Field Tools: Woodworking: Materials and Methods: Fiber Line, Wire Rope, and Scaffolding: Leveling, Grading, and Excavating: Concrete: Masonry: Light Frame Construction: Floor and Wall: Roof Framing: Exterior Finish: Interior Finish: Plastering: Stuccoing, and Ceramic Tile: Paints and Preservatives: Advanced Base Field Structures: and Heavy Construction. The Nonresident Career Course follows the index. It contains 18 assignment and learning objectives with related sets of teaching items to be answered. Learning objectives and items are based on subject matter or study material in the textbook. (YLB)

* Reproductions supplied by EDRS are the best that can be made *
* from the original document. *

ED210471



U.S. DEPARTMENT OF EDUCATION
NATIONAL INSTITUTE OF EDUCATION
EDUCATIONAL RESOURCES INFORMATION
CENTER (ERIC)

- ✓ This document has been reproduced as received from the person or organization originating it.
- Minor changes have been made to improve reproduction quality.
- Points of view or opinions stated in this document do not necessarily represent official NIE position or policy.

BUILDER 3 & 2

Although the words "he", "him" and "his", are used sparingly in this manual to enhance communication, they are not intended to be gender driven nor to affront or discriminate against anyone reading *Builder 3 & 2*, NAVEDTRA 10648-G.

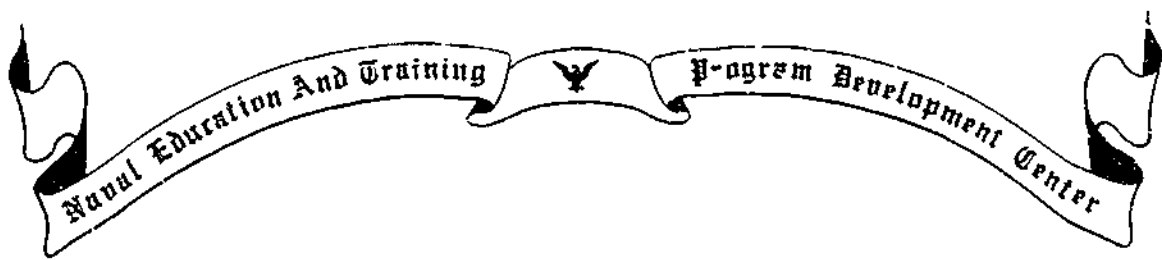

BUILDER 3 & 2

NAVEDTRA 10648-G



*1981 Edition Prepared by
BUCS Gene L. Countryman*



PREFACE

The ultimate purpose of training Naval personnel is to produce a combatant Navy which can insure victory at sea. A consequence of the quality of training given them is their superior state of readiness. Its result is a victorious Navy.

This Rate Training Manual and Nonresident Career Course (RTM/NRCC) form a self-study package that will enable Builders Third and Second Class help themselves fulfill the requirements of their rating. They perform tasks required for construction, maintenance and repair of wooden, concrete, and masonry structures, concrete pavement, and waterfront and underwater structures; perform rough and finish carpentry; erect or repair waterfront structures, wooden and concrete bridges and trestles; fabricate and erect forms; mix, place, and finish concrete; lay and set masonry; and paint or varnish new and refinished surfaces.

Designed for individual study and not formal classroom instruction, the RTM provides subject matter that relates directly to the occupational standards of the Builder rating. The NRCC provides a way of satisfying the requirements for completing the RTM. Assignments in the NRCC include learning objectives and supporting items designed to lead the student through the RTM.

This RTM/NRCC was prepared by the Naval Education and Training Program Development Center, Pensacola, Florida, for the Chief of Naval Education and Training. Technical assistance was provided by the Naval Facilities Engineering Command, Alexandria, Virginia, the Naval Construction Training Center, Port Hueneme, California, the Naval Construction Training Center, Gulfport, Mississippi, and the Civil Engineering Support Office, Port Hueneme, California.

Revised 1981

Stock Ordering No.
0502-LP-053-2410

Published by
NAVAL EDUCATION AND TRAINING
PROGRAM DEVELOPMENT CENTER

UNITED STATES
GOVERNMENT PRINTING OFFICE
WASHINGTON, D.C.: 1981

THE UNITED STATES NAVY

GUARDIAN OF OUR COUNTRY

The United States Navy is responsible for maintaining control of the sea and is a ready force on watch at home and overseas, capable of strong action to preserve the peace or of instant offensive action to win in war.

It is upon the maintenance of this control that our country's glorious future depends; the United States Navy exists to make it so.

WE SERVE WITH HONOR

Tradition, valor, and victory are the Navy's heritage from the past. To these may be added dedication, discipline, and vigilance as the watchwords of the present and the future.

At home or on distant stations we serve with pride, confident in the respect of our country, our shipmates, and our families.

Our responsibilities sober us; our adversities strengthen us.

Service to God and Country is our special privilege. We serve with honor.

THE FUTURE OF THE NAVY

The Navy will always employ new weapons, new techniques, and greater power to protect and defend the United States on the sea, under the sea, and in the air.

Now and in the future, control of the sea gives the United States her greatest advantage for the maintenance of peace and for victory in war.

Mobility, surprise, dispersal, and offensive power are the keynotes of the new Navy. The roots of the Navy lie in a strong belief in the future, in continued dedication to our tasks, and in reflection on our heritage from the past.

Never have our opportunities and our responsibilities been greater.

CONTENTS

CHAPTER	Page
1. Construction Administration	1-1
2. Drawings and Specifications	2-1
3. Woodworking Shop and Field Tools	3-1
4. Woodworking: Materials and Methods	4-1
5. Fiber Line, Wire Rope, and Scaffolding	5-1
6. Leveling, Grading, and Excavating	6-1
7. Concrete	7-1
8. Masonry	8-1
9. Light Frame Construction: Floor and Wall	9-1
10. Roof Framing	10-1
11. Exterior Finish	11-1
12. Interior Finish	12-1
13. Plastering, Stuccoing, and Ceramic Tile	13-1
14. Paints and Preservatives	14-1
15. Advanced Base Field Structures	15-1
16. Heavy Construction	16-1
INDEX	I-1

Nonresident Career Course follows Index

CREDITS

The illustrations listed below are included in this edition of *Builder I & C*, through the courtesy of the designated sources. Permission to use these illustrations is greatly acknowledged. Permission to reproduce illustration and other materials in this publication must be obtained from the source.

Source	Figure
Butler Manufacturing Company	15-3 through 15-22
Delmar Publishers Inc.	3-48
Delta Manufacturing Company	3-57
D. Van Nostrand Company Inc.	5-29
Eugene Dietzgen Company	6-1, 6-4
Great Lakes Steel Corporation	15-1, 15-2
Keuffel and Esser Company	6-3
Oliver Manufacturing Corporation	3-58
Rockwell Manufacturing Corporation	3-37
Theo Audel and Company	3-9, 3-13
Thor Power Tool Company	7-44, 7-45
United States Steel Corporation	5-11
Worthington Corporation	16-14, 16-15, 16-16

CHAPTER 1

CONSTRUCTION ADMINISTRATION

When you first "sew on the crow," you take a big step in your naval career. You become a **PETTY OFFICER**. This step carries with it many responsibilities, including those of a leader and administrator. It won't be long before you are called on to serve as the leader of a **BUILDER (BU)** team or crew. Your examples of leadership will influence the crewmembers, so you must always exhibit a strong sense of personal integrity and dedication to your work and to the Navy.

ADMINISTRATION

Crews may perform a variety of jobs related to the BU rating. Your duties as a crew leader may vary from one activity to another. At most activities, you can expect duties that involve planning work assignments, supervising work teams, initiating requisitions, and keeping timecards. The following paragraphs will contain basic guidelines for carrying out these duties.

PLANNING WORK ASSIGNMENTS

For purposes of this discussion, planning is the process of determining requirements and devising and developing methods and schemes of action for performing a task. Proper planning saves time and money and makes the job easier for all concerned. Here are some pointers that will aid you in planning day-to-day work assignments for work teams.

When you are assigned a project, whether in writing or orally, one of the first things to do is to make sure you understand clearly just what is

to be done. Study the plans and specifications carefully. If you have any questions, find the answers from those in a position to supply the information you need. Among other things, make sure you understand the priority of the project, expected time of completion, and any special instructions to be followed.

In planning for a small or large project, you must consider the capability of your crew. Determine who is to do what and how long it should take to complete the assignment. Also consider the tools and equipment you will need and arrange to have them available at the jobsite at the time the work is to get underway. Determine who will use the tools, and make sure the crewmembers to whom they are assigned know how to use them properly and safely.

To help insure that the project is done properly and on time, you will want to consider the method of accomplishment. If there is more than one way of doing a particular assignment, you should analyze the methods and select the one most suited to job conditions. Listen to suggestions from others. If you can simplify a method and save time and effort, by all means do it.

Establish goals for each workday and encourage your crewmembers to work together as a team in accomplishing these goals. You want to set goals which will keep your crew busy, but make sure your goals are realistic. Discuss the project with your crewmembers so that they will know what you expect from each one of them. During an emergency, most crewmembers will make an all-out effort to meet the deadline. But people are not machines, and

when there is no emergency, they cannot be expected to continuously work at an excessive high rate.

SUPERVISING WORK TEAMS

After a job has been properly planned, it is necessary to supervise the job carefully to insure that it is completed properly and on time.

Prior to starting a project, make sure your crew know what is to be done. Give instructions clearly, and urge your crew to ask questions on all points that are not clear to them. Be honest in your answers. If you do not know, say so, then find the answer and inform your crew.

While the job is underway, check from time to time to insure that the work is progressing satisfactorily. Determine if the proper methods, materials, tools, and equipment are being used. If crewmembers are doing the job wrong, stop them, and point out what is being done wrong. Then explain the correct procedure and check to see that it is followed.

NOTE: When you check the work of your crewmembers try to do so in such a way that they will feel that the purpose of checking is to teach, guide, or direct, rather than to criticize or find fault.

Make sure that your crewmembers take all applicable safety precautions and wear safety apparel when required. Also watch for hazardous conditions, improper use of tools and equipment, and unsafe work practices which could cause accidents and possibly result in injury to personnel. Many young persons ignore danger or think a particular regulation is unnecessary. This can normally be corrected by proper instruction and training.

When time permits, rotate crewmembers on various jobs. Rotation gives them varied experience and will help insure your having those who can do the work if someone is hospitalized, transferred, or goes on leave.

As a crew leader, you should be able to get others to work together in getting the job

accomplished. Maintain an approachable attitude toward your crew so that any crewmember will feel free to seek your advice when in doubt about any phase of the work. Emotional balance is especially important; you must not panic before your crew, or be unsure of yourself in the face of conflict.

Be tactful and courteous in dealing with your crew. Never show partiality to certain members of the crew. Keep your crewmembers informed on matters which affect them personally or concern their work. Also seek to maintain a high level of morale, keeping in mind that low morale can have a definite effect upon the quantity and quality of their work.

As you advance in rate, more and more of your time will be spent in supervising others. Therefore, learn as much as you can about the subject of supervision. Study books on supervision as well as leadership. Also watch how other supervisors operate and do not be afraid to ASK QUESTIONS.

PREPARING REQUISITIONS

As a crew leader, you should become familiar with forms that are used to request material or services through the naval supply system. Printed forms are available which provide all the necessary information for physical transfer of the material and accounting requirements.

Two forms used for ordering materials are the Single Line Item Consumption/Management Document (Manual), NAVSUP Form 1250 (fig. 1-1) and the Requisition and Invoice/Shipping Document, DD Form 1149 (fig. 1-2).

As a crew leader, you are not usually required to make up the entire NAVSUP Form 1250, however, you must list the item's stock number (when available), the quantity required, and the name or description of each item needed. This form is turned in to the expeditor who will check it over, complete the rest of the information required and sign it. Then it is forwarded to the Material Liaison Officer (MLO) or Supply Department for processing.

Chapter 1—CONSTRUCTION ADMINISTRATION

OPTIONAL ENTRY

ENTRY, AS REQUIRED,
IF ITEM IS NIS 'NC

A. MAT. REQ. DIV. & LEAD NO. 0196 0691 B. REQ. DATE C	1. STOCK NUMBER 5920296244	2. REFERENCE SYMBOL FUSE	3. QUANTITY EA 3	4. UNIT PRICE 57039600	5. FUND R5219206010326P3CT
--	-------------------------------	-----------------------------	---------------------	---------------------------	-------------------------------

ENTRIES REQUIRED IF DATA BLOCK 14 IS BLANK

17.104

Figure 1-1.—Single Line Item Consumption/Management Document. NAVSUP Form 1250.

You are not likely to use DD Form 1149 often since the items most frequently ordered are bulk fuels and lubricants. This form is limited to a single page and must contain no more than nine line items. It is not necessary to fill in all the blocks of this form when it is used as a requisition.

In ordering material, you will need to know about the National Stock Number (NSN) system. Information on the NSN system and other topics relating to supply is given in *Military Requirements for Petty Officer 3 & 2*, NAVEDTRA 10056.

TIMEKEEPING

In a battalion overseas, as well as at shore-based activities, your duties may involve

the posting of entries on timecards for military personnel. Therefore, you should know the type of information called for on timecards and understand the importance of accuracy in labor reporting. You will find that the labor reporting system primarily used in Naval Mobile Construction Battalions and the system employed at shore-based activities are similar.

In order to record and measure the number of man-hours that a unit spends on various functions, a labor accounting system is mandatory. In this system, labor utilization data is collected daily in sufficient detail and in a way that enables the operations officer to compile the data readily. This helps the operations officer manage manpower resources and prepare reports to higher authority.

Although labor accounting systems may vary slightly from one command to another, the system described here can be considered typical.

SHIPPING CONTAINER TALLY → 1 2 3 4 5 6 7 8 9 10 11 12 13 14 15 16 17 18 19 20 21 22 23 24 25 26 27 28 29 30 31 32 33 34 35 36 37 38 39 40 41 42 43 44 45 46 47 48 49 50

REQUISITION AND INVOICE/SHIPPING DOCUMENT													SHEET NO. OF SHEETS 1 1		REQUISITION DATE 8 DEC. 19-		REQUISITION NUMBER 0450A/ 1			
FROM EQUIPMENT DIVISION, NCTC													DATE MATERIAL REQUIRED 9 DEC. 19-		PRIORITY 10					
TO SUPPLY DEPT. NAVAL CONSTRUCTION TRAINING CENTER NCBC, PORT HUENEME, CA.													AUTHORITY OR PURPOSE K. Saunders, EOC, USN		VOUCHER NUMBER AND DATE					
SHIP TO MAKE FOR M/F EQUIPMENT DIVISION GREASE RACK													DATE SHIPPED		MODE OF SHIPMENT		BILL OF LADING NUMBER		AIR MOVEMENT DESIGNATOR OR PORT REFERENCE NO.	
APPROPRIATION AND SUBJECT			OBJ. CL.	BUR. CONT. NO.	SUBAL. LOT	AUTHORIZATION ACCTG. ACTIVITY	TRANS. TYPE	PROPERTY ACCTG. ACTIVITY	COUN. TRY	COST CODE		AMOUNT								
ITEM NO.	FEDERAL STOCK NUMBER DESCRIPTION AND CODING OF MATERIAL AND/OR SERVICES						UNIT OF ISSUE	QUANTITY REQUESTED	SUPPLY ACTION	TYPE CONTAINER	CON. TAINERS NOS.	UNIT PRICE	TOTAL COST							
1	9150-00-057-8977 GREASE, AUTOMOTIVE (HD2)						DR	5												
2	9150-00-189-6729 OIL, LUBRICATING, ENGINE MIL-L-2104C						DR	2												
16 TRANSPORTATION VIA MATS OR MSPC CHANGEABLE													17 SPECIAL HANDLING							
RECAPITULATION OF SHIPMENT	ISSUED BY	TOTAL CONTAINER	TOTAL ON HAND	DESCRIPTION	TOTAL WEIGHT	TOTAL CUBIC	19 CONTAINERS RECEIVED EXCEPT AS NOTED		DATE	BY	SHEET TOTAL									
	CHECKED BY						QUANTITIES RECEIVED EXCEPT AS NOTED		DATE	BY	GRAND TOTAL									
	PACKED BY						POSTED		DATE	BY	20 RECEIVED'S VOUCHER NO.									
	← TOTAL →																			

DD FORM 1149 (9 PT) MAR 54
REPLACES EDITION OF 1 MAY 58 WHICH MAY BE USED
S/N 0102 LF 011 1401
ORIGINAL

14

BUILDER 3 & 2

Figure 1-2.—Requisition and Invoice/Shipping Document, DD Form 1149.

43.3

A unit must account for all labor used to carry out its assignment so that management can figure the amount of labor used on the project. Labor costs are figured and actual man-hours are compared with previous estimates based on jobs of a similar nature. When completed, this information is used by unit managers and higher commands for developing planning standards.

The type of labor performed must be broken down and reported by category, the purpose of which is to show how labor has been used.

For timekeeping and labor reporting purposes, all labor is classified either productive or overhead.

PRODUCTIVE LABOR includes labor that directly or indirectly contributes to the accomplishment of the unit's mission, including construction operations, military operations, and training. Productive labor is accounted for in three categories, direct labor, indirect labor, and military, which is called "other" on some timekeeping cards.

1. **DIRECT LABOR** includes labor expended directly on assigned construction tasks either in the field or in the shop, which contributes directly to the completion of an end product. Direct labor must be reported separately for each assigned construction task.

2. **INDIRECT LABOR** comprises labor required to support construction operations, but which does not produce an end product itself.

3. **MILITARY (other)** includes military functions and training necessary to support the mission.

OVERHEAD LABOR is not considered to be productive labor in that it does not contribute directly or indirectly to the completion of an end product. It includes labor that must be performed regardless of the assigned mission.

During the planning and scheduling of a construction project, each phase of the project considered as direct labor is given an identifying code, usually by the Operations Department. Because there are many types of construction

projects involving different operations, codes for direct labor reporting may vary from one activity to another. For example, "excavating and setting forms" may be assigned code R-15, "laying block" R-16, and "installing bond beams" R-17. You will use direct labor codes in reporting each hour spent by each of your crewmembers during each work day on assigned construction tasks.

You will also use codes to report time spent by crewmembers in the following categories: indirect labor, military operations and readiness, disaster control operations, training, and overhead labor. The codes shown in figure 1-3 are used at most activities to indicate time spent in these categories.

Your report is submitted on a daily labor distribution report form (timekeeping card) like the one shown in figure 1-4. It immediately provides a breakdown by man-hours of the activities in the various labor codes for each crewmember for each day on any given project. It is reviewed at the company level by the staff and Platoon Commander and then initialed by the Company Commander before it is forwarded to the Operations Department. It is tabulated by the Management Division of the Operations Department, along with all of the daily labor distribution reports received from each company and department in the unit. This report is the means by which the Operations Officer analyzes the labor distribution of total manpower resources for each day, and as feeder information for the preparation of the monthly operations report, and any other resource reports required of the unit. This information must be accurate and timely. Each level in the company organization should review the report for an analysis of its own internal construction management and performance.

PERSONNEL READINESS CAPABILITY PROGRAM

The Personnel Readiness Capability Program (PRCP) was developed for use within the Naval Construction Force (NCF). It is designed to provide crew leaders with information on

PRODUCTIVE LABOR. Productive labor includes all labor that directly contributes to the accomplishment of the Naval Mobile Construction Battalion, including construction operations and readiness, disaster recovery operations, and training.

DIRECT LABOR. This category includes all labor expended directly on assigned construction tasks, either in the field or in the shop, and which contributes directly to the completion of the end product.

INDIRECT LABOR. This category comprises labor required to support construction operations, but which does not produce in itself. Indirect labor reporting codes are as follows.

- | | | |
|---|---|-----------------------------------|
| X01 Construction Equipment Maintenance,
Repair and Records | X04 Project Expediting
(Shop Planners) | X07 Tool and Spare
Parts Issue |
| X02 Operation and Engineering | X05 Location Moving | X08 Other |
| X03 Project Supervision | X06 Project Material
Support | |

MILITARY OPERATIONS AND READINESS. This category comprises all manpower expended in actual military operations, unit embarkation, and planning and preparations necessary to insure unit military and mobility readiness. Reporting codes are as follows:

- | | | | |
|-------------------------|--------------------------|--|-----------|
| M01 Military Operations | M04 Unit Movement | M07 Military Administrative
Functions | M09 Other |
| M02 Military Security | M05 Mobility Preparation | M08 Mobility & Defense
Exercise | |
| M03 Embarkation | M06 Contingency | | |

DISASTER CONTROL OPERATIONS

- | | |
|---------------------------------|-------------------------------|
| D01 Disaster Control Operations | D02 Disaster Control Exercise |
|---------------------------------|-------------------------------|

TRAINING. This category includes attendance at service schools, factory, and industrial training courses, fleet type training, and short courses, military training and organized training conducted within the battalion. Reporting codes are as follows:

- | | | |
|------------------------|-------------------------------|----------------------------------|
| T01 Technical Training | T03 Disaster Control Training | T05 Safety Training |
| T02 Military Training | T04 Leadership Training | T06 Training Adminis-
tration |

OVERHEAD LABOR. This category includes labor which must be performed regardless of whether a mission is assigned, and which does not contribute to the assigned mission. Reporting codes are as follows:

- | | | |
|--|---|-------------------------|
| Y01 Administrative & Personnel | Y06 Camp Upkeep & Repairs | Y10 Personal
Affairs |
| Y02 Medical & Dental Department | Y07 Security | Y11 Lost Time |
| Y03 Navy Exchange and Special Services | Y08 Leave & Liberty | Y12 TAD not
for unit |
| Y04 Supply & Disbursing | Y09 Sickcall, Dental &
Hospitalization | Y13 Other |
| Y05 Commissary | | |

Figure 1.3.—Labor codes.

When you become a crew leader, it will be your responsibility to your crewmembers to provide them with the opportunity to learn new skills. This may be done through training or by assigning your crew to various types of work whenever possible. You and your crewmembers can gain a higher level by determining the training requirements needed and satisfying them. Then you report these newly acquired skills to the PRCP coordinator who adds them to your other skills and those of each crewmember. It is your responsibility to see that this skill information is kept current and accurate.

SAFETY PROGRAM

As a petty officer, you must be familiar with the safety program at your activity. You cannot function effectively as a petty officer unless you are aware of how you fit into this program. You should know who (or what group) arbitrates and establishes the safety policies and procedures you must follow. You should also know who provides guidelines for safety training and supervision. Every Naval Mobile Construction Battalion (NMCB) is required to implement a formal safety organization.

SAFETY ORGANIZATION

The NMCB's safety organization provides for (1) the establishment of safety policy and (2) control and reporting. As illustrated in figure 1-5, the Battalion Safety Policy Organization is made up of the policy committee, supervisors' committee, and equipment, shop, and crew committees. The SAFETY POLICY COMMITTEE is presided over by the executive officer. Its primary purpose is to develop safety rules and policy for the battalion. This committee reports to the commanding officer, who must approve all changes in safety policy.

The SAFETY SUPERVISORS' COMMITTEE is presided over by the battalion's safety chief and include safety supervisors assigned by company commanders, project officers, or officers in charge of detail. This committee provides a convenient forum for

work procedures, safe practices, and safety suggestions. Its recommendations are sent to the policy committee.

The EQUIPMENT, SHOP, AND CREW COMMITTEES are assigned as required. Each committee is usually presided over by the company or project safety supervisor. Its main objective is to propose changes in the battalion's safety policy in order to eliminate unsafe working conditions or prevent unsafe acts. These committees are your contact for recommending changes in safety matters. In particular, the equipment committee reviews all vehicle accident reports, determines the cause of each accident, and recommends corrective action. As a crew leader, you can expect to serve as a member of the equipment, shop, or crew safety committee. Each committee forwards reports and recommendations to the safety supervisors' committee.

SAFETY DUTIES

Figure 1-5 also shows the Battalion Safety Control and Reporting Organization. As a crew leader, you will report to the safety supervisor, who directs the safety program of a project. Duties of the safety supervisor include indoctrinating new crewmembers, compiling accident statistics for the project, reviewing accident reports submitted to the Safety Office, and comparing safety performances of all crews.

The crew leader is responsible for carrying out safe working practices under the direction of the safety supervisor or others in positions of authority (project chief, project officer, safety chief, safety officer). You, the crew leader, must be sure each crewmember is thoroughly familiar with these working practices, has a general understanding of pertinent safety regulations, and makes proper use of protective clothing and safety equipment. Furthermore, be ready at all times to correct every unsafe working practice you observe and report it immediately to the safety supervisor or other person in charge. When an unsafe condition exists, they have the power to stop work on the project until the condition is corrected.

BATTALION SAFETY POLICY ORGANIZATION

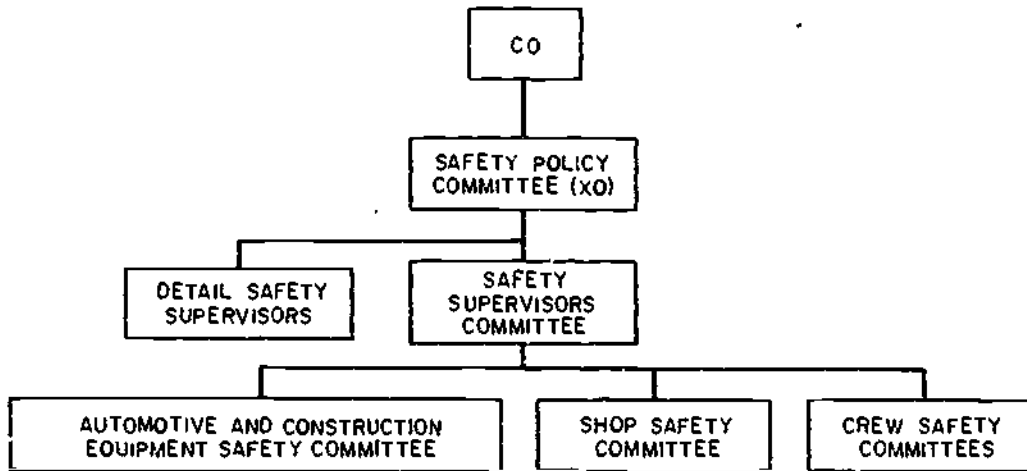

BATTALION SAFETY CONTROL AND REPORTING ORGANIZATION

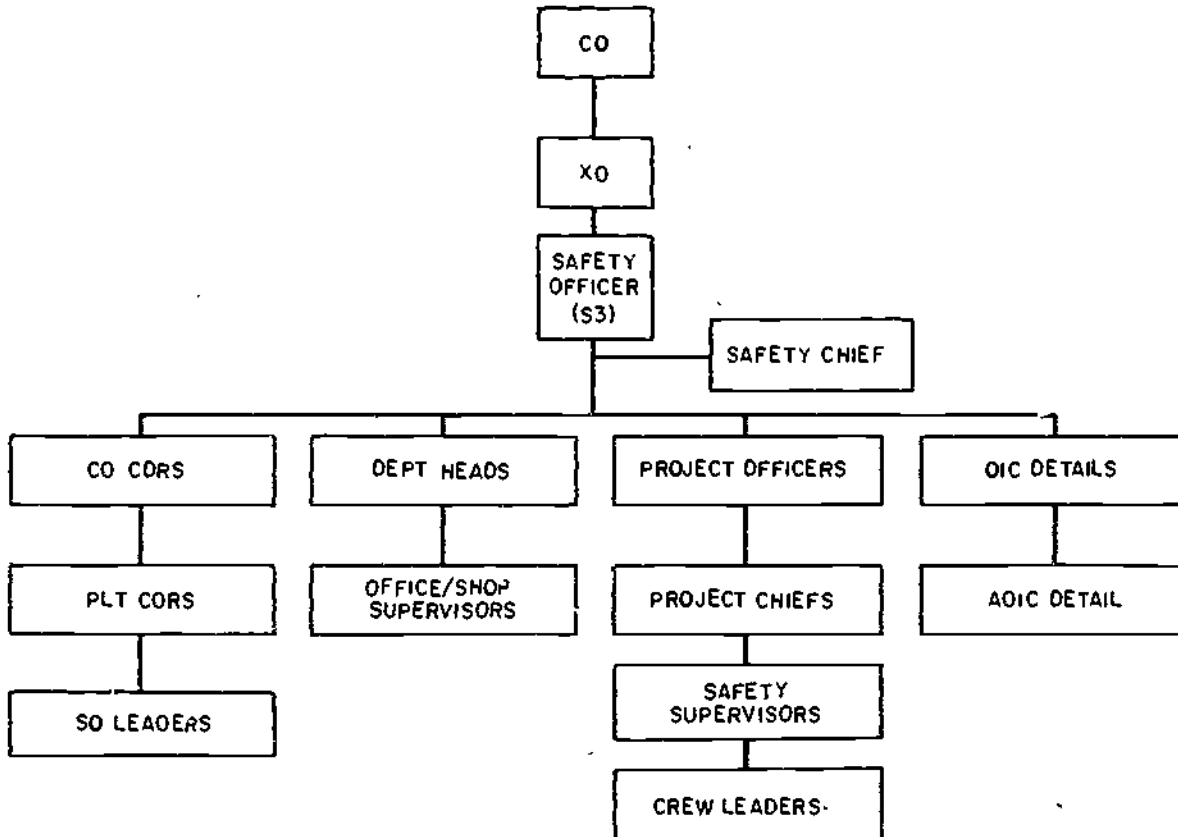

Figure 1-5.-The NMCB safety organization chart.

1.

In case of an accident, you must make sure the injured get proper medical care as quickly as possible. Investigate each accident involving crewmembers to determine its cause. Remove or permanently correct defective tools, materials, and machines as well as environmental conditions that contribute to the cause of an accident. Afterwards, submit the written reports that are required.

SAFETY TRAINING

New methods and procedures for safely maintaining and operating equipment are constantly being developed. Therefore, you must keep abreast of the latest in maintenance and operation safety and then pass it on to your crewmembers. Keep them informed by holding so-called standup safety meetings before the day's work starts. Although responsible for the actual conduct of each meeting, you usually pass on information that the safety supervisor has organized and assembled. Information (such as the type of safety equipment to use, where to obtain it, and how to use it) is often the result of safety suggestions received by the safety supervisors' committee. Why not encourage your crewmembers to submit their ideas or suggestions to this committee?

At times, you may hold a group discussion to pass the word on specific accidents that are to be guarded against or may have happened on the job. Be sure to give plenty of thought to what you are going to say beforehand. Make the discussion interesting and urge the crew to participate. The final result should be a group conclusion as to how the specific accidents could have been prevented.

Your standup safety meetings also give you the chance to discuss matters pertaining to prestart checks, operation, or maintenance of automotive vehicles assigned to a project. Since these vehicles are used for transporting crewmembers as well as cargo, it is important to emphasize how the prestart checks are to be made and how the vehicles are to be cared for.

Likewise, you can hold a standup safety meeting to solve safety problems that develop from a new procedure for starting a particular piece of equipment just being introduced. In this case, you can demonstrate the safe starting procedure for the equipment, and then have your crewmembers practice the procedure.

However, there are all too many facts to remember and operating procedures to follow because of the variety of vehicles that may be assigned to a project. It will help to know where to look for these facts and procedures. By referring to chapter 2 of *RTM/NRCC Constructionman*, you can learn much about vehicle prestart checks as well as vehicle use forms. You can get general information about cargo weight distribution, troubleshooting, general operation, and vehicle safety by referring to chapter 5 of *RTM/NRCC Equipment Operator 3 & 2*. But for specific information on prestart checks, operation, and maintenance of each vehicle assigned, you should refer to the manufacturer's operators/maintenance manuals.

In addition to standup safety meetings, you are also concerned with day-to-day instruction and on-the-job training. Although it is beyond the scope of this manual to describe teaching methods, a few words on your approach to safety and safety training at the crew level are appropriate. Getting your crew to work safely, like most other supervisory functions, is essentially a matter of leadership. Therefore, don't overlook the power of personal example in leading and teaching your crewmembers. Soon you will discover that they are quick to detect differences between what you say and what you do. It is unreasonable to expect them to measure up to a standard of safe conduct which you, yourself, do not. As a crew leader, therefore, you must make visible at all times your genuine concern for the safety of your crew. Although not the only technique you can apply, leadership by example has proven to be one of the most practical of those available to you.

CHAPTER 2

DRAWINGS AND SPECIFICATIONS

Having worked as a crewmember on various building projects, you probably did your tasks without thinking much about what it takes to lay out structures so they will conform to their location, size, shape, and other building features. In this chapter, you will learn how to extract information from drawings and specifications that will enable you to perform assigned tasks and contribute to the completion of building projects. Also, you will be shown how to draw, read, and work from simple shop drawings and sketches. Information is given on the conversion of standard weights and measures to the metric system, and the fundamentals of mathematics as they apply to building projects.

STRUCTURAL DESIGN

From the Builder's standpoint, you must realize that building designs and construction methods depend on many factors and that no two building projects can be treated alike. However, the factors usually considered before a structure is designed are its geographical location and the availability of construction materials. It is easy to see why the geographical location is important to the design of a structure, especially its main parts. When located in a temperate zone, for example, the roof of a structure must be sturdy enough not to collapse under the weight of snow and ice. Also, the foundation walls will have to extend below the frostline to guard against the effects of freezing and thawing. In the tropics, a structure will have a flat or nearly flat roof and be built on a concrete slab or have shallow foundation walls. Likewise, the availability of construction materials can

influence the design of a structure. This happens when material is scarce in a geographical location and the costs of shipping it in are too high. In such a case, particularly overseas, the structure is likely to be built with materials purchased locally. In turn, this could have an effect on the way construction materials are used since it means working with foreign drawings and metric units of weights and measures.

STRUCTURAL MEMBERS

By comparing the designs of the two structures shown in figures 2-1 and 2-2, you will notice that each is designed according to its function. By referring to these figures often, you will learn the terminology for common structural members. Depending on the use of the structure, you may use any combination of structural members.

The main parts of a structure are the **LOAD-BEARING STRUCTURAL MEMBERS**, which support and transfer the loads on the structure while remaining equal to each other. The places where members are connected to other members are called **JOINTS**. The sum total of the load supported by the structural members at a particular instant is equal to the total **DEAD LOAD** plus the total **LIVE LOAD**.

The total dead load is the total weight of the structure, which gradually increases as the structure rises, and remains constant once it is completed. The total live load is the total weight of movable objects (such as people, furniture, bridge traffic or the like) which the structure happens to be supporting at a particular instant.

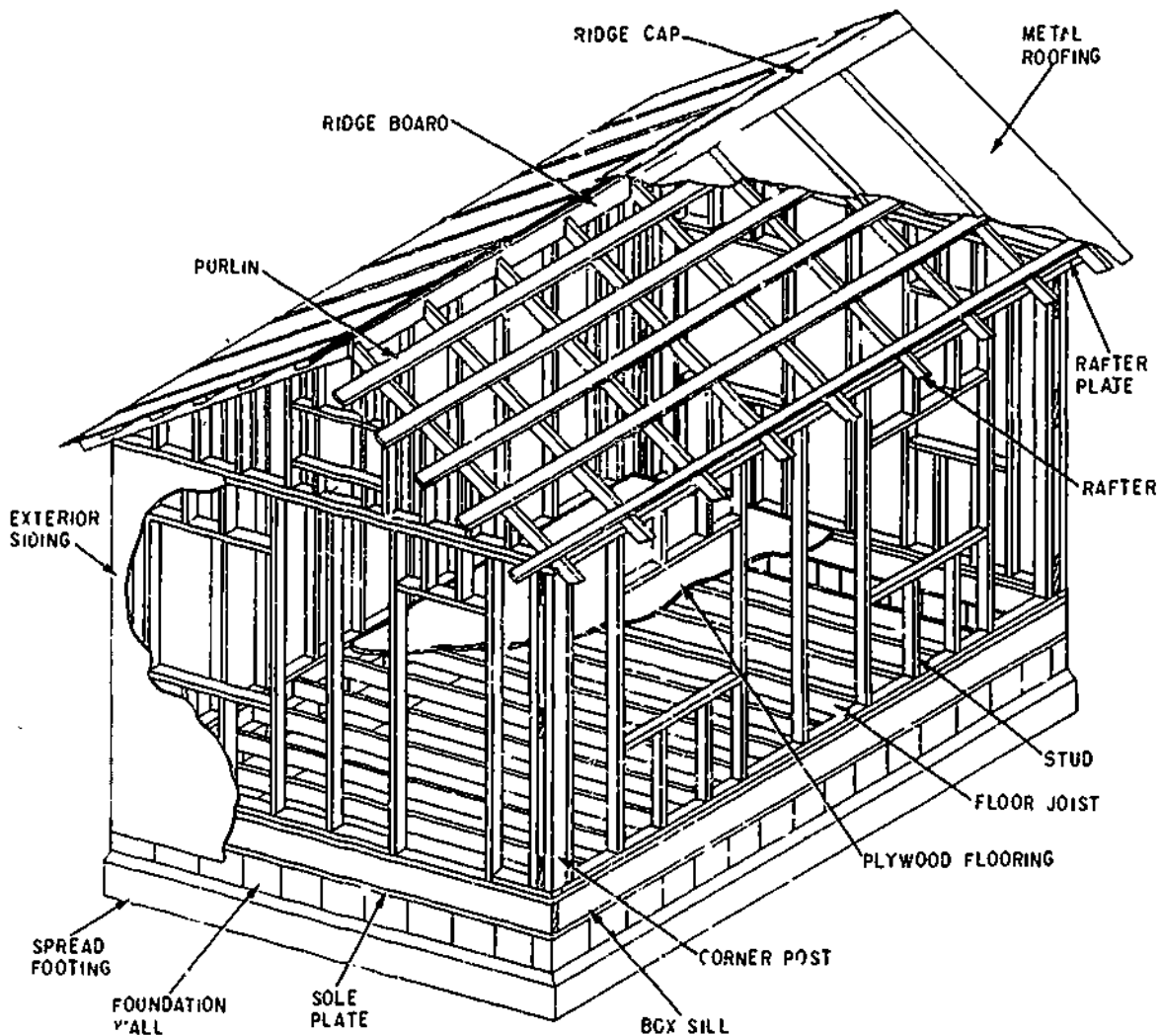

133.418

Figure 2-1.—Typical light-frame construction.

The live loads in a structure are transmitted through the various load-bearing structural members to the ultimate support of the earth as follows. Immediate or direct support for the live loads is provided by HORIZONTAL members, these are in turn supported by VERTICAL members; which in turn are supported by FOUNDATIONS and/or FOOTINGS; and these are then supported by the earth. The ability of the earth to support a load is called the SOIL BEARING CAPACITY. It varies considerably with different types of soil, and a soil of a given bearing capacity will bear a heavier load on a

wide foundation or footing than it will on a narrow one. Figure 2-1 illustrates both horizontal and vertical members of a typical light-frame structure. The weight of the metal roof is distributed over the top supporting members (purlins and rafters) and transferred through all joining members to the soil.

VERTICAL STRUCTURAL MEMBERS

In heavy construction vertical structural members are high strength columns (fig.

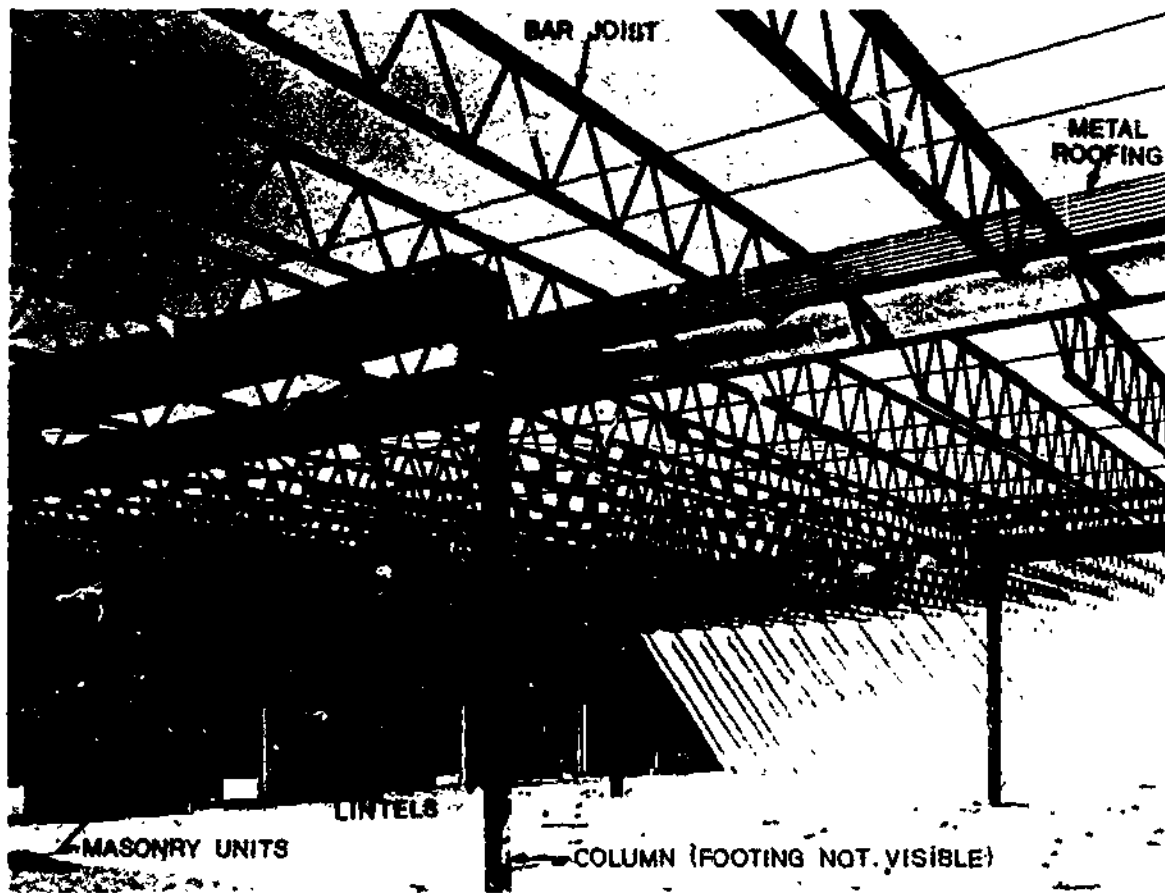

127.347

Figure 2-2.—Typical concrete masonry and steel structure.

2-2); they are called **PILARS** in large buildings. Outside-wall columns and inside bottom-floor columns usually rest directly on footings. Outside-wall columns usually extend from the footing or foundation to the roof line. Inside bottom-floor columns extend upward from footings or foundations to the horizontal members which in turn support the first floor or roof as shown in figure 2-2. Upper-floor columns usually are located directly over lower-floor columns.

A **PIER** in building construction might be called a short column. It may rest directly on a footing as shown in figure 2-3, or it may be simply set or driven into the ground. Building

piers usually support the lowermost horizontal structural members.

In bridge construction a pier is a vertical member which provides intermediate support for the bridge superstructure.

The chief vertical structural members in light frame construction are called **STUDS** (figs. 2-1 and 2-3). They are supported by horizontal members called **SILLS** or **SOLE PLATES** and are topped by horizontal members called **TOP PLATES** or **RAFTER PLATES**, as shown in figure 2-1. **CORNER POSTS** are enlarged studs, as it were, located at the building corner. In

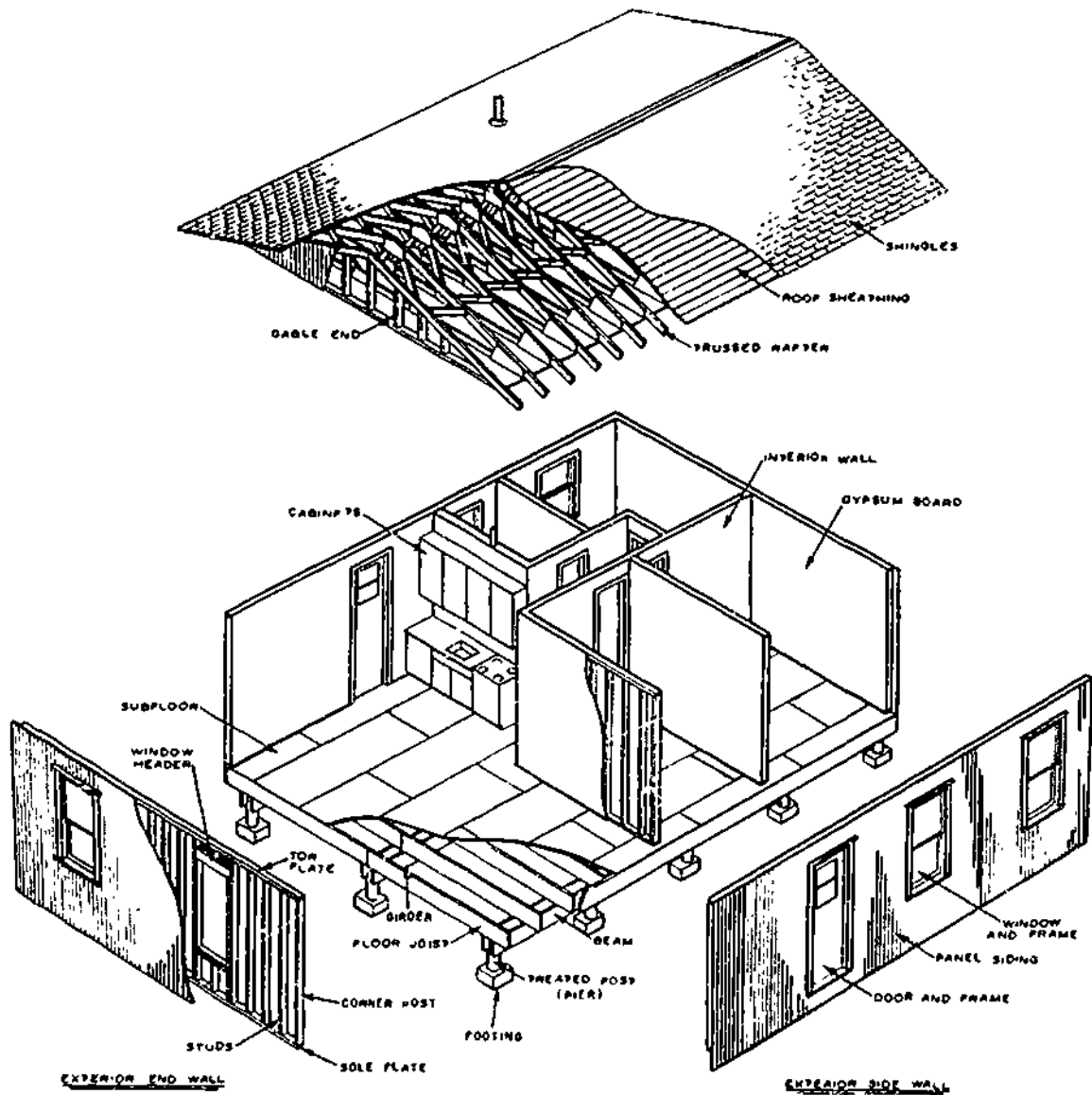

Figure 2-3.—Exploded view of a typical light-frame house.

133.419

early FULL-FRAME construction a corner post was usually a solid piece of larger timber. In most modern construction BUILT-UP corner posts are used which consist of various members of ordinary studs, nailed together in various ways.

HORIZONTAL STRUCTURAL MEMBERS

In technical terminology, any horizontal loadbearing structural member which spans a space, and which is supported at both ends, is

considered a BEAM. A member which is FIXED at one end only is called a CANTILEVER. Steel members which consist of solid pieces of the regular structural steel are referred to as STRUCTURAL SHAPES. (A GIRDER is shown in figure 2-2.) Other prefabricated open web structural-steel shapes are called BAR JOISTS (fig. 2-2).

Horizontal structural members which support the ends of floor beams or joists in wood frame construction are called SILLS, GIRTS, or GIRDERS, depending on the type of framing being done and the location of the member in the structure. (See figs. 2-1, 2-2, and 2-3.) Horizontal members which support studs are called SILLS or SOLE PLATES, depending on the type of framing. Horizontal members which support the wall-ends of rafters are called RAFTER PLATES. Horizontal members which assume the weight of concrete or masonry walls above door and window openings are called LINTELS, as shown in figure 2-2.

The horizontal or inclined members which provide support to a roof are called RAFTERS. (See fig. 2-1.) The lengthwise (right angle to the rafters) member which supports the peak-ends of the rafters in a roof is called the RIDGE. The ridge may be called a ridge board, the ridge piece, or the ridge pole. Lengthwise members other than ridges are called PURLINS. (See fig. 2-1.) In wood frame construction the wall ends of rafters are supported on horizontal members called RAFTER PLATES, which are in turn supported by the outside wall studs. In concrete or masonry wall construction, the wall ends of rafters may be anchored directly on the walls, or on plates bolted to the walls.

A beam of given strength, without intermediate supports below, can support a given load over only a certain maximum span. If the span is wider than this maximum, intermediate supports, such as a column must be provided for the beam. Sometimes it is not feasible or possible to install intermediate supports. When such is the case, a TRUSS may be used instead of a beam.

A beam consists of a single horizontal member. A truss, however, is a framework,

consisting of two horizontal (or nearly horizontal) members, joined together by a number of vertical and/or inclined members (fig. 2-3). The horizontal members are called the UPPER and LOWER CHORDS; the vertical and/or inclined members are called the WEB MEMBERS.

TYPES OF DRAWINGS

The building of any structure is described by a set of related drawings that give the Builder a complete sequential graphic description of each phase of the construction process. In most cases, a set of drawings begins by showing the location, boundaries, contours, and outstanding physical features of the construction site and its adjoining areas. Succeeding drawings may give instructions for the excavation and disposition of existing ground; erection of the foundations and superstructure; installation of utilities which includes plumbing, heating, lighting, air-conditioning, interior and exterior finishes, and whatever else is required to complete the structure.

The architect and the engineer, working together, decide upon the materials to be used in the structure and the construction methods which are to be followed. The engineer determines the loads which supporting members will carry and the strength qualities the members must have to bear the loads. The engineer also designs the mechanical systems of the structure, such as the lighting, heating, and plumbing systems. The end-result is the preparation of architectural and engineering DESIGN SKETCHES. The purpose of these sketches is to guide draftsmen in the preparation of CONSTRUCTION DRAWINGS.

CONSTRUCTION DRAWINGS

Generally, construction (working) drawings furnish enough information for the Builder to complete an entire project. Normally, they incorporate all three main groups of drawings.

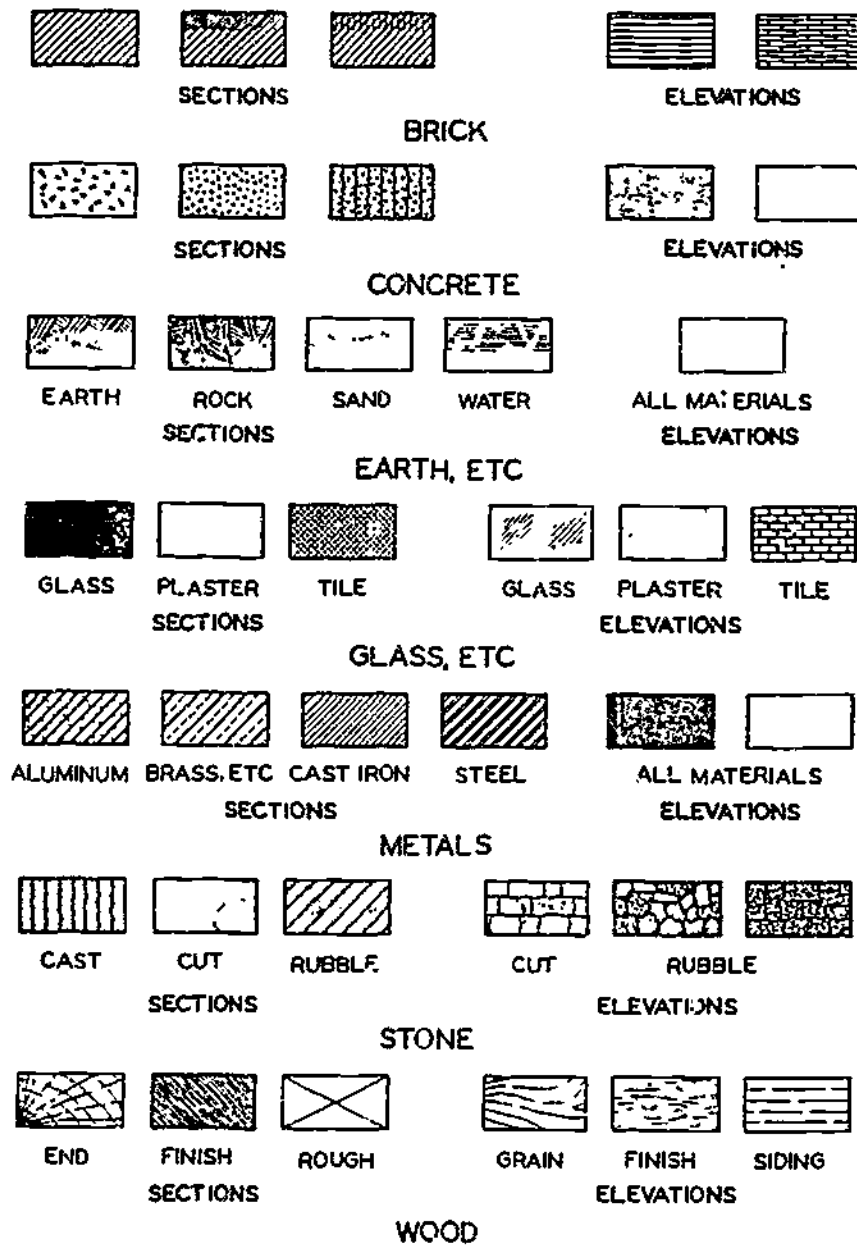

45.271(45B)4
 Figure 2-4 - Architectural symbols for plans and elevations recommended by the American Standards Association.
 (Note: Symbols may vary according to section or elevation drawings.)

the architectural, electrical, and mechanical. In drawings for simple structures, this grouping may be hard to discern, because the same single drawing may contain both the electrical and mechanical layouts. In complicated structures, combination of layouts are not possible because of overcrowding. In this case, the floor plan may be traced over and over for drawings for the electrical and mechanical layouts.

However, if any one of the three main groups of drawings furnish enough information for the tradesman to complete a project, it is to be considered a construction drawing. Normally, construction drawings will include the detail drawings, assembly drawings, bill of materials, and the specifications.

A detail drawing shows a particular item on a larger scale than that of the general drawing in which the item appears—or it may show an item too small to appear at all on a general drawing.

An assembly drawing is either an exterior or sectional view of an object showing the details in the proper relationship to one another. Usually assembly drawings are drawn to a smaller scale from the dimensions of the detail drawings, which provide a check on the accuracy of the design of the detail drawings and often discloses errors.

Depending on the space available on the drawing sheet, the bill of materials may be incorporated in the drawing; otherwise, it is listed on a separate sheet. The bill of materials lists the quantities, types, sizes, and units of the materials required to construct the object presented in the drawing.

The specifications are normally found on a separate sheet and convey a complete description of the work to be done in a brief, clear, and concise manner. They will state the actual minimum needs of the government and all other known conditions, directly and explicitly.

Construction drawings consist mostly of ORTHOGRAPHIC views prepared by draftsmen employing the standard technical drawing techniques, symbols, and other designations, as explained in MIL-STD-14, MIL-STD-17-1, and

MIL-STD-100B. Figure 2-4 illustrates the conventional symbols for the more common types of material used on structures. A thorough study of the symbols should be made before proceeding further with this chapter. Figure 2-5 shows the more common symbols used for doors and windows. Figures 2-6, 2-7, and 2-8, show common plumbing, heating, and electrical symbols respectively. General drawings consist of plans (views from above) and elevations (side or front views), drawn on a relatively small scale. The first section of the construction drawings consists of the plot or site plans, foundation plans, floor plans, and framing plans.

Plot Plans

A plot plan (fig. 2-9) shows the contours, boundaries, roads, utilities, trees, structures, and any other significant physical features on or near the construction site. The locations of proposed structures are shown in outline. The plan shows corner locations with reference to reference lines shown on the plot and which can be located at the site. Thus, the plot plan furnishes the essential data for laying out the building.

By showing both existing and finish contours, it furnishes essential data for the graders.

Foundation Plans

A foundation plan (fig. 2-10) is a plan view of a structure as it would look if projected onto a horizontal plane passed through the structure slightly below the level of the top of the foundation wall. The plan in figure 2-10 shows that the main foundation will consist of 12 in. and 8 in. concrete masonry unit (CMU's) walls measuring 28 ft lengthwise and 22 ft crosswise. The lower portion of each lengthwise section of wall will be 12 in. thick, to provide a concrete ledge 4 in. wide.

A girder running through the center of the building will be supported at the ends by two 4-by-12-in. concrete pilasters which will butt against the end foundation walls. Intermediate

DOOR SYMBOLS	
TYPE	SYMBOL
SINGLE SWING WITH THRESHOLD IN EXTERIOR MASONRY WALL	
SINGLE DOOR, OPENING IN	
DOUBLE DOOR, OPENING OUT	
SINGLE SWING WITH THRESHOLD IN EXTERIOR FRAME WALL	
SINGLE DOOR, OPENING OUT	
DOUBLE DOOR, OPENING IN	
REFRIGERATOR DOOR	

TYPE	WINDOW SYMBOLS		
	WOOD OR METAL SASH IN FRAME WALL	METAL SASH IN MASONRY WALL	WOOD SASH IN MASONRY WALL
DOUBLE HUNG			
CASEMENT			
DOUBLE, OPENING OUT			
SINGLE, OPENING IN			

Figure 2-5.—Architectural symbols (doors and windows).

65.112

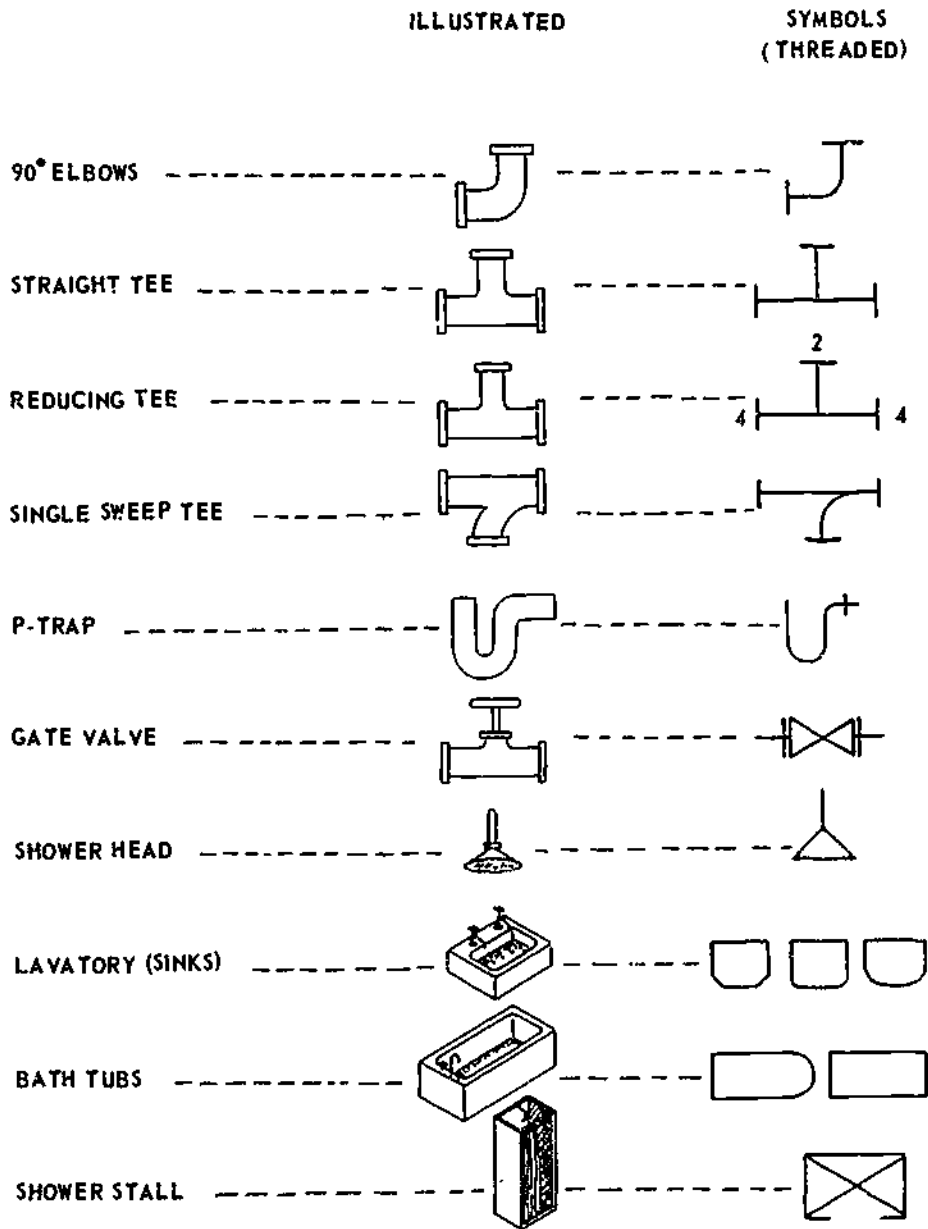

Figure 2-6.—Common plumbing symbols.

11.330(6S)

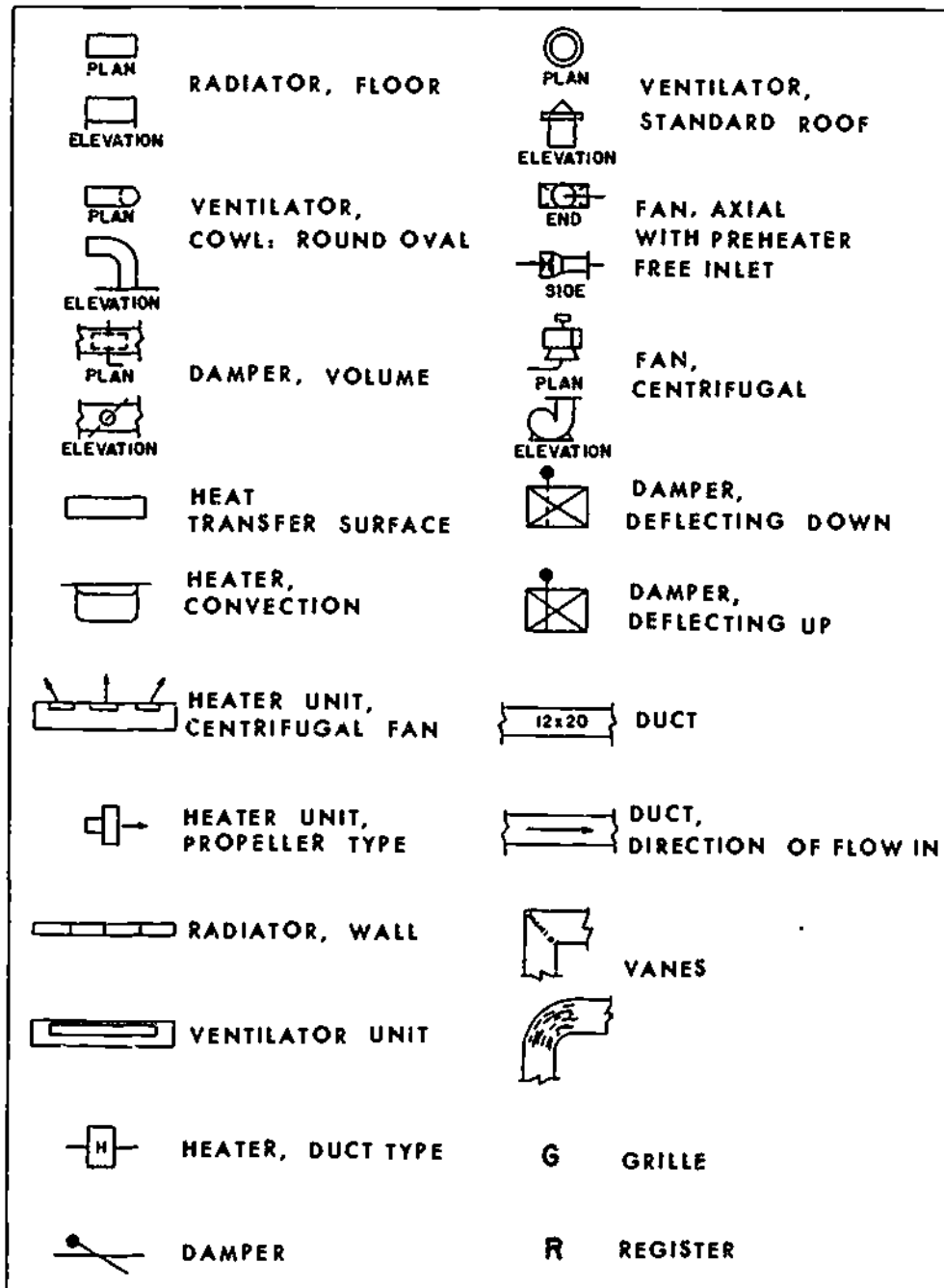

Figure 2.7.—Heating symbols.

45.732

Chapter 2—DRAWINGS AND SPECIFICATIONS

	BATTERY, MULTICELLS		FIRE-ALARM BOX, WALL TYPE		S SINGLE-POLE SWITCH
	SWITCH BREAKER		LIGHTING PANEL		S ₂ DOUBLE-POLE SWITCH
	AUTOMATIC RESET BREAKER		POWER PANEL		Ⓢ PULL SWITCH CEILING
	BUS		BRANCH CIRCUIT, CONCEALED IN CEILING OR WALL		Ⓢ PULL SWITCH WALL
	VOLTMETER		BRANCH CIRCUIT, CONCEALED IN FLOOR		Ⓢ FIXTURE, FLUORESCENT, CEILING
	TOGGLE SWITCH DPST		BRANCH CIRCUIT, EXPOSED		Ⓢ FIXTURE, FLUORESCENT, WALL
	TRANSFORMER, MAGNETIC CORE		FEEDERS		Ⓢ JUNCTION BOX, CEILING
	BELL		UNDERFLOOR DUCT AND JUNCTION BOX		Ⓢ JUNCTION BOX, WALL
	BUZZER, AC		MOTOR		L LAMPHOLDER, CEILING
	Crossing not connected (not necessarily at a 90° angle)		CONTROLLER		L LAMPHOLDER, WALL
	JUNCTION		STREET LIGHTING STANDARD		L _{PS} LAMPHOLDER WITH PULL SWITCH, CEILING
	TRANSFORMER, BASIC		OUTLET, FLOOR		L _{PS} LAMPHOLDER WITH PULL SWITCH, WALL
	GROUND		CONVENIENCE, DUPLEX		Ⓢ SPECIAL PURPOSE
	OUTLET, CEILING		FAN, WALL		☎ TELEPHONE, SWITCHBOARD
	OUTLET, WALL		FAN, CEILING		T THERMOSTAT
	FUSE		KNIFE SWITCH DISCONNECTED		Ⓢ PUSHBUTTON

Figure 2-8.—Electrical symbols.

13.5(45B)

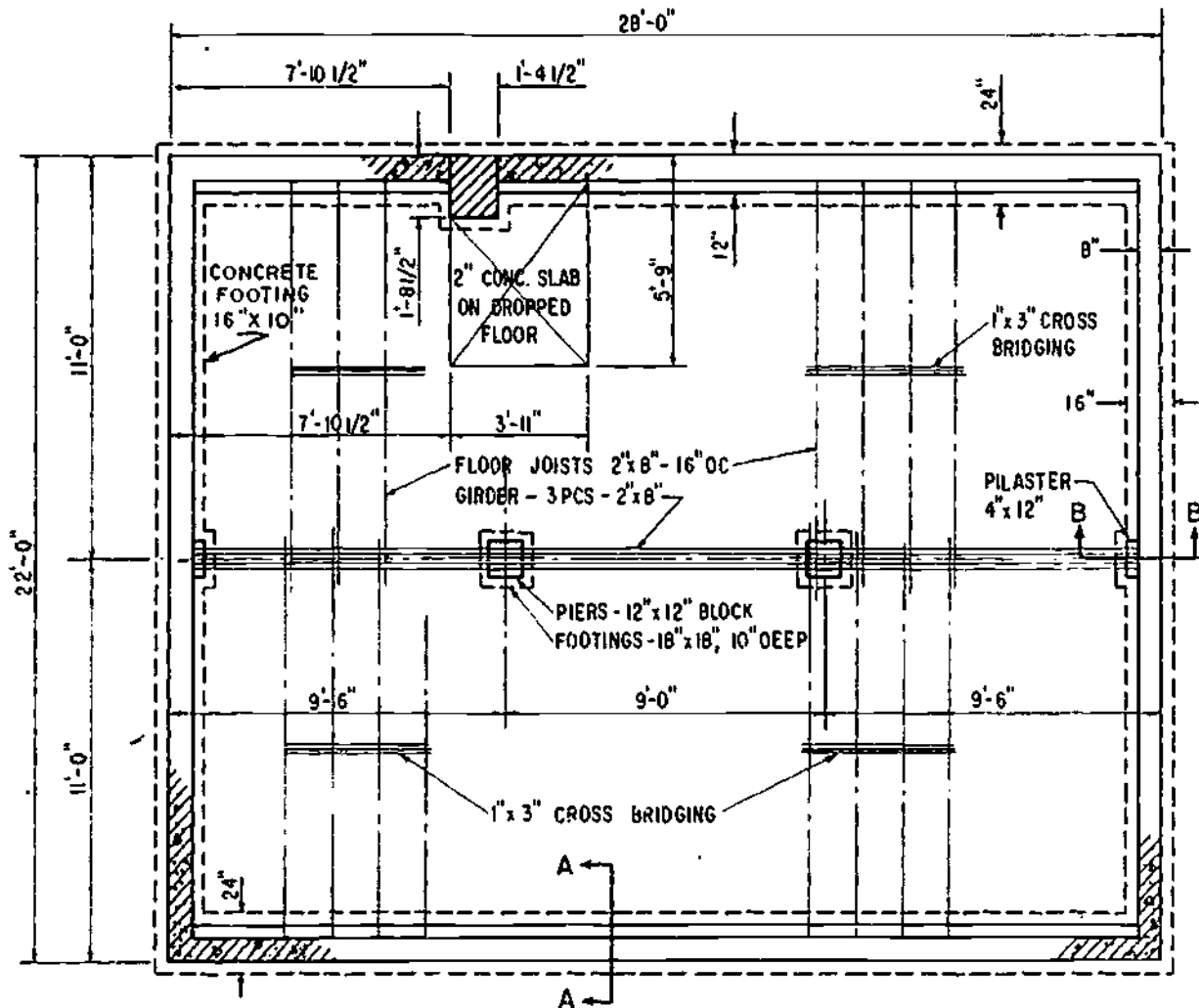

Figure 2-10.—Foundation plan.

45.513

support for the girder will be provided by two 12- by 12-in. concrete piers, each supported on 18- by 18-in. spread footings 10 in. deep. The dotted lines around the foundation walls indicate that these walls will also rest on spread footings.

Floor Plans

Figure 2-11 shows the manner in which a floor plan is developed. An architectural or

structural floor plan shows the structural characteristics of the building at the level of the plane of projection. A mechanical floor plan shows the plumbing and heating systems and any other mechanical appurtenances other than those which are electrical. An electrical floor plan shows the electrical lighting system and any other systems which are electrical.

Figure 2-12 shows an architectural floor plan. It shows the lengths, thicknesses, and character of the outside walls and partitions at

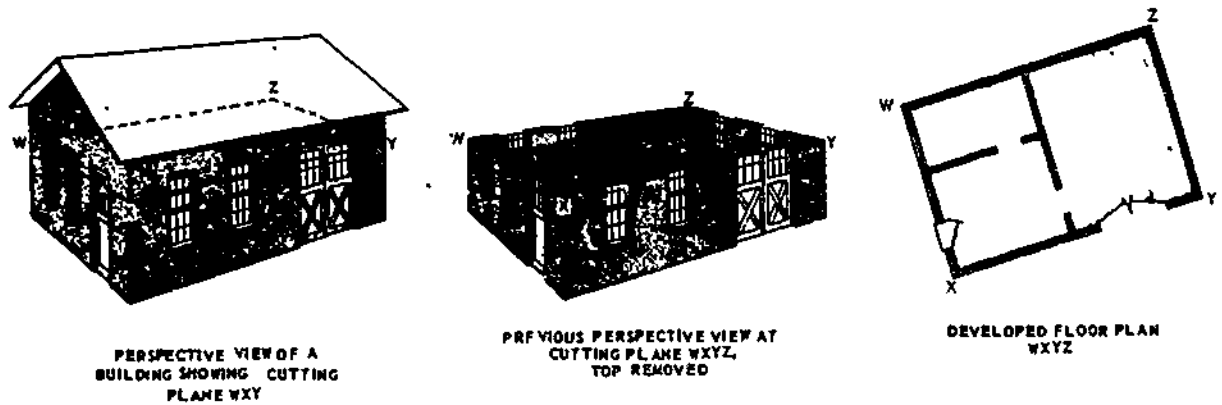

Figure 2-11.—Floor plan development.

45.514

the particular floor level. It also shows the number, dimensions, and arrangement of the rooms, the widths and locations of doors and windows, and the locations and character of bathroom, kitchen, and other utility features. Study figure 2-12 carefully. In dimensioning floor plans, it is very important to check the overall dimension against the sum of the partial dimensions of each part of the structure.

building. The schedule shows the dimensions of the finished opening and the character and dimensions of the lintel for each window. For window A, for example, the lintel will consist of an angle combined with a channel, for each of the other windows the lintel will consist of two angles. The schedule indicates that the sash will be metal casement sash. The dotted lines on the elevations show how each section of sash will swing.

Elevations

The front, rear, and sides of a structure, as they would appear projected on vertical planes, are shown in elevations. Elevations for a small building are shown in figure 2-13. They show that the wall surfaces of this house will consist of brick and roof covering of composition shingles. The top of the rafter plate will be 8 ft 2 1/4 in. above the level of the finished first floor, and the tops of the finished door and window openings 7 ft 1-3/4 in. above the same level. The roof will be a gable roof and will have 4 units of rise for every 12.

Each window shown in the elevations is identified by a capital letter. Figure 2-14 shows a window schedule applying to the same

Framing Plans

Framing plans show the size, number, and location of the structural members (steel or wood) constituting the building framework. Separate framing plans may be drawn for the floors, the walls, and the roof. The floor framing plan must specify the sizes and spacing of joists, girders, and columns used to support the floor. Detail drawings must be added, if necessary, to show the methods of anchoring joists and girders to the columns and foundation walls or footings. Wall framing plans show the location and method of framing openings and ceiling heights so that studs and posts can be cut. Roof framing plans show the construction of the rafters used

Chapter 2—DRAWINGS AND SPECIFICATIONS

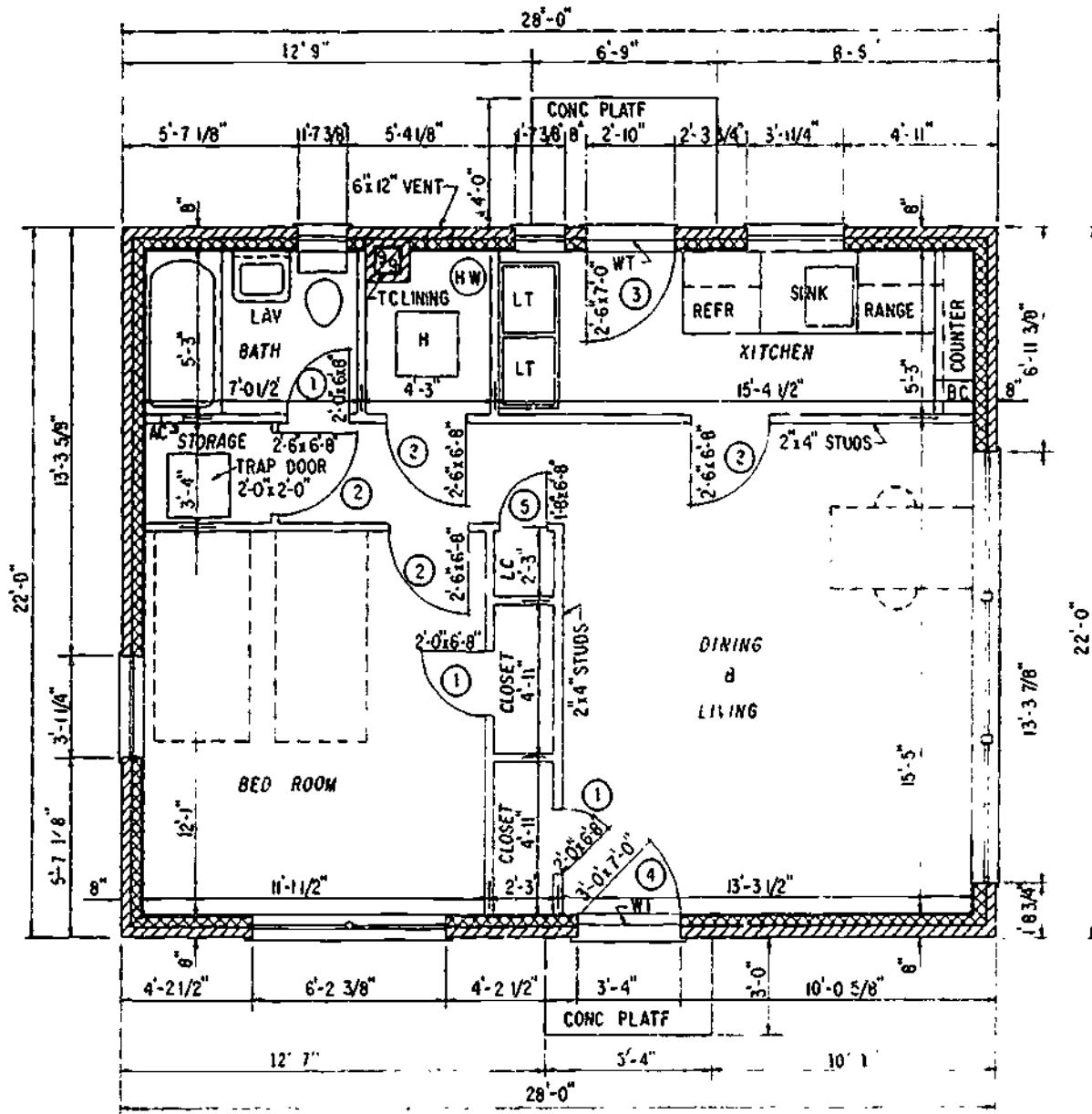

DOOR SCHEDULE			
①	- 2'-0" x 6'-8"	③	- 2'-6" x 7'-0"
②	- 2'-6" x 6'-8"	④	- 3'-0" x 7'-0"
⑤	- 1'-8" x 6'-8"		

45.515(54)A

Figure 2-12—Floor plan.

BUILDER 3 & 2

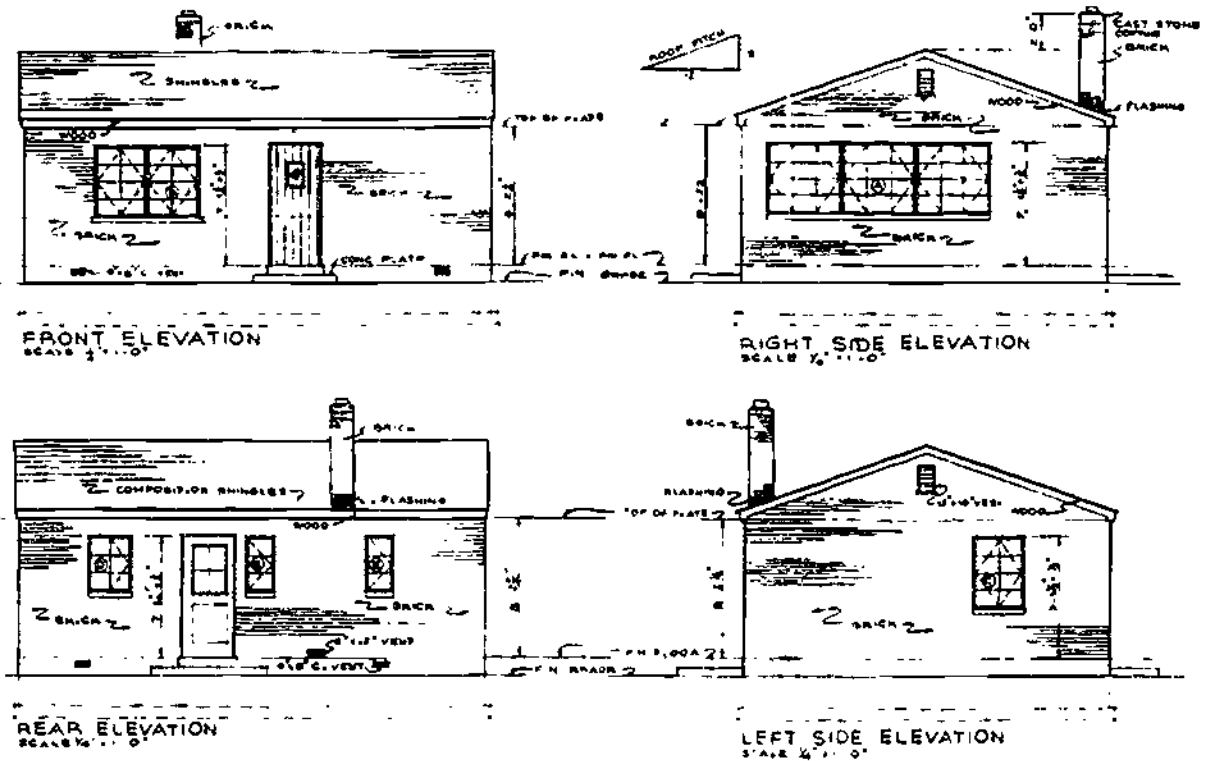

Figure 2-13.—Elevations.

45.518

to span the building and support the roof. Size, spacing, roof slope, and all details are shown.

FLOOR.—Framing plans for floors are basically plan views of the girders and joists. The unbroken double-line symbol is used to indicate joists, which are drawn in the positions they will occupy in the completed building. Double framing around openings and beneath bathroom

fixtures is shown where used. Figure 2-15 shows the manner of presenting floor framing plans.

1. Bridging is also shown by a double-line symbol which runs perpendicular to the joists. The number of rows of cross bridging is controlled by the span of the joist, they should not be placed more than 7 or 8 ft apart. A 14-ft span needs only one row of bridging, but a 16-ft span needs two rows.

2. Notes identify floor openings, bridging, and girts or plates. Use nominal sizes in specifying lumber.

3. Dimensions need not be given between joists. Such information is given along with notes. For example, 1" x 6" joists @ 2'-0" c.c., indicates that the joists are to be spaced at intervals of 2 ft 0 in. from center to center. Lengths may not be indicated in framing plans, the overall building dimensions and the

SCHEDULE FOR METAL CASEMENT SASH		
SYMBOL	SIZE	LINTEL
A	3'-4 ⁵ / ₈ " x 4'-2 ³ / ₈ "	JL 9' x 3" x 3" x 3"
B	2'-3 ¹ / ₂ " x 4'-2 ³ / ₈ "	JL 2' x 3" x 3" x 3"
C	1'-3 ¹ / ₂ " x 4'-2 ³ / ₈ "	JL " " " "
D	1'-3 ¹ / ₂ " x 3'-2"	JL " " " "
E	1'-1 ¹ / ₂ " x 3'-2"	JL " " " "

45.519

Figure 2-14.—Window schedule for building shown in figure 2-13.

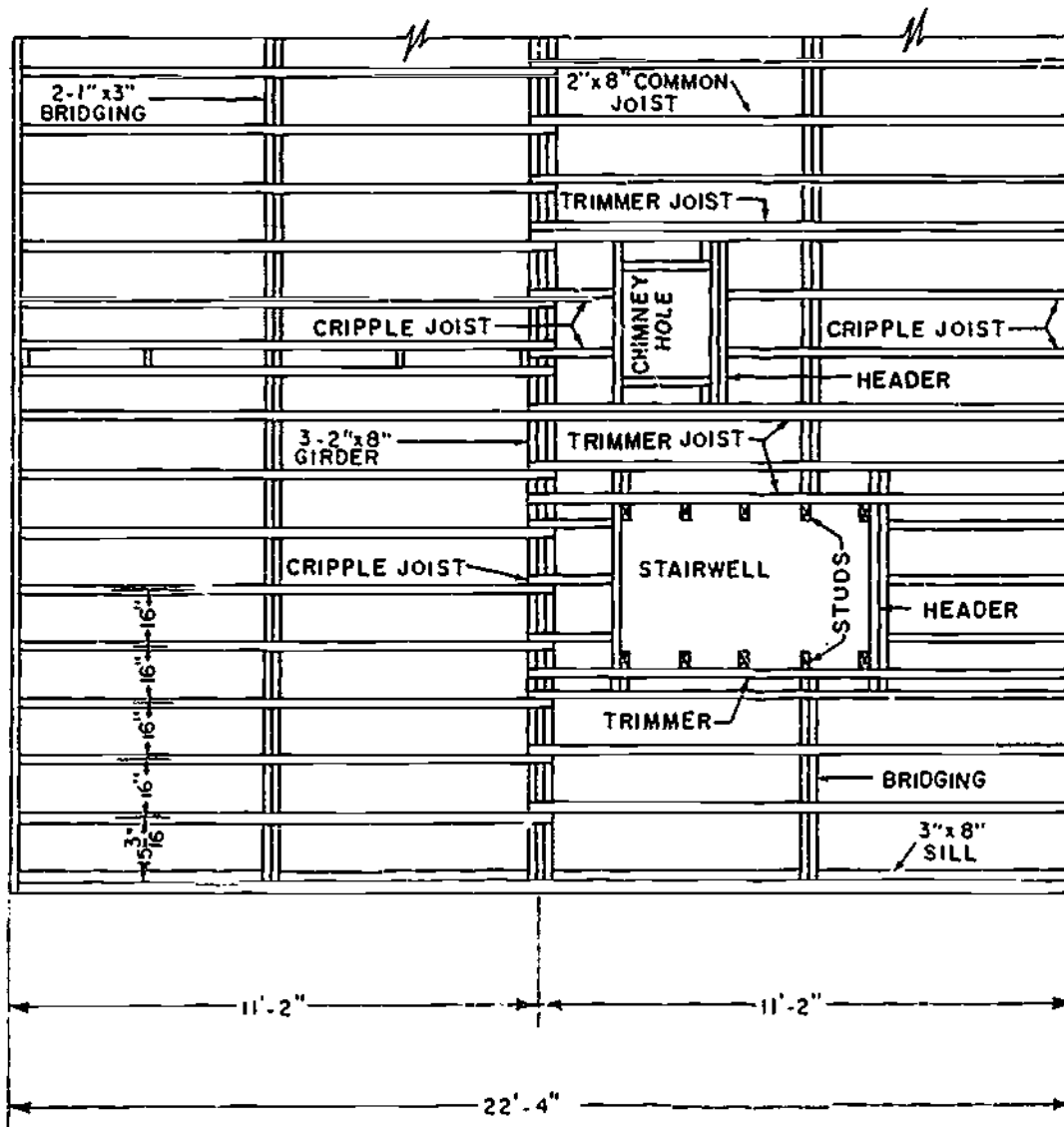

Figure 2-15.—Floor framing plan.

65.114

dimensions for each bay or distances between columns or posts provide such data.

ROOF.—Framing plans for roofs are drawn in the same manner as floor framing plans. A Builder should visualize the plan as looking down on the roof before any of the roofing material (sheathing) has been added. Rafters are shown in the same manner as joists.

Sections

SECTIONAL VIEWS, or SECTIONS. provide important information as to height, materials, fastening and support systems, and concealed features. They show how a structure looks when cut vertically by a cutting plane. The cutting plane is not necessarily continuous, but, as with the horizontal cutting plane in building plans, may be staggered to include as much

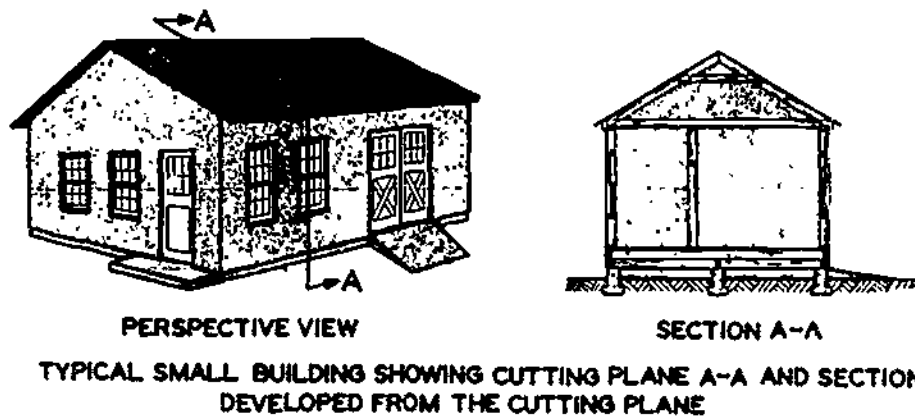

Figure 2-16.—Development of a section view.

45.520

construction information as possible. Like elevations, sectional views are vertical projections. Being detail drawings, they are drawn to large scale. This facilitates reading and provides information that cannot be given on elevation or plan views. Sections are classified as TYPICAL and SPECIFIC. Figure 2-16 shows the initial development of a section. A typical section is illustrated in figure 2-17.

units, and serve to form a 4 in. support for the brick facing which is to begin an unspecified depth below ground level. The main wall is then laid with standard 2 1/2-by 4-by 8-in. face brick backed by 4-by 8-by 16-in. CMU's.

Typical sections represent the average condition throughout a structure and are used when construction features are repeated many times. Figure 2-17 shows wall section A-A of the foundation plan in figure 2-10. It shows the construction details which are repeated at regular intervals throughout the building. Study figure 2-17 very closely. You can see that it gives a great deal of information that is necessary for those performing the construction of the building.

The foundation plan shown in figure 2-10 shows that the main foundation of this structure will consist of a 22-by 28-ft concrete block rectangle. Figure 2-17, which is section A-A of the foundation plan, shows that the front and rear portion of the foundation (28 ft measurements) are made of 12-by 8-by 16-in. CMU's centered on a 10-by 24-in. concrete footing to an unspecified height. These are followed by 8 in. CMU's which form a 4 in. ledger for floor joist support on top of the 12 in.

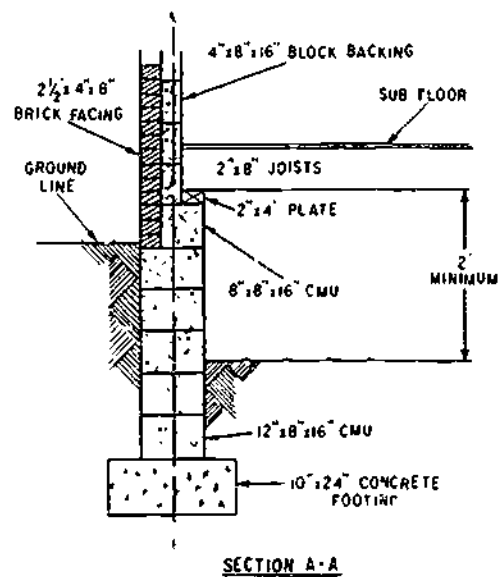

Figure 2 17.—Section A-A illustrates a typical section of a masonry building.

133.420

Chapter 2—DRAWINGS AND SPECIFICATIONS

The foundation plan shown in figure 2-10 also shows that both side walls (22 ft measurements) are 8 in. thick centered on a 16 in. concrete footing to an unspecified height. Section B-B (fig. 2-18) illustrates the PILASTER, a specific section of the wall to be constructed for support of the girder. It shows that the pilaster is constructed of 12- by 8- by 16-in. CMU's alternated with 4- by 8- by 16-in. and 8- by 8- by 16-in. CMU's. The hidden lines (dashed lines) on the 12 in. wide units indicate that the thickness of the wall beyond the pilaster is 8 in. thick. Note how the extra 4 in. thickness of the pilaster provides a center support for the girder, which in turn will support the floor joists.

Details

Details are large-scale drawings showing the builders of a structure how its various parts are

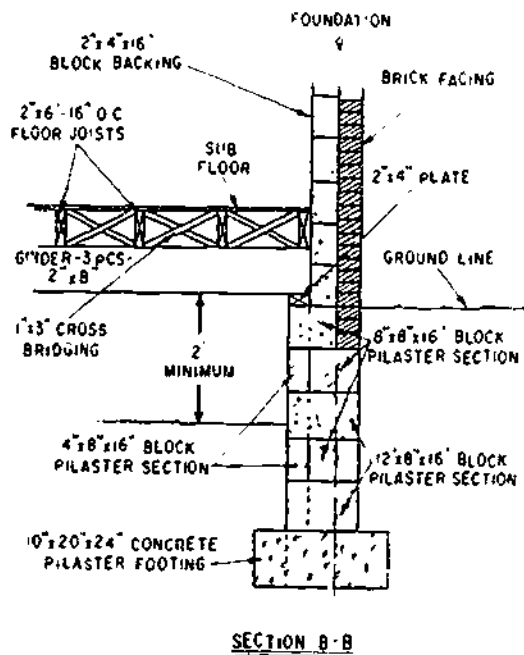

133.421

Figure 2-18.—Wall section B-B shows a pilaster, a specific section of a concrete masonry unit wall.

to be connected and placed. Details do not use the cutting plane indication, but they are closely related to sections, in that sections are often used as parts of detail drawings. The construction of doors, windows, and eaves is customarily shown in detail drawings of buildings. (See fig. 2-19.) Detail drawings are used whenever the information provided in elevations, plans, and sections is not clear enough for the constructors on the job. They are usually grouped so that references may be made more easily from the general drawing.

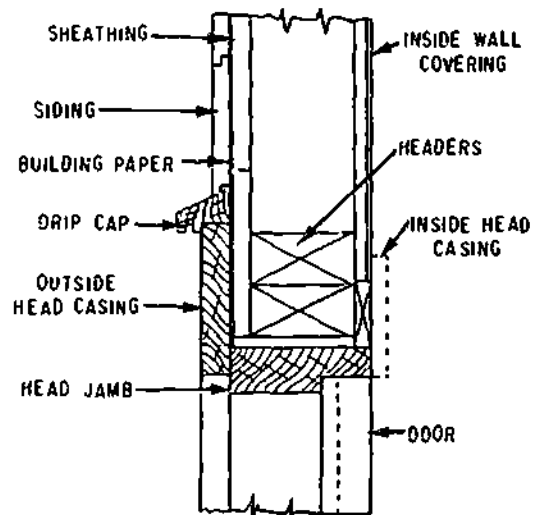

SECTION THROUGH HEAD JAMB

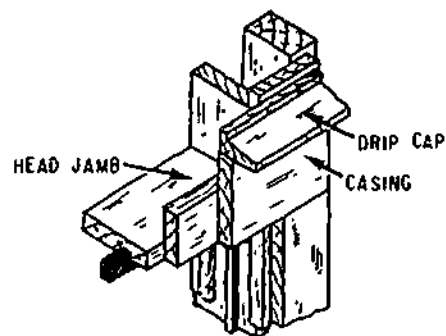

UPPER-LOWER CORNER DETAILS WINDOW FRAME

45.501:502

Figure 2-19.—Door and window details.

Schedules

General notes usually are grouped according to materials of construction in a tabular form and are called a SCHEDULE. As used in this training manual, the category, General Notes, refers to all notes on the drawing not accompanied by a leader and arrowhead. Item schedules for doors, rooms, footings, and so on are more detailed. Typical door and window schedule formats are presented below.

1. Door Schedule. The doors shown by symbol in a plan view may be identified as to size, type, and style with code numbers placed next to each symbol. This code number, or mark, is then entered on a line in a door schedule and the principal characteristics of the door are entered in successive columns along the line. The No. column allows a quantity check on doors of the same design as well as the total number of doors required. By using a number with a letter, the mark can serve a double purpose: the number identifies the floor on which the door is located, and the letter identifies the door designwise. For example, mark 1-D would mean door style D on the first floor. The sequence of door sizes are written in width by height by thickness. The description column allows identification by type (panel, flush), style, and material. The remarks column allows reference to the appropriate detail drawing. The schedule is a convenient way of presenting pertinent data without making the Builder refer to the specifications. A typical door schedule follows:

No.	Mark	Size	Description	Remarks
6	1-D	5 x 7	Flush-	Double door hinged
9	2-D	2½ x 7	Panel-	Single door linged

2. Window Schedule. A window schedule is similar to a door schedule for providing an organized presentation of the significant window

characteristics. The code mark used in the schedule is placed next to the window symbol that applies on the plan view or elevation view. (See figs. 2-13 and 2-14.) A similar window schedule follows:

No.	Mark	Size	Description	Remarks
16	W-1	5 x 9	Double Hung	Slide from bottom to top and top to bottom
17	W-2	4 x 7	Casement	Hinged at top

ARCHITECTURAL DRAWINGS

The design of any structure represents close cooperation between architects and engineers. One of the principal factors influencing the design of a structure is its function, that is, the use for which it is intended. In the case of a building, factors, such as overall size, external appearance, arrangement of internal space, and number, size, and kind of doors, windows, and fittings are the responsibility of the architect. The structural engineer prepares design sketches of the structure based upon calculations concerned with the strength of the supporting members. In addition, the mechanical systems of a building, such as plumbing, lighting, heating, ventilating, and air conditioning are designed by mechanical/electrical engineers rather than architects. The architect and engineer determine the construction materials to be used and methods of construction.

MECHANICAL DRAWINGS

Mechanical drawings include all drawings and notes which have something to do with water supply, sewage systems, drainage, heating and ventilating systems, refrigeration, air-conditioning, POL (Petroleum, Oils, and

Lubricants), and the gas supply system. It may also include other drawings that are necessary to properly present the system in relation to the other portions of the project, such as site plans, grading plans, and building layouts.

The symbols that are used in a mechanical drawing are shown in figures 2-6 and 2-7. They should be drawn in heavier lines than the outline of the floor plan.

ELECTRICAL DRAWINGS

Electrical drawings consist of those relating to electric power and wire communication systems. An electrical drawing includes the electrical distribution system, electrical wiring, lighting system, telephone system, and the like. As in mechanical drawings, electrical drawings may also include other drawings that are necessary to tie in the system with the rest of the project.

The symbols used in electrical drawings are shown in figure 2-8. Ordinary electrical drawings for structures are easy to make, except for the details which require more time, because they are generally shown in different views and sections, or in a pictorial form.

SHOP DRAWINGS

Shop drawings are drawings, schedules, diagrams, and other data prepared by the contractor (Builder) to illustrate some portion of the work. As a Builder, you will be required to draft shop drawings for minor shop and field projects. They may include shop items such as doors, cabinets, and small portable buildings, prefabricated berthing quarters, and modifications of existing structures.

Shop drawings are prepared from portions of design drawings, or from freehand sketches based on the Builder's past building experience. They must include enough information for the crew to complete the job. Normally, the Builder

would base the amount of required detailing on the level of experience of the crew expected to complete the project. When an experienced building crew will be doing the work, it would not be necessary to show all the fine standard details.

When making actual drawings it is recommended that templates be used for standard symbols, if they are available. Use of standard technical drawing techniques is recommended, but not mandatory. For techniques in the skill of drawing, refer to *Blueprint Reading and Sketching*, NAVEDTRA 10077-E.

BILL OF MATERIALS

A bill of materials is a tabulated statement of material requirements for a given project. (See fig. 2-20.) It contains information, such as stock numbers, unit of issue, quantity, line item number, description, vendor, and cost. Sometimes the bill of materials will be submitted on material estimate sheets, or material takeoff sheets, but each will contain similar information. Actually, a bill of material is a grouped compilation based on takeoffs and estimates of all material needed to complete a structure. The takeoff usually is an actual tally and check-off of the items shown, noted, or specified on the construction drawings and specifications. The estimated quantities are those known to be necessary but which may not have been placed on the drawings, such as nails, cement, concrete-form lumber and tie wire, temporary bracing or scaffold lumber, and so on. These are calculated from the knowledge of construction methods that will be used for field erection.

Most NAVFAC drawings will contain a bill of materials incorporated within the drawings. As a crew leader, you will find it useful in identifying the materials ordered for your project. You can determine whether all materials are actually on site prior to starting the project or have been overlooked and must be placed on

BILL OF MATERIAL
 1100 CFC 1043/212 731
 0400 11 021-3010

PROJECT: INTERIM WATER SYSTEM REINDEER STATION (CANTONMENT AREA)

SHIP APRIL 19-

SM NO. DIW 112

BILL OF MATERIAL										ACCOUNTING DATA		PAGE									
ROUT IDENT	SERV & REGION	SERV & SUPP ADDRESS	FUND CODE	PROJECT	PAR	RDD	JOB ORDER			UNIT COST	TOTAL COST	LOCATION	QTY/DATE REC'D	QTY/DATE ISSUED							
P96	2	N62583 N	YIWI12	ATNM	ZM9	OS	094	4K6404													
DGC IDENT	ASC	STOCK NUMBER	UNIT OF MEAS	QUANTITY	DOCUMENT NUMBER	DATE SERIAL	COG	ADV	L	QTY	PLM	DESCRIPTION/SPECIFICATION/VENDORS	UNIT COST	TOTAL COST	LOCATION	QTY/DATE REC'D	QTY/DATE ISSUED				
ADE			SH	69	4DBI7903				1			PLYWOOD, 3/4" X 4' X 8' BB EXTERIOR TYPE. SUGGESTED VENDOR: THOMPSON LUMBER CO	12.00	828.00							
			BF	30	7904				2			LUMBER, SOFTWOOD, 1" X 6' X 12' STANDARD CONSTRUCTION GRADE 2 OR BETTER SUGGESTED VENDOR: THOMPSON LUMBER CO.	.18	5.40							
			BF	2422	7905				3			LUMBER, SOFTWOOD, 2" X 4' X 16' STANDARD CONSTRUCTION GRADE 2 OR BETTER. SUGGESTED VENDOR: THOMPSON LUMBER CO.	28	678.16							
			BF	.44	7906				4			LUMBER, SOFTWOOD, 2" X 6' X 16' STANDARD CONSTRUCTION GRADE 2 OR BETTER. SUGGESTED VENDOR: THOMPSON LUMBER CO	28	40.32							
			BF	1172	7907				5			LUMBER, SOFTWOOD, 4" X 4' X 16' STANDARD CONSTRUCTION GRADE 2 OR BETTER. SUGGESTED VENDOR: THOMPSON LUMBER CO	33	387.09							
APPROVED BY: E B WASON										DATE: 20 MAR		APPROVED BY: T J ABERNATHY		DATE: 22		SM TOTAL LINE ITEMS		PRG TOTAL \$1938.97		SM TOTAL \$	

2-22

BUILDER 3 & 2

133.422

Figure 2-20.—Typical bill of materials.

42

43

order to insure timely completion of your project.

SPECIFICATIONS

Construction drawings are supplemented by written SPECIFICATIONS, commonly referred to as SPECS. Specifications give detailed instructions regarding materials and methods of construction. They cover various factors relating to the job, such as general conditions, scope of work, quality of materials, standards of workmanship, and protection of finished work. The drawings and specifications define the project in detail and show how it is to be constructed. Usually, any set of drawings for an important project is accompanied by a set of specifications. Actually, in such a case, the drawings and specifications are inseparable; the drawings indicate what the specs did not cover; and the Specs indicate what the drawings did not portray, or it clarifies further details that have not been covered amply by the drawings and notes.

Specifications usually begin with a GENERAL REQUIREMENT for the structure, stating type of foundation, character of load-bearing members (wood-frame, steel-frame, concrete), type or types of doors and windows, types of mechanical and electrical installations, and the principal function of the building.

Next come the SPECIFIC CONDITIONS which must be carried out by the constructors. These are grouped in divisions under headings applying to each major phase of construction, as in the following typical list of divisions.

2.—SITE WORK 3.—CONCRETE 4.—MASONRY 5.—METALS 6.—CARPENTRY 7.—MOISTURE CONTROL 8.—DOORS, WINDOWS, AND GLASS 9.—FINISHES 10.—SPECIALITIES 11.—EQUIPMENT 12.—FURNISHINGS 13.—SPECIAL CONSTRUCTION 14.—CONVEYING SYSTEMS 15.—MECHANICAL and 16.—ELECTRICAL.

Sections under one of these general categories generally begin with GENERAL REQUIREMENTS for that category. For example: under DIVISION 6.—CARPENTRY, the first section might read:

6-01.—GENERAL REQUIREMENTS.—All framing, rough carpentry, and finishing woodwork required for the proper completion of the building shall be provided. All woodwork must be protected from the weather, and the building shall be thoroughly dry before the finish is placed. All finish shall be dressed, smoothed, and sandpapered at the mill, and, in addition, must be hand-smoothed and sandpapered at the building, when necessary to produce proper finish. Nailing shall be done, as far as practicable, in concealed places, and all nails in finishing work shall be set (meaning to drive heads slightly below the surface with a hammer-driven tool called a "nail set").

All lumber shall be S4S (surfaced four sides); all materials for millwork (doors, window sash, and the like) and finish shall be kiln-dried (meaning dried or "cured" in heated kilns, rather than simply air-dried), all rough and framing lumber shall be air- or kiln-dried (meaning, absolutely no "green" lumber to be used).

Any cutting, fitting, framing, and blocking necessary for the accommodation of other work shall be provided. All nails, spikes, screws, bolts, plates, clips, and other fastening and rough hardware (a whole list of items too small or too numerous to be shown on the drawings) shall be provided. All finishing hardware shall be installed in accordance with the manufacturer's instructions. Calking and flashing (thin sheets of metal or other material, installed around window openings, chimney openings, and at other places where leakage might occur; shall be

provided where indicated or where necessary to provide weathertight construction.

Subsequent sections under division 6.-CARPENTRY would specify various quality criteria and standards of workmanship for the various types of rough and finish carpentry, as, for example:

6-07.-STUDDING for walls and partitions shall have doubled plates and doubled caps. Studs shall be set plumb and not to exceed 16 in. centers and in true alinement. They shall be bridged with one row of 2 x 4 pieces, set flatwise and fitted tightly, and nailed securely to each stud. Studding shall be doubled around openings, and the headers for openings shall rest on the inner studs. Openings more than 4-ft wide in partitions shall have trussed headers. Studs shall be trebled at corners to form corner posts.

With very few exceptions, the material used by the SEABEES is covered by a Government spec, a NAVFAC spec, a Federal spec, or a Military spec. Commercial specs may be used in conjunction with Government specs for specialized materials.

It is very important that the proper spec be used to cover the material requested. In cases in which the material is not covered by a Government spec, the ASTM (American Society for Testing Materials) spec or some other approved commercial spec may be used. It is **EXTREMELY IMPORTANT** when specifications are used to cite all amendments, including the latest changes.

As a rule, the specs are provided for each project by the A/E (ARCHITECT-ENGINEERS). They are OFFICIAL guidelines approved for use during construction by the Commander, NAVFAC or his representative. They should NOT be deviated from without prior approval from proper authority. This approval is usually obtained by means of a change order. When there is disagreement between the specifications

and drawings, the specifications should normally be followed; however, check with higher authority in each case. Many claims have been made against the government as a result of inconsistencies or ambiguities between specifications and drawings.

FREEHAND SKETCHES

As a Builder you must be able to read and work from drawings and specifications, and to make quick, accurate sketches when it comes to conveying technical information or ideas.

One of the main advantages of sketching is that few materials are required. Basically all you need are a pencil and paper. However, the type of sketch prepared and your personal preference will determine the material used.

Most of your sketches will be done on some type of scratch paper. The advantage of sketching on tracing paper is the ease with which sketches can be modified or redeveloped simply by placing transparent paper over previous sketches or existing drawings. Cross section or graph paper may be used to save time when you are required to draw sketches to scale.

For making dimensional sketches in the field, you will need some sort of measuring tape or pocket rule, depending on the extent of the measurements taken.

In freehand pencil sketching draw each line with a series of short strokes instead of with one stroke. Strive for a free and easy movement of your wrist and fingers. You need not be a draftsman or an artist to prepare working sketches. Sketches which you will prepare may be for your own use or for use by other crewmembers.

An example of a freehand sketch is shown in figure 2-21. The sketch was developed for use within the kitchen of the floor plan (See fig. 2-12.) The sketch depicts different construction phases to be considered by the BU when engaged in putting together low-cost interior finish kitchen cabinets. Freehand sketches are

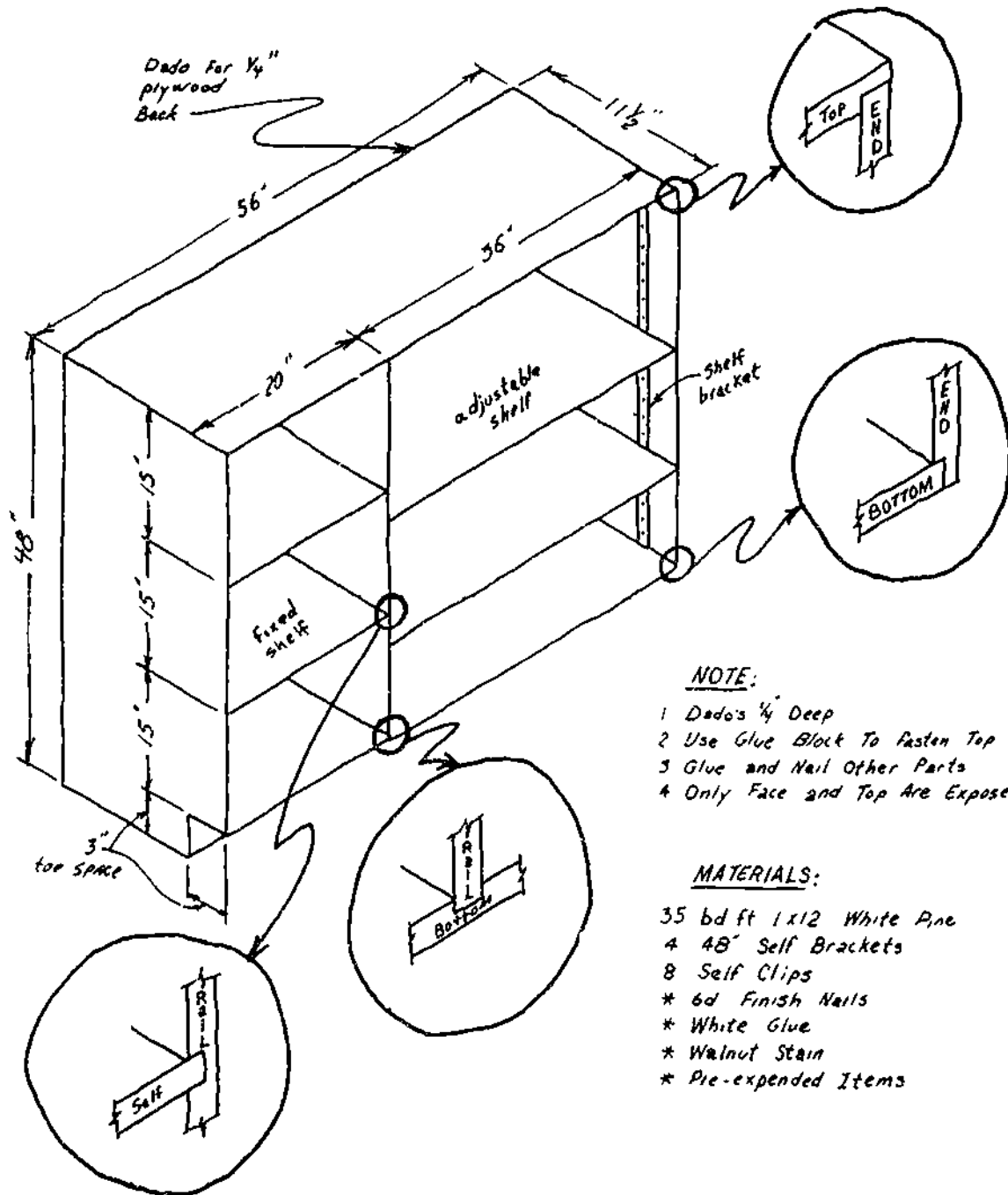

Figure 2-21.—Freehand sketch.

133.423

prepared by the crewleader responsible for the job. Therefore, any information may be included which will make the project more understandable. By following the above procedure, you should be able to sketch freehand from any plans covering building operations. Sketches need not be prepared in great detail.

BUILDING MATHEMATICS

The Builder has many occasions for the employment of the processes of ordinary arithmetic, and you must be thoroughly familiar with the methods of determining the areas and volumes of the various plane and solid geometrical figures. For more detailed explanations in the procedures for working area and volume problems refer to *Mathematics*, Vol. 1, NAVPERS 10096-C. Only a few practical applications and suggestions for the Builders use are given here.

RATIO AND PROPORTION

Ratio and proportion and the manner of solving proportional equations are explained in *Mathematics*, Vol. 1. There are a great many practical applications of ratio and proportion in the construction field. A few examples are as follows:

Some dimensions on construction drawings (for example, distances from base lines and elevations of surfaces) are given in ENGINEER'S instead of CARPENTER'S measure. Engineer's measure is measure in feet and decimal parts of a foot, or in inches and decimal parts of an inch, such as 100.15 ft or 11.14 in. Carpenter's measure is measure in yards, feet, inches, and even-denominator fractions of an inch, such as 1/2 in., 1/4 in., 1/16 in., 1/32 in., and 1/64 in.

You must know how to convert an engineer's measure given on a construction drawing to a carpenter's measure. Besides this, it will often happen that calculations you make yourself may produce a result in feet and decimal parts of a foot, in which you will have to convert the results to carpenter's measure. To

convert engineer's to carpenter's measure you can use ratio and proportion as follows:

Let's say that you want to convert 100.14 ft to feet and inches to the nearest 1/16 in. The 100 you don't need to convert, since it is already in feet. What you need to do, first, is to find out how many twelfths of a foot (that is, how many inches) there are in 14/100 ft. Set this up as a proportional equation as follows: $x:12::14:100$.

You know that in a proportional equation the product of the means equals the product of the extremes. Consequently, $100x = (12 \times 14)$, or 168. Then $x = 168/100$, or 1.68 in. The next question is, how many 16ths of an in. are there in 68/100 in.? Set this up, too, as a proportional equation, thus: $x:16::68:100$. Then $100x = 1088$, and $x = 1088/100$ sixteenths. Since 88/100 of a sixteenth is more than one-half of a sixteenth, you ROUND OFF by calling it 11/16. In 100.14 ft, then, there are 100 ft 1 11/16 in. For example:

A. $x:12::14:100$
 means
 x:12::14:100
 Extremes

Product of extremes = product of means:

$$100x = 168$$

$$x = 1.68 \text{ in.}$$

B. $x:16::68:100$

$$100x = 1088$$

$$x = 10.88$$

$$x = 10 \frac{88}{100} \text{ sixteenths}$$

Rounded off to 11/16

Another way to convert engineer's measurements to carpenter's measurements is to multiply the decimal portion of a foot by 12 to get inches, multiply the decimal by 16 to get the fraction of an inch.

There are many other practical applications of ratio and proportion in the construction field. Suppose, for example, that a table tells you that, for the size and type of brick wall you happen to be laying, 12,321 bricks and 195 cu ft of mortar are required per every 1000 sq ft of wall. How many bricks and how much mortar will be needed for 750 sq ft of the same wall? You simply set up equations as follows:

Brick: $x:750::12,321:1000$
 Mortar: $x:750::195:1000$

Brick: $\frac{x}{750} = \frac{12,321}{1000}$ Cross multiply

$1000x = 9,240,750$ Divide
 $x = 9,240.75 = 9241$ Brick.

Mortar: $\frac{x}{750} = \frac{195}{1000}$ Cross multiply

$1000x = 146,250$ Divide
 $x = 146.25 = 146 \frac{1}{4}$ cu ft

Suppose, for another example, that the ingredient proportions by volume for the type of concrete you are making are 1 cu ft cement to 1.7 cu ft sand to 2.8 cu ft coarse aggregate. Suppose you know, by reference to a table, that ingredients combined in these amounts indicated will produce 4.07 cu ft of concrete. How much of each ingredient will be required to make a cu yd of concrete?

Remember here, first, that there are not 9, but 27 (3 ft x 3 ft x 3 ft) cu ft in a cu yd. Your proportional equations will be as follows:

Cement: $x:27::1:4.07$

Sand: $x:27::1.7:4.07$

Coarse aggregate: $x:27::2.8:4.07$

Cement: $x:27::1:4.07$

$\frac{x}{27} = \frac{1}{4.07}$
 $4.07x = 27$

$x = 6.63$ cu ft cement

Sand: $x:27::1.7:4.07$

$\frac{x}{27} = \frac{1.7}{4.07}$

$4.07x = 45.9$

$x = 11.28$ cu ft sand

Coarse aggregate: $x:27::2.8:4.07$

$\frac{x}{27} = \frac{2.8}{4.07}$

$4.07x = 75.6$

$x = 18.57$ cu ft coarse aggregate

ARITHMETICAL OPERATIONS

The formulas for finding the area and volume of geometric figures are expressed in algebraic equations which are called formulas. A few of the more important formulas and their mathematical solutions will be discussed in this section.

To get an area, you multiply 2 linear measures together, and to get a volume you multiply 3 linear measures together. The linear measures you multiply together must all be expressed in the SAME UNITS; you cannot, for example, multiply a length in feet by a width in inches to get a result in square feet or in square inches.

Dimensions of a feature on a construction drawing are not always given in the same units. For a concrete wall, for example, the length and height are usually given in feet and the thickness in inches. Furthermore, you may want to get a result in units which are different from any shown on the drawing. Concrete volume, for example, is usually expressed in cubic yards, while the dimensions of concrete work are given on the drawings in feet and inches.

You can save yourself a good many steps in calculating by using fractions to convert the original dimension units into the desired end-result units. Take 1 in., for example. To

express 1 in. in feet, you simply put it over 12, thus: 1/12 ft. To express 1 in. in yards, you simply put it over 36, thus: 1/36 yd. In the same manner, to express 1 ft in yards you simply put it over 3, thus 1/3 yd.

Suppose now that you want to calculate the number of cu yd of concrete in a wall 32 ft long by 14 ft high by 8 in. thick. You can express all these in yards and set up your problem thus:

$$\frac{32}{3} \times \frac{14}{3} \times \frac{8}{36}$$

Next you can cancel out, thus:

$$\frac{\cancel{12}}{3} \times \frac{\cancel{14}}{3} \times \frac{8}{\cancel{36}} = \frac{896}{81}$$

Dividing 896 by 81, you get 11.06 cu yds of concrete in the wall.

The right triangle is a triangle which contains one right (90°) angle. The following letters will denote the parts of the triangle indicated in figure 2-22-a = altitude, b = base, c = hypotenuse.

In solving a right triangle, the length of any side may be found if the lengths of the other two sides are given. The combinations of 3-4-5 (lengths of sides) or any multiple of these combinations will come out to a whole number. The following examples show the formula for finding each side. Each of these formulas is derived from the master formula $c^2 = a^2 + b^2$.

(1) Find c when a = 3, and b = 4.

$$c = \sqrt{a^2 + b^2} = \sqrt{3^2 + 4^2} = \sqrt{9 + 16} = \sqrt{25} = 5$$

(2) Find a when b = 8, and c = 10.

$$a = \sqrt{c^2 - b^2} = \sqrt{10^2 - 8^2} = \sqrt{100 - 64} = \sqrt{36} = 6$$

(3) Find b when a = 9, and c = 15.

$$b = \sqrt{c^2 - a^2} = \sqrt{15^2 - 9^2} = \sqrt{225 - 81} = \sqrt{144} = 12$$

There are tables from which the square roots of numbers may be found; otherwise, they may

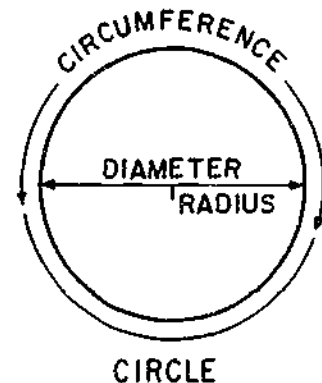
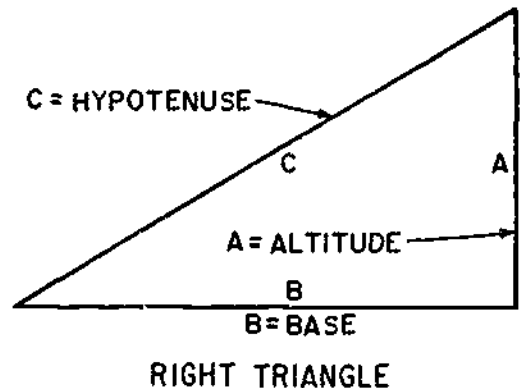

133.1

Figure 2-22.—Right triangle and circle.

be found arithmetically as explained later in this chapter.

Areas And Volumes Of Geometric Figures

This section on areas and volumes of geometric figures will be limited to the most commonly used geometric figures. Reference books, such as *Mathematics*, Vol. 1, are available for additional information if needed. Areas are expressed in square units and volumes in cubic units.

1. A circle is a plane figure bounded by a curved line in which every point is the same distance from the center.

a. The curved line is called the circumference.

- b. A straight line drawn from the center to any point on the circumference is called a radius. ($r = 1/2$ the diameter.)
- c. A straight line drawn from one point of the circumference through the center and terminating on the opposite point of the circumference is called a diameter. ($d = 2$ times the radius.) See figure 2-22.
- d. The area of a circle is found by the following formulas: $A = \pi r^2$ or $A = .7854 d^2$. (π is pronounced pie = 3.1416 or 3 1/7, .7854 is 1/4 of π .) Example: Find the area of a circle whose radius is 7". $A = \pi r^2 = 3 1/7 \times 7^2 = 22/7 \times 49 = 154$ sq in. If you use the second formula you obtain the same results.
- e. The circumference of a circle is found by multiplying π times the diameter or 2 times π times the radius. Example. Find the circumference of a circle whose diameter is 56 inches. $C = \pi d = 3.1416 \times 56 = 175.9296$ inches.

2. The area of a right triangle is equal to one-half the product of the base by the altitude. (Area = $1/2$ base \times altitude.) Example. Find the area of a triangle whose base is 16 in. and altitude 6 in. Solution

$$A = 1/2 bh = 1/2 \times 16 \times 6 = 48 \text{ sq in.}$$

3. The area of a rectangle is found by multiplying its length by its width.

$$A = L \times W$$

Example. Find the area of a rectangle when the length is 12 ft and its width 9 ft. Solution

$$A = 12 \times 9 = 108 \text{ sq ft}$$

4. The area of a regular polygon of many sides (5, 6, 7, 8, etc.) equals one-half the number of sides times the length of a side times the radius of the inscribed circle. See figure 2-23. The formula is $A = 1/2 (n \times b \times r)$, where n = number of sides.

Exampl. Find the area of a regular 6-sided polygon whose sides are 18 inches long and radius of the inscribed circle is 12 inches. Solution:

$$A = 1/2 (6 \times 18 \times 12) = 648 \text{ sq in.}$$

5. The volume of a cylinder is found by multiplying the area of the base times the height. ($V = 3.1416 \times r^2 \times h$). Example Find the volume of a cylinder which has a radius of 8 in. and a height of 4 ft. Solution:

$$8 \text{ in.} = \frac{2}{3} \text{ ft and } \left(\frac{2}{3}\right)^2 = \frac{2}{3} \times \frac{2}{3} = \frac{4}{9} \text{ sq ft}$$

$$V = 3.1416 \times \frac{4}{9} \times 4 = \frac{50.2656}{9} = 5.59 \text{ cu ft.}$$

6. The volume of a rectangular solid or prism equals the length \times width \times height ($V = lwh$). Example Find the volume of a rectangular solid or prism which has a length of 6 ft, a width of 3 ft, and a height of 2 ft. Solution

$$V = lwh = 6 \times 3 \times 2 = 36 \text{ cu ft}$$

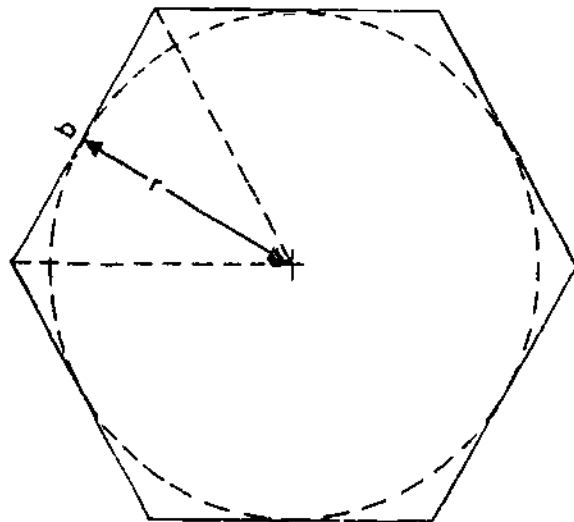

45.680(45B)

Figure 2-23.—Regular polygon.

7. The volume of a cone may be found by multiplying one-third times the area of the base times the height.

$$(V = \frac{1}{3} \pi r^2 h)$$

Example: Find the volume of a cone when the radius of its base is 2 ft and its height is 9 ft.
Solution:

$$\pi = 3.1416; r = 2; r^2 = 4; h = 9$$

$$V = \frac{1}{3} \pi r^2 h = \frac{1}{3} \times 3.1416 \times 4 \times 9 = 37.70 \text{ cu ft.}$$

8. The volume of a pyramid may be found by multiplying one-third times the area of its base times its height. ($V = \frac{Ah}{3}$)

Example: Find the volume of a pyramid when its base is 3 in. by 4 in. and whose height is 6 in.
Solution:

$$A = 3 \times 4 = 12 \text{ sq in.}$$

$$V = \frac{12 \times 6}{3} = 24 \text{ cu in.}$$

9. The volume of a cube may be found by multiplying together three measurements ($V = L \times W \times H$)

Example: Find the volume of a cube 12 ft long, 12 ft wide, and 12 ft deep. Solution:

$$V = LWH = 12 \times 12 \times 12 = 1728 \text{ cu ft.}$$

Powers And Roots

1. Powers—When we multiply several numbers together, as $2 \times 3 \times 4 = 24$, the numbers 2, 3, and 4 are factors and 24 the product. The operation of raising a number to a power is a special case of multiplication in which the factors are all equal. The power of a number is the number of times the number itself is to be taken as a factor. Example: 2^4 is 16. The second power is called the square of the number, as 3^2 . The third power of a number is called the cube of the number, as 5^3 . The exponent of a number is a number placed to the right and above a base

to show how many times the base is used as a factor. Example:

$$4^3 \begin{array}{l} \leftarrow \text{exponent} = \\ \leftarrow \text{base} \end{array}$$

$$4 \times 4 \times 4 = 64.$$

2. Roots—To indicate a root, use the sign $\sqrt{\quad}$, which is called the radical sign. A small figure, called the index of the root, is placed in the opening of the sign to show which root is to be taken. The square root of a number is one of the two equal factors into which a number is divided. Example: $\sqrt{81} = \sqrt{9 \times 9} = 9$. The cube root is one of the three equal factors into which a number is divided. Example: $\sqrt[3]{125} = \sqrt[3]{5 \times 5 \times 5} = 5$.

Square Root

1. The square root of any number is that number which, when multiplied by itself, will produce the first number. For example; the square root of 121 is 11 because 11 times 11 equals 121.

2. How to extract the square root arithmetically:

$$\sqrt{9025} \quad \sqrt{90'25.}$$

: -81

$$180 \quad 925$$

$$\underline{+5} \quad \underline{-925}$$

$$185 \quad 000$$

- Begin at the decimal point and divide the given number into groups of 2 digits each (as far as possible), going from right to left and/or left to right.
- Find the greatest number (9) whose square is contained in the first or left hand group (90). Square this number (9) and place it under the first pair of digits (90), then subtract.
- Bring down the next pair of digits (25) and add it to the remainder (9).

- d. Multiply the first digit in the root by 20 and use it as a trial divisor (180). This trial divisor (180) will go into the new dividend (925) five times. This number, 5 (second digit in the root), is added back to the trial divisor, obtaining the true divisor (185).
- e. The true divisor (185) is multiplied by the second digit (5) and placed under the remainder (925). Subtract and the problem is solved.
- f. If there is still a remainder and you want to carry the problem further, add zeros (in pairs) and continue the above process.

Coverage Calculations

You will frequently have occasion to estimate the number of linear feet of boards of a given size, or the number of tiles, asbestos shingles, and the like, required to cover a given area. Let's take the matter of linear feet of boards first.

What you do here is first calculate the number of linear feet of board required to cover 1 sq ft. For boards laid edge-to-edge, you base your calculations on the total width of a board. For boards which will lap each other, you base your calculations on the width laid TO THE WEATHER, meaning the total width minus the width of the lap.

Since there are 144 sq in. in a sq ft, linear footage to cover a given area can be calculated as follows. Suppose your boards are to be laid 8 in. to the weather. If you divide 8 in. into 144 sq in., the result (which is 18 in., or 1.5 ft) will be the linear footage required to cover a sq ft. If you have, say, 100 sq ft to cover, the linear footage required will be 100×1.5 , or 150 ft.

To estimate the number of tiles, asbestos shingles, and the like required to cover a given area, you first calculate the number of units required to cover a sq ft. Suppose, for example, you are dealing with 9- by 9-in. asphalt tiles. The area of one of these is 9- by 9-in. or 81 sq in. In a sq ft there are 144 sq in. If it takes 1 to cover 81 sq in., how many will it take to cover

144 sq in.? Just set up a proportional equation as follows.

$$1.81 \times 144$$

When you work this out, you will find that it takes 1.78 tiles to cover a sq ft. To find the number of tiles required to cover 100 sq ft, simply multiply by 100. How do you multiply anything by 100? Just move the decimal point 2 places to the right. Consequently, it takes 178 9- by 9-in. asphalt tiles to cover 100 sq ft of area.

Board Measure

BOARD MEASURE is a method of measuring lumber in which the basic unit is an abstract volume 1 ft long by 1 ft wide by 1 in. thick. This abstract volume or unit is called a BOARD FOOT.

There are several formulas for calculating the number of board feet in a piece of given dimensions. Since lumber dimensions are most frequently indicated by width and thickness in inches and length in feet, the following formula is probably the most practical.

$$\frac{\text{Thickness in inches} \times \text{width in inches} \times \text{length in ft}}{12} = \text{board feet}$$

Suppose you are calculating the number of board feet in a 14-ft length of 2 x 4. Applying the formula, you get

$$\frac{2 \times 4 \times 14}{12} = \frac{28}{3} = 9 \frac{1}{3} \text{ bd ft}$$

The chief practical use of board measure is in cost calculations, since lumber is bought and sold by the board foot. Any lumber less than 1 in. thick is presumed to be 1 in. thick for board measure purposes. Board measure is calculated on the basis of the NOMINAL, not the ACTUAL, dimensions of lumber. As explained in chapter 4, the actual size of a piece of dimension lumber (such as a 2 by 4, for example) is usually less than the nominal size.

METRIC SYSTEM

The metric system was developed by French scientists in 1790 and was specifically designed to be an easily used system of weights and measures to benefit science, industry, and commerce. Soon after development, scientists the world over adopted it for their work.

Early in the 19th century many European countries adopted the new system for engineering and commerce. It was possible for these countries to trade manufactured goods with one another and not be concerned with having to buy special wrenches and tools to repair the machinery received in trade. Countries could buy and sell machine tools and precision instruments without having to modify or alter them.

In 1975 Congress passed the Metric Conversion Act, which was signed into Public Law (94-168) by President Ford.

By that time, the only remaining nonmetric users were a few small countries. Meanwhile, our conversion to metrics is in full swing. The International System of Units (SI) is the formal name for the metric system. The use of SI units is expected to become universal by 1980. Much of the equipment in the United States Navy is already measured in SI units. Certain of its weapons are sized in metric units, such as 20 millimeters and 40 millimeters. Existing maps and charts may show distances in meters (instead of yards) and kilometers (instead of miles). To better understand conversion to metric units, you should study *The Metric System*, NAVEDTRA 475-01-00-79.

Some SI units are base units, that is metric standards defined and adopted by international treaty. Other SI units are derived from the base units and are either expressed in terms of the base unit or are specially named. The base unit for measuring distance, the meter, is defined as one ten-millionth of the distance from the Equator to the North Pole. The metric standard for weight, the gram, is defined as the weight of one cubic centimeter of pure water. Other SI standards include the second (time) and the degree Celsius (temperature), which was formerly called centigrade. The square meter (area), cubic meter (volume), and meter per second (speed) are derived units expressed in terms of the base unit. Derived units having

special names include the hertz (frequency), watt (power), farad (capacitance), volt (electromotive force), and ohm (electric resistance).

The metric system is a base-10 (decimal) number system. It is convenient and easy to use because one unit of measure is converted to smaller and larger units of measure by dividing and multiplying by powers of ten, or by shifting the decimal point. For example, 12.3 millimeter convert to 1.23 centimeters. Calculations, such as dividing by 16 (to convert ounces to pounds) and multiplying by 12 (to convert feet to inches) are eliminated.

The result of multiplying a base unit by a power of ten is referred to as a multiple; the result of dividing by a power of ten is referred to as a submultiple. Names of multiples and submultiples of the base unit are formed by adding prefixes to the name of the base unit. The already mentioned millimeter, centimeter, and kilometer are examples. Figure 2-24 illustrates a set of 8 prefixes (and their symbols) for forming multiples and submultiples.

It is rather simple to relate SI units to non-SI units. Compared to the yard, the meter is a little longer (about 1.1 yd). In long distance measurements, the SI unit is the kilometer, which is slightly farther than 1/2 mile (about 0.6 mile). The basic unit of volume, the liter, is a little larger than a quart (about 1.06 qt). The weight of a liter of pure water is 1 kilogram,

Multiples and Submultiples	Prefixes	Symbols
1 000 000 = 10 ⁶	mega (něg' à)	M*
1 000 = 10 ³	kilo (kìl' ò)	k*
100 = 10 ²	hecto (hěk' tò)	h
10 = 10	deka (děk' à)	da
0.1 = 10 ⁻¹	deci (dēs' ï)	d
0.01 = 10 ⁻²	centi (sěn' ï)	c*
0.001 = 10 ⁻³	milli (mìl' ï)	m*
0.000 001 = 10 ⁻⁶	micro (mì' krò)	μ*

* MOST COMMONLY USED

Figure 2-24.—Metric system prefixes and their symbols.

Chapter 2—DRAWINGS AND SPECIFICATIONS

which is a little more than 2 pounds (about 2.2 lb). The SI unit for measuring power, the kilowatt, is somewhat bigger than one horsepower (about 1.2 hp).

In working with non-SI units and SI units, it helps to have a reference of common equivalent weights and measures. Tables 2-1 through 2-5 give the factors you multiply by in order to convert a non-SI unit to an SI unit, or vice versa. For example:

$$3 \text{ inches} = 3 \times 25.4 \text{ or } 76.2 \text{ mm}$$

$$5 \text{ kilometers} = 5 \times 0.6 \text{ or } 3 \text{ miles}$$

Table 2-1.—Length Conversion

When You Know:	You Can Find:	If You Multiply By:
Inches	millimeters	25.4
inches	centimeters	2.54
feet	centimeters	30
feet	meters	0.3
yards	centimeters	90
yards	meters	0.9
miles	kilometers	1.6
miles	meters	1 600
millimeters	inches	0.04
centimeters	inches	0.4
centimeters	feet	0.032 8
meters	feet	3.3
centimeters	yards	0.010 9
meters	yards	1.1
meters	miles	0.000 621
kilometers	miles	0.6
meters	nautical miles	0.000 54
nautical miles	meters	1852

Table 2-2.—Weight Conversion

When You Know:	You Can Find:	If You Multiply By:
ounces	grams	28.3
pounds	kilograms	0.45
short tons (2000 lbs)	megagrams (metric tons)	0.9
grams	ounces	0 035 3
kilograms	pounds	2.2
megagrams (metric tons)	short tons (2000 lbs)	1.1

Table 2-3.—Volume Conversion

When You Know:	You Can Find:	If You Multiply By:
teaspoons	milliliters	5
tablespoons	milliliters	15
fluid ounces	milliliters	30
cups	liters	0.24
pints	liters	0.47
quarts	liters	0.95
gallons	liters	3.8
milliliters	teaspoons	0.2
milliliters	tablespoons	0.067
milliliters	fluid ounces	0.034
liters	cups	4.2
liters	pints	2.1
liters	quarts	1.06
liters	gallons	0.26
cubic feet	cubic meters	0.028
cubic yards	cubic meters	0.765
cubic meters	cubic feet	35.3
cubic meters	cubic yards	1.31

Table 2-4.—Area Conversion

When You Know:	You Can Find:	If You Multiply By:
square inches	square centimeters	6.45
square inches	square meters	0 000 6
square feet	square centimeters	929
square feet	square meters	0.092 9
square yards	square centimeters	8 360
square yards	square meters	0.836
square miles	square kilometers	2.6
square centimeters	square inches	0.155
square meters	square inches	1 550
square centimeters	square feet	0.001
square meters	square feet	10.8
square centimeters	square yards	0.000 12
square meters	square yards	1.2
square kilometers	square miles	0.4

Table 2-5.—Temperature Conversion

When You Know	You Can Find:	If You
degrees Fahrenheit	degrees Celsius	subtract 32 then multiply by 5/9
degrees Celsius	degrees Fahrenheit	multiply by 9/5 then add 32
degrees Celsius	kelvins	add 273.15°

CHAPTER 3

WOODWORKING SHOP AND FIELD TOOLS

As a Builder, your woodworking hand and power tools are essential parts of the trade. You must be a general woodworking craftsman who is able to use and maintain effectively a large variety of shop and field tools. You must have, choose, and use the correct tools in order to do your work quickly, accurately, and safely. Without the proper tools and the knowledge of how to use them, you waste time, reduce efficiency, and may even injure yourself.

In this chapter, several of the most common hand and power tools are described outlining their uses, general characteristics, attachments, safety and operating features.

HANDTOOLS

After reading *Tools and Their Uses*, NAVPERS 10085-B, you should be familiar with a variety of basic handtools. However, the fundamentals of using certain basic wood-working and field tools will be discussed further.

THE FRAMING SQUARE

The FRAMING SQUARE is one of the most generally used tools. The problems that can be solved with the square are so many and varied that books have been written on the square alone. Only a few of the more common uses of the square can be presented here; the Builder who desires to take full advantage of the square's capacities for solving a whole host of construction problems should obtain and study one of the books on the square.

The framing square consists of a wide, long member called the BLADE and a narrow, short

member called the TONGUE, which forms a right angle with the blade. The FACE of the square is the side one sees when the square is held with the blade in the left hand, tongue in the right hand, heel pointed away from the body. The manufacturer's name is usually stamped on the face. The blade is 24 in. long and 2 in. wide and the tongue varies from 14 to 18 in. long and 1 1/2 in. wide, as measured from the outer corner, where the blade and the tongue meet. This corner is called the HEEL of the square.

The outer and inner edges of the tongue and the blade, on both face and back, are graduated in inches. The first thing you must do is memorize the manner in which the inch is subdivided in the scales on the BACK of the square. In the scales on the face, the inch is subdivided in the regular units of carpenter's measure (eighths or sixteenths of an inch). On the back of the square, the outer edge of the blade and outer edge of the tongue are graduated in inches and TWELFTHS of inches, the inner edge of the tongue is graduated in inches and TENTHS of inches, and the inner edge of the blade is graduated in inches and thirty-seconds of inches on most squares.

Common uses of the twelfth and tenth scales on the back of the framing square will be described later.

Basic Problems Solved by the Framing Square

The framing square is used most frequently to find the length of the hypotenuse (longest

side) of a right triangle when the lengths of the other two sides are known. This is the basic problem involved in determining the length of a roof rafter, a brace, or any other member which forms the hypotenuse of an actual or an imaginary right triangle.

Figure 3-1 shows you how the framing square is used to determine the length of the hypotenuse of a right triangle with the other sides each 12 in. long. Plane a true, straightedge on a board, and set the square on the board so as to bring the 12-in. mark on the tongue and the 12-in. mark on the blade even with the edge of the board. Draw the pencil marks shown in the second view. The distance between these marks, as measured along the edge of the board, is the length of the hypotenuse of a right triangle with the other sides each 12 in. long. You will find that the distance, which is called the BRIDGE MEASURE, measures just a shade under 17 in. To be exact, it is 16.97 in., as shown in the figure, but for most practical Builder's purposes 16.97 in. may be rounded off to 17 in.

UNIT AND TOTAL RUN AND RISE. In figure 3-1 the problem could be solved by a single set (called a CUT) of the framing square, because the dimensions of the triangle in

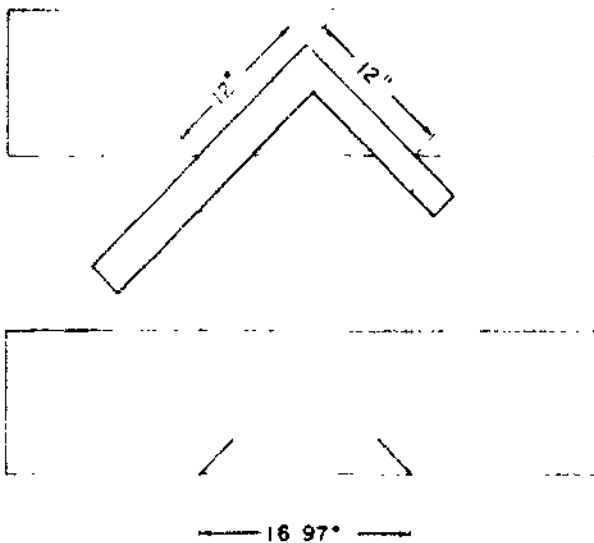

133.47

Figure 3-1.—Basic Problem solved by the framing square.

question lie within the dimensions of the square. Now suppose that you are trying to find the length of the hypotenuse of a right triangle with the two known sides being 48 in. long each. Let's assume that the member whose length you are trying to determine is the brace shown in figure 3-2. The TOTAL RUN of this brace is 48 in., and the TOTAL RISE is also 48 in.

To figure the length of the brace, you first reduce the triangle in question to a similar triangle which is within the dimensions of the framing square. The length of the vertical shorter side of this triangle is called the UNIT OF RISE, and the length of the horizontal shorter side is called the UNIT OF RUN. By a general custom of the trade, unit of run is always taken as 12 in., and measured on the tongue of the framing square.

Now, if the total run is 48 in., the total rise 48 in., and the unit of run 12 in., what is the unit of rise? Well, since the sides of similar triangles are proportional, the unit of rise must be the value of x in the proportional equation $48/48 = 12/x$. In this case, then, the unit of rise is obviously 12 in.

To get the length of the brace, you set the framing square to the unit of run (12 in.) on the tongue and to the unit of rise (also 12 in.) on the blade as shown in figure 3-2, and then "step off" this cut as many times as the unit of run goes into the total run. In this case that is $48/12$, or 4 times, as shown in the figure.

This problem involved a situation in which the total run and total rise were the same, from which it followed that the unit of run and unit of rise were also the same. Suppose now that you want to know the length of a brace with a total run of 60 in and a total rise of 72 in. Since the unit of run is 12 in., the unit of rise must be the value of x in the proportional equation $60/72 = 12/x$. When you work this out, you will find that the unit of rise is 14.4 in. This is near enough to 14 3/8 in. to serve any practical purpose.

To lay out the full length of the brace, you set the square to the unit of rise (14 3/8 in.) and the unit of run (12 in.), as shown in figure 3-3

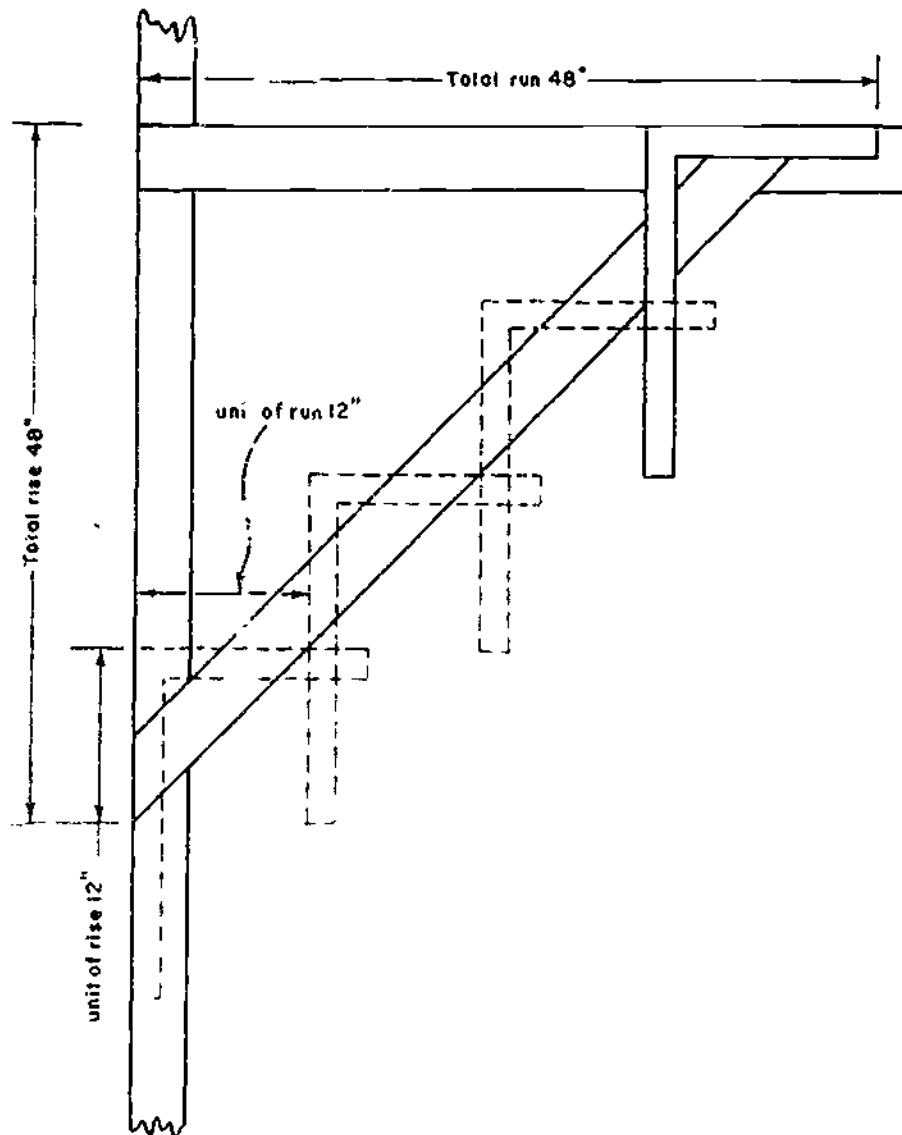

Figure 3-2.—“Stepping off” with the framing square.

133.48

and then step off this cut as many times as the unit of run goes into the total run (in this case $60/12$, or 5 times).

LINE LENGTH.—If you do not go through the procedure of stepping off, you can figure the total length of the member in question by first determining the **BRIDGE MEASURE**. The line length is the length of the hypotenuse of a right triangle with the other sides equal to the unit of

run and the unit of rise. Take the situation shown in figure 3-3, for example. The unit of run here is 12 in., and the unit of rise is $14 \frac{3}{8}$ in. Set the square to this cut as shown in figure 3-4, and mark the edges of the board as shown. If you measure the distance between the marks, you will find that it is $18 \frac{3}{4}$ in.

To get the total length of the member, you simply multiply the bridge measure by the number of times that the unit of run goes into

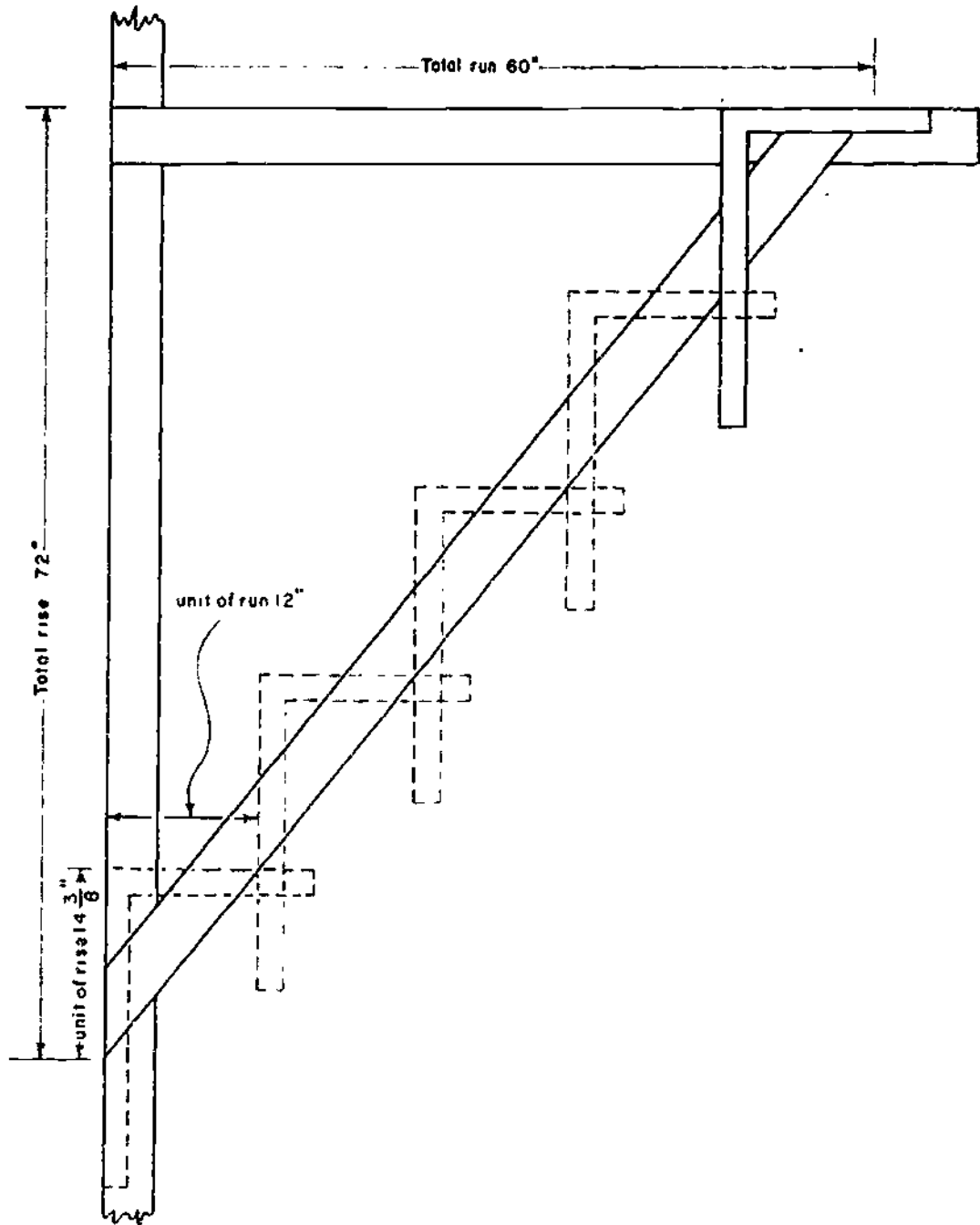
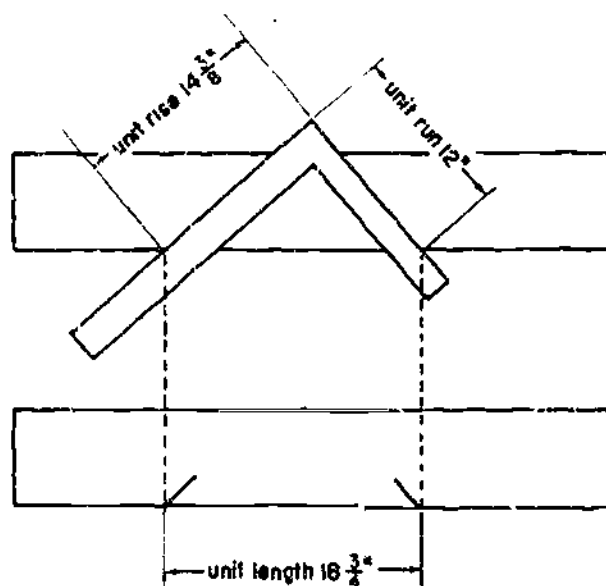

Figure 3-3.—"Stepping off" with the square when the unit of run and unit of rise are different

133.49



133.50

Figure 3-4.—Unit length.

the total run. Since that is 5 in this case, the total length of the member is $18 \frac{3}{4} \times 5$, or $93 \frac{3}{4}$ in. Actually, the length of the hypotenuse of a right triangle with the other sides 60 and 72 in. long is between 93.72 in. and 93.73 in., but $93 \frac{3}{4}$ in. is close enough for any practical purpose.

Once you have determined the total length of the member, all you need to do is measure it off and make end cuts. To make these cuts at the proper angles, you simply set the square to the unit of run on the tongue and unit of rise on the blade and draw a line for the cut along the blade (lower end cut) or the tongue (upper end cut).

USING THE TWELFTHS SCALE.—The graduations in inches which are located on the back of the square, along the outer edges of the blade and tongue, are called the TWELFTHS SCALE. The chief purpose of the twelfth scale is to provide various shortcuts in problem solving with the framing square. Since the scale is graduated in inches and twelfths of inches, dimensions in feet and inches can be reduced to 1/12th of size by simply allowing each

graduation on the twelfth scale to represent 1 in. For example: $2 \frac{6}{12}$ in. on the twelfth scale may be taken to represent 2 ft 6 in.

A few examples will show you how the twelfth scale is used. Suppose you want to know the total length of a rafter with a total run of 10 ft and a total rise of 6 ft 5 in. Set the square on a board with the twelfth scale on the blade at 10 in. and the twelfth scale on the tongue at $6 \frac{5}{12}$ in., and make the usual marks. If you measure the distance between the marks, you will find it to be $11 \frac{11}{12}$ in. The total length of the rafter is 11 ft 11 in.

Suppose now that you know the unit of run, unit of rise, and total run of a rafter and you want to find the total rise and the total length. Let us say that unit of run and unit of rise are 12 in. and 8 in., respectively, and that total run is 8 ft 9 in. Set the square to the unit rise on the tongue and unit run on the blade, as shown in the first view of figure 3-5. Then slide the square

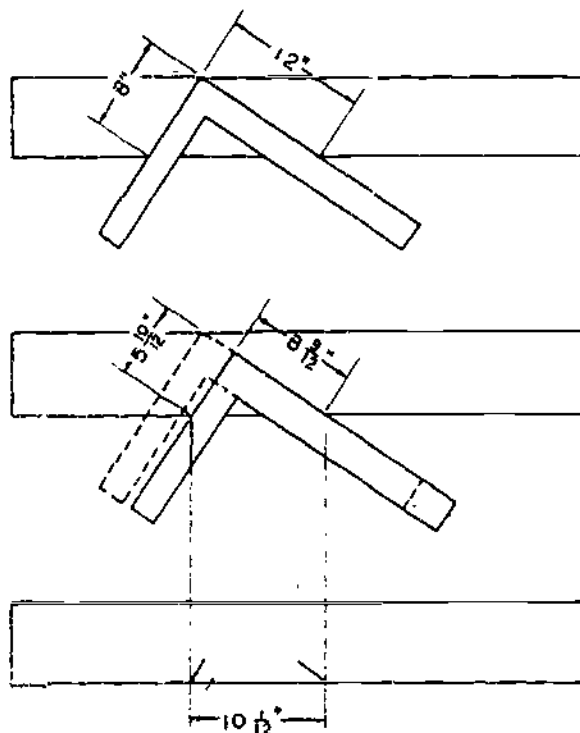

133.51

Figure 3-5.—Finding total rise and total length when unit of run, unit of rise, and total run are known.

to the right until the $8 \frac{9}{12}$ in. mark on the blade (representing the total run of 8 ft 9 in.) comes even with the edge of the board, as shown in the second view. The figure of $5 \frac{10}{12}$ in. which is now indicated on the tongue is one-twelfth of the total rise. The total rise is therefore 5 ft 10 in. The distance between pencil marks ($10 \frac{7}{12}$ inches) drawn along the tongue and the blade is one-twelfth of the total length. The total length is therefore 10 ft 7 in.

The twelfths scale may also be used to determine dimensions by inspection for proportional reductions or enlargements. Suppose, for example, that you have a panel 10 ft 9 in. long by 7 ft wide, and you want to cut a panel 7 ft long with the same proportions. Set the square as shown in figure 3-5, but with the blade at $10 \frac{9}{12}$ in. and the tongue at 7 in. Then slide the blade to 7 in. and read the figure indicated on the tongue, which will be $4 \frac{7}{12}$ in. The smaller panel should then be 4 ft 7 in. wide.

USING THE TENTHS SCALE.—The scale along the inner edge of the back of the tongue, which is graduated in inches and tenths of inches, is called the TENTHS SCALE. This scale can be used with the scale along the inner edge of the back of the blade (which is graduated in inches and sixteenths of inches) to determine various proportions by inspection. Suppose that a crew can excavate 44 linear ft of trench in 8 hours. How many feet can they excavate in $3 \frac{1}{4}$ hours? Set the square on a board with the tenth scale on the tongue at the 4.4-in. mark and the scale on the inner edge of the blade at the 8-in. mark. Then slide the blade down to the $3 \frac{1}{4}$ -in. mark. The reading on the tenth scale will now be 1.8 in. Since you took 4.4 to represent 44, 1.8 must represent 18, and the crew should therefore be able to excavate approximately 18 linear ft in $3 \frac{1}{4}$ hours.

USING THE HUNDREDTHS SCALE.—The hundredths scale is on the back of the tongue, in the corner of the square, near the brace table. This scale is called the HUNDREDTHS SCALE because 1 in. is divided into one hundred parts. The longer lines indicate 25 hundredths while the next shorter lines indicate 5 hundredths, etc. By using dividers, a fraction of an inch can be easily obtained.

The inch is graduated in sixteenths, and located below the hundredths scale; therefore, the conversion from hundredths to sixteenths can be made at a glance without the use of dividers. This can be a great help when determining rafter lengths, using the figures of the rafter tables where hundredths are given.

USING THE OCTAGON SCALE.—The OCTAGON SCALE (sometimes called the EIGHT-SQUARE SCALE) is located in the middle of the face of the tongue. The octagon scale is used to lay out an octagon (8-sided figure) in a square of given even-inch dimensions. The procedure is as follows.

Suppose you want to cut an 8-in. octagonal piece for a stair newel. First square the stock to 8 by 8 inches and smooth the end-section, and draw crossed centerlines on the end-section as shown in figure 3-6. Then set a pair of dividers

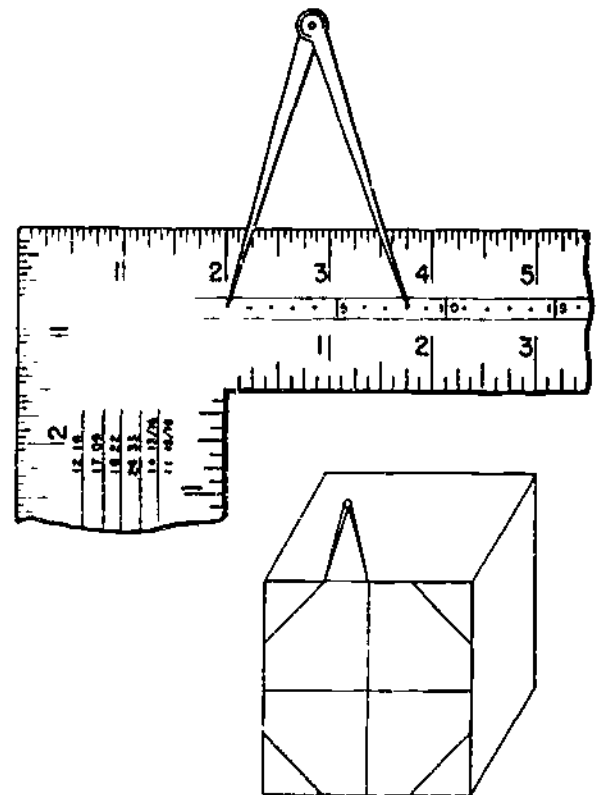

4.16(133D)A

Figure 3-6.—Using the octagon square.

to the distance from the first to the eighth dot on the octagon scale, and lay off this distance on either side of the centerlines on the 4 slanting sides of the octagon.

When you use the octagon scale, set one leg of the dividers on the first dot and the other leg on the dot whose number corresponds to the width in inches of the square from which you are cutting the piece. This distance amounts to one-half the length of a side of the octagon.

Using the Framing Tables on the Framing Square

There are three tables on the framing square, as follows: (1) the UNIT LENGTH RAFTER TABLE, located on the face of the blade, (2) the BRACE TABLE, located on the back of the tongue, and (3) the ESSEX BOARD MEASURE TABLE, located on the back of the blade. Before you can use the unit length rafter table, you must be familiar with the different types of rafters and with the methods of framing them. Consequently, the use of the unit length rafter table is described in Chapter 10, Roof Framing. The other two tables are discussed below.

USING THE BRACE TABLE.—The brace table sets forth a series of equal runs and rises for every 3-unit interval from 24/24 to 60/60, together with the brace length, or length of the hypotenuse, for each given run and rise. The table can be used to determine by inspection the length of the hypotenuse of a right triangle with equal shorter sides of any length given in the table.

For example, in the segment of the brace table shown in figure 3-7, you can see that the

15	14	13	3	2	1
33"	38"	42"	64"	30	
13	12	11	1		

4.16(133D)A

Figure 3-7.—Brace table.

length of the hypotenuse of a right triangle with two sides 24 units long is 33.94 units; with two sides 27 units long, 38.18 units; with two sides 30 units long, 42.43 units, and so on.

By applying simple arithmetic, you can use the brace table to determine the hypotenuse of a right triangle with equal sides of practically any even-unit length. Suppose that you want to know the length of the hypotenuse of a right triangle with two sides 8 in. long. The brace table shows that a right triangle with two sides 24 in. long has a hypotenuse 33.94 in. long. Since 8 amounts to 24/3, a right triangle with two shorter sides 8 in. long must have a hypotenuse of $33.94/3$, or 11.31 in. long.

Suppose you want to find the length of the hypotenuse of a right triangle with two sides 40 in. each. The sides of similar triangles are proportional, and any right triangle with two equal sides is similar to any other right triangle with two equal sides. The brace table shows you that a right triangle with the two shorter sides being 30 in. each in length and has a hypotenuse 42.43 in. long. The length of the hypotenuse of a right triangle with the two shorter sides being 40 in. each in length must be the value of x in the proportional equation $30:42.43:40:x$, or 56.57 in.

Notice that the last item in the brace table (the one furthest to the right in fig. 3-7) gives you the hypotenuse of a right triangle with the other sides 18 and 24 units long respectively. The proportions 18:24:30 are those of the most common type of unequal-sided right triangle, which is called the "3-4-5" right triangle. Any triangle with sides in the proportions of 3:4:5 must be a right triangle.

USING THE ESSEX BOARD MEASURE TABLE.—Since the chief practical use of the board measure is in connection with lumber costs, you may not have much use for the Essex board measure table. The table makes it possible for you to determine by inspection the board measure of a 1-in. thick piece of given length and width. A segment of the table is shown in figure 3-8.

The inch graduations above the table (1, 2, 3, 4, and so on) represent the width in inches of

	7	8	9	10	11	12	13
5	35	40	45	50	55	60	65
6	42	48	54	60	66	72	78
7	49	56	63	70	77	84	91
8	56	64	72	80	88	96	104
9	63	72	81	90	99	108	117
10	70	80	90	100	110	120	130
11	77	88	99	110	121	132	143
12	84	96	108	120	132	144	156
13	91	104	117	130	143	156	169

4.16(133D)C

Figure 3-8.—Segment of Essex board measure table.

the piece to be measured. The figures under the 12-in. graduation (8, 9, 10, 11, 13, 14, and 15, arranged in column) represent lengths in feet. The figure 12 itself represents a 12-ft length. The column headed by the figure 12 is the starting point for all calculations.

To use the table, run down the figure 12 column to the figure that represents the length of the piece in feet. Then run horizontally to the figure which is directly below the inch mark that corresponds to the width of the stock in inches. The figure you find will be the number of board feet and twelfths of board feet in a 1-in. thick piece of given length and width.

For example, suppose you want to figure the board measure of a piece 10 ft long by 9 in. wide by 1 in. thick. Run down the column headed by the 12-in. graduation to 10, and then run horizontally to the left to the figure directly below the 9-in. graduation. You will find the figure to be 7.5 or $7 \frac{6}{12}$ bd ft.

What do you do if the piece is more than 1 in. thick? Obviously, all you have to do is multiply the result obtained for a 1-in. piece by the actual thickness of the piece in inches. For example: if the board described in the preceding paragraph were 5 in. thick instead of 1 in. thick, you would follow the procedure described and then multiply the result by 5.

The board measure scale can be read only for pieces from 8 to 15 ft in length, inclusive. If your piece is longer than 15 ft, you can proceed in one of two ways. If the length of the piece is evenly divisible by one of the tabulated lengths in the table, you can read for that length and multiply the result by the number of times that the tabulated length goes into the length of the

piece. For example: suppose you want to find the number of board feet in a piece of 33 ft long by 7 in. wide by 1 in. thick. Since 33 is evenly divisible by 11, go down the 12 in. column to 11 and then run left to the 7 in. column. The figure given there (which is $6 \frac{5}{12}$ bd ft is one-third of the number of bd ft in a piece 33 ft long by 7 in. wide by 1 in. thick. The total number of bd ft is $6 \frac{5}{12} \times 3$ or $19 \frac{3}{12}$ bd ft.

If the length of the piece is not evenly divisible by one of the tabulated lengths, you can divide it into two tabulated lengths, read the table for these two, and add the results together. For example: suppose you want to find the board measure of a piece 25 ft long by 10 in. wide by 1 in. thick. This length can be divided into 10 ft and 15 ft. The table shows that the 10-ft length contains $8 \frac{4}{12}$ bd ft and the 15-ft length $12 \frac{6}{12}$ bd ft. The total length, then, contains $8 \frac{4}{12}$ plus $12 \frac{6}{12}$, or $20 \frac{10}{12}$ bd ft.

MITER BOX

A MITER BOX permits sawing a piece of stock to a given angle without laying out a line. The standard miter box will cut wood stock up to 4 in. thick and 8 in. wide, but it is normally used for light carpentry work, such as interior finishing. Although the miter box can be used to cut any desired angle, it must be checked for correct adjustment, thus reducing possible inaccurate cuts. Figure 3-9 illustrates a typical

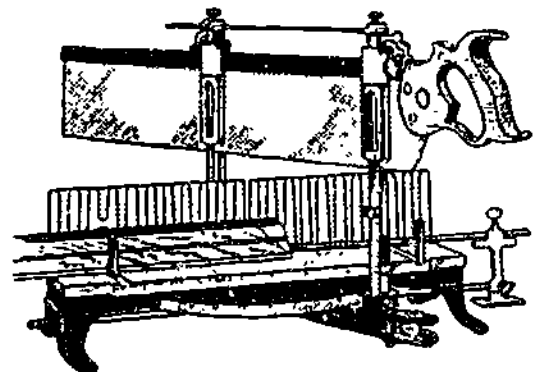

68.10(133D)BX

Figure 3-9.—Steel miter box.

steel miter box that can be set and used to cut wood stock at any desired angle.

LEVELS

The term "level" usually describes a horizontal surface which, throughout its extent, lies on a line corresponding to that of the horizon. The term "plumb" means vertical, or at right angles to level. Instruments at your disposal for checking levelness are the line level and the carpenter's level.

Line Level

The LINE level (fig. 3-10) consists of a bubble tube set into a metal case with a hook at each end to permit it to be hung on a line or cord.

The line level is used to test whether a line or cord is level. It is particularly useful when the distance between two points to be checked for level is too long to permit the use of a board and the carpenter's level. However, the line level will show a disadvantage at a long distance because the line has a tendency to sag. To use the level, stretch a cord between the two points which are to be checked for level. Hang the line level on the cord and see whether the bubble is in the middle of the tube. If it is not, raise the end of the cord which is toward the lower end of the bubble until the bubble rests in the middle of the tube. Unhook the level and turn it end for end, hang it on the cord, and retest. Continue testing until the bubble rests in the same relative position in its tube when the level is turned end

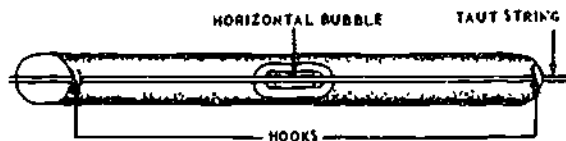

Figure 3-10.—Line level.

29.14

for end. Remember, to make the bubble rise in the tube, lift that end of the cord which is toward the lower end of the bubble.

The line level is a delicate instrument; therefore, it must be kept in a box when not in use, to protect the bubble tube from being broken and the hooks from being bent. Never clean the level with water or any liquid because condensation will appear.

Carpenter's Level

The CARPENTER'S level (fig. 3-11) is usually 24 in. long and made of wood or lightweight metal with true-surface edges. There are normally two or three bubble tubes in it. The horizontal bubble tube is centered lengthwise. The other one or two (vertical bubble tubes) are parallel to the short edges of the level.

Bubble tubes are glass tubes nearly filled with alcohol. They are slightly curved. As a bubble of air in such a tube will rise to the highest point, the bubble will take its place in

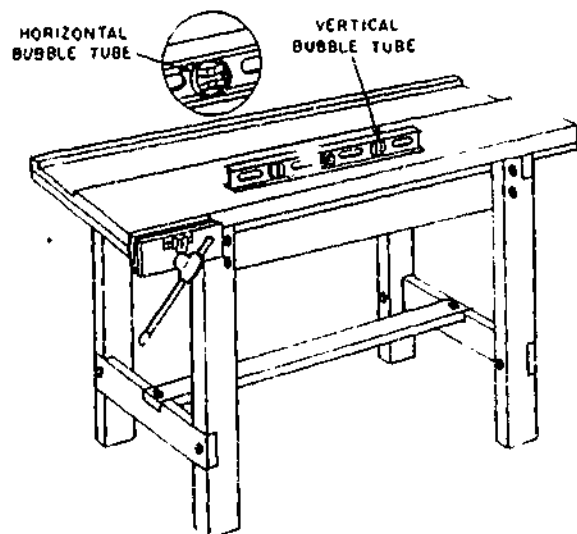

Figure 3-11.—Leveling a bench with a carpenter's level.

133.430

the middle of the tube when the tube is in a horizontal position.

Scratch marks at equal distances from the middle of the tube mark the proper position of the bubble when the surface on which the tube rests is level. To test for levelness of a surface, lay the carpenter's level on the surface and see where the bubble comes to rest. If the surface is level and the level is in adjustment, it will come to rest exactly between the two scratch marks mentioned above. Turn the level end for end and recheck. The bubble should come to rest in the same place. If it does not, raise the end of the surface being tested which is toward the low end of the tube until it checks level.

To check for plumb, set the long side of the carpenter's level against the upright to be tested and use the bubble which is set in the end in the same way as described above. Turn the level end for end to insure accuracy, as mentioned above.

TAPE

The tape (fig. 3-12) is a steel ribbon, normally 3/8 in. in width, ranging from 6 to 100 ft in length. It is graduated in feet, inches, and fractions of an inch down to 1/16 inch. One end of the tape is fastened to a reel which is housed in a metal box provided with a slot

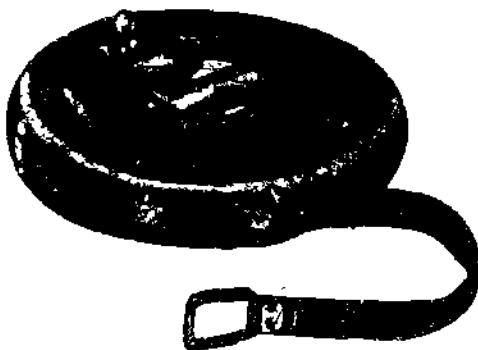

29.250(133F)

Figure 3-12.—Steel tape.

through which the other end of the tape protrudes. This end has a metal ring or hook attached to it. The ring will not pass through the slot in the case, thus it forms a handle by which the tape may be drawn from the case.

To measure with the tape, hold the ring end at the starting point, either by slipping it over a nail or by other means. Walk in the direction to be measured, letting the tape be pulled from the case as you walk. Stretch the slack out of the tape, making sure it is parallel to the surface or edge to be measured. Read the graduation which falls at the end of the distance to be measured.

Reel the tape back into its case whenever it is not actually being used. Do not permit the tape to be kinked. It is easily kinked by being used for measuring around corners or by permitting a vehicle to run over it. Keep the tape lightly oiled. If it gets wet or damp, it will stain or rust making it difficult to read. Wipe it thoroughly dry and oil it before returning it to its case.

CHALK LINE

Long straight lines between distant points on surfaces are marked by snapping a CHALK LINE, as shown in figure 3-13. The line is first chalked by holding the chalk in the hand and drawing the line across it several times. It is then stretched between the points and snapped as shown. For an accurate snap, never snap a chalk line over a 20-ft distance. The chalk line may be

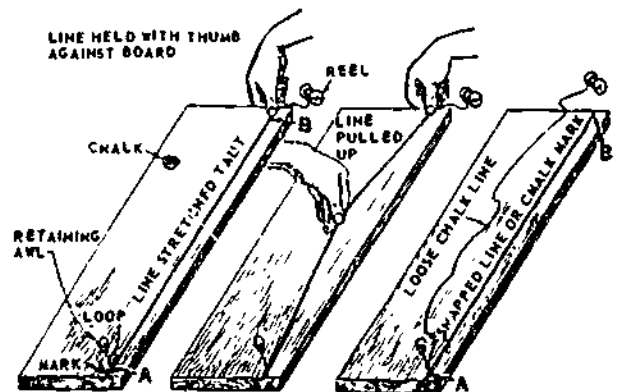

133.54X

Figure 3-13.—Snapping a chalk line.

designed with reels which are enclosed within a metal or plastic case containing powdered chalk, allowing the line to be coated with the chalk as it is withdrawn from the reel.

SAW-SHARPENING EQUIPMENT

The saw vise (view A, fig. 3-14) is a special vise or clamp with long jaws designed for securing saw blades while they are being filed. It has a handle on front which only needs pulling away from the vise in order to open the jaws. Closing the handle puts pressure on the jaws of the vise by means of a cam, so that the blade of the saw is held securely.

The vise is held to the workbench by means of a clamp (view A, fig. 3-14). The clamping assembly is equipped with a turn screw to hold it securely to the bench and a wing nut which permits the vise to be set at various angles to the clamp.

The file holder (view A, fig. 3-14) consists of a wooden handle to which is attached a triangular file. A pair of clamping screws on the file holder fastens the frame to the jaws of the vise. It can be adjusted to hold the file at any desired angle to the teeth being filed. A clamp on the top of the frame permits the file to be held at any position along the blade.

The saw set (view B, fig. 3-14) is a tool which, by means of a plunger and anvil, bends the teeth of the saw outward to make the kerf wider than the thickness of the blade of the saw.

The reconditioning kit for large crosscut saws consists of a jointer, which is a file holder by which a flat or mill file can be held and guided while jointing the saw; two gages, one for the raker tooth and one for checking the set of the teeth; and a setting block (frequently called a stumping tool).

There are five basic steps involved in the sharpening of a saw: Jointing, shaping, setting, filing, and dressing.

JOINTING is always the first step. Its purpose is to make all the teeth the same height. First place the saw in the vise, and, with a flat file held in the jointing tool, file lengthwise from heel to toe of the saw until a flat top has been filed on the tip of each tooth (fig. 3-15). On the

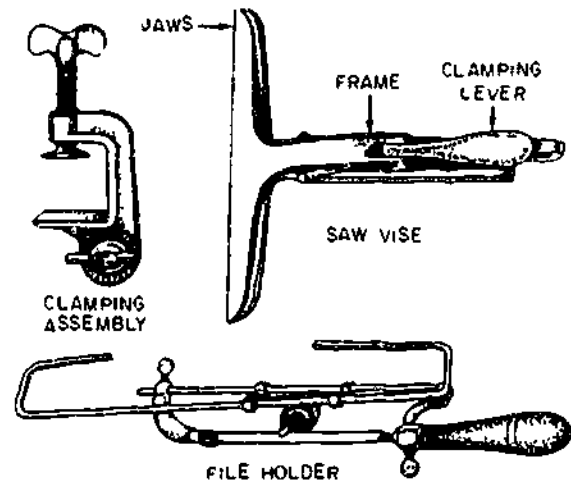

A VISE, CLAMPING ASSEMBLY, AND FILE HOLDER

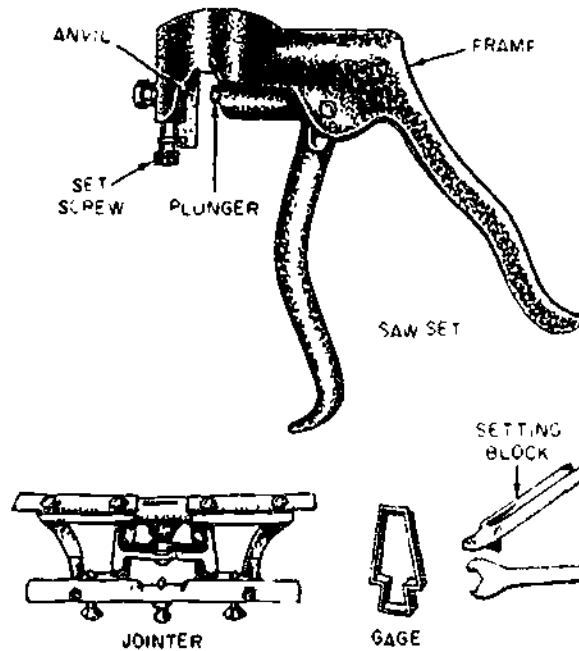

B SAW SET AND RECONDITIONING KIT

133.335

Figure 3-14.—Saw-sharpening equipment.

large crosscut saws, the raker teeth are filed about 1/64th in. shorter than the cutting teeth.

SHAPING is done only when the teeth are unevenly spaced or shaped. To shape, file the

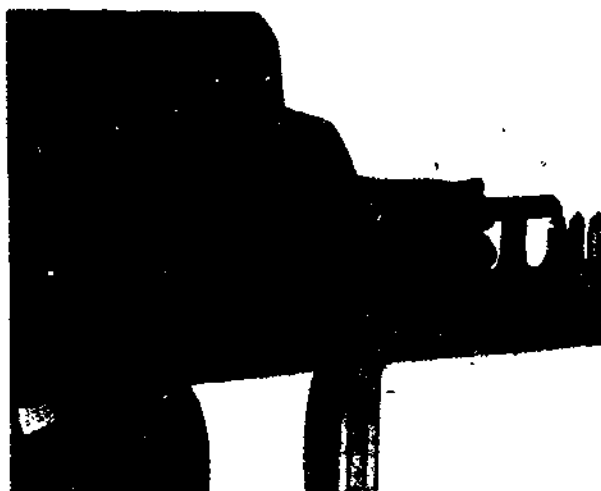

133.336

Figure 3-15.—Jointing a saw blade.

teeth with a tapered file to a sharp point, the gullet well rounded, and the teeth filed straight across, not rounded. In filing the rip saw, in addition to adjusting the saw for the angles shown in view A, figure 3-16, lower the file handle about 2 inches to give a bevel on the top of the teeth which lean away from you. For the crosscut handsaw, the front of the tooth should be filed with an angle of 15° from the vertical, while the back slope should be 45° with the vertical (view B, fig. 3-16). Disregard the bevel of the teeth, and file straight across at right angles to the blade with the file well down in the gullet while shaping. If the teeth are of unequal size, file the teeth with the largest flat tops until the center of the flat tops made by jointing is reached. Then move the file to the next gullet and file until the rest of the flat top disappears and the tooth has been brought to a point. Do not bevel the teeth while jointing. The teeth are now ready for setting.

In **SETTING**, particular care must be taken to see that the set is regular. It must be the same width for the entire length of the blade and the same width on both sides of the blade. The depth should never be more than half the depth of the tooth. If the set is made deeper, it may spring, crimp, crack the blade, or break out the teeth.

To set the handsaw, the saw set is placed over the blade so that the guides are over the

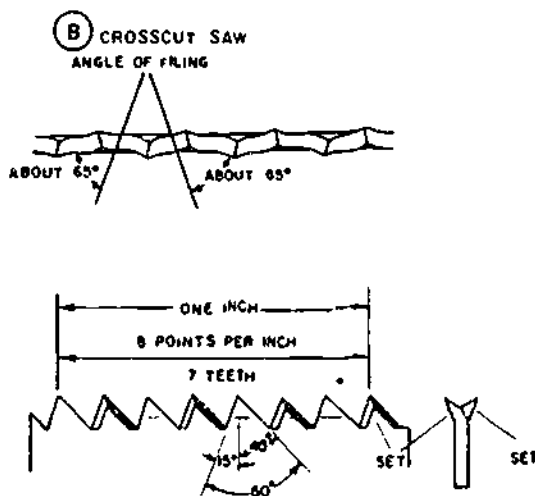
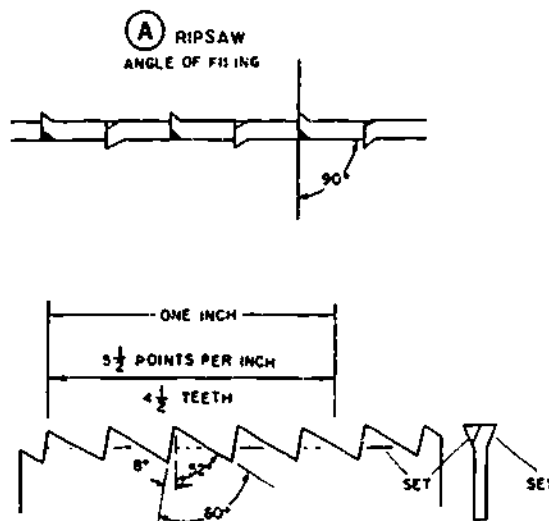

29.15A(133F)B

Figure 3-16.—Angles of saw teeth.

teeth with the anvil behind the tooth to be set (view D, fig. 3-17). The anvil, with its bevel at the top, is held in the frame by means of the setscrew. The handles are now pressed together. The plunger will press the tooth against the anvil and bend it to the angle of the bevel of the anvil. Each tooth is set in this manner, alternating to either side of the blade.

To **FILE** the handsaw (fig. 3-18), place the saw in the vise with the handle to the left. Begin to file at the heel. Adjust the file holder so that

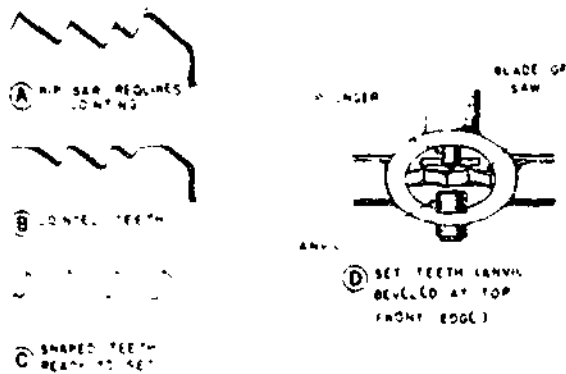

133.337

Figure 3-17.—Jointed and shaped teeth, and use of saw set.

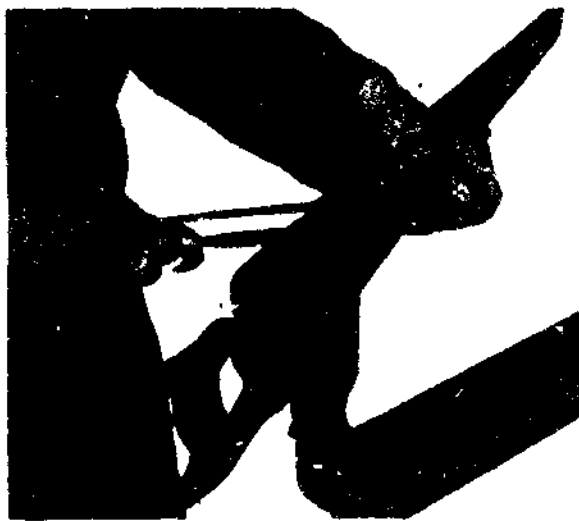

133.338

Figure 3-18.—Filing the handsaw

the file is held at the proper angle as shown in view B, figure 3-16 and that the file is between two teeth. File both teeth at once with one or more strokes of the file. Work down the whole saw shifting the file by means of the clamp on the top of the file holder. Then turn the saw around so that the handle is to the right, readjust the file holder, and work down the entire length of the saw again.

Dressing of the saw is necessary only when there are burrs left on the side of the teeth by filing. These burrs cause the saw to work in a ragged fashion. They are removed by laying the saw on a flat surface and running an oilstone or fine file lightly across the side of the teeth. Make sure both rows of teeth are of the same length. If they are not, the saw will curve as it cuts. Set the teeth before filing to avoid damage to the cutting edges. Never make the depth of the set more than half that of the tooth itself.

EQUIPMENT FOR HOLDING WORK

A woodworking BENCH VISE, designed for holding work for planing, sawing, or chiseling on the bench is shown in figure 3-19. Turning the SCREW by means of the HANDLE causes the MOVABLE JAW on the vise to move in or out on the SLIDE BARS (sometimes called the GUIDE BARS). On a vise with a CONTINUOUS SCREW, the movable jaw must be threaded all the way. On a vise with an INTERRUPTED SCREW (which is called a QUICK-ACTING vise) the movable jaw can be moved rapidly in or out when the screw is in a certain position. When the jaw is in the desired position against the work, the quick-acting vise can be tightened by a partial turn of the handle.

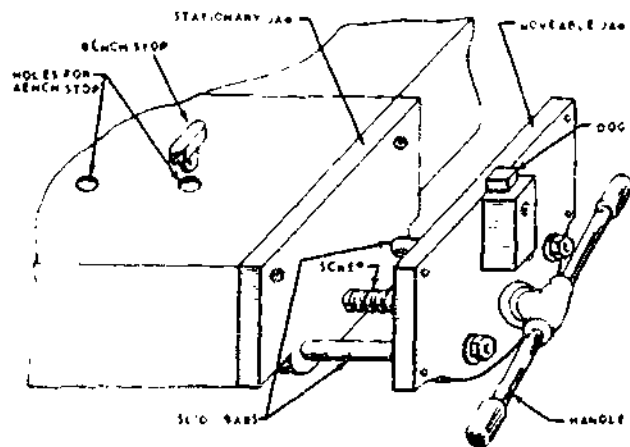

133.64

Figure 3-19.—Woodworking bench vise.

Most woodworking vises are equipped with a DOG as shown in the figure. The dog, which can be raised as shown or lowered flush with the top of the vise, is used in conjunction with a BENCH STOP to hold work which is too wide for the maximum span of the vise.

Sometimes a bench is equipped with two vises, so that long work can be held at both ends. When this is the case, the principal vise is called the SIDE VISE and the auxiliary vise the TAIL VISE.

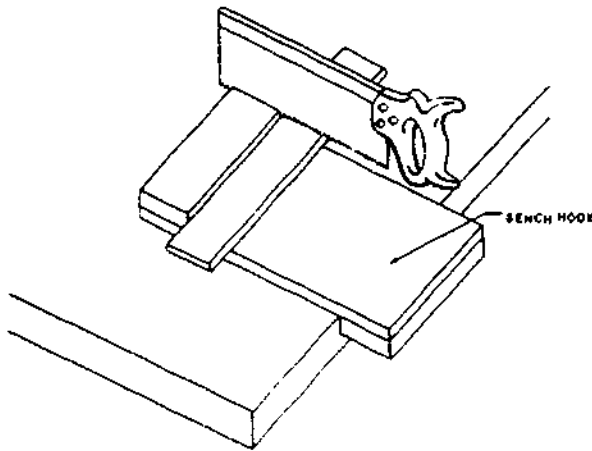

Figure 3-20.—Bench hook. 29.20

The screws and slide bars on vises should be lubricated regularly with preservative lubricating oil. Never hammer the jaws of a vise, and never use a woodworking vise to hold a metal article. Never use a piece of pipe or similar device to increase the leverage of the handle. There is danger, not only of breaking the handle, but also of damaging the screw and the jaws.

Always keep the jaws on a handscrew parallel to each other. Tightening the handscrew with the jaws cocked will bend the spindles and damage the jaws. NEVER use anything but the hands to tighten the spindles. Keep the jaws well varnished to protect the wood.

A BENCH HOOK (fig. 3-20) is a wooden device for holding work for backsawing.

The SAWHORSE might be called the carpenter's portable workbench and scaffold. If you do not already have a good sawhorse you will have to make one, and the layout part of the job will give you an idea of the practical use you can make of the framing square. A working drawing for a good, sturdy sawhorse is shown in figure 3-21. A few pointers on the layout part of the job are as follows:

The first layout problem is laying off the end cuts for the legs. If you think about it for a moment while examining the drawing, you will

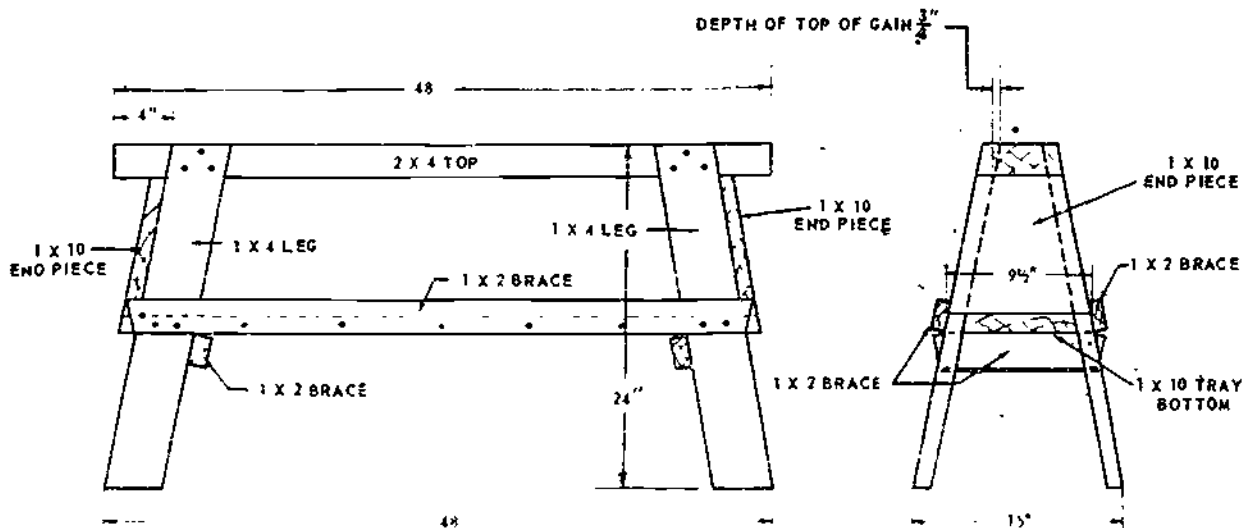

Figure 3-21.—Sawhorse

29.16

see that there is a right triangle involved here, with a total rise of 24 in. (vertical height of the sawhorse) and a total run of 4 in. (amount that the top of the leg is set away from the end of the top). To get the correct end cuts, then, you set the square to 4 in. on the tongue and 24 in. on the blade, as shown in figure 3-22. How long a piece will you need to start with? Well, if you measure the hypotenuse, as shown in the figure, you will find that the length of the finished piece will be a little more than 24 1/4 in. You better start with a piece about 26 in. long.

Mark the left-hand end-cut along the tongue, and mark the point where the end of the blade contacts the edge of the piece at the opposite end. Then turn the square over and mark the opposite end-cut as shown. Saw off the ends and use the piece as a pattern for laying out the end-cuts on the other three legs.

The next problem is to lay off the **SIDE CUTS** on the legs. Once again there is a right

triangle involved, and once again the total rise is 24 in. (vertical height of the sawhorse). The total run is a little harder to figure. If you study figure 3-21 closely, you will see that the total run must amount to one-half the span of the legs (15 in. divided by 2, or 7 1/2 in.) minus the horizontal thickness of the leg (you can call that 3/4 in.), and minus one-half the **ACTUAL** width of the top (2 by 4 is usually only about 3 3/4 in. wide, and half of that is 1 7/8 in.), less the depth of the top of the gain, which is shown in the drawing to be 3/8 in.

If you can't quite see why this is so, study the simplified drawing in figure 3-23 where the

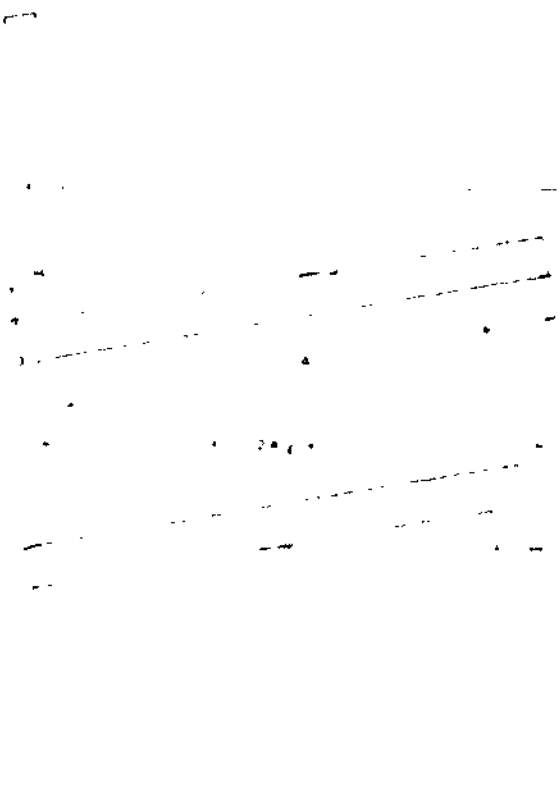

133.65

Figure 3-22 -Laying off and cuts for legs

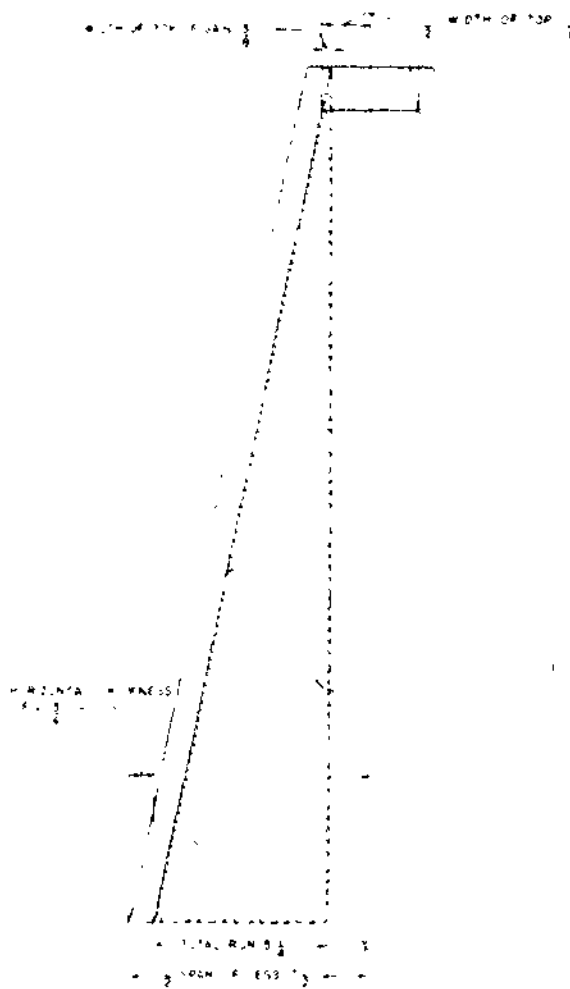

133.66

Figure 3-23 -Basic triangle for end cuts for legs.

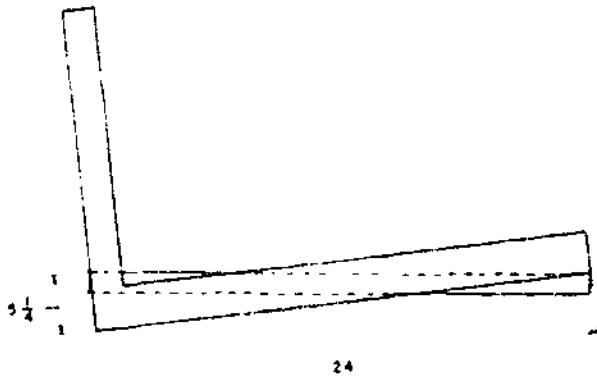

133.67
Figure 3-24 -Laying off side cuts for legs.

basic triangle you are solving is shaded in. If you work out the arithmetic in the previous paragraph, you will find that the total run is $5 \frac{1}{4}$ in. To lay off the side cuts for the legs, then, you set the square to $5 \frac{1}{4}$ in. on the tongue and 24 in. on the blade, on the edge of a leg, as shown in figure 3-24. Mark a line along the tongue, carry the line across the face of the

piece, parallel to the line of the end-cut, and bevel the end down to the line with a plane.

To lay out the gain on the side of the top, first set the top of a leg in place against the side, 4 in. from the end, as shown in figure 3-25, top view, and draw the lines for the sides of the gain. Then use the marking gage to score a line $\frac{3}{8}$ in. from the edge to the top, and chisel out the gain as indicated in the lower view.

The set of the framing square for the edges of the 1 by 10 end piece is the same as the set for the side cuts of the legs; a study of figure 3-23 will show you why. Select a piece that is ACTUALLY 10 in. wide, and lay off the line for one of the edges as shown in figure 3-26. Since you would not be able to end-for-end the square to get the line for the other edge in this case, the best way to lay that line off is to set the T-bevel to the other line, measure off the prescribed $9 \frac{1}{2}$ in. along the bottom, reverse the T-bevel,

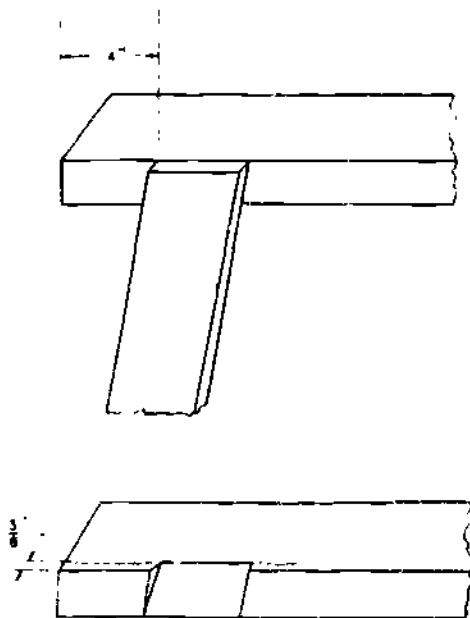

133.68
Figure 3-25.-Laying out the gains for the legs.

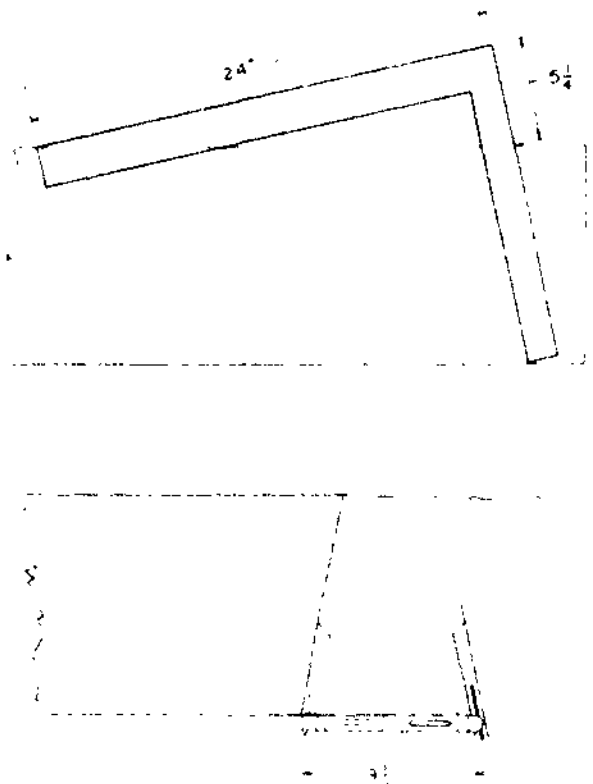

133.69
Figure 3-26.-Laying off the 1 x 10 end piece.

se. it to the mark, and lay off the line as indicated in figure 3-26.

The set of the framing square for the edge cuts for the 1 by 10 tray is also 5 1/2 in. on the tongue and 24 in. on the blade, but the best way to fit the tray is to set it in place and mark it after the top, legs, and end pieces have been assembled. Use 8-penny coated galvanized nails to nail the pieces together.

POWER TOOLS

Your duties as a Builder will also involve developing and improving your skills and techniques when working with different power tools. Therefore, in this section we will identify and discuss the most common power tools that are found in the Builder's workshop. We will also discuss safety precautions as they relate to the particular power tool under discussion. You must keep in mind and continually stress to your crew that woodworking power tools can be dangerous and that safety is everyone's responsibility.

TRAILER-MOUNTED FIELD SAW

Like all trailer-mounted field saws used by the SI ABILES, model EH-295, shown in figure 3-27, is designed to operate under adverse climatic conditions. Being self-contained, it is especially suited for use in remote locations. Not only can it furnish electric power for a normal sawing load, but also power for floodlights and smaller tools. The basic unit consists of a diesel engine and generator set, electrical equipment, engine-generator control panel, distribution panel, and radial overarm saw.

The diesel engine and generator set (fig 3-28) is located at the front of the unit, the engine-generator control panel (fig 3-29) on the right side, and the distribution panel (fig 3-30) on the left side. The electrical equipment

(extension cords and floodlights) are located in the storage boxes on the right side of the unit. The radial overarm saw is a typical shop type saw with few modifications for field use. All components of the basic unit, except the radial overarm saw, are covered by a weatherproof sheet-metal housing. The radial overarm saw is protected by a canvas cover. Figure 3-31 shows it mounted on a field trailer.

The field trailer is a two-wheel unit having a retractable front stand, two retractable stabilizing jacks at the rear for leveling and maintaining the radial overarm saw in its operating position, safety towing chains, two parking brakes, left and right roller conveyor tables, grounding rod, and a 12-volt vehicle lighting system.

Preparation For Use

When getting the trailer-mounted saw ready for use, thoroughly inspect the complete unit for any loose connections, particularly the fuel and electrical systems. Tighten loose connections, parts, bolts, nuts, and other hardware. Also inspect for evidence of damage to meter glasses, lights, and other breakable parts. Check to see that trailer tires are properly inflated. Operate movable control devices by hand, making sure they operate freely.

Be sure to fill the engine lubricating system with the proper grade of oil and to the level recommended. Check the air cleaner (dry type) on the engine for any dirt or dust that may have accumulated in the air cleaner filter. Fill the fuel tank with suitable diesel fuel.

Make sure the trailer-mounted field saw is suitably located where there is adequate operating room and ventilation for dissipation of engine heat and exhaust. Position the trailer on level ground. Set the brakes by pulling forward the hand-brake levers in the front of the trailer. Lower the stabilizing jacks in the rear of the trailer until the trailer is level (fig 3-27). Put blocks in front of the trailer-wheels. Remove the grounding rod from its stowed position and then

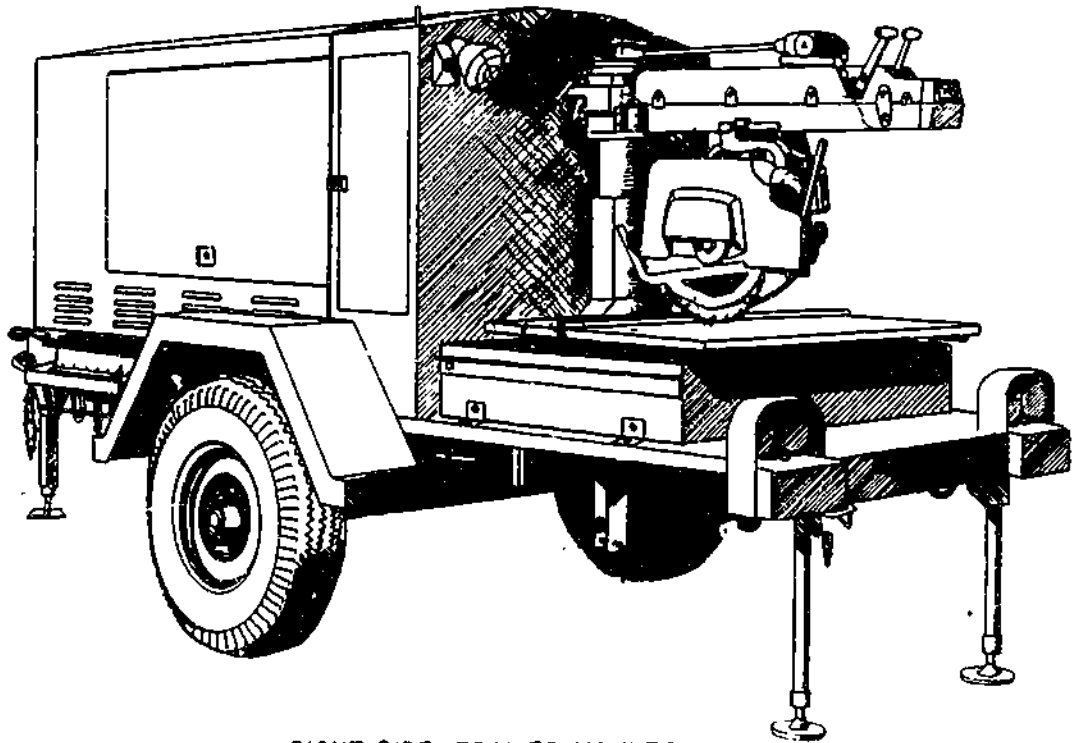

RIGHT SIDE, TRAILER MOUNTED SAW

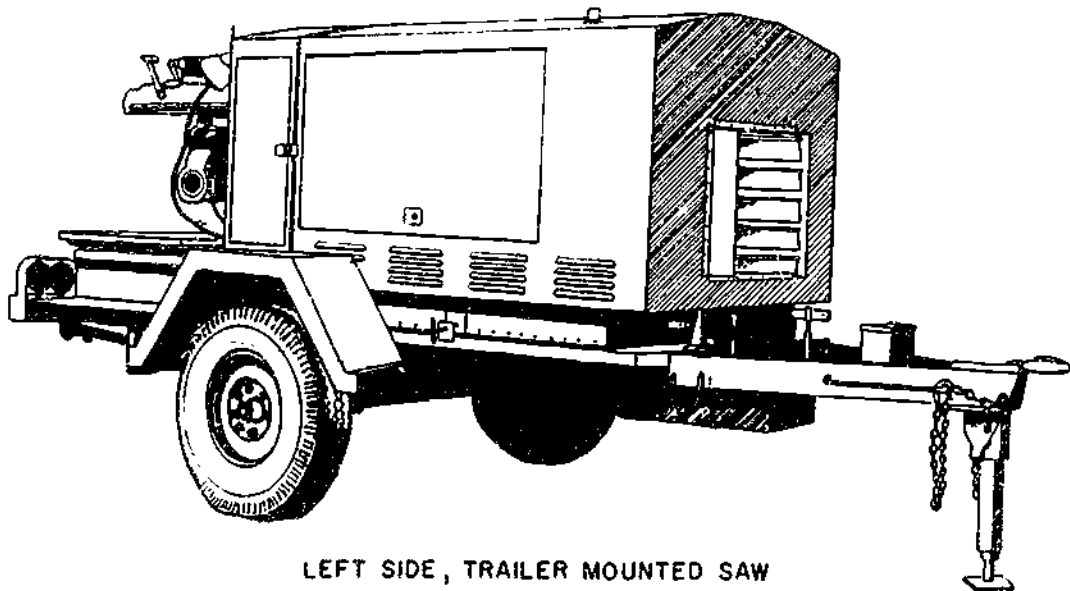

LEFT SIDE, TRAILER MOUNTED SAW

Figure 3-27.—Trailer-mounted overarm field saw.

133A31

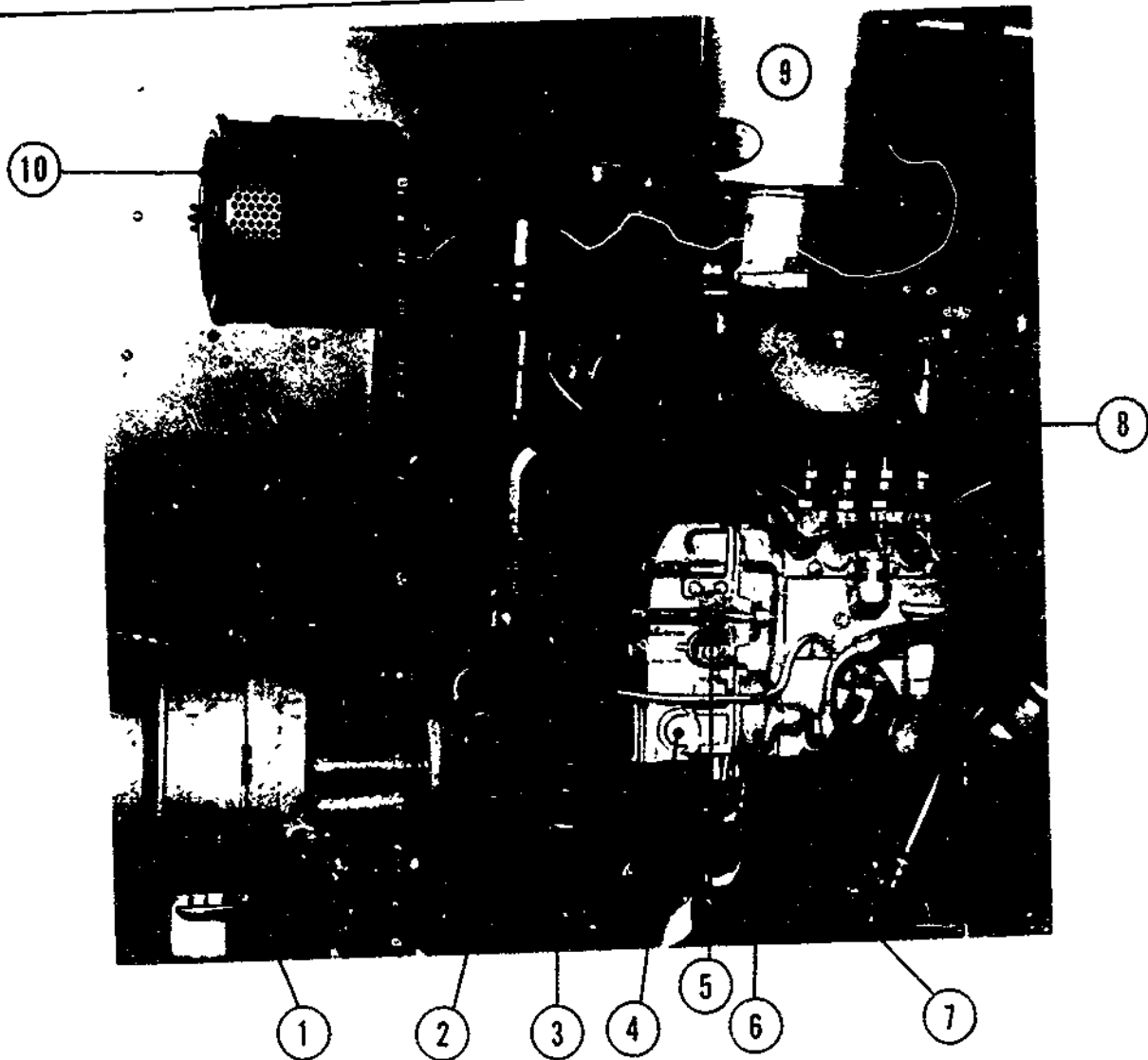

ITEM
NUMBER

DESCRIPTION

- | | |
|----|---|
| 1 | 10 KW GENERATOR. |
| 2 | FOUR CYLINDER DIESEL ENGINE. |
| 3 | ENGINE OIL FILTER. |
| 4 | PUMP GOVERNOR. |
| 5 | ENGINE THROTTLE ADJ. (VERNIER CONTROL). |
| 6 | ENGINE FUEL INJECTION PUMP. |
| 7 | DIESEL FUEL SUPPLY VALVES. |
| 8 | ENGINE FUEL FILTER. |
| 9 | ENGINE SILENCER. |
| 10 | ENGINE AIR CLEANER. |

133.432

Figure 3-28.—Diesel engine and generator unit.

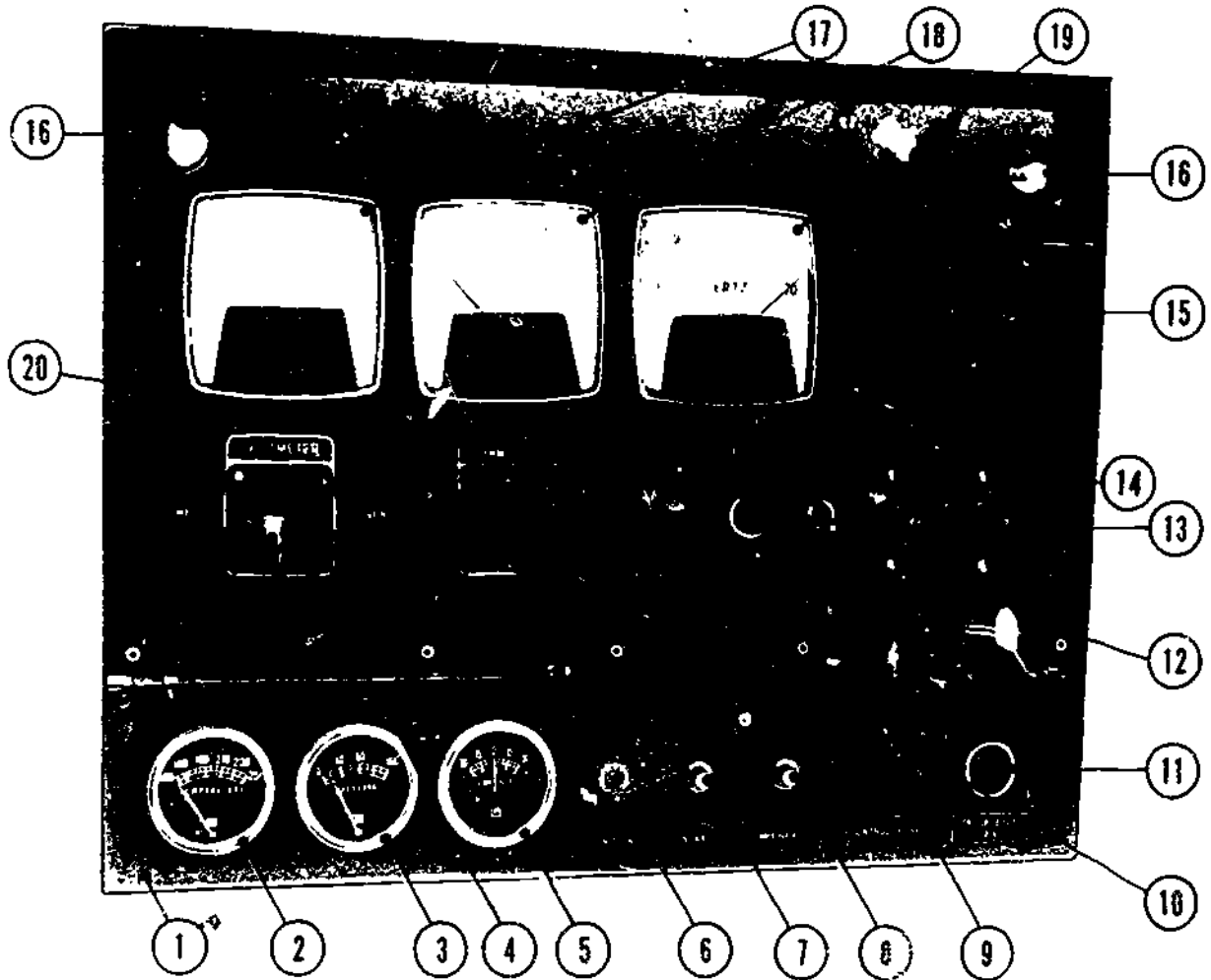

ITEM NUMBER	DESCRIPTION	ITEM NUMBER	DESCRIPTION
1	ENGINE, GENERATOR CONTROL PANEL HOUSING.	11	TROUBLE LIGHT RECEPTACLE.
2	ENGINE WATER TEMPERATURE GAGE.	12	FAILURE INDICATOR LIGHT.
3	ENGINE OIL PRESSURE GAGE.	13	PANEL LIGHTS OFF-ON SWITCH.
4	GENERATOR VOLTMETER SWITCH.	14	120 V, 15 AMP OUTLET RECEPTACLES.
5	ENGINE AMPERES GAGE.	15	ENGINE-GENERATOR OPERATING TIME METER.
6	ENGINE OFF-ON IGNITION SWITCH.	16	PANEL LIGHTS.
7	ENGINE STARTING BUTTON.	17	GENERATOR VOLTS METER.
8	PREHEAT SWITCH.	18	GENERATOR AMPERES METER.
9	PANEL CONTROL FUSE.	19	GENERATOR FREQUENCY METER.
10	GENERATOR VOLTAGE ADJUSTMENT.	20	GENERATOR AMMETER SELECTOR SWITCH.

Figure 3-29 -Engine generator control panel.

134.433

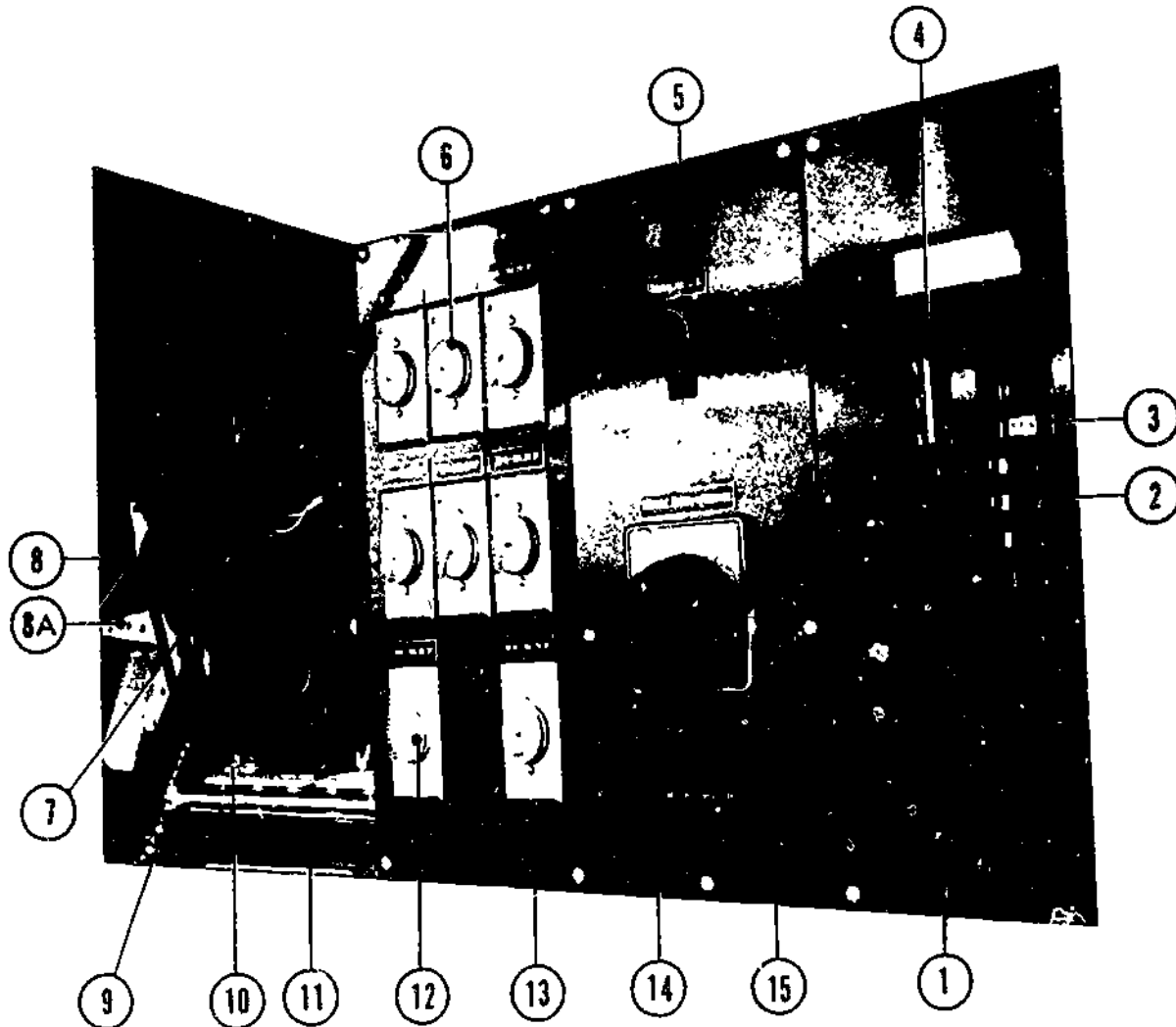

NUMBER	DESCRIPTION	NUMBER	DESCRIPTION
1	CIRCUIT BREAKER FOR LIGHTS.	8A	ENGINE FAN.
2	CIRCUIT BREAKERS FOR ITEMS 12 & 6	9	RADIATOR EXTENSION HOSE.
3	UNIT MAIN CIRCUIT BREAKER.	10	EXTENSION ADAPTER.
4	CIRCUIT BREAKER FOR SAW MOTOR.	11	12 VOLT BATTERY.
5	CIRCUIT BREAKER FOR GENERATOR.	13	DISTRIBUTION PANEL HOUSING.
6 & 12	120-VOLT, 1-PHASE OUTLET RECEPTACLE.	14	AUXILIARY OR GENERATOR SWITCH.
7	GENERATOR FOR ENGINE.	15	AUXILIARY POWER INPUT JACK (INSIDE DOOR).
8	ENGINE RADIATOR.		

134.434

Figure 3-30.--Distribution panel and engine items.

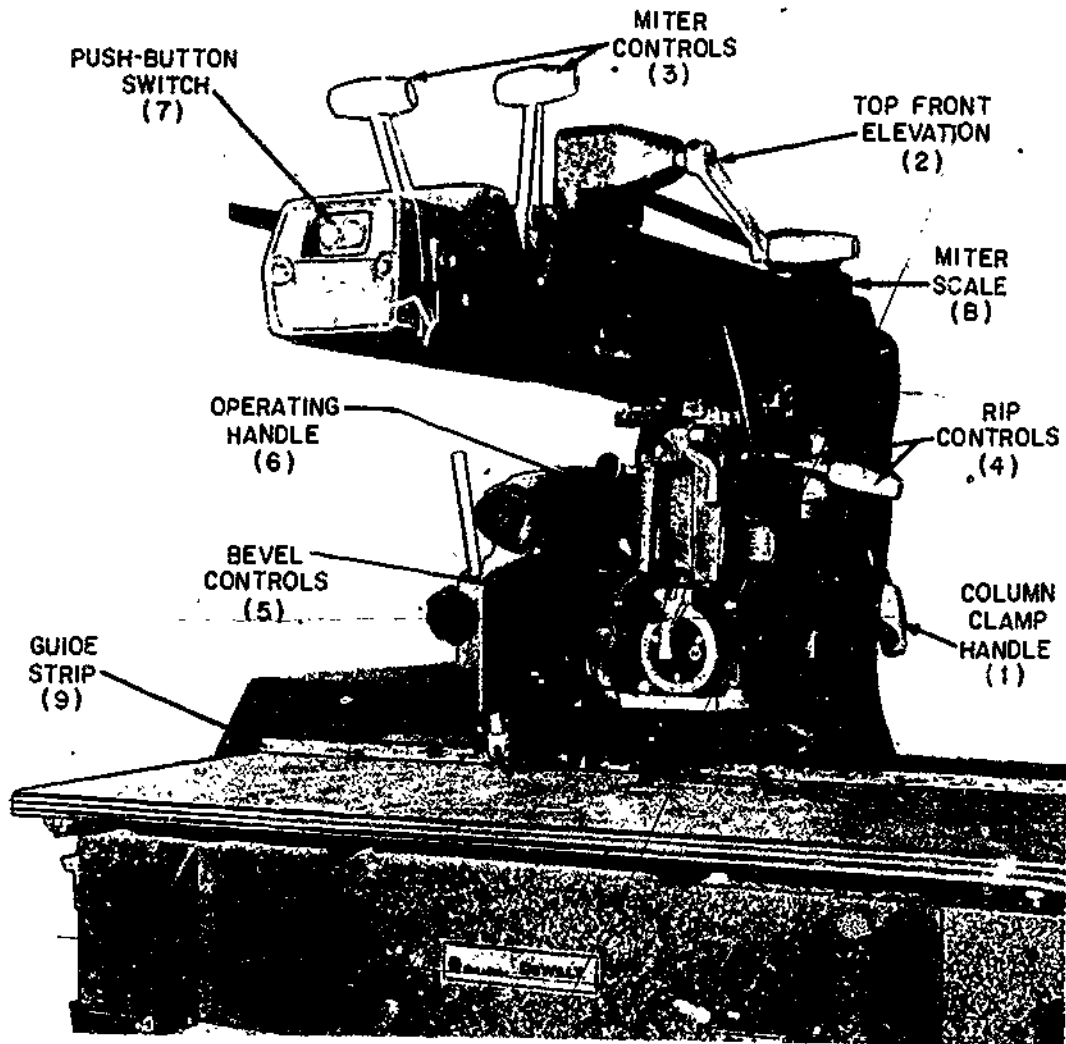

Figure 3-31.—Trailer-mounted radial overarm field saw.

134.435

connect the lug and wire assembly to the grounding rod. Always drive the grounding rod firmly into the ground and attach the ground clamp solidly to the trailer.

CAUTION: A good ground is essential to the safe operation of this unit.

Open all doors for access to all components. Remove the electrical equipment required, such as extension cords and floodlights. Plug cables

into output receptacles. Remove saw accessories and tools required for the task assigned.

Operation of the Engine and Generator Set

To start the engine and generator set, do the following:

Make sure all circuit breakers in the power distribution panel (fig. 3-30) are off.

Depress the preheat switch (fig. 3-29) to heat glow plugs. Hold the switch down for 30 seconds only.

Set the ignition switch (fig. 3-29) to the ON position by pushing it up.

Depress the engine starter button (fig. 3-29). Hold it down until the engine starts. When the engine starts, check the ammeter selector switch for correct charge.

After the engine warms up for a minimum of 5 minutes, check the frequency meter (fig. 3-29) to see if a 60-cycle reading has been obtained. If necessary, adjust the vernier control (fig. 3-28) to get this reading.

Make the generator voltage adjustment at the required level, by turning the generator ammeter selector switch (fig. 3-29) from OFF to any of the three indicated positions. Note whether the voltmeter indicates 208 volts phase-to-phase. If not, adjust the generator voltage accordingly.

NOTE: The automatic voltage regulator will maintain constant voltage regardless of changes in load or power factor. However, it will not compensate for poor governor operation, low engine speed, or engine power loss under load conditions.

Connect the floodlights and other electrical tools or equipment to the outlet receptacles located on the distribution panel (fig. 3-30) and activate by engaging the circuit breakers.

Preparing the Field Saw for Operation

To get the radial overarm field saw ready for operation, do the following:

1. Remove the canvas cover on the saw and stow it in a dry place.
2. Place the roller conveyor tables (left and right side) in their working positions.
3. Close both the right and left side engine doors.
4. Open the engine cooling louvers (fig. 3-27).
5. Position floodlights if needed for nighttime working.
6. Set handbrakes for trailer parking.

Before cutting, become familiar with the operating controls of the trailer-mounted radial overarm field saw (fig. 3-31) by reading the manufacturer's manual.

The numbers in parentheses correspond to those used in figure 3-31 to indicate what control is used when the saw is set in any cutting position desired as shown in figure 3-32.

RAISING AND LOWERING SAW ARM.—

To raise or lower the saw arm, pull the column clamp handle (1) forward, then turn the elevating crank (2) in the desired direction. Be sure to lock the column clamp handle by pushing it backward before turning the motor on.

REVOLVING SAW ARM.—To change the position of the saw arm, pull both miter controls (3) forward. Then, observing the miter scale (8), swing the saw arm either right or left to the desired angle. When you have located the saw arm at the desired position, engage both miter controls (3) by pushing the handles back.

REVOLVING SAW YOKE.—While the yoke is revolving horizontally on the saw arm, pull the saw carriage to the front of the saw arm. Then, pull the yoke clamp handle of the rip controls (4) forward and lift the swivel latch handle of the rip controls (4). The yoke and saw motor can now be turned either right or left for rip cuts. When the yoke is in the required position, secure the rip controls (4) accordingly.

REVOLVING SAW MOTOR.—To revolve the saw motor vertically on the saw arm, release the bevel clamp handle and lift the bevel latch handle of the bevel controls (5) and swing the saw motor to the bevel position desired. Lock the saw motor in position by engaging the locking and bevel controls (5).

CROSSCUTTING.—When you are cross-cutting, be sure to lock the saw arm in the 0° position. Place the material against the guide strip (9), engage the push-button switch (7) to the ON position and then draw the saw blade across the material using the operating handle (6). After the cut has been completed, return the blade behind the guide strip (9) and push in the OFF button.

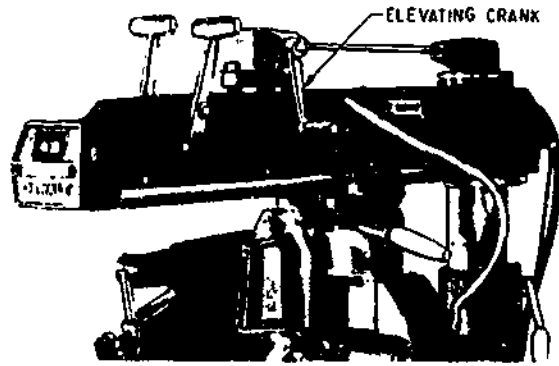

RAISE AND LOWER SAW ARM

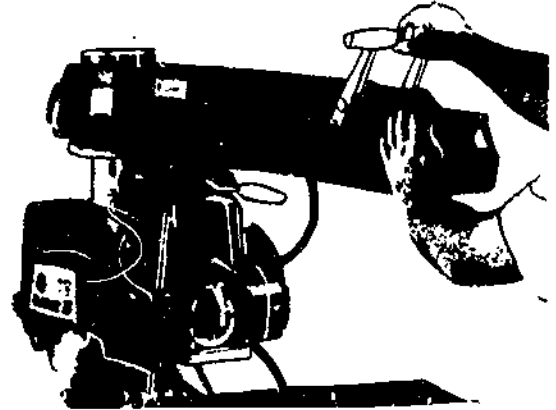

REVOLVE SAW ARM HORIZONTALLY

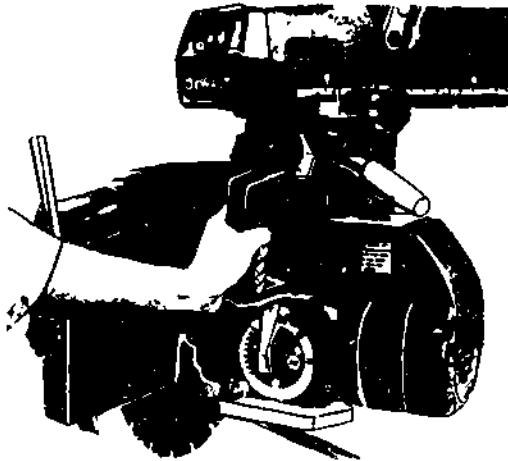

REVOLVE SAW YOKE HORIZONTALLY

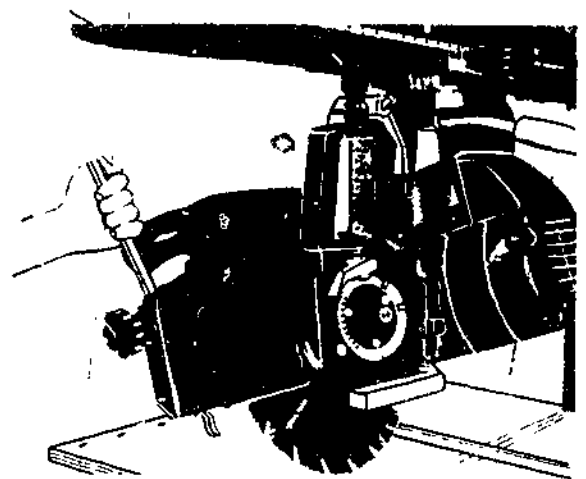

REVOLVE THE SAW MOTOR VERTICALLY

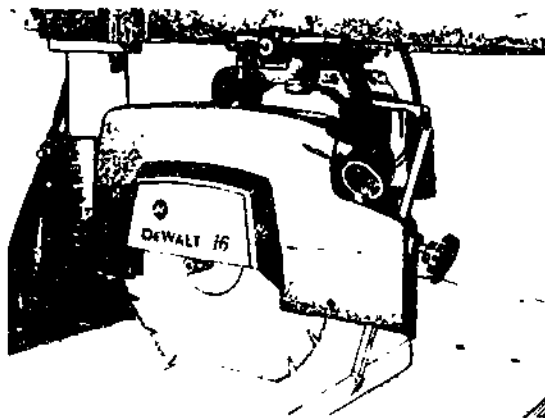

CROSSCUTTING

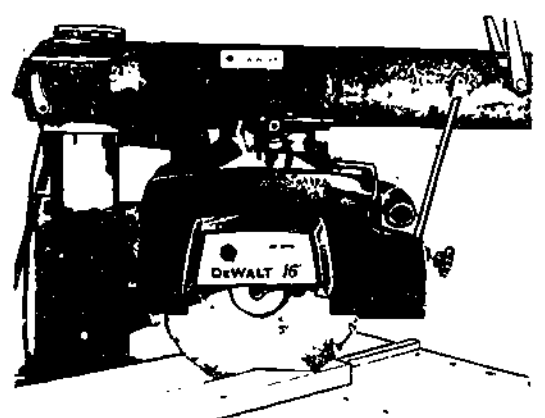

MITERING

Figure 3-32.—Radial overarm field saw cutting positions.

134.436

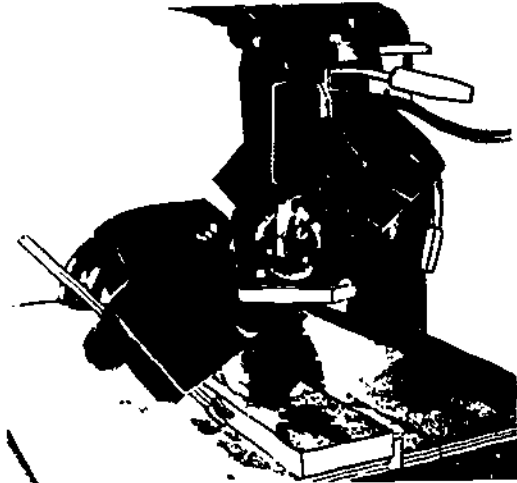

COMPOUND MITER

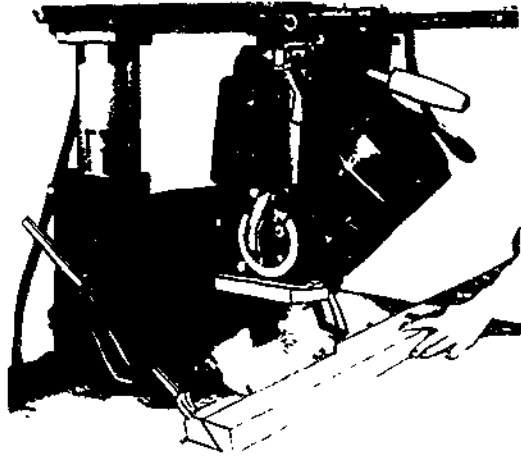

BEVEL RIPPING

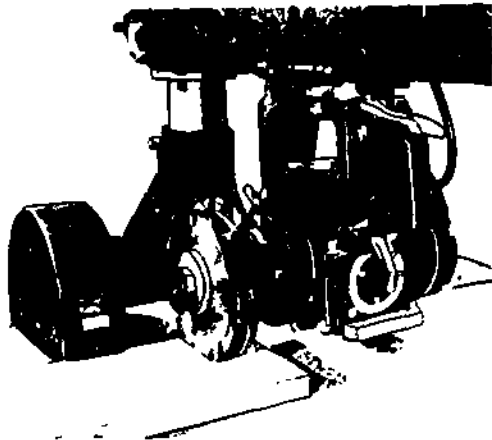

DADO

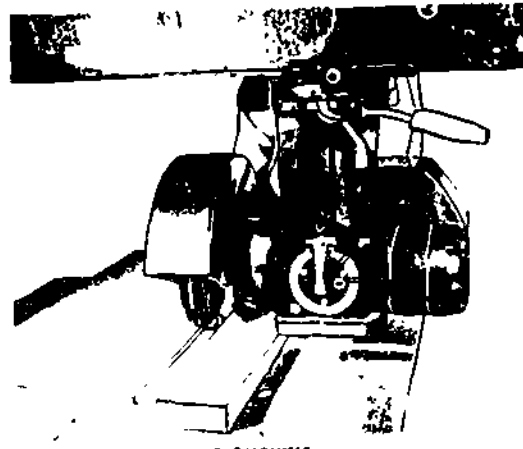

PLOUGHING

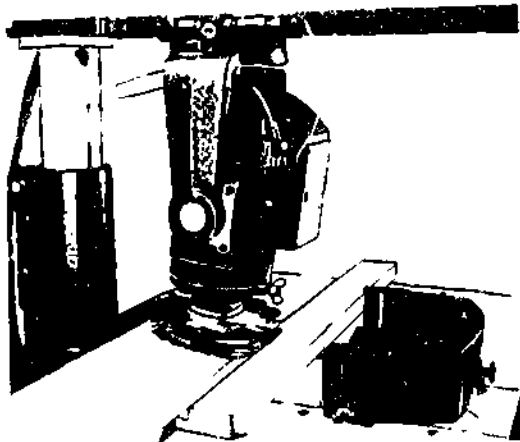

RABBET

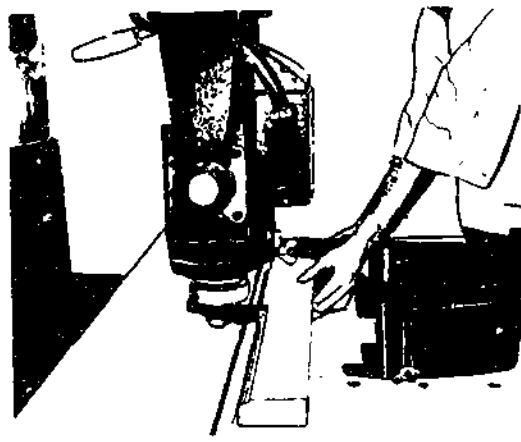

SHAPING

Figure 3-32.—Radial overarm field saw cutting positions—Continued.

134.436

NOTE: NEVER push the saw blade into the material. Instead, always pull the blade slowly and firmly across the material, from the rear of the saw arm.

MITERING.—To miter a piece of material, release the miter control handles (3). Swing the arm to the required angle as indicated on the miter scale (8), and then relock the miter control handles (3). Engage the push-button switch (7) to the ON position and pull the saw blade through the material. After the cut has been completed, return the blade behind the guide strip (9) and push in the OFF button.

A compound miter is merely a combination of the bevel cut and miter cut. Set the saw in the bevel cutting position and mitering angle as previously stated. Engage the push-button switch (7) to the ON position and pull the saw blade through the material as you would for crosscutting. After the cut has been completed, return the blade behind the guide strip (9) and push in the OFF button.

RIPPING.—To bevel rip, lock the saw arm in the crosscut position. Elevate the motor. Revolve the yoke to the rip position, and the motor to the desired bevel position. Now lock all latches and clamps and be sure to tighten the rip lock (4). Adjust the safety guard and kick-back before turning on the motor and feed the material through the saw.

DADOES—To make dadoes, replace the saw blade with the required dado cutter heads and use the saw as you would for normal crosscutting materials. Be sure to determine the depth and width of your dado cut as you assemble the dado heads and spacers. Be sure to attach the accessory tool guard before starting the machine.

PLOUGHING.—For ploughing of materials, place the saw equipped with the dado cutter head in the rip position. Tighten the rip lock (4) and adjust the dado cutter to the required depth. Attach the accessory tool guard on the feed-in side of the blade before starting the machine to cut and be sure to have a push stick available to prevent kick-back as you feed the material through the saw.

RABBETING.—For straight rabbeting of material, elevate the saw motor into the 90° bevel position. Lower the dado cutterhead and bring the forward edge of the cutter in front of the guide so that it will give the required cut and then tighten the rip lock (4). For bevel rabbeting of material, simply tilt the motor in the proper position. Be sure to attach the accessory tool guard before starting the machine and cutting.

SHAPING.—By replacing the saw blade with a shaper cutter and setting up the saw as you did for rabbeting, you can adjust the shaper blade for the required shape desired on the material. Be sure to lock all handles and clamps and tighten the rip lock (4). Be sure to place the material being shaped firmly against the guide strip (9) and be sure to attach the accessory tool guard before starting the machine and cutting.

Every Builder working with the trailer-mounted radial overarm field saw equipment will be required to perform saw setups that were discussed in the previous sections.

Preventive Maintenance Services and Lubrication

The trailer-mounted radial overarm field saw must be properly maintained if it is to give satisfactory service. The preventive maintenance services chart in table 3-1 indicates the various items to be checked and the services to be performed at prescribed intervals.

In addition to those services given in the table, be sure to keep the cutting blade sharp and properly set, the blade and arbor collars clean and insure that the recessed sides of the collars are against the blade; never oil or grease the arm trackway or motor and keep the motor clean and free of dirt.

The lubrication chart, figure 3-33, indicates how often to lubricate the points on the trailer-mounted radial overarm field saw and what lubricants to use. The frequencies shown are for the daily, weekly, monthly, or semiannual intervals.

Chapter 3—WOODWORKING SHOP AND FIELD TOOLS

Table 3-1.—Preventive Maintenance Services

OPERATION	DAILY OR 10 HRS.	WEEKLY OR 50 HRS.	MONTHLY OR 200 HRS.	SEMIANNUALLY OR 1200 HRS.
ENGINE				
INSPECT FOR LOOSE BOLTS, SCREWS, ELECTRICAL CONNECTIONS			X	
LUBRICATING OIL LEVEL	X			
FUEL AND OIL FILTERS			X	
AIR CLEANERS		X		
FUEL SUPPLY	X			
COOLANT LEVEL	X			
ANTI-FREEZE		X		
FAN-BELT ADJUSTMENT			X	
RADIATOR HOSE				X
CLEAN RADIATOR				X
DRAIN FUEL TANK AND CLEAN				X
INSPECT FOR OIL, FUEL, OR COOLANT LEAKS			X	
TIGHTEN LINES AND CONNECTIONS				X
BATTERIES				
CHECK WITH HYDROMETER, ADD DISTILLED WATER IF NECESSARY		X		
CLEAN TERMINALS AND COAT WITH PETROLATUM			X	
IN PART AND TIGHTEN TABLES AND GROUND STRAP			X	
CHECK HOLD-DOWN INSPECT CONTAINERS FOR LEAKS			X	
TRAILER				
CHECK SPRING FOR CORROSION OR BREAKS			X	
CHECK HANDBRAKE LINKAGE			X	
APPEARANCE AND CLEANLINESS	X			
WHEELS AND TIRES				
INSPECT FOR DAMAGE		X		
CHECK PRESSURE		X		
CHECK FOR UNEVEN OR EXCESSIVE WEAR			X	
TIGHTEN HUB NUTS			X	
LUBRICATION			X	
ELECTRICAL SYSTEM				
GENERATOR AIR FILTERS		X		
STARTER BRUSHES				X
STARTER COMMUTATOR				X
REGULATOR POINTS				X

143.437

BUILDER 3 & 2

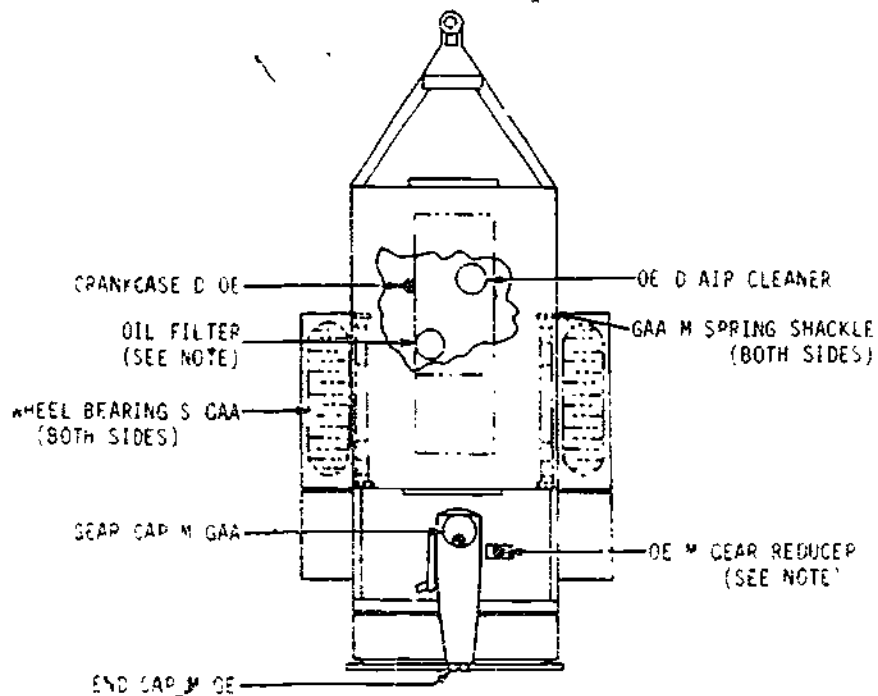

LUBRICANT	LUBRICATION KEY ABOVE 30 F	30 TO 20 F	BELOW 20 F
OE= OIL, ENGINE GAA= GREASE AUTOMOTIVE AND ARTILLERY	9250 OR 01-30 GAA	9250 OR 01-30 GAA	ARCTIC OIL GAA

INTERVAL

- D= DAILY
- W= WEEKLY
- M= MONTHLY
- S= SEMIANNUALLY

NOTES

OIL FILTER	REPLACE ELEMENT EACH TIME CRANKCASE OIL IS DRAINED AND REPLACED.
AIR CLEANER	INSPECT WEEKLY, REPLACE OIL MONTHLY
SAW GEAR REDUCER	CHECK OIL WITH LEVEL PLUG MONTHLY
SAW GEAR CAP	GREASE MONTHLY WITH GUN
SAW END CAP	FILL OIL CUPS MONTHLY
OIL CAN POINTS	LUBRICATE LINKAGE, CHAIN HINGES, AND SHAFTS MONTHLY

143.438

Figure 3-33.—Lubrication instructions.

3-28

Field Radial Overarm
Field Saw Safety

Various safety precautions applicable to the field saw have been pointed out in preceding sections of this discussion. Some additional safety precautions to be observed are listed as follows

All safety regulations must be observed to prevent accidents and injuries. Use all safety devices and guards when working with the field saw, and learn to control your work and actions so as to avoid injury.

Wear well-fitting clothing or coveralls and keep them in good repair. Wear safety glasses during sawing operations, in addition to a dust mask or respirator if cutting operations are dusty.

Keep your saw tools sharp and clean because dull tools are dangerous; any extra force exerted in using dull tools could result in losing control of the tool or in losing your footing or balance.

When you have to work in a wet area, wear rubber gloves and rubber-soled shoes to help prevent electric shock

Make all adjustments, blade changes, and inspections with the power off and the electric cord disconnected.

Make a habit of checking to see that adjusting keys and wrenches are removed from the saw before turning on the saw.

Keep your work area clean and clear of scrap lumber. Remove or hammer down all protruding nails to eliminate the possibility of you or a crewmember stepping on them and sustaining a foot injury

SHOP RADIAL ARM SAW

Figure 3-34 illustrates another popular type of shop radial arm saw. The procedures used in the operation, maintenance, lubrication, and the safety precautions to be observed of this saw are the same as described and illustrated in previous portions of this chapter for the trailer-mounted radial overarm saw. The primary difference is the location of controls.

TILT-ARBOR TABLE BENCH SAW

A TILT-ARBOR table bench saw is shown in figure 3-35. This saw is called a tilt-arbor saw

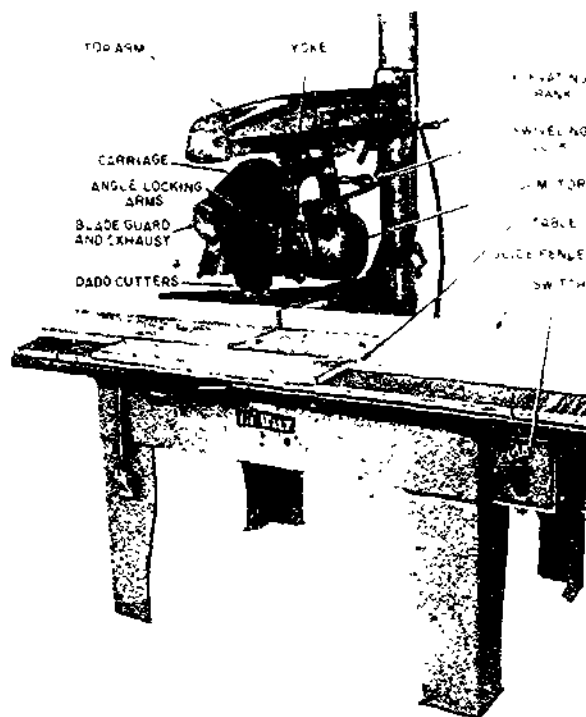

143.439

Figure 3-34.—A shop radial arm saw.

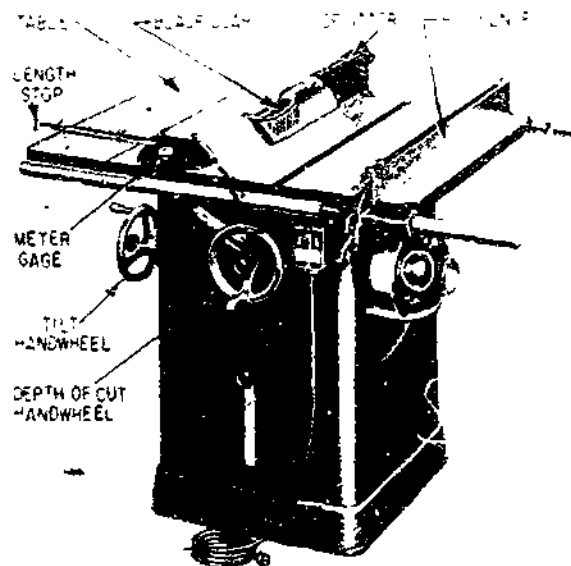

29.136(29C)

Figure 3-35.—Tilt-arbor bench saw.

because the saw blade can be tilted for cutting bevels and the like, by tilting the arbor. In the earlier types of bench saws the saw blade remained stationary and the table was tilted. A canted (tilted) saw table is hazardous in many ways, however, most modern table saws are of the tilt-arbor type.

For ripping stock, the CUTOFF GAGES are removed and the RIPPING FENCE is set a distance away from the saw which is equal to the desired width of the piece to be ripped off. The piece is placed with one edge against the fence and fed through with the fence as a guide.

For cutting stock off square, the cutoff gage is set at 90° to the line of the saw, and the ripping fence is set to the outside edge of the table, away from the stock to be cut. The piece is then placed with one edge against the cutoff gage, held firmly, and fed through by pushing the gage along its slot.

The procedure for cutting stock off at an angle other than 90° (called MITER CUTTING) is similar, except that the cutoff gage is set to bring the piece to the desired angle with the line of the saw.

For ordinary ripping or cutting off, the distance the saw blade should extend above the table top is 1.8 in. plus the thickness of the piece to be sawed. The vertical position of the saw is controlled by the DEPTH OF CUT HANDWHEEL shown in figure 3-35. The angle of the saw blade is controlled by the TILT HANDWHEEL. EXCEPT WHEN ITS REMOVAL IS ABSOLUTELY UNAVOIDABLE THE GUARD MUST BE KEPT IN PLACE.

The slot in the table through which the saw blade extends is called the THROAT. The throat is contained in a small, removable section of the table called the THROAT PLATE. The throat plate is removed when it is necessary to insert a wrench to remove the saw blade. The blade is held on the arbor by a nut called the ARBOR NUT. A saw is usually equipped with several throat plates, containing throats of various widths. A wider throat is required when a DADO HEAD is used on the saw. A dado head consists of two outside GROOVING SAWS (which are much like combination saws) and as many intermediate chisel-type CUTTERS (called chippers) as are required to make up the designated width of the groove or dado. Grooving saws are usually 1.8 in. thick,

consequently, one grooving saw will cut a 1.8-in. groove, and the two, used together, will cut a 1/4-in. groove. Intermediate cutters come in various thicknesses.

This equipment should be used with special care, and here are some operating precautions, especially for the circular saw.

Do not use a rip saw blade for crosscutting or a crosscut saw blade for ripping. When ripping and crosscutting frequently, you should install a combination blade to eliminate changing the blade constantly. See that the saw blade is sharp, unbroken, and free from cracks before using it. The blade should be changed if dull, cracked, chipped, or warped.

Be sure the saw blade is set at proper height above the table to cut through the wood.

Avoid "kickbacks" by standing to one side of the saw—not in line with it.

Always use a push stick to push short narrow pieces between the saw blade and the gage.

Keep material of any kind from accumulating on the saw table and in the immediate working area.

NEVER reach over the saw to obtain material from the other side.

When cutting, do not feed wood into the saw blade faster than it will cut freely and cleanly.

Never leave the sawing machine unattended with the power on.

PORTABLE ELECTRIC CIRCULAR SAW

The PORTABLE ELECTRIC circular saw is used chiefly as a great labor-saver in sawing wood framing members on the job. The saw shown in figure 3-36 can be set to cut a piece of wood off square (as it is set in the figure) or to cut it off at any bevel angle up to 45° . To make an accurate ripping cut, the RIPPING GUIDE is set a distance away from the saw equal to the width of the strip to be ripped off, and placed against the edge of the piece as a guide for the saw. For cutting off, the ripping guide is turned upside down, so that it will be out of the way.

The size of a portable circular saw is designated by the maximum diameter of the blade in inches it will support within its guard.

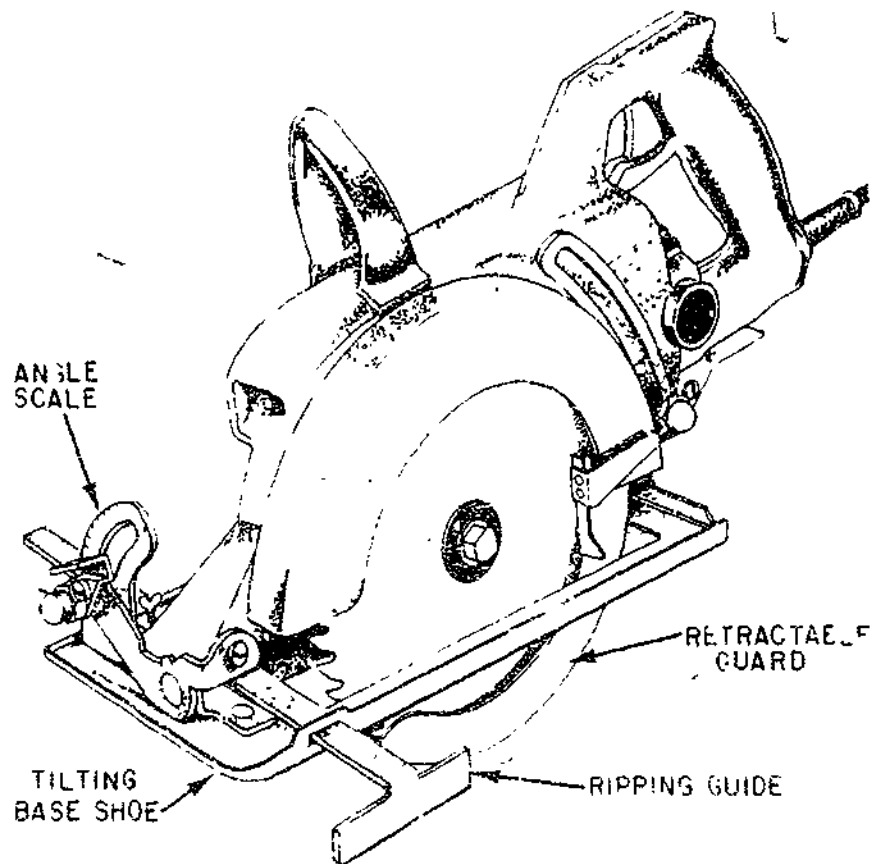

29 133(133F)

Figure 3-36.—Portable electric circular saw.

All portable, power-driven saws should be equipped with guards which will automatically adjust themselves to the work when in use, so that none of the teeth protrude above the work. The guard over the blade should be adjusted so that it slides out of its recess and covers the blade to the depth of the teeth when the saw is lifted off the work.

Goggles or face shields should be worn while using the saw and while cleaning up debris afterward.

Saws are to be grasped with both hands and held firmly against the work. Care should be taken that the saw does not break away, thereby causing injury.

The blade should be inspected at frequent intervals and always after it has locked, pinched, or burned. The electrical connection should be broken before this examination.

The saw motor should not be overloaded by pushing too hard or cutting stock that is too heavy.

Before using the saw, the material to be cut should be carefully examined and freed of nails or other metal substances. Cutting into or through knots should be avoided as far as possible.

The electric plug should be pulled before any adjustments or repairs are made to the saw. This includes changing the blade.

SABER SAW

The saber saw (fig. 3-37) is a power driven jigsaw that will let you cut smooth and decorative curves in wood and light metal. Most saber saws are light duty machines and are not designed for extremely fast cutting.

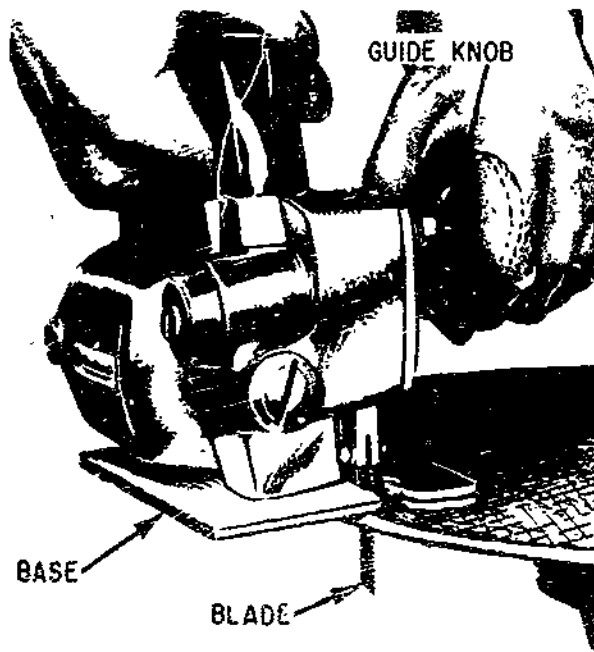

44.213X

Figure 3-37.--Saber saw.

There are several different blades designed to operate in the saber saw and they are easily interchangeable. Some blades are designed for cutting wood and some for cutting metal.

The best way to learn how to handle this type of tool is to use it. Before trying to do a finished job with the saber saw, clamp down a piece of scrap plywood and draw some curved as well as straight lines to follow. You will develop your own way of gripping the tool, and this will be affected somewhat by the particular tool you are using. On some tools, for example, you will find guiding easier if you apply some downward pressure on the tool as you move it forward. If you are not firm with your grip, the tool will tend to vibrate excessively and this will roughen the cut. Do not force the cutting faster than the design of the blade allows or you will break the blade.

Prior to working with the saber saw, be sure to remove your rings, wristwatch, bracelets, and other jewelry.

Roll up your sleeves if you are wearing clothing with long sleeves.

Be sure that the saber saw is properly grounded.

Use the proper saw blade for the work to be done, and insure the blade is securely locked in place.

Be sure the material to be cut is free of any obstructions.

Keep your full attention focused on the work being performed.

Grip the saw's handle firmly and control the forward and turning movements with your free hand on the front guide.

To start a cut, place the forward edge of the saw base on the edge of the material being worked, start the motor, and move the blade into the material.

PORTABLE RECIPROCAL SAW

The portable reciprocal-saw (fig. 3-38) is a heavy-duty power tool which you may use for a variety of woodworking maintenance work, remodeling, and roughing-in jobs. It can cut rectangular openings, curved openings, along straight or curved lines, and flush.

Blades for reciprocating saws are made in a great variety of sizes and shapes. They vary in length from 2 1/2 to 12 in. and are made of high-speed steel or carbon steel. The saw has a two-position shoe or footplate, which adjusts for vertical or horizontal cutting. When the shoe is moved in or out, a different section of the blade is brought to bear on the work being cut. This increases the life of the blade.

Before operating the saw, be sure the type of blade is right for the job. The manufacturer's instruction manual shows the kind of saw blade to use on any material. The blade must be pushed securely into the opening provided. Rock it slightly to insure a correct fit. Then tighten the setscrew.

To start a cut, place the saw blade near the material to be cut. Then start the motor and move the blade into the material. Keep the

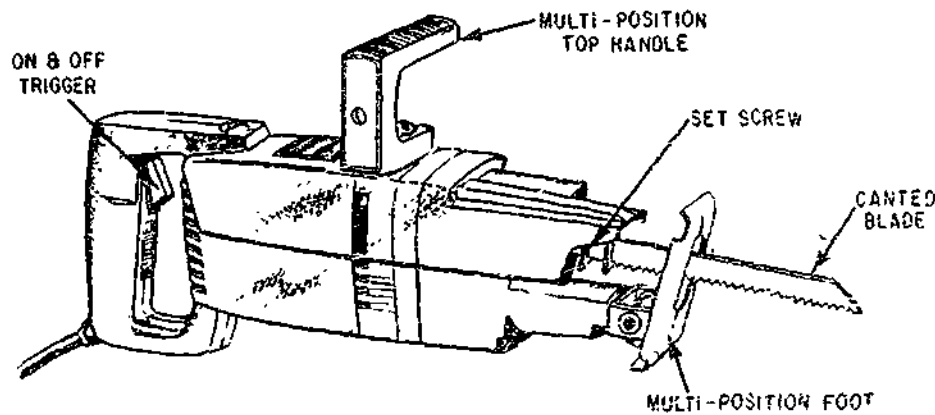

Figure 3-38.—Reciprocating saw.

133.440

cutting pressure constant, but do not overload the saw. Never reach underneath the material being cut.

When through cutting, turn OFF the saw switch. Do not put the saw down until the motor stops. Then disconnect the saw from the power source and remove the saw blade. Be careful not to drop the saw; misalignment of parts may result.

The reciprocating saw is initially lubricated at the factory and should be lubricated only as directed in the manufacturer's instruction manual. Usually, additional lubrication is not required for several weeks or after a designated number of hours of use.

Keep the inlet and outlet passages clean to insure a cool running motor. Blow any accumulated dust off the motor frame with compressed air. In addition, check the saw periodically for loose parts and screws.

BANDSAW

While the bandsaw (fig. 3-39) is designated primarily for making curved cuts, it can also be used for straight cutting. Unlike the circular saw, the bandsaw is frequently used for freehand cutting.

The bandsaw has two large wheels on which a continuous narrow saw blade or BAND turns, just as a belt is turned on pulleys. The LOWER WHEEL located below the WORKING TABLE is connected to the motor directly or by means

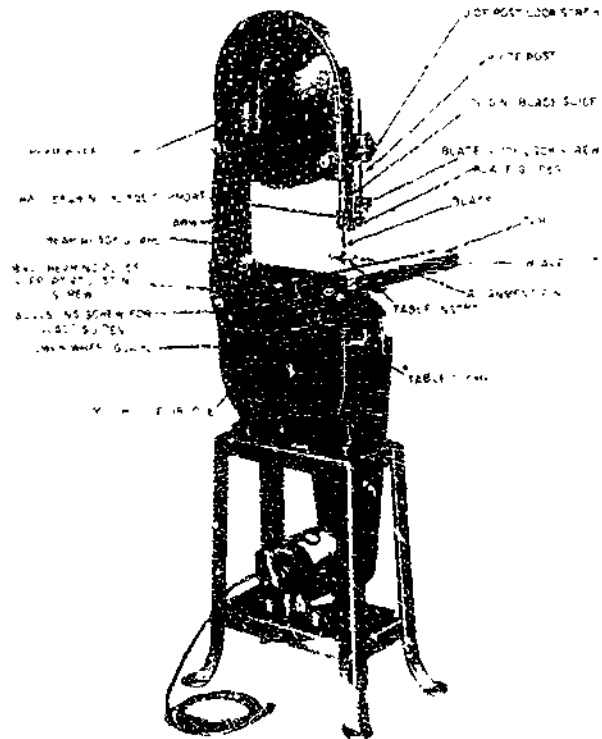

Figure 3-39.—Bandsaw.

29.137

of pulleys or gears and serves as the driver pulley. The UPPER WHEEL is the driven pulley.

The saw blade is guided and kept in line by two sets of BLADE GUIDES, one fixed set below the table and one set above with a vertical sliding adjustment. The alignment of the blade is adjusted by a mechanism on the backside of the upper wheel. TENSIONING of the blade—tightening and loosening—is provided by another adjustment located just back of the upper wheel.

Cutoff gages and ripping fences are sometimes provided for use with bandsaws, but you'll do most of your work freehand with the table clear. With this type of saw it is difficult to make accurate cuts when gages or fences are used.

The size of a bandsaw is designated by the diameter of the wheels. Common sizes are 14-, 16-, 18-, 20-, 30-, 36-, 42-, and 48-in. machines. The 14-in. size is the smallest practical bandsaw. With the exception of capacity, all bandsaws are much the same as regards maintenance, operation, and adjustment.

Blades or bands for bandsaws are designated by POINTS (tooth points per inch), THICKNESS (gage), and WIDTH. The required length of a blade is found by adding the circumference of one wheel to twice the distance between the wheel centers. Length can vary within a limit of twice the tension adjustment range. Blades are set and filed much the same as with a hand rip saw.

Here are some SAFETY pointers to keep in mind when you are operating a bandsaw. Keep your fingers away from the moving blade. Keep the table clear of stock and scraps so your work will not catch as you push it along. Keep the upper guide just above the work, not excessively high. Do not stand to the right of the machine while it is running and do not lean on the table at any time.

Bandsaw wheels should be tested by experienced operators at least once a week with a small machinist's hammer to detect cracks. The sound of a cracked or broken wheel is dull and flat.

Cracked blades should not be used. If a blade develops a "click" as it passes through the work, the operator should shut off the power because the click is a signal that the blade is

cracked and may be ready to break. After the saw blade has stopped moving, it should be replaced with one in proper condition.

If the saw blade breaks, the operator should shut off the power, and not attempt to remove any part of the saw blade until the machine is completely stopped.

If the work binds or pinches on the blade, the operator should never attempt to back the work away from the blade while the saw is in motion since this may break the blade. He should always see that the blade is working relatively freely through the cut.

A bandsaw should not be operated in a location where the temperature is below 45°F as it may break when the machine is started.

Using a small saw for large work or forcing a wide saw on a small radius is bad practice. The saw blade should in all cases be as wide as the nature of the work will permit.

Bandsaws should not be stopped by thrusting a piece of wood against the cutting edge or side of the bandsaw blade immediately after the power has been shut off because the blade may break. Bandsaws 16 in. and larger should have a hand or footbrake.

Particular care should be taken when sharpening or brazing a bandsaw blade to see that the blade is not overheated and that the brazed joints are thoroughly united and are finished to the same thickness as the rest of the blade. **IT IS RECOMMENDED THAT ALL BANDSAW BLADES BE BUTT WELDED WHERE POSSIBLE, AS THIS METHOD IS MUCH SUPERIOR TO THE OLD STYLE OF BRAZING.**

CARE AND MAINTENANCE OF POWERSAW BLADES

The most important factors in the care and maintenance of a mechanical saw are the proper lubrication of all moving parts and the proper conditioning of the saw blade. A saw blade which is dull, or one in which the teeth are incorrectly shaped or improperly set, will "labor" in the wood. This in turn will place an excessive strain on the driving mechanism. The correct shapes of rip saw and crosscut saw teeth are shown in figure 3-40. In a combination saw

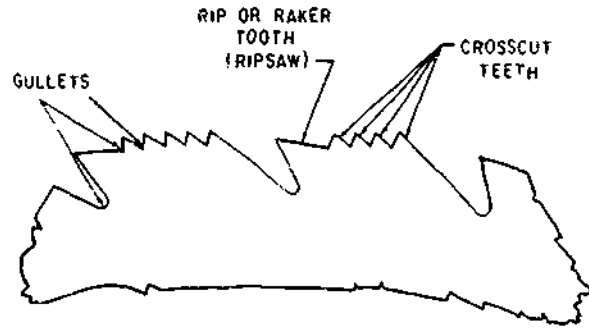
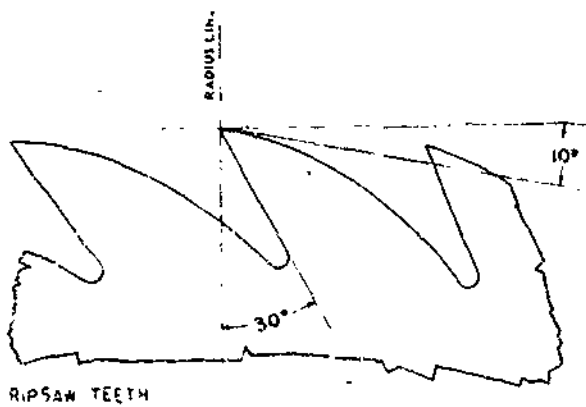

29.15(133E)

Figure 3-41.--Teeth on a combination saw blade.

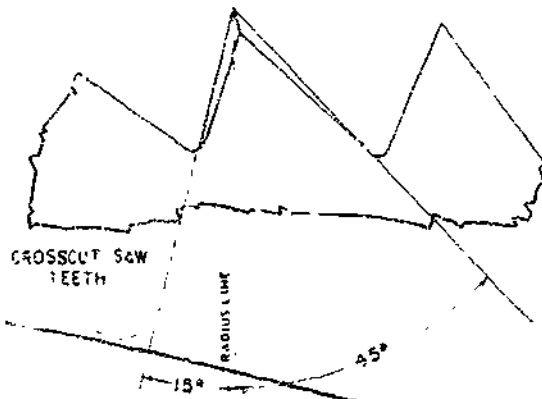

29.15(44)A

Figure 3-40.--Correct shapes of circular rip saw and crosscut saw teeth.

the RIP or RAKER teeth are shaped like rip saw teeth and the CROSSCUT teeth like the teeth of the crosscut blade, as shown in figure 3-41. As is the case with handsaws, the front and backslope of a circular rip saw tooth are filed square across, while the front and back slope of a circular crosscut saw blade are beveled as shown in figure 3-40.

Complete reconditioning of a circular saw blade consists of (1) JOINTING, (2) GUMMING, (3) SETTING, and (4) SHARPENING.

JOINTING is done when wear and repeated sharpenings have caused the points on the saw to become out of round. The procedure for jointing is as follows:

PUT ON SAFETY GOGGLES. Remove all sawdust from the working area. Install the saw

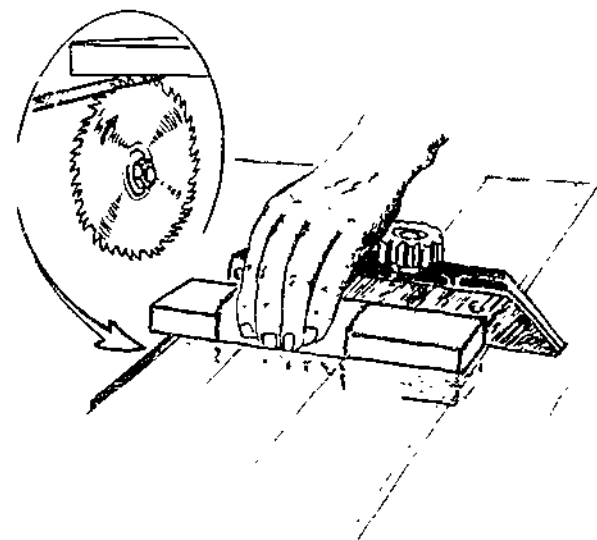

133.441

Figure 3-42.--Using carborundum stone for jointing saw teeth.

blade slightly and repeat the jointing procedure. Do not joint a saw blade any more than necessary, as this will require more grinding in the gumming process.

GUMMING is done when wear and repeated sharpening have caused the gullets of the blade to become too shallow. This procedure is very similar to that performed on a handsaw called **SHAPING**.

A rip saw blade may be gummed with a hand file of suitable shape or with a saw **GUMMER** and **SHARPENER** like the one shown in figure 3-43.

SETTING of saw blade teeth is accomplished by the use of a tool such as the one shown in figure 3-44. The saw blade is placed over the spindle and held in place with a collar and locking screw. Saw blade teeth are set by striking the steel punch with a hammer. Set every other tooth on one side of the saw blade, then turn the saw blade over and repeat the procedure for setting every other tooth in the opposite direction.

SHARPENING of a saw blade may be accomplished with a saw filing machine like that shown in figure 3-45. This machine works a file with a cross-section of the same shape as that of

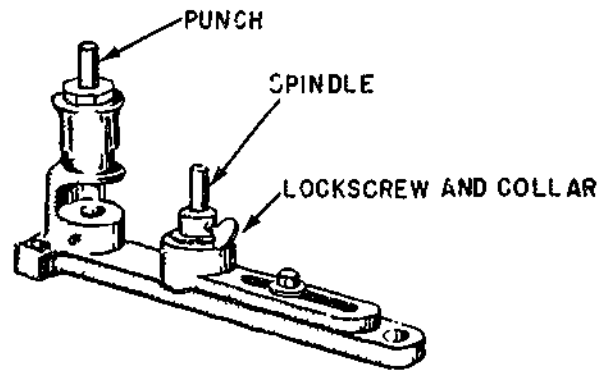

133.442

Figure 3-44.—Circular saw blade setting tool.

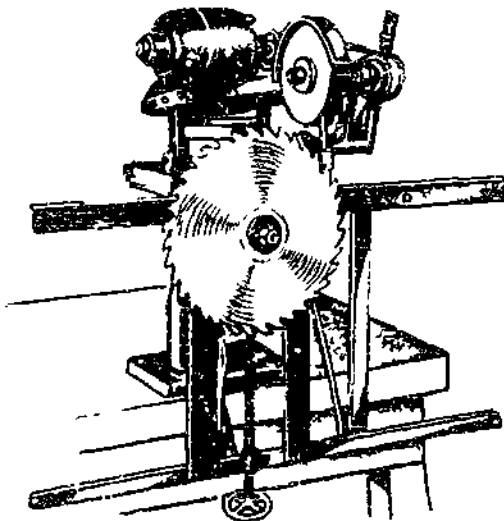

103.31

Figure 3-43.—Circular saw sharpener and gummer.

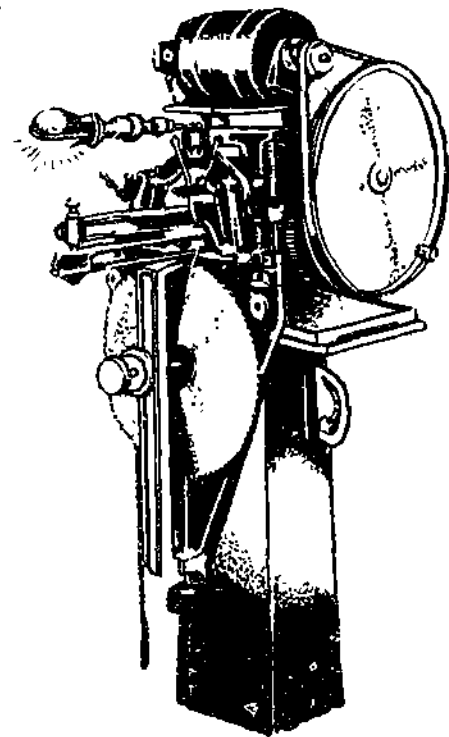

103.32

Figure 3-45.—Saw filing machine.

the gullet of the blade. This machine works in the same manner as the machine shown in figure 3-43, except that it files the front of one tooth and the back slope of the tooth next ahead in a single operation.

BANDSAW teeth are shaped like the teeth in a hand rip saw, which means that their fronts are filed at 90° to the line of the saw. Reconditioning procedures are the same as they are for a hand rip saw, except that very narrow bandsaws with very small teeth must usually be set and sharpened by special machines.

POWER SHAVING TOOLS

Smooth surfaces and edges on woodworking materials used in various building projects are obtained with power shaving tools such as routers, planes, jointers, surfacers, and shapers.

Router

The router is a versatile portable power tool which may be used freehand or with jigs and attachments. Figure 3-46 shows a router which is typical of most models. It consists of a motor containing a chuck into which the router bits are attached. The motor slides into the base in a vertical position. By means of the depth adjustment ring, easy regulation of the depth of a cut is possible. Routers vary in size from 1/4 to 2 1/2 hp and motor speed varies from 18,000 to 27,000 rpm.

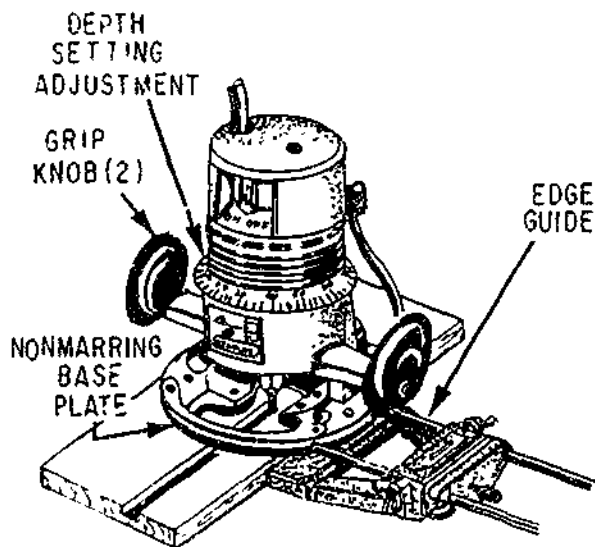

68.209(68C)A

Figure 3-46.—Portable router with edge guide.

One of the most practical accessories for the router is the edge guide. It is used to guide the router in a straight line along the edge of the board (fig. 3-46). The edge guide is particularly useful for cutting grooves on long pieces of lumber. The two rods on the edge guide slip into the two holes provided on the router base. The edge guide may be adjusted to move in or out along the two rods to obtain the desired lateral depth cut.

There are two classifications of router bits. The built-in shank-type bits fit into the chuck of the router. The screw-type bits have a threaded hole through the center of the cutting head; allowing the cutting head to be screwed to the shank. Figure 3-47 shows a few of the most common router bits.

Before operating the router, be sure the workpiece is held rigidly in the desired position and free of obstructions. The router must be properly grounded. Make sure it is disconnected from the power source before you make adjustments or insert a router bit. Select the proper bit for the work being done. Insert the bit shank in the collet chuck and tighten

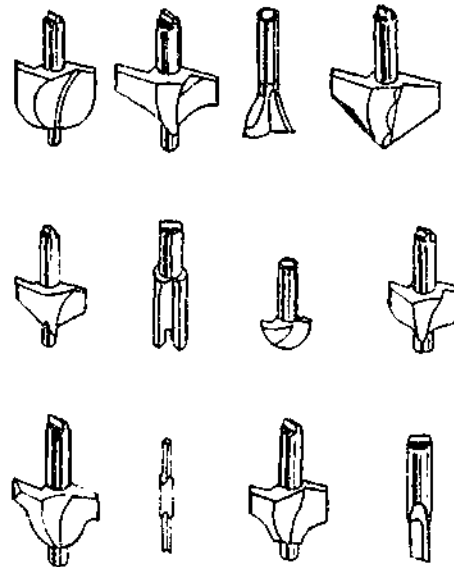

Figure 3-47.—Router bits.

68.210

properly. Do not wear jewelry or loose-fitting clothes that might become entangled with the fast-turning router bit.

In operating the router, use both hands to hold it firmly against the workpiece. Keep cutting pressure constant, but do not overload the router. When finished routing, release the trigger switch and disconnect the router from its power source. Then remove the router bit.

Portable Power Plane

The portable electric power plane (fig. 3-48) is widely used for trimming panels, doors,

frames, etc. It is a precision tool capable of exact depth of cut up to 3/16 in. on some of the heavier models. However, the maximum safe depth of cut on any model is 3/32 in. in any one pass.

The power plane is essentially a high speed motor which drives a cutter bar, containing either straight or spiral blades, at high speed.

Operating the power plane is simply a matter of setting the depth of cut and passing the plane over the work. The stock being planed should be held in a vise, clamped to the edge of a bench, or otherwise firmly held after first making careful measurements of the piece, where it is to fit, and determining how much material has to be removed. Check the smoothness and straightness of all the edges.

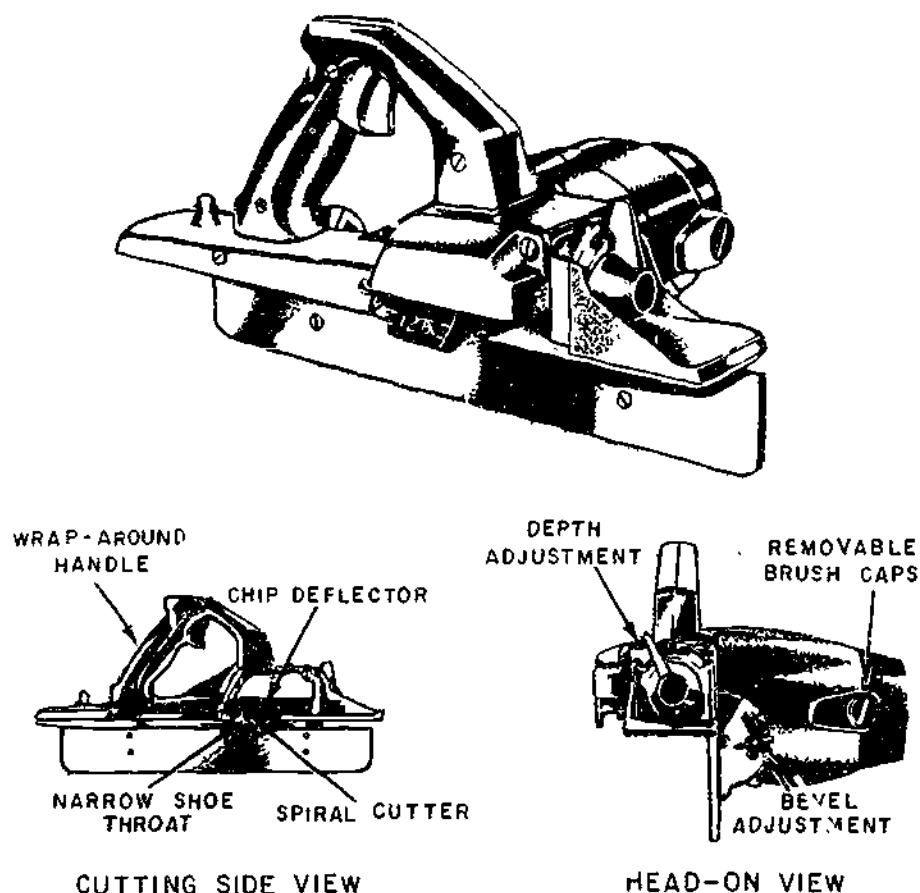

Figure 3-48.—Portable electric Power plane.

69.212X

To operate the plane, connect it to the power source. Before doing so, make sure the plane switch is in the off position. Do not wear loose clothing that might get tangled with the fast-turning cutter.

If a smoothing cut is desired, make that first, then check the dimensions again. Make as many passes as necessary with the plane to reach the desired dimension, checking frequently so as not to remove too much. The greater the depth of the cut, the slower you must feed the tool into the work. Feed pressure should be enough to keep the tool cutting, but not so much as to slow it down excessively. Keep chips off the work, as they can mar the surface as the tool passes over them. Do not come in contact with the cutter when a cut is finished.

The L-shaped base or fence of the plane should be pressed snugly against the work when planing, assuring that the edge will be cut square. For bevel cuts, loosen the setscrew on the base, set the base at the desired bevel, and then tighten the setscrew.

Always disconnect the plane from its power source before making adjustments or replacing a cutter. When finished planing, make sure the motor is turned off.

Jointer

THE JOINTER is a machine for power-planing stock on faces, edges, and ends. The planing is done by a revolving CUTTERHEAD, equipped with two or more KNIVES, as shown in figure 3-49. Tightening the SETSCREWS forces the THROAT PIECE against the knife for holding the knife in position. Loosening the setscrews releases the knife for removal. The size of a jointer is designated by the width in inches of the cutterhead; sizes range from 4-in. to 36-in. A 6-in. jointer is shown in figure 3-50.

The principle on which the jointer functions is illustrated in figure 3-51. The TABLE consists of two parts on either side of the cutterhead. The stock is started on the INFEEED TABLE and

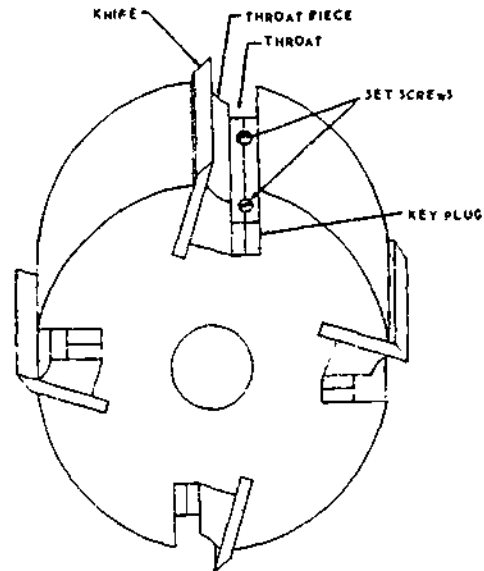

133.73

Figure 3-49.—Four-knife cutterhead for a jointer.

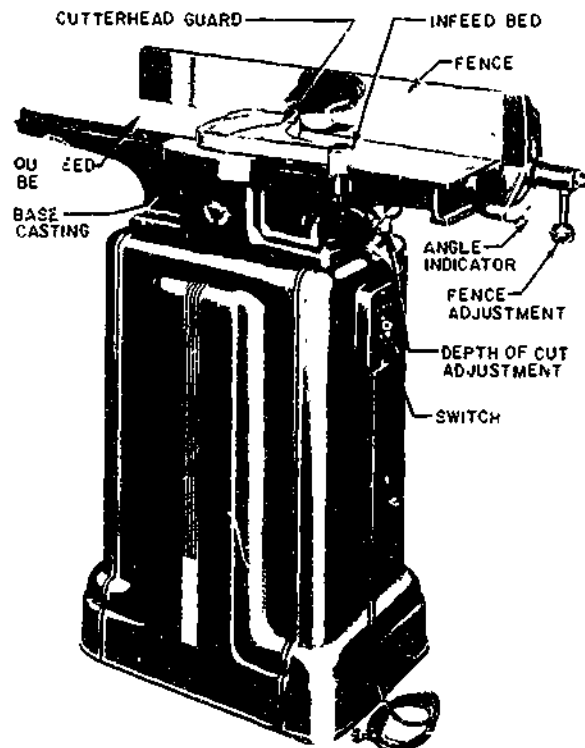

29.138

Figure 3-50.—Six-inch jointer.

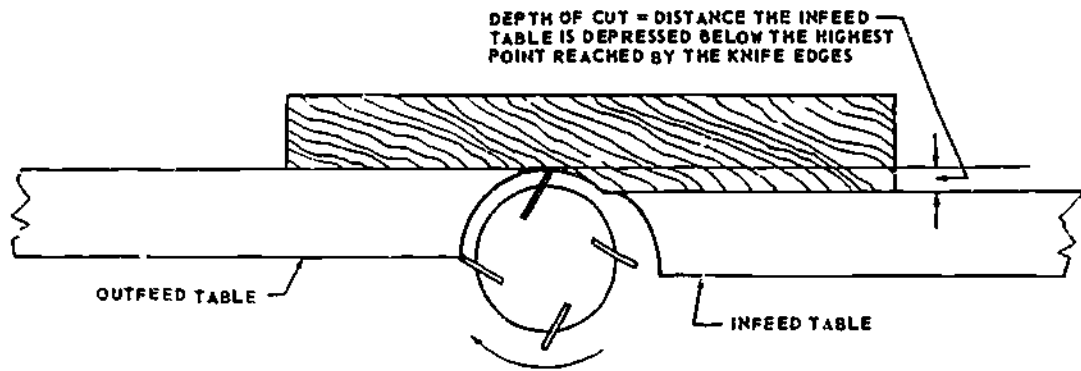

133.74

Figure 3.51.—Principle of operation of the jointer.

fed past the cutterhead onto the **OUTFEED TABLE**. The surface of the outfeed table must be exactly level with the highest point reached by the knife edges. The surface of the infeed table is depressed below the surface of the outfeed table, an amount equal to the desired depth of cut. The usual depth of cut is about 1/16 to 1/8 in.

The level of the outfeed table must be frequently checked to insure that the surface is exactly even with the highest point reached by the knife edges. If the outfeed table is too high, the cut will become progressively more shallow as the piece is fed through. If the outfeed table is too low, the piece will drop downward as its end leaves the infeed table, and the cut for the last inch or so will be too deep.

The outfeed table can be set to the correct height as follows:

Feed a piece of waste stock past the cutterhead until a few inches of it lie on the outfeed table. Then stop the machine and look under the outfeed end of the piece. If the outfeed table is too low, there will be a space between the surface of the table and the lower face of the piece. Raise the outfeed table until this space is eliminated. If no space appears, lower the outfeed table until a space does appear. Now run the stock back through the machine. If there is still a space then raise the table just enough to eliminate it.

Note that the cutterhead cuts toward the infeed table, therefore, in order to cut with the

grain, you must place the piece with the grain running toward the infeed table. A piece is **EDGED** by feeding it through on edge with one of the faces held against the **FENCE**. A piece is **SURFACED** by feeding it through flat with one of the edges against the fence. This operation however should, if possible, be limited to straightening the face of the stock. The fence can be set at 90° to produce squared faces and edges, or at any desired angle to produce beveled edges or ends.

Only sharp and evenly balanced knives should be used in a jointer cutting head.

The knives must not be set to take too heavy a cut, as a kickback is almost certain to result especially if there is a knot or change of grain in the stock.

The knives must be securely fastened after the machine has been standing in a cold building over the weekend.

When pieces shorter than 18 in. are machined, a push block should be used.

Each hand-fed jointer should be equipped with a cylindrical cutting head, the throat of which should not exceed 7/16 in. in depth nor 5/8 in. in width. It is strongly recommended that no cylinder be used in which the throat exceeds 3/8 in. in depth or 1/2 in. in width.

Each hand-fed jointer should have an automatic guard which will cover all the sections of

the head on the working side of the fence or gage. The guard should automatically adjust horizontally for edge jointing and vertically for surface work, and should remain in contact with the material at all times.

In operating the jointer there are safety precautions to be observed. These include:

Always plane with the grain. A piece of wood planed against the grain on a jointer may be kicked back.

Never place your hands directly over the jointer cutterhead. Should the piece of wood kick back, your hands will drop on the blades. Start with your hands on the infeed bed. When the piece of wood is halfway through, reach around with your left hand and steady the piece of wood on the outfeed bed. Finish with both your hands on the outfeed bed.

Never feed a piece of wood with your thumb and/or fingers against the end of the piece of wood being fed into the jointer. Keep your hands on top of the wood at all times.

Avoid jointing short pieces of wood whenever possible. Joint a longer piece of wood and then cut it to the desired size. If you must joint a piece of wood shorter than 18 in., use a push stick to feed it through the jointer.

Never use a jointer with dull cutter blades. Dull cutter blades have a tendency to kick the piece of wood, and a kickback is always dangerous.

Keep the jointer table and the floor around the jointer clear of scraps, chips, and shavings. Always stop the jointer before brushing off and cleaning up those scraps, chips, and shavings.

Never joint a piece of wood that contains loose knots.

Keep your eyes and undivided attention on the jointer as you are working it. Do not talk to anyone while operating the jointer.

Remember that the jointer is one of the most dangerous machines in the woodworking shop, and all the basic safety precautions given above are to be followed and only experienced and responsible personnel should be allowed to operate it.

Surfacer

A SINGLE SURFACER (also called a SINGLE PLANER) is shown in figure 3-52. This machine surfaces stock on one face (the upper face) only; double surfacers, which surface both faces at the same time, are used only in large planing mills.

The surfacer cuts with a cutterhead like the one on the jointer, but on the single surfacer the cutterhead is located above instead of below driven rollers, and the part adjacent to the cutterhead is pressed down against the FEED BED by a couple of members called the CHIP BREAKERS (just ahead of the cutterhead) and the PRESSURE BAR (just behind the cutterhead). The pressure bar temporarily straightens out any warp a piece may have; in effect, a piece that goes into the surfacer warped will come out still warped. This is not a defect in the machine; the surfacer is designed for surfacing only, not for truing warped stock. If true, plane surfaces are desired, one face of the stock (the face which goes down in the surfacer) must be trued on the jointer before the piece is fed through the surfacer. If the face that goes down in the surfacer is true, the surfacer will plane the other face true.

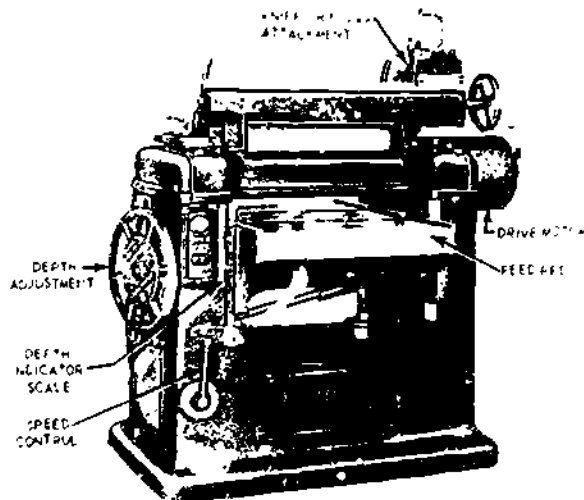

Figure 3-52.—Single surfacer.

29.135

Each surfacing machine should have all cutting heads, covered by a metal guard. If such a guard is constructed of sheet metal, the material used should not be less than 1/16 in. in thickness; and if cast iron is used, it should not be less than 3/16 in. in thickness.

Where an exhaust system is used, the guards should form part or all of the exhaust hood and should be constructed of metal of a thickness not less than the above.

Feed rolls should be guarded by a hood or a semicylindrical guard to prevent the hands of the operator from coming in contact with the in-running rolls at any point. The guard should be fastened to the frame carrying the rolls so as to remain in adjustment for any thicknesses of the stock.

Sectional feed rolls should be provided for surfacers. Where solid feed rolls are used, the sectional finger devices should be used to prevent kickbacks.

Shaper

The SHAPER is designed primarily for edging curved stock and for cutting ornamental edges, as on moldings; but it can also be used for rabbeting, grooving, FLUTING, and BEADING. A FLUTE is a straight groove with a curved rather than a rectangular cross-section. A BEAD might be called the reverse of a flute. A shaper is shown in figure 3-53.

The flat cutter or knives on a shaper are mounted on a vertical SPINDLE and held in place by a hexagonal SPINDLE NUT. A grooved COLLAR is placed below and above the cutter or knives to receive the edge of the knives. Ball bearing collars are available for use as guides on irregular work where the fence isn't used. The part of the edge that is to remain uncut runs against the ball bearing collar, as shown in the bottom view of figure 3-54.

A THREE WING CUTTER fits over the spindle, as shown in the upper view of figure

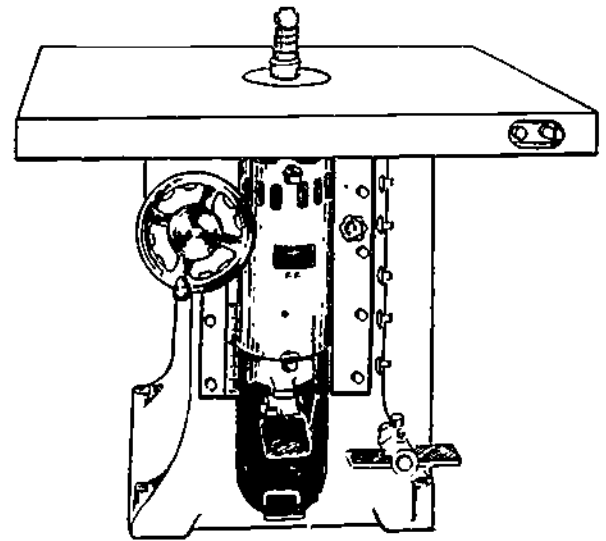

133.75
Figure 3-53.—Wood shaper.

3-54. FLAT KNIFE cutters are assembled in pairs between collars. Both cutters and knives come with cutting edges in a great variety of shapes. BLANK flat knives are available which may be ground to any desired shape of cutting edge. This is done only by experienced personnel.

For shaping the side edges on a rectangular piece, a light-duty shaper has an ADJUSTABLE FENCE, like the one shown on the shaper in figure 3-55. For shaping the end edges on a rectangular piece, a machine of this type has a SLIDING FENCE, similar to the cutoff gage on a circular saw. The sliding fence slides in the groove shown in the table top.

On larger machines, the fence consists of a board straightedge, clamped to the table with a handscrew, as shown in figure 3-56. A semicircular opening is sawed in the edge of the straightedge to accommodate the spindle and the cutters or knives. Whenever possible, a guard of the type shown in the figure should be placed over the spindle.

For shaping curved edges there are usually a couple of holes in the table, one on either side



133.76

Figure 3-54.—Three-wing cutter and flat knives for a shaper.

of the spindle, in which vertical STARTER PINS can be inserted. When a curved edge is being shaped, the piece is guided by and steadied against the starter pin and the ball bearing collar on the spindle.

Like the jointer and surfacer, the shaper cuts toward the infeed side of the spindle, which is against the rotation of the spindle. Stock should therefore be placed with grain running toward the infeed side.

Make sure the knives are sharp and are well secured.

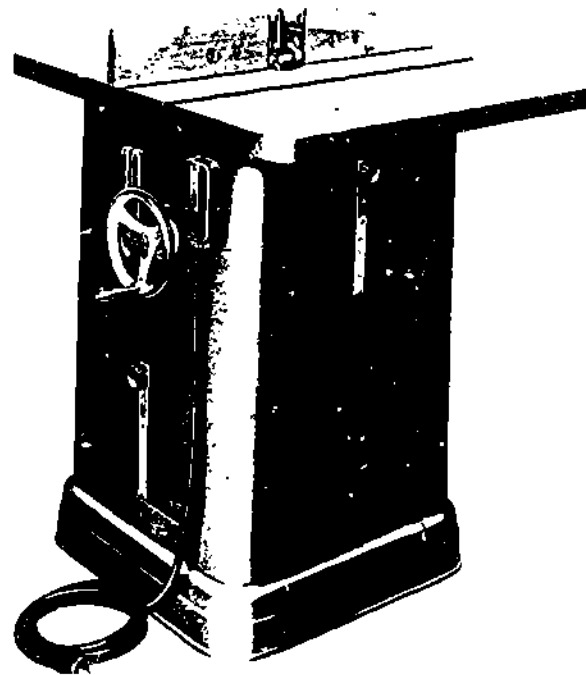

68.27

Figure 3-55.—Light-duty shaper with adjustable fence.

If curved or irregularly-shaped edges are to be shaped, place the stock in position and check to see that the collar will rub against part of the edge which should not be removed.

Whenever the straight fence cannot be used, always use a starting pin in the table top.

Never make extremely deep cuts.

Make sure the shaper knives rotate toward the work.

Whenever possible, always use a guard, pressure bar, holddown, or holding jig.

If possible, place the cutter on the shaper spindle so that the cutting will be done on the lower side of the stock.

Do not attempt to shape small pieces of wood.

Check all adjustments before turning on the power.

“The spindle shaper is probably one of the most DANGEROUS machines used in the shop. Use extreme caution at all times.”

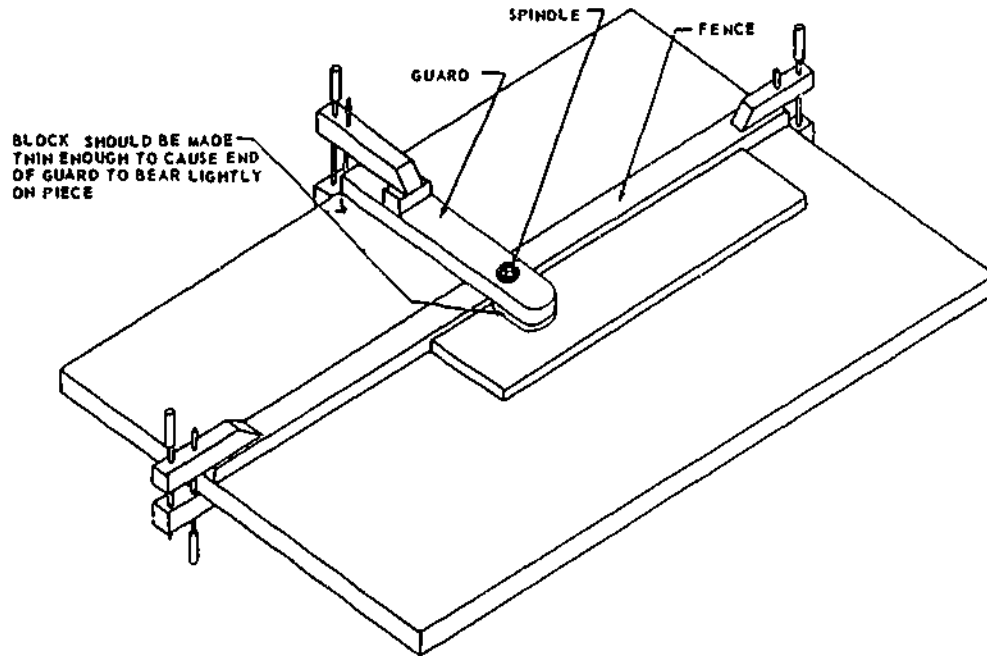

133.77

Figure 3-56.—Shaper table, showing straightedge fence and guard.

Care and Maintenance of Power Shaving Tools

The two most important factors in the care and maintenance of a jointer, surfacer, or shaper are the proper lubrication of all moving parts and the proper sharpening and adjustment of the knives and/or cutters. Dull knives and cutters deteriorate the machinery by causing it to "labor," and to "chatter" or vibrate. Besides, a dull knife or cutter on a power shaving machine is a very dangerous hazard. A dull knife or cutter tends to "catch" in the wood, and since the machine is cutting toward the operator the result of a catch is a violent throw-back of the stock toward the operator. The piece may strike the operator, but more serious than this is the fact that the operator's hands, when the piece is torn out of them, may be driven against the knives or the cutters.

The best way to sharpen the knives on a jointer or surfacer is with a **KNIFE GRINDING ATTACHMENT**, like the one shown on the

surfacers in figure 3-52. With one of these devices the knives can be sharpened without removing them from the cutterhead. The knife grinding attachment consists of a small motor-driven grinding wheel, mounted in a **SADDLE** which can be cranked back and forth on a steel bar called a **BRIDGE**. The bridge can be mounted over the cutterhead by means of a couple of **BRIDGE BRACKETS**. The general procedure for sharpening with a knife-grinding attachment is as follows:

Open the starting switch on the machine and lock it open. If the powerline has a main switch which can be opened, open that switch as well.

Revolve the cutterhead by hand until a knife is in a position where the cutterhead **LOCKING PIN** can be put on. The locking pin holds the uppermost knife in correct grinding position.

Loosen the setscrews until they are holding the knife only lightly, and move the knife up about 1/12 in. The best way to do this and still

keep the knife level is to use a **THREE-PRONGED KNIFE GAGE**. This device has two prongs which fit against the cutterhead on either side of the knife, and a third prong in the center which can be set to any desired amount of protrusion of the knife edge. When the knife has been set at the desired height, tighten the setscrews.

Adjust the knife edges of the other knives to the same height.

Set the grinding attachment in place, bring the grinder down to contact the bevel on the first knife, and crank the grinder back and forth over the knife several times. Take a light cut, and crank fast enough to keep the knife from overheating. Repeat on the other two knives.

When the first knife is again under the grinder, lower the grinder slightly and repeat the above procedure on all three knives. Repeat this whole process, lowering the grinder a little every time you get back to the first knife, until all nicks have been ground away and there is a perfect bevel on every knife in the cutterhead.

The next step is **JOINTING** the knives, which means, as in the case of a circular saw, insuring that the knife edges form a perfect circle as the cutterhead revolves. Remove the motor from the saddle and install a **JOINTING ATTACHMENT**. A jointing attachment is a device with a fine whetstone attached to its lower end, the whetstone can be set so that it barely touches the knife edges. Set it so, revolving the cutterhead by hand to insure that there is the barest contact and no more.

Start the machine and crank the jointing attachment back and forth several times over the revolving knives. Stop the machine and examine the knife edges. If they have not all been slightly touched, lower the stone just a little and repeat the process until every knife edge has been touched.

In the absence of a knife grinding attachment, the knives must be removed from the cutterhead and ground on an oilstone grinder or in some other manner.

To readjust the knives in the cutterhead of a jointer, place a builder's level or a wooden straightedge on the outfeed table and line the highest point reached by each knife edge with the lower edge of the straightedge as follows. Place the knife in the cutterhead and set the setscrews up lightly. Place the straightedge over one end of the knife and raise or lower the knife until the edge barely contacts the straightedge when the cutterhead is rotated by hand. Move the straightedge to the other end of the knife and repeat the same procedure. Tighten the setscrews and make a final check for correct height at both ends of the knife. Repeat the same procedure with the remaining knives.

A flat shaper knife with a straight cutting edge is ground and whetted like a plane iron or a chisel. As is the case with a jointer or surfacer, the knives in a shaper must be exactly equal in size and weight. Three-way cutters and knives with curved edges must be sharpened "free-hand" with a small portable grinding wheel called a "grinding pencil." The greatest care must be taken to keep pairs of knives and the cutting extensions in a three-way cutter exactly alike in size, weight, and shape.

DRILL PRESS

The drill press (fig. 3-57) is an electrically operated power machine that was originally designed as a metal-working tool. As such, its use would be limited in the average woodworking shop. Available accessories such as a router bit or shaper heads, plus jigs and special techniques, now make it a versatile wood-working tool as well.

The motor is mounted to a bracket at the rear of the head assembly and designed to permit V belt changing for desired spindle speed without removing the motor from its mounting bracket. Four spindle speeds are obtained by locating the V-belt on any one of the four steps of the spindle-driven and motor-driven pulleys.

The controls of drill presses are all similar. The terms "right" and "left" are relative to the operator's position standing in front of and facing the drill press. Forward applies to

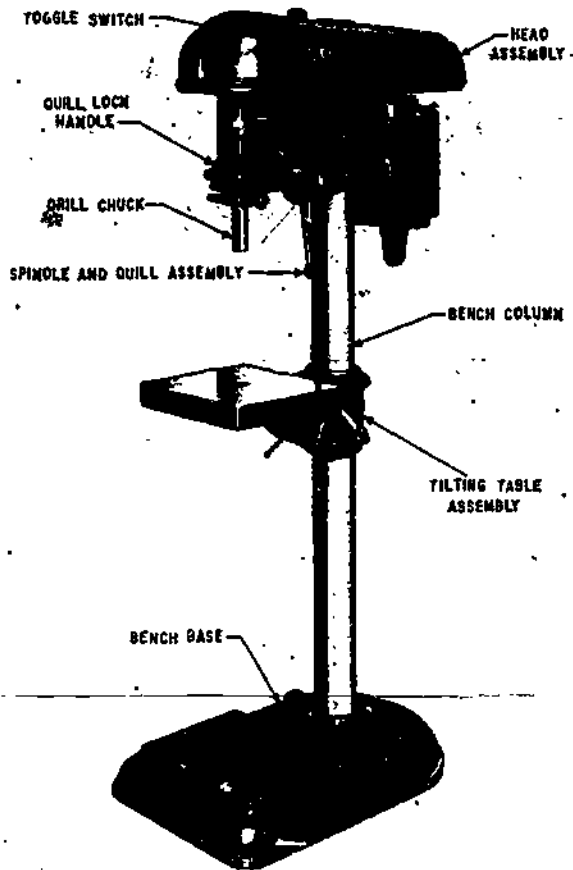

11.10X

Figure 3-57. Drill press.

movement toward the operator. Rearward applies to movement away from the operator.

The toggle switch is located on the right side of the head assembly. The switch is single-pole single-throw. Start the motor by placing the switch in the ON position.

The spindle and quill feed handles radiate from the spindle and quill pinion feed hub which is located on the lower right-front side of the head assembly. Pulling forward and down on any one of the three spindle and quill feed handles, which point upward at the time, moves the spindle and quill assembly downward.

Release the feed handle and the spindle and quill assembly will return to the retracted or upper position by spring action.

The quill lock handle is located at the lower left-front side of the head assembly. Turn the quill lock handle clockwise to lock the quill at a desired operating position. Release the quill by turning the quill lock handle counterclockwise. However, in most cases, the quill lock handle will be in the released position.

The head lock handle is located at the left-rear side of the head assembly. Turn the head lock handle clockwise to lock the head assembly at a desired vertical height on the bench column. Turn the head lock handle counterclockwise to release the head assembly. When operating the drill press, the head lock handle must be tight at all times.

The head collar support lock handle is located at the right side of the head collar support and below the head assembly. The handle locks the head collar support, which secures the head vertically on the bench column, and prevents the head from dropping when the head lock handle is released. Turn the head collar support lock handle clockwise to lock the support to the bench column and counterclockwise to release the support. When operating the drill press, the head collar support lock handle must be tight at all times.

The tilting table lock handle is located at the left-rear side of the tilting table bracket. Turn the tilting table lock handle counterclockwise to release the tilting table bracket so it can be moved up and down or around the bench column. Lock the tilting table assembly at the desired height by turning the lock handle clockwise. When operating the drill press, the tilting table lock handle must be tight at all times.

The tilting table lockpin is located below the tilting table assembly. The lockpin secures the table at a horizontal or 45° angle left or right from the horizontal position. To tilt the table left or right from its horizontal position, remove the lockpin and turn the table to align the

lockpin holes. Insert the lockpin through the table and bracket holes after the desired position is obtained.

The adjusting and locknuts are located on the depth gage rod. The purpose of the adjusting and locknuts is to regulate depth drilling. Turn the adjusting and locknut clockwise to decrease the downward travel of the spindle. The locknut must be secured against the adjusting nut when operating the drill press.

When operating a drill press make sure the drill is properly secured in the chuck and that the work you are drilling is properly secured in position. Do not remove the work from the tilting table or mounting device until the drill press has stopped.

Operate the spindle and quill and feed handles with a slow, steady pressure. If too much pressure is applied, the V-belt may slip in the pulleys, the twist drill may break, or the starting switch in the motor may open and stop the drill press. If the motor should stop because of overheating, the contacts of the starting switch will remain open long enough for the motor to cool, then automatically close to resume normal operation. Always turn the toggle switch to OFF position while the motor is cooling.

Check occasionally to make sure all locking handles are tight, and that the V-belt is not slipping.

Before operating any drill press, visually inspect the drill press to determine if all parts are in the proper place, secure, and in good operating condition. Check all assemblies, such as the motor, head, pulleys, and bench for loose mountings. Check adjustment of V-belt and adjust as necessary in accordance with the manufacturer's manual. Make sure the electric cord is securely connected and that the insulation is not damaged, chafed, or cracked.

While the drill press is operating, be alert for any sounds that may be signs of trouble, such as squeaks or unusual noise. Report any unusual or unsatisfactory performance to the petty officer in charge of the shop.

After operating a drill press, wipe off all dirt, oil, and metal particles. Inspect the V-belt to make sure no metal chips are imbedded in the driving surfaces.

WOODWORKING LATHE

The WOODWORKING LATHE is without question the oldest of all woodworking machines. In its early form, it consisted of two holding centers with the suspended stock being rotated by an endless rope belt. It was operated by having one person pull on the rope hand-over-hand while the cutting was done by a second person holding crude hand lathe tools on an improvised beam rest.

The actual operations of woodturning performed on a modern lathe are still done to a great degree with woodturner's handtools. However, machine lathe work is coming more and more into use with the introduction of newly designed lathes for that purpose.

The lathe is used in turning or shaping round billets, drums, disks, and any object that requires a true diameter. The size of a lathe is determined by the maximum diameter of the work it can swing over its bed. There are various sizes and types of wood lathes, ranging from very small sizes for delicate work to large surface or "bull lathes" that can swing jobs 15 ft in diameter.

Figure 3-58 illustrates a type of lathe that you may find in your shop. It is made in three sizes to swing 16-, 20-, and 24-in. diameter stock. The lathe has four major parts (1) bed, (2) headstock, (3) tailstock, and (4) toolrest.

The lathe shown in figure 3-58 has a bed of iron. It can be obtained in any other length desired. The bed is a broad flat surface that supports the other parts of the machine.

The headstock is mounted on the left end of the lathe bed. All power for the lathe is transmitted through the headstock. It has a fully enclosed motor that will give a variable-spindle speed (from 600 to 3600 rpm). The spindle is threaded at the front end to receive the

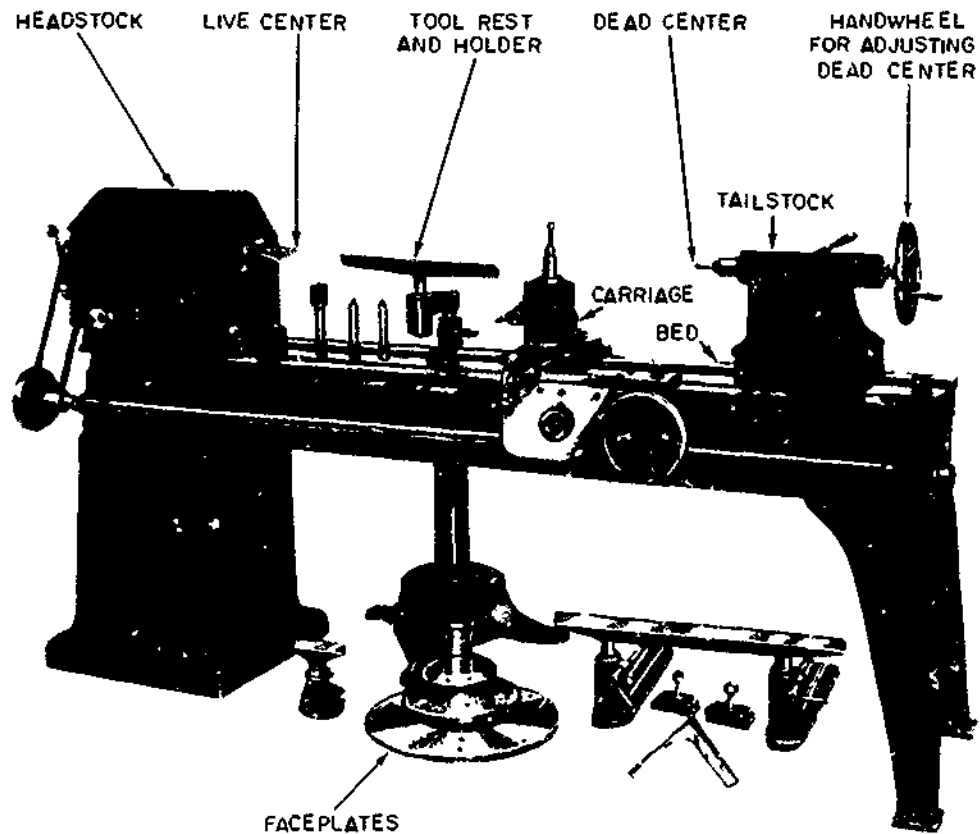

Figure 3-58.—A woodturning lathe with accessories.

28.69X

faceplates. A faceplate attachment to the motor spindle is furnished to hold or mount small jobs having large diameters. There is also a flange on the rear end of the spindle to receive large faceplates, which are held securely by four stud bolts.

The tailstock is located on the right end of the lathe and is movable along the length of the bed. It supports one end of the work while the other end is being turned by the headstock spur. The tail center may be removed from the stock simply by backing the screw. The shank is tapered to automatically center the point.

Most large sizes of lathes are provided with a power-feeding carriage. A cone-pulley bolt

arrangement provides power from the motor, and trackways are cast to the side of the bed for sliding the carriage back and forth. All machines have a metal bar that may be attached to the bed of the lathe between the operator and the work. This serves as a handtool rest and provides support for the operator in guiding tools along the work. It may be of any size and is adjustable to any desired position.

In lathe work, wood is rotated against the special cutting tools illustrated in figure 3-59. The special lathe tools include turning gouges, skew chisels; parting tools; round-nose, square-nose, and spear-point chisels; tooling irons; and auxiliary aids such as calipers, dividers, and templates.

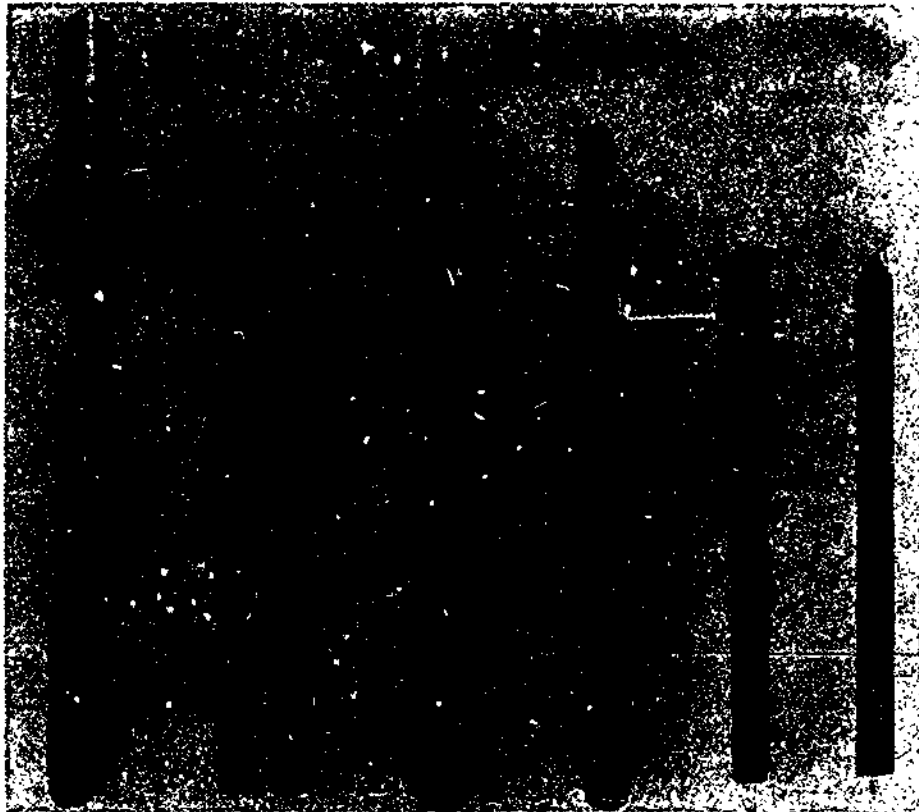

Figure 3-59.—Lathe cutting tools.

28.66

Turning gouges are used chiefly to rough out nearly all shapes in spindle turning. The gouge sizes vary from 1/8 to 2 or more in., with 1/4-, 3/4-, and 1-in. sizes being most common.

Skew chisels are used for smoothing cuts to finish a surface, turning beads, trimming ends or shoulders, and for making V-cuts. They are made in sizes from 1/8 to 2 1/2 in. in width and in right-handed and left-handed pairs.

Parting tools are used to cut recesses or grooves with straight sides and a flat bottom and also to cut off finished work from the faceplate. These tools are available in sizes ranging from 1/8 to 3/4 in.

Scraping tools of various shapes are used for the most accurate turning work, especially for most faceplate turning. A few of the more commonly used shapes are illustrated in D, E, and F of figure 3-59. The chisels shown in B, E, and F are actually old jointer blades which have been ground to the required shape; the wood handles for these homemade chisels are not shown in the illustration.

A tothing iron is basically a square-nose turning chisel with a series of parallel grooves cut into the top surface of the iron. (See fig. 3-60.) These turning tools are used for rough turning of segment work mounted on a



68.16

Figure 3-60.—Tothing iron lathe tool.

faceplate. The points of the tothing iron created by the parallel grooves serve as a series of spear-point chisels; therefore, the tool is not likely to catch and dig into the work like a square-nose turning chisel. The tothing iron is made with coarse, medium, and fine parallel grooves and varies from 1/2 to 2 in. in width.

Lathe turning may be divided into two categories: center-to-center turning (also called between turning and spindle turning) and faceplate turning.

Here are some safety precautions to observe.

When starting the lathe motor, stand to one side to avoid the hazard of flying debris in the event of defective material.

Use the tool rest as much as possible.

Adjust and set the compound or tool rest for the start of the cut before turning the switch on.

Take very light cuts, especially when using handtools.

Never attempt to use calipers on interrupted surfaces while the work is in motion.

ABRASIVE GRINDERS

A GRINDSTONE is an abrasive wheel made of natural stone—usually sandstone. A GRINDING WHEEL is an abrasive wheel made of some synthetic abrasive material, such as emery or corundum. Most modern wheels are synthetic wheels which are usually called GRINDERS.

Grinders vary in design and construction from the small hand-driven DRY grinder shown in figure 3-61 to the ball-bearing motor-driven,

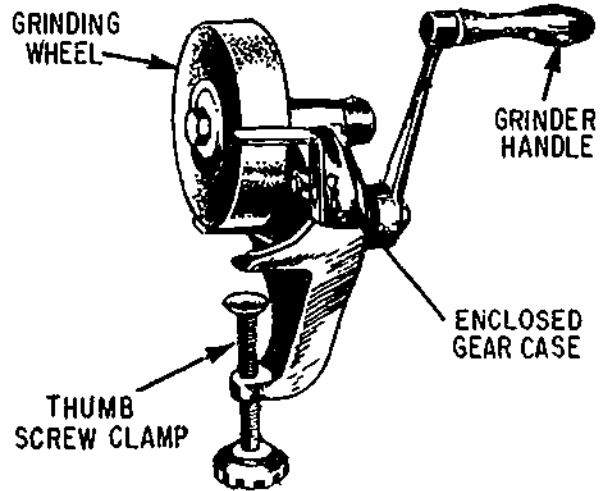

44.34

Figure 3-61.—Hand-driven dry grinder.

multi-wheel OILSTONE grinder shown in figure 3-62. The grinder in figure 3-62 has two large CUPPED oilstone wheels, one coarse and the other fine, for grinding plane irons and chisels. A drip-spout on each wheel drips oil into the cup of the wheel and thus keeps the wheel properly

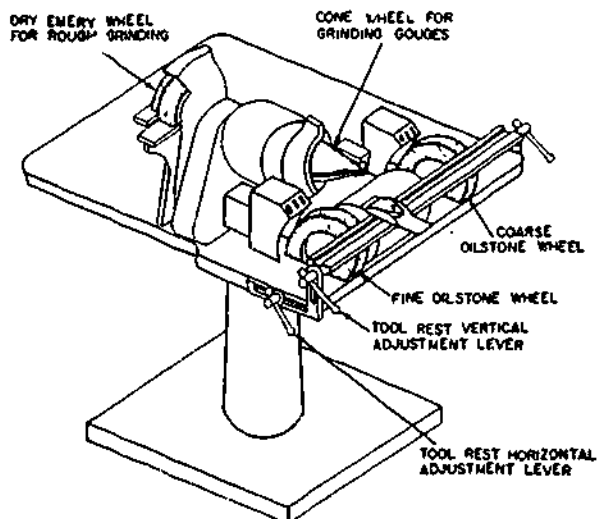

133.71

Figure 3-62.—Power-driven oilstone grinder.

oiled. The tool rest can be adjusted both vertically and horizontally to get just the right bevel angle on a tool. The tool holder slides back and forth in a groove on the tool rest, so that the tool which is being sharpened remains in correct position with respect to the face of the wheel. Besides the oilstone wheels, the grinder has a DRY WHEEL for rough grinding and a CONE WHEEL for grinding inside-bevel gouges.

Sharpening Stones

Sharpening stones are divided into two groups, natural and artificial. Some of the natural stones are oil treated during and after the manufacturing processes. The stones that are oil treated are sometimes called oilstones. Artificial stones are normally made of silicone carbide or aluminum oxide. Natural stones have very fine grains and are excellent for putting razorlike edges on fine cutting tools. Most sharpening stones have one coarse and one fine face. Some of these stones are mounted, and the working face of some of the sharpening stones is a combination of coarse and fine grains. Stones are available in a variety of shapes, as shown in figure 3-63.

A fine cutting oil is generally used with most artificial sharpening stones, however, other lubricants such as kerosene may be used. When a

tool has been sharpened on a grinder or grindstone, there is usually a wire edge or a feather edge left by the coarse wheel. The sharpening stones are used to hone this wire or feather edge off the cutting edge of the tool. Do not attempt to do a honing job with the wrong stone. Use a coarse stone to sharpen large and very dull or nicked tools. Use a medium grain stone to sharpen tools not requiring a finished edge, such as tools for working soft wood, cloth, leather, and rubber. Use a fine stone and an oilstone to sharpen and hone tools requiring a razorlike edge.

Prevent glazing of sharpening stones by applying a light oil during the use of the stone. Wipe the stone clear with a wiping cloth or cotton waste after each use. If the stone becomes glazed or gummed up, clean it with aqueous ammonia or drycleaning solvent. If necessary, clean it with aluminum oxide abrasive cloth or flint paper attached to a flat block.

At times, stones will become uneven from improper use. True the uneven surfaces on an old grinding wheel or on a grindstone. Another method of truing the surface is to lap it with a block of cast iron or other hard material covered with a waterproof abrasive paper, dipping the stone in water at regular intervals and continuing the lapping until the stone is true.

Stones must be carefully stored in boxes or on special racks when not in use. Never lay them

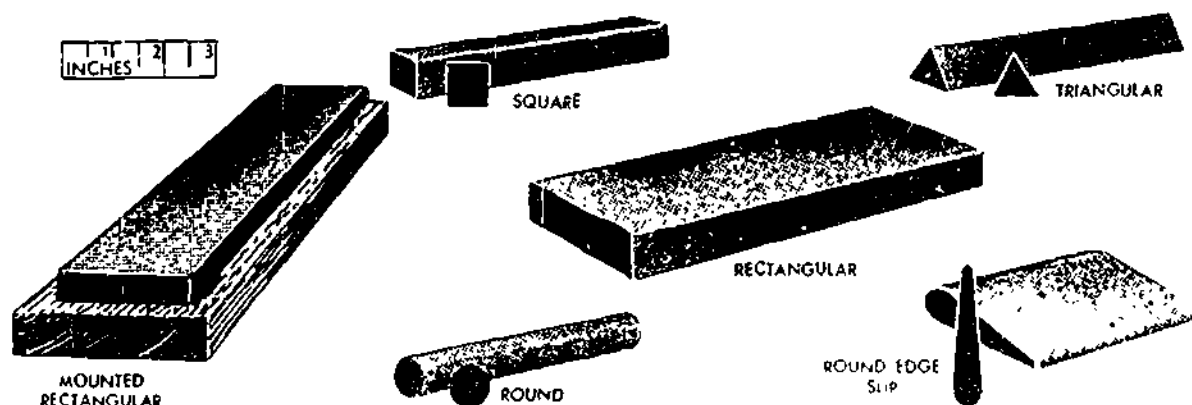

Figure 3-63.—Shapes of sharpening stones and oilstones.

44.35

down on uneven surfaces or place them where they may be knocked off a table or bench, or where heavy objects can fall on them. Do not store in a hot place.

Care and Maintenance of Abrasive Grinders

Abrasive wheels and oilstones are very easily broken or cracked, and must be handled and stowed with the greatest care. A wheel should be given a regular RING TEST for cracks. Tap the wheel with a rubber-faced hammer or mallet. A ringing sound indicates a sound wheel. A dull thudding sound indicates a cracked wheel. NEVER USE A CRACKED WHEEL.

When you are installing a new wheel, NEVER force the wheel onto the spindle. The wheel must slide easily with about 0.003 to 0.005 in. clearance. If it does not, IT IS NOT THE RIGHT SIZE FOR THE SPINDLE. (Always check the grinder wheel for the proper rpm.)

Tighten the spindle nut just enough to set the flanges firmly against the wheel. Overtightening may crack the wheel. After installing, GET YOURSELF AND EVERYBODY ELSE OUT OF THE LINE OF THE WHEEL, turn the power on, and keep clear until the grinder has run long enough to indicate that the wheel is not going to fly apart.

If a wheel GLAZES rapidly, decrease the speed of the grinder or put on a softer wheel. If a wheel LOADS rapidly (LOADING means the clogging of surface pores with the material being ground), increase the speed of the grinder or put on a softer wheel.

A glazed or loaded wheel should be DRESSED, and a wheel which has become out-of-round or irregular on the surface must be TRUED. The same procedure is used to cure both conditions. It is called DRESSING, and it is done with a WHEEL DRESSER. CUTTER and TUBE type dressers are shown in figure 3-64. A DIAMOND wheel dresser, which is the most effective, is shown in figure 3-65.

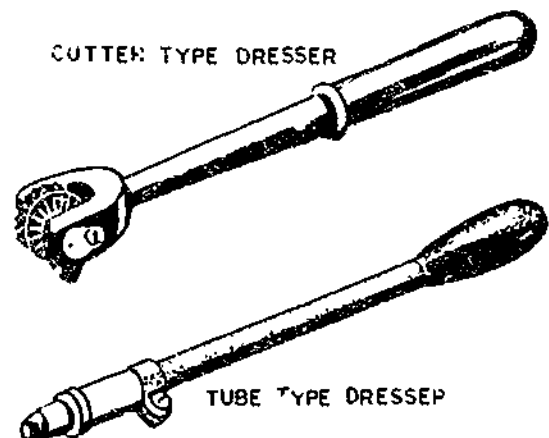

28.53(133E)A

Figure 3-64.—Cutter- and tube-type wheel dressers.

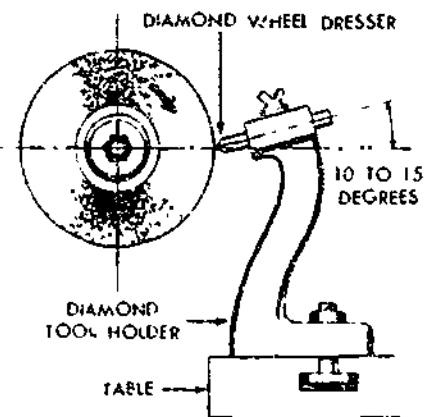

28.63(133E)B

Figure 3-65.—Diamond wheel dresser.

The procedure for dressing a wheel is as follows:

Adjust the tool rest to permit the wheel dresser to contact the centerline of the wheel, as shown in figure 3-66. The cutter type dresser is held with the lug on the cutter against the front edge of the tool rest, as shown in the figure. The tube-type dresser is held flat on the tool rest, as shown in figure 3-67.

Start the wheel and slowly press the dresser against the face until you feel the dresser start to "bite."



28.63(28C)

Figure 3-66.—Dressing with a cutter-type dresser.

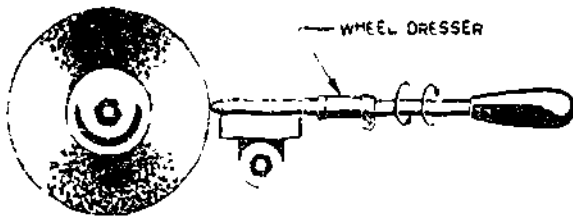

28.63(133E)D

Figure 3-67.—Dressing with a tube-type dresser.

Move the dresser from side to side and gradually press it forward until you feel it "bite" all the way across the face of the wheel.

Do not grind against the sides or corners of a wheel unless it is absolutely impossible to do the grinding job on the face.

A grinding wheel will gradually wear down, or will gradually be dressed down, to a diameter

which is much smaller than the original diameter. As the wheel becomes smaller, the speed of the grinder should be increased to allow for the reduced speed of travel of the smaller grinding face. If the same speed is maintained for the smaller wheel, the wheel will "act soft," and it will also wear down too rapidly.

For whetting plane irons, chisels, and the like, the faces of an oilstone must be perfectly flat. An uneven face can be trued up on the side of an old grinding wheel, or by rubbing on a piece of moistened waterproof artificial abrasive paper laid on a flat, true, hard surface.

The fragments of a broken oilstone can be rejoined as follows:

Bake all the oil out of the stone by heating the fragments on a hot plate.

Scrub the fragments thoroughly with drycleaning solvent or aqua ammonia.

Dust the broken edges thickly with flake or ground orange shellac. Work the shellac carefully into all recesses.

Reheat the fragments to melt the shellac, join them together, and clamp them securely in a handscrew.

If shellac is not available, cut a recess in a wooden block to mount the fragments. Make the recess a shade smaller than the length and width of the stone, and make it one-half as deep as the stone is thick. Assemble the fragments and tap them into the recess with the mallet.

Keep oilstones away from heat and store them in a cool place. Heat causes the oil in a stone to form a gummy residue on the surface

CHAPTER 4

WOODWORKING: MATERIALS AND METHODS

Of all the different construction materials, wood is probably the most often used and perhaps the most important. The variety of uses of wood is practically unlimited. Few SEABEE construction projects are accomplished without using some type of wood. It is used for permanent structures as well as concrete forms, scaffolding, shoring, and bracing which may be used again and again. The types, sources, uses, and characteristics of common woods are given in table 4-1. The types and classifications of wood for a large project are usually designated in the project specifications and included in the project drawings.

Many methods and procedures are used in woodworking. These are described later in the chapter and include the layout, cutting, fitting, and installation of moldings, cornices, cabinets, and trim. In woodworking, regardless of the method or procedure used, there is always the concern for safety. Precautions must be observed as they apply to the job being done.

LUMBER

The terms wood, lumber, and timber are often spoken or written in ways to suggest that their meanings are alike or nearly so. But in the Builders' language, the terms have distinct, separate meanings. WOOD is the hard, fibrous substance forming the major part of the trunk and branches of a tree. LUMBER is wood that has been cut and surfaced for use in construction work. TIMBER is lumber that is 5 inches or more in both thickness and width.

SEASONING OF LUMBER

Seasoning of lumber is the result of removing moisture from the small and large cells of wood. The advantages of seasoning lumber are to reduce its weight, increase its strength and resistance to decay, and decrease shrinkage which tends to avoid checking and warping after it is placed. Lumber is seasoned by drying, which means exposure to air. By a seldom used and rather slow method of seasoning, lumber is air-dried in a shed or stacked in the open until dry. By a faster method, known as kiln drying, the lumber is placed in a large oven or kiln and dried with heat supplied by gas- or oil-fired burners. Lumber is considered dry enough for most uses when its moisture content has been reduced to about 12 or 15 percent. As a Builder, you will learn to judge the dryness of lumber by its color, weight, smell, and feel. Also, after the lumber is cut, you will be able to judge the moisture content by looking at the shavings and chips.

DEFECTS AND BLEMISHES

A DEFECT in lumber is any flaw which tends to affect the strength, durability, or utility value of the lumber. A BLEMISH is a flaw which mars only the appearance of lumber. But a blemish affecting the utility value of lumber is also considered to be a defect. For example, a tight knot which mars the appearance of lumber intended for fine cabinet work.

Various flaws apparent in lumber are listed below. As described, each flaw is considered to be a defect unless identified as a blemish.

BUILDER 3 & 2

Table 4-1.--Common Woods

Type	Sources	Uses	Characteristics
Ash	East of Rockies . .	Oars, boat thwarts, benches, gratings, hammer handles, cabinets, ball bats, wagon construction farm implements.	Strong, heavy, hard, tough, elastic, close straight grain, shrinks very little, takes excellent finish, lasts well.
Balsa	Ecuador	Rafts, food boxes, linings of refrigerators, life preservers, loud speakers, sound-proofing, air-conditioning devices, model airplane construction.	Lightest of all woods, very soft, strong for its weight, good heat insulating qualities, odorless.
Basswood .	Eastern half of U. S. with exception of coastal regions.	Low-grade furniture, cheaply constructed buildings, interior finish, shelving, drawers, boxes, drainboards, woodenware, novelties, excelsior, general millwork.	Soft, very light, weak, brittle, not durable, shrinks considerably, inferior to poplar, but very uniform, works easily, takes screws and nails well and does not twist or warp.
Beech	East of Mississippi, Southeastern Canada.	Cabinetwork, imitation mahogany furniture, wood dowels, capping, boat trim, interior finish, tool handles, turnery, shoe lasts, carving, flooring.	Similar to birch but not so durable when exposed to weather, shrinks and checks considerably, close grain, light or dark red color.
Birch	East of Mississippi River and North of Gulf Coast States, Southeast Canada, Newfoundland.	Cabinetwork, imitation mahogany furniture, wood dowels, capping, boat trim, interior finish, tool handles, turnery, carving.	Hard, durable, fine grain, even texture, heavy, stiff, strong, tough, takes high polish, works easily, forms excellent base for white enamel finish, but not durable when exposed. Heartwood is light to dark reddish brown in color.
Butternut	Southern Canada, Minnesota, Eastern U. S. as far south as Alabama and Florida.	Toys, altars, woodenware, millwork, interior trim, furniture, boats, scientific instruments.	Very much like walnut in color but softer, not so soft as white pine and basswood, easy to work, coarse grained, fairly strong.

103.127.1

Chapter 4—WOODWORKING: MATERIALS AND METHODS

Table 4-1.—Common Woods—Continued

Type	Sources	Uses	Characteristics
Cypress	Maryland to Texas, along Mississippi valley to Illinois.	Small boat planking, siding, shingles, sash, doors, tanks, silos, railway ties.	Many characteristics similar to white cedar. Water resistant qualities make it excellent for use as boat planking.
Douglas Fir . .	Pacific Coast, British Columbia.	Deck planking on large ships, shores, strong-backs, plugs, filling pieces and bulkheads of small boats, building construction, dimension timber, plywood.	Excellent structural lumber, strong, easy to work, clear straight grained, soft, but brittle. Heartwood is durable in contact with ground, best structural timber of northwest.
Elm	States east of Colorado.	Agricultural implements, wheel-stock, boats, furniture, crossties, posts, poles.	Slippery, heavy, hard, tough, durable, difficult to split, not resistant to decay.
Hickory	Arkansas, Tennessee, Ohio, Kentucky.	Tools, handles, wagon stock, hoops, baskets, vehicles, wagon spokes.	Very heavy, hard, stronger and tougher than other native woods, but checks, shrinks, difficult to work, subject to decay and insect attack.
Lignum Vitae	Central America.	Block sheaves and pulleys, waterexposed shaft bearings of small boats and ships, tool handles, small turned articles, and mallet heads.	Dark greenish brown, unusually hard, close grained, very heavy, resinous, difficult to split and work, has soapy feeling.
Live Oak . . .	Southern Atlantic and Gulf Coasts of U.S., Oregon, California.	Implements, wagons, ship building.	Very heavy, hard, tough, strong, durable, difficult to work, light brown or yellow sap wood nearly white.
Mahogany . . .	Honduras, Mexico, Central America, Florida, West Indies, Central Africa, other tropical sections.	Furniture, boats, decks, fixtures, interior trim in expensive homes, musical instruments.	Brown to red color, one of most useful of cabinet woods, hard, durable, does not split badly, open grained, takes beautiful finish when grain is filled but checks, swells, shrinks, warps slightly.

103.127.2

BUILDER 3 & 2

Table 4-1.--Common Woods--Continued

Type	Sources	Uses	Characteristics
Maple	All states east of Colorado, Southern Canada.	Excellent furniture, high-grade floors, tool handles, ship construction cross-ties, counter tops, bowling pins.	Fine grained, grain often curly or "Bird's Eyes," heavy, tough, hard, strong, rather easy to work, but not durable. Heartwood is light brown, sap wood is nearly white.
Norway Pine	States bordering Great Lakes.	Dimension timber, masts, spars, piling, interior trim.	Light, fairly hard, strong, not durable in contact with ground.
Philippine Mahogany . .	Philippine Islands	Pleasure boats, medium-grade furniture, interior trim.	Not a true mahogany, shrinks, expands, splits, warps, but available in long, wide, clear boards.
Poplar	Virginias, Tennessee, Kentucky, Mississippi Valley.	Low-grade furniture cheaply constructed buildings, interior finish, shelving, drawers, boxes.	Soft, cheap, obtainable in wide boards, warps, shrinks, rots easily, light, brittle, weak, but works easily and holds nails well, fine-textured.
Red Cedar . . .	East of Colorado and north of Florida.	Mothproof chests, lining for linen closets, sills, and other uses similar to white cedar.	Very light, soft, weak, brittle, low shrinkage, great durability, fragrant scent, generally knotty, beautiful when finished in natural color, easily worked.
Red Oak	Virginias, Tennessee, Arkansas, Kentucky, Ohio, Missouri, Maryland.	Interior finish, furniture, cabinets, millwork, crossties when preserved.	Tends to warp, coarse grain, does not last well when exposed to weather, porous, easily impregnated with preservative, heavy, tough, strong.
Redwood	California.	General construction, tanks, paneling.	Inferior to yellow pine and fir in strength, shrinks and splits little, extremely soft, light, straight grained, very durable, exceptionally decay resistant

103.127.3

Chapter 4—WOODWORKING: MATERIALS AND METHODS

Table 4-1.—Common Woods—Continued

Type	Sources	Uses	Characteristics
Spruce	New York, New England, West Virginia, Central Canada, Great Lakes States, Idaho, Washington, Oregon.	Railway ties, resonance wood, piles, airplanes, oars, masts, spars, baskets.	Light, soft, low strength, fair durability, close grain, yellowish, sap wood indistinct.
Sugar Pine	California, Oregon.	Same as white pine.	Very light, soft, resembles white pine.
Teak	India, Burma, Siam, Java.	Deck planking, shaft logs for small boats.	Light brown color, strong, easily worked, durable, resistant to damage by moisture.
Walnut	Eastern half of U.S. except Southern Atlantic and Gulf Coasts, some in New Mexico, Arizona, California.	Expensive furniture, cabinets, interior woodwork, gun stocks, tool handles, airplane propellers, fine boats, musical instruments.	Fine cabinet wood, coarse grained but takes beautiful finish when pores closed with woodfiller, medium weight, hard, strong, easily worked, dark chocolate color, does not warp or check, brittle.
White Cedar	Eastern Coast of U.S., and around Great Lakes..	Boat planking, railroad ties, shingles, siding, posts, poles.	Soft, light weight, close grained, exceptionally durable when exposed to water, not strong enough for building construction, brittle, low shrinkage, fragment, generally knotty.
White Oak . .	Virginias, Tennessee, Arkansas, Kentucky, Ohio, Missouri, Maryland, Indiana.	Boat and ship stems, sternposts, knees, sheer strakes, fenders, capping, transoms, shaft logs, framing for buildings, strong furniture, tool handles, crossties, agricultural implements, fence posts.	Heavy, hard, strong, medium coarse grain, tough, dense, most durable of hardwoods, elastic, rather easy to work, but shrinks and likely to check. Light brownish grey in color with reddish tinge, medullary rays are large and outstanding and present beautiful figures when quarter sawed, receives high polish

103.127.4

BUILDER 3 & 2

Table 4-1.—Common Woods—Continued

Type	Sources	Uses	Characteristics
White Pine	Minnesota, Wisconsin, Maine, Michigan, Idaho, Montana, Washington, Oregon, California	Patterns, any interior job or exterior job that doesn't require maximum strength, window sash, interior trim, millwork, cabinets, cornices.	Easy to work, fine grain, free of knots, takes excellent finish, durable when exposed to water, expands when wet, shrinks when dry, soft, white, nails without splitting, not very strong, straight grained.
Yellow Pine	Virginia to Texas.	Most important lumber for heavy construction and exterior work, keelsons, risings, filling pieces, clamps, floors, bulkheads of small boats, shores, wedges, plugs, strong-backs, staging, joists, posts, piling, ties, paving blocks.	Hard, strong, heartwood is durable in the ground, grain varies, heavy, tough, reddish brown in color, resinous, medullary rays well marked.

103.127.6

BARK POCKET—Patch of bark over which the tree has grown, and which it has entirely or almost entirely enclosed.

CHECK—Separation along the lengthwise grain, caused by too rapid or nonuniform drying.

CROSS GRAIN—Grain does not run parallel to or spirals around the lengthwise axis.

DECAY—Deterioration caused by various fungi.

KNOT—Root section of a branch that may appear on a surface in cross section or lengthwise. A cross-section knot may be loose or tight. A lengthwise knot is called a **SPIKE KNOT**.

PITCH POCKET—Deposit of solid or liquid pitch enclosed in the wood.

SHAKE—Separation along the lengthwise grain that exists before the tree is cut. A **HEART SHAKE** moves outward from the center of the tree and is caused by decay at the center of the trunk. A **WIND SHAKE** follows the circular lines of the annual rings; its cause is not definitely known.

BLUE STAIN—Blemish caused by a mold fungus; it does not weaken the wood.

WANE—Flaw in an edge or corner of a board or timber. It is caused by the presence of bark or lack of wood in that part.

WARP—Twist or curve that develops in a once flat or straight board due to shrinkage.

SIZES OF LUMBER

Standard lumber sizes have been established in the United States for uniformity in planning

structures and in ordering materials. Lumber is identified by **NOMINAL SIZES**. The nominal size of a piece of lumber is larger than the actual **DRESSED** dimensions. By referring to table 4-2, you can determine the common widths and thicknesses of lumber in their **NOMINAL** and **DRESSED** dimensions.

CLASSIFICATION OF LUMBER

In general, softwood lumber is classified according to its use, type of manufacture, and size.

Use

Softwood lumber is classified by use as **YARD, STRUCTURAL, FACTORY, and SHOP** lumber. Yard lumber consists of those grades, sizes, and patterns generally intended for ordinary building purposes. Structural lumber is 2 or more in. in nominal thickness and width and is used where working stresses are required. Factory and shop lumber is used primarily for building cabinets and interior finish work.

Manufacturing

Manufacturing classifications consist of **ROUGH, DRESSED (surfaced), and WORKED** lumber. Rough lumber has not been dressed, but has been sawed, edged, and trimmed. Dressed lumber has been planed on one or more sides to attain smoothness and uniformity. Worked lumber, in addition to being dressed, has also been matched, shiplapped, or patterned. Matched lumber is tongue and groove, either sides and/or ends. Shiplapped lumber has been rabbeted on both edges to provide a close-lapped joint. Patterned lumber is designed to a pattern or molded form.

Size

Softwood lumber is classified by its nominal size as **BOARDS, DIMENSIONS, and TIMBERS**.

(See table 4-2.) Boards are less than 2 inches in thickness and 2 or more inches in width. Those less than 6 inches in width may be classified as strips. Dimensions are from 2 in. to, but not including, 5 inches in thickness and 2 in. or more in width. Joists, planks, rafters, and studs are examples of dimension lumber. Timbers are 5 or more in. in both thickness and width. Beams, girders, posts, caps, etc., are classified as timbers.

GRADING OF LUMBER (SOFTWOODS)

Lumber is graded for quality in accordance with American Lumber Standards set by the National Bureau of Standards for the U.S. Department of Commerce. The major quality grades, in descending order of quality, are **SELECT LUMBER, and COMMON LUMBER**. Each of these grades has subdivisions in descending order of quality as follows:

GRADE A lumber is select lumber which is practically free of defects and blemishes.

GRADE B lumber is select lumber which contains a few minor blemishes.

GRADE C lumber is finish lumber which contains more numerous and more significant blemishes than grade B. It must be capable of being easily and thoroughly concealed with paint.

GRADE D lumber is finish lumber which contains more numerous and more significant blemishes than grade C, but which is still capable of presenting a satisfactory appearance when painted.

NO. 1 COMMON lumber is sound, tightknotted stock, containing only a few minor defects. It must be suitable for use as watertight lumber.

NO. 2 COMMON lumber contains a limited number of significant defects, but no knotholes

BUILDER 3 & 2

Table 4-2.—Nominal and Dressed Sizes of Lumber

ITEM	THICKNESSES		FACE WIDTHS	
	NOMINAL	DRESSED Inches	NOMINAL	DRESSED Inches
Boards	1 1-1/4 1-1/2	3/4 1 1-1/4	2	1-1/2
			3	2-1/2
			4	3-1/2
			5	4-1/2
			6	5-1/2
			7	6-1/2
			8	7-1/4
			9	8-1/4
			10	9-1/4
			11	10-1/4
			12	11-1/4
14	13-1/4			
16	15-1/4			
Dimension	2 2-1/2 3 3-1/2	1-1/2 2 2-1/2 3	2	1-1/2
			3	2-1/2
			4	3-1/2
			5	4-1/2
			6	5-1/2
			8	7-1/4
			10	9-1/4
			12	11-1/4
			14	13-1/4
			16	15-1/4
			Dimension	4 4-1/2
3	2-1/2			
4	3-1/2			
5	4-1/2			
6	5-1/2			
8	7-1/4			
10	9-1/4			
12	11-1/4			
14				
16				
Timbers	5 & Thicker			

or other serious defects. It must be suitable for use as graintight lumber.

NO. 3 COMMON lumber contains a few defects which are larger and coarser than those in No. 2 Common; occasional knotholes, for example.

NO. 4 COMMON lumber is low-quality material, containing serious defects like knotholes, checks, shakes, and decay.

NO. 5 COMMON is capable only of holding together under ordinary handling.

BOARD MEASURE

BOARD MEASURE is a method of measuring lumber in which the basic unit is an abstract volume 1 ft long by 1 ft wide by 1 in. thick. This abstract volume or unit is called a BOARD FOOT.

There are several formulas for calculating the number of board feet in a piece of given dimensions. Since lumber dimensions are most frequently indicated by width and thickness in inches and length in feet, the following formula is probably the most practical.

$$\frac{\text{Thickness in inches} \times \text{width in inches} \times \text{length in feet}}{12} = \text{board feet}$$

Suppose you are calculating the number of board feet in a 14-ft length of 2 by 4. Applying the formula, you get.

$$\frac{2 \times 4 \times 14}{12} = \frac{28}{3} = 9 \frac{1}{3} \text{ bd ft}$$

The chief practical use of board measure is in cost calculations, since lumber is bought and sold by the board foot. Any lumber less than 1 in. thick is presumed to be 1 in. thick for

board measure purposes. Board measure is calculated on the basis of the NOMINAL, not the DRESSED (actual), dimensions of lumber. As explained above, the actual size of a piece of dimension lumber (such as a 2 by 4, for example) is usually less than the nominal size.

HANDLING AND STORAGE OF LUMBER

The advances made in the mechanized handling of lumber have to a great extent changed storage and handling methods. The development of handling equipment, such as forklift and straddle trucks or carriers, that can be used to pile, unpile, and transport lumber has brought about revolutionary changes in storage and handling practices; the most notable being the handling of lumber in packages (drafts). Regardless of whether lumber is handled by mechanized equipment or by manual labor, the objectives of storage and handling are unchanged.

The objective of lumber storage is to maintain the lumber at or bring it to a moisture content suitable for its end use with a minimum of deterioration. The objective of lumber handling is to load, transport, unload, pile, and unpile lumber economically and without damage. Both of these objectives are obtained easily if good handling and storage practices are followed. Adequate protection of lumber in storage will help prevent attack by fungi, insects, and changes in moisture content that will result in checking, warping, and stain in lumber and make it unsuitable for the intended use.

The storage yard should be located near a spot where the lumber is easily accessible for use. The best location would be on high, level, and well-drained ground—away from bodies of water or wind-obstructing objects, such as tall trees or buildings, and away from operating vehicles or equipment that might damage the lumber. A low level site is likely to be damp and sheltered from the flow of fresh air—conditions that may retard drying and expose the lumber to stain and decay.

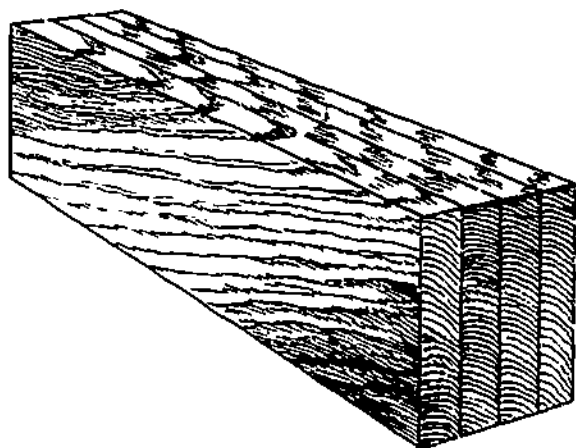

103.3

Figure 4-1.—Laminated lumber.

The lumber must be stacked on level timber sills with solid supports to prevent direct contact with the ground. All nails protruding from used lumber should be pulled out before it is stacked. The height of the lumber pile should not exceed 16 ft; the width should be less than one-fourth the height. Cross strips of wood, called stickers, must be placed in piles that are stacked more than 4 ft high. When the lumber is unplied, each layer must be removed before another is begun.

Lumber handlers should wear leather gloves and hard hats. They should use their legs in lifting to avoid straining their backs. A load that is too heavy or awkward to be handled for one person requires handling by two or more persons.

LAMINATED LUMBER

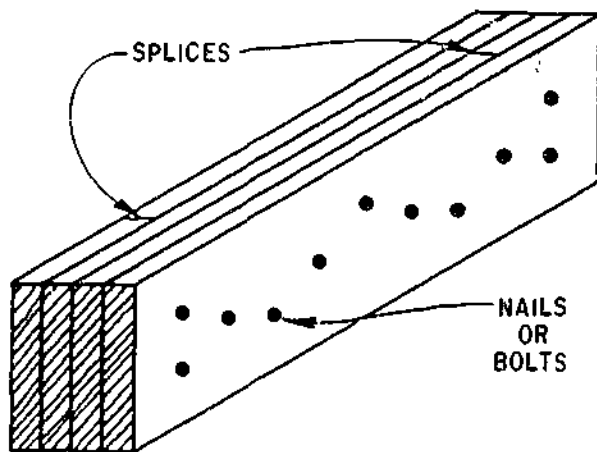

45.869

Figure 4-2.—Built-up beam.

Laminated lumber (fig. 4-1) is made of several pieces of lumber, called laminations. Usually $1\frac{1}{2}$ in. thick, the pieces are nailed, bolted, or glued together with the grain of all pieces running parallel. Laminating greatly increases the wood's load-carrying capacity and rigidity. When extra length is needed, the pieces are spliced—with the splices staggered so that no two adjacent laminations are spliced at the same point. Built-up beams and girders are examples of laminated lumber. They are built as shown in figure 4-2, usually nailed or bolted together and spliced.

Laminations may be used independently or with other materials in the construction of a structural unit. Trusses can be made with

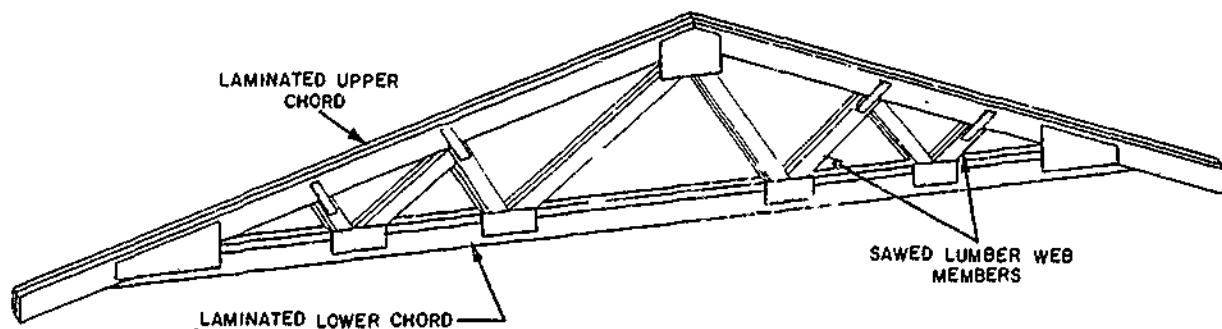

45.871

Figure 4-3.—Truss using laminated and sawed lumber.

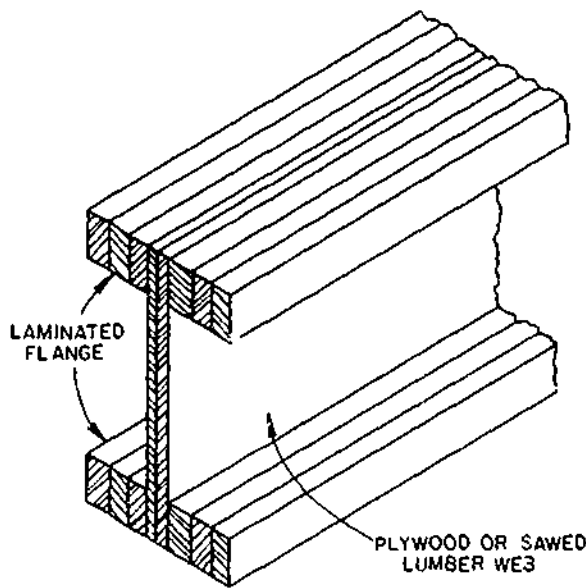

45.871
Figure 4-4.—Laminated and sawed lumber or plywood beam.

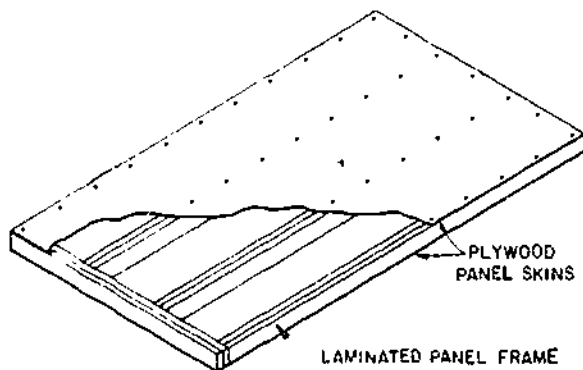

45.872
Figure 4-5.—Stressed skin panel.

laminations for the chords and sawed lumber for the web members. (See fig. 4-3.) Special beams may be constructed with laminations for the flanges and plywood or sawed lumber for the web, as shown in figure 4-4. A unit, such as plywood box beams and stressed skin panels, can contain both plywood and laminations. (See fig. 4-5.)

Probably the greatest use of laminations is in the fabrication of large beams and arches. Beams

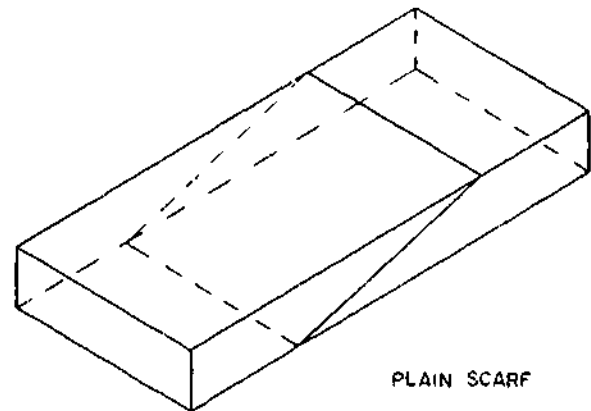

PLAIN SCARF

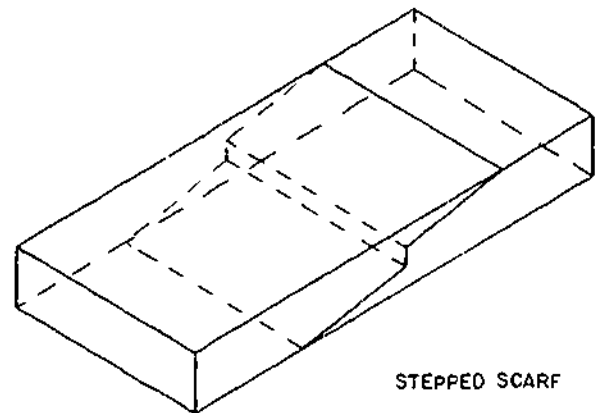

STEPPED SCARF

45.873
Figure 4-6.—Scarf joints.

with spans in excess of 100 ft and depths of 8 1/2 ft have been constructed using 2-in. boards. Laminations this large are factory produced. They are glued together under pressure. Most laminations are spliced using SCARF JOINTS (fig. 4-6), and the entire piece is dressed to insure uniform thickness and width. The depth of the lamination is placed in a horizontal position and is usually the full width of the beam. (See fig. 4-7.)

PLYWOOD

Plywood is a panel product made from thin sheets (plys) of wood called veneers which are

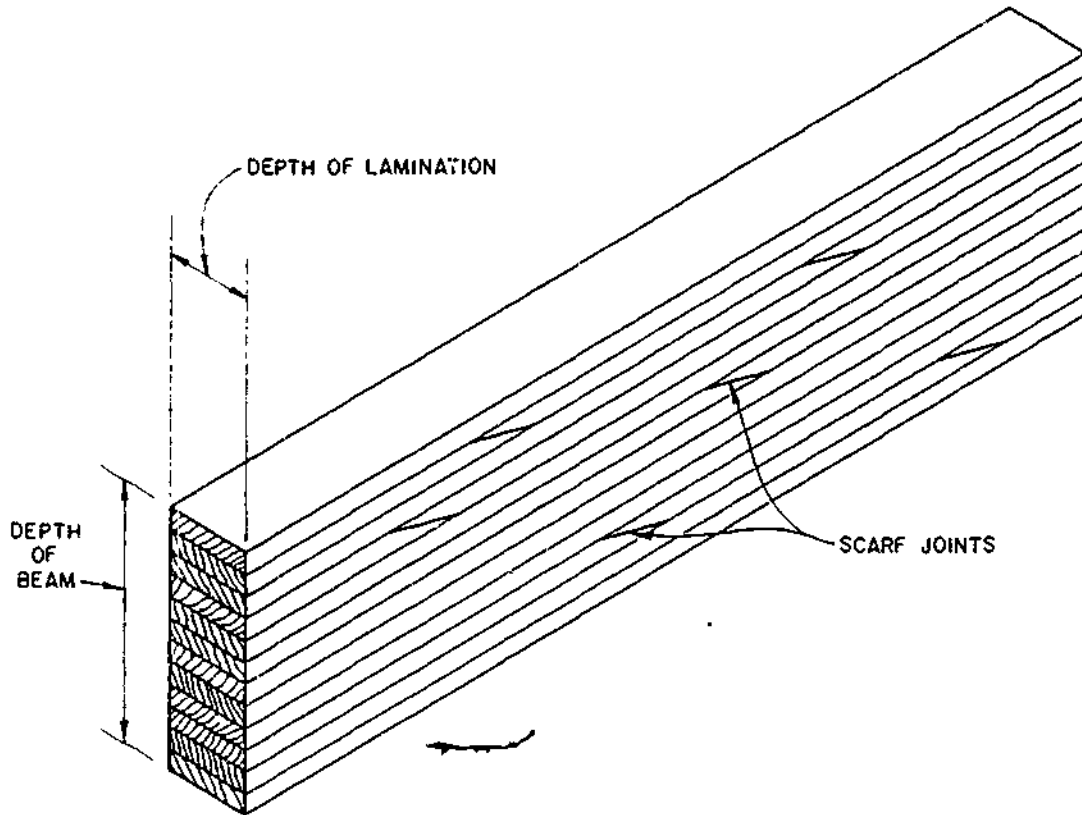

Figure 4-7.—Laminated beam.

45.874

laminated together. The grain of each ply normally runs at right angles to adjacent plys. (See fig. 4-8.) An odd number of veneers—three, five, or seven—is generally used so the grain direction on the face and back of the panel run in the same direction. Cross-lamination distributes the grain strength in both directions, creating a panel that is split-proof and pound for pound, one of the strongest building materials available. Plywood can be worked quickly and easily with common carpentry tools. It holds nails well and normally does not split when nails are driven close to the edges. Finishing plywood presents no unusual problems as it may be sanded or texture coated with a permanent finish, or it may be left to weather naturally.

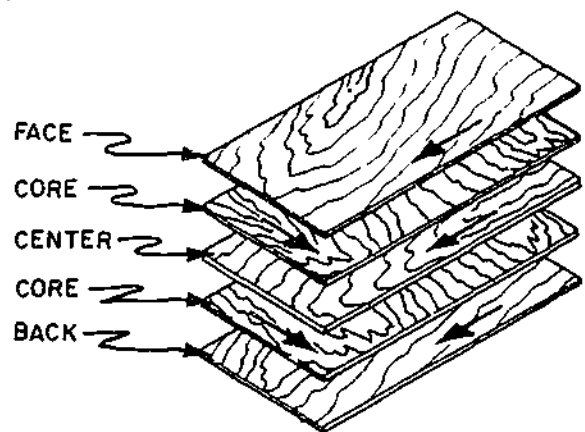

Figure 4-8.—Grain direction in a sheet of plywood.

133.424

There is probably no building material as versatile as plywood. It is used for concrete

forms, wall and roof sheathing, flooring, box beams, soffits, stressed-skin panels, paneling, shelving, doors, furniture, cabinets, crates, signs, and many other items.

SIZES OF PLYWOOD

Plywood panels commonly used in building construction come in standard sizes of 4 ft by 8 ft or 48 in. by 96 in. In metric, this might very well go to 1200 by 2400 millimeters.

Plywood is available, however, in panel widths of 36, 48, and 60 in. Panel lengths range from 60 to 144 inches in 12 in. increments. Other sizes of plywood are available on special order. The thickness of plywood usually runs from 1/4 to 3/4 in. but other sizes and thickness may be obtained.

- N Special order "natural finish" veneer. Select all heartwood or all sapwood. Free of open defects. Allows some repairs.
- A Smooth and paintable. Neatly made repairs permissible. Also used for natural finish in less demanding applications.
- B Solid surface veneer. Circular repair plugs and tight knots permitted.
- C Knotholes to 1". Occasional knotholes 1/2" larger permitted providing total width of all knots and knotholes within a specified section does not exceed certain limits. Limited splits permitted. Minimum veneer permitted in Exterior-type plywood.
- C Improved C veneer with splits limited to 1/8" in width and knotholes and borer holes limited to 1/4" by 1/2".
- D Permits knots and knotholes to 2-1/2" in width and 1/2" larger under certain specified limits. Limited splits permitted.

Figure 4-9.—Plywood veneer grades.

GRADES OF PLYWOOD

All plywood panels are graded as to quality, based on products standards (currently PS 1-74). The grade of each type of plywood is determined by the kind of veneer (N, A, B, C, or D) used for the face and back of the panel (fig. 4-9) and also, the type of glue used in construction. For example, a sheet of plywood having the designation A-C would have the A grade veneer on the face and the C grade veneer on the back. Grading is also based on the number of defects, such as knotholes, pitch pockets, splits, discolorations, and patches in the face of each panel. Each panel or sheet of plywood has a stamp on the back which gives all the information you will need. (See fig. 4-10.)

TYPICAL BACK-STAMP

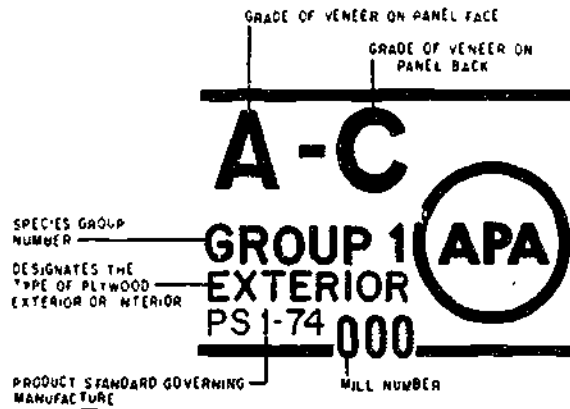

TYPICAL EDGE-MARK

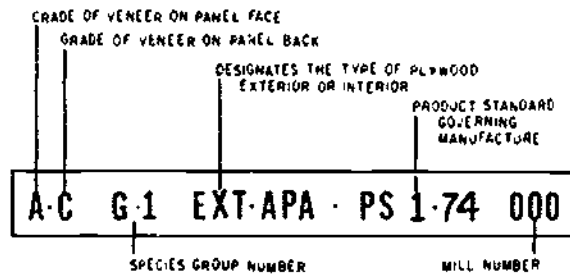

Figure 4-10.—Standard identification symbols.

133.425

TYPES OF PLYWOOD

Plywood is classified into two types, INTERIOR and EXTERIOR. Types are determined by their capability to withstand weather exposure and also denotes their veneer grade and adhesive durability. There are a number of grades within each type of plywood which are based on the quality of the veneer of the panel.

Interior-type plywood will withstand an occasional wetting during construction, but should not be permanently exposed to the elements. Within the interior-type classification, there are three levels of adhesive durability: (1) interior with interior glue, which may be used where the plywood will not be subject to continuing moisture conditions or extreme humidity; (2) interior with intermediate glue which is bonded with adhesives possessing high-level resistance to bacteria, mold, and moisture; and (3) interior with exterior waterproof glue. Because of the roughness of the inner plys of interior plywood, these panels are not equal in durability to exterior plywood.

Exterior-type plywood is produced with C grade veneers or better throughout and bonded thoroughly with a waterproof adhesive. It retains the glue bond when wet and dried repeatedly or otherwise subjected to the weather. It is intended for permanent exterior exposure.

SPECIAL PURPOSE PLYWOOD

Some types of plywood are manufactured for specific purposes. Among these types are the structural, sheathing, overlaid panels, decorative panels, and concrete form panels. See figure 4-11 for some of the suggested uses of the various types of plywood.

Structural

These are unsanded grades of C-D plywood made only with exterior glue. Structural

plywood is recommended for heavy load application where strength properties are of maximum importance. Such would include box beams, gusset plates, and stressed skin panels.

Sheathing

Interior-type standard C-D sheathing is used for subflooring, wall sheathing, and roof decking. The face and back are of the lower grades and an exterior-type glue is used. It is basically used in places that may be exposed to moisture during construction, but is covered when construction is complete.

Overlaid Panels

Overlaid panels are exterior or interior plywood which has a resin-treated fiber-surfacing material on one or both sides. The overlaid panels are treated so they will take and hold paint and finishes more readily. They are recommended for use in furniture, millwork, and cabinets, or exterior trim and painted finishes.

Decorative Panels

Decorative panels are manufactured for both interior and exterior uses. Both types are basically used for wall sheathing. The exterior type is manufactured in a multitude of designs and patterns. It can be painted, stained, or left to weather naturally. Interior paneling also is available in many designs and patterns, but is usually prefinished. Decorative panels are not only available in the wood and wood-like finishes, but also in many other types of finishes.

Concrete Form Panels

This type of plywood has a coating over its exterior face to make it moisture resistant and

SOFTWOOD PLYWOOD GRADES FOR EXTERIOR USES				
GRADE (EXTERIOR)	FACE	BACK	INNER PLYS	USES
A-A	A	A	C	Outdoor where appearance of both sides is important.
A-B	A	B	C	Alternate for A-A, where appearance of one side is less important.
A-C	A	C	C	Siding, soffits, fences. Face is finish grade.
B-C	B	C	C	For utility uses such as farm buildings, some kinds of fences, etc.
C-C (Plugged)	C Plugged	C	C	Excellent base for tile and linoleum, backing for wall coverings.
C-C	C	C	C	Unsanded, for backing and rough construction exposed to weather.
B-B Concrete Forms	B	B	C	Concrete forms. Re-use until wood literally wears out.
MDO	B	B or C	C or C-Plugged	Medium Density Overlay. Ideal base for paint; for siding, built-ins, signs, displays.
HDO	A or B	A or B	C-Plugged	High Density Overlay. Hard surface; no paint; needed. For concrete forms, cabinets, counter tops, tanks.

SOFTWOOD PLYWOOD GRADES FOR INTERIOR USES				
GRADE (INTERIOR)	FACE	BACK	INNER PLYS	USES
A-A	A	A	D	Cabinet doors, built-ins, furniture where both sides will show.
A-B	A	B	D	Alternate of A-A. Face is finish grade, back is solid and smooth.
A-D	A	D	D	Finish grade face for paneling, built-ins, backing.
B-D	B	D	D	Utility grade. One paintable side. For backing, cabinet sides, etc.
STANDARD	C	D	D	Sheathing and structural uses such as temporary enclosures, subfloor. Unsanded.

Figure 4-11.—Plywood uses.

nonadhesive to concrete when used as forming material. The exterior coating reduces the number of times the forms must be oiled and allows the panels to be reused many times.

IDENTIFICATION STAMPS

Grading identification stamps, indicating the kind and type of plywood, are placed not only on the back but are also placed on the edges of each sheet of plywood. (See fig. 4-10.)

Figure 4-12 illustrates the stamps found on the backs of structural and sheathing panels. They vary somewhat from the standard stamps. The grade is not given nor is the species group. The index numbers 48/24 and 32/16 give the maximum spacing in inches. The number to the left of the slash is the maximum on center spacing of supports for roof decking. The number to the right of the slash is the maximum on center spacing of supports for subfloors. A number 0 on the right of the slash would indicate that the panel should not be used for subflooring. No reference to the index number is needed when the panel is to be used for wall sheathing.

PLYWOOD STORAGE

Because of the conditions of its manufacture, plywood can generally be assumed

to be dry when received. It should therefore, be stored in a closed shed. For long storage in winter or the rainy season, a heated storage building is recommended.

Plywood is commonly piled solid. Under humid conditions, there is some tendency for the edges to swell causing an uneven dish-like pattern especially in the upper panels of high stacked piles. Dishing can be minimized by placing stickers (strips of wood) in the pile at intervals so that the plywood will not bend between them.

COMMON WOOD SUBSTITUTES

There are many other common construction materials which for various reasons are used as wood or plywood substitutes. Some are significantly less expensive than plywood, and others are more suitable because of their decorative appearance, weather-resistant, or fire resistant qualities. Some of these wood substitutes are hardboard, fiberboard, particleboard, gypsum wallboard, and cement-asbestos board.

HARDBOARD

Hardboard is made by separating and treating wood fibers which are subjected to heat and heavy pressure. Hardboard is available in thickness from 1/8 to 3/8 in. and the most common size sheets are 4 by 8 ft, but other sizes are available. The finish may be obtained in a plain, smooth surface or in any number of glossy finishes, some of which imitate tile or stone. Because hardboard is produced by compressing separated wood fibers, it has no grain, and therefore, no splitting or slivering occurs when working with it. Its strength is equal in all directions, and it can be bent into various shapes.

FIBERBOARD

Fiberboard which conforms to Federal Specification LL-F-321, is made of wood or

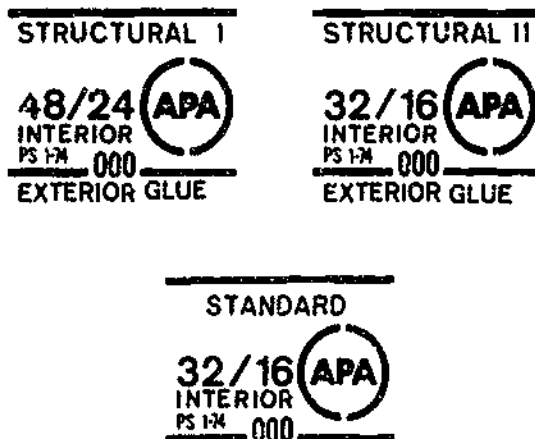

133.429

Figure 4-12.—Structural and sheathing identification symbols.

vegetable fiber, and compressed to form sheets or board. It is available in sizes from 1/2 in. to 1 in. thick, 2 to 4 ft in width, and 8 ft to 12 ft in length. Fiberboards are comparatively soft and provide good insulation and sound absorbing qualities. Fiberboard usually has a rough surface, but is also available with finished surfaces.

PARTICLEBOARD

Particleboard is commonly referred to as flakeboard or chipboard. It is produced by mixing a resin bonding agent with wood particles and bonded together by means of heat and pressure. The most common size sheets are 4 ft by 8 ft and vary from 1/4 in. to 1 1/2 in. thick. Particleboard is very low in strength and generally is limited to nonstructural use, such as furniture or floor underlayment.

GYPSUM WALLBOARD

Gypsum wallboard, which conforms to Federal Specifications SS-L-306, is composed of gypsum between two layers of heavy paper. The most common thicknesses of this wallboard are 1/4-, 3/8-, 1/2-, and 5/8 in. Its width is usually 4 ft and its length varies from 8 to 14 ft.

Some types have unfinished surfaces, while others have finishes which represents woodgrain or tile. The joints of the unfinished type may be covered with strips of joint paper to form panels. Another commonly used type of gypsum wallboard has depressed or tapered edges. The joints are filled with a special cement and then taped so that the joints do not show and then can be painted. This procedure is commonly known as DRYWALL. It is particularly useful in office and berthing spaces where sound deadening and fire resistant materials are desired.

CEMENT-ASBESTOS BOARD

Cement-asbestos board (CAB) is a light-weight material produced by mixing portland

cement and asbestos fibers. It is light gray in color, and is fire and weather resistant. Cement-asbestos board can be obtained in flat or corrugated sheets, but the flat 1/4 in. by 4 ft by 8 ft sheets are the most common used in construction. CAB is not normally used by the SEABEES in new construction, but is most frequently used for exterior repairs on older buildings. Remember, this type material contains asbestos, and extreme caution in avoiding breathing of asbestos particles must be observed when working with it. Asbestos has been determined to have caused cancer. Prior to working with asbestos, review article 2058 of the *Safety Precaution for Shore Activities* manual NAVMAT P-5100. This article covers safety precautions to observe while working around mineral dusts.

WOODWORKING METHODS

The following sections will explain some of the methods used in wood working by explaining the procedures involved when developing various woodworking joints.

PLANING AND SQUARING TO DIMENSIONS

Planing and squaring a small piece of board to dimensions is what you might call the first lesson in woodworking. Like many other things that you might of tried to accomplish, it looks easy until you try it. The six major steps in this process are illustrated and described in figure 4-13. You should practice these steps until you can get a smooth, square board with a minimum of planing.

JOINTS AND JOINING

One basic skill of woodworking is the art of JOINING pieces of wood to form tight, strong, well-made JOINTS. The two pieces which are to

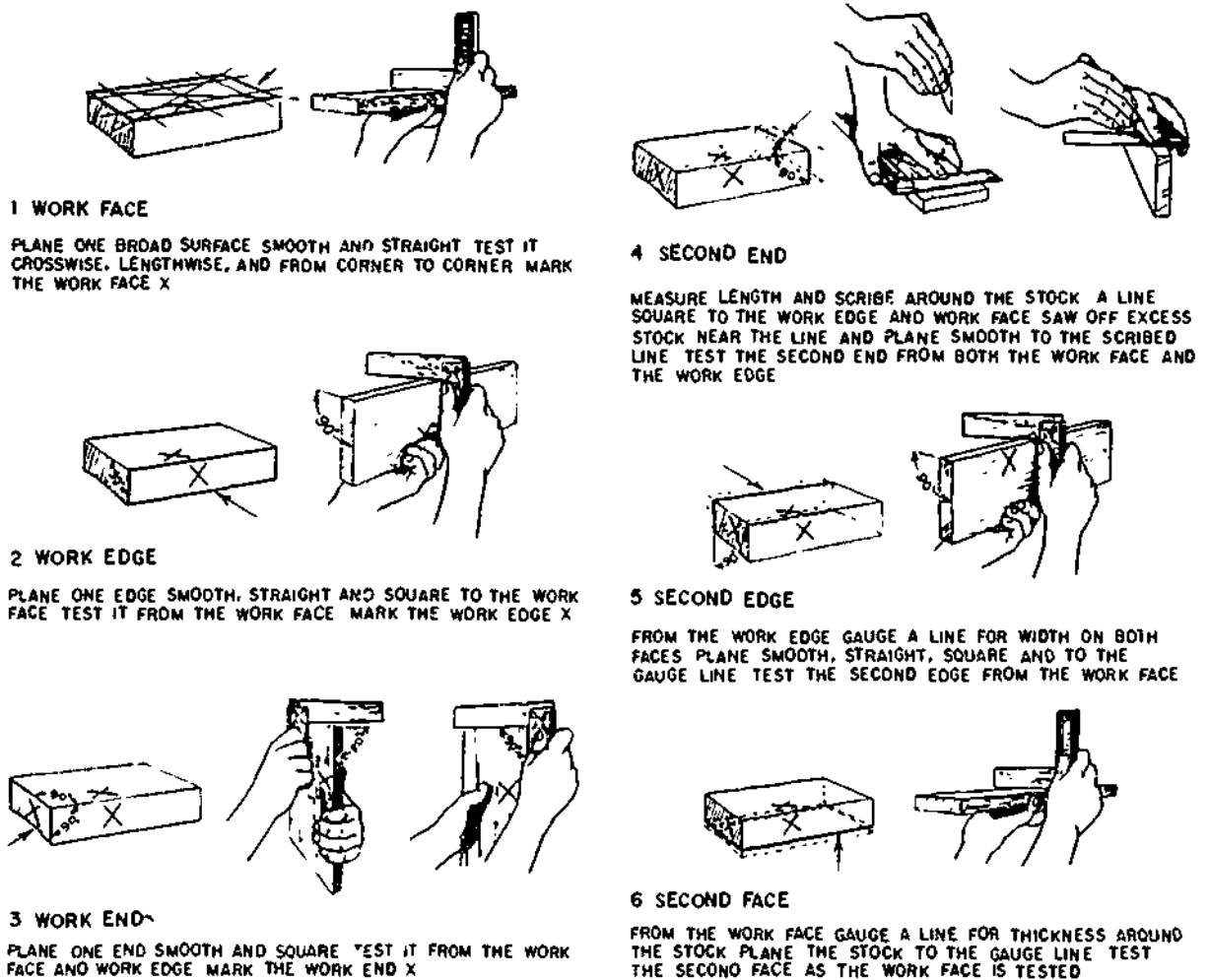

44.108

Figure 4-13.—Planing and squaring to dimensions.

be joined together are called **MEMBERS**. The two major steps in making joints are the layout of the joint on the ends, edges, or faces of the members, and the cutting of the members to the required shapes for joining.

The instruments normally used for laying out joints are the try, miter, combination square, the sliding T-bevel, the marking or mortising gage, and a scratch awl, sharp pencil, or knife for scoring lines. For cutting the more complex joints by hand, the backsaw, dovetail saw, and various chisels are essential. The rabbet-and-fillister plane (for rabbet joints) and

the router plane (for smoothing the bottoms of dados and gains) are also helpful.

Simple joints like the **BUTT** (figs. 4-14 and 4-15), the **LAP** joints (fig. 4-16), and the **MITER** joints (fig. 4-17) are used mostly in rough or finish carpentry, though they may be used occasionally in millwork and furniture making. More complex joints like the **RABBET** joints (fig. 4-18), the **DADO** and **GAIN** joints (fig. 4-19), the **MORTISE-AND-TENON**- and **SLIP TENON** joints (fig. 4-20), the **BOX CORNER** joint (fig. 4-21) and the **DOVETAIL** joints (fig. 4-22) are used mostly in making furniture or

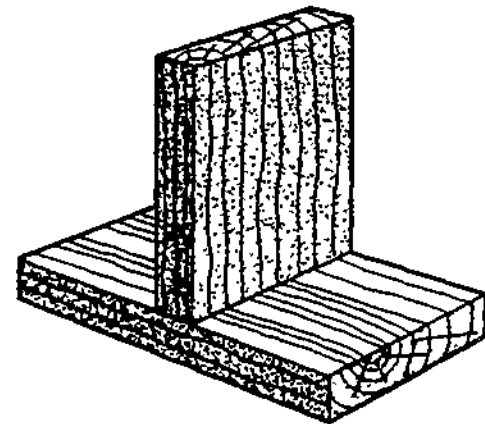
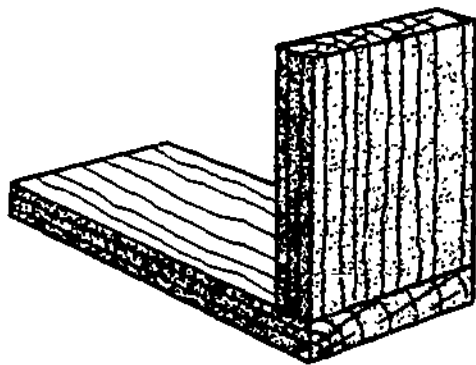

44.108
Figure 4-14.—90-degree plain butt joints.



68.38.1
Figure 4-15.—End butt joint with fish plates.

cabinets, and millwork. Of the **EDGE** joints shown in figure 4-23, the **DOWEL** and **SPLINE** are used mainly in furniture and cabinet work, while the **PLAIN BUTT** and the **TONGUE-AND-GROOVE** are used in practically all types of woodworking.

The joints used in rough and finish carpentry are for the most part simply nailed together. Nails in a 90-degree plain butt joint may be

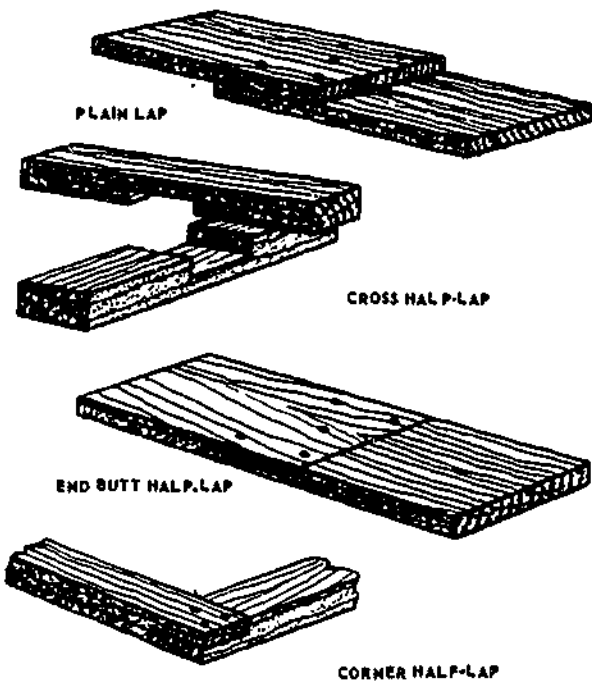

68.38.2
Figure 4-16.—Lap joints.

driven through the member abutted against and into the end of the abutting member, or they may be **TOENAILED** at an angle through the faces of the abutting member into the face of the member abutted against, as shown in figure 4-24. Studs and joists are usually toenailed to sole plates and sills.

The more complex furniture and cabinet-making joints are usually fastened with glue, with additional strength provided as necessary by dowels, splines, corrugated fasteners, slip feathers, keys, and other types of joint-fasteners. In the **dado joint**, the **gain joint**, and **mortise-and-tenon joint**, the **box corner joint**, and the **dovetail joint**, the interlocking character of the joint is an additional factor in fastening.

With the possible exception of the dovetail joint, all the joints which have been mentioned can be cut either by hand or by machine. Whatever the method used, and whatever the type of joint, always remember the following rule: **TO INSURE A TIGHT JOINT, ALWAYS CUT ON THE WASTE SIDE OF THE LINE,**

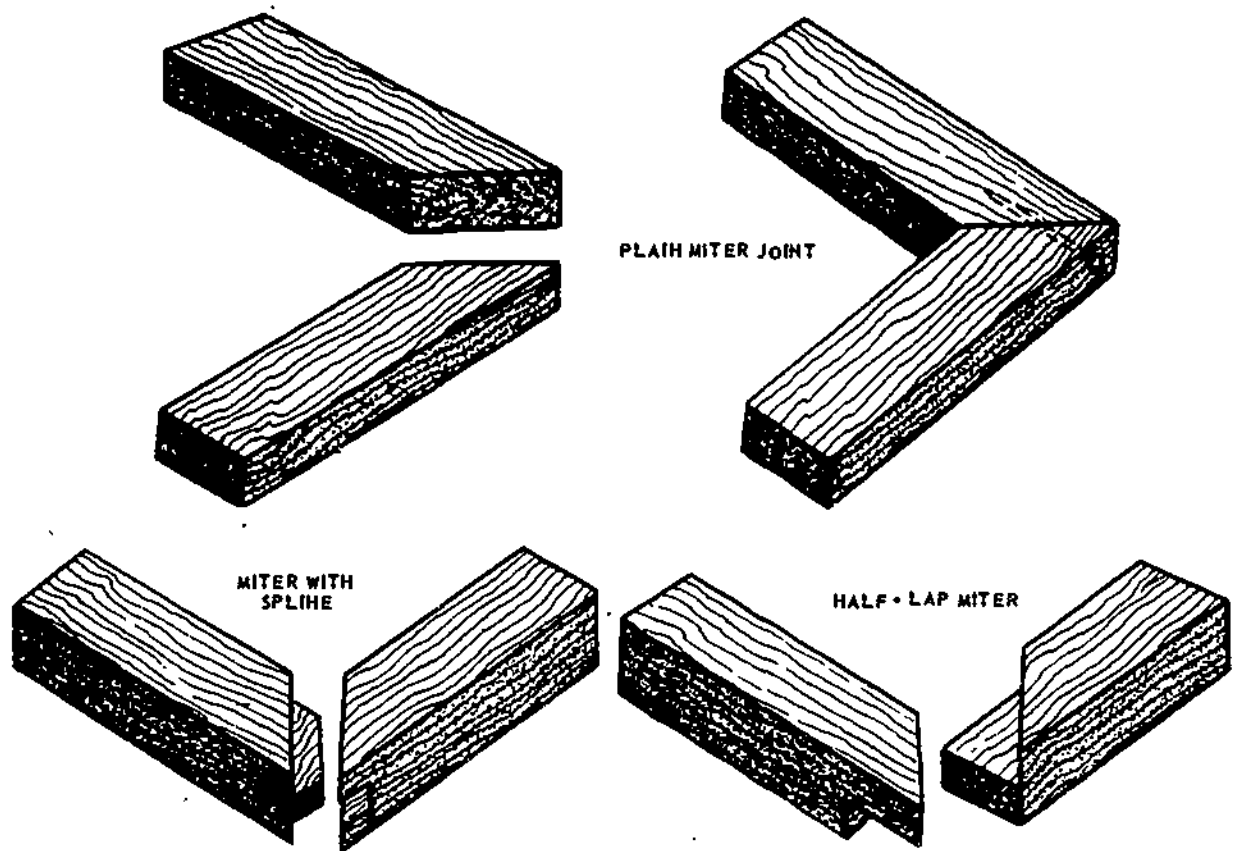

Figure 4-17.—Miter joints.

68.38.3

NEVER ON THE LINE ITSELF. Preliminary grooving on the waste side of the line with a knife or chisel will help a backsaw start smoothly.

Half-Lap Joints

For half-lap joints, the members to be jointed are usually of the same thickness, as shown in figure 4-16. The method of laying out and cutting an end butt half-lap (fig. 4-16), is to measure off the desired amount of lap from each end of each member and square a line all the way around at this point. For a corner half lap (fig. 4-16), measure off the width of the member from the end of each member and square a line all the way round. These lines are called **SHOULDER** lines.

Next, select the best surface for the **FACE**, and set a marking gage to one-half the thickness and score a line (called the **CHEEK LINE**) on the edges and end of each member, from the shoulder line on one edge to the shoulder line on the other edge. **BE SURE AND GAGE THE CHEEK LINE FROM THE FACE OF EACH MEMBER.** This insures that the faces of each member will be flush after the joints are cut.

Next, make the shoulder cuts by cutting along the waste side of the shoulder lines down to the waste side of the cheek line. Then make the cheek cuts along the waste side of the cheek lines. When all cuts have been made, the members should fit together with faces, ends, and edges flush, or near enough to be made flush with the slight paring of a wood chisel.

Other half lap joints are laid out in a similar manner. The main difference is in the method of

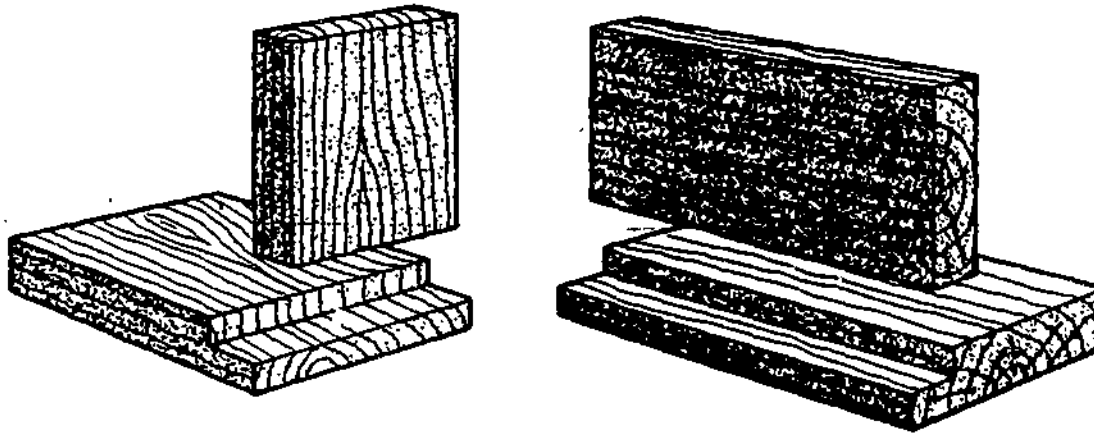

Figure 4-18.—Rabbet joints.

103.10

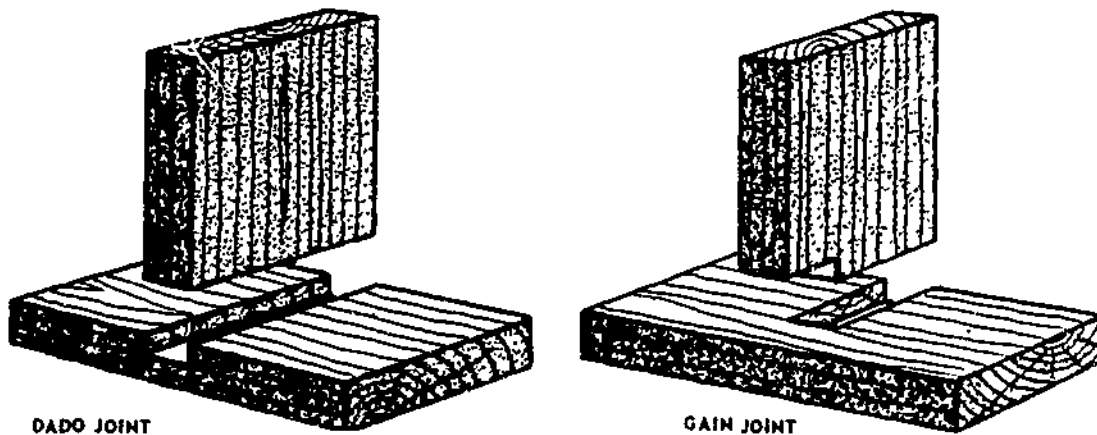

Figure 4-19.—Dado and gain joints.

103.9

cutting. A cross half lap joint may best be cut with a DADO head or wood chisel rather than a hand saw. Others may easily be cut on a bandsaw, being certain to cut on the waste side of the lines, and making all lines from the face of the material.

Miter Joints

A miter joint is made by MITERING (cutting at an angle) the ends or edges of the

members which are to be joined together. (See fig. 4-17.) The angle of the miter cut is one-half of the angle which will be formed by the joined members. In rectangular mirror frames, windows, door casing, boxes, and the like, adjacent members form a 90° angle, and the correct angle for mitering is consequently one-half of 90° , or 45° . For members which will form an equal-sided figure with other than 4 sides (such as an octagon or a pentagon), the correct mitering angle can be found by dividing

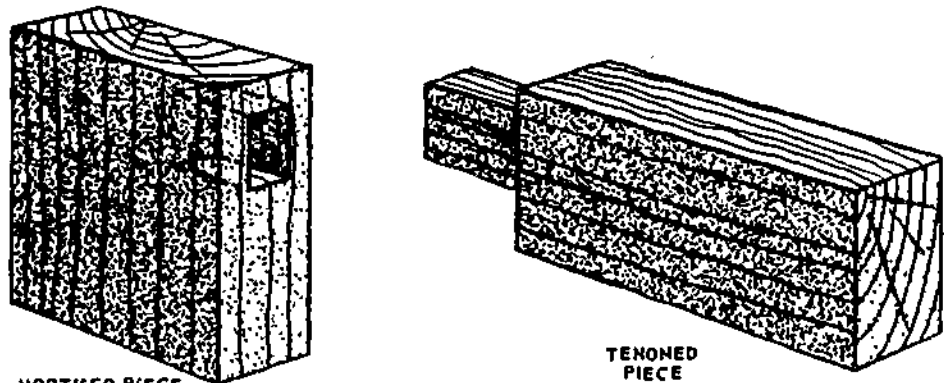

MORTISED PIECE

TENONED PIECE

BLIND MORTISE AND TENON JOINT

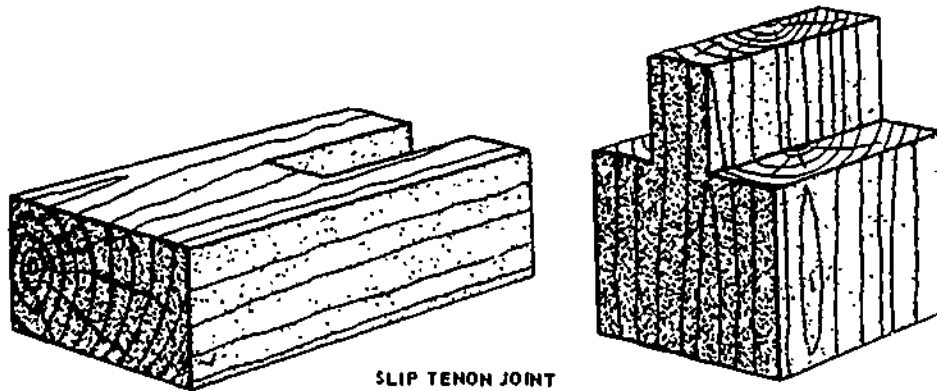

SLIP TENON JOINT

Figure 4-20.—Mortise-and-tenon and slip-tenon joints.

103.13

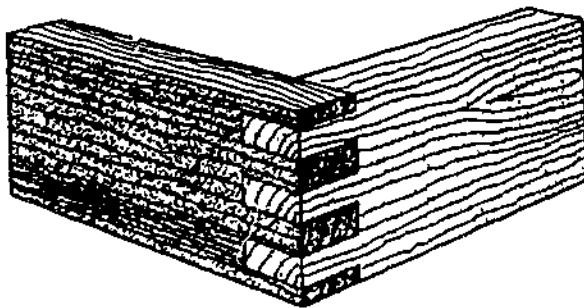

103.12

Figure 4-21.—Box corner joint.

the number of sides the figure will have into 180 and subtracting the result from 90. For an octagon (8-sided figure), the mitering angle is 90 minus $\frac{180}{8}$, or 67.5°. For a pentagon (5-sided figure), the angle is 90 minus $\frac{180}{5}$, or 54°.

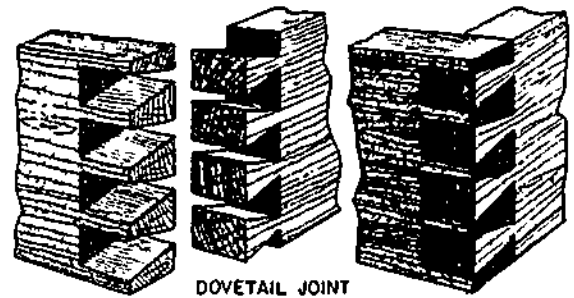

DOVETAIL JOINT

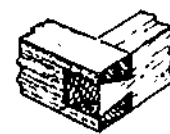

THROUGH SINGLE DOVE TAIL

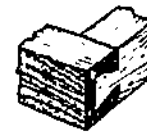

BLIND SINGLE DOVE TAIL

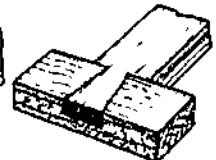

THROUGH HALF-LAP SINGLE DOVE TAIL

103.11

Figure 4-22.—Dovetail joints.

4-22

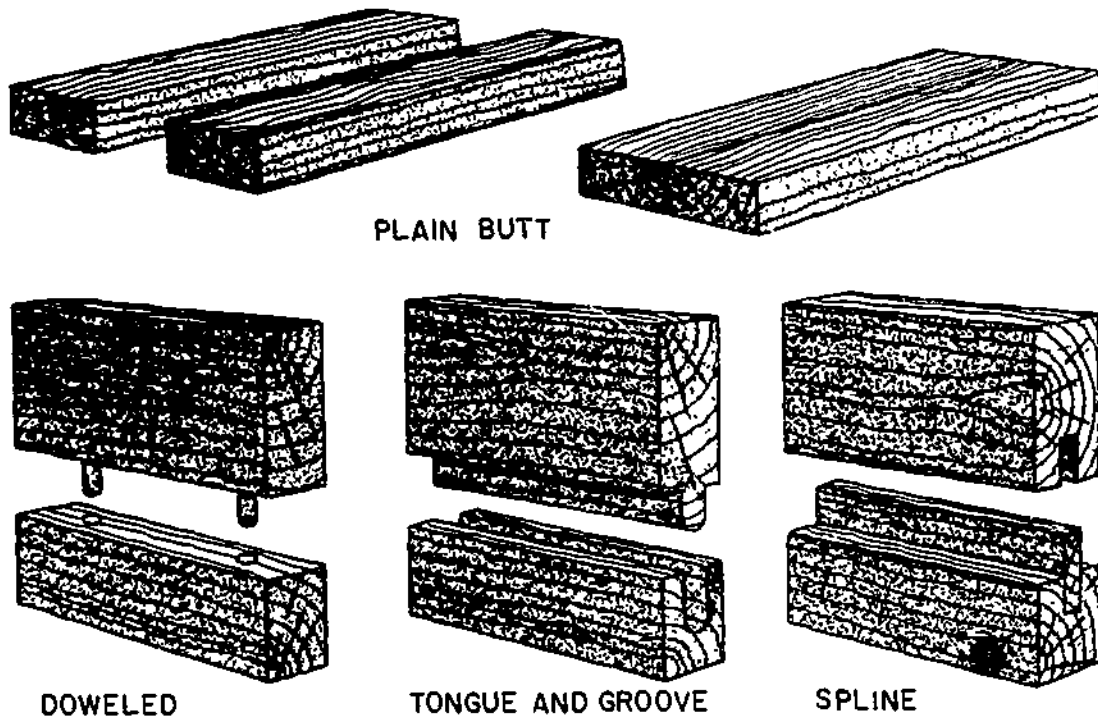

PLAIN BUTT

DOWELED

TONGUE AND GROOVE

SPLINE

68.37

Figure 4-23.—Edge joints.

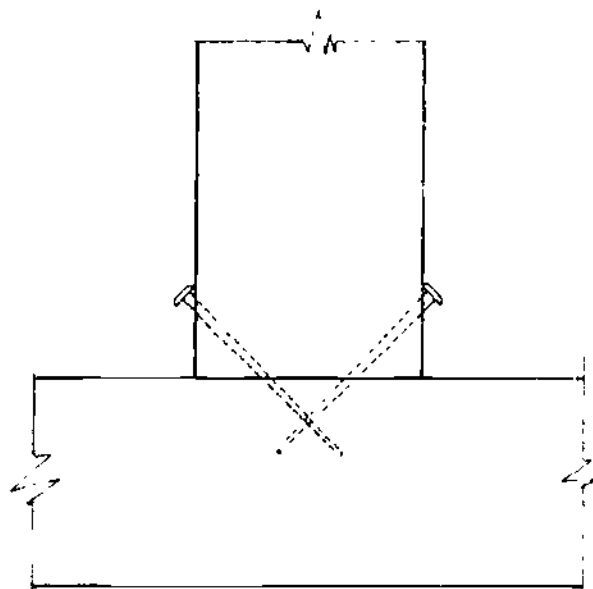

Figure 4-24.—Toenailing.

133.82

Members can be end-mitered to 45° in the wooden miter box and to any angle in the steel miter box by setting the saw to the desired angle or on the circular saw by setting the meter gage to the desired angle. Members can be edge-mitered to any angle on the circular saw by tilting the saw to the required angle.

Sawed edges are sometimes unsuitable for gluing; however, if the joint is to be glued, the edges may be mitered on a jointer as illustrated in figure 4-25.

Since abutting surfaces of end-mitered members do not hold well when they are merely glued, they should be reinforced. One type of reinforcement is the CORRUGATED FASTENER. This is a corrugated strip of metal with one edge sharpened for driving into the joint. The fastener is placed at a right angle to the line between the members, half on one member and half on the other, and driven down

4-23

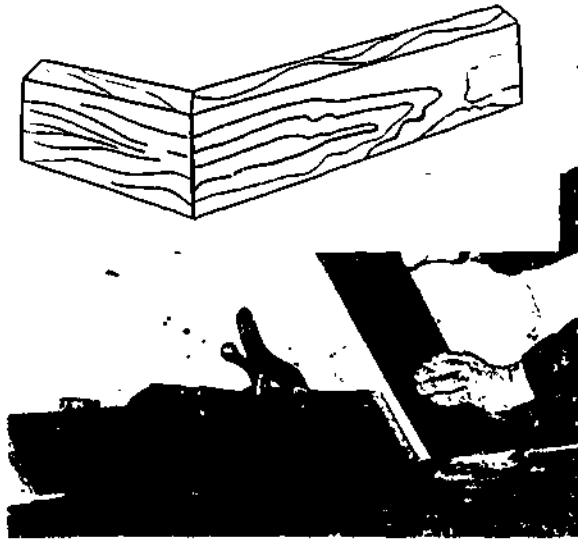

133.83
 Figure 4-25.—Beveling on a jointer for a mitered edge joint.

flush with the member. The corrugated fastener mars the appearance of the surface into which it is driven, and therefore, it is used only on the backs of picture frames and the like.

A more satisfactory type of fastener for a joint between end-mitered members is the SLIP FEATHER. This is a thin piece of wood or veneer which is glued into a kerf cut in the thickest dimension of the joint. First, saw about halfway through the wood from the outer to the inner corner, then apply glue to both sides of the slip feather, pushing the slip feather into the kerf. Clamp it tight and allow the glue to dry. After it has dried, remove the clamp and chisel off the protruding portion of the slip feather.

A joint between edge-mitered members may also be reinforced with a SPLINE. This is a thin piece of wood which extends across the joint into grooves cut in the abutting surfaces. A spline for a plain miter joint is shown in figure 4-17. The groove for a spline can either be cut by hand or by a circular saw.

Grooved Joints

A GROOVE is a three-sided recess running with the grain, and a recess running across the

grain is called a DADO. A groove or dado which does not extend all the way across the wood is called a STOPPED groove or a STOPPED dado. A stopped dado is also known as a GAIN. (See fig. 4-19.) A two-sided recess running along an edge is called a RABBET. (See fig. 4-18.) Dados, gains, and rabbets are not, strictly speaking, grooves, but joints which include them are generally called GROOVED joints.

A groove or dado can be cut on the circular saw as follows: lay out the groove or dado on the end wood (for a groove) or edge wood (for a dado) which will first come in contact with the saw. Set the saw to the desired depth of the groove above the table, and set the fence at a distance from the saw which will cause the first cut to run on the waste side of the line that indicates the left side of the groove. Start the saw and bring the wood into light contact with it; then stop the saw and examine the layout to insure that the cut will be on the waste side of the line. Readjust the fence, if necessary. When the position of the fence is right, make the cut. Then reverse the wood and proceed to set and test as before for the cut on the opposite side of the groove. Then make as many recuts as necessary to remove the waste stock between the side kerfs.

The procedure for grooving or dadoing with the dado head is about the same, except that in many cases the dado head can be built up to take out all the waste in a single cut. The two outside cutters alone will cut a groove 1/4 in. wide. Inside cutters vary in thickness from 1/16- to 1/4 in.

A stopped groove or stopped dado can be cut on the circular saw, using either a saw blade or a dado head, as follows. If the groove or dado is stopped at only one end, clamp a STOP BLOCK to the rear of the table in a position that will stop the wood from being fed any further when the saw has reached the place where the groove or dado is supposed to stop. If the groove or dado is stopped at both ends, clamp a STOP BLOCK to the rear of the table and a STARTING BLOCK to the front. The starting block should be placed so the saw will contact the place where the groove is supposed

to start when the infeed end of the piece is against the block. Start the cut by holding the wood above the saw, with the infeed end against the starting block and the edge against the fence. Then lower the wood gradually onto the saw, and feed it through to the stop block.

A rabbet can be cut on the circular saw as follows: the cut into the face of the wood is called the **SHOULDER** cut and the cut into the edge or end, the **CHEEK** cut. To make the shoulder cut (which should be made first), set the saw to extend above the table a distance equal to the desired depth of the shoulder, and set the fence a distance away from the saw equal to the desired depth of the cheek. Be sure to measure this distance from a saw tooth **SET TO THE LEFT** or **AWAY FROM** the ripping fence. If you measure it from a tooth set to the right or toward the fence, the cheek will be too deep by an amount equal to the width of the saw kerf.

By using the dado head, you can cut most ordinary rabbets in a single cut. First, build up a dado head equal in thickness to the desired width of the cheek. Next, set the head to protrude above the table a distance equal to the desired depth of the shoulder. Clamp a 1-in. board to the fence to serve as a guide for the piece, and set the fence so the edge of the board barely contacts the right side of the dado head. Set the piece against the miter gage (set at 90°), hold the edge or end to be rabbeted against the 1-in. board, and make the cut.

On some jointers, a **RABBETING** ledge attached to the outer edge of the infeed table can be depressed for rabbeting as in figure 4-26. The ledge is located on the outer end of the cutterhead. To rabbet on a jointer of this type, you depress the infeed table and the rabbeting ledge the depth of the rabbet below the outfeed table, and set the fence the width of the rabbet away from the outer end of the cutterhead. When the piece is fed through, the unrabbeted part feeds onto the rabbeting ledge. The rabbeted portion feeds onto the outfeed table.

Various combinations of the grooved joints are used in woodworking. The **TONGUE AND GROOVE** joint is a combination of the groove

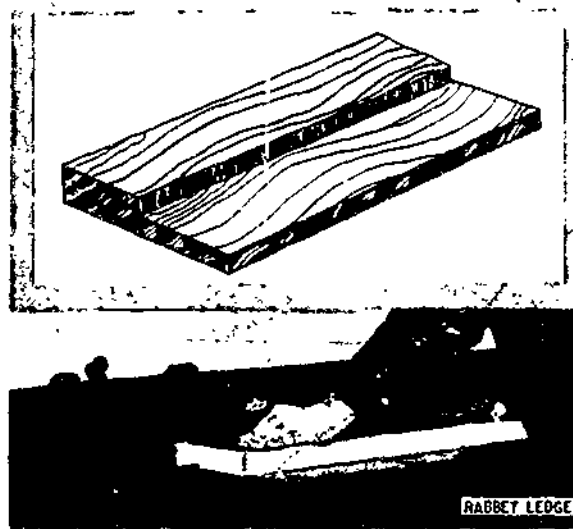

133.84

Figure 4-26.—Rabbeting on a jointer with a rabbeting ledge.

and the rabbet, with the tongued member rabbeted on both faces. In some types of paneling, the tongue is made by rabbeting only one face. A tongue of this kind is called a **BAREFACED** tongue. A joint often used in making boxes, drawers, cabinets, and the like is the **DADO AND RABBET** joint shown in figure 4-27. As you can see, one of the members is

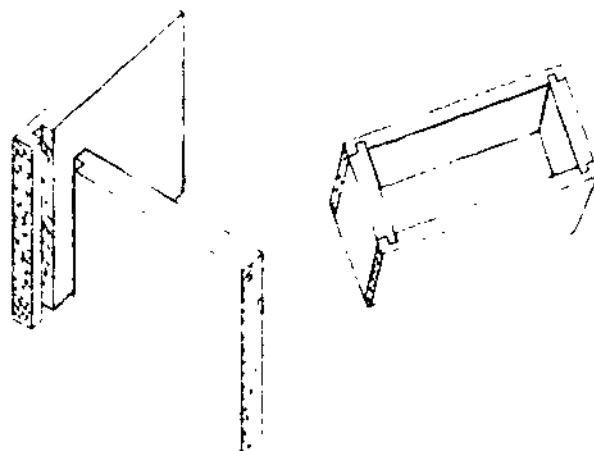

103.15

Figure 4-27—Dado and rabbet joint

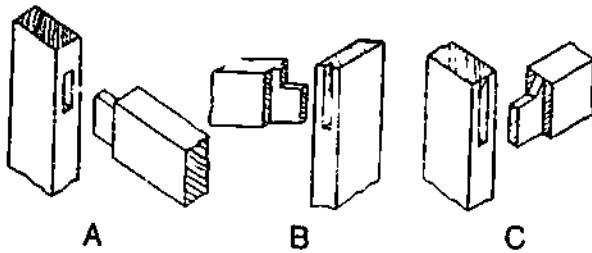

103.20
Figure 4-28.—Stub, haunched, and table-haunched mortise-and-tenon joints.

rabbeted on one face to form a barefaced tongue.

Mortise-and-Tenon Joints

The MORTISE-AND-TENON joint is most frequently used in furniture and cabinet work. In the BLIND mortise-and-tenon joint, the tenon does not penetrate all the way through the mortised member. (See fig. 4-20.)

A joint in which the tenon does penetrate all the way through is a THROUGH mortise-and-tenon joint. Besides the ordinary STUB joint (view A, figure 4-28), there are HAUNCHED joints (view B, of figure 4-28) and TABLE-HAUNCHED joints (view C, of figure 4-28). Haunching and table-haunching increase the strength and rigidity of the joint.

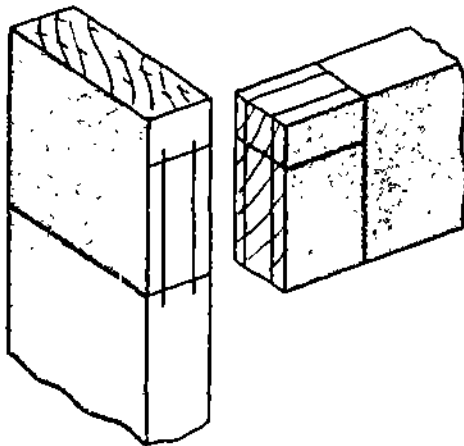

103.21
Figure 4-29.—Layout of stub mortise-and-tenon joint.

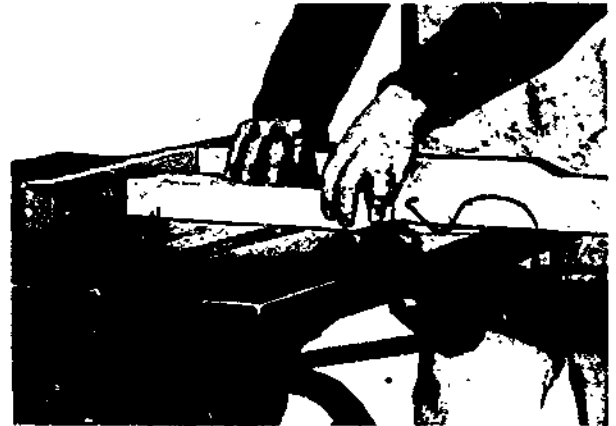

103.22
Figure 4-30.—Making tenon shoulder cut on a circular saw.

The layout procedure for an ordinary stub mortise-and-tenon joint is shown in figure 4-29. The shoulder and cheek cuts of the tenon are shown in figures 4-30 and 4-31. To maintain the stock upright while making the cheek cuts, use a PUSH BOARD similar to the one shown in figure 4-31. Tenons can also be cut with a dado

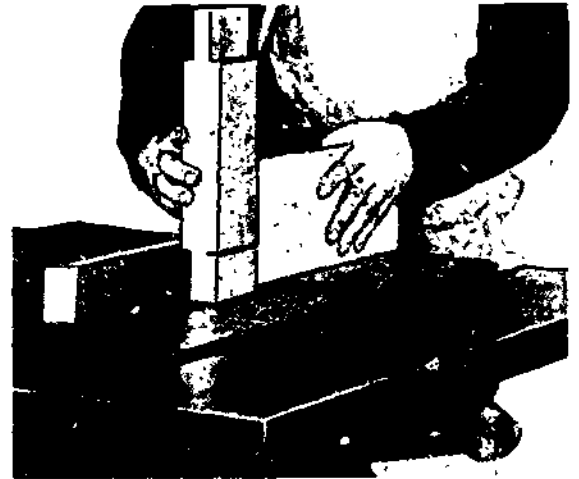

103.23
Figure 4-31.—Making tenon cheek cut on a circular saw using a push board.

head by the same method previously described for cutting end half lap joints.

Mortises are cut mechanically on a **HOLLOW-CHISEL MORTISING MACHINE** like the one shown in figure 4-32. The cutting mechanism on this machine consists of a boring bit encased in a square, hollow, steel chisel. As the mechanism is pressed into the wood, the bit takes out most of the waste while the chisel pares the sides of the mortise square. Chisels come in various sizes, with corresponding sizes of bits to match. If a mortising machine is not available, the same results can be attained by using a simple drill press to take out most of the waste, and a hand chisel for paring the sides square.

In some mortise-and-tenon joints, such as those between rails and legs in tables, the tenon

member is much thinner than the mortise member. Sometimes a member of this kind is too thin to shape in the customary manner, with shoulder cuts on both faces. When this is the case, a **BAREFACED** mortise-and-tenon joint may be used. In a barefaced joint, the tenon member is shoulder cut on one side only. The cheek on the opposite side is simply a continuation of the face of the member.

Mortise-and-tenon joints are fastened with glue and with additional fasteners as required

Dovetail Joint.

The **DOVETAIL** joint (see fig. 4-22) is the strongest of all the woodworking joints. It is used principally for joining the sides and ends of drawers in fine grades of furniture and cabinets. In the **SEABEE** units, you will seldom use dovetail joints since they are laborious and time-consuming.

A **THROUGH** dovetail joint is a joint in which the pins pass all the way through the tail member. Where the pins pass only part way through, the member is known as a **BLIND** dovetail joint.

The simplest of the dovetail joints is the **DOVETAIL HALF LAP** joint shown in figure 4-33. Figure 4-34 shows how this type joint is

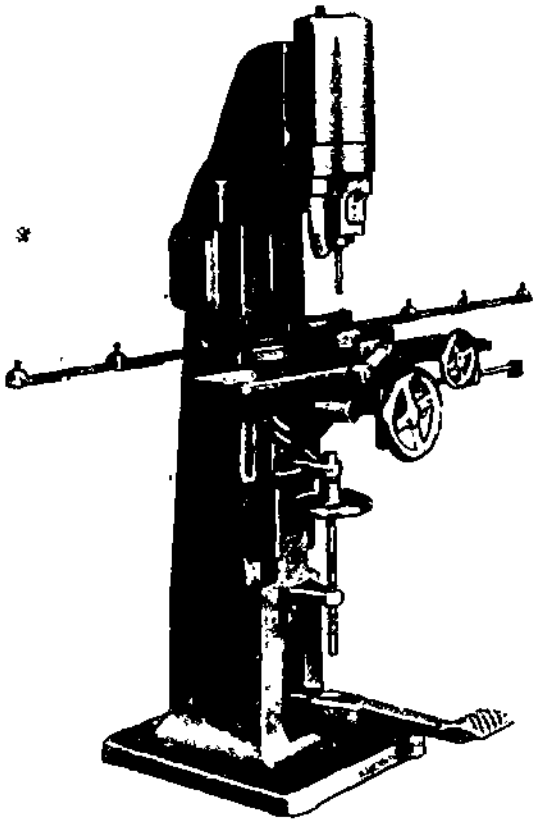

103.24

Figure 4-32.—Hollow-chisel mortising machine.

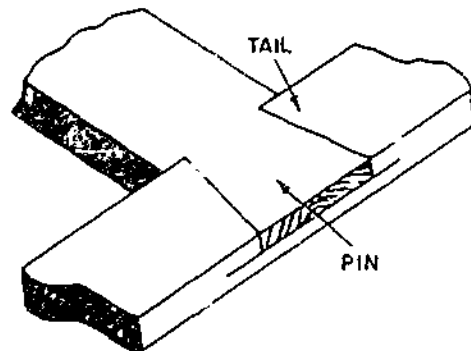

133.86

Figure 4-33.—Dovetail half-lap joint.

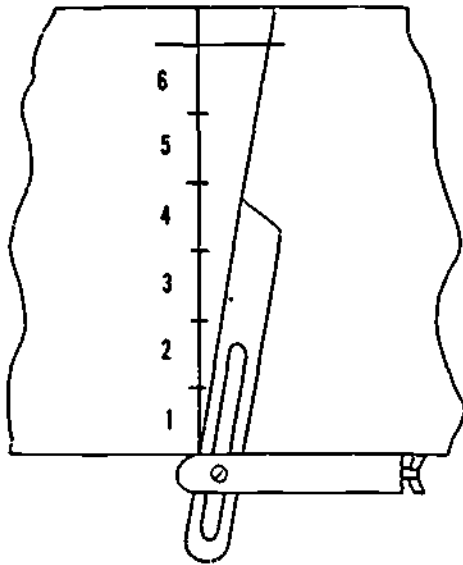

103.16

Figure 4-34.—Laying off 10° angle for dovetail joint.

laid out, and figure 4-35 shows the completed joint.

A **MULTIPLE** dovetail joint is shown in figure 4-36, while figure 4-37 indicates how the waste is chiseled from the multiple joint.

Box Corner Joints

With the exception of the obvious difference in the layout, the **BOX CORNER JOINT** (fig.

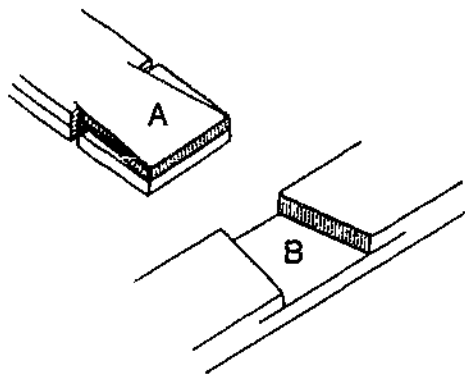

103.17

Figure 4-35.—Making a dovetail half-lap joint.

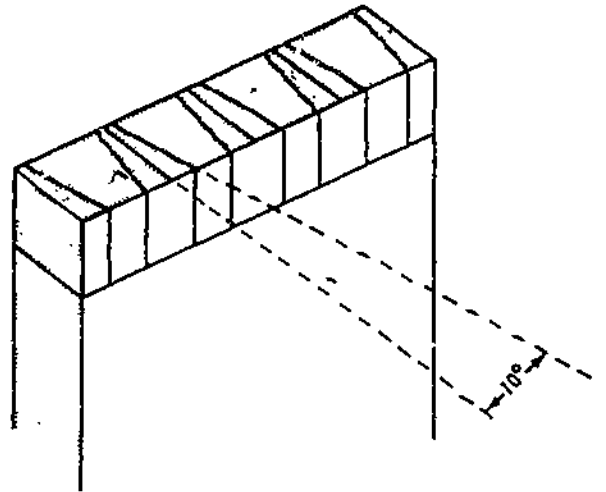

103.18

Figure 4-36.—Laying out a pin member for a through-multiple-dovetail joint.

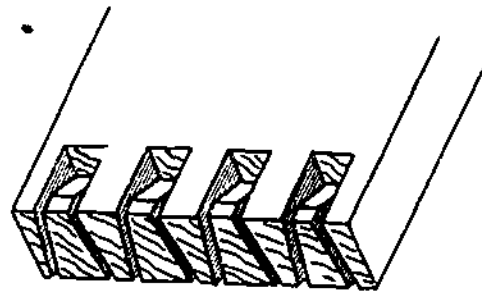

103.19

Figure 4-37.—Chiseling out waste in a through-multiple-dovetail joint.

4-21) is made in a similar manner as the through-multiple-dovetail joint.

Coping Joints

Inside corner joints between molding trim members are usually made by butting the end of one member against the face of the other. Figure 4-38 shows the method of shaping the end of the abutting member to fit the face of the other member. First, saw off the end of the abutting member square, as you would for an ordinary

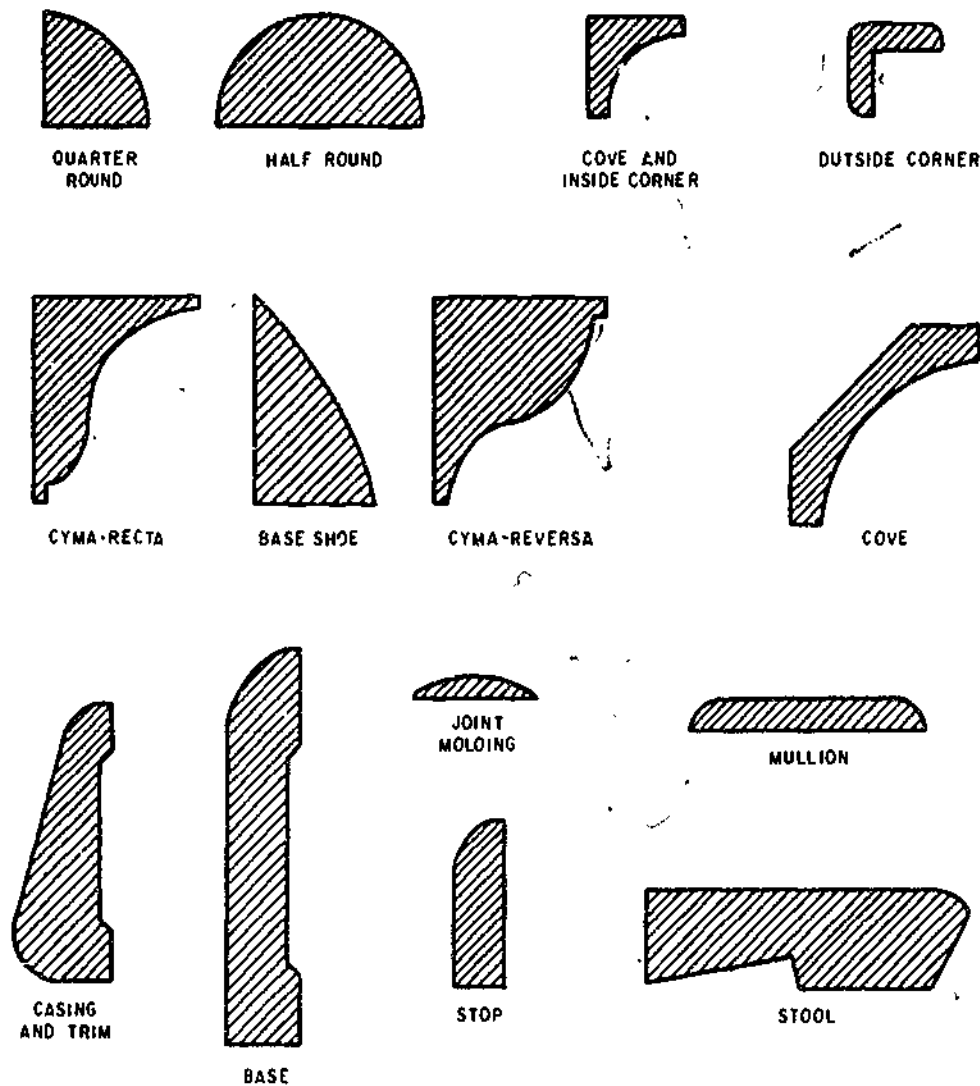

Figure 4-38.—Simple molding and trim shapes.

133.42b

butt joint between ordinary flat-faced members. Then, miter the end to 45° as shown in the first and second views of figure 4-38. Set the coping saw at the top of the line of the miter cut, hold the saw at 90° to the lengthwise axis of the piece, and saw off the segment shown in the third view, following closely the face line left by the 45° miter cut. The end of the abutting member will then match the face of the other member as shown in the third view. A joint made in this manner is called a COPING JOINT.

CONTOUR CUTTING

The term CONTOUR CUTTING refers to the cutting of ornamental face curves on wood stock which is used for molding and other trim. Some moldings and trims are procured in preformed shapes; however, most contour cutting is done on a shaper equipped with a cutter or blades, or with a combination of cutters and/or blades, arranged to produce the

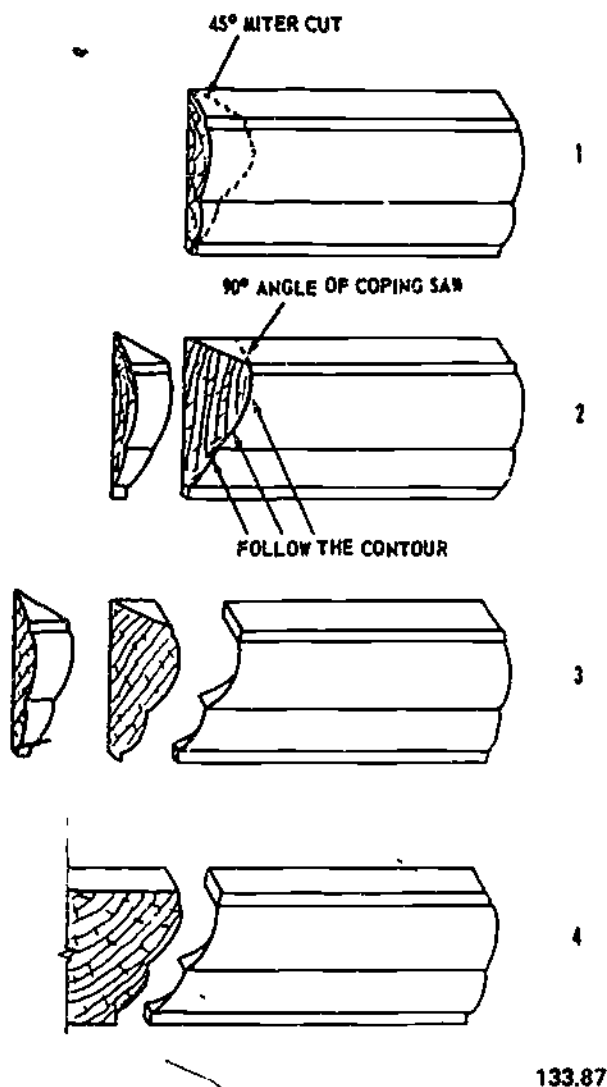

Figure 4-39.—Making a coping joint.

133.87

desired contour. Figure 4-39 shows the simplest and most common moldings and trims used in woodworking.

MILLWORK

As a general term, MILLWORK usually embraces most wood products and components which require manufacturing. It not only includes the interior trim and doors, but also kitchen cabinets, and similar units. Most of these

units are produced in a millwork manufacturing plant and are ready to install. They usually require only fastening to the wall or floor. Figures 4-40 and 4-41 show typical types of millwork. If the need arises for you to install this type of unit, you should refer to the manufacturer's instructions.

The construction details for various kinds of furniture and cabinets are similar. Dressers, chest of drawers, kneeholes, and built-in-cabinets all have drawers for storage purposes and are constructed in a similar way.

A number of pieces of stock glued edge to edge should provide sufficient width for the CABINET SIDE. The sides usually range in width from 16 to 20 in. and finished 3/4 in. thick. Some constructions require the use of a square post in each corner of the case. If the

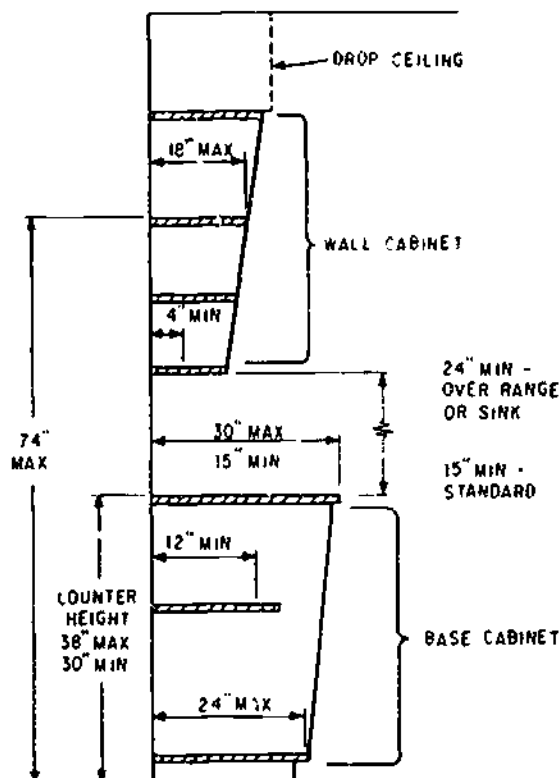

133.427

Figure 4-40.—Typical kitchen cabinet dimensions.

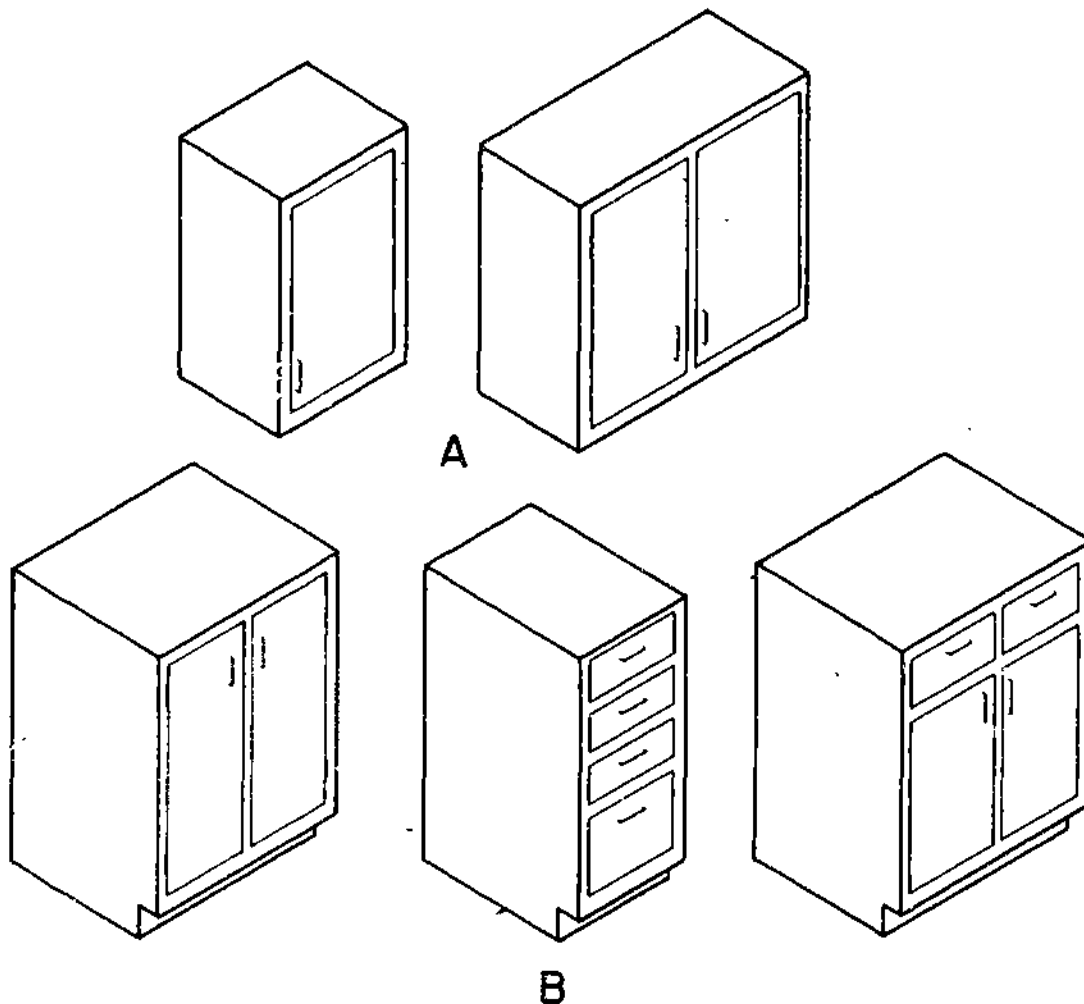

Figure 4-41.—Typical kitchen cabinets: A. Wall, B. Base.

133.428

square posts are used, they are usually connected with the rails.

Division rails and bearing rails are used to make up the **DRAWER DIVISION FRAMES**. These frames are usually made of stock $\frac{3}{4}$ in. thick and 2 in. wide and fastened together at the corners with blind mortise and tenon joints. The frames are glued and checked to insure they are square and the same size. Usually a gain is cut on the front edge of the frames, as shown in figure 4-42 and fitted and glued into the dados on the inside faces of the sides. The frames should be

made $\frac{1}{4}$ in. narrower than the sides when $\frac{1}{4}$ -in. plywood is used. This measurement will allow the plywood back to be glued and fastened into place. To keep dust and insects out of the case, a plywood panel can be installed in the lower frame.

The **DRAWERS** should have special attention so they will fit accurately. Drawers have been known to expand or shrink in the front, sides, and back, therefore, some allowance must be made accordingly. It will be helpful to you if you would remember **WOOD SHRINKS**

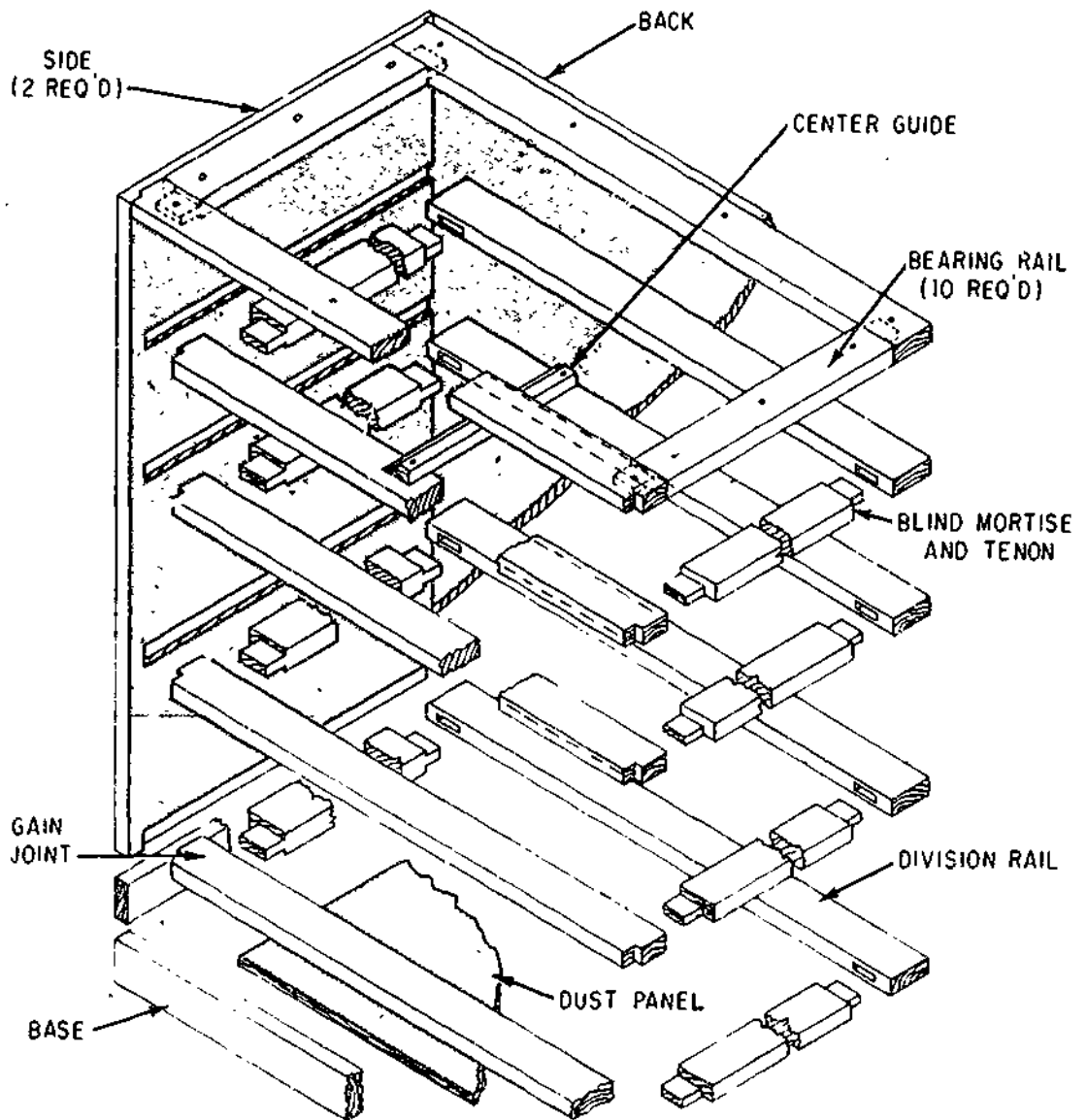

133.347

Figure 4-42.—Cabinet details.

OR EXPANDS MOSTLY ACROSS THE GRAIN AND VERY LITTLE LENGTHWISE OR WITH THE GRAIN. The height of the drawer opening should be $1/8$ to $3/16$ in. wider than the drawer sides and back. The edges and ends should be slightly beveled toward the back face and the drawer front fitted to the opening. (The lip type drawer may be fitted more loosely because the

lip extension will cover the opening at the ends and top.)

There are several types of joints that can be used to join the drawer sides to the front and they are: plain rabbet joint, half blind dovetail, and the dado tongue and rabbet.

The bottom of the drawer is usually grooved into all four sides of the drawer and a plain

grooved or dovetail center guide fastened to the bottom. After the drawer has been fitted into place and the front lined up with the front face of the case, the center guide is fastened permanently to the drawer rails, with screws. You may find it to be more convenient if you leave the back off the case until the drawer guides have been fastened to the drawer rails.

To minimize expansion and shrinkage of the wood, a sealer coat of finish should be applied, to the inside and outside surfaces of the case and its drawers.

METHODS OF FASTENING

The following sections will discuss the various devices used for fastening wood during construction.

The fastening devices most commonly used are usually made of metal; and they are classified accordingly such as: nails, screws, bolts, driftpins, corrugated fasteners, and timber connectors. Each type mentioned above will be explained in the following sections except timber connectors. Timber connectors will be discussed in a later chapter.

NAILS

The standard nail used by the Builder is the wire nail, so called because it is made from steel wire. There are many types of nails, all of which are classified according to use and form. The wire nail is round-shafted, straight, pointed, and may vary in size, weight, size and shape of head, type of point, and finish. All normal requirements of construction and framing are filled by one of the nail types below. There are a few general rules to be followed in the use of nails in building. A nail, whatever the type, should be at least three times as long as the thickness of wood it is intended to hold. Two-thirds of the length of the nail is driven into the second piece for proper anchorage while

one-third provides the necessary anchorage of the piece being fastened. Nails should be driven at an angle slightly toward each other and should be carefully placed to provide the greatest holding power. Nails driven with the grain do not hold as well as nails driven across the grain. A few nails of proper type and size, properly placed and properly driven, will hold better than a great many driven close together. Nails can generally be considered the cheapest and easiest fasteners to be applied. In terms of holding power alone, nails provide the least, screw of comparable size provide more, and bolts provide the greatest amount.

COMMON WIRE NAILS and box nails are the same except that the wire sizes are one or two numbers smaller for a given length of the box nail than they are for the common nail. The common wire nail (A, fig. 4-43) is used for housing-construction framing. The common wire nail and the box nail are generally used for structural construction.

The **FINISHING NAIL** (B, fig. 4-43) is made from finer wire and has a smaller head than the common nail. It may be set below the surface of the wood into which it is driven and will leave only a small hole easily puttied up. It is generally used for interior or exterior finishing work and is used for finished carpentry and cabinetmaking.

The **DUPLEX NAIL** (C, fig. 4-43) is made with what may appear to be two heads. The lower head, or shoulder, is provided so that the nail may be driven securely home to give maximum holding power while the upper head projects above the surface of the wood to make its withdrawal simple. The reason for this design is that the duplex nail is not meant to be permanent. It is used in the construction of temporary structures such as scaffolding and staging and is classified for temporary construction.

ROOFING NAILS (D, fig. 4-43) are round-shafted, diamond-pointed, galvanized nails of

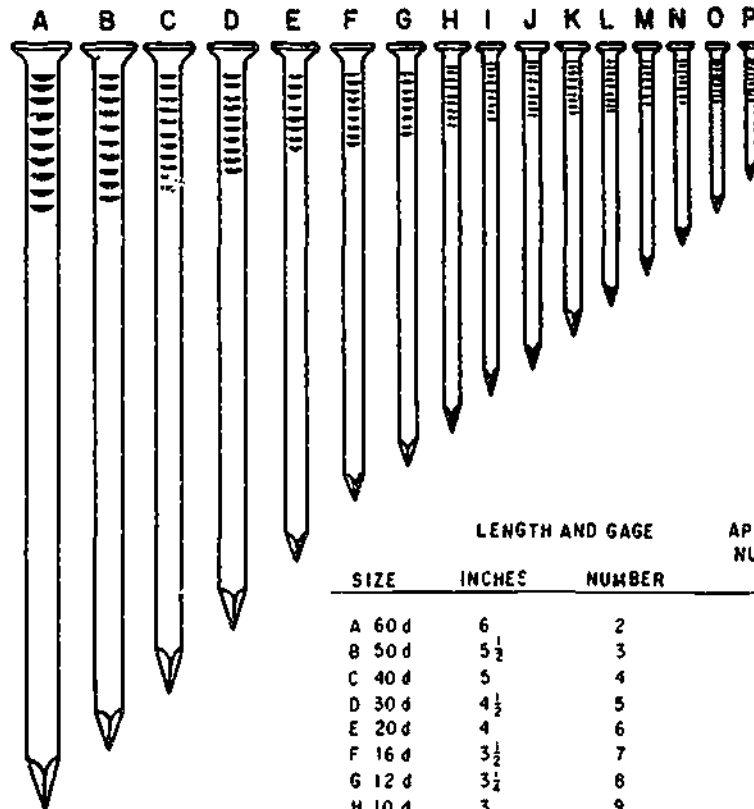
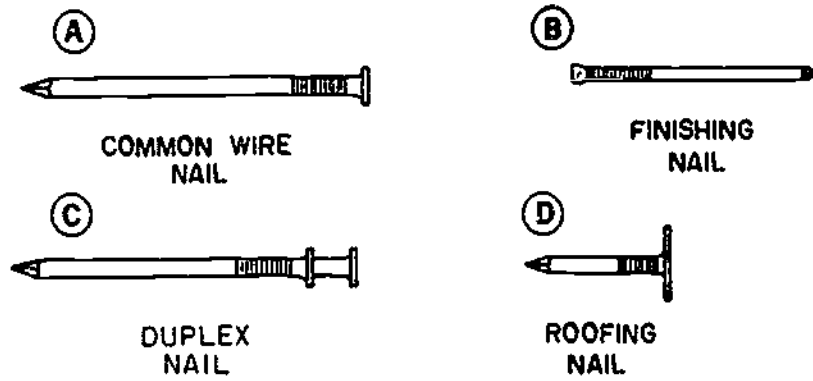

COMMON WIRE NAILS

SIZE	LENGTH AND GAGE		APPROXIMATE NUMBER TO POUND
	INCHES	NUMBER	
A 60d	6	2	11
B 50d	5½	3	14
C 40d	5	4	18
D 30d	4½	5	24
E 20d	4	6	31
F 16d	3½	7	49
G 12d	3¼	8	63
H 10d	3	9	69
I 9d	2¾	10¼	96
J 8d	2½	10¼	106
K 7d	2¼	11½	161
L 6d	2	11½	161
M 5d	1¾	12½	271
N 4d	1½	12½	316
O 3d	1¼	14	568
P 2d	1	15	876

Figure 4-43.—Types of nails and nail sizes.

relatively short length and comparatively large heads. They are designed for fastening flexible roofing materials and for resisting continuous exposure to weather. Several general rules apply to the use of roofing nails, especially their use with asphalt shingles. If shingles or roll roofing is being applied over old roofing, the roofing nails selected must be of sufficient length to go through the old material and secure the new. Asphalt roofing material is fastened with corrosion resistant nails, never with plain nails. Nailing is begun in the center of the shingle, just above the cutouts or slots, to avoid buckling.

Nail sizes are designated by the use of the term penny. This term designates the length of the nail (1 penny, 2 penny, etc.), which is the same for all types. The approximate number of nails per pound, varies according to the type and

size. The wire gage number varies according to type. Figure 4-43 provides the information implicit in the term penny for each of the type of nails referenced to in this section. The d adjacent to the numbers in the Size column is the accepted abbreviation of the word penny as used in nail sizing and should be read 2 penny, 3 penny, etc. Table 4-3 gives the general size and type of nail preferable for specific applications.

SCREWS

The use of screws, rather than nails, as fasteners may be dictated by a number of factors. These may include the type of material to be fastened, the requirement for greater holding power than could be obtained by the use of nails, the finished appearance desired, and

Table 4-3.—Size, Type, and Use of Nails

SIZE	LGTH (IN.)	DIAM (IN.)	REMARKS	WHERE USED
2d	1	.72	SMALL HEAD	FINISH WORK, SHOP WORK
2d	1	.72	LARGE FLATHEAD	SMALL TIMBER, WOOD SHINGLES, LATH
3d	1 1/2	.78	SMALL HEAD	FINISH WORK, SHOP WORK
3d	1 1/2	.78	LARGE FLATHEAD	SMALL TIMBER, WOOD SHINGLE, LATH
4d	2	.84	SMALL HEAD	FINISH WORK, SHOP WORK
4d	2	.84	LARGE FLATHEAD	SMALL TIMBER, LATHES, SHOP WORK
5d	2 1/2	.90	SMALL HEAD	FINISH WORK, SHOP WORK
5d	2 1/2	.90	LARGE FLATHEAD	SMALL TIMBER, LATHES, SHOP WORK
6d	3	.96	SMALL HEAD	FINISH WORK, CASING, TOPS, ETC., SHOP WORK
6d	3	.96	LARGE FLATHEAD	SMALL TIMBER, SIDING, SHEATHING, ETC., SHOP WORK
7d	3 1/2	1.02	SMALL HEAD	CASING, BASE, CEILING, STOPS, ETC.
7d	3 1/2	1.02	LARGE FLATHEAD	SHEATHING, SIDING, SUBFLOORING, LIGHT FRAMING
8d	4	1.08	SMALL HEAD	CASING, BASE, CEILING, WAINSCOT, ETC., SHOP WORK
8d	4	1.08	LARGE FLATHEAD	SHEATHING, SIDING, SUBFLOORING, LIGHT FRAMING, SHOP WORK
8d	4	1.08	EXTRA-LARGE FLATHEAD	ROLL ROOFING, COMPOSITION SHINGLES
9d	4 1/2	1.14	SMALL HEAD	CASING, BASE, CEILING, ETC.
9d	4 1/2	1.14	LARGE FLATHEAD	SHEATHING, SIDING, SUBFLOORING, FRAMING, SHOP WORK
10d	5	1.20	SMALL HEAD	CASING, BASE, CEILING, ETC., SHOP WORK
10d	5	1.20	LARGE FLATHEAD	SHEATHING, SIDING, SUBFLOORING, FRAMING, SHOP WORK
12d	6	1.32	LARGE FLATHEAD	SHEATHING, SUBFLOORING, FRAMING
16d	8	1.62	LARGE FLATHEAD	FRAMING, BRIDGES, ETC.
20d	10	1.92	LARGE FLATHEAD	FRAMING, BRIDGES, ETC.
30d	14	2.52	LARGE FLATHEAD	HEAVY FRAMING, BRIDGES, ETC.
40d	18	3.12	LARGE FLATHEAD	HEAVY FRAMING, BRIDGES, ETC.
50d	24	4.08	LARGE FLATHEAD	EXTRA-HEAVY FRAMING, BRIDGES, ETC.
60d	30	5.04	LARGE FLATHEAD	EXTRA-HEAVY FRAMING, BRIDGES, ETC.

NOTE: THE WIRE GAGE NUMBER IS NOT SHOWN IN THIS TABLE, ALTHOUGH IT MAY BE USED TO DETERMINE THE LENGTH OF A NAIL.

the fact that the number of fasteners that can be used is limited. The use of screws, rather than nails, is more expensive in terms of time and money but is often necessary to meet requirements for superior results. The main advantages of screws are—they provide more holding power; can be easily tightened to draw the items being fastened securely together; are neater in appearance if properly driven; and may be withdrawn without damaging the material. The common wood screw is usually made of unhardened steel, stainless steel, aluminum, or brass. The steel may be bright finished or blued, or zinc, cadmium, or chrome plated. Wood screws are threaded from a gimlet point for approximately 2/3 of the length of the screw and are provided with a slotted head designed to be driven by an inserted driver.

WOOD screws as shown in figure 4-44 are designated according to head style. The most common types are flathead, ovalhead, and roundhead, both in slotted and phillips heads. To prepare wood for receiving the screws, bore a pilot hole the diameter of the screw to be used in the piece of wood that is to be fastened (fig. 4-45). Then bore a smaller, starter hole in the piece of wood that is to act as anchor or hold

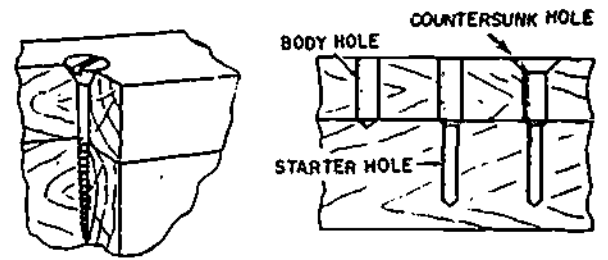

29.123

Figure 4-45.—Sinking screw Properly.

the threads of the screw. The starter hole is drilled with a diameter less than that of the screw threads and to a depth 1/2 or 2/3 the length of the threads to be anchored. The purpose of this careful preparation is to assure accuracy in the placement of the screws, to reduce the possibility of splitting the wood, and to reduce the time and effort required to drive the screw. Properly set slotted and phillips flathead and ovalhead screws are countersunk sufficiently to permit a covering material to be used to cover the head. Slotted roundhead and phillips roundhead screws are not countersunk, but are driven so that the head is firmly flush with the surface of the wood. The slot of the roundhead screw is left parallel with the grain of the wood.

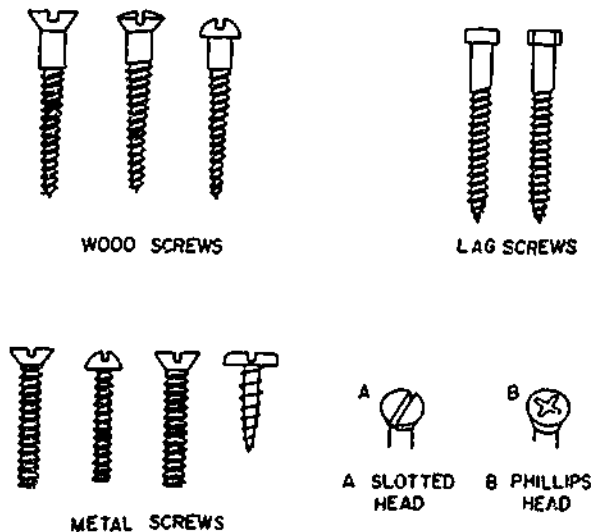

29.123

Figure 4-44.—Types of screws.

The proper name for LAG screws (fig. 4-44) is lag bolt, wood screw type. These screws are often required in construction building. They are longer and much heavier than the common wood screw and have coarser threads which extend from a cone or gimlet point slightly more than half the length of the screw. Squarehead and hexagonhead lag screws are always externally driven, usually by means of a wrench. They are used when ordinary wood screws would be too short or too light and spikes would not be strong enough. For sizes of lag screws, see table 4-4. Combined with expansion anchors, they are used to frame timbers to existing masonry.

Expansion shields, or expansion anchors as they are sometimes called, are used for inserting a predrilled hole, usually in masonry, to provide

Table 4-4.—Lag Screws

LENGTHS (INCHES)	DIAMETERS (INCHES)			
	1/4	3/8, 7/16, 1/2	5/8, 3/4	7/8, 1
1-----	X	X	-----	-----
1 1/2-----	X	X	X	-----
2, 2 1/2, 3, 3 1/2, etc., 7 1/2, 8 to 10	X	X	X	X
11 to 12-----	-----	X	X	X
13 to 16-----	-----	-----	Y	X

133.342

a gripping base or anchor for a screw, bolt, or nail intended to fasten an item to the surface in which the hole was bored. The shield may be obtained separately or may include the screw, bolt, or nail. After the expansion shield is inserted in the predrilled hole, the fastener is driven into the hold in the shield, expanding the shield and wedging it firmly against the surface of the hole.

For the assembly of metal parts, SHEET METAL screws are used. These screws are made regularly in steel and brass with four types of heads: flat, round, oval, and fillister, as shown in that order in figure 4-44.

Wood screws come in sizes which vary from 1/4 in. to 6 inches. Screws up to 1 in. in length increase by eighths, screws from 1 to 3 in. increase by quarters, and screws from 3 to 6 in. increase by half-inches. Screws vary in length and size of shaft. Each length is made in a number of shaft sizes specified by an arbitrary number that represents no particular measurement but indicates relative differences in the diameter of the screws. Proper nomenclature of a screw as illustrated in figure 4-46, includes the type, material, finish, length, and screw size number which indicates the wire gage of the body, drill or bit size for the body hole, and drill or bit size for the starter hole. Tables 4-5 and 4-6 provide size, length, gage, and application drill and auger bit sizes for screws, table 4-4 gives lengths and diameters of lag screws.

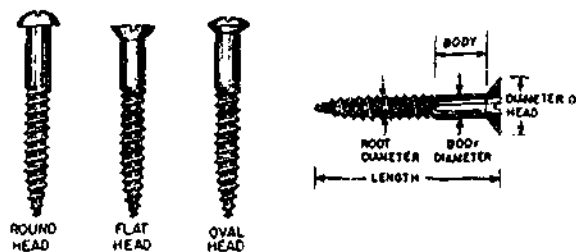

29.123

Figure 4-46.—Types of wood screws and nomenclature.

BOLTS

Bolts are used in construction when great strength is required or when the work under construction must be frequently disassembled. Their use usually implies the use of nuts for fastening and sometimes the use of washers to protect the surface of the material they are used to fasten. Bolts are selected for application to specific requirements in terms of length, diameter, threads, style of head, and type. Proper selection of head style and type of bolt will result in good appearance as well as good construction. The use of washers between the nut and a wood surface or between both the nut and the head and their opposing surfaces will avoid marring the surfaces and permit additional torque in tightening.

BUILDER 3 & 2

Table 4-5 --Screw Sizes and Dimensions

Length (in.)	Size numbers																							
	0	1	2	3	4	5	6	7	8	9	10	11	12	13	14	15	16	17	18	20	22	24		
1/4	x	x	x	x																				
3/8	x	x	x	x	x	x	x	x	x	x														
1/2		x	x	x	x	x	x	x	x	x	x	x												
5/8		x	x	x	x	x	x	x	x	x	x	x	x											
3/4			x	x	x	x	x	x	x	x	x	x	x				x							
7/8			x	x	x	x	x	x	x	x	x	x	x				x							
1				x	x	x	x	x	x	x	x	x	x				x			x				
1 1/4					x	x	x	x	x	x	x	x	x				x			x	x		x	
1 1/2						x	x	x	x	x	x	x	x				x			x	x		x	
1 3/4							x	x	x	x	x	x	x				x			x	x		x	
2								x	x	x	x	x	x				x			x	x		x	
2 1/4									x	x	x	x	x				x			x	x		x	
2 1/2										x	x	x	x				x			x	x		x	
2 3/4											x	x	x				x			x	x		x	
3												x	x				x			x	x		x	
3 1/2													x				x			x	x		x	
4																	x			x	x		x	
4 1/2																	x			x	x		x	
5																	x			x	x		x	
6																	x			x	x		x	
Threads per inch	32	28	26	24	22	20	18	16	15	14	13	12	11			10			9			8	8	7
Diameter of screw (in.)	.060	.073	.086	.099	.112	.125	.138	.151	.164	.177	.190	.203	.216			.242			.268			.294	.320	.372

133.343

Table 4-6.—Drill and Auger Bit Sizes for Wood Screws

Screw size No.		1	2	3	4	5	6	7	8	9	10	12	14	16	18
Nominal screw		.073	.086	.099	.112	.126	.138	.151	.164	.177	.190	.216	.242	.268	.294
Body diameter		$\frac{5}{64}$	$\frac{9}{82}$	$\frac{8}{32}$	$\frac{7}{64}$	$\frac{1}{8}$	$\frac{9}{64}$	$\frac{5}{32}$	$\frac{11}{64}$	$\frac{11}{64}$	$\frac{3}{16}$	$\frac{7}{32}$	$\frac{15}{64}$	$\frac{17}{64}$	$\frac{19}{64}$
Pilot hole	Drill size	$\frac{5}{64}$	$\frac{3}{32}$	$\frac{7}{64}$	$\frac{7}{64}$	$\frac{1}{8}$	$\frac{9}{34}$	$\frac{5}{32}$	$\frac{11}{64}$	$\frac{3}{16}$	$\frac{3}{16}$	$\frac{7}{32}$	$\frac{1}{4}$	$\frac{17}{64}$	$\frac{19}{64}$
	Bit size											4	4	5	6
Starter hole	Drill size		$\frac{1}{16}$	$\frac{1}{16}$	$\frac{5}{64}$	$\frac{5}{64}$	$\frac{3}{32}$	$\frac{7}{64}$	$\frac{7}{64}$	$\frac{1}{8}$	$\frac{1}{8}$	9	5	8	18
	Bit size											64	32	16	64

133.344

145



CARRIAGE bolts fall into three categories. square neck (fig. 4-47) bolt, finned neck bolt, and ribbed neck bolt. These bolts have roundheads that are not designed to be driven. They are threaded only part of the way up the shaft, usually the threads are two to four times the diameter of the bolt in length. In each type of carriage bolt, the upper part of the shank, immediately below the head, is designed to grip the material in which the bolt is inserted and keep the bolt from turning when a nut is tightened down on it or removed. The finned type is designed with two or more fins extending from the head to the shank. The ribbed type is designed with longitudinal ribs, splines, or serrations on all or part of a shoulder located immediately beneath the head. Holes bored to receive carriage bolts are bored to be a tight fit for the body of the bolt and counterbored to permit the head of the bolt to fit flush with, or below the surface of, the material being

fastened. The bolt is then driven through the hole with a hammer. Carriage bolts are chiefly for wood-to-wood application but may also be used for wood-to-metal applications. If used for wood-to-metal application, the head should be fitted to the wood item. Metal surfaces are sometimes predrilled and countersunk to permit the use of carriage bolts metal-to-metal. Carriage bolts can be obtained from 1/4 in. to 1 in. in diameter, and from 3/4 in. to 20 in. long (table 4-7). A common flat washer should be used with carriage bolts between the nut and the wood surface.

MACHINE bolts (fig. 4-47) are made with cut National Fine or National Coarse threads extending in length from twice the diameter of the bolt plus 1/4 in. (for bolts less than 6 in. in length), to twice the diameter of the bolt plus 1/2 in. (for bolts over 6 in. in length). They are precision made and generally applied metal-to-metal where close tolerance is desirable. The head may be square, hexagon, rounded, or flat countersunk. The nut usually corresponds in shape to the head of the bolt with which it is used. Machine bolts are externally driven only. Selection of the proper machine bolt is made on the basis of head style, length, diameter, number of threads per inch, and coarseness of thread. The hole through which the bolt is to pass is bored to the same diameter as the bolt. Machine bolts are made in diameters from 1/4 in. to 3 in. and may be obtained in any length desired (table 4-8).

STOVE bolts (fig. 4-47) are less precisely made than machine bolts. They are made with either flat or round slotted heads and may have threads extending over the full length of the body, over part of the body, or over most of the body. They are generally used with square nuts and applied metal-to-metal, wood-to-wood, or wood-to-metal. If flatheaded, they are countersunk, if roundheaded, they are drawn flush to the surface.

An EXPANSION bolt (fig. 4-47) is a bolt used in conjunction with an expansion shield to provide anchorage in substances in which a threaded fastener alone is useless. The shield, or expansion anchor, inserted in a predrilled hole expands when the bolt is driven into it and becomes wedged firmly in the hole, providing a secure base for the grip of the fastener.

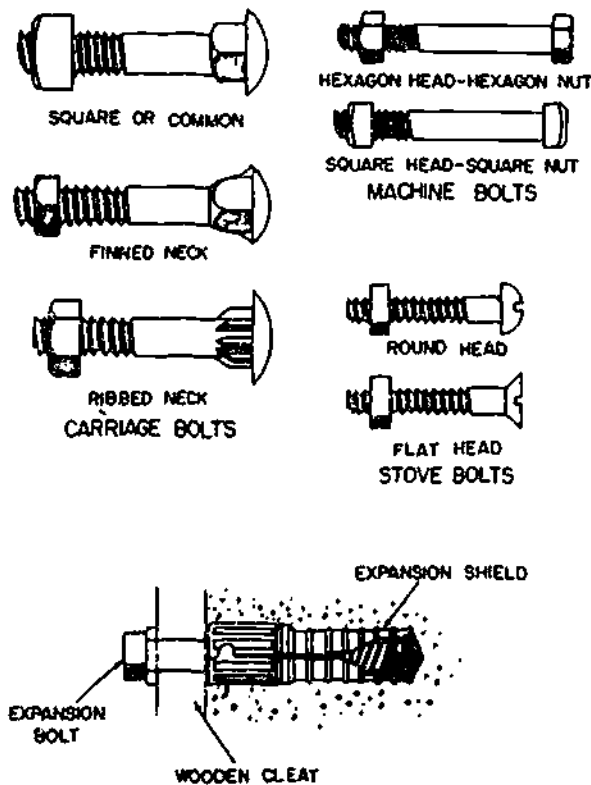

Figure 4-47.—Types of bolts.

29.124

BUILDER 3 & 2

Table 4-7.—Carriage Bolts

LENGTHS (INCHES)	DIAMETERS (INCHES)			
	$\frac{3}{16}$, $\frac{1}{4}$, $\frac{5}{16}$, $\frac{3}{8}$	$\frac{7}{16}$, $\frac{1}{2}$	$\frac{9}{16}$, $\frac{5}{8}$	$\frac{3}{4}$
$\frac{3}{4}$ -----	X	-----	-----	-----
1-----	X	X	-----	-----
$1\frac{1}{4}$ -----	X	X	X	-----
$1\frac{1}{2}$, 2, $2\frac{1}{2}$, etc., $9\frac{1}{2}$, 10 to 20	X	X	X	X

133.345

Table 4-8.—Screw, Cap (machine Bolts)

LENGTHS (INCHES)	DIAMETERS (INCHES)				
	$\frac{1}{4}$, $\frac{3}{8}$	$\frac{7}{16}$	$\frac{1}{2}$, $\frac{9}{16}$, $\frac{5}{8}$	$\frac{1}{2}$, $\frac{7}{8}$, 1	$1\frac{1}{8}$, $1\frac{1}{4}$
$\frac{3}{4}$ -----	X	-----	-----	-----	-----
1, $1\frac{1}{4}$ -----	X	X	X	-----	-----
$1\frac{1}{2}$, 2, $2\frac{1}{2}$ -----	X	X	X	X	-----
3, $3\frac{1}{2}$, 4, $4\frac{1}{2}$, etc., $9\frac{1}{2}$, 10 to 20	X	X	X	X	X
21 to 25-----	-----	-----	X	X	X
26 to 39-----	-----	-----	-----	X	X

133.346

DRIFTPINS are long, heavy, threadless bolts used to hold heavy pieces of timber together (fig. 4-48). The term "driftpin" is almost universally used in practice. However, for supply purposes the correct designation is "driftbolt."

Driftpins have heads and they vary in diameter from $\frac{1}{2}$ to 1 in. and in length from 18 to 26 inches.

To use the driftpin, a hole slightly smaller than the diameter of the pin is made in the timber. The pin is driven into the hole and is

held in place by the compression action of the wood fibers.

The CORRUGATED FASTENER is one of the many means by which joints and splices are fastened in small timber and boards. It is used particularly in the miter joint. Corrugated fasteners are made of sheet metal of 18 to 22 gage with alternate ridges and grooves, the ridges vary from $\frac{3}{16}$ to $\frac{5}{16}$ in., center to center. One end is cut square, the other end is

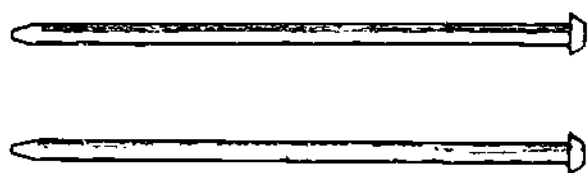

29.121

Figure 4-48.—Driftpins (driftbolts).

sharpened with beveled edges. There are two types of corrugated fasteners: One with the ridges running parallel (fig. 4-49); the other with ridges running at a slight angle to one another (fig. 4-49). The latter type has a tendency to compress the material since the ridges and grooves are closer at the top than at the bottom. These fasteners are made in several different lengths and widths. The width varies from 5/8 to 1 1/8 in., while the length varies from 1/4 to 3/4 inch. The fasteners also are made with different numbers of ridges, ranging from three to six ridges per fastener. Corrugated fasteners are used in a number of ways, to fasten parallel boards together, as in fastening tabletops; to make any type of joint; and as a substitute for nails where nails may split the timber. The fasteners have a greater holding power than nails in small timber. The proper method of using the fasteners is also shown in figure 4-49.

GLUE

One of the oldest materials used for fastening is glue. In museums you will find furniture which was assembled with glue hundreds of years ago. It is still in good condition. Good glue applied properly will form a joint which is stronger than the wood itself.

There are several classes of glue. Probably the best one for joint work and furniture construction is ANIMAL glue. It may be obtained commercially in a variety of forms—liquid, ground, chipped, flaked, powdered, or formed into sticks. The best grades of animal glue are made from hides. Some of the best bone glues, however, may give as good results as the low grades of hide glue



RIDGES
PARALLEL



RIDGES AT
SLIGHT ANGLE

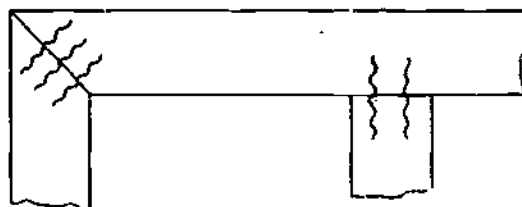
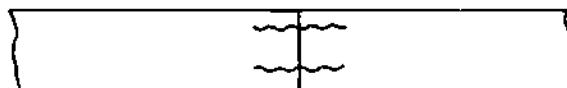

METHOD OF USE

68.45

Figure 4-49.—Corrugated fasteners and their uses.

FISH glue is a good all-around wood shop glue, but it is not as strong as animal glue. It is usually made in liquid form, and it has a disagreeable odor.

VEGETABLE glue is manufactured by a secret process for use in some veneering work. It is NOT a satisfactory glue for wood joints.

CASEIN glue is made from milk in powdered form. The best grades of casein glue are water-resistant and are, therefore, excellent for forming waterproof joints. Casein glue, however, doesn't adhere well to oak. To join oak surfaces with it, coat the wood with a 10-percent solution of caustic soda and allow it to dry. Then apply the casein glue to form a strong joint.

BLOOD ALBUMIN glue is also practically waterproof, but to use it, you need very expensive equipment. It is, therefore, not often used.

PLASTIC RESIN glue may be procured in either liquid or powder form. It is durable and water resistant, but like casein glue, it doesn't adhere too well to oak. Plastic resin glue is used in the manufacture of balsa wood and plywood life floats.

Each type of glue must be prepared and used in a special manner if you are to get the strongest possible joint. Instructions are always found on the label of the container. Study these carefully before you attempt to use the glue. There are also certain general principles which you should follow when you apply any glue.

A lot depends on the wood itself. Dry wood makes stronger joints than wood which is not well seasoned. This is easy to understand if you'll remember that water in the wood will decrease the amount of glue which can be absorbed.

WOODWORKING SAFETY

Practically everything used in woodworking is dangerous, particularly the power wood-working equipment. Yet the human factor remains by far the largest cause of woodworking accidents. Those which are caused by inherent

defects in equipment cause only a small percentage of total accidents. Statistics show that the average military woodworking casualty is not the beginner at the trade, but a person with considerable experience. A new crew-member who hears the high-pitched screams of a circular saw for the first time is likely to be acutely conscious of the fact that the machine is dangerous, but experienced crewmembers often take dangerous equipment too much for granted.

The vast majority of woodworking accidents can be prevented by the observance of well-established safety rules. Some of these are rules of general application, others apply to specific tools and equipment. To be effective, these rules must be KNOWN, and OBSERVED. You should insure that general safety rules are posted on bulletin boards and in other areas where everyone will see them. Rules applying to specific tools and equipment should be posted somewhere near the equipment or published in pamphlets and manuals which should be available to the operator of the equipment. DO NOT OPERATE A PIECE OF DANGEROUS EQUIPMENT UNTIL YOU KNOW THE SAFETY RULES WHICH APPLY TO IT. Once you know them. OBSERVE THEM.

CHAPTER 5

FIBER LINE, WIRE ROPE, AND SCAFFOLDING

Information is presented in this chapter on how to use fiber line, wire rope, and timber in rigging and erecting hoisting devices, such as shear legs, tripods, blocks and tackles, and swinging scaffolds.

Formulas are given on how to determine or find the safe working load (SWL) of all this material. In addition, the correct use, care, and breaking strengths of fiber line and wire rope are covered. You will also find in this chapter information on how to erect scaffolding and the proper use of ladders.

FIBER LINE

The vegetable fibers commonly used in the manufacture of fiber line include manila, sisal, and hemp. In addition to vegetable fibers, certain synthetic fibers are used also. These include nylon, orlon, and dacron.

SOURCES AND CHARACTERISTICS OF FIBERS

The best of the vegetable line-making fibers is MANILA, which comes from the banana-like abaca plant, grown mainly in the Phillipines. Manila fibers range in length from 4 to 12 ft. A good grade of manila is cream in color, smooth, clean, and pliable; poorer grades are distinguished by shades of brown. A fiber line made of good quality manila possesses the following desirable qualities: elasticity, strength, and resistance to wear and deterioration. Manila line is especially useful in hoisting operations where a strong, dependable line is essential.

The next best vegetable line-making fiber is SISAL. This fiber is similar to manila, but lighter in color. It is grown in the East Indies, Africa, and Central America. Sisal fibers are usually 26 to 40 in. long, but are only about 80 percent as strong as manila fibers. Sisal line withstands exposure to seawater exceptionally well. It is frequently used in towing, mooring, and other such purposes.

HEMP fibers come from the stalk of the hemp plant, which is grown in Russia, Italy, South America, and the United States. The Navy uses hemp or "small stuff" after it has been tarred or treated with some other suitable preservative. This makes the small stuff last longer by providing protection against moisture. The term "small stuff," is used to denote small cordage, the sort which a layman might call string, yarn or cord.

NYLON is the synthetic fiber most widely used by the Navy. It is lighter, more flexible, less bulky, and easier to handle and store than manila line. It is highly resistant to mildew, rot, and marine borers. When nylon line is wet or frozen, the loss of strength is relatively small. It will hold a load even though several strands may be frayed. Ordinarily, the line can be made reusable by cutting away the chafed section and splicing the end.

FABRICATION OF LINE

The fabrication of line consists essentially of three twisting operations. First, the FIBERS are twisted to the right to form the YARNS. Next, the yarns are twisted to the left to form the STRANDS. Finally the strands are twisted to

the right to form the LINE. Figure 5-1 shows you how the fibers are grouped to form a 3-strand line.

The operations just described are standard procedure, and the resulting product is known as a RIGHT-LAID line. When the process is reversed, you have a LEFT-LAID line. In either instance, the principle of opposite twists must always be observed. The two main reasons for the principle of opposite twists are to keep the line tight to prevent the fibers from unlaying with a load suspended on it and to prevent moisture penetration.

TYPES OF LINE LAYS

There are three types of fiber line lays: hawser-laid, shroud-laid, and cable-laid lines. Each type is illustrated in figure 5-2.

HAWSER-LAID LINE generally consists of three strands twisted together, usually in a right-hand direction. A SHROUD-LAID line ordinarily is composed of four strands twisted together in a right-hand direction around a center strand or core, which usually is of the same material, but smaller in diameter than the four strands. You will find that shroud-laid line is more pliable and stronger than hawser-laid line, but it has a strong tendency toward kinking. In most instances, it is used on sheaves and drums. This not only prevents kinking, but also makes use of its pliability and strength. CABLE-LAID line usually consists of three right-hand hawser-laid lines twisted together in a left-hand direction. It is especially safe to use in

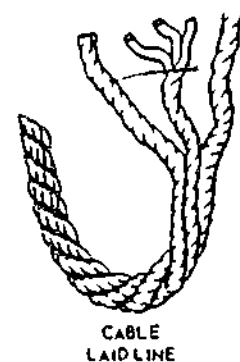
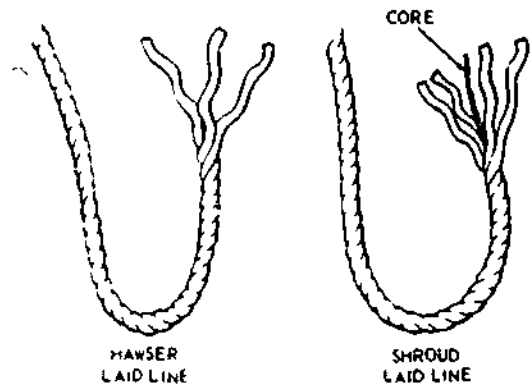

Figure 5 2.—Three types of fiber line. 29.171

heavy construction work because, in case it untwists it will tend to tighten any regular right-hand screw connection to which attached.

SIZE DESIGNATION

Line 1 3/4 in. or less in circumference is called SMALL STUFF and is usually designated as to size by the number of THREADS (or yarns) that make up each strand. You may use anywhere from 6- to 24-thread, but the most commonly used are 9- to 21-thread. (See fig. 5-3.) You may hear some small stuff designated by name, without reference to size. One such type is MARLINE, a tarred, 2-strand, left-laid hemp. Marline is the small stuff you will use most for seizings. When you need something stronger than marline, you will use a tarred, 3-strand, left-laid hemp called HOUSELINE.

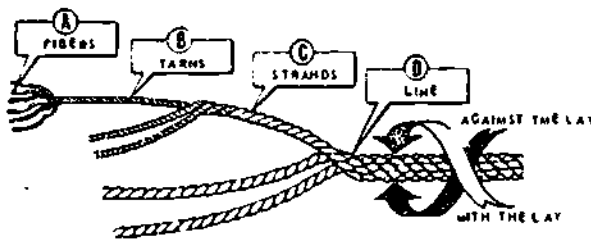
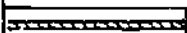
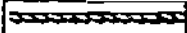
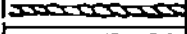









Figure 5-1.—Fiber groupings in a 3-strand line. 29.170

MANILA LINE			
SOME COMMONLY USED SIZES	* CIRCUMFERENCE		THREAD
	INCHES	MILLIMETERS	
	3/4	19.05	6
	1	25.40	9
	1 1/8	28.58	12
	1 1/4	31.76	15
	1 1/2	38.10	21
	1 3/4	44.45	24
	2	50.80	
	3	76.20	
	4	101.6	
	5	127.0	
	6	152.4	

* SIZE IS DESIGNATED BY THE CIRCUMFERENCE

127.40

Figure 5-3.—Some commonly used sizes of manila line.

Line larger than 1 3/4 in. in circumference is generally designated as to size by its CIRCUMFERENCE in inches. A 6-in. manila line, for instance, would be constructed of manila fibers and measure 6 in. in circumference. Line is available in sizes ranging up to 16 in. in circumference, but 12 in. is about the largest carried in stock. Anything larger is used only on special jobs. (See fig. 5-3.)

If you have occasion to order line, you may find that in the catalogs it is designated and ordered by diameter. The catalog may also use the term rope (rather than line).

ROPE YARNS for temporary seizings, whippings, and lashings, are pulled from large strands of old line which has outlived its usefulness. Pull your yarn from the middle, away from the ends, or it will get fouled.

STRENGTH OF FIBER LINE

Overloading a line poses a serious threat to the safety of personnel, not to mention the heavy losses likely to result through damage to material. To avoid overloading, you must know the strength of the line with which you are

working. This involves three factors: breaking strength, safe working load, and safety factor.

BREAKING STRENGTH refers to the tension at which the line will part when a load is applied. Breaking strength has been determined through tests made by rope manufacturers, and tables have been set up to provide this information. In the absence of manufacturers' tables, a rule of thumb for finding the breaking strength of manila line is:

$$C^2 \times 900 = BS$$

In this rule, C = circumference in in. and BS = breaking strength in pounds. To find BS, the circumference is squared and the figure obtained is then multiplied by 900. With a 3-in. line, for example, you will get a BS of 8100, figuring as follows:

$$3 \times 3 \times 900 = 8100 \text{ lb}$$

The breaking strength of manila line is higher than that of sisal line. This is caused by the difference in strength of the two fibers. The fiber from which a particular line is constructed has a definite bearing on its breaking strength.

The breaking strength of nylon line is almost three times that of manila line of the same size. The best rule of thumb for the breaking strength of nylon is:

$$BS = C^2 \times 2400$$

The symbols in the rule are the same as those for fiber line.

For 2 1/2-in. nylon line

$$BS = 2.5 \times 2.5 \times 2400 = 15,000 \text{ lb}$$

Briefly defined, the **SAFE WORKING LOAD** of a line is the load that can be applied without causing any kind of damage to the line. Note that the safe working load is considerably less than the breaking strength. A wide margin of difference between breaking strength and safe working load is necessary to allow for such factors as additional strain imposed on the line

by jerky movements in hoisting or bending over sheaves in a pulley block.

You may not always have a chart available to tell you the safe working load for a particular size line—so what do you do then? Fortunately, there is a rule of thumb which will adequately serve your needs on such an occasion.

$$SWL = C^2 \times 150$$

where SWL = the safe working load in pounds and C = the circumference of the line in in. Simply take the circumference of the line, square it, and then multiply by 150. For a 3-inch line, here is how the rule works.

$$3 \times 3 \times 150 = 1350 \text{ lb}$$

Thus the safe working load of a 3-in. line is equal to 1350 pounds.

If the line is in good shape, add 30 percent to the SWL arrived at by means of the rule, or if it is in bad shape, subtract 30 percent from the SWL. In the example given above for the 3-in. line, adding 30 percent to the 1350 lb would give you a safe working load of 1755 lb. On the other hand, subtracting 30 percent from the 1350 lb would leave you a safe working load of 945 lb.

Remember that the strength of a line will decrease with age, use, and exposure to excessive heat, boiling water, or sharp bends. Especially with used line, these and other factors affecting strength should be given careful consideration, and proper adjustment made in the breaking strength and safe working load capacity of the line. Manufacturers of line provide tables to show the breaking strength and safe working load capacity of line. You will find such tables very useful in your work. You must remember, however, that the values given in manufacturers' tables **ONLY** apply to **NEW LINE** being used under favorable conditions. For that reason, you must **PROGRESSIVELY REDUCE** the values given in manufacturer's tables as the line ages or deteriorates with use.

Keep in mind that a strong strain on a kinked or twisted line will put a permanent distortion in the line. Figure 5-4 shows what frequently happens when pressure is applied to a line with a kink in it. The kink that could have



80.17

Figure 5-4.—Result of a strong strain on a line with a kink in it.

been worked out is now permanent, and the line is ruined.

The **SAFETY FACTOR** of a line is the ratio between the breaking strength and the safe working load. Usually a safety factor of 4 is acceptable, but this is not always the case. In other words, the safety factor will vary, depending on such things as the condition of the line and circumstances under which it is to be used. While the safety factor should **NEVER** be less than 3, it often must be well above 4 (possibly as high as 8 or 10). For best, average, or unfavorable conditions, the safety factor indicated below may often be suitable.

BEST conditions (new line): 4.

AVERAGE conditions (line used, but in good condition): 6.

UNFAVORABLE conditions (frequently used line, such as running rigging): 8.

HANDLING AND CARE

If the fiber line you work with is to give safe and dependable service, you must make a special effort to insure that it is handled and cared for properly. Study the precautions and procedures given here, and make sure you carry them out properly in duties involving fiber line.

Loose ends of fiber line should be whipped or spliced to prevent unlaying of the line. (See fig. 5-5.) When fiber line is to be cut, put two whippings on the line 1 or 2 in. apart and then make the cut between the whippings.

When fiber line is being stored, care should be taken to prevent deterioration. It should be dried carefully and stored uncovered in a dry place, such as on gratings or in some manner to allow air to circulate through the coil.

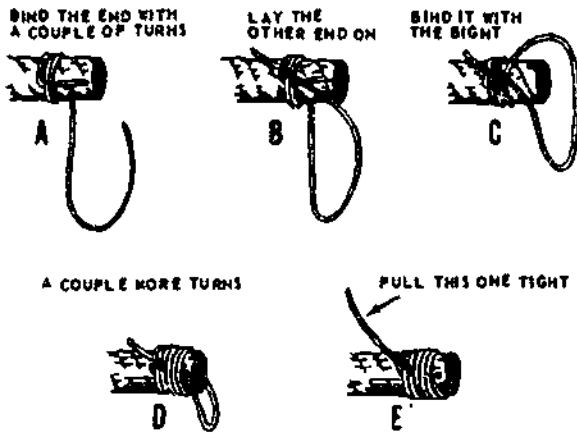

3.215

Figure 5-5.—Plain-whipping a line.

Never cover a line unless absolutely necessary, as covering it will hold in the moisture and prevent discovery of any deterioration.

When possible, slacken a dry, taut line before it is exposed to rain or damp weather as line contracts when wet and may become overstrained and weakened.

The strength of fiber line decreases rapidly with use because of breakage and slipping of the fibers. The fibers will slip a small amount under each strain in spite of the twisting, and no attempt should be made to load a line to its maximum after it has been used for some time. Breakage of fibers should be avoided as much as possible.

Muddy line should be cleaned by washing in water only. Do not use soap because it will take the natural oils out of the fibers.

Avoid pulling line over sharp edges. Place chafing gear, such as a board, folded cardboard, canvas, or part of a firehose between the line and the sharp edge to reduce breakage of the strands.

Since sand or dirt has an abrasive action on the inner fibers of line, avoid dragging line through sand or dirt. If sand gets on the line, carefully wash the line in water only.

Wherever possible, use knots that can be untied easily to eliminate the necessity for cutting the line

If a nylon line becomes slippery because of grease, it should be cleaned with light oils, such as kerosene or diesel oil.

Do not stow nylon line in strong sunlight. Cover it with tarpaulins. In stowage, keep it away from heat and strong chemicals.

WIRE ROPE

Wire rope consists of three parts: wires, strands, and core. (See fig. 5-6.) In the manufacture of rope, a number of WIRES are laid together to form a STRAND. Then a number of strands are laid together, usually around a central CORE, to form the rope. The basic unit of wire rope construction then is the individual wire, which may be made of steel, iron, or other metal, in various sizes. In making a rope, the number of strands will vary, depending on the purpose for which the rope is intended. Wire rope is designated by the outside diameter, by the number of strands per rope, and by the number of wires per strand. Thus, a 1/2 in. 6 x 19 rope will have 6 strands with 19 wires per strand, but will have the same outside diameter as a 1/2 in. 6 x 37 wire rope, which will have 6 strands with 37 small size wires per strand. Wire rope made up of a large number of small wires is flexible, but the small wires are easily broken so the wire rope is not resistant to external abrasion. Wire rope made up of a smaller

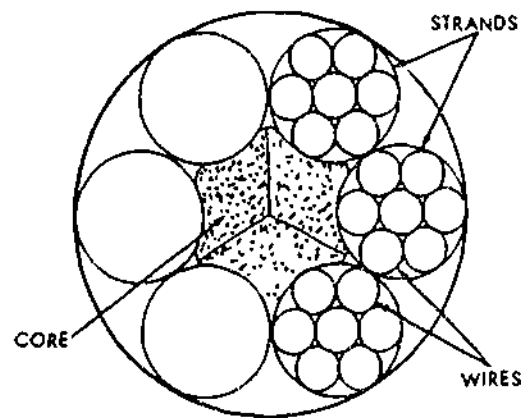

29.172(29C)

Figure 5-6.—Parts of a wire rope.

number of larger wires is more resistant to external abrasion, it is also less flexible.

The central CORE—the element around which the strands are laid to form the rope—may be a hard fiber (such as manila, hemp, or sisal), a wire strand, or an independent wire rope. Each type of core serves the same basic purpose, that of affording support to the strands laid around it.

FIBER CORE offers the advantage of increased flexibility. In addition, it serves as a cushion to reduce the effects of sudden strain and acts as a reservoir for the oil necessary for lubrication of the wires and strands to reduce friction between them. Wire rope having a fiber core is used in places where no severe heat is involved and where flexibility on the part of the rope is important.

A WIRE STRAND CORE not only provides more resistance to heat than a fiber core, but also adds about 7 1/2 percent to the strength of the rope. On the other hand, the wire strand makes the rope less flexible than when a fiber core is used. This type of rope is used in places where hot work (cutting, welding, etc.) is involved.

An INDEPENDENT WIRE ROPE CORE is a separate wire rope over which the main strands of the rope are laid. It usually consists of six 7-wire strands laid around either a fiber core or a wire strand core. This type of core gives the rope additional strength, provides support against crushing, and supplies maximum resistance to heat.

Wire rope may be fabricated by either of two methods. If the strands or wires are shaped to conform to the curvature of the finished rope prior to laying up, the rope is termed PREFORMED. If they are not shaped before fabrication, the rope is termed NON-PREFORMED. When cut, preformed wire rope tends not to unlay, and it is more flexible than nonpreformed wire rope. Preforming eliminates the locked up stress and strain existing in nonpreformed wire rope, and prevents the rope from flying apart when cut or broken, and also resists kinking. Preformed rope is more easily spliced since the strands fit perfectly into place. With nonpreformed wire rope, the twisting process produces a stress in the wires, and when it is cut or broken, the stress causes the strands

to unlay. In nonpreformed wire unlaying is rapid and almost instantaneous, and could cause serious injury to someone not familiar with it.

The main types of wire rope used by the Navy consist of 6, 7, 12, 19, 24, or 37 wires in each strand. Usually, the rope has 6 strands laid around a fiber or steel center.

Two common types of wire rope, 6 x 19 and 6 x 37 rope, are illustrated in figure 5-7. The 6 x 19 type, having 6 strands with 19 wires in each strand, is commonly used for rough hoisting and skidding work where abrasion is likely to occur. The 6 x 37 wire rope, having 6 strands with 37 wires in each strand, is the most flexible of the standard 6-strand ropes. For that reason, it is particularly suitable when small sheaves and drums are to be used, such as on cranes and similar machinery.

MEASURING WIRE ROPE

The size of wire rope is designated by its diameter. The true diameter of a wire rope is considered as being the diameter of the circle which will just enclose all of its strands. Both the correct and incorrect methods of measuring wire rope are illustrated in figure 5-8. Note, in particular, that the CORRECT WAY is to measure from the top of one strand to the top of the strand directly opposite it. The wrong way is to measure across two strands side by side. Use calipers to take the measurement; if they are not available, an adjustable wrench will do.

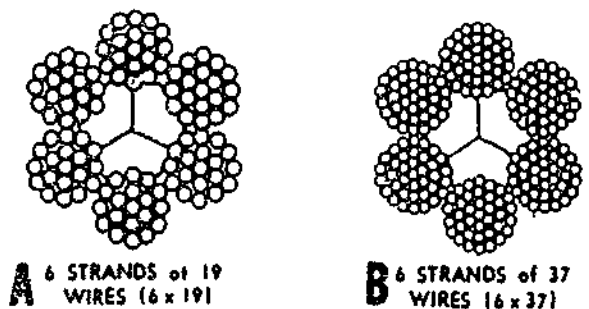

29.172(29C)

Figure 5-7.—Two common types of wire rope.

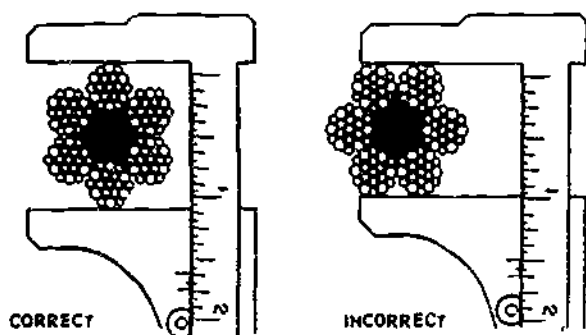

29.173(133E)

Figure 5-8.—Correct and incorrect methods of measuring wire rope.

To insure an accurate measurement of the diameter of a wire rope, always measure the rope at three places, at least 5 ft apart. Use the average of the three measurements as the diameter of the rope.

SAFE WORKING LOAD

The term **SAFE WORKING LOAD (SWL)**, as used in reference to wire rope, means the load that can be applied and still obtain the most efficient service and also prolong the life of the rope. Most manufacturers provide tables which show the safe working load for their rope under various conditions. In the absence of these tables, it is often necessary to apply a thumb rule formula to obtain the SWL. There are rules of thumb which may be used to compute the strength of wire rope. The one recommended by the Naval Facilities Engineering Command (NAVFAC) is

$$\text{SWL (in tons)} = D^2 \times 4$$

This particular formula provides an ample safety margin to account for such variables as the number, size, and location of sheaves and drums on which the rope runs, and such dynamic stresses as the speed of operation, and the acceleration and deceleration of the load, all of which can affect the endurance and breaking strength of the rope

In the above formula, D represents the diameter of the rope in in. Suppose you want to find the SWL of a 2-in. rope. Using the formula above, your figures would be:

$$\begin{aligned} \text{SWL} &= (2)^2 \times 4 \\ \text{SWL} &= 4 \times 4 = 16 \end{aligned}$$

The answer is 16, meaning that the rope has an SWL of 16 tons.

It is very important to remember that any formula for determining SWL is **ONLY A RULE OF THUMB**. In computing the SWL of old rope, worn rope, or rope which is otherwise in poor condition, you should reduce the SWL as much as 50 percent, depending on the condition of the rope.

The manufacturer's data concerning the breaking strength (BS) of wire rope should be used if available. But if you do not have that information, one rule of thumb recommended is:

$$\text{BS} = C^2 \times 8000 \text{ lb}$$

As you know, wire rope is measured by the diameter (D). To obtain the circumference (C) required in the formula, multiply D by pi (π), which is approximately 3.1416. Thus the formula to find the circumference is:

$$C = D\pi$$

WIRE ROPE FAILURE

Some of the common causes of wire rope failure are listed below

1. Using incorrect size, construction, or grade.
2. Dragging over obstacles.
3. Having improper lubrication.
4. Operating over sheaves and drums of inadequate size.
5. Overriding or crosswinding on drums
6. Operating over sheaves and drums with improperly fitted grooves or broken flanges.
7. Jumping off sheaves.
8. Subjecting to acid fumes.
9. Attaching fitting improperly.

10. Promoting internal wear by allowing grit to penetrate between the strands.
11. Subjecting to severe or continuing overload.
12. Kinking.
13. Having an excessive fleet angle.

CLEANING AND LUBRICATION

Used wire rope should be cleaned at frequent intervals to remove any accumulation of dirt, grit, rust, or other foreign matter. The frequency of cleaning will depend on how much the rope is used. However, rope should always be cleaned well prior to lubrication. The rope may be cleaned by wire brushes, compressed air, or steam. Do not use oxygen in place of compressed air as it becomes very dangerous when it comes in contact with grease or oil. The purpose is to remove all old lubricant, as well as foreign matter from the valleys between the strands and from the spaces between the outer wires, so that the newly applied lubricant will have ready entrance into the rope. Wire brushing affords a good opportunity to find any broken wires that may otherwise go unnoticed.

Wire rope is initially lubricated by the manufacturer, but this initial lubrication will only last so long before periodic applications have to be made by the user. Each time a wire rope bends and straightens, the wires in the strands and the strands in the rope slide upon each other. To prevent the rope wearing out by this sliding action, a film of lubricant is needed between the surfaces in contact. The lubricant also helps to prevent corrosion of the wires and deterioration of fiber centers. A rusty wire rope is a liability! With wire rope, the same as with any machine or piece of equipment, proper lubrication is essential to smooth, efficient performance.

The lubricant should be a good grade of lubricating oil, free from acids and corrosive substances. It must also be of a consistency that will penetrate to the center of the core, yet heavy enough to remain as a coating on the outer surfaces of the strands.

Two good lubricants for this purpose are raw linseed oil and a medium graphite grease. Raw linseed oil dries and is not greasy to handle.

Graphite grease is highly resistant to saltwater corrosion. Of course, other commercial lubricants may be obtained and used. The best is a semiplastic compound which is thinned by heating before being applied. It will penetrate while hot, then cool to a plastic filler, preventing the entrance of water.

One method of applying the lubricant is by using a brush. In doing so, remember to apply the coating of fresh lubricant evenly and to work it in well. Another method involves passing the wire rope through a trough or box containing hot lubricant (fig. 5-9). In this method, the heated lubricant is placed in the trough, and then the rope is passed through it over sheaves and under a center guide wheel. Hot oils or greases have very good penetrating qualities. And, upon cooling, they have high adhesive and film-strength around each wire.

As a safety precaution, always wipe off any excess when lubricating wire rope. This is especially important where heavy equipment is involved. Too much lubricant is liable to get onto brakes or clutches, causing them to fail. While in use, the motion of machinery may throw excess oil around over crane cabs and onto catwalks, making them unsafe to work on.

STORAGE

Wire rope should not be stored in places where acid is or has been kept. The slightest trace of acid coming in contact with wire rope will damage it at that particular spot. Many times wire rope which has given away has been found to be acid damaged. The importance of keeping acid or acid fumes away from wire rope must be stressed to all hands.

It is especially important that wire rope be cleaned and lubricated properly before it is placed in storage. Fortunately, corrosion of wire rope during storage can be virtually eliminated, IF the lubricant film is applied properly beforehand and if adequate protection is provided from the weather. Bear in mind that rust, corrosion of wires, and deterioration of the fiber core greatly reduces the strength of wire rope. It is not possible to state exactly the loss

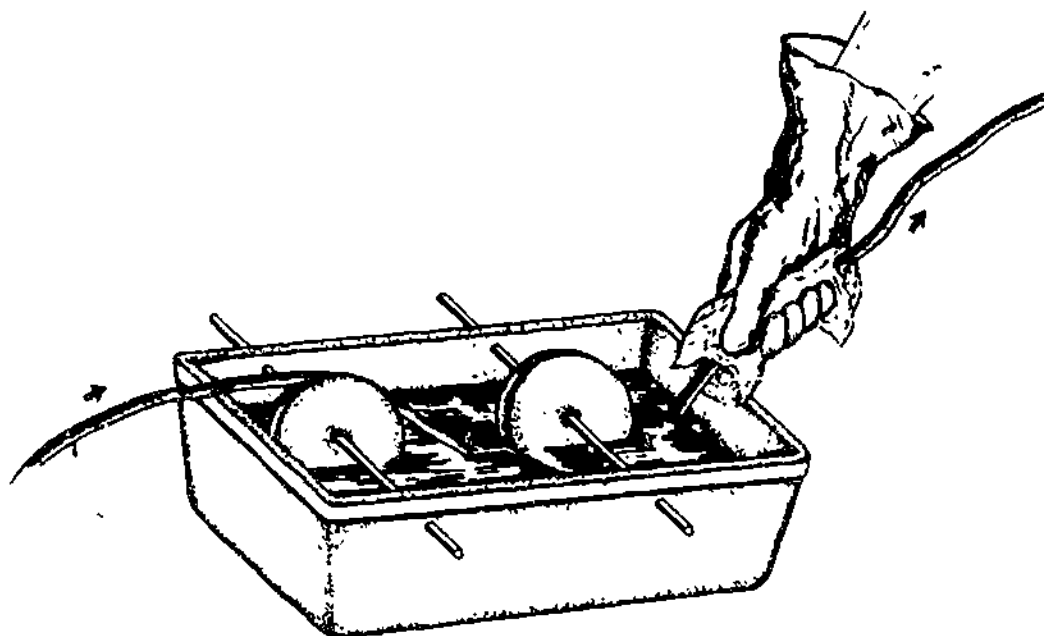

Figure 5-9.—Method of field lubrication.

127.48

of strength which results from these effects. It is certainly great enough to require close observance of those precautions prescribed for protection against such effects

INSPECTION

Wire rope should be inspected at regular intervals, the same as fiber line. In determining the frequency of inspection, the amount of use of the rope and conditions under which it is used are factors deserving careful consideration.

During an inspection, the rope should be examined carefully for fishhooks, kinks, and worn, corroded spots. Usually, breaks in individual wires will be concentrated in those portions of the rope that consistently run over the sheaves or bend onto the drum. Abrasion or reverse and sharp bends cause individual wires to break and bend back. The breaks are known as fishhooks. When wires are only slightly worn but have broken off squarely and stick out all over the rope, the condition is usually caused by overloading or rough handling. If the breaks are

confined to one or two strands, then the strength of the rope may be seriously reduced. When 4 percent of the total number of wires in the rope are found to have breaks within the length of one lay of the rope, the wire rope is unsafe. Consider the rope unsafe when three broken wires are found in one strand of 6 by 7 rope, six broken wires in one strand of 6 by 19 rope, or nine broken wires in one strand of 6 by 37 rope.

Overloading a rope also causes its diameter to be reduced. Failure to lubricate the rope is another cause of reduced diameter inasmuch as the hemp core will dry out and eventually collapse or shrink. The surrounding strands are thus deprived of support, and the rope's strength and dependability are correspondingly reduced. Rope that has its diameter reduced to less than 75 percent of its original diameter should be removed from service.

A wire rope should also be removed from service when an inspection reveals widespread corrosion and pitting of the wires. Particular attention should be given to signs of corrosion

and rust in the valleys or small spaces between the strands. Since such corrosion is usually the result of improper or infrequent lubrication, the internal wires of the rope are then subject to extreme friction and wear. This form of internal, and often invisible, destruction of the wire is one of the most frequent causes of unexpected and sudden failure of wire rope. The best safeguard, of course, is to keep the rope well lubricated and to handle and store it properly.

WIRE ROPE ATTACHMENTS

In addition to splicing (permanent arrangement of the rope), there are a number of wire rope attachments, such as sockets and wire rope clips, which can be put on a wire rope so that it may be used with other ropes, chains, pad eyes, or equipment. In general, these attachments permit the wire rope to be employed with greater flexibility than would be possible with the more permanent splice, since the attachments allow the same wire rope to be made up in a variety of different arrangements.

A temporary eye splice may be put in wire rope by using clips. A single clip, as shown in figure 5-10, consists of three parts: U-bolt, saddle, and nuts. The correct and two incorrect methods of applying these clips to wire rope are also shown in figure 5-10; the second incorrect method shown is the most common one made. Notice that the CORRECT way is to apply the clips so that the U-bolts bear against the bitter end; that is, the short end of the rope. If the

clips are attached incorrectly the result will be distortion or mashed spots on the live end or working end of the rope. After a rope is under strain, tighten the clips again. On operating ropes, tighten the clips daily and inspect the ropes carefully at points where there are clips. Pay particular attention to the wire at the clip farthest from the eye, as vibration and whipping are dampened here and fatigue breaks are likely to occur.

To obtain maximum strength in the temporary eye splice, use the correct size and number of wire clips. Their size is stamped on the saddle between the tow holes. A rule of thumb for determining the number of clips required for various sizes of rope is to multiply the diameter of the rope by 3 and add 1, stated as a formula this means.

$$3D + 1 = \text{number of clips.}$$

For example, if the rope has a diameter of 1 in., you determine the number of clips as follows:

$$(3 \times 1) + 1 = 4 \text{ clips.}$$

In case the answer contains a fraction, then use the next largest whole number. In other words, suppose you want to find the number of clips for a wire rope 1/2 in. in diameter. Using

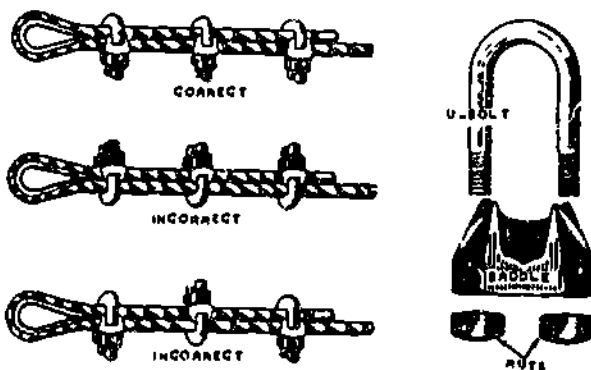

56.226

Figure 5-10.—Use of wire rope clips.

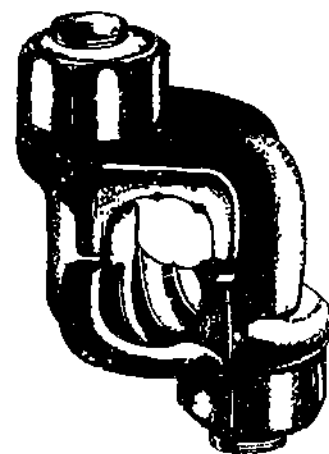

80.70X

Figure 5-11.—Improved type of wire rope clip.

the formula, the answer would be 2 1/2 clips, which obviously is a practical impossibility. Thus, you simply raise the fraction to the next higher number, 3, to get the correct answer.

The clips should be properly spaced to provide a good hold on the rope. The correct distance between the clips may be determined by multiplying 6 times the diameter of the rope. $6D = \text{DISTANCE BETWEEN CLIPS}$, where D is equal to the diameter. Here, as in determining the number of clips, if the answer contains a fraction, use the next largest whole number.

An improved type of wire rope clip which has been developed is shown in figure 5-11. This type has a few advantages over that shown in figure 5-10. In the improved type, both halves are identical and provide a bearing surface for both parts of the rope. Thus, it cannot be put on wrong and it will not destroy the wire. It also allows a full swing with a wrench.

Wire rope clips should be inspected and tightened at regular intervals. Also, after comparatively long use, the clips should be removed and the rope examined for broken wires. If any are present, the damaged area should be removed and a new attachment made.

Another type of attachment is the WEDGE SOCKET end fitting, which is easy to install and may be changed quickly. (See fig. 5-12.) The wedge socket is frequently used to attach dead ends of wires to pad eyes or similar fittings on earthmoving rings. It is made in two parts. The socket itself has a tapered opening for the wire rope and a small wedge to go in this tapered

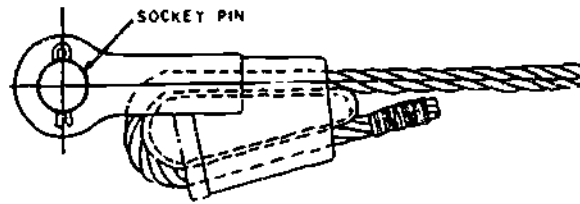

115.178

Figure 5-13.—A Properly installed wedge socket.

socket. The right method of installing a wedge socket is shown in figure 5-13. It might be noted that the strength of a wedge-type socket is such that the overall strength of a rope having one attached is reduced by about one-third. The safe working load of the rope must also be reduced accordingly.

To install the wedge socket on a wire rope, remove the wedge and insert a loop of the wire rope through the tapered opening from the bottom of the socket up. Place the wedge through the loop and pull the ends of the wire rope back through the tapered opening until the wedge forces the wire rope against the sides of the wedge socket. The loop of wire rope must be inserted in the wedge socket so that the standing part of the wire rope will form a nearly direct line to the socket pin of the fitting (note fig 5-13). A properly made-up wedge socket connection will tighten when a strain is placed on the wire rope.

In selecting a socket, be sure you get the right size socket and wedge. The size is indicated on most sockets and on some wedges. Figure 5-14 shows how to measure a wedge if the size is

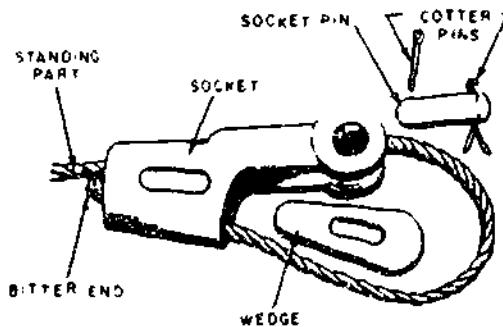

115.177

Figure 5-12.—Parts of a wedge socket.



127.53

Figure 5-14.—How to measure a wedge.

not stamped on the socket. If the wrong size of wedge is used, it can be harmful to the wire rope. If the wedge is too small, it will cut the wire rope; if it is too large, the wire rope will slip.

BLOCK AND TACKLE

A **BLOCK** consists of one or more sheaves fitted in a wood or metal frame supported by a hook or shackle inserted in the strap of the block. A **TACKLE** is an assembly of blocks and lines used to gain a mechanical advantage in lifting or pulling.

In a tackle assembly, the line is reeved over the sheaves of blocks. There are two types of tackle systems: simple and compound. A **SIMPLE** tackle system is an assembly of blocks in which a single line is used. (See view A, fig. 5-15.) A **COMPOUND** tackle system is an

assembly of blocks in which more than one line is used. (See view B, fig. 5-15.)

TACKLE TERMS

To help avoid confusion in working with tackle, it is important that you be familiar with various technical terms. Here are some commonly used tackle terms which you should know and understand. (See fig. 5-16.)

A **FALL** is a line, either fiber line or wire rope, reeved through a pair of blocks to form a tackle.

The **HAULING PART** is the part of the fall leading from one of the blocks upon which the power is exerted. The **STANDING PART** is the end of the fall which is attached to one of the blocks.

The **MOVABLE (or RUNNING) BLOCK** of a tackle is the block attached to the object to be moved. The **FIXED (or STANDING) BLOCK** is the block attached to a fixed object or support. When a tackle is being used, the movable block moves and the fixed block remains stationary.

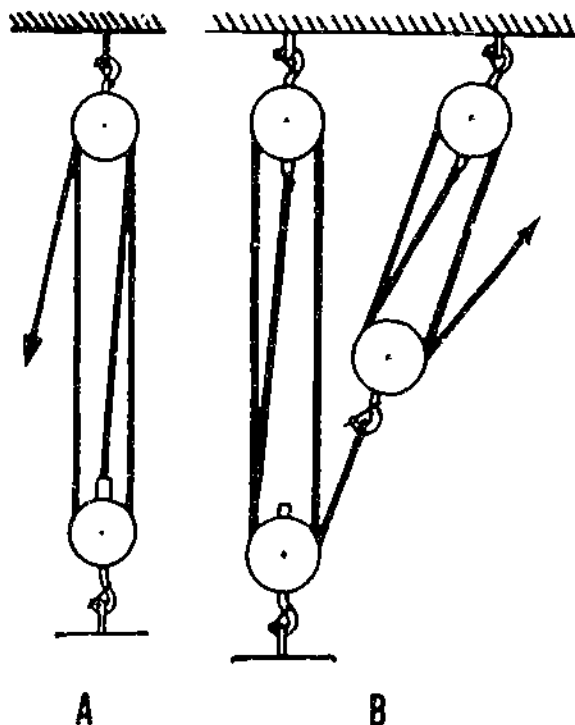

127.487
Figure 5-15.—Types of tackle. A. Simple tackle, B. Compound tackle.

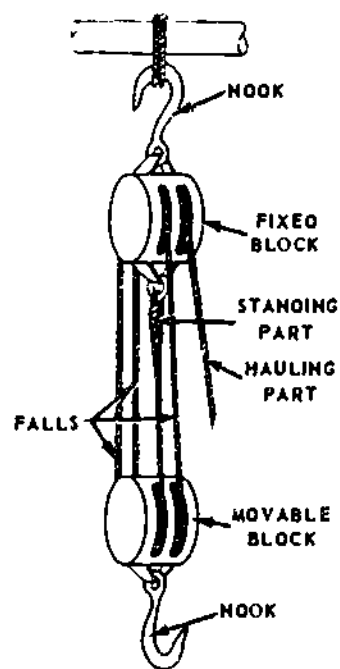

29.187B
Figure 5-16.—Parts of a tackle.

The term **TWO-BLOCKED** means that both blocks of a tackle are as close together as they will go. You may also hear this same condition referred to as **BLOCK-AND-BLOCK**.

To **OVERHAUL** is to lengthen a tackle by pulling the two blocks apart.

To **ROUND IN** means to bring the blocks of a tackle toward each other, usually without a load on the tackle (opposite of overhaul).

Don't be surprised if your coworkers use a number of different terms in referring to a tackle. Such terms as **LINE-AND-BLOCKS**, **PURCHASE**, and **BLOCK-AND-FALLS** are typical of other names frequently used for tackle.

BLOCK NOMENCLATURE

Blocks are constructed for use with fiber line or with wire rope. Wire rope blocks are heavily constructed, and have a large sheave containing a deep groove. Fiber line blocks are generally not as heavily constructed as wire rope blocks and have smaller sheaves with shallower wide grooves. A large sheave is necessary with wire rope to prevent sharp bending. Since fiber line has greater flexibility and pliability, it does not require a sheave as large as does the same size of wire rope.

Blocks fitted with one, two, three, or four sheaves are often referred to as single, double, triple, and quadruple blocks, respectively. Blocks are fitted with a varying number of attachments, depending upon their particular use. Some of the most commonly used fittings are hooks, shackles, eyes, and rings.

The function of the block or blocks in a tackle assembly is to change the direction of pull or provide mechanical advantage or both. The name and location of the principal parts of a fiber line block are shown in figure 5-17.

The **FRAME** (or **SHELL**), made of wood or metal, houses the sheaves.

The **SHEAVE** is a round, grooved wheel over which the line runs. Ordinarily, blocks used in your work will have one, two, three, or four sheaves. Blocks can be obtained, of course, with more than this number of sheaves, blocks have been made with as many as 11 sheaves.

The **CHEEKS** are the portions of the shell enclosing the sheaves.

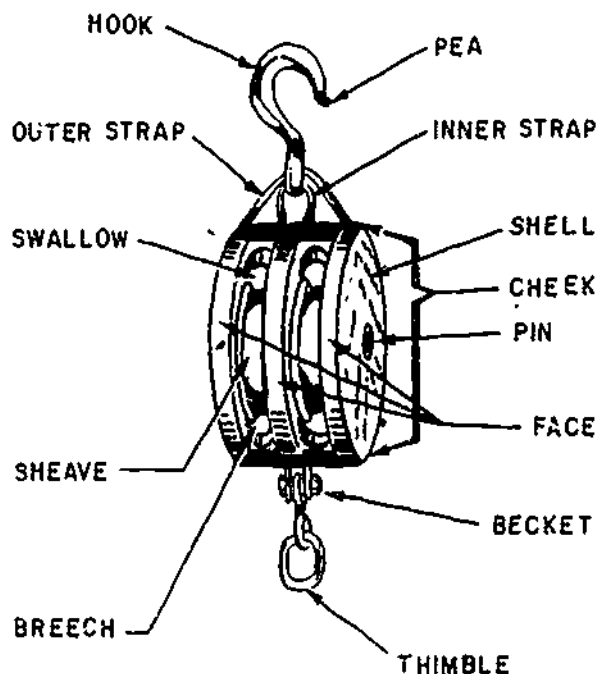

80.131

Figure 5-17.—Nomenclature of a fiber line block.

The **PIN** is a metal axle that the sheave turns on. It runs from cheek to cheek through the middle of the sheave.

The **BECKET** is a metal loop formed at one or both ends of a block; the standing part of the line is fastened to this part.

The **STRAPS** (one inner and one outer type) are used to enclose the shell, hold the block together, and support the pin on which the sheaves rotate.

The **SWALLOW** is the opening in the block through which the line passes.

The **BREECH** is the part of the block opposite the swallow.

RATIO OF SIZE OF BLOCK TO SIZE OF LINE OR WIRE USED

The size of fiber line blocks is designated by the length in inches of the shell or cheek. The size of standard wire rope blocks is controlled by the diameter of the rope. With nonstandard and special-purpose wire rope blocks, the size is

determined by measuring the diameter of one of its sheaves in inches.

Make sure you exercise care in selecting the proper size line or wire for the block to be used. If a fiber line is reeved on to a tackle whose sheaves are below a certain minimum diameter, the line will be distorted and will wear badly in a very short time. A wire rope too large for a sheave will have a tendency to be pinched, causing damage to the sheave. The wire also will be damaged because of too short a radius of bend. A wire rope too small for a sheave lacks the necessary bearing surface, thus placing the strain on only a few strands and shortening the life of the wire.

With fiber line, the length of the block used should be about three times the circumference of the line. However, an in. or so either way doesn't matter too much. For example, a 3-in. line may be reeved on to an 8-in block with no

ill effects. As a rule, you are more likely to know the block size than you are the sheave diameter. However, it may be said that the sheave diameter should be about twice the size of the circumference of the line used.

Manufacturers of wire issue tables which give the proper sheave diameters to be used with the various types and sizes of wire they manufacture. In the absence of these, a rough rule of thumb is that the sheave diameter should be about 20 times the diameter of the wire. Remember that with wire, it is DIAMETER rather than circumference, and that this rule refers to the diameter of the SHEAVE rather than the size of the block as with line.

SNATCH BLOCKS AND FAIR-LEADS

A snatch block (fig. 5-18) is a single sheave block made so that the shell opens on one side

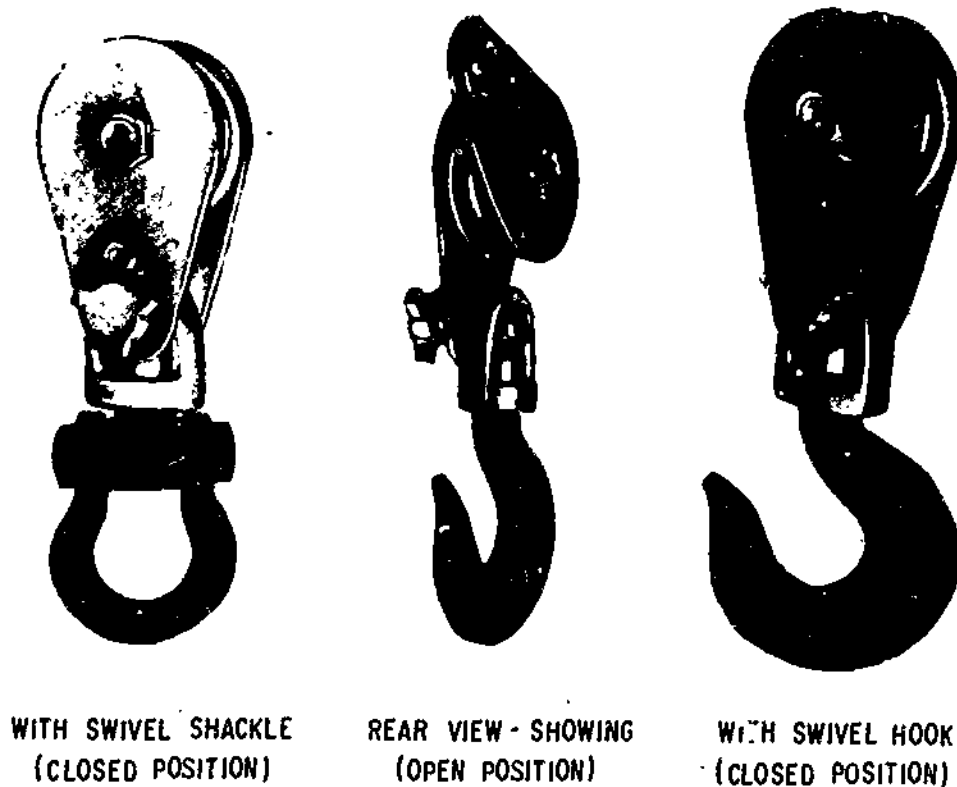

WITH SWIVEL SHACKLE
(CLOSED POSITION)

REAR VIEW - SHOWING
(OPEN POSITION)

WITH SWIVEL HOOK
(CLOSED POSITION)

Figure 5-18.—Top deadend snatch blocks.

127.489

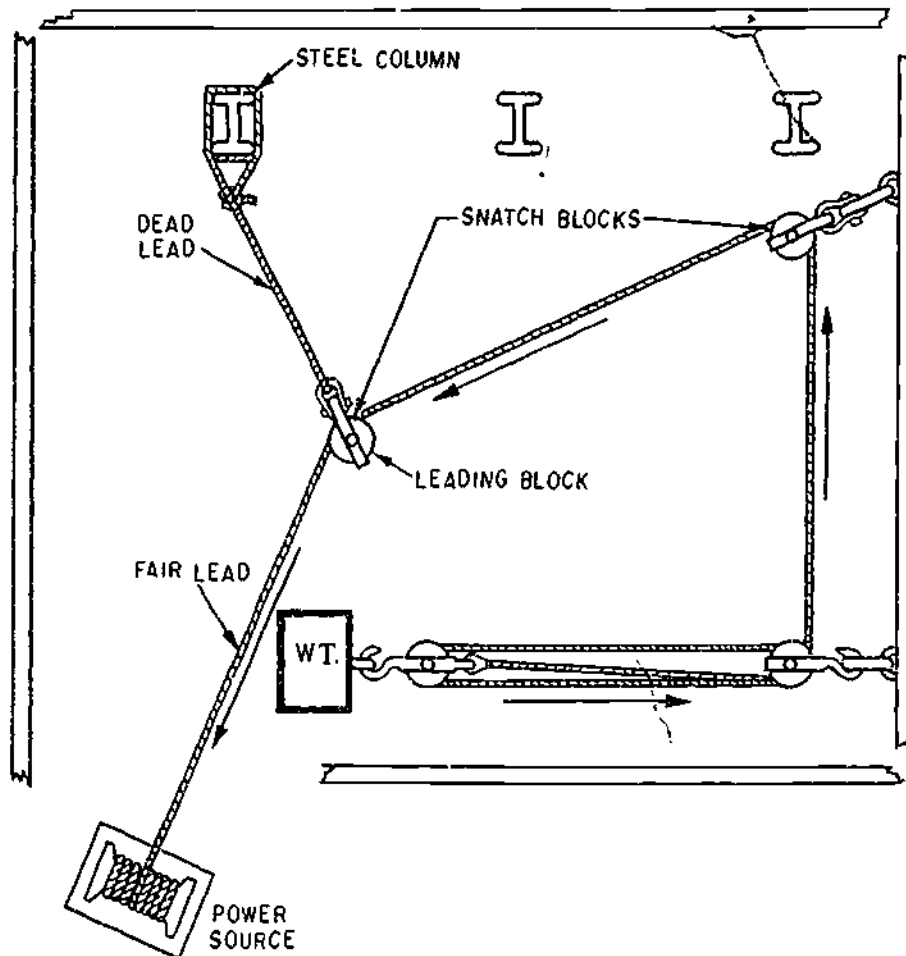

127.490

Figure 5-19.—Moving a heavy object horizontally along a floor with limited access using snatch blocks and fair lead

at the base of the hook to permit a rope or line to be slipped over a sheave without threading the end of it through the block. Snatch blocks ordinarily are used where it is necessary to change the direction of the pull on a line. Figure 5-19 shows a system of moving a heavy object horizontally away from the power source using snatch blocks, this is an ideal way to move objects in limited spaces. You will note that the weight is pulled by a single luff tackle which has a mechanical advantage of 3. By adding snatch blocks to a rigging to change the direction of pull, the mechanical advantage is NOT affected. Therefore, it would be wise to select the proper rigging system to be used, based upon the weight

of the object and the type and capacity of the power that is available. The snatch block that is used as the last block in the direction of pull to the power source is called the leading block. This block may be placed in any convenient location provided it is within 20 drum widths of the power source. This is required because the fair-lead angle or fleet angle cannot exceed 2 degrees from the centerline of the drum. Therefore, the 20 drum widths distance from the power source to the leading block will assure the fair-lead angle. If the fair-lead angle is not maintained, the line could jump the sheave of the leading block and cause the line on the reel to jump a riding turn.

TYPES OF TACKLE

Tackles are designated according to (1) the number of sheaves in the blocks that are used to make the tackle, such as single whip or twofold purchase; or (2) the purpose for which the tackle is used, such as yard tackles or stay tackles. In this section, we will discuss some of the different types of tackle in common use; namely, single whip, runner, gun tackle, single luff, twofold purchase, double luff, and threefold purchase. Before proceeding, we should explain that the purpose of the numbers and arrows in figures 5-20 through 5-26 is to indicate the sequence and direction in which the standing part of the fall is led in reeving. You may want to refer back to these illustrations when we take up the reeving of blocks in the following sections.

A SINGLE WHIP tackle consists of one single sheave block (tail block) fixed to a support with a rope passing over the sheave. (See fig. 5-20.) It has a mechanical advantage of 1,

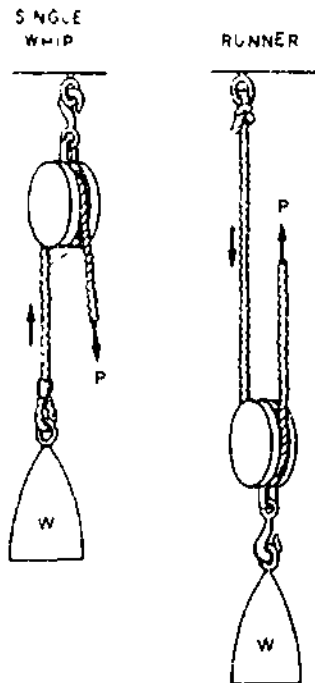

Figure 5-20.—Single whip and runner tackle.

29.187

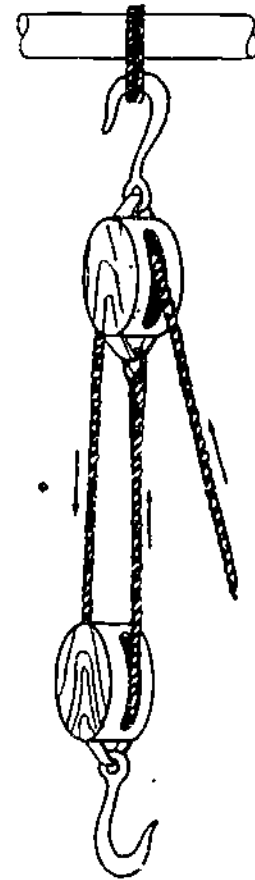

Figure 5-21.—Gun tackle.

29.187.1

and if a 100-lb load were to be lifted, it would require a pull of 100 lb plus an allowance for friction.

A RUNNER (fig. 5-20) is a single-sheave movable block that is free to move along the line on which it is reeved. It has a mechanical advantage of 2.

A GUN TACKLE is made up of two single sheave blocks (fig. 5-21). This tackle got its name in the old days because it was used to haul muzzle-loading guns back into the battery after the guns had been fired and reloaded.

A gun tackle has a mechanical advantage of 2. To lift a 200-lb load with a gun tackle would require 100 lb of power, disregarding friction.

By inverting any tackle, a mechanical advantage of 1 is always gained because the number of parts at the movable block is increased. By inverting a gun tackle, for example, a mechanical advantage of 3 is attained (fig. 5-22). When a tackle is inverted, the direction of pull is difficult. This can easily be overcome by adding a snatch block, which changes the direction of the pull, but does not increase the mechanical advantage.

A SINGLE LUFF TACKLE consists of a double and a single block, as indicated in figure 5-23. This type has a mechanical advantage of 3.

A TWOFOLD PURCHASE consists of two double blocks, as illustrated in figure 5-24. It has a mechanical advantage of 4.

A DOUBLE LUFF TACKLE has one triple and one double block. (See fig. 5-25.) A mechanical advantage of 5 is gained by using this tackle.

A THREEFOLD PURCHASE consists of two triple blocks with a mechanical advantage of 6. (See fig. 5-26.)

REEVING TACKLE

In reeving a simple tackle, lay the blocks a few feet apart. The blocks should be placed down with the sheaves at right angles to each other and the becket ends pointing toward each other.

To begin reeving, lead the standing part of the falls through one sheave of the block which has the greatest number of sheaves. If both blocks have the same number of sheaves, begin at the block fitted with the becket. Then pass the standing part around the sheaves from one block to the other, making sure no lines are crossed, until all sheaves have a line passing over

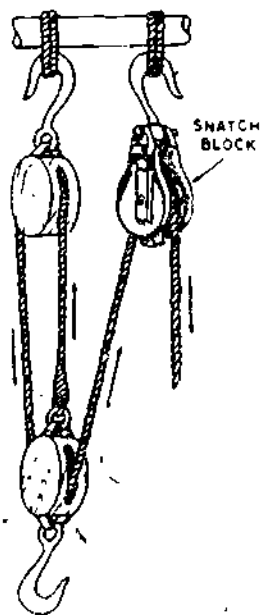

29.187(127)C

Figure 5-22.—Inverted gun tackle.



29.187.2

Figure 5-23.—Single luff tackle.

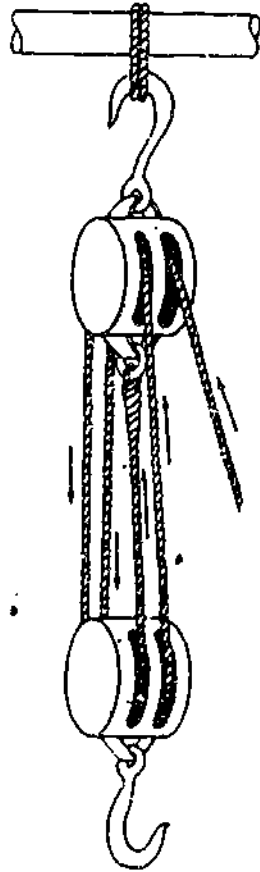

29.187.3

Figure 5-24.—Twofold Purchase.

them. Now secure the standing part of the falls at the becket of the block containing the least number of sheaves, using a becket hitch for a temporary securing, or an eye splice for a permanent securing.

With blocks of more than two sheaves, the standing part of the falls should be led through the sheave nearest the center of the block. This method places the strain on the center of the block and prevents the block from toppling and the lines from being cut by rubbing against the edges of the block.

Falls are generally reeved through 8-in. or 10-in. wood or metal blocks, in such a manner as to have the lower block at right angles to the upper. Two 3-sheave blocks is the usual arrangement, and the method of reeving these is

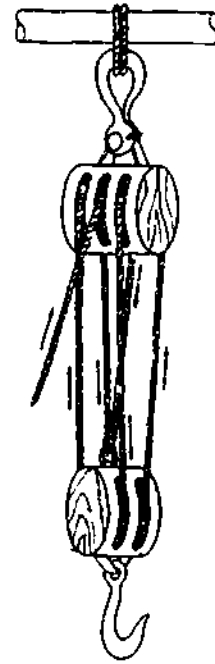

29.187E

Figure 5-25.—Double luff tackle.

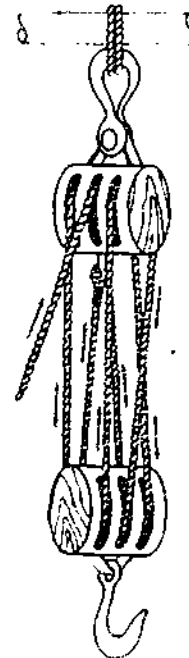

29.187F

Figure 5-26.—Threefold Purchase.

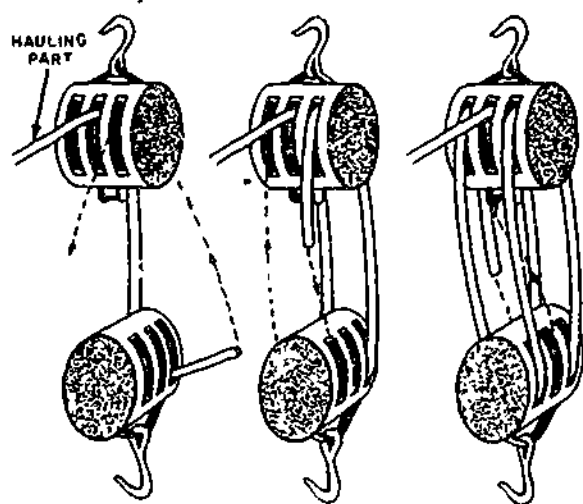

29.187G

Figure 5-27.—Reeving a threefold purchase.

shown in figure 5-27. The hauling part must go through the middle sheave of the upper block, or the block will tilt to the side and the falls jam when a strain is taken.

If a 3- and 2-sheave block rig is used, the method of reeving is about the same (fig. 5-28), but here the becket for the dead end must be on the lower rather than the upper block.

Naturally you must reeve the blocks before you splice in the becket thumble, or you will have to reeve the entire fall through from the opposite end.

MECHANICAL ADVANTAGE

The mechanical advantage of a tackle is the term applied to the relationship between the load being lifted and the power required to lift it. If the load and the power required to lift it are the same, the mechanical advantage is one. However, if a load of 50 lb requires only 10 lb to lift it, then you have a mechanical advantage of 5 to 1, or 5 units of weight are lifted for each unit of power applied.

The easiest way to determine the mechanical advantage of a tackle is by counting the number

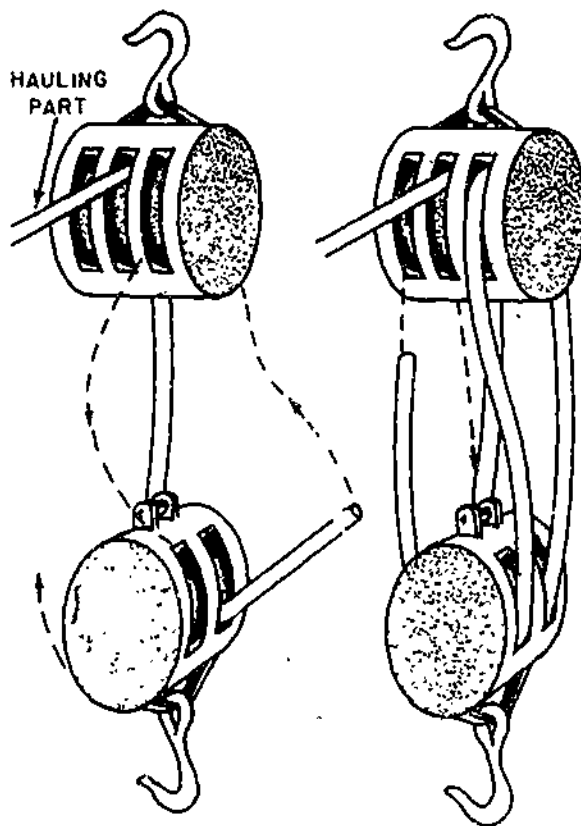

29.187H

Figure 5-28.—Reeving a double luff tackle.

of parts of the falls at the running block. If there are two parts, the mechanical advantage is two times the power applied (disregarding friction). A gun tackle, for instance, has a mechanical advantage of 2. Therefore, to lift a 200-lb load with a gun tackle would require 100 lb of power, disregarding friction.

To ascertain the amount of power required to lift a given load by means of a tackle, determine the weight of the load to be lifted and divide that by the mechanical advantage. Example: if it is necessary to lift a 600 lb load by means of a single luff tackle, first determine the mechanical advantage gained by using this type of tackle. Upon examination, it is found that by counting the parts of the falls at the movable block, we have a mechanical advantage of 3. Therefore, by dividing the weight to be

lifted, 600 lb, by the mechanical advantage in this tackle, 3, we find that 200 lb of power is required to lift a weight of 600 lb using a single luff tackle.

Remember though, a certain amount of the force applied to a tackle is lost through friction. Friction will develop in a tackle by the lines rubbing against each other, or against the shell of a block. Therefore, an adequate allowance for the loss due to friction must be added. Roughly, 10 percent of the load must be allowed for each sheave in the tackle.

SAFE WORKING LOAD OF A TACKLE

You know that the force applied at the hauling part of a tackle is multiplied as many times as there are parts of the fall on the movable block; also that an allowance for friction must be made which adds roughly 10 percent to the weight to be lifted for every sheave in the system. For example, if you are lifting a weight of 100 lb with a tackle containing five sheaves, you must add 10 percent times 5, or 50 percent, of 100 lb to the weight in your calculations. In other words, you figure that this tackle is going to lift 150 lb instead of 100 lb.

Disregarding friction, the safe working load of a tackle would be equal to the safe working load of the line or wire used, multiplied by the number of parts of the fall on the movable block. To make the necessary allowance for friction, you multiply this result by 10, and then divide what you get by 10 plus the number of sheaves in the system.

Suppose you have a threefold purchase, a mechanical advantage of 6, reeved with a line whose safe working load is 2 tons. Disregarding friction, 6 times 2, or 12 tons would be the safe working load of this setup. To make the necessary allowance for friction, however, you first multiply 12 by 10, which gives you 120. This you divide by 10 plus 6 (number of sheaves in a threefold purchase), or 16. The answer is 7 1/2 tons, safe working load.

LIFTING A GIVEN WEIGHT

To find the size of fiber line required to lift a given load, use this formula.

$$C \text{ (in inches)} = \sqrt{15 \times P \text{ (tons)}}$$

C in the formula is the circumference, in inches, of the line that is safe to use. The number 15 is the conversion factor. P is the weight of the given load, expressed in tons. The radical sign, or symbol, over $15 \times P$, indicates that you are to find the SQUARE ROOT OF that product.

To square a number means to multiply that number by itself. Finding the square root of a number simply means finding the number which, multiplied by itself, will give you the number whose square root you are seeking. If you do not understand how to work square roots, refer to *Mathematics, Volume 1, NAVPERS 10069-C*. Now let us figure what size fiber line you would need to hoist a 5-ton load.

$$C = \sqrt{15 \times 5} \text{ or } \sqrt{75}$$

The number which, multiplied by itself, comes nearest to 75 is 8.6. Therefore, a fiber line 8 1/2 in. in circumference will do the job.

The formula for finding the size of wire rope required to lift a given load is

$$C \text{ (in in.)} = \sqrt{2.5 \times P \text{ (tons)}}$$

Work this formula in the manner explained above for fiber line. One point you should be careful not to overlook is that these formulas call for the CIRCUMFERENCE of the wire. You are used to talking about wire rope in terms of its diameter, so remember that circumference is about 3 times the diameter, roughly speaking. You can also determine circumference by the following formula, which is more accurate than the rule of thumb. Circumference = diameter times Pi (π). In using this formula, remember that π equals 3.14.

**SIZE OF LINE TO USE
IN A TACKLE**

To find the size of line to use in a tackle for a given load, add one-tenth (10 percent for friction) of its value to the weight to be hoisted for every sheave in the system. Divide the result you get by the number of parts of the fall at the movable block, and use this result as P in the formula $C = \sqrt{15 \times P}$.

For example, let's say you are trying to find the size of fiber line to reeve in a threefold purchase to lift 10 tons. There are six sheaves in a threefold purchase, so you add 1/10 by 6, or 6/10 of 10, to the 10 tons. This gives you a theoretical weight to be lifted of 16 tons.

Divide 16 tons by 6 (number of parts on the movable block in a threefold purchase), and you get about 2 2/3. Using this as P in the formula $C = \sqrt{15 \times P}$, you get

$$C = \sqrt{15 \times 2 \frac{2}{3}}, \text{ or } \sqrt{40}$$

The square root of 40 is about 6.3, so it will take about a 6 1/2 in. line in this purchase to hoist 10 tons safely. As you seldom find three-sheave blocks which will take a line as large as 6 1/2 in., you will probably have to rig two threefold purchases with a continuous fall, as shown in figure 5-29. As each of these will have half the load, to find the size of line to use, calculate what size fiber line in a threefold purchase will lift 5 tons. It works out to about 4 1/2 in.

TACKLE SAFETY PRECAUTIONS

In hoisting and moving heavy objects, using blocks and tackle, you must keep SAFETY uppermost in your mind; this includes safety for crewmembers and material.

Always check the condition of blocks and sheaves before using them on a job to make sure they are in safe working order. See that the blocks are properly greased. Also make sure that the line and sheave are the right size for the job.

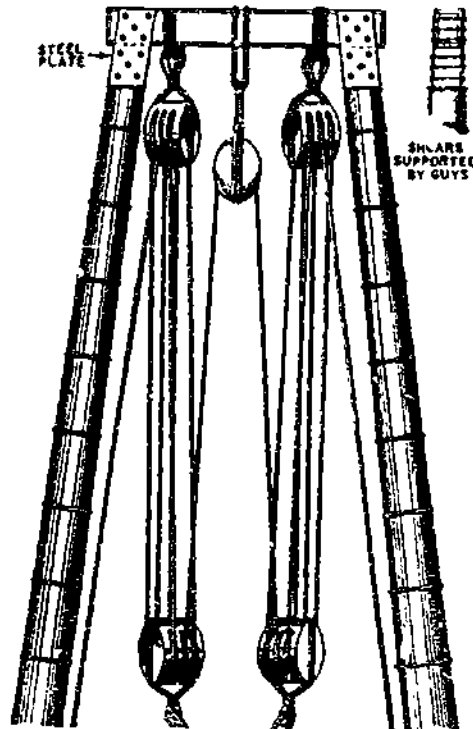

29.187X

Figure 5-29.—Rigging two tackles with a continuous fall.

Remember that sheaves or drums which have become worn or chipped or have corrugated grooves must not be used because they will injure the line. It is important to make sure the mechanical advantage is great enough to make the load as easy to handle as possible.

Sheaves and blocks designed for use with fiber line must NOT be used for wire rope, since they are not strong enough for that service and the wire rope does not fit the sheave grooves. Moreover, sheaves and blocks built for wire rope should NEVER be used for fiber line.

SHEAR LEGS

The SHEAR LEGS is formed by crossing two timbers, poles, planks, pipes, or steel bars and lashing or bolting them together near the top. A sling is suspended from the lashed intersection and is used as a means of supporting

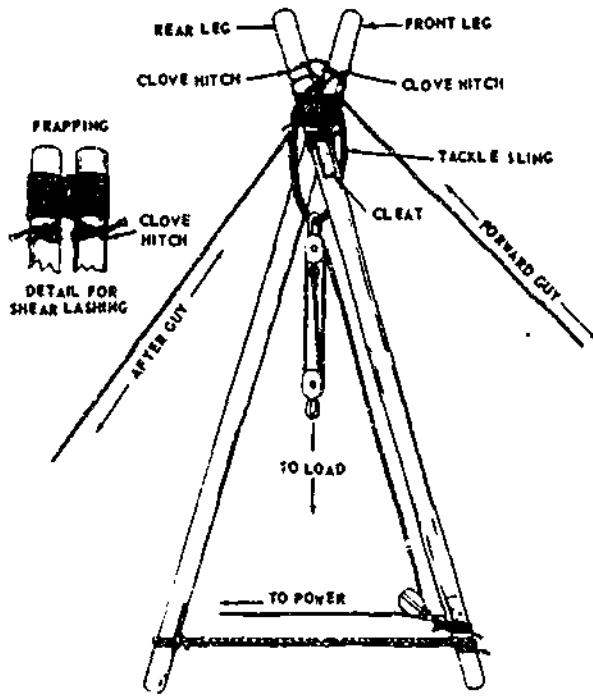

29.195

Figure 5-30.—Shear legs.

RIGGING

In rigging the shears, place your two spars on the ground parallel to each other and with their butt ends even. Next, put a large block of wood under the tops of the legs just below the point of lashing, and place a small block of wood between the tops at the same point to facilitate handling of the lashing. Now separate the poles a distance equal to about one-third the diameter of one pole.

As lashing material, use 18- or 21-thread small stuff. In applying the lashing, first make a clove hitch around one of the legs. Then take about 8 or 9 turns around both legs above the hitch, working towards the top of the legs. Remember to wrap the turns tightly so that the finished lashing will be smooth and free of kinks. To apply the frapping (tight lashings), make 2 or 3 turns around the lashing between the legs; then, with a clove hitch, secure the end of the line to the other leg just below the lashing (fig. 5-30).

Now, cross the legs of the shears at the top and separate the butt ends of the two legs so that the spread between them is equal to one-half the height of the shears. Dig shallow holes, about 1 foot (30 cm) deep, at the butt end of each leg. The butts of the legs should be placed in these holes in erecting the shears. Placing the legs in the holes will keep them from kicking out in operations where the shears is at an angle other than vertical.

The next step is to form the sling for the hoisting falls. To do this, take a short length of line, pass it a sufficient number of times over the cross at the top of the shears, and tie the ends together.

Now, reeve a set of blocks and place the hook of the upper block through the sling; then secure the hook by mousing the open section of the hook with rope yarn to keep it from slipping off the sling. Fasten a snatch block to the lower part of one of the legs, as indicated in figure 5-30.

If you need to move the load horizontally by moving the head of the shears, you must rig a tackle in the after guy—near its anchorage.

the load tackle system. (See fig. 5-30.) In addition to the name SHEAR LEGS, this rig often is referred to simply as a SHEARS. (It has also been called an A-frame.)

The shear legs is used to lift heavy machinery and other bulky objects. It may also be used as end supports of a cableway and highline. The fact that the shears can be quickly assembled and erected is a major reason why it is used in field work.

A shears requires only two guy lines and can be used for working at a forward angle. The forward guy does not have much strain imposed on it during hoisting. This guy is used primarily as an aid in adjusting the drift of the shears and in keeping the top of the rig steady in hoisting or placing a load. The after guy is a very important part of the shears' rigging, as it is under considerable strain when hoisting. It should be designed for a strength equal to one-half the load to be lifted. The same principles for thrust on the spars or poles apply; that is, the thrust increases drastically as the shear legs go off the perpendicular.

The guys—one forward guy and one after guy—are secured next to the top of the shears. Secure the forward guy to the rear leg and the after guy to the front leg, using a clove hitch in both instances. (See fig. 5-30.)

ERECTING

Several persons are needed for safe, efficient erection of the shears, the number being determined largely by the size of the rig. To help insure good results, the erection crew should lift the top of the frame and walk it up by hand until the after guy tackle system takes over the load. When this point is reached, complete the raising of the shears into final position by hauling in on the tackle.

Remember to secure the forward guy to its anchorage before raising the legs and maintain a slight tension on the line to control the movement. Also, after the shears has been

raised, lash the butt ends with chain, line, or boards to keep them from spreading when a load is applied.

SAFE WORKING LOAD OF SHEAR LEGS

Overloading shear legs poses a serious threat to the safety of personnel, not to mention the damage and loss of the material being lifted. To help avoid this problem, a study of table 5-1 will show that the load-carrying capacities vary with the length and size of timbers used in the construction of shear legs.

TRIPODS

A tripod consists of three legs of equal length, which are lashed together at the top.

Table 5-1.—Load-Carrying Capacities of Shear Legs and Tripods

Pole Size (inches)	Length (feet)	Working Capacity (tons) Shear Legs (2) poles	Working Capacity (tons) Tripods (3) poles
6 x 6	20	8	13
	25	5	7
	30	3	5
8 x 8	25	12	18
	30	8	13
	40	5	7
10 x 10	50	3	5
	20	35	52
	25	26	39
	30	17	26
12 x 12	40	10	15
	50	7	10
	30	35	52
	40	21	31
	50	14	21
	60	10	15

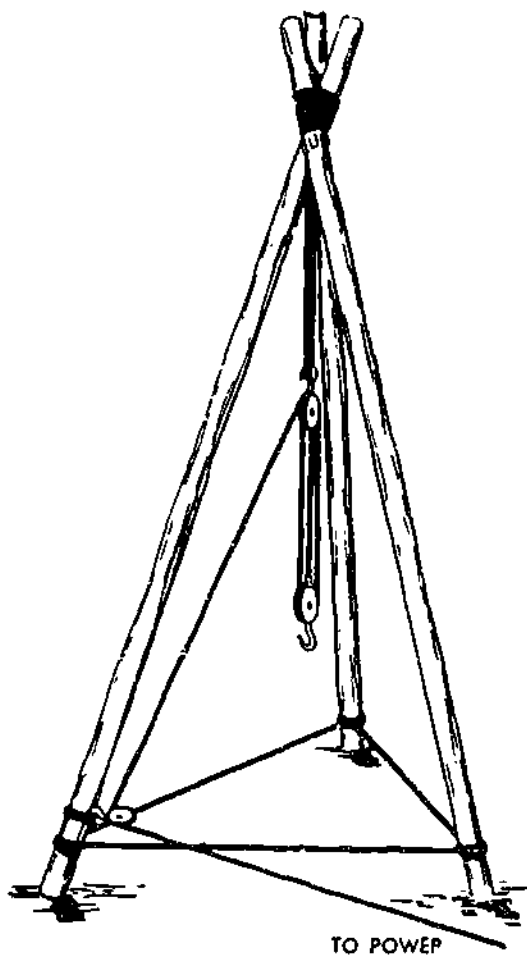

29.196

Figure 5-31.—Tripod.

(See fig 5-31.) The legs are generally made of timber poles or pipes. Materials used for lashing include fiber line, wire rope, and chain. Metal rings joined with short chain sections are also available for insertion over the top of the tripod legs.

The fact that the tripod can only be used where hoisting is vertical places it at a distinct disadvantage in comparison with other hoisting devices. Its use will be limited primarily to jobs that involve hoisting over wells, mine shafts, or other such excavations. A major advantage of the tripod is its great stability. In addition, it requires no guys or anchorages, and its load capacity is approximately one-third greater than

shears made of the same size timbers. (See table 5-1.)

RIGGING

The strength of a tripod depends largely on the strength of the material used for lashing, as well as the amount of lashing used. The following procedure for lashing applies to a line 3 in. in circumference or smaller. For extra heavy loads, use more turns than specified in the procedure given here; for light loads, use fewer turns than specified here.

As the first step of the procedure, take three spars of equal length and place a mark near the top of each to indicate the center of the lashing. Now, lay two of the spars parallel with their TOPS resting on a skid (or block). Place the third spar between the two, with the BUTT end resting on a skid. Position the spars so that the lashing marks on all three are in line. Leave an interval between the spars equal to about one-half the diameter of the spars. This will keep the lashing from being drawn too tight when the tripod is erected.

With the 3-in. line, make a clove hitch around one of the outside spars; put it about 4 in. above the lashing mark. Then make 8 or 9 turns with the line around all three spars. (See view A, fig. 5-32.) In making the turns, remember to maintain the proper amount of space between the spars.

Now, make 1 or 2 close frapping turns around the lashing between each pair of spars. Do not draw the turns too tight. Finally, secure the end of the line with a clove hitch on the center spar just above the lashing, as shown at A, figure 5-32.

There is another method of lashing a tripod which you may find preferable to the method just given. It may be used in lashing slender poles up to 20 ft in length, or when some means other than hand power is available for erection.

First, place the three spars parallel to each other, leaving an interval between them slightly greater than twice the diameter of the line to be used. Rest the top of each pole on a skid so that

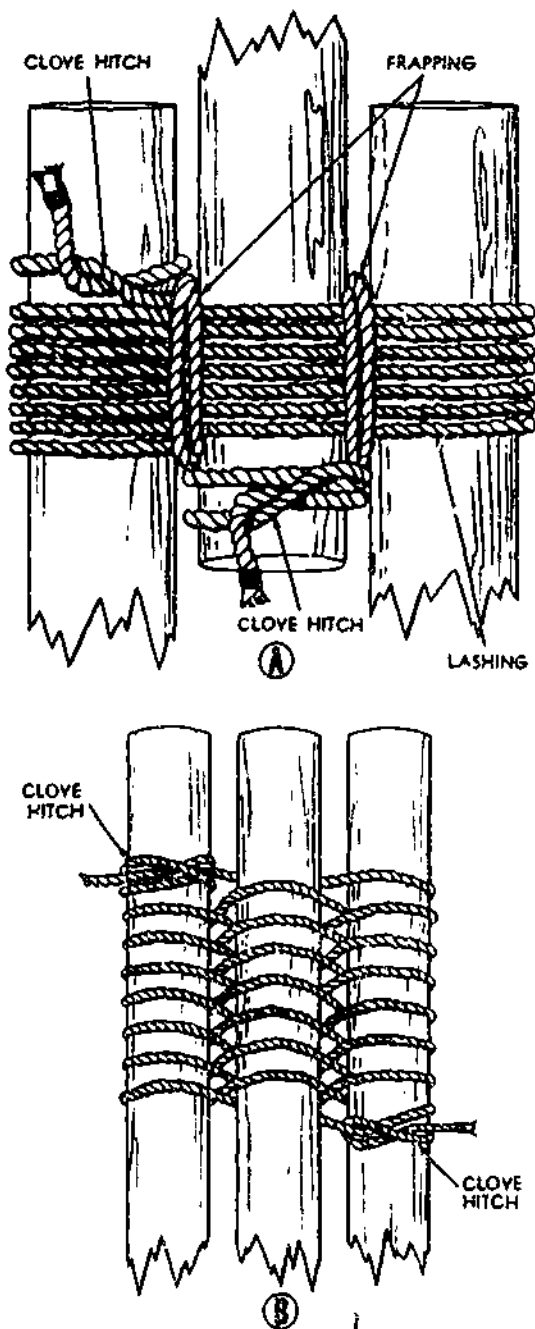

Figure 5-32.—Lashings for a tripod.

58.10

the end projects about 2 ft over the skid. Then, line up the butts of the three spars, as indicated at B, figure 5-32.

Next, make a clove hitch on one outside leg at the bottom of the position the lashing will

occupy, which is about 2 ft from the end. Now, proceed to weave the line over the middle leg, under and around the other outside leg, under the middle leg, over and around the first leg, and so forth, until completing about 8 or 9 turns. Finish the lashing by forming a clove hitch on the other outside leg (view B, fig. 5-32).

ERECTING

In the final position of an erected tripod, it is important that the legs be spread an equal distance apart. The spread between legs must be not more than two-thirds, nor less than one-half, the length of a leg. Small tripods, or those lashed according to the first procedure given in the preceding section, may be raised by hand. Here are the main steps which make up the hand-erection procedure.

Start by raising the top ends of the three legs about 4 ft, keeping the butt ends of the legs on the ground. Now, cross the tops of the two outer legs and position the top of the third or center leg so that it rests on top of the cross.

A sling for the hoisting tackle can be attached readily by first passing the sling over the center leg, and then around the two outer legs at the cross. Place the hook of the upper block of a tackle on the sling, and secure the hook by mousing.

The raising operation can now be completed. To raise an ordinary tripod, a crew of about eight may be required. As the tripod is being lifted, spread the legs so that when it is in the upright position the legs will be spread the proper distance apart. After getting the tripod in its final position, lash the legs near the bottom with line or chain to keep them from shifting (fig. 5-31).

Where desirable, a leading block for the hauling part of the tackle may be lashed to one of the tripod legs, as indicated in figure 5-31

In erecting a large tripod, you may need a small gin pole to aid in raising the tripod into position. When called on to assist in the erection of a tripod lashed according to the first lashing

procedure described in the preceding section, the first thing to do is to raise the tops of the legs far enough from the ground to permit spreading them apart. Use guys or tag lines to help hold the legs steady while they are being raised. Now, with the legs clear of the ground, cross the two outer legs and place the center leg so that it rests on top of the cross. Then attach the sling for the hoisting tackle. Here, as with a small tripod, simply pass the sling over the center leg and then around the two outer legs at the cross.

LADDERS

A sufficient supply of ladders, as indicated by the nature of the work, must be provided at the site before construction can begin. However, the use of ladders, where scaffolds, platforms, or other substantial working levels could have been provided, has caused many serious accidents. Any work performed on ladders should be confined to a minimum.

TYPES OF LADDERS

A number of different types of ladders are available in construction today. Among the various types which you may use frequently for construction work are single portable ladders, extension ladders, fixed ladders, and stepladders. Ladders are designed with safety in mind, and a safe working load factor has been established by the manufacturer and is normally shown on the ladders. These ladders are usually designed for an approximate 250 lb load plus a safety factor of 4 or its ultimate load capacity of 1,000 lb.

A SINGLE PORTABLE ladder is a ladder of one section which may be used at various locations. This type should not exceed 30 ft in length. In the placement of a ladder, careful consideration must be given for placing it at a safe angle against the wall or other fixed object to be scaled. Figure 5-33 illustrates the correct positioning of a single portable construction ladder. Unless the ladder is securely fastened or someone is holding it, the base should be one-fourth the ladder length from the vertical plane of the top support. Where the rails extend above the top landing, the ladder length to the top support only is considered.

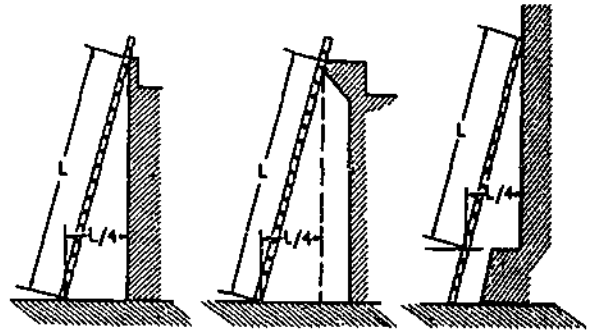

Figure 5-33.—Correct angles for ladder placement.

127.61

The clearance space IN BACK of a single portable ladder should always be sufficient to obtain a secure foothold on the rungs. A back clearance of at least 6 in. is recommended. The clearance space IN FRONT of the ladder should be such that it will not be necessary to assume a cramped or unnatural position when climbing. A front clearance of at least 30 in. is recommended.

If a portable ladder is to be used on smooth floors, concrete walks, or sloping surfaces, make sure it is equipped with a nonslip base or that other suitable means is provided to prevent displacement while in use. Single portable ladders not constructed for use as sectional ladders must not be spliced together to form a longer ladder.

An EXTENSION ladder is one consisting of two sliding sections which can be adjusted to different heights. No extension ladder may contain more than two sections, nor may it be extended to more than 60 ft. An extension ladder must be constructed to bring the RUNGS (horizontal members) of overlapping parts of sections opposite each other when the ladder is locked in extended position. Again, when an extended ladder is placed in position for use, the horizontal distance from the vertical plane of the upper support to the base should be one-fourth of the ladder length.

For extension lengths up to 38 ft the minimum section overlap should be 3 ft; for lengths from 38 to 44 ft it should be 4 ft, and for lengths from 44 to 60 ft it should be 5 ft.

Most requirements for a ladder are satisfied with the single portable and extension types. However, the fixed ladder and the stepladder may be required under certain conditions.

A **FIXED** ladder is one which is fastened to a structure in a more or less permanent manner. Top, bottom, and intermediate fastenings must be used as required. The **RAILS** (vertical members) of a fixed ladder must extend at least 36 in. above the top landing. If the landing at the top requires passing between the rails, rungs above the landing must be removed.

A **STEPLADDER** is a portable ladder which opens out, sawhorse-fashion, for self-support. The maximum permissible height for a stepladder is 16 ft. Stepladders must always be used fully opened, and they should not be used as regular working platforms.

LADDER SAFETY

Here are a few important safety precautions which apply to ladders in general.

Ladders should be inspected at regular and frequent intervals. Ladders with weakened, broken, or missing treads, rungs, or cleats, or broken or "splintered" side rails should not be used.

Ladders should be kept coated with a clear shellac or other transparent material, or treated with linseed oil. Painting with opaque (nontransparent) paint is forbidden.

Separate ladders for ascending and descending should be provided in building construction of more than 2 stories in height, or where traffic is heavy.

Where a ladder is installed wide enough to permit traffic in both directions at the same time, a center rail should be provided. One side of the ladder should be plainly marked "up" and the other side "down".

Ladders used in passageways, driveways, or thoroughfares should be guarded by barricades (guardrails). Doors which open adjacent to portable ladders should be locked or otherwise blocked or guarded while the ladder remains in use.

Ladders should be placed so that the rails have a secure footing and a substantial support at or near the top.

Ladders should not be placed against sash, window panes, or unstable supports such as loose boxes or barrels. The use of ladders during a storm or in a high wind should be avoided unless absolutely necessary, in which case the ladder should be securely lashed in position.

If a ladder is to be placed against a window frame, a board should first be spiked across the side rails at the top.

Ladders should not normally be placed or used in elevator shafts or hoistways. Should such a procedure be necessary, the ladders should be protected from objects from operation at higher elevations in or adjoining the shaft.

Ladders should not be left standing, especially on the outside, for long periods of time unless securely anchored at both top and bottom.

Ladders should be handled carefully when being lowered. They should not be allowed to drop on their sides or to fall heavily endwise on one rail.

Ladders constructed of metal should not be used near electricity.

Until such time as satisfactory specification for portable metal ladders approved by the Navy Department is issued, the use of such ladders is not recommended. These ladders should not be used within 4 ft of any electrical wiring or equipment. All portable metal ladders should be marked with signs or decals reading **CAUTION—DO NOT USE NEAR ELECTRICAL EQUIPMENT**. Such signs should be placed on the inside rails between the third and fourth rungs.

When ascending or descending a ladder, the user should always face the ladder.

No one should go up or down a ladder without the free use of both hands. If handling material, a rope should be used.

No one should run up or down a ladder, or slide down a ladder, at any time.

Before attempting to climb a ladder, crewmembers should remove oil or grease from the soles of their shoes.

When doing maintenance work above the ground, crewmembers should always wear a safety belt, with a lifeline long enough for necessary movement, but short enough to prevent falls.

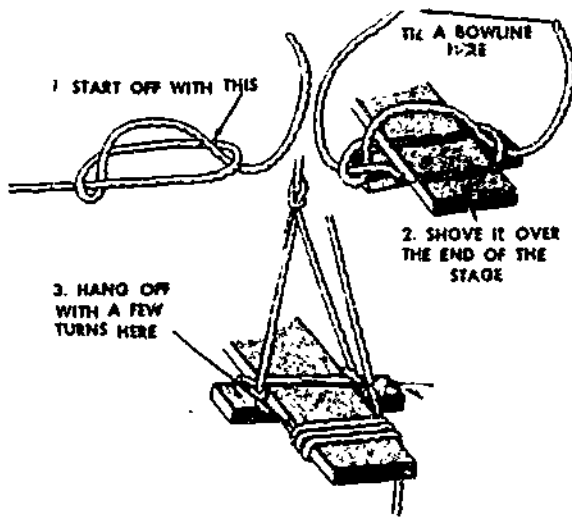

118.37

Figure 5-34.—Making a scaffold hitch.

Single portable ladders over 30 ft in length should not be used.

Fixed ladders should be securely held in place by top, bottom, and intermediate fastenings as required.

Sloping ladders which require climbing on the underside of the ladder should not be used.

Rails of ladders fixed to top landing should extend a distance of at least 36 in. above the landing. Rungs above the landing should be omitted when it is necessary to pass through the ladder. Landing platforms should be provided where a person must step a greater distance than 14 in. from the ladder to roof, tank, etc.

SCAFFOLDING

As the working level of a structure rises above the reach of crewmembers on the ground, temporary elevated platforms called SCAFFOLDING are erected to support the crewmembers, their tools, and materials.

There are two types of scaffolding in use today wood and prefabricated. The wood types

include the swinging scaffold which is suspended from above, and the pole scaffold which is supported on the ground. The prefabricated type is made of metal and is put together in sections as needed.

SWINGING SCAFFOLD CONSTRUCTION

The simplest type of swinging scaffold is one which consists simply of a stout plank (minimum thickness 2 in.) with a couple of transverse HORNS nailed or bolted to the underside, near the ends. The stage hangs from a couple of lines, (minimum size, 2 in.) which lead up and over or through some supporting device (such as a pair of shackles secured to outriggers at the roof line) and back to the stage.

Figure 5-34 shows the method of bending a bowline to a stage by means of a SCAFFOLD HITCH. A stage provides a convenient means for working down from upward (painting down a wall from roof line to ground level, for instance), but since you can't hoist yourself

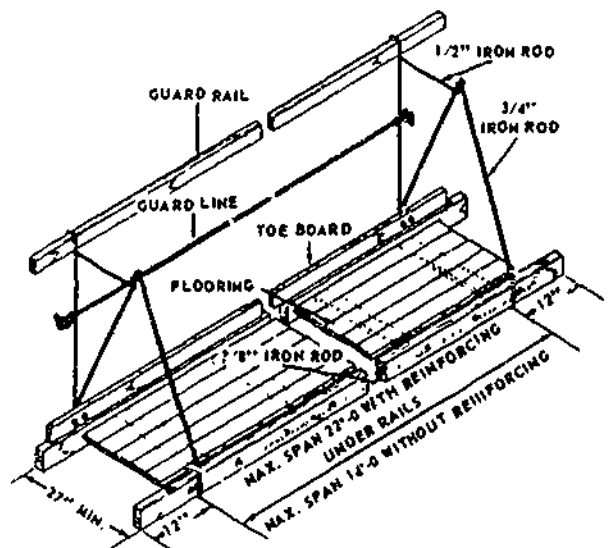

Figure 5-35.—Swinging scaffold.

127.59

aloft on a stage, it's no good for working from down upward.

When the rig shown in figure 5-35 is hooked to the tackles, you can move up or down at will, simply by heaving in or slacking out on the tackles. The two projecting timbers to which the tackles will be attached are called **OUT-RIGGERS**.

POLE SCAFFOLD CONSTRUCTION

The poles on a job-built pole scaffold should not exceed 40 ft in height. If higher poles than this are required, the scaffolding must be designed by an engineer. (See figs. 5-36, 5-37, and 5-38.)

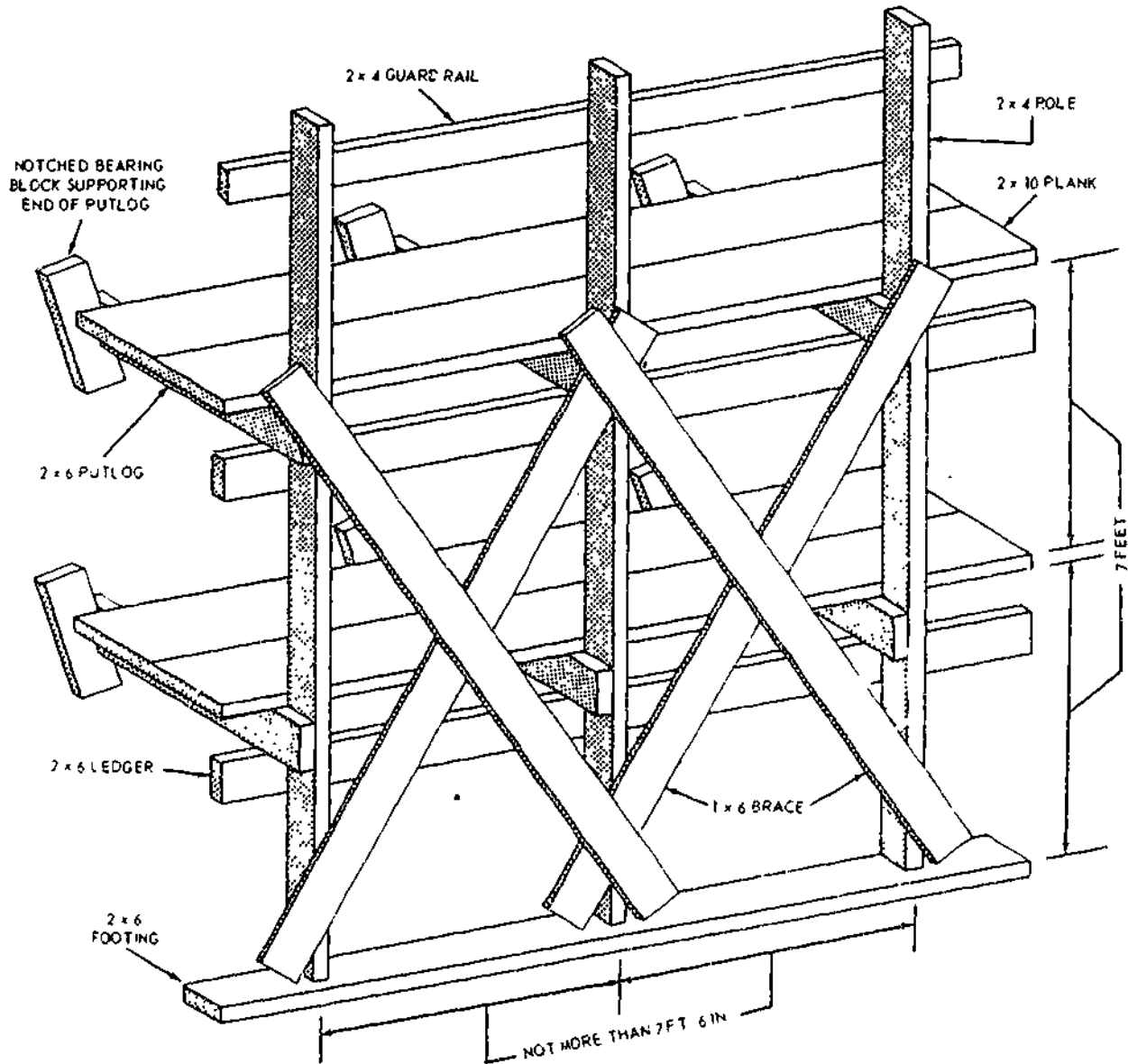

Figure 5-36.—Single pole scaffolding.

133.2

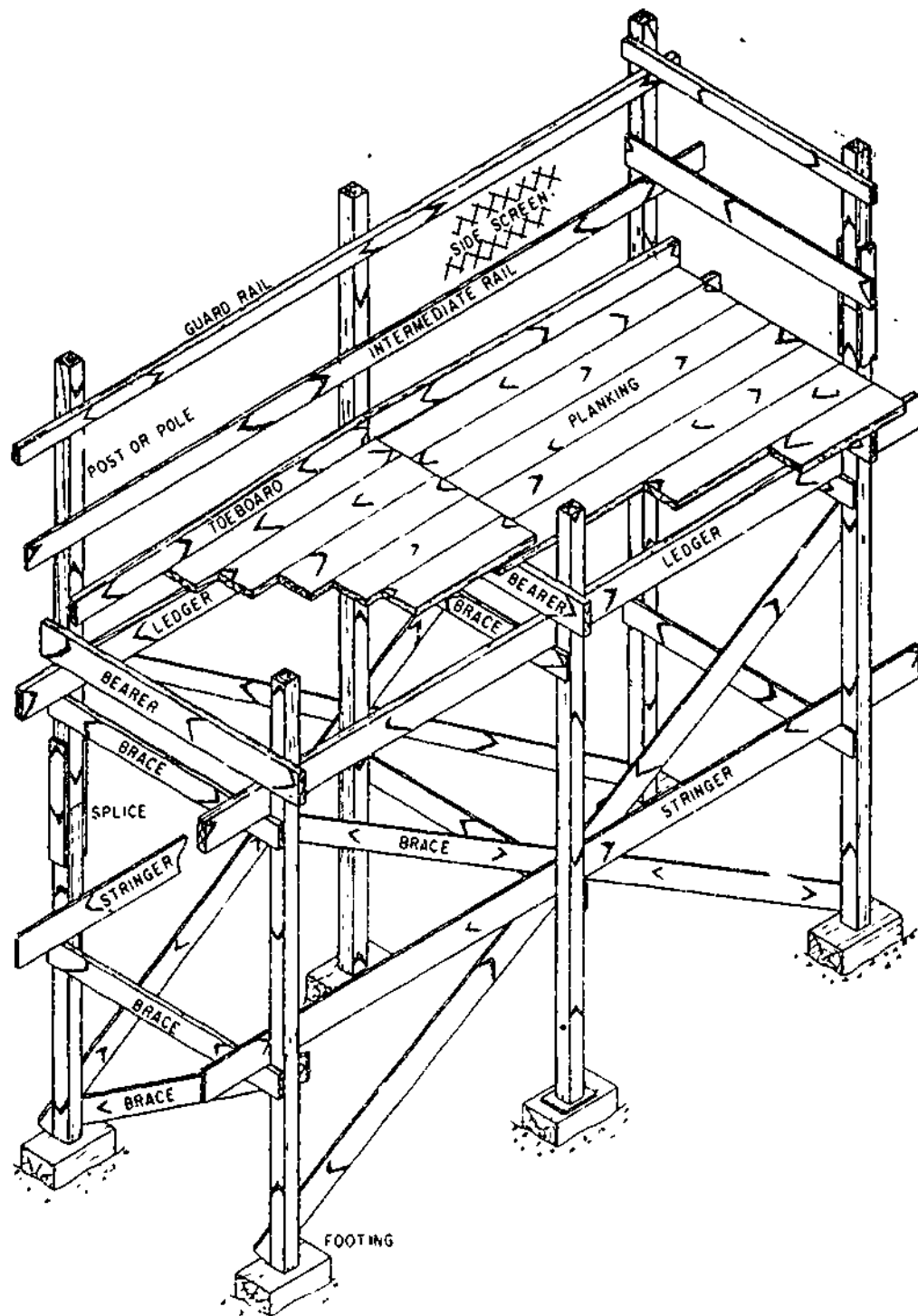

Figure 5-37.—Double-pole or independent-pole scaffolding.

133.443

5-30

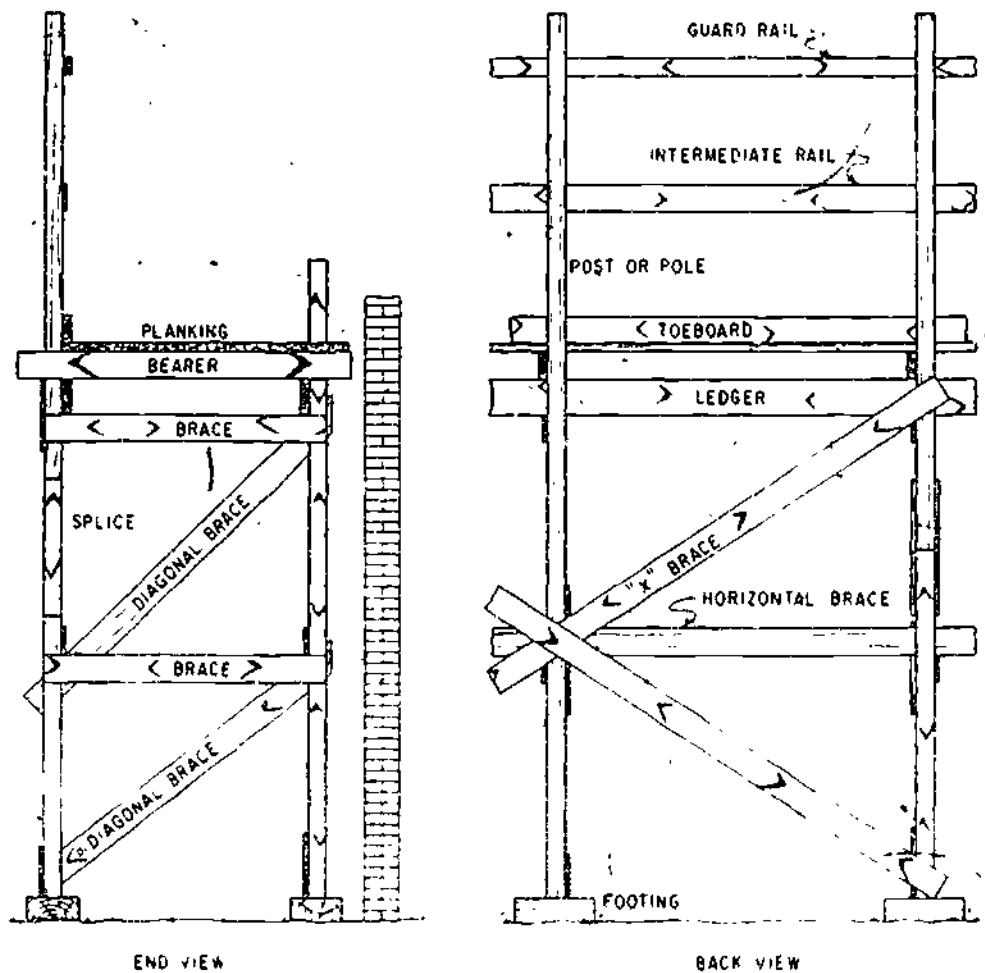

Figure 5-38.—Diagonal bracing shown for double-pole or independent-pole scaffolding.

133.444

For a light-duty (not over 25 lb per sq ft) scaffold, either single-pole or double-pole, the minimum lumber dimensions are as follows:

Poles: 24 ft or less, 2 by 4, 24 ft to 40 ft, 2 by 6
 Putlogs: 2 by 6 on edge
 Ledgers: 2 by 6
 Braces: 1 by 4
 Planking: 2 by 10
 Guardrails: 2 by 4

For a heavy-duty (25 to 75 lb per sq ft) single-pole scaffold the minimum dimensions are as follows:

Poles: 24 ft or less, 2 by 6, 24 ft to 40 ft, doubled 2 by 4
 Putlogs: doubled 2 by 4, or 2 by 8 on edge
 Ledgers: 2 by 8
 Braces: 1 by 6
 Planking: 2 by 10
 Guardrails: 2 by 4

For a heavy-duty double-pole scaffold the minimum lumber dimensions are as follows.

Poles:	24 ft or less, 2 by 6, 24 ft to 40 ft: for load from 25 to 50 lb per sq ft, double 2 by 4, for load from 50 to 75 lb per sq ft, double 2 by 6
Putlogs:	2 by 8 on edge
Ledgers	2 by 8
Braces:	1 by 6
Planking	2 by 10
Guardrails:	2 by 6

The longitudinal maximum pole spacing for a light-duty scaffold is 7 ft 6 in. For a heavy-duty scaffold it is 7 ft.

The transverse maximum pole spacing for light- or heavy-duty independent-pole scaffold with poles up to 24 ft is 6 ft 6 in. For a light-duty independent-pole scaffold with poles 24 to 40 ft the transverse maximum pole spacing is 7 ft. For a heavy-duty independent-pole scaffold with poles 24 to 40 ft the transverse maximum spacing is 10 ft.

For a single-pole light- or heavy-duty scaffold the pole spacing from the wall should be from 3 to 9 ft.

For a light-duty scaffold the maximum ledger vertical spacing is 7 ft. For a heavy-duty scaffold the maximum ledger vertical spacing is 4 ft 6 in.

Construction requirements for pole scaffolds are as follows:

All poles must be set up perfectly plumb.

The lower ends of poles must not bear directly on a natural earth surface. If the surface is earth, a board footing 2 in. thick and from 6 to 12 in. wide (depending on the softness of the earth) must be placed under the poles.

If poles must be spliced, splice plates must not be less than 4 ft long, not less than the

width of the pole wide, and each pair of plates must have a combined thickness not less than the thickness of the pole. Adjacent poles must not be spliced at the same level.

A ledger must be long enough to extend over two pole spaces; and it must overlap the poles at the ends by at least 4 in. Ledgers must be spliced by overlapping and nailing AT POLES—never between poles. If platform planks are raised as work progresses upward, the ledgers and putlogs on which the planks previously rested must be left in place to brace and stiffen the poles. For a heavy-duty scaffold, ledgers must be supported by cleats, nailed or bolted to the poles, as well as by being nailed themselves to the poles.

A single putlog must be set with the longer section dimension vertical, and putlogs must be long enough to overlap the poles by at least 3 in. They should be both face nailed to the poles and toenailed to the ledgers. When the inner end of the putlog butts against the wall (as it does in a single-pole scaffold), it must be supported by a 2 x 6 bearing block not less than 12 in. long, notched out the width of the putlog and securely nailed to the wall. The inner end of the putlog should be nailed to both the bearing block and the wall. If the inner end of a putlog is located in a window opening, it must be supported on a stout plank nailed across the opening. If the inner end of a putlog is nailed to a building stud, it must be supported on a cleat of the same thickness as the putlog, nailed to the stud.

A platform plank must never be less than 2 in. thick. Edges of planks should be close enough together to prevent tools or materials from falling through the opening. A plank must be long enough to extend over 3 putlogs, with an overlap of at least 6 in. But not more than 12 in.

PREFABRICATED SCAFFOLD ERECTION

Several types of patent independent scaffolding are available for simple and rapid

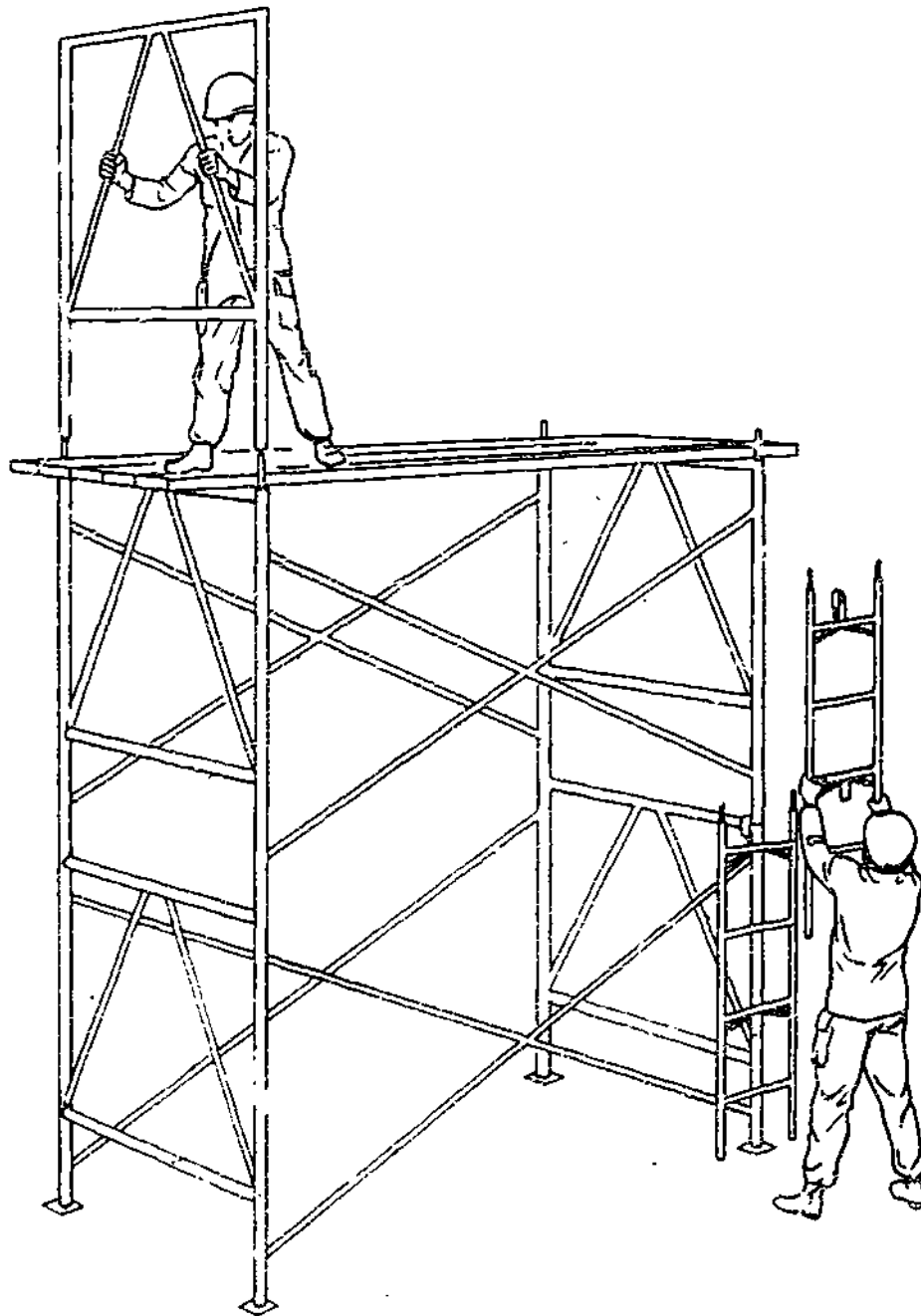

133.247

Figure 5-39.—Assembling prefabricated independent-pole scaffolding

erection as shown in figure 5-39. The scaffold uprights are braced with diagonal members as shown in figure 5-40, and the working level is covered with a platform of planks. All bracing must form triangles and the base of each column

requires adequate footing plates for bearing area on the ground. The patented steel scaffolding is usually erected by placing the two uprights on the ground and inserting the diagonal members. The diagonal members have end fittings which

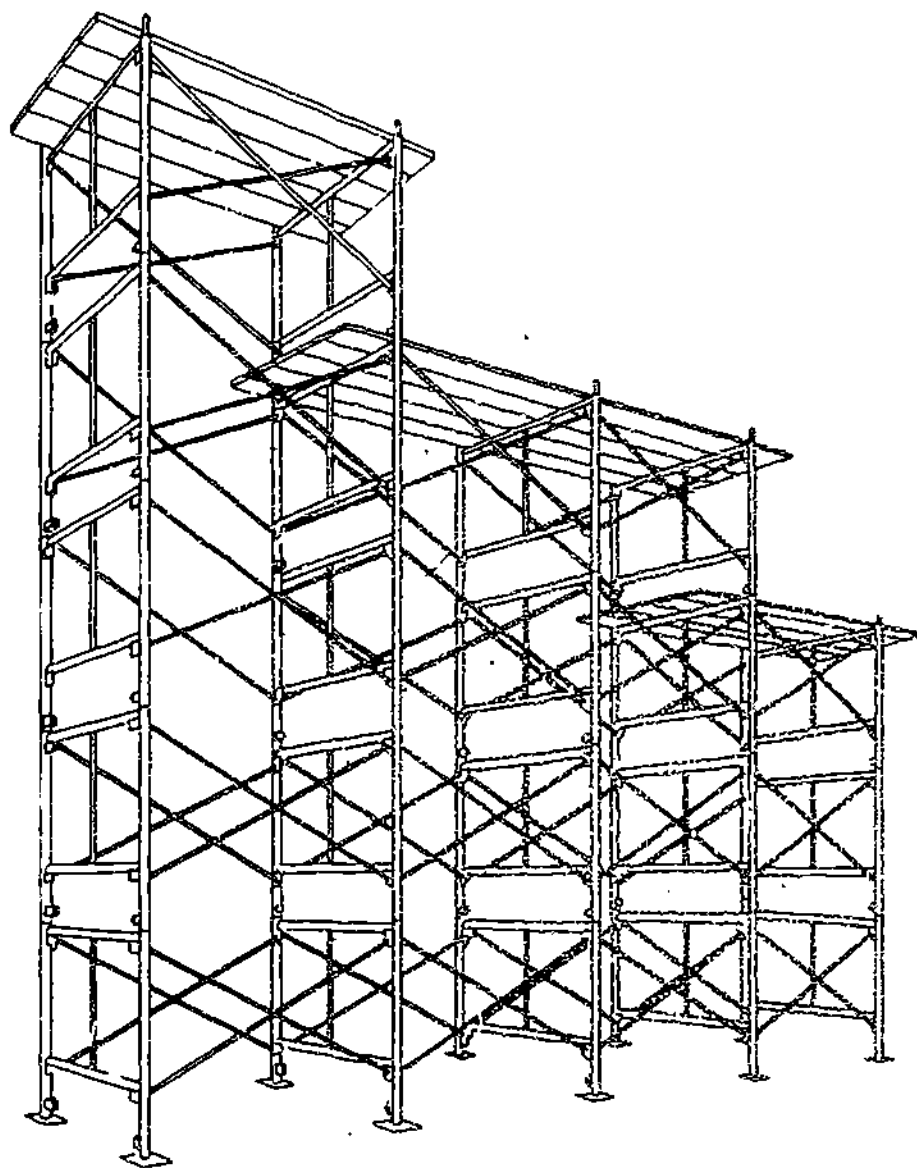

Figure 5-40.—Prefabricated independent-pole scaffolding.

133.248

permit rapid locking in position. The first tier is set on steel bases on the ground, and a second tier is placed in the same manner on the first tier with the bottom of each upright locked to the top of the lower tier. A third and fourth upright can be placed on the ground level and locked to the first set with diagonal bracing. The scaffolding can be built as high as desired, but

high scaffolding should be tied in to the main structure.

Steel and aluminum scaffolding is used to speed up construction and maintenance operations. For interior work and erection, there are many types. Figure 5-41 shows a type of scaffolding used around many construction sites because this type can be disassembled and

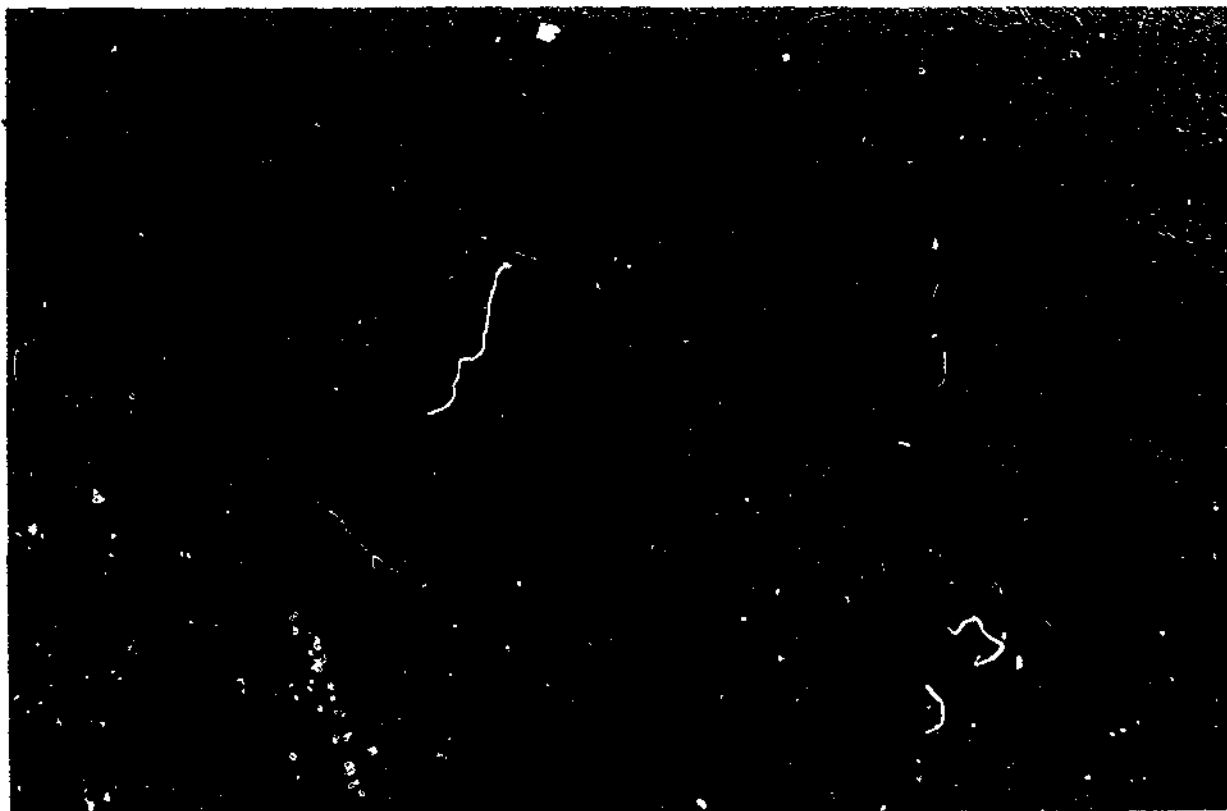

133.5

Figure 5-41.—The scaffolding used for interior work and erection of a construction project.

transported whenever necessary. They are mounted on steel casters, with brakes and adjustable supports, which permit quick movement and positioning of each tower. This scaffolding is equipped with special, trussed planks, 12 ft long, which are placed to enable crewmembers to be within comfortable and safe working distance of all building connections.

BRACKET SCAFFOLDS

Bracket scaffolding (fig. 5-42) has certain advantages over the ones previously discussed, it is easier to erect, involves less labor, and requires less material. This type scaffold can be easily constructed of wood and, in some areas, is readily available in prefabricated steel.

Caution is a must when fastening steel bracket scaffolding in place with nails, because

the nails must be driven as not to break the heads. Nails with broken heads are definitely unsafe for scaffolds. Some brackets are even fastened to the wall with spikes while others may be hooked around a stud. The latter type of bracket is safe, but requires the making of a hole in the sheathing for withdrawal of the bracket. To fasten another type steel bracket, you need to bore a hole in a 2 by 4 crosspiece nailed to the inside of a stud.

The most simple bracket and yet sturdy is the wooden bracket and the Builder can construct it on the job. Some wooden brackets are fastened to the wall and some are not. The ones not fastened to the wall are supported by 2 by 4's set at an angle of 45 degrees. The brackets are held in place and kept from tipping or sliding on the wall by using cross braces of 1 by 6 material.

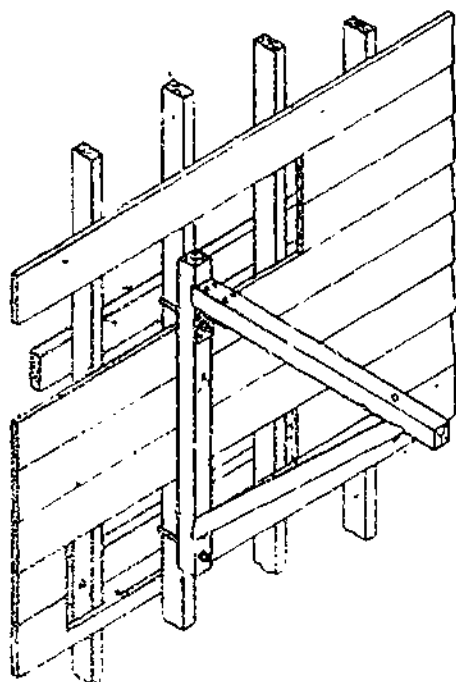

133.445

Figure 5-42.—Carpenter's portable bracket for scaffolding.

Another type of commonly used bracket scaffolding is the ladder jack, as shown in figure 5-43. This type of bracket scaffolding requires very little material and labor to set it up.

SCAFFOLD SAFETY

The following scaffolding safety precautions must be observed by all persons working on scaffolds or tending other persons who are working on scaffolds. Builder petty officers must not only observe the safety precautions themselves, but also promulgate them to their crew and insure that the crew observe them.

Standard scaffolds suitable to the work at hand must be provided and used. The use of makeshift substitutes is prohibited.

All scaffolds must be maintained in a safe condition, and a scaffold must not be altered or disturbed while in use. Personnel must not be allowed to use damaged or weakened scaffolds.

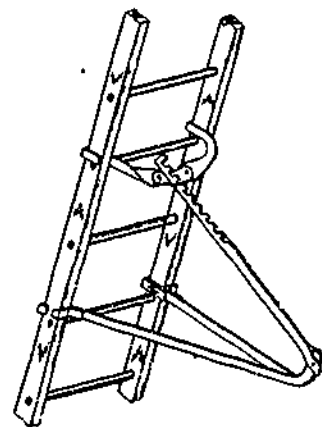

133.446

Figure 5-43.—Ladder jack for scaffolding.

Structural members, supporting lines and tackles, and other scaffold equipment must be inspected daily before work on scaffolding is started.

When crewmembers working on a scaffold are directly below others working above, the ones below must be sheltered against possible falling objects by protective headgear.

If the frequent presence of personnel directly under a scaffold is unavoidable, a protective covering must be set up under the scaffold. A passageway or thoroughfare under a scaffold must have both overhead and side protection.

Access to scaffolds must be by standard stairs or fixed ladders only.

The erection, alteration, and dismantling of scaffolds must be done under the supervision of crewmembers who are experienced in scaffold work.

When scaffolding is being dismantled it should be cleaned, and ready for storage or use. Scaffolding that is not ready for use should never be stored.

Work on scaffolds should be secured during storms or high winds, or when scaffolds are covered with ice or snow.

Chapter 5 -FIBER LINE, WIRE ROPE, AND SCAFFOLDING

Unstable objects, such as barrels, boxes, loose brick, or building blocks, must not be used to support scaffold planking.

No scaffold may be used for the storage of materials in excess of those currently required for the job.

Tools not in immediate use on scaffolds must be stowed in containers, to prevent tools left afloat from being knocked off. Tool containers must be lashed or otherwise secured to the scaffolds.

Scaffolds must be kept clear of accumulations of tools, equipment, materials, and rubbish.

If part of a scaffold must be used as a loading or landing stage for materials, the scaffold must be additionally braced and reinforced at and around the landing stage area.

Throwing objects to or dropping them from scaffolds is absolutely prohibited. Handlines must be used for raising or lowering objects which cannot be passed hand-to-hand.

A standard guardrail and toeboard should be provided on the open side of all platforms 5 ft or more above ground, otherwise safety belts tied off to safety lines must be used.

If the space between the scaffold and building is more than 18 in, a standard guardrail should be erected on the building side.

No person should remain on the rolling scaffold while it is being moved.

No person will lean on or against or stand or sit on any guardrail or guardline.

When a light-duty portable scaffold is formed of planks supported or latched on trestle ladders, the base of the ladder should be secured against opening up to the full spread before laying on the planks.

A scaffold must NEVER be overloaded. Scaffolds are built in the following strength categories: (1) extra-heavy-duty, (2) heavy-duty, (3) light-duty, and (4) an intermediate category between light and heavy, for scaffolds used by stucco workers and by lathers and plasterers. The maximum uniform safe working

load per sq ft of platform for each of these categories is as follows:

Extra-heavy-duty (stone masons)	75 lb
Heavy-duty (stone setters and bricklayers)	50 lb
Light-duty (carpenters and miscellaneous)	25 lb
Intermediate (stucco workers and plasterers)	30 lb

To get the load per sq ft of platform of a pile of materials on a platform, divide the total weight of the pile by the number of sq ft of platform it covers.

HOISTING SAFETY SIGNALS AND RULES

ONE PERSON, and ONE PERSON ONLY, should be designated as official signalman for the operator of a piece of hoisting equipment, and both the signalman and the operator must be thoroughly familiar with the standard hand signals. Whenever possible, the signalman should wear some distinctive article of dress, such as a bright-colored helmet. The signalman must maintain a position from which the load and the crew working on it can be seen, and also where he can be seen by the operator.

Figure 5-44 shows the standard hand signals for hoisting equipment. Some of the signals shown apply only to mobile equipment, others only to a piece of equipment with a boom which can be raised, lowered, and swung in a circle.

The two-arm hoist and lower signals are used when the signalman desires to control the speed of hoisting or lowering. The one-arm hoist or lower signal allows the operator to take the load right on up, or to lower it right on down.

To DOG OFF the load and boom means to set the brakes so as to lock both the hoisting

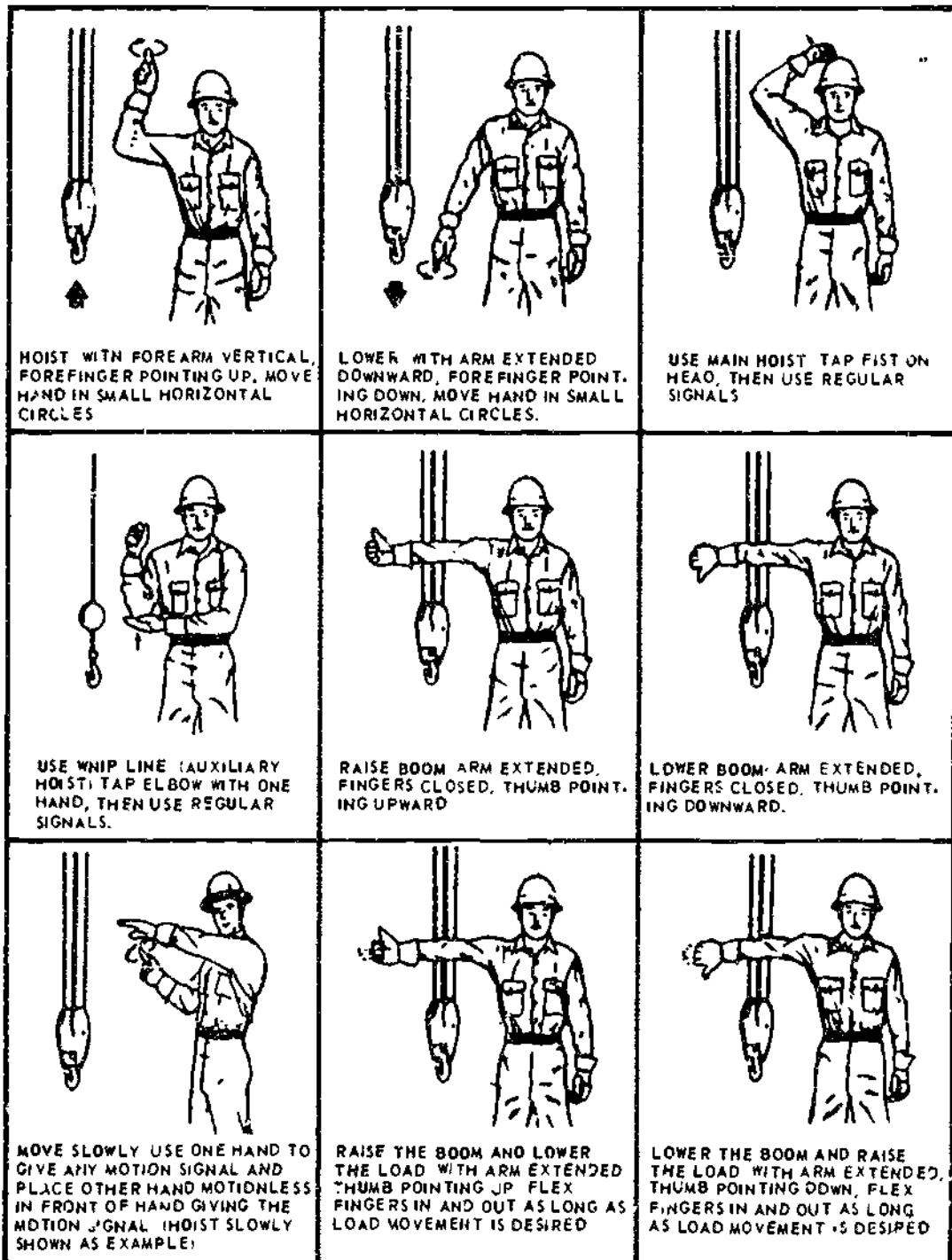

Figure 5-44.—Construction hand signals.

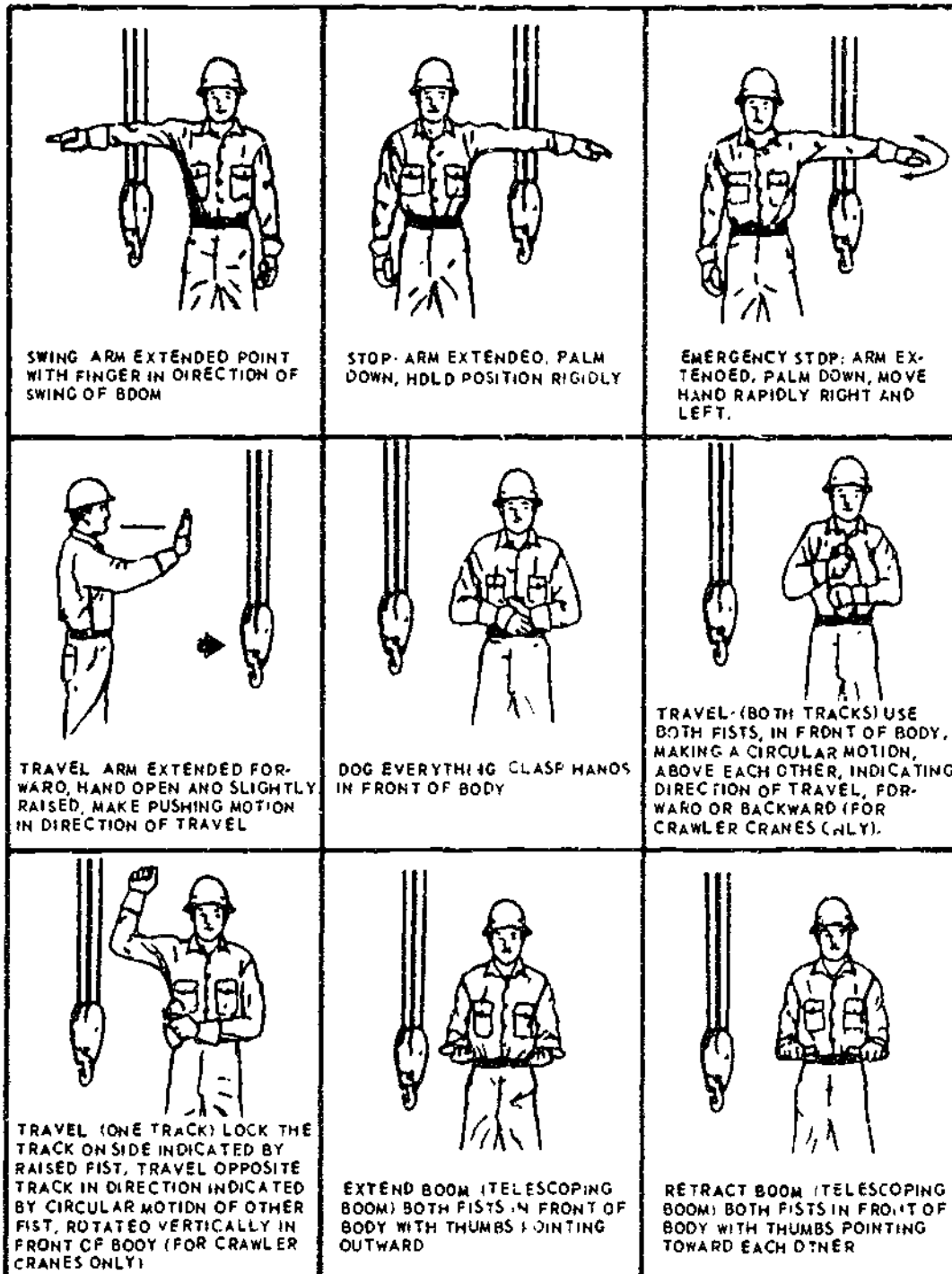
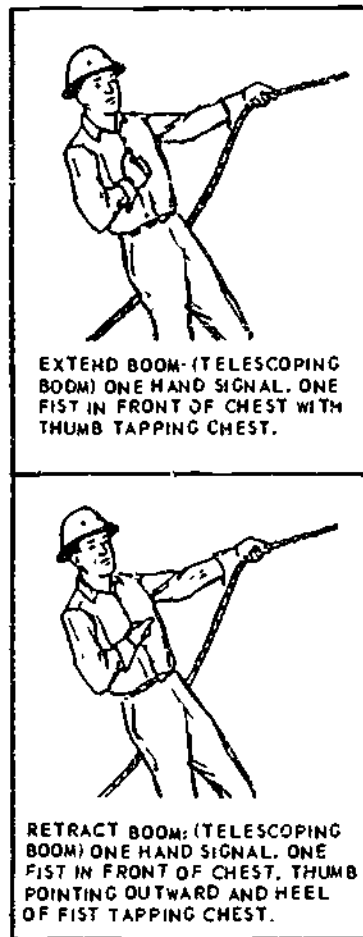

Figure 5-44.—Construction hand signals—Continued.

29.86



29.86

Figure 5-44.—Construction hand signal:—Continued.

mechanism and the boom hoist mechanism. The signal is given when circumstances require that the load be left hanging motionless in the air for some time.

With the exception of the EMERGENCY STOP signal, which may be given by anyone who sees a necessity for it, and which must be obeyed instantly by the operator, only the official signalman gives the signals.

The signalman is responsible for making sure that members of the crew remove their hands from slings, hooks, and loads before giving a signal. The signalman should also make sure that

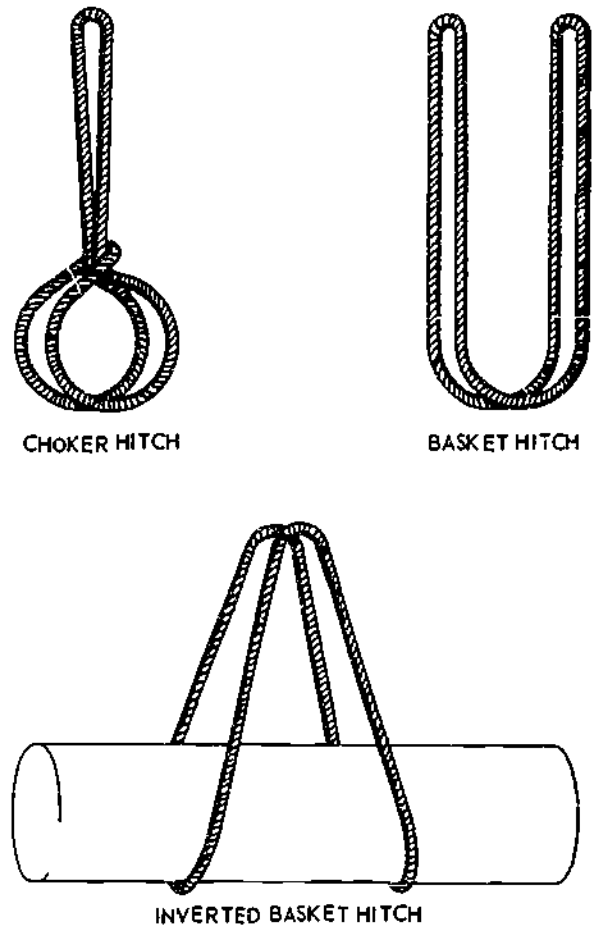

29.190

Figure 5-45.—Ways of hitching on a sling.

all persons are clear of bights and snatch clock lines.

The most common way of attaching a load to a lifting hook is to put a SLING around the load and hang the sling on the hook. (See fig. 5-45.) A sling may be made of line, wire, or wire rope with an eye in each end, (also called a STRAP) or an ENDLESS SLING. (See fig. 5-46.) Both of these types are described and illustrated in *Constructionman*, NAVEDTRA 10630-F. When a sling is passed through its own bight or eye, or shackled or hooked to its own standing part, so that it tightens around the load like a lasso when the load is lifted, the sling is said to be CHOKED, or it may be called a CHOKER as shown in figures 5-45 and 5-46. A

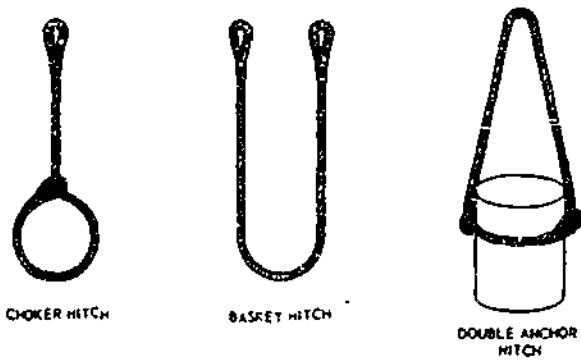

29.191

Figure 5-46.--Ways of hitching on straps.

two-legged sling which supports the load at two points is called a BRIDLE as shown in figure 5-47.

The following safety rules must be promulgated to and observed by all hands engaged in hooking on.

The person in charge of hooking on must know the safe working load of the rig and the weight of every load to be hoisted. The hoisting of any load heavier than the safe working load of the rig is absolutely prohibited.

When a cylindrical metal object such as a length of pipe, a gas cylinder, or the like, is hoisted in a choker bridle, each leg of the bridle should be given a round turn around the load before it is hooked or shackled to its own part. The purpose of this is to insure that the legs of the bridle will not slide together along the load, thereby upsetting the balance and possibly dumping the load.

The point of strain on a hook must never be at or near the point of the hook.

Before the HOIST signal is given, the person in charge must be sure that the load will balance evenly in the sling.

Before the HOIST signal is given, the person in charge should be sure that the lead of the whip or falls is vertical. If it is not, the load will take a swing as it leaves the deck.

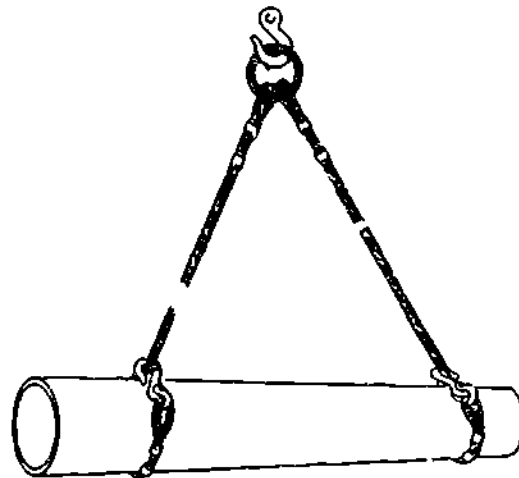

80.155(127D)

Figure 5-47.--Bridles.

As the load leaves the deck, the person in charge must watch carefully for kinked or fouled falls or slings. If any are observed, the load must be lowered at once for clearing.

Tag lines must be used to guide and steady a load whenever there is a possibility that the load might get out of control.

Before any load is hoisted, it must be inspected carefully for loose parts or objects which might drop as the load goes up.

All personnel must be cleared from and kept out of any area which is under a suspended load, or over which a suspended load may pass.

BUILDER 3 & 2

NEVER walk or run under a suspended load.

Loads must not be placed and left at any point closer than 4 ft to 8 in. from the nearer rail of a railroad track or crane track, or in any position where they would impede or prevent access to firefighting equipment.

Whenever materials are being loaded or unloaded from any vehicle by crane, the vehicle operators and all other persons except the rigging crew should stand clear.

Whenever materials are placed in work or storage areas, dunnage or shoring must be provided as necessary to prevent tipping of the load or shifting of the materials.

All crewmembers must stand clear of loads which tend to pread out when landed.

When slings are being heaved out from under a load, all crewmembers must stand clear to avoid a backlash, and also to avoid a toppling or a tip of the load which might be caused by fouling of a sling.

CHAPTER 6

LEVELING, GRADING, AND EXCAVATING

In this chapter the common types and uses of leveling instruments, principles, and procedures of establishing elevations, techniques of laying out building lines, and fundamentals of excavating are described. As a Builder, you will find the information especially useful in performing duties, such as setting up a level, selecting turning points, reading a leveling rod, interpreting and setting grade stakes, setting batter boards, and determining dimensions of below-grade structures. Also included in this chapter are practices and measures that help prevent slides and cave-ins at excavation sites and the procedures for computing volume of land mass.

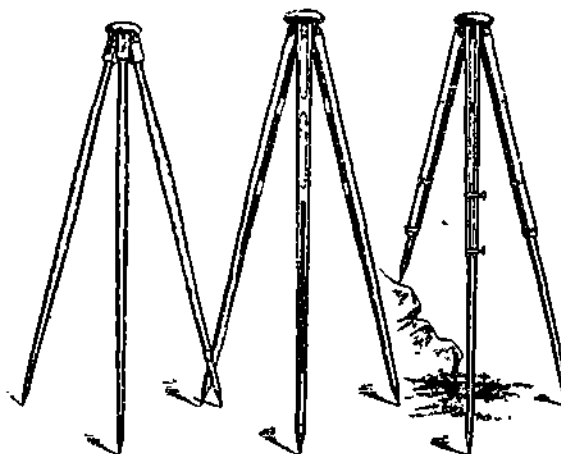

29.243AX

Figure 6-1.—Tripods.

LEVELS

The **ENGINEER'S LEVEL**, often referred to as the **DUMPY LEVEL**, is the instrument most commonly used to attain the level line of sight required for differential leveling (defined later). The **DUMPY LEVEL** and the **SELF-LEVELING LEVEL** can be mounted for use on a **TRIPOD**, usually with adjustable legs. (See fig. 6-1.) Mounting is done by engaging threads at the base of the instrument (called the **FOOTPLATE**) with the threaded **HEAD** on the tripod. These levels are the ones most frequently used in ordinary leveling projects. For rough leveling, the **HAND LEVEL** is used.

DUMPY/ENGINEER'S

Figure 6-2 shows a **DUMPY/ENGINEER'S** level and its nomenclature. Notice that the

telescope is rigidly fixed to the supporting frame.

Inside the telescope there is a ring or diaphragm known as the **RETICLE** (not shown), which supports the **CROSSHAIRS**. The crosshairs are brought into exact focus by manipulating the knurled **EYEPiece FOCUSING RING** near the **EYEPiece** or the eyepiece itself on some models. If the crosshairs get out of horizontal adjustment, they can be made horizontal again by slackening the **RETICLE ADJUSTING SCREWS** and turning the screws in the appropriate direction.

The object to which you are sighting is called a **TARGET**, regardless of its shape. The target is brought into clear focus by manipulating the **FOCUSING KNOB** shown on

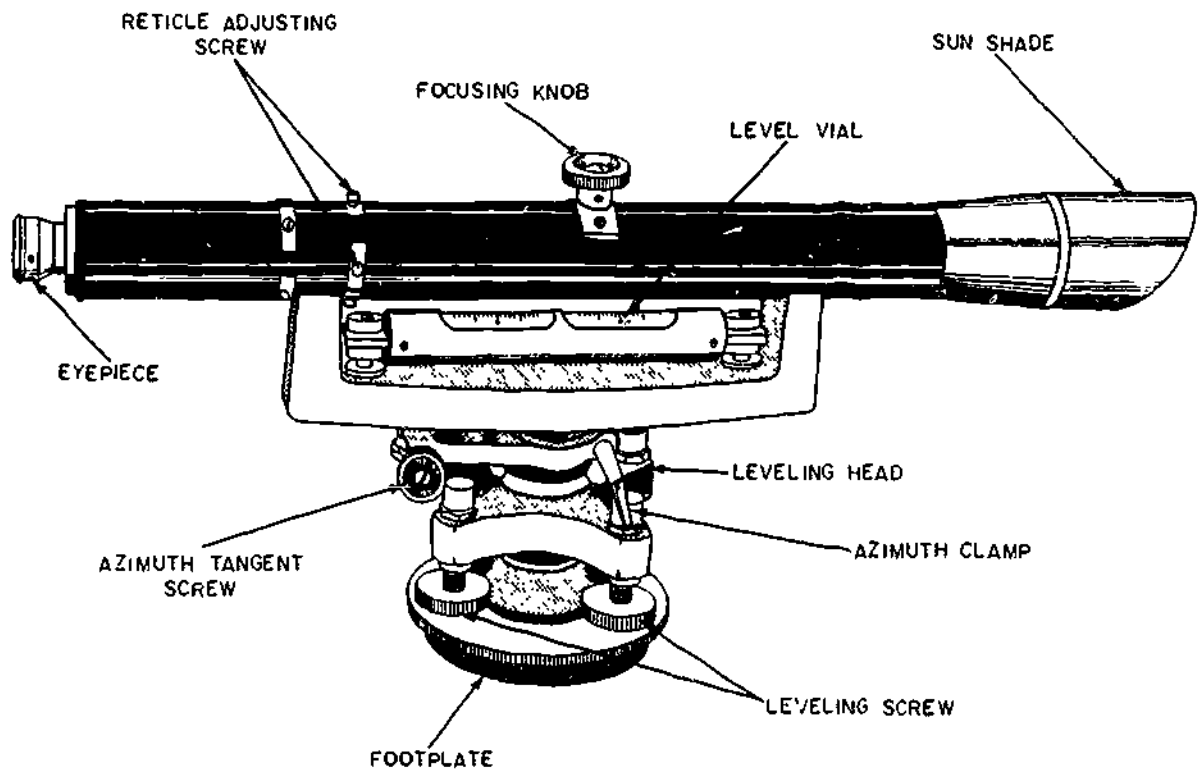

29.245A

Figure 6-2.—Dumpy level.

top of the telescope. The telescope can only be rotated horizontally, but before it can be rotated, the AZIMUTH CLAMP must be released. After training the telescope as nearly on the target as you can get it, you tighten the azimuth clamp. Then you bring the vertical crosshair into exact alignment on the target by rotating the AZIMUTH TANGENT SCREW.

The LEVEL VIAL, LEVELING HEAD, LEVELING SCREWS, and FOOTPLATE are all used to adjust the instrument to a perfectly level line-of-sight, once it is mounted on the tripod.

SELF-LEVELING

It is timesaving to use the self-leveling or so-called automatic level in leveling operations. The self-leveling level (fig. 6-3) has completely

eliminated the use of the tubular spirit level, which required an excessive amount of time to center the bubble, and the bubble had to be reset quite often during operation.

The self-leveling level is equipped with a small bull's-eye level and three leveling screws. The leveling screws, which set on a triangular footplate, are used to center as much as possible the bubble of the bull's-eye level. The line-of-sight automatically becomes horizontal and remains horizontal as long as the bubble remains approximately centered.

HAND

The hand level, like all surveying levels, is an instrument which combines a level vial and a

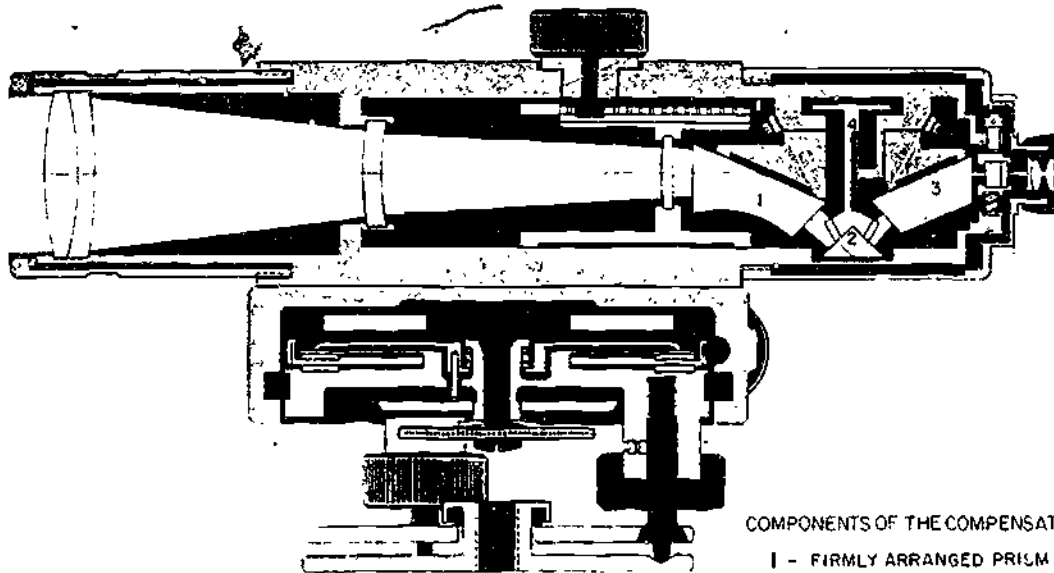

COMPONENTS OF THE COMPENSATOR

- 1 - FIRMLY ARRANGED PRISM
- 2 - PRISM SUSPENDED ON 4 WIRES
- 3 - FIRMLY ARRANGED ROOF PRISM
- 4 - AIR DAMPING

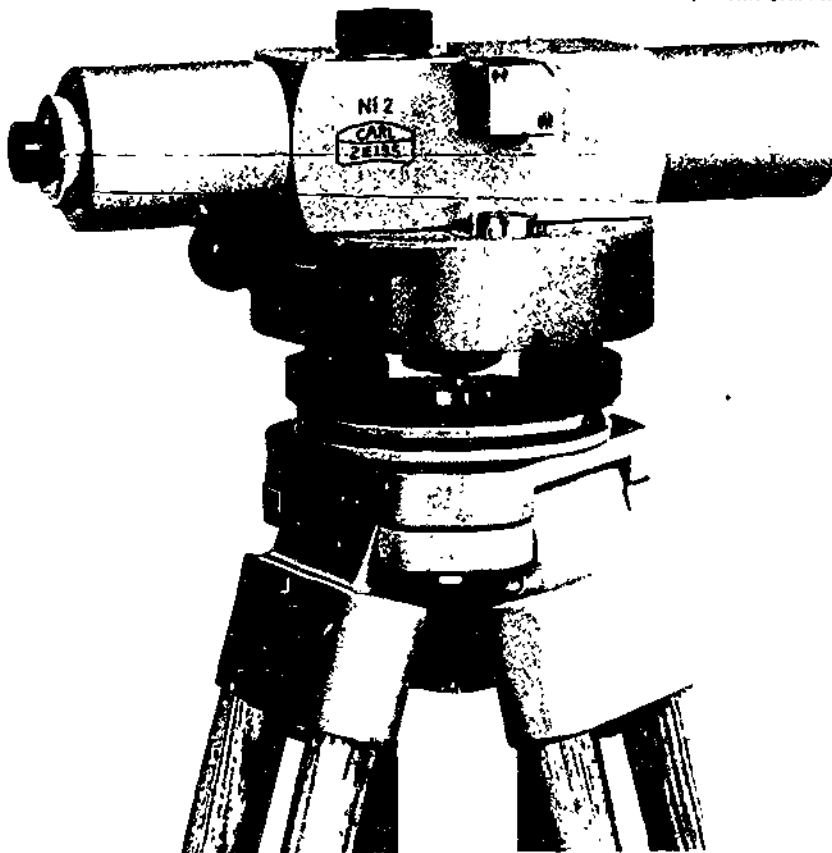

Figure 6-3.—Self-leveling level.

45.750X

sighting device. Figure 6-4 shows the Locke level which is also known as a hand level. A horizontal line, called an index line, is provided in the sight tube as a reference line. The level vial is mounted atop a slot in the sighting tube in which a reflector is set at a 45° angle. This permits the observer who is sighting through the tube, to see the object, the position of the level bubble in the vial, and the index line at the same time.

In order to get the correct sighting through the tube, you the observer should stand straight, using the height of your eye (if known) above the ground to find the target. When your eye height is not known, you can find it by sighting the rod at eye height in front of your body. Since the distances over which you sight a hand level are rather short, no magnification is provided in the tube.

DIFFERENTIAL LEVELING

The most common procedure for determining elevations in the field, or for locating points at specified elevations, is known as DIFFERENTIAL LEVELING. This procedure, as its name implies, is nothing more than finding the vertical DIFFERENCE between the known or assumed elevation of a bench mark and the elevation of the point in question. Once the difference is measured, it can be added to, or subtracted from (depending on the circumstances), the bench mark elevation to determine the elevation of the new point.

ELEVATION AND REFERENCE

The ELEVATION of any object is its vertical distance above or below an established height on the earth's surface. This established height is referred to as either a REFERENCE PLANE or simple REFERENCE. The most commonly used reference plane for elevations is MEAN (or average) SEA LEVEL, which has been assigned an assumed elevation of 000.0 ft. However, the reference plane for a construction project is usually the height of some permanent or semipermanent object in the immediate vicinity, such as the rim of a manhole cover, a



29.246X

Figure 6-4.—Locke level.

road, or the finish floor of an existing structure. This object may be given its relative sea-level elevation, if that happens to be known; or it may be given a convenient, arbitrarily assumed elevation, usually a whole number, such as 100.0 ft. An object of this type, with a given, known, or assumed elevation which is to be used in determining the elevations of other points, is called a BENCH MARK.

PRINCIPLES OF DIFFERENTIAL LEVELING

Figure 6-5 illustrates the principle of differential leveling. The instrument shown in the center represents an ENGINEER'S LEVEL. This optical instrument provides a perfectly level line of sight through a telescope which can be trained in any direction. Point A in the figure is a bench mark (it could be a concrete monument, a wooden stake, a sidewalk curb, or any other of a variety of objects) having a known elevation of 365.01 ft. Point B is a ground surface point whose elevation is desired.

The first step in finding the elevation point of Point B is to determine the elevation of the line-of-sight of the instrument. This is known as the height of instrument and is often written and referred to as simply H.I. To determine the H.I. you take a BACKSIGHT on a LEVEL ROD held vertically on the bench mark (B.M.), as shown, by a rodman. A backsight (B.S.) is always taken after a new instrument position is set up by sighting back to a known elevation in order to get the new H.I. A leveling rod is graduated upward in ft, from 0 at its base, with appropriate subdivisions in ft.

In figure 6-5 the backsight reading is 11.56 ft. It follows then, that the elevation of

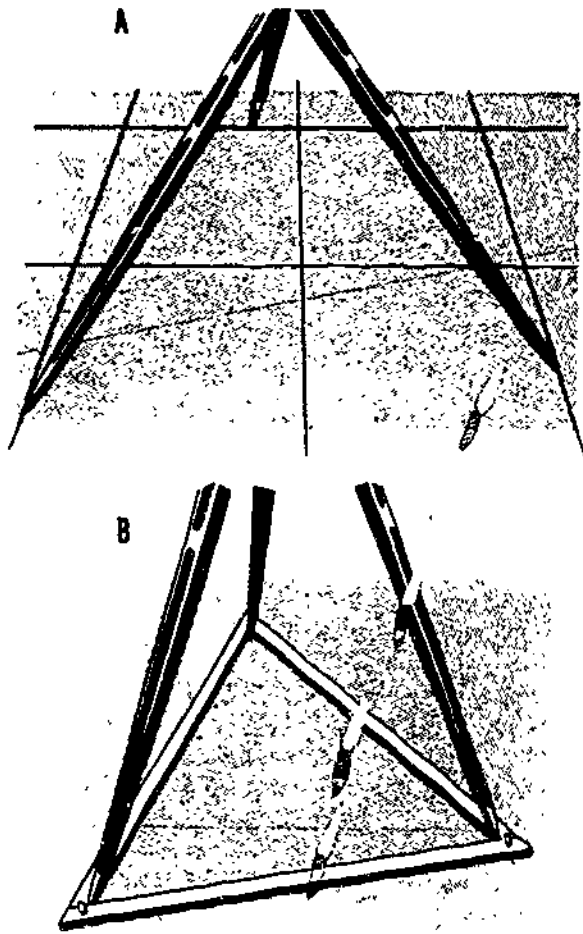

45.94
Figure 6-6.—Methods of preventing tripod legs from spreading.

LEVELING A LEVEL

To function accurately, the level must provide a line of sight which is PERFECTLY HORIZONTAL (that is, LEVEL) in any direction the telescope is trained. To insure this, the instrument must be leveled as follows.

As already explained, when the tripod and instrument are first set up, the footplate should be made as nearly level as possible. Next, train the telescope over a pair of diagonally opposite leveling screws and clamp it in that position. Then manipulate the leveling thumbscrews, as shown in figure 6-7, to bring the bubble in the

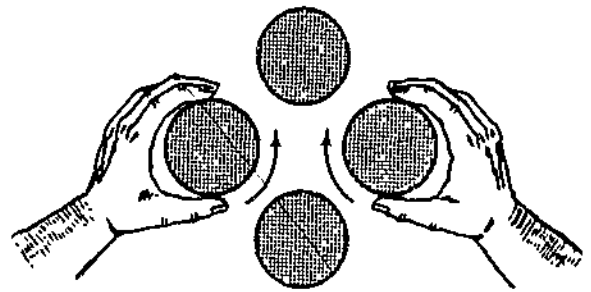

45.95
Figure 6-7.—Manipulating leveling thumbscrews.

level vial exactly into the marked center position.

The thumbscrews are manipulated by simultaneously turning them in opposite directions, a procedure which shortens one SPIDER LEG (threaded member running through the thumbscrew) while it lengthens the other. It is helpful to remember that the level vial bubble will move in the same direction that your left thumb moves while you rotate the thumbscrews. To put this another way: when your left thumb pushes the thumbscrew CLOCKWISE, the bubble will move towards your left hand; when you turn the left thumbscrew COUNTER-CLOCKWISE, the bubble moves toward your right hand.

After leveling the telescope over one pair of screws, train it over the other pair and repeat the process. As a check, set the telescope in all four possible positions and be sure that the bubble centers exactly in each.

Various techniques for using the level will develop with experience; however, in this section we will only discuss the techniques that we believe are essential to the Builder rating. If you, as a Builder, find that you need more information concerning leveling techniques, refer to the latest edition of *Engineering Aid 3 & 2*.

BALANCING SHOTS

No matter how carefully an instrument is leveled, the line-of-sight through the telescope is

likely to be not quite exactly horizontal. The error which this introduces is directly proportional to the distance between the level and the object sighted. This means that the error increases as the distance increases. To help overcome this INSTRUMENTAL ERROR, you should take BALANCING SHOTS.

Balancing shots are nothing more than equalizing, as much as possible, the backsight and foresight distances by selecting setup points which are as nearly as possible equidistant from the points backsighted and foresighted.

TURNING POINTS

In the procedure shown in figure 6-5, you were able to determine the desired elevation from a single instrument setup, because the difference in elevation between the bench mark and the point was small enough to make this possible. However, figure 6-8 shows a situation in which the difference in elevation is too large for a single setup.

In such a case, determine the elevations of as many intermediate TURNING POINTS (T.P.) as you need to bring the instrument to a setup point from which you can read a rod set on the summit. You start here by setting up at a point on the slope where you can get a pretty high

backsight reading on a rod set on the bench mark. The backsight reading is 12.02 ft; therefore, the H.I. at the first setup is $100.00 + 12.02$, or 112.02 ft. You then train the telescope ahead, in the direction of the summit, and set up the rod on a point where you can get a low reading of 2.06 ft. The elevation of this point is $112.02 - 2.06$, or 109.96 ft. This point is the first turning point.

You can see in the figure how it was used to backsight on from the next forward setup, and how the elevation of a second T.P. was obtained. From a third setup, between this T.P. and the summit, it is possible to determine the elevation of the summit.

SELECTION OF TURNING POINTS

Suppose you want to determine the elevation of a certain point A. The nearest point of known elevation is a certain B.M. Because of distance, steepness of slope, or both, you have to make the run by way of a series of intermediate T.P.'s. Somebody else has determined the elevation of the B.M., but each of the T.P.'s is a point whose elevation you must determine yourself. The accuracy of the elevation you determine for point A will depend

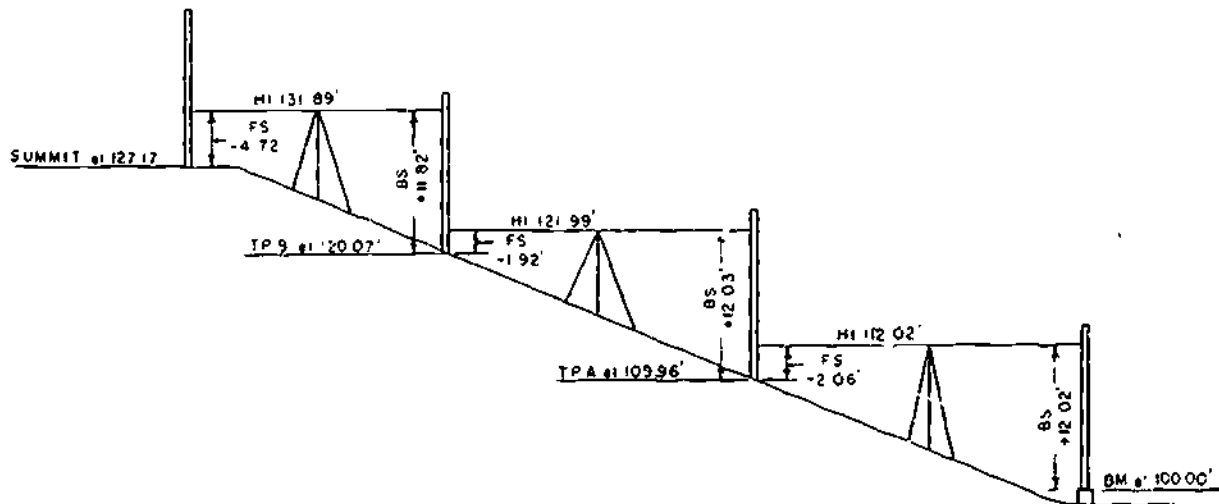

45.41

Figure 6-8.—Turning points (TP).

on the accuracy with which you can determine the elevation of each intermediate T.P.

For most ordinary leveling, it is customary to limit B.S. and F.S. distances to a maximum of 300 horizontal ft. Consequently, the first setup point should be not more than 300 ft from the B.M., and the first T.P. should be about the same distance from the setup point (if the required accuracy calls for balancing shots).

In general, T.P.'s and setup points should be selected to make rod readings as small as possible. This means that the best setup point is one at which the difference in elevation between the B.M. and the H.I. is as small as possible, and the best T.P. is one with an elevation as near that of the H.I. as possible.

Why are small rod readings desirable? Because if a rod is held slightly out of plumb, each reading on the rod will be larger by a

certain amount than it should be, and this amount increases as the size of the rod reading increases. Suppose, for example, that a rodman holds a rod so far out of plumb as to cause it to read 12.01 ft when it would have read 12.00 ft if it were plumb. The error for a 12.00-ft distance, then, is 0.01 ft. For a 2.00-ft distance on the same rod held in the same manner, however, the error would equal the value of x in the equation $12.00:0.01::2.00:x$, or only about 0.002 ft.

A selected T.P. must furnish a firm, unyielding support for the base of the rod. This prevents the rod from settling into the ground between instrument setups. When you cannot avoid working in soft, yielding ground, the base of the rod should be placed on a stake driven flush with the ground, or, or a specially made TURNING POINT PIN or TURNING POINT PLATE, as those illustrated in figure 6-9.

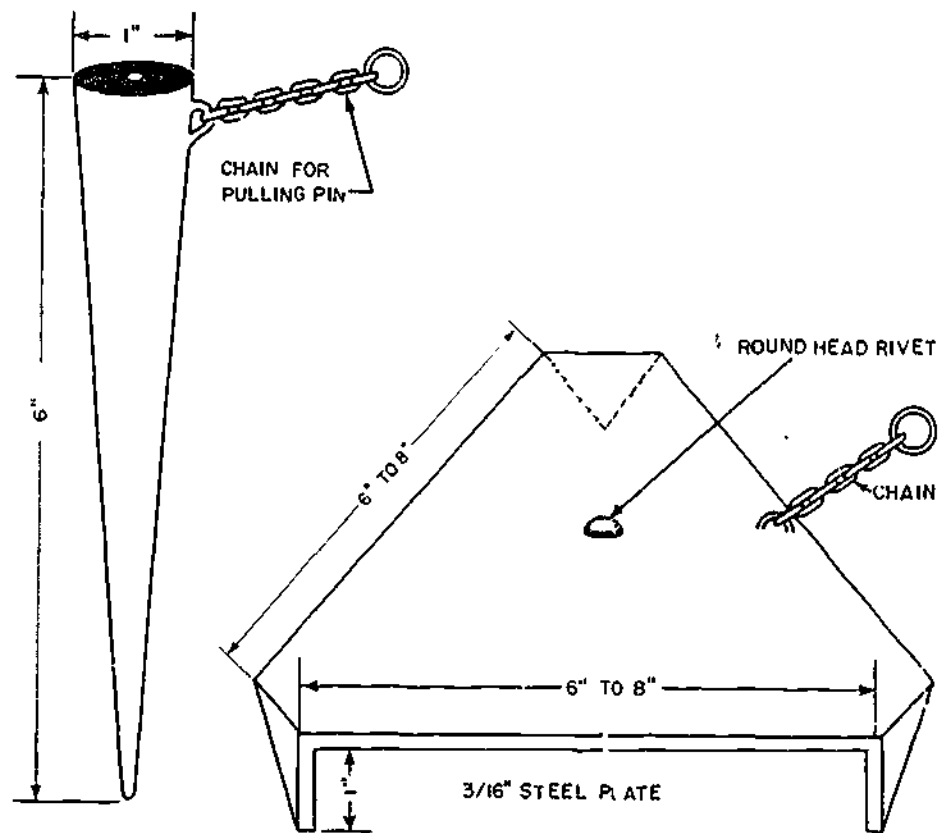

Figure 6-9.—Turning point pin and turning point plate.

45.42

6-8

CARE OF LEVELS

An engineer's level is a precision instrument containing many delicate and some fragile parts. It must be handled gently and with the greatest care at all times, and it must never be subjected to shock or jar. Movable parts (if not locked or clamped in place) should work easily and smoothly. If a movable part resists normal pressure, there is something wrong somewhere, and if you **FORCE** the part to move you will probably damage the instrument. You will also cause wear and/or damage if you tighten clamps, screws, and the like excessively.

The **ONLY** proper place to stow the instrument when it is detached from the tripod is in its own carrying box or case. The carrying case is designed to reduce the effect of jarring to a minimum, and it is strongly made and well padded to protect the instrument from damage. Before stowing, the azimuth clamp and leveling screws should be slightly tightened to prevent movement of parts inside the box. When it is being transported in a vehicle, the case containing the instrument should be placed as nearly as possible midway between the front and rear wheels. This is the point where jarring of the wheels has the least effect on the chassis.

You should never lift the instrument out of the case by grasping the telescope. Wrenching the telescope in this manner will damage a number of delicate parts. Instead, lift it out by reaching down and grasping the foot plate or the level bar.

When the instrument is attached to the tripod, and it is to be carried from one point to another, the azimuth clamp and level screws should be set up tight enough to prevent part motion during the transport, but loose enough to allow a "give" in case of an accidental bump against some object. When you are carrying the instrument over terrain which is free of possible contacts (across an open field, for example), you may carry it over your shoulder, like a rifle. When there are obstacles around, you should carry it as shown in figure 6-10. Carried in this manner, the instrument is always visible to you, and this makes it possible for you to avoid striking it against obstacles.



45.93

Figure 6-10.—Safest carrying position for instrument when obstacles may be encountered.

LEVELING RODS

LEVELING RODS are used to measure the precise vertical distance between the object or point in question and the exactly level line-of-sight of the instrument. For example, in figure 6-5, the leveling rod was held at points A and B and vertical heights of 11.56 ft and 1.42 ft were read respectively. There are two general types of leveling rods. These are the **DIRECT READING** type (also called **SELF-READING** type) and the **TARGET-READING** type. Since most target-reading rods can also be read direct, it is really more accurate to say that most leveling rods are direct-reading and some are also equipped for target-reading.

Philadelphia Rod

Perhaps the most frequently used leveling rod is the **PHILADELPHIA** rod shown in figure 6-11. The face of the rod is shown to the left, the back to the right. The rod consists of two sliding sections which can be fully extended to a total length of 13.10 ft. When the sections are entirely closed, the total length is 7.10 ft. For direct readings (that is, for readings on the face of the rod) of up to 7.10 ft and 13.10 ft, it is used extended and read on the back by the rodman.

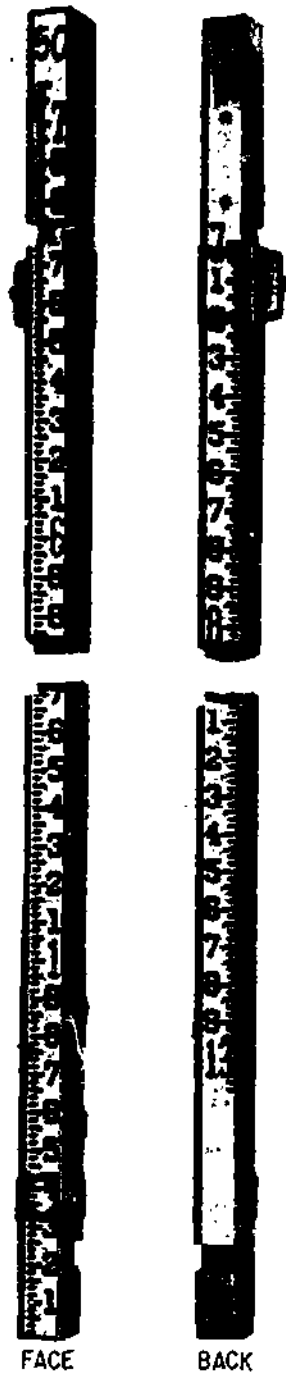

29.265A
 Figure 6-11.—Face and back of Philadelphia leveling rod.

In **DIRECT** readings, it is the person at the instrument who reads the graduation on the rod intercepted by the crosshair through the telescope. In **TARGET** readings, it is the **RODMAN** who reads the graduation on the face of the rod intercepted by a **TARGET**. In figure 6-11, the target does not appear; it is shown however, in figure 6-12. As you can see, it is a sliding, circular, red-and-white device which can be moved up or down the rod and clamped in position. It is placed by the rodman on signals given by the instrumentman.

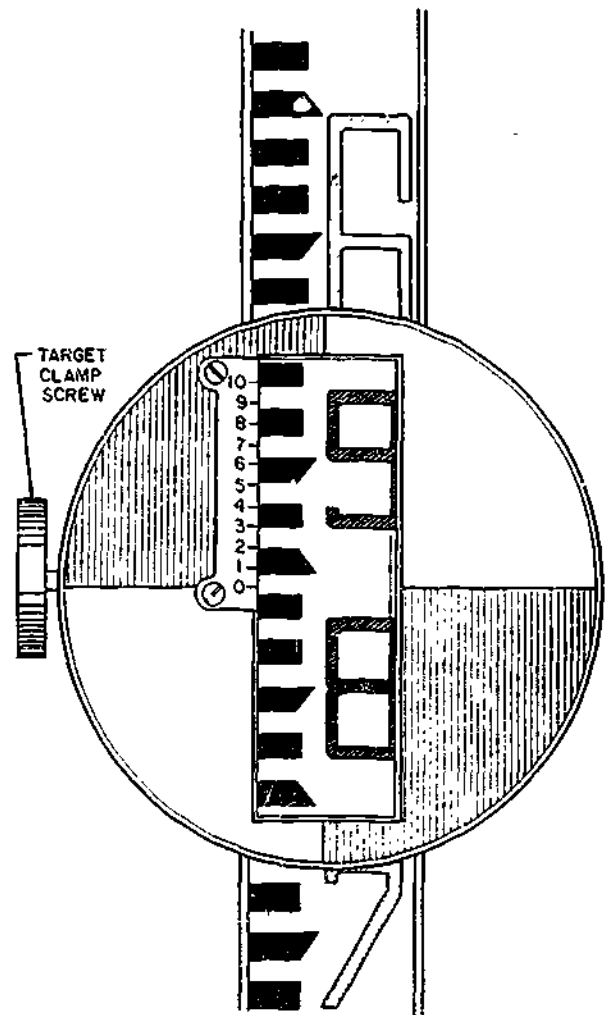

29.267A
 Figure 6-12.—Philadelphia rod set for target reading of less than 7.000 ft.

The rod shown in the figures is graduated in ft and hundredths of a ft. Each even ft is marked with a large red numeral, and between each pair of adjacent red numerals the intermediate tenths of a ft are marked with smaller black numerals. Each intermediate hundredth of a ft between each pair of adjacent tenths is indicated by the top or bottom of one of the short, black dash graduations.

DIRECT READINGS.—As the levelman, you may make direct readings on a self-reading rod held plumb on the point by the rodman. If you are working to tenths of a ft, it is relatively simple to read the ft mark below the crosshair and the tenth mark which is closest to the crosshair. But if greater precision is required,

and you must work to hundredths, the reading is more complicated, as shown in figure 6-13.

For example, suppose you are making a direct reading which should come out to 5.67 ft. If the rod is a Philadelphia rod, the interval between the top and the bottom of each black graduation, and the interval between the black graduations (see fig. 6-14), each represents 0.01 ft. For a reading of 5.76 ft, there are 3 black graduations between the 5.70-ft mark and the 5.76-ft mark. Since there are 3 graduations, a beginner may have a tendency to misread 5.76 ft as 5.73 ft.

As you can see, neither the 5-ft mark nor the 6-ft mark are shown in figure 6-14. Sighting through the telescope, you might not be able to see the ft marks to which you must refer the

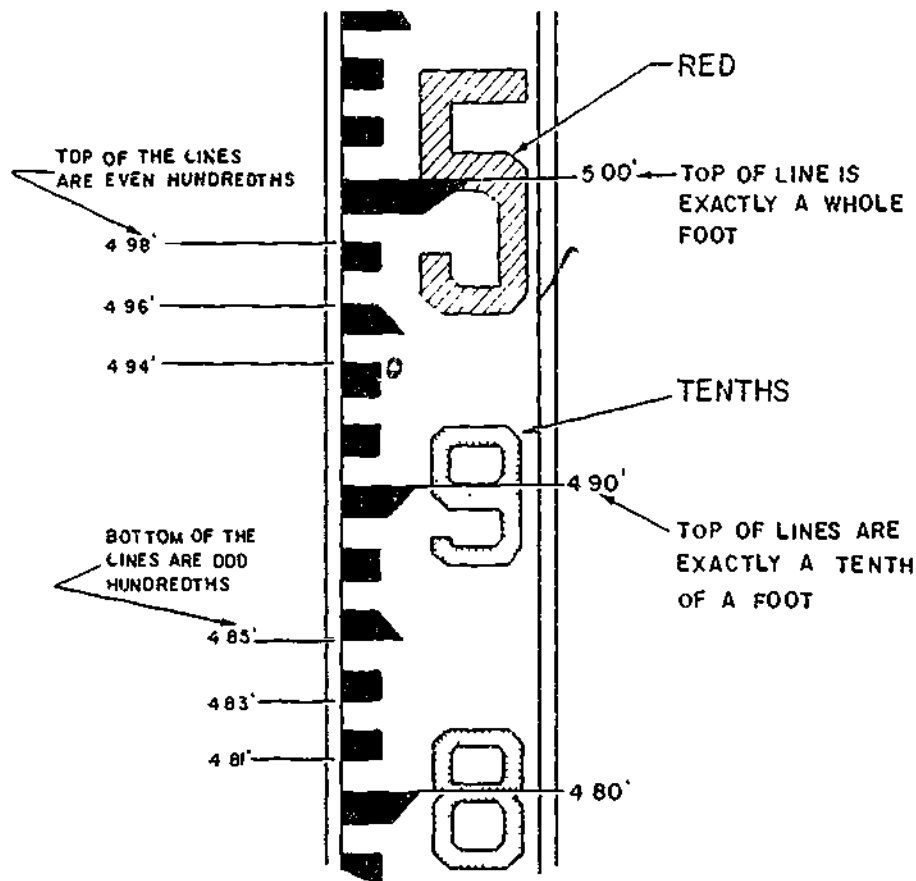
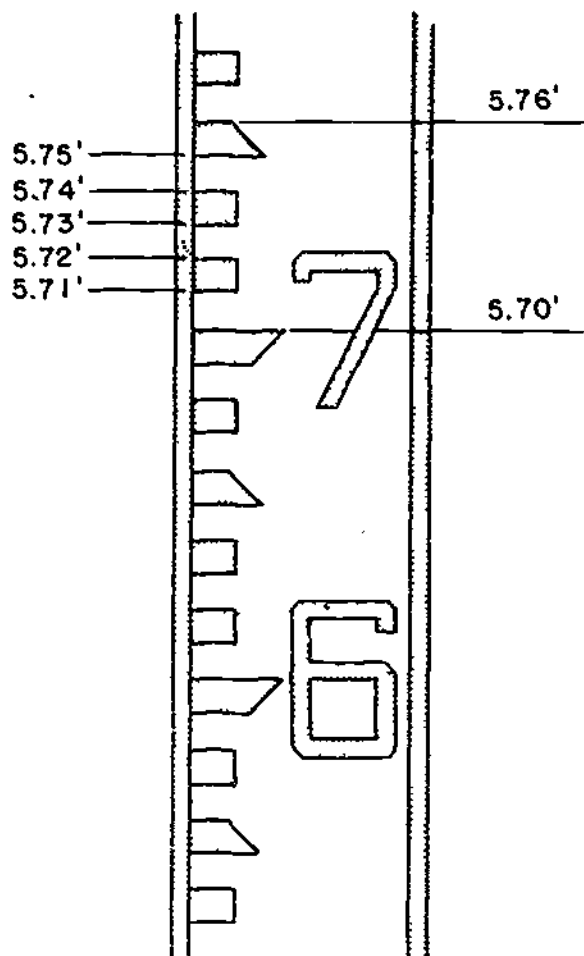

Figure 6-13.—Philadelphia rod markings.

133.447



45.96
Figure 6-14.—Direct reading of 5.76 ft. on Philadelphia rod.

reading. When you can not see the next lower ft mark through the telescope, it is a good idea to order the rodman to "raise the red." The "red" has reference to the fact that the numerals which indicate whole ft on the Philadelphia rod are in the red. When the rodman hears this order, the rodman slowly raises the rod until the next lower red figure comes into view.

TARGET READINGS—For more precise vertical measurements, level rods may be equipped with a rod target that can be set and clamped by the rodman at the directions of the instrumentman. When the engineer's level rod

target and the vernier scale are being used, it is possible to make readings of 0.001 (1/1000ft) which is approximately 1/32nd of an inch. The indicated reading of the target can be read either by the rodman or the instrumentman. In figure 6-15, you can see that the 0 on the vernier scale is in exact alinement with the 4-ft mark. If the position of the 0 on the target is not in exact alinement with a line on the rod, go up the vernier scale on the target to the line that is in exact alinement with the hundredths line on the rod and the number located would be the reading in thousandths.

There are three situations in which target reading rather than direct reading is done on the face of the rod: when the rod is too far from the level to be read directly through the telescope; and when a reading to the nearest 0.001 ft, rather than to the nearest 0.01 ft, is desired (a VERNIER on the target or on the back of the rod makes this possible as explained shortly); and when the instrumentman desires to insure against the possibility of reading the wrong ft (large red letter) designation on the rod.

For target readings up to 7.000 ft, the rod is used fully closed, and the rodman, on signals from the instrumentman sets the target at the point where its horizontal axis is intercepted by the crosshair, as seen through the telescope.

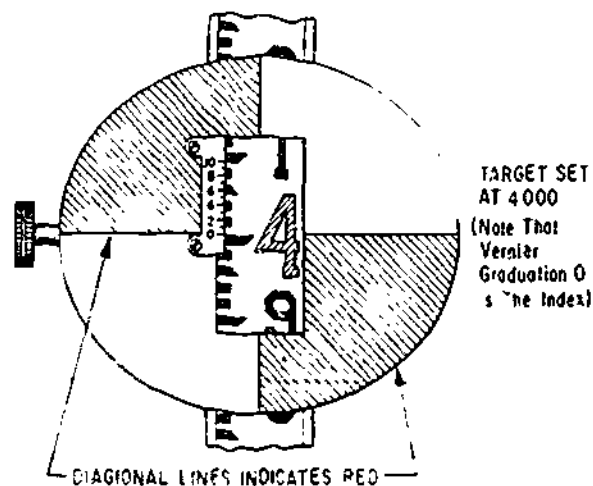

29.267
Figure 6-15.—Target.

When the target is located, it is clamped in place with the TARGET SCREW CLAMP, as shown in figure 6-12. When a reading to only the nearest 0.01 ft is desired, the graduation indicated by the target horizontal axis is read; in figure 6-12, this reading is 5.84 ft.

If reading to the nearest 0.001-ft is desired, the rodman reads the VERNIER (small scale running from 0 to 10) on the target. The 0 on the vernier indicates that the reading lies between 5.840 ft and 5.850 ft. To determine how many thousandths of a ft over 5.840 there are, you examine the graduations on the vernier to determine which one is most exactly in line with a graduation (top or bottom of a black dash) on the rod. In figure 6-12, this graduation on the vernier is the 3; therefore, the reading to the nearest 0.001 ft is 5.843 ft.

For target readings of more than 7.000 ft the procedure is a little different. If you look at the right-hand view of figure 6-11 (showing the BACK of the rod), you will see that only the back of the UPPER section is graduated, and that it is graduated DOWNWARD from 7.000 ft at the top to 13.09 ft at the bottom. You can also see that there is a ROD VERNIER fixed to the top of the LOWER section of the rod. This vernier is read against the graduations on the back of the upper section.

For a target reading of more than 7.000 ft, the rodman first clamps the target at the upper section of the rod. Then, on signals from the instrumentman, the rodman extends the rod upward to the point where the horizontal axis of the target is intercepted by the crosshair. The rodman then clamps the rod, using the ROD CLAMP SCREW shown in figure 6-16, and reads the vernier on the BACK of the rod, also shown in that figure. In this case the 0 on the vernier indicates a certain number of thousandths more than 7.100 ft. REMEMBER THAT IN THIS CASE, YOU READ THE ROD AND THE VERNIER DOWN FROM THE TOP, NOT UP FROM THE BOTTOM. To determine the thousandths, determine which vernier graduation lines up most exactly with a graduation on the rod. In this case it is the 7; therefore, the rod reading is 7.107 ft.

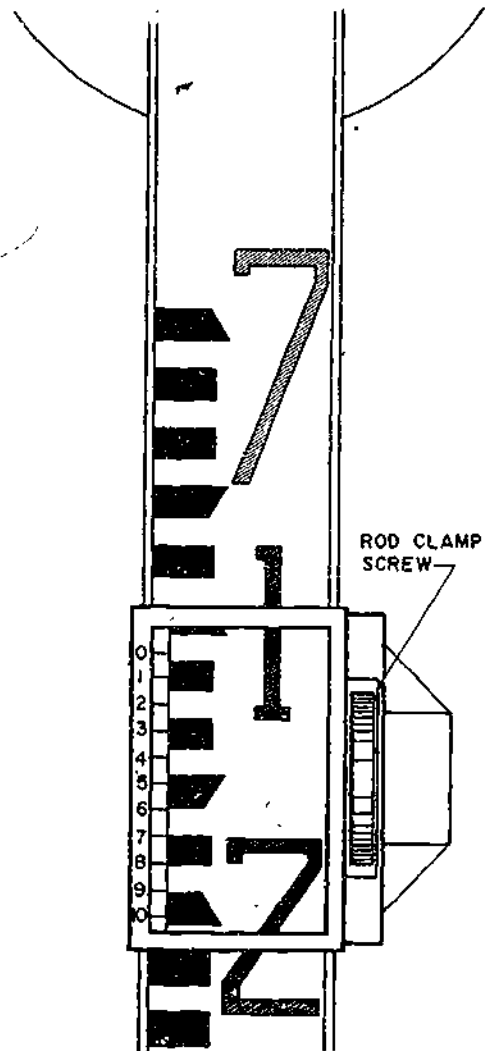

29.267B

Figure 6-16.—Philadelphia rod target reading of more than 7.000 ft.

Rod Levels

A rod reading is accurate only if the rod is perfectly PLUMB (vertical) at the time of the reading. If the rod is out of plumb, the reading will be greater than the actual vertical distance between the H.I. and the base of the rod. On a windy day, the rodman may have difficulty holding the rod plumb. In this case, the levelman can have the rodman wave the rod back and forth allowing the levelman to read the lowest

reading touched on the engineer's level crosshairs.

The use of a ROD LEVEL insures a vertical rod. A BULL'S-EYE rod level is shown in figure 6-17. When it is held as shown (on a part of the rod where readings are not being taken, to avoid interference with the instrumentman's view of the scale), and the bubble is centered, the rod is plumb. A VIAL rod level has two spirit vials, each of which is mounted on the upper edge of one of a pair of hinged metal LEAVES. The vial level is used like the bull's-eye level, except that two bubbles must be watched instead of one.

Care of Leveling Rods

A leveling rod is a precision instrument and must be treated as such. Most rods are made of carefully selected, kiln-dried, well-seasoned hardwood. Scale graduations and numerals on some are painted directly on the wood; on most rods, however, they are painted on a metal strip attached to the wood. Unless a rod is handled at all times with great care, the painted scale will soon become scratched, dented, worn, or otherwise marked and obscured. Accurate readings on a scale in this condition are difficult.

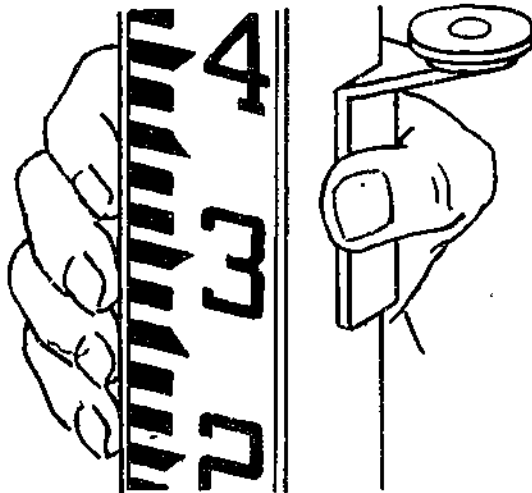

Figure 6-17.—Bull's-eye rod level.

45.40

Allowing an extended sliding-section rod to close "on the run," by permitting the upper section to drop, may jar the vernier scale out of position or otherwise injure the rod. Always close an extended rod by easing the upper section down gradually.

A rod will read accurately only if it is perfectly straight. It follows that anything which might bend or warp the rod must be avoided. Do not lay a rod down flat unless it is supported throughout, and never use a rod for a seat, a lever, or a pole vault. In short, never use a rod for any purpose except the one for which it is designed.

Store a rod not in use in a DRY place to avoid warping and swelling caused by dampness. Always wipe off a wet rod before putting it away. If there is dirt on the rod, RINSE it off, but do not SCRUB it off. If a soap solution must be used (to remove grease, for example), make it a very mild one. The use of a strong soap solution will soon cause the paint on the rod to degenerate.

Protect a rod as much as possible against prolonged exposure to strong sunlight. Such exposure causes paint to CHALK—meaning to degenerate into a chalk-like substance which flakes from the surface.

FIELD NOTES

It is not often that you will be required to keep FIELD NOTES; however, if you had to make the level run illustrated in figure 6-8, you should keep a record in a FIELD NOTEBOOK similar to that shown in figure 6-18. The left-hand page shown is called the DATA page, the right-hand page, the REMARKS page. On the data page there are, from left to right, columns headed Sta. (for station), B.S. (for backsight), H.I. (for height of instrument), F.S. (for foresight), and Elev. (for elevation). The first entry under Sta. is the starting point or the bench mark, entered as B.M. 1. Beside this entry, under Elev. is the bench mark elevation of 100.00 ft. The first B.S. reading on the rod held on the B.M. is 12.02, as entered beside B.M. 1 in the column headed B.S. The H.I. of $100.00 + 12.02$, or 112.02, is entered under H.I.

which is 0.02 ft higher than its actual elevation. Whether or not this discrepancy would be considered too large would depend on the order of precision required in the level run. For most preliminary Builder leveling purposes, it would probably be considered satisfactory.

ERRORS AND MISTAKES IN LEVELING

You might think that an error and a mistake are much the same thing; however, in surveyor's technical terminology there is a distinction. An error, in the technical sense, is an inaccuracy caused by built-in circumstances, while a mistake is, simply, a "boner," such as subtracting a B.S. reading from, instead of adding it to a B.M. elevation to determine the H.I.

An INSTRUMENTAL error is one caused by an imperfection, maladjustment, or malfunction in the instrument used. A rod, for example, which indicated 5.00 ft when it was actually measuring only 4.99 ft would contain an instrumental error. Similarly, a level on which the bubble in the vial centered when the telescope was not actually level would contain an instrumental error. The error in the rod could not be eliminated; it would have to be compensated for, by applying a correction to every reading taken on the rod. Fortunately, rods seldom contain significant instrumental errors, and for the purposes for which a Builder is usually using a rod, you may assume the rod to be free of error. Similarly, the level you use is checked periodically by an EA or Instrumentman for proper level adjustment.

PERSONAL errors exist as a result of natural limitations on the powers of the human senses. When, for example, you align, by eye, the horizontal crosshair in a level telescope with a point on a distant rod, your alignment is never absolutely exact. You must reduce personal errors to a minimum by care and practice.

The commonest personal error in leveling occurs as a result of holding the level rod out of plumb. Other common personal errors are as follows:

Failure to center the bubble in the level tube vial exactly when the instrument is being leveled.

Failure to bring the image of the crosshair and/or image of the rod into clear focus. If these images are out of focus, the reading cannot be made with exactness.

Failure, in target reading, to clamp the target or the upper section of rod securely before making the reading, so that the target or upper section of rod changes position slightly before the reading is made.

Most personal errors can be reduced, but they cannot be eliminated entirely. Mistakes, however, can and must be avoided. Common mistakes made in leveling are:

Setting the rod on the wrong B.M. or T.P., or on a point mistaken for a B.M. or T.P.

Misreading the rod.

Recording readings incorrectly, such as recording the right figures in the wrong column or the wrong figures in the right one.

Incorrect computing. This includes, besides all the common types of arithmetical mistakes, the common mistakes of subtracting instead of adding the B.S. or adding instead of subtracting a F.S. To avoid this, it is a good idea to develop the habit of calling a B.S. a "plus-sight" and a F.S. a "minus-sight."

GRADING

The term GRADE is used in several different senses in construction. In one sense it refers to the steepness of a slope, a slope, for example, which rises 3 vertical ft for every 100 horizontal ft has a grade of 3 percent. Although the term "grade" is commonly used in this sense, the more accurate term for indicating steepness of slope is GRADIENT.

In another sense, the term "grade" simply means surface. On a wall section, for example, the line which indicates the ground surface level outside the building is marked GRADE or GRADE LINE.

The elevation of a surface at a particular point is a GRADE ELEVATION. A grade elevation may refer to an existing, natural earth

surface or a hub or stake used as a reference point, in which case the elevation is that of **EXISTING GRADE** or **EXISTING GROUND**; or it may refer to a proposed surface to be created artificially, in which case the elevation is that of **PRESCRIBED GRADE**, **PLAN GRADE**, or **FINISHED GRADE**.

Grade elevations of the surface area around a structure are indicated on the plot plan. Because a natural earth surface is usually irregular in contour, existing grade elevations on such a surface are indicated by **CONTOUR LINES** on the plot plan—that is, by lines which indicate points of equal elevation on the ground. Contour lines which indicate existing grade are usually made dotted; however, existing contour lines on maps are sometimes represented by **SOLID LINES**. If the prescribed surface to be created artificially will be other than a horizontal-plane surface, prescribed grade elevations will be indicated on the plot plan by solid contour lines.

On a level, horizontal-plane surface, the elevation is the same at all points. Grade elevation of a surface of this kind cannot be indicated by contour lines, because each contour line indicates an elevation different from that of each other contour line. Therefore, a prescribed level surface area, to be artificially created, is indicated on the plot plan by outlining the area and inscribing inside the outline the prescribed elevation, such as "First Floor Elevation 127.50 ft."

BUILDING LAYOUT

Before foundation and footing excavation for a building can begin, the building lines must be laid out to determine the boundaries of the excavations. Points shown on the plot plan, such as building corners are located at the site from a system of **HORIZONTAL CONTROL** points established by the battalion EA's. This system consists of a framework of stakes, driven pipes, or other markers, located at points of known horizontal location. A point in the structure, such as a building corner, is located on the ground by reference to one or more nearby horizontal control points.

We cannot describe here all the methods of locating a point with reference to a horizontal control point of a known horizontal location. We will take as an illustrative example the situation shown in figure 6-19. This figure shows two horizontal control points, consisting of **MONUMENTS A** and **B**. The term "monument," incidentally, doesn't necessarily mean an elaborate stone or concrete structure. In structural horizontal control, it simply means any relatively permanently located object, either artificial, such as a driven length of pipe or natural, such as a tree, of known horizontal location.

In figure 6-19 the straight line from **A** to **B** is a control **BASE LINE**, from which the building corners can be located. Corner **E**, for example, can be located by first measuring 15 ft along the base line from **A** to locate point **C**; then measuring off 35 ft on **CE**, laid off at 90° to (that is, perpendicular to) **AB**. By extending **CE** another 20 ft, you can locate building corner **F**. Corners **G** and **H** can be similarly located along a perpendicular run from

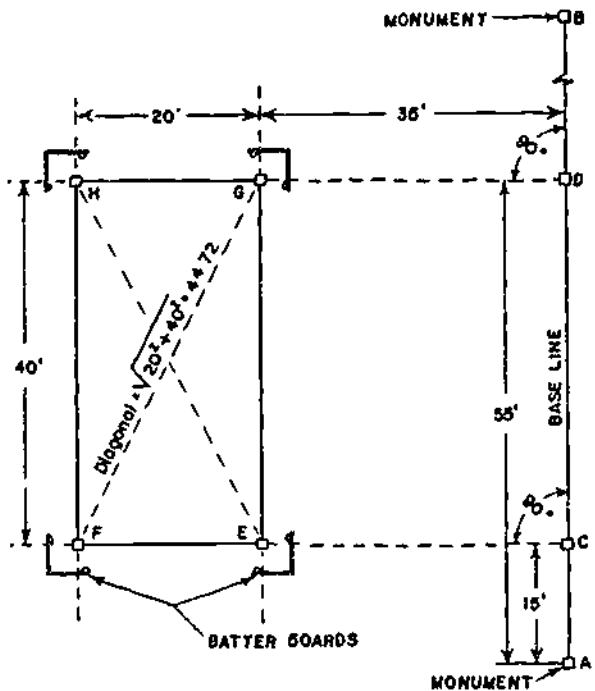

117.40

Figure 6-19.—Locating building corners.

point D, which is itself located by measuring 55 ft along the base line from A.

**PERPENDICULAR BY
PYTHAGOREAN THEOREM**

The easiest and most accurate to locate points on a line or to turn a given angle, such as 90° from one line to another is by the use of a surveying instrument called a TRANSIT. However, if you do not have a transit, you can locate the corner points by tape measurements by applying the Pythagorean theorem. First stretch a cord from monument A to monument B, and locate points C and D by tape measurements from A. Now, if you examine figure 6-19, you will observe that straight lines connecting points C, D, and E would form a right triangle with one side 40 ft long and the adjacent side 35 ft long. By the Pythagorean theorem, the length of the hypotenuse of this triangle (the line ED) would equal the square root of $35^2 + 40^2$, which is about 53.1 ft. Because the figure EGCD is a rectangle, the diagonals both ways (ED and CG) are equal; therefore, the line from C to G should also measure 53.1 ft. If you have one person hold the 53.1-ft mark of a tape on D, have another hold the 35-ft mark of another tape on C, and have a third person walk away with the joined 0-ft ends, when the tapes come taut the jointed 0-ft ends will lie on the correct location for point E. The same procedure, but this time with the 53.1-ft length of tape running from C and the 35-ft length running from D, will locate corner point G. Corner points F and H can be located by the same process, or by extending CE and DG 20 ft.

**PERPENDICULAR BY
3:4:5 TRIANGLE**

If you would rather avoid the square root calculations required in the Pythagorean theorem method, you can apply the basic fact that any triangle with sides in the proportions of 3:4:5 is a right triangle. In locating point E, you know that this point lies 35 ft from C on a line perpendicular to the base line. You also know that a triangle with sides 30 and 40 ft long and a hypotenuse 50 ft long is a right triangle.

To get the 40-ft side, you would measure off 40 ft from C along the base line; in figure 6-19, the segment from C to D happens to measure 40 ft. Now if you run a 50-ft tape from D and a 30-ft tape from C, the joined ends will lie on a line perpendicular from the base line, 30 ft from C. Drive a hub at this point, and extend the line to E (5 more ft) by stretching a cord from C across the mark on the hub.

BATTER BOARDS

Hubs driven at the exact locations of building corners will be disturbed as soon as the excavation for the foundation begins. To preserve the corner locations, and also to provide a reference for measurement down to the prescribed elevations, BATTER BOARDS are erected, as shown in figure 6-20.

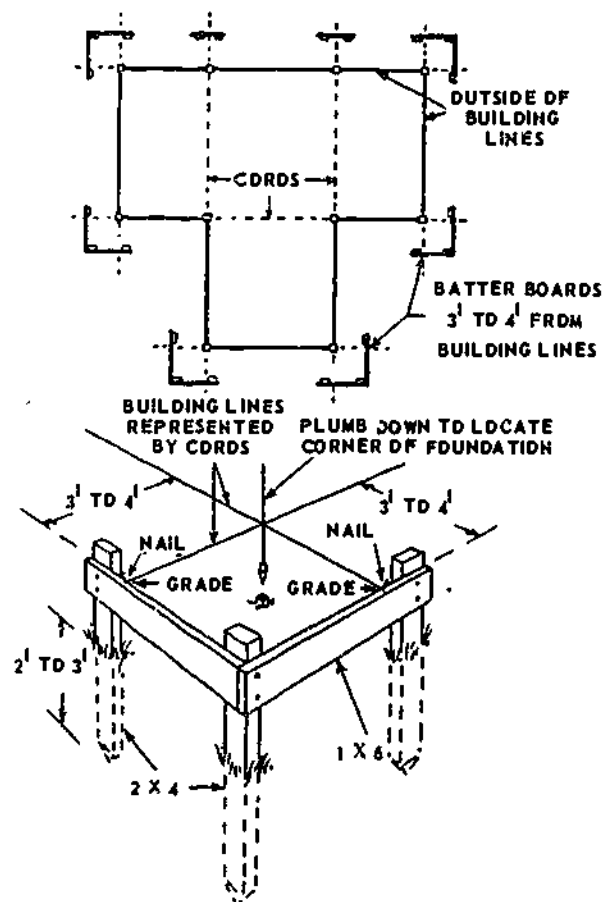

Figure 6-20.—Batter boards.

117.41

Each pair of boards is nailed to three 2 by 4 corner stakes, as shown. The stakes are driven far enough outside the building lines so that they will not be disturbed during excavating. The top edges of the boards are located at a specific elevation, usually some convenient number of whole ft above a significant prescribed elevation such as that of the top of the foundation. Cords located directly over the lines through corner hubs, placed by holding plumb bobs on the hubs, are nailed to the batter boards. Figure 6-20 shows how a corner point can be located in the excavation by dropping a plumb bob from the point of intersection between two cords.

In addition to their function in horizontal control, batter boards are also used for vertical control. The top edge of a batter board is placed at a specific elevation. Elevations of features in the structure, such as foundations and floors, may be located by measuring downward or upward from the cords stretched between the batter boards.

You should always make sure that you have complete information as to exactly what lines and elevations are indicated by the batter boards.

It should be emphasized to your crewmembers to exercise extreme caution while working around batter boards. If they are damaged or moved additional work will be required to replace them and to relocate reference points.

CLEARING PRIOR TO EXCAVATION

During clearing operations, appropriate protective equipment, such as hard hats, goggles, and safety shoes or boots must be worn by workers at all times for protection against injuries in all kinds of weather and under all conditions. Protective equipment, such as carrying cases and sheaths, should be used at all times for sharp-edged tools. Ample working space should be given for persons using axes, machetes or other sharp-edged tools in hacking

and clearing underbrush, such as vines and small trees. All people should stand clear of all moving machinery. When operations are conducted at night, adequate illumination must be provided either in the form of floodlights (trailer-mounted) or by general lighting of the work area.

All trees in the area should be thoroughly inspected for quality before felling. They should be inspected for rot, hollow cores, dead or entangled limbs or other factors which might present a hazard in felling. Trees which could possibly present a hazard should be felled under the supervision of the project supervisor. These trees are never felled with a power chain saw.

People engaged in felling trees should look over the area carefully before starting, and mentally note the existing avenues of escape. In particular, operators of chain saws must be cautious when felling trees. All trees must be properly undercut before felling, with a deep "V" grooved notch on the side in the direction the tree is to fall. A loud warning call, "TIMBER," must be given at the time of the felling to warn all persons in the danger area. Except in an emergency, working in or on trees during high winds is prohibited and then only under direct supervision. Before felled trees are trimmed, they should be properly secured from rolling by chocking or other means to prevent them from rolling.

BURNING

Burning operations must be kept under strict control and not left unattended. They must always be conducted in the clear, where the fire will not ignite leaves, dry wooded areas, or nearby buildings. Crewmembers should not stand in the smoke. Firing, punching, and placing of material for burning should be done from the windward side. This is especially important when poison oak, poison sumac, or poison ivy is being burned. Crewmembers should never use flammable liquids on piles of material which are burning or smoldering. All burning or smoldering material must be completely extinguished before the crew leaves the scene.

POISONOUS PLANTS

When handling poisonous plants, crewmembers should always wear heavy gloves and clothing. Persons who come in contact with poison ivy, poison oak, or sumac, should swab the skin with alcohol and then, scrub it with laundry soap and water. A brush or rough cloth is not used because it might irritate the skin and increase the danger of poisoning. The clothing worn by these persons should be cleaned daily. When personnel are burning poisonous vines, it is important that they keep away from the smoke to avoid inhalation of poisonous fumes. Also, they should consult a medical officer if infection develops after contact with poisonous plants. Self-medication with poisonous plant immunization or desensitization extracts should never be undertaken. Persons who are extremely sensitive to these poisons should be transferred to other jobs.

SAFETY

Where applicable, Federal, state, or local codes, rules, regulations, and ordinances governing any and all phases of excavation work should be observed at all times.

Every effort should be made before excavating to determine whether or not sewers, utility lines, fuel tanks, and the like have been installed in the area. If so, they should be located from blueprints, when available, or by careful probing and digging. When uncovered, lines should be properly supported and protected. Before excavation is started, trees, boulders, and other surface obstructions that create a hazard at any time during operations must be removed.

If the stability of adjoining buildings or walls is endangered by excavations, necessary shoring, bracing, or underpinning must be provided to insure their stability. Such shoring, bracing or underpinning should be frequently inspected by a competent person and the protection effectively maintained. If it is necessary to operate or place power shovels, derricks, trucks, material, or other heavy objects on a level above and near an excavation, the side of the

excavation must be sheet-piled, shored, and braced as necessary to resist the extra pressure. Whenever any side of an excavation is a masonry wall, the wall should be braced to insure stability. Reinforced concrete walls known to be of ample strength do not require bracing. Temporary sheet piling which has been installed to permit the construction of a retaining wall must not be removed until the wall has acquired full strength.

Except in hard rock, excavations below the level of the base or footing of any foundation or retaining wall should not be permitted unless the wall is underpinned and all other precautions taken to insure the stability of the adjacent walls for the protection of the crewmembers. Undercutting of earth banks should not be permitted unless they are adequately shored. Excavations should be inspected after every rain, storm or other hazard-increasing occurrence, and any protection against slides and cave-ins increased if necessary. All fixed-in-place ladders and stairways giving access to levels 20 or more ft apart should be provided with landing platforms at vertical intervals of not more than 20 ft. Every landing platform should be equipped with standard railings and toeboards.

Particular attention should be given to shoring of trenches, especially if there are roadways or railroad lines in the vicinity of the excavation or if personnel are to work in the trench. In the following paragraphs, provisions for shoring and bracing of excavations should apply, except when the full depth of the excavation is in stable solid rock, hard slag, or hard shale, or the shoring plan has been designed by the engineering office.

The sides of excavations 4 ft or more in depth or in which the soil is so unstable that it is not considered safe even at lesser depths should be supported by substantial and adequate sheet piling, bracing, shoring, etc. or the sides sloped to the angle of repose. Surface areas adjacent to the sides should be well drained. Trenches in partly saturated, filled, or unstable soils, should be suitably braced.

Excavated or other material must not be stored closer than 2 ft from the edge of a trench.

In the case of extremely deep trenches, material should be stored farther away than 2 ft. The safe storage distance is in proportion to the depth of the trench; the deeper the trench the farther away the material should be stored. Where both pedestrian and vehicular traffic are to be maintained over or adjacent to excavations, proper safeguards should be provided, such as walkways, bridges, guardrails, barricades, warning flags and lights.

Where an excavation is close to a cut, particularly when nearer to the cut than its depth, special shoring should be used. Persons working in deep trenches should wear hardhats as a protection against falling material. Access to excavations over 5 ft deep should be by ramps, ladders, stairways, or hoists. Crewmembers should not jump into the trench nor use the bracing as a stairway.

No tools, materials, or debris should be left on walkways, ramps, struts, or near the edge of an excavation. Such material might be knocked off or cause persons to lose their footing. Personnel working in trenches with picks and shovels must keep sufficient distance apart so they cannot injure each other with their tools.

Extra care should be used in excavating around gas mains, oil tanks, gasoline or oil pipe lines, etc. Smoking or open fires of any kind are prohibited in places where gaseous conditions are suspected. The air should be tested in such places and, if gas is present, ventilation should be provided by portable blowers or other satisfactory methods.

EXCAVATING

Generally speaking, grading means, the earthmoving required to create a surface of desired grade elevation at and adjacent to the place where a structure will be erected. After this has been accomplished, further earthmoving is usually required. If the structure is to have a below-grade basement, earth lying within the building lines must be removed down to the prescribed finished basement floor elevation, plus the thickness of the basement floor paving

and subfill. After this earth is removed, further earth may have to be removed for footings under the foundation walls. This type of earth-removal is generally known as EXCAVATING.

To estimate the cubic yards of earth that you may have to remove for a basement, foundation, or footing, simply multiply the length by the width by the depth. Should the depth vary because the ground raises and falls, use an average of the depths at the four corners of the excavation or at other points where the depth may vary. For example, if the excavation is to be 24 ft wide by 36 ft long and is to be on a slope where the depths at the corners are 3 ft, 3.5 ft, 5 ft, and 3 ft; add the four corners together and then divide by 4. This gives you i.e., $\frac{3' + 3.5' + 5' + 3'}{4} = \frac{14.5'}{4} = 3.625'$ average depth to be excavated. Therefore, 36 ft by 24 ft by 3.625 ft equals 4234 cu ft. You then divide 4234 cu ft by 27 cu ft to obtain 157 cu yd of material to be excavated.

If the excavation is to be extremely long, it may be necessary to divide the excavation into smaller sections and figure the cu yd for each section separately.

DIMENSIONS OF EXCAVATIONS

The dimensions of cellar or basement excavations are given in the specifications which usually have something like the following:

Excavations shall extend 2' 0" outside of all basement wall planes and to 9" below finished planes of basement floor levels.

The 2 ft space is the customary allowance made for working space outside the foundation walls. It must be backfilled after the foundations have set. The 9 in. below finished planes of basement floor levels is the usual allowance for basement floor thickness, usually about 3 in., plus the thickness of the cinder or other fill placed under the basement floor, usually about 6 inches.

The actual depth below grade to which a basement excavation must be carried is determined by the study of a wall section. It is

the one shown in figure 6-21. This section shows that the depth of the basement excavation would in this case equal 8 ft 0 in., the vertical distance between the basement and the first floor finished planes, minus 1 ft 6 in. (vertical distance between the surface grade and the first floor finished plane), plus 9 in. (3 in. pavement floor plus 6 in. cinder fill), or a total of 7 ft 3 in. below surface grade.

The top of the footing comes level with the top of the 6-in. cinder fill. However, the footing is 2 in. deeper than the fill. Therefore, the footing excavation should be carried 2 in. lower than the basement floor elevation or to 7 ft 5 in. below grade.

If a specific elevation were prescribed for the finished floor line, then the basement floor and footing excavation would be carried down to the corresponding elevation, without reference to surface grade. Suppose, for example, that the

specified elevation for the finished first floor line were 163.50 ft. Obviously, the elevation to which the basement floor elevation would be carried would be $163.50 - (8 \text{ ft} + 3 \text{ in.} + 6 \text{ in.})$, or $163.50 - (8 \text{ ft} + 0.25 \text{ ft} + 0.50 \text{ ft})$, or 154.75 ft. The elevation to which the footing excavation would be carried would be $163.50 \text{ ft} - 8 \text{ ft} + 0.25 \text{ ft} + 0.67 \text{ ft}$, or 154.58 ft. Suppose the batter board cords were at an elevation of 165.00 ft. Then the vertical distance from the cords to the bottom of the basement floor excavation would be $165.00 \text{ ft} - 154.75 \text{ ft}$, or 10.25 ft, or 10 ft 3 in. The vertical distance from the cords to the bottom of the footing excavation would be $165.00 - 154.58$, or 10.42 ft, or 10 ft 5 inches.

Excavations should never be carried below the proper depths. If a basement floor or footing excavation is by mischance so carried, the error should not ordinarily be corrected by refilling. It is almost impossible to attain the necessary load-bearing density by comacting the refill unless special, carefully controlled procedures are used. For a basement floor excavation, a relatively small error should be corrected by increasing the vertical dimension of the subfloor fill by the amount of the error. For a footing excavation, the error should be corrected by increasing the vertical dimension of the footing by the amount of the error. Both of these corrections mean additional and unnecessary expense for the extra material and added labor costs.

PREVENTION OF SLIDES AND CAVE-INS

When your work involves excavation, there are definite precautions that you should observe to prevent accidents.

To avoid slides or cave-ins, the sides of excavations 4 ft or more in depth should be supported by substantial and adequate sheathing, sheet piling, bracing, shoring, etc., or the sides sloped to the angle of repose. The angle of repose is the angle, measured from the horizontal, of the natural slope of the side of a pile of granular material formed by pouring grains of particles through a funnel, practically without impact. The angle of repose varies with

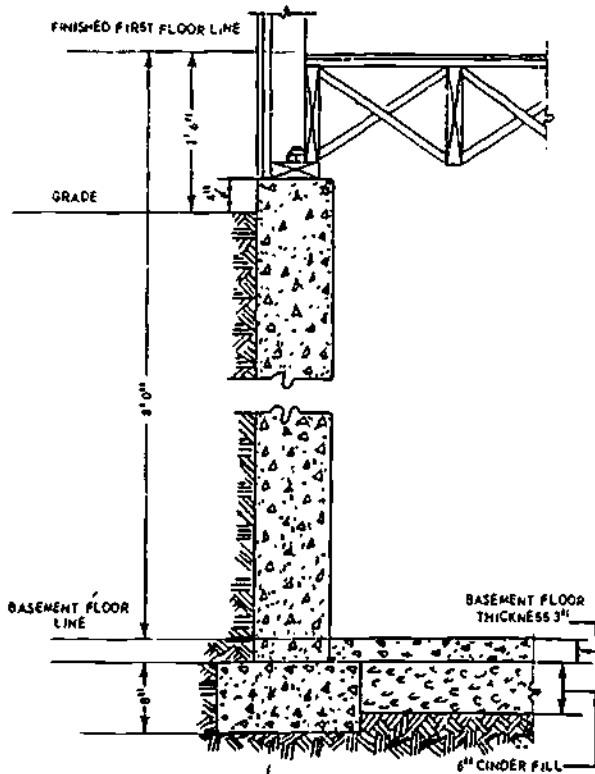

117.42

Figure 6-21.—Wall section, showing excavation depth data.

the moisture content and the type of earth or other material. For ordinary earth, the angle of repose varies from about 20 to 45 degrees, corresponding to slopes of from about 2.8:1 to 1:1. The sides of an excavation do not consist of poured particles, however; many types of earth, because of their cohesive qualities, will stand vertically without failure. But because of the nonuniformity of most soils, the times and places of local and intermittent cave-ins and slides cannot ordinarily be predicted. Therefore, it is conservative and safe to require laying the bank back to the angle of repose or the natural slope of the material being excavated.

It is seldom practical to slope the sides of foundation and footing excavations to the angle of repose. Therefore, any such excavation 4 ft deep or more must be supported as specified. Many people wonder about this, in view of the fact that most adults are a good deal more than 4 ft tall. The reason lies in the fact that a person needs to be buried **ONLY TO CHEST LEVEL** to suffocate in a cave-in. The pressure against the

chest makes breathing impossible, and if the chest is not freed within a minute or two, the person will suffocate, even though the head and shoulders are out in the air. This is a terrible way to die, and people die this way, somewhere in the world, in an excavation which should have been supported but which was not nearly every day.

Sheathing

SHEATHING consists of wooden planks, placed edge-to-edge, either horizontally or vertically. Horizontal planking is used for excavations with plane faces, vertical planking when it is necessary to follow curved faces. Sheathing is supported by longitudinal **WALES** or **RANGERS** which are nailed to the sheathing and which bear against transverse **SHORES** or **BRACES**.

Sheathing must be progressively installed and braced as every 4-ft stage of depth is reached. Vertical and horizontal wood sheathing are illustrated in figure 6-22.

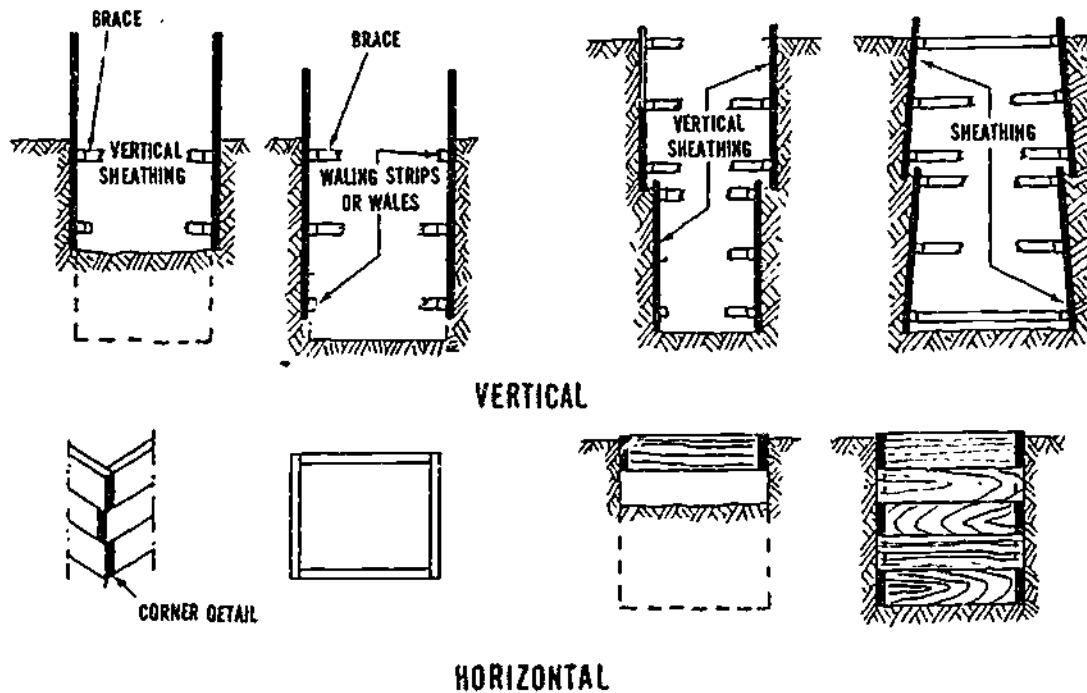
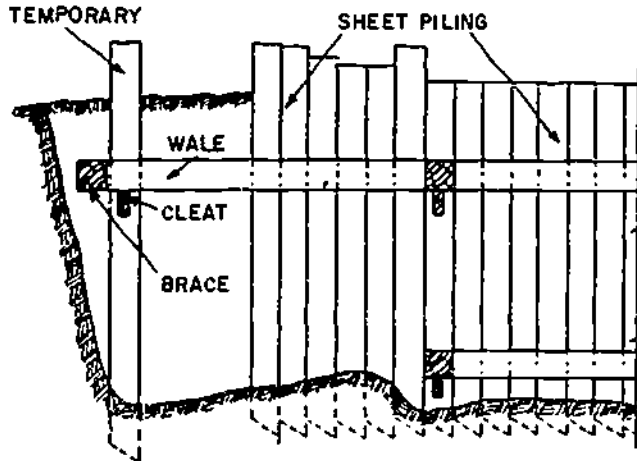

Figure 6-22.—Vertical and horizontal sheathing.

Wooden Sheet Piling

WOODEN SHEET PILING (fig. 6-23) is driven before the excavation begins. Wooden sheet piling consists of 2-, 3-, or 4-in. planks,

beveled at the lower end to facilitate penetration of the soil. Also, the lower ends are cut at an angle, as shown in View A, fig. 6-23, so as to cause the edge of the pile being driven to bear against the edge of the one previously driven.



SECTION OF A TRENCH SHEET-PILING METHOD

(A)

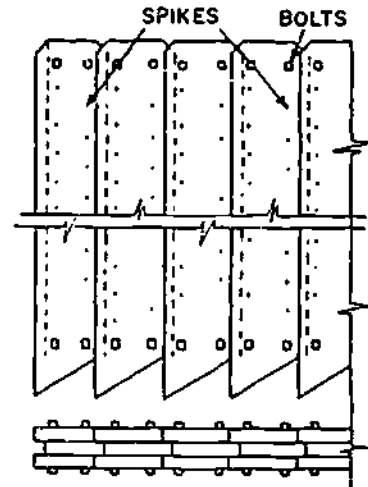

WAKEFIELD SHEET-PILING WOOD

(B)

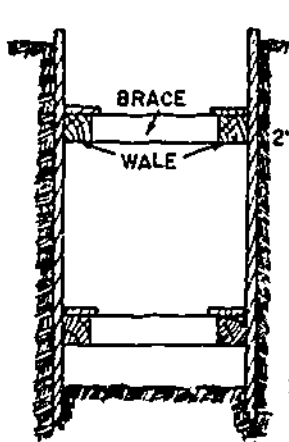

TRENCH CROSS SECTION SHOWING SHEET PILING

(C)

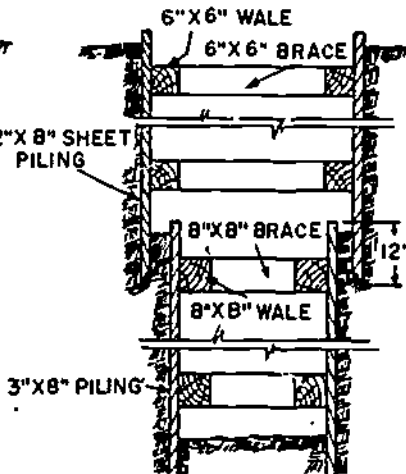

TWO-SECTION SHEET PILING DEEP EXCAVATION

(D)

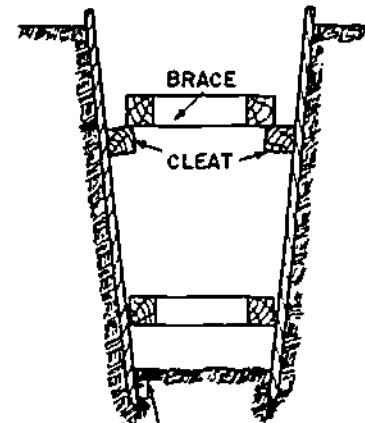

REDUCED WORKING SURFACE EFFECT OF INCORRECTLY TURNED BEVEL IN DRIVING SHEET PILING

(E)

Figure 6-23.—Wooden sheet piling.

Obviously, care must be taken to place a pile with this angle inclined in the proper direction. The bevel on the lower end-edge, too, must face toward the excavation. As a pile is driven, it tends to slant off in the direction away from the bevel. If the bevel is incorrectly turned away from the excavation, the excavation will progressively narrow, as shown in View E, fig. 6-23.

In WAKEFIELD sheet piling, each pile consists of three planks, bolted together with the center plank offset for tongue-and-groove joining, as shown in View B, fig. 6-23.

To set wooden piles for driving, you first dig a shallow notch along the excavation line, wide enough to admit the bottoms of the piles and deep enough to hold them upright. For

additional upright support, lay pairs of wales along the notch and stake them in position. If the piles are too long to stand this way, the wales must be braced in an elevated position.

In favorable soil, a 2-in. sheet pile can be driven to a depth of about 16 ft, a 3-in. sheet pile to about 24 ft, and a 4-in. sheet pile to about 32 ft. When piles are too short to cover full excavation depth, they are driven in stages called SECTIONS, as shown in View D, fig. 6-23.

The removal of the material near the foundations of a structure may threaten the stability of the foundations. When this is a possibility, temporary supports must be provided before excavation reaches the dangerous stage.

CHAPTER 7

CONCRETE

This chapter provides information and guidance for the Builder engaged in or responsible for concrete construction using the natural resource available. It includes information on materials, mix design, production, placement, finishing, and curing concrete.

Information is given on the procedures used in cutting, forming, placing, and tying reinforcing steel for placement in concrete footings, walls, columns, beams, and overhead slab forms.

Information on the principles of operating and maintaining concrete pumping machines is also given in this chapter.

Safety precautions must be rigidly observed in concrete operations, particularly in the placement of concrete mix. Safety precautions will be noted at various points, where applicable, throughout the chapter.

CONCRETE CHARACTERISTICS

CONCRETE is a synthetic construction material made by mixing CEMENT, FINE AGGREGATE (usually sand), COARSE AGGREGATE (usually gravel or crushed stone) and WATER together in proper proportions. The product is not concrete unless all four of these ingredients are present. A mixture of cement, sand, and water, without coarse aggregate, is not concrete but MORTAR or GROUT.

The fine and coarse aggregate in a concrete mix are called the INERT ingredients; the

cement and water are the ACTIVE ingredients. The inert ingredients and the cement are thoroughly mixed together first. As soon as the water is added, a chemical reaction between the water and the cement begins, and it is this reaction (which is called HYDRATION) that causes the concrete to harden.

Always remember that the hardening process is caused by hydration of the cement by the water, not by the DRYING OUT of the mix. Instead of being dried out, the concrete must be kept as moist as possible during the initial hydration process. Drying out would cause a drop in water content below the amount required for satisfactory hydration of the cement.

The fact that the hardening process has nothing whatever to do with the drying out of the concrete is clearly shown by the fact that concrete will harden just as well under water as it will in the air.

CONCRETE AS BUILDING MATERIAL

Concrete may be cast into bricks, blocks, and other relatively small building units which are used in concrete MASONRY construction which is covered in the next chapter. This chapter is concerned with the concrete itself and the casting of larger structural components.

The proportion of concrete to other materials used in building construction has greatly increased in recent years, to the point where large, multistory modern buildings are constructed entirely of concrete, with concrete footings, foundations, columns, walls, girders, beams, joists, floors, and roofs.

STRENGTH OF CONCRETE

The COMPRESSIVE strength of concrete is very high, but its TENSILE strength (meaning its ability to resist stretching, bending, or twisting) is relatively low. Consequently, concrete which must resist a good deal of stretching, bending, or twisting such as concrete in beams, girders, walls, columns, and the like must be REINFORCED with steel. Concrete which must resist compression only may not require reinforcement.

As will be seen later, the most important factor controlling the strength of concrete is the WATER-CEMENT RATIO, or the proportion of water to cement in the mix.

DURABILITY OF CONCRETE

The DURABILITY of concrete means the extent to which the material is capable of resisting the deterioration caused by exposure to service conditions. Ordinary structural concrete which is to be exposed to the elements must be watertight and weather resistant. Concrete which is subject to wear such as floor slabs and pavements must be capable of resisting abrasion.

It has been found that the major factor controlling durability is strength—in other words, the stronger the concrete is, the more durable it will be. As mentioned previously, the chief factor controlling strength is the water-cement ratio, but the character, size, and grading (distribution of particle sizes between the largest permissible coarse and the smallest permissible fine) of the aggregate also have important effects on both strength and durability. When given a water-cement ratio which will produce maximum strength consistent with workability requirements, the maximum strength and durability will still not be attained unless the sand and coarse aggregate you use consist of well-graded, clean, hard, and durable particles free from undesirable substances. (See fig. 7-1.)

WATERTIGHTNESS OF CONCRETE

The ideal concrete mix would be one made with just the amount of water required for

complete hydration of the cement. This would be a DRY mix, however, too stiff to pour in forms. A mix which is fluid enough to be poured in forms always contains a certain amount of water over and above that which will combine with the cement, and this water will eventually evaporate, leaving voids or pores in the concrete.

Even so, penetration of the concrete by water would still be impossible if these voids were not interconnected. They are interconnected, however, as a result of a slight sinking of solid particles in the mix during the hardening period. As these particles sink, they leave water-filled channels which become voids when the water evaporates.

The larger and more numerous these voids are, the more the watertightness of the concrete will be impaired. Since the size and number of the voids vary directly with the amount of water used in excess of the amount required to hydrate the cement, it follows that to keep the concrete as watertight as possible, you must not use more water than the minimum amount required to attain the necessary degree of workability.

GENERAL REQUIREMENTS FOR GOOD CONCRETE

The first requirement for good concrete is, of course, a supply of good cement of a type suitable for the work at hand. Next is a supply of satisfactory sand, coarse aggregate, and water. Everything else being equal, the mix with the best graded, strongest, best shaped, and cleanest aggregate will make the strongest and most durable concrete.

The amount of cement, sand, coarse aggregate, and water required for each batch must be carefully weighed or measured in accordance with NAVFAC Specifications, TS-03300.

The best designed, best graded, and highest-quality mix in the world will not make good concrete if it is not WORKABLE enough to fill the form spaces thoroughly. On the other hand, too much fluidity will result in certain defects.

Chapter 7—CONCRETE

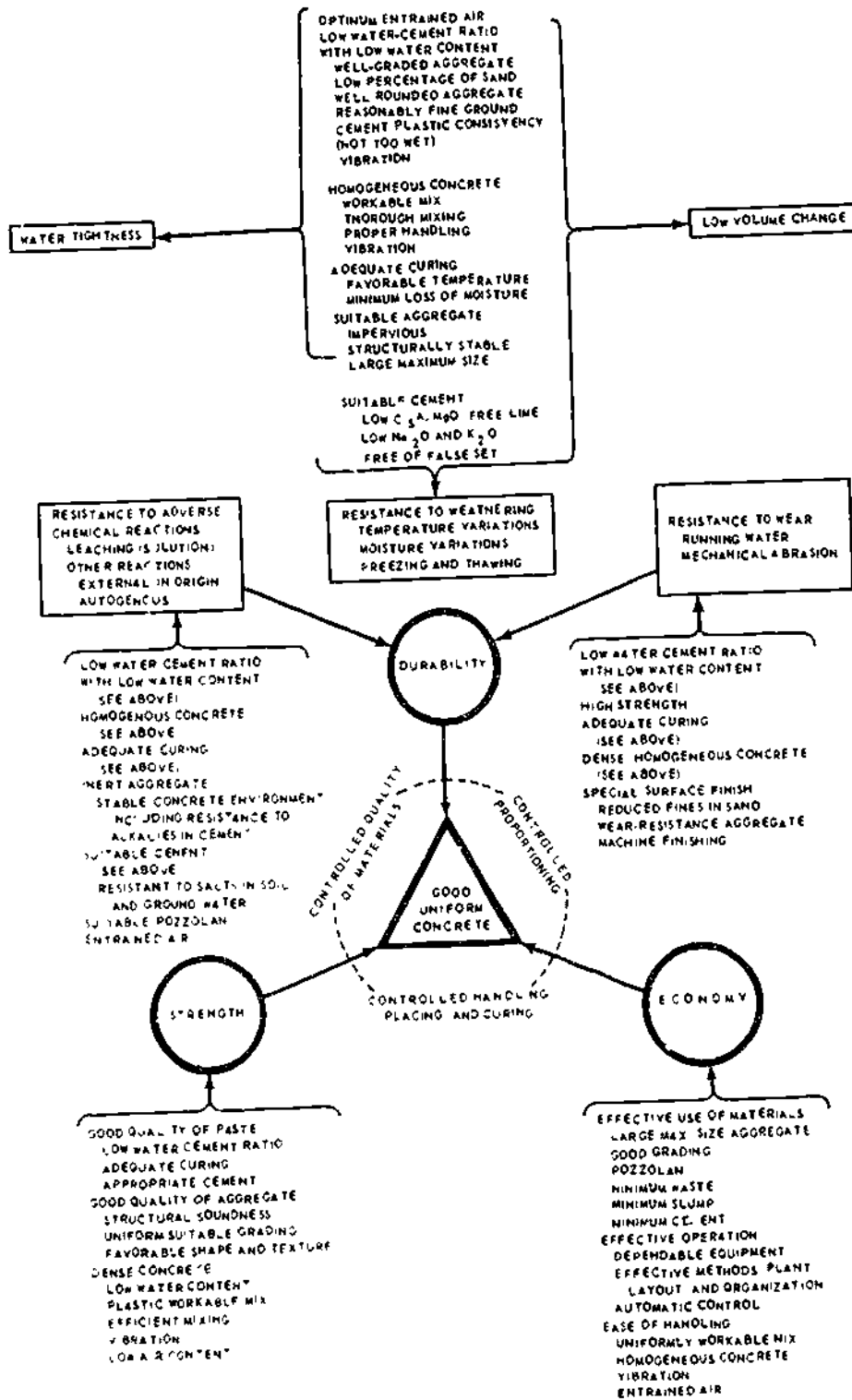

117.83

Figure 7-1.—The principal properties of good concrete.

Improper handling during the whole concrete-making process (from the initial aggregate handling to the final placement of the mix) will cause segregation of aggregate particles by sizes, resulting in nonuniform, poor concrete.

Finally, the best designed, best graded, highest quality, and best placed mix in the world will not produce good concrete if it is not properly CURED—meaning, properly protected against loss of moisture during the earlier stages of setting.

CONCRETE INGREDIENTS

The essential ingredients of concrete are cement, aggregate, and water. A mixture of only cement and water is called cement paste, but such a mixture, in large quantities, is prohibitively expensive for practical construction purposes.

CEMENT

Most cement used today is PORTLAND cement, which is usually manufactured from limestone mixed with shale, clay, or marl. The properly proportioned raw materials are pulverized and fed into kilns, where they are heated to a temperature of 2700°F and maintained at that temperature for a certain time. As a result of certain chemical changes produced by the heat, the material is transformed into a clinker. The clinker is then ground down so fine that it will pass through a sieve containing 40,000 openings per square inch.

Types

There are a number of types of portland cement, of which the most common are types I through V and air-entrained.

References to cement can be assumed to mean "portland cement," which is the primary type used in concrete. There are five common types of portland cement in use today. The type of construction, chemical type of the soil, economy, and the requirements for use of the

finished concrete are factors which influence the selection of the type of cement to be used. The different types of cement are discussed below.

Type I (normal portland cement) is used for all general types of construction. It is used in pavement and sidewalk construction, reinforced concrete buildings and bridges, railways, tanks reservoirs, sewers, culverts, water pipes, masonry units, and soil-cement mixtures. In general, it is used when concrete is not subject to special sulfate hazard or where the heat generated by the hydration of the cement will not cause an objectionable rise in temperature.

Type II (modified portland cement) has a lower heat of hydration than type I, and lower heat generated by the hydration of the cement improves resistance to sulfate attack. It is intended for use in structures of considerable size where cement of moderate heat of hydration will tend to minimize temperature rise, as in large piers, heavy abutments, and heavy retaining walls.

In cold weather when the heat generated is helpful, type I cement may be preferable for these uses. Type II cement is also intended for places where an added precaution against sulfate attack is important, as in drainage structures where the sulfate concentrations are higher than normal, but not usually severe.

Type III (high-early-strength portland cement) is used where high strengths are desired at very early periods. It is used where it is desired to remove forms as soon as possible, to put the concrete in service as quickly as possible, and in cold weather construction to reduce the period of protection against low temperatures. High strengths at early periods can be obtained more satisfactorily and more economically using high-early-strength cement rather than using richer mixes of type I cement. Type III develops strength at a faster rate than other types of cement, such as: 28-day strength for types I and II, which is reached by type III in about 7 days, and 7-day strength for types I and II, while type III takes about 3 days.

Type IV (low-heat portland cement) is a special cement for use where the amount and

rate of heat generated must be kept to a minimum. This type of cement was first developed for use on the Hoover Dam. It develops strength at a slow rate and should be cured and protected from freezing for at least 21 days. For this reason it is unsuitable for structures of ordinary dimensions, and is available only on special order from a manufacturer.

Type V (sulfate-resistant portland cement) is a cement intended for use only in structures exposed to high alkali content. It has a slower rate of hardening than normal portland cement. The sulfates react chemically with the hydrated lime and the hydrated calcium aluminate in the cement paste. This reaction results in considerable expansion and disruption of the paste. Cements which have a low content of calcium aluminate have a great resistance to sulfate attack. Thus, type V portland cement is used exclusively for situations involving severe sulfate concentrations.

Air-entrained portland cement is a special cement that can be used with good results for a variety of conditions. It has been developed to produce concrete that has a resistance to freeze-thaw action and scaling caused by chemicals applied for severe frost and ice removal. In this cement, very small quantities of air-entraining materials are added as the clinker is being ground during manufacturing. Concrete made with this cement contains minute, well-distributed and completely separated air bubbles. The bubbles are so minute that it is estimated that there are many millions of them in a cubic foot of concrete. Air bubbles provide space for water to expand due to freezing, without damage to the concrete. Air-entrained concrete has been used in pavements in the northern states for about 25 years with excellent results. Air-entrained concrete also reduces the amount of water loss and the capillary and water-channel structure. This agent may be added to types I, II, and III portland cement. The manufacturer will specify the percentage of air-entrainment which can be expected in the concrete. An advantage of using air-entrained cement is that it can be used and batched like normal cement.

Storage

Portland cement is packed in cloth or paper sacks, each of which contains 94 lb of cement. A 94-lb sack of cement amounts to about 1 cu ft by loose volume.

Cement will retain its quality indefinitely if it does not come in contact with moisture. If it is allowed to absorb appreciable moisture in storage, it will set more slowly and its strength will be reduced. Sacked cement should be stored in warehouses or sheds made as watertight and airtight as possible. All cracks in roof and walls should be closed, and there should be no opening between walls and roof. The floor should be above ground to protect the cement against dampness. All doors and windows should be kept closed.

Sacks should be stacked against each other to prevent circulation of air between them, but they should not be stacked against outside walls. If stacks are to stand undisturbed for long intervals, they should be covered with tarpaulins.

When shed or warehouse storage cannot be provided, sacks which must be stored in the open should be stacked on raised platforms and covered with waterproof tarps. The tarps should extend beyond the edges of the platform so as to deflect water away from the platform and the cement.

Cement sacks which have been stacked in storage for long periods sometimes acquire a hardness called WAREHOUSE PACK. This can usually be loosened up by rolling the sack around. No cement should be used which has lumps or is not free flowing.

AGGREGATE

The material which is combined with cement and water to make concrete is called AGGREGATE. Aggregate helps to increase the strength of concrete while reducing the

shrinking tendencies of the cement. Not only does aggregate aid in the strength of concrete, but it is also used as a filler for economical purposes. The aggregate is divided into FINE (usually consisting of sand) and COARSE. For most ordinary building concrete, the coarse aggregate usually consists of gravel or crushed stone, running not more than about 1 1/2 in. in size. In massive structures like dams, however, the coarse aggregate may include natural stones or rocks ranging up to 6 in. or more in size.

What might be called the fundamental structural mechanics of a concrete mix are about as follows. The large, solid coarse aggregate particles form the basic structural members of the concrete. The voids between the larger coarse aggregate particles are filled by smaller particles, and the voids between the smaller particles are filled by still smaller particles, until finally the voids between the smallest coarse aggregate particles are filled by the largest fine aggregate particles. In turn, the voids between the largest fine aggregate particles are filled by smaller fine aggregate particles, the voids between the smaller fine aggregate particles by still smaller particles, and so on. You can see from this that the better the aggregate is GRADED (that is, the better the distribution of particle sizes), the more solidly all voids will be filled, and the denser and stronger will be the concrete.

The cement and water forms a paste which binds the aggregate particles solidly together when it hardens. In a well graded, well designed, and well-mixed batch, each aggregate particle is thoroughly coated with the cement-water paste, so that each particle is solidly bound to adjacent particles when the cement-water paste hardens.

The existing GRADATION, or distribution of particle sizes from coarse to fine, in a supply of fine or coarse aggregate is determined by extracting a representative sample of the material, screening the sample through a series of sieves ranging in size from coarse to fine, and determining the percentage of the total sample which is retained on the fine aggregate sieve, or which passes the coarse aggregate sieve. This procedure is called making a SIEVE ANALYSIS.

The size of a fine aggregate sieve is designated by a number which corresponds to the number of meshes to the linear inch that the sieve contains. Obviously, then, the higher the number, the finer the sieve. Any material retained on the No. 4 sieve is considered coarse aggregate, and any material which will pass the No. 200 sieve is too fine to be used in the making of concrete. When an analysis reveals the presence of a substantial percentage of material which will pass the No. 200, the aggregate must be washed before being used.

The finest coarse-aggregate sieve is the same No. 4 used as the coarsest fine-aggregate sieve. With this exception, a coarse-aggregate sieve is designated by the size of one of its openings. The sieves commonly used are 1 1/2 in., 3/4 in., 1/2 in., 3/8 in., and No. 4.

Experience and experiments have shown that for ordinary building concrete, certain particle distributions seem consistently to produce the best results. For fine aggregate, the recommended distribution of particle sizes from No. 4 to No. 100 is shown in table 7-1.

The percentages given are CUMULATIVE, meaning that each is a percentage of the TOTAL SAMPLE, not of the amount remaining on a particular sieve. For example: suppose the total sample weighs 1 lb. Place this on the No. 4 sieve, and shake the sieve until nothing more will

Table 7-1.—Recommended Distribution of Particle Sizes

Steve Number	Percent retained on square mesh laboratory sieves
3/8"	0
No. 4	18
No. 8	27
No. 16	20
No. 30	20
No. 50	10
No. 100	4

go through. If what is left on the sieve weighs 0.05 lb, then 5 percent of the total sample was retained on the No. 4 sieve. Place what passed through on the No. 8 sieve and shake it. Suppose you find that what stays on the sieve weighs 0.1 lb. Since 0.1 lb is 10 percent of 1 lb, it follows that 10 percent of the total sample was retained on the No. 8 sieve.

The nominal size of coarse aggregate to be used is usually specified as a range between a minimum and a maximum size. For example 2 in. to No. 4, 1 in. to No. 4, 2 in. to 1 in., and so on. The recommended particle size distributions vary with maximum and minimum nominal size limits, as shown in table 7-2.

A blank space in table 7-2 indicates a sieve which is not required in the indicated analysis. For example: for the 2-in. to No. 4 nominal size, there are no values listed under the 4-in., the 3 1/2-in., and the 3-in. sieves. The reason for this is that since 100 percent of this material should pass a 2 1/2-in. sieve, the use of sieves coarser than 2 1/2 in. is superfluous. For the same size designation, there are no values listed under the 1 1/2-in., the 3/4-in., and the 3/8-in. sieves. This is because experience has shown that it is not necessary to use these sieves in making this particular analysis.

Note that when you are analyzing coarse aggregate, you determine the percentage of material which PASSES a sieve, not the percentage which is retained on a sieve.

Quality Criteria

Since from 66 to 78 percent of the volume of the finished concrete consists of aggregate, it is imperative that the aggregate measure up to certain minimum quality standards. It should consist of clean, hard, strong, durable particles which are free of any chemicals which might interfere with hydration, and of any superfine material which might prevent bond between the aggregate and the cement-water paste. The undesirable substances most frequently found in aggregate are dirt, silt, clay, coal, mica, salts, and organic matter. Most of these can be removed by washing.

Aggregate may be field tested for an excess of silt, clay, and the like, as follows: fill a quart jar with the aggregate to a depth of 2 in.; add water until the jar is about three-fourths full; shake the jar for 1 minute; and allow it to stand for 1 hour. If at the end of that time more than 1/8 in. of sediment has settled on the top of the

Table 7-2.—Recommended Maximum and Minimum Particle Sizes

Size of coarse aggregate, inches	Percentages by weight passing laboratory sieves having square openings										
	4-in.	3 1/2 in.	3-in.	2 1/2 in.	2-in.	1 1/2 in.	1-in.	3/4 in.	1/2 in.	3/8 in.	No. 4
1.5	--	--	--	--	100	95-100	--	35-70	--	10-30	0-5
2	--	--	--	100	95-100	--	35-70	--	10-30	11	0-5
2.5	--	--	100	90-100	--	35-70	--	10-40	--	0-15	0-5
3.5	100	90-100	--	45-80	--	25-50	--	10-30	--	0-15	0-5

133.245

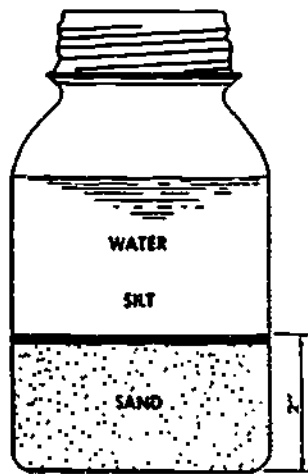

133.249
Figure 7-2.—Quart-jar method of determining silt content of sand.

are undesirable. Shale, stones laminated with shale, and most varieties of chert (impure flintlike rock) are especially to be avoided. For most ordinary concrete work, visual inspection is enough to reveal any weaknesses in the coarse aggregate. For work in which aggregate strength and durability is of vital importance, such as paving concrete, aggregate must be laboratory tested.

Handling and Storage

A mass of aggregate containing particles of different sizes has a natural tendency toward SEGREGATION, meaning that particles of the same size tend to gather together whenever the material is being loaded, transported, or otherwise disturbed. Aggregate should always be handled and stored by a method which will minimize segregation.

aggregate, as shown in figure 7-2, the material should be washed. An easily constructed rig for washing a small amount of aggregate is shown in figure 7-3.

Weak, friable (easily pulverized), or laminated (containing layers) aggregate particles

Stockpiles should not be built up in cone shapes, made by dropping successive loads at the same spot. This procedure causes larger aggregate particles to segregate and roll down the sides, leaving the pile with a preponderance of fine at the top and a preponderance of coarse at the bottom. A pile should be built up in

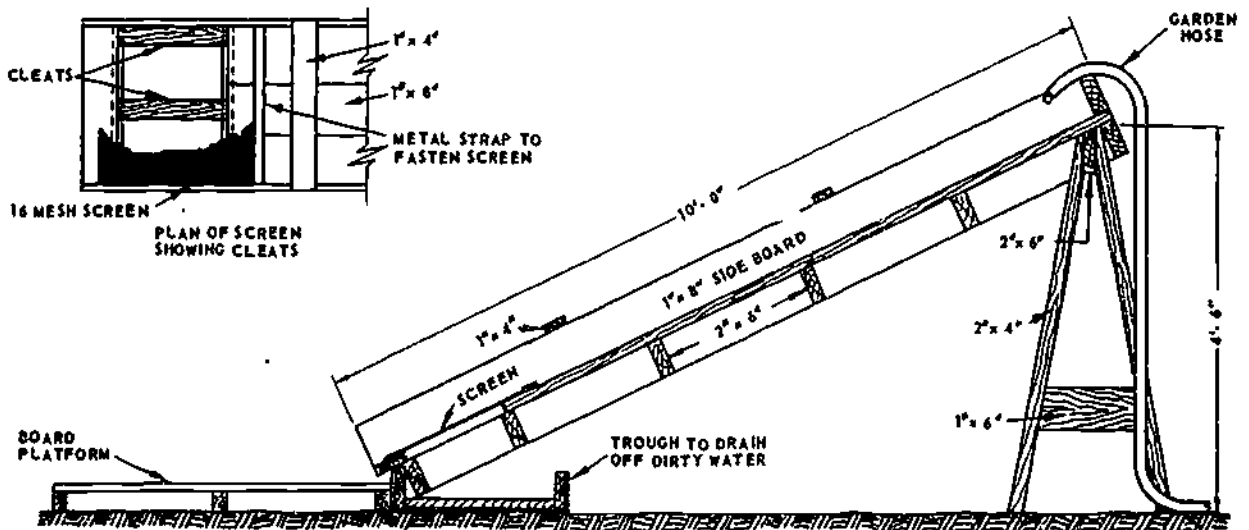

133.250
Figure 7-3.—Field-constructed rig for washing aggregate.

layers, each made by dumping successive loads alongside each other.

If aggregate is dropped in a free fall from a clamshell, bucket, or conveyor, some of the fine material may be blown aside, causing a segregation of fines on the lee side of the pile. Conveyors, clamshells, and buckets should be discharged in contact with the pile.

The bottom of a storage bin should always slope at least 50 degrees toward the central outlet. If the slope is less than 50 degrees, segregation will occur as the material is discharged. When a bin is being charged, the material should be dropped from a point directly over the outlet. Material chuted in at an angle, or material discharged against the side of a bin, will segregate. Since a long drop causes both segregation and the breakage of aggregate particles, the length of a drop into a bin should be minimized by keeping the bin as full as possible at all times.

WATER

The principal function of the water in a concrete mix is to bring about the hardening of the concrete through hydration of the cement. Another essential function is to make the mix workable enough to satisfy the requirements of the job at hand. To attain this result, a mix which is to be poured in forms must contain additional water over and above the amount required for complete hydration of the cement. Too much water will cause a loss of strength by upsetting the water-cement ratio. It will also cause "water-gain" on the surface, a condition which leaves a surface layer of weak material called LAITANCE. Also, as previously mentioned, an excess of water will impair the watertightness of the concrete.

Water used in mixing concrete must be clean and free from acids, alkalis, oils, and organic materials. Most specifications recommend that the water used in mixing concrete be suitable for drinking should such water be available.

Seawater can be used for mixing concrete under certain circumstances. An example of this would be where there is a limited supply of

freshwater. Tests show that the compressive strength of the concrete will be 10 to 30 percent less than that obtained using freshwater. Most of the adverse effects of using seawater can be minimized by using a richer mix (additional cement).

ADMIXTURES

Admixtures include all materials other than portland cement, water, and aggregates that are added to concrete, mortar, or grout immediately before or during mixing. Admixtures are sometimes used in concrete mixtures to improve certain qualities such as workability, strength, durability, watertightness, and wear resistance. They may also be added to reduce segregation, and the heat of hydration, entrain air, and accelerate or retard setting and hardening. The same results can often be obtained by changing the mix proportions or by selecting other suitable materials without resorting to the use of admixtures (except air-entraining admixtures when necessary). Whenever possible, comparison should be made between these alternatives to determine which is more economical and/or convenient. Any admixture to be in concrete should be added in accordance with current specifications and under the direction of the crew leader.

CONCRETE MIX DESIGN

The ingredient proportions to be used for the concrete on a particular job are usually set forth in the specifications under "CONCRETE-General requirements." A typical specification of this type reads as follows:

See table 7-3 for examples of normal concrete-mix design according to NAVFAC specifications.

In this specification, one of the FORMULAS for 3000 psi is 5.80 (bag of cement per cu yd), 233 lb of sand (per bag of cement), 297 lb of coarse aggregate (per bag of cement), and the WATER-CEMENT RATIO is 6.75 gals water to each bag of cement. These proportions are based

BUILDER 3 & 2

Table 7-3.—Normal Concrete

Class of concrete (Figure denotes size of coarse aggregate in inches)	Estimated 28-day compressive strength (pounds per square inch)	Cement factor, bags (94 pounds) of cement per cubic yard of concrete freshly mixed	Maximum water per bag (94 pounds) of cement (gallons)	Fine aggregate by weight	Approximate weight of saturated surface-dry aggregates per bag (94 pounds) of cement	Coarse aggregate	Fine aggregate	
							gate range in percent of total	Aggregate pounds
(1)	(2)	(3)	(4)	(5)	(6)	(7)	(8)	(9)
B-1	1,500	4.10	9.50	42.52	368	415		
B1.5	1,500	3.80	9.50	38.48	376	498		
B-2	1,500	3.60	9.50	35.45	378	567		
B-2.5	1,500	3.50	9.50	33.43	373	609		
B-3.5	1,500	3.25	9.50	30.40	378	702		
C-1	2,000	4.45	8.75	41.51	329	387		
C-1.5	2,000	4.10	8.75	37.47	338	467		
C-2	2,000	3.90	8.75	34.44	336	529		
C-2.5	2,000	3.80	8.75	32.42	332	565		
C-3.5	2,000	3.55	8.75	29.39	334	648		
D-0.5	2,500	5.70	7.75	50.60	282	231		
D-0.75	2,500	5.30	7.75	45.55	288	286		
D-1	2,500	5.05	7.75	40.50	279	341		
D-1.5	2,500	4.65	7.75	36.46	287	413		
D-2	2,500	4.40	7.75	34.42	288	509		
D-2.5	2,500	4.25	7.75	32.40	287	589		
D-3.5	2,500	4.00	7.75	29.37	285	578		
E-0.5	3,000	6.50	6.75	50.58	238	203		
E-0.75	3,000	6.10	6.75	45.53	240	249		
E-1	3,000	5.80	6.75	40.48	233	297		
E-1.5	3,000	5.35	6.75	36.44	239	359		
E-2	3,000	5.05	6.75	33.41	241	410		
E-2.5	3,000	4.90	6.75	31.39	236	441		
E-3.5	3,000	4.60	6.75	28.36	237	503		
F-0.375	3,500	7.70	6.00	56.64	210	140		
F-0.5	3,500	7.35	6.00	48.56	198	183		
F-0.75	3,500	6.85	6.00	43.51	201	226		
F-1	3,500	6.50	6.00	38.46	195	270		
F-1.5	3,500	6.00	6.00	34.42	200	325		
F-2	3,500	5.70	6.00	31.22	199	369		
F-2.5	3,500	5.50	6.00	29.37	197	400		
F-3.5	3,500	5.20	6.00	27.35	200	444		
G-0.25	4,000	8.95	5.50	100	281	-		
G-0.375	4,000	8.40	5.50	56.3	186	129		
G-0.5	4,000	8.00	5.50	47.55	178	168		
G-0.75	4,000	7.45	5.50	42.50	209	209		
G-1	4,000	7.10	5.50	37.45	172	247		
G-1.5	4,000	6.55	5.50	33.41	175	299		
G-2	4,000	6.20	5.50	30.38	175	340		
G-2.5	4,000	6.00	5.50	28.36	173	368		
G-3.5	4,000	5.65	5.50	26.34	176	411		
H-0.25	5,000	11.50	4.25	100	202	-		
H-0.375	5,000	10.80	4.25	53.51	130	98		
H-0.5	5,000	10.35	4.25	45.53	126	126		
H-0.75	5,000	9.65	4.25	40.48	123	157		
H-1	5,000	9.20	4.25	35.43	119	186		
H-1.5	5,000	8.45	4.25	31.39	122	228		
H-2	5,000	8.00	4.25	28.36	122	260		

upon the assumption that the inert ingredients are in a SATURATED SURFACE-DRY condition, meaning that they contain all the water they are capable of absorbing, but no additional FREE water over and above this amount.

This is a condition which almost never exists in the field. The amount of free water in the coarse aggregate is usually small enough to be ignored, but the ingredient proportions set forth in the specs must almost always be adjusted to allow for the existence of free water in the fine aggregate. Furthermore, since free water in the fine aggregate increases its measured volume or weight over that of the sand itself, the specified volume or weight of sand must be increased to offset the volume or weight of the water in the sand. Finally, the number of gallons of water used per sack of cement must be reduced to allow for the free water in the sand—that is to say, the amount of water actually added at the mixer must be the specified amount per sack, LESS the amount of free water which is already in the ingredients in the mixer.

Except as otherwise specified in the project specifications, concrete shall be proportioned by weighing and shall conform to NAVFAC Specifications TS-03300. (See table 7-3 for normal concrete.)

MATERIAL ESTIMATES

When tables, such as table 7-3 are not available for determining quantities of material required for 1 cu yd of concrete, the following "rule of thumb", known as rule 41 or 42 may be used for a rough estimation. This rule states that it will take 41 or 42 cu ft of the combined dry amounts of cement, sand, and aggregates to produce 1 cu yd of mixed concrete.

A bag of cement contains 94 lb by weight or about 1 cu ft by loose volume. A batch formula is usually based on the number of bags of cement used in the mixing machine.

Rule 41 is used in calculating the quantities of material for concrete when the size of the coarse aggregate is not over 1 in.

Rule 42 is used when the size of the coarse aggregate is not over 2 1/2 in.

For estimating the amount of dry materials needed to mix 1 cu yd of concrete, rule 41 or 42 worked in the same manner. For example, say that the specifications called for a 1:2:4 mix with 2-in. coarse aggregates:

$$1 + 2 + 4 = 7$$

$$42 \div 7 = 6 \text{ bags or } 6 \text{ cu ft of cement.}$$

$$6 \times 2 = 12 \text{ cu ft of sand.}$$

$$6 \times 4 = 24 \text{ cu ft of coarse aggregates.}$$

$$6 + 12 + 24 = 42, \text{ so your calculations have been proven correct.}$$

Frequently, it will be necessary to convert volumes in cu ft to weights in lb. In converting, multiply the required cu ft of cement by 94 since 1 cu ft or 1 standard bag of cement weighs 94 lb. When using rule 41 for coarse aggregates, multiply the quantity of coarse gravel in cu ft by 105 since the average weight of dry-compacted fine aggregate or gravel is 105 lb per cu ft. By rule 42, however, multiply the cu ft of rock (1-in.-size coarse aggregate) by 100 since the average dry-compacted weight of this rock is 100 lb per cu ft.

A handling-loss factor is added in ordering materials for jobs. An additional 5 percent of materials is added for jobs requiring 200 or more cu yd of concrete, and 10 percent is added for smaller jobs. This loss factor is based on material estimates after the requirements have been calculated. Additional loss factors may be added where conditions indicate the necessity for excessive handling of materials before batching.

MEASURING WATER

The water-measuring controls on a machine concrete mixer will be described later in this chapter. Water measurement for handmixing may be done with a 14-qt bucket, marked off on the inside in gallons, half-gallons, and quarter-gallons.

NEVER add water to the mix without measuring it carefully, and always remember that the amount of water actually placed in the mix varies according to the amount of free water that is already in the aggregate. This means that if the aggregate is wet by a rainstorm, the proportion of water in the mix may have to be changed.

MEASURING AGGREGATE

The accuracy of aggregate measurement by volume depends upon the accuracy with which the amount of the "bulking", caused by moisture in the aggregate, can be determined. The amount of bulking varies, not only with different moisture contents, but also with different gradations. Fine sand, for example, is bulked more than coarse sand by the same moisture content. Furthermore, moisture content itself varies from time to time, and a rather small variation causes a rather large change in the amount of bulking. For these and other reasons, aggregate should be measured by weight rather than by volume whenever possible.

To make grading easier, to keep segregation low, and to insure that each batch is uniform, coarse aggregate should be stored in and measured from separate piles or hoppers, in each of which the ratio of maximum to minimum particle size should not exceed 2:1 for a maximum nominal size larger than 1 in. and 3:1 for a maximum nominal size smaller than 1 in. A mass of aggregate with a nominal size of 1 1/2 in. to 1/4 in., for example, should be separated into one pile or hopper containing 1 1/2 in. to 3/4 in., and another pile or hopper containing 3/4 in. to 1/4 in. A mass with a nominal size of 3 in. to 1/4 in. should be separated into one pile or hopper containing 3 in. to 1 1/2 in., another containing 1 1/2 in. to 3/4 in., and a third containing 3/4 in. to 1/4 in.

WATER-CEMENT RATIO

The specified ingredient proportions are those which, it has been calculated, will produce an economical concrete of the strength and durability required for the project. Durability is

to a large extent controlled by strength—meaning that the stronger the concrete is, the more durable it will be as well. However, the quality of the aggregate, the aggregate grading, and the proportion of fine to coarse also have an important effect on durability.

It has been discovered that the major factor controlling strength, everything else being equal, is the amount of water used per bag of cement. Maximum strength would be obtained by using just the amount of water, and no more, than would be required for the complete hydration of the cement.

As previously mentioned, however, a mix of this type would be too dry to be workable, and therefore, a plastic-concrete mix always contains more water than the amount required to attain maximum strength. The point for you to remember is that the strength of the concrete decreases as the amount of this extra water increases.

The specified water-cement ratio is the happy medium between the maximum possible strength of the concrete and the necessary minimum requirements as to workability. The strength of building concrete is expressed in terms of the compressive strength in psi (lb per sq in.) reached after a 7-day set and/or after a 28-day set, usually referred to as PROBABLE AVERAGE 7-DAY STRENGTH and PROBABLE AVERAGE 28-DAY STRENGTH.

SLUMP TEST

The slump test is used to measure the consistency of the concrete. The test is made by using a SLUMP CONE; the cone is made of No. 16 gage galvanized metal with the base 8 in. in diameter, the top 4 inches in diameter, and the height 12 in. The base and the top are open and parallel to each other and at right angles to the axis of the cone. A tamping rod 5/8 in. in diameter and 24 in. long is also needed. The tamping rod should be smooth and bullet pointed (not a piece of rebar).

Samples of concrete for test specimens should be taken at the mixer or, in the case of ready-mixed concrete, from the transportation

vehicle during discharge. The sample of concrete from which test specimens are made will be representative of the entire batch. Such samples should be obtained by repeatedly passing a scoop or pail through the discharging stream of concrete, starting the sampling operation at the beginning of discharge and repeating the operation until the entire batch is discharged. The sample being obtained should be transported to the testing site. To counteract segregation, the concrete should be mixed with a shovel until the concrete is uniform in appearance. The location in the work of the batch of concrete being sampled should be noted for future reference. In the case of paving concrete, samples may be taken from the batch immediately after depositing on the subgrade. At least five samples should be taken from different portions of the pile and these samples should be thoroughly mixed to form the test specimen.

The cone should be dampened and placed on a flat, moist, nonabsorbent surface. From the sample of concrete obtained, the cone should immediately be filled in three layers, each approximately one-third the volume of the cone. In placing each scoopful of concrete the scoop should be moved around the top edge of the cone as the concrete slides from it, in order to ensure symmetrical distribution of concrete within the cone. Each layer should be **RODDED IN** with 25 strokes. The strokes should be distributed uniformly over the cross section of the cone and should penetrate into the underlying layer. The bottom layer should be rodded throughout its depth.

Should the cone be overfilled, strike off the excess concrete flush with the top with a straightedge. The cone should be immediately removed from the concrete by raising it carefully in a vertical direction. The slump should then be measured to the center of the slump immediately by determining the difference between the height of the cone and the height at the vertical axis of the specimen, as shown in figure 7-4.

The consistency should be recorded in terms of inches of subsidence of the specimen during the test, which is called slump. Slump equals 12 inches of height after subsidence.

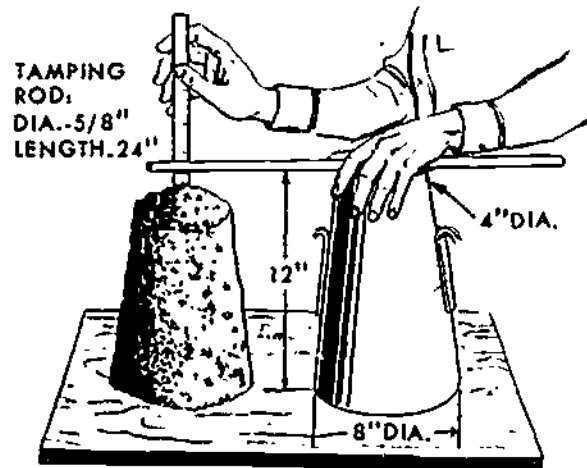

45.574

Figure 7-4.—Measurement of slumps.

After the slump measurement is completed, the side of the mix should be tapped gently with the tamping rod. The behavior of the concrete under this treatment is a valuable indication of the cohesiveness, workability, and placeability of the mix. If the mix is well-proportioned, tapping will only cause it to slump lower, without crumbling apart or segregating by the dropping of larger aggregate particles to a lower level in the mix. If the concrete crumbles apart, it is oversanded; if it segregates, it is undersanded.

WORKABILITY

A mix must be **WORKABLE** enough to fill the form spaces completely of its own accord, or with the assistance of a reasonable amount of shoveling, spading, and vibrating. Since a fluid or "runny" mix will do this more readily than a dry or "stiff" mix, it follows that workability varies directly with fluidity. The workability of a mix is determined by the slump test. The amount of the slump, in inches, is the measure of the concrete's workability—the more the slump, the higher the workability.

The slump can be controlled by a change in any one or all of the following: gradation of

aggregates, proportion of aggregates, or the moisture content. (If the moisture content should change, you should add more cement to maintain the proper water-cement ratio.)

The desired degree of workability is attained by running a series of trial batches, using various amounts of fine to coarse aggregate, until a batch is produced in which the slump is as desired. Once the amount of increase or decrease required to produce the desired slump is determined, the aggregate proportions, not the water proportion, in the field mix should be altered to conform. If the water proportion were changed, the water-cement ratio would be upset.

Never yield to the temptation to throw in more water without making the corresponding adjustment in the cement content, and make sure crewmembers who are spreading a stiff mix by hand do not ease their labors this way without telling you about it.

As you gain experience, you will discover that adjustments in workability can be made by making minor changes in the amount of fines in the fine aggregate or of coarses in the coarse aggregate; also by making minor changes in the proportion of fine to coarse. In general, everything else remaining the same, an increase in the proportion of fines stiffens a mix, and an increase in the proportion of coarse loosens a mix.

Before you alter the proportions set forth in the specification, you must, find out from higher authority whether or not you are allowed to make any such alterations, and if you are, what the permissible limits are beyond which you must not go.

GROUT

As previously mentioned, concrete consists of four essential ingredients: water, cement, sand, and coarse aggregate. A mixture of water, cement, sand, and lime is not concrete but MORTAR. Mortar, which is used chiefly for bonding masonry units together, will be discussed in the next chapter.

The term GROUT refers to a water-cement mixture (called NEAT-CEMENT GROUT) or a water-sand-cement mixture called SAND-CEMENT GROUT) used to plug holes or cracks in concrete, to seal joints, to fill spaces between machinery bed plates and concrete foundations, and for similar plugging or sealing purposes. The consistency of grout may range from stiff (about 4 gal of water per sack of cement) to fluid (as many as 10 gal water per sack of cement), depending upon the nature of the grouting job at hand.

BATCHING

When bagged cement is being used, the field-mix proportions are usually given in terms of designated amounts of fine and coarse aggregate per bag (or per 94 lb) of cement. The amount of material which is mixed at a time is called a BATCH, and the size of a batch is usually designated by the number of bags of cement it contains, as: a 4-bag batch, a 6-bag batch, and so on.

The process of weighing out or measuring out the ingredients for a batch of concrete is called BATCHING. When mixing is to be done by hand, the size of the batch will depend upon the number of persons who are available to turn it with hand shovels. When mixing is to be done by machine, the size of the batch will depend upon the rated capacity of the mixer. The rated capacity of the mixer is given in terms of cu ft of MIXED CONCRETE, not of dry ingredients.

BATCHING PLANT

On large jobs, the aggregate is weighed out in an aggregate BATCHING PLANT (usually shortened to "batch plant") like the one shown in figure 7-5. Whenever possible, a batch plant is located near and used in conjunction with a CRUSHING AND/OR SCREENING plant. In a crushing and screening plant, stone is crushed into various particle sizes, which are then screened into separate piles. In a screening plant,

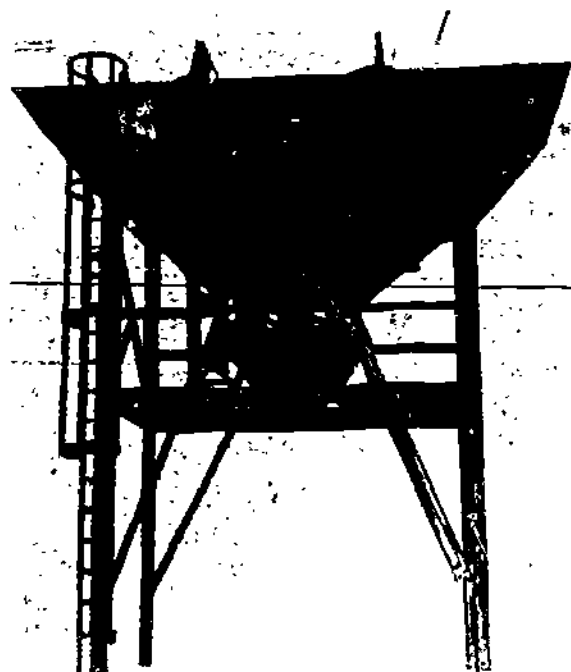

29.153

Figure 7-5.—Aggregate batching Plant.

the aggregate in its natural state is screened by sizes into separate piles.

The batch plant, which is usually a portable affair that can be knocked down and moved from site to site, is generally set up adjacent to the pile of screened aggregate. The plant may include separate hoppers for several sizes of fine and coarse aggregates or it may include one hopper for fine aggregate and another for coarse aggregate; or it may include one or more DIVIDED hoppers, each containing two or more separate compartments for different sizes of aggregates.

Each storage hopper or storage hopper compartment can be discharged into a WEIGH BOX, which can in turn be discharged into a mixer or a batch truck. When a specific weight of aggregate is called for, the operator sets the weight on a beam scale. The operator then opens the discharge chute on the storage hopper. When the desired weight has been reached in the weigh box, the scale beam rises and the operator closes

the storage hopper discharge chute. The operator then opens the weigh box discharge chute, and the aggregate discharges into the mixer or batch truck. Batch plant aggregate storage hoppers are usually loaded with clamshell-equipped cranes.

All personnel working in the batch plant area should wear hard hats at all times.

While persons are working on or in conveyor line areas, the switches and controls are to be secured and tagged so that no one can engage them until all personnel are clear.

When hoppers are being loaded with clamshell or other loaders, the personnel should stay away from the area of falling aggregate.

The scale operator should be the only person on the scale platform during batching operations.

Housekeeping of charging area is important and personnel should do everything possible to keep the area clean and free of spoiled material or overflow.

Debris in aggregate causes much of the damage to conveyors, so keep the material clean at all times.

When batch operations are conducted at night, good maximum lighting is a must.

Personnel working in batch plants should use good eye hygiene, as continual neglect of eye care can have serious consequences.

VAPOR-TYPE GOGGLES SHOULD BE WORN BY PERSONNEL IN BATCH PLANT OPERATIONS.

MIXING CONCRETE

Mixing concrete is done by one of the two methods, by hand or machine. No matter which method is used, a well established procedure must be followed if you expect the finished concrete to be of good quality. An oversight in this phase of concrete construction, whether through lack of competence or inattention to detail, cannot be overcome later.

MIXING BY HAND

A batch which is to be handmixed by a couple of crewmembers should not be much larger than about a cu yd. The equipment required consists of a watertight metal or wooden platform, two shovels, a metal-lined measuring box, and a graduated bucket for measuring the water.

The mixing platform need not be fabricated of expensive materials, but may only be an abandoned concrete slab or concrete parking lot than can be cleaned after use. If there is not a suitable place available, it may be necessary to construct a 10-by 12-ft square wooden platform of 3/4-in. plywood and 2 by 4's. A strip of 2-by 2-in. lumber should be nailed along the outer edges, to prevent water or fluid material from flowing off the platform. For the same reason, the platform must be level.

Mix the sand and cement together first, using the following procedure. Say that the batch is to consist of 2 bags of cement, 5.5 cu ft of sand, and 6.4 cu ft of coarse aggregate. Dump 3 cu ft of sand on the platform first, spread it out in a layer, and dump a bag of cement over it. Spread the cement out in a layer, and dump the rest of the sand (2.5 cu ft) over it. Then dump the other sack of cement on top of the lot. This use of alternate layers of sand and cement reduces the amount of shoveling required for complete mixing.

Personnel doing the mixing should face each other from opposite sides of the pile, and they should work from the outside to the center, turning the material as many times as is necessary to produce a uniform color throughout. When the cement and sand have been completely mixed, the pile should be leveled off and the coarse material should be added and mixed in by the necessary number of turnings.

The pile should next be troughed in the center, and the mixing water, after being carefully measured, should be poured into the trough. The dry materials should then be turned into the water, with great care taken to insure

that none of the water escapes. When all the water has been taken up, the batch should be mixed to a uniform consistency. At least four complete turnings are usually required.

MIXING BY MACHINE

A concrete mixer is designated as to size by its **RATED CAPACITY**, expressed in terms of the volume of mixed concrete—not of dry ingredients—it can mix in a single batch. Rated capacities run from as small as 2 cu ft to as large as 7 cu yd (189 cu ft). For most ordinary building construction, the most commonly used mixer is the Model 16-S (fig. 7-6) with a capacity of 16 cu ft.

The 16-S concrete mixer is a self-contained unit capable of producing 16 cubic feet of concrete plus a 10 percent overload per batch. The hourly production capacity will vary between 10 and 15 cu yd depending on the efficiency of the personnel. Aggregate larger than 3 in. will damage the mixer. The mixer consists of a frame which is equipped with wheels and towing tongue for easy movement,

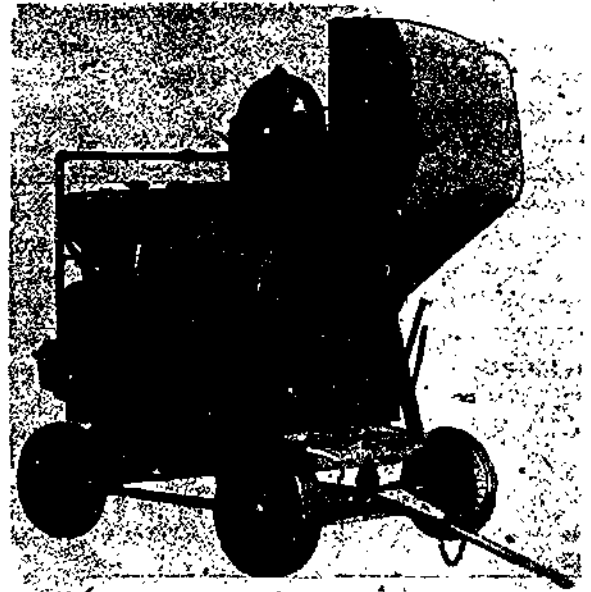

Figure 7-6.—Model 16-S concrete mixer.

29.151

an engine, a power loader skip, mixing drum, water tank, and auxiliary water pump. The mixer may be used as a central mixing plant.

Charging the Mixer

There are two ways of charging concrete mixers, by hand and with the mechanical skip. Before loading the mechanical skip, remove the towing tongue. Then cement, sand, and gravel can be loaded and dumped into the mixer together while the water runs into the mixing drum on the side opposite the skip. The mixing water is measured from a storage tank on top of the mixer a few seconds before the skip is dumped to wash the mixer between batches. The coarse aggregate is placed in the skip first, the cement next and the sand is placed on top to prevent excessive loss of cement as the batch enters the mixer.

Mixing Time

On mixing machines 27 cu ft or larger the mixing time for a 1-cu yd batch is 1 1/2 minutes. Another 15 seconds should be allowed for each additional 1/2 cu yd or fraction thereof. The water should be started into the drum a few seconds before the skip begins to dump, so that the inside of the drum will get a washout before the batched ingredients go in. The mixing period should be measured from the time all the batched ingredients are in, provided that all the water is in before one-fourth of the mixing time has elapsed. The time elapsing between the introduction of the mixing water to the cement and aggregates and the placing of the concrete in the forms should not exceed 1 1/2 hr.

Discharging the Mixer

When the material is ready for discharge from the mixer, the discharge chute is moved into place to receive the concrete from the drum of the mixer. In some cases, dry concrete has a

tendency to carry up to the top of the drum and not drop down in time to be deposited on the chute. Very wet concrete may not carry up high enough to be caught by the chute. This condition can be corrected by adjusting the speed of the mixer. For very wet concrete, the speed of the drum should be increased and for dry concrete, it should be slowed down.

Cleaning and Maintaining the Mixer

The mixer should be cleaned daily when it is in continuous operation or following each period of use if it is in operation less than a day. If the outside of the mixer is kept coated with form oil, the cleaning process can be speeded up. The outside of the mixer should be washed with a hose and all accumulated concrete should be knocked off. If the blades of the mixer become worn, or coated with hardened concrete, the mixing action will be less efficient. Badly worn blades should be replaced. Hardened concrete should not be allowed to accumulate in the mixer drum. The mixer drum must be cleaned out whenever it is necessary to shut down for more than 1 1/2 hours. Place a volume of coarse aggregate in the drum equal to one-half of the capacity of the mixer and allow it to revolve for about 5 minutes. Discharge the aggregate and flush out the drum with water. Do not pound the discharge chute, drum shell, or the skip to remove aggregate or hardened concrete, for concrete will more readily adhere to the dents and bumps created.

For complete instructions on the operation, adjustment, and maintenance of the mixer, study the manufacturer's manual.

All gears, chains, and rollers of mixers should be properly guarded. All moving parts should be cleaned and properly serviced so as to give safe performance of the equipment.

Skip loader cables and brakes must be inspected frequently to prevent injuries caused by falling skips.

Whenever working under an elevated skip is unavoidable, the skip must be shored up to prevent it from falling in the event that the brake should fail or be accidentally released.

The mixer operator must never lower the skip without first making sure that there is no one under it.

The area around the mixer must be kept clear.

Dust protection equipment must be issued to the crew engaged in handling cement, and the crew must wear the equipment when so engaged. Crewmembers should stand with their backs to the wind whenever possible, to prevent cement and sand from being blown into their eyes and faces.

Whenever the mixer drum is being cleaned, the switches must be open, the throttles closed, and the control mechanism locked in the OFF position.

HANDLING AND TRANSPORTING CONCRETE

If mixed plastic concrete is carried by the ordinary type of vehicle (dump truck, for example), there is a strong tendency for the larger aggregate particles to segregate by settling to the bottom. To avoid this, ready-mixed concrete is usually delivered to a job by a transit-mix truck.

When ready-mixed concrete is carried by the ordinary type of carrier (such as a dump truck, wheelbarrow, or buggy), any jolting of the carrier increases the natural tendency of the concrete to segregate. Carriers should therefore be equipped with pneumatic tires whenever possible, and the surface over which they travel should be as smooth as possible.

A long free fall will cause concrete to segregate. If the concrete must be discharged at a level more than 4 ft above the level of placement, it should be dumped into an ELEPHANT TRUNK like the one shown in figure 7-7.

Segregation also occurs whenever discharged concrete is allowed to glance off a surface, such as the side of a form or of a chute. Wheelbarrows, buggies, and conveyors should therefore be discharged so as to cause the concrete to fall clear.

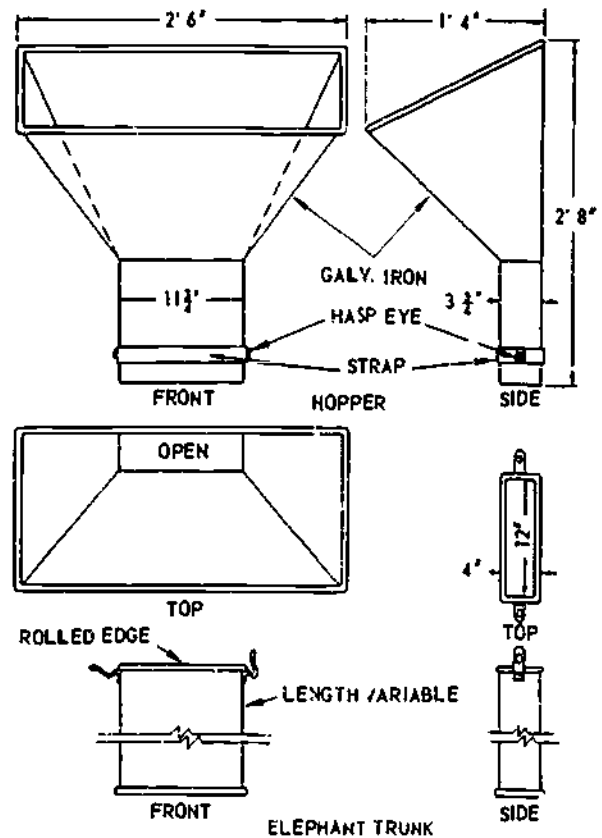

133.9
Figure 7-7.—Chute or down pipe used to check free fall of concrete.

Concrete should be transported by chute for short distances only, since it tends to segregate and also to dry out when handled in this manner. For a mix of average workability, the best slope for a chute is about 1 ft of rise to 2 or 3 ft of run. For a mix of this type, a steeper slope will cause segregation, while a flatter slope will either cause the concrete to run slowly or not at all. For a stiffer mix, a steeper slope will be required.

All chutes and spouting used in re-ete pours should be clean and well supported by proper bracing and guys.

When spouting and chutes run overhead, the area beneath must be cleared and barricaded during placing to eliminate the danger of falling concrete or possible collapse causing injuries.

READY-MIXED CONCRETE

On some jobs, such as large highway jobs, it is possible to use a batch plant which contains its own mixer. A plant of this type discharges ready-mixed concrete into dump trucks or agitator trucks, which haul it to the construction site. An agitator truck carries the mix in a revolving chamber much like the one on a mixer. Keeping the mix agitated en route prevents segregation of aggregate particles. SEABEES have used concrete pavers as central mixing plants, stationing the paver adjacent to a cut so that trucks may be driven under the bucket boom.

A ready-mix plant is usually portable, so that it can follow the job along. It must be certain, of course, that a truck will be able to deliver the mix at the site before it starts to set.

Discharge of the concrete from the drum should be completed within 1 1/2 hr.

TRANSIT-MIXED CONCRETE

A TRANSIT-MIX truck is a traveling concrete mixer. The truck carries a mixer and a water tank, from which the driver can, at the proper time, introduce the required amount of water into the mix. The truck picks up the dry ingredients at the batch plant, together with a slip which tells how much water is to be introduced to the mix upon arrival at the pour site. The mixer drum is kept revolving enroute and at the job site so that the dry ingredients do not segregate. Transit-mix trucks are part of the battalion's equipment inventory and are the most widely used on all but the smallest concrete jobs assigned to a battalion.

FORMWORK

Most structural concrete is made by placing (CASTING) plastic concrete into spaces enclosed by previously constructed FORMS. The plastic concrete hardens into the shape

outlined by the forms, after which the forms are usually removed.

Forms for concrete structures must be tight, rigid, and strong. If the forms are not tight, there will be a loss of paste which may cause weakness or a loss of water which may cause SAND STREAKING. The forms must be strong enough and well-braced enough to resist the high pressure exerted by the concrete.

Forms, or parts of forms, are often omitted when a firm earth surface exists which is capable of supporting and/or molding the concrete. In most footings, the bottom of the footing is cast directly against the earth and only the sides are molded in forms. Many footings are cast with both the bottom and the sides against the natural earth. In these cases, however, the specifications usually call for larger footings. A foundation wall is often cast between a form on the inner side and the natural earth surface on the outer side.

FORM MATERIALS

Forms are generally constructed from three different materials. earth, metal, and wood.

Earth forms are used in subsurface construction where the soil is stable enough to retain the desired shape of the concrete structure. The advantages of this type of form are that less excavation is required and there is better settling resistance. The obvious disadvantage is a rough surface finish, so the use of earth forms is generally restricted to footings and foundations.

Metal forms are used where added strength is required or where the construction will be duplicated at another location. Metal forms are more expensive, but they may be more economical than wooden forms if they can be used often enough. Examples of their use would be highway paving forms or curb and sidewalk forms.

Wooden forms are by far the most common type used in building construction. They have

the advantage of economy, ease in handling, ease of production, and adaptability to many desired shapes. Added economy may result from reusing form lumber later for roofing, bracing, or similar purposes. Lumber should be straight, structurally sound, strong, and only partially seasoned. Kiln-dried timber has a tendency to swell when soaked with water from the concrete. If the boards are tight jointed the swelling causes bulging and distortion. When green lumber is used, an allowance should be made for shrinkage or the forms should be kept wet until the concrete is in place. Soft woods, such as pine, fir, and spruce make the best and most economical form lumber since they are light, easy to work with, and available in almost every region. Lumber that comes in contact with the concrete should be surfaced on one side at least and on both edges. The surfaced side is turned toward the concrete. The edges of the lumber may be square, shiplap, or tongue and groove. The latter makes a more watertight joint and tends to prevent warping. Plywood can be used economically for wall and floor forms if it is made with waterproof glue and is identified for use in concrete forms. Plywood is more warp resistant and can be reused more often than lumber. Plywood is made in thicknesses of 1/4, 3/8, 9/16, 5/8, and 3/4 in. and in widths up to 48 in. Although longer lengths are manufactured, 8-ft lengths are the most commonly used. The 5/8- and 3/4-in. thicknesses are most economical, the thinner sections will require solid backing to prevent deflection. The 1/4-in. thickness is useful for curved surfaces.

FORM DESIGN

Forms for concrete construction must support the plastic concrete until it has hardened. Stiffness is an important feature in forms and failure to provide for this may cause unfortunate results. Forms must be designed for all the weight they are liable to be subjected to, including the dead load of the forms, the plastic concrete in the forms, the weight of the workmen, the weight of equipment and materials whose weight may be transferred to the forms, and the impact due to vibration.

These factors vary with each project, but none should be neglected. Ease of erection and removal are also important factors in the economical design of forms. Platform and ramp structures independent of formwork are sometimes preferred to avoid displacement of forms due to loading and impact shock from workmen and equipment.

When concrete is placed in the forms, it is in a plastic state and exerts hydrostatic pressure on the forms. The basis of form design, therefore, is the maximum pressure developed by the concrete during placing. The maximum pressure developed will depend on the rate of placing and the temperature. The rate of placing will affect the pressure because it determines how much hydrostatic head will be built up in the form. The hydrostatic head will continue to increase until the concrete takes its initial set, usually in about 90 minutes. However, at low temperatures, the initial set takes place much more slowly so it is necessary to consider the temperature, at the time of placing. Knowing these two factors, and the type of form material to be used, a tentative design may be calculated.

FORM CONSTRUCTION

Strictly speaking, it is only those parts of the formwork which directly mold the concrete that are correctly referred to as the "forms." The rest of the formwork consists of various bracing and tying members used to strengthen the forms and to hold them rigidly in place.

In the following discussion of the various common types of forms, you should study the illustrations until you have learned the names of all the formwork members.

Footing Forms

When possible, the earth should be excavated so as to form a mold for concrete wall footings. Otherwise, forms must be constructed. In most cases, footings for columns are square or rectangular. The four sides should be built and

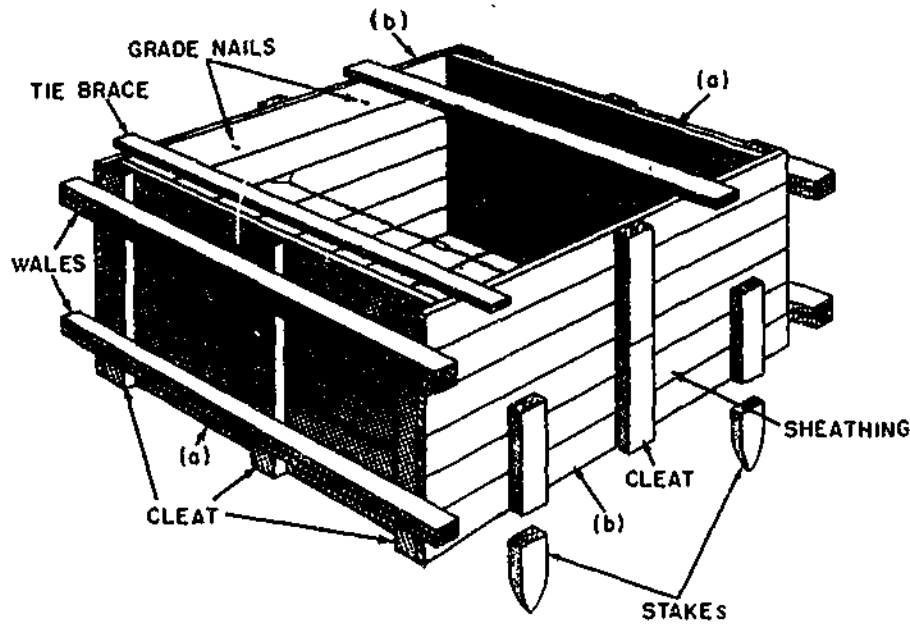

133.251

Figure 7-8.—Typical large footing form.

erected in panels. The panels for the opposite sides of the footing are made to the exact footing width. The 1-in.-thick sheathing is nailed to vertical cleats spaced on 2-ft centers. See (a) in figure 7-8 which shows a typical form for a large footing. Two-inch-dressed lumber should be used for the cleats and cleats spaced 2 1/2 in. from each end of the panel as shown. The other pair of panels (b), figure 7-8 have two end cleats on the inside spaced the length of the footing plus twice the sheathing thickness. The panels are held together by No. 8 or 9 soft, black-annealed-iron wire wrapped around the center cleats. All reinforcing bars must be in place before the wire is installed. The holes on each side of the cleat permitting the wire to be wrapped around the cleat should be less than 1/2 in. in diameter to prevent leakage of mortar through the hole. The panels may be held in place with form nails until the tie wire is installed. All form (duplex) nails should be driven from the outside if possible to make stripping easier. For forms 4 ft square or larger, stakes should be driven as shown. These stakes and 1 by 6 boards nailed across the top prevent spreading. The side panels may be higher than

the required depth of footing since they can be marked on the inside to indicate the top of the footing. If the footings are less than 1 ft deep and 2 ft square, the forms can be constructed of 1-in. sheathing without cleats. Boards for the sides of the form are cut and nailed as shown in figure 7-9. The form can be braced and no wire ties are needed.

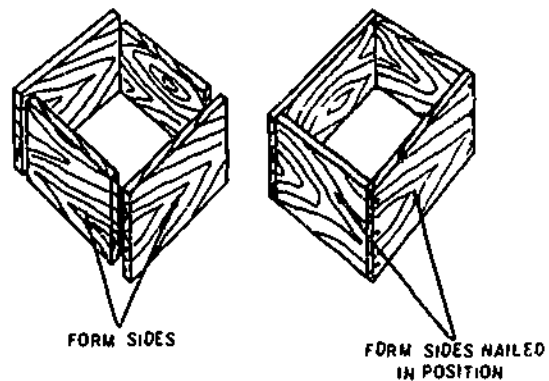

133.252

Figure 7-9.—Typical small footing form.

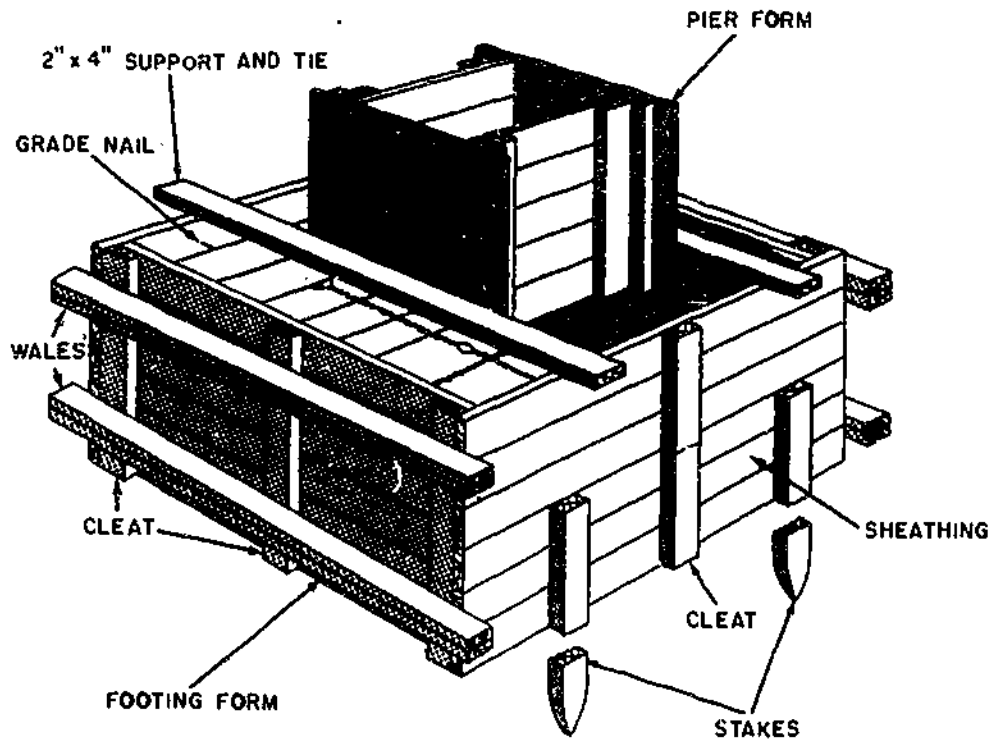

Figure 7-10.—Typical footing and pier form.

133.253

Sometimes it may be necessary to place a footing and a small pier or column at the same time. The form for this type of concrete construction is shown in figures 7-10 and 7-11. The units are similar to the one shown in figure 7-8. Support for the upper form must be provided in such a way that it does not interfere with the placement of concrete in the lower form. This is accomplished by nailing a 2 by 2 or 4 by 4 to the lower form as shown. The top form is then nailed to these support pieces.

Foundations

Foundation forms may include forms for wall footings, column footings, and pier footings. These foundations or footings are relatively low in height and have the primary function of supporting the structure. The depth of concrete is usually small; therefore, the pressure on the form is relatively low. Thus, design based on strength consideration generally

is not necessary. Whenever possible, the earth should be excavated and the hole used as a mold for the concrete footings.

Walls

Wall forms (fig. 7-12) may be built-in-place or prefabricated, depending on shape and desirability of reuse of forms. Some of the elements that make up wooden forms are sheathing, studs, wales, braces, shoe plates, spreaders, and tie wires.

Sheathing forms the surfaces of the concrete. It should be as smooth as possible, especially if the finished surfaces are to be exposed. Since the concrete is in a plastic state when placed in the form, the sheathing should be watertight. Tongue-and-groove sheathing gives a smooth watertight surface. Plywood or hardboard can also be used.

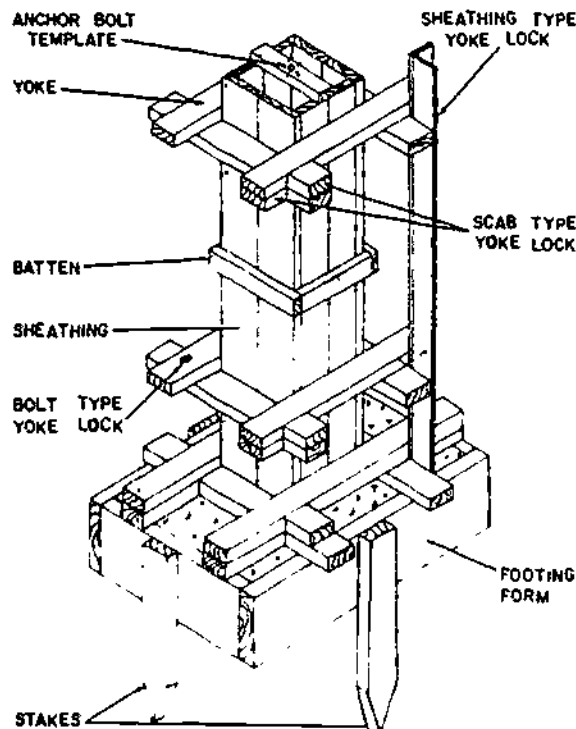

133.487

Figure 7-11.—Form for concrete column.

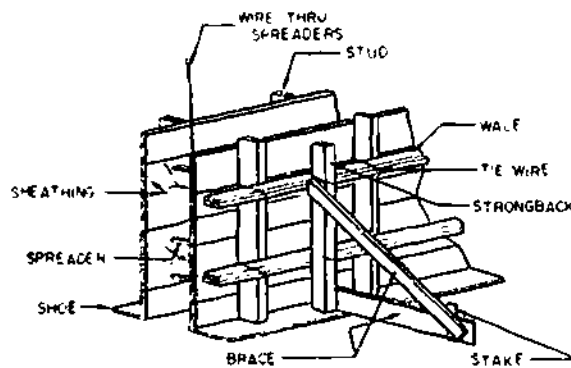

133.486

Figure 7-12.—Form for a concrete wall.

The weight of the plastic concrete will cause the sheathing to bulge if it is not reinforced. Studs are run vertically to add rigidity to the wall form. Studs are generally made from 2 by 4 or 3 by 6 material.

Studs also require reinforcing when they extend over 4 or 5 ft. This reinforcing is supplied by double wales. Double wales also serve to tie prefabricated panels together and keep them in a straight line. They run horizontally and are lapped at the corners of the forms to add rigidity. Wales are usually made from the same material as the studs.

There are many types of braces which can be used to give the forms stability. The most common type is a diagonal member and horizontal member nailed to a stake and to a stud or wale. The diagonal member should make a 30° angle with the horizontal member. Additional bracing may be added to the form by placing vertical members (strongbacks) behind the wales or by placing vertical members in the corner formed by intersecting wales. Braces are not part of the form design and are not considered as providing any additional strength.

The shoe plate is nailed into the foundation or footing and is carefully placed to maintain the correct wall dimension and alignment. The studs are tied into the shoe and spaced according to the correct design.

In order to maintain proper distance between forms, small pieces of wood are cut to the same length as the thickness of the wall and are placed between the forms. These are spreaders. The spreaders are not nailed but are held in place by friction and must be removed before the concrete hardens. A wire should be securely attached to the spreaders so that they can be pulled out after the concrete has exerted enough pressure to the walls to allow them to be easily removed.

Tie wire is a tensile unit designed to hold the concrete forms secure against the lateral pressure of unhardened concrete. A double strand of tie wire is always used.

Wall forms are usually additionally reinforced against displacement by the use of TIES. Two types of simple wire ties, used with wood SPREADERS, are shown in figure 7-13. The wire is passed around the studs, the wales and through small holes bored in the sheathing.

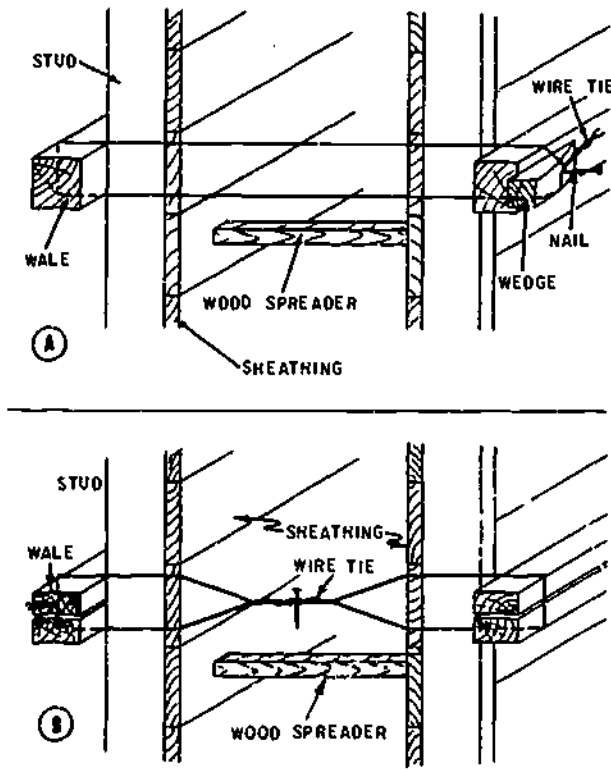

Figure 7-13.—Wire ties for wall forms.

133.10

The spreader is placed as close as possible to the studs, and the tie is set taut by the wedge shown in the upper view, or by twisting with a small toggle as shown in the lower view. When the concrete reaches the level of the spreader, the spreader is knocked out and removed. The parts of the wire which are inside the forms remain in the concrete; the outside surplus is cut off after the forms are removed.

Wire ties and wooden spreaders have been largely replaced by various manufactured devices in which the function of the tie and the spreader are combined. Figure 7-14 shows one of these: it is called a SNAP TIE. These ties are made in various sizes to fit various wall thicknesses. The tie holders can be removed from the tie rod. The rod goes through small holes bored in the sheathing, and also through the wales, which are usually doubled for that purpose. Tapping the tie holders down on the ends of the rod brings the sheathing to bear solidly against the spreader

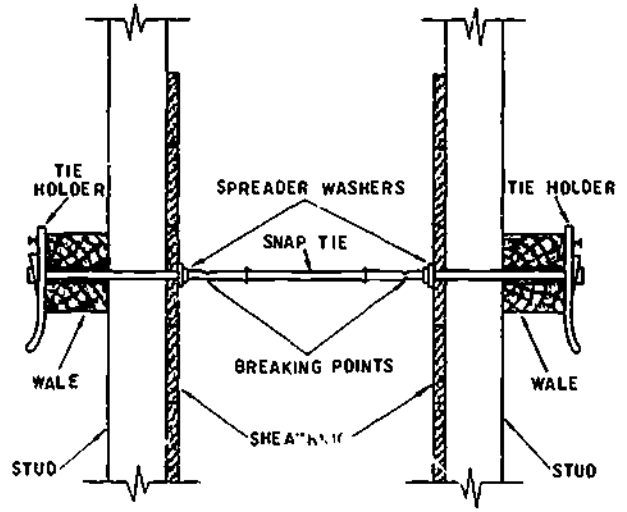

Figure 7-14.—Snap tie.

45.470

washers. (To prevent the tie holder from coming loose, drive a duplex nail in the provided hole.) After the concrete has hardened, the tie holders can be detached to strip the forms. After the forms are stripped, a special wrench is used to break off the outer sections of rod, which break off at the breaking points, located about 1 in. inside the surface of the concrete. Small surface holes remain, which can be plugged with grout if necessary.

Another type of wall-form tie is the TIE ROD shown in figure 7-15. The rod in this type consists of three sections: an inner section which is threaded on both ends, and two threaded outer sections. The inner section, with the cones set to the thickness of the wall, is placed between the forms, and the outer sections are passed through the wales and sheathing and threaded into the cone nuts. The clamps are then threaded up on the outer sections to bring the forms to bear against the cone nuts. After the concrete hardens, the clamps are loosened and the outer sections of rod are removed by threading them out of the cone nuts. After the forms are stripped, the cone nuts are removed from the concrete by threading them off the inner sections of rod with a special wrench. The cone-shaped surface holes which remain may be plugged with grout. The inner sections of rod

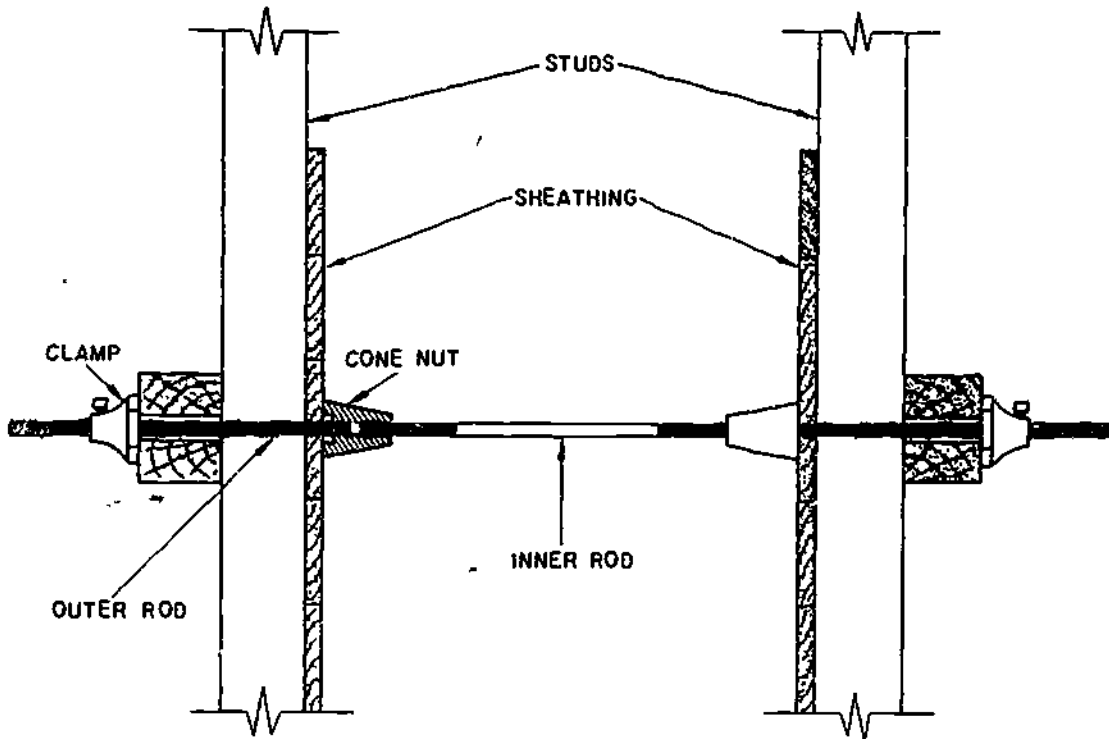
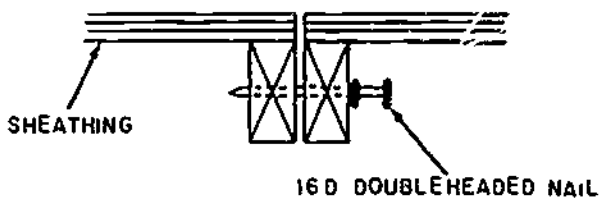

Figure 7-15.—Tie rod.

45.471

remain in the concrete. The outer sections and the cone nuts may be reused indefinitely.

Wall forms are usually constructed as separate panels, each made by nailing sheathing to a number of studs. Panels are joined to each other in line as shown in figure 7-16. A method of joining panels at a corner is shown in figure 7-17.



133.11

Figure 7-16.—Joining wall form panels together inline.

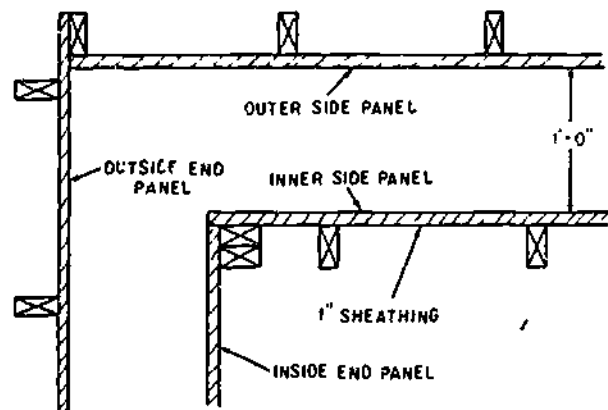

133.12

Figure 7-17.—Method of joining wall form panels at a corner.

Columns

Figure 7-18 shows a column form. Since the rate of placing in a column form is very high, and the bursting pressure exerted on the form by the concrete increases directly with the rate of placing, a column form must be securely braced by the yokes shown in the figure. Since the bursting pressure is greater at the bottom of the form than it is at the top, the yokes are placed closer together at the bottom than they are at the top.

The panels for the form are made up first, by nailing the yoke members to the sheathing. On two panels the yoke members come flush with the edges of the sheathing; on the other two they project beyond the edges as shown. Bolt holes are bored in these projections as shown, and bolts are inserted to back up the wedges which are driven to tighten the yokes.

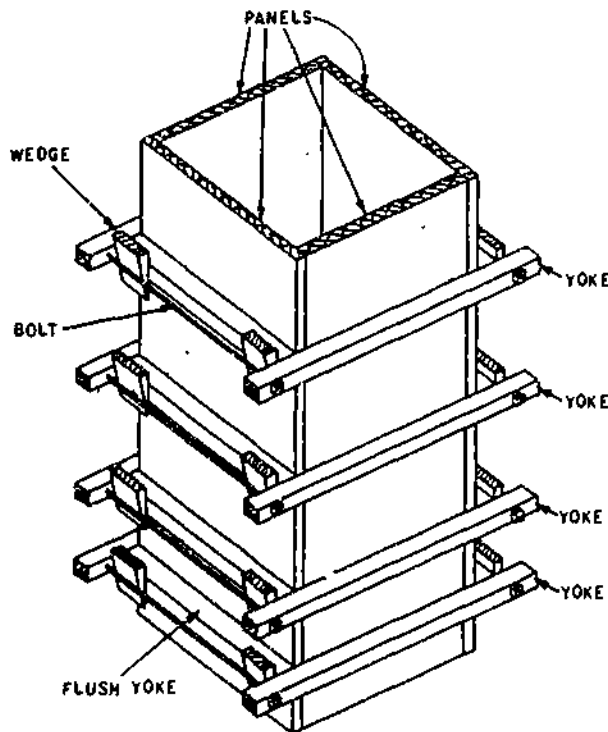

Figure 7-18.—Column form.

45.472

Beams and Girders

The type of construction to be used for beam forms depends upon whether the form is to be removed in one piece or whether the sides are to be stripped and the bottom left in place until such time as the concrete has developed enough strength to permit removal of the shoring. The latter type beam form is preferred and details for this type are shown in figure 7-19. Beam forms are subjected to very little bursting pressure but must be shored up at frequent intervals to prevent sagging under the weight of the fresh concrete.

The bottom of the form has the same width as the beam and is in one piece for the full width. The sides of the form should be 1-in.-thick tongue-and-groove sheathing and should lap over the bottom as shown. The sheathing is nailed to 2- by 4-in. struts placed on 3-ft centers. A 1- by 4-in. piece is nailed along the struts. These pieces support the joist for the floor panel, as shown in figure 7-20. The beam sides of the form are not nailed to the bottom but are held in position by continuous strips, as shown in detail E. The cross pieces nailed on top serve as spreaders. After erection, the slab panel joists hold the beam sides in position. Girder forms (fig. 7-19) are the same as beam forms except that the sides are notched to receive the beam forms. Temporary cleats should be nailed across the beam opening when the girder form is being handled.

The entire method of assembling beam and girder forms is illustrated in figure 7-20. The connection of the beam and girder is illustrated in detail D. The beam bottom butts up tightly against the side of the girder form and rests on a 2- by 4-in. cleat nailed to the girder side. Detail C shows the joint between the beam and slab panel and details A and B show the joint between the girder and column. The clearances given in these details are needed for stripping and also to allow for movement that will occur due to the weight of the fresh concrete. The 4 by 4 posts (Detail E) used for shoring the beams and girders should be spaced so as to provide support for the concrete and forms and wedged at the bottom to obtain proper elevation.

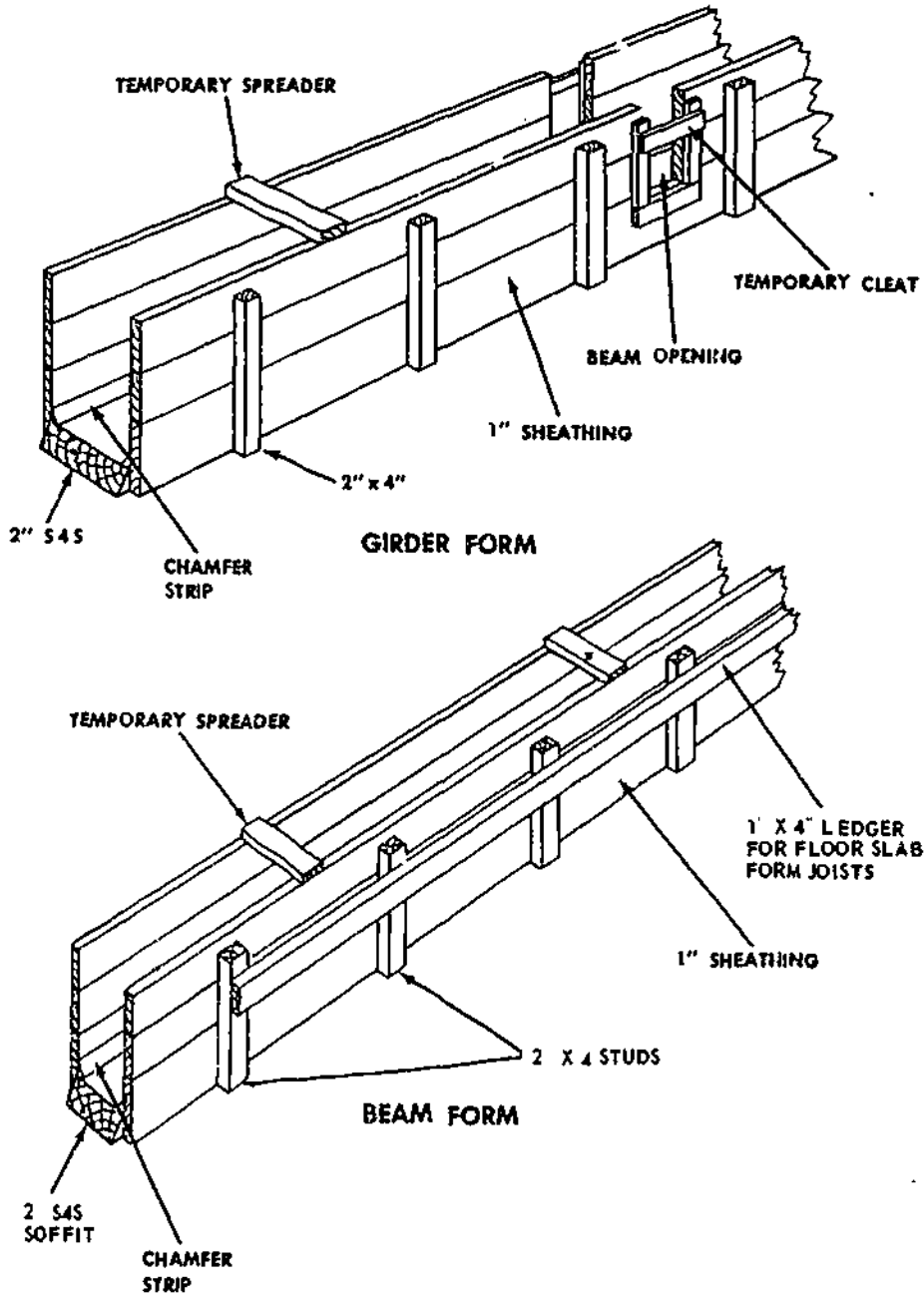

Figure 7.19.—Typical beam and girder forms.

45.474(133F)

OILING AND WETTING FORMS

Before concrete is placed in forms which are to be stripped, the forms must be coated with a suitable form oil or other material which will

prevent bond between the forms and the concrete. Almost any light-bodied petroleum oil makes a satisfactory bond-preventer for wood forms. The use of oil however, should be avoided where finished concrete surfaces are to

If form oil or its equivalent is not available, the forms may be wetted thoroughly to help prevent sticking. This method of bond-prevention should be used only when a suitable bond-preventing compound is unobtainable.

REINFORCED CONCRETE

Concrete is strong in compression, but relatively weak in tension. The reverse is true when steel is used in the concrete—one makes up for the deficiency of the other. When steel is embedded in concrete in a manner which assists it in carrying imposed loads, the combination is known as reinforced concrete. The steel may consist of welded-wire mesh or expanded-metal mesh, but it commonly consists of steel bars called REINFORCING BARS.

Before placing reinforcing steel in forms, all form oiling should be completed. Oil on reinforcing bars is objectionable because it reduces the bond between the bars and the concrete. Use a piece of burlap to clean the bars of rust, scale, grease, mud, or other foreign matter. A tight film of rust or mill scale is not objectionable.

There are several types of ties that can be used with deformed bars: some more effective than others. Figure 7-21 illustrates the six types used by the SEABEES: (A) snap tie or simple tie; (B) saddle tie; (C) wall tie; (D) saddle tie with twist; (E) double strand single tie; and (F) cross tie or figure eight tie. As a Builder, you will only be concerned with the snap tie and saddle tie.

When making the SNAP TIE or SIMPLE TIE, the wire is simply wrapped once around the two crossing bars in a diagonal manner with the two ends on top, and these are twisted together with a pair of sidecutters until they are very tight against the bars. Then the loose ends of the wire are cut off. This tie is used mostly on floor slabs. When making the SADDLE TIE, the wires pass halfway around one of the bars on either side of the crossing bar and are brought squarely or diagonally around the crossing bar, with the ends twisted together and cut off. This tie is used on special locations (walls).

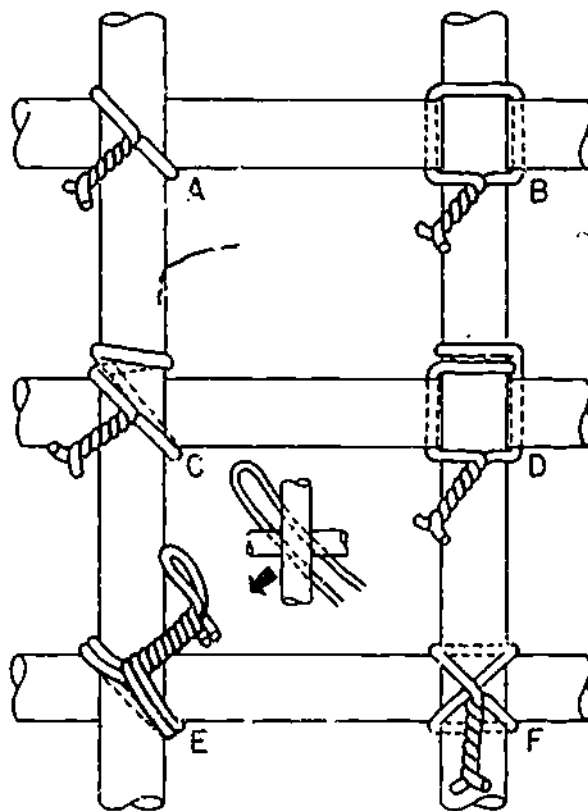

Figure 7-21.—Types of ties.

127.80

When you are tying reinforcing bars you must have a supply of the wire available. There are several ways you can carry your tie wire. One way is to coil it to a diameter of 18 in., then slip it around your neck and under one arm, as shown in figure 7-22. This leaves a free end for tying. Coil enough wire so it weighs about 9 lb.

Another way to carry tie wire is to take pieces of wire about 9 in. long, fold them and hook one end in your belt; then you can pull the wires out as needed. The tools you will use in tying reinforcing bars include a 6-ft folding rule, sidecutters, leather gloves, 50-ft tape measure, and a keel crayon, either yellow, red, or blue.

The proper location for the reinforcing bars is usually given on the drawings. In order for the structure to withstand the loads it must carry,



127.81

Figure 7-22.—Carrying tie wire.

place the steel in the position shown. Secure the bars in position in such a way that they will not move when the concrete is placed. This can be accomplished by the use of the reinforcing bar supports shown in figures 7-23, 7-24, and 7-25.

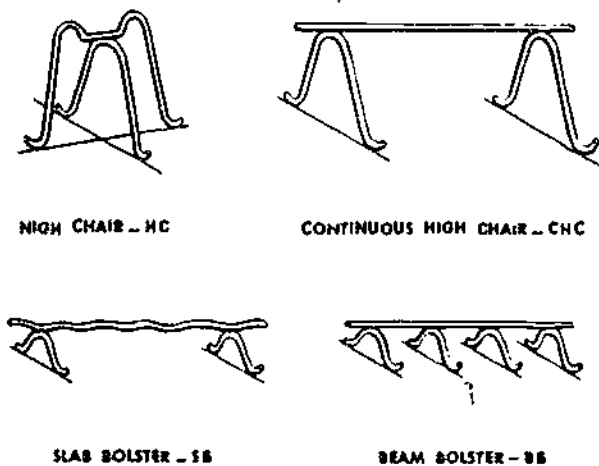

45.480

Figure 7-23.—Devices used to support horizontal reinforcing bars.

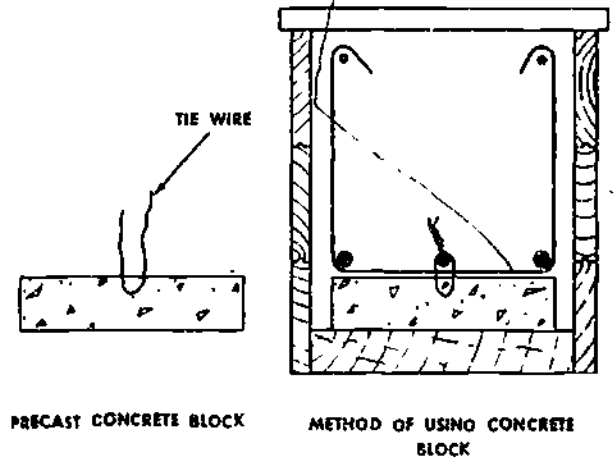

127.83.1

Figure 7-24.—Precast-concrete block used for reinforcing steel support.

Footings and other principal structural members which are against the ground should have at least 3 in. of concrete between steel and ground. If the concrete surface is to be in contact with the ground or exposed to the

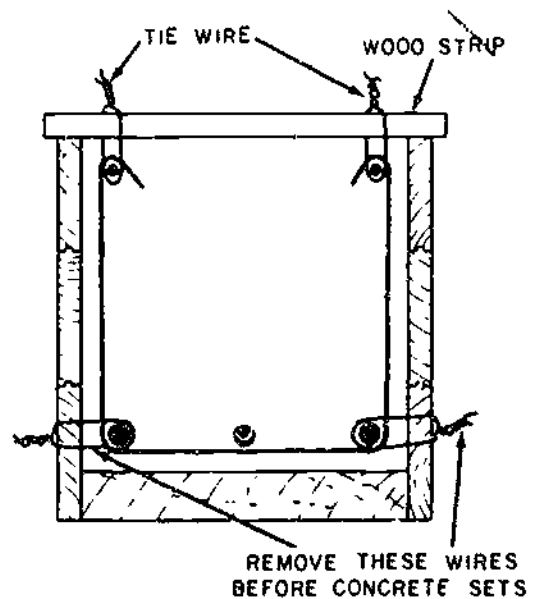

127.83.2

Figure 7-25.—Beam-reinforcing steel hung in place.

weather after removal of the forms, the protective covering of concrete over the steel should be 2 in. It may be reduced to 1 1/2 in. for beams and columns, and 3/4 in. for slabs and interior-wall surfaces, but it should be 2 in. for all exterior wall surfaces.

Specifications and designs are usually used when wire mesh is being lapped. However, as a rule of thumb, one complete lap is usually sufficient with a minimum of 2 in. between laps. Whenever the rule of thumb is not allowed, use the end-lap or side-lap method.

In the end-lap method, the wire mesh is lapped by overlapping one full mesh measured from the end of the longitudinal wires in one piece to the end of longitudinal wires in the adjacent piece, and then tying the two pieces at 1-ft by 6-in. centers with a snap tie

In the side-lap method, the two longitudinal side wires are placed one alongside and overlapping the other, and then are tied with a snap tie every 3 ft

When splices in reinforcing steel are not dimensioned on the drawings, the bars should be lapped not less than 30 times the bar diameter, nor less than 12 in

The stress in a tension bar can be transmitted through the concrete and into another adjoining bar by a lap splice of proper length. The lap is expressed as the number of bar diameters. If the bar is No. 2, make the lap at least 12 in. Tie the bars together with a snap tie, as shown in figure 7-26.

The minimum clear distance between parallel bars in beams, footings, walls, and floor slabs should be not less than 1 in., nor less than one and one-third times the largest size aggregate particle in the concrete. In columns, the clear



127.86

Figure 7-26 --Bars spliced by lapping.

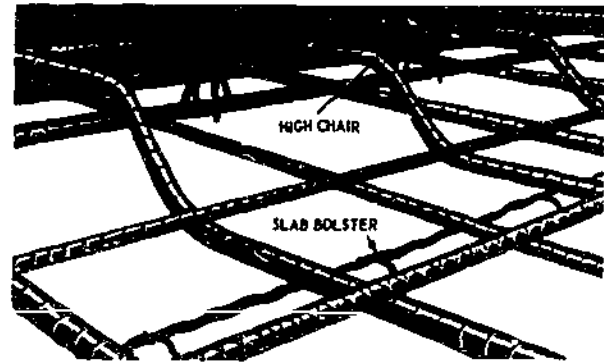

127.86

Figure 7-27.--Reinforcing steel for a floor slab.

distance between parallel bars should be not less than one and one-half times the bar diameter, 1 1/2 times the maximum size of the coarse aggregate, nor 1 1/2 inches.

The support for reinforcing steel in floor slabs is shown in figure 7-27. The height of the slab bolster is determined by the concrete protective cover required. Concrete blocks made of sand-cement mortar can be used in place of the slab bolster. Wood blocks should never be used for this purpose if there is any possibility that the concrete can become wet and if the construction is of a permanent type. Bar chairs of a type shown in figure 7-27 can be obtained in heights up to 6 in. If a height greater than this is required, make the chair of No. 0 soft annealed iron wire. Tie the bars together at frequent intervals with a snap tie where they cross to hold the bars firmly in position

Steel for column ties may be assembled with the verticals into cages, by laying the vertical bars for one side of the column horizontally across a couple of sawhorses. The proper number of ties are slipped over the bars, the remaining vertical bars are added, and then the ties are spaced out as required by the placing plans. A sufficient number of intersections are wired together to make the assembly rigid, so that it may be hoisted and set as a unit.

After the column is raised, it is tied to the dowels or reinforcing steel carried up from below. This holds it firmly in position at the

base. The column form is erected and the reinforcing steel is tied to the column form at 5-ft intervals, as shown in figure 7-28.

The use of metal supports to hold beam reinforcing steel in position is shown in figure 7-29. Note the position of the beam bolster. The stirrups are tied to the main reinforcing steel with a snap tie. Wherever possible, you should assemble the stirrups and main reinforcing steel outside the form and then place the assembled unit in position. Wood blocks should be substituted for the metal supports only if there is no possibility of the concrete becoming wet or if the construction is known to be temporary. Precast concrete blocks, as shown in figure 7-24, may be substituted for metal supports or, if none of the types of bar supports described above seems suitable, the method shown in figure 7-25 may be used.

Placement of steel in walls is the same as for columns except that the steel is erected in place and not preassembled. Horizontal steel is tied to

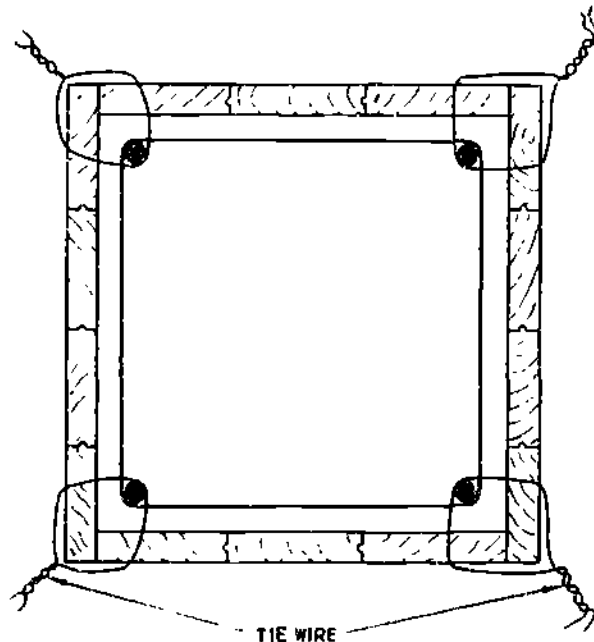

127.83.4

Figure 7-28. Securing column with reinforcing steel against displacement.

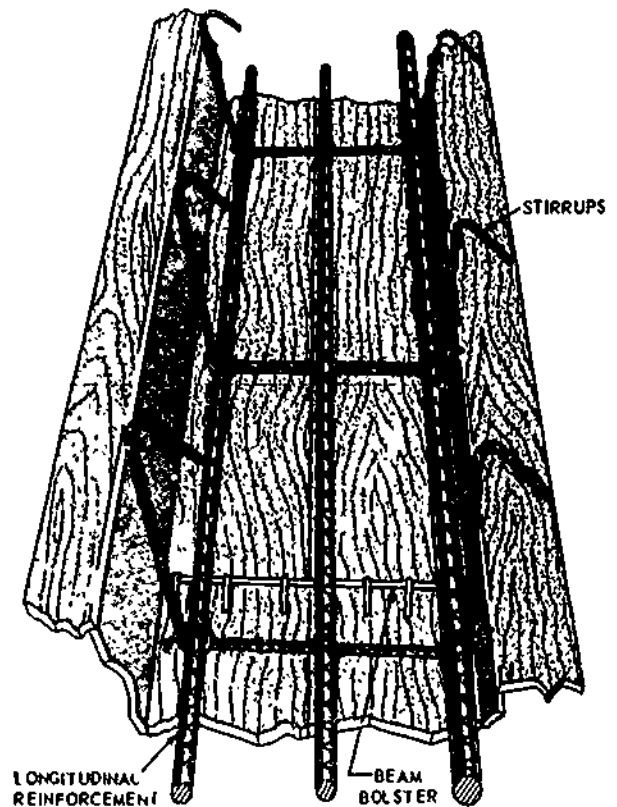

45.481

Figure 7-29. -Beam reinforcing steel supported on beam bolsters.

vertical steel at least three times in any bar length. Steel in place in a wall is shown in figure 7-30. The wood block is removed when the form has been filled up to the level of the block. For high walls, ties in between the top and bottom should be used.

Steel is placed in footings very much as it is placed in floor slabs. Stones, rather than steel supports, may be used to support the steel at the proper distance above the subgrade. Steel mats in small footings are generally preassembled and placed after the forms have been set. A typical arrangement is shown in figure 7-31. Steel mats in large footings are constructed in place.

Form construction has its peculiarities in each job, however, certain natural conditions will prevail in all situations. Wet concrete will

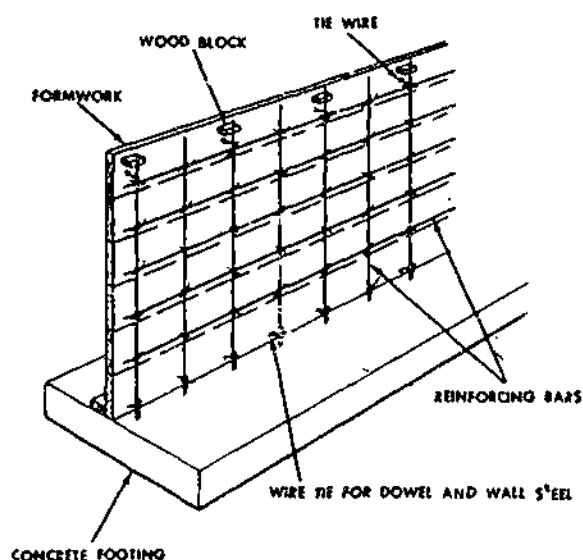

127.88

Figure 7-30.--Steel in place in a wall.

Careless nailing and exposed nails in form work cause accidents, all nailing should be correctly placed and secured.

All personnel placing concrete in elevated or high wall forms should wear hard hats, shirt sleeves should be rolled down and gloves should be worn. These precautions are for safety first and also to assist in decreasing the exposure of skin to "cement poisoning."

As a crew leader, you should check all forms for tightness prior to each pour.

Tools, particularly hammers, should be inspected frequently.

Mud sills should be placed under shoring that rest in the ground.

Raising of large form panels should not be attempted in heavy gusts of wind either by hand or by crane.

CONCRETE CONSTRUCTION JOINTS

Construction joints are used between the units of a structure and located so they will not cause weakness. It would be preferable theoretically that each beam, girder, column, wall, or floor slab be placed in one operation to produce a homogeneous member without seams or joints, but for practical reasons, this procedure is usually impossible. The planes separating the work done on different days, called construction joints, are placed where they will cause the minimum amount of weakness to the structure, and where the shearing stresses and bending moments are small or where the joints will be supported by other members.

At a construction joint between a wall and its footing, a keyway is usually necessary to transfer the shearing stresses. A keyway must always be used if no reinforcing steel or dowels tie the wall and footing together. This keyway can be formed by pressing a slightly beveled 2 by 4 into the concrete before it has set and removing the 2 by 4 after the concrete has hardened. The 2 by 4 should be well oiled before it is used. Such a keyway is shown in

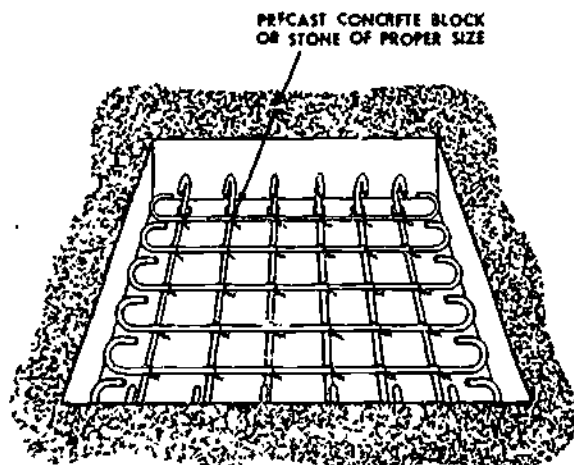

127.89

Figure 7-31 --Steel in place in a footing.

always develop hydrostatic pressure and strain on forms. Therefore, all stakes, braces, walers, ties, and shebolts should be properly secured before placing concrete.

The use of safety belts by personnel tying reinforcing bars in high places will expedite the job and provide safety at all times

figure 7-32. If the wall and footing can be placed at one time, a construction joint is not necessary.

VERTICAL JOINTS

If it is desirable to deposit the concrete for the full wall height, the forms should be divided into sections by vertical bulkheads as shown in figure 7-33. These bulkheads should be spaced so that the complete section can be filled in one continuous operation. Experience has shown that the V-joint in figure 7-34 is less likely to break off than the joint shown in figure 7-33. If reinforcing steel or dowels cross the joint no projection is needed.

BEAM, COLUMN, AND FLOOR SLAB JOINTS

The proper place to end a pour in construction involving beams, columns, and

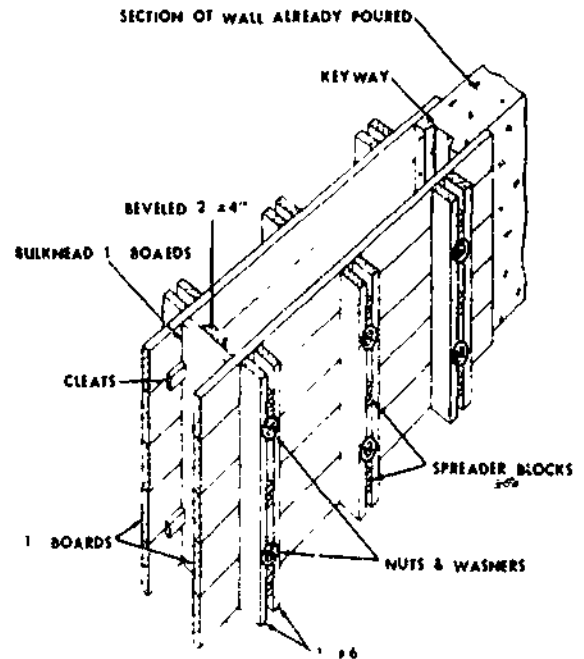

133.489
Figure 7-33.—Vertical bulkhead in wall.

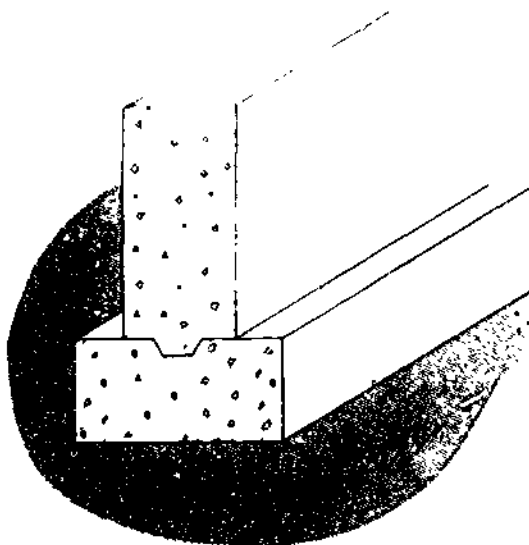

133.488
Figure 7-32.—Construction joint between wall and footing with a keyway.

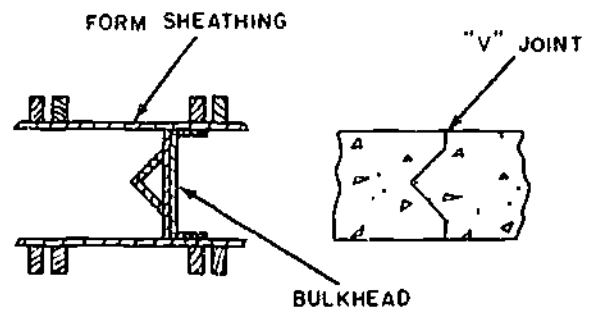

133.490
Figure 7-34.—Vertical V-construction joint.

floor slabs is shown in figure 7-35. The concrete in each column should be placed to the underside of the beam or floor slab above. A construction joint in a beam or floor slab should occur at the center of the span so as to avoid points of maximum shear. All construction joints in beams and slabs should be vertical.

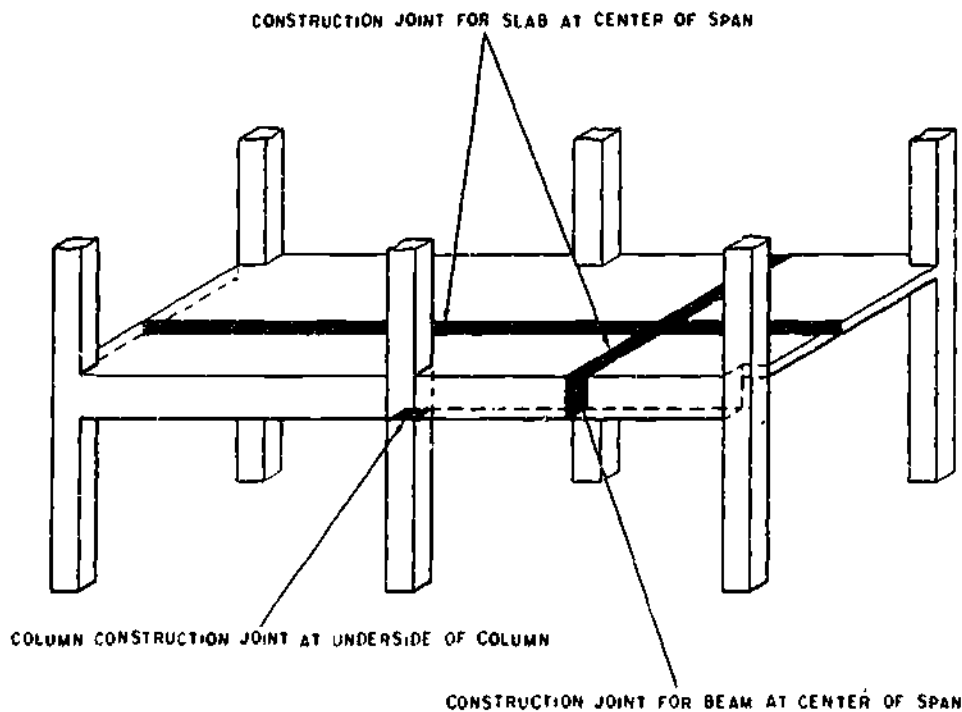

Figure 7-35.—Location of construction joints in beams, columns, and floor slabs.

133.491

Reinforcing steel or dowels should extend across the joint. A beam or slab should never be placed in two lifts vertically, for this produces a weak joint between the two layers.

EXPANSION AND CONTRACTION JOINTS

Shrinkage of concrete during hydration is comparable to a drop in temperatures of 30° to 80° F depending on the richness of the mix. Contraction joints are necessary to permit the concrete to shrink during the curing process without damage to the structure. The operations office will consider the best place for the joints from a standpoint of serving the purpose. They are usually placed where there is a change in thickness, at offsets and where the concrete will tend to crack if shrinkage and deformations due to temperature are restrained. Joints should be about 30 ft center-to-center in exposed structures.

Expansion joints, in the form of vertical joints through the concrete, are used to isolate adjacent units of a structure, to prevent cracking due to shrinkage or temperature changes. Generally, an expansion joint is used with a premolded mastic or cork filler, if an elongation of adjacent parts and a closing of the joint is anticipated. Expansion joints for different types of structures are illustrated in figures 7-36 through 7-38. Expansion joints should be installed every 20 ft.

The purpose of contraction joints is to control cracking due to temperature changes incident to shrinkage of the concrete. If the concrete cracks, it will usually occur at these joints. Usually, the contraction caused by shrinkage will offset a large part of the expansion due to a rise in temperature. Contraction joints are usually made with no filler or with a thin coat of asphalt, paraffin, or some other material to break the bond. Joints, as shown in figure 7-39, should be installed at 15-ft intervals or closer depending on the extent

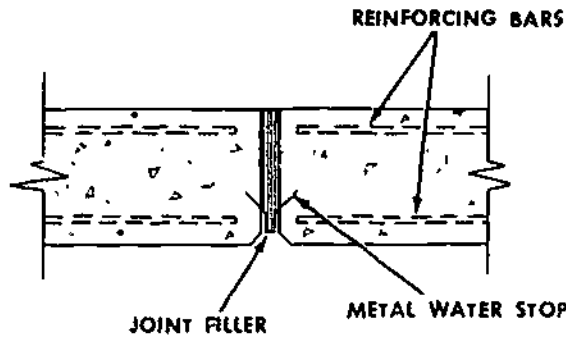

133.492
Figure 7-36.—Expansion joint for wall.

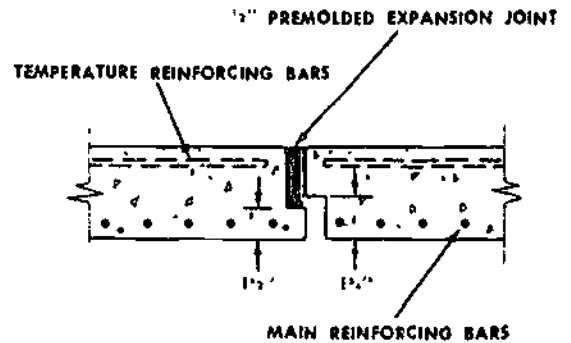

133.494
Figure 7-38.—Expansion joint for floor slab.

of local temperature change. These dummy contraction joints are formed by cutting to a depth of one-fourth to one-third the thickness of the section. Contraction and expansion joints are not used in beams and columns. Contraction and expansion joints in reinforced concrete floor slabs should be placed at 15 to 25 ft intervals in each direction.

PLACING CONCRETE

Plan ahead before placing concrete by being prepared with the necessary material, tools, and

equipment. Additionally, be sure complete compaction, trimming, and moistening of the subgrade, erecting forms, and setting of reinforcing steel has been completed.

Concrete will not attain its maximum possible strength, density, and uniformity unless proper methods are used to place it in the forms. Proper methods are methods which will insure the thorough filling of all form spaces, while at the same time confining segregation to a minimum.

Concrete should be deposited in even horizontal layers and should not be puddled or vibrated into place. The layers should be from 6 to 24 in. in depth depending on the type of construction. The initial set should not take place before the next layer is added. After the concrete is in place, to prevent honeycombing or to avoid spaces in the concrete, the concrete should be vibrated or spaded. This is particularly desirable in wall forms with considerable reinforcing. Care should be taken not to

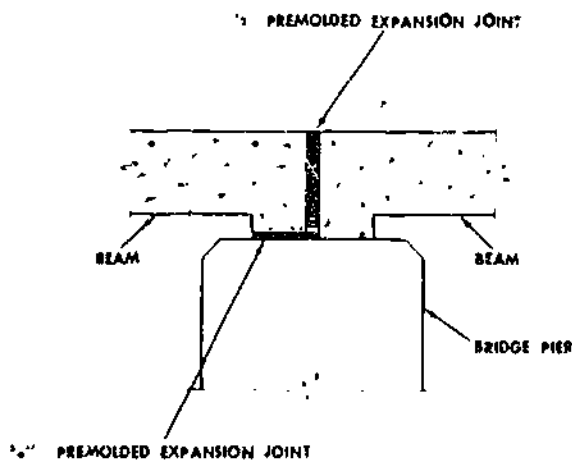

133.493
Figure 7-37.—Expansion joint for bridge.

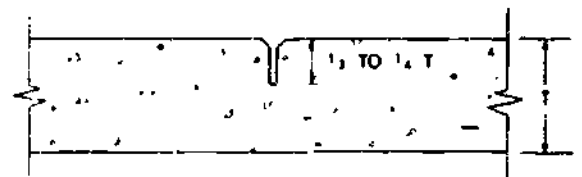

133.496
Figure 7-39.—Dummy construction joint.

overvibrate, because segregation and a weak surface may result.

There is a temptation, in the interests of time and effort, to drop the concrete from the point to which it has been transported regardless of the height of the forms, but the free fall of concrete into the forms should be reduced to a maximum of 3 to 5 ft unless vertical pipes, suitable drop chutes, or baffles are provided.

Concrete should be deposited in horizontal layers whenever possible and each layer consolidated before the succeeding layer is placed. Each layer should be placed in one operation. In mass concrete work, where concrete is deposited from buckets, the layers should be from 15 to 20 in. thick. For reinforced concrete members, the layers should be from 6 to 20 in. thick. The thickness of the layers depends on the width between forms and the amount of reinforcement.

Concrete should be placed as nearly as possible in its final position. Horizontal movement should be avoided since this results in segregation because mortar tends to flow ahead of coarser material. Concrete should be worked thoroughly around the reinforcement and bedded fixtures, into the corners, and on the sides of the forms.

On large pours so as to avoid excess pressure on forms, the rate of filling should not exceed 4 ft per hr measured vertically, except for columns. Placing will be coordinated so that the concrete is not deposited faster than it can be properly compacted. In order to avoid cracking during settlement an interval of at least 4 hr, but preferably 24 hr, should elapse between completion of columns and walls and the placing of slabs, beams, or girders supported by them.

For walls, the first batches should be placed at the ends of the section. Placing should then proceed toward the center for each layer, if more than one layer is necessary, to prevent water from collecting at the ends and corners of the forms. This method should also be used in placing concrete for beams and girders. For wall construction, the inside form should be stopped off at the level of construction. Overtill the form

for about 2 in. and remove the excess just before setting occurs to insure a rough, clean surface. Before the next lift of concrete is placed on this surface, a 1/2- to 1-in.-thick layer of sand-cement mortar should be deposited on it. The mortar should have the same water content as the concrete and should have a slump of about 6 in. to prevent stone pockets and help produce a watertight joint.

For slabs, the concrete should be placed at the far end of the slab, each batch dumped against previously placed concrete.

The concrete should not be dumped in separate piles and the piles then leveled and worked together. Nor should the concrete be deposited in big piles and then moved horizontally to its final position, since this practice results in segregation.

Always deposit the concrete at the bottom of the slope first, and proceed up the slope as each batch is dumped against the previous one. Compaction is thus increased by the weight of the newly added concrete when it is consolidated.

CONSOLIDATING CONCRETE

With the exception of concrete placed under water, concrete is compacted or consolidated after placing. Consolidation may be accomplished by the use of handtools such as spades, puddling sticks, and tampers, but the use of mechanical vibrators is preferred. Compacting devices must reach the bottom of the form and must be small enough to pass between reinforcing bars. Consolidation eliminates rock pockets and air bubbles and brings enough fine material to the surface and against forms to produce the desired finish. In the process of consolidation, the concrete is carefully worked around all reinforcing steel to assure proper embedding of the steel in the concrete. Displacement of reinforcing steel must be avoided since the strength of the concrete member depends on proper location of the reinforcement.

Consolidation is effectively accomplished by use of mechanical vibrators, as shown in figure 7-40. Vibrators consolidate concrete by pushing the coarse aggregate down and away from the point of vibration. With vibrators, it is possible to place concrete mixtures too stiff to be placed in any other way. In most structures, concrete with a 1- or 2-in. slump can be deposited. Stiff mixtures require less cement and are therefore more economical. Moreover, there is less danger of segregation and excessive bleeding. The mix must not be so stiff that an excessive amount of labor is required to place it. The internal vibrator involves insertion of a vibrating element into the concrete. The external type is applied to the forms. It is powered by an electric motor, a gasoline engine, or compressed air. The internal vibrator should be inserted in the concrete at intervals of approximately 18 in. for 5 to 15 seconds to allow some overlap of the area vibrated at each insertion. Whenever possible the vibrator should be lowered vertically into the concrete and allowed to descend by gravity. The vibrator should pass through the layer being placed and penetrate the layer below for several inches to insure a good bond between the layers. Under normal conditions, there is little likelihood of damage from the vibration of lower layers provided the disturbed concrete in these lower layers becomes plastic under the vibratory action. Sufficient vibration has taken place when a thin line of mortar appears along the form near the vibrator, when the coarse aggregate has sunk into the concrete, or when the paste just appears near the vibrator head. The vibrator should then be withdrawn vertically at about the same rate that it descended. The length of time that a vibrator should be left in the concrete depends on the slump of the concrete. Mixes that can be easily consolidated by spading should not be vibrated because segregation may occur. Concrete that has a slump of 5 or 6 in. should not be vibrated. Vibrators should not be used to move concrete any distance in the form. Some hand spading or puddling should accompany vibration.

Hand methods for consolidating concrete include the use of spades or puddling sticks and various types of tampers. For consolidation by spading, the spade should be shoved down along the inside surface of the forms through the layer



BEFORE VIBRATION

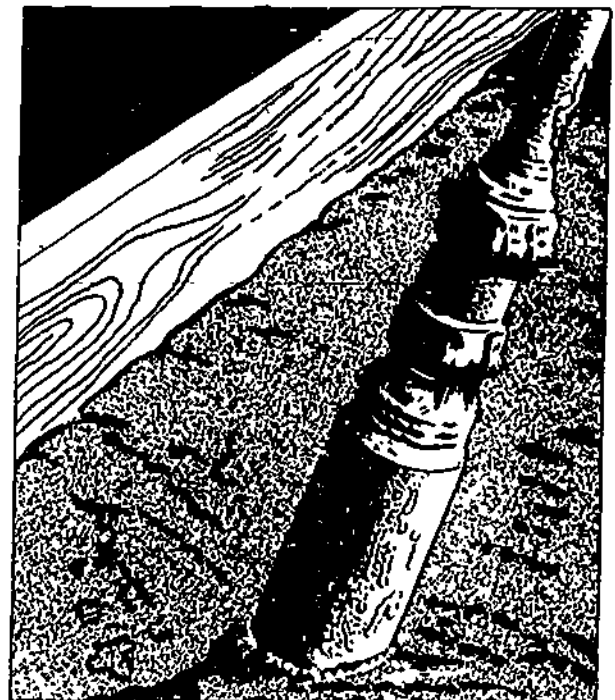

AFTER VIBRATION

29.158

Figure 7-40.—The use of a vibrator to consolidate concrete.

7-38
201

deposited and down into the lower layer for a distance of several inches, as shown in figure 7-41. Spading or puddling should continue until the coarse aggregate has disappeared into the mortar.

PLACING CONCRETE UNDER WATER

Concrete should be placed in air rather than under water whenever possible. When it is placed under water, the work should be done under

experienced supervision and certain precautions should be taken. For best results, concrete should not be placed in water having a temperature below 45°F and should not be placed in water flowing with a velocity greater than 10 ft per minute, although sacked concrete may be used for water velocities greater than this. If the water temperature is below 45°F, the temperature of the concrete when it is deposited should be above 60°F but in no case above 80°F. If the water temperature is above 45°F, no temperature precautions need be taken. Coffers or forms must be tight enough to reduce the current to less than 10 ft per minute through the space to be concreted. Pumping of water should not be permitted while concrete is being placed or for 24 hrs thereafter.

Concrete can be placed under water by several methods, the most common of which is with a tremie. The tremie method involves a device as shown in figure 7-42. A tremie is a pipe having a funnel-shaped upper end into which the concrete is fed. The pipe must be long enough to

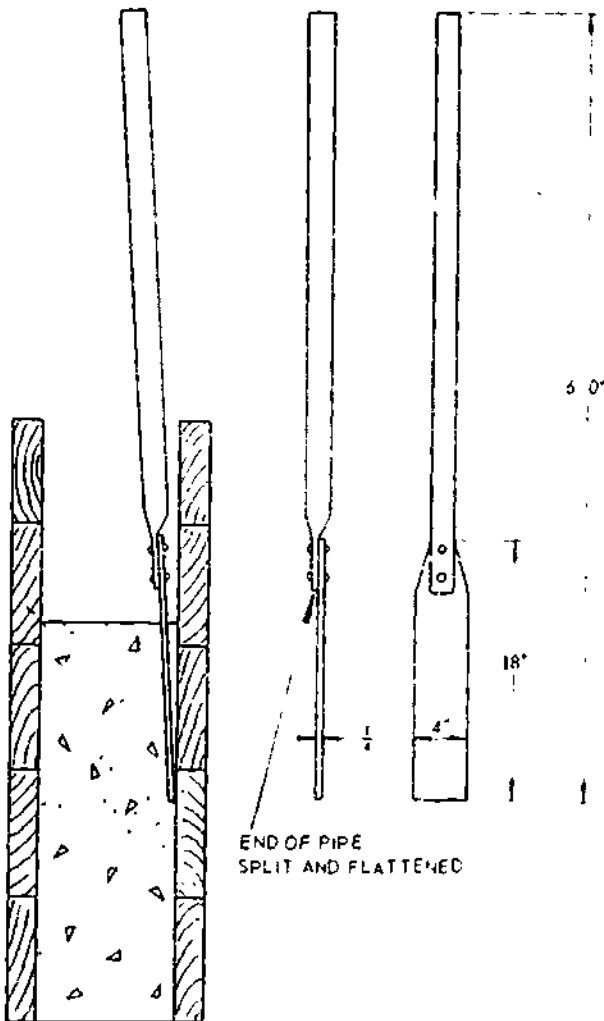

29.157
Figure 7-41.—Consolidation by spading and the spading tool

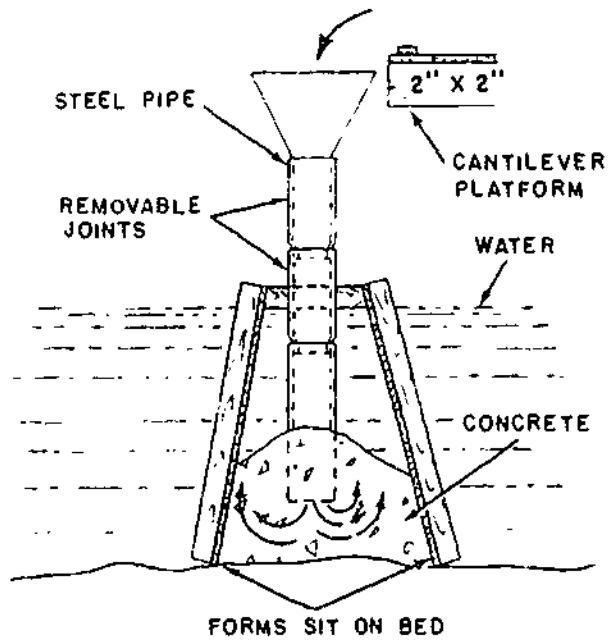

133.496
Figure 7-42.—Placing concrete under water with a tremie.



133.14

Figure 7-43.—Screeding by hand.

reach from a working platform above water level to the lowest point at which the concrete is to be deposited. Frequently, the tower end of the pipe is equipped with a gate, permitting filling before insertion in water. This gate can be opened from above at the proper time. The bottom or discharge end is kept continuously buried in newly placed concrete, and air and water are excluded from the pipe by keeping it constantly filled with concrete. The tremie should be lifted slowly to permit the concrete to flow out. Care must be taken not to lose the seal at the bottom. If lost, it is necessary to raise the tremie, plug the lower end, and lower the tremie into position again. The tremie should not be moved laterally through the deposited concrete. When it is necessary to move the tremie, it should be lifted out of the concrete and moved to the new position, keeping the top surface of the concrete as level as possible. A number of tremies should be used if the concrete is to be deposited over a large area. They should be spaced on 20- to 25-ft centers. Concrete should be supplied at a uniform rate to all tremies with no interruptions at any of them. Pumping from a mixer is the best method of supplying the concrete. Large tremies can be suspended from a

crane boom and can be easily raised and lowered with the boom. Concrete that is placed with a tremie should have a slump of about 6 in. and a cement content of seven sacks per cubic yard of concrete. About 50 percent of the total aggregate should be sand and the maximum coarse aggregate size should be from 1 1/2 to 2 in.

Concrete can be placed at considerable depth below the water surface by means of open-top buckets with a drop bottom. Concrete placed by bucket can be slightly stiffer than that placed by tremie, but it should still contain seven sacks of cement per cubic yard. The bucket is completely filled and the top covered with a canvas flap. The flap is attached to one side of the bucket only. The bucket is lowered slowly into the water so that the canvas will not be displaced. Concrete must not be discharged from the bucket before the surface upon which the concrete is to be placed has been reached. Soundings should be made frequently so that the top surface is kept level.

In an emergency, concrete can be placed under water in sacks. Jute sacks of about 1-cu ft capacity, filled about two-thirds full, are lowered into the water, preferably shallow

water. These sacks are placed in header and stretcher courses, interlocking the entire mass. A header course is placed so that the length of the sack is at right angles to the direction in which the stretcher-course sacks are laid. Cement from one sack seeps into adjacent sacks and they are thus bonded together. Experience has shown that the less air concrete under water is disturbed after placement, the better it will be. For this reason, compaction should not be attempted.

FINISHING CONCRETE

The concrete finishing process may be performed in many ways, depending on the effect desired. Occasionally only the correction of surface defects, such as filling bolt holes or cleaning is necessary. Unformed surfaces may require only screeding to proper contour and elevation, or a broomed, floated, or troweled finish may be specified. Each step of the finishing operation is discussed below.

SCREEDING

The first step in finishing a slab is **SCREEDING**. A hand-operated strike-off board and the method of using it are shown in figure 7-43. The chief purpose of screeding is to level the surface of the slab by striking off the excess concrete. The strike-off board rides on the edges of the side forms or on wood or metal strips (screeds) set up for this purpose. Two crewmembers give the strike-off board a sawing motion while moving it along the slab.

Screeding by means of mechanical equipment is shown in figure 7-44.

The vibrating screed is being used more and more in construction for striking off concrete slabs on highways, bridge decks, and deck slabs. The screed, incorporating the use of vibration, permits the use of stronger and more economical, low slump concrete as it strikes off this relatively dry material smoothly and quickly. The advantages of vibration are greater

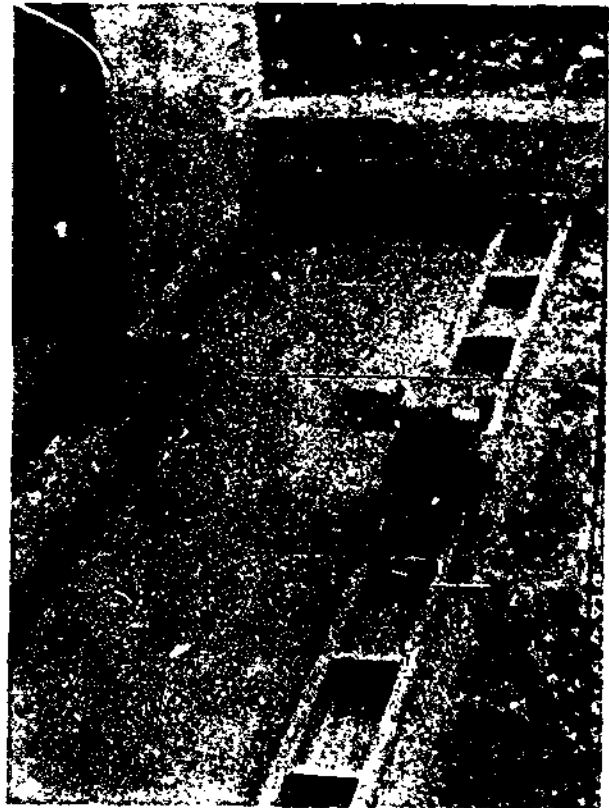

133.15X

Figure 7-44.—Mechanical screeding.

density and stronger concrete. Not only do vibratory finishing screeds give a better finish, and reduce maintenance, but they also save considerable time due to the speed at which they operate. Then, too, as far as the crew are concerned, screeds are much less fatiguing to operate than hand strike offs.

A vibratory finishing screed usually consists of a beam or beams with a gasoline engine or an electric motor and vibrating mechanism which is generally mounted in the center of the beam. Most screeds are exceedingly heavy and equipped with wheels, and a raising device to facilitate rolling it back for a second pass. However, there are lightweight screeds which are not equipped with wheels, and are easily lifted by two crewmembers and set back for the second pass if required. The vibration is

normally transmitted through the length of the beam directly to the concrete.

Screeds are pulled by either ropes or pipe handles by a crewmember at each end. The speed at which it is pulled is directly related to the slump of the concrete—the less the slump, the slower the speed—the more the slump, the faster the speed. The finishing screed, having no transverse (crosswise) movement of the beam, is merely drawn directly forward riding on the forms or rails. (See fig. 7-44.) Whether the screed is electric motor or gas engine operated, in either case a method is provided to quickly start or stop the screed's vibration. This is important to prevent overvibration when the screed might be standing still.

The concrete is usually placed from 15 to 20 ft ahead of the strikeboard and shoveled as close as possible to its final resting place. The screed is then put into operation and pulled along by two crewmembers (one at each end of the screed). (See fig. 7-45) It is very important that sufficient concrete is kept in front of the screed. Should the concrete be below the level of the screed beam, voids or bare spots will appear on the concrete surface as the screed passes over the slab. Should this occur, a shovelful or so of concrete is thrown on the bare spot, and the screed is lifted up and carried back

for a second pass. In some cases, the screed crew will endeavor to work out the void or bare spot with a hand-operated bull float, rather than make the second pass with the screed. It may be found that intermediate vibration speeds are more desirable for particular mixes and different length beams. Generally, the stiffer the mix and the longer the beam, the greater the vibration speed required. Then, too, the speed at which the screed is moved will affect the resulting finish of the slab. After a few minutes of operation, a satisfactory vibration speed and pulling speed can be established. After the vibratory finishing screed has passed over the slab, the surface is then ready for broom, or burlap finishing.

Where possible, it is advisable to lay out or engineer the concrete slab specifically for use of a vibratory finishing screed. Forms should be laid out in lanes of equal widths, so that the same length screed can be used on all lanes or slabs. It should also be planned, if possible, that any vertical columns will be next to the forms, so that the screed can easily be lifted or maneuvered around the column.

The following are the important advantages of using a vibratory finishing screed:

1. It allows the use of low slump concrete resulting in stronger slabs.

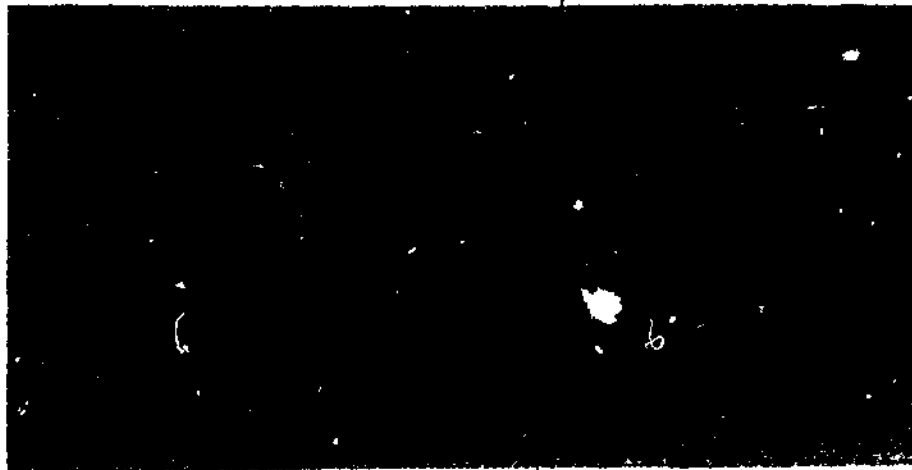

Figure 7-45.—Pulling a mechanical screed.

2. It reduces and sometimes eliminates the necessity of bull floating.

3. It increases the density of the concrete resulting in a superior wearing surface.

4. In the case of floor slabs, it makes it possible to start troweling sooner since drier mixes can be used which set up more quickly.

FLOATING

If a smoother surface is required than the one obtained by screeding, the surface should be worked sparingly with a wood or metal float or finishing machine. A wood float and the method of using it is shown in figure 7-46. This process should take place shortly after screeding and while the concrete is still plastic and workable. High spots are eliminated, low spots filled in, and enough mortar is brought (floated) to the surface to produce the desired finish. The concrete must not be overworked while it is still plastic to avoid bringing an excess of water and mortar to the surface. This fine material will form a thin, weak layer that will scale or wear off under usage. Where a coarse texture is desired as the final finish, it is usually necessary to float the surface a second time after it has partially hardened so that the required surface will be obtained. In slab construction, long-handled wood floats are used, as shown in figure 7-47.

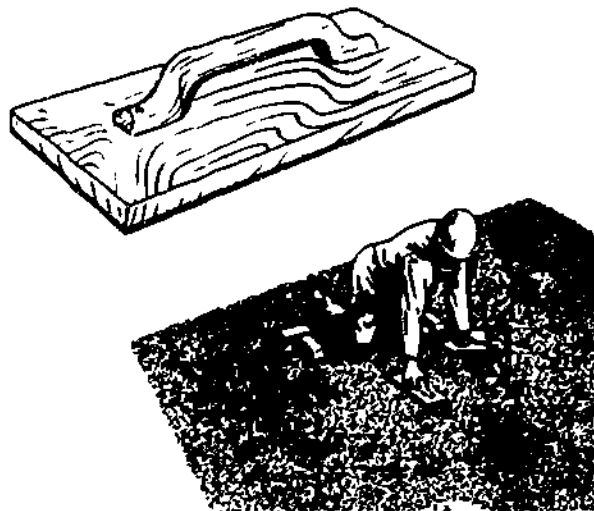

29.162

Figure 7-46.—Wood float and floating operation.

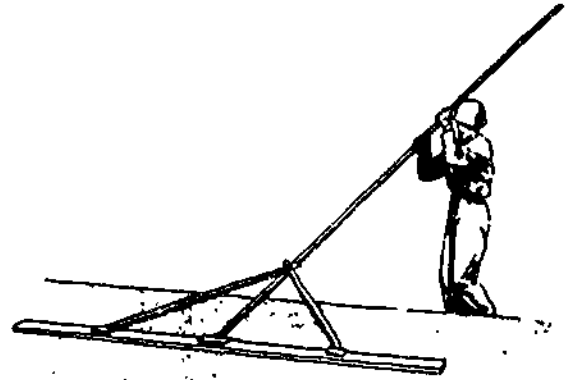

29.163

Figure 7-47.—Long-handle wood float and floating operation.

The steel float is used the same way as the wood float, but it gives the finished concrete a much smoother surface.

To avoid cracking and dusting of the finished concrete, steel floating should begin when the sheen of the water disappears from the concrete surface. Cement or water should not be used to aid in finishing the surface.

EDGING

As the sheen of water begins to leave the surface, edging should begin. All edges of the slab, which do not abut another structure, are finished with an edger (fig. 7-48) which dresses

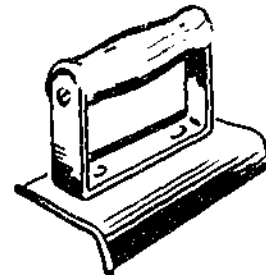

133.497

Figure 7-48.—Edger.

corners, and rounds or bevels the concrete edges. Edging the slab helps prevent chipping at the corners when the concrete is struck with a hard object and presents a finished appearance.

TROWELING

If a dense, smooth finish is desired, floating must be followed by steel troweling (fig. 7-49) at some time after the moisture film or sheen disappears from the floated surface and when the concrete has hardened enough to prevent fine material and water from being worked to the surface. This step should be delayed as long as possible. Excessive troweling too early tends to produce crazing and lack of durability; too long a delay in troweling results in a surface too hard to finish properly. The usual tendency is to start to trowel too soon. Troweling should leave the surface smooth, even, and free of marks and ripples. Spreading dry cement on a wet surface to take up excess water is not good practice

where a wear-resistant and durable surface is required. Wet spots must be avoided if possible; when they do occur, finishing operations should not be resumed until the water has been absorbed, has evaporated, or has been mopped up. A surface that is fine textured but not slippery may be obtained by troweling lightly over the surface with a circular motion immediately after the first regular troweling. In this process, the trowel is kept flat on the surface of the concrete. Where a **HARD STEEL-TROWELED FINISH** is required, the first regular troweling is followed by a second troweling after the concrete has become hard enough so that no mortar adheres to the trowel and a ringing sound is produced as the trowel passes over the surface. During this final troweling, the trowel should be tilted slightly and heavy pressure exerted to thoroughly compact the surface. Hairline cracks are usually due to a concentration of water and fines at the surface resulting from overworking the concrete during finishing operations. Such cracking is aggravated by too rapid drying and cooling. Checks that develop before troweling usually can be closed by pounding the concrete with a hand float.

The mechanical troweling machine, like the one shown in figure 7-50 is used to good

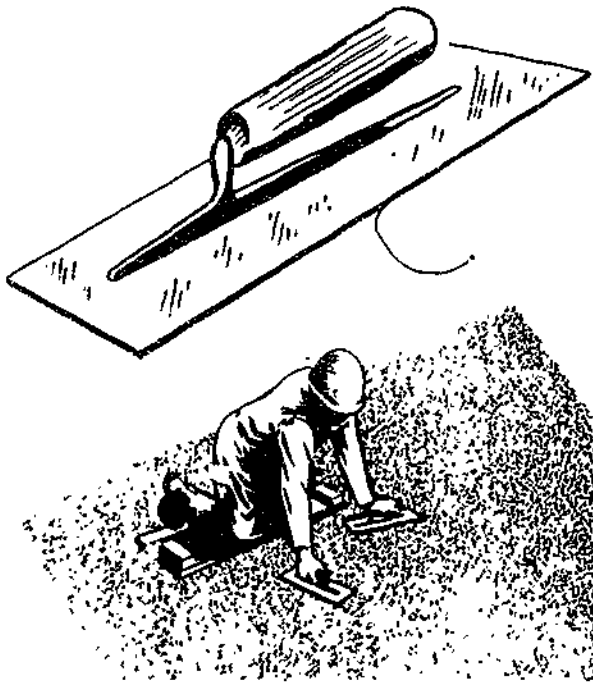

29.164
Figure 7-49.—Steel finishing tools and troweling operations.

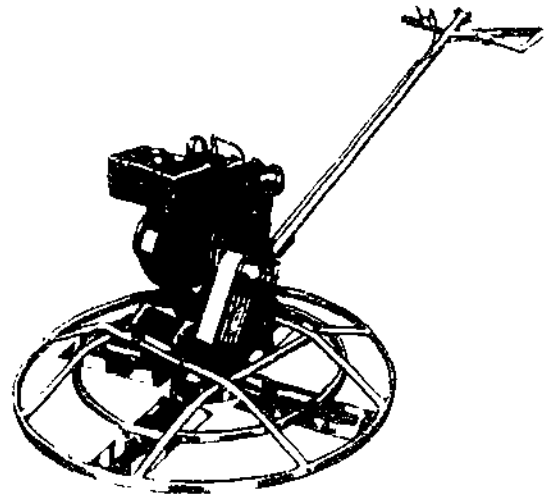

133.498
Figure 7-50.—Mechanical troweling machine.

advantage on flat slabs with stiff consistency. The concrete must be set enough to support the weight of the machine and the operator. Machine finishing is faster than by hand, where the machine will fit in with the type of construction. Refer to the manufacturers manual for operation and maintenance of the machine you are using.

BROOMING

A nonskid surface can be produced by brooming the concrete before it has thoroughly hardened. Brooming is carried out after the floating operation. For some floors and sidewalks where severe scoring is not desirable, the broomed finish can be produced with a hair brush after the surface has been troweled to a smooth finish once. Where rough scoring is required, a stiff broom made of steel wire or coarse fiber should be used. Brooming should be done in such a way that the direction of the scoring is at right angles to the direction of the traffic.

GRINDING

When properly constructed of good quality materials, ground floors are dustless, dense, easily cleaned, and attractive in appearance. When grinding is specified, it should be started after the surface has hardened sufficiently to prevent dislodgment of aggregate particles and should be continued until the coarse aggregate is exposed. The machines used should be of an approved type with stones that cut freely and rapidly. The floor is kept wet during the grinding process, and the cuttings are removed by squeegeeing and flushing with water. After the surface is ground, airholes, pits, and other blemishes are filled with a thin grout composed of 1 part No.80-grain carborundum grit and 1 part portland cement. This grout is spread over the floor and worked into the pits with a straightedge, after which it is rubbed into the floor with the grinding machine. When the fillings have hardened for 7 days, the floor receives a final grinding to remove the film and to give the finish a polish. All surplus material is then removed by washing thoroughly

SACK-RUBBED FINISH

A sack-rubbed finish is sometimes necessary when the appearance of formed concrete falls considerably below expectations. This treatment is performed after all required patching and correction of major imperfections have been completed.

The surfaces are thoroughly wetted and sack rubbing is commenced while they are still damp. The mortar used consists of 1 part cement; 2 parts, by volume, of sand passing a No. 16 screen; and enough water so that the consistency of the mortar will be that of a thick cream. It may be necessary to blend the cement with white cement to obtain a color that will match that of the surrounding concrete surface. The mortar is rubbed thoroughly over the area with clean burlap or sponge rubber float, so as to fill all pits. While the mortar in the pits is still plastic, the surface should be rubbed over with a dry mix of the above proportions and material. This serves to remove all of the excess plastic material and place enough dry material in the pits to stiffen and solidify the mortar so that the fillings will be flush with the surface. No material should remain on the surface except that within the pits. Curing of the surface is then continued.

RUBBED FINISH

A rubbed finish is required when a uniform and attractive surface must be obtained although it is possible to produce a surface of satisfactory appearance without rubbing if plywood or lined forms are used. The first rubbing should be done with coarse carborundum stones as soon as the concrete has hardened so that the aggregate is not pulled out. The concrete should then be cured until final rubbing. Finer carborundum stones are used for the final rubbing. The concrete should be kept damp while being rubbed. Any mortar used to aid in this process and left on the surface should be kept damp for 1 to 2 days after it sets in order to cure properly. The mortar layer should be kept to the minimum as it is likely to scale off and mar the appearance of the surface

EXPOSED-AGGREGATE FINISH

An exposed-aggregate finish provides a nonskid surface when the specifications call for it. To obtain this finish, the concrete is allowed to harden sufficiently to support the finisher. The aggregate is exposed by brushing and flushing the concrete surface with water. Since timing is important, test panels should be used to determine the correct time to expose the aggregate.

CURING CONCRETE

As previously mentioned, concrete hardens as a result of the HYDRATION of the cement by the water. Freshly placed concrete contains more than enough water to hydrate the cement completely, but if the concrete is not protected against drying out the water content, especially

at and near the surface, the water content will drop below that required for complete hydration.

The procedure called CURING is designed to prevent surface evaporation of water during the period between beginning and final set. Concrete takes a beginning set in about 1 hr, a final set takes about 7 days.

Curing is brought about by keeping the concrete surfaces continuously moist. Depending upon the type of structure, this may be done by spraying or ponding; by covering with continually moistened earth, sand, burlap, straw, or by covering with a water-retaining membrane.

Concrete made with ordinary cement should be kept moist for a minimum of 7 days. It should be protected from direct sunlight for at least the first 3 days of the curing period. Wet burlap is excellent for this purpose. Wood forms left in place also furnish good protection against



Figure 7-51.—Sprinkling burlap mats used for curing.

133.257

sunlight, but they should be loosened at the time when they might safely be removed, and the space between the forms and the concrete should be flooded with water at frequent intervals.

Curing by ponding is usually confined to large slabs. An earth dike is built around the area to be cured, and the space inside the dike is filled with water.

A highway pavement, laid in the open air and perhaps under a hot sun, is especially likely to dry out rapidly. It is vital that the pavement receive full and continuous protection for the full time set in the specifications, but it is during the first few days that pavement is most affected by drying. The first 24 hours are the most important of all.

In hot weather, the pavement should be protected as soon as the last finishing operation is completed. This is best accomplished by placing a wet-burlap or cotton-mat cover over the concrete and keeping the cover moist by sprinkling with a fine spray, as shown in figure 7-51. This procedure will prevent HAIR

CHECKS, or fine surface cracks which occur when the surface dries out much faster than the underlying mass.

The coverings may be either burlap or cotton mats. Burlap covers consist of two or more layers of burlap having a combined weight of 14 oz or more per square yard in a dry condition. Burlap should either be new or have been used only for curing concrete. Cotton mats and burlap strips should have a length, after shrinkage, of at least 1 ft greater than necessary to cover the entire width and edges of the pavement lane. The mats should overlap each other at least 6 in. The mats should be thoroughly wetted before placing and kept continuously wet and in intimate contact with the pavement edges and surface for the duration of the required curing period.

When the waterproof-paper blankets or unpermeable sheets are used, the surface of the concrete should be wetted with a fine spray of water and then covered with waterproof-paper blankets (fig 7-52). Polyethylene-coated-burlap blankets or polyethylene sheets if available. The

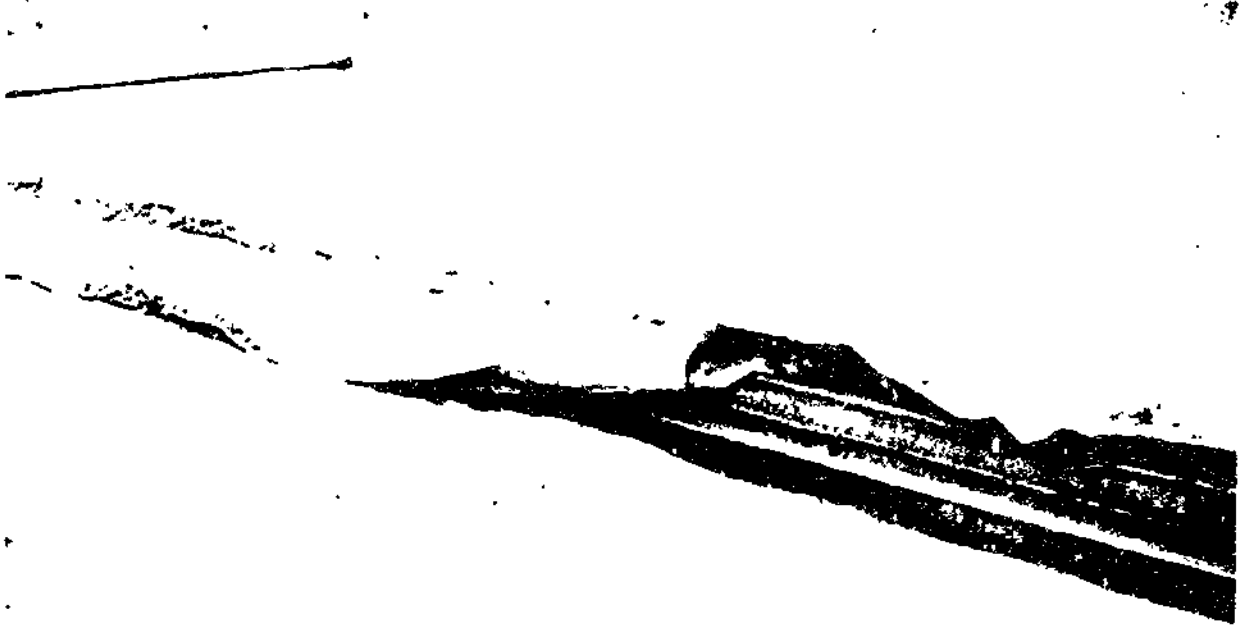

Figure 7-52 - Waterproof-curing Paper used after burlap curing

133.258

burlap of the polyethylene-coated burlap should be thoroughly saturated with water before placing. The waterproof-paper blankets, polyethylene-coated-burlap blankets, or polyethylene sheeting should be in pieces large enough to cover the entire width and edges of the slab. (Polyethylene sheets carefully lapped will eliminate the necessity for two curing treatments. This material is also lighter, cheaper, and more easily handled than polyethylene-coated-burlap.) The sheets should be placed with the light-colored side up. Adjacent sheets should overlap not less than 12 in. with the lapped edges securely weighted down and cemented or taped to form a continuous cover and a completely closed joint. These coverings must be adequately weighted down to prevent displacement or billowing from winds. Covering should be folded down over the side of the pavement edges and secured by a continuous bank of earth or other approved means. Tears and holes must be patched immediately. The coverings should remain in place during the entire specified curing period.

Hay and straw absorb moisture readily and retain it well. The minimum depth of a layer should be at least 6 in. Whatever wet method of curing is used, the entire pavement from edge to edge must be KEPT wet during the entire curing period.

Much pavement curing is done by the mechanical application of membranes to the surface. The entire exposed surface of the concrete should be uniformly coated with a pigmented membrane curing compound. The curing compounds are either wax or resin base. The concrete should not be allowed to dry out before the application of membrane. If any drying has occurred, the surface of the concrete should be moistened with a spray of water.

The curing compound is applied to the finished surfaces by an approved automatic-spraying machine (fig. 7-53) as soon as the free water has disappeared. The spraying machine should be self-propelled and ride on the side forms or previously constructed pavement, straddling the newly paved lane. The machine should be equipped with a spraying nozzle or

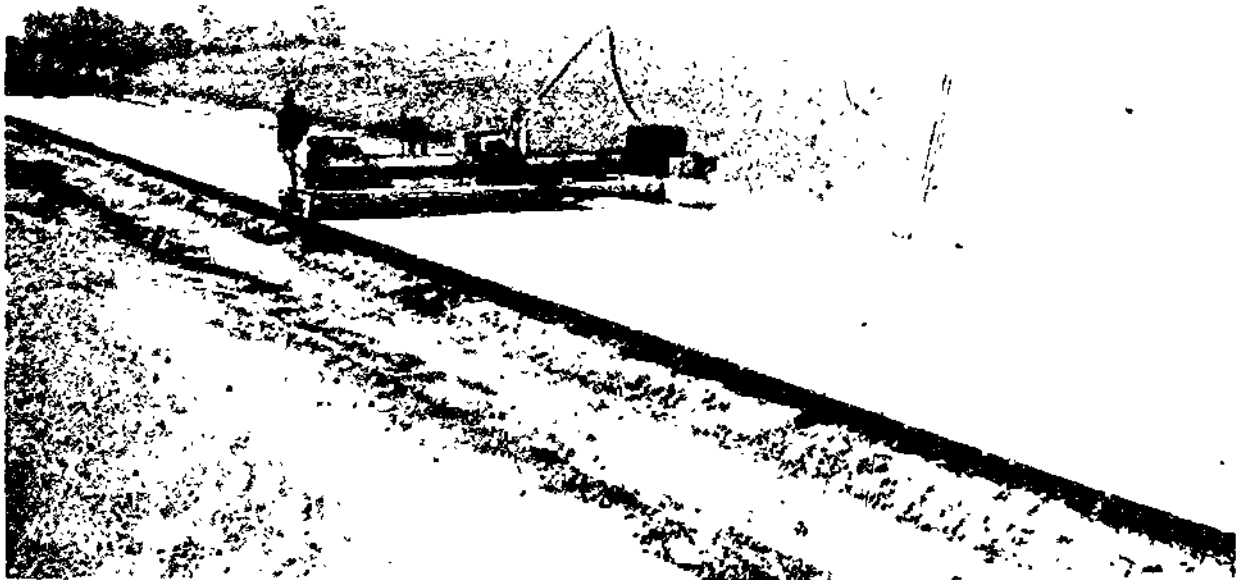

Figure 7-53.—Application of curing compound.

133.259

7-48

264

nozzles that can be controlled and operated to completely and uniformly cover the pavement surface with the required amount of curing compound. The curing compound in the storage drum used for the spraying operation should be thoroughly and continuously agitated mechanically throughout the full depth of the drum during the application. Air agitation may be used only to supplement mechanical agitation. Spraying pressure should be sufficient to produce a fine spray and cover the surface thoroughly and completely with a uniform film. Spray equipment must be maintained in first-class mechanical condition and the spray nozzle should be provided with an adequate wind guard. The curing compound should be applied with an overlapping coverage that will give a two-coat application at a coverage of not more than 200 sq ft per gal for both coats.

The application of curing compound by hand-operated pressure sprayers is satisfactory only on odd widths or shapes of slabs and on concrete surfaces exposed by the removal of forms, as authorized. When application is made by hand-operated sprayers, the second coat is applied in a direction approximately at right angles to the direction of the first coat. The compound should form a uniform, continuous, cohesive film that will not check, crack, or peel, and be free from pinholes and other imperfections. If discontinuities, pinholes, or abrasions exist, an additional coat should be applied to the affected areas within 30 minutes. Concrete surfaces that are subjected to heavy rainfall within 3 hours after the curing compound has been applied should be resprayed.

Necessary precautions should be taken to assure that the concrete is properly cured at the joints, but that no curing compound enters the joints that are to be sealed with joint-sealing compound. The top of the joint opening and the joint groove at exposed edges should be tightly sealed as soon as the joint-sawing operations have been completed. After application of the seal, the concrete in the region of the joint should be sprayed with curing compound. The method used for sealing the joint groove is also effective in preventing loss of moisture from the joint during the entire specified curing period.

Approved standby facilities for curing concrete pavement should be provided at a location readily accessible to the site of the

work. These would be for use in the event of mechanical failure of the spraying equipment or any other conditions that might prevent correct application of the membrane-curing compound at the proper time.

Concrete surfaces to which membrane curing compounds have been applied should be adequately protected for the duration of the entire curing period from pedestrian and vehicular traffic, except as required for joint-sawing operations and surface tests, and from any other possible damage to the continuity of the membrane. Any area covered with curing compound that is damaged by subsequent construction operations within the curing period must be resprayed.

REMOVAL OF FORMS

Forms should, whenever possible, be left in place for the entire curing period (about 7 days). Forms which are to be reused, however, must be stripped for reuse as soon as possible. In any event, forms must not be stripped until the concrete has hardened enough to hold its own weight and any other weight it may be carrying. The surface must be hard enough to remain unimpaired and unmarked when reasonable care is used in stripping the forms.

Under ordinary circumstances, forms for various types of construction may be removed after intervals as follows:

Haunch boards (side forms) on	
girders/beams	1 day
Soffits on girders and beams	7 days
Floor slab forms	10 days
Wall forms	1 day
Column forms	3 days

After removing the forms, the concrete should be inspected for surface defects. These defects may be rock pockets, inferior quality, ridges at form joints, bulges, bolt holes and form-stripping damage. Experience has proven that no steps can be omitted or carelessly performed without harming the serviceability of the work. If not properly performed, the repaired area will later become loose, will crack at the edges and will not be watertight.

Sometime repairs may not be necessary, but if they are necessary, they should be done immediately after stripping the forms (within 24 hours).

Various defects can be repaired in various ways; therefore, we will discuss repairing several defects that you may encounter when inspecting new concrete.

RIDGES and BULGES may be repaired by careful chipping followed by rubbing with a grinding stone.

Defective areas such as **HONEYCOMB** must be chipped out of solid concrete, the edges cut as straight as possible at right angles to the surface or slightly undercut to provide a key at the edge of the patch. If a shallow layer of mortar is placed on top of the honeycomb concrete, moisture will form in the voids and subsequent weathering will cause the mortar to spall off. Shallow patches may be filled with mortar placed in layers not more than 1/2 in. thick. Each layer is given a scratch finish to match the surrounding concrete by floating, rubbing or tooling or on formed surfaces by pressing the form material against the patch while the mortar is still in place.

Large or deep patches may be filled with concrete held in place by forms. These patches should be reinforced and doweled to the hardened concrete (fig. 7-54). Patches usually appear darker than the surrounding concrete. Some white cement should be used in the mortar or concrete used for patching if appearance is important. A trial mix should be tried to determine the proportion of white and gray cements to use. Before mortar or concrete is placed in patches, the surrounding concrete should be kept wet for several hours. A grout of cement and water mixed to the consistency of paint should then be brushed into the surfaces to which the new material is to be bonded. Curing should be started as soon as possible to avoid early drying. Damp burlap, tarpaulins and membrane-curing compounds are useful for this purpose.

BOLT HOLES should be filled with grout carefully packed into place in small amounts. The grout should be mixed as dry as possible, with just enough water so that it will be tightly

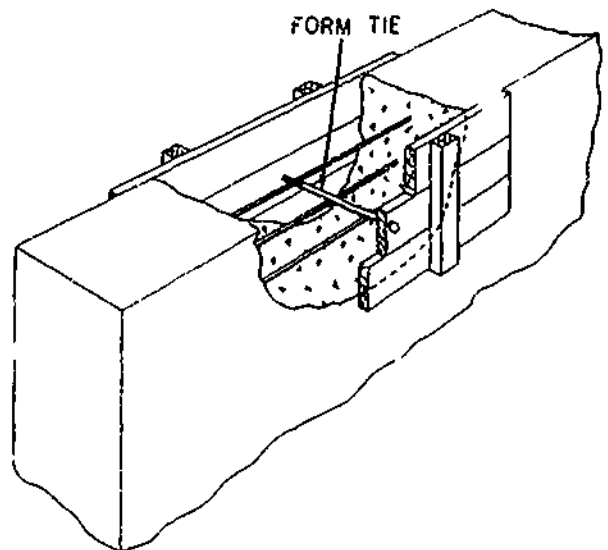

133.26f

Figure 7-54.—Repair of large volumes of concrete.

compacted when forced into place. Tie-rod holes extending through the concrete can be filled with grout with a pressure gun similar to an automatic grease gun.

ROCK POCKETS or honeycomb and other defective concrete should be completely chipped out. The chipped-out hole should have sharp edges and should be so shaped that the grout patch will be keyed in place. This is shown in figure 7-55. The surface of all holes that are to

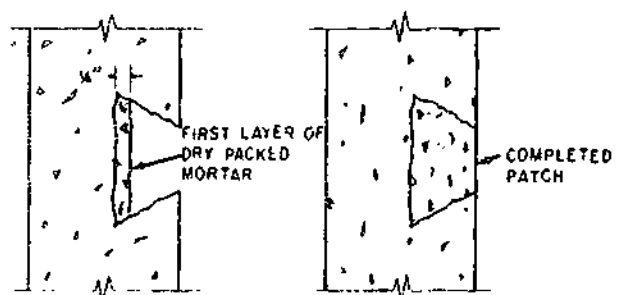

133.261

Figure 7-55.—Repairing concrete with dry-packed mortar.

be patched should be kept moist for several hours before applying the grout. Grout should be placed in these holes in layers not over 1/4 in. thick and should be well compacted. The grout should be allowed to set as long as possible before being used, to reduce the amount of shrinkage and make a better patch. Each layer should be scratched rough to improve the bond with the succeeding layer, and the last layer smoothed to match the adjacent surface. Where absorptive form lining has been used, the patch can be made to match the rest of the surface by pressing a piece of the form lining against the fresh patch.

Feathered edges around a patch will break down. (See view A, fig. 7-56.) The chipped area should be at least 1 in. deep with the edges at right angles to the surface. (See view B, fig. 7-56.) The correct method of screeding a patch is shown in view C, fig. 7-56. The new concrete should project slightly beyond the surface of the old concrete. It should be allowed to stiffen and then troweled and finished to match the adjoining surfaces.

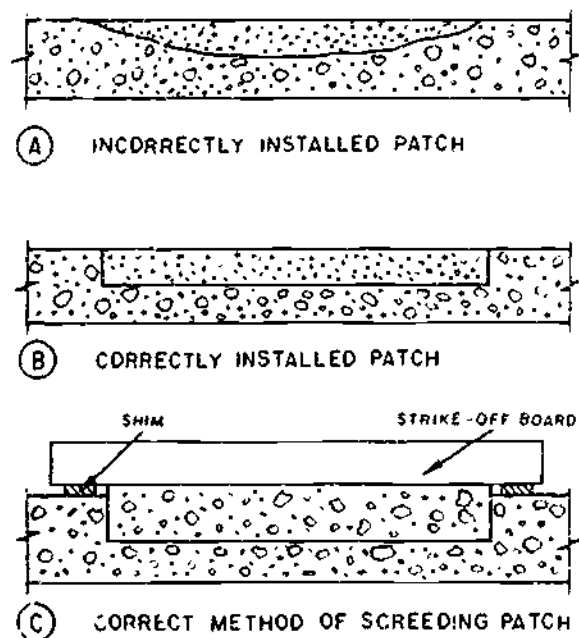

133.262

Figure 7-56.—Patching concrete.

Only crewmembers actually engaged in stripping the forms should be permitted in the immediate work area.

Stripped forms should be piled immediately to avoid congestion, exposed nails, and other hazards.

Wires under tension should be cut with caution to avoid backlash.

CONCRETE SAW

The concrete saw is used to cut longitudinal and transverse joints in finished concrete pavements. Several types of blades are available, the most common of which have either diamond or carborundum cutting surfaces. The diamond blade is used for hard cutting and the carborundum blade for cuts after aggregate has been displaced by vibration. The unit is small and can be operated by one person. (See fig. 7-57.) Once the cut has been started, the machine will provide its own tractive power. A water spray is used to flush the saw cuttings from the cutting area and to cool the cutting blade.

Considering that concrete saws cost almost as much as a new car, it is surprising how little attention is often given to proper breaking-in, maintenance and storage.

You would not take a new car and run it at 90 mph, but many operators will run a new engine at top speed and maximum load from the very beginning.

The following suggestions apply to all makes of concrete saws, and if followed carefully, will prolong their useful life many times.

A new engine should be operated at low speeds (1000-1200 rpm) for an hour without any load. The speed should then be increased gradually over a period of 2 hr until it is up to governed speed. Only after this break-in period should the engine be subjected to any load. If the saw has a water pump (for cooling the saw blade), it should be disconnected during this period.

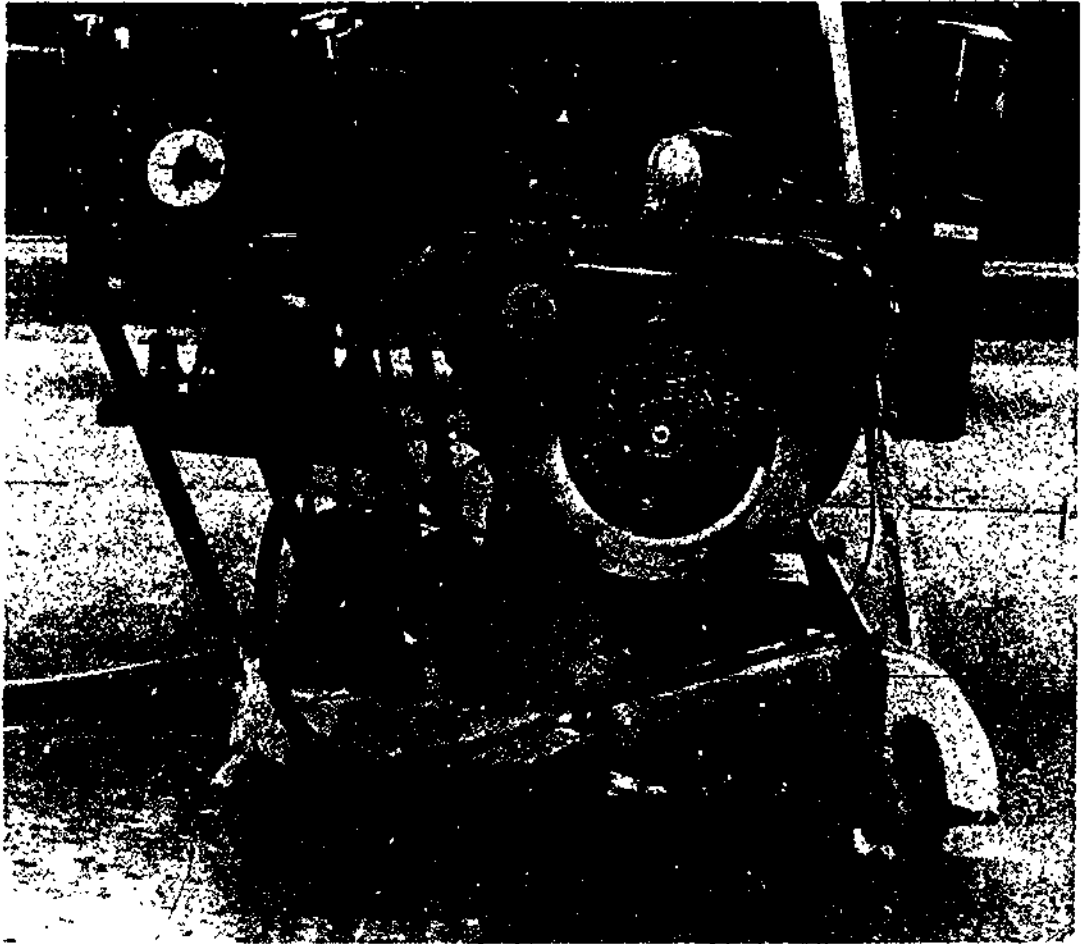

Figure 7-57.—Concrete saw.

133.18

Always operate the engine at proper governed top speed. Blade life can be seriously reduced if the engine is running too slowly. For the same reason, do not use 12-in. diameter blades on 18-in. blade capacity saws, which have a slower blade shaft speed.

Concrete sawing creates a sludge which is deposited on the engine cooling fan and in the air passages. This can cause serious overheating unless removed regularly. Air cleaners must be inspected daily. Crank case oil should be checked daily and changed every 50 hours. Use only regular gasoline.

Many saws have hydraulic pumps for raising and lowering of the blade and variable speed transmissions for self-propulsion. It is most important to use correct oils as specified in these systems. Under no circumstances should brake fluid be added. The transmissions can be damaged seriously if the proper fluid level is not maintained. Always refer to the manufacturers' manual for information on maintenance and repairs of the machine.

Most concrete saws have a slight tendency to lead off from a straight line when sawing, since the blade is located to the right and outside of the four wheels. Therefore, they require a

minimum amount of "steering" to keep them cutting in a straight line. However, most saws have an adjustment built in to compensate for leadoff. When steering becomes too hard, consult the manufacturer's handbook for corrective action.

Two types of blades are used for the cutting of concrete: diamond blades, and abrasive blades.

Diamond blades have segments, made from a sintered mixture of industrial diamonds and metal powders, which are brazed to a steel disc. They are generally used for old concrete, asphalt, and green concrete containing the harder aggregates, and must always be used wet. Many grades of diamond blades are available to suit the conditions of the job.

Twelve-inch diameter is the most popular size of diamond blades. It allows a depth of cut of about 3 1/4 in. Larger size blades are used for deeper cuts.

Low-cost, abrasive blades are now widely used to cut green concrete with some of the softer aggregates, such as limestone, dolomite, coral, or slag. These blades are made from a mixture of silicon carbide grains and a resin bond, which is pressed and baked. In many cases, even some of the medium-hard aggregates can be cut if the step cutting method is employed—two or more saws cut the same joint, but each one cuts only a part of the total depth. This principle is also used on the longitudinal saw which has two individually adjustable cutting heads. When a total depth of 2 1/2 in. is cut, the leading blade cuts about an inch deep and the trailing blade, which is slightly narrower, cuts to the remaining depth.

Abrasive blades are made in 14-in and 18-in diameters and in various thicknesses to cut joints from 1/4 in to 1/2 in. wide.

When is the best time to saw green concrete? In the case of abrasive blades, there is only one answer—as soon as the concrete will support the equipment and the joint can be cut with a minimum of raveling. In the case of diamond blades, two factors must be considered. In the

interest of long blade life, sawing should be delayed, but control of random cracking makes it necessary to saw at the transverse joints as early as possible. Where transverse joints are spaced closely, every second or third joint can be cut initially and the rest later. Sawing of longitudinal joints can be delayed as much as 7 days or longer.

PRECAST CONCRETE

Concrete which is cast in the position which it is to occupy in the finished structure is called **CAST-IN-PLACE** concrete. Concrete which is cast and cured elsewhere, and erected as a prefabricated unit, is called **PRECAST** concrete.

Wall construction, for example, is frequently done with precast wall **PANELS** originally cast horizontally (sometimes one above the other) as slabs. This method has many advantages over the conventional method of casting in place in vertical wall forms. Since a slab form requires only edge forms and a single surface form, the amount of form work and form materials required is greatly reduced. The labor involved in slab form concrete casting is much less than that involved in filling a high wall form. One side of a precast unit cast as a slab may be finished by hand to any desired quality of finish. The placement of reinforcing steel is much easier in slab forms, and it is easier to attain thorough filling and thorough vibrating. Precasting of wall panels as slabs may be expedited by mass production methods not available when casting in place.

Relatively light panels for concrete walls are precast as slabs (fig. 7-58), and attached to erected concrete frames (fig. 7-59). The panels are set in place by cranes, using spreader bars, hairpin lifting, or a vacuum lift (fig. 7-60).

Weight considerations also add up to an advantage for prestressed concrete construction. The high precision of placement and high tensile strength of steels normally used in prestressing, along with the use of concrete under compressive stress to carry the tensile loads, make for maximum efficiency in size and weight of structural members, thus providing space economy and transportation economy in the building of modern structures.



Figure 7-58.—Precast wall panels in stacks of three each.

133.499

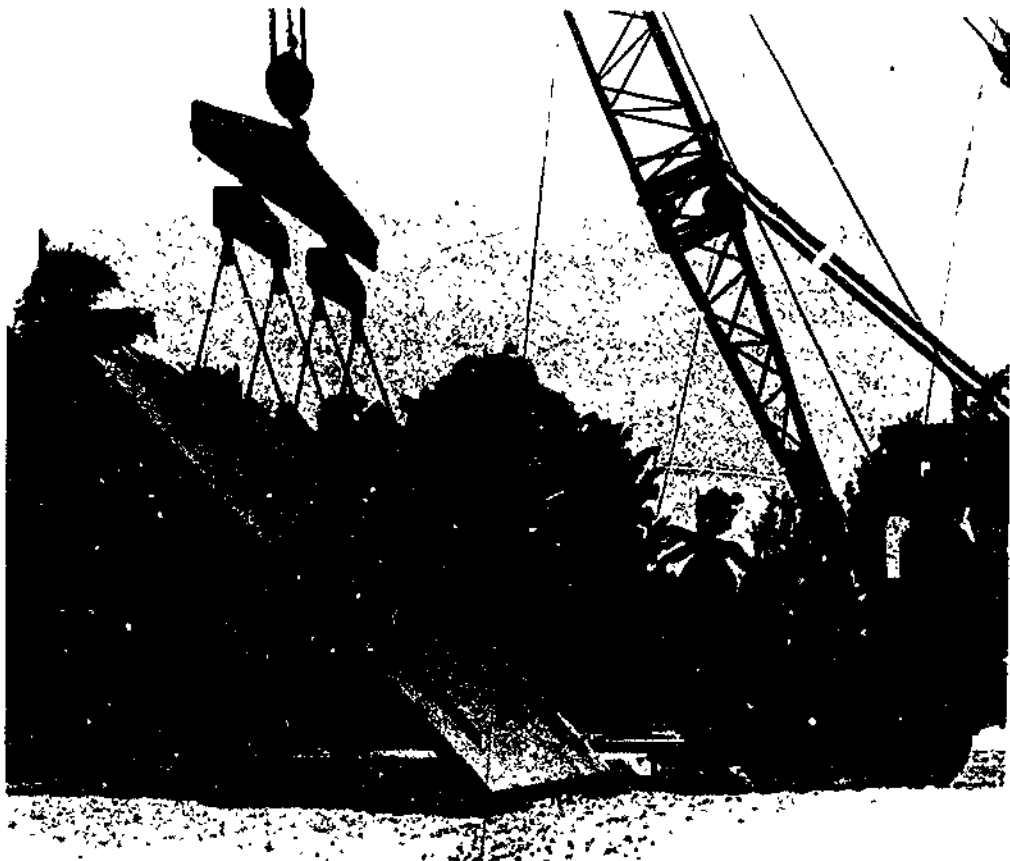

Figure 7-59.—Precast panels being erected by use of crane and spreader bars.

133.500

7-54

270

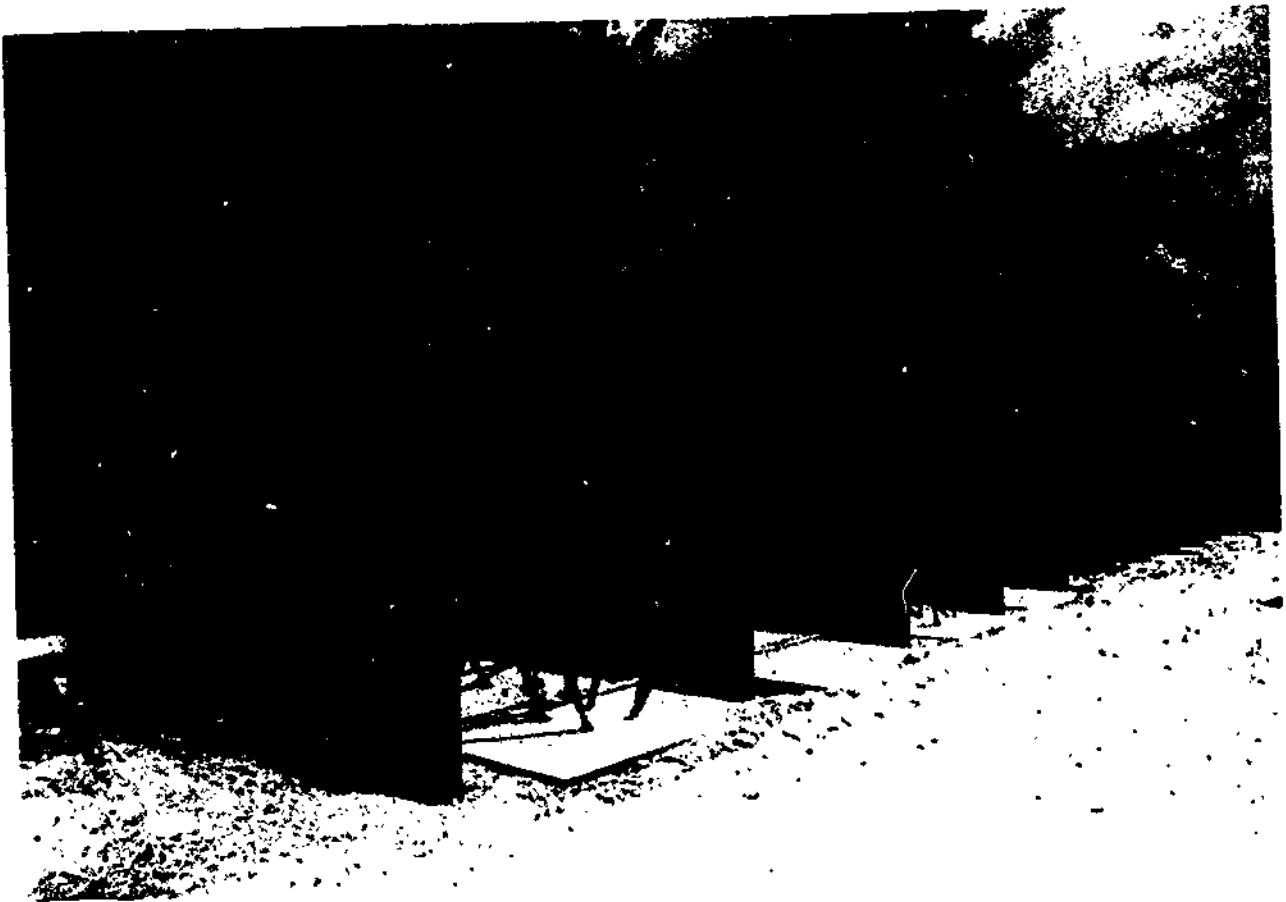

Figure 7-60.—Precast panels in position.

133.501

Applications of the various prestressed features enable quick assembly of standard units, such as repetitive bridge designs, building frames, and roof and bridge decks to provide important construction time economies. It is possible that the structure can even be largely fabricated elsewhere while the site is being prepared.

PRECAST CONCRETE FLOOR AND ROOF SLABS, WALLS, AND PARTITIONS

The commonly used precast slabs or panels for FLOOR and ROOF DECKS are the channel, double-T, and tongue-and-groove types. (See fig. 7-61.)

The channel slab varies in size with a depth ranging from 9 to 12 in., width from 2 to

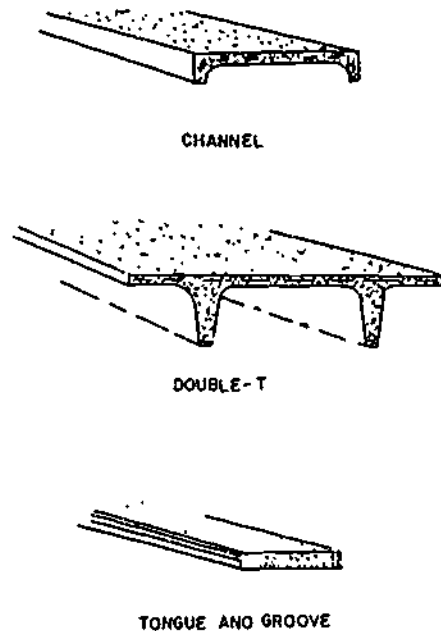

Figure 7-61.—Typical precast panels.

133.263

7-55

5 ft. and thickness from 1 to 2 in. It has been used in spans up to 50 ft. If desired or needed, the legs of the channels may extend across the ends, and if used in combination with the top slab it may be stiffened with occasional cross ribs. Wire mesh may be used in the top slab for reinforcement. The longitudinal grooves located along the top of the channel legs may be grouted to form keys between adjacent slabs.

The double-T slab varies in size from 4 to 6 ft in width and 9 to 16 ft in depth. It has been used in spans as long as 50 ft also. When the top slab size ranges from 1 1/2 to 2 in. in thickness, it should be reinforced with wire mesh.

The tongue-and-groove panels could vary extensively in size according to the design requirement. They are placed in position much like tongue-and-groove lumber is placed. That is, the tongue of one panel is placed against the groove of an adjacent panel. They are often used as decking panels in large pier construction.

Welding matching plates are ordinarily used to connect the supporting members to the floor and roof slabs.

Panels precast in a horizontal position, in a casting yard or on the floor of the building, are ordinarily used in the makeup of bearing and nonbearing WALLS and PARTITIONS. These panels are placed in their vertical position by cranes or by the tiltup procedure.

Usually, these panels are solid reinforced slabs 5 to 8 in. in thickness. The length varies according to the distances between columns or other supporting members. When windows and door openings are cast in the slabs, extra reinforcements should be installed around the openings.

A concrete floor slab with a smooth regular surface can be used as a casting surface. In casting on smooth surface, the casting surface should be covered with some form of liquid or sheet material to prevent bonding between the surface and the wall panel. The upper surface of the panel may be finished as regular concrete is finished by troweling, floating, or brooming.

SANDWICH PANELS are panels that consist of two thin, dense, reinforced concrete face slabs separated by a core of insulating material, such as lightweight concrete, cellular glass, plastic foam, or some other rigid insulating material, and these panels are sometimes used for exterior walls to provide additional heat insulation. The thickness of the sandwich panel varies from 5 to 8 in. and the face slabs are tied together with wire, small rods, or in some other manner. Welded or bolted matching plates are also used to connect the wall panels to the building frame, top and bottom. Calking on the outside and grouting on the inside should be used to make the points between the wall panels watertight.

PRECAST CONCRETE JOISTS, BEAMS, GIRDERS, AND COLUMNS

Small closely spaced beams used in floor construction are usually called **JOISTS**; however, these same beams whenever used in roof construction are called **PURLINS**. The cross sections of these beams are shaped like a T or an I. The ones with the inverted T-sections are usually used in composite construction where they support cast-in-place floor or roof slabs.

BEAMS and **GIRDERS** are terms usually applied to the same members, but the one with the longer span should be referred to as the girder. Beams and girders may be conventional precast design or prestressed. Most of the beams will be I-shaped unless the ends are rectangular. The T-shaped ones can also be used.

Precast concrete **COLUMNS** may be solid or hollow. If the hollow type is desired, heavy cardboard tubing should be used to form the core. A looped rod is cast in the column footing and projects upward into the hollow core to help hold the column upright. An opening should be left in the side of the column so that the column core can be filled with grout, this way the looped rod becomes embedded to form an anchor. (The opening is dry-packed.)

ADVANTAGES

Precast concrete has the greatest advantage when there are identical members to be cast,

because the same forms can be used several times. In addition to using the same forms precast concrete has other advantages, such as:

- 1 Control on the quality of concrete.
- 2 Smoother surfaces, and plastering is not necessary.
- 3 Less storage space is needed
- 4 Concrete member can be cast under all weather conditions
- 5 Better protection for curing
- 6 Weather conditions do not affect erection.
- 7 Faster erection time

HANDLING

Precast concrete should not be lifted or otherwise subjected to strain until the concrete has attained the specified strength or until after the specified curing period. Except as otherwise specified, casting forms should not be removed earlier than 24 hours after placing the concrete. Precast concrete moved prior to completion of the curing period, or before the concrete has attained specified strength, should be handled according to an approved procedure, with equipment of an approved type. Care should be taken to insure that the precast member is not overstressed or otherwise damaged during the specified curing period. Precast members, including piles, should not be skidded, rolled, driven, or subjected to full design load until they have attained their 28-day strengths, as indicated by cylinders made from the same concrete, at the same time as the precast concrete, and cured in the same manner. Handling of cured precast members should be either as specified or indicated, or as approved.

STEAM CURING

Use of steam curing is particularly advantageous under certain conditions, chiefly because of the higher curing temperature and the fact that moisture conditions are favorable. This type of curing is permitted by NAVFAC in the manufacture of precast units. Its benefits are also realized in connection with the use of live steam for cold-weather protection of concrete. Steam-cured precast units attain strength so

rapidly that the forms can be removed and reused very soon after concrete placing.

The necessary duration of steam curing depends on the concrete mix, the temperature, and the desired results.

PNEUMATIC-APPLIED CONCRETE

Concrete or cement mortar can often be applied by a pneumatic procedure. In this procedure, called GUNITING, a dry or damp mixture of cement and sand is placed in a charging chamber and mechanically fed into an airstream. This mixture is suspended in the airstream and passes through a hose to the nozzle, where water is injected through numerous small holes. Mixing occurs in the nozzle, and the proper amount of water added is under control of the nozzleman.

The mixture hydrates as it is being shot onto the surface, thus, eliminating the weakening excess of water that is needed to make hand-placed or poured concrete, or mortar. Should a continuous operation be required, dual-chambered guns can be used—one chamber discharging, while the other is refilling.

The nozzle can be operated close to the machine, or at distances up to 2,000 ft horizontally and 500 ft vertically from the machine without affecting its performance.

Material can be applied in thicknesses from a fraction of an in. up to 10 or 12 in. The area to which it is applied may be a small crack or patch, or several thousand square yards of a concrete structure. Surfaces can be flat or irregular, in any dimension, and depending upon the application, there could be heavy steel reinforcement, thin-gage wire mesh, or no reinforcement at all. This type (GUNITED) of placed material is dense, nonporous, extremely strong, and adheres to almost any surface better than other concrete-cement mortar materials placed by other means.

CONCRETE PUMPING MACHINES

For any construction project that requires the rehandling and placement of concrete between a ready-mix truck and the form,

concrete pumping machines can place this concrete with a minimum of equipment without damaging or altering the mix design.

The SEABEES use various makes and models of concrete pumping machines. It is beyond the scope of this manual to present information on all designs of concrete pumps. Therefore, the Challenge Squeeze-Crete 250 series trailer-mounted concrete pump has been selected for discussion in this section. Information on the operation, maintenance, and safety precautions of this pump are presented

Figures 7-62 and 7-63 show the trailer-mounted gasoline-powered concrete pump. The basic unit consists of a 4-cylinder air-cooled gasoline engine, a closed-loop hydraulic system, a centralized control panel, a pump chamber, and a receiving hopper.

The Squeeze-Crete trailer is a two-wheel unit having a front pedestal support, two rear pedestal supports for leveling and maintaining the pump in its operating position, safety tow chains, and a trailer handbrake.

PREPARATION FOR USE

When getting the trailer-mounted concrete pump ready for use, thoroughly inspect the complete unit for any loose connections, particularly the fuel and electrical systems. Tighten loose connections, parts, bolts, nuts, and other hardware. Also inspect for evidence of damage to meter and inspection glasses, lights, and other breakable parts. Check to see that the trailer tires are properly inflated. Operate the movable control devices by hand to make sure they operate freely.

Be sure to fill the engine lubricating system with the proper grade of oil and also the hydraulic system to the level recommended. Fill the fuel tank with suitable fuel.

There are several factors to be considered in positioning the trailer. Make provisions to have adequate water on the job site, and determine whether the concrete will be supplied by truck mixer, portable batch plant, or another method. Locate the machine the shortest distance possible from the point of placement of the concrete to provide quick and efficient handling of the discharge hose, and to provide adequate operating room and ventilation for dissipation of

the engine's heat and exhaust. Position the trailer on level ground, but if the ground is soft, use planking under the supports to increase stability. Set the trailer parking brakes, block the wheels, and set the pedestal supports on a firm footing to allow the front support to raise the front-end of the trailer frame and partially lift the pump off the trailer springs to increase stability.

Will rigging be required? Estimate the time required to make the necessary rigging. Each job will present specific problems of line arrangement. On vertical rises, always use pipe sections with the necessary rigging to support the pipe. Each pipe section must be individually secured to the vertical scaffolding.

Since rubber hose develops more friction on the concrete, it should be held to a minimum, and where possible, rigid pipeline or slickline should be used. The initial line connection to the outlet or pressure side of the machine may be made with a combination of metal tube bends or with one section of rubber hose. However, metal pipe sections should begin as close to the machine as possible and continue to the placement site.

When there is a vertical drop in the placement line which may be necessary for placement below ground level, the tube bend at the top of the drop must be vented by drilling a small hole in the outer radius of the bend (approximately 1/8 in.). This is necessary to prevent separation of the mix in the line when the pumping is interrupted. The hole may occasionally become plugged. It can be unplugged with a piece of wire.

It is important in laying out the line (and also in moving it) to keep the hose sections free of sharp bends to avoid plugging or excess pressure. Try to maintain a minimum 6-ft radius bend in laying out the rubber hose sections. If plugging occurs in the placement line, reduce line pressure by reversing and then stopping the pump. Locate where the plug has developed and then strike the hose with a sledge. The sudden jar usually helps to expel the plug. When line pressure is increased, the plug will be driven through. This can only be done on rubber hose sections.

Steel pipe and rubber hose sections are furnished with grooved fittings. The line sections

Chapter 7—CONCRETE

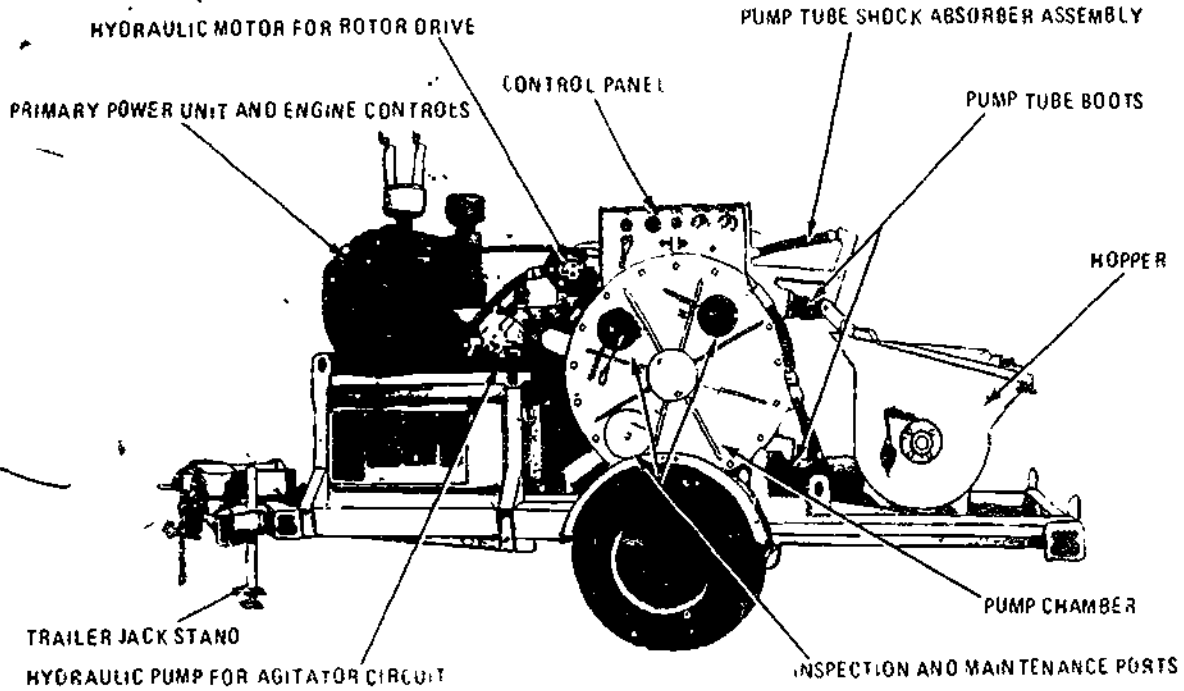

Figure 7-62.—Trailer-mounted Squeeze-Crete concrete pump, left side view.

133.502

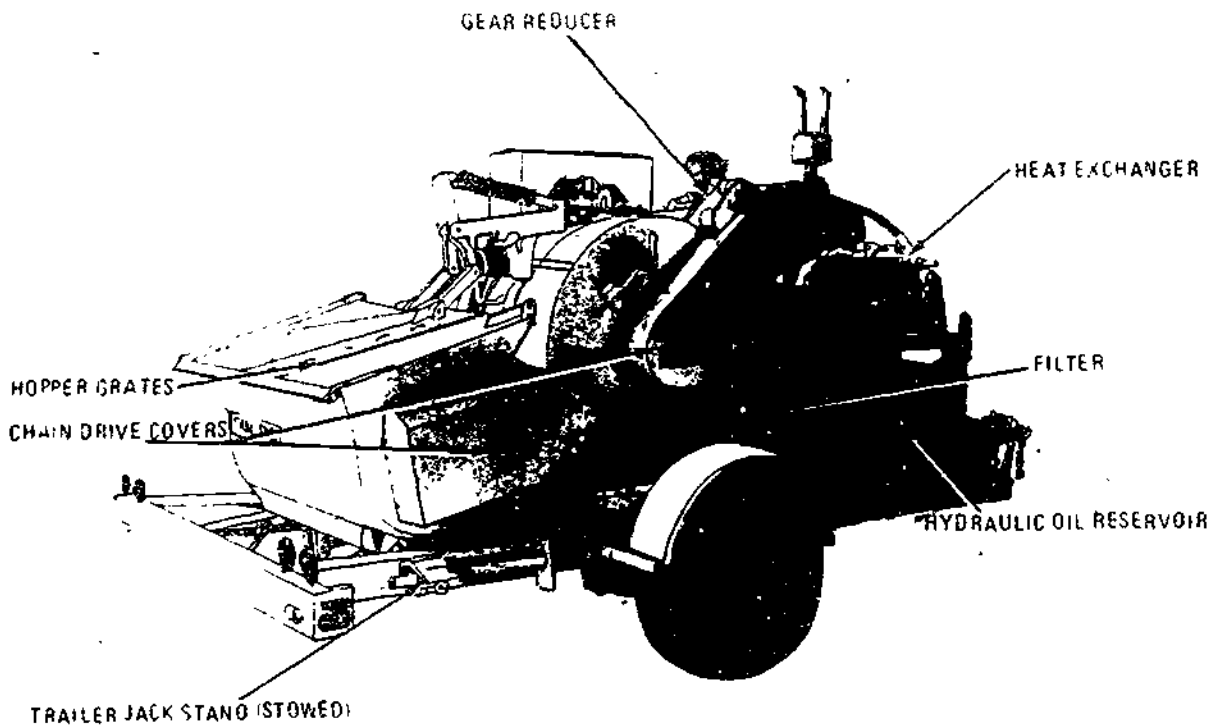
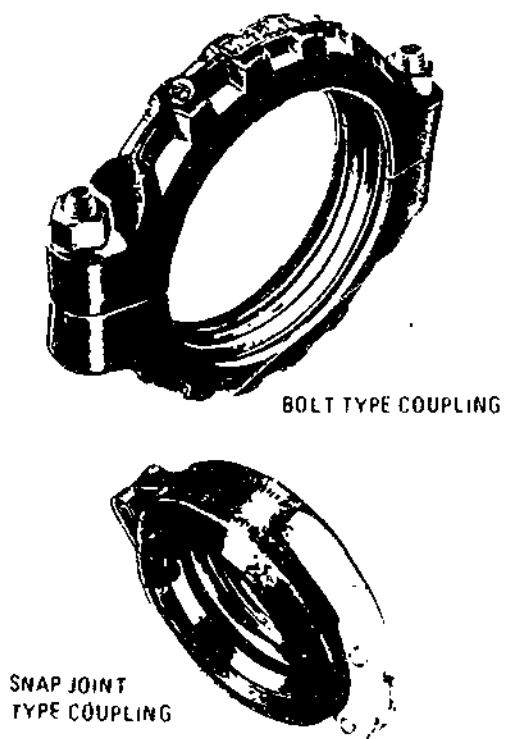

Figure 7-63.—Trailer-mounted Squeeze-Crete concrete pump, right side view.

133.503



133.504

Figure 7-64.—Concrete line sections couplings.

are fastened with couplings. On vertical pipe, use the two-bolt type coupling (fig. 7-64). On horizontal pipe use the snap-joint-type coupling (fig. 7-64).

To complete the setup during your preparation for use, attach the transfer hose to the pump outlet assembly with a coupling. Attach the other end of the transfer hose to the slickline.

CAUTION: Do not connect a rigid pipeline or slickline directly to the outlet assembly. A flexible transfer hose must be used to absorb the longitudinal movement of the outlet assembly or the pulsations of the pump tube may cause mechanical failure.

Tighten the clamps on all slicklines. The couplings between the pump tube and inlet and outlet assemblies and the transfer hose and

slicklines must be fully mated and securely fastened to prevent accidental escape of concrete under maximum pressure (of 200 to 250 lb per sq in.). The accidental uncoupling of the material pressure line may result in the whipping or uncontrollable thrashing of a hose line like a fire hose out of control. It may strike and injure personnel. A deluge of concrete may pour through the opening with dangerous consequences. When pumping vertically, you may empty the entire contents of the vertical pipeline through the opening, accidentally created. You must always be aware of the consequences of pressure within the delivery line, whether from pump pressure or from the potential energy of gravity flow, so be sure that the pipeline connections and pipeline hoses are secure and that the pipeline is never inadvertently disconnected under pressure.

Verify that the supply of hydraulic oil in the tank is adequate so the pumps will get oil when the engine is started.

CAUTION Both the primary and secondary pump require an adequate supply of hydraulic oil for lubrication purposes. Never run the engine unless there is an adequate supply of hydraulic oil in the tank and the pumps are supplied with a full flow of hydraulic oil.

If, at the end of the first minute of operation, the charge pump fails to develop pressure, shut down the engine and investigate. Without lubrication, the pump may be ruined.

Lubricate the agitator shaft bearings in the receiver hopper by applying a grease gun to the zerk fittings and fill the shaft seal constant-pressure lubricators as well.

Verify that the plugs in the cleanout holes in the bottom of the receiving hopper are securely in place. Also verify that the expansion plugs in the bottom of the pump chamber are in place.

PRINCIPLE OF OPERATION

"Like squeezing toothpaste out of a tube" is the usual description of the principle on which the Challenge Squeez-Crete 250 series concrete pump operates. Figure 7-65 shows a collector hopper into which the concrete is received and then remixed by the rotating agitator blades

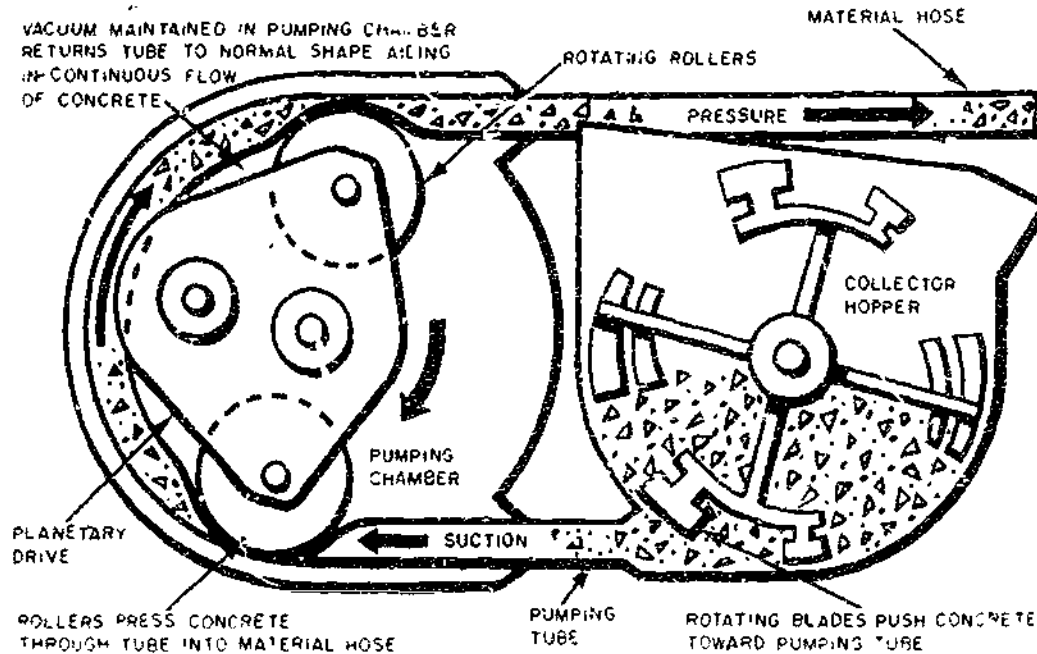

133.505

Figure 7-65.—Receiver hopper pumping action.

which also act to move the concrete into the pumping tube. The pumping tube is made of steel reinforced rubber and has an inside diameter of 3 in. It is looped inside drum-shaped pumping chamber from which the air has been evacuated. A rotor assembly with two large rollers revolves continuously within the chamber so the rollers alternately squeeze the pump tube against the inner surface of the drum and thus force the trapped concrete to move within the tube ahead of the advancing roller.

Reloading of the tube with concrete is accomplished as follows: as the roller passes by, the flattened and collapsed pump tube is drawn back into its normal, tubular shape by a vacuum within the pumping chamber. Atmospheric pressure on the concrete in the hopper combined with the action of the moving agitator blades, forces a charge of concrete into the pumping tube. Then the next pass of a roller flattens the tube again and squeezes this load of concrete out of the pump tube and discharges it through the material hose and slickline.

The pump assembly consists of three main components:

1. The pumping chamber case is lined with rubber compression pads. The pads are channel shaped sections which line the entire inner circumference of the pump case where the pump tube lies. The pump tube lies in the channel and the raised rails on each side of the pads provide traction for the rotor rollers, as well as help to hold the pump tube in place.

2. The rotor-roller assembly uses a planetary drive principle applied through chains and sprockets from the main rotor axle to drive the rollers which press against the pump tube. The rollers are padded with rubber, also.

3. The pump tube is a steel reinforced rubber hose approximately 9 ft long. As the rotor revolves, the pump tube is held in place sideways by the rails of the compression pad and also by eight tube guides carried by the rotor. The pump tube moves longitudinally a few in. with each passage of a roller. This motion is absorbed and dampened by a spring and shock

BUILDER 3 & 2

absorber assembly to which the pump tube end is fitted. The pump tube enters and exits the cylindrical drum through rubber boots which are capable of sealing a vacuum in the chamber.

OPERATION OF TRAILER-MOUNTED CONCRETE PUMPS

This section provides information on indicators and controls found on trailer-mounted concrete pumps, and procedures for starting, operating, and securing the pump. Some differences can obviously be expected in the operation of various makes and models of concrete pumps, so bear in mind that we are mainly concerned here with the Challenge Squeeze-Crete 250 series trailer-mounted concrete pump. For detailed instructions on concrete pump operations, consult the operator's manual supplied by the manufacturer of the concrete pump concerned.

NOTE Before starting or operating the concrete pump, be sure you and your crewmembers wear hard hats, safety shoes, and goggles.

Starting the Concrete Pump Primary Power Source

First, perform the routine prestart checks of the engine crankcase oil level, transmission oil level, fuel supply, battery water level, and hydraulic oil level. Be sure that the proper amount of lubricant, electrolyte, and hydraulic oil is added, when required. Next, place all controls in the NEUTRAL positions. Then turn on the ignition switch and check the engine gauges for proper operation. Start the engine and let it warm up at fast idle. Observe the control panel gauges for excess pressure readings. Momentarily, move the main pump control into the FORWARD position and note the pressure indicated on the gage marked "pump hydraulic pressure." The pressure should rise to 190 psi or more and the rotor should begin to move. If so, then you can place the control back in its NEUTRAL position.

CAUTION If no pressure develops in the first minute of operation, indicating the charge

pump is not developing pressure, shut down the engine and investigate. Without lubrication, the charge pump may be ruined.

Allow the hydraulic oil to warm up to its temperature operating range of between 40° and 160°F. Check oil pressure and tachometer readings. Maintain a minimum engine speed of 1,000 rpm. Prior to pumping concrete, set the engine to deliver power at its rated maximum continuous 2,400 rpm operating speed.

Concrete Pump Indicators and Controls

For safe and efficient operation of the trailer-mounted concrete pump, you must be familiar with its different indicators and controls. Figure 7-66 shows the location of various indicators and controls on the Squeeze-Crete 250 series trailer-mounted concrete pump. If you are familiar with the indicators and controls on this type concrete pump, you should have little difficulty with indicators and controls on other types. The purposes or functions of specific indicators and controls shown in figure 7-66 are given below; the number in parentheses correspond to those used in the illustration to indicate the location of individual indicators and controls.

The VACUUM GAGE (1) indicates the vacuum or pressure in the suction line to the double pump. Under normal operating conditions, the reading should be between 25 and 27 in. If the vacuum does not develop, investigate for air leaks.

The TACHOMETER (2) indicates the speed of the gasoline engine. The maximum operating speed of the engine for pump operation is 2,400 rpm.

The OIL TEMPERATURE GAGE (3) indicates the temperature of the hydraulic oil from 120° to 140°F which is ideal for this hydraulic system.

The COLLECTOR HOPPER HYDRAULIC PRESSURE GAGE (4) registers the hydraulic pressure (approximately 100 psi) in the collector hopper hydraulic circuit.

The HYDRO-STAT SYSTEM HYDRAULIC PRESSURE GAGE (5) registers the hydraulic pressure (190 psi or more) in the closed-loop

7-62
213

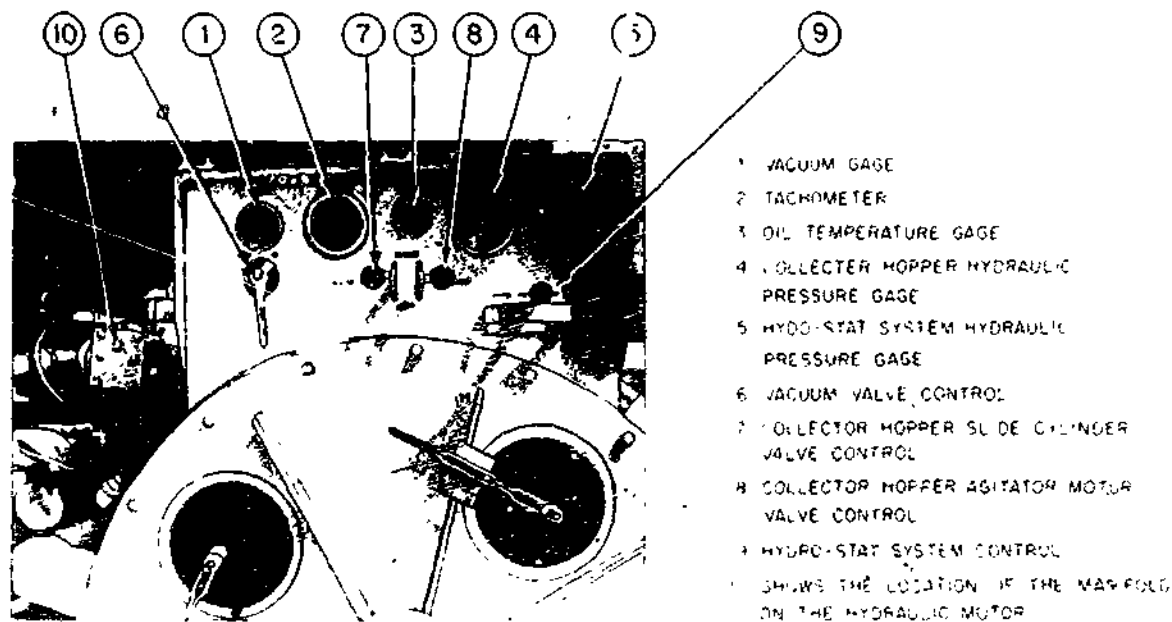

Figure 7-66.—Control and instrument panel.

133.608

circuit of the hydro-stat system that powers the concrete pump.

The VACUUM VALVE CONTROL (6) allows the air valve to vent the pumping chamber. When it is in the ON position, the vacuum pump acts to reduce the air pressure within the pumping chamber. In the OFF position, the valve is open to allow air to be drawn into the chamber and through the vacuum pump.

THE COLLECTOR HOPPER SLIDE CYLINDER VALVE CONTROL (7) is used intermittently to place the concrete receiver hopper in the desired location during placement. The hopper can be positioned forward and backward within a range of approximately 8 in by a hydraulic ram.

The COLLECTOR HOPPER AGITATOR MOTOR VALVE CONTROL (8) allows slurry mixing before placement operation begins and to remix, and agitate the concrete to be pumped. It has three detent positions which allows FULL flow or NO flow through the valve and diverts the flow to the reservoir when the valve control is placed in the OFF position.

The HYDRO-STAT SYSTEM CONTROL (9) allows the operator to control the primary hydraulic pump which is the source for controlling movement of the rotating roller whether FORWARD pumping action, REVERSE pumping action, or STOP. (See fig. 7-65.)

Starting and Adjusting the Concrete Pump

The following procedure is given for starting and adjusting the pump before running the concrete pump.

Place the vacuum control-valve control handle (6) to the ON position. Observe the vacuum pressure gage and wait until the vacuum reaches 25 to 27 psi. If the vacuum does not develop, investigate for air leaks. Make sure all access port covers are sealed. Check to see that the boots are sealed around the pump tube where the tube enters and exits the pump chamber. Check to see that the cleanout expansion plugs are in place.

Ready the slurry mix which lubricates the inside of the concrete pump and slickline system prior to pumping concrete for placement. The general rule to follow for this mix is 2 or 3 bags of cement for the first 100 to 150 ft of line and one additional bag of cement for each additional 100 ft of line. Attach the slurry paddle to the left agitator blade prior to mixing and remember to remove it after the mixing process.

Always place a greased cleanout sponge in the suction cone prior to adding water and mixing slurry. This helps prevent water, and unmixed cement from entering the pumping tube or plugging the suction cone. By operating the pump in reverse after the slurry is mixed, the sponge will be expelled from the suction cone. On downhill runs of slicklines, leave the sponge in the suction cone and pump it through the system ahead of the slurry. This will insure proper coating of all inside surfaces in the slickline system.

Place 15 to 20 gallons of water in the hopper. Add cement slowly while the agitator blades are turning. **DO NOT DUMP THE CEMENT IN ALL AT ONCE**, as it will form lumps and defeat the purpose of the slurry. The slurry should be the consistency of thick cream. Continue adding cement and water until a sufficient amount of slurry has been made to coat the inside surfaces of the concrete pump and all the slicklines. Continue the agitation and cycle the slurry several times at slow speed. This action feeds the slurry into the pump and discharge line. Only when most of the slurry has been pumped out of the hopper should the concrete be dumped into the hopper. However, introduce the concrete before pumping all of the slurry out of the hopper. The transition from slurry to concrete should be continuous. This is done by instructing the transit-mix operators to keep the hopper at least two-thirds full of concrete at all times. Now you are ready to commence pumping the concrete for placement.

Running the Concrete Pump

By moving the main hydraulic-pump-control lever (9) in the FORWARD direction, the concrete starts through the system. Be sure the gasoline engine is running at its rated (2,400 rpm) maximum continuous operating

speed. Before placing the agitator-control-valve lever (8) in the FORWARD position, make certain the hopper grates are in position. When these grates are NOT in position, it is possible for you or other persons near the hopper to become entangled with, or struck by, the moving blades of the agitator. NEVER reach into the hopper while the agitator is moving. Climbing, standing, or kneeling on the hopper grates while the agitator is in motion could result in personal injury. Be sure the mixer-truck-discharge chutes do NOT come in contact with the hopper during delivery. The agitator must NEVER be operated with the guard removed from the sprocket and chain drive. Make sure that the concrete being discharged through the system is on a continuous basis, if not, the machine will pump air which is being compressed and the concrete being propelled from the end of the line will segregate badly, and there is the danger of it splattering and causing possible injury to placement crewmembers.

After the slurry has been pumped out and the slurry paddles removed, place the agitator-valve-control lever (8) in the REVERSE position. Fill the hopper two-thirds full of concrete and allow the blades to rotate in REVERSE long enough to blend the balance of the slurry with the concrete. When this is accomplished, stop the rotation of the agitator blades and then place both agitator rotation and pump control in the FORWARD direction. This allows the pump to deliver the concrete to the placement site. Be sure to adjust the hydraulic pump control lever (9) to deliver the concrete at the desired rate.

Be sure you keep a ready supply of concrete in the hopper at all times while pumping. Never allow the supply level to go below the agitator blade shaft.

Pumping may be stopped at any time when it is necessary to relocate and/or shorten the discharge line. If the waiting period is lengthy, agitate the mix in the REVERSE direction. But do not over agitate as prolonged agitation affects the quality of the concrete mix.

NOTE. There may often be delays in mix deliveries. Plugging due to delays can be avoided by making sure that the collector hopper is full

of concrete. If the hopper is full, small quantities can be pumped through the line every 10 to 15 minutes. This will prevent the material from setting-up or plugging the line until the next load arrives. If the pump plugs on the hopper side, it will be evident from the collapsing of the discharge hose and the increased strain on the pump rotor. To eliminate such a plug, REVERSE the pump direction for one rotor cycle and immediately go back to the FORWARD position. This action may be repeated several times. When the line is unplugged, observe the concrete in the hopper and remove the object (with the agitator blades stopped). Also, if there are delays in concrete delivery and the weather is hot and sunny, the hopper should be covered with a tarp or some suitable material to prevent the sun from beating directly on the mix and drying it out.

When the power-source engine stalls during placement, the following should be followed for restarting the pumping cycle:

Place the speed control in the NEUTRAL POSITION and then place the agitator-control lever in the OFF position. Next, relieve the vacuum in the pump chamber (if necessary) to take the entire load off the engine. Now restart the engine and bring it up to its rated maximum continuous rpm speed. After the engine has started, turn the vacuum-control lever to the ON position until normal vacuum pressure is attained. Then place the agitator-control lever in the FORWARD position. Slowly advance the speed control from NEUTRAL to FORWARD position and then correlate the power required with the pumping resistance by advancing the hydraulic-pump speed-control level slowly to keep the engine from stalling again.

Concrete Pumping Procedures

Before beginning concrete pumping, you should establish with the placement operator a set of pumping signals for "STOP," "START," "SLOW DOWN," "SPEEDUP," etc.

Periodically during extended-pumping operations, check the hydraulic filter to verify the hydraulic fluid is clean. Also, lubricate the grease fitting on the hopper and keep the constant pressure lubricators filled with grease.

Keep an eye on the instrument and control panel, and observe the gages for proper pressures and temperatures. As you become more experienced in the operation of the pump, its sound during operation should alert you as to whether adjustments are needed to keep the systems functioning smoothly. Be sure that your acceleration and decelerations are made slowly and evenly to avoid possible strain on the power train.

In some loads of concrete, there may be some oversize rocks, mixer tailings, or foreign objects. The pump will normally handle these; however, should several large rocks enter the pump tube at the same time, the tube may plug. An obstruction of this type can be removed by reversing the pump and rotation direction of the hopper agitator blades until the hose at the discharge end begins to collapse. At this time the pump can be turned off, allowing only the agitator blades to operate in reverse. Continued operation of the agitator will either distribute the obstruction or cause it to work to the surface of the hopper where it can be removed. On occasion, if the plugging is severe, the pump and agitator may have to be operated in forward and reverse several times. However, continued operation of the rotor over a severely plugged tube may damage the tube or completely collapse the discharge hose away from the rubber boot at the discharge cone and break the vacuum in the pump chamber. In that case, the pump tube may have to be removed to clear the block. If the blockage is in the slickline, the slickline may have to be dismantled.

The ability to reverse the pump does not permit the entire discharge hose and slickline assembly to be pumped clean in the reverse direction. As noted, the reverse suction action of the pump rotor will collapse the first section of the discharge hose attached to the outlet side of the pump and thus stop the reverse flow of concrete beyond that point.

Location of the blockage can sometimes be determined by tapping the slickline with a hammer. Listen for a change of pitch in the sound. Blockages within a material hose can sometimes be broken loose by pounding on the hose at the location of the blockage while pumping.

BUILDER 3 & 2

WARNING. In the event of a blockage which requires the dismantling of the slickline or material hose, extreme care should be taken that the line does not whip or thrash like a broken fire hose and cause an accident. Beware of a

backflow of concrete upon opening of the pumping line at any of its joints.

To prolong the life of the pump tube (fig. 7-67), the position of the tube in the pump case

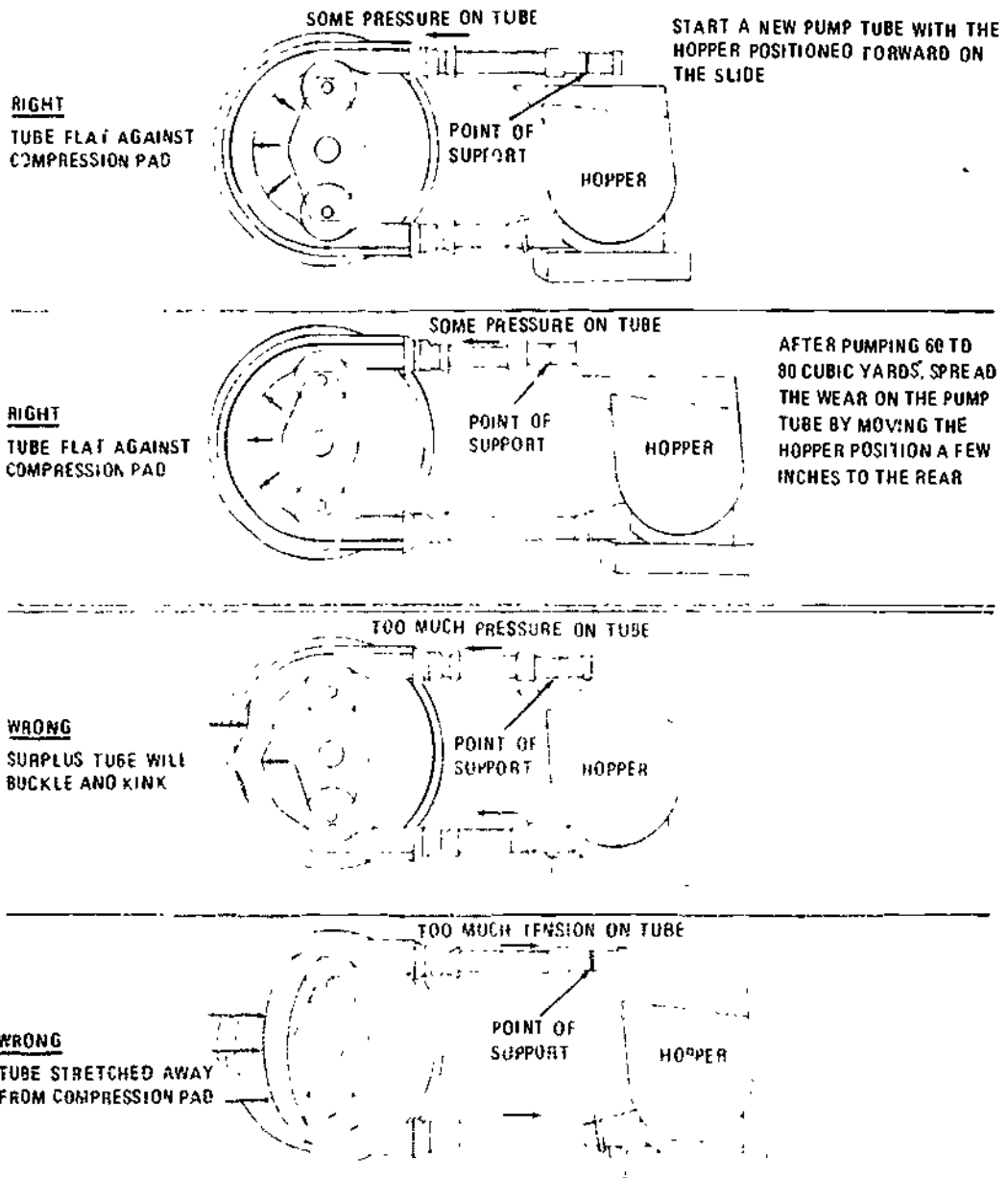

Figure 7-67.—Concrete pump tube adjustments.

133.507

7-66

282

should be changed after each batch of 60 to 80 cu yd of concrete has been pumped. To do this, turn the vacuum valve control (6) to its OFF position and then stop the agitator. Then, loosen and remove the outlet shock absorber assembly from its trunnion (pin or pivot) holder. Now, move the hopper on its slide base about 2 in. by simultaneously operating the collector-hopper cylinder-valve control (7) in the desired direction and slowly operate the pump rotor in the opposite direction. You can now reconnect the outlet shock absorber assembly in its trunnion, using the holes nearest the pins. You must reseal the boots where the boots touch the tube by applying silicone grease about a 1/2 in. long and about the diameter of a lead pencil to the area between the pump tube and the backing pad at the 12:00 o'clock position. Spread the lubricant with your finger tips and be careful not to spread it on the rollers or on the compression pad rails. The rollers are drive wheels and must have traction on the rails. Now, turn the vacuum valve control (6) to the ON position, check for vacuum, and resume agitating and pumping.

At the end of each work shift, the tube may be loosened from the inlet and outlet fixtures and rotated 60 to 90 degrees and reconnected or the tube may be removed and reinstalled in the different position.

CAUTION: Roller damage may occur if the pump tube is permitted to wear until the steel belt is exposed. Frequent inspection of the tube is advisable. Very light exposure of the steel belt will not damage the rollers. However, continued pumping until heavy exposure is evident will result in a rasping effect on the rollers. Broken steel strands will severely damage the rollers.

It is better NOT to store the concrete pump with the pump tube installed. A permanent bend can develop in the tube if it is left in the case. It is also advisable to move the rotor occasionally so that a permanent set does NOT develop in the rubber of the rollers and compression pads from continued pressure on one location.

Cleanup After Pumping

After pumping is completed, clean the hopper by removing the two cleanout plugs at

the bottom of the hopper. Wet a cleanout sponge and stuff it into the suction cone. The sponge should be placed in the suction cone before any water is used to wash out the hopper. After the remaining concrete is thoroughly washed off the shaft, agitator blades, and hopper, replace the cleanout plugs and fill the hopper full of clear water.

Stop the agitator blades and operate the pump until the water level in the collector hopper falls to the top of the suction cone. Then insert a second sponge in the suction cone, refill the hopper with water, and operate the pump to deliver the remaining concrete and water to the end of the placement line. The second sponge will hold a uniform column of water in the line and thus provide a more thorough cleaning action than can be obtained by using only one sponge.

If it is permissible to discharge the remaining concrete and water into the placement area, or if a suitable waste area is available adjacent to the placement area, the remaining concrete and water may be pumped through the line without interruption. After the second sponge emerges from the end of the line, the sponges should be rinsed clean and the cleanout procedure repeated to insure that the line is entirely free of concrete residue.

If the placement line is rigged on a vertical rise and it is impossible to discharge the remaining concrete and water near the pour site, the line may be disconnected at the bottom of the rise and the concrete allowed to drain back down the line before any water is run through. An alternate method is to pump the concrete through the line ahead of the sponge and water and remove it from the pour area by some suitable conveyance. The last bit of concrete in the line will be slightly diluted by a small amount of water which will bleed through the sponge. When this diluted material begins to emerge from the line, the pump should be stopped, the line disconnected near the pump, and the water and sponges allowed to drain back through the line. Once again the cleaning procedure with the water and sponges should be repeated to completely scrub the inside of the line.

During the cleaning process, it may be desirable to know the location of the first sponge in the line. This can be determined by

BUILDER 3 & 2

Reference	Lubrication Specification	Service	Period of Application
Seals Agitator Shaft	Union Unoba HD Grease	Two Zerk fittings. Apply pressure gun. Charge both constant pressure lubricators.	Fill twice each shift or re-charge as often as necessary.
Bearings Agitator Shaft	Union Unoba HD Grease	Two Zerk fittings. Apply pressure gun.	Once each shift.
Bearings Rotor Shaft	Union Unoba HD Grease	One Zerk fitting on pump case (external, RH side). One Zerk fitting in pump case, (internal, thru access port, LH side). Apply pressure gun.	Once each shift.
Bearings Wheel (roller) Shaft	Union Unoba HD Grease	One Zerk fitting on each end of each wheel (roller) shaft. Total of four. (Thru access ports both sides of pump case.) Apply pressure gun.	Once each shift.
Chain Roller Drive	Aerosol Spray Lubricant CCB Part No. 1590031	Spray on chain.	Once each shift.
Chain Roller Serpentine	(If not available use SAE 30 Motor Oil)	Apply to chain with paint brush.	
Gear Reservoir Case	SAE 20 MS Motor Oil	Maintain case 1/3 to 1/2 full. Drain, flush, & re-fill.	Check level weekly. Every 3 months.
Hydraulic Oil	Mob fluid No. 300 recommended. See text for names of acceptable alternates.	Maintain level in reservoir. Approximately 40 gallons capacity.	Change oil after break in period of 50 hours. Drain, flush, and refill with new oil once each year or after each 1000 hours of operation.
Filter Hydraulic Oil Return (10 micron)	See Parts Book for part number of replacement cartridge.	Clean case and change cartridge.	Change filter cartridge each time oil is changed. Also change every six months or after each 500 hours of operation.
Strainers (Two 100 Mesh located within hydraulic reservoir)	Maintain for flow.	Clean.	Clean every six month period or after each 500 hours of operation.
Oil Vacuum Pump	GAST AD 220 see text for names of substitutes.	Maintain oil level in reservoir.	Check daily.
Filters (Two Vacuum Filter)	Empty condensate from can.	Empty condensate from can. Wash felt filter in solvent. Replace felt filter.	After each 40 hours of operation. After each 100 hours of operation.
Woppe Slide	Cop grease	Apply manually.	Each six month period. Weekly as required.
Outlet Slide	Cop grease	Apply manually.	Weekly as required.
Spring & Shock Assemblies (20 pts)	SAE 30 Grease multigrade	Apply with oil can.	Daily as required.
Batteries	Distilled water	Fill to proper level.	Monthly.

133.508

Figure 7-68.--Lubrication chart for concrete pump (250 series).

7-68

291

tapping the steel pipe with a metal object. The pipe filled with concrete will produce a dull sound when tapped. After the sponge passes and the pipe is filled with water, the tapping will produce a sharper ring.

When the final cleanout operation is complete, the placement line should be disassembled and each section thoroughly drained. It may be advisable to "walk out" the rubber hose sections to remove the remaining water.

Each coupling used on the discharge line should be thoroughly cleaned, and the coupling gaskets should be washed off and greased when couplings are disassembled.

Never permit the suction cone in the hopper to become uncovered. This caution must always be observed any time the pump is being operated regardless of the material, even water. The machine will pump air when the suction cone in the hopper is uncovered.

Compressed air should NOT be used to clean the placement line because of the danger of damage to any object or person struck by the concrete with the force of air behind it. Concrete propelled from the end of the line by compressed air will also segregate badly and adversely affect the quality of the mix. There is also the danger of the air shooting through the column of concrete rather than moving it as a mass. This not only causes the concrete to segregate, but makes the ensuing cleaning much more difficult.

Pump Shutdown

Observe the following shutdown steps for securing the concrete pump after placement and cleanup has been completed.

1. Place the speed control in the NEUTRAL position

2. Place the agitator control in the OFF position.
3. Relieve the vacuum in the pump chamber by placing the vacuum control lever to the OFF position.
4. Place the collector hopper slide cylinder in the OFF position.

Stopping the Pump Engine

To stop the concrete-pump engine, here are the steps to follow:

1. Reduce the engine speed to 1,000 rpm, minimum, before shutting down. This permits the engine to cool down and provides gradual and uniform cooling of engine parts.
2. Turn the ignition switch to the OFF position.

Concrete Pump Care and Maintenance

As with most equipment, the operator's and maintenance manual supplied by the equipment manufacturer contains the complete instructions for service and maintenance (including lubrication) of the pump. The life and performance of a concrete pump depends on the care that is given. Proper lubrication, performed at definite intervals, will aid greatly in prolonging the life of the pump and in reducing operating expense.

A lubrication guide for the Challenge Squeeze-Crete 250 series trailer-mounted concrete pump is presented in figure 7-68. The guide shows a lubrication chart indicating lubrication specifications, capacities, and intervals to be followed by those operating the pump.

CHAPTER 8

MASONRY

The American Standard Building Code Requirements for Masonry defines masonry as a "built-up construction or combination of building units of materials, such as clay, shale, glass, gypsum or stone, set in mortar or plain concrete." However, by a second definition, masonry is construction made up of prefabricated masonry units, such as concrete blocks, structural clay tile, or brick, laid in various ways and joined together with mortar. Such masonry is sometimes called unit masonry.

This chapter describes the various tools, equipment, and materials that the Builder uses when working with prefabricated masonry units. Also described are masonry construction methods and safe working practices.

MASONRY TOOLS AND EQUIPMENT

The mason's tools include trowels, a brick chisel, a hammer and a jointer; these tools are illustrated in figure 8-1.

The mason's TROWEL may be a BRICK, a BUTTERING, or a POINTING trowel, as shown in figure 8-1. The trowel is used for mixing, placing, and spreading mortar, the hammer is used for tapping masonry units into the beds where necessary, and for chipping and rough-cutting. For smoother cutting, the brick chisel is used. Breaking into bats and closures are done with the chisel peen on the MASON'S HAMMER. Splitting and rough breaking are done with the head or flat of the hammer.

The JOINTER, of which there are several types other than the one shown in figure 8-1, is

used for making various joint finishes which will be described later.

The mason must maintain a constant check on the courses to insure that they are level and plumb; otherwise the courses will appear wavy and the plane surfaces warped. The equipment for this vital purpose consists of a length of line, a steel square and level, and a straightedge like the one shown in figure 8-2. The square is used to lay out corners and for other right-angle work. The mason's level is used exactly as the carpenter's level is in wood construction. The straightedge is used in conjunction with the level for leveling or plumbing long stretches.

A MORTAR BOARD for holding a supply of ready-to-use mortar should be constructed as

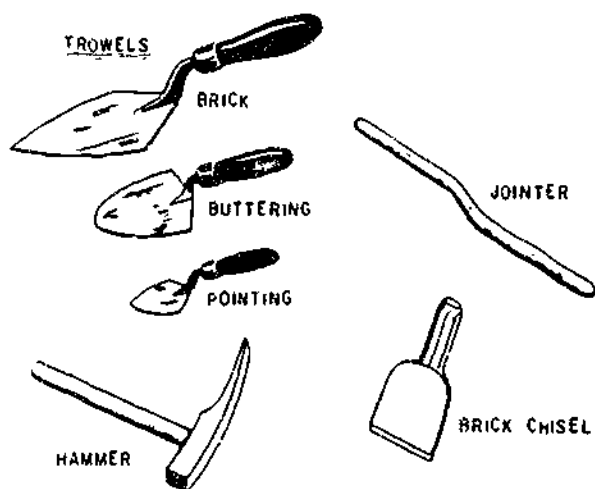
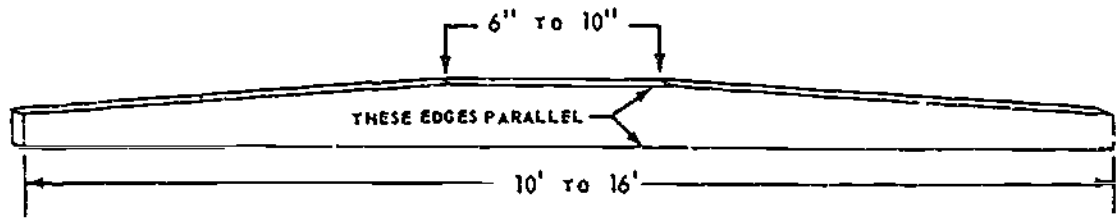

Figure 8-1.—Mason's tools.

28.164



133.25

Figure 8-2.—Mason's straightedge.

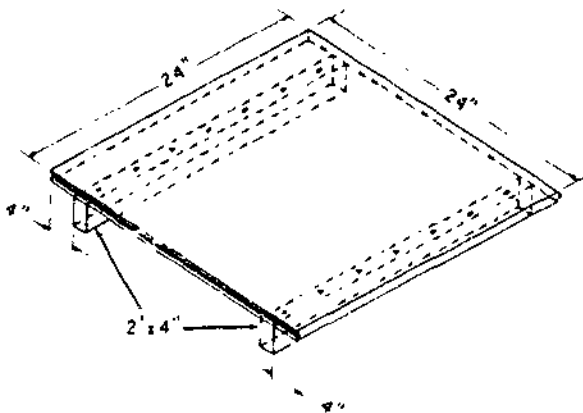

133.26

Figure 8-3.—Mortar board.

metal will make mixing easier and also prolong the life of the box. Other required equipment includes shovels, mortar hoes, wheelbarrows, and buckets.

A mortar mixing machine as shown in figure 8-5, is used for mixing large quantities of mortar. The mixer consists primarily of a metal drum containing mixing blades mounted on a chassis equipped with wheels for towing from one job site to another. The mixer is powered by either an electric motor or a gasoline powered engine. Mortar is mixed by the rotation of the blades inside the drum. After mixing, the mortar is discharged into a wheelbarrow, usually by tilting the mixer drum. As with any type machine, refer to the manufacturer's operator and maintenance manual before, during, and after operation.

shown in figure 8-3. If mortar is to be mixed by hand, it should be mixed in a MORTAR BOX like the one shown in figure 8-4. However, if the box is expected to be used over a period of time, it should be lined with some type of metal. The

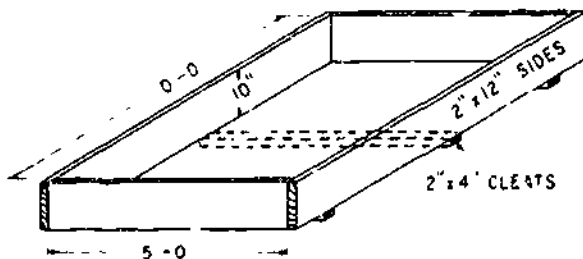

133.27

Figure 8-4.—Mortar box.



117.75

Figure 8-5.—Mortar mixing machine.

CONCRETE MASONRY

Concrete masonry has become increasingly important as a construction material. Important technological developments in the manufacture and utilization of the units have accompanied the rapid increase in the use of concrete masonry. Concrete masonry walls properly designed and constructed will satisfy varied building requirements including fire, safety, durability, economy, appearance, utility, comfort, and good acoustics.

Concrete blocks are classified by weight, light or heavy. The heavyweight blocks are made from cement, water, and aggregates, such as sand, gravel, or crushed limestone. Lightweight blocks are made by combining cement and water with a lightweight aggregate, such as vermiculite, expanded slag, or pumice. Lightweight blocks are usually about 30% lighter than the heavyweight type and are usually lower in compressive strength and more expensive to produce.

Concrete blocks may be manufactured either by machine or by hand. A concrete block



103.29

Figure 8-6.—Block Machine.

machine as shown in figure 8-6, is fed a dry mix from the hopper into the block mold and in turn is automatically tamped until the material is hard enough. Then, the mold is removed and the block is put aside to set up without losing its shape. In the hand method, a plastic mix is poured into sets of iron molds which can be stripped after the mix has set.

BLOCK SIZES AND SHAPES

Concrete masonry units are made in sizes and shaped to fit different construction needs. Units are made in full and half-length sizes as shown in figure 8-7. Concrete unit sizes are usually referred to by their nominal dimensions. A unit measuring $7\frac{5}{8}$ in. wide, $7\frac{5}{8}$ in. high, and $15\frac{5}{8}$ in. long is referred to as an $8 \times 8 \times 16$ in. unit. When it is laid in a wall with $\frac{3}{8}$ -in. mortar joints, the unit will occupy a space exactly 16 in. long and 8 in. high. Besides the basic $8 \times 8 \times 16$ units, the illustration shows a smaller partition unit and other units which are used much as cut brick are in brick masonry.

The corner unit is laid at a corner or some other similar point where a smooth rather than a recessed end is required. The header unit is used in a backing course placed behind a brick face tier header course. Part of the block is cut away to admit the brick headers. The uses of the other specials shown are self-evident. Besides the shapes shown in figure 8-7, a number of smaller shapes for various special purposes are available. Units may be cut to desired shapes with a bolster or, more conveniently and accurately, with a power-driven masonry saw such as that shown in figure 8-8. Be sure to follow the manufacturer's manual for operation and maintenance of this saw.

BLOCK MORTAR JOINTS

The sides and the recessed ends of a concrete block are called the **SHELL**; and the material which forms, as it were, the partitions between the cores is called the **WEB**. Each of the long sides of a block is called a **FACE SHELL**, and each of the recessed ends is called an **END SHELL**. The vertical ends of the face shells, on

BUILDER 3 & 2

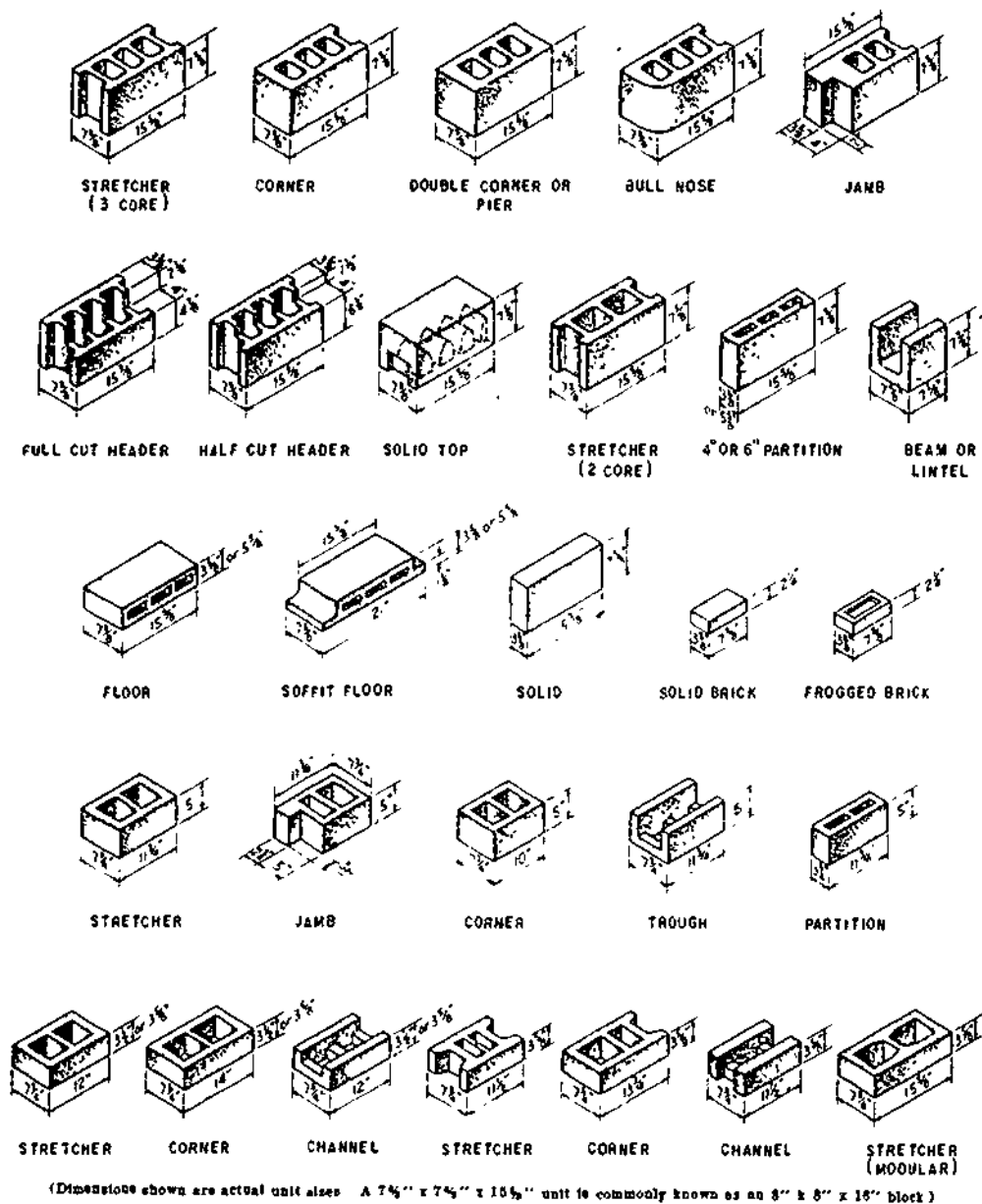

29.142(133F)

Figure 8-7.—Typical sizes and shapes of concrete masonry units.

either side of the end shells, are called the EDGES. Bed joints on first courses and bed joints in column construction are mortared by spreading a 1-in. layer of mortar. This is called FULL MORTAR BEDDING. For most other bed joints, only the upper edges of the face

shells need to be mortared. This is called FACE SHELL MORTAR BEDDING.

Head joints may be mortared by buttering both edges of the block being laid or by buttering one edge on the block being laid and the opposite edge on the block already in place.



Figure 8-8.—Masonry saw.

133.21

MASONRY MORTAR

There are two common kinds of masonry mortar: LIME and PORTLAND CEMENT-LIME. Lime mortar is a mixture of sand, hydrated lime, and water proportioned to produce a plastic, workable paste. When the mortar sticks to the tools, more sand is added; but when it lacks cohesion and fails to adhere to masonry units, more lime is added. When it is too stiff for easy mixing and troweling, more water is added. Lime mortar is normally used only in temporary work, where the masonry units can be salvaged to be used again.

Although portland cement mortar can be made with portland cement, sand, and water only (leaving out the lime), it is hard to work. Workability and "fatness" of masonry mortar are improved through the addition of lime. There are two types of portland cement-mortar. Type A is strong, intended primarily for use in permanent, reinforced masonry structures. The ingredient proportions for type A are:

1 sack portland cement
3 cu ft of damp sand
13 lb hydrated lime

Type B should not be used for reinforced masonry, but it is strong enough for nearly all other purposes. The ingredient proportions for type B are:

1 sack portland cement
6 cu ft damp sand
50 lb hydrated lime

Sufficient mixing water should be added to obtain the desired consistency. If a large quantity of mortar is required, it should be mixed in a drum-type mixer similar to those used for mixing concrete. The mixing time should not be less than 3 minutes. All dry ingredients should be placed in the mixer first and mixed for 1 minute before adding the water.

Unless large amounts of mortar are required, the mortar is mixed by hand using a mortar box like the one shown in figure 8-4. Care must be taken to mix all the ingredients thoroughly to obtain a uniform texture. As in machine mixing, all dry material should be mixed first. A steel drum filled with water should be kept close to the mortar box for the water supply. A second drum of water should be available for shovels and hoes when not in use.

MODULAR PLANNING

Concrete masonry walls should be laid out to make maximum use of full- and half-length units, thus minimizing cutting and fitting of units on the job. Length and height of wall, width and height of openings and wall areas between doors, windows, and corners should be planned to use full-size and half-size units which are usually available (fig. 8-9). This procedure assumes that window and door frames are of modular dimensions which fit modular full- and half-size units. Then, all horizontal dimensions should be in multiples of nominal full-length masonry units and both horizontal and vertical dimensions should be designed to be in multiples of 8 inches. Table 8-1 lists nominal length of concrete masonry walls by stretchers and table

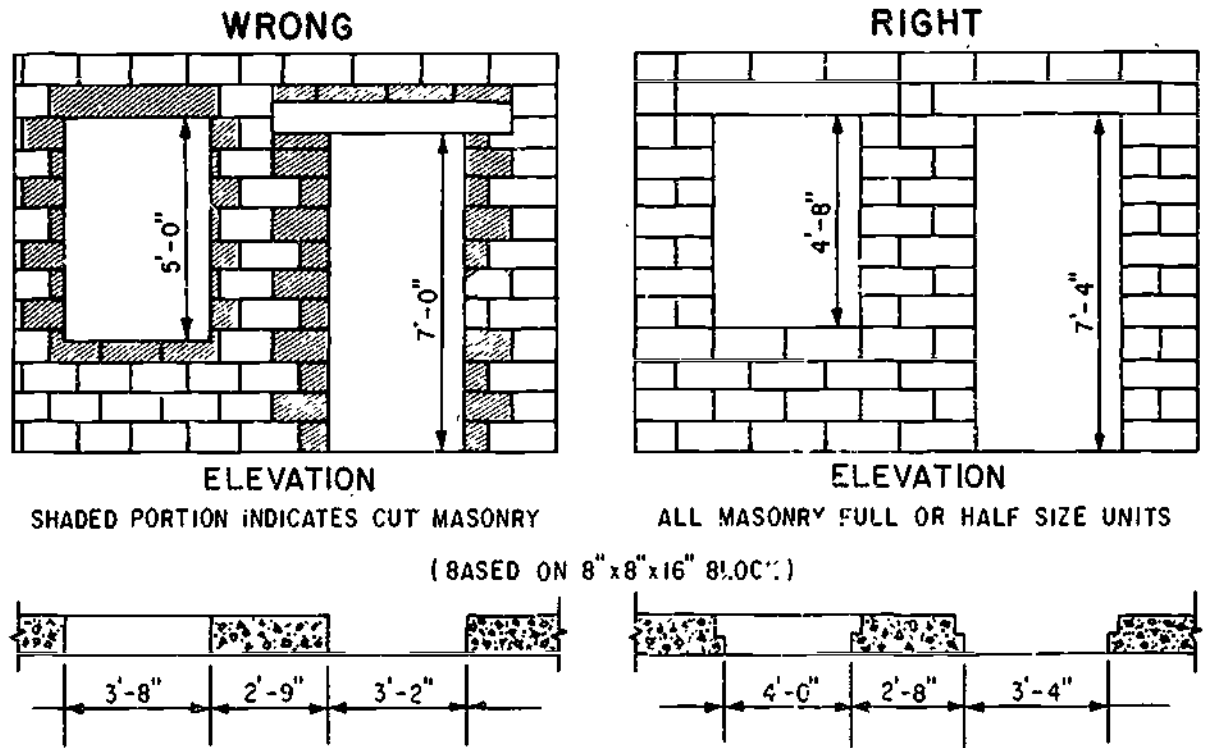

Figure 8.9.—Planning concrete masonry wall openings.

45.728

8-2 lists nominal height of concrete masonry walls by courses. When units 8 x 4 x 16 are used, the horizontal dimensions should be planned in multiples of 8 in. (half-length units) and the vertical dimensions in multiples of 4 inches. If the thickness of the wall is greater or less than the length of a half unit, a special length unit is required at each corner in each course. Table 8-3 lists the average number of concrete masonry units by size and approximate number of cu ft of mortar, for every 100 sq ft of concrete masonry wall.

ESTIMATING MORTAR

You will be able to use rule 38 for calculating the amount of raw material needed to mix one yard of mortar without a great deal of paper work. This calculating rule will not give the accurate amount of required raw materials for large masonry construction jobs, you will

have to use the absolute volume or weight formulae. However, in most cases, particularly in advanced base construction, you can use the rule of thumb to quickly estimate the quantities of the required raw materials.

Builders have found that it takes about 38 cu ft of raw materials to make 1 cu yd of mortar. In using the 38 calculating rule for mortar, take the rule number and divide it by the sum of the quantity figures specified in the mix. For example, let us assume that the building specifications call for a 1:3 mix for mortar $1 + 3 = 4$. Then $38 \div 4 = 9 \frac{1}{2}$. You will then need $9 \frac{1}{2}$ sacks or $9 \frac{1}{2}$ cu ft of cement. In order to calculate the amount of fine aggregate (sand), you simply multiply $9 \frac{1}{2}$ by 3. The product $28 \frac{1}{2}$ cu ft is the amount of sand you need to mix one cu yd of mortar using a 1:3 mix. The sum of the two required quantities should always equal the calculating rule 38. Therefore, you can always check in

Chapter 8—MASONRY

Table 8-1.—Nominal Length of Concrete Masonry Walls by Stretchers

(Actual length of wall is measured from outside edge to outside edge of units and is equal to the nominal length minus $\frac{1}{4}$ " (one mortar joint).

No. of stretchers	Nominal length of concrete masonry walls	
	Units 15 $\frac{1}{4}$ " long and half units 7 $\frac{1}{2}$ " long with $\frac{3}{8}$ " thick bed joints.	Units 11 $\frac{1}{4}$ " long and half units 5 $\frac{1}{2}$ " long with $\frac{3}{8}$ " thick bed joints.
1.....	1' 4".....	1' 0".....
1 $\frac{1}{2}$	2' 0".....	1' 6".....
2.....	2' 8".....	2' 0".....
2 $\frac{1}{2}$	3' 4".....	2' 6".....
3.....	4' 0".....	3' 0".....
3 $\frac{1}{2}$	4' 8".....	3' 6".....
4.....	5' 4".....	4' 0".....
4 $\frac{1}{2}$	6' 0".....	4' 6".....
5.....	6' 8".....	5' 0".....
5 $\frac{1}{2}$	7' 4".....	5' 6".....
6.....	8' 0".....	6' 0".....
6 $\frac{1}{2}$	8' 8".....	6' 6".....
7.....	9' 4".....	7' 0".....
7 $\frac{1}{2}$	10' 0".....	7' 6".....
8.....	10' 8".....	8' 0".....
8 $\frac{1}{2}$	11' 4".....	8' 6".....
9.....	12' 0".....	9' 0".....
9 $\frac{1}{2}$	12' 8".....	9' 6".....
10.....	13' 4".....	10' 0".....
10 $\frac{1}{2}$	14' 0".....	10' 6".....
11.....	14' 8".....	11' 0".....
11 $\frac{1}{2}$	15' 4".....	11' 6".....
12.....	16' 0".....	12' 0".....
12 $\frac{1}{2}$	16' 8".....	12' 6".....
13.....	17' 4".....	13' 0".....
13 $\frac{1}{2}$	18' 0".....	13' 6".....
14.....	18' 8".....	14' 0".....
14 $\frac{1}{2}$	19' 4".....	14' 6".....
15.....	20' 0".....	15' 0".....
20.....	26' 8".....	20' 0".....

45.730

Table 8-2.—Nominal Height of Concrete Masonry Walls by Courses

(For concrete masonry units 7 $\frac{1}{2}$ " and 3 $\frac{1}{2}$ " in height laid with $\frac{3}{8}$ " mortar joints. Height is measured from center to center of mortar joints.)

No. of courses	Nominal height of concrete masonry walls	
	Units 7 $\frac{1}{2}$ " high and $\frac{3}{8}$ " thick bed joint	Units 3 $\frac{1}{2}$ " high and $\frac{3}{8}$ " thick bed joint
1.....	8".....	4".....
2.....	1' 4".....	8".....
3.....	2' 0".....	1' 0".....
4.....	2' 8".....	1' 4".....
5.....	3' 4".....	1' 8".....
6.....	4' 0".....	2' 0".....
7.....	4' 8".....	2' 4".....
8.....	5' 4".....	2' 8".....
9.....	6' 0".....	3' 0".....
10.....	6' 8".....	3' 4".....
15.....	10' 0".....	5' 0".....
20.....	13' 4".....	6' 8".....
25.....	16' 8".....	8' 4".....
30.....	20' 0".....	10' 0".....
35.....	23' 4".....	11' 8".....
40.....	26' 8".....	13' 4".....
45.....	30' 0".....	15' 0".....
50.....	33' 4".....	16' 8".....

45.731

order to see if you are using the correct amounts. In the above example, 9 1/2 sacks of cement, plus 28 1/2 cu ft of sand, equal 38.

SAFE HANDLING OF MATERIAL

Personnel handling cement or lime bags should wear goggles and snug-fitting neck and wrist bands. They should always practice personal cleanliness and never wear clothing that has become hard and stiff with cement. Such clothing irritates the skin and may cause serious infection. Any susceptibility of their skin to cement and lime burns should be reported. Personnel who are allergic to cement or lime should be transferred to other jobs.

Table 8-3.—Average Concrete Masonry Units and Mortar per 100 sq ft of Wall

DESCRIPTION, SIZE OF BLOCK (in.)	THICKNESS WALL (in.)	WEIGHT PER UNIT (lb.)	NUMBER OF UNITS PER 100 SQ. FT. OF WALL AREA	MORTAR (cu. ft.)	WEIGHT, POUNDS PER 100 SQ. FT. OF WALL AREA
8 X 8 X 16	8	50	110	3.25	5850
8 X 8 X 12	8	38	146	3.5	6000
8 X 12 X 16	12	85	110	3.25	9700
8 X 3 X 16	3	20	110	2.75	2600
9 X 3 X 18	3	26	87	2.5	2500
12 X 3 X 12	3	23	100	2.5	2550
8 X 3 X 12	3	15	146	3.5	2550
8 X 4 X 16	4	28	110	3.25	3450
9 X 4 X 18	4	35	87	3.25	3350
12 X 4 X 12	4	31	100	3.25	3450
8 X 4 X 12	4	21	146	4	3500
8 X 6 X 16	6	42	110	3.25	5000

133.454

Bags of cement or lime should not be piled more than 10 bags high on a pallet except when stored in bins or enclosures built for such purposes. The bags around the outside of the pallet should be placed with the mouths of the bags facing the center. To prevent piled bags from falling outward, the first five tiers of bags each way from any corner must be crosspiled and a setback made commencing with the sixth tier. If necessary to pile above the tenth tier, another setback must be made. The back tier, when not resting against a wall of sufficient strength to withstand the pressure, should be set back one bag every five tiers, the same as the end tiers.

During unpiling, the entire top of the pile should be kept level and the necessary setbacks every five tiers maintained.

Lime and cement must be stored in a dry place. This helps to prevent lime from crumbling and the cement from hydrating before it is used.

CONCRETE MASONRY CONSTRUCTION

After locating the corners of the wall, the Builder usually checks the layout by stringing out the blocks for the first course without mortar (fig. 8-10). A chalked snapline is useful

to mark the footing and align the block accurately. A full bed of mortar is then spread and furrowed with the trowel to insure plenty of mortar along the bottom edges of the face shells of the block for the first course (fig. 8-11). The



Figure 8-10.—Stringing out blocks. 133.265

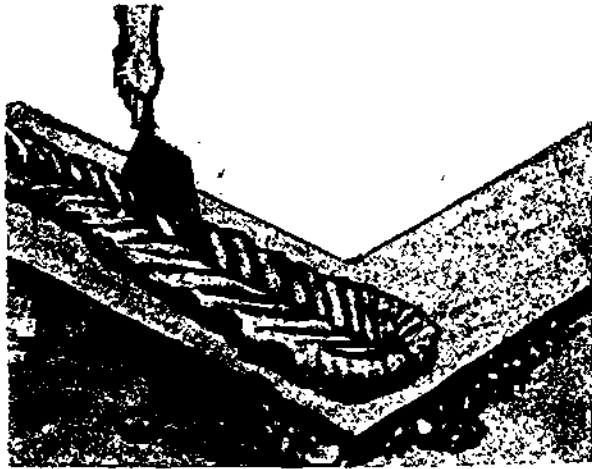

133.266

Figure 8-11.—Spread and furrow mortar bed.

corner block should be laid first and carefully positioned (fig. 8-12). All block should be laid with the thicker end of the face shell up to provide a larger mortar-bedding area (fig. 8-13). Mortar is applied only to the ends of the face shells for vertical joints. Several blocks can be placed on end and the mortar applied to the vertical face shells in one operation. Each block is then brought over its final position and



133.267

Figure 8-12.—Position corner block.



133.268

Figure 8-13.—Blocks buttered for vertical joints.

pushed downward into the mortar bed and against the previously laid block to obtain a well-filled vertical mortar joint (fig. 8-14). After three or four blocks have been laid, the mason's level is used as a straightedge to assure correct alinement of the blocks. Then the blocks are carefully checked with the level and brought to the proper grade and made plumb by tapping with the trowel handle (fig. 8-15). The first course of concrete masonry should be laid with great care, to make sure it is properly alined, leveled, and plumbed, and to assure that succeeding courses, and finally the wall, are straight and true.

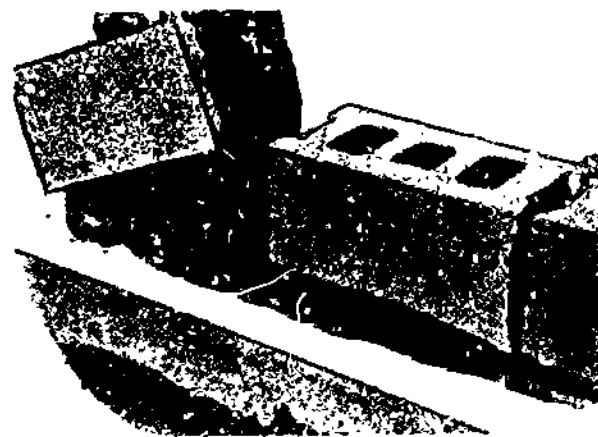

133.269

Figure 8-14.—Positioning block.

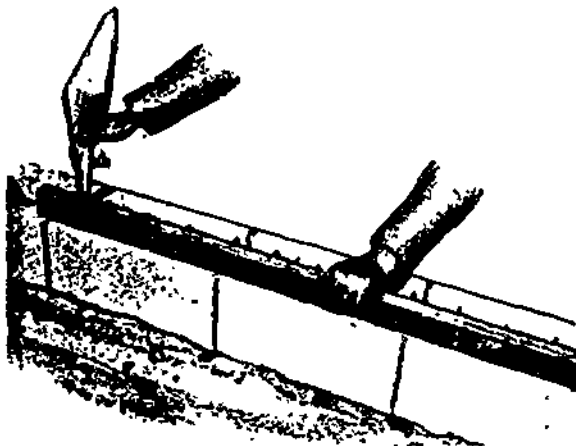

LEVELING BLOCK

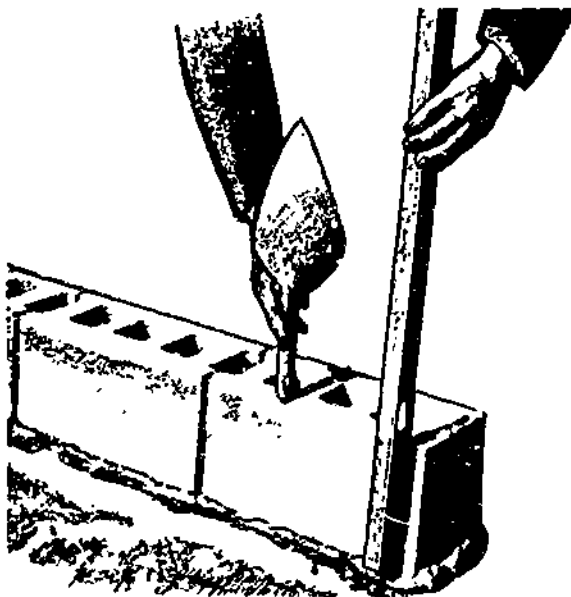

PLUMBING BLOCK

133.270

Figure 8-15.—Checking first course of blocks.

After the first course is laid, mortar is applied only to the horizontal face shells of the block (face-shell mortar bedding). Mortar for the vertical joints may be applied to the vertical faceshells of the block to be placed or to the block previously laid or both, to insure well-filled joints (fig. 8-16). The corners of the wall are built first, usually four or five courses higher than the center of the wall. As each



133.271

Figure 8-16.—Vertical joints.

course is laid at the corner, it is checked with a level for alinement, for levelness, and for plumbness, as shown in figure 8-17. Each block is carefully checked with a level or straightedge to make certain that the faces of the block are all in the same plane to insure true, straight walls. The use of a story or course-pole, a board with markings 8 in. apart, provides an accurate method of determining the height for each masonry course (fig. 8-18). Joints are $\frac{3}{8}$ -in. thick. Each course, in building the corners, is stepped back a half block and the Builder checks the horizontal spacing of the block by placing the level diagonally across the corners of the block (fig. 8-19).

When filling in the wall between the corners, a mason's line is stretched from corner to corner for each course and the top outside edge of each block is laid to this line. The manner of gripping the block is important. It should be tipped slightly towards the Builder so the edge of the course below can be seen enabling the lower edge of the block to be placed directly over the course below (fig. 8-20). All adjustments to final position must be made while the mortar is soft and plastic. Any adjustments made after the

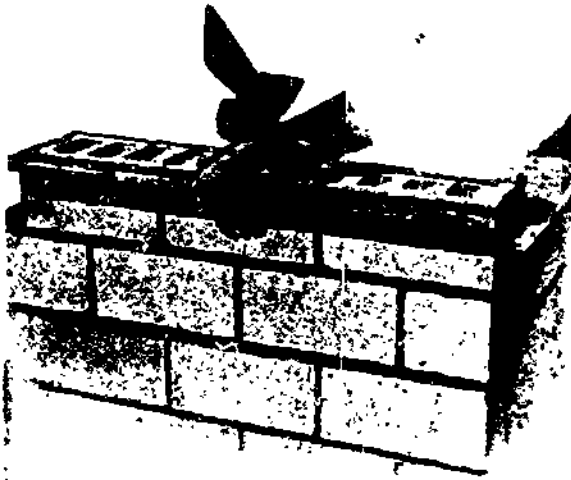

ALIGNING

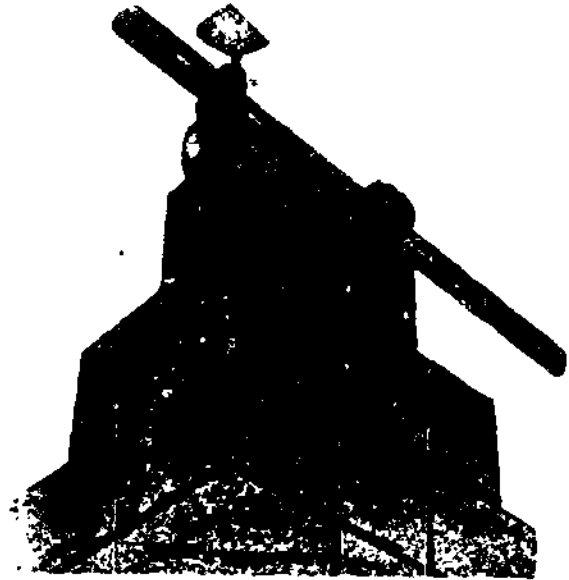

LEVELING

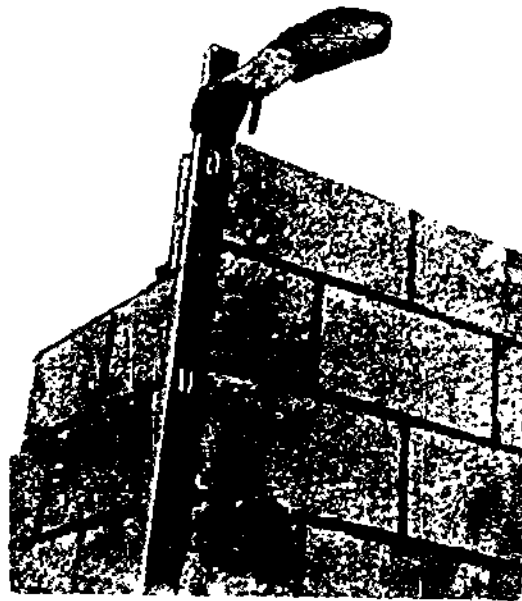

PLUMBING

Figure 8-17.—Checking each course.

133.272

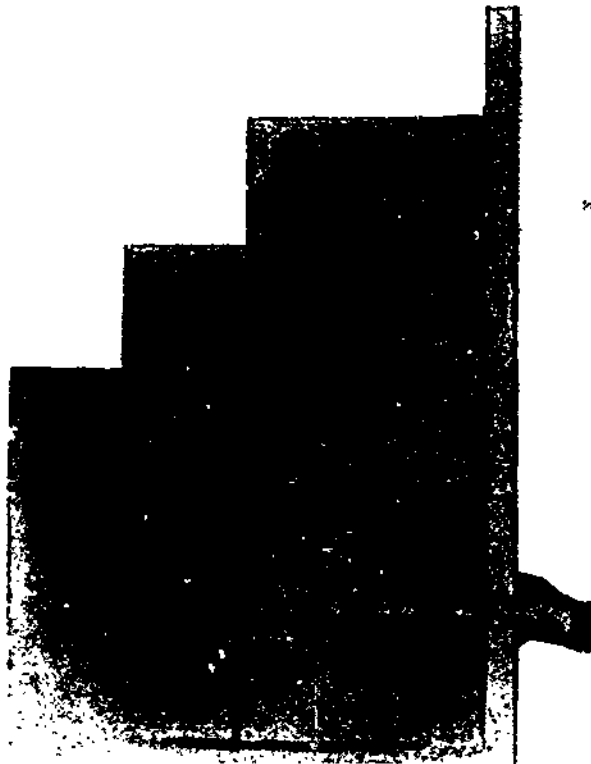

133.273

Figure 8-18.—Use of story or course pole.

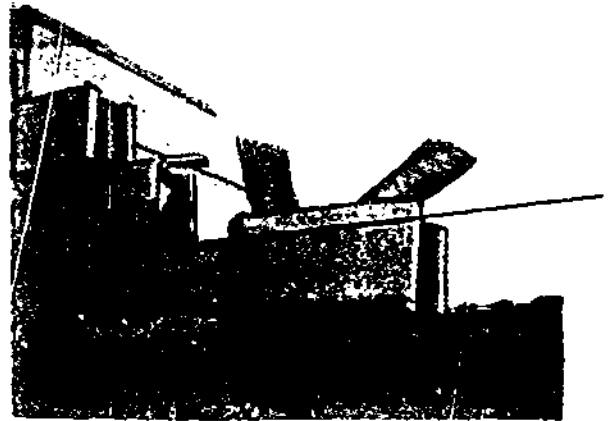

133.275

Figure 8-20.—Adjusting block between corners.

mortar has stiffened will break the mortar bond and allow the penetration of water. Each block is leveled and alined to the mason's line by tapping them lightly with the trowel handle. The use of the mason's level between corners is limited to checking the face of each block to keep it lined up with the face of the wall.

To assure a good bond, mortar should not be spread too far ahead of actual laying of the block or it will stiffen and lose its plasticity. As each block is laid, excess mortar extruding from the joints is cut off with the trowel (fig. 8-21)

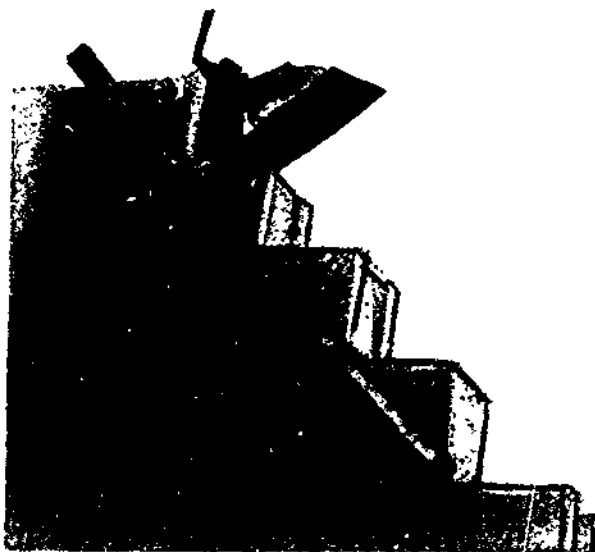

133.274

Figure 8-19.—Checking horizontal spacing of block.

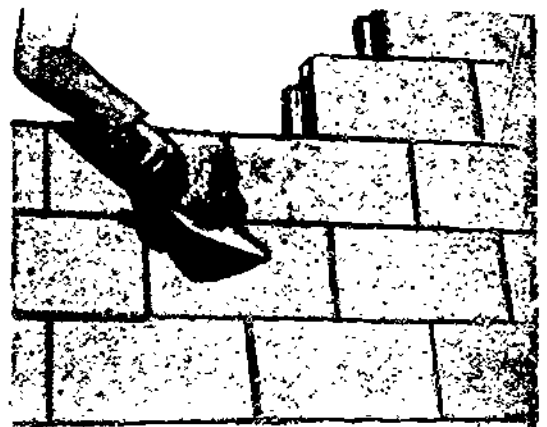

133.276

Figure 8-21.—Cutting off excess mortar.

and is thrown back on the mortar board to be reworked into the fresh mortar. Dry mortar that has been picked up from the scaffold or from the floor should not be used.

When the closure block is being installed, all edges of the opening and all four vertical edges of the closure block are buttered with mortar and the closure block is carefully lowered into place (fig. 8-22). If any of the mortar falls out leaving an open joint, the block should be removed and the procedure repeated.

Weather-tight joints and neat appearance of concrete block walls are dependent on proper tooling. The mortar joints should be tooled after a section of the wall has been laid and the mortar has become "thumb-print" hard. Tooling (fig. 8-23) compacts the mortar and forces it tightly against the masonry on each side of the joint. All joints should be tooled either concave or V-shaped. Horizontal joints should be tooled first, followed by striking the vertical joints with a small S-shaped jointer. Mortar burrs remaining after tooling is completed should be trimmed off flush with the face of the wall with a trowel or removed by rubbing with a burlap bag or soft bristle brush.

Wood plates are fastened to tops of concrete masonry walls by anchor bolts 1/2 in. in diameter, 18 in. long and spaced not more than 4 ft apart. The bolts are placed in the cores of the top two courses of block with the cores filled with concrete or mortar. Pieces of metal lath placed in the second horizontal mortar joint

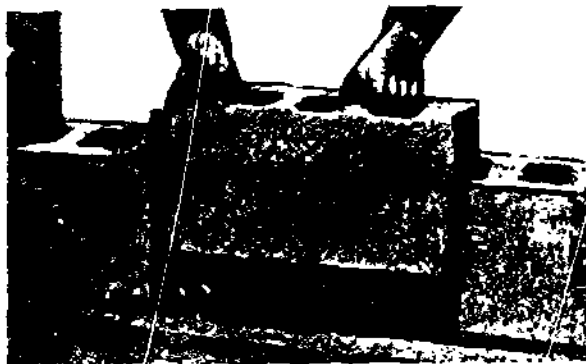

133.277

Figure 8-22.—Installing closure block.

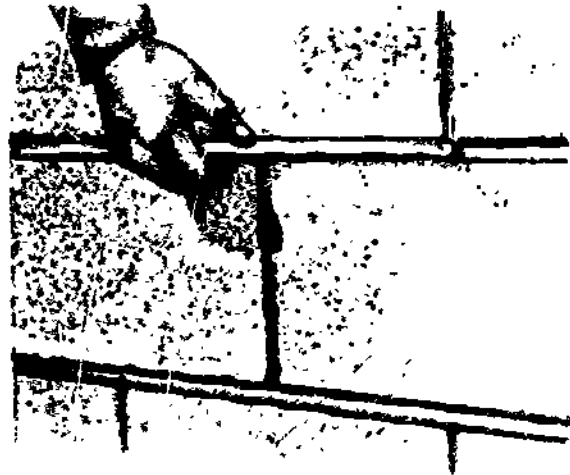

TOOLING HORIZONTAL JOINTS

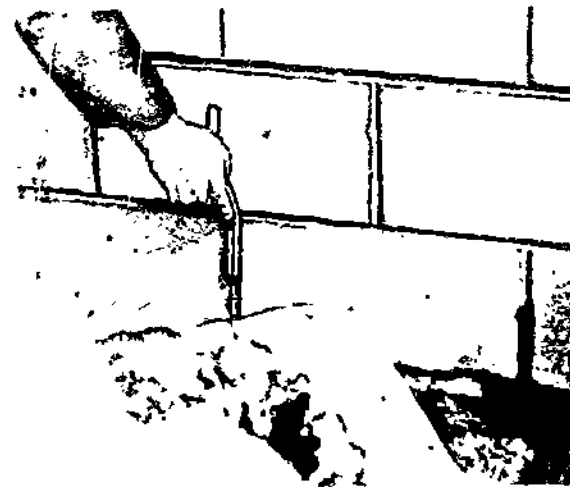

STRIKING VERTICAL JOINTS

133.278

Figure 8-23.—Tooling mortar joints.

from the top of the wall and under the cores to be filled (fig. 8-24) will hold the concrete or mortar filling in place. The threaded end of the bolt should extend above the top of the wall.

CONTROL JOINTS

Control joints are continuous vertical joints built into concrete masonry walls to control

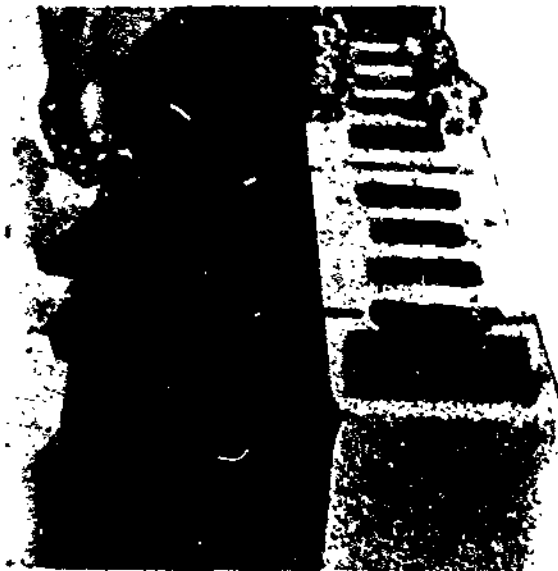

PLACING METAL LATH

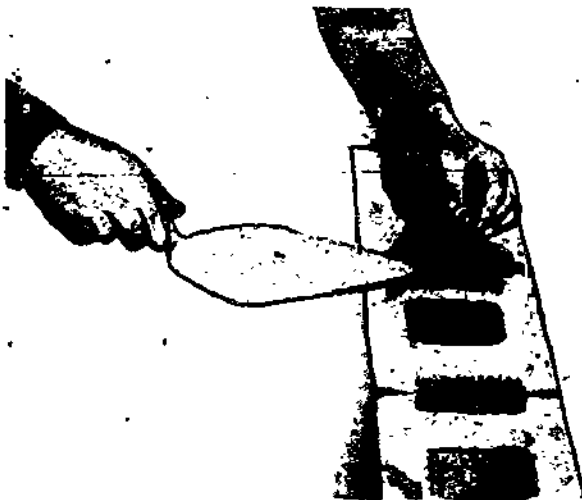

SETTING ANCHOR BOLT

133.279

Figure 8-24.—Installing anchor bolts on top of wall.



1 FULL AND HALF LENGTH BLOCK FOR JOINT



2 RAKING MORTAR FROM JOINT

133.280

Figure 8-25.—Control joint.

cracking resulting from unusual stresses. The joints are intended to permit slight wall movement without cracking. Control joints should be laid up in mortar just as any other joint. Full- and half-length block are used to form a continuous vertical joint (fig. 8-25). If this type of joint is exposed to the weather or to view, it should be caulked. After the mortar is

quite stiff, it should be raked out to a depth of about 3/4 in to provide a recess for the caulking material. A thin, flat caulking trowel is used to force the caulking compound into the joint. Another type of control joint can be constructed with building paper or roofing felt inserted in the end core of the block and extending the full height of the control joint

(fig. 8-26). The paper or felt, cut to convenient lengths and wide enough to extend across the joint, prevents the mortar from bonding on one side of the joint. Sometimes control joints are used if available.

To provide lateral support, metal ties can be laid across the joint in every other horizontal course.

INTERSECTING WALLS

Except at the corners, intersecting concrete block bearing walls should not be tied together in a masonry bond. Instead, one wall should terminate at the face of the other wall with a control joint at the point. Bearing walls are tied together with a metal tiebar that is bent at right

angles on each end (fig. 8-27). Tiebars are spaced not over 4 ft apart vertically. Bends at the ends of the tiebars are embedded in cores filled with mortar or concrete. Pieces of metal lath placed under the cores support the concrete or mortar filling as previously shown in figure 8-24.

To tie nonbearing block walls to other walls, strips of metal lath or 1/4-in. mesh galvanized hardware cloth are placed across the joint between the two walls (fig. 8-28), in alternate courses in the wall. When the first wall is



133.281

Figure 8-26.—Paper or felt used for control joints.

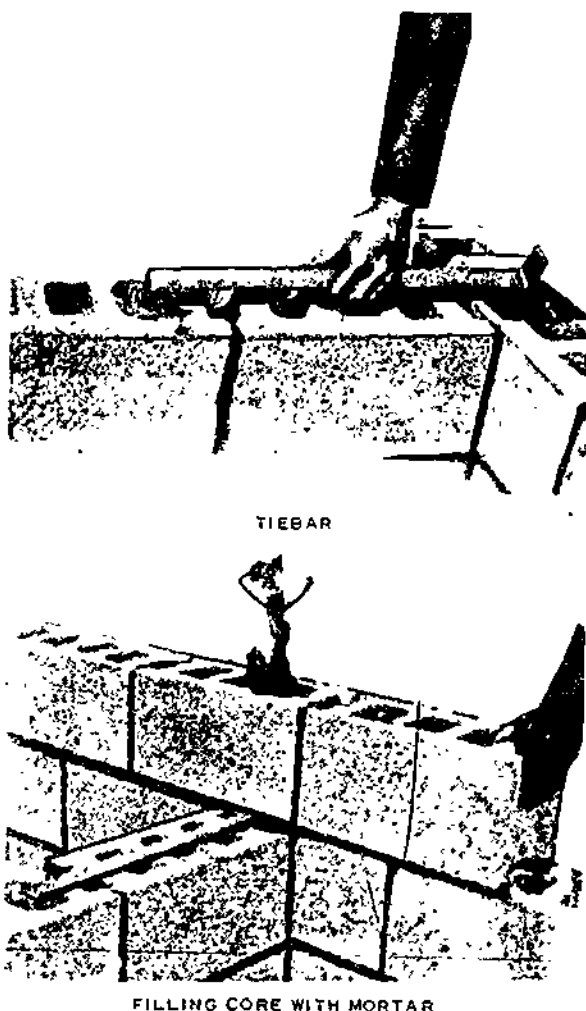

133.282

Figure 8-27.—Tying intersecting bearing walls.

constructed, the metal strips are built into the wall and later tied into the mortar joint of the second wall. Control joints are constructed where the two walls meet.

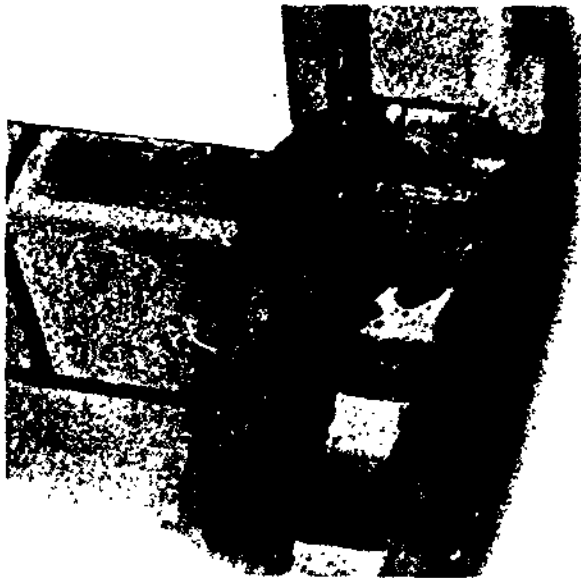

USE OF METAL LATH

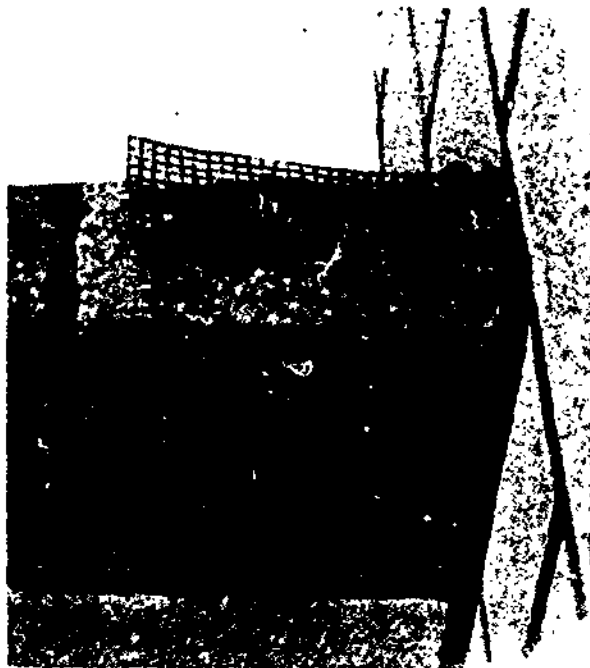

MORTAR JOINT BETWEEN WALLS

133.283

Figure 8-28.—Tying intersecting nonbearing walls.

LINTELS

The top of openings for door and windows in masonry construction may be made in two different ways. One is to use a precast concrete lintel; in this way the opening can be formed before the door or window frame is set. The other method is to use the lintel block like that shown in figure 8-29. Here the frame is set in place and the block wall is built around it. Lintel blocks are used across the top and are extended a minimum of 8 in. past each edge of the opening. Reinforcing bars and concrete are placed in the lintel blocks. Window and door openings in masonry should be planned to bring the top or bottom course in line with the openings.

REINFORCED BLOCK WALLS

Block walls may be reinforced vertically or horizontally. To reinforce vertically, place reinforcing rods into the cores at the specified

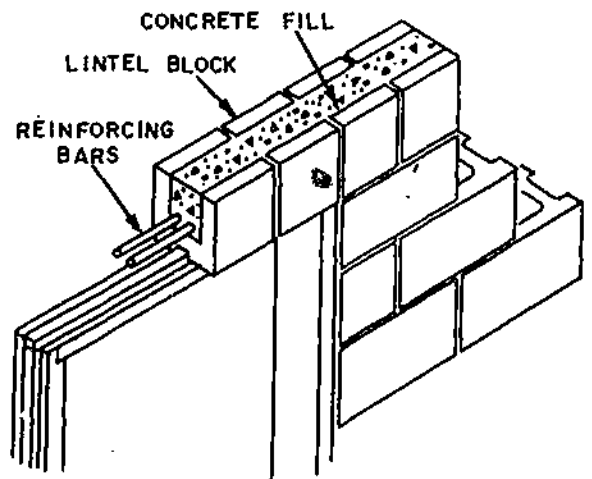

133.37

Figure 8-29.—Lintel made from blocks.

spacing and fill the cores with a relatively high slump concrete. Rebars (studs) should be placed at each corner and at both sides of each opening. The vertical rebars should generally be spaced a maximum of 32 in. O.C. in walls. Where spliced block are required, the bars should be lapped 40 diameters. The concrete should be placed in one continuous pour from foundation to plate line. A cleanout block may be placed in the first course at every rebar (stud) for cleanout of excess mortar and to insure proper alinement and laps of rebars.

Horizontal rebars should be placed in bond beam units which are laid with the channel up and then filled with concrete. Bond beams may be installed both below windows and at the top of the wall at the plate line. Typically, the reinforcing rebars used may be two 3/8 in. diameter deformed bars (lapped 40 diameters at splices). You should always check the specifications carefully for the size and number of rebars to be used. A pilaster block may be used to provide lateral strength and greater bearing area for the beam ends carried on the wall. One type of pilaster is shown in figure 8-30.

Practical experience indicates that control of cracking and wall flexibility can be achieved

with the use of horizontal joint reinforcing. The amount of joint reinforcement depends largely upon the type of construction. Horizontal joint reinforcing, where required, should consist of not less than two deformed longitudinal No. 9 (or heavier) cold-drawn steel wires. Truss type cross wires should be 1/8 in. diameter (or heavier) of the same quality. Figure 8-31 shows joint reinforcement at a vertical spacing of 16 in.

The location and details of bond beams, control joints, and joint reinforcing should all be shown on the drawings.

PATCHING AND CLEANING BLOCK WALLS

Any patching of the mortar joints or filling of holes left by nails or line pins should be done with fresh mortar.

Hardened, embedded mortar smears cannot be removed and paint cannot be depended on to hide smears, so particular care should be taken to prevent smearing mortar into the surface of the block. Concrete block walls should not be cleaned with an acid wash to remove smears or mortar droppings. Mortar droppings that stick to the block wall should be allowed to dry before removal with a trowel (view A, fig. 8-32). Most of the mortar can be

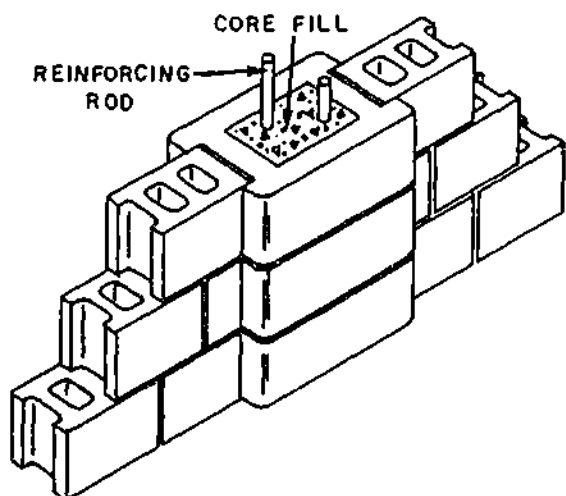

Figure 8-30.—One type of pilaster.

133.38

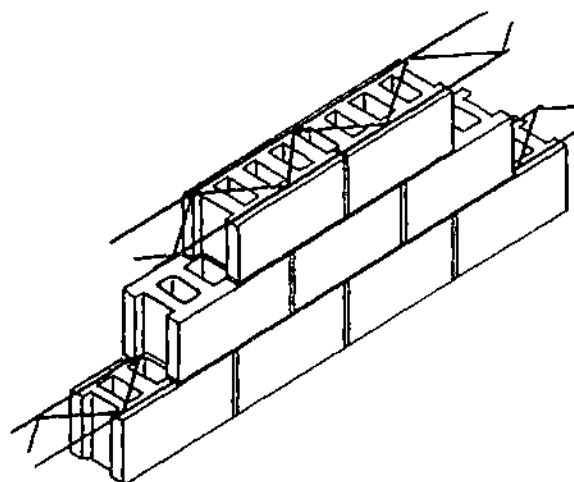

Figure 8-31.—Masonry wall horizontal joint reinforcement.

133.39



A. REMOVING MORTAR WITH TROWEL



B. USING PIECE OF BROKEN BLOCK



C. BRUSHING

Figure 8-32.—Patching and cleaning concrete block.

133.284

removed by rubbing with a small piece of concrete (broken) block after the mortar is dry and hard (view B, fig. 8-32). Finally brushing the rubbed spots will remove practically all of the mortar (view C, fig. 8-32).

WATERTIGHT BLOCK WALLS

To insure that block walls below grade will be watertight, they should be covered with plaster and sealed. Plastering consists of applying two 1/4-in. coats of plaster, using 1:2 1/2 mortar mix. The wall should be dampened before applying the plaster in order to get a good bond. The first coat should extend from 6 in. above the grade line down to the footing. When it is partially set up, roughen the surface with a wire brush and then allow it to set for at least 24 hours. Dampen the wall again before the second coat is applied. After the second coat is applied, the wall should be kept damp for 48 hours.

In poorly drained or heavily wet soils, the plaster should be covered with two coats of asphalt waterproofing, brushed on. The wall may be further protected by laying a line of drainage tile around the outside of the footing. Cover the tile joints with pieces of building paper and cover the tile with about 12 in. of washed gravel before the back filling is done.

STRUCTURAL CLAY TILE MASONRY

Hollow masonry units made of burned clay or shale are called by various names, such as

structural tiles, building tiles, hollow tiles, structural clay tiles, structural clay hollow tiles, and structural clay hollow building tiles. They are referred to as **BUILDING TILES** in this manual. In building tile manufacture, plastic clay is pugged through a die and the shape which emerges is cut off into units. The units are then burned much as bricks are burned.

The openings in a building tile, which correspond to the cores in a brick or a concrete block, are called **CELLS**. The solid sides of a tile are called the **SHELL**, and the perforated material enclosed by the shell is called the **WEB**. A tile which is laid on one of its shell faces is called a **SIDE-CONSTRUCTION** tile; one which is laid on one of its web faces is called an **END-CONSTRUCTION** tile. Figures 8-33 and 8-34 show the sizes and shapes of basic side- and end-construction building units. Special shapes for use at corners and openings, or for use as closures, are also available.

PHYSICAL CHARACTERISTICS

The compressive strength of the individual tile depends upon the materials used and upon the method of manufacture, in addition to the thickness of the shells and webs. A minimum compressive strength of tile masonry of 300 lb per sq in. based on the gross section may be expected. The tensile strength of structural clay tile masonry is small. In most cases, it is less than 10 percent of the compressive strength.

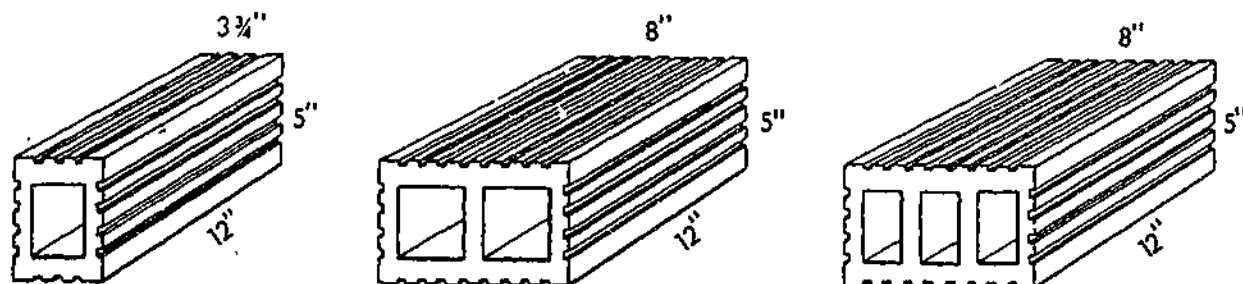
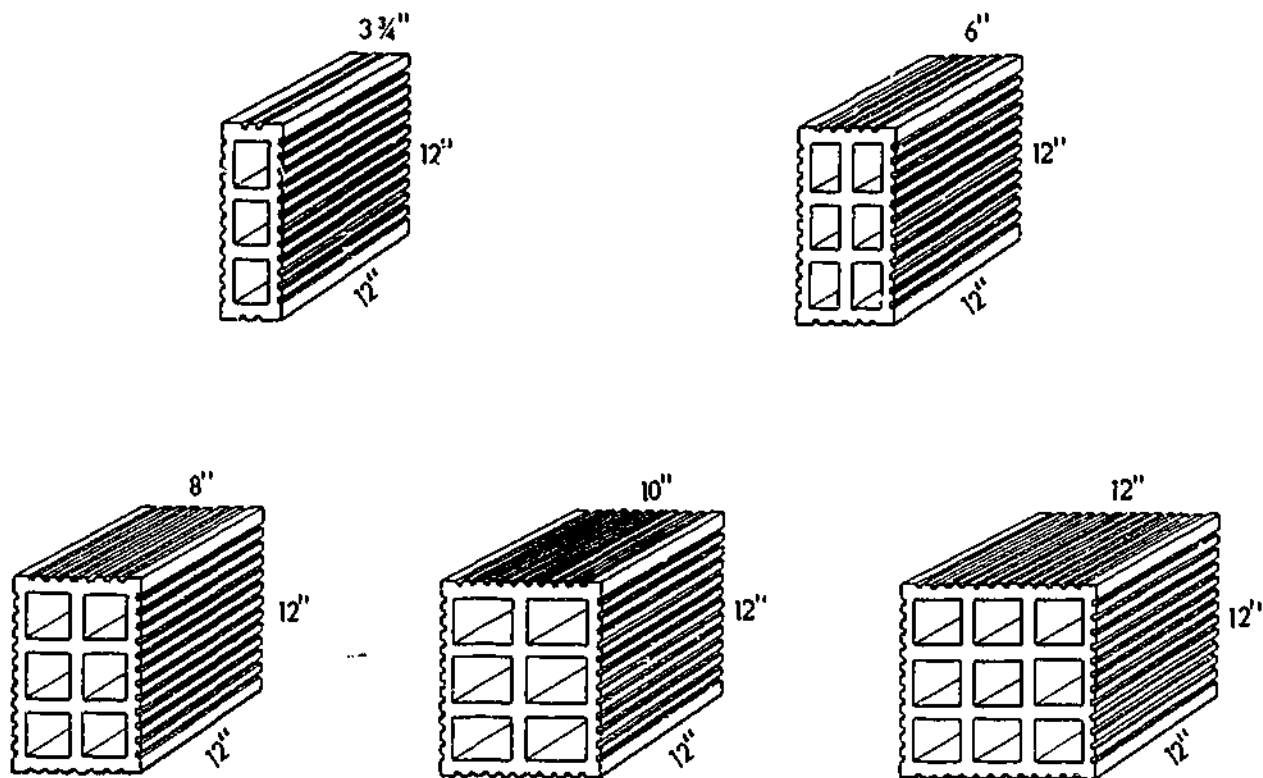

Figure 8-33.—Standard shapes of side-construction building tiles.

29.143



29.144

Figure 8-34.—Standard shapes of end-construction building tiles.

The abrasion resistance of clay tile depends primarily upon its compressive strength. The stronger the tile, the greater its resistance to wearing. The abrasion resistance decreases as the amount of water absorbed increases.

Structural clay facing tile has excellent resistance to weathering. Freezing and thawing action produces almost no deterioration. Tile that will NOT absorb more than 16 percent of their weight of water have never given unsatisfactory performance in resisting the effect of freezing and thawing action. Only portland cement-lime mortar or mortar prepared from masonry cement should be used if the masonry is exposed to the weather.

Walls containing structural clay tile have better heat-insulating qualities than do walls composed of solid units, due to dead air space

that exists in tile walls. The resistance to sound penetration of this type of masonry compares favorably with the resistance of solid masonry walls, but is somewhat less.

The fire resistance of tile walls is considerably less than the fire resistance of solid masonry walls. It can be improved by applying a coat of plaster to the surface of the wall. Partitions walls of structural clay tiles 6 in. thick will resist a fire for 1 hr provided the fire does not produce a temperature higher than 1,700° F.

The solid material in structural clay tile weighs about 125 lb per cu ft. Since the tile contains hollow cells of various sizes, the weight of tile varies, depending upon the manufacture and type. A 6-in. tile wall weighs approximately 30 lb per sq ft; a 12-in. tile wall weighs approximately 45 lb per sq ft.

USES FOR STRUCTURAL CLAY TILE

Structural clay tile may be used for exterior walls of either the load-bearing or nonload-bearing type. It is suitable for both belowgrade and above-grade construction.

Nonload-bearing partition walls of from 4- to 12-in. thickness are frequently made of structural clay tile. These walls are easily built, light in weight, and have good heat- and sound-insulating properties.

Figure 8-35 illustrates the use of structural clay tile as a backing unit for a brick wall. Figure 8-35 also shows the use of header brick to tie the brick tier to the tile used for backing.

MORTAR JOINTS FOR STRUCTURAL CLAY TILE

In general, the procedure for making mortar joints for structural clay tile is the same as for concrete block.

The bed joint for the end-construction is made by spreading a 1-in. thickness of mortar on the shell of the bed tile, but not on the webs. The mortar should be spread for a distance of about 3 ft ahead of the laying of the tile. The position of the tile above does not coincide with the position of the tile below since the head joints are to be staggered as shown in view A, fig. 8-36. The web of the tile above will not contact the web of the tile below and any mortar placed on these webs is useless.



29.148
Figure 8-35.—Structural clay tile used as a backing unit.

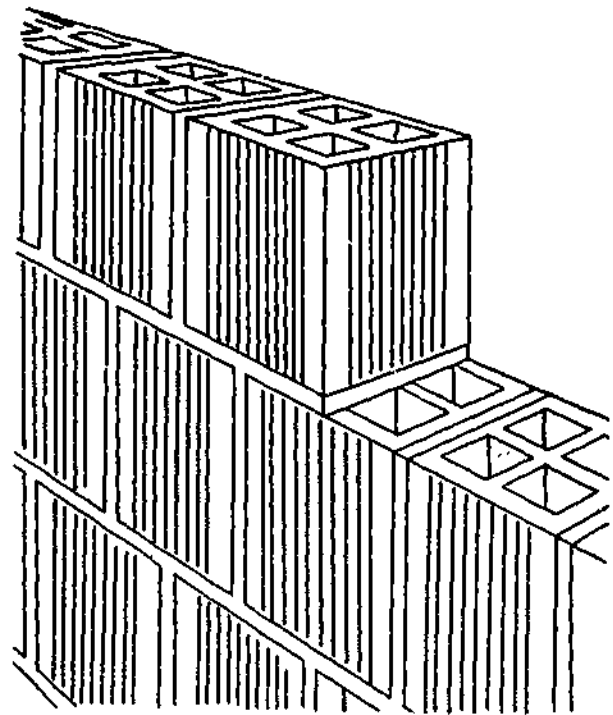

A. BED JOINT

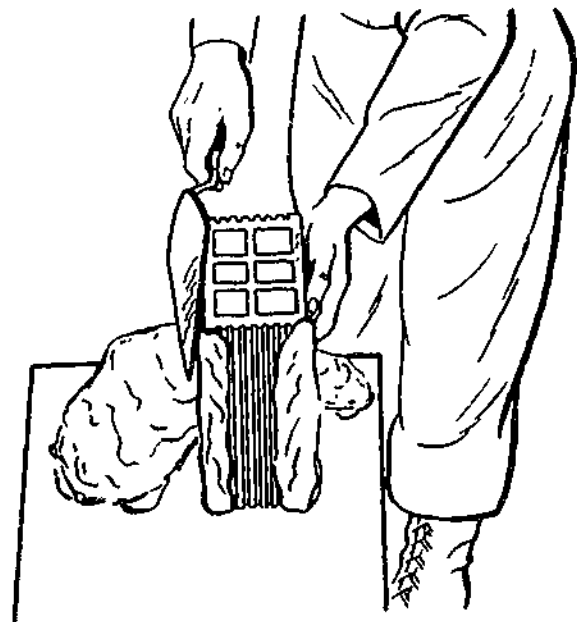

B. HEAD JOINT

133.289
Figure 8-36.—Laying end-construction tile.

The head joint for the end-construction is formed by spreading plenty of mortar along each edge of the tile, as shown in view B, fig. 8-36, and then pushing the tile into the mortar bed until in its proper position. Enough mortar should be used to cause excess mortar to squeeze out of the joints. This excess mortar is cut off with a trowel. The head joint need not be a solid joint as recommended for head joints in brick masonry unless the joint is to be exposed to the weather. Clay tile units are heavy, which requires you to use both hands when placing the tile in position in the wall. The mortar joint should be about 1/2-in. thick, depending upon the type of construction.

The bed joint for the side-construction is made by spreading the mortar to a thickness of about 1 in. for a distance of about 3 ft ahead of the laying of the tile. A furrow need not be made.

There are two methods of laying the head joint. In the first method, as much mortar as will adhere is spread on both edges of tile as shown in view A, fig. 8-37. The tile is then pushed into the mortar bed against the tile already in place until in its proper position. Excess mortar is cut off. In the second method, as much mortar as will adhere is placed on the interior edge of the tile already in place and on the opposite edge of the unit being placed. This is also shown in view B, fig. 8-37. The tile is then shoved in place and the excess mortar cut off.

The mortar joints should be about 1/2 in. thick, depending upon the type of construction.

EIGHT-INCH WALL WITH FOUR-INCH STRUCTURAL CLAY TILE BACKING

For this wall, there will be six stretcher courses between the header courses. The backing tile is side-constructed with tiles that are 4 in. wide, 5 in. high and 12 in. long. The 5-in. height is equal to the height of two brick courses and a 1/2-in. mortar joint. These tiles are laid with a bed joint so that the top of the tile will be level with every second course of brick. The thickness of the bed joint, therefore depends upon the thickness of the bed joint used for the brick.

The first course of the wall is temporarily laid out without mortar as recommended for

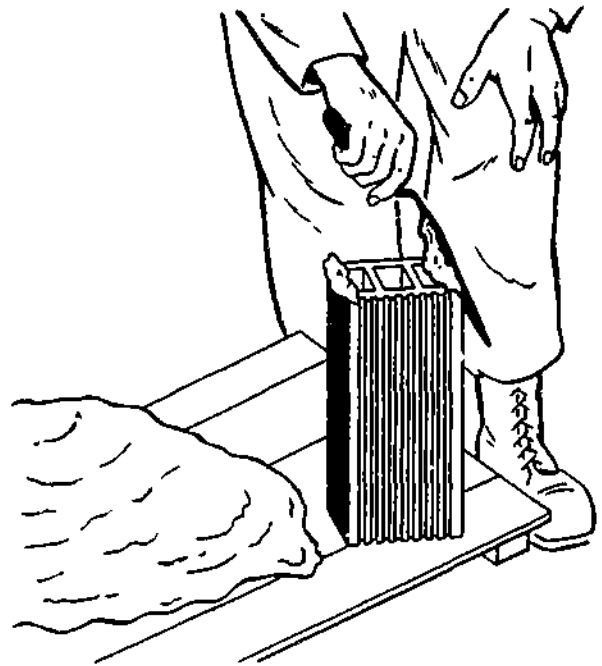

A. METHOD A FOR MAKING HEAD JOINT

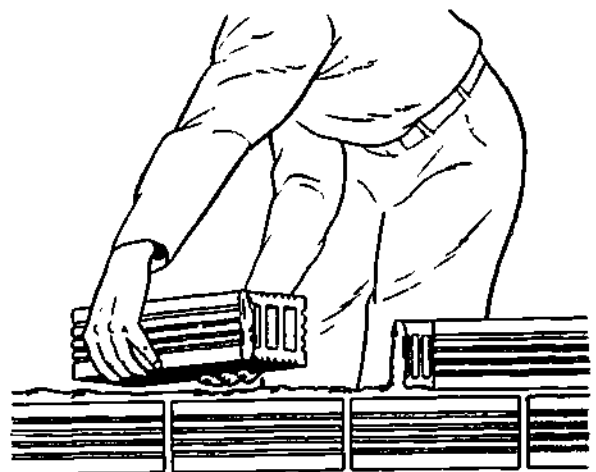

B. METHOD B FOR MAKING HEAD JOINT

133.40(133F)

Figure 8-37.—Laying side-construction tile.

solid brick walls. This will establish the number of brick required for one course.

As shown in figure 8-38, the first course of the corner lead is identical to the first course of

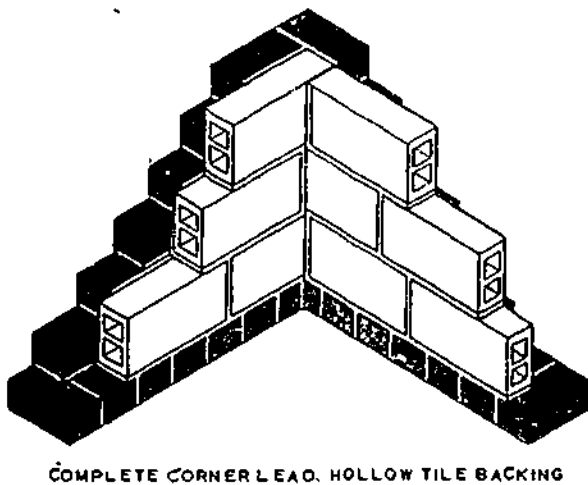
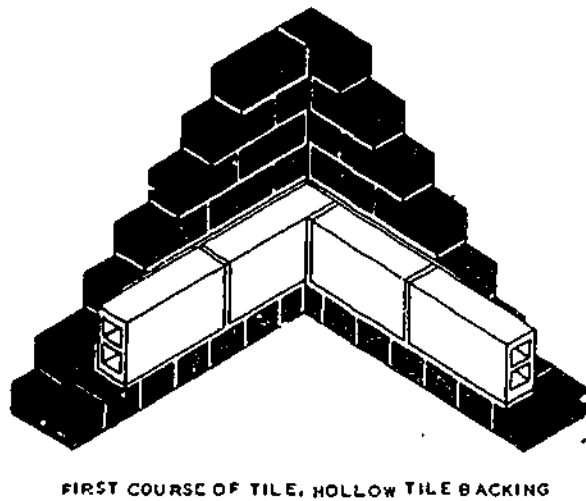
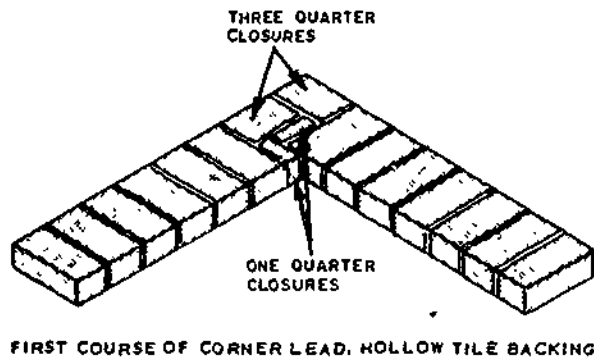

133.40(133F)

Figure 8-38.—Corner lead hollow tile backing.

the corner lead for a solid 8-in. brick wall except that one brick is laid.

All the brick required for the corner lead are laid before any tile is placed. The first course of tile and the completed corner lead are also shown in figure 8-38.

EIGHT-INCH STRUCTURAL CLAY TILE WALL

By referring to figure 8-39, you can see how the corner leads of a structural clay wall are erected. This wall is constructed of 8- by 5- by 12-in. tiles (8 in. wide, 5 in. high, and 12 in. long) and 2- by 5- by 8-in. soap tiles. Tiles a and b are laid first, then c and d. The level is checked as they are laid. Tiles e and f are laid and their level checked. Tile b must be laid so that it projects 6 in. from the inside corner as shown to provide for the half-lap bond. Corner tiles, such as b, g, and h, should be end-construction tile in order to avoid exposure of the open cells at the face of the wall. The remainder of the tiles in the corner are then laid, and the level of each is checked. After the corner leads are erected, the wall between is laid using the line.

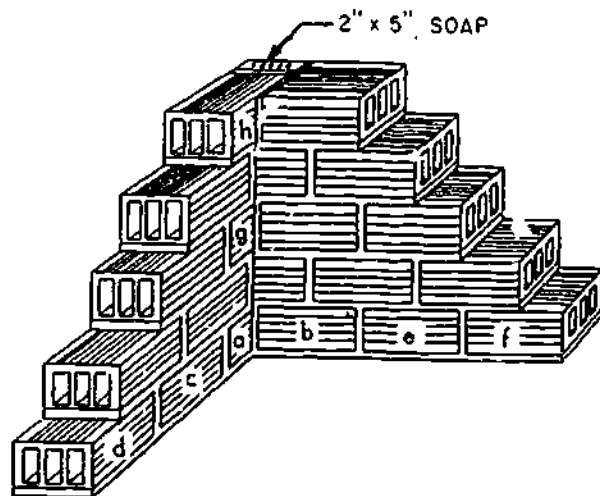

133.41

Figure 8-39.—Eight-inch structural clay tile wall.

JOINT FINISHING

The exterior surfaces of joints are finished to make the masonry more watertight and to improve its appearance. Concave and V-shaped mortar joints (fig. 8-40) are recommended for walls of exterior masonry in preference to struck or raked joints that form small lodges which may hold water. Some joints can be made with the trowel, while others have to be made with the jointer. With modular-size masonry units, mortar joints will be approximately 3/8-in. thick. Experience has shown that this thickness of joint when properly made helps to produce a weathertight, neat and durable masonry wall.

There is a process called POINTING that may have to be done after jointing has occurred. Pointing is the process of inserting mortar into horizontal and vertical joints after the unit has been laid. Basically, pointing is done to restore or replace deteriorated surface mortar in old work. Pointing of this nature is called TUCK pointing. However, even in freshly laid masonry, pointing may be necessary for filling holes or correcting defective joints.

SAFE HANDLING OF BLOCK AND HOLLOW TILE

Block and tile should always be stacked in tiers on a solid foundation. Stacked piles should be limited to a height of 6 ft whenever possible. When block and tile are stacked higher than 6 ft, the pile must be stepped back, braced, and propped, or stickers placed between the tiers to prevent the pile from toppling.

Blocks should not be dropped or thrown from high places or delivered through fully enclosed chutes.

BRICK MASONRY

Brick masonry is that type of construction in which units of baked clay or shale of uniform size, small enough to be placed with one hand, are laid in courses with mortar joints to form

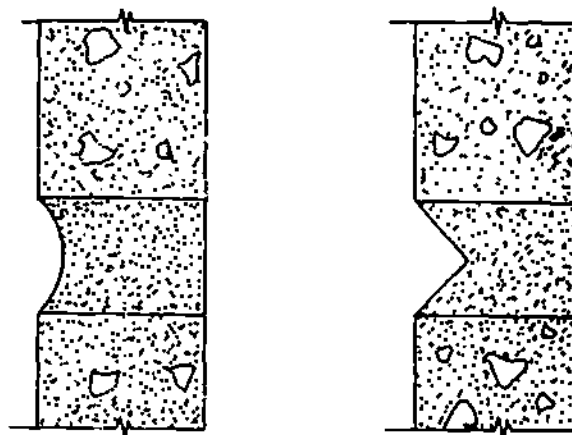

CONCAVE JOINT

V-JOINT

133.43

Figure 8-40.—Tooled mortar joints for watertight concrete.

walls of virtually unlimited length and height. Bricks are kiln-baked from various clay and shale mixtures. The chemical and physical characteristics of the ingredients vary considerably; these and the kiln temperatures combine to produce brick in a variety of colors and hardnesses. In some regions, pits are opened and found to yield clay or shale which, when ground and moistened, can be formed and baked into durable brick; in other regions, clays or shales from several pits must be mixed.

The dimensions of a U. S. standard building brick are 2 1/4 by 3 3/4 by 8 in. The actual dimensions of brick may vary a little because of shrinkage during burning. Other special purpose brick also vary in size.

BRICK TERMINOLOGY

Frequently the Builder must cut the brick into various shapes. The more common of these are shown in figure 8-41. They are called half or bat, three-quarter closure, quarter closure, king closure, queen closure, and split. They are used to fill in the spaces at corners and such other places where a full brick will not fit.

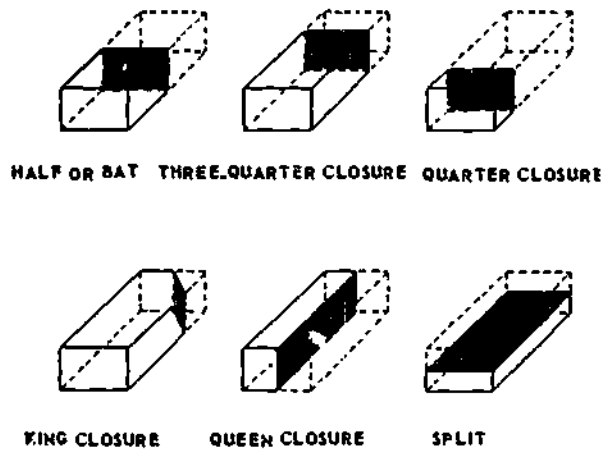

133.28

Figure 8-41.—Nomenclature of common shapes of cut brick.

The six surfaces of a brick are called the face, the side, the cull, the end, and the beds, as shown in figure 8-42.

BRICK CLASSIFICATION

A finished brick structure contains FACE brick (brick placed on the exposed face of the structure) and BACKUP brick (brick placed behind the face brick). The face brick is often of higher quality than the backup brick; however, the entire wall may be built of COMMON brick.

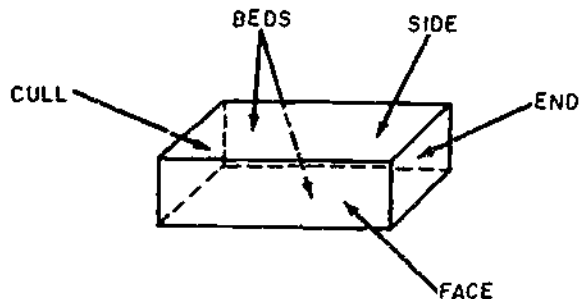

29.141

Figure 8-42.—Names of brick surfaces.

Common brick is brick which is made from pit-run clay, with no attempt at color control and no special surface treatment like glazing or enameling. Most common brick is red.

Although any surface brick is a face brick as distinguished from a backup brick, the term face brick is also used to distinguish high-quality brick from brick which is of common brick quality or less. Applying this criterion, face brick is more uniform in color than common brick, and it may be obtained in a variety of colors as well. It may have a particular type of finish on the surface, and in any case it has a better surface appearance than common brick. It may also be more durable, as a result of the use of select clay and other materials, or as a result of special manufacturing methods.

Backup brick may consist of brick which is inferior in quality even to common brick. Brick which has been underburned or overburned, or brick made with inferior clay or by inferior methods, is often used for backup brick.

Still another type of classification divides brick into grades in accordance with the probable climatic conditions to which it is to be exposed, as follows:

GRADE SW is designed to withstand exposure to below-freezing temperatures in moist climate like that of the northern regions of the United States.

GRADE MW is designed to withstand exposure to below freezing temperatures in a drier climate than that mentioned in the previous paragraph.

GRADE NW is primarily intended for interior or backup brick. However, it may be used exposed in regions where no frost action occurs or in regions where frost action occurs, but the annual rainfall is less than 15 inches.

TYPES OF BRICKS

There are many types of brick. Some are different in formation and composition while

others vary according to their use. Some commonly used types of brick are:

BUILDING brick, formerly called common brick, is made of ordinary clays or shales and burned in the usual manner in the kilns. These bricks do not have special scorings or markings and are not produced in any special color or surface texture. Building brick is also known as hard and kiln run brick. It is used generally for the backing courses in solid or cavity brick walls. The harder and more durable kinds are preferred for this purpose.

FACE brick are used in the exposed face of a wall and are higher quality units than backup brick. They have better durability and appearance. The most common colors of face brick are various shades of brown, red, gray, yellow, and white.

A dry process is used to make **PRESS** brick which has regular smooth faces, sharp edges, and perfectly square corners. **PRESS** brick is ordinarily used as face brick.

Bricks that are overburned in the kilns are called **CLINKER** brick. They are usually hard and durable, may be irregular in shape, and can be used in the same manner as building brick.

GLAZED brick has one surface of each brick glazed in white or other color. The ceramic glazing consists of mineral ingredients which fuse together in a glass-like coating during burning. This type of brick is particularly suited for walls or partitions in hospitals, dairies, laboratories, or other buildings where cleanliness and ease of cleaning is necessary.

FIREBRICK is made of a special type of fire clay which will withstand the high temperatures of fireplaces, boilers and similar usage without cracking or decomposing. **FIREBRICK** is generally larger than regular structural brick and often it is hand molded.

CORED bricks are bricks made with two rows of five holes extending through their beds to reduce weight. There is no significant difference between the strength of walls constructed with cored brick and those constructed with solid brick. Resistance to moisture penetration is about the same for both

types of walls. The most easily available brick that will meet requirements should be used whether the brick is cored or solid.

SAND LIME bricks are made from a lean mixture of slaked lime and fine silicious sand molded under mechanical pressure and hardened under steam pressure.

MORTAR FOR BRICK MASONRY

Mortar is used to bond the brick together and unless properly mixed and applied will be the weakest part of brick masonry. Both the strength and resistance to rain penetration of brick masonry walls are dependent to a great degree on the strength of the bond. Water in the mortar is essential to the development of bond and if the mortar contains insufficient water the bond will be weak and spotty. When brick walls leak it is usually through the mortar joints. Irregularities in dimensions and shape of bricks are corrected by the mortar joint.

Mortar should be plastic enough to work with a trowel. The properties of mortar depend largely upon the type of sand used in it. Clean, sharp sand produces excellent mortar. Too much sand in mortar will cause it to segregate, drop off the trowel, and weather poorly.

The selection of mortar for brick construction depends on the use requirements of the structure. For example, the recommended mortar for use in laying up interior nonload-bearing partitions would not be satisfactory for foundation walls. In many cases, the Builder relies upon a fixed proportion of cement, lime and sand to provide a satisfactory mortar. The following types of mortar are proportioned on a volume basis:

TYPE M is 1 part portland cement, 1/4 part hydrated lime or lime putty, and 3 parts sand; or 1 part portland cement, 1 part type II masonry cement, and 6 parts sand. This mortar is suitable for general use and is recommended specifically for masonry below grade and in contact with earth, such as foundations, retaining walls, and walks.

TYPE S is 1 part portland cement, 1/2 part hydrated lime or lime putty, and 4 1/2 parts sand, or 1/2 part portland cement, 1 part type II masonry cement and 4 1/2 parts sand. This mortar is also suitable for general use and is recommended where high resistance to lateral forces is required.

TYPE N is 1 part portland cement, 1 part hydrated lime or lime putty, and 6 parts sand; or 1 part type II masonry cement and 3 parts sand. This mortar is suitable for general use in exposed masonry above grade and is recommended specifically for exterior walls subjected to severe exposures.

TYPE O is 1 part portland cement, 2 parts hydrated lime or lime putty, and 9 parts sand; or 1 part type I or type II masonry cement and 3 parts sand. This mortar is recommended for load-bearing walls of solid units where the compressive stresses do not exceed 100 lb per sq in. and the masonry will not be subjected to freezing and thawing in the presence of excessive moisture.

RESISTANCE TO WEATHERING

The resistance of masonry walls to weathering depends almost entirely upon their resistance to water penetration because freezing and thawing action is virtually the only type of weathering that affects brick masonry. With the best workmanship, it is possible to build brick walls that will resist the penetration of rain water during a storm lasting as long as 24 hrs accompanied by a 50- to 60-mile-per-hr wind. In most construction, it is unreasonable to expect the type of workmanship required to build a wall that will allow no water penetration. It is advisable to provide some means of taking care of moisture after it has penetrated the brick masonry. Properly designed flashing and cavity walls are two ways of handling moisture that has entered the wall.

Important factors in preventing the entrance of water are tooled mortar joints and caulking around windows and door frames.

The joints between the brick must be solidly filled, especially in the face tier. Slushing or grouting the joints after the brick has been laid does not completely fill the joint. The mortar joint should be tooled to a concave surface before the mortar has had a chance to set up. In tooling, sufficient force should be used to press the mortar tight against the brick on both sides of the mortar joint.

Mortar joints that are tightly bonded to the brick have been shown to have greater resistance to moisture penetration than joints that are not.

GENERAL CHARACTERISTICS OF BRICK MASONRY

Solid brick masonry walls provide very little insulation against heat and cold. A cavity wall or a brick wall backed with hollow clay tile has much better insulating value.

Because brick walls are exceptionally massive, they have good sound-insulating properties. In general, the heavier the wall, the better will be its sound-insulating value; however, there is no appreciable increase in sound insulation by a wall more than 12 in. thick as compared to a wall between 10 and 12 in. thick. The expense involved in constructing a thicker wall merely to take advantage of the slight increase is too excessive to be worthwhile. Dividing the wall into two or more layers, as in the case of a cavity wall, will increase its resistance to the transmission of sound from one side of the wall to the other. Brick walls are poor absorbers of sound originating within the walls and reflect much of it back into the structure. Sounds caused by impact, as when the wall is struck with a hammer, will travel a great distance along the wall.

Brick masonry expands and contracts with temperature change. Walls up to a length of 200 ft do not need expansion joints. Longer walls need an expansion joint for every 200 ft of wall. The joint can be made as shown in figure

8-43. A considerable amount of the expansion and contraction is taken up in the wall itself. For this reason, the amount of movement that theoretically takes place does not actually occur.

The resistance of brick to abrasion depends largely upon its compressive strength, related to the degree of burning. Well-burned brick have excellent wearing qualities.

The weight of brick varies from 100 to 150 lb per cu ft depending upon the nature of the materials used in making the brick and the degree of burning. Well-burned brick are heavier than underburned brick.

BRICKLAYING METHODS

Good bricklaying procedure depends on good workmanship and efficiency. Means of obtaining good workmanship are treated below. Efficiency involves doing the work with the fewest possible motions. The Builder should study the operations to determine those motions that are unnecessary. Each motion should have a purpose and should accomplish a definite result. After learning the fundamentals, every Builder should develop methods for achieving maximum efficiency. The work must be arranged in such a way that the Builder is continually supplied with brick and mortar. The scaffolding required must be planned before the work begins. It must be built in such a way as to cause the least interference with other crew members.

Bricks should never be piled directly on uneven or soft ground; they should always be stacked on planks. Do not store bricks on

scaffolds or runways. This does not prohibit putting the normal supplies on scaffolding during actual bricklaying operations.

Except where stacked in sheds, brick piles should never be more than 7 ft high. When a pile of brick reaches a height of 4 ft, it must be tapered back 1 in. in every foot of height above the 4 ft level. The tops of brick piles must be kept level; and the taper maintained during unpling operations.

Masonry Terms

Specific terms are used to describe the various positions of masonry units and mortar joints in a wall (fig. 8-44):

COURSE. One of the continuous horizontal layers (or rows) of masonry which, bonded together, form the masonry structure.

STRETCHER. A masonry unit laid flat with its longest dimension parallel to the face of the wall.

HEADER. A masonry unit laid flat with its longest dimension perpendicular to the face of the wall. It is generally used to tie two wythes of masonry together.

ROWLOCK. A brick laid on its edge (face).

BULL-STRETCHER. A rowlock brick laid with its longest dimension parallel to the face of the wall.

BULL-HEADER. A rowlock brick laid with its longest dimension perpendicular to the face of the wall.

SOLDIER. A brick laid on its end so that its longest dimension is parallel to the vertical axis of the face of the wall.

Types of Bonds

The word bond, when used in reference to masonry, may have three different meanings:

STRUCTURAL BOND is the method by which individual masonry units are interlocked

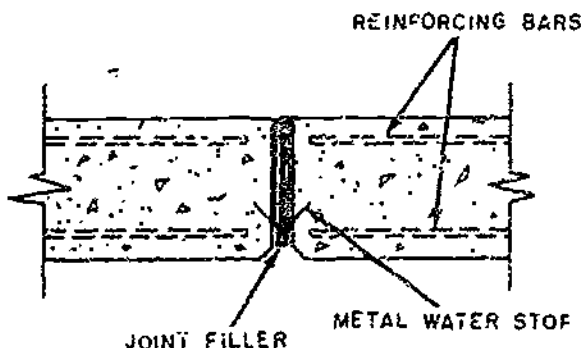

133.287

Figure 8-43.—Expansion joint for wall.

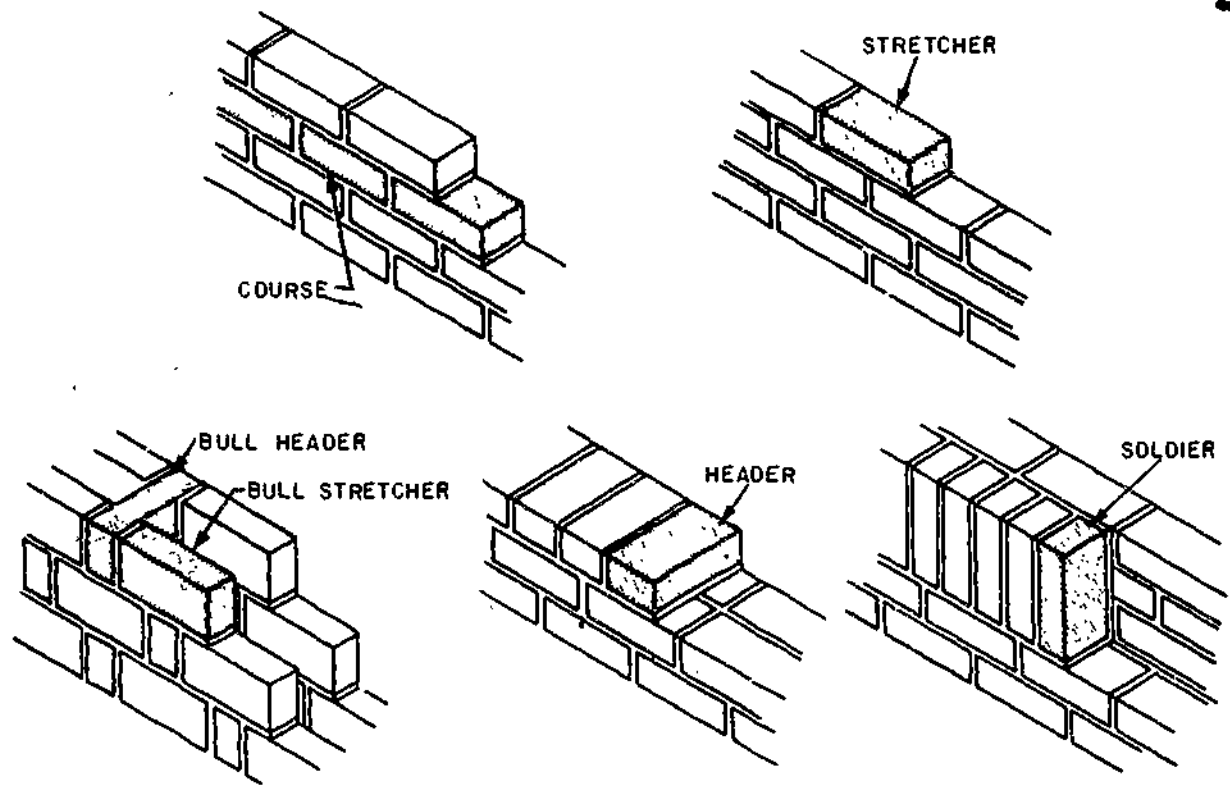

133.289

Figure 8-44.—Masonry units and mortar joints.

or tied together to cause the entire assembly to act as a single structural unit. Structural bonding of brick and tile walls may be accomplished in three ways. First, by overlapping (interlocking) the masonry units, second by the use of metal ties imbedded in connecting joints, and third by the adhesion of grout to adjacent wythes of masonry.

MORTAR BOND is the adhesion of the joint mortar to the masonry units or to the reinforcing steel.

PATTERN BOND is the pattern formed by the masonry units and the mortar joints on the face of a wall. The pattern may result from the type of structural bond used or may be purely a decorative one in no way related to the structural bond. There are five basic pattern bonds in common use today as shown in figure

8-45. Running bond, common bond, stack bond, Flemish bond, and English bond.

RUNNING BOND is the simplest of the basic pattern bonds, the running bond consists of all stretchers. Since there are no headers used in this bond, metal ties are usually used. Running bond is used largely in cavity wall construction and veneered walls of brick and often in facing tile walls where the bonding may be accomplished by extra width stretcher tile

COMMON OR AMERICAN BOND is a variation of running bond with a course of full length headers at regular intervals. These headers provide structural bonding as well as pattern. Header courses usually appear at every fifth, sixth, or seventh course depending on the structural bonding requirements. In laying out

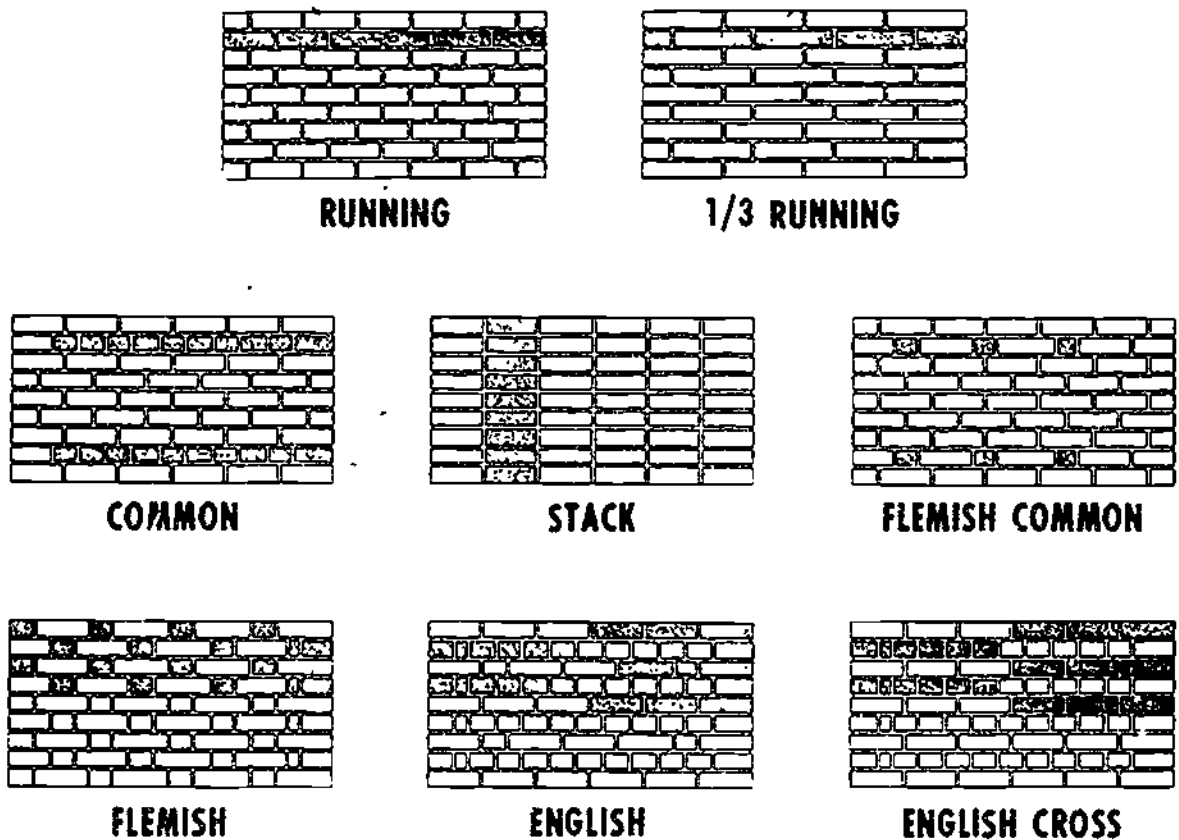

Figure 8-45.—Some types of brick masonry bond.

133.288

any bond pattern it is very important that the corners be started correctly. For common bond, a three-quarter brick must start each header course at the corner. Common bond may be varied by using a Flemish header course.

STACK BOND is purely a pattern bond. There is no overlapping of the units, all vertical joints being aligned. Usually this pattern is bonded to the backing with rigid steel ties, but when 8 in. thick stretcher units are available, they may be used. In large wall areas and in load-bearing construction it is advisable to reinforce the wall with steel pencil rods placed in the horizontal mortar joints. The vertical alignment requires dimensionally accurate units, or carefully prematched units, for each vertical joint alignment. Variety in pattern may be

achieved by numerous combinations and modifications of the basic patterns shown.

FLEMISH BOND is made up of alternate stretchers and headers, with the headers in alternate courses centered over the stretchers in the intervening courses. Where the headers are not used for the structural bonding, they may be obtained by using half brick, called blind-headers. There are two methods used in starting the corners. Figure 8-45 shows the so called **FLEMISH** corner in which a three-quarter brick is used to start each course and the "English" corner in which 2 in. or quarter-brick closures must be used.

ENGLISH BOND is composed of alternate courses of headers and stretchers. The headers are centered on the stretchers and joints

between stretchers. The vertical (head) joints between stretchers in all courses line up vertically. Blind headers are used in courses which are not structural bonding courses. The English cross bond is a variation of English bond and differs only in that vertical joints between the stretchers in alternate courses do not line up vertically. These joints center on the stretchers themselves in the courses above and below.

Metal Ties

Metal ties can be used to tie the brick on the outside face of the wall to the backing courses. These are used when no header courses are installed. They are not as satisfactory as header courses. Typical metal ties are shown in figure 8-46.

Flashing

Flashing is installed in masonry construction to divert moisture, which may enter the

masonry at vulnerable spots, to the outside. Flashing should be provided under horizontal masonry surfaces, such as sills and copings, at intersections of masonry walls with horizontal surfaces, such as roof and parapet or roof and chimney, over heads of openings, such as doors and windows, and frequently at floor lines, depending upon the type of construction. To be most effective, the flashing should extend through the outer face of the wall and be turned down to form a drop. Weep holes should be provided at intervals of 18 in. to 2 ft to permit the water which accumulates on the flashing to drain to the outside. If, because of appearance, it is necessary to stop the flashing back of the face of the wall, weep holes are even more important than when the flashing extends through the wall. Concealed flashings with tooled mortar joints frequently will retain water in the wall for long periods and, by concentrating moisture at one spot, may do more harm than good.

Mortar Joints and Pointing

The trowel should be held in a firm position. (See fig. 8-47.) The thumb should rest on top of the handle and should not encircle it. A

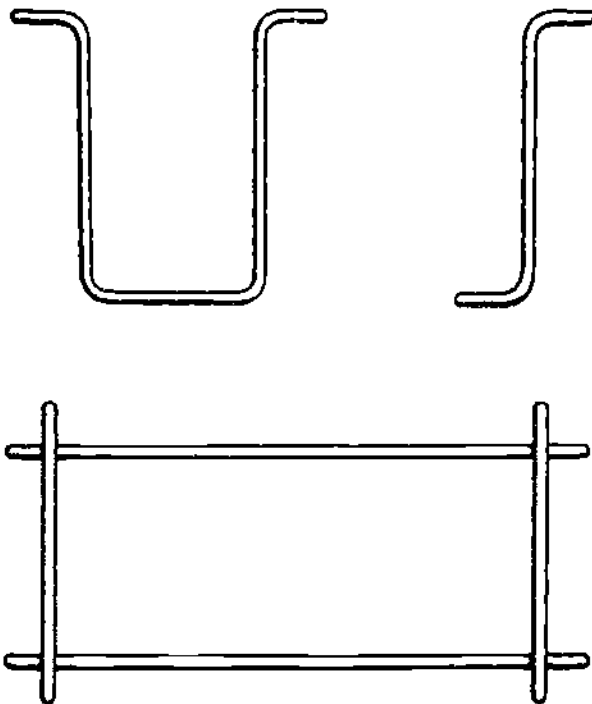

127.77(133F)

Figure 8-46.—Metal ties.

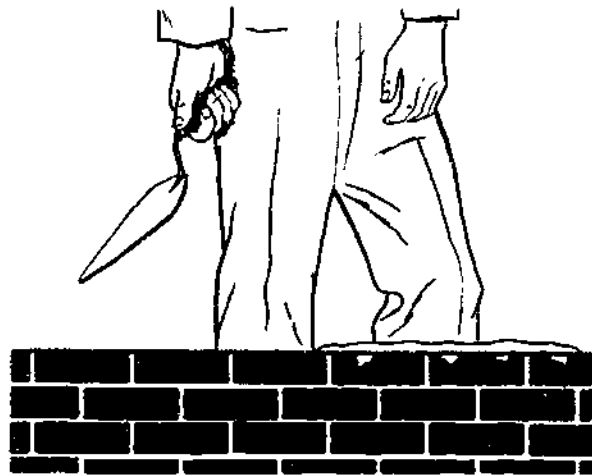

133.290

Figure 8-47.—One way to hold a trowel.

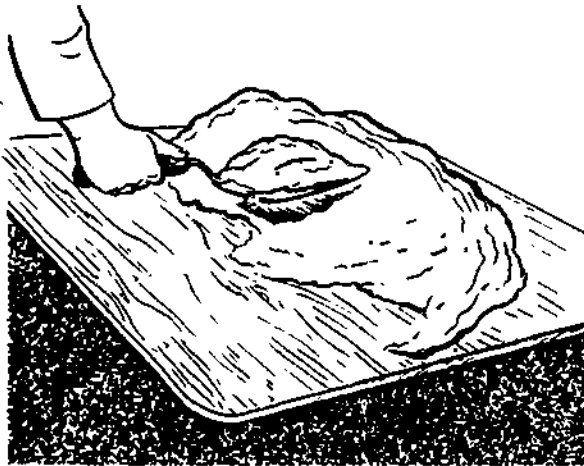

133.291

Figure 8-48.—Proper way to pick up mortar.

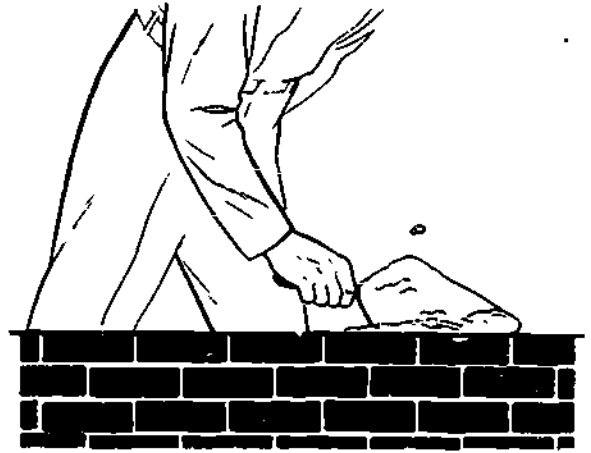

133.293

Figure 8-50.—Mortar thrown on brick.

right-handed Builder picks up mortar with the left edge of the trowel from the outside of the pile (fig. 8-48). The amount of mortar picked up is spread on as many as five bricks, depending on the wall space and the Builder's skill. A pickup for one brick forms a small windrow along the left edge of the trowel. A pickup for five bricks is a full load for a large trowel. (See fig. 8-49.)

Builder tilts the trowel slightly and moves it to the right, dropping a windrow of mortar along the wall until the trowel is empty as shown in figures 8-50 and 8-51. In some instances mortar will be left on the trowel when the spreading of mortar on the course below has been completed. When this occurs the remaining mortar is returned to the board. A right-handed Builder works from left to right along the wall.

Holding the trowel with its left edge directly over the centerline of the previous course, the

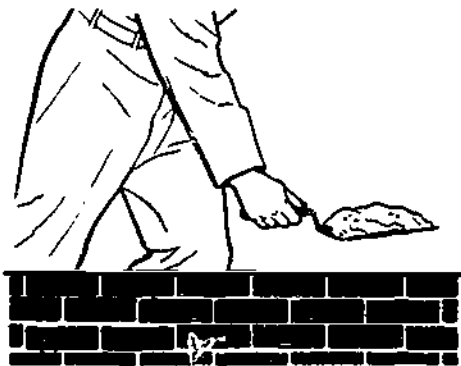

133.292

Figure 8-49.—Trowel full of mortar.

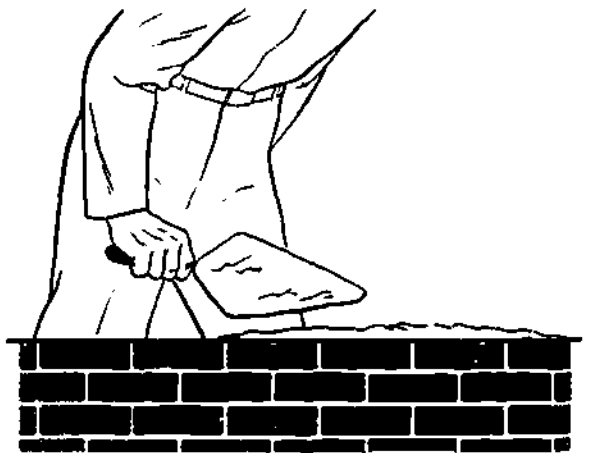

133.294

Figure 8-51.—Mortar spread for a distance of 3 to 5 brick.

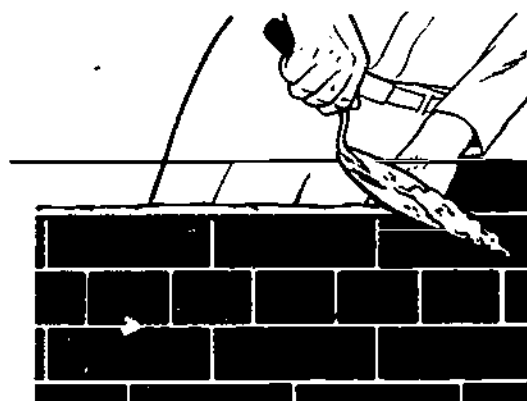

STEP 1

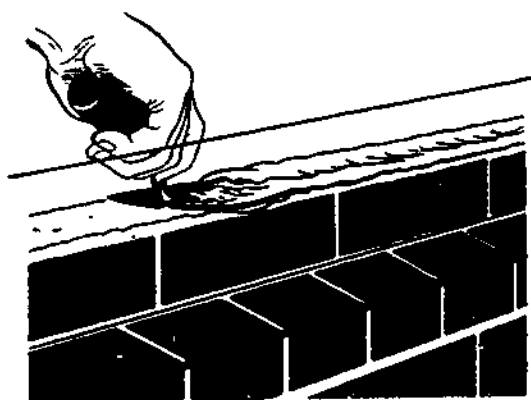

STEP 2

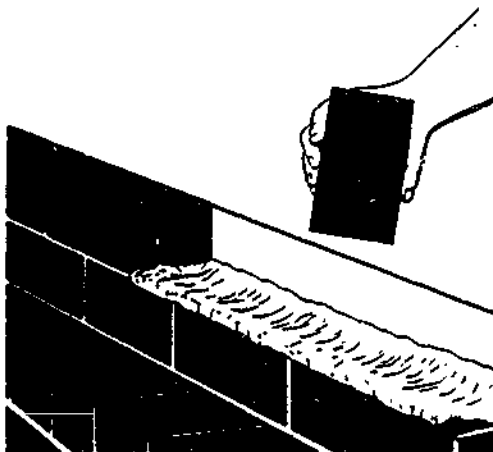

STEP 3

Mortar projecting beyond the wall line is cut off with the trowel edge (step 1, fig. 8-52) and thrown back on the mortar board, but enough is retained to "butter" the left end of the first brick to be laid in the fresh mortar.

With the mortar spread about 1 in. thick for the bed joint, as shown in step 1, fig. 8-52, a shallow furrow is made (step 2, fig. 8-52) and the brick pushed into the mortar (step 3, fig. 8-52). If the furrow is too deep, there will be a gap left between the mortar and the brick bedded in the mortar. This gap will reduce the resistance of the wall to water penetration. The mortar for a bed joint should not be spread out too far in advance of the laying. A distance of 4 or 5 bricks is advisable. Mortar that has been spread out too far will dry out before the brick is bedded in it. This results in a poor bond as can be seen in figure 8-53. The mortar must be soft and plastic so that the brick can be easily bedded in it.

The next step after the bed joint mortar has been spread is the laying of the brick. The brick to be laid is picked up as shown in figure 8-54 with the thumb on one side of the brick and the fingers on the other. As much mortar as will stick is placed on the end of the brick. The brick should then be pushed into place so that excess

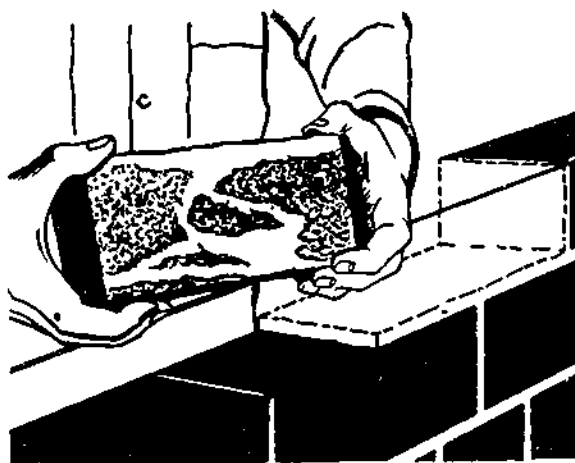

Figure 8-53.—A poorly bonded brick.

Figure 8-52.—Bed joint and furrow.

133.296

133.296



133.297

Figure 8-54.—Proper way to hold a brick.

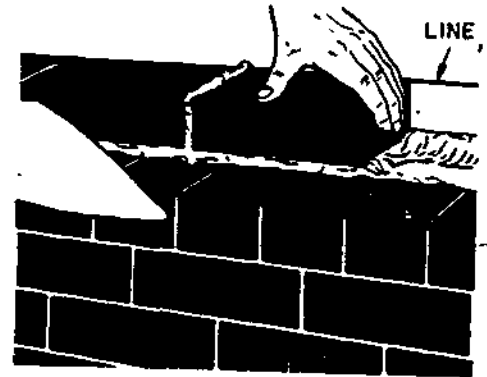

133.298

Figure 8-55.—Head joint in a stretcher course.



STEP 1

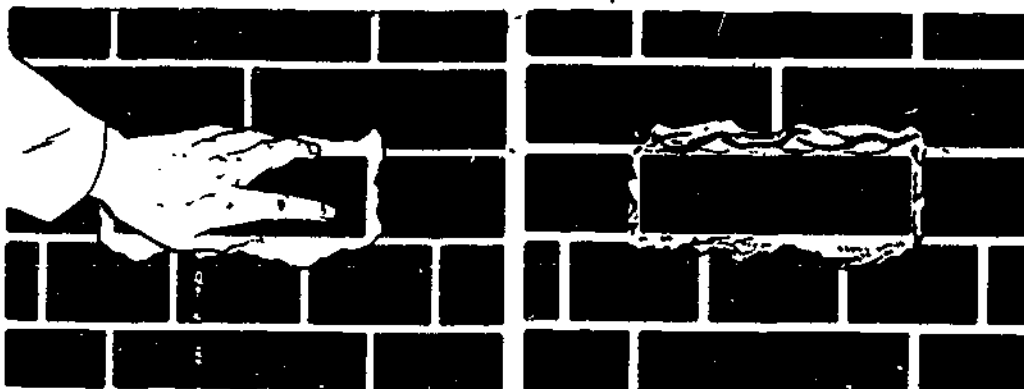

STEP 2

STEP 3

133.299

Figure 8-56.—Laying inside brick.

mortar squeezes out at the head joint and at the sides of the wall as indicated in figure 8-55. The head joint must be completely filled with mortar. This can only be done by placing plenty of mortar on the end of the brick. After the brick is bedded, the excess mortar is cut off and used for the next end joint. Surplus mortar should be thrown to the back of the mortar board for retempering (the process of remixing) if necessary. The proper position of the brick is

determined by the use of a line which can be seen in figure 8-55.

The method of inserting a brick in a space left in a wall is shown in figure 8-56. A thick bed of mortar is spread (step 1, fig. 8-56) and the brick shoved into this deep bed of mortar (step 2, fig. 8-56) until it squeezes out at the top of the joint at the face tier, and at the header joint (step 3, fig. 8-56) so that the joints are full of mortar at every point.

The position of a cross joint is illustrated in figure 8-57. These joints must be completely filled with mortar. The mortar for the bed joint should be spread several brick widths in advance. The mortar is spread over the entire side of the header brick before it is placed in the wall (step 1, fig. 8-57). The brick is then shoved into place so that the mortar is forced out at the top of the joint and the excess mortar cut off, as shown in step 2, fig. 8-57.

Figure 8-58 shows the method of laying a closure brick in a header course. Before laying the closure brick, plenty of mortar should be placed on the sides of the brick already in place (step 1, fig. 8-58). Mortar should also be spread on both sides of the closure brick to a thickness of about 1 inch (step 2, fig. 8-58). The closure brick should then be laid in position without disturbing the brick already in place (step 3, fig. 8-58).

Before laying a closure brick for a stretcher course, the ends of the brick on each side of the opening to be filled with the closure brick should be well covered with mortar (step 1, fig. 8-59). Plenty of mortar should then be thrown on both ends of the closure brick (step 2, fig. 8-59) and the brick laid without disturbing those already in place (step 3, fig. 8-59). If any of the adjacent brick are disturbed they must be removed and relaid. Otherwise, cracks will form between the brick and mortar, allowing moisture into the wall.

There is no hard and fast rule regarding the thickness of the mortar joint. Brick that are irregular in shape may require mortar joints up to 1/2-in. thick. All brick irregularities are taken up in the mortar joint. Mortar joints 1/4 in. thick are the strongest and should be used when the bricks are regular enough to permit it.

Slushed joints are made by depositing the mortar on the head joints in order that the



STEP 1



STEP 2

133.300

Figure 8-57.—Making cross joints in header courses.

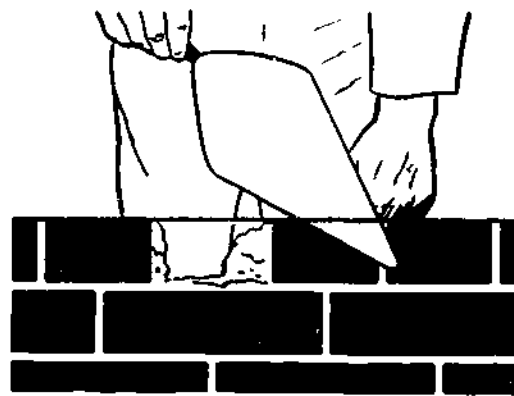

STEP 1

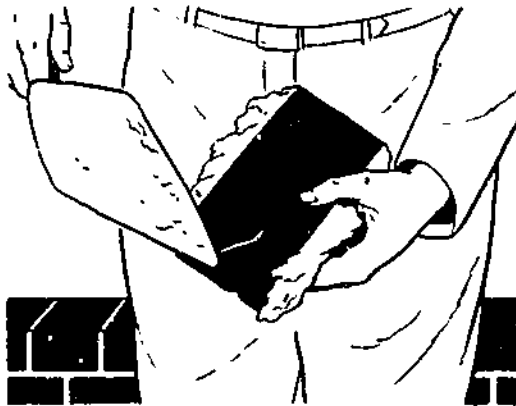

STEP 2

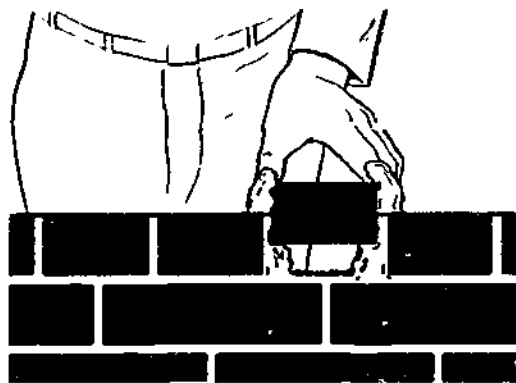

STEP 3

133.301
Figure 8-58.—Making closure joints in header courses.

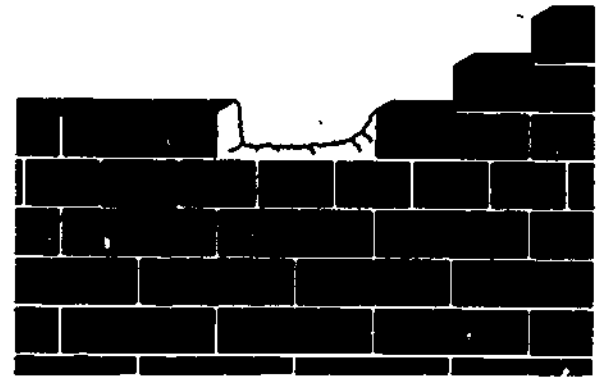

STEP 1

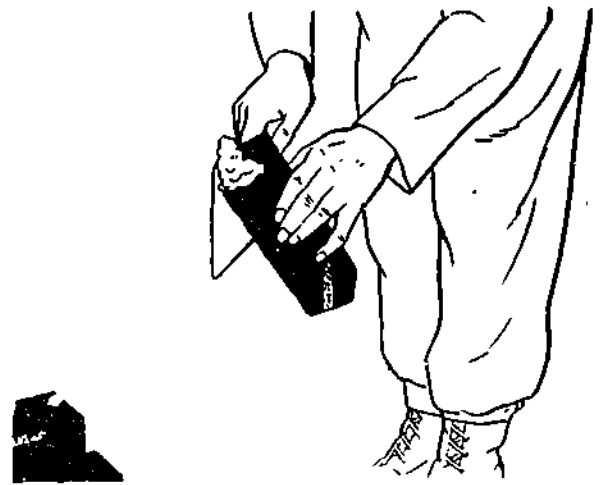

STEP 2

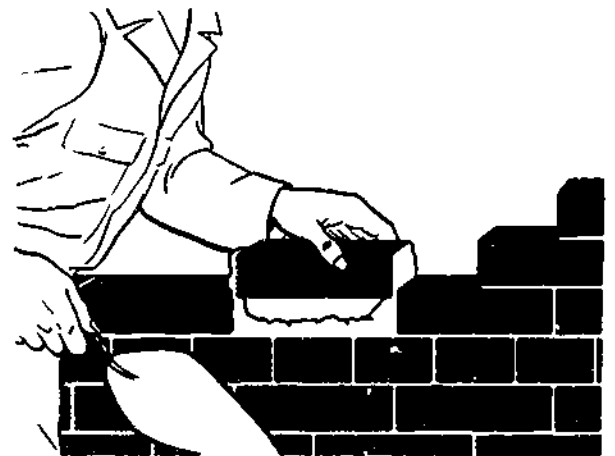

STEP 3

133.302
Figure 8-59.—Making closure joints in stretcher courses.

mortar will run down between the brick to form a solid joint. **THIS SHOULD NOT BE DONE.** Even when the space between the brick is completely filled, there is no way to compact the mortar against the faces of the brick and **A POOR BOND WILL RESULT.**

Filling exposed joints with mortar immediately after the wall has been laid is called **POINTING.** Pointing is frequently necessary to fill holes and correct defective mortar joints. The pointing trowel is used for this purpose. (See fig. 8-1.)

Cutting Brick

If a brick is to be cut to exact line, the brick chisel should be used. When using these tools, the straight side of the cutting edge should face the part of the brick to be saved and also face the Builder. One blow of the hammer on the brick set should be enough to break the brick. Extremely hard brick will need to be cut roughly with the head of the hammer in such a way that there is enough brick left to be cut accurately with the brick chisel. (See fig. 8-60.)

For normal cutting work, such as is required for making the closures and bats required around openings in walls and for the completion of corners, the brick hammer should be used. The first step is to cut a line all the way around the brick with light blows of the hammer head (fig. 8-61). When the line is complete, a sharp blow to one side of the cutting line will split the

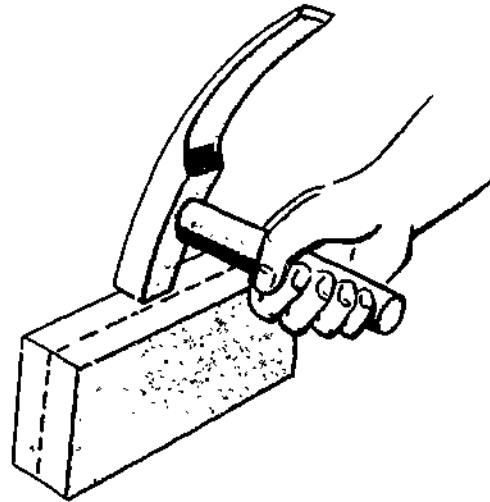

STRIKING BRICK TO ONE SIDE OF CUTTING LINE

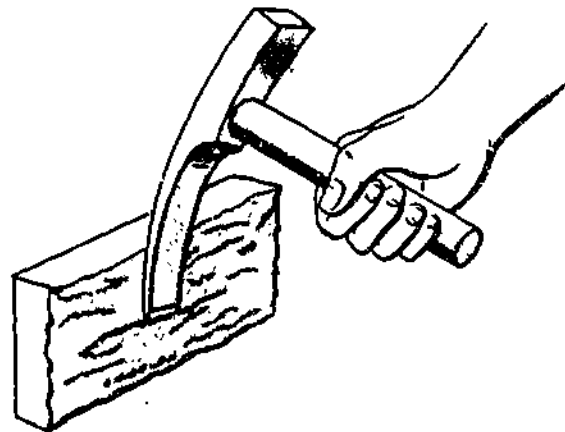

TRIMMING ROUGH SPOTS

133.304

Figure 8-61.—Cutting brick with a hammer.

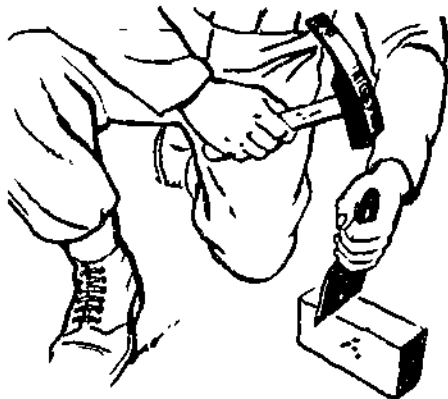

133.303

Figure 8-60.—Cutting brick with a brick chisel.

brick at the cutting line. Rough places are trimmed using the blade of the hammer, as shown in figure 8-61. The brick can be held in the hand while being cut.

Joint Finishes

Exterior surfaces of mortar joints are finished to make the brickwork more waterproof and to improve the appearance. There are several types of joint finishes, as

shown in figure 8-62. The more important of these are discussed below. When joints are cut flush with the brick and not finished, cracks are immediately apparent between the brick and the mortar. Although these cracks are not deep, they are undesirable and can be eliminated by finishing or tooling the joint. In every case, the mortar joint should be finished before the mortar has hardened to any appreciable extent. The jointing tool is shown in figure 8-1.

The best joint from the standpoint of weathertightness is the **CONCAVE** joint. This joint is made with a special tool after the excess mortar has been removed with the trowel. The tool should be slightly larger than the joint. Force is used to press the mortar tight against the brick on both sides of the mortar joint.

The **FLUSH** joint (fig. 8-62) is made by keeping the trowel almost parallel to the face of the wall while drawing the point of the trowel along the joint.

A **WEATHER** joint sheds water more easily from the surface of the wall and is formed by pushing downward on the mortar with the top edge of the trowel.

STRUCK, RAKED, AND BEAD joints are used mainly for interior decorative work where water tightness is not a factor.

BRICK CONSTRUCTION

An attractive brick construction depends upon the interpretation of the plans and the

abilities of the Strikers and Builders. Whether building an eight- or twelve-in. wall they must be able to work together and carry out their duties properly.

Striker's Duties

The Striker mixes mortar, carries brick and mortar to the Builder laying brick, and keeps the Builder supplied with these materials at all times. The Striker fills the mortar board and places it in a position convenient for the Builder laying brick. The Striker assists in the laying out and, at times, such as during rapid backup bricklaying, the Striker may lay out brick in a line on an adjacent course so that the Builder needs to move each brick only a few inches in laying backup work.

Wetting brick is also the duty of the Striker. This is done when bricks are laid in warm weather. There are four reasons for wetting brick just before they are laid:

There will be a better bond between the brick and the mortar.

The water will wash just and dirt from the surface of the brick. Mortar adheres better to a clean brick.

If the surface of the brick is wet, the mortar spreads more evenly under it.

A dry brick may absorb water from the mortar rapidly. This is particularly bad when mortar containing portland cement is used. In

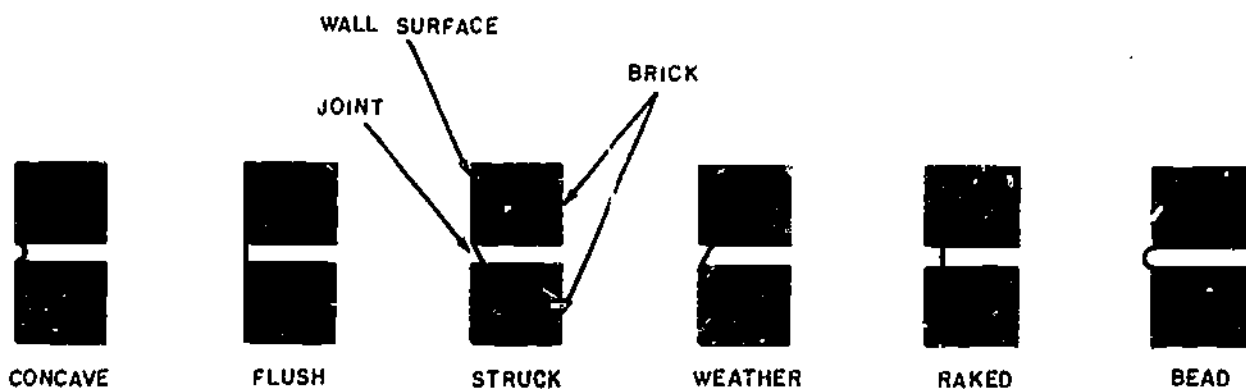

Figure 8-62.—Joint finishes.

order for cement to harden properly, sufficient moisture must be present to complete the hydration of the cement. If the brick robs the mortar of too much water, there will not be enough left to hydrate the cement properly.

Builder's Duties

The Builder does the actual laying of the brick. It is the Builder's responsibility to lay out the job so that the finished masonry will be properly done. In construction involving walls, the Builder must see that the walls are plumb and the courses level.

Footings

A footing is required under a wall when the bearing capacity of the supporting soil is not sufficient to withstand the wall load without a further means of redistribution. The footing must be wider than the thickness of the wall, as illustrated in figure 8-63. The required footing width and thickness for walls of considerable height or for walls that are to carry a heavy load should be determined by a qualified Builder. Every footing should be below the frost line in order to prevent heaving and settlement of the foundation. For the usual one-story building

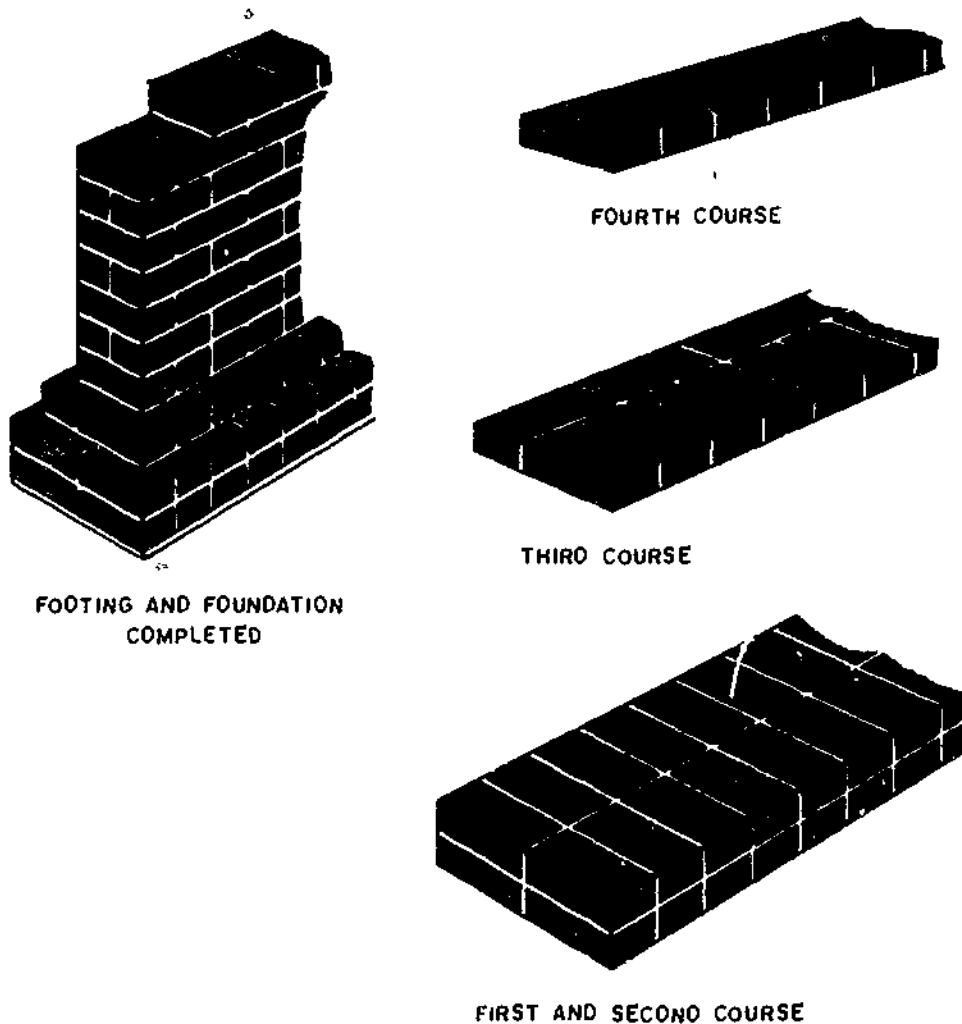

Figure 8-63.—Wall footing.

133.306

with an 8-in.-thick wall, a footing 16 in. wide and approximately 8 in. thick is usually enough. Although brickwork footings are satisfactory, footings are normally concrete, leveled on top to receive the brick or stone foundation wall. As soon as the subgrade is prepared, the Builder should place a bed of mortar about 1 in. thick on the subgrade to take up all irregularities. The first course of the foundation is laid on this bed of mortar. The other courses are then laid on this first course.

A column footing for a 12- by 16-in. brick column is shown in figure 8-64. The construction method for this footing is the same as for the wall footing.

Eight-Inch Common Bond Brick Wall

For a wall of given length, the Builder makes a slight adjustment in the width of head joints so that some number of brick, or some number including one-half brick, will just make up the length. The Builder first lays the brick on the foundation without mortar as shown in figure 8-65. The distance between the bricks is equal to

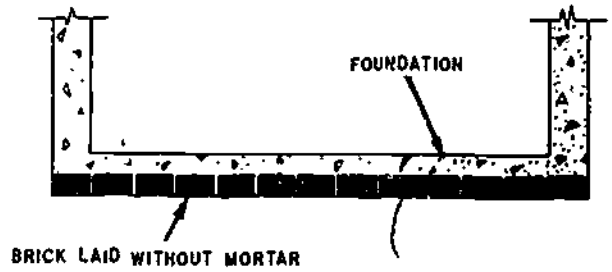

133.308

Figure 8-65.—Determination of vertical brick joints and number of bricks in one course.

the thickness of the head mortar joints. Tables 8-4, 8-5, and 8-6 give the number of courses and horizontal joints required for a given wall height.

The corners are erected first. This is called "laying of leads." The Builder will use these leads as a guide in laying the remainder of the wall.

The first step in laying a corner lead is shown in first step, figure 8-66. Two three-quarter closure bricks are cut and a 1-inch-thick mortar bed is laid on the foundation. Three-quarter closure brick a (in the second step of figure 8-66) is pressed down into the mortar bed until the bed joint becomes 1/2 in. thick. Next, mortar is placed on the end of three-quarter closure brick b and a head joint is formed as described previously. The head joint between the two three-quarter closures should be 1/2 in. thick also. Excess mortar that has been squeezed out of the joints is cut off. The level of the two three-quarter closures should now be checked by means of the mason's level placed in the positions indicated by the heavy dashed lines in the second step, fig. 8-66. The edges of both must be even with the outside face of the foundation. Next, mortar is spread on the side of brick c and it is laid as shown in the third step, fig. 8-66. Its level is checked using the mason's level in the position given in the third step, fig. 8-66. Its end must also be even with the outside face of the foundation. Brick d is laid and its level and position checked. When brick d is in the proper position, the quarter closures e and f should be cut and placed according to the recommended procedures for

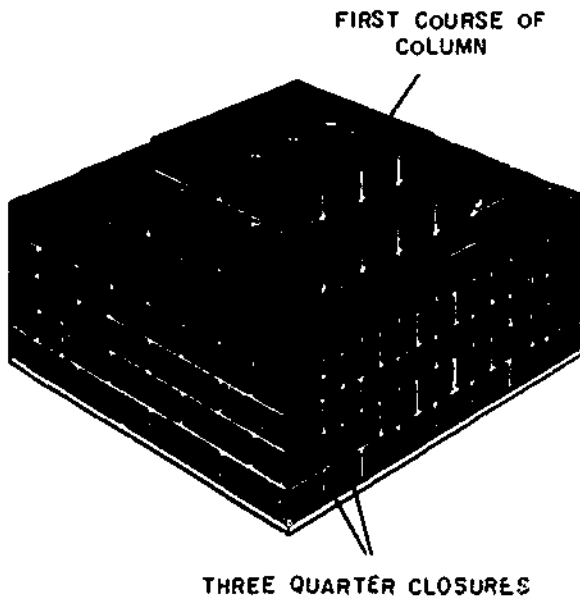

133.307

Figure 8-64.—Column footing.

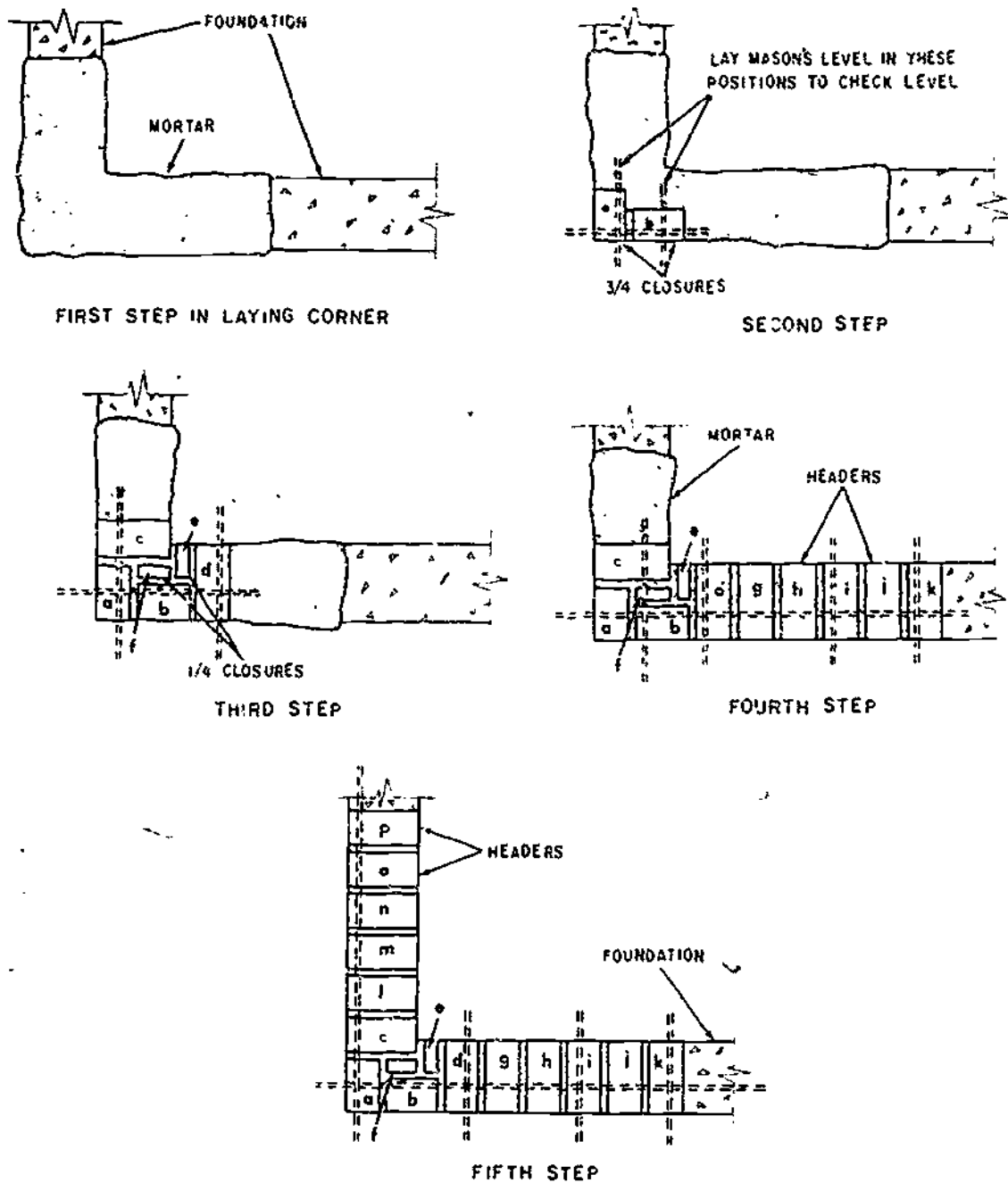

Figure 8-66.—First course of corner lead for 8-inch common bond brick wall.

133.309

laying closure brick. All excess mortar should be removed and the tops of these quarter closures checked to see that they are at the same level as the tops of surrounding brick.

Brick g (fourth step, fig. 8-66) is now shoved into position after mortar has been spread on its

face. Excess mortar should be removed. Bricks h, i, j, and k are laid in the same manner. The level of the brick is checked by placing the mason's level in the several positions indicated in the fourth step, fig. 8-66. All brick ends must be flush with the surface of the foundation. Bricks

BUILDER 3 & 2

Table 8-4.—Height of Courses: 2 1/4-inch Brick, 3/8-inch Joint

Courses	Height	Courses	Height	Courses	Height	Courses	Height	Courses	Height
1	0' 2 3/4"	21	4' 7 1/2"	41	8' 1 1/2"	61	13' 4 1/2"	81	17' 8 1/2"
2	0' 5 1/4"	22	4' 9 1/4"	42	9' 2 1/4"	62	13' 6 1/4"	82	17' 11 1/4"
3	0' 7 3/4"	23	5' 0 3/4"	43	9' 4 3/4"	63	13' 9 3/4"	83	18' 1 3/4"
4	0' 10 1/4"	24	5' 3"	44	9' 7 1/4"	64	14' 0"	84	18' 4 1/4"
5	1' 1 1/4"	25	5' 5 1/4"	45	9' 10 1/4"	65	14' 2 1/4"	85	18' 7 1/4"
6	1' 3 3/4"	26	5' 8 1/4"	46	10' 0 1/4"	66	14' 5 1/4"	86	18' 9 3/4"
7	1' 6 1/4"	27	5' 10 1/2"	47	10' 3 1/4"	67	14' 7 1/4"	87	19' 0 1/4"
8	1' 9"	28	6' 1 1/4"	48	10' 6"	68	14' 10 1/4"	88	19' 3"
9	1' 11 1/4"	29	6' 4 1/4"	49	10' 8 1/4"	69	15' 1 1/4"	89	19' 5 1/4"
10	2' 2 1/4"	30	6' 6 1/4"	50	10' 11 1/4"	70	15' 3 1/4"	90	19' 8 1/4"
11	2' 4 3/4"	31	6' 9 1/4"	51	11' 1 1/4"	71	15' 6 1/4"	91	19' 10 1/4"
12	2' 7 1/4"	32	7' 0"	52	11' 4 1/4"	72	15' 9"	92	20' 1 1/4"
13	2' 10 1/4"	33	7' 2 3/4"	53	11' 7 1/4"	73	15' 11 1/4"	93	20' 4 1/4"
14	3' 0 1/4"	34	7' 5 1/4"	54	11' 9 1/4"	74	16' 2 1/4"	94	20' 6 1/4"
15	3' 3 3/4"	35	7' 7 3/4"	55	12' 0 1/4"	75	16' 4 1/4"	95	20' 9 1/4"
16	3' 6"	36	7' 10 1/4"	56	12' 3"	76	16' 7 1/4"	96	21' 0"
17	3' 8 3/4"	37	8' 1 1/4"	57	12' 5 1/4"	77	16' 10 1/4"	97	21' 2 1/4"
18	3' 11 1/4"	38	8' 3 3/4"	58	12' 8 1/4"	78	17' 0 1/4"	98	21' 5 1/4"
19	4' 1 1/4"	39	8' 6 1/4"	59	12' 10 1/4"	79	17' 2 1/4"	99	21' 7 1/4"
20	4' 4 1/4"	40	8' 9"	60	13' 1 1/4"	80	17' 6"	100	21' 10 1/4"

133.331

Table 8-5.—Height of Courses: 2 1/4-inch Brick, 1/2-inch Joint

Courses	Height	Courses	Height	Courses	Height	Courses	Height	Courses	Height
1	0' 2 3/4"	21	4' 9 1/4"	41	9' 4 3/4"	61	13' 11 1/4"	81	18' 6 1/4"
2	0' 5 1/4"	22	5' 0 3/4"	42	9' 7 1/4"	62	14' 2 1/4"	82	18' 9 1/4"
3	0' 8 1/4"	23	5' 3 1/4"	43	9' 10 1/4"	63	14' 5 1/4"	83	19' 0 1/4"
4	0' 11"	24	5' 6"	44	10' 1"	64	14' 8"	84	19' 3"
5	1' 1 1/4"	25	5' 8 3/4"	45	10' 3 1/4"	65	14' 10 1/4"	85	19' 5 1/4"
6	1' 4 1/4"	26	5' 11 1/4"	46	10' 6 1/4"	66	15' 1 1/4"	86	19' 8 1/4"
7	1' 7 1/4"	27	6' 2 1/4"	47	10' 9 1/4"	67	15' 4 1/4"	87	19' 11 1/4"
8	1' 10"	28	6' 5"	48	11' 0"	68	15' 7"	88	20' 2"
9	2' 0 1/4"	29	6' 7 1/4"	49	11' 2 1/4"	69	15' 9 1/4"	89	20' 4 1/4"
10	2' 3 1/4"	30	6' 10 1/4"	50	11' 5 1/4"	70	16' 0 1/4"	90	20' 7 1/4"
11	2' 6 1/4"	31	7' 1 1/4"	51	11' 8 1/4"	71	16' 3 1/4"	91	20' 10 1/4"
12	2' 9"	32	7' 4"	52	11' 11"	72	16' 6"	92	21' 1"
13	2' 11 1/4"	33	7' 6 3/4"	53	12' 1 3/4"	73	16' 8 3/4"	93	21' 3 3/4"
14	3' 2 1/4"	34	7' 9 1/4"	54	12' 4 1/4"	74	16' 11 1/4"	94	21' 6 1/4"
15	3' 5 1/4"	35	8' 0 1/4"	55	12' 7 1/4"	75	17' 2 1/4"	95	21' 9 1/4"
16	3' 8"	36	8' 3"	56	12' 10"	76	17' 5"	96	22' 0"
17	3' 10 3/4"	37	8' 5 1/4"	57	13' 0 1/4"	77	17' 7 1/4"	97	22' 2 1/4"
18	4' 1 1/4"	38	8' 8 1/4"	58	13' 3 1/4"	78	17' 10 1/4"	98	22' 5 1/4"
19	4' 4 1/4"	39	8' 11 1/4"	59	13' 6 1/4"	79	18' 1 1/4"	99	22' 8 1/4"
20	4' 7"	40	9' 2"	60	13' 9"	80	18' 4"	100	22' 11"

133.332

Chapter 8—MASONRY

Table 8-6.—Height of Courses: 2 1/4-inch Brick, 5/8-inch Joint

Courses	Height	Courses	Height	Courses	Height	Courses	Height	Courses	Height
1.....	0' 2 3/4"	21.....	5' 0 3/4"	41.....	9' 0 3/4"	61.....	14' 7 3/4"	81.....	19' 4 3/4"
2.....	0' 5 3/4"	22.....	5' 3 3/4"	42.....	10' 0 3/4"	62.....	14' 10 3/4"	82.....	19' 7 3/4"
3.....	0' 8 3/4"	23.....	5' 6 3/4"	43.....	10' 3 3/4"	63.....	15' 1 3/4"	83.....	19' 10 3/4"
4.....	0' 11 3/4"	24.....	5' 9"	44.....	10' 6 3/4"	64.....	15' 4"	84.....	20' 1 3/4"
5.....	1' 2 3/4"	25.....	5' 11 3/4"	45.....	10' 9 3/4"	65.....	15' 6 3/4"	85.....	20' 4 3/4"
6.....	1' 5 3/4"	26.....	6' 2 3/4"	46.....	11' 0 3/4"	66.....	15' 9 3/4"	86.....	20' 7 3/4"
7.....	1' 8 3/4"	27.....	6' 5 3/4"	47.....	11' 3 3/4"	67.....	16' 0 3/4"	87.....	20' 10 3/4"
8.....	1' 11"	28.....	6' 8 3/4"	48.....	11' 6"	68.....	16' 3 3/4"	88.....	21' 1"
9.....	2' 1 3/4"	29.....	6' 11 3/4"	49.....	11' 8 3/4"	69.....	16' 6 3/4"	89.....	21' 3 3/4"
10.....	2' 4 3/4"	30.....	7' 2 3/4"	50.....	11' 11 3/4"	70.....	16' 9 3/4"	90.....	21' 6 3/4"
11.....	2' 7 3/4"	31.....	7' 5 3/4"	51.....	12' 2 3/4"	71.....	17' 0 3/4"	91.....	21' 9 3/4"
12.....	2' 10 3/4"	32.....	7' 8"	52.....	12' 5 3/4"	72.....	17' 3 3/4"	92.....	22' 0 3/4"
13.....	3' 1 3/4"	33.....	7' 10 3/4"	53.....	12' 8 3/4"	73.....	17' 5 3/4"	93.....	22' 3 3/4"
14.....	3' 4 3/4"	34.....	8' 1 3/4"	54.....	12' 11 3/4"	74.....	17' 8 3/4"	94.....	22' 6 3/4"
15.....	3' 7 3/4"	35.....	8' 4 3/4"	55.....	13' 2 3/4"	75.....	17' 11 3/4"	95.....	22' 9 3/4"
16.....	3' 10"	36.....	8' 7 3/4"	56.....	13' 5"	76.....	18' 2 3/4"	96.....	23' 0"
17.....	4' 0 3/4"	37.....	8' 10 3/4"	57.....	13' 7 3/4"	77.....	18' 5 3/4"	97.....	23' 2 3/4"
18.....	4' 3 3/4"	38.....	9' 1 3/4"	58.....	13' 10 3/4"	78.....	18' 8 3/4"	98.....	23' 5 3/4"
19.....	4' 6 3/4"	39.....	9' 4 3/4"	59.....	14' 1 3/4"	79.....	18' 11 3/4"	99.....	23' 8 3/4"
20.....	4' 9 3/4"	40.....	9' 7"	60.....	14' 4 3/4"	80.....	19' 2"	100.....	23' 11 3/4"

133.333

l, m, n, o, and p are then laid in the same manner. The number of leader bricks that must be laid in the first course of the corner lead can be determined from the fifth step, fig. 8-66. It will be noted that six header bricks are required on each side of the three-quarter closures a and b.

The second course, a stretcher course, is now laid. The procedure is shown in step 1, fig. 8-67. A 1-in. thick layer of mortar should be spread over the first course and a shallow furrow made in the mortar bed. Brick a (step 2, fig. 8-67) is then laid in the mortar bed and shoved down until the mortar joint is 1/2-in. thick. Brick b may now be shoved into place after mortar has been spread on its end. Excess mortar is removed and the joint checked for thickness. Bricks c, d, e, f, and g are laid in the same manner and checked to make them level and plumb. The level is checked by placing the mason's level in the position indicated in step 2, fig. 8-67. The brick are plumbed by using the mason's level in a vertical position as shown in

figure 8-68. This should be done in several places. As may be determined from 3, fig. 8-67, seven bricks are required for the second course. The remaining brick in the corner lead are laid in the manner described for the brick in the second course.

Since the portion of the wall between the leads is laid using the leads as a guide, the level of the courses in the lead must be checked continually, and after the first few courses the lead is plumbed. If the brickwork is not plumb, bricks must be moved in or out until the lead is accurately plumb. It is not good practice to move brick much once they are laid in mortar; therefore, care is taken to place the brick accurately at the start. Before the mortar has set, the joints are tooled or finished.

A corner lead at the opposite end of the wall is built in the same manner. It is essential that the level of the tops corresponding courses be the same in each lead. That is, the top of the second course in one corner lead must be at the same height above the foundation as the second

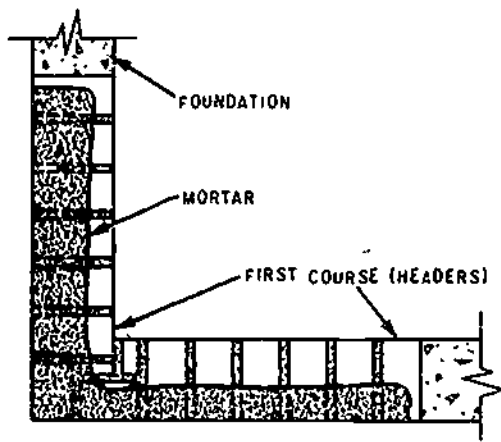

STEP 1

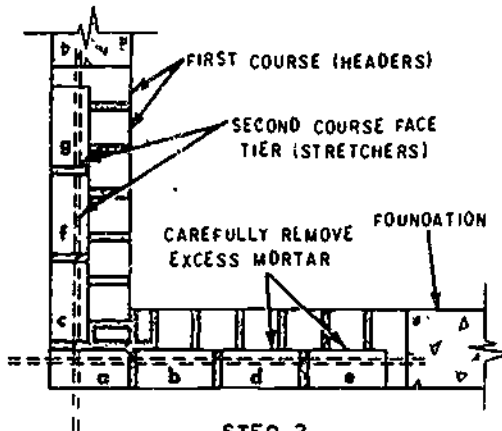

STEP 2

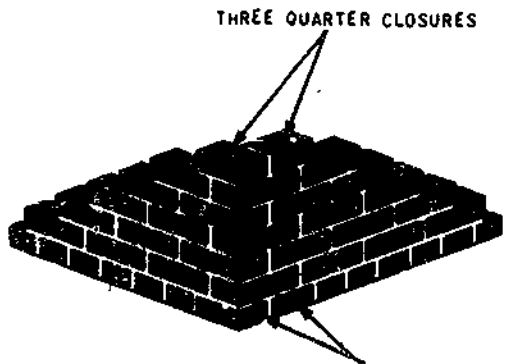

STEP 3

133.310
Figure 8-67.—Second course of corner lead for 8-inch common bond brick wall.

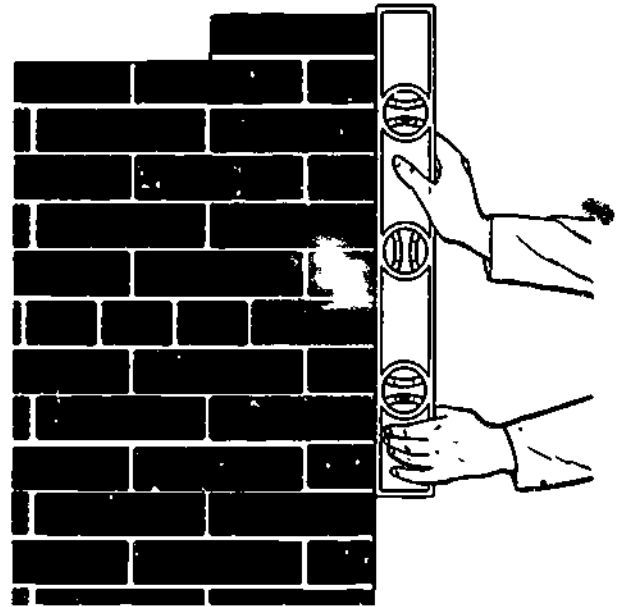

133.311

Figure 8-68.—Plumbing a corner.

course in the other corner lead. A long 2-by-2-in. pole can be used to mark off the heights of the different courses above the foundation. This pole can be used to check the course height in the corner leads. The laying of leads should be closely supervised and only skilled Builders should be employed in this work.

With the corner leads at each end of the wall completed, the face tier of brick for the wall between the leads is laid. It is necessary to use a line, as shown in figure 8-69.

Knots are made in each end of the line to hold it within the slot of the line block as shown in figure 8-69. The line can be made taut by hooking one of the line blocks to each end of the wall.

The line is positioned 1/16 in. outside the wall face level with the top of the brick.

With the line in place, the first or header course is laid in place between the two corner leads. The brick is shoved into position so that its top edge is 1/16 in. behind the line. Do not crowd the line. If the corner leads are accurately built, the entire wall will be level or plumb. It is not necessary to use the level on the section of

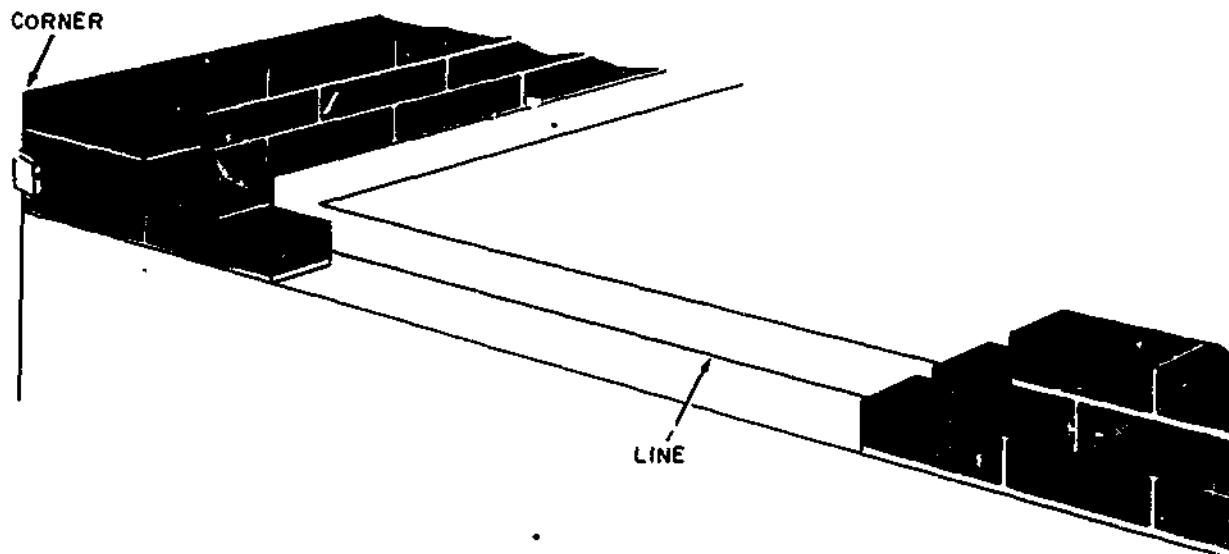

133.312

Figure 8-69.—Use of the line.

the wall between the leads; however, it is advisable to check it with the level at several points. For the next course, the line is moved to the top of the next mortar joint. The brick in the stretcher course should be laid as described previously. Finish the face joints before the mortar hardens.

When the face tier of brick for the wall between the leads has been laid up to, but not including the second header course, normally six courses, the backup tier is laid. The procedure for laying backup brick has already been described. The backup brick for the corner leads are laid first and the remaining brick afterwards (fig. 8-70). The line need not be used for the backup brick in an 8-in. wall. When the backup brick have been laid up to the height of the second header course, the second header course is laid.

The wall for the entire building is built up to a height including the second header course at which time corner leads are continued six more courses. The wall between the leads is constructed as before and the entire procedure repeated until the wall has been completed to the required height.

Window and Door Openings

If windows are to be installed in the wall, openings are left for them as the bricklaying proceeds. The height to the top of one full course should be exactly the height of the window sill. When the distance from the foundation to the bottom of the window sill is known, the Builder can determine how many courses are required to bring the wall up to that height. If the sill is to be 4 ft 4 1/4 in. above the foundation and 1/2-in. mortar joints are used, 19 courses will be required. (Each brick plus one mortar joint is $2\frac{1}{4} + \frac{1}{2} = 2\frac{3}{4}$ inches. One course is thus $2\frac{3}{4}$ in. high. Four ft 4 1/4 in. divided by $2\frac{3}{4}$ is 19, the number of courses required.

With the brick laid up to sill height, the rowlock sill course is laid as shown in figure 8-71. The rowlock course is pitched downward. The slope is away from the window and the rowlock course normally takes up a vertical space equal to two courses of brick. The exterior surface of the joints between the brick in the rowlock course must be carefully finished to make them watertight.

The window frame is placed on the rowlock sill as soon as the mortar has set. The window frame must be temporarily braced until the

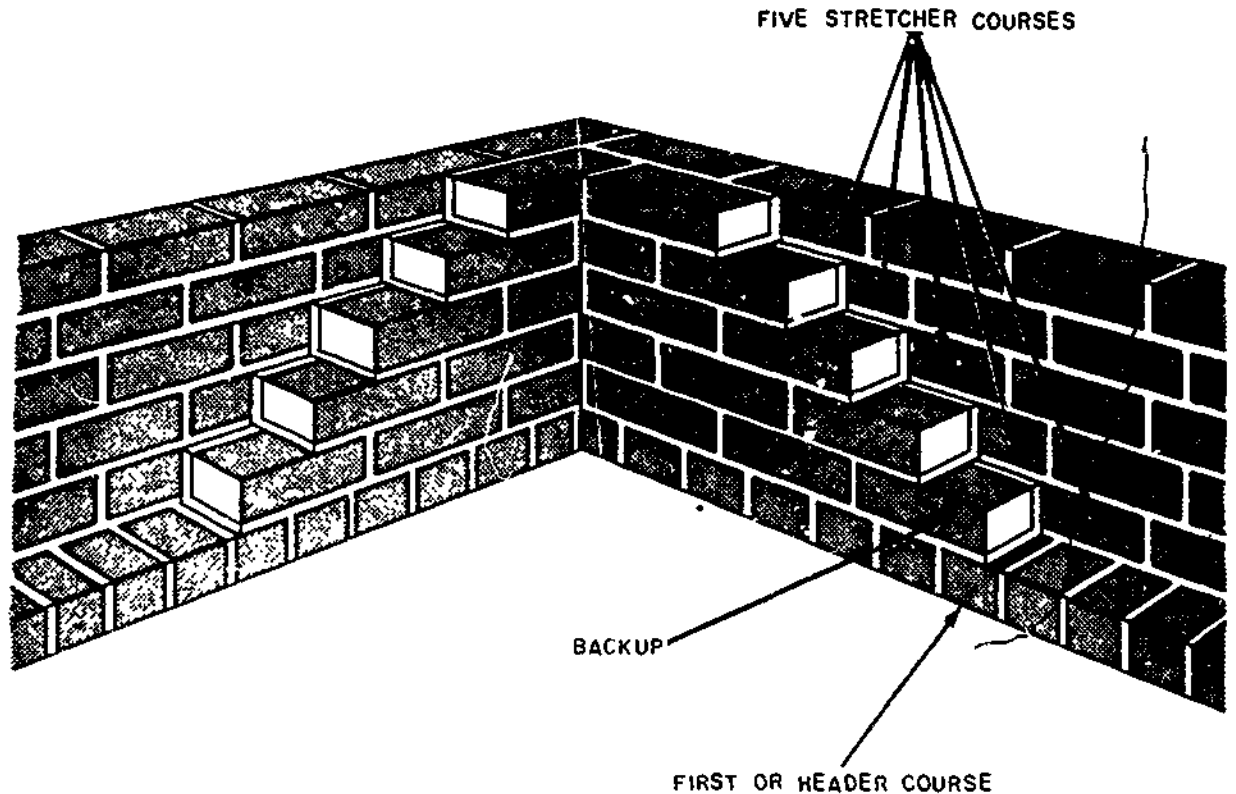

133.313

Figure 8-70.—Backing brick at the corner—8-inch common bond brick wall.

brickwork has been laid up to about one-third the height of the window frame. These braces are not removed for several days in order that the wall above the window frame will set properly. Now the Builder lays up the brick in the rest of the wall in such a way that the top of the brick in the course at the level of the top of the window frame is not more than $1/4$ in. above the frame. To do this, the top of each course is marked with a pencil on the window frame. If the top course does not come to the proper level, the thickness of the joints is changed slightly until the top course is at the proper level. The corner leads should be laid up after the height of each course at the window is determined.

The mortar joint thickness for the corner leads is made the same as that determined at the window opening. With the corner leads erected, the line is installed as already described and is

stretched across the window opening. The brick can now be laid in the rest of the wall. If the window openings have been planned properly, the brick in the face tier can be laid with a minimum of brick cutting.

Lintels

LINTELS are placed above windows and doors to carry the weight of the wall above them. They rest on the brick course that is level or approximately level with the frame head, and are firmly bedded in mortar at the sides. Any space between the window frame and the lintel is closed with blocking and weather-stripped with bituminous materials. The wall is then continued above the window after the lintel is placed.

The same procedure can be used for laying brick around a door opening as was used for

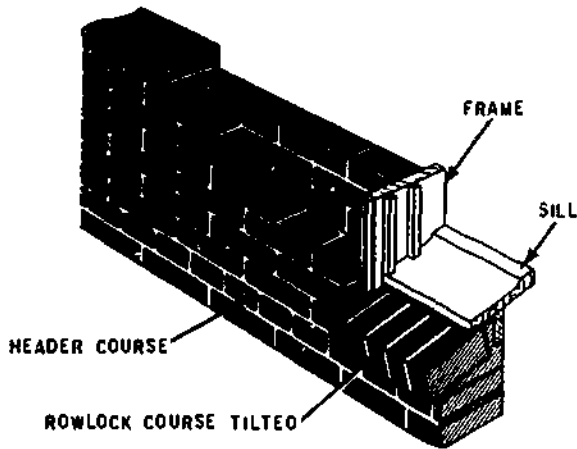

133.314

Figure 8-71.—Construction at a window opening.

laying brick around a window opening, including placement of the lintel. The arrangement at a door opening is given in figure 8-72. Pieces of wood cut to the size of a half closure are laid in mortar as brick to provide for anchoring the

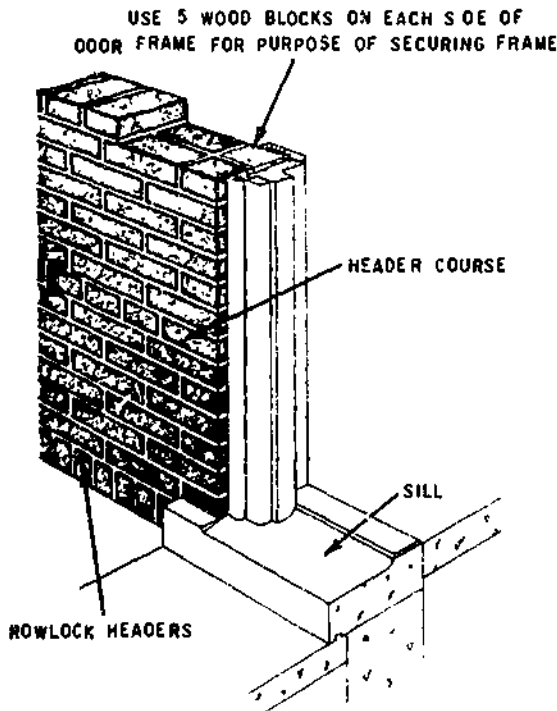

133.315

Figure 8-72.—Construction at a door opening.

door frame by means of screws or nails. These wood locks are placed at several points along the top and sides of the door opening to allow for plumbing the frame.

Lintels can be made of steel, precast reinforced concrete beams, or wood. The use of wood should be avoided as much as possible. If reinforced brick masonry is employed, the brick above the wall opening can be supported by the proper installation of steel reinforcing bars. This will be discussed later. Figure 8-73 illustrates one of the methods of placing lintels for different wall thicknesses. The relative placement and position is determined both by wall thickness and the type of window being used.

Installation of a lintel for an 8-in. wall is shown in figure 8-73. The thickness of the angle for a two-angle lintel should be 1/4 inch. This makes it possible for the two-angle legs that project up into the brick to fit exactly in the 1/2-in. joint between the face and backing-up ties of an 8-in. wall.

Corbeling

Corbeling consists of courses of brick set out beyond the face of the wall in order to form a self-supporting projection. This type of

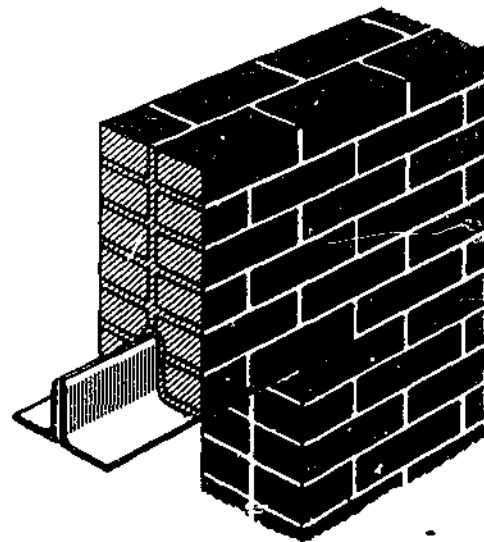

45.485

Figure 8-73.—Lintels for an 8-inch wall.

Watertight Walls

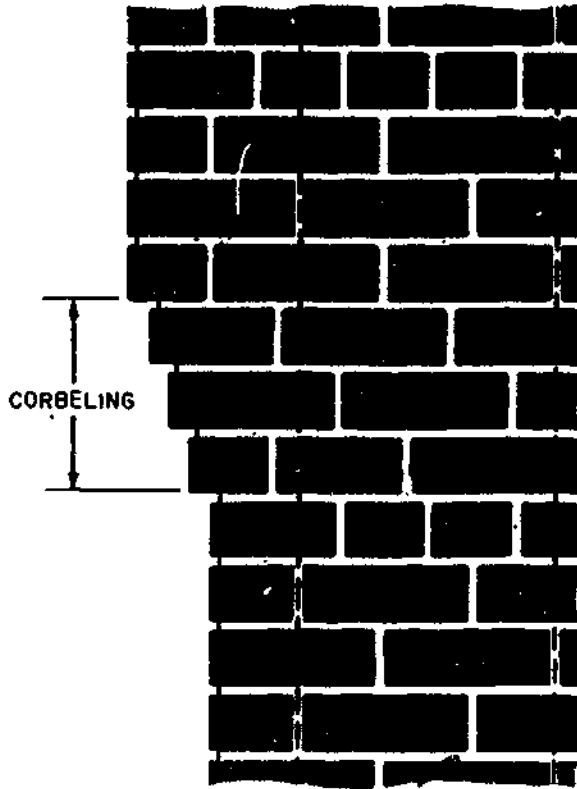

Figure 8-74.—Corbeled brick wall.

133.316

construction is shown in figure 8-74. The portion of a chimney that is exposed to the weather is frequently corbeled out and increased in thickness to improve its weathering resistance. Headers should also be used as much as possible in corbeling. It is usually required to use various-sized bats. If necessary, the first projecting course may be the stretcher course. No course should extend out more than 2 in. beyond the course below it and the total projection of the corbeling should not be more than the thickness of the wall.

Corbeling must be done carefully for the construction to have maximum strength. All mortar joints should be carefully made and completely filled with mortar. When the corbeled-out brick masonry is to withstand large loads, you should consult the design division of the operation department.

The water that passes through brick walls does not usually enter through the mortar or brick but through cracks between brick and mortar. Sometimes these cracks are formed because the bond between the brick and mortar is poor. They are more apt to occur in head joints than in bed joints. To prevent this, some brick must be wetted. If the position of the brick is changed after the mortar has begun to set, the bond between the brick and mortar will be destroyed and a crack will result. Shrinkage of the mortar is also frequently responsible for the formation of cracks.

Both the size and number of cracks between the mortar and the brick can be reduced if the exterior face of all the mortar joints is tooled to a concave finish. All head joints and bed joints must be completely filled with mortar if watertightness is to be obtained.

A procedure found effective in producing a leakproof wall is shown in figure 8-75. The back of the brick in the face tier is plastered with at least 3/8 in. of rich cement mortar before the backing brick are laid. This is called PARGING or back plastering. Since parging should not be done over mortar protruding from the joints, all joints on the back of the face tier of bricks must be cut flush.

Membrane waterproofing, installed in the same way as specified for concrete walls, should be used if the wall is subject to considerable water pressure. The membrane, if properly installed, is able to adjust to any shrinkage or settlement without cracking. If the wall is to be

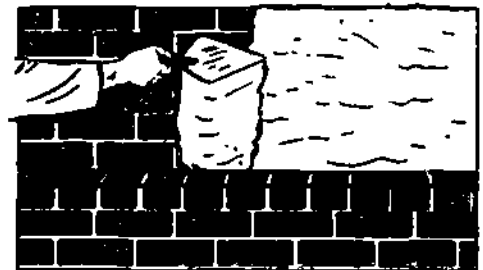

Figure 8-75.—Parging.

133.319

subjected to considerable ground water or the surrounding soil is impervious, tile drains, or French drains, if drainage tile is not available, should be constructed around the base of the wall (fig. 8-76).

For a foundation wall below ground level, two coats of bituminous mastic applied to the outside surface of the brick will yield satisfactory results. Asphalt or coal-tar pitch may be used and applied with mops.

The watertightness of brick walls above ground level is improved by the application of transparent waterproof paints such as a water solution of sodium silicate. Varnish is also effective. When used, these paints should be applied as specified by the manufacturer. Certain white and colored waterproofing paints are also available. In addition, good results have been obtained by the use of high-quality oil base paints.

Portland cement pain generally gives excellent results. The brick wall should be at least 30 days old before the portland cement

paint is applied and all efflorescence (a white powdery crystalline deposit) must be removed from the surface to be painted. Manufacturer's instructions for mixing and applying the paint are to be followed. Surfaces must be damp when the paint is applied, which is an advantage. A water spray is the best means of wetting the surface. Whitewash or calcimine type brushes are used to apply the paint. Portland cement paint can be applied with a spray gun but its rain resistance will be reduced.

Fire-Resistant Bricks

Firebricks are manufactured for such uses as lining furnaces and incinerators. Their purpose is to protect the supporting structure or outer shell from intense heat. This outer shell may consist of common brick or, in some cases, steel, neither of which has good heat resistance.

There are two types of fire-resistant brick:

FIREBRICKS are made from a special clay known as fire clay. They will withstand high temperatures and are heavier and usually larger than common brick. The standard size is 9 by 4 1/2 by 2 1/2 in.

SILICA BRICK should be used if resistance to acid gases is required. Silica brick should not be used if it is to be alternately heated and cooled. Most incinerators, therefore, should be lined with firebrick rather than silica brick.

Thin joints are of the utmost importance in laying firebrick. This is especially true when the bricks are exposed to high temperatures, such as those occurring in incinerators. The bricks should be kept in a dry place until the time they are used.

The mortar to be used in laying firebrick consists of fire clay mixed with water. The consistency of the mortar should be that of thick cream. Fire clay can be obtained by grinding used firebrick.

The brick is dipped in the mortar in such a way that all faces except the top face are covered. The brick is then tapped firmly in place with a bricklayer's hammer. The joint between the brick should be as thin as possible and the brick should fit tightly together. Any cracks

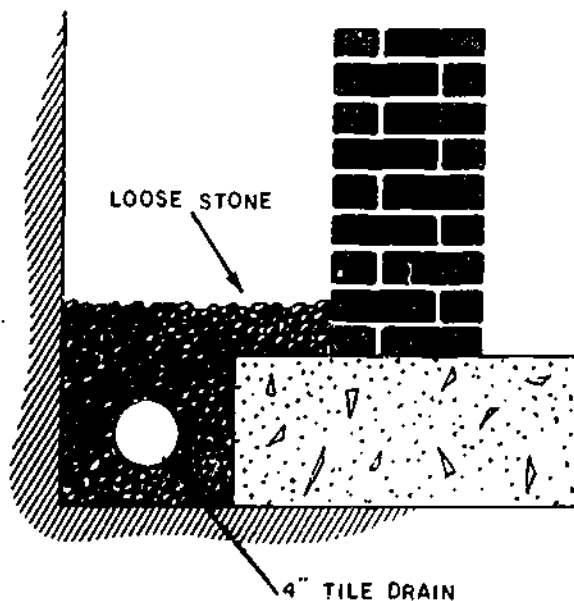

WHEN TILE DRAIN IS OMITTED, THE DRAIN IS CALLED A FRENCH DRAIN

133.320

Figure 8-76.—Drain around foundation.

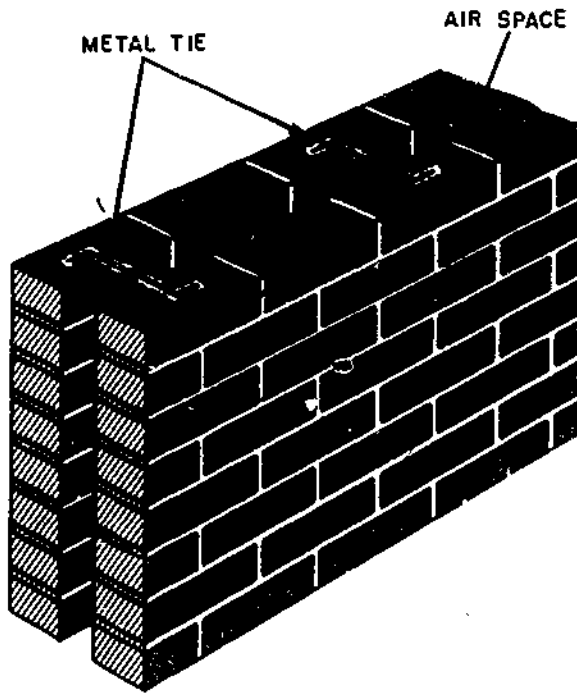

133.321

Figure 8-77.—Details for a cavity wall.

between the fire brick will allow heat to penetrate to the outside shell of the incinerator or furnace and damage it. The firebrick in one course lap those in the course below by one-half brick. The head joints are thus staggered in the same way as they are staggered in the usual type of brick construction.

Silica brick are laid without mortar. They fit so closely that they fuse together at the joints when subjected to high temperatures. The head joints for silica brick are staggered, as for firebrick.

Special Types of Walls

Different types of walls, such as cavity, rowlock, and partition are built of brick. Wood frame and concrete block walls can also be finished by brick, known as VENEER.

CAVITY WALLS provide a means of obtaining a watertight wall that may be plastered without the use of furring or lathing. From the outside they appear the same as solid walls without header courses (fig. 8-77). No

headers are required because the two tiers of brick are held together by means of metal ties installed every sixth course and on 24-in. centers. To prevent waterflow to the inside tier, ties must be angled in a downward direction from the inside tier to the outside tier.

The 2-in. cavity between the two tiers of brick provides a space down which water that penetrates the outside tier may blow without passing through to the inside of the wall. The bottom of the cavity is above ground level and is drained by weep holes placed in the vertical joints between two bricks in the first course of the outer tier. These holes may be formed by leaving the mortar out of some of the vertical joints in the first course. The holes should be spaced at about 24-in. intervals. The air space also gives the wall better heat- and sound-insulating properties.

One type of ROWLOCK WALL is shown in figure 8-78. The face tier of this wall has the

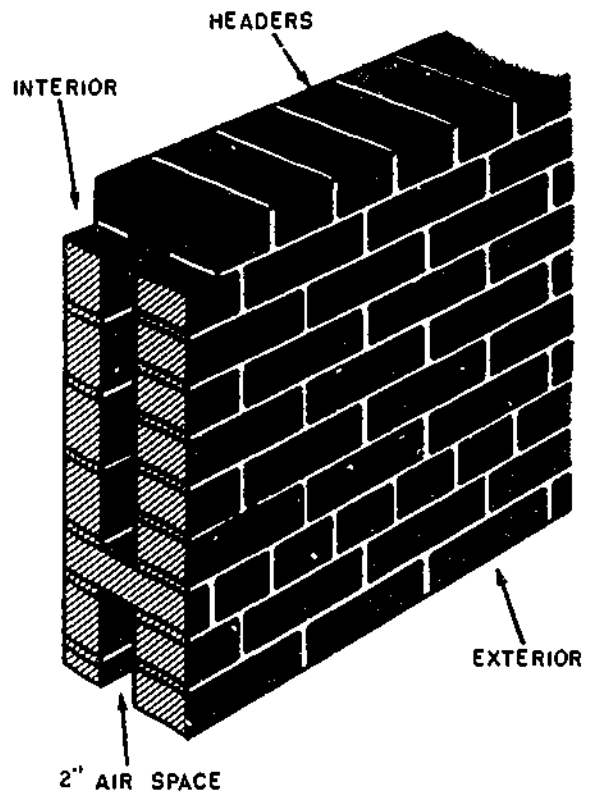

133.322

Figure 8-78.—Details of a rowlock backwall.

same appearance as a common bond wall with a full header course every seventh course. The backing tier is laid with the brick on edge. The face tier and backing tier are tied together by a header course as shown. A 2-in. space is provided between the two tiers of brick, as for a cavity wall.

An all-rowlock wall is constructed with brick in the face and backing tier both laid on edge. The header course would be installed at every fourth course: three rowlock courses to every header course. A rowlock wall is not as watertight as the cavity wall. Water is able to follow any crack present in the header course and pass through the wall to the inside surface.

PARTITION WALLS that carry very little load can be made using one tier of brick only.

This produces a wall 4 in. thick. A wall of this thickness is laid up without headers.

Brick are laid in cavity walls and partition walls according to the procedure given for making bed joints, head joints, cross joints, and closures. The line is used the same as for common bond-wall. Corner leads for these walls are erected first and the wall between is built up afterward.

Facing or finishing a wood frame wall with BRICK VENEER (fig. 8-79) is done by sheathing the frame with either plywood or boards and then applying the facing brick to the sheathing. Be sure to leave a 1-in. air space between the brick and the sheathing and anchor the brick to the frame with metal ties spaced at least 24 in. apart both horizontally and vertically.

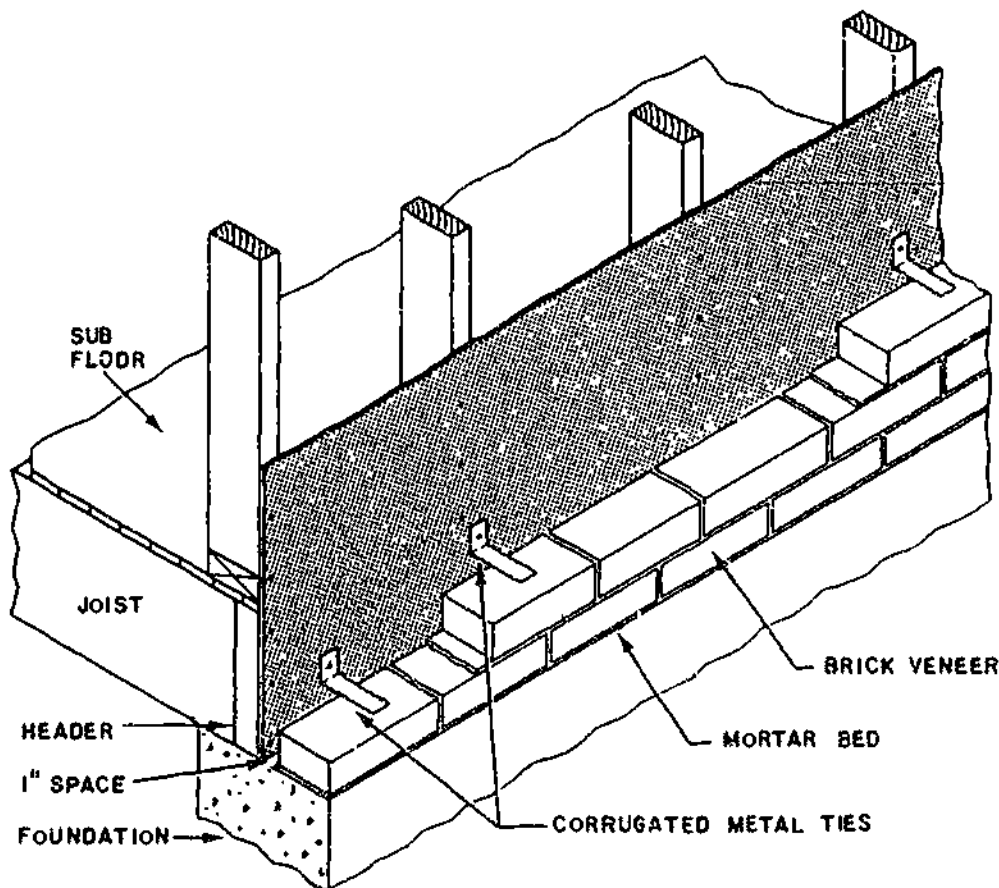
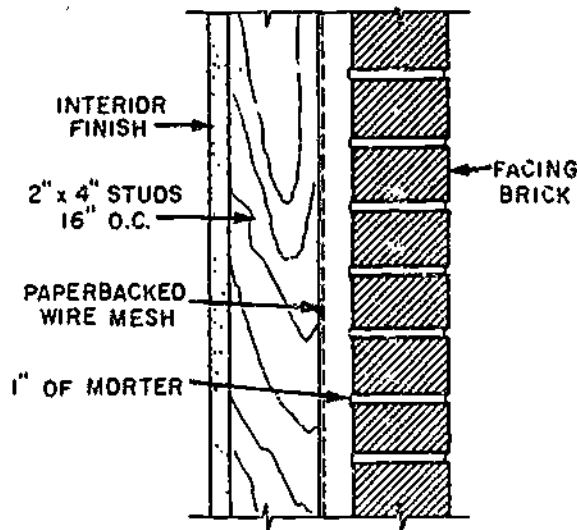

Figure 8-79.—Brick veneer over wood frame.

133.448



133.449

Figure 8-80.—Brick veneer on wire mesh.

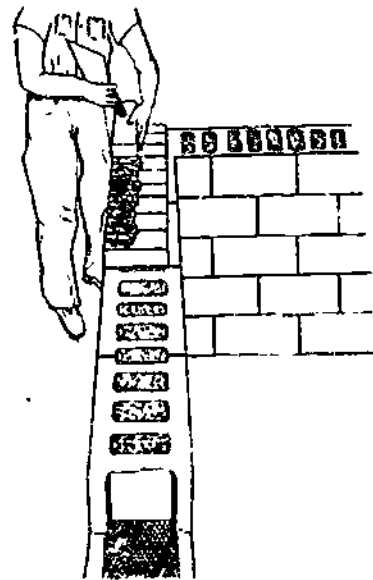

133.451

Figure 8-82.—Beginning brick veneer on block foundation.

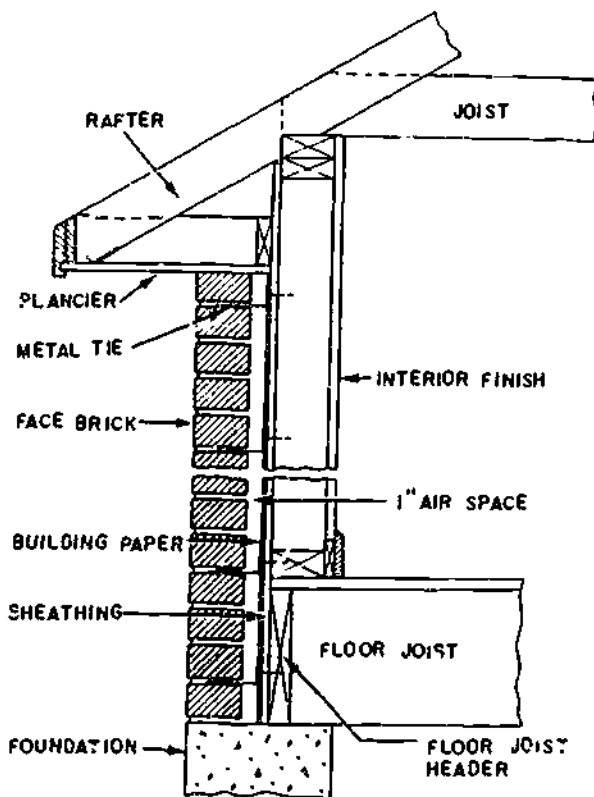

133.450

Figure 8-81.—Typical wall section, brick veneer on frame.

In another method (fig. 8-80), the framing is covered with a paper-backed, weld-wire mesh. The mesh is then covered with mortar at least 1 in. thick so that the brick will be separated from the framing. Figure 8-81 shows a typical wall section that has been brick veneered.

There are several steps taken in applying a BRICK VENEER over a concrete block wall. Figure 8-82 shows that 10-in. concrete blocks are used for the foundation. Then, as shown in figure 8-83, a course of header brick is laid, followed by 4-in. concrete block set behind the brick veneer course. Finally, the back of the facing brick is mortared, as shown in figure 8-84.

REINFORCED BRICK MASONRY

Because the strength of brick masonry in tension is low, as compared with its compressive strength, reinforcing steel is used when tensile stresses are to be resisted. In this respect brick masonry and concrete construction are identical. The reinforcing steel is placed in the horizontal or vertical mortar joints. Reinforced brick masonry may be used for beams, columns, walls, and footings in the same manner as reinforced concrete is used. Structures built of reinforced brick masonry have successfully resisted the

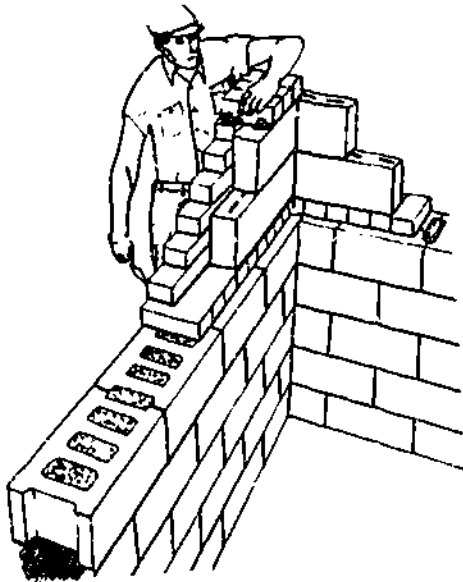

133.452

Figure 8-83.—Header brick in place for structural bond.

effect of earthquake shocks intense enough to damage unreinforced brick structures severely. The design of reinforced brick masonry structures is similar to the design of reinforced concrete structures.

Brick used for reinforced brick masonry is the same as that used for ordinary brick masonry. It should, however, have a compressive strength of at least 2,500 lb per sq inch.

The reinforcing steel is the same as the steel used to reinforce concrete and it is stored and

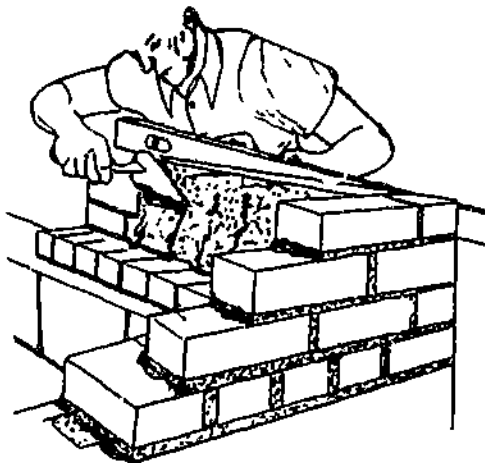

133.453

Figure 8-84.—Back plastering the facing brick.

fabricated in the same way. Hard-grade steel should not be used except in emergencies because many sharp bends are required in this type of construction.

Type N mortar is used because of its high strength.

Wire for tying reinforcing steel should be 16-gage soft annealed iron wire.

Construction Methods for Reinforced Brick Masonry

Bricklaying procedures and those for normal brick masonry are the same. Mortar joint thickness is 1/8 in. more than the diameter of the steel bar used for reinforcing. This will allow 1/16 in. of mortar between the surface of the brick and the bar. When large steel bars are used, the thickness of the mortar joint will exceed 1/2 inch.

All reinforcing steel must be firmly embedded in mortar.

Horizontal bars are laid in a bed of mortar and pushed down until in position. More mortar is spread on top of the rods and smoothed out until a bed joint of the proper thickness can be made. The next course of brick is then laid in this mortar bed according to the procedure outlined for laying brick without reinforcing steel.

Stirrups for most reinforced brick beams must be of the shape shown in figure 8-85, in order to place them in the mortar joints. The lower leg is placed under the horizontal bars and in contact with them. Note that this may require a thicker joint at this point.

Vertical bars are placed in the vertical mortar joints. They are held in position by wood templets in which holes have been drilled at the proper bar spacing or by wiring to a horizontal bar. The brick is laid up around the vertical bars.

Horizontal and vertical bars need not be wired together as was recommended for reinforcing steel in concrete walls.

The minimum center-to-center spacing between parallel bars is 1 1/2 times the bar diameter.

Reinforced brick beams require form work for the same reason that reinforced concrete beams need form work. The form will consist only of a support for the bottom of the beam. No side form work is required. The form for the

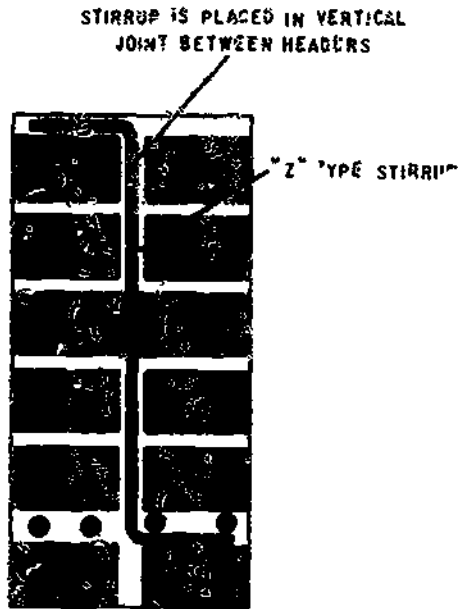

133.323

Figure 8-85.—Reinforced brick and masonry beam.

bottom is the same and is supported in the same way as recommended for concrete beams. No form work is required for walls, columns, or footings.

Where the beam joins a wall or another beam, the form should be cut 1/4 in. short and the gap filled with mortar to allow for swelling of the lumber and to permit easy removal of the forms. (At least 10 days should elapse before the bottom form work for beams is removed.)

Reinforced Brick Masonry Beams

The width and depth of beams depend upon brick dimensions, thickness of the mortar joints, and the load that the beam is required to support. Beam widths are usually the same as the wall thicknesses; that is, 4, 8, 12, and 16 inches. The depth should not exceed about three times the width.

The first course of brick is laid on the form with full head joints but without a bed joint (fig. 8-85).

A bed of mortar about 1/8-in. thicker than the diameter of the horizontal reinforcing bars is spread on the first course of brick and the bars embedded in it as already described.

If stirrups are required, the leg of the stirrup is slipped under the horizontal bars as shown in figure 8-85. Care must be taken to get the stirrup in the center of the vertical mortar joint in which it is to be placed.

After the stirrups and the horizontal bars are in the proper position, spread additional mortar on the bed joint if necessary, and smooth the surface of the mortar. The mortar bed is now ready for the remaining courses which are laid in the usual way.

All of the brick in one course are laid before any brick in the next course are placed. This is necessary to insure a continuous bond between the mortar and steel bars. It is frequently necessary to have three or four Builders working on one beam in order to get the bed joint mortar for the entire course spread, reinforcing steel placed, and the brick laid before the mortar sets up.

The proper placement of reinforcing steel in the brick wall above a window or door opening will serve the purpose of a lintel.

The steel bars should be 3/8 in. in diameter or less if it is necessary to maintain a 1/2-in. thick mortar joint. The bars should extend

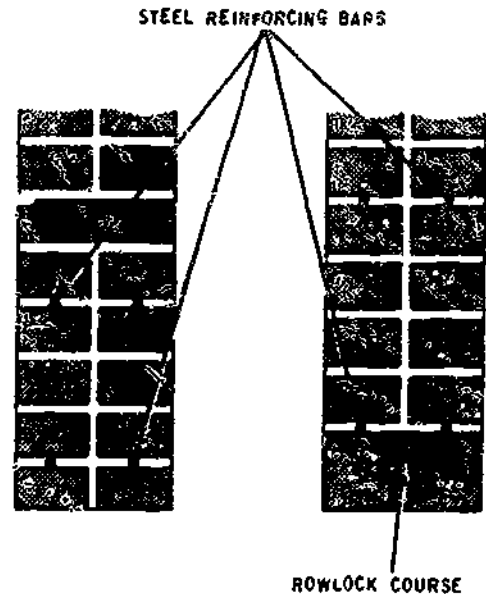

133.324

Figure 8-86.—Reinforced brick masonry lintels.

15 in. into the brick wall on each side of the opening and should be placed in the first mortar joint above the opening and also in the fourth joint above the opening (fig. 8-86). The lintel acts as a beam and needs a bottom form. The number and size bars required for different width wall openings are as follows:

Width of wall opening in feet	Number and size of bars
6	2 ea 1/4-in diameter bars
9	3 ea 1/4-in. diameter bars
12	3 ea 3/8-in. diameter bars

Reinforced Brick Masonry Foundations

In large footings, reinforcing steel is usually needed because of the tensile stresses that

develop. As in all brick foundations, the first course of brick is laid in a bed of mortar about 1 in. thick that has been spread on the subgrade.

A typical wall footing is shown in figure 8-87. The dowels extend above the footing; their purpose is to tie the footing and brick wall together. The No. 3 bars shown running parallel to the direction of the wall are used to prevent the formation of cracks perpendicular to the wall.

Column footings are usually square or rectangular and are reinforced as shown in figure 8-88. The dowels are needed to anchor the column to the footing and to transfer stress from the column to the footing. Note that both layers of horizontal steel are placed in the same mortar joint. This is not necessary and, if large bars are used one layer of steel should be placed in the second mortar joint above the bottom. If

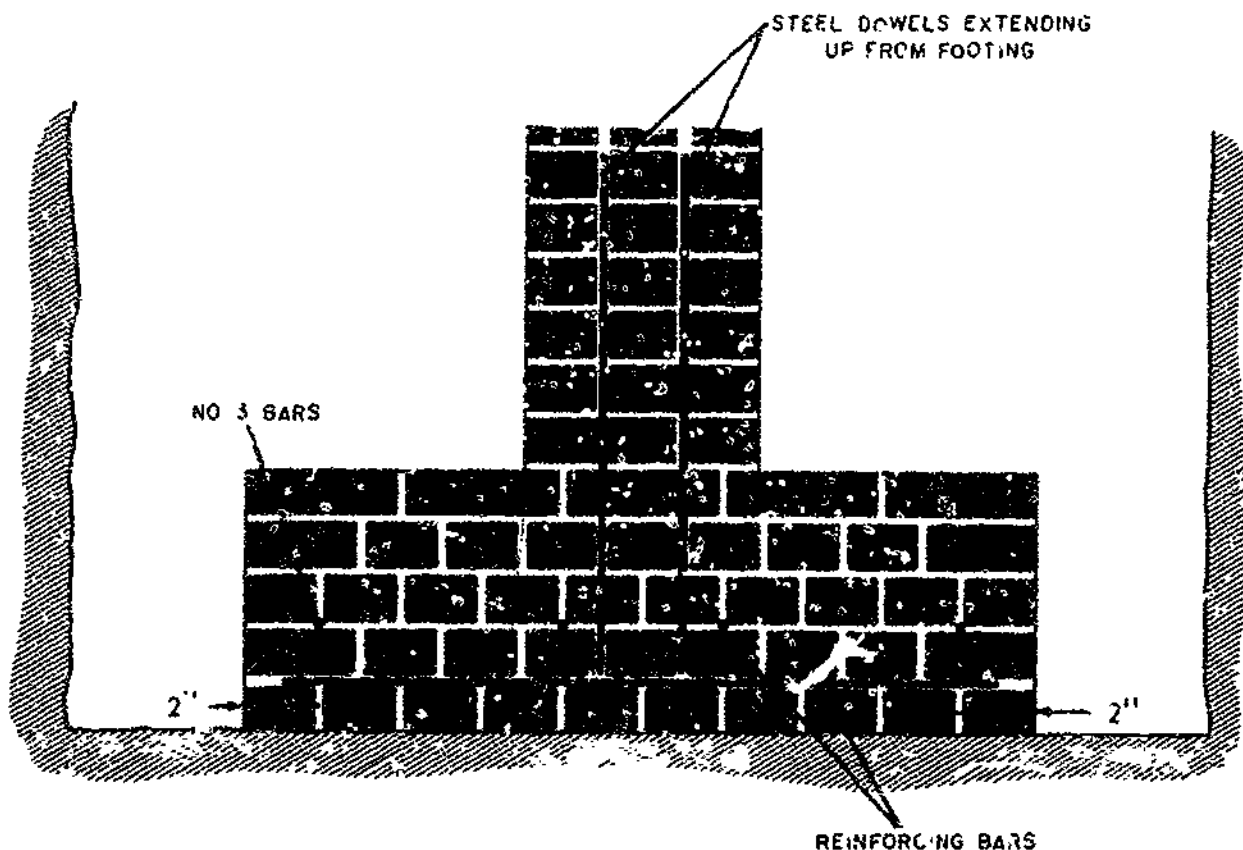

Figure 8-87.—Reinforced masonry wall footing.

133 325

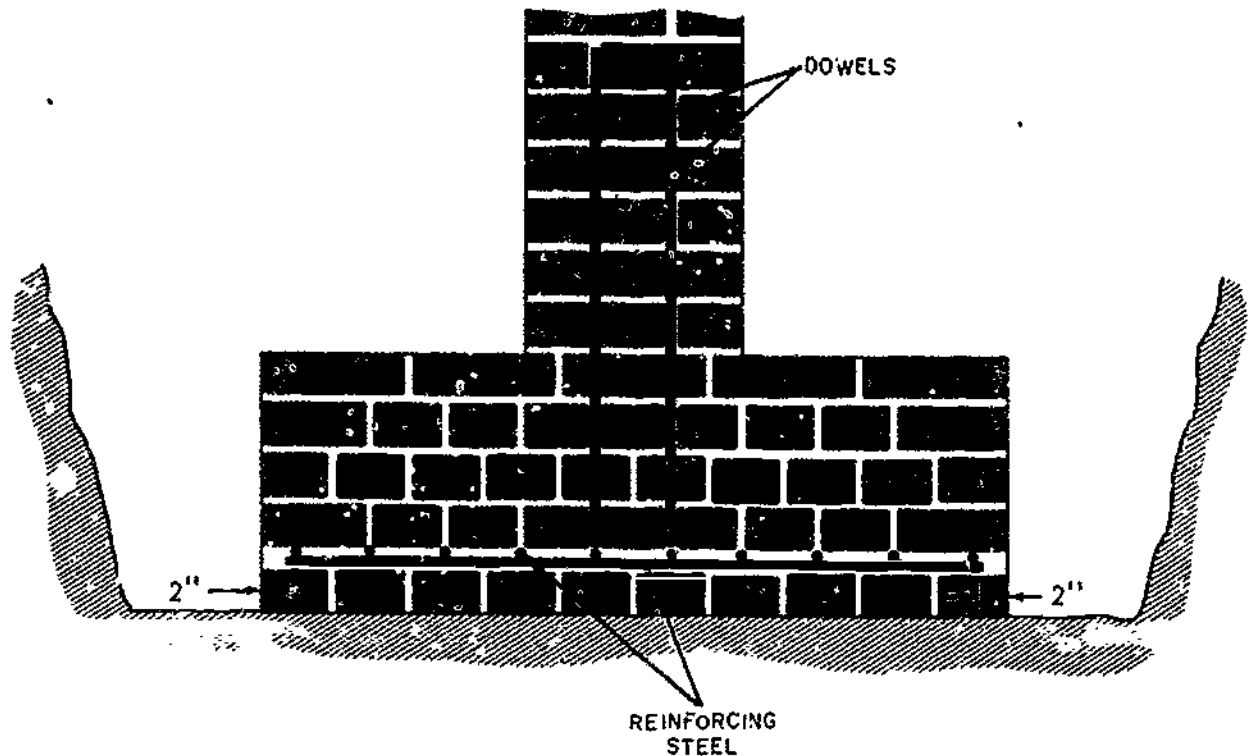

Figure 8-88.—Reinforced masonry column footing.

133-328

this is done, the spacing between the bars in the upper layer of steel must be reduced.

Reinforced Brick Masonry Columns and Walls

The load-carrying capacity of brick columns is increased when they are reinforced with steel bars. There should be at least $1\frac{1}{2}$ in. of mortar or brick covering the reinforcing bars and these bars should be held in place with $\frac{3}{8}$ -in. diameter steel hoops or ties as shown in figure 8-89. When possible, the hoops or ties should be circular rather than rectangular or square. The ends of the hoop or tie should be lap-welded together or bent around a reinforcing bar. Hoops should be installed at every course of brick.

After the footings are completed, the column reinforcing steel is tied to the dowels projecting from the footing. The required number of hoops is then slipped over the

longitudinal reinforcing bars and temporarily fastened to these bars some distance above the level at which brick are being laid but within reach of the Builder laying brick. It is not necessary for the hoops to be held in position by wiring them to the longitudinal reinforcing. The tops of the longitudinal reinforcing bars are held in position by means of a wood templet or by securely tying them to a hoop placed near the top of a column.

The brick are laid as described previously. The hoops are placed in a full bed of mortar and the mortar smoothed out before the next course of brick is laid. Brick bats may be used in the core of the column or where it is inconvenient or impossible to use full-size brick. After all the brick in a course are laid, the core and all remaining space around the reinforcing bars is filled with mortar. Any bats required are then pushed into the mortar until completely

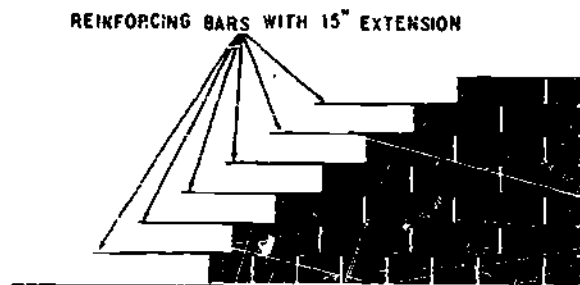
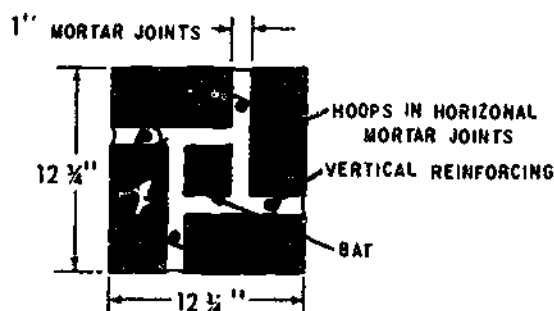

133.328

Figure 8-90.—Corner lead for reinforced brick masonry wall.

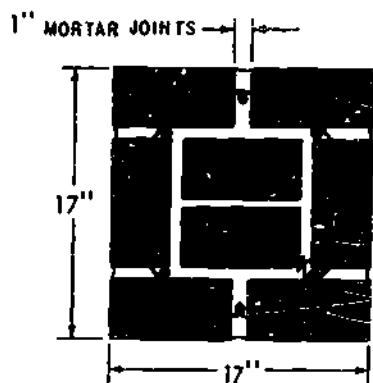

133.327

Figure 8-89.—Reinforced brick masonry columns.

embedded. The next mortar bed is now spread and the process repeated.

Reinforcing steel for walls consists of both horizontal and vertical bars and is placed as discussed previously. The vertical bars are wired to the dowels projecting up from the footing below and are placed in the mortar joint between tiers of brick. As the brick are laid, all space around the bars is filled with mortar. Otherwise, the wall is constructed as specified.

In the construction of corner leads, bars should be placed in the corner as shown in figure 8-90. The extension is 15 in. and the bar size should be the same as that used for horizontal bars in the rest of the wall. The horizontal bars in the remainder of the wall lap these corner bars by the same 15 inches. As for beams, all the brick in one course between corner leads are laid before any other brick are laid. This is necessary since the entire reinforcing bar must be embedded in mortar at the same time.

ESTIMATING BRICK AND MORTAR

You can estimate the number of bricks and the quantity of mortar needed for a 4-, 8-, or 12-inch wall when given the thickness of the mortar joint and the exact size of the bricks. The following example shows the method of estimating the number of bricks for a 4-inch wall measuring 8 ft high and 14 ft long. **EXAMPLE:** Specifications call for the use of 2 1/4 by 3 3/4 by 8-inch bricks and bed and end joints of 1/2 inch each. The brick face with its mortar joints measure 2 3/4 in. high by 8 1/2 in. long, as shown in figure 8-91.

Step 1. Find the surface area by multiplying the height and the length of a brick (including the mortar joints). $2\frac{3}{4}$ in. \times $8\frac{1}{2}$ in. = 2.75 in. \times 8.50 in. = 23.38 sq in.

Step 2. Find the number of bricks per square foot of wall. Since 1 sq ft = 144 sq in., divide

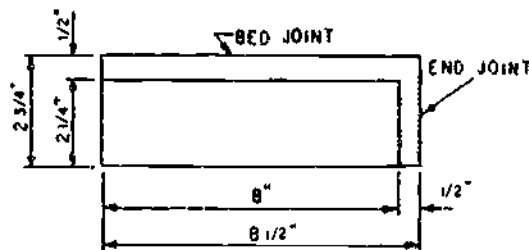

Figure 8-91.—Average size brick with mortar joint.

Table 8-7.—Mortar Requirements

Cubic Feet of Mortar Required for 1000 Bricks (No Allowance for Waste Included, add 10% for Waste)					
Joint Thickness (in.)	Various Wall Thicknesses (in.)				
	4	8	12	16	20
1/2	5.7	8.7	9.7	10.2	10.5
3/4	8.7	11.8	12.9	13.4	13.7
1	11.7	15.0	16.2	16.8	17.1
1 1/4	14.8	18.3	19.5	20.1	20.5

133.455

144 by 23.38. This gives you the number of bricks (6.16) for a 4-inch wall. (Double this number for an 8-inch wall, triple it for a 12-inch wall.)

Step 3. Find the area of the brick wall by multiplying its height by its length. 8 ft x 14 ft = 112 sq ft.

Step 4. Multiply the area of the wall by the number of bricks per square foot. In this case, 112 x 6.16 or 690 bricks.

Note: If there are windows, doors, and other openings on the wall, you subtract the area of these openings from the overall area of the wall to get the net area. Then, in step 4, you multiply the number of bricks per square foot by the net area.

In finding how much mortar is required to build a given wall, divide the total number of

bricks by 1,000, multiply the result by the factor given in table 8-7, and allow 10% for waste. EXAMPLE: A total of 13,832 bricks are required to build an 8-inch wall where the mortar joints are 1/2 in. thick. Find the amount of mortar required.

Step 1. $13,832 \div 1,000 = 13.832$.

Step 2. In table 8-7, find the appropriate factor. For an 8-inch wall and 1/2-inch joint, the factor is 15.0.

Step 3. $13.832 \times 15 = 207.5$ cu ft.

Step 4. Add 10% for waste. Waste allowance = 207.5×0.10 or 20.75 cu ft. $207.5 + 20.75 = 228.25$ cu ft.

Therefore, 228.25 cu ft is the amount of mortar required to lay 13,832 bricks for an 8-inch wall, using 1/2-inch-thick mortar joints.

CHAPTER 9

LIGHT FRAME CONSTRUCTION: FLOOR AND WALL

This chapter provides general information on your job as a Builder on how the various members of floor and wall framing are assembled. An explanation of the procedures applicable to the installation of subflooring, interior construction, doors, windows, and sheathing is also given.

Be sure safety is given prime consideration by you and your crewmembers during all phases of light frame construction.

THEORY OF FRAMING

The two major parts of a building are the foundation and the part above the foundation, which is called the SUPERSTRUCTURE. A FRAME building is one in which the skeleton of the superstructure consists of a framework of wooden structural members. This framework is called the FRAMING of the building, and the framing is subdivided into FLOOR FRAMING AND WALL AND ROOF FRAMING. Floor framing consists for the most part of horizontal members called JOISTS and wall framing for the most part of vertical members called STUDS. Roof framing consists of both horizontal and vertical members which will be discussed in a later chapter.

In the days when lumber and labor were plentiful and nails were scarce, it was the custom to use large-dimension timbers (4-by, 6-by, 8-by, etc.) for framing members, and to join members together with mortise-and-tenon joints, fastened with wooden pins. As lumber and labor became more expensive, as nails became cheaper, and as the machinery for cutting lumber to smaller

dimensions became more highly developed, the large-timber method of framing (called FULL framing) gradually went out of use. Newer methods, in which the framing members consist of small-dimension lumber (usually 2-by) fastened together with nails, are now used.

Of the newer framing methods, the most common is PLATFORM FRAMING (also called WESTERN and STORY-BY-STORY FRAMING). In platform framing there are separate studs for each floor, anchored on SOLE PLATES laid on the subflooring, as shown in figure 9-1.

SILL FRAMING

The work involved in sill construction is a very important one for the Builder. The foundation wall is the support upon which all structure rests. The sill is the foundation on which all framing structure rests and it is the real point of departure for actual building activities.

The sills are the first part of the frame to be set in place. They rest either directly on the foundation piers or on the ground, and may extend all around the building; they are joined at the corners and spliced when necessary. Figure 9-2 shows some common types of sills. The type used depends upon the general type of construction used in the frame.

The BOX-SILL assembly shown in figure 9-3 is the type most frequently used in platform-frame construction. In this type, the ends of the joists are framed against a HEADER-JOIST which is set flush with the outer edge of the sill.

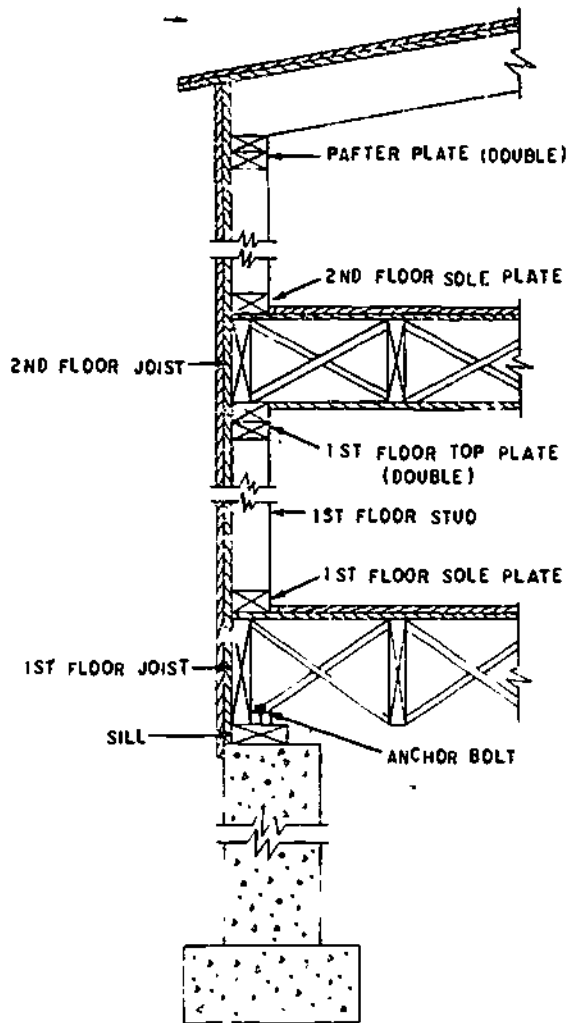

133.88
Figure 9-1.—Platform-frame wall section.

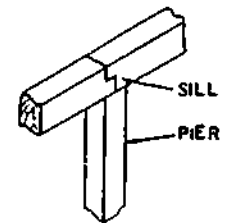
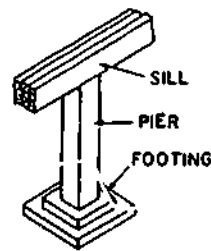
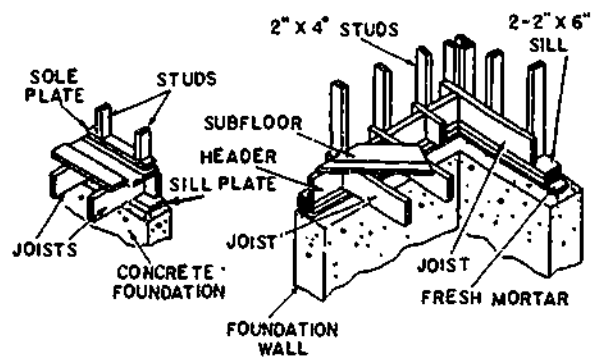
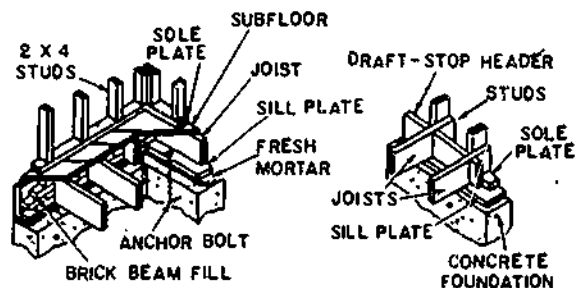

133.352
Figure 9-2.—Types of sills.

Sills are usually single, as shown in the examples which have been illustrated, but a double sill is occasionally specified.

Balloon-frame construction uses a nominal 2-in. or thicker wood sill upon which the joists rest. The studs also bear on this member and are nailed both to the floor joists and the sill. The subfloor is laid diagonally or at right angles to the joists and a fire-stop added between the studs at the floorline. (See fig. 9-4.) When diagonal subfloor is used, a nailing member is normally required between joists and studs at the wall lines.

SILL LAYOUT

The sill is normally the first member to be laid out. As indicated in figure 9-1, the edge of the sill is usually set back from the edge of the foundation a distance equal to the thickness of the sheathing. When this is the case, the length of sill stock required to cover a section of foundation wall is equal to the length of the wall section minus twice the amount of the set-back.

To make up this length, you should select lengths of sill stock which will most

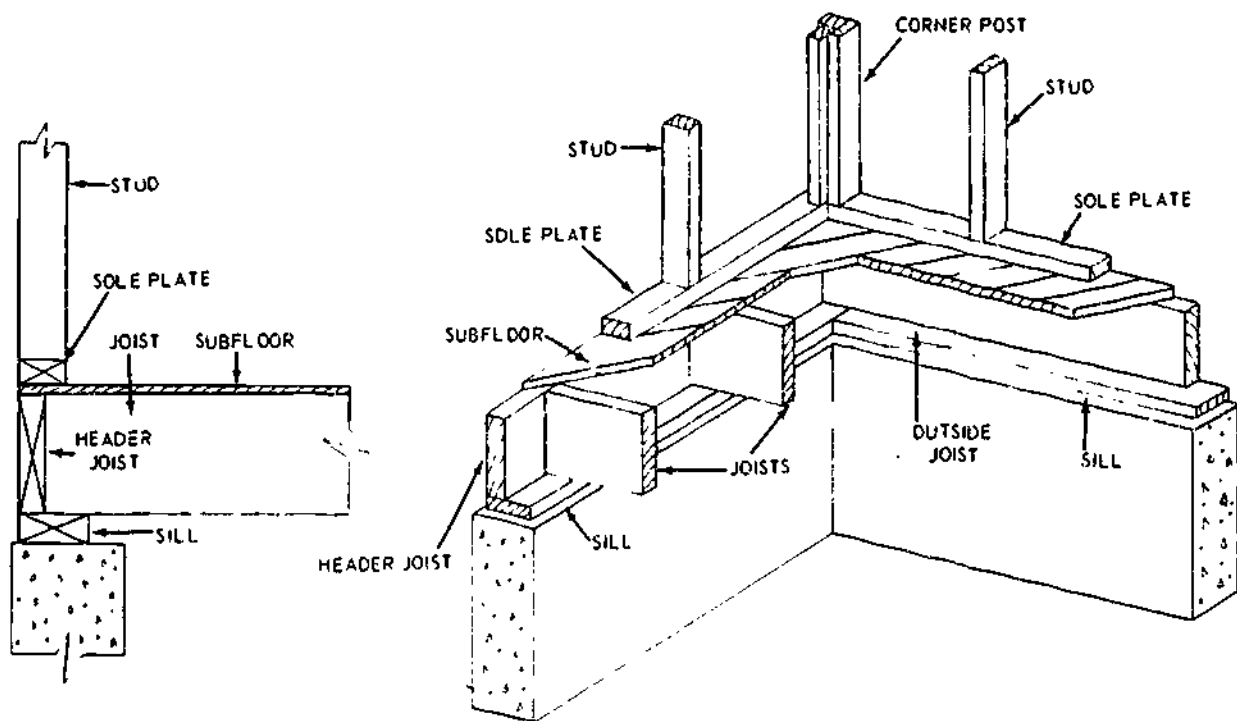

45.446

Figure 9-3.—Box-sill assembly.

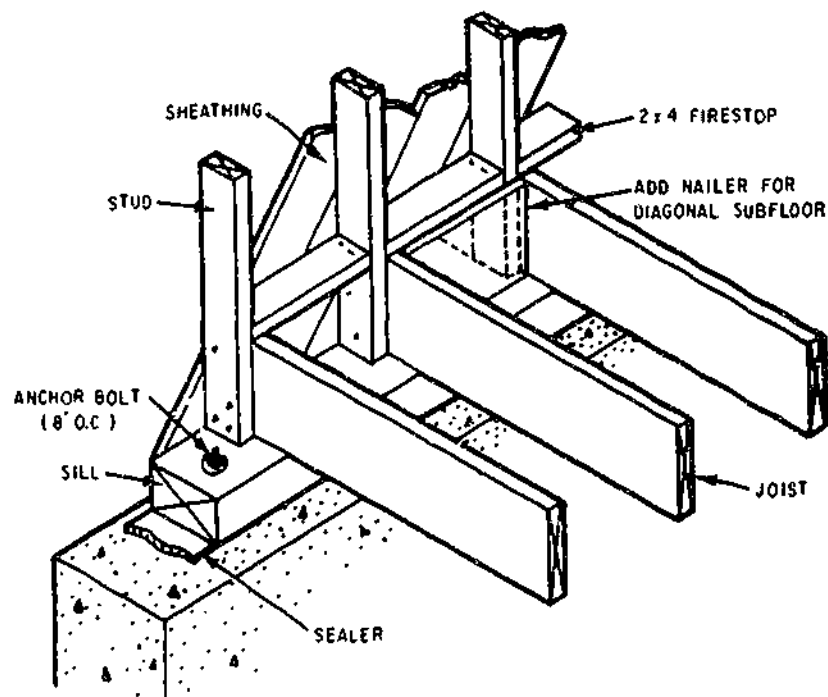

133.458

Figure 9-4.—Sill for balloon framing.

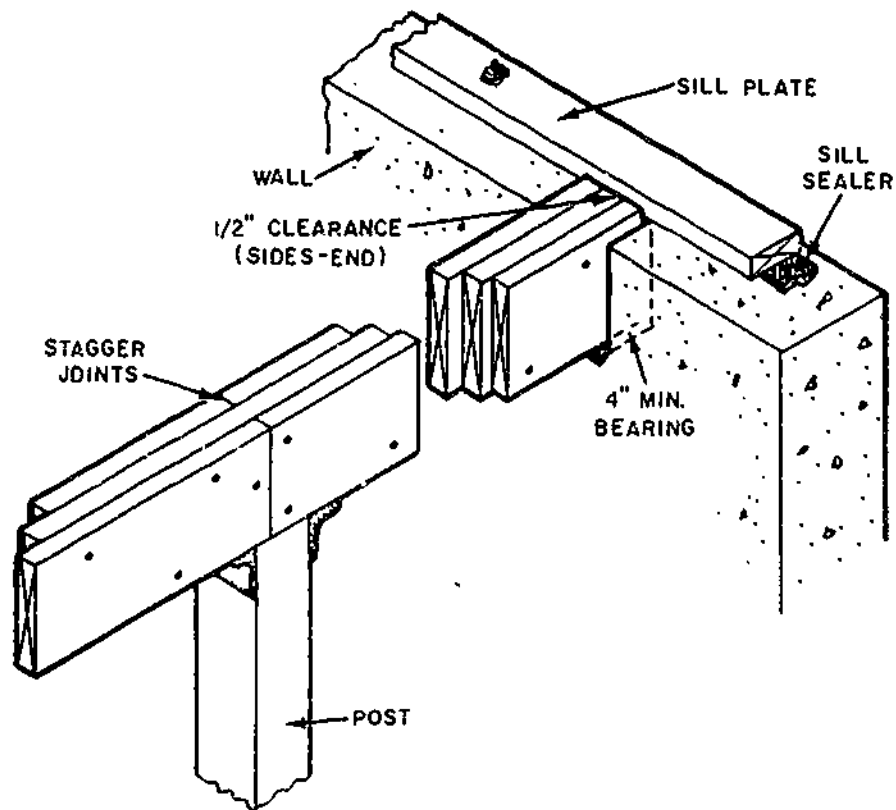

Figure 9-5.—Built-up wood girder.

133.459

conveniently and economically make up the total required length. Suppose, for example, that the section of wall calls for 33 ft of 2 by 8 sill stock and you have 2 by 8's available in 18-ft, 16-ft, 14-ft, and 6-ft lengths. You could select two 18-ft pieces and cut 3 ft off one of them, or you could select two 14-ft pieces and a 6-ft piece and cut a foot off the 6-ft piece. In the first instance, however, you would have 3 ft of waste, while in the second you would have two joints in the sill. To minimize both waste and the number of joints, you should select one 18-ft and one 16-ft piece and cut 1 ft off of one of them.

Once the required length has been made up, the next step is to lay out the locations of the anchor bolt holes as follows: place each piece of sill stock on the foundation, inboard of the

bolts, but otherwise in exactly the position it is to occupy, and square a line across the stock from the center of each bolt. To lay out the bolt-hole center on each of these lines, measure the distance from the center OF EACH BOLT to the outer edge of the foundation, subtract the amount of the sill set-back from this distance, and lay off the remainder ON THE CORRESPONDING BOLT LINE, measuring from what is to be the outer edge of the sill.

The reason you must lay out each bolt hole separately is that the bolts may be set at slightly varying distances from the edge of the foundation and from each other.

SILL PLACEMENT

Bore the bolt holes with an auger bit 1/8 in. larger in diameter than the bolt diameter, to

allow for making slight adjustments in the location of the sill. When all the holes have been bored, try the stock for the whole section on the bolts for a fit. If the fit is satisfactory, remove the pieces of stock and place a thin layer of sealer on top of the foundation. Replace the pieces and check the whole sill for line and level. Place small wedges, if necessary, to hold the pieces level until the sealer sets. Then place the washers on the bolts, screw on the nuts, and bolt the sill down.

FLOOR FRAMING

The floors of a frame building are supported on a series of JOISTS. Depending upon the length of the SPAN (distance between the end-supports of the joists) and the expected size of the combined live and dead load on the floor, joists may run anywhere from 2 by 4 to 3 by 10.

The usual joist size for most ordinary frame construction is 2 by 10. The outside-wall ends of first-floor joists are toenailed to the sill.

In platform framing the outside-wall ends of upper-floor joists are anchored on the lower floor top plates. In most cases they butt against, and are nailed to, a HEADER JOIST, set flush with the outer edge of the plate. This amounts to a repeat of the box-sill framing arrangement used on the first floor.

FRAMING JOISTS TO GIRDERS

The distance between an opposing pair of outside walls is often too great to be spanned by a single joist. When two or more joists are required to cover the span, intermediate support for the inboard joist-ends is provided by one or more girders. First-floor girders are supported on piers or on basement columns; upper-floor girders are supported on lower-floor columns. Girders may consist of wood, either solid or LAMINATED, built up of several wooden members spiked or bolted together, or they may consist of steel beams. (See fig. 9-5.)

Figure 9-6 shows three common methods of framing inside ends of joists to wooden girders. In view A, fig. 9-6, the joist ends are lapped on and toenailed to the girder, and spiked to each other. In view B, fig. 9-6, the joist ends are notched so as to bear partly on the girder and partly on a LEDGER PLATE nailed to the side of the girder. Again the joists are toenailed to the girder and spiked to each other.

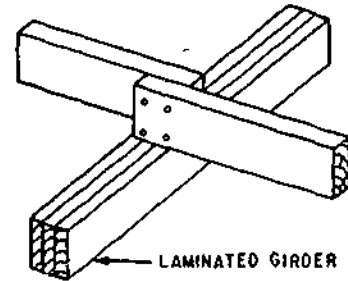

A

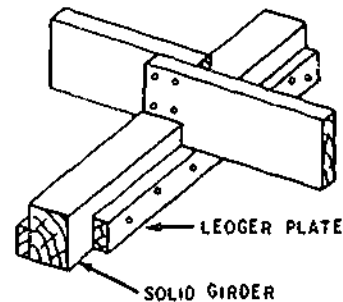

B

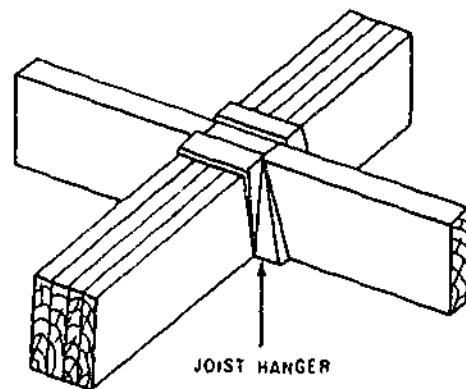

C

133.91

Figure 9-6.—Methods of framing joists to wooden girders.

Specifications usually require that joists not be notched to more than one-third of their depths. The JOIST HANGER (also called a STIRRUP) shown in view C, fig. 9-6, is used when the nature of the construction requires that the upper and lower edges of the joists come flush with the top and bottom of the girder.

When a space is required for heat ducts in a partition supported on the girder, a spaced wood girder is sometimes necessary. (See fig. 9-7.) Solid blocking is used at intervals between the two members. A single post support for a spaced girder usually requires a bolster, preferably metal, with sufficient span to support the two members.

Joists may be arranged with a steel beam generally the same way as illustrated for a wood beam. Perhaps the most common methods, depending on joist sizes, are:

1. The joists rest directly on the top of the beam.

2. Joists rest on a wood ledger or steel angle iron, which is bolted to the web, as shown in view A, fig. 9-8.

3. Joists bear directly on the flange of the beam as shown in view B, of fig. 9-8.

In the third method, wood blocking is required between the joists near the beam flange to prevent overturning.

JOIST LAYOUT

A COMMON JOIST is a full-length joist that spans from wall-to-wall or from wall-to-girder. The best way to layout common joists for cutting is to figure the correct length of a common joist, cut a piece of stock to this length, notch it for identification, and use the piece as a PATTERN from which to cut the other common joists.

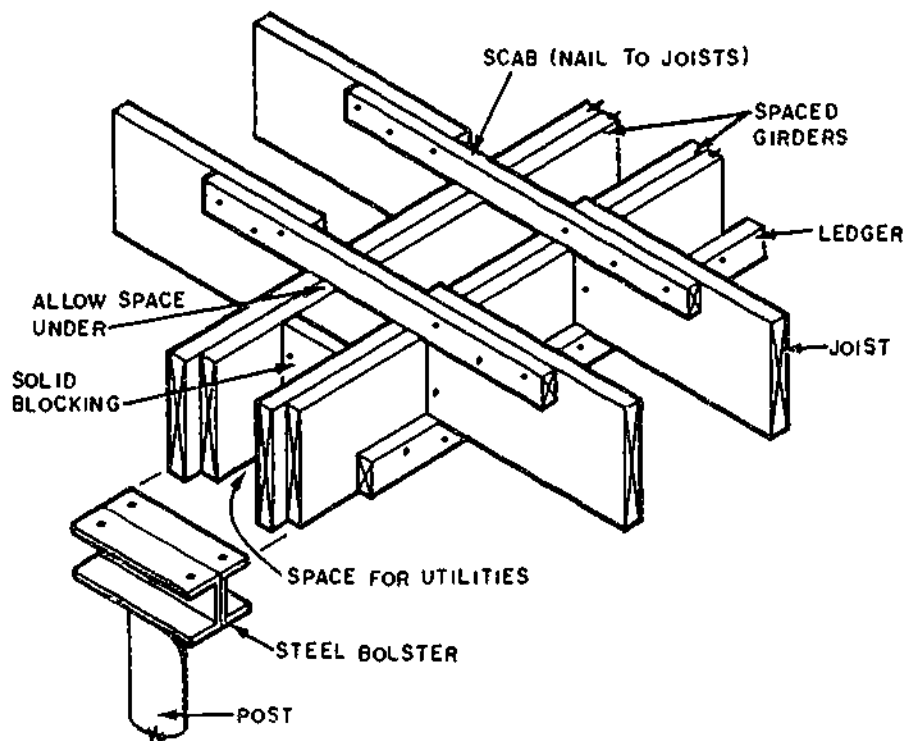
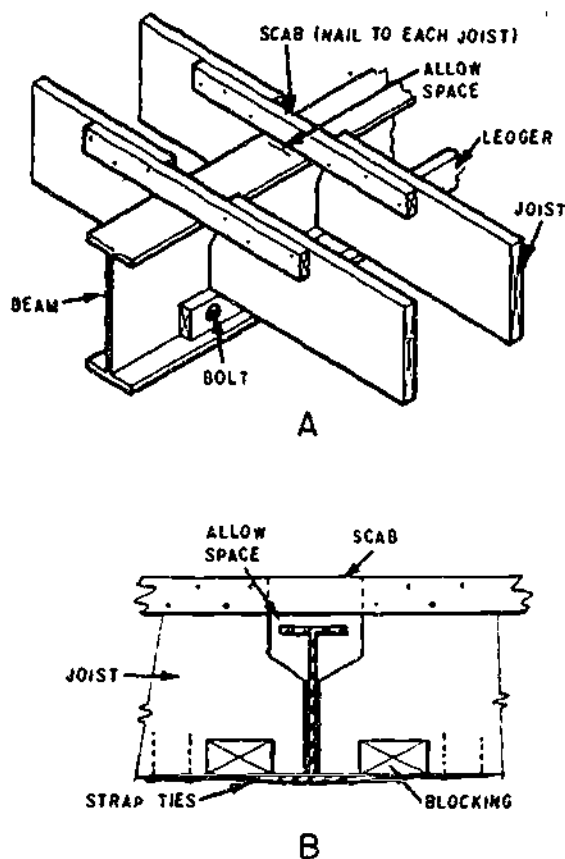

Figure 9-7.—Spaced wood girder.



133.461
Figure 9-8.—Steelbeam and joists: A. Bearing on ledger
B. Bearing on flange.

A CRIPPLE JOIST is similar to a common joist with the exception that it does not extend the full span as a common joist does. Cripples are normally interrupted by floor openings. The best way to lay out cripples for cutting is to postpone the cripple layout until after the headers have been placed: then measure the spaces which are to be spanned by the cripples.

In platform framing, the outer ends of the joists usually butt against a header joist which is set flush with the outer edge of the sill. In this case the length of a wall-to-wall common joist will be the distance between the outer edges of the sills, minus twice the thickness of a header joist.

The length of the common joist required to cover a given span between an outside wall and a girder varies with the character of the wall framing and also with the manner in which the joists are framed to the girder. The length of the common joist required to cover a given span between two girders varies with the manner in which the joists are framed to the girders. Joists which lap a girder with full bearing (meaning joists which extend all the way across the top of the girder) must obviously be longer than joists which butt each other on the top of a girder. Joists in hangers, which butt against the sides of a girder, are shorter than joists which butt each other on top of a girder.

The whole floor-framing situation must be studied closely before a common joist pattern is cut. Whenever possible, the cutting of a pattern should be delayed until the sills, headers, and other supporting or abutting members are erected. The joist length can then be determined by measurements taken on the actual structure. Whenever possible, the common joist pattern should be tried on the actual structure for a fit before any joists are cut from it.

The location of a joist end is marked on a sill or a header joist by squaring a line across and drawing an X alongside it. The X indicates the side of the line on which the joist end-section is to be placed.

The location of one of the outside joists is marked first, and the locations of the others are then measured off from this one in accordance with the specified spacing of joists O.C.

Figure 9-9 shows the method of laying out joist locations on the header joists in a platform-frame box sill, in which the headers and outside joists come flush with the outer edges of the sill.

Before you start laying out the joist locations, you should study the floor framing plan to learn the locations of any double trimmers which will be needed to provide additional support around floor openings. Locations of double trimmers are marked with two lines and two X's. The locations of cripples

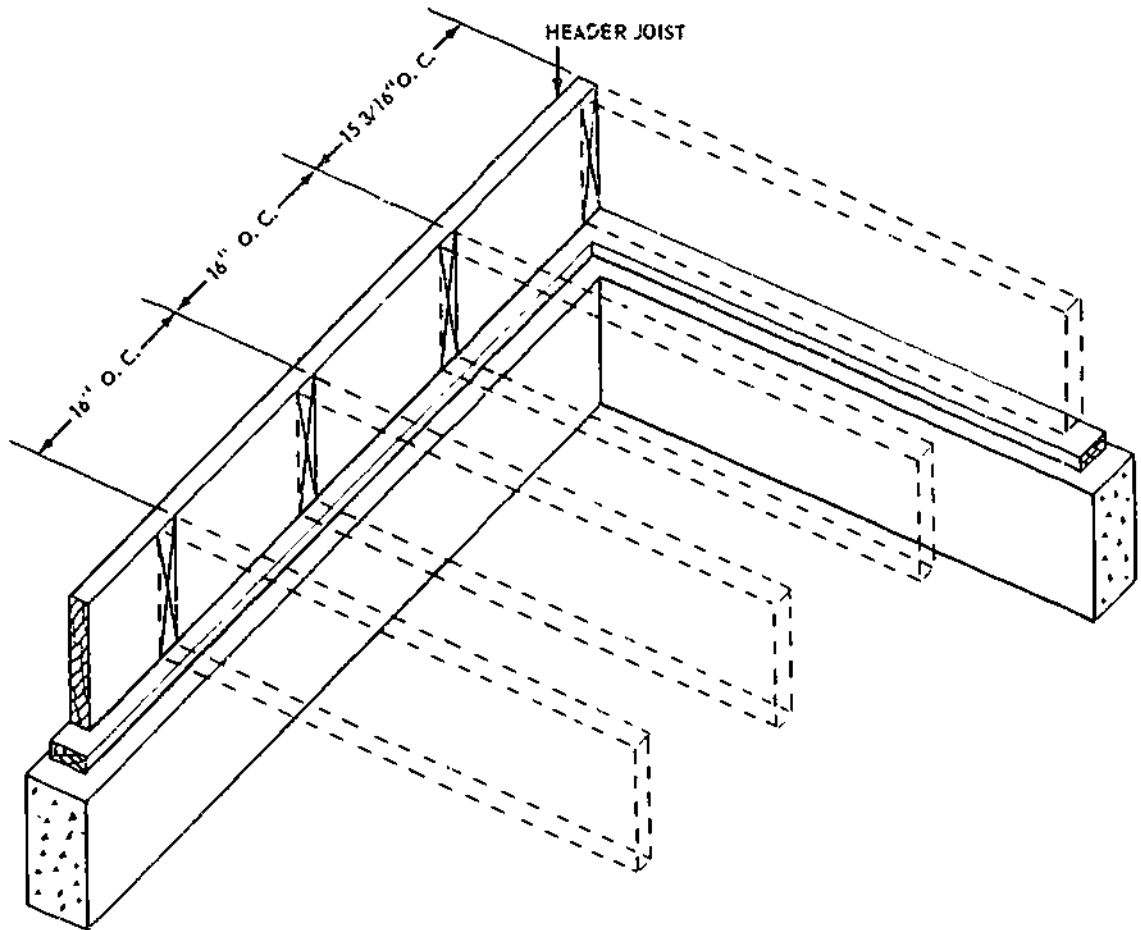

Figure 9-9.—Joist location layout-platform-frame box sill assembly with header joists.

133.104

are marked the same as the locations of common joists, but with the word CRIP written in alongside.

JOIST ERECTION

The usual procedure for erecting joists is as follows: if there are any header joists, these joists are cut and erected first. As a general rule, the length of a platform-frame header is equal to the shortest distance between the outer edges of the sills. Header joists are toenailed to the sills with 10-penny nails spaced 16 in. O.C.

As soon as a common joist pattern has been laid out and cut as previously described, a

CUTTING PARTY starts cutting common joists. As each joist is cut, a two-person CARRYING PARTY carries it to its location and lays it flat across the span. A two-person CONSTRUCTION PARTY (one person at each end of the span) erects the outside joists first. Each of these is toenailed down to the sill or plate with 10-penny nails spaced 16 in. O.C., and end-nailed through the headers with three 16-penny nails. (See table 9-1.) Incidentally, many joists have a slight curve to them, and the convex edge of a joist is called the CROWN. A joist should always be placed with the crown UP.

Next the joists lying between the outside joists are set on edge and the ends of each joist

Chapter 9—LIGHT FRAME CONSTRUCTION: FLOOR AND WALL

Table 9-1.—Recommended Schedule for Nailing the Framing and Sheathing of a Wood-Frame Building

Joining	Nailing method	Nails		
		Number	Size	Placement
Header to joist	End-nail	3	16d	
Joist to sill or girder	Toenail	2	10d or	
		3	8d	
Header and stringer joist to sill	Toenail		10d	16 in. on center
Bridging to joist	Toenail each end	2	8d	
Ledger strip to beam, 2 in. thick		3	16d	At each joist
Subfloor, boards:				
1 by 6 in. and smaller		2	8d	To each joist
1 by 8 in.		3	8d	To each joist
Subfloor, plywood:				
At edges			8d	6 in. on center
At intermediate joists			8d	8 in. on center
Subfloor (2 by 6 in., T&G) to joist or girder	Blind-nail (causing) and face-nail	2	16d	
Soleplate to stud, horizontal assembly	End-nail	2	16d	At each stud
Top plate to stud	End-nail	2	16d	
Stud to soleplate	Toenail	4	8d	
Soleplate to joist or blocking	Face-nail		16d	16 in. on center
Doubled studs	Face-nail, stagger		16d	16 in. on center
End stud of intersecting wall to exterior wall stud	Face-nail		16d	16 in. on center
Upper top plate to lower top plate	Face-nail		16d	16 in. on center
Upper top plate, laps and intersections	Face-nail	2	16d	
Continuous header, two pieces, each edge			12d	12 in. on center
Ceiling joist to top wall plates	Toenail	3	8d	
Ceiling joist laps at partition	Face-nail	1	16d	
Rafter to top plate	Toenail	2	8d	
Rafter to ceiling joist	Face-nail	1	16d	
Rafter to valley or hip rafter	Toenail	3	16d	
Ridge board to rafter	End-nail	1	16d	
Rafter to rafter through ridge board	Face-nail	1	8d	
	Edge-nail	1	16d	
Collar beam to rafter				
2 in. member	Face-nail	2	12d	
1 in. member	Face-nail	1	8d	
1-in. diagonal let-in brace to each stud and plate (4 nails at top)		2	8d	
Built-up corner studs:				
Studs to blocking	Face-nail	2	16d	Each side
Intersecting stud to corner studs	Face-nail		16d	12 in. on center
Built-up girders and beams, three or more members	Face-nail		20d	32 in. on center, each side
Wall sheathing:				
1 by 8 in. or less, horizontal	Face-nail	2	8d	At each stud
1 by 6 in. or greater, diagonal	Face-nail	3	8d	At each stud
Wall sheathing, vertically applied plywood				
$\frac{3}{4}$ in. and less thick	Face-nail		6d	6 in. edge
$\frac{1}{2}$ in. and over thick	Face-nail		8d	12 in. intermediate
Wall sheathing, vertically applied fiberboard				
$\frac{1}{2}$ in. thick	Face-nail		1 1/2 in. roofing nail	3 in. edge and
$\frac{3}{8}$ in. thick	Face-nail		1 3/4 in. roofing nail	6 in. intermediate
Roof sheathing, boards, 4, 6, 8 in. width	Face-nail	2	8d	At each rafter
Roof sheathing, plywood				
$\frac{3}{4}$ in. and less thick	Face-nail		6d	6 in. edge and 12 in. intermediate
$\frac{1}{2}$ in. and over thick	Face-nail		8d	

133,462

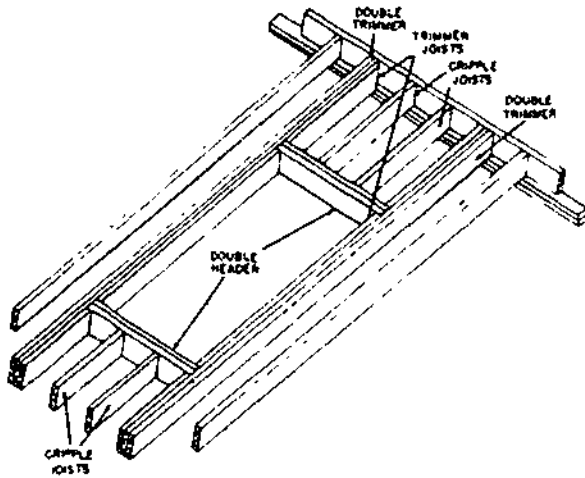

133.93
Figure 9-10.—Framing around floor opening.

are toenailed down to the sill or plate with two 10-penny nails, one on each side of the joist. Only the inner trimmer of each pair of trimmers is erected at this time, and no cripples are cut at this time. If it is necessary to splice the joists

over a girder or center beam, each joist should be toenailed to the girder beam with 10-penny nails; then nailed to each other with three or four 16-penny nails. If a nominal 2-in. scab is used across butt-ended joists, it should be nailed to each joist with at least three 16-penny nails at each side of the joist. After all the common joists, and trimmers have been set on edge and toenailed, the joists are plumbed and temporarily braced as follows:

A temporary brace (usually a 1 by 6) is then laid across the tops of the joists at the center of the span. The outer ends of this brace are tacked down to the outside joists with 8-penny nails, driven only part-way in to allow for ease in extraction when the brace is removed. Beginning with the joist next to an outside joist, the joists are plumbed consecutively, and as each joist is plumbed, it is braced with an 8-penny nail, driven through the brace into the joist.

A joist that butts against a header is plumbed by lining up the joist end with the perpendicular location line on the header. When the joist is in

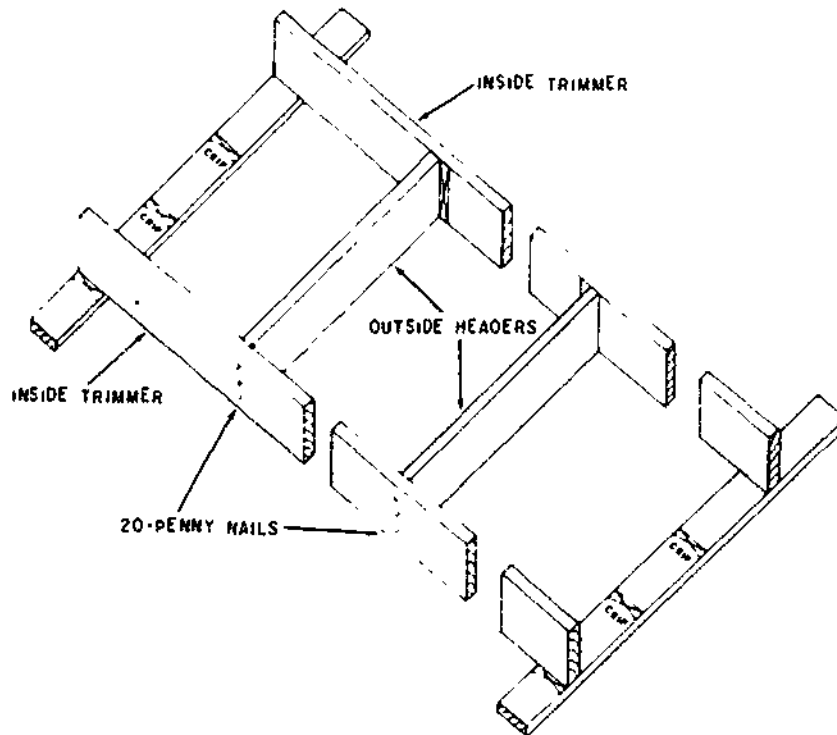

Figure 9-11.—First step in framing around floor opening.

133.105

plumb position, it is nailed at the ends with 20-penny nails, 2 to each end, driven through the header into the joist.

FRAMING AROUND FLOOR OPENINGS

Where a floor opening occurs, such as a stairway opening, the parts of the common joists which would extend across if there were no opening must be cut away. The segments remaining on either side of the opening are called CRIPPLE or TAIL joists. The wall-opening ends of cripples are framed against HEADERS, as shown in figure 9-10. Specifications usually require that headers be doubled—sometimes tripled. The location of the headers are determined from a study of the floor framing plan.

Headers are framed between the full-length joists which lie on either side of the floor opening. These joists are called TRIMMERS, and

they, too, are usually doubled or tripled. Headers up to 6 ft in length are fastened with nails, driven through the trimmers into the ends of the headers. Headers more than 6 ft in length should be fastened with joist hangers. Next the length of a header is determined by measurement of the shortest distance between the inside trimmers. The four pieces of joist stock which will form the double headers are then cut to correct length, after which the outside header of each pair is set in place and fastened to the inside trimmers with nails driven through the trimmers into the ends of the headers, as shown in figure 9-11.

Once the outside headers are in place, the lengths of the cripple joists can be determined by simple measurement. The cripples are cut, set in place, plumbed, fastened at the outer ends like common joists, and fastened at the floor-opening ends with nails driven through the outside headers into the ends of the cripples, as shown in figure 9-12.

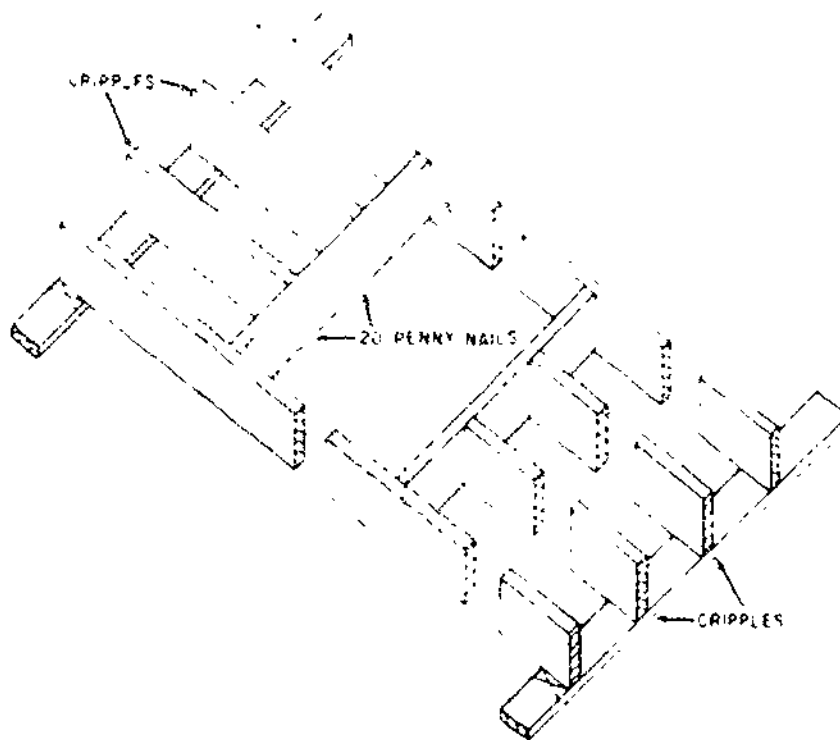

Figure 9-12.—Second step in framing around floor opening.

Next the inside headers are fastened to the outside headers and fastened to the inside trimmers with 16-penny nails, which are nailed through the trimmers into the ends of the headers (fig. 9-13). Finally the outside trimmers are set in place and nailed to the inside trimmer with 16-penny nails spaced 12 in. O.C., as shown in figure 9-14.

FLOOR FRAMING UNDER PARTITION

A PARTITION is a wall other than one of the outside walls of the structure. An upper-story partition is not always supported by a partition located directly under it on the story below. When it is not, the floor must be strengthened to carry the load of the partition. For a partition running parallel to the lines of

the joists, strengthening is accomplished by doubling the joist under the partition (fig. 9-15).

The joist is doubled by nailing two joists to a series of SOLID BRIDGES, usually placed from 14 to 20 in. O.C. The bridges must separate the joists by the width of the partition sole plate, to insure that the upper edges of the joists will be available as nailing surfaces for the finish flooring. Sole plate stock, cut in lengths equal to the depth of the joist, is the best material to use for the bridging.

For a partition which runs across rather than parallel to the joists, every other joist in the floor (or every joist, if so specified) is doubled in the same manner.

FLOOR FRAMING AT WALL PROJECTIONS

The framing for a wall projection, such as a bay window or first or second floor extensions

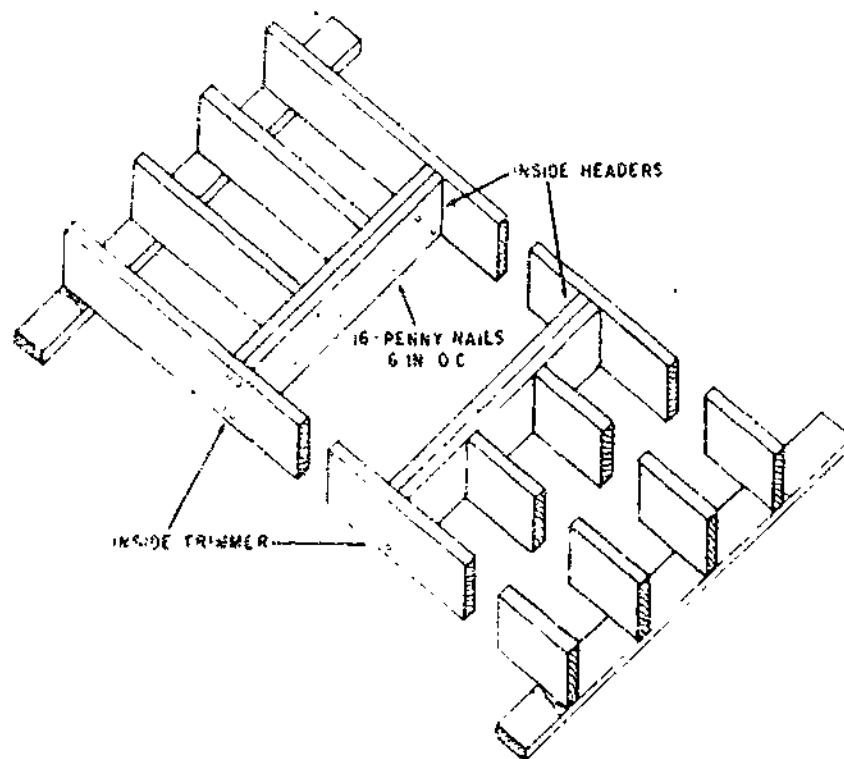

Figure 9-13.—Third step in framing around floor opening.

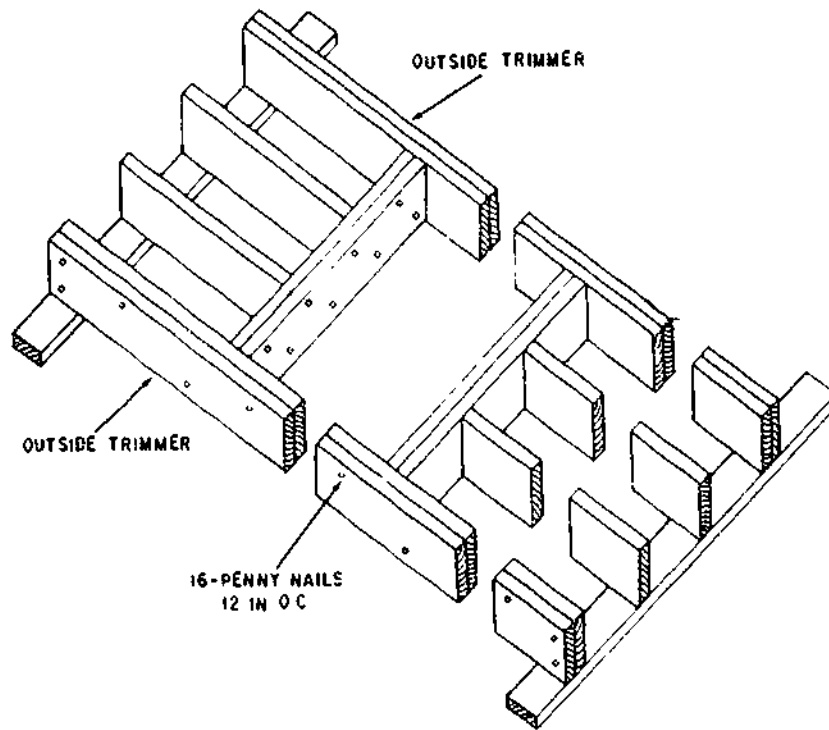

Figure 9-14.—Fourth step in framing around floor opening.

133.108

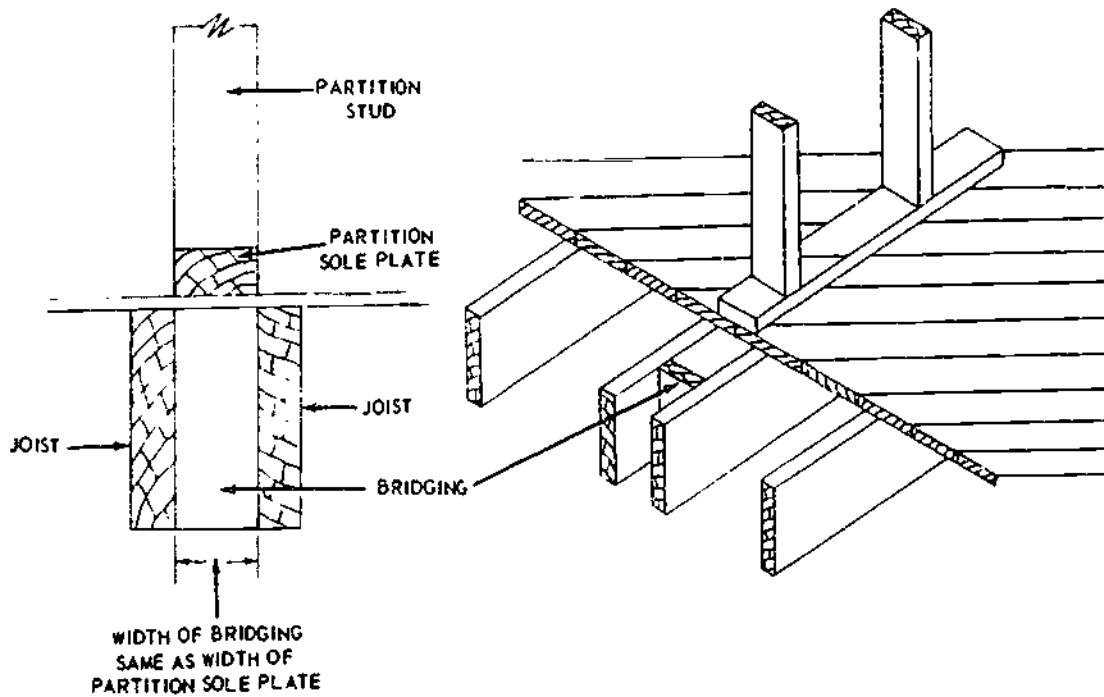

Figure 9-15.—Method of doubling joist under partition.

133.06

beyond the lower wall, should generally consist of the projection of the floor joists. (See fig. 9-16.) This extension normally should not exceed 24 in. unless designed specifically for greater projections, which may require special anchorage at the opposite ends of the joists. The joists forming each side of the bay should be doubled. Nailing, in general, should conform to that for stair openings. The subflooring is carried to and sawed flush with the outer framing member. Rafters are often carried by a header constructed in the main wall over the bay area, which supports the roofload. Thus the wall of the bay has less load to support.

Projections at right angles to the length of the floor joists should generally be limited to small areas and extensions. In this construction, the cripple should be carried by single or double

joists (view B, of fig. 9-16). Joist hangers or a ledger will provide good connections for the ends of members.

BRIDGING

The system of bracing the joists to each other is called BRIDGING. The chief purpose of bridging is to hold the joists plumb and in correct alinement, but bridging also serves to distribute part of a concentrated heavy load, such as the weight of a piano, over several joists next to those directly under the load.

As soon as enough common joists have been erected, the installation of bridging begins. Cross-bridging struts are nailed (usually with 8-penny nails) at the top ends only at this time. Bottom ends will be nailed from below, after the

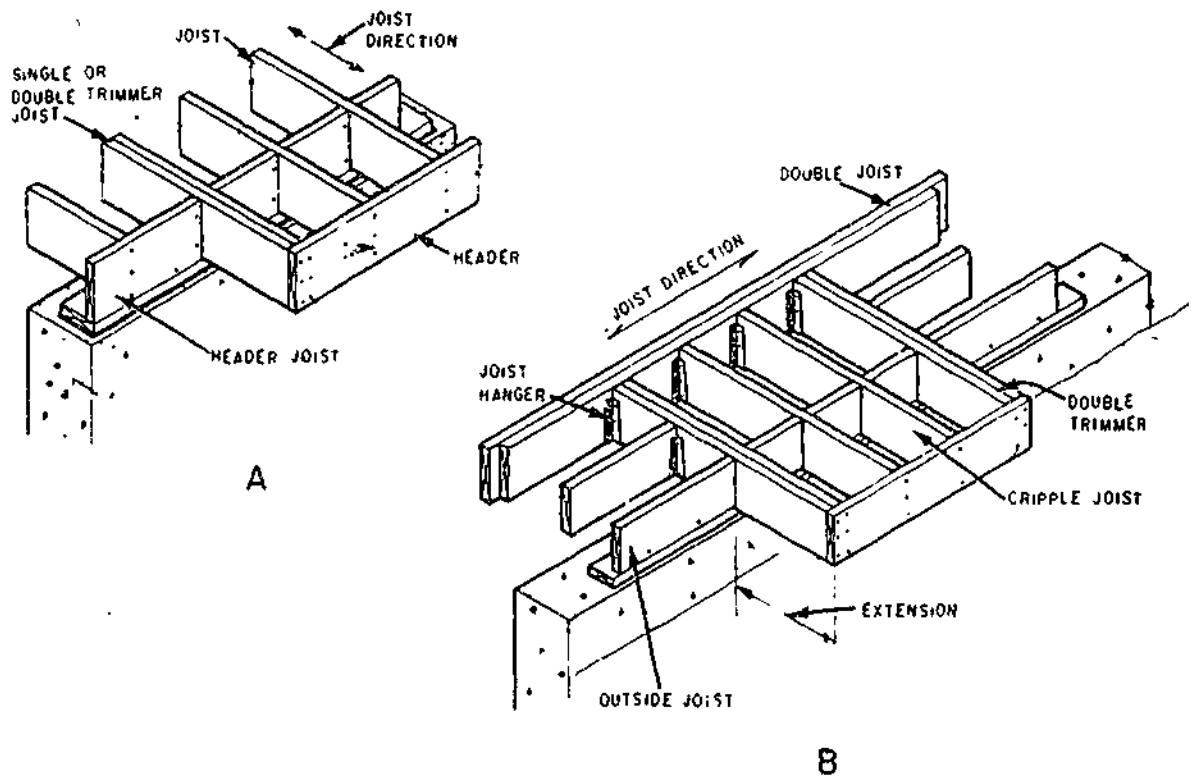

Figure 9-16. -Floor framing at wall projections. A. Projection of joist for bay window extensions B. Projection at right angles to joists.

133.483

joists have adjusted themselves to the weight of the subflooring. Remember the joist should be placed with the crown up, so that any settlement under the weight of the flooring will tend toward a level instead of toward a sag.

There are two types of bridging. CROSS bridging (view A, fig. 9-17) and SOLID bridging (view B, fig. 9-17). Cross bridging consists of pairs of STRUTS (common sizes of strut stock are 1 by 3, 1 by 4, 2 by 2, and 2 by 4), set diagonally between the joists. Solid bridging consists of pieces of joist-size stock set at right angles to the joists and can be staggered for easier installation. Compared to solid bridging,

cross bridging is more effective and more frequently used in construction. Bridging should be provided for all spans greater than 6 ft, but the maximum spacing between rows of bridging must not exceed 8 ft.

The required length of a cross-bridging strut and the required angle of cut for the ends may be figured as follows: select a piece of board equal in width to the ACTUAL depth of a joist, and 4 or 5 in. longer than the specified spacing of joists O.C. Square two lines across the board, separated from each other by a distance between the two joists. These two lines represent the opposing faces of the two adjacent joists.

Next, sketch in the edge outline of one of the struts, as shown in figure 9-18, using the ACTUAL thickness of the material. The measured length of this outline is the required length of a strut. To cut struts to this length and to the correct end-angle, proceed to make a miter box as follows

First, edge-butt a length of 2 by 4 to a length of 2 by 6, as shown in the second and third views of figure 9-19. Then set the framing square on the layout, as shown in the first view, with a convenient figure on the tongue intersected by the lower end of the strut outline. Note the figure that the outline intersects on the blade, as indicated. Set the framing square to this cut on the upper edge of the 2 by 6, as shown in the second view, and draw a line along the tongue.

A kerf sawed square from this line will guide the saw at the correct angle for making the end cuts. Measure off from the kerf the length of a strut, and nail a stop block to the miter box at this point, as shown in the third view. Struts may now be sawed to the correct length and the correct angle by placing the strut stock on edge in the miter box with the end against the stop block.

The bridging is installed after the joists have been set in place, but before the subfloor is laid. At this time only the upper ends of the struts are nailed. The nailing of the lower ends is postponed until after the joists have adjusted to the weight of the subflooring.

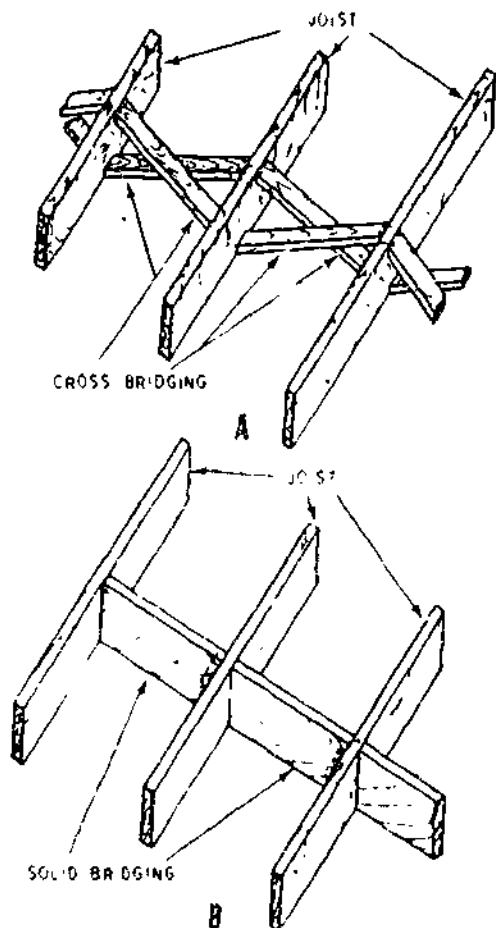

45.440

Figure 9-17.--Cross bridging and solid bridging.

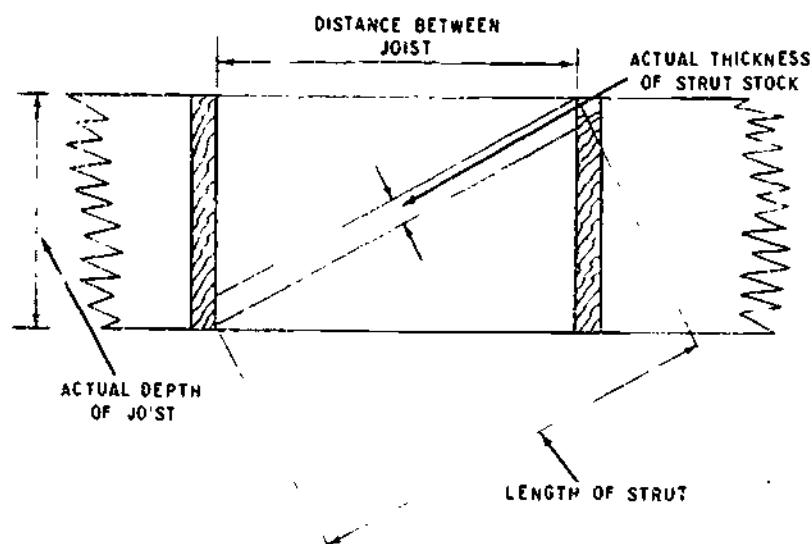

Figure 9-18.—Layout for cross-bridging struts.

133.95

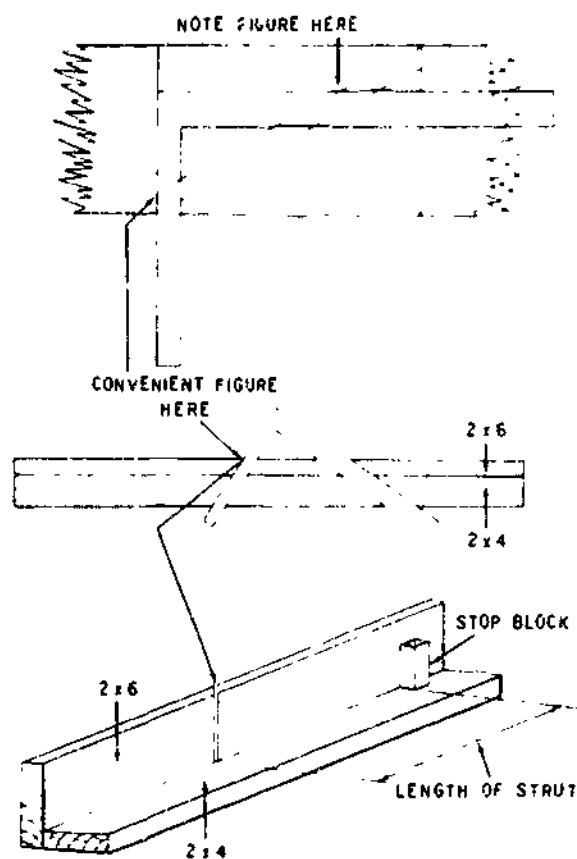

Figure 9-19.—Making a miter box for cutting cross-bridging struts.

133.95

SUBFLOORING

Subflooring is used over the floor joists to form a working platform and base for finish flooring. It usually consists of square-edge or tongue-and-grooved boards or plywood 1/2 to 3/4 in. thick, depending on the type of finish floor, and spacing of joists, as shown in figure 9-20.

Boards

Subflooring may be applied either diagonally (most common) or at right angles to the joists. When subflooring is placed at right angles to the joists, the finish floor should be laid at right angles to the subflooring. Diagonal subflooring permits finish flooring to be laid either parallel or at right angles (most common) to the joists. End joints of the boards should always be made directly over the joists. Subflooring is nailed to each joist with two 8-penny nails for widths under 8 in. and three 8-penny nails for 8-in. widths.

The joist spacing should not exceed 16 in. O.C. when finish flooring is laid parallel to the joists or where parquet finish flooring is used.

Where balloon framing is used, blocking should be installed between ends of joists at the

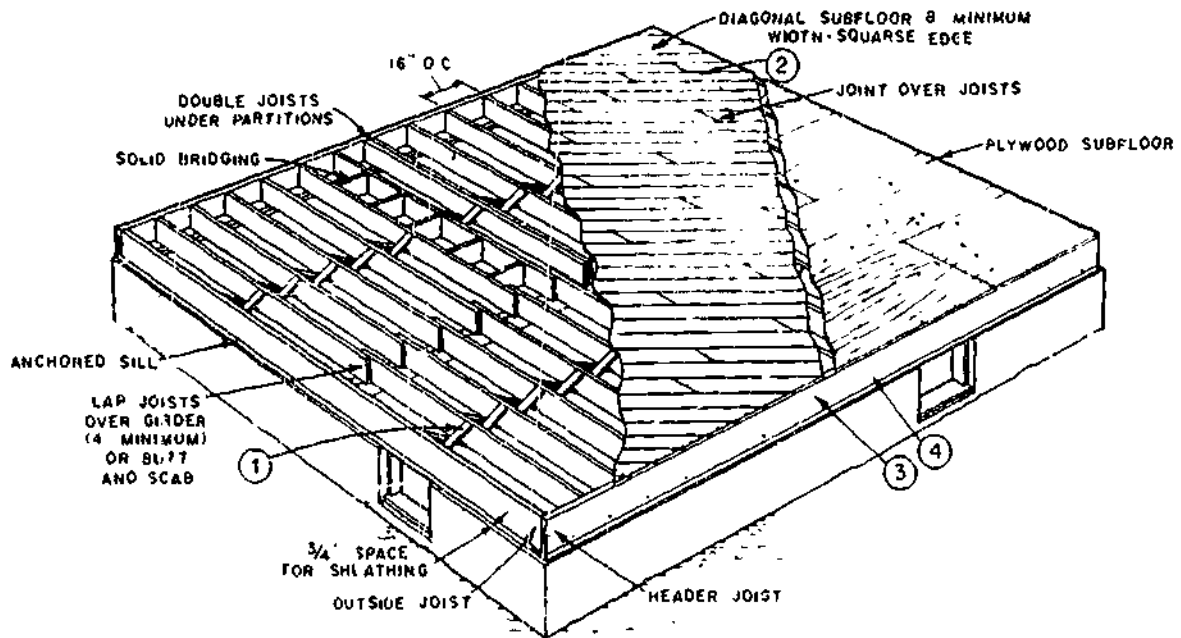

133.464

Figure 9-20.—Floor framing: 1. Nailing bridging to joists; 2. Nailing board subfloor to joists; 3. Nailing header to joists, 4. Toenailing header to sill.

wall for nailing the ends of diagonal subfloor boards. (See fig. 9-4.)

Plywood

Plywood can be obtained in a number of grades designed to meet a broad range of end-use requirements. All interior-type grades are also available with fully waterproof adhesive identical with those used in exterior plywood. This type is useful where a hazard of prolonged moisture exists, such as in underlayments, or subfloors adjacent to plumbing fixtures and for roof sheathing which may be exposed for long periods during construction. Under normal conditions and for sheathing used on walls, standard sheathing grades are satisfactory.

Plywood suitable for subfloor, such as standard sheathing, structural I and II, and C-C exterior grades, has a panel identification index marking on each sheet. These markings indicate the allowable spacing of rafters and floor joists for the various thicknesses when the plywood is used as roof sheathing or subfloor. For example,

an index mark of 32/16 indicates that the plywood panel is suitable for a maximum spacing of 32 in. for rafters and 16 in. for floor joists. Thus, no problem of strength differences between species is involved as the correct identification is shown for each panel.

Plywood can also serve as combined plywood subfloor and underlayment, eliminating separate underlayment because the plywood functions as both structural subfloor and a good substrate. This applies to thin resilient floorings, carpeting, and other nonstructural finish flooring.

Plywood should be installed with the grain direction of the outer plies at right angles to the joists and be staggered so that end joints in adjacent panels break over different joists. Plywood which is 1/2 in. to 3/4 in. thick should be nailed to the joist at each bearing with 8-penny common or 7-penny threaded nails. Space nails 6 in. apart along all edges and 10 in. along intermediate members.

For the best performance, plywood should not be laid up with tight joints whether used on

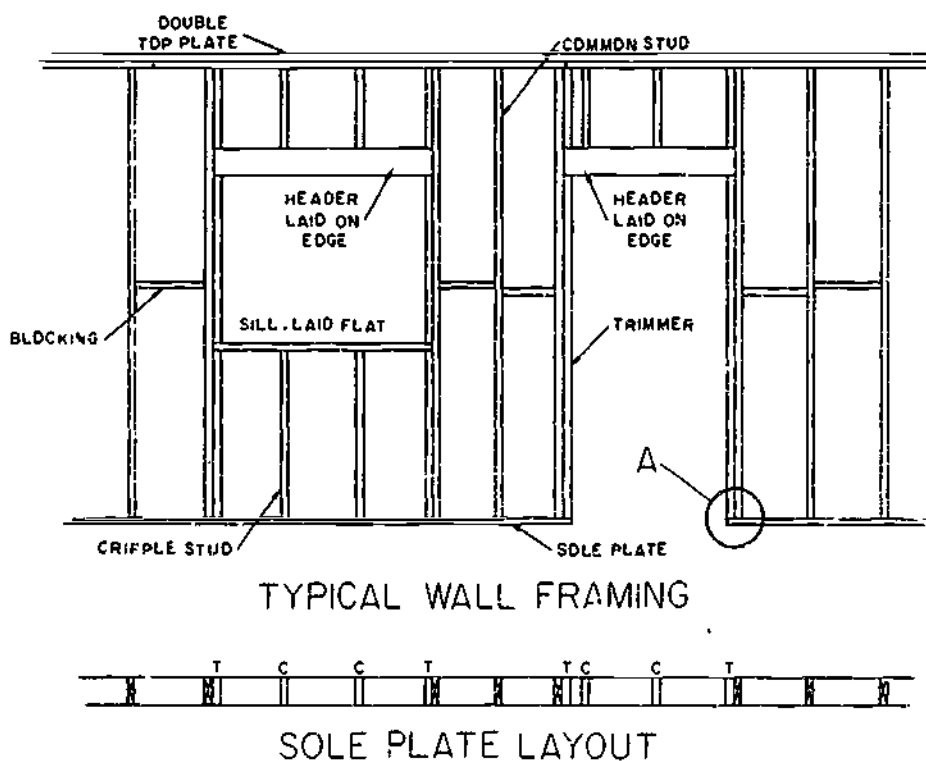



SYMBOLS
 - COMMON STUD
 - TRIMMER STUD
 - CRIPPLE STUD

Figure 9-2* - Typical wall framing details.

133.354

the interior or exterior. Allow 1/16-in. spacing at panel ends and 1/8 in. at panel edges. This will allow for expansion if moisture should enter joints.

WALL FRAMING

Wall framing (fig. 9-21) is composed of regular studs, cripples, trimmers, headers, and fire blocks and is supported by the floor soleplate. The vertical members of the wall framing are the studs, which support the top plates and all of the weight of the upper part of the building or everything above the top plate line. They provide the framework to which the wall sheathing is nailed on the outside and which supports the lath, plaster, and insulation on the inside.

Walls and partitions classed as framed constructions are composed of usually closely spaced, slender, vertical members called studs. (See fig. 9-22.) These are arranged in a row with their ends bearing on a long horizontal member called a bottom plate or soleplate, and their tops capped with another plate, called a top plate. Double top plates are used in bearing walls and partitions. The bearing strength of stud walls is determined by the strength of the studs.

The wall framing members used in conventional construction are generally nominal 2- by 4-in. studs spaced 16 in. O.C. Depending on the thickness of the covering material, 24-in. spacing might be considered. Top plates and soleplates are also nominal 2- by 4-in. in size. Headers over doors or windows in load-bearing

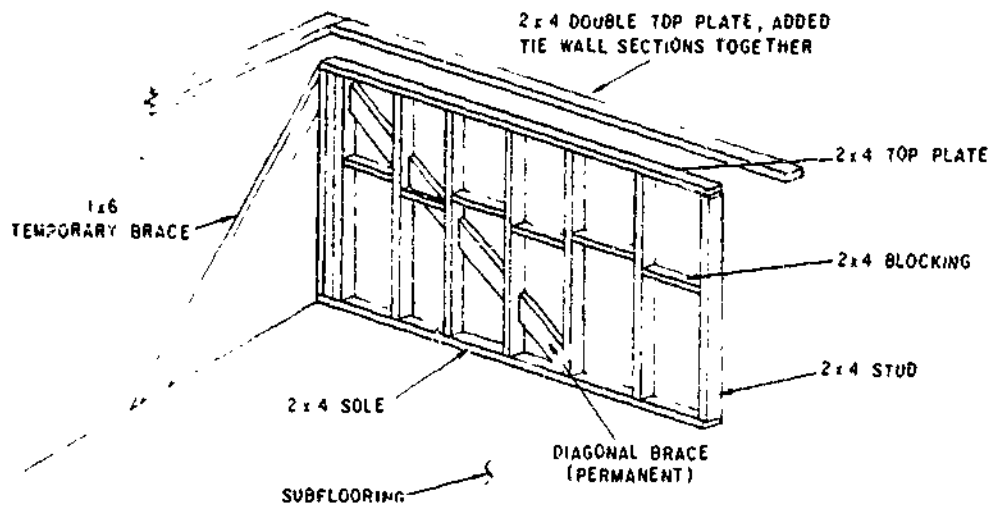

WALL SECTION INPLACE WITH TEMPORARY BRACING

Figure 9-22.—Typical wall construction.

133.355

walls consist of doubled 2-by 4-in. and deeper members, depending on the span of the opening.

The requirements for wall-framing lumber are good stiffness, good nail-holding ability, freedom from warp, and ease of working. Species used may include Douglas fir, the hemlocks, southern pine, the spruces, pines, and white fir. It is common practice to use the third grade for studs and plates and the second grade for headers over doors and windows.

All framing lumber for walls should be reasonably dry. Material at about 15-percent moisture content is desirable. When the higher moisture content is used (as studs, plates, and headers), it is advisable to allow the moisture content to reach inservice conditions before applying interior trim.

Ceiling height for the first floor is 8 ft under most conditions. It is common practice to rough-frame the wall (subfloor to top of upper plate) to a height of 8 ft 1 1/2 in. In platform construction, precut studs are often supplied to a length of 7 ft 8 5/8 in. for plate thickness of 1 5/8 in. When dimension material is 1 1/2 in. thick, precut studs are 7 ft 5 in. long which

allow the use of 8-ft high drywall sheets and still provides clearance for floor and ceiling finish or for plaster grounds at the floor line. Second-floor ceiling heights should not be less than 7 ft 6 in. in the clear, except for that portion under sloping ceilings. One-half of the floor area, however, should have at least a 7-ft 6-in. clearance. As with floor construction, two general types of wall framing are commonly used; platform construction and balloon-frame construction. The platform method is more often used because of its simplicity.

TOP PLATE AND SOLEPLATE

The top plate serves two purposes—to tie the studding together at the top and form a finish for the walls (fig. 9-21), and to furnish a support for the lower ends of the rafters. The top plate serves as a connecting link between the wall and the roof, just as the sills and girders are connecting links between the floors and the walls. The plate is made up of one or two pieces of lumber of the same size as the studs. In those cases where the studs at the end of the building

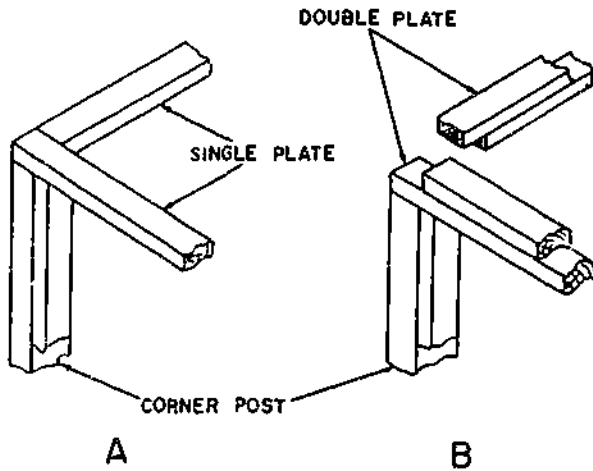

133.359
Figure 9-23.—Plate construction.

extend to the rafters, no plate is used at the end of the building. When it is used on top of partition walls, it is sometimes called the cap. Where the plate is doubled, the first plate or bottom section is nailed with 16-penny nails to the top of the corner posts and to the studs, the connection at the corner is made as shown in view A, fig. 9-23. After the single plate is nailed

securely and the corner braces are nailed into place, the top part of the plate is then nailed to the bottom section by means of 16-penny nails. The edges of the top section should be flush with the bottom section and the corner joints lapped, as shown in views A and B, fig. 9-23.

Stud locations are marked on soleplates in the same manner as joist locations. The soleplate is marked first, as shown in figure 9-24. These marks are then transferred to the corresponding top plate or rafter plate, by "matching" the top plate or rafter plate against the marked soleplate and squaring the marks across.

LAYING OUT STUDS FOR CUTTING

Before you can lay out any studs for cutting, you must calculate how long the studs must be. The best way to do this is to lay out to full scale on a piece of stud stock certain data obtained from the wall sections and elevations, and then use the piece of stock as a pattern for cutting studs.

A pattern layout for platform-frame studs is shown in figure 9-25. Since the bottom of a platform-frame stud rests on the soleplate, which in turn rests on the subflooring, you should first lay off the vertical distance between

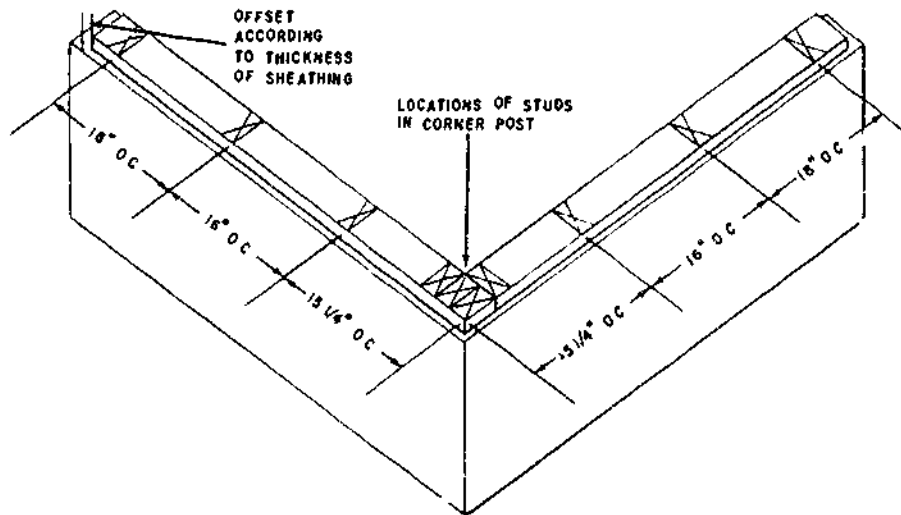

133.111
Figure 9-24.—Stud location layout.

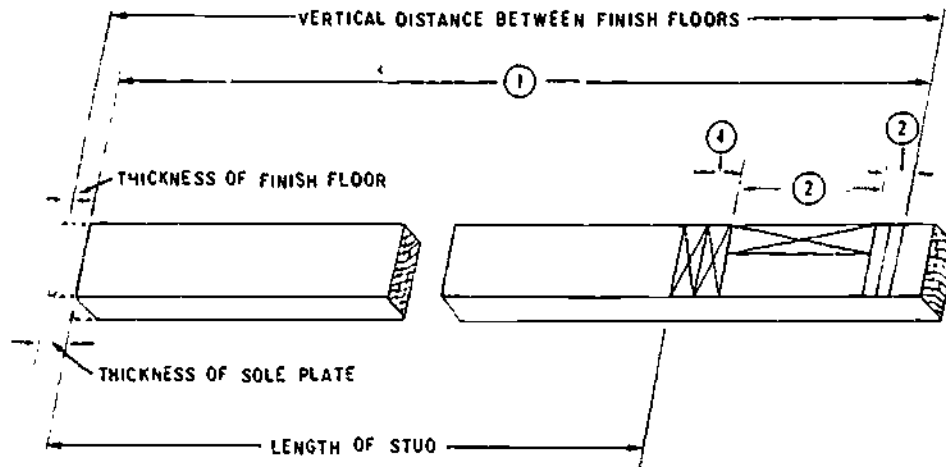

133.110

Figure 9-25. Pattern layout for platform-frame studs.

the finish floors, MINUS the thickness of the soleplate, PLUS the thickness of the finish floor. This is distance 1 in figure 9-25; laying it off will give you the level of the upper finish floor. Lay off back from this level the combined thickness of the upper floor flooring, the depth of an upper floor joist, and the thickness of the top plate. You now have the length of a stud, as shown in the figure.

After the posts, plates, and braces are in place, the studs are placed and nailed with two 16-penny nails through the top plate. Before the studs are set in place, the window and door openings are laid out. Then the remaining or intermediate studs are laid out on the soleplates by measuring from one corner the distances the studs are to be set apart. Studs are normally spaced 12, 16, and 24 in. O.C., depending upon the type of building and the type of outside and inside finish. Where vertical siding is used, studs may be set wider apart since the horizontal blocking between them affords nailing surface.

PARTITION

Partition walls are walls that divide the inside space of a building. These walls in most cases are framed as part of the building. In cases where floors are to be installed after the outside of the building is completed, the partition walls are left unframed. There are two types of

partition walls: bearing and nonbearing. The bearing type supports ceiling joists. The nonbearing type supports only itself. This type may be put in after the other framework is installed. Only one cap or plate is used. A soleplate should be used in every case, as it helps to distribute the load over a larger area. Partition walls are framed in the same manner as outside walls, and door openings are framed as outside openings. Where there are corners or where one partition wall joins another, corner posts or T-posts are used as in the outside walls; these posts provide nailing surfaces for the inside wall finish. Partition walls in a one-story building may or may not extend to the roof. The top of the studs has a plate when the wall does not extend to the roof; but when the wall extends to the roof, the studs are joined to the rafters.

BRACES

Bracing stiffens framed construction and helps to resist the effects of winds or storms and twisting or straining that stems from any cause. Good bracing keeps corners square and plumb and prevents warping, sagging, and shifts resulting from lateral forces that would otherwise tend to distort the frame and cause badly fitting doors and windows and the cracking of plaster. There are three commonly used methods of bracing frame structures.

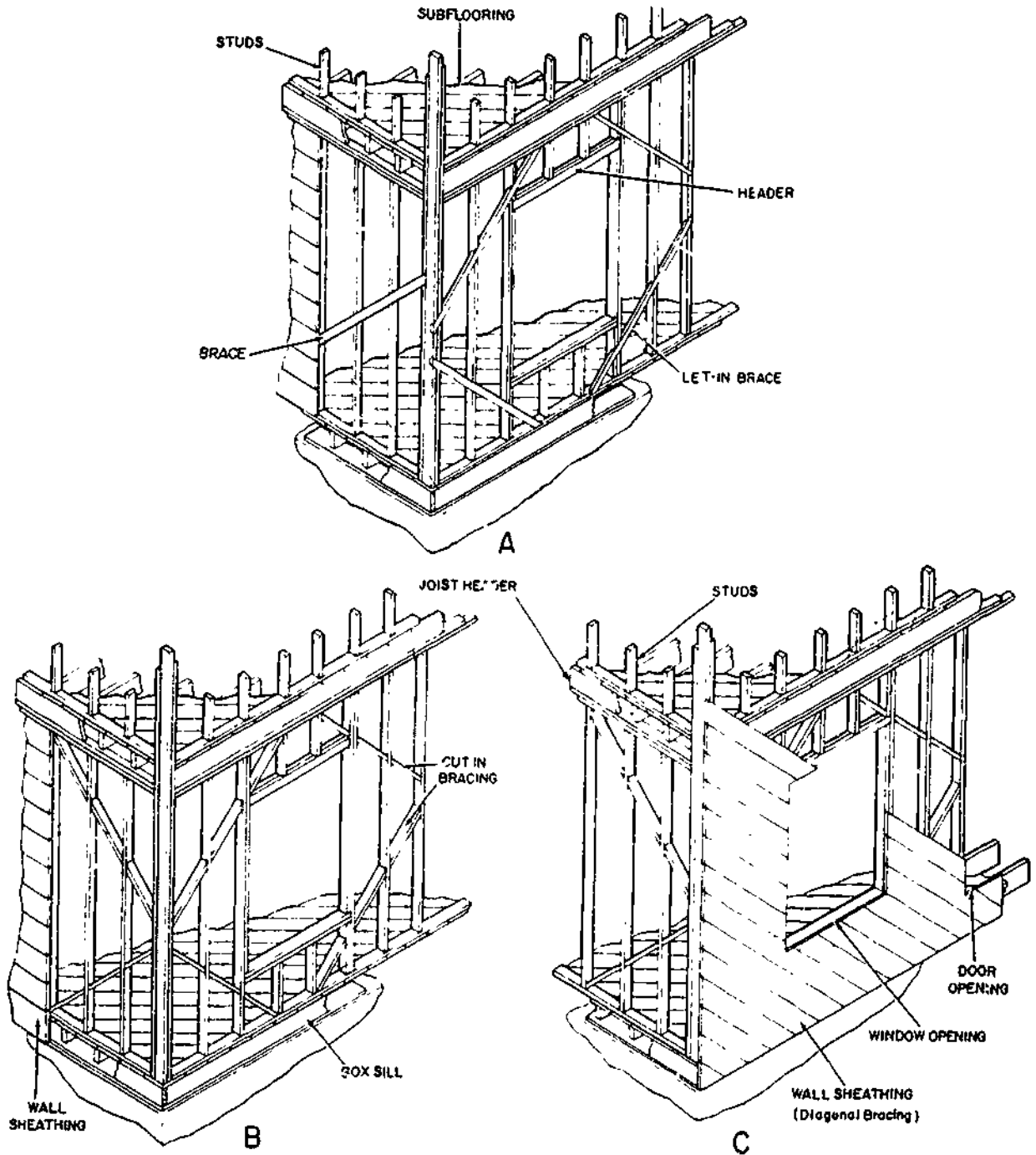

Figure 9-26.—Common types of bracing.

133.103

LET-IN BRACING, as shown in view A, fig. 9-26, is set into the edges of studs so as to be flush with the surface. The studs are always cut to let in the braces; the braces are never cut. Usually 1 by 4's or 1 by 6's are used, set diagonally from top plates to soleplates.

CUT-IN BRACING, as shown in view B, fig. 9-26, is toenailed between studs. It usually consists of 2 by 4's cut at an angle to permit toenailing, inserted in diagonal progression between studs running up and down from corner posts to sill or plates.

DIAGONAL SHEATHING, as shown in view C, fig. 9-26, is a type of bracing that is strongest when applied diagonally. Each board acts as a brace of the wall. If plywood sheathing or lumber is used, other methods of bracing may be omitted.

GABLE-END STUDS

Gable-end studs are installed at the end wall of a wooden structure having a gable roof. In order to lay out gable-end studs, you should be able to calculate the common difference of a gable-end stud.

In figure 9-27, the line AC indicates the level of the side-wall rafter plate, and line AB indicates the roof line of the building. Somewhere on the elevations you will find a small triangle like the one shown in the upper left of the figure. This is called the **ROOF TRIANGLE**, and it gives the proportion of run to rise in the roof. In this case this is also the proportion of run to rise between line AC and line AB, and the proportion is 8 in. of rise to every 12 in. of run.

The lines DE and FG represent the portions of two gable-end studs that extend above the level of the top of the side-wall rafter plate. You can calculate the length of DE as follows. Since the studs are spaced 16 in. O.C., the run of the right triangle AED is 16 in. The rise of this triangle is the length of the line DE. From the roof triangle, you know that the rise of a similar triangle with a run of 12 in. is 8 in. If the rise of a right triangle with a run of 12 in. is 8 in., the rise of a similar right triangle with a run of 16 in. must be the value of x in the proportional

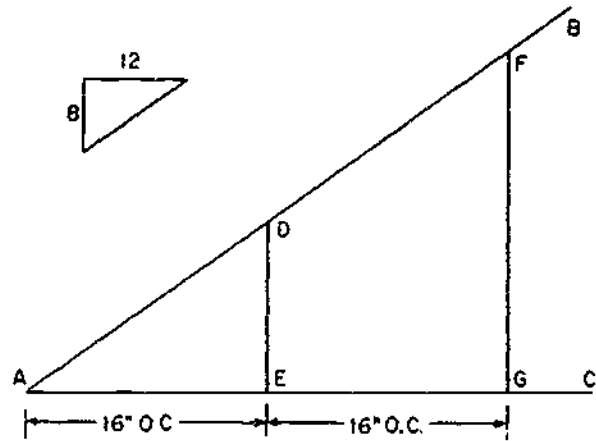

133.109

Figure 9-27.—Calculating common difference of gable-end studs.

equation $12:8::16:x$, or $10 \frac{2}{3}$ in. The length of DE, therefore, is $10 \frac{2}{3}$ in. Rounded off to the nearest $\frac{1}{16}$ in., this is $10 \frac{11}{16}$ in. The common difference may also be found as follows. Multiply the cut of the roof, expressed as a fraction, by the spacing of the studs. Assume a roof cut of 8 in. and 12 in. and a stud spacing of 16 in. The common difference in the length of the gable stud is $16 \text{ in.} \times \frac{8}{12} \text{ in.} = 10 \frac{2}{3} \text{ in.}$ Expressed as a formula, stud spacing \times cut of the roof = common difference.

If the rise of a right triangle for 16 in. of run is $10 \frac{11}{16}$ in., the rise for twice as much run, or 32 in., must be twice as much, or $2 \times 10 \frac{11}{16}$ in.; the rise for three times as much run must be $3 \times 10 \frac{11}{16}$; and so on. This means that, moving inboard from the rafter plates, each gable-end stud is $10 \frac{11}{16}$ in. longer than the preceding gable-end stud.

Knowing this, you can lay off the lengths of the gable-end studs by laying off $10 \frac{11}{16}$ in. (which is called the common difference of gable-end studs) progressively for each stud, from the shortest to the longest, in either side of the end wall. The top end cut of the gable stud is laid out by using the cut of the roof and marking on the rise side.

FRAMING ALLOWANCE

The studs around wall openings require special treatment. First locate the centerline of the opening by examining the floor plan. Say that the opening is a door and that the plan shows that the centerline of this door lies 7 ft 5 in. from one of the building corners. Measure this off and square a line across the sill or plate at this point. Next look on the door schedule and find the width of this door. Say that it is Door A, and you find that Door A is 3 ft wide. Lay off one-half of this, or 1 ft 6 in., on either side of the centerline and square lines across.

These lines mark the boundaries of the FINISHED door opening. The trimmer studs on either side of the opening must be located at the boundaries of the ROUGH opening. To get the width of the rough opening, you add a FRAMING ALLOWANCE to the width of the finished opening. First, the width of the rough opening must exceed the width of the finished opening by the combined thicknesses of the SIDE JAMBS on the door, less the combined width of the rabbets if the door fits into rabbets cut in the side jambs.

Besides the allowance for the thickness of the jambs, you must make an additional FRAMING ALLOWANCE. As you will see later, the side jambs are wedged in place with wooden wedges, driven between the jambs and the trimmers. The usual wedging allowance should be 1/4 to 1/2 in. on both sides.

To make all this clear, look at figure 9-28 which shows the side jambs and the head jamb of a door frame wedged in place in the rough opening. The width of the finished opening, which is the same as the width of the door, is the horizontal distance between the side jambs. The width of the rough opening is the same horizontal distance, plus the combined width of the jambs, plus the combined width of the wedging allowance.

The width of the finished opening, which is the same as the width of the door, is the horizontal distance between the side jambs. The width of the rough opening is the same horizontal distance, plus the combined width of the jambs, plus the combined width of the wedging allowance.

To locate the trimmers, lay off on either side of the centerline, one-half the width of the door, plus the thickness of a side jamb, which should be measured on the actual stock, plus the wedging allowance (usually 1/2 in.). Mark the trimmer locations with the word TRIM, and postpone the cutting of the trimmers until after the header has been cut and set in place.

The header will be nailed between the first two full-length studs lying outside the boundaries of the finished opening. To locate the header at the right height, you must add to the height of the door a framing allowance as follows. You must make allowance for the thickness of the head jamb and also for the depth of the SIDE JAMB LUGS. The side jamb lugs are the portions of the side jambs which extend above the head jamb dadoes. Since you will be measuring from the top of the subflooring and since the bottom of the door will have to clear the finish flooring, you must allow for the thickness of the finish flooring. If there is to be a threshold under the door, you must allow for the thickness of the threshold. If there will be no threshold, you must add a CLEARANCE ALLOWANCE which will permit the door to swing clear of any rugs or carpets. The usual clearance allowance is 5/8 in., which is also the usual thickness of a threshold. If the carpeting is to be extra thick, the clearance allowance may have to be more than 5/8 in.

The framing allowance for a window opening is calculated as follows: locate and mark the window centerline and lay off on either side of the centerline one-half the width of the window, as obtained from the window schedule. Allow 1/4 to 1/2 in. wedging allowance on both sides. This will locate the limits of the finished window opening. The top header and subsill header will be set between the first two full-length studs lying outside these limits.

Further, the window-opening layout should be postponed until the subsill header has been set in place. The height of the subsill header is determined by examining the appropriate elevation, the height of the top of the window sill above the finish flooring. Since you will be measuring from the subflooring, add the thickness of the finish flooring. From this,

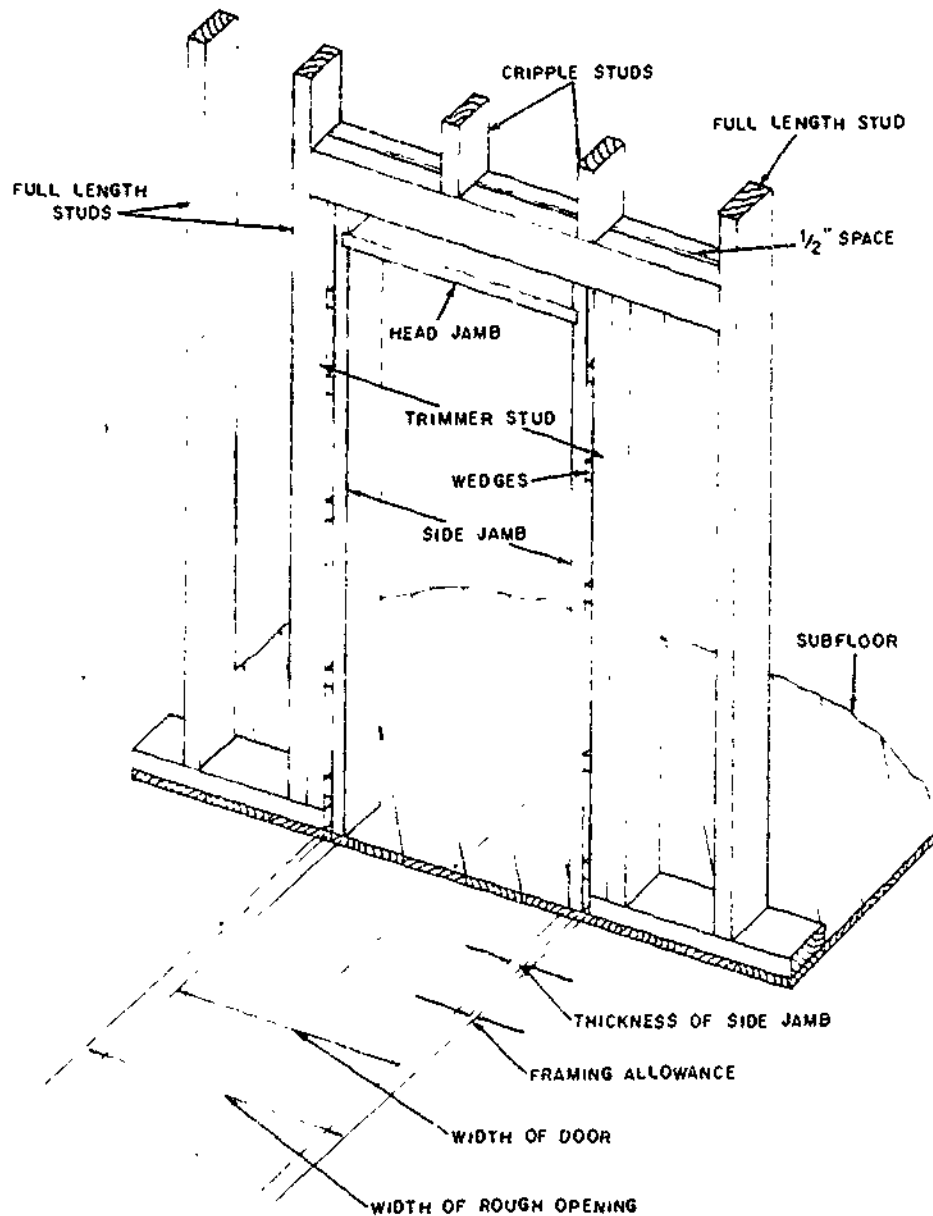

Figure 9-28.—Door framing allowance.

133.112

subtract the thickness of the window sill, plus the sill BEVEL ALLOWANCE, or the amount that the sill will be raised by tilting. This is usually about 3/4 in. To sum up, the height of the top of the subsill header above the finish flooring will be the vertical distance between the top of the window sill and the top of the finish

floor, MINUS the thickness of the window sill, the sill bevel allowance (usually 3/4 in.), and the thickness of the finish flooring.

The next step is to locate the top header at the proper height. On the elevation you will find the vertical distance between the finished first floor line and the bottom of the window head

jamb. Since you will measure this distance from the top of the subfloor, add to it the thickness of the finish floor. Next, add the thickness of the head jamb plus the depth of the window side jamb lugs, which are similar to those on a door. The total will be the vertical distance between the top of the subfloor and the bottom of the top header.

As the span of the opening increases, it is necessary to increase the depth of the headers to support the ceiling and roofloads. A header is made up of two 2-in. members, usually spaced with 1/2-in. lath or wood strips, all of which are nailed together. (See fig. 9-29.) They are supported at the ends by the inner studs of the double-stud joint at exterior walls and interior

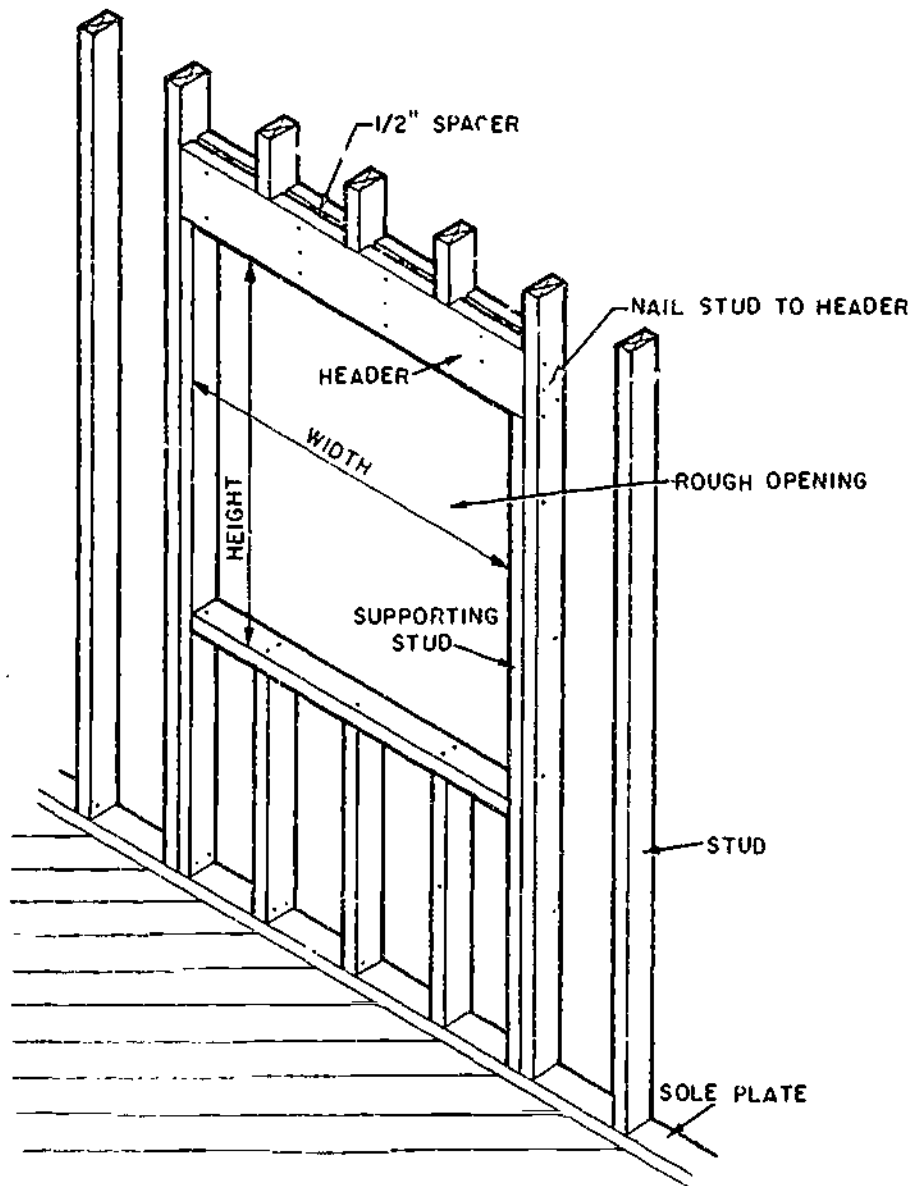

Figure 9-29.—Headers for windows and door openings.

133.405

bearing walls. The following sizes might be used as a guide for headers:

MAXIMUM SPAN (ft)	HEADER SIZE (in.)
3 1/2	2 by 6
5	2 by 8
6 1/2	2 by 10
8	2 by 12

For other than normal light-frame construction, an independent design may be necessary. Wider openings often require trussed headers, which may also need special design.

To locate the trimmers proceed as follows: transfer the window centerline to the subsill header and lay off on either side of it one-half the width of the window schedule. Add on either side a framing allowance consisting of the thickness of the side jamb plus a wedging allowance of 1/4 to 1/2 in. on each side.

Location of the studs, headers, and sills around window openings should conform to the rough opening sizes recommended by the

manufacturers of the millwork. The framing height of the bottom of the window and door headers should be based on the door heights, normally 6 ft 8 in. for the main floor. Thus to allow for the thickness and clearance of the head jams of window and door frames and the finish floor, the bottoms of the headers are usually located 6-ft 10-in. to 6-ft 11-in. above the subfloor, depending on the type of finish floor used.

BALLOON CONSTRUCTION

As described earlier in this chapter, the main difference between platform and balloon framing is that studs extend from the sill of the first floor to the top plate or end rafter of the second floor, whereas the platform-framed wall is complete for each floor.

In balloon-frame construction, both the wall studs and the floor joists rest on the anchored sill. (See fig. 9-30.) The studs and joists are

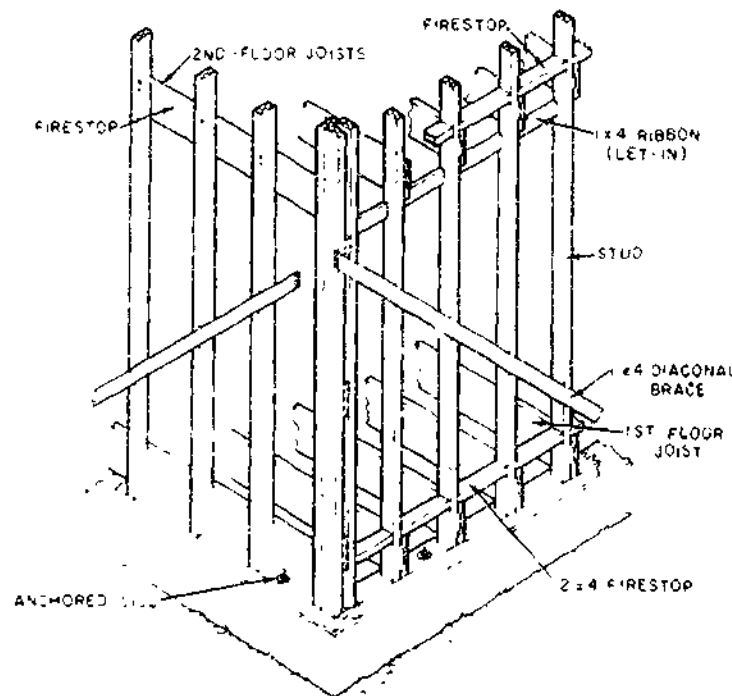

Figure 9-30.—Wall framing used in balloon construction.

133.468

toenailed to the sill with 8-penny nails and nailed to each other with 16-penny nails.

The ends of the second-floor joists bear on a 1-by 4-in. ribbon that has been let into the studs. In addition, the joists are nailed to the studs at these connections. (See fig. 9-30.) The end joists parallel to the exterior on both the second floors are also nailed to each stud.

Other nailing details should conform in general to those described for platform construction.

In most areas, building codes require that firestops be used in balloon framing to prevent the spread of fire through the open wall passages. These firestops are ordinarily of

2-by 4-in. blocking placed between the studs or as required by local regulations. (See fig. 9-30.)

Because there is less potential shrinkage in exterior walls with balloon framing than in the platform type, balloon framing is occasionally preferred over the platform type.

PLATFORM CONSTRUCTION

The wall framing in platform construction is erected above the subfloor which extends to all edges of the building, as shown in figure 9-31. A combination of platform construction for the first floor sidewalls and full-length studs for end

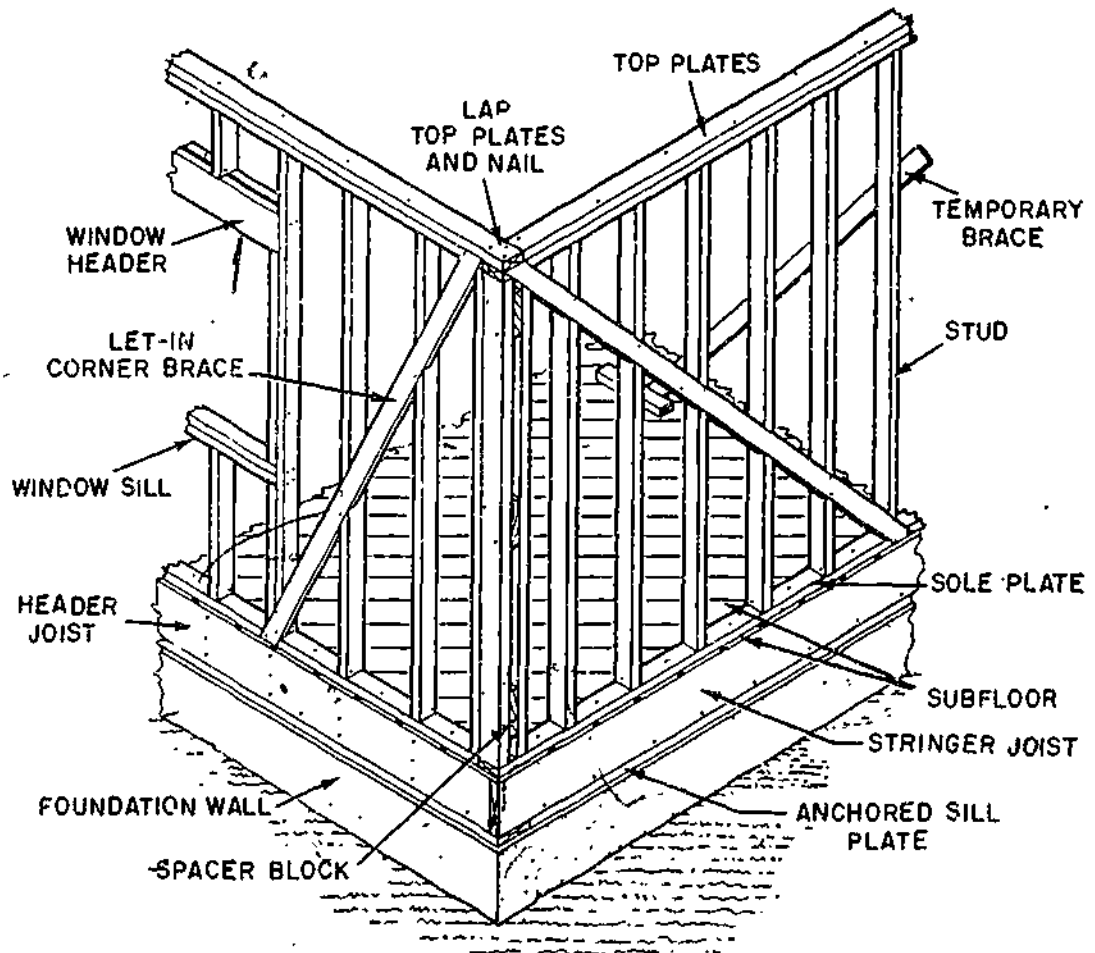

Figure 9-31.—Wall framing used with platform construction.

133.467

walls extending to end rafters of the gable ends is commonly used in single-story houses.

One common method of framing is the horizontal assembly (on the subfloor) or "tilt-up" of wall sections. When a sufficient work crew is available, full-length wall sections are erected. Otherwise, shorter length sections easily handled by a smaller crew can be used. This system involves laying out precut studs, window and door headers, cripple studs (short-length studs), and windowsills. Top and soleplates are then nailed to all vertical members and adjoining studs to headers and sills with 16-penny nails. Let-in corner bracing should be provided when required. The entire section is then erected, plumbed, and braced.

A variation of this system includes fastening the studs only at the top plate and, when the wall is erected, toenailing studs to the soleplates which have been previously nailed to the floor. Corner studs and headers are usually nailed together beforehand to form a single unit. Complete finished walls with windows and door units in place and most of the siding installed can also be fabricated in this manner.

When all exterior walls have been erected, plumbed, and braced, the remaining nailing is completed. Soleplates are nailed to the floor joists and headers or stringers (through the subfloor), corner braces (when used) are nailed to studs and plates, door and window headers are fastened to adjoining studs, and corner studs are nailed together.

Several arrangements of studs at outside corners can be used in framing the walls of a structure. Figure 9-31 shows one method commonly used. Blocking between two corner studs which provides a nailing edge for interior finish is shown in view A, fig. 9-32. View B and C of figure 9-32 shown other methods of stud arrangement to provide the needed interior nailing surfaces as well as good corner support.

Interior walls should be well fastened to all exterior walls they intersect. The intersection should also provide nailing surfaces for the plaster base or dry-wall finish. This may be accomplished by doubling the outside studs at the interior wall line as shown in view A, fig.

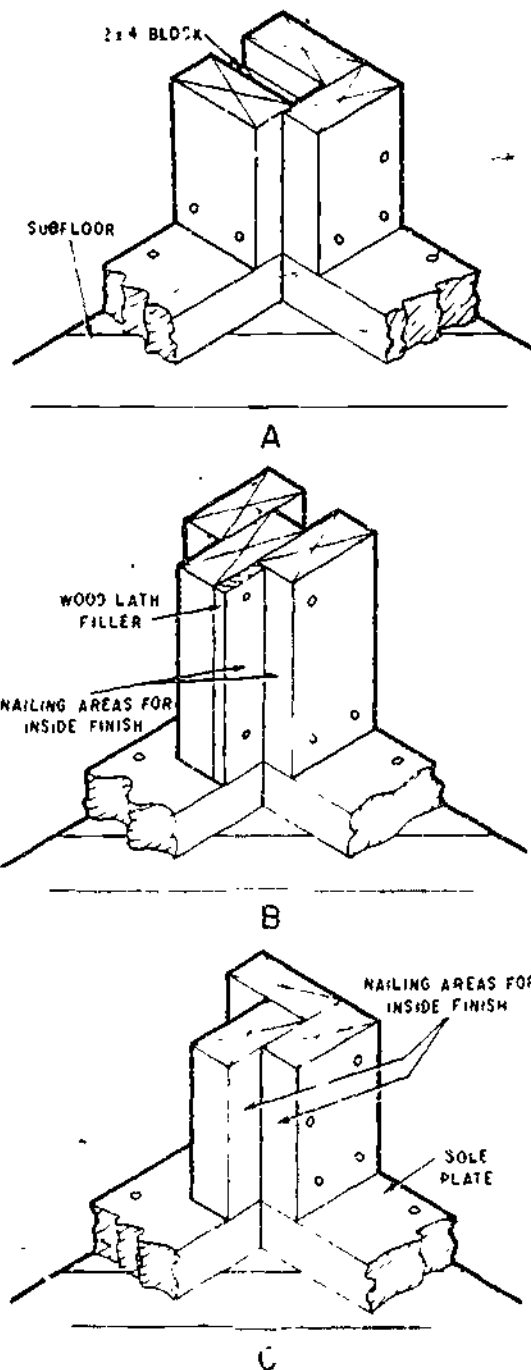

133.468
 Figure 9-32.—Examples of corner stud assembly: A. Standard outside corner B. Special corner with lath filler C. Special corner without lath filler.

9-33. Another method used when the interior wall joins the exterior wall between studs is shown in view B, fig 9-33.

Short sections of 2-by 4-in. blocking are used between studs to support and provide backing for a 1-by 6-in. nailer. A 2-by 6-in. vertical member might also be used.

The same general arrangement of members is used at the intersection or crossing of interior walls. Nailing surface must be provided in some form or another at all interior corners.

After all walls are erected, a second top plate is added that laps the first at corners and wall intersections. (See fig. 9-31.) This gives an

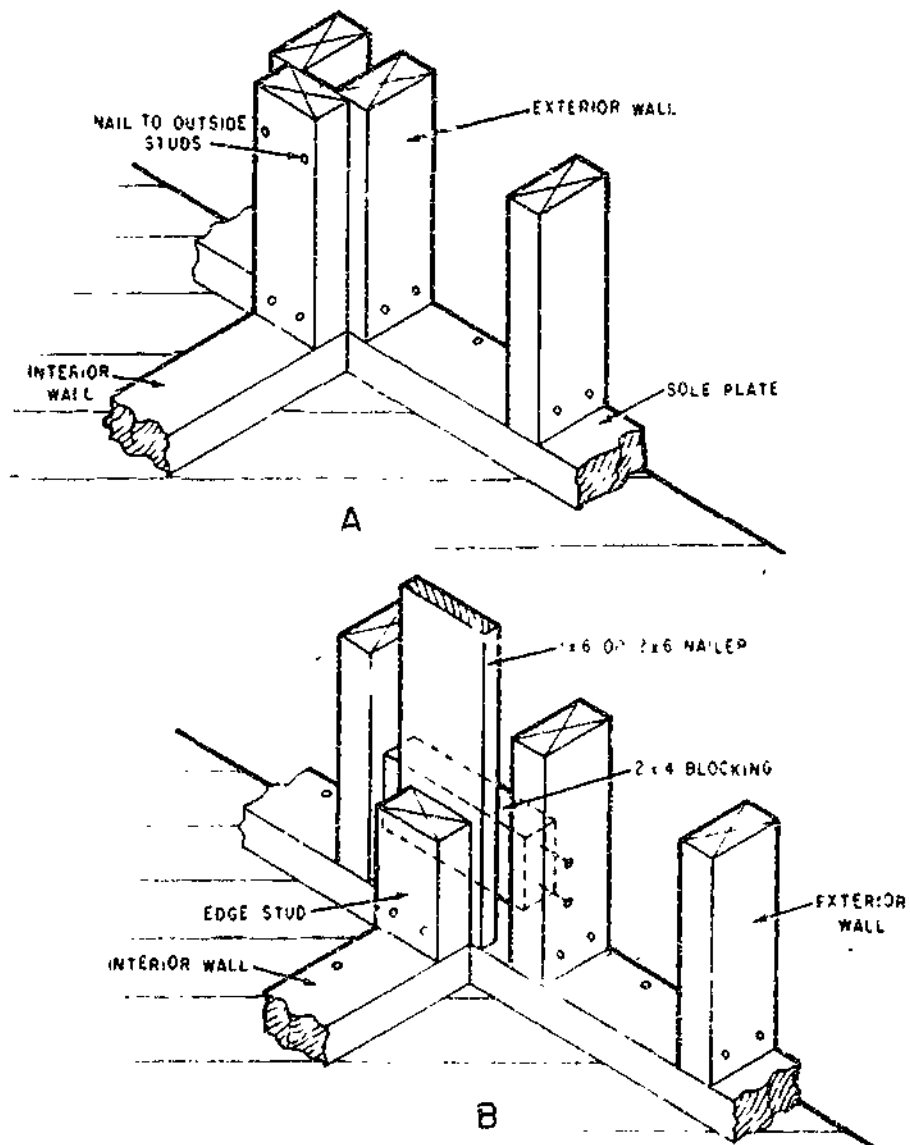

Figure 9-33. -Intersection of interior wall with exterior wall. A. With doubled studs on outside wall B. Partition between outside studs.

133.469

9-30
373

additional tie to the framed walls. These top plates can also be partly fastened in place when the wall is in a horizontal position. Top plates are nailed together with 16-penny nails spaced 16 in. apart and with two nails at each wall intersection. Walls are normally plumb and aligned before the top plate is added. By using 1-by-6- or 1-by-8-in. temporary braces on the studs between intersecting partitions, a straight wall is assured. These braces are nailed to the studs at the top of the wall and to a 2-by-4-in. block fastened to the subfloor or joists. The temporary bracing may be left in place until the ceiling and the roof framing are completed and sheathing is applied to the outside walls.

END-WALL FRAMING

The framing for the end walls in platform and balloon construction varies somewhat. Figure 9-34 shows a commonly used method of wall and ceiling framing for platform construction in 1 1/2- or 2-story structures with finished rooms above the first floor. The floor joist is toenailed to the top wall plate with nails spaced 16 in. on center. The subfloor, soleplate, and wall framing are then installed in the first and second floors. (See fig. 9-35.)

As for the first floor, 2-by-4-in. firestops are cut between each stud. The subfloor is applied in a normal manner. Details of the sidewall

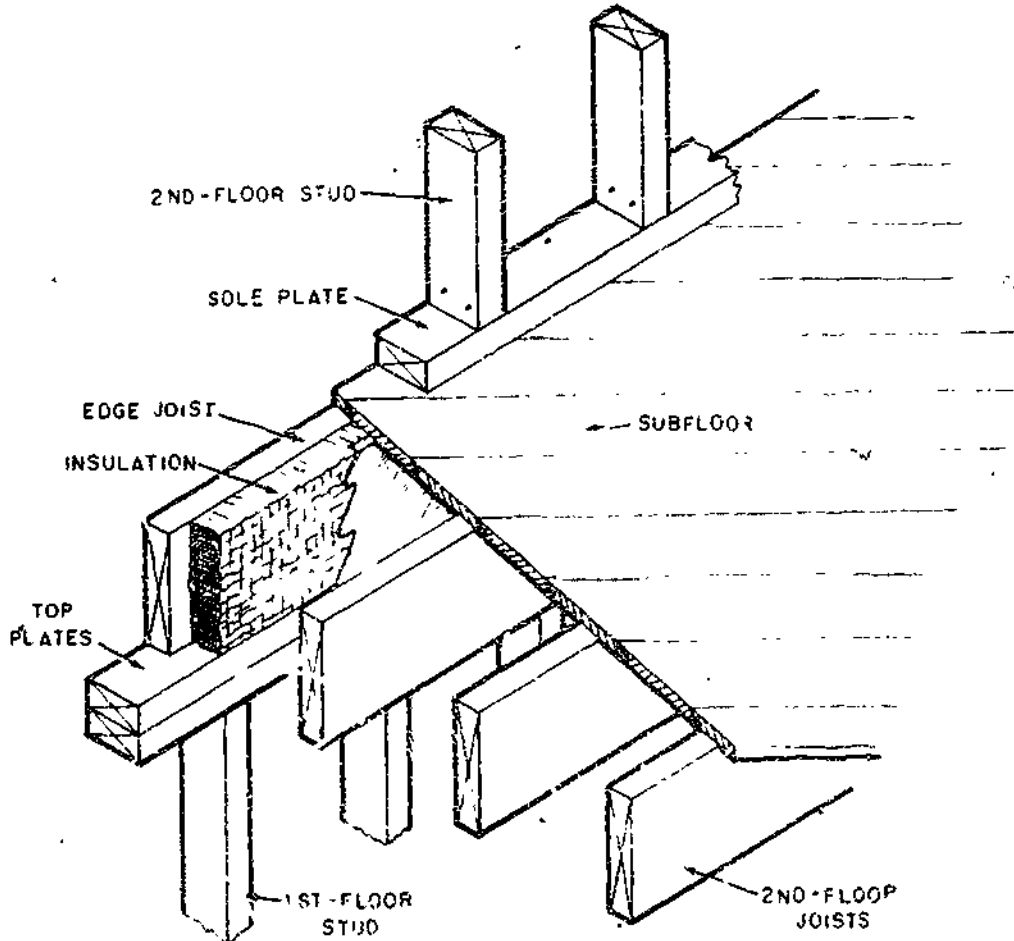

133.470

Figure 9-34.—End-wall framing for platform construction (junction of first floor ceiling with upper-story floor framing).

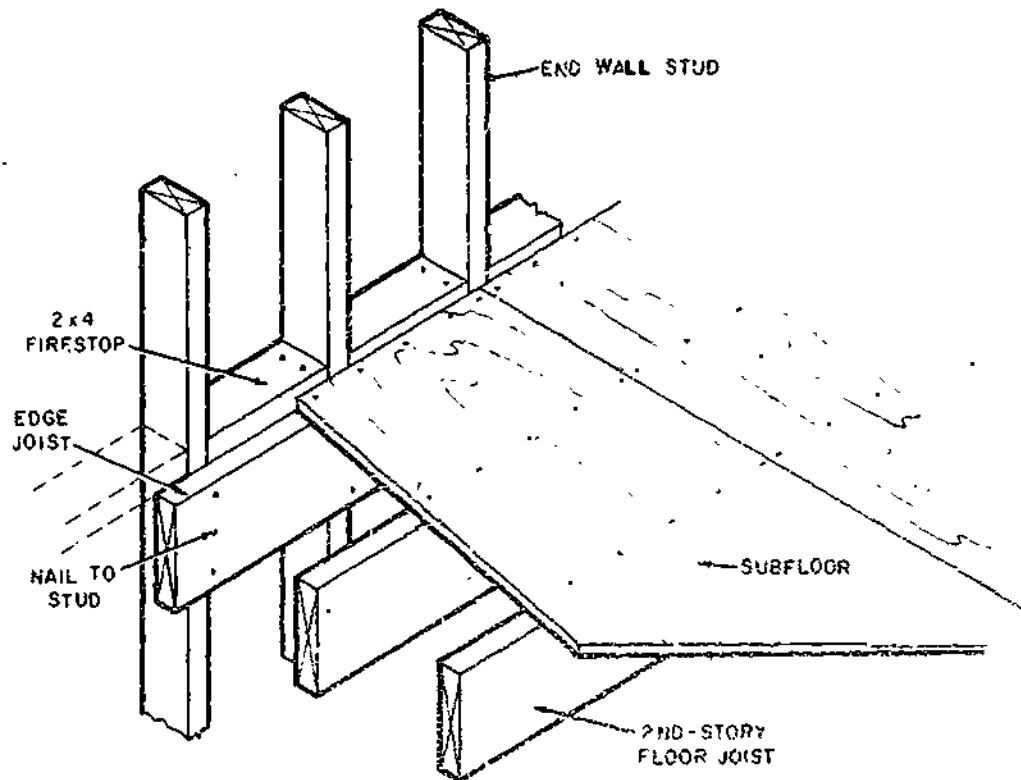

Figure 9-35.—End-wall framing for balloon construction (junction of first floor ceiling and upper story floor framing). 133,471

supporting the ends of the joists are shown in figure 9-35.

INTERIOR WALLS

The interior walls in a structure with conventional joist and rafter roof construction are normally located to serve as bearing walls for the ceiling joists as well as room dividers. Walls located parallel to the direction of the joists are commonly nonload bearing.

Spacing of the studs is usually controlled by the thickness of the covering material. For example, 24-in. stud spacing may require 1/2-in. gypsum board for dry-wall interior covering.

The interior walls are assembled and erected in the same manner as exterior walls, with a single bottom (sole) plate and double top plates. The upper top plate is used to tie intersecting

and crossing walls to each other. A single framing stud can be used at each side of a door opening in nonload-bearing partitions, but they must be doubled for load-bearing walls. Thus, location of the walls, and size and spacing of the studs are determined by the room size desired and type of interior covering selected. The bottom chords of the trusses are used to fasten and anchor crossing partitions. When partition walls are parallel to and located between trusses, they are fastened to 2- by 4-in. blocks which are nailed between the lower chords.

LATH NAILERS

During the framing of walls and ceilings, it is necessary to provide for both vertical and horizontal fastening of plaster-base lath or dry wall at all inside corners. See figures 9-32 and 9-33, which illustrate corner and intersecting wall construction and also show lath nailers.

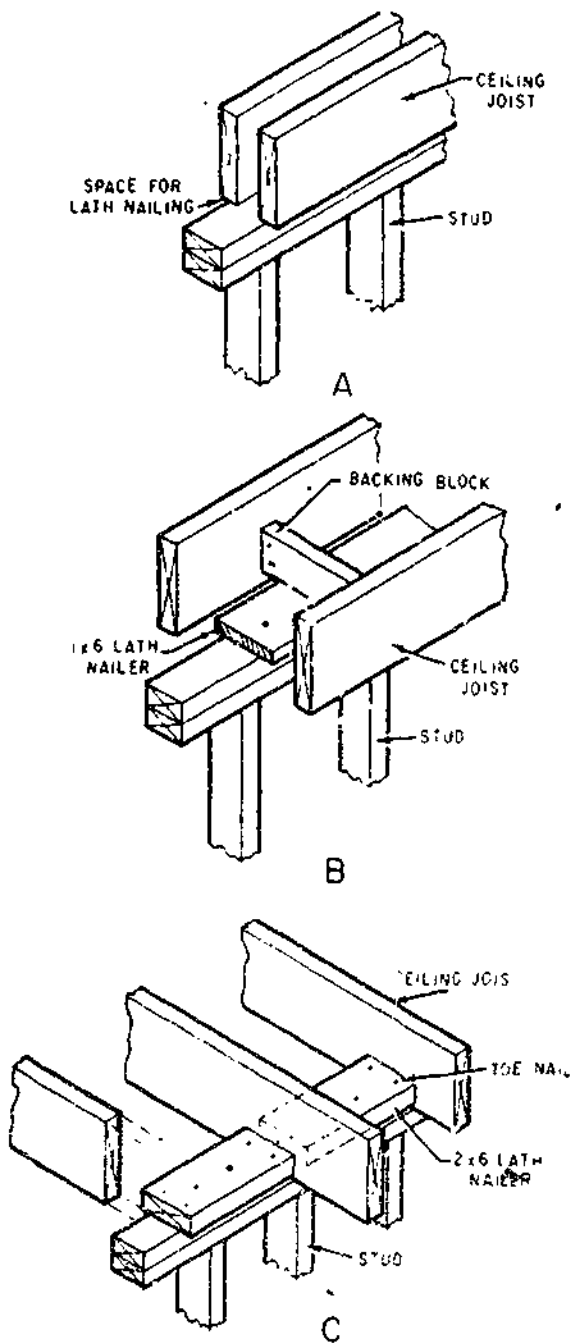

133.472
 Figure 9-36.—Horizontal lath catchers at ceiling: A. Using ceiling joists over stud wall B. Lath nailer between ceiling joists C. Stud wall at right angle to joist.

Horizontal lath nailers at the junction of wall and ceiling framing may be provided in several ways. View A, figure 9-36, shows double ceiling joists above the wall, spaced so that nailing surface is provided by each joist. In view B, figure 9-36, the parallel wall is located between two ceiling joists. A 1-by 6-in. lath nailer is placed and nailed to the top plates with backing blocks spaced on 3- to 4-ft centers. A 2-by 6-in. member might also be used here in place of the 1 by 6.

When the partition wall is at a right angle to the ceiling joists, one method of providing lath nailers is to let in 2- by 6-in. blocks between the joists. (See fig. 9-36.) They are nailed directly to the top plate and toenailed to the ceiling joists.

CEILING JOISTS

After exterior and interior walls are plumbed, braced and top plates added, ceiling joists can be positioned and nailed in place. They are normally placed across the width of the structure, as are the rafters. The partitions of the structure are usually located so that ceiling joists of even lengths (10, 12, 14, 16 ft. and so on) can be used without waste to span from exterior walls to loadbearing interior walls. The sizes of the joists depend on the span, wood species, spacing between joists, and the load on the second floor or attic.

When preassembled trussed rafters (roof trusses) are used, the lower chord acts as the ceiling joist. The truss also eliminates the need for load-bearing partition.

Second grades of the various species are commonly used for ceiling joists and rafters. It is also desirable, particularly in two-story structures and when material is available, to limit the moisture content of the second-floor joists to no more than 15 percent. This applies as well to other lumber used throughout the building.

Ceiling joists are used to support ceiling finishes. They often act as floor joists for second and attic floors and as ties between exterior walls and interior partitions. Since ceiling joists also serve as tension members to resist the thrust of the rafters of pitched roofs, they must be securely nailed to the plate at outer and inner walls. They are also nailed together, directly or

with wood or metal cleats, where they cross or join at the load-bearing partition or to the rafter at the exterior walls. (See view A and B, fig. 9-37.)

In areas of severe windstorms, the use of metal strapping or other systems of anchoring ceiling and roof framing to the wall is a good practice. When ceiling joists are perpendicular to rafters, collar beams and cross ties should be used to resist thrust.

FLUSH CEILING FRAMING

In many structural designs, a wide, continuous ceiling area between the two rooms is often desirable. This can be created with a flush beam, which replaces the load-bearing partitions used in the remainder of the structure. A nail-laminated beam, designed to carry the ceiling load, supports the ends of the joists. Joists are toenailed into the beam and supported

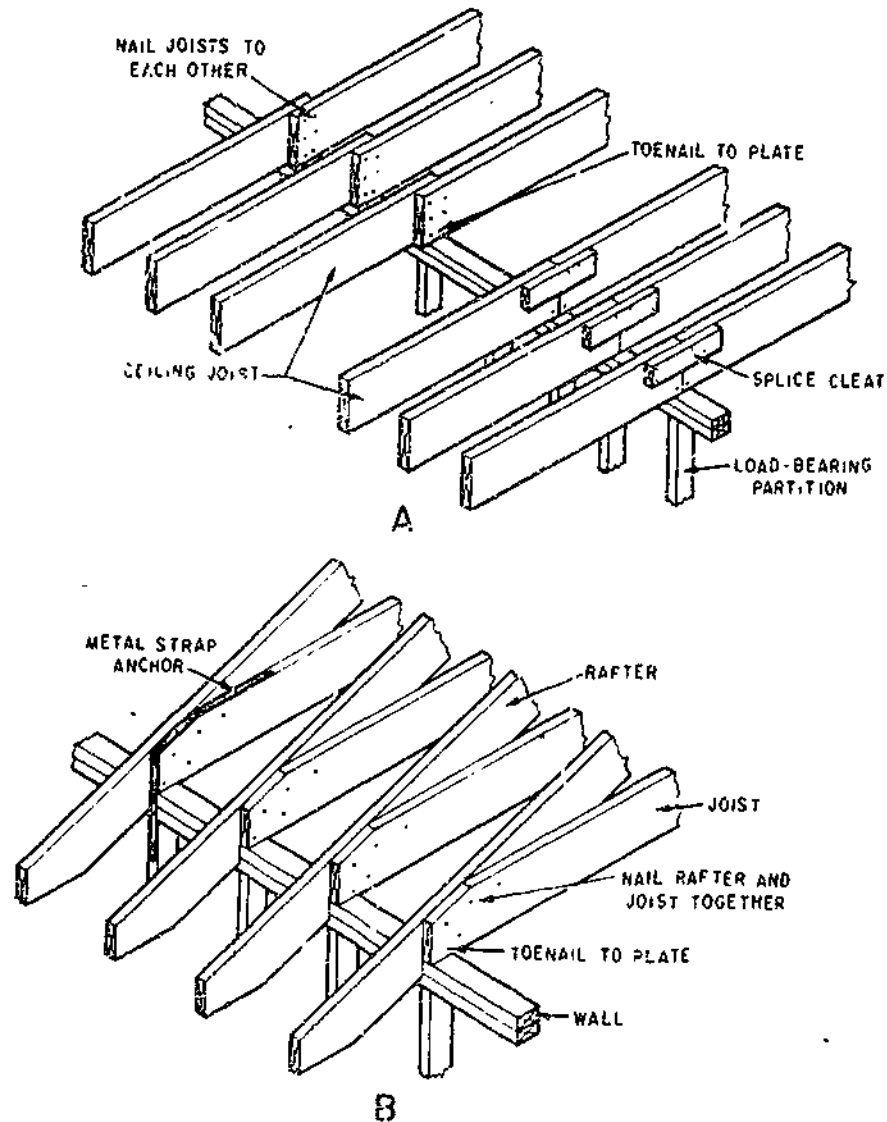

Figure 9-37.—Ceiling joist connections. A. At center partition with joists lapped or butted B. At outside wall.

133,473

by metal joist hangers, as shown in view A, figure 9-38 or by wood hangers. (See view B, fig. 9-38.) To resist the thrust of the rafters for longer spans, it is often desirable to provide added resistance by using metal strapping. Strapping should be nailed to each opposite joist with three or four 8-penny nails.

POST AND BEAM FRAMING

In some structures, exposed beams are often a part of the interior design and may also replace

interior and exterior load-bearing walls. With post and beam construction, exterior walls can become fully glazed panels between posts, requiring no other support. Areas below interior beams within the house can remain open or can be closed in with wardrobes, cabinets, or light curtain walls.

This type of construction, while not adaptable to many styles of architecture, is simple and straightforward. However, design of the structure should take into account the need for shear or racking resistance of the exterior walls. This is usually accomplished by solid

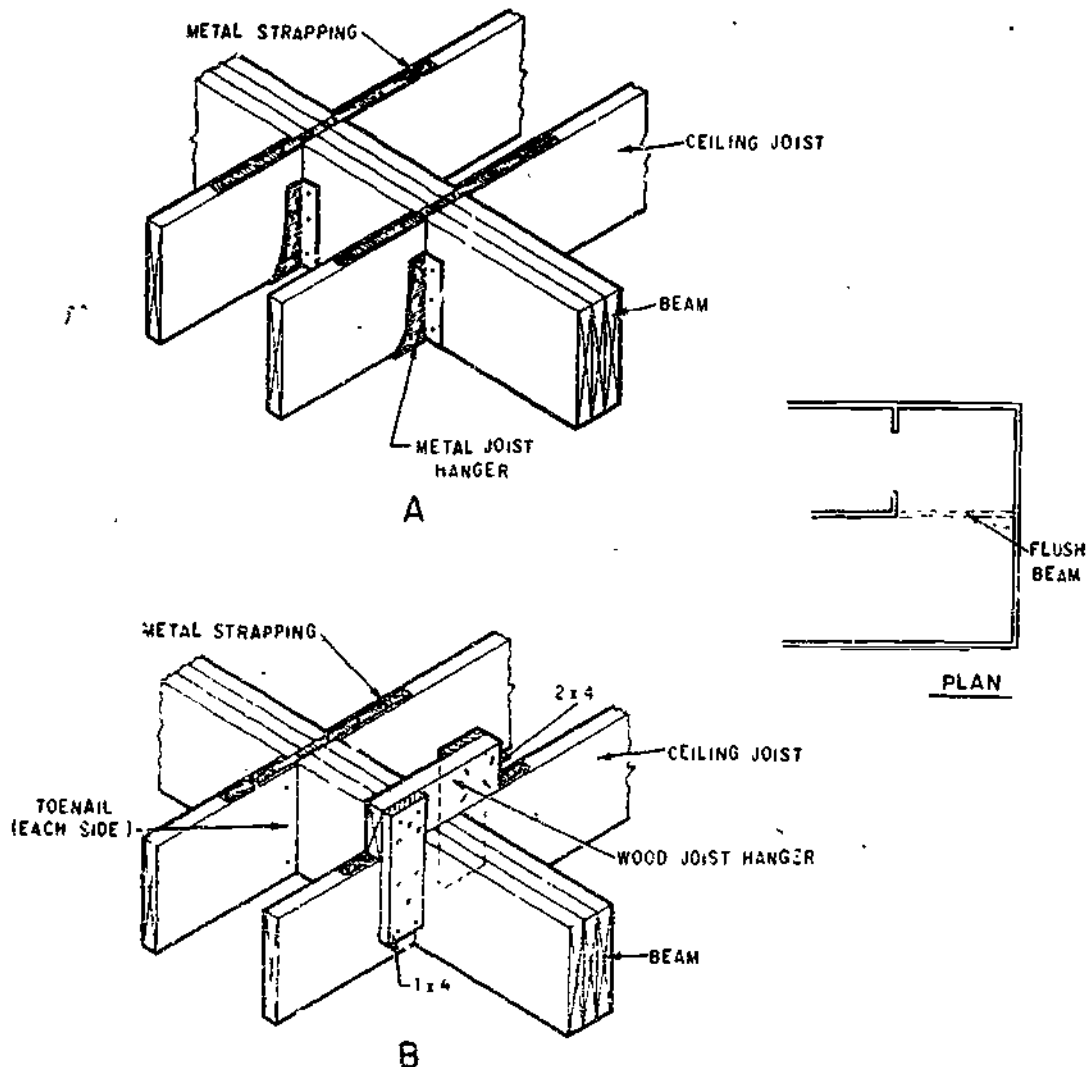

Figure 9-38.—Flush ceiling framing: A. Metal joist hanger B. Wood hanger.

133.474

masonry walls or fully sheathed frame walls between open glazed areas.

Roofs of such structures are often either flat or low-pitched and may have a conventional rafter-joist combination or consist of thick wood decking spanning between beams. The need for a well-insulated roof often dictates the type of construction that might be used.

The connection of the supporting posts at the floor plate and beam is important to provide uplift resistance. Figure 9-39 shows connections at the soleplate and at the beam for solid or spaced members. The solid post and beam are fastened together with metal angles nailed to the top plate and to the soleplate as well as the roof beam (see view A, fig. 9-39). The spaced beam and post are fastened together with a 3/8-in. or thicker plywood cleat extending between and nailed to the spaced members. (See view B, fig.

9-39.) A wall header member between beams can be fastened with joist hangers.

Continuous headers are often used with spaced posts in the construction of framed walls or porches requiring large glazed openings. The beams should be well fastened and reinforced at the corners with lag screws or metal straps. View A, figure 9-40 illustrates one connection method using metal strapping.

In a low-pitch or flat roof construction for a post and beam system, wood or fiberboard decking is often used. Wood decking, depending on thickness, is frequently used for beam spacings up to 10 or more ft. However, for the longer spans, special application instructions are required. Depending on the type, 2- to 3-in. thick fiberboard decking normally is limited to a beam or purlin spacing of 4 ft.

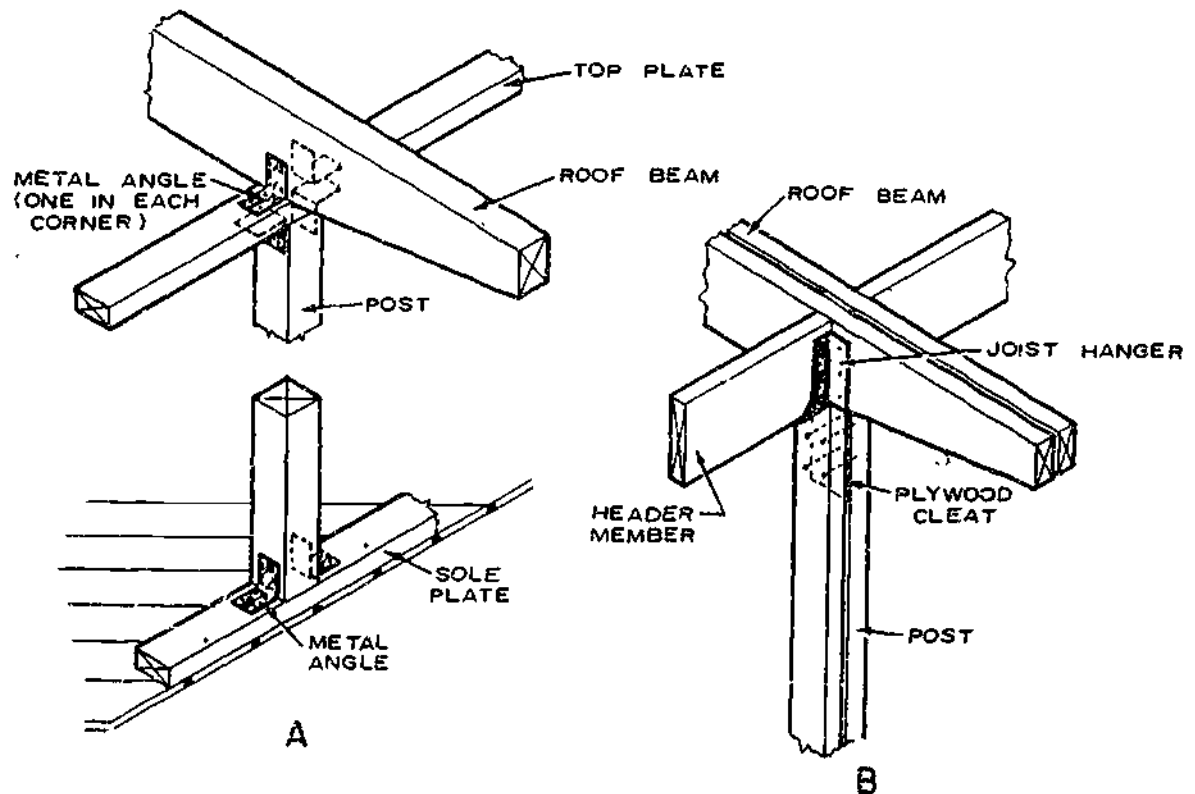
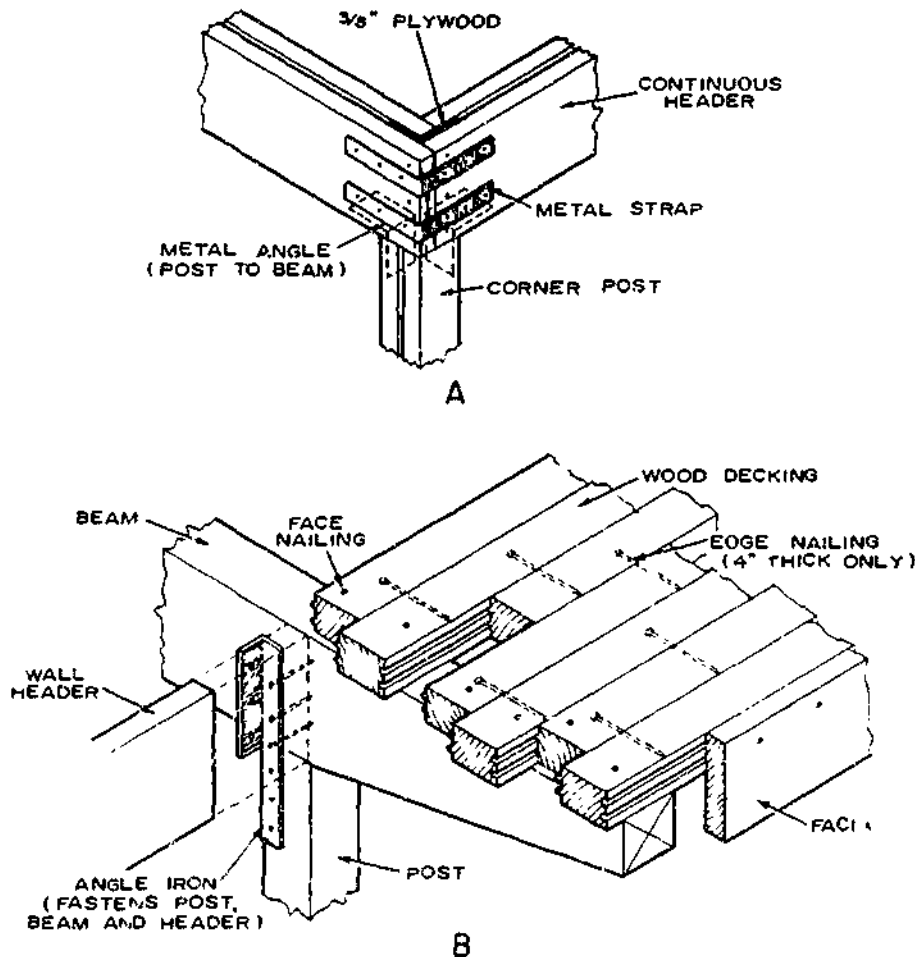

Figure 9-39.—Post and beam connections: A. Solid post and beam B. Spaced post and beam.

133.475



133.476

Figure 9-40.—Post and beam details. A. Corner connection with continuous header B. With roof decking.

Tongued-and-grooved solid wood decking, 3 by 6 and 4 by 6 in. in size, should be toenailed and face-nailed directly to the beams and edge-nailed to each other with long nails used in predrilled holes, as shown in view B, figure 9-40. Thinner decking is usually only face-nailed to the beams. Decking is usually square end-trimmed to provide a good fit. If additional insulation is required for the roof, fiberboard or an expanded foamed plastic in sheet form is fastened to the decking before the built-up or similar type of roof is installed. The moisture content of the decking should be near its inservice condition to prevent joists opening later as the wood dries.

TYPES OF SHEATHING

WALL SHEATHING is the outside covering used over the wall framework of studs, plates, and window and door headers. It forms a flat base upon which the exterior finish can be applied. Certain types of sheathing and methods of application can provide great rigidity to the house, eliminating the need for corner bracing. Sheathing serves to minimize air infiltration and, in certain forms, provides some insulation.

Some sheet materials serve both as sheathing and siding. It is a versatile material and manufacturers produce it in many forms. Perhaps the most common types used in

construction are boards, plywood, structural insulating board, and gypsum sheathing.

WOOD SHEATHING

Wood sheathing is usually of nominal 1-in. boards in a shiplap, a tongue-and-grooved, or a

square-edge pattern. Resawn 11/16-in. boards are also allowed under certain conditions. The requirements for wood sheathing are easy working, easy nailing, and moderate shrinkage. Widths commonly used are 6, 8, and 10 in. Sheathing may be applied horizontally or diagonally, as shown in view A, figure 9-41. It is

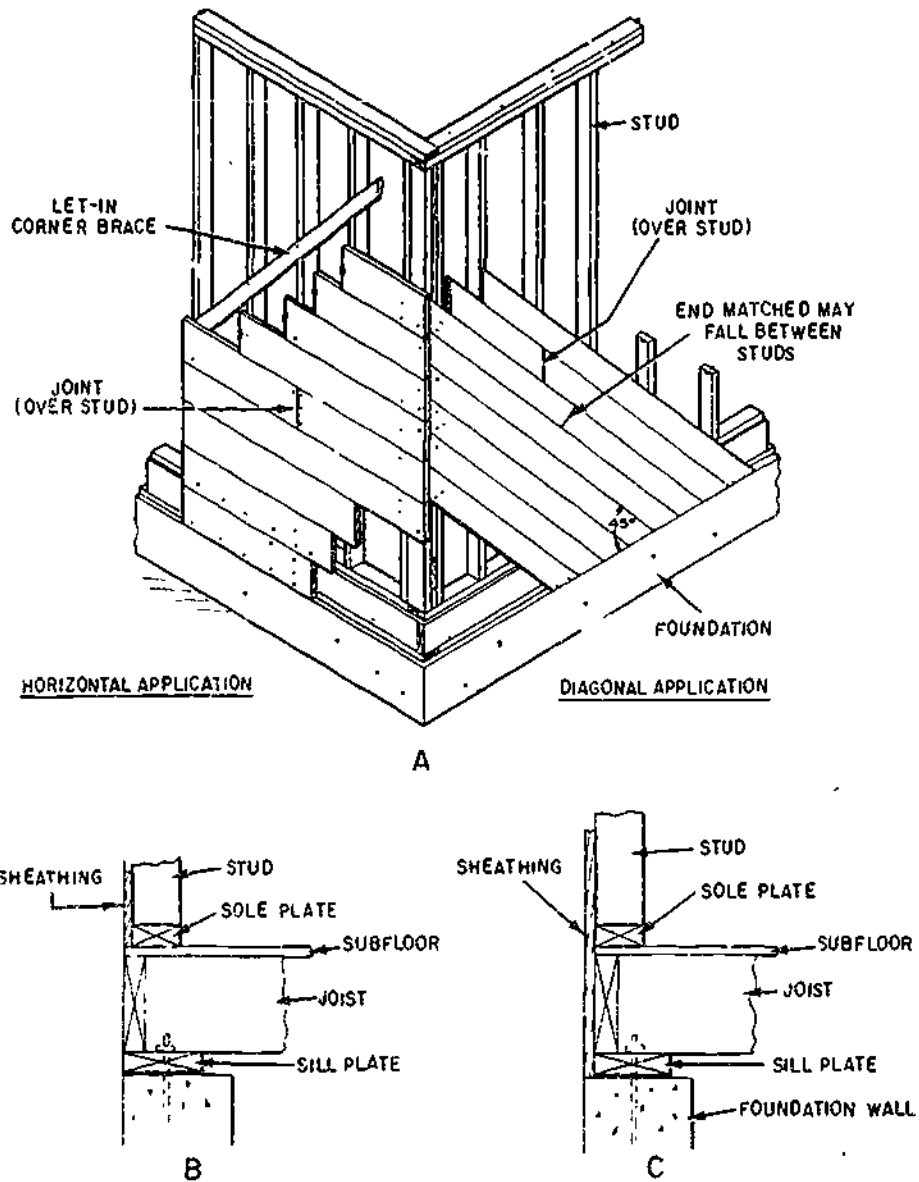

133.477
 Figure 9-41.—Application of wood sheathing: A. Horizontal and diagonal B. Started at subfloor C. Started at foundation wall.

sometimes carried only to the subfloor as seen in view B, figure 9-41, but when a diagonal sheathing or sheet materials are placed, as shown in view C, figure 9-41, greater strength and rigidity result.

Some manufacturers produce random-length side- and end-matched boards for sheathing. Most softwood species, such as spruces, Douglas-fir, southern pine, hemlock, and the soft pines, are suitable for sheathing. Grades vary between species, but structural grade sheathing is commonly used.

PLYWOOD SHEATHING

Plywood is used extensively for sheathing of walls, applied vertically, normally in 4- by 8-ft and longer sheets. (See fig. 9-42.) This method

of sheathing eliminates the need for diagonal corner bracing; but, as with any sheathing material, it should be well nailed.

Standard sheathing grade is commonly used for sheathing. For severe exposures, this same plywood is furnished with an exterior glue-line. While the minimum plywood thickness for 16-in. stud spacing is 5/16 in., it is often desirable to use 3/8 in. and thicker, especially when the exterior finish must be nailed to the sheathing. The selection of plywood thickness is also influenced somewhat by standard jamb widths in window and exterior door frames. This may occasionally require sheathing of 1/2-inch or greater thicknesses. Some modification of jambs is required and readily accomplished when other plywood thicknesses are used.

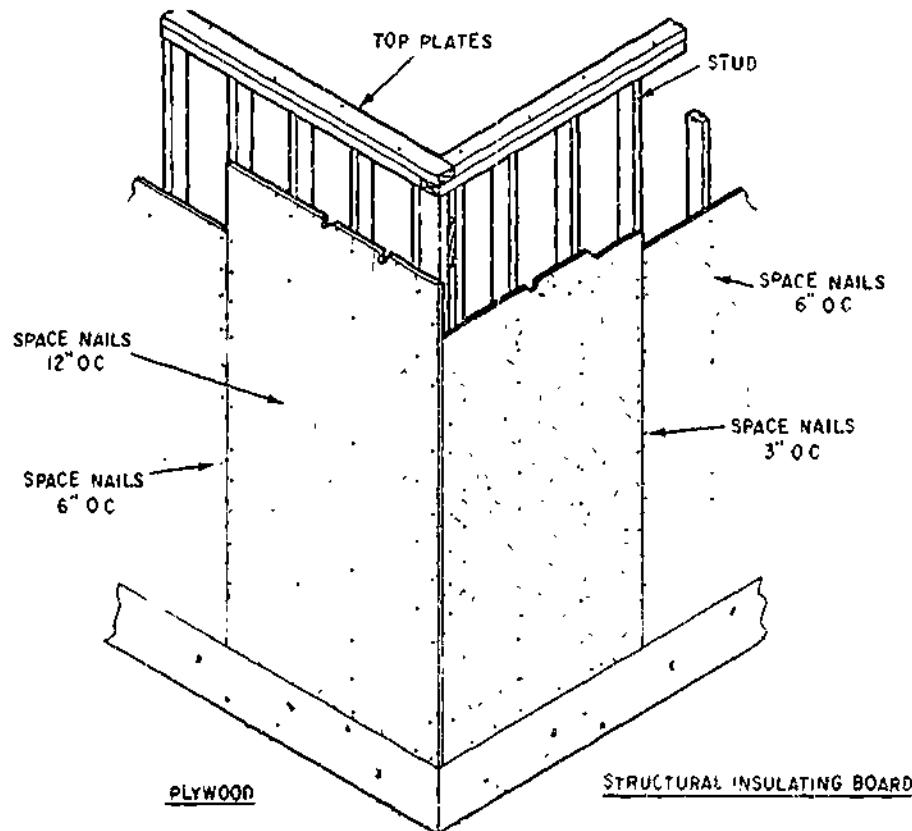

Figure 9-42.—Vertical application of plywood or structural insulating board sheathing.

133.478

STRUCTURAL INSULATING BOARD SHEATHING

The three common types of insulating board (structural fiberboards) used for sheathing include regular density, intermediate density, and nail-base. Insulating board sheathings are coated or impregnated with asphalt or given other treatment to provide a water-resistant product. Occasional wetting and drying that occur during construction will not damage the sheathing material.

Regular-density sheathing is manufactured in 1/2- and 25/32-in. thicknesses and in 2-by 8-, 4-by 8-, and 4-by 9-ft sizes. Intermediate-density and nail-base sheathing are denser products than regular-density. They are regularly manufactured only in 1/2-in. thickness and in 4-by 8- and 4-by 9-ft sizes. While 2-by 8-ft sheets with matched edge are used horizontally, 4-by 8-ft and longer sheets are usually installed with the long dimension vertical.

Corner bracing is required on horizontally applied sheets and usually on applications of 1/2-in. regular-density sheathing applied vertically. Additional corner bracing is usually not required for regular-density insulating board sheathing 25/32 in. thick or for intermediate-density and nail-base sheathing when properly applied with long edges vertical. (See fig. 9-42.) Naturally fastenings must be adequate around the perimeter and at intermediate studs, and adequately fastened (nails, staples, or other fastening system). Nail-base sheathing also permits shingles to be applied directly to it as siding if fastened with special annular-grooved nails. Galvanized or other corrosion-resistant fasteners are recommended for installation of insulating-board sheathing.

GYPSUM SHEATHING

Gypsum sheathing is 1/2 in. thick, 2-by 8 ft in size, and is applied horizontally for stud spacing of 24 in. or less. (See fig. 9-43.) It is

composed of treated gypsum filler faced on two sides with water-resistant paper, often having one edge grooved, and the other with a matched V edge. This makes application easier, adds a small amount of tie between sheets, and provides some resistance to air and moisture penetration.

INSTALLATION OF SHEATHING

Types of sheathing that provide adequate bracing are: (a) wood sheathing, when applied diagonally, (b) plywood, when applied vertically in sheets 4 ft wide by 8 or more ft high and where attached with nails or staples spaced not more than 6 in. apart on all edges and not more than 12 in. at intermediate supports; and (c) structural insulating board sheathing 4 ft wide and 8 ft or longer (25/32-in.-thick regular grade and 1/2-in.-thick intermediate-density or nail-base grade) applied with long edges vertical with nails or staples spaced 3 in. along all edges and 6 in. at intermediate studs.

Another method of providing the required rigidity and strength for wall framing consists of a 1/2-in. plywood panel at each side of each outside corner and 1/2-in. regular-density fiberboard at intermediate areas. The plywood must be in 4-ft-wide sheets and applied vertically with full perimeter and intermediate stud nailing.

Where corner bracing is required, use 1-by 4-in. or wider members let into the outside face of the studs, and set at an angle of 45° from the bottom of the soleplate to the top of the wallplate or corner stud. Where window openings near the corner interfere with 45° braces, the angle should be increased but the full-length braces should cover at least three stud spaces.

WOOD

The minimum thickness of wood sheathing is generally 3/4 in. However, for particular uses, depending on exterior coverings, resawn boards of 11/16 in. thickness may be used as sheathing. Thicknesses commonly used are 6, 8, 10, and 12 in.

The 6- and 8-in. widths will have less shrinkage than 10 and 12 in. widths, so that smaller openings will occur between boards.

The boards should be nailed at each stud crossing with two nails for the 6- and 8-in. widths and three nails for the 10- and 12-in. widths. When diagonal sheathing is used, one more nail can be used at each stud; for example, three nails for 8-in. sheathing. Joints should be placed over the center of studs, as shown in view A, figure 9-41, unless end-matched (tongued-and-grooved) boards are used. End-matched tongued-and-grooved boards are applied continuously, either horizontally or diagonally, allowing end joints to fall where they may, even if between studs. However, when

end-matched boards are used, no two adjoining boards should have end joints over the same stud space and each board should bear on at least two studs.

Two arrangements of floor framing and soleplate location may be used which affect wall sheathing application. The first method has the soleplate set in from the outside wall line so that the sheathing is flush with the floor framing. (See view B, fig. 9-41.) This does not provide a positive tie between wall and floor framing and in high wind areas should be supplemented with metal strapping placed over the sheathing. The second method has the sill plate located so that the distance from the outside edge of the foundation wall to the plate is equal to the

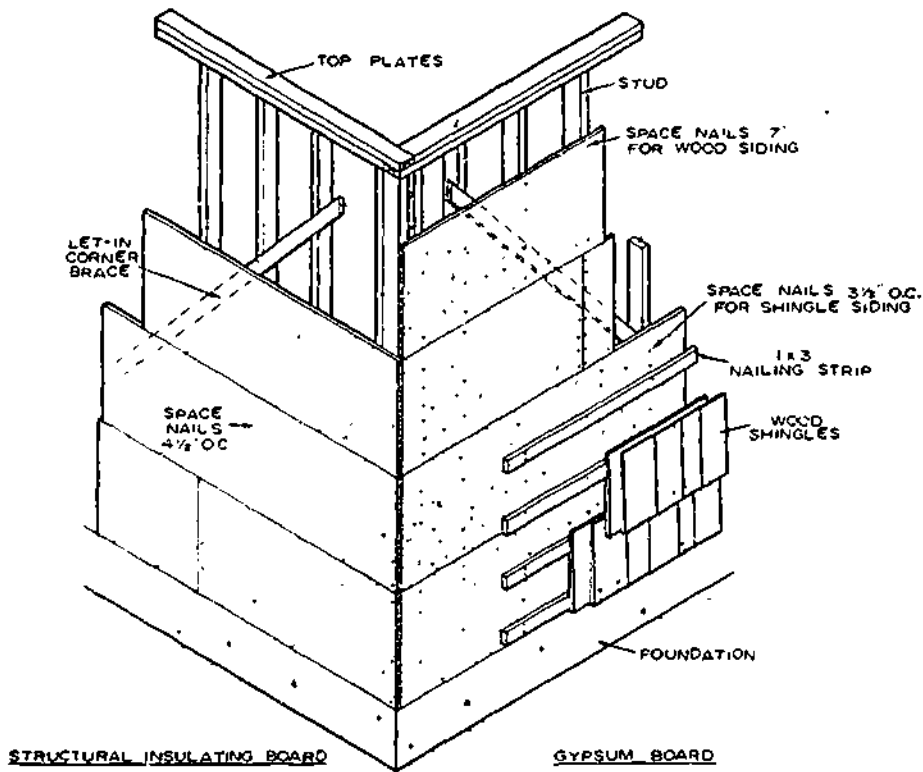

Figure 9-43.—Horizontal application of 2- by 8-ft structural insulating board or gypsum sheathing.

133.479

thickness of the sheathing (view C, fig. 9-41). When vertically applied plywood or diagonal wood sheathing is used, a good connection between the wall and floor framing is obtained. This method is usually preferred where good wall-to-floor-to-foundation connections are desirable.

Wood sheathing is commonly applied horizontally because it is easy to apply and there is less lumber waste than with diagonal sheathing. Horizontal sheathing, however, requires diagonal corner bracing for wall sheathing.

Diagonal sheathing should be applied at a 45° angle, which adds greatly to the rigidity of the wall and eliminates the need for corner bracing. There is more lumber waste than with horizontal sheathing because of angle cuts, and application is somewhat more difficult. End joints should be made over studs.

PLYWOOD

Plywood used for sheathing should be 4 by 8 ft or longer and applied vertically with perimeter nailing to eliminate the need for corner bracing. (See fig. 9-42.) Use 6-penny nails for plywood 3/8 in. or less in thickness, 8-penny nails for plywood 1/2 in. or more in thickness. Spacing should be a minimum of 6 in. at edges and 12 in. at intermediate framing members.

Plywood may also be applied horizontally, but not being as efficient from the standpoint of rigidity and strength, it normally requires diagonal bracing. However, blocking between studs to provide for horizontal edge nailing will improve the rigidity and usually eliminate the need for bracing. When shingles or similar exterior finishes are employed, it is necessary to use threaded nails for fastening when plywood is only 5/16 or 3/8 in. thick. Allow 1/8-in. edge spacing and 1/16-in. end spacing between plywood sheets when installing.

Particleboard, hardboard, and other sheet materials may also be used as a sheathing.

However, their use is somewhat restricted because cost is usually higher than the sheet materials previously mentioned.

STRUCTURAL INSULATING BOARD

Vertical application of structural insulating board (fig. 9-42) in 4- by 8-ft sheets is usually recommended by the manufacturer because perimeter nailing is possible. Depending on local building regulations, spacing nails 3 in. on edges and 6 in. at intermediate framing members usually eliminates the need for corner bracing when 25/32-in. structural insulating board sheathing or 1/2-in. medium-density structural insulating board sheathing is used. Use 1 3/4-in. galvanized roofing nails for the 25/32-inch sheathing and 1 1/2-in. nails for the 1/2-in. sheathing. Manufacturers usually recommend 1/8-in. spacing between sheets. Joints are centered on framing members.

GYPSUM AND INSULATING BOARD

Gypsum and insulating board sheathing in 2- by 8-ft sheets applied horizontally require corner bracing. (See fig. 9-43.) Vertical joints should be staggered. The 25/32-in. board should be nailed to each crossing stud with 1 3/4-in. galvanized roofing nails spaced about 4 1/2 in. apart.

The 1/2-in. gypsum and insulating board sheathing should be nailed to the framing members with 1 1/2-in. galvanized roofing nails spaced about 3 1/2 in. apart.

When wood bevel or similar sidings are used over plywood sheathing less than 5/8 in. thick, and over insulating board and gypsum board, nails must usually be located so as to contact the stud. When wood shingles and similar finishes are used over gypsum and regular density insulating board sheathing, the walls are stripped with 1- by 3-in. horizontal strips spaced to conform to the shingle exposure. The wood strips are nailed to each stud crossing with two

8-penny or 10-penny threaded nails, depending on the sheathing thickness. (See fig. 9-43.) Nail-base sheathing board usually does not require stripping when threaded nails are used.

SHEATHING PAPER

Sheathing paper should be water resistant but not vapor resistant. It is often called "breathing" paper as it allows the movement of water vapor but resists entry of direct moisture. It also serves to resist air infiltration. Rosen,

15-pound asphalt felt, and similar papers are considered satisfactory.

Sheathing paper should be used behind a stucco or masonry veneer finish and over wood sheathing. It should be installed horizontally starting at the bottom of the wall. Succeeding layers should be lapped about 4 in. Ordinarily, it is not used over plywood, fiberboard, or other sheet materials that are water-resistant. However, 8 in. or wider strips of sheathing paper should be used around window and door openings to minimize air infiltration.

CHAPTER 10

ROOF FRAMING

This chapter provides the fundamentals of roof design and construction. Included are definitions of roof construction terms, descriptions of various roofs and rafters, and techniques of laying out, cutting, and erecting rafters and other roof framing members.

TYPES OF ROOFS

The primary object of a roof in any climate is to keep out the rain and the cold. The roof must be sloped so as to shed water. Where heavy snows cover the roofs for long periods of time, roofs must be constructed rigidly to bear the extra weight. They must also be strong enough to withstand high winds. The most commonly used types of roof construction include the gable, the lean-to or shed, the hip, and the intersecting.

The GABLE roof (fig. 10-1) has two roof slopes meeting at the center, or ridge, to form a gable. This form of roof is the one most commonly used by the Navy, since it is simple in design, economical to construct, and may be used on any type of structure.

LEAN-TO or SHED ROOF (fig. 10-1), is a near-flat roof and is used where large buildings are framed under one roof, where hasty or temporary construction is needed, and where sheds or additions to buildings are erected. The pitch of the roof is in one direction only. The roof is held up by the walls or posts on four sides; one wall or the posts on one side are at a higher level than those on the opposite side.

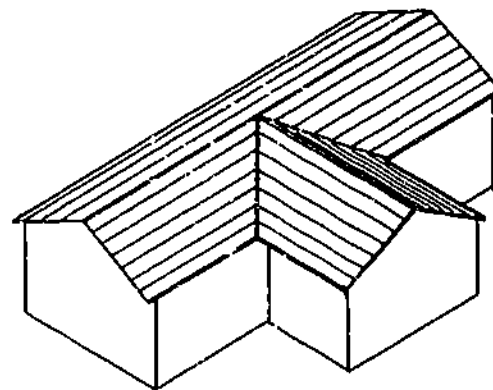

INTERSECTING

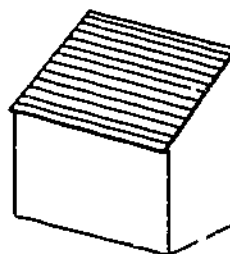

SHED ROOF

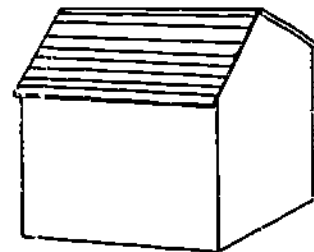

GABLE ROOF

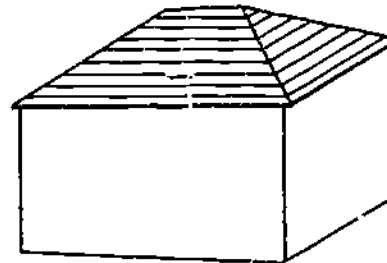

HIP ROOF

45.449

Figure 10-1.—Most common types of pitched roofs.

The HIP roof (fig. 10-1) consists of four sides or slopes running toward the center of the building. Rafters at the corners extend diagonally to meet at the center or ridge. Into these rafters, other rafters are framed.

The INTERSECTING roof (fig. 10-1) consists of a gable and valley or hip and valley intersecting each other. The valley is that portion where the roofs meet with each roof slanting in a different direction. This type of roof is more complicated and requires more time and labor to construct. Although there are many variations of this type of roof, the intersections are usually at right angles.

ROOF CONSTRUCTION TERMS

A roof has several characteristics or construction features which are illustrated in figures 10-2 and 10-3. They are defined or described as follows:

SPAN of a roof is the shortest distance between two opposite rafter seats. In other words, it is the distance between the outside plates, measured at right angles to the direction of the ridge.

UNIT OF RUN is a fixed unit of measure, always 12 inches. It is the same for the roof as for any other part of the building.

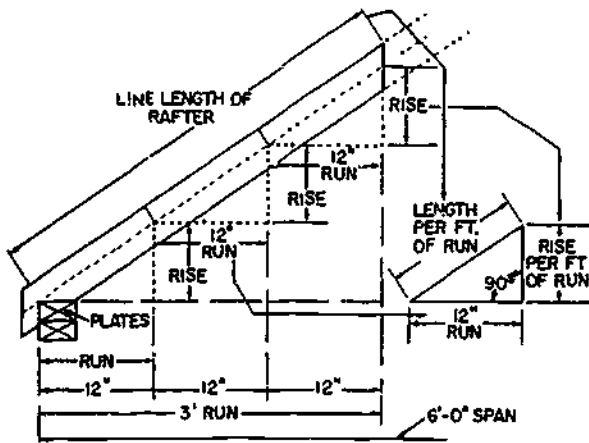

133.362

Figure 10-2.—Span, total rise and total run.

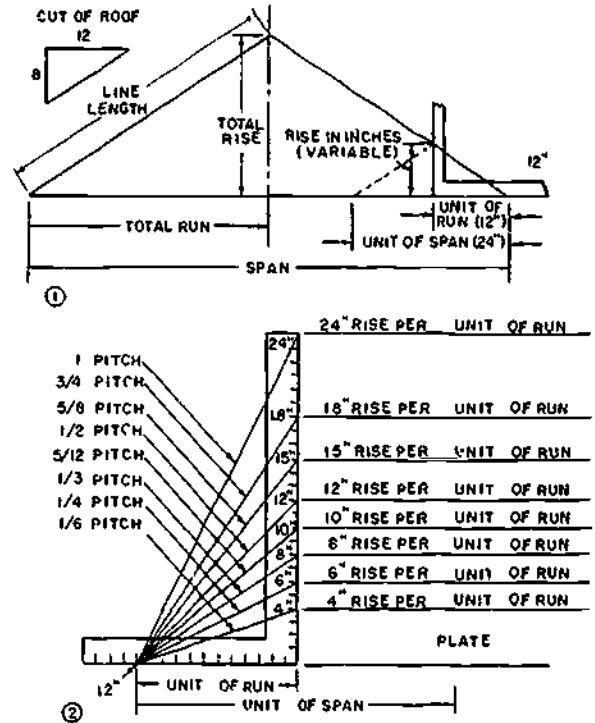

133.114

Figure 10-3.—Roof framing terms.

UNIT OF SPAN is likewise a fixed unit of measure, always twice the unit of run or 24 inches.

TOTAL RUN is the horizontal distance over which a rafter extends.

TOTAL RISE is the vertical distance from the plate to the point where an adjacent rafter intersects the ridge.

PITCH is the ratio of the total rise to the span. It describes the slope of a roof. Pitch is expressed as a fraction, such as 1/4 or 1/2 pitch. The term PITCH is gradually being replaced by the term CUT.

CUT of a roof is the angle that the roof surface makes with a horizontal plane. This angle is usually expressed as a fraction in which the numerator equals the unit rise and the denominator equals the unit of run (12 in.),

such as 6/12 or 8/12. Sometimes cut is expressed in inches per foot. For example, a 6 in. or 8 in. cut per foot. Here the unit of run (12 in.) is understood.

LINE LENGTH is the hypotenuse of a triangle whose base equals the total run and whose altitude equals the total rise.

RAFTERS

The pieces which make up the main body of the framework of all roofs are called rafters. They do for the roof what the joists do for the floor and what the studs do for the wall. Rafters are inclined members spaced from 16 to 48 in. apart which vary in size, depending on their length and the distance at which they are spaced. The tops of the inclined rafters are fastened in one of the various common ways determined by the type of roof. The bottoms of the rafters rest on the plate member which provides a connecting link between wall and roof and is really a functional part of both. The structural relationship between rafters and wall is the same in all types of roofs. The rafters are not framed into the plate, but are simply nailed to it, some being cut to fit the plate while others, in hasty construction, are merely laid on top of the plate and nailed in place. Rafters may extend a short distance beyond the wall to form the eaves and protect the sides of the building.

TERMS USED IN CONNECTION WITH RAFTERS

Since rafters, with ridgeboards and plates, are the principal members of roof framing, it is important to understand the following terms that apply to them.

The **COMMON** rafters (No. 1, fig. 10-4) extend from plate to ridgeboard at right angles to both.

HIP rafters (No. 2, fig. 10-4) extend diagonally from the outside corners formed by perpendicular plates to the ridgeboard.

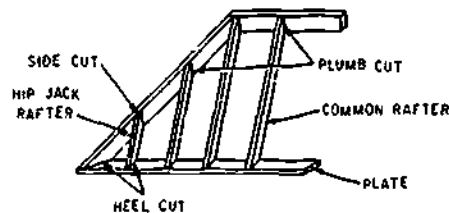
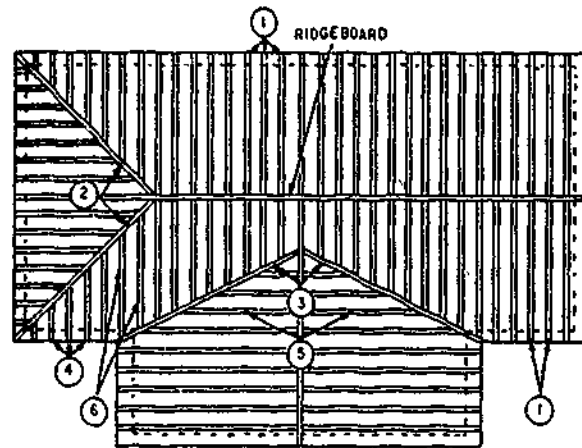

- | | | |
|------------------|------------------|-----------------|
| 1 COMMON RAFTERS | 3 VALLEY RAFTERS | 5 VALLEY JACKS |
| 2 HIP RAFTERS | 4 HIP JACK | 6 CRIPPLE JACKS |

133.363

Figure 10-4.—Rafter terms.

VALLEY rafters (No. 3, fig. 10-4) extend from the plates to the ridgeboard along the lines where two roofs intersect.

JACK rafters never extend the full distance from plate to ridgeboard. Jack rafters are subdivided into the hip jacks (No. 4, fig. 10-4), the lower ends rest on the plate and the upper ends against the hip rafter; valley jacks (No. 5, fig. 10-4), the lower ends of which rest against the valley rafters and the upper ends against the ridgeboard; and cripple jacks (No. 6, fig. 10-4), which are nailed between hip and valley rafters.

TOP or **PLUMB CUT** is the cut made at the end of the rafter to be placed against the ridgeboard or, if the ridgeboard is omitted, against the opposite rafters.

SEAT, BOTTOM, or HEEL CUT is the cut made at the end of the rafter which is to rest on the plate.

SIDE or CHEEK CUT is a bevel cut on the side of a rafter to fit it against another frame member.

RAFTER LENGTH is the shortest distance between the outer edge of the plate and the center of the ridge line.

EAVE or TAIL is the portion of the rafter extending beyond the outer edge of the plate.

MEASURE LINE is an imaginary reference line laid out down the middle of the face of a rafter. If a portion of a roof is represented by a right triangle (fig. 10-5), the measure line will correspond to the hypotenuse, the rise to the leg, and the run to the base.

PLUMB LINE is any line that is vertical when the rafter is in its proper position (fig. 10-5).

LEVEL LINE is any line that is horizontal when the rafter is in its proper position (fig. 10-5).

COMMON RAFTER LAYOUT

Rafters must be laid out and cut with slope, length, and overhang exactly right so that they will fit when placed in the position they are to occupy in the finished roof.

The Builder first determines the length of the rafter and the length of the piece of lumber from which the rafter may be cut. If he is working from a set of plans which includes a roof plan, the rafter lengths and the width of the building may be obtained from this plan. If no plans are available, the width of the building may be measured with a tape. To determine the rafter length, first find the total run, which is one-half of the distance between the outside plates. Total run is the horizontal distance that a common rafter will cover. The amount of rise per ft has yet to be considered. If the building to

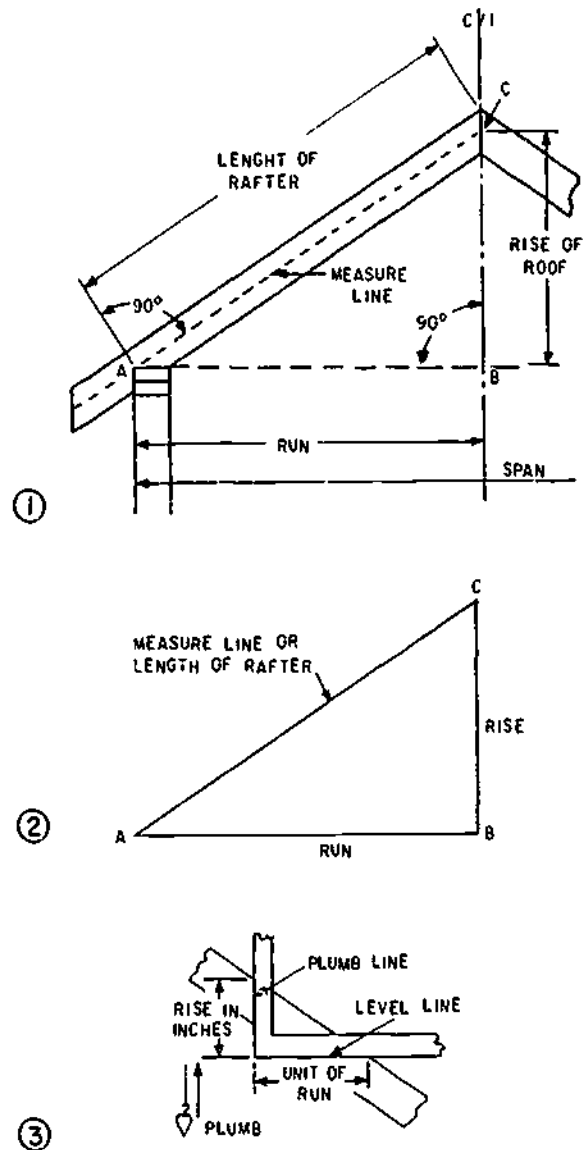

133.364

Figure 10-5.—Rafter terms—Continued.

be roofed is 20 ft wide, half the span will be 10 ft. For example, the rise per ft is to be 8 inches. To determine the approximate overall length of a rafter, measure on the steel carpenter square the distance between 8 on the tongue and 12 on the blade. because 8 is the rise and 12 is the unit of run. This distance is $14 \frac{5}{12}$ in. and represents the line length of a rafter with a total

run of 1 ft and a rise of 8 in. Since the run of the rafter is 10 ft, multiply 10 by the line length for 1 ft. The answer is 144 1/2 in., or 12 ft and 1/6 in. The amount of overhang, normally 1 ft, must be added if an overhang is to be used. This makes a total of 13 ft for the length of the rafter, but since 13 ft is an odd length for timber, a 14-ft timber is used.

After the length has been determined, the timber is laid on sawhorses, sometimes called saw benches, with the crown or bow, if any, as the top side of the rafter. If possible, select a straight piece for the pattern rafter. If a straight piece is not available, have the crown toward the person laying off the rafter. Hold the square with the tongue in the right hand, the blade in the left, the heel away from the body, and place the square as near the upper end of the rafter as possible. In this case, the figure 8 on the tongue and 12 on the blade are placed along the edge of timber which is to be the top edge of the rafter as shown in view 1, figure 10-6. Mark along the tongue edge of the square, which will be the

plumb cut at the ridge. Since the length of the rafter is known to be 12 ft and 1/6 in., measure the distance from the top of the plumb cut and mark it on the timber. Hold the square in the same manner with the 8 mark on the tongue directly over the 12-ft and 1/6-in. mark. Mark along the tongue of the square to give the plumb cut for the seat (view 2, fig. 10-6). Next measure off, perpendicular to this mark, the length of overhang along the timber and make a plumb cut mark in the same manner, keeping the square on the same edge of the timber (view 3, fig. 10-6). This will be the tail cut of the rafter; often the tail cut is made square across the timber.

The level cut or width of the seat is the width of the plate, measured perpendicular to the plumb cut, as shown in view 4, figure 10-6. Using the try square, square lines down on the sides from all level and plumb cut lines. Now the rafter is ready to be cut.

If a building is 20 ft 8 in. wide, the run of the rafter would be 10 ft 4 in., or half the span. Instead of using the above method, the rafter length may be determined by "stepping it off" by successive steps with the square, as shown in figure 10-7. Stake the same number of steps as there are ft in the run, which leaves 4 in. over a

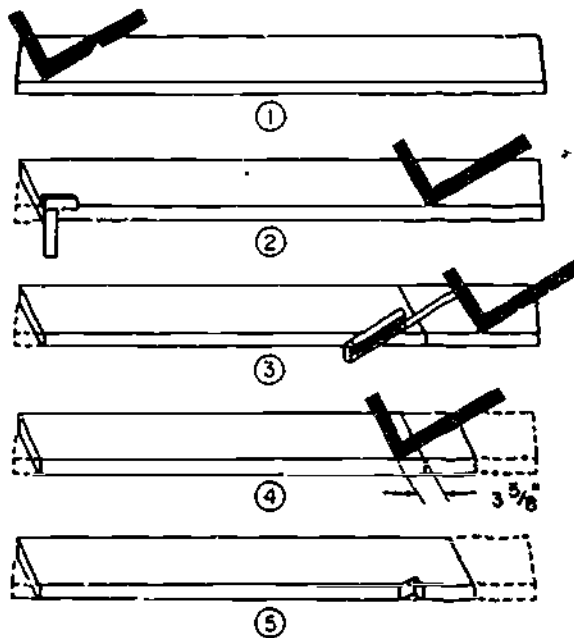

133.365
Figure 10-6.—Rafter layout-scale or measurement method.

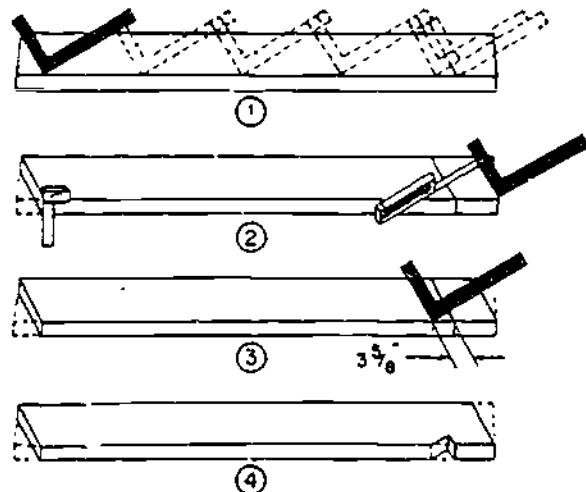

133.366
Figure 10-7.—Rafter layout-step-off method.

ft. This 4 in. is taken care of in the same manner as the full ft run; that is, with the square at the last step position, make a mark on the rafters at the 4-in. mark on the blade, then move the square along the rafter until the tongue rests at the 4-in. mark. With the square held for the same cut as before, make a mark along the tongue. This is the line length of the rafter. The seat cut and hangover are made as described above. When laying off rafters by any method, be sure to recheck the work carefully. When two rafters have been cut, it is best to put them in place to see if they fit. Minor adjustments may be made at this time without serious damage or waste of material.

in the first line represents the length of common rafters per ft of run, as the title indicates at the lefthand end of the blade. Each set of figures under each in. division mark represents the length of rafter per ft of run with a rise corresponding to the number of in. over the number. For example, under the 16-in. mark appears the number 20.00 in. This number equals the length of a rafter with a run of 12 in. and a rise of 16 in., or, under the 13-in. mark appears the number 17.69 in. which is the rafter length for a 12-in. run and a 13-in. rise. The other five lines of figures in the table will not be discussed as they are seldom used.

TABLE METHOD, USING RAFTER TABLE ON FRAMING SQUARE

The rafter table which is located on the blade gives both the line length of any pitch or rafter per ft of run and the line length of any hip or valley rafter per ft of run. The difference in length of the jack rafter spaced 16- or 24 in. O.C. is also shown in the table. Where the jack rafter, hip, or valley rafter requires side cuts, the cut is given in the table.

To use the table for laying out rafters, the width of the building must first be known. Suppose the building is 20 ft 8 in. wide and the rise of the rafters is to be 8 in. per ft of run. The total run of the rafter will be 10 ft 4 in. Look in the first line of figures, under the 8-in. mark appears the number 14.42, which is the length in in. of a rafter with a run of 1 ft and a rise of 8 in. To find the line length of a rafter with a total run of 10 ft 4 in., multiply 14.42 in. by 10 1/3 and divide by 12 so as to get the answer in ft. The 14.42 in. by 10 1/3 equals 149.007 in., which is divided by 12 to equal 12 5/12 ft. Therefore 12 ft 5 in. is the line length of the rafter. The remaining procedure for laying out the rafters after the length has been determined was described above.

The table (fig. 10-8) appears on the face of the blade. It is used to determine the length of the common, valley, hip, and jack rafters, and the angles at which they must be cut to fit at the ridge and plate. To use the table, the Builder first must become familiar with it and know what each figure represents. The row of figures

When the roof has an overhang, the rafter is usually cut square to save time. When the roof has no overhang, the rafter cut is plumb, but no notch is cut in the rafter for a seat. The level cut

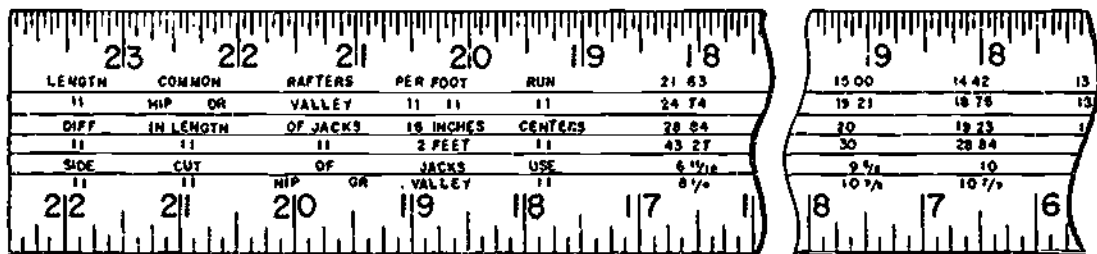

Figure 10-8.—Rafter table method.

133.367

is made long enough to extend across the plate and the wall sheathing. This type of rafter saves material, although little protection is given to the side wall.

BIRD'S MOUTH

A rafter with a projection has a notch in it called a BIRD' MOUTH, as shown in figure 10-9. The plumb cut of the bird's mouth, which bears against the side of the rafter plate is called the HEEL cut; the level cut, which bears on the top of the rafter plate, is called the SEAT cut.

The size of the bird's mouth is usually stated in terms of the depth of the heel cut rather than in terms of the width of the seat cut. You lay out the bird's mouth in about the same way you lay out the seat on a rafter without a projection. Measure off the depth of the heel on the heel plumb line, set the square as shown in figure 10-10, and draw the seat line along the blade.

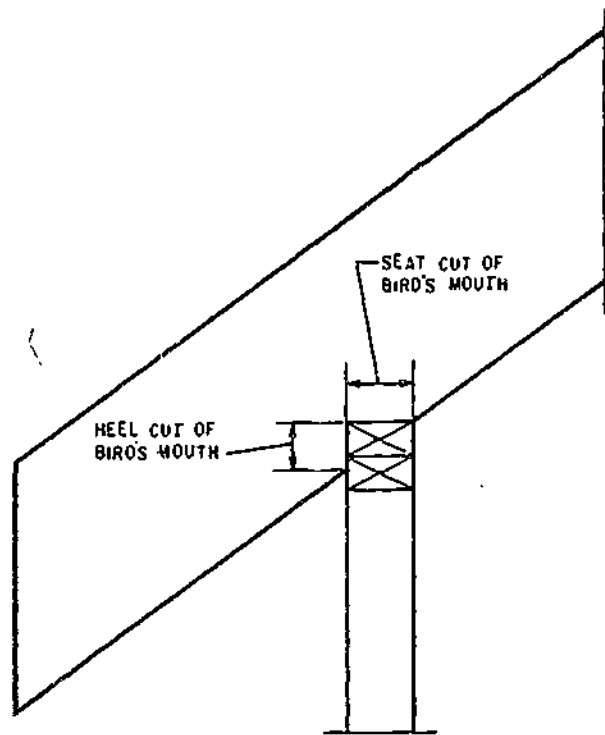

133.119

Figure 10-9.—Bird's mouth on a rafter with projection.

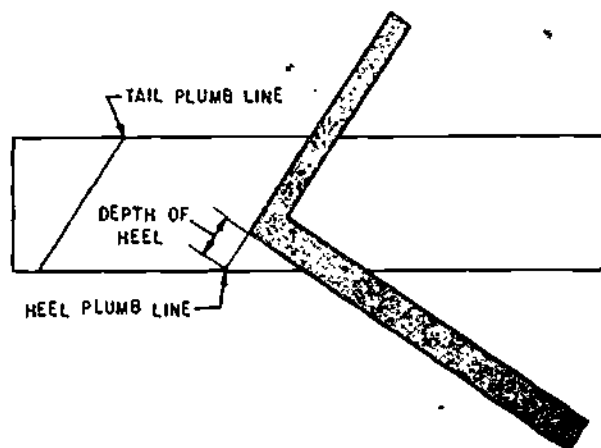

133.120

Figure 10-10.—Laying out a bird's mouth.

For the roof surface. ALL RAFTERS should be exact, therefore, the amount above the seat cut, rather than the bottom edge of the rafters, is the most important measurement. Suppose that on a hip roof, or an intersecting roof, the hips or valley rafters are 2 by 6 and the common rafters 2 by 4. The amount above the seat cut should be such as to adequately support the overhang of the roof, plus personnel working on the roof. The width of the seat cut is important as a bearing surface. The maximum width of the common rafter should not exceed the width of the plate.

HIP RAFTER LAYOUT

Most hip roofs are EQUAL-PITCH hip roofs, in which the angle of slope on the roof end or ends is the same as the angle of slope on the sides. Unequal-pitch hip roofs do exist, but they are quite rare, and they require special layout methods. The UNIT LENGTH RAFTER TABLE on the framing square applies only to equal pitch hip roofs.

In the following discussion of hip roof framing, it will be assumed that in every case the roof is an equal-pitch hip roof.

The length of a hip rafter, like the length of a common rafter, is calculated on the basis of

bridge measure times the unit of run. Any of the methods previously described for a common rafter may be used. Some of the basic data for a hip rafter, however, are different.

Take a look at figure 10-11, which shows part of a ROOF FRAMING DIAGRAM for an EQUAL-PITCH hip roof. A roof framing diagram may be included among the working drawings: if it is not, you should lay one out for yourself. Lay the building lines out to scale first; you can find the span and the length of the building on the working drawings. Then draw a horizontal line along the center of the span.

In an equal-pitch hip roof framing diagram, the lines which indicate the hip rafters (FA, GA, IB, and KB in fig. 10-11) forms 45° angles with the building lines. Draw these lines in at 45°, as shown. The points where they meet the centerline are the THEORETICAL ends of the ridge piece. The ridge-end common rafters CA, DA, EA, HB, JB, and LB join the ridge at the same points.

A line which indicates a rafter in the roof framing diagram is equal in length (to scale, of course) to the TOTAL RUN of the rafter it represents. You can see from the diagram that the total run of a hip rafter (represented by lines FA, CA, IB, and KB) is the hypotenuse of a right triangle with shorter sides each equal to the

total run of a common rafter. You know the total run of a common rafter: it is one-half the span, or one-half the width of the building. Knowing this, you can find the total run of a hip rafter by applying the Pythagorean theorem.

Let us suppose, for example, that the span of the building is 30 ft. Then one-half the span, which is the same as the total run of a common rafter, is 15 ft. By the Pythagorean theorem, the total run of a hip rafter is the square root of $(15^2 + 15^2)$, or 21.21 ft.

What is the total rise? Since a hip rafter joins the ridge at the same height as a common rafter, the total rise for a hip rafter is the same as the total rise for a common rafter. You know how to figure the total rise of a common rafter. Let us suppose that this roof has a unit run of 12 and a unit rise of 8. Since the total run of a common rafter in the roof is 15 ft, the total rise of a common rafter is the value of x in the proportional equation $12 : 8 :: 15 : x$, or 10 ft.

Knowing the total run of the hip rafter (21.21 ft) and the total rise (10 ft), you can figure the line length by applying the Pythagorean theorem. The line length is the square root of $(21.21^2 + 10^2)$, or 23.44 ft. or about 23 ft 5 1/4 in.

To find the length of a hip rafter on the basis of bridge measure, you must first determine the bridge measure. As with a common rafter, the bridge measure of a hip rafter is the length of the hypotenuse of a triangle with shorter sides equal to the unit run and unit rise of the rafter. The unit rise of a hip rafter is always the same as that of a common rafter, but THE UNIT RUN OF A HIP RAFTER IS DIFFERENT.

The unit run of a hip rafter in an equal-pitch hip roof is the hypotenuse of a right triangle with shorter sides each equal to the unit run of a common rafter. Since the unit run of a common rafter is 12, the unit run of a hip rafter is the square root of $(12^2 + 12^2)$ or 16.97.

If the unit run of the hip rafter is 16.97 and the unit rise (in this particular case) is 8, the unit

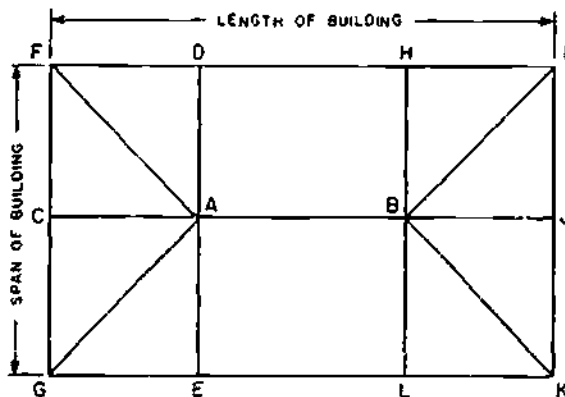

133.121
Figure 10-11.—Equal pitch hip roof framing diagram.

length of the hip rafter must be the square root of $(16.97^2 + 8^2)$, or 18.76. This means that for every 16.07 units of run the rafter has 18.76 units of length. Since the total run of the rafter is 21.21 ft, the length of the rafter must be the value of x in the proportional equation $16.97:18.76::21.21:x$, or 23.44 ft.

Like the unit length of a common rafter, the bridge measure of a hip rafter may be obtained from the unit length rafter table on the framing square. If you turn back to figure 10-8, you will see that the second line in the table is headed "Length hip or valley rafters per ft run." This means "per foot run of A COMMON RAFTER IN THE SAME ROOF." Actually, the unit length given in the tables is the unit length for every 16.97 units of run OF THE HIP RAFTER ITSELF. If you run across to the unit length given under 8, you will find the same figure, 18.76 units, that you calculated above.

An easy way to calculate the length of an equal-pitch hip roof rafter is to multiply the bridge measure by the number of ft in the total run of a common rafter, which is the same as the number of ft in one-half of the span of the building. One-half of the span of the building in this case is 15 ft; the length of the hip rafter is therefore 18.76×15 , or 281.40 in., which is $281.40/12$, or 23.45 ft. Note that when you use this method you get a result in in., which you must convert to ft. The slight difference of 0.01 ft between this result and the one previously obtained amounts to less than $1/8$ in., and may be ignored.

You step off the length of an equal-pitch hip roof rafter just as you do the length of a common rafter, except for the fact that you set the square to a unit of run of 16.97 in. instead of to a unit of run of 12 in. Since 16.97 in. is the same as 16 in. and 15.52 sixteenths of an in., setting the square to a unit of run of 17 in. is close enough for most practical purposes. Bear in mind that for any plumb cut line on an equal-pitch hip roof rafter you set the square to the unit rise of a common rafter and to a unit run of 17.

You step off the same number of times as there are ft in the total run of a common rafter

in the same roof; only the size of each step is different. For every 12-in. step in a common rafter, a hip rafter has a 17-in. step. In the roof on which we are working, the total run of a common rafter is exactly 15 ft; this means that you would step off the hip-rafter cut (17 in. and 8 in.) exactly 15 times.

Suppose, however, that there was an ODD UNIT in the common rafter total run. Assume, for example, that the total run of a common rafter is 15 ft 10 1/2 in. How would you make the odd fraction of a step on the hip rafter?

You remember that the unit run of a hip rafter is the hypotenuse of a right triangle with other sides each equal to the unit run of a common rafter. This being the case, the run of the odd unit on the hip rafter must be the hypotenuse of a right triangle with other sides each equal to the odd unit of run of the common rafter, which in this case is 10 1/2 in. You can figure this by the Pythagorean theorem (square root of $(10.5^2 + 10.5^2)$), or you can set the square on a true edge to 10 1/2 in. on the tongue and 10 1/2 in. on the blade and measure the distance between the marks. It comes to 14.84 in., which rounded off to the nearest 1/16 in. equals 14 13/16 in.

To lay off the odd unit, set the tongue of the framing square to the plumb line for the last full step made and measure off 14 13/16 in. along the blade. Place the tongue of the square at this mark, set the square to the hip rafter plumb cut of 8 in. on the tongue and 17 in. on the blade, and draw the line length cut line.

Hip Rafter Shortening Allowance

As is the case with a common rafter, the line length of a hip rafter does not take into account the thickness of the ridge piece. The size of the ridge-end shortening allowance for a hip rafter depends upon the manner in which the ridge end of the hip rafters joined to the other structural members. As shown in figure 10-12, the ridge end of the hip rafter may be framed against the ridge piece (view A, fig. 10-12) or against the

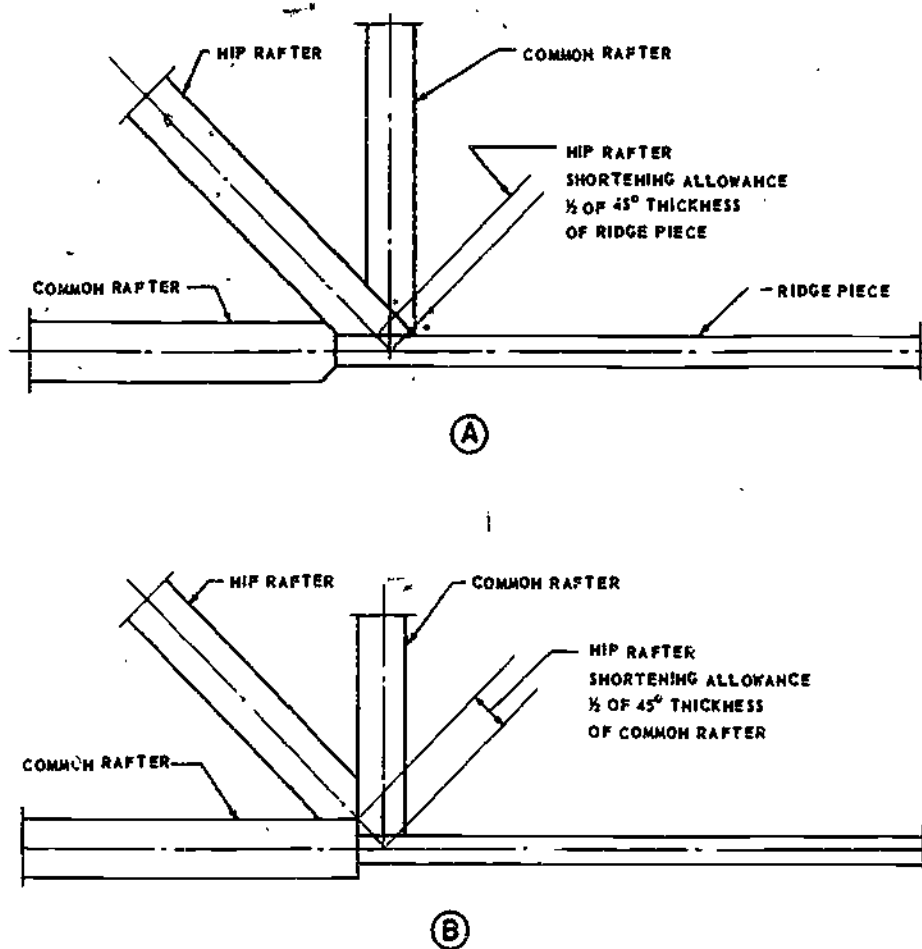

Figure 10-12.—Hip rafter shortening allowance.

133.122

ridge-end common rafters (view B, fig. 10-12). If the hip rafter is framed against the ridge piece, the shortening allowance is one-half of the 45° thickness of the ridge piece. The 45° thickness of stock is the length of a line laid at 45° across the thickness dimension of the stock. If the hip rafter is framed against the common rafters, the shortening allowance is one-half of the 45° thickness of a common rafter. To lay off the shortening allowance, set the tongue of the framing square to the line length ridge cut line, measure off the shortening allowance along the blade, set the square at the mark to the cut of the rafter (8 in. and 17 in.), and draw the actual ridge plumb cut line.

Hip Rafter Projection

A hip rafter projection, like a common rafter, is figured as a separate problem. The run of a hip rafter projection, however, is not the same as the run of a common rafter projection in the same roof. Figure 10-13 shows you why. The run of the hip rafter projection, as you can see, is the hypotenuse of a right triangle with shorter sides each equal to the run of a common rafter projection. If the run of the common rafter overhang is 18 in., the run of the hip rafter is the square root of $(18^2 + 18^2)$, or 25.45 in. Since the rafter rises 8 units for every 17 units of run, the total rise of the projection is

10-10

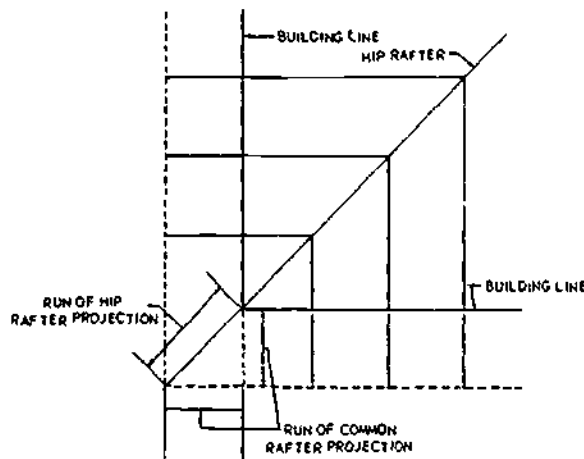

133.123

Figure 10-13.—Run of hip rafter projection.

the value of x in the proportional equation $17:8::25.45:x$, or 11.9 in. If the total run is 25.45 in. and the total rise 11.9 in., the length of the projection is the square root of $(25.45^2 + 11.9^2)$, or about 28 in.

Hip Rafter Side Cuts

Since a common rafter runs at 90° to the ridge, the ridge end of a common rafter is cut square, or at 90° to the lengthwise line of the rafter. A hip rafter, however, joins the ridge, or the ridge ends of the common rafters, at an angle, and the ridge end of a hip rafter must therefore be cut to a corresponding angle, called a **SIDE CUT**. The angle of the side cut is more acute for a high unit rise than it is for a low one.

The angle of the side cut is laid out as shown in figure 10-14. Place the tongue of the framing square along the ridge cut line, as shown, and measure off one-half the thickness of the hip rafter along the blade. Shift the tongue to the mark, set the square to the cut of the rafter (17 in. and 8 in.), and draw the plumb line marked A in the figure. Then turn the rafter edge-up, draw an edge centerline, and draw in the angle of the side cut as indicated in the lower view of figure 10-14. For a hip rafter which is to be framed against the ridge there will

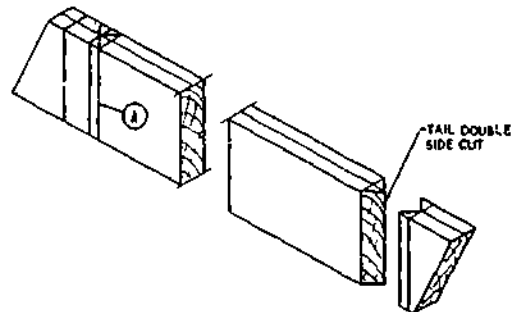
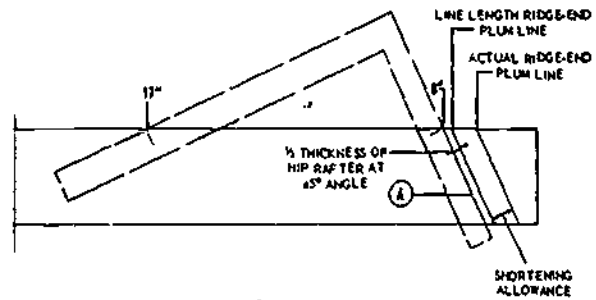

133.124

Figure 10-14.—Laying out hip rafter side cut.

be only a single side cut, as indicated by the dotted line; for one which is to be framed against the ridge ends of the common rafters there will be a double side cut, as shown. The tail of the rafter must have a double side cut at the same angle, but in the reverse direction.

The angle of the side cut on a hip rafter may also be laid out by referring to the unit length rafter table on the framing square. If you turn back to figure 10-8, you will see that the bottom line in the table is headed "Side cut hip or valley use." If you follow this line over to the column headed by the figure 8 (for a unit rise of 8), you will find the figure $10\frac{7}{8}$. If you place the framing square face-up on the rafter edge, with the tongue on the ridge-end cut line, and set the square to a cut of $10\frac{7}{8}$ in. on the blade and 12 in. on the tongue, you can draw the correct side-cut angle along the tongue.

If the bird's mouth on a hip rafter had the same depth as the bird's mouth on a common rafter, the edges of the hip rafter would extend above the upper ends of the jack rafters as

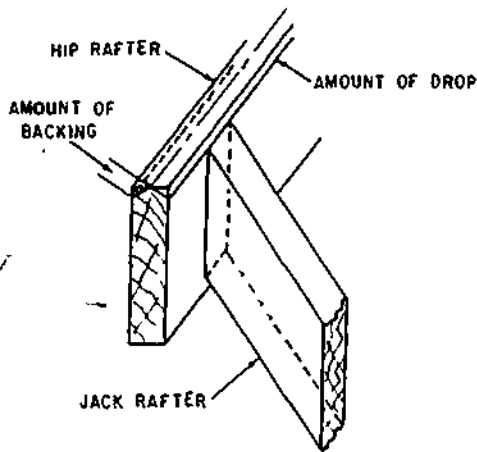

133.125

Figure 10-15.—Backing or dropping a hip rafter.

surface, or the top edge of the hip rafter. Dropping means to deepen the bird's mouth so as to bring the top edge of the hip rafter down to the upper ends of the jacks. The amount of drop is taken on the heel plumb line.

The amount of backing or drop required is calculated as shown in figure 10-16. Set the framing square to the cut of the rafter (8 in. and 17 in.) on the upper edge and measure off one-half the thickness of the rafter from the edge along the blade. A line drawn through this mark, parallel to the edge, will indicate the bevel angle, as shown, if the rafter is to be backed. The perpendicular distance between the line and the edge of the rafter will be the amount of drop—meaning the amount that the depth of the hip rafter bird's mouth should exceed the depth of the common rafter bird's mouth.

shown in figure 10-15. This can be corrected by either BACKING or DROPPING the hip rafter. Backing means to bevel the upper edge of the hip rafter. As shown in figure 10-15, the amount of backing is taken at the right angle to the roof

VALLEY RAFTER LAYOUT

A valley rafter follows the line of intersection between a main roof surface and a

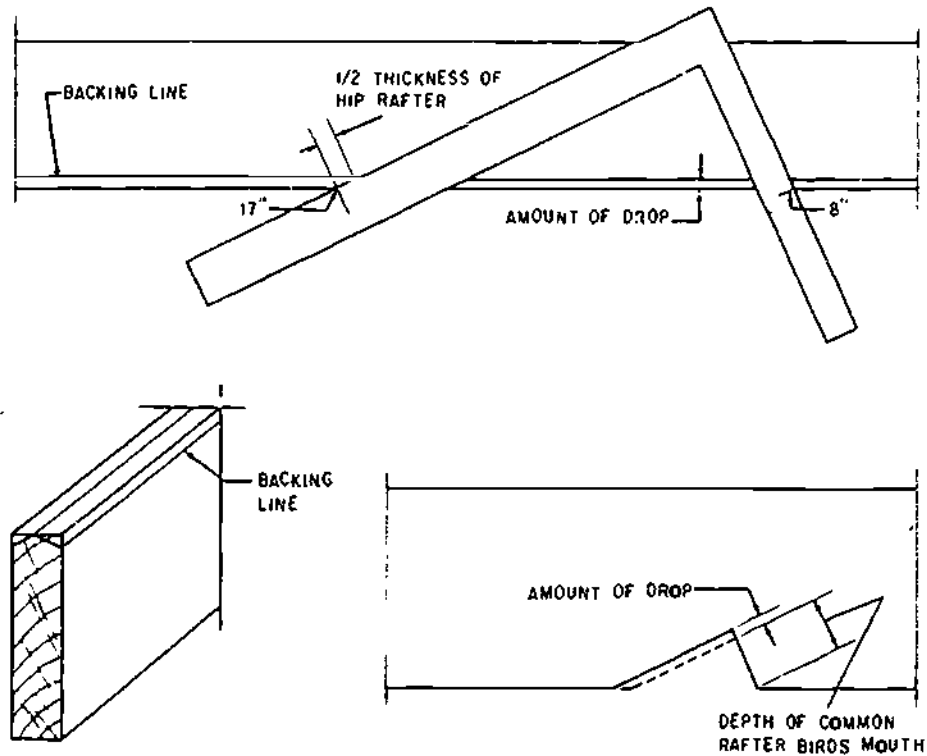
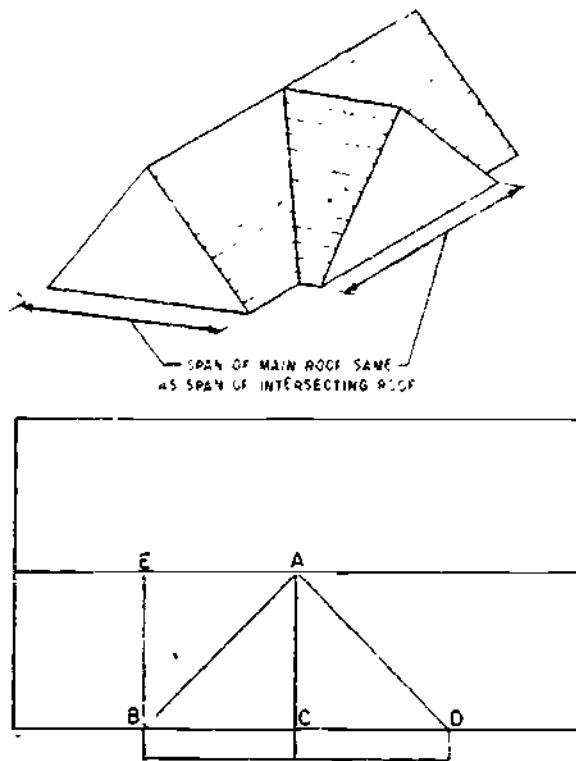

Figure 10-16.—Determining required amount of backing or drop.

133.126

gable-roof addition or a gable-roof dormer surface. Most roofs which contain valley rafters are EQUAL-PITCH roofs, in which the pitch of the addition or dormer roof is the same as the pitch of the main roof. There are UNEQUAL-PITCH valley-rafter roofs, but they are quite rare, and they require special framing methods. In the discussion of valley rafter layout, it will be assumed that the roof is in every case an equal pitch roof, in which the unit of run and unit of rise of an addition or dormer common rafter is the same as the unit of run and unit of rise of a main roof common rafter. In an equal-pitch roof, the valley rafters always run at 45° to the building lines and the ridge pieces.

Figure 10-17 shows an EQUAL-SPAN framing situation, in which the span of the addition is the same as the span of the main roof. Since the pitch of the addition roof is the



133.127

Figure 10-17.—Equal span main roof and intersection roof.

same as the pitch of the main roof, equal spans bring the ridge pieces to equal heights.

If you look at the roof framing diagram in the figure, you will see that the total run of a valley rafter (indicated by AB and AD in the diagram) is the hypotenuse of a right triangle with shorter sides equal to the total run of a common rafter in the main roof. The unit run of a valley rafter is therefore 16.97, the same as the unit run for a hip rafter. It follows that figuring the length of an equal-span valley rafter is the same as figuring the length of an equal-pitch hip roof hip rafter.

A valley rafter, however, does not require backing or dropping. The projection, if any, is figured just as it is for a hip rafter. Side cuts are laid out as they are for a hip rafter; the valley-rafter tail has a double side cut, like the hip-rafter tail, but in the reverse direction, since the tail cut on a valley rafter must form an inside rather than an outside corner. As indicated in figure 10-18, the ridge-end shortening allowance in this framing situation amounts to one-half of the 45° thickness of the ridge.

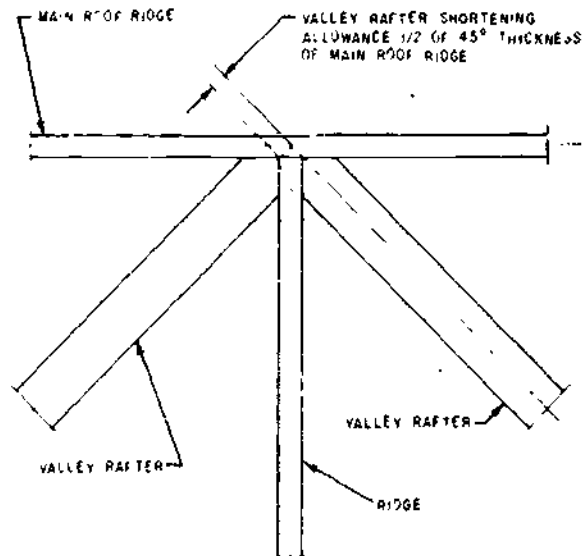

133.128

Figure 10-18.—Ridge-end shortening allowance for equal span intersection valley rafter.

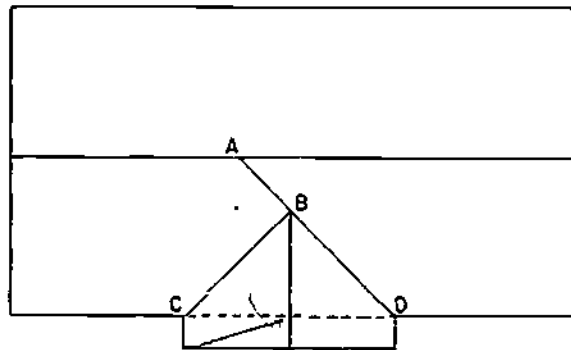
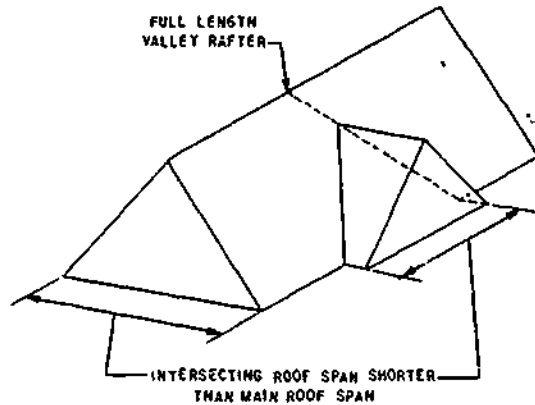

133.129

Figure 10-19.—Equal-pitch but unequal span framing situation.

Figure 10-19 shows a framing situation in which the span of the addition is shorter than the span of the main roof. Since the pitch of the addition roof is the same as the pitch of the main roof, the shorter span of the addition brings the addition ridge down to a lower level than that of the main roof ridge.

There are two ways of framing an intersection of this type. By the method shown in figure 10-19, a full-length valley rafter (AD in the figure) is framed between the rafter plate and the ridge piece, and a shorter valley rafter (CB in the figure) is then framed to the longer one. If you study the framing diagram, you will see that the total run of the longer valley rafter is the hypotenuse of a right triangle with shorter sides each equal to the total run of a common rafter IN THE MAIN ROOF. The total run of

the shorter valley rafter, on the other hand, is the hypotenuse of a right triangle with shorter sides each equal to the total run of a common rafter IN THE ADDITION. The total run of a common rafter in the main roof is equal to one-half the span of the main roof; the total run of a common rafter in the addition is equal to one-half the span OF THE ADDITION.

Knowing the total run of a valley rafter, or of any rafter, for that matter, you can always find the line length by applying the bridge measure times the total run. Suppose, for example, that the span of the addition in figure 10-19 is 30 ft, and that the unit rise of a common rafter in the addition is 9. The total run of the shorter valley rafter is the square root of $(15^2 + 15^2)$, or 21.21 ft. If you refer back to the unit length rafter table in figure 10-8, you will see that the bridge measure for a valley rafter in a roof with a common-rafter unit rise of 9 is 19.21. Since the unit run of a valley rafter is 16.97 and the total run of this rafter is 21.21 ft,

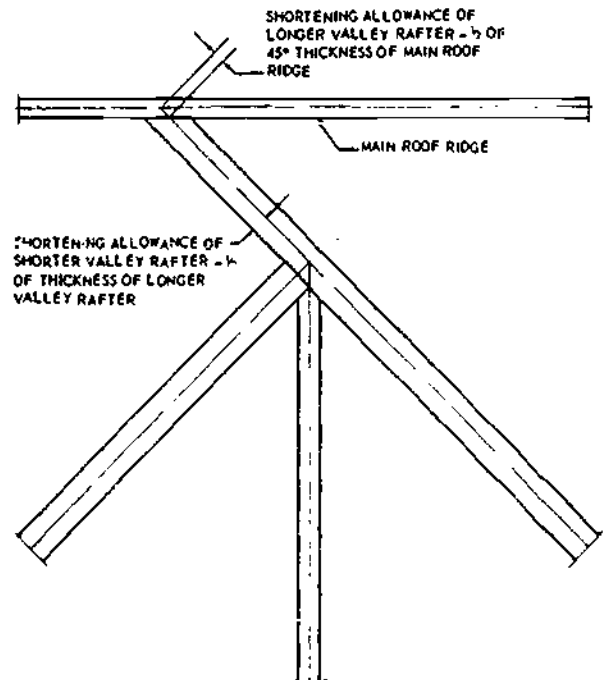

133.130

Figure 10-20.—Long and short valley rafter shortening allowance.

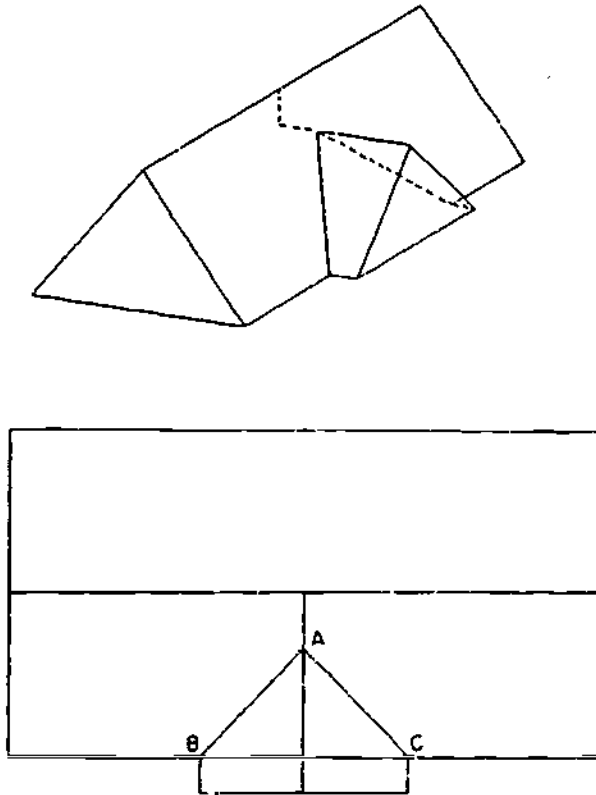

133.131

Figure 10-21.—Another method of framing equal-pitch unequal span intersection.

the line length must be the value of x in the proportional equation $16.97:19.21::21.21:x$, or 24.01 ft.

An easier way to find the length of a valley rafter is to simply multiply the bridge measure by the number of ft in one-half the span OF THE ROOF TO WHICH THE VALLEY RAFTER BELONGS. The length of the longer valley rafter in figure 10-19, for example, would be 19.21 times one-half the span OF THE MAIN ROOF. The length of the shorter valley rafter is 19.21 times one-half the span OF THE ADDITION. Since one-half the span of the addition is 15 ft, the length of the shorter valley rafter is 15×19.21 , or 288.15 in., which is $288.15/12$, or 24.01 ft. Note again that when you use this method you get a result in in., which you must change to ft.

Figure 10-20 shows the long and short valley rafter shortening allowances. Note that the long

valley rafter has a single side cut for framing to the main roof ridge piece, while the short valley rafter is cut square for framing to the addition ridge.

Figure 10-21 shows another method of framing an equal-pitch unequal-span addition. In this method, the inboard end of the addition ridge is nailed to a piece which hangs from the main roof ridge. As shown in the framing diagram, this method calls for two short valley rafters, each of which extends from the rafter plate to the addition ridge. The framing diagram shows that the total run of each of these valley rafters is the hypotenuse of a right triangle with shorter sides, each equal to the total run of a common rafter IN THE ADDITION.

As indicated in figure 10-22, the shortening allowance of each of the short valley rafters is

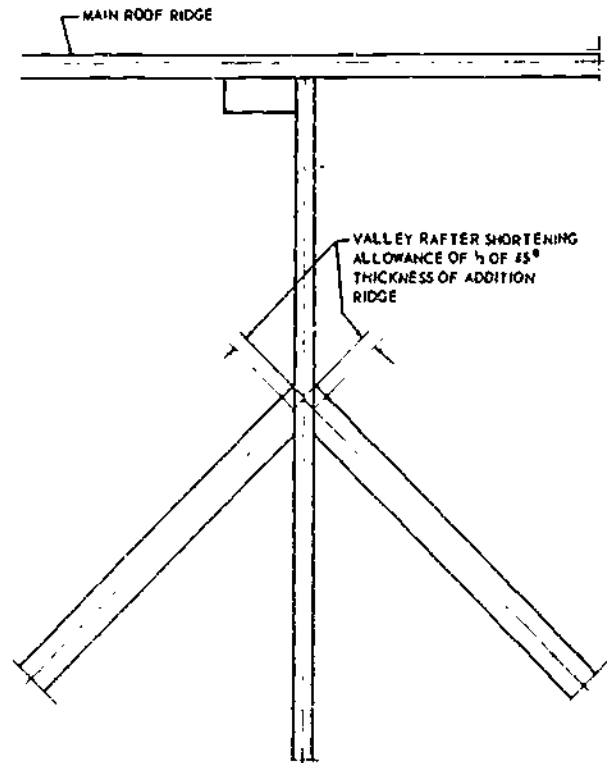

133.132

Figure 10-22.—Shortening allowance of valley rafters in suspended ridge method of intersection roof framing.

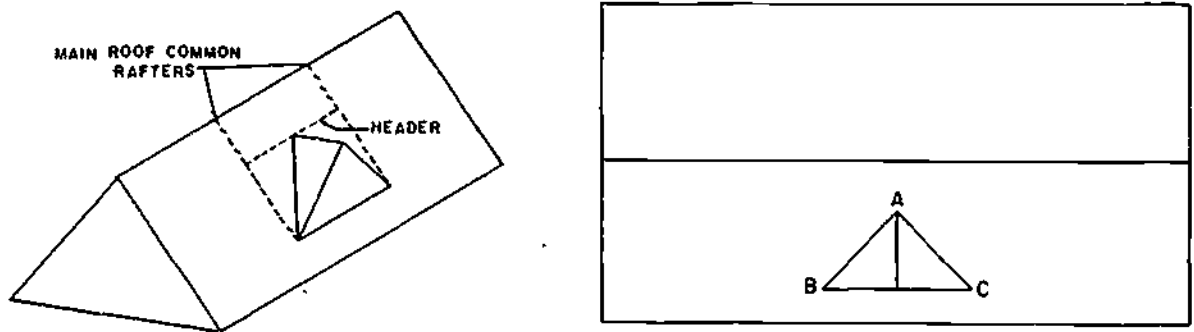

Figure 10-23.—Method of framing dormer without sidewalls.

133.133

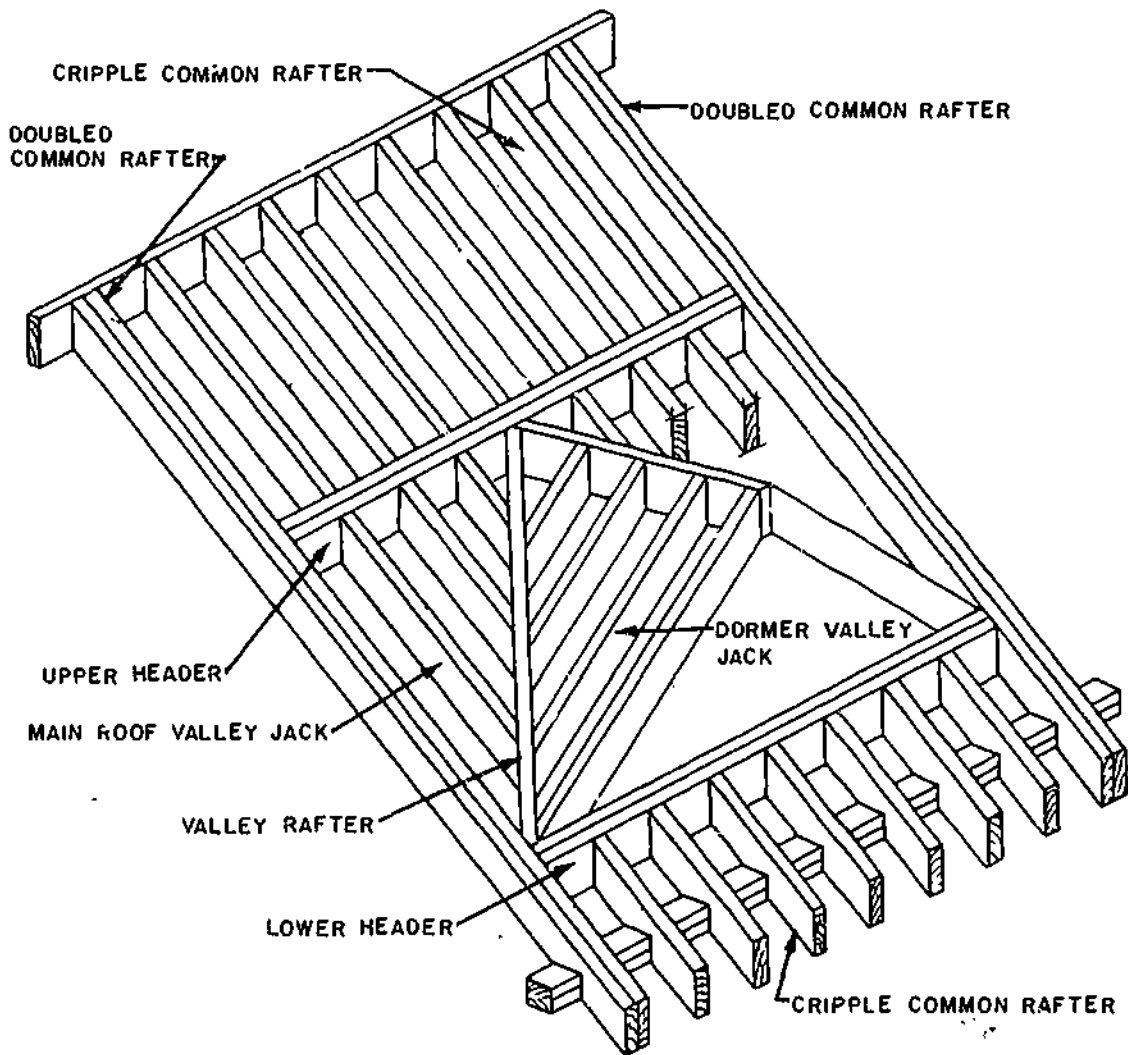

Figure 10-24.—Arrangement and names of framing members for dormer without sidewall.

45.457.0

one-half of the 45° thickness of the addition ridge. Each rafter is framed to the addition ridge with a single side cut.

Figure 10-23 shows a method of framing a gable dormer without side walls. The dormer ridge is framed to a header set between a couple of doubled main-roof common rafters. The valley rafters are framed between this header and a lower header. As indicated in the framing diagram, the total run of a valley rafter is the hypotenuse of a right triangle with shorter sides each equal to the total run of a common rafter IN THE DORMER.

Figure 10-24 shows the arrangement and names of framing members in this type of dormer framing.

Figure 10-24 also shows that the upper edges of the headers must be beveled to the cut of the main roof. Figure 10-25 shows that in this method of framing the shortening allowance for the upper end of a valley rafter is one-half of the 45° thickness of the inside member in the upper doubled header. There is also a shortening allowance for the lower end, consisting of one-half of the 45° thickness of the inside member of the doubled common rafter. The figure also shows that each valley rafter has a

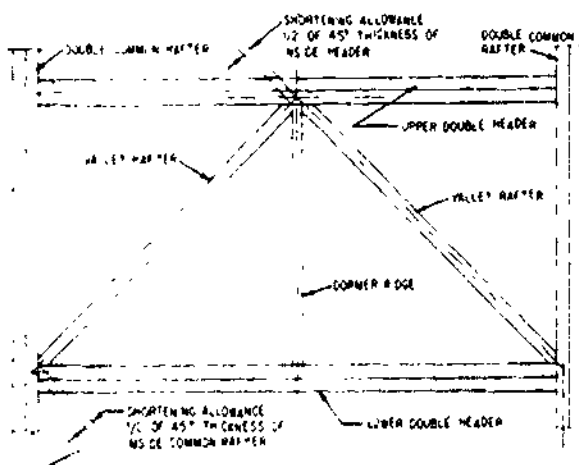

133.134

Figure 10-25.—Valley rafter shortening allowance for dormer without sidewall.

double side cut at the upper end and a double side cut at the lower end.

Figure 10-26 shows a method of framing a gable dormer with side walls. As indicated in the framing diagram, the total run of a valley rafter is again the hypotenuse of a right triangle with shorter sides each equal to the run of a common rafter IN THE DORMER. You figure the lengths of the dormer corner posts and side studs just as you do the lengths of gable-end studs, and you lay off the lower-end cut-off angle by setting the square to the cut of the main roof.

Figure 10-27 shows the valley rafter shortening allowances for this method of framing a dormer with side walls.

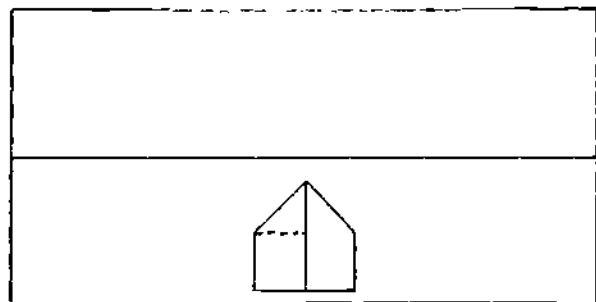
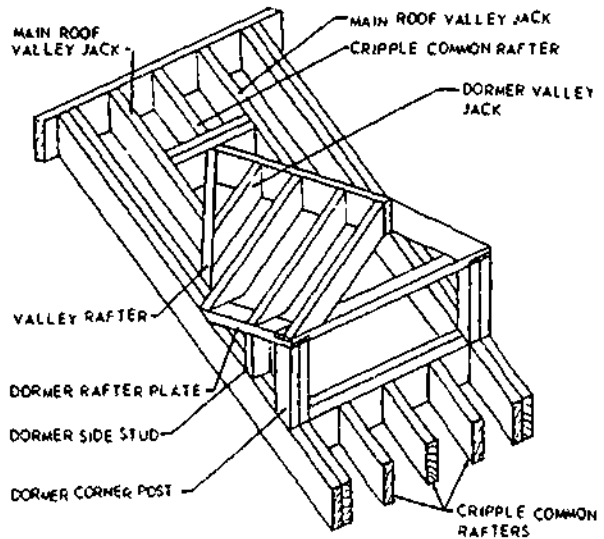

45.458

Figure 10-26.—Method of framing gable dormer with sidewalls.

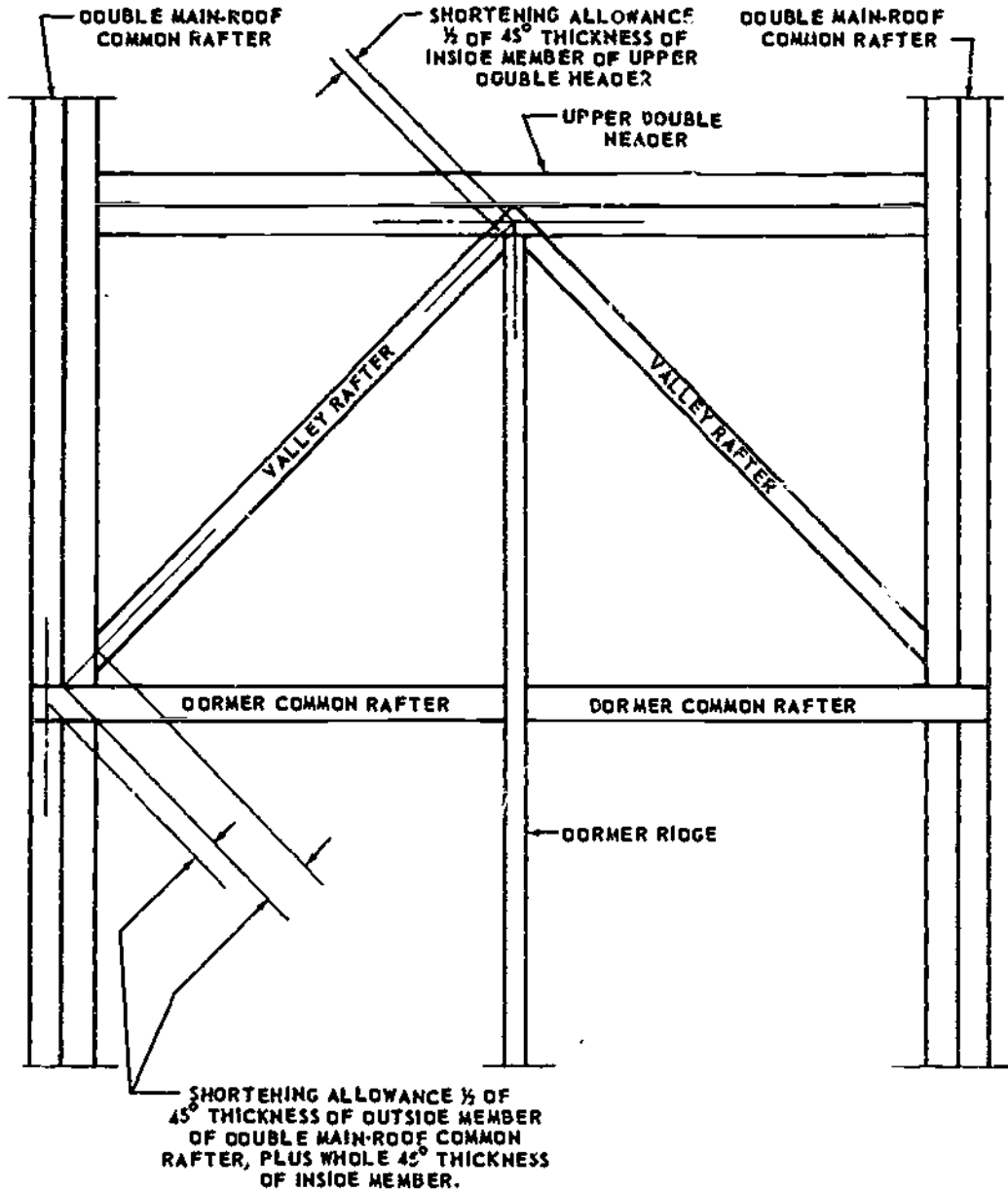

Figure 10-27.--Valley rafter shortening allowances for dormer with sidewall.

133.135

JACK RAFTER LAYOUT

A jack rafter is a part of a common rafter, shortened for framing a hip rafter, a valley rafter, or both. This means that in an equal-pitch framing situation, the unit rise of a jack rafter is

always the same as the unit rise of a common rafter.

A HIP JACK rafter is one which extends from a hip rafter to a rafter plate. A VALLEY JACK rafter is one which extends from a valley rafter to a ridge. A CRIPPLE JACK rafter is one

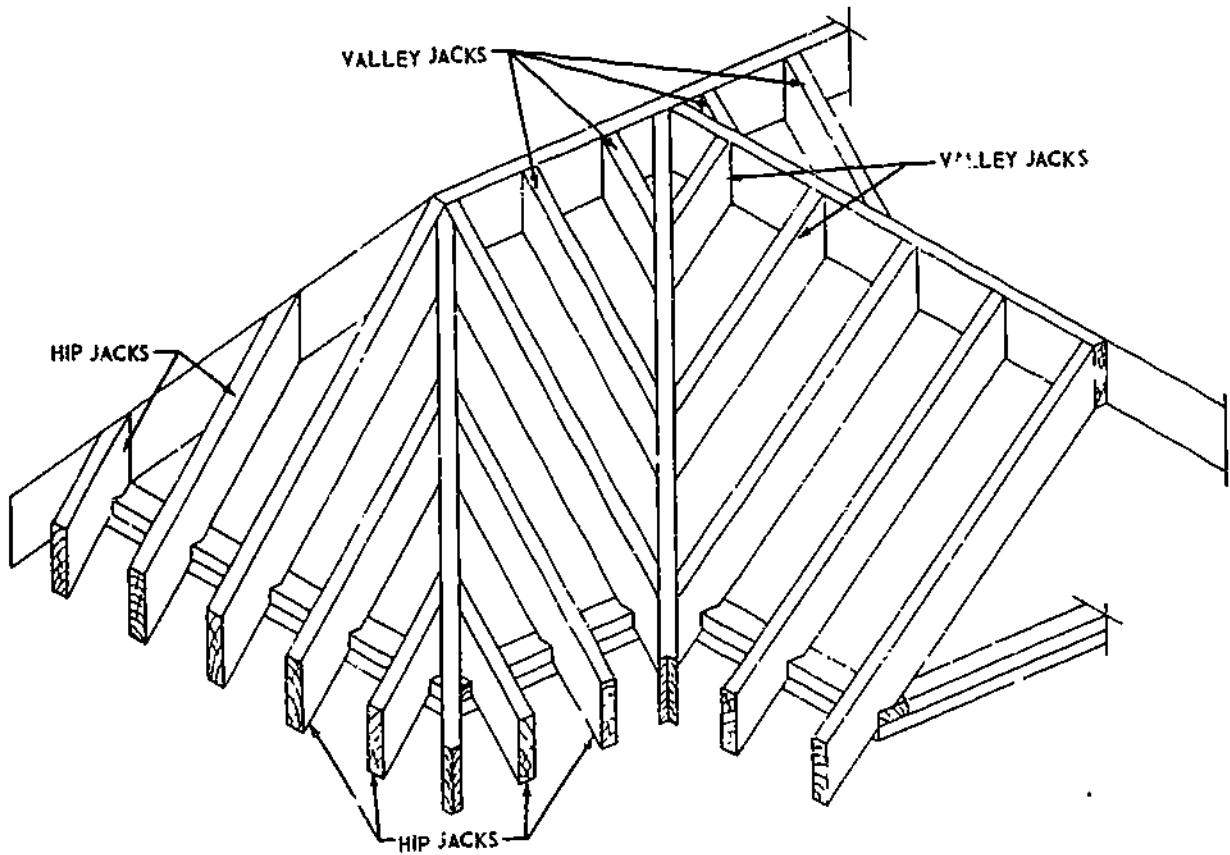

45.469

Figure 10-28.—Types of jack rafters.

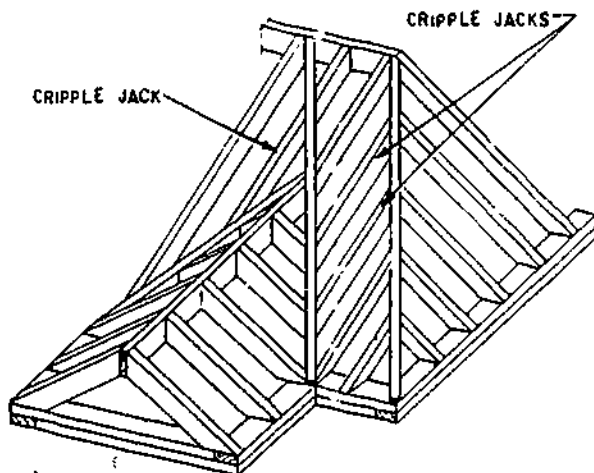

45.460

Figure 10-29.—Valley cripple jack and hip-valley cripple jacks.

which does not contact either a rafter plate or a ridge. A VALLEY CRIPPLE JACK is one which extends between two valley rafters in the long-and-short-valley-rafter method of addition framing. A HIP-VALLEY CRIPPLE JACK is one which extends from a hip rafter to a valley rafter. All types of jacks except cripple jacks are shown in figure 10-28. A valley cripple jack and a couple of hip-valley cripple jacks are shown in figure 10-29.

Lengths of Hip Jack Rafters

Figure 10-30 shows a roof framing diagram for a series of hip jack rafters. The jacks are always on the same spacing O.C. as the common rafters. Suppose that the spacing in this instance is 16 in. O.C. You can see that the total run of

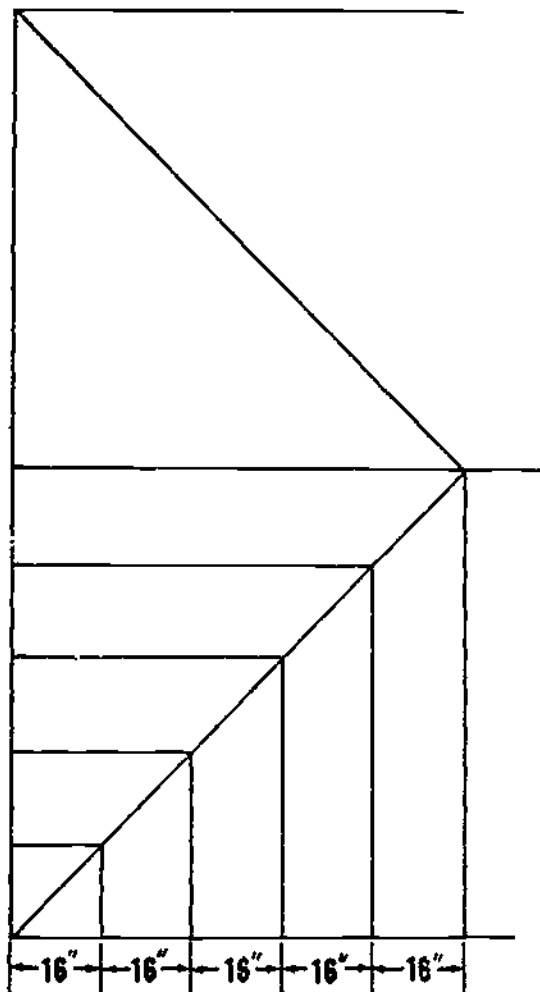

133.136

Figure 10-30.—Hip jack framing diagram.

the shortest jack is the hypotenuse of a right triangle with shorter sides each 16 in. long. The total run of the shortest jack is therefore the square root of $(16^2 + 16^2)$, or 22.62 in.

Suppose that a common rafter in this roof has a unit rise of 8. The jacks have the same unit rise as a common rafter. The unit length of a jack in this roof is the square root of $(12^2 + 8^2)$, or 14.42. This means that a jack is 14.42 units long or every 12 units of run. The length of the shortest hip jack in this roof is therefore the value of x in the proportional equation $12:14.42::16:x$, or 19.23 in.

This is always the length of the shortest hip jack when the jacks are spaced 16 in. O.C. and

the common rafter in the roof has a unit rise of 8. It is also the COMMON DIFFERENCE OF JACKS, meaning that the next hip jack will be 2(19.23 in.) long, the next 3(19.23 in.) long, and so on.

The common difference for hip jacks spaced 16 in. O.C., and also for hip jacks spaced 24 in. O.C., is given in the unit length rafter table on the framing square for unit rises ranging from 2 to 18 inclusive. Turn back to figure 10-8, which shows a segment of the unit length rafter table. Note the third line in the table, which reads "Diff. in length of jacks 16 in. centers." If you follow this line over to the figure under 8 (for a unit rise of 8), you will find the same unit length (19.23 in.) that you worked out above.

The best way to figure the length of a valley jack or a cripple jack is to apply the bridge measure to the total run. The bridge measure of any jack is the same as the bridge measure of a common rafter having the same unit of rise as the jack. Suppose that the jack has a unit rise of 8. In figure 10-8, look along the line on the unit length rafter tables headed "Length common rafters per foot run" for the figure in the column under 8, and you will find a unit length of 14.42. You should know by this time how to apply this to the total run of a jack to get the line length.

The best way to figure the total runs of valley jacks and cripple jacks is to lay out a framing diagram and study it to determine what these runs must be. Figure 10-31 shows part of a framing diagram for a main hip roof with a long-and-short-valley-rafter gable addition. By studying the diagram, you can figure the total runs of the valley jacks and cripple jacks as follows:

The run of valley jack No. 1 is obviously the same as the run of hip jack No. 8, which is the run of the shortest hip jack. The length of valley jack No. 1 is therefore equal to the common difference of jacks.

The run of valley jack No. 2 is the same as the run of hip jack No. 7, and the length is therefore twice the common difference of jacks.

The run of valley jack No. 3 is the same as the run of hip jack No. 6, and the length is therefore three times the common difference of jacks.

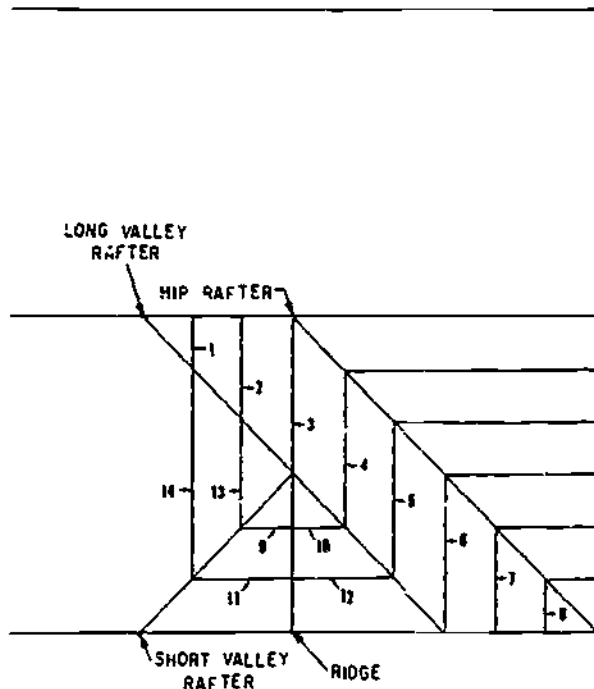

133.137

Figure 10-31.—Jack rafter framing diagram.

The run of hip-valley cripple No. 4, and also of hip-valley cripple No. 5, is the same as the run of valley jack No. 3.

The run of valley jack No. 9, and also of valley jack No. 10, is equal to the spacing of jacks O.C. Therefore, the length of one of these jacks is equal to the common difference of jacks.

The run of valley jacks Nos. 11 and 12 is twice the run of valley jacks Nos. 9 and 10, and the length of one of these jacks is therefore twice the common difference of jacks.

The run of valley cripple No. 13 is twice the spacing of jacks O.C., and the length is therefore twice the common difference of jacks.

The run of valley cripple No. 14 is twice the run of valley cripple No. 13, and the length is therefore 4 times the common difference of jacks.

Jack Rafter Shortening Allowances

A hip jack rafter has a shortening allowance at the upper end consisting of one-half of the 45° thickness of the hip rafter. A valley jack

rafter has a shortening allowance at the upper end, consisting of one-half of the thickness of the ridge, and another at the lower end, consisting of one-half of the 45° thickness of the valley rafter. A hip-valley cripple has a shortening allowance at the upper end, consisting of one-half of the 45° thickness of the hip rafter, and another at the lower end, consisting of one-half of the 45° thickness of the valley rafter. A valley cripple has a shortening allowance at the upper end, consisting of one-half of the 45° thickness of the long valley rafter, and another at the lower end, consisting of one-half the 45° thickness of the short valley rafter.

Jack Rafter Side Cuts

The side cut on a jack rafter can be laid out by the method illustrated in figure 10-14 for laying out the side cut on a hip rafter. Another method is to use the fifth line of the unit length rafter table, which is headed "Side cut of jacks use" (fig. 10-8). If you follow that line over to the figure under 8 (for a unit rise of 8), you will see that the figure given is 10. To lay out the side cut on a jack, set the square face-up on the edge of the rafter to 12 in. on the tongue and 10 in. on the blade, and draw the side-cut line along the tongue.

Jack Rafter Bird's Mouth and Projection

A jack rafter is a shortened common rafter; consequently, the bird's mouth and projection on a jack rafter are laid out just as they are on a common rafter.

RIDGE LAYOUT

Laying out the ridge for a gable roof presents no particular problem, since the line length of the ridge is equal to the length of the building. The actual length would include any overhang. For a hip main roof, however, the ridge layout requires a certain amount of calculation.

As previously mentioned, in an equal-pitch hip roof, the line length of the ridge amounts to the length of the building minus twice the total

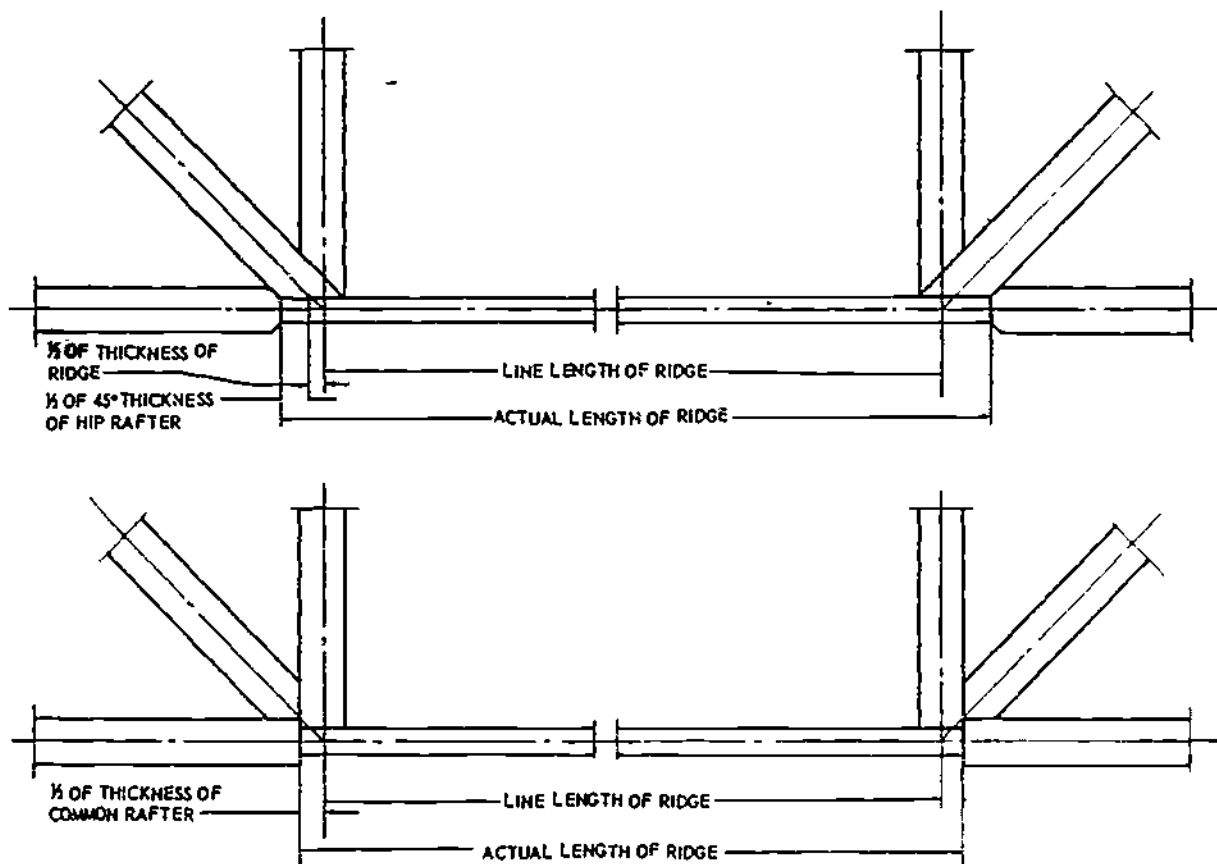

133.138

Figure 10-32.—Line and actual lengths of hip roof ridge.

run of a main roof common rafter. The ACTUAL length depends upon the way in which the hip rafters are framed to the ridge.

As indicated in figure 10-32, the line length ends of the ridge are at the points where the ridge centerline and the hip rafter centerlines cross. In figure 10-32, the hip rafter is framed against the ridge; in this method of framing, the actual length of the ridge exceeds the line length, at each end, by one-half of the thickness of the ridge, plus one-half of the 45° thickness of the hip rafter. In figure 10-32, the hip rafter is framed between the common rafters; in this method of framing the actual length of the ridge exceeds the line length, at each end, by one-half of the thickness of a common rafter.

Figure 10-33 shows that the length of the ridge for an equal-span addition is equal to the length of the addition rafter plate, plus one-half the span of the building, minus the shortening

allowance at the main roof ridge; the shortening allowance amounts to one-half of the thickness of the main roof ridge. Figure 10-33 shows that the length of the ridge for an unequal-span addition varies with the method of framing the ridge. If the addition ridge is suspended from the main roof ridge, the length is equal to the length of the addition rafter plate plus one-half the span of the building. If the addition ridge is framed by the long-and-short valley rafter method, the length is equal to the length of the addition rafter plate, plus one-half of the span of the addition, minus a shortening allowance consisting of one-half of the 45° thickness of the long valley rafter. If the addition ridge is framed to a double header set between a couple of double main roof common rafters, the length of the ridge is equal to the length of the addition side-wall rafter plate, plus one-half the span of the addition, minus a shortening allowance

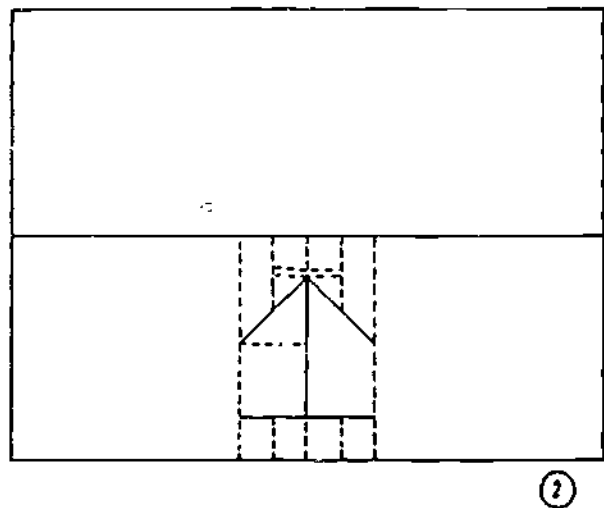
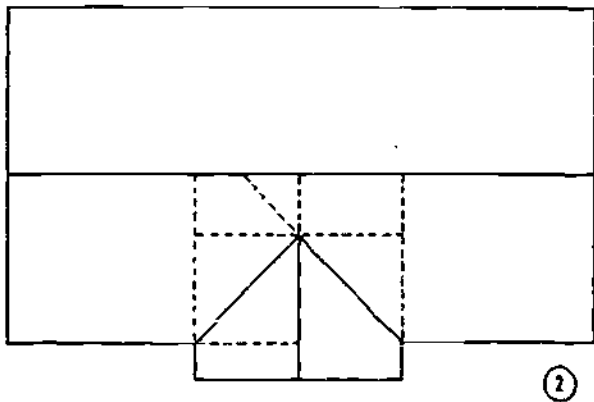
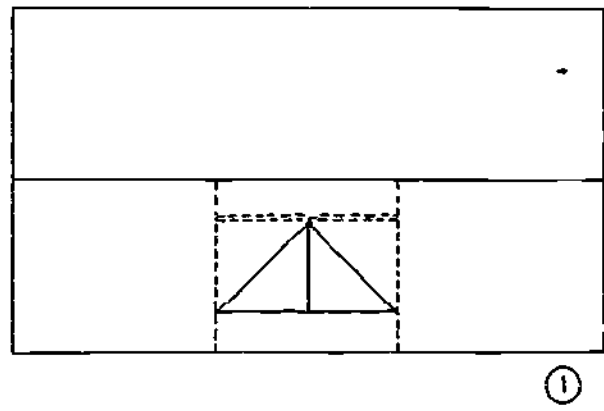
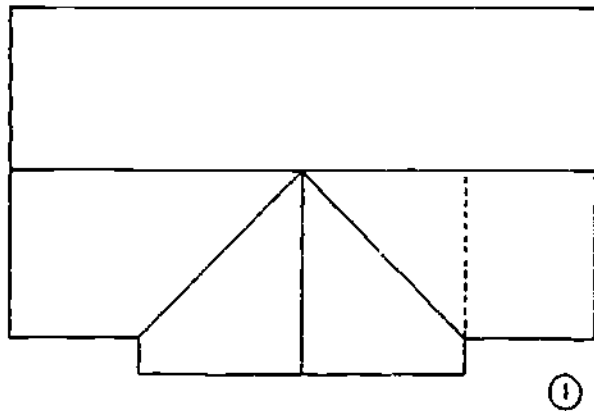

133.139

Figure 10-33.—Lengths of addition ridge.

133.140

Figure 10-34.—Lengths of dormer ridge.

consisting of one-half the thickness of the inside member of the double header.

Figure 10-34 shows that the length of the ridge on a dormer without side walls is equal to one-half of the span of the dormer, less a shortening allowance consisting of one-half the thickness of the inside member of the upper double header. Figure 10-34 shows that the length of the ridge on a dormer with side walls amounts to the length of the dormer rafter plate, plus one-half the span of the dormer, minus a shortening allowance consisting of one-half the thickness of the inside member of the upper double header.

SHED ROOF FRAMING

As previously mentioned a SHED or SINGLE-PITCH roof is essentially one-half of a

gable or double-pitch roof. Like the full-length rafters in a gable roof, the full-length rafters in a shed roof are COMMON rafters. Note, however, that as shown in figure 10-35, the total run of a shed roof common rafter is equal to the span of the building MINUS THE WIDTH OF THE RAFTER PLATE ON THE HIGHER RAFTER-END WALL. Note also, that the run of the projection on the higher wall is measured from the INNER EDGE of the rafter plate. To this must be added the width of the plate and the length of the overhang at the top. Shed-roof common rafters are laid out like gable-roof common rafters. A shed-roof common rafter has two bird's mouths, but they are laid out just like the bird's mouth on a gable-roof common rafter.

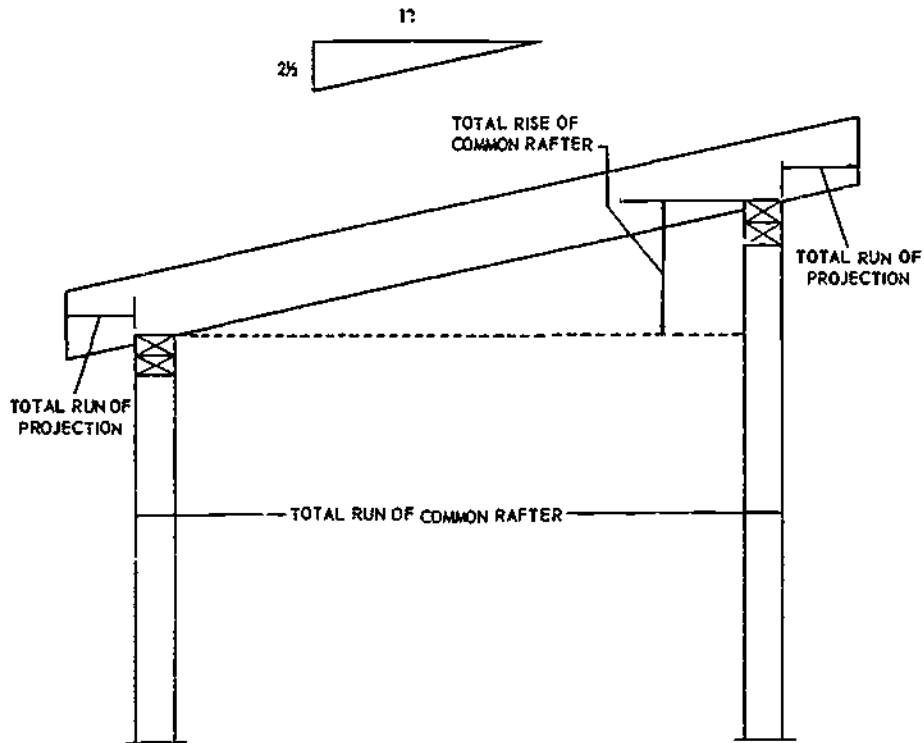

Figure 10-35.—Shed roof framing.

133.141

Figure 10-35 also shows that the height of the higher rafter-end wall must exceed the height of the lower by an amount equal to the total rise of a common rafter.

Figure 10-36 shows a method of framing a shed dormer. There are 3 layout problems to be solved here, as follows: (1) determining the total run of a dormer rafter, (2) determining the angle of cut on the inboard ends of the dormer rafters, and (3) determining the lengths of the dormer side-wall studs.

To determine the total run of a dormer rafter, you divide the height of the dormer end wall, in in., by the difference between the unit rise of the dormer roof and the unit rise of the main roof. Take the dormer shown in figure 10-37, for example; the height of the dormer end-wall is 9 ft, or 108 in. The unit rise of the main roof is 8; the unit rise of the dormer roof is $2\frac{1}{2}$; the difference between them is $5\frac{1}{2}$. The total run of a dormer rafter is therefore 108

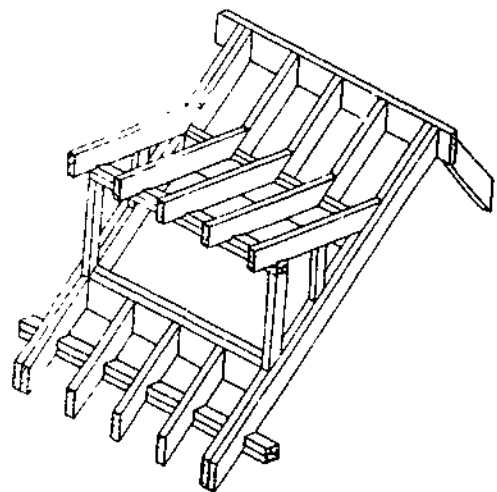
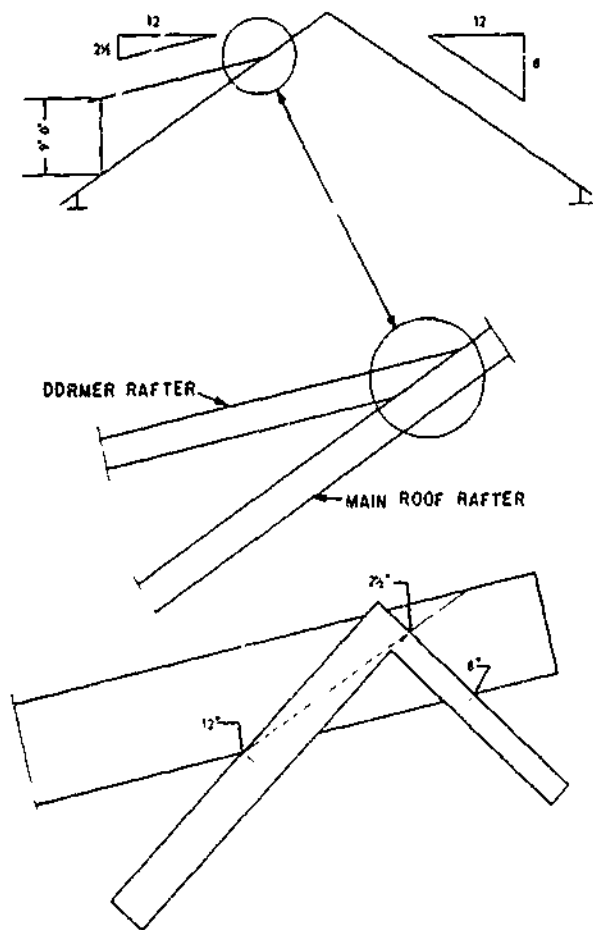

Figure 10-36.—Method of framing a shed dormer.

133.142



133.143

Figure 10-37.—Shed dormer framing calculations.

divided by $5\frac{1}{2}$, or 19.63 ft. Knowing the total run and the unit rise, you can figure the length of a dormer rafter by any of the methods already described.

As indicated in figure 10-37, the inboard ends of the dormer rafters must be cut to fit the slope of the main roof. To get the angle of this cut, set the square on the rafter to the cut of the main roof, as shown in the third view of figure 10-37; measure off the unit size of the dormer roof from the heel of the square along the tongue as indicated; make a mark at this point; and draw the cutoff line through this mark from the 12-in. mark.

You figure the lengths of the side-wall studs on a shed dormer as follows: in the roof shown

in figure 10-37, a dormer rafter raises $2\frac{1}{2}$ units for every 12 units of run, and a main roof common rafter rises 8 units for every 12 units of run. If the studs were spaced 12 in. O.C., the length of the shortest stud (which is also the COMMON DIFFERENCE of studs) would be the difference between 8 and $2\frac{1}{2}$ in., or $5\frac{1}{2}$ inches. This being the case, if the stud spacing is 16 in., the length of the shortest stud is the value of x in the proportional equation $12:5\frac{1}{2}::16:x$, or $7\frac{5}{16}$ in. The shortest stud, then, will be $7\frac{5}{16}$ in. long; the next stud will be $2(7\frac{5}{16})$ in. long, and so on. To get the lower-end cutoff angle for studs you set the square on the stud to the cut of the main roof; to get the upper-end cutoff angle you set it to the cut of the dormer roof.

RAFTER LOCATION LAYOUT

Rafter locations are laid out on plates, ridge and other rafters with the same lines and X's used to layout stud and joist locations. For a gable roof, the rafter locations are laid out on the rafter plates first, and the locations are then transferred to the ridge by matching the ridge against a rafter plate.

The rafter-plate locations of the ridge-end common rafters in an equal-pitch hip roof measure one-half of the span (or the run of a main-roof common rafter) away from the building corners. These locations, plus the rafter-plate locations of the rafters lying between the ridge-end common rafters, can be transferred to the ridge by matching the ridge against the rafter plates.

The locations of additional ridge and valley rafters can be determined as indicated in figure 10-38. In an equal-span situation (illustrated in Nos. 1 and 2, fig. 10-38), the valley rafter locations on the main roof ridge lie alongside the addition ridge location. In No. 1 of figure 10-38, the distance between the end of the main roof ridge and the addition ridge location is equal to distance A plus distance B, distance B being one-half the span of the addition. In No. 2 of figure 10-38, the distance between the line length end of the main roof ridge and the addition ridge location is the same as distance A. In both cases, the line length of the addition ridge is equal to one-half the span of the

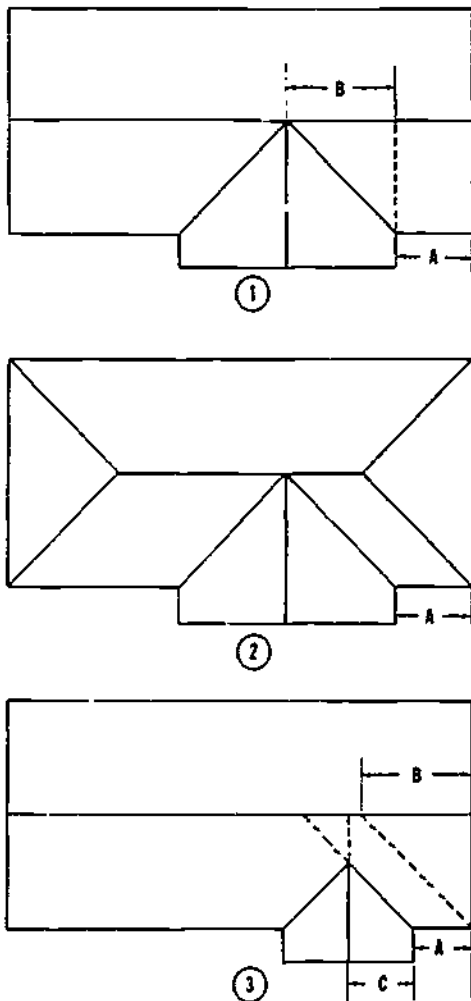

133.144
Figure 10-38.—Intersection ridge and valley rafter location layout.

addition plus the length of the addition side-wall rafter plate.

No. 3 of figure 10-38 shows an unequal-span situation. If framing is by the long-and-short valley rafter method, the distance from the end of the main roof ridge to the upper end of the longer valley rafter is equal to distance A plus distance B, distance B being one-half of the span of the main roof. The location of the inboard end of the shorter valley rafter on the longer valley rafter can be determined as follows: first calculate the unit length of the longer valley rafter, or obtain it from the unit-length rafter tables. Let us suppose that the common-rafter

unit rise is 8; in that case the unit length of a valley rafter is 18.76.

The total run of the longer valley rafter between the point where the shorter rafter ties in and the rafter plate is the hypotenuse of a right triangle with other sides each equal to one-half of the span of the addition. Suppose the addition is 20 ft wide; then the total run in question is the square root of $(10^2 + 10^2)$, or 14.14 ft.

You know that the valley rafter is 18.76 units long for every 16.97 units of run. The length of rafter for 14.14 ft of run must therefore be the value of x in the proportional equation $16.97:18.76::14.14:x$, or 15.63 ft. The location mark for the inboard end of the shorter valley rafter on the longer valley rafter, then, will be 15.63 ft, or 15 ft $7 \frac{9}{16}$ in., from the heel plumb cut line on the longer valley rafter. The length of the additional ridge will be equal to one-half the span of the addition, plus the length of the additional side-wall rafter plate, minus a shortening allowance equal to one-half of the 45° thickness of the longer valley rafter.

If framing is by the suspended-ridge method, the distance between the suspension point on the main roof ridge and the end of the main roof ridge is equal to distance A plus distance C; distance C is one-half of the span of the addition. The distance between the point where the inboard ends of the valley rafters (both short in this method of framing) tie into the addition ridge and the out-board end of the ridge is equal to one-half the span of the addition plus the length of the additional side-wall rafter plate. The length of the additional ridge is equal to one-half of the span of the main roof plus the length of the addition side wall rafter plate.

COLLAR TIE

Gable or double-pitch roof rafters are often reinforced by horizontal members called collar ties (fig. 10-39). In a finished attic, the ties may also function as ceiling joists.

To find the line length of a collar tie, divide the amount of drop of the tie in in. by the unit of rise of the common rafter. This will equal one-half the length of the tie in ft. Double the

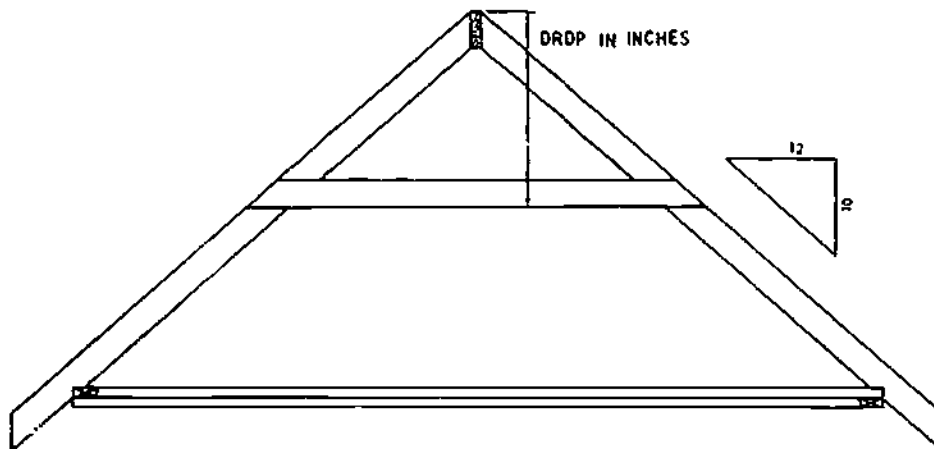

133.145

Figure 10-39.—Calculation for a collar tie.

result for the actual length. The formula is: Drop in in. x 2 over unit of rise, equals the length in ft.

The length of the collar tie depends on whether the drop is measured to the top edge or

bottom edge of the collar tie (fig. 10-39). The tie must fit the slope of the roof. To obtain this angle, use the framing square. Hold unit of run and unit of rise of the common rafter. Mark and cut on unit of run side (fig. 10-40).

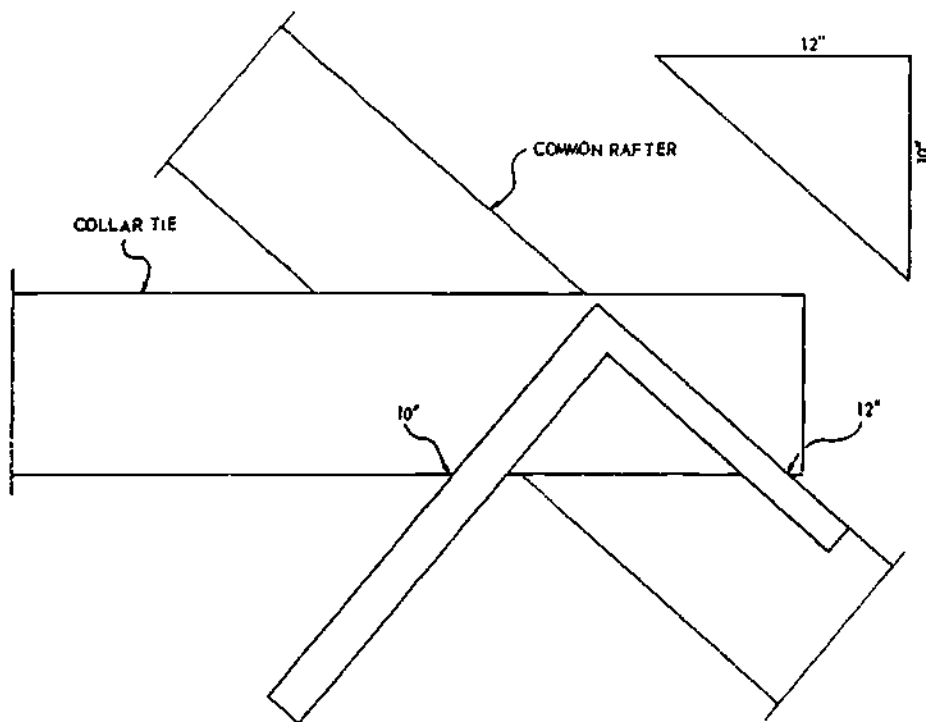

133.146

Figure 10-40.—Laying out end cut on a collar tie.

ROOF TRUSSES

The simple truss or trussed rafter is an assembly of members forming a rigid framework of triangular shapes that can support loads over relatively long spans. See view A of figure 10-41. The webs, chords (lower and upper), and gussets make up the assembly. Chords and webs are connected to one another by means of gussets—metal plates or plywood pieces that are nailed, glued, or bolted in place. In some trusses, split rings are used instead of gussets.

Using simple trusses in roof construction results in saving building materials and shortening the time it takes to put a structure under roof. Important in selecting the type of truss to use is the load that the roof must carry. Factors to consider include weight of snowfall, ice, and the roof itself; forces due to the wind; slope of the roof, and span. The loading

requirement usually increases as weights and forces increase, cut of the roof decreases, and span lengthens. To help support bigger loads, trusses are made stronger by adding more members as well as using larger sized members, better grades of lumber, and stronger connections.

TYPES OF TRUSSES

The most common types of light wood trusses are the king post, W, and scissors. The KING POST truss is the simplest type used for structures. It consists of upper and lower chords and a vertical centerpost, as shown in view B, fig. 10-41. The W-truss, as shown in view A, fig. 10-41, is perhaps the most widely used light wood truss. Notice that it has no vertical centerpost, using instead four web members assembled in the shape of the letter W. As shown in view C, fig. 10-41, the SCISSORS truss is used for structures in which a sloping room ceiling is desired, such as a cathedral ceiling.

Trusses are easily adaptable to a rectangular structure since uniform width calls for only one type of truss. They can also be used in constructing the roof of an L-shaped structure. Special trusses can be fabricated for hip roofs.

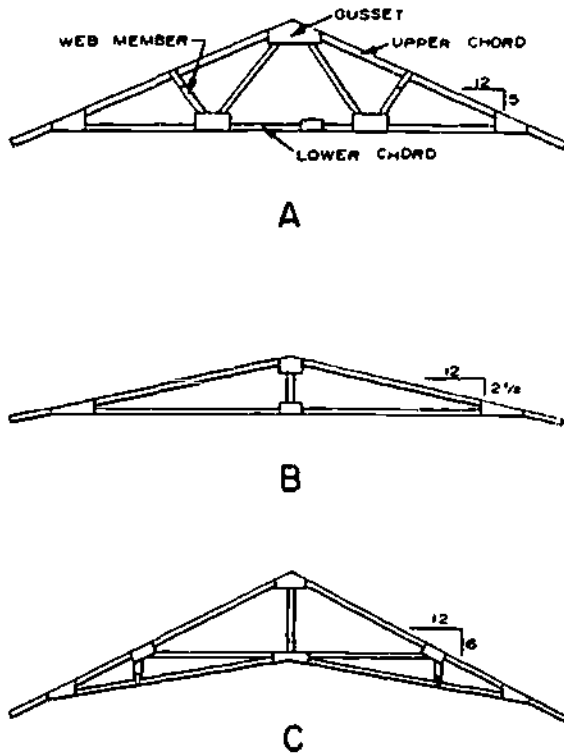

133.456
 Figure 10-41.—Light wood trusses: A. W-type; B. King post; C. Scissors.

FABRICATION

The construction features of a typical W-truss are shown in figure 10-42. Also shown are gusset cutout sizes and nailing patterns for nail-glueing. The span of this truss is 26 ft and cut of roof is 4/12. When spaced 24 in. apart and made of good quality 2- by 4-inch members, the trusses should be able to support a total roof load of 40 lb per sq ft.

Gussets for light wood trusses are cut from 3/8- or 1/2-inch standard plywood with an exterior glue line or from sheathing grade exterior plywood. Glue is spread on the clean surfaces of the gussets and truss members. Staples are used to supply pressure until the glue is set. Under normal conditions and where the

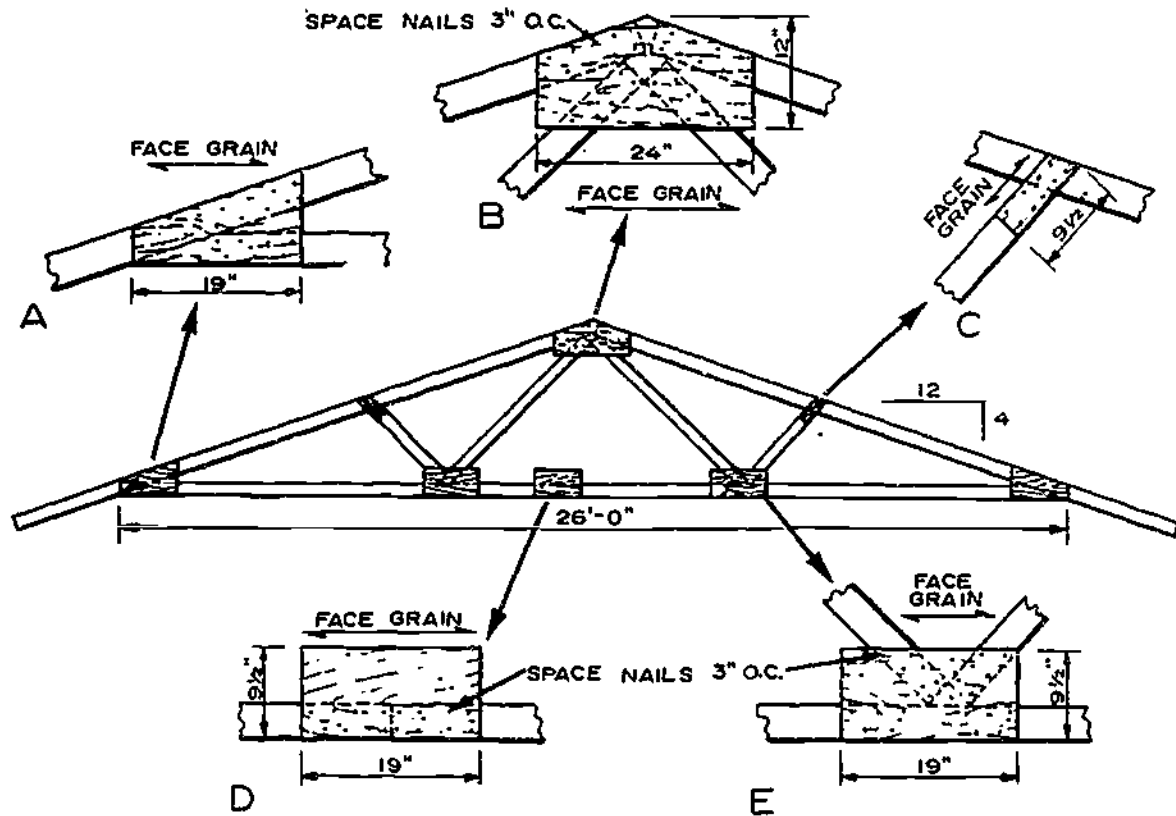

133.457

Figure 10-42.—Construction of a 26-ft W-truss: A. Bevel-heel gusset; B. Peak gusset; C. Upper chord intermediate gusset; D, Splice of lower chord; E. Lower chord intermediate gusset.

relative humidity of air in attic spaces tends to be high, a resorcinol glue is applied. In dry and arid areas, a casein or similar glue is used. Two rows of 4-penny nails are used for either the 3/8- or 1/2-inch thickness of plywood. The nails are spaced so that they are 3 in. apart and 3/4 in. from the edges of the truss members. Gussets are nail-glued to both sides of the truss.

Plywood-gusset, king-post trusses are limited to spans of 26 ft or less if spaced 24 in. apart and fabricated with 2- by 4-inch members and a 4/12 roof cut. The spans are somewhat less than those allowed for W-trusses having the same-sized members. The shorter span for the king-post truss is due in part to the unsupported upper chord. On the other hand, because it has more members than the king-post truss and distances between connections are shorter, the W-truss can span up to 32 ft without

intermediate support and its members can be made of lower grade lumber.

HANDLING

Trusses are designed to carry roofloads in a vertical or upright position, so it is important that they be lifted and stored in this position. If they must be handled in a horizontal or flat position, enough workers or supports should be used to minimize bending. A truss is never to be supported at its center only or at each end only when in a flat position.

ROOF FRAMING ERECTION

Roof framing should be done from a scaffold with planking not less than 4 ft below

the level of the main roof ridge. The usual type of roof scaffold consists of diagonally-braced two-legged horses, spaced about 10 ft apart and extending the full length of the ridge.

If the building has an addition, as much as possible of the main roof is framed before the addition framing is started. Cripples and jack rafters are usually left out until after the headers, hip rafters, valley rafters, and ridges to which they will be framed have been installed.

For a gable roof, the two pairs of gable-end rafters and the ridge are usually erected first.

Two crewmembers, one at each end of the scaffold, hold the ridge in position, while another crewmember sets the gable-end rafters in place and toenails them at the rafter plate with 8-penny nails, one to each side of a rafter. Before we proceed any further, see table 9-1 as to the type and size nails used in roof framing erection. Each crewmember on the scaffold then end-nails the ridge to one of the rafters with two 10-penny nails, driven through the ridge into the end of the rafter; and toenails the other rafter to the ridge and to the first rafter with two 10-penny nails, one on each side of the rafter. Temporary braces, like those for a wall, should be set up at the ridge ends to hold the rafters approximately plumb, after which the rafters between the end-rafters should be erected. The braces should then be released, and the pair of rafters at one end should be plumbed with a plumb line, fastened to a stick extended from the end of the ridge. The braces should then be reset, and they should be left in place until enough sheathing has been installed to hold the rafters plumb. Collar ties, if any, are nailed to common rafters with 8-penny nails, three to each end of a tie. Ceiling-joists ends are nailed to adjacent rafters with 10-penny nails.

On a hip roof, the ridge-end common rafters and ridges are erected first, in about the same manner as for a gable roof, and the intermediate common rafters are then filled in. After that, the ridge-end common rafters extending from the ridge ends to the midpoints on the end walls are erected. The hip rafters and hip jacks are installed next. The common rafters in a hip roof

do not require plumbing; if the hip rafters are correctly cut, installing the hip rafters will bring the common rafters plumb. Hip rafters are toenailed to plate corners with 10-penny nails. Hip jacks are toenailed to hip rafters with 10-penny nails.

For an addition or dormer, the valley rafters are usually erected first. Valley rafters are toenailed to plates and to ridge pieces and headers with 10-penny nails. Ridges and ridge-end common rafters are erected next, other addition common rafters next, and valley and cripple jacks last. A valley jack should be held in position for nailing as shown in figure 10-43. When properly nailed, the end of a straightedge laid along the top edge of the jack should contact the centerline of the valley rafter as shown.

In erecting trusses, it is important to anchor them properly. Because of their single member

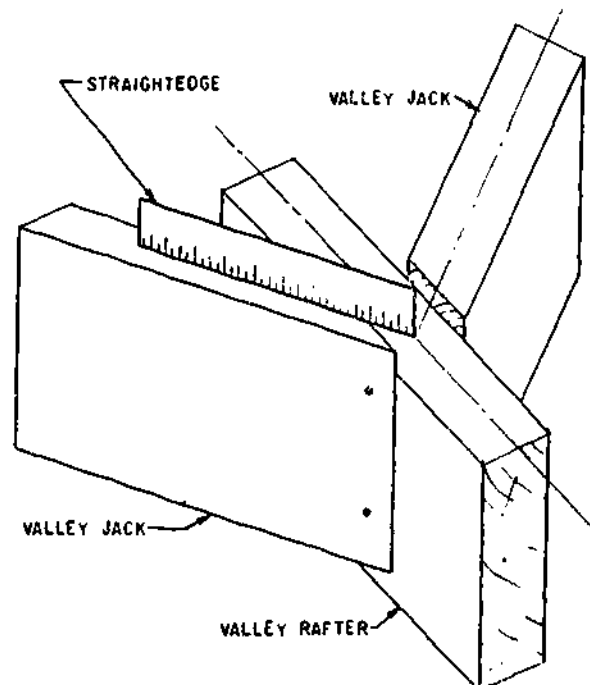

133.147

Figure 10-43.—Correct position for nailing a valley jack rafter.

thickness and use of plywood gussets at the wallplates, some kind of metal connector or plate anchor is used to supplement the toenailings. Trusses are often furnished with a 2 by 4-inch soffit return at the end of each upper chord to provide nailings for the soffit.

ROOF SHEATHING

The lower layer of roof covering is called the ROOF SHEATHING; the upper layer is called the ROOF COVERING or the ROOFING. The roof sheathing, like the wall sheathing and the subflooring, is a structural element and therefore a part of the framing. The roof covering or roofing is a part of the exterior finish. Roof sheathing, like wall sheathing and subflooring, may be laid either horizontally or diagonally. Horizontal sheathing may be either CLOSED sheathing (laid with no spaces between courses) or OPEN sheathing (laid with spaces between courses). Open sheathing is used for the most part only when the roof covering is to consist of wooden shingles. Closed sheathing is usually nominal 8-in. in width; it may consist of

square-edged boards but may be dressed-and-matched or shiplapped. Open sheathing usually consists of 1 by 3 or 1 by 4 strips, with spacing O.C. equal to the specified exposure of shingles TO THE WEATHER. An 18-in. shingle which is lapped 12 in. by the shingle above it is said to be laid 6 in. to the weather.

Sheathing should be nailed with two 8-penny nails to each rafter crossing. End-joint requirements are the same as those previously described for wall sheathing. The sheathing ends should be sawed flush with the outer face of the end-wall sheathing, unless a projection of the roof sheathing over the end-walls is called for. If such a projection is needed, projecting sheathing boards must be long enough to span at least three rafter spaces.

Plywood, usually in 8- by 4-ft sheets, laid horizontally, is frequently used for roof sheathing. In trussed rafter construction where the trusses are spaced 2 ft apart, the interior sheathing is thicker than that used in conventional rafter construction with 16-in. spacing. Nailing requirements are the same as those previously described for 8- by 4-ft sheets of plywood wall sheathing.

CHAPTER 11

EXTERIOR FINISH

Chapters 9 and 10 dealt with the process of framing wood structures. The main framework materials included joists, studs, rafters, and other structural members. These structural members constitute the ROUGH CARPENTRY in a structure. They are the main supports of the wood-frame structure, whereas the subflooring and the wall and roof sheathing strengthen and brace the frame.

The rest of the work on the structure concerns installation of the nonstructural members. This work is called FINISH CARPENTRY, and includes mainly the installation of practical members, such as door and window frames, the doors and windows themselves, the roof covering, and stairs. Some nonstructural members are purely ornamental. Examples are the casings on doors and windows and the moldings on cornices and inside walls. Installation of the purely ornamental members is called TRIM CARPENTRY.

Finish carpentry is divided into EXTERIOR FINISH and INTERIOR FINISH. Exterior finish consists of ROOF SHEATHING, EXTERIOR TRIM, ROOF COVERING, and outside WALL SHEATHING. Exterior finish materials are installed after the rough carpentry has been completed. This chapter deals with exterior finish and how to install it safely. Chapter 12 concerns interior finish materials and installation.

ROOF SHEATHING

Normally, roof sheathing is installed as soon as possible to allow work inside a structure to

progress during inclement weather. Roof sheathing is the covering over the rafters or trusses and usually consists of nominal 1-in. lumber or plywood. In some types of flat or low-pitched roofs with post-and-beam construction, wood roof planking or fiberboard roof decking might be used. Diagonal wood sheathing on flat or low-pitched roofs provides racking resistance where areas with high winds demand added rigidity. Plywood sheathing provides the same desired rigidity and bracing effect. Sheathing should be thick enough to span the supports and provide a solid base for fastening the roofing material.

Roof sheathing boards are generally the third grades of species, such as the pines, redwoods, and hemlocks. It is important that thoroughly seasoned material be used with asphalt shingles. Unseasoned wood will dry out and shrink in width causing buckling or lifting of the shingles, along the length of the board.

LUMBER SHEATHING

Board roof sheathing used under asphalt shingles, metal-sheet roofing, or other roofing materials that require continuous support should be laid closed (without spacing). (See fig. 11-1.) The boards should be matched, shiplapped, or square-edged with joints made over the center of rafters. Not more than two adjacent boards should have joints over the same support. It is preferable to use boards no wider than 6 or 8 in. to minimize problems which can be caused by shrinkage. Boards should have a minimum thickness of 3/4 in. for rafter spacing of 16 to

PLYWOOD ROOF SHEATHING

When plywood roof sheathing is used, it should be laid with the face grain perpendicular to the rafters. (See fig. 11-2.) Standard sheathing grade plywood is commonly specified, but where damp conditions occur, it is desirable to use a standard sheathing grade with exterior glue. End joints are made over the center of the rafters and should be staggered by at least one rafter 16 or 24 in. or more.

PLANK ROOF DECKING

Plank roof decking, consisting of 2 in. and thicker tongued-and-grooved wood planking, is commonly used in flat or low-pitched roofs in post and beam construction. Common sizes are nominal 2-by-6, 3-by-6, and 4-by-6-in. V-grooved members, with the thicker planking being suitable for spans up to 10 or 12 ft.

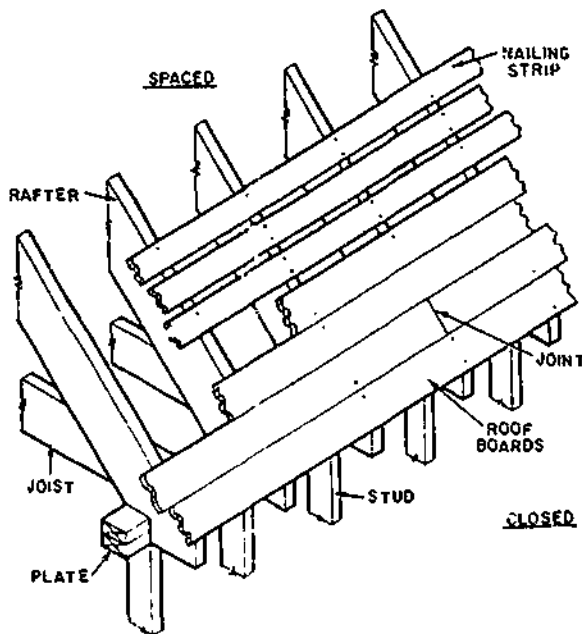

133.571

Figure 11-1.—Installation of board roof sheathing, showing both closed and spaced types.

24 in. and be nailed at each bearing point. End matched tongued-and-grooved boards can also be used and joints can be made between rafters. However, in no case should the joints of adjoining boards be made over the same rafter space. Each board should be supported by at least two rafters.

Use of long sheathing boards at roof ends is desirable to obtain good framing anchorage, especially in gable roofs where there is a substantial rake overhang.

When wood shingles or shakes are used in damp climates, it is common to have spaced roof boards. (See fig. 11-1.) Wood nailing strips in nominal 1-by-3- or 1-by-4-in. size are spaced the same distance on centers as the shingles are to be laid to the weather. For example, if shingles are laid 5 in. to the weather and nominal (surfaced) 1-by-4-in. strips are used, there would be spaces of 1 3/8 to 1 1/2 in. between each board to provide the needed ventilation spaces.

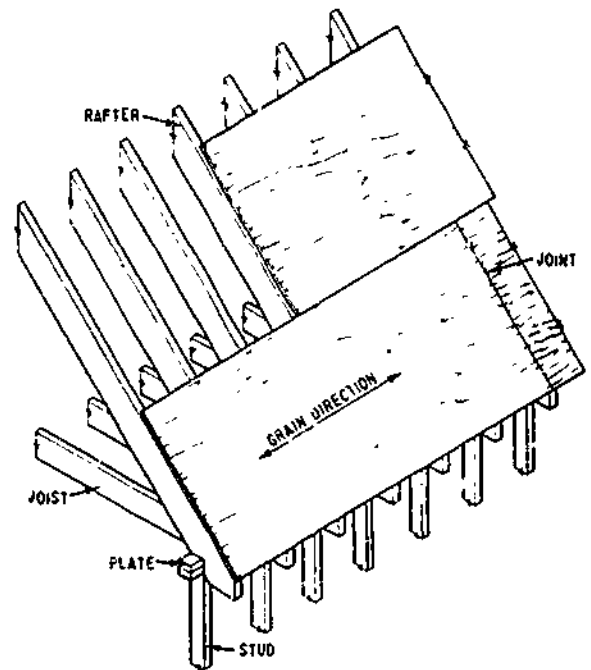

133.572

Figure 11-2.—Application of plywood roof sheathing.

Special load requirements may reduce these allowable spans. Roof decking can serve both as an interior ceiling finish and as a base for roofing. Heat loss is greatly reduced by adding fiberboard or other rigid insulation over the wood decking.

The decking is blind nailed through the tongue and also face nailed at each support. In 4- by 6-in. size, it is predrilled for edge nailing. For thinner decking, a vapor barrier is ordinarily installed between the top of the plank and the roof insulation when the planking does not provide sufficient insulation.

EXTENSION OF ROOF SHEATHING AT GABLE ENDS

A method of installing board or plywood roof sheathing at the gable ends of the roof is shown in figure 11-3. Where the gable ends of the structure have little or no extension (rake projection), roof sheathing is placed flush with the outside of the wall sheathing.

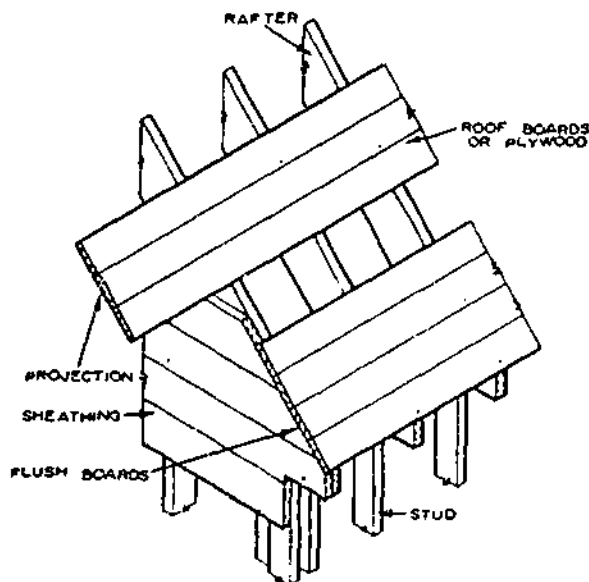

133.573

Figure 11-3.—Board roof sheathing at ends of gable.

Roof sheathing that extends beyond end walls for a projected roof at the gables should span not less than three rafter spaces to insure anchorage to the rafters and to prevent sagging. (See fig. 11-3.) When the projection is greater than 16 to 20 in., special ladder framing is used to support the sheathing.

Plywood extension beyond the end wall is usually governed by the rafter spacing to minimize waste. Thus, a 16-in. rake projection is commonly used when rafters are spaced 16-in. oncenter. Butt joints of the plywood sheets should be alternated so they do not occur on the same rafter.

Wood or plywood sheathing at the valleys and hips should be installed to provide a tight joint and should be securely nailed to hip and valley rafters. (See fig. 11-4.) This will provide a solid and smooth base for metal flashing.

EXTERIOR TRIM

Exterior trim includes window and door trim, cornice moldings, fascia boards and soffits, rake or gable-end trim, and moldings. Contemporary designs with simple cornices and moldings will contain little of this material, while traditional designs will have considerably more. Much of the exterior trim, in the form of finish lumber and moldings, is cut and fitted on the job. Other materials or assemblies, such as shutters, louvers, railings, and posts, are shop fabricated and arrive on the job ready to be fastened in place.

In materials used for exterior trim, the properties desired are good painting and weathering characteristics, easy working qualities, and maximum freedom from warp. In addition, decay resistance is also desirable where materials may absorb moisture. Heartwood of the cedar, cypress, and redwood has high decay resistance. Less durable species may be treated to make them decay resistant. Many manufacturers predip with a water-repellent preservative at the factory, such materials as siding, window sash, window and door frames, and trim. On-the-job dipping of end joints or

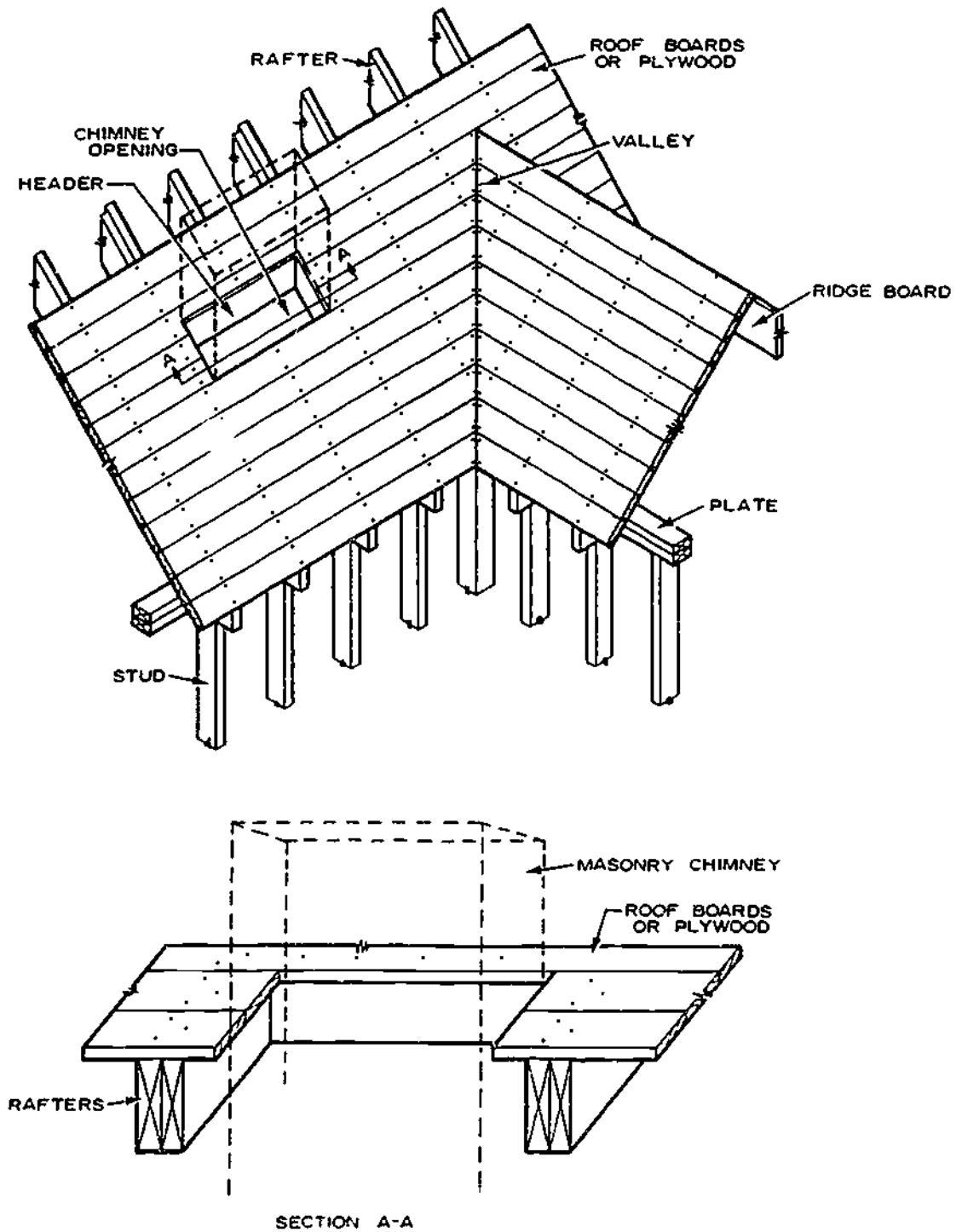

133.574
Figure 11 4. -Board roof sheathing detail at valley and chimney openings. Section A A shows distance from masonry.

miters cut at the building site is recommended when resistance to water entry and increased protection are desired.

Fastenings used for trim, whether nails or screws, should preferably be rust-resistant; that is, galvanized, stainless steel, or aluminum. When a natural finish is used, nails should be stainless steel or aluminum to prevent staining and discoloration. Cement-coated nails are not rust-resistant.

Siding and trim are normally fastened in place with a standard siding nail, which has a small flat head. However, finish or casing nails might also be used for some purposes. If not rust-resistant, they should be set below the surface and puttied after the prime coat of paint has been applied. Most of the trim along the shingle line, such as at gable ends and cornices, is installed before the roof shingles are applied.

CORNICES

The exterior finish at and just below the eaves is called the CORNICE. It is usually installed along with the roof sheathing. But in some cases, the cornice may be installed before the roof sheathing is complete when the installation can be made easier.

The parts of the roof that project beyond the face of the wall are called the EAVES or OVERHANG. Therefore, a structure with a hip roof has eaves all the way around it. In addition, the parts of the roof that project beyond the sidewalls of a gable roof are called eaves. But, the upward slopes of the gable ends are called RAKES.

Cornice work includes the installation of the lookout ledger, lookouts, plancier, ventilation screens, fascia, freize, and the moldings at and below the eaves, and along the sloping sides of the gable end (rake). The ornamental parts of a cornice are called CORNICE TRIM and consist mainly of molding; but, the molding which runs up the side of the rakes of a gable roof is called GABLE CORNICE TRIM. Besides the main

roof, the additions and dormers may have cornices, and cornice trim.

Types of Cornices

The type of cornice required for a particular structure is indicated on the wall sections of the drawings, and there are usually cornice detail drawings as well. A roof with no rafter overhang or eave usually has the SIMPLE cornice shown in figure 11-5. This cornice consists of a single strip or board called a FRIEZE, which is beveled on the upper edge to fit under the overhang or eave, and rabbeted on the lower edge to overlap the upper edge of the top course of siding. If trim is used, it usually consists of molding placed as shown in the figure. Molding trim in this position is called CROWN molding.

A roof with a rafter overhang may have an OPEN cornice or a CLOSED (also called a BOX) cornice. The simplest type of open cornice is

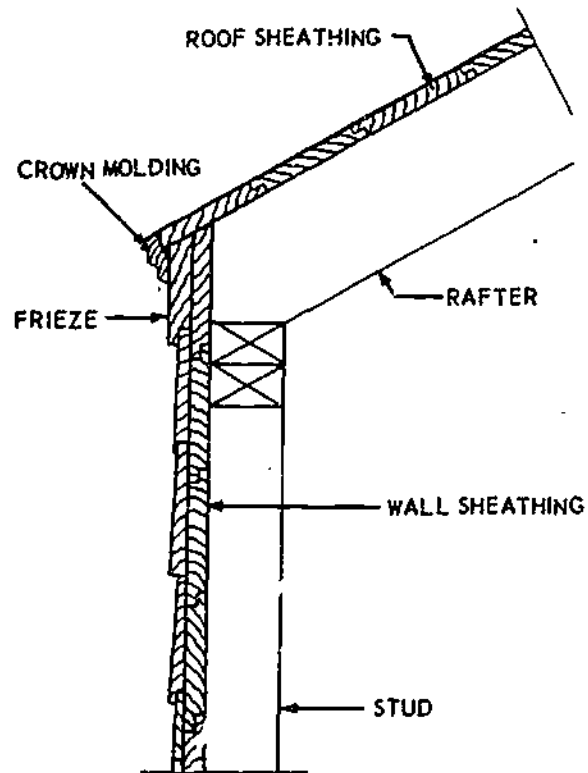
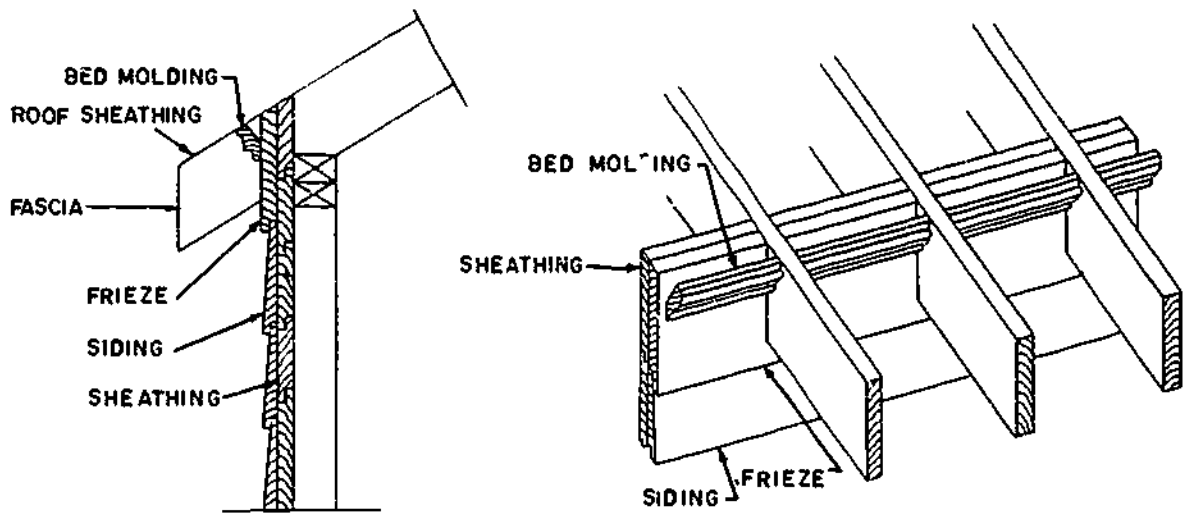

Figure 11-5.—Simple cornice.

45.493



45.494

Figure 11-6.—Simplest type of open cornice.

shown in figure 11-6. Like the simple cornice, it consists only of a frieze, which in this case must be notched to fit around the rafters. If trim is used, it usually consists of molding cut to fit between the rafters as indicated. Molding trim in this position is called BED molding.

A closed or box cornice is shown in figure 11-7. In this type, the rafter overhang is entirely boxed in by the roof covering, the fascia, and a bottom strip called a PLANCIER. The plancier is nailed to the lower edges of a series of

horizontal members called LOOKOUTS, which are cut to fit between the rafter ends and the face of the wall sheathing. The frieze, if any, is set just below the lookouts. The trim, if any, is placed and named as shown in the figure.

The gable cornice trim on a gable-roof structure with a simple or an open cornice is made by nailing the frieze and the crown molding to the rakes as shown in figure 11-8.

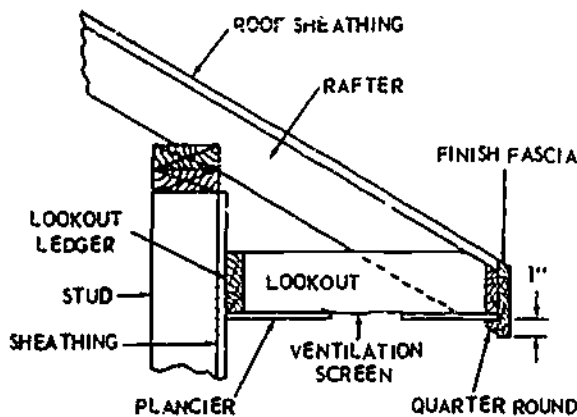

133.148

Figure 11-7.—Closed or box cornice.

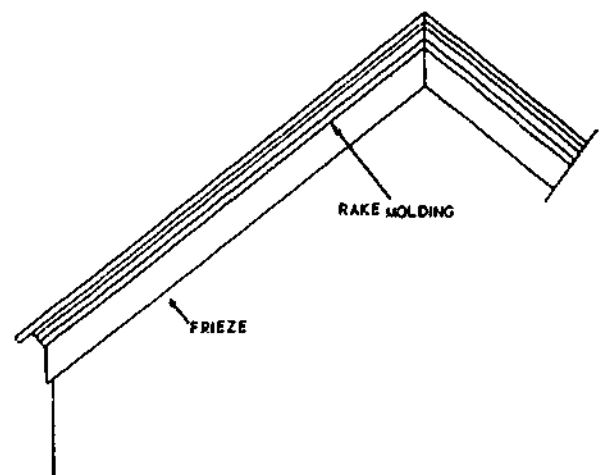

45.497

Figure 11-8.—Gable cornice trim on gable-roof structure with simple cornice.

Molding trim along the rakes, however, is called **RAKE** molding.

Cornice Construction

Most specifications call for **BUILDING PAPER** or **FELT** between the wall sheathing and the siding. Building paper is impregnated with a waterproofing material, such as asphalt or paraffin; it is used to make the walls watertight and to keep out air and dust. It is usually applied horizontally, with a 2- to 4-in. overlap.

Before the cornice can be erected, the top course of building paper must be applied to the wall sheathing. For the open and closed cornice, the paper must be cut to fit around the rafters to insure good insulation.

To prevent ice dams, cornices should be fully insulated in areas where moderate to severe snowfalls occur. (See view A, fig. 11-9.) Ice dams are formed when the snow melts, runs down the roof, and freezes at the colder cornice area. Gradually, the ice forms a dam that backs up water under the shingles. Under these conditions, it is good practice to use an undercourse of 45-lb smooth-surface roll roofing along the eave line as a flashing. (See view B, fig. 11-9.) This will lessen the chance of water backing up and entering the wall. Both good attic ventilation and sufficient ceiling insulation are of primary importance in eliminating ice dams.

Constructing a simple or an open cornice is simply a matter of laying out, beveling, rabbeting, notching (if required) and nailing on the frieze and the trim. Nails should be coated-casing, or finish, the size depends on the thickness of the piece being set in place. Carry a supply of fourpenny, sixpenny, and eightpenny nails, and drive the nails in only part way until all the pieces of the cornice have been set in place. All joints should be planed smooth with a block plane and fitted together tightly. All members must be mitered for joining on outside corners and mitered or coped for joining on inside corners.

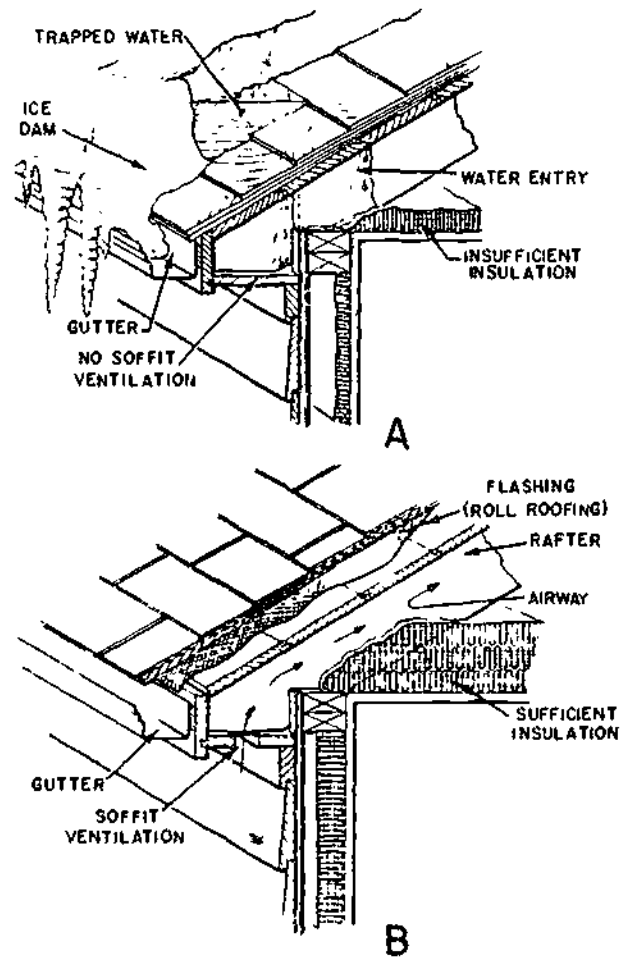

133.575

Figure 11-9.—A. Ice dams; B. Eave Protection against ice dams.

The normal procedure for constructing a closed cornice is as follows:

1. Line up the tail plumb cuts and lower corners of the rafters by stretching a line and planing or sawing down any irregularities.
2. Lay out and cut the lookouts and nail them in place (if this was not done in the framing stage). Lookouts must be level, with bottom edges and outer ends in perfect alinement. Each lookout should be first nailed to the rafter and then toenailed against the ledger.

3. Lay out, cut, and rabbet the frieze, and nail it in place just below the lookouts.
4. Lay out and cut the plancier, and fit and nail it to the bottom edges of the lookouts.
5. Lay out, cut, and bevel the fascia, and nail it to the ends of the rafters and lookouts.
6. Lay out, cut, bevel (if necessary), and nail on the moldings.

Cornice Return

The CORNICE RETURN is the end finish of the cornice on a gable roof. In hip roofs and flat roofs, the cornice is usually continuous around the entire structure. On a gable roof, however, it must be terminated or joined with the gable ends. The type of detail selected depends to a great extent on the type of cornice and the projection of the gable roof beyond the end wall.

A narrow box cornice often used in houses with Cape Cod or Colonial details has a boxed return when the rake section has some projection. (See view A, fig. 11-10.) The fascia board and shingle molding of the cornice are carried around the corner of the rake projection.

When a wide box cornice has no horizontal lookout members (fig. 11-7), the soffit of the gable-end overhang is at the same slope and coincides with the cornice soffit. (See view B, fig. 11-10.) The system is simple, and often used where there are wide overhangs at both sides and ends of the structure

A closed rake (gable end with little projection) may be used with a narrow box cornice or a close cornice. The frieze board of the gable end, into which the siding butts, joins the frieze board or fascia of the cornice. (See view C, fig. 11-10.)

While closed rakes and cornices with little overhang are lower in cost, the extra material and labor required for good gable and cornice overhangs are usually justified. Better sidewall protection and lower paint maintenance costs are only two of the benefits derived from good roof extensions.

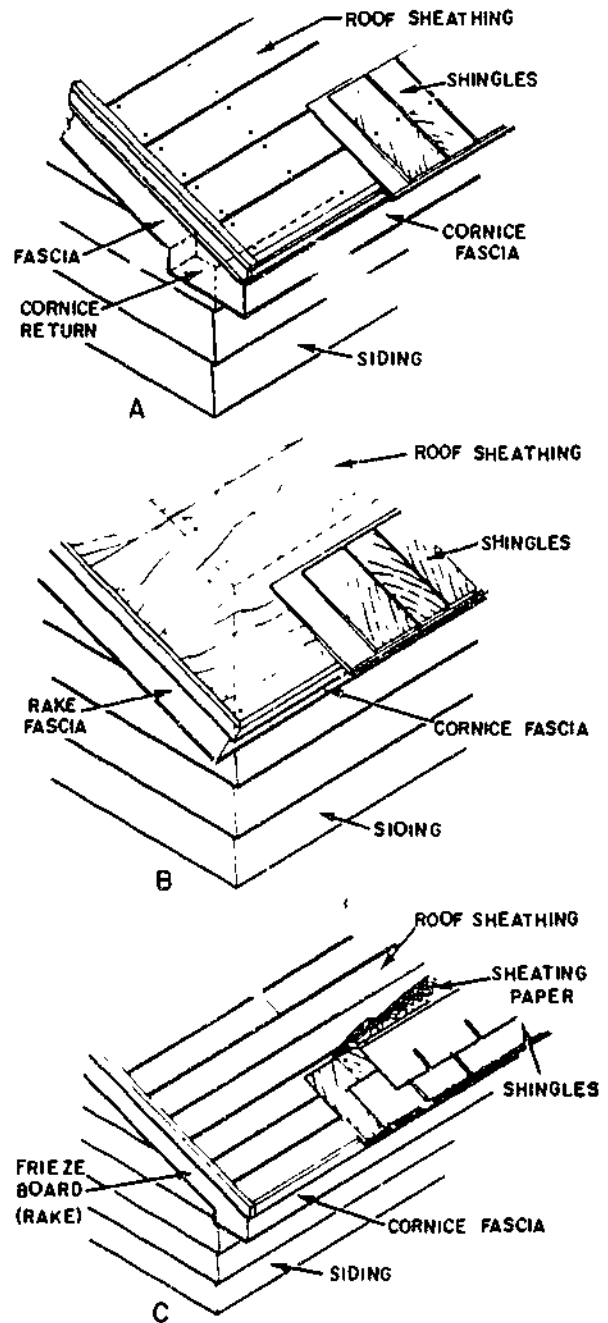

133.576
Figure 11 10.—Cornice returns. A. Narrow cornice with boxed return. B. Wide overhang at cornice and rake. C. Narrow box cornice and closed rake.

RAKE (GABLE-END) TRIM

The rake section is the extension of a gable roof beyond the end wall of the structure. This section might be classed as being a close rake with little projection or a boxed or open extension of the gable roof, from 6 in. to 2 ft in length or more. Sufficient projection of the roof at the gable is desirable to provide some protection to the sidewalls. It usually results in longer paint life.

When the rake extension is only 6 to 8 in., the fascia and soffit can be nailed to a series of short lookout blocks. (See view A, fig. 11-11.)

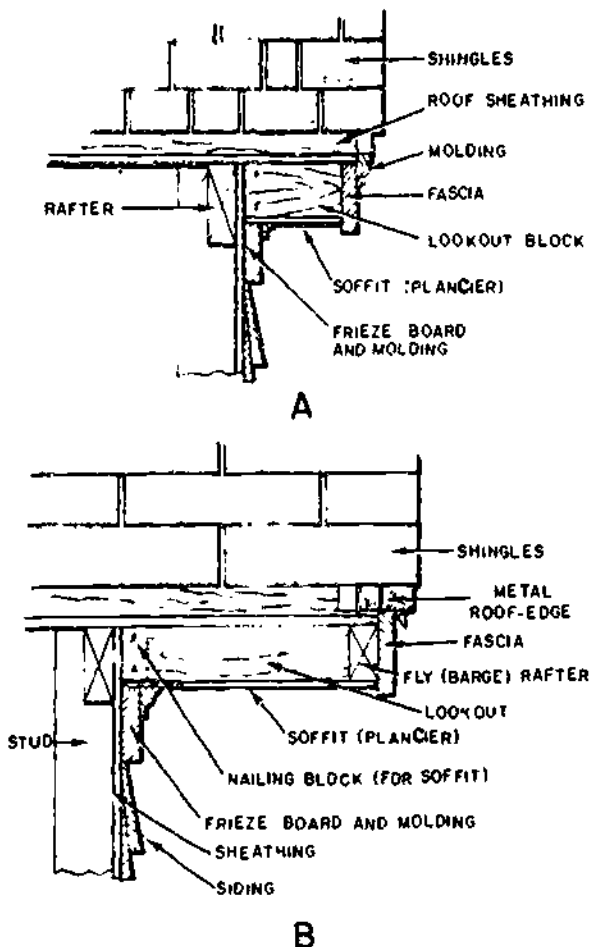

133.577
 Figure 11-11.—Normal gable-end extensions. A. Narrow overhang; B. Moderate overhang.

In addition, the fascia is further secured by nailing through the projecting roof sheathing. A frieze board and appropriate moldings complete the construction.

In a moderate overhang of up to 20 inches, both the extended sheathing and the fly (barge) rafter aid in supporting the rake section. (See view B, fig. 11-11.) The fly (barge) rafter extends from the ridge board to the nailing header which connects the ends of the rafters. The roof sheathing boards or the plywood should extend from inner rafters to the end of the gable projection to provide rigidity and strength.

The roof sheathing is nailed to the fly (barge) rafter and to the lookout blocks which aid in supporting the rake section and also serve as a nailing area for the soffit. Additional nailing blocks against the sheathing are sometimes required for thinner soffit materials.

Wide gable extensions (2 ft or more) require rigid framing to resist roof loads and to prevent deflection of the rake section. This is usually accomplished by lookout members that are nailed to a fly (barge) rafter at the outside edge and supported by the end wall and a doubled interior rafter. (See views A and B, fig. 11-12.) The framing is often called a "ladder" and may be constructed in place or on the ground or other convenient area and hoisted in place.

When ladder framing is preassembled, it is usually made up with a header rafter on the inside and a fly rafter on the outside. Each is nailed to the ends of the lookouts which bear on the gable end wall. When the header is the same size as the rafter, be sure to provide a notch for the wall plates the same as for regular rafters. In moderate width overhangs, nailing the header and fly rafter to the lookouts with supplemental toenailing is usually sufficiently strong to eliminate the need for the metal hangers, as shown in view B, figure 11-12. The header rafters can be face nailed directly to the fly rafters which are spaced 16 to 20 in. apart.

Other details of soffit, fascia, frieze board, and moldings can be similar to those used for a wide gable overhang. Lookouts should be spaced 16 to 24 in. apart, depending on the thickness of the soffit material.

ROOF COVERING

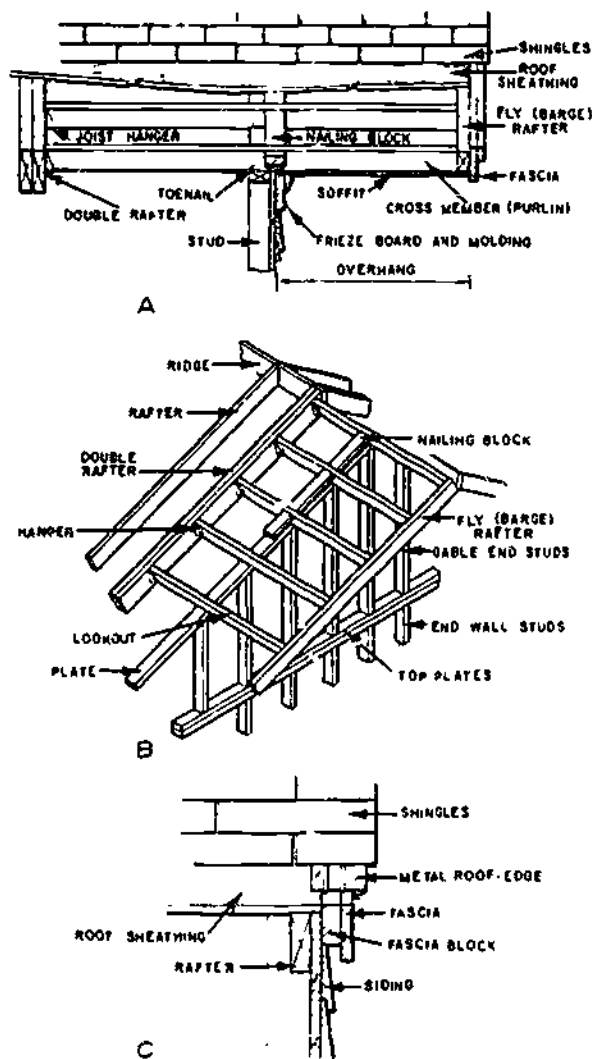

133.578
 Figure 11-12.—Special gable-end extensions: A. Extra wide overhang. B. Ladder framing for wide overhang. C. Closed rake.

A closed rake has no extension beyond the end wall other than the frieze board and moldings. Some additional protection and overhang can be provided by using a 2-by 3- or 2-by 4-in. fascia block over the sheathing. (See view C, fig. 11-12.) This member acts as a frieze board, as the siding can be butted against it. The fascia, often 1 by 6 inches, serves as a trim member. Metal roof edging is often used along the rake section as flashing.

Roof coverings should provide a long-life waterproof finish that will protect a building and its contents from rain, snow, and wind. Many materials have withstood the test of time and have proved satisfactory under given service conditions.

Materials used for pitched roofs are wood and asphalt shingles, and also, tile and slate. Sheet materials, such as roll roofing, galvanized iron, aluminum, copper, and tin are also used. Built-up construction is used mainly for flat or low-pitched roofs but can be used on steeper slopes by the use of special materials and methods.

An asphalt-saturated felt underlay is required for most roofs before the roof covering is installed. Roof underlay material should be applied on all pitched roofs which are to be covered with asphalt or shake shingles, and slate or tile roofing.

In shingle application, the exposure distance is important, and the amount of exposure generally depends on the roof slope and the type of material used. This may vary from a 5-in. exposure for standard-size asphalt and wood shingles on a moderately steep slope to about 3 1/2 in. for flatter slopes.

ASPHALT-FELT UNDERLAYMENT

Once the roof sheathing is in place, it is covered with an asphalt felt underlayment commonly called ROOFING FELT. Roofing felt is asphalt saturated and serves three basic purposes. It keeps the roof sheathing dry until the shingles can be applied; after the shingles have been laid, it acts as a secondary barrier against wind-driven rain and snow; it also protects the shingles from any resinous materials which could be released from the sheathing.

Roofing felt is designated by the weight per SQUARE. A square is equal to 100 sq ft and is the common unit to describe the amount of roofing material. Roofing felt is commonly available in rolls of 15 and 30 lb per square. The rolls are usually 36 in. wide. A roll of 15-lb felt is 144 ft long, whereas, a roll of 30-lb felt is 72 ft long. After you allow for a 4-in. overlap, a

roll of 15-lb felt will cover 4 sq, and roll of 30-lb felt will cover 2 sq.

The roofing felt is laid directly on the sheathing. Usually, a strip is laid in each valley of the roof first. After the valleys are covered, start at the lower edge of the roof, and lay the roofing felt perpendicular to the rafters. Each succeeding strip overlaps the lower one by a minimum of 4 in. for a single coverage. Double and triple coverage of the felt will require thicker ridge caps. Once the ridge is reached from both sides, a double strip is run down the ridge and hips.

ASPHALT SHINGLES

The usual minimum recommended weight for square-butt strip shingles is 235 lb per sq, although heavier weights are available. The square-butt strip shingle is 12 in. wide, and 36 in. long with three self-sealing type tabs for wind resistance. (See fig. 11-13.) They are usually laid with 5 in. exposed to the weather. They are available in bundles of 27 strips and should be stored flat so that the strips will not curl after the bundles are open.

An asphalt-shingle roof can also be protected from ice dams by adding an initial layer of 45 lb or heavier roll roofing. The roll roofing is 36 in. wide and insures good ventilation and insulation within the attic space. (See view B, fig. 11-9.) A metal edging is often used at the gable end to provide additional protection.

Before application, a course of wood shingles or a metal edging may be used along the eave line of the asphalt shingles. The first course of asphalt shingles is doubled; or, if desired, a starter course may be reversed and used under

the first asphalt-shingle course. This first course should extend downward beyond the wood shingles (or edging) about 1/2 in. to prevent the water from backing up under the shingles. A 1/2-in. projection should also be used at the rake.

Galvanized roofing nails with large heads should be used. Start 1 to 2 in. from the side edge, and place the nails approximately 1 in. above both sides of the tab notch.

The method of laying an asphalt-shingle roof is shown in figure 11-14.

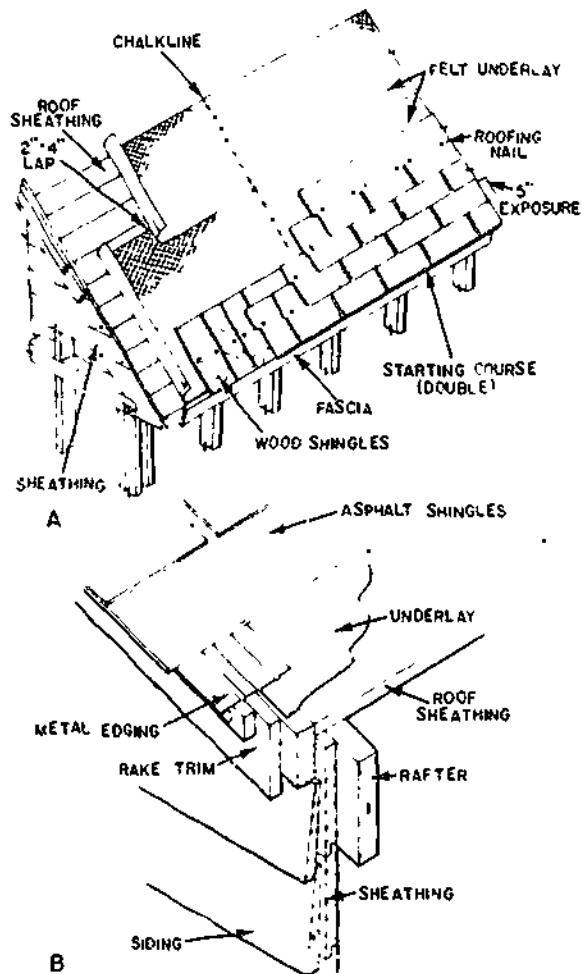

29.120
Figure 11-13.—A 12 by 36 in. square-butt asphalt shingle.

133.579
Figure 11-14.—Application of asphalt shingles: A. Common method with strip shingles; B. Metal edging at gable end.

**WOOD SHINGLES AND
WOOD SHAKES**

Wood shingles are available in three standard lengths—16, 18, and 24 inches. The 16-in. length is perhaps the most popular. It has five-butts thicknesses per 2 in. of width, when it is green (designated a 5/2). These shingles are packed in bundles. Four bundles will cover 100 sq ft of wall or roof with an exposure of 5 inches. The 18- or 24-in.-long shingles have thicker butts—five in 2 1/4 in. for the 18-in. shingles, and four in 2 in. for the 24-in. shingles. The recommended exposures for the standard wood-shingle size are shown in table 11-1.

Figure 11-15 illustrates the proper method of applying a wood-shingle roof. Underlay or roofing felt is not required for wood shingles except for protection in ice jam areas. Although spaced or solid sheathing is optional, spaced roof sheathing under wood shingles is most common. The following general rules should be followed in the application of wood shingles.

1. Extend shingles about 1 1/2 in. beyond the eave line and about 3/4 in. beyond the rake (gable) edge.
2. Use two rust-resistant nails in each shingle; spacing them about 3/4 in. from the edge and 1 1/2 in. above the butt line of the next course.
3. Double the first course of shingles. In all courses, allow 1/8- to 1/4-in. space between each

Table 11-1.—Recommended Exposure For Wood Shingles

Shingle length	Shingle thickness (Green)	Maximum exposure	
		Slope less than 4 in 12	Slope 5 in 12 and over
16	5 butts in 2 in.	3 3/4	5
18	5 butts in 2 1/4 in.	4 1/4	5 1/2
24	4 butts in 2 in.	5 3/4	7 1/2

133.580

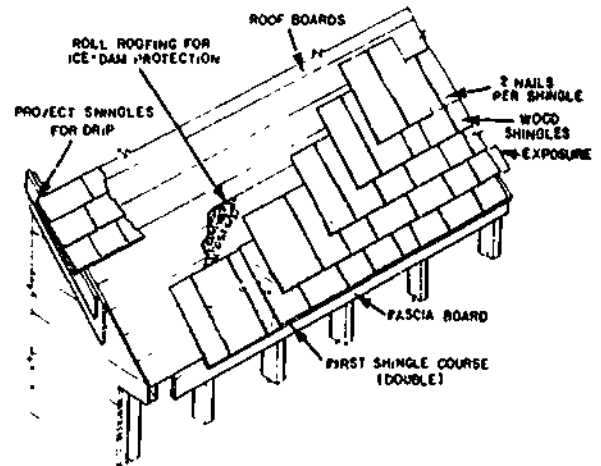

133.581

Figure 11-15.—Installation of wood shingles.

shingle for expansion when they are wet. Offset the joints between shingles at least 1 1/2 in. from the joints between shingles in the course below. In addition, space the joints in succeeding courses so that they do not directly line up with joints in the second course below.

4. Where valleys are present, shingle away from them. Select and precut wide valley shingles.

5. Use a metal edging along the gable end to aid in guiding the water away from the sidewalls.

Wood shakes are usually available in several types, but the split-and-resawn type is the most popular. The sawed face is used as the back face and is laid flat on the roof. The butt thickness of each shake ranges between 3/4 and 1 1/2 inches. They are usually packed in bundles of 20 sq ft with five bundles to the square.

Wood shakes are applied in much the same way as wood shingles. Because shakes are much thicker (longer shakes have the thicker butts), use long, galvanized nails. To create a rustic appearance, the butts are often laid unevenly. Because shakes are longer than shingles, they

have a greater exposure. Exposure distance is usually 7 1/2 in. for 18-in. shakes, 10 in. for 24-in. shakes, and 13 in. for 32-in. shakes. Shakes are not smooth on both faces, and because wind-driven rain or snow might enter, it is essential to use an underlay between each course. A layer of felt should be used between each course with the bottom edge positioned above the butt edge of the shakes a distance equal to double the weather exposure. A 36-in.-wide strip of the asphalt felt is used at the eave line. Solid sheathing should be used when wood shakes are used for roofs in areas where wind-driven snow is experienced.

FINISH AT THE RIDGE, HIP, AND VALLEY

The most common type of ridge and hip finish for wood and asphalt shingles is known as the Boston ridge. Asphalt-shingle squares (one-third of a 12- by 36-in. strip) are used over the ridge and blind nailed. (See view A, fig. 11-16.) Each shingle is lapped 5 to 6 in. to give double coverage. In areas where driving rains occur, use metal flashing under the shingle ridge to help prevent water entering. The use of a ribbon of asphalt roofing cement under each lap will also help.

A wood-shingle roof should be finished with a Boston ridge. (See view B, fig. 11-16.) Shingles, 6 in. wide, are alternately lapped, fitted, and blind nailed. As shown, the shingles are nailed in place so that the exposed trimmed edges are alternately lapped. Preassembled hip and ridge units for wood-shingle roofs are available and save both time and money.

A metal ridge can also be used on asphalt-shingle or wood-shingle roofs. (See view C, fig. 11-16.) This ridge is formed to the roof slope and should be copper, galvanized iron, or aluminum. Some metal ridges are formed so that they provide an outlet ventilating area. However, the design should be such that it prevents rain or snow from blowing in.

One side of a hip or valley shingle must be cut at an angle to obtain an edge that will match

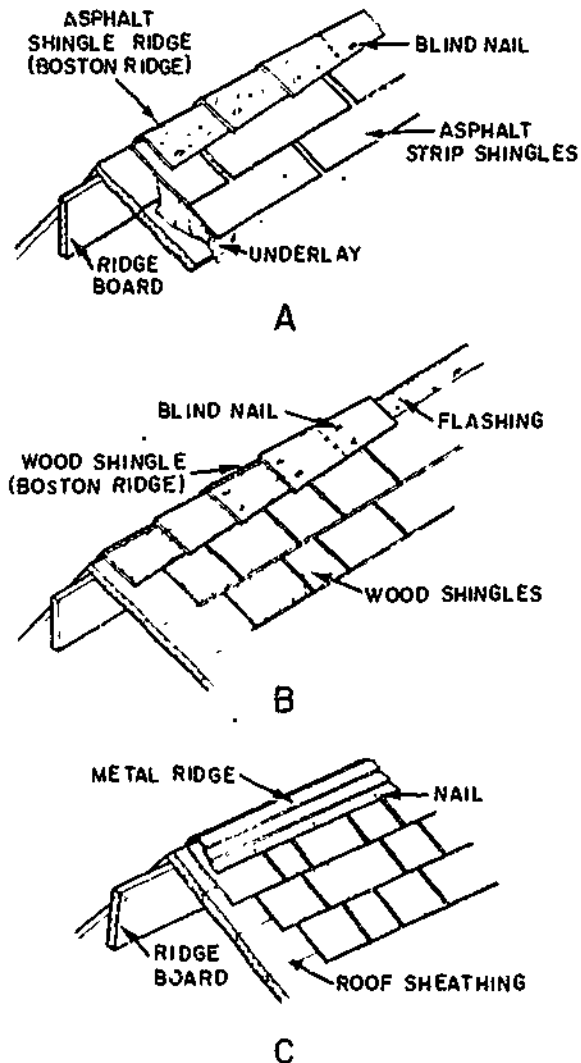

133.682
Figure 11-16.—Finish at ridge: A. Boston ridge with asphalt shingles; B. Boston ridge with wood shingles; C. Metal ridge.

the line of the hip or valley rafter. One way to cut these shingles is to use a pattern made as follows:

Select a piece of 1 by 6, 7 ft long. Determine the UNIT LENGTH of a common rafter in the roof (if you do not already know it); set the framing square on the piece to get the unit run

of the common rafter on the blade, and the unit rise of the common rafter on the tongue, as shown in the top view of figure 11-17. Draw a line along the tongue; then saw the piece along this line, and use it as a pattern to cut the shingles, as shown in the bottom view of figure 11-17.

BUILT-UP ROOFING

Built-up roofing is exactly what the name implies—alternate layers of bituminous-saturated, or saturated and coated felt, or fabric and bitumen built up on the job.

Relatively slight-sloped roofs (2 in. or less per ft) are particularly suitable for the built-up roof, because they practically furnish a continuous flat surface. When proper precautions are taken, the built-up roof may be applied on slopes steeper than 2 in. per ft.

The layers of building paper or felt in a built-up roof function primarily to hold the layers of bitumen in place. Generally, felt layers

do not materially contribute to the waterproofing of the roof and are not suitable for exposure to the weather. Built-up roofs are always designated by the number of plies of felt they contain; for example, 3- and 5-ply roofs contain 3 and 5 plies, respectively. Felts may be: organic-fiber (wool, paper, rag), coal-tar saturated, glass-fiber, asphalt-saturated, and asbestos, asphalt-saturated. Asphalt-saturated and coated felts are manufactured for use as a vapor barrier. For built-up roofs, glass-fiber felt with kraft paper backing is also available for vapor barriers. Coated felts surfaced with mineral granules are sometimes used for the wearing surface (cap sheets) on built-up roofs. Glass-fiber felts should not be used in extremely cold weather locations.

Aggregate surfacing for built-up roofs serves several important functions: it permits the use of thick surface coatings of bitumen; it protects the bitumen from sunlight and heat, and it increases the wind and fire resistance of the roofing. Surfacing materials may be gravel, slag, marble, and other suitable materials. Built-up roofs, except those surfaced with promenade tile or similar surfacing, are not intended to carry much foot traffic. On roof areas that are subjected to regular traffic, tile surfacing, concrete, or wood must be provided. Aggregate surfacing must not be used on built-up roofs near a flight line, because the aggregate may be blown off the roofs and sucked into the aircraft's jet engines.

A smooth surface treatment may be employed in lieu of aggregate surfacing to provide a weathering surface on asphalt built-up roofs where it is necessary to hold roof loads to a minimum. This treatment may also be used where there is a possibility of surfacing aggregates blowing off and damaging sensitive or critical material and equipment, and where required by roof configuration, or other reasons. Smooth-surface treatments include mineral-surfaced cap sheets (roll roofing), and either mopped-on, brushed-on, or sprayed-on asphalt coatings.

A built-up roof, like a shingled roof, is started at the eaves so the strips will overlap in the direction of the watershed. Figure 11-18

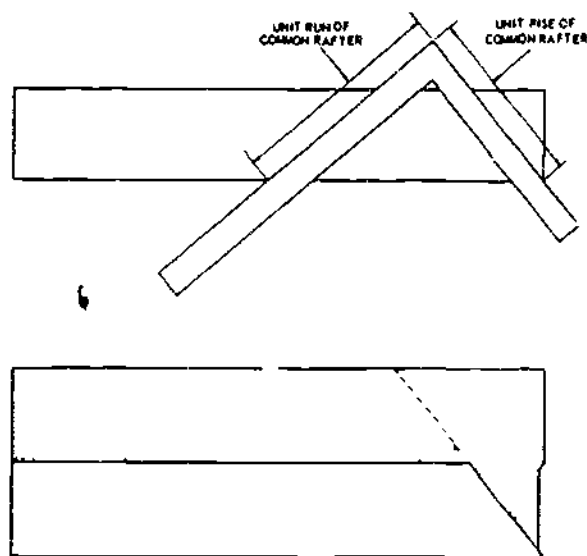

117.52

Figure 11-17.—Laying out pattern for cutting hip and valley shingle.

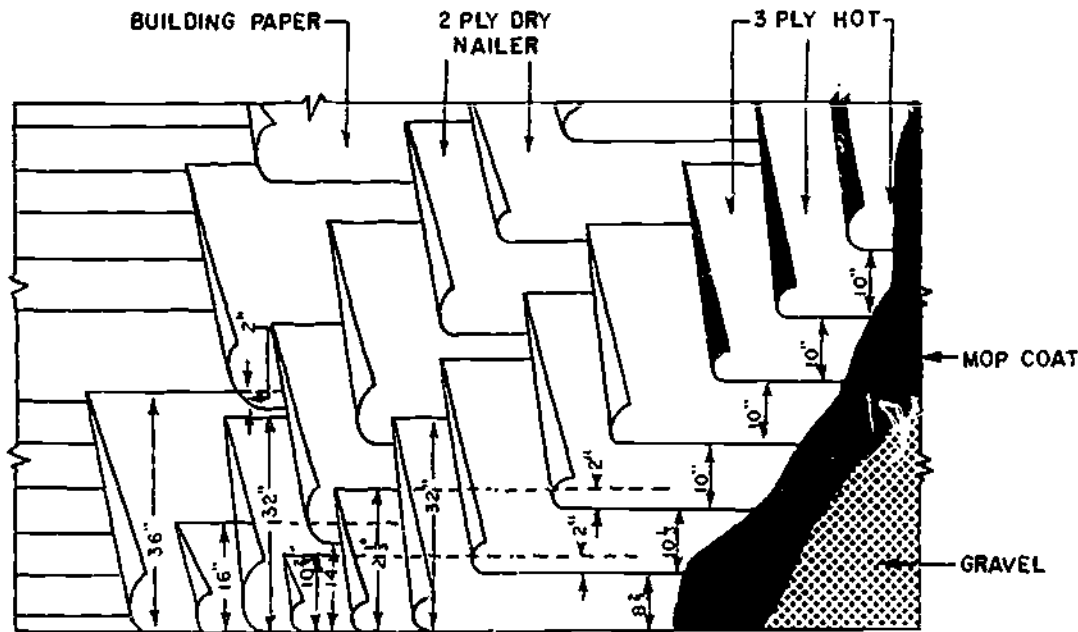

45.499

Figure 11-18.—Laying a 5-ply built-up roof.

shows how 32-inch building paper is layed over a wood sheathing roof to get 5-ply coverage at all points in the roof. The procedure for laying follows:

1. Lay the building paper with a 2-in. overlap, as shown. Spot-nail it down just enough to keep it from blowing away.
2. Cut a 16-in. strip of saturated felt and lay it along the eaves. Nail it down with nails placed 1 in. from the back edge and spaced 12 in. on center.
3. Nail a full-width (32 in.) strip over the first strip, using the same nailing schedule.
4. Nail the next full-width strip with the outer edge 14 in. from the outer edges of the first two, to obtain a 2-in. overlap over the edge of the first strip laid. Continue laying full-width strips with the same exposure (14 in.) until the opposite edge of the roof is reached. Finish off with a half-strip along this edge. This completes the 2-ply dry nailer.

5. Start the 3-ply hot with one-third of a strip, covered by two-thirds of a strip, and then by a full strip, as shown. To obtain a 2-in. overlap of the outer edge of the second full strip over the inner edge of the first strip laid, the outer edge of the second full strip must be $8 \frac{2}{3}$ in. from the outer edges of the first three strips laid. To maintain the same overlap, the outer edge of the third full strip must be $10 \frac{1}{3}$ in. from the outer edge of the second full strip. Subsequent strips may be laid with an exposure of 10 inches. Finish off at the opposite edge of the roof with a full strip, two-thirds of a strip, and one-third of a strip, to maintain 3 plys throughout.

6. Spread a layer of hot asphalt (the mop coat) over the entire roof. An asphalt heating kettle, like the one shown in figure 11-19, is used to draw off and spray on the asphalt.

7. Sprinkle a layer of gravel over the entire roof. Crushed stone or slag may be used instead of gravel.

Hot roofing work is done by a crew consisting of a mopper, felt layer, broomer,

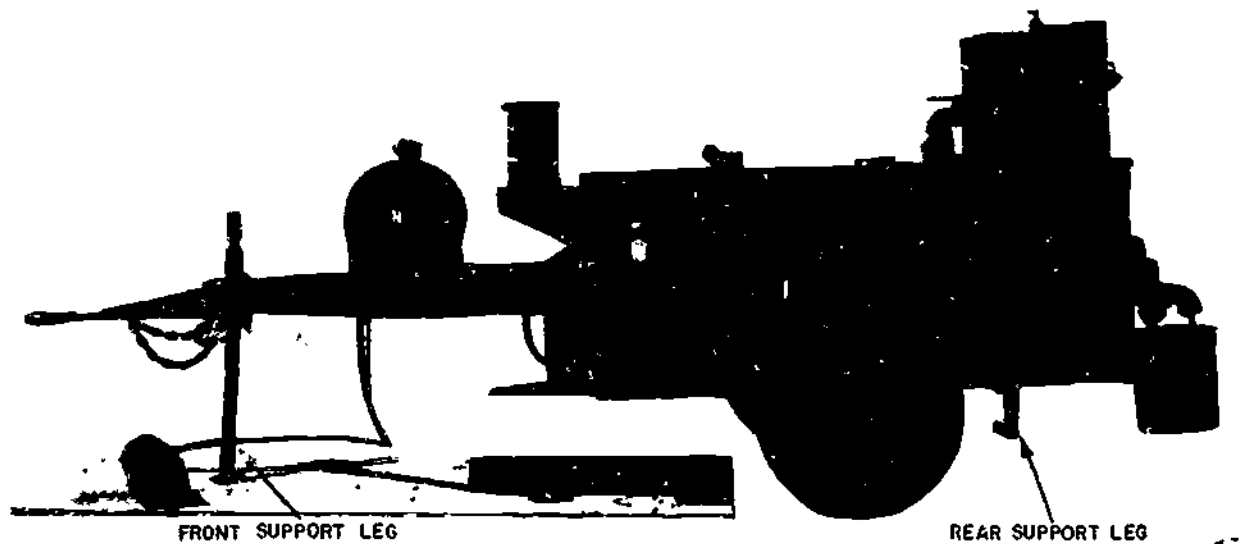

Figure 11-19.—Asphalt heating kettle.

133.583

nailer, asphalt carrier, and operator of the asphalt heating kettle. In charge of the crew, the mopper makes sure the temperature of the asphalt is neither too hot nor too cold. Asphalt that is too hot will burn the felt and form a layer that is too thin after mopping. Besides, thin layers will crack eventually and separate from the felt. Cold asphalt forms a layer that is too thick after mopping. Thick layers require the use of too much asphalt.

Once the 2-ply dry nailers are in place and hot mopping begins, the felt layer must get the felt down as soon as possible after the asphalt has been mopped. If the time between mopping and felt laying is too long, the asphalt will cool to the point where it will not bond well with the felt. The felt layer should follow the mopper at a distance of not more than 3 feet. The broomer should follow immediately behind the felt layer, brooming out all air bubbles and imbedding the felt solidly in the asphalt. When carried, buckets of hot asphalt should never be more than three-fourths full. Nor should they be carried faster than the carrier can walk. Whenever possible, the mopper should work downwind from the felt layer and broomer, to reduce the danger of spattering. The mopper should lift the mop out of the bucket without dragging it

across the rim. Dragging could upset the bucket and spread hot asphalt to the feet or legs of crewmembers working nearby.

ASPHALT HEATING KETTLE

A trailer-mounted asphalt heating kettle has either an 80- or 165-gallon heating unit. A flue stack, located on the forward end of the heating unit over the top of the baffle and burner assembly, provides an escape for the exhaust gases from the fuel burner. A gage inserted through an insulated pipe into the heating tank indicates the temperature of the asphalt.

A four-cycle, single-cylinder engine drives the pump that forces asphalt through a flexible metal hose that reaches the roof surface. This hose connects the pump to a spray bar assembly. Figures 11-20 through 11-22 show the positions, parts, and controls for the asphalt heating kettle.

OPERATION

Before operating the asphalt heating kettle, inspect inside the kettle to insure it is absolutely dry. Any water there will turn to steam when

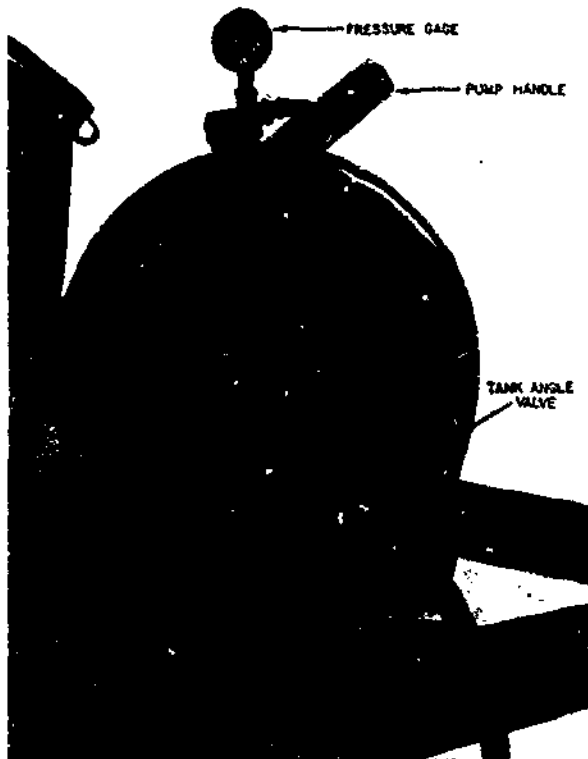

133.584

Figure 11-20.—Burner fuel tank and parts.

the kettle gets hot enough. This may cause the asphalt to bubble over, creating a fire hazard. In any case, be sure a dry-chemical fire extinguisher in good working order is handy. Guidelines for operating the kettle follow:

1. Make sure the kettle is suitably located, and level it by adjusting the front and rear support legs (fig. 11-9). Position it broadside to the wind, if possible. Do NOT operate when unattended or while the trailer is in transit or in a confined area.

2. Check and fill the engine crankcase with a high quality detergent oil.

3. Fill the fuel tank completely with clean, fresh, lead-free or regular grade automotive gasoline.

CAUTION: Do NOT mix oil with gasoline

4. Pull out the manual choke control.

5. Pull out the hand throttle approximately 1 1/2 inches.

6. Pull out the ignition switch button.

CAUTION: Make sure all valve handles are in their proper position before starting the engine.

7. Pull out the starting cord to start the engine.

8. Push in the hand choke gradually after the engine starts.

9. Warm up the engine at moderate speed.

10. Pull the hand throttle completely out to reach operating speed.

To start the burner fuel tank, check the fuel supply (kerosene) in the tank (fig. 11-20). If necessary, fill the fuel tank with kerosene to within 2 in. of the top of tank. Make sure the tank does NOT leak. NEVER fill the tank to the top. Be sure both the tank angle and burner valves (figs. 11-20 and 11-21, respectively) are closed. Then, pump air into the tank until the air pressure gage (fig. 11-20) on the tank reads between 35 and 40 pounds. Completely open the tank angle valve, then open the burner valve (fig. 11-21) approximately one-fourth turn until the burner pan (fig. 11-21) is about one-half full of kerosene. Now, light pieces of paper and insert them into the pan. Let the burner generate for about 5 minutes, then open the burner valve another one-fourth turn and allow the burner to operate until it is burning freely. If the burner has not been generated in the kettle, place it in the kettle and adjust the burner valve for a good, strong flame to heat the material. The temperature will depend on the type of material to be heated. For example, the temperature gage (fig. 11-22) should read between 300° and 450°F before asphalt is pumped. Do NOT heat asphalt beyond the manufacturer's recommended temperatures. Remember, before the asphalt heating kettle is started, place valves 8, 13, 16, and 24 (fig.

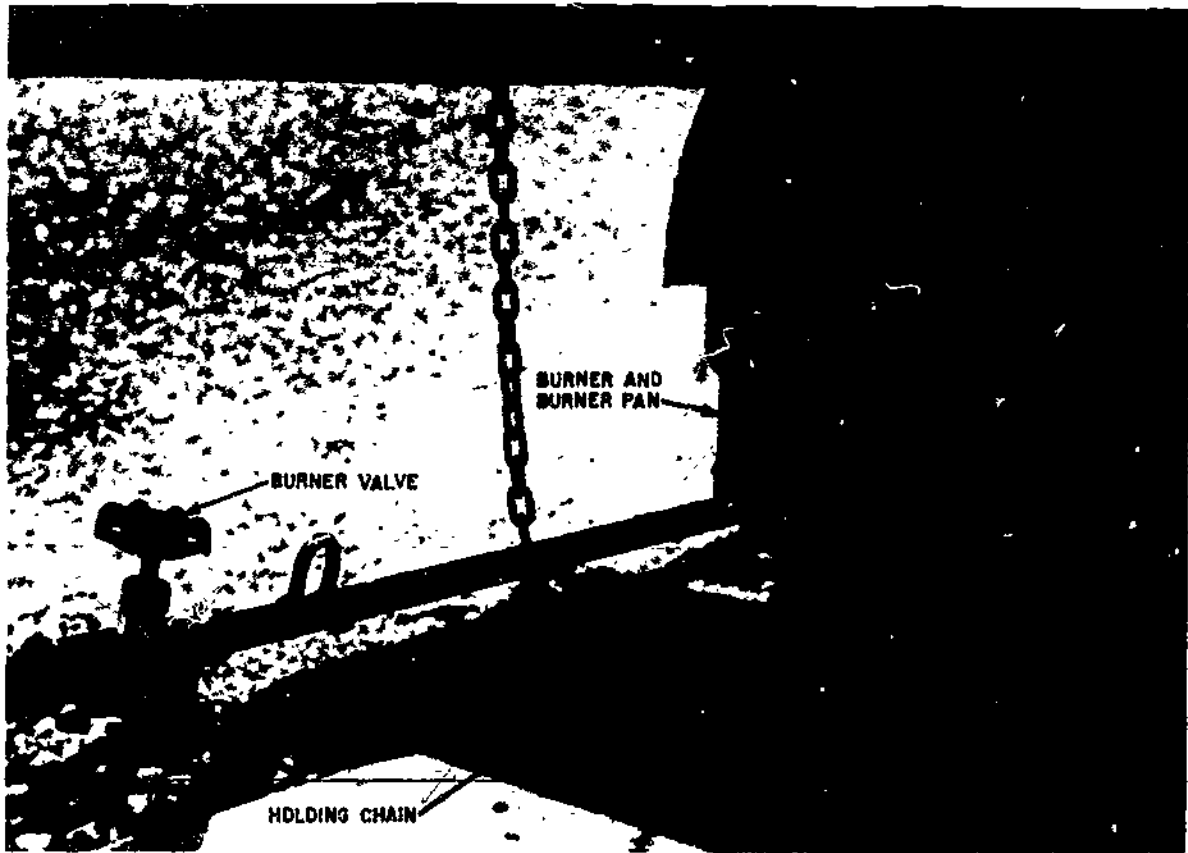

Figure 11-21.—Burner assembly.

133.585

11-22) in the No 1 positions. After doing so, prepare to circulate the heated material throughout the system. Secure connections before turning the valves to eliminate leaks. First, place valves 8, 13, and 16 in the No. 2 position. Next, place valve 24 in the No. 2 position. Leave the valves in this position for about 2 minutes to obtain full circulation so that the asphalt or pitch can heat the pump and the pipes. To circulate through the bypass valve (fig. 11 22), place valves 8 and 16 in position No. 3, and operate on this position for 1 minute so that the material can heat the bypass valve and return to the heating kettle.

To use the spray bar, place valve 13 in the horizontal position. Then open the spray-bar handle valve. Wear gloves or use insulated

material when handling the spray bar, pipes, or hose. Be careful NOT to spray asphalt on others working nearby.

When the kettle is being secured, stop the engine. Push the throttle completely in, and immediately place the manual stop switch against the engine spark plug. Place valves 8, 13, 16, and 24 in the No. 1 position, and leave the spray-bar handle valve open. Now, place a bucket of flushing material that is recommended by the manufacturer under the flushing pipe (fig. 11-22). Restart the engine. Do this immediately after spraying so that the pump lines do NOT set up with cold material. At this time, asphalt or pitch will flow from the spray bar. Place the spray nozzle into the flushing material bucket so that the flushing material can circulate and clean the pump lines. When the

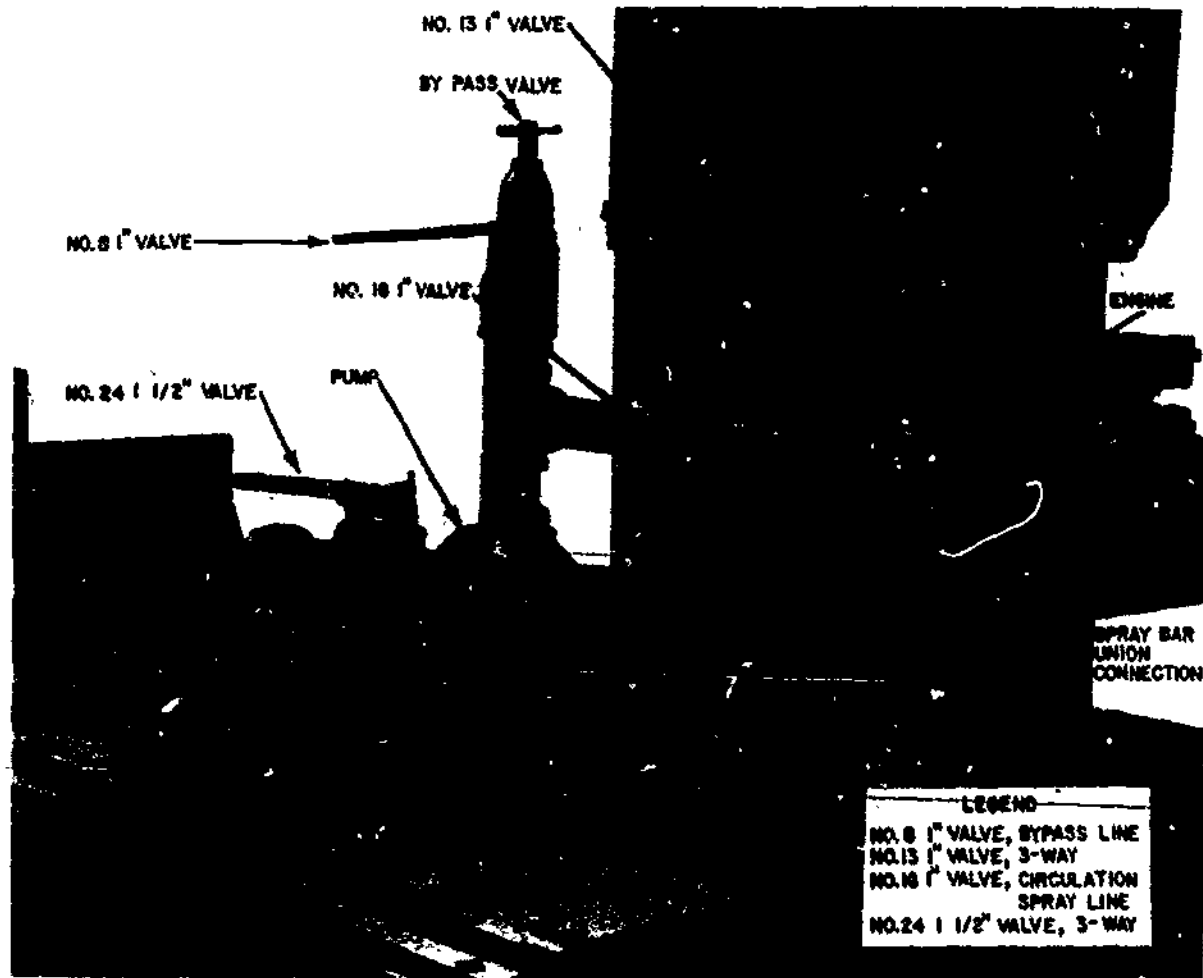

Figure 11-22.—Kettle engine, pump, valves, and temperature gage.

133.688

material has been flushed thoroughly, shut down the engine and leave all valves in the No. 1 position for the next "engine start" procedure. Now, secure the burner by closing the burner valve (fig. 11-21), and then the burner fuel tank angle valve (fig. 11-20).

CAUTION: Do NOT remove asphalt from the tank while the burner is in operation.

CARE AND MAINTENANCE

The general operating instructions include steps the kettle operator takes in caring for or

maintaining the asphalt heating kettle. In addition, the operator must keep the unit clean, lubricate it, and service the engine. The operator also checks for loose bolts, loose nuts, and worn parts. The spring shackles on the trailer are greased monthly and trailer wheel bearings are packed once a year.

OUTSIDE WALL COVERINGS

Because siding and other types of coverings for exterior walls affect the appearance as well

as the maintenance of a structure, the pattern should be selected carefully.

Wood siding can be obtained in many different patterns and can be finished naturally, stained, or painted. Wood shingles, plywood, wood siding or paneling, fiberboard, and hardboard are some of the types of material used as exterior coverings. Masonry, veneers, metal or plastic siding, and other nonwood materials are additional choices. Many prefinished sidings are available, and the coatings and films applied to several types of base materials may eliminate the need of refinishing for many years.

WOOD SIDING

One of the materials most characteristic of the exteriors of structures is wood siding. The essential properties required for siding are good painting characteristics, easy working qualities, and freedom from warp. Such properties are present to a high degree in cedar, eastern white pine, sugar pine, western white pine, cypress, and redwood; to a good degree in western hemlock, ponderosa pine, spruce, and yellow-popular, and to a fair degree in Douglas fir, western larch, and southern pine.

Material used for exterior siding which is to be painted should preferably be of a high grade and free from knots, pitch pockets, and waney edges. Vertical grain and mixed grain (both vertical and flat) are available in some species, such as redwood and western red cedar.

The moisture content at the time of application should be that which it would attain in service. To minimize seasonal movement due to changes in moisture content, vertical-grain (edge-grain) siding is preferred. While this is not as important for a stained finish, the use of edge-grain siding for a paint finish will result in longer paint life. A 3-minute dip in a water-repellent preservative before siding is installed will not only result in longer paint life but will also resist moisture entry and decay. Some manufacturers supply siding with this treatment. Freshly cut ends should be brush-treated on the job.

TYPES OF HORIZONTAL SIDING

Some wood siding patterns are used only horizontally and others only vertically. Some may be used in either manner if adequate nailing areas are provided. A description of each of the general types of horizontal siding follows.

Bevel Siding

Plain bevel siding can be obtained in sizes from 1/2 by 4 inches to 1/2 by 8 inches and also in sizes of 3/4 by 8 inches and 3/4 by 10 inches. "Anzac" siding (figure 11-23) is 3/4 by 12 inches in size. Usually, the finished width of bevel siding is about 1/2 inch less than the size listed. One side of bevel siding has a smooth planed surface, while the other has a rough resawn surface. For a stained finish, the rough or sawn side is exposed because wood stain works best and lasts longer on rough wood surfaces.

Dolly Varden Siding

Dolly Varden siding is similar to true bevel siding except that it has shiplap edges. The shiplap edges have a constant exposure distance. (See fig. 11-23.) Because it lays flat against the studs, it is sometimes used for garages and similar buildings without sheathing. Diagonal bracing is then needed to stiffen the building and helps to resist winds, twist, and strain.

Other Types of Horizontal Siding

Regular drop siding can be obtained in several patterns, two of which are shown in figure 11-23. This siding, with matched or shiplap edges, can be obtained in 1-by-6-in. and 1-by-8 in. sizes. It is commonly used for low cost dwellings and for garages, usually without benefit of sheathing. Tests have shown that the tongued-and-grooved (matched) patterns have greater resistance to the penetration of wind-driven rain than the shiplap patterns, when both are treated with a water-repellent preservative.

Fiberboard and hardboard sidings are also available in various forms. Some have a backing to provide rigidity and strength while others are

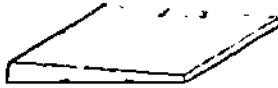
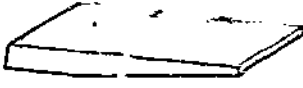
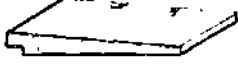
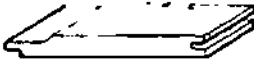
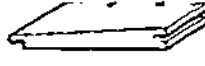
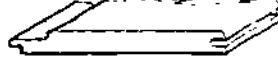
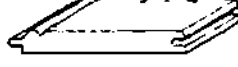
	TYPE	NOMINAL SIZES
	BEVEL	1 1/2 x 4 TO 3 1/2 x 6
	"ANZAC" (BEVEL)	3/4 x 2
	DOLLY VARDEN	3/4 x 8 TO 3 1/2 x 10
	DROP (PATTERN 106)	1 1/2 x 10 TO 1 1/2 x 12
	DROP (PATTERN 24)	1 1/2 x 10 TO 1 1/2 x 12
HORIZONTAL APPLICATION		
	PANELING (PATTERN 30)	1 1/2 x 10 TO 1 1/2 x 12
	PANELING (PATTERN 31)	1 1/2 x 10 TO 1 1/2 x 12
VERTICAL APPLICATION		

133.587

Figure 11-23.—Wood siding types.

used directly over sheathing. Plywood horizontal lap siding, with a medium density overlaid surface, is also available as an exterior covering material. It is usually 3/8 in. thick and 12 or 16 in. wide. It is applied in much the same manner as wood siding, except that a shingle wedge is used behind each vertical joint.

TYPES OF HORIZONTAL OR VERTICAL SIDING

A number of siding or paneling patterns can be used horizontally or vertically (fig. 11-23). These are manufactured in nominal 1 in. thicknesses and in widths from 4 to 12 inches. Both dressed and matched and shiplapped edges are available. The narrow and medium-width

patterns will likely be more satisfactory where there are moderate moisture content changes. Wide patterns are more successful if they are vertical grained to keep shrinkage to a minimum. The correct moisture content is necessary to prevent shrinkage to a point where the tongue is exposed.

If the edges of drop, matched, and shiplapped sidings are treated with a water-repellent preservative, it usually prevents wind-driven rain from penetrating the joints exposed to the weather. In areas under wide overhangs or in porches or other protected sections, the treatment is not as important. Some manufacturers provide siding with this treatment applied at the factory.

Vertical Board Siding

A method of siding application, popular for some architectural styles, utilizes rough-sawn boards and battens applied vertically. These can be arranged in three ways: board and batten, batten and board, and board and board. (See fig. 11-24.)

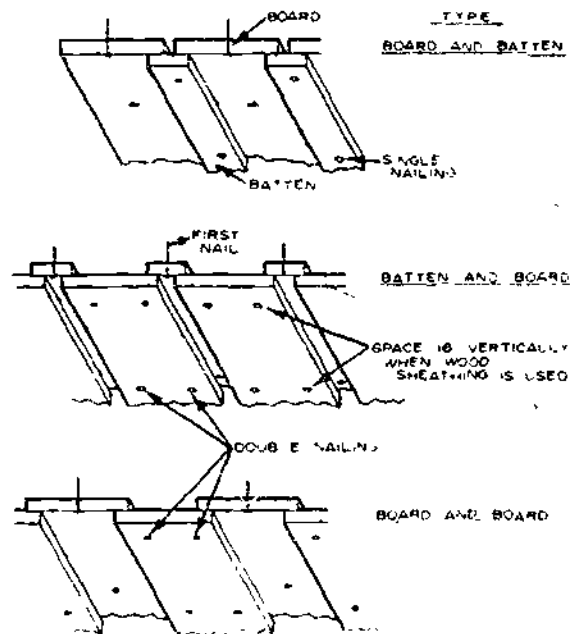

133.588

Figure 11-24.—Vertical board siding.

Sheet Siding

A number of sheet materials are now available for use as siding. These include plywood in a variety of face treatments and species, paper-overlaid plywood, and hardboard. Plywood or paper-overlaid plywood, also known as panel siding, is sometimes used without sheathing. Paper-overlaid plywood has many of the advantages of plywood besides providing a very satisfactory base for paint. A medium-density, overlaid plywood is most common. Where the stud spacing is 16 inches, the minimum thickness of panel siding is 3/8 inch. However, 1/2- or 5/8-inch-thick sheets perform better due to their greater thickness and strength.

These sheets are 4 by 8 ft and longer. They must be applied vertically with intermediate and perimeter nailing to provide the desired rigidity. Most other methods of applying sheet materials require some type of sheathing beneath. Where horizontal joints are necessary, they should be protected by a simple flashing.

An exterior-grade plywood should always be used for siding, and can be obtained in grooved, brushed, and saw-textured surfaces. These surfaces are usually finished with a type of stain. If shiplap or matched edges are not provided, the joints should be waterproofed. Waterproofing often consists of caulking and a batten at each joint and a batten at each stud if closer spacing is desired for appearance. An edge treatment of water-repellent preservative will also aid in reducing moisture penetration. When plywood is being installed in sheet form, allow a 1/16-inch edge and end spacing.

Exterior grade particleboard might also be considered for panel siding. Normally, a 5/8-inch thickness is required for 16-inch stud spacing and 3/4 inch thickness for 24-inch stud spacing. The finish must be with an approved paint, and the stud wall behind must have corner bracing.

Medium-density fiberboards might also be used in some areas as exterior coverings over certain types of sheathing. Many of these sheet materials resist the passage of water vapor. Hence, when they are used, it is important that a good vapor barrier, well insulated, be employed on the warm side of the insulated walls.

NONWOOD SIDING

Nonwood materials, such as asbestos-cement siding and shingles and metal sidings, are used in some types of architectural design. Stucco or a cement-plaster finish, preferably over a wire mesh base, is common in the Southwest and the West Coast areas. Masonry veneers may be used effectively with wood siding in various finishes to enhance the beauty of both materials.

Some designated structures favor an exterior covering which requires a minimum of maintenance. Although nonwood materials are often chosen for this reason, the paint industry is providing comparable long-life coatings for wood-base materials. Plastic films on wood siding or plywood are also promising because little or no refinishing is necessary for the life of the building.

INSTALLATION OF SIDING

Siding can only be installed after the window and door frames. In order to present a uniform appearance, it must line up properly with the drip caps and the bottom of the window and door sills. And, at the same time, it must line up at the corners. Siding must be properly lapped to increase wind resistance, and watertightness. In addition, it must be installed with the proper nails and in the correct nailing sequence.

FASTENERS

One of the most important factors in successful performance of various siding materials is the type of fasteners used. Nails are the most common of these, and it is poor economy indeed to use them sparingly. Galvanized, aluminum, and stainless steel corrosive-resistant nails, or similar metals, may cost more, but their use will insure spot-free siding under adverse conditions.

Two types of nails are commonly used with siding—the small-head finishing nail and the moderate-size flathead siding nail.

The small-head finishing nail is set (driven with a nail set) about 1/16 in. below the face of the siding, and the hole is filled with putty after

the prime coat of paint is applied. The flathead siding nail, most commonly used, is nailed flush with the face of the siding and the head later covered with paint.

Ordinary steel-wire nails tend to rust in a short time and cause a disfiguring stain on the face of the siding. In some cases, the small-head nails will show rust spots through the putty and paint, but noncorrosive nails that will not cause rust are readily available.

If the siding is to be "natural finished" with a water-repellent preservative or stain, it should be fastened with stainless steel or aluminum nails. In some types of prefinished sidings, nails with color-matched heads are supplied.

Nails with modified shanks have now become quite popular. They include the annularly threaded shank nail and the spirally threaded shank nail. Both have greater withdrawal resistance than the smooth shank nail and, for this reason, a shorter nail is often used.

In siding, exposed nails should be driven flush with the surface of the wood. Overdriving may not only show the hammer mark, but may also cause objectionable splitting and crushing of the wood. In sidings with prefinished surfaces or overlays, the nails should be driven so as not to damage the finished surface.

BEVEL SIDING

The minimum lap for bevel siding should not be less than 1 inch. The average exposure distance is usually determined by the distance from the underside of the window sill to the top of the drip cap. (See fig. 11-25.) From the standpoint of weather resistance and appearance, the butt edge of the first course of siding above the window should coincide with the top of the window drip cap. In many one-story structures with an overhang, this course of siding is often replaced with a frieze board. (See fig. 11-6.) It is also desirable that the bottom of a siding course be flush with the underside of the window sill. However, this may not always be possible because of varying window heights and types that might be used in a structure.

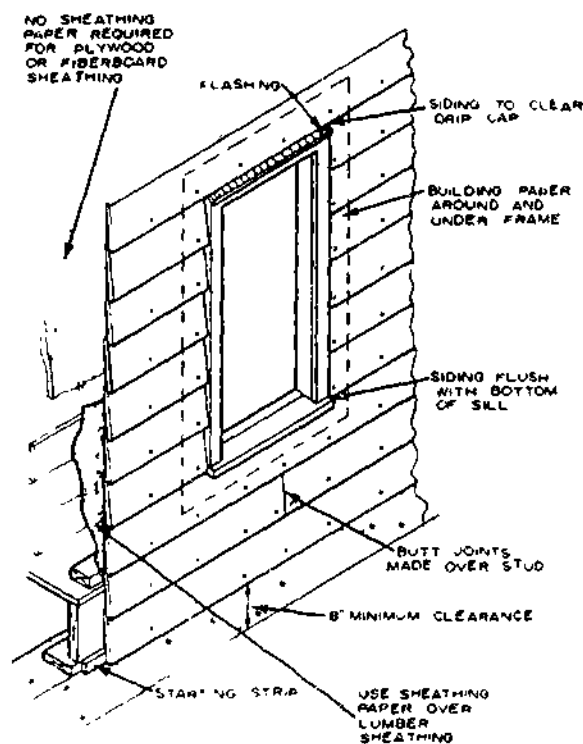

133.589

Figure 11-25.—Installation of bevel siding.

One system used to determine the siding exposure width so that it is about equal both above and below the window sill is described below

Divide the overall height of the window frame by the approximate recommended exposure distance for the siding used (4 in. for 6-in.-wide siding, 6 in. for 8-in.-wide siding, 8 in. for 10-in.-wide siding, and 10 in. for 12-in.-wide siding). This result will be the number of courses between the top and the bottom of the window. For example, the overall height of our sample window from the top of the drip cap to the bottom of the sill is 61 inches. If 12-in.-wide siding is used, the number of courses would be $61/10 = 6.1$ or six courses. To obtain the exact exposure distance, divide 61 by 6 and the result would be $10 \frac{1}{6}$ inches. The next step is to determine the exposure distance from the bottom of the sill to just below the top of the

foundation wall. If this distance is 31 inches, use three courses of 10 1/3 in. each. Thus, the exposure distance above and below the window would be almost the same. (See fig. 11-25.)

When this system is not satisfactory because of big differences in the two areas, it is preferable to use an equal exposure distance for the entire wall height and notch the siding at the window sill. The fit should be tight to prevent moisture from entering.

Siding may be installed starting with a bottom course. It is normally blocked out with a starting strip the same thickness as the top of the siding board. (See fig. 11-25.) Each succeeding course overlaps the upper edge of the lower course. Siding should be nailed to each stud or on 16-in. centers. When plywood or wood sheathing or spaced wood nailing strips are used over nonwood sheathing, sevenpenny or eightpenny nails may be used for 3/4-in.-thick

siding. However, if gypsum or fiberboard sheathing is used, the tenpenny nail is recommended to penetrate into the stud. For 1/2-in.-thick siding, nails may be 1/4 in. shorter than those used for 3/4-in. siding.

The nails should be located far enough up from the butt to miss the top of the lower siding course. (See fig. 11-26.) The clearance distance is usually 1/8 inch. This allows for slight movement of the siding due to moisture changes without causing splitting. Such an allowance is especially required for the wider sidings, 8 to 12 inches.

It is good practice to avoid butt joints whenever possible. Use the longer sections of siding under windows and other long stretches, and utilize the shorter lengths for areas between windows and doors. When possible, butt joints should be made over a stud and staggered between courses as much as practical.

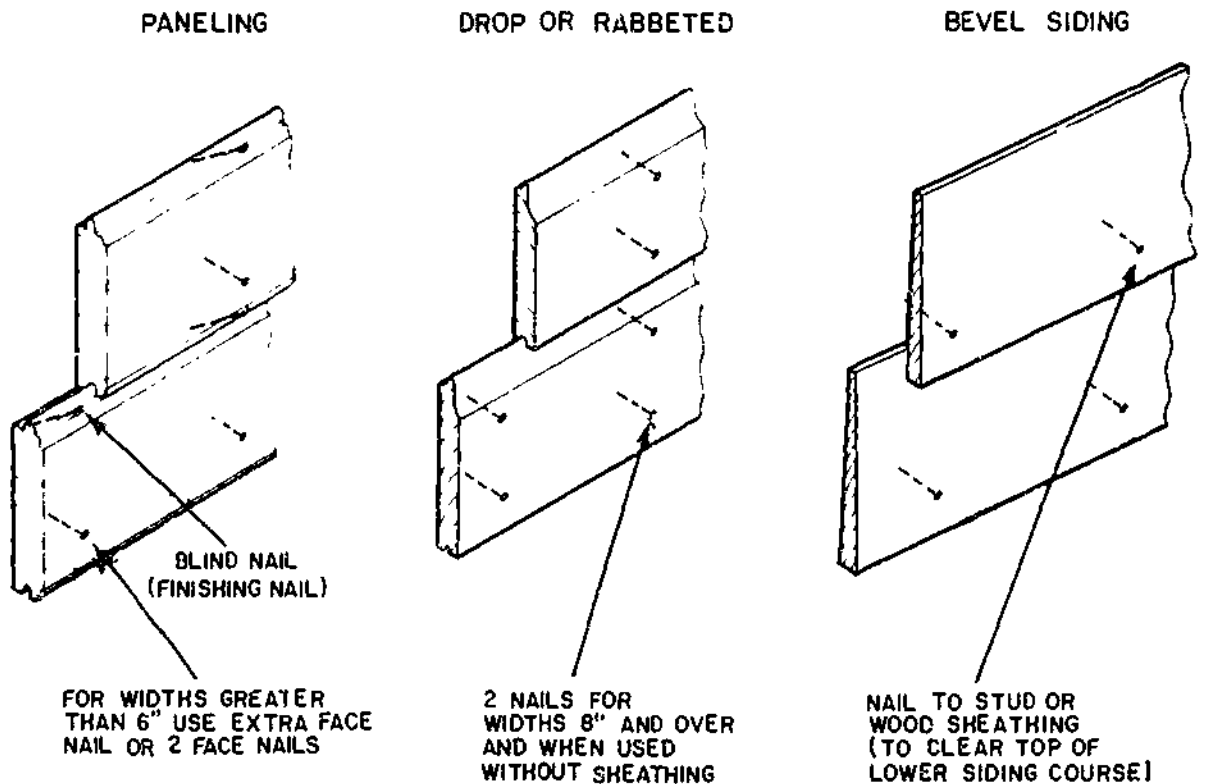

Figure 11-26 --Nailing the siding.

133.590

Siding should be square cut to provide a good joint at window and door casings and butt joints. Open joints permit moisture to enter and often lead to paint deterioration. It is a good practice to brush or dip the freshcut ends of the siding in a water-repellent preservative before boards are nailed in place. After the siding is in place, it is helpful to use a small finger-actuated oil can to apply the water-repellent preservative at the end and butt joints.

DROP AND SIMILAR SIDINGS

Drop siding is installed in much the same way as lap siding except for spacing and nailing. Drop, Dolly Varden, and similar sidings have a constant exposure distance. The face width is normally 5 1/4 in. for 1- by 6-in. siding and 7 1/4 in. for 1- by 8-in. siding. Normally, one or two nails should be used at each stud, depending on the width. (See fig. 11-26.) The length of the nail depends on the type of sheathing used, but penetration into the stud or through the wood backing should be at least 1-1/2 inches.

Horizontally applied matched paneling in narrow widths should be blind nailed at the tongue with a corrosion-resistant finishing nail. (See fig. 11-26.) For widths greater than 6 inches, an additional nail should be used as shown.

Other materials, such as plywood, hardboard, or medium-density fiberboard, which are used horizontally in widths up to 12 inches, should be applied in the same manner as lap or drop siding, depending on the pattern. Prepackaged siding should be applied according to the manufacturers directions.

VERTICAL SIDING

Vertically applied matched and similar sidings with interlapping joints are nailed in the same manner as when they are applied horizontally. However, they should be nailed to blocking used between studs or to wood or

plywood sheathing. Blocking is spaced from 16 to 24 in. apart. With plywood or nominal 1-in.-board sheathing, nails should be spaced on 16-in. centers.

When the various combinations of boards and battens are used, they should also be nailed to blocking spaced from 16 to 24 in. apart between studs, or closer for wood sheathing. The first boards or battens should be fastened with nails at each blocking, to provide at least 1 1/2 in. penetration. For wide underboards, two nails spaced about 2 in. apart may be used rather than the single row along the center. (See fig. 11-24.) Nails of the top board or batten should always miss the underboards and should not be nailed through them. (See fig. 11-24.) In such applications, double nails should be spaced closely to prevent splitting if the board shrinks. It is also a good practice to use sheathing paper, such as 15-lb asphalt felt, under vertical siding.

SHEET SIDING

Exterior-grade plywood, paper-overlaid plywood, and similar sheet materials used for siding are usually applied vertically.

The nails should be driven over the studs and the total effective penetration into the wood should be at least 1 1/2 inches. For example, 3/8-in.-plywood siding over 3/4-in. wood sheathing would require about a sevenpenny nail, which is 2 1/4 in. long. This would result in a 1 1/8-in. penetration into the stud, but a total effective penetration of 1 7/8 in. into the wood sheathing.

All types of sheet material should have the joints caulked with mastic unless the joints are of the interlapping or matched type of battens. It is a good practice to place a strip of 15-lb asphalt felt under uncaulked joints.

CORNER COVERING

The outside corners of a wooden-frame structure can be finished in several ways. Siding

boards can be miter joined at the corners. Shingles can be edge lapped alternately, first from one side, and then from the other. The ends of siding boards can be butted at the corners and then covered with a metal cap. A type of corner finish which can be used with almost any kind of outside-wall covering is called a CORNER BOARD. This corner board can be applied to the corner with the siding or shingles end-or-edge-butted against the board.

A corner board usually consists of two pieces of stock—one piece, 3 in. wide, and the other, 4 in. wide, if an edge-butt joint between boards is used. The boards are cut to a length which will extend from the top of the water table to the bottom of the frieze. They are edge butted and nailed together before they are nailed to the corner. This procedure insures a good tight joint. (See fig. 11-27.) A strip of building paper should be tacked over the corner before the corner board is nailed in position (always allow an overlap of paper to cover the subsequent crack formed where the ends of the siding butts against the cornerboard).

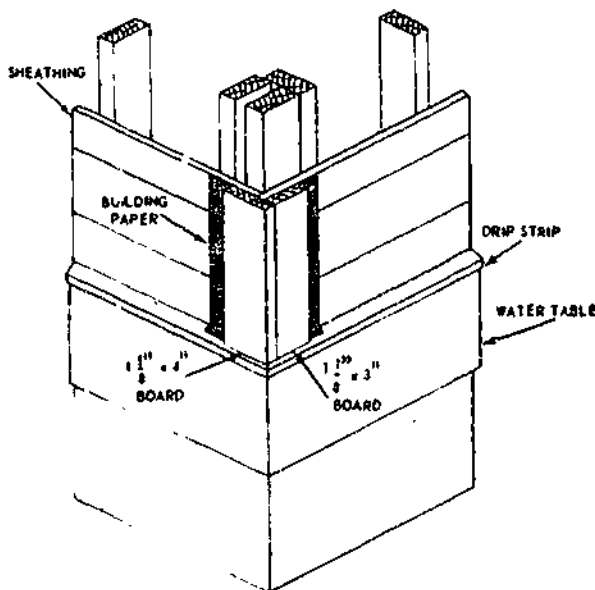

45.505

Figure 11-27.—Corner board.

Mitering corners (view A, fig. 11-28) of bevel and similar sidings is not always satisfactory, unless it is carefully done to prevent openings. To maintain a good joint, it is necessary that the joint fit tightly the full depth of the miter. It is also a good practice to treat the ends with a water-repellent preservative prior to nailing.

Metal corners (view B, fig. 11-28) are perhaps more commonly used than the mitered corner and give a mitered effect. They are easily placed over each corner as the siding is installed. The metal corners should fit tightly without openings and should be nailed on each side to the sheathing or corner stud beneath. When made of galvanized iron, they should be cleaned with a mild acid wash, and primed with a metal primer before the structure is painted to prevent early peeling of the paint. Weathering of the metal will also prepare them for the prime paint coat.

Corner boards of various types and sizes may be used for horizontal sidings of all types. (See fig. 11-27.) They also provide a satisfactory termination for plywood and similar sheet materials. Vertical applications of matched paneling or of boards and battens are terminated by lapping one side and nailing into the edge of this member, as well as to the nailing members beneath. Corner boards are usually 1 1/8 or 1 3/8 inches wide. To give a distinctive appearance, they should be quite narrow. Plain outside casing commonly used for window and door frames can be adapted for corner boards.

Prefinished shingle or shake exteriors are sometimes used with color-matched metal corners. They can also be lapped over the adjacent corner shingle, alternating each course. This kind of corner treatment, called lacing, usually requires that flashing be used beneath.

When siding returns against a roof surface, such as at a dormer, there should be a clearance of about 2 inches. (See view C, fig. 11-28.) Siding which is cut for a tight fit against the shingles retains moisture after rains and usually results in paint peeling. Shingle flashing extending well up on the dormer wall will

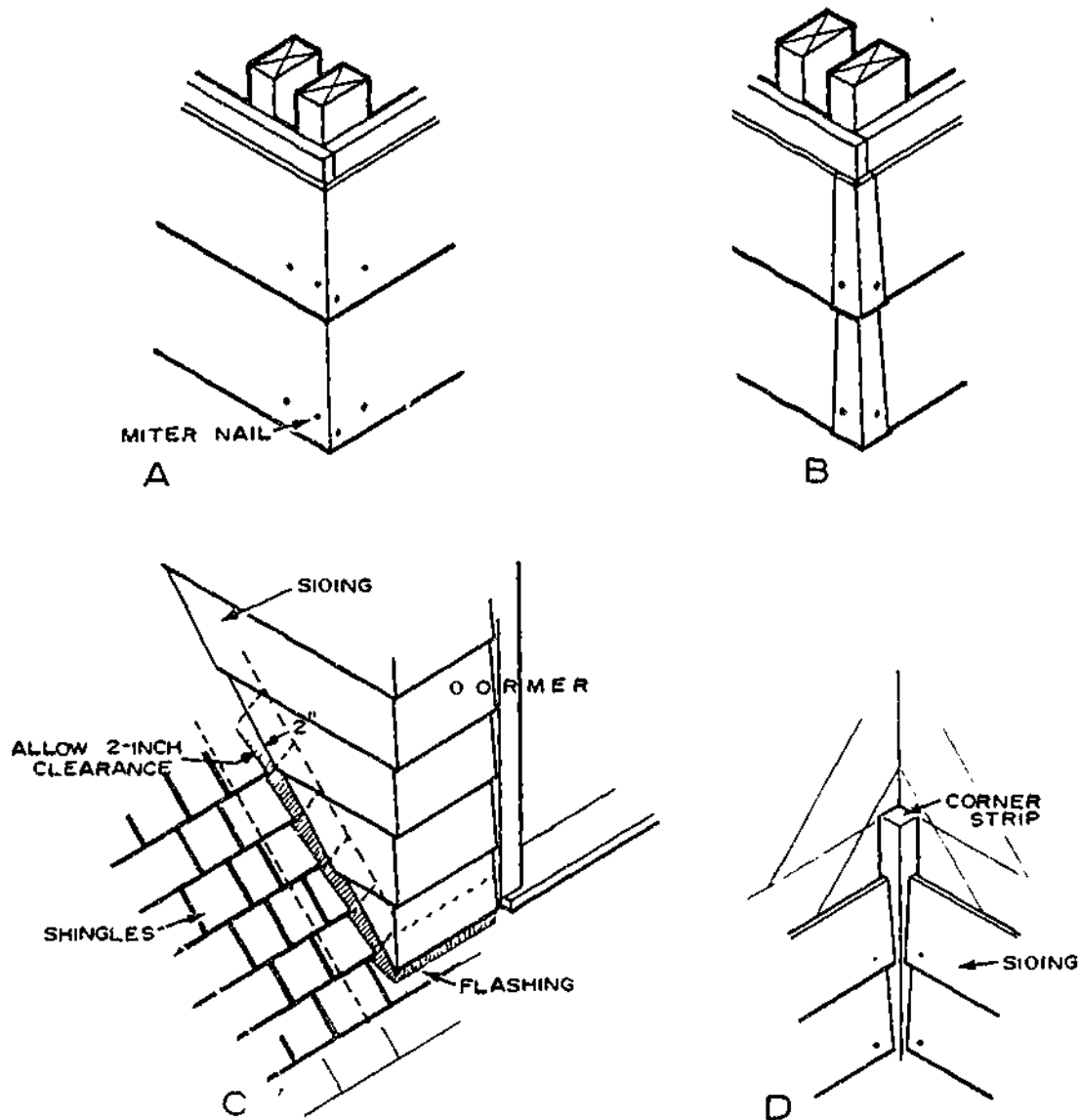

133.591

Figure 11-28.—Siding details: A. Miter corner; B. Metal corners; C. Siding return of roof; D. Interior corner.

provide the necessary resistance to entry of wind-driven rain. Here again, a water-repellent preservative should be used on the ends of the siding at the roofline.

Interior corners (view D, fig. 11-28) are butted against a square corner board of nominal 1 1/4 or 1 3/8 in. size, depending on the thickness of the siding.

MATERIAL TRANSITION

At times, the materials used in the gable ends and in the walls below differ in form and application. The details of construction used at the juncture of the two materials should be such that good drainage is assured. For example, when vertical boards and battens are used at the gable end and horizontal siding below, a drip cap

or similar molding might be used (fig. 11-29). Flashing should be used over and above the drip cap so that moisture will clear the gable end material.

WOOD SHINGLES AND WOOD SHAKE SIDING

Wood shingles and shakes are applied in a single- or double-course pattern. They may be used over wood or plywood sheathing. When sheathing is 3/8-in. plywood, use threaded nails. For nonwood sheathing, 1-by 3-inch or 1-by 4-inch wood nailing strips are used as a base. In the single-course method, one course is simply laid over the other as lap siding is applied. The shingles can be second grade because only one-half or less of the butt portion is exposed. (See fig. 11-30.) Shingles should not be soaked before application but should usually be laid with about 1/8 to 1/4 in. space between adjacent shingles to allow for expansion during

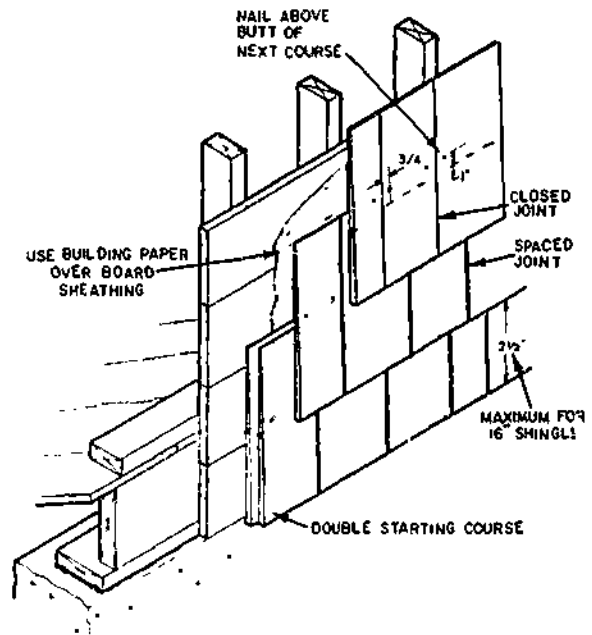

133.593

Figure 11-30.—Single-coursing of sidewalls (wood shingles-shakes).

rainy weather. When a “siding effect” is desired, shingles should be laid so that they are in contact, but only lightly. Prestained or treated shingles provide the best results.

In a double-course system, the undercourse is applied over the wall, and the top course is nailed directly over a 1/4- to 1/2-in. projection of the butt. (See fig. 11-31.) The first course should be nailed only enough to hold it in place while the outer course is being applied. The first shingles can be a lower quality, such as third grade or the undercourse grade. Because much of the shingle length is exposed, the top course should be first-grade shingles.

Shingles and shakes should be applied with rust-resistant nails long enough to penetrate into the wood backing strips or sheathing. In a single course, a threepenny or fourpenny zinc-coated “shingle” nail is commonly used. In a double course, where nails are exposed, a fivepenny zinc-coated nail with a small flathead is used for the top course, and a threepenny or

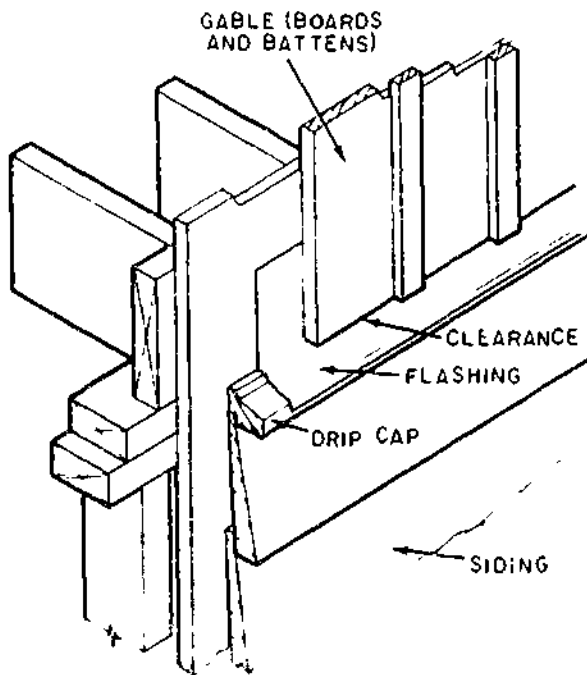

133.592

Figure 11-29.—Gable-end finish (material transition).

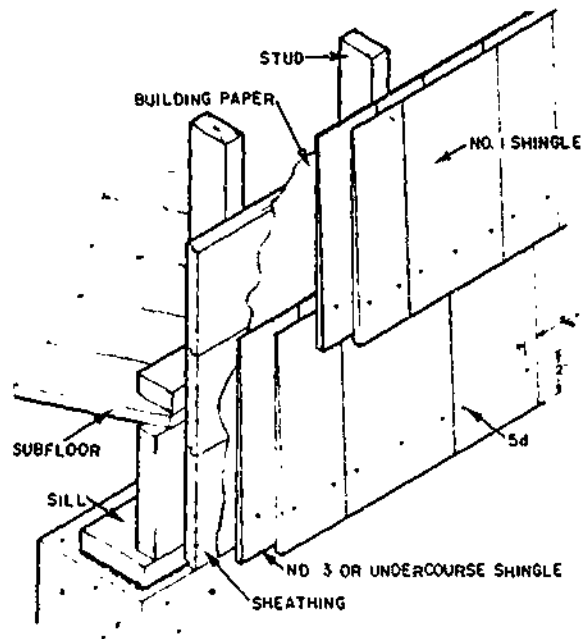

133.594

Figure 11-31.—Double-coursing of sidewalls (wood shingles-shakes).

fourpenny size for the undercourse. Use building paper over lumber sheathing.

FLASHING

Flashing should be installed at the junction of material changes, chimneys, and roof-wall intersections. It should also be used over exposed doors and windows, roof ridges and valleys, and along the edge of a pitched roof, or any other place where rain and melted snow may penetrate.

To prevent corrosion or deterioration where unlike metals come together, use fasteners made of the same kind of metal as the flashing. For aluminum flashing, use only aluminum or stainless steel nails, screws, hangers, and clips.

For copper flashing, use copper nails and fittings. Galvanized sheet metal or terneplate

should be fastened with galvanized or stainless-steel fasteners.

MATERIAL CHANGES

One wall area which requires flashing is at the intersection of two types of siding materials. For example, a stucco-finish gable end and a wood-siding lower wall should be flashed (view A, fig. 11-32). A wood molding, such as a drip cap, separates the two materials and is covered by the flashing which extends behind the stucco. The flashing should extend at least 4 in. above the intersection. When sheathing paper is used, it should lap the flashing (view A, fig. 11-32).

When a wood-siding pattern change occurs on the same wall, the intersection should also be flashed. A vertical board-sided upper wall with horizontal siding below usually requires some type of flashing (view B, fig. 11-32). A small space above the molding provides a drip for rain. This will prevent paint peeling which could occur if the boards were in tight contact with the molding. A drip cap is sometimes used as a terminating molding. (See fig. 11-29.)

DOORS AND WINDOWS

The same type of flashing, as shown in view A, figure 11-32, should be used over door and window openings exposed to driving rain. However, window and doorheads protected by wide overhangs in a single-story structure with a hip roof do not ordinarily require the flashing. When building paper is used on the sidewalls, it should lap the top edge of the flashing. To protect the walls behind the window sill in a brick veneer exterior, flashing should extend under the masonry sill up to the underside of the wood sill.

FLAT ROOFS

Flashing is also required at the junctions of an exterior wall and a flat or low-pitched

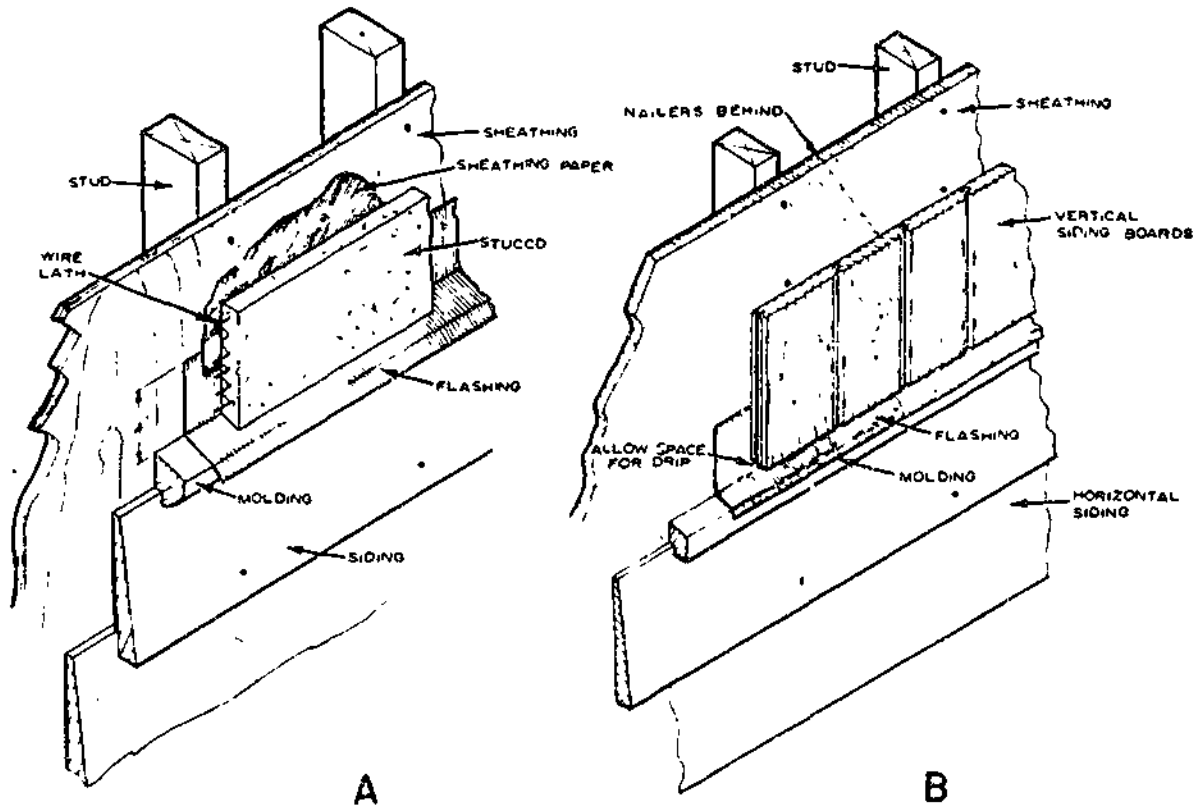

Figure 11-32 - Flashing of material changes. A. Stucco above, siding below, B. Vertical siding above, horizontal below. 133.595

built-up roof. (See view C, fig. 11-33.) Where a metal roof is used, the metal is turned up on the wall and covered by the siding. A clearance should be allowed at the bottom of the siding to protect against melted snow and rain.

shingles on the upper side. The lower edge of the collar laps the shingles. Sides are nailed to the shingles and caulked with a roofing mastic.

RIDGES

VALLEYS

To prevent water entry, (see view B, fig. 11-16), ridge flashing should be used under a Boston ridge when either a wood or asphalt shingle, or a shake roof is used. The flashing should extend about 3 in. on each side of the ridge and be nailed in place only at the outer edges. The ridge shingles or shakes, which are 6 to 8 in. wide, cover the flashing.

A valley, formed by two intersecting rooflines, is usually covered with metal flashing. Some building regulations allow the use of two thicknesses of mineral-surfaced roll roofing in place of the metal flashing. As an alternate, one 36-in.-wide strip of roll roofing with closed or woven asphalt shingles is also allowed.

Stack vents and roof ventilators are provided with flashing collars which are lapped by the

The width of the valley between shingles should increase from the top to the bottom, as shown in view A, figure 11-34. The minimum

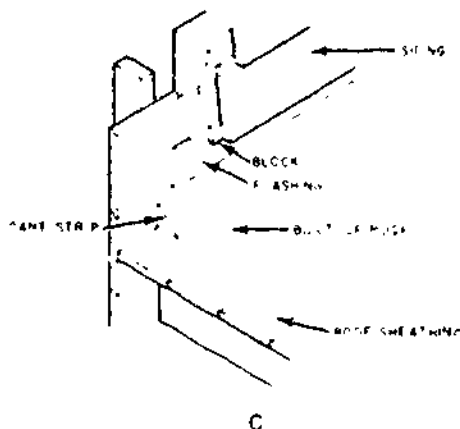
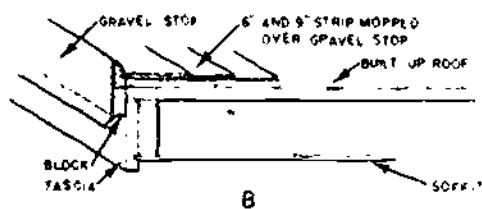
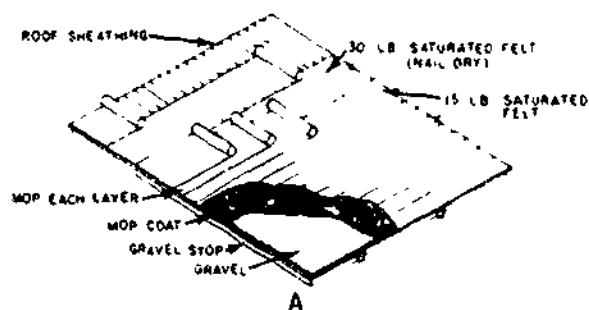

133.598

Figure 11-33.—Built-up roof: A. Installation of roof; B. Gravel stop; C. Flashing at building line.

open width at the top is 4 in. and should be increased at the rate of about 1/8 in. per ft. Widths can be chalklined on the flashing before shingles are applied.

Where adjacent roof slopes vary, such as a low-slope porch roof intersecting a steeper main roof, a 1-inch crimped standing seam should be used. (See view B, fig. 11-34.) This will keep heavy rains on the steeper slopes from overrunning the valley and being forced under the shingles on the adjoining slope. Nails for the shingles should be kept back as far as possible to

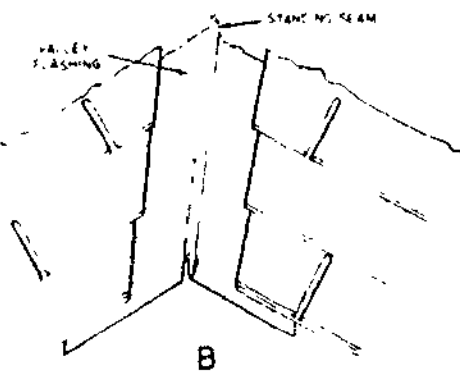
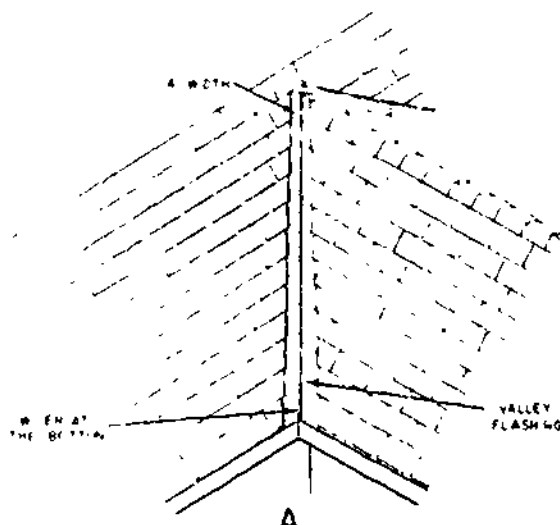

133.597

Figure 11-34.—Valley flashing: A. Valley; B. Standing seam.

eliminate holes in the flashing. A ribbon of asphalt-roofing mastic is often used under the edge of the shingles. It is wise to use the wider valley flashings supplemented by a width of 15- or 30-lb-asphalt felt where ice dams may cause the water from melting snow to back under the shingles.

ROOF-WALL INTERSECTIONS

Where shingles on a roof intersect a vertical wall, shingle flashing is used at the junction. Tin

or galvanized-metal shingles are bent at a 90° angle and extend up the side of the wall over the sheathing, as shown in view A, figure 11-35. When used under the shingle, roofing felt is turned up on the wall and covered by the flashing. One piece of flashing is used at each shingle course. The siding is then applied over the flashing with about a 2-in. space allowed between the bevel edge of the siding and the roof.

If the roof intersects a brick wall or chimney, the same type of metal shingle flashing is used at the end of each shingle course as described for the wood-sided wall. In addition, counterflashing or brick flashing is used to cover

the shingle flashing, as shown in view B, figure 11-35. Often performed in sections, this counterflashing is inserted in open mortar joints. Unless soldered together, each section should overlap the next, with the joint caulked. As the chimney or the brick wall is layed up, the mortar is usually raked out to a depth of about 1 in. at flashing locations. Lead wedges are driven into the joint above the flashing to hold it in place. The joint is then caulked to provide a watertight connection. In chimneys, this counterflashing is often preformed to cover one entire side.

ROOF EDGES

The cornice and the rake section of the roof are sometimes protected by a metal edging. This edging forms a desirable drip edge at the rake and prevents rain from entering behind the shingles. (See view B, fig. 11-14.)

At the eave line, a similar metal edging may be used to advantage (view A, figure 11-36). This edging, with the addition of a roll roof flashing, (see view B, fig. 11-9), will aid in resisting water entry from ice dams. Variations of it are shown in views B and C, figure 11-36. They form a good drip edge and prevent or minimize the chance of rain being blown back under the shingles. This type of drip edge is desirable whether or not a gutter is used.

GUTTERS AND DOWNSPOUTS

Several types of gutters are available to guide the rainwater to the downspouts and away from the foundation. Some gutters are built in the cornice. These are lined with sheet metal and connected to the downspouts. On flat roofs, water is often drained from one or more locations and carried through an inside wall to an underground drain. All downspouts connected to an underground drain should

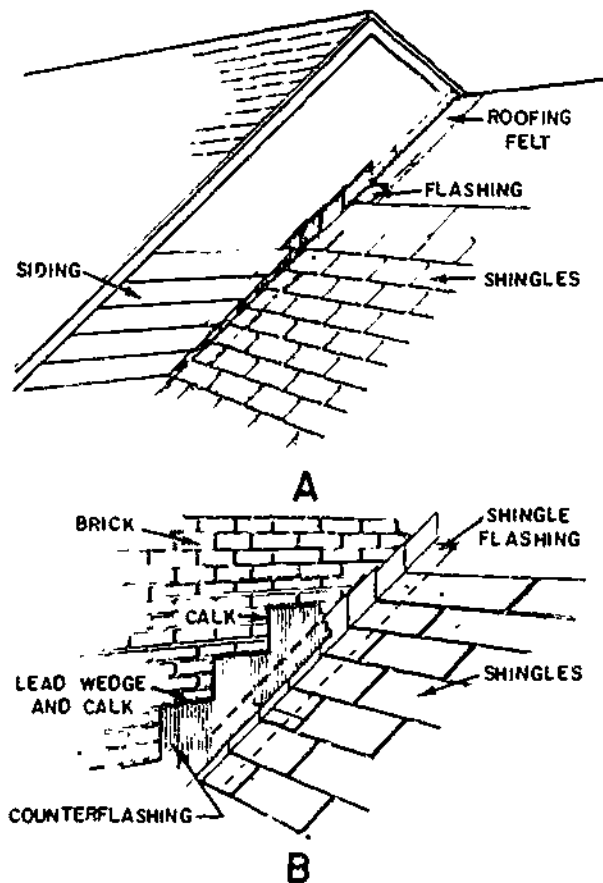

133.598
Figure 11-35.—Roof and wall intersection: A. Wood siding wall; B. Brick wall.



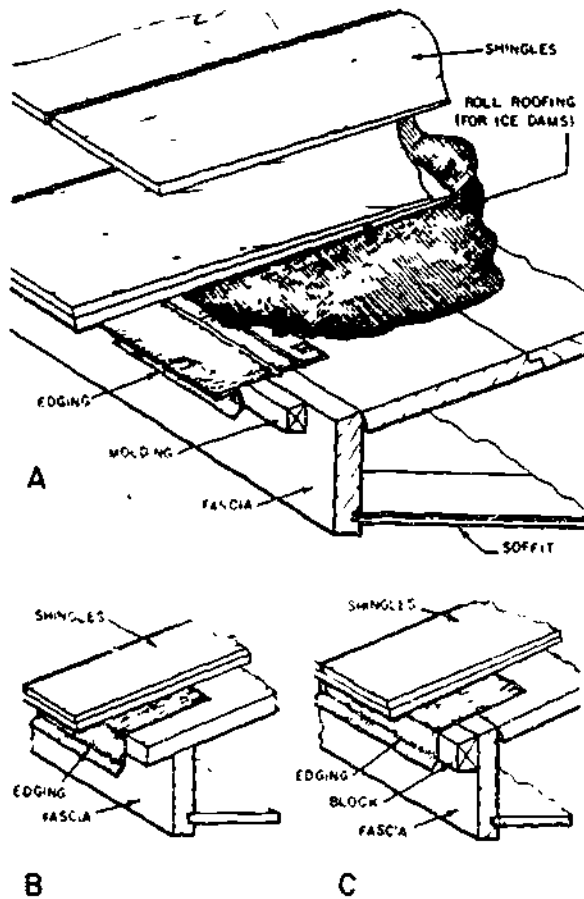

133.599

Figure 11-36.—Cornice flashing: A. Formed flashing; B. Flashing without wood blocking; C. Flashing with wood blocking.

contain basket strainers at the junctions of the gutter.

Perhaps the most commonly used gutter is the type hung from the edge of the roof or fastened to the edge of the cornice fascia. Metal gutters may be the half-round (view A, fig. 11-37), or a formed type (view B, fig. 11-37), and may be made of galvanized metal, copper, or aluminum. Some have a factory-applied enamel finish.

Downspouts are round or rectangular (views C and D, fig. 11-37), but the round type is used for the half-round gutters. They are usually

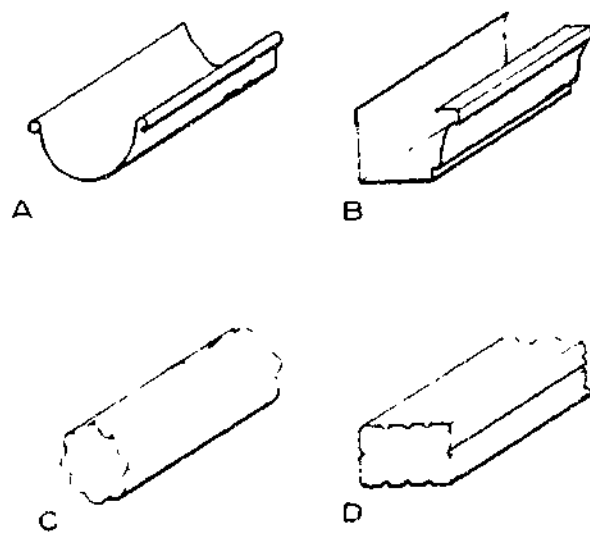

133.600

Figure 11-37.—Gutters and downspouts: A. Half-round gutter; B. Formed gutter; C. Round downspout; D. Rectangular downspout.

corrugated to provide extra stiffness and strength. Corrugated patterns are less likely to burst when plugged with ice.

On long runs of gutters, such as required around a hip-roof structure, at least four downspouts are desirable. Gutters should be

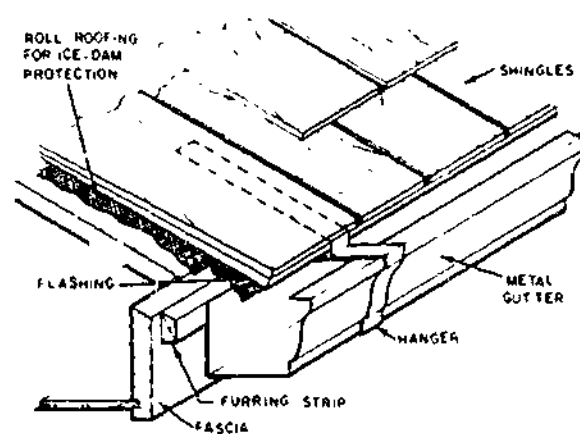

133.601

Figure 11-38.—Formed metal gutters.

installed with a slight pitch toward the downspouts. Metal gutters are often suspended from the edge of the roof with hangers, as shown in figure 11-38. Hangers should be spaced 48 in. apart when made of galvanized steel and 30 in. apart when made of copper or aluminum. Formed gutters may be mounted on furring strips, but the gutter should be reinforced with wrap-around hangers at 48-in. intervals. Gutter splices, downspout connections, and corner joints should be soldered or provided with watertight joints.

Downspouts are fastened to the wall by straps or hooks (view A, fig. 11-39). Several patterns of these fasteners allow a space between the wall and downspout. One common type consists of a galvanized metal strap with a spike and spacer collar. After the spike is driven through the collar and into the siding and backing stud, the strap is fastened around the pipe. Downspouts should be fastened at the top and bottom. In addition, a strap or hook should be used every 6 ft on long downspouts.

An elbow should be used at the bottom of the downspout, as well as a splash block, to carry the water away from the wall. However, a tile line is sometimes used to carry the water to a storm sewer (See view B, fig. 11-39.)

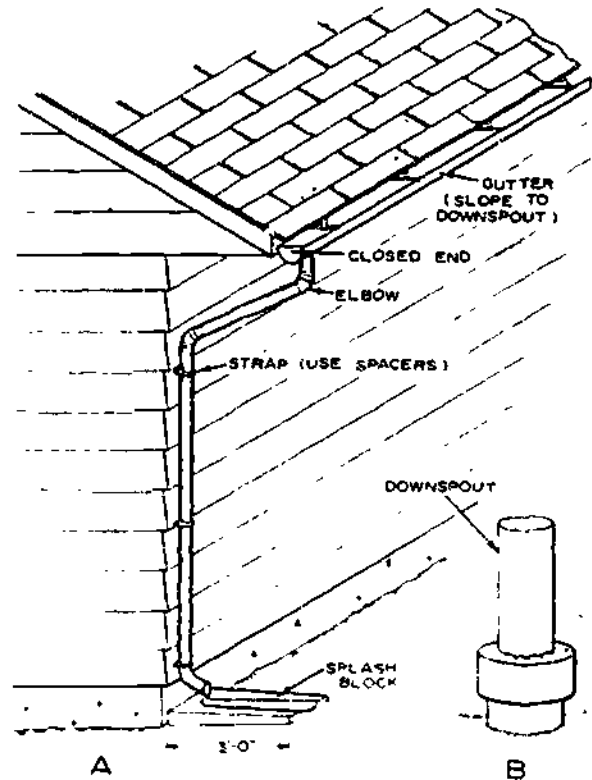

133.802

Figure 11-39.—Downspout installation: A. Downspout with splash block; B. Drain to storm sewer.

CHAPTER 12

INTERIOR FINISH

As a Builder, you and your crewmembers will be responsible for putting many finishing touches on the interiors of the buildings of a construction project. The interior finish consists mainly of the coverings applied to the rough walls, ceilings, and floors. Interior finish also involves the installation of windows and doors (included under exterior finish too); window and door trim; other trim such as base and cornice; stairs; hardware; and where required, kitchen and built-in cabinets.

WALL AND CEILING COVERINGS

Though lath-and-plaster finish is widely used in building construction, the use of dry-wall finishes has been increasing. It usually saves time in construction. Being wet, plaster finish requires drying time before other interior work can be started. Dry-wall finish does not since little, if any, water is required for application. However, a gypsum dry wall demands a moderately low moisture content of the framing members to prevent "nail-pops." These result when frame members dry out to moisture equilibrium, causing the nailhead to form small "humps" on the surface of the board. Furthermore, stud alignment is important for single-layer gypsum finish to prevent a wavy, uneven appearance. Thus, there are advantages to both plaster and gypsum dry-wall finishes and each should be considered along with the initial cost and maintenance.

There are many types of dry-wall finishes, but one of the most widely used is gypsum board in 4 by 8-ft sheets and in lengths up to 16 ft which are used for horizontal application.

Plywood, hardboard, fiberboard, particleboard, wood paneling, and similar types, many in prefinished form, are also used.

The use of thin sheet materials, such as gypsum board or plywood requires that studs and ceiling joists have good alignment to provide a smooth, even surface. Wood sheathing will often correct misaligned studs on exterior walls. A "strong back" provides for alignment of ceiling joists of unfinished attics. (See view A, fig. 12-1.) It can be used at the center of the span when ceiling joists are uneven.

INSTALLATION OF GYPSUM BOARD

Gypsum board is a sheet material composed of a gypsum filler faced with paper. Sheets are normally 4 ft wide and 8 ft long, but can be obtained in lengths up to 16 ft. The edges along the length are usually tapered, although some types are tapered on all edges. This allows for a filled and taped joint. This material may also be obtained with a foil back which serves as a vapor barrier on exterior walls. It is also available with vinyl or other prefinished surfaces. In new construction, 1/2-in. thickness is recommended for single-layer application. In laminated two-ply applications, two 3/8-in.-thick sheets are used. The 3/8-in. thickness, while considered minimum for 16-in. stud spacing in single-layer applications, is normally specified for repair and remodeling work.

When the single-layer system is used, the 4-ft-wide gypsum sheets are applied vertically or horizontally on the walls after the ceiling has been covered. Vertical application covers three stud spaces when studs are spaced 16-in.

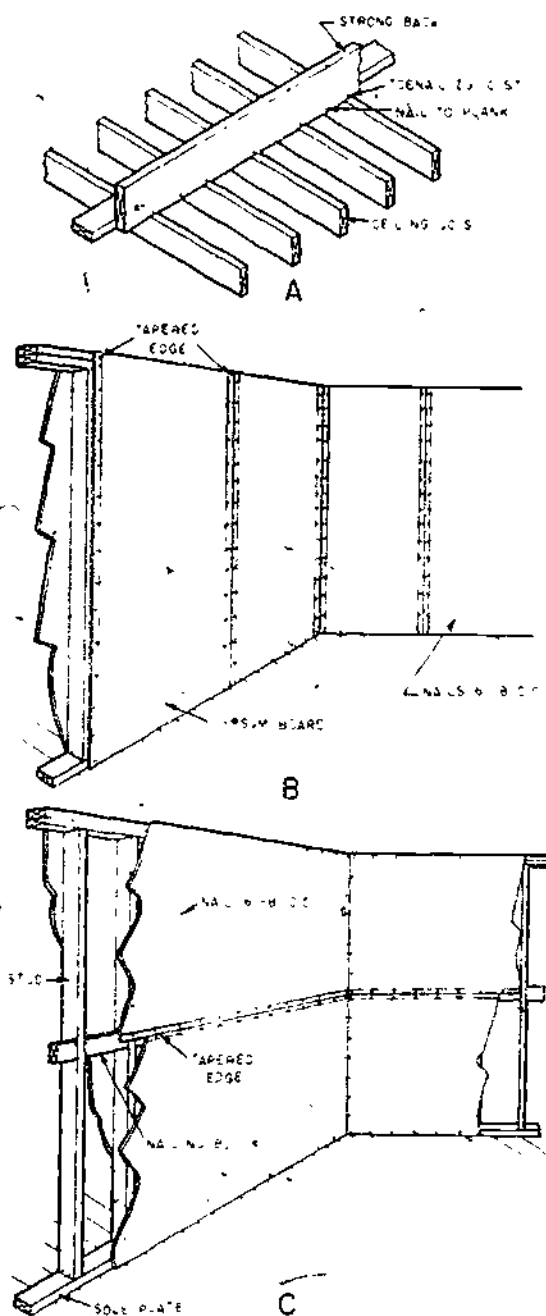

133.509
 Figure 12-1.—Application of gypsum board finish: A. Strong back; B. Vertical application; C. Horizontal application.

oncenter, and two when spacing is 24 in. Edges should be centered on studs, and only moderate contact should be made between edges of the sheet.

Fivepenny wallboard-type nails (1 5/8 in. long) should be used with 1/2-in. gypsum, and fourpenny (1 3/8 in. long) with the 3/8-in. thick material. Ring-shank nails, about 1/8-in. shorter, can also be used. Some manufacturers often recommend the use of special screws to reduce "bulging" of the surface ("nail-pops" caused by drying out of the frame members).

Nails should be spaced 6 to 8 in. apart for sidewalls (view B, fig. 12-1) and 5 to 7 in. apart for ceiling application whereas the minimum edge distance is 3/8 in.

The horizontal method of application is best adapted to rooms in which full-length sheets can be used, as it minimizes the number of vertical joints. Where joints are necessary, they should be made at windows or doors. Nail spacing is the same as that used in vertical application. When stud spacing is not greater than 16-in. oncenter and the gypsum board is 3/8 in. or thicker, the horizontal nailing blocks are not normally required. However, when spacing is greater, or an impact-resistant joint is required, nailing blocks should be used. (See view C, fig. 12-1.)

Another method of gypsum-board application (laminated two-ply) includes an undercourse of 3/8-in. material applied vertically and nailed in place. The finish 3/8-in. sheet is applied horizontally, usually in room-size lengths, with an adhesive. This adhesive is either applied in ribbons, or is spread with a notched trowel. The manufacturer's recommendations should be followed in all respects.

Nails in the finish gypsum wallboard should be driven with the heads slightly below the surface. The crowned head of the hammer will form a small dimple in the wallboard. (See view A, fig. 12-2.)

A nail set should not be used, and care should be taken to avoid breaking the paper on the gypsum wallboard.

Joint cement, "spackle," is used to apply the tape over the tapered edge joints and to smooth and level the surface. It comes in powder form

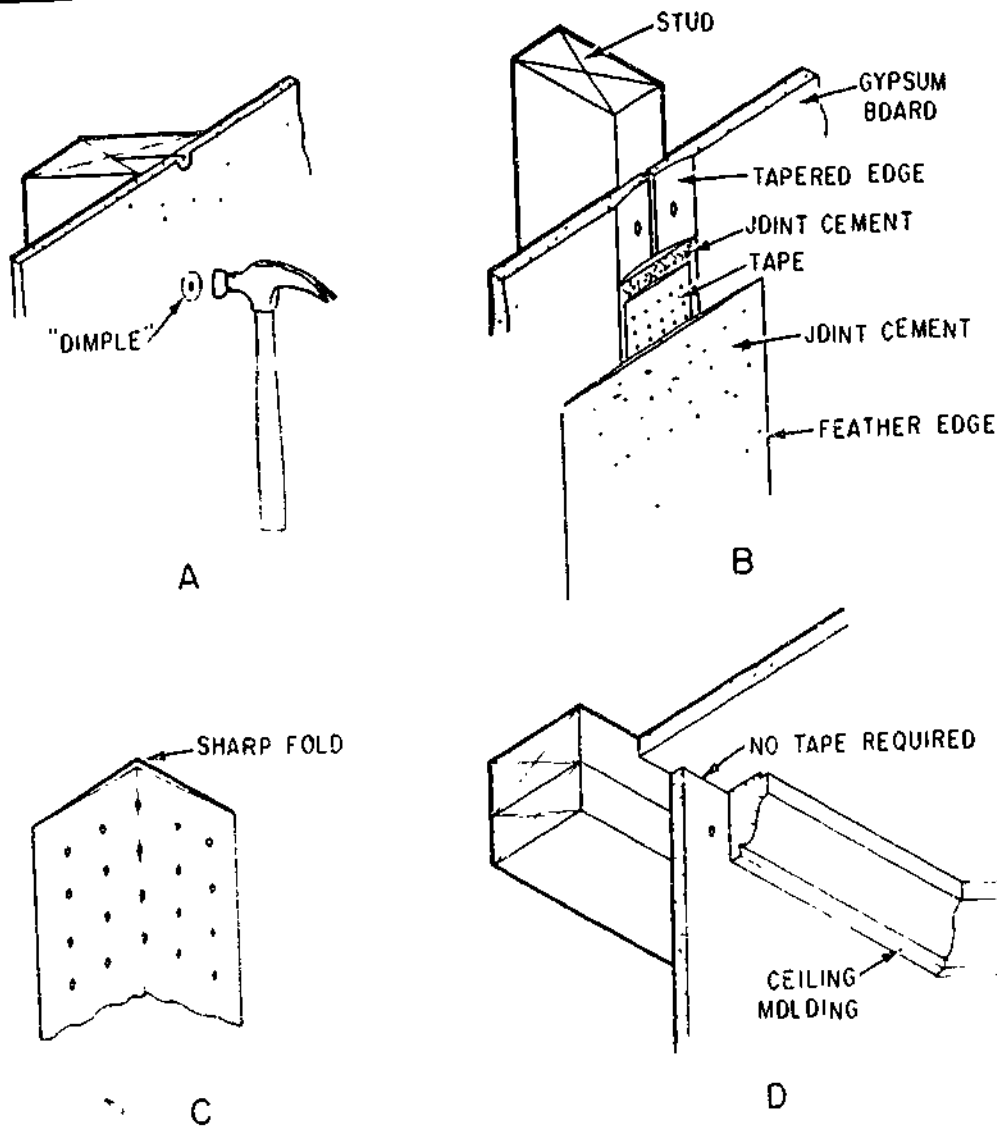

133.510
 Figure 12-2.—Preparing gypsum dry-wall sheets for painting: A. Driving nails in "dimple" fashion; B. Detail of joint treatment; C. corner tape; D. Ceiling molding.

and is mixed with water to a soft putty consistency so that it can be easily spread with a trowel or putty (drywall) knife (See fig. 12-3.) It can also be obtained in premixed form. The general procedure for taping, as shown in view B, fig. 12-2, is as follows

1. Use a wide spackling knife (5 in.) and spread the cement in the tapered edges, starting at the top of the wall.

2. Press the tape into the recess with the putty knife until the joint cement is forced through the perforations.

3. Cover the tape with additional cement, feathering the outer edges.

4. Allow to dry, sand the joint lightly, and then apply the second coat, feathering the edges. A steel trowel is sometimes used in applying the second coat. For best results, a third coat may be applied, feathering beyond the second coat.

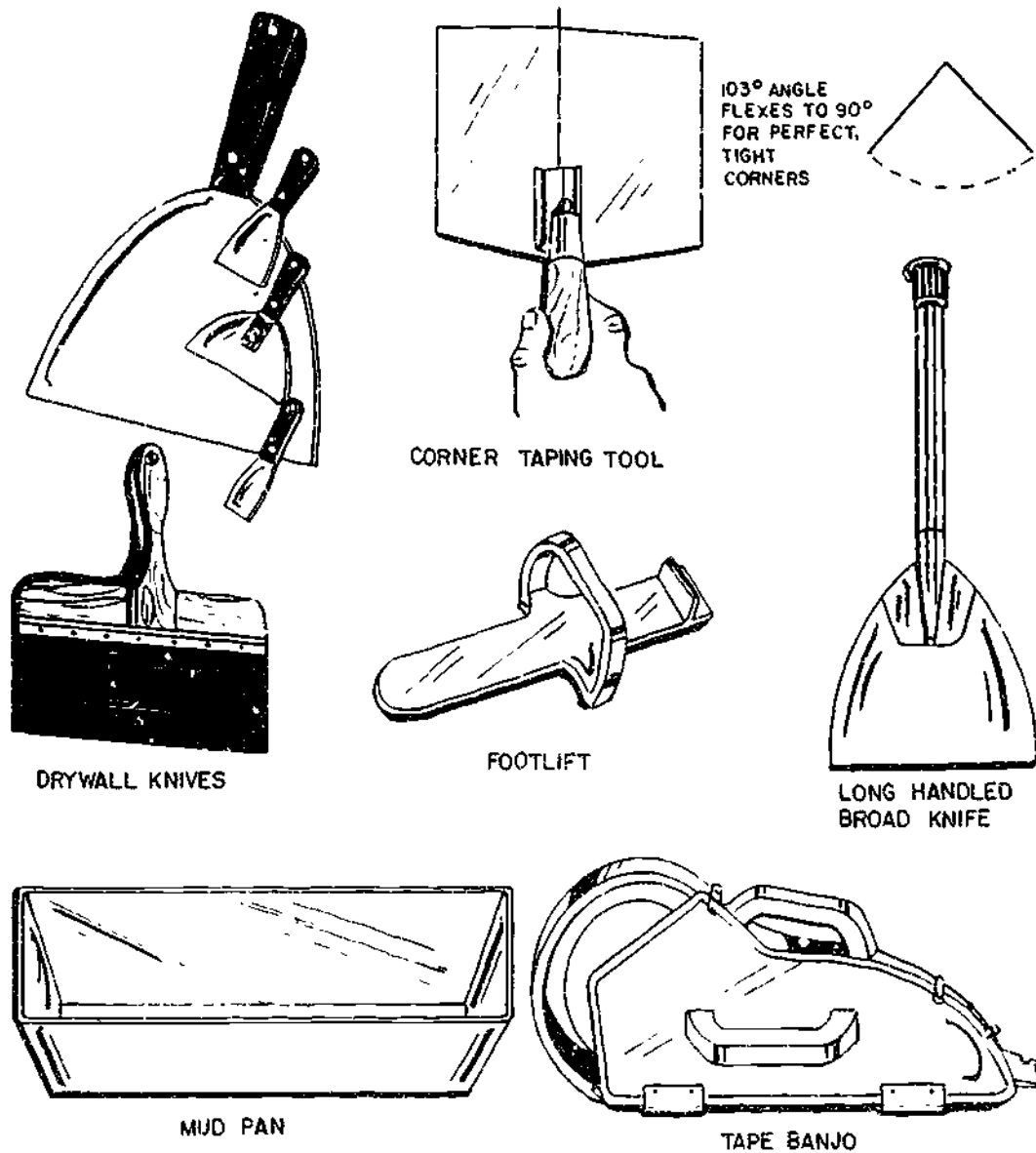

Figure 12-3.—Basic dry-wall hand tools.

133.511

5. After the joint cement is dry, sand it smooth (an electric hand vibrating sander works well).

6. To hide hammer indentations, fill them with joint cement and sand then smooth when dry. Repeat with a second coat when necessary.

Interior corners may be treated with tape. Fold the tape down the center to a right angle

(view C, fig. 12-2), and (1) apply cement at the corner, (2) press the tape in place, and (3) finish the corner with joint cement. Sand it smooth when dry and apply a second coat.

The interior corners between walls and ceilings may also be concealed with some type of molding, as shown in view D, fig. 12-2. When moldings are used, taping this joint is not necessary. Wallboard corner beads at exterior

corners will prevent damage to the gypsum board. They are fastened in place and covered with the joint cement.

INSTALLATION OF PLYWOOD

Prefinished plywood is available in a number of kinds, and its use should not be overlooked for accent walls or to cover entire room wall areas. Plywood for interior covering may be used in 4 by 8-ft lengths and longer sheets. They may be applied vertically or horizontally, but with solid backing at all edges. For 16-in. frame-member spacing, 1/4-in. thickness is considered minimum. For 20- or 24-in. spacing, 3/8-in. plywood is the minimum thickness. Casing or finishing nails 1 1/4 to 1 1/2 in. long are used. Space them 8 in. apart on the walls and 6 in. apart on the ceilings. Edge nailing distance should be not less than 3/8 in. Allow 1/32-in. end and edge distance between sheets when installing. Most wood or wood-base panel materials should be exposed to the conditions of the room before installation. Place them around the heated room for at least 24 hrs.

Adhesives may also be used to fasten prefinished plywood and other sheet materials to wall studs. These panel adhesives usually eliminate the need for more than two guide nails for each sheet. Application usually conforms to the following procedures. (1) position the sheet and fasten it with two nails for guides at the top or side. (2) remove plywood and spread contact or similar adhesive on the framing members; (3) press the plywood in place for full contact using the nails for positioning. (4) pull the plywood away from the studs and allow adhesive to set; and (5) press plywood against the framing members and tap lightly with a rubber mallet for full contact. Manufacturers of adhesives supply full instructions for application of sheet materials.

NOTE: When rework or new construction in public buildings is done, fire regulations often require a fire retardant material, such as gypsum board be installed prior to placing plywood paneling or any other combustible material.

However, there are now on the market fire resistant finished plywood panels, but they are normally very expensive compared to the standard panels.

INSTALLATION OF HARDBOARD AND FIBERBOARD

Hardboard and fiberboard are applied the same way as plywood. Hardboard should be at least 1/4-in. thick when used over open framing spaced 16-in. oncenter. Rigid backing of some type is required for 1/8-in.-thick hardboard.

Fiberboard in tongued-and-grooved plank or sheet form should be 1/2 in. thick when frame members are spaced 16-in. oncenter and 3/4-in. when 24-in. spacing is used, as previously outlined. The casing or finishing nails must be slightly longer than those used for plywood or hardboard; spacing is about the same. Fiberboard is also used in the ceiling as acoustic tile and may be nailed to strips fastened to ceiling joists. It is also installed in 12 by 12 in. or larger tile forms on wood or metal hangers which are hung from the ceiling joists. This system is called a "suspended ceiling."

INSTALLATION OF WOOD PANELING

Various types and patterns of woods are available for application on walls to obtain the desired decorative effects. For informal treatment, knotty pine, white-pocket Douglas-fir, sound wormy chestnut, and pecky cypress, finished natural or stained and varnished, may be used to cover one or more sides of a room. The wood paneling should be thoroughly dry. Allow the material to reach this condition by placing it flat on the floor of a heated room.

The panels (boards) may be applied horizontally or vertically, but the same general methods of application should pertain to each. The following guidelines may be used in the application of matched wood paneling:

1. The boards should not be wider than 8 in. except when a long tongue or matched edges are used. (See figure 12-4.)

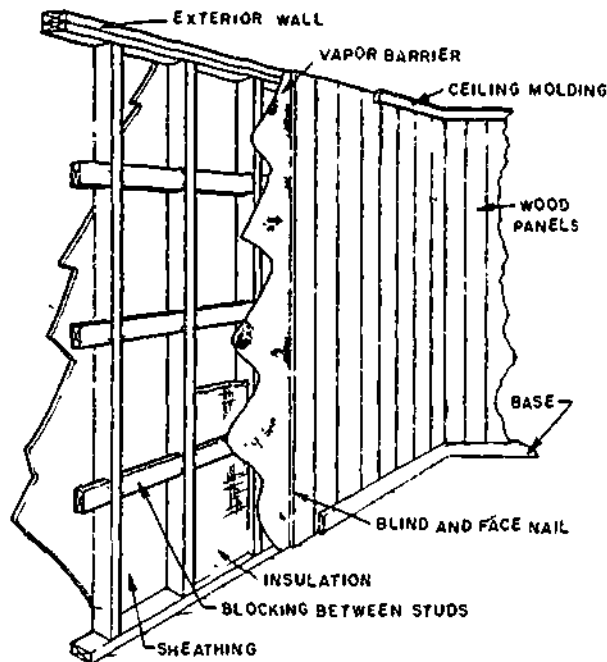

133.512

Figure 12-4.—Application of vertical paneling.

2. The thickness of the boards should be at least 3/8 in. for 16-in. spacing of frame members, 1/2 in. for 20-in. spacing, and 5/8 in. for 24-in. spacing.

3. The boards should be nailed over a vapor barrier and insulated when application is on the exterior wall framing or blocking.

4. The maximum spacing of supports for nailing should be 24 in. oncenter (blocking for vertical application).

5. The nails should be fivepenny or sixpenny casing or finishing.

6. You should use two nails for boards 6 in. or less in width and three nails for boards 8 in. or wider. One nail can be blind-nailed in matching paneling.

Wood panels in the form of small plywood squares can also be used for the interior wall coverings. (See fig. 12-5.) When used over framing and a vapor barrier, blocking should be located so that each edge has full bearing. Each edge should be fastened with casing or finish nails. When two sides are tongued-and-grooved,

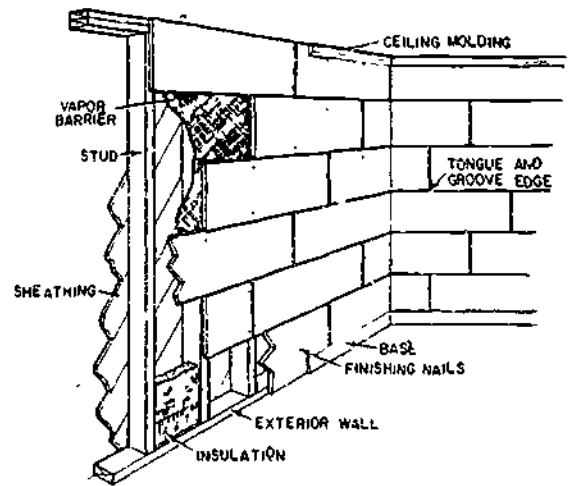

133.513

Figure 12-5.—Application of tongued-and-grooved paneling over studs.

one edge (tongued side) may be blind-nailed. When paneling (16 by 18 in. or larger) crosses studs, it should be nailed at each intermediate bearing. Matched (tongued-and-grooved) sides should be used when no horizontal blocking is provided or paneling is not used over a solid backing.

SUSPENDED ACOUSTIC CEILING SYSTEMS

Suspended acoustical ceiling systems can be installed to lower a ceiling, finish off exposed joints, cover damaged plaster, or make any room quieter and brighter. The majority of the systems available are primarily designed for acoustical control; however, many manufacturers offer systems which integrate the functions of lighting, air distribution, fire protection and acoustical control. Individual characteristics of acoustical tiles, including sound absorption coefficients, noise reduction coefficients, light reflection values, flame resistance, and architectural applications, are available from the manufacturer. Tiles are available in 12 to 60 in. widths, 12 to 60 in. lengths, and 3/16 to 3/4-in. thickness. The larger

sizes are referred to as panels. The most commonly used panels in suspended ceiling systems are the standard 2- by 2-ft and 2- by 4-ft acoustic panels composed of mineral or cellulose fibers.

It is beyond the scope of this training manual to acquaint you with each of the suspended acoustical ceiling systems in use today. Just as the components of these systems vary according to manufacturers, so do the procedures involved in their installation. With this in mind, the following discussion is designed to acquaint you with the principles involved in the installation of a typical suspended acoustical ceiling system that is adaptable to both standard sizes of acoustical panels.

PREPARATION FOR INSTALLATION

The success of a suspended ceiling project, as with any construction project, is just as dependent on planning as it is with construction methods and procedures. Planning in this case involves the selection of a grid system (either steel or aluminum), the selection and layout of a grid pattern (2 by 2 ft or 2 by 4 ft), and the determination of material requirements. Figure 12-6 shows the major components of a steel and aluminum ceiling grid system which are used for the 2- by 2-ft or 2- by 4-ft grid patterns shown in figure 12-7

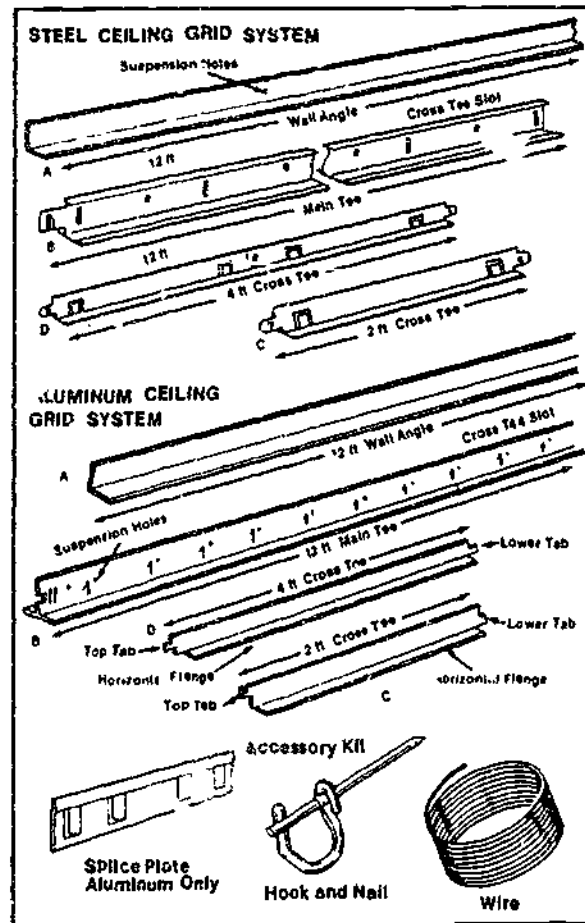

117.363

Figure 12-6.—Grid system component.

Grid Pattern Layout

The layout of a grid pattern and the material requirements are based on the ceiling measurements, the length and width of the room at the new ceiling height. If the ceiling length and/or width is not divisible by 2 ft, increase that dimension to the next higher foot divisible by 2 ft. For example, if a ceiling measures 13 ft, 7 in. by 10 ft, 4 in., it should be considered as being a 14- by 12-ft ceiling for material and layout purposes. The next step is to draw a layout on graph paper, making sure that the main tees run perpendicular to the joists. Position the main tees on your drawing so that the border panels at room edges are equal and as large as possible. Try several layouts to see which looks best with the main tees. Draw in cross tees so the border panels at the room ends

are equal and as large as possible. Try several combinations to determine the best one. For 2- by 4-ft patterns, space across tees 4 ft apart. For 2- by 2-ft patterns, space cross tees 2 ft apart. For smaller areas, the 2- by 2-ft pattern is recommended.

Material Requirements

As indicated in figure 12-6, wall angles and main tees come in 12-ft pieces. Using the perimeter of room at suspended ceiling height, you can determine the number of pieces of wall angle by dividing the perimeter by 12 and adding 1 additional piece for any fraction. Determine the number of 12-ft main tees, 2-ft

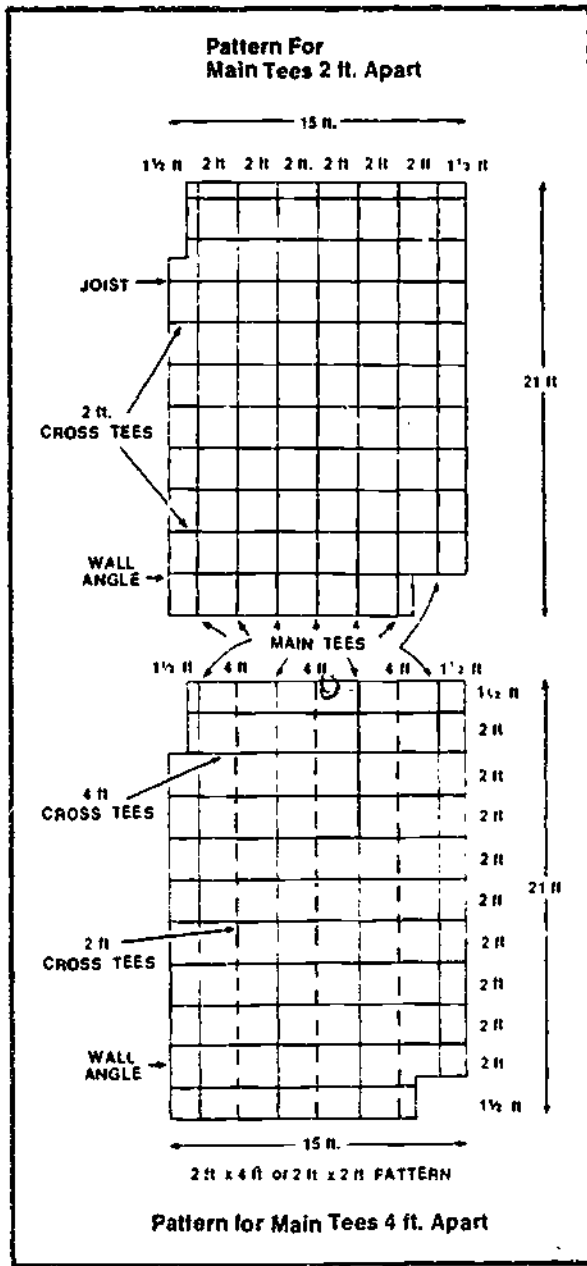

117.364

Figure 12-7.—Grid patterns.

and/or 4-ft cross tees by counting them on the grid pattern layout. In determining the number of 2-ft or 4-ft cross tees for border panels, you must remember that no more than 2 border tees can be cut from one cross tee.

INSTALLATION

The tools normally required for the installation of a grid system of the type under discussion include a hammer, chalk, or pencil, pliers, tape measure, screwdriver, hacksaw, knife, and tinsnips. With these tools on hand, you can begin installation by installing the wall angles, then the suspension wires followed by the main tees, cross tees, and acoustical panels.

Wall Angles

The first step is to install the wall angles at the new ceiling height which, in the case of the grid system under discussion, can be as close as 2 in. below the existing ceiling. Begin by marking a line around the entire room to indicate wall angle height and to serve as a level reference. Make sure to mark continuously to insure that the lines at intersecting walls meet. (See fig. 12-8.) On gypsum board, plaster or paneled walls, install wall angles with nails or

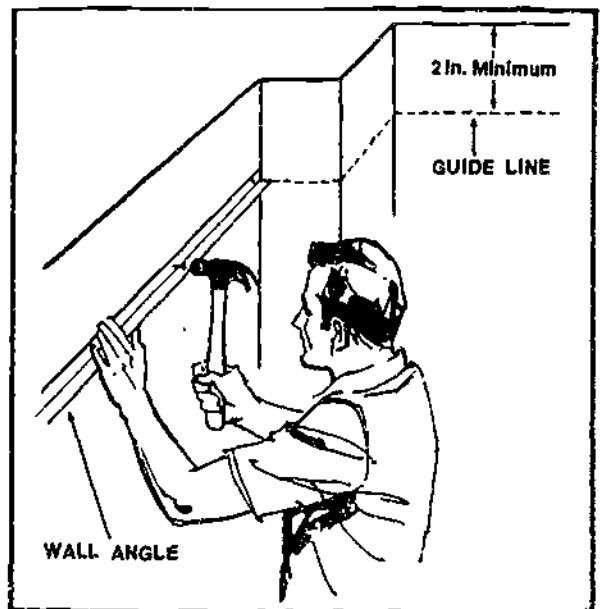

117.365

Figure 12-8.—Wall angle installation.

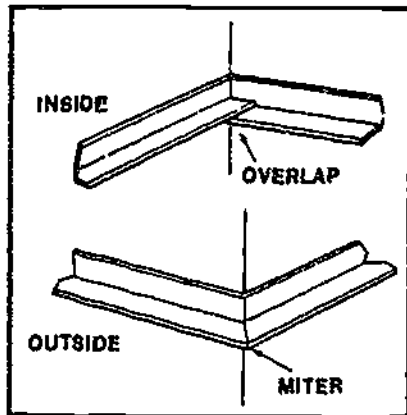

117.366
Figure 12-9.—Corner treatment.

screws. On masonry walls, use concrete nails spaced 24 in. apart taking care to insure that the wall angle is level. (See figure 12-9 for treatment at corners.) After the wall angles are installed, the next step is to attach the suspension wires.

Suspension Wires

Suspension wires are required every 4-ft along main tees and on each side of all splices.

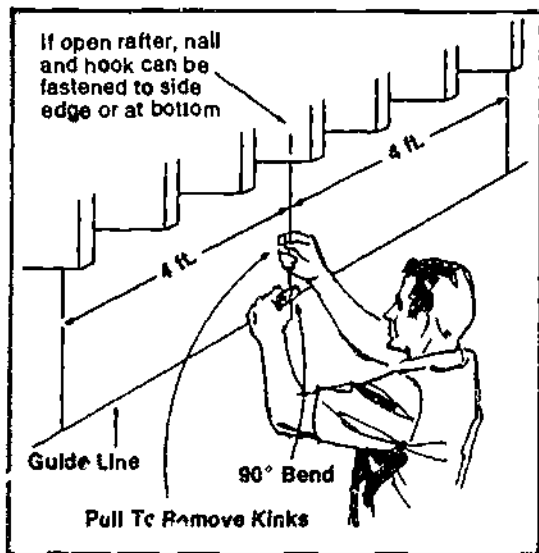

117.367
Figure 12-10.—Suspension wire installation.

Attach wires to the existing ceiling with nails or screw eyelets. Before attaching the first wire, measure the distance from the wall to the first main tee. Then stretch a guideline from opposite wall angles to show the correct position of the first main tee. Position suspension wires for the first tee along the guide. Wires should be cut to proper length, which is at least 2 in. longer than the distance between the old and new ceiling. Attach additional wires at 4-ft intervals. Pull wires to remove kinks and make 90° bends in the wires where they intersect the guideline. Move the guideline, as required, for each row. (See fig. 12-10.) After the suspension wires are attached, the next step is to install the main tees.

Main Tees

Main tees, 12 ft or less in length, are installed by resting the ends on opposite wall angles and inserting the necessary suspension wires. (See fig. 12-11.) Hang one wire near the

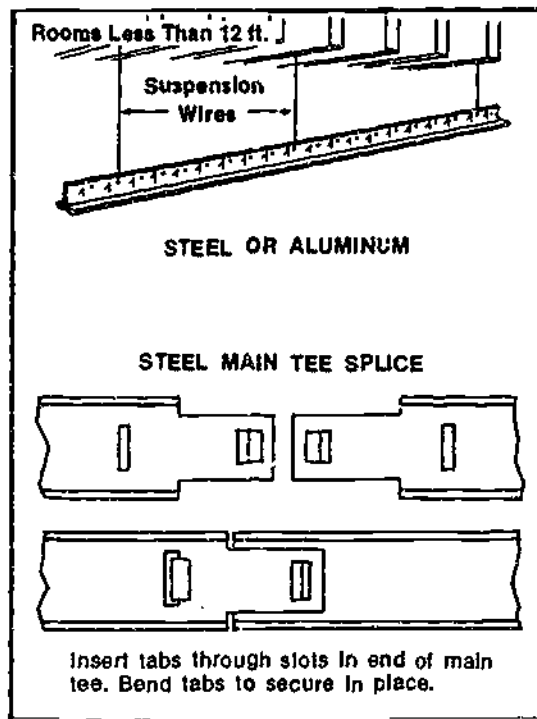

117.368
Figure 12-11.—Main tee suspension and steel tee splice.

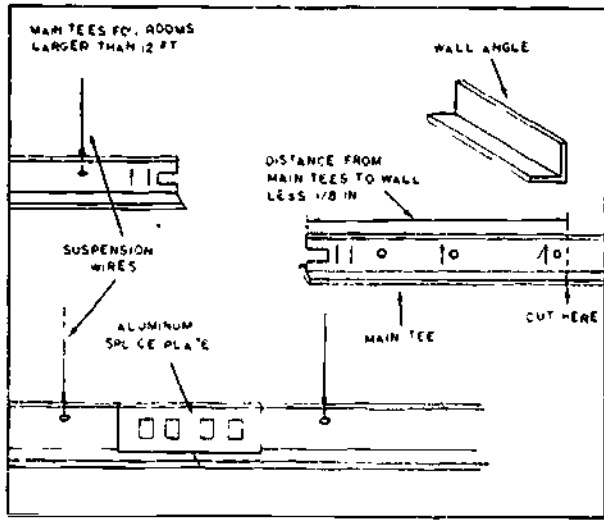

117.370

Figure 12-12.—Main tee suspension and aluminum tee splice.

middle of the main tee, level and adjust the wire length, then secure all the wires by making the necessary turns in the wire.

If the main tees required are over 12 ft in length, they must be cut to insure that the cross tees will not intersect the main tee at a splice joint. Begin the installation by resting the cut end on the wall angle and attaching the suspension wire closest to the opposite end.

Attach the remaining suspension wires, while making sure the main tee is level before securing. The remaining tee or tees are installed by making the necessary splices as shown in figures 12-11 and 12-12, and resting the end on the opposite wall angle. After the main tees are installed, leveled, and secured, the next step is to install the cross tees.

Cross Tees

Aluminum cross tees have "high" and "low" tab ends which provide easy positive installation without tools. Installation begins by cutting border tees (when necessary) to fit between the first main tee and the wall angle. Cut off the high tab end and rest this end in the main tee slot. Repeat this procedure until all border tees are installed on one side of the room. Continue across the room, installing the remaining cross tees in accordance with your grid pattern layout. An aluminum cross tee assembly is shown in figure 12-13. At the opposite wall angle, cut off the low tab of the border tee and rest the cut end on the wall angle. If the border edge is less than half the length of the cross tee, you can use the remaining portion of the border tee that was previously cut.

Steel cross tees have the same tab on both ends and, like the aluminum tees, they do not require tools for installation. The procedures used in their installation are the same as those just mentioned for aluminum. A steel cross tee assembly is shown in figure 12-14. The final step

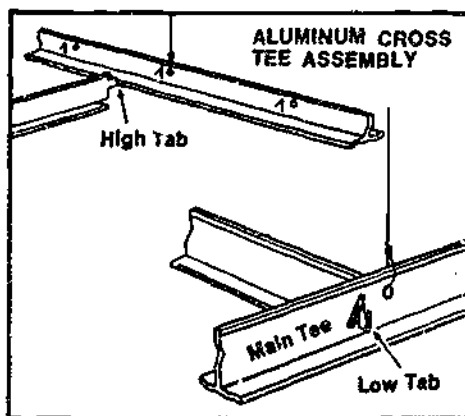

117.371

Figure 12-13.—Aluminum cross tee assembly.

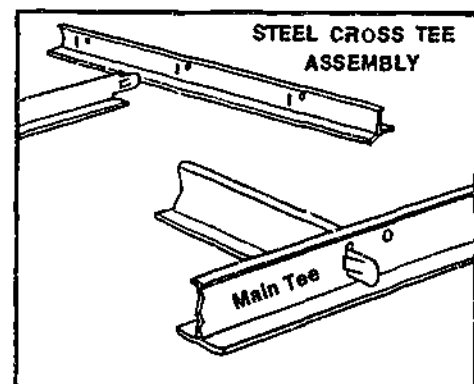

117.372

Figure 12-14.—Steel cross tee assembly.

after completion of the grid system is the installation of the acoustical panels.

Acoustical Panels

Panel installations is started by laying in all full ceiling panels. Border panels should be installed last after they have been cut to proper size. To cut the panel, turn the finish side up, scribe with a sharp utility knife, and saw with a sharp handsaw having 12 or 14 teeth per in.

The majority of the ceiling panel patterns are random and do not require orientation. However, some fissured panels are designed to be installed in a specific direction and are so marked on the back with directional arrows. When installing panels on a large project, you should work from several cartons. The reason for this is that the color, pattern, or texture might vary slightly, and by working from several cartons, you avoid a noticeable change in uniformity.

Since ceiling panels are prefinished, handle them with care. Keep their surfaces clean by using talcum powder or corn meal on your hands or by wearing clean canvas gloves. If panels do become soiled, art gum or a plastic type wallpaper can be used to remove spots, smudges, and fingerprints. Some panels can be washed with a light application of a sponge dampened with a mild detergent solution. However, before washing or performing other maintenance services, such as painting, always refer to the manufacturer's instructions.

CEILING TILE

Ceiling tile may be installed in several ways, depending on the type of ceiling or roof construction. When a flat-surfaced backing is present, such as between beams of a beamed ceiling in a low-slope roof, the tiles are fastened with adhesive as recommended by the manufacturer. A small spot of a mastic type of construction adhesive at each corner of a 12- by 12-in. tile is usually sufficient. When tile is edge-matched, stapling is also satisfactory.

Perhaps the most common method of installing ceiling tile is with the use of wood strips nailed across the ceiling joists or roof trusses. These are spaced 12-in. oncenter A

nominal 1- by 3-in. or 1- by 4-in. wood member can be used for roof or ceiling members spaced not more than 24-in. oncenter. (See view A, fig. 12-15.) A nominal 2- by 2-in. or 2- by 3-in. member should be satisfactory for truss or ceiling joist spacing of up to 48 in.

In locating the strips, first measure the width of the room (the distance parallel to the direction of the ceiling joists). If, for example, this is 11 ft 6 in., use 10 full 12-in.-square tiles and a 9-in.-wide tile at each side edge. Thus, the second wood strips from each side are located so that they center the first row of tiles, which can now be ripped to a width of 9 in. The last row will also be 9 in., but do not rip these tiles until the last row is reached so that they fit tightly. The tile can be fitted and arranged the same way for the ends of the room.

Ceiling tiles normally have a tongue on two adjacent sides and a groove on the opposite adjacent sides. Start with the leading edge ahead and to the open side so that they can be stapled to the nailing strips. A small finish nail or adhesive should be used at the edge of the tiles in the first row against the wall. Stapling is done at the leading edge and the side edge of each tile. (See view B, fig. 12-15.) Use one staple at each wood strip at the leading edge and two at the open side edge. At the opposite wall, a small finish nail or adhesive must again be used to hold the tile in place.

Most ceiling tile of this type has a factory finish, and painting or finishing is not required after it is in place. Because of this, do not soil the surface as it is installed.

INSULATION

Most materials used in construction have some insulating value. Even air spaces between studs resist the passage of heat. However, when these stud spaces are filled or partially filled with a material high in resistance to heat transmission, namely thermal insulation, the stud space has many times the insulating value of the air alone.

The inflow of heat through outside walls and roofs in hot weather or its outflow during cold weather have important effects upon the comfort of the occupants of a building, and the

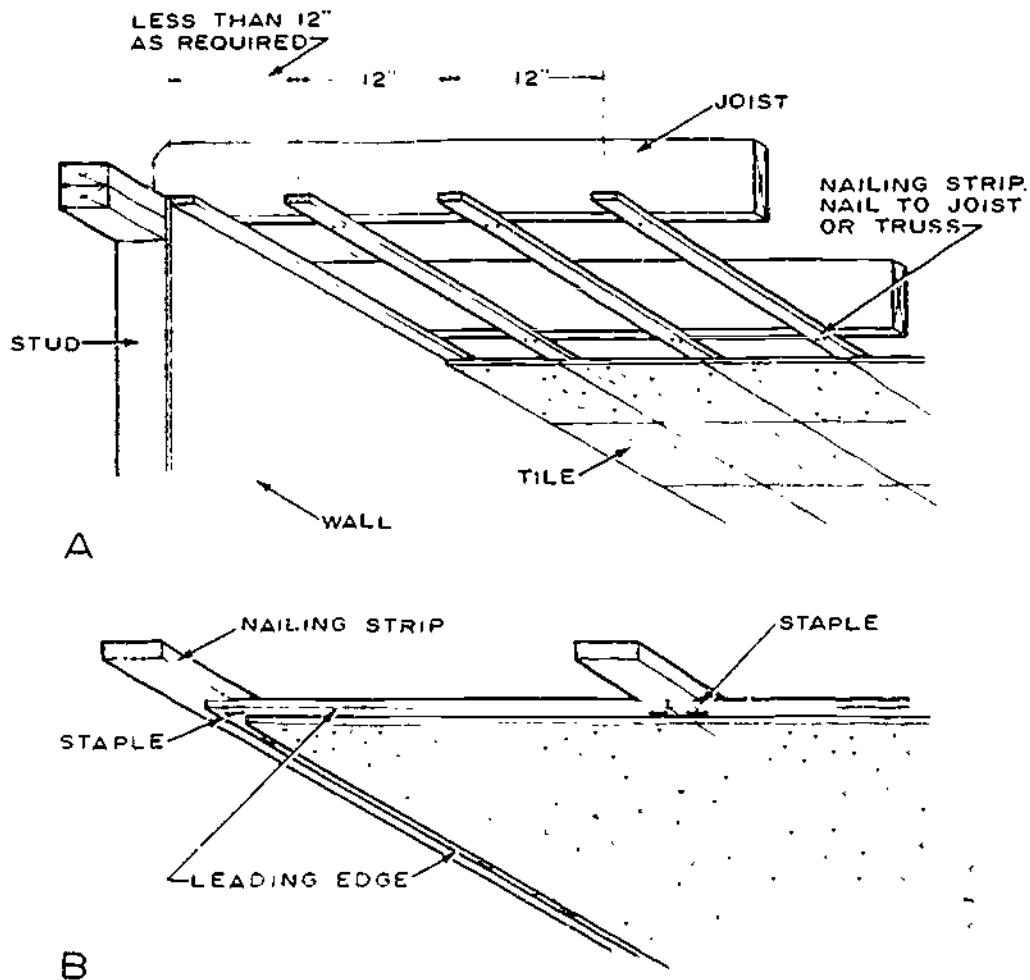

Figure 12-15.—Ceiling tile assembly: A. Nailing strip location; B. Stapling.

133.514

cost of providing either heating or cooling to maintain temperatures at acceptable limits for occupancy. During cold weather, high resistance to heat flow also means a saving in fuel. While the wood in the walls provides good insulation, commercial insulating materials are usually incorporated into exposed walls, ceilings, and floors to increase the resistance to heat passage. The use of insulation in warmer climates is justified with air conditioning, not only because of reduced operating costs but also because units of smaller capacity are required. Thus, weather from the standpoint of thermal insulation alone

in cold climates or whether for the benefit of reducing cooling costs, the use of 2 in. or more of insulation in the walls can certainly be justified.

INSULATING MATERIALS

Commercial insulation is manufactured in a variety of forms and types, each with advantages for specific uses. Materials commonly used for insulation may be grouped in the following general classes. (1) flexible insulation (blanket and batt), (2) loose-fill insulation; (3) reflective

insulation; (4) rigid insulation (structural and nonstructural); and (5) miscellaneous types.

The insulating value of the wall will vary with different types of construction, with the different kinds of materials used in construction, and with the different types and thicknesses of insulation.

Air spaces add to the total resistance of a wall section to heat transmission, but an air space is not as effective as it would be if it were filled with an insulating material. Great importance is frequently given to dead-air spaces in speaking of a wall section. Actually, the air is never dead in cells where there are differences in temperature on opposite sides of the space, because the difference causes convection currents.

Flexible Insulation

Flexible insulation is manufactured in two types, BLANKET and BATT. Blanket insulation (view A, fig. 12-16) is furnished in rolls or

packages in widths suited to 16- and 24-in. stud and joist spacing. Usual thicknesses are 1 1/2, 2, and 3 in. The body of the blanket is made of felted mats of mineral or vegetable fibers, such as rock or glass wool, wood fiber, and cotton. Organic insulations are treated to make them resistant to fire, decay, insects, and vermin. Most blanket insulation is covered with paper or other sheet material with tabs on the sides for fastening to studs or joists. One covering sheet serves as a vapor barrier to resist movement of water vapor and should always face the warm side of the wall. Aluminum foil or asphalt or plastic laminated paper are commonly used as barrier materials.

Batt insulation (view B, fig. 12-16) is also made of fibrous material preformed to thicknesses of 4 and 6 in. for 16- and 24-in. joist spacing. It is supplied with or without a vapor barrier. One friction type of fibrous glass batt is supplied without a covering and is designed to remain in place without the normal fastening methods.

Loose Fill Insulation

Loose fill insulation (view C, fig. 12-16) is usually composed of materials used in bulk form, supplied in bags or bales, and placed by pouring, blowing, or packing by hand. This includes rock or glass wool, wood fibers, shredded redwood bark, cork, wood pulp products, vermiculite, sawdust, and shavings.

Fill insulation is suited for use between first-floor ceiling joists in unheated attics. It is also used in sidewalls of existing houses that were not insulated during construction. Where no vapor barrier was installed during construction, suitable paint coatings, as described later in this chapter, should be used for vapor barriers when blow insulation is added to an existing house.

Reflective Insulation

Most materials have the property of reflecting radiant heat, and some materials have

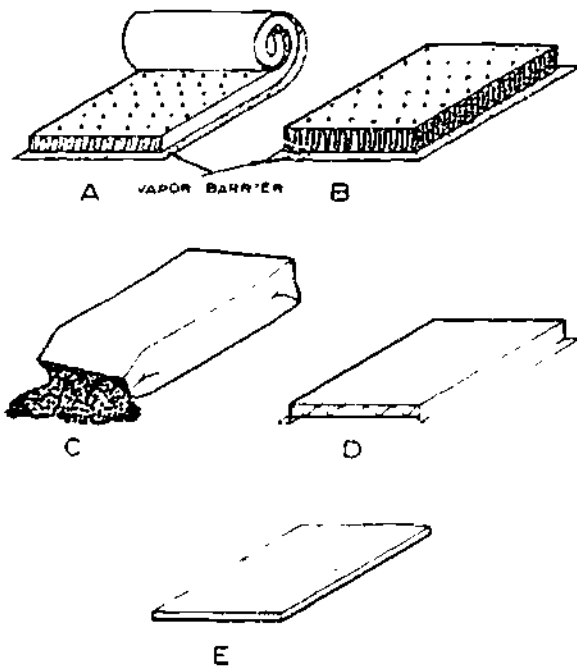

133.515

Figure 12-16.—Types of insulation: A, Blanket; B, Batt; C, Fill; D, Reflective (one type); E, Rigid.

this property to a very high degree. Materials high in reflective properties include aluminum foil, sheet metal with a tin coating, and paper products coated with a reflective oxide composition. Such materials can be used in enclosed stud spaces, attics, and similar locations to retard heat transfer by radiation. Reflective insulations are effective only where the reflective surface faces air space at least 3/4 in. deep. Where this surface contacts another material, the reflective properties are lost and the material has little or no insulating value. Reflective insulations are equally effective whether the reflective surface faces the warm or cold side.

Reflective insulation of the foil type is sometimes applied to blankets and to the stud-surface side of gypsum lath. Metal foil suitable mounted on some supporting base makes an excellent vapor barrier. The type of reflective insulation shown in view D, fig. 12-16 includes reflective surfaces and air spaces between the other sheets.

Rigid Insulation

Rigid insulation is usually a fiberboard material manufactured in sheet and other forms. It is made from processed wood, sugarcane, or other vegetable products (See view E, fig. 12-16) Structural insulating boards, in densities ranging from 15 to 31 lb per cu ft are fabricated as building boards, roof decking, sheathing, and wallboard. While they have moderately good insulating properties, their primary purpose is structural.

Roof insulation is nonstructural and serves mainly to provide thermal resistance to heat flow in roofs. It is called "slab" or "block" insulation and is manufactured in rigid units 1/2 to 3 in. thick and usually 2 by 4 ft in size.

In building construction, perhaps the most common forms of rigid insulation are sheathing and decorative covering in sheets or in tile squares. Sheathing board is made in thicknesses of 1/2 and 25/32 in. It is coated or impregnated with an asphalt compound to provide water resistance. Sheets are made in 2 by 8 ft sizes for horizontal application and 4 by 8 ft or longer for vertical application.

Miscellaneous Insulation

Some insulations do not fit in the classifications previously described, such as insulation blankets made up of multiple layers of corrugated paper. Other types, such as lightweight vermiculite and perlite aggregates, are sometimes used in plaster as a means of reducing heat transmission.

Other materials are foamed-in-place insulations, which include sprayed and plastic foam types. Sprayed insulation is usually inorganic fibrous material blown against a clean surface which has been primed with an adhesive coating. It is often left exposed for acoustical as well as insulating properties.

Expanded polystyrene and urethane plastic forms may be molded or foamed-in-place. Urethane insulation may also be applied by spraying. Polystyrene and urethane in board form can be obtained in thicknesses from 1/2 to 2 in.

WHERE TO INSULATE

In most climates, all walls, ceilings, roofs, and floors that separate heated spaces from unheated spaces should be insulated to reduce the heat loss from the structure during cold weather. The insulation should be placed on all outside walls and in the ceiling. In structures that have unheated crawl spaces, insulation should be placed between the floor joists or around the wall perimeter. If a flexible type of insulation (blanket or batt) is used, it should be well supported between joists by slats and a galvanized wire mesh, or by a rigid board with the vapor barrier installed toward the subflooring. Press-fit or friction insulations fit tightly between joists and require only a small amount of support to hold them in place. Reflective insulation is often used for crawl spaces, but only dead-air space should be assumed in calculating heat loss when the crawl space is ventilated. A ground cover of roll roofing or plastic film, such as polyethylene, should be placed on the soil of crawl spaces to decrease the moisture content of the space as well as of the wood members.

Insulation should be placed along all walls, floors and ceilings that are adjacent to unheated

areas. These include stairways, dwarf (knee) walls, and dormers of 1 1/2 story structures. Provisions should be made for ventilation of the unheated areas.

Where attic space is unheated and a stairway is included, insulation should be used around the stairway as well as in the first-floor ceiling. The door leading to the attic should be weather-stripped to prevent heat loss. Walls adjoining an unheated garage or porch should also be insulated. In structures with flat or low-pitched roofs, insulation should be used in the ceiling area with sufficient space allowed above for clear unobstructed ventilation between the joists. Insulation should be used along the perimeter of houses built on slabs. A vapor barrier should be included under the slab.

In the summer, outside surfaces exposed to the direct rays of the sun may attain temperatures of 50°F or more above shade temperatures and, of course, tend to transfer this heat toward the inside of the house. Insulation in the walls and in attic areas retards the flow of heat and, consequently, less heat is transferred through such areas, resulting in improved summer comfort conditions.

Where air-conditioning systems are used, insulation should be placed in all exposed ceilings and walls in the same manner as insulating against cold-weather heat loss. Shading of glass against direct rays of the sun and the use of insulated glass will aid in reducing the air-conditioning load.

Ventilation of attic and roof spaces is an important adjunct to insulation. Without ventilation, an attic space may become very hot and hold the heat for many hours. Ventilation methods suggested for protection against cold-weather condensation apply equally well to protection against excessive hot-weather roof temperatures.

The use of storm windows or insulated glass will greatly reduce heat loss. Almost twice as much heat loss occurs through a single glass as through a window glazed with insulated glass or protected by a storm sash. Furthermore, double glass will normally prevent surface condensation or frost forming on inner glass surfaces in winter. When excessive condensation persists, paint failures and decay of the sash rail can occur.

HOW TO INSULATE

Blanket insulation or batt insulation with a vapor barrier should be placed between framing members so that the tabs of the barrier lap the edge of the studs as well as the top and bottom plates. This method is not often popular with the contractor because it is more difficult to apply the dry wall or rock lath (plaster base). However, it assures a minimum amount of vapor loss compared to the loss when tabs are stapled to the sides of the studs. To protect the head and soleplate as well as the headers over openings, it is good practice to use narrow strips of vapor barrier material along the top and bottom of the wall. (See view A, fig. 12-17.)

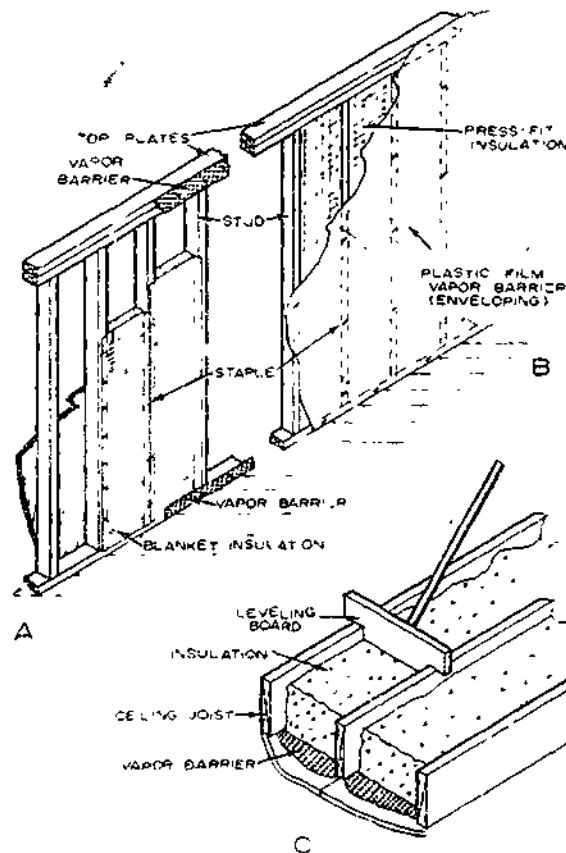

133.516

Figure 12-17.—Application of insulation: A. Wall section with blanket type; B. Wall section with "press fit" insulation; C. Ceiling with fill insulation.



Ordinarily, these areas are not covered too well by the barrier on the blanket or batt. A hand stapler is commonly used to fasten the insulation and the barriers in place.

For insulation without a barrier (press-fit or friction type), a plastic film vapor barrier, such as 4-mil polyethylene is commonly used to envelop the entire exposed wall and ceiling (view B, fig. 12-17). It covers the openings as well as the window and door headers and edge studs. This system is one of the best from the standpoint of resistance to vapor movement. Furthermore, it does not have the installation inconveniences encountered when tabs of the insulation are stapled over the edges of the studs. After the dry wall is installed or plastering is completed, the film is trimmed around the window and door openings.

Reflective insulation, in a single-sheet form with two reflective surfaces, should be placed to divide the space formed by the framing members into two approximately equal spaces. Some reflective insulations include air spaces and are furnished with nailing tabs. This type is fastened to the studs to provide at least a 3/4-in. space on each side of the reflective surfaces.

Fill insulation is commonly used in ceiling areas and is poured or blown into place (view C, fig. 12-17). A vapor barrier should be used on the warm side (the bottom, in case of ceiling joists) before insulation is placed. A leveling board (as shown in view C) will give a constant insulation thickness. Thick batt insulation is also used in ceiling areas. Batt and fill insulation might also be combined to obtain the desired thickness with the vapor barrier against the back face of the ceiling finish. Ceiling insulation 6 or more in. thick greatly reduces heat loss in the winter and also provides summertime protection.

Areas over door and window frames and along side and head jambs also require insulation. Because these areas are filled with small sections of insulation, a vapor barrier must be used around the opening as well as over the header above the openings. (See view A, fig. 12-18.) Enveloping the entire wall eliminates the need for this type of vapor-barrier installation.

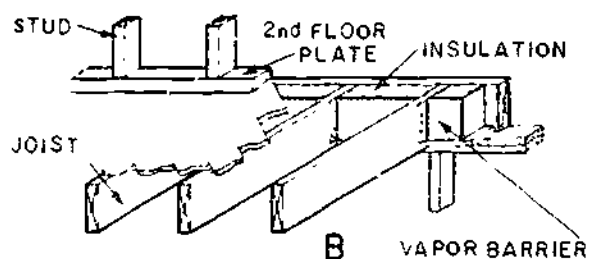
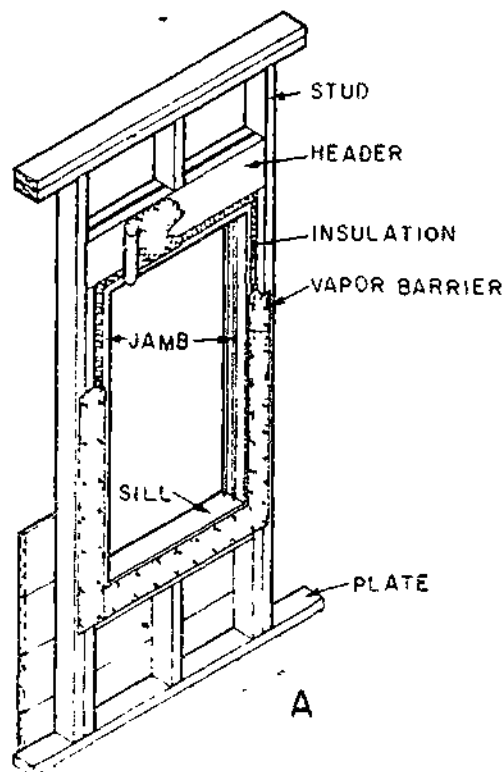

133.517
Figure 12-18.—Precautions in insulating. A. Around openings; B. Joist space in outside walls.

In 1 1/2- and 2-story structures and in basements, the area at the joist header at the outside walls should be insulated and protected with a vapor barrier, as shown in view B, fig. 12-18.

Insulation should be placed behind electrical outlet boxes and other utility connections in exposed walls to minimize condensation on cold surfaces.

VAPOR BARRIERS

Most building materials are permeable to water vapor. This presents problems because considerable water vapor is generated in a house from cooking, dishwashing, laundering, bathing, humidifiers, and other sources. In cold climates during cold weather, this vapor may pass through wall and ceiling materials and condense in the wall or attic space; subsequently, in severe cases, it may damage the exterior paint and interior finish, or even result in decay in structural members. For protection, a material highly resistive to vapor transmission, called a VAPOR BARRIER, should be used on the warm side of a wall or below the insulation in an attic space.

Among the effective vapor-barrier materials are asphalt laminated papers, aluminum foil, and plastic films. Most blanket and batt insulations are provided with a vapor barrier on one side and some of them with paper-backed aluminum foil. Foil-backed gypsum lath or gypsum boards are also available and serve as excellent vapor barriers.

Some types of flexible blanket and batt insulations have a barrier material on one side. Such flexible insulations should be attached with the tabs at their sides fastened on the inside (narrow) edges of the studs, and the blanket should be cut long enough so that the cover sheet can lap over the face of the soleplate at the bottom and over the plate at the top of the stud space. However, such a method of attachment is not the common practice of most installers. When a positive seal is desired, wa. height rolls of plastic-film vapor barriers should be applied over studs, plates, and window and door headers. This system, called "enveloping," is used over insulation having no vapor barrier or to insure excellent protection when used over any type of insulation. The barrier should be fitted tightly around outlet boxes and sealed if necessary. A ribbon of sealing compound around an outlet or switch box will minimize vapor loss at this area. Cold-air returns in outside walls should consist of metal ducts to prevent vapor loss and subsequent paint problems. Paint coatings cannot be considered a substitute for the membrane types of vapor barriers, but they do

provide some protection for houses where other types of vapor barriers were not installed during construction.

Of the various types of paint, one coat of ALUMINUM PRIMER followed by two decorative coats of FLAT WALL or LEAD AND OIL paint is quite effective. For rough plaster or for buildings in very cold climates, two coats of the aluminum primer may be necessary. A primer and sealer of the pigmented type, followed by decorative finish coats or two coats of rubber-base paint, are also effective in retarding vapor transmission.

VENTILATION

Condensation of moisture vapor may occur in attic spaces and under flat roofs during cold weather. Even where vapor barriers are used, some vapor will probably work into these spaces around pipes and other inadequately protected areas and some through the vapor barrier itself. Although the amount might be unimportant if equally distributed, it may be sufficiently concentrated in some cold spot to cause damage. While wood shingle and wood shake roofs do not resist vapor movement, such roofings as asphalt shingles and built-up roofs are highly resistant. The most practical method of removing the moisture is by adequately ventilating the roof spaces.

A warm attic that is inadequately ventilated and insulated may cause formation of ICE DAMS at the cornice. During cold weather after a heavy snowfall, heat causes the snow next to the roof to melt. Water running down the roof freezes on the colder surface of the cornice, often forming an ice dam at the gutter which may cause water to back up at the eaves and into the wall and ceiling. Similar dams often form in roof valleys. Ventilation thus provides part of the answer to the problems. With a well-insulated ceiling and adequate ventilation, attic temperatures are low and melting of snow over the attic space will be greatly reduced.

In hot weather, ventilation of attic and roof spaces offers an effective means of removing hot air and thereby materially lowering the temperature in these spaces. Insulation should be used between ceiling joists below the attic or roof space to further retard heat flow into the

rooms below and materially improve comfort conditions.

It is common practice to install louvered openings in the end walls of gable roofs for ventilation. Air movement through such openings depends primarily on wind direction and velocity, and no appreciable movement can be expected when there is no wind or unless one or more openings face the wind. More positive air movement can be obtained by providing openings in the soffit areas of the roof overhang in addition to openings at the gable ends or ridge. Hip-roof houses are best ventilated by inlet ventilators in the soffit area and by outlet ventilators along the ridge. The differences in temperature between the attic and the outside will then create an air movement independent of the wind, and also a more positive movement when there is wind.

Where there is a crawl space under the house or porch, ventilation is necessary to remove the moisture vapor rising from the soil. Such vapor may otherwise condense on the wood below the floor and facilitate decay. A permanent vapor

barrier on the soil of the crawl space greatly reduces the amount of ventilating area required.

Tight construction (including storm window and storm doors) and the use of humidifiers have created potential moisture problems which must be resolved through planning of adequate ventilation as well as the proper use of vapor barriers. Blocking of ventilating areas, for example, must be avoided as such practices will prevent ventilation of attic spaces. Inadequate ventilation will often lead to moisture problems which can result in unnecessary costs to correct.

Various styles of gable-end ventilators are available and ready for installation. Many are made with metal louvers and frames, while others may be made of wood to fit the house design more closely. However, the most important factors are to have sufficient net ventilating area and to locate ventilators as close to the ridge as possible without affecting house appearance.

One of the types commonly used fits the slope of the roof and is located near the ridge. (See view A, fig. 12-19.) It can be made of wood

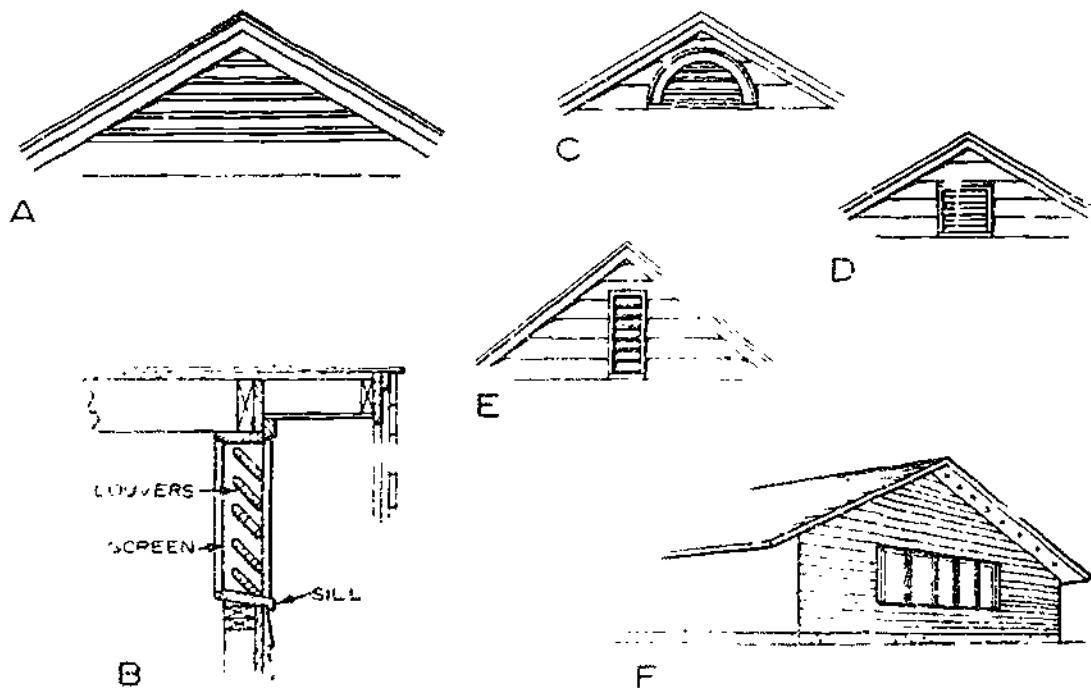

Figure 12 19.- Outlet ventilators. A. Triangular, B. Typical cross section, C. Half-circle, D. Square, E. Vertical, F. Soffit.

133518

or metal. In metal it is often adjustable to conform to the roof slope. A wood ventilator of this type is enclosed in a frame and placed in the rough opening much as a window frame (view B, fig. 12-19). Other forms of gable-end ventilators which might be used are shown in views C, D, and E, fig. 12-19.

A system of attic ventilation which can be used on structures with a wide roof overhang at the gable end consists of a series of small vents or a continuous slot located on the underside of the soffit areas. (See view F, fig. 12-19.) Several large openings located near the ridge might also be used. This system is especially desirable on low-pitched roofs where standard wall ventilators may not be suitable.

Small, well-distributed ventilators or continuous slots in the soffit provide inlet ventilation. These small louvered and screened

vents can be obtained in most lumberyards or hardware stores and are simple to install.

Only small sections need to be cut out of the soffit; these can be sawed out before the soffit is applied. It is more desirable to use a number of smaller well-distributed ventilators than several large ones. Any blocking which might be required between rafters at the wall line should be installed to provide an airway into the attic area.

A continuous screened slot, which is often desirable, should be located near the outer edge of the soffit near the fascia. (See fig. 12-20.) Locating the slot in this area will minimize the chance of snow entering. This type may also be used on the extension of flat roofs.

STAIRS

There are many different kinds of stairs, but all have two main parts in common: the TREADS people walk on, and the STRINGERS (also called STRINGS, HORSES, and CARRIAGES) which support the treads. A very simple type of stairway, consisting only of stringers and treads, is shown in the left-hand view of figure 12-21. Treads of the type shown are called PLANK treads, and this simple type of stairway is called a CLIP stairway, because of the cleats attached to the stringers to support the treads.

A more finished type of stairway has the treads mounted on two or more sawtooth-edged stringers and includes RISERS, as shown in the right-hand view of figure 12-21. The stringers shown are cut out of solid pieces of dimensional lumber (usually 2 by 12), and are therefore called CUTOUT or SAWED stringers.

STAIRWAY LAYOUT

The first step in stairway layout is to determine the UNIT RISE and UNIT RUN shown in figure 12-21. The unit rise is calculated on the basis of the TOTAL RISE of the stairway, and the fact that the customary

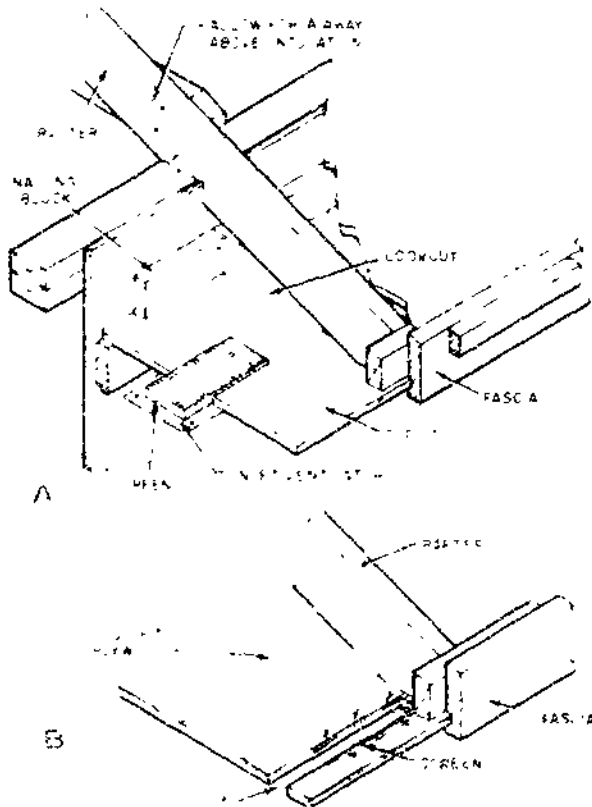

133.519

Figure 12-20.—Inlet ventilators. A. Small insert ventilator; B. Slot ventilator.

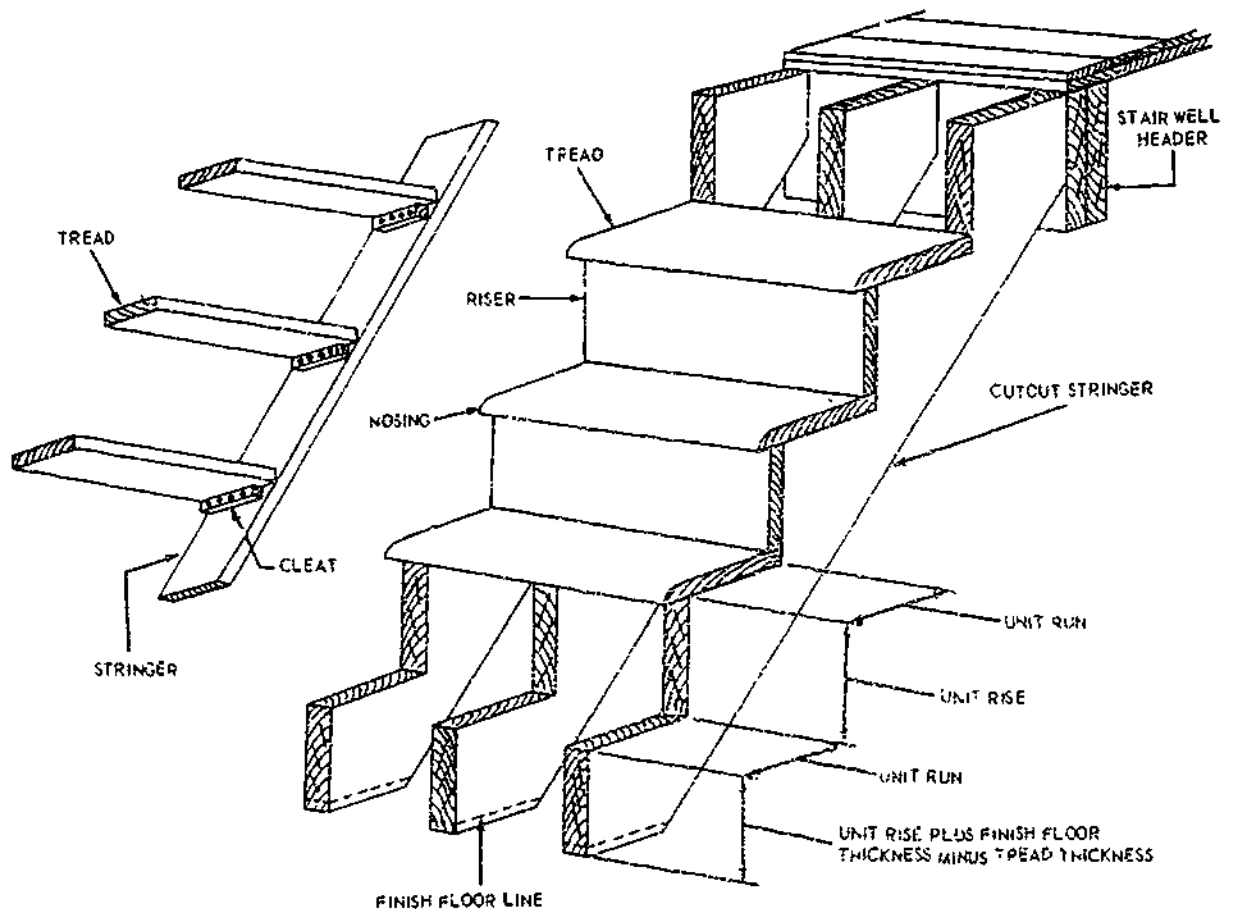

Figure 12-21.—Stairway nomenclature.

45.507

permissible unit rise for stairs is in the vicinity of 7 in.

The total rise is the vertical distance between the lower finish-floor level and the upper finish-floor level. This may be shown in the elevations, however, since the actual vertical distance as constructed may vary slightly from what it should have been, and since it is the actual distance you are dealing with, the distance should be measured.

At the time that stairs are to be laid out, only the subflooring is laid. If both the lower and the upper floors are to be covered with finish flooring of the same thickness, the measured vertical distance from the lower

subfloor surface to the upper subfloor surface will be the same as the eventual distance between the finish floor surfaces, and therefore equal to the total rise of the stairway. But if you are measuring up from a finish floor, such as a concrete basement floor, then you must add to the measured distance the thickness of the upper finish flooring to get the total rise of the stairway. If the upper and lower finish floors will be of different thicknesses, then you must add the difference in thickness to the measured distance between subfloor surfaces to get the rise of the stairway. To measure the vertical distance, use a straight piece of lumber plumb in the stair opening with a spirit level or a plumb bob and cord.

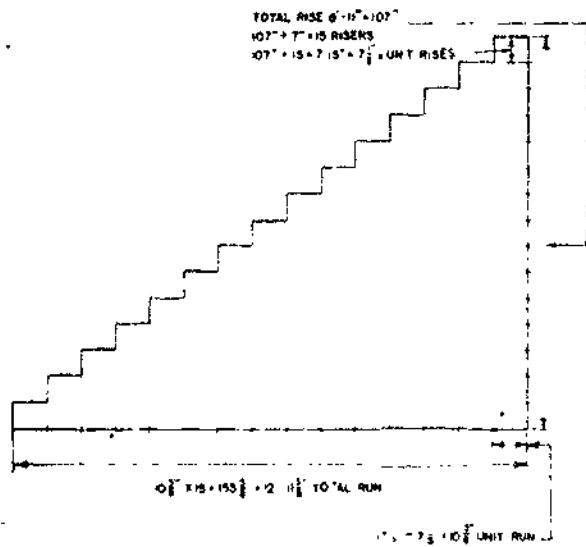

117.54

Figure 12-22.—Stairway layout computations.

Assume that the total rise measures 8 ft 11 in., as shown in figure 12-22. Knowing this, you can determine the unit rise as follows. First, reduce the total rise to inches—in this case it comes to 107 in. Next, divide the total rise in inches by the average permissible unit rise, which is 7 in. The result, disregarding any fraction, is the number of RISERS the stairway will have—in this case, $107/7$ or 15. Now divide the total rise in inches by the number of

risers—in this case, $107/15$, or nearly $7\frac{1}{8}$ in. This is the unit rise as shown in figure 12-22.

The unit run is calculated on the basis of the unit rise and a general architect's rule that the sum of the unit run and unit rise should be $17\frac{1}{2}$ in. Then, by this rule, the unit run is $17\frac{1}{2}$ in. minus $7\frac{1}{8}$ in. or $10\frac{3}{8}$ in.

You can now calculate the TOTAL RUN of the stairway. The total run is obviously equal to the product of the unit run times the total number of treads in the stairway. However, the total number of treads depends upon the manner in which the upper end of the stairway will be anchored to the header.

In figure 12-23, three methods of anchoring the upper end of a stairway are shown. In the first view, there is a complete tread at the top of the stairway. This means that the number of complete treads is the same as the number of risers. For the stairway shown in figure 12-21, there are 15 risers and 15 complete treads. Therefore, the total run of the stairway is equal to the unit run times 15, or 12 ft 11 $\frac{5}{8}$ in., as shown.

In figure 12-23, second view, there are only parts of a tread at the top of the stairway. If this method were used for the stairway shown in figure 12-22, the number of complete treads would be ONE LESS than the number of risers, or 14. The total run of the stairway would be

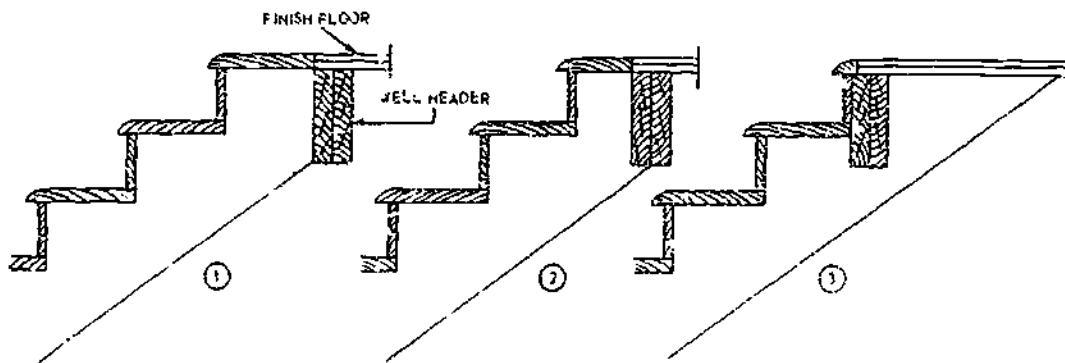

Figure 12-23.—Three methods of anchoring upper end of a stairway.

45.507

the product of 14 by 10 3/8, PLUS THE RUN OF THE PARTIAL TREAD AT THE TOP. Where this run is 7 inches, for example, the total run equals 152 1/4 in., or 12 ft 8 1/4 in.

In figure 12-23, third view, there is no tread at all at the top of the stairway, the upper finish flooring serves as the top tread. In this case, the total number of complete treads is again 14, but since there is no additional partial tread, the total run of the stairway is 14 times 10 3/8, or 145 1/4 in. or 12 ft 1 1/4 in.

When you have calculated the total run of the stairway, drop a plumb bob from the well head to the floor below and measure off the total run from the plumb bob. This locates the anchoring point for the lower end of the stairway.

Cutout stringers for main stairways are usually made from 2 by 12 stock. The first question is, About how long a piece of stock will you need? Assume that you are to use the method of upper-end anchorage shown in the first view of figure 12-23 to lay out a stringer for the stairway shown in figure 12-22. This

stairway has a total rise of 8 ft 11 in. and a total run of 12 ft 11 5/8 in. The stringer must be long enough to form the hypotenuse of a triangle with sides of those two lengths. For an approximate length estimate, call the sides 9 and 13 ft long. The length of the hypotenuse, then, will equal the square root of $9^2 + 13^2$, or the square root of 250, or about 15.8 ft, or about 15 ft 9 1/2 in.

Figure 12-24 shows the layout at the lower end of the stringer. Set the framing square to the unit run on the tongue and the unit rise on the blade, and draw the line AB. This line represents the bottom tread. Then draw AD perpendicular to AB, in length equal to the unit rise.

This line represents the bottom riser in the stairway. Now, you have probably noticed that, up to this point, the thickness of a tread in the stairway has been ignored. This thickness is now about to be accounted for, by making an allowance in the height of this first riser, a process which is called DROPPING THE STRINGER.

As you can see in figure 12-21, the unit rise is measured from the top of one tread to the top

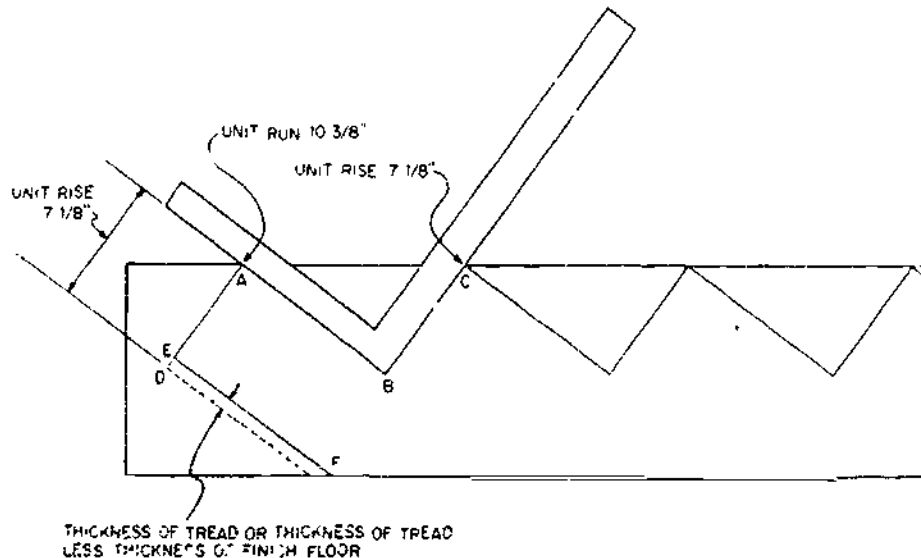

Figure 12-24.—Layout of lower end of cutout stringer.

of the next for ALL RISERS EXCEPT THE BOTTOM ONE. For this one, the unit rise is measured FROM THE FINISHED FLOOR SURFACE TO THE SURFACE OF THE FIRST TREAD. If AD were cut to the unit rise, the actual rise of the first step would be the sum of the unit rise plus the thickness of a tread. Therefore, the length of AD is shortened by the thickness of a tread, as shown in figure 12-24 or by the thickness of a tread less the thickness of the finish flooring. The first is done if the stringer will rest on a finish floor, such as a concrete basement floor. The second is done if the stringer will rest on subflooring.

When you have shortened AD to AE, draw EF parallel to AB. This line represents the bottom horizontal anchor-edge of the stringer. Then proceed to lay off the remaining risers and treads to the unit rise and unit run, until you have laid off 15 risers and 15 treads. Figure 12-25 shows the layout at the upper end of the stringer. The line AB represents the top—that is, the 15th tread. BC, drawn perpendicular to AB, represents the upper vertical-anchor edge of the stringer, which will butt against the stairwell leader.

STAIRWAY CONSTRUCTION

We have been dealing with a common STRAIGHT-FLIGHT stairway, meaning one which follows the same direction throughout.

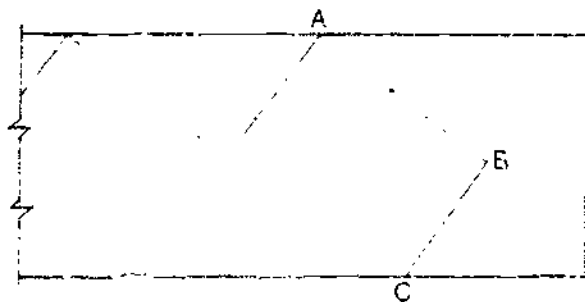

117.56

Figure 12-25.—Layout at upper end of cutout stringer.

When floor space is not extensive enough to permit construction of a straight-flight stairway, a CHANGE stairway is installed—meaning, one which changes direction one or more times. The most common types of these are a 90-DEGREE change and a 180-DEGREE change. These are usually PLATFORM stairways—that is, successive straight-flight lengths, connecting platforms at which the direction changes 90 degrees or doubles back 180 degrees. Such a stairway is laid out simply as a succession of straight-flight stairways.

The stairs in a structure are broadly divided into PRINCIPAL stairs and SERVICE stairs. Service stairs are porch, basement, and attic stairs. Some of these may be simple cleat stairways; others may be OPEN-RISER stairways. An open-riser stairway has treads anchored on cut-out stringers or stair-block stringers, but no risers. The lower ends of the stringers on porch, basement, and other stairs anchored on concrete are fastened with a KICK-PLATE like the one shown in figure 12-26.

A principal stairway is usually more finished in appearance. Rough cutout stringers are concealed by FINISH stringers like the one

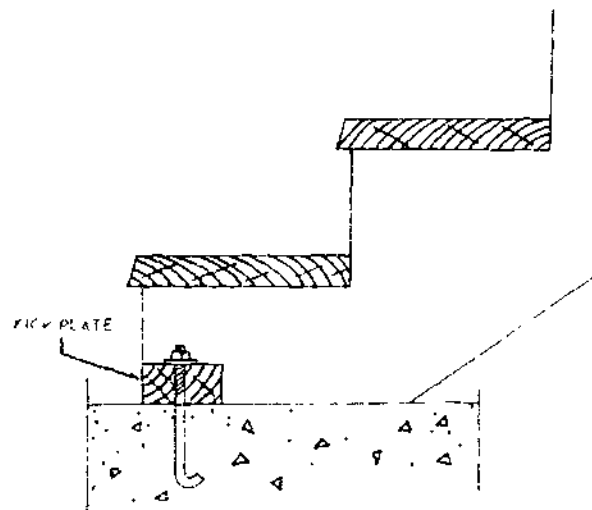

117.57

Figure 12-26.—Kickplate for anchoring stairs to concrete.

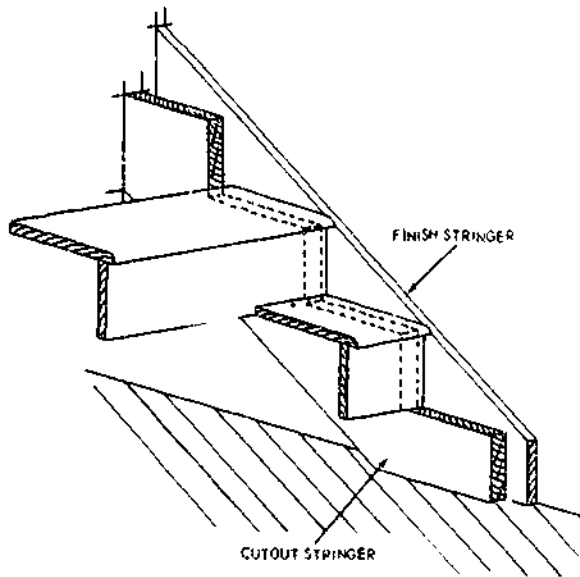

117.58

Figure 12-27.—Finish stringer.

shown in figure 12-27. Treads and risers are often rabbet-joined, as shown in figure 12-28. To prevent squeaking, triangular blocks may be glued into the joints, as shown in the same figure.

The vertical members which support a stairway handrail are called **BALUSTERS**. Figure 12-29 shows a method of joining balusters to treads. For this method, dowels

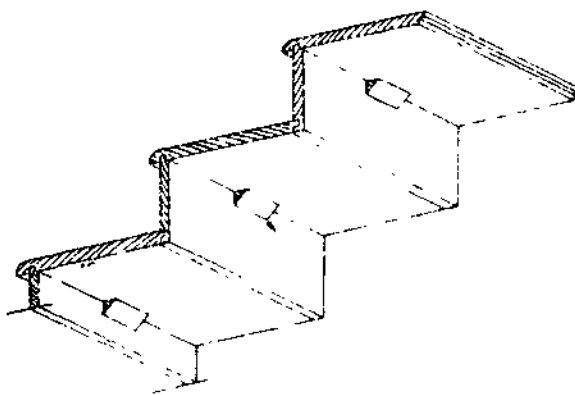

117.59

Figure 12-28.—Rabbet-joined treads and risers.

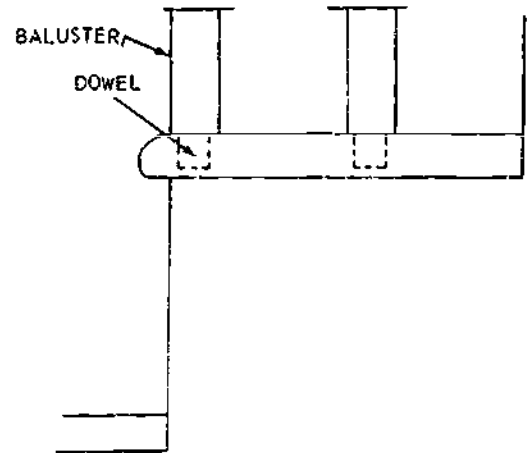

117.60.1

Figure 12-29.—One method of joining a baluster to the tread.

shaped on the lower ends of the balusters are glued into holes bored in the treads.

Stringers should be toenailed to well headers with tennenny nails, three to each side of the stringer. Those which face against trimmer joists should be nailed to the joist with at least three sixteenpenny nails apiece. At the bottom, a stringer should be toenailed with tennenny nails, four to each side, driven into the subflooring and if possible into a joist below.

Treads and risers should be nailed to stringers with sixpenny, eightpenny, or tennenny finish nails, depending on the thickness of the stock

FLOOR COVERINGS

Numerous flooring materials now available may be used over a variety of floor systems. Each has a property that adapts it to a particular usage. Of the practical properties, perhaps durability and ease of maintenance are the most important. However, initial cost, comfort, and beauty or appearance must also be considered. Specific service requirements may call for special properties, such as resistance to hard wear in warehouses and on loading platforms, or comfort to users in offices and shops.

There is a wide selection of wood materials that may be used for flooring. Hardwoods and softwoods are available as strip flooring in a

variety of widths and thicknesses and as random-width planks and block flooring. Other materials include linoleum, asphalt, rubber, cork, vinyl, and other materials in tile or sheet forms. Tile flooring is also available in a particleboard which is manufactured with small wood particles combined with resin and fabricated under high pressure. Ceramic tile and carpeting are used in many areas in ways not thought practical a few years ago. Plastic floor coverings used over concrete or a stable wood subfloor are another variation in the types of finishes available.

WOOD-STRIP FLOORING

Softwood finish flooring costs less than most hardwood species and is often used to good advantage in bedroom and closet areas where traffic is light. It might also be selected to fit the interior decor. It is less dense than the

hardwoods, less wear-resistant, and shows surface abrasions more readily. Softwoods most commonly used for flooring are southern pine, Douglas-fir, redwood, and western hemlock.

Softwood flooring has tongued-and-grooved edges and may be hollow-backed or grooved. Some types are also end-matched. Vertical-grain flooring generally has better wearing qualities than flat-grain flooring under hard usage.

Hardwoods most commonly used for flooring are red and white oak, beech, birch, maple, and pecan, which can be prefinished or unfinished.

Perhaps the most widely used flooring is made of 25/32 by 2 1/4 in. strips. These strips are laid lengthwise in a room and normally at right angles to the floor joists. A subfloor of diagonal boards or plywood is normally used under the finish floor. The strips are tongued-and-grooved and end-matched. (See fig. 12-30.) Strips are random length and may vary

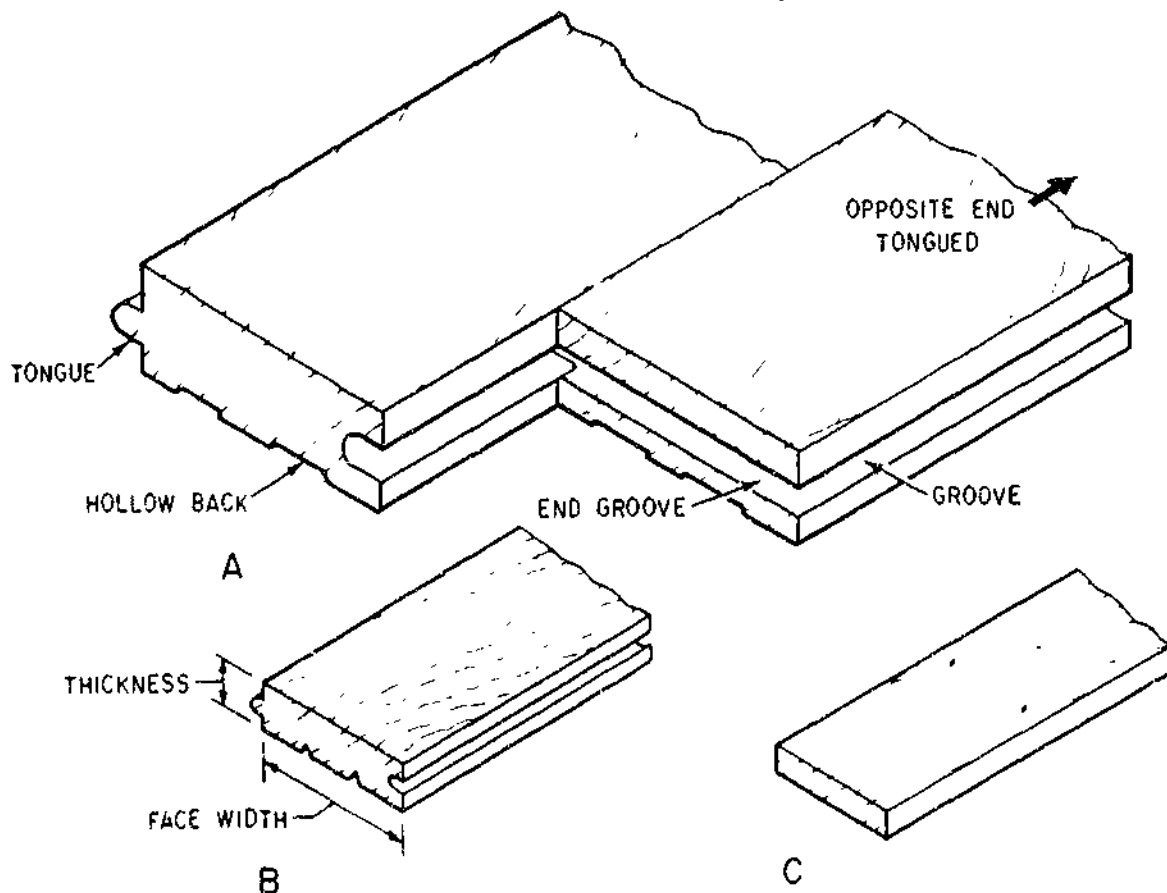

Figure 12-30.—Types of strip flooring. A. Side-and-end-matched—25/32 in.. B. Thin flooring strips—matched; C. Thin flooring strips—square-edges.

133.520

from 2 to 16 ft or more. End-matched strip flooring is $25/32$ in. thickness and is generally hollow backed, as shown in view A, fig. 12-30. The top is slightly wider than the bottom so that tight joints result when flooring is laid. The tongue fits tightly into the groove to prevent movement and floor "squeaks."

Another flooring is made of $3/8$ -by-2-in. strips, as shown in fig. 12-30. This flooring is commonly used for remodeling work or when the subfloor is edge-blocked or thick enough to provide very little deflection under loads.

Square-edged strip flooring as shown in view C, fig. 12-30 is also used occasionally. The strips are usually $3/8$ by 2 in. and laid over a substantial subfloor. Face-nailing is required.

Wood-block flooring (fig. 12-31) is made in a number of patterns. Blocks may vary in size from 4 by 4 in. to 9 by 9 in. and larger. Thickness varies by type from $25/32$ in. for

laminated blocking or plywood block tile to $1/8$ in. for stabilized veneer. Solid wood tile is often made up of narrow strips of wood splined or keyed together in a number of ways. Edges of the thicker tile are tongued and grooved, but thinner sections of wood are usually square-edged. Plywood blocks may be $3/8$ in. and thicker and are usually tongue-and-grooved. Many block floors are factory-finished and require only waxing after installation. While stabilized veneer squares are still in the development stage, it is likely that research will produce a low-cost wood tile which can even compete with some of the cheaper nonwood resilient tile now available.

Installation of Wood-Strip Flooring

Flooring should be laid after plastering or other interior wall and ceiling finish is completed and dried out, windows and exterior doors are in place, and most of the interior trim, except base, casing, and jambs, are installed to prevent damage by wetting or by construction activity.

Board subfloors should be clean and level and covered with a deadening felt or heavy building paper. This felt or paper will stop a certain amount of dust, will somewhat deaden sound, and, where a crawl space is used, will increase the warmth of the floor by preventing air infiltration. To provide nailing into the joists wherever possible, location of the joists should be chalklined on the paper as a guide. Plywood subfloor do not normally require building paper.

Strip flooring should normally be laid crosswise to the floor joists as shown in view A, fig. 12-32. In conventional structures, the floor joists span the width of the building over a center supporting beam or wall. Thus, the finish flooring of the entire floor area of a rectangular structure will be laid in the same direction. Flooring with "L" or "T" shaped plans will usually have a direction change at the wings, depending on joist direction. As joists usually span the short way in a living room, the flooring will be laid lengthwise to the room. This is

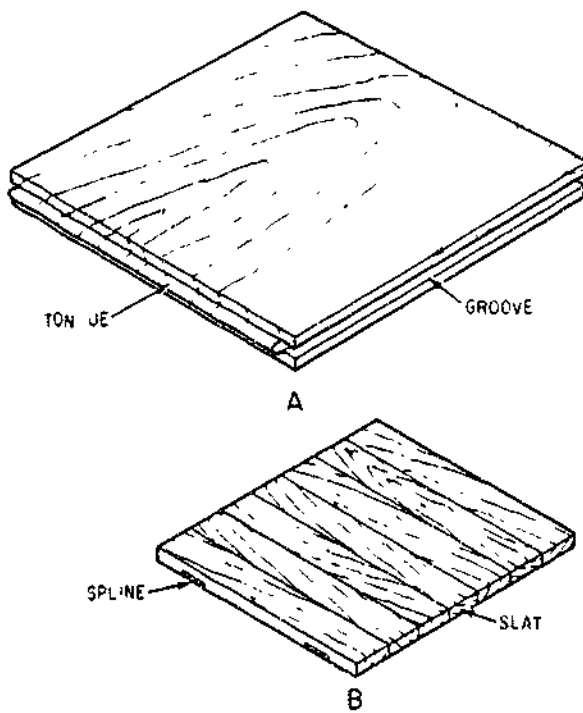

133.521
Figure 12-31.—Wood block flooring. A. Tongued-and-grooved; B. Square-edged-splined.

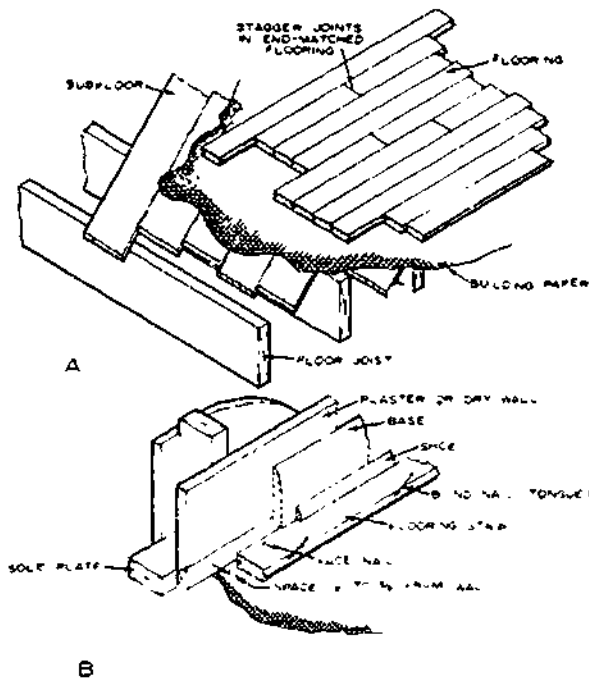

133.522

Figure 12-32.—Application of strip flooring: A. General application; B. Starting strip.

desirable appearance-wise and also will reduce shrinkage and swelling effects on the flooring during seasonal changes.

Flooring should be delivered only during dry weather and stored in the warmest and driest place available in the buildings. Moisture absorbed after delivery to the building site is the most common cause of open joints between flooring strips that appear after several months of the heating season.

Floor squeaks are usually caused by movement of one board against another. Such movement may occur because: (1) floor joists are too light, causing excessive deflection; (2) sleepers over concrete slabs are not held down tightly; (3) tongues are loose fitting; or (4) nailing is poor. Adequate nailing is an important means of minimizing squeaks, and another is to apply the finish floors only after the joists have dried to 12 percent moisture content or less. A much better job results when it is possible to

nail the finish floor through the subfloor into the joists than if the finish floor is nailed ONLY to the subfloor.

Various types of nails are used in nailing different thicknesses of flooring. In using them, it is well to check with the floor manufacturer's recommendations as to size and diameter for specific uses. Flooring brads are also available with blunted points to prevent splitting of the tongue.

View B, fig. 12-32 shows the method of nailing the first strip of flooring placed 1/2 to 5/8 in. away from the wall. The space is to allow for expansion of the flooring when moisture content increases. The nail is driven straight down, through the board at the groove edge. The nails should be driven into the joist and near enough to the edge so that they will be covered by the base or shoe molding. The first strip of flooring can also be nailed through the tongue. (See view A, fig. 12-33.) The figure shows in detail how nails should be driven into the tongue

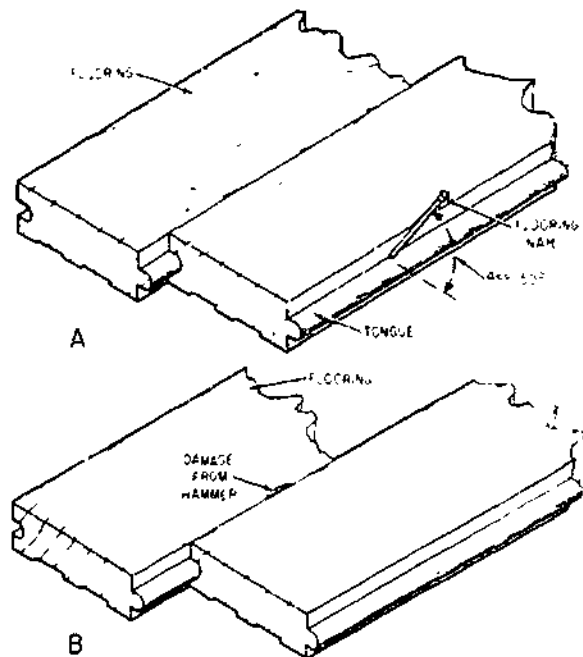

133.523

Figure 12-33.—Nailing of flooring: A. Nail angle; B. Damage from hammer.

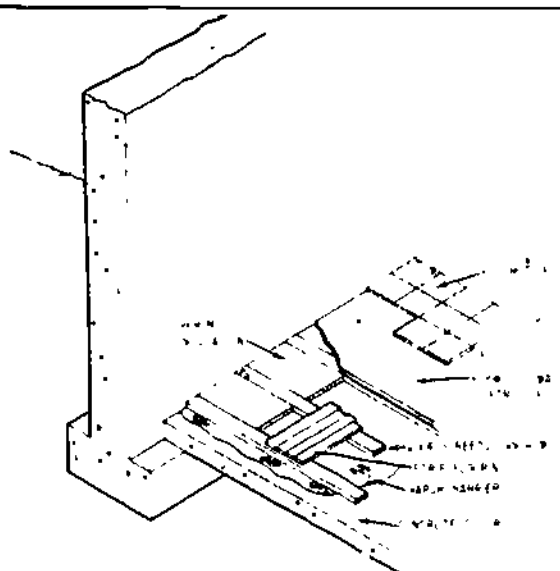

133.524

Figure 12-34.—Basement floor details for existing construction.

of the flooring at an angle of 45° to 50° . The nail should not be driven quite flush so as to prevent damaging the edge by the hammerhead as shown in view B, fig. 12-33. The nail can be set with a nail set or larger nail.

To prevent splitting the flooring, it is sometimes desirable to predrill through the tongue, especially at the ends of the strip. For the second course of flooring from the wall, select pieces so that the butt joints will be well separated from those in the first course. Under normal conditions, each board should be driven up tightly against the previous board. Crooked pieces may require wedging to force them into alignment or may be cut and used at the ends of the course or in closets. In completing the flooring, a $1/2$ - to $5/8$ -in. space is provided between the wall and the last flooring strip. Because of the closeness of the wall, this strip is usually face-nailed so that the base or shoe covers the set nailheads.

Installation of Wood Flooring Over Concrete Slabs

One of the important factors in satisfactory performance is the use of a good vapor barrier under the slab to resist the movement of ground moisture and vapor. The vapor barrier is placed

under the slab during construction. However, an alternate method must be used when the concrete is already in place. (See fig. 12-34.)

Another system of preparing a base for wood flooring when there is no vapor barrier under the slab is shown in figure 12-35. To resist decay, treated 1-by-4-in. furring strips are anchored to the existing slab, shimming when necessary to provide a level base. Strips should be spaced no more than 16-in. on center. A good waterproof or water-vapor resistant coating on the concrete before the treated strips are applied is usually recommended to aid in reducing moisture movement. A vapor barrier, such as a 4-mil polyethylene or similar membrane, is then laid over the anchored 1-by-4-in. wood strips and a second set of 1 by 4's nailed to the first. Use $1\frac{1}{2}$ -in.-long nails spaced 12 to 16 in. apart in a staggered pattern. The moisture content of these second members should be about the same as that of the strip flooring to be applied. Strip flooring can then be installed as previously described.

When other types of finish floor, such as a resilient tile, are used plywood is placed over the 1 by 4's as a base.

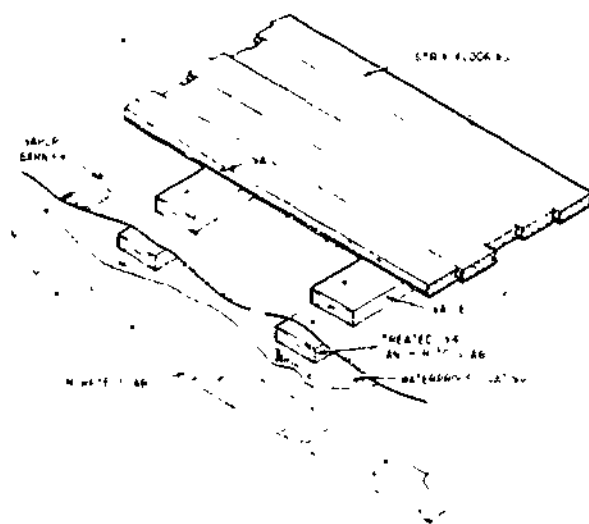

133.525

Figure 12-35.—Base for wood flooring on concrete slab (without an underlying vapor barrier).

WOOD AND PARTICLEBOARD TILE FLOORING

Wood and particleboard tile are, for the most part, applied with adhesive on a plywood or similar base. The exception is 25/32-in. wood block floor, which has tongues on two edges and grooves on the other two edges. If the base is wood, these tiles are commonly nailed through the tongue into the subfloor. However, wood block may be applied on concrete slabs with an adhesive. Wood block flooring is installed by changing the grain direction of alternate blocks. This minimizes the effects of shrinking and swelling of the wood.

One type of wood floor tile is made up of a number of narrow slats to form 4-by-4-in. squares or larger squares. Four or more of these squares, with alternating grain direction, form a block. Slats, squares, and blocks are held together with an easily removed membrane. Adhesive is spread on the concrete slab or underlayment with a notched trowel and the blocks installed immediately. The membrane is then removed and the blocks tamped in place for full adhesive contact.

TYPES OF RESILIENT FLOORING

In Navy construction, wood-strip flooring has been largely replaced by various types of RESILIENT flooring, most of which are applied in the form of 6- by 6-, 9- by 9-, or 12- by 12-in. squares called TILES. The types most frequently used are LINOLEUM, ASPHALT, VINYL, CORK, and RUBBER.

Linoleum

Linoleum may be obtained in various thicknesses and grades, usually in 6-ft or wider rolls. It should not be laid on concrete slabs on the ground. Manufacturer's directions should be followed. After the linoleum is laid, it is usually rolled to insure complete adhesion to the floor.

Asphalt Tile

Asphalt tile is one of the lower cost resilient coverings and may be laid on a concrete slab

which is in contact with the ground. However, the vapor barrier under the slab is still necessary. Asphalt tile is about 1/8 in. thick and usually 9 by 9 in. or 12 by 12 in. in size. Because most types are damaged by grease and oil, it is not used in kitchens.

Asphalt tile is ordinarily installed with an adhesive spread with a notched trowel. Both the type of adhesive and size of notches are usually recommended by the manufacturer.

Other Tile Forms

Vinyl, vinyl asbestos, rubber, cork, and similar coverings are manufactured in tile form, and several types are available for installation in 6-ft or wider rolls. These materials are usually laid over some type of underlayment and not directly on a concrete slab. Standard tile size is 9 by 9 in. but it may also be obtained in 12- by 12-in. size and larger. Decorative strips may be used to outline or to accent the room's perimeter.

In installing all types of square or rectangular tile, it is important that the joints do not coincide with the joints of the underlayment. For this reason, it is recommended that a layout be made before tile is laid. Normally, the manufacturer's directions include laying out a baseline at or near the center of the room and parallel to its length. The center or near center, depending on how the tile will finish at the edges, is used as a starting point. This might also be used as a point in quartering the room with a second guideline at exact right angles to the first. The tile is then laid in quarter-room sections after the adhesive is spread.

Seamless

A liquid-applied seamless flooring, consisting of resin chips combined with a urethane binder, is a relatively new development in floor coverings. It is applied in a 2-day cycle and can be used over a concrete base or a plywood subfloor. Plywood in new construction should be at least a C-C plugged exterior grade in 5/8-in. thickness, or 3/8-in. plywood over existing floors. This type of floor covering can be easily renewed.

INSTALLATION OF RESILIENT TILE

Most producers of resilient tile provide detailed instructions regarding installation. This covers the underlayment, adhesives, and other requirements. However, most resilient tiles are applied in much the same way.

The underlayment may be plywood which serves both as a subfloor and an underlayment for the tile. A subfloor of wood boards requires an underlayment of plywood, hardboard, or particleboard. Nails should be driven flush with the surface, cracks and joints filled and sanded smooth, and the surface thoroughly cleaned.

Next, a center baseline should be marked on the subfloor in each direction of the room, as shown in view A, fig. 12-36. Centerlines should be exactly 90° (a right angle) with each other. This can be assured by using a 3:4:5-foot

measurement along two sides and the diagonal. In a large room, a 6:8:10-foot measuring combination can be used.

Now, spread the adhesive with a serrated trowel (both as recommended by the manufacturer) over one of the quarter-sections outlined by the centerlines. Waiting (drying) time should conform to the directions for the adhesive.

Starting at one inside corner, lay the first tile exactly in line with the marked centerlines. The second tile can be laid adjacent to the first on one side, as shown in view B, fig. 12-36. The third tile is laid adjacent to the first at the other centerline on the other side of the quarter section. Thus, in checkerboard fashion, the entire section can be covered. The remaining three sections can be covered in the same way. Some tile requires only pressing in place; others should be rolled after installation for better adherence.

The edge tiles around the perimeter of the room must be trimmed to fit the edge of the wall. A clearance of 1/8 to 1/4 in. should be allowed at all sides for expansion. This edge is covered with a cove base of the same resilient material or with a standard wood base. Wood base is usually lower in cost than the resilient cove base, but installation costs are somewhat greater.

CARPETING

Carpeting is gaining popularity as a floor covering. However, its cost may be much higher and its life may be much less than that of a finished wood floor; but still, the advantages of carpeting in absorbing sound impact should be considered. Especially in structures where reduction of impact noise is important. Where carpeting is used, the subfloor may consist of 5/8-in. plywood sheets applied over joists that are 16-in. oncenter. The top face of the plywood should be C plugged grade or better. Mastic adhesives may be used in applying the plywood sheets to the floor joists. Plywood, particleboard, or other underlayments may serve as a base where carpeting is installed over a subfloor.

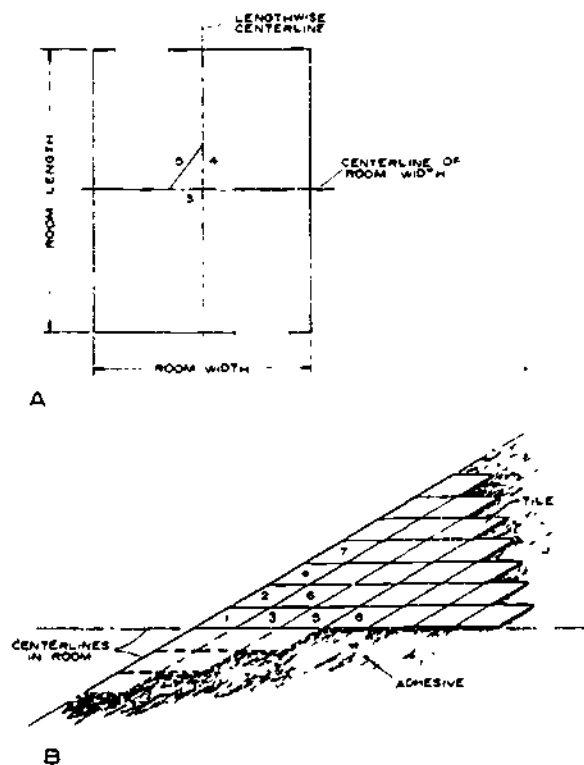

133.526
Figure 12-36.—Installing resilient tile. A. Center baseline. B. Order of laying tile.

DOORS

Doors, and their frames are millwork items that are usually fully assembled at the factory. Standard combination storms and screens or separate units may also be included. Door frames are normally assembled and ready for use in the building. All wood components are treated with a water-repellent preservative at the factory to provide protection before and after they are placed in the walls.

Interior trim, doorframes, and doors are normally installed after the finish floor is in place. Cabinets, built-in bookcases and fireplace mantels, and other millwork units are also placed and secured at this time.

Exterior doors are usually 1 3/4 in. thick and not less than 6 ft 8 in. high. The main entrance door is 3 ft wide, and the side or rear door is normally 2 ft 8 in. wide.

The frames for these doors are made of 1 1/8 in. or thicker material, so that rabbeting of side and head jambs provides stops for the main door. (See view B, fig. 12-37.) The wood sill is often oak for wear resistance, but when softer species are used, a metal nosing and wear strips are included. As in many of the window units, the outside casings provide space for the 1 1/8-in. combination or screen door.

The frame is nailed to studs and headers of the rough opening through the outside casing. The sill must rest firmly on the header or stringer joist of the floor framing, which commonly must be trimmed with a saw, hand ax or other means. After the finish flooring is in place, a hardwood or metal threshold with a plastic weatherstop covers the joints between the floor and sill.

The exterior trim around the main entrance door can vary from a simple casing to a molded or plain pilaster with a decorative head casing. Decorative designs should always be in keeping with the architecture of the house. Many combinations of door and entry designs are used with contemporary houses, and manufacturers have millwork which is adaptable to this and similar styles. If there is an entry hall, it is usually desirable to have glass included in the main door if no other light is provided.

Rough openings in the stud walls for interior doors are usually framed out to be 3 in. more than the door height and 2 1/2 in. more than the door width. This provides for the frame and its plumbing and leveling in the opening. Interior doorframes are made up of two side JAMBS, a head jamb, and the stop moldings upon which the door closes. The most common of these jambs is the one-piece type (view A, fig. 12-38). Jambs may be obtained in standard 5 1/4-in. widths for plaster walls and 4 5/8-in. widths for walls with 1/2-in. dry-wall finish. The two- and three-piece adjustable jambs are also standard types (views B and C, fig. 12-38). Their principal advantage is in being adaptable to a variety of wall thicknesses.

Some manufacturers produce interior doorframes with the door fitted and prehung, ready for installing. Application of the casing completes the job. When used with two- or three-piece jambs, casings can even be installed at the factory.

Common minimum widths for single interior doors are: (1) bedrooms and other habitable rooms, 2 ft 6 in.; (2) bathrooms, 2 ft 4 in.; and (3) small closets and linen closets, 2 ft. These sizes vary a great deal, and sliding doors, folding door units, and similar types are often used for wardrobes and may be 6 ft or more in width. However, in most cases, the jamb stop, and casing parts are used in some manner to frame and finish the opening.

Standard interior and exterior door heights are 6 ft 8 in. for first floors, but 6-ft 6-in. doors are sometimes used on the upper floors.

CASING

CASING is the edge trim around interior door openings and is also used to finish the room side of windows and exterior door frames. Casing usually varies in width from 2 1/4 to 3 1/2 in., depending on the style. Casing may be obtained in thicknesses from 1/2 to 3/4 in., although 11/16 in. is standard in many of the narrow-line patterns. Two common patterns are shown in views D and E, fig. 12-38.

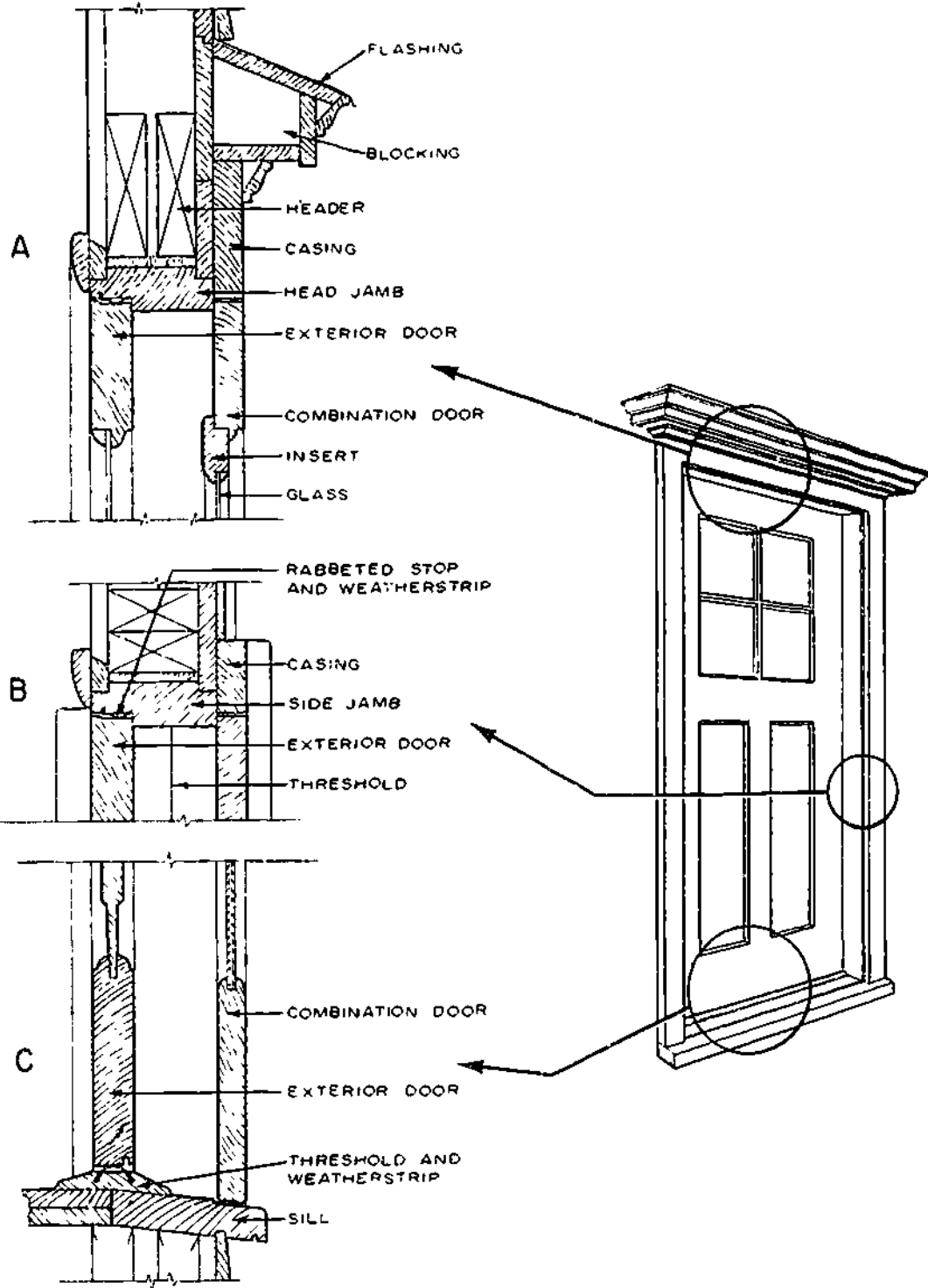

133.527
 Figure 12 37. - Exterior door and frame. Exterior door and combination door (screen and storm) cross sections. A. Head jamb; B. Side jamb; C. Sill.

12-32

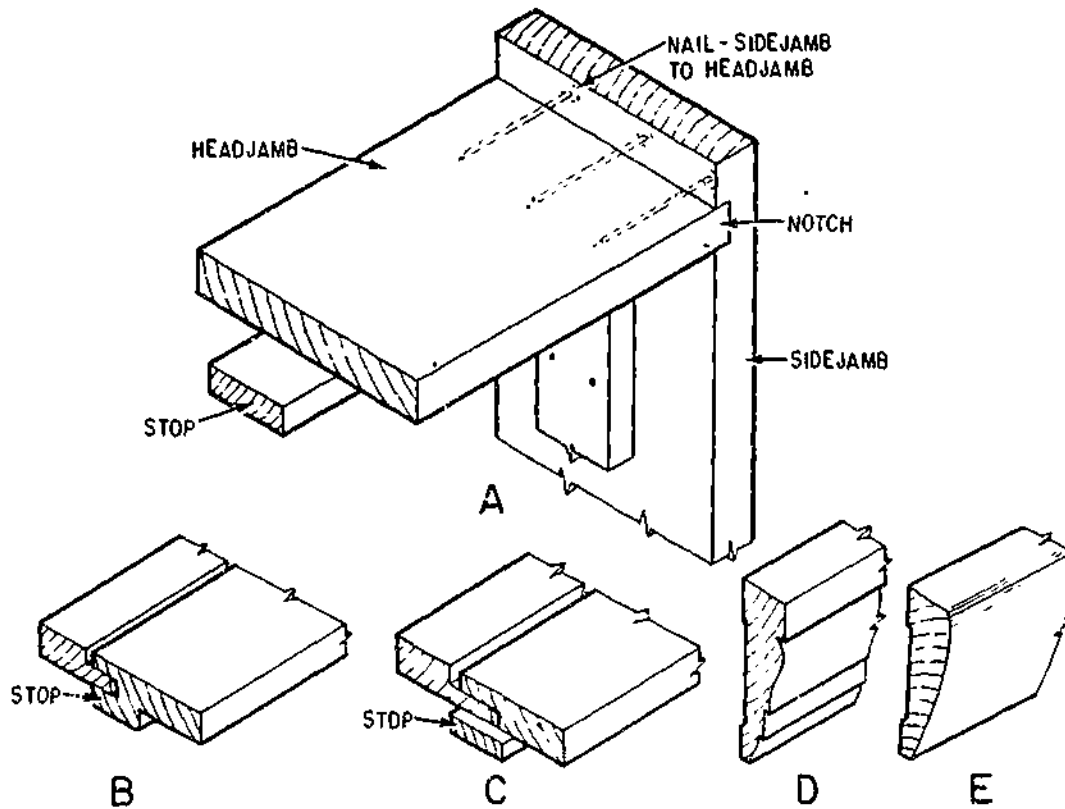

133.528

Figure 12-38.—Interior parts: A. Door jambs and stops: B. Two-piece jamb; C. Three-piece jamb; D. Colonial casing; E. Ranch casing.

EXTERIOR DOORS

Exterior doors, outside combinations, and storm doors may be obtained in a number of designs to fit the style of almost any house. Doors in the traditional pattern are usually the **PANEL TYPE** (view A, fig. 12-39).

They consist of **STILES** (solid vertical members), **RAILS** (solid cross members), and **FILLER PANELS** in a number of designs. Glazed upper panels are combined with raised wood or plywood lower panels.

Exterior flush doors should be of the solid-core type rather than hollow-core to minimize warping during the heating season. (Warping is caused by a difference in moisture content on the exposed and unexposed faces.)

Flush doors consist of thin plywood faces over a framework of wood with a woodblock or particle board core. Many combinations of

designs can be obtained, ranging from plain flush doors to others that have a variety of panels and glazed openings (view B, fig. 12-39).

Wood combination doors (storm and screen) are available in several styles (view C, fig. 12-39). Panels which include screen and storm inserts are normally located in the upper portion of the door. Some types can be obtained with self-storing features, similar to window combination units. Heat loss through metal combination doors is greater than through similar type wood doors.

Weatherstripping of the 1 3/4-in.-thick exterior door will reduce both air infiltration and frosting of the glass on the storm door during cold weather.

INTERIOR DOORS

As in exterior door styles, the two general interior types are the flush and the panel door.

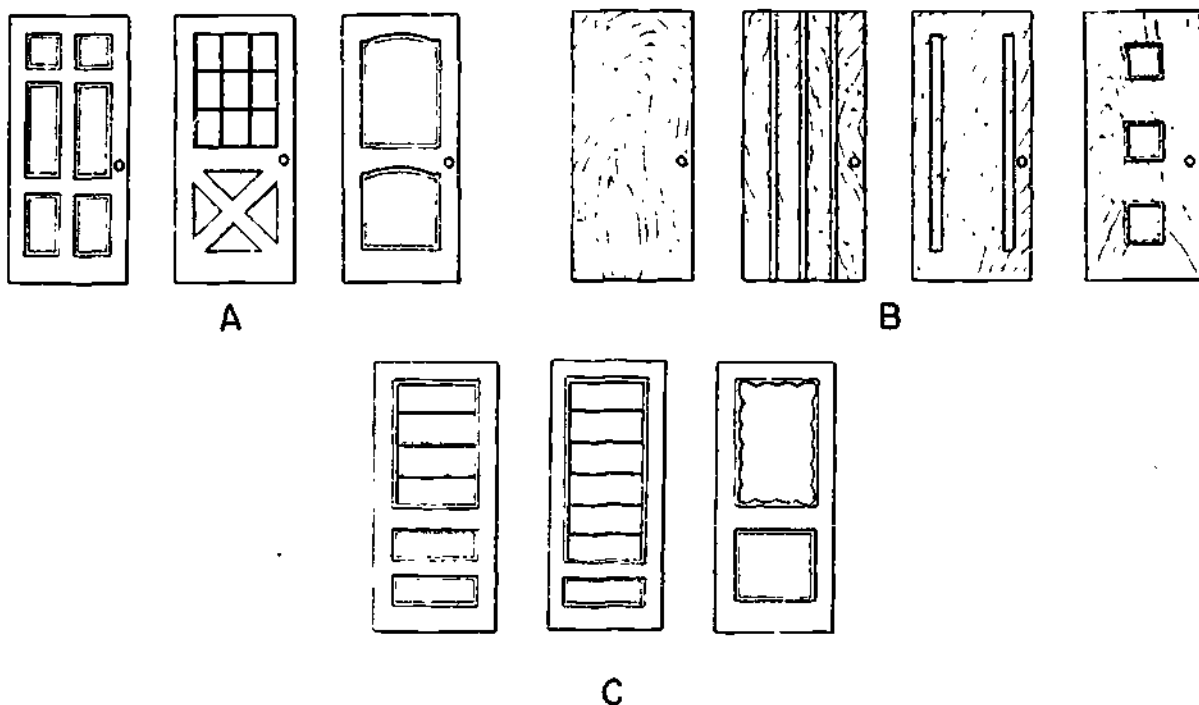

Figure 12-39.—Exterior doors: A. Traditional panel; B. Flush; C. Combination.

133.529

Novelty doors, such as the folding door unit, might be flush or louvered. Most standard interior doors are 1 3/8 in. thick.

The flush interior door is usually made up with a hollow core of light framework of some type with thin plywood or hardboard (view A, fig. 12-40). Plywood-faced flush doors may be obtained in gum, birch, oak, mahogany, and woods of other species, most of which are suitable for natural finish. Nonselected grades are usually painted as are hardboard-faced doors.

The panel door consists of solid STILES (vertical side members), RAILS (cross pieces), and PANEL FILTERS of various types. The five-cross panel and the Colonial-type panel doors are perhaps the most common of this style (view B and C, fig. 12-40). The louvered door (view D, fig. 12-40) is also popular and is commonly used for closets because it provides some ventilation. Large openings for wardrobes are finished with sliding or folding doors, or with flush or louvered doors (view E, fig. 12-40). Such doors are usually 1 1/8 in. thick.

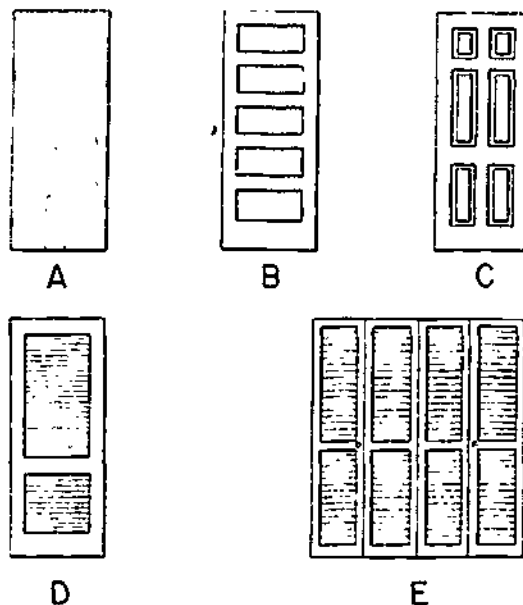

133.529A
Figure 12-40.—Interior doors: A. Flush; B. Panel (five-cross); C. Panel (colonial); D. Louvered; E. Folding (louvered).

Hinged doors should open or swing in the direction of natural entry, against a blank wall whenever possible, and should not be obstructed by other swinging doors. Doors should NEVER be hinged to swing into a hallway.

DOORFRAME AND TRIM INSTALLATION

When the frame and doors are not assembled and prefitted, the side jambs should be fabricated by nailing through the notch into the head jamb with three sevenpenny or eightpenny

coated nails. (See view A, fig. 12-38.) The assembled frames are then fastened in the rough openings by shingle wedges used between the side jamb and the stud (view A, fig. 12-41). One jamb is plumbed and leveled using four or five sets of shingle wedges for the height of the frame. Two eightpenny finishing nails are used at each wedged area, one driven so that the doorstop will cover it. The opposite side jamb is now fastened in place with shingle wedges and finishing nails, using the first jamb as a guide in keeping a uniform width.

Casings are nailed to both the jamb and the framing studs or header, allowing about a 3/16-in. edge distance from the face of the jamb.

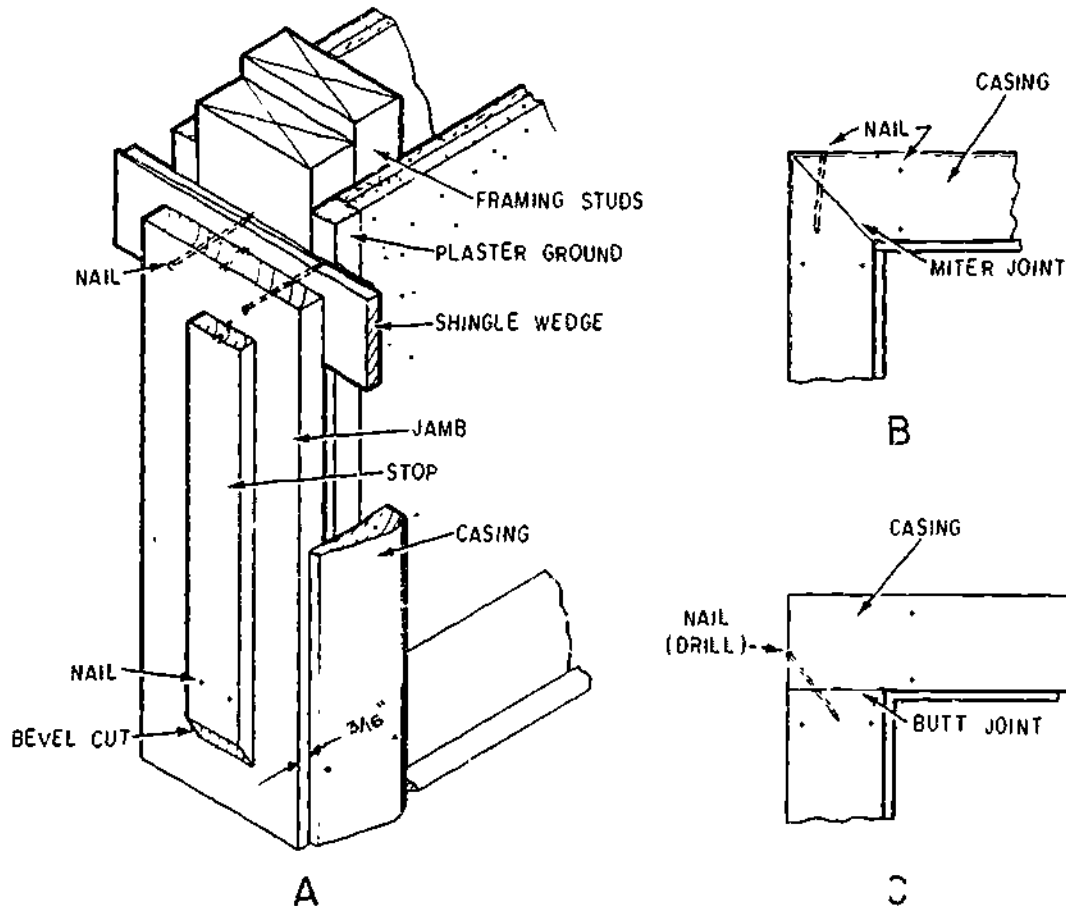

Figure 12-41.—Doorframe and trim: A. Installation; B. Miter joint for casing; C. Butt joint for casing. 133.530



Finish or casing nails in sixpenny or sevenpenny sizes, depending on the thickness of the casing, are used to nail into the stud. Fourpenny or fivepenny finishing nails or 1 1/2-in. brads are used to fasten the thinner edge of the casing to the jamb. In hardwood, it is usually advisable to predrill to prevent splitting. Nails in the casing are located in pairs and spaced about 16 in. apart along the full height of the opening and at the head jamb.

Casing with any form of molded shape must have a mitered joint at the corners. (See view B, fig. 12-41.) When casing is square-edged, a butt joint may be made at the junction of the side and head casing (view C, fig. 12-41). If the moisture content of the casing material is high, a mitered joint may open slightly at the outer edge as the material dries. This can be minimized by using a small glued spline at the corner of the mitered joint. Actually, use of a spline joint under any moisture condition is considered good practice, and some prefitted jamb, door, and casing units are provided with splined joints. Nailing into the joint after drilling will aid in retaining a close fit.

The door opening is now complete except for fitting and securing the hardware and nailing the stops in proper position. Interior doors are normally hung with two 3 1/2-by 3 1/2-in. loose-pin butt hinges. The door is fitted into the opening with the clearances shown in figure 12-42. The clearance and location of hinges, lock set, and doorknob may vary somewhat, but they are generally accepted by craftsmen and conform to most millwork standards. The edge of the lock stile should be beveled slightly to permit the door to clear the jamb when swung open. If the door is to swing across heavy carpeting, the bottom clearance may be slightly more.

Thresholds are used under exterior doors to close the space allowed for clearance. Weather strips around exterior door openings are very effective in reducing air infiltration.

In fitting doors, the stops are usually temporarily nailed in place until the door has

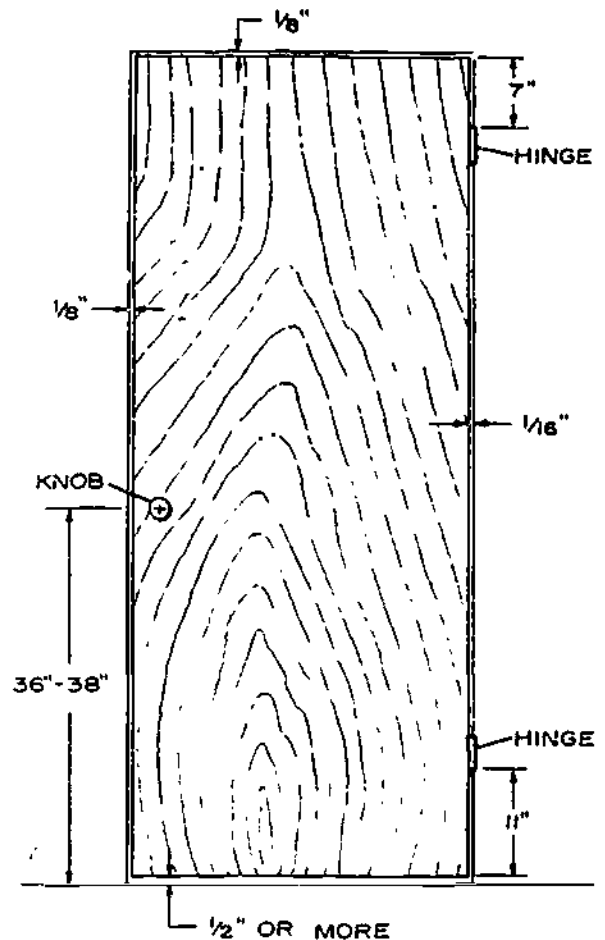

133.530.A

Figure 12-42.—Door clearances.

been hung. Stops for doors in single-piece jambs are generally 7/16 in. thick and may be 3/4 to 2 1/4 in. wide. They are installed with a mitered joint at the junction of the side and head jambs. A 45° bevel cut at the bottom of the stop, about 1 to 1 1/2 in. above the finish floor, will eliminate a dirt pocket and make cleaning or refinishing of the floor easier (view A, fig. 12-41).

Some manufacturers supply prefitted door jambs and doors with the hinge slots routed and ready for installation. A similar door buck (jamb) of sheet metal with formed stops and casing is also available.

**INSTALLATION
OF DOOR
HARDWARE**

Hardware for doors may be obtained in a number of finishes, with brass, bronze, and nickel perhaps the most common. Door sets are usually classified as: (1) entry lock for exterior doors; (2) bathroom set (inside lock control with safety slot for opening from the outside); (3) bedroom lock (keyed lock); and (4) passage set (without lock).

Doors should be hinged so that they open in the direction of natural entry. They should also swing against a blank wall whenever possible and never into a hallway. The door swing directions and sizes are usually shown on the working drawings.

The "hand of the door" is the expression used to describe the direction in which a door is to swing and the side from which it is to hang.

Stand outside the door. If the hinges are on your right, it is a right-hand door; if it is on your left, it is a left-hand door. Should the door swing away from you, it is considered to be a regular door; if it swings toward you, it is considered to be a reverse door. (See fig. 12-43.)

When ordering hardware for a door, be sure to specify whether it is a left-hand door, a right-hand door, a left-hand reverse door, or a right-hand reverse door.

Hinges

Using three hinges for hanging 1 3/4-in. exterior doors and two hinges for the lighter interior doors is common practice. There is some tendency for exterior doors to warp during the winter because of the difference in exposure on the opposite sides. The three hinges reduce this tendency. Three hinges are also useful on doors that lead to unheated attics and for wider and heavier doors that may be used within the

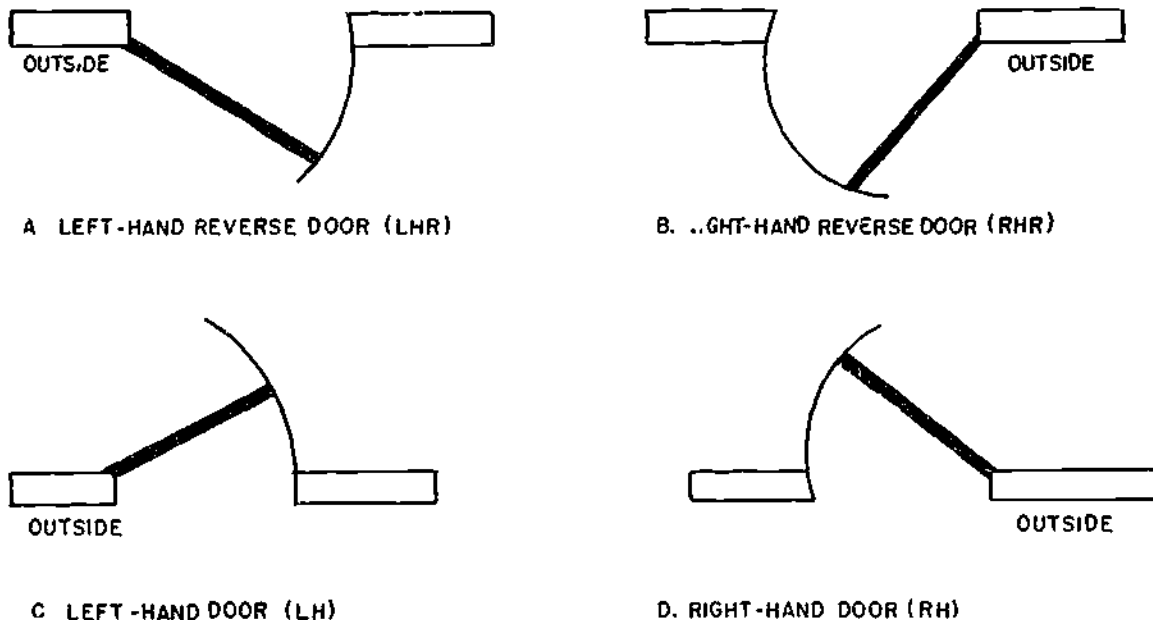

Figure 12-43.—Hands of doors. Face outside of door when making determination.

133.531

house. If a third hinge is required, center it between the top and bottom hinges.

Loose-pin butt hinges should be used and must be of the proper size for the door they support. For 1 3/4-in.-thick doors, use 4-by 4-in.-butts; for 1 3/8-in. doors, 3 1/2-by 3 1/2-in.-butts. After the door is fitted to the framed opening, with the proper clearances, hinge halves are fitted to the door. They are routed into the door edge with about a 3/16-in. back distance. (See view A, fig. 12-44.) One hinge half should be set flush with the surface and must be fastened square with the edge of the door. Screws are included with each pair of hinges.

The door is now placed in the opening and blocked up at the bottom for proper clearance. The jamb is marked at the hinge locations, and the remaining hinge half is routed and fastened in place. The door is then positioned in the

opening and the pins slipped in place. If hinges have been installed correctly and the jambs are plumb, the door will swing freely.

Locks

Types of door locks differ with regard to installation, cost, and the amount of labor required to set them. Some types, such as mortise locks, combination deadbolt, and latch lock sets require drilling of the edge and face of the door and then routing of the edge to accommodate the lock set and faceplate (view B, fig. 12-44). A bored lock set (view C, fig. 12-44) is easy to install since it requires only one hole drilled in the edge and one in the face of the door. Boring jigs and faceplate markers are available to insure accurate installation.

The lock should be installed so that the doorknob is 36 to 38 in. above the floorline.

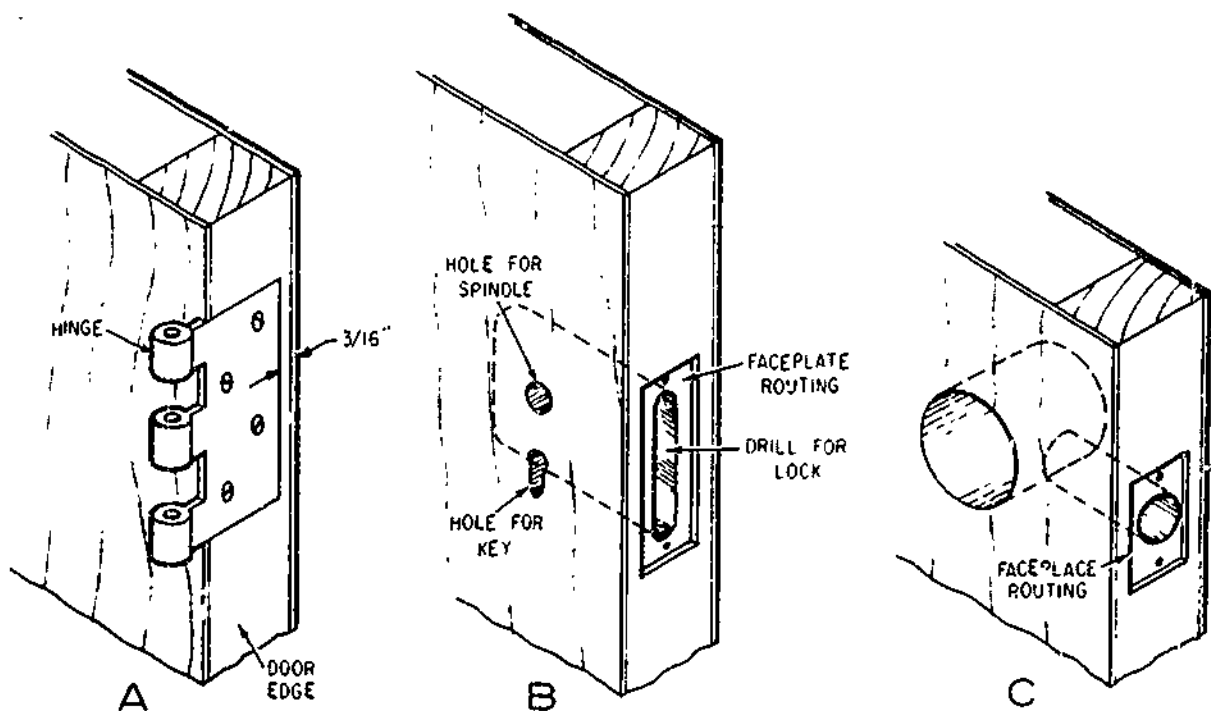
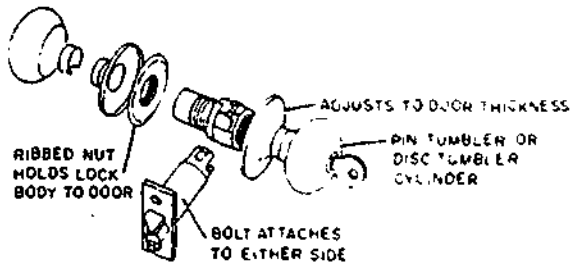

Figure 12-44.—Installation of door hardware: A. Hinge; B. Mortise lock; C. Bored lock set.

133.532



133.161

Figure 12-45.—Parts of a cylinder lock.

Most sets come with paper templates marking the location of the lock and size of the holes to be drilled.

The parts of an ordinary cylinder lock for a door are shown in figure 12-45. The procedure for installing a lock of this type is as follows:

1. Open the door to a convenient working position and check it in place with wedges under the bottom near the outer edge.

2. Measure up 36 in. from the floor (the usual knob height), and square a line across the face and edge of the lock stile.

3. Place the template that is usually supplied with a cylinder lock on the face of the door at proper height and alignment with layout lines and mark the centers of holes to be drilled. (See fig. 12-46.)

4. Drill the holes through the face of the door and then the one through the edge to receive the latch bolt. It should be slightly deeper than the length of the bolt.

5. Cut a gain for the latch-bolt mounting plate, and install the latch unit.

6. Install the interior and exterior knobs.

7. Find the position of the strike plate and install it in the jamb.

Strike Plates

The strike plate, which is routed into the door jamb, holds the door in place by contact with the latch. To install, mark the location of the latch on the door jamb and locate the strike plate in this way. Rout out the marked outline

DRILL TEMPLATE

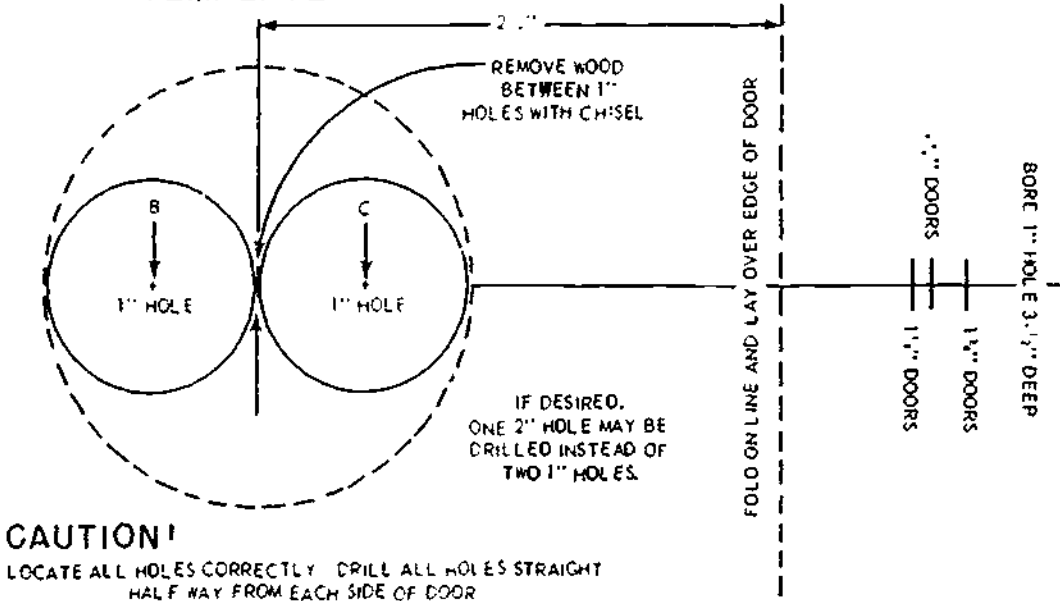

133.162

Figure 12-46.—One type of template.

with a chisel and also rout for latch (view A, fig. 12-47). The strike plate should be flush with or slightly below the face of the door jamb. When the door is latched, its face should be flush with the edge of the jamb.

Doorstops

The stops which have been set temporarily during the fitting of the door and the hardware may now be nailed in place permanently. Finish nails or brads, 1 1/2 in. long, should be used. The stop at the lock side should be nailed first, setting it tight against the door face when the door is latched. Space the nails 16 in. apart in pairs.

The stop behind the hinge side is nailed next, and a 1/32-in. clearance from the door face should be allowed to prevent scraping as the door is opened. The head-jamb stop is then nailed in place. Remember that when the door and trim are painted, some of the clearance will be taken up.

**COMMERCIAL/INDUSTRIAL
HARDWARE**

The items of commercial/industrial hardware shown in figures 12-48 through 12-52 are usually installed in office buildings, not family housing. These items are used where applicable, in new construction or alteration, and repairs of

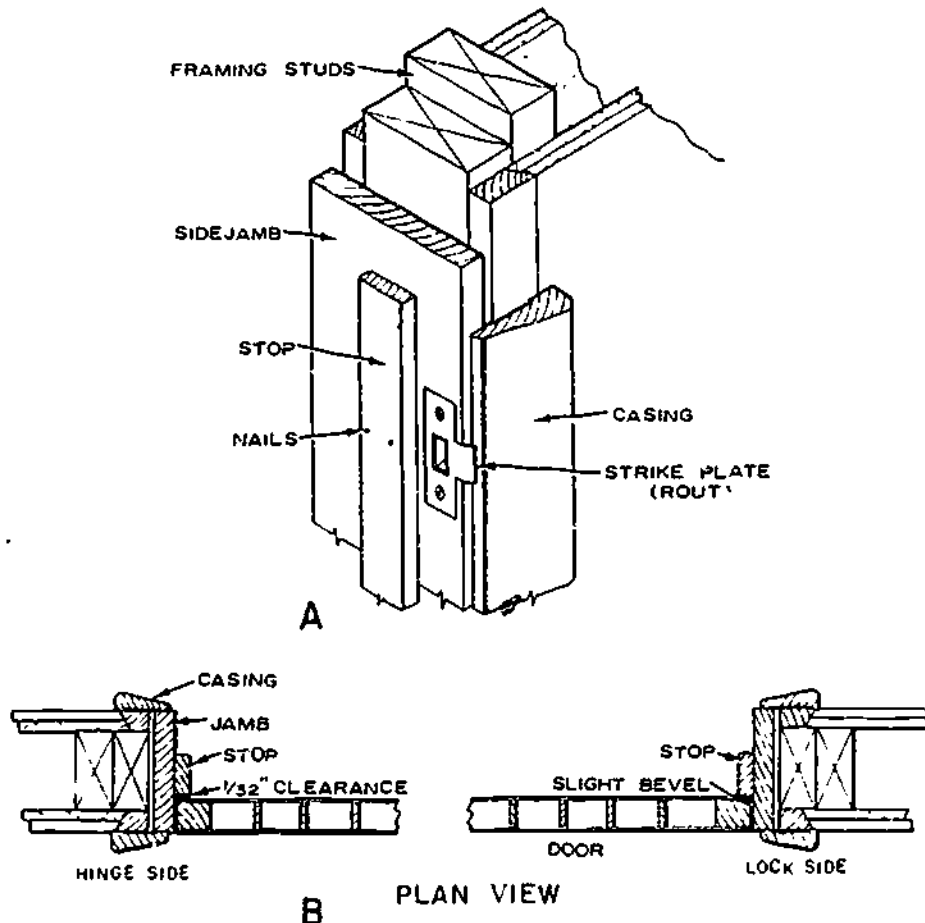
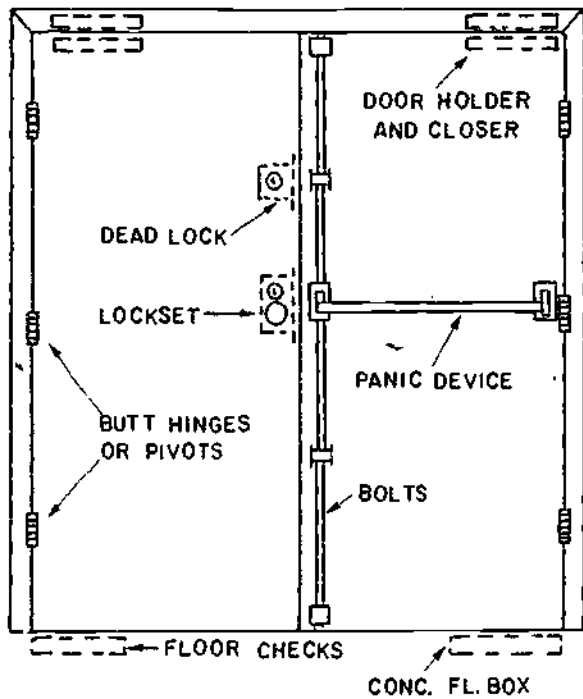

Figure 12-47.—Door details: A. Installation of strike plate; B. Location of stops.

133.533

12-40

491



133.534

Figure 12-48.—Hardware reinforcement.

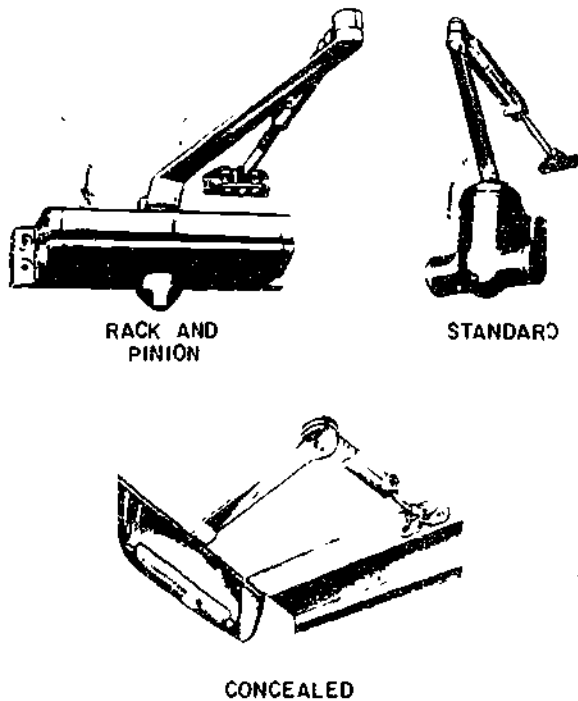

133.536

Figure 12-49.—Door closers.

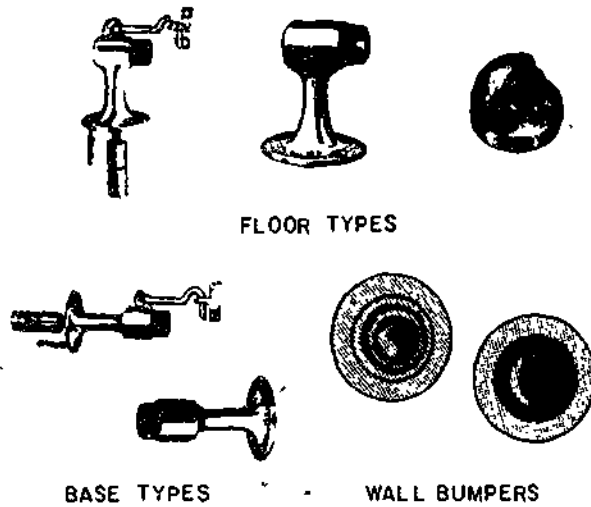

133.536

Figure 12-50.—Door stops.

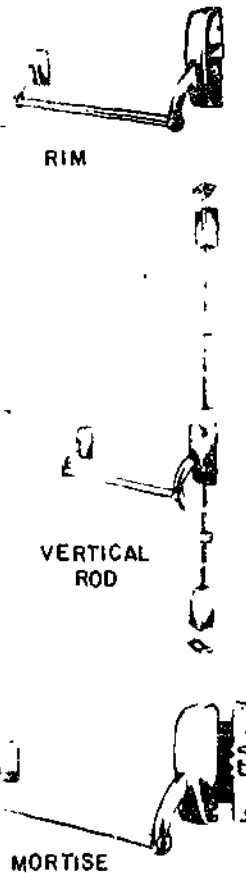

133.537

Figure 12-51.—Exit devices.

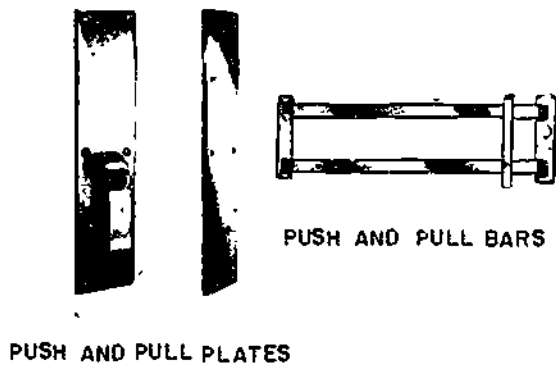

133.538
Figure 12-52.—Push and pull plates and bars.

existing facilities. Many of these items are made of metal for use in or on metal doors, whereas others are made of wood to fit the door design more closely.

WINDOWS

Windows are used mainly to allow entry of light and air, but may also be an important part of the architectural design of a building. Windows and their frames are millwork units that are usually fully assembled at the factory, ready for use in buildings. These units often have the sash fitted and weatherstripped, frame assembled, and exterior casing in place. Standard combination storms and screens or separate units can also be included. Wood components are treated with a water-repellent preservative at the factory to provide protection before and after they are placed in the walls.

TYPES OF WINDOWS

Windows are available in many types, each having advantages. The principal types are double-hung, casement, stationary, awning, and horizontal sliding. They may be made of wood or metal. Heat loss through metal frames and sash is much greater than through similar wood units. Glass blocks are sometimes used for admitting light in places where transparency or ventilation is not required.

Insulated glass, used both for stationary and moveable sash, consists of two or more sheets of spaced glass with hermetically-sealed edges. It resists heat loss more than a single thickness of glass and is often used without a storm sash.

Window frames and sash should be made from a clear grade of all-heartwood stock of a decay-resistant wood or from wood which is given a preservative treatment. Examples include pine, cedar, cypress, redwood, and spruce.

Double-Hung Windows

The double-hung window is perhaps the most familiar window type. It consists of an upper and lower sash that slide vertically in separate grooves in the side jambs or in full-width metal weatherstripping (fig. 12-53). This type of window provides a maximum face opening for ventilation of one-half the total window area. Each sash is provided with springs, balances, or COMPRESSION WEATHERSTRIPPING to hold it in place in any location. Compression weatherstripping, for example, prevents air infiltration, provides tension, and acts as a counterbalance, several types allow the sash to be removed for easy painting or repair.

The JAMBS (sides and top of the frames) are made of nominal 1-in. lumber, the width provides for use with dry wall or plastered interior finish. Sills are made from nominal 2-in. lumber and sloped at about 3 inches in 12 inches for good drainage. Wooden sash is normally 1 3/8 in. thick and wood combination storm and screen windows are usually 1 1/8 in. thick. Figure 12-54 shows an assembled window stool and apron.

Sash may be divided into a number of lights by small wood members called MUNTINS. Some manufacturers provide preassembled dividers which snap in place over a single light, dividing it into six or eight lights. This simplifies painting and other maintenance.

Assembled frames are placed in the rough opening over strips of building paper put around the perimeter to minimize air infiltration. The frame is plumbed and nailed to side studs and

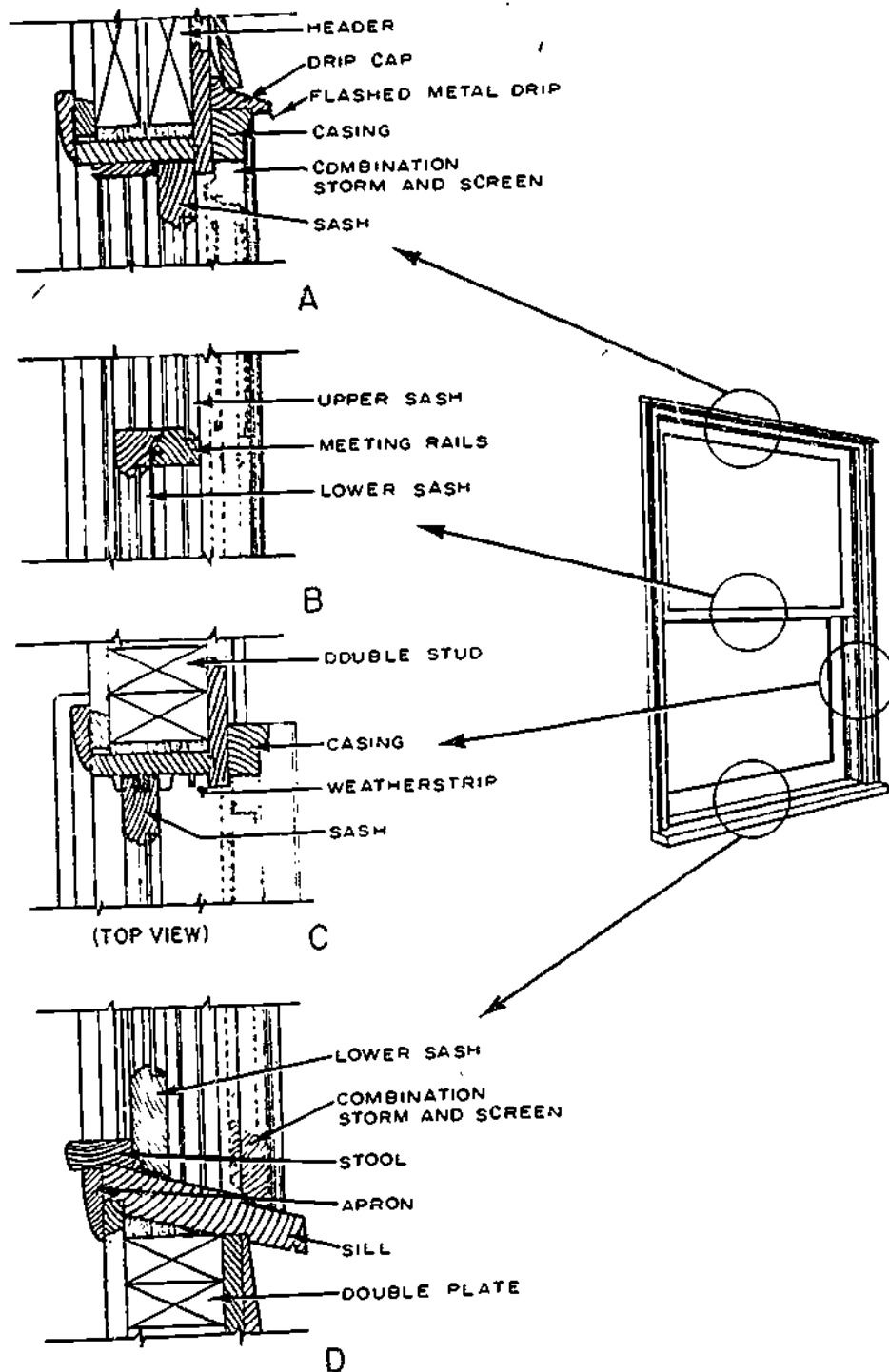

133.539

Figure 12-53.—Double-hung windows. Cross sections: A. Head jamb; B. Meeting rails; C. Side jambs; D. Sill.

12-43

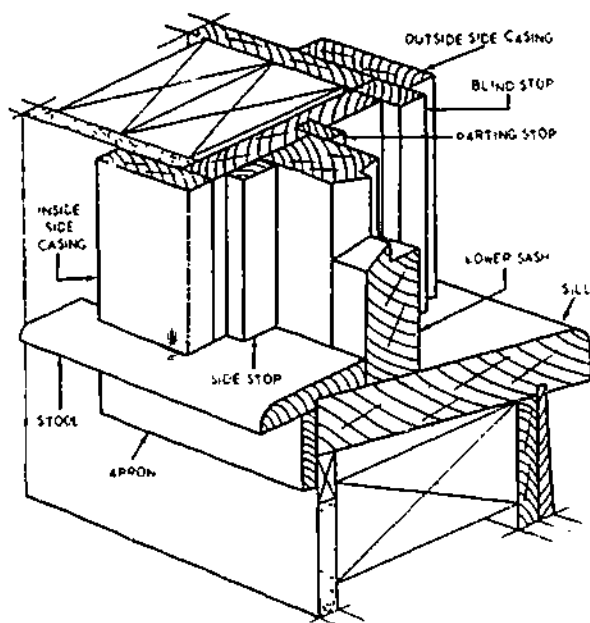

117.64

Figure 12-54.—Window stool and apron.

header through the casings or the blind stops at the sides. Where nails are exposed, such as on the casing, use the corrosion-resistant type.

Hardware for double-hung windows includes the sash lifts that are fastened to the bottom rail, although they are sometimes eliminated by providing a finger groove in the rail. Other hardware consists of sash locks or fasteners located at the meeting rail. They not only lock the window, but draw the sash together to provide a "windtight" fit.

Double-hung windows can be arranged in a number of ways—as a single unit, doubled (or mullion) type, or in groups of three or more. One or two double-hung windows on each side of a large stationary insulated window are often used to create a window wall. Such large openings must be framed with headers large enough to carry roofloads.

Casement Windows

CASEMENT WINDOWS consist of side-hinged sash, usually designed to swing outward (fig. 12-55) because this type can be made more

weathertight than the inswinging style. Screens are located inside these outswinging windows and winter protection is obtained with a storm sash or by using insulated glass in the sash. One advantage of the casement window over the double-hung type is that the entire window area can be opened for ventilation.

Weatherstripping is also provided for this type of window, and units are usually received from the factory entirely assembled with hardware in place. Closing hardware consists of a rotary operator and sash lock. As in the double-hung units, casement sash can be used in a number of ways—as a pair or in combinations of two or more pairs. Style variations are achieved by divided lights. Snap-in muntins provide a small, multiple-pane appearance for traditional styling.

Metal sash is sometimes used but, because of low insulating value, should be installed carefully to prevent condensation and frosting on the interior surfaces during cold weather. A full storm-window unit is sometimes necessary to eliminate this problem in cold climates.

Stationary Windows

Stationary windows used alone or in combination with double-hung or casement windows usually consist of a wood sash with a large single light of insulated glass. They are designed to provide light, as well as be attractive, and are fastened permanently into the frame (fig. 12-56). Because of their size, (sometimes 6 to 8 ft wide), 1 3/4-in.-thick sash is used to provide strength. The thickness is usually required because of the thickness of the insulating glass.

Other types of stationary windows may be used without a sash. The glass is set directly into rabbeted frame members and held in place with stops. As with all window-sash units, back puttying and face puttying of the glass (with or without a stop) will assure moisture-resistance.

TYPES OF GLASS

Single-strength glass is approximately 1/10 in. thick and used for small areas, never to

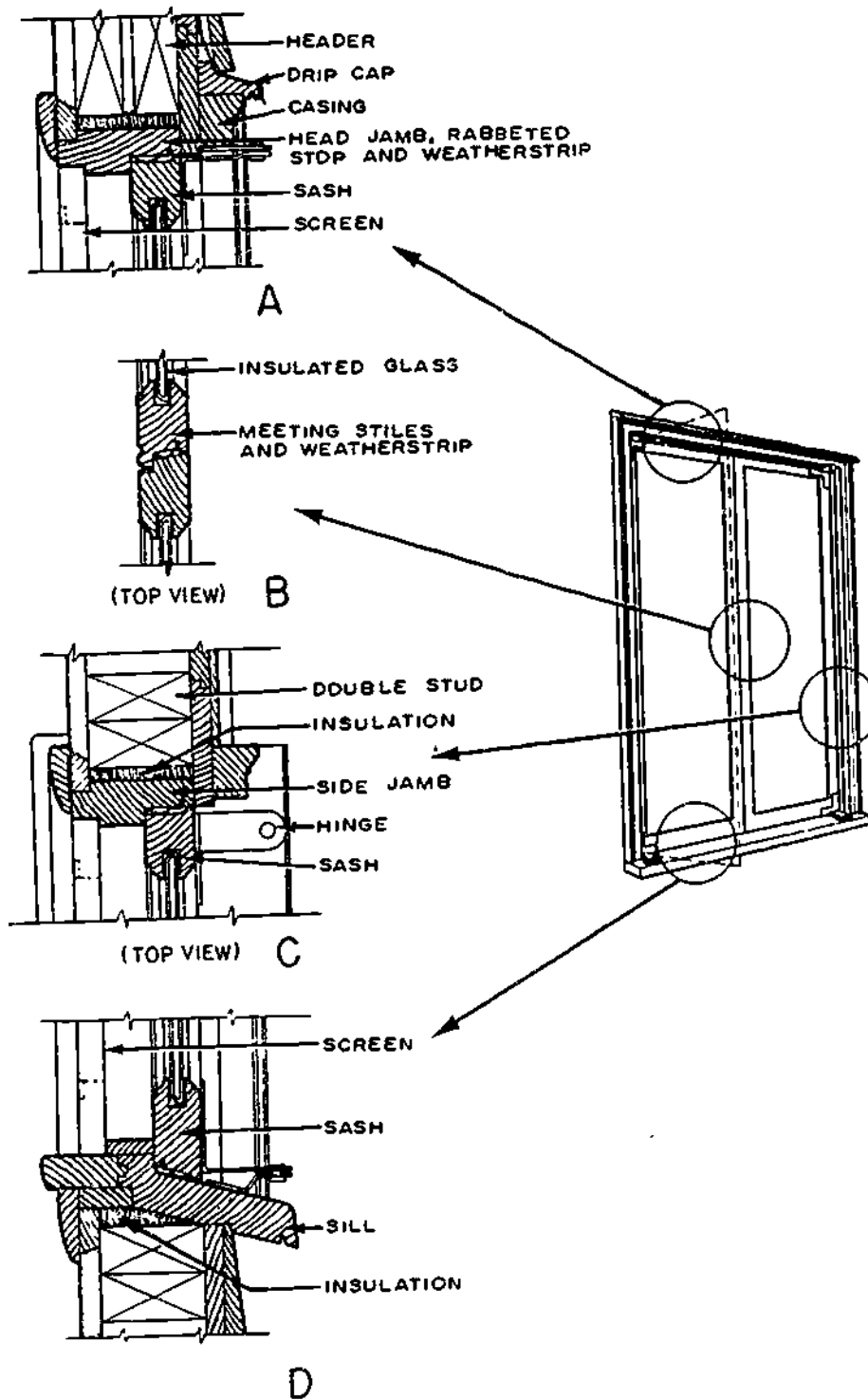

133.640
 Figure 12-55.—Outswinging casement sash. Cross sections: A. Head jamb; B. Meeting sills; C. Side jambs; D. Sill.

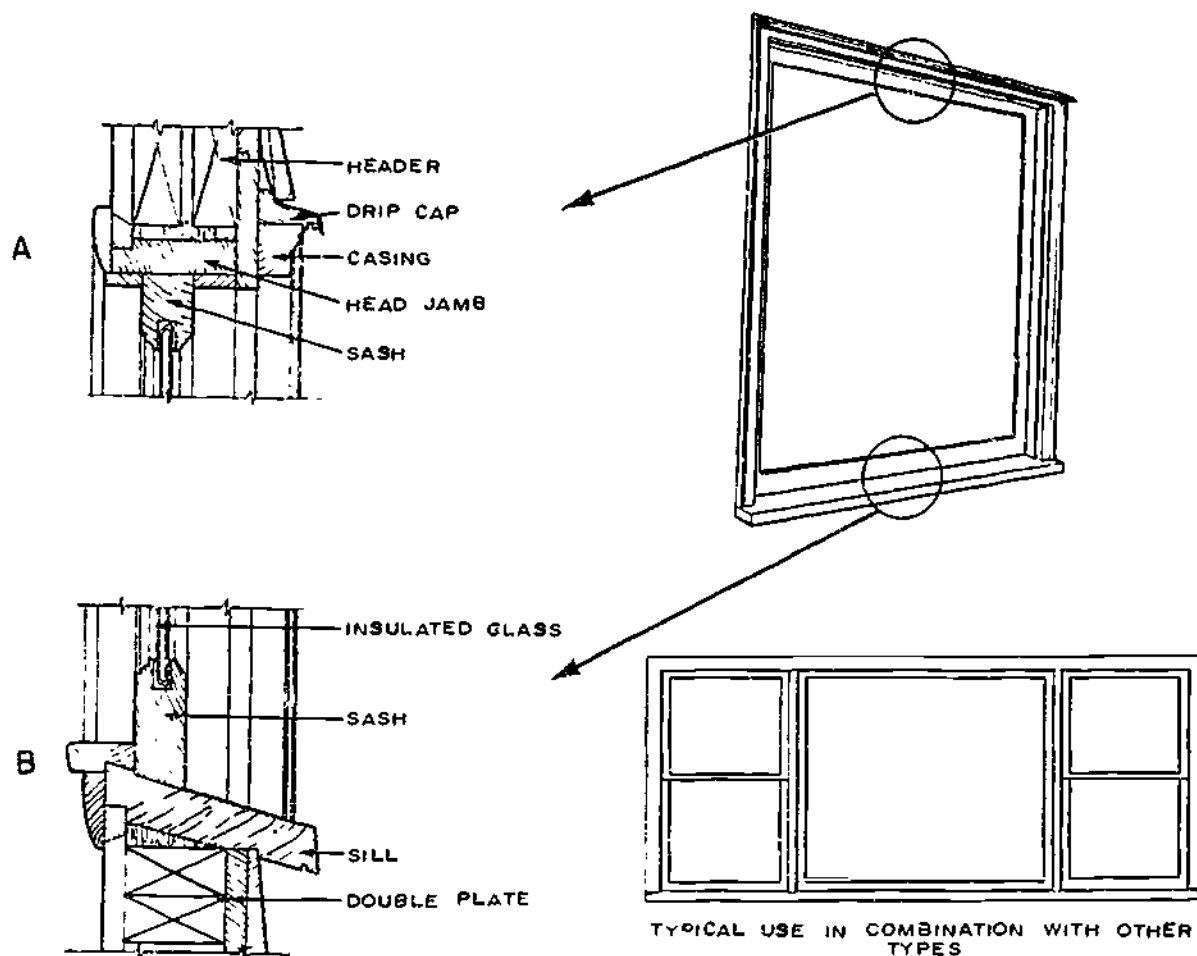

133.541

Figure 12-55.—Stationary window. Cross sections: A. Head jamb; B. Sill.

exceed 400 sq in. Double-strength glass is approximately 9/64 in. thick and is used where high wind resistance is necessary. Window glass comes in three grades: (AA) or superior grade, (A) or very good, and (B) general or utility grade.

Heavy sheet glass comes in various thicknesses from 3/16 in. to 1/4 in. and in sheet sizes up to 76 in. by 120 in. Sheet glass is sometimes used for windows but usually greenhouses. It is slightly wavy and may cause a slight distortion of images viewed through it.

Plate glass is manufactured in a continuous ribbon and cut into large sheets. It is ground and polished for high quality, and comes in

thicknesses from 1/8 in. to 1 1/4 in. It is usually used for large windows, such as store fronts.

Tempered glass is glass that has been reheated to just below its melting point and suddenly cooled by the oil bath method. Tempered glass cannot be cut or drilled after tempering and must be ordered to exact size. It will withstand heavy impacts and great pressures but if tapped near the edge it will disintegrate into small pieces.

Heat strengthened glass is made of polished plate or patterned glass and is reheated and cooled to strengthen it. It is used in curtain wall designs as spandrel glazing of multistoried buildings. Patterned glass is a rolled flat glass

with an impressed design on one or both sides.

Wire glass is a regular rolled flat glass with either a hexagonal twisted or a diamond-shaped, welded continuous wire mesh as near as possible in the center of the sheet. The surface may be either patterned, figured, or polished.

Heat absorbing glass is usually a heavy sheet of glass 1/8 in. or 1/4 in. thick and is either a bluish or greenish color. It has the ability to absorb the sun's infrared rays and thereby exclude heat.

Insulating glass units are comprised of two or more sheets of glass separated by 3/16-, 1/4-, or 1/2-in. air space. These units are factory sealed and the captive air is hydrated at atmospheric pressure. They are made of either window glass or polished plate glass. Special units may be obtained of varying combinations of heat absorbing, laminated patterned, or tempered glass.

Glare reducing glass is available in double strength, in panes up to 60 in. by 80 in., and 3/16 in., 7/32 in., and 1/4 in. in panes up to 72 in. by 120 in. in size. It is light gray in color, gives clear vision and is also slightly heat absorbent. One-fourth in. glass will exclude about 21 percent of the sun's heat rays.

Laminated glass is comprised of two or more sheets of glass with one or more layers of transparent vinyl plastic sandwiched between the glass. An adhesive applied with heat and pressure cements the layers into one unit. The elasticity of the plastic cushions any blow against the glass, preventing sharp pieces from flying. There is also laminated glare-reducing glass where the pigment in the vinyl plastic laminate controls glare.

SASH PREPARATION

Attach the sash so it will withstand the design load and comply with the specifications. Adjust, plumb, and square the sash to within 1/8 in. of nominal dimensions on shop drawings. Remove all rivets, screws, bolts, nailheads, welding fillets, and other projections from specified clearances. Seal all sash corners and fabrication intersections to make the sash

watertight. Put a coat of primer paint on all sealing surfaces of wood sash and carbon steel sash. Use appropriate solvents to remove grease, lacquers and other organic protecting finishes from sealing surfaces of aluminum sash.

GLASS CUTTING

Insofar as possible, glass should be purchased and stocked in sizes that can be used without cutting. Glass of special sizes is cut in the shop. For glass sizes, measure all four sides of the sash and deduct 1/16 to 1/8 in. in the light size for irregularities in the sash. Minimum equipment required for glass cutting consists of a table, a common wood or metal T-square, and a glass cutter. The table should be about 4 ft square, with front and left-hand edges square. Mark off the surface of the table vertically and horizontally in inches. A thin coating of turpentine or kerosene on the glass line to be cut is helpful in lubricating the action of the cutter wheel. A sharp cutter must be carefully drawn only ONCE along the line of the desired cut. Additional strokes of the cutter may result in breakage.

Check dimensions related to sash openings to be sure that adequate clearances are maintained on all four sides of the perimeter. No attempt should be made to change the size of heat strengthened, tempered or doubled glazed units, since any such effort will result in permanent damage. All heat absorbing glass must be clean cut. Nipping to remove flares or to reduce oversized dimensions of heat-absorbing glass is not permitted.

PREPARATION BEFORE GLAZING

Old wood sash: Clean all putty runs of broken glass fragments and glazier's points. Remove loose paint and putty by scraping. Wipe the surface clean with a cloth saturated in mineral spirits or turpentine, prime the putty runs and allow them to dry.

New wood sash: Remove the dust, prime the putty runs, and allow them to dry. All new wood sash should be pressure treated for decay protection.

Old metal sash: Remove loose paint or putty by scraping. Use steel wool or sandpaper to remove rust. Clean the surfaces thoroughly with a cloth saturated in mineral spirits or turpentine. Prime bare metal and allow it to dry thoroughly.

New metal sash: Wipe the sash thoroughly with a cloth saturated in mineral spirits or turpentine to remove dust, dirt, oil, or grease. Remove any rust with steel wool or sandpaper. If the sash is not already factory primed, prime it with rust-inhibitive paint and allow it to dry thoroughly.

GLAZING

Glazing wood and metal sashes and doors consists of sash conditioning and placement of glass. Maintenance often involves only replacement of loose, deteriorated, or missing putty. When replacing glazing items in buildings and structures, use the same type materials as were used in the original work. Use replacement materials of improved quality only when justified by obvious inadequacy of the materials that have failed or by planned future utilization of the building or structure.

Wood sash may be glazed at the factory or on the job. In some instances, it will reduce breakage and labor costs to have glazing done at the job site after sash is fitted. When a large number of stock-size wood sash are used, it is generally cheaper to have glazing done at the factory.

Steel sash are generally furnished open and glazing is performed on the job.

Cost of material varies with the size and kind of glass and whether the glass is bedded in putty and face puttied, face puttied only, or set with wood or metal beads.

SETTING GLASS IN WOOD AND METAL SASH

Do not glaze or reglaze exterior sash when the temperature is 40° or lower unless absolutely necessary. Sash and door members must be thoroughly cleaned of dust with a brush

or cloth dampened with turpentine or mineral spirits. Lay a continuous 1/6-in.-thick bed of putty or compound in the putty run, as shown in figure 12-57. The glazed face of the sash can be recognized as the size on which the glass was cut. If the glass has a bowed surface, it should be set with the concave side in. Wire glass is set with the twist vertical. Press the glass firmly into place so that the bed putty will fill all irregularities.

When glazing wood sash, insert two glazier's points per side for small lights and about 8 in. apart on all sides for large lights. When glazing metal sash, use the wire clips or metal glazing beads.

After the glass has been bedded, lay a continuous bead of putty against the perimeter of the glass-face putty run. Press the putty with a putty knife or glazing tool with sufficient pressure to insure its complete adhesion to the glass and sash. Finish with full, smooth, accurately formed bevels with clean cut miters. Trim up the bed putty on the reverse side of the glass. When glazing or reglazing interior sash and transoms, whether fixed or movable, and interior doors, you use wood or metal glazing beads. Exterior doors and hinged transoms should have glass secured in place with inside wood or metal glazing beads bedded in putty. In setting wire glass for security purposes, set wood or metal glazing beads, secured with screws, on the side facing the area to be protected. Wood sash putty should be painted as soon as it has surface-hardened. Do not wait longer than 2 months after glazing. Metal sash, Type I, elastic compound, should be painted immediately after a firm skin forms on the surface. Depending on weather conditions, the time for skinning over may be 2 to 10 days. Type II, metal sash putty, can usually be painted within 2 weeks after placing. This putty should not be painted before it has hardened because early painting may retard the set.

Clean the glass on both sides after painting. A cloth moistened with mineral spirits will remove putty stains. Ammonia, acid solutions, or water containing caustic soaps must not be used. When scrapers are used, care should be exercised to avoid breaking the paint seal at the putty edge.

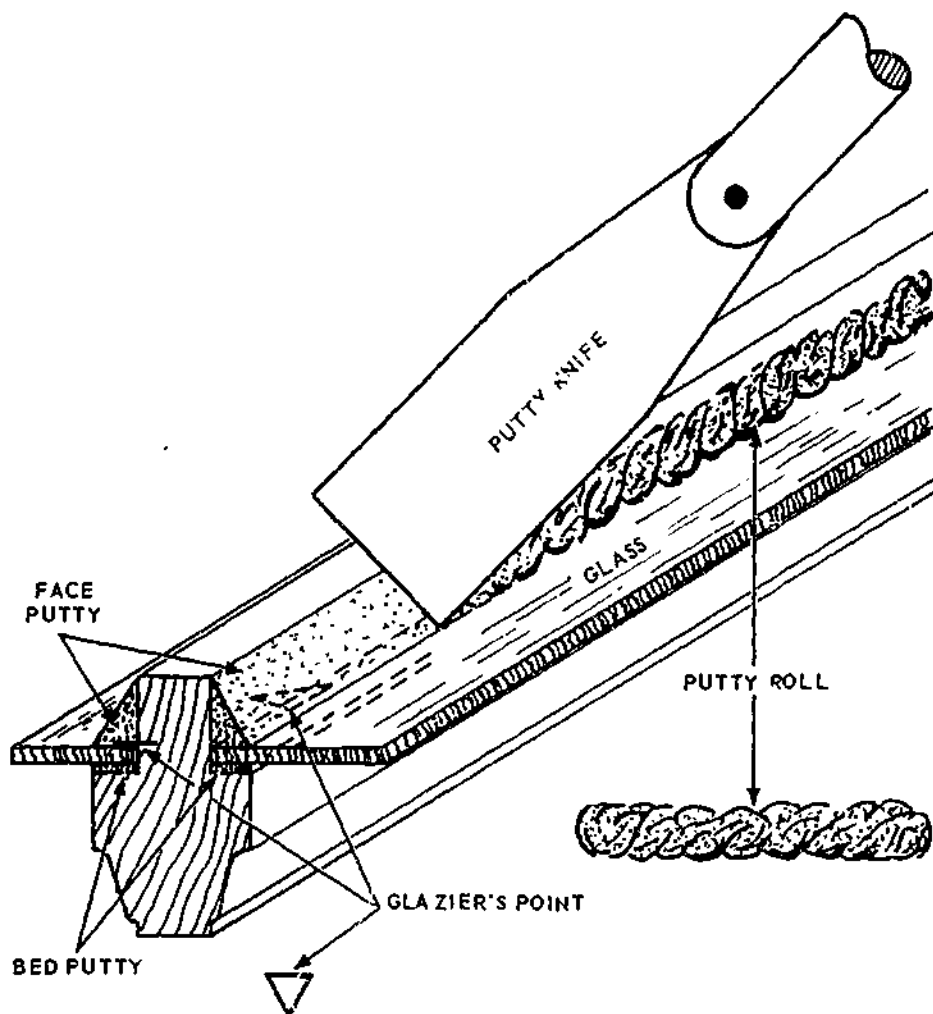

133.160

Figure 12-57.—Setting glass with glazier's points and putty.

Handling and cutting glass creates a serious hazard. Appropriate gloves and other personal protective equipment must be provided and adequate procedures for the disposal of cuttings and broken glass established.

WOOD-TRIM INSTALLATION

The casing around the window frames on the interior of the house should be the same pattern as that used around the interior door frames. Other trim which is used for a double-hung

window frame includes the sash stops, stool, and apron (view A, fig. 12-58). Another method of using trim around windows has the entire opening enclosed with casing (view B, fig. 12-58). The stool is then a filler member between the bottom sash rail and the bottom casing.

The STOOL is the horizontal trim member that laps the window sill and extends beyond the casing at the sides, with each end notched against the plastered wall. The APRON serves as a finish member below the stool. The window stool is the first piece of window trim to be

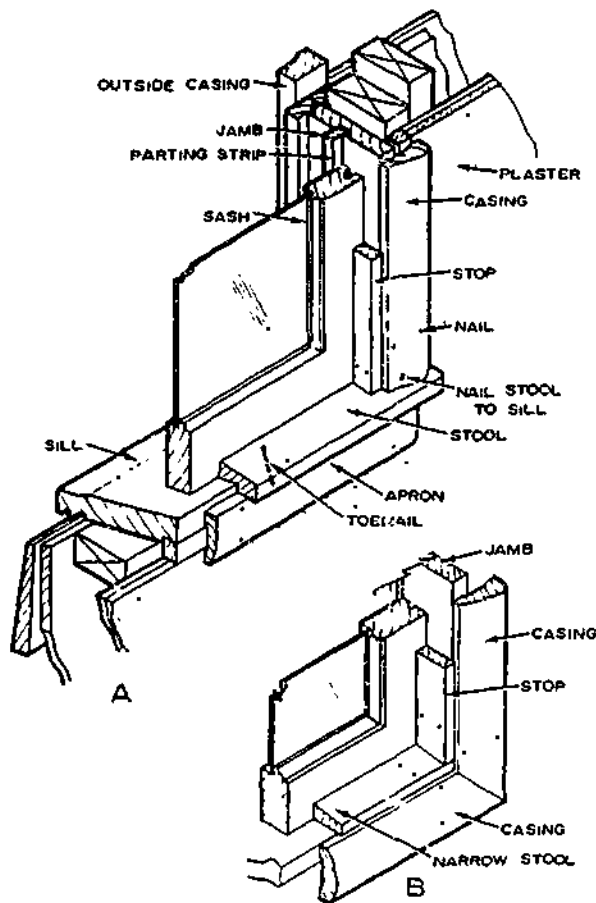

133.542
Figure 12-58.—Installation of window trim: A. With stool and apron; B. Enclosed with casing.

installed and is notched and fitted against the edge of the jamb and the plaster line, with the outside edge being flush against the bottom rail of the window sash. The stool is blind-nailed at the ends so that the casing and the stop will cover the nailheads. Pre-drilling is usually necessary to prevent splitting. The stool should also be nailed at midpoint to the sill and to the apron with finishing nails. Face nailing to the sill is sometimes substituted or supplemented with toenailing of the outer edge to the sill.

The casing is applied and nailed as described for doorframes (view A, fig. 12-41) except that the inner edge is flush with the inner face of the jambs so that the stop will cover the joint between the jamb and casing. The window stops

are then nailed to the jambs so that the window sash slides smoothly. Channel-type weather stripping often includes full-width metal subjams into which the upper and lower sash slide, replacing the parting strip. Stops are located against these instead of the sash to provide a small amount of pressure. The apron is cut to a length equal to the outer width of the casing line (view A, fig. 12-58). It is nailed to the window sill and to the 2- by 4-in. framing sill below.

When casing is used to finish the bottom of the window frame as well as the sides and top, the narrow stool butts against the side window jamb. Casing is then mitered at the bottom corners (view B, fig. 12-58) and nailed as previously described.

BASE MOLDING

Base molding serves as a finish between the finished wall and floor. It is available in several widths and forms. Two-piece base consists of a baseboard topped with a small base cap (view A, fig. 12-59). When plaster is not straight and true,

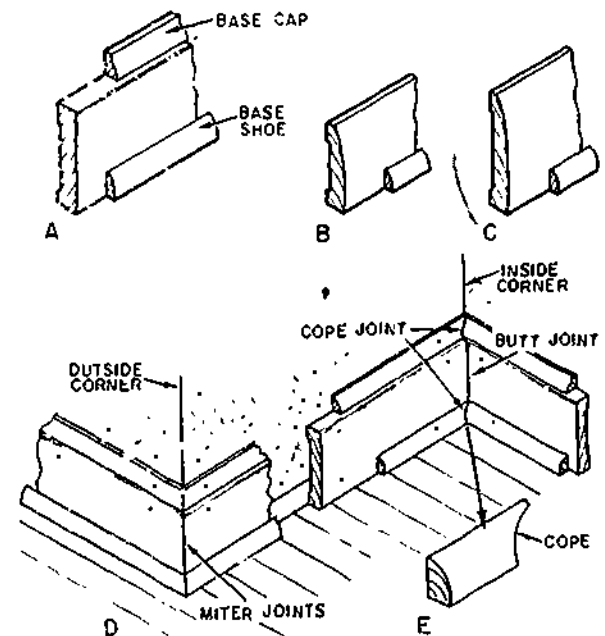

133.543
Figure 12-59.—Base molding: A. Square-edge base; B. Narrow ranch base; C. Wide ranch base; D. Installation; E. Cope.

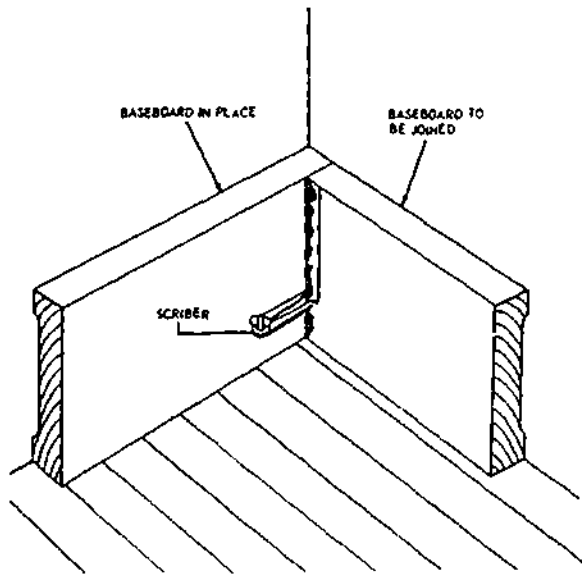

117.62

Figure 12-60.—Butt-joining baseboard at an inside corner.

the small base molding will conform more closely to the variations than will the wider base alone. A common size for this type of baseboard is 5/8 by 3 1/4 in. or wider. One-piece base varies in size from 7/16 by 2 1/4 in. to 1/2 by 3 1/4 in. and wider (views B and C, fig. 12-59). Although a wood member is desirable at the junction of the wall and carpeting to serve as a protective "bumper", wood trim is sometimes eliminated entirely.

Most baseboards are finished with a 1/2- by 3/4-in. base shoe. A single base molding without the shoe is sometimes placed at the wall-floor junction, especially where carpeting might be used.

Square-edged baseboard should be installed with a butt joint at inside corners and a mitered joint at outside corners (view D, fig. 12-59). It should be nailed to each stud with two eightpenny finishing nails. Molded single-piece base, base moldings, and base shoe should have a coped joint at inside corners and a mitered joint at outside corners. A coped joint is one in which the first piece is square-cut against the plaster or base and the second molding coped. This is accomplished by sawing a 45° miter cut and

with a coping saw trimming the molding along the inner line of the miter (view E, fig. 12-59). The base shoe should be nailed into the subfloor with long slender nails and not into the baseboard itself. Thus, if there is a small amount of shrinkage of the joists, no opening will occur under the shoe.

To butt-join a piece of baseboard to another piece already in place at an inside corner, set the piece to be joined in position on the floor, bring the end against or near the face of the other piece, and take off the line of the face with a scribe, as shown in figure 12-60. Use the same procedure when butting ends of baseboard against the side casings of doors.

For miter-joining at an outside corner, proceed as shown in figure 12-61. First, set a MARKER PIECE of baseboard across the wall corner, as shown in the left-hand view and mark the floor along the edge of the piece. Then set the piece to be mitered in place, and mark the point where the wall corner intersects the top edge and the point where the mark on the floor intersects the bottom edge. Lay 45° lines across the edge from these points to make a 90° corner; connect these lines with a line across the face, and miter to the lines as indicated.

CEILING MOLDING

Ceiling moldings are sometimes used at the junction of the wall and ceiling for an

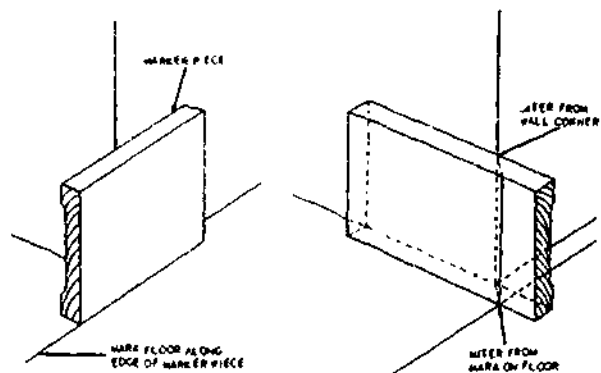

117.73

Figure 12-61.—Miter-joining baseboard at an outside corner.

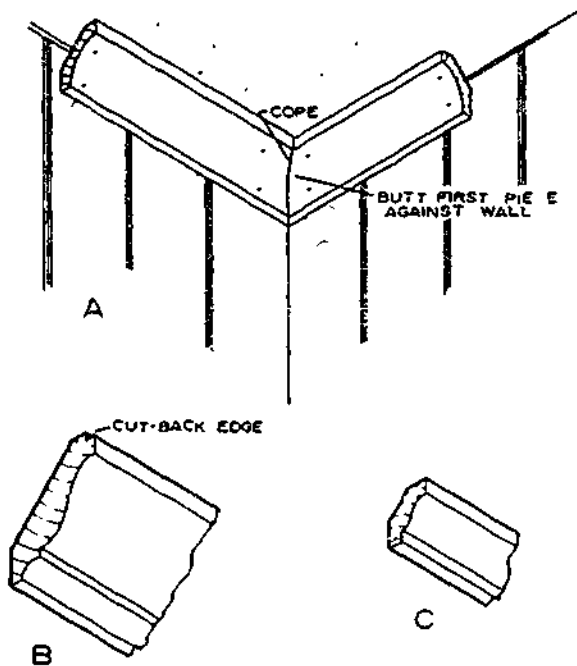

133.544

Figure 12-62.—Ceiling moldings: A. Installation (inside corner); B. Crown molding; C. Small crown molding.

architectural effect or to terminate dry-wall paneling of gypsum board or wood (view A, fig. 12-62). As with the base moldings, inside corners should also be cope-jointed. This insures a tight joint and retains a good fit if there are minor moisture changes.

A cutback edge at the outside of the molding will partially conceal any unevenness of the plaster and make painting easier where there are color changes (view B, fig. 12-62). For gypsum dry-wall construction, a small simple molding might be desirable (view C, fig. 12-62). Finish nails should be driven into the upper wall-plates and also into the ceiling joists for large molding when possible.

DECORATIVE TREATMENT

The decorative treatment for interior doors, trim, and other millwork may be paint or a

natural finish with stain, varnish, or other nonpigmented material. The paint or natural finish desired for the woodwork in various rooms often determines the species of wood to be used. Interior finish that is to be painted should be smooth, close-grained, and free from pitch streaks. Some species having these requirements, to a high degree include ponderosa pine, northern white pine, redwood, and spruce. Birch, gum and yellow poplar are recommended for their hardness and resistance to hard usage. Ash, birch, cherry, maple, oak, and walnut provide a natural finish decorative treatment. Some require staining to improve appearance.

The recommended moisture content for interior finish varies from 6 to 11 percent, depending on the climatic conditions.

LAMINATED PLASTICS

Plastic-laminated products are manufactured in a variety of forms or shapes. They are commonly used on construction projects for wall surfaces, countertops, tabletops and the like.

There are various methods of fastening the laminated plastics. For example, a plastic-laminated countertop is installed as follows:

Measure and cut a piece of the laminate to the desired size. Allow at least 1/4 in. extra to project past the edge of the countertop surface. Next, mix and apply the contact bond cement to the underside of the laminate and to the topside of the countertop surface.

NOTE: Be sure to follow the manufacturer's recommended directions for application.

Allow the contact bond cement to set or dry. To check for bonding, press a piece of brown wrapping paper on the cement-coated surface. When no adhesive residue shows, it is ready to be bonded. Be sure to lay a full sheet of brown wrapping paper across the countertop. This allows you to adjust the laminate into the desired position without permanent bonding.

Chapter 12--INTERIOR FINISH

Now, you can gradually slide the wrapping paper out from under the laminate, and the laminate becomes bonded to the countertop surface.

Be sure to roll the laminate flat by hand, removing any air bubbles and getting a good

firm bond. After sealing the laminate to the countertop surface, trim the edges by using either a router with a special guide or a small block plane. If you want to bevel the countertop edge, use a mill file.

CHAPTER 13

PLASTERING, STUCCOING, AND CERAMIC TILE

PLASTER and STUCCO, like concrete, are construction materials which are applied in a plastic condition, and harden in place after being applied. The fundamental difference between plaster and stucco is simply one of location: if the material is used internally, it is called plaster; if it is used externally, it is called stucco.

Walls in bathrooms, shower rooms, galleys, corridors, and the like are sometimes entirely or partly covered with CERAMIC TILE. The tile is made of clay, pressed into shape, and baked in an oven.

This chapter provides information on procedures, methods, and techniques used in plastering, stuccoing, and tile setting. Also described are the various tools, equipment, and materials that the Builder uses when working with plaster, stucco, and ceramic tile.

Safety precautions will be noted at various points, where applicable, throughout the chapter.

PLASTER INGREDIENTS

A plaster mix, like a concrete mix, is made plastic for application by the addition of water to the dry ingredients which are the binders and aggregates. Again like concrete, it is a reaction of the binder to the water called HYDRATION that causes the mix to harden.

The binders most commonly used in plaster are GYPSUM, LIME, and PORTLAND CEMENT. Because gypsum plaster should not be exposed to water or severe moisture conditions, it is usually confined to interior use. Lime and portland cement plaster may be used both internally and externally.

The aggregates most commonly used in plaster are SAND, VERMICULITE, and PERLITE.

GYPSUM PLASTER

Gypsum is a naturally occurring sedimentary gray, white, or pink rock. The natural rock is crushed and then heated to a high temperature, a process (known as CALCINING) which drives off about three-quarters of the WATER OF CRYSTALLIZATION which forms about 20 percent by weight of the rock in a natural state. The calcined material is then ground to a fine powder, to which certain ADDITIVES are added to control set, stabilization, and other physical or chemical characteristics.

For a type of gypsum plaster called KEENE'S CEMENT, the crushed gypsum rock is heated until nearly all of the water of crystallization is driven off. To offset slow-setting caused by the absence of so much WATER OF HYDRATION, an Englishman named Keene patented a process of adding alum as an accelerator. The resulting plaster, called Keene's cement, produces a very hard, fine-textured finish coat.

The removal of water of crystallization from natural gypsum is a DEHYDRATION process. In the course of setting, mixing water (water of hydration) added to the mix REHYDRATES with the gypsum, thus causing RECRYSTALLIZATION. Recrystallization causes the plaster to harden.

There are four common types of gypsum basecoat plasters:

GYPSUM NEAT plaster is gypsum plaster without aggregate, intended for mixing with aggregate and water on the job.

GYPSUM READY-MIXED plaster consists of gypsum and ordinary mineral aggregate; at the job it requires only the addition of water.

GYPSUM WOOD-FIBERED plaster consists of calcined gypsum combined with not less than 0.75 percent by weight of nonstaining wood fibers. It may be used as is or mixed with 1 part sand to produce base coats of superior strength and hardness.

GYPSUM BOND plaster is so-called because it is designed to bond to properly prepared monolithic concrete. It consists essentially of calcined gypsum mixed with from 2 to 5 percent of lime by weight.

There are five common types of gypsum-finish coat plasters:

READY-MIX GYPSUM-FINISH plasters are designed for use over gypsum-plaster basecoats. They consist of finely ground calcined gypsum, some with, and others without, aggregate. At the job, they require addition of water only.

GYPSUM ACOUSTICAL plasters are designed to reduce sound reverberation.

GYPSUM GAGING plasters contain **LIME PUTTY**, the inclusion of which provides certain setting properties, increases dimensional stability during drying, and provides initial surface hardness. Gaging plasters are obtainable as **SLOW-SET**, **QUICK-SET**, and **SPECIAL HIGH STRENGTH**.

GYPSUM MOLDING plasters are used primarily in casting and ornamental plaster work. It is available neat (that is, without admixtures) or with lime. As with portland cement mortar, the addition of lime to a plaster mix makes the mix more "buttery."

KEENE'S CEMENT is a fine, high-density plaster capable of creating a highly polished surface. It is customarily used with lime putty, and with fine sand which provides crack-resistance.

LIME PLASTER

LIME is obtained principally from the burning (called calcining) of **LIMESTONE**, a very common mineral. During the calcining process, certain chemical changes occur which transform the limestone into what is called **QUICKLIME**. Quicklime which meets certain

requirements is pulverized for building use; other quicklime is further processed into **HYDRATED lime** for building use.

Before being used for plastering, quicklime must be **SLAKED**. Slaking consists of adding the quicklime to water. When quicklime is added to water be careful because of a chemical change that will occur. For example, always add quick-slaking lime to water; when escaping steam appears, the lime should be hoed and just enough lime added to stop the steaming.

In mixing medium-slaking and slow-slaking limes, the water should be added to the lime. The slow-slaking lime must be mixed under an ideal temperature; thereby making it necessary to heat the water in cold weather. Magnesium lime is easily "drowned" so be careful not to add too much water to quick-slaking calcium lime. When too little water is added to either calcium or magnesium limes, they can be "burned." Whenever lime is burned or drowned, a part of it is spoiled, and it will not harden and the paste is not as viscous and plastic as it should be. The quicklime must be soaked for an extended period of as much as 21 days. The end-product is plastic **LIME PUTTY**.

Because of the delays involved in the slaking process of quicklime most building lime is hydrated lime. **NORMAL** hydrated lime is converted into lime putty by soaking for at least 16 hr. **SPECIAL** hydrated lime develops immediate plasticity when mixed with water and may be used right after mixing.

Like calcined gypsum, lime plaster tends to return to its original rock-like state after application.

For interior basecoat work, lime plaster has been largely supplanted by gypsum plaster. It is now used principally for interior finish coats. Because lime putty is the most plastic and workable of the cementitious materials used in plaster, it is often added to other less workable plaster materials to improve plasticity. For lime plaster, lime (in the form of either dry hydrate or lime putty) is mixed with sand, water, and a **GAGING MATERIAL**. A gaging material is intended to produce early strength and to counteract shrinkage tendencies. The gaging material may be either gypsum gaging plaster or Keene's cement for interior work, or portland cement for exterior work.

PORTLAND CEMENT

Portland cement plaster is similar to the portland cement mortar used in masonry. It may contain cement, sand, and water only; however, lime, ground asbestos, or some other plasticizing material is usually added for "butteriness."

Portland cement plaster may be applied direct to exterior and interior masonry walls and over metal lath. NEVER apply portland cement plaster over gypsum plasterboard or over gypsum tile. Portland cement plaster is recommended for use in plastering walls and ceilings of large walk-in refrigerators and cold storage spaces, basement spaces, toilets, showers, and similar areas where an extra hard or highly water-resistant surface is required.

AGGREGATES

SAND for plaster, like sand for concrete, must be free of more than a specified minimum of organic impurities and harmful chemicals. Certain tests for these impurities and chemicals are conducted by qualified personnel.

Proper aggregate gradation influences plaster strength and workability, and likewise has an effect on the tendency of the material to shrink or expand while setting.

Plaster strength is reduced if excessive fine aggregate material is present in a mix. The greater quantity of mixing water required raises the water:cement ratio, thereby reducing the dry set density. The cementitious material becomes overextended, because it must coat a relatively larger overall aggregate surface.

An excess of coarse aggregate adversely affects workability; the mix becomes "harsh working" and difficult to apply.

Plaster shrinkage during drying may be caused by an excess of either fine or coarse aggregate. Because an excess of fine increases the aggregate total surface area, a larger quantity of binder paste is needed to coat all particles. The mix becomes too rich in cementitious material, and it is the cementitious material which is unstable after application. The end-effect is much the same if there is too much coarse aggregate; in this case, there is not enough fine aggregate to fill the voids between coarse particles, and more cementitious material must

be used to fill these voids. Again the result is a rich and relatively unstable material.

Generally speaking, any sand retained on the No. 4 sieve is too coarse to use in plaster, and only a small percentage of the material (about 5 percent) should pass the No. 200 sieve.

VERMICULITE is a MICACEOUS mineral—meaning a mineral in which each particle is LAMINATED, or made up of adjoining layers. When vermiculite particles are exposed to intense heat, steam forms between the layers forcing them apart; this causes each particle to increase from 6 to 20 times in volume. The expanded material is soft and pliable with a color varying between silver and gold.

For ordinary plaster work, vermiculite is used only with gypsum plaster—therefore, in general, only for interior plastering. For acoustical plaster, vermiculite is combined with a special acoustical binder.

The approximate dry weight of a cu ft of 1:2 gypsum-vermiculite plaster is 50 to 55 lb, the dry weight of a cu ft of comparable sanded plaster is 104 to 120 lb.

Raw PERLITE is a volcanic glass which, when flash-roasted, expands to form frothy particles of irregular shape that contain countless minute air cells. Expansion causes the particles to "pop," forming a frothy mass of glass bubbles 4 to 20 times the volume of the raw particles. The color of expanded perlite ranges from pearly white to grayish white.

Perlite is used with calcined gypsum or portland cement for interior plastering; it is also used with special binders for acoustical plaster. The approximate dry weight of a cu ft of 1:2 gypsum-perlite plaster is 50 to 55 lb, or about half the weight of a cu ft of sand-plaster.

Although sand, vermiculite, and perlite constitute the great preponderance of plaster aggregate, certain other materials are used. Wood fiber may be added to neat gypsum plaster at the time of manufacture, to improve the working qualities of the gypsum. PUMICE is a naturally formed volcanic glass similar to perlite, but heavier (28 to 32 lb per cu ft, against 7.5 to 15 lb for perlite). The weight differential gives perlite an economic advantage, and limits the use of pumice to localities near where it is produced.

WATER

The mixing water in plaster performs two functions. First, it transforms the dry ingredients into a plastic, workable mass; second, it combines mechanically and/or chemically with the binder to induce hardening. As is the case with concrete, there is a maximum quantity of water per unit of binder required for complete hydration, and an excess over this amount reduces the plaster strength below the maximum attainable.

However, in all plaster mixing, more water is added than is necessary for complete hydration of the binder; the excess is necessary to bring the mix to workable consistency. The amount that must be added for workability depends on the characteristics and age of the binder, the method of application, the drying conditions, and the tendency of the base to absorb water. A porous masonry base, for example, will draw a good deal of water out of a plaster mix. If this reduces the water content of the mix below the maximum required for hydration, incomplete curing will result.

As a general rule, only the amount of water required to attain workability is added to a mix and no more. The water should be clean and fresh, and it must contain no dissolved chemicals which might accelerate or retard the set. Water previously used to wash plastering tools should never be used for mixing plaster; it may contain particles of set plaster which may accelerate setting. Stagnant water should be avoided, because it may contain organic material which may retard setting and possibly cause staining.

PLASTER BASES

For plastering there must be a continuous surface to which the plaster can be applied and to which it will cling; such a surface is called a plaster **BASE**. A continuous concrete or masonry surface may serve as a base without the necessity for further treatment.

For plaster planes, such as those defined by the inner edges of studs or the lower edges of joists, however, base material must be installed to form a continuous surface which will span the spaces between the structural members. Material

of this kind is called **LATH**. Lath formerly consisted of thin wooden strips which were nailed at right angles to the studs or joists. Narrow openings were left between adjacent laths, through which the plaster penetrated to form a **KEY** which bonded the plaster to the lath.

In modern plastering, wooden lath has been almost entirely superseded by **GYPSUM** lath and **METAL** lath.

GYPSUM LATH

Gypsum lath is made by sandwiching a core of gypsum plaster between two sheets of a fibrous, absorbent paper. For **PLAIN** (non-perforated) gypsum lath, bond is effected by absorption or suction of the face of the lath. This absorption draws in some of the cementitious material in the plaster. As the plaster sets, particles of this absorbed material interlock with nonabsorbed particles in the plaster. For **PERFORATED** (punched with 3/4-in. holes 4 in. apart) gypsum plaster, suction bond is supplemented by keys formed by plaster which penetrates the holes.

The standard sheet size for gypsum lath is 16 in. by 48 in., except in the western U.S., where it is 16 1/5 in. by 48 in. **LONG LENGTH** gypsum lath comes 16 or 24 in. wide and any length up to 12 ft. Available thicknesses are 3/8 in. and 1/2 in. **INSULATING** gypsum lath has aluminum foil bonded to the back of the sheet, this material provides thermal insulation and also serves as a vapor barrier.

Gypsum lath is nailed to studs, joists, or furring strips with 1 1/8-in. to 1-1/4 in. flatheaded **GYPSUM LATH NAILS**, 5 nails to each stud, joist, or strip crossing. It may also be attached with power-driven staples.

METAL LATH

Metal lath consists essentially of a metal screen. Bond is created by keys formed by plaster forced through the screen openings; as the plaster hardens, it and the metal become rigidly interlocked.

WIRE lath consists simply of wire screen, formed by weaving or welding intersecting wires together. **SHEET** metal lath consists of sheet

metal perforated with openings of various shapes.

EXPANDED METAL LATH

FLAT EXPANDED metal lath is manufactured by first cutting staggered slits in a sheet and then expanding (stretching) the sheet to form the screen openings. **RIB EXPANDED** metal lath contains V-shaped metal ribs for the purpose of furring the lath out from the surface to which it is attached.

Flat Expanded Lath

DIAMOND MESH lath, suitable for all types of plastering, comes in 24-in. by 96-in. and 27-in. by 96-in. sheets.

SELF-FURRING DIAMOND MESH contains **DIMPLES** which fur it out 1/4 in. from the surface to which it is attached. This lath may be nailed to smooth concrete or masonry surfaces, or wrapped around structural steel, without the necessity for previous furring. It is widely used for replastering old walls and ceilings when the removal of the old plaster is not desired. Standard sizes are the same as for diamond mesh.

PAPER-BACKED DIAMOND MESH is designed to receive plaster applied by machine.

STUCCO MESH has larger openings than diamond mesh; it is intended primarily for exterior plastering.

Rib Expanded Lath

Rib expanded lath has ribs 1/8 in. deep, 3/8 in. deep, or 3/4 in. deep. Standard sheet sizes for 1/8 in. and 3/8 in. rib expanded lath are the same as for diamond mesh lath. For 3/4 in. rib expanded lath, the widths are the same, but lengths of 120 in. and 144 in. are available besides 96 in.

ATTACHMENT OF METAL LATH

Metal lath is nailed to vertical wooden supports, such as wall studs or wall furring strips with 4d common nails. It is nailed to horizontal wooden supports such as ceiling joists or ceiling

furring strips with 1 1/2-in. barbed roofing nails. It may also be attached to wooden supports with power-driven staples. For attachment to metal supports, tie wires are used. In handling metal lath, wear heavy gloves.

LATHING ACCESSORIES

LATHING ACCESSORIES consist of **STRUCTURAL COMPONENTS** and **MISCELLANEOUS ACCESSORIES**. The principal use of structural components is in the construction of **HOLLOW PARTITIONS**. A hollow partition is one which contains no building framing members, such as studs and plates. Structural components are lathing accessories which take the place of the missing framing members in supporting the lath. They include prefabricated **METAL STUDS** and floor and ceiling **RUNNER TRACKS**. The runner tracks take the place of missing stud top and bottom plates; they usually consist of metal **CHANNELS**. Channels are also used for furring and bracing.

Miscellaneous accessories consist principally of various devices attached to the lath at the corners and at other locations. They serve to define and reinforce corners, to provide dividing strips between plaster and the edges of baseboard or other trim, or to define plaster edges at unframed openings. **CORNER BEADS** are the most common miscellaneous accessories. Figure 13-1 shows a **STANDARD FLANGE** corner bead, in which the flanges are perforated metal. There are also **EXPANDED FLANGE** and **WIDE FLANGE** corner beads. **CASING BEADS** are similar devices for providing dividing strips between plaster edges and the edges of door and window casing. **BASE BEADS** (also called **BASE**

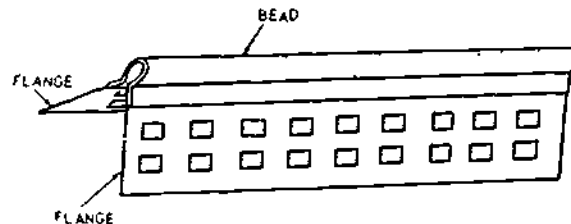

117.42
Figure 13-1.—Standard flange corner bead.

SCREEDS) provide dividing strips between plaster edges and the edges of baseboards. All of these devices are attached to the lath before plaster is applied.

JOINT REINFORCING

Because some drying usually takes place in the wood framing members after a structure is completed, some shrinkage can be expected, in turn, this may cause plaster cracks to develop around openings and in the corners. To minimize, if not eliminate, these cracks, expanded metal lath is used in certain key positions over the plaster-base material as reinforcement. Strips of expanded metal lath may be used over window and door openings (view A, fig. 13-2). A strip about 10 by 20 in. is placed diagonally across each upper corner of the opening and tacked in place.

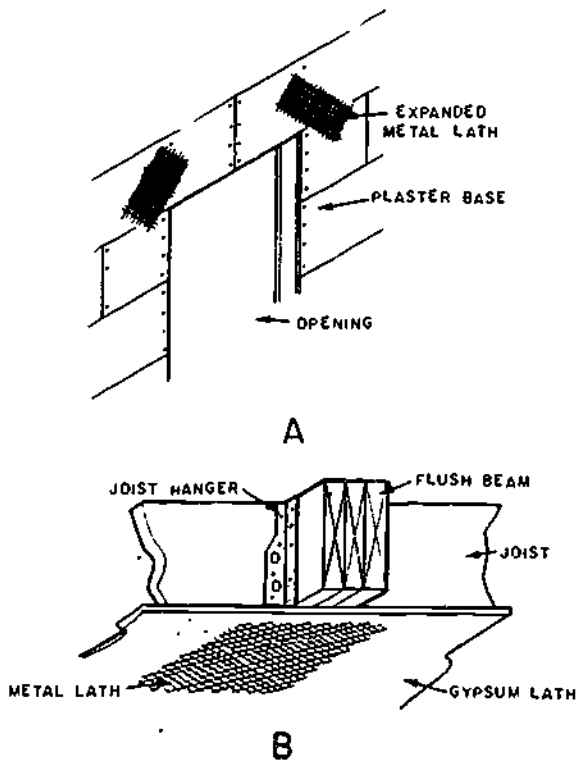

133.480
Figure 13-2.—Metal lath used to minimize cracking: (A) at door and window openings; (B) under flush beams.

Metal lath should also be used under flush ceiling beams to prevent plaster cracks (view B, fig. 13-2). On wood drop beams extending below the ceiling line, the metal lath is applied with furring nails to provide space for keying of the plaster.

Corner beads of expanded metal lath or of perforated metal should be installed on all exterior corners (view A, fig. 13-3). They should be applied plumb and level. The bead acts as a leveling edge when walls are plastered and reinforces the corner against mechanical damage. To minimize plaster cracks, inside corners at the juncture of walls and of ceilings should also be reinforced. Metal lath or wire fabric (cornerites) are tacked lightly in place in these corners. Cornerites provide a key width of 2 to 2 1/2 in. at each side for plaster (view B, fig. 13-3).

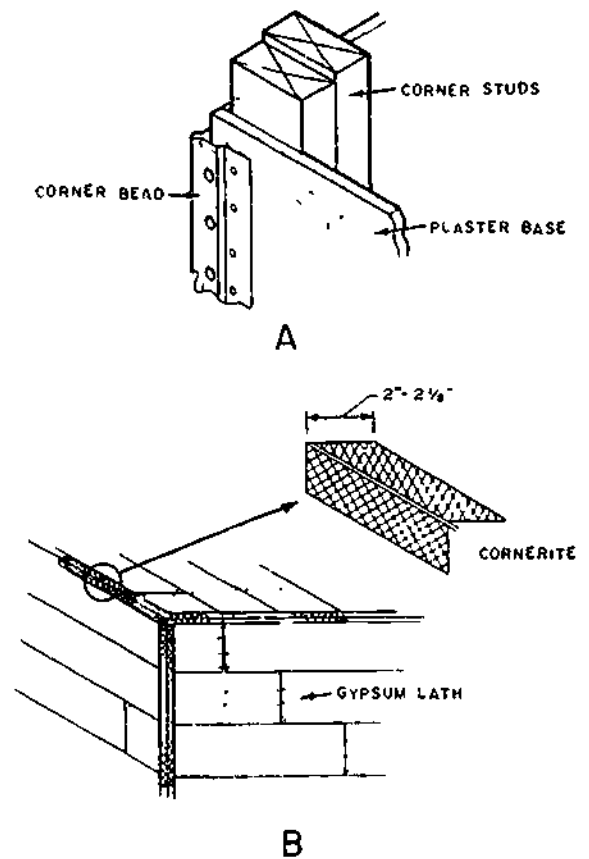

133.481
Figure 13-3.—Reinforcing of plaster at corners: (A) outside; (B) inside.

PLASTER GROUNDS

Plaster grounds are strips of wood used as plastering guides or strike-off edges and are located around window and door openings and at the base of the walls. Grounds around interior door openings are often full-width pieces nailed to the sides over the studs and to the underside of the header (view A, fig. 13-4). They are 5 1/4 in. wide, which coincides with the standard jamb width for interior walls with a plaster finish. They are removed after plaster has dried. Narrow strip grounds might also be used

around these interior openings (view B, fig. 13-4).

In window and exterior door openings, the frames are normally in place before the plaster is applied. Thus, the inside edges of the side and head jamb can, and often do, serve as grounds. The edge of the window might also be used as a ground, or a narrow 7/8-in.-thick ground strip is nailed to the edge of the 2- by 4-in. sill. Narrow 7/8- by 1-in. grounds might also be used around window and door openings (view C, fig. 13-4). These are normally left in place and are covered by the casing.

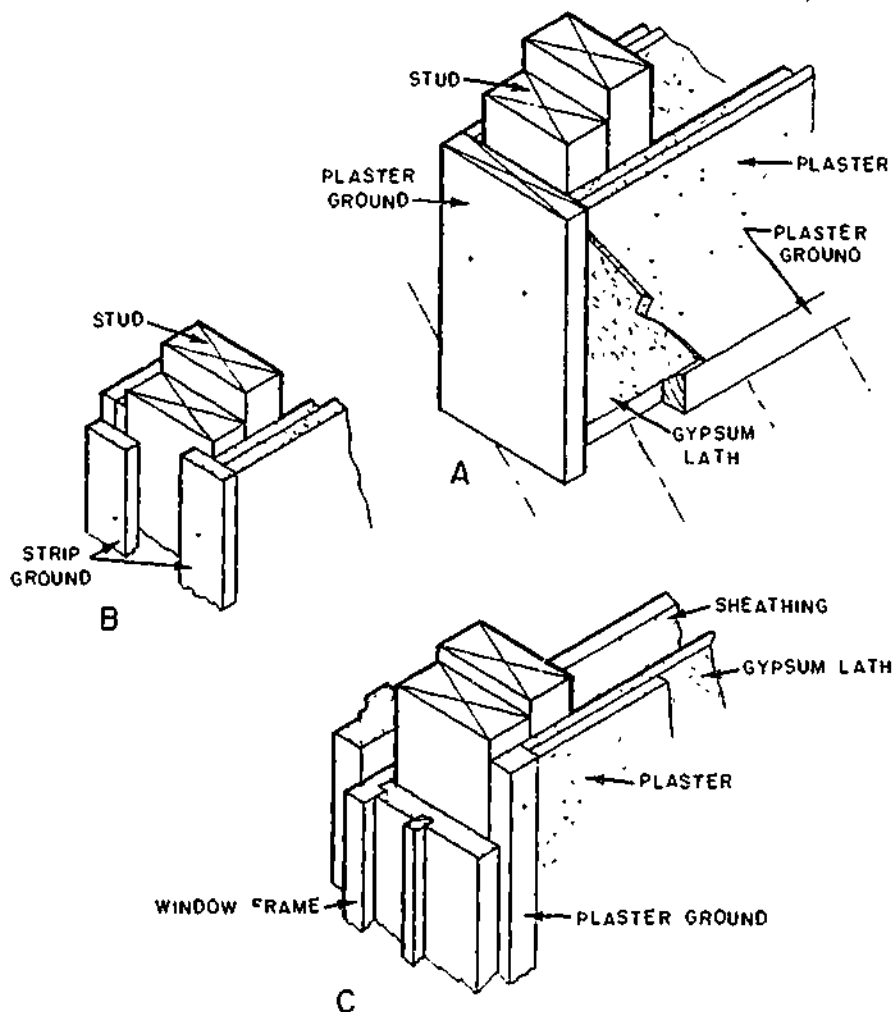

Figure 13-4.—Plaster grounds: (A) at doorway and floor; (B) strip ground at doorway; (C) ground at window.

133.482

A similar narrow ground or screed is used at the bottom of the wall to control thickness of the gypsum plaster, and to provide an even surface for the baseboard and molding. This screed is also left in place after plaster has been applied.

INSTALLATION OF PLASTER BASE

Gypsum lath should be applied horizontally with joints broken (fig. 13-5). Vertical joints should be made over the center of studs or joists and nailed with 12- or 13-gage gypsum-lathing nails 1 1/2 in. long and with a 3/8-in. flat head. Nails should be spaced 5-in. oncenter, or four nails for the 16-in. height, and used at each stud or joist crossing. Some manufacturers specify the ring-shank nails with a slightly greater spacing. Lath joints over heads of openings should not occur at the jamb lines (fig. 13-5).

Insulating lath should be installed much the same as gypsum lath, except that slightly longer blued nails should be used. A special waterproof facing is provided on one type of gypsum board

for use as a ceramic tile base when the tile is applied with an adhesive.

Metal lath is often used as a plaster base around tub recesses and other bath and kitchen areas (fig. 13-6). It is also used when ceramic tile is applied over a plastic base. It must be backed with water-resistant sheathing paper over the framing. The metal lath is applied horizontally over the waterproof backing with side and end joints lapped. It is nailed with No. 11 and No. 12 roofing nails long enough to provide about 1 1/2-in. penetration into the framing member or blocking.

MIXING PLASTER

Some plaster comes ready-mixed, requiring only the addition of enough water on the job to attain minimum required workability. For job-mixing, tables are available which give recommended ingredient proportions for gypsum, lime, lime-portland cement, and portland cement plaster for base coats on lath or on various types of concrete or masonry surfaces, and for finish coats of various types. This chapter presents recommended proportions for only the more common types of plastering

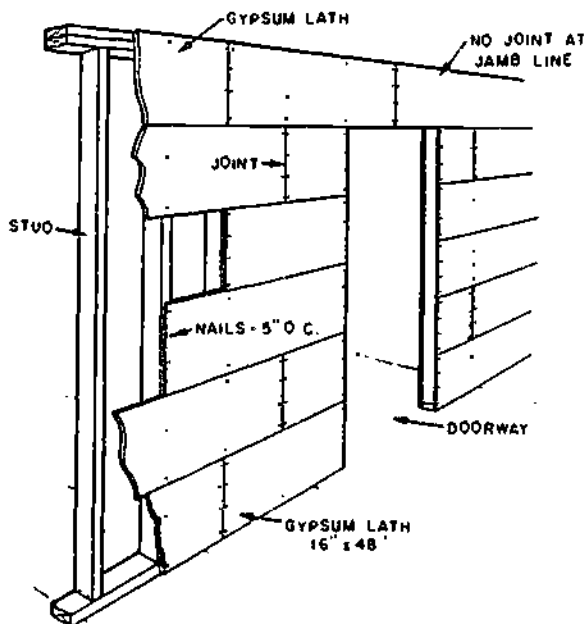

133.483

Figure 13-5.—Application of gypsum lath.

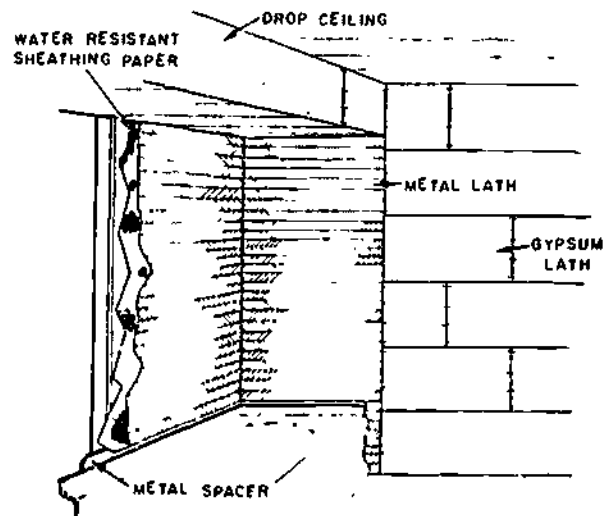

133.484

Figure 13-6.—Application of metal lath.

situations. In the following sections, 1 part of cementitious material means 100 lb (1 sack) gypsum, 100 lb (2 sacks) hydrated lime, 1 cu ft lime putty, or 94 lb (1 sack) portland cement. One part of aggregate means 100 lb sand or 1 cu ft vermiculite or perlite. Vermiculite and perlite are NOT used with lime plaster; therefore, while aggregate parts given for gypsum or portland cement plaster may be presumed to refer to either sand or vermiculite/perlite, aggregate parts given for lime plaster means sand only.

BASE COAT PROPORTIONS

TWO-COAT plaster work consists of a single base coat and a finish coat. THREE-COAT plaster work consists of two base coats (the first is called the SCRATCH coat, and the second the BROWN coat) and a finish coat.

Portland cement plaster can NOT be applied to a gypsum base. Lime plaster can in theory, but in practice, only gypsum plaster is applied to gypsum lath as a base coat. For two-coat work on gypsum lath, the recommended base coat proportions for gypsum plaster are 1:2.5.

For two-coat work on a masonry (using this term to mean either monolithic concrete or masonry) base the recommended base coat proportions are as follows:

Gypsum plaster: 1:3
Lime plaster using hydrated lime: 1:7.5
Lime plaster using lime putty: 1:3.5

Portland cement plaster is NOT used for two-coat work, and two-coat work is NOT usually done on metal lath.

For three-coat work on gypsum lath the recommended base coat proportions for gypsum plaster are: scratch coat 1:2, brown coat, 1:3; or both coats, 1:2.5.

For three-coat work on metal lath the recommended base coat proportions are as follows:

Gypsum plaster: same as for three-coat work on gypsum lath

Lime plaster using hydrated lime: scratch 1:6.75, brown 1:9
Lime plaster using lime putty: scratch 1:3, brown 1:4
Portland cement plaster: both coats 1:3 to 1:5

For three-coat work on a masonry base, the recommended base coat proportions are as follows:

Gypsum plaster: both coats 1:3
Portland cement plaster: both coats 1:3 to 1:5

Lime plaster is NOT usually used for three-coat work on a masonry base.

FINISH COAT PROPORTIONS

A lime finish may be applied over a lime, gypsum, or portland cement base coat; other finishes, however, should be applied only to base coats containing the same cementitious material. A gypsum-vermiculite finish should be applied only to a gypsum-vermiculite base coat.

Finish coat proportions vary according to whether the surface is to be finished with a TROWEL or with a FLOAT. These tools are described later. The trowel attains a smooth finish; the float attains a texture finish.

For a trowel-finish coat using gypsum plaster, the recommended proportions are 200 lb hydrated lime or 5 cu ft lime putty to 100 lb gypsum gauging plaster.

For a trowel-finish coat using lime-Keene's cement plaster, the recommended proportions are, for a medium-hard finish, 50 lb hydrated lime or 100 lb lime putty to 100 lb Keene's cement. For a hard finish, the recommended proportions are 25 lb hydrated lime or 50 lb lime putty to 100 lb Keene's cement.

For a trowel-finish coat using lime-portland cement plaster, the recommended proportions are 200 lb hydrated lime or 5 cu ft lime putty to 94 lb portland cement.

For a finish coat using portland cement-sand plaster, the recommended ingredient proportions are 300 lb sand to 94 lb portland cement. This plaster may be either trowled or floated. Hydrated lime up to 10 percent by weight of the portland cement, or lime putty up to 25 percent of the volume of the portland cement, may be added as a plasticizer.

For a trowel-finish coat using gypsum gaging or gypsum neat plaster and vermiculite aggregate the recommended proportions are 1 cu ft vermiculite to 100 lb plaster.

Recommended proportions for various types of float-finish coats are as follows:

- Lime putty 2: Keene's cement 1.5: sand 4.5, by volume
- Hydrated lime 1: gypsum gaging plaster 1.5: sand 2.3, by weight
- Hydrated lime 2: portland cement 1: sand 2.5, by weight
- Lime putty 1: sand 3, by volume
- Gypsum neat plaster 1: sand 2, by weight

PLASTER QUANTITY ESTIMATES

The total volume of plaster required for a job is the product of the thickness of the plaster times the net area to be covered. Plaster specifications state a minimum thickness, which the plasterer must not go under, and which should be exceeded as little as possible, because a tendency to cracking increases with thickness. Specified minimum thickness for gypsum plaster on metal lath, wire lath, masonry/concrete walls, and masonry ceilings is usually 5/8 in.; for gypsum lath, it is 1/2 in.; for monolithic concrete ceilings, it is 3/8 in. For interior lime plaster on metal lath (3-coat work), the specified minimum thickness is usually 7/8 in.; for exterior lime plaster on metal lath, it is 1 in. For lime plaster on interior masonry walls/ceilings, the minimum thickness is 5/8 in., for exterior lime plaster on masonry, it is 3/4 in. For lime plaster on interior concrete ceilings, the minimum thickness is 1/16 in. to 1/8 in.; for

interior walls, 5/8 in. For lime plaster on exterior concrete, the minimum thickness is 3/4 in. For portland cement plaster, either interior or exterior, recommended thicknesses are 3/8 in. for each base coat (3-coat work) and 1/8 in. for the finish coat.

It has been found that it takes about 38 cu ft of raw materials to make 1 cu yd of mortar. In using the 38 calculating rule for mortar, take the rule number and divide it by the sum of the quantity figures specified in the mix. For example, when the building specifications call for a 1:3 mix for mortar, $1 + 3 = 4$, $38 \div 4 = 9\ 1/2$. You will then need 9 1/2 bags or 9 1/2 cu ft of cement. In order to calculate the amount of fine aggregate (sand), you simply multiply 9 1/2 by 3. The product of 28 1/2 cu ft is the amount of sand you need to mix 1 cu yd of mortar using a 1:3 mix. The sum of the two required quantities should equal the calculating rule 38. Therefore, you can always check in order to see if you are using the correct amounts. In the above example, 9 1/2 bags of cement plus 28 1/2 cu ft of sand, equal 38.

Materials needed for mixing 100 sq ft of plaster or stucco are shown in table 13-1.

MIXING PLASTER BY HAND

For mixing plaster by hand, the equipment consists of a flat, shallow-sided MIXING BOX and a hoe, the hoe usually has a perforated blade. Mixed plaster is transferred from the mixing box to a MORTAR BOARD, similar to the one used in bricklaying. The personnel applying the plaster pick it up from the mortar board.

In hand mixing, the dry ingredients are first placed in the mixing box and thoroughly mixed until a uniform color is obtained. The pile is then coned up and troughed, and the water is mixed as it is in hand concrete mixing. Mixing is continued until the materials have been thoroughly blended and proper consistency has been attained. With experience, a person acquires a "feel" for proper consistency. Mixing should NOT be continued for more than 10 or

Chapter 13—PLASTERING, STUCCOING, AND CERAMIC TILE

Table 13-1.—Plaster and Stucco: Materials Per 100 Square Feet

Thick- ness (In.)	Mortar (Cu Ft)	Cement-Sand Mixes									
		1:1		1:1 1/2		1:2		1:2 1/2		1:3	
		Cement Bags	Sand (Cu Ft)	Cement Bags	Sand (Cu Ft)	Cement Bags	Sand (Cu Ft)	Cement Bags	Sand (Cu Ft)	Cement Bags	Sand (Cu Ft)
1/4	2.08	1.3	1.3	1.1	1.7	1.0	2.0	0.9	2.3	0.8	2.4
3/8	3.12	2.0	2.0	1.7	2.6	1.5	3.0	1.3	3.3	1.1	3.3
1/2	4.17	2.7	2.7	2.3	3.5	2.0	4.0	1.7	4.3	1.5	4.5
3/4	6.25	4.0	4.0	3.4	5.1	2.9	5.8	2.6	6.5	2.3	6.9
1	8.33	5.3	5.3	4.5	6.8	3.9	7.8	3.4	8.5	3.0	9.0

15 minutes after the materials have been thoroughly blended, because excessive agitation may hasten the rate of solution of the cementitious material and thereby cause accelerated set.

Finish-coat lime plaster is usually hand-mixed on a small 5 by 5 ft mortar board called a **FINISHING BOARD**. If the lime used is hydrated lime, it is first converted to lime putty by soaking in an equal amount of water for 16 hours. In mixing the plaster, the lime putty is first formed into a ring on the finishing board. Water is then poured into the ring, and the gypsum or Keene's cement is then sifted into the water to avoid lumping. The mix is allowed to stand for 1 minute, after which the materials are thoroughly blended. Sand, if it is to be used, is then added and mixed in.

MIXING PLASTER BY MACHINE

A plaster mixing machine (fig. 13-7) consists primarily of a metal **DRUM** containing **MIXING BLADES**, mounted on a chassis equipped with wheels for road towing. Mixing is accomplished either by rotation of the drum or by rotation of the blades inside the drum. Discharge into a

wheelbarrow or other receptacle is usually accomplished by tilting the drum.

Steps in the machine mixing of gypsum plaster are as follows:

For job-mixed gypsum plaster:

1. Put in the approximate amount of water
Approximate water amounts for various

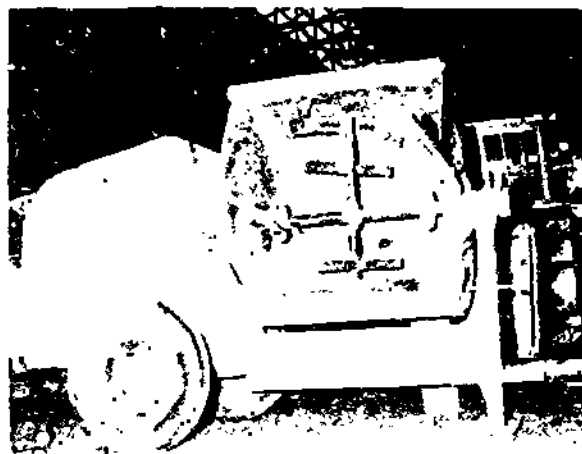

117.75
Figure 13-7.—Plaster mixing machine.

BUILDER 3 & 2

gypsum-aggregate proportions and the common aggregates are as follows:

Aggregate	Gypsum-Aggregate Proportions		
	1:2	1:2.5	1:3
Sand	6.8 gal	7.4 gal	8.2 gal
Perlite	7.7 gal	8.5 gal	9.1 gal
Vermiculite	9.0 gal	10.0 gal	10.1 gal

2. If sand is used, add approximately one-half of the aggregate. If perlite or vermiculite is used, add all the aggregate.

3. Add all the cementitious material.

4. Add the remainder of the sand aggregate.

5. Mix to the required consistency, adding more water IF NECESSARY.

For ready-mix gypsum plaster:

1. Put in the approximate amount of water as prescribed by manufacturer's instructions printed on the sack.

2. Add the plaster.

3. Mix to the required consistency, adding water IF NECESSARY.

For machine mixing of lime and portland cement plaster, place the dry ingredients in the drum first and mix dry until a uniform color is attained. Then add the water and mix to the required consistency. Approximate water amount is 8 gal per 100 lb of cementitious material.

It is generally recommended that the mixer be allowed to run longer than 3 minutes after all materials have been added.

SAFE HANDLING OF MATERIALS

Personnel handling cement or lime bags should wear goggles and snug-fitting neckbands and wristbands. They should always practice personal cleanliness and NEVER wear clothing that has become hard and stiff with cement. Such clothing irritates the skin and may cause serious infection. Any susceptibility of their skin to cement and lime burns should be reported. Personnel who are allergic to cement or lime should be transferred to other jobs.

Bags of cement or lime should NOT be piled more than 10 bags high on a pallet except when stored in bins or enclosures built for such purposes. The bags around the outside of the pallet should be placed with the tops of the bags facing the center. To prevent piled bags from falling outward, the first five tiers of bags, each way from any corner, must be crosspiled and a setback made commencing with the sixth tier. If necessary to pile above the tenth tier, another setback must be made. The back tier, when not resting against a wall of sufficient strength to withstand the pressure, should be setback one bag every five tiers, the same as the end tiers.

During unpiling, the entire top of the pile should be kept level and the necessary setbacks every five tiers maintained.

Lime and cement must be stored in a dry place to help prevent lime from crumbling and the cement from hydrating before it is used.

APPLYING PLASTER

To attain complete structural integrity, a plaster layer must be uniform in thickness; also, a plane plaster surface must be flat enough to appear flat to the eye and to receive surface-applied materials, such as casings and other trim, without the appearance of noticeable spaces. Specified flatness tolerance is usually 1/8 in. in 10 ft.

PLASTERING TOOLS

Steel TROWELS are used to apply, spread, and smooth plaster. The shape and size of the

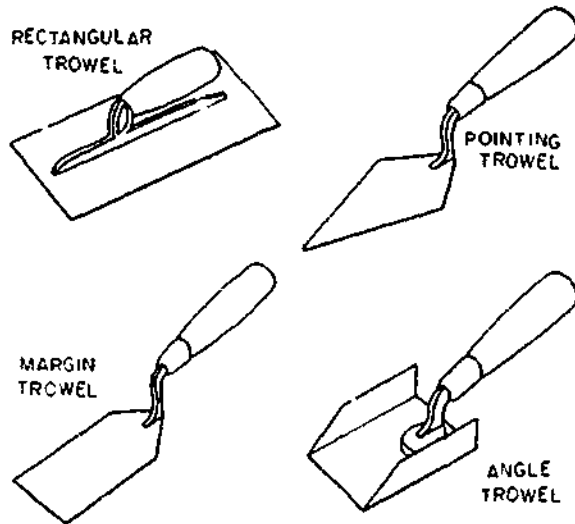

Figure 13-8.—Plastering trowels. 29.164

blade of a trowel is determined by the purpose for which the tool is used and manner of using it.

The four common types of plastering trowels are shown in figure 13-8. The **RECTANGULAR TROWEL**, with a blade approximately 4 1/2 in. wide by 11 in. long, serves as the principal conveyor and manipulator of plaster. The **POINTING** trowel, 2 in. wide by about 10 in. long, is designed for use in places where the rectangular trowel will not fit. The **MARGIN** trowel is another smaller trowel, similar to the pointing trowel, but with a square rather than a pointed end. The **ANGLE** trowel is used for finishing corner angles formed by adjoining right-angle plaster surfaces.

The **HAWK** (fig. 13-9) is a square, lightweight sheet metal platform with a vertical central handle, used for carrying mortar from the mortar board to the place where it is to be applied. The plaster is then removed from the hawk with the trowel. The size of a hawk varies from a 10 in. square to a 14 in. square.

The **FLOAT** is glided over the surface of the plaster to fill voids and hollows, to level bumps left by previous operations, and to impart a

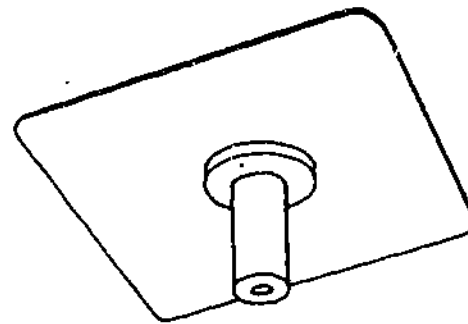

Figure 13-9.—Hawk. 117.76

texture to the surface. Common types of floats are shown in figure 13-10. The **WOOD** float has a wood blade, the **ANGLE** float a stainless steel or aluminum blade. The **SPONGE** float is faced with foam rubber or plastic, intended to attain a certain surface texture. A **CARPET** float is similar to a sponge float, but faced with a layer of carpet material. A **CORK** float is faced with cork.

A float blade is 4 or 5 in. wide and about 10 in. long.

The **ROD** or **STRAIGHTEDGE** consists of a wood or lightweight metal blade 6 in. wide by from 4 to 8 ft long. This is the first tool used in leveling and straightening applied plaster between the grounds. A wood rod has a slot for a handle cut near the center of the blade. A metal rod usually has a shaped handle running

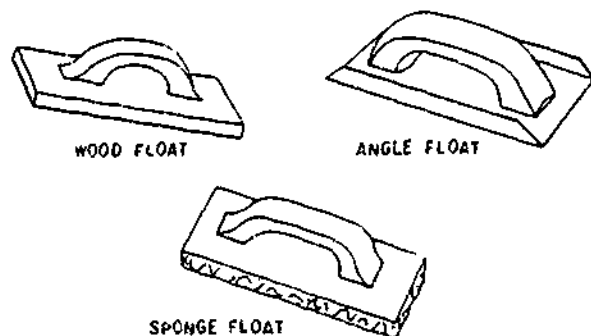
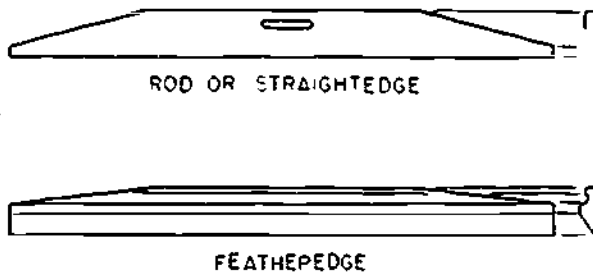

Figure 13-10.—Plastering floats. 29.161



117.77

Figure 13-11.—Rod or straightedge and featheredge.

the length of the blade. A wood rod is shown in figure 13-11.

The FEATHEREDGE (fig. 13-11) is similar to the rod, except that the blade tapers to a sharp edge. It is used to cut in corners and to shape sharp, straight lines at corner lines of intersection.

The DARBY (fig. 13-12) is, in effect, a float with an extra-long (3 1/2 to 4 ft) blade, equipped with handles for two-handed manipulation. It is used for further straightening of the base coat after rodding is completed, to level plaster screeds, and to level finish coats. The blade of the darby is held nearly flat against the plaster surface, and in such a way that the line of the edge makes an angle 45° with the line of direction of the stroke.

When a plaster surface is being leveled, the leveling tool must move over the plaster smoothly. If the surface is too dry, lubrication must be provided by moistening. In base coat

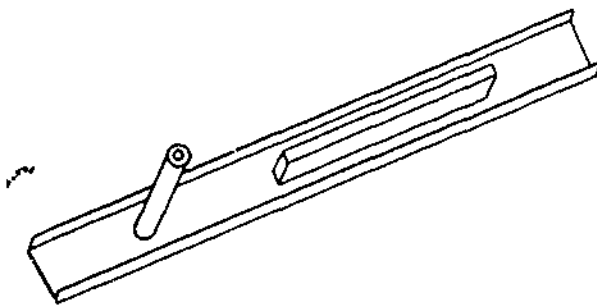

117.78

Figure 13-12.—Darby.

operations, this is accomplished by dashing or brushing water on with a water-carrying brush called a BROWNING brush. This is a fine-bristled brush about 4 or 5 in. wide and 2 in. thick, with bristles about 6 in. long. For finish coat operations a FINISHING brush with softer, more pliable bristles is used.

The SCARIFIER (fig. 13-13), is a tool that leaves furrows by raking approximately 1/8 in. deep, 1/8 in. wide, and 1/2 to 3/4 in. apart. The furrows are intended to improve the bond between the scratch coat and the brown coat.

A MECHANICAL TROWEL (often called a POWER TROWEL) is an electrically operated rotating trowel which weighs about 6 lb and resembles a 6-bladed fan. There are usually two sets of blades, one more flexible than the other. The flexible set is used for preliminary troweling, and the stiffer set for final troweling. Mechanical troweling can be done to within 1/2 in. of corner angles, leaving the angles to be finished by angle troweling.

There are two types of PLASTERING MACHINES. The WET MIX PUMP carries mixed plaster from the mixing machine to a hose nozzle. The DRY MIX machine carries dry ingredients to a mixing nozzle where water under pressure combines with the mix and provides spraying force. Most plastering machines are of the wet mix pump variety.

A wet mix pump may be of the WORM DRIVE, PISTON PUMP, or HAND HOPPER

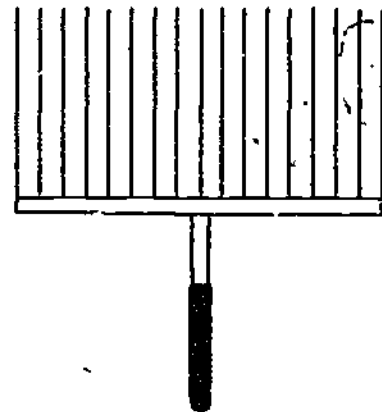

Figure 13-13.—Scarifier.

13-14
518

type. In a worm drive machine, mixed plaster is fed into a hopper and forced through the hose to the nozzle by the screw action of a rotor and stator assembly in the neck of the machine. A machine of this type has a hopper capacity of from 3 to 5 cu ft, and can deliver from 0.5 to 2 cu ft of plaster per minute.

On a piston pump machine, a hydraulic, air-operated, or mechanically operated piston supplies the force for moving the wet plaster. On a hand-hopper machine the dry ingredients are placed in a hand-held hopper just above the nozzle. Hopper capacity is usually around 1/10 cu ft. These machines are used principally for applying finish plaster.

Machine application cuts down on the requirements for the use of the hawk and trowel in initial plaster application; however, the use of straightening and finishing hand tools remains about the same for machine-applied plaster.

PLASTERING CREWS

A typical plastering crew for hand application consists of a crew chief, 2 to 4 plasterers, and 2 to 4 TENDERS. The plasterers, under the crew chief's supervision, set all levels and lines and apply and finish the plaster. The tenders mix the plaster, deliver it to the plasterers, construct scaffolds, handle materials, and do cleanup tasks.

For a machine application, a typical crew consists of a NOZZLEMAN who applies the material, 2 or 3 plasterers leveling and finishing, and 2 or 3 tenders.

APPLICATION OF PLASTER

Lack of uniformity in the thickness of a plaster coat detracts from the structural performance of the plaster, and the thinner the coat, the smaller the permissible variation from uniformity. Specifications usually require that plaster be finished "true and even, within 1/8 in. tolerance in 10 ft, without waves, cracks, or imperfections." The standard of 1/8 in. appears to be the closest practical tolerance to which a

plasterer can work by the methods commonly in use.

The importance of adhering to the recommended minimum thickness for the plaster cannot be overstressed. A plaster wall becomes more rigid as thickness over the minimum recommended increases—which means in effect that the tendency to cracking increases as thickness increases. However, tests have shown that a reduction of thickness from a recommended minimum of 1/2 in. to 3/8 in., with certain plasters, decreases cracking resistance by as much as 60 percent, while reduction to 1/4 in. decreases it as much as 82 percent.

Base Coat Application

GYPSUM BASE COATS.—The sequence of operations in three-coat gypsum plastering is as follows:

1. Install the plaster base.
2. Attach the grounds.
3. Apply the scratch coat approximately 3/16 in. thick.
4. Before the scratch coat sets, RAKE and CROSS-RAKE.
5. Allow the scratch coat to set firm and hard.
6. Apply plaster screeds if required.
7. Apply the brown coat to a depth of the screeds.
8. Using the screeds as guides, straighten the surface with a rod.
9. Fill in any hollows and rod again.
10. Level and compact the surface with a darby; then rake and cross-rake to receive the finish coat.
11. Define angles sharply with angle float and featheredge, and trim back plaster around grounds so that finish coat can be applied flush with grounds.

LIME BASE COATS.—Steps for lime base coat work are similar to the steps for gypsum work, except that for lime an additional floating is required the day after the brown coat is applied. This extra floating is required to increase the density of the slab and to fill in any cracks which may have developed because of

shrinkage of the plaster. A wood float with one or two nails protruding 1/8 in. from the sole (called a DEVIL'S float) is used for the purpose.

Allow the brown coat to dry for 24 hours, then float the surface with a devil's float.

PORTLAND CEMENT BASE COATS.—

Portland cement plaster is actually cement mortar, subject to the control procedures described in the chapter on concrete. It is usually applied in three coats, the steps being the same as those described for gypsum plaster. Minimum recommended thicknesses are usually scratch coat 3/8 in., brown coat 3/8 in., finish coat 1/8 in.

Portland cement plaster should be moist cured, like concrete. The best procedure is fog-spraying curing. The scratch coat should be fog-spray cured for 48 hr., then the brown coat for the same interval. The finish coat should not be applied for at least 7 days after the brown coat; for application, it, too, should be spray-cured for 48 hr.

Finish Coat Application

Interior plaster may be finished by troweling, floating, or spraying. Troweling makes a smooth finish, floating or spraying makes a finish of a desired surface texture.

LIME PUTTY-GYPSUM TROWEL FINISH.—Finish plaster made of gypsum gaging plaster and lime putty (called WHITE COAT or PUTTY COAT) is the most widely used material for smooth finish coats. A putty coat is usually applied by a team of two or more personnel. Steps are as follows:

1. One person applies plaster at the angles.
2. Another person follows immediately, straightening the angles with a rod or featheredge.
3. The remaining surface is covered with a SKIM coat of plaster. Pressure on the trowel must be sufficient to force the material into the rough surface of the base coat, to insure good bond.
4. The surface is immediately doubled back to bring the finish coat to final thickness.
5. All angles are floated, with additional plaster added if required to fill hollows.

6. The remaining surface is floated, and all hollows filled. This operation is called DRAWING UP; the hollows being filled are called CAT FACES.

7. The surface is allowed to DRAW for a few minutes. As the plaster begins to set, the surface-water glaze disappears and the surface becomes dull. At this point, troweling should begin. The plasterer holds the water brush in one hand and the trowel in the other, so troweling can be done immediately after water is brushed on.

8. Water is brushed on lightly and the entire surface is rapidly troweled, with enough pressure fully to compact the finish coat. The troweling operation is repeated until the plaster has set.

The sequence of steps for trowel finishes for other types of finish plaster are about the same. Gypsum-finish plaster requires less troweling than white-coat plaster. Regular Keene's cement requires longer troweling, but quicksetting Keene's cement requires less. Preliminary finishing of portland cement-sand is done with a wood float, after which the steel trowel is used. To avoid excessive drawing of fines to the surface, troweling of portland cement-sand should be delayed as long as possible. For the same reason, the surface must not be troweled too long.

Steps in float finishing are about the same as those described for trowel finishing, except, of course, that the final finish is obtained with the float. A surface is usually floated twice; a rough floating with a wooden float first, then final floating with a rubber or carpet float. The plasterer applies brush water with one hand while the float in the other hand moves in a circular motion immediately behind the brush.

Some special interior-finish textures are obtained otherwise than by floating, or by procedures used in addition to floating. A few of these are as follows:

STIPPLED FINISH.—After the finish coat has been applied, additional plaster is daubed over the surface with a stippling brush.

SPONGE FINISH.—By pressing a sponge against the surface of the finish coat, a very soft, irregular texture can be obtained.

DASH COAT FINISH.—This texture is obtained by throwing plaster onto the surface from a brush. It produces a fairly coarse finish, which can be modified by brushing the plaster with water before it sets.

TRAVERTINE FINISH.—The plaster is jabbed at random with a whisk broom, wire brush, or other tool that will form a dimpled surface. As the plaster begins to set, it is troweled intermittently to form a pattern of rough and smooth areas.

PEBBLE DASH.—This is a rough finish obtained by throwing small pebbles or crushed stone against a newly plastered surface. If necessary, a trowel is used to press the stones lightly into the plaster.

APPLYING STUCCO

Stucco is the term applied to plaster whenever it is applied on the exterior of a building or structure. Stucco can be applied over wood frames or masonry structures. The material is a combination of cement or masonry cement, sand, and water, and frequently a plasticizing material. Color pigments are also often used in the finish coat, which is usually a factory prepared mix. The end product has all the desirable properties of concrete. It is hard, strong, fire resistant, weather resistant, does not deteriorate after repeated wetting and drying, resists rot and fungus, and retains colors.

The material used in a stucco mix should be free of contaminants and unsound particles. Type I normal portland cement is generally used for stucco, although type II, type III, and air-entraining may be used. The plasticizing material added to the mix is hydrated lime and asbestos fibers. Mixing water should be clean. The aggregate used in cement stucco can greatly affect the quality and performance of the finished product. It should be well graded, clean, and free from loam, clay, or vegetable matter, since these foreign materials prevent the cement paste from properly binding the aggregate particles together. The project specification should be followed as to the type of cement, lime, and aggregate to be used.

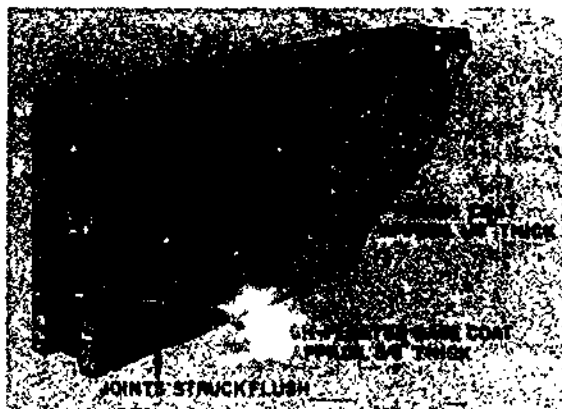

133.155
Figure 13-14.—Masonry (2-coat work directly applied).

Metal reinforcement should be used whenever stucco is applied on the following: wood frame, steel frame, flashing, masonry, or any surfaces not providing a good bond.

Stucco may be applied directly on masonry. The rough-floated base coat is approximately 3/8 in. thick. The finish coat is approximately 1/4 in. thick (fig. 13-14). On open-frame construction (fig. 13-15), nails are driven 1/2 their length into the wood. Spacing should be 5 to 6 in. on center from the bottom. Nails should

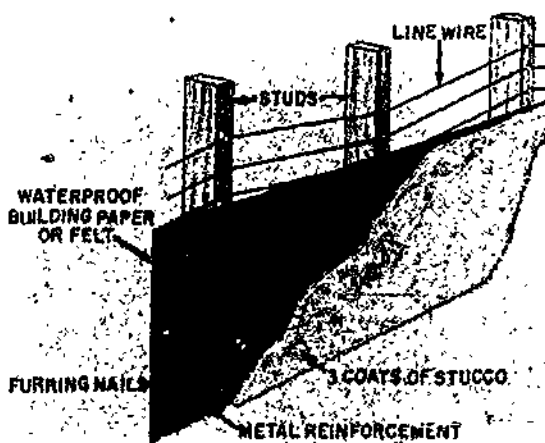

133.156
Figure 13-15.—Open frame construction.

be placed at all corners and openings throughout the entire structure on the exterior. The next step is to place wire on the nails, this is called installing the line wire. Next, a layer of waterproof paper is applied over the line wire. Laps should be 3 to 4 in. and nailed with roofing nails. Next, install wire mesh (stucco netting), which is used as the reinforcement for the stucco. Furring nails are used to hold the wire away from the paper to a thickness of three-eighths of an inch. (Fig. 13-16.) Stucco or sheathed form construction is the same as an open frame, except no line wire is required. The open and sheathed frame construction requires three coats of 3/8-in. scratch coat horizontally scored or scratched, a 3/8-in. brown coat, and a 1/8-in. finish coat.

PREPARATION OF BASE AND APPLICATION OF STUCCO

Stucco should be applied in three coats. The first coat is the SCRATCH coat, the second the BROWN coat, and the final coat the FINISH coat. However, on masonry where no reinforcement is used, two coats may be sufficient. Start at the top and work down the wall. This will eliminate the ball of mortar from falling on the completed work. The first or

scratch coat should be pushed through the mesh to insure that the metal reinforcement is completely embedded for mechanical bond. The second or brown coat should be applied as soon as the scratch coat has set up enough to carry the weight of both coats (usually about 4 or 5 hours). The brown coat should be moist-cured for about 48 hours and then allowed to dry for about 5 days. Just prior to the application of the finish coat, the brown coat should be uniformly dampened. The third or finish coat is frequently pigmented to obtain decorative colors. Although the colors may be job mixed, a factory-prepared mix is recommended. The finish coat may be applied by hand or machine. Stucco finishes are obtainable in an unlimited variety of textures, patterns, and colors.

Before the various coats of stucco can be applied, the surfaces have to be prepared properly. Roughen the surfaces of masonry units enough to provide good mechanical key and clean off paint, oil, dust, soot, or any other material which may prevent a tight bond. Joints may be struck off flush or slightly raked. Old walls softened and disintegrated by weather action, surfaces that cannot be cleaned thoroughly (painted brick-work, etc.), and all masonry chimneys should be covered with galvanized metal reinforcement before applying

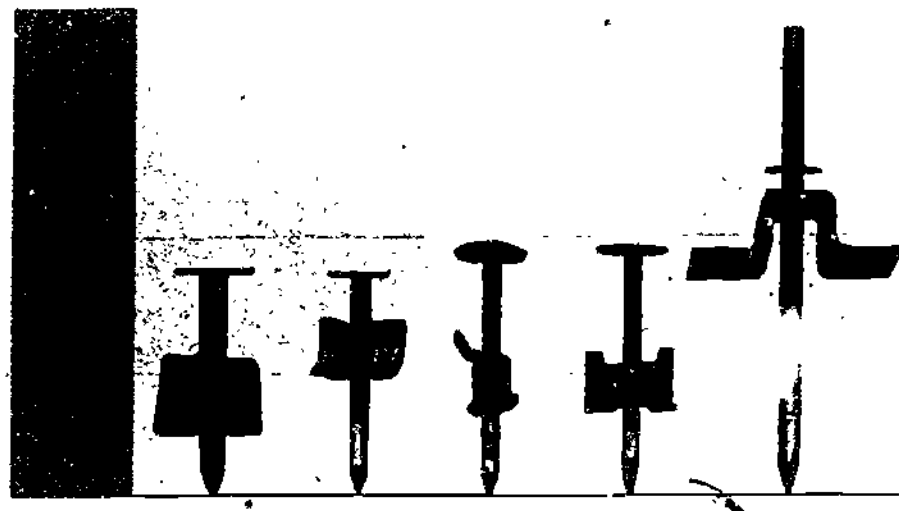

Figure 13-16.—Several types of furring nails.

29.121

the stucco. When masonry surfaces are not rough enough to provide good mechanical key, one or more of the following actions may be taken.

Old cast-in-place concrete or other masonry may be roughened with bush hammers or other suitable hand tools. Roughen at least 70 percent of the surface, with the hammer marks uniformly distributed. Wash the roughened surface free of chips and dust. Let the wall dry thoroughly.

Concrete surfaces may be roughened with an acid wash. Use a solution of one part of muriatic acid to six parts of water. First wet the wall so that the acid will act on the surface only. More than one application may be necessary. After the acid treatment, wash the wall thoroughly to remove all acid. Allow the washed wall to dry thoroughly.

When your crewmembers are using muriatic acid, insure that they wear goggles, rubber gloves, and other protective clothing and equipment.

Rapid roughing of masonry surfaces may be accomplished by the use of a power-driven machine equipped with a cylindrical cage fitted with a series of hardened steel cutters (fig. 13-17). The cutters should be mounted to provide a flailing action which results in a scored pattern. After roughing, wash the wall clean of all chips and dust and let it dry.

Suction is absolutely necessary in order to attain a proper bond of stucco on concrete and masonry surfaces. It is also necessary in first and second coats so that the following coats will bond properly. Uniform suction helps to obtain a uniform color. If one part of the wall draws more moisture from the stucco than another, the finish coat may be spotty. Obtain uniform suction by dampening the wall evenly, but not soaking, before applying the stucco. The same applies to the scratch and brown coats. If the surface becomes dry in spots, dampen those areas again to restore suction. Use a fog spray for dampening.

When the masonry surface is not rough enough to insure adequate bond for a trowel-applied-scratch coat, use the dash method. Acid-treated surfaces usually require a dashed scratch coat. Dashing on the scratch coat aids in getting a good bond by excluding air

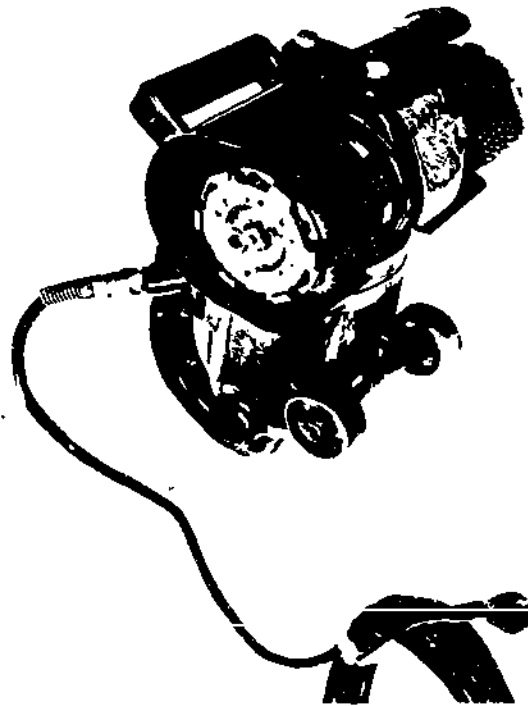

133.370

Figure 13-17.—Power driven roughing machine.

which might get trapped behind a trowel-applied coat. Apply the dash coat with a fiber brush or whisk broom, using a strong whipping motion at right angles to the wall. A cement gun or other machine which can apply the dash coat with considerable force will produce a suitable bond. Keep the dash coat damp for at least two days immediately following its application and then allow it to dry.

Protect the finish coat against exposure to sun and wind for at least six days after application. During this time, keep the stucco moist by frequent fog-spraying.

There may be times when the finish is not what you had expected. To help you understand the reasons for discoloration and stains in stucco, we will provide some reasons. Some of the common reasons for discoloration and stains are listed below.

1. Failure to have uniform suction in either of the base coats.

2. Improper mixing of the finish coat materials.
3. Changes in materials or proportions during progress of the work.
4. Variations in the amount of mixing water.
5. Use of additional water to retemper mortar.
6. Corrosion and rust of flashings or other metal attachments and failure to provide drips and washes on sills and projecting trim often cause surface stains.

CONTROL JOINTS

Cracks can develop in stucco through many causes or combinations of causes, such as foundation settlement, shrinkage, and building movement. It is difficult to prevent cracking, but this can be largely controlled by dividing the area into rectangular panels every 20 ft by means of metal-control joints. (See fig. 13-18.) The control joint is also used where frame construction joins masonry construction.

Grounds are wood strips of uniform thickness installed around all openings and other places where trim is required. They serve as a guide in bringing the stucco to a uniform thickness. Temporary wood grounds are often used in gaging the thickness of scratch and brown coats of stucco.

CERAMIC TILE

Ceramic tile can be set in a bed of TILE MORTAR, or it can be set in a TILE

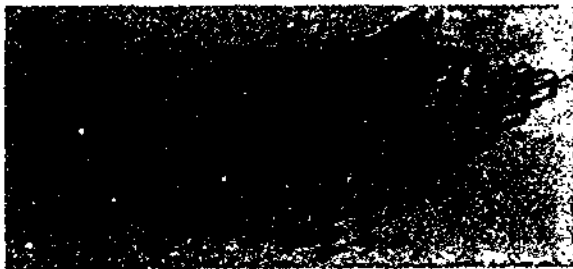

Figure 13-18.—Control Joint.

133.157

ADHESIVE furnished by the manufacturer. The type of ceramic tile most commonly used is 3/8-in.-thick GLAZED INTERIOR tile, mostly in 4 1/4-in. or 6-in. squares. Margins, corners, and base lines are finished with TRIMMERS of various shapes. Available shapes and sizes of trimmers are shown on a TRIMMER CHART provided by the manufacturer.

MORTAR APPLICATION

For mortar bed setting on a wall with wooden studs, a layer of waterproof paper is first tacked to the studs, and metal lath is then nailed on over the paper. The first coat of mortar applied on a wall for setting tile is a scratch coat and the second, a float, leveling, or a brown coat. A scratch coat for application as a foundation coat must be NOT less than 1/4 in. thick and composed of 1 part cement to 3 parts sand, with the addition of 10-percent hydrated lime by volume of the cement used. While still plastic, the scratch coat is deeply scored or scratched and cross scratched. The scratch coat should be protected and kept reasonably moist during the seasoning period. All mortar for scratch and float coats should be used within 1 hour after mixing. The retempering of partially hardened mortar will NOT be permitted. The scratch coat should be applied not more than 48 hours, nor less than 24 hours, before starting the setting of tile.

The float coat should be composed of 1 part cement, 1 part of hydrated lime, and 3 1/2 parts sand. It should be brought flush with screeds or temporary guide strips, so placed as to give a true and even surface at the proper distance from the finished face of the tile.

Wall tile should be thoroughly soaked in clean water before it is set. It is set by troweling a skim coat of neat portland cement mortar on the float coat, or applying a skim coat to the back of each tile unit, and immediately floating the tile into place. Joints must be straight, level, perpendicular, and of even width not exceeding 1/16 in. Wainscots are built of full courses, which may extend to a greater or lesser height, but in no case more than 1 1/2 in. difference than the specified or figured height. Vertical

joints must be maintained plumb for the entire height of the tile work.

All joints in wall tile should be grouted full with a plastic mix of neat white cement or commercial tile grout immediately after a suitable area of the tile has been set. The joints should be tooled slightly concave and the excess mortar cut off and wiped from the face of tile. Any interstices or depressions in the mortar joints after the grout has been cleaned from the surface should be roughened at once and filled to the line of the cushion edge (if applicable) before the mortar begins to harden. Tile bases or coves should be solidly backed with mortar. All joints between wall tile and plumbing or other built-in fixtures should be made with a light-colored calking compound. Immediately after the grout has had its initial set, tile wall surfaces should be given a protective coat of noncorrosive soap or other approved protection. Wall tile installed over existing and patched or new plaster surfaces in an existing building are completed as described, except that such wall tile is applied by the adhesive method.

Where wall tile is to be installed in areas subject to intermittent or continual wetting, the wall areas should be primed as recommended by the manufacturer of the adhesive used.

ADHESIVE APPLICATION

Wall tile may be installed either by the floating method or by the buttering method. In the floating method, apply the adhesive uniformly over the prepared wall surface, using quantities recommended by the adhesive manufacturer. Use a notched trowel held at the proper angle to insure a uniformly spread coating of the proper thickness. Touch up thin or bare spots by an additional coating of adhesive. The area coated at one time should not be any larger than that recommended by the manufacturer of the adhesive. In the buttering method, daub the adhesive on the back of each tile in such an amount that the adhesive, when

compressed, will form a coating not less than 1/16 in. thick over 60 percent of the back of each tile.

SETTING TILE

When the floating method is used, one edge of the tile is pressed firmly into the wet adhesive, the tile snapped into place in a manner to force out all air, then alined by using a slight twisting movement. Tile should not be shoved into place. Joints must be cleaned of any excess adhesive to provide for a satisfactory grouting job. When the buttering method is used, tile is pressed firmly into place, using a "squeegee" motion to spread the daubs of adhesive. After the adhesive partially sets, but before it is completely dry, all tiles must be realined so that faces are in same plane and joints are of proper width, with vertical joints plumb and horizontal joints level.

The adhesives should be allowed to set for 24 hours before grouting is done. Joints must be cleaned of dust, dirt, and excessive adhesive, and should be thoroughly soaked with clean water before grouting. A grout consisting of portland cement, lime, and sand, or an approved ready-mix grout may be used, but the grout should be water resistant and nonstaining.

Nonstaining calking compound should be used at all joints between built-in fixtures and tile-work, and at the top of ceramic tile bases, to insure complete waterproofing. Internal comers should be calked before comer bead is applied.

Cracked and broken tile should be replaced promptly to protect the edges of adjacent tile and to maintain waterproofing and appearance. Timely pointing of displaced joint material and spalled areas in joints is necessary to keep tiles in place.

Newly tiled surfaces should be cleaned to remove job marks and dirt. Cleaning should be done according to the tile manufacturer's recommendations to avoid damage to the glazed surfaces.

CHAPTER 14

PAINTS AND PRESERVATIVES

As a Builder, you should see that each job of painting is done properly so it will not be necessary to redo the job before it would normally be required. Also, you should insure that the best possible use is made of time, equipment, and material. Thus, it becomes important to know the purpose of painting, the techniques of preparing surfaces that are to be painted, and the techniques of painting these surfaces.

PURPOSES OF PAINTING

To employ paint materials and painting man-hours effectively and economically, the fundamental purposes of painting must be borne in mind. The importance of each of these purposes depends, of course, on the particular surface which is to be painted. The following is a brief discussion of each of these fundamental purposes of painting.

PREVENTIVE MAINTENANCE

The primary purpose of painting is protection. This is provided initially with new construction and maintained by a sound and progressive preventive maintenance program.

Resistance to moisture from rain, snow, ice, and condensation constitutes perhaps the greatest single protective characteristic of paint. Moisture causes metal to corrode and wood to swell, warp, or rot. Interior wall finishes of buildings can be ruined by moisture entering through neglected exterior surfaces. Porous

masonry is attacked and destroyed by moisture. Therefore, paint films must be as impervious to moisture as possible to provide a protective, waterproof film over the surface to which they are applied. Paint also acts as a protective film against attack by acids, alkalies, or marine organisms.

SANITATION AND CLEANLINESS

Paint coatings provide smooth, non-absorptive surfaces that are easily washed and kept free of dirt. Such surfaces tend to prevent foodstuffs from adhering. Adhering foodstuffs harbor germs and cause disease. The coating of rough or porous areas seals out dust and grease that would otherwise be difficult to remove. Therefore, painting is an essential part of the general maintenance programs for hospitals, kitchens, messhalls, offices, warehouses, and living quarters.

FIRE RETARDANCE

Certain paints delay the spread of fire and assist in confining the fire to the area of its origin. This allows more time for firefighting equipment to arrive to extinguish the fire before it gets out of control. Fire-retardant paints should not be considered as substitutes for conventional paints. The use of fire-retardant paint is restricted to areas of highly combustible surfaces.

CAMOUFLAGE

Camouflage paints have special properties which are different from conventional paints

and their uses are limited to special applications. You should not use camouflage paints as substitutes for conventional paints.

ILLUMINATION AND VISIBILITY

White and light-tinted paints applied to ceilings and walls reflect both natural and artificial light and help brighten rooms and increase visibility. On the other hand, darker colors reduce the amount of reflected light. Flat paints diffuse, soften, and evenly distribute illumination, whereas gloss finishes reflect more like mirrors and may create glare. Color contrasts improve visibility of the painted surface, especially, when the paint is applied in distinctive patterns. For example, white on black, white on orange, or yellow on black can be seen at greater distances than single colors or other combinations of colors.

IDENTIFICATION AND SAFETY

Certain colors are used as standard means of identifying objects and promoting safety. For example, fire-protection equipment is painted red. Containers for kerosene, gasoline, solvents and other flammable liquids should be painted a



133.546

Figure 14-2.—Wood scraper.

brilliant YELLOW and marked with large BLACK letters to identify their contents. The colors of signal lights and painted signs help to control traffic safely by providing directions and other travel information.

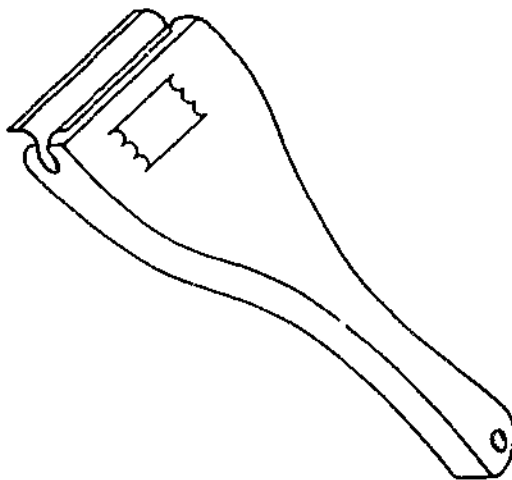

133.545

Figure 14-1.—Paint scraper.

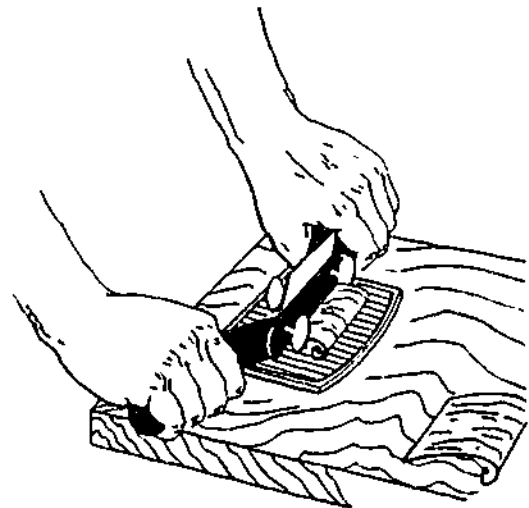

133.547

Figure 14-3.—Cabinet scraper.

Chapter 14—PAINTS AND PRESERVATIVES

Table 14-1.—Abrasive Grit Number Comparisons

	Garnet and Aluminum Oxide	Flint
Superfine	10/0-400	
Extra fine	9/0-300	
	8/0-280	
	7/0-240	
Very fine	6/0-220	4/0
	5/0-180	3/0
	4/0-150	2/0
Fine	3/0-120	
	2/0-100	0
Medium	0-80	1/2
	1/2-60	1
Coarse	1-50	1 1/2
	1 1/2-40	2
Very Coarse	2-36	2 1/2
	2 1/2-30	3
	3-24	

TOOLS AND EQUIPMENT

It is important for you to know how to use the tools and equipment that are required in preparing surfaces for painting and in painting the surfaces. Of the many types of painting tools and equipment, the ones commonly used in the Navy are discussed in this chapter. You will also

find information on surface preparation, application of paint by brush, and care of paintbrushes in *BASIC MILITARY REQUIREMENTS*, NAVEDTRA 10054-D.

SCRAPERS

Scrapers are used for various purposes. Figure 14-1 shows a scraper for removing deteriorated paint. With the scraper shown in figure 14-2, you can remove plane marks and mill marks made by wood-working machines. The scraper shown in figure 14-3 can also be used to remove mill marks.

ABRASIVES

Abrasives are commonly used in preparing a surface for painting. They are glued or bonded to sheets, belts, and disks of paper or fiber cloth. Flint, garnet, emery, and silicon carbide are popular kinds of abrasives. Hand sanding is done with flint and garnet; flint costs less but it dulls and wears quicker than garnet. Emery is used mainly for metal polishing and rust removal, silicon carbide for wet or dry sanding of lacquers and plastics. Manufacturers label their abrasives fine, medium, coarse, and so on. Table 14-1 shows the corresponding numbers and grit comparisons. Table 14-2 is a guide for selecting the correct kind and size of abrasive. Information contained in these tables may vary depending on the manufacturer.

Table 14-2.—Selecting Proper Abrasives

Abrasive	Coarse	Medium	Fine	Use
Aluminum Oxide	2 1/2-1 1/2	1/2-0	2/0-3/0	Hardwood Aluminum Copper Steel & Sheet Metal
	1 1/2	1/2-0	2/0	
	1 1/2-1 3-2 1/2	0-2 1/2 1/2-0	2/0-3/0 2/0	
Garnet	2 1/2-1 1/2	1/2-0	2/0-3/0	Hardwood Softwood
	1 1/2-1	0	2/0	
Flint	3-1 1/2	1/2-0		Removing paint and rough scale

As an abrasive, metallic wool (steel wool) has many uses. It is obtainable in six grades, as shown by table 14-3.

In addition to the abrasives already mentioned, there are powdered abrasives, such as pumice stone, rottenstone, and jeweler's rouge. Powders are used on wood furniture to obtain a smooth finish between coats or to obtain a fine finish, and to polish metal surfaces.

BRUSHES

Brushes, as with other tools, must be of first quality and maintained in perfect working condition at all times. Brushes are identified first, by the type of bristle used. Brushes are made with natural, synthetic, or mixed bristles. Chinese hog bristle represents the finest of the natural bristles because of its length, durability, and resiliency. Due to a unique characteristic, called flagging, bristle ends fork out like tree branches. Flagging permits more paint to be carried on a brush and leaves finer brush marks on the painted surface which flow together more readily resulting in a smoother finish. Horsehair is not a good substitute for hog bristle. Compared to hog bristle, horsehair quickly becomes limp, holds far less paint, and does not spread paint as well. The ends of horsehair do

not flag so that brush marks left on painted surfaces tend to be coarse and do not level out smoothly. Some brushes contain a mixture of hog bristle and horsehair, and their quality depends upon the percentage of each type used. Animal hair is used in very fine brushes for special purposes. Badger hair, for example, produces a particularly good varnish brush. Squirrel and sable hair make good stripping, lining, lettering, and freehand art brushes.

Of the synthetics used for brushes, nylon is by far the most common. By artificially "exploding" the ends and kinking the fibers, manufacturers have increased the paint load nylon can carry and have reduced the coarseness of brush marks. Nylon brushes are almost always superior to horsehair brushes. Since nylon is a synthetic, a nylon brush is unsuitable for applying lacquer, shellac, many creosotes, and other coatings that would soften or dissolve bristles. Because nylon bristles are not affected much by water, they are recommended for use with water-based latex paint.

Brushes are not only identified by their bristles but by shapes and sizes required for specific painting jobs. See figures 14-4 and 14-5.

Table 14-3.—Selecting Steel Wool

	GRADE	USE
Very Fine	000	Final Smoothing
	00	Between Coatings (with oil)
Fine	0	Most Commonly Used
Medium	1	General Purpose
	2	Rough Work
Coarse	3	Restoration Work

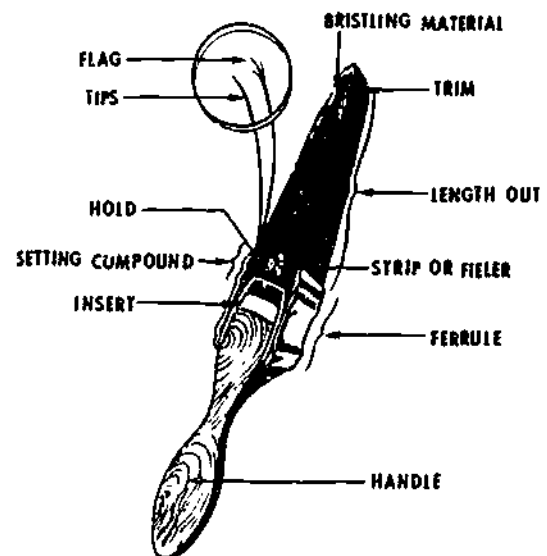

3.210(133F)A

Figure 14-4.—Typical paintbrush.



WALL BRUSH

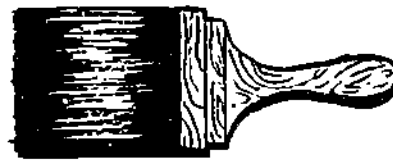

STUCCO BRUSH



FLATTING
WALL BRUSH



OVAL AND SEMI-OVAL
PAINT AND VARNISH BRUSHES



FLAT VARNISH BRUSH



FLAT SASH
AND TRIM BRUSH



ANGULAR SASH
AND TRIM BRUSH



ENAMELING BRUSH



OVAL SASH BRUSH



DUSTER

133.548

Figure 14-5.—Types of brushes.

1. WALL BRUSHES: Flat and square-edged, wall brushes range in widths from 3 to 6 in., and are used for painting large, continuous surfaces, either interior or exterior.

2. SASH AND TRIM BRUSHES: These brushes are available in four shapes: flat and

square edged, flat and angle edged, round, and oval. They range in width from 1 to 1 1/2 to 3 in. or have diameters of 1/2 to 2 in. Uses include painting of window frames, sashes, narrow boards, and interior and exterior trim surfaces. For fine-line painting, the bristle end of

such a brush is often chisel shaped to make precise edging easy.

3. ENAMELING AND VARNISH BRUSHES: Flat and square edged or chisel edged, these brushes are available in widths from 2 to 3 in. Their select, fine, short bristles cause relatively high-viscosity gloss finishes to lay down in a smooth, even film.

4. STUCCO AND MASONRY BRUSHES: These brushes have the general appearance of flat-wall brushes and are available in widths ranging from 5 to 6 in. Bristles are nylon or hog or other natural bristles. Nylon is preferred for rough surfaces because of its resistance to abrasion

Use the right-size brush for the job. Avoid a brush that is too small or too large. A large-area job does not necessarily go faster with an oversize brush. When the brush size is out of balance, you tend to apply coatings at an uneven rate, general workmanship declines, and you actually tire faster because of the extra effort required per stroke.

Synthetic bristle brushes are ready to use when received. The performance of natural bristle brushes is much improved by soaking 48 hours in linseed oil, followed by a thorough cleaning in mineral spirits. The bristles are made more flexible and tend to swell in the ferrule of the brush, resulting in fewer bristles working loose when the brush is used.

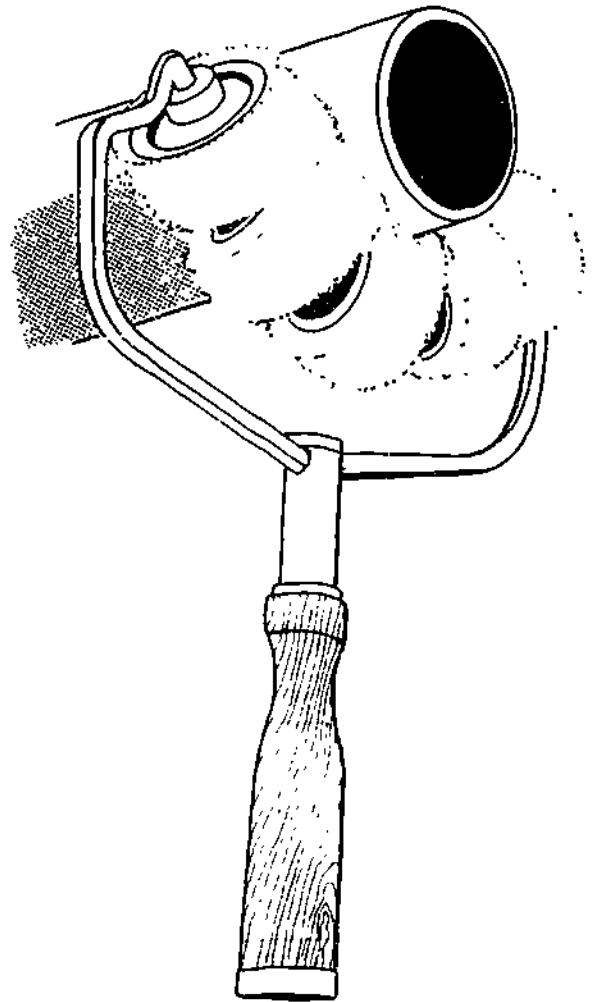

29.140(133F)B

Figure 14-7.—Pipe roller.

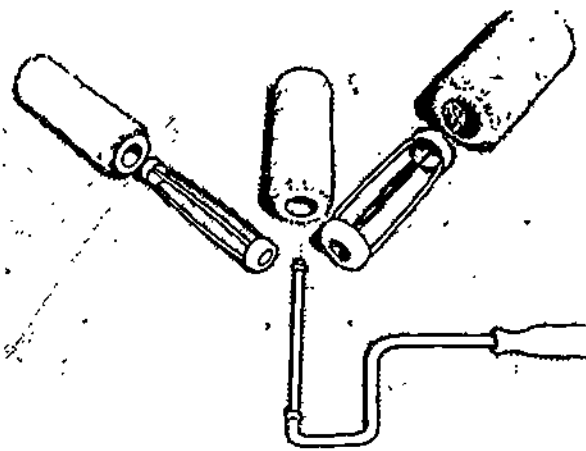

29.140(133F)A

Figure 14-6.—Parts of a roller.

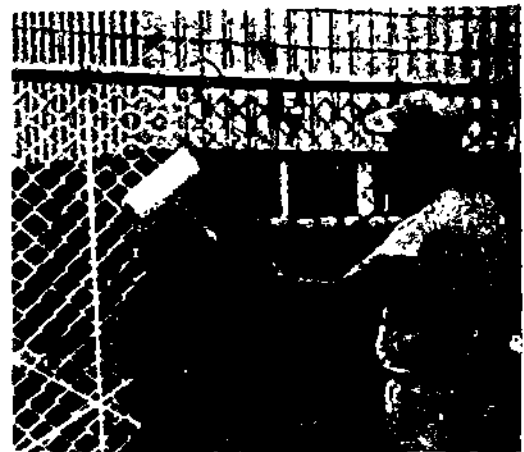

Figure 14-8.—Fence roller. 29.140(133F)C

Chapter 14—PAINTS AND PRESERVATIVES

Table 14-4.—Roller Selection Guide

Type of Paint	Type of Surface		
	Smooth (1)	Semismooth (2)	Rough (3)
Aluminum	C	A	A
Enamel or Semigloss (Alkyd).....	A or B	A	
Enamel undercoat	A or B	A	
Epoxy coatings	B or D	D	D
Exterior House Paint:			
Latex for wood	C	A	
Latex for masonry	A	A	A
Oil or alkyd—wood	C	A	
Oil or alkyd—masonry	A	A	A
Floor enamel—all types	A or B	A	
Interior Wall paint:			
Alkyd or oil	A	A or D	A
Latex	A	A	A
Masonry sealer	B	A or D	A or D
Metal primers	A	A or D	
Varnish—all types	A or B		
Roller Cover Key*		Nap Length (inches)	
A—Dyrol (modified acrylic)	¼-¾	¾-¾	1-1½
B—Mohair	¾-¾		
C—Dacron Polyester	¼-¾	¾	
D—Lamb wool pelt	¼-¾	½-¾	1-1½

(1) Smooth Surface: hardboard, smooth metal, smooth plaster, drywall, etc.

(2) Semismooth Surface: sand finished plaster and drywall, light stucco, blasted metal, semismooth masonry.

(3) Rough Surface: concrete or cinder block, brick, heavy stucco, wire fence.

* Comprehensive product standards do not exist in the Paint Roller Industry. Roller covers vary significantly in performance between manufacturers and most manufacturers have more than one quality level in the same generic class. This table is based on field experience with first line products of one manufacturer.

133.409

ROLLERS

A paint roller consists of a cylindrical sleeve or cover that slips onto a rotatable cage to which a handle is attached. (See fig. 14-6.) The cover may be 1 1/2 to 2 1/4 inches (inside diameter) and 3, 4, 7, or 9 inches long. Special rollers are available in 1 1/2- to 18-inch lengths. Proper roller application depends on the selection of the specific fabric and the thickness of fabric (nap length) based on the type of paint used and the smoothness or roughness of the surface to be painted. Special rollers are used for painting pipes, fences, and hard-to-reach places. (See figs.

14-7 and 14-8.) The fabrics generally used for rollers are lamb's wool pelt, mohair, dyrol, and dacron. (See Table 14-4.)

Lamb's wool pelt is solvent resistant and available in nap lengths up to 1 1/4 inch. It is recommended for application of synthetic finishes on semismooth and rough surfaces. It mats badly in water and is not recommended for water-based paints.

MOHAIR is made primarily of Angora hair. It is also solvent resistant. Supplied in nap lengths of 3/16 inch and 1/4 inch, it is recommended for application of synthetic

enamels and water-based paints on smooth surfaces.

DYNEL is a modified acrylic fiber that is water resistant. It is best for application of water-based paints and paints containing solvents, except strong solvents, such as ketones. It is available in nap lengths ranging from 1/4 to 1 1/4 inch.

DACRON is a synthetic fiber somewhat softer than dynel. It is best suited for exterior oil-based or latex paints. It is available in nap lengths ranging from 5/16 to 1/2 inch.

Immediately after use, rollers should be cleaned with the type of thinner recommended for the paint in which the roller was used. After being cleaned with thinner, the roller should be thoroughly washed in soap and water, rinsed in clear water and dried.

SPRAY GUNS

A spray gun is a precision tool that mixes air under pressure with paint, breaks it up into spray, and ejects it out in a controlled pattern.

There are several types, either with a container attached to the gun or with the gun connected to a separate container by means of hoses. There are bleeder or nonbleeder, external- or internal-mix, and pressure- or suction-feed guns.

The BLEEDER gun allows air to leak—or bleed—from some part of the gun in order to prevent air pressure from building up in the air hose. In this gun, the trigger controls the fluid only. It is generally used with small air compressors that have no pressure control on the air line.

The NONBLEEDER gun is equipped with an air valve which shuts off the air when the trigger is released. It is used with air compressors that have a pressure-controlling device.

An EXTERNAL-MIX gun is one which mixes air and paint outside and in front of the gun's air cap. This gun can do a wide variety of work and has the power to throw a very fine spray, even of heavy material. It also permits exact control over the spray pattern. An external-mix air cap is shown in figure 14-9.

An INTERNAL-MIX spray gun mixes the air and fluid inside the air cap as pictured in figure 14-10. It is not as widely used as the external-mix gun.

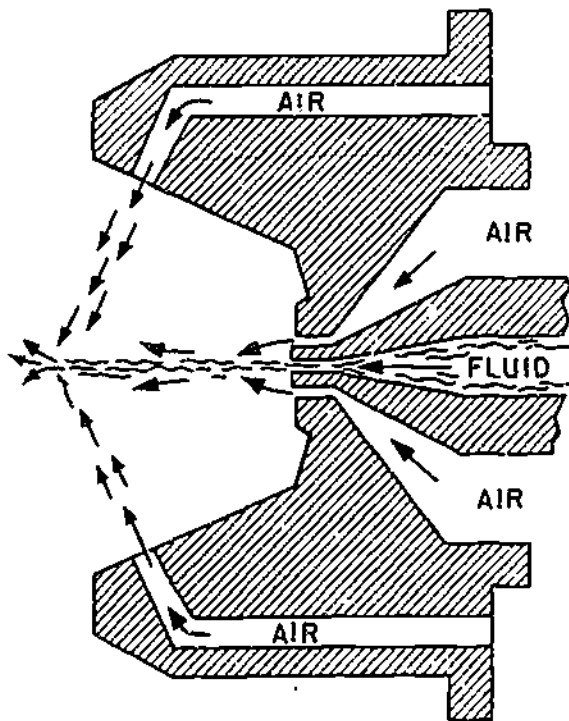

80.233

Figure 14-9.—An external-mix air cap.

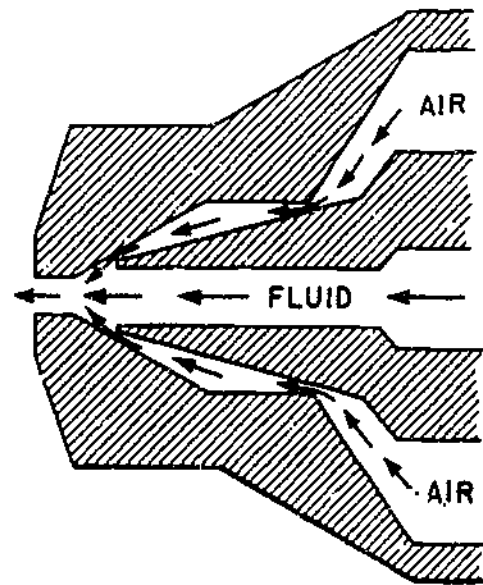

80.234

Figure 14-10.—An internal-mix air cap.

In a **SUCTION FEED** spray gun, the air cap, shown in figure 14-11, is designed to draw the fluid from the container by suction—in somewhat the same way that an insect spray gun operates. The suction-feed spray gun is usually used with 1-quart (or smaller) containers.

A **PRESSURE-FEED** gun operates by air pressure, which forces the fluid from the container into the gun. This type (fig. 14-12) is used for large-scale painting.

The two main assemblies of the spray gun are the gun-body assembly and the spray-head assembly. Each of these assemblies is a collection of small parts, all of which are designed to do specific jobs.

The principal parts of the gun-body assembly are shown in figure 14-13. The air valve controls the supply of air and is operated by the trigger. The spreader-adjustment valve regulates the amount of air that is supplied to the spreader-horn holes of the air cap, thus varying the paint pattern. It is fitted with a dial which can be set to give the pattern desired. The fluid-needle adjustment controls the amount of spray material that passes through the gun. The spray-head-locking bolt locks the gun body and the removable spray head together.

Most guns are now fitted with a removable spray-head assembly. They can be easily cleaned, and permit quick change of the head when you want to use a new color or material. Also, if the head is damaged, a new head can be put on the old gun body.

The principal parts of the spray-head assembly are the air cap, the fluid tip, fluid needles, and the spray-head barrel, pictured in figure 14-14.

The fluid tip regulates the flow of the spray material into the airstream. The tip encloses the end of the fluid needle. The spray head barrel is the housing which encloses the head mechanism.

AIRLESS SPRAY GUN

In airless-spray painting, the spray is created by the forcing of paint through a restricted orifice at very high pressure. The paint is atomized without the use of airjets, thus, the name airless spray. Liquid pressures of 1500 psi and higher are developed in special air or electrically operated high-pressure pumps and delivered to the gun through a single hose line.

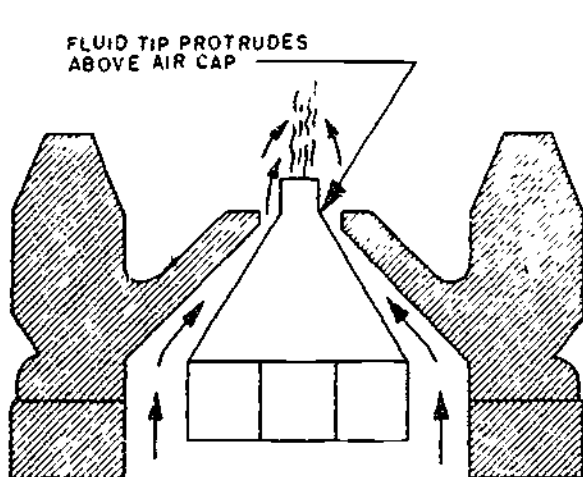

80.236

Figure 14-11.—A suction-feed air cap.

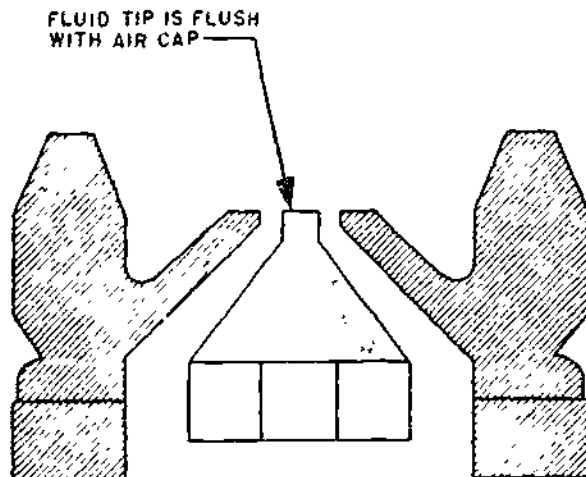

80.236

Figure 14-12.—A pressure-feed air cap.

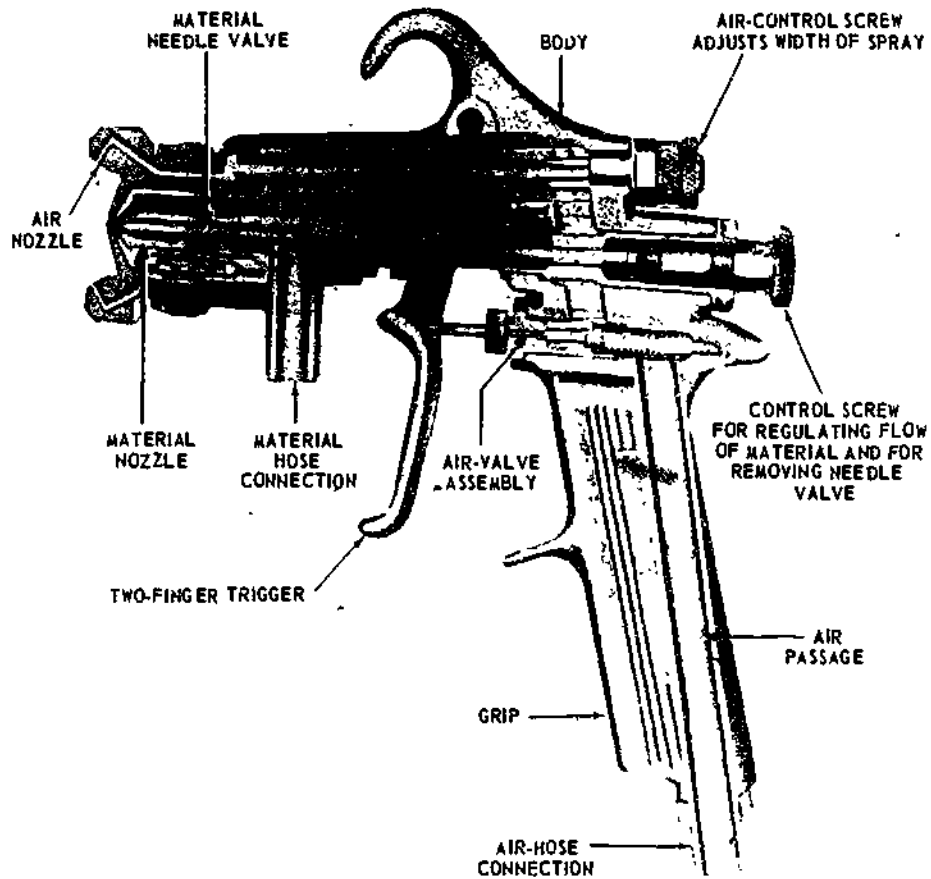
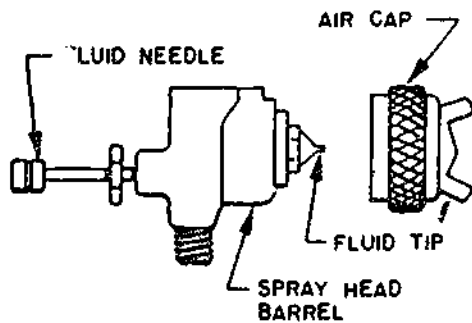

Figure 14-13.—Cross section of a spray-gun.

80.237

The airless-spray system provides a rapid means of covering large surfaces with wide-angle spray without overspray mist or rebound. The single small-diameter hose line makes gun handling easy. The spray produced has a full wet



80.238

Figure 14-14.—Principal parts of the spray head.

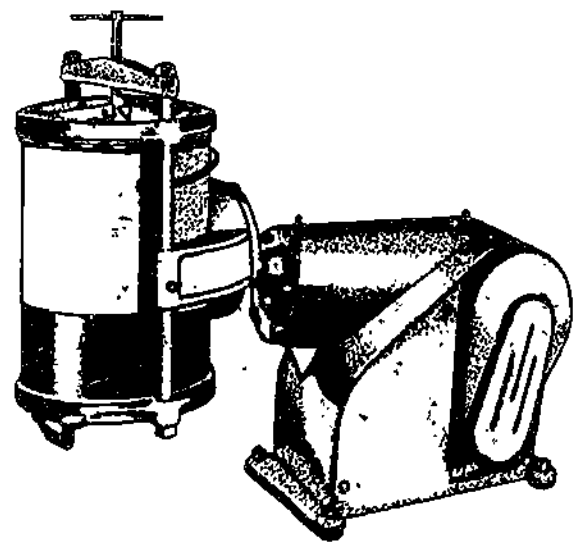

133.549

Figure 14 15.—Paint-mixer vibrating shaker.

pattern for quick film buildup, but requires extra care in lapping and stroking to avoid excessive coverage that would result in runs, sags, and wrinkles.

There are many advantages of airless spraying. The airless-spray gun is simple to operate. On some models, pattern width and amount of paint is controlled with spray caps of various sizes. The choice of spray cap is determined by the thickness of the paint. A thin material, like lacquer, is sprayed through a gun cap with an orifice about as large as the period at the end of this sentence.

The absence of air also reduces rebounding of the paint in crevices and corners, thus providing more uniform coverage. Airless spraying usually permits the use of higher viscosity products. Thus, less thinning is

required, better film buildup is obtained, and production is increased. The need for just a single hose leading into the gun makes it lighter to handle and less tiring for the operator. To be successfully used, the airless system requires special attention to details, such as straining of paints and thorough cleaning of the gun after use. Still, the gun strainer or cap orifice may plug up even though you have strained the paint. Here, it may be that the paint is not sprayable by the airless method. In this case, the high-pressure-pumping action wrings out the volatile or liquid components of the paint, which causes the residue to clog the gun strainer or cap orifice.

PAINT MIXERS

The two most commonly used power-driven paint mixers are those that shake full, tightly sealed containers and those that stir the paint with propellers or paddles inserted into open containers. See figures 14-15 and 14-16. Vibrator-type mixers are available in capacities ranging from a half pint to four 1-gallon cans or one 5-gallon can. Paint can also be stirred with an attachment (fig. 14-17) that is driven by an electric drill.

TYPES OF COATINGS

Many factors are considered when paint is being selected for a particular job. An important factor is the type of coating which, in turn,

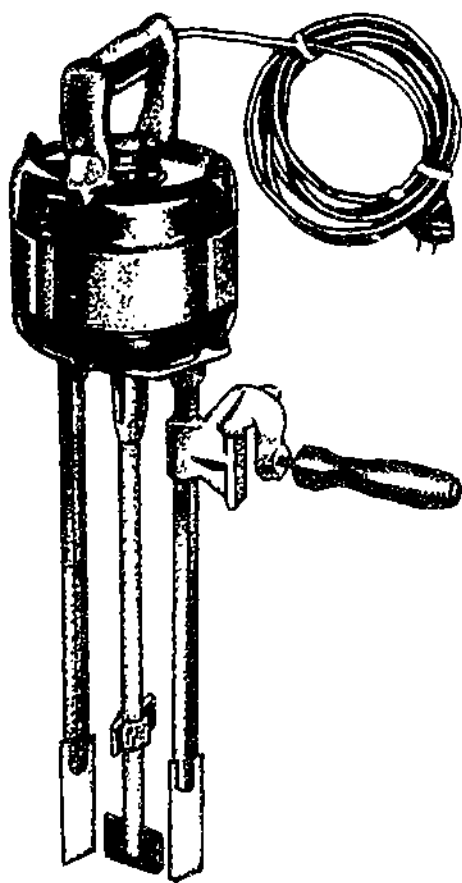

133.550

Figure 14-16.—Paint mixer-propeller type

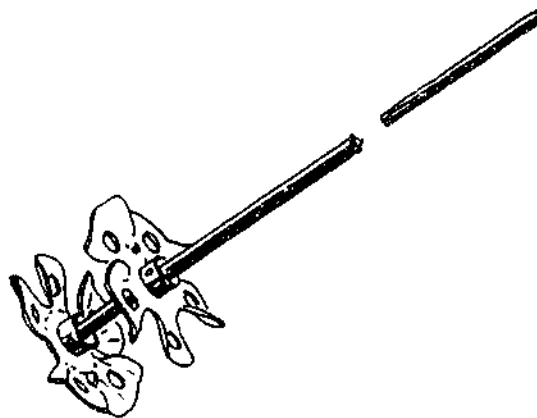

133.551

Figure 14-17.—Paint-mixer-drill attachment.

depends on the composition of paint and the properties of its ingredients. Paint is composed of various ingredients, such as pigment, nonvolatile vehicle or binder, and solvent or thinner.

PIGMENTS are insoluble solids, divided finely enough to remain suspended in the vehicle for a considerable time after thorough stirring or shaking. **OPAQUE** pigments give the paint its hiding or covering capacity, and contribute other properties. **WHITE LEAD, ZINC OXIDE, and TITANIUM DIOXIDE** are examples.

COLOR pigments give the paint its color. They may be inorganic, such as **CHROME GREEN, CHROME YELLOW, and IRON OXIDE**; or organic, such as **TOLUIDINE RED and PHTHALOCYANINE BLUE**.

TRANSPARENT or **EXTENDER** pigments contribute bulk and also control the application properties, durability, and resistance to abrasion of the coating.

There are other special-purpose pigments, such as those that enable paint to resist heat, control corrosion, or reflect light.

The **VEHICLE, or BINDER**, of paint is the material that holds the pigment together and also adheres to the surface. In general, the durability of the paint is determined by the resistance of the binder to the exposure conditions.

Linseed oil, once the most common binder, has been superseded mainly by the synthetic **ALKYD** resins. These result from the reaction of glyceryl phthalate and an oil and may be made with almost any property desired. Other synthetic resins, which may be used by themselves or mixed with oil, include **PHENOLIC** resin, **VINYL, EPOXY, URETHANE, POLYESTER, and CHLORINATED RUBBER**. Each has its own advantages and disadvantages. It is particularly important in the use of these materials that the manufacturer's instructions be followed exactly.

The only purpose of a **SOLVENT** or **THINNER** is to adjust the consistency of the material so that it may be applied readily to the surface. The solvent then evaporates, contributing nothing further to the film. For this reason, the cheapest suitable solvent should be used. This solvent is likely to be **NAPHTHA** or **MINERAL SPIRITS**. Although **TURPENTINE** is

sometimes used, it contributes little that other solvents do not and costs much more. Since synthetic resins usually require a special solvent, it is **IMPORTANT THAT THE CORRECT ONE BE USED**; otherwise, the paint may be spoiled entirely.

OIL-BASED PAINTS

Oil-based paints consist mainly of a drying oil (usually linseed) mixed with one or more pigments. The pigments and quantities of oil in oil paints are usually selected on the basis of cost and their ability to impart to the paint the desired properties, such as durability, economy, and color. An oil-based paint is characterized by easy application and slow drying. It normally chalks in such a manner as to permit recoating without costly surface preparation. Adding small amounts of varnish tends to decrease the time it takes an oil-based paint to dry and to increase the paint's resistance to water. Oil-based paints are not recommended for surfaces that are submerged in water.

ENAMEL PAINTS

Enamels are generally harder, tougher, and more resistant to abrasion and moisture penetration than oil-based paints. Enamels are obtainable in flat, semigloss, and gloss. The extent of pigmentation of the paint or enamel determines its gloss. Generally, gloss is reduced by adding lower-cost pigments called extenders. Typical extenders are calcium carbonate (whiting), magnesium silicate (talc), aluminum silicate (clay), and silica. The level of gloss depends on the ratio of pigment to binder.

EPOXY PAINTS

Epoxy paints are made up of a resin and a polyamide hardener, which are mixed before use. When mixed, the two ingredients react to form the end product. Epoxy paints have a limited working or pot life, usually a working day. They are outstanding in hardness, adhesion, and flexibility. Furthermore, they resist corrosion, abrasion, alkali, and solvents. The

major uses of epoxy paints are as tile-like glaze coatings for concrete or masonry, and for structural steel in corrosive environments.

LATEX PAINTS

Latex paints contain a synthetic chemical, called LATEX, which is dispersed in water. The kinds of latexes usually found in paints are STYRENE-BUTADIENE (so-called synthetic rubber), POLYVINYL ACETATE (PVA or vinyl), and ACRYLIC. Latex paints differ from other paints in that the vehicle is an emulsion of binder and water. Being water based, latex paints have the advantage of being easy to apply. They dry through evaporation of the water. Many latex paints have excellent durability, which makes them particularly useful for coating plaster and masonry surfaces.

RUBBER-BASED PAINTS

Rubber-based paints are solvent thinned and should not be confused with latex binders which are often called rubber-based emulsions. Rubber-based paints are lacquer-type products and dry rapidly to form finishes which are highly resistant to water and mild chemicals. They are used for coating exterior masonry and areas that are wet, humid, or subject to frequent washing, such as laundry rooms, showers, washrooms, and kitchens.

PORTLAND CEMENT PAINTS

Portland cement mixed with several ingredients acts as a paint binder when it reacts with water. The paints are supplied as a powder to which the water is added before being used. Cement paints are used on rough surfaces, such as concrete, masonry, and stucco. They dry to form hard, flat, porous films that permit water vapor to pass through readily. When properly cured, cement paints of good quality are quite durable, when improperly cured, they chalk excessively on exposure and may present problems in repainting.

ALUMINUM PAINTS

Aluminum paints are available in two forms: ready mixed and ready to mix. Ready-mixed aluminum paints are supplied in one package and are ready for use after normal mixing. They are made with vehicles that will retain metallic brilliance after moderate periods of storage. They are more convenient to use and allow for less error in mixing than the ready-to-mix form.

Ready-to-mix aluminum paints are supplied in two packages: one containing the clear varnish and the other the required amount of aluminum paste (usually $2/3$ aluminum flake and $1/3$ solvent). You mix just before using by slowly adding the varnish to the aluminum paste and stirring. Ready-to-mix aluminum paints allow a wider choice of vehicles and present less of a problem with storage stability. A potential problem with aluminum paints is moisture in the closed container. When present, moisture may react with the aluminum flake to form hydrogen gas that pressurizes the container. Pressure can cause the container to bulge or even pop the cover off the container. Check the containers of ready-mixed paints for bulging. If they do, puncture the covers carefully before opening to relieve the pressure. Be sure to use dry containers when mixing aluminum paints.

VARNISHES

In contrast to paints, varnishes contain little or no pigment and do not obscure the surface to which applied. Usually a liquid, varnish will dry to a hard, transparent coating when spread in a thin film over a surface, affording protection and decoration.

Of the common types of varnishes, the most important are the oil varnishes, including spar varnish, flat varnish, rubbing varnish, and color varnish. These varnishes are extensively used to finish and refinish interior—and exterior—wood surfaces, such as floors, furniture, and cabinets. SPAR varnish is intended for exterior use in normal or marine environments; it has limited exterior durability.

Varnishes produce a durable, elastic, and tough surface which normally dries to a high-gloss finish and does not mar easily. Exterior varnishes are especially formulated to

resist weathering. Often, a lower gloss may be obtained by rubbing the surface with a very fine steel wool. However, it is simpler to use a FLAT VARNISH whose gloss has been reduced by the addition of transparent-flattening pigments, such as certain synthetic silicas. These pigments are dispersed in the varnish to produce a clear finish that will dry to a low gloss, but still not obscure the surface underneath (that is, the grain of the wood).

SHELLAC

Shellac is made by refining seed lac which is the binder; the vehicle is wood alcohol. The natural color of shellac is orange, although it can be obtained in a white color. Shellac is used extensively as a finishing material and a sealant. Applied over knots it prevents bleeding.

LACQUERS

Lacquers may be clear or pigmented and can be lusterless, semigloss, or glossy. Lacquers dry or harden quickly, producing a firm oil and water-resistant film. But many coats are required to achieve adequate dry-film thickness. It generally costs more to use lacquers than most paints.

STAINS

Stains are obtainable in four different kinds. Oil, water, spirit, and chemical stains. Oil stains have an oil vehicle, and you can add mineral spirits to help increase the penetration. Water stains are solutions of aniline dyes and water. Spirit stains contain alcohol, not water. Chemical stains work by means of a chemical reaction when dissolved by water. The type of stain to use will depend largely on the purpose, the location, and the type of wood being covered.

SURFACE PREPARATION FOR PAINTING

Proper surface preparation is essential if paint is to last a long time. The best quality paint will not perform effectively if applied on a

poorly prepared surface. The initial cost of adequate surface preparation is more than compensated for by increased durability, minimum repairs, and ease of repainting.

The selection of surface preparations for painting depends on:

1. Condition of the surface to be painted.
2. Type of exposure.
3. Type of paint to be applied.
4. Economic (cost) considerations.
5. Practical limitations, such as time, location, space, and the availability of equipment.
6. Safety factors.

HAND CLEANING

Hand cleaning will remove only loose or loosely adhering surface contaminants. These include rust scale, loose rust, mill scale, and loosely adhering paint. Do not think of hand cleaning as a means of removing tight mill scale and all traces of rust. In general, hand cleaning cannot be expected to do more than remove major surface contamination. It is primarily recommended for spot-cleaning in areas where corrosion is not a serious factor. In extreme situations, as when areas are not accessible to power tools, cleaning must be done by hand. Inasmuch as hand cleaning will remove only the loosest contamination, primers are required which will thoroughly wet the surface.

Before hand cleaning, the surface must be free of oil, grease, dirt, and chemicals. This can best be accomplished with solvent cleaners. Then remove rust scale and heavy buildup of old coatings with impact tools, such as chipping hammers, chisels, and scalers. Remove loose mill scale and nonadhering paint with wire brushes and scrapers. Finish up by sanding, especially on woodwork. In using tools, avoid making deep marks or scratches on the surface. Start painting as soon as possible after cleaning.

POWER TOOL CLEANING

Power tool cleaning methods provide faster and more adequate surface preparation than

handtool methods. Power tools are used for removing small amounts of tightly adhering contaminants which handtools cannot remove. Yet, the use of power tools is costly and time consuming in contrast to blasting for large area removal of tight mill scale, rust, or old coatings. Power tools are driven either electrically or pneumatically and include a variety of attachments for the basic units. Chipping hammers are used for removing tight rust, mill scale, and heavy paint coats. Rotary and needle scalers are used for removing rust, mill scale, and old paint from large metallic and masonry areas. Wire brushes (cup or radial) are used for removing loose mill scale, oil paint, weld flux, slag, and dirt deposits. Grinders and sanders are used for complete removal of old paint, rust, or mill scale on small surfaces, and for smoothing rough surfaces. As with handtools, care must be exercised with power-impact and grinding tools not to cut too deeply into the surface, since this may result in burrs that are difficult to protect satisfactorily.

Power tool cleaning is to be preceded by solvent or chemical treatment, and painting must be started and completed as soon after power cleaning as possible.

BLAST CLEANING

Blast cleaning involves the high-velocity impact of abrasive particles on the surface. The abrasive is discharged, either wet or dry, under pressure. The wet system differs from the dry in that water, or a solution of water and rust inhibitor, is incorporated with the blast abrasive. The water is either mixed with the abrasive in the pressure tank or is introduced into the blast stream just behind or just in front of the blast nozzle. All blasted metal surfaces require that prime painting be started and completed the same day to prevent new rust from forming, since such blast-cleaned surfaces are subject to rapid rusting if not coated. Metal or synthetic shot, grit, or a similar abrasive is used where recovery of the agent is possible. Sand is used where the agent is expendable. The agent, in any case, must be of a size sufficient to remove

surface contamination without working the surface to excess.

Conventional Blasting

Conventional blast cleaning is a term used to designate the usual method of field blasting, in which no effort is made to alleviate the dust hazard or reclaim the blast abrasive. (See figs. 14-18 and 14-19.) This method precludes the need for special rinsing, as required for wet blasting, but requires that health precautions be taken to protect the operator and other personnel in the area from the fine, abrasive dust. Machinery in the vicinity must also be shielded. After blasting, the surface must be brushed, vacuumed, or air cleaned to remove residues or trapped grit.

Vacuum Blasting

Vacuum blasting, a relatively new method, minimizes the dust hazard and enables the blast abrasive to be reclaimed. This method, also known as dry honing, provides for practically no dust to escape and contaminate the atmosphere. Dry honing is less efficient than conventional



133.552

Figure 14-18.—Dry-blast cleaning setup.

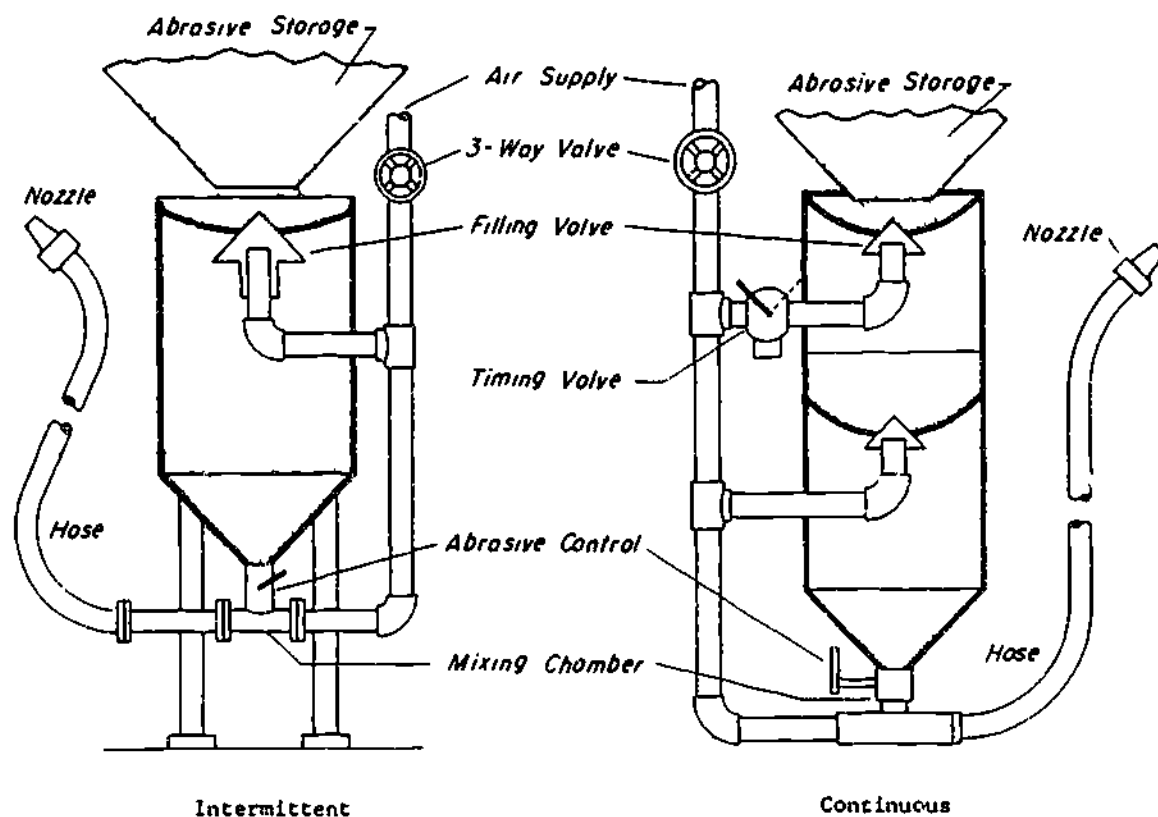

Figure 14-19.—Direct-pressure blast-cleaning tanks.

133.553

blasting methods on highly irregular surfaces because of the poor vacuum on such surfaces. When the blasting cone is held firmly against the surface to prevent abrasive loss and the surface is heavily contaminated with rust, algae, or other foreign matter, the cleaner (fig. 14-20) may not be able to function more than a short time without becoming clogged. In such instances, the vacuum blaster is used as a semiopen blasting device, that is, the cone containing the nozzle is held a slight distance away from the surface. The dust created is appreciable (workers must wear respirators) but not nearly as great as with conventional blasting equipment. However, vacuum blasting is efficient and economical for cleaning repeatedly small-scale surfaces in a shop. The method results in considerable savings in abrasive coats and also reduces the dust and health hazard.

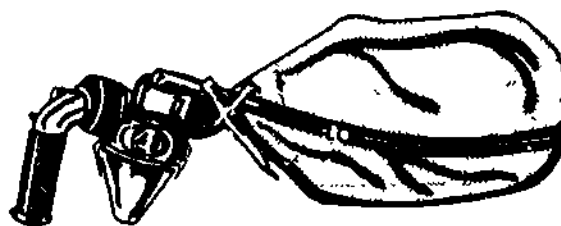

Figure 14-20.—Vacuum-blast cleaner.

133.554

Wet Blasting

Although not suitable for all types of work, wet blasting reduces to a minimum the dust associated with blasting. If used on steel structures containing many ledges formed by

upturned angles and horizontal girders, for example, wet blasting presents much troublesome cleanup work. The wet sand and blast residues trapped on these ledges are more difficult to remove than dry materials. Also, enough sludge adheres to wet-blasted surfaces to necessitate its removal by rinsing, brushing, or air blowing. Moreover, the wet-blasted surface tends to rust even though an inhibitor is present in the mixing and rinsing water. Figure 14-21 is a cross-section view of the attachment that sucks water from any water source for wet-blast cleaning. The blasted surface must be thoroughly dry before coatings are applied.

PAINT REMOVERS

Paint and varnish removers generally are used for small areas. Solvent-type removers or solvent mixtures are selected according to the type and condition of the old finish. Removers are available as flammable or nonflammable types, also liquid or semipaste in consistency. Whereas most paint removers require scraping or steel wool to physically remove the softened paint, types are available that allow the loosened finish to be flushed off with steam or hot water. Many flammable and nonflammable removers contain paraffin wax to retard evaporation. It is absolutely essential that the wax residue be removed from the surface prior to painting. Otherwise paint will not adhere properly to the surface. Follow the manufacturer's label directions or use mineral spirits to remove any

wax residue. Although nonflammable paint removers eliminate fire hazards, they are toxic to a degree as are all paint removers. Proper ventilation must be provided whenever they are used.

FERROUS METALS

Cleaning ferrous metals, such as iron and steel, involves the removal of oil, grease, previous coatings, and dirt. Do so using a cleaning method discussed earlier in this chapter. Keep in mind that once you prepare a metal surface for painting, it will start to rust immediately unless a primer or pretreatment is used to protect the surface.

NONFERROUS METALS

The nonferrous metals are brass, bronze, copper, tin, zinc, aluminum, nickel, and others not derived from iron ore. A galvanized metal is one which has a zinc-coated surface; it is treated as a nonferrous metal for painting purposes.

Nonferrous metals are generally cleaned with a solvent-type cleaner. After cleaning, you should apply a prime coat or a pretreatment.

CONCRETE AND MASONRY

In Navy construction, concrete and masonry are normally not painted unless painting is required for dampproofing. Cleaning concrete and masonry involves the removal of dirt, mildew, and EFFLORESCENCE (a white, powdery, crystalline deposit which often forms on concrete and masonry surfaces).

Dirt and fungus are removed by washing with a solution of TRISODIUM PHOSPHATE; the strength of the solution may vary from 2 oz to 8 oz of trisodium phosphate per gal of water, depending upon the amount of dirt and/or mildew on the surface. Immediately after

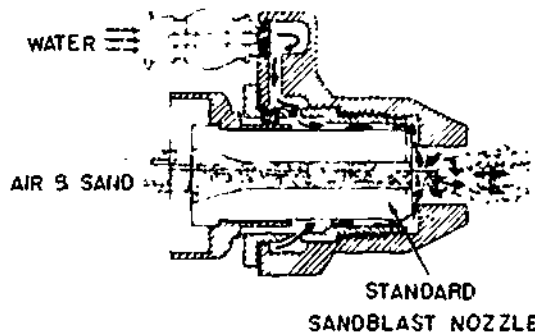

133.565

Figure 14-21—Wet-blast attachment.

washing, rinse off all the trisodium phosphate with clear water. If oil paint is to be used, allow the surface to dry thoroughly before painting.

For efflorescence, first remove as much as possible of the deposit by dry brushing with a wire brush or a stiff fiber brush. Next, wet the surface thoroughly with clear water, and then scrub with a stiff brush dipped in a 5 percent solution (by weight) of muriatic acid. Allow the acid solution to remain on the surface about 3 minutes before scrubbing, but rinse thoroughly with clear water **IMMEDIATELY AFTER** scrubbing. Work on small areas, not larger than 4 sq ft. Wear rubber gloves, a rubber apron, and goggles when mixing and applying the acid solution. In mixing the acid, **ALWAYS** add acid to water. Do **NOT** add water to acid which can cause the mixture to explode.

For a very heavy deposit, the acid solution may be increased to 10 percent and allowed to remain on the surface for 5 minutes before it is scrubbed.

All defects in a concrete or masonry surface must be repaired before painting. To repair a large crack, cut the crack out to an inverted-V shape and plug it with grout (a mixture of 2 or 3 parts of mortar sand, 1 part of portland cement, and enough water to make it puttylike in consistency). After the grout sets, damp cure it by keeping it wet for 48 hours. If oil paint is to be used, allow at least 90 days for weathering before painting over a grout-filled crack.

PLASTER AND WALLBOARD

Whenever possible, allow new plaster to age at least 2 months before painting. Prior to painting, fill all holes and cracks with **SPACKLING COMPOUND** or **PATCHING PLASTER**. Cut out the material along the crack or hole in an inverted-V shape. To avoid excessive absorption of water from the patching material, wet the edges and bottom of the crack or hole before applying the material. Fill the opening to within 1/4 inch of the surface and

allow the material to set partially before bringing the level up flush with the surface. After the material has thoroughly set, use fine sandpaper to smooth out the rough spots. Allow at least 72 hours for setting before painting. Plaster and wallboard should have a sealer or a prime coat prior to painting.

WOOD

Before being painted, a wood surface should be closely inspected for loose boards, defective lumber, protruding nailheads, and other defects or irregularities. Loose boards should be nailed tight, defective lumber should be replaced, and all nailheads should be countersunk.

A dirty wood surface is cleaned for painting by sweeping, dusting, and washing with solvent or soap and water. In washing wood, take care to avoid excessive wetting, which tends to raise the grain. Wash a small area at a time, then rinse and dry it immediately.

Wood which is to be given a **NATURAL** finish (meaning not concealed by an opaque surface coating) may require **BLEACHING** to a uniform and/or light color. To bleach, apply a solution of 1 pound of **OXALIC ACID** to 1 gallon of hot water. More than one application may be required. After the solution has dried, the surface should be smoothed with fine sandpaper.

Rough wood surfaces must be sanded smooth for painting. Mechanical **SANDERS** are used for large areas, hand sanding for small areas. In sanding by hand, wrap sandpaper around a rubber, wood, or metal **SANDING BLOCK**. For a very rough surface, start with a coarse paper, about No. 2 or 2 1/2; follow up with a No. 1/2, No. 1, or No. 1 1/2; and finish with about a No. 2/0 grit. For fine work, such as furniture work, finish with a finer grit.

Sap or resin in wood will stain through a coat, or even several coats, of paint. Remove sap or resin by scraping and/or sanding. Knots in

Chapter 14 -PAINTS AND PRESERVATIVES

resinous wood should be treated with KNOT SEALER, Military Specification MIL-S 12935.

CONDITIONERS, SEALERS, AND FILLERS

Conditioners are often applied on masonry to seal a chalky surface in order to improve adhesion of water-base topcoats. Sealers are used on wood to prevent resin exudation or bleeding. Fillers are used to produce a smooth finish on open-grain wood and rough masonry. (See table 14-5.)

Since latex (water-thinned) paints do not adhere well to chalky masonry surfaces, an oil-base CONDITIONER is applied to the chalky substrate before the latex paint is applied. The entire surface should be vigorously wire brushed by hand or power tools, then dusted to remove all loose particles and chalk residue. The conditioner is then brushed on freely to assure

effective penetration and allowed to dry. It is NOT intended for use as a finish coat.

SEALERS are applied to bare wood like coats of paint. Freshly exuded resin, while still soft, may be scraped off with a putty knife and the affected area solvent cleaned with alcohol. Hardened resin may be removed by scraping or sanding. Since the sealer is not intended for use as a prime coat, it should be used only when necessary, and applied over the affected area only. When previous paint becomes discolored over knots on pine lumber, the sealer should be applied over the old paint before the new paint is applied.

FILLERS are used on porous wood, concrete, and masonry to fill the pores to provide a smoother finish coat.

Wood fillers are used on open-grained hardwoods. In general, hardwoods with pores larger than in birch should be filled. (See table

Table 14-5.—Treatment of Various Substrates

	Wood	Metal		Concrete Masonry	Plaster Wallboard
		Steel	Other		
<i>Mechanical</i>					
Hand Cleaning	S	S	S	S	S
Power Tool Cleaning	S*	S		S	
Flame Cleaning		S			
Blast Cleaning					
Brush-Off		S	S	S	
All Other		S			
<i>Chemical and Solvent</i>					
Solvent Cleaning	S	S	S		
Alkali Cleaning		S		S	
Steam Cleaning		S		S	
Acid Cleaning		S		S	
Pickling		S			
<i>Pretreatments</i>					
Hot Phosphate		S			
Cold Phosphate		S			
Wash Primers		S	S		
<i>Conditioners, Sealers and Fillers</i>					
Conditioners				S	
Sealers	S				
Fillers	S			S	

S.—Satisfactory for use as indicated

* Sanding only

133.410

14-6) Necessary filling is done after staining. Stain should be allowed to dry for 24 hours before the filler is applied. If staining is not warranted, natural (uncolored) filler is applied directly to the bare wood. The filler may be colored with some of the stain in order to accentuate the grain pattern of the wood. To apply, you first thin the filler with mineral spirits to a creamy consistency, then liberally brush it across the grain, followed by a light brushing along the grain. Allow it to stand 5 to 10 minutes until most of the thinner has evaporated, at which time the finish will have lost its glossy appearance. Before it has a chance to set and harden, wipe the filler off ACROSS the grain using burlap or other coarse cloth, rubbing the filler into the pores of the wood while removing the excess. Finish by stroking along the grain with clean rags. All excess filler

must be removed. Knowing when to start wiping is important; wiping too soon will pull the filler out of the pores, while allowing the filler to set too long will make it hard to wipe off. A simple test for dryness consists of rubbing a finger across the surface. If a ball is formed, it is time to wipe. If the filler slips under the pressure of the finger, it is still too wet for wiping. Allow the filler to dry for 24 hours before applying finish coats.

Masonry fillers are applied by brush to bare and previously prepared (all loose, powdery, flaking material removed) rough concrete, concrete block, stucco, or other masonry surfaces, both new and old. The purpose is to fill the open pores in the surface in order to produce a fairly smooth finish. If the voids on the surface are large, it is preferable to apply two coats of filler, rather than one heavy coat,

Table 14-6.—Characteristics of Wood

Name of Wood	Type Grain	Soft		Hard		Notes on Finishing
		Closed	Open	Closed	Open	
Ash			X			Requires filler
Alder		X				Stains well.
Aspen					X	Paints well.
Basswood					X	Paints well.
Beech					X	Paints poorly, varnishes well.
Birch					X	Paints and varnishes well
Cedar		X				Paints and varnishes well
Cherry					X	Varnishes well.
Chestnut			X			Requires filler; paints poorly
Cottonwood					X	Paints well.
Cypress					X	Paints and varnishes well.
Elm			X			Requires filler; paints poorly
Fir		X				Paints poorly.
Gum					X	Varnishes well.
Hemlock		X				Paints fairly well.
Hickory			X			Requires filler.
Mahogany			X			Requires filler.
Maple					X	Varnishes well.
Oak			X			Requires filler
Pine		X				Variable depending on grain
Teak			X			Requires filler.
Walnut			X			Requires filler.
Redwood		X				Paints well.

Note: Any type finish may be applied unless otherwise specified.

in order to avoid mud cracking. Allow 1 to 2 hours drying time between coats. Allow the final coat to dry 24 hours before painting.

PAINT MIXING AND CONDITIONING

Most paints used in the Navy are READY-MIXED, meaning that they are provided with the ingredients already mixed together in the proper proportions. When oil paints are left in storage for long periods of time, the pigments settle to the bottom, and must be mixed again into the vehicle before the paint is used. The purposes of conditioning and mixing are to redisperse or reblend settled pigment with the vehicle; eliminate lumps, skins, or other impediments to proper application; and bring the paints to their proper application temperature. All paints should be placed in the paint shop at least 24 hours before use in order to bring their temperatures between 65°F and 85°F. After time has elapsed, the paints are mixed, thinned, or tinted, if specified, and then strained, if necessary.

MIXING

Paints should be mixed in the paint shop just before they are issued. Mixing procedures will vary among different types of paints. Regardless of the procedure used, try not to overmix, which introduces too much air in the mixture. Table 14-7 outlines the type of equipment and procedure to be followed for various coatings. Mixing is done by either a manual or mechanical method, but the latter is definitely preferred to insure maximum uniformity. Manual mixing is less efficient than mechanical in terms of time, effort, and results. It should be done only when absolutely necessary and be limited to containers no larger than one gallon. Nevertheless, it is possible to stir 5-gallon containers by hand. To do so, first pour half of the paint into an empty container and then stir the remainder thoroughly, being certain to scrape off and break up any settled matter on the bottom or lower sides of the container. Continue to stir the paint as you return the other half slowly to its original container. The stirred paint must have a completely blended appearance with no evidence of varicolored

Table 14-7.—Mixing Procedures

Coating	Equipment	Remarks
Enamel, semigloss or flat paints (oil type).	Manual, propeller or shaker	Mix until homogeneous.
Water based paints (latex type)	Manual or Propeller	Use extreme care to avoid air entrapment.
Clear finishes	Manual, propeller or shaker	Generally require little or no mixing.
★Extremely viscous finishes, e.g. coal tar paints	Drum-type mixer	Use extreme care to avoid air entrapment.
Two package metallic paints, e.g. aluminum paints	Propeller	Add small amount of liquid to paste; mix well. Slowly add remainder of vehicle, while stirring, until coating is homogeneous. With metallic powder, first make into a paste with solvent, and then proceed as above.
★Two Component Systems	Propeller, shaker or drum-type mixer	Mix until homogeneous. Check label for special instructions.

133.555

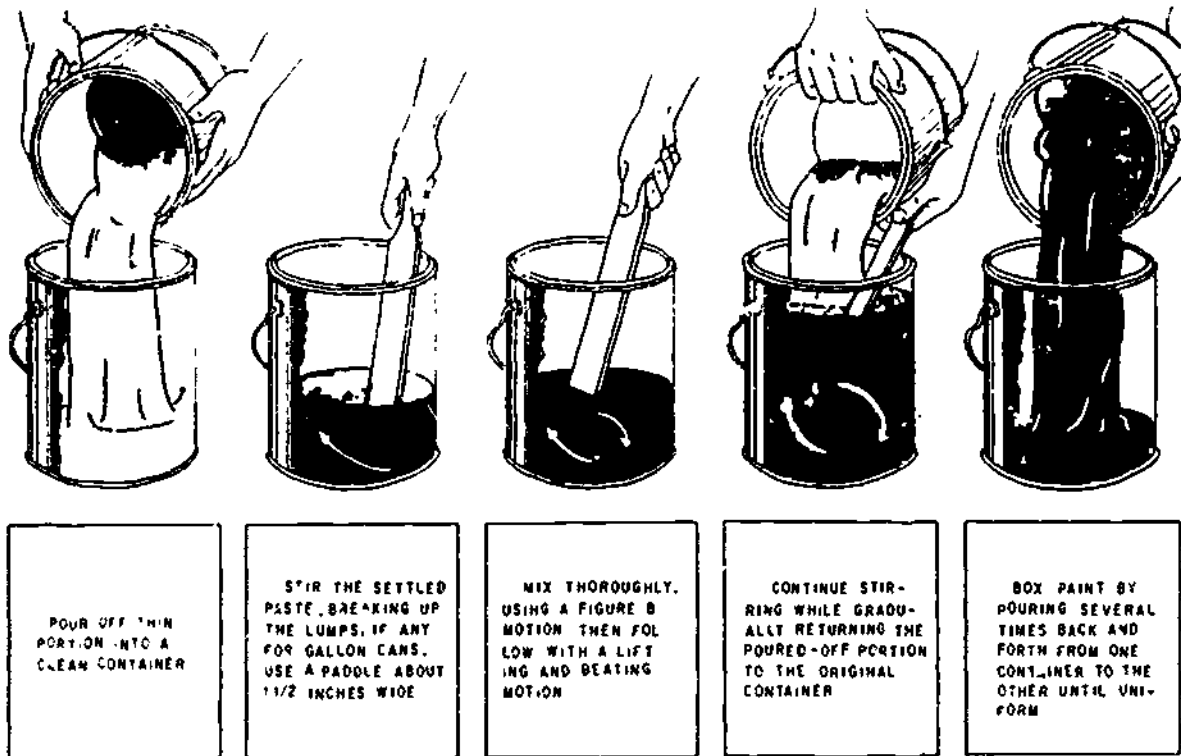

133.557

Figure 14-22.—Manual mixing and boxing.

swirls at the top, including unmixed pigment or vehicle. Neither should there be evidence of lumps indicating the presence of unredispersed solids or foreign matter. (See fig. 14-22.)

There are only three primary true-pigmented colors—red, blue, and yellow. Shades, tints, and hues are derived by mixing these colors in various proportions. Figure 14-23 illustrates a color triangle with one primary color at each of its points. The lettering in the triangle indicates the hues that will result when colors are mixed together as follows:

Equal proportions of red and blue produce purple.

Equal proportions of red and yellow produce orange.

Equal proportions of blue and yellow produce green.

Three parts of red to one part of blue produce carmine.

Three parts of red to one part of yellow produce reddish-orange.

Three parts of blue to one part of red produce red-violet.

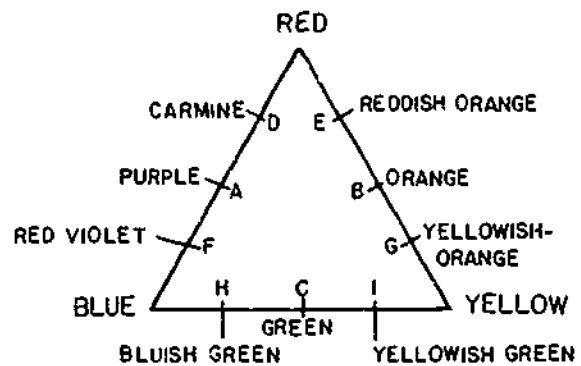

58.160

Figure 14-23.—A color triangle.

Three parts of yellow to one part of red produce yellowish-orange

Three parts of blue to one part of yellow produce blue-green

Three parts of yellow to one part of blue produce yellowish-green

Hues are known as chromatic colors, whereas black, white, and gray are the achromatic (neutral) colors. Gray can be produced by mixing black and white in different proportions.

THINNING

When received, paints should be ready for application by brush or roller. Thinner can be added for either application but the supervisor or inspector must give prior approval. However, thinning is often required for spray application. Unnecessary or excessive thinning causes an inadequate thickness of the applied coating which adversely affects the longevity and protective qualities of the coating. When necessary, thinning is done by competent personnel using only the thinning agents named by the specifications or label instructions. Thinning is not done to make easy the brushing or rolling of overly cold paint materials. These should be preconditioned (heated) to bring them up to 65° F to 85° F.

STRAINING

Normally, paint in freshly opened containers should not require straining. But in cases where lumps, color flecks or foreign matter are evident, paints are strained after mixing. Skins, however, are removed from the paint before mixing. If necessary, the next step is thinning. Finally, the paint is strained through a fine sieve or commercial paint strainer. When paint is to be sprayed, it must be strained to avoid clogging of the spray gun.

TINTING

The general practice of tinting paints should be avoided to reduce waste and eliminate the problem of matching special colors at a later date. Tinting also affects the properties of the

paint to which colorants are added, often reducing performance to some extent. One exception is the tinting of an intermediate coat in order to differentiate between that coat and the topcoat which helps assure that there are no missed areas. Here, use only colorants which are known to be compatible. Try not to add more than 4 oz per gal of paint. If more is added, the paint may not dry well and otherwise perform poorly.

When necessary, tinting should be done in the paint shop, and then only by experienced personnel. The paint must be at application viscosity before tinting. Colorants must be compatible, fresh and fluid, so as to mix readily. Mechanical agitation will help distribute the colorants uniformly throughout the paint.

METHODS OF APPLYING PAINT

The common methods of applying paint are brushing, rolling, and spraying. The choice of method is based on several factors, such as speed of application, environment, type and amount of surface, type of coating to be applied, appearance of finish, and training and experience of painters. Brushing is the slowest method, rolling is much faster, and spraying is usually the fastest by far. Brushing is ideal for small surfaces and odd shapes or for cutting in corners and edges. Rolling and spraying are efficient on large flat surfaces. Spraying can also be used for round or irregular shapes.

The general surroundings may prohibit the spraying of paint due to fire hazards or potential damage from overspraying. Examples include parking lots and open storage areas. Adjacent areas, not to be coated, must be covered when spraying is performed. This results in loss of time, and if extensive, may offset the speed advantage of spraying.

Brushing may leave brush marks after the paint is dry, rolling leaves a stippled effect, whereas spraying yields the smoothest finish, if done properly. Lacquer-type products, such as vinyls, dry rapidly and should be sprayed. Applying them by brush or roller may be difficult, especially in warm weather or outdoors.

on breezy days. With regard to the amount of training that painters require, most is spent on spraying and least on rolling.

BRUSH-PAINTING TECHNIQUES

Select the type of brush and paint pot needed for the job. The best type of pot for brush painting is a 1-gal paint can from which the lip around the top has been removed. (The lid of the can is fitted to the lip around the top.) You can cut this lip off with a cold chisel. When you leave the lip on the pot, it fills up with paint as you scrape the brush. This paint will flow over the lip, run down the outside of the can, and drip off.

Dip the brush to only one-third the length of the bristles, and scrape the surplus paint off the lower face of the brush, so there will be no drip as you transfer the brush from the pot to the surface to be painted

For complete coverage in applying paint by brush, use the laying-on, laying-off method. This means using long, horizontal brush strokes first (laying-on), then crossing your first strokes by working up and down (laying-off). See figure 14-24. By laying-on and laying-off, you distribute the paint evenly over the surface, cover the surface completely, and use a minimum amount of paint. A good rule is to lay-on the paint the shortest distance across the area and lay off the longest distance. When painting walls or any vertical surface, you should lay-on in horizontal strokes, and lay-off in vertical strokes.

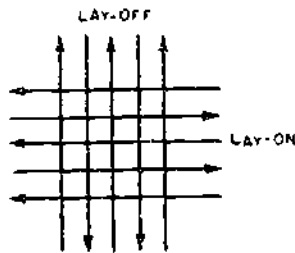

Figure 14-24.—Laying-on and laying-off.

3.212

Always paint the ceiling first and work from the far corner. By painting the ceiling first, you can keep the wall free of drippings by wiping as you go along. Be sure to carry a rag for "wiping up." You will also find that paint coats on the ceiling should normally be laid-on for the shortest ceiling distance and laid-off for the longest ceiling distance.

To avoid brush marks when finishing up a square, you should use strokes directed toward the last square finished, gradually lifting the brush near the end of the stroke while the brush is still in motion. Every time the brush touches the painted surface at the start of a stroke, it leaves a mark. For this reason, you should never finish a square by brushing toward the unpainted area, but always end up by brushing back toward the area already painted.

When painting pipes and narrow straps, beams, and angles, lay-on and lay-off as shown in figure 14-25.

ROLLER-PAINTING TECHNIQUES

Pour premixed paint into a tray (fig. 14-26) to about one-half of its depth. Immerse the roller, then move it back and forth along the ramp of the tray to fill the cover completely and remove excess paint. As an alternative to using the tray, place a specially designed



Figure 14-25.—Painting pipes and stanchions.

3.213

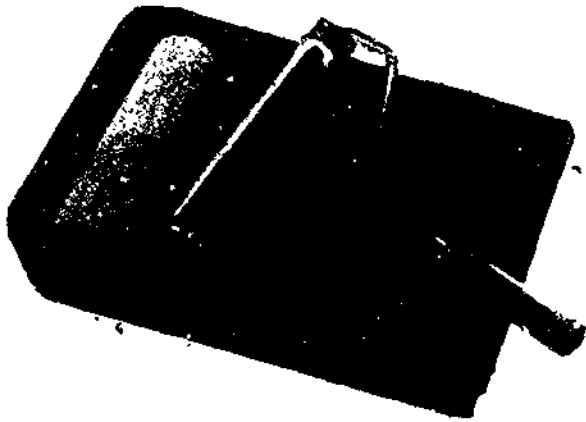

29.140(133F)D

Figure 14-26.--Roller and tray.

galvanized-wire screen into a 5-gal can of paint. This screen attaches to the can and remains at the correct angle for loading and spreading paint on the roller. (See figure 14-27.) To remove entrapped air from the roller cover, work the first load of paint out on newspaper. You are now ready to apply the paint. (You should have already trimmed around corners, moldings, etc.) In rolling paint onto a surface, always work a dry area into the just-painted area. Never roll completely in the same or one direction. Do not roll too fast to avoid spinning the roller at the end of a stroke. Always feather out final strokes to pick up any excess paint on the surface. Do this by rolling out the final stroke with minimal pressure. Get as close as possible to surfaces already trimmed by brush, maintaining the same texture.

SPRAY METHOD

When you squeeze the trigger of a paint spray gun, an air valve opens to admit compressed air. The air passes through the gun body to the spray head. In an external-mix type of spray head, the air does not come in contact with the paint inside the gun, but is blown out through small holes drilled in the air cap. A thin jet of paint is shot out of the nozzle, and the force of the air striking it spreads the jet into a fine spray.



29.140(133F)E

Figure 14-27 --Roller and wire-screen attachment to can.

Spray-Gun Adjustment

The first step is correctly adjusting the AIR-CONTROL and MATERIAL-CONTROL screws in order to produce the type of spray best suited to the work. The air-control screw adjusts the width and the density of the spray. Turning this screw clockwise concentrates the material into a round, dense spray, turning

counterclockwise widens the spray into a fan-shaped, diffused spray. As the spray is widened, the flow of material must be increased. To do so, turn the material-control screw clockwise. Turning this screw counterclockwise decreases the flow. The most desirable form of spray (ranging from round and solid to fan-shaped and diffused) depends upon the characteristics of the surface and the type of material being sprayed. Experience and trial are your only guides here. Practice spraying on waste material, making different adjustments, until you get a spray that covers uniformly and adequately.

Operational Defects of the Spray Gun

Uneven distribution of the spray pattern results when one or more air outlets are clogged or the control screws are adjusted incorrectly.

SPITTING is the alternate discharge of paint and air. Common causes of spitting are dry packing around the material-control-needle valve, looseness of the material nozzle, and dirt in the material-nozzle seat. To remedy dry packing, back off the material-control needle valve and place two drops of machine oil on the packing. To remedy looseness of the material nozzle and dirt on the nozzle seat, first remove the nozzle. Next, clean the nozzle and the seat with thinner. Then, screw the nozzle tightly back into place.

AIR LEAKAGE from the front of the gun is usually caused by improper seating of the air valve in the **AIR-VALVE ASSEMBLY** shown in figure 14-13. Improper seating may be caused by foreign matter on the valve or seat, by wear on or damage to the valve or seat, by a broken valve spring, or by sticking of the valve stem caused by lack of lubrication.

PAINT LEAKAGE from the front of the gun is usually caused by improper seating of the material-needle valve. Improper seating may be caused by damage to the valve stem or tip, by foreign matter on the tip or seat, or by a broken valve spring.

Spray-Painting Techniques

Complete instructions for the care, maintenance, and operation of a spray gun are contained in the manufacturer's manual, and these instructions should be carefully followed. A few of the major spray-painting techniques are given here. The handling of a spray gun is best learned by practice, but this section will give you some tips for using a spray gun.

Before starting to spray, check adjustments and operation of the gun by testing the spray on a surface similar to that which you intend to coat.

There are no set rules for spray-gun pressure or distance to hold the gun from the surface because pressure and distance vary considerably with the nozzle, the paint used, and the surface to be coated. The minimum pressure necessary to do the work is the most desirable, and the distance normally is from 6 to 10 in.

Always keep the gun perpendicular to and at the same distance from the surface being

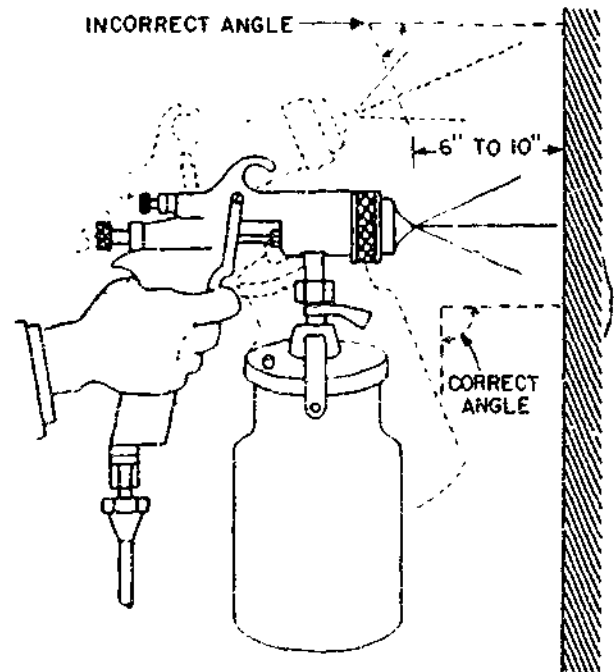

80.242

Figure 14-28.—Hold spray-gun perpendicular to surface.

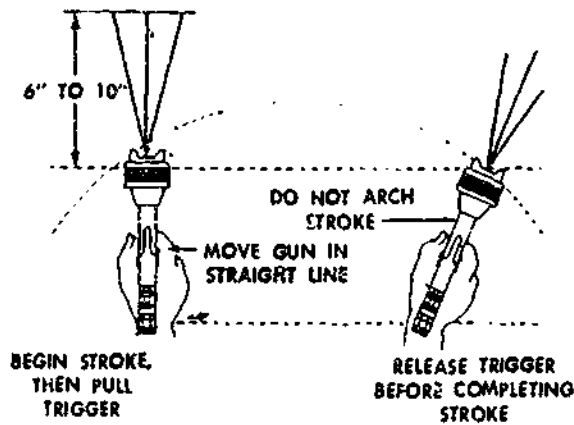

Figure 14-29.—Proper spray-gun stroke.

80.243

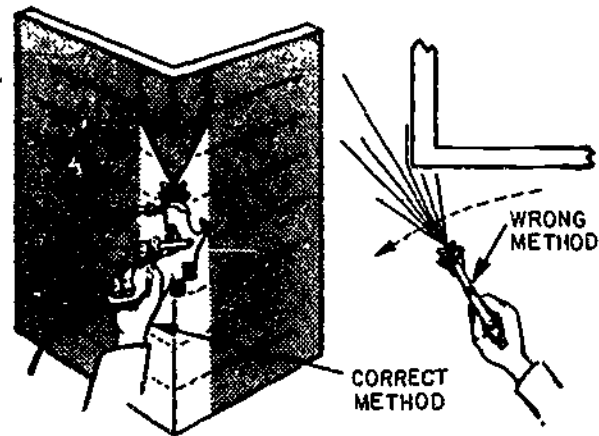

Figure 14-30.—Right and wrong methods of spraying an outside corner.

80.244

Painted. (See figs. 14-28 and 14-29.) Start the stroke before squeezing the trigger, and release the trigger before completing the stroke. When the gun is not held perpendicular or is held too far away, part of the paint spray will evaporate and strike the surface in a nearly dry state. This is called dusting. When you fail to start the stroke before starting the spray or spraying to the end of the stroke, it will cause the paint to build up at each end of the stroke, and the paint will run or sag. When you arch the stroke, it is impossible to deposit the paint in a uniform coat.

When spraying an inside or outside corner, stop 1 or 2 inches short of the corner, as shown in figure 14-30. Do this on both sides, then turn your gun on its side, and starting at the top, spray downward, coating both sides at once.

In spraying a large area into which small parts and pieces protrude, first coat them lightly. Then, go over the whole surface. In painting an office, for example, first spray the door frames and all small items secured to the walls, then do the entire office. This eliminates a lot of touching up later.

Common Spraying Defects

The most common defects in sprayed paint coats are "orange peel," runs and sags, pinholes, blushing, peeling and bleeding.

ORANGE PEEL describes a dried painted surface having a pebbled texture resembling an orange peel. It may be caused by using improper thinners, a spray which is not fine enough, holding the gun too far from (or too close to) the surface, improper mixing of the material, drafts, or low humidity.

RUNS are usually caused by using paint that is too thin. They can also be caused by allowing too much lap in spraying strokes and by poor adjustment of the spray gun or pressure tank.

PINHOLES may be caused by the presence of water or excessive thinner in the paint, or by heavy applications of quick-drying paint. In either case, small bubbles form then break while drying, leaving small holes.

BLUSHING resembles a powdering of the paint. What happens is that the cellulose material in the paint separates from its solvent and returns to its original powder form. The usual cause of blushing is moisture in the air. When blushing occurs, you will have to remove the defective coating because the moisture is trapped within the material and will remain there unless the coating is removed.

PEELING is nearly always due to carelessness in cleaning the surface. Before spraying is attempted, the surface must be

absolutely clean. Cheap spray materials will sometimes adhere poorly, but not if standard Navy paints are used.

BLEEDING occurs when the color of a previous coat discolors the finish coat. It is caused by spraying another color over paint containing a strong aniline dye.

Care of the Spray Head

Spray guns must be cleaned thoroughly after they are used. The steps in cleaning a pressure-feed gun are shown in figure 14-31. First, back up the fluid needle-adjusting screw and release the pressure from the pressure tank by means of the release valve. Hold a cloth over the air cap and pull the trigger—this forces the spray material back into the tank. Now remove

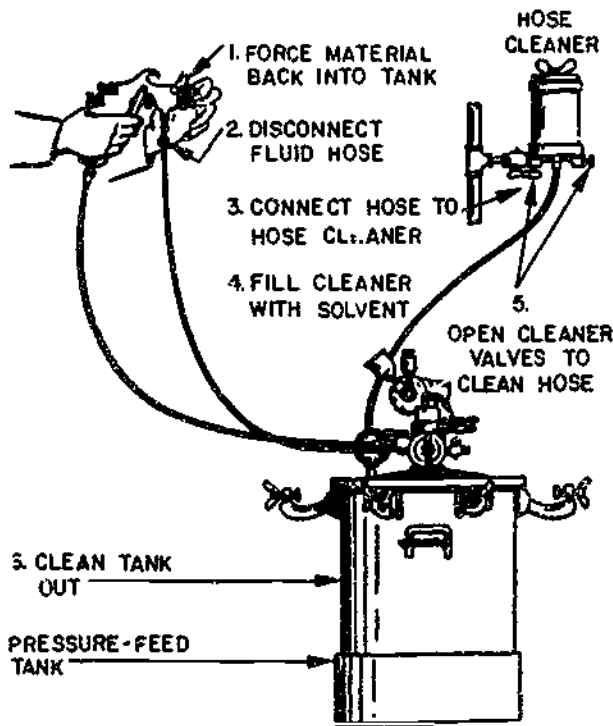

80.245
Figure 14-31.—Steps in cleaning a pressure-feed gun.

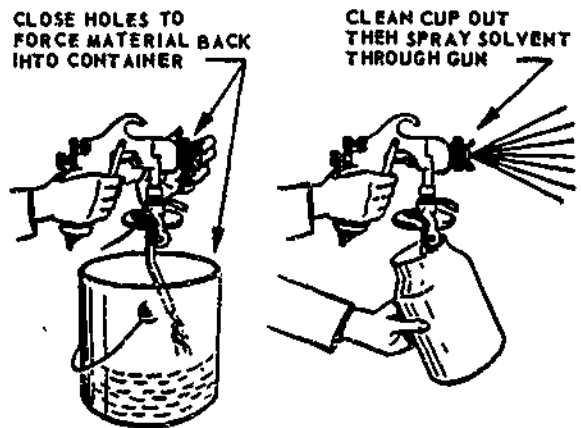

2.166
Figure 14-32.—Steps in cleaning a container-type gun.

the fluid hose from the gun and run a solvent through it. There is a special hose cleaner made for this purpose. Dry out the tip and clean the tank. Soak the air cap in solvent. If the holes are clogged, use a toothpick to clean them. Put all clean parts back in place, and the gun is ready for use again.

To clean a container-type gun (fig. 14-32), first remove the container. Then, hold a cloth over the air cap and pull the trigger. Empty the

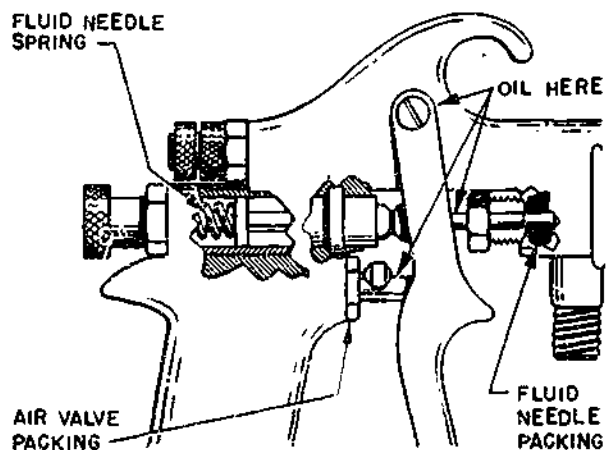

80.246
Figure 14-33.—Lubrication points of a spray-gun.

Chapter 14—PAINTS AND PRESERVATIVES

Table 14-8.—Spray-Gun Troubles, Possible Causes, and Remedies

TROUBLES	POSSIBLE CAUSES	REMEDIES
Air leaks from front of gun	Foreign matter on valve seat Worn or damaged valve seat Sticking valve stem Bent valve stem Packing nut loose	Clean Replac. Lubricate Replace Adjust
Fluid leaks from front of gun	Worn or damaged fluid tip or needle Foreign matter in fluid tip Packing nut too tight Wrong size needle	Replace Clean Adjust Replace
Jerky or fluttering spray	(both suction—and pressure feed) Insufficient material in container Tipping container to excessive angle Obstructed fluid passageway Loose or cracked fluid tube Loose fluid tip or damaged tip seat	Refill Take greater care Clean Tighten or replace Tighten or replace
Jerky or fluttering spray (suction feed only)	Too heavy a material Clogged air vent in container lid Loose or damaged coupling nut or cup lid Fluid tube resting on bottom	Change to pressure-feed Clean Tighten or replace Use proper fluid tube
Defective spray pattern	Air cap horn holes partially plugged Dirt on air cap or fluid nozzle	Rotate air cap 1/2 turn and spray another pattern. If defect is inverted, fault is on/in air cap. If pattern is same, fault is on/in fluid nozzle. Clean proper part.

container and pour in a small quantity of solvent. Attach the container to the gun and spray in the usual way. This process cleans out all passageways. Clean the air cap by soaking it in a solvent, then replace it. Some spray-gun troubles, their possible causes, and their remedies are listed in table 14-8.

Lubrication of the Spray Gun

Your spray gun also needs a little lubrication from time to time. The fluid-needle packing should be removed and softened with oil. The fluid-needle spring should be coated with grease or petrolatum. Figure 14-33 shows these parts

and also holes where you should occasionally put in a few drops of light oil.

Removing the Spray Head

To clean or repair the spray head, or to change the color of paint, you may have to remove the spray head, usually a simple operation. First, remove the gun from the air- and fluid-hose lines. Holding the gun in the left hand, pull the trigger all the way back and loosen the locking bolt with the wrench provided for the purpose. Push the trigger forward as far as possible, and pull the spray head forward. (See fig. 14-34.) To replace the head, push the trigger forward and insert the spray head. Then, hold the trigger back and tighten the locking bolt.

of the average coverage per gallon for brush painting.

You should develop the ability to estimate the number of man-hours and amount of paint required to do the ordinary painting jobs. It helps to keep a set of notes on the jobs that your crewmembers do. Note such things as the number of square feet per gallon that different types of paint will cover when applied by each method of painting, the time required to ready the equipment for spraying, the number of square feet a team can paint in an hour, the number of gallons of paint required for each structure, and so on.

For example:

Paint coverage (square feet per gallon)

1. Enamel-400 (brush)
2. Enamel-425 (spray)
3. Flat-400 (brush)
4. Flat-430 (spray)

Team #1 (experience _____)

Readying equipment __hr (_____ helpers)

Average __ sq ft per hr

COVERAGE OF PAINT

The area a gallon of paint will cover depends on the nature of the surface, character of the paint, method of application, and other variables. It is impossible to lay down hard and fast rules for estimating coverage because of these variables. Table 14-9 gives a rough estimate

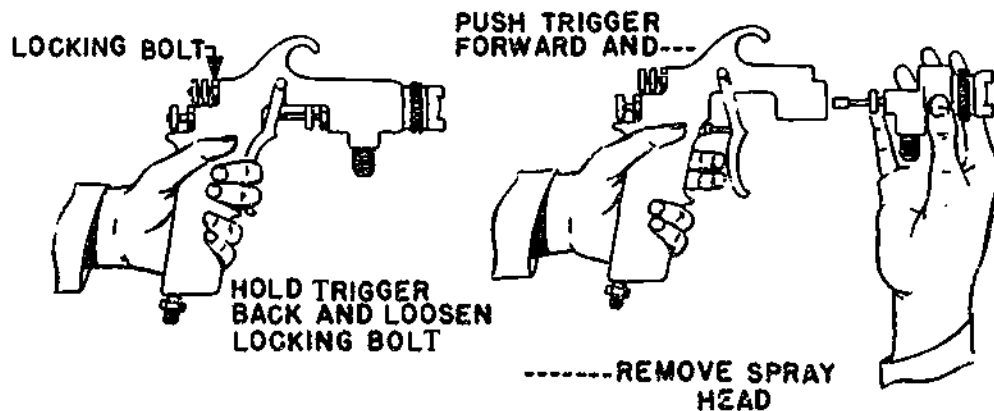

Figure 14-34. Removing the spray head.

60.247

Chapter 14—PAINTS AND PRESERVATIVES

Table 14-9.—Average Paint Coverage

Type of Surface	Area in Square Feet per Gallon		
	Primer or First Coat	Second Coat	Third Coat
Exterior			
Wood Siding and Trim			
Flat Oil	300	350	400
Shingle	80	125	
Stain			
Concrete Masonry Unit			
Cement Base	100	150	200
Latex	150	200	250
Interior			
Plaster			
Flat Oil	300	350	400
Gloss Oil	300	350	400
Latex	300	350	400
Concrete Masonry Unit			
Cement Base	100	150	200
Latex	150	200	250

133.412

PAINT FAILURES

A paint which reaches the end of its useful life prematurely is said to have failed. Even protective coatings properly selected and applied on well-prepared surfaces will gradually deteriorate and eventually fail. The speed of deterioration under such conditions is less than when improper painting procedures are carried out. Inspectors and personnel responsible for maintenance painting must recognize signs of deterioration in order to establish an effective and efficient system of inspection and programmed painting. Repainting at the proper time will avoid the problems resulting from painting either too soon or too late. Applying paint ahead of schedule is costly and eventually results in a heavy buildup that tends to quicken deterioration of the paint. Applying paint after it is scheduled results in costly surface preparation and may be responsible for damage

to the structure, which then may require expensive repairs.

The following sections describe the common types of paint failures, the reasons for such failures, methods of prevention, and/or cures.

CHALKING

Chalking is the result of paint weathering at the surface of the coating. The vehicle is broken down by sunlight and other destructive forces, leaving behind loose, powdery pigment that can easily be rubbed off with the finger. (See fig. 14-35.) Chalking takes place rapidly with soft paints, such as those based on linseed oil. Chalking is most rapid in areas exposed to sunshine. In the northern hemisphere, for example, chalking will be most rapid on the south side of a building. On the other hand, little chalking will take place in areas protected

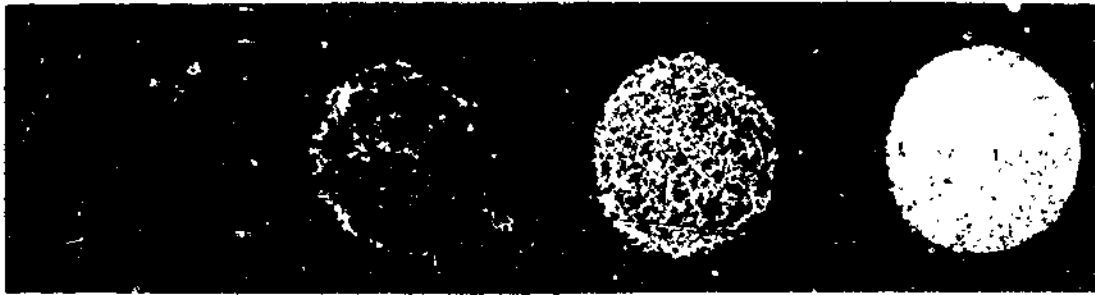

Figure 14-35.—Degrees of chalk.

133.405

from sunshine and rain, such as under eaves or overhangs. Controlled chalking can be an asset, especially in white paints, since it is a self-cleaning process and helps to keep the surface clean and white. Furthermore, the gradual wearing away reduces the thickness of the coating, thus allowing continuous repainting without making the coating too thick for satisfactory service. Chalked paints are also generally easier to repaint since the underlying paint is in good condition and requires little surface preparation. This is not so in the case of water-thinned paints, they adhere poorly to chalky surfaces.

ALLIGATORING

Alligating describes a pattern in a coating which looks like the hide of an alligator. It is caused by uneven expansion and contraction of the undercoat. (See fig. 14-36.) Alligating can be caused by:

1. Applying an enamel over an oil primer.
2. Painting over bituminous paint, asphalt, pitch, or shellac.
3. Painting over grease or wax.

PEELING

PEELING (fig. 14-37) results from inadequate bonding of the topcoat with the undercoat or the underlying surface. It is nearly always caused by inadequate surface preparation. A topcoat will peel when applied to a wet surface, a dirty surface, an oily or waxy surface, or a glossy surface. All glossy surfaces must be sanded before painting.



133.239(133F)

Figure 14-36.—Alligating.

BLISTERING

BLISTERING (fig. 14-38) is caused by the development of gas or liquid pressure under the paint. The root cause of most blistering, other than that caused by excessive heat, is inadequate ventilation plus some structural defect that allows moisture to accumulate under the paint. All blisters should be scraped off, the paint edges around them should be feathered with sandpaper, and the bare places primed before the blistered area is repainted.

CHECKING AND CRACKING

Checking and cracking describe breaks in the paint film which are formed as the paint



Figure 14-37.—Peeling. 133.240

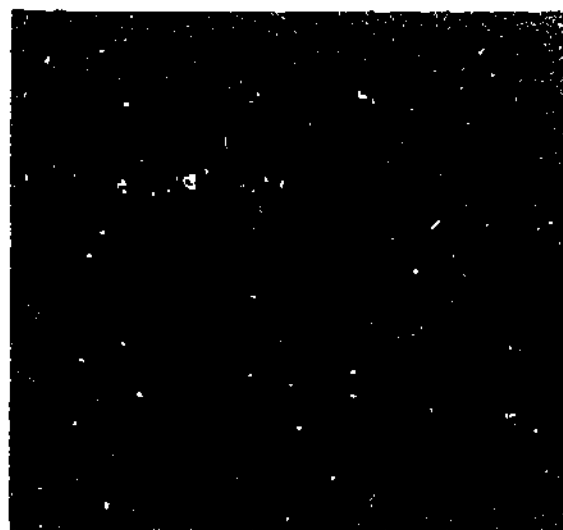
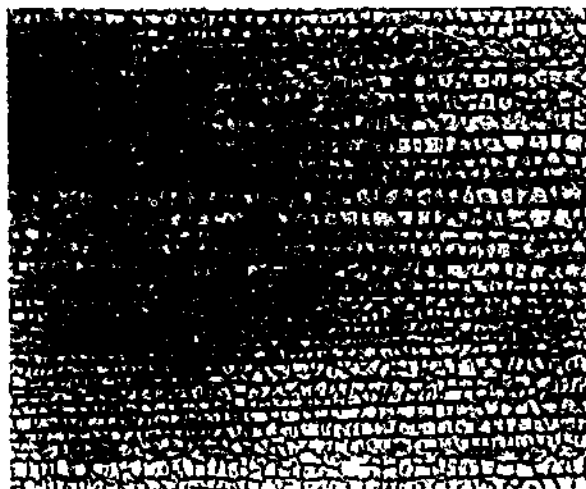

Figure 14-38.—Blistering. 133.241

becomes hard and brittle. Temperature changes cause the substrate and overlying paint to expand and contract. As the paint becomes hard, it gradually loses its ability to expand without breaking to some extent. Checking is



133.242(133F)A
Figure 14-39.—Severe checking.

described as tiny breaks which take place only in the upper coat or coats of the paint film without penetrating to the substrate. The pattern is usually similar to a crow's foot. (See fig. 14-39.) Cracking describes larger and longer breaks which extend through to the substrate. (See fig. 14-40.) Both are a result of stresses which exceed the strength of the coating. Whereas checking arises from stresses within the paint

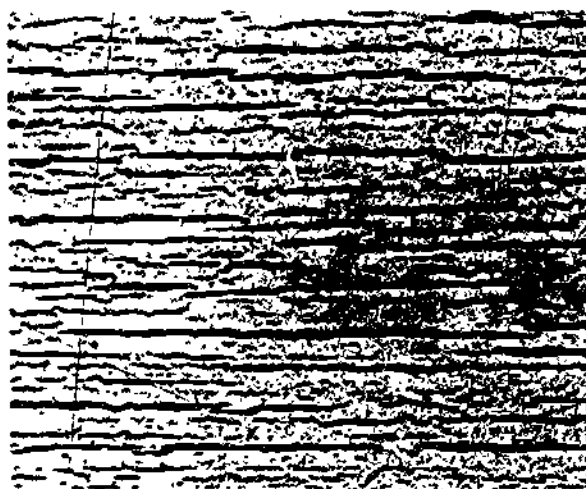

133.242(133F)B
Figure 14-40.—Severe cracking.

film, cracking is caused by stresses between the film and the substrate. Cracking will generally take place to a greater extent on wood than on other substrates because of its grain. Therefore, the stress in the coating is greatest across the grain causing cracks to form parallel to the grain of the wood. Checking and cracking are aggravated by excessively thick coatings due to their reduced elasticity.

CRAWLING

Crawling describes the failure of a new coat of paint to wet and form a continuous film over the preceding coat. This happens when latex paints are applied over high-gloss enamel or when paints are applied on concrete or masonry treated with a silicone water repellent. (See fig. 14-41.)

INADEQUATE GLOSS

Sometimes a glossy paint fails to attain the normal amount of gloss. This may be caused by (1) inadequate surface preparation, (2) application over an undercoat which is not thoroughly dry, and (3) application in cold or foggy weather.

PROLONGED TACKINESS

A coat of paint is dry when it ceases to be "tacky" to the touch, and prolonged tackiness

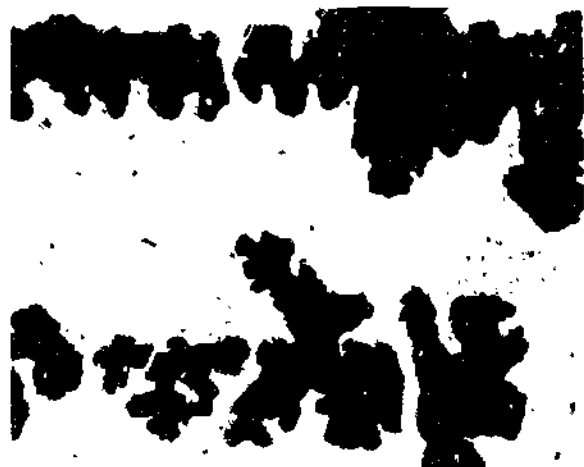

Figure 14-41.—Crawling. 133.406

indicates excessively slow drying. This may be caused by (a) insufficient drier in the paint, (b) a low-quality vehicle in the paint, (c) applying the paint too thickly, (d) painting over an undercoat which is not thoroughly dry, (e) painting over a waxy, oily, or greasy surface, and/or (f) painting in damp, wet, or foggy weather.

WRINKLING

When paint is applied too thickly, especially in cold weather, the surface of the coat dries to a skin over a layer of undried paint underneath. This usually causes WRINKLING like that shown in figure 14-42. Wrinkling can be avoided in brush painting or roller painting by brushing or rolling each coat of paint as thinly as possible. In spray painting, you can avoid wrinkling by keeping the gun in constant motion over the surface whenever the trigger is down.

WOOD PRESERVATIVES

Damage to wood buildings and other structures by termites, wood bores, and fungi is needless waste. Defects in wood have been caused by improper care after preservation treatment. All surfaces of treated wood that are



Figure 14-42.—Wrinkling. 133.243

Chapter 14 PAINTS AND PRESERVATIVES

Table 14-10.—Recommended Preservatives and Retentions for Ties, Lumber, Piles, Poles, and Posts (Fed Spec TT-W-571)

Product	Minimum net retention of—(Pounds per cubic foot)				
	Coal-tar creosote (TT-W-556)	Creosote-coal tar solution (TT-W-566)	Creosote-petroleum solution (TT-W-568)	Pentachlorophenol, 5 percent in petroleum (TT-W-570)	Copper naphthenate (0.75 percent copper metal) in petroleum (AWPA P8)
Ties (crossties, switch ties, and bridge ties)	8	8	9		
Lumber, and structural timbers:					
For use in coastal waters:					
Douglas fir (coast type) lumber and timbers.	14	14			
Southern yellow pine lumber and timbers	20	20			
For use in fresh water, in contact with ground or for important structural members not in contact with ground or water.	10	10	12	10	10
For other use not in contact with ground or water.	6	6	7	6	6
Piles:					
For use in coastal waters:					
Douglas fir (coast type) . . .	17	17			
Southern yellow pine	20	20			
For land or fresh water use . .	12	12	14	12	
Poles (utility and building)	8, 10	8, 10	8, 10
Posts (round, fence)	6	6	7	6	6

133.415

cut or drilled to expose the untreated interior must be treated with the proper application of wood preservative.

The capacity of any wood to resist dry rot, termites, and decay can be greatly increased by impregnating the wood with a general-purpose wood preservative or fungicide. Prescribed preservatives are listed in table 14-10.

Different woods have different capacities for absorbing preservatives or other liquids. In any given wood, the sapwood is more absorbent than the heartwood. Hardwoods are in general, less absorbent than softwoods. Naturally, the extent

to which a preservative protects increases directly with the distance to which it penetrates below the surface of the wood. The best penetration is obtained by a pressure method which requires equipment you will not have generally available. Nonpressure methods of applying preservatives to a surface include dipping, brushing, and spraying.

Figure 14-43 shows how you can improvise long tanks for the dipping method. Absorption is rapid at first, much slower later. A rule of thumb says that in 3 minutes, wood will have absorbed one-half the total amount of

STORAGE OF EQUIPMENT

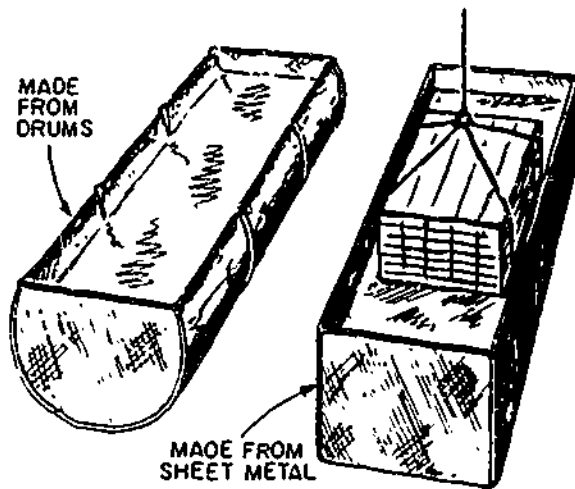

133.244

Figure 14-43.—Improvised tanks for dipping lumber.

preservative it will absorb in 2 hours. However, the extent of the penetration will depend upon the type of wood, its moisture content, and the length of time it remains immersed.

Surface application by brush or spray is the least satisfactory method of treating wood, from the standpoint of maximum penetration. However, it is more or less unavoidable in the case of already installed wood, as well as treated wood which has been cut or drilled to expose the untreated interior.

Pentachlorophenol and creosote coal tar are likely to be the only field-mixed preservatives used by the Builder. The type of treatment or preservative depends on the severity of exposure and the desired life of the end product. Types and uses of wood preservatives are shown in table 14-10. When applying preservatives, the Builder should make it a practice to

1. Avoid undue skin contact
2. Avoid touching the face or rubbing the eyes when handling pretreated material.
3. Avoid inhalation of toxic (poisonous) material.
4. Work only in a properly ventilated space and use approved respirators.
5. Wash with soap and water after contact.

The amount and kinds of EQUIPMENT available will depend on the job to which you are assigned. This equipment may include either a paint spray outfit of 5-gal capacity or a lightweight, portable, 1-qt capacity sprayer, driven either by air or electrically. The equipment may also include a paint mixer of the type used with a portable electric or pneumatic drill and respirators of the chemical-cartridge or mechanical-filter type. The number and types of brushes available also will vary.

You will have to use your own judgment as to the number of brushes to be kept available for daily use. The equipment should include a stencil-cutting machine with supplies and several sets of metal-stenciling letters. (Incidentally, the paper used in stencil-cutting machines is referred to as stencilboard.)

This equipment must be properly maintained to prolong its life and to derive best results from its use. Before new paintbrushes are used, they should be rinsed with thinner. Rinsing tightens the bristles and also removes those which are loose. Brushes should not be soaked in water to tighten the bristles as this will cause the metal ferrule to rust or split due to the swelling of the wooden handle. Brushes that are to be reused the following day should be marked and used for the same type of colors, light or dark. Excess paint should be removed with thinner and the brushes suspended by the handle with the bristles immersed in thinner or linseed oil to just below the bottom of the ferrule. A brush must not be allowed to rest on its bristles, its weight will cause them to become distorted. Brushes that are not to be reused immediately should be carefully cleaned with the type of thinner recommended by the manufacturer, washed thoroughly with soap and water, then rinsed. A protective cover and preservative should be applied to the brushes when appropriate. They should either be stored suspended from racks or laid flat.

To clean a frozen brush, soak it in a solvent-type, nonflammable paint and varnish remover, squeeze and scrape the softened paint out of the bristles, and then clean the brush with thinner as previously described.

Paint-mixing attachments driven by an electric-powered or pneumatic drill should be

cleaned with thinner. They should be removed from the drill before cleaning.

The spraying equipment used by the Navy is of very high quality and will give excellent service for years when it is given proper care. Frequent causes of unsatisfactory operation are faulty assembly, improper adjustment, and clogging due to dirt or hardened paint. Spray equipment should be cleaned with an appropriate thinner after each job or at the end of each day.

The paint-supply hose should be disconnected from the tank and a container of thinner connected. Pulling the trigger will force the thinner through the paint hose and gun, and clean out the paint remaining in them. The gun should be taken apart and each part cleaned. Do not soak the packing or lubricated parts with thinner; soaking will remove the lubricant and cause the packing to become hard. When needed, clean the paint tank with thinner and wipe dry. All the equipment should be stored in its assigned place. The air and paint hoses should always be coiled before being stored.

Respirators used in spray painting should be thoroughly cleaned with thinner after being used in order to remove the accumulation of paint. They should then be wiped with a light soap-and-water solution to remove the thinner, then wiped with clear fresh water, and thoroughly dried. If left damp, the metal parts will rust and the rubber parts will deteriorate.

It is advisable to wipe each respirator with a diluted disinfectant solution, since more than one individual may wear it. When necessary, the mechanical filters or chemical cartridges should be removed and checked after each use and renewed. Do not use paint remover to clean the respirator, paint hose, mixer, or spray gun. The corrosive agent contained in the remover will cause this equipment to deteriorate.

PAINTING SAFETY

Every painting assignment exposes Builders to conditions and situations that represent actual or potential danger to themselves and to others in the area. The necessity to use toxic and flammable materials, pressurized equipment, ladders, scaffolding, and rigging always makes painting a hazardous job. Hazards may also be

inherent in the very nature of the environment or result from ignorance or carelessness of the painter. Therefore, painting hazards may be broadly divided into three major types

1. Injury hazards involved in the use of scaffolds, ladders, rigging, tools, and equipment.
2. Fire hazards from flammable materials.
3. Health hazards from toxic and skin-irritating materials.

EQUIPMENT HAZARDS

The main causes of painting accidents are unsafe working conditions or equipment and careless personnel. The proper setting up and dismantling of equipment, the required safety checks, and the proper care of equipment may require more time than is spent in using it. Nevertheless, safety measures must be taken.

1. Avoid wearing torn or ripped clothes, cuffs, loose pockets, loose ties, and jewelry since they are potential causes of accidents.
2. Wear hardhats and steel-toed safety shoes whenever there is a chance you might be struck by a falling object. To prevent foreign material from getting into your eyes, wear safety goggles or a face shield.
3. In operating a sandblaster, keep your hands and other body parts away from the nozzle. Never point the nozzle in the direction of any person. Blasters must wear hoods, masks, or air helmets of the positive-pressure type (fig. 14-44). Also rubber and leather gloves and other protective clothing. When working on elevated places where guardrails are not provided, blasters must wear safety belts as a safeguard against falling.

FIRE HAZARDS

Certain general rules regarding fire and explosion hazards apply to all situations. All paint materials should have complete label instructions which stipulate the potential fire hazards and precautions to be taken. Painters must be continuously advised and reminded of the fire hazards that exist under the particular conditions of each job, so that they will be aware of the dangers involved and the need to work safely. Firefighting equipment of the

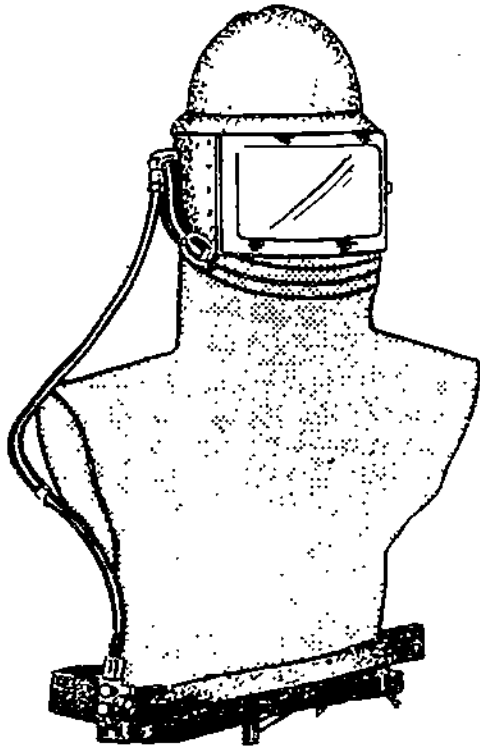

133 558

Figure 14-44.—Abrasive-blasting helmet.

proper type must always be readily available in the paint shop, sprayroom, and other work areas where potential fire hazards exist. Electric wiring and equipment installed or used in the paint shop, including storage room and sprayroom, must conform to the applicable requirements of the National Electrical Code (NEC) for hazardous areas. The following precautions against fire must be carefully observed by all paint-handling personnel

1. Prohibit smoking in all places where paint is stored, prepared for use, or applied.
2. Provide for adequate ventilation in these places. If natural ventilation doesn't work, provide artificial ventilation.
3. Perform recurrent spray operations on portable items, such as signs, in an approved spray booth that is adequately ventilated, and equipped with a water-wash system for fume removal and explosion-proof electrical gear.

4. Wet down spray-booth surfaces before cleaning them.

5. Use rubber feet on metal ladders, and be certain that personnel wear safety shoes having nonskid-rubber soles when working in enclosed spaces where flammable vapors are present.

6. Use nonsparking scrapers and brushes to clean metal surfaces where fire hazards are present.

7. Wet down paint sweepings, rags, and waste with water; then store them in closed metal containers until disposed of in an approved manner.

8. Extinguish all pilot lights on water heaters, furnaces, and other open-flame equipment on all floors of the structure being painted. Be sure to turn off the gas valve.

9. Open all electrical switches and tag them to prevent their being turned on inadvertently, while painting in confined areas near machinery or electrical equipment.

10. Be sure that all electric-powered mixers, pumps, and motors, in the paint shop, sprayroom, or on the job are grounded, and lights are explosion proof.

11. Use pails of sand (never sawdust) near dispensing pumps and spigots to absorb spillage or overflow.

12. While painting, keep fire extinguishers nearby, be sure that they are of the proper type.

13. Make a regular check of the ventilation and temperature in confined areas.

14. Consult with the Construction Electricians before painting in areas where high-voltage lines and equipment are located.

15. Keep all work areas clear of obstructions.

16. Clean up before, during, and after painting, dispose of sweepings and waste daily.

HEALTH HAZARDS

Many poisons are used in the manufacture of paint. They are classified as toxic materials and skin-irritating materials. While the body can withstand nominal quantities of poisons for relatively short periods of time, overexposure to them may have harmful effects. Furthermore, continued exposure to some may cause the body to become sensitized so that subsequent contact, even in small amounts, may cause an aggravated

reaction. To this extent these poisons are a definite threat to normally healthy individuals and a serious danger to persons having chronic illnesses or disorders. Nevertheless, health hazards can be avoided by a common sense approach of avoiding unnecessary contact with toxic or skin-irritating materials.

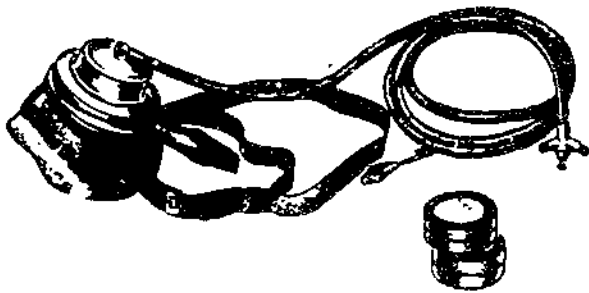

80 250

Figure 14-45 - Air supply respirator

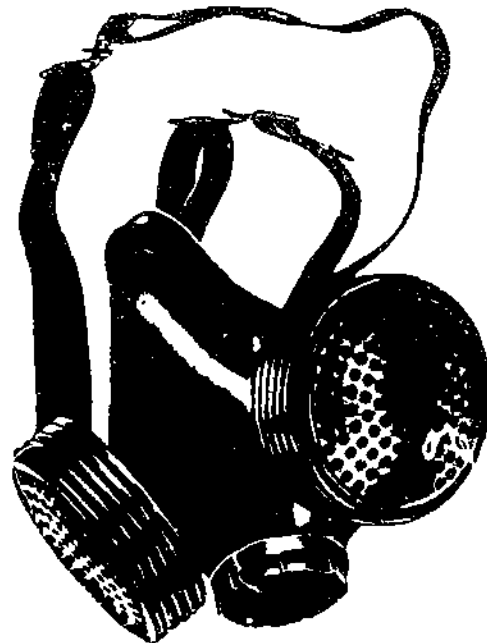

133.560

Figure 14-47 - Chemical cartridge respirator



133 559

Figure 14-46 - Mechanical filter respirator

In spray painting fumes and particles of the pigment and the vehicle are released into the air. Breathing these fumes and particles or otherwise absorbing them into your body could be fatal.

1. Always use an air-supply respirator (fig 14-45) when working in holds, tanks or other places where there is no ventilation. Fresh air, purified by a charcoal cartridge, is led to the breathing compartment of this respirator through a compressed air line.

2. Wear a mechanical-filter respirator (fig 14-46) to protect against dust caused by sanding. This type of respirator contains filters only.

3. Wear a chemical-cartridge respirator (fig 14-47) to protect against fumes. It contains an activated-carbon cartridge which absorbs the fumes.

4. Wear clean clothing which covers you as much as possible to avoid skin contact with the paint or cleaning materials.

CHAPTER 15

ADVANCED BASE FIELD STRUCTURES

By using a variety of preengineered buildings, a construction battalion is able to set up living quarters, messhalls, latrines, storage spaces, and other essential accommodations. The construction battalion may be called upon to erect an advanced base using preengineered buildings and tents. Examples include the use of tents in constructing refugee centers on Guam and at several sites in the United States.

PREPLANNING

A preplan of the erection procedures, based upon a study of the working drawings and of the manufacturer's instructions, should be made in advance. Consideration should be given to the manpower, equipment, rigging, and tools that will be required, and everything necessary in this line should be procured. Advantages of constructing and using jigs or templates for assembling parts of similar trusses, frames, and the like should also be considered.

The component parts of a prefabricated structure are shipped K.D., which stands for knocked down. A manufacturer's instruction manual, containing working drawings and detailed instructions as to how the parts should be assembled, accompanies the shipment. Directions vary with different types of structures, but there are certain basic erection procedures which should be followed in all cases.

The working drawings will show that certain items are NOT prefabricated and included in the shipment, but must be constructed in the field. Plans must be made in advance for the procurement of necessary materials for these items as required. Foundations, for example, are often designated "to be constructed in the field."

Preplanning should also include the establishment of the most logical and expeditious construction sequence.

IMPORTANCE OF FOUNDATIONS

In addition to the usual reasons for stressing the importance of a square and level foundation, there is another reason peculiar to the erection of a prefabricated structure. Prefabricated parts are designed to fit together without forcing. If the foundation is even slightly out of square and/or level, many of the parts will not fit together as designed.

DISTRIBUTION OF PARTS

Parts are assembled for shipment in various kinds of groups, bundles, and containers, which are called PACKAGES. When the shipment arrives at the site, the packages should be arranged in the storage areas so as to be available in the order indicated by the preestablished erection sequences.

As unpackaging proceeds, check the parts against the bill of materials to insure that all parts have been included in the shipment. If any part is missing, you should report this fact at once so that steps can be taken immediately to remedy the situation. Examine all parts closely for damage or defects, and promptly report any damage or defect noted.

As parts are unpackaged, mark their order of erection, if necessary, and then distribute them to the positions indicated by the working drawings or sequence of construction. Whenever possible, make a precheck to insure that adjoining parts will fit together accurately when erected.

Remember that prefabricated parts are designed to fit together WITHOUT FORCING.

If they do not, the cause is one of the following. (1) foundation is not right, (2) one of the parts is the wrong part, or (3) one of the parts was not constructed correctly.

TYPES OF FIELD STRUCTURES

The Quonset hut and the Butlerhut are types of metal buildings that are of concern to a Builder. Although the Quonset hut is no longer being manufactured, many are still in use at various construction sites that are being maintained by the SEABEES.

The Butlerhut is a preengineered building, built to specifications by the Butler Manufacturing Company for use by the Armed Forces. The Butlerhut is a small version of a 40- by 100-foot Butler building. It is normally erected by the Steelworkers, but Builders often assist.

THE QUONSET HUT

The Quonset hut, a prefabricated structure developed during World War II at Quonset Point, Rhode Island (thus, the name Quonset hut) has since been used extensively at advanced bases for almost any purpose imaginable—from the housing of personnel to the storing of supplies and equipment. Its use, however, will be discontinued upon depletion from storage depot stock. It is being replaced by a similar type of prefabricated structure—a rigid-frame, straight-walled building measuring 20 by 48 ft. Although you probably will not have the opportunity of completely erecting a Quonset hut, there is a need to repair and maintain existing structures.

Erected on metal joists and sills, or on a square, level concrete slab, the basic 20 by 48-ft Quonset hut consists of a series of steel-arched ribs spaced 4-ft. on center and connected on each side at the base to steel channels which in turn are bolted to the slab or screwed to the floor assembly.

Three metal purlins at the top provide longitudinal support and proper spacing. The entire exterior is covered with corrugated-sheet metal, as shown in figure 15-1. Notice that the roof is covered with preformed curved-roofing

metal sheets. Since these sheets are often hard to replace, care should be taken in making repairs to any section of the hut.

The endwalls of this building consist of steel studs, precut corrugated-sheet-metal siding, one door, two windows, and a louver. However, the endwalls of the 40 by 100-ft Quonset consist of large metal, prehung sliding doors allowing for the movement, in or out, of material and/or equipment. In tropical areas, one of these metal endwalls may have been removed and replaced with a concrete block wall as protection against typhoons or hurricanes.

Any major repair work needed for the exterior of these buildings may consist of replacing the corrugated metal, caulking around seams and openings, and applying heat-reflective or other preservative-type paint.

The interior walls are covered with precut, fiber-wallboard panels, thus covering the insulating material which has been placed between each 4-ft frame. The horizontal joints are held in metal splines and the vertical joints are covered with fiberboard battens. (See fig. 15-2.)

Again, much of the interior repair work consists of removing old panels and insulating material when needed. Interior panels may be replaced by 1/4-in. plywood or 1/8-in. tempered masonite or other suitable material. If plywood is used, additional wooden nailers must be installed prior to nailing on the plywood.

BUTLERHUT

The 20- by 48-ft rigid-frame straight-walled building, mentioned earlier, is called the "Butlerhut". Like the Quonset hut, this building is prefabricated and shipped in compact crates, ready for erection. Each component comes equipped with basic tools and a manual for erection purposes. It is extremely important that the manual be consulted from time to time, because you can very easily install a part wrong.

The 20- by 48-ft rigid-frame building is designed to be erected with basic hand tools and a minimum number of personnel. The erection manual suggests that the Butlerhut can be erected by seven persons. However, for military construction two team/work crews are recommended with an E-6 supervisor. The Butlerhut is designed to be erected on a floor

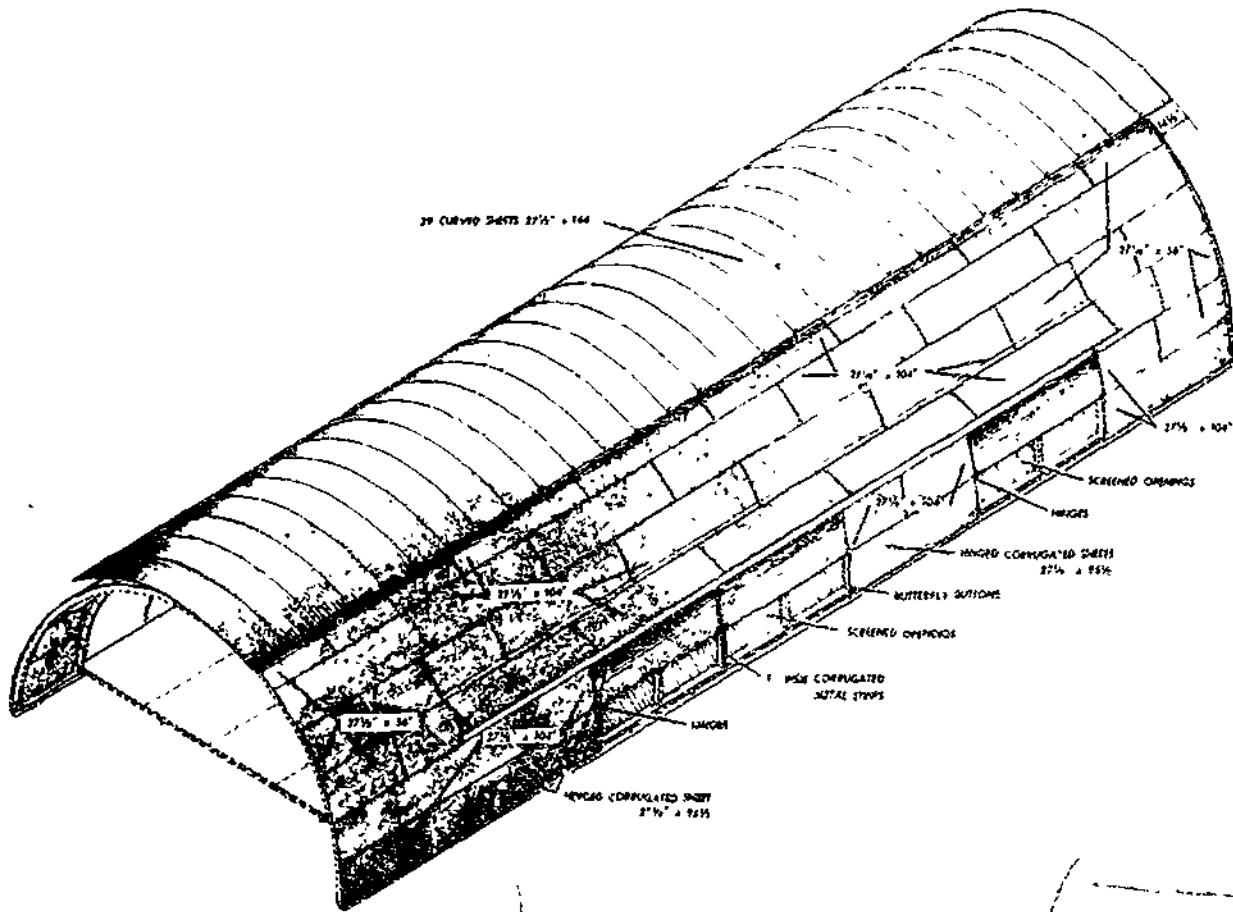

133.180X

Figure 15-1.—Layout of corrugated sheets.

system with piers, concrete blocks, or a concrete slab.

Whenever one rigid-frame building has been completed, it can easily be expanded to provide additional space. If desired, buildings can be erected end to end, as in figure 15-3 or side by side "in multiple." As this type building utilizes only bolted connections, it can be disassembled easily, moved to a new location, and erected again without waste or damage.

Preerection Work

A lot of preliminary work is necessary before the actual erection of the Butlerhut can begin. After the building site is selected, the foundation is outlined by Engineering Aids and leveled by Equipment Operators. Batter boards

are set up at each corner, where the foundation is to be located. Forms for the concrete piers must be set and then the concrete placed.

Before concrete for the foundation piers can be poured, templates for the anchor bolts are placed on the forms, and anchor bolts are inserted in the holes. The threads of the bolts are greased, and nuts are placed on them to protect the threads from the concrete. After a last minute check to insure that all forms are level and the anchor bolts are properly aligned, concrete is placed in the form and carefully worked around the bolts so that they remain vertical and true.

While the foundation is being prepared, your job supervisor will probably assign work crews to perform various kinds of preliminary work; such as uncrating material and checking it off on

BUILDER 3 & 2

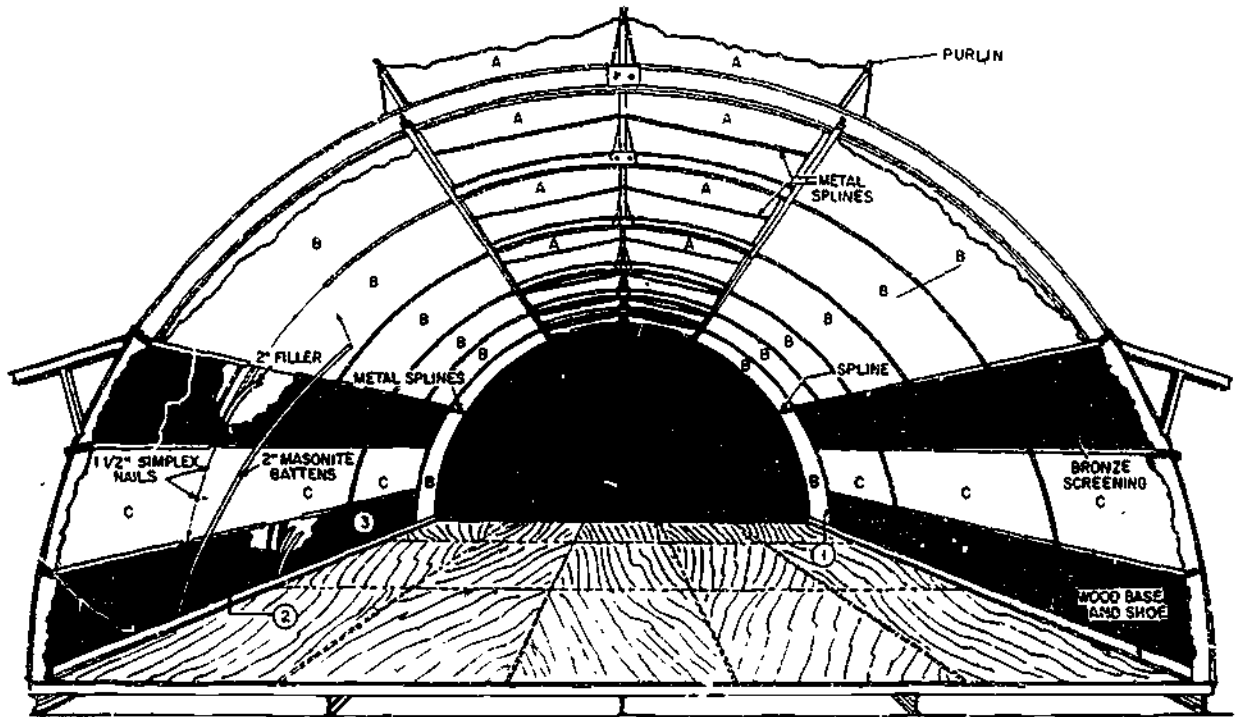

Figure 15-2.—Cutaway view.

133.176X

the shipping list, bolting up rigid-frame assemblies, assembling door leaves, and glazing windows. When all preliminary work is properly done, assembly and erection of the entire building is likely to be completed as quickly as possible.

All material except paneling should be uncrated and laid out in an orderly manner so that parts can be easily found, but do not

uncrate panels until you are ready to install them. When opening the crates, do not damage the lumber since it can be used for scaffolding, props, and sawhorses.

After the building foundation has been prepared, where practicable, building materials should be placed in and around the building site near the place where they will be used, similar to the layouts shown in figure 15-4. This

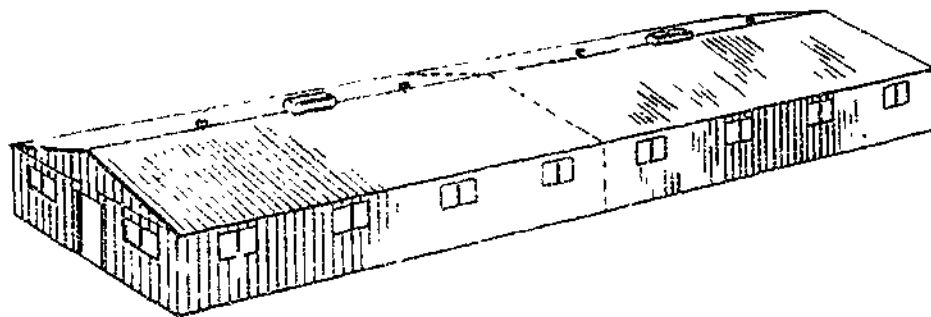

Figure 15-3.—20-by-48-ft-rigid-frame Butlerhut.

133.371X

15-4

568

Chapter 15—ADVANCED BASE FIELD STRUCTURES

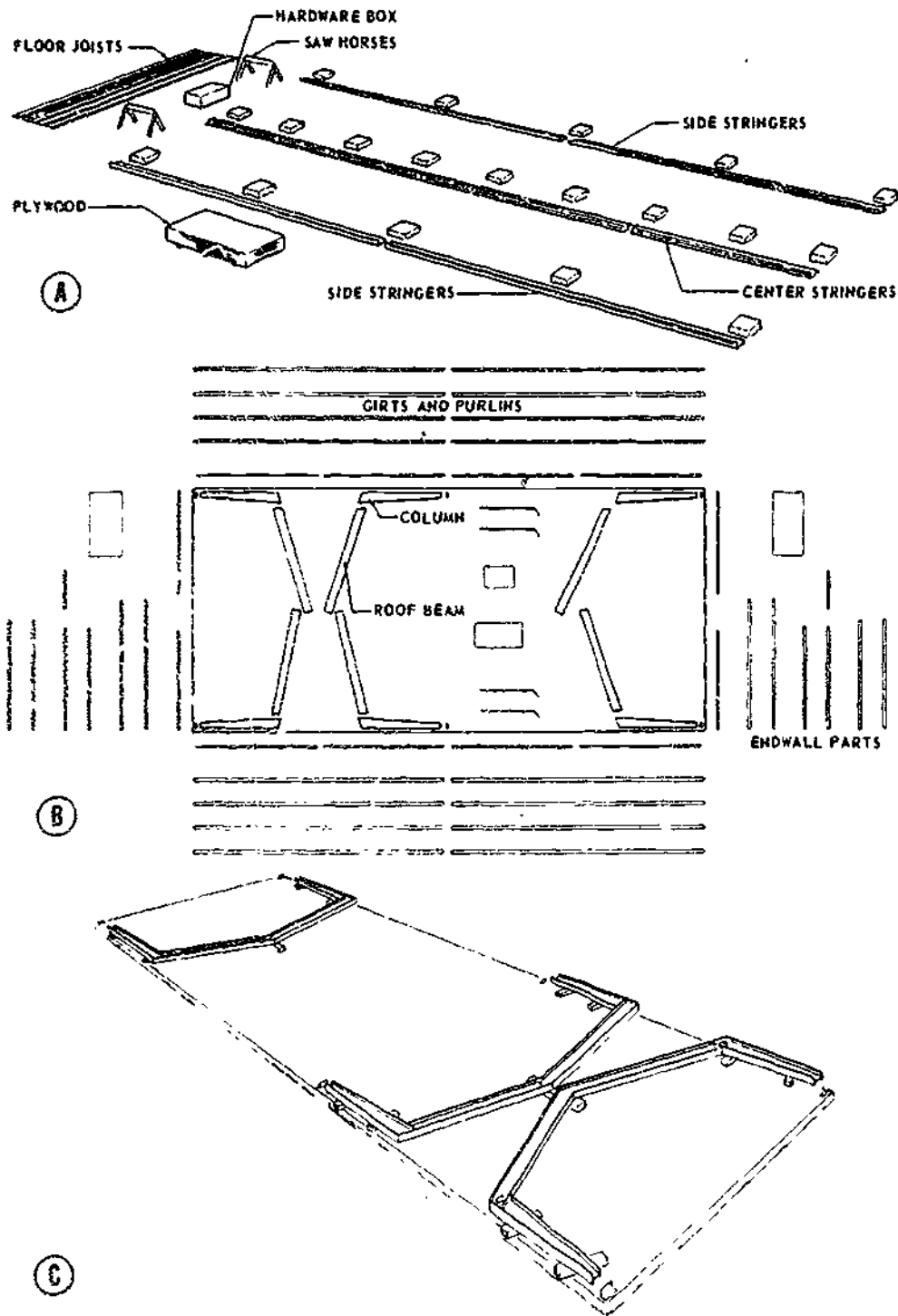

Figure 15-4.—Building material layouts.

133.372X

BUILDER 3 & 2

arrangement offers the greatest convenience and accessibility during assembly.

Girts, purlins, eave struts, and brace rods should be equally divided along each side of the foundation. Panels and miscellaneous parts, which will not be used immediately, should be placed on each side of the foundation on boards and covered with tarpaulins or similar covering until needed. Parts making up the rigid frame

assemblies are laid out ready for assembly and in position for raising.

Care should always be exercised in unloading materials. Remember that damaged parts can cause delay in getting the job done in the shortest possible time. To avoid damage, lower the materials to the ground—do not drop them.

Figure 15-5 will help you identify the various structural members of the Butlerhut and

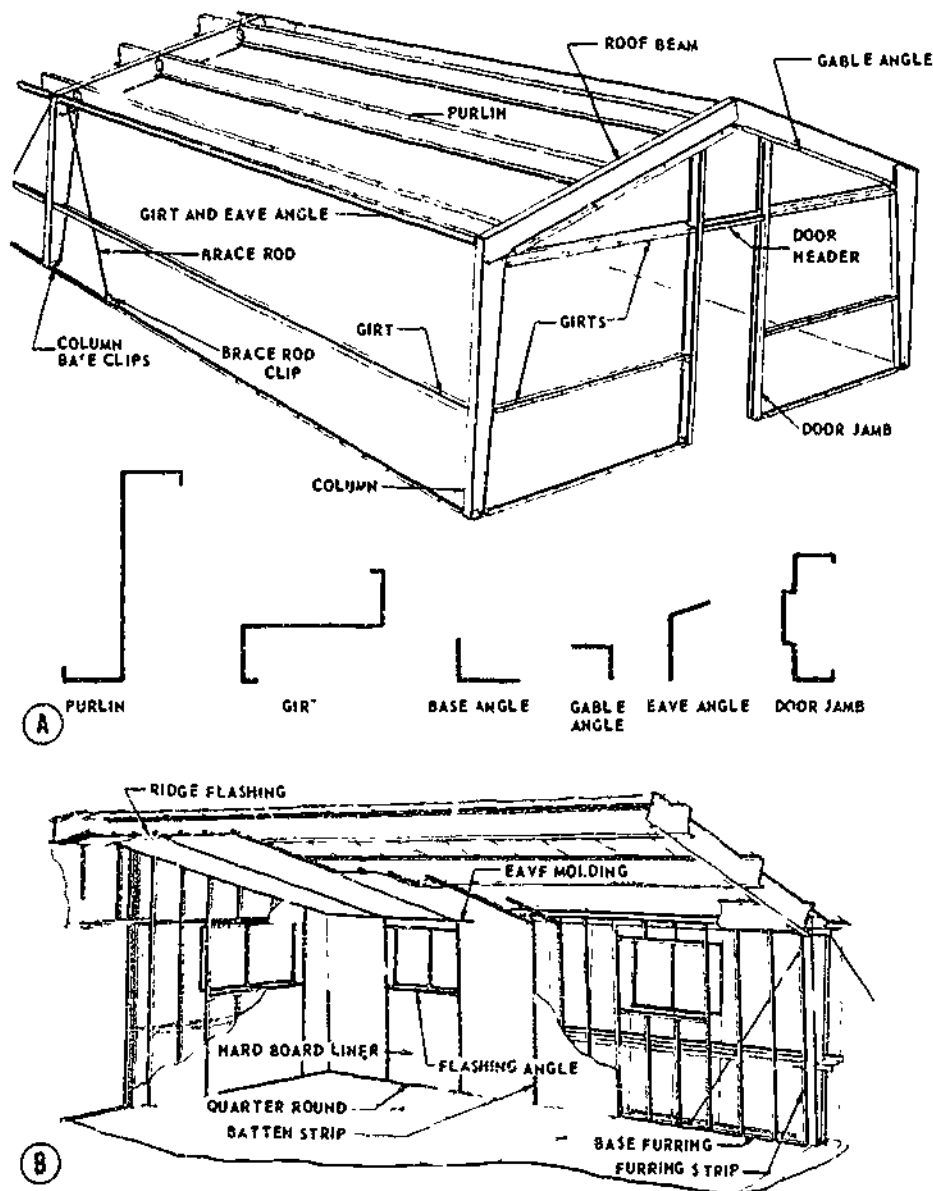

Figure 15-5 Identification of structural members and the liner panels.

133.373X

15-65 (1)

their location. Each part serves a specific purpose and must be installed in the location called for to insure a sound structure. **NEVER OMIT ANY PART CALLED FOR ON THE DETAILED ERECTION DRAWINGS.** Each of the members, parts, and accessories of the building is labeled by stencil, so that it is not necessary to guess which part goes where. Refer to the erection plans and find the particular members you need as you work.

High-strength steel bolts are used at rigid-frame connections—roof-beam splice and roof beam to column. Note, that these high strength bolts are identified by a "Y" embossing on the head, as shown in figure 15-6. It is important that all high-strength steel bolts and nuts be tightened to give at least the required minimum bolt tension values. The bolts may be tightened with a torque wrench, an impact wrench, or an open-end wrench, as shown in figure 15-6.

Floor Erection Procedures

The floor system material, as it is uncrated, should be placed around the building site near the location where it will be used. Open all crates carefully and save the lumber for other use.

The side and center stringers should be positioned on the PIER anchor bolts, and

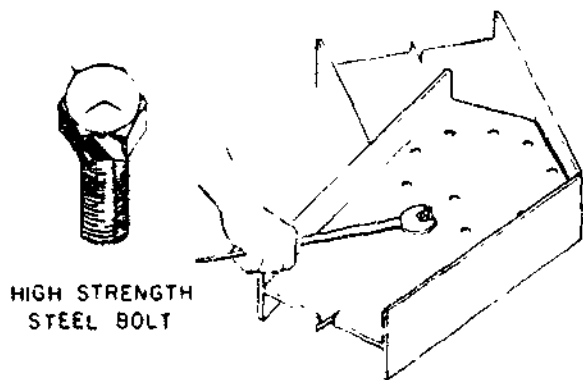

HIGH STRENGTH
STEEL BOLT

127.125(133F)X

Figure 15-6.—High strength steel bolt.

secured in place with a 1/2-in. nut and flat washer. The top flange of the side stringers must face to the outside of the building.

Start installing **FLOOR JOISTS** at one end of the building, as shown in figure 15-7, and assemble the appropriate joist clips to both ends of the floor joists. The floor joists are placed 2-ft oncenter; the top flange of the starting joist, with the 5/16-in. diameter holes, is placed 2-ft oncenter and must face toward the outside of the building. The intermediate joists are set with the top flange in the same direction as the starting joists, maintaining 2 ft center to center of joists. The last joist is turned so that the 5/16-in. holes will face the outside of the building. Braces are installed, and the floor is checked for squareness and proper alignment. When the squareness and alignment has been proven correct, you should tighten all connections.

The plywood **DECK** comes in 4-by-8 ft sheets of 1/2-in. plywood with steel splines for all longitudinal joints of the plywood. Lay out the plywood carefully, and make sure that

1. The joists are properly positioned at the joints.
2. The end joints are tight
3. The sides are firmly nested into the steel splines.
4. The flooring is started at the center joist by placing a 4-by-8 ft sheet in such a position that the 8-ft side extends 3 1/4 in. FROM THE WEB of the side stringer. If done properly, the 4-ft side should line up with the centerline of the holes in the center joist

NOTE. It is necessary to cut out the plywood for the column bearing plates at each frame column.

Basic Structural Erection

After the floor system or concrete slab has been prepared, the next step is to uncrate and lay out the structural parts, as shown in view B, figure 15-4. The structural parts should be laid out as follows:

Parts making up the frame assembly should be laid out ready for assembly and in a position for raising.

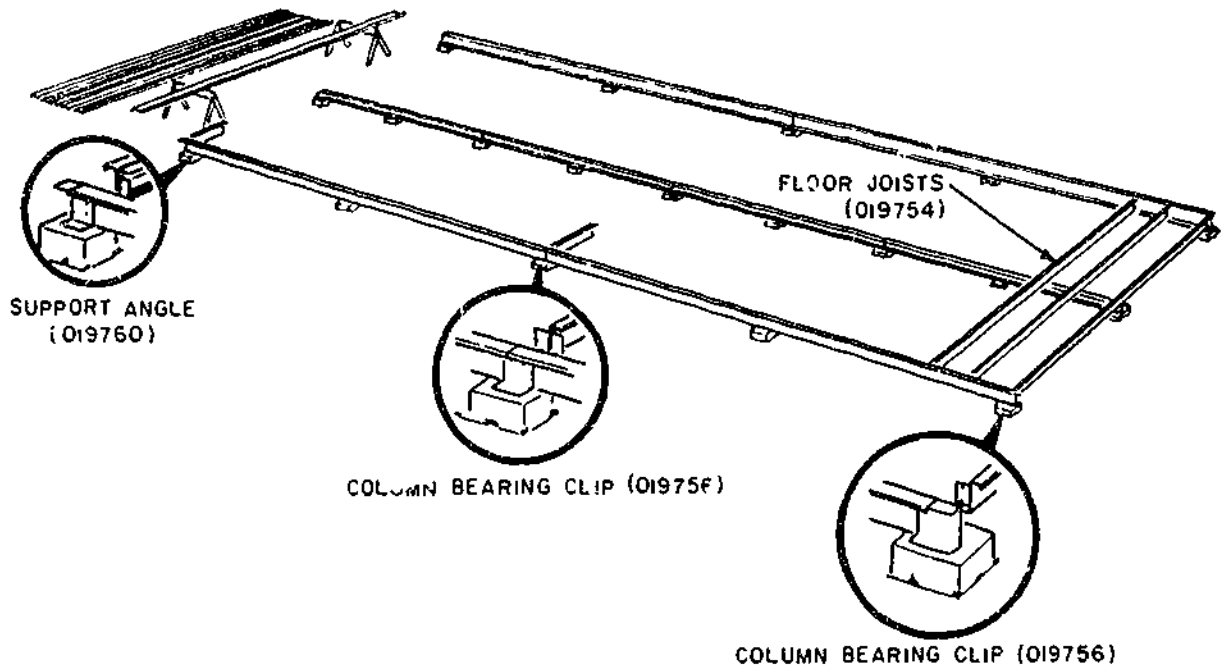

Figure 15-7.—Layout of the floor system for the 20-by-48-ft Butlerhut.

133.374X

Girts, purlins, and base angles should be divided (equally) along each side of the foundation.

Endwall parts should be divided (equally) between the two ends.

All miscellaneous parts should be centrally located.

Panels and other parts which are not used immediately should be placed on boards and covered with a tarpaulin.

Lay out the column and roof beams for assembly using the crate lumber to block up the frames. Erect the center frame first. Use just enough high-strength bolts to bring the frame members together. Install the remaining bolts to acquire the proper tightness.

Galvanized machine bolts (3/8 in. by 1 in.) should be used to assemble the girt and purlin

clips to the frame. Bear in mind that the end frames have girt and purlin clips on one side ONLY; while the center frame has girt and purlin clips on each side of the frame.

The eave girts are to be attached to the eave angles with 5/16-in. left-hand nuts and shoulder bolts as shown in figure 15-8. You will need two eave angles for each eave girt. In fastening these together remember that the short section of the eave angle is always fastened to the left hand of the eave girt, whereas the long section of the eave angle is fastened to the right hand of the eave girt.

Use 3/8-by 1-inch galvanized machine bolts to attach the gable angles and door jambs top clips to the bottom flange of the end frame roof beams.

To erect the frame, place the "A" frames in position—one 8-ft frame at each side of the building, and a 10-ft frame in the center of the building. Prop the frame on two sawhorses, and

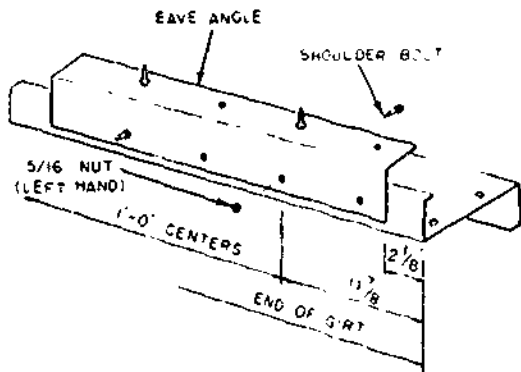

133.375X

Figure 15-8.—Attaching eave angle to girt.

attach tag lines to assist in raising the ridge. Raise the frame and brace it up with the "A" frames, as shown in figure 15-9. The end frames are erected in a similar manner, except they are held in position by installing purlins and girts.

After all sidewall girts, eave girts, and base angles have been installed, install the brace rods as shown in figure 15-10. The brace rods are installed in the following manner:

1. Attach brace rod clips to the floor.

2. Insert the end of the brace rod down through the hole in the sidewall girt. Connect the top end through the eave girt and the eave girt clip.

3. Connect the bottom end through the clip on the floor.

As soon as the four brace rods are in position, use them to plumb the building. To plumb the rigid frame, tighten or loosen the rod nuts at the brace rod clips to adjust the column

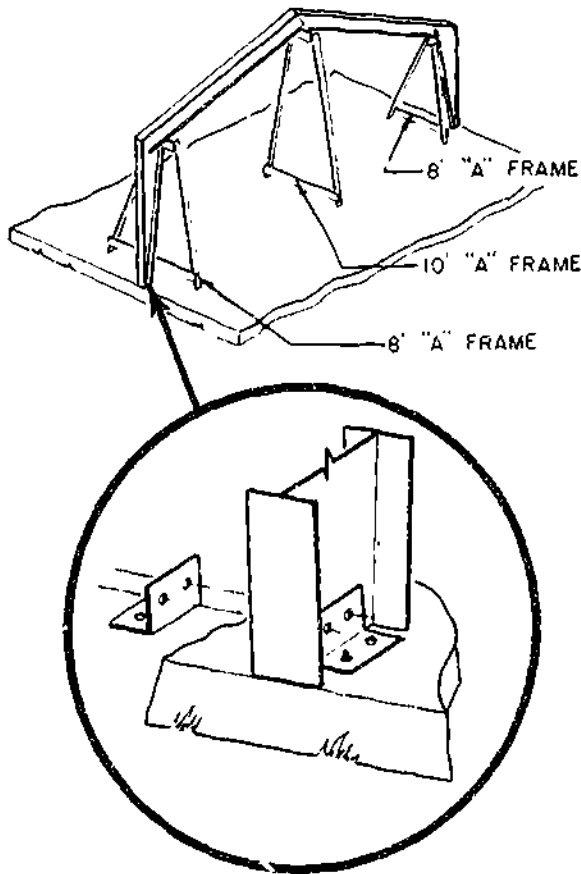

133.376X

Figure 15-9.—Frame erection with "A" frame props.

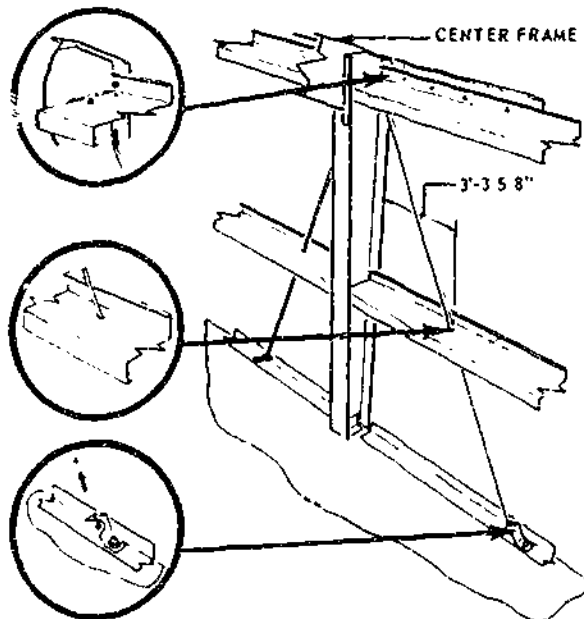

133.377X

Figure 15-10.—Installing brace rods.

to plumb condition. Do not forget, when you tighten one side, the other side must be loosened.

To make sure you are installing the endwall members correctly, snap a chalkline across the building using one edge of the columns for positioning the line. Mark the center of the building on this line. Now, drop a plumb bob from the center of the joint of the roof beams at the ridge, with the line over the same side of the roof beam as the chalkline. Adjust the frame so the plumb bob is directly over the center mark, and then brace the roof beam in this position until the roof panels are in place.

The next operation is to uncrate exterior PANELS and distribute them near where they will be used. First, separate and place panels for each endwall. Place full length wall panels at each corner. Centrally locate lower-and-upper sidewall panels, above and below window panels, along each side of the building. Place roof and ridge panels in stacks of eight each on the floor. Remember, make all joints properly, tighten all fasteners, use metal-backed-neoprene washers with all roof fasteners and with all shoulder bolts in the sidewalls; and apply BLACK MASTIC properly to all roof panel sidelaps and endlaps.

Start paneling the ENDWALL at one corner and work across to the other corner. Install the corner panel, locating the bottom of the panel over the first two shoulder bolts in the base angle. Use a level to plumb this panel with the other shoulder bolts located at the center of the corrugations. Locate the "below window panel" over the base angle shoulder bolts, and impale over the shoulder bolts. Remove the panel and reinstall it, so it underlaps the first panel by pulling out on the corrugated edge of the first panel.

Follow the same general instructions for paneling and installing windows as were given for the endwall. However, be sure that the girts are in a straight line before impaling panels onto shoulder bolts. It is very important to block the

girts in a straight line with crating lumber cut to the correct length. The drawings should be checked for proper location of shoulder bolts. The first shoulder bolt should be 12 in. from the center of the column, then 12 in. oncenter.

Recheck the center frame for plumbness. Adjust the brace rods to plumb as required. Check the drawing for locations of base angles.

The upperwall panels must lap over the lower wall panels for weathertightness. Remember—metal backed neoprene washers and No. 10 hex nuts are used on all shoulder bolts; machine screws (1/4 in. by 3/4 in.) are used for panel-to-panel-connections at sidelaps.

Since the ROOF PANELS are factory punched for panel-to-purlin connection, it is important that the purlins be accurately aligned. Spacer boards constructed from crating lumber can be used, as in figure 15-11, to align purlins. Move the spacer boards ahead to the next bay as the paneling progresses. Before you actually start paneling the roof, place the spacer board over the shoulder bolts, and insert nails in the 5/16-in. holes in the ridge purlins.

The roof paneling operation should start at one end of the building. Place the panels so the

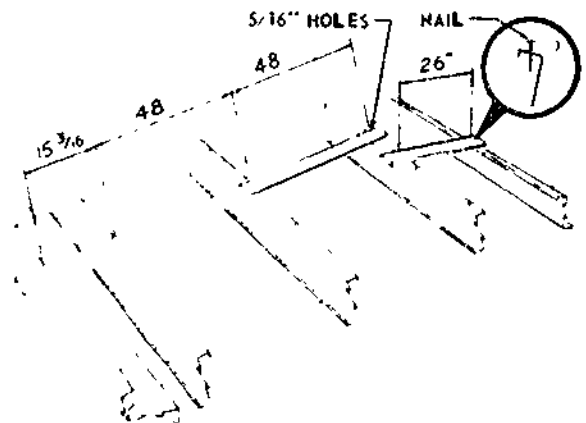

133.378X

Figure 15-11.—Aligning purlins with spacer board.

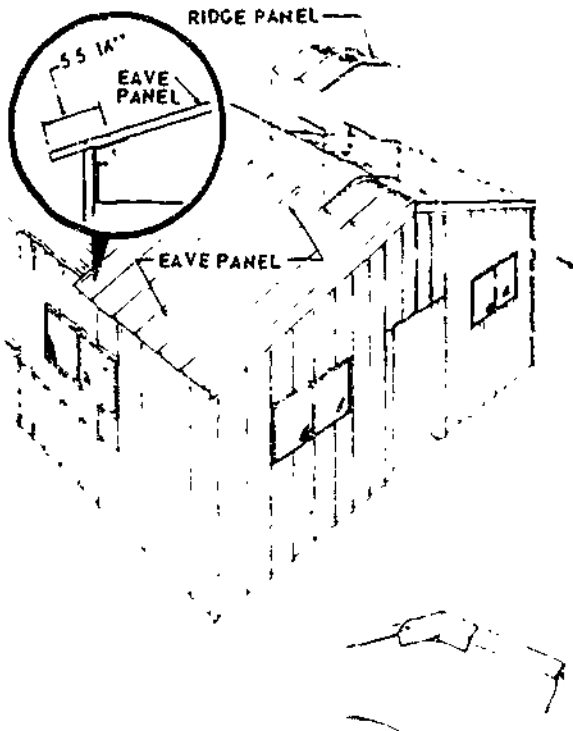

133.379X

Figure 15-12.--Installing ridge and eave panel.

noles in the corrugation line up with the shoulder bolts in the roof beam, eave angles and ridge purlins, install one eave panel to each side of the building. The eave panels should be installed one row ahead of the ridge panels (See fig. 5-12.) Before proceeding with the work, make sure you are applying enough black mastic. Roof paneling should continue in this order to insure a weathertight joint at the corner laps. However, you should check the drawings for the location and installation of the smoke stacks and ridge ventilation.

DOORS.--The door jambs to the Butlerhut can be hung anytime after the endwall structurals are completed. But, they **MUST** be hung prior to installing the interior lining. A helpful hint is to hang the doors before installing the exterior endwall paneling, this way

adjustments on the door frame can be made easier.

Hinges are factory welded to the door jamb and the entrance door is supposed to swing to the **INSIDE** of the building. Remove the hinge leaf from the door jamb and attach it to the door with 1 inch, No. 10 flat-head wood screws. Hang the door and make adjustments to get the proper clearances at the top and sides of the door. Install the lockset in the door and attach the face plate to the door with 3/4 inch, No. 8 flat head wood screws. Attach the strike plate to the door jamb with 1/2 inch, No. 8 flat-head machine screws.

Hinges are also factory welded to the screen doors and the screen doors swing to the **OUTSIDE** of the building. The method used in hanging the screen door is similar to hanging the entrance door. However, a spring is needed to hold the screen door closed.

LINER PANELS.--The basic operations in the installation of liner panels consist of installing furring strips, hardboard liner panels, and trim and battens. View B, figure 15-5 shows the various liner panel parts.

ENDWALLS. The liner panels are precut according to the cutting diagrams. The hardboard must be installed with the smooth surface exposed and with an 1/8-in. gap between panels, as shown in figure 15-13. A scrap piece of hardboard or batten can be used as a shim to maintain the proper gap.

Nail the base furring to the floor, 3 in. from each end and 2 ft 3 in. O.C., with the inside edge

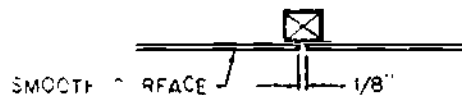

133.380X

Figure 15-13.--Installation of hard board.

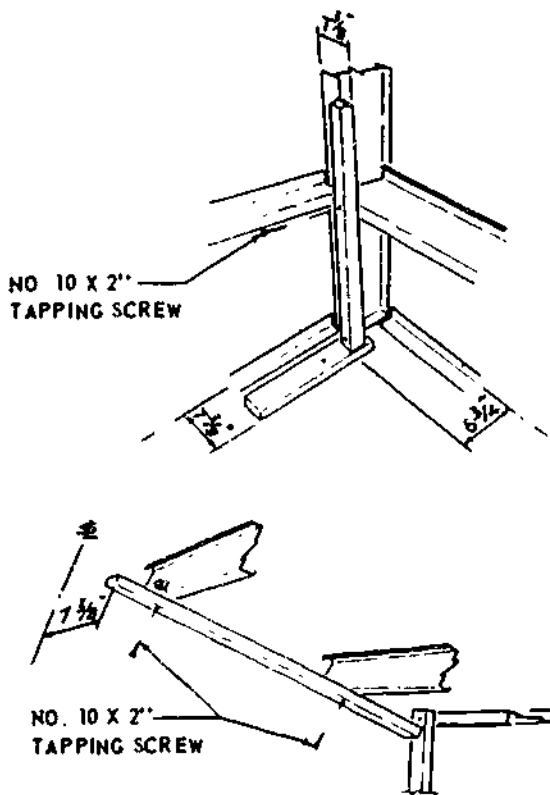
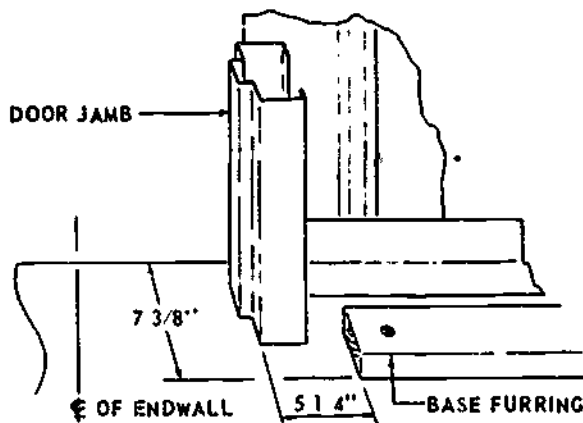

133.381X

Figure 15-14.—Installing furring for the end wall liners.

7 3/8 in. from the building structural line. This is shown in figure 15-14. When the base furring is to be used on a wood floor, use 8d box nails, and use 1 1/4 inch, No. 9 concrete nails with a concrete floor. Drill the 2 by 2's and girts with a 5/32 in. drill so that furring can be attached to

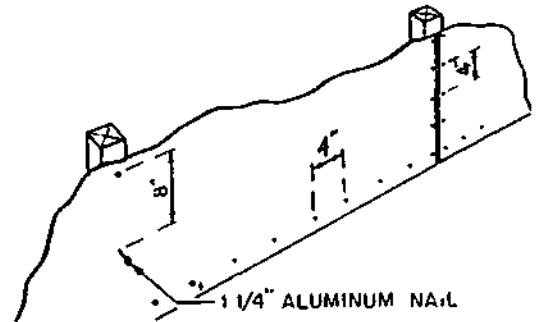

133.382X

Figure 15-15.—Nailing pattern for attaching hard board to furring.

the sidewall and cave girt with 2-in. pan-head, No. 10, sheet-metal screws. Attach the hardboard to the furring strips with 1 1/4-in. aluminum-shingle nails, on 4-in. centers at the sides and ends; on 8-in. centers at the intermediate furring. (See figure 15-15.)

The vertical furring should be installed immediately after the base, corner, and gable furrings are in place (see figure 15-16). The centerline of the furring on each side of the window should be in line with the centerline of the endwall-panel corrugations. After the endwall hardboard has been installed, then come the door side and top flashing. Attach flashing (fig. 15-17) to the furring with 4d aluminum nails and to the door frame with 1/2 inch, No. 10 sheetmetal screws.

SIDEWALLS.—After you have installed the endwall liner, furring should come next for the sidewall and ceiling. The base furring should be cut in such a way that the end will just clear the inside flange of the center-frame column. The furring is nailed in the same manner as the endwalls.

Now that you have the furring in place, the hardboard liner can be installed. Install top and bottom hardboard flashings, as shown in figure 15-18. Insert outside edge into retaining grooves in the window. Nail metal flashing angle and

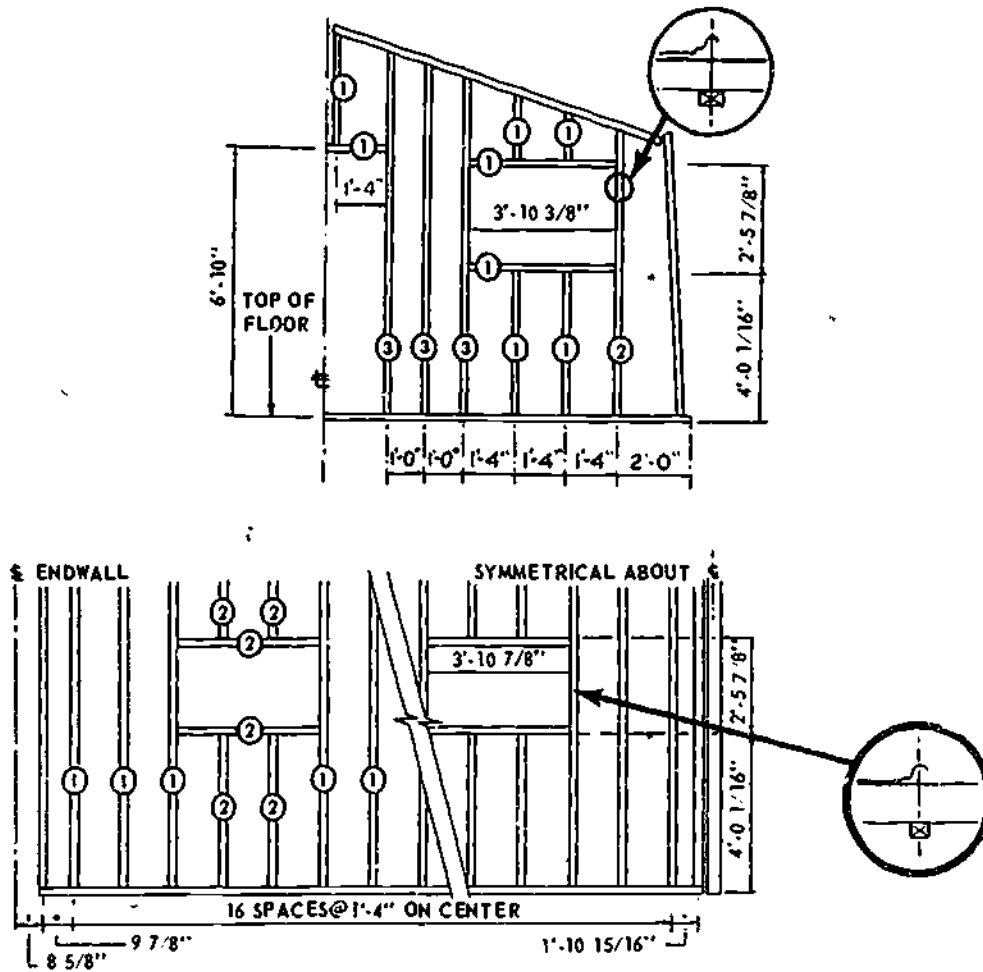
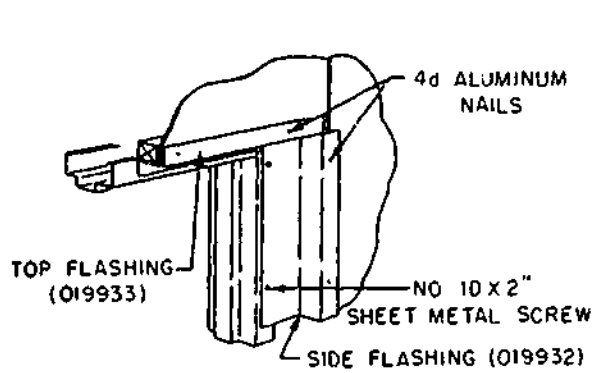

Figure 15-16.—Placement of furring for liners.

133.383X



133.384X

Figure 15-17.—Side and top flashing for doors.

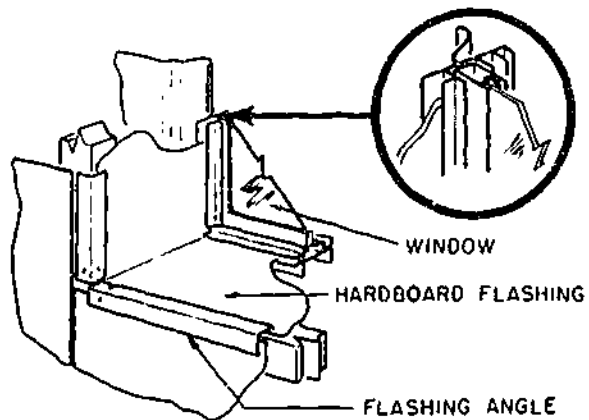

133.385X

Figure 15-18.—Top and bottom hard board flashing.

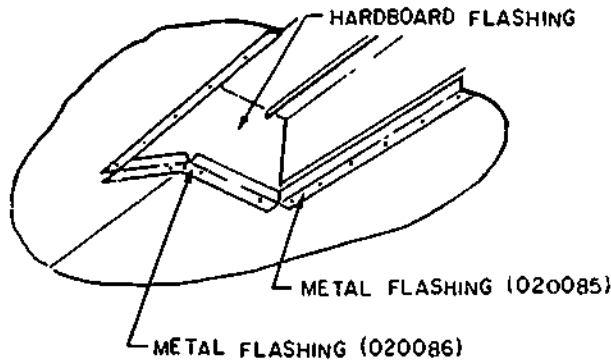

133.386X

Figure 15-19.—Metal ventilator flashing.

hardboard to the horizontal furring with 4d aluminum nails 1 ft 8 in. O.C. Install side hardboard flashings and metal flashing angles using the same procedures discussed above.

CEILING.—The ceiling furring is to be installed in the vicinity of the sidewall furring.

Whenever all the ceiling furring has been installed, the hardboard liner can be installed. **REMEMBER THE 1/8-IN. GAP BETWEEN PANELS.**

The smoke stack assembly is to be attached to the blocking and furring with 4d aluminum nails.

Hand trim the hardboard flashings for the ends of the ventilator opening and attach metal ventilator flashings, as shown in figure 15-19.

Install eave molding with the beveled edge against the ceiling panels and attach each sidewall furring strip with 4d aluminum nails. Use quarter-round molding to trim ceiling to the endwall, endwall to sidewall, and walls to floor, and use metal ridge flashings, as shown in figure 15-20 to trim ridge of ceiling liner. It can be attached to the ceiling furrings with 4d aluminum nails. Check the drawings to make sure you are installing it right. Now, cut battens to the required length and attach them to the furring with 4d aluminum nails, 8-in. O.C. (See fig. 15-21.)

GENERAL NOTES: Bolts, nuts, and miscellaneous fasteners have been furnished in quantities greater than actual requirements. However, be careful in using these fasteners to prevent scattering them on the ground. Each evening empty your pockets of fasteners and small parts before leaving the erection site.

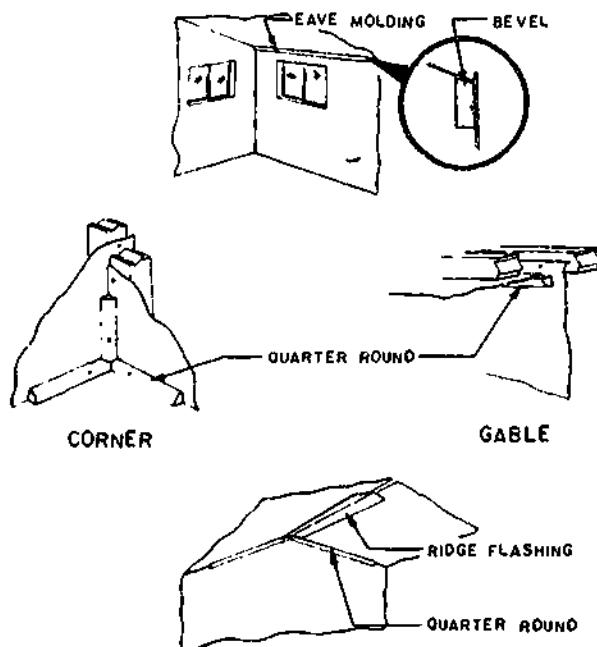

133.387X

Figure 15-20.—Interior trim.

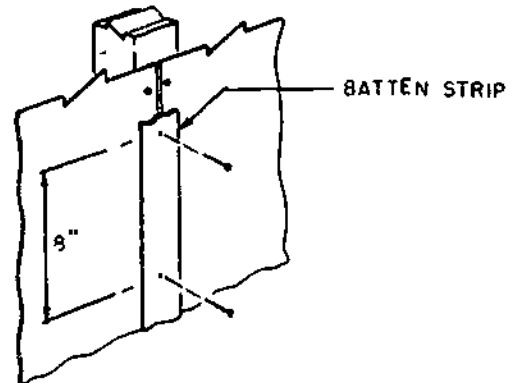

133.388X

Figure 15-21.—Batten strip.

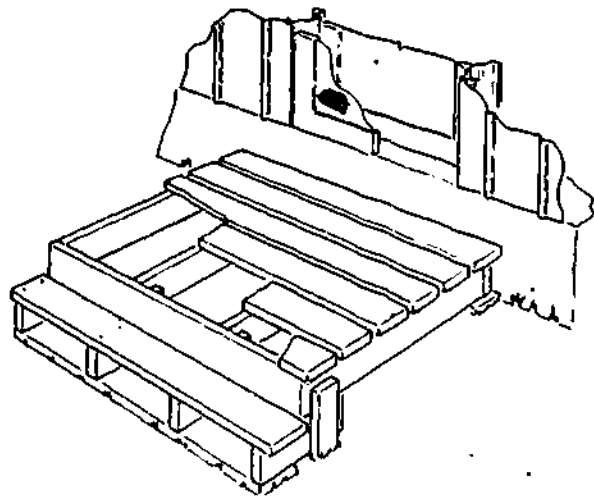

133.389X

Figure 15-22.--Crate platform.

An excessive amount of BLACK MASTIC is also furnished with each Butlerhut. Here too, reasonable care in applying mastic to roof panels and roof accessories will insure an adequate supply.

Crating lumber can also be used to construct an entrance platform and stairs at each end of the Butlerhut, as shown in figure 15-22

WOOD-FRAME TENTS

Figure 15-23 shows working drawings for framing and flooring of a 16- by 32-ft wood-frame tent. Tents of this type are used for temporary housing, storage, shower, washrooms, latrines, and utility spaces at an advanced base. Tent floors consist of floor joists which are 16-ft lengths of 2 by 4, and sheathing which is 4- by 8-ft sheets of 1/2-in. plywood. They are normally prefabricated before deployment to the job site. The supports for the flooring are doubled 2 by 4 posts anchored on 2 by 12 by 12 footings. The wall-framing members are 2 by 4 studs which are spaced 4 ft oncenter. The roof-framing members are 2 by 4 rafters, spaced 4 ft oncenter. The plates (2 by 4's), and the

bracing members (1 by 6's) are fabricated in the field.

Figure 15-24 shows a floor framing plan for a field type shower and washroom.

When the 16- by 32-ft wood-frame tent is modified with a metal roof, extended rafters, and screened-in areas, as shown in figure 15-25, it is called a Southeast Asia (SEA) hut. This SEA hut was originally developed in Vietnam for use in tropical areas by U.S. troops for berthing; however, it can readily be adapted for other use, such as a galley or mess hall. It is also known as the STRONGBACK because of the roof and sidewall materials. The SEA hut is usually a standard prefabricated unit but the design can be easily changed, to fit the existing requirements, such as lengthening the floor or making the roof higher.

The SEA hut should be built on a concrete slab, when possible, because it has been proven that a 16- by 32-ft concrete slab 4 in. thick is cheaper to construct than a floor constructed of wood having the same width and length.

As stated before, basically all field structures are derived from the 15- by 32-ft wood-frame tent; however, if more tent space is needed, a 40- by 80-ft tent is available. This tent is easy to assemble because it is put together without a floor. It can be erected without a strongback frame since it comes complete with ridge pieces, poles, stakes, and line, and therefore does not require framing. But no matter how easy erection may seem, always read and follow the instructions.

FIELD-TYPE LATRINES

Upon arrival at an advanced base, temporary facilities must be provided immediately for the disposal of human waste. A number of field-type latrines are designed for this purpose. A 16- by 32-ft-wood-frame tent may be used to shelter the field-type latrine.

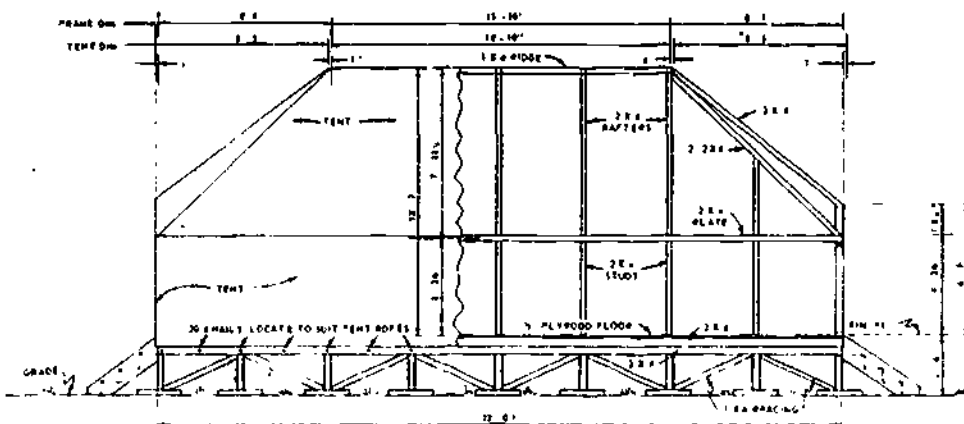

SIDE ELEVATION
SCALE = 1/4" = 1'-0"

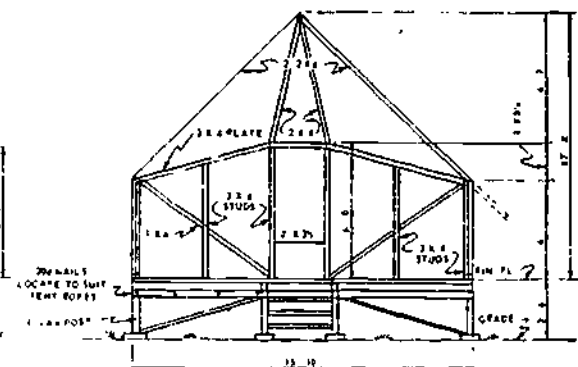

END ELEVATION
SCALE = 1/4" = 1'-0"

15-16

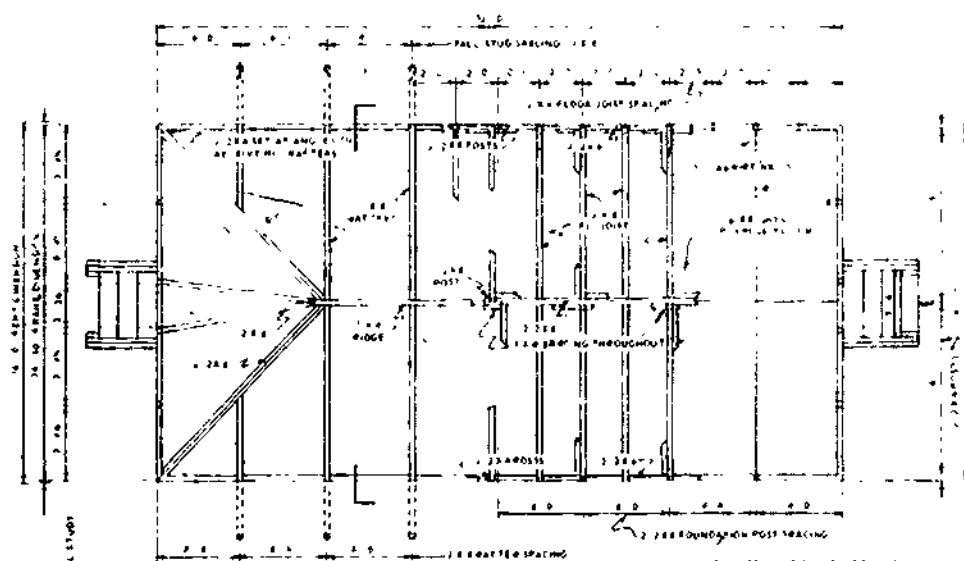

PLAN
SCALE = 1/4" = 1'-0"

500

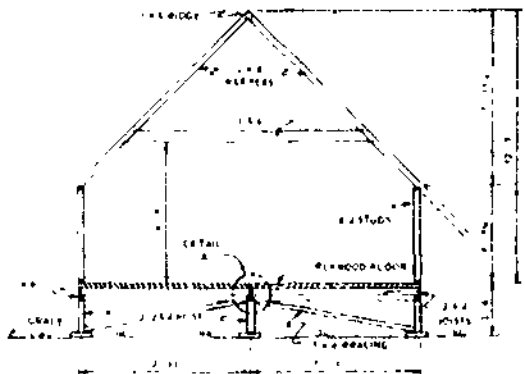

SECTION A-B
SCALE = 1/4" = 1'-0"

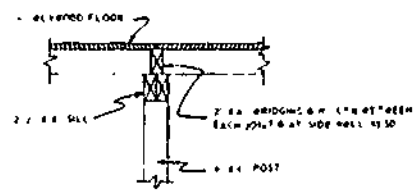

DETAIL OF CENTER SILL
SCALE = 1/4" = 1'-0"

BUILDER 3 & 2

581

133.184

Figure 15-23.—Framing and flooring plans for 16-by-32-ft-wood-frame tent.

BUILDER 3 & 2

A prefabricated 4-seat latrine box is illustrated in figure 15-26. This box can be collapsed for shipment, as shown in figure 15-27.

A plan view of an 8-seat field-type latrine is shown in figure 15-28. Two 4-seat boxes are

placed so as to straddle a 3- by 7-ft pit. After the pit is dug, and before the boxes are placed, a 4-ft-wide margin around the pit is excavated to a depth of 6 in., as shown in figure 15-29. A layer of oil-soaked burlap is laid in this excavation, after which the excavated earth is soaked with

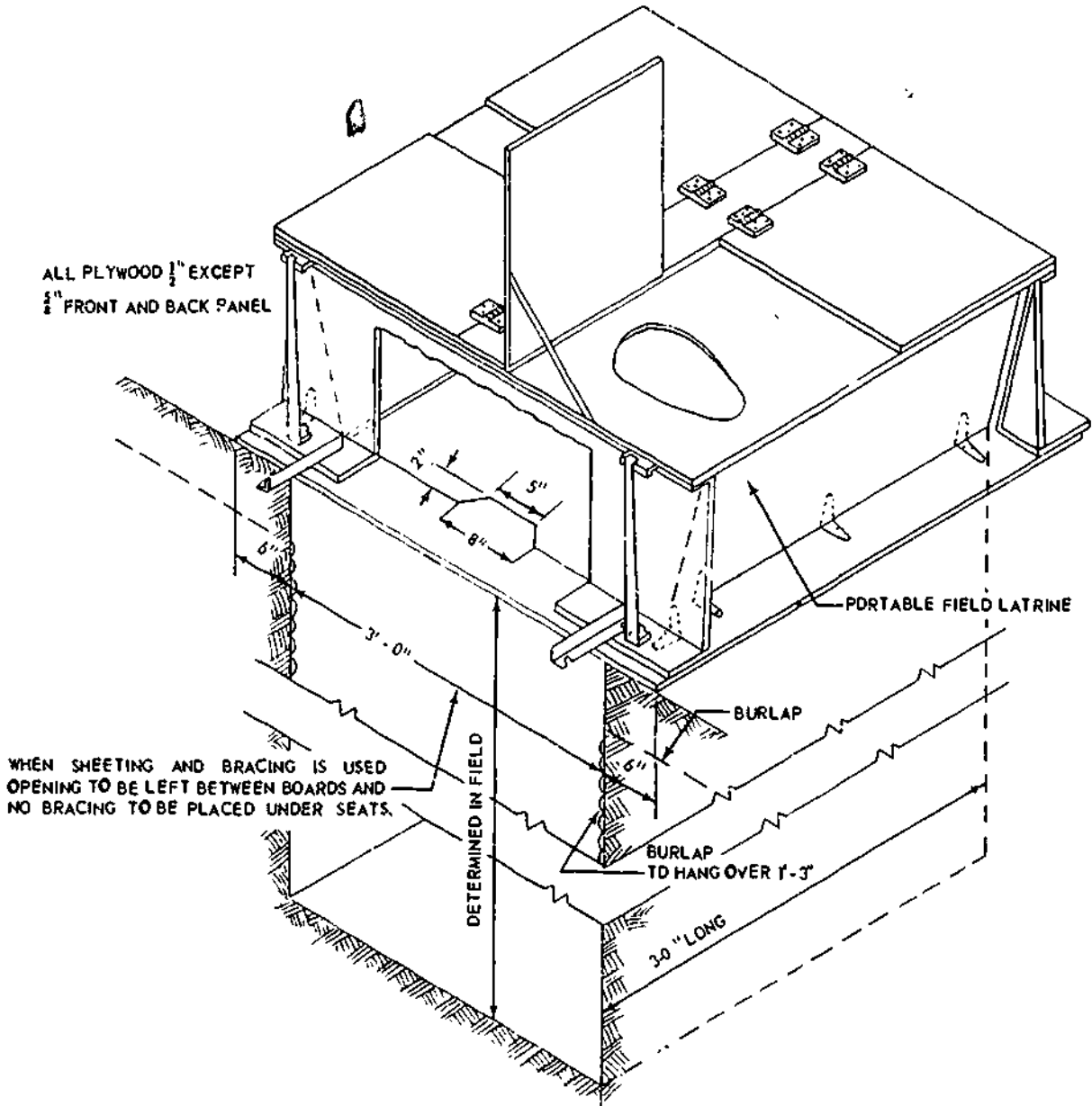
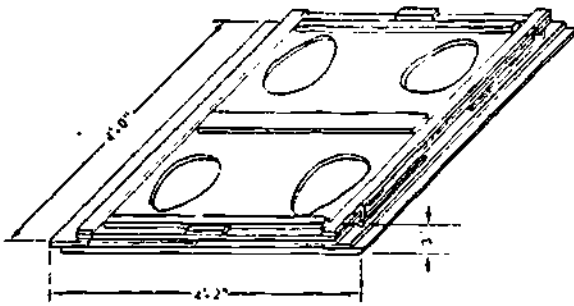

Figure 15-26.—Prefabricated 4-seat latrine box.

133.189



133.190

Figure 15-27.--Latrine box collapsed for shipment.

oil, replaced, and tamped down, to keep surface water out.

Two 4-ft 6 in. trough-type urinals are furnished with the 8-seat latrine. Each is mounted in a frame constructed as shown in figure 15-30. A 2-in.-urinal drain pipe leads from the down pipe on each urinal to a 6-by 6-ft URINAL SEEPAGE PIT, located as shown in figure 15-30. The seepage pit is constructed as shown in figure 15-31.

As indicated in figure 15-28, the 8-seat field-type latrine can be expanded to a 16-seat field-type latrine.

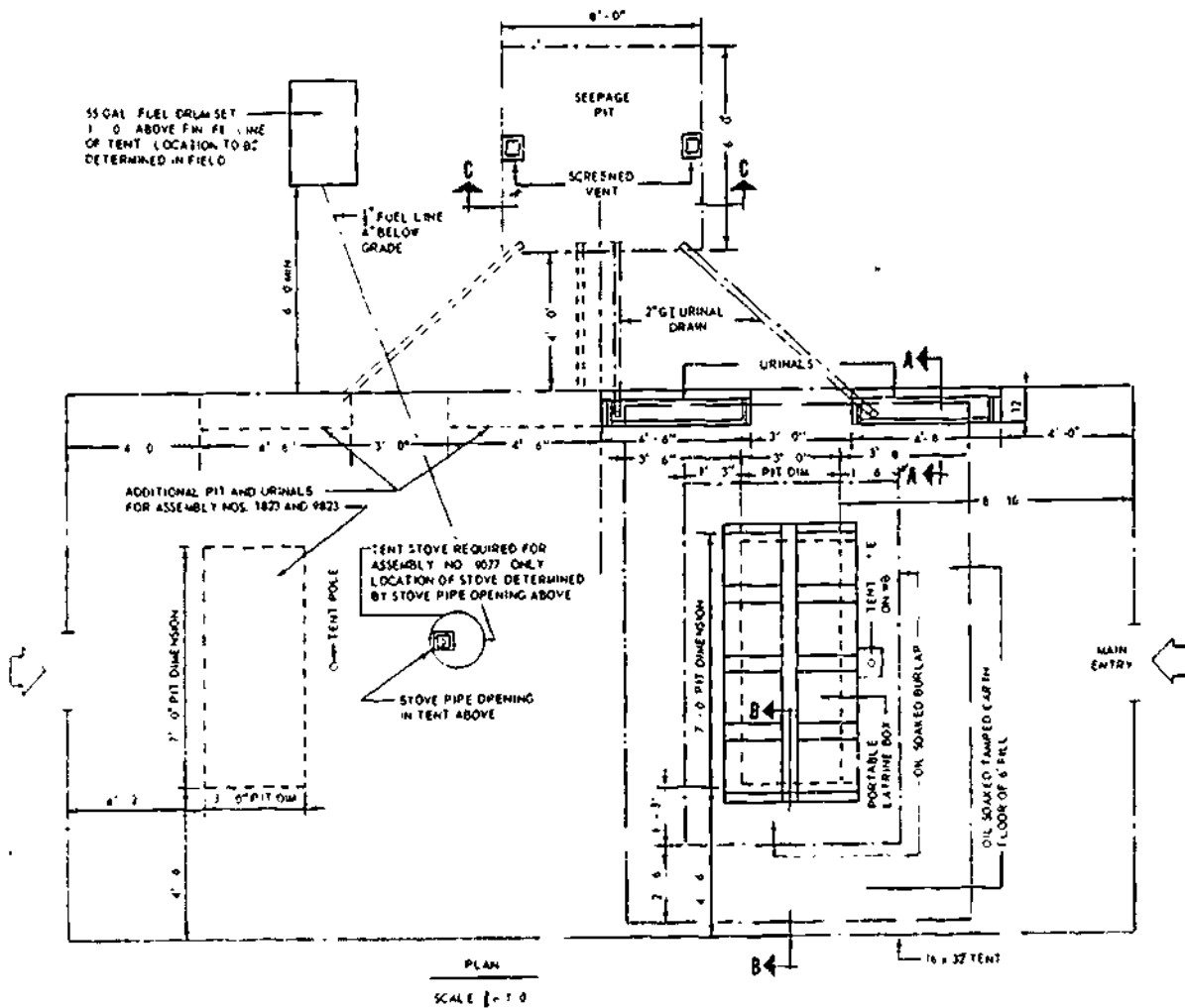

PLAN
SCALE 1/4" = 1'-0"

133.191

Figure 15-28.--Plan view of 8-seat field-type latrine.

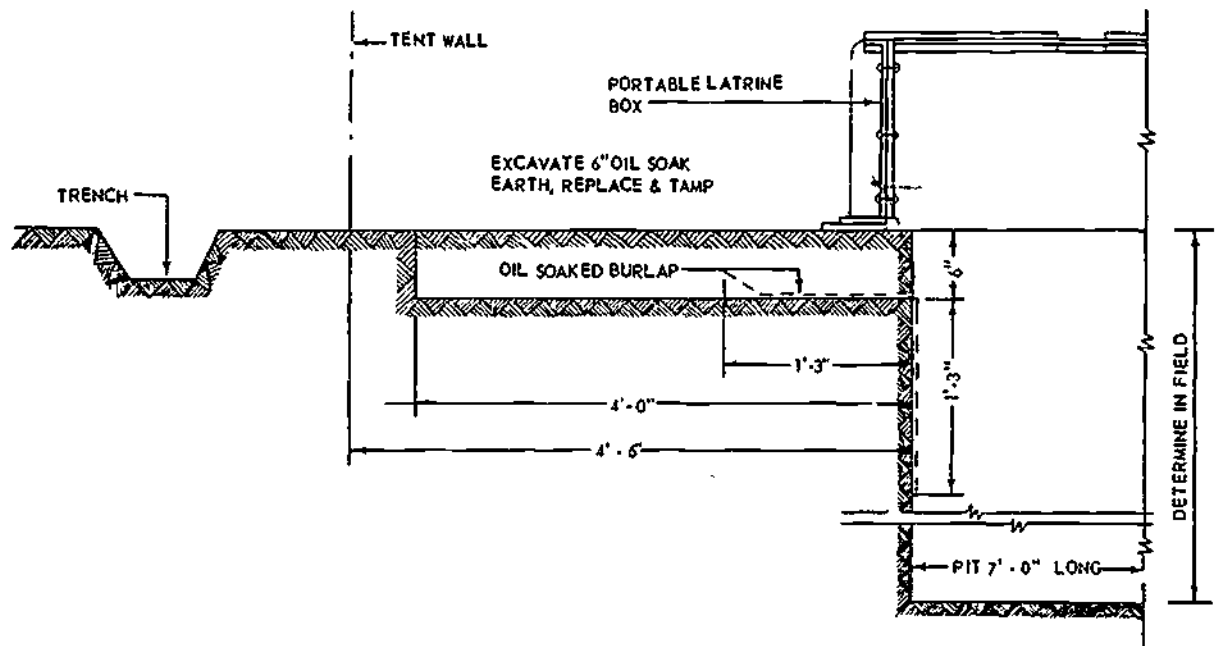

133.192

Figure 15-29.—Margin of oil-soaked earth around latrine boxes.

A complete plan view of a 4-hole burnout field-type latrine is shown in figure 15-32. This type of latrine is used at most advanced or temporary bases. The burnout latrine is kept in an orderly condition

(daily) by the camp maintenance personnel or the assigned sanitation crew. It can be maintained easily by spreading lime over the waste material or using diesel fuel to burn the waste material.

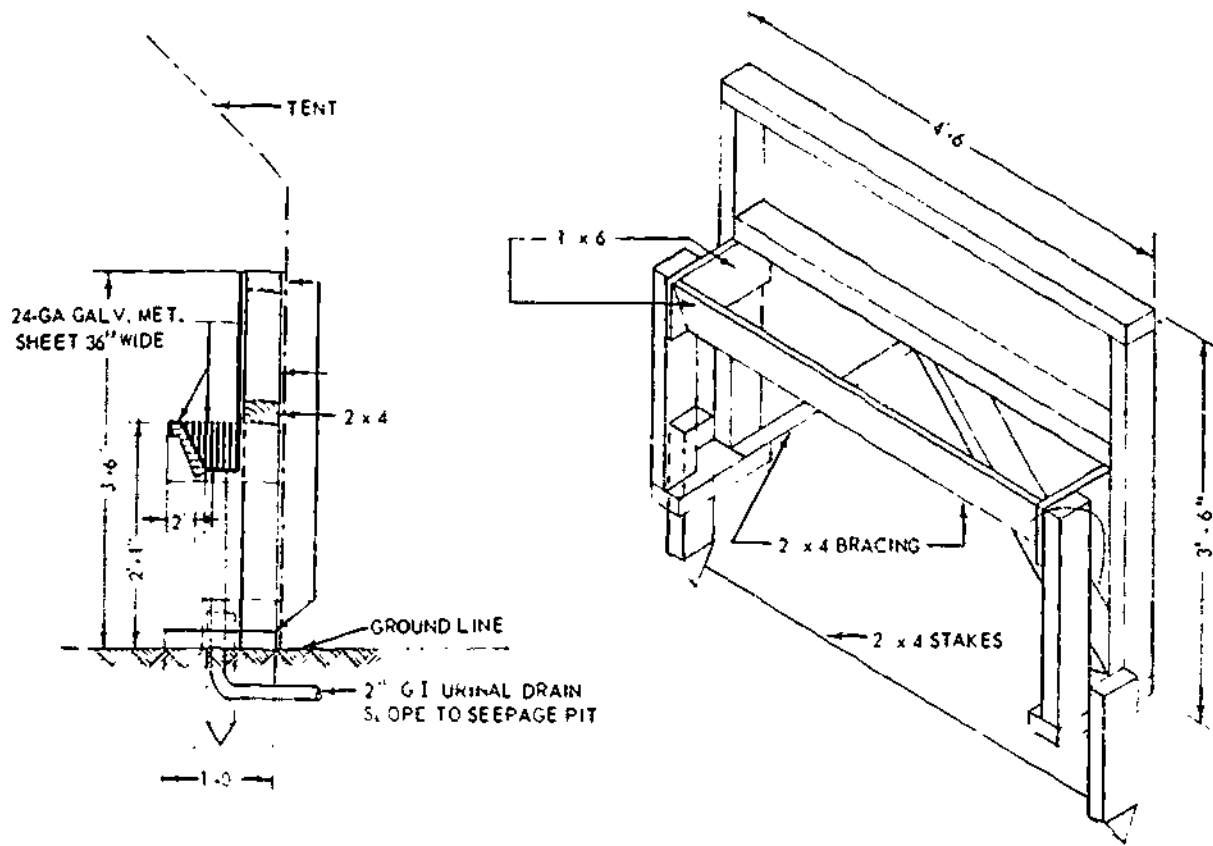

Figure 15-30.—Frame for urinal trough.

133.193

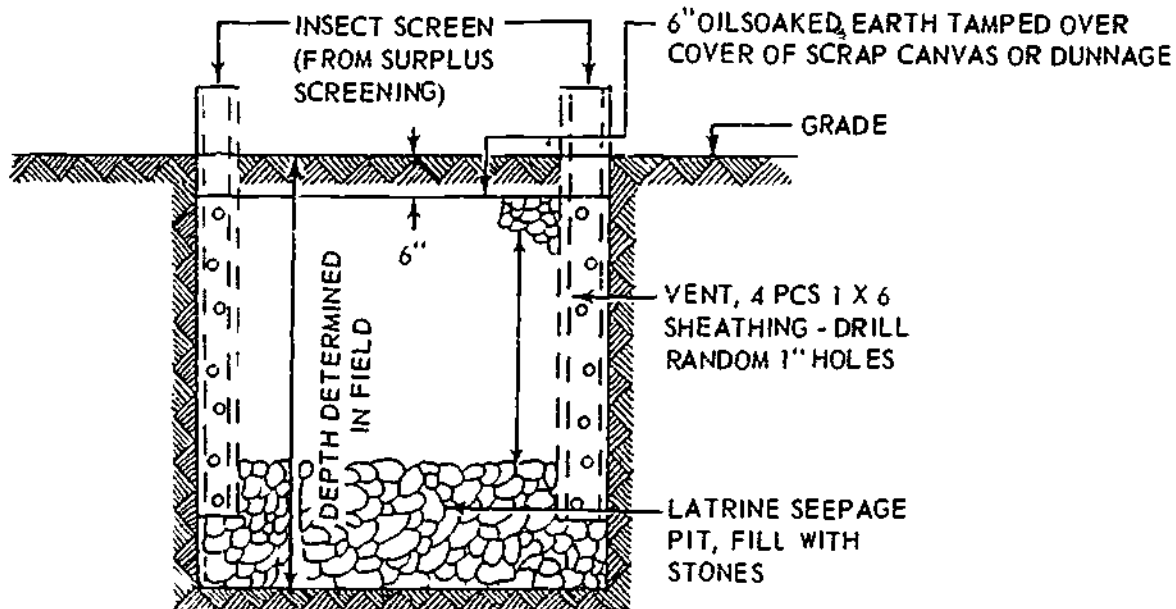
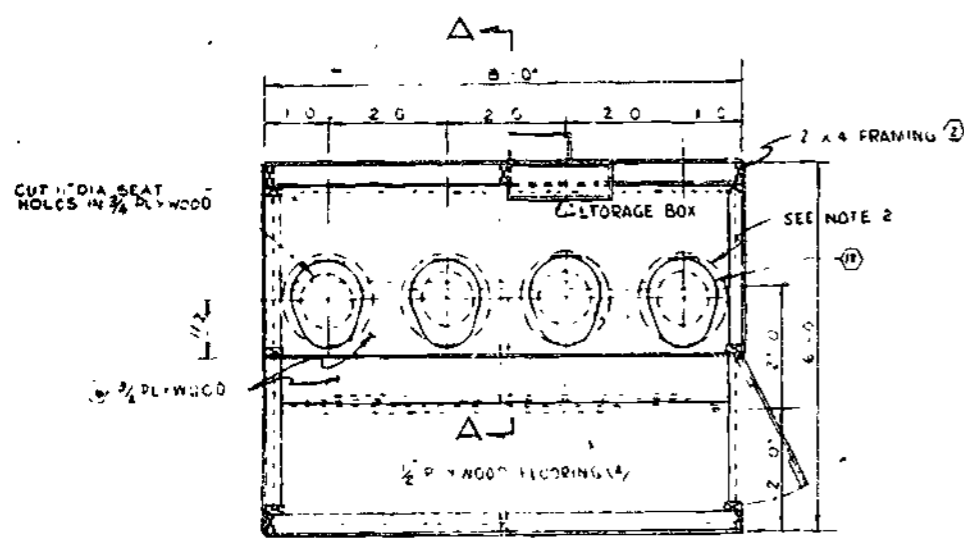
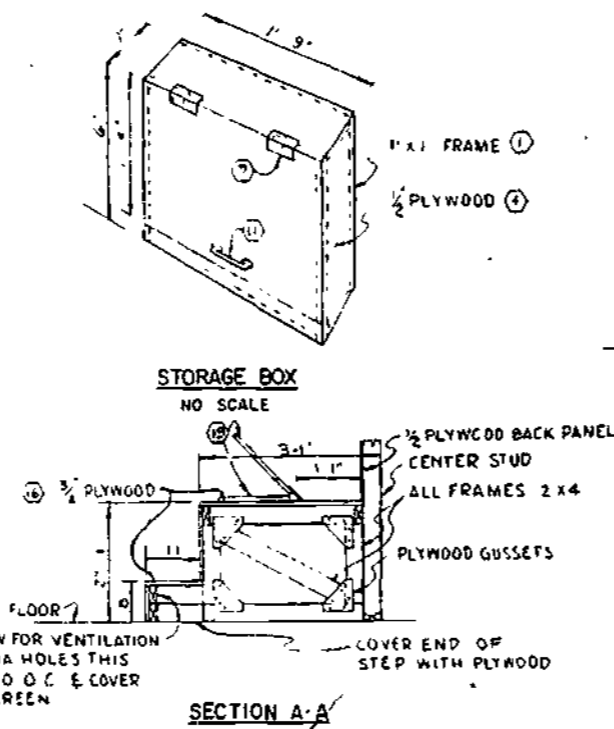

Figure 15-31.—Urinal seepage pit.

133.94



PLAN VIEW



SECTION A-A

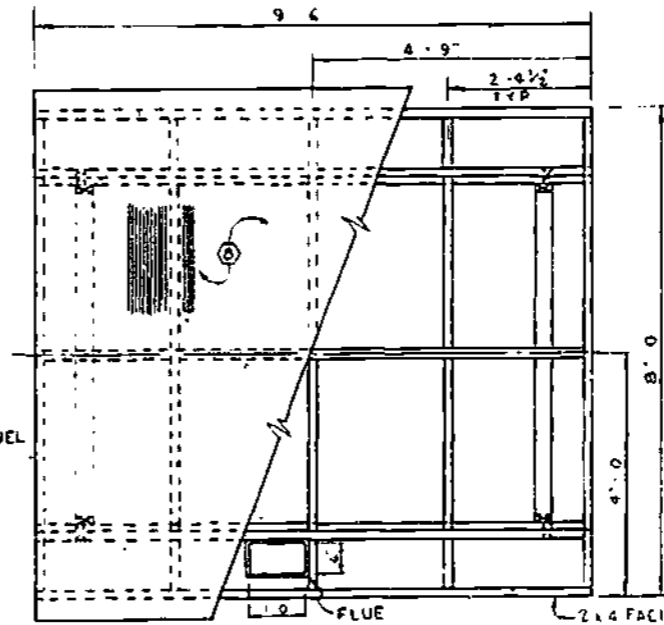

ROOF FRAME DETAIL

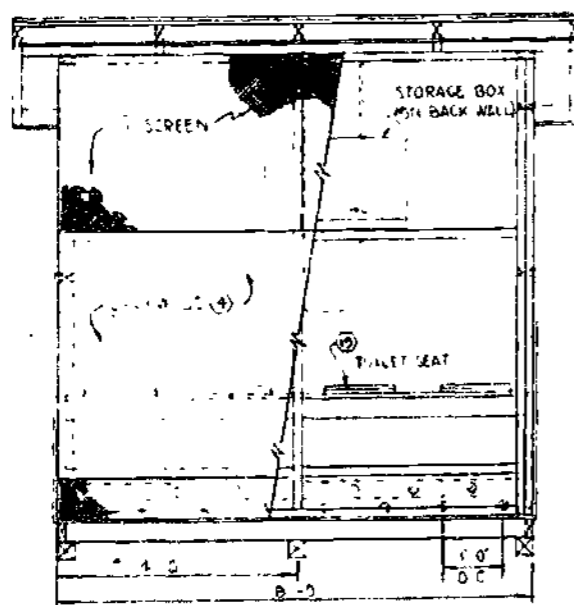

FRONT ELEVATION

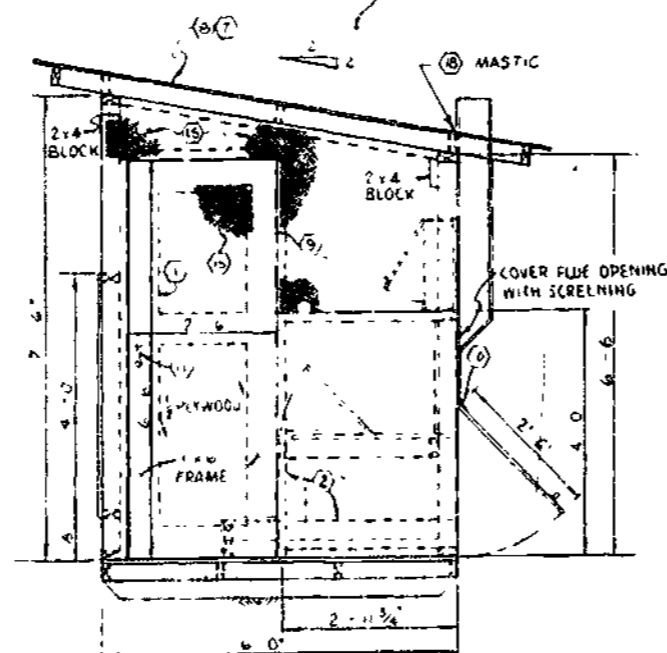

SIDE ELEVATION
OPP SIDE W/O DOOR

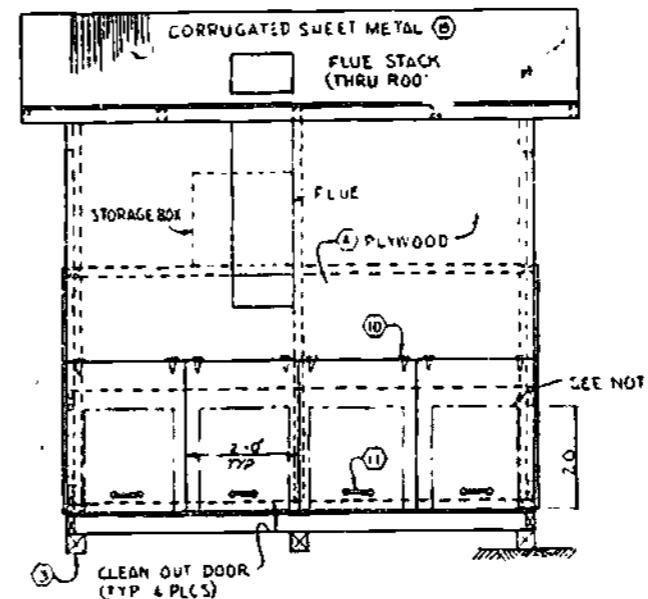

REAR ELEVATION

BILL OF MATERIAL					
ITEM	DESCRIPTION	UNIT	ASSEMBLY	QUAN.	BOM#
	HEAD, FOUR HOLE		1156		
(1)	LUMBER 1 X 1 X 12'	LF		21	
(2)	LUMBER 2 X 2 X 12'	LF		162	
(3)	LUMBER 2 X 2 X 12'	LF		32	
(4)	PLYWOOD 1/2 X 4 X 8	SM		12	
(5)	NAILS 2D COMM	LB		60	
(6)	NAILS 10D COMM	LB		5	
(7)	NAILS 1/2 X 10 X 1 1/2	PC		5	
(8)	COB SHE MET 17 1/2 X 26"	SM		1	
(9)	HINGE BUTT 2 1/2"	PC		2	
(10)	HINGE TEE 2"	PC		2	
(11)	DOOR PULL	EA		1	
(12)	SPRING DOOR 1"	EA		1	
(13)	STRAP TACKER, 1/2"	EA		1	
(14)	PLASTIC CONDUIT 50 FT 1"	EA		1	
(15)	SCREEN 1/2 X 4"	EA		20	
(16)	PLYWOOD 1/2 X 4 X 8	EA		1	
(17)	STEEL BAR 2 1/2 X 1/2	EA		1	
(18)	CELENS COMPOUND	EA		1	
(19)	SEAL, WATER CLOSET	EA		1	

NOTES

1. SEE SYMBOL ON BILL OF MATERIAL IDENTIFIES ITEM SHOWN ON DRAWING.
2. CUT SUPPLY DUCTS 10" HIGH AND WELD HARDNET USING ITEM 17.
3. DRAWING DEVELOPED FOR INFORMATION ON THIS DRAWING SEE 1109837-1000.

SYM	DESCRIPTION	BY	DATE
REVISIONS			
FUNCTIONAL COMPONENT		ASSEMBLY NO. 1156	
DEPARTMENT OF THE NAVY		NAVAL FACILITIES ENGINEERING COMMAND	
U. S. NAVAL CONSTRUCTION BATTALION CENTER		PORT HUENEME, CALIFORNIA	
MATERIAL DEPARTMENT		ADVANCED BASE	
HEAD BURN OUT TYPE FOUR HOLE			
DATE	BY	DATE	BY
SATISFACTORY TO		SCALE 3/4" = 1'-0" (SEE NO. 1109837)	
DATE		NAVYAC DRAWING NO. 1109837	

133.391

Figure 15-32.—Burnout type, 4-hole latrine.

CHAPTER 16

HEAVY CONSTRUCTION

As a Builder, you may be called upon to perform various construction operations involving heavy structures. Heavy structures are made of steel, timber, concrete, or a combination of these materials. Trestles, timber piers, and waterfront structures are examples of heavy structures. Heavy construction requires the use of certain tools and equipment that are not commonly used in ordinary rough and finish carpentry. Among the most widely used tools are crosscut saws, axes, and chain saws. This chapter describes the tools, equipment, and materials used in building heavy structures as well as methods and techniques of heavy construction, including shoring and excavation. In addition, this chapter contains the procedures used in the maintenance of heavy construction. Since heavy construction is hazardous, the use of safe working practices at all times can help prevent injuries to personnel and damage to equipment.

HANDTOOLS

Various cutting, chopping, striking, and material-handling tools are used in building or erecting heavy structures.

CUTTING TOOLS

Large crosscut saws are used for heavy work, such as felling trees, cutting large trees into logs, and sawing heavy timbers. Every crosscut saw (fig. 16-1) has a high-grade steel blade with two types of teeth, known as cutters and rakers. The cutters are the crosscut or ripping teeth; they score parallel grooves in the bottom of the kerf. The rakers chisel out waste that remains

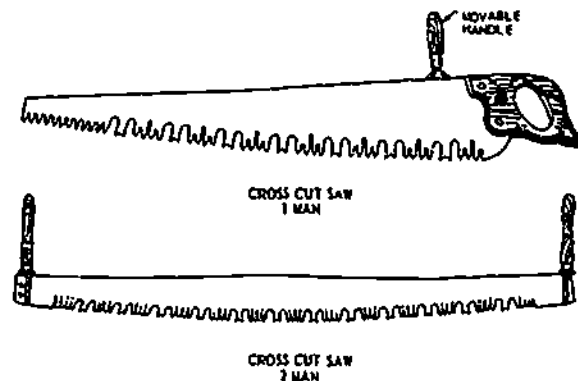

44.13

Figure 16-1.—One-man and two-man crosscut saws.

between the grooves. There are usually two or four cutters in a section of the blade, with one raker separating each of the cutter sections (fig. 16-2). The points of the cutters should extend slightly beyond those of the rakers. The rakers are conditioned like the teeth of a rip handsaw except that the rakers are not set.

The one-man crosscut saw (fig. 16-1) is about 36 inches long and has a handle at one end similar to that of the handsaw. It can also be operated by two men. The movable handle shown in figure 16-1 can be attached to the back of the blade. When loosened, this handle can be slid from the heel of the blade to the toe.

When using a crosscut saw, you should insure that loose logs or timbers are placed or blocked to prevent them from moving. When the saw is held teeth down to make a vertical cut into a log or timber, the saw's weight is enough

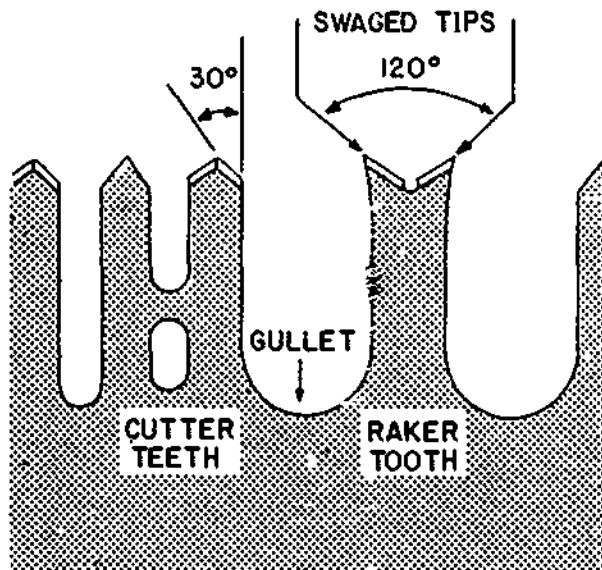

133.581

Figure 16-2.—Enlarged view of the large crosscut saw teeth.

to make downward pressure unnecessary. Only in horizontal cutting is light pressure needed on the saw. Oil or paraffin on the saw blade helps to make sawing easy.

The two man crosscut saw (fig. 16-1) is 5 to 6 1/2 feet long. A handle is attached at each end of the blade, fastened by a metal piece that fits over the end. You tighten the handles by turning the wooden portion of each handle clockwise.

This crosscut saw must be operated by two persons. It is moved across a log or timber by a pulling action only; one person pulls the saw, while another guides the blade. The procedure is then reversed and alternated until sawing is completed.

CHOPPING TOOLS

Figure 16-3 shows an ADZ, various types of AXES, and a HALF-HATCHET (commonly called a HATCHET). In heavy timber construction, the adz is used chiefly for hewing

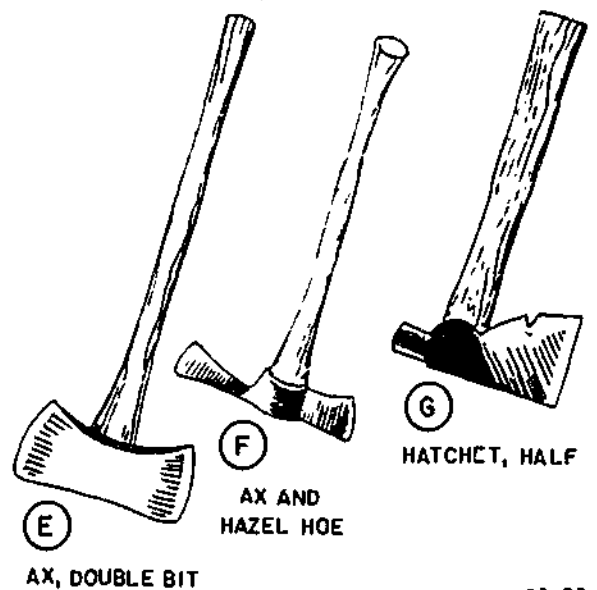
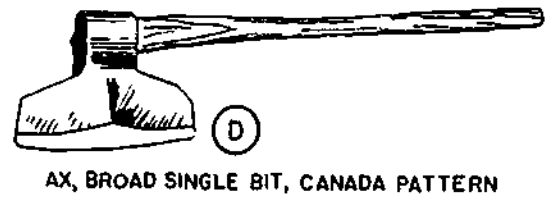
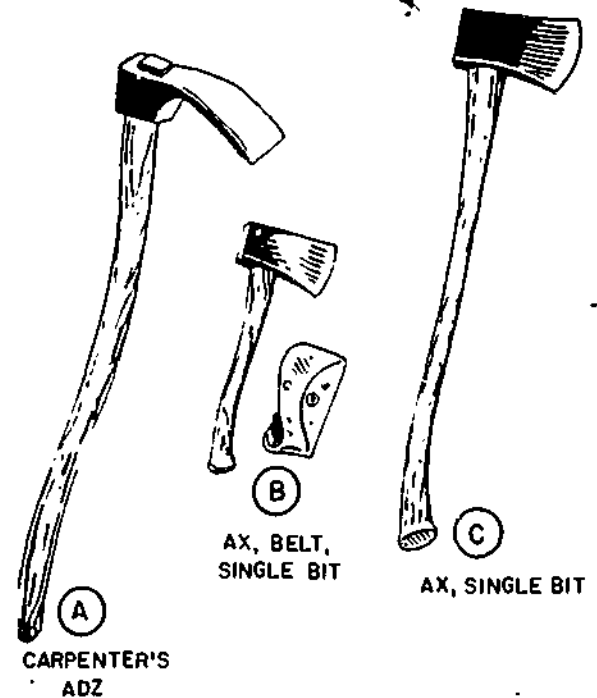

29.83

Figure 16-3.—Chopping tools.

plane surfaces, as shown in figure 16-4. It has a straight blade with a single bevel on the underside. The blade of the CARPENTER'S adz is 4 inches wide and the blade of the RAILROAD adz is 5 inches wide. In using the

adz, take short, choppy strokes rather than long ones. Be careful to keep the work clear of chips that might deflect the blade. Since the adz cuts toward the user, it is a very dangerous tool. To avoid injury, wear shin guards.

The ax is also used in heavy timber construction, chiefly for notching and for general hewing and shaping, as shown in figure 16-4. Of the axes shown in figure 16-3, the SINGLE-BIT ax is most frequently used. Its head weighs about four pounds and has a curved edge that is beveled on both sides.

Before using the ax, clear the work area of material that might deflect the ax blade. Your body weight should be distributed evenly on both legs, with the knees set, but not tense. Your feet should be spread apart at a comfortable distance to retain balance. Also, your body should be relaxed and free to swing and bend at the waist.

The half-hatchet is used to make cuts that do not require a smooth finish nor be exact. It has a claw or a notch in its blade for pulling eight-penny nails or smaller.

Handles on chopping tools must be inspected constantly to insure that they are tight and not split or broken. You should reseat a loose handle in the EYE (hole through the head) of the tool by striking the end of the handle with a mallet and then driving a wood or metal wedge into the handle. If one wedge does not spread the handle enough to tighten it firmly in the eye, add another wedge. If this is not possible, remove the wedge and insert a larger one.

Sharp-edged chopping tools must be stowed in a manner which will best protect their edges. For short-term storage, the heads should be cleaned and coated with light oil. For long-term storage, the heads should be cleaned and coated with a rust preventive.

STRIKING TOOLS

The DOUBLE-FACE SLEDGEL (fig. 16-5) is the percussion tool most frequently used in

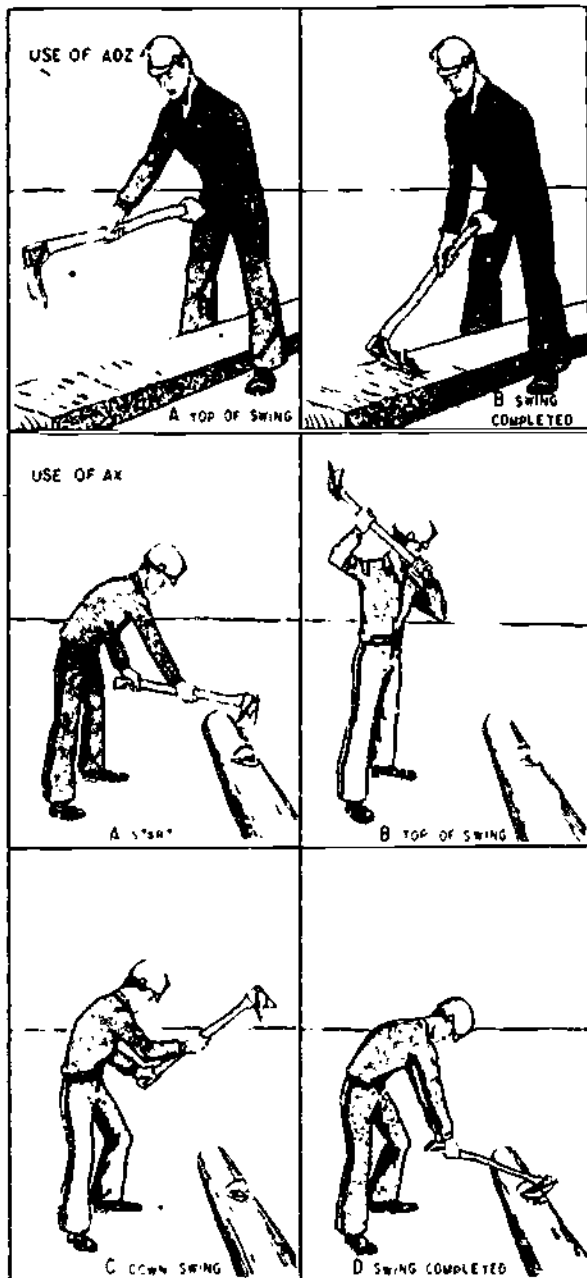

29.84

Figure 16-4.—Using the adz and the ax.



45.36

Figure 16-5.—Double-face sledge.

heavy timber construction. The size of a sledge is designated by the weight of the head in pounds, such as 6, 8, 12, 14, or 16 pounds. The sledge is also designated as either **SHORT-HANDLED** or **LONG-HANDLED**. A short-handled, lightweight sledge is used for driving spikes and drift bolts; a long-handled, heavy sledge is used for drifting (pounding into place) heavy timbers.

When used for drifting timbers, a sledge is likely to mark the wood. The reinforced-head, double-face wood **MAUL** shown in figure 16-6, can be used for drifting to avoid marking. Wood mauls come with heads weighing between 15 and 25 pounds. The usual head size is 8 inches in diameter by 10 inches long. The lengths of the handles range between 30 and 36 inches. Mauls are also used for driving wooden stakes and posts, but **NEVER** for driving metal stakes which would damage them.

Do not use a sledge with rounded faces, it may glance off the object being driven and injure you or somebody else. If the faces of a sledge become rounded or damaged, they must be reground squarely. In doing so, take an equal amount off each face to preserve the balance of

the sledge. Dip the head of the sledge in water frequently during grinding to prevent overheating.

The procedure for reseating loose handles on sledges or on chopping tools is the same. Storage procedures are likewise the same, but with the additional caution that wood mauls should not be stowed in hot sunlight or near hot water pipes or other sources of heat. Excessive heat may dry out the head of a wood maul enough to cause splitting.

The railroad track maul, or so-called spike maul, consists of a long, slender hammerlike metal head and a long wood handle. The head weighs about 10 pounds and has a flat rectangular face at each end, with an eye between the faces for securing the handle. One face is smaller than the other. See figure 16-7.

TIMBER-HANDLING TOOLS AND EQUIPMENT

Tools for handling heavy timbers by hand are shown in figure 16-8. The **CANT HOOK** and the **PEAVY** are used to roll, turn, and sometimes carry large timbers—especially cylindrical timbers. The chief difference between the two is that the cant hook has a blunt end and the peavy has a pike point. The **TIMBER CARRIER** is a pair of tongs which grasps a timber when the handles are lifted. Two cant hooks or two peavys, with handles located on opposite sides of the timber, can do the same job but should not be used when a carrier is available. The **GRAPPLE HOOK**, when hung on the hook of a crane or tackle, hoists timbers in the same manner as the timber carrier.

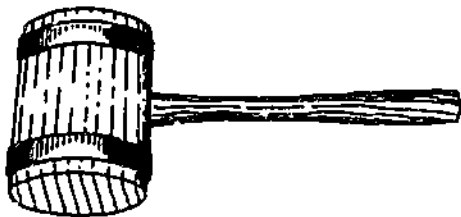

44.2(1330)

Figure 16-6.—Reinforced-head double-face wood maul.



133.562

Figure 16-7.—Railroad track maul.

16-4

592

POWER TOOLS

A pneumatic tool is one which operates on the energy of compressed air. Saws, nail drivers, drills, and other tools can be driven with this energy. Advantages of pneumatic tools over gasoline or electric-powered tools include having fewer parts that wear out or require maintenance and being more rugged and less affected by the weather, except extreme cold or high humidity.

Pneumatic tools have some disadvantages. The radius of operation for a pneumatic tool is limited by the length and size of the airhose to which it must be attached. If the tool is moved too far from the source of power (200 feet maximum with 3/4-inch-diameter hose), friction line loss will hinder its operation. Also, a pneumatic tool is often difficult to handle because of its attachment to the airhose. This is particularly true in rough terrain where the hose has a tendency to get hung on rocks or bushes.

PNEUMATIC CIRCULAR SAW

The pneumatic circular saw (figure 16-9) will perform the same functions as the portable

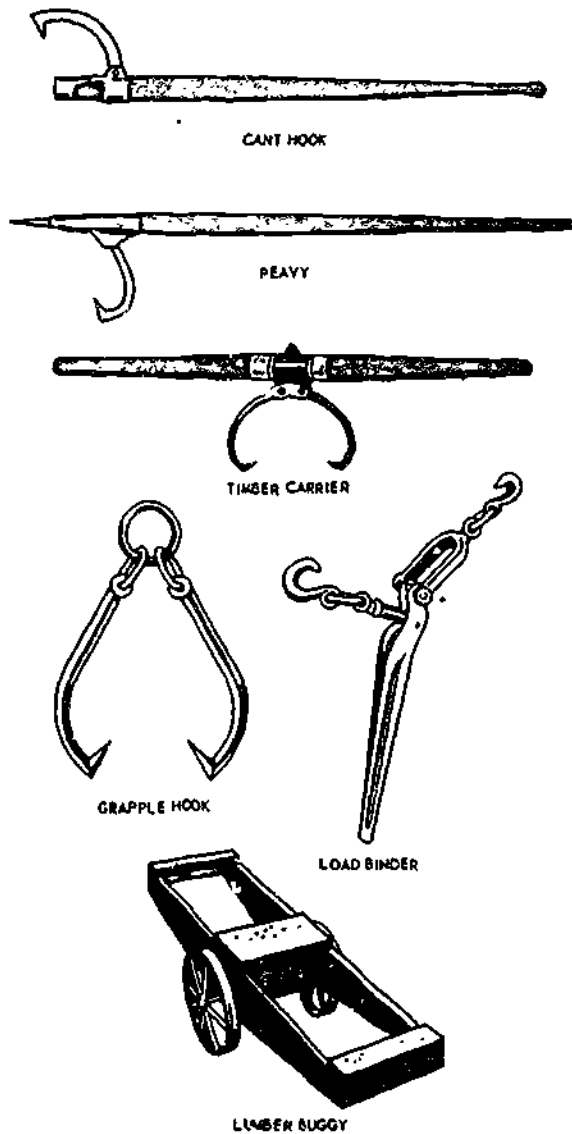

133.197
Figure 16-8.—Timber-handling tools and equipment.

The LUMBER BUGGY is a two-wheeled pushcart for carrying timbers over short distances. The LOAD BINDER is a device for binding timbers carried on the buggy. A length of chain is passed around the load and hung on the hooks of the binder. When the lever on the binder is brought down, the chain tightens around the load.

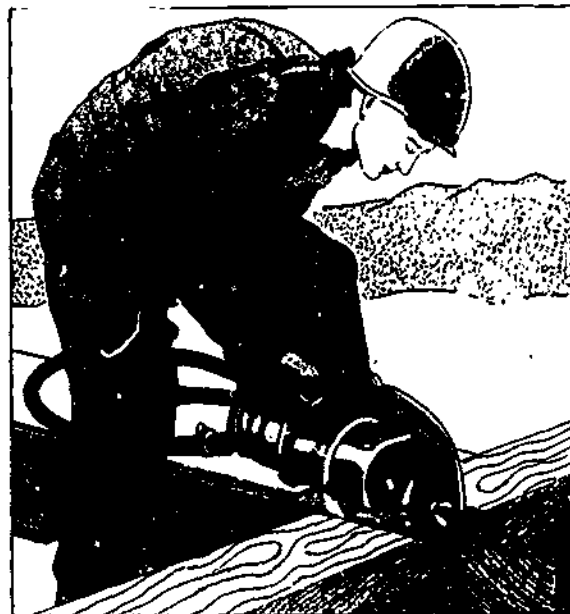

29.133
Figure 16-9.—Pneumatic circular saw.

electric circular saw. However, it is most often used for ripping and crosscutting. The handle assembly includes a D-shaped handle, trigger-type throttle with a thumb-operated plunger lock, spring-loaded throttle valve, 1/2-inch connection, and an oil reservoir. The top handle is used to control and guide the operation of the saw. The base plate is hinged to the front of the upper blade guard through a sector (angle segment). After a wing nut on this sector is loosened, the base plate can be tilted for bevel cuts up to 45°. At the back of the base plate, a second sector permits adjustment of the depth of the cut from 2 3/8 to 4 3/8 inches. Two V-notches on the front of the base plate simplify cutting along lines. The deep cut is in line with the blade for right angle cuts, while the shallow notch is in line with the blade for 45° bevel cuts. A fixed blade guard protects the operator from the blade. A telescopic blade guard covers the lower portion of the blade when the saw is not being used. This guard is spring loaded so it closes automatically when the blade is lifted from the cut, but folds into the fixed blade guard when the saw is operating.

PNEUMATIC CHAIN SAW

The pneumatic chain saw (fig. 16-10) is a heavy-duty saw intended primarily for cutting trees or timbers. The capacity of a chain saw, such as 24-inch, 36-inch, or 48-inch, is a measure of the largest tree diameter or timber width that the saw can cut. Chain lengths vary according to saw capacity.

The head assembly consists of a drive housing, two handles, saw guide bracket, bumper, and air connection. The guard bar is a heavy steel bar extending from the head assembly to the idler assembly and slightly arched so it lies about 3/4 inch from the upper portion of the chain. Its purpose is to protect the operator from injury if the saw chain breaks. Complete instructions for the saw, including the conditioning of the blade, are contained in the manufacturer's manual.

PNEUMATIC NAIL DRIVER

The pneumatic nail driver (fig. 16-11) is a long stroke piston-type riveting hammer with nail-driving attachments for holding 1/2-inch and 3/4-inch-diameter nailheads. The handle contains the air inlet, air control valve, and a thumb-operated throttle lever that controls the admission of air through the air control valve. An air strainer screws into the handle air inlet and keeps scale, rust, particles of rubber hose, dirt, and the like from the working parts of the tool. The barrel houses the valve mechanism, the piston, and the nail set. A sleeve on the end of the set prevents the tool from sliding off the head of the nail. A retainer made of heavy spring wire screws on the nozzle end of the barrel and holds the set in the tool at all times. The nail driver is designed for driving heavy drift pins and spikes. However, spikes should be started by hand, then nailed with the driver. CAUTION. Retainer housings on nail drivers often break because the operator fails to keep the nail set against the work.

PNEUMATIC WOOD DRILL

The pneumatic, reversible wood drill (fig. 16-12) is a heavy duty, low-speed machine designed to drive ship augers (drill bits). It is used extensively to bore holes for bolts or pins in trestle bridges and other timber construction work. The drill body houses a four-vane rotary-type pneumatic motor, a gear train for reducing the motor speed to a chuck speed of about 800 rpm, and an oil reservoir. A chuck is provided for 1/2-inch-diameter drill-bit shanks and a large Allen-type setscrew holds them in place. Three handles are provided on this drill: a throttle handle, a fixed handle mounted directly opposite the chuck and a grip handle extending opposite the throttle handle. The air line is attached to the end of the throttle handle. The shaft on which the chuck is mounted is drilled so the shank will extend into the base of the grip handle, where a wedge can be inserted against the end of a bit to loosen it when jammed in the chuck.

Ship augers are available in 1- and 3-foot lengths and, in 7/16-, 3/4-, 1-, and 2-inch diameters.

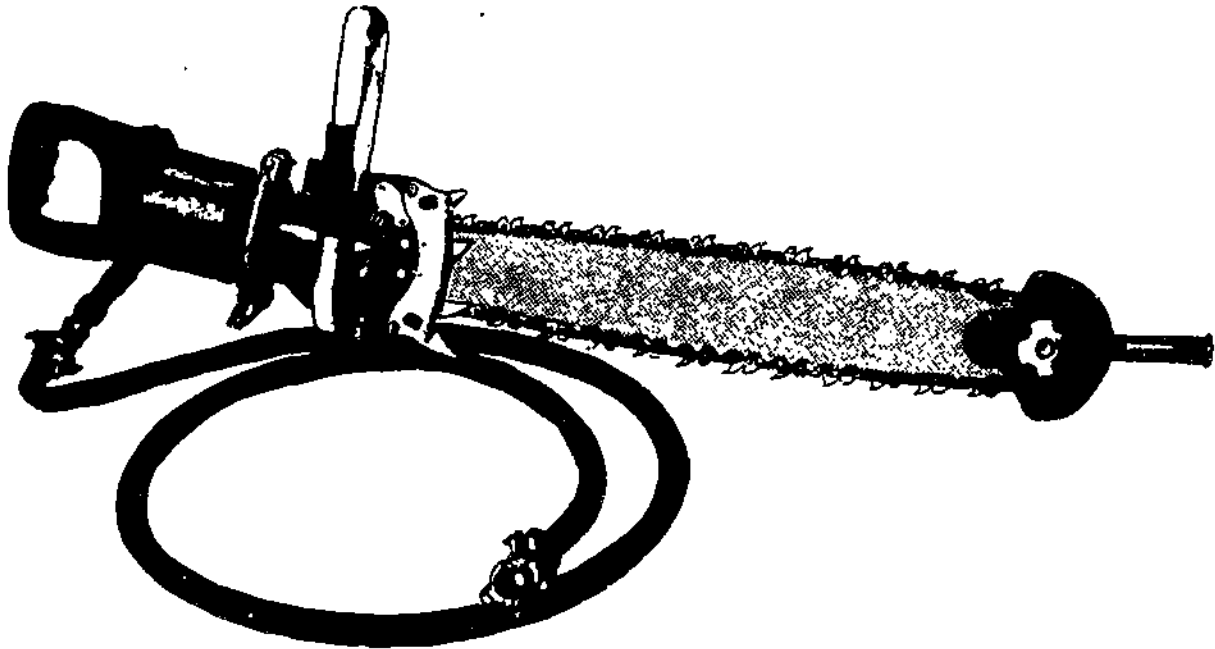

133.563

Figure 16-10.—Pneumatic chain saw.

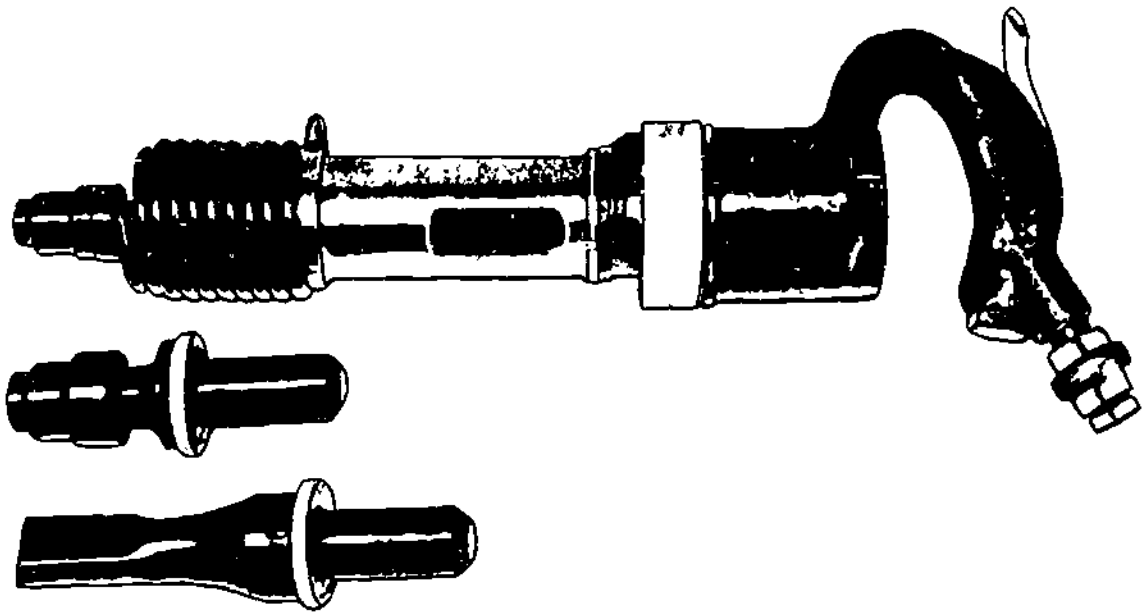

133.564

Figure 16-11.—Pneumatic nail driver.

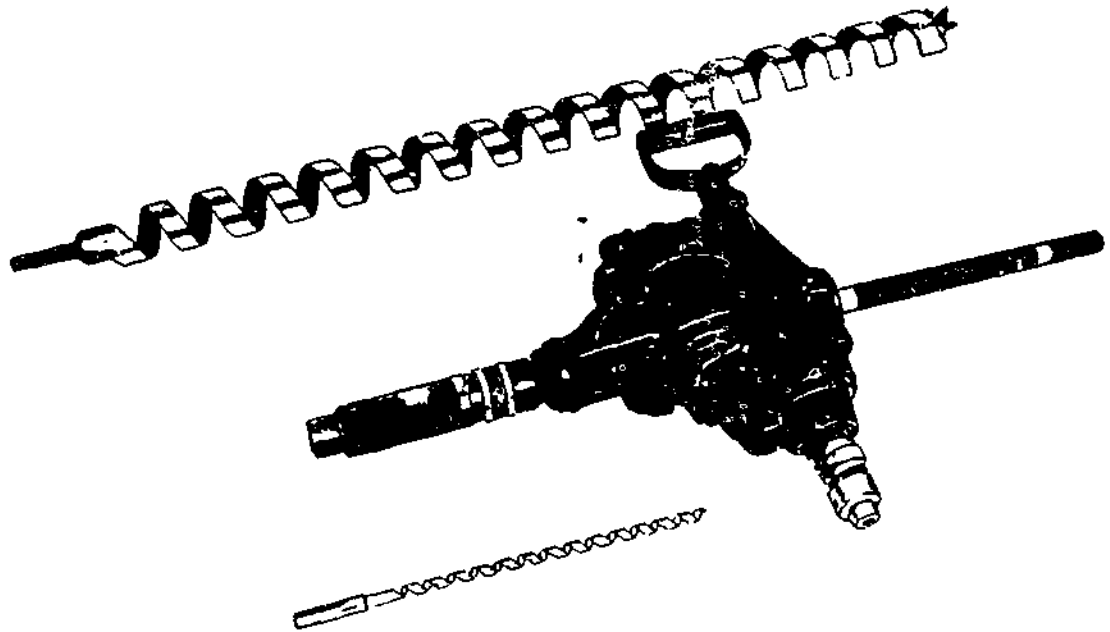

Figure 16-12.—Pneumatic reversible wood drill.

133.565

GASOLINE CHAIN SAW

The gasoline-driven chain saw (fig. 16-13) is a portable one-man saw with the teeth arranged on a flexible-steel chair-like belt that rotates so

the teeth cut only in one direction, clockwise. It has a pistol-grip handle and a sturdy bar frame above the engine for holding and guiding. In sawing, the chain saw is held against a tree or timber and guided through the work under light pressure. The pushbutton chain oiler should be used periodically to lubricate the chain. Some chain saws are equipped with automatic oilers. Chain saw sizes range from 16 inches through 36 inches.



29 132

Figure 16-13.—Gasoline engine-driven chain saw

AIR COMPRESSORS

One of several types of air compressors that Builders operate is the Worthington 600-cfm portable compressor (fig. 16-14). Like the others, it consists of a driving unit, a compressing unit, and accessories. The driving unit is a gasoline or diesel engine that provides power to operate the compressor. The compressing unit increases the pressure of air by reducing the volume of air. Among the

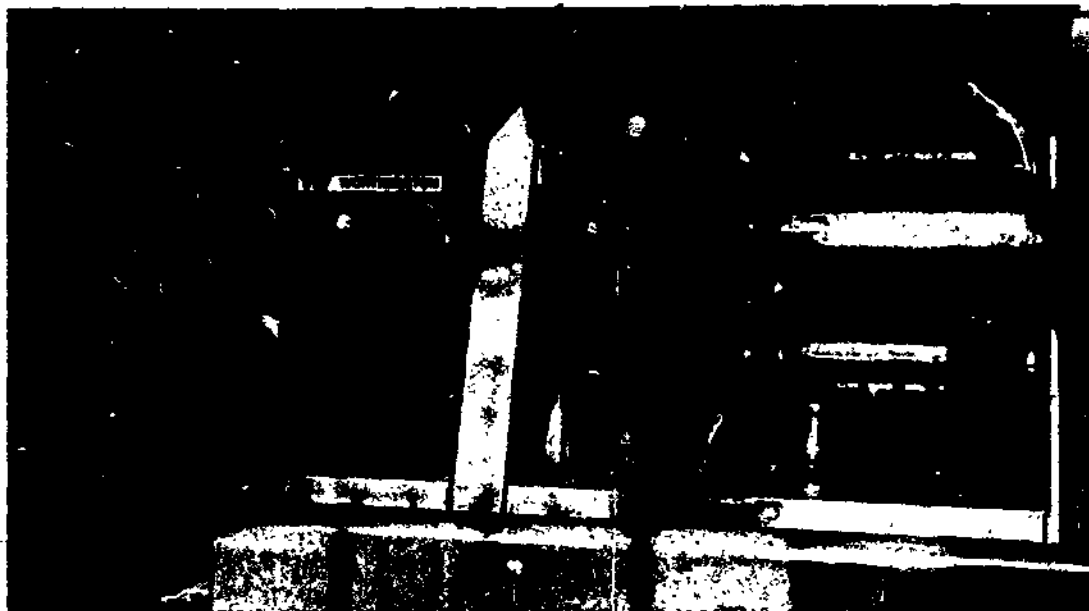

115.377X

Figure 16-14.—Worthington 600 CFM portable rotary air compressor.

accessories are the pneumatic controls (fig. 16-15) and a pressure control system which limits the pressure of compressed air to between 70 and 100 pounds per square inch.

STARTING THE DRIVING UNIT (DIESEL ENGINE)

Before starting the engine check the level of the engine oil. If necessary, add oil but do NOT overfill. Also check the engine cooling system. If necessary, add soft, clean water until the radiator is filled to the bottom of the filler neck. In cold weather, use permanent antifreeze that contains a rust inhibitor. Make sure the fuel tanks contain enough clean fuel.

Take the following steps in starting the engine during mild or warm weather:

1. Open the service valve about one quarter turn—not wide open.
2. Make sure the clutch is engaged.

3. Position the low-pressure engine-oil safety-control knob to ON. See figure 16-16.

4. Turn the ignition switch to start position. Immediately after the engine starts, release the ignition switch. If the engine fails to start within 30 seconds, release the ignition switch and allow the starting motor to cool off for a few minutes before trying again.

5. With the engine running, check the oil pressure gage. If no pressure is indicated, turn the engine off. Otherwise, let the oil pressure rise to 22 psi or more.

NOTE: The oil pressure gage registers erratically until the engine oil warms up

6. Check the low-pressure engine-oil switch. Its knob should be in the RUN position.

7. After the engine has run about 3 minutes, check the water or engine-coolant temperature. It should be less than 210°F; if higher, SHUT OFF THE ENGINE.

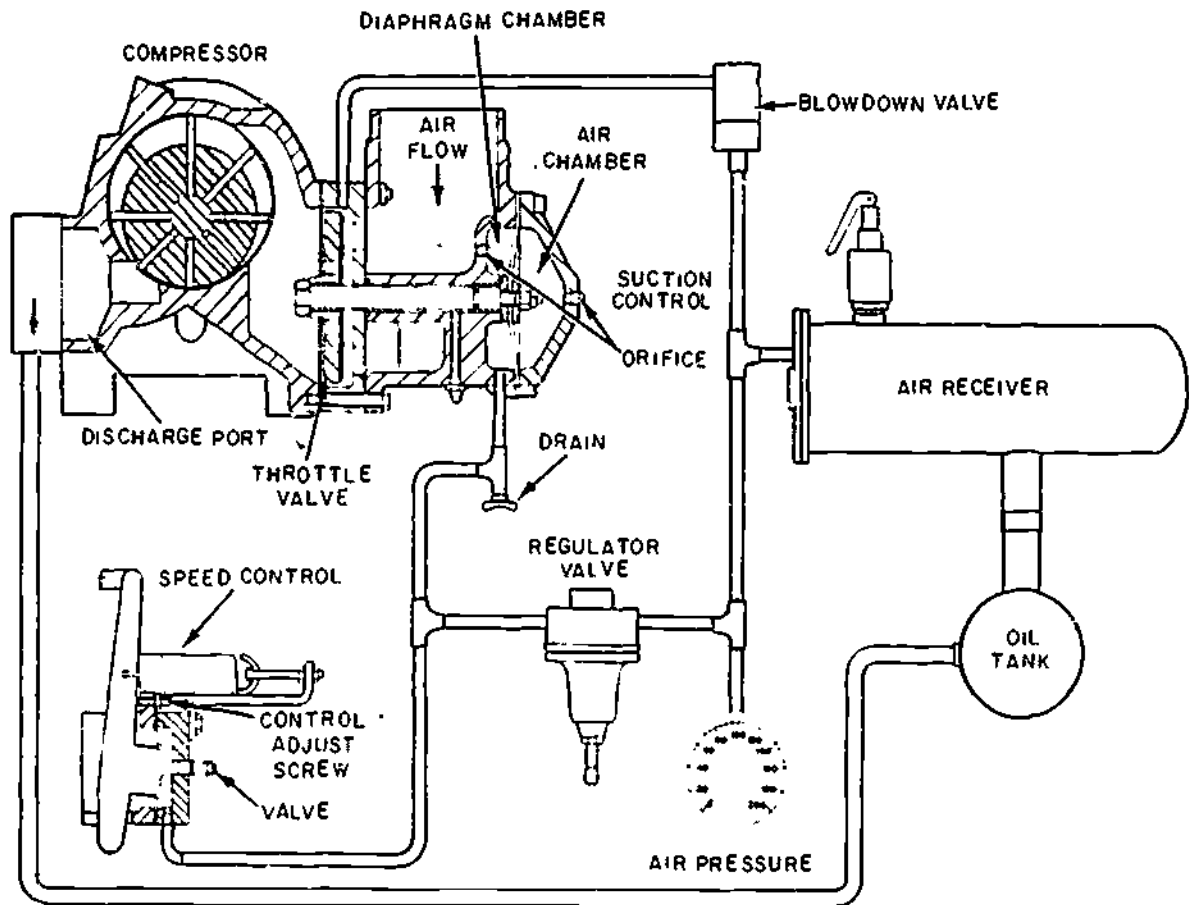
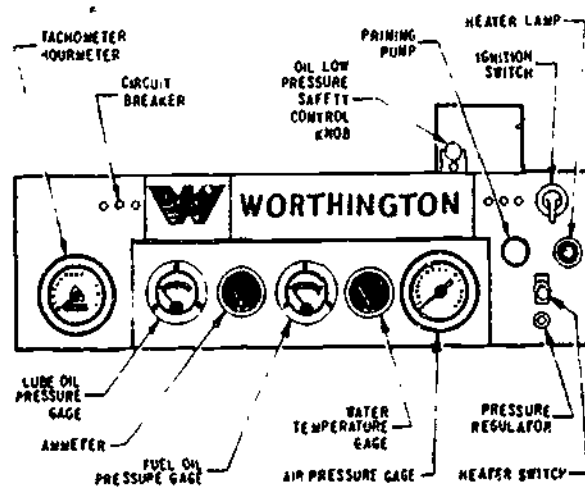

Figure 16-15.—Pneumatic controls.

115.380X



115.383X

Figure 16-16.—Air compressor instrument panel.

Take the following steps in starting the unit during cold weather:

1. Disengage the clutch. This permits engine warmup at idling speed.
2. Start the engine using the heater switch and priming pump in accordance with the engine manual.
3. Run the engine until the engine coolant temperature reaches 120°F.
4. Turn the ignition switch to OFF.
5. After the engine stops, engage the clutch.
6. Start the engine again.
7. Let the compressor run until the gages indicate normal operating conditions.

STOPPING

When stopping the unit at the end of the day's run, first close the service valve and let the engine run at idle speed for 5 minutes. This allow the engine-coolant temperature to level off and the entire unit to cool. Then turn the ignition switch to the OFF position.

PORTABLE TYPE GENERATORS/FLOODLIGHTS

At overseas bases, generators are used to provide electric power for camp and project lighting, communications, and other equipment. Engine-driven generators supply electricity for field equipment, such as the portable floodlight

unit (figure 16-17). This self-contained unit (Essex Electric Engineer's Model A172) is especially suited for use in remote locations as an emergency floodlight source. It can also furnish electric power for small handtools. Model A172 consists of an engine-generator set, six portable floodlights, eight extension cords, and a control panel. All components are mounted on a two-wheel trailer covered by a weatherproof sheetmetal housing.

Each floodlight is rated 500 watts; the lamp is rough-service incandescent. The floodlights are mounted on top of the housing during operation. They can swivel in different directions and pivot in various positions.

The extension cords enable the floodlights to be used away from the unit. The cords should not be allowed to kink or come in contact with

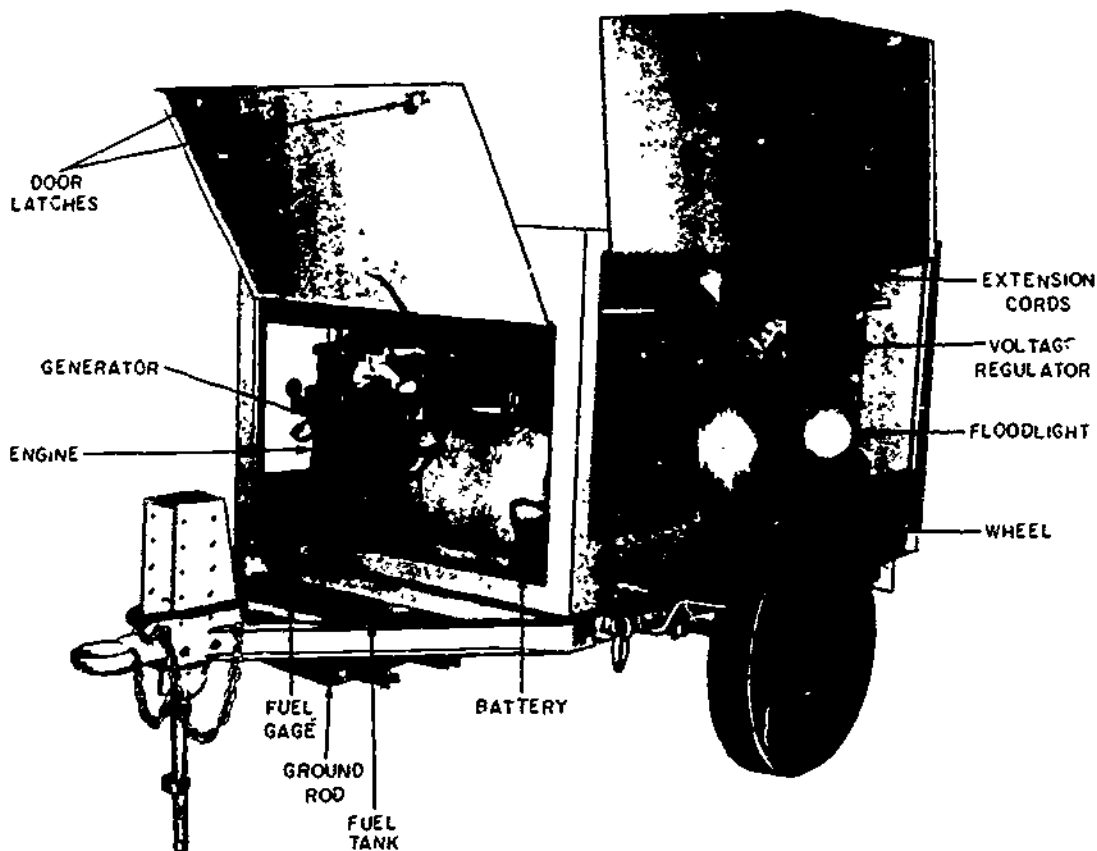

Figure 16-17.—Portable generator floodlight unit.

115.210

sharp objects, oil or grease, hot surfaces, or chemicals. Nor should they be left where they might be run over. Damaged cords must be replaced. They are NOT to be patched with tape. After use, the cords should be stored properly, loosely coiled, inside the housing.

Before use, the floodlight unit must be inspected for (1) loose connections, bolts, nuts, or other hardware and (2) damaged meter glasses, lights, extension cords, or other parts. Electrical apparatus must NOT be installed by personnel whose hands, clothes, or shoes are wet. Electrical circuits must be tested by a Construction Electrician. If the unit is operated in an enclosed area, engine exhaust fumes must be piped outdoors.

The control panel for the generator and floodlights (fig. 16-18) is located at the rear of the unit. The panel is divided into two sections: (1) A top section containing the output

voltmeter, output ammeter, control fuse, field flash switch, panel light switch, voltage control, main 60-ampere circuit breaker, and eight 15-ampere receptacle circuit breakers; and (2) a lower section containing eight weatherproof receptacles.

The trailer has a retractable front stand, safety towing chains, parking brake, lifting eyes, adjustable coupling, and a 12-volt vehicle lighting system.

STARTING THE ENGINE

Take the following steps in starting the engine:

1. Pull out the low oil-pressure switch shaft and insert the spring in the recess to override the switch.
2. Pull out the choke control.

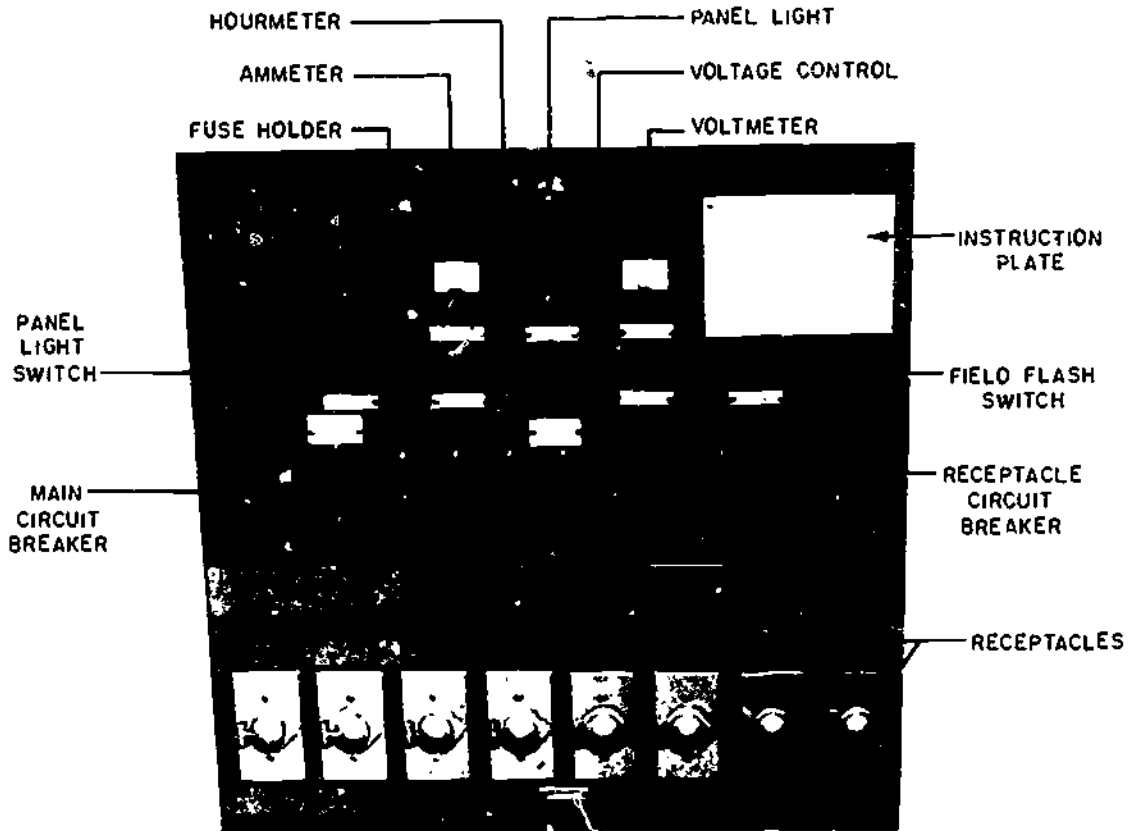

Figure 16-18.—Portable generator floodlight unit control panel.

143.286

3. Pull out hand throttle approximately 1 1/2 inches.
4. Pull out the ignition switch button.
5. Start the engine by depressing the start switch until the engine fires, then release.
6. Warm the engine at a moderate speed. As the engine warms up, push the choke in gradually.
7. Reset the low oil-pressure switch.
8. Extend the hand throttle fully and then lock into position.

FLASHING THE GENERATOR

Before flashing the generator, make sure that the main circuit breaker is in the OFF position. Then turn the voltage control completely counterclockwise to set it to minimum voltage. Wait until the voltage builds up before you field flash by momentarily operating the field flash switch. Next, turn the voltage control clockwise until the output indicates 115 volts. Now apply the load by turning on the main circuit breaker and the individual receptacles' output circuit breakers.

STOPPING THE ENGINE

The engine must be stopped before it is fueled or lubricated. When stopping the engine at the end of the day's run, take the following steps:

1. Turn off the main circuit breaker.
2. Cool the engine at its rated speed for 5 minutes with the throttle rod fully extended.
3. Stop the engine by first pushing the throttle rod all the way in and then immediately pushing the ignition switch button. **CAUTION:** Do not idle the engine with the generator excited because excessive field current can burn out the generator field windings. Never shut down the engine while the generator is under load.

TIMBER FASTENERS AND CONNECTORS

As a Builder working in heavy construction, you will be concerned with the common types of fasteners and connectors used in heavy construction and the methods of attaching them.

TIMBER FASTENERS

The BOLTS used to fasten heavy timbers usually have square heads and come in 1/2-, 3/4-, and 1-inch diameters. Round steel washers are placed under the heads and the nuts (also square). The bolts are tightened until the washers bite well into the wood, to compensate for future shrinkage. Bolts should be spaced at LEAST 9 inches on center. Edge distance should not be less than 2 1/2 inches and end distance not less than 7 inches.

End butt joints are customarily fastened with DRIFT BOLTS (often called DRIFT PINS). A drift bolt is a long, threadless bolt which is driven into a hole bored through the member it is butted against and into the end of the abutting member. The bored hole is made slightly smaller than the bolt diameter and about 3 inches shorter than the bolt length. Drift bolt diameters run from 1/2 to 1 inch; lengths from 18 to 26 inches.

End butt joints are also fastened with a SCAB, which is a short length of timber, spiked or bolted to the adjoining members at the joint as shown in figure 16-19.

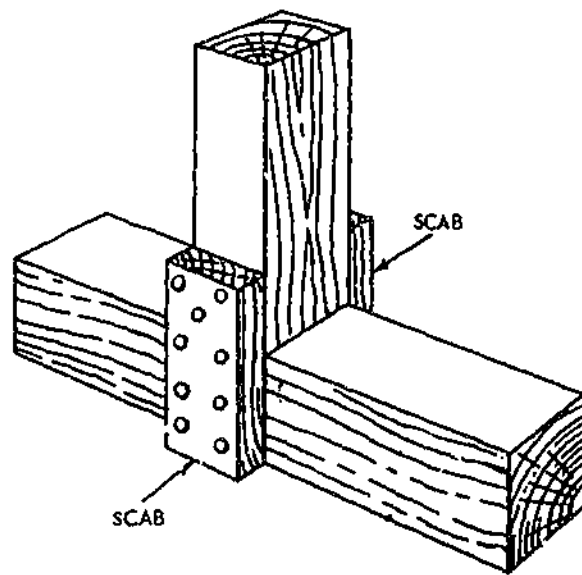
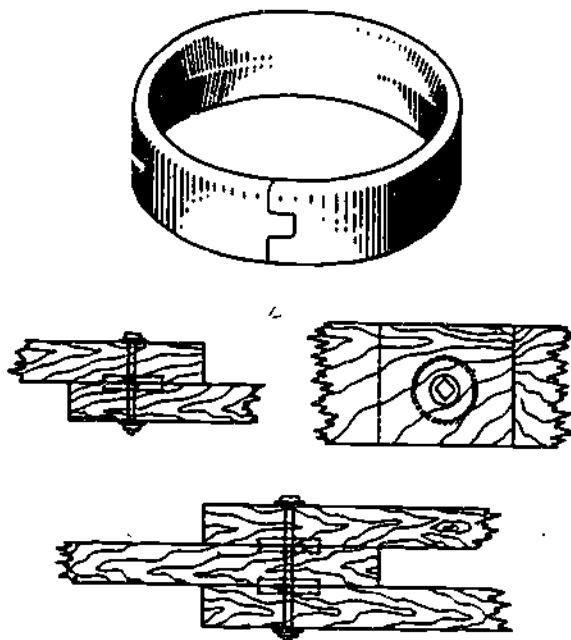

Figure 16-19.—Scabs.

133.198

TIMBER CONNECTORS

TIMBER CONNECTOR is any device used to increase the strength and rigidity of bolted lap joints between heavy timbers. For example, the SPLIT RING shown in figure 16-20. It is embedded in circular grooves, which are cut with a special type of bit in the faces of the timbers that are to be joined. Split rings come in diameters of 2 1/4, 4, 6, and 8 inches. The 2 1/2-inch ring takes a 1/2-inch bolt, the others a 3/4-inch bolt. When more than one ring is used at a joint, minimum spacing between ring centers should be 9 inches. Also, this spacing should be 2 1/2 ring diameters if the pull on the joint is parallel to the grain, but only 1 1/2-ring diameters if the pull is perpendicular to the grain. Edge distance, measured from the center of the ring to the edge of the member, should not be less than 1/2 the ring diameter plus 1 inch. End distance, measured from the center of the ring to the end of the member, should not be less than 7 inches.



45.543

Figure 16-20.—Split ring and split-ring joint.

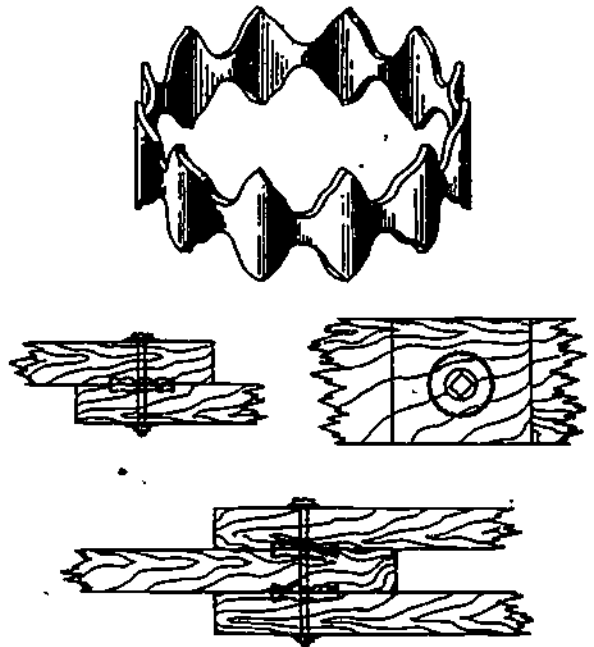

45.544

Figure 16-21.—Toothed ring and toothed-ring joint.

TOOTHED RINGS (fig. 16-21) function in much the same manner as split rings, but can be embedded without having to cut grooves in the members. A toothed ring is embedded by the pressure produced by tightening a bolt of high-tensile strength, as shown in figure 16-22.

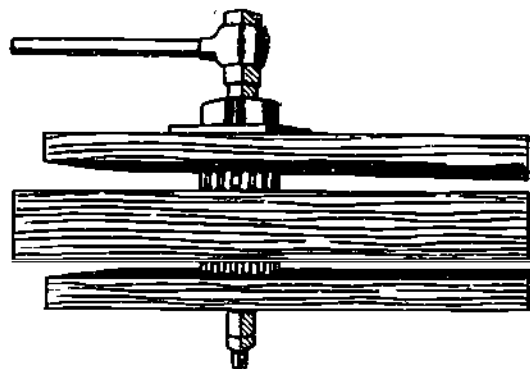

133.199

Figure 16-22.—Embedding toothed rings.

The hole for the bolt is made 1/16 inch larger than the bolt diameter, so that the bolt may be easily extracted after the ring is embedded. It is then replaced by an ordinary steel bolt.

Toothed rings come in 2-, 2 5/8-, 3 3/8-, and 4-inch diameters. The 2-inch ring takes a 1/2-inch bolt; the 2 5/8-inch ring a 5/8-inch bolt; and the others, a 3/4-inch bolt. The spacings, edge distances, and end distances are the same as they are for split rings.

SPIKE GRIDS are shown in figure 16-23. A spike grid may be FLAT (for joining two flat surfaces), SINGLE-CURVED (for joining a flat and a curved surface), or DOUBLE-CURVED (for joining two curved surfaces). A spike grid is embedded in the same manner as a toothed ring.

TIMBER TRESTLES

A TRESTLE is a braced framework of timbers, piles, or steel members. It is built to carry a roadway across a depression, such as a

gully, a canyon, or the valley of a stream. The two main subdivisions of a trestle are the SUBSTRUCTURE, consisting of the supporting members, and the SUPERSTRUCTURE, consisting of the DECKING and the STRINGERS on which the decking is laid.

The substructure of a timber trestle consists of a series of transverse frameworks called BENTS. TRESTLE bents are used on solid, dry ground, or in shallow water with solid ground. PILE bents are used in soft or marshy ground, or where the water is so deep, or the current so swift that the use of trestle bents is impossible. The posts of a pile bent are BEARING piles or vertical members driven in the ground.

NOMENCLATURE

A trestle bent may be a SINGLE-STORY bent or a MULTISTORY bent. The parts of a single-story bent are shown in figure 16-24. A two-story bent is shown in figure 16-25.

The principal parts of a trestle and their definitions are as follows.

ABUTMENT.-The ground support at each of the extreme ends of the superstructure. (See figs. 16-26 and 16-27.)

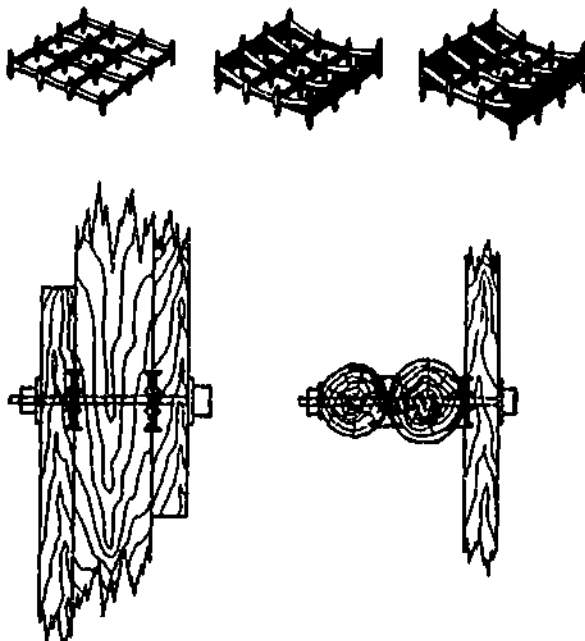

46.546

Figure 16-23.-Spike grid and spike-grid joints.

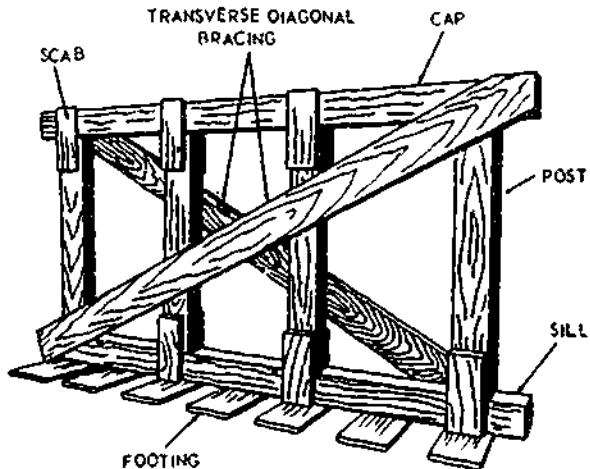

46.523

Figure 16-24.-Parts of a single-story trestle bent.

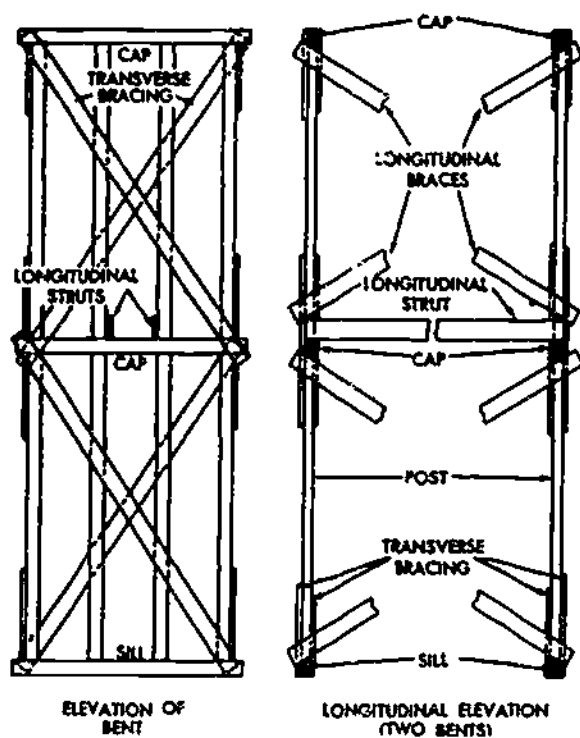

133.200
Figure 16-25.—Two-story trestle bent.

BRACING.—The timbers used to brace a trestle bent, called **TRANSVERSE** bracing, or the timbers used to brace bents to each other, called **LONGITUDINAL** bracing. Longitudinal bracing is shown in figure 16-25.

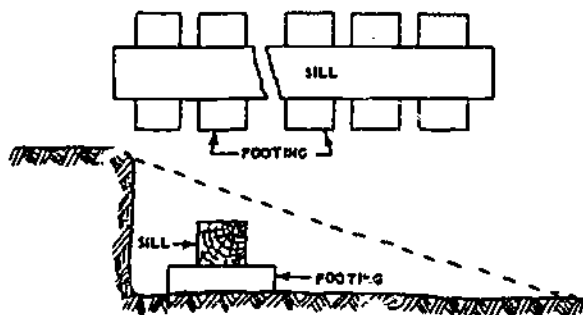

45.524
Figure 16-26.—Abutment sill and footing and abutment excavation.

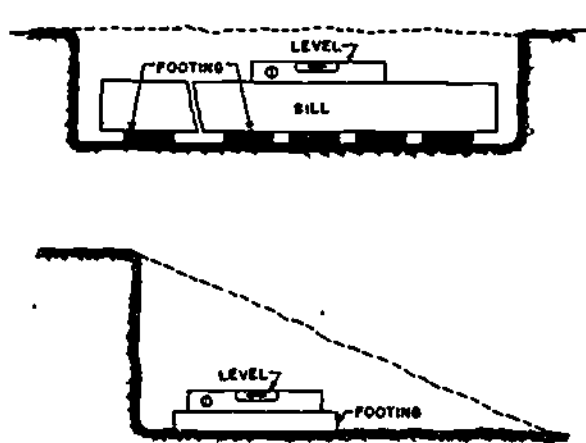

133.201
Figure 16-27.—Placing and leveling abutment footings and abutment sill.

CAP.—The uppermost transverse horizontal structural member of a bent; it is laid across the tops of the posts.

DECKING.—The structure laid on the girders to form the roadway across the trestle; it consists of a lower layer of timbers (**FLOORING**) and an upper layer of timbers (**TREADWAY**).

FLOORING.—See **DECKING**.

FOOTINGS.—The supports placed under the sills. In an all-timber trestle, the footings consist of a series of short lengths of plank. Whenever possible, however, the footings are made of concrete.

GIRDER.—One of a series of longitudinal supports for the deck which is laid on the caps.

POST.—One of the vertical structural members.

SILL.—The bottom transverse horizontal structural member of a trestle bent, on which the posts are anchored, or transverse horizontal member which supports the ends of the girders at an abutment.

STRINGER.—Same as girder.

SUBSTRUCTURE.—The supporting structure of braced trestle bents, as distinguished from the superstructure.

SUPERSTRUCTURE.—The spanning structure of girders and decking, as distinguished from the substructure.

TREADWAY.—See DECKING.

CONSTRUCTING A TIMBER TRESTLE

After location of the centerline of a trestle has been decided upon, the next step is to locate the abutment on each bank at the desired or prescribed elevation. The abutments are then excavated to a depth equal to the combined depths of the decking and the stringers, less an allowance for settlement. The abutment footings and the abutment sills are then cut, placed, and leveled, as shown in figure 16-27.

The horizontal distance from an abutment sill to the first bent and from one bent to the next is controlled by the length of the girder stock. It is usually made equal to the length of the stock, minus about 2 ft for overlap. Girder stock usually comes in 14-ft lengths; the center-to-center horizontal distance between bents is usually 14 minus 2, or 12 ft.

The locations of the seats for the trestle bents and the heights of the bents can be determined as follows. Stretch a tape from the abutment along the centerline, and use a builder's level or a line level to level the tape. Drop a plumb bob from the 12-ft mark on the tape to the ground. The position of the plumb bob on the ground will be the location of the first bent. The vertical distance from the location of the bob to the horizontal tape, less the thickness of a footing, will be the height of the first bent. Next, stretch the tape from the location of the first bent, level it as before, and again drop a plumb bob from the 12-ft mark. The position of the plumb bob will be the location of the section bent. The vertical distance from the location of the bob to the horizontal tape, PLUS THE HEIGHT OF THE FIRST BENT, less the thickness of the footing,

will be the height of the second bent. Next, stretch the tape from the location of the second bent and proceed as before. The vertical distance from the location of the bob to the horizontal tape, plus the height of the second bent, less the thickness of a footing, will be the height of the third bent, and so on. (See fig. 16-28.)

CONSTRUCTING A TRESTLE BENT

A trestle bent is laid out and constructed as follows. The length of the posts is equal to the height of the bent, less the combined depths of the cap and sill. In a 4-post bent, the centers of the two outside posts are located from 1 to 2 1/2 feet inboard of the ends of the sill, and the centers of the two inner posts are spaced equidistant between the other two.

Sills, caps, and posts are commonly made of stock from 12 by 12 to 14 by 16; if a sill or cap is not square in a cross section (as in the case of 14 by 16 stock), the larger dimension should be placed against the ends of the posts. The usual length for a sill or cap is 2 feet more than the width of the roadway on the trestle. The minimum width for a single-lane trestle is 14 feet; for a two-lane trestle, 18 feet.

Part of the terrain at an assembly site may be graded flat and used as a **FRAMING YARD**, or a low platform may be constructed for use as a **FRAMING PLATFORM**. To assemble a bent, lay the posts out parallel and properly spaced, and set the cap and sill in position against the ends. Bore the holes for the drift pins through the cap and the sill into the ends of the posts, and drive in the drift pins. Cut a pair of 2 by 8 by 18 scabs for each joint and then spike,

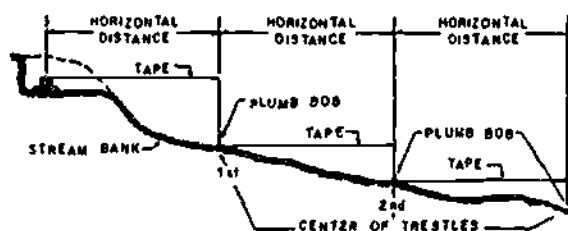

133.202

Figure 16-28.—Locating seats for trestle bents.

lag-screw, or bolt the scabs to the joints. Finally, measure the diagonals to determine the lengths of the transverse diagonal braces. Cut the braces to length, and spike, lag-screw, or bolt them to the sills, caps, and posts. Transverse diagonal bracing is usually made of 2 by 8 stock.

ERECTING A TRESTLE BENT

The usual method of erecting trestle bents is as follows. A traveling crane (or, in the absence of a traveling crane, the best available means of transport) brings the assembled first bent to the abutment, swings it out, and sets it in place on the footings at the seat. The bent is carefully plumbed and temporarily braced with timbers running from the top of the bent to stakes driven at the abutment. The superstructure (girders and decking) is laid from the abutment out to the top of the first bent. The crane then brings the second bent out to the end of the superstructure and sets it in place. The second bent is plumbed, the diagonals are measured to determine the lengths of the longitudinal diagonal braces between the first bent and the second, and the braces are then cut and spiked, lag-screwed, or bolted in place. The superstructure is then carried out to the second bent, after which the crane brings the third bent out to the end of the superstructure. This procedure is repeated, usually by parties working out from both abutments, until the entire span is completed. In the absence of a crane, either a gin pole or a set of shears is erected and moved out with the superstructure.

CONSTRUCTING THE SUPERSTRUCTURE

Timber girders are usually 10 by 16's, 14 feet long, spaced 3 feet 3 1/2 inches oncenter. Various methods of fastening timber girders to timber caps are shown in the first view of figure 16-29. Various methods of fastening steel girders to timber caps are shown in the second view of figure 16-29. This view also shows three ways of fastening a timber-nailing anchorage for flooring to the top of a steel girder.

Timber decking consists of two layers of 3-inch planks. The lower layer, called the FLOORING, is laid at right angles to the girders

and nailed with two 60-penny spikes to each girder crossing. The upper layer, called the TREADWAY, is laid at a 45° angle to the girders and securely nailed to the lower layer.

As indicated in figure 16-30, most of the flooring planks and all the treadway planks are cut to lengths which will bring the ends of the planks flush with the outer faces of the outside stringers. However, at every 5 feet along the superstructure, a flooring plank is left long enough to extend 2 feet 8 inches beyond the outer faces of the outside stringers. The extension serves as a support for the CURB RISERS, the CURB, and the HANDRAIL POSTS, as shown in the figure. The curb risers consist of 3-foot lengths of 6 by 6, one of which is set in front of each handrail post as shown. A continuous 2 by 6 handrail is nailed to 4 by 4 handrail posts. Each handrail post is supported by a 2 by 4 KNEE BRACE, as shown.

As indicated in figure 16-31, an END DAM is set at each end of the superstructure to prevent the approach of the road to the trestle from washing out or eroding between the abutment and the girders.

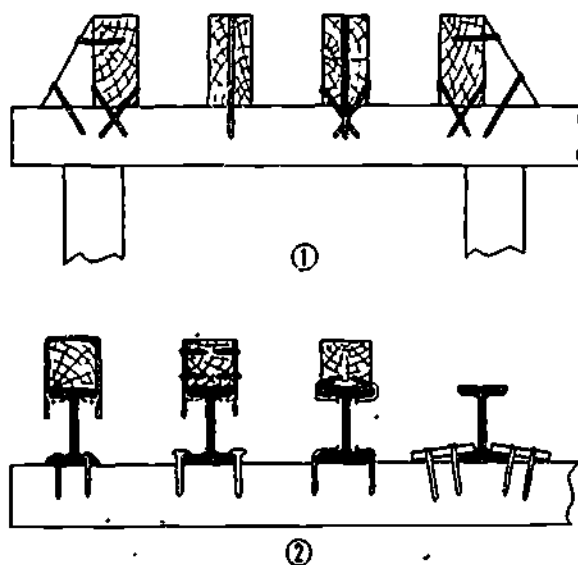

133.203
Figure 16-29.—Methods of fastening timber and steel girders to timber caps.

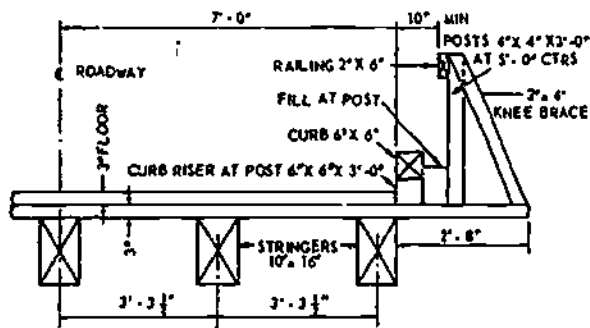

133.204

Figure 16-30.—Details of superstructure of a timber trestle.

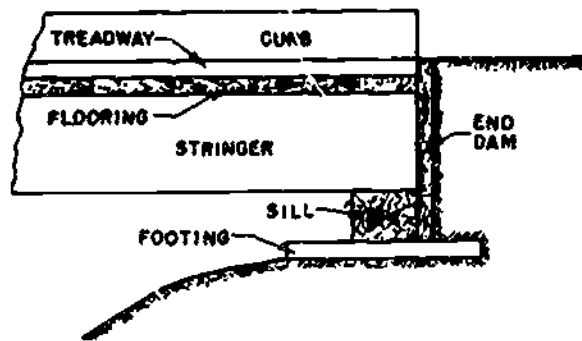

133.205

Figure 16-31.—End dam.

PILES

The principal structural members in many types of waterfront structures are PILES. Made of wood, steel, or concrete they are driven into the ground. A vertical, or bearing, pile sustains a vertical downward pressure. A BATTER pile is set at an angle to sustain a diagonal pressure. SHEET piles are equipped for edge joining and are driven edge to edge to form a wall which sustains a lateral (horizontal) pressure.

As a Builder, you will be most concerned with timber piles. Steel piling ranks next in importance, especially where the construction must accommodate heavy loads or the foundation is expected to be used over a long

period of time. Steel is best suited for use as bearing piles where piles must be driven under the following conditions: piles are longer than 80 feet; column strength exceeds the compressive strength of timber; to reach bedrock for maximum bearing surface through overlying layers of partially decomposed rock; to penetrate layers of coarse gravel or soft rock, such as coral; or to attain greater depth of penetration for stability. For example, driving piles in a rock-bedded, swiftly flowing stream where timber piles cannot be driven deeply enough for stability.

Concrete and composite piles are seldom used since they require material and equipment not normally available through military supply channels. They are likely to be used in cases where local materials are readily available, whereas standard military piling would have to be received in large quantities from CONUS. Interlocking steel-sheet piling is often used in military construction, but concrete-sheet piling can be manufactured in the field when local materials are available.

Besides availability of material, the following factors influence the type of piles to be used in heavy construction:

- Anticipated pile loads.
- Anticipated length of piles and ease of adjusting length, if necessary.
- Soil conditions at the site.
- Ground water conditions at the site.
- Availability of equipment for handling and driving piles.
- Time available for construction.
- Degree of permanence required and exposure conditions for completed structure.
- Physical properties of available pile types.
- Accessibility of site and transportation facilities.
- Costs.

In HASTY construction, any and all readily available materials can be used to construct a pile foundation capable of supporting the superstructure and maximum load during the short term period of the structure. Of course, the tactical situation and considerations of time and effort dictate whether construction will be hasty or not.

TIMBER BEARING PILES

Timber bearing piles are usually straight tree trunks cut off above ground swell, with the branches closely trimmed and the bark removed. Occasionally, sawed timbers may be used as bearing piles.

A good timber pile has the following characteristics:

Free of sharp bends, large or loose knots, shakes, splits, and decay; uniformly tapered from butt to tip; and centers of butt and tip are endpoints of a straight line that lies within the body of the pile.

Cross-section dimensions that limit the use of timber as piles are:

Piles shorter than 40 feet, tip diameters between 8 and 11 inches, and butt diameters between 12 and 18 inches.

Piles longer than 40 feet, tip diameters between 6 and 8 inches, and butt diameters between 13 and 20 inches. The butt diameter must not be greater than the distance between the pile leads.

Preparation of Piles for Driving

Timber piles can be damaged while being driven, particularly under hard-driving conditions. To protect a pile against damage, the butt of the pile is cut off square so that the pile hammer will strike it evenly. The butt is also chamfered. When a driving cap is used, the chamfered butt must fit the cap. When a cap is not used, the top end of the pile is wrapped with 10 or 12 turns of wire at a distance of about one diameter below the head of the pile, as shown in views A and B, figure 16-32. As an alternative to wrapping, two half-rings of 3/8-inch steel are clamped around the butt (view D, fig. 16-32). When a hole is bored in the butt of the pile, double wrappings are used, as shown in view C, figure 16-32. The pile is also wrapped or clamped if the butt is crushed or split.

The tip of the pile is cut off perpendicular to its axis. When driven into soft or moderately

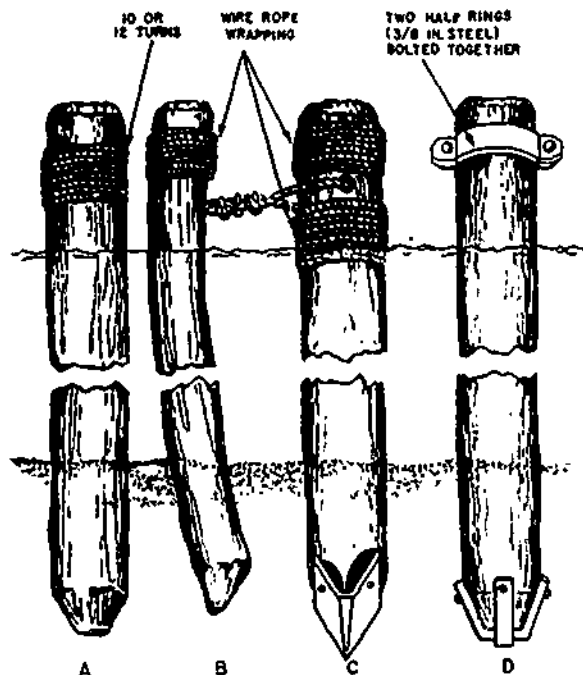

133.586

Figure 16-32.—Preparation of timber piles for driving.

compressible soil, the tip of the pile may be left unpointed. A blunt-end pile provides a larger bearing surface than a pointed-end pile as an end-bearing pile. When driven, a blunt-end pile that strikes a root or small obstruction may break through it. In case the soil is only slightly compressible and must be displaced, the tip of the pile is usually sharpened to the shape of a truncated pyramid (view A, fig. 16-32). The blunt end is about 4 to 6 inches square, the length of the point is 1 1/2 to 2 times the diameter of the pile at its foot. A crooked pile may be pointed for driving, as shown in view B, fig. 16-32. For hard driving, steel shoes are used to protect the tips of piles (view C, fig. 16-32). Improvised steel shoes are shown in view D, fig. 16-32.

Reinforcement of Wood Piles

Piles that have been weakened by marine borers can be strengthened and protected by

encasing them in concrete jackets. Steel reinforcing can be used in a concrete jacket either in the form of bars or wire mesh. Where damage is limited, concrete encasement may be used to cover a short section of the pile, as shown in figure 16-33, or may be extended well below the waterline or to the mud line.

The surface of a damaged pile should be scraped down to sound wood. Either metal or wood forms may be used. When wood forms are used, a 2-inch creosoted tongue-and-groove material should be used and left in place. Fender piles that are broken between the top and bottom wales can be repaired by cutting off the pile just below the break, then installing a new section of pile and fitting. A pile section or timber section is placed and bolted directly behind the fender pile from the top to the bottom wales. A metal wearing strip is then spiked to the wearing edge of the pile.

Preservation of Wood Piles

All timber used for piling and any other structure exposed to marine borers should be pressure treated with a creosote-coal tar solution containing approximately 30 percent coal tar. The treatment must be thorough and the penetration as deep as possible. The retention should be equivalent to at least 20 pounds of creosote per cubic foot of timber in the case of Douglas fir and 25 pounds per cubic foot in the case of Southern Yellow Pine. The use of untreated wood can seldom be justified, even for temporary structures, because marine borers can destroy it in a short period of time.

When pressure-treated materials have been cut or bored as to expose untreated wood, the untreated surface should be field treated with a generous application of a grease preservative or a hot creosote solution. Holes for bolting should

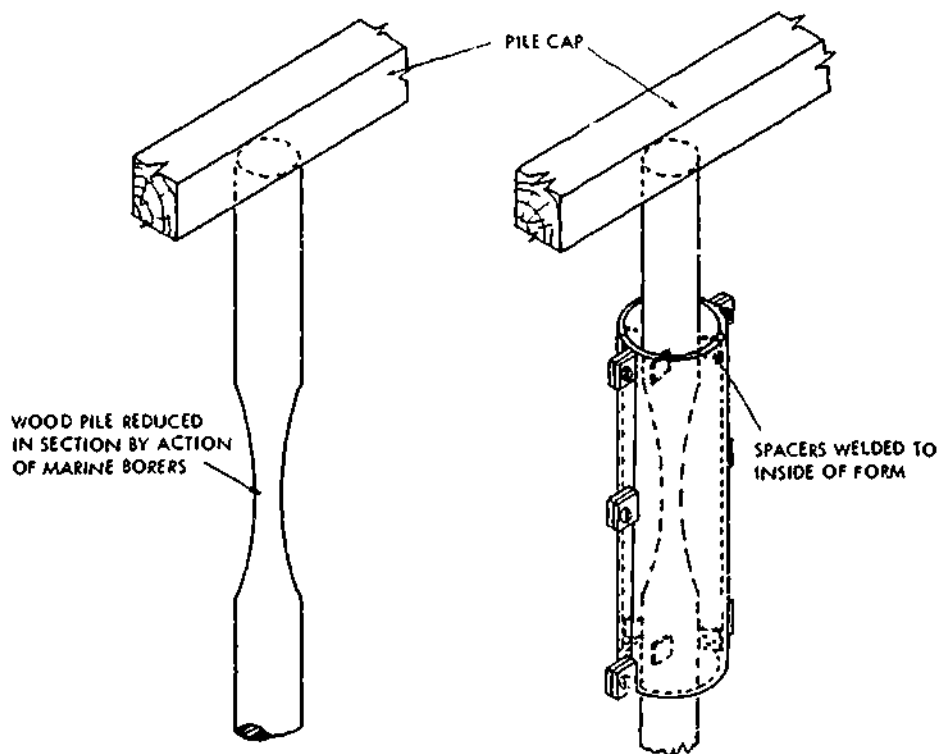
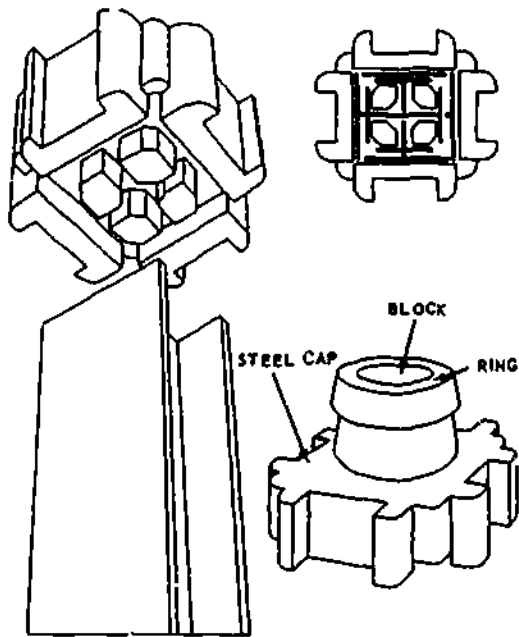

Figure 16-33.—Concrete encasement of short section of wood pile.

133.207



133.208

Figure 16-34.—HP-bearing pile and special cap for driving.

be neat but not oversized. They should be treated with a preservative applied with a bolt-hole treater or, if this cannot be done, with hot creosote poured into the holes. Grease preservatives can be applied with a grease gun. All cut surfaces should have a minimum of three brushed-on coats of hot creosote or a heavy coating of grease preservative applied immediately after exposure of the surface. In an emergency where time will not permit procurement of pressure-treated wood to repair a superstructure above the waterline, piles can be treated on the job. After replacement piles are cut and bored, they are soaked in hot creosote, pentachlorophenol, or a copper-naphthenate solution for a minimum of 2 hours before use. This is only a substitute for the pressure treatment and NOT to be used when pressure-treated wood is available.

STEEL BEARING PILES

The two most common types of steel bearing piles are the HP or so-called H-pile and

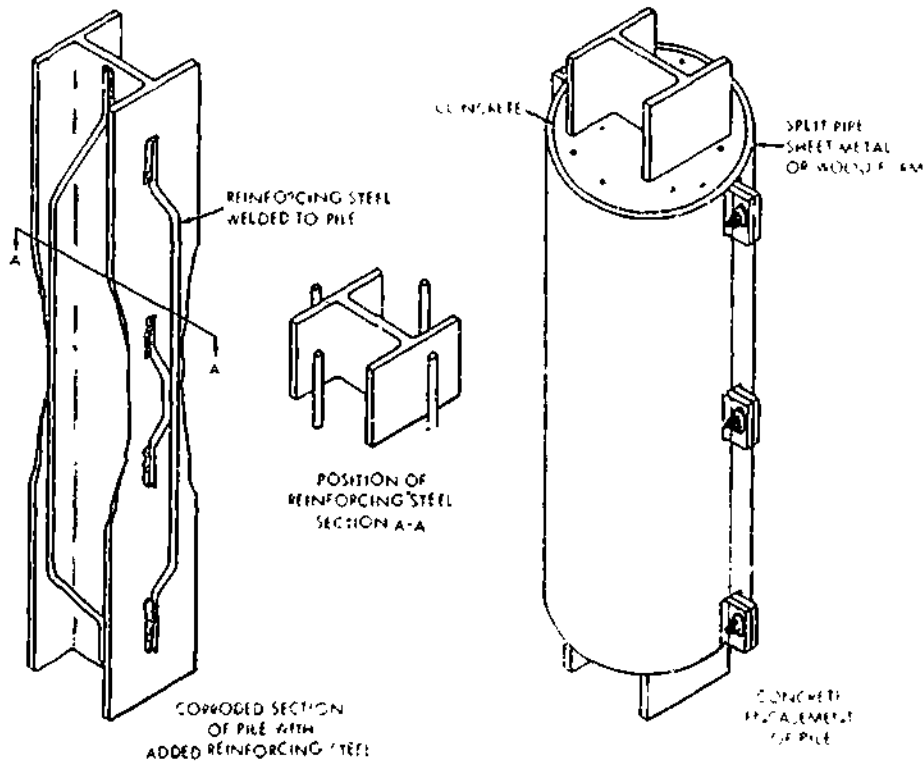

Figure 16-35.—Concrete encasement of steel piles.

133.208

the pipe pile. An OPEN-END pipe pile is open at the bottom; a CLOSED-END pipe pile is closed at the bottom. A special pipe-driving cap, as shown in figure 16-34, is used to drive the steel piles.

Reinforcement of Steel Piles

Steel members that have corroded in only limited areas may be repaired by welding metal fishplates onto the flanges and web. The corroded section should be first thoroughly cleaned out and any featheredges should be burned off back to a point where the metal is of sufficient thickness to hold a weld. The fishplates should have sufficient cross-sectional area to develop the full strength of the original section and should extend beyond the top and bottom of the corroded section as directed by the engineering department. Another method used is to encase the corroded section in reinforced concrete. After the corroded section is cleaned and corroded edges cut back, reinforcing rods are welded to the flanges and web. A form is then placed around the corroded section and filled with concrete. Figure 16-35 illustrates this procedure for steel piles. The same system can be used for other structural steel members

Preservation of Steel Piles

Protecting against corrosion is the main consideration in the maintenance of steel structures. In areas above the waterline, protection is afforded by means of protective coatings or encasement in concrete. The effectiveness of any coating or covering is its ability to prevent moisture and air from reaching the steel. Sandblasting is the most commonly used method of preparing steel so it can be protected. In wet sandblasting, a rust inhibitor, such as sodium nitrate, should be used. Power tools used for cleaning include rotary wire brushes, abrasive disks and wheels, chipping hammers, and rotary impact tools. They may be either electric or pneumatic. Handtools should

be used for small areas. Cleaning should remove all rust and scale down to the base metal. Oil and grease must be removed by a cleaner or solvent before the protective coating or covering is applied. All necessary safety precautions must be observed, including the use of goggles and respirators.

Hot coal-tar enamel applied over a coal-tar primer works effectively. The enamel is applied in two coats at right angles or in overlapping coats to a thickness of 3/32 inch. Since coal-tar enamel is somewhat brittle, it is apt to be damaged by contact with boats or heavy floating debris. In this case, cold coal tar can be applied instead. Also in the case where it is difficult to apply the hot enamel. Coal tar may be applied by a brush or a spray gun in two coats. The first coat should be permitted to dry for at least 24 hours before the second coat is applied. To protect against weathering, a coating of bituminous emulsion is applied also.

CONCRETE BEARING PILES

A concrete bearing pile may be CAST-IN-PLACE or PRECAST. A cast-in-place concrete pile may be a SHELL type or a SHELL-LESS type. A shell type cast-in-place pile is constructed as shown in figure 16-36.

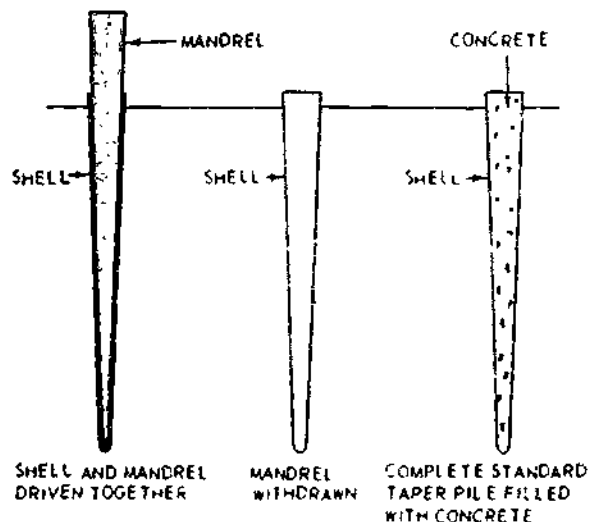

45.526

Figure 16-36.—Shell type cast-in place concrete pile.

A steel core called a MANDREL is used to drive a hollow-steel shell into the ground. The mandrel is then withdrawn, and the shell is filled with concrete. If the shell is strong enough, it may be driven without a mandrel.

A shell-less cast-in-place concrete pile is made by placing the concrete in direct contact with the earth. The hole for the pile may be made by driving a shell or a mandrel and shell, or it may be simply bored with an EARTH AUGER. If a mandrel and shell are used, the mandrel, and usually also the shell, are removed before the concrete is poured. In one method, however, a cylindrical mandrel and shell are used, and only the mandrel is removed before the concrete is poured. The concrete is poured into the shell, after which the shell is extracted. (See fig. 16-37.)

Casting in place is not usually feasible for concrete piles used in waterfront structures. Concrete piles for waterfront structures are usually PRECAST. Precast concrete piles are usually either square or octagonal in cross section; square-section piles run from 6 to 24 in. square. Concrete piles more than 100 ft long can be cast, but are usually too heavy for handling without special equipment.

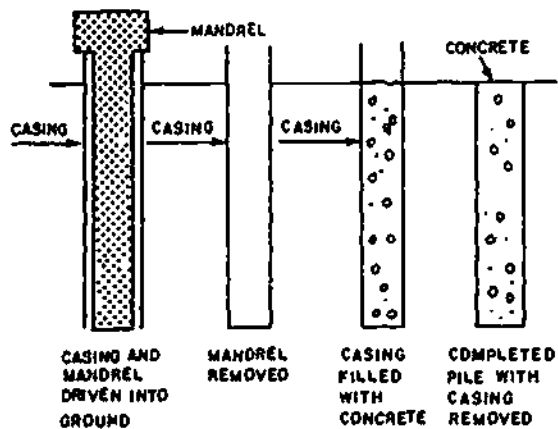

133.567
Figure 16-37.—Procedure for placing cast-in-ground concrete piles.

Repairs above the waterline can be made to free-standing components for such defects as spalling or cracks in piles and bracing. Pressure-applied mortar, epoxy formulations, normal portland cement concrete, or grout are applicable materials. Encasement of damaged portions in reinforced concrete (fig. 16-38) is the conventional method of repairing piling. It is always preferable to place concrete in a dry condition if economical and feasible; however, this requires cofferdams, pumping and working in the dry condition and is not always an economical solution. When the situation dictates, concrete can be placed under water. Forms may be used as shown in figure 16-38. Additional reinforcing in the form of rods or mesh is placed around the damaged pile, and sectional forms are used to hold the concrete in place until it cures. Forms may be made of pipe, sheet metal, or wood and are split in half vertically so that they can be placed around the pile and bolted together above the water. Each section is then slid into place and new sections added until the desired length is obtained. The form is then filled with concrete. Forms may be left in place or removed for reuse. Where only a section of the pile is to be encased in concrete and the forms do not extend to the mud line, the lowest section of the forms must be closed to hold the concrete or aggregate and grout in place. Pressure-applied concrete may be used to make sectional forms. These are built upon cylinders of expanded-metal laths shaped to fit around the pile. Wire-mesh reinforcement may be used outside of the metal lath where additional strength is required. Pressure-applied concrete is used to make a sectional form 1 or 2 inches thick, and the concrete is allowed to set. This form is then dropped into place and filled with concrete.

SHEET PILES

Sheet piles are special shapes of interlocking piles made of steel, wood, or formed concrete. They are widely used to form a continuous wall to resist horizontal pressures resulting from earth or water loads. Examples include retaining walls, cutoff walls, trench sheathing, cofferdams,

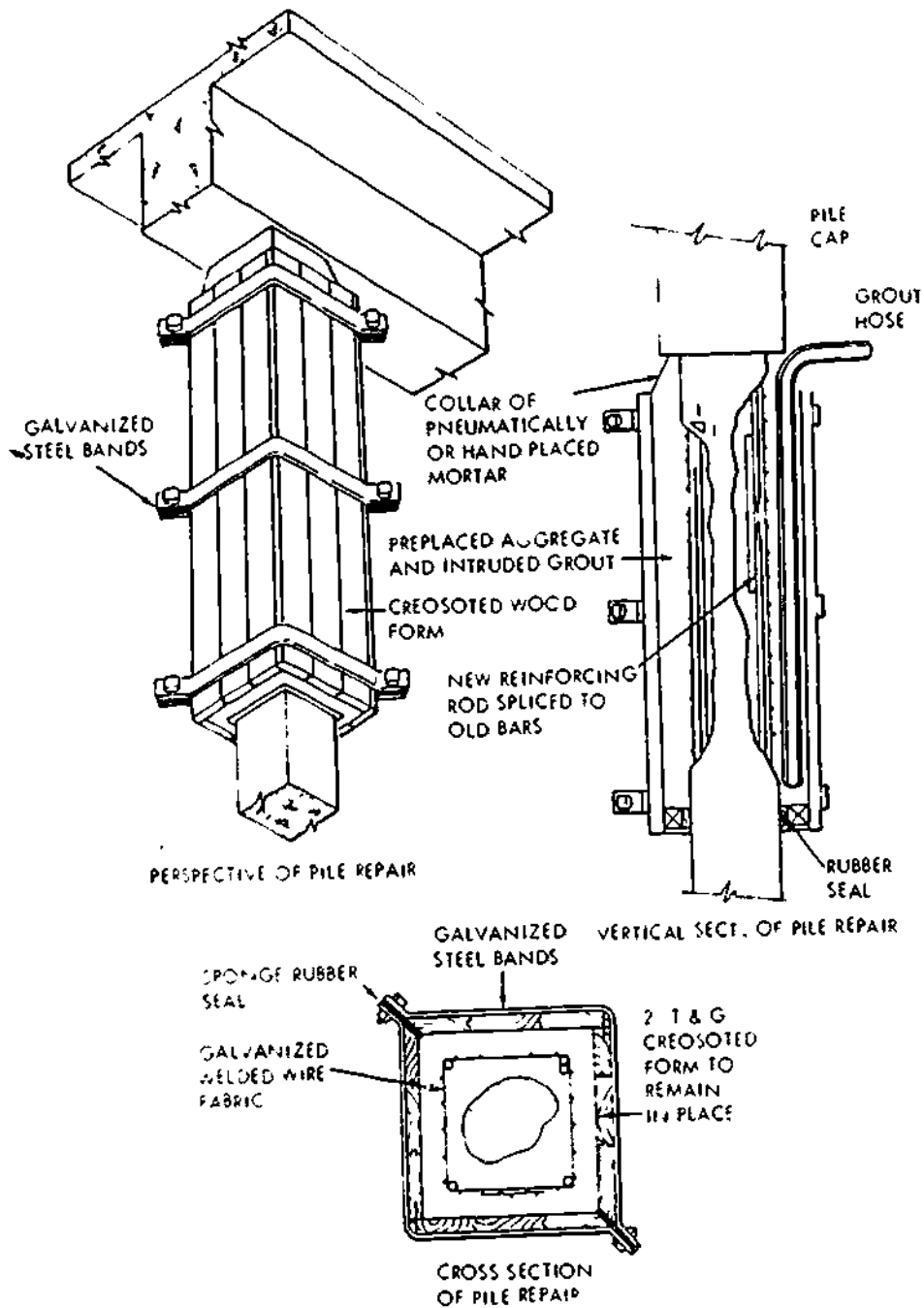

133.209

Figure 16-38.—Encasement of damaged piles.

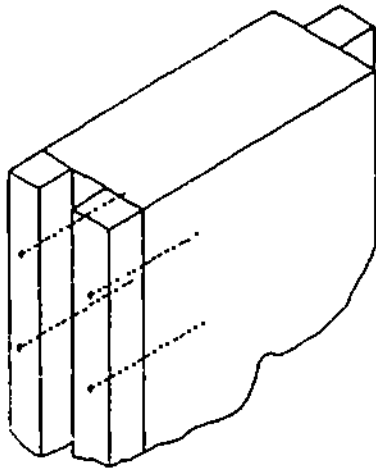

133.393
Figure 16-39.—Fabricated tongue-and-groove timber sheet piling.

and bulkheads in wharves, docks, or other waterfront structures. Cofferdams exclude water and earth from an excavation so that construction can proceed easily. Cutoff walls are built beneath water-retaining structures to retard the flow of water through the foundation.

Sheet piles may also be used in the construction of piers for bridges and left in place. Here, steel-sheet piles are driven to form a square or rectangular enclosure. The material inside is then excavated to the desired depth and replaced with concrete.

Fabricated Timber-Sheet Piles

When timber is abundant in a theater of operations and the supply of steel-sheet piles is limited, timber-sheet piling may be fabricated to resist light lateral pressures. Where marine borers

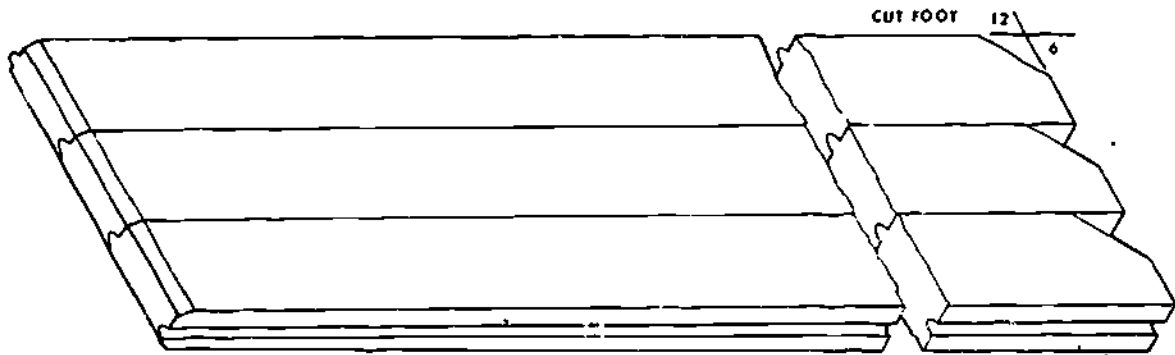

133.394
Figure 16-40.—Timber-sheet piling fabricated from planking.

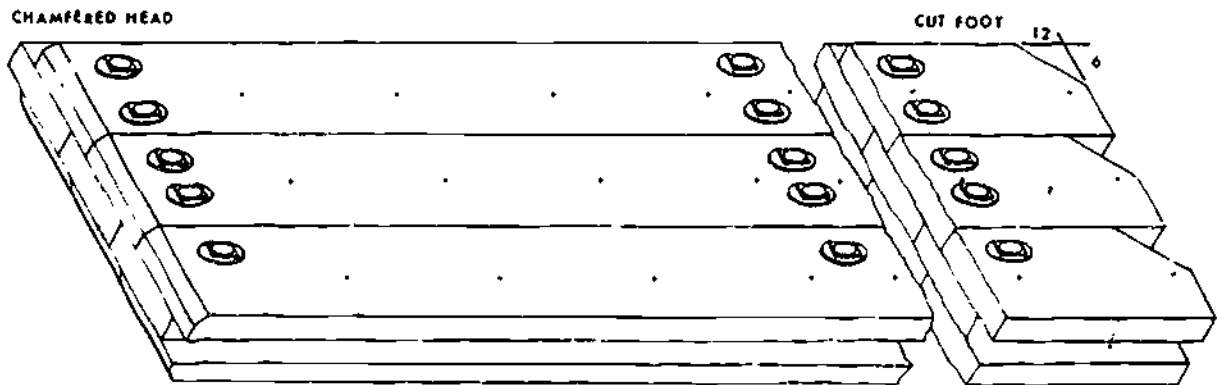

133.395
Figure 16-41.—Fabricated timber-sheet piling, Wakefield type.

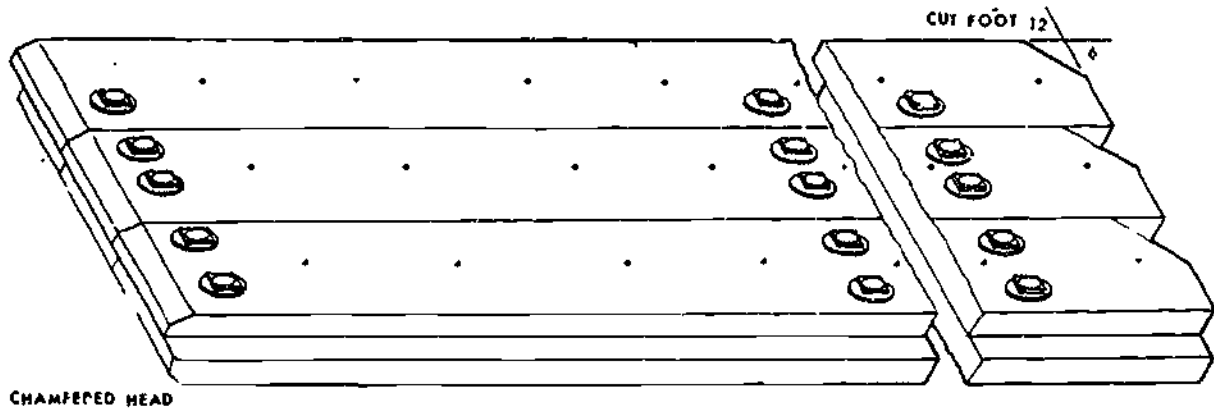

133.396

Figure 16-42.—Timber-sheet piling fabricated from heavy timbers.

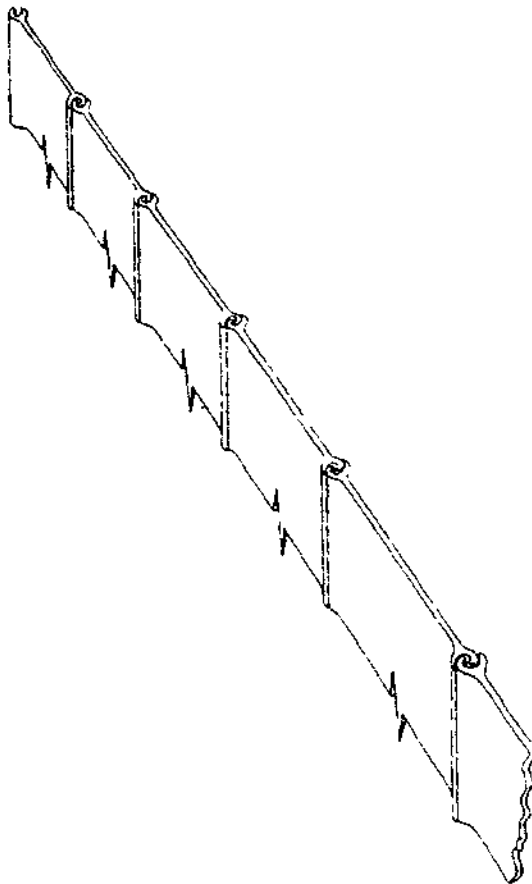

133.397

Figure 16-43.—Standard straight-web steel-sheet pile (section type SA-23).

are active or the structures are permanent rather than temporary, the timber-sheet piling is creosoted. Tongue-and-groove piling of single thickness (fig. 16-39) is used where only earth pressures are involved, such as in excavating a trench above the water table. For heavy lateral pressures and watertightness, other types of fabricated timber-sheet piling are used. See figures 16-40, 16-41, and 16-42.

Steel-Sheet Piles

The edges of steel-sheet piles are called INTERLOCKS, because they are shaped for locking the piles together edge to edge. The part of the pile between the interlocks is called the WEB. Piles are manufactured in five standard section shapes: STRAIGHT WEB (fig. 16-43), ARCH (fig. 16-44), DEEP ARCH (fig. 16-45), Z-SECTION, and CORNER-SECTION. Sections vary slightly in shape with different manufacturers, each of which has a particular letter and number symbol.

Concrete-Sheet Piles

Concrete-sheet piles are reinforced precast concrete piles of rectangular cross section, with tongue-and-groove interlocks. A working

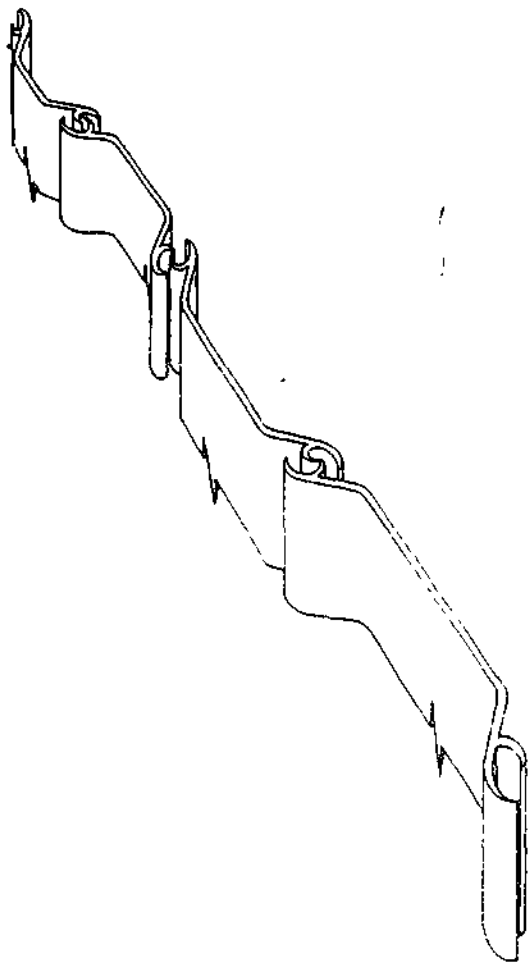

133.398

Figure 16-44.—Standard shallow-arch steel-sheet pile (section type AP-3).

drawing for a concrete-sheet pile is shown in figure 16-46.

Sheet Piling Repair

Local damage or holes can be repaired by welding on plates or sections of steel-sheet piling. Wooden plugs can be used to fill small holes.

Sometimes, damaged sheet piling can be protected with a concrete facing. All rust, scale, and marine growth are removed before the concrete is placed. When applied to the exposed

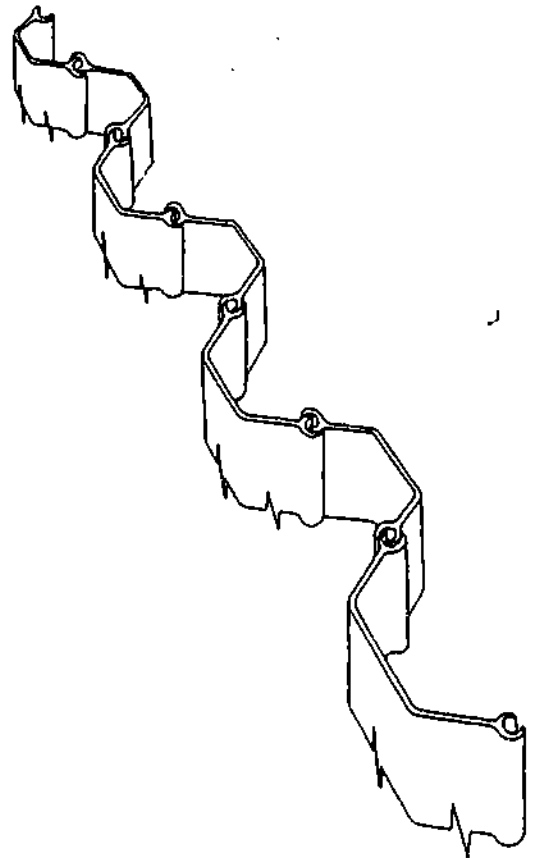

133.399

Figure 16-45.—Standard deep-arch steel-sheet pile (section type DA-27).

exterior face of the piling, concrete should be at least 6 inches thick and extend well beyond the area of corrosion damage, or deterioration. Forms should be made of wood and supported in place with zinc-coated stud bolts that are welded to the sheet piling.

PILE-DRIVING EQUIPMENT

Under normal operating conditions, piles are driven with a steel-frame, skid-mounted piledriver or a crane-shovel rigged with standard pile-driving attachments. A piledriver supports the leads (hammer guides), raises the pile in the leads, and operates the hammer, which delivers the driving force. The leads support and align

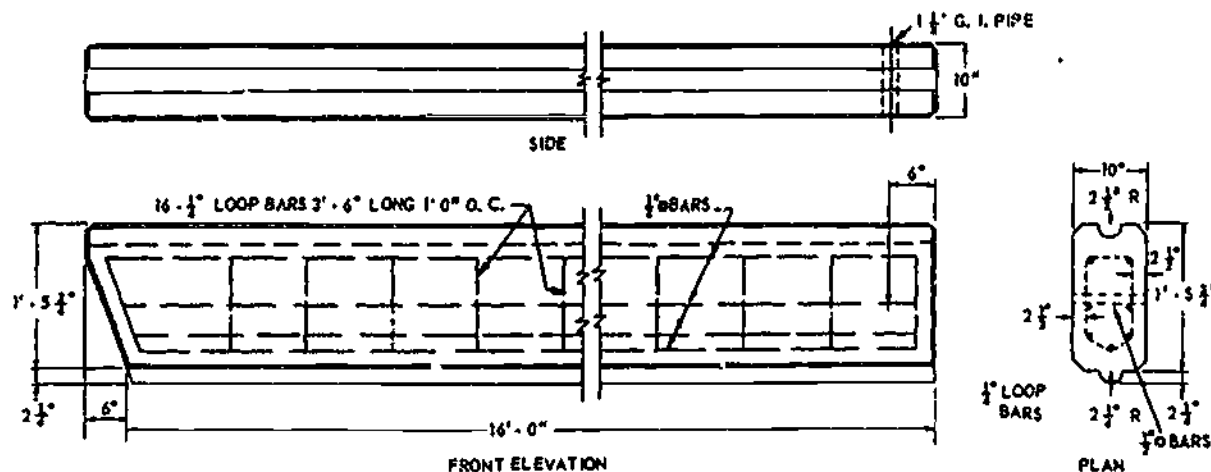

Figure 16-46.—Concrete-sheet pile.

133.213

the pile during driving and control the lateral motion of the hammer. Other equipment is needed to handle stockpiled piling and to straighten, cut, cap, or brace the piles. Under special driving conditions, additional support equipment may be required.

The principal types of pile-driving hammers used by SEABEES are the DROP HAMMER, the SINGLE- or DOUBLE-ACTING PNEUMATIC HAMMER, and the DIESEL HAMMER.

DROP HAMMER

The drop hammer is usually a block of steel that is set into the leads, raised, and then dropped onto the pile. Hammer weights range from 1500 to 12,000 pounds, depending on the type of piles being driven. The hammer should weigh 1 1/2 to 2 times as much as the pile and fall a distance of 6 to 15 feet. Fifteen to twenty hammer blows are struck per minute. A driving cap is installed on most hammers to keep the pile from brooming. The driving cap is a block of steel that slips over the head of a pile. The hammer falls onto a block of wood that fits into the top of the driving cap, as shown in figure 16-47.

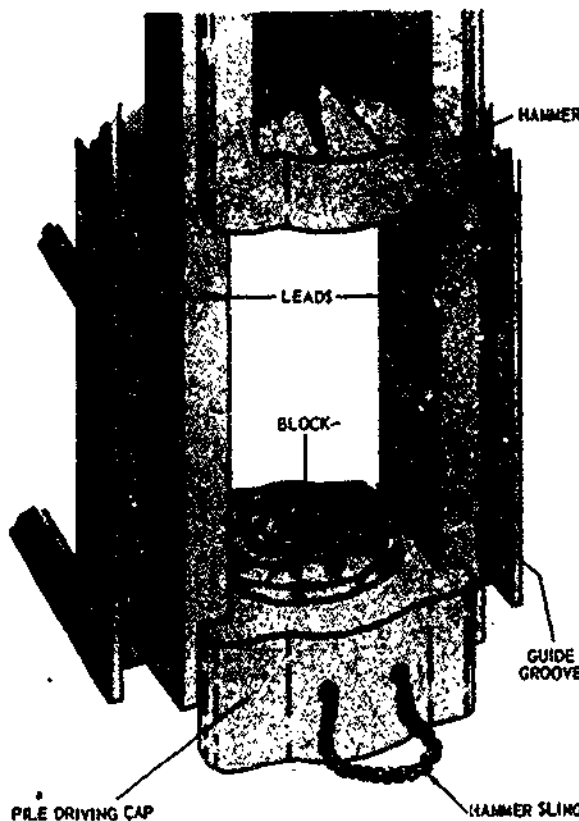
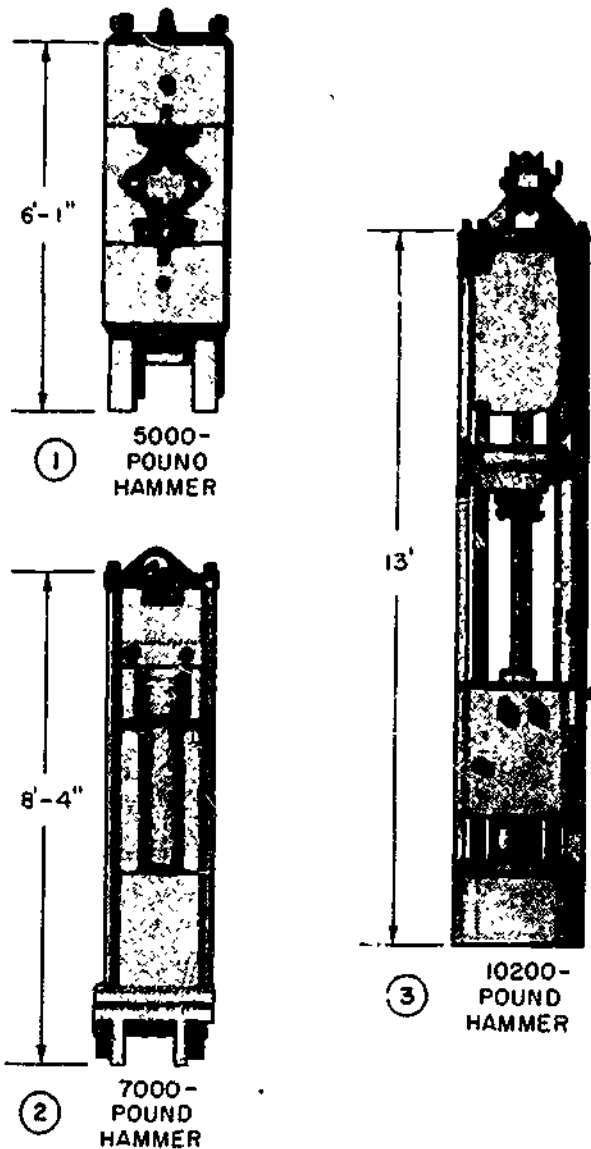

Figure 16-47.—Cap for driving timber piles by drop hammer.

133.214

**SINGLE-ACTING
PNEUMATIC HAMMER**

A single-acting pneumatic hammer consists of a stationary cylinder and a moving part (the ram) which includes the piston and striking lead. The piston is raised by air or steam pressure and falls by gravity through a distance of 32 to 36 inches. Fifty to eighty blows are struck per



133.215
Figure 16-48.—Steam or pneumatic pilehammers.



133.216
Figure 16-49.—Pile being driven with a pneumatic hammer.

minute. Ram weights range from 3000 to 14,000 pounds. See figure 16-48.

DOUBLE-ACTING PNEUMATIC HAMMER

In a double-acting pneumatic hammer, the ram is raised by air or steam pressure and also forced down by pressure. Ram weights vary from 5000 to 10,000 pounds. Between 80 and 550 blows are struck per minute; each stroke

travels less than 2 feet. The operating pressure for pneumatic hammer is about 100 psi. Air or steam is fed through a 2-inch hose at a rate of 100 to 600 cfm (cubic feet per minute). A double-acting hammer is generally used to drive light or average weight piles into soils of average density because the rapidity of blows tend to keep the pile in motion and thereby reduce the effects of friction. Because of its lighter ram and shorter strokes, the double-acting hammer is faster than the single-acting hammer. The pile-driving rigs shown in figures 16-49 and 16-50 are equipped with pneumatic hammers.



Figure 16-50.—Pneumatic piledriver in operation on a barge.

133.687

DIESEL HAMMER

The diesel hammer works about twice as fast as a conventional pneumatic hammer of comparable size and weight. A self-contained unit, the diesel hammer is constructed in sizes capable of delivering up to 22,400 foot-pounds of energy per blow.

The McKiernan-Terry pilehammer illustrated in figure 16-51 is made up of a cylinder, ram-piston, fuel pump, built-in fuel tank that holds supplies for three days, and an inertia oil pump that mechanically lubricates during operation.



133.217

Figure 16-51.—Diesel hammer.

PILE-DRIVING OPERATIONS

The piledriver must be securely ballasted, guyed, anchored, or otherwise fastened in place to avoid a shift of position. If the piledriver shifts during driving, the blows of the hammer will be out of line with the axis of the pile and both the pile and the hammer will be damaged.

The pile should be carefully watched for any indication of a split or break below ground. If driving suddenly becomes easier, or if the pile suddenly changes direction, a break or split has probably occurred. When this happens, further driving is useless.

Pile-driving leads serve as tracks along which the hammer runs and as guides for positioning and steadying the pile before it is driven. See figure 16-52. Leads can be constructed of either wood or steel. Figure 16-53 illustrates the assembly of sections of steel leads. Adapters connect the leads of the piledriver to the point of the crane boom, as shown in figure 16-54. All leads and adapters have a standard bolt-hole layout. Sheaves are attached to the point of the crane boom and cables run from the crane through the sheaves for lifting the hammer and piling. The lead sections are assembled on the ground and attached to the crane boom, as shown in figure 16-55. The leads are then raised by topping up the boom, as shown in figure 16-56. Booms or leads must NOT be brought into contact with overhead high-tension wires.

A ladder is attached to the back of the leads. Crewmembers work from this ladder when guiding the piles into place and unhooking the cable from the piles. The foot of the leads is braced with a telescoping catwalk (fig. 16-57), connected to the base of the boom. The hammer and pile cap are then placed in the leads, as shown in figures 16-58 and 16-59, respectively. The length of the catwalk and the angle of the boom are varied so the leads can be held in a vertical position for driving bearing piles or sloped for driving batter piles. On a skid rig or barge, a slightly curved beam (called moonbeam) is placed transversely at the forward end of the skid frame to regulate side batter, as shown in

16-32

620



Figure 16-52.—Pile positioning before driving.

133.568

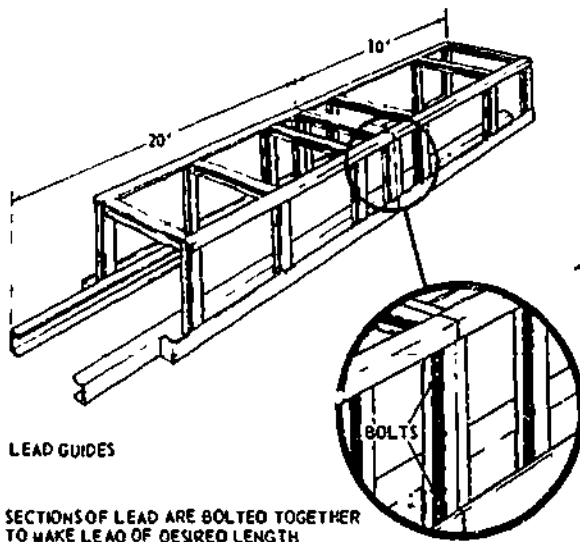

143.17
Figure 16-53.—Assembly of 10- and 20-ft lead sections.

figure 16-60. Each rig working over the water must be equipped with lifelines and life preservers.

The signalman is the boss of the rig and normally the only person giving signals to the operator of the rig and valve operator. The only signal any other person may give that the operator will obey is the **EMERGENCY STOP SIGNAL**. Working on the lead ladder, the

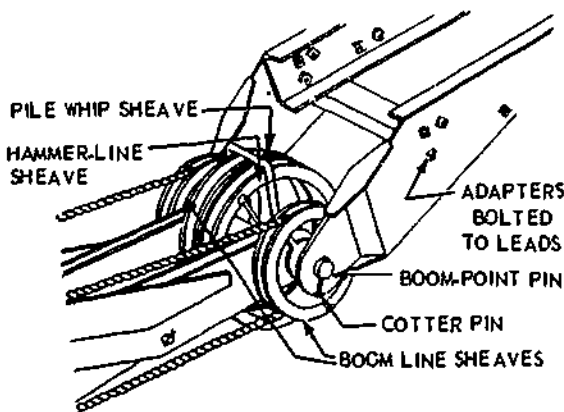

143.19
Figure 16-54.—Crane-shovel adapters bolted to standard leads.



143.18
Figure 16-55.—Leads on ground and attached to boom with adapter.

loftman guides the pile under the hammer and into the leads and unhooks the line from the pile. The loftman also helps on the ground around the rig. The hoisting engineer runs the crane or the winches in lifting piles and the hammer. The valve operator controls the air or steam for the hammer. The hook-on crewmember hooks the line onto the piling to be driven, chamfers and points all the piling to be used, and helps set the pile into the leads. Everybody must be careful **NOT** to place parts of the body under a suspended hammer unless it is dogged or blocked in the leads.

After the first bent is driven, piles in subsequent bents may be located by the use of a

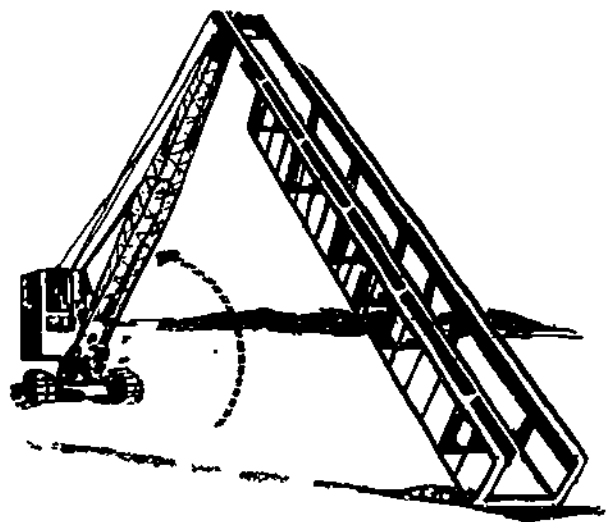

143.20
Figure 16-56.—Raising leads with boom.

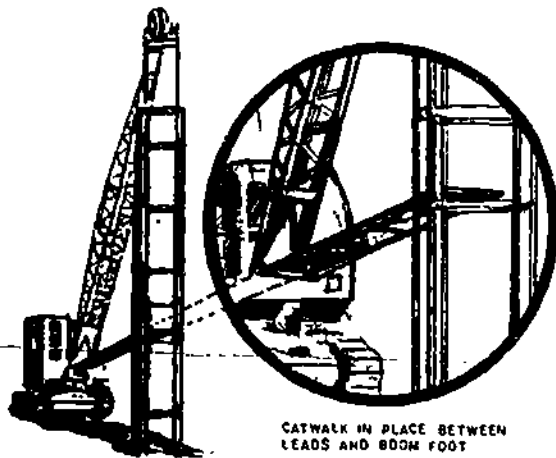

133.569
Figure 16-57.—Catwalk attached to foot of boom and leads.

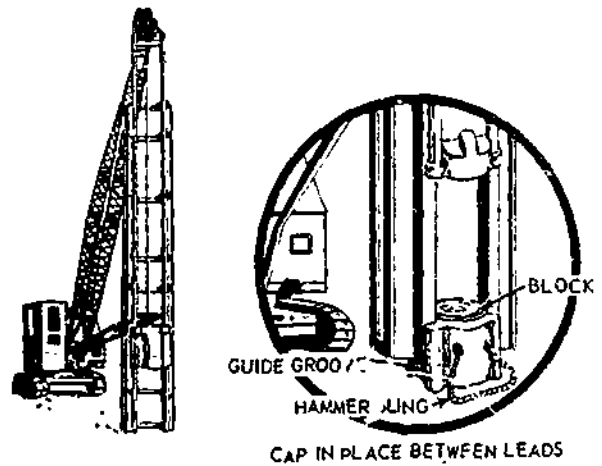

143.22
Figure 16-59.—Placing pile cap in leads.

floating TEMPLATE like the one shown in figure 16-61. Pairs of BATTENS, spaced in accordance with the specified spacing between piles in a bent, are nailed across a pair of timbers, spaced in accordance with the specified spacing between bents. The parts of each batten lying beyond the timbers are hinged for raising. The template is lashed to the outer piles in the bent already driven by means of a pair of wire

ropes, equipped with turnbuckles as shown. After the piles in the new bent are driven, the hinged parts of the battens are raised, the wire ropes are let go, and the template is floated out from between the bents.

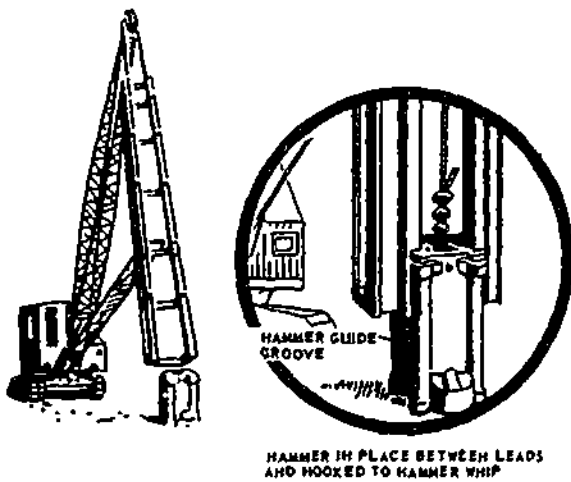

143.21
Figure 16-58.—Placing hammer in leads.

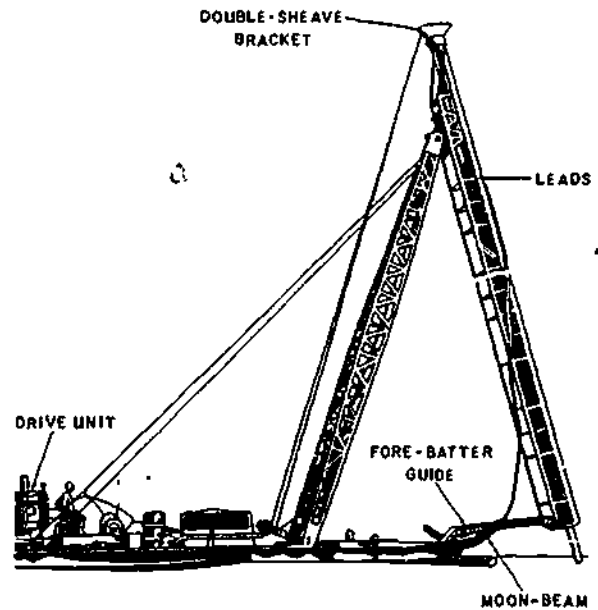

133.219
Figure 16-60.—Steel-frame, skid-mounted piledriver.

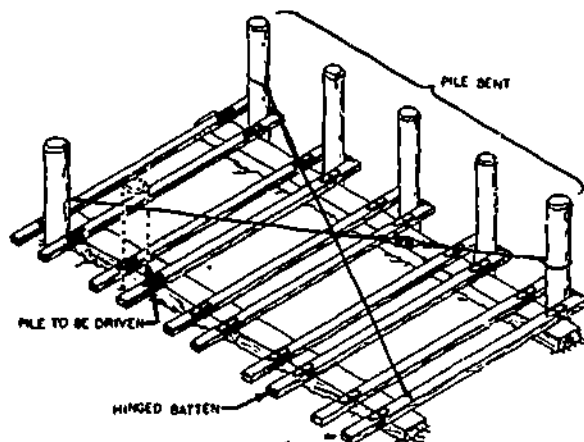

133.220

Figure 16-61.—Floating template for positioning piles.

Piles can be driven either tip or butt down, they may be driven butt first if a large bearing area is required or if the pile is to resist an upward force.

When a pile driver is not in use, the hammer must be held in place at the bottom of the leads by a cleat or a timber fastened to the leads.

The main working platform on a pile driver must be kept clear of lumber, ropes, tools, debris, and all other unnecessary obstructions.

When handling piles, crewmembers must wear heavy gloves, safety shoes, and hard hats. Also goggles and protective cream on exposed skin, if the piles are creosoted. And respirators, if the working area is confined. While working over the water, crewmembers must wear lifevests. Those who point piles with axes must wear guards to protect their shins and feet.

DRIVING BEARING PILES

When bearing piles are driven on land, the position of each pile is usually located by the Engineering Aid and marked with a stake. The positions of a series of pile bents driven in water are located by means of a wire rope long enough to stretch between the abutments. This rope is marked with pieces of tape, each spaced in accordance with the distance between bents.

There are four major steps in driving a bearing pile with a drop-hammer rig. In step 1, the piledriver is brought into position over the pile location, and the hammer and cap are run up to the top of the leads. In step 2, the hoist line is attached to a choker line which is placed near the top of the pile. The pile is raised into the leads. (See fig. 16-62.) The tip of the pile is placed in the proper position. A member of the pile crew can climb the leads and use a tag line to help align the pile in the leads. (See fig. 16-52.) In step 3, the hammer and cap are lowered onto the top of the pile, and the cap is detached from the hammer. In step 4, the hammer is raised then dropped to drive the pile.

Driving should be started slowly with a drop hammer; the hammer should be raised only a few inches until the pile is firmly set. The height of the drop should then be gradually increased to a maximum of 10 or 15 ft. Blows should be applied as rapidly as possible, to keep the pile moving and prevent resistance caused by inertia and friction.

With the pneumatic hammer the first blows should be given under reduced pressure, until the pile is firmly set. Pressure should then be gradually increased to the maximum.

DRIVING BATTER PILES

The prescribed angle for a batter pile is indicated on working drawings as shown in figure 16-63. The angle is obtained by setting the leads. On a crane rig, the leads are set by adjusting the length of the catwalk. On a steel-frame, skid-mounted rig, the leads are set by adjusting the length of the fore batter guide, position of the leads on the moonbeam, or both.

A certain amount of figuring is required, both for setting the leads and for locating the point of penetration of the pile. Here is a sample lead-setting problem. Suppose the leads are 65 ft high and must be set for a 1-in-12 batter. How far must the foot of the leads be offset from the vertical position to get the required batter?

In this case, the batter indicates a unit of run of 1 for every 12 units of rise. The total rise of the leads is the height of the leads, or 65 ft. The total run of the leads must be offset from the vertical position by a distance equal to the value

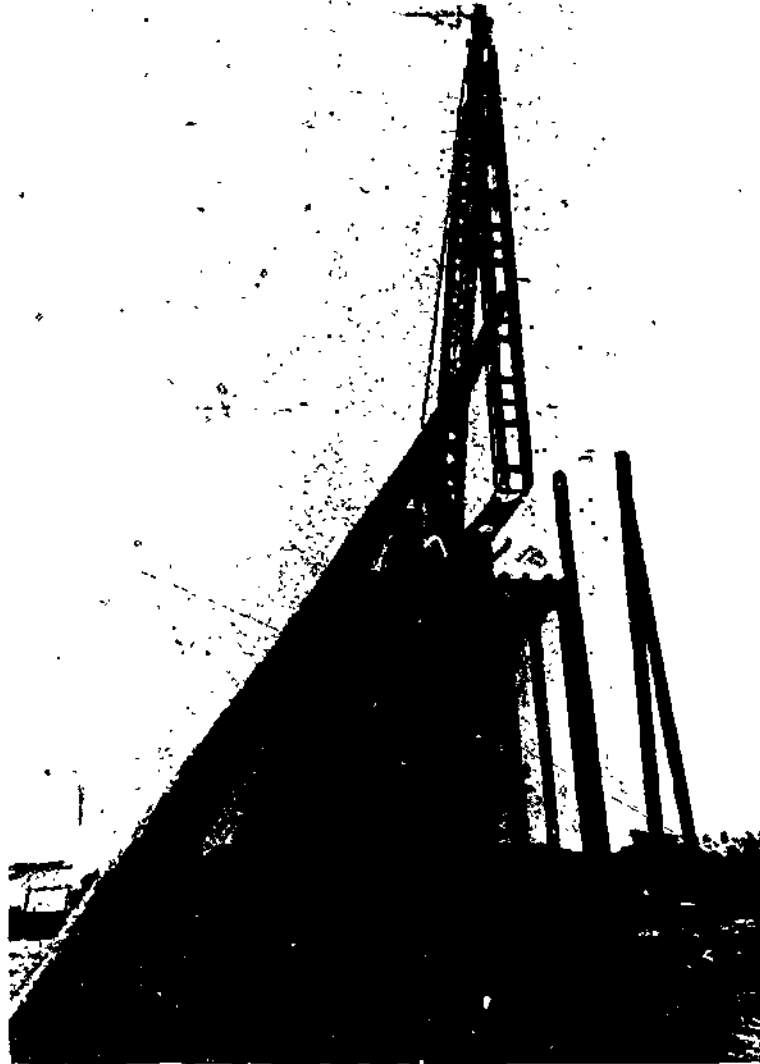

Figure 16-62.—Pile being raised into position.

133.570

of x in the proportional equation $1:12::x:65$ ft or $5\frac{5}{12}$ ft, or 5 ft 5 in.

The problem of locating the point of penetration of a batter pile is illustrated in figure 16-64. The working drawings show the location of the head of the pile and the vertical distance of the top of the pile above the ground line after the pile is driven. For a given batter, the point of penetration of the pile will be a given distance away from a point on the ground directly below the location of the head of the pile. Suppose the batter is again 1 in 12 and the vertical distance

of the top of the driven pile above the ground line is 36 ft. The distance between the point of penetration of the pile and a point on the ground directly below the location of the head of the pile must therefore be the value of x in the proportional equation $1:12::x:36$ ft or 3 ft.

DRIVING SHEET PILES

Sheet piles are frequently driven without leads, as shown in figure 16-65. A FLYING

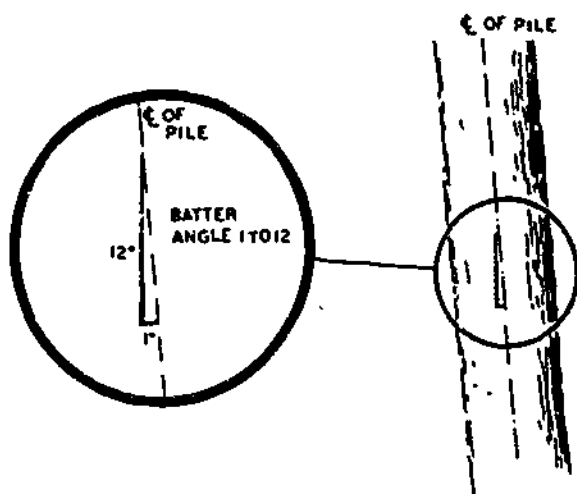

45.525

Figure 16-63 --Batter angle of a pile.



133.222

Figure 16-65.--Driving sheet piles with flying hammer.

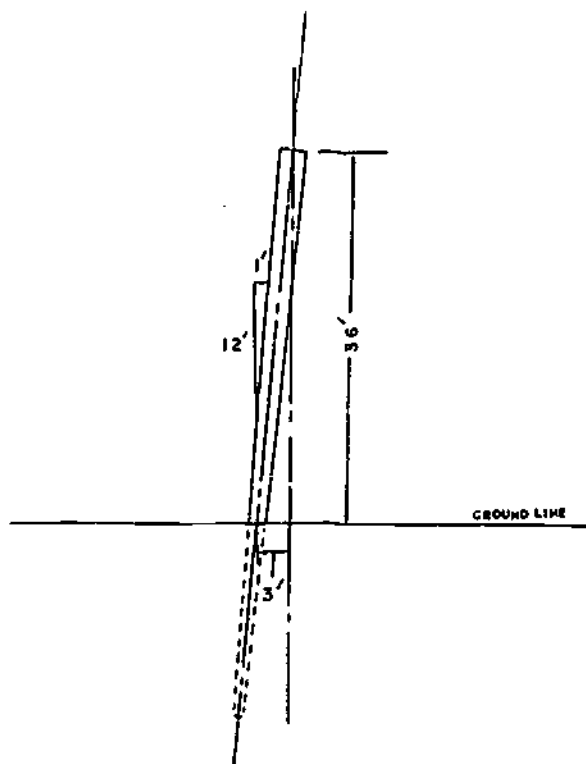

133.221

Figure 16-64.--Locating point of penetration for a batter pile.

hammer is used, NOT the drop hammer. The cap of the hammer is equipped with a device which fits over the top of the pile. The crane operator slacks the hammer hoist line just enough to keep the hammer in contact with the pile as the pile goes down.

When driven with a flying hammer, sheet piles are held upright by one or more pairs of elevated wales, supported by a braced framework of studs. The wales also guide the alignment of the piles. For piles driven in deep water, a system of floating wales is used.

Steel sheet piles must be locked together as they are driven. After the first pile is driven, or set in place for driving, the next pile must be hoisted high enough to bring its foot level with the head of the pile already in place. A crewmember on the head of the first pile guides the interlock on the second pile into the interlock on the first. This crewmember, who is hoisted to the top of the pile by the pile whip, is supported by a steel STIRRUP which straddles the top of the pile.

When arch or deep-arch-steel sheet piles are driven with the arch webs all extending in the same direction, the piles are said to be driven **WEBS IN LINE**. When the piles are driven with arch webs extending alternately in opposite directions, they are said to be driven **WEBS REVERSED**. In interlocking, the **BALL** on the interlock of one pile fits into the **SOCKET** on the interlock of the adjoining pile. In driving, the **BALL** pile is driven first and the socket pile is fitted to it; this is called driving the piles **BALL-END LEADING**. If the socket pile were driven first, the socket would fill up the soil which would compact under the ball on the ball pile. This could create enough pressure to force open the socket.

Springing and Bouncing

SPRINGING means an excessive lateral vibration of the pile. It occurs when the pile is crooked, or when the butt is not square, or when the axis of the pile is not in line with the direction of fall of the hammer or ram. When the pile is out of line with the hammer, the head of the pile may be damaged severely, the hammer may be damaged as well, and a great deal of force of the hammer blow will be lost.

Excessive **BOUNCING** of the hammer may be caused if the hammer is too light. It is usually caused, however, by a crushed or **BROOMED** head on a timber pile, or when the tip or foot of the pile has met an underground obstruction, such as a rock or a layer of extra-dense soil. If the butt of a timber plate has been crushed or broomed for more than an inch or so, it should be cut back to solid wood before driving is continued.

With a double-action hammer, excessive bouncing may be caused when the steam or air pressure is too high.

Obstruction and Refusal

When a pile has reached a level where 6 blows of a drop hammer or 20 blows of a steam or air hammer will not drive it more than an average of 1/8 in. per blow, the pile has either encountered an obstruction or it has been driven to **REFUSAL**. In either case, further driving is likely to break or split the pile. If the lack of

penetration seems to be caused by an obstruction, 10 or 15 blows of less than maximum force may be tried, in the hope that they may cause the pile to displace or penetrate the obstruction. For obstructions which cannot be disposed of in this manner, it is often necessary to **PULL** (extract) the pile and blast out the obstruction with an explosive lowered to the bottom of the hole.

When a pile has been driven to a depth where further penetration is prevented by friction, the pile has been driven to refusal. A pile which is intended to be supported by skin friction alone is called a **FRICTION** pile. A pile which is intended to be supported by bedrock or an extra-dense layer of soil at the tip is called an **END-BEARING** pile. A pile which is intended to be supported partly by skin friction and partly by a substratum of extra-dense soil at the tip is called a **COMBINATION END-BEARING AND FRICTION** pile.

It is not always necessary to drive a friction pile to refusal; such a pile needs to be driven only to the depth where friction develops the required load-bearing capacity.

PULLING PILES

A pile which has met an obstruction, or which has been driven in the wrong place, or which has split or broken in driving, or which is to be salvaged (steel sheet piles are frequently salvaged for reuse) is usually **PULLED** (extracted). Pulling should be done as soon as possible after driving; the longer the pile stays in the soil, the more compact the soil becomes, and the greater the resistance to pulling will be. Methods of pulling piles are described below.

In the **DIRECT LIFT** method, a crane is used to pull the pile. The crane whip is slung to the pile and a gradually increased pull is applied, up to just a little less than the amount which is expected to start it. Lateral blows from a **SKULL CRACKER** (heavy steel ball, swung on a crane whip to demolish walls), or a few light blows on the butt or head with a driving hammer, are given to break the skin friction, and the crane pull is then increased to maximum capacity.

The 5000-pound double-acting hammer, shown in figure 16-66 may be used in an inverted position to pull piles. The hammer is turned over and a wire rope sling is passed over it and attached to the pile. After the hammer whip is heaved taut, upward blows of the ram on the sling, plus the pull of the hammer whip are usually enough to pull the pile.

TIDAL LIFT is often used to pull piles driven in tidewater. Slings on the piles are attached to barges or pontoons at low tide; the rising tide pulls the piles as it lifts the barges or pontoons.

PLACING PILES BY JETTING

Pile penetration is often made easier by JETTING, or forcing water under pressure around and under the pile to lubricate and/or displace the surrounding soil as shown in figure

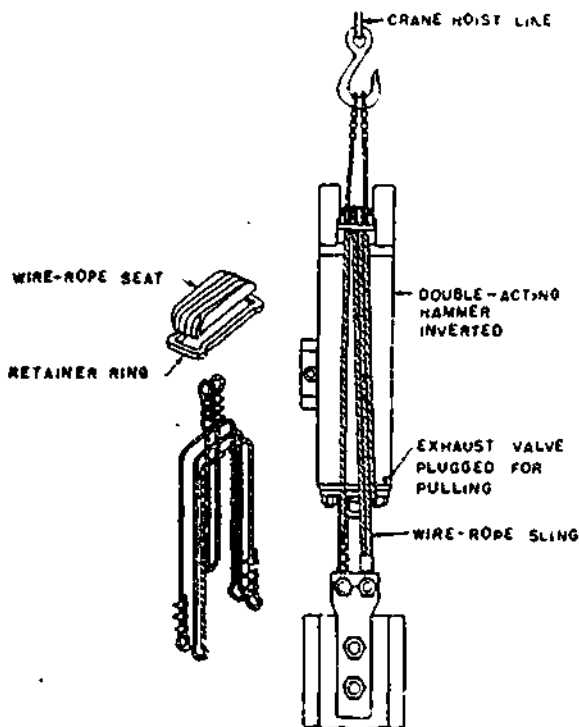

177.414
Figure 16-66.—Wire-rope sling used with 5,000 lb air steam hammer to pull piles.

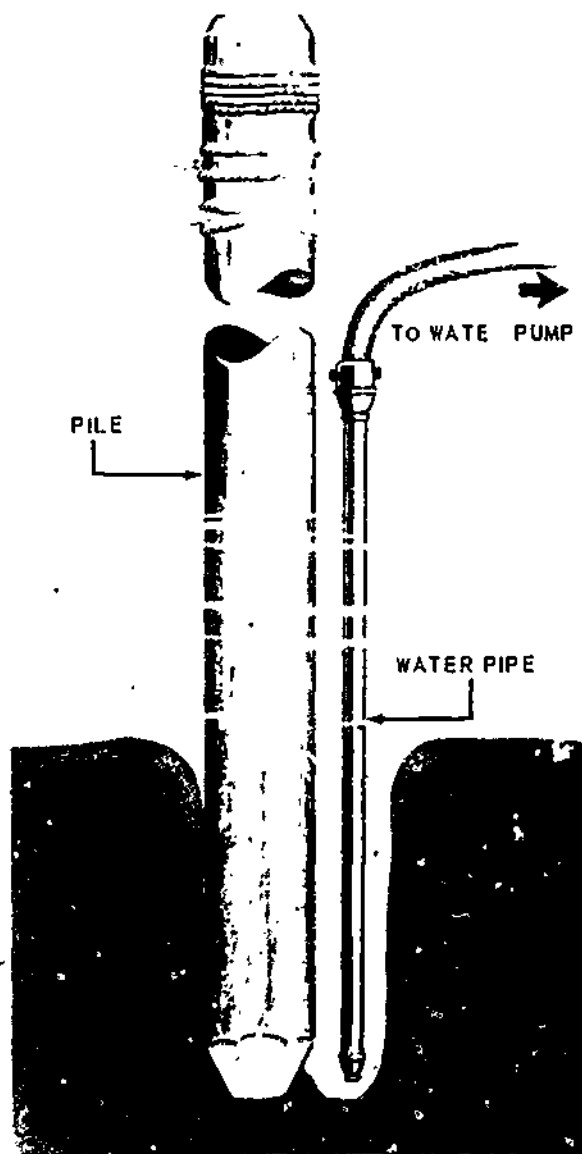

133.226
Figure 16-67.—Jetting with a single jet pipe.

16-67. Jetting equipment consists of a water pump, a length of flexible hose, and a metal JET PIPE; jet pipes run from 2 1/2 to 3 1/2 inches in diameter.

A single jet pipe is used as follows. The pile is set in position, with the hammer resting on it for extra weight, and the jet pipe is manipulated

to loosen and wash away the soil from under the tip as shown in figure 16-67. As the soil is washed away, the pile sinks under its own weight and that of the hammer. A few hammer blows are struck occasionally to keep the pile moving downward. When it is within a few feet of the desired final position, the jet pipe is

withdrawn and the pile is driven the rest of the way with the hammer.

The action of a single jet pipe on one side of a pile tends to send the pile out of plumb. Whenever possible, two pipes should be used, lashed to the pile on opposite sides, as shown in figure 16-68.

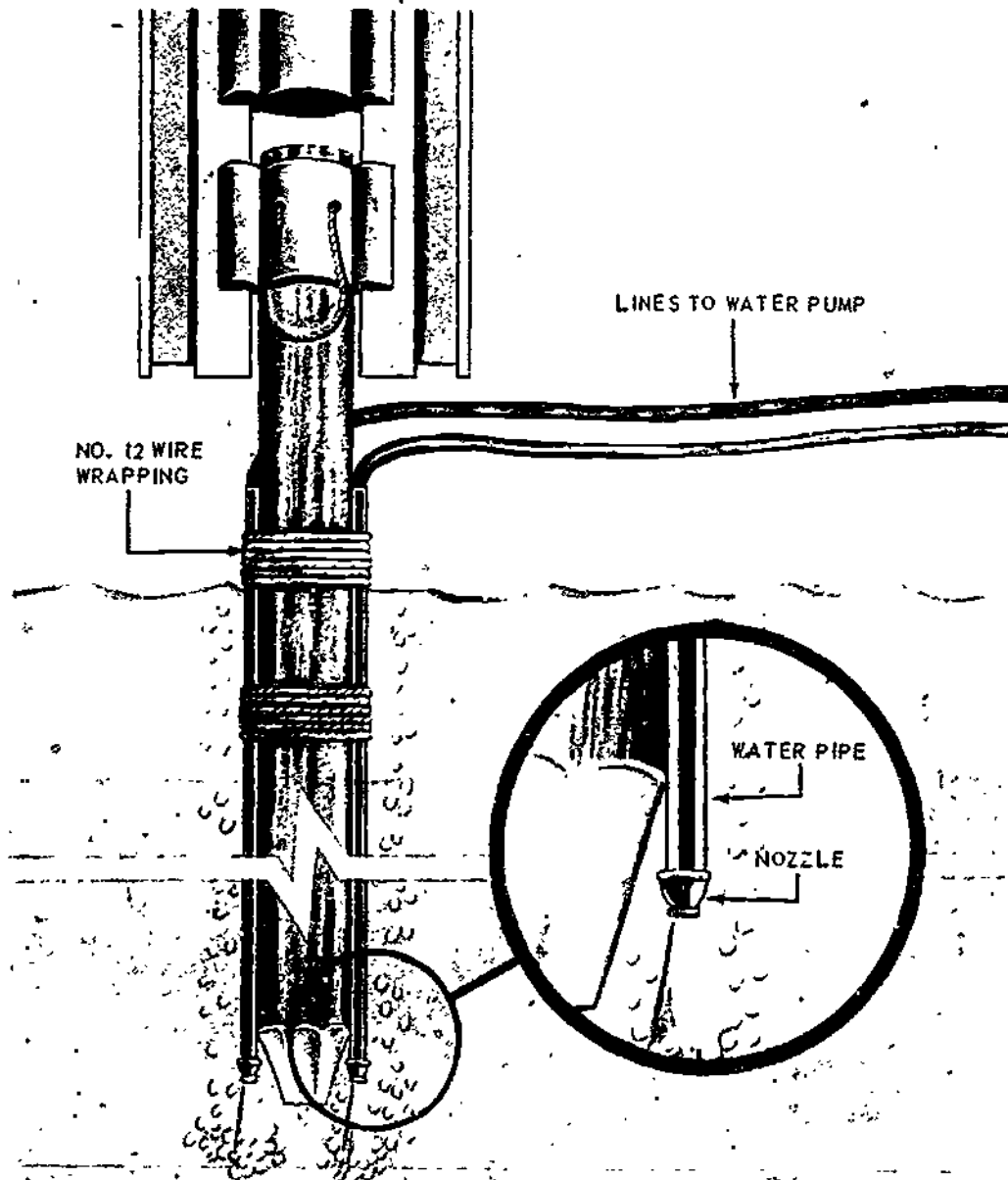
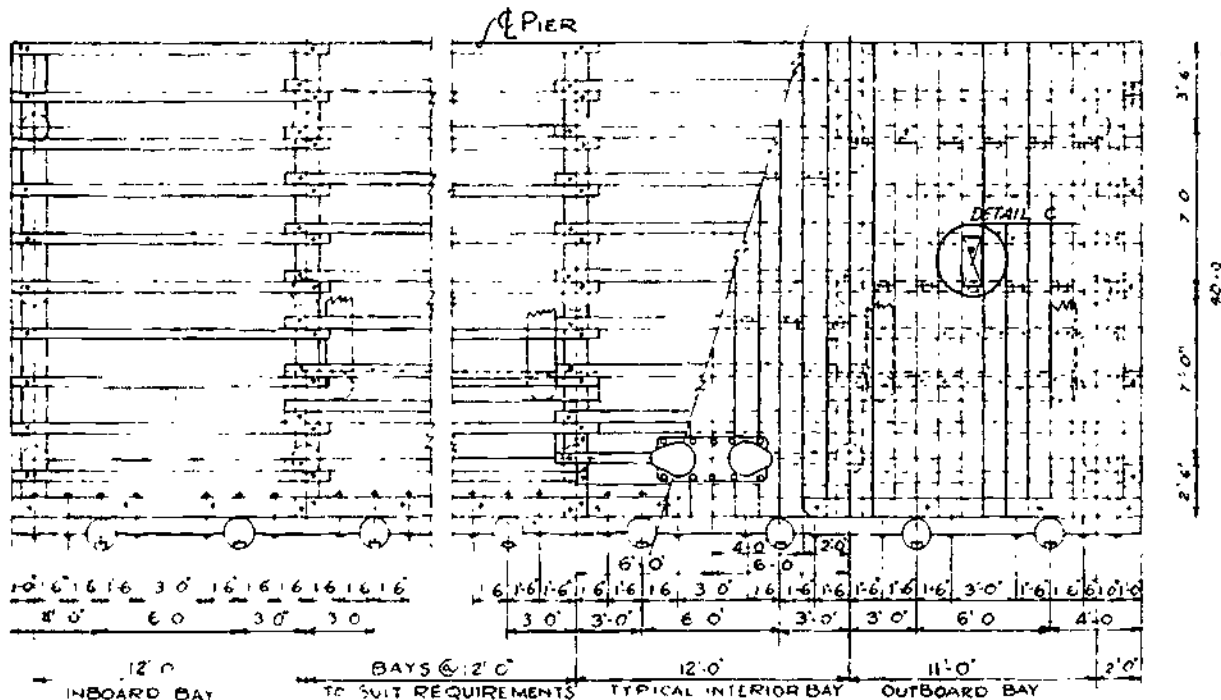

Figure 16-68.—Jetting with two jet pipes.

133.224



PART PLAN

45.538

Figure 16-71.—Part plan of an advanced base timber pier.

and as many 12-foot interior bays as desired to suit requirements.

The cross section shows that each bent, consists of six bearing piles. The bearing piles are braced transversely by diagonal braces. Additional transverse bracing for each bent is provided by a pair of batter piles. The batter angle is specified as 5 in 12. One pile of each pair is driven on either side of the bent, as shown in the general plan. The butts of the batter piles are joined to 12-inch by 12-inch by 14-foot longitudinal batter-pile caps, each of which is bolted to the undersides of two adjacent bearing-pile caps with bolts, in the positions shown in the part plan. The batter-pile caps are placed 3 feet inboard of the centerlines of the outside bearing piles in the bent. They are

backed by 6- by 14-inch batter-pile cap blocks, each of which is bolted to a bearing-pile cap. Longitudinal bracing between bents consists of 14-foot lengths of 3 by 10 planks, bolted to the bearing piles.

The superstructure consists of a single layer of 4 by 12 planks laid on 19 inside stringers measuring 6 inches by 14 inches by 14 feet. The **INSIDE STRINGERS** are fastened to the pile caps with drift bolts. The **OUTSIDE STRINGERS** are fastened to the pile caps with bolts. The deck planks are fastened to the stringers with 3/8- by 8-inch spikes. After the deck is laid, 12-foot lengths of 8 by 10 are laid over the outside stringers to form the **CURBING**. The lengths of curbing are distributed as shown in the general plan. The

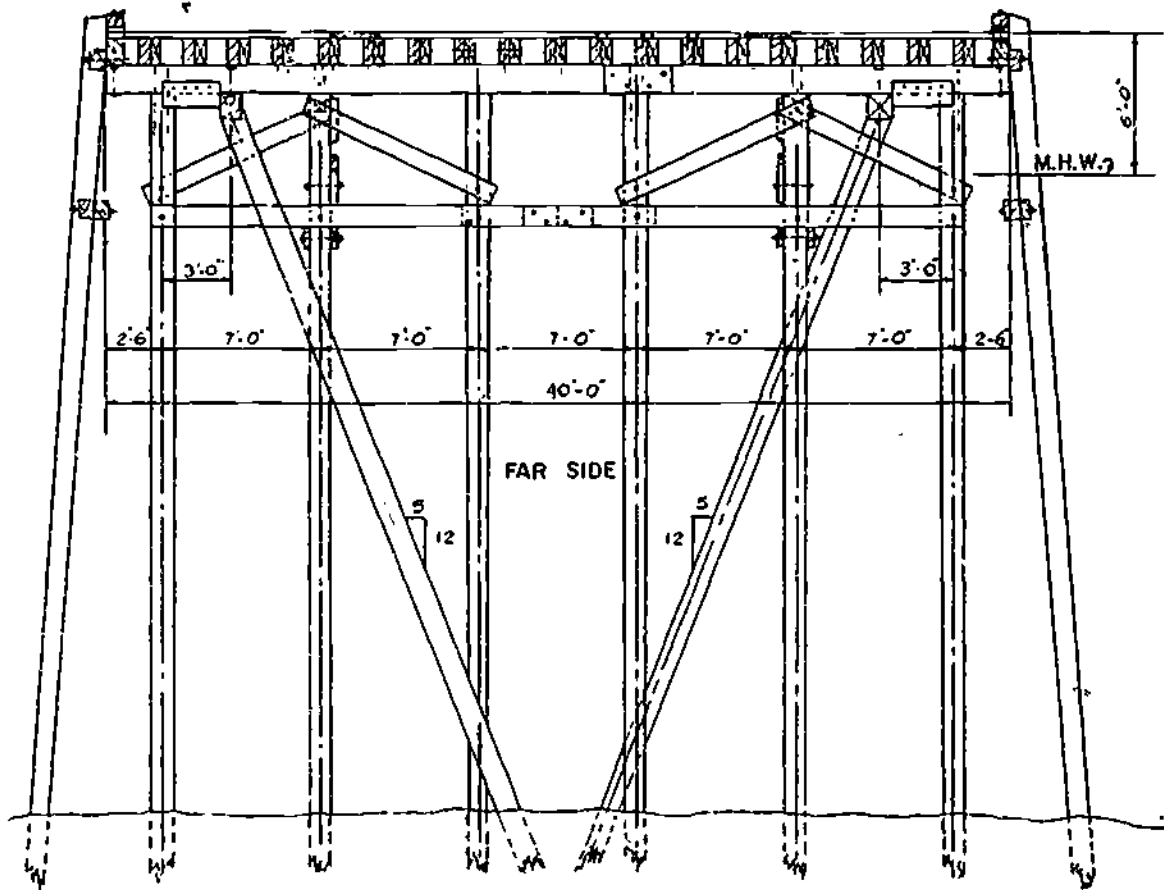

CROSS SECTION

45.538.0

Figure 16-72.—Cross section of advanced base timber pier.

curbing is bolted to the outside stringers with bolts; it is interrupted at the CLEATS.

The pier is equipped with a FENDER SYSTEM for protection against shock caused by contact with vessels coming or lying alongside. FENDER piles, spaced as shown in the part plan, are driven along both sides of the pier and bolted to the outside stringers with bolts. The heads of these bolts are countersunk below the surfaces of the piles. An 8 by 10 FENDER WALE is bolted to the backs of the fender piles with bolts. Lengths of 8 by 10 called FENDER PILE CHOCKS are cut to fit between the piles and bolted to the outside stringers and the

fender wales. The spacing for these bolts is shown in the part plan. As indicated in the general plan, the fender system also includes two 14-pile DOLPHINS, located 15 feet beyond the end of the pier. A dolphin is an isolated cluster of piles, constructed as shown in figure 16-73. A similar cluster attached to a pier is called a PILE CLUSTER.

WATERFRONT STRUCTURES

Waterfront structures are broadly divided into three main categories: (1) offshore

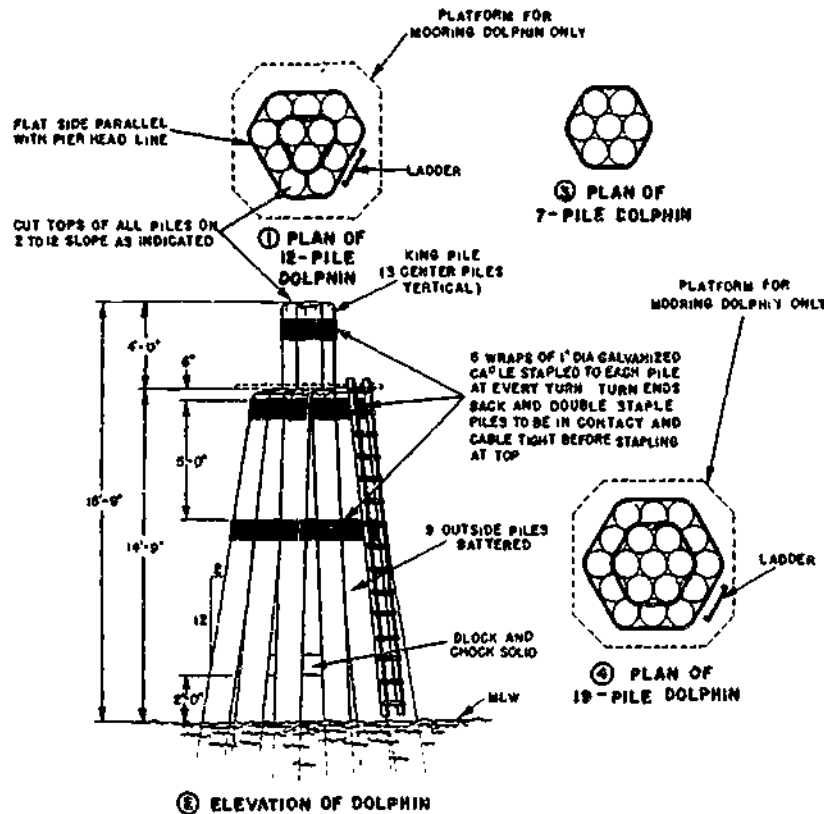

Figure 16-73.--Dolphins.

45.539

structures, like breakwaters or jetties, designed to create a sheltered harbor, (2) alongshore structures, like seawalls, designed to establish and maintain a stable shoreline, and (3) wharfage structures designed to make it possible for vessels to lie alongside for loading or unloading.

BREAKWATERS AND JETTIES

Breakwaters and jetties are alike in construction; they differ mainly in function. An offshore barrier, the **BREAKWATER** interrupts the action of the waves of the open sea in order to create an area of calm water between it and the shore. The **JETTY** works to direct and confine a current or tidal flow into a selected channel.

The simplest type of breakwater or jetty is the **RUBBLE MOUND** (also called **ROCK MOUND**) shown in figure 16-74. The width of its **CAP** may vary from 15 or 20 feet to 70 feet. The width of its base depends on the width of the cap, height of the structure, and slopes of the inner and outer **FACES**.

Rubble-mound breakwaters or jetties are constructed by dumping rock from either scows or rail cars that run on temporary pile-bent structures, and by placing upper rock and cap rock with floating cranes.

For a deepwater site or one with an extreme range between high and low tides, a rubble-mound breakwater or jetty may be topped with a **CAP STRUCTURE** to form the

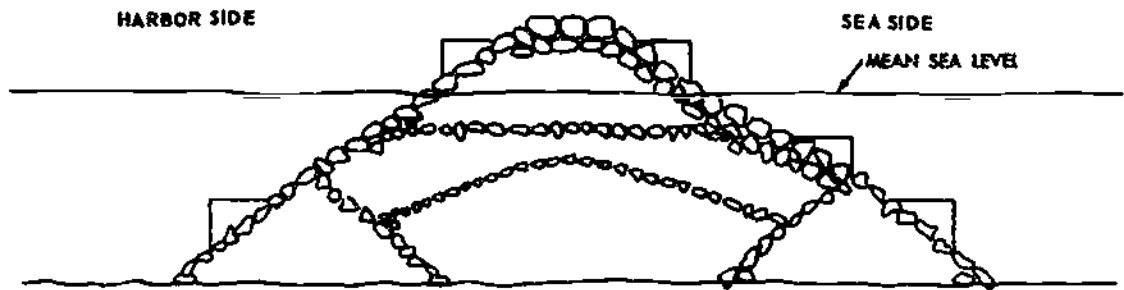

Figure 16-74.—Rubble-mound breakwater/jetty.

45.527

COMPOSITE type shown in figure 16-75. In this case, the cap structure consists of a series of precast concrete boxes called CAISSONS, each of which is floated over its final location and sunk into place by filling with rock. A single-piece concrete cap is then cast in place on the top of each caisson. Breakwaters and jetties are sometimes built entirely of caissons, as shown in figure 16-76. A jetty may also be constructed to serve as a wharfage structure. If so, it is still called a jetty.

GROINS

A GROIN is built like a breakwater or jetty and extends out from the shore. Again they

differ mainly in function. A groin is used where a shoreline is in danger of erosion caused by a current or wave action running obliquely against or parallel to the shoreline. The groin is placed so as to check the current or wave action, or to deflect it away from the shoreline.

Groins generally consist of tight sheet piling of creosoted timber, steel, or concrete, braced with wales and with round piles of considerable length. The groins are constructed perpendicular to the direction of the littoral drift and follow the general slope of the beach from above maximum high water to low water. Groins are usually built with their tops a few feet above the sloping beach surface that is to be maintained or restored.

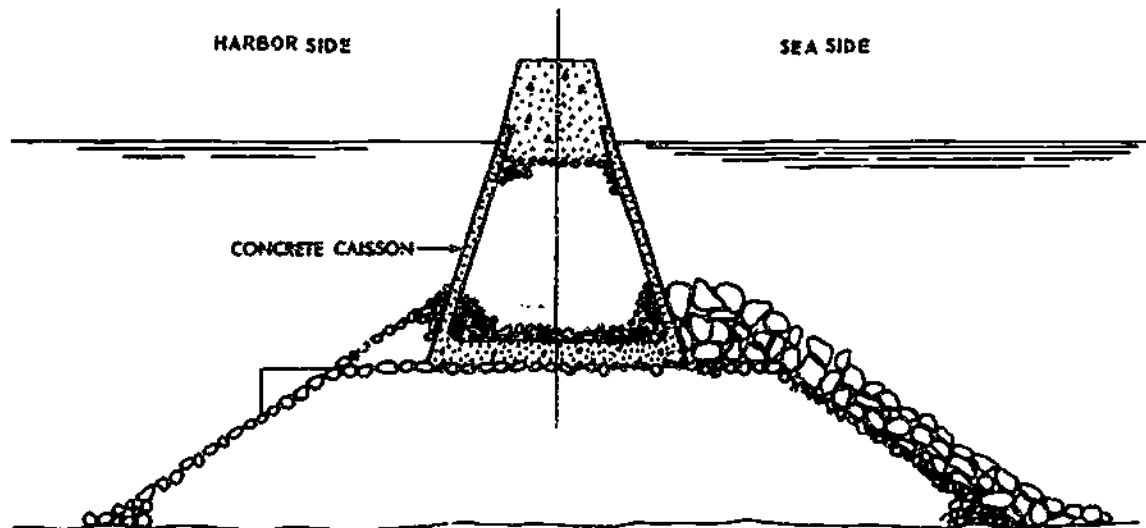
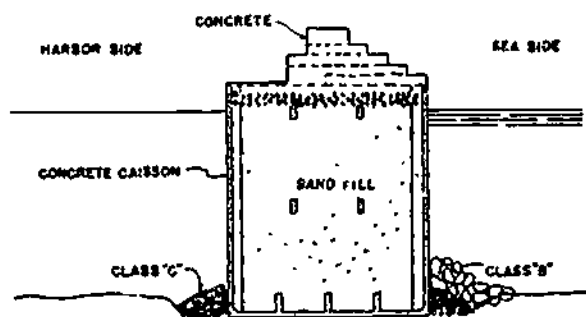

Figure 16-75.—Composite breakwater/jetty.

45.528



133.228

Figure 16-76.—Caisson breakwater/letty.

MOLES

A MOLE is a breakwater that serves as a wharfage structure. Its inner or harbor face must be vertical and its top must function as a deck.

SEAWALLS

Seawalls vary widely in details of design and materials, depending on the severity of the exposure, the value of the property to be protected, and other considerations. Basically they consist of some form of barrier designed to break up or reflect the waves and a deep, tight cutoff wall to preclude washing out of the sand or soil behind and under the barrier. The cutoff wall is generally of timber, steel, or concrete-sheet piling. Figure 16-77 shows a rubble-stone seawall, built much like a rubble-mound breakwater. Stone which is used to protect a shoreline against erosion, however, is called RIPRAP. Therefore, a rubble-stone seawall is called a RIPRAP seawall.

Various types of cast-in-place concrete seawalls are the VERTICAL-FACE, the INCLINED-FACE, the CURVED-FACE, the STEPPED-FACE, and the COMBINATION CURVED-FACE and STEPPED-FACE. Note, the sea or harbor bottom along the TOE (bottom of the outside face) of a seawall is usually protected against erosion (caused by the

backpull of receding waves) by riprap piled against the toe.

BULKHEADS

A BULKHEAD has the same general purpose as a seawall, namely, to establish and maintain a stable shoreline. Whereas the seawall is self-contained, relative thick, and supported by its own weight, the bulkhead is a relatively thin wall supported by a series of TIE WIRES or TIE RODS, running back to a buried ANCHORAGE. A timber bulkhead for a bridge abutment is shown in figure 16-78. It is made of wood SHEATHING (square-edged, single-layer planks), laid horizontally.

Most bulkheads, however, are made of steel sheet piles. See figure 16-79. The outer ends of the tie rods are anchored to a steel WALE which runs horizontally along the outer face of the bulkhead. This wale is usually made up of pairs of steel CHANNELS bolted together back to back. (A channel is a structural steel member with a U-shaped section.) Sometimes the wale is placed on the inner face of the bulkhead and the piles are bolted to it.

The anchorage shown in figure 16-79 is covered by backfill. In stable soil above the ground water level, the anchorage may consist simply of a buried timber, a concrete deadman, or a row of driven and buried sheet piles. A more substantial anchorage for each tie rod is used below the ground water level. Two common types of anchorages are shown in figure 16-80. In view A, fig. 16-80, the anchorage for each tie rod consists of a timber CAP, supported by a batter pile which is bolted to a bearing pile. In view B, fig. 16-80, the anchorage consists of a reinforced concrete cap, supported by a pair of batter piles. As indicated in the figure, tie rods are supported by piles located midway between the anchorage and the bulkhead.

Bulkheads are constructed from working drawings like those shown in figure 16-81. The detail plan for the bulkhead shows that the anchorage consists of a row of sheet piles to



Figure 16-77.—Riprap seawall.

133.229

which the inner ends of the tie rods are anchored by means of a channel wale.

The order of construction sequences is indicated in the section. The shore and bottom are first excavated to the level of the long,

sloping dotted line. The sheet piles for the bulkhead and the anchorage are then driven. The supporting piles for the tie rods are driven next, after which the tie rods between the bulkhead and the anchorage are set in place and the wales

16-48

636

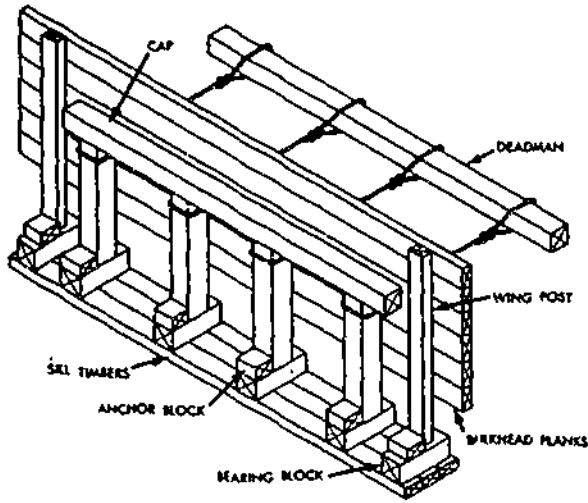

133.230

Figure 16-78.—Timber bulkhead for bridge abutment.

tie rods are then set to bring the bulkhead plumb, and the rest of the backfill is worked out to the bulkhead. After the backfilling is completed, the bottom outside the bulkhead is dredged to the desired depth—in this case, 30 feet.

CONSTRUCTION IN THE DRY

When construction is carried on below the ground water level, or when underwater structures like seawalls, bridge piers, and the like are erected, it is usually necessary to temporarily keep the water out of the construction area. This is usually done through the use of WELLPOINTS, COFFERDAMS, or CAISSONS.

are bolted on. The tie rods are prestressed lightly and uniformly, and the backfilling then begins.

The first backfilling operation consists of placing fill over the anchorage, out to the dotted line shown in the plan. The turnbuckles on the

WELLPOINTS

WELLPOINTS are long pipes which are thrust into the ground down to the elevation to



133.231

Figure 16-79.—Constructed steel-sheet pile bulkhead.

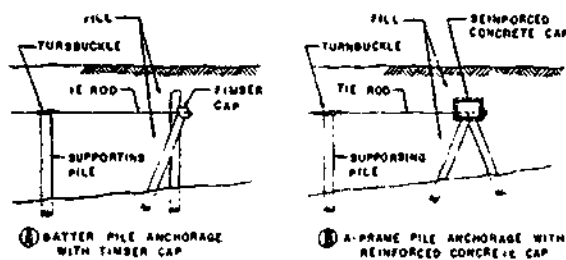

133.232

Figure 16-80.—Two types of tie-rod anchorages for bulkheads.

which the water must be excluded. They are connected to each other by a pipeline system which heads up at a water pump. Wellpoint engineers determine the ground water level and the direction of flow of the ground water, and the wellpoint system is placed so as to cut off the flow into the construction area. Wellpointing requires highly specialized personnel and expensive equipment.

COFFERDAMS AND CAISSONS

The COFFERDAM is a temporary structure usually built in place and built tight enough so that the water can be pumped out of the structure and kept out while construction on the foundations is in progress. Common types are the earth cofferdam, the steel-sheeting cofferdam, the cellular type, the wooden-sheeting cofferdam, the crib type, and the framed and puddled type. Figure 16-82 shows a cofferdam under construction.

The earth cofferdam is built by dumping into the water an earth fill, shaped so that it will surround the construction area without encroaching upon it. Because swiftly moving currents would carry the material away, the use of earth cofferdams is limited to sluggish waterways where the velocities do not exceed 5 ft per second. The use is also limited to shallow waters, because the quantities of material required in deep waters would be largely due to the flat slopes to which the earth

settles when deposited in the water. For this latter reason, the earth type is commonly combined with another type such as sheeting or cribbing to reduce the quantities of earthwork. Steel in the form of piles or pipes is commonly used for cofferdam construction. Steel piling is manufactured in many interlocking designs and in many weights and shapes for varying load conditions. The piling is driven as sheeting in a row to form a relatively tight structure surrounding the construction area. This pile wall is supported in several ways; it may be built in shape of small arches, the abutments of which are supported by crossmembers; it may be supported by a framework of stringers and struts, the cofferdam wall might consist of a double row of piles tied together with heavy steel ties and filled with earth, and then this would be built in a square rectangular, circular or oval shape for stability around the construction area. Wooden sheeting in lieu of steel is similarly used in cofferdam constructions. Interlocking timber sheeting is one of the many types used. The timber sheeting is driven as a single wall and supported by stringers and cross struts between walls; or it is driven in double rows as a wall, the sheeting in each row being connected and tied with braces and the space between being filled with a watertight puddle. Wooden or concrete cribbing may be used in cofferdam construction, by building them to offer stability to the cofferdam wall and then by filling into and against the cribbing with earth and rock to obtain watertightness. Movable cofferdams of timber, steel or concrete have been built, but their uses and designs are very similar to those discussed under boxes and open caissons.

CAISSONS are boxes or chambers used for construction work under water. There are three forms of caissons used in constructing foundations under water the box caisson, the open caisson, and the pneumatic caisson. If the structure is open at the top and closed at the bottom it is called a box caisson. If it is open both at the top and bottom it is an open caisson. BUT, if it is open at bottom and closed at the top, and compressed air is used, it is a pneumatic caisson. It is sometimes difficult to distinguish between a cofferdam and a caisson. In general, if

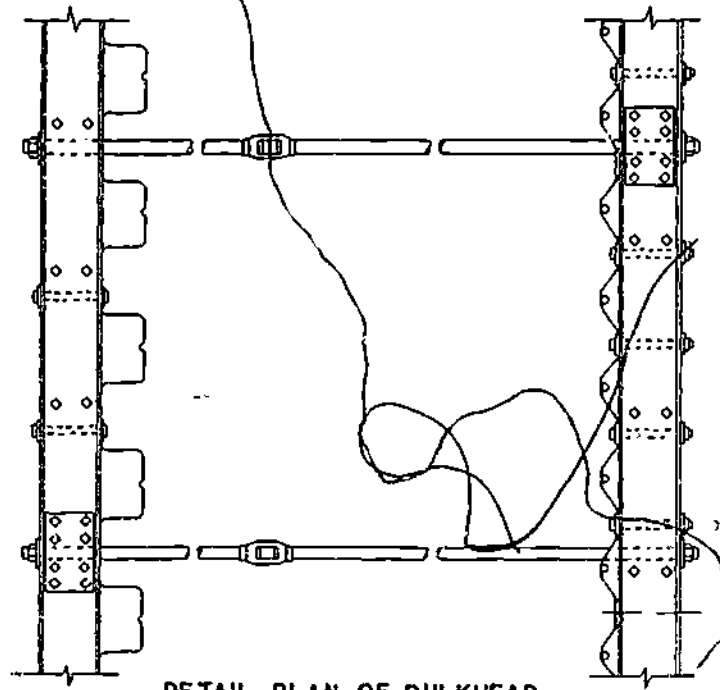

DETAIL PLAN OF BULKHEAD

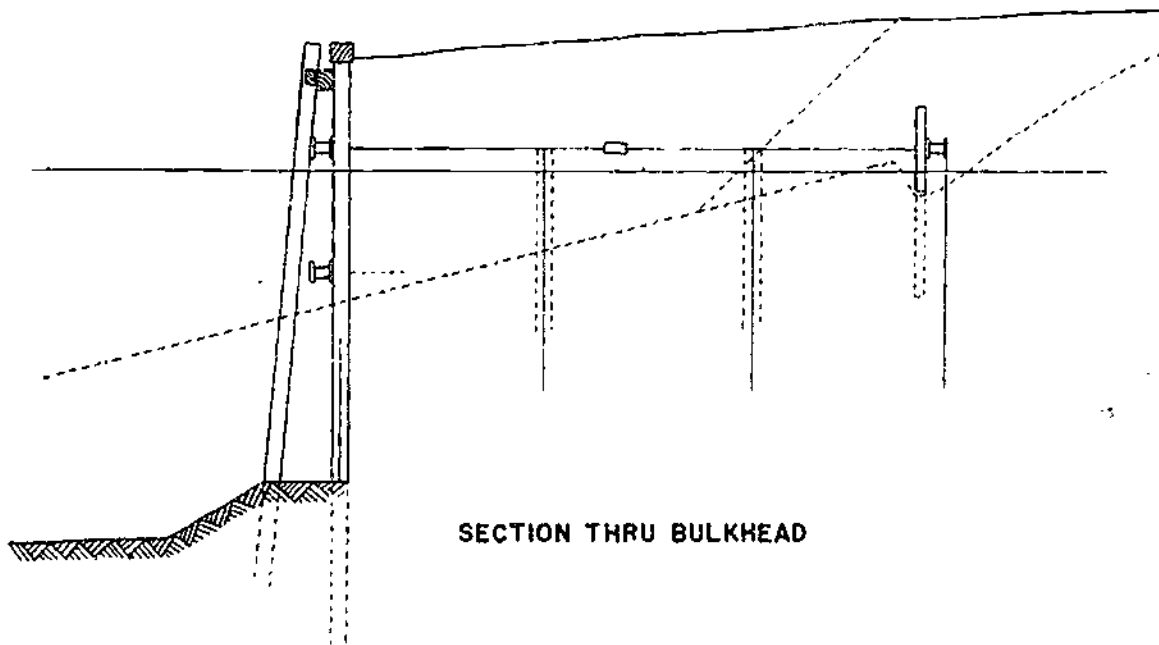

SECTION THRU BULKHEAD

Figure 16-81.—Working drawing for a steel-sheet pile bulkhead.

45.534

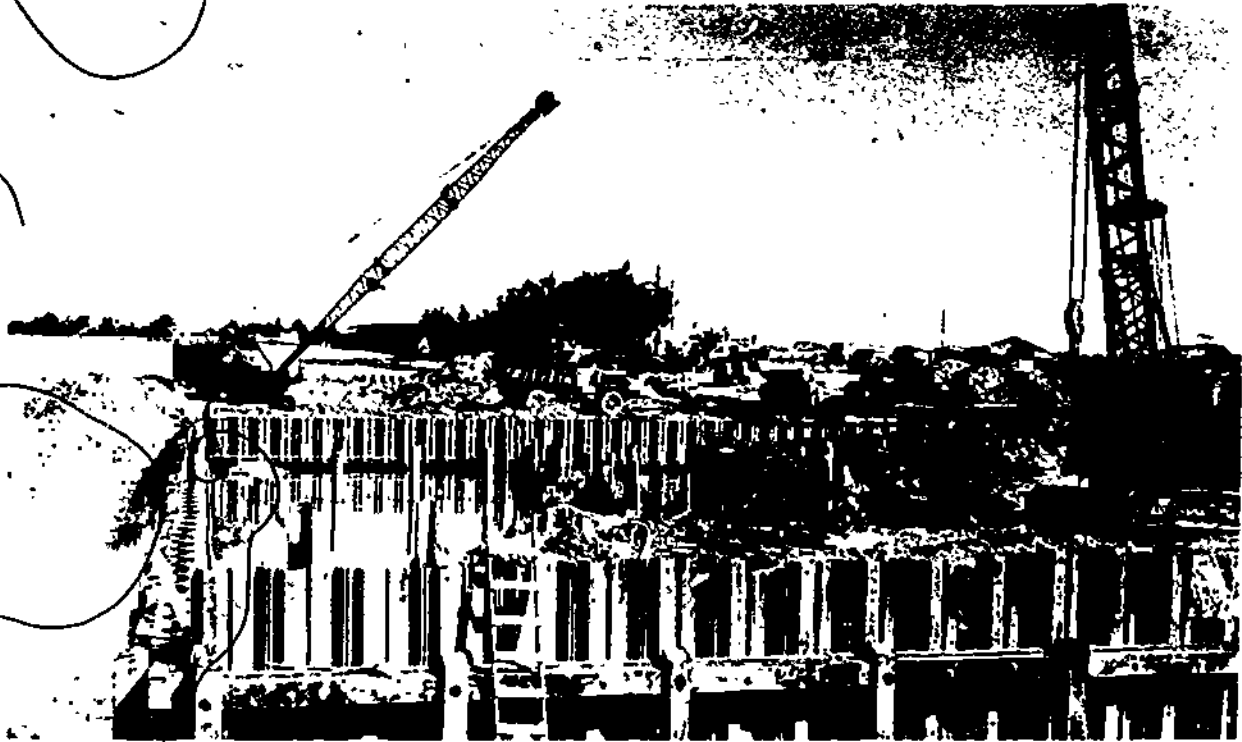

133.233(133F)

Figure 16-82.—Cofferdam under construction.

the structure is self-contained and does not depend upon the surrounding material for support, it is a caisson. However, if the structure requires such support as sheathing or sheet piling, it is a cofferdam. Retaining walls and

piers may be built of boxes of wood, steel or reinforced concrete, floated into place and then filled with various materials. These are known as floating caissons. Open caissons may be constructed of wood or steel sheet piling.

INDEX

A

- Abrasive grinders, 3-50 to 3-53
 - care and maintenance, 3-52 to 3-53
 - sharpening stones, 3-51
- Abrasives, painting, 14-3
- Adhesive application, ceramic tile, 13-21
- Administration, construction, 1-1 to 1-5
 - planning work assignments, 1-1
 - preparing requisitions, 1-2
 - supervising work teams, 1-2
 - timekeeping, 1-3 to 1-5
- Admixtures, concrete ingredients, 7-9
- Advanced base field structures, 15-1 to 15-21
 - field-type latrines, 15-15 to 15-21
 - preplanning, 15-1 to 15-15
 - Butlerhut, 15-2 to 15-15
 - distribution of parts, 15-1
 - importance of foundations, 15-1
 - Quonset hut, 15-2
 - types of field structures, 15-2
 - wood-frame tents, 15-15
- Aggregate, concrete ingredients, 7-5 to 7-9
 - handling and storage, 7-8 to 7-9
 - quality criteria, 7-7
- Aggregates, plaster ingredients, 13-3
- Air compressors, heavy construction, 16-8 to 16-11
 - starting the driving unit (diesel engine), 16-9 to 16-10
 - stopping, 16-11
- Airless spray guns, 14-9 to 14-11
- Alligatoring, paint failures, 14-32
- Aluminum paints, 14-13
- Applying paint, methods of, 14-23 to 14-30
 - brush-painting techniques, 14-24
 - roller-painting techniques, 14-24
 - spray-method, 14-25 to 14-30

- Applying plaster, 13-12 to 13-17
 - application of plaster, 13-15 to 13-17
 - base coat, 13-15
 - finish coat, 13-16 to 13-17
 - crews, 13-15
 - tools, 13-12 to 13-15
- Architectural drawings, 2-20
- Arithmetical operations, building materials, 2-27 to 2-31
 - areas and volumes of geometric figures, 2-28 to 2-30
 - board measure, 2-31
 - coverage calculations, 2-31
 - power and roots, 2-30
 - square root, 2-30
- Asphalt-felt underlayment, 11-10
- Asphalt heating kettle, 11-16 to 11-19
 - care and maintenance, 11-19
 - operation, 11-16 to 11-19
- Asphalt shingles, 11-11
- Attachment of metal lath, 13-5
- Attachments, wire rope, 5-10 to 5-12

B

- Balancing shots, differential leveling, 6-6
- Balloon construction, 9-27 to 9-28
- Bandsaw, 3-33 to 3-34
- Base coat portions, mixing plaster, 13-9
- Base molding, wood-trim installation, 12-50
- Batching, concrete mix design, 7-14
- Batching plant, concrete mix design, 7-14 to 7-15
- Batter boards, building layout, 6-18 to 6-19
- Beam, column, and floor slab, 7-34 to 7-35
- Beams and girders, formwork, 7-26
- Bevel siding, 11-20

- Bill of materials, 2-21 to 2-23
- Bird's mouth, rafters, 10-7
- Blast cleaning, painting, 14-15 to 14-17
 conventional blasting, 14-15
 vacuum blasting, 14-15
 wet blasting, 14-16 to 14-17
- Blistering, paint failures, 14-32
- Block and tackle, 5-12 to 5-21
 block nomenclature, 5-13
 lifting a given weight, 5-20
 mechanical advantage, 5-19
 ratio of size of block to size of line or wire used, 5-13
 reeving tackle, 5-17 to 5-19
 safe working load of a tackle, 5-20
 size of line to use in a tackle, 5-21
 snatch blocks and fair-leads, 5-14 to 5-15
 tackle safety precautions, 5-21
 tackle terms, 5-12
 types of tackle, 5-16
- Block mortar joints, concrete masonry, 8-3 to 8-4
- Block nomenclature, 5-13
- Block sizes and shapes, concrete masonry, 8-3
- Block walls, patching and cleaning, concrete masonry, 8-17 to 8-19
- Board measure, lumber, 4-9
- Bolts, fastening, 4-37 to 4-41
- Box corner joints, 4-28
- Braces, wall framing, 9-21 to 9-23
- Bracket scaffolds, 5-35
- Breakwaters and jetties, waterfront structures, 16-47
- Brick masonry, 8-24 to 8-58
 bricklaying methods, 8-28 to 8-38
 characteristics, 8-27
 classification, 8-25
 construction, 8-38 to 8-52
 estimating brick and mortar, 8-57 to 8-58
 mortar, 8-26
 reinforced brick masonry, 8-52 to 8-57
 resistance to weathering, 8-27
 terminology, 8-24
 types, 8-25
- Bricklaying methods, 8-28 to 8-38
 cutting brick, 8-37
 flashing, 8-31
 joint finishes, 8-37 to 8-38
 masonry terms, 8-28
 metal ties, 8-31
 mortar joints and pointing, 8-31 to 8-37
 types of bonds, 8-28 to 8-31
- Bridging, floor framing, 9-14 to 9-15
- Brooming, finishing concrete, 7-45
- Brushes, painting, 14-4 to 14-6
- Brush-painting techniques, applying paint, 14-24
- Building layout, 6-17 to 6-19
 batter boards, 6-18 to 6-19
 perpendicular by 3:4:5 triangle, 6-18
 perpendicular by Pythagorean theorem, 6-18
- Building materials, 2-26 to 2-31
 arithmetical operations, 2-27 to 2-31
 ratio and proportion, 2-26
- Bulkheads waterfront structures, 16-47 to 16-49
- Burning, cleaning prior to excavation, 6-19 to 6-21
- Butlerhut, 15-2 to 15-15
 basic structural erection, 15-7 to 15-15
 floor erection procedures, 15-7
 preerection work, 15-3 to 15-7

C

- Camouflage, painting, 14-1
- Care and maintenance of powersaw blades, 3-34 to 3-37
- Carpeting, 12-30
- Casement windows, 12-44
- Ceiling joists, platform construction, 9-33
- Ceiling molding, wood-trim installation, 12-51 to 12-52
- Cement-asbestos board, wood substitute, 4-17
- Cement, concrete ingredients, 7-4 to 7-5
 storage, 7-5
 types, 7-4
- Ceramic tile, 13-20 to 13-21
 adhesive application, 13-21
 mortar application, 13-20
 setting tile, 13-21
- Chain saw, gasoline, 16-8
- Chain saw, pneumatic, 16-6
- Chalk line, handtools, 3-10
- Chalking, paint failures, 14-31



INDEX

- Characteristics, brick masonry, 8-27
- Characteristics, structural clay, 8-19 to 8-21
- Checking and cracking, paint failures, 14-32 to 14-34
- Chopping tools, heavy construction, 16-2
- Circular saw, pneumatic, 16-5
- Classification, brick, 8-25
- Classification of lumber, 4-7
 - manufacturing, 4-7
 - size, 4-7
 - use, 4-7
- Cleaning and lubrication, wire rope, 5-8
- Coatings, types of, paintings, 14-11 to 14-14
 - aluminum paints, 14-13
 - enamel paints, 14-12
 - epoxy paints, 14-12
 - lacquers, 14-14
 - latex paints, 14-13
 - oil-based paints, 14-12
 - portland cement paints, 14-13
 - rubber-based paints, 14-13
 - shellac, 14-14
 - stains, 14-14
 - varnishes, 14-13
- Cofferdams and caissons, construction in the dry, 16-50 to 16-52
- Columns, formwork, 7-26
- Collar tie, roof framing, 10-26 to 10-27
- Common rafter layout, 10-4 to 10-6
- Concrete, 7-1 to 7-69
 - characteristics, 7-1 to 7-4
 - concrete as building material, 7-1
 - durability, 7-2
 - general requirements for good concrete, 7-2 to 7-4
 - strength, 7-2
 - watertightness, 7-2
 - concrete construction joints, 7-33 to 7-36
 - beam, column, and floor slab, 7-34 to 7-35
 - expansion and contraction, 7-35 to 7-36
 - vertical, 7-34
 - concrete ingredients, 7-4 to 7-9
 - admixtures, 7-9
 - aggregate, 7-5 to 7-9
 - cement, 7-4
 - water, 7-9
- Concrete—Continued
 - concrete mix design, 7-9 to 7-15
 - batching, 7-14
 - batching plant, 7-14 to 7-15
 - grout, 7-14
 - material estimates, 7-11
 - measuring aggregate, 7-12
 - measuring water, 7-11
 - slump test, 7-12 to 7-13
 - water-cement ratio, 7-12
 - workability, 7-13
 - concrete pumping machines, 7-57 to 7-69
 - operation of trailer-mounted, 7-62 to 7-69
 - preparation for use, 7-58 to 7-60
 - principle of operation, 7-60 to 7-62
 - concrete saw, 7-51 to 7-53
 - consolidating concrete, 7-37 to 7-39
 - curing concrete, 7-46 to 7-49
 - finishing concrete, 7-41 to 7-46
 - brooming, 7-45
 - edging, 7-43
 - exposed-aggregate finish, 7-46
 - floating, 7-43
 - grinding, 7-45
 - rubbed finish, 7-45
 - sack-rubbed finish, 7-45
 - screeding, 7-41 to 7-43
 - troweling, 7-44
 - formwork, 7-19 to 7-29
 - form construction, 7-20 to 7-27
 - form design, 7-20
 - form materials, 7-19
 - oiling and wetting forms, 7-27 to 7-29
 - handling and transporting concrete, 7-18
 - transit-mixed concrete, 7-19
 - mixing concrete, 7-15 to 7-18
 - by hand, 7-16
 - by machine, 7-16 to 7-18
 - placing concrete, 7-36 to 7-37
 - placing concrete under water, 7-39 to 7-41
 - pneumatic-applied concrete, 7-57
 - precast concrete, 7-53 to 7-57
 - advantages, 7-56
 - floor and roof slabs, walls and partitions, 7-55
 - handling, 7-57
 - joists, beams, girders, and columns, 7-56
 - steam curing, 7-57

- Concrete—Continued
 reinforced concrete, 7-29 to 7-33
 removal of forms, 7-49 to 7-51
- Concrete and masonry, painting, 14-17
- Concrete masonry, 8-3 to 8-19
 block mortar joints, 8-3 to 8-4
 block sizes and shapes, 8-3
 concrete masonry construction, 8-8 to 8-13
 control joints, 8-13 to 8-15
 estimating mortar, 8-6
 intersecting walls, 8-15
 lintels, 8-16
 masonry mortar, 8-5
 modular planning, 8-5
 patching and cleaning block walls, 8-17 to 8-19
 reinforced block walls, 8-16
 safe handling of material, 8-7
 watertight block walls, 8-19
- Conditioners, sealers, and fillers, painting, 14-19 to 14-21
- Consolidating concrete, 7-37 to 7-39
- Construction administration, 1-1 to 1-10
 administration, 1-1 to 1-5
 planning work assignments, 1-1
 preparing requisitions, 1-2
 supervising work teams, 1-2
 timekeeping, 1-3 to 1-5
 Personnel Readiness Capability Program, 1-5 to 1-8
 safety program, 1-8 to 1-10
 duties, 1-8
 organization, 1-8
 training, 1-10
- Construction, brick, 8-38 to 8-52
 builder's duties, 8-39
 corbeling, 8-47
 eight-inch common bond brick wall, 8-40 to 8-45
 fire-resistant bricks, 8-49
 footings, 8-39
 lintels, 8-46
 special types of walls, 8-50 to 8-52
 striker's duties, 8-38
 watertight walls, 8-48
 window and door openings, 8-45
- Construction drawings, 2-5 to 2-20
 details, 2-19
 elevations, 2-14
 floor plans, 2-13 to 2-14
 foundation plans, 2-7, 2-13
 framing plans, 2-14 to 2-17
 plot plans, 2-7, 2-12
 schedules, 2-20
 sections, 2-17 to 2-19
- Construction in the dry, 16-49 to 16-52
 cofferdams and caissons, 16-50 to 16-52
 wellpoints, 16-49
- Contour cutting, 4-29 to 4-30
- Control joints, concrete masonry, 8-13 to 8-15
- Conventional blasting, 14-15
- Coverage of paint, 14-30
- Coping joints, 4-28 to 4-29
- Corbeling, brick construction, 8-47
- Cornices, exterior trim, 11-5 to 11-8
 construction, 11-7
 return, 11-8
 types, 11-5 to 11-7
- Crawling, paint failures, 14-34
- Crews, applying plaster, 13-15 to 13-17
- Curing concrete, 7-46 to 7-49
- Cutting tools, heavy construction, 16-1
- D
- Decorative treatment, interior finish, 12-52
- Defects and blemishes, lumber, 4-1, 4-6 to 4-7
- Diesel hammer, pile-driving equipment, 16-32
- Differential leveling, 6-4 to 6-16
 balancing shots, 6-6
 care of levels, 6-9
 elevation and reference, 6-4
 errors and mistakes in leveling, 6-16
 field notes, 6-14 to 6-16
 leveling a level, 6-6
 leveling rods, 6-9 to 6-14
 principles, 6-4
 selection of turning points, 6-7 to 6-8
 setting up a level, 6-5
 turning points, 6-7

INDEX

Dolly Varden siding, 11-20

Doors, interior finish, 12-31 to 12-42
 casing, 12-31 to 12-32
 commercial/industrial hardware, 12-40 to 12-42
 doorframe and trim installation, 12-35 to 12-36
 exterior, 12-33
 installation of door hardware, 12-37 to 12-40
 doorstops, 12-40
 hinges, 12-37
 locks, 12-38
 strike plates, 12-39
 interior, 12-33 to 12-35

Double-acting pneumatic hammer, pile-driving equipment, 16-31

Double-hung windows, 12-42 to 12-44

Dovetail joints, 4-27

Drawings and specifications, 2-1 to 2-33
 building materials, 2-26 to 2-31
 arithmetical operations, 2-27 to 2-31
 ratio and proportion, 2-26
 freehand sketches, 2-24 to 2-26
 metric system, 2-32 to 2-33
 specifications, 2-23 to 2-24
 structural design, 2-1
 structural members, 2-1 to 2-5
 horizontal, 2-4 to 2-5
 vertical, 2-2 to 2-4
 types of drawings, 2-5 to 2-23
 architectural drawings, 2-20
 bill of materials, 2-21 to 2-23
 construction drawings, 2-5 to 2-20
 electrical drawings, 2-21
 mechanical drawings, 2-20
 shop drawings, 2-21

Drill press, 3-45 to 3-47

Driving batter piles, 16-36

Driving bearing piles, 16-36

Driving sheet piles, 16-37 to 16-39

 obstruction and refusal, 16-39

 springing and bouncing, 16-39

Drop hammer, pile-driving equipment, 16-29

Dumpy/engineer's, levels, 6-1

Durability of concrete, 7-2

E

Edging, finishing concrete, 7-43

Eight-inch structural clay tile wall, 8-23

Eight-inch wall with four-inch structural clay tile backing, 8-22

Electrical drawings, 2-21

Elevation and reference, differential leveling, 6-4

Enamel paints, 14-12

End-wall framing, platform construction, 9-31

Epoxy paints, 14-12

Equipment for holding work, 3-13 to 3-17

Equipment hazards, painting safety, 14-37

Erecting, shear legs, 5-23

Erecting, tripods, 5-25 to 5-26

Erection, roof framing, 10-29 to 10-31

Estimating brick and mortar, 8-57 to 8-58

Estimating mortar, concrete masonry, 8-6

Expanded metal lath, 13-5

 flat, 13-5

 rib, 13-5

Expansion and contraction joints, 7-35 to 7-36

Exposed-aggregate finish, concrete, 7-46

Extension of roof sheathing at gable ends, 11-3

Exterior finish, 11-1 to 11-34

 asphalt heating kettle, 11-16 to 11-19

 care and maintenance, 11-19

 operation, 11-16 to 11-19

 built-up roofing, 11-14 to 11-16

 exterior trim, 11-3 to 11-10

 cornices, 11-5 to 11-8

 rake (gable-end) trim, 11-9 to 11-10

 flashing, 11-29 to 11-32

 door and windows, 11-29

 flat roofs, 11-29

 material changes, 11-29

 ridges, 11-30

 roof edges, 11-32

 roof-wall intersection, 11-31

 valleys, 11-30

 gutters and downspouts, 11-32 to 11-34

Exterior finish—Continued

- installation of siding, 11-22 to 11-29
 - bevel siding, 11-23 to 11-25
 - corner covering, 11-25 to 11-27
 - drop and similar sidings, 11-25
 - fasteners, 11-22
 - material transition, 11-27
 - sheet siding, 11-25
 - vertical siding, 11-25
 - wood shingles and wood shake siding, 11-28
- roof covering, 11-10 to 11-14
 - asphalt-felt underlayment, 11-10
 - asphalt shingles, 11-11
 - finish at the ridge, hip, and valley, 11-13 to 11-14
 - wood shingles and wood shakes, 11-12
- roof sheathing, 11-1 to 11-3
 - extension of roof sheathing at gable ends, 11-3
 - lumber sheathing, 11-2
 - plank roof decking, 11-2
 - plywood roof sheathing, 11-2
- wall sheathing, outside, 11-19 to 11-22
 - horizontal or vertical siding, types of, 11-21 to 11-22
 - horizontal siding, types of, 11-20
 - nonwood siding, 11-22
 - wood siding, 11-20

F

- Fabrication of line, fiber line, 5-1
- Failure, wire rope, 5-7
- Fastening, methods of, 4-33 to 4-42
 - bolts, 4-37 to 4-41
 - glue, 4-41 to 4-42
 - nails, 4-33 to 4-35
 - screws, 4-35 to 4-37
- Ferrous metals, painting, 14-17
- Fiber line, wire rope, and scaffolding, 5-1 to 5-42
 - block and tackle, 5-12 to 5-21
 - block nomenclature, 5-13
 - lifting a given weight, 5-20
 - mechanical advantage, 5-19
 - ratio of size of block to size of line or wire used, 5-13
 - reeving tackle, 5-17 to 5-19
 - safe working load of a tackle, 5-20
 - size of line to use in a tackle, 5-21
 - snatch blocks and fair-leads, 5-14 to 5-15

Fiber line, wire rope, and scaffolding—Continued

- block and tackle—Continued
 - tackle safety precautions, 5-21
 - tackle terms, 5-12
 - types of tackle, 5-16
- fiber line, 5-1 to 5-5
 - fabrication of line, 5-1
 - handling and care, 5-4 to 5-5
 - size designation, 5-2
 - sources and characteristics of fibers, 5-1
 - strength of fiber line, 5-3
 - types of line lays, 5-2
- hoisting safety signals and rules, 5-37 to 5-42
- ladders, 5-26 to 5-28
 - safety, 5-27 to 5-28
 - types, 5-26
- scaffolding, 5-28 to 5-37
 - bracket scaffolds, 5-35
 - pole scaffold construction, 5-29 to 5-32
 - prefabricated scaffold erection, 5-32 to 5-35
 - safety, 5-36 to 5-37
 - swinging scaffold construction, 5-28
- shear legs, 5-21 to 5-23
 - erecting, 5-23
 - rigging, 5-22
 - safe working load, 5-23
- tripods, 5-23 to 5-26
 - erecting, 5-25 to 5-26
 - rigging, 5-24
- wire rope, 5-5 to 5-12
 - attachments, 5-10 to 5-12
 - cleaning and lubrication, 5-8
 - failure, 5-7
 - inspection, 5-9
 - measuring, 5-6
 - safe working load, 5-7
 - storage, 5-8
- Fiberboard, wood substitutes, 4-16
- Field notes, differential leveling, 6-14 to 6-16
- Field structures, types of, 15-2
- Finish at the ridge, hip, and valley, 11-13 to 11-14
- Finish coat proportions, mixing plaster, 13-9 to 13-10

INDEX

- Finishing concrete, 7-41 to 7-46
 brooming, 7-45
 edging, 7-43
 exposed-aggregate finish, 7-46
 floating, 7-43
 grinding, 7-45
 rubbed finish, 7-45
 sack-rubbed finish, 7-45
 screeding, 7-41 to 7-43
 troweling, 7-44
- Fire hazards, painting safety, 14-37
- Fire retardance, painting, 14-1
- Fire-resistant bricks, 8-49
- Flashing, 11-29 to 11-32
 door and windows, 11-29
 flat roofs, 11-29
 material changes, 11-29
 ridges, 11-30
 roof edges, 11-32
 roof-wall intersection, 11-31
 valleys, 11-30
- Flashing the generator, heavy construction,
 16-13
- Flexible insulation, 12-13
- Floating, finishing concrete, 7-43
- Floor coverings, 12-24 to 12-30
 carpeting, 12-30
 installation of resilient tile, 12-30
 types of resilient flooring, 12-29
 wood and particleboard tile flooring, 12-29
 wood-strip flooring, 12-25 to 12-28
 installation, 12-26 to 12-28
 wood flooring over concrete slabs,
 installation, 12-28
- Floor erection procedures, Butlerhut, 15-7
- Floor framing, 9-5 to 9-17
 bridging, 9-14 to 9-15
 floor framing at wall projections, 9-12 to
 9-14
 floor framing under partition, 9-12
 framing around floor openings, 9-11
 framing joists to girders, 9-5
 joist erection, 9-8 to 9-11
 joist layout, 9-6 to 9-8
 subflooring, 9-16 to 9-17
- Flush ceiling framing, 9-34 to 9-35
- Footing forms, 7-20 to 7-22
- Footings, brick construction, 8-39
- Forms, removal of, 7-49 to 7-51
- Formwork, 7-19 to 7-29
 construction, 7-20
 beams and girders, 7-26
 columns, 7-26
 footing forms, 7-20 to 7-22
 foundations, 7-22
 walls, 7-22 to 7-25
 design, 7-20
 materials, 7-19
 oiling and wetting forms, 7-27 to 7-29
- Foundations, formwork, 7-22
- Framing allowance, wall framing, 9-24 to 9-27
- Framing square, 3-1 to 3-8
 basic problems solved by the framing square,
 3-1 to 3-7
 using the framing tables on the framing
 square, 3-7 to 3-8
- Framing, theory of, 9-1
- Freehand sketches, 2-24 to 2-26
- G**
- Gable-end studs, wall framing, 9-23
- Gasoline chain saw, 16-8
- Glass cutting, 12-47
- Glass, types of, windows, 12-44 to 12-47
- Glazing, 12-47 to 12-48
- Gloss, inadequate, paint failures, 14-34
- Glue, fastening, 4-41 to 4-42
- Grades, plywood, 4-13
- Grading, 6-16 to 6-17
- Grading (softwoods), lumber, 4-7, 4-9
- Grinding, finishing concrete, 7-45
- Groins, waterfront structures, 16-46
- Grooved joints, 4-24 to 4-26
- Grout, concrete mix design, 7-14
- Gutters and downspouts, 11-32 to 11-34
- Gypsum, 9-40, 9-42
 insulating board, 9-42
 type of sheathing, 9-40
- Gypsum board, installation of, 12-1 to 12-5
- Gypsum lath, 13-4
- Gypsum plaster, 13-1
- Gypsum wallboard, wood substitute, 4-17

H

Half-lap joints, 4-20
 Hand cleaning, painting, 14-14
 Hand, levels, 6-2, 6-4
 Handling and care, fiber line, 5-4 to 5-5
 Handling and storage, lumber, 4-9 to 4-10
 Handling and transporting concrete, 7-18
 transit-mixed concrete, 7-19
 Handtools, 3-1 to 3-13
 chalk line, 3-10
 framing square, 3-1 to 3-8
 levels, 3-9 to 3-10
 miter box, 3-8
 saw-sharpening equipment, 3-11 to 3-13
 tape, 3-10
 Handtools, heavy construction, 16-1 to 16-5
 chopping tools, 16-2
 cutting tools, 16-1
 striking tools, 16-3
 timber-handling tools and equipment, 16-4
 to 16-5
 Hardboard, wood substitutes, 4-16
 Hardboard and fiberboard, installation of, 12-5
 Health hazards, painting safety, 14-38 to 14-39
 Heavy construction, 16-1 to 16-52
 air compressors, 16-8 to 16-11
 starting the driving unit (diesel
 engine), 16-9 to 16-10
 stopping, 16-11
 construction in the dry, 16-49 to 16-52
 cofferdams and caissons, 16-50 to
 16-52
 wellpoints, 16-49
 handtools, 16-1 to 16-5
 chopping tools, 16-2
 cutting tools, 16-1
 striking tools, 16-3
 timber-handling tools and equipment,
 16-4 to 16-5
 pile-driving equipment, 16-28 to 16-32
 diesel hammer, 16-32
 double-acting pneumatic hammer,
 16-31
 drop hammer, 16-29
 single-acting pneumatic hammer,
 16-30

Heavy construction—Continued

pile-driving operations, 16-32 to 16-42
 driving batter piles, 16-36
 driving bearing piles, 16-36
 driving sheet piles, 16-37 to
 16-39
 placing piles by jetting, 16-40
 to 16-41
 pulling piles, 16-39
 straightening piles, 16-42
 piles, 16-19 to 16-28
 concrete bearing piles, 16-23 to
 16-24
 sheet piles, 16-24 to 16-28
 steel bearing piles, 16-22 to 16-23
 timber bearing piles, 16-20 to 16-22
 portable type generators/floodlights, 16-11
 to 16-13
 flashing the generator, 16-13
 starting the engine, 16-12
 stopping the engine, 16-13
 power tools, 16-5 to 16-8
 gasoline chain saw, 16-8
 pneumatic chain saw, 16-6
 pneumatic circular saw, 16-5
 pneumatic nail driver, 16-6
 pneumatic wood drill, 16-6
 timber fasteners and connectors, 16-13 to
 16-15
 timber connectors, 16-14 to 16-15
 timber fasteners, 16-13
 timber pier construction, 16-42 to 16-44
 timber trestles, 16-15 to 16-18
 constructing a timber trestle, 16-17
 constructing a trestle bent, 16-17
 constructing the superstructure,
 16-18
 erecting a trestle bent, 16-18
 nomenclature, 16-15 to 16-17
 waterfront structures, 16-44 to 16-49
 breakwater and jetties, 16-45
 bulkheads, 16-47 to 16-49
 groins, 16-46
 moles, 16-47
 seawalls, 16-17
 Hip rafter layout, 10-7 to 10-12
 projection, 10-10
 shortening allowance, 10-9
 side cuts, 10-11 to 10-12

INDEX

Hoisting safety signals and rules, 5-37 to 5-42
Horizontal siding, types of, 11-20
 bevel, 11-20
 Dolly Varden, 11-20
 other types, 11-20
Horizontal structural members, 2-4 to 2-5

I

Identification and safety, painting, 14-2
Identification stamps, plywood, 4-16
Illumination and visibility, painting, 14-2
Inspection, wire rope, 5-9
Installation of plaster base, 13-8
installation of sheathing, 9-40
 gypsum and insulating board, 9-42
 plywood, 9-42
 sheathing paper, 9-43
 structural insulating board, 9-42
 wood, 9-40 to 9-42
Insulation, 12-11 to 12-19
 how to insulate, 12-15 to 12-17
 insulating materials, 12-12 to 12-14
 flexible, 12-13
 loose fill, 12-13
 miscellaneous, 12-14
 reflective, 12-13
 rigid, 12-14
 vapor barriers, 12-17
 ventilation, 12-17 to 12-19
 where to insulate, 12-14 to 12-15
Interior finish, 12-1 to 12-53
 decorative treatment, 12-52
 doors, 12-31 to 12-42
 casing, 12-31 to 12-32
 commercial/industrial hardware,
 12-40
 doorframe and trim installation,
 12-35 to 12-36
 exterior, 12-33
 installation of door hardware,
 12-37 to 12-40
 interior, 12-33 to 12-35
 floor coverings, 12-24 to 12-30
 carpeting, 12-30
 installation of resilient tile,
 12-30
 types of resilient flooring, 12-29

Interior finish—Continued

 floor coverings—Continued
 wood and particleboard tile
 flooring, 12-29
 wood-strip flooring, 12-25 to 12-28
 insulation, 12-11 to 12-19
 how to insulate, 12-15 to 12-17
 insulating materials, 12-12
 vapor barriers, 12-17
 ventilation, 12-17 to 12-19
 where to insulate, 12-14 to 12-15
 laminated plastics, 12-52 to 12-53
 stairs, 12-19 to 12-24
 stairway construction, 12-23
 stairway layout, 12-19 to 12-23
 suspended acoustic ceiling systems, 12-6
 to 12-11
 ceiling tile, 12-11
 installation, 12-8 to 12-11
 preparation for installation, 12-7
 wall and ceiling coverings, 12-1 to 12-6
 installation of gypsum board, 12-1
 to 12-5
 installation of hardboard and
 fiberboard, 12-5
 installation of plywood, 12-5
 installation of wood paneling,
 12-5 to 12-6
 windows, 12-42 to 12-49
 glass cutting, 12-47
 glazing, 12-48
 preparation before glazing, 12-47
 sash preparation, 12-47
 setting glass in wood and metal
 sash, 12-48 to 12-49
 types of glass, 12-44 to 12-47
 types of windows, 12-42 to 12-44
 wood-trim installation, 12-49 to 12-52
 base molding, 12-50
 ceiling molding, 12-51 to 12-52
Interior walls, platform construction, 9-32
Intersecting walls, concrete masonry, 8-15

J

Jack rafter layout, 10-18 to 10-21
 bird's mouth and projection, 10-21
 length, 10-19 to 10-21
 shortening allowance, 10-21
 side cuts, 10-21

Joint finishing, structural clay, 8-24
 Joint reinforcing, 13-6
 Jointer, power shaving tools, 3-39 to 3-41
 Joints and joining, 4-17 to 4-29
 box corner joints, 4-28
 coping joints, 4-28 to 4-29
 dovetail joints, 4-27
 grooved joints, 4-24 to 4-26
 half-lap joints, 4-20
 miter joints, 4-21 to 4-24
 mortise-and-tenon joints, 4-26
 Joints, concrete construction, 7-33 to 7-36
 beam, column, and floor slab, 7-34 to 7-35
 expansion and contraction, 7-35 to 7-36
 vertical, 7-34
 Joints, control, applying stucco, 13-20
 Joist erection, floor framing, 9-8 to 9-11
 Joist layout, floor framing, 9-6 to 9-8
 Joists to girders, framing, 9-5

L

Lacquers, coatings, 14-14
 Ladders, 5-26 to 5-28
 safety, 5-27 to 5-28
 types, 5-26
 Laminated lumber, 4-10 to 4-11
 Laminated plastics, 12-52 to 12-53
 Latex paints, 14-13
 Lath nailers, platform construction, 9-32
 Lathing accessories, 13-5
 Latrines, field-type, 15-15 to 15-21
 Laying out studs for cutting, 9-20
 Leveling, grading, and excavating, 6-1 to 6-25
 building layout, 6-17 to 6-19
 batter boards, 6-18 to 6-19
 perpendicular by 3:4:5 triangle, 6-18
 perpendicular by Pythagorean theorem, 6-18
 clearing prior to excavation, 6-19 to 6-21
 burning, 6-19
 poisonous plants, 6-20
 safety, 6-20 to 6-21
 differential leveling, 6-4 to 6-16
 balancing shots, 6-6
 care of levels, 6-9
 elevation and reference, 6-4

Leveling, grading, and excavating- Continued
 differential leveling-Continued
 errors and mistakes in leveling, 6-16
 field notes, 6-14 to 6-16
 leveling a level, 6-6
 leveling rods, 6-9 to 6-14
 principles, 6-4
 selection of turning points, 6-7 to 6-8
 setting up a level, 6-5
 turning points, 6-7
 excavating, 6-21 to 6-25
 dimensions, 6-21
 prevention of slides and cave-ins, 6-22 to 6-25
 grading, 6-16 to 6-17
 levels, 6-1 to 6-4
 dumpy/engineer's, 6-1
 hand, 6-2, 6-4
 self-leveling, 6-2, 6-3

Leveling rods, 6-9 to 6-14
 care, 6-14
 Philadelphia rod, 6-9 to 6-13
 rod levels, 6-13
 Levels, 6-1 to 6-4
 dumpy engineer's, 6-1
 hand, 6-2, 6-4
 self-leveling, 6-2, 6-3
 Levels, handtools, 3-9 to 3-10
 carpenter's level, 3-9 to 3-10
 line level, 3-9
 Lifting a given weight, 5-20
 Light frame construction, floor and wall, 9-1 to 9-43
 balloon construction, 9-27 to 9-28
 floor framing, 9-5 to 9-17
 bridging, 9-14 to 9-15
 floor framing at wall projections, 9-12 to 9-14
 floor framing under partition, 9-12
 framing around floor openings, 9-11
 framing joists to girders, 9-5
 joist erection, 9-8 to 9-11
 joist layout, 9-6 to 9-8
 subflooring, 9-16 to 9-17
 installation of sheathing, 9-40 to 9-43
 gypsum and insulating board, 9-42
 plywood, 9-42
 sheathing paper, 9-43
 structural insulating board, 9-42
 wood, 9-40 to 9-42

INDEX

Light frame construction: floor and wall— Continued

- platform construction, 9-28 to 9-35
 - ceiling joists, 9-33
 - end-wall framing, 9-31
 - flush ceiling framing, 9-34 to 9-35
 - interior walls, 9-32
 - lath nailers, 9-32
 - post and beam framing, 9-35 to 9-37
 - sill framing, 9-1 to 9-5
 - sill layout, 9-2 to 9-4
 - sill placement, 9-4 to 9-5
 - theory of framing, 9-1
 - types of sheathing, 9-37 to 9-40
 - gypsum, 9-40
 - plywood, 9-39
 - structural insulating board sheathing, 9-40
 - wood, 9-38
 - wall framing, 9-18 to 9-27
 - braces, 9-21 to 9-23
 - framing allowance, 9-24 to 9-27
 - gable-end studs, 9-23
 - laying out studs for cutting, 9-20
 - partition, 9-21
 - top plate and soleplate, 9-19
- Lime plaster, 13-2
- Line lays, types of, fiber line, 5-2
- Lintels, brick construction, 8-46
- Lintels, concrete masonry, 8-16
- Loose fill insulation, 12-13
- Lumber, 4-1 to 4-10
 - board measure, 4-9
 - classification, 4-7
 - defects and blemishes, 4-1, 4-6 to 4-7
 - grading (softwoods), 4-7, 4-9
 - handling and storage, 4-9 to 4-10
 - seasoning, 4-1
- Lumber sheathing, 11-1

M

Masonry, 8-1 to 8-58

- brick masonry, 8-24 to 8-58
 - bricklaying methods, 8-28 to 8-38
 - characteristics, 8-27
 - classification, 8-25
 - construction, 8-38 to 8-52

Masonry—Continued

brick masonry—Continued

- estimating brick and mortar, 8-57 to 8-58
- mortar, 8-26
- reinforced brick masonry, 8-52 to 8-57
- resistance to weathering, 8-27
- terminology, 8-24
- types, 8-25

concrete masonry, 8-3 to 8-19

- block mortar joints, 8-3 to 8-4
- block sizes and shapes, 8-3
- construction, 8-8 to 8-13
- control joints, 8-13 to 8-15
- estimating mortar, 8-6
- intersecting walls, 8-15
- lintels, 8-16
- masonry mortar, 8-5
- modular planning, 8-5
- patching and cleaning block walls, 8-17 to 8-19
- reinforced block walls, 8-16
- safe handling of material, 8-7
- watertight block walls, 8-19

structural clay tile masonry, 8-19 to 8-24

- eight-inch structural clay tile wall, 8-23
- eight-inch wall with four-inch structural clay tile backing, 8-24
- joint finishing, 8-24
- mortar joints, 8-21
- physical characteristics, 8-19 to 8-21
- safe handling of block and hollow tile, 8-24
- uses, 8-21

tools and equipment, 8-1 to 8-2

- Material estimates, concrete mix design, 7-11
- Measuring aggregate, concrete mix design, 7-12
- Measuring water, concrete mix design, 7-11
- Measuring wire rope, 5-6
- Mechanical advantage, 5-19
- Mechanical drawings, 2-20
- Metal lath, 13-4
- Metric system, 2-32 to 2-33
- Millwork, 4-30 to 4-33
- Miter box, 3-8
- Miter joints, 4-21 to 4-24
- Mix design, concrete, 7-9 to 7-15

Mixing concrete, 7-15 to 7-18
 by hand, 7-16
 by machine, 7-16 to 7-18
 charging the mixer, 7-17
 cleaning and maintaining the mixer,
 7-17 to 7-18
 discharging the mixer, 7-17
 mixing time, 7-17
 Mixing, paint, 14-21
 Mixing plaster, 13-8 to 13-12
 base coat, 13-9
 finish coat, 13-9 to 13-10
 mixing by hand, 13-10
 mixing by machine, 13-11 to 13-12
 plaster quantity estimates, 13-10
 safe handling of materials, 13-12
 Modular planning, concrete masonry, 8-5
 Moles, waterfront structures, 6-47
 Mortar application, ceramic tile, 13-20
 Mortar, brick masonry, 8-26
 Mortar joints, structural clay, 8-21
 Mortar, masonry, concrete, 8-5
 Mortise-and-tenon joints, 4-26

N

Nail driver, pneumatic, 16-5
 Nails, fastening, 4-33 to 4-35
 Nonferrous metals, painting, 14-17
 Nonwood siding, 11-22

O

Oil-based paints, 14-12
 Oiling and wetting forms, 7-27 to 7-29
 Outside wall sheathing, 11-19 to 11-22

P

Paint failures, 14-31 to 14-34
 alligatoring, 14-32
 blistering, 14-32
 chalking, 14-31
 checking and cracking, 14-32 to 14-34
 crawling, 14-34
 inadequate gloss, 14-34

Paint failures—Continued
 peeling, 14-32
 prolonged tackiness, 14-34
 wrinkling, 14-34
 Paint mixers, 14-11
 Paint mixing and conditioning, 14-21 to 14-23
 mixing, 14-21
 straining, 14-23
 thinning, 14-23
 tinting, 14-23
 Paint removers, 14-17
 Painting, purposes of, 14-1 to 14-2
 camouflage, 14-1
 fire retardance, 14-1
 identification and safety, 14-2
 illumination and visibility, 14-2
 preventive maintenance, 14-1
 sanitation and cleanliness, 14-1
 Painting safety, 14-37 to 14-39
 equipment hazards, 14-37
 fire hazards, 14-37
 health hazards, 14-38 to 14-39
 Paints and preservatives, 14-1 to 14-39
 coverage of paint, 14-30
 methods of applying paint, 14-23 to 14-30
 brush-painting techniques, 14-24
 roller-painting techniques, 14-24
 spray method, 14-25 to 14-30
 paint failures, 14-31 to 14-34
 alligatoring, 14-32
 blistering, 14-32
 chalking, 14-31
 checking and cracking, 14-32 to
 14-34
 crawling, 14-34
 inadequate gloss, 14-34
 peeling, 14-32
 prolonged tackiness, 14-34
 wrinkling, 14-34
 paint mixing and conditioning, 14-21 to
 14-23
 mixing, 14-21
 straining, 14-23
 thinning, 14-23
 tinting, 14-23
 painting safety, 14-37 to 14-39
 equipment hazards, 14-37
 fire hazards, 14-37
 health hazards, 14-38 to 14-39

INDEX

- Paints and preservatives--Continued
- purposes of painting, 14-1 to 14-2
 - camouflage, 14-1
 - fire retardance, 14-1
 - identification and safety, 14-2
 - illumination and visibility, 14-2
 - preventive maintenance, 14-1
 - sanitation and cleanliness, 14-1
 - storage of equipment, 14-36 to 14-37
 - surface preparation for painting, 14-14 to 14-21
 - blast cleaning, 14-15 to 14-17
 - concrete and masonry, 14-17
 - conditioners, sealers, and fillers, 14-19 to 14-21
 - ferrous metals, 14-17
 - hand cleaning, 14-14
 - nonferrous metals, 14-17
 - paint removers, 14-17
 - plaster and wallboard, 14-18
 - power tool cleaning, 14-14
 - wood, 14-18
 - tools and equipment, 14-3 to 14-11
 - abrasives, 14-3
 - airless spray guns, 14-9 to 14-11
 - brushes, 14-4 to 14-6
 - paint mixers, 14-11
 - rollers, 14-7
 - scrapers, 14-3
 - spray guns, 14-8
 - types of coatings, 14-11 to 14-14
 - aluminum paints, 14-13
 - enamel paints, 14-12
 - epoxy paints, 14-12
 - lacquers, 14-14
 - latex paints, 14-13
 - oil based paints, 14-12
 - portland cement paints, 14-13
 - rubber-based paints, 14-13
 - shellac, 14-14
 - stains, 14-14
 - varnishes, 14-13
 - wood preservatives, 14-34 to 14-36
- Panels, plywood, 4-14 to 4-16
- concrete form, 4-14, 4-16
 - decorative, 4-14
 - overlaid, 4-14
- Particleboard, wood substitutes, 4-17
- Partition, wall framing, 9-21
- Peeling, paint failures, 14-32
- Personnel Readiness Capability Program, 1-5 to 1-8
- Philadelphia rod, 6-9 to 6-13
- Pile-driving equipment 16-28 to 16-32
- diesel hammer, 16-32
 - double-acting pneumatic hammer, 16-31
 - drop hammer, 16-29
 - single-acting pneumatic hammer, 16-30
- Pile-driving operations, 16-32 to 16-42
- driving batter piles, 16-36
 - driving bearing piles, 16-36
 - driving sheet piles, 16-37 to 16-39
 - placing piles by jetting, 16-40 to 16-41
 - putting piles, 16-39
 - straightening piles, 16-42
- Piles, heavy construction, 16-19 to 16-28
- concrete bearing piles, 16-23 to 16-24
 - sheet piles, 16-24 to 16-28
 - steel bearing piles, 16-22 to 16-23
 - timber bearing piles, 16-20 to 16-22
- Placing concrete, 7-36 to 7-37
- Placing piles by jetting, 16-40 to 16-41
- Planing and squaring to dimensions, 4-17
- Plank roof decking, 11-2
- Planning work assignments, 1-1
- Plaster and wallboard, painting, 14-18
- Plaster bases, 13-4 to 13-8
- attachment of metal lath, 13-5
 - expanded metal lath, 13-5
 - gypsum lath, 13-4
 - installation of plaster base, 13-8
 - joint reinforcing, 13-6
 - lathing accessories, 13-5
 - metal lath, 13-4
 - plaster grounds, 13-7
- Plaster grounds, 13-7
- Plaster ingredients, 13-1 to 13-4
- aggregates, 13-3
 - gypsum plaster, 13-1
 - lime plaster, 13-2
 - portland cement, 13-3
 - water, 13-4
- Plaster quantity estimates, 13-10
- Plastering, stuccoing, and ceramic tile, 13-1 to 13-21
- applying plaster, 13-12 to 13-17
 - application of plaster, 13-15 to 13-17
 - crews, 13-15
 - tools, 13-12 to 13-15

Plastering, stuccoing, and ceramic tile--

Continued

- applying stucco, 13-17 to 13-20
 - control joints, 13-20
 - preparation of base and application of stucco, 13-18 to 13-20
- ceramic tile, 13-20 to 13-21
 - adhesive application, 13-21
 - mortar application, 13-20
 - setting tile, 13-21
- mixing plaster, 13-8 to 13-12
 - base coat, 13-9
 - finish coat, 13-9 to 13-10
 - mixing by hand, 13-10
 - mixing by machine, 13-11 to 13-12
 - plaster quantity estimates, 13-10
 - safe handling of materials, 13-12
- plaster bases, 13-4 to 13-8
 - attachment of metal lath, 13-5
 - expanded metal lath, 13-5
 - gypsum lath, 13-4
 - installation of plaster base, 13-8
 - joint reinforcing, 13-6
 - lathing accessories, 13-5
 - metal lath, 13-4
 - plaster grounds, 13-7
- plaster ingredients, 13-1 to 13-4
 - aggregates, 13-3
 - gypsum plaster, 13-1
 - lime plaster, 13-2
 - portland cement, 13-3
 - water, 13-4
- Platform construction, 9-28 to 9-35
 - ceiling joists, 9-33
 - end-wall framing, 9-31
 - flush ceiling framing, 9-34 to 9-35
 - interior walls, 9-32
 - lath nailers, 9-32
- Plywood, 4-11 to 4-16, 9-39, 9-42
 - grades, 4-13
 - identification stamps, 4-16
 - installation of sheathing, 9-42
 - sizes, 4-13
 - special purpose, 4-14 to 4-16
 - storage, 4-16
 - type of sheathing, 9-39
 - types, 4-14
- Plywood, installation of, 12-5
- Plywood roof sheathing, 11-2
- Pneumatic-applied concrete, 7-57
- Pneumatic chain saw, 16-6
- Pneumatic circular saw, 16-5
- Pneumatic nail driver, 16-6
- Pneumatic wood drill, 16-6
- Poisonous plants, clearing prior to excavation, 6-20
- Pole scaffold construction, 5-29 to 5-32
- Portable electric circular saw, 3-30 to 3-31
- Portable reciprocal saw, 3-32 to 3-33
- Portable type generators/floodlights, heavy construction, 16-11 to 16-13
 - flashing the generator, 16-13
 - starting the engine, 16-12
 - stopping the engine, 16-13
- Portland cement, 13-3
- Portland cement paints, 14-13
- Post and beam framing, 9-35 to 9-37
- Power plane, portable, 3-38
- Power tool cleaning, painting, 14-14
- Power tools, heavy construction, 16-5 to 16-8
 - gasoline chain saw, 16-8
 - pneumatic chain saw, 16-6
 - pneumatic circular saw, 16-5
 - pneumatic nail driver, 16-6
 - pneumatic wood drill, 16-6
- Power tools, woodworking, 3-17 to 3-53
 - abrasive grinders, 3-50
 - bandsaw, 3-33 to 3-34
 - care and maintenance of powersaw blades, 3-34 to 3-37
 - drill press, 3-45 to 3-47
 - portable electric circular saw, 3-30 to 3-31
 - portable reciprocal saw, 3-32 to 3-33
 - power shaving tools, 3-37 to 3-45
 - saber saw, 3-31 to 3-32
 - shop radial arm saw, 3-29
 - tilt-arbor table bench saw, 3-29 to 3-30
 - trailer-mounted field saw, 3-17 to 3-29
 - woodworking lathe, 3-47 to 3-50
- Precast concrete, 7-53 to 7-57
 - advantages, 7-56
 - floor and roof slabs, walls and partitions, 7-55
 - handling, 7-57
 - joists, beams, girders, and columns, 7-56
 - steam curing, 7-57
- Preerection work, Butlerhut, 15-3 to 15-7
- Prefabricated scaffold erection, 5-32 to 5-35

INDEX

Preplanning, advanced base field structures,
15-1

distribution of parts, 15-1
importance of foundations, 15-1

Pulling piles, 16-39

Pumping machines, concrete, 7-57 to 7-69

operation of trailer-mounted concrete pumps,
7-62 to 7-69

care and maintenance, 7-69
cleanup after pumping, 7-67 to 7-69
indicators and controls, 7-62
procedures, 7-65 to 7-67
pump shutdown, 7-69
running, 7-64
starting and adjusting, 7-63
starting the power source, 7-62
stopping the pump engine, 7-69
preparation for use, 7-58 to 7-60
principle of operation, 7-60 to 7-62

Pythagorean theorem, building layout, 6-18

Q

Quonset hut, 15-2

R

Rafter location layout, 10-25 to 10-26

Rafters, 10-3 to 10-26

bird's mouth, 10-7
common rafter layout, 10-4 to 10-6
hip rafter layout, 10-7 to 10-12
projection, 10-10
shortening allowance, 10-9
side cuts, 10-11 to 10-12

jack rafter layout, 10-18 to 10-21
bird's mouth and projection, 10-21
length, 10-19 to 10-21
shortening allowance, 10-21
side cuts, 10-21

Rafters—Continued

rafter location layout, 10-25 to 10-26
ridge layout, 10-21 to 10-23
shed roof framing, 10-23 to 10-25
table method, using rafter table on framing
square, 10-6
terms used, 10-3
valley rafter layout, 10-12 to 10-17

Ratio and proportion, building materials, 2-26

Ratio of size of blocks to size of line or wire
used, 5-13

Reeving tackle, 5-17 to 5-19

Reflective insulation, 12-13

Reinforced block walls, concrete masonry, 8-16

Reinforced brick masonry, 8-52 to 8-57

beams, 8-54 to 8-56
columns and walls, 8-56 to 8-57
construction methods, 8-53

Reinforced concrete, 7-29 to 7-33

Requirements for good concrete, general, 7-2 to
7-4

Requisitions, preparing, 1-2

Resilient flooring, 12-29 to 12-30

installation, 12-30

types, 12-29

asphalt tile, 12-29

linoleum, 12-29

other tile forms, 12-29

seamless, 12-29

Ridge layout, rafters, 10-21 to 10-23

Rigging, shear legs, 5-22

Rigging, tripods, 5-24

Rigid insulation, 12-14

Rod levels, 6-13

Roller-painting techniques, applying paint,
14-24

Rollers, painting, 14-7

Roof construction terms, 10-2

Roof covering, 11-10 to 11-14

asphalt-felt underlayment, 11-10

asphalt shingles, 11-11

finish at the ridge, hip, and valley,
11-13 to 11-14

wood shingles and wood shakes, 11-12

Roof framing, 10-1 to 10-31

collar tie, 10-26 to 10-27

rafters, 10-3 to 10-26

bird's mouth, 10-7

common rafter layout, 10-4 to 10-6

hip rafter layout, 10-7 to 10-12

jack rafter layout, 10-18 to 10-21

Roof framing—Continued
 rafters—Continued
 ridge layout, 10-21 to 10-23
 rafter location layout, 10-25 to 10-26
 shed roof framing, 10-23 to 10-25
 table method, using rafter table on framing square, 10-6
 terms used, 10-3
 valley rafter layout, 10-12 to 10-17
 roof construction terms, 10-2
 roof framing erection, 10-29 to 10-31
 roof sheathing, 10-31
 roof trusses, 10-28 to 10-29
 fabrication, 10-28
 handling, 10-29
 types, 10-28
 types of roofs, 10-1
 Roof sheathing, 11-1 to 11-3
 extension of roof sheathing at gable ends, 11-3
 lumber sheathing, 11-1
 plank roof decking, 11-2
 plywood roof sheathing, 11-2
 Roofing, built-up, 11-14 to 11-16
 Router, power shaving tools, 3-37
 Rubbed finish, concrete, 7-45
 Rubber-based paints, 14-13

S

Saber saw, 3-31 to 3-32
 Sack-rubbed finish, concrete, 7-45
 Safe handling of block and hollow tile, 8-24
 Safe handling of material, concrete masonry, 8-8 to 8-13
 Safe working load of a tackle, 5-20
 Safe working load, shear legs, 5-23
 Safe working load, wire rope, 5-7
 Safety, clearing prior to excavation, 6-20 to 6-21
 Safety, ladders, 5-27 to 5-28
 Safety program, construction administration, 1-8 to 1-10
 duties, 1-8
 organization, 1-8
 training, 1-10
 Safety, scaffolds, 5-36 to 5-37
 Safety, woodworking, 4-42

Sanitation and cleanliness, painting, 14-1
 Sash preparation, 12-47
 Saw, concrete, 7-51 to 7-53
 Saw-sharpening equipment, 3-11 to 3-13
 Scaffolding, 5-28 to 5-37
 bracket scaffolds, 5-35
 pole scaffold construction, 5-29 to 5-32
 prefabricated scaffold erection, 5-32 to 5-35
 safety, 5-36 to 5-37
 swinging scaffold construction, 5-28
 Scrapers, painting, 14-3
 Screeding, finishing concrete, 7-41 to 7-43
 Screws, fastening, 4-35 to 4-37
 Seasoning, lumber, 4-1
 Seawalls, waterfront structures, 16-47
 Self-leveling, 6-2, 6-3
 Setting glass in wood and metal sash, 12-48 to 12-49
 Shaper, power shaving tools, 3-42 to 3-43
 Shaving tools, power, 3-37 to 3-45
 care and maintenance, 3-44 to 3-45
 jointer, 3-39 to 3-41
 portable power plane, 3-38
 router, 3-37
 shaper, 3-42 to 3-43
 surfacers, 3-41
 Shear legs, 5-21 to 5-23
 erecting, 5-23
 rigging, 5-22
 safe working load, 5-23
 Sheathing paper, 9-43
 Sheathing, plywood, 4-14
 Sheathing, roof, 10-31
 Sheathing, types of, 9-37 to 9-40
 gypsum, 9-40
 plywood, 9-39
 structural insulating board sheathing, 9-40
 wood, 9-38
 Shed roof framing, 10-21 to 10-23
 Sheet piles, heavy construction, 16-24 to 16-28
 concrete-sheet piles, 16-27
 fabricated timber-sheet piles, 16-26
 sheet piling repair, 16-28
 steel-sheet piles, 16-27
 Sheet siding, 11-22
 Shellac, coatings, 14-14
 Shop drawings, 2-21
 Shop radial arm saw, 3-29

INDEX

- Siding, installation of, 11-22 to 11-29
 bevel siding, 11-23 to 11-25
 corner covering, 11-25 to 11-27
 drop and similar sidings, 11-25
 fasteners, 11-22
 material transition, 11-27
 sheet siding, 11-25
 vertical siding, 11-25
 wood shingles and wood shake siding, 11-28
- Sill framing, 9-1 to 9-5
 layout, 9-2 to 9-4
 placement, 9-4 to 9-5
- Single-acting pneumatic hammer, pile-driving equipment, 16-30
- Size designation, fiber lines, 5-2
- Size of line to use in a tackle, 5-21
- Sizes, plywood, 4-13
- Sketches, freehand, 2-24 to 2-26
- Slides and cave-ins, prevention of, 6-22 to 6-25
 sheathing, 6-23
 wooden sheet piling, 6-24 to 6-25
- Slump test, concrete mix design, 7-12 to 7-13
- Snatch block and fair-leads, 5-14 to 5-15
- Sources and characteristics of fibers, 5-1
- Special purpose plywood, 4-14 to 4-16
 concrete form panels, 4-14, 4-16
 decorative panels, 4-14
 overlaid panels, 4-14
 sheathing, 4-14
 structural, 4-14
- Specifications, 2-23 to 2-24
- Spray guns, painting, 14-8 to 14-11
 airless, 14-9 to 14-11
- Spray method, applying paint, 14-25 to 14-30
 care of the spray head, 14-28
 common spraying defects, 14-27
 lubrication of the spray gun, 14-29
 operational defects of the spray gun, 14-26
 removing the spray head, 14-30
 spray-gun adjustment, 14-25
 spray-painting techniques, 14-26
- Stains, coatings, 14-14
- Stairs, 12-19 to 12-24
 stairway construction, 12-23 to 12-24
 stairway layout, 12-19 to 12-23
 ternary windows, 12-44
- Steam curing, precast concrete, 7-57
- Steel bearing piles, 16-22 to 16-23
 preservation, 16-23
 reinforcement, 16-23
- Storage of equipment, paints and preservatives, 14-36 to 14-37
- Storage, plywood, 4-16
- Storage, wire rope, 5-8
- Straightening piles, 16-42
- Straining, paint, 14-23
- Strength of concrete, 7-2
- Strength of fiber line, 5-3
- Striking tools, heavy construction, 16-3
- Structural clay tile masonry, 8-19 to 8-24
 eight-inch structural clay tile wall, 8-23
 eight-inch wall with four-inch structural clay tile backing, 8-22
 joint finishing, 8-24
 mortar joints, 8-21
 physical characteristics, 8-19 to 8-21
 safe handling of block and hollow tile, 8-24
 uses, 8-21
- Structural design, 2-1
- Structural erection, basic, Butlerhut, 15-7 to 15-15
- Structural insulating board, 9-40, 9-42
 installation of sheathing, 9-42
 types of sheathing, 9-40
- Structural members, 2-1 to 2-5
 horizontal, 2-4 to 2-5
 vertical, 2-2 to 2-4
- Structural, plywood, 4-14
- Stucco, applying, 13-17 to 13-20
 control joints, 13-20
 preparation of base and application of stucco, 13-18 to 13-20
- Subflooring, 9-16 to 9-17
 boards, 9-16
 plywood, 9-17
- Supervising work teams, 1-2
- Surface preparation for painting, 14-14 to 14-21
 blast cleaning, 14-15
 concrete and masonry, 14-17
 conditioners, sealers, and fillers, 14-19 to 14-21
 ferrous metals, 14-17
 hand cleaning, 14-14
 nonferrous metals, 14-17
 paint removers, 14-17
 plaster and wallboard, 14-18
 power tool cleaning, 14-14
 wood, 14-18
- Surfacet, power shaving tools, 3-41

Suspended acoustic ceiling systems. 12-6 to 12-11

- ceiling tile. 12-11
- installation. 12-8 to 12-11
 - acoustical panels. 12-11
 - cross tees. 12-10
 - main tees. 12-9
 - suspension wires. 12-9
 - wall angles. 12-8
- preparation for installation. 12-7
 - grid pattern layout. 12-7
 - material requirements. 12-7

Swinging scaffold construction. 5-28

Table method. using rafter table on framing square. 10-6

Tackiness. prolonged. paint failures. 14-34

Tackle safety precautions. 5-21

Tackle terms. 5-12

Tackle. types of. 5-16

Tape. handtools. 3-10

Terminology. brick. 8-24

Thinning. paint. 14-23

Tile. setting. ceramic tile. 13-21

Tilt-arbor table bench saw. 3-29 to 3-30

Timber bearing piles. 16-20 to 16-22

- preparation of piles for driving. 16-20
- preservation of wood piles. 16-21 to 16-22
- reinforcement of wood piles. 16-20

Timber fasteners and connectors. 16-13 to 16-15

- timber connectors. 16-14 to 16-15
- timber fasteners. 16-13

Timber-handling tools and equipment. heavy construction. 16-4 to 16-5

Timber pier construction. 16-42 to 16-44

Timber trestles. heavy construction. 16-15 to 16-18

- constructing a timber trestle. 16-17
- constructing a trestle bent. 16-17
- constructing the superstructure. 16-18
- erecting a trestle bent. 16-18
- nomenclature. 16-15 to 16-17

Timekeeping. 1-3 to 1-5

Tinting. paint. 14-23

Tools and equipment. masonry. 8-1 to 8-2

Tools and equipment. painting. 14-3 to 14-11

- abrasives. 14-3
- airless spray guns. 14-9 to 14-11
- brushes. 14-4 to 14-6
- paint mixers. 14-11
- rollers. 14-7
- scrapers. 14-3
- spray guns. 14-8

Tools. applying plaster. 13-12 to 13-15

Top plate and sole plate. wall framing. 9-19

Trailer-mounted field saw. 3-17 to 3-29

- field radial overarm field saw safety. 3-29
- operation of the engine and generator set. 3-22 to 3-26
- preparation for use. 3-17 to 3-22
- preventive maintenance services and lubrication. 3-26

Transit-mixed concrete. 7-19

Trestle bent. 16-17. 16-18

- constructing. 16-17
- erecting. 16-18

Trim. exterior. 11-3 to 11-10

- cornices. 11-5 to 11-8
- rake (gable-end) trim. 11-9 to 11-10

Tripods. 5-23 to 5-26

- erecting. 5-25 to 5-26
- rigging. 5-24

Troweling. finishing concrete. 7-44

Trusses. roof. 10-28

- fabrication. 10-28
- handling. 10-29
- types. 10-28

Turning points differential leveling. 6-7 to 6-8

- selection. 6-7 to 6-8

Types of brick. 8-25

Types of ladders. 5-26

Types of roofs. 10-1

Types. plywood. 4-14

V

Vacuum blasting. 14-15

Valley rafter layout. 10-12 to 10-17

Vapor barriers. insulation. 12-17

Varnishes. coatings. 14-13

Vertical board siding. 11-21

Vertical joints. 7-34

Vertical structural members. 2-2 to 2-4

INDEX

- W
- Wall and ceiling coverings, 12-1 to 12-6
 gypsum board, 12-1 to 12-5
 hardboard and fiberboard, 12-5
 plywood, 12-5
 wood paneling, 12-5 to 12-6
- Wall framing, 9-18 to 9-27
 braces, 9-21 to 9-23
 framing allowance, 9-24 to 9-27
 gable-end studs, 9-23
 laying out studs for cutting, 9-20
 partition, 9-21
 top plate and soleplate, 9-19
- Wall sheathing, outside, 11-19 to 11-22
 horizontal or vertical siding, types of
 11-21 to 11-22
 horizontal siding, types of, 11-20
 nonwood siding, 11-22
 wood siding, 11-20
- Walls, formwork, 7-22 to 7-25
- Water, concrete ingredients, 7-9
- Water, placing concrete under, 7-39 to 7-41
- Water, plaster ingredients, 13-4
- Water-cement ratio, concrete mix design
 7-12
- Waterfront structures, 16-44 to 16-49
 breakwaters and jetties, 16-45
 bulkheads, 16-47 to 16-49
 groins, 16-46
 moles, 16-47
 seawalls, 16-47
- Watertight block walls, concrete masonry, 8-19
- Watertight walls, brick construction, 8-48
- Watertightness of concrete, 7-2
- Weathering, resistance to, 8-27
- Wellports, construction in the dry, 16-49
- Wet blasting, 14-16 to 14-17
- Window and door openings, brick construction,
 8-45
- Windows, interior finish, 12-42 to 12-49
 glass cutting, 12-47
 glazing, 12-48
 preparation before glazing, 12-47
 sash preparation, 12-47
 setting glass in wood and metal sash, 12-48
 to 12-49
 types of glass, 12-44 to 12-47
- Windows, interior finish - Continued
 types of windows, 12-42 to 12-44
 casement, 12-44
 double-hung, 12-42 to 12-44
 stationary, 12-44
- Wire rope, 5-5 to 5-12
 attachments, 5-10 to 5-12
 cleaning and lubrication, 5-8
 failure, 5-7
 inspection, 5-9
 measuring, 5-6
 safe working load, 5-7
 storage, 5-8
- Wood and particleboard tile flooring, 12-29
- Wood drill, pneumatic, 16-6
- Wood, painting, 14-18
- Wood paneling, installation of, 12-5 to 12-6
- Wood preservatives, 14-34 to 14-36
- Wood shingles and wood shakes, 11-12
- Wood, sheathing, 9-39 to 9-42
 installation of sheathing, 9-39 to 9-42
 types of sheathing, 9-38
- Wood substitutes, common, 4-16 to 4-17
 cement-asbestos board, 4-17
 fiberboard, 4-16
 gypsum wallboard, 4-17
 hardboard, 4-16
 particleboard, 4-17
- Wood-frame tents, 15-15
- Wood-strip flooring, 12-25 to 12-28
- Wood-trim installation, 12-49 to 12-52
 base molding, 12-51
 ceiling molding, 12-51 to 12-52
- Woodworking lathe, 3-47 to 3-50
- Woodworking materials and methods, 4-1 to
 4-42
 common wood substitutes, 4-16 to 4-17
 cement-asbestos board, 4-17
 fiberboard, 4-16
 gypsum wallboard, 4-17
 hardboard, 4-16
 particleboard, 4-17
 laminated lumber, 4-10 to 4-11
 lumber, 4-1 to 4-10
 board measure, 4-9
 classification, 4-7
 defects and blemishes, 4-1, 4-6 to
 4-7

BUILDER 3 & 2

Woodworking materials and methods - Continued

lumber - Continued

grading (softwoods), 4-7, 4-9
handling and storage, 4-9 to 4-10
seasoning, 4-1

methods of fastening, 4-33 to 4-42

bolts, 4-37 to 4-41
glue, 4-41 to 4-42
nails, 4-33 to 4-35
screws, 4-35 to 4-37

millwork, 4-30 to 4-33

plywood, 4-11 to 4-16

grades, 4-13
identification stamps, 4-16
sizes, 4-13
special purpose, 4-14 to 4-16
storage, 4-16
types, 4-14

safety, 4-42

woodworking methods, 4-17 to 4-30

contour cutting, 4-29 to 4-30
joints and joining, 4-17 to 4-29
planing and squaring to dimensions,
4-17

Woodworking shop and field tools, 3-1 to 3-53 equipment for holding work, 3-13 to 3-17

Woodworking shop and field tools - Continued handtools, 3-1 to 3-13

chalk line, 3-10
framing square, 3-1 to 3-8
levels, 3-9 to 3-10
miter box, 3-8
saw-sharpening equipment, 3-11 to
3-13
tape, 3-10

power tools, 3-17 to 3-53

abrasive grinders, 3-50 to 3-53
bandsaw, 3-33 to 3-34
care and maintenance of powersaw
blades, 3-34 to 3-37
drill press, 3-45 to 3-47
saber saw, 3-31 to 3-32
shop radial arm saw, 3-29
portable electric circular saw,
3-30 to 3-31
portable reciprocal saw, 3-32 to 3-33
power shaving tools, 3-37 to 3-45
tilt-arbor table bench saw, 3-29
to 3-30
trailer-mounted field saw, 3-17 to
3-29
woodworking lathe, 3-47 to 3-50

Workability, concrete mix design, 7-13

Wrinkling, paint failures, 14-34

BUILDER 3&2

NAVEDTRA 10648-G

Prepared by the Naval Education and Training Program Development Center, Pensacola, Florida

Your NRCC contains a set of assignments and perforated answer sheets. The Rate Training Manual, Builder 3&2, NAVEDTRA 10648-G is your textbook for the NRCC. If an errata sheet comes with the NRCC, make all indicated changes or corrections. Do not change or correct the textbook or assignments in any other way.

HOW TO COMPLETE THIS COURSE SUCCESSFULLY

Study the textbook pages given at the beginning of each assignment before trying to answer the items. Pay attention to tables and illustrations as they contain a lot of information. Making your own drawings can help you understand the subject matter. Also, read the learning objectives that precede the sets of items. The learning objectives and items are based on the subject matter or study material in the textbook. The objectives tell you what you should be able to do by studying assigned textual material and answering the items.

At this point you should be ready to answer the items in the assignment. Read each item carefully. Select the BEST ANSWER for each item, consulting your textbook when necessary. Be sure to select the BEST ANSWER from the subject matter in the textbook. You may discuss difficult points in the course with others. However, the answer you select must be your own. Remove a perforated answer sheet from the back of this text, write in the proper assignment number, and enter your answer for each item.

Your NRCC will be administered by your command or, in the case of small commands, by the Naval Education and Training Program Development Center. No matter who administers your course you can complete it successfully by earning a 3.2 for each assignment. The unit breakdown of the course, if any, is shown later under Naval Reserve Retirement Credit.

WHEN YOUR COURSE IS ADMINISTERED BY LOCAL COMMAND

As soon as you have finished an assignment, submit the completed answer sheet to the officer

designated to grade it. The graded answer sheet will not be returned to you.

If you are completing this NRCC to become eligible to take the fleetwide advancement examination, follow a schedule that will enable you to complete all assignments in time. Your schedule should call for the completion of at least one assignment per month.

Although you complete the course successfully, the Naval Education and Training Program Development Center will not issue you a letter of satisfactory completion. Your command will make an entry in your service record, giving you credit for your work.

WHEN YOUR COURSE IS ADMINISTERED BY THE NAVAL EDUCATION AND TRAINING PROGRAM DEVELOPMENT CENTER

After finishing an assignment, go on to the next. Retain each completed answer sheet until you finish all the assignments in a unit (or in the course if it is not divided into units). Using the envelope provided, mail your completed answer sheets to the Naval Education and Training Program Development Center where they will be graded and the score recorded. Make sure all blanks at the top of each answer sheet are filled in. Unless you furnish all the information required, it will be impossible to give you credit for your work. The graded answer sheets will not be returned.

The Naval Education and Training Program Development Center will issue a letter of satisfactory completion to certify successful completion of the course (or a creditable unit of the course). To receive a course-completion letter, follow the directions given on the course-completion form in the back of this NRCC.

You may keep the textbook and assignments for this course. Return them only in the event you disenroll from the course or otherwise fail to complete the course. Directions for returning the textbook and assignments are given on the book-return form in the back of this NRCC.

PREPARING FOR YOUR ADVANCEMENT EXAMINATION

Your examination for advancement is based on the Occupational Standards for your rating as found in the MANUAL OF NAVY ENLISTED MANPOWER AND PERSONNEL CLASSIFICATIONS AND OCCUPATIONAL STANDARDS (NAVPERS 18068). These Occupational Standards define the minimum tasks required of your rating. The sources of questions in your advancement examination are listed in the BIBLIOGRAPHY FOR ADVANCEMENT STUDY (NAVEDTRA 10052). For your convenience, the Occupational Standards and the sources of questions for your rating are combined in a single pamphlet for the series of examinations for each year. These OCCUPATIONAL STANDARDS AND BIBLIOGRAPHY SHEETS (called Bib Sheets), are available from your ESO. Since your textbook and NPCC are among the sources listed in the bibliography, be sure to study both as you take the course. The qualifications for your rating may have changed since your course and textbook were printed, so refer to the latest edition of the Bib Sheets.

NAVAL RESERVE RETIREMENT CREDIT

This course is evaluated at 24 Naval Reserve retirement points. These points are creditable to personnel eligible to receive them under current directives governing retirement of Naval Reserve personnel. Points will be credited in units upon satisfactory completion of assignments as follows:

Assignment	Points
1 through 9	1 through 9
10 through 18	10 through 18

COURSE OBJECTIVE

While completing this nonresident career course, you will demonstrate an understanding of course materials by correctly answering items on the following: principles of job planning, supervision, and labor accounting; fundamentals of the Personnel Readiness Capability Program and accident prevention programs; techniques of using plans, details, elevations, and specifications; lumber classifications and storage methods; operation and maintenance of woodworking handtools, power cutting tools, and spray painting equipment; use of the framing square to solve carpentry problems; fundamentals of rigging, scaffolding, leveling, grading, and excavating; techniques of mixing, placing, finishing, and curing concrete; construction of light wood frame structures and masonry structures; layout and installation of floor, wall, and ceiling coverings; maintenance and repair of wood, masonry, and metal structures; techniques of applying paints and paint materials; erection of timber structures, pre-engineered buildings, and advanced base structures; and operation and maintenance of engine-driven air compressors, portable generators, concrete pumping machines, and trailer-mounted field saws.

While working on this correspondence course, you may refer freely to the text. You may seek advice and instruction from others on problems arising in the course, but the solutions submitted must be the result of your own work and decisions. You are prohibited from referring to or copying the solutions of others, or giving completed solutions to anyone else taking the same course.

Naval courses may include a variety of questions -- multiple-choice, true-false, matching, etc. The questions are not grouped by type; regardless of type, they are presented in the same general sequence as the textbook material upon which they are based. This presentation is designed to preserve continuity of thought, permitting step-by-step development of ideas. Some courses use many types of questions, others only a few. The student can readily identify the type of each question (and the action required) through inspection of the samples given below.

MULTIPLE-CHOICE QUESTIONS

Each question contains several alternatives, one of which provides the best answer to the question. Select the best alternative, and blacken the appropriate box on the answer sheet.

SAMPLE

s-1. The first person to be appointed Secretary of Defense under the National Security Act of 1947 was

1. George Marshall
2. James Forrestal
3. Chester Nimitz
4. William Halsey

Indicate in this way on the answer sheet:

	1	2	3	4	
s-1	<input type="checkbox"/>	<input checked="" type="checkbox"/>	<input type="checkbox"/>	<input type="checkbox"/>	---

TRUE-FALSE QUESTIONS

Mark each statement true or false as indicated below. If any part of the statement is false the statement is to be considered false. Make the decision, and blacken the appropriate box on the answer sheet.

SAMPLE

s-2. Any naval officer is authorized to correspond officially with any systems command of the Department of the Navy without his commanding officer's endorsement.

Indicate in this way on the answer sheet:

	T	F			
s-2	<input type="checkbox"/>	<input checked="" type="checkbox"/>	<input type="checkbox"/>	<input type="checkbox"/>	---

MATCHING QUESTIONS

Each set of questions consists of two columns, each listing words, phrases or sentences. The task is to select the item in column B which is the best match for the item in column A that is being considered. Items in column B may be used once, more than once, or not at all. Specific instructions are given with each set of questions. Select the numbers identifying the answers and blacken the appropriate boxes on the answer sheet.

SAMPLE

In questions s-3 through s-6, match the name of the shipboard officer in column A by selecting from column B the name of the department in which the officer functions.

- | | | |
|-------------------------------|---------------------------|--|
| A | B | |
| s-3. Damage Control Assistant | 1. Operations Department | |
| s-4. CIC Officer | 2. Engineering Department | |
| s-5. Disbursing Officer | 3. Supply Department | |
| s-6. Communications Officer | | |

Indicate in this way on the answer sheet.

	1	2	3	4	
s-3	<input type="checkbox"/>	<input checked="" type="checkbox"/>	<input type="checkbox"/>	<input type="checkbox"/>	---
s-4	<input checked="" type="checkbox"/>	<input type="checkbox"/>	<input type="checkbox"/>	<input type="checkbox"/>	---
s-5	<input type="checkbox"/>	<input type="checkbox"/>	<input checked="" type="checkbox"/>	<input type="checkbox"/>	---
s-6	<input checked="" type="checkbox"/>	<input type="checkbox"/>	<input type="checkbox"/>	<input type="checkbox"/>	---

Assignment 1

Construction Administration and Drawings and Specifications

Textbook Assignment: Pages 1-1 through 1-10 and 2-1 through 2-30

In this course you will demonstrate that learning has taken place by correctly answering training items. The mere physical act of indicating a choice on an answer sheet is not in itself important; it is the mental achievement, in whatever form it may take, prior to the physical act that is important and toward which course learning objectives are directed. The selection of the correct choice for a course training item indicates that you have fulfilled, at least in part, the stated objective(s).

The accomplishment of certain objectives, for example, a physical act such as drafting a memo, cannot readily be determined by means of objective type course items; however, you can demonstrate by means of answers to training items that you have acquired the requisite knowledge to perform the physical act. The accomplishment of certain other learning objectives, for example, the mental acts of comparing, recognizing, evaluating, choosing, selecting, etc., may be readily demonstrated in a course by indicating the correct answers to training items.

The comprehensive objective for this course has already been given. It states the purpose of the course in terms of what you will be able to do as you complete the course.

The detailed objectives in each assignment state what you should accomplish as you progress through the course. They may appear singly or in clusters of closely related objectives, as appropriate; they are followed by items which will enable you to indicate your accomplishment.

All objectives in this course are learning objectives and items are teaching items. They point out important things, they assist in learning, and they should enable you to do a better job for the Navy.

This self-study course is only one part of the total Navy training program; by its very nature it can take you only part of the way to a training goal. Practical experience, schools, selected reading, and the desire to accomplish are also necessary to round out a fully meaningful training program.

Learning Objective: Denote the principles and techniques a crew leader applies in job planning, supervision, and production.
Textbook pages 1-1 and 1-2.

- 1-1. In first becoming a petty officer, you take on the additional responsibilities of a
1. company clerk
 2. project manager
 3. project estimator
 4. crew leader

- 1-2. When planning a project you must consider the capability of your crew as well as the tools and equipment you will need.

- 1-3. To insure that a job is completed on schedule, you should do which of the following?
1. Order extra equipment
 2. Conduct disaster control training
 3. Demand quantity work
 4. Encourage teamwork and establish goals

- 1-4. Crew members who are doing their jobs wrong should be
1. placed on report
 2. assigned extra work so they can learn
 3. stopped and given correct job procedures
 4. transferred to another crew

- 1-5. Of the following factors, which will enable a crew leader to develop teamwork among members of the crew?
1. By insuring they understand what duties they should perform
 2. By providing additional training for them
 3. By explaining why they are doing a particular job
 4. Each of the above

Learning objective: Specify the procedures used in material requisitioning. Textbook pages 1-2 and 1-3.

- 1-6. Which form does a crew leader normally use for ordering materials?
1. NAVSUP Form 1250
 2. DD Form 1148
 3. DD Form 1250
 4. NAVSIB Form 1149
- 1-7. Of the following rate training manuals, which offers information on the National Stock Number system?
1. Military Requirements for Petty Officer 3&2
 2. Blueprint Reading and Sketching
 3. Tools and Their Uses
 4. Constructionman

Learning objective: Specify the purpose of reporting labor hours used on given projects, the categories of labor, and the type of information that is entered on the daily labor distribution report. Textbook pages 1-4 through 1-7.

- 1-8. A labor accounting system is required to

In answering items 1-11 and 1-12, refer to column 2 of the type 1-16 of the daily labor distribution report.

- 1-11. Labor that contributes to the project but does not produce a product is called
- 1-12. Labor that is used to maintain and repair the equipment used on the project is called
- 1-13. Labor that is used to maintain and repair the equipment used on the project is called
- 1-14. Labor that is used to maintain and repair the equipment used on the project is called

In answering items 1-12 and 1-13, refer to textbook figure 1-3.

- 1-12. The identifying code for an embarkation exercise is
1. X05
 2. M03
 3. M08
 4. D02
- 1-13. If you attend a leadership school at Fort Huachuca, your time will be reported on the daily time card under the identifying code of
1. X01
 2. X02
 3. M05
 4. X04
- 1-14. Refer to the textbook figure 1-4. The 2 hours shown for Aaron represent time spent in which category?
1. Training
 2. Disaster control operations
 3. Overhead labor
 4. Indirect labor
- 1-15. After being filled out, a daily labor distribution report form should be initiated by the
1. company chief
 2. platoon commander
 3. assistant company commander
 4. company commander

- 1-16. The daily labor distribution reports from each company are compiled and calculated by the
1. operations officer
 2. management division of the operations department
 3. operations chief
 4. engineering and P&I division

- 1-17. Information from the daily labor distribution report serves as a tender report to the operations officer as well as a construction management analysis source for which of the following personnel?
1. crew leaders
 2. platoon leaders
 3. the company chief
 4. All of the above

Learning objective: Understand principles of the Personnel Readiness Capability Program (PRCP) and the role of the crew leader. Textbook pages 1-7 and 1-8.

1-18. PRCF provides for collecting information on which of the following subjects.

1. Predeployment planning
2. Readiness condition of NCF
3. Training publications available to the NCF
4. Prior military service organizations

1-19. Newly required skills are reported to which of the following personnel?

1. Education services officer
2. Company commander
3. Company clerk
4. EROF coordinator

1-20. The safety policy committee is initiated by the

1. safety chief
2. company chief
3. administrative officer
4. executive officer

1-21. What is the primary objective of a safety policy committee?

1. To develop a safety doctrine and policy for a battalion
2. To discipline personnel who are involved in accidents
3. To elect a battalion's safety chief and members of the committee
4. To review all vehicle accident reports and determine the causes of accidents

1-22. The purpose of a commander's safety committee is to

1. maintain safety programs on all projects
2. collect and exchange safety information and policies between projects
3. advise the safety division of safety procedures
4. investigate accidents that occur on the projects

1-23. Recommendations for improvement on the job should be forwarded to the safety policy committee via the supervisor if the safety committee

1-24. When a safety group with 70% of a NCF unit has been recommended to the safety committee

1. safety division
2. supervisory and executive officers
3. safety policy committee
4. support the commander

1-25. As the leader of a crew working on a construction project, you are responsible for which of the following duties?

1. Training your crew members
2. Correcting unsafe practices and conditions
3. Executing certain procedures should a crewmember be involved in an accident
4. All of the above

1-26. Who is responsible for conducting short, once a week, standup safety meetings?

1. Safety chief
2. Safety officer
3. Crew petty officer
4. Company chief

1-27. In addition to discussing project safety during standup safety meetings, which of the following topics of concern should be included?

1. Vehicle safety
2. Prestart checks
3. Equipment maintenance
4. All of the above

1-28. General information about large vehicle safety and prestart checks may be found in which publication?

1. Constructionman only
2. Equipment Operator 3&2 only
3. Constructionman or Equipment Operator 3&2
4. NAVFAC P-100

1-29. What is one of the most practical safety techniques that you, as a crew leader, can apply?

1. Standup meeting
2. Reprimanding violators in view of their peers
3. Designating a crewmember as your safety representative
4. Leadership by example

Learning Objective: Explain the terms relating to common structural members and the purpose of these members. Textbook pages 2-4 through 2-5.

1-30. A full supported by the structural members at any one time consists of the

1. dead loads only
2. live loads only
3. total dead load plus the total live load

- 1-31. Of the following supports, which provide immediate support for the live loads in a structure?
1. Footings
 2. Horizontal members
 3. Vertical members

- 1-32. Which is the best definition of an outside wall column?
1. It is usually located directly over the inside lower floor columns.
 2. It rests on the ground and extends to the roof line.
 3. It is a high-strength horizontal structural member.
 4. It is a high-strength vertical structural member usually extending from the footing to the roof line.

- 1-33. What type of column is used in building construction to support the lowermost horizontal structural members?
1. Bottom floor inside column
 2. Outside-wall column
 3. Upper floor column
 4. Short column

- 1-34. What is on top of the wall studs and supports the roof framing members?
1. Header
 2. Rafter plate
 3. Stud
 4. Sill

- 1-35. What structural member supports the ends of a joist in wood-frame construction?
1. Girder
 2. Bridging
 3. Stud
 4. Lintel

- 1-36. The peak ends of rafters are supported by the
1. purlins
 2. rafter plates
 3. ridge
 4. studs

- 1-37. The deflection caused in a 30-foot beam by a concentrated load of 5 tons is too great for structural integrity. If supports cannot be established along the beam, what other structural member can be used to adequately support the load?
1. Pier
 2. Truss
 3. Suspension cable
 4. Rafter

- 1-38. A framework of members which increases the strength of a load-bearing member spanning a space is a
1. chord
 2. truss
 3. gusset
 4. joist

Learning Objective: Identify techniques of using plans, elevations, details, and specifications. Text-book pages 2-5 through 2-24.

- 1-39. For what type of drawings is the end result of the combination of engineering and architectural design sketches used?
1. Symbol
 2. Perspective
 3. Combination
 4. Construction

- 1-40. Where are you most likely to find information on items too small to appear on general drawings?
1. Detail drawings
 2. Assembly drawings
 3. Bills of Materials
 4. Specifications

- 1-41. Which of the following is the architectural symbol for brick, as shown in elevation drawings?



1-42. Which of the following is the architectural symbol for a double door, opening out, where the threshold is in an exterior masonry wall?

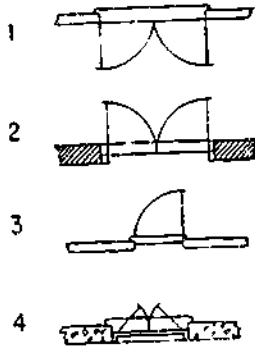

1-43. What is the plumbing symbol for a bathtub?

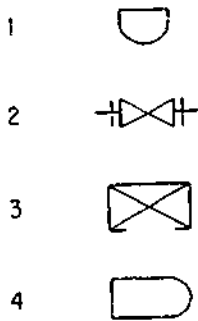

1-44. What is the heating symbol for a standard roof ventilator as shown on an elevation drawing.

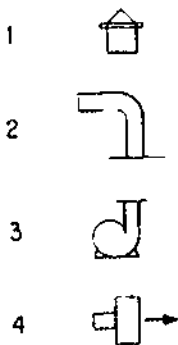

1-45. What is the electrical symbol for a wall outlet?

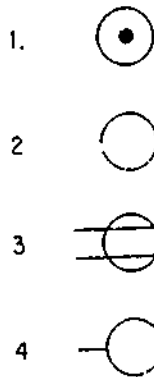

1-46. A plot plan is most likely to present information about the

1. materials to be used
2. location of windows
3. reference or base line.
4. location of studs

1-47. In order to determine the dimensions and arrangement of rooms, you should refer to what type of plan?

1. Plot
2. Foundation
3. Floor
4. Site

1-48. To which of the following plans drawings should you refer when determining the type of wall and roof covering to be installed?

1. Elevation
2. Floor
3. Plot
4. Foundation

1-49. To check the overall height of the finished floors, doors, and windows, you should consult the

1. plot plans
2. elevations
3. sections
4. floor plans

1-50. What type of plan shows you the dimensions, number, and arrangement of structural members in wood-frame construction?

1. Foundation
2. Floor
3. Wall framing
4. Framing

1-51. To find out what type of bridging is to be used on the floors of a building, you should consult the

1. plot plan
2. sections
3. elevations
4. floor framing plan

1-52. Refer to textbook figure 2-11. To determine the size of blocks used for backing in a brick-faced wall, you should consult the

1. detail drawings
2. elevations
3. floor framing plan
4. plot plan

1-53. For structural information about which of the following items is given on detail drawings

1. Doors
2. Windows
3. Cornices
4. All of the above

1-54. Generalized presentations of significant window characteristics are shown

1. in means of drawings
2. in detail
3. in window schedules
4. in window notes

1-55. Information about window opening and setting is usually shown on what type of drawings

1. Mechanical
2. Electrical
3. Architectural
4. Shop

1-56. What type of drawing should you use to build, prepare for the fieldwork

1. Mechanical
2. Shop
3. Architectural
4. Electrical

1-57. What information is contained in a bill of materials

1. Stock numbers
2. Quantities
3. Vendor
4. All of the above

1-58. Refer to textbook figure 2-12. What is the document number date series for 4 27 4's needed for a page 2.

1. 100
2. 200
3. 300
4. 400

1-59. To find out what grade of lumber is required for the window sashes of a structure, you should consult the

1. specifications
2. sections
3. elevations
4. floor plans

1-60. Government specifications are provided for the different materials you will be using. When will you refer to the ASTM specifications?

1. Whenever possible
2. When material is not covered by a government specification
3. When material is covered by a NAVFAC specification
4. When material is not covered by a military specification

Learning Objective: Describe basic procedures of freehand sketching. Textbook pages 2-24 and 2-25.

1-61. Lines for freehand pencil sketching are usually drawn by means of a

1. series of uniform strokes
2. long single stroke
3. series of short strokes

1-62. Refer to textbook figure 2-21. How wide is the top space at the bottom of the built cabinet

1. 1/2 in.
2. 1 in.
3. 3/4 in.
4. 6 in.

Learning Objective: Perform basic arithmetic operations and conversions of measuring units. Textbook pages 2-16 through 2-18.

1-63. What converted to imperial measure, 2.27 feet to the nearest 1/16 inch equals

1. 2 1/2 in.
2. 3 1/4 in.
3. 3 in.
4. 3 3/4 in.

1-64. The equivalent of 97.4 feet in imperial measure to the nearest 1/16 inch is

1. 97 ft 4 16 in.
2. 97 ft 1 16 in.
3. 97 ft 4 16 in.
4. 97 ft 1 16 in.

- 1-65. The measurement 100.43 feet converted into feet and inches to the nearest thirty-second of an inch, becomes
1. 100 ft 3 7/32 in.
 2. 100 ft 5 5/32 in.
 3. 100 ft 7 3/32 in.
 4. 100 ft 7 5/32 in.

- 1-66. To the nearest sixty-fourth of an inch, 0.24 equals
1. 15.64 in.
 2. 16.64 in.
 3. 24.64 in.
 4. 42.64 in.

- 1-67. How much mortar will be needed for a 600-square foot wall containing 3,724 bricks and 195 cubic feet of mortar per 1,000 square feet of wall?
1. 20⁰⁰ cu ft
 2. 11⁰⁰ cu ft
 3. 13⁰⁰ cu ft
 4. 14,25 cu ft

- 1-68. When 1.5 cubic feet of cement are required to produce 5.5 cubic feet of concrete, how much cement is required to produce a cubic yard of the concrete?
1. 3.3 cu ft
 2. 4.5 cu ft
 3. 7.4 cu ft
 4. 9.0 cu ft

- 1-69. Which formula is used for finding the hypotenuse of a right triangle

1. $C^2 = A^2 + B^2$

2. $C^2 = A^2 \times B^2$

3. $C^2 = \frac{A^2 \times B^2}{A^2 \times B^2}$

4. $C^2 = \frac{A^2 + B^2}{A^2 + B^2}$

Assignment 2

Drawings and Specifications (continued): Woodworking Shop and Field Tools

Textbook Assignment: Pages 2-28 through 2-33 and 3-1 through 3-30

Learning Objective (continued):
Perform basic arithmetical operations and conversions of measuring units. Textbook pages 2-28 through 2-33.

In answering 2-1 through 2-5, select from column B the formula used to determine the quantity in column A.

<u>A. Quantities</u>	<u>B. Formulas</u>
2-1. Circumference of a circle	1. $1/2 BH$
2-2. Area of a right triangle	2. $1/3 \cdot 22/7 \cdot R^2 \cdot H$
2-3. Circumference of a cylinder	3. LWH
2-4. Volume of a rectangular solid	4. $22/7 \cdot D$
2-5. Volume of a cone	
<hr/>	
2-6. A circle with a diameter of 5 inches will occupy an area of about	
1. 17.4 sq in.	
2. 17.8 sq in.	
3. 19.2 sq in.	
4. 19.6 sq in.	
2-7. What is the area of a regular 5-sided polygon whose sides are 20 inches long and the radius of the inscribed circle is 12 inches?	
1. 720 sq in.	
2. 650 sq in.	
3. 620 sq in.	
4. 600 sq in.	

- 2-8. Find the volume of a pyramid whose base is 6 by 10 inches and height is 24 inches.
1. 220 cu in.
 2. 360 cu in.
 3. 480 cu in.
 4. 520 cu in.

- 2-9. What is the square root of 697,241 carried out to two decimal places?
1. 805.35
 2. 820.18
 3. 835.00
 4. 850.03

● For items 2-10 and 2-11, apply the arithmetic method of extracting square root to find the square root of 529.

- 2-10. The initial step is to divide the digits into groups as follows: 5 29. The second step is to find the
1. largest factor of 5
 2. largest number whose square is contained in 5
 3. largest number whose square is contained in 29
 4. square root of 5

- 2-11. The second step yields the first digit of your answer. This digit is squared, the square is subtracted from 5, and the remainder brought down along with the second group, 29, to become the dividend, 129, for the next step. What is the true divisor (at the left in the computation), which, when divided into 129, yields the second digit of your answer?
1. 23
 2. 40
 3. 43
 4. 129

- 2-12. How many linear feet of lumber do you need to cover 150 square feet of wall when the boards are to be laid 9 inches to the weather?
1. 100 ft
 2. 150 ft
 3. 200 ft
 4. 250 ft

- 2-13. When tiles are laid without overlap, how many 12-by-12-inch tiles are required to cover an area of 10 square feet?
1. 10
 2. 12
 3. 15
 4. 20
- 2-14. Which of the following arithmetic expressions produces the number of board feet in a plank that is 2 inches thick, 6 inches wide, and 16 feet long?
1. $\frac{2 + 6 + 16}{12}$
 2. $\frac{2 \times 6 \times 16}{12}$
 3. $2/12 \times 6/12 \times 16$
 4. $12(2 + 6 + 16)$
- 2-15. How many board feet are there in a 9-foot-long 2 by 4?
1. 11
 2. 6
 3. 9
 4. 4
- 2-16. How many board feet are there in 10 pieces of 2-by-6-inch stock when each piece is 12 feet long?
1. 72
 2. 96
 3. 120
 4. 144
- 2-17. The dimensions, 2 inches by 6 inches by 16 feet, of a board purchased at a retail lumber yard are
1. actual dimensions
 2. slightly smaller than actual dimensions
 3. nominal dimensions or slightly larger than actual dimensions
- 2-18. What is the formal name for the Metric System?
1. International Metric System
 2. Standard Unit Measuring System
 3. Universal System of Units
 4. International System of Units
- 2-19. For measuring distance, the metric base unit is the
1. gram
 2. celsius
 3. hertz
 4. meter
- 2-20. Refer to textbook figure 2-24. What is the Prefix for the multiple of a 100?
1. Hecto
 2. Deka
 3. Centi
 4. Milli
- 2-21. Refer to textbook table 2-1. To convert centimeters to inches, you multiply by
1. 0.1
 2. 0.02
 3. 0.04
 4. 0.4
- 2-22. Refer to textbook table 2-2. A 94-pound bag of cement weighs how many kilograms?
1. 10.4
 2. 42.3
 3. 206.8
 4. 424.8
- 2-23. Refer to textbook table 2-3. A 5-gallon can of gasoline contains how many liters?
1. 19.0
 2. 21.2
 3. 35.0
 4. 38.6
- 2-24. Refer to textbook table 2-4. Estimate in square meters, the area of a 20-by-20-foot wall.
1. 13.4
 2. 28.3
 3. 37.2
 4. 49.0
- 2-25. Refer to textbook table 2-5. What should you do to convert 50 degrees Celsius to degrees Fahrenheit?
1. Subtract 32 from 50, then multiply by $5/9$
 2. Add 273.15 to 50
 3. Multiply 50 by $9/5$, then add 32
 4. Subtract 32 from 50
-
- Learning Objective: Name the parts of the framing square and solve basic problems using the graduated scales and tables found on the framing square. Textbook pages 3-1 through 3-8,
-
- 2-26. The blade of the framing square is 24 inches in length. The tongue of the framing square varies in length from
1. 14 to 18 in.
 2. 14 to 24 in.
 3. 18 to 20 in.
 4. 19 to 24 in.

Information for items 2-27 through 2-30.
 The framing squares in figure 2A are lying on a table. One is face down, the other is face up. You are standing on the spot marked X looking down at the squares.

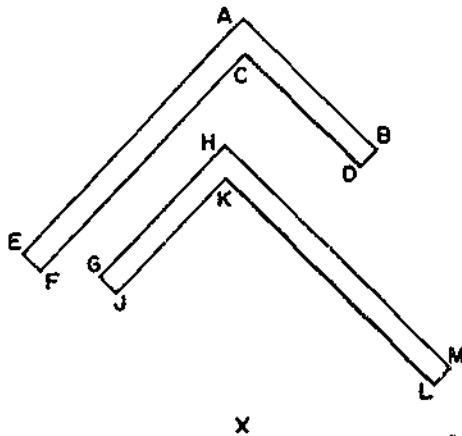

Figure 2A.-Two views of a framing square.

- 2-27. The heel of the square that is face up is located at point
1. A
 2. C
 3. H
 4. K
- 2-28. Which edge of either square is graduated in inches and tenths of an inch?
1. AB
 2. CF
 3. JK
 4. KL
- 2-29. Which edge of either square is graduated in inches and in eighths or sixteenths of an inch?
1. AE
 2. GH
 3. JK
 4. HM
- 2-30. Consider the triangle formed by drawing lines between G and H, H and M, and G and M. Which line represents a bridge measure?
1. GH
 2. GM
 3. HM

In items 2-31 and 2-32, assume that you are to find the brace length where the run is 36 inches and the rise is 48 inches.

- 2-31. What unit of run and unit of rise do you use to step off the brace?
1. Unit of run, 12 in.; unit of rise, 12 in.
 2. Unit of run, 12 in.; unit of rise, 15 in.
 3. Unit of run, 16 in.; unit of rise, 12 in.
 4. Unit of run, 12 in.; unit of rise, 16 in.
- 2-32. How many times do you step off the cut in finding the length of the brace?
1. 6
 2. 2
 3. 3
 4. 4
- 2-33. In order to determine line length without "stepping off", you multiply the bridge measure by the
1. number of times the unit of run goes into the total run
 2. number of times the unit of rise goes into the total run
 3. number of times the total rise goes into the unit of rise
 4. unit of rise only
- 2-34. When you are using the twelfth scale on a framing square to figure the total length or total rise of a rafter, the 10 6/12 mark on the square is equivalent to
1. 10 1/2 in.
 2. 10 ft 1/2 in.
 3. 10 1/2 ft
 4. 15 ft
- 2-35. The longest lines on the hundredths scale indicate how many hundredths of an inch?
1. 5
 2. 10
 3. 25
 4. 50
- 2-36. To use the octagon scale, you set one leg of the dividers on the first dot of the scale, and the other leg of the divider on the dot whose number corresponds to what dimension of the piece to be cut?
1. Width in inches divided by eight
 2. Width in inches divided by four
 3. One-half the length of the centerline
 4. Width in inches only

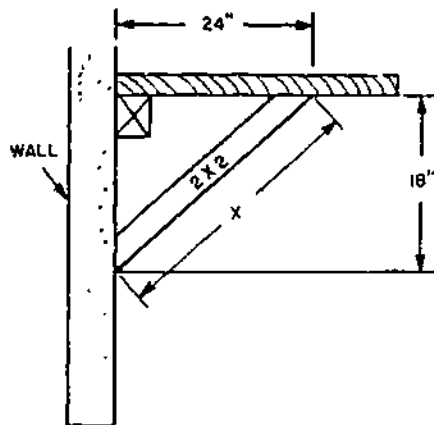

Figure 2B. - Shelf Section

- 2-37. What is the length of diagonal X in figure 2B?
1. 14 in.
 2. 22 in.
 3. 30 in.
 4. 48 in.
- 2-38. Refer to textbook figure 3-8. How many board feet are contained in a 1-inch by 8-inch by 14-foot board?
1. 10.6
 2. 9.4
 3. 8.8
 4. 8.2
-
- Learning Objective: State the purpose, use, and care of handtools used in woodworking. Textbook pages 3-8 through 3-10.
-
- 2-39. In order to cut a piece of stock to any given angle without marking the stock, you should use a
1. wooden miter box
 2. steel miter box
 3. line level
 4. framing square
- 2-40. To check the level of a cord that has been stretched between two points, use a
1. hand level
 2. carpenter's level
 3. line level
 4. plumb bob
- 2-41. Which of the following is used to check if an object is plumb and level?
1. Line level
 2. Carpenter's level
 3. Plumb bob
 4. Framing square

- 2-42. In order to prevent a tape from becoming stained, you should
1. coat it with a light coat of oil
 2. rinse it in hot water, then air dry
 3. coat it with paste wax
 4. dip it in kerosene, then air dry
- 2-43. What is the maximum distance a chalkline can be used to accurately mark a straight line between two points?
1. 10 ft
 2. 20 ft
 3. 30 ft
 4. 40 ft

Learning Objective: Identify the equipment and procedures used in reconditioning handsaws. Textbook pages 3-11 through 3-13.

- 2-44. Which part of a saw sharpening vice is used to secure it to a bench?
1. Jaws
 2. Clamp
 3. Cam handle
 4. Wing nut
- 2-45. Which of the following tools should you use in order to make the saw kerf wider than the thickness of the blade?
1. File holder
 2. Jointer
 3. Saw set
 4. Saw vise
- 2-46. Saw teeth are all made the same height by which process?
1. Setting
 2. Dressing
 3. Filing
 4. Jointing
- 2-47. What is the correct order of the steps listed for reconditioning a saw?
1. Shaping, filing, setting, jointing
 2. Setting, shaping, jointing, filing
 3. Jointing, shaping, setting, filing
 4. Filing, setting, shaping, jointing
- 2-48. In saw reconditioning, you must shape a handsaw after
1. jointing
 2. setting only
 3. sharpening only
 4. setting and sharpening

- 2-49. In setting the teeth on a handsaw, the depth of the set should NEVER be more than
1. 1/4 the length of the tooth
 2. 1/2 the depth of the tooth itself
 3. the same depth as the tooth
 4. twice the depth of the tooth itself
- 2-50. What procedure should be followed when filing a crosscut saw once the file holder has been adjusted?
1. File one tooth at a time, working down the whole saw
 2. File both teeth at once, working down the whole saw
 3. File and set each tooth separately
 4. File and dress one side, turn, and file and dress the other side

Learning Objective: Identify the parts of a woodworking vise and state how to use, care for, and safely operate holding tools. Textbook pages 3-13 and 3-14.

- In answering items 2-51 and 2-52, refer to figure 2C.

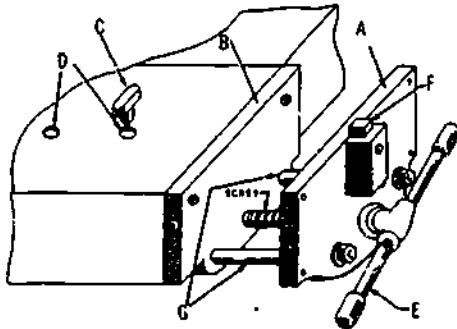

Figure 2C.-Woodworking bench vise.

- 2-51. The bench vise movable jaw is indicated by the letter
1. E
 2. F
 3. G
 4. A
- 2-52. Which letter represents the device used in conjunction with the bench stop to hold material that is wider than the maximum span of the vise?
1. A
 2. D
 3. F
 4. G

- 2-53. Where are the dog and the bench stop for a bench vise located?
1. On the movable jaw
 2. On the stationary part of the vise
 3. The dog on the stationary part of the vise and the bench stop on the movable jaw
 4. The bench stop on the bench and the dog on the movable jaw
- 2-54. What device would you use to hold material on a work bench when back-sawing?
1. Bench stop
 2. Miter box
 3. Bench hook
 4. C-clamp

Learning Objective: Determine the set for the framing square when constructing a sawhorse. Textbook pages 3-15 and 3-16.

- In items 2-55 and 2-56, assume that you are making a sawhorse similar to the one shown in figure 3-21 of your textbook.

- 2-55. In laying off the end cuts for legs, the first mark on the right end of the leg is indicated by which part of the framing square?
1. End of the blade
 2. End of the tongue
 3. Outer edge of the tongue
 4. Outer edge of the blade
- 2-56. The set of the framing square for the end cuts of the 1 by 10 end piece is the same as the set for which of the following cuts?
1. End cuts for the legs
 2. Edge cuts for the 1 by 10 tray
 3. Side cuts for the legs
 4. Both 2 and 3 above

Learning Objective: Identify fundamentals of setting up, safely operating, and performing operator's maintenance on the trailer-mounted field saw. Textbook pages 3-17 through 3-29.

- 2-57. The trailer-mounted field saw is a typical shop-type radial overarm saw with slight modifications for field use.

- 2-58. The field trailer has four retractable stabilizing jacks for leveling, and maintaining the radial overarm saw in its operating position.
- 2-59. A good electrical ground is essential to the safe operation of the field saw.
- 2-60. At what point after starting the field-saw engine should the frequency meter be checked to insure a 60-hertz reading?
1. Immediately after starting
 2. After the engine has warmed up for two minutes
 3. After the engine has warmed up for five minutes
- 2-61. What voltage should the voltmeter indicate phase-to-phase under normal operation?
1. 110
 2. 208
 3. 220
 4. 440
- 2-62. Of the following procedure, which should you use to revolve the saw arm to a desired position?
1. Push both miter controls backward, swing saw right or left
 2. Push right miter control backward to swing right, and left miter control backward to swing left
 3. Pull both miter controls forward, and swing saw right or left
 4. Pull bevel controls forward, and swing saw right or left
- 2-63. When crosscutting, in what position should you lock the saw arm?
1. 0°
 2. 20°
 3. 30°
 4. 40°
- 2-64. A radial-arm field saw can be used to perform which of the following operations?
1. Bevel ripping
 2. Compound mitering
 3. Shaping
 4. All of the above
- 2-65. The radial-arm field saw may be used for rabbeting when equipped with a dado head.
- 2-66. When installing the blade on the radial-arm field saw, you turn the recessed sides of the collars against the blade.
- 2-67. When you are using the radial-arm field saw, which of the following safety precautions should be observed?
1. Wearing safety glasses
 2. Removing all tools and wood scraps prior to starting the saw
 3. Adjusting the saw for the depth of cut before starting
 4. All of the above
-
- Learning Objective: Describe how to operate a tilt-arbor bench saw safely. Textbook page 3-30.
-
- 2-68. Which of the following parts of the saw moves with the stock as you make the cut?
1. Cutoff gage
 2. Ripping fence
 3. Throat plate
 4. Blade
- 2-69. Which combination of grooving saws and chisel-type cutters make up a dado head?
1. No saws and two cutters
 2. One saw and one cutter
 3. One saw and two cutters
 4. Two saws and one or more cutters
- Items 2-70 through 2-73, are to be judged True or False based on the safe operation of a tilt-arbor bench saw.
- 2-70. Blade guards should be kept in place EXCEPT when their removal is absolutely unavoidable.
- 2-71. When feeding material through the saw, stand to one side of the saw to avoid kickbacks.
- 2-72. Short, narrow pieces of material may be pushed between the saw and the gage by using a push stick.
- 2-73. You may reach over the saw to remove material from the other side when it is in operation.

Assignment 3

Woodworking Shop and Field Tools (continued): Woodworking: Materials and Methods

Textbook Assignment: Pages 3-30 through 3-53 and 4-1 through 4-7

Learning Objective: Point out safe practices in the operation of a portable electric saw. Textbook pages 3-30 through 3-33.

- 3-1. The portable electric circular saw can cut a piece of lumber square or at any bevel angle up to
1. 75°
 2. 60°
 3. 30°
 4. 45°
- 3-2. The ripping guide on the portable electric circular saw is turned upside-down for cutting off.
- 3-3. When using the portable electric circular saw, you should always grasp the saw with
1. the right hand and guide the work with the left hand
 2. both hands and hold it firmly against the work
 3. both hands after removing the blade guard
 4. both hands and pull the saw toward yourself
- 3-4. Provided the proper blade is used, the saber saw will cut both wood and light metal.
- 3-5. If you do not maintain a firm grip on the saber saw, it will tend to
1. glide smoothly over the work
 2. overheat
 3. vibrate excessively
- 3-6. The foot plate of the portable reciprocal saw is fixed at a 30° angle to allow for working in corners. *
- 3-7. You should never attempt to change blades on a reciprocal saw without first disconnecting it from the power source.

Learning Objective: Recognize principles of operating a bandsaw. Textbook page 3-34.

- 3-8. The size of a bandsaw is designed by the
1. tooth points per inch
 2. width and gage of the blades
 3. diameter of the wheels
 4. cutoff gages and gears
- 3-9. If a clicking sound develops while you are cutting material with the bandsaw, you should shut off the motor because the sound is an indication that the blade is
1. cracked
 2. pinched
 3. binding
 4. too small for the work
- To answer item 3-10 use the formula for finding the circumference of a circle $C = \pi D$, where C is the circumference, D is the diameter, and π is 22/7.
- 3-10. Approximately how long a blade is required for a 14-inch bandsaw whose wheel centers are 32 inches apart?
1. 76 in.
 2. 86 in.
 3. 108 in.
 4. 152 in.
- 3-11. A hand or foot brake should be installed on all bandsaws that are
1. 24 inches
 2. 30 inches
 3. 36 inches or larger

Learning Objective: Point out techniques of reconditioning a circular saw blade. Textbook pages 3-35 and 3-36.

- 3-12. Which of the following reconditioning operations should be performed on a circular saw if the teeth have become out of round?
1. Jointing
 2. Gumming
 3. Setting
 4. Sharpening
- 3-13. In a jointing operation, the blade is first removed from the arbor and then
1. installed in the reverse order
 2. placed in a limestone holder
 3. marked for jointing with a file
 4. secured on the bench with the jointing fence
- 3-14. How do you determine whether or not the jointing of a circular saw blade is completed?
1. By visual inspection of the teeth
 2. By the sound of the blade striking an abrasive wheel
 3. By the evenness of the pressure exerted by the blade on an abrasive wheel
 4. By the speed at which the blade rotates
- 3-15. Gumming a saw blade is done where the gullets of the blade have become too
1. dull
 2. deep
 3. rounded
 4. shallow

Learning Objective: Point out safe practices in the use of power shaving tools. Textbook pages 3-37 through 3-45.

- 3-16. The cutting depth of a router is maintained by adjusting the
1. depth setscrew
 2. depth ring
 3. chuck nut
 4. edge guide
- 3-17. A router lateral depth is obtained by adjusting the
1. end guide
 2. top guide
 3. edge guide
 4. foot guide

- 3-18. You can avoid danger of an "out of control" planer by checking to insure that the switch on the portable planer is in the OFF position before connecting it to the power source.
- 3-19. If a jointer makes a cut that is deeper at the beginning of the cut than at the end, the jointer should be adjusted by
1. raising the infeed table
 2. lowering the infeed table
 3. raising the outfeed table
 4. lowering the outfeed table
- 3-20. The fence on a jointer can be set to produce beveled edges at
1. a maximum of 45°
 2. a maximum of 60°
 3. a maximum of 75°
 4. any desired angle
- 3-21. When setting the knives on the jointer, be sure that you do NOT set them for too heavy a cut since this may cause
1. the jointer to stop
 2. gaps in the spindle
 3. a kickback
 4. a sharp edge to form on the outfeed table
- 3-22. How should you true a warped board and plane its top surface if the tools available include a jointer and a single surfacer?
1. Simply feed the board through the surfacer once.
 2. Feed the board through the surfacer and then turn the board over and feed it through again.
 3. True one face of the board on the jointer and then feed the board through the surfacer with the trued face down.
 4. True one face of the board with the jointer and then feed the board through the surfacer with the trued face up.
- 3-23. When a cast iron guard is used on the surfacing machine, the thickness of the metal should not be less than
1. 1/16 of an inch
 2. 3/16 of an inch
 3. 1/4 of an inch
 4. 1/2 of an inch
- 3-24. Even though a shaper can be used for fluting and heading, it is primarily designed for
1. rabbeting and grooving
 2. edging curved stock and cutting ornamental edges
 3. surfacing the face of large pieces of stock
 4. edging flat smooth surfaces

- 3-25. When shaping an edge of a piece of stock on the shaper, you feed the stock to the cutter head in which of the following ways?
1. Feed stock through in the same direction as the spindle is rotating.
 2. Feed the stock against the rotation of the spindle.
 3. Feed the stock through in the same direction as the spindle is rotating but against the rotation of the spindle.
 4. Feed the stock through either direction.
- 3-26. If curved or irregularly shaped edges are to be shaped, the regular straight fence is removed and replaced by a
1. starting pin placed in the table top
 2. C-clamp with a handscrew
 3. 3-wing cutter
 4. straightedged board
- Items 3-27 and 3-28 refer to the following steps in sharpening a jointer knife with a knife-grinding attachment:
- A. Loosening the set screws
 - B. Tightening the set screws
 - C. Inserting the cutterhead locking pin
 - D. Setting the grinding attachment in place
- 3-27. In what order are these steps performed?
1. A, B, C, D
 2. E, D, C, A
 3. C, A, B, D
 4. D, A, C, B
- 3-28. Between which steps is the jointer knife moved up?
1. A and B
 2. B and C
 3. B and D
 4. C and D
- 3-29. Suppose that you are going to sharpen and joint the knives of a jointer that has a knife-grinding attachment. If there are three knives on the cutterhead, how many times will you use the three-pronged knife gage?
1. One
 2. Two
 3. Three
 4. Six

Learning Objective: Identify safe practices in operating the drill press. Textbook pages 3-45 through 3-47.

- 3-30. The speed of a drill press is changed by which of the following means?
1. By the 2-speed switch control
 2. By locating the V-belt on the spindle
 3. By the variable speed control knob
 4. By changing the drive pulley
- 3-31. What component of the drill press, shown in textbook figure 3-57, engages the spindle and quill assembly downward?
1. Head lock handle
 2. Head collar support lock handle
 3. Quill lock handle
 4. Spindle and quill feed handle
- 3-32. At what angle left or right from the horizontal position may the table on a drill press be positioned?
1. 15°
 2. 25°
 3. 30°
 4. 45°
- 3-33. If too much pressure is applied to the feed handle, which of the following problems may develop?
1. The switch may open and the motor stop
 2. The V-belt may slip
 3. The twist drill may break
 4. All of the above
-
- Learning Objective: Recognize principles and techniques of operating a woodworking lathe. Textbook pages 3-47 through 3-50.
-
- 3-34. The size of a lathe is determined by the
1. diameter of stock that the lathe will accommodate
 2. circumference of the stock that the lathe will accommodate
 3. length of stock that can be mounted on the lathe
 4. horsepower of the lathe motor
- 3-35. Of the four major parts of the lathe, which part supports all other parts?
1. Headstock
 2. Tailstock
 3. Bed
 4. Toolrest
- 3-36. What part of a lathe can be moved along the length of its bed?
1. Headstock
 2. Tailstock
 3. Motor spindle
 4. Faceplate

In answering items 3-37 through 3-40, select from column B the special tool used to perform the operation in column A.

A. Operations	B. Special Tools
3-37. Cut recesses or grooves with straight sides and a flat bottom	1. Turning gouges 2. Skew chisels 3. Parting tools
3-38. Rough cut all shapes by spindle turning	4. Scraping tools
3-39. Faceplate turning	
3-40. Smooth cutting, V cuts, and trimming edges	

- 3-41. Which of the following is a safe practice in operating a woodworking lathe?
1. Standing to one side when starting the motor
 2. Making adjustments with the motor running
 3. Using calipers on irregular surfaces while the lathe is in motion
 4. Each of the above

Learning Objective: Identify practices in maintaining cutting tools. Textbook pages 3-51 through 3-53.

- 3-42. Which of the following grinding wheels on the multiwheel oilstone grinder is used to grind inside-bevel gouges?
1. Dry emery
 2. Fine oilstone
 3. Coarse oilstone
 4. Cone
- 3-43. To put the sharpest edge on a fine tool, you should use an oilstone made of
1. natural stone
 2. aluminum oxide
 3. silicone carbide
 4. quartz
- 3-44. What should you do to prevent glazing of a sharpening stone?
1. Soak it in aluminum oxide
 2. Dip it in water after use
 3. Clean it with a wire brush between uses
 4. Sprav it with light oil during use

- 3-45. What test is used to check whether or not an abrasive wheel is cracked?
1. Finger
 2. Ring
 3. Oil
 4. Water

- 3-46. In the operation of a power grinder, you may be able to correct glazing of an abrasive wheel by
1. putting on a softer wheel or decreasing speed
 2. putting on a harder wheel or increasing speed
 3. reversing the wheel

- 3-47. The most effective wheel dresser for turning an out-of-round abrasive wheel is the
1. tube
 2. cutter
 3. diamond
 4. soft

- 3-48. Where is the lug of the cutter-type wheel dresser held while the wheel is being dressed?
1. Against the front edge of the tool rest
 2. In the center of the tool rest
 3. Either to the right or left of the center of the toolrest

- 3-49. What, if anything, should you do to prevent a grinding wheel from wearing rapidly as it becomes smaller?
1. Increase its speed
 2. Decrease its speed
 3. Nothing

- 3-50. While whetting chisels with an oilstone, you must keep the faces of the oilstone perfectly flat.

- 3-51. What bonding material should you use to mend a broken oilstone?
1. Varnish
 2. Shellac
 3. All-purpose cement
 4. Wood glue

Learning Objective: Identify the types, characteristics, and uses of various woods. Textbook pages 4-2 through 4-6.

- 3-52. Of the following woods, which is the strongest and toughest?
1. Ash
 2. Birch
 3. Hickory
 4. Live oak

- 3-53. For heavy construction, such as shaft logs, which of the following woods is used?
1. Red oak
 2. White oak
 3. Beech
 4. Birch
- 3-54. Which of the following woods could you use for interior trim?
1. Norway pine
 2. White pine
 3. Mahogany
 4. Each of the above
- 3-55. What is probably the hardest and strongest wood grown on the West Coast?
1. Redwood
 2. Red cedar
 3. Live oak
 4. Douglas fir
- 3-56. What do beech, birch, mahogany, red oak, and walnut have in common?
1. All have a reddish color.
 2. All are used for cabinetwork.
 3. All are used in making small boats.
- 3-57. Yellow pine is preferred to white pine for damage control work because it
1. is stronger
 2. is easier to work
 3. has straighter grain
 4. has fewer knots
- 3-58. What is the best structural lumber native to the Northwest?
1. Douglas fir
 2. Live Oak
 3. Poplar
 4. Redwood
-
- Learning Objective: Explain factors relating to the seasoning, cutting, classification, uses, and grades of lumber. Textbook pages 4-1 through 4-7.
-
- 3-59. Wood cut to which of the following dimensions is timber?
1. 1 in. by 12 in. by 8 ft
 2. 2 in. by 12 in. by 8 ft
 3. 3 in. by 5 in. by 12 ft
 4. 5 in. by 7 in. by 16 ft
- 3-60. Which of the following is an advantage of seasoned lumber?
1. Decreased shrinkage
 2. Increased strength
 3. Reduced weight
 4. Each of the above
- 3-61. Lumber is considered dry enough for most uses when the moisture content is NOT more than
1. 12 to 15 pct
 2. 17 to 19 pct
 3. 20 to 23 pct
 4. 25 to 28 pct
- 3-62. Which, if any, of the following knots in a board might be considered more a blemish than a defect by a carpenter who uses the board for framing a house?
1. A spike knot
 2. A loose cross-section knot
 3. A tight cross-section knot
 4. None
- 3-63. A blemish in a piece of lumber is classified as a defect when it affects the lumber's
1. utility value
 2. strength
 3. durability
 4. size
- 3-64. A root section of a branch appearing on a surface in cross section is a
1. pitch pocket
 2. knot
 3. check
 4. shake
- 3-65. Twists or curves that develop in flat boards are
1. wind shakes
 2. wanes
 3. checks
 4. warps
- 3-66. When framing lumber 2 in. by 4 in. by 10 1/2 ft is ordered directly from the yards, what are the actual dimensions of the lumber received?
1. 1 1/2 in. by 3 1/2 in. by 10 1/2 ft
 2. 2 in. by 4 in. by 10 1/2 ft
 3. 1 1/2 in. by 3 1/2 in. by 12 ft
 4. 2 in. by 4 in. by 12 ft
- 3-67. What type of wood is used for constructing boxes and crates?
1. Yard lumber
 2. Shop lumber
 3. Structural material
 4. stock lumber

Assignment 4

Woodworking: Materials and Methods (continued)

Textbook Assignment: Pages 4-7 through 4-42

Learning Objective (continued):
Explain factors relating to the seasoning, cutting, classification, uses, and grades of lumber. Textbook pages 4-7 through 4-9.

Learning Objective: Describe procedures in safely handling and storing lumber without damage and deterioration. Textbook pages 4-9 and 4-10.

In answering items 4-1 through 4-5, select the grade of lumber from column B that best fits the description in column A.

	<u>A. Descriptions</u>	<u>B. Grades</u>
4-1.	Lumber that is practically free of defects and blemishes	1. No. 1 common lumber 2. Grade A select lumber
4-2.	Lumber that contains a few minor blemishes	3. No. 5 common lumber
4-3.	Lumber that is sound, tight-knotted stock, containing only a few minor defects	4. Grade B lumber
4-4.	Lumber that is capable only of holding together under ordinary handling	
4-5.	Lumber that is suitable for use as watertight lumber	
4-6.	How many board feet are there in a piece of lumber that is 2 in. thick, 6 in. wide, and 24 ft long? 1. 12 2. 16 3. 20 4. 24	

- 4-7. One purpose of storing lumber is to keep it from deteriorating by maintaining its moisture content.
- 4-8. What is the minimum safe width for 2-in. by 12-in. by 12-ft pieces of lumber stacked 16 ft high?
1. 8 ft
2. 6 ft
3. 5 ft
4. 9 ft
- 4-9. Stickers are required for all lumber piles that are stacked more than how many feet high?
1. 10
2. 8
3. 6
4. 4

Learning Objective: State the advantages of laminated lumber as used in framing. Textbook pages 4-10 and 4-11.

- 4-10. What is the primary advantage of laminated lumber?
1. Light in weight
2. Low cost
3. Increased load-carrying capacity
4. Increased resistance to decay

- 4-11. Which of the following types of structures would most likely use laminated lumber?
1. Office buildings
 2. Bridges
 3. Warehouses
 4. All of the above

- 4-12. Most laminations are spliced by the use of what type of joint?
1. Tongue and groove
 2. Scarf
 3. Ship lap
 4. Half lap

Learning objective: Specify descriptive markings and uses and prescribe measures to minimize dishing of plywood during storage. Textbook pages 4-12 through 4-16.

- 4-13. The fact that pounds for pound, plywood is one of the strongest building materials available is attributed to its:
1. cross lamination
 2. high strength glue
 3. number of plies
 4. grade of wood

- 4-14. Which of the following is not included in an article made of plywood?
1. Form work
 2. Sheathing
 3. Furniture
 4. Each of the above

- 4-15. Plywood having a solid surface veneer with circular repair plugs would be considered what grade?
1. A
 2. B
 3. C
 4. N

- 4-16. Which of the following descriptive markings will be found on most sheets of plywood?
1. Type of exterior or interior and the grade of the face and back sheets
 2. Grade of the face and back sheets and the overall thickness
 3. Type of exterior and interior and plywood dimensions
 4. Quality and guarantee of the plywood

- 4-17. Of the special-purpose plywoods, which would normally be used for cabinet doors?
1. A-A exterior
 2. C-C exterior
 3. A-A interior
 4. B-D interior

- 4-18. What type of plywood is normally used for subflooring?
1. A-C interior
 2. B-C exterior
 3. Flugged C-C exterior
 4. Standard C-D interior

- 4-19. In which of the following ways do concrete form panels differ from standard plywood panels?
1. Concrete form panels weigh less than standard plywood panels
 2. Only concrete form panels have a moisture resistant surface
 3. Only concrete form panels have a metal facing
 4. Only form panels always have seven or more plies

- 4-20. The index numbers (8-2) appear on a grading identification stamp. What does the 8 indicate?

1. Minimum on center spacing of supports for subfloors
2. Maximum on center spacing of supports for roof decking
3. Maximum on center spacing of supports for subfloor
4. Maximum on center spacing of wall studs

- 4-21. When plywood is stored, what could cause dishing?

1. Plywood edges swelling under humid conditions
2. Sealing the edges of the plywood with white lead
3. Painting the edges of the plywood with a red sealer
4. Placing the plywood in a heated storage shed

- 4-22. During storage, the dishing of plywood can be minimized by:

1. placing plywood in vertical racks
2. placing 1-in. board strips between the layers of plywood at intervals
3. oiling the edges with pale oil
4. making many piles of not more than 10 layers each

Learning objective: Identify common wood and panel substitutes and their uses. Textbook pages 4-16 and 4-17.

In answering items 4-23 through 4-28, select the type of wallboard from column B that matches the characteristic in column A.

A. Characteristics	B. Types of Wallboard
4-23. Made of wood or vegetable fibers, relatively soft	1. Gypsum 2. Hardboard
4-24. Both fire resistant and sound deadening	3. Fiberboard
4-25. Does not contain wood	4. Particleboard
4-26. Tapered edge	
4-27. Made of compressed wood fibers, no grain, strong	
4-28. Made of bonded wood flakes or chips, relatively weak	
4-29. Prior to working with any form of cement asbestos board, you should review which of the following publications? 1. NAFAC P-31 2. NAFAC P-2601 3. NAFAC P-5100 4. NAFAC P-317	

Learning objective: Identify the types of simple and complex joints and some of the methods and procedures used in their development. Textbook pages 4-17 through 4-30.

4-30. In planning and squaring the work end of a board, you test it from both the work face and the work edge.

In answering items 4-31 and 4-32, refer to figure 4A.

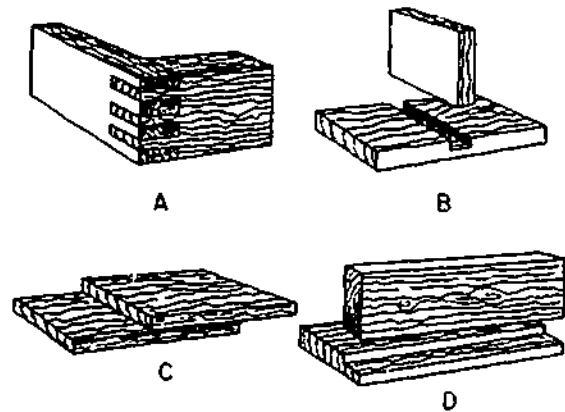

Figure 4A. Joints.

- 4-31. Of the joints shown, which is a dado?
1. A
2. B
3. C
4. D
- 4-32. A rabbet joint is shown at
1. A
2. B
3. C
4. D
- 4-33. To insure a tight rabbet, half, or other joint, you cut directly to the tapered end instead of the waste side of the line.
- 4-34. In laying off a piece for an end butt half-lap joint, the shoulder line is drawn around the board at a distance equal to
1. one board width from the end
2. one board thickness from the end
3. the desired amount of lap from the end
4. one-half the board thickness from the end
- 4-35. In laying off a piece for a full-lap joint, you gauge the cheek line from the
1. edge only
2. face only
3. edge or end
4. face or end
- 4-36. In cutting an end butt half-lap joint, which cut do you make first?
1. Face
2. Shoulder
3. Back
4. Cheek

- 4-37. When mitering pieces for a hexagonal (six-sided) frame, what miter angle should you use?
1. 22.5°
 2. 30.0°
 3. 60.0°
 4. 67.5°
- 4-38. Slip feathers are often preferred over corrugated fasteners for the reinforcement of miter joints because they are
1. stronger
 2. easier to apply
 3. easier to remove
 4. less likely to detract from the appearance of the joints
- 4-39. A three-sided recess running across the grain from one side of the board to the other is a
1. grooved joint
 2. stopped dado
 3. dado
 4. stopped groove
- 4-40. A two-sided recess running along an edge of a board, either across the grain or with the grain, is a
1. groove
 2. dado
 3. stopped dado
 4. rabbet
- 4-41. A stopped groove can be cut on a circular saw with the use of a
1. stop block
 2. rabbet ledge
 3. haunch board
 4. carriage block
- 4-42. To adjust the fence to the depth of the cheek when cutting a rabbet joint on a circular saw, you would measure from what point?
1. Left side of the raker tooth
 2. Centerline of saw blade
 3. Saw tooth set to the left
 4. Saw tooth set to the right
- 4-43. The rabbeting ledge of a jointer is used for
1. depressing the outfeed table
 2. adjusting the width of the cheek cut
 3. raising the blade for rabbet cuts
 4. carrying the unrabbeted portion of stock
- 4-44. A mortise-and-tenon joint in which the tenon does NOT penetrate all the way through the mortised member is a
1. through mortise and tenon
 2. blind mortise and tenon
 3. barefaced tenon
 4. haunched tenon
- 4-45. Table haunching a mortise-and-tenon joint tends to weaken the joint.
- 4-46. When the tenon member is too thin to permit shoulder cuts on both faces, what kind of mortise-and-tenon joint is used?
1. Barefaced joint
 2. Stub joint
 3. Haunched joint
 4. Table-haunched joint
- 4-47. The strongest of all woodworking joints is considered to be the
1. mortise-and-tenon
 2. rabbet
 3. dovetail
 4. tongue-and-groove
- 4-48. What angle is normally used in making the cuts of a dovetail half-lap joint?
1. 10°
 2. 15°
 3. 22°
 4. 28°
- 4-49. When cutting inside corner molding, which of the following handsaws should you normally use for following the contour?
1. Back saw
 2. Compass saw
 3. Coping saw
 4. Dovetail saw
- 4-50. Which machine is normally used for cutting ornamental face curves on wood stock?
1. Shaper
 2. Jointer
 3. Lathe
 4. Router

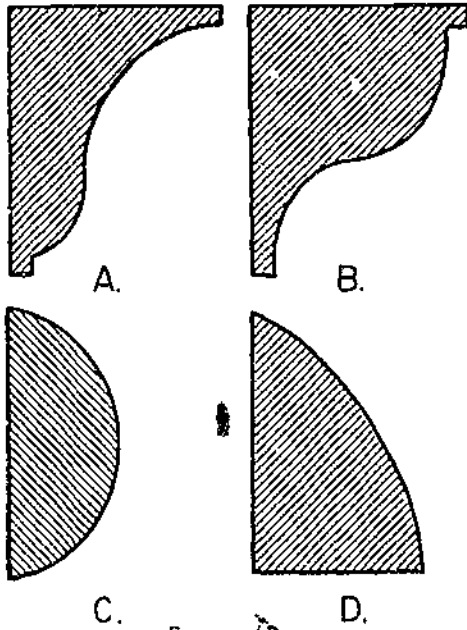

Figure 4B.

- 4-51. Which type of molding, shown in figure 4B would normally be used as a wall-to-floor molding?
1. A
 2. B
 3. C
 4. D

Learning Objective: Identify basic procedures of furniture and cabinet making. Textbook pages 4-31 through 4-33.

- 4-52. What type of joint is normally used in the manufacturing of cabinet drawer division frames?
1. Rabbet
 2. Blind mortise and tenon
 3. Tongue-and-groove
 4. Gain
- 4-53. What should be done to minimize expansion and shrinkage of all wooden members?
1. Use only air-dried lumber
 2. Use only over-dried lumber
 3. Apply a coat of sealer to all surfaces
 4. Apply linseed oil to all surfaces

Learning Objective: Indicate the purpose and use of wood fastening devices. Textbook pages 4-33 through 4-41.

- 4-54. Which of the following is a technique in driving nails where maximum holding power is necessary?
1. Place the nails to avoid knots and cracks
 2. Drive the nails at slight angles
 3. Drive the nails across the grain
 4. All of the above
- 4-55. A good rule for selecting the length of a nail to be used in wood construction is that the nail should be
1. the same length as the board thickness it is intended to support
 2. $2/3$ the thickness of the board it is to hold
 3. at least 3 times the thickness of the wood it is intended to hold
 4. at least 4 times the thickness of the board it is intended to hold
- 4-56. What type of nail is generally used for both structural and housing-construction framing?
1. Common wire
 2. Duplex
 3. Finishing
 4. Molding
- 4-57. Which of the following nails should you use to fasten asphalt roofing material?
1. Plum roofing
 2. Molding
 3. Corrosion resistant roofing
 4. Box
- In answering item 4-58, refer to Test Book table 4-3.
- 4-58. What type and size of nail should you use for roll roofing?
1. 10d large flathead
 2. 8d extra large flathead
 3. 7d small flathead
 4. 5d large flathead
- 4-59. Which of the following factors favor the use of screws instead of nails?
1. Screws are less expensive
 2. The holding power of screws is less
 3. Screws can be withdrawn with less damage
- 4-60. Why should the starter hole for a wood screw be drilled to a depth $1/2$ or $2/3$ the length of the threads to be anchored?
1. To reduce time and effort required to drive the screw
 2. To insure accuracy in the placement of the screw
 3. To reduce chances of splitting the wood
 4. Each of the above

- 4-61. In order to provide a gripping base for a bolt that is to be installed in a pre-drilled hole, you should use
1. predrilled shields
 2. expansion fillisters
 3. wedging shims
 4. expansion shields
- 4-62. Refer to textbook table 4-6. What drill size would be used to drill a pilot hole for a No. 5 screw?
1. 1/16
 2. 7/64
 3. 1/8
 4. 1/4
- 4-63. Which type of bolt has the upper part of its shank designed to grip the material in which it is inserted?
1. Carriage
 2. Stove
 3. Machine
 4. Expansion
- 4-64. Where a close tolerance is required in fastening metal to metal, which of the following bolts should you use?
1. Stove
 2. Machine
 3. Expansion
 4. Carriage
- 4-65. Holes drilled in wood for driftpins are slightly smaller than pin diameter to enable wood fibers to hold the driftpins tightly.
- 4-66. What type of fastener should you use to join the mitered corners of a picture frame?
1. Corrugated
 2. Driftpins
 3. Compression
 4. Flanged bolts
- 4-67. Which of the following glues is generally used for joint work and furniture construction?
1. Animal
 2. Vegetable
 3. Fish
 4. Casein
- 4-68. Most Navy woodworking accidents are caused by
1. violations of safety rules
 2. faulty equipment
 3. lack of woodworking experience
 4. inadequate supervision
- 4-69. By which of the following means can you help spread the word about safe practices in equipment operation?
1. Post safety rules near the equipment
 2. Post safety rules on bulletin boards
 3. Make safety rules available to equipment operators
 4. All of the above

Learning Objective: State the causes of most Navy woodworking accidents and list some of the precautions to be observed within the working spaces. Textbook pages 4-41 and 4-42.

Assignment 5

Fiberline, Wire Rope, and Scaffolding

Textbook Assignment: Pages 5-1 through 5-28

Learning Objective: Recognize the types, sizes, and load bearing capacities of fiber line and wire rope and the care of line. Textbook pages 5-1 through 5-11.

- 5-1. What kind of fiber is best for making fiber lines?
1. Hemp
 2. Sisal
 3. Manila
 4. Cotton
- 5-2. What kind of vegetable fiber is used for small cordage?
1. Manila
 2. Hemp
 3. Sisal
- 5-3. In areas that are highly susceptible to marine borers, what type of fiber line should be used?
1. Hemp
 2. Manila
 3. Nylon
 4. Sisal
- 5-4. In line fabrication, opposite twisting of fibers prevents moisture from entering the line and keeps the fibers from unlaying under a load.
- 5-5. What type of line is composed of four strands twisted together in a right-hand direction around a core?
1. Hawse-laid
 2. Shroud-laid
 3. Cable-laid
 4. Plain-laid
- 5-6. The size of small stuff is designated by its
1. diameter
 2. circumference
 3. number of strands
 4. number of threads per strand
- 5-7. What is the largest size of manila line ordinarily carried in stock?
1. 12 in.
 2. 2 in
 3. 8 in
 4. 16 in.
- 5-8. The rule of thumb for finding the breaking strength (BS) of manila line is
1. $C^2 \times 900$
 2. $C^2 \times 2400$
 3. $D^2 \times 900$
 4. $D^2 \times 2400$
- 5-9. Why is a wide margin between the safe working load and the breaking strength of fiber line desirable?
1. To allow for the strain imposed only by jerky movements
 2. To allow for the strain imposed only when the line is bent over sheaves
 3. To allow for the strain imposed by jerky movements and when the line is bent over sheaves
 4. To allow for the various types of fibers used
- 5-10. What is the formula for finding the safe working load (SWL) of fiber line in pounds?
1. $D \times 150$
 2. $C \times 150$
 3. $D^2 \times 150$
 4. $C^2 \times 150$
- 5-11. What is the SWL of a line whose circumference is 6 inches?
1. 1800 lb
 2. 2400 lb
 3. 3800 lb
 4. 5400 lb
- 5-12. What percentage of the SWL for a new line can be added without exceeding the breaking strength of the line?
1. 10%
 2. 20%
 3. 30%
 4. 40%

- 5-13. What is the safety factor of a frequently used line?
1. 8
 2. 6
 3. 3
 4. 4
- 5-14. What is the only agent to use in cleaning a muddy fiber line?
1. Water
 2. Kerosene
 3. Linseed oil
 4. Soapy water
- 5-15. The size of wire rope is designated by its
1. circumference
 2. diameter
 3. weight per running foot
- 5-16. Which of the following wire ropes is most flexible?
1. 6 X 14
 2. 6 X 19
 3. 6 X 21
 4. 6 X 37
- 5-17. Wire ropes having wire strand cores are less heat resistant but more flexible than fiber-core wire ropes.
- 5-18. Preformed wire rope has a tendency to fly apart when it is cut or broken.
- 5-19. What is the size of the wire rope shown in figure 5A?
1. 1 in., 6 X 19
 2. 1 in., 6 X 24
 3. 3 1/8 in., 6 X 37
 4. 7/8 in., 6 X 24
- 5-20. What is the NAVFAC formula for finding the SWL of wire rope in tons?
1. $C \times 4$
 2. $D \times 4$
 3. $C^2 \times 4$
 4. $D^2 \times 4$
- 5-21. What is the SWL in tons, of a 1-1/2 in. wire rope?
1. 12
 2. 9
 3. 7
 4. 6
- 5-22. The SWL of old wire rope should be reduced by what percent?
1. 15
 2. 25
 3. 50
 4. 70
- 5-23. Which of the following is a common cause of wire rope failure?
1. Kinking
 2. Jumping-off sheaves
 3. Being dragged over obstacles
 4. Each of the above
- 5-24. Which of the following lubricants is best for wire rope that has been exposed to salt water?
1. Wax
 2. Linseed oil
 3. Graphite grease
 4. Mineral spirits
- 5-25. What percentage of broken wires in a wire rope renders the rope unsafe for normal use?
1. 10%
 2. 8%
 3. 6%
 4. 4%
- 5-26. Failure to lubricate a hemp-core wire rope will cause the core to dry out and collapse or shrink.
- 5-27. When rope clips are used to make eye splices in wire rope, the U-bolt of the clip should bear against the working end of the rope.

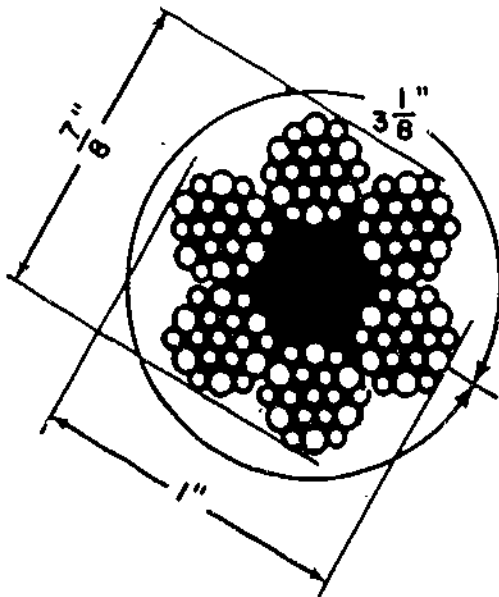

Figure 5A.

- 5-28. To make a temporary eye splice with a 3/4 in. wire rope, how many clips should you use?
1. One
 2. Two
 3. Three
 4. Four

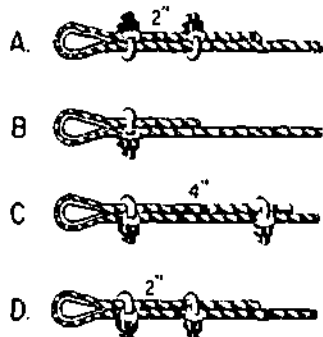

Figure 58.

- 5-29. Which illustration in figure 58 shows the correct method of forming an eye splice in a 1/4-in. wire rope?
1. A
 2. B
 3. C
 4. D
- 5-30. The wedge socket end fitting on a wire rope tightens when a strain is placed on the wire rope.

Learning Objective: Recognize the fundamentals and practices associated with the use of block and tackle assemblies. Textbook pages 5-12 through 5-21.

- 5-31. What type of tackle system is an assembly of blocks in which more than one line is used?
1. Compound
 2. Double whip
 3. Simple
 4. Triblock
- 5-32. The standing part of the line is attached to the
1. breech
 2. becket
 3. sheave
 4. strap

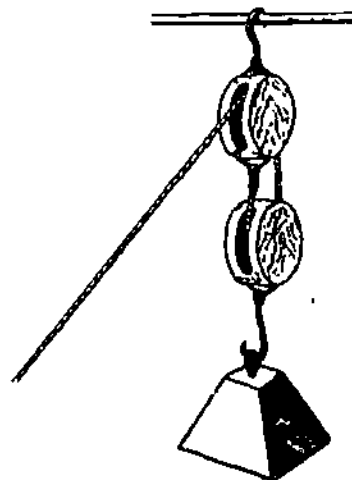

Figure 5C.

- 5-33. Which of the following terms describes the condition of the blocks shown in figure 5C?
1. Double tackle
 2. Tackle to tackle
 3. Two-blocked
 4. Close-blocked
- 5-34. Why are blocks used in a tackle assembly?
1. To change direction of pull only
 2. To provide a mechanical advantage only
 3. To change direction of pull and provide a mechanical advantage
- 5-35. The opening in the block through which the line passes is the
1. swallow
 2. cheek
 3. breech
 4. frame
- 5-36. When selecting a block for use with fiber line, as a rule you should select one whose length is about
1. 10 times the diameter of the line
 2. 2 times the circumference of the line
 3. 3 times the circumference of the line
 4. 4 times the diameter of the line
- 5-37. In the absence of a table, a rule of thumb for determining the diameter of a wire rope sheave says that the sheave diameter be about
1. 10 times the diameter of the wire
 2. 20 times the diameter of the wire
 3. 3 times the circumference of the wire
 4. 4 times the circumference of the wire

- 5-38. In rigging a tackle with 1/2-in. wire rope, you should select blocks that have a
1. sheave diameter of about 10 in.
 2. length of about 20 in.
 3. sheave circumference of about 10 in.
 4. sheave diameter of about 20 in.

- 5-39. What type of block can be installed at any point of a wire rope or fiber line without threading through the block?
1. Swivel fairlead
 2. Swivel shackle
 3. Snatch
 4. Quick latch

- 5-40. When a snatch block is used in a rigging system for the purpose of changing direction it does not affect the mechanical advantage of the tackle in this system.

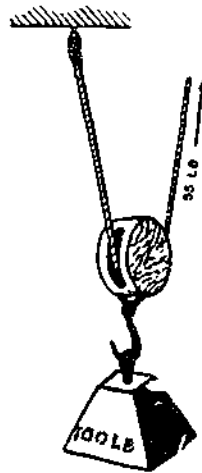

Figure 5D.

- 5-41. What type of tackle is used to lift the 100 lb weight in figure 5D?
1. Single luff
 2. Gun
 3. Runner
 4. Single whip
- 5-42. Inverting a tackle always results in losing a mechanical advantage of one.
- 5-43. When blocks are reeved with more than two sheaves, the standing part of the falls should be first led through either of the outside sheaves of the block.

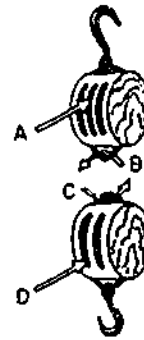

Figure 5E.

- 5-44. In reeving a tackle with the blocks shown in figure 5E, you should first insert the standing end of the fall as shown by
1. A
 2. B
 3. C
 4. D
- 5-45. The simplest method of determining the mechanical advantage of a tackle is by
1. counting the sheaves at the running block
 2. determining the diameter of the sheaves
 3. counting the standing parts at the stationary block
 4. counting the number of parts of the fall at the running block
- 5-46. Of the following type tackles, which provides the greatest mechanical advantage?
1. Inverted gun
 2. Inverted single luff
 3. Double luff
 4. Twofold purchase

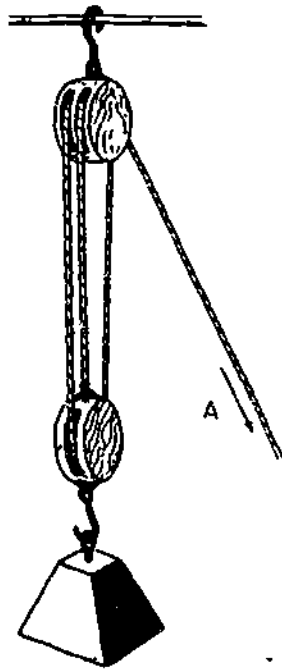

Figure 5F.

● In answering items 5-47 and 5-48, refer to figure 5F.

- 5-47. The load on the tackle is 150 lb. If the effects of friction are ignored, how much force must be applied at A to hoist the load?
1. 100 lb
 2. 75 lb
 3. 50 lb
 4. 20 lb
- 5-48. If the load is 900 lb, how much pull must be applied at A to overcome the friction and lift the load?
1. 300 lb
 2. 330 lb
 3. 390 lb
 4. 570 lb
- 5-49. What formula determines the size of wire rope it takes to make a direct lift of a known weight?
1. $C = \sqrt{15 \times P}$
 2. $C = \sqrt{a^2 + b^2}$
 3. $BS = \sqrt{C^2 \times 8000}$
 4. $C = \sqrt{2.5 \times P}$

- 5-50. When a threefold purchase is used to hoist a load of 4500 lb, what is the smallest manila line that can be safely used to reeve the tackle?
1. 1 1/2 in.
 2. 2 in.
 3. 2 1/2 in.
 4. 3 in.

- 5-51. When a certain size of fiber line is NOT strong enough for use in a block and tackle arrangement, wire rope of the same size should be substituted for the fiber line.

Learning Objective: Recognize practices associated with the erection and use of shear legs and tripods. Textbook pages 5-22 through 5-25.

- 5-52. How many guy lines are required for operating shear legs?
1. One
 2. Two
 3. Three
 4. Four
- 5-53. The after guy on a shear legs assembly should be designed for strength equal to what part of the load?
1. 1/4
 2. 1/3
 3. 1/2
- 5-54. After wrapping the tops of the poles for a shear legs with small stuff, you would tighten and secure the lashing by
1. mousing
 2. frapping
 3. guying
 4. shearing
- 5-55. When preparing to erect a 40-ft shears, approximately how far apart should you dig the holes that will support the legs?
1. 10 ft
 2. 16 ft
 3. 20 ft
 4. 24 ft
- 5-56. What is the working capacity, in tons, of shears legs having 3-by 8-inch poles that are 40 ft long?
1. 10
 2. 8
 3. 7
 4. 5

- 5-57. What advantage does a tripod have over shear legs?
1. It is more stable
 2. Requires no guys
 3. Has greater load capacity
 4. Each of the above
- 5-58. Before the tops of large spars are lashed, about what interval should be maintained between the spars?
1. 1/4 the diameter of the spars
 2. 1/2 the diameter of the spars
 3. 3 times the diameter of the line used for lashing
 4. 4 times the diameter of the line used for frapping
- 5-59. What interval should you maintain before lashing the tops of slender poles that are less than 20 ft long?
1. 1/4 the diameter of the poles
 2. The circumference of the line
 3. 1/3 the circumference of the pole
 4. Slightly greater than twice the diameter of the line used
- 5-60. The spread of tripod legs should NOT be more than one-half the length of the legs.
- 5-61. The hook of the upper block of a tackle assembly is held in position by means of a
1. sling placed over the center leg and around the outside two legs
 2. sling over either outside leg
 3. wedge socket attached to the center leg
 4. eye splice attached to either outside leg
-
- Learning Objective: Recognize the types and uses of ladders and scaffolds. Textbook pages 5-26 through 5-28.
-
- 5-62. A single portable ladder should NOT be longer than
1. 18 ft
 2. 20 ft
 3. 25 ft
 4. 30 ft
- 5-63. How far from the vertical plane of its upper support may the foot of an unlashed 20-ft portable ladder safely be placed?
1. 5 ft
 2. 8 ft
 3. 9 ft
 4. 10 ft
- 5-64. The maximum length that any extension ladder should be extended is
1. 50 ft
 2. 60 ft
 3. 70 ft
 4. 80 ft
- 5-65. The sections of a 55-ft extension ladder must have a minimum overlap of
1. 5 ft
 2. 6 ft
 3. 3 ft
 4. 4 ft
- 5-66. How many inches above a landing should the rails of a fixed ladder extend?
1. 12
 2. 24
 3. 36
 4. 48
- 5-67. The maximum permissible height for a stepladder is
1. 14 ft
 2. 16 ft
 3. 18 ft
 4. 20 ft
- 5-68. In dealing with ladders, you must NEVER do which of the following?
1. Inspect ladders at regular intervals
 2. Paint ladders with opaque paint
 3. Discard ladders with missing rungs
 4. Protect the bases of ladders set up in thoroughfares and driveways by barricades
- 5-69. Metal ladders should NOT be used within how many feet of electrical equipment or wiring?
1. 8
 2. 6
 3. 5
 4. 4
- 5-70. What are the minimum dimensions for (a) the plank and (b) line of a stage?
1. (a) 1 in., (b) 1 in.
 2. (a) 1 in., (b) 2 in.
 3. (a) 2 in., (b) 1 in.
 4. (a) 2 in., (b) 2 in.

Assignment 6

Fiberline, Wire Rope, and Scaffolding (continued): Leveling, Grading, and Excavating

Textbook Assignment: Pages 5-28 through 5-42 and 6-1 through 6-21

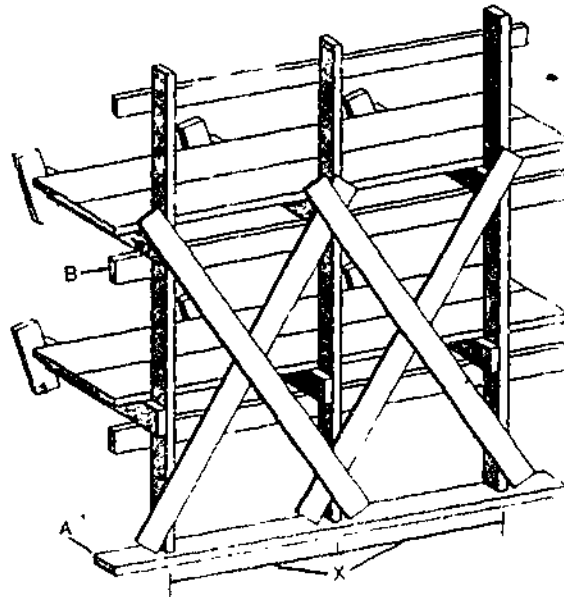

Figure 6A

Learning Objective: (Continued):
Recognize the types of uses of
ladders and scaffolds. Textbook
pages 5-28 through 5-37.

- 6-1. A stage primarily allows a Builder to move
1. upward
 2. downward
 3. side ways
- 6-2. When attached to outriggers, the swinging scaffold can be moved up or down with a block and tackle.

In answering items 6-3 through 6-5, refer to figure 6A.

- 6-3. The minimum size lumber that can be used with 26-ft poles in the figure is
1. 2 by 4
 2. 2 by 6
 3. 2 by 8
 4. 4 by 8
- 6-4. When 26-ft poles are used, what is the maximum permissible distance of X in the figure?
1. 5 ft
 2. 6 ft 6 in.
 3. 7 ft
 4. 7 ft 6 in.

- 6-5. The minimum dimensions of A in the figure are
1. 1 by 6 in.
 2. 2 by 6 in.
 3. 1 by 8 in.
 4. 2 by 10 in.
- 6-6. In splicing a vertical pole, what is the minimum length of the splice plate that you should use?
1. 6 ft
 2. 2 ft
 3. 8 ft
 4. 4 ft
- 6-7. When the inner end of a single-pole scaffold putlog is located in a window opening, what must you do?
1. Relocate the scaffold
 2. Install an inner pole
 3. Support it on a stout plank nailed across the opening
 4. Support it with a sling
- 6-8. The minimum size of lumber that can be used as a bearing plate for a pole scaffold is
1. 1 by 6 by 12 in.
 2. 2 by 6 by 12 in.
 3. 2 by 4 by 12 in.
 4. 1 by 12 by 12 in.
- 6-9. A platform plank must NEVER be less than (a) what thickness, and must be long enough to extend over (b) how many putlogs with a minimum of (c) how much overlap?
1. (a) 2 in. (b) 2 (c) 6 in.
 2. (a) 2 in. (b) 3 (c) 6 in.
 3. (a) 2 1/2 in. (b) 3 (c) 1. in.
 4. (a) 3 in. (b) 2 (c) 6 in.
- 6-10. Patented steel scaffolding includes the use of which of the following features?
1. Diagonal members for bracing the uprights
 2. Plank platforms at the working levels
 3. Footing plates at the column bases
 4. Each of the above
- 6-11. Bracket scaffolding and ladder jacks include which of the following advantages over other types of scaffolding?
1. Ease of erection
 2. Less labor required to set it up
 3. Less material required to set it up
 4. All of the above
- 6-12. How often must scaffold equipment be inspected?
1. Daily before work on a scaffold is started
 2. A minimum of once a week
 3. Immediately after the erection of the scaffold and once a month thereafter
 4. Twice daily, once before work commences in the morning, and once before work commences in the afternoon
- 6-13. A scaffold may be used for storing material being used by crews other than the crews working on the scaffold as long as the material is secured properly.
- 6-14. A standard guardrail or safety belt and line must be used on any scaffold that is more than how many feet above ground?
1. 10
 2. 8
 3. 6
 4. 5
- 6-15. When you are asked to construct a scaffold for a crew of bricklayers, in what strength category should the scaffold be built?
1. Extra heavy duty
 2. Heavy duty
 3. Light duty
 4. Intermediate

Learning objective: Recognize the standard Navy hand signals and slings used for hoisting operations and associated safety measures to take while working around buildings. Textbook pages 5-17 through 5-21.

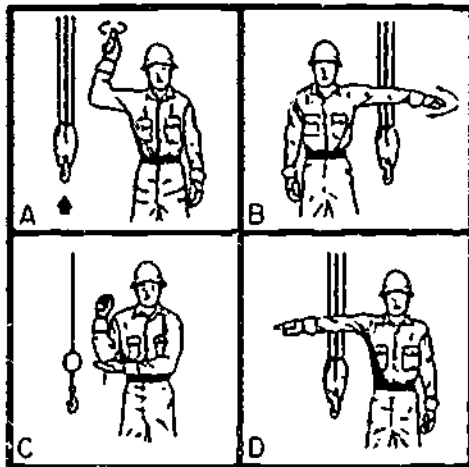

Figure 6B

- In answering items 6-16 through 6-18, refer to figure 6B.

- 6-16. Which of the views in the figure should the instrument operator use regardless of who gives the signal?
- A
 - B
 - C
 - D
- 6-17. The signal given to the instrument operator in part A tells the instrument operator to:
- swing the level
 - raise the level
 - travel
 - take off the instrument
- 6-18. A signal given to the instrument operator in part B would expect the instrument operator to:
- swing the level
 - lower the level
 - back
 - stop suddenly
- 6-19. A sling that passes through the low light or eye is called a:
- bridle
 - basket
 - hook
 - hooker
- 6-20. Which of the following safety precautions must be applied during leveling operations?
- Never work under a suspended load
 - Use tie lines to guide and steady load
 - Inspect load for any loose objects which may fall
 - All of the above

Learning Objective: Identify the common types of leveling instruments and their uses. Textbook pages 6-1 through 6-4.

- 6-21. The engineer's level has been roughly sighted in on target and the instrument-man finds that the crosshair is NOT quite horizontal. To correct this, the instrument-man must first:
- rotate the azimuth tangent screw
 - manipulate the focusing knob
 - release the azimuth clamp
 - slacken the reticle adjusting screws
- 6-22. You can bring the vertical crosshair of the dumpy level into exact alignment with the target by rotating the:
- leveling screws
 - leveling head
 - azimuth head
 - azimuth tangent screw
- 6-23. What type of level was designed to eliminate the use of the tubular spirit level and excessive setup time?
- Auto
 - Dumpy
 - Self-leveling
 - Wood
- 6-24. A self-leveling level will automatically give a level line of sight when the level bubble is approximately within the center of the:
- triangle
 - level
 - ball's socket
 - crosshair
- 6-25. Which level has no magnification device since it is used for short-distance sighting?
- Wood
 - Auto
 - Automatic
 - Dumpy

Learning Objective: Recognize the basic principles of differential leveling. Textbook pages 6-4 through 6-16.

- 6-26. Differential leveling is a procedure for finding the
1. line of sight between two points
 2. horizontal difference between two points
 3. vertical difference between two points
 4. radius of horizontal curves
- 6-27. A bench mark with a mean sea-level elevation of 100 feet is used as the controlling object for a construction site. It is given an arbitrary elevation of 50 feet. For construction purposes what is the elevation of an object 10 feet higher than the bench mark?
1. 50 ft
 2. 60 ft
 3. 100 ft
 4. 110 ft
- 6-28. After setting up the engineer's level, you take a backsight reading to give the
1. height of instrument (H.I.)
 2. distance of the bench mark
 3. location of foresight
 4. height of foresight
- In answering items 6-29 and 6-30, assume that Booth, B², trains a perfectly adjusted vye level on a 210-foot bench mark and that the horizontal crosshair intersects a rod, resting vertically on the bench mark, at the rod's 5-foot mark. Booth then turns the level 180° and trains it on a target rod set vertically on the target stake. The reading on this target rod is 10 feet.
- 6-29. What is the (H.I.) of Booth's level?
1. 205 ft
 2. 210 ft
 3. 215 ft
 4. 220 ft
- 6-30. What is the elevation of Booth's target?
1. 205 ft
 2. 210 ft
 3. 215 ft
 4. 220 ft
- 6-31. In order to remove the dumpy level from its case, what part should you grip?
1. Telescope
 2. Level bar
 3. Footplate
 4. Leveling plate
- 6-32. The following steps are taken in setting up a level:
- A. Mount instrument
 - B. Remove thread protector cap
 - C. Raise instrument from box
 - D. Set tripod
- In what order should they be performed?
1. A, C, B, D
 2. A, B, C, D
 3. D, B, C, A
 4. D, A, C, B
- 6-33. In leveling an engineer's level, the bubble will move in the direction that
1. your left hand moves when the left-hand thumbscrew is turned counter-clockwise
 2. your right thumb moves when you rotate the thumbscrew
 3. your right hand moves when the right-hand thumbscrew is turned clockwise
 4. your left thumb moves when you rotate the thumbscrews
- 6-34. A good way to eliminate instrument error in a level run is to
1. adjust the instrument carefully
 2. take backsights and foresights
 3. use the most precise instrument
 4. select setup points to equalize backsight and foresight distances

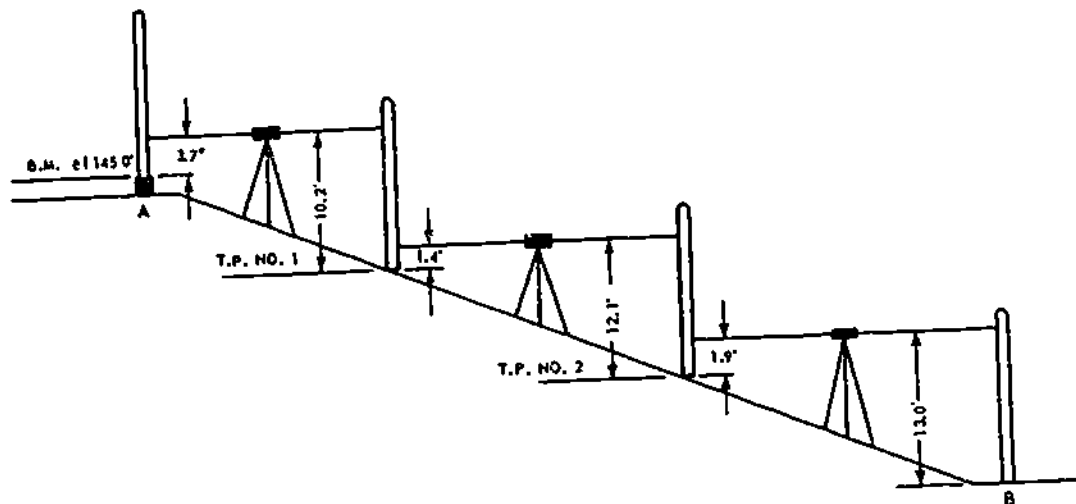

Figure 6C.—Series of turning points.

- In answering items 6-35 and 6-36, refer to figure 6C.
- 6-35. What is the H.I. of the second setup?
1. 6.5 ft
 2. 135.8 ft
 3. 138.5 ft
 4. 139.9 ft
- 6-36. What is the elevation of point B?
1. 109.7 ft
 2. 116.7 ft
 3. 129.7 ft
 4. 135.0 ft
- 6-37. When you are leveling an instrument it is a good practice to have a distance between the BM and FS of less than
1. 100 ft
 2. 300 ft
 3. 500 ft
 4. 700 ft
- 6-38. What effect, if any, will holding a rod out of plumb have on the rodman's reading?
1. The reading is increased
 2. The reading is decreased
 3. None
- 6-39. When you are stowing the level, it is desirable to slightly tighten the azimuth clamp and leveling screws to prevent movement of parts inside the case.
- 6-40. When carrying the level and tripod through heavy brush, you should carry them over the shoulder like a rifle.
- 6-41. In the target reading method of surveying, who reads the rod?
1. Chairman
 2. instrumentman
 3. Flagman
 4. Rodman
- 6-42. What color are the large numerals that indicate the foot markings on Philadelphia rod?
1. Red
 2. White
 3. Black
 4. Yellow
- 6-43. When unable to read the foot markings on the rod, what should you have the rodman do?
1. "Read the rod"
 2. "Lower the rod"
 3. "Raise the rod"
 4. "Wave the rod"

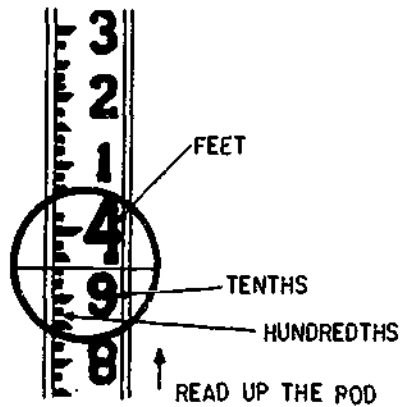

Figure 6D

- 6-44. What is the direct reading of the rod in figure 6D?
1. 3.87
 2. 3.94
 3. 4.03
 4. 4.06
- 6-45. The use of the vernier scale aids you to make readings up to what fraction of a foot?
1. 1/10
 2. 1/12
 3. 1/100
 4. 1/1000

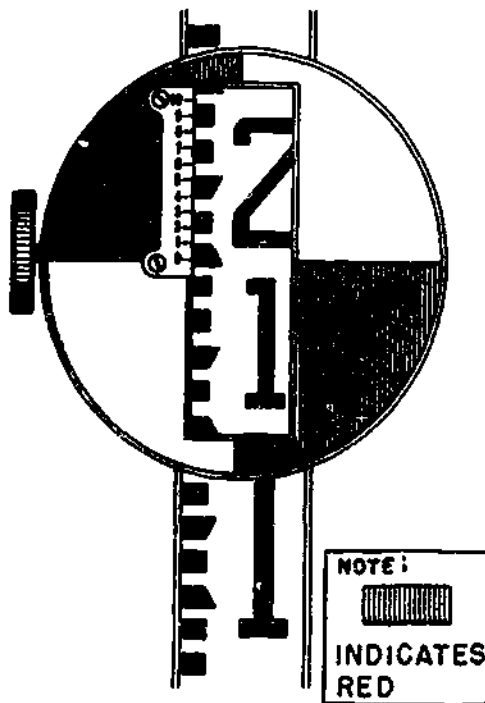

Figure 6E.-Target

- 6-46. In figure 6E, the target reading is
1. 1.125 ft
 2. 1.154 ft
 3. 1.302 ft
 4. 1.540 ft

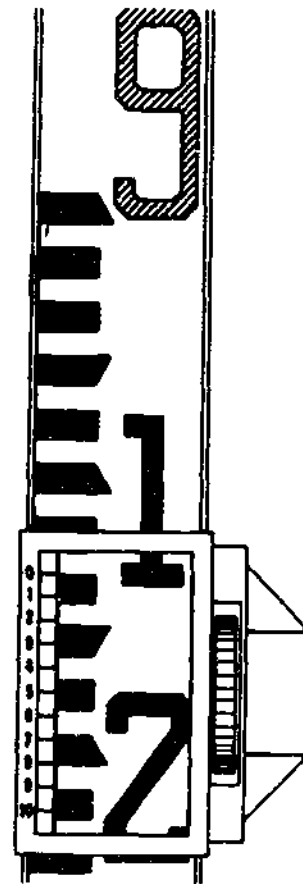

Figure 6F.-Rod Vernier

- 6-47. Figure 6F shows a rod vernier reading of
1. 8.128 ft
 2. 8.260 ft
 3. 9.120 ft
 4. 9.128 ft
- 6-48. When the rodman finds it difficult to hold the rod perfectly plumb, it should be waved back and forth to allow the levelman to read the lowest reading touched by the crosshair.
- 6-49. What should be used to clean grease and dirt from the Philadelphia rod?
1. Paint thinner
 2. Fine steel wool
 3. Turpentine
 4. Mild soap

- 6-50. The correct expression of the mathematical check for the level run of textbook figure 6-18 is
1. sum of foresights - sum of backsights = elevation of summit - elevation of base
 2. sum of foresights + sum of backsights = elevation of summit - elevation of base
 3. sum of backsights - sum of foresights = elevation of base + elevation of summit
 4. sum of backsights - sum of foresights = elevation of summit - elevation of base
- 6-51. While leveling, the instrumentman fails to center the bubble in the level tube vial. This is classified as a/an
1. natural error
 2. personal error
 3. instrument error
 4. mistake
- 6-52. Recording a value in the wrong column in a fieldbook is classified as a/an
1. natural error
 2. personal error
 3. instrument error
 4. mistake

Learning Objective: Recognize fundamentals of laying out building lines and locating corner points; recognize the function of batter boards, and determining dimensions of excavations according to specifications. Textbook pages 6-16 through 6-19.

- 6-53. Which of the following terms refers to the elevation of a proposed surface that is artificially created?
1. Plan grade
 2. Existing grade
 3. Gradient
 4. Line grade
- 6-54. The grade elevation of a level horizontal plane surface is shown on a plot plan by
1. solid contour lines
 2. broken contour lines
 3. outlining the area and writing the elevation inside
 4. evenly spaced contour lines
- 6-55. Building corners can be laid out with reference to
1. a control baseline
 2. contour lines
 3. batter boards
 4. vertical control points

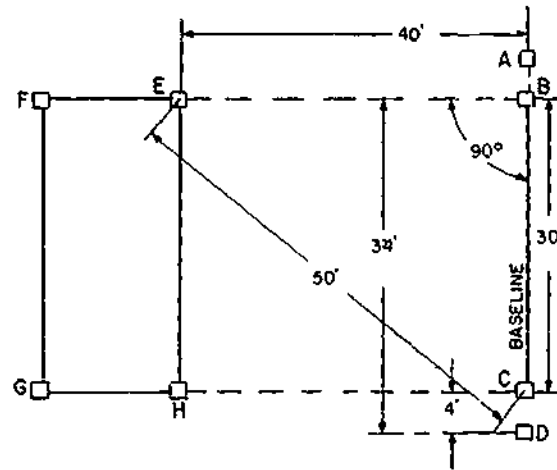

Figure 6G.-Layout of a small building.

- In answering items 6-56 and 6-57, refer to figure 6G.
- 6-56. Applying the Pythagorean theorem, what lines should you use to calculate the hypotenuse?
1. AH and BC
 2. AE and BC
 3. AD and AE
 4. B \bar{C} and BD
- 6-57. Assume that line EH is parallel to line BC. To set points E and H in the figure by the use of tapes, and without square root calculations or a transit, you should mark the tapes with lengths of
1. 15 and 20 ft
 2. 27 and 36 ft
 3. 40 and 50 ft
 4. 40 and 70 ft
- 6-58. The function of batter boards is to
1. protect corner stakes from being knocked over
 2. prevent cave-ins at excavation corners
 3. provide a means for reestablishing building lines when the stakes have been disturbed
 4. mark the outside dimensions of excavations
- 6-59. Batter boards are used for both horizontal and vertical control in maintaining specific elevations.

Learning Objective: Point out safety practices applicable to clearing, burning, and excavating operations. Textbook pages 6-19 through 6-21.

- 6-60. Before the start of filling operations, which of the following tasks should be performed?
1. Clear the area of all growth that would interfere with operations
 2. Inspect all trees for dead or entangling limbs
 3. Look the area over carefully for avenues of escape
 4. All of the above
- 6-61. Which of the following practices must NOT be permitted in the felling or trimming of trees?
1. Felling hollow trees with chain saws
 2. Carrying unguarded sharp-edged tools while climbing
 3. Trimming dead limbs in high winds
 4. All of the above
- 6-62. When poison oak, poison sumac, or poison ivy is being burned, placing or punching these materials while burning operations are being carried on should be done
1. from the windward side
 2. downwind from the burning material
 3. in the direction from which the wind blows
- 6-63. Personnel working with poisonous plants should NOT wear the same clothing more than 1 day, unless it has been cleaned.
- 6-64. Prior to excavating an area for a building foundation, you should check which of the following factors?
1. Federal, state, or local codes
 2. Your equipment to insure that it will not come in contact with utility lines
 3. The area for boulders, trees, buildings or other objects that, when undercut, will become hazards to personnel and equipment
 4. All of the above
- 6-65. Where heavy objects are to be placed on a level above and near an excavation, the sides of the excavation must be shored, braced, and sheet-piled.
- 6-66. All fixed-in-place ladders and platforms used in excavations should have landings at vertical intervals of NOT more than
1. 25 ft
 2. 20 ft
 3. 15 ft
 4. 8 ft
- 6-67. The sides of an excavation need NOT be supported by shoring and bracing when the
1. personnel are not required to work in the trench
 2. depth of the trench does not exceed 4 ft
 3. sides of the excavation are sloped to the angle of repose
 4. excavation is being completed in a previously filled area
- 6-68. How close to an open 5-foot-deep trench should excavated material be placed?
1. Between 1 and 5 feet from the edge
 2. As close as possible but not so close that the earth will fall back into the trench
 3. No closer than 2 feet
 4. No closer than 3 feet
- 6-69. For safety, at what depth should excavation be provided with ramps or ladders?
1. 8 ft
 2. 6 ft
 3. 5 ft
 4. 4 ft

Assignment 7

LEVELING, GRADING, AND EXCAVATING (continued): CONCRETE

Textbook Assignment: Pages 6-21 through 6-25 and 7-1 through 7-31.

Learning Objective: Recognize fundamentals of excavating and identify excavation safety measures. Textbook pages 6-21 through 6-25

- 7-1. Excavating is a term which deals with the removal of soil for parts of a structure which will be below finish grade.
- 7-2. How much cubic yards of earth must be removed from an excavation that is 25 ft wide by 50 ft long, with the depths of the corners being 2 ft, 3.5 ft, 5 ft, and 6 ft?
1. 135 cu yd
 2. 156 cu yd
 3. 191 cu yd
 4. 218 cu yd

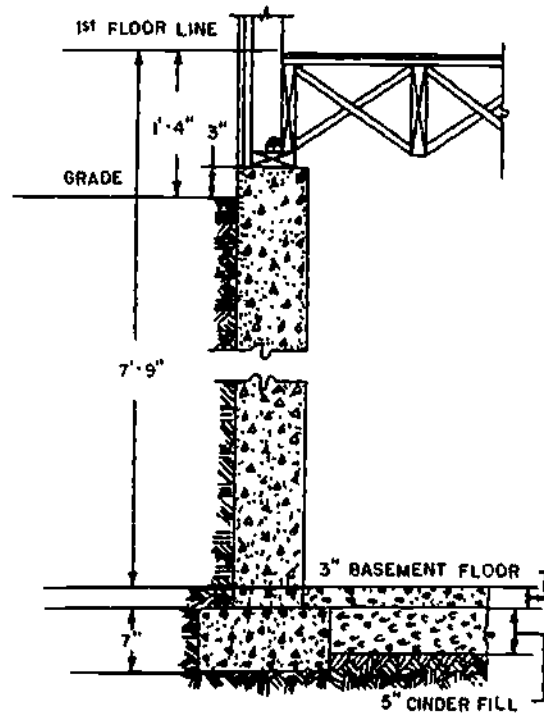

Figure 7A. Wall section, showing excavation data.

- In answering items 7-3 and 7-4 refer to figure 7A.

- 7-3. When specifications call for an excavation to be 8 inches below finished planes of the basement floor levels, how deep an excavation is required for the section?
1. 5 ft 9 in.
 2. 6 ft 5 in.
 3. 7 ft 1 in.
- 7-4. How far below the bottom of the basement excavation does the bottom of the footing extend?
1. 1 in.
 2. 2 in.
 3. 3 in.
 4. 4 in.
- 7-5. If the excavation for the wall section were actually made to a depth of 8 ft 1 in., what should be done?
1. The fill should be decreased by a foot
 2. The fill should be increased by a foot
 3. One vertical foot of excavated material should be compacted into the excavation
 4. The vertical dimension of the footing should be increased by a foot
- 7-6. When excavating in an area that is mostly dirt, what should you make the angle of repose?
1. 5° to 10°
 2. 10° to 20°
 3. 20° to 45°
 4. 45° to 60°
- 7-7. To be safe, at what minimum depth should you provide support to the walls of an excavation?
1. 1 ft
 2. 2 ft
 3. 3 ft
 4. 4 ft
- 7-8. Supported by longitudinal wales or rangers, sheathing consists of wooden planks vertically placed edge-to-edge.
- 7-9. Sheathing must be progressively installed and braced at what interval of depth?
1. 8 ft
 2. 6 ft
 3. 5 ft
 4. 4 ft
- 7-10. What type of sheet piling has three planks bolted together with the center plank offset for tongue-and-groove joining?
1. Wakefield
 2. Wales
 3. Bearing
 4. Batter
- 7-11. For excavation depths up to approximately 32 feet, the thickness of wooden sheet piling must be at LEAST
1. 6 in
 2. 2 in.
 3. 3 in.
 4. 4 in.
-
- Learning Objective: Explain procedures in obtaining quality concrete. Textbook pages 7-1 through 7-4.
-
- 7-12. What causes concrete to harden?
1. The active ingredients dry out
 2. The inert ingredients dry out
 3. The active ingredients combine chemically
 4. The inert ingredients combine chemically
- 7-13. Concrete has a very high ability to resist stretching, bending, and twisting.
- 7-14. What is the Principal factor that controls the strength of concrete?
1. Drying out
 2. Water-cement ratio
 3. Durability
 4. Reinforcement
- 7-15. The major factor that controls the durability of concrete is its strength.

7-16. As water is added to the mix beyond the amount that is needed to hydrate the cement, concrete becomes more workable and less

1. porous
2. heavy
3. fluid
4. watertight

7-17. The production of good concrete is impossible unless good quality materials are used in a mix and they are properly

1. cured and dried
2. puddled and dried
3. worked and cured
4. fortified and cured

Learning Objective: Describe the ingredients of concrete, and their uses in the mix. Textbook pages 7-4 through 7-9.

7-18. The portland cement in general use today is manufactured from finely ground limestone which is mixed with which of the following materials?

1. Clay
2. Shale
3. Marl
4. Each of the above

7-19. Type III portland cement is sometimes preferred to Type I cement for highway construction because concrete made with Type III cement requires

1. finer aggregate
2. less reinforcement
3. less curing time
4. coarser aggregate

7-20. What type of cement was developed to produce good results in areas highly susceptible to severe frost and ice conditions?

1. Air entrained
2. Keene's
3. Type V
4. Type IV

7-21. Why should cement be stored in a dry place?

1. To prevent it from becoming concrete while in storage
2. To prevent it from setting too fast and producing weak concrete
3. To prevent it from setting too slow and producing weak concrete
4. To avoid warehouse pack

7-22. When storing sacks of cement in a warehouse, you should stack them close together to

1. enable them to draw moisture from each other
2. restrict the circulation of air between them
3. prevent them from becoming warehouse packed

7-23. Before using warehouse-packed cement you should make it lumpy free by

1. stacking the sacks to allow air to circulate around them
2. raising the temperature in the area where the cement is stored
3. rolling the sacks around
4. covering the sacks with tarpaulins

7-24. A concrete wall that is made with well-graded aggregate is stronger than a similar wall made with poorly graded aggregate because it

1. has fewer empty spaces in it
2. contains relatively little coarse aggregate
3. contains no fine aggregate
4. has a better water-cement ratio

- 7-25. In the laboratory analysis of aggregate, material is classified as 1 1/2 in. if all of the sample passes through a
1. 1-in. sieve
 2. 2-in. sieve
 3. 1 1/2-in. sieve
 4. 1/2-in. sieve
- 7-26. When analyzing coarse aggregate, you are determining the percentage of material which is retained on the sieve.
- 7-27. When a field test for cleanliness of aggregate shows 1/4 inch of sediment on a sample, why should the aggregate be washed?
1. The sediment decreases the workability of concrete
 2. The sediment prevents the aggregate from becoming friable
 3. The sediment may obstruct hydration and the cement's binding with the aggregate
 4. The sediment will detract from the appearance of the concrete
- 7-28. To prevent the aggregate from segregating during stockpiling, the piles should be built up in layers by dumping successive loads alongside each other.
- 7-29. Laitance is produced on concrete when the mixing is done with
1. salt water
 2. drinking water
 3. the minimum amount of water possible
 4. an excess of water
-
- Learning Objective: Determine quantities of materials for concrete mixes that include cement, water, and aggregates. Textbook pages 7-9 through 7-15.
-
- 7-30. In a field mix, the number of gallons of water per sack of cement must be increased because of saturated surface-dry condition of the sand.
- 7-31. Refer to textbook table 7-3. When the specifications for a driveway call for 3,000-psi concrete using 1-inch coarse aggregate, how many bags of cement per cubic yard of concrete will be required?
1. 8.40
 2. 7.10
 3. 6.50
 4. 5.80
- 7-32. When the size of aggregate is 1 1/2 inch, which rule of thumb should be used to calculate quantities of raw materials?
1. Rule 38
 2. Rule 41
 3. Rule 42
 4. Rule 38 or 41, depending on whether mixing is done by hand or by machine
- Information for items 7-33 through 7-35. Use the rule of thumb for determining the amounts of ingredients for a 1 2:5 concrete mix when 2-inch coarse aggregate is used.
- 7-33. How many bags of cement will be required to make 1 cubic yard of concrete?
1. 8
 2. 7 1/2
 3. 6
 4. 5 1/4
- 7-34. How many cubic feet of sand will be required to make 1 cubic yard of concrete?
1. 5
 2. 7 1/2
 3. 10 1/2
 4. 12
- 7-35. How many cubic feet of sand and coarse aggregate will be required to make 40 cubic yards of concrete?
1. 500 cu ft of sand and 1240 cu ft of coarse aggregate
 2. 480 cu ft of sand and 1200 cu ft of coarse aggregate
 3. 475 cu ft of sand and 1180 cu ft of coarse aggregate
 4. 420 cu ft of sand and 1050 cu ft of coarse aggregate

- 7-36. You may measure water for handmixing concrete with a 14-qt bucket that is marked off on the inside in which of the following units of measure?
1. Quarter-gallons
 2. Half-gallons
 3. Gallons
 4. All of the above
- 7-37. To measure fine aggregate which of the following units of measurement is most accurate?
1. Cubic feet
 2. Pounds
 3. Cubic yards
 4. Square feet
- 7-38. Concrete should NOT be mixed with just enough water to completely hydrate the cement because such concrete would be deficient in
1. tensile strength
 2. workability
 3. durability
 4. compressive strength
- 7-39. For each layer of concrete placed in the mold for a slump test, how many times should you rod it?
1. 25
 2. 50
 3. 75
 4. 100
- 7-40. Which of the following characteristics of concrete is measured by the slump test?
1. Ratio of water to cement
 2. Silt content
 3. Early strength
 4. Consistency and workability
- 7-41. When using the slump test, how should you bring the slump to the desired workability?
1. By decreasing or increasing the amount of aggregate
 2. By changing the proportions of the fine to coarse aggregate
 3. By 1 or 2 above
 4. By adding water to the batch
- 7-42. The water-cement mixture is commonly referred to as
1. mortar
 2. sand-cement grout
 3. neat-cement grout
 4. concrete
- 7-43. The rated capacity of the concrete mixing machine is determined by the
1. cubic feet of the mixed concrete
 2. cubic feet of the dry ingredients
 3. cubic yards of the dry ingredients
 4. weight of the dry ingredients
- 7-44. In batch plant operations, the aggregates must pass through a weigh box prior to discharging into the mixer.
- 7-45. Which of the following safety precautions applies to concrete batching plants?
1. Only the scale operator should be on the platform during operations
 2. All personnel should stay away from hoppers during loading operations
 3. All personnel should wear vapor-type goggles during batching operations
 4. Each of the above
-
- Learning Objective: Recognize procedures for mixing concrete by hand and machine, and point out advantages of specific methods of mixing. Textbook pages 7-15 through 7-18.
-
- 7-46. You are to mix a 1:2:4 batch of concrete by hand. After putting the sand onto a mixing platform, in which order do you add and mix the other ingredients?
1. Cement, water, aggregate
 2. Aggregate, water, cement
 3. Aggregate, cement, water
 4. Cement, aggregate, water
- 7-47. In a 16-S concrete mixer, what is the maximum size of aggregate that should be used?
1. 3/4 in.
 2. 1 1/2 in.
 3. 3 in.
 4. 4 in.
- 7-48. Water should be introduced into the mixing drum of the 16-S mixer before the dry materials.
- 7-49. You are to charge the skip of the 16-S concrete mixer. In what order should you add the ingredients?
1. Cement, aggregate, sand
 2. Aggregate, cement, sand
 3. Sand, cement, aggregate
 4. Aggregate, sand, cement

- 7-50. When using a large mixing machine, how much time should you allow for mixing 2 1/2 cubic yards of concrete?
1. 1 min, 15 sec
 2. 1 min, 30 sec
 3. 2 min, 15 sec
 4. 2 min, 45 sec
- 7-51. When discharging the mixer, you should increase the speed to the mixing drum to
1. carry very wet concrete up high enough to be caught by the chute
 2. keep the dry materials from mixing with the water
 3. allow the operator to mix the concrete faster
 4. decrease the mixing time
- 7-52. The inside of a concrete mixer's mixing drum should be cleaned if the drum is expected to be idle for more than
1. 20 min
 2. 30 min
 3. 1 hr
 4. 1 1/2 hr
- 7-53. Which of the following safety precautions applies to the skip of the mixer and should always be observed?
1. Frequently inspect brakes and cables
 2. Prior to lowering the skip, insure no personnel are under it
 3. Prior to working under the skip, provide shoring for it
 4. Each of the above

Learning Objective: Point out fundamentals of handling and transporting concrete. Textbook pages 7-18 and 7-19.

- 7-54. To transport concrete, why is a transit-mix truck better than a dump truck?
1. It prevents the concrete from hardening
 2. It prevents mixing en route
 3. It reduces segregation of the aggregate
 4. It can carry the concrete faster
- 7-55. When concrete must be discharged 3 or more feet above the level of placement, it should be dumped into an elephant trunk to
1. reduce segregation
 2. prevent spattering
 3. place it accurately
 4. guarantee a workable consistency

- 7-56. From the time mixing begins, concrete should be dumped from the drum of the mixing plant within how many minutes?
1. 30
 2. 60
 3. 90
 4. 120
- 7-57. What type of concrete mixer can mix concrete en route to the job site?
1. Ready mixer
 2. Portable mixer
 3. Transit-mix truck
 4. Agitator truck

Learning Objective: Recognize the fundamentals of formwork, reinforcing concrete, and the placing, consolidating, and finishing of concrete. Textbook pages 7-19 through 7-29.

- 7-58. Sand streaking in cast concrete is caused by
1. rapid casting
 2. casting against earth surfaces
 3. escape of moisture from loose forms
 4. escape of mortar from loose forms
- 7-59. The most common material used in building construction is
1. wood
 2. earth
 3. steel
 4. fiberboard
- 7-60. What kind of board edge makes watertight joints for concrete forming material?
1. Shiplap
 2. Tongue and groove
 3. Square edge
 4. Rough-sawed edge
- 7-61. The hydrostatic head exerted on concrete forms during placing operations will normally continue for approximately
1. 1 1/2 hr
 2. 6 hr
 3. 24 hr
 4. 72 hr
- 7-62. To prevent leakage of mortar from footing forms, the holes on each side of the cleat for the passage of wire used to wrap the cleat should be less than 1/2 inch in diameter.

- 7-63. To make form stripping easy, form nails should be driven from the inside whenever possible.

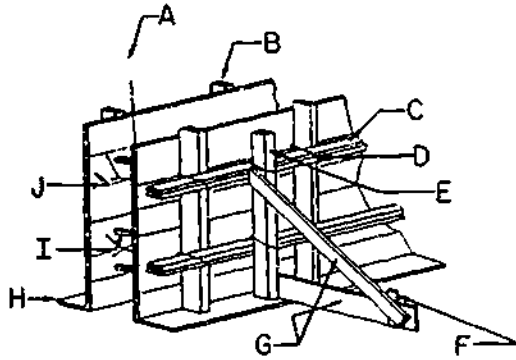

Figure 7B. Form for a Concrete Wall

- In answering items 7-64 through 7-66, refer to figure 7B.

- 7-64. The wales are indicated at
1. B
 2. C
 3. E
 4. G
- 7-65. The spreaders are indicated at
1. B
 2. E
 3. F
 4. I
- 7-66. The tie wires are indicated at
1. A
 2. D
 3. H
 4. J
- 7-67. What devices are used for tightening the simple wire ties that are used in wall forms?
1. Screed boards
 2. Toggle
 3. Cone nuts
 4. Tee rods
- 7-68. What type of form-tying device is used with cone nuts?
1. Tie wire
 2. Snap tie
 3. Shear tie
 4. Tie rod
- 7-69. Because the bursting pressure is greater at the top of column forms than at the bottom, the yokes are spaced closer together at the top.
- 7-70. How much clearance is given in details A, B, and C of textbook figure 7-20 to allow for form movement due to the weight of the pour?
1. 1/4 in.
 2. 3/8 in.
 3. 3/4 in.
 4. 1 1/2 in.
- 7-71. When a column of reinforced concrete is being erected, what is the best way to prevent the wood forms from binding to the concrete?
1. Add extra water to the concrete mix.
 2. Oil the surface of the forms before erecting them.
 3. Paint the surface of the forms after erecting them.
 4. Add oil to the concrete mix.
- 7-72. When a suitable bond-preventing compound is NOT available, what substance is applied to the forms to prevent bonding between them and the concrete?
1. Wax compound
 2. Lacquer
 3. Marine engine oil
 4. Water
-
- Learning Objective: State the purpose of reinforced concrete and identify types commonly used. Textbook pages 7-29 through 7-31.
-
- 7-73. What type of reinforcing bar tie do Builders use on special locations, such as walls?
1. Figure eight
 2. Cross
 3. Double strand
 4. Saddle
- 7-74. What minimum thickness of concrete should be provided in footings between the ground and steel?
1. 6 in.
 2. 8 in.
 3. 3 in.
 4. 4 in.
- 7-75. You are splicing a 1/2 inch thick bar of reinforcing steel without the benefit of drawing specifications. What is the minimum distance that the bar should be lapped?
1. 10 in.
 2. 15 in.
 3. 20 in.
 4. 25 in.

Assignment 8

Concrete (continued)

Textbook Assignment: Pages 7-31 through 7-69

Learning Objective (continued):
State the purpose of reinforced concrete and identify types commonly used. Textbook pages 7-31 and 7-32.

- 8-1. All steel reinforcing bars for floor slabs must be separated by at LEAST
1. 1 in.
 2. 3/4 in.
 3. a distance equal to 1 1/3 times the diameter of the largest bar
 4. a distance equal to 1 1/2 times the diameter of the smallest bar
- 8-2. When a column assembly of reinforcing bars is raised into place, the reinforcing steel is tied to the column form at intervals of
1. 5 ft
 2. 2 ft
 3. 3 ft
 4. 4 ft
- 8-3. Under what condition is the use of wood blocks prescribed for holding beam reinforcing steel in place?
1. When wire stirrups are unavailable
 2. When precast concrete blocks are unavailable
 3. When the construction is considered permanent
 4. When the construction is temporary or the concrete is protected from moisture
- 8-4. In footing construction, stones may be used instead of steel supports under reinforcing bars that are the proper distance above subgrade.

Learning Objective: Identify fundamentals of concrete joint construction. Textbook pages 7-33 through 7-36.

- 8-5. When reinforcing bars or dowels have NOT been installed, what must be used to transfer shear stresses between the walls and footings?
1. Bolster
 2. Keyway
 3. High chair
 4. Stirrup
- 8-6. In vertical joints, the V-joint is LESS likely to break than the keyway.
- 8-7. At which of the following points are expansion and contraction joints likely to be placed?
1. Where changes in thickness exist
 2. Offsets
 3. Where cracks due to shrinkage may occur
 4. All of the above
- 8-8. Dummy contraction joints are cut to what depth?
1. 1 in.
 2. 2 in.
 3. 1/4 to 1/3 the thickness of the section
 4. 2/3 to 7/8 the thickness of the section

Learning Objective: Describe the procedures for placing concrete. Textbook pages 7-36 and 7-37.

- 8-9. When concrete is being placed in layers, the initial set should take place before the next layer is added.

- 8-10. When concrete is being placed in forms, normally the free fall of the concrete should NOT be more than
1. 5 ft
 2. 6 ft
 3. 8 ft
 4. 10 ft

- 8-11. When concrete is being placed, the best way to minimize segregation is to
1. distribute each batch with a shovel after dumping it
 2. dump each batch as close as possible in its final position
 3. scatter consecutive batches
 4. pile consecutive batches

- 8-12. When placing concrete in long wall forms, you should begin at
1. the center and work toward the ends
 2. the ends and work toward the center
 3. one end and work toward the other

Learning Objective: Indicate the purpose and methods of consolidating concrete. (Textbook pages 7-33 through 7-34)

- 8-11. After a layer of concrete is placed in a form, it should be carefully consolidated to
1. eliminate rock pockets and air spaces
 2. prevent a mortar surface from forming along the sides
 3. segregate the aggregate
 4. determine whether the form is firmly in place

- 8-14. The internal vibrator should be inserted in the concrete at (a) what intervals and (b) for how long?
1. (a) 6 in. (b) 40 to 60 sec
 2. (a) 10 in. (b) 25 to 35 sec
 3. (a) 15 in. (b) 20 to 30 sec
 4. (a) 18 in. (b) 5 to 15 sec

- 8-15. Hand spading or puddling should continue until the coarse aggregate disappears into the mortar.

Learning Objective: Recognize methods of placing concrete underwater. Textbook pages 7-39 through 7-41.

- 8-16. By which of the following methods may concrete be placed under water?
1. Tremie
 2. Bucket
 3. Sack
 4. Each of the above

- 8-17. When concrete is poured at a water temperature of 60°F, the temperature of the concrete should be between
1. 40° and 60°F
 2. 50° and 70°F
 3. 60° and 80°F
 4. 70° and 90°F

Learning Objective: Name the various types of concrete finishes, and explain the procedures used in finishing. Textbook pages 7-41 through 7-46.

- 8-18. When a formed concrete surface is leveled, the excess concrete is removed by
1. consolidating
 2. screeding
 3. floating
 4. troweling

The speed at which a vibrating screed is pulled depends directly on the

1. amount of concrete poured
2. density of the concrete
3. slump of the concrete
4. length of the beam

- 8-20. The finish of a concrete slab laid out for use of a vibrating screed depends on which of the following factors?
1. The stiffness of the mix
 2. The vibration speed
 3. The speed at which the screed is pulled across the concrete
 4. All of the above

- 8-21. Troweling a vibratory screed-finished floor slab is usually delayed because of the slow setup time needed for the concrete mix.

- 8-22. How is a smoother concrete surface obtained after the screeding process has been completed?
1. By floating
 2. By troweling
 3. By jointing
 4. By edging

- 8-23. Which of the following is an advantage of edging concrete slabs?
1. It dresses the corners
 2. It helps prevent chipping at the corners
 3. It presents a finished appearance
 4. Each of the above
- 8-24. To give a concrete deck a smooth finish, you should strike the concrete with a
1. canvas belt
 2. wooden float
 3. broom
 4. steel trowel
- 8-25. Hairline cracks in a concrete slab are caused by overworking the concrete during the finishing operation.
- 8-26. By what process is a marked or tooled concrete surface finished?
1. Skidding
 2. Streaking
 3. Brooming
 4. Grinding
- 8-27. What process is used to obtain a polished surface on a concrete slab?
1. Sack rubbing
 2. Power troweling
 3. Grinding
- 8-28. When mortar is being used to red or rub a concrete surface, how long should the surface be kept moist to cure?
1. 8 hr
 2. 1 to 2 days
 3. 3 to 4 days
 4. 7 days
- Learning Objective: Indicate procedures of curing concrete. Textbook pages 7-46 through 7-49.
- 8-29. During the curing period, concrete surfaces are kept moist by which of the following means?
1. Covering with continually moistened earth or burlap
 2. Spraying
 3. Ponding
 4. All of the above
- 8-30. Concrete made with ordinary cement is generally cured for a minimum period of
1. 11 days
 2. 7 days
 3. 3 days
 4. 15 days
- 8-31. A concrete surface is kept moist while it is setting because rapid drying tends to result in
1. surface cracks
 2. excessive hydration
 3. laitance
 4. excessive curing
- 8-32. When polyethylene sheets are placed in the concrete curing process, what is the minimum overlap of adjacent sheets?
1. 12 in.
 2. 8 in.
 3. 6 in.
 4. 4 in.
- 8-33. The mechanical application of wax or resin-base membranes to the surface of freshly placed concrete is the method used for much of the pavement curing today.
- Learning Objective: Recognize technique of removing concrete forms and repairing surface defects. Textbook pages 7-44 through 7-51.
- 8-34. Under ordinary circumstances, the forms for floor slabs may be removed after
1. 1 day
 2. 6 days
 3. 10 days
 4. 15 days
- 8-35. In patching concrete, mortar should be applied in layers NOT exceeding what thickness?
1. 1 1/2 in.
 2. 2 in.
 3. 3/4 in.
 4. 1 2 in.
- 8-37. After forms are removed, a pressure gun similar to an automatic grease gun may be used to repair the concrete by forcing mortar into the
1. honeycomb
 2. joints
 3. floor holes
 4. rock pockets

- 8-38. When screeding a patch of concrete, you should screed as follows:
1. Slightly below the surface of the existing concrete
 2. Level with the surface of the existing concrete
 3. Slightly above the surface of the existing concrete

Learning Objective: Designate the principles of operating concrete saws. Textbook pages 7-51 through 7-53.

- 8-39. When breaking in a new concrete saw, the operator must NOT subject the saw engine to a load. If the saw is equipped with a water pump for cooling the saw blade, it is the recommended practice that, during the break-in period, the engine be operated in which of the following ways?
1. With its water pump disconnected
 2. At speeds between 1,000 and 1,200 rpm for the first hour without any load
 3. At speeds between 1,000 and 1,200 rpm and gradually increasing it up to the governed speed for the second and third hours
 4. All of the above

- 8-40. What type of blade is generally used for cutting seasoned concrete?
1. Abrasive
 2. Diamond
 3. Blow Steel
 4. Carbide

- 8-41. Concrete saws equipped with abrasive-type blades can be used to cut medium hard aggregates by
1. Increasing engine speeds above governed speeds
 2. Using slightly narrower blades than is normally required
 3. Using a cutting compound mixed with the cooling water
 4. Using two or more saws with each one making part of the cut

Learning Objective: Point out fundamentals of using precast concrete units in construction prefabrication. Textbook pages 7-54 through 7-7.

- 8-42. For which of the following reasons are precast concrete panels preferable to cast-in-place concrete panels?
1. Less forming material is required
 2. Placing the rebar is made easier
 3. Thorough filling and vibrating are made easier
 4. All of the above

- 8-43. What type of precast panels is possible by a method like the one for placing wood subflooring?
1. Double-I
 2. Tongue and Groove
 3. I-beam
 4. Channel

- 8-44. What panels have a core made of insulating material?
1. Double-I
 2. Channel
 3. Sawtooth
 4. I-beam

- 8-45. In precast construction, which of the following concrete beams are called "T-beams"?
1. T-beams
 2. I-beams
 3. Double-I
 4. Channel

- 8-46. Since the size of the joints in precast concrete is generally a disadvantage when identifying members, are the joints

- 8-47. Precast members are placed in concrete at least
1. 10 feet
 2. 12 feet
 3. 18 feet
 4. 24 feet

- 8-48. An advantage of steel-reinforced precast concrete is its ability to strengthen rapidly so that forms can be removed sooner.

Learning Objective: Describe the procedures for applying concrete pneumatically. Textbook pages 7-7 through 7-10.

- 8-49. During the gunning process, materials are mixed in the nozzle and the proper amount of air and water is controlled by the nozzleman.
- 8-50. Wire mesh reinforcement bars are used during unit placement.



Learning Objective: Identify the operation, maintenance, and service procedures of concrete pumping machines. Textbook pages 7-57 through 7-69.

- 8-51. The Squeeze-Crete trailer has three-pedestal supports for leveling and maintaining the trailer during pumping operations.
- 8-52. When the pumping trailer is being positioned, which of the following factors should be considered?
1. The method of concrete supply
 2. Whether or not rigging will be required for pipe sections
 3. Whether or not the pumping machine has plenty of ventilation
 4. Each of the above
- 8-53. To reduce friction of concrete during pumping operations, rigid pipeline should be used where possible.
- 8-54. To insure a smooth flow of concrete through the pipeline, what minimum radius bend should be maintained in the line?
1. 8 ft
 2. 6 ft
 3. 5 ft
 4. 4 ft
- 8-55. A flexible transfer hose MUST be used to connect the slickline to the pump outlet assembly.
- 8-56. An uncontrolled whipping of the line or deluge of concrete may be caused by a loose or improperly mated slickline coupling.
- 8-57. How much time is normally required for the charge pump to develop pressure after the engine has been started?
1. 1 min
 2. 1 1/2 min
 3. 30 sec
 4. 45 sec
- 8-58. The pumping tube is reloaded by the atmosphere pressure on the concrete in the hopper and the action of the moving agitator blades.
- 8-59. Prior to operation what minimum pressure reading should be observed on the hydraulic pump pressure gage of the Challenge Squeeze-Crete 250 series pump?
1. 60 psi
 2. 90 psi
 3. 190 psi
 4. 220 psi
- 8-60. Under normal operating conditions, what pressure should be on the suction line to the double pump?
1. 10 to 15 in.
 2. 25 to 27 in.
 3. 38 to 45 in.
 4. 60 to 64 in.
- 8-61. What component is used to control the movement of the rotating rollers?
1. Collector hopper slide cylinder valve control
 2. Vacuum valve control
 3. Hydro-star system control
 4. Collector hopper agitator motor valve control
- 8-62. As a general rule, how many bags of cement are used for the slurry mix to lubricate the first 100 to 150 feet of line?
1. 1 to 2
 2. 2 to 3
 3. 3 to 4
 4. 4 to 6
- 8-63. What should be placed in the suction cone to prevent unmixed cement from entering the pumping tube?
1. Wooden plug
 2. Rubber plug
 3. Burlap sack
 4. Greased sponge
- 8-64. When the transition is being made from the slurry mix to concrete, how full should the hopper be maintained with concrete?
1. 1/3
 2. 1/2
 3. 2/3
 4. Full
- 8-65. What engine speed should be maintained for safe pumping operations?
1. 800 rpm
 2. 2400 rpm
 3. 3200 rpm
 4. 4400 rpm

- 8-66. What will happen if the concrete is not pumped through the system on a continuous basis?
1. The pump will lose suction and have to be reprimed with slurry
 2. The compressed air being pumped will cause concrete to segregate
 3. The compressed air will cause splat-tering and possible injury to workers
 4. Both 2 and 3 above
- 8-67. If the pump is plugged on the hopper side, what should be done to unplug it?
1. Reverse the pump 3- to 4-pump rotor cycles then go back to forward
 2. Reverse the pump 1-rotor cycle, then immediately go back to forward, repeat if necessary
 3. Flood the hopper with water and agitate
 4. Disconnect the line at the outlet, then force water back through the system
- 8-68. The concrete pump operator and the placement operations crew leader should establish a set of standard signals before the pump is started.
- 8-69. Locating and eliminating a blockage in the slickline while the pump is being used, can often be accomplished by tapping with a hammer.
- 8-70. To prolong the life of the tube, when should the position of the pump tube be changed?
1. After every 30 hr of operation
 2. After every 60 to 80 cu yd of concrete pumped
 3. After every day's use
 4. After the machine is cleaned for temporary shut down
- 8-71. Where should the hopper be positioned when a new pump tube is being installed?
1. Forward on the slide
 2. Midway on the slide
 3. To the rear on the slide
- 8-72. What damage could develop during lengthy storage of the pumping machine if it is NOT started often?
1. Permanent bends in the tube
 2. Permanent set in the rubber of the rollers
 3. Permanent set in the rubber of the compression pads
 4. All of the above
- 8-73. When the pumping machine is being cleaned, it is NOT advisable to use more than one cleaning sponge at a time as it tends to plug the pump tube.
- 8-74. The suction cone must always be covered with water.
- 8-75. To enable the pump engine to cool uniformly before it is shut down, its speed should be reduced to
1. 1500 rpm
 2. 1000 rpm
 3. 800 rpm
 4. 500 rpm

Assignment 9

MASONRY

Textbook Assignment: Pages 8-1 through 8-28.

Learning Objective: State the purpose of the tools and equipment used by the Builder in working with mortar and masonry units. Textbook pages 8-1 and 8-2.

- 9-1. When required to smooth cut a concrete masonry unit, you should use the
1. mason's hammer
 2. brick chisel
 3. brick trowel
 4. pointing trowel
- 9-2. The Builder uses the mason's hammer for
1. smooth cutting concrete masonry units
 2. chipping and rough-cutting concrete masonry units
 3. checking level courses
 4. laying out corners
- 9-3. Of the following mason's tools, which would be required to make various joint finishes?
1. Trowel
 2. Bolster
 3. Mortar board
 4. Jointer

- 9-4. When placing masonry units, the Builder uses a steel square for
1. leveling short columns
 2. laying out corners
 3. plumbing long stretches
 4. finishing joints
- 9-5. The function of a Mortar board is to
1. hold ingredients that are to be mixed by hand
 2. serve as a holding table for the Builder's tools
 3. hold a supply of ready-to-use mortar
 4. serve as a straightedge for jointing

Learning Objective: Determine the amounts of material for a mortar mixture, number of blocks for a block wall, and the use of concrete masonry units and their parts. Textbook pages 8-3 through 8-8.

- 9-6. Lightweight concrete masonry units are normally what percentage lighter than heavyweight blocks?
1. 15%
 2. 25%
 3. 30%
 4. 50%
- 9-7. What is the actual size of a 4 x 8 x 16 in. partition block?
1. $3 \frac{5}{8} \times 7 \frac{5}{8} \times 15 \frac{5}{8}$ in.
 2. $4 \times 8 \times 15 \frac{5}{8}$ in.
 3. $4 \times 7 \frac{5}{8} \times 15 \frac{5}{8}$ in.
 4. $3 \frac{3}{4} \times 7 \frac{3}{4} \times 15 \frac{3}{4}$ in.

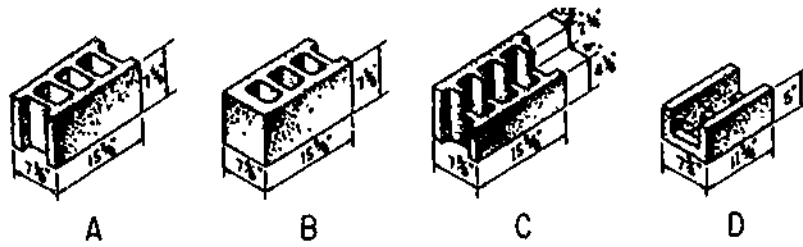

Figure 9A.-Concrete masonry units.

● In answering items 9-8 and 9-9 refer to figure 9A.

- 9- 8. A corner unit is indicated by the letter
1. A
 2. B
 3. C
 4. D
- 9- 9. When a backing course is placed behind a brick face tier header course, which of the concrete masonry units is used?
1. A
 2. B
 3. C
 4. D

- 9-11. The end shell is indicated by the letter
1. A
 2. B
 3. C
 4. D

- 9-12. In the construction of a column, which part(s) of the concrete block would be buttered for a bed joint?
1. C
 2. F
 3. E and F
 4. A, F, and E

- 9-13. To make a head joint for the first course of a concrete block wall concern lead, which part(s) of the concrete block would be buttered?
1. C
 2. F
 3. E or F
 4. A, F, or E

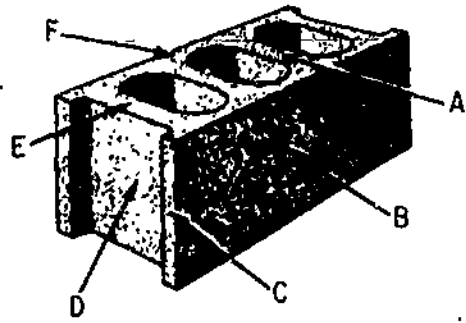

Figure 9B.-8 x 8 x 16-inch concrete masonry unit.

● In answering items 9-10 through 9-13 refer to figure 9B.

- 9-10. A web is indicated by the letter
1. A
 2. B
 3. C
 4. D

- 9-14. When lime mortar tends to adhere to the trowel during spreading, the mix should be changed by the addition of
1. lime
 2. water
 3. cement
 4. sand

- 9-15. When masonry units are to be salvaged for reuse, which of the following types of mortar should be used?
1. Portland cement-lime
 2. lime
 3. Portland cement-lime-sand
 4. Portland cement-sand

- 9-16. What type of mortar is intended for use in permanent, reinforced masonry structures?
1. Type A portland cement-lime
 2. Type B portland cement-lime
 3. Type A portland cement-sand
 4. Type B portland cement-sand
- 9-17. In preparing the most common type of mix for a general purpose job, which of the following ratios would be proper?
1. 1/2 sack cement, 1 1/2 cu ft damp sand, 6 1/2 lb hydrated lime
 2. 2 sacks cement, 3 cu ft damp sand, 7 lb hydrated lime
 3. 1/2 sack cement, 3 cu ft damp sand, 25 lb hydrated lime
 4. 4 sacks cement, 12 cu ft damp sand, 30 lb hydrated lime
- 9-18. How many 8 x 8 x 16 in. basic units will be required for a concrete wall 10 feet long?
1. 6 1/2
 2. 7 1/2
 3. 8 1/2
 4. 9 1/2
- 9-19. How many courses of basic units will be required in a concrete block wall 10 feet high?
1. 14
 2. 15
 3. 16
 4. 17
- 9-20. In laying 600 square feet of wall, you would need approximately (a) how many 8 x 4 x 12 in. concrete blocks and (b) how many cubic feet of mortar?
1. (a) 520 blocks (b) 15 cu ft mortar
 2. (a) 680 blocks (b) 16 cu ft mortar
 3. (a) 770 blocks (b) 19 cu ft mortar
 4. (a) 876 blocks (b) 24 cu ft mortar

Information for items 9-21 and 9-22. Use rule 38 for calculating the amount of raw material needed to mix mortar.

- 9-21. Building specifications call for a 1:2 mix for mortar. How many sacks of cement will be required to make up a 2-cubic yard mix?
1. 7
 2. 13
 3. 20
 4. 26
- 9-22. How many cubic feet of sand will be required to complete the 1:2 mix for 2 cubic yards of mortar?
1. 7
 2. 13
 3. 26
 4. 52
- 9-23. When bags of cement or lime are stacked on pallets, a setback must commence at what tier?
1. Eighth
 2. Sixth
 3. Fifth
 4. Fourth

Learning Objective: Explain the procedures for constructing a concrete block wall. Textbook pages 8-8 through 8-19.

- 9-24. After the corners are located, the next step in the construction of a concrete block wall is to
1. spread and furrow the mortar bed for the first course
 2. string out the block for the first course with mortar
 3. string out the blocks for the first course without mortar
 4. position the corner block
- 9-25. In applying mortar to the concrete block for horizontal joints, you should lay the block with the
1. narrow end of face shell up
 2. web facing up
 3. end shell up
 4. thicker end of the face shell up
- 9-26. What part of a block wall is laid immediately after the first course?
1. Corners
 2. Second course
 3. lintels
 4. lateral supports
- 9-27. When building the corners of a concrete block wall, how will you insure that each course is being stepped back a half block?
1. By placing a level horizontally across the corner of the block
 2. By placing a level vertically across the corner of the block
 3. By placing a level diagonally across the corners of the block
 4. By placing a mason's line between the corners of the wall
- 9-28. During the construction of a concrete block wall, when will you be required to butter all vertical edges of the block?
1. When the corner blocks are being placed
 2. When the closure block is being installed
 3. When all stretchers are placed
- 9-29. To insure weathertight joints, when should you start tooling of the mortar joints?
1. Immediately after laying each course
 2. As soon as the mortar becomes thumb-print hard
 3. After the excess mortar falls off the block
- 9-30. Any excess mortar remaining on the concrete block after the joints are tooled should be removed by
1. rubbing with a burlap bag
 2. flushing with water
 3. striking the mortar with the small jointer
- 9-31. To help limit the cracking of a block wall, what type of control joint should you use?
1. Metal ties laid across each horizontal joint
 2. Metal straps laid in the joints between the horizontal courses
 3. Continuous vertical joints filled with caulking compound
 4. Reinforcing bars placed in the lintel blocks

- 9-32. By inserting roofing felt in the end core of the concrete block when constructing the control joint, you
1. permit the wall to move without cracking
 2. eliminate bonding of the mortar on both sides of the joint
 3. prevent raking of the outside block
 4. eliminate bonding of the mortar on one side of the joint
- 9-33. By what means are intersecting bearing walls tied together?
1. Masonry bonds in alternate courses
 2. Hardware cloths placed across the courses
 3. Metal tie bars bent at right angles
 4. Anchor bolts located in alternate courses
- 9-34. At what minimum length should the lintel blocks extend past the edge of the opening?
1. 8 in.
 2. 12 in.
 3. 16 in.
 4. 20 in.
- 9-35. When reinforcing a block wall, where should you place the rebars?
1. At each corner
 2. At each side of a wall opening
 3. At points spaced no more than 32 in. O. C. in the wall
 4. All of the above
- 9-36. When reinforcing a block wall you can insure proper alinement of the rebar by
1. placing a cleanout block at every stud in all courses
 2. pouring concrete as each course is laid
 3. placing a cleanout block at every stud in the first course
 4. pouring concrete around the rebar as it is placed.
- 9-37. Mortar smears on concrete block walls should NOT be cleaned with an acid wash.
- 9-38. When waterproofing a block wall which extends below grade, you should apply
1. one 1/4-inch coat of plaster starting 6 inches above grade and extending 6 inches below grade
 2. one 1/4-inch coat of plaster starting at the grade and extending to the footing
 3. two 1/4-inch coats of plaster starting 6 inches above grade and extending to the footing
 4. two 1/4-inch coats of plaster starting 6 inches above grade and extending 6 inches below grade

Learning Objective: Identify the parts, physical characteristics and uses of structural clay tile masonry. Textbook pages 8-19 through 8-24.

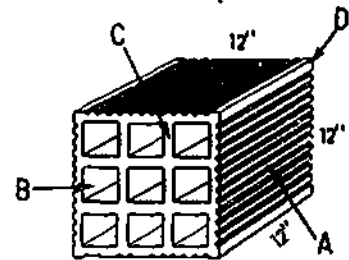

Figure 9C.-Building tile.

In answering items 9-39 and 9-40 refer to figure 9C.

- 9-39. A cell is indicated by the letter
1. a
 2. B
 3. C
 4. D
- 9-40. A web is indicated by the letter
1. A
 2. B
 3. C
 4. D
- 9-41. A wall constructed of building tile has a better heat-insulating quality, than one constructed of solid units, due to the
1. dead air space that exists in tile walls
 2. thickness of the shell of the tile
 3. abrasion resistance of clay tile
 4. tile having excellent resistance to weathering
- 9-42. In building construction, structural clay tile may be used for which of the following purposes?
1. Nonload bearing partition walls
 2. Load bearing exterior walls
 3. Backing units for brick walls
 4. All of the above

9-43. When placing tile for end-construction, how should you place the tile after the bed joint mortar has been spread?

1. So that the web of the tile contacts the same web of the tile below
2. So the positioning of the tile and the one below it do not coincide
3. Push into the mortar until all webs are covered with mortar
4. Lay it 1 inch off center of the tile below

9-44. Full mortar bedding is NOT used in end-construction with building tile because

1. the webs do not touch
2. the corrugated shell takes the place of a furrow in brick mortaring
3. you butter one edge of the tile to be placed and the opposite edge of the tile already in place
4. the mortar would fall down into the cell

9-45. The bed joint for end-construction need not be a solid joint unless the joint is to be exposed to the weather.

9-46. When using 4-inch clay tile for backing an 8-inch brick wall, you should lay the tiles so the tops of the tiles are level with what course of brick?

1. First
2. Second
3. Third
4. Fourth

9-47. To make the surface of a masonry waterproof, what types of mortar joints are recommended for exterior walls?

1. Concave and struck
2. Concave and raked
3. Convex and struck
4. Convex and raked

9-48. In setting a brick in mortar, mortar is applied to the bed and head joints after

1. setting
2. setting
3. setting
4. setting

9-49. In setting a brick in mortar, at what angle should the mortar be applied to the bed joint?

1. 45°
2. 90°
3. 135°
4. 180°

Learning Objective: Explain the types and classification of brick and identify a brick arrangement by nomenclature Textbook pages 8-24 through 8-26.

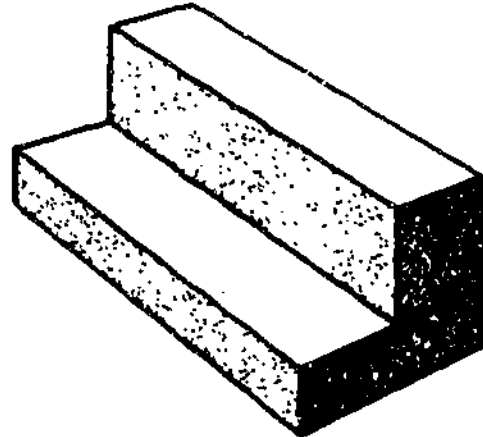

Figure 9D.-Brick arrangement

9-50. The brick arrangement shown in Figure 9D. may be described as

1. half on split
2. queen closure on half
3. queen closure on split
4. half on quarter closure

9-51. Common brick is best described as

1. unglazed, uniform in color, and made from select clay
2. unglazed, variable in color, and made from inferior clay
3. unglazed, variable in color, and made from pit-run clay
4. glazed, uniform in color, and made from select clay

9-52. Which of the following types of brick should be used as the backing course for a cavity wall?

1. Face
2. Brick made with inferior clay
3. Glazed
4. Fire

● In answering items 9-53 through 9-56, select from column B the grade of brick to be used in regions having the climatic condition in column A.

<u>A. Climatic Conditions</u>	<u>B. Grades</u>
9-53. Normal, no frost action	1. MW
9-54. Moist, below-freezing temperatures	2. NW
9-55. Annual rainfall below 15 in. frost action	3. SW
9-56. Dry, below-freezing temperatures	
9-57. What type of brick should be used where cleanliness and ease of cleaning the brick is necessary? 1. Face 2. Cored 3. Glazed 4. Sand-lime	
9-58. What type of brick is used to withstand high temperatures without cracking or decomposing? 1. Cored 2. Press 3. Clinker 4. Fire	

Learning Objective: Indicate the types and uses of mortar used by the Builder for brick masonry. Textbook pages 8-26 and 8-27.

● In answering items 9-59 through 9-63, select from column B the type of mortar that fulfills the requirement in column A.

<u>A. Requirements</u>	<u>B. Types of Mortar</u>
9-59. Load-bearing walls where the masonry will not be subjected to freezing and thawing	1. M 2. N 3. O
9-60. High resistance to lateral forces	4. S
9-61. Below-grade construction and in contact with earth	
9-62. Exterior walls subjected to severe exposures	
9-63. General use in exposed masonry above ground	

Learning Objective: Indicate some properties of brick masonry walls, structural bonding procedures, and the type of bonds used in masonry construction. Textbook pages 8-27 and 8-28.

- 9-64. Which of the following is a cause of rain penetration and leakage in masonry walls?
1. Weak mortar joints
2. Too much flashing
3. Undersized cavity walls
4. Use of caulking around windows
- 9-65. Brick masonry walls are desirable for the construction of buildings because of which characteristic?
1. Ability to insulate against heat and cold
2. Good sound insulating properties
3. Ability to absorb sound originating within the walls
4. Each of the above
- 9-66. How many expansion joints are placed in a brick masonry wall?
1. One for every 20 feet of wall
2. One for every 100 feet of wall
3. One for every 200 feet of wall
4. One for every corner
- 9-67. Your crew has been assigned the task of stockpiling bricks for an upcoming project. You instruct your crew to keep the piles of brick as vertical as possible and NOT to exceed a height of 7 feet for each pile as the ground is uneven. Have you properly instructed your crew to meet the required safety precautions for piling bricks? Why?
1. Yes; except where stacked in sheds, brick piles should never be over 7 feet in height and may be placed upon uneven ground as long as the sides are vertical
2. Yes; bricks may be stacked higher than 7 feet and by keeping the height down to 7 feet you can double the required safety margin
3. No; bricks should be stacked on planks when the ground is uneven and must be tapered back 1 inch for each foot over the 4-foot level to a maximum height of 7 feet
4. No; bricks should, normally, never be stacked in the open and, if allowed, must never be stacked higher than 4 feet

Assignment 10

Masonry (continued): and Light Frame Construction: Floor and Wall

Textbook Assignment: Pages 8-28 through 8-58 and 9-1 through 9-14

Learning Objective (continued):
indicate some properties of brick masonry walls, structural bonding procedures, and the type of bonds used in masonry construction.
Textbook pages 8-28 through 8-31

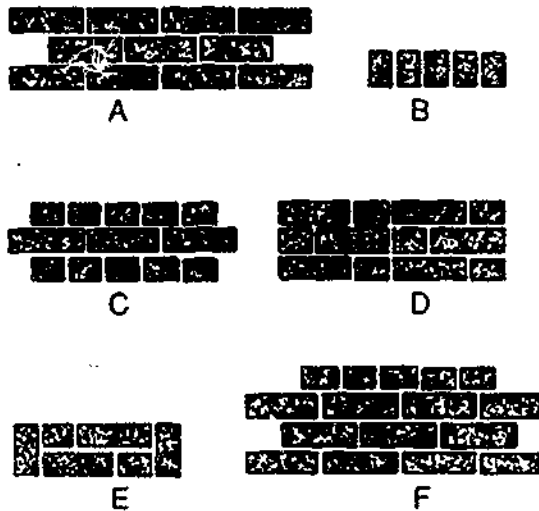

Figure 10A.-Brick Bonds

- In answering items 10-1 through 10-3, refer to figure 10A.

- 10-1. The course that contains bull-headers is labeled
1. A
 2. B
 3. D
 4. F
- 10-2. The simplest pattern bond made up entirely of stretchers is indicated by the letter
1. A
 2. B
 3. C
 4. D
- 10-3. The common bond is indicated by the letter
1. A
 2. B
 3. C
 4. F
- 10-4. Structural bonding of brick walls causes the entire assembly to act as a single unit. This method of bonding is accomplished by which of the following means?
1. Adhesion or grout to adjacent walls of masonry
 2. Metal ties embedded in mortar joints
 3. Interlocking the mortar joints
 4. All of the above
- 10-5. In which of the following patterns must you place a three-quarter brick at the corner of each header course?
1. Common
 2. English
 3. Block
 4. Stacked
- 10-6. An English bond pattern wall is composed of alternate courses of
1. three-quarter and blind headers
 2. stretchers and bull-headers
 3. headers and stretchers
 4. headers and rigid steel ties

Learning Objective: State the purpose of metal ties, flashing, and weep holes used in masonry construction. Textbook page 9-11

10-7. What should you use to tie the brick on the outside face of a wall to the backing courses, when no header courses are to be installed?

1. Copings
2. Metal ties
3. Flashing
4. Metal sills

10-8. What should you use to prevent moisture from seeping under a horizontal masonry surface?

1. Sills
2. Copings
3. Parapets
4. Flashing

10-9. Water which accumulates on the flashing should be allowed to drain to the outside by means of

1. parapets
2. concealed flashing
3. weep holes
4. sills

Learning objective: Specify the procedures used in the construction of given joints. Textbook pages 8-32 through 8-38.

10-10. When making a bed joint, why should you form a shallow furrow in the mortar?

1. To maintain the required width of brick spacing
2. To save on mortar
3. To keep a gap from forming and allowing water to enter the wall
4. To allow the mortar to dry out before placing the brick

10-11. Mortar that is being spread for the bed joint should NOT exceed a distance of

1. 5 bricks
2. 7 bricks
3. 9 bricks
4. 11 bricks

10-12. How much mortar do you place on the edge of the brick when making a head joint?

1. 1 inch to allow for making the furrow
2. Just enough to prevent excess mortar from being pushed out when the brick is placed
3. Enough mortar to insure that the joint is filled to the halfway point on the next brick
4. As much mortar as will stick

10-13. In brick placement, horizontal alignment for each course is controlled by a

1. cross joint
2. header joint
3. line
4. closure

10-14. The thickness of mortar joints should NEVER exceed 1/4 inch.

10-15. To insure a good bond between the mortar and the brick, you should avoid

1. slushed joints
2. bed joints
3. cross joints
4. head joints

10-16. What should you do when cutting a brick to an exact line with a brick chisel or brick set?

1. Break the brick with one blow of the hammer
2. Let the straight side of the cutting edge face you
3. Let the straight side of the cutting edge face the part of the brick that is to be saved
4. All of the above

10-17. From the standpoint of weather-tightness, the best type of joint finish is the

1. flush
2. bed
3. concave
4. weather

Learning objective: Point out fundamentals of laying an eight-inch common-bond brick wall. Textbook pages 8-38 through 8-45.

10-18. Which of the following is an advantage of wetting bricks before they are laid?

1. Mortar spreads evenly
2. Mortar adheres better to wet brick than dry
3. Wet brick will not dry out the mortar rapidly
4. Each of the above

10-19. Because brickwork is unsatisfactory for footings, concrete is always used.

10-20. What is the first step of the procedure for erecting an 8-inch common-bond brick wall?

1. Laying of the leads
2. Placing mortar for the foundation
3. Laying brick on the foundation without mortar
4. Placing two three-quarter closures

- Use the following alternatives in answering items 10-21 and 10-22.
1. Place mortar on the edge of a three-quarter closure and press into the mortar to form a 1/2-inch-thick head joint.
 2. Place six header bricks on each side of the three-quarter closure.
 3. Spread a 1-inch-thick bed of mortar on the foundation.
 4. Check the three-quarter closure with the mason's level to insure that the edges are even.
- 10-21. What is the first step of the procedure for laying the corner lead for an 8-inch common-bond brick wall?
- 10-22. You are laying the corner lead for an 8-inch common-bond brick wall. What should you do after pressing the first three-quarter closure brick into the mortar until a 1/2-inch bed joint is formed?
- 10-23. After placing one header brick on each side of the three-quarter closure bricks, your next step in laying the leads is to place the
1. quarter closures
 2. half closures
 3. full course of headers
 4. full course of stretchers
- 10-24. The stretcher course of the corner lead for an 8-inch common-bond brick wall is placed after the
1. fourth course
 2. third course
 3. second course
 4. first course
- 10-25. What is normally used to keep each course of brick at the same height on all corners above the foundation?
1. Wooden pole
 2. Mason's level
 3. Plumb bob
 4. Framing square
- 10-26. After laying the corner leads of the 8-inch common-bond brick wall, you are then ready to lay the
1. backing tier
 2. footings
 3. face tier
 4. king closure
- 10-27. The backup brick for a common-bond brick wall is normally laid at what point?
1. At the eighth course of face brick
 2. At the tenth course of face brick
 3. Just prior to the second header course
 4. Just after the second header course
-
- Learning Objective: List the steps used in constructing a window frame in a brick wall. Textbook pages 8-45 and 8-46
-
- 10-28. How many courses of 2 1/4-inch brick will be required to bring the wall up to the height of the window sill when the bottom of the sill will be 5 feet 8 3/4 inches above the foundation and 1/2-inch mortar joints will be used?
1. 22
 2. 23
 3. 24
 4. 25
- 10-29. The next step in constructing the window frame after the brick has been laid up to the sill is the placing of the
1. header course sill
 2. top course of brick
 3. rowlock sill
 4. corner leads
- 10-30. Before the brick courses have been placed, what can be done to insure that the top of the brick in a course will be level with the top of the window frame?
1. Mark on the window frame the top of each course
 2. Lay a 1/2-inch brick closure in the rowlock sill
 3. Lay the brick up without mortar, and add 3 inches to the height
 4. Lay the corner leads and use them as a guide
-
- Learning Objective: State the purpose of a lintel and the requirement applicable to corbeling and preparing for parging. Textbook pages 8-46 through 8-49.
-

- 10-31. What is the purpose of a lintel?
1. To carry the weight of the wall above doors and windows
 2. To assist the Builder in laying a rowlock
 3. To replace the use of a trig
 4. To carry the load beyond the face of the wall

- 10-32. Which of the following materials may be used for lintels?
1. Precast reinforced concrete
 2. Wood
 3. Steel
 4. Each of the above

- 10-33. The corbeled portion of a chimney should NOT project beyond the face of a wall more than
1. the thickness of the wall
 2. the thickness of the mortar
 3. 2 in.
 4. 4 in.

- 10-34. How must the joints on the back of the first tier of a brick wall be finished in preparation for parging?
1. Raked
 2. Flushed
 3. Struck
 4. Concaved

- 10-35. Brick foundations below ground level are normally made watertight by the application of
1. varnish
 2. two coats of cement paint
 3. two coats of bituminous mastic
 4. sodium silicate

Learning Objective: Recognize special types of fire-resistant brick and their uses. Textbook pages 8-49 and 8-50.

- 10-36. What type of brick should be used where (a) acid gases and (b) heat are to be considered?
1. (a) Glazed (b) silica
 2. (a) Silica (b) fire
 3. (a) Fire (b) backup
 4. (a) Backup (b) glazed

- 10-37. Joints between firebrick should be made as thin as possible.

- 10-38. Because they fuse together at the joints when subjected to high temperatures, silica bricks do NOT require mortar.

Learning Objective: Recognize the types of hollow brick walls and explain how water is removed from a cavity wall. Textbook pages 8-50 through 8-52.

- 10-39. Water that penetrates to the inside of a cavity wall is allowed to escape due to the
1. 24-inch cavity installed in the center
 2. weep holes that are placed above ground level in the first course of the outer tier
 3. headers that are installed every six courses
 4. 12-inch cavity installed in the center

- 10-40. Due to the presence of header courses, rowlock walls are NOT as watertight as cavity walls.

- 10-41. What is the minimum (a) horizontal and (b) vertical spacing in inches of the metal ties used in brick veneer walls?
1. (a) 12 (b) 24
 2. (a) 24 (b) 18
 3. (a) 24 (b) 24
 4. (a) 24 (b) 36

- 10-42. The structural bond between brick veneer and concrete block is formed with
1. metal ties
 2. header bricks
 3. wire mesh
 4. masonry nails

Learning Objective: State the purpose of reinforcing steel and explain construction practices used by the Builder in reinforced brick masonry construction. Textbook pages 8-52 through 8-57.

- 10-43. Reinforcing steel is used in brick masonry to
1. resist tensile stresses
 2. raise the compressive strength above 5,000 lb per sq in.
 3. assist tensile stress
 4. raise compressive strength to 2,500 lb per sq in.

10-44. Because of its high strength, what type of mortar is normally used for reinforced brick masonry?

1. M
2. N
3. O
4. S

10-45. In masonry construction, vertical reinforcing bars are held in place with

1. templates.
2. stirrups
3. tie bars
4. snap ties

10-46. Where reinforced brick beams require form work, how many days should pass before the bottom form work is removed?

1. 10
2. 2
3. 6
4. *

10-47. Reinforced brick beams are constructed with all the brick in one course being laid before any brick in the next course is placed to insure

1. a bed of mortar at least 1/2 in. thicker than the diameter of the reinforcing bar
2. that the depth of the beams will not exceed the width
3. a continuous bond between the mortar and the steel bars
4. the proper placement of the cavity

10-48. To create an opening of 12 feet, you need (a) how many reinforcing bars and of (b) what diameter?

1. (a) 1 (b) 3/8 inch
2. (a) 2 (b) 1/4 inch
3. (a) 3 (b) 3/8 inch
4. (a) 4 (b) 3/8 inch

10-49. Reinforcing bars in wall footings which run parallel to the direction of the wall are used to prevent cracks perpendicular to the wall.

10-50. Reinforcing bars in brick columns should be tied with steel hoops at every

1. course
2. second course
3. third course
4. fourth course

10-51. When full size bricks will NOT fit, what may be used to fill voids in the column?

1. Soldiers
2. Brick bats
3. Spits
4. King closure

Learning Objective: Estimate quantities of brick and mortar for simple structures. Textbook pages 8-57 and 8-58.

Information for Items 10-52 and 10-53.
Assume you are constructing a 4-inch brick-veneer wall over plywood sheathing. The wall is to be 10 ft high and 26 ft long. Use a standard running bond with standard 2 1/4- by 3 3/4- by 8-in. common brick.

10-52. Approximately how many bricks will be required to construct this wall?

1. 826
2. 1242
3. 1478
4. 1602

10-53. Approximately how many cubic feet of mortar will be required to construct this wall?

1. 8.5
2. 16.0
3. 20.6
4. 26.0

Learning Objective: State the purpose, and types of sills used in the construction of a building. Textbook pages 9-1 through 9-5.

10-54. What type of framing is the most commonly used?

1. A-frame
2. Full
3. Platform
4. Balloon

10-55. In the construction of a building, what does the sill support?

1. The whole structure
2. All the framing structure
3. The foundation
4. The exterior walls

10-56. In box-sill construction, the floor joist is framed against what structural member?

1. Girder
2. Stud
3. Header joist
4. Soffit

- 10-57. At what distance is the edge of the sill usually set back from the outside edge of the foundation wall?
1. The thickness of the siding
 2. The thickness of the sheathing
 3. Twice the thickness of the sheathing
 4. The thickness of the header material

- 10-58. After the bolt holes are drilled and the sill fitted properly, what should be the next step?
1. Tighten the anchor bolts
 2. Install the header joint
 3. Place the sealer
 4. Install the floor joist

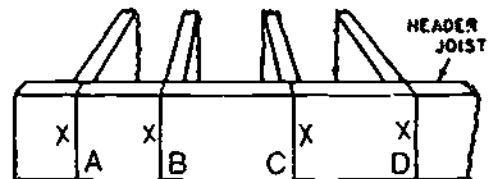

Figure 10B.—Joist layout.

Learning Objective: Identify by nomenclature the members used in floor framing, and the function of bridging, and the construction methods used with floor, subfloor and bridging. Textbook pages 9-5 through 9-14.

- 10-59. In platform framing, the outside-wall ends of the upper-floor joists are nailed to the
1. sill
 2. header joist
 3. second floor soleplate
 4. ledger plate
- 10-60. Which of the following is a method of framing the inside ends of joists to a wooden girder?
1. Hanging the ends onto a stirrup
 2. Lapping one end to another, toenailing both to the girder, then spiking them to each other
 3. Notching the ends, lapping one to another, placing them partly on the girder and partly on a ledger plate nailed to the sides of the girder, toenailing both ends to the girder, then spiking them to each other
 4. Each of the above
- 10-61. A joist that extends from a sill to a stairwell is called a
1. cripple
 2. trimmer
 3. common
 4. header

- 10-62. Which of the layouts in figure 10B is correct?
1. A
 2. B
 3. C
 4. D
- 10-63. Joist members should always be placed with the crowns turned up.
- 10-64. How are header and stringer joists nailed to the sill?
1. By face-nailing with 12-penny nails
 2. By face-nailing with 16-penny nails, 16 in. on center
 3. By toenailing with 10-penny nails, 16 in. on center
 4. By end-nailing with 10-penny nails
- 10-65. Usually doubled-up joists which lie on the sides of a floor opening are called
1. Tull
 2. Trimmer
 3. Cripple
 4. Common
- 10-66. Assume that you are constructing a double joist that is to parallel an upper-story partition. If the soleplate is a 2 by 4 and the joists are 2 by 10's, what size lumber will you use for the solid bridges?
1. 2 x 4 x 6
 2. 2 x 4 x 10
 3. 2 x 8 x 6
 4. 2 x 6 x 10
- 10-67. Which of the following are used to support joists that project at right angles to the lengths of the floor joists?
1. Joist hangers
 2. Hurricane clips
 3. Tie rods
 4. Splice blocks

10-68. Besides holding the joists plumb and aligned, bridging serves what other purpose?

1. Distributes part of a concentrated load over several joists
2. Increases the area available for nailing subfloor material
3. Increases the strength of the finished floor
4. Decreases the number of joists required

Assignment 11

Light Frame Construction: Floor and Wall (continued) and Roof Framing

Textbook Assignment: Pages 9-15 through 9-43, and 10-1 through 10-20

Learning Objective (continued):
Identify by nomenclature the members used in floor framing, and the function of bridging, and the construction methods used with floor, subfloor and bridging.
Textbook pages 9-15 through 9-18.

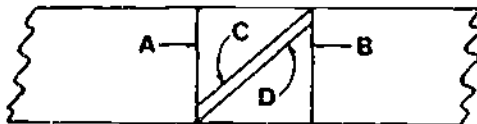

Figure 11A.—Laying out cross bridging.

- In answering items 11-1 and 11-2, refer to figure 11A.
- 11-1. The distance between lines A and B is equal to the
1. length of the cross-bridging set out
 2. distance between the joists
 3. length of the joists
 4. length of the stock from which struts will be cut
- 11-2. The shortest line that can be drawn between lines C and D is equal to the
1. width of the strut stock
 2. thickness of the strut stock
 3. width of the joist stock
 4. thickness of the joist stock
- 11-3. What is the correct sequence for securing a subfloor and bridging to the floor joists of a building?
1. Nail the subfloor, then the top and bottom of the bridging.
 2. Nail the bottom of the bridging, then the subfloor, and finally the top of the bridging.
 3. Nail the top of the bridging, then the subfloor, and finally the bottom of the bridging.
 4. Nail the top and bottom of the bridging, then the subfloor.
- 11-4. Lumber that is used for the subflooring is NEVER square-edged.
- 11-5. To secure 1- by 6-inch subflooring when the boards cross 10 joists, what minimum number of nails is required in each joist?
1. 8
 2. 10
 3. 20
 4. 30
- 11-6. Plywood subflooring with an index mark of 42/16 would be suitable for use with which of the following joist spacing?
1. 16 in. O.C.
 2. 18 in. O.C.
 3. 24 in. O.C.
- 11-7. For the best performance of plywood subflooring, what expansion allowance should be used between the (a) ends and (b) edges?
1. (a) 1/16 in., (b) 1/8 in.
 2. (a) 1/8 in., (b) 1/8 in.
 3. (a) 1/8 in., (b) 1/16 in.
 4. (a) 1/4 in., (b) 1/8 in.

Learning Objective: Identify the wall framing members, their purpose, and how to utilize these members in building construction. Textbook pages 9-18 through 9-34.

- 11-8. The bearing strength of stud walls is determined by the strength of the
1. fire blocks
 2. girts
 3. studs
 4. plates
- 11-9. In rough-wall framing the first floor of a building, the ceiling height is usually maintained at
1. 7 ft., 8 in.
 2. 8 ft., 0 in.
 3. 8 ft., 1 1/2 in.
 4. 8 ft., 8 5/8 in.
- 11-10. Which of the following is a function of the top plate?
1. Ties the studding together at the top
 2. Support the lower ends of the rafters
 3. Serves as a connecting link between the walls and the roof
 4. Each of the above
- 11-11. In layout of the lower end of a partition stud, which of the following sequences is correct?
1. First the vertical distance between the finish floors, plus the thickness of the soleplate, plus the thickness of the finish floor.
 2. First the vertical distance between the finish floors, minus the thickness of the soleplate, plus the thickness of the finish floor
 3. First the vertical distance between the finish floors, minus the thickness of the soleplate, minus the thickness of the finish floor
- 11-12. What type of partition wall may be installed after the other framework is completed?
1. T-post
 2. Bearing
 3. Nonbearing
 4. Let-in
- 11-13. When placing let-in bracing, you should make sure that the bracing is
1. cut 1/2 inch longer than the width of the stud to which it is nailed
 2. set into the studs horizontally
 3. set into the edges of studs so as to be flush with the surface
 4. never cut except when it is to be placed at an angle
- 11-14. Which of the following bracing methods should be used to obtain the highest strength?
1. Let-in
 2. Cut-in
 3. Horizontal sheathing
 4. Diagonal sheathing
- 11-15. Refer to textbook figure 9-27. If the cut of the roof was given as 9 inches, what would be the line length of PG?
1. 8 1/2 in.
 2. 12 in.
 3. 17 1/2 in.
 4. 24 in.
- 11-16. A door is indicated as 2 ft 6 in. wide on a door section. If the side jambs are 1 1/4 in. thick, the rabbets are 1/4 in., and the framing allowance is 1/2 in., how wide should you make the rough opening for the door?
1. 1 ft 6 in.
 2. 1 ft 7 in.
 3. 2 ft 9 in.
 4. 2 ft 10 in.
- 11-17. What is the approximate distance between the subfloor of the building and the bottom of the header for a door 6 ft 10 in. high, if a 2-in. door jamb is used, the lugs are 1 in. deep, and the clearance allowance totals 5/8 in.?
1. 6 ft 6 3/8 in.
 2. 6 ft 10 in.
 3. 7 ft
 4. 7 ft 2 in.
- 11-18. How high is the top of a subsill header above a building subfloor when the top of the 1-in.-thick window sill is 1 ft 10 in. above the finish floor; the sill bevel allowance is 3/4 in., and the finish floor is 3/8 in. thick?
1. 1 ft 7 7/8 in.
 2. 2 ft 10 in.
 3. 2 ft 11 3/8 in.
 4. 3 ft 1/8 in.

- 11-19. In balloon construction, the second-floor joists are nailed to the studs and bear on top of a
1. 1- by 6-in. ledger
 2. 2- by 4-in. header
 3. 1- by 4-in. ribbon
 4. 2- by 4-in. let-in brace

11-20. The tilt-up method of wall framing is NEVER used for walls over 12 ft in length.

- 11-21. When using the horizontal wall framing assembly, you may install which of the following components?
1. Windows only
 2. Doors only
 3. Siding only
 4. Windows, doors, and siding

11-22. After erection of walls, you can assure they are straight by

1. applying a chalkline
2. inserting temporary braces in the studs between intersecting partitions
3. Adding a third top plate
4. intersecting the exterior and interior walls

11-23. How are the location of the walls and the size and spacing of studs determined for interior walls?

1. By the width of the floor joists
2. By the type of interior covering selected
3. By the room size desired
4. Both 2 and 3 above

11-24. When preassembled trussed rafters are being installed, how many load-bearing partitions, if any, are normally required?

1. One
2. Two
3. Three
4. None

11-25. In areas where continuous ceiling areas are desired, flush beams may be used as substitutes for load-bearing partitions.

Learning Objective: Explain how beam and post framing is used in place of interior and exterior load-bearing walls. Textbook page 9-36.

11-26. In building a structure with post-and-beam framing, you use a flat or low pitched roof.

- 11-27. What is used to fasten spaced beams and posts together?
1. Metal angles
 2. Joist hangers
 3. 3/4-in. or thicker plywood cleats
 4. U-bolts

Learning Objective: Describe the different types of sheathing used to complete wall framing. Textbook pages 9-39 and 9-40.

11-28. To eliminate corner bracing and increase greater rigidity to the building, how far down on the exterior wall should you place wood sheathing?

1. To the soleplate
2. To the subfloor
3. To the header joist
4. To the sill plate

11-29. What is (a) the minimum thickness and (b) the often desirable thickness of plywood that should be used for sheathing material?

1. (a) 1/4 in. (b) 1/2 in.
2. (a) 5/16 in. (b) 3/8 in.
3. (a) 3/8 in. (b) 5/8 in.
4. (a) 1/2 in. (b) 3/4 in.

11-30. How are 2- by 8 ft sheets of structural insulating board sheathing installed?

1. Horizontally
2. Vertically
3. Diagonally

Learning Objective: Explain the procedures used when wall sheathing is being installed. Textbook pages 9-40 through 9-43.

11-31. When the sheathing is NOT satisfactory to serve as bracing around window openings, what is the minimum number of stud spaces a full length 1- by 4-inch let-in corner brace should cover?

1. Five
2. Two
3. Three
4. Four

11-32. When end-matched tongue-and-grooved sheathing is used to provide adequate bracing, how many studs should the sheathing bear on?

1. One
2. Two
3. Three

- 11-33. What is the minimum edge spacing of nails used on plywood sheathing?
1. 12 in.
 2. 10 in.
 3. 8 in.
 4. 6 in.

- 11-34. To install 25/32 in. structural insulating board, what type of nail should be used?
1. 1 in. wallboard
 2. 6d galvanized box
 3. 6d common
 4. 1 3/4-in. galvanized roofing

- 11-35. Prior to installing wood shingles, what must you install on gypsum board sheathing?
1. Metal lath
 2. Hurricane clips
 3. Wood strips
 4. Wall ties

- 11-36. How many inches should horizontally applied sheathing paper be lapped?
1. 12
 2. 8
 3. 6
 4. 4

Learning Objective: Name various types of roofs and indicate the use of each type. Textbook pages 19-1 and 19-2.

In answering items 11-37 through 11-41, select the type of roof in column B that matches the description given in column A.

A. Descriptions of Roofs	B. Types of Roof
11-37. Near flat	1. Gable
11-38. Four sides with slopes running toward the center of the building	2. Hip
11-39. Two roof slopes	3. Lean-to
11-40. May be used as an type of structure	4. Intersecting
11-41. Most complicated to construct	

Learning Objective: Define roof framing terms commonly used during construction. Textbook pages 10-2 and 10-3.

- 11-42. The span of any roof is defined as the shortest distance between (the)
1. plate and the cap
 2. two opposite rafter seats
 3. inside plates
 4. plumb and level lines

- 11-43. If a building is 24 ft 6 in. wide and has a gable roof, what is the total run of the common rafters?
1. 8 ft 2 in.
 2. 12 ft 3 in.
 3. 24 ft 6 in.
 4. 49 ft

- 11-44. While looking over the specifications for a gable roof, you find the cut is listed as 4 in. What does this indicate?
1. 4 in. of run in 12 in. of rise
 2. 4 in. of rise in 12 in. of run
 3. 4 in. of rise in 12 ft of run
 4. 4 in. of rise in 24 ft of run

- 11-45. In roofing terms, the hypotenuse of a triangle whose base equals the total run and whose altitude equals the total rise is known as the
1. span
 2. total rise
 3. line length
 4. total run

Learning Objective: Identify the use of rafters and the terms used in conjunction with them. Textbook pages 10-1 through 10-20.

- 11-46. What members make up the main body of a roof framework?
1. Rafters
 2. Studs
 3. Bangers
 4. Girders
- 11-47. What type of rafter is used at the intersection of the main roof ridge and the intersecting roof ridge?
1. Ridge
 2. Hip
 3. Common
 4. Valley



- 11-48. What rafters do NOT meet either the top plate or ridgeboard?
1. Common
 2. Cripple-jack
 3. Valley-jack
 4. Hip-jack

- 11-55. When you use the framing square shown in figure 10-8 of your textbook, what is the line length per foot of run for the common rafter?
1. 13.00 in.
 2. 14.42 in.
 3. 15.62 in.
 4. 16.97 in.

In answering items 11-49 through 11-51, select from column B the definition of the term given in column A.

	<u>A. Terms</u>	<u>B. Definitions</u>
11-49.	Seat cut	1. That portion of a rafter extending beyond the outer edge of the plate
11-50.	Side cut	2. A bevel cut on the side of a rafter to fit against another frame member
11-51.	Eave	3. A cut made at the end of the rafter which is to rest on the plate
		4. That distance between the outer edge of the plate and the center of the ridge line

- 11-56. What is the line length of a common rafter for the hip roof?
1. 16 ft 9 7/8 in.
 2. 17 ft 2 in.
 3. 18 ft 2 11/16 in.
 4. 18 ft 3 5/8 in.

- 11-57. When a bird's mouth is being cut in a rafter, the most important measurement is the
1. length of the seat cut
 2. length of the heel cut
 3. angle of the tail plumb line
 4. distance from the seat cut to the top of the rafter

- 11-58. Refer to textbook figure 10-11. What is the number of common rafters you might have at each end of a typical hip roof?
1. Two
 2. Three
 3. Four
 4. Five

- 11-59. The unit rise is always the same for hip and common rafters, but the unit run of a hip rafter is different.

In answering items 11-52 through 11-56, refer to figures 10-3 and 10-4 in your textbook. You will be working with an equal pitch hip roof and the dimensions are:

Span: 28 feet
 Pitch: 1/3
 Projection: 12 inches
 Ridge size: 1 by 6 inches
 Length of building: 40 feet

- 11-60. Assume that you are using a framing square for making plumb cuts for the hip rafters of an equal-pitch hip roof whose common rafters have a unit run of 12 in. To what unit of run should you set your square?
1. 12 in.
 2. 15 in.
 3. 17 in.
 4. 22 in.

- 11-52. What is the total run of the rafter disregarding the projection and ridgeboards?
1. 10 ft
 2. 12 ft
 3. 14 ft
 4. 18 ft

- 11-61. With a hip rafter framed against a common rafter, the shortening allowance will be
1. one-half of the 45° thickness of the ridge
 2. one-fourth of the 45° thickness of a common rafter
 3. one-half of the 45° thickness of a common rafter
 4. one-half of the thickness of the ridge

- 11-53. What is the unit rise for the roof?
1. 8 in.
 2. 10 in.
 3. 12 in.
 4. 15 in.

- 11-54. What is the cut of the roof?
1. 6/12
 2. 8/12
 3. 9/12
 4. 10/12

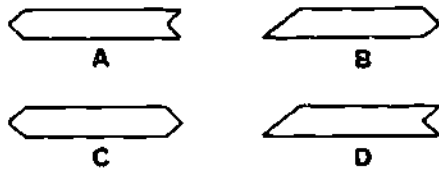

Figure 11B.-Edge views of rafters.

- 11-62. In the figure, the edge view of a hip rafter framed to the ridge piece of an equal-pitch hip roof is represented by
1. A only
 2. B only
 3. A and C
 4. B and D
- 11-63. At what points will you hold the framing square for determining the angle of the side cut on a hip rafter with a unit rise of 9 inches?
1. 9 and 10 $\frac{5}{8}$
 2. 9 and 12
 3. 12 and 10 $\frac{5}{8}$
 4. 12 and 17
- 11-64. How do the common rafters of an intersecting roof compare with the common rafters of the main roof which is of equal-pitch and unequal-span?
1. The line length of the common rafters will be the same throughout the roof, except for the angle of the ridge-end side cuts, which will be different for both the main roof rafters and for the intersecting roof rafters
 2. The actual length of the main roof common rafters will be longer than the common rafters of the intersecting roof, but the angle of the ridge-end cuts will be the same throughout
 3. The line length of the common rafters will be the same throughout, and the angle of the ridge-end cut will also be the same
 4. The actual length of the common rafters will be the same throughout, except for angle of the ridge-end cuts, which will be different for main roof than for the intersecting roof
- 11-65. Which technique is used in constructing a dormer that has a long and a short valley rafter?
1. Frame both valley rafters up against the main ridge
 2. Frame both valley rafters up against the intersecting ridge
 3. Frame the long valley rafter up against the intersecting ridge and the short rafter up against the main ridge
 4. Frame the long valley rafter up against the main ridge and the short rafter up against the long one
- In answering items 11-66 and 11-67, refer to textbook figure 10-8.
- 11-66. What is the bridge measure of a valley rafter in a roof that has a common rafter unit rise of 8 inches?
1. 13.28 in.
 2. 14.42 in.
 3. 15.63 in.
 4. 18.76 in.
- 11-67. What is the length of a valley rafter in a roof that has a span of 29 ft and a common rafter unit rise of 9 inches?
1. 14.40 ft
 2. 15.63 ft
 3. 16.90 ft
 4. 18.76 ft
- 11-68. What is the shortening allowance of a valley rafter for a dormer without side walls framed between double headers with a combined actual thickness of 3 $\frac{1}{4}$ inches?
1. One-half of the 45° thickness of the inside upper double header
 2. One-half of the 45° thickness of the common rafter
 3. Both 1 and 2 above
 4. one-half of the total thickness of the upper and lower double header.
- 11-69. What structural members are framed between the hip and valley rafters?
1. Valley cripple jacks
 2. Hip jacks
 3. Hip-valley cripple jacks
 4. Valley jacks
- 11-70. When you use the framing square shown in figure 10-8, what is the unit length of a hip jack rafter which is to be spaced 24-in. on center of a roof with a 9-in. cut?
1. 19.23 in.
 2. 20.00 in.
 3. 22.84 in.
 4. 27.00 in.

Assignment 12

Roof Framing (Continued): Exterior Finish

Textbook Assignment: Pages 10-20 through 10-31 and 11-1 through 11-28.

Learning Objective (Continued):

Identify the use of rafters and the terms used in conjunction with them. Textbook pages 10-20 through 10-27.

- When figuring the length of hips, valleys, or hip-valley cripple jacks knowing the centers, you should use the difference in the length-of-jacks table on the framing square.
- 12-1. What is the length of valley cripple No. 14 shown in textbook figure 10-31?
1. 4 times the length of jack No. 8
 2. 2 times the length of jack No. 7
 3. 4 times the difference in length of the jack
 4. Each of the above
- 12-2. How many numbered jacks shown in textbook figure 10-31 will be cut to the line length of 3 ft 4 in. with a unit rise of 9 in. and placed on center?
1. Two
 2. Three
 3. Four
 4. Five
- 12-3. Which of the jack rafters shown in textbook figure 10-31 will have a shortening allowance of 45 degrees on both ends of the rafter?
1. 1 and 14
 2. 2 and 13
 3. 3 and 7
 4. 4 and 5
- 12-4. When marking hip jack side cuts which have a unit rise of 10 in., and placed 16 in. on center, at what points should you hold your framing square on the edge of a rafter?
1. Face up holding 12 on the blade and 9 on the tongue, marking the side cut line along the blade
 2. Face up holding 12 on the tongue and $9 \frac{1}{4}$ on the blade, marking the side cut line along the tongue
 3. Back up holding 12 on the tongue and $9 \frac{1}{2}$ on the blade, marking the side cut line along the tongue
 4. Back up holding 12 on the tongue and 10 on the blade, marking the side cut line along the blade
- 12-5. The methods used for calculating the actual ridge length for a hip roof are dependent on how the rafters are framed against the ridge at each end.
- 12-6. By which formula should you figure the actual length of a gable dormer ridge with side walls, using the long and short valley framing method?
1. Length of the dormer side wall rafter plate plus total run minus the shortening allowance at the main roof ridge
 2. Length of the dormer side wall rafter plate plus total run of the dormer minus the shortening allowance of the long valley rafter
 3. Length of the dormer side wall rafter plate plus total run of the dormer minus the shortening allowance of the header
 4. Total run of the dormer minus the shortening allowance of the header
- 12-7. What should be the difference in height of the two walls shown in textbook figure 10-35 when the total run of a common rafter equals 10 ft?
1. 3 ft 6 in.
 2. 4 ft 2 in.
 3. 4 ft 8 in.
 4. 5 ft

12-8. To get the lower-end cutoff angle of shed dormer studs, you set the square on the stud to the cut of the main roof; to get the upper-end cutoff angle, you set it to the cut of the dormer roof.

12-9. According to the layout shown in textbook figure 10-38 (3), the location point where the long valley rafter intersects the main ridge is equal to
 1. B+C
 2. B+C-A
 3. A+B-C
 4. A+B

12-10. What should be the actual length of the collar tie for the gable roof shown in textbook figure 10-39 with a unit rise of 10 inches and a 48-inch drop from the top edge of the ridge to the top edge of the tie?
 1. 9 ft 2 1/8 in.
 2. 9 ft 7 3/16 in.
 3. 11 ft 2 1/4 in.
 4. 10 ft 6 5/8 in.

Learning Objective: Describe types of roof trusses and name their parts. Explain procedures in fabricating, handling, and erecting wood trusses. Textbook pages 10-26 and 10-29.

In answering items 12-11 through 12-14, refer to textbook figure 10-41, and select from column B the phrase which best describes the term in column A.

A. Terms	B. Phrases
12-11. Gusset	1. Vertical bracing and connecting member
12-12. Upper chord	2. Consists of rafters
12-13. Lower chord	3. Plywood plate used to join corners
12-14. Web	4. Nailing joist

12-15. Which type of truss should be used for cathedral ceilings?
 1. Scissors
 2. W
 3. Y-intersect
 4. Brace

12-16. When 4-penny nails are used on gussets of light-wood trusses, what nailing sequence is used?
 1. One row, 2 in. apart, 1 1/4 in. from the edge of the truss member
 2. Two rows, 2 in. apart, 3/4 in. from the edge of the truss member
 3. Two rows, 3 in. apart, 3/4 in. from the edge of the truss member
 4. Two rows, 3 in. apart, 1 1/4 in. from the edge of the truss member

12-17. Trusses should always be stored in the upright position.

Learning Objective: Recognize the recommended procedures for roof framing erection. Textbook pages 10-29 through 10-31.

12-18. At what point in the framing of a gabled roof are the rafters for the second gable end erected?
 1. Immediately after the erection of the rafters for the first gable end
 2. After the rafters between the first and second gable ends have been filled in
 3. Immediately before the ridge piece is hoisted into position for nailing
 4. When one-half of the rafters between the first and second gable ends have been filled in

12-19. In roof framing, what are 10-penny nails used to toenail?
 1. Valley rafters to plates and toenail valley rafters to ridge
 2. Hip jacks to common rafters and nail collar beams to common rafters
 3. Valley rafters to ridge and toenail hip jacks to hip rafters
 4. Hip jacks to hip rafters and nail collar ties to common rafters

12-20. If a roof projection is required, the sheathing boards must be long enough to span how many rafter spaces?
 1. One
 2. Two
 3. Three
 4. Four

Learning Objective: Identify uses of various types of roof sheathing. Textbook pages 11-1 through 11-3.

12-21. Plywood sheathing is LESS desirable than wood sheathing because it does NOT provide the desired bracing effect that diagonal wood sheathing provides.

12-22. Board roof sheathing normally falls in which of the following categories?

1. Shiplapped
2. Matched tongue-and-groove
3. Square-edged
4. Each of the above

12-23. Each board used for sheathing must be supported by at LEAST how many rafters?

1. One
2. Two
3. Three
4. Four

12-24. In relation to the rafters, in what direction should the face grain of plywood sheathing run?

1. Perpendicular
2. Parallel
3. Diagonal

12-25. To prevent sagging, roof sheathing that extends beyond the end walls should span at LEAST how many rafters?

1. Five
2. Two
3. Three
4. Four

Learning Objective: Identify the types and some of the means of construction or installing cornices. Textbook pages 11-5 through 11-9.

12-26. For exterior trim that is expected to be painted, which of the following types of nails or screws are preferred?

1. Galvanized only
2. Stainless steel only
3. Aluminum only
4. Galvanized, stainless steel, and aluminum

12-27. What part of a gable roof projects beyond the end walls in an upward slope?

1. Rake
2. Eave
3. Fascia
4. Drip

12-28. On a roof that has NO overhang, what type of finish is normally used?

1. Flat
2. Gable
3. Round
4. Square

12-29. What is the name given to gable cornice trim used on a structure that has a gable roof with an open cornice?

1. Crown molding
2. Rake molding
3. Bed molding
4. Plancier molding

12-30. Before an open cornice can be constructed, what must you do to a building?

1. Apply building paper in a horizontal direction to the complete wall.
2. Cut and apply building paper to the sheathing that is fitted around the rafters.
3. Apply J-cosote to all freshly cut rafter ends.

12-31. Along eave lines where ice dams might occur, what type of roll roofing is recommended?

1. 15-lb felt
2. 30-lb smooth-surface
3. 45-lb smooth-surface
4. 45-lb mineral-surface

12-32. When constructing a closed cornice, what should you do after nailing the fascia into position?

1. Cut and nail the lookouts in place.
2. Cut and nail the frieze in place.
3. Cut and nail the plancier in place.
4. Cut and nail the molding in place.

12-33. Moderate and wide cornice overhangs have which of the following advantages over narrow overhangs and closed rakes?

1. Lower paint maintenance
2. Better sidewall protection
3. Both 1 and 2 above
4. Lower cost

12-34. What framing unit is normally used for wide gable extensions of 2 feet or more?

1. Truss
2. Ladder
3. Lattice
4. Stair

Learning Objective: Identify the types and characteristics of roof coverings and the procedures followed in laying them. Textbook pages 11-10 through 11-13.

12-35. On a flat roof, what type of roof covering is normally used?

1. Asphalt shingles
2. Sheet metal
3. Wood shingles
4. Built-up roofing

- 12-36. Which of the following is a purpose for using roofing felt over sheathing?
1. To provide a secondary barrier against wind-driven rain
 2. To protect shingles against the effects of resinous materials released from the sheathing
 3. To keep the sheathing dry until shingles are applied
 4. Each of the above

- 12-37. When allowing for a 4-inch overlap, how many rolls of 15-lb felt will you require to cover 1,000 sq ft of roof sheathing?
1. One
 2. Two
 3. Three
 4. Five

- 12-38. In applying asphalt shingles, how far past the edge line of the roof should you extend the first course to prevent water from backing up under the shingles?
1. 1 in.
 2. 1 1/2 in.
 3. 3 in.
 4. 5 in.

- 12-39. For 24-inch-long wood shingles, the recommended maximum exposure is how many inches?
1. 7 in.
 2. 5 3/4
 3. 3 1/4
 4. 4 1/4

- 12-40. Wood shake installation differs from wood shingle installation in that the shakes require
1. shorter nails
 2. less exposure
 3. an underlayment between each course

- 12-41. What is the most common type of ridge used on an asphalt shingle roof?
1. Sheet metal
 2. Preassembled pipe
 3. Board
 4. Tile

Learning Objective: Describe materials and methods used for built-up roofing. Textbook pages 11-14 through 11-16.

- 12-42. The main purpose of using felt paper on a built-up roof is to waterproof the roof.

- 12-43. In built-up roofing, which of the following types of building felt is used?
1. Coal tar
 2. Asphalt
 3. Glass fiber
 4. Each of the above

- 12-44. Which of the following is a function of the aggregate on a built-up roof?
1. To protect the bitumen from sunlight
 2. To increase wind and fire resistance
 3. To permit use of a thick surface coating of bitumen
 4. Each of the above

- 12-45. After the building paper has been tacked down, you are ready to start the built-up roofing job at the
1. center
 2. eaves
 3. top
 4. dormer

- 12-46. The first two layers in a five-ply roof are referred to as the dry nailer.

- 12-47. In a 5-ply built-up roof, what are the respective widths in inches of the first 3 plies receiving binder?
1. 10 2/3, 21 1/3, 32
 2. 32, 16, 32
 3. 36, 16, 32
 4. 36, 10 2/3, 9 2/3

- 12-48. The distance maintained between the roller and the felt layer should NOT be more than
1. 9 ft
 2. 7 ft
 3. 3 ft
 4. 5 ft

Learning Objective: Point out procedures in operating and maintaining the asphalt heating kettle. Textbook pages 11-16 through 11-19.

- 12-49. The first duty of the kettle operator is to insure that the kettle is perfectly dry before adding binder and lighting the burner unit.

- 12-50. Prior to lighting the burner, how much air pressure should be pumped into the burner fuel tank?
1. 15 to 20 psi
 2. 25 to 30 psi
 3. 35 to 40 psi
 4. 45 to 55 psi

12-51. To bring the pump and pipes up to operating temperature for full circulation, how long should the appropriate valves be in the No. 2 position?

1. 1 min
2. 2 min
3. 3 min
4. 4 min

12-52. While in the process of securing the asphalt heating kettle, there is NO best time to flush out the pump lines.

12-53. In caring for the kettle, the operator is responsible for taking which of the following steps?

1. Checking for loose bolts
2. Keeping the unit clean
3. Checking engine lubrication
4. Each of the above

Learning Objective: Identify types of outside wall coverings and their uses. Textbook pages 11-20 through 11-22.

12-54. Which of the following properties is considered essential for wood siding?

1. Free of warpage
2. Easily workable
3. Good paintability
4. Each of the above

12-55. Compared to flat-grain siding, vertical-grain siding is less subject to seasonal movement brought on by changes in moisture content.

12-56. Of the following horizontal sidings, which can be obtained with either shiplap or tongue-and-groove edges?

1. Bevel
2. Drop
3. Dolly Varden

12-57. To prevent shrinkage of the tongue-and-groove siding joints, the edges should be treated with a water-repellent preservative before the siding is installed.

12-58. In the installation of vertical board siding, the vertical nailing space should be how many inches on center?

1. 12
2. 16
3. 24
4. 36

12-59. When installing 4- by 8-foot vertical plywood siding, which of the following material should you apply to the joints to insure maximum watertightness?

1. Battens
2. Calking
3. Water-repellent preservative
4. All of the above

Learning Objective: Identify procedures used in the installation of siding. Textbook pages 11-22 through 11-28.

12-60. To prevent a uniform appearance, siding should line up with which of the following parts?

1. Drip caps of the doors and windows
2. Bottoms of the doors and windows
3. Opposing corners
4. All of the above

12-61. When wood siding must have a natural finish, what type of nails should be used?

1. Aluminum only
2. Stainless steel only
3. Aluminum or stainless steel
4. Galvanized

12-62. The average exposure of horizontal siding is usually determined by the distance between the

1. bottom of the window sill to the foundation wall
2. bottom of the door and the drip cap of the door
3. underside of the window sill to the top of the drip cap

12-63. What would be the exact exposure of 8-inch siding installed on a building where the overall height of its windows is 68 inches?

1. 5 7/8 in.
2. 6 in.
3. 6 3/4 in.
4. 6 7/8 in.

12-64. The first installed course of bevel siding is usually blocked out with

1. bridging
2. flashing
3. a starting strip
4. a batten

12-65. To avoid butt joints, it is a good practice to use long sections of siding between doors and windows.

- 12-66. Of the following, which is considered a good practice in making siding butt joints?
1. Square cutting the siding
 2. Dipping siding butt ends
 3. Applying water-repellent preservative after the siding is in place
 4. Each of the above
- 12-67. To face nail 10-in-h-wide drop siding over studs (no sheathing), how many nails should be used per panel at each stud?
1. One
 2. Two
 3. Three
 4. Four
- 12-68. Blocking for vertical siding without sheathing should be spaced at what maximum distance?
1. 12 in.
 2. 16 in.
 3. 24 in.
 4. 48 in.
- 12-69. When board and batten vertical siding is being nailed, nails of the top board should penetrate the edge of the board or batten underneath.
- 12-70. What type of corner covering can be used with almost any kind of outside wall covering?
1. Miter-joined siding boards
 2. Two-piece corner board
 3. Butted siding boards covered with a metal cap
 4. Alternate edge-lapped shingles
- 12-71. Mitered corners of bevel and similar sidings should fit tightly over the full miter depth.
- 12-72. Siding that returns against a roof surface, such as a dormer, should be joined with
1. miter & corners
 2. metal corners
 3. flashing
 4. corner boards
- 12-73. To apply wood shingles or shakes over 3/8-inch plywood sheathing, what type of nails should you use?
1. Threaded
 2. Square
 3. Round
 4. Barbed
- 12-74. When applying wood shingles where the "siding effect" is NOT a consideration, what spacing should you use to allow for expansion during rainy weather?
1. 1/16 to 1/8 in.
 2. 1/8 to 1/4 in.
 3. 1/4 to 1/2 in.

Assignment 13

EXTERIOR FINISH (continued): INTERIOR FINISH

Textbook Assignment: Pages 11-29 through 11-34, and 12-1 through 12-30.

Learning Objective: Identify common types of flashings and methods of installation on wood-frame structures. Textbook pages 11-29 through 11-32.

- 13-1. To prevent corrosion and deterioration, what type of nail should be used with copper flashing?
1. Galvanized
 2. Stainless steel
 3. Copper
 4. Aluminum
- 13-2. Which of the following places on a wall require flashing?
1. Where stucco-finished siding butts into wood siding
 2. Where vertical-applied wood siding butts into horizontally applied wood siding
 3. Where vertical or horizontal siding butts into the tops of doors or windows
 4. All of the above
- 13-3. When applying flashing on the roof ridge, how far down each side of the ridge should you extend the flashing?
1. 1 in.
 2. 2 in.
 3. 3 in.
 4. 6 in.
- 13-4. Where metal valley flashing is used, the minimum open width at the top of the valley should be (a) how many inches and should increase down the slope at the rate of (b) how many inches per foot?
1. (a) 6 in. (b) 1/4 in.
 2. (a) 6 in. (b) 1/8 in.
 3. (a) 4 in. (b) 1/4 in.
 4. (a) 4 in. (b) 1/8 in.
- 13-5. When using shingle flashing at the intersection of a vertical wall and a shingle roof, how should you install the flashing?
1. Under the wall siding and over the roof shingles after the shingles are in place
 2. Over the wall siding and shingles after both siding and shingles are in place
 3. Under the wall siding and under the shingles as each course of shingles is placed
-
- Learning Objective: Identify various types of gutters and downspouts, wall and ceiling coverings, and describe procedures for installing them. Textbook pages 11-32 through 11-34 and 12-1 through 12-6.
-

- 13-6. Gutters and downspouts are normally made of which of the following materials?
1. Copper only
 2. Aluminum only
 3. Galvanized metal only
 4. Copper, aluminum, and galvanized metal

- 13-7. In installing gutters, you should space hangers at what intervals for (a) galvanized steel and for (b) copper or aluminum?
1. (a) 48 in. (b) 60 in.
 2. (a) 48 in. (b) 30 in.
 3. (a) 30 in. (b) 48 in.
 4. (a) 60 in. (b) 48 in.

- 13-8. A 16-foot-long downspout should be installed with how many straps?
1. Six
 2. Two
 3. Three
 4. Four

11-9. In terms of drywall construction, "nail pops" are a result of which of the following factors?

1. Misalignment of studs
2. Tying out of the moisture in studs
3. Chemical reaction with coating on nails
4. Improper nail size

11-10. In a dry ceiling system an unfinishing attic, which type of structural member is used?

1. A ribbon board
2. A ledger
3. A string beam
4. A rafter beam

11-11. Which thickness of gypsum board is recommended for new multi-layer applications?

1. 1/2 in.
2. 1 1/2 in.
3. 5/8 in.
4. 1 in.

11-12. When applying 1/2 in. gypsum board to a ceiling (a) what size nail and (b) what nail spacing should you use?

1. (a) 4d, (b) 6 to 8 in. oncenter
2. (a) 4d, (b) 7 to 7 1/2 in. oncenter
3. (a) 4d, (b) 8 to 8 1/2 in. oncenter
4. (a) 4d, (b) 9 to 9 1/2 in. oncenter

11-13. Nail heads should be driven slightly below the surface of the gypsum board. How should you start the nail driving?

1. Start in the center
2. Start at the edge
3. Start at the corner
4. Start at the joint

11-14. In nailing a joint between two pieces of drywall, what should you do after the nail is driven at the joint?

1. The joint is taped
2. The joint is feathered
3. The joint is mudded
4. The joint is allowed to dry

11-15. Select from the following list the proper materials for finishing drywall joints.

- ✓ Sandpaper
- ✓ Taped paper
- ✓ Nifty finish coat of joint compound
- ✓ Feather edge
- ✓ Feathered edge

11-16. To prevent damage to gypsum board corners, what materials are used?

1. Wallboard corner beads
2. Corner moldings
3. Furring strips
4. Flashings

11-17. When nailing plywood to ceilings, what spacing should you maintain between nails?

1. 8-in. oncenter
2. 2-in. oncenter
3. 6-in. oncenter
4. 4-in. oncenter

11-18. Prior to installation, how long should most wood panel materials be exposed to the conditions of the room?

1. 12 hr
2. 14 hr
3. 18 hr
4. 24 hr

11-19. When adhesive is used to install plywood, the fourth step in the procedure is to

1. press the plywood against the framing members
2. tap the plywood with a rubber mallet
3. install guide nails
4. pull the plywood away from the framing members to allow adhesive to set

11-20. What is the recommended minimum thickness of hardboard used over framing members spaced 16 in. oncenter?

1. 1/8 in.
2. 1/4 in.
3. 3/8 in.
4. 1/2 in.

11-21. The maximum number of joints should be allowed for any panel that is used in a ceiling. How many joints?

1. 1
2. 2
3. 3
4. 4

11-22. Identify the materials and procedures used in the installation of a given type of a ceiling system. (Check pages 12-6 through 12-11.)

11-23. If the ceiling is characterized by sound reflection, light reflection, flame resistance, and sound absorption, what material is used?

1. Sound absorption
2. Light reflection
3. Flame resistance
4. Sound reflection



- 13-23. Assume that the dimensions of a ceiling is 16 ft 8 in. by 10 ft 2 in., when calculating the material requirements, what dimensions should you use?
1. 16 ft 0 in. by 10 ft 0 in.
 2. 16 ft 8 in. by 10 ft 2 in.
 3. 17 ft 0 in. by 11 ft 0 in.
 4. 18 ft 0 in. by 12 ft 0 in.
- 13-24. Assume you have to lay out the grid pattern for a ceiling. The main tees in the grid pattern should run
1. parallel to the joists
 2. at a 45° angle to the joists
 3. perpendicular to the joists
 4. in a crisscross pattern between the joists
- 13-25. How many pieces of wall angle would be required for a room 12 ft by 40 ft?
1. 5
 2. 8
 3. 0
 4. 11
- 13-26. In what order should the following items be installed?
- A. Acoustic panels
 - B. Cross tees
 - C. Wall angles
 - D. Suspension wires
 - E. Main tees
1. Acoustical panels, cross tees, wall angles, suspension wires, and main tees
 2. Cross tees, main tees, wall angles, acoustical panels, and suspension wires
 3. Wall angles, suspension wires, main tees, cross tees, and acoustical panels
 4. Suspension wires, main tees, cross tees, wall angles and acoustical panels
- 13-27. The height at which the wall angles are supposed to be installed is indicated by a previously
1. cut cross tee
 2. cut main tee
 3. cut suspension wire
 4. marked line
- 13-28. Assume that a new acoustical ceiling will be installed 12 in. lower than the old ceiling. What is the minimum length that the suspension wires should be cut?
1. 14 in.
 2. 16 in.
 3. 18 in.
 4. 20 in.
- 13-29. Where on the main tee should the first tie wire be installed?
1. 2 ft from either end
 2. 4 ft from either end
 3. At the first cross tee connections
 4. At the center
- 13-30. When installed in accordance with the grid patterns shown in textbook figure 12-12, which components require the use of splice plates?
1. Aluminum main tees
 2. Aluminum cross tees
 3. Steel main tees
 4. Steel cross and border tees
- 13-31. When installing acoustical panels, why should you work from several cartons at the same time?
1. All the panels may not be of the same dimension
 2. Every other panel in a carton has a different edge cut
 3. The color, pattern, or texture may vary slightly, thus avoid a change in uniformity
 4. All panels cannot be cut or used as border panels
- 13-32. When installing 12-inch-square ceiling tile in a 15-foot, 8-inch-wide room, what pattern should you use in terms of rows and size?
1. 15 full rows and two 4-inch tiles
 2. 15 full rows and one 8 inch tile
 3. 14 full rows and one 10-inch tile
 4. 14 full rows and two 10-inch tiles
-
- Learning Objective: Identify types of insulation and describe methods of installation. Textbook pages 12-11 through 12-19.
-
- 13-33. To increase the resistance to heat passage, insulating materials are usually installed in which of the following locations?
1. Exposed walls
 2. Ceilings
 3. Floors
 4. All of the above
- 13-34. Into which of the following categories may insulation be grouped?
1. Blanket
 2. Loose fill
 3. Rigid
 4. All of the above

13-35. What is the primary function of the asphalt sheet material attached to blanket-type insulation?
1. To resist water vapor
2. To resist heat
3. To resist infestation of insects

13-36. Which of the following methods may be used to install loose fill insulation?
1. Pouring
2. Blowing
3. Packing by hand
4. Each of the above

13-37. To be effective, what is the minimum air space reflective insulations must have?
1. 3/4 in.
2. 1 1/2 in.
3. 3 in.
4. 6 in.

13-38. Rigid insulation may be used for which of the following structural purposes?
1. Sheathing
2. Building boards
3. Roof decking
4. All of the above

13-39. Which of the following substances is sometimes mixed with plaster in order to reduce transmission of heat?
1. Vermiculite or perlite aggregate
2. Rock or glass wool
3. Sawdust
4. Shredded redwood bark

13-40. To reduce the moisture content and protect the wood frame members, what type of material should be used as ground cover in crawl spaces?
1. Roll roofing only
2. Polyethylene only
3. Both roll roofing and polyethylene may be used
4. Blanket insulation

13-41. Where houses are built on slabs it is good practice to install a vapor barrier under each slab.

13-42. When insulation is used without a vapor barrier, what material is normally used to envelop the entire exposed wall and ceiling?
1. Building paper
2. Building board
3. Plastic film
4. Fiberglass

13-43. When placing fill insulation over ceilings, you can insure a uniformly thick layer by using a
1. screed
2. leveling board
3. carpenter's level
4. batten board

13-44. Of the following materials, which is an effective vapor barrier against condensation created by dishwashing, bathing, cooking, or any other source?
1. Aluminum foil
2. Asphalt laminated paper
3. Plastic film
4. Each of the above

13-45. How are hip roofs best ventilated?
1. Inlet ventilators along the rake and outlet ventilators along the soffits
2. Inlet ventilators along the ridge and outlet ventilators along the soffits
3. Inlet ventilators along the soffits and outlet ventilators along the ridge
4. Inlet and outlet ventilators along the ridge

13-46. The most desirable system of inlet ventilation on a low-pitched roof is the
1. triangle
2. continuous slot
3. ridge
4. wall

Learning Objective: Describe how to erect a given type of stairway and how to frame a set of stairs according to the quantity of stairs, height of the risers, tread run and the drop of the stair carriage. Textbook pages 12-19 through 12-24.

13-47. When you calculate the unit rise of a stairway, what is the customary permissible unit rise in inches?
1. 9
2. 7
3. 3
4. 5

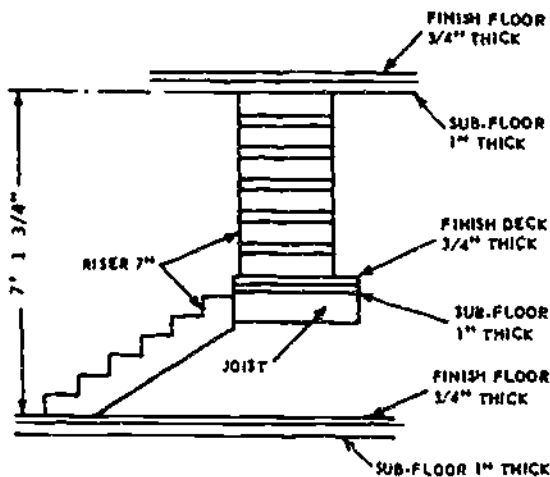

Figure 13A.-Platform stairway

In answering items 13-48 and 13-49 refer to figure 13A.

- 13-48. The total rise of the stairway is
1. 7 ft 5 1/4 in.
 2. 7 ft 6 1/4 in.
 3. 7 ft 7 in.
 4. 7 ft 8 3/4 in.
- 13-49. What is the height of the finish deck of the stairway platform above the subfloor of the lower deck?
1. 3 ft 11 1/4 in.
 2. 3 ft 8 1/4 in.
 3. 3 ft 9 7/8 in.
 4. 4 ft 1 3/4 in.

Information for items 13-50 through 13-52: The vertical distance between the upper and lower levels of a stairwell is 9 ft 6 1/2 in. as measured from the subflooring of both levels. The upper level is to have a 1-in. finish floor, and the lower level is to have a 1/2-in. finish floor.

- 13-50. What is the total rise of the stairway?
1. 114 in.
 2. 114 1/2 in.
 3. 115 in.
 4. 115 1/2 in.
- 13-51. What is the unit rise of the stairway to the nearest sixteenth of an inch?
1. 6 7/16 in.
 2. 7 in.
 3. 7 3/16 in.
 4. 7 3/4 in.

- 13-52. In using the architects' rule, what is the unit run of the stairway?
1. 10 in.
 2. 10 5/16 in.
 3. 10 1/2 in.
 4. 11 in.

- 13-53. What is the total run of a stairway that extends between two finish floors that are 12 ft 3 in. apart when the stairway has a full tread on the level of the upper finish floor?
1. 12 ft 3 in.
 2. 14 ft 4 in.
 3. 15 ft 5 in.
 4. 18 ft 4 1/2 in.

- 13-54. In stairways where the upper finish floor serves as the top tread, the total risers equal the total treads.

- 13-55. Assume that a sawed stranger for a straight-flight stairway is to be anchored on the subflooring. If the treads are 1 1/4 in. thick and the finish flooring is 7/8 in. thick, how much should the stranger be dropped?
1. 3/8 in.
 2. 7/8 in.
 3. 1 1/4 in.
 4. 2 1/8 in.

- 13-56. A stairway that consists of two straight flight stairways set off at a 90° angle to each other and separated by a rectangular platform is commonly called a
1. cleat stairway
 2. change stairway
 3. cleat stairway (open riser)
 4. straight-flight stairway

- 13-57. Squeaking is prevented on principal stairways by using
1. triangular blocks that are glued to the back of the joints where treads and risers meet
 2. balusters that are glued into holes bored into treads
 3. balusters that are doweled or dove-tailed into treads

Learning Objective: Identify common types of floor coverings, and describe procedures for laying coverings. Textbook pages 12-24 through 12-30.

13-58. Vertical-grain wood flooring generally has better wearing qualities than flat-grain wood flooring.

13-59. How are subfloor boards normally laid over joists?
1. Parallel
2. Diagonal
3. Perpendicular

13-60. Building paper is used over subfloors in order to reduce:
1. noise only
2. dust only
3. air flow only
4. noise, dust, and air flow

13-61. What factor usually causes cracks to appear in finish floors several months after the floor has been laid?
1. Expansion of subfloor material
2. Tying out of the finished floor
3. Poor nailing
4. Weak floor joists

13-62. At what range of angles should nails be driven through the tongue of tongue-and-groove flooring?
1. 20° to 30°
2. 30° to 40°
3. 40° to 45°
4. 45° to 50°

13-63. In nailing a tongue-and-groove floor, how is splitting of the tongue prevented?
1. Using soft nails
2. Pre-drilling the nail hole
3. Using a cleat joint nail
4. Waxing the nail stake

13-64. When laying a pattern in a tiled floor, what should be done before it is poured?
1. Further preparation is required in installing the wood flooring

13-65. To minimize shrinkage or swelling of wood block flooring, how should it be installed?
1. With adhesives
2. By first exposing the wood to 24 hr of sunlight, then nailing it
3. By alternating the grain direction of the blocks
4. By nailing each block corner first

13-66. Being highly resistant to grease, asphalt tile is ideal for kitchen use.

13-67. Before laying vinyl tile on a floor surface, you should square off the floor, apply the adhesive, and then begin laying the tile from the:
1. center of the floor working towards the walls so that the border widths can be adjusted accordingly
2. center of a continuous wall working towards the center of the floor
3. corner of the floor working towards the opposite corner
4. start of or door opening working towards the opposite wall

13-68. What is the expansion allowance for vinyl tile around the perimeter of the room?
1. 1/16 to 1/8 in.
2. 1/8 to 1/4 in.
3. 1/4 to 1/2 in.
4. 1/2 to 1 in.

13-69. What is the primary advantage to using vinyl over other types of floor coverings?
1. Easy to repair
2. It is cheap
3. Polished maintenance
4. It is durable



Assignment 14

Interior Finish (Continued): Plastering, Stuccoing, and Ceramic Tile

Textbook Assignment: Pages 12-31 through 12-53 and 13-1 through 13-8.

Learning Objective: Describe the procedures for laying out and installing readymade doors and door frames including hardware. Textbook pages 12-35 through 12-43.

- 14-1. What is the size of a typical main entrance door?
- 1 1/2 in. thick, 2 ft 8 in. wide, 6 ft 8 in. high
 - 1 3/4 in. thick, 3 ft 0 in. wide, 6 ft 8 in. high
 - 1 3/4 in. thick, 2 ft 8 in. wide, 6 ft 8 in. high
 - 1 3/4 in. thick, 3 ft 0 in. wide, 7 ft 0 in. high
- 14-2. In framing rough openings for interior doors, what allowance is made in the stud walls?
- 3 in. less than the door height and 2 in. less than the door width
 - 2 1/2 in. more than the door height and 3 in. more than the door width
 - 3 in. more than the door height and 2 1/2 in. more than the door width
 - 2 1/2 in. less than the door height and 4 in. less than the door width
- 14-3. The edge trim around interior door openings is known as the
- side jamb
 - threshold
 - casing
 - sill
- 14-4. What type of exterior door is made of thin plywood faces over a wood framework with a particle board core?
- Panel
 - Flush
 - Combination
 - Clad
- 14-5. Louvered doors are suitable for closet use because they
- are less expensive
 - require less space
 - allow ventilation
 - are more durable
- 14-6. How should hinged residential doors swing or open?
- Against a blank wall
 - Toward the natural entry
 - Both 1 and 2 above are correct
 - Into the hallway
- 14-7. When plumbing and leveling a door frame, what materials do you use?
- Casing wedges
 - Wood shingle wedges
 - Wood shake wedges
 - Hairpin wedges
- 14-8. What edge distance allowance is made when the casing is nailed to the jamb?
- 1/16 in.
 - 1/8 in.
 - 3/16 in.
 - 3/8 in.
- 14-9. What should you do to a mitered casing joint to lessen the chance of its opening up as the casing material dries?
- Glue the joint
 - Install a wood screw
 - Use a glued spline
 - Use a wood filler
- In answering items 14-10 and 14-11, refer to textbook figure 12-42.
- 14-10. The recommended clearance allowance at the top and at the knob side of a well-fitted door in the finished opening should be at LEAST
- 1/8 in.
 - 3/8 in.
 - 1/2 in.
 - 3/4 in.

- 14-11. The standard hinge spacing for an interior door is how many inches from (a) the top and (b) the bottom?
1. (a) 11 in. (b) 8 in.
 2. (a) 11 in. (b) 7 in.
 3. (a) 8 in. (b) 12 in.
 4. (a) 7 in. (b) 11 in.

- 14-12. Refer to textbook figure 12-43. As you stand facing a door, you notice that the door is hinged on the left and swings away from you. What type of door is it?
1. Left-hand reverse door
 2. Left-hand door
 3. Right-hand reverse door
 4. Right-hand door

- 14-13. What size loose-pin butt hinge do you use for a door 1 3/8 in. thick?
1. 5 in. extra heavy
 2. 5 in. by 5 in.
 3. 3 1/2 in. by 3 1/2 in.
 4. 4 in. by 4 in.

- 14-14. What is the standard height of a door-knob?
1. 30 to 32 in.
 2. 32 to 34 in.
 3. 34 to 36 in.
 4. 36 to 38 in.

- 14-15. To prevent scraping as a door is opened, what clearance is allowed for the door-stop on the hinge side of the door?
1. 1/32 in.
 2. 1/16 in.
 3. 1/8 in.
 4. 1/4 in.

- 14-16. Refer to textbook figure 12-51. What type of panic device has locking mechanisms that are mounted at the top and bottom of the door?
1. Rim
 2. Vertical rod
 3. Mortise

Learning Objective: Identify the types of windows used in wood frame structures, and describe how they are installed. Textbook pages 12-43 through 12-49.

- 14-17. Heat loss through metal window frames is less than through those made of wood.

- 14-18. What small wood members separate the lights in a sash?
1. Meeting rails
 2. Parting beads
 3. Muntins
 4. Weatherstrips

In answering items 14-19 through 14-21, select from column B the type of window that best matches the description in column A.

A. Descriptions	B. Types of Windows
14-19. Wood sash with large single light	1. Casement 2. Double hung
14-20. Side-hinged sash usually designed to swing outward	3. Stationary 4. Jalousie
14-21. Upper and lower sash that slide vertically in separate grooves	

- 14-22. What advantage does the casement window have over the double-hung window?
1. Provides more light
 2. Provides better insulation
 3. Provides better ventilation
 4. Is easier to install

- 14-23. Which type of glass should you order for a house window 3 1/2 feet square located in an area subject to high winds?
1. Single-strength glass
 2. Double-strength glass
 3. Plate glass
 4. Tempered glass

- 14-24. What type of glass should you order for a building that requires large panes of glass approximately 1/4-inch thick?
1. Heavy sheet glass
 2. Plate glass
 3. Tempered glass
 4. Glare reducing glass



In answering items 14-25 through 14-28, select from column B the type of glass that best matches the description in column A.

	<u>A. Descriptions</u>	<u>B. Types of Glass</u>
14-25.	Two or more sheets of glass separated by a 1/2-in. air space	1. Wire glass 2. Heat absorbing glass 3. Insulating glass
14-26.	Glass pane containing a wire mesh centered as far as possible throughout the pane	4. Shatter-reducing glass
14-27.	Light gray colored glass that is designed to exclude a portion of the sun's heat rays	
14-28.	Heavy sheet glass that is bluish or greenish in color that has the ability to absorb the infrared rays of heat	

- 14-29. What should be done to a wooden sash after you have used a sealer to make it waterproof at all corners and fabrication joints?
1. Insert the glass pane
 2. Lay a bead of glazing compound on the clearance for the glass
 3. Put a coat of prime paint on all wood surfaces
 4. Remove all unnecessary projections from the sash

Information for items 14-30 and 14-31:
Chief Builder Brown is preparing to demonstrate the correct method of cutting a glass pane for a window 17 5/8 in. long by 12 1/4 in. wide.

- 14-30. What is the minimum equipment required to perform this job?
1. A glass cutter
 2. A glass cutter and T-square
 3. A 4-ft square table and a glass cutter
 4. A 4-ft square table, T-square, and glass cutter

- 14-31. Having the necessary glass cutting equipment, Chief Brown's next step is to mark a cutting line on
1. both sides of the pane to the exact inside dimensions of the window sash
 2. the glass, deducting 1/8 to 3/16 in. from the inside dimensions of the window sash to allow for irregularities in the sash
 3. the glass pane, deducting 1/16 to 1/8 in. from the inside dimensions of the window sash to allow for irregularities in the sash

- 14-32. Which types of sash should be primed before the glass has been inserted?
1. Old wood sash and new wood sash
 2. Old metal sash and new metal sash
 3. Both 1 and 2 above
- 14-33. What is the lowest temperature at which it is safe to glaze or reglaze an exterior sash?
1. 19°F
 2. 31°F
 3. 41°F
 4. 49°F

- 14-34. When mounting wire glass in a small wooden window frame, you should first
1. insert the glass into the window frame with the wire twist in the vertical position
 2. lay a continuous 1/6-in.-thick bed run of putty on the frame
 3. insert the glass into the window frame with the concave side facing out
 4. lay a continuous bead of putty against the perimeter of the glass

- 14-35. To clean glass after glazing or painting, what material is recommended?
1. Ammonia
 2. Mineral spirits
 3. Caustic soap
 4. Acid solution

Learning Objective: Identify the kinds of interior molding trim used by the Builder. Textbook pages 12-50 through 12-53.

- 14-36. What is the first inside window trim member to be installed?
1. Stool
 2. Casing
 3. Apron
 4. Stop

14-37. Name the three sections that you would sometimes use to construct lines of baseboard.

1. Base cap
2. Upper cap
3. Chain rail
4. Base

14-38. Name the three sections of a plaster base coat.

1. Corners
2. Base
3. Shoe
4. Rail

14-39. What type of joint can be used at inside corners of ceiling moldings.

1. Butt
2. Cop
3. Miter
4. Box

Learning Activities: Describe the procedures in laying out, cutting, fitting, and installing laminates. Textbook pages 12-13 and 12-51.

14-40. What is the minimum clearance of the laminate that will allow it past the edge of the substrate surface for trim work.

1. 1/4 in.
2. 1/2 in.
3. 3/4 in.
4. 1 in.

14-41. Before bedding laminates on a surface coated with joint cement, you should work the excess of the cement by

1. pressing wrapping paper on the surface
2. touching the surface with your fingers
3. brushing the surface with a metal knob
4. brushing with a stiff broom on the surface

14-42. What type of joint is used to join trim laminate to a wall or ceiling and (B) level the adjacent edges.

1. Galvanized only (B) corner only
2. Galvanized (A) 1/2 in. thick plate
3. Galvanized (A) 1/2 in. thick plate (B) mill finish
4. Galvanized (A) 1/2 in. thick plate (B) mill finish

Learning Activities: Identify the ingredients of plaster, the principles of plastering, the procedures for plastering, and the types of plastering.

14-43. Of the following material, which is a binder for plaster that should NOT be exposed to severe moisture conditions.

1. Portland cement
2. Lime
3. Gypsum
4. Contact cement

14-44. To produce base coats of superior strength and hardness, which type of gypsum base coat plaster should you use.

1. Wood fibered without added ingredients
2. Wood fibered with 1 part sand
3. Bond with 1 part sand
4. Ready-mixed

14-45. What substances make up the essential ingredients in gypsum bond plaster.

1. Calcined gypsum combined with 3.75 percent by weight of nonstaining wood fibers
2. Calcined gypsum mixed with 2 to 3 percent of lime by weight
3. Gypsum plaster with no aggregate
4. Gypsum and ordinary mineral aggregate

14-46. Which of the following is called gypsum aging plaster?

1. Contains lime putty which increases the dimensional stability of the plaster while drying and increases critical surface hardness
2. Has a high density, yields a highly polished surface, and provides extra resistance when used with fire sand
3. Contains finely granulated wood or without aggregate
4. Contains no aggregate and is used for interior masonry

14-47. Plaster that is used for interior work must be soaked for an extended period which could be as long as

1. 1 day
2. 2 months
3. 3 days
4. 4 months

14-48. The minimum soaking time to prevent cement normal hydrated lime plaster from cracking is

1. 3 hours
2. 16 hours
3. 12 days
4. 21 days

14-49. Drying material is added to plaster mixtures for what of the following reasons.

1. To induce strength and to reduce shrinkage tendency
2. To produce early strength and to reduce shrinkage tendency
3. To induce late strength and to reduce shrinkage tendency
4. All of the above

- 14-50. Portland cement plaster should NOT be applied directly over what type of walls?
1. Exterior masonry
 2. Interior masonry
 3. Interior or exterior, metal-lath covered
 4. Gypsum tile or gypsum Plasterboard
- 14-51. When the aggregate material is excessively fine grained, why is the plaster strength reduced?
1. The smaller quantity of water required raises the water:cement ratio, and increases the dry set ratio
 2. The greater quantity of water required raises the cement:water ratio, and reduces the dry set density
 3. Less binder paste is used because of the lack of space between particles of the fine, which results in a weak mixture
 4. More binder paste is needed to coat all particle surfaces, which results in sufficient fines to close all voids, and leaves a rich, but unstable mixture
- 14-52. Of the following aggregates, which would be used in plaster?
1. Sand
 2. Vermiculite
 3. Perlite
 4. Each of the above
- 14-53. What is the approximate dry weight of a cubic foot of 1:2 gypsum-perlite plaster?
1. 15-25 lb
 2. 30-35 lb
 3. 40-45 lb
 4. 50-55 lb
- 14-54. The reason for adding wood fiber to neat gypsum plaster is to
1. lower the density of the plaster mix
 2. increase its acoustical properties
 3. improve the working qualities of the gypsum
 4. absorb excess water used in mixing
- 14-55. In mixing plaster, why is more water added to the mix than required for complete hydration of the binder?
1. Gives it more strength
 2. Reduces its setting time
 3. Brings it to a workable consistency
 4. Accelerates its setting
- 14-56. A bond is effected between plaster and nonperforated gypsum lath by the
1. sheets of fibrous absorbent paper contacting the plaster core
 2. expansion of the gypsum plaster core when in contact with moist plaster
 3. absorption of cementitious material from the plaster which then interlocks with nonabsorbed particles in the plaster
 4. absorption of particles of plaster which interlock with absorbed cementitious material from the plaster
- 14-57. What type of lath provides thermal insulation and serves as a vapor barrier?
1. Perforated
 2. Insulating
 3. Plain
 4. Metal
- 14-58. Metal lath that is rib expanded contains V-shaped metal strips for the purpose of
1. stretching the sheet to provide screen openings
 2. furring the lath out from its attached surface
 3. providing perforated openings of various shapes
 4. staggering slits cut into the lath

In answering items 14-59 through 14-62, select from column B the type of lath that best fits the statement given in column A.

A. Statements	B. Types of Lath
14-59. Suitable for all types of plastering	1. Stucco mesh 2. Diamond mesh
14-60. Intended primarily for exterior plastering	3. Paper-backed diamond mesh 4. Self-furring diamond mesh
14-61. Contains dimples which fur it out from the surface to which it is attached	
14-62. Designed to receive plaster applied by machine	

Learning Objective: Correlate the name and purpose of each type of lath used in plastering. Textbook pages 13-4 through 13-8.

14-63. What is the purpose of installing casing beads?

1. To reinforce the lath and inside corners
2. To reinforce the door and window casings
3. To provide dividing strips between plaster edges and the edges of baseboards
4. To provide dividing strips between plaster edges and the edges of doors and window casings

14-64. To minimize shrinking and cracking around the upper corners of doors and windows, you should install

1. plaster grounds
2. expanded metal lath strips
3. base screeds
4. casing beads

14-65. To assure that the plaster will be applied evenly and to the correct thickness, what material is installed?

1. Expanded metal lath
2. Corner bead
3. Door and window casing
4. Cornerite

14-66. Which of the following serve as temporary guides around window and door openings and are removed after the plaster has set?

1. Cornerite
2. Corner beads
3. Plaster grounds
4. Lath strips

14-67. What is the recommended spacing of gypsum-lath nails?

1. 5 in. OC
2. 6 in. OC
3. 8 in. OC
4. 12 in. OC

Assignment 15

Plastering, Stuccoing, and Ceramics III (Continued): Paints and Preservation

Textbook Assignment: Pages 13-8 through 13-21 and 14-1 through 14-11

Learning Objective: Identify the procedures used in plastering, including the estimating of materials and the procedures for mixing and placing. (Objectives pages 13-8 through 13-12.)

- 15-1. What is the recommended proportion for two-coat plaster used on a masonry or concrete base?
1. Gypsum plaster 1:2:5
 2. Lime plaster using lime putty 1:1:5
 3. Portland cement 1:5
 4. Lime plaster using hydrated lime 1:4:5
- 15-2. It is NOT appropriate to apply a finish finish to which of the following base coats?
1. Gypsum
 2. Portland cement
 3. Gypsum-vermiculite
 4. Lime
- 15-3. When added as a plasticizer to a finish coat made up of 500 pounds of sand and 1 sack of portland cement, what weight of hydrated lime should NOT be exceeded?
1. 3.5 lb
 2. 6.5 lb
 3. 9.5 lb
 4. 12.5 lb
- 15-4. On an interior masonry wall, what should be the minimum thickness for lime plaster?
1. 1/4 in.
 2. 1/2 in.
 3. 5/8 in.
 4. 3/4 in.
- In answering items 15-5 through 15-7, use the rule of 38 for estimating square yards of mortar. The building specifications call for a 1:3 mix for the mortar.
- 15-5. How many cubic feet of materials will be required?
1. 20
 2. 38
 3. 64
 4. 127
- 15-6. How many cubic feet of mortar will be required?
1. 187
 2. 228
 3. 258
 4. 267
- 15-7. How many cubic feet of mortar will be required?
1. 30
 2. 28
 3. 24
 4. 26
- In answering items 15-8 and 15-9, refer to table 13-1 in the textbook. Determine the amount of materials needed for plastering 1000 sq ft. Specifications require the plaster coat to be 3/4 in. thick.
- 15-8. When a 1:2 mix is used, how many cubic feet of materials will be required?
1. 29
 2. 58
 3. 87
 4. 110
- 15-9. When a 1:3 mix is used, how many bags of cement are required?
1. 23
 2. 35
 3. 39
 4. 46

1-11. When mortar materials are mixed by hand, what is the maximum time that mixing should continue after all the materials have been blended?

1. 2 to 5 min
2. 5 to 10 min
3. 10 to 15 min
4. 15 to 20 min

15-11. When using a mixing machine for preparing plaster mix, you should add about half of the aggregate to the water when the aggregate is

1. perlite
2. sand
3. vermiculite

15-12. When machine mixing is used, approximately, how many gallons of water should be used per 100 pounds of materials?

1. 10
2. 7
3. 5
4. 3

15-13. After all ingredients for a ready-mixed gypsum plaster mix have been added, what minimum time should a plasterer allow for all wet materials to

1. 7 min
2. 10 min
3. 15 min
4. 20 min

15-14. While using a hand troweling blade, what element of wear should be worn on the wear surface of the blade? (Select all items)

1. Abrasives
2. No. 80 sand
3. Topples
4. All of the above

Learning Objective: Identify uses for various plastering tools. Text-book pages 13-12 through 13-15.

15-15. What tool is used for carrying mortar?

1. A rectangular trowel
2. A darby
3. An angle trowel
4. A hawk

In answering items 15-16 through 15-18, select from column B the tool having the use in column A.

	A. Uses	B. Tools
15-16.	obtaining a certain surface texture	1. Pointing trowel 2. Darby
15-17.	Leveling plaster between grounds	3. Straightedge 4. Sponge float
15-18.	Replacing a tool in areas where the rectangular trowel will not fit	
15-19.	The plastering tool known as a feather-edge is used to	
	1. fill voids and smooth lumps in the plaster surface	
	2. cut in corners and shape straight lines at corner lines of intersection	
	3. level applied plaster between grounds	
	4. straighten the base coat after rodding is completed	
15-20.	To improve the bond, what tool is used to rake furrows between coats?	
	1. Darby	
	2. Browning brush	
	3. Cork float	
	4. Straighter	

Learning Objective: Recognize techniques of plastering. Text-book pages 13-15 through 13-17.

15-21. In a typical plastering crew, which of the following individuals would mix the plaster?

1. Crew chief
2. Tender
3. Plasterer
4. Nozzleman

15-22. Applied plaster should be maintained within a tolerance of 1/8 inch in 10 feet because

1. plaster rigidity decreases as plaster thickness increases
2. plaster rigidity increases as plaster thickness decreases
3. plaster tends to crack as thickness increases
4. plaster tends to crack as the thickness decreases

15-23. Approximately how thick should the scratch coat of a three-coat gypsum plaster be?

1. 1/8 in.
2. 3/16 in.
3. 1/8 in.
4. 1/2 in.

15-24. For lime base coat work, why is additional floating required the day after a brown coat is applied?

1. To form and harden the scratch coat
2. To improve the bond between the scratch coat and the brown coat
3. To smooth and level the surface
4. To fill any cracks caused by shrinkage of the plaster

15-25. Which of the following statements is applicable to the fog-spray curing of portland cement plaster?

1. The finish coat should be applied at least 3 days after the brown coat is applied
2. The finish coat should be sprayed for 48 hours after its application
3. The brown coat should be fog-sprayed for 48 hours followed by the same treatment for the scratch coat
4. The scratch coat should be fog-sprayed for 24 hours and the brown coat fog-sprayed for 36 hours

15-26. A mottled plaster finish is ready for troweling when the

1. angles have been straightened
2. surface has been doubled back
3. skim coat has been applied
4. plaster begins to set and the surface becomes dull

15-27. In the final step of float finishing, the plasterer moves the

1. float in a circular motion with one hand while applying brush water just ahead of the float with the other hand
2. brush in a circular motion while moving the float immediately ahead of the brush with the other hand
3. float in a back-and-forth motion with one hand while moving the brush in a circular motion with the other hand just behind the float
4. brush in a back-and-forth motion with one hand while moving the float in a circular motion with the other hand just ahead of the brush

15-28. By throwing plaster on a surface with a brush, which of the following finish textures may be obtained?

1. Stippled
2. Travertine
3. Fish coat
4. Pebble

Learning Objective: Identify the composition of stucco and the procedures for mixing, applying, and curing for it, Textbook pages 13-17 through 13-20.

15-29. Define stucco.

1. A combination of cement, sand, and water and when applied resembles concrete having a hard, strong, fire resistant surface which resists rot and fungus and retains color
2. A combination of masonry cement, sand, and water and when applied resembles cement having a medium hard surface which requires frequent painting to prevent rot and fungus
3. A combination of cement, sand, and water and when applied needs a plasticizing material to act as a sealer in preventing rot and fungus
4. A combination of masonry cement, sand, and water and when applied resembles a smooth hard surface which, if not painted immediately after application, will begin to mildew

15-30. Which of the following types of cements is generally used in stucco?

1. I
2. II
3. III
4. IV

15-31. When stucco is applied over open-frame construction, what step follows the application of the line wire?

1. Installation of wire mesh
2. Driving nails into the wood
3. Application of the scratch coat
4. Installation of waterproof paper

15-32. Over open-frame construction, what coat(s) of stucco would normally be required?

1. Scratch only
2. Brown only
3. Finish only
4. Scratch, brown, and finish

15-31. A brown stain of stains should be moist cured for about how many hours?

1. 8
2. 16
3. 24
4. 32

15-32. When using an acid wash to prepare a concrete surface for stucco, you should use 1 part acid to how many parts of water?

1. 6
2. 10
3. 12
4. 20

15-33. Since some areas of a surface draw more moisture than other areas, which of the following flaw is caused?

1. Settling
2. Cracking
3. Spitting
4. Flaking

15-34. Cracks in stucco can be largely controlled by means of

1. thin wooden strips imbedded in the brown coat to give flexibility to the finish
2. metal strips placed at intervals to serve as control joints
3. plasticizing materials to give the stucco at the recesses flexibility
4. fine wire to give the necessary flexibility in cases of expansion and contraction and to minimize cracks due to settling and movement of the building foundation

Learning Objective: Identify the procedures for laying ceramic wall tile. Textbook pages 13-20 and 13-21.

15-35. How many parts of hydrated lime and sand should be used with 1 part of cement for a float coat of a mortar bed setting for ceramic tile?

1. 1 part lime and 7 parts sand
2. 6 parts lime and 10.5 parts sand
3. 3 parts lime and 10.5 parts sand
4. 8 parts lime and 21 parts sand

15-36. When a tile wall is being laid, the width of each joint should NOT exceed

1. 1/32 in.
2. 5/16 in.
3. 1/32 in.
4. 1/8 in.

15-39. During the construction of a ceramic tile wall, when should a non-abrasive soap be applied?

1. Before the tiles are floated onto the skim coat
2. After the tiles have been floated onto the skim coat
3. After the joints have been grouted
4. After each tile has been grouted

15-40. You are using the buttering method to set tile which will be subject to frequent wetting down. When preparing the adhesive, should cover

1. 50% of the back of each tile and form a coating not more than 1/16 in. thick
2. 50% of the back of each tile and form a coating not less than 1/16 in. thick
3. 60% of the back of each tile and form a coating not less than 1/16 in. thick
4. 60% of the back of each tile and form a coating not less than 1/8 in. thick

15-41. Before grouting you should allow the ceramic tile adhesive to set for how many hours?

1. 2
2. 10
3. 24
4. 36

Learning Objective: State the reasons for painting a surface; the types, characteristics, and composition of each type of paint; and the purpose of each type of paint. Textbook pages 14-1 and 14-2.

15-42. An object or structure is painted for which of the following reasons?

1. Protection of surfaces
2. Sanitation
3. Identification
4. All of the above

15-43. The greatest single protective characteristic of paint is its ability to resist

1. chalking and warping
2. wrinkling and checking
3. moisture and condensation

15-44. For diffusing and softening illumination, what type of paint is used?

1. Gloss
2. Semigloss
3. Flat
4. Camouflage

Learning Objective: Identify common painting tools and equipment and their uses. Point out operating and maintenance principles for spray painting equipment. Textbook pages 14-3 through 14-11.

- 15-45. Of the following types of abrasives, which is mainly used for rust removal?
1. Flint
 2. Emery
 3. Garnet
 4. Silicon
- 15-46. When required to do some fine, finish sanding on a maple table top, what (a) type and (b) number of abrasive should you select?
1. (a) garnet (b) 3
 2. (a) aluminum oxide (b) 1/2
 3. (a) flint (b) 3
 4. (a) garnet (b) 0
- 15-47. For sanding between a coat of shellac and a coat of varnish, what grade of steel wool should you use?
1. 1
 2. 2
 3. 3
 4. 00
- 15-48. To obtain a smooth finish between coats of finishing material, which of the following powdered abrasives may be used?
1. Rottenstone
 2. Jeweler's rouge
 3. Pumice stone
 4. Each of the above
- 15-49. Of the following bristles, which carries more paint and leaves finer brush marks on the finished surface?
1. Horsehair
 2. Hog
 3. Squirrel
 4. Nylon
- 15-50. A paint brush that is intended to be used for freehand artwork should be made of either squirrel hair or
1. badger hair
 2. sable hair
 3. horsehair
 4. hog bristles

- 15-51. When water-based latex and similar paints are used, what type of paintbrush bristles is recommended?
1. Oxhair
 2. Camelhair
 3. Horsehair
 4. Synthetic
- 15-52. For painting a rough stucco surface, what type of paintbrush bristles is preferred?
1. Hog
 2. Camel's hair
 3. Horsehair
 4. Nylon

In answering items 15-53 through 15-57, select from column B the roller fabric that is best for painting with the type of paint on the surface in column A.

A. Types of Paints and Surfaces	B. Roller Fabrics
15-53. Exterior latex on a smooth wood surface	1. Dvnel
15-54. Interior latex on a smooth plaster surface	2. Mohair
15-55. Masonry sealer on a smooth plaster surface	3. Dacron Polyester
15-56. Epoxy coating on a rough concrete surface	4. Lamb's Wool pelt
15-57. Exterior latex on a semismooth wood surface	

In answering items 15-58 through 15-61, select from column B the type of spray gun that operates on the principle in column A.

	A. Operating Principles	B. Types of Spray Guns
15-58	Air and paint are mixed outside of the air cap	1. Bleeder 2. Nonbleeder 3. External-mix 4. Internal-mix
15-59	To prevent building up of air in the hose, air is allowed to leak from some part of the gun	
15-60	When the trigger is released, a valve shuts off the air	
15-61	Air and paint are mixed inside the air cap	

15-62. What type of spray gun operates similar to an insect spray gun?

1. Pressure feed
2. Bleeder
3. Suction-feed
4. External-mix

15-63. Of the following spray gun parts, which controls the amount of spray material that passes through the gun?

1. Air valve
2. Spreader adjustment
3. Fluid needle
4. Spray head

15-64. What part of a spray gun controls the flow of the spray material into the stream?

1. Trigger
2. Fluid tip
3. Spreader-adjustment valve
4. Spray-head barrel

15-65. The airless spray gun has which of the following advantages over the air-type guns?

1. Less thinning required
2. Less overspray mist
3. Lighter to handle
4. Each of the above

15-66. Which of the following means are commonly used to mix paint?

1. Vibrators
2. Propellers
3. Electric drill attachments
4. All of the above

Assignment 16

Paint and Preservatives (Continued).

Textbook Assignment: Pages 14-11 through 14-36.

Learning Objective: Indicate types of paint and finishes and the general characteristics of each.
Textbook pages 14-11 through 14-14.

- 16-1. Which of the following constituents of paint provides the coloring?
1. Drier
2. Pigment
3. Thinner
4. Vehicle
- 16-2. Which of the following constituents of paint acts as the binder?
1. Pigment
2. Drier
3. Vehicle
4. Thinner
- 16-3. All of the following chemical compounds are synthetic resins EXCEPT
1. naphthas
2. Phenolics
3. epoxies
4. chlorinated rubbers
- 16-4. What is the purpose of a paint solvent?
1. To give more body to the paint
2. To prevent blistering of the paint
3. To add gloss to the paint
4. To adjust the consistency of the paint
- 16-5. To increase resistance of oil-base paint to water and decrease drying time, what material may be added to the paint in small amounts?
1. Linseed oil
2. Polyester
3. Varnish
4. Naptha
- 16-6. Which of the following ratios determines the level of gloss in enamel paints?
1. Pigment to binder
2. Thinner to pigment
3. Vehicle to binder
4. Binder to drier
- 16-7. To obtain a tile-like glaze coating on masonry surfaces, what type of paint is normally used?
1. Oil-base
2. Enamel
3. Epoxy
4. Latex
- 16-8. In areas that require frequent washings, what type of paint is desirable?
1. Portland cement
2. Latex
3. Aluminum
4. Rubber-base
- 16-9. When a can of ready-mixed aluminum paint is bulging, how should the pressure be released?
1. By carefully removing the lid
2. By carefully puncturing the lid
3. By shaking the can in a vibrator
4. By discarding the can
- 16-10. Each of the following materials is designed to obscure the surface to which it is applied EXCEPT
1. varnish
2. primer
3. enamel
4. flat
- 16-11. Which of the following types of varnish is intended for exterior use?
1. Flat
2. Spar
3. Rubbing
4. Color
- 16-12. Of the following material, which is often used as a sealant over wood knots to prevent bleeding?
1. Lacquer
2. Stain
3. Shellac
4. Varnish
- 16-13. Which type of stain contains alcohol as a vehicle?
1. Spirit
2. Chemical
3. Oil
4. Water

Learning Objective: Describe the procedures used in preparing surfaces for painting. Textbook pages 14-14 through 14-20.

- 16-14. Which of the following advantages can be gained by proper surface preparation?
1. Minimum repair
 2. Increased durability
 3. Ease of repainting
 4. Each of the above
- 16-15. Before removing rust scale from a surface, you must also remove which of the following substances?
1. Oil
 2. Dirt
 3. Chemicals
 4. All of the above
- 16-16. Which of the following tools may be used in the removal of mill scale?
1. Chipping hammer
 2. Rotary scaler
 3. Sander
 4. Each of the above
- 16-17. Of the following conditions, which is a disadvantage of vacuum blasting over conventional blasting?
1. It creates a bigger dust hazard
 2. It does not allow abrasives to be reclaimed
 3. It is less efficient on irregular surfaces
 4. Each of the above
- 16-18. What is the primary advantage of wet blasting?
1. It reduces dust to a minimum
 2. It results in less cleanup
 3. It keeps rust from forming on the surface
- 16-19. Both flammable and nonflammable paint removers are toxic and must be used in properly ventilated spaces.
- 16-20. To prepare a galvanized iron surface for painting, what type of cleaner is generally used?
1. Solvent
 2. Hot alkaline
 3. Emulsion
- 16-21. Dirt and fungus are removed from concrete and masonry by washing with a solution of water and
1. hot alkaline
 2. emulsion
 3. trisodium phosphate
 4. efflorescence
- 16-22. During the process of removing efflorescence from concrete, what should you do after scrubbing with an acid solution?
1. Let the solution remain on the surface about 10 minutes
 2. Let the solution dry, and then remove the efflorescence by dry brushing
 3. Rinse it thoroughly with clear water
 4. Increase the strength of the acid solution, and let it remain on the surface for 30 minutes
- 16-23. When muriatic acid and water are mixed, the correct procedure for mixing is to add
1. the acid to the water
 2. the water to the acid
 3. 15 percent acid to 85 percent water
 4. half acid and half water
- 16-24. To repair large defects in a concrete or masonry surface, which of the following grout mixtures is used?
1. Two parts mortar sand, 1 part portland cement, 1 part water
 2. Two parts portland cement, 2 parts mortar sand, 2 parts water
 3. Three parts mortar sand, 1 part portland cement, enough water to make a putty-like consistency
 4. Two parts mortar sand, 1 part portland cement, enough water to make a soupy-like consistency for pouring
- 16-25. Prior to painting, what is the minimum time that should be allowed for a repaired plaster patch to set?
1. 1 day
 2. 2 days
 3. 3 days
 4. 3 hr
- 16-26. When preparing soiled or dirty wood surfaces for painting, which of the following methods should you follow?
1. Sweeping, dusting, and washing the surface with a solvent or water and soap
 2. Bleaching the surface with a solution of oxalic acid and water
 3. Sanding the surface to a uniform color
 4. Pretreating the surface with a wood cleaner, formula #117

- 16-27. Before painting, what is the procedure for sanding a rough wood surface?
1. Start with a No. 1 coarse sandpaper; follow up with a No. 2; and finish with a No. 3
 2. Start with a No. 3 sandpaper; follow up with a No. 2; and finish with a No. 1
 3. Start with a No. 2 coarse sandpaper; follow up with a No. 1; and finish with a No. 2/0 Grit
 4. Start with a No. 2 sandpaper and finish up with a No. 2 and 2/0 grit

- 16-33. To fill in deep pores in open grained hardwoods and similar items, what procedure should you follow?
1. Brush thinned filler across the grain, immediately wipe off across the grain, and finish by wiping along the grain
 2. Brush thinned filler across the grain, follow by light brushing, wait 5 to 10 min, wipe filler across the grain before it sets and hardens, and finish by stroking along the grain
 3. Brush thinned filler across the grain, wait 5 min, follow by light brushing, wipe filler off, and finish by stroking across the grain
 4. Brush thinned filler along the grain, wait 5 min to 10 min, wipe filler along the grain before it hardens, and finish by stroking across the grain

In answering items 16-28 through 16-30, select from column B the material that fulfills the purpose in column A.

A. Purposes	B. Materials
16-28. When used on porous wood, concrete, and masonry, provides a smoother finish coat	1. Conditioner 2. Sealer 3. Filler 4. Latex paint
16-29. When applied to chalky substrates, improves adhesion of water-based paints	
16-30. Prevents resin exudation through applied paint coatings	
16-31. Before applying filler to open-grained wood, staining operations should be performed and allowed to dry for a minimum of	
1. 12 hr 2. 24 hr 3. 36 hr 4. 48 hr	
16-32. Prior to varnishing, which of the following open-grained woods should have a filler?	
1. Beech 2. Walnut 3. Maple 4. Birch	

- Learning Objective: Indicate the techniques used in mixing paint before it is applied to a given surface. Textbook pages 14-21 through 14-23.
- 16-34. To mix two package metallic paints, what mixing equipment is recommended?
1. Shaker
 2. Manual
 3. Propeller
 4. Each of the above
- 16-35. During the paint mixing process, what is meant by "boxing the paint"?
1. Mixing it with a metal paddle
 2. Mixing it with a mechanical agitator
 3. Pouring it back and forth from one container to another
 4. Cutting it with a suitable thinner
- 16-36. What are the three primary or true colors that are the basis for all subsequent shades, tints, and hues?
1. Blue, red, and green
 2. Red, black, and white
 3. Black, yellow, and white
 4. Yellow, blue, and red

704

In answering items 16-37 through 16-40, select from column B the chromatic color produced by the mixture in column A.

A. Mixtures	B. Chromatic Colors
16-37. One part of yellow to 3 parts of blue	1. Orange
16-38. Three parts of red, to 1 part of blue	2. Carmine
16-39. One part of red to 1 part of yellow	3. Blue green
16-40. Three parts of yellow to 1 part of blue	4. Yellowish green

- 16-41. Prior to its application by roller, a ready-mix paint must be thinned.
- 16-42. What is the recommended maximum amount of tint for 1 gallon of paint?
1. 1 oz
 2. 2 oz
 3. 3 oz
 4. 4 oz

Learning Objective: Describe the principles and techniques of applying various types of finishes and paints. Textbook pages 14-23 through 14-30.

- 16-43. In painting, what is "laying on" and "laying off"?
1. Applying the paint with a back-and-forth motion of the brush without lifting the brush from the surface
 2. Applying the paint with long horizontal strokes and then (laying off) crossing those strokes
 3. Applying the paint by moving the brush in one direction, lifting the brush from the surface, and then moving the brush across the same area in the opposite direction
 4. Applying the paint with a zig-zag motion of the brush and then (laying off) filling in between the strokes

- 16-44. When painting a bulkhead that is made up of vertical panels 3 feet wide, how do you apply the finish coat?
1. Cover the entire bulkhead with horizontal strokes, and finish by using vertical strokes
 2. Paint the entire bulkhead by using vertical strokes, and after the first coat dries put on a second coat using horizontal strokes
 3. Paint each panel separately using the most convenient strokes for each use
 4. Paint each panel separately by laying on horizontally and laying off vertically
- 16-45. What painting practice usually prevents brush marks?
1. Starting and ending each stroke on the painted surface
 2. Starting strokes on the painted surface and ending them on the unpainted surface
 3. Starting strokes on the unpainted surface and ending them on the painted surface
 4. Painting in one direction only and always towards the unpainted surface
- 16-46. What is the correct method of "laying on" and "laying off", respectively, when painting pipes or stanchions?

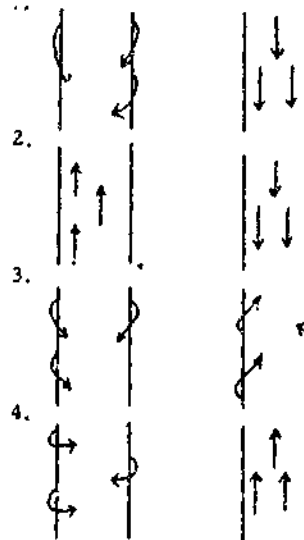

- 16-47. Which of the following is the technique for painting with a roller in order to cover large areas where few obstructions exist?
1. Paint the large areas first and cover near the moldings later
 2. Paint the areas around the moldings first and then cover the large areas
 3. Paint the large areas with strokes in one direction only
 4. Paint from a wet area into a dry area
- 16-48. What part of the spray gun adjusts the width of the spray pattern?
1. Fluid needle
 2. Air-control screw
 3. Material-control screw
 4. Air cap
- 16-49. Dirt in some of the air ports of a paint spray gun usually results in
1. spitting
 2. air leaks
 3. uneven spray
 4. material leaks
- 16-50. Dirt in the material-nozzle seat of a paint spray gun usually results in
1. spitting
 2. air leak
 3. excessive air in the mixture
 4. material leaks
- 16-51. Paint leakage from the front of the gun is usually due to a malfunction of the
1. material-hose connection
 2. air-hose connection
 3. air-valve assembly
 4. material-needle valve
- 16-52. What is the normal distance that should be maintained between the spray gun and the surface to be painted?
1. 16 to 20 in.
 2. 12 to 14 in.
 3. 6 to 10 in.
 4. 4 to 5 in.
- 16-53. Prior to starting the spray, failure to start the stroke will result in
1. dusting
 2. runs
 3. overspray
 4. blushing
- 16-54. When spraying inside and outside corners, (a) where should you start the gun from, and (b) in what direction should you work?
1. (a) left (b) right
 2. (a) right (b) left
 3. (a) top (b) bottom
 4. (a) bottom (b) top
- 16-55. When spray painting large office spaces, you should start by painting door frames and small areas and finish by painting walls.
- 16-56. Which of the following defects may be caused by moisture or excessive thinner in the paint?
1. Blushing
 2. Sags
 3. Orange peel
 4. Pinholes
- 16-57. When the color of the previous coat discolors the finish coat, what defect occurs?
1. Bleeding
 2. Peeling
 3. Blushing
 4. Sagging
- 16-58. When the spray gun is being cleaned, what method is used to force material back into the tank?
1. Connect air hose to hose cleaner and pull trigger
 2. Hold cloth over air cap and pull trigger
 3. Disconnect fluid hose and pull trigger
 4. Open cleaner valve and pull trigger
- 16-59. Of the following conditions, which is a possible cause of an ineffective spray pattern?
1. Dirt on air cap
 2. Packing nut too tight
 3. Cracked fluid tube
 4. Bent valve stem
- 16-60. Which of the following is a lubrication point for a spray gun?
1. Fluid-needle packing
 2. Fluid-needle spring
 3. Air-valve packing
 4. Each of the above
- 16-61. How much paint will it take to cover an interior plaster wall 25 feet long by 10 feet high using a latex paint for the first coat?
1. 1 gal
 2. 5/6 gal
 3. 2/3 gal
 4. 1/2 gal
- 16-62. A good supervisor should keep on-the-job notes of work performed by crews. These notes should contain what data?
1. The type of paint and coverage in square feet
 2. The time required to ready equipment
 3. The team's experience
 4. All of the above

Learning Objective: Identify the common types of paint failures and state the reasons for such failures. Textbook pages 14-31 through 14-34.

- 16-63. The end result of the sun's destructive rays on a paint vehicle is
1. peeling
 2. blistering
 3. alligatoring
 4. chalking
- 16-64. Besides inadequate bonding of the top coat of paint with the undercoat, what other cause is a prime reason for peeling?
1. High surface temperature
 2. Improper surface preparation
 3. Inferior paint
 4. Improper mixing of paint
- 16-65. Temperature changes that cause the substrate and overlaying paint film to expand and contract will cause
1. checking and cracking
 2. peeling
 3. alligatoring
 4. blistering

In answering items 16-66 through 16-68, refer to figure 16A.

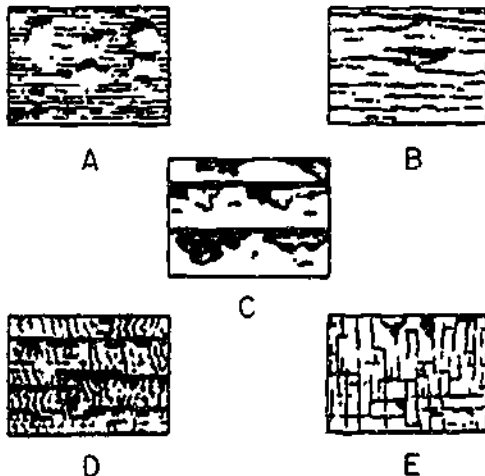

- 16-66. The accumulation of moisture under the paint is indicated by which failure?
1. A
 2. B
 3. C
 4. D

- 16-67. Cracking that takes place between the paint film and substrate is indicated by which failure?
1. B
 2. C
 3. D
 4. E

- 16-68. When you aim a spray gun too long at one spot on a surface, you will probably cause which failure?
1. A
 2. B
 3. C
 4. D

- 16-69. Failure of a gloss paint to attain its normal amount of gloss may be caused by which of the following factors?
1. Application in cold weather
 2. Inadequate surface preparation
 3. Application of the paint before the undercoat has dried
 4. Each of the above

Learning Objective: Indicate the factors to be considered in treating wood for protection against dry rot, termites, and decay. Textbook pages 14-34 through 14-36.

- 16-70. The amount of protection offered to wood by the use of a wood preservative depends on which of the following conditions?
1. The type of wood
 2. The moisture content of the wood
 3. The length of time the wood is treated
 4. Each of the above
- 16-71. The type of treatment or preservative that is to be used on wood will depend upon the severity of exposure and the
1. desired life of the end product
 2. size of the termites encountered
 3. method of applying the preservative
 4. safety precautions to be followed
- 16-72. Which of the following is a safe practice when preservatives are being applied?
1. Working in a ventilated space
 2. Avoiding undue skin contact
 3. Not rubbing face and eyes
 4. Each of the above

Assignment 17

Paint and Preservatives (Continued): Advanced Base Field Structures, Heavy Construction

Textbook Assignment: Pages 14-36 through 14-39, 15-1 through 15-22, and 16-1 through 16-18.

Learning Objective: Explain how to clean and care for brushes and painting equipment. Textbook pages 14-36 and 14-37.

- 17-1. You have stopped painting for today, but you will paint again tomorrow using the same oil-base paint. How should you stow your paintbrush?
1. Leave it suspended in a container of paint so the bristles are completely covered
 2. Clean it thoroughly in paint thinner, dry it, and stow it flat
 3. Clean it in paint thinner, and stow it suspended in a container of the proper thinner so the bristles are covered
 4. Wash it thoroughly in soap or detergent and water, rinse it in fresh water, and hang it to dry
- 17-2. What is the proper procedure for cleaning and stowing a paintbrush that is NOT to be used again?
1. Clean it in the proper thinner, wash it in soap or detergent and water, rinse it in fresh water, hang it to dry, wrap it with a protective cover, and stow it flat
 2. Clean it in the proper thinner, dry it with a soft cloth, wrap it in wax paper, and stow it flat
 3. Wash it thoroughly in soap or detergent and water, hang it to dry, and stow it flat
 4. Wash it thoroughly with paint thinner, rinse it in fresh water, dry it thoroughly, and hang it to dry
- 17-3. In cleaning a spray-painting gun, care should be taken to insure that the packing and lubricated parts of the gun are
1. soaked in thinner to remove the paint
 2. soaked in thinner to keep the packing soft
 3. soaked in thinner to replace the lubricant loss during operation
 4. not soaked in thinner, as this will remove the lubricant and cause the packing to become hard
- 17-4. After a respirator has been thoroughly cleaned with thinner to remove paint accumulation, it should be
1. wiped with a light soap-and-water solution, wiped with clear fresh water, and placed in a locker to dry
 2. wiped with a light soap-and-water solution, wiped with clear fresh water, and thoroughly dried
 3. wiped with a light soap-and-water solution, thoroughly dried, and placed in a locker
 4. soaked in a light soap-and-water solution, wiped with fresh water, and thoroughly dried
- 17-5. Do NOT use paint remover to clean the respirator, paint hose, mixer, or spray gun, as the corrosive agent contained in the remover will cause deterioration of this equipment.

Learning Objective: Indicate the safety rules and basic procedures to follow in using equipment, flammable materials, and toxic materials in painting operations. Textbook pages 14-37 through 14-39.

17-6. Which of the following hazards is usually associated with painting?
 1. Equipment
 2. Fire
 3. Health
 4. Each of the above

17-7. Which of the following is not a paint equipment hazard?
 1. Improper ventilation
 2. Improperly grounded motor
 3. Furnace pilot light
 4. Missing guardrail

17-8. Where should recurring safety inspections be performed?
 1. Outside
 2. Open bays
 3. Ventilated paths

17-9. What type of light fixtures should be installed in paint shops?
 1. Fluorescent
 2. Flood
 3. Spot
 4. Explosion-proof

17-10. Which of these steps is performed first?
 1. A
 2. B
 3. C
 4. D

17-11. During which of these steps should components be examined for defects?
 1. A and B
 2. B and C
 3. B and D
 4. C and D

17-12. The basic framework members of the gusset net which give it a unique shape are the
 1. Jurlin
 2. ribs
 3. hammer
 4. ribs

17-13. Major exterior repairs of the gusset net include which of the following tasks?
 1. Applying heat-reflective paint
 2. Caulking seams and openings
 3. Replacing corrugated metal
 4. All of the above

In answering items 17-19 through 17-22, select from column B the type of respiratory protection against the effects of working under the conditions in column A.

A. Workshop conditions B. Type of Respirator

17-14. Working in an unventilated painting booth
 1. Mechanical filter
 17-15. Spraying in a well-ventilated booth
 2. Air-supply
 17-16. Working in a well-ventilated booth
 3. Chemical attack

17-17. Working in a well-ventilated booth with exposure to lead paint
 1. Mechanical filter
 17-18. Working in a well-ventilated booth with exposure to lead paint
 2. Air-supply
 17-19. Working in a well-ventilated booth with exposure to lead paint
 3. Chemical attack

17-20. Working in a well-ventilated booth with exposure to lead paint
 1. Mechanical filter
 17-21. Working in a well-ventilated booth with exposure to lead paint
 2. Air-supply
 17-22. Working in a well-ventilated booth with exposure to lead paint
 3. Chemical attack

17-23. In military construction, how many coats are recommended for the creation of the bathtub?
 1. One
 2. Two
 3. Three
 4. Four

17-24. Because of its non-ferrous, non-flammable, straight-walled building, rigid-frame buildings can easily be disassembled, moved, and erected again without waste or damage because it utilizes
 1. Bolted connections only
 2. Large metal C-clamps
 3. Prestressed concrete joints
 4. Interzard panels only

17-25. Before pouring concrete for the foundation tiers of a rigid-frame building, which of the following tasks should you perform?
 1. Aligning the anchor bolts
 2. Placing templates for the anchor bolts
 3. Fastening nuts on the anchor bolts
 4. All of the above

17-26. While the foundation is being prepared for the 29- by 46-foot, rigid-frame building, which of the following work assignments can you perform?
 1. Glazing the windows
 2. Bolting the rigid-frame assemblies
 3. Assembling the door leaves
 4. Each of the above

- 17-21. Until ready to be used, which of the following materials should remain crated?
1. Girts
 2. Panels
 3. Eave struts
 4. Brace rods
- 17-22. What should you do to insure that building materials are accessible during assembly of the Butlerhut?
1. Keep all building materials in one central location
 2. Keep the building materials on trucks so they can be moved when needed
 3. Place the materials around the building site where they will be used
 4. Maintain at least 50 feet of clearance between the stockpiles of building materials
- 17-23. High strength bolts used to connect the rigid-frame assemblies are identified by what means?
1. A painted mark across the bolt threads
 2. A notch at the base of each bolt
 3. An embossed HS on each bolt head
 4. An embossed Y on each bolt head
- 17-24. When the side stringer of a rigid-frame building is being positioned, the top flange must
1. face to the inside of the building
 2. be secured with a 1-in. nut and flat washer
 3. face to the outside of the building
 4. rest on the floor joist
- 17-25. The distance from the center of one floor joist to the center of the next floor joist should be
1. 1 ft
 2. 2 ft
 3. 3 ft
 4. 4 ft
- 17-26. When laying the plywood deck for a rigid-frame building, you should do which of the following tasks?
1. Tighten the end joints
 2. Nestle the sides firmly into the steel splines
 3. Position the joists properly at all joints
 4. All of the above
- 17-27. Once all the parts have been laid out and checked, erection of the Butlerhut should begin with the center frame member.
- 17-28. When attaching eave girts to eave angles, you should fasten the shortest eave angle section to the left-hand side of the eave girt.
- 17-29. During the course of erecting a Butlerhut, when is the framework first plumbed?
1. Before the sidewall girts are installed
 2. After the exterior panels are positioned
 3. Before the base angles are installed
 4. After all the brace rods are in position
- 17-30. Which of the following steps must be taken before the panels of a Butlerhut are installed?
1. Install the furring strips
 2. Install the windows
 3. Straighten the girts
 4. Straighten the stringers
- 17-31. When placing the upper and lower wall panels, you must insure that the
1. 1/4- by 1-in. machine screws are in place
 2. upper wall panels are placed before the lower wall panels
 3. upper wall panels overlap the lower wall panels for weathertightness
 4. lower wall panels overlap the upper wall panels for weathertightness
- 17-32. Where should the eaves panels for a Butlerhut be installed?
1. One row ahead of the ridge panels
 2. Two rows ahead of the ridge panels
 3. One row behind the ridge panels
 4. Two rows behind the ridge panels
- 17-33. The doors to a Butlerhut can be hung anytime after the interior lining is installed.
- 17-34. What kind of concrete nails should you use to nail the base furring to the concrete deck of a Butlerhut?
1. 8d box nails
 2. 12 inch, No. 10
 3. 1 1/4 inch, No. 9
 4. 3/4 inch, No. 8 flathead
- 17-35. After placing the base, corner, and gable furrings, you should install the
1. hardboard liners
 2. eave moldings
 3. batten strips
 4. vertical furring
- 17-36. When installing hardboard, you should insure that the gap between panels measures
1. 1/8 in.
 2. 1/4 in.
 3. 5/16 in.
 4. 3/8 in.

- 17-37. The Butlerhut should be completed after you finish
1. glazing
 2. assembling door leaves
 3. attaching battens
 4. trimming ridge of ceiling liner

Learning Objective: Identify characteristics of wood-frame tents and field-type latrines. Textbook pages 15-15 through 15-22.

- 17-38. For the flooring of a wood-frame tent, what material is used?
1. 3/8-inch fiberboard
 2. 5/8-inch pressboard
 3. 1/2-inch plywood
 4. 1/4-inch tempered masonite
- 17-39. What is the spacing of the wall and roof framing members of the 16- by 24-foot wood-frame tent?
1. 1-ft OC
 2. 2-ft OC
 3. 3-ft OC
 4. 4-ft OC
- 17-40. When modified with a metal roof, extended rafters, and screened-in areas, the 16- by 32-foot tent frame becomes a
1. Southeast Asia hut
 2. Caribbean hut
 3. wood-frame hut
 4. tropical hut
- 17-41. When two 4-seat latrine boxes are set up side by side, the required pit size is
1. 3 by 6 ft
 2. 2 by 6 ft
 3. 3 by 7 ft
 4. 4 by 8 ft
- 17-42. How many trough-type urinals are furnished with the 4-seat latrine?
1. One
 2. Two
 3. Three
 4. Four

Learning Objective: State the purpose, use, and care of handtools and equipment used in heavy construction. Textbook pages 16-1 through 16-5.

- 17-43. On large crosscut saws, the points of the raker teeth should be slightly longer than the points of the cutter teeth.

- 17-44. How can you help make easy the sawing of a heavy timber?
1. By applying wax to the saw blade
 2. By applying oil to the saw blade
 3. Both 1 and 2 above
 4. By applying thinner to the saw blade

- 17-45. What makes the adz a dangerous tool?
1. It cuts towards the user
 2. It removes large chips of wood
 3. It requires long swinging strokes during use

- 17-46. What is the sledge used for?
1. To drive spikes
 2. To drift bolts
 3. To drive large timbers into place
 4. All of the above

- 17-47. When you want to drift heavy timbers without damaging them, which of the following tools should be used?
1. 20-lb double-face wood maul with a reinforced head
 2. 16-lb long-handled sledge
 3. 16-lb short-handled sledge
 4. 12-lb cross-peen sledge

- 17-48. The reinforced-head, double-face, wood maul should be used for driving bolts.

- 17-49. What tool should NOT be stored in direct sunlight or exceedingly hot places?
1. Sledge
 2. Crosscut saw
 3. Bit axe
 4. Wood maul

- 17-50. Which of the following tools may you use to carry timbers?
1. Cant hook and peavy
 2. Timber carrier
 3. Crapple hook
 4. All of the above

Learning Objective: State the purpose, use, and care of power tools used in heavy construction. Textbook pages 16-5 through 16-8.

- 17-51. When pneumatic tools are being used, what maximum length of 3/4-inch-diameter airhose may be used and still maintain maximum efficiency of the tool?
1. 100 ft
 2. 200 ft
 3. 300 ft
 4. 400 ft

- 17-52. The base plate of the pneumatic circular saw can be tilted for bevel cuts to (a) how many degrees and (b) adjusted to cut depths of how many inches?
1. (a) 30 (b) 3 1/2
 2. (a) 45 (b) 3 1/2
 3. (a) 45 (b) 4 3/8
 4. (a) 60 (b) 4 3/8

- 17-53. The size of the pneumatic chain saw is designated by the
1. length of the chain
 2. largest tree diameter it can cut
 3. length of the saw guide
 4. horsepower of the motor

- 17-54. The drill bit of the pneumatic, reversible wood drill is held in the chuck by (a) what device and (b) removed with what tool?
1. (a) wedge (b) wedge
 2. (a) wedge (b) hammer
 3. (a) Allen type setscrew (b) hammer
 4. (a) Allen type setscrew (b) wedge

Learning Objective: Describe the procedures for operating and maintaining gas or diesel air compressors and generators. Textbook pages 16-8 through 16-13.

- 17-55. With the following alternatives, show the correct starting sequence for the Worthington air compressor in warm or mild weather:

- A. Turn low-oil pressure knob to ON position
- B. Turn ignition switch to START position
- C. Engage clutch
- D. Open service valve 1/4 turn

1. C, A, B, D
2. D, A, B, C
3. D, C, A, B
4. A, B, D, C

- 17-56. Before you operate the Worthington air compressor, what is the minimum oil pressure, in p.s.i., that should be obtained?

1. 18
2. 22
3. 38
4. 44

- 17-57. When shutting down the air compressor, you should allow the engine to cool by closing the service valve and letting the engine idle for how many more minutes?

1. 1
2. 5
3. 8
4. 10

- 17-58. Which of the following, if any, is a safe practice in setting up a portable generator/floodlight unit?

1. Using tape to patch a damaged extension cord
2. Letting electrical equipment be installed by workers whose hands, clothes, or shoes are wet
3. Placing extension cords where they cannot touch or be run over by vehicles
4. None of the above

- 17-59. To prevent burnout of the generator field windings, the engine should NOT be set to idle with the generator excited.

Learning Objective: State the purpose and uses of timber connectors. Textbook pages 16-13 through 16-15.

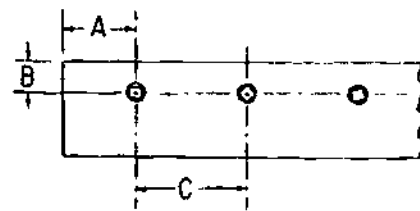

Figure 17A-Bolted timber.

- In answering items 17-60 through 17-62, refer to figure 17A.

- 17-60. Distance A should be at LEAST

1. 9 in.
2. 7 in.
3. 6 in.
4. 4 in.

- 17-61. Distance B should be at LEAST

1. 1 in.
2. 1/2 in.
3. 1 1/2 in.
4. 2 1/2 in.

- 17-62. Distance C should be at LEAST

1. 2 1/2 in.
2. 4 1/2 in.
3. 7 in.
4. 9 in.

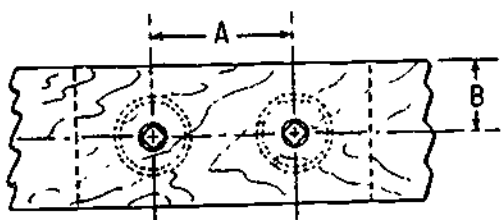

Figure 17B-Timber joint.

In answering items 17-63 and 17-64, refer to figure 17B.

- 17-63. When you use two 4-inch split rings in the timber joint, distance A should be equal to
1. 10 in.
 2. 8 in.
 3. 5 in.
 4. 4 in.
- 17-64. When 4-in. split rings are used in the joint, distance B should be NO less than
1. 5 in.
 2. 2 in.
 3. 3 in.
 4. 4 in.

In answering items 17-65 through 17-69, select from column B the timber connector which fits the description in column A.

A. Descriptions	B. Timber Connectors
17-65. Requires circular grooves	1. Single-Curved Spike Grid
17-66. Does NOT require grooves but is embedded by pressure	2. Double-Curved Spike Grid
17-67. Used to join round logs	3. Toothed Ring
17-68. Used to join a round log to a squared beam	4. Split Ring
17-69. Requires the use of a high-tensile strength bolt	

Learning Objective: Identify the parts of a given trestle and describe procedures of erecting bents and superstructures. Textbook pages 16-15 through 16-18.

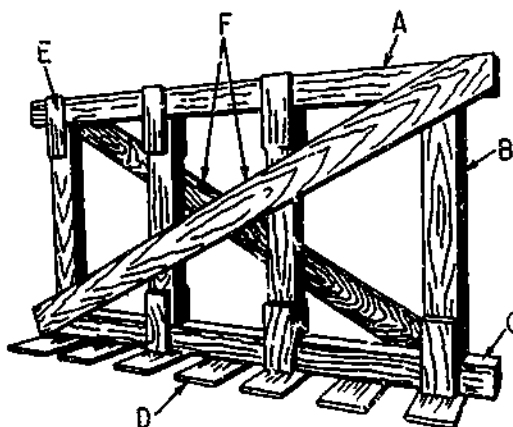

Figure 17C-Parts of a single-story trestle bent.

In answering items 17-70 through 17-73, refer to figure 17C.

- 17-70. The sill is labeled
1. A
 2. B
 3. C
 4. D
- 17-71. The footing is labeled
1. A
 2. B
 3. C
 4. D
- 17-72. The cap is labeled
1. A
 2. B
 3. E
 4. F
- 17-73. The transverse diagonal bracing is labeled
1. A
 2. B
 3. E
 4. F
- 17-74. If the settling allowance is 4 inches, to what depth should abutments be excavated for a trestle with 12-inch-deep stringers, 3-inch-thick flooring, and a 3-inch-thick treadway?
1. 12 in.
 2. 14 in.
 3. 16 in.
 4. 20 in.

17-75. When laying out the flooring members for a minimum-width, single-lane trestle, how long should you cut the planks that will support the handrail posts?

1. 17 ft 4 in.
2. 17 ft 6 in.
3. 19 ft 4 in.
4. 20 ft 4 in.

Assignment 18

Heavy Construction (continued):

Textbook Assignment: Pages 16-19 through 16-52

Learning Objective: Identify the types of piles used in heavy construction and describe the procedures used in preparing piles for driving. Textbook pages 16-19 through 16-28.

In answering items 18-1 through 18-4, select the type of pile in column B which is most suitable for the situation described in column A.

A. Situations	B. Types of Piles
18-1. Where bedrock to be used as bearing material is 90 feet down	1. Concrete sheet 2. Timber
18-2. Where exceptionally heavy, vertical trestle loads are expected	3. Steel
18-3. For use as bearing piles with light, vertical loads	
18-4. For use as a retaining wall	

In answering items 18-5 through 18-8, determine which of the following classifications apply:

1. The pile is acceptable
 2. The pile is NOT acceptable
- 18-5. The timber pile is split but NOT at driving end.
- 18-6. A line drawn from the centers of both ends does NOT lie within the body of the pile.
- 18-7. The pile is 27 feet long and 10 inches in diameter at the large end.
- 18-8. The pile is 54 feet long and 15 inches in diameter at the large end and 8 inches in diameter at the small end.

18-9. When a cap is NOT used in driving timber piling, the top end of a pile is wrapped with (a) how many turns of wire and (b) at what distance below the head of the pile?

- | | |
|-----------------|------------------|
| 1. (a) 1 or 3 | (b) 4 in. |
| 2. (a) 4 or 6 | (b) 8 in. |
| 3. (a) 7 or 9 | (b) 1/2 diameter |
| 4. (a) 10 or 12 | (b) 1 diameter |

18-10. To prepare the tip of a timber pile for driving in hard soil, what should you do?

1. Sharpen it into the shape of a truncated pyramid
2. Sharpen it to a point
3. Install a steel shoe over the tip
4. Cut it off blunt

18-11. Wood piles are reinforced to

1. increase their strength to where they can be driven beyond 80 ft
2. prevent the entrance of excessive moisture
3. restore them to their original strength after being weakened
4. reduce the cost of piling by enabling the use of smaller diameter timber

18-12. When reinforcing wood piles, what type of wood forms should you use?

1. Creosoted flooring planks
2. Creosoted tree trunks
3. Creosoted tongue-and-groove lumber

18-13. The best method of preventing marine borers from destroying timber piles calls for

1. an application of grease-type preservatives
2. soaking the timber in a hot creosote solution
3. peeling hot creosote over the entire pile
4. pressure treating the wood with a creosote-coal tar solution

- 18-14. Wood piling can be protected from marine bore damage through an application of preservative in the amount of
1. 25 pounds per cubic foot on Douglas fir and 20 pounds per cubic foot on Southern Yellow Pine
 2. 20 pounds per cubic foot on Douglas fir and 25 pounds per cubic foot on Southern Yellow Pine
 3. 25 pounds per cubic foot on Douglas fir and Southern Yellow Pine
 4. 20 pounds per cubic foot on Southern Yellow Pine and Douglas fir
- 18-15. Which of the following materials can be used in the preservation treatment of timber piles?
1. Hot creosote
 2. Pentachlorophenol
 3. Copper naphthenate solution
 4. Each of the above
- 18-16. Steel piles damaged by corrosion may be repaired by
1. reinforcing with timber
 2. cutting back the corroded edges
 3. welding and feather edging
 4. welding fish-plates to the flanges and web
- 18-17. What method is most commonly used to prepare steel piles to take a protective coating?
1. Sandblasting
 2. Wire brushing
 3. Chipping
 4. Flame clearing
- 18-18. To protect a galvanized treated pile from weathering, what material should you use
1. Linseed oil
 2. Latex paint
 3. Bituminous emulsion
 4. Red lead paint
- 18-19. The placement of which of the following bearing piles requires the use of a mandrel?
1. Cast-in-place concrete pile
 2. Precast concrete pile
 3. H-pile
 4. Timber pile
- 18-20. When used in waterfront structures, concrete bearing piles are usually
1. cast in place
 2. round in cross section
 3. precast
 4. longer than 100 feet
- 18-21. The forms used in repairing concrete piling may be filled with which of the following materials?
1. Epoxy
 2. Grout
 3. Portland cement concrete
 4. Each of the above
- 18-22. Below-the-waterline concrete piling may be repaired by which of the following methods?
1. Placing the concrete in wooden forms around the piling in the water
 2. Placing the concrete in metal forms around the piling in the water
 3. Building cofferdams so the concrete can be placed under dry conditions
 4. Each of the above
- 18-23. In order to insure a tight joint between timber sheet piles, what is the size of the bevel cut at the foot of the pile?
1. 8 and 14 in.
 2. 6 and 12 in.
 3. 5 and 8 in.
 4. 4 and 6 in.
- 18-24. You can repair a damaged steel sheet piling by doing which of the following?
1. Welding plates over the damaged section
 2. Inserting wooden plugs into the holes
 3. Pouring a concrete cover over the damaged section
 4. Each of the above
- 18-25. In covering damaged sheet piling, you should use a concrete layer of what thickness?
1. 1 in.
 2. 2 in.
 3. 6 in.
 4. 4 in.

Learning Objective: Describe the operating principles of pile-driving equipment. Textbook pages 16-28 through 16-32.

18-26. To insure that a pile is driven in the desired direction, what part of the pile-driving equipment is used?

1. Auxiliary support equipment
2. Hammer
3. Leads
4. pile bracing

18-27. If the pile to be driven weighs 3,600 pounds, what should be the minimum weight of the drop hammer?

1. 1,800 lb
2. 3,600 lb
3. 5,400 lb
4. 6,000 lb

18-28. In the single-acting hammer, what is the driving force?

1. Air pressure
2. Steam pressure
3. Gravity

18-29. In the double-acting hammer, by what means could the ram be raised?

1. Steam pressure only
2. Air pressure only
3. Steam or air pressure
4. Cables or lines

18-30. What pile-driving unit is self contained?

1. Diesel
2. Drop
3. Air
4. Steam

Learning Objective: Describe the procedures and techniques of placing driving piles. Textbook pages 16-32 through 16-42.

18-31. During pile-driving operations, what is used to brace the foot of the leads?

1. Telescoping catwalk
2. Skid rig
3. Boom
4. Batter pile

18-32. On a skid-mounted piledriver, what regulates side batter?

1. Moonbeam
2. Catwalk
3. Double-sheave bracket
4. Fore-batter

In answering items 18-33 through 18-37, select from column B the crewmember who does the task in column A.

	A. Tasks	B. Crewmembers
18-33.	Signals the rig and valve operators	1. Valve operators
18-34.	Works on the lead ladder	2. Hoisting engineer
18-35.	Operates the air and steam for the hammer	3. Signaller
18-36.	Operates the crane in lifting the piles	4. Loftman
18-37.	Bosses the rig	

18-38. On a pile-driving rig, which of the following crewmembers may give the rig operator an emergency stop signal?

1. Hoisting engineer
2. Valve operator
3. Hook-on man
4. Each of the above

18-39. A pile that resists an upward force may be driven butt first.

18-40. Arrange in correct sequence the following four major steps in driving a pile.

- A. The hammer and cap are set on the pile
- B. The pile hammer is positioned over the pile location
- C. The pile is winched into the leads
- D. The hammer is raised and dropped onto the pile

1. A, B, C, D
2. A, C, B, D
3. B, C, A, D
4. B, A, C, D

18-41. After a pile is firmly set, you should allow the drop hammer to fall a maximum of how many feet?

1. 9
2. 12
3. 15
4. 20

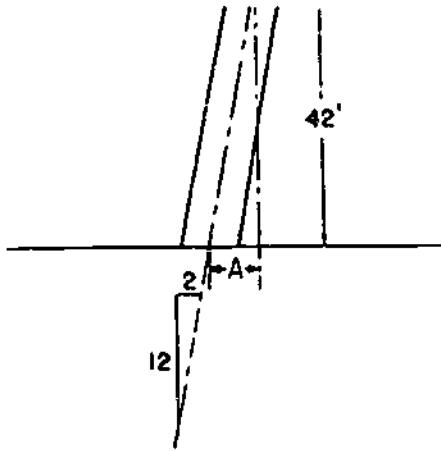

Figure 18A-Batter pile.

- In answering items 18-42 and 18-43, refer to figure 18A.

- 18-42. Distance A is equal to
1. 7 ft
 2. 8 ft
 3. 9 ft
 4. 10 ft
- 18-43. What is distance A if the batter were change to 3 in 12?
1. 6.0 ft
 2. 7.5 ft
 3. 8.5 ft
 4. 10.5 ft
- 18-44. Timber piles are supported by the leads during driving, and sheet piles are supported by wales.

In answering items 18-45 through 18-50, match the cause or description in column A by selecting from column B the symptom of trouble.

A. Causes/Descriptions	B. Symptoms of Trouble
18-45. Inability to overcome the friction of a pile being driven	1. Springing 2. Refusal
18-46. Caused by a crushed pile	3. Obstruction 4. Bouncing
18-47. Caused by the incorrect weight of the hammer	
18-48. Caused by the misalignment of the pile	
18-49. A substance through which a pile can NOT be driven	
18-50. Caused by a crooked pile	
<hr/>	
18-51. If circumstances permit, when should an underwater pile be pulled if it has been driven in the wrong place?	1. Immediately 2. After the earth around the pile has recompactd completely 3. During high tide 4. During low tide
18-52. A pile which is to be reused may be pulled by which of the following methods?	1. Direct lift 2. An air or steam double-action hammer 3. Tidal lift 4. Each of the above

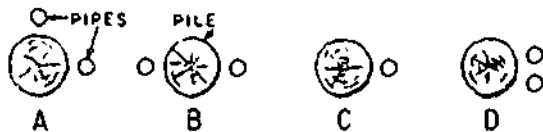

Figure 18B—Piles and jet pipes.

18-53. As a pile is being driven, which arrangement of jet pipes shown in Figure 18B is best suited for keeping it plumb?

1. A
2. B
3. C
4. D

Learning Objective: Identify the correct procedures for constructing an advanced base timber pier. Textbook pages 16-42 through 16-44.

18-54. How many bays are constructed for an advanced base timber pier?

1. 14
2. 12
3. The number depends on the total length of the pier
4. The number depends on the width of the pier

18-55. Support for a pier is usually provided by

1. cable
2. pile bent
3. sheet pile
4. rock fill

18-56. What is the difference between the bearing piles and the batter piles of an advanced base timber pier?

1. The bearing piles are smaller in diameter
2. The bearing piles are driven rip down
3. The batter piles are shorter than the bearing piles
4. The batter piles are set at 6 in 12

18-57. A pier is protected against shock damage from a ship tied alongside it by a system of

1. batter piles
2. bearing piles
3. stringers
4. fender piles

18-58. Which of the following is an isolated cluster of piles located about 15 feet from the end of a pier?

1. Pile cluster
2. Fender pile chock
3. Dolphin
4. Fender wale

Learning Objective: Correlate the names of waterfront structures with their purposes and appropriate construction techniques. Textbook pages 16-45 through 16-49.

In answering items 18-59 through 18-62, select from column B the waterfront structure having the purpose in column A.

A. Purpose	B. Waterfront Structures
18-59. Is designed to reduce the action of the waves of the sea	1. Jetty 2. Groin
18-60. Confines tidal flow to a selected channel	3. Seawall 4. Breakwater
18-61. Reflects the current away from the shore to prevent erosion	
18-62. Is built along the shoreline to protect property from erosion	
18-63. From what material is the top of a breakwater/jetty constructed?	1. Concrete poured in a single unit 2. Cap rock 3. Concrete caissons 4. Each of the above
18-64. In constructing a seawall, the harbor bottom is prevented from being eroded away from the toe of the wall by the use of	1. an inclined-face, cast-in-place cutoff wall 2. a vertical-face, cast-in-place cutoff wall 3. riprap 4. sand and clay

18-65. What waterfront structure requires the use of tie rods and anchors?

1. Jetty
2. Dolphin
3. Bulkhead
4. Groin

18-66. The sheet piling used in the construction of most bulkheads is made of

1. concrete
2. wood only
3. steel only
4. wood and steel

18-67. When a steel sheet pile bulkhead is constructed, the sheet piles for the bulkhead and anchorage are driven after the

1. tie rods are prestressed
2. supporting piles for the bulkhead are driven
3. wales are bolted on
4. shore and bottom are excavated to the proper level

18-68. After the steel sheet piles for a bulkhead are successfully driven, what is the next step in construction?

1. The tie rod supports are placed
2. The tie rods are set in place
3. The tie rods are prestressed
4. The tie rods are adjusted to bring the piles into plumb

Learning Objective: Identify the construction methods and uses of caissons and cofferdams. Textbook pages 16-49 through 16-52.

18-69. To cut off the flow of water into a construction site, what piping system is used?

1. Caisson
2. Cofferdam
3. Wellpoint
4. Pipeline

18-70. What is the purpose of a caisson or cofferdam?

1. To channel strong currents away
2. To act as fenders for wharves
3. To pump and keep water out of the structure during construction

18-71. How is the pile wall for a cofferdam supported?

1. By a framework of stringers and struts
2. By itself, if built in the shape of small arches with abutments supported by cross-members
3. By a double row of piles tied together with heavy steel ties built in a rectangular or oval shape and filled with earth
4. Each of the above

In answering items 18-72 through 18-74, select from column B the description of the caisson in column A.

	<u>A. Caissons</u>	<u>B. Descriptions</u>
18-72.	Box	1. Top closed, open at the bottom
18-73.	Pneumatic	2. Open at the top, bottom closed
18-74.	Open	3. Open top and bottom
		4. Closed top and bottom

COURSE DISENROLLMENT

All study materials must be returned. On disenrolling, fill out only the upper part of this page and attach it to the inside front cover of the textbook for this course. Mail your study materials to the Naval Education and Training Program Development Center.

PRINT CLEARLY

NAVEDTRA NUMBER
10648-G

COURSE TITLE
Builder 3&2

Name Last

First

Middle

Rank/Rate

Designator

Social Security Number

COURSE COMPLETION

Letters of satisfactory completion are issued only to personnel whose courses are administered by the Naval Education and Training Program Development Center. On completing the course, fill out the lower part of this page and enclose it with your last set of answer sheets. Be sure mailing addresses are complete. Mail to the Naval Education and Training Program Development Center.

PRINT CLEARLY

NAVEDTRA NUMBER
10648-G

COURSE TITLE
Builder 3&2

Name

ZIP CODE

MY SERVICE RECORD IS HELD BY:

Activity

Address

ZIP CODE

Signature of enrollee

773

A FINAL QUESTION: What did you think of this course? Of the text material used with the course? Comments and recommendations received from enrollees have been a major source of course improvement. You and your command are urged to submit your constructive criticisms and your recommendations. This tear-out form letter is provided for your convenience. Typewrite if possible, but legible handwriting is acceptable.

Date _____

From: _____
(RANK, RATE, CIVILIAN)

ZIP CODE _____

To: Naval Education and Training Program Development Center (PD8)
Pensacola, Florida 32509.

Subj: NRCC Builder 3&2, NAVEDTRA 10648-G

1. The following comments are hereby submitted:

U.S. GOVERNMENT PRINTING OFFICE 1981 - 740-086 9

779

(Fold along dotted line and staple or tape)

(Fold along dotted line and staple or tape)

DEPARTMENT OF THE NAVY
NAVAL EDUCATION AND TRAINING PROGRAM
DEVELOPMENT CENTER (PD 8)
PENSACOLA, FLORIDA 32509

OFFICIAL BUSINESS
PENALTY FOR PRIVATE USE, \$300

POSTAGE AND FEES PAID
NAVY DEPARTMENT
DOD-316



NAVAL EDUCATION AND TRAINING PROGRAM DEVELOPMENT CENTER
BUILDING 2435 (PD 8)
PENSACOLA, FLORIDA 32509

7811

PRINT OR TYPE

BUILDER 3&2
NAVEDTRA 10648-G

NAME _____ ADDRESS _____
Last First Middle Street/Ship/Unit/Division, etc.
City or FPO State Zip

RANK/RATE _____ SOC. SEC. NO. _____ DESIGNATOR _____ ASSIGNMENT NO. _____
 USN USNR ACTIVE INACTIVE OTHER (Specify) _____ DATE MAILED _____

SCORE

	1	2	3	4	
	T	F			
1	<input type="checkbox"/>	<input type="checkbox"/>	<input type="checkbox"/>	<input type="checkbox"/>	-----
2	<input type="checkbox"/>	<input type="checkbox"/>	<input type="checkbox"/>	<input type="checkbox"/>	-----
3	<input type="checkbox"/>	<input type="checkbox"/>	<input type="checkbox"/>	<input type="checkbox"/>	-----
4	<input type="checkbox"/>	<input type="checkbox"/>	<input type="checkbox"/>	<input type="checkbox"/>	-----
5	<input type="checkbox"/>	<input type="checkbox"/>	<input type="checkbox"/>	<input type="checkbox"/>	-----
6	<input type="checkbox"/>	<input type="checkbox"/>	<input type="checkbox"/>	<input type="checkbox"/>	-----
7	<input type="checkbox"/>	<input type="checkbox"/>	<input type="checkbox"/>	<input type="checkbox"/>	-----
8	<input type="checkbox"/>	<input type="checkbox"/>	<input type="checkbox"/>	<input type="checkbox"/>	-----
9	<input type="checkbox"/>	<input type="checkbox"/>	<input type="checkbox"/>	<input type="checkbox"/>	-----
10	<input type="checkbox"/>	<input type="checkbox"/>	<input type="checkbox"/>	<input type="checkbox"/>	-----
11	<input type="checkbox"/>	<input type="checkbox"/>	<input type="checkbox"/>	<input type="checkbox"/>	-----
12	<input type="checkbox"/>	<input type="checkbox"/>	<input type="checkbox"/>	<input type="checkbox"/>	-----
13	<input type="checkbox"/>	<input type="checkbox"/>	<input type="checkbox"/>	<input type="checkbox"/>	-----
14	<input type="checkbox"/>	<input type="checkbox"/>	<input type="checkbox"/>	<input type="checkbox"/>	-----
15	<input type="checkbox"/>	<input type="checkbox"/>	<input type="checkbox"/>	<input type="checkbox"/>	-----
16	<input type="checkbox"/>	<input type="checkbox"/>	<input type="checkbox"/>	<input type="checkbox"/>	-----
17	<input type="checkbox"/>	<input type="checkbox"/>	<input type="checkbox"/>	<input type="checkbox"/>	-----
18	<input type="checkbox"/>	<input type="checkbox"/>	<input type="checkbox"/>	<input type="checkbox"/>	-----
19	<input type="checkbox"/>	<input type="checkbox"/>	<input type="checkbox"/>	<input type="checkbox"/>	-----
20	<input type="checkbox"/>	<input type="checkbox"/>	<input type="checkbox"/>	<input type="checkbox"/>	-----
21	<input type="checkbox"/>	<input type="checkbox"/>	<input type="checkbox"/>	<input type="checkbox"/>	-----
22	<input type="checkbox"/>	<input type="checkbox"/>	<input type="checkbox"/>	<input type="checkbox"/>	-----
23	<input type="checkbox"/>	<input type="checkbox"/>	<input type="checkbox"/>	<input type="checkbox"/>	-----
24	<input type="checkbox"/>	<input type="checkbox"/>	<input type="checkbox"/>	<input type="checkbox"/>	-----
25	<input type="checkbox"/>	<input type="checkbox"/>	<input type="checkbox"/>	<input type="checkbox"/>	-----

	1	2	3	4	
	T	F			
26	<input type="checkbox"/>	<input type="checkbox"/>	<input type="checkbox"/>	<input type="checkbox"/>	-----
27	<input type="checkbox"/>	<input type="checkbox"/>	<input type="checkbox"/>	<input type="checkbox"/>	-----
28	<input type="checkbox"/>	<input type="checkbox"/>	<input type="checkbox"/>	<input type="checkbox"/>	-----
29	<input type="checkbox"/>	<input type="checkbox"/>	<input type="checkbox"/>	<input type="checkbox"/>	-----
30	<input type="checkbox"/>	<input type="checkbox"/>	<input type="checkbox"/>	<input type="checkbox"/>	-----
31	<input type="checkbox"/>	<input type="checkbox"/>	<input type="checkbox"/>	<input type="checkbox"/>	-----
32	<input type="checkbox"/>	<input type="checkbox"/>	<input type="checkbox"/>	<input type="checkbox"/>	-----
33	<input type="checkbox"/>	<input type="checkbox"/>	<input type="checkbox"/>	<input type="checkbox"/>	-----
34	<input type="checkbox"/>	<input type="checkbox"/>	<input type="checkbox"/>	<input type="checkbox"/>	-----
35	<input type="checkbox"/>	<input type="checkbox"/>	<input type="checkbox"/>	<input type="checkbox"/>	-----
36	<input type="checkbox"/>	<input type="checkbox"/>	<input type="checkbox"/>	<input type="checkbox"/>	-----
37	<input type="checkbox"/>	<input type="checkbox"/>	<input type="checkbox"/>	<input type="checkbox"/>	-----
38	<input type="checkbox"/>	<input type="checkbox"/>	<input type="checkbox"/>	<input type="checkbox"/>	-----
39	<input type="checkbox"/>	<input type="checkbox"/>	<input type="checkbox"/>	<input type="checkbox"/>	-----
40	<input type="checkbox"/>	<input type="checkbox"/>	<input type="checkbox"/>	<input type="checkbox"/>	-----
41	<input type="checkbox"/>	<input type="checkbox"/>	<input type="checkbox"/>	<input type="checkbox"/>	-----
42	<input type="checkbox"/>	<input type="checkbox"/>	<input type="checkbox"/>	<input type="checkbox"/>	-----
43	<input type="checkbox"/>	<input type="checkbox"/>	<input type="checkbox"/>	<input type="checkbox"/>	-----
44	<input type="checkbox"/>	<input type="checkbox"/>	<input type="checkbox"/>	<input type="checkbox"/>	-----
45	<input type="checkbox"/>	<input type="checkbox"/>	<input type="checkbox"/>	<input type="checkbox"/>	-----
46	<input type="checkbox"/>	<input type="checkbox"/>	<input type="checkbox"/>	<input type="checkbox"/>	-----
47	<input type="checkbox"/>	<input type="checkbox"/>	<input type="checkbox"/>	<input type="checkbox"/>	-----
48	<input type="checkbox"/>	<input type="checkbox"/>	<input type="checkbox"/>	<input type="checkbox"/>	-----
49	<input type="checkbox"/>	<input type="checkbox"/>	<input type="checkbox"/>	<input type="checkbox"/>	-----
50	<input type="checkbox"/>	<input type="checkbox"/>	<input type="checkbox"/>	<input type="checkbox"/>	-----

	1	2	3	4	
	T	F			
51	<input type="checkbox"/>	<input type="checkbox"/>	<input type="checkbox"/>	<input type="checkbox"/>	-----
52	<input type="checkbox"/>	<input type="checkbox"/>	<input type="checkbox"/>	<input type="checkbox"/>	-----
53	<input type="checkbox"/>	<input type="checkbox"/>	<input type="checkbox"/>	<input type="checkbox"/>	-----
54	<input type="checkbox"/>	<input type="checkbox"/>	<input type="checkbox"/>	<input type="checkbox"/>	-----
55	<input type="checkbox"/>	<input type="checkbox"/>	<input type="checkbox"/>	<input type="checkbox"/>	-----
56	<input type="checkbox"/>	<input type="checkbox"/>	<input type="checkbox"/>	<input type="checkbox"/>	-----
57	<input type="checkbox"/>	<input type="checkbox"/>	<input type="checkbox"/>	<input type="checkbox"/>	-----
58	<input type="checkbox"/>	<input type="checkbox"/>	<input type="checkbox"/>	<input type="checkbox"/>	-----
59	<input type="checkbox"/>	<input type="checkbox"/>	<input type="checkbox"/>	<input type="checkbox"/>	-----
60	<input type="checkbox"/>	<input type="checkbox"/>	<input type="checkbox"/>	<input type="checkbox"/>	-----
61	<input type="checkbox"/>	<input type="checkbox"/>	<input type="checkbox"/>	<input type="checkbox"/>	-----
62	<input type="checkbox"/>	<input type="checkbox"/>	<input type="checkbox"/>	<input type="checkbox"/>	-----
63	<input type="checkbox"/>	<input type="checkbox"/>	<input type="checkbox"/>	<input type="checkbox"/>	-----
64	<input type="checkbox"/>	<input type="checkbox"/>	<input type="checkbox"/>	<input type="checkbox"/>	-----
65	<input type="checkbox"/>	<input type="checkbox"/>	<input type="checkbox"/>	<input type="checkbox"/>	-----
66	<input type="checkbox"/>	<input type="checkbox"/>	<input type="checkbox"/>	<input type="checkbox"/>	-----
67	<input type="checkbox"/>	<input type="checkbox"/>	<input type="checkbox"/>	<input type="checkbox"/>	-----
68	<input type="checkbox"/>	<input type="checkbox"/>	<input type="checkbox"/>	<input type="checkbox"/>	-----
69	<input type="checkbox"/>	<input type="checkbox"/>	<input type="checkbox"/>	<input type="checkbox"/>	-----
70	<input type="checkbox"/>	<input type="checkbox"/>	<input type="checkbox"/>	<input type="checkbox"/>	-----
71	<input type="checkbox"/>	<input type="checkbox"/>	<input type="checkbox"/>	<input type="checkbox"/>	-----
72	<input type="checkbox"/>	<input type="checkbox"/>	<input type="checkbox"/>	<input type="checkbox"/>	-----
73	<input type="checkbox"/>	<input type="checkbox"/>	<input type="checkbox"/>	<input type="checkbox"/>	-----
74	<input type="checkbox"/>	<input type="checkbox"/>	<input type="checkbox"/>	<input type="checkbox"/>	-----
75	<input type="checkbox"/>	<input type="checkbox"/>	<input type="checkbox"/>	<input type="checkbox"/>	-----

PRINT OR TYPE

BUILDER 3&2
NAVEDTRA 10648-G

NAME _____ ADDRESS _____
Last First Middle Street/Ship/Unit/Division, etc.

City or PFO State Zip
RANK/RATE _____ SOC. SEC. NO. _____ DESIGNATOR _____ ASSIGNMENT NO. _____

USN USNR ACTIVE INACTIVE OTHER (Specify) _____ DATE MAILED _____

SCORE

	1	2	3	4	
	T	F			
1	<input type="checkbox"/>	<input type="checkbox"/>	<input type="checkbox"/>	<input type="checkbox"/>	-----
2	<input type="checkbox"/>	<input type="checkbox"/>	<input type="checkbox"/>	<input type="checkbox"/>	-----
3	<input type="checkbox"/>	<input type="checkbox"/>	<input type="checkbox"/>	<input type="checkbox"/>	-----
4	<input type="checkbox"/>	<input type="checkbox"/>	<input type="checkbox"/>	<input type="checkbox"/>	-----
5	<input type="checkbox"/>	<input type="checkbox"/>	<input type="checkbox"/>	<input type="checkbox"/>	-----
6	<input type="checkbox"/>	<input type="checkbox"/>	<input type="checkbox"/>	<input type="checkbox"/>	-----
7	<input type="checkbox"/>	<input type="checkbox"/>	<input type="checkbox"/>	<input type="checkbox"/>	-----
8	<input type="checkbox"/>	<input type="checkbox"/>	<input type="checkbox"/>	<input type="checkbox"/>	-----
9	<input type="checkbox"/>	<input type="checkbox"/>	<input type="checkbox"/>	<input type="checkbox"/>	-----
10	<input type="checkbox"/>	<input type="checkbox"/>	<input type="checkbox"/>	<input type="checkbox"/>	-----
11	<input type="checkbox"/>	<input type="checkbox"/>	<input type="checkbox"/>	<input type="checkbox"/>	-----
12	<input type="checkbox"/>	<input type="checkbox"/>	<input type="checkbox"/>	<input type="checkbox"/>	-----
13	<input type="checkbox"/>	<input type="checkbox"/>	<input type="checkbox"/>	<input type="checkbox"/>	-----
14	<input type="checkbox"/>	<input type="checkbox"/>	<input type="checkbox"/>	<input type="checkbox"/>	-----
15	<input type="checkbox"/>	<input type="checkbox"/>	<input type="checkbox"/>	<input type="checkbox"/>	-----
16	<input type="checkbox"/>	<input type="checkbox"/>	<input type="checkbox"/>	<input type="checkbox"/>	-----
17	<input type="checkbox"/>	<input type="checkbox"/>	<input type="checkbox"/>	<input type="checkbox"/>	-----
18	<input type="checkbox"/>	<input type="checkbox"/>	<input type="checkbox"/>	<input type="checkbox"/>	-----
19	<input type="checkbox"/>	<input type="checkbox"/>	<input type="checkbox"/>	<input type="checkbox"/>	-----
20	<input type="checkbox"/>	<input type="checkbox"/>	<input type="checkbox"/>	<input type="checkbox"/>	-----
21	<input type="checkbox"/>	<input type="checkbox"/>	<input type="checkbox"/>	<input type="checkbox"/>	-----
22	<input type="checkbox"/>	<input type="checkbox"/>	<input type="checkbox"/>	<input type="checkbox"/>	-----
23	<input type="checkbox"/>	<input type="checkbox"/>	<input type="checkbox"/>	<input type="checkbox"/>	-----
24	<input type="checkbox"/>	<input type="checkbox"/>	<input type="checkbox"/>	<input type="checkbox"/>	-----
25	<input type="checkbox"/>	<input type="checkbox"/>	<input type="checkbox"/>	<input type="checkbox"/>	-----

	1	2	3	4	
	T	F			
26	<input type="checkbox"/>	<input type="checkbox"/>	<input type="checkbox"/>	<input type="checkbox"/>	-----
27	<input type="checkbox"/>	<input type="checkbox"/>	<input type="checkbox"/>	<input type="checkbox"/>	-----
28	<input type="checkbox"/>	<input type="checkbox"/>	<input type="checkbox"/>	<input type="checkbox"/>	-----
29	<input type="checkbox"/>	<input type="checkbox"/>	<input type="checkbox"/>	<input type="checkbox"/>	-----
30	<input type="checkbox"/>	<input type="checkbox"/>	<input type="checkbox"/>	<input type="checkbox"/>	-----
31	<input type="checkbox"/>	<input type="checkbox"/>	<input type="checkbox"/>	<input type="checkbox"/>	-----
32	<input type="checkbox"/>	<input type="checkbox"/>	<input type="checkbox"/>	<input type="checkbox"/>	-----
33	<input type="checkbox"/>	<input type="checkbox"/>	<input type="checkbox"/>	<input type="checkbox"/>	-----
34	<input type="checkbox"/>	<input type="checkbox"/>	<input type="checkbox"/>	<input type="checkbox"/>	-----
35	<input type="checkbox"/>	<input type="checkbox"/>	<input type="checkbox"/>	<input type="checkbox"/>	-----
36	<input type="checkbox"/>	<input type="checkbox"/>	<input type="checkbox"/>	<input type="checkbox"/>	-----
37	<input type="checkbox"/>	<input type="checkbox"/>	<input type="checkbox"/>	<input type="checkbox"/>	-----
38	<input type="checkbox"/>	<input type="checkbox"/>	<input type="checkbox"/>	<input type="checkbox"/>	-----
39	<input type="checkbox"/>	<input type="checkbox"/>	<input type="checkbox"/>	<input type="checkbox"/>	-----
40	<input type="checkbox"/>	<input type="checkbox"/>	<input type="checkbox"/>	<input type="checkbox"/>	-----
41	<input type="checkbox"/>	<input type="checkbox"/>	<input type="checkbox"/>	<input type="checkbox"/>	-----
42	<input type="checkbox"/>	<input type="checkbox"/>	<input type="checkbox"/>	<input type="checkbox"/>	-----
43	<input type="checkbox"/>	<input type="checkbox"/>	<input type="checkbox"/>	<input type="checkbox"/>	-----
44	<input type="checkbox"/>	<input type="checkbox"/>	<input type="checkbox"/>	<input type="checkbox"/>	-----
45	<input type="checkbox"/>	<input type="checkbox"/>	<input type="checkbox"/>	<input type="checkbox"/>	-----
46	<input type="checkbox"/>	<input type="checkbox"/>	<input type="checkbox"/>	<input type="checkbox"/>	-----
47	<input type="checkbox"/>	<input type="checkbox"/>	<input type="checkbox"/>	<input type="checkbox"/>	-----
48	<input type="checkbox"/>	<input type="checkbox"/>	<input type="checkbox"/>	<input type="checkbox"/>	-----
49	<input type="checkbox"/>	<input type="checkbox"/>	<input type="checkbox"/>	<input type="checkbox"/>	-----
50	<input type="checkbox"/>	<input type="checkbox"/>	<input type="checkbox"/>	<input type="checkbox"/>	-----

	1	2	3	4	
	T	F			
51	<input type="checkbox"/>	<input type="checkbox"/>	<input type="checkbox"/>	<input type="checkbox"/>	-----
52	<input type="checkbox"/>	<input type="checkbox"/>	<input type="checkbox"/>	<input type="checkbox"/>	-----
53	<input type="checkbox"/>	<input type="checkbox"/>	<input type="checkbox"/>	<input type="checkbox"/>	-----
54	<input type="checkbox"/>	<input type="checkbox"/>	<input type="checkbox"/>	<input type="checkbox"/>	-----
55	<input type="checkbox"/>	<input type="checkbox"/>	<input type="checkbox"/>	<input type="checkbox"/>	-----
56	<input type="checkbox"/>	<input type="checkbox"/>	<input type="checkbox"/>	<input type="checkbox"/>	-----
57	<input type="checkbox"/>	<input type="checkbox"/>	<input type="checkbox"/>	<input type="checkbox"/>	-----
58	<input type="checkbox"/>	<input type="checkbox"/>	<input type="checkbox"/>	<input type="checkbox"/>	-----
59	<input type="checkbox"/>	<input type="checkbox"/>	<input type="checkbox"/>	<input type="checkbox"/>	-----
60	<input type="checkbox"/>	<input type="checkbox"/>	<input type="checkbox"/>	<input type="checkbox"/>	-----
61	<input type="checkbox"/>	<input type="checkbox"/>	<input type="checkbox"/>	<input type="checkbox"/>	-----
62	<input type="checkbox"/>	<input type="checkbox"/>	<input type="checkbox"/>	<input type="checkbox"/>	-----
63	<input type="checkbox"/>	<input type="checkbox"/>	<input type="checkbox"/>	<input type="checkbox"/>	-----
64	<input type="checkbox"/>	<input type="checkbox"/>	<input type="checkbox"/>	<input type="checkbox"/>	-----
65	<input type="checkbox"/>	<input type="checkbox"/>	<input type="checkbox"/>	<input type="checkbox"/>	-----
66	<input type="checkbox"/>	<input type="checkbox"/>	<input type="checkbox"/>	<input type="checkbox"/>	-----
67	<input type="checkbox"/>	<input type="checkbox"/>	<input type="checkbox"/>	<input type="checkbox"/>	-----
68	<input type="checkbox"/>	<input type="checkbox"/>	<input type="checkbox"/>	<input type="checkbox"/>	-----
69	<input type="checkbox"/>	<input type="checkbox"/>	<input type="checkbox"/>	<input type="checkbox"/>	-----
70	<input type="checkbox"/>	<input type="checkbox"/>	<input type="checkbox"/>	<input type="checkbox"/>	-----
71	<input type="checkbox"/>	<input type="checkbox"/>	<input type="checkbox"/>	<input type="checkbox"/>	-----
72	<input type="checkbox"/>	<input type="checkbox"/>	<input type="checkbox"/>	<input type="checkbox"/>	-----
73	<input type="checkbox"/>	<input type="checkbox"/>	<input type="checkbox"/>	<input type="checkbox"/>	-----
74	<input type="checkbox"/>	<input type="checkbox"/>	<input type="checkbox"/>	<input type="checkbox"/>	-----
75	<input type="checkbox"/>	<input type="checkbox"/>	<input type="checkbox"/>	<input type="checkbox"/>	-----



PRINT OR TYPE

BUILDER 3&2
NAVEDTRA 10648-G

NAME _____ ADDRESS _____
Last First Middle Street/Ship/Unit/Division, etc.

RANK/RATE _____ SOC. SEC. NO. _____ DESIGNATOR _____ ASSIGNMENT NO. _____
City or PPO State Zip

USN USNR ACTIVE INACTIVE OTHER (Specify) _____ DATE MAILED _____

SCORE

	1	2	3	4	
1	<input type="checkbox"/>	<input type="checkbox"/>	<input type="checkbox"/>	<input type="checkbox"/>	-----
2	<input type="checkbox"/>	<input type="checkbox"/>	<input type="checkbox"/>	<input type="checkbox"/>	-----
3	<input type="checkbox"/>	<input type="checkbox"/>	<input type="checkbox"/>	<input type="checkbox"/>	-----
4	<input type="checkbox"/>	<input type="checkbox"/>	<input type="checkbox"/>	<input type="checkbox"/>	-----
5	<input type="checkbox"/>	<input type="checkbox"/>	<input type="checkbox"/>	<input type="checkbox"/>	-----
6	<input type="checkbox"/>	<input type="checkbox"/>	<input type="checkbox"/>	<input type="checkbox"/>	-----
7	<input type="checkbox"/>	<input type="checkbox"/>	<input type="checkbox"/>	<input type="checkbox"/>	-----
8	<input type="checkbox"/>	<input type="checkbox"/>	<input type="checkbox"/>	<input type="checkbox"/>	-----
9	<input type="checkbox"/>	<input type="checkbox"/>	<input type="checkbox"/>	<input type="checkbox"/>	-----
10	<input type="checkbox"/>	<input type="checkbox"/>	<input type="checkbox"/>	<input type="checkbox"/>	-----
11	<input type="checkbox"/>	<input type="checkbox"/>	<input type="checkbox"/>	<input type="checkbox"/>	-----
12	<input type="checkbox"/>	<input type="checkbox"/>	<input type="checkbox"/>	<input type="checkbox"/>	-----
13	<input type="checkbox"/>	<input type="checkbox"/>	<input type="checkbox"/>	<input type="checkbox"/>	-----
14	<input type="checkbox"/>	<input type="checkbox"/>	<input type="checkbox"/>	<input type="checkbox"/>	-----
15	<input type="checkbox"/>	<input type="checkbox"/>	<input type="checkbox"/>	<input type="checkbox"/>	-----
16	<input type="checkbox"/>	<input type="checkbox"/>	<input type="checkbox"/>	<input type="checkbox"/>	-----
17	<input type="checkbox"/>	<input type="checkbox"/>	<input type="checkbox"/>	<input type="checkbox"/>	-----
18	<input type="checkbox"/>	<input type="checkbox"/>	<input type="checkbox"/>	<input type="checkbox"/>	-----
19	<input type="checkbox"/>	<input type="checkbox"/>	<input type="checkbox"/>	<input type="checkbox"/>	-----
20	<input type="checkbox"/>	<input type="checkbox"/>	<input type="checkbox"/>	<input type="checkbox"/>	-----
21	<input type="checkbox"/>	<input type="checkbox"/>	<input type="checkbox"/>	<input type="checkbox"/>	-----
22	<input type="checkbox"/>	<input type="checkbox"/>	<input type="checkbox"/>	<input type="checkbox"/>	-----
23	<input type="checkbox"/>	<input type="checkbox"/>	<input type="checkbox"/>	<input type="checkbox"/>	-----
24	<input type="checkbox"/>	<input type="checkbox"/>	<input type="checkbox"/>	<input type="checkbox"/>	-----
25	<input type="checkbox"/>	<input type="checkbox"/>	<input type="checkbox"/>	<input type="checkbox"/>	-----

	1	2	3	4	
26	<input type="checkbox"/>	<input type="checkbox"/>	<input type="checkbox"/>	<input type="checkbox"/>	-----
27	<input type="checkbox"/>	<input type="checkbox"/>	<input type="checkbox"/>	<input type="checkbox"/>	-----
28	<input type="checkbox"/>	<input type="checkbox"/>	<input type="checkbox"/>	<input type="checkbox"/>	-----
29	<input type="checkbox"/>	<input type="checkbox"/>	<input type="checkbox"/>	<input type="checkbox"/>	-----
30	<input type="checkbox"/>	<input type="checkbox"/>	<input type="checkbox"/>	<input type="checkbox"/>	-----
31	<input type="checkbox"/>	<input type="checkbox"/>	<input type="checkbox"/>	<input type="checkbox"/>	-----
32	<input type="checkbox"/>	<input type="checkbox"/>	<input type="checkbox"/>	<input type="checkbox"/>	-----
33	<input type="checkbox"/>	<input type="checkbox"/>	<input type="checkbox"/>	<input type="checkbox"/>	-----
34	<input type="checkbox"/>	<input type="checkbox"/>	<input type="checkbox"/>	<input type="checkbox"/>	-----
35	<input type="checkbox"/>	<input type="checkbox"/>	<input type="checkbox"/>	<input type="checkbox"/>	-----
36	<input type="checkbox"/>	<input type="checkbox"/>	<input type="checkbox"/>	<input type="checkbox"/>	-----
37	<input type="checkbox"/>	<input type="checkbox"/>	<input type="checkbox"/>	<input type="checkbox"/>	-----
38	<input type="checkbox"/>	<input type="checkbox"/>	<input type="checkbox"/>	<input type="checkbox"/>	-----
39	<input type="checkbox"/>	<input type="checkbox"/>	<input type="checkbox"/>	<input type="checkbox"/>	-----
40	<input type="checkbox"/>	<input type="checkbox"/>	<input type="checkbox"/>	<input type="checkbox"/>	-----
41	<input type="checkbox"/>	<input type="checkbox"/>	<input type="checkbox"/>	<input type="checkbox"/>	-----
42	<input type="checkbox"/>	<input type="checkbox"/>	<input type="checkbox"/>	<input type="checkbox"/>	-----
43	<input type="checkbox"/>	<input type="checkbox"/>	<input type="checkbox"/>	<input type="checkbox"/>	-----
44	<input type="checkbox"/>	<input type="checkbox"/>	<input type="checkbox"/>	<input type="checkbox"/>	-----
45	<input type="checkbox"/>	<input type="checkbox"/>	<input type="checkbox"/>	<input type="checkbox"/>	-----
46	<input type="checkbox"/>	<input type="checkbox"/>	<input type="checkbox"/>	<input type="checkbox"/>	-----
47	<input type="checkbox"/>	<input type="checkbox"/>	<input type="checkbox"/>	<input type="checkbox"/>	-----
48	<input type="checkbox"/>	<input type="checkbox"/>	<input type="checkbox"/>	<input type="checkbox"/>	-----
49	<input type="checkbox"/>	<input type="checkbox"/>	<input type="checkbox"/>	<input type="checkbox"/>	-----
50	<input type="checkbox"/>	<input type="checkbox"/>	<input type="checkbox"/>	<input type="checkbox"/>	-----

	1	2	3	4	
51	<input type="checkbox"/>	<input type="checkbox"/>	<input type="checkbox"/>	<input type="checkbox"/>	-----
52	<input type="checkbox"/>	<input type="checkbox"/>	<input type="checkbox"/>	<input type="checkbox"/>	-----
53	<input type="checkbox"/>	<input type="checkbox"/>	<input type="checkbox"/>	<input type="checkbox"/>	-----
54	<input type="checkbox"/>	<input type="checkbox"/>	<input type="checkbox"/>	<input type="checkbox"/>	-----
55	<input type="checkbox"/>	<input type="checkbox"/>	<input type="checkbox"/>	<input type="checkbox"/>	-----
56	<input type="checkbox"/>	<input type="checkbox"/>	<input type="checkbox"/>	<input type="checkbox"/>	-----
57	<input type="checkbox"/>	<input type="checkbox"/>	<input type="checkbox"/>	<input type="checkbox"/>	-----
58	<input type="checkbox"/>	<input type="checkbox"/>	<input type="checkbox"/>	<input type="checkbox"/>	-----
59	<input type="checkbox"/>	<input type="checkbox"/>	<input type="checkbox"/>	<input type="checkbox"/>	-----
60	<input type="checkbox"/>	<input type="checkbox"/>	<input type="checkbox"/>	<input type="checkbox"/>	-----
61	<input type="checkbox"/>	<input type="checkbox"/>	<input type="checkbox"/>	<input type="checkbox"/>	-----
62	<input type="checkbox"/>	<input type="checkbox"/>	<input type="checkbox"/>	<input type="checkbox"/>	-----
63	<input type="checkbox"/>	<input type="checkbox"/>	<input type="checkbox"/>	<input type="checkbox"/>	-----
64	<input type="checkbox"/>	<input type="checkbox"/>	<input type="checkbox"/>	<input type="checkbox"/>	-----
65	<input type="checkbox"/>	<input type="checkbox"/>	<input type="checkbox"/>	<input type="checkbox"/>	-----
66	<input type="checkbox"/>	<input type="checkbox"/>	<input type="checkbox"/>	<input type="checkbox"/>	-----
67	<input type="checkbox"/>	<input type="checkbox"/>	<input type="checkbox"/>	<input type="checkbox"/>	-----
68	<input type="checkbox"/>	<input type="checkbox"/>	<input type="checkbox"/>	<input type="checkbox"/>	-----
69	<input type="checkbox"/>	<input type="checkbox"/>	<input type="checkbox"/>	<input type="checkbox"/>	-----
70	<input type="checkbox"/>	<input type="checkbox"/>	<input type="checkbox"/>	<input type="checkbox"/>	-----
71	<input type="checkbox"/>	<input type="checkbox"/>	<input type="checkbox"/>	<input type="checkbox"/>	-----
72	<input type="checkbox"/>	<input type="checkbox"/>	<input type="checkbox"/>	<input type="checkbox"/>	-----
73	<input type="checkbox"/>	<input type="checkbox"/>	<input type="checkbox"/>	<input type="checkbox"/>	-----
74	<input type="checkbox"/>	<input type="checkbox"/>	<input type="checkbox"/>	<input type="checkbox"/>	-----
75	<input type="checkbox"/>	<input type="checkbox"/>	<input type="checkbox"/>	<input type="checkbox"/>	-----



PRINT OR TYPE

NAME _____ ADDRESS _____
Last First Middle Street/Ship/Unit/Division, etc.

City or FPO State Zip
RANK/RATE _____ SOC. SEC. NO. _____ DESIGNATOR _____ ASSIGNMENT NO. _____

USN USNR ACTIVE INACTIVE OTHER (Specify) _____ DATE MAILED _____
SCORE

<table border="0" style="width: 100%;"> <tr><td></td><td>1</td><td>2</td><td>3</td><td>4</td><td></td></tr> <tr><td></td><td>T</td><td>F</td><td></td><td></td><td></td></tr> <tr><td>1</td><td><input type="checkbox"/></td><td><input type="checkbox"/></td><td><input type="checkbox"/></td><td><input type="checkbox"/></td><td>-----</td></tr> <tr><td>2</td><td><input type="checkbox"/></td><td><input type="checkbox"/></td><td><input type="checkbox"/></td><td><input type="checkbox"/></td><td>-----</td></tr> <tr><td>3</td><td><input type="checkbox"/></td><td><input type="checkbox"/></td><td><input type="checkbox"/></td><td><input type="checkbox"/></td><td>-----</td></tr> <tr><td>4</td><td><input type="checkbox"/></td><td><input type="checkbox"/></td><td><input type="checkbox"/></td><td><input type="checkbox"/></td><td>-----</td></tr> <tr><td>5</td><td><input type="checkbox"/></td><td><input type="checkbox"/></td><td><input type="checkbox"/></td><td><input type="checkbox"/></td><td>-----</td></tr> <tr><td>6</td><td><input type="checkbox"/></td><td><input type="checkbox"/></td><td><input type="checkbox"/></td><td><input type="checkbox"/></td><td>-----</td></tr> <tr><td>7</td><td><input type="checkbox"/></td><td><input type="checkbox"/></td><td><input type="checkbox"/></td><td><input type="checkbox"/></td><td>-----</td></tr> <tr><td>8</td><td><input type="checkbox"/></td><td><input type="checkbox"/></td><td><input type="checkbox"/></td><td><input type="checkbox"/></td><td>-----</td></tr> <tr><td>9</td><td><input type="checkbox"/></td><td><input type="checkbox"/></td><td><input type="checkbox"/></td><td><input type="checkbox"/></td><td>-----</td></tr> <tr><td>10</td><td><input type="checkbox"/></td><td><input type="checkbox"/></td><td><input type="checkbox"/></td><td><input type="checkbox"/></td><td>-----</td></tr> <tr><td>11</td><td><input type="checkbox"/></td><td><input type="checkbox"/></td><td><input type="checkbox"/></td><td><input type="checkbox"/></td><td>-----</td></tr> <tr><td>12</td><td><input type="checkbox"/></td><td><input type="checkbox"/></td><td><input type="checkbox"/></td><td><input type="checkbox"/></td><td>-----</td></tr> <tr><td>13</td><td><input type="checkbox"/></td><td><input type="checkbox"/></td><td><input type="checkbox"/></td><td><input type="checkbox"/></td><td>-----</td></tr> <tr><td>14</td><td><input type="checkbox"/></td><td><input type="checkbox"/></td><td><input type="checkbox"/></td><td><input type="checkbox"/></td><td>-----</td></tr> <tr><td>15</td><td><input type="checkbox"/></td><td><input type="checkbox"/></td><td><input type="checkbox"/></td><td><input type="checkbox"/></td><td>-----</td></tr> <tr><td>16</td><td><input type="checkbox"/></td><td><input type="checkbox"/></td><td><input type="checkbox"/></td><td><input type="checkbox"/></td><td>-----</td></tr> <tr><td>17</td><td><input type="checkbox"/></td><td><input type="checkbox"/></td><td><input type="checkbox"/></td><td><input type="checkbox"/></td><td>-----</td></tr> <tr><td>18</td><td><input type="checkbox"/></td><td><input type="checkbox"/></td><td><input type="checkbox"/></td><td><input type="checkbox"/></td><td>-----</td></tr> <tr><td>19</td><td><input type="checkbox"/></td><td><input type="checkbox"/></td><td><input type="checkbox"/></td><td><input type="checkbox"/></td><td>-----</td></tr> <tr><td>20</td><td><input type="checkbox"/></td><td><input type="checkbox"/></td><td><input type="checkbox"/></td><td><input type="checkbox"/></td><td>-----</td></tr> <tr><td>21</td><td><input type="checkbox"/></td><td><input type="checkbox"/></td><td><input type="checkbox"/></td><td><input type="checkbox"/></td><td>-----</td></tr> <tr><td>22</td><td><input type="checkbox"/></td><td><input type="checkbox"/></td><td><input type="checkbox"/></td><td><input type="checkbox"/></td><td>-----</td></tr> <tr><td>23</td><td><input type="checkbox"/></td><td><input type="checkbox"/></td><td><input type="checkbox"/></td><td><input type="checkbox"/></td><td>-----</td></tr> <tr><td>24</td><td><input type="checkbox"/></td><td><input type="checkbox"/></td><td><input type="checkbox"/></td><td><input type="checkbox"/></td><td>-----</td></tr> <tr><td>25</td><td><input type="checkbox"/></td><td><input type="checkbox"/></td><td><input type="checkbox"/></td><td><input type="checkbox"/></td><td>-----</td></tr> </table>		1	2	3	4			T	F				1	<input type="checkbox"/>	<input type="checkbox"/>	<input type="checkbox"/>	<input type="checkbox"/>	-----	2	<input type="checkbox"/>	<input type="checkbox"/>	<input type="checkbox"/>	<input type="checkbox"/>	-----	3	<input type="checkbox"/>	<input type="checkbox"/>	<input type="checkbox"/>	<input type="checkbox"/>	-----	4	<input type="checkbox"/>	<input type="checkbox"/>	<input type="checkbox"/>	<input type="checkbox"/>	-----	5	<input type="checkbox"/>	<input type="checkbox"/>	<input type="checkbox"/>	<input type="checkbox"/>	-----	6	<input type="checkbox"/>	<input type="checkbox"/>	<input type="checkbox"/>	<input type="checkbox"/>	-----	7	<input type="checkbox"/>	<input type="checkbox"/>	<input type="checkbox"/>	<input type="checkbox"/>	-----	8	<input type="checkbox"/>	<input type="checkbox"/>	<input type="checkbox"/>	<input type="checkbox"/>	-----	9	<input type="checkbox"/>	<input type="checkbox"/>	<input type="checkbox"/>	<input type="checkbox"/>	-----	10	<input type="checkbox"/>	<input type="checkbox"/>	<input type="checkbox"/>	<input type="checkbox"/>	-----	11	<input type="checkbox"/>	<input type="checkbox"/>	<input type="checkbox"/>	<input type="checkbox"/>	-----	12	<input type="checkbox"/>	<input type="checkbox"/>	<input type="checkbox"/>	<input type="checkbox"/>	-----	13	<input type="checkbox"/>	<input type="checkbox"/>	<input type="checkbox"/>	<input type="checkbox"/>	-----	14	<input type="checkbox"/>	<input type="checkbox"/>	<input type="checkbox"/>	<input type="checkbox"/>	-----	15	<input type="checkbox"/>	<input type="checkbox"/>	<input type="checkbox"/>	<input type="checkbox"/>	-----	16	<input type="checkbox"/>	<input type="checkbox"/>	<input type="checkbox"/>	<input type="checkbox"/>	-----	17	<input type="checkbox"/>	<input type="checkbox"/>	<input type="checkbox"/>	<input type="checkbox"/>	-----	18	<input type="checkbox"/>	<input type="checkbox"/>	<input type="checkbox"/>	<input type="checkbox"/>	-----	19	<input type="checkbox"/>	<input type="checkbox"/>	<input type="checkbox"/>	<input type="checkbox"/>	-----	20	<input type="checkbox"/>	<input type="checkbox"/>	<input type="checkbox"/>	<input type="checkbox"/>	-----	21	<input type="checkbox"/>	<input type="checkbox"/>	<input type="checkbox"/>	<input type="checkbox"/>	-----	22	<input type="checkbox"/>	<input type="checkbox"/>	<input type="checkbox"/>	<input type="checkbox"/>	-----	23	<input type="checkbox"/>	<input type="checkbox"/>	<input type="checkbox"/>	<input type="checkbox"/>	-----	24	<input type="checkbox"/>	<input type="checkbox"/>	<input type="checkbox"/>	<input type="checkbox"/>	-----	25	<input type="checkbox"/>	<input type="checkbox"/>	<input type="checkbox"/>	<input type="checkbox"/>	-----	<table border="0" style="width: 100%;"> <tr><td></td><td>1</td><td>2</td><td>3</td><td>4</td><td></td></tr> <tr><td></td><td>T</td><td>F</td><td></td><td></td><td></td></tr> <tr><td>26</td><td><input type="checkbox"/></td><td><input type="checkbox"/></td><td><input type="checkbox"/></td><td><input type="checkbox"/></td><td>-----</td></tr> <tr><td>27</td><td><input type="checkbox"/></td><td><input type="checkbox"/></td><td><input type="checkbox"/></td><td><input type="checkbox"/></td><td>-----</td></tr> <tr><td>28</td><td><input type="checkbox"/></td><td><input type="checkbox"/></td><td><input type="checkbox"/></td><td><input type="checkbox"/></td><td>-----</td></tr> <tr><td>29</td><td><input type="checkbox"/></td><td><input type="checkbox"/></td><td><input type="checkbox"/></td><td><input type="checkbox"/></td><td>-----</td></tr> <tr><td>30</td><td><input type="checkbox"/></td><td><input type="checkbox"/></td><td><input type="checkbox"/></td><td><input type="checkbox"/></td><td>-----</td></tr> <tr><td>31</td><td><input type="checkbox"/></td><td><input type="checkbox"/></td><td><input type="checkbox"/></td><td><input type="checkbox"/></td><td>-----</td></tr> <tr><td>32</td><td><input type="checkbox"/></td><td><input type="checkbox"/></td><td><input type="checkbox"/></td><td><input type="checkbox"/></td><td>-----</td></tr> <tr><td>33</td><td><input type="checkbox"/></td><td><input type="checkbox"/></td><td><input type="checkbox"/></td><td><input type="checkbox"/></td><td>-----</td></tr> <tr><td>34</td><td><input type="checkbox"/></td><td><input type="checkbox"/></td><td><input type="checkbox"/></td><td><input type="checkbox"/></td><td>-----</td></tr> <tr><td>35</td><td><input type="checkbox"/></td><td><input type="checkbox"/></td><td><input type="checkbox"/></td><td><input type="checkbox"/></td><td>-----</td></tr> <tr><td>36</td><td><input type="checkbox"/></td><td><input type="checkbox"/></td><td><input type="checkbox"/></td><td><input type="checkbox"/></td><td>-----</td></tr> <tr><td>37</td><td><input type="checkbox"/></td><td><input type="checkbox"/></td><td><input type="checkbox"/></td><td><input type="checkbox"/></td><td>-----</td></tr> <tr><td>38</td><td><input type="checkbox"/></td><td><input type="checkbox"/></td><td><input type="checkbox"/></td><td><input type="checkbox"/></td><td>-----</td></tr> <tr><td>39</td><td><input type="checkbox"/></td><td><input type="checkbox"/></td><td><input type="checkbox"/></td><td><input type="checkbox"/></td><td>-----</td></tr> <tr><td>40</td><td><input type="checkbox"/></td><td><input type="checkbox"/></td><td><input type="checkbox"/></td><td><input type="checkbox"/></td><td>-----</td></tr> <tr><td>41</td><td><input type="checkbox"/></td><td><input type="checkbox"/></td><td><input type="checkbox"/></td><td><input type="checkbox"/></td><td>-----</td></tr> <tr><td>42</td><td><input type="checkbox"/></td><td><input type="checkbox"/></td><td><input type="checkbox"/></td><td><input type="checkbox"/></td><td>-----</td></tr> <tr><td>43</td><td><input type="checkbox"/></td><td><input type="checkbox"/></td><td><input type="checkbox"/></td><td><input type="checkbox"/></td><td>-----</td></tr> <tr><td>44</td><td><input type="checkbox"/></td><td><input type="checkbox"/></td><td><input type="checkbox"/></td><td><input type="checkbox"/></td><td>-----</td></tr> <tr><td>45</td><td><input type="checkbox"/></td><td><input type="checkbox"/></td><td><input type="checkbox"/></td><td><input type="checkbox"/></td><td>-----</td></tr> <tr><td>46</td><td><input type="checkbox"/></td><td><input type="checkbox"/></td><td><input type="checkbox"/></td><td><input type="checkbox"/></td><td>-----</td></tr> <tr><td>47</td><td><input type="checkbox"/></td><td><input type="checkbox"/></td><td><input type="checkbox"/></td><td><input type="checkbox"/></td><td>-----</td></tr> <tr><td>48</td><td><input type="checkbox"/></td><td><input type="checkbox"/></td><td><input type="checkbox"/></td><td><input type="checkbox"/></td><td>-----</td></tr> <tr><td>49</td><td><input type="checkbox"/></td><td><input type="checkbox"/></td><td><input type="checkbox"/></td><td><input type="checkbox"/></td><td>-----</td></tr> <tr><td>50</td><td><input type="checkbox"/></td><td><input type="checkbox"/></td><td><input type="checkbox"/></td><td><input type="checkbox"/></td><td>-----</td></tr> </table>		1	2	3	4			T	F				26	<input type="checkbox"/>	<input type="checkbox"/>	<input type="checkbox"/>	<input type="checkbox"/>	-----	27	<input type="checkbox"/>	<input type="checkbox"/>	<input type="checkbox"/>	<input type="checkbox"/>	-----	28	<input type="checkbox"/>	<input type="checkbox"/>	<input type="checkbox"/>	<input type="checkbox"/>	-----	29	<input type="checkbox"/>	<input type="checkbox"/>	<input type="checkbox"/>	<input type="checkbox"/>	-----	30	<input type="checkbox"/>	<input type="checkbox"/>	<input type="checkbox"/>	<input type="checkbox"/>	-----	31	<input type="checkbox"/>	<input type="checkbox"/>	<input type="checkbox"/>	<input type="checkbox"/>	-----	32	<input type="checkbox"/>	<input type="checkbox"/>	<input type="checkbox"/>	<input type="checkbox"/>	-----	33	<input type="checkbox"/>	<input type="checkbox"/>	<input type="checkbox"/>	<input type="checkbox"/>	-----	34	<input type="checkbox"/>	<input type="checkbox"/>	<input type="checkbox"/>	<input type="checkbox"/>	-----	35	<input type="checkbox"/>	<input type="checkbox"/>	<input type="checkbox"/>	<input type="checkbox"/>	-----	36	<input type="checkbox"/>	<input type="checkbox"/>	<input type="checkbox"/>	<input type="checkbox"/>	-----	37	<input type="checkbox"/>	<input type="checkbox"/>	<input type="checkbox"/>	<input type="checkbox"/>	-----	38	<input type="checkbox"/>	<input type="checkbox"/>	<input type="checkbox"/>	<input type="checkbox"/>	-----	39	<input type="checkbox"/>	<input type="checkbox"/>	<input type="checkbox"/>	<input type="checkbox"/>	-----	40	<input type="checkbox"/>	<input type="checkbox"/>	<input type="checkbox"/>	<input type="checkbox"/>	-----	41	<input type="checkbox"/>	<input type="checkbox"/>	<input type="checkbox"/>	<input type="checkbox"/>	-----	42	<input type="checkbox"/>	<input type="checkbox"/>	<input type="checkbox"/>	<input type="checkbox"/>	-----	43	<input type="checkbox"/>	<input type="checkbox"/>	<input type="checkbox"/>	<input type="checkbox"/>	-----	44	<input type="checkbox"/>	<input type="checkbox"/>	<input type="checkbox"/>	<input type="checkbox"/>	-----	45	<input type="checkbox"/>	<input type="checkbox"/>	<input type="checkbox"/>	<input type="checkbox"/>	-----	46	<input type="checkbox"/>	<input type="checkbox"/>	<input type="checkbox"/>	<input type="checkbox"/>	-----	47	<input type="checkbox"/>	<input type="checkbox"/>	<input type="checkbox"/>	<input type="checkbox"/>	-----	48	<input type="checkbox"/>	<input type="checkbox"/>	<input type="checkbox"/>	<input type="checkbox"/>	-----	49	<input type="checkbox"/>	<input type="checkbox"/>	<input type="checkbox"/>	<input type="checkbox"/>	-----	50	<input type="checkbox"/>	<input type="checkbox"/>	<input type="checkbox"/>	<input type="checkbox"/>	-----	<table border="0" style="width: 100%;"> <tr><td></td><td>1</td><td>2</td><td>3</td><td>4</td><td></td></tr> <tr><td></td><td>T</td><td>F</td><td></td><td></td><td></td></tr> <tr><td>51</td><td><input type="checkbox"/></td><td><input type="checkbox"/></td><td><input type="checkbox"/></td><td><input type="checkbox"/></td><td>-----</td></tr> <tr><td>52</td><td><input type="checkbox"/></td><td><input type="checkbox"/></td><td><input type="checkbox"/></td><td><input type="checkbox"/></td><td>-----</td></tr> <tr><td>53</td><td><input type="checkbox"/></td><td><input type="checkbox"/></td><td><input type="checkbox"/></td><td><input type="checkbox"/></td><td>-----</td></tr> <tr><td>54</td><td><input type="checkbox"/></td><td><input type="checkbox"/></td><td><input type="checkbox"/></td><td><input type="checkbox"/></td><td>-----</td></tr> <tr><td>55</td><td><input type="checkbox"/></td><td><input type="checkbox"/></td><td><input type="checkbox"/></td><td><input type="checkbox"/></td><td>-----</td></tr> <tr><td>56</td><td><input type="checkbox"/></td><td><input type="checkbox"/></td><td><input type="checkbox"/></td><td><input type="checkbox"/></td><td>-----</td></tr> <tr><td>57</td><td><input type="checkbox"/></td><td><input type="checkbox"/></td><td><input type="checkbox"/></td><td><input type="checkbox"/></td><td>-----</td></tr> <tr><td>58</td><td><input type="checkbox"/></td><td><input type="checkbox"/></td><td><input type="checkbox"/></td><td><input type="checkbox"/></td><td>-----</td></tr> <tr><td>59</td><td><input type="checkbox"/></td><td><input type="checkbox"/></td><td><input type="checkbox"/></td><td><input type="checkbox"/></td><td>-----</td></tr> <tr><td>60</td><td><input type="checkbox"/></td><td><input type="checkbox"/></td><td><input type="checkbox"/></td><td><input type="checkbox"/></td><td>-----</td></tr> <tr><td>61</td><td><input type="checkbox"/></td><td><input type="checkbox"/></td><td><input type="checkbox"/></td><td><input type="checkbox"/></td><td>-----</td></tr> <tr><td>62</td><td><input type="checkbox"/></td><td><input type="checkbox"/></td><td><input type="checkbox"/></td><td><input type="checkbox"/></td><td>-----</td></tr> <tr><td>63</td><td><input type="checkbox"/></td><td><input type="checkbox"/></td><td><input type="checkbox"/></td><td><input type="checkbox"/></td><td>-----</td></tr> <tr><td>64</td><td><input type="checkbox"/></td><td><input type="checkbox"/></td><td><input type="checkbox"/></td><td><input type="checkbox"/></td><td>-----</td></tr> <tr><td>65</td><td><input type="checkbox"/></td><td><input type="checkbox"/></td><td><input type="checkbox"/></td><td><input type="checkbox"/></td><td>-----</td></tr> <tr><td>66</td><td><input type="checkbox"/></td><td><input type="checkbox"/></td><td><input type="checkbox"/></td><td><input type="checkbox"/></td><td>-----</td></tr> <tr><td>67</td><td><input type="checkbox"/></td><td><input type="checkbox"/></td><td><input type="checkbox"/></td><td><input type="checkbox"/></td><td>-----</td></tr> <tr><td>68</td><td><input type="checkbox"/></td><td><input type="checkbox"/></td><td><input type="checkbox"/></td><td><input type="checkbox"/></td><td>-----</td></tr> <tr><td>69</td><td><input type="checkbox"/></td><td><input type="checkbox"/></td><td><input type="checkbox"/></td><td><input type="checkbox"/></td><td>-----</td></tr> <tr><td>70</td><td><input type="checkbox"/></td><td><input type="checkbox"/></td><td><input type="checkbox"/></td><td><input type="checkbox"/></td><td>-----</td></tr> <tr><td>71</td><td><input type="checkbox"/></td><td><input type="checkbox"/></td><td><input type="checkbox"/></td><td><input type="checkbox"/></td><td>-----</td></tr> <tr><td>72</td><td><input type="checkbox"/></td><td><input type="checkbox"/></td><td><input type="checkbox"/></td><td><input type="checkbox"/></td><td>-----</td></tr> <tr><td>73</td><td><input type="checkbox"/></td><td><input type="checkbox"/></td><td><input type="checkbox"/></td><td><input type="checkbox"/></td><td>-----</td></tr> <tr><td>74</td><td><input type="checkbox"/></td><td><input type="checkbox"/></td><td><input type="checkbox"/></td><td><input type="checkbox"/></td><td>-----</td></tr> <tr><td>75</td><td><input type="checkbox"/></td><td><input type="checkbox"/></td><td><input type="checkbox"/></td><td><input type="checkbox"/></td><td>-----</td></tr> </table>		1	2	3	4			T	F				51	<input type="checkbox"/>	<input type="checkbox"/>	<input type="checkbox"/>	<input type="checkbox"/>	-----	52	<input type="checkbox"/>	<input type="checkbox"/>	<input type="checkbox"/>	<input type="checkbox"/>	-----	53	<input type="checkbox"/>	<input type="checkbox"/>	<input type="checkbox"/>	<input type="checkbox"/>	-----	54	<input type="checkbox"/>	<input type="checkbox"/>	<input type="checkbox"/>	<input type="checkbox"/>	-----	55	<input type="checkbox"/>	<input type="checkbox"/>	<input type="checkbox"/>	<input type="checkbox"/>	-----	56	<input type="checkbox"/>	<input type="checkbox"/>	<input type="checkbox"/>	<input type="checkbox"/>	-----	57	<input type="checkbox"/>	<input type="checkbox"/>	<input type="checkbox"/>	<input type="checkbox"/>	-----	58	<input type="checkbox"/>	<input type="checkbox"/>	<input type="checkbox"/>	<input type="checkbox"/>	-----	59	<input type="checkbox"/>	<input type="checkbox"/>	<input type="checkbox"/>	<input type="checkbox"/>	-----	60	<input type="checkbox"/>	<input type="checkbox"/>	<input type="checkbox"/>	<input type="checkbox"/>	-----	61	<input type="checkbox"/>	<input type="checkbox"/>	<input type="checkbox"/>	<input type="checkbox"/>	-----	62	<input type="checkbox"/>	<input type="checkbox"/>	<input type="checkbox"/>	<input type="checkbox"/>	-----	63	<input type="checkbox"/>	<input type="checkbox"/>	<input type="checkbox"/>	<input type="checkbox"/>	-----	64	<input type="checkbox"/>	<input type="checkbox"/>	<input type="checkbox"/>	<input type="checkbox"/>	-----	65	<input type="checkbox"/>	<input type="checkbox"/>	<input type="checkbox"/>	<input type="checkbox"/>	-----	66	<input type="checkbox"/>	<input type="checkbox"/>	<input type="checkbox"/>	<input type="checkbox"/>	-----	67	<input type="checkbox"/>	<input type="checkbox"/>	<input type="checkbox"/>	<input type="checkbox"/>	-----	68	<input type="checkbox"/>	<input type="checkbox"/>	<input type="checkbox"/>	<input type="checkbox"/>	-----	69	<input type="checkbox"/>	<input type="checkbox"/>	<input type="checkbox"/>	<input type="checkbox"/>	-----	70	<input type="checkbox"/>	<input type="checkbox"/>	<input type="checkbox"/>	<input type="checkbox"/>	-----	71	<input type="checkbox"/>	<input type="checkbox"/>	<input type="checkbox"/>	<input type="checkbox"/>	-----	72	<input type="checkbox"/>	<input type="checkbox"/>	<input type="checkbox"/>	<input type="checkbox"/>	-----	73	<input type="checkbox"/>	<input type="checkbox"/>	<input type="checkbox"/>	<input type="checkbox"/>	-----	74	<input type="checkbox"/>	<input type="checkbox"/>	<input type="checkbox"/>	<input type="checkbox"/>	-----	75	<input type="checkbox"/>	<input type="checkbox"/>	<input type="checkbox"/>	<input type="checkbox"/>	-----
	1	2	3	4																																																																																																																																																																																																																																																																																																																																																																																																																																																																																																				
	T	F																																																																																																																																																																																																																																																																																																																																																																																																																																																																																																						
1	<input type="checkbox"/>	<input type="checkbox"/>	<input type="checkbox"/>	<input type="checkbox"/>	-----																																																																																																																																																																																																																																																																																																																																																																																																																																																																																																			
2	<input type="checkbox"/>	<input type="checkbox"/>	<input type="checkbox"/>	<input type="checkbox"/>	-----																																																																																																																																																																																																																																																																																																																																																																																																																																																																																																			
3	<input type="checkbox"/>	<input type="checkbox"/>	<input type="checkbox"/>	<input type="checkbox"/>	-----																																																																																																																																																																																																																																																																																																																																																																																																																																																																																																			
4	<input type="checkbox"/>	<input type="checkbox"/>	<input type="checkbox"/>	<input type="checkbox"/>	-----																																																																																																																																																																																																																																																																																																																																																																																																																																																																																																			
5	<input type="checkbox"/>	<input type="checkbox"/>	<input type="checkbox"/>	<input type="checkbox"/>	-----																																																																																																																																																																																																																																																																																																																																																																																																																																																																																																			
6	<input type="checkbox"/>	<input type="checkbox"/>	<input type="checkbox"/>	<input type="checkbox"/>	-----																																																																																																																																																																																																																																																																																																																																																																																																																																																																																																			
7	<input type="checkbox"/>	<input type="checkbox"/>	<input type="checkbox"/>	<input type="checkbox"/>	-----																																																																																																																																																																																																																																																																																																																																																																																																																																																																																																			
8	<input type="checkbox"/>	<input type="checkbox"/>	<input type="checkbox"/>	<input type="checkbox"/>	-----																																																																																																																																																																																																																																																																																																																																																																																																																																																																																																			
9	<input type="checkbox"/>	<input type="checkbox"/>	<input type="checkbox"/>	<input type="checkbox"/>	-----																																																																																																																																																																																																																																																																																																																																																																																																																																																																																																			
10	<input type="checkbox"/>	<input type="checkbox"/>	<input type="checkbox"/>	<input type="checkbox"/>	-----																																																																																																																																																																																																																																																																																																																																																																																																																																																																																																			
11	<input type="checkbox"/>	<input type="checkbox"/>	<input type="checkbox"/>	<input type="checkbox"/>	-----																																																																																																																																																																																																																																																																																																																																																																																																																																																																																																			
12	<input type="checkbox"/>	<input type="checkbox"/>	<input type="checkbox"/>	<input type="checkbox"/>	-----																																																																																																																																																																																																																																																																																																																																																																																																																																																																																																			
13	<input type="checkbox"/>	<input type="checkbox"/>	<input type="checkbox"/>	<input type="checkbox"/>	-----																																																																																																																																																																																																																																																																																																																																																																																																																																																																																																			
14	<input type="checkbox"/>	<input type="checkbox"/>	<input type="checkbox"/>	<input type="checkbox"/>	-----																																																																																																																																																																																																																																																																																																																																																																																																																																																																																																			
15	<input type="checkbox"/>	<input type="checkbox"/>	<input type="checkbox"/>	<input type="checkbox"/>	-----																																																																																																																																																																																																																																																																																																																																																																																																																																																																																																			
16	<input type="checkbox"/>	<input type="checkbox"/>	<input type="checkbox"/>	<input type="checkbox"/>	-----																																																																																																																																																																																																																																																																																																																																																																																																																																																																																																			
17	<input type="checkbox"/>	<input type="checkbox"/>	<input type="checkbox"/>	<input type="checkbox"/>	-----																																																																																																																																																																																																																																																																																																																																																																																																																																																																																																			
18	<input type="checkbox"/>	<input type="checkbox"/>	<input type="checkbox"/>	<input type="checkbox"/>	-----																																																																																																																																																																																																																																																																																																																																																																																																																																																																																																			
19	<input type="checkbox"/>	<input type="checkbox"/>	<input type="checkbox"/>	<input type="checkbox"/>	-----																																																																																																																																																																																																																																																																																																																																																																																																																																																																																																			
20	<input type="checkbox"/>	<input type="checkbox"/>	<input type="checkbox"/>	<input type="checkbox"/>	-----																																																																																																																																																																																																																																																																																																																																																																																																																																																																																																			
21	<input type="checkbox"/>	<input type="checkbox"/>	<input type="checkbox"/>	<input type="checkbox"/>	-----																																																																																																																																																																																																																																																																																																																																																																																																																																																																																																			
22	<input type="checkbox"/>	<input type="checkbox"/>	<input type="checkbox"/>	<input type="checkbox"/>	-----																																																																																																																																																																																																																																																																																																																																																																																																																																																																																																			
23	<input type="checkbox"/>	<input type="checkbox"/>	<input type="checkbox"/>	<input type="checkbox"/>	-----																																																																																																																																																																																																																																																																																																																																																																																																																																																																																																			
24	<input type="checkbox"/>	<input type="checkbox"/>	<input type="checkbox"/>	<input type="checkbox"/>	-----																																																																																																																																																																																																																																																																																																																																																																																																																																																																																																			
25	<input type="checkbox"/>	<input type="checkbox"/>	<input type="checkbox"/>	<input type="checkbox"/>	-----																																																																																																																																																																																																																																																																																																																																																																																																																																																																																																			
	1	2	3	4																																																																																																																																																																																																																																																																																																																																																																																																																																																																																																				
	T	F																																																																																																																																																																																																																																																																																																																																																																																																																																																																																																						
26	<input type="checkbox"/>	<input type="checkbox"/>	<input type="checkbox"/>	<input type="checkbox"/>	-----																																																																																																																																																																																																																																																																																																																																																																																																																																																																																																			
27	<input type="checkbox"/>	<input type="checkbox"/>	<input type="checkbox"/>	<input type="checkbox"/>	-----																																																																																																																																																																																																																																																																																																																																																																																																																																																																																																			
28	<input type="checkbox"/>	<input type="checkbox"/>	<input type="checkbox"/>	<input type="checkbox"/>	-----																																																																																																																																																																																																																																																																																																																																																																																																																																																																																																			
29	<input type="checkbox"/>	<input type="checkbox"/>	<input type="checkbox"/>	<input type="checkbox"/>	-----																																																																																																																																																																																																																																																																																																																																																																																																																																																																																																			
30	<input type="checkbox"/>	<input type="checkbox"/>	<input type="checkbox"/>	<input type="checkbox"/>	-----																																																																																																																																																																																																																																																																																																																																																																																																																																																																																																			
31	<input type="checkbox"/>	<input type="checkbox"/>	<input type="checkbox"/>	<input type="checkbox"/>	-----																																																																																																																																																																																																																																																																																																																																																																																																																																																																																																			
32	<input type="checkbox"/>	<input type="checkbox"/>	<input type="checkbox"/>	<input type="checkbox"/>	-----																																																																																																																																																																																																																																																																																																																																																																																																																																																																																																			
33	<input type="checkbox"/>	<input type="checkbox"/>	<input type="checkbox"/>	<input type="checkbox"/>	-----																																																																																																																																																																																																																																																																																																																																																																																																																																																																																																			
34	<input type="checkbox"/>	<input type="checkbox"/>	<input type="checkbox"/>	<input type="checkbox"/>	-----																																																																																																																																																																																																																																																																																																																																																																																																																																																																																																			
35	<input type="checkbox"/>	<input type="checkbox"/>	<input type="checkbox"/>	<input type="checkbox"/>	-----																																																																																																																																																																																																																																																																																																																																																																																																																																																																																																			
36	<input type="checkbox"/>	<input type="checkbox"/>	<input type="checkbox"/>	<input type="checkbox"/>	-----																																																																																																																																																																																																																																																																																																																																																																																																																																																																																																			
37	<input type="checkbox"/>	<input type="checkbox"/>	<input type="checkbox"/>	<input type="checkbox"/>	-----																																																																																																																																																																																																																																																																																																																																																																																																																																																																																																			
38	<input type="checkbox"/>	<input type="checkbox"/>	<input type="checkbox"/>	<input type="checkbox"/>	-----																																																																																																																																																																																																																																																																																																																																																																																																																																																																																																			
39	<input type="checkbox"/>	<input type="checkbox"/>	<input type="checkbox"/>	<input type="checkbox"/>	-----																																																																																																																																																																																																																																																																																																																																																																																																																																																																																																			
40	<input type="checkbox"/>	<input type="checkbox"/>	<input type="checkbox"/>	<input type="checkbox"/>	-----																																																																																																																																																																																																																																																																																																																																																																																																																																																																																																			
41	<input type="checkbox"/>	<input type="checkbox"/>	<input type="checkbox"/>	<input type="checkbox"/>	-----																																																																																																																																																																																																																																																																																																																																																																																																																																																																																																			
42	<input type="checkbox"/>	<input type="checkbox"/>	<input type="checkbox"/>	<input type="checkbox"/>	-----																																																																																																																																																																																																																																																																																																																																																																																																																																																																																																			
43	<input type="checkbox"/>	<input type="checkbox"/>	<input type="checkbox"/>	<input type="checkbox"/>	-----																																																																																																																																																																																																																																																																																																																																																																																																																																																																																																			
44	<input type="checkbox"/>	<input type="checkbox"/>	<input type="checkbox"/>	<input type="checkbox"/>	-----																																																																																																																																																																																																																																																																																																																																																																																																																																																																																																			
45	<input type="checkbox"/>	<input type="checkbox"/>	<input type="checkbox"/>	<input type="checkbox"/>	-----																																																																																																																																																																																																																																																																																																																																																																																																																																																																																																			
46	<input type="checkbox"/>	<input type="checkbox"/>	<input type="checkbox"/>	<input type="checkbox"/>	-----																																																																																																																																																																																																																																																																																																																																																																																																																																																																																																			
47	<input type="checkbox"/>	<input type="checkbox"/>	<input type="checkbox"/>	<input type="checkbox"/>	-----																																																																																																																																																																																																																																																																																																																																																																																																																																																																																																			
48	<input type="checkbox"/>	<input type="checkbox"/>	<input type="checkbox"/>	<input type="checkbox"/>	-----																																																																																																																																																																																																																																																																																																																																																																																																																																																																																																			
49	<input type="checkbox"/>	<input type="checkbox"/>	<input type="checkbox"/>	<input type="checkbox"/>	-----																																																																																																																																																																																																																																																																																																																																																																																																																																																																																																			
50	<input type="checkbox"/>	<input type="checkbox"/>	<input type="checkbox"/>	<input type="checkbox"/>	-----																																																																																																																																																																																																																																																																																																																																																																																																																																																																																																			
	1	2	3	4																																																																																																																																																																																																																																																																																																																																																																																																																																																																																																				
	T	F																																																																																																																																																																																																																																																																																																																																																																																																																																																																																																						
51	<input type="checkbox"/>	<input type="checkbox"/>	<input type="checkbox"/>	<input type="checkbox"/>	-----																																																																																																																																																																																																																																																																																																																																																																																																																																																																																																			
52	<input type="checkbox"/>	<input type="checkbox"/>	<input type="checkbox"/>	<input type="checkbox"/>	-----																																																																																																																																																																																																																																																																																																																																																																																																																																																																																																			
53	<input type="checkbox"/>	<input type="checkbox"/>	<input type="checkbox"/>	<input type="checkbox"/>	-----																																																																																																																																																																																																																																																																																																																																																																																																																																																																																																			
54	<input type="checkbox"/>	<input type="checkbox"/>	<input type="checkbox"/>	<input type="checkbox"/>	-----																																																																																																																																																																																																																																																																																																																																																																																																																																																																																																			
55	<input type="checkbox"/>	<input type="checkbox"/>	<input type="checkbox"/>	<input type="checkbox"/>	-----																																																																																																																																																																																																																																																																																																																																																																																																																																																																																																			
56	<input type="checkbox"/>	<input type="checkbox"/>	<input type="checkbox"/>	<input type="checkbox"/>	-----																																																																																																																																																																																																																																																																																																																																																																																																																																																																																																			
57	<input type="checkbox"/>	<input type="checkbox"/>	<input type="checkbox"/>	<input type="checkbox"/>	-----																																																																																																																																																																																																																																																																																																																																																																																																																																																																																																			
58	<input type="checkbox"/>	<input type="checkbox"/>	<input type="checkbox"/>	<input type="checkbox"/>	-----																																																																																																																																																																																																																																																																																																																																																																																																																																																																																																			
59	<input type="checkbox"/>	<input type="checkbox"/>	<input type="checkbox"/>	<input type="checkbox"/>	-----																																																																																																																																																																																																																																																																																																																																																																																																																																																																																																			
60	<input type="checkbox"/>	<input type="checkbox"/>	<input type="checkbox"/>	<input type="checkbox"/>	-----																																																																																																																																																																																																																																																																																																																																																																																																																																																																																																			
61	<input type="checkbox"/>	<input type="checkbox"/>	<input type="checkbox"/>	<input type="checkbox"/>	-----																																																																																																																																																																																																																																																																																																																																																																																																																																																																																																			
62	<input type="checkbox"/>	<input type="checkbox"/>	<input type="checkbox"/>	<input type="checkbox"/>	-----																																																																																																																																																																																																																																																																																																																																																																																																																																																																																																			
63	<input type="checkbox"/>	<input type="checkbox"/>	<input type="checkbox"/>	<input type="checkbox"/>	-----																																																																																																																																																																																																																																																																																																																																																																																																																																																																																																			
64	<input type="checkbox"/>	<input type="checkbox"/>	<input type="checkbox"/>	<input type="checkbox"/>	-----																																																																																																																																																																																																																																																																																																																																																																																																																																																																																																			
65	<input type="checkbox"/>	<input type="checkbox"/>	<input type="checkbox"/>	<input type="checkbox"/>	-----																																																																																																																																																																																																																																																																																																																																																																																																																																																																																																			
66	<input type="checkbox"/>	<input type="checkbox"/>	<input type="checkbox"/>	<input type="checkbox"/>	-----																																																																																																																																																																																																																																																																																																																																																																																																																																																																																																			
67	<input type="checkbox"/>	<input type="checkbox"/>	<input type="checkbox"/>	<input type="checkbox"/>	-----																																																																																																																																																																																																																																																																																																																																																																																																																																																																																																			
68	<input type="checkbox"/>	<input type="checkbox"/>	<input type="checkbox"/>	<input type="checkbox"/>	-----																																																																																																																																																																																																																																																																																																																																																																																																																																																																																																			
69	<input type="checkbox"/>	<input type="checkbox"/>	<input type="checkbox"/>	<input type="checkbox"/>	-----																																																																																																																																																																																																																																																																																																																																																																																																																																																																																																			
70	<input type="checkbox"/>	<input type="checkbox"/>	<input type="checkbox"/>	<input type="checkbox"/>	-----																																																																																																																																																																																																																																																																																																																																																																																																																																																																																																			
71	<input type="checkbox"/>	<input type="checkbox"/>	<input type="checkbox"/>	<input type="checkbox"/>	-----																																																																																																																																																																																																																																																																																																																																																																																																																																																																																																			
72	<input type="checkbox"/>	<input type="checkbox"/>	<input type="checkbox"/>	<input type="checkbox"/>	-----																																																																																																																																																																																																																																																																																																																																																																																																																																																																																																			
73	<input type="checkbox"/>	<input type="checkbox"/>	<input type="checkbox"/>	<input type="checkbox"/>	-----																																																																																																																																																																																																																																																																																																																																																																																																																																																																																																			
74	<input type="checkbox"/>	<input type="checkbox"/>	<input type="checkbox"/>	<input type="checkbox"/>	-----																																																																																																																																																																																																																																																																																																																																																																																																																																																																																																			
75	<input type="checkbox"/>	<input type="checkbox"/>	<input type="checkbox"/>	<input type="checkbox"/>	-----																																																																																																																																																																																																																																																																																																																																																																																																																																																																																																			



PRINT OR TYPE

NAME _____ ADDRESS _____
Last First Middle Street/Ship/Unit/Division, etc.
City or FPO State Zip
RANK/RATE _____ SOC. SEC. NO. _____ DESIGNATOR _____ ASSIGNMENT NO _____
 USN USNR ACTIVE INACTIVE OTHER (Specify) _____ DATE MAILED _____
SCORE

	1	2	3	4
1	<input type="checkbox"/>	<input type="checkbox"/>	<input type="checkbox"/>	<input type="checkbox"/>
2	<input type="checkbox"/>	<input type="checkbox"/>	<input type="checkbox"/>	<input type="checkbox"/>
3	<input type="checkbox"/>	<input type="checkbox"/>	<input type="checkbox"/>	<input type="checkbox"/>
4	<input type="checkbox"/>	<input type="checkbox"/>	<input type="checkbox"/>	<input type="checkbox"/>
5	<input type="checkbox"/>	<input type="checkbox"/>	<input type="checkbox"/>	<input type="checkbox"/>
6	<input type="checkbox"/>	<input type="checkbox"/>	<input type="checkbox"/>	<input type="checkbox"/>
7	<input type="checkbox"/>	<input type="checkbox"/>	<input type="checkbox"/>	<input type="checkbox"/>
8	<input type="checkbox"/>	<input type="checkbox"/>	<input type="checkbox"/>	<input type="checkbox"/>
9	<input type="checkbox"/>	<input type="checkbox"/>	<input type="checkbox"/>	<input type="checkbox"/>
10	<input type="checkbox"/>	<input type="checkbox"/>	<input type="checkbox"/>	<input type="checkbox"/>
11	<input type="checkbox"/>	<input type="checkbox"/>	<input type="checkbox"/>	<input type="checkbox"/>
12	<input type="checkbox"/>	<input type="checkbox"/>	<input type="checkbox"/>	<input type="checkbox"/>
13	<input type="checkbox"/>	<input type="checkbox"/>	<input type="checkbox"/>	<input type="checkbox"/>
14	<input type="checkbox"/>	<input type="checkbox"/>	<input type="checkbox"/>	<input type="checkbox"/>
15	<input type="checkbox"/>	<input type="checkbox"/>	<input type="checkbox"/>	<input type="checkbox"/>
16	<input type="checkbox"/>	<input type="checkbox"/>	<input type="checkbox"/>	<input type="checkbox"/>
17	<input type="checkbox"/>	<input type="checkbox"/>	<input type="checkbox"/>	<input type="checkbox"/>
18	<input type="checkbox"/>	<input type="checkbox"/>	<input type="checkbox"/>	<input type="checkbox"/>
19	<input type="checkbox"/>	<input type="checkbox"/>	<input type="checkbox"/>	<input type="checkbox"/>
20	<input type="checkbox"/>	<input type="checkbox"/>	<input type="checkbox"/>	<input type="checkbox"/>
21	<input type="checkbox"/>	<input type="checkbox"/>	<input type="checkbox"/>	<input type="checkbox"/>
22	<input type="checkbox"/>	<input type="checkbox"/>	<input type="checkbox"/>	<input type="checkbox"/>
23	<input type="checkbox"/>	<input type="checkbox"/>	<input type="checkbox"/>	<input type="checkbox"/>
24	<input type="checkbox"/>	<input type="checkbox"/>	<input type="checkbox"/>	<input type="checkbox"/>
25	<input type="checkbox"/>	<input type="checkbox"/>	<input type="checkbox"/>	<input type="checkbox"/>

	1	2	3	4
26	<input type="checkbox"/>	<input type="checkbox"/>	<input type="checkbox"/>	<input type="checkbox"/>
27	<input type="checkbox"/>	<input type="checkbox"/>	<input type="checkbox"/>	<input type="checkbox"/>
28	<input type="checkbox"/>	<input type="checkbox"/>	<input type="checkbox"/>	<input type="checkbox"/>
29	<input type="checkbox"/>	<input type="checkbox"/>	<input type="checkbox"/>	<input type="checkbox"/>
30	<input type="checkbox"/>	<input type="checkbox"/>	<input type="checkbox"/>	<input type="checkbox"/>
31	<input type="checkbox"/>	<input type="checkbox"/>	<input type="checkbox"/>	<input type="checkbox"/>
32	<input type="checkbox"/>	<input type="checkbox"/>	<input type="checkbox"/>	<input type="checkbox"/>
33	<input type="checkbox"/>	<input type="checkbox"/>	<input type="checkbox"/>	<input type="checkbox"/>
34	<input type="checkbox"/>	<input type="checkbox"/>	<input type="checkbox"/>	<input type="checkbox"/>
35	<input type="checkbox"/>	<input type="checkbox"/>	<input type="checkbox"/>	<input type="checkbox"/>
36	<input type="checkbox"/>	<input type="checkbox"/>	<input type="checkbox"/>	<input type="checkbox"/>
37	<input type="checkbox"/>	<input type="checkbox"/>	<input type="checkbox"/>	<input type="checkbox"/>
38	<input type="checkbox"/>	<input type="checkbox"/>	<input type="checkbox"/>	<input type="checkbox"/>
39	<input type="checkbox"/>	<input type="checkbox"/>	<input type="checkbox"/>	<input type="checkbox"/>
40	<input type="checkbox"/>	<input type="checkbox"/>	<input type="checkbox"/>	<input type="checkbox"/>
41	<input type="checkbox"/>	<input type="checkbox"/>	<input type="checkbox"/>	<input type="checkbox"/>
42	<input type="checkbox"/>	<input type="checkbox"/>	<input type="checkbox"/>	<input type="checkbox"/>
43	<input type="checkbox"/>	<input type="checkbox"/>	<input type="checkbox"/>	<input type="checkbox"/>
44	<input type="checkbox"/>	<input type="checkbox"/>	<input type="checkbox"/>	<input type="checkbox"/>
45	<input type="checkbox"/>	<input type="checkbox"/>	<input type="checkbox"/>	<input type="checkbox"/>
46	<input type="checkbox"/>	<input type="checkbox"/>	<input type="checkbox"/>	<input type="checkbox"/>
47	<input type="checkbox"/>	<input type="checkbox"/>	<input type="checkbox"/>	<input type="checkbox"/>
48	<input type="checkbox"/>	<input type="checkbox"/>	<input type="checkbox"/>	<input type="checkbox"/>
49	<input type="checkbox"/>	<input type="checkbox"/>	<input type="checkbox"/>	<input type="checkbox"/>
50	<input type="checkbox"/>	<input type="checkbox"/>	<input type="checkbox"/>	<input type="checkbox"/>

	1	2	3	4
51	<input type="checkbox"/>	<input type="checkbox"/>	<input type="checkbox"/>	<input type="checkbox"/>
52	<input type="checkbox"/>	<input type="checkbox"/>	<input type="checkbox"/>	<input type="checkbox"/>
53	<input type="checkbox"/>	<input type="checkbox"/>	<input type="checkbox"/>	<input type="checkbox"/>
54	<input type="checkbox"/>	<input type="checkbox"/>	<input type="checkbox"/>	<input type="checkbox"/>
55	<input type="checkbox"/>	<input type="checkbox"/>	<input type="checkbox"/>	<input type="checkbox"/>
56	<input type="checkbox"/>	<input type="checkbox"/>	<input type="checkbox"/>	<input type="checkbox"/>
57	<input type="checkbox"/>	<input type="checkbox"/>	<input type="checkbox"/>	<input type="checkbox"/>
58	<input type="checkbox"/>	<input type="checkbox"/>	<input type="checkbox"/>	<input type="checkbox"/>
59	<input type="checkbox"/>	<input type="checkbox"/>	<input type="checkbox"/>	<input type="checkbox"/>
60	<input type="checkbox"/>	<input type="checkbox"/>	<input type="checkbox"/>	<input type="checkbox"/>
61	<input type="checkbox"/>	<input type="checkbox"/>	<input type="checkbox"/>	<input type="checkbox"/>
62	<input type="checkbox"/>	<input type="checkbox"/>	<input type="checkbox"/>	<input type="checkbox"/>
63	<input type="checkbox"/>	<input type="checkbox"/>	<input type="checkbox"/>	<input type="checkbox"/>
64	<input type="checkbox"/>	<input type="checkbox"/>	<input type="checkbox"/>	<input type="checkbox"/>
65	<input type="checkbox"/>	<input type="checkbox"/>	<input type="checkbox"/>	<input type="checkbox"/>
66	<input type="checkbox"/>	<input type="checkbox"/>	<input type="checkbox"/>	<input type="checkbox"/>
67	<input type="checkbox"/>	<input type="checkbox"/>	<input type="checkbox"/>	<input type="checkbox"/>
68	<input type="checkbox"/>	<input type="checkbox"/>	<input type="checkbox"/>	<input type="checkbox"/>
69	<input type="checkbox"/>	<input type="checkbox"/>	<input type="checkbox"/>	<input type="checkbox"/>
70	<input type="checkbox"/>	<input type="checkbox"/>	<input type="checkbox"/>	<input type="checkbox"/>
71	<input type="checkbox"/>	<input type="checkbox"/>	<input type="checkbox"/>	<input type="checkbox"/>
72	<input type="checkbox"/>	<input type="checkbox"/>	<input type="checkbox"/>	<input type="checkbox"/>
73	<input type="checkbox"/>	<input type="checkbox"/>	<input type="checkbox"/>	<input type="checkbox"/>
74	<input type="checkbox"/>	<input type="checkbox"/>	<input type="checkbox"/>	<input type="checkbox"/>
75	<input type="checkbox"/>	<input type="checkbox"/>	<input type="checkbox"/>	<input type="checkbox"/>

PRINT OR TYPE

BUILDER 3&2
NAVEDTRA 10648-G

NAME _____ ADDRESS _____
Last First Middle Street/Ship/Unit/Division, etc.

RANK/RATE _____ SOC. SEC. NO. _____ DESIGNATOR _____ ASSIGNMENT NO _____
City or FPO State Zip

USN USNR ACTIVE INACTIVE OTHER (Specify) _____ DATE MAILED _____

SCORE

1	<input type="checkbox"/>	<input type="checkbox"/>	<input type="checkbox"/>	<input type="checkbox"/>	26	<input type="checkbox"/>	<input type="checkbox"/>	<input type="checkbox"/>	<input type="checkbox"/>	51	<input type="checkbox"/>	<input type="checkbox"/>	<input type="checkbox"/>	<input type="checkbox"/>
2	<input type="checkbox"/>	<input type="checkbox"/>	<input type="checkbox"/>	<input type="checkbox"/>	27	<input type="checkbox"/>	<input type="checkbox"/>	<input type="checkbox"/>	<input type="checkbox"/>	52	<input type="checkbox"/>	<input type="checkbox"/>	<input type="checkbox"/>	<input type="checkbox"/>
3	<input type="checkbox"/>	<input type="checkbox"/>	<input type="checkbox"/>	<input type="checkbox"/>	28	<input type="checkbox"/>	<input type="checkbox"/>	<input type="checkbox"/>	<input type="checkbox"/>	53	<input type="checkbox"/>	<input type="checkbox"/>	<input type="checkbox"/>	<input type="checkbox"/>
4	<input type="checkbox"/>	<input type="checkbox"/>	<input type="checkbox"/>	<input type="checkbox"/>	29	<input type="checkbox"/>	<input type="checkbox"/>	<input type="checkbox"/>	<input type="checkbox"/>	54	<input type="checkbox"/>	<input type="checkbox"/>	<input type="checkbox"/>	<input type="checkbox"/>
5	<input type="checkbox"/>	<input type="checkbox"/>	<input type="checkbox"/>	<input type="checkbox"/>	30	<input type="checkbox"/>	<input type="checkbox"/>	<input type="checkbox"/>	<input type="checkbox"/>	55	<input type="checkbox"/>	<input type="checkbox"/>	<input type="checkbox"/>	<input type="checkbox"/>
6	<input type="checkbox"/>	<input type="checkbox"/>	<input type="checkbox"/>	<input type="checkbox"/>	31	<input type="checkbox"/>	<input type="checkbox"/>	<input type="checkbox"/>	<input type="checkbox"/>	56	<input type="checkbox"/>	<input type="checkbox"/>	<input type="checkbox"/>	<input type="checkbox"/>
7	<input type="checkbox"/>	<input type="checkbox"/>	<input type="checkbox"/>	<input type="checkbox"/>	32	<input type="checkbox"/>	<input type="checkbox"/>	<input type="checkbox"/>	<input type="checkbox"/>	57	<input type="checkbox"/>	<input type="checkbox"/>	<input type="checkbox"/>	<input type="checkbox"/>
8	<input type="checkbox"/>	<input type="checkbox"/>	<input type="checkbox"/>	<input type="checkbox"/>	33	<input type="checkbox"/>	<input type="checkbox"/>	<input type="checkbox"/>	<input type="checkbox"/>	58	<input type="checkbox"/>	<input type="checkbox"/>	<input type="checkbox"/>	<input type="checkbox"/>
9	<input type="checkbox"/>	<input type="checkbox"/>	<input type="checkbox"/>	<input type="checkbox"/>	34	<input type="checkbox"/>	<input type="checkbox"/>	<input type="checkbox"/>	<input type="checkbox"/>	59	<input type="checkbox"/>	<input type="checkbox"/>	<input type="checkbox"/>	<input type="checkbox"/>
10	<input type="checkbox"/>	<input type="checkbox"/>	<input type="checkbox"/>	<input type="checkbox"/>	35	<input type="checkbox"/>	<input type="checkbox"/>	<input type="checkbox"/>	<input type="checkbox"/>	60	<input type="checkbox"/>	<input type="checkbox"/>	<input type="checkbox"/>	<input type="checkbox"/>
11	<input type="checkbox"/>	<input type="checkbox"/>	<input type="checkbox"/>	<input type="checkbox"/>	36	<input type="checkbox"/>	<input type="checkbox"/>	<input type="checkbox"/>	<input type="checkbox"/>	61	<input type="checkbox"/>	<input type="checkbox"/>	<input type="checkbox"/>	<input type="checkbox"/>
12	<input type="checkbox"/>	<input type="checkbox"/>	<input type="checkbox"/>	<input type="checkbox"/>	37	<input type="checkbox"/>	<input type="checkbox"/>	<input type="checkbox"/>	<input type="checkbox"/>	62	<input type="checkbox"/>	<input type="checkbox"/>	<input type="checkbox"/>	<input type="checkbox"/>
13	<input type="checkbox"/>	<input type="checkbox"/>	<input type="checkbox"/>	<input type="checkbox"/>	38	<input type="checkbox"/>	<input type="checkbox"/>	<input type="checkbox"/>	<input type="checkbox"/>	63	<input type="checkbox"/>	<input type="checkbox"/>	<input type="checkbox"/>	<input type="checkbox"/>
14	<input type="checkbox"/>	<input type="checkbox"/>	<input type="checkbox"/>	<input type="checkbox"/>	39	<input type="checkbox"/>	<input type="checkbox"/>	<input type="checkbox"/>	<input type="checkbox"/>	64	<input type="checkbox"/>	<input type="checkbox"/>	<input type="checkbox"/>	<input type="checkbox"/>
15	<input type="checkbox"/>	<input type="checkbox"/>	<input type="checkbox"/>	<input type="checkbox"/>	40	<input type="checkbox"/>	<input type="checkbox"/>	<input type="checkbox"/>	<input type="checkbox"/>	65	<input type="checkbox"/>	<input type="checkbox"/>	<input type="checkbox"/>	<input type="checkbox"/>
16	<input type="checkbox"/>	<input type="checkbox"/>	<input type="checkbox"/>	<input type="checkbox"/>	41	<input type="checkbox"/>	<input type="checkbox"/>	<input type="checkbox"/>	<input type="checkbox"/>	66	<input type="checkbox"/>	<input type="checkbox"/>	<input type="checkbox"/>	<input type="checkbox"/>
17	<input type="checkbox"/>	<input type="checkbox"/>	<input type="checkbox"/>	<input type="checkbox"/>	42	<input type="checkbox"/>	<input type="checkbox"/>	<input type="checkbox"/>	<input type="checkbox"/>	67	<input type="checkbox"/>	<input type="checkbox"/>	<input type="checkbox"/>	<input type="checkbox"/>
18	<input type="checkbox"/>	<input type="checkbox"/>	<input type="checkbox"/>	<input type="checkbox"/>	43	<input type="checkbox"/>	<input type="checkbox"/>	<input type="checkbox"/>	<input type="checkbox"/>	68	<input type="checkbox"/>	<input type="checkbox"/>	<input type="checkbox"/>	<input type="checkbox"/>
19	<input type="checkbox"/>	<input type="checkbox"/>	<input type="checkbox"/>	<input type="checkbox"/>	44	<input type="checkbox"/>	<input type="checkbox"/>	<input type="checkbox"/>	<input type="checkbox"/>	69	<input type="checkbox"/>	<input type="checkbox"/>	<input type="checkbox"/>	<input type="checkbox"/>
20	<input type="checkbox"/>	<input type="checkbox"/>	<input type="checkbox"/>	<input type="checkbox"/>	45	<input type="checkbox"/>	<input type="checkbox"/>	<input type="checkbox"/>	<input type="checkbox"/>	70	<input type="checkbox"/>	<input type="checkbox"/>	<input type="checkbox"/>	<input type="checkbox"/>
21	<input type="checkbox"/>	<input type="checkbox"/>	<input type="checkbox"/>	<input type="checkbox"/>	46	<input type="checkbox"/>	<input type="checkbox"/>	<input type="checkbox"/>	<input type="checkbox"/>	71	<input type="checkbox"/>	<input type="checkbox"/>	<input type="checkbox"/>	<input type="checkbox"/>
22	<input type="checkbox"/>	<input type="checkbox"/>	<input type="checkbox"/>	<input type="checkbox"/>	47	<input type="checkbox"/>	<input type="checkbox"/>	<input type="checkbox"/>	<input type="checkbox"/>	72	<input type="checkbox"/>	<input type="checkbox"/>	<input type="checkbox"/>	<input type="checkbox"/>
23	<input type="checkbox"/>	<input type="checkbox"/>	<input type="checkbox"/>	<input type="checkbox"/>	48	<input type="checkbox"/>	<input type="checkbox"/>	<input type="checkbox"/>	<input type="checkbox"/>	73	<input type="checkbox"/>	<input type="checkbox"/>	<input type="checkbox"/>	<input type="checkbox"/>
24	<input type="checkbox"/>	<input type="checkbox"/>	<input type="checkbox"/>	<input type="checkbox"/>	49	<input type="checkbox"/>	<input type="checkbox"/>	<input type="checkbox"/>	<input type="checkbox"/>	74	<input type="checkbox"/>	<input type="checkbox"/>	<input type="checkbox"/>	<input type="checkbox"/>
25	<input type="checkbox"/>	<input type="checkbox"/>	<input type="checkbox"/>	<input type="checkbox"/>	50	<input type="checkbox"/>	<input type="checkbox"/>	<input type="checkbox"/>	<input type="checkbox"/>	75	<input type="checkbox"/>	<input type="checkbox"/>	<input type="checkbox"/>	<input type="checkbox"/>

PRINT OR TYPE

FUILDER 3&2
NAVEDTRA 10648-G

NAME _____ ADDRESS _____
Last First Middle Street/Ship/Unit/Division, etc.

RANK/RATE _____ SOC. SEC. NO. _____ DESIGNATOR _____ ASSIGNMENT NO. _____
City or PFO State Zip

USN USNR ACTIVE INACTIVE OTHER (Specify) _____ DATE MAILED _____

SCORE

	1	2	3	4	
	T	F			
1	<input type="checkbox"/>	<input type="checkbox"/>	<input type="checkbox"/>	<input type="checkbox"/>	-----
2	<input type="checkbox"/>	<input type="checkbox"/>	<input type="checkbox"/>	<input type="checkbox"/>	-----
3	<input type="checkbox"/>	<input type="checkbox"/>	<input type="checkbox"/>	<input type="checkbox"/>	-----
4	<input type="checkbox"/>	<input type="checkbox"/>	<input type="checkbox"/>	<input type="checkbox"/>	-----
5	<input type="checkbox"/>	<input type="checkbox"/>	<input type="checkbox"/>	<input type="checkbox"/>	-----
6	<input type="checkbox"/>	<input type="checkbox"/>	<input type="checkbox"/>	<input type="checkbox"/>	-----
7	<input type="checkbox"/>	<input type="checkbox"/>	<input type="checkbox"/>	<input type="checkbox"/>	-----
8	<input type="checkbox"/>	<input type="checkbox"/>	<input type="checkbox"/>	<input type="checkbox"/>	-----
9	<input type="checkbox"/>	<input type="checkbox"/>	<input type="checkbox"/>	<input type="checkbox"/>	-----
10	<input type="checkbox"/>	<input type="checkbox"/>	<input type="checkbox"/>	<input type="checkbox"/>	-----
11	<input type="checkbox"/>	<input type="checkbox"/>	<input type="checkbox"/>	<input type="checkbox"/>	-----
12	<input type="checkbox"/>	<input type="checkbox"/>	<input type="checkbox"/>	<input type="checkbox"/>	-----
13	<input type="checkbox"/>	<input type="checkbox"/>	<input type="checkbox"/>	<input type="checkbox"/>	-----
14	<input type="checkbox"/>	<input type="checkbox"/>	<input type="checkbox"/>	<input type="checkbox"/>	-----
15	<input type="checkbox"/>	<input type="checkbox"/>	<input type="checkbox"/>	<input type="checkbox"/>	-----
16	<input type="checkbox"/>	<input type="checkbox"/>	<input type="checkbox"/>	<input type="checkbox"/>	-----
17	<input type="checkbox"/>	<input type="checkbox"/>	<input type="checkbox"/>	<input type="checkbox"/>	-----
18	<input type="checkbox"/>	<input type="checkbox"/>	<input type="checkbox"/>	<input type="checkbox"/>	-----
19	<input type="checkbox"/>	<input type="checkbox"/>	<input type="checkbox"/>	<input type="checkbox"/>	-----
20	<input type="checkbox"/>	<input type="checkbox"/>	<input type="checkbox"/>	<input type="checkbox"/>	-----
21	<input type="checkbox"/>	<input type="checkbox"/>	<input type="checkbox"/>	<input type="checkbox"/>	-----
22	<input type="checkbox"/>	<input type="checkbox"/>	<input type="checkbox"/>	<input type="checkbox"/>	-----
23	<input type="checkbox"/>	<input type="checkbox"/>	<input type="checkbox"/>	<input type="checkbox"/>	-----
24	<input type="checkbox"/>	<input type="checkbox"/>	<input type="checkbox"/>	<input type="checkbox"/>	-----
25	<input type="checkbox"/>	<input type="checkbox"/>	<input type="checkbox"/>	<input type="checkbox"/>	-----

	1	2	3	4	
	T	F			
26	<input type="checkbox"/>	<input type="checkbox"/>	<input type="checkbox"/>	<input type="checkbox"/>	-----
27	<input type="checkbox"/>	<input type="checkbox"/>	<input type="checkbox"/>	<input type="checkbox"/>	-----
28	<input type="checkbox"/>	<input type="checkbox"/>	<input type="checkbox"/>	<input type="checkbox"/>	-----
29	<input type="checkbox"/>	<input type="checkbox"/>	<input type="checkbox"/>	<input type="checkbox"/>	-----
30	<input type="checkbox"/>	<input type="checkbox"/>	<input type="checkbox"/>	<input type="checkbox"/>	-----
31	<input type="checkbox"/>	<input type="checkbox"/>	<input type="checkbox"/>	<input type="checkbox"/>	-----
32	<input type="checkbox"/>	<input type="checkbox"/>	<input type="checkbox"/>	<input type="checkbox"/>	-----
33	<input type="checkbox"/>	<input type="checkbox"/>	<input type="checkbox"/>	<input type="checkbox"/>	-----
34	<input type="checkbox"/>	<input type="checkbox"/>	<input type="checkbox"/>	<input type="checkbox"/>	-----
35	<input type="checkbox"/>	<input type="checkbox"/>	<input type="checkbox"/>	<input type="checkbox"/>	-----
36	<input type="checkbox"/>	<input type="checkbox"/>	<input type="checkbox"/>	<input type="checkbox"/>	-----
37	<input type="checkbox"/>	<input type="checkbox"/>	<input type="checkbox"/>	<input type="checkbox"/>	-----
38	<input type="checkbox"/>	<input type="checkbox"/>	<input type="checkbox"/>	<input type="checkbox"/>	-----
39	<input type="checkbox"/>	<input type="checkbox"/>	<input type="checkbox"/>	<input type="checkbox"/>	-----
40	<input type="checkbox"/>	<input type="checkbox"/>	<input type="checkbox"/>	<input type="checkbox"/>	-----
41	<input type="checkbox"/>	<input type="checkbox"/>	<input type="checkbox"/>	<input type="checkbox"/>	-----
42	<input type="checkbox"/>	<input type="checkbox"/>	<input type="checkbox"/>	<input type="checkbox"/>	-----
43	<input type="checkbox"/>	<input type="checkbox"/>	<input type="checkbox"/>	<input type="checkbox"/>	-----
44	<input type="checkbox"/>	<input type="checkbox"/>	<input type="checkbox"/>	<input type="checkbox"/>	-----
45	<input type="checkbox"/>	<input type="checkbox"/>	<input type="checkbox"/>	<input type="checkbox"/>	-----
46	<input type="checkbox"/>	<input type="checkbox"/>	<input type="checkbox"/>	<input type="checkbox"/>	-----
47	<input type="checkbox"/>	<input type="checkbox"/>	<input type="checkbox"/>	<input type="checkbox"/>	-----
48	<input type="checkbox"/>	<input type="checkbox"/>	<input type="checkbox"/>	<input type="checkbox"/>	-----
49	<input type="checkbox"/>	<input type="checkbox"/>	<input type="checkbox"/>	<input type="checkbox"/>	-----
50	<input type="checkbox"/>	<input type="checkbox"/>	<input type="checkbox"/>	<input type="checkbox"/>	-----

	1	2	3	4	
	T	F			
51	<input type="checkbox"/>	<input type="checkbox"/>	<input type="checkbox"/>	<input type="checkbox"/>	-----
52	<input type="checkbox"/>	<input type="checkbox"/>	<input type="checkbox"/>	<input type="checkbox"/>	-----
53	<input type="checkbox"/>	<input type="checkbox"/>	<input type="checkbox"/>	<input type="checkbox"/>	-----
54	<input type="checkbox"/>	<input type="checkbox"/>	<input type="checkbox"/>	<input type="checkbox"/>	-----
55	<input type="checkbox"/>	<input type="checkbox"/>	<input type="checkbox"/>	<input type="checkbox"/>	-----
56	<input type="checkbox"/>	<input type="checkbox"/>	<input type="checkbox"/>	<input type="checkbox"/>	-----
57	<input type="checkbox"/>	<input type="checkbox"/>	<input type="checkbox"/>	<input type="checkbox"/>	-----
58	<input type="checkbox"/>	<input type="checkbox"/>	<input type="checkbox"/>	<input type="checkbox"/>	-----
59	<input type="checkbox"/>	<input type="checkbox"/>	<input type="checkbox"/>	<input type="checkbox"/>	-----
60	<input type="checkbox"/>	<input type="checkbox"/>	<input type="checkbox"/>	<input type="checkbox"/>	-----
61	<input type="checkbox"/>	<input type="checkbox"/>	<input type="checkbox"/>	<input type="checkbox"/>	-----
62	<input type="checkbox"/>	<input type="checkbox"/>	<input type="checkbox"/>	<input type="checkbox"/>	-----
63	<input type="checkbox"/>	<input type="checkbox"/>	<input type="checkbox"/>	<input type="checkbox"/>	-----
64	<input type="checkbox"/>	<input type="checkbox"/>	<input type="checkbox"/>	<input type="checkbox"/>	-----
65	<input type="checkbox"/>	<input type="checkbox"/>	<input type="checkbox"/>	<input type="checkbox"/>	-----
66	<input type="checkbox"/>	<input type="checkbox"/>	<input type="checkbox"/>	<input type="checkbox"/>	-----
67	<input type="checkbox"/>	<input type="checkbox"/>	<input type="checkbox"/>	<input type="checkbox"/>	-----
68	<input type="checkbox"/>	<input type="checkbox"/>	<input type="checkbox"/>	<input type="checkbox"/>	-----
69	<input type="checkbox"/>	<input type="checkbox"/>	<input type="checkbox"/>	<input type="checkbox"/>	-----
70	<input type="checkbox"/>	<input type="checkbox"/>	<input type="checkbox"/>	<input type="checkbox"/>	-----
71	<input type="checkbox"/>	<input type="checkbox"/>	<input type="checkbox"/>	<input type="checkbox"/>	-----
72	<input type="checkbox"/>	<input type="checkbox"/>	<input type="checkbox"/>	<input type="checkbox"/>	-----
73	<input type="checkbox"/>	<input type="checkbox"/>	<input type="checkbox"/>	<input type="checkbox"/>	-----
74	<input type="checkbox"/>	<input type="checkbox"/>	<input type="checkbox"/>	<input type="checkbox"/>	-----
75	<input type="checkbox"/>	<input type="checkbox"/>	<input type="checkbox"/>	<input type="checkbox"/>	-----

PRINT OR TYPE

BUILDER 362
NAVEDTRA 10648-G

NAME _____ ADDRESS _____
Last First Middle Street/Ship/Unit/Division, etc

RANK/RATE _____ SOC. SEC. NO. _____
DESIGNATOR _____ ASSIGNMENT NO _____

USN USNR ACTIVE INACTIVE OTHER (Specify) _____ DATE MAIL ED _____
SCORE

	1	2	3	4	
1	<input type="checkbox"/>	<input type="checkbox"/>	<input type="checkbox"/>	<input type="checkbox"/>	-----
2	<input type="checkbox"/>	<input type="checkbox"/>	<input type="checkbox"/>	<input type="checkbox"/>	-----
3	<input type="checkbox"/>	<input type="checkbox"/>	<input type="checkbox"/>	<input type="checkbox"/>	-----
4	<input type="checkbox"/>	<input type="checkbox"/>	<input type="checkbox"/>	<input type="checkbox"/>	-----
5	<input type="checkbox"/>	<input type="checkbox"/>	<input type="checkbox"/>	<input type="checkbox"/>	-----
6	<input type="checkbox"/>	<input type="checkbox"/>	<input type="checkbox"/>	<input type="checkbox"/>	-----
7	<input type="checkbox"/>	<input type="checkbox"/>	<input type="checkbox"/>	<input type="checkbox"/>	-----
8	<input type="checkbox"/>	<input type="checkbox"/>	<input type="checkbox"/>	<input type="checkbox"/>	-----
9	<input type="checkbox"/>	<input type="checkbox"/>	<input type="checkbox"/>	<input type="checkbox"/>	-----
10	<input type="checkbox"/>	<input type="checkbox"/>	<input type="checkbox"/>	<input type="checkbox"/>	-----
11	<input type="checkbox"/>	<input type="checkbox"/>	<input type="checkbox"/>	<input type="checkbox"/>	-----
12	<input type="checkbox"/>	<input type="checkbox"/>	<input type="checkbox"/>	<input type="checkbox"/>	-----
13	<input type="checkbox"/>	<input type="checkbox"/>	<input type="checkbox"/>	<input type="checkbox"/>	-----
14	<input type="checkbox"/>	<input type="checkbox"/>	<input type="checkbox"/>	<input type="checkbox"/>	-----
15	<input type="checkbox"/>	<input type="checkbox"/>	<input type="checkbox"/>	<input type="checkbox"/>	-----
16	<input type="checkbox"/>	<input type="checkbox"/>	<input type="checkbox"/>	<input type="checkbox"/>	-----
17	<input type="checkbox"/>	<input type="checkbox"/>	<input type="checkbox"/>	<input type="checkbox"/>	-----
18	<input type="checkbox"/>	<input type="checkbox"/>	<input type="checkbox"/>	<input type="checkbox"/>	-----
19	<input type="checkbox"/>	<input type="checkbox"/>	<input type="checkbox"/>	<input type="checkbox"/>	-----
20	<input type="checkbox"/>	<input type="checkbox"/>	<input type="checkbox"/>	<input type="checkbox"/>	-----
21	<input type="checkbox"/>	<input type="checkbox"/>	<input type="checkbox"/>	<input type="checkbox"/>	-----
22	<input type="checkbox"/>	<input type="checkbox"/>	<input type="checkbox"/>	<input type="checkbox"/>	-----
23	<input type="checkbox"/>	<input type="checkbox"/>	<input type="checkbox"/>	<input type="checkbox"/>	-----
24	<input type="checkbox"/>	<input type="checkbox"/>	<input type="checkbox"/>	<input type="checkbox"/>	-----
25	<input type="checkbox"/>	<input type="checkbox"/>	<input type="checkbox"/>	<input type="checkbox"/>	-----

	1	2	3	4	
26	<input type="checkbox"/>	<input type="checkbox"/>	<input type="checkbox"/>	<input type="checkbox"/>	-----
27	<input type="checkbox"/>	<input type="checkbox"/>	<input type="checkbox"/>	<input type="checkbox"/>	-----
28	<input type="checkbox"/>	<input type="checkbox"/>	<input type="checkbox"/>	<input type="checkbox"/>	-----
29	<input type="checkbox"/>	<input type="checkbox"/>	<input type="checkbox"/>	<input type="checkbox"/>	-----
30	<input type="checkbox"/>	<input type="checkbox"/>	<input type="checkbox"/>	<input type="checkbox"/>	-----
31	<input type="checkbox"/>	<input type="checkbox"/>	<input type="checkbox"/>	<input type="checkbox"/>	-----
32	<input type="checkbox"/>	<input type="checkbox"/>	<input type="checkbox"/>	<input type="checkbox"/>	-----
33	<input type="checkbox"/>	<input type="checkbox"/>	<input type="checkbox"/>	<input type="checkbox"/>	-----
34	<input type="checkbox"/>	<input type="checkbox"/>	<input type="checkbox"/>	<input type="checkbox"/>	-----
35	<input type="checkbox"/>	<input type="checkbox"/>	<input type="checkbox"/>	<input type="checkbox"/>	-----
36	<input type="checkbox"/>	<input type="checkbox"/>	<input type="checkbox"/>	<input type="checkbox"/>	-----
37	<input type="checkbox"/>	<input type="checkbox"/>	<input type="checkbox"/>	<input type="checkbox"/>	-----
38	<input type="checkbox"/>	<input type="checkbox"/>	<input type="checkbox"/>	<input type="checkbox"/>	-----
39	<input type="checkbox"/>	<input type="checkbox"/>	<input type="checkbox"/>	<input type="checkbox"/>	-----
40	<input type="checkbox"/>	<input type="checkbox"/>	<input type="checkbox"/>	<input type="checkbox"/>	-----
41	<input type="checkbox"/>	<input type="checkbox"/>	<input type="checkbox"/>	<input type="checkbox"/>	-----
42	<input type="checkbox"/>	<input type="checkbox"/>	<input type="checkbox"/>	<input type="checkbox"/>	-----
43	<input type="checkbox"/>	<input type="checkbox"/>	<input type="checkbox"/>	<input type="checkbox"/>	-----
44	<input type="checkbox"/>	<input type="checkbox"/>	<input type="checkbox"/>	<input type="checkbox"/>	-----
45	<input type="checkbox"/>	<input type="checkbox"/>	<input type="checkbox"/>	<input type="checkbox"/>	-----
46	<input type="checkbox"/>	<input type="checkbox"/>	<input type="checkbox"/>	<input type="checkbox"/>	-----
47	<input type="checkbox"/>	<input type="checkbox"/>	<input type="checkbox"/>	<input type="checkbox"/>	-----
48	<input type="checkbox"/>	<input type="checkbox"/>	<input type="checkbox"/>	<input type="checkbox"/>	-----
49	<input type="checkbox"/>	<input type="checkbox"/>	<input type="checkbox"/>	<input type="checkbox"/>	-----
50	<input type="checkbox"/>	<input type="checkbox"/>	<input type="checkbox"/>	<input type="checkbox"/>	-----

	1	2	3	4	
51	<input type="checkbox"/>	<input type="checkbox"/>	<input type="checkbox"/>	<input type="checkbox"/>	-----
52	<input type="checkbox"/>	<input type="checkbox"/>	<input type="checkbox"/>	<input type="checkbox"/>	-----
53	<input type="checkbox"/>	<input type="checkbox"/>	<input type="checkbox"/>	<input type="checkbox"/>	-----
54	<input type="checkbox"/>	<input type="checkbox"/>	<input type="checkbox"/>	<input type="checkbox"/>	-----
55	<input type="checkbox"/>	<input type="checkbox"/>	<input type="checkbox"/>	<input type="checkbox"/>	-----
56	<input type="checkbox"/>	<input type="checkbox"/>	<input type="checkbox"/>	<input type="checkbox"/>	-----
57	<input type="checkbox"/>	<input type="checkbox"/>	<input type="checkbox"/>	<input type="checkbox"/>	-----
58	<input type="checkbox"/>	<input type="checkbox"/>	<input type="checkbox"/>	<input type="checkbox"/>	-----
59	<input type="checkbox"/>	<input type="checkbox"/>	<input type="checkbox"/>	<input type="checkbox"/>	-----
60	<input type="checkbox"/>	<input type="checkbox"/>	<input type="checkbox"/>	<input type="checkbox"/>	-----
61	<input type="checkbox"/>	<input type="checkbox"/>	<input type="checkbox"/>	<input type="checkbox"/>	-----
62	<input type="checkbox"/>	<input type="checkbox"/>	<input type="checkbox"/>	<input type="checkbox"/>	-----
63	<input type="checkbox"/>	<input type="checkbox"/>	<input type="checkbox"/>	<input type="checkbox"/>	-----
64	<input type="checkbox"/>	<input type="checkbox"/>	<input type="checkbox"/>	<input type="checkbox"/>	-----
65	<input type="checkbox"/>	<input type="checkbox"/>	<input type="checkbox"/>	<input type="checkbox"/>	-----
66	<input type="checkbox"/>	<input type="checkbox"/>	<input type="checkbox"/>	<input type="checkbox"/>	-----
67	<input type="checkbox"/>	<input type="checkbox"/>	<input type="checkbox"/>	<input type="checkbox"/>	-----
68	<input type="checkbox"/>	<input type="checkbox"/>	<input type="checkbox"/>	<input type="checkbox"/>	-----
69	<input type="checkbox"/>	<input type="checkbox"/>	<input type="checkbox"/>	<input type="checkbox"/>	-----
70	<input type="checkbox"/>	<input type="checkbox"/>	<input type="checkbox"/>	<input type="checkbox"/>	-----
71	<input type="checkbox"/>	<input type="checkbox"/>	<input type="checkbox"/>	<input type="checkbox"/>	-----
72	<input type="checkbox"/>	<input type="checkbox"/>	<input type="checkbox"/>	<input type="checkbox"/>	-----
73	<input type="checkbox"/>	<input type="checkbox"/>	<input type="checkbox"/>	<input type="checkbox"/>	-----
74	<input type="checkbox"/>	<input type="checkbox"/>	<input type="checkbox"/>	<input type="checkbox"/>	-----
75	<input type="checkbox"/>	<input type="checkbox"/>	<input type="checkbox"/>	<input type="checkbox"/>	-----

PRINT OR TYPE

BUILDER 362
NAVY JUN 1948-0

NAME _____ ADDRESS _____
Last First Middle Street/Ship/Unit/Division, etc.
City or FPO State Zip

RANK/RATE _____ SOC. SEC. NO. _____ DESIGNATOR _____ ASSIGNMENT NO _____
 USN USNR ACTIVE INACTIVE OTHER (Specify) _____ DATE MAILED _____

SCORE

	1	2	3	4
1	<input type="checkbox"/>	<input type="checkbox"/>	<input type="checkbox"/>	<input type="checkbox"/>
2	<input type="checkbox"/>	<input type="checkbox"/>	<input type="checkbox"/>	<input type="checkbox"/>
3	<input type="checkbox"/>	<input type="checkbox"/>	<input type="checkbox"/>	<input type="checkbox"/>
4	<input type="checkbox"/>	<input type="checkbox"/>	<input type="checkbox"/>	<input type="checkbox"/>
5	<input type="checkbox"/>	<input type="checkbox"/>	<input type="checkbox"/>	<input type="checkbox"/>
6	<input type="checkbox"/>	<input type="checkbox"/>	<input type="checkbox"/>	<input type="checkbox"/>
7	<input type="checkbox"/>	<input type="checkbox"/>	<input type="checkbox"/>	<input type="checkbox"/>
8	<input type="checkbox"/>	<input type="checkbox"/>	<input type="checkbox"/>	<input type="checkbox"/>
9	<input type="checkbox"/>	<input type="checkbox"/>	<input type="checkbox"/>	<input type="checkbox"/>
10	<input type="checkbox"/>	<input type="checkbox"/>	<input type="checkbox"/>	<input type="checkbox"/>
11	<input type="checkbox"/>	<input type="checkbox"/>	<input type="checkbox"/>	<input type="checkbox"/>
12	<input type="checkbox"/>	<input type="checkbox"/>	<input type="checkbox"/>	<input type="checkbox"/>
13	<input type="checkbox"/>	<input type="checkbox"/>	<input type="checkbox"/>	<input type="checkbox"/>
14	<input type="checkbox"/>	<input type="checkbox"/>	<input type="checkbox"/>	<input type="checkbox"/>
15	<input type="checkbox"/>	<input type="checkbox"/>	<input type="checkbox"/>	<input type="checkbox"/>
16	<input type="checkbox"/>	<input type="checkbox"/>	<input type="checkbox"/>	<input type="checkbox"/>
17	<input type="checkbox"/>	<input type="checkbox"/>	<input type="checkbox"/>	<input type="checkbox"/>
18	<input type="checkbox"/>	<input type="checkbox"/>	<input type="checkbox"/>	<input type="checkbox"/>
19	<input type="checkbox"/>	<input type="checkbox"/>	<input type="checkbox"/>	<input type="checkbox"/>
20	<input type="checkbox"/>	<input type="checkbox"/>	<input type="checkbox"/>	<input type="checkbox"/>
21	<input type="checkbox"/>	<input type="checkbox"/>	<input type="checkbox"/>	<input type="checkbox"/>
22	<input type="checkbox"/>	<input type="checkbox"/>	<input type="checkbox"/>	<input type="checkbox"/>
23	<input type="checkbox"/>	<input type="checkbox"/>	<input type="checkbox"/>	<input type="checkbox"/>
24	<input type="checkbox"/>	<input type="checkbox"/>	<input type="checkbox"/>	<input type="checkbox"/>
25	<input type="checkbox"/>	<input type="checkbox"/>	<input type="checkbox"/>	<input type="checkbox"/>

	1	2	3	4
26	<input type="checkbox"/>	<input type="checkbox"/>	<input type="checkbox"/>	<input type="checkbox"/>
27	<input type="checkbox"/>	<input type="checkbox"/>	<input type="checkbox"/>	<input type="checkbox"/>
28	<input type="checkbox"/>	<input type="checkbox"/>	<input type="checkbox"/>	<input type="checkbox"/>
29	<input type="checkbox"/>	<input type="checkbox"/>	<input type="checkbox"/>	<input type="checkbox"/>
30	<input type="checkbox"/>	<input type="checkbox"/>	<input type="checkbox"/>	<input type="checkbox"/>
31	<input type="checkbox"/>	<input type="checkbox"/>	<input type="checkbox"/>	<input type="checkbox"/>
32	<input type="checkbox"/>	<input type="checkbox"/>	<input type="checkbox"/>	<input type="checkbox"/>
33	<input type="checkbox"/>	<input type="checkbox"/>	<input type="checkbox"/>	<input type="checkbox"/>
34	<input type="checkbox"/>	<input type="checkbox"/>	<input type="checkbox"/>	<input type="checkbox"/>
35	<input type="checkbox"/>	<input type="checkbox"/>	<input type="checkbox"/>	<input type="checkbox"/>
36	<input type="checkbox"/>	<input type="checkbox"/>	<input type="checkbox"/>	<input type="checkbox"/>
37	<input type="checkbox"/>	<input type="checkbox"/>	<input type="checkbox"/>	<input type="checkbox"/>
38	<input type="checkbox"/>	<input type="checkbox"/>	<input type="checkbox"/>	<input type="checkbox"/>
39	<input type="checkbox"/>	<input type="checkbox"/>	<input type="checkbox"/>	<input type="checkbox"/>
40	<input type="checkbox"/>	<input type="checkbox"/>	<input type="checkbox"/>	<input type="checkbox"/>
41	<input type="checkbox"/>	<input type="checkbox"/>	<input type="checkbox"/>	<input type="checkbox"/>
42	<input type="checkbox"/>	<input type="checkbox"/>	<input type="checkbox"/>	<input type="checkbox"/>
43	<input type="checkbox"/>	<input type="checkbox"/>	<input type="checkbox"/>	<input type="checkbox"/>
44	<input type="checkbox"/>	<input type="checkbox"/>	<input type="checkbox"/>	<input type="checkbox"/>
45	<input type="checkbox"/>	<input type="checkbox"/>	<input type="checkbox"/>	<input type="checkbox"/>
46	<input type="checkbox"/>	<input type="checkbox"/>	<input type="checkbox"/>	<input type="checkbox"/>
47	<input type="checkbox"/>	<input type="checkbox"/>	<input type="checkbox"/>	<input type="checkbox"/>
48	<input type="checkbox"/>	<input type="checkbox"/>	<input type="checkbox"/>	<input type="checkbox"/>
49	<input type="checkbox"/>	<input type="checkbox"/>	<input type="checkbox"/>	<input type="checkbox"/>
50	<input type="checkbox"/>	<input type="checkbox"/>	<input type="checkbox"/>	<input type="checkbox"/>

	1	2	3	4
51	<input type="checkbox"/>	<input type="checkbox"/>	<input type="checkbox"/>	<input type="checkbox"/>
52	<input type="checkbox"/>	<input type="checkbox"/>	<input type="checkbox"/>	<input type="checkbox"/>
53	<input type="checkbox"/>	<input type="checkbox"/>	<input type="checkbox"/>	<input type="checkbox"/>
54	<input type="checkbox"/>	<input type="checkbox"/>	<input type="checkbox"/>	<input type="checkbox"/>
55	<input type="checkbox"/>	<input type="checkbox"/>	<input type="checkbox"/>	<input type="checkbox"/>
56	<input type="checkbox"/>	<input type="checkbox"/>	<input type="checkbox"/>	<input type="checkbox"/>
57	<input type="checkbox"/>	<input type="checkbox"/>	<input type="checkbox"/>	<input type="checkbox"/>
58	<input type="checkbox"/>	<input type="checkbox"/>	<input type="checkbox"/>	<input type="checkbox"/>
59	<input type="checkbox"/>	<input type="checkbox"/>	<input type="checkbox"/>	<input type="checkbox"/>
60	<input type="checkbox"/>	<input type="checkbox"/>	<input type="checkbox"/>	<input type="checkbox"/>
61	<input type="checkbox"/>	<input type="checkbox"/>	<input type="checkbox"/>	<input type="checkbox"/>
62	<input type="checkbox"/>	<input type="checkbox"/>	<input type="checkbox"/>	<input type="checkbox"/>
63	<input type="checkbox"/>	<input type="checkbox"/>	<input type="checkbox"/>	<input type="checkbox"/>
64	<input type="checkbox"/>	<input type="checkbox"/>	<input type="checkbox"/>	<input type="checkbox"/>
65	<input type="checkbox"/>	<input type="checkbox"/>	<input type="checkbox"/>	<input type="checkbox"/>
66	<input type="checkbox"/>	<input type="checkbox"/>	<input type="checkbox"/>	<input type="checkbox"/>
67	<input type="checkbox"/>	<input type="checkbox"/>	<input type="checkbox"/>	<input type="checkbox"/>
68	<input type="checkbox"/>	<input type="checkbox"/>	<input type="checkbox"/>	<input type="checkbox"/>
69	<input type="checkbox"/>	<input type="checkbox"/>	<input type="checkbox"/>	<input type="checkbox"/>
70	<input type="checkbox"/>	<input type="checkbox"/>	<input type="checkbox"/>	<input type="checkbox"/>
71	<input type="checkbox"/>	<input type="checkbox"/>	<input type="checkbox"/>	<input type="checkbox"/>
72	<input type="checkbox"/>	<input type="checkbox"/>	<input type="checkbox"/>	<input type="checkbox"/>
73	<input type="checkbox"/>	<input type="checkbox"/>	<input type="checkbox"/>	<input type="checkbox"/>
74	<input type="checkbox"/>	<input type="checkbox"/>	<input type="checkbox"/>	<input type="checkbox"/>
75	<input type="checkbox"/>	<input type="checkbox"/>	<input type="checkbox"/>	<input type="checkbox"/>



PRINT OR TYPE

BUILDER 3&2
NAVEDTRA 10648-G

NAME _____ ADDRESS _____
Last First Middle Street/Ship/Unit/Division, etc.

City or FPO State Zip
RANK/RATE _____ SOC. SEC. NO. _____ DESIGNATOR _____ ASSIGNMENT NO. _____

USN USNR ACTIVE INACTIVE OTHER (Specify) _____ DATE MAILED _____
SCORE

	1	2	3	4	
	T	F			
1	<input type="checkbox"/>	<input type="checkbox"/>	<input type="checkbox"/>	<input type="checkbox"/>	-----
2	<input type="checkbox"/>	<input type="checkbox"/>	<input type="checkbox"/>	<input type="checkbox"/>	-----
3	<input type="checkbox"/>	<input type="checkbox"/>	<input type="checkbox"/>	<input type="checkbox"/>	-----
4	<input type="checkbox"/>	<input type="checkbox"/>	<input type="checkbox"/>	<input type="checkbox"/>	-----
5	<input type="checkbox"/>	<input type="checkbox"/>	<input type="checkbox"/>	<input type="checkbox"/>	-----
6	<input type="checkbox"/>	<input type="checkbox"/>	<input type="checkbox"/>	<input type="checkbox"/>	-----
7	<input type="checkbox"/>	<input type="checkbox"/>	<input type="checkbox"/>	<input type="checkbox"/>	-----
8	<input type="checkbox"/>	<input type="checkbox"/>	<input type="checkbox"/>	<input type="checkbox"/>	-----
9	<input type="checkbox"/>	<input type="checkbox"/>	<input type="checkbox"/>	<input type="checkbox"/>	-----
10	<input type="checkbox"/>	<input type="checkbox"/>	<input type="checkbox"/>	<input type="checkbox"/>	-----
11	<input type="checkbox"/>	<input type="checkbox"/>	<input type="checkbox"/>	<input type="checkbox"/>	-----
12	<input type="checkbox"/>	<input type="checkbox"/>	<input type="checkbox"/>	<input type="checkbox"/>	-----
13	<input type="checkbox"/>	<input type="checkbox"/>	<input type="checkbox"/>	<input type="checkbox"/>	-----
14	<input type="checkbox"/>	<input type="checkbox"/>	<input type="checkbox"/>	<input type="checkbox"/>	-----
15	<input type="checkbox"/>	<input type="checkbox"/>	<input type="checkbox"/>	<input type="checkbox"/>	-----
16	<input type="checkbox"/>	<input type="checkbox"/>	<input type="checkbox"/>	<input type="checkbox"/>	-----
17	<input type="checkbox"/>	<input type="checkbox"/>	<input type="checkbox"/>	<input type="checkbox"/>	-----
18	<input type="checkbox"/>	<input type="checkbox"/>	<input type="checkbox"/>	<input type="checkbox"/>	-----
19	<input type="checkbox"/>	<input type="checkbox"/>	<input type="checkbox"/>	<input type="checkbox"/>	-----
20	<input type="checkbox"/>	<input type="checkbox"/>	<input type="checkbox"/>	<input type="checkbox"/>	-----
21	<input type="checkbox"/>	<input type="checkbox"/>	<input type="checkbox"/>	<input type="checkbox"/>	-----
22	<input type="checkbox"/>	<input type="checkbox"/>	<input type="checkbox"/>	<input type="checkbox"/>	-----
23	<input type="checkbox"/>	<input type="checkbox"/>	<input type="checkbox"/>	<input type="checkbox"/>	-----
24	<input type="checkbox"/>	<input type="checkbox"/>	<input type="checkbox"/>	<input type="checkbox"/>	-----
25	<input type="checkbox"/>	<input type="checkbox"/>	<input type="checkbox"/>	<input type="checkbox"/>	-----

	1	2	3	4	
	T	F			
26	<input type="checkbox"/>	<input type="checkbox"/>	<input type="checkbox"/>	<input type="checkbox"/>	-----
27	<input type="checkbox"/>	<input type="checkbox"/>	<input type="checkbox"/>	<input type="checkbox"/>	-----
28	<input type="checkbox"/>	<input type="checkbox"/>	<input type="checkbox"/>	<input type="checkbox"/>	-----
29	<input type="checkbox"/>	<input type="checkbox"/>	<input type="checkbox"/>	<input type="checkbox"/>	-----
30	<input type="checkbox"/>	<input type="checkbox"/>	<input type="checkbox"/>	<input type="checkbox"/>	-----
31	<input type="checkbox"/>	<input type="checkbox"/>	<input type="checkbox"/>	<input type="checkbox"/>	-----
32	<input type="checkbox"/>	<input type="checkbox"/>	<input type="checkbox"/>	<input type="checkbox"/>	-----
33	<input type="checkbox"/>	<input type="checkbox"/>	<input type="checkbox"/>	<input type="checkbox"/>	-----
34	<input type="checkbox"/>	<input type="checkbox"/>	<input type="checkbox"/>	<input type="checkbox"/>	-----
35	<input type="checkbox"/>	<input type="checkbox"/>	<input type="checkbox"/>	<input type="checkbox"/>	-----
36	<input type="checkbox"/>	<input type="checkbox"/>	<input type="checkbox"/>	<input type="checkbox"/>	-----
37	<input type="checkbox"/>	<input type="checkbox"/>	<input type="checkbox"/>	<input type="checkbox"/>	-----
38	<input type="checkbox"/>	<input type="checkbox"/>	<input type="checkbox"/>	<input type="checkbox"/>	-----
39	<input type="checkbox"/>	<input type="checkbox"/>	<input type="checkbox"/>	<input type="checkbox"/>	-----
40	<input type="checkbox"/>	<input type="checkbox"/>	<input type="checkbox"/>	<input type="checkbox"/>	-----
41	<input type="checkbox"/>	<input type="checkbox"/>	<input type="checkbox"/>	<input type="checkbox"/>	-----
42	<input type="checkbox"/>	<input type="checkbox"/>	<input type="checkbox"/>	<input type="checkbox"/>	-----
43	<input type="checkbox"/>	<input type="checkbox"/>	<input type="checkbox"/>	<input type="checkbox"/>	-----
44	<input type="checkbox"/>	<input type="checkbox"/>	<input type="checkbox"/>	<input type="checkbox"/>	-----
45	<input type="checkbox"/>	<input type="checkbox"/>	<input type="checkbox"/>	<input type="checkbox"/>	-----
46	<input type="checkbox"/>	<input type="checkbox"/>	<input type="checkbox"/>	<input type="checkbox"/>	-----
47	<input type="checkbox"/>	<input type="checkbox"/>	<input type="checkbox"/>	<input type="checkbox"/>	-----
48	<input type="checkbox"/>	<input type="checkbox"/>	<input type="checkbox"/>	<input type="checkbox"/>	-----
49	<input type="checkbox"/>	<input type="checkbox"/>	<input type="checkbox"/>	<input type="checkbox"/>	-----
50	<input type="checkbox"/>	<input type="checkbox"/>	<input type="checkbox"/>	<input type="checkbox"/>	-----

	1	2	3	4	
	T	F			
51	<input type="checkbox"/>	<input type="checkbox"/>	<input type="checkbox"/>	<input type="checkbox"/>	-----
52	<input type="checkbox"/>	<input type="checkbox"/>	<input type="checkbox"/>	<input type="checkbox"/>	-----
53	<input type="checkbox"/>	<input type="checkbox"/>	<input type="checkbox"/>	<input type="checkbox"/>	-----
54	<input type="checkbox"/>	<input type="checkbox"/>	<input type="checkbox"/>	<input type="checkbox"/>	-----
55	<input type="checkbox"/>	<input type="checkbox"/>	<input type="checkbox"/>	<input type="checkbox"/>	-----
56	<input type="checkbox"/>	<input type="checkbox"/>	<input type="checkbox"/>	<input type="checkbox"/>	-----
57	<input type="checkbox"/>	<input type="checkbox"/>	<input type="checkbox"/>	<input type="checkbox"/>	-----
58	<input type="checkbox"/>	<input type="checkbox"/>	<input type="checkbox"/>	<input type="checkbox"/>	-----
59	<input type="checkbox"/>	<input type="checkbox"/>	<input type="checkbox"/>	<input type="checkbox"/>	-----
60	<input type="checkbox"/>	<input type="checkbox"/>	<input type="checkbox"/>	<input type="checkbox"/>	-----
61	<input type="checkbox"/>	<input type="checkbox"/>	<input type="checkbox"/>	<input type="checkbox"/>	-----
62	<input type="checkbox"/>	<input type="checkbox"/>	<input type="checkbox"/>	<input type="checkbox"/>	-----
63	<input type="checkbox"/>	<input type="checkbox"/>	<input type="checkbox"/>	<input type="checkbox"/>	-----
64	<input type="checkbox"/>	<input type="checkbox"/>	<input type="checkbox"/>	<input type="checkbox"/>	-----
65	<input type="checkbox"/>	<input type="checkbox"/>	<input type="checkbox"/>	<input type="checkbox"/>	-----
66	<input type="checkbox"/>	<input type="checkbox"/>	<input type="checkbox"/>	<input type="checkbox"/>	-----
67	<input type="checkbox"/>	<input type="checkbox"/>	<input type="checkbox"/>	<input type="checkbox"/>	-----
68	<input type="checkbox"/>	<input type="checkbox"/>	<input type="checkbox"/>	<input type="checkbox"/>	-----
69	<input type="checkbox"/>	<input type="checkbox"/>	<input type="checkbox"/>	<input type="checkbox"/>	-----
70	<input type="checkbox"/>	<input type="checkbox"/>	<input type="checkbox"/>	<input type="checkbox"/>	-----
71	<input type="checkbox"/>	<input type="checkbox"/>	<input type="checkbox"/>	<input type="checkbox"/>	-----
72	<input type="checkbox"/>	<input type="checkbox"/>	<input type="checkbox"/>	<input type="checkbox"/>	-----
73	<input type="checkbox"/>	<input type="checkbox"/>	<input type="checkbox"/>	<input type="checkbox"/>	-----
74	<input type="checkbox"/>	<input type="checkbox"/>	<input type="checkbox"/>	<input type="checkbox"/>	-----
75	<input type="checkbox"/>	<input type="checkbox"/>	<input type="checkbox"/>	<input type="checkbox"/>	-----



PRINT OR TYPE

BUILDER 3&2
NAVEDTRA 10648-G

NAME _____ ADDRESS _____
Last First Middle Street/Ship/Unit/Division, etc.

RANK/RATE _____ SOC. SEC. NO. _____ DESIGNATOR _____ ASSIGNMENT NO _____
City or FPO State Zip

USN USNR ACTIVE INACTIVE OTHER (Specify) _____ DATE MAILED _____
SCORE

	1	2	3	4	
1	<input type="checkbox"/>	<input type="checkbox"/>	<input type="checkbox"/>	<input type="checkbox"/>	-----
2	<input type="checkbox"/>	<input type="checkbox"/>	<input type="checkbox"/>	<input type="checkbox"/>	-----
3	<input type="checkbox"/>	<input type="checkbox"/>	<input type="checkbox"/>	<input type="checkbox"/>	-----
4	<input type="checkbox"/>	<input type="checkbox"/>	<input type="checkbox"/>	<input type="checkbox"/>	-----
5	<input type="checkbox"/>	<input type="checkbox"/>	<input type="checkbox"/>	<input type="checkbox"/>	-----
6	<input type="checkbox"/>	<input type="checkbox"/>	<input type="checkbox"/>	<input type="checkbox"/>	-----
7	<input type="checkbox"/>	<input type="checkbox"/>	<input type="checkbox"/>	<input type="checkbox"/>	-----
8	<input type="checkbox"/>	<input type="checkbox"/>	<input type="checkbox"/>	<input type="checkbox"/>	-----
9	<input type="checkbox"/>	<input type="checkbox"/>	<input type="checkbox"/>	<input type="checkbox"/>	-----
10	<input type="checkbox"/>	<input type="checkbox"/>	<input type="checkbox"/>	<input type="checkbox"/>	-----
11	<input type="checkbox"/>	<input type="checkbox"/>	<input type="checkbox"/>	<input type="checkbox"/>	-----
12	<input type="checkbox"/>	<input type="checkbox"/>	<input type="checkbox"/>	<input type="checkbox"/>	-----
13	<input type="checkbox"/>	<input type="checkbox"/>	<input type="checkbox"/>	<input type="checkbox"/>	-----
14	<input type="checkbox"/>	<input type="checkbox"/>	<input type="checkbox"/>	<input type="checkbox"/>	-----
15	<input type="checkbox"/>	<input type="checkbox"/>	<input type="checkbox"/>	<input type="checkbox"/>	-----
16	<input type="checkbox"/>	<input type="checkbox"/>	<input type="checkbox"/>	<input type="checkbox"/>	-----
17	<input type="checkbox"/>	<input type="checkbox"/>	<input type="checkbox"/>	<input type="checkbox"/>	-----
18	<input type="checkbox"/>	<input type="checkbox"/>	<input type="checkbox"/>	<input type="checkbox"/>	-----
19	<input type="checkbox"/>	<input type="checkbox"/>	<input type="checkbox"/>	<input type="checkbox"/>	-----
20	<input type="checkbox"/>	<input type="checkbox"/>	<input type="checkbox"/>	<input type="checkbox"/>	-----
21	<input type="checkbox"/>	<input type="checkbox"/>	<input type="checkbox"/>	<input type="checkbox"/>	-----
22	<input type="checkbox"/>	<input type="checkbox"/>	<input type="checkbox"/>	<input type="checkbox"/>	-----
23	<input type="checkbox"/>	<input type="checkbox"/>	<input type="checkbox"/>	<input type="checkbox"/>	-----
24	<input type="checkbox"/>	<input type="checkbox"/>	<input type="checkbox"/>	<input type="checkbox"/>	-----
25	<input type="checkbox"/>	<input type="checkbox"/>	<input type="checkbox"/>	<input type="checkbox"/>	-----

	1	2	3	4	
26	<input type="checkbox"/>	<input type="checkbox"/>	<input type="checkbox"/>	<input type="checkbox"/>	-----
27	<input type="checkbox"/>	<input type="checkbox"/>	<input type="checkbox"/>	<input type="checkbox"/>	-----
28	<input type="checkbox"/>	<input type="checkbox"/>	<input type="checkbox"/>	<input type="checkbox"/>	-----
29	<input type="checkbox"/>	<input type="checkbox"/>	<input type="checkbox"/>	<input type="checkbox"/>	-----
30	<input type="checkbox"/>	<input type="checkbox"/>	<input type="checkbox"/>	<input type="checkbox"/>	-----
31	<input type="checkbox"/>	<input type="checkbox"/>	<input type="checkbox"/>	<input type="checkbox"/>	-----
32	<input type="checkbox"/>	<input type="checkbox"/>	<input type="checkbox"/>	<input type="checkbox"/>	-----
33	<input type="checkbox"/>	<input type="checkbox"/>	<input type="checkbox"/>	<input type="checkbox"/>	-----
34	<input type="checkbox"/>	<input type="checkbox"/>	<input type="checkbox"/>	<input type="checkbox"/>	-----
35	<input type="checkbox"/>	<input type="checkbox"/>	<input type="checkbox"/>	<input type="checkbox"/>	-----
36	<input type="checkbox"/>	<input type="checkbox"/>	<input type="checkbox"/>	<input type="checkbox"/>	-----
37	<input type="checkbox"/>	<input type="checkbox"/>	<input type="checkbox"/>	<input type="checkbox"/>	-----
38	<input type="checkbox"/>	<input type="checkbox"/>	<input type="checkbox"/>	<input type="checkbox"/>	-----
39	<input type="checkbox"/>	<input type="checkbox"/>	<input type="checkbox"/>	<input type="checkbox"/>	-----
40	<input type="checkbox"/>	<input type="checkbox"/>	<input type="checkbox"/>	<input type="checkbox"/>	-----
41	<input type="checkbox"/>	<input type="checkbox"/>	<input type="checkbox"/>	<input type="checkbox"/>	-----
42	<input type="checkbox"/>	<input type="checkbox"/>	<input type="checkbox"/>	<input type="checkbox"/>	-----
43	<input type="checkbox"/>	<input type="checkbox"/>	<input type="checkbox"/>	<input type="checkbox"/>	-----
44	<input type="checkbox"/>	<input type="checkbox"/>	<input type="checkbox"/>	<input type="checkbox"/>	-----
45	<input type="checkbox"/>	<input type="checkbox"/>	<input type="checkbox"/>	<input type="checkbox"/>	-----
46	<input type="checkbox"/>	<input type="checkbox"/>	<input type="checkbox"/>	<input type="checkbox"/>	-----
47	<input type="checkbox"/>	<input type="checkbox"/>	<input type="checkbox"/>	<input type="checkbox"/>	-----
48	<input type="checkbox"/>	<input type="checkbox"/>	<input type="checkbox"/>	<input type="checkbox"/>	-----
49	<input type="checkbox"/>	<input type="checkbox"/>	<input type="checkbox"/>	<input type="checkbox"/>	-----
50	<input type="checkbox"/>	<input type="checkbox"/>	<input type="checkbox"/>	<input type="checkbox"/>	-----

	1	2	3	4	
51	<input type="checkbox"/>	<input type="checkbox"/>	<input type="checkbox"/>	<input type="checkbox"/>	-----
52	<input type="checkbox"/>	<input type="checkbox"/>	<input type="checkbox"/>	<input type="checkbox"/>	-----
53	<input type="checkbox"/>	<input type="checkbox"/>	<input type="checkbox"/>	<input type="checkbox"/>	-----
54	<input type="checkbox"/>	<input type="checkbox"/>	<input type="checkbox"/>	<input type="checkbox"/>	-----
55	<input type="checkbox"/>	<input type="checkbox"/>	<input type="checkbox"/>	<input type="checkbox"/>	-----
56	<input type="checkbox"/>	<input type="checkbox"/>	<input type="checkbox"/>	<input type="checkbox"/>	-----
57	<input type="checkbox"/>	<input type="checkbox"/>	<input type="checkbox"/>	<input type="checkbox"/>	-----
58	<input type="checkbox"/>	<input type="checkbox"/>	<input type="checkbox"/>	<input type="checkbox"/>	-----
59	<input type="checkbox"/>	<input type="checkbox"/>	<input type="checkbox"/>	<input type="checkbox"/>	-----
60	<input type="checkbox"/>	<input type="checkbox"/>	<input type="checkbox"/>	<input type="checkbox"/>	-----
61	<input type="checkbox"/>	<input type="checkbox"/>	<input type="checkbox"/>	<input type="checkbox"/>	-----
62	<input type="checkbox"/>	<input type="checkbox"/>	<input type="checkbox"/>	<input type="checkbox"/>	-----
63	<input type="checkbox"/>	<input type="checkbox"/>	<input type="checkbox"/>	<input type="checkbox"/>	-----
64	<input type="checkbox"/>	<input type="checkbox"/>	<input type="checkbox"/>	<input type="checkbox"/>	-----
65	<input type="checkbox"/>	<input type="checkbox"/>	<input type="checkbox"/>	<input type="checkbox"/>	-----
66	<input type="checkbox"/>	<input type="checkbox"/>	<input type="checkbox"/>	<input type="checkbox"/>	-----
67	<input type="checkbox"/>	<input type="checkbox"/>	<input type="checkbox"/>	<input type="checkbox"/>	-----
68	<input type="checkbox"/>	<input type="checkbox"/>	<input type="checkbox"/>	<input type="checkbox"/>	-----
69	<input type="checkbox"/>	<input type="checkbox"/>	<input type="checkbox"/>	<input type="checkbox"/>	-----
70	<input type="checkbox"/>	<input type="checkbox"/>	<input type="checkbox"/>	<input type="checkbox"/>	-----
71	<input type="checkbox"/>	<input type="checkbox"/>	<input type="checkbox"/>	<input type="checkbox"/>	-----
72	<input type="checkbox"/>	<input type="checkbox"/>	<input type="checkbox"/>	<input type="checkbox"/>	-----
73	<input type="checkbox"/>	<input type="checkbox"/>	<input type="checkbox"/>	<input type="checkbox"/>	-----
74	<input type="checkbox"/>	<input type="checkbox"/>	<input type="checkbox"/>	<input type="checkbox"/>	-----
75	<input type="checkbox"/>	<input type="checkbox"/>	<input type="checkbox"/>	<input type="checkbox"/>	-----



PRINT OR TYPE

BUILDER 342
NAVEDTRA 10648-G

NAME _____ ADDRESS _____
Last First Middle Street/Ship/Unit/Division, etc.
City or PFO State Zip
RANK/RATE _____ SOC. SEC. NO. _____ DESIGNATOR _____ ASSIGNMENT NO _____
 USN USNR ACTIVE INACTIVE OTHER (Specify) _____ DATE MAILED _____
SCORE

	1	2	3	4	
	T	F			
1	<input type="checkbox"/>	<input type="checkbox"/>	<input type="checkbox"/>	<input type="checkbox"/>	-----
2	<input type="checkbox"/>	<input type="checkbox"/>	<input type="checkbox"/>	<input type="checkbox"/>	-----
3	<input type="checkbox"/>	<input type="checkbox"/>	<input type="checkbox"/>	<input type="checkbox"/>	-----
4	<input type="checkbox"/>	<input type="checkbox"/>	<input type="checkbox"/>	<input type="checkbox"/>	-----
5	<input type="checkbox"/>	<input type="checkbox"/>	<input type="checkbox"/>	<input type="checkbox"/>	-----
6	<input type="checkbox"/>	<input type="checkbox"/>	<input type="checkbox"/>	<input type="checkbox"/>	-----
7	<input type="checkbox"/>	<input type="checkbox"/>	<input type="checkbox"/>	<input type="checkbox"/>	-----
8	<input type="checkbox"/>	<input type="checkbox"/>	<input type="checkbox"/>	<input type="checkbox"/>	-----
9	<input type="checkbox"/>	<input type="checkbox"/>	<input type="checkbox"/>	<input type="checkbox"/>	-----
10	<input type="checkbox"/>	<input type="checkbox"/>	<input type="checkbox"/>	<input type="checkbox"/>	-----
11	<input type="checkbox"/>	<input type="checkbox"/>	<input type="checkbox"/>	<input type="checkbox"/>	-----
12	<input type="checkbox"/>	<input type="checkbox"/>	<input type="checkbox"/>	<input type="checkbox"/>	-----
13	<input type="checkbox"/>	<input type="checkbox"/>	<input type="checkbox"/>	<input type="checkbox"/>	-----
14	<input type="checkbox"/>	<input type="checkbox"/>	<input type="checkbox"/>	<input type="checkbox"/>	-----
15	<input type="checkbox"/>	<input type="checkbox"/>	<input type="checkbox"/>	<input type="checkbox"/>	-----
16	<input type="checkbox"/>	<input type="checkbox"/>	<input type="checkbox"/>	<input type="checkbox"/>	-----
17	<input type="checkbox"/>	<input type="checkbox"/>	<input type="checkbox"/>	<input type="checkbox"/>	-----
18	<input type="checkbox"/>	<input type="checkbox"/>	<input type="checkbox"/>	<input type="checkbox"/>	-----
19	<input type="checkbox"/>	<input type="checkbox"/>	<input type="checkbox"/>	<input type="checkbox"/>	-----
20	<input type="checkbox"/>	<input type="checkbox"/>	<input type="checkbox"/>	<input type="checkbox"/>	-----
21	<input type="checkbox"/>	<input type="checkbox"/>	<input type="checkbox"/>	<input type="checkbox"/>	-----
22	<input type="checkbox"/>	<input type="checkbox"/>	<input type="checkbox"/>	<input type="checkbox"/>	-----
23	<input type="checkbox"/>	<input type="checkbox"/>	<input type="checkbox"/>	<input type="checkbox"/>	-----
24	<input type="checkbox"/>	<input type="checkbox"/>	<input type="checkbox"/>	<input type="checkbox"/>	-----
25	<input type="checkbox"/>	<input type="checkbox"/>	<input type="checkbox"/>	<input type="checkbox"/>	-----

	1	2	3	4	
	T	F			
26	<input type="checkbox"/>	<input type="checkbox"/>	<input type="checkbox"/>	<input type="checkbox"/>	-----
27	<input type="checkbox"/>	<input type="checkbox"/>	<input type="checkbox"/>	<input type="checkbox"/>	-----
28	<input type="checkbox"/>	<input type="checkbox"/>	<input type="checkbox"/>	<input type="checkbox"/>	-----
29	<input type="checkbox"/>	<input type="checkbox"/>	<input type="checkbox"/>	<input type="checkbox"/>	-----
30	<input type="checkbox"/>	<input type="checkbox"/>	<input type="checkbox"/>	<input type="checkbox"/>	-----
31	<input type="checkbox"/>	<input type="checkbox"/>	<input type="checkbox"/>	<input type="checkbox"/>	-----
32	<input type="checkbox"/>	<input type="checkbox"/>	<input type="checkbox"/>	<input type="checkbox"/>	-----
33	<input type="checkbox"/>	<input type="checkbox"/>	<input type="checkbox"/>	<input type="checkbox"/>	-----
34	<input type="checkbox"/>	<input type="checkbox"/>	<input type="checkbox"/>	<input type="checkbox"/>	-----
35	<input type="checkbox"/>	<input type="checkbox"/>	<input type="checkbox"/>	<input type="checkbox"/>	-----
36	<input type="checkbox"/>	<input type="checkbox"/>	<input type="checkbox"/>	<input type="checkbox"/>	-----
37	<input type="checkbox"/>	<input type="checkbox"/>	<input type="checkbox"/>	<input type="checkbox"/>	-----
38	<input type="checkbox"/>	<input type="checkbox"/>	<input type="checkbox"/>	<input type="checkbox"/>	-----
39	<input type="checkbox"/>	<input type="checkbox"/>	<input type="checkbox"/>	<input type="checkbox"/>	-----
40	<input type="checkbox"/>	<input type="checkbox"/>	<input type="checkbox"/>	<input type="checkbox"/>	-----
41	<input type="checkbox"/>	<input type="checkbox"/>	<input type="checkbox"/>	<input type="checkbox"/>	-----
42	<input type="checkbox"/>	<input type="checkbox"/>	<input type="checkbox"/>	<input type="checkbox"/>	-----
43	<input type="checkbox"/>	<input type="checkbox"/>	<input type="checkbox"/>	<input type="checkbox"/>	-----
44	<input type="checkbox"/>	<input type="checkbox"/>	<input type="checkbox"/>	<input type="checkbox"/>	-----
45	<input type="checkbox"/>	<input type="checkbox"/>	<input type="checkbox"/>	<input type="checkbox"/>	-----
46	<input type="checkbox"/>	<input type="checkbox"/>	<input type="checkbox"/>	<input type="checkbox"/>	-----
47	<input type="checkbox"/>	<input type="checkbox"/>	<input type="checkbox"/>	<input type="checkbox"/>	-----
48	<input type="checkbox"/>	<input type="checkbox"/>	<input type="checkbox"/>	<input type="checkbox"/>	-----
49	<input type="checkbox"/>	<input type="checkbox"/>	<input type="checkbox"/>	<input type="checkbox"/>	-----
50	<input type="checkbox"/>	<input type="checkbox"/>	<input type="checkbox"/>	<input type="checkbox"/>	-----

	1	2	3	4	
	T	F			
51	<input type="checkbox"/>	<input type="checkbox"/>	<input type="checkbox"/>	<input type="checkbox"/>	-----
52	<input type="checkbox"/>	<input type="checkbox"/>	<input type="checkbox"/>	<input type="checkbox"/>	-----
53	<input type="checkbox"/>	<input type="checkbox"/>	<input type="checkbox"/>	<input type="checkbox"/>	-----
54	<input type="checkbox"/>	<input type="checkbox"/>	<input type="checkbox"/>	<input type="checkbox"/>	-----
55	<input type="checkbox"/>	<input type="checkbox"/>	<input type="checkbox"/>	<input type="checkbox"/>	-----
56	<input type="checkbox"/>	<input type="checkbox"/>	<input type="checkbox"/>	<input type="checkbox"/>	-----
57	<input type="checkbox"/>	<input type="checkbox"/>	<input type="checkbox"/>	<input type="checkbox"/>	-----
58	<input type="checkbox"/>	<input type="checkbox"/>	<input type="checkbox"/>	<input type="checkbox"/>	-----
59	<input type="checkbox"/>	<input type="checkbox"/>	<input type="checkbox"/>	<input type="checkbox"/>	-----
60	<input type="checkbox"/>	<input type="checkbox"/>	<input type="checkbox"/>	<input type="checkbox"/>	-----
61	<input type="checkbox"/>	<input type="checkbox"/>	<input type="checkbox"/>	<input type="checkbox"/>	-----
62	<input type="checkbox"/>	<input type="checkbox"/>	<input type="checkbox"/>	<input type="checkbox"/>	-----
63	<input type="checkbox"/>	<input type="checkbox"/>	<input type="checkbox"/>	<input type="checkbox"/>	-----
64	<input type="checkbox"/>	<input type="checkbox"/>	<input type="checkbox"/>	<input type="checkbox"/>	-----
65	<input type="checkbox"/>	<input type="checkbox"/>	<input type="checkbox"/>	<input type="checkbox"/>	-----
66	<input type="checkbox"/>	<input type="checkbox"/>	<input type="checkbox"/>	<input type="checkbox"/>	-----
67	<input type="checkbox"/>	<input type="checkbox"/>	<input type="checkbox"/>	<input type="checkbox"/>	-----
68	<input type="checkbox"/>	<input type="checkbox"/>	<input type="checkbox"/>	<input type="checkbox"/>	-----
69	<input type="checkbox"/>	<input type="checkbox"/>	<input type="checkbox"/>	<input type="checkbox"/>	-----
70	<input type="checkbox"/>	<input type="checkbox"/>	<input type="checkbox"/>	<input type="checkbox"/>	-----
71	<input type="checkbox"/>	<input type="checkbox"/>	<input type="checkbox"/>	<input type="checkbox"/>	-----
72	<input type="checkbox"/>	<input type="checkbox"/>	<input type="checkbox"/>	<input type="checkbox"/>	-----
73	<input type="checkbox"/>	<input type="checkbox"/>	<input type="checkbox"/>	<input type="checkbox"/>	-----
74	<input type="checkbox"/>	<input type="checkbox"/>	<input type="checkbox"/>	<input type="checkbox"/>	-----
75	<input type="checkbox"/>	<input type="checkbox"/>	<input type="checkbox"/>	<input type="checkbox"/>	-----



PRINT OR TYPE

BUILDER 3-2
NAVEDTRA 10648-G

NAME _____ ADDRESS _____
Last First Middle Street/Ship/Unit/Division, etc.

City or FPO State Zip

RANK/RATE _____ SOC. SEC. NO. _____ DESIGNATOR _____ ASSIGNMENT NO _____

USN USNR ACTIVE INACTIVE OTHER (Specify) _____ DATE MAILED _____
SCORE

	1	2	3	4	
	T	P			
1	<input type="checkbox"/>	<input type="checkbox"/>	<input type="checkbox"/>	<input type="checkbox"/>	-----
2	<input type="checkbox"/>	<input type="checkbox"/>	<input type="checkbox"/>	<input type="checkbox"/>	-----
3	<input type="checkbox"/>	<input type="checkbox"/>	<input type="checkbox"/>	<input type="checkbox"/>	-----
4	<input type="checkbox"/>	<input type="checkbox"/>	<input type="checkbox"/>	<input type="checkbox"/>	-----
5	<input type="checkbox"/>	<input type="checkbox"/>	<input type="checkbox"/>	<input type="checkbox"/>	-----
6	<input type="checkbox"/>	<input type="checkbox"/>	<input type="checkbox"/>	<input type="checkbox"/>	-----
7	<input type="checkbox"/>	<input type="checkbox"/>	<input type="checkbox"/>	<input type="checkbox"/>	-----
8	<input type="checkbox"/>	<input type="checkbox"/>	<input type="checkbox"/>	<input type="checkbox"/>	-----
9	<input type="checkbox"/>	<input type="checkbox"/>	<input type="checkbox"/>	<input type="checkbox"/>	-----
10	<input type="checkbox"/>	<input type="checkbox"/>	<input type="checkbox"/>	<input type="checkbox"/>	-----
11	<input type="checkbox"/>	<input type="checkbox"/>	<input type="checkbox"/>	<input type="checkbox"/>	-----
12	<input type="checkbox"/>	<input type="checkbox"/>	<input type="checkbox"/>	<input type="checkbox"/>	-----
13	<input type="checkbox"/>	<input type="checkbox"/>	<input type="checkbox"/>	<input type="checkbox"/>	-----
14	<input type="checkbox"/>	<input type="checkbox"/>	<input type="checkbox"/>	<input type="checkbox"/>	-----
15	<input type="checkbox"/>	<input type="checkbox"/>	<input type="checkbox"/>	<input type="checkbox"/>	-----
16	<input type="checkbox"/>	<input type="checkbox"/>	<input type="checkbox"/>	<input type="checkbox"/>	-----
17	<input type="checkbox"/>	<input type="checkbox"/>	<input type="checkbox"/>	<input type="checkbox"/>	-----
18	<input type="checkbox"/>	<input type="checkbox"/>	<input type="checkbox"/>	<input type="checkbox"/>	-----
19	<input type="checkbox"/>	<input type="checkbox"/>	<input type="checkbox"/>	<input type="checkbox"/>	-----
20	<input type="checkbox"/>	<input type="checkbox"/>	<input type="checkbox"/>	<input type="checkbox"/>	-----
21	<input type="checkbox"/>	<input type="checkbox"/>	<input type="checkbox"/>	<input type="checkbox"/>	-----
22	<input type="checkbox"/>	<input type="checkbox"/>	<input type="checkbox"/>	<input type="checkbox"/>	-----
23	<input type="checkbox"/>	<input type="checkbox"/>	<input type="checkbox"/>	<input type="checkbox"/>	-----
24	<input type="checkbox"/>	<input type="checkbox"/>	<input type="checkbox"/>	<input type="checkbox"/>	-----
25	<input type="checkbox"/>	<input type="checkbox"/>	<input type="checkbox"/>	<input type="checkbox"/>	-----

	1	2	3	4	
	T	P			
26	<input type="checkbox"/>	<input type="checkbox"/>	<input type="checkbox"/>	<input type="checkbox"/>	-----
27	<input type="checkbox"/>	<input type="checkbox"/>	<input type="checkbox"/>	<input type="checkbox"/>	-----
28	<input type="checkbox"/>	<input type="checkbox"/>	<input type="checkbox"/>	<input type="checkbox"/>	-----
29	<input type="checkbox"/>	<input type="checkbox"/>	<input type="checkbox"/>	<input type="checkbox"/>	-----
30	<input type="checkbox"/>	<input type="checkbox"/>	<input type="checkbox"/>	<input type="checkbox"/>	-----
31	<input type="checkbox"/>	<input type="checkbox"/>	<input type="checkbox"/>	<input type="checkbox"/>	-----
32	<input type="checkbox"/>	<input type="checkbox"/>	<input type="checkbox"/>	<input type="checkbox"/>	-----
33	<input type="checkbox"/>	<input type="checkbox"/>	<input type="checkbox"/>	<input type="checkbox"/>	-----
34	<input type="checkbox"/>	<input type="checkbox"/>	<input type="checkbox"/>	<input type="checkbox"/>	-----
35	<input type="checkbox"/>	<input type="checkbox"/>	<input type="checkbox"/>	<input type="checkbox"/>	-----
36	<input type="checkbox"/>	<input type="checkbox"/>	<input type="checkbox"/>	<input type="checkbox"/>	-----
37	<input type="checkbox"/>	<input type="checkbox"/>	<input type="checkbox"/>	<input type="checkbox"/>	-----
38	<input type="checkbox"/>	<input type="checkbox"/>	<input type="checkbox"/>	<input type="checkbox"/>	-----
39	<input type="checkbox"/>	<input type="checkbox"/>	<input type="checkbox"/>	<input type="checkbox"/>	-----
40	<input type="checkbox"/>	<input type="checkbox"/>	<input type="checkbox"/>	<input type="checkbox"/>	-----
41	<input type="checkbox"/>	<input type="checkbox"/>	<input type="checkbox"/>	<input type="checkbox"/>	-----
42	<input type="checkbox"/>	<input type="checkbox"/>	<input type="checkbox"/>	<input type="checkbox"/>	-----
43	<input type="checkbox"/>	<input type="checkbox"/>	<input type="checkbox"/>	<input type="checkbox"/>	-----
44	<input type="checkbox"/>	<input type="checkbox"/>	<input type="checkbox"/>	<input type="checkbox"/>	-----
45	<input type="checkbox"/>	<input type="checkbox"/>	<input type="checkbox"/>	<input type="checkbox"/>	-----
46	<input type="checkbox"/>	<input type="checkbox"/>	<input type="checkbox"/>	<input type="checkbox"/>	-----
47	<input type="checkbox"/>	<input type="checkbox"/>	<input type="checkbox"/>	<input type="checkbox"/>	-----
48	<input type="checkbox"/>	<input type="checkbox"/>	<input type="checkbox"/>	<input type="checkbox"/>	-----
49	<input type="checkbox"/>	<input type="checkbox"/>	<input type="checkbox"/>	<input type="checkbox"/>	-----
50	<input type="checkbox"/>	<input type="checkbox"/>	<input type="checkbox"/>	<input type="checkbox"/>	-----

	1	2	3	4	
	T	P			
51	<input type="checkbox"/>	<input type="checkbox"/>	<input type="checkbox"/>	<input type="checkbox"/>	-----
52	<input type="checkbox"/>	<input type="checkbox"/>	<input type="checkbox"/>	<input type="checkbox"/>	-----
53	<input type="checkbox"/>	<input type="checkbox"/>	<input type="checkbox"/>	<input type="checkbox"/>	-----
54	<input type="checkbox"/>	<input type="checkbox"/>	<input type="checkbox"/>	<input type="checkbox"/>	-----
55	<input type="checkbox"/>	<input type="checkbox"/>	<input type="checkbox"/>	<input type="checkbox"/>	-----
56	<input type="checkbox"/>	<input type="checkbox"/>	<input type="checkbox"/>	<input type="checkbox"/>	-----
57	<input type="checkbox"/>	<input type="checkbox"/>	<input type="checkbox"/>	<input type="checkbox"/>	-----
58	<input type="checkbox"/>	<input type="checkbox"/>	<input type="checkbox"/>	<input type="checkbox"/>	-----
59	<input type="checkbox"/>	<input type="checkbox"/>	<input type="checkbox"/>	<input type="checkbox"/>	-----
60	<input type="checkbox"/>	<input type="checkbox"/>	<input type="checkbox"/>	<input type="checkbox"/>	-----
61	<input type="checkbox"/>	<input type="checkbox"/>	<input type="checkbox"/>	<input type="checkbox"/>	-----
62	<input type="checkbox"/>	<input type="checkbox"/>	<input type="checkbox"/>	<input type="checkbox"/>	-----
63	<input type="checkbox"/>	<input type="checkbox"/>	<input type="checkbox"/>	<input type="checkbox"/>	-----
64	<input type="checkbox"/>	<input type="checkbox"/>	<input type="checkbox"/>	<input type="checkbox"/>	-----
65	<input type="checkbox"/>	<input type="checkbox"/>	<input type="checkbox"/>	<input type="checkbox"/>	-----
66	<input type="checkbox"/>	<input type="checkbox"/>	<input type="checkbox"/>	<input type="checkbox"/>	-----
67	<input type="checkbox"/>	<input type="checkbox"/>	<input type="checkbox"/>	<input type="checkbox"/>	-----
68	<input type="checkbox"/>	<input type="checkbox"/>	<input type="checkbox"/>	<input type="checkbox"/>	-----
69	<input type="checkbox"/>	<input type="checkbox"/>	<input type="checkbox"/>	<input type="checkbox"/>	-----
70	<input type="checkbox"/>	<input type="checkbox"/>	<input type="checkbox"/>	<input type="checkbox"/>	-----
71	<input type="checkbox"/>	<input type="checkbox"/>	<input type="checkbox"/>	<input type="checkbox"/>	-----
72	<input type="checkbox"/>	<input type="checkbox"/>	<input type="checkbox"/>	<input type="checkbox"/>	-----
73	<input type="checkbox"/>	<input type="checkbox"/>	<input type="checkbox"/>	<input type="checkbox"/>	-----
74	<input type="checkbox"/>	<input type="checkbox"/>	<input type="checkbox"/>	<input type="checkbox"/>	-----
75	<input type="checkbox"/>	<input type="checkbox"/>	<input type="checkbox"/>	<input type="checkbox"/>	-----

PRINT OR TYPE

BUILDER 3&2
NAVEDTRA 10648-G

NAME _____ ADDRESS _____
Last First Middle Street/Ship/Unit/Division, etc.

City or PPO State Zip

RANK/RATE _____ SOC. SEC. NO. _____ DESIGNATOR _____ ASSIGNMENT NO _____

USN USNR ACTIVE INACTIVE OTHER (Specify) _____ DATE MAILED _____

SCORE

	1	2	3	4	
	T	F			
1	<input type="checkbox"/>	<input type="checkbox"/>	<input type="checkbox"/>	<input type="checkbox"/>	-----
2	<input type="checkbox"/>	<input type="checkbox"/>	<input type="checkbox"/>	<input type="checkbox"/>	-----
3	<input type="checkbox"/>	<input type="checkbox"/>	<input type="checkbox"/>	<input type="checkbox"/>	-----
4	<input type="checkbox"/>	<input type="checkbox"/>	<input type="checkbox"/>	<input type="checkbox"/>	-----
5	<input type="checkbox"/>	<input type="checkbox"/>	<input type="checkbox"/>	<input type="checkbox"/>	-----
6	<input type="checkbox"/>	<input type="checkbox"/>	<input type="checkbox"/>	<input type="checkbox"/>	-----
7	<input type="checkbox"/>	<input type="checkbox"/>	<input type="checkbox"/>	<input type="checkbox"/>	-----
8	<input type="checkbox"/>	<input type="checkbox"/>	<input type="checkbox"/>	<input type="checkbox"/>	-----
9	<input type="checkbox"/>	<input type="checkbox"/>	<input type="checkbox"/>	<input type="checkbox"/>	-----
10	<input type="checkbox"/>	<input type="checkbox"/>	<input type="checkbox"/>	<input type="checkbox"/>	-----
11	<input type="checkbox"/>	<input type="checkbox"/>	<input type="checkbox"/>	<input type="checkbox"/>	-----
12	<input type="checkbox"/>	<input type="checkbox"/>	<input type="checkbox"/>	<input type="checkbox"/>	-----
13	<input type="checkbox"/>	<input type="checkbox"/>	<input type="checkbox"/>	<input type="checkbox"/>	-----
14	<input type="checkbox"/>	<input type="checkbox"/>	<input type="checkbox"/>	<input type="checkbox"/>	-----
15	<input type="checkbox"/>	<input type="checkbox"/>	<input type="checkbox"/>	<input type="checkbox"/>	-----
16	<input type="checkbox"/>	<input type="checkbox"/>	<input type="checkbox"/>	<input type="checkbox"/>	-----
17	<input type="checkbox"/>	<input type="checkbox"/>	<input type="checkbox"/>	<input type="checkbox"/>	-----
18	<input type="checkbox"/>	<input type="checkbox"/>	<input type="checkbox"/>	<input type="checkbox"/>	-----
19	<input type="checkbox"/>	<input type="checkbox"/>	<input type="checkbox"/>	<input type="checkbox"/>	-----
20	<input type="checkbox"/>	<input type="checkbox"/>	<input type="checkbox"/>	<input type="checkbox"/>	-----
21	<input type="checkbox"/>	<input type="checkbox"/>	<input type="checkbox"/>	<input type="checkbox"/>	-----
22	<input type="checkbox"/>	<input type="checkbox"/>	<input type="checkbox"/>	<input type="checkbox"/>	-----
23	<input type="checkbox"/>	<input type="checkbox"/>	<input type="checkbox"/>	<input type="checkbox"/>	-----
24	<input type="checkbox"/>	<input type="checkbox"/>	<input type="checkbox"/>	<input type="checkbox"/>	-----
25	<input type="checkbox"/>	<input type="checkbox"/>	<input type="checkbox"/>	<input type="checkbox"/>	-----

	1	2	3	4	
	T	F			
26	<input type="checkbox"/>	<input type="checkbox"/>	<input type="checkbox"/>	<input type="checkbox"/>	-----
27	<input type="checkbox"/>	<input type="checkbox"/>	<input type="checkbox"/>	<input type="checkbox"/>	-----
28	<input type="checkbox"/>	<input type="checkbox"/>	<input type="checkbox"/>	<input type="checkbox"/>	-----
29	<input type="checkbox"/>	<input type="checkbox"/>	<input type="checkbox"/>	<input type="checkbox"/>	-----
30	<input type="checkbox"/>	<input type="checkbox"/>	<input type="checkbox"/>	<input type="checkbox"/>	-----
31	<input type="checkbox"/>	<input type="checkbox"/>	<input type="checkbox"/>	<input type="checkbox"/>	-----
32	<input type="checkbox"/>	<input type="checkbox"/>	<input type="checkbox"/>	<input type="checkbox"/>	-----
33	<input type="checkbox"/>	<input type="checkbox"/>	<input type="checkbox"/>	<input type="checkbox"/>	-----
34	<input type="checkbox"/>	<input type="checkbox"/>	<input type="checkbox"/>	<input type="checkbox"/>	-----
35	<input type="checkbox"/>	<input type="checkbox"/>	<input type="checkbox"/>	<input type="checkbox"/>	-----
36	<input type="checkbox"/>	<input type="checkbox"/>	<input type="checkbox"/>	<input type="checkbox"/>	-----
37	<input type="checkbox"/>	<input type="checkbox"/>	<input type="checkbox"/>	<input type="checkbox"/>	-----
38	<input type="checkbox"/>	<input type="checkbox"/>	<input type="checkbox"/>	<input type="checkbox"/>	-----
39	<input type="checkbox"/>	<input type="checkbox"/>	<input type="checkbox"/>	<input type="checkbox"/>	-----
40	<input type="checkbox"/>	<input type="checkbox"/>	<input type="checkbox"/>	<input type="checkbox"/>	-----
41	<input type="checkbox"/>	<input type="checkbox"/>	<input type="checkbox"/>	<input type="checkbox"/>	-----
42	<input type="checkbox"/>	<input type="checkbox"/>	<input type="checkbox"/>	<input type="checkbox"/>	-----
43	<input type="checkbox"/>	<input type="checkbox"/>	<input type="checkbox"/>	<input type="checkbox"/>	-----
44	<input type="checkbox"/>	<input type="checkbox"/>	<input type="checkbox"/>	<input type="checkbox"/>	-----
45	<input type="checkbox"/>	<input type="checkbox"/>	<input type="checkbox"/>	<input type="checkbox"/>	-----
46	<input type="checkbox"/>	<input type="checkbox"/>	<input type="checkbox"/>	<input type="checkbox"/>	-----
47	<input type="checkbox"/>	<input type="checkbox"/>	<input type="checkbox"/>	<input type="checkbox"/>	-----
48	<input type="checkbox"/>	<input type="checkbox"/>	<input type="checkbox"/>	<input type="checkbox"/>	-----
49	<input type="checkbox"/>	<input type="checkbox"/>	<input type="checkbox"/>	<input type="checkbox"/>	-----
50	<input type="checkbox"/>	<input type="checkbox"/>	<input type="checkbox"/>	<input type="checkbox"/>	-----

	1	2	3	4	
	T	F			
51	<input type="checkbox"/>	<input type="checkbox"/>	<input type="checkbox"/>	<input type="checkbox"/>	-----
52	<input type="checkbox"/>	<input type="checkbox"/>	<input type="checkbox"/>	<input type="checkbox"/>	-----
53	<input type="checkbox"/>	<input type="checkbox"/>	<input type="checkbox"/>	<input type="checkbox"/>	-----
54	<input type="checkbox"/>	<input type="checkbox"/>	<input type="checkbox"/>	<input type="checkbox"/>	-----
55	<input type="checkbox"/>	<input type="checkbox"/>	<input type="checkbox"/>	<input type="checkbox"/>	-----
56	<input type="checkbox"/>	<input type="checkbox"/>	<input type="checkbox"/>	<input type="checkbox"/>	-----
57	<input type="checkbox"/>	<input type="checkbox"/>	<input type="checkbox"/>	<input type="checkbox"/>	-----
58	<input type="checkbox"/>	<input type="checkbox"/>	<input type="checkbox"/>	<input type="checkbox"/>	-----
59	<input type="checkbox"/>	<input type="checkbox"/>	<input type="checkbox"/>	<input type="checkbox"/>	-----
60	<input type="checkbox"/>	<input type="checkbox"/>	<input type="checkbox"/>	<input type="checkbox"/>	-----
61	<input type="checkbox"/>	<input type="checkbox"/>	<input type="checkbox"/>	<input type="checkbox"/>	-----
62	<input type="checkbox"/>	<input type="checkbox"/>	<input type="checkbox"/>	<input type="checkbox"/>	-----
63	<input type="checkbox"/>	<input type="checkbox"/>	<input type="checkbox"/>	<input type="checkbox"/>	-----
64	<input type="checkbox"/>	<input type="checkbox"/>	<input type="checkbox"/>	<input type="checkbox"/>	-----
65	<input type="checkbox"/>	<input type="checkbox"/>	<input type="checkbox"/>	<input type="checkbox"/>	-----
66	<input type="checkbox"/>	<input type="checkbox"/>	<input type="checkbox"/>	<input type="checkbox"/>	-----
67	<input type="checkbox"/>	<input type="checkbox"/>	<input type="checkbox"/>	<input type="checkbox"/>	-----
68	<input type="checkbox"/>	<input type="checkbox"/>	<input type="checkbox"/>	<input type="checkbox"/>	-----
69	<input type="checkbox"/>	<input type="checkbox"/>	<input type="checkbox"/>	<input type="checkbox"/>	-----
70	<input type="checkbox"/>	<input type="checkbox"/>	<input type="checkbox"/>	<input type="checkbox"/>	-----
71	<input type="checkbox"/>	<input type="checkbox"/>	<input type="checkbox"/>	<input type="checkbox"/>	-----
72	<input type="checkbox"/>	<input type="checkbox"/>	<input type="checkbox"/>	<input type="checkbox"/>	-----
73	<input type="checkbox"/>	<input type="checkbox"/>	<input type="checkbox"/>	<input type="checkbox"/>	-----
74	<input type="checkbox"/>	<input type="checkbox"/>	<input type="checkbox"/>	<input type="checkbox"/>	-----
75	<input type="checkbox"/>	<input type="checkbox"/>	<input type="checkbox"/>	<input type="checkbox"/>	-----



PRINT OR TYPE

BUILDER 3&2
NAVEDTRA 10648-G

NAME _____ ADDRESS _____
Last First Middle Street/Ship/Unit/Division, etc.

City or FPO State Zip
RANK/RATE _____ SOC. SEC. NO. _____ DESIGNATOR _____ ASSIGNMENT NO. _____

USN USNR ACTIVE INACTIVE OTHER (Specify) _____ DATE MAILED _____

SCORE

	1	2	3	4	
	T	P			
1	<input type="checkbox"/>	<input type="checkbox"/>	<input type="checkbox"/>	<input type="checkbox"/>	-----
2	<input type="checkbox"/>	<input type="checkbox"/>	<input type="checkbox"/>	<input type="checkbox"/>	-----
3	<input type="checkbox"/>	<input type="checkbox"/>	<input type="checkbox"/>	<input type="checkbox"/>	-----
4	<input type="checkbox"/>	<input type="checkbox"/>	<input type="checkbox"/>	<input type="checkbox"/>	-----
5	<input type="checkbox"/>	<input type="checkbox"/>	<input type="checkbox"/>	<input type="checkbox"/>	-----
6	<input type="checkbox"/>	<input type="checkbox"/>	<input type="checkbox"/>	<input type="checkbox"/>	-----
7	<input type="checkbox"/>	<input type="checkbox"/>	<input type="checkbox"/>	<input type="checkbox"/>	-----
8	<input type="checkbox"/>	<input type="checkbox"/>	<input type="checkbox"/>	<input type="checkbox"/>	-----
9	<input type="checkbox"/>	<input type="checkbox"/>	<input type="checkbox"/>	<input type="checkbox"/>	-----
10	<input type="checkbox"/>	<input type="checkbox"/>	<input type="checkbox"/>	<input type="checkbox"/>	-----
11	<input type="checkbox"/>	<input type="checkbox"/>	<input type="checkbox"/>	<input type="checkbox"/>	-----
12	<input type="checkbox"/>	<input type="checkbox"/>	<input type="checkbox"/>	<input type="checkbox"/>	-----
13	<input type="checkbox"/>	<input type="checkbox"/>	<input type="checkbox"/>	<input type="checkbox"/>	-----
14	<input type="checkbox"/>	<input type="checkbox"/>	<input type="checkbox"/>	<input type="checkbox"/>	-----
15	<input type="checkbox"/>	<input type="checkbox"/>	<input type="checkbox"/>	<input type="checkbox"/>	-----
16	<input type="checkbox"/>	<input type="checkbox"/>	<input type="checkbox"/>	<input type="checkbox"/>	-----
17	<input type="checkbox"/>	<input type="checkbox"/>	<input type="checkbox"/>	<input type="checkbox"/>	-----
18	<input type="checkbox"/>	<input type="checkbox"/>	<input type="checkbox"/>	<input type="checkbox"/>	-----
19	<input type="checkbox"/>	<input type="checkbox"/>	<input type="checkbox"/>	<input type="checkbox"/>	-----
20	<input type="checkbox"/>	<input type="checkbox"/>	<input type="checkbox"/>	<input type="checkbox"/>	-----
21	<input type="checkbox"/>	<input type="checkbox"/>	<input type="checkbox"/>	<input type="checkbox"/>	-----
22	<input type="checkbox"/>	<input type="checkbox"/>	<input type="checkbox"/>	<input type="checkbox"/>	-----
23	<input type="checkbox"/>	<input type="checkbox"/>	<input type="checkbox"/>	<input type="checkbox"/>	-----
24	<input type="checkbox"/>	<input type="checkbox"/>	<input type="checkbox"/>	<input type="checkbox"/>	-----
25	<input type="checkbox"/>	<input type="checkbox"/>	<input type="checkbox"/>	<input type="checkbox"/>	-----

	1	2	3	4	
	T	P			
26	<input type="checkbox"/>	<input type="checkbox"/>	<input type="checkbox"/>	<input type="checkbox"/>	-----
27	<input type="checkbox"/>	<input type="checkbox"/>	<input type="checkbox"/>	<input type="checkbox"/>	-----
28	<input type="checkbox"/>	<input type="checkbox"/>	<input type="checkbox"/>	<input type="checkbox"/>	-----
29	<input type="checkbox"/>	<input type="checkbox"/>	<input type="checkbox"/>	<input type="checkbox"/>	-----
30	<input type="checkbox"/>	<input type="checkbox"/>	<input type="checkbox"/>	<input type="checkbox"/>	-----
31	<input type="checkbox"/>	<input type="checkbox"/>	<input type="checkbox"/>	<input type="checkbox"/>	-----
32	<input type="checkbox"/>	<input type="checkbox"/>	<input type="checkbox"/>	<input type="checkbox"/>	-----
33	<input type="checkbox"/>	<input type="checkbox"/>	<input type="checkbox"/>	<input type="checkbox"/>	-----
34	<input type="checkbox"/>	<input type="checkbox"/>	<input type="checkbox"/>	<input type="checkbox"/>	-----
35	<input type="checkbox"/>	<input type="checkbox"/>	<input type="checkbox"/>	<input type="checkbox"/>	-----
36	<input type="checkbox"/>	<input type="checkbox"/>	<input type="checkbox"/>	<input type="checkbox"/>	-----
37	<input type="checkbox"/>	<input type="checkbox"/>	<input type="checkbox"/>	<input type="checkbox"/>	-----
38	<input type="checkbox"/>	<input type="checkbox"/>	<input type="checkbox"/>	<input type="checkbox"/>	-----
39	<input type="checkbox"/>	<input type="checkbox"/>	<input type="checkbox"/>	<input type="checkbox"/>	-----
40	<input type="checkbox"/>	<input type="checkbox"/>	<input type="checkbox"/>	<input type="checkbox"/>	-----
41	<input type="checkbox"/>	<input type="checkbox"/>	<input type="checkbox"/>	<input type="checkbox"/>	-----
42	<input type="checkbox"/>	<input type="checkbox"/>	<input type="checkbox"/>	<input type="checkbox"/>	-----
43	<input type="checkbox"/>	<input type="checkbox"/>	<input type="checkbox"/>	<input type="checkbox"/>	-----
44	<input type="checkbox"/>	<input type="checkbox"/>	<input type="checkbox"/>	<input type="checkbox"/>	-----
45	<input type="checkbox"/>	<input type="checkbox"/>	<input type="checkbox"/>	<input type="checkbox"/>	-----
46	<input type="checkbox"/>	<input type="checkbox"/>	<input type="checkbox"/>	<input type="checkbox"/>	-----
47	<input type="checkbox"/>	<input type="checkbox"/>	<input type="checkbox"/>	<input type="checkbox"/>	-----
48	<input type="checkbox"/>	<input type="checkbox"/>	<input type="checkbox"/>	<input type="checkbox"/>	-----
49	<input type="checkbox"/>	<input type="checkbox"/>	<input type="checkbox"/>	<input type="checkbox"/>	-----
50	<input type="checkbox"/>	<input type="checkbox"/>	<input type="checkbox"/>	<input type="checkbox"/>	-----

	1	2	3	4	
	T	P			
51	<input type="checkbox"/>	<input type="checkbox"/>	<input type="checkbox"/>	<input type="checkbox"/>	-----
52	<input type="checkbox"/>	<input type="checkbox"/>	<input type="checkbox"/>	<input type="checkbox"/>	-----
53	<input type="checkbox"/>	<input type="checkbox"/>	<input type="checkbox"/>	<input type="checkbox"/>	-----
54	<input type="checkbox"/>	<input type="checkbox"/>	<input type="checkbox"/>	<input type="checkbox"/>	-----
55	<input type="checkbox"/>	<input type="checkbox"/>	<input type="checkbox"/>	<input type="checkbox"/>	-----
56	<input type="checkbox"/>	<input type="checkbox"/>	<input type="checkbox"/>	<input type="checkbox"/>	-----
57	<input type="checkbox"/>	<input type="checkbox"/>	<input type="checkbox"/>	<input type="checkbox"/>	-----
58	<input type="checkbox"/>	<input type="checkbox"/>	<input type="checkbox"/>	<input type="checkbox"/>	-----
59	<input type="checkbox"/>	<input type="checkbox"/>	<input type="checkbox"/>	<input type="checkbox"/>	-----
60	<input type="checkbox"/>	<input type="checkbox"/>	<input type="checkbox"/>	<input type="checkbox"/>	-----
61	<input type="checkbox"/>	<input type="checkbox"/>	<input type="checkbox"/>	<input type="checkbox"/>	-----
62	<input type="checkbox"/>	<input type="checkbox"/>	<input type="checkbox"/>	<input type="checkbox"/>	-----
63	<input type="checkbox"/>	<input type="checkbox"/>	<input type="checkbox"/>	<input type="checkbox"/>	-----
64	<input type="checkbox"/>	<input type="checkbox"/>	<input type="checkbox"/>	<input type="checkbox"/>	-----
65	<input type="checkbox"/>	<input type="checkbox"/>	<input type="checkbox"/>	<input type="checkbox"/>	-----
66	<input type="checkbox"/>	<input type="checkbox"/>	<input type="checkbox"/>	<input type="checkbox"/>	-----
67	<input type="checkbox"/>	<input type="checkbox"/>	<input type="checkbox"/>	<input type="checkbox"/>	-----
68	<input type="checkbox"/>	<input type="checkbox"/>	<input type="checkbox"/>	<input type="checkbox"/>	-----
69	<input type="checkbox"/>	<input type="checkbox"/>	<input type="checkbox"/>	<input type="checkbox"/>	-----
70	<input type="checkbox"/>	<input type="checkbox"/>	<input type="checkbox"/>	<input type="checkbox"/>	-----
71	<input type="checkbox"/>	<input type="checkbox"/>	<input type="checkbox"/>	<input type="checkbox"/>	-----
72	<input type="checkbox"/>	<input type="checkbox"/>	<input type="checkbox"/>	<input type="checkbox"/>	-----
73	<input type="checkbox"/>	<input type="checkbox"/>	<input type="checkbox"/>	<input type="checkbox"/>	-----
74	<input type="checkbox"/>	<input type="checkbox"/>	<input type="checkbox"/>	<input type="checkbox"/>	-----
75	<input type="checkbox"/>	<input type="checkbox"/>	<input type="checkbox"/>	<input type="checkbox"/>	-----



PRINT OR TYPE

BUILDER 3&2
NAVEDTRA 10648-G

NAME _____ ADDRESS _____
Last First Middle Street/Ship/Unit/Division, etc.

City or FPO State Zip

RANK/RATE _____ SOC. SEC. NO. _____ DESIGNATOR _____ ASSIGNMENT NO _____

USN USNR ACTIVE INACTIVE OTHER (Specify) _____ DATE MAILED _____

SCORE

	1	2	3	4	
	T	P			
1	<input type="checkbox"/>	<input type="checkbox"/>	<input type="checkbox"/>	<input type="checkbox"/>	-----
2	<input type="checkbox"/>	<input type="checkbox"/>	<input type="checkbox"/>	<input type="checkbox"/>	-----
3	<input type="checkbox"/>	<input type="checkbox"/>	<input type="checkbox"/>	<input type="checkbox"/>	-----
4	<input type="checkbox"/>	<input type="checkbox"/>	<input type="checkbox"/>	<input type="checkbox"/>	-----
5	<input type="checkbox"/>	<input type="checkbox"/>	<input type="checkbox"/>	<input type="checkbox"/>	-----
6	<input type="checkbox"/>	<input type="checkbox"/>	<input type="checkbox"/>	<input type="checkbox"/>	-----
7	<input type="checkbox"/>	<input type="checkbox"/>	<input type="checkbox"/>	<input type="checkbox"/>	-----
8	<input type="checkbox"/>	<input type="checkbox"/>	<input type="checkbox"/>	<input type="checkbox"/>	-----
9	<input type="checkbox"/>	<input type="checkbox"/>	<input type="checkbox"/>	<input type="checkbox"/>	-----
10	<input type="checkbox"/>	<input type="checkbox"/>	<input type="checkbox"/>	<input type="checkbox"/>	-----
11	<input type="checkbox"/>	<input type="checkbox"/>	<input type="checkbox"/>	<input type="checkbox"/>	-----
12	<input type="checkbox"/>	<input type="checkbox"/>	<input type="checkbox"/>	<input type="checkbox"/>	-----
13	<input type="checkbox"/>	<input type="checkbox"/>	<input type="checkbox"/>	<input type="checkbox"/>	-----
14	<input type="checkbox"/>	<input type="checkbox"/>	<input type="checkbox"/>	<input type="checkbox"/>	-----
15	<input type="checkbox"/>	<input type="checkbox"/>	<input type="checkbox"/>	<input type="checkbox"/>	-----
16	<input type="checkbox"/>	<input type="checkbox"/>	<input type="checkbox"/>	<input type="checkbox"/>	-----
17	<input type="checkbox"/>	<input type="checkbox"/>	<input type="checkbox"/>	<input type="checkbox"/>	-----
18	<input type="checkbox"/>	<input type="checkbox"/>	<input type="checkbox"/>	<input type="checkbox"/>	-----
19	<input type="checkbox"/>	<input type="checkbox"/>	<input type="checkbox"/>	<input type="checkbox"/>	-----
20	<input type="checkbox"/>	<input type="checkbox"/>	<input type="checkbox"/>	<input type="checkbox"/>	-----
21	<input type="checkbox"/>	<input type="checkbox"/>	<input type="checkbox"/>	<input type="checkbox"/>	-----
22	<input type="checkbox"/>	<input type="checkbox"/>	<input type="checkbox"/>	<input type="checkbox"/>	-----
23	<input type="checkbox"/>	<input type="checkbox"/>	<input type="checkbox"/>	<input type="checkbox"/>	-----
24	<input type="checkbox"/>	<input type="checkbox"/>	<input type="checkbox"/>	<input type="checkbox"/>	-----
25	<input type="checkbox"/>	<input type="checkbox"/>	<input type="checkbox"/>	<input type="checkbox"/>	-----

	1	2	3	4	
	T	P			
26	<input type="checkbox"/>	<input type="checkbox"/>	<input type="checkbox"/>	<input type="checkbox"/>	-----
27	<input type="checkbox"/>	<input type="checkbox"/>	<input type="checkbox"/>	<input type="checkbox"/>	-----
28	<input type="checkbox"/>	<input type="checkbox"/>	<input type="checkbox"/>	<input type="checkbox"/>	-----
29	<input type="checkbox"/>	<input type="checkbox"/>	<input type="checkbox"/>	<input type="checkbox"/>	-----
30	<input type="checkbox"/>	<input type="checkbox"/>	<input type="checkbox"/>	<input type="checkbox"/>	-----
31	<input type="checkbox"/>	<input type="checkbox"/>	<input type="checkbox"/>	<input type="checkbox"/>	-----
32	<input type="checkbox"/>	<input type="checkbox"/>	<input type="checkbox"/>	<input type="checkbox"/>	-----
33	<input type="checkbox"/>	<input type="checkbox"/>	<input type="checkbox"/>	<input type="checkbox"/>	-----
34	<input type="checkbox"/>	<input type="checkbox"/>	<input type="checkbox"/>	<input type="checkbox"/>	-----
35	<input type="checkbox"/>	<input type="checkbox"/>	<input type="checkbox"/>	<input type="checkbox"/>	-----
36	<input type="checkbox"/>	<input type="checkbox"/>	<input type="checkbox"/>	<input type="checkbox"/>	-----
37	<input type="checkbox"/>	<input type="checkbox"/>	<input type="checkbox"/>	<input type="checkbox"/>	-----
38	<input type="checkbox"/>	<input type="checkbox"/>	<input type="checkbox"/>	<input type="checkbox"/>	-----
39	<input type="checkbox"/>	<input type="checkbox"/>	<input type="checkbox"/>	<input type="checkbox"/>	-----
40	<input type="checkbox"/>	<input type="checkbox"/>	<input type="checkbox"/>	<input type="checkbox"/>	-----
41	<input type="checkbox"/>	<input type="checkbox"/>	<input type="checkbox"/>	<input type="checkbox"/>	-----
42	<input type="checkbox"/>	<input type="checkbox"/>	<input type="checkbox"/>	<input type="checkbox"/>	-----
43	<input type="checkbox"/>	<input type="checkbox"/>	<input type="checkbox"/>	<input type="checkbox"/>	-----
44	<input type="checkbox"/>	<input type="checkbox"/>	<input type="checkbox"/>	<input type="checkbox"/>	-----
45	<input type="checkbox"/>	<input type="checkbox"/>	<input type="checkbox"/>	<input type="checkbox"/>	-----
46	<input type="checkbox"/>	<input type="checkbox"/>	<input type="checkbox"/>	<input type="checkbox"/>	-----
47	<input type="checkbox"/>	<input type="checkbox"/>	<input type="checkbox"/>	<input type="checkbox"/>	-----
48	<input type="checkbox"/>	<input type="checkbox"/>	<input type="checkbox"/>	<input type="checkbox"/>	-----
49	<input type="checkbox"/>	<input type="checkbox"/>	<input type="checkbox"/>	<input type="checkbox"/>	-----
50	<input type="checkbox"/>	<input type="checkbox"/>	<input type="checkbox"/>	<input type="checkbox"/>	-----

	1	2	3	4	
	T	P			
51	<input type="checkbox"/>	<input type="checkbox"/>	<input type="checkbox"/>	<input type="checkbox"/>	-----
52	<input type="checkbox"/>	<input type="checkbox"/>	<input type="checkbox"/>	<input type="checkbox"/>	-----
53	<input type="checkbox"/>	<input type="checkbox"/>	<input type="checkbox"/>	<input type="checkbox"/>	-----
54	<input type="checkbox"/>	<input type="checkbox"/>	<input type="checkbox"/>	<input type="checkbox"/>	-----
55	<input type="checkbox"/>	<input type="checkbox"/>	<input type="checkbox"/>	<input type="checkbox"/>	-----
56	<input type="checkbox"/>	<input type="checkbox"/>	<input type="checkbox"/>	<input type="checkbox"/>	-----
57	<input type="checkbox"/>	<input type="checkbox"/>	<input type="checkbox"/>	<input type="checkbox"/>	-----
58	<input type="checkbox"/>	<input type="checkbox"/>	<input type="checkbox"/>	<input type="checkbox"/>	-----
59	<input type="checkbox"/>	<input type="checkbox"/>	<input type="checkbox"/>	<input type="checkbox"/>	-----
60	<input type="checkbox"/>	<input type="checkbox"/>	<input type="checkbox"/>	<input type="checkbox"/>	-----
61	<input type="checkbox"/>	<input type="checkbox"/>	<input type="checkbox"/>	<input type="checkbox"/>	-----
62	<input type="checkbox"/>	<input type="checkbox"/>	<input type="checkbox"/>	<input type="checkbox"/>	-----
63	<input type="checkbox"/>	<input type="checkbox"/>	<input type="checkbox"/>	<input type="checkbox"/>	-----
64	<input type="checkbox"/>	<input type="checkbox"/>	<input type="checkbox"/>	<input type="checkbox"/>	-----
65	<input type="checkbox"/>	<input type="checkbox"/>	<input type="checkbox"/>	<input type="checkbox"/>	-----
66	<input type="checkbox"/>	<input type="checkbox"/>	<input type="checkbox"/>	<input type="checkbox"/>	-----
67	<input type="checkbox"/>	<input type="checkbox"/>	<input type="checkbox"/>	<input type="checkbox"/>	-----
68	<input type="checkbox"/>	<input type="checkbox"/>	<input type="checkbox"/>	<input type="checkbox"/>	-----
69	<input type="checkbox"/>	<input type="checkbox"/>	<input type="checkbox"/>	<input type="checkbox"/>	-----
70	<input type="checkbox"/>	<input type="checkbox"/>	<input type="checkbox"/>	<input type="checkbox"/>	-----
71	<input type="checkbox"/>	<input type="checkbox"/>	<input type="checkbox"/>	<input type="checkbox"/>	-----
72	<input type="checkbox"/>	<input type="checkbox"/>	<input type="checkbox"/>	<input type="checkbox"/>	-----
73	<input type="checkbox"/>	<input type="checkbox"/>	<input type="checkbox"/>	<input type="checkbox"/>	-----
74	<input type="checkbox"/>	<input type="checkbox"/>	<input type="checkbox"/>	<input type="checkbox"/>	-----
75	<input type="checkbox"/>	<input type="checkbox"/>	<input type="checkbox"/>	<input type="checkbox"/>	-----

NAVY
MILITARY



PRINT OR TYPE

BUILDER 3&2
NAVEDTRA 10648-G

NAME _____ ADDRESS _____
Last First Middle Street/Ship/Unit/Division, etc.

RANK/RATE _____ SOC. SEC. NO. _____ DESIGNATOR _____ ASSIGNMENT NO. _____
City or FPO State Zip

USN/ USNR ACTIVE INACTIVE OTHER (Specify) _____ DATE MAILED _____

SCORE

	1	2	3	4	
	T	F			
1	<input type="checkbox"/>	<input type="checkbox"/>	<input type="checkbox"/>	<input type="checkbox"/>	-----
2	<input type="checkbox"/>	<input type="checkbox"/>	<input type="checkbox"/>	<input type="checkbox"/>	-----
3	<input type="checkbox"/>	<input type="checkbox"/>	<input type="checkbox"/>	<input type="checkbox"/>	-----
4	<input type="checkbox"/>	<input type="checkbox"/>	<input type="checkbox"/>	<input type="checkbox"/>	-----
5	<input type="checkbox"/>	<input type="checkbox"/>	<input type="checkbox"/>	<input type="checkbox"/>	-----
6	<input type="checkbox"/>	<input type="checkbox"/>	<input type="checkbox"/>	<input type="checkbox"/>	-----
7	<input type="checkbox"/>	<input type="checkbox"/>	<input type="checkbox"/>	<input type="checkbox"/>	-----
8	<input type="checkbox"/>	<input type="checkbox"/>	<input type="checkbox"/>	<input type="checkbox"/>	-----
9	<input type="checkbox"/>	<input type="checkbox"/>	<input type="checkbox"/>	<input type="checkbox"/>	-----
10	<input type="checkbox"/>	<input type="checkbox"/>	<input type="checkbox"/>	<input type="checkbox"/>	-----
11	<input type="checkbox"/>	<input type="checkbox"/>	<input type="checkbox"/>	<input type="checkbox"/>	-----
12	<input type="checkbox"/>	<input type="checkbox"/>	<input type="checkbox"/>	<input type="checkbox"/>	-----
13	<input type="checkbox"/>	<input type="checkbox"/>	<input type="checkbox"/>	<input type="checkbox"/>	-----
14	<input type="checkbox"/>	<input type="checkbox"/>	<input type="checkbox"/>	<input type="checkbox"/>	-----
15	<input type="checkbox"/>	<input type="checkbox"/>	<input type="checkbox"/>	<input type="checkbox"/>	-----
16	<input type="checkbox"/>	<input type="checkbox"/>	<input type="checkbox"/>	<input type="checkbox"/>	-----
17	<input type="checkbox"/>	<input type="checkbox"/>	<input type="checkbox"/>	<input type="checkbox"/>	-----
18	<input type="checkbox"/>	<input type="checkbox"/>	<input type="checkbox"/>	<input type="checkbox"/>	-----
19	<input type="checkbox"/>	<input type="checkbox"/>	<input type="checkbox"/>	<input type="checkbox"/>	-----
20	<input type="checkbox"/>	<input type="checkbox"/>	<input type="checkbox"/>	<input type="checkbox"/>	-----
21	<input type="checkbox"/>	<input type="checkbox"/>	<input type="checkbox"/>	<input type="checkbox"/>	-----
22	<input type="checkbox"/>	<input type="checkbox"/>	<input type="checkbox"/>	<input type="checkbox"/>	-----
23	<input type="checkbox"/>	<input type="checkbox"/>	<input type="checkbox"/>	<input type="checkbox"/>	-----
24	<input type="checkbox"/>	<input type="checkbox"/>	<input type="checkbox"/>	<input type="checkbox"/>	-----
25	<input type="checkbox"/>	<input type="checkbox"/>	<input type="checkbox"/>	<input type="checkbox"/>	-----

	1	2	3	4	
	T	F			
26	<input type="checkbox"/>	<input type="checkbox"/>	<input type="checkbox"/>	<input type="checkbox"/>	-----
27	<input type="checkbox"/>	<input type="checkbox"/>	<input type="checkbox"/>	<input type="checkbox"/>	-----
28	<input type="checkbox"/>	<input type="checkbox"/>	<input type="checkbox"/>	<input type="checkbox"/>	-----
29	<input type="checkbox"/>	<input type="checkbox"/>	<input type="checkbox"/>	<input type="checkbox"/>	-----
30	<input type="checkbox"/>	<input type="checkbox"/>	<input type="checkbox"/>	<input type="checkbox"/>	-----
31	<input type="checkbox"/>	<input type="checkbox"/>	<input type="checkbox"/>	<input type="checkbox"/>	-----
32	<input type="checkbox"/>	<input type="checkbox"/>	<input type="checkbox"/>	<input type="checkbox"/>	-----
33	<input type="checkbox"/>	<input type="checkbox"/>	<input type="checkbox"/>	<input type="checkbox"/>	-----
34	<input type="checkbox"/>	<input type="checkbox"/>	<input type="checkbox"/>	<input type="checkbox"/>	-----
35	<input type="checkbox"/>	<input type="checkbox"/>	<input type="checkbox"/>	<input type="checkbox"/>	-----
36	<input type="checkbox"/>	<input type="checkbox"/>	<input type="checkbox"/>	<input type="checkbox"/>	-----
37	<input type="checkbox"/>	<input type="checkbox"/>	<input type="checkbox"/>	<input type="checkbox"/>	-----
38	<input type="checkbox"/>	<input type="checkbox"/>	<input type="checkbox"/>	<input type="checkbox"/>	-----
39	<input type="checkbox"/>	<input type="checkbox"/>	<input type="checkbox"/>	<input type="checkbox"/>	-----
40	<input type="checkbox"/>	<input type="checkbox"/>	<input type="checkbox"/>	<input type="checkbox"/>	-----
41	<input type="checkbox"/>	<input type="checkbox"/>	<input type="checkbox"/>	<input type="checkbox"/>	-----
42	<input type="checkbox"/>	<input type="checkbox"/>	<input type="checkbox"/>	<input type="checkbox"/>	-----
43	<input type="checkbox"/>	<input type="checkbox"/>	<input type="checkbox"/>	<input type="checkbox"/>	-----
44	<input type="checkbox"/>	<input type="checkbox"/>	<input type="checkbox"/>	<input type="checkbox"/>	-----
45	<input type="checkbox"/>	<input type="checkbox"/>	<input type="checkbox"/>	<input type="checkbox"/>	-----
46	<input type="checkbox"/>	<input type="checkbox"/>	<input type="checkbox"/>	<input type="checkbox"/>	-----
47	<input type="checkbox"/>	<input type="checkbox"/>	<input type="checkbox"/>	<input type="checkbox"/>	-----
48	<input type="checkbox"/>	<input type="checkbox"/>	<input type="checkbox"/>	<input type="checkbox"/>	-----
49	<input type="checkbox"/>	<input type="checkbox"/>	<input type="checkbox"/>	<input type="checkbox"/>	-----
50	<input type="checkbox"/>	<input type="checkbox"/>	<input type="checkbox"/>	<input type="checkbox"/>	-----

	1	2	3	4	
	T	F			
51	<input type="checkbox"/>	<input type="checkbox"/>	<input type="checkbox"/>	<input type="checkbox"/>	-----
52	<input type="checkbox"/>	<input type="checkbox"/>	<input type="checkbox"/>	<input type="checkbox"/>	-----
53	<input type="checkbox"/>	<input type="checkbox"/>	<input type="checkbox"/>	<input type="checkbox"/>	-----
54	<input type="checkbox"/>	<input type="checkbox"/>	<input type="checkbox"/>	<input type="checkbox"/>	-----
55	<input type="checkbox"/>	<input type="checkbox"/>	<input type="checkbox"/>	<input type="checkbox"/>	-----
56	<input type="checkbox"/>	<input type="checkbox"/>	<input type="checkbox"/>	<input type="checkbox"/>	-----
57	<input type="checkbox"/>	<input type="checkbox"/>	<input type="checkbox"/>	<input type="checkbox"/>	-----
58	<input type="checkbox"/>	<input type="checkbox"/>	<input type="checkbox"/>	<input type="checkbox"/>	-----
59	<input type="checkbox"/>	<input type="checkbox"/>	<input type="checkbox"/>	<input type="checkbox"/>	-----
60	<input type="checkbox"/>	<input type="checkbox"/>	<input type="checkbox"/>	<input type="checkbox"/>	-----
61	<input type="checkbox"/>	<input type="checkbox"/>	<input type="checkbox"/>	<input type="checkbox"/>	-----
62	<input type="checkbox"/>	<input type="checkbox"/>	<input type="checkbox"/>	<input type="checkbox"/>	-----
63	<input type="checkbox"/>	<input type="checkbox"/>	<input type="checkbox"/>	<input type="checkbox"/>	-----
64	<input type="checkbox"/>	<input type="checkbox"/>	<input type="checkbox"/>	<input type="checkbox"/>	-----
65	<input type="checkbox"/>	<input type="checkbox"/>	<input type="checkbox"/>	<input type="checkbox"/>	-----
66	<input type="checkbox"/>	<input type="checkbox"/>	<input type="checkbox"/>	<input type="checkbox"/>	-----
67	<input type="checkbox"/>	<input type="checkbox"/>	<input type="checkbox"/>	<input type="checkbox"/>	-----
68	<input type="checkbox"/>	<input type="checkbox"/>	<input type="checkbox"/>	<input type="checkbox"/>	-----
69	<input type="checkbox"/>	<input type="checkbox"/>	<input type="checkbox"/>	<input type="checkbox"/>	-----
70	<input type="checkbox"/>	<input type="checkbox"/>	<input type="checkbox"/>	<input type="checkbox"/>	-----
71	<input type="checkbox"/>	<input type="checkbox"/>	<input type="checkbox"/>	<input type="checkbox"/>	-----
72	<input type="checkbox"/>	<input type="checkbox"/>	<input type="checkbox"/>	<input type="checkbox"/>	-----
73	<input type="checkbox"/>	<input type="checkbox"/>	<input type="checkbox"/>	<input type="checkbox"/>	-----
74	<input type="checkbox"/>	<input type="checkbox"/>	<input type="checkbox"/>	<input type="checkbox"/>	-----
75	<input type="checkbox"/>	<input type="checkbox"/>	<input type="checkbox"/>	<input type="checkbox"/>	-----



PRINT OR TYPE

BUILDER 3&2
NAVEDTRA 10648-G

NAME _____ ADDRESS _____
Last First Middle Street/Ship/Unit/Division, etc.

City or FPO State Zip

RANK/RATE _____ SOC. SEC. NO. _____ DESIGNATOR _____ ASSIGNMENT NO _____

USN USNR ACTIVE INACTIVE OTHER (Specify) _____ DATE MAILED _____

SCORE

	1	2	3	4	
	T	P			
1	<input type="checkbox"/>	<input type="checkbox"/>	<input type="checkbox"/>	<input type="checkbox"/>	-----
2	<input type="checkbox"/>	<input type="checkbox"/>	<input type="checkbox"/>	<input type="checkbox"/>	-----
3	<input type="checkbox"/>	<input type="checkbox"/>	<input type="checkbox"/>	<input type="checkbox"/>	-----
4	<input type="checkbox"/>	<input type="checkbox"/>	<input type="checkbox"/>	<input type="checkbox"/>	-----
5	<input type="checkbox"/>	<input type="checkbox"/>	<input type="checkbox"/>	<input type="checkbox"/>	-----
6	<input type="checkbox"/>	<input type="checkbox"/>	<input type="checkbox"/>	<input type="checkbox"/>	-----
7	<input type="checkbox"/>	<input type="checkbox"/>	<input type="checkbox"/>	<input type="checkbox"/>	-----
8	<input type="checkbox"/>	<input type="checkbox"/>	<input type="checkbox"/>	<input type="checkbox"/>	-----
9	<input type="checkbox"/>	<input type="checkbox"/>	<input type="checkbox"/>	<input type="checkbox"/>	-----
10	<input type="checkbox"/>	<input type="checkbox"/>	<input type="checkbox"/>	<input type="checkbox"/>	-----
11	<input type="checkbox"/>	<input type="checkbox"/>	<input type="checkbox"/>	<input type="checkbox"/>	-----
12	<input type="checkbox"/>	<input type="checkbox"/>	<input type="checkbox"/>	<input type="checkbox"/>	-----
13	<input type="checkbox"/>	<input type="checkbox"/>	<input type="checkbox"/>	<input type="checkbox"/>	-----
14	<input type="checkbox"/>	<input type="checkbox"/>	<input type="checkbox"/>	<input type="checkbox"/>	-----
15	<input type="checkbox"/>	<input type="checkbox"/>	<input type="checkbox"/>	<input type="checkbox"/>	-----
16	<input type="checkbox"/>	<input type="checkbox"/>	<input type="checkbox"/>	<input type="checkbox"/>	-----
17	<input type="checkbox"/>	<input type="checkbox"/>	<input type="checkbox"/>	<input type="checkbox"/>	-----
18	<input type="checkbox"/>	<input type="checkbox"/>	<input type="checkbox"/>	<input type="checkbox"/>	-----
19	<input type="checkbox"/>	<input type="checkbox"/>	<input type="checkbox"/>	<input type="checkbox"/>	-----
20	<input type="checkbox"/>	<input type="checkbox"/>	<input type="checkbox"/>	<input type="checkbox"/>	-----
21	<input type="checkbox"/>	<input type="checkbox"/>	<input type="checkbox"/>	<input type="checkbox"/>	-----
22	<input type="checkbox"/>	<input type="checkbox"/>	<input type="checkbox"/>	<input type="checkbox"/>	-----
23	<input type="checkbox"/>	<input type="checkbox"/>	<input type="checkbox"/>	<input type="checkbox"/>	-----
24	<input type="checkbox"/>	<input type="checkbox"/>	<input type="checkbox"/>	<input type="checkbox"/>	-----
25	<input type="checkbox"/>	<input type="checkbox"/>	<input type="checkbox"/>	<input type="checkbox"/>	-----

	1	2	3	4	
	T	P			
26	<input type="checkbox"/>	<input type="checkbox"/>	<input type="checkbox"/>	<input type="checkbox"/>	-----
27	<input type="checkbox"/>	<input type="checkbox"/>	<input type="checkbox"/>	<input type="checkbox"/>	-----
28	<input type="checkbox"/>	<input type="checkbox"/>	<input type="checkbox"/>	<input type="checkbox"/>	-----
29	<input type="checkbox"/>	<input type="checkbox"/>	<input type="checkbox"/>	<input type="checkbox"/>	-----
30	<input type="checkbox"/>	<input type="checkbox"/>	<input type="checkbox"/>	<input type="checkbox"/>	-----
31	<input type="checkbox"/>	<input type="checkbox"/>	<input type="checkbox"/>	<input type="checkbox"/>	-----
32	<input type="checkbox"/>	<input type="checkbox"/>	<input type="checkbox"/>	<input type="checkbox"/>	-----
33	<input type="checkbox"/>	<input type="checkbox"/>	<input type="checkbox"/>	<input type="checkbox"/>	-----
34	<input type="checkbox"/>	<input type="checkbox"/>	<input type="checkbox"/>	<input type="checkbox"/>	-----
35	<input type="checkbox"/>	<input type="checkbox"/>	<input type="checkbox"/>	<input type="checkbox"/>	-----
36	<input type="checkbox"/>	<input type="checkbox"/>	<input type="checkbox"/>	<input type="checkbox"/>	-----
37	<input type="checkbox"/>	<input type="checkbox"/>	<input type="checkbox"/>	<input type="checkbox"/>	-----
38	<input type="checkbox"/>	<input type="checkbox"/>	<input type="checkbox"/>	<input type="checkbox"/>	-----
39	<input type="checkbox"/>	<input type="checkbox"/>	<input type="checkbox"/>	<input type="checkbox"/>	-----
40	<input type="checkbox"/>	<input type="checkbox"/>	<input type="checkbox"/>	<input type="checkbox"/>	-----
41	<input type="checkbox"/>	<input type="checkbox"/>	<input type="checkbox"/>	<input type="checkbox"/>	-----
42	<input type="checkbox"/>	<input type="checkbox"/>	<input type="checkbox"/>	<input type="checkbox"/>	-----
43	<input type="checkbox"/>	<input type="checkbox"/>	<input type="checkbox"/>	<input type="checkbox"/>	-----
44	<input type="checkbox"/>	<input type="checkbox"/>	<input type="checkbox"/>	<input type="checkbox"/>	-----
45	<input type="checkbox"/>	<input type="checkbox"/>	<input type="checkbox"/>	<input type="checkbox"/>	-----
46	<input type="checkbox"/>	<input type="checkbox"/>	<input type="checkbox"/>	<input type="checkbox"/>	-----
47	<input type="checkbox"/>	<input type="checkbox"/>	<input type="checkbox"/>	<input type="checkbox"/>	-----
48	<input type="checkbox"/>	<input type="checkbox"/>	<input type="checkbox"/>	<input type="checkbox"/>	-----
49	<input type="checkbox"/>	<input type="checkbox"/>	<input type="checkbox"/>	<input type="checkbox"/>	-----
50	<input type="checkbox"/>	<input type="checkbox"/>	<input type="checkbox"/>	<input type="checkbox"/>	-----

	1	2	3	4	
	T	P			
51	<input type="checkbox"/>	<input type="checkbox"/>	<input type="checkbox"/>	<input type="checkbox"/>	-----
52	<input type="checkbox"/>	<input type="checkbox"/>	<input type="checkbox"/>	<input type="checkbox"/>	-----
53	<input type="checkbox"/>	<input type="checkbox"/>	<input type="checkbox"/>	<input type="checkbox"/>	-----
54	<input type="checkbox"/>	<input type="checkbox"/>	<input type="checkbox"/>	<input type="checkbox"/>	-----
55	<input type="checkbox"/>	<input type="checkbox"/>	<input type="checkbox"/>	<input type="checkbox"/>	-----
56	<input type="checkbox"/>	<input type="checkbox"/>	<input type="checkbox"/>	<input type="checkbox"/>	-----
57	<input type="checkbox"/>	<input type="checkbox"/>	<input type="checkbox"/>	<input type="checkbox"/>	-----
58	<input type="checkbox"/>	<input type="checkbox"/>	<input type="checkbox"/>	<input type="checkbox"/>	-----
59	<input type="checkbox"/>	<input type="checkbox"/>	<input type="checkbox"/>	<input type="checkbox"/>	-----
60	<input type="checkbox"/>	<input type="checkbox"/>	<input type="checkbox"/>	<input type="checkbox"/>	-----
61	<input type="checkbox"/>	<input type="checkbox"/>	<input type="checkbox"/>	<input type="checkbox"/>	-----
62	<input type="checkbox"/>	<input type="checkbox"/>	<input type="checkbox"/>	<input type="checkbox"/>	-----
63	<input type="checkbox"/>	<input type="checkbox"/>	<input type="checkbox"/>	<input type="checkbox"/>	-----
64	<input type="checkbox"/>	<input type="checkbox"/>	<input type="checkbox"/>	<input type="checkbox"/>	-----
65	<input type="checkbox"/>	<input type="checkbox"/>	<input type="checkbox"/>	<input type="checkbox"/>	-----
66	<input type="checkbox"/>	<input type="checkbox"/>	<input type="checkbox"/>	<input type="checkbox"/>	-----
67	<input type="checkbox"/>	<input type="checkbox"/>	<input type="checkbox"/>	<input type="checkbox"/>	-----
68	<input type="checkbox"/>	<input type="checkbox"/>	<input type="checkbox"/>	<input type="checkbox"/>	-----
69	<input type="checkbox"/>	<input type="checkbox"/>	<input type="checkbox"/>	<input type="checkbox"/>	-----
70	<input type="checkbox"/>	<input type="checkbox"/>	<input type="checkbox"/>	<input type="checkbox"/>	-----
71	<input type="checkbox"/>	<input type="checkbox"/>	<input type="checkbox"/>	<input type="checkbox"/>	-----
72	<input type="checkbox"/>	<input type="checkbox"/>	<input type="checkbox"/>	<input type="checkbox"/>	-----
73	<input type="checkbox"/>	<input type="checkbox"/>	<input type="checkbox"/>	<input type="checkbox"/>	-----
74	<input type="checkbox"/>	<input type="checkbox"/>	<input type="checkbox"/>	<input type="checkbox"/>	-----
75	<input type="checkbox"/>	<input type="checkbox"/>	<input type="checkbox"/>	<input type="checkbox"/>	-----