

DOCUMENT RESUME

ED 208 242

CE 030 388

TITLE Military Curriculum Materials for Vocational and Technical Education. Builders School, Finish Carpentry I. Classroom Course 3-10.

INSTITUTION Ohio State Univ., Columbus. National Center for Research in Vocational Education.

SPONS AGENCY Office of Education (DHEW), Washington, D.C.

PUB DATE [80]

NOTE 161p.; For a related document see CE 030 389.

EDRS PRICE MF01/PC07 Plus Postage.

DESCRIPTORS \*Carpentry; \*Construction (Process); \*Construction Materials; Course Content; Curriculum Guides; Curriculum Research; Educational Resources; Experiential Learning; \*Finishing; Information Dissemination; Instructional Materials; \*Learning Modules; Military Training; Postsecondary Education; Structural Elements (Construction); Teaching Guides; \*Vocational Education

IDENTIFIERS Military Curriculum Project

ABSTRACT

Adapted from military service training materials, this publication contains course materials for teaching finish carpentry, both in the classroom and through practical experience. Students completing this short course will be able to finish carpentry projects involving wallboard, plywood panel, composition floor tile, and acoustical ceiling tile. Both theory and shop assignments are provided with the course materials. The first unit contains an introduction to the course, stressing safety, while the second unit covers the following topics: wallboard, plywood paneling, composition floor tile, and acoustical ceiling tile. Instructor's guides are prepared for each section describing instructional materials, aids, terminal and enabling objectives, criterion tests, and homework assignments. Each section includes an outline of instruction, instructor activities, and student activities. To help the student, five job sheets and one information sheet are provided, along with a copy of a chapter of a Navy text on building. (The military-developed curriculum materials in this course package were selected by the National Center for Research in Vocational Education Military Curriculum Project, acquired, evaluated, adapted, and disseminated to the six regional Curriculum Coordination Centers and other instructional materials agencies.)

(KC)

\*\*\*\*\*  
 \* Reproductions supplied by EDRS are the best that can be made \*  
 \* from the original document. \*  
 \*\*\*\*\*

## MILITARY CURRICULUM MATERIALS

The military-developed curriculum materials in this course package were selected by the National Center for Research in Vocational Education Military Curriculum Project for dissemination to the six regional Curriculum Coordination Centers and other instructional materials agencies. The purpose of disseminating these courses was to make curriculum materials developed by the military more accessible to vocational educators in the civilian setting.

The course materials were acquired, evaluated by project staff and practitioners in the field, and prepared for dissemination. Materials which were specific to the military were deleted, copyrighted materials were either omitted or approval for their use was obtained. These course packages contain curriculum resource materials which can be adapted to support vocational instruction and curriculum development.

# The National Center Mission Statement

The National Center for Research in Vocational Education's mission is to increase the ability of diverse agencies, institutions, and organizations to solve educational problems relating to individual career planning, preparation, and progression. The National Center fulfills its mission by:

- Generating knowledge through research
- Developing educational programs and products
- Evaluating individual program needs and outcomes
- Installing educational programs and products
- Operating information systems and services
- Conducting leadership development and training programs

## FOR FURTHER INFORMATION ABOUT Military Curriculum Materials

### WRITE OR CALL

Program Information Office  
The National Center for Research in Vocational  
Education  
The Ohio State University  
1960 Kenny Road, Columbus, Ohio 43210  
Telephone: 614/486-3655 or Toll Free 800/  
848-4815 within the continental U.S.  
(except Ohio)



THE NATIONAL CENTER  
FOR RESEARCH IN VOCATIONAL EDUCATION  
The Ohio State University 1960 Kenny Road-Columbus, Ohio 43210  
Tel. (614) 486-3655  
Cable: CVOCEDOSU/Columbus, Ohio

# Military Curriculum Materials for Vocational and Technical Education

Information and Field  
Services Division

The National Center for Research  
in Vocational Education



## Military Curriculum Materials Dissemination Is . . .

an activity to increase the accessibility of military-developed curriculum materials to vocational and technical educators.

This project, funded by the U.S. Office of Education, includes the identification and acquisition of curriculum materials in print form from the Coast Guard, Air Force, Army, Marine Corps and Navy.

Access to military curriculum materials is provided through a "Joint Memorandum of Understanding" between the U.S. Office of Education and the Department of Defense.

The acquired materials are reviewed by staff and subject matter specialists, and courses deemed applicable to vocational and technical education are selected for dissemination.

The National Center for Research in Vocational Education is the U.S. Office of Education's designated representative to acquire the materials and conduct the project activities.

### Project Staff:

Wesley E. Budke, Ph.D., Director  
National Center Clearinghouse

Shirley A. Chase, Ph.D.  
Project Director

## What Materials Are Available?

One hundred twenty courses on microfiche (thirteen in paper form) and descriptions of each have been provided to the vocational Curriculum Coordination Centers and other instructional materials agencies for dissemination.

Course materials include programmed instruction, curriculum outlines, instructor guides, student workbooks and technical manuals.

The 120 courses represent the following sixteen vocational subject areas:

|                         |                            |
|-------------------------|----------------------------|
| Agriculture             | Food Service               |
| Aviation                | Health                     |
| Building & Construction | Heating & Air Conditioning |
| Trades                  | Machine Shop               |
| Clerical Occupations    | Management & Supervision   |
| Communications          | Meteorology & Navigation   |
| Drafting                | Photography                |
| Electronics             | Public Service             |
| Engine Mechanics        |                            |

The number of courses and the subject areas represented will expand as additional materials with application to vocational and technical education are identified and selected for dissemination.

## How Can These Materials Be Obtained?

Contact the Curriculum Coordination Center in your region for information on obtaining materials (e.g., availability and cost). They will respond to your request directly or refer you to an instructional materials agency closer to you.

### CURRICULUM COORDINATION CENTERS

#### EAST CENTRAL

Rebecca S. Douglass  
Director  
100 North First Street  
Springfield, IL 62777  
217/782-0759

#### NORTHWEST

William Daniels  
Director  
Building 17  
Airdustrial Park  
Olympia, WA 98504  
206/753-0879

#### MIDWEST

Robert Patton  
Director  
1515 West Sixth Ave.  
Stillwater, OK 74704  
405/377-2000

#### SOUTHEAST

James F. Shill, Ph.D.  
Director  
Mississippi State University  
Drawer DX  
Mississippi State, MS 39762  
601/325-2510

#### NORTHEAST

Joseph F. Kelly, Ph.D.  
Director  
225 West State Street  
Trenton, NJ 08625  
609/292-6562

#### WESTERN

Lawrence F. H. Zane, Ph.D.  
Director  
1776 University Ave.  
Honolulu, HI 96822  
808/948-7834

Developed by  
United States Navy

Development and  
Review Dates  
July, 1975

D.O.T. No.:  
860.381

Occupational Area:  
Building and Construction

Target Audiences:  
Grades 10-adult

Print Pages

120

Cost:

\$2.50

Availability:  
Military Curriculum Project, The Center  
for Vocational Education, 1960 Kenny  
Rd., Columbus, OH 43210

Contents:

| Contents:                     | Type of Materials: |                  |                   |           |                 |                | Instructional Design:   |        |                   |                                | Type of Instruction: |                 |
|-------------------------------|--------------------|------------------|-------------------|-----------|-----------------|----------------|-------------------------|--------|-------------------|--------------------------------|----------------------|-----------------|
|                               | Lesson Plans:      | Programmed Text: | Student Workbook: | Handouts: | Text Materials: | Audio-Visuals: | Performance Objectives: | Tests: | Review Exercises: | Additional Materials Required: | Group Instruction:   | Individualized: |
| Unit 1.1 - Introduction       |                    |                  |                   |           |                 |                |                         |        |                   |                                |                      |                 |
| 1.1.2 Safety                  | •                  |                  |                   |           |                 | ★              | •                       | •      |                   |                                | •                    |                 |
| Unit 1.2 - Finish Carpentry I |                    |                  |                   |           |                 |                |                         |        |                   |                                |                      |                 |
| 1.2.1 Wallboard               | •                  |                  |                   | •         | •               | ★              | •                       | •      |                   | ★                              | •                    | •               |
| 1.2.2 Plywood Panel           | •                  |                  |                   | •         | •               | ★              | •                       | •      |                   | ★                              | •                    | •               |
| 1.2.3 Composition Floor Tile  | •                  |                  |                   | •         | •               |                | •                       | •      |                   | ★                              | •                    | •               |
| 1.2.4 Acoustical Ceiling Tile | •                  |                  |                   | •         | •               | ★              | •                       | •      |                   | ★                              | •                    | •               |
|                               |                    |                  |                   |           |                 |                |                         |        |                   |                                |                      |                 |
|                               |                    |                  |                   |           |                 |                |                         |        |                   |                                |                      |                 |
|                               |                    |                  |                   |           |                 |                |                         |        |                   |                                |                      |                 |
|                               |                    |                  |                   |           |                 |                |                         |        |                   |                                |                      |                 |
|                               |                    |                  |                   |           |                 |                |                         |        |                   |                                |                      |                 |
|                               |                    |                  |                   |           |                 |                |                         |        |                   |                                |                      |                 |
|                               |                    |                  |                   |           |                 |                |                         |        |                   |                                |                      |                 |
|                               |                    |                  |                   |           |                 |                |                         |        |                   |                                |                      |                 |
|                               |                    |                  |                   |           |                 |                |                         |        |                   |                                |                      |                 |

★ Materials are recommended but not provided.

Course Description

Students completing this short course will be able to finish carpentry projects involving wallboard, plywood panel, composition floor tile, and acoustical ceiling tile.

Both theory and shop assignments are provided with the course materials. Two units are covered in this course. The first section of the first unit is not suitable for vocational programs. This section deals with military chain of command and reporting procedures and was deleted. The remaining sections are suitable.

Unit 1.1 - Introduction contains a thirty minute class on safety. No shop time is required.

Unit 1.2 - Finish Carpentry I contains the following four sections covering 29 hours of class and shop time.

- 1.2.1 Wallboard (3 hours class instruction, 13 hours shop)
- 1.2.2 Plywood Panel (3 hours class instruction)
- 1.2.3 Composition Floor Tile (2 hours class instruction, 3 hours shop)
- 1.2.4 Acoustical Ceiling Tile (2 hours class instruction, 3 hours shop)

Instructors' guides are prepared for each section describing instructional materials, aids, terminal and enabling objectives, criterion tests and homework assignments. Each section includes an outline of instruction, instructor activities and student activities. To help the student, five job sheets and one information sheet are available.

The text is Chapter 13 and pages 348-354 of a Navy training manual, *Builder 3 & 2, NAVPERS 10648-F*. This text material is provided. Three commercially produced books are also recommended. A list of course tools, equipment and materials is provided as well as a list of training aids and devices, and teacher prepared materials needed. The following audiovisual support materials are recommended but are not provided

- HOW-014 *How to Use Hammers* (12 min.)
- HOW-016 *How to Use Measuring Tapes* (12 min.)
- HOW-015 *How to Use Saws* (12 min.)
- HOW-013 *How to Use Chisels and Gauges* (12 min.)
- HOW-017 *How to Use Planes* (10 min.)
- GIF-001 *The Gift of Life* (18 min.)

BUILDERS SCHOOL, FINISH CARPENTRY I

## Table of Contents

|   | <u>Page</u> |
|---|-------------|
| Course Description  | 1           |
| Introductory Materials  | 4           |
| Instructor Guides   |             |
| Safety  | 18          |
| Wallboard   | 22          |
| Job Sheets  |             |
| Laying Out, Cutting and Installing Wallboard                    | 34          |
| Taping a Wallboard Joint  | 38          |
| Instructor Guide  |             |
| Plywood Wall Panel  | 41          |
| Information Sheet   |             |
| Laying Out, Cutting and Installing Plywood Wall Panel           | 53          |
| Instructor Guide  |             |
| Composition Floor Tile  | 57          |
| Job Sheets  |             |
| Installing Floor Tiles  | 68          |
| Repairing Damaged Floor Tile                                    | 72          |
| Instructor Guide  |             |
| Accoustical Ceiling Tile  | 74          |
| Job Sheet   |             |
| Laying Out, Cutting, and Installing Accoustical<br>Ceiling Tile | 81          |
| Reference Materials   |             |
| Interior Finish   | 84          |

3



# SPECIAL CONSTRUCTION BATTALION TRAINING

## BUILDERS SCHOOL 164.1 FINISH CARPENTRY I

July 1975



3-10

1i



HOW TO USE THE INSTRUCTOR GUIDE

Instructor guides (I.G.'s) are provided for each topic. They include supporting instructional material and aids identified by the topic number and a letter-code designation. The letter codes used in I.G.'s are as follows:

- |                        |                             |
|------------------------|-----------------------------|
| AS - Assignment Sheet  | PF - Performance Evaluation |
| CN - Class Notes       | PI - Programmed Instruction |
| DS - Diagram Sheet     | PS - Problem Sheet          |
| EG - Evaluation Guide  | PT - Practical Test         |
| FT - Final Test        | T - Test                    |
| IS - Information Sheet | TR - Transparency           |
| JS - Job Sheet         | WS - Work Sheet             |
| OS - Operation Sheet   |                             |

The instructor guides are intended to be used as master lesson plans, but subject however to personalization by the individual instructor. The instructor should study and refer to the listing of references, materials and aids given in the appropriate enclosed annex when annotating the instructor guides.

The first page of each instructor guide contains the following functional information:

1. Topic of lesson
2. Average time in periods (class and practical)
3. Instructional materials such as texts, references, equipment, tools, training aids, etc.
4. Instructional aids such as job sheets, handouts, etc.
5. Terminal and enabling objectives.
6. Criterion Test
7. Homework assignment

The second page is the "Outline of Instruction" page whereby each instructor will develop an appropriate introduction for each topic that will: (1) create interest; (2) show the value of the topic to the student; (3) relate the topic to previous and future topics in the course; and (4) communicate the learning objectives to the student. Well prepared lesson introductions can provide direction for student motivation and establish readiness for learning.

5

The pages that follow the "Information" and "Outline of Instruction" pages is the body of the instruction guide. The pages are divided into three columns; the column on the left includes the outlines of instruction required by the objectives of the lesson; the center column is for listing instructor activity that corresponds to the particular portion of the lesson; and the right hand column contains student activity that corresponds to the particular portion of the lesson. Instructor creativity in designing learning exercises, techniques and training aids to meet course objectives can enhance the lesson and should be utilized and noted in the appropriate column. In addition, student comments pertaining to updating, additions, deletions, etc., to the lesson should be encouraged and noted for continual revision of the lesson.

OUTLINE OF INSTRUCTION

| TOPIC | Unit 1.1                 | CLASS     | PRACT     | TOTAL     | PAGE |
|-------|--------------------------|-----------|-----------|-----------|------|
|       | Introduction             |           |           |           |      |
| 1.1.1 | Orientation              | 1.5       | 0         | 1.5       | 3    |
| 1.1.2 | Safety                   | <u>.5</u> | <u>0</u>  | <u>.5</u> | 3    |
|       |                          | 2         | 0         | 2         |      |
|       | Unit 1.2                 |           |           |           |      |
|       | Finish Carpentry I       |           |           |           |      |
| 1.2.1 | Wallboard                | 3         | 13        | 16        | 3    |
| 1.2.2 | Plywood Panel            | 3         | 0         | 3         | 3    |
| 1.2.3 | Composition Floor Tile   | 2         | 3         | 5         | 4    |
| 1.2.4 | Accoustical Ceiling Tile | 2         | 3         | 5         | 4    |
|       |                          | <u>10</u> | <u>19</u> | <u>29</u> | 4    |

- \* Total Periods Classroom: 12
- \* Total Periods Practical: 19
- Total Hours for Course: 31
- Total Weeks for Course: 1 week

\* Each period of instruction represents 60 minutes of actual instruction

7

OUTLINE OF TRAINING OBJECTIVES

Unit 1.1 INTRODUCTION

Contact Hours: 2

Terminal Objective: Upon completion of this unit the student will have; reported to Builder School, received the school's orientation and safety procedures required to complete the assigned course of instruction as a SCBT student.

Topic 1.1.1 ORIENTATION

Contact Hours: 1.5

Enabling Objectives: Upon completion of this topic the student will have; reported for the course and answered questions pertaining to key points on the organization, mission and regulations of NAVCONSTRACEN.

Topic 1.1.2 SAFETY

Contact Hours: .5

Enabling Objectives: Upon completion of this topic the student will be able to report accidents or fire, and state the safety practices that will be enforced in the school.

Unit 1.2 FINISH CARPENTRY I

Contact Hours: 29

Terminal Objective: Upon completion of this unit the student will have completed finish carpentry projects involving wall board, plywood panel, composition floor tile and accoustical ceiling tile. All work is to be done by following procedures in accordance with job sheets and in meeting the specifications as stated on the job sheets.

Topic 1.2.1 WALLBOARD

Contact Hours: 16

Enabling Objectives: Upon completion of this topic the student will be able to lay out, cut, install, tape and finish wallboard by following job sheet procedures. The finished wallboard project will meet job sheet specifications. Each student will be provided with job sheets, SCBT 164.1 BU JS 1.2.1.1, "Laying Out , Cutting and Installing Wallboard" and SCBT 164.1 BU JS 1.2.1.2, "Taping a Wallboard Joint".

Topic 1.2.2 PLYWOOD PANEL

Contact Hours: 3

Enabling Objectives: Upon completion of this topic the student will be able to orally answer (with 100% accuracy) key questions pertaining to the lay out, preparation, installation, finishing and job requirements of plywood panel wall covering. All answers must be compatible with information sheet SCBT 164.1 BU IS 1.2.2.1, "Laying Out, Cutting and Installing Plywood Panel".

4  
Topic: 1.2.3 COMPOSITION FLOOR TILE

Contact Hours: 15

Enabling Objectives: Upon completion of this topic the student will be able to lay out, prepare the floor to receive floor tile, and install composition floor tile; and replace damaged floor tile by following job sheet procedures. The completed floor tile projects will meet job sheet specifications. Student will be provided with job sheets, SCBT 164.1 BU JS 1.2.3.1, "Installing Floor Tile" and SCBT 164.1 BU JS 1.2.3.2, "Replacing Damaged Floor Tile".

Topic: 1.2.4 ACCOUSTICAL CEILING TILE

Contact Hours: 5

Enabling Objectives: Upon completion of this topic the student will be able to lay out, cut, prepare and install accoustical ceiling tile by following procedures in accordance with job sheet, SCBT 164.1 BU JS 1.2.4.1, "Laying out, Cutting, Preparing and Installing Accoustical Ceiling Tile". The finished ceiling will be within job sheet specifications. Job sheet will be provided for each student.

10

ANNEX I

TEXTS

1. Builder 3 & 2, NAVPERS 10648-F.

10

ANNEX II

REFERENCES

1. Drywall Construction Handbook, United States Gypsum.
2. Complete Do-it-Yourself Manual, Reader's Digest.
3. Fundamentals of Carpentry, Volume 2, W.E. Durbahn and I.W. Sundberg.

ANNEX III

TOOLS, EQUIPMENT AND MATERIALS

TOOLS

1. 4 foot t-square.
2. Measuring tape.
3. Combination square.
4. Framing square.
5. Hand level.
6. Chalk line.
7. Rasp.
8. Sheet rock knife.
9. Hammer.
10. Compass saw.
11. Trowel.
12. Taping knife.
13. Inside corner tool.
14. Drywall jacks.
15. Corder bead crimper.
16. Banjo.
17. Potato masher.
18. Saber saw.
19. Lifter carrier.
20. Sanding pad with pole.
21. Meat loaf pan.
22. Block plane.



12

23. Cross-cut saw.
24. Chisel.
25. Nail set.
26. Chalking gun.
27. Putty knife.
28. Linoleum knife.
29. Blow torch.
30. Notched trowel.
31. Tin snip.
32. Wooden paddle.

EQUIPMENT

1. Step ladder.
2. Saw horses.
3. 2" x 12" plank.

MATERIALS

1. Sandpaper.
2. 1/2" x 4' 0" x 8' 0" Gypsum wallboard.
3. Gypsum wallboard cement.
4. Wallboard corner bead.
5. Nails, sheetrock.
6. Putty stick.
7. 3/8" x 4' 0" x 8' 0" plywood.
8. 3/16" x 4' 0" x 8' 0" Pre-finished plywood.
9. Plywood panel adhesive.
10. Nails, 3d finish.
11. Accoustical tile 1/2 x 12" x 12".

20

12. Accoustical tile adhesive.
13. Composition floor tile 9" x 9".
14. Composition tile adhesive.
15. Hand cleaner.

ANNEX IV

TRAINING AIDS AND DEVICES

A. Films:

- 1. HOW 014 "How to Use Hammers" (12 min.).
- 2. HOW 016 "How to Use Measuring Tapes" (12 min.).
- 3. HOW 018 "How to Use Saws" (12 min.).
- 4. HOW 013 "How to Use Chisels and Gauges" (12 min.).
- 5. HOW 017 "How to Use Planes" (10 min.).
- 6. GIF 001 "The Gift of Life".

B. Mock-up.

- 1. Layout and Installation of Floor Tile.

C. Locally Prepared Materials:

1. Job Sheets:

- a. SCBT 164.1 BU JS 1.2.1.1, "Laying Out, Cutting and Installing Wallboard".
- b. SCBT 164.1 BU JS 1.2.1.2, "Taping a Wallboard Joint".
- c. SCBT 164.1 BU JS 1.2.3.1, "Installing Floor Tile".
- d. SCBT 164.1 BU JS 1.2.3.2, "Replacing Damaged Floor Tile".
- e. SCBT 164.1 BU JS 1.2.4.1, "Laying Out, Cutting and Installing Accoustical Ceiling Tile".

2. Information Sheets:

- a. SCBT 164.1 BU IS 1.2.2.1, "Laying Out, Cutting and Installing Plywood Panel".

15

ANNEX V

TRAINING AIDS EQUIPMENT

1. 16mm movie projector.

ANNEX VI

MASTER SCHEDULE

SCBT 164.1 FINISH CARPENTRY I

FIRST WEEK

| <u>TOPIC NO.</u> | <u>TYPE</u> | <u>PERIOD</u> | <u>TITLE</u> | <u>RATIO</u> |
|------------------|-------------|---------------|--------------|--------------|
|------------------|-------------|---------------|--------------|--------------|

FIRST DAY

|       |   |     |             |      |
|-------|---|-----|-------------|------|
| 1.1.1 | C | 1   | Orientation | 16/1 |
|       |   | 2   |             |      |
| 1.1.2 | C | 2.5 | Safety      | 16/1 |
| 1.2.1 | C | 3   | Wallboard   | 16/1 |
|       |   | 4   |             |      |
|       |   | 5   |             |      |
|       |   | 6   |             |      |
|       |   | 7   |             |      |

SECOND DAY

|       |   |    |                      |      |
|-------|---|----|----------------------|------|
| 1.2.1 | P | 8  | Wallboard            | 8/1  |
|       |   | 9  |                      |      |
|       |   | 10 |                      |      |
|       |   | 11 |                      |      |
| 1.2.2 | C | 12 | <u>Plywood panel</u> | 16/1 |
|       |   | 13 |                      |      |
|       |   | 14 |                      |      |

THIRD DAY

|       |   |    |                        |      |
|-------|---|----|------------------------|------|
| 1.2.1 | P | 15 | Wallboard              | 8/1  |
|       |   | 16 |                        |      |
|       |   | 17 |                        |      |
| 1.2.3 | C | 18 | Composition floor tile | 16/1 |
|       |   | 19 |                        |      |
|       | P | 20 |                        | 8/1  |
|       |   | 21 |                        |      |

FOURTH DAY

|       |   |    |                          |      |
|-------|---|----|--------------------------|------|
| 1.2.  |   |    |                          |      |
| 1.2.3 | P | 22 | Composition Floor tile   | 8/1  |
| 1.2.1 | P | 23 | Wallboard                | 8/1  |
|       |   | 24 |                          |      |
|       |   | 25 |                          |      |
|       |   | 26 |                          |      |
| 1.2.4 | C | 27 | Accoustical Ceiling Tile | 16/1 |
|       |   | 28 |                          |      |

FIFTH DAY

|       |   |    |                          |     |
|-------|---|----|--------------------------|-----|
| 1.2.4 | P | 29 | Accoustical ceiling tile | 8/1 |
|       |   | 30 |                          |     |
|       |   | 31 |                          |     |

n

MODIFICATIONS

Instructor Guide  
1.1.1

of this publication has (have) been deleted in adapting this material for inclusion in the "Trial Implementation of a Model System to Provide Military Curriculum Materials for Use in Vocational and Technical Education." Deleted material involves extensive use of military forms, procedures, systems, etc. and was not considered appropriate for use in vocational and technical education.

NAVAL CONSTRUCTION TRAINING CENTER  
PORT HUENEME, CALIFORNIA 93043  
SPECIAL CONSTRUCTION BATTALION TRAINING COURSE (SCBT) 100 - 190

Classification: Unclassified

Topic: Safety

Average Time: 0.5 Periods (Class)

Instructional Materials:

- A. Texts: None.
- B. References.
  - 1. NAVCONSTRACENINST. 5400.4, (current series)  
"Organization Manual of NAVCONSTRACEN."
  - 2. "Safety Practices for Shore Activities,"  
NAVMAT P-5100, (Jan 1973).
- C. Tools and Equipment: None.
- D. Training Aids and Devices.
  - 1. Film
    - a. GIF-001, "The Gift of Life," (18 min.)
- E. Training Aids Equipment
  - 1. 16mm Movie Projector.

Terminal Objective: Upon completion of this unit the student will have reported to Builder School, received the school orientation and safety procedures required to complete the assigned course of instruction as a SCBT student.

Enabling Objectives: Upon completion of this topic the student will be able to report accidents or fire, and state the safety practices that will be enforced in the school.

Criterion Test: The student will answer orally specific question pertaining to the method of reporting and fighting fires as established by NAVCONSTRACEN and CBC regulations, and will conform to the safety policies for the duration of this assignment to Builder School.

Homework: None.

19

OUTLINE OF INSTRUCTION

- I. Introduction to the Lesson:
- A. Establish contact.
    - 1. Name:
    - 2. Topic: Safety
  - B. Establish readiness.
    - 1. Purpose.
    - 2. Assignment.
  - C. Establish effect.
    - 1. Value.
      - a. Pass course.
      - b. Perform better on the job.
  - D. Overview.
    - 1. You will be able to answer orally specific questions related to the methods of reporting and fighting fires as established by NAVCONSTRACEN and CBC regulations and conform to the safety practices that will be enforced in this school.
    - 2. Ask questions.
    - 3. Take notes.

SCBT-100 - 190-BU-IG-1.1.2

INSTRUCTOR ACTIVITY

STUDENT ACTIVITY

- I.A. Introduce self and topic.
- I.B. Motivate student.
- I.C. Bring out need and value of material being presented.
- I.D. State learning objectives.
  - 1. State information and materials necessary to guide student.



OUTLINE OF INSTRUCTION

SCBT-100 -- 190-BU-IG-1.1.2  
INSTRUCTOR ACTIVITY

20  
STUDENT ACTIVITY

II. Presentation:

A. Safety.

1. Reporting accidents.

- a. Class safety man.
- b. Instructor.
- c. School director.
- d. First aid when appropriate.

1.a. Pick safety man and explain job.

2. Fire safety.

- a. Evacuation routes.
- b. Reporting fires.
- c. Fighting fire.
  - (1) Location of extinguishers.

3. Field safety.

- a. Show film: GIF-001, "The Gift of Life."
- b. Discuss film highlights.

A.3. Introduce film.

a. Discuss key points to look for.

b. Show film.

3.b. Lead discussion.

1. Ask questions.

2. Stress safety.

3.b. Participate in discussion - ask questions as necessary

(3 of 4)

21

OUTLINE OF INSTRUCTION

SCBT-100 - 190-BU-IG-1.1.2

INSTRUCTOR ACTIVITY

STUDENT ACTIVITY

III. Application

A. Discussion.

III.A. Questions to be developed by the instructor.

III.A. Answer and ask questions.

IV. Summary:

A. Safety.

1. Reporting accidents.
2. Fire safety.
3. Field safety.

V. Test:

A. None.

(4 of 4)

32

33

NAVAL CONSTRUCTION TRAINING CENTER  
 PORT HUENEME, CALIFORNIA 93043  
 SPECIAL CONSTRUCTION BATTALION TRAINING (SCBT) 164.1

Classification: Unclassified

Topic: Wallboard

Average Time: 3 Periods (Class), 13 Periods (Pract)

Instructional Materials:

A. Texts:

1. Builder 3 & 2, NAVPERS 10648-F, Chapter 13.

B. References:

1. Drywall Construction Handbook, United States Gypsum.
2. Complete Do-it-Yourself Manual, Reader's Digest.

C. Tools, Equipment and Materials:

1. 4 foot T-square.
2. Measuring Tape.
3. Combination square.
4. Framing square.
5. Hand level.
6. Chalk line.
7. Rasp.

Terminal Objective: Upon completion of this unit the student will have completed finish carpentry projects involving wall board, plywood panel, composition floor tile and accoustical ceiling tile. All work is to be done by following procedures in accordance with job sheets and in meeting the specifications as stated on the job sheets.

Enabling Objectives: Upon completion of this topic the student will be able to lay out, cut, install, tape and finish wallboard by following job sheet procedures. The finished walboard project will meet job sheet specifications. Each student will be provided with job sheets, SCBT 164.1 BU JS 1.2.1.1, "Laying Out, Cutting and Installing Wallboard" and SCBT 164.1 BU JS 1.2.1.2, "Taping a Wallboard Joint".

Criterion Test: The student is to be tested on his ability to install and finish wallboard such that the wallboard joints and nail recesses cannot be detected and the finished surface is without void.

Homework: Read: Builder 3 & 2, NAVPERS 10648-F, pages 379 - 385.

- 23
8. Sheet rock knife.
  9. Hammer.
  10. Compass saw.
  11. Trowel.
  12. Taping knife.
  13. Inside corner tool.
  14. Sand paper.
  15. Dry wall jacks.
  16. Corner bead crimper.
  17. Banjo.
  18. Potato masher.
  19. Saber saw.
  20. Lifter carrier.
  21. Sanding pad with pole.
  22. Step ladder.
  23. Saw horses.
  24. 2" x 12" plank.
  25. Meat loaf pan.
  26. 1/2" x 4' 0" x 8' 0" gypsum wallboard.

(2 of 12)

37

30

27. Gypsum wallboard cement.
28. Gypsum wallboard tape.
29. Wallboard corner bead.
30. Sheetrock nails.

D. Training Aids and Devices:

1. Films:

- a. HOW 014 "How to Use Hammers"(12 min.).
- b. HOW 016 "How to use Measuring Tapes" (12 min.).
- c. HOW 018 "How to use Saws" (12 min.).

2. Locally Prepared Materials:

- a. Job Sheets.
  - (1) SCBT 164.1 BU JS 1.2.1.1, "Laying Out, Cutting and Installing Wallboard".
  - (2) SCBT 164.1 BU JS 1.2.1.2, "Taping a Wallboard Joint"

3. Samples of tools.

- a. 4 foot T-square.
- b. Measuring tape.
- c. Combination square.
- d. Hand level.
- e. Chalk line.

- 25
- f. Rasp.
  - g. Sheet rock knife.
  - h. Hammer.
  - i. Compass Saw.
  - j. Trowel.
  - k. Taping knife.
  - l. Inside corner tool.
  - m. Drywall jacks.
  - n. Corner bead crimper.
  - o. Banjo.
  - p. Potato masher.
  - q. saber saw.
  - r. Lifter carrier.
4. Samples of materials.
- a. Gypsum wallboard.
  - b. Wallboard tape.
  - c. Wallboard cement.
  - d. Sheetrock nails.
  - e. Corner beads.

40

E. Training Aids Equipment:

1. 16mm movie projector.

(4 of 12)

41

I. Introduction to the Lesson.

A. Establish contact.

1. Name:
2. Topic: Wallboard Installation, Taping and Finishing.

B. Establish readiness.

1. Purpose - gypsum wallboard is cheap, strong, durable and fire resistant. This building material is used extensively in the construction trade. It will be to your benefit to learn this portion of training.
2. Assignment.
  - a. Read Builder 3 & 2, NAVPERS 10648-F, pages 379 - 385.

C. Establish effect.

1. Value.
  - a. Pass course.
  - b. Perform better on the job.
  - c. Get advanced.
  - d. Be a better builder.

D. Overview

1. Job sheets.

I.A. Introduce self and topic.

I.B.1. Motivate student by reading the statement on gypsum wallboard.

I.C. State learning objectives.

I.C.1. Upon completion of this topic you will be able to install wallboard, tape wallboard joints, and finish wall surfaces for painting.

27  
OUTLINE OF INSTRUCTION

INSTRUCTOR ACTIVITY

SCBT 164.1 BU IG 1.1.1  
STUDENT ACTIVITY

- a. SCBT 164.1 BU JS 1.2.1.1.
- b. SCBT 164.1 BU JS 1.2.1.2.
2. Pay close attention to the demonstration by the instructor.
3. Safety precautions.
  - a. Sheetrock knives are very sharp - extreme care must be taken in using the knives.
4. Ask questions.

II. Presentation.

A. Introduce job sheets and hand out.

1. SCBT 164.1 BU JS 1.2.1.1, "Laying Out, Cutting and Installing Wallboard".
2. SCBT 164.1 BU JS 1.2.1.2, "Taping A Wallboard Joint".
3. United States Gypsum Handyman's Guide.

B. Tools and Equipment common to wallboard installation.

1. 4 foot T-square.
2. Measuring tape.
3. Combination square.
4. Framing square.

II.A. Hand out job sheets and handout.

II.B. Give lecture on tools and equipment used on a drywall project - show tools and equipment to reinforce lecture.



OUTLINE OF INSTRUCTION

INSTRUCTOR ACTIVITY

- 5. Hand level.
- 6. Chalk line.
- 7. Rasp.
- 8. Sheetrock knife.
- 9. Hammer.
- 10. Compass saw.
- 11. Taping knife.
- 12. Inside corner tool.
- 13. Sand paper.
- 14. Drywall jacks.
- 15. Corner bead crimper.
- 16. Banjo.
- 17. Potato masher.
- 18. Saber saw.
- 19. Lifter carrier.
- 20. Sanding pad with pole.
- 21. Introduce films, discuss key points to look for, show the films and discuss film highlights and safety (one film at a time).
  - a. HOW 014, "How to Use Hammers".

II.B.21. Introduce film, discuss key points prior to showing of film, show the film and lead discussion on film highlights and safety.

II.B.21. Participate in discussion.

29

OUTLINE OF INSTRUCTION

INSTRUCTOR ACTIVITY

SCBT 164.1 BU IG 1.2.1  
STUDENT ACTIVITY

- b. HOW 016, "How to Use a Measuring Tape".
- c. HOW 018, "How to Use Saws".
- C. Drywall materials.
  - 1. Gypsum wallboard.
  - 2. Wallboard tape.
  - 3. Wallboard cement.
    - a. Powder.
    - b. Ready mix.
- D. Steps of procedure.
  - 1. Laying out, cutting and installing wallboard.
    - a. Determine starting point for ceiling.
      - (1) Measure out 48 1/4".
      - (2) Snap a chalk line.
    - b. Lay and secure drywall sheet on ceiling.
      - (1) Set up scaffolds with 2" x 12" planks.
      - (2) Lay and secure drywall sheets with sheetrock nails.

II.C. Give lecture on drywall materials - show material samples to reinforce lecture.

II.D. Take student out to the training site - call student's attention to job sheet SCBT 164.1 BU JS 1.2.1.1. Demonstrate wallboard layout, cutting, installing, taping and finishing technique.

II.D. Turn to job sheet and follow instruction/demonstration.

OUTLINE OF INSTRUCTIONINSTRUCTOR ACTIVITY

- g. Cut out openings for the receptacles.
- (1) Use chisel or screw driver for starter hole.
  - (2) Use compass saw to cut out for the opening undercut.
- h. Position and secure this piece.
- i. Lay out for door or window openings.
- (1) Measure from installed wall-board to the opening.
  - (2) Measure from the ceiling to opening.
- j. Cut out, position and secure piece.
2. Taping wallboard.
- a. Check for improperly recessed nails.
    - (1) Run a hammer head over the nails.
  - b. Apply joint compound over nails.
  - c. Apply tape over wallboard joints.
    - (1) Heavy bed coat.
    - (2) Measure and cut tape to length.
    - (3) Center the tape over the joint and work off excess joint compound.

II.D.1.g. Demonstrate cut out technique.

II.D.2. Call student's attention to job sheet SCBT 164.1 BU JS 1.2.1.2.

II.D.2. Turn to job sheet and follow instructions/demonstration.

5.

31

OUTLINE OF INSTRUCTION

INSTRUCTOR ACTIVITY

SCBT 164.1 BU IG 1.1  
STUDENT ACTIVITY

- (a) 8" on the edges.
  - (b) 12" on inner ceiling joists.
  - c. Determine starting point for wall.
    - (1) Start with a full sheet.
  - d. Position and secure drywall to the wall.
    - (1) Place sheet in position such that the edges fall on the center of studs.
    - (2) Plumb the edge, raising the sheet snugly to the ceiling.
    - (3) Nail with sheet rock nails 8" on center and 5/8" from the edges and 12" on center on the inner studs.
  - e. Install succeeding sheets.
    - (1) Against installed sheet.
    - (2) Against the ceiling.
  - f. Lay out for receptacles.
    - (1) Measure from installed wall-board to both sides of the receptacle box- record dimensions on a piece of paper.
    - (2) Measure down from the ceiling to the top and bottom of the receptacle box-record as before.
- II.D.1.f. State that double checking lay out work is always a good practice.

OUTLINE OF INSTRUCTION

INSTRUCTOR ACTIVITY

- d. Apply tape over wallboard at the inside corner.
  - (1) Heavy bed coat.
  - (2) Measure and cut tape to length.
  - (3) Fold tape in half lengthwise.
  - (4) Place folded tape in position - running the edge of your hand at the center of tape to insure tape in position.
  - (5) Work off excessive joint compound.
- e. Apply first coat of joint compound over tape and nail covering.
  - (1) Sand surface smooth.
  - (2) Apply thin coat of compound over the nails.
  - (3) Apply a medium coat of compound over the tape.
  - (4) Feather with a plastering trowel out 6" from joint.
- f. Apply second coat of joint compound.
- g. Apply third coat.
- h. Sand the surface smooth.

III. Application.

33

OUTLINE OF INSTRUCTION

A. Student practice.

IV. Summary.

A. Tools commonly used in installing and finishing wallboard.

B. Cutting wallboard.

C. Nailing wallboard.

D. Finishing wallboard.

INSTRUCTOR ACTIVITY

III.A. Issue materials and assign work area to each student.

SCBT 164.1 BU IG 1.;

STUDENT ACTIVITY

III.A. Students practice.

50

51

NAVAL CONSTRUCTION TRAINING CENTER  
PORT HUENEME, CALIFORNIA 93043  
SPECIAL CONSTRUCTION BATTALION TRAINING COURSE (SCBT) 164.1

JOB SHEET

TITLE: Laying Out, Cutting and Installing Wallboard

INTRODUCTION: This job sheet is to guide you in installing wallboard.

REFERENCES:

1. Builder 3&2, NAVPERS 10648-F, Chapter 13.
2. Drywall Construction Handbook.
3. Complete Do-It-Yourself Manual, Reader's Digest, pp. 93 - 95.

TOOLS AND EQUIPMENT:

1. Measuring tape.
2. Hammer.
3. Combination Square.
4. Framing square.
5. Hand level.
6. Sheet rock knife.
7. Compass saw.
8. rasp.
9. Saw horses.
10. Four foot T square.
11. Chalk line.
12. Dry wall jacks.
13. Corner bead crimper.
14. Saber saw.
15. Lifter carrier.
16. Step ladder.

(1 of 4)

## MATERIALS:

1. 1/2" x 4' x 8' Drywall.
2. Sheet rock nails.

## PROCEDURES:

1. Determine starting point for ceiling.
  - a. From opposite corners of the room and parallel with the ceiling joists, measure out and mark 48 1/4" on the top plates.
    - (1) The 1/4" is for clearance allowance.
  - b. Strike a chalk line across the ceiling joists from these points.
2. Lay and secure drywall sheets on ceiling.
  - a. Set up scaffolds using saw horses and 2 x 12 planks.
  - b. From one end of the room, lay and secure first drywall sheet with sheetrock nails at 8" apart on the edges and 12" apart on the inner ceiling joists.
    - (1) The ends of the drywall sheet must fall on a ceiling joist.
  - c. Cut as necessary and install drywall to cover all of the ceiling.
    - (1) End joints should be staggered.
3. Determine starting point for wall.
  - a. With a pencil, mark the center of all studs on ceiling.
  - b. Using a measuring tape, locate a section where the studs are 4' on center and where a full sheet could be laid.
4. Position and secure drywall to the walls.
  - a. Place a sheet of drywall in position such that the edges fall on the center of the studs.
    - (1) The first sheet should always be plumbed so that the succeeding sheet butted against it will also be plumb.



- b. Using a hand level to plumb and a jig to raise the sheet snugly to the ceiling.
  - c. Secure the sheet with sheetrock nails at 8" on center and 5/8" from the edges at the edges and 12" on center on the inner studs.
5. Install succeeding sheets.
- a. Place succeeding sheets against the installed wallboard and against the ceiling.
    - (1) Use extreme caution in using a sheet rock knife.
6. Lay out for receptacles.
- a. Measure the distances from installed wallboard to both sides of the receptacle box and record them on a scrap of paper.
  - b. Measure the distances from the ceiling to the top and the bottom of the receptacle box and record them as before.
  - c. Mark for receptacle cut out allowing 1/16" clearance all around.
7. Cut out opening for the receptacle.
- a. With a chisel or screw driver punch a hole with-in the opening.
  - b. Using a compass saw cut out for the opening with a slight undercut such that the back opening is larger than the front opening.
8. Install prepared sheet.
- a. Place prepared sheet in position.
  - b. Secure as in step 4b.
9. Laying out for door/window openings.
- a. Measure the distance from wallboard in place to opening.
  - b. Measure the distance from ceiling to opening.
  - c. Allowing 1/4" clearance layout for opening on a drywall sheet.

10. Cut out for the opening.
  - a. Using a sheetrock knife and/or compass saw.
11. Clean up work site.
12. Check work with the instructor.
  - a. All wallboard must be laid with the front side out and nails cinched.

NAVAL CONSTRUCTION TRAINING CENTER  
PORT HUENEME, CALIFORNIA 93043  
SPECIAL CONSTRUCTION BATTALION TRAINING COURSE (SCBT) 164.1

## JOB SHEET

TITLE: Taping a Wallboard Joint

INTRODUCTION: This job sheet is to guide you in the taping of wallboard joints.

## REFERENCE:

1. Complete Do-It-Yourself Manual, Reder's Digest, pp. 96 - 97.

## TOOLS AND EQUIPMENT:

1. 6" taping knife.
2. 10" plastering trowel.
3. Hammer.
4. Sanding block.
5. 10" meat loaf pan.
6. Saw Horses.
7. Panjo.
8. Inside corner tool.
9. Potato masher.
10. Sanding pad with pole.
11. Step ladder.

## MATERIALS:

1. Wallboard tape.
2. Joint compound.
3. Sand paper (coarse and fine).

## PROCEDURES:

1. Check for improperly recessed nails.

(1 of 3)

- a. By running the hammer head over the nails- a metallic clicking sound indicates nail needing recessing.
2. Apply joint compound over nails.
  - a. Using a 6" taping knife and a meat loaf pan with joint compound, apply a smooth coat of joint compound over nails.
    - (1) Laying drop cloth may help in keeping floor clean of joint compound.
3. Apply tape over wallboard joints.
  - a. Using the taping knife and the pan apply a heavy coat of joint compound over the wallboard joint.
    - (1) The heavy coat is to insure a good bond between the tape and wallboard.
  - b. Measure and cut tape to length.
  - c. Keeping the tape centered over the joint start at the bottom and work upward or at the top and downward.
  - d. Using the taping knife, press the tape into the compound, working off all excessive joint compound and being careful not to wrinkle the tape.
4. Apply joint compound over wallboard at the inside corner.
  - a. Using a 6" taping knife, apply a heavy coat of joint compound to insure a good bond.
5. Apply the tape.
  - a. Measure and cut wallboard tape to length.
  - b. Fold tape in half lengthwise keeping both edges even.
  - c. Apply this tape at the bottom and work upward or at the top and downward.
  - d. Run the edge of your hand at the center of the tape to insure the center of the tape is in the corner.
  - e. Using the inside corner tool press the tape into the compound working off all excessive compound and being careful not to wrinkle the tape.

6. Apply first coat of joint compound over tape and nail covering.
  - a. Using a medium grade sand paper on a sanding block, sand surface to be recovered.
    - (1) Joint compound must be completely dry.
  - b. Apply a thin coat of joint compound over the nails.
  - c. Apply a medium coat of joint compound over tape.
  - d. Feather the joint compound with the plastering trowel out about 6" from joint.
    - (1) A fine job of feathering and smoothing will minimize sanding.
7. Apply second coat of joint compound.
  - a. Same as in step #7.
    - (1) Feather out a little further than the previous coat.
8. Apply third coat.
  - a. Same as in step #7.
9. Sand the surface.
  - a. Using a fine sandpaper on a sanding block, prepare surface to receive paint.
10. Check work with the instructor.
  - a. The prepared surface must be such that joints or nail recesses cannot be detected and that there are no voids or wrinkles.

81

NAVAL CONSTRUCTION TRAINING CENTER  
PORT HUENEME, CALIFORNIA 93043  
SPECIAL CONSTRUCTION BATTALION TRAINING (SCBT) 164.1

Classification: Unclassified

Topic: Plywood Wall Panel

Average Time: 3 Periods (Class)

Instructional Materials:

A. Texts:

1. Builder 3 & 2, NAVPERS 10648-F, Chapter 13.

B. Reference:

1. Complete DO-it-Yourself Manual, Reader's Digest.

C. Tools, Equipment and Materials:

1. Measuring tape.
2. Hammer.
3. Block plane.
4. Cross-cut saw.
5. Hand level.
6. Compass saw.
7. Chisel.
8. Nail set.
9. Chalking gun.

Terminal Objective: Upon completion of this unit the student will have completed finish carpentry projects involving wall board, plywood panel, composition floor tile and accoustical ceiling tile. All work is to be done by following procedures in accordance with job sheets and in meeting the specifications as stated on the job sheets.

Enabling Objectives: Upon completion of this topic the student will be able to orally answer (with 100% accuracy) key questions pertaining to the lay out, preparation, installation, finishing and job requirements of plywood panel wall covering. All answers must be compatible with information sheet SCBT 165.1 BU IS 1.2.2.1, "Laying Out, Cutting and Installing Plywood Panel".

Criterion Test: The class as a whole will be tested in answering with 100% accuracy the seven (7) specific questions on the instructor guide, pertaining to the plywood wall panel.

Homework: Read: Builder 3 & 2, NAVPERS 10646-F, pages 363 - 364.

10. Putty stick.

11. Saw horse.

12. 2 x planks.

D. Training Aids and Devices:

1. Films:

- a. HOW 013, "How to Use Chisels and Gauges"  
(12 min.).
- b. HOW 017, "How to Use Planes"(10 min.).

2. Samples.

a. Plywood.

- (1) 3/8".
- (2) 3/16" pre-finished.

b. Tools and Equipment (new).

- (1) Chisel.
- (2) Block planes.
- (3) Nail set.
- (4) Chalking gun.
- (5) Putty stick.

3. Locally Prepared Material:

- a. Information sheet.

(1) SCBT 164.1 BU IS 1.2.2.1, "Laying Out,  
Cutting and Installing Plywood Panel.

4. Materials:

- a. 3/8" x 4' 0" x 8' 0" plywood.
- b. 3/16" x 4' 0" x 8' 0" pre-finished plywood.
- c. Panel adhesive.
- d. 3d finish nails.

E. Training Aids Equipment:

1. 16mm movie projector.



OUTLINE OF INSTRUCTION

INSTRUCTOR ACTIVITY

SCBT 164.1 BU IG 1.2.2  
STUDENT ACTIVITY

44

I. Introduction to the lesson.

A. Establish contact.

1. Name:

2. Topic: Plywood Wall Panel.

B. Establish readiness.

1. Purpose - plywood wall panel is used extensively in interior finishing. This training will be helpful to you in developing finishing techniques.

2. Assignment.

a. Read: Builder 3 & 2, pages 363 & 364.

C. Establish effect.

1. Value.

a. Pass course.

b. Perform better on the job.

c. Get advanced.

d. Be a better builder.

D. Overview:

1. Information sheet.

a. SCBT 164.1 BU IS 1.2.2.1.

I.A. Introduce self and topic.

I.B. Motivate student by reading statement on plywood wall panel.

I.C. State learning objectives.

a. Upon completion of this topic you will be able to lay out, prepare and install plywood and prefinished plywood panel.

OUTLINE OF INSTRUCTION

INSTRUCTOR ACTIVITY

2. Pay close attention to demonstration by the instructor.
3. Safety precautions.
4. Ask questions.

II. Presentation.

A. Introduce information sheet.

1. SCBT 164.1 BU IS 1.2.2.1, "Laying Out, Cutting and Installing Plywood Wall Panel." sheet. II.A.1. Pass out information sheet.

B. Tools, Equipment and materials:

1. Tools and equipment.
  - a. Chisel.
  - b. Block plane.
  - c. Nail set.
  - d. Chalking gun.
2. Materials.
  - a. 3/8" x 4' 0" x 8' 0" plywood.
  - b. 3/16" x 4' 0" x 8' 0" prefinished plywood.
  - c. 3d finish nails.
  - d. Plywood panel adhesive.
  - e. Putty stick.

OUTLINE OF INSTRUCTION

INSTRUCTOR ACTIVITY

- 3. Introduce films.
  - a. HOW 013, "How to Use Chisels and Gauges".
  - b. HOW 017, "How to Use Planes".
- 4. Discuss key points to look for.
- 5. Show film.
- 6. Discuss film.
  - a. Highlights.
  - b. Safety.

- II.B.3. Introduce one film at a time.
- II.B.4. Discuss key points.
- II.B.5. Show film.
- II.B.6. Discuss film:

C. Procedures.

PART I PLYWOOD

- 1. Plywood placement layout.
  - a. Determine room dimension and starting point for wall panelling.
    - (1) Stress that end panels should be 16" or wider.
- 2. Prepare plywood.
  - a. Use work bench.
    - (1) 2 x's and saw horses.
  - b. Chamfer the edges.
    - (1) Chamfer to be 1/16 - 1/8 of an inch.

- II.C.1. Give lecture/demonstration in calculating technique - call student attention to information sheet SCBT 164.1 BU IS 1.2.2.1.
- II.C.2. Demonstrate chamfering technique.

II.C.1. Turn to information sheet and follow presentation.

OUTLINE OF INSTRUCTION

INSTRUCTOR ACTIVITY

SCBT 164.1 BU IG 1.1  
STUDENT ACTIVITY

47

3. Position and secure plywood.
  - a. Edges on the center of stud.
  - b. Must be plumb.
  - c. Fit snugly to ceiling.
  - d. 3d finish nails to secure.
    - (1) 8" on center, 1/2 in from edge.
    - (2) 12" on center on inner studs.
4. Laying out for receptacles.
  - a. Measure from installed sheet to both sides of box.
  - b. Measure from ceiling to top and bottom of box.
  - c. Recheck lay out work.
5. Cut out opening for receptacle.
  - a. Cut with slight undercut.
  - b. Cut outside of layout lines.
  - c. Use chisel to punch out starter hole - hole must be within cut out.
6. Laying out for door/window openings.

OUTLINE OF INSTRUCTION

INSTRUCTOR ACTIVITY

- a. Measure from installed sheet.
  - b. Measure distance from ceiling.
  - c. Allow 1/4" for clearance.
  - d. Check layout work.
7. Set nail.
- a. 1/16" deep.

PART II PREFINISHED PANEL

1. Starting point.
  - a. End panels, 12 inches or more.
2. Place panel in position and mark the edges on wall board.
  - a. Must be plumb.
  - b. Fit snugly to ceiling.
3. Apply adhesive to drywall.
  - a. Use chalking gun.
  - b. Apply bead within perimeter of the panel.
  - c. Apply bead at 16 inches interval horizontally and vertically.
4. Position panel and secure top of panel with 2 nails.

OUTLINE OF INSTRUCTION

INSTRUCTOR ACTIVITY

- a. Nails to create a hinging effect.
  - b. Press panel against drywall to transfer some adhesive to the panel.
  - c. Pull bottom of panel about 10" away and prop out with wood blocks.
  - d. Wait about 8 minutes, remove blocks and push panel back in position.
  - e. Press panel firmly against drywall.
  - f. To insure better contact, use hammer and cloth covered block and tap the panel.
5. Drive and set the nails.
  6. Fill nail holes with putty stick.

III. Application.

A. Student answer the following questions.

III.A. Ask question, then select student to answer it.

III.A. Raise your hand if able to answer the question.

Question:

Answer:

1. How wide must the end plywood panel be?

1. 16" or wider.

2. How wide must the end pre-finished plywood panel be?

2. 12" or wider.

3. Where do you place the plywood panel adhesive?

3. Around the perimeter of the panel and at 16" interval horizontally and vertically.

OUTLINE OF INSTRUCTION

IV. Summary.

A. Plywood.

1. Layout of plywood placement.
  - a. End panel should be 16" or wider.
2. Preparation.
  - a. Chamfer the edges.
3. Position and secure plywood.
  - a. Join on center of stud.
  - b. Plumb.
  - c. Fit snugly to ceiling.
  - d. Nail.
    - (1) 1/2" in from edge and at 8" on center.

INSTRUCTOR ACTIVITY

4. Where do you place your nails to secure the plywood panels?
5. What is used to fill nail holes on prefinished panels?
6. Chamfer on plywood is to be \_\_\_\_\_?
7. How wide are the end panels to be for a wall 14' 7" long for prefinished plywood panel?

SCBT 164.1 BU IG 1.7

STUDENT ACTIVITY

4. 8" on center, 1/2" in at the edges and 12" on center on inner studs.
5. Putty sticks.
6. 1/16 - 1/8 inch.
7. 15 1/2".

50

OUTLINE OF INSTRUCTION

INSTRUCTOR ACTIVITY

SCBT 164.1 BU IG 1.2  
STUDENT ACTIVITY

57

- (2) 12" on center on inner studs.
- 4. Laying out for receptacles.
  - a. Recheck layout work.
- 5. Cut for receptacles.
  - a. Outside of line.
  - b. With slight undercut.
- 6. Laying out for door/window openings.
  - a. Allow 1/4" for clearance.
  - b. Recheck lay out work.
- 7. Set nails.
- B. Prefinished panel.
  - 1. Starting point - from a corner.
    - a. End panels should be 12" or more.
    - b. Must be plumb.
    - c. Fit ceiling snugly.
  - 2. Apply adhesive to drywall.
    - a. Use chaulking gun to apply adhesive.
      - (1) Perimeter of panel.
      - (2) 16" interval horizontally and vertically.



OUTLINE OF INSTRUCTION

INSTRUCTOR ACTIVITY

SCBT 164.1 BU IG 1.2  
STUDENT ACTIVITY

57

3. Position panel and secure at top with nails.
  - a. Press panel against drywall.
  - b. Pull bottom of panel out and prop.
  - c. Wait about 9 minutes, remove prop and push panel into position.
  - d. Press panel firmly.
  - e. Tap panel with block and hammer.
4. Set nails and fill nail holes with putty stick.

87

NAVAL CONSTRUCTION TRAINING CENTER  
PORT HUENEME, CALIFORNIA 93043  
SPECIAL CONSTRUCTION BATTALIAN TRAINING (SCBT) 164.1

INFORMATION SHEET

TITLE: Laying Out, Cutting and Installing Plywood Wall Panel

INTRODUCTION: This job sheet is to guide you in installing plywood to wall frame and or drywall.

TOOLS AND EQUIPMENT:

1. Measuring tape.
2. Hammer.
3. Block plane.
4. Cross cut saw.
5. Framing square.
6. Combination square.
7. Hand level.
8. Compass saw.
9. Chisel.
10. Nail set.
11. Portable electric circular saw.
12. Saw horses.
13. 2 x planks.

MATERIAL:

1. 3/8" x 4' 0" x 8' 0" plywood.
2. 3/16" x 4' 0" x 8' 0" prefinished panel.
3. 3d finish nails.
4. Plywood panel adhesive.

## PROCEDURES:

## PART I - Plywood panel to wall frame.

1. Determine starting point for wall paneling.
  - a. Measure length of wall.
  - b. Divide this distance by 4 foot, the width of a sheet of plywood.
  - c. Divide the remainder by 2. If the quotient is  $\frac{1}{3}$  of the width of plywood (16") or less, off set starting point by one stud.
2. Prepare plywood.
  - a. Set up a work bench consisting of 2 saw horses and 3 pieces of 2 x's.
  - b. Place a sheet of plywood with the finish surface up on the work bench.
  - c. Use block plane to chamfer the edges. The chamfer must be within  $\frac{1}{16}$  -  $\frac{1}{8}$  of an inch.
3. Position and secure plywood to the wall.
  - a. Place a sheet of plywood in position such that the edges fall on the center of the studs.
  - b. Use hand level to plumb and a jig to raise the sheet of plywood snugly to the ceiling.
  - c. Secure the plywood with 3d finish nails at 8" on center and  $\frac{1}{2}$ " from the edges at the edges and 12" on center on the inner studs.
4. Install succeeding sheets of plywood.
  - a. Prepare, position and secure succeeding sheets against the installed plywood and against the ceiling.
5. Layout for receptacles.
  - a. Measure distances from installed sheet of plywood to both sides of the receptacle box and record them on a piece of paper.
  - b. Measure the distances from the ceiling to the top and bottom of the receptacle box and record them.
  - c. Layout for receptacle, allow  $\frac{1}{16}$ " clearance all around the box.
  - d. Recheck your work - it is a good practice to check work prior to cutting of your materials.

6. Cut out opening for the receptacle.
  - a. With the use of a chisel, punch out a starter hole within the opening.
  - b. Use compass saw to cut out for the opening with a slight undercut such that the back opening is larger than the front opening.
7. Install prepared sheet.
  - a. Place in position and secure prepared sheet.
8. Layout for door/window openings.
  - a. Measure distance from installed plywood to opening.
  - b. Measure distance from ceiling to opening.
  - c. Allow 1/4" clearance in laying out for opening.
  - d. Check layout work prior to cutting.
9. Install prepared sheet.
10. Set nails.
  - a. Use nail set to set all nails in to a depth of 1/16".
11. Clean up work site.
12. Check work with the instructor.
  - a. All sheets of plywood must be laid with their edges chamfered within 1/16 - 1/8 of an inch, all nails must be set to receive putty or wood dough, the spacing of the edges must be within 1/16" and all openings for receptacles must be within 1/8 of an inch from the receptacle boxes.

#### PART II - Prefinishing paneling to gypsum wallboard.

1. Determine starting point such that the end panels are 12" or wider.
  - a. Measure length of wall, divide this dimension by 4' 0" (a full sheet) and divide the remainder by 2 for width of end panels.
  - b. If end panels are less than 12", add 48" (a full sheet) to the remainder and divide by 2 for end panels.
2. Place prefinished panel in position and mark the edges of the panel on the wallboard.

- a. The panel is to be plumb and aligned to a mark for the end panel.
- b. The panel is to fit snugly to the ceiling.
- c. Mark the edges of the panel.
3. Apply adhesive to the drywall.
  - a. With the use of a chalking gun, apply a bead of panel adhesive within the perimeter of the panel.
  - b. Apply bead of adhesive at 16 inches intervals horizontally and vertically.
4. Position panel and secure top of panel to drywall with 2 nails.
  - a. Drive 2 nails through top of panel and into the drywall - the nails are to create a hinging effect between panel and drywall.
  - b. Press panel against drywall to transfer some adhesive to back of panel.
  - c. Pull bottom of panel about 10" away from drywall and prop out with wood blocks.
  - d. After 8 minutes, remove blocks and push panel back in position.
  - e. Press panel firmly against drywall.
  - f. Use hammer on a cloth covered block and tap sheet to insure better adhesive - panel contact.
5. Drive and set nails.
6. Fill nail holes with putty stick.

NAVAL CONSTRUCTION TRAINING CENTER  
 PORT HUENEME, CALIFORNIA 93043  
 SPECIAL CONSTRUCTION BATTALION TRAINING (SCBT) 164.1

Classification: Unclassified

Topic: Composition Floor Tile

Average Time: 2 Periods (Class), 3 Periods (Pract)

Instructional Materials:

A. Texts:

1. Builder 3 & 2, NAVPERS 10648-F, Chapter 13.

B. References:

1. Complete Do-it-Yourself Manual, Reader's Digest.

C. Tools, Equipment and Materials:

1. Measuring tape.
2. Chalk line.
3. Combination square.
4. Linoleum knife.
5. Putty knife.
6. Hammer.
7. Blow torch.
8. Notched trowel.
9. Tin snip.

Terminal Objective: Upon completion of this unit the student will have completed finish carpentry projects involving wall board, plywood panel, composition floor tile and accoustical ceiling tile. All work is to be done by following procedures in accordance with job sheets and in meeting the specifications as stated on the job sheets.

Enabling Objectives: Upon completion of this topic the student will be able to lay out, prepare the floor to receive floor tile and install composition floor tile; and replace damaged floor tile by following job sheet procedures. The completed floor tile projects will meet job sheet specifications. Student will be provided with job sheets, SCBT 164.1 BU JS 1.2.3.1, "Installing Floor Tile" and SCBT 164.1 BU JS 1.2.3.2, "Replacing Damaged Floor tile".

Criterion Test: The student is to be tested on his ability to install composition floor tile such that the tiles are laid with the finish face up, the end tiles are larger than half a tile and the end tiles laid to within 1/16" from the wall finish.

Homework: Read Builder 3 & 2, NAVPERS 10648-F, pages 348 - 354.

10. Wooden paddle.
11. Composition floor tile.
12. Composition tile adhesive.
13. Hand cleaner.

D. Training Aids and Devices:

1. Locally Prepared Material.
  - a. Mock up.
    - (1) Layout and installation of floor tile.
  - b. Job sheets.
    - (1) SCBT 164.1 BU JS 1.2.3.1, "Installing Floor Tile".
    - (2) SCBT 164.1 BU JS 1.2.3.2, "Replacing Damaged Floor Tile".
2. Samples of Tools.
  - a. Linoleum knife.
  - b. Putty knife.
  - c. Blow torch.
  - d. Notched trowel.
  - e. Tin snip.
  - f. Wooden paddle.

3. Samples of materials.

a. Composition floor tile.

b. Tile adhesive.

c. Hand cleaner.

E. Training Aids Equipment: None.



OUTLINE OF INSTRUCTOR

INSTRUCTOR ACTIVITY

SCBT 164.1 BU IG 1. 1  
STUDENT ACTIVITY

60

I. Introduction to the lesson.

A. Establish contact.

1. Name:
2. Topic: Composition Floor Tile

B. Establish readiness.

1. Purpose - composition floor tile is used extensively in the construction trade. This training will be useful to you.
2. Assignment: Read, Builder 3 & 2, pages 348 - 354.

C. Establish effect.

1. Value.
  - a. Pass course.
  - b. Perform better on the job.
  - c. Get advanced.
  - d. Be a better builder.

D. Overview:

1. Job sheets.
  - a. SCBT 164.1 BU JS 1.2.3.1.
  - b. SCBT 164.1 BU JS 1.2.3.2.

I.A. Introduce self and topic.

I.B. Motivate student by reading the statement on composition floor tile.

I.C. State learning objectives.

a. Upon completion of this topic you will be able to lay out, prepare and install composition floor tile.

OUTLINE OF INSTRUCTION

INSTRUCTOR ACTIVITY

- 2. Pay close attention to demonstration by the instructor.
- 3. Safety precautions.
- 4. Ask questions.

II. Presentation.

A. Introduce job sheets.

- 1. SCBT 164.1 BU JS 1.2.3.1, "Installing Floor Tile".
- 2. SCBT 164.1 BU JS 1.2.3.2, "Replacing Damaged Floor Tile".

B. Tool and materials.

- 1. Composition tile.
  - a. Ashpalt.
  - b. Vinyl.
  - c. Linoleum.
- 3. Tile installing tools.
  - a. Chalk line.
  - b. Linoleum knife.
  - c. Putty knife.
  - d. blow torch.

II.A. Hand out job sheets.

II.B. Give a lecture on tools and materials - show items to reinforce lecture.



OUTLINE OF INSTRUCTION

INSTRUCTOR ACTIVITY

SCBT 164.1 BU IG 3  
STUDENT ACTIVITY

62

- e. Tin snip.
- f. Notched trowel.
- g. Wooden paddle.

C. Procedures:

1. Tile placement lay out.

- a. Determine room dimensions.
- b. Calculate width of end tile for length of the room.
  - (1) Calculate on using 9" x 9" tile.
  - (2) Stress that end tile should be at least half as wide as a full tile (4 1/2").

II.C.1.b. Give a lecture on end tile calculating technique use chalk board to demonstrate this technique - call students attention to Job Sheet SCBT 164.1 BU JS 1.2.3.1.

II.C.1.b. Turn to Job Sheet and follow instruction/demonstration

- c. Calculate width of end tile for width of the room.
- d. Determine tile placement guide lines.
  - (1) Add a full tile to the width of the end tile (for the width of the room) for dimension.
  - (2) Mark out this dimension at each end of the room from the wall with the door.
  - (3) Snap a chalk line from these markings.

II.C.1.c. Give lecture/demonstration in the placing of guide line - use mock-up on "Layout and Installation of Floor Tile" for reinforcement.

OUTLINE OF INSTRUCTION

INSTRUCTOR ACTIVITY

- (4) From the end of the wall nearest the door opening - determining the number of full tiles that will be needed to the center of the opening.
- (5) Add the width of end tile (for ~~the length of the room~~) to the product obtained by multiplying 9" x the number of tiles needed in step (4).
- (6) Locate and mark this dimension on the chalk line.
- (7) Using the 3, 4, and 5 triangulation method, locate a point that is perpendicular to the chalk line mark of step (6) on the wall opposite the door.
- (8) Tack a nail at this mark (close to the wall) and secure chalk line.
- (9) Snap chalk line perpendicular to the former chalk line and to the door opening.
- (10) Tack a nail on the chalk line in the door opening
- (11) Temporarily secure chalk line to the upper portion of door opening.
- (12) Mark the point of intersection of chalk lines and circle it.



OUTLINE OF INSTRUCTION

INSTRUCTOR ACTIVITY

SCBT 164.1 BU IG 1.2  
STUDENT ACTIVITY

64

2. Prepare for tile placement.
  - a. Assure room is clear of all debris.
  - b. Spread tile adhesive.
    - (1) Use wooden paddle to deposit tile adhesive strategically around the room.
    - (2) Use notched trowel to spread adhesive over surface - do not get adhesive on wall.
    - (3) Start from corner furthest away from door and work toward the door. Do not cover the circled mark in step C.I.d.(12).
    - (4) Check adhesive for readiness.
      - (a) Place back of your hand lightly on the adhesive that is spread. If hand is clear, the floor is ready to receive tile - if hand is unclean, wait a little longer.
    - (5) Snap chalk line.
      - (a) Take chalk line from door opening - stretch it taut over the nail and snap the line for guide line.

3. Lay floor tiles.

II.C.3. Give a brief lecture/ demonstration on floor tile laying technique - use mock up on "Lay out and Installation of Floor Tile" for reinforcement.

OUTLINE OF INSTRUCTION

INSTRUCTOR ACTIVITY

- a. Resecure chalk line on door opening.
  - b. Lay first tile aligned to guide line and with corner of tile exactly on the circled mark.
  - c. Lay other tile in a cross grained pattern and in step fashion and cover entire floor.
4. Cut and lay end tiles.
- a. Start at the center of wall - and lay a tile cross grained directly over a tile.
  - b. Place a second tile over this tile with one end flush to the wall and strike a pencil mark at the end of the second tile marking the lower tile.
  - c. Using a linoleum knife and a straight edge, scribe this mark then snap the tile.
  - d. Lay the cut end tile in place.
  - e. Lay remainder of end tiles.
5. Replacing damaged floor tile.
- a. Remove damaged tile.
  - b. Remove old adhesive.
  - c. Fit new tile to opening.
  - d. Apply adhesive.
  - e. Install new tile.

II.C.5. Call student attention to job sheet SCBT 164.1 BU JS 1.2.3.2 and give a brief lecture/ demonstration in replacing of a damaged floor tile.

II.C.5. Turn to job sheet and follow presentation.



OUTLINE OF INSTRUCTION

INSTRUCTOR ACTIVITY

SCBT 164.1 BU IG 1;  
STUDENT ACTIVITY

66

III. Application.

- A. Student practice as a team member in laying out a room for floor tile placement; and laying out, cutting and placing of end tiles.

III.A. Assign student to a team and a work area to lay out a room for floor tile placement; and give tools, materials and work site to practice end tile placement.

III.A. Student practice as a team member and individually.

IV. Summary.

A. Tools and materials.

1. Composition tile.
2. Tile adhesive.
3. Tile installing tools.

B. Procedures.

1. Tile placement lay out.
  - a. Calculating of end tiles for both length and width of room.
  - b. Calculate for guide line.
    - (1) 3, 4, and 5 method.
    - (2) To the door opening.
2. Prepare for tile placement.
  - a. Sweep the room.
  - b. Spread adhesive.
    - (1) Do not get adhesive on wall.
  - c. Check adhesive for readiness.

OUTLINE OF INSTRUCTIONINSTRUCTOR ACTIVITY

- d. Snap chalk line.
3. Lay floor tile.
  - a. Aligned to guide line.
  - b. Corner of first tile on the circled mark.
  - c. Lay tile cross grained and in a step like pattern.
4. Cut and lay end tile.
  - a. Always start from the center and work outward.
5. Replacing damaged floor tile.
  - a. Remove damaged tile.
  - b. Clean up adhesive.
  - c. Fit tile.
  - d. Apply adhesive.
  - e. Lay new tile.

114

113

(11 of 11)



NAVAL CONSTRUCTION TRAINING CENTER  
PORT HUENEME, CALIFORNIA 93043  
SPECIAL CONSTRUCTION BATTALION TRAINING (SCBT) 164.1

## JOB SHEET

TITLE: Installing Floor Tiles

INTRODUCTION: This job sheet is to guide you in laying floor tiles.

## REFERENCE:

1. Builder 3 & 2, NAVPERS 10648-F, Chapter 13, pp. 374.

## TOOLS AND EQUIPMENT:

1. Measuring tape.
2. Chalk line.
3. Combination square.
4. Linoleum knife.
5. Blow torch.
6. Notched trowel.
7. Tin snip.
8. Wooden paddle.

## MATERIALS:

1. Floor tile.
2. Tile adhesive.
3. Hand cleaner.

## PROCEDURES:

1. Clean up work site.
  - a. By thoroughly sweeping the room.
    - (1) Debris left behind will hinder laying of adhesive and tile.
2. Determine room dimensions.
  - a. Using a measuring tape, measure and record dimensions of all four sides.

(1 of 4)

3. Calculate width of end tiles for length of room.
  - a. Divide length of room by 9" to determine the number of full tiles needed.
    - (1) Tiles come in two sizes, 9" x 9" and 12" x 12" - calculation shown here is for the 9" x 9" tile.
  - b. Add 9" to the remainder and divide by 2 to determine the width of end tiles.
4. Calculate width of tiles for width of room.
5. Prepare for tile laying.
  - a. Add 9" (a full tile) to the width of the end tile (for the width of the room) for working space.
  - b. Mark out this dimension at each end of the room from the wall with the door opening.
  - c. Snap a line from these markings.
  - d. From the end of the wall nearest the door opening - determine the number of full tiles that will be needed to the center of the door opening.
  - e. Add the width of end tile (for the length of the room) to the product obtained by multiplying 9" x the number of tiles needed in step 5d.
  - f. Locate and mark this dimension on chalk line.
  - g. Using the 3, 4 and 5 triangulation method, locate a point that is perpendicular to the chalkline marking (of step 5f) to the wall opposite the door opening.
    - (1) 3, 4, and 5 triangle is known as the Egyptian Triangle where the legs of a right triangle are 3 units and 4 units and the hypotenuse 5 units.
  - h. Tack a nail at this mark (close to the wall) and secure chalkline.
  - i. Snap chalkline, perpendicular to the former chalkline, all the way across to the door opening.
  - j. Tack a nail on the chalkline in the door opening.
  - k. Temporarily secure chalkline to the upper portion of door opening.

1. Circle the point of intersection of the perpendicular chalkline.
  - (1) This circled point of intersection is to be the exact corner placement of the first floor tile.
  
6. Spread tile adhesive.
  - a. Using a wooden paddle deposit tile adhesive strategically around the room.
    - (1) Deposit close to the wall.
  - b. Using a notched trowel spread adhesive over floor surface caution not to get adhesive on wall.
  - c. Start spreading from corner furthest away from door opening and work toward the opening.
    - (1) Do not get trapped in a corner.
  
7. Check adhesive for readiness.
  - a. Lightly rest the back of your hand on the adhesive that is spread, and inspect. If your hand is clean, the floor is ready for tile laying, however, if hand is unclean wait a little longer.
  
8. Snap guide line.
  - a. By taking the chalk line from the door opening and pulling it taut over the nail in step, snap the line for guide line.
  
9. Lay floor tiles.
  - a. Remove nail in step and lay the first tile along guide line with a corner of the tile over the nail hole.
    - (1) The first tile should be laid as accurately as possible and all tile must be laid with the finished surface up.
  - b. Lay other tiles in a cross-grain pattern.
  
10. Cut and lay end tiles.
  - a. Starting from the proximity of the center of wall-side lay a tile across grained to the last full tile.
    - (1) Tile should be laid with edges even.

- b. Place a second tile over this tile with an end flush with the wall.
- c. Strike a pencil mark at the other end of the tile.
- d. Using a linoleum knife, scribe at this mark. Snap tile to desired width.
- (1) A sharp linoleum knife is recommended.
- e. Lay tile in position.
- f. In like manner, cut and lay remainder of end tiles.
- (1) Always work from the center outward.
11. Clean up work area.
- a. Any adhesive on the finished surface must be cleaned.
12. Check work with instructor.
- a. All tile must be laid with the top side up and cross grained. Tolerance for end tiles is 1/16".

## QUESTIONS:

1. Tile adhesive must be \_\_\_\_\_ before tile could be laid on it.
2. Tiles are normally laid in a \_\_\_\_\_ grained pattern.

NAVAL CONSTRUCTION TRAINING CENTER  
PORT HUENEME, CALIFORNIA 93043  
SPECIAL CONSTRUCTION BATTALION TRAINING (SCBT) 164.1

JOB SHEET

TITLE: Repairing Damaged Floor Tile

INTRODUCTION: This job sheet is to guide you in replacing a damaged floor tile.

REFERENCES:

1. Complete Do-it-Yourself Manual, Readers Digest, pp. 358 - 361.

TOOLS AND EQUIPMENT:

1. Putty knife.
2. Blow torch.
3. Linoleum knife.
4. Notched trowel.

MATERIALS:

1. Floor tile.
2. Tile adhesive.
3. Hand cleaner.

PROCEDURES:

1. Remove damaged tile.
  - a. With the use of a blow torch, heat the damaged tile.
  - b. Use putty knife and carefully pry damaged tile off. Do not damage surrounding floor tiles.
    - (1) Heat is to soften the adhesive.
2. Remove old adhesive from open area.
  - a. Use empty container to deposit old adhesive.
3. Fit new tile(s) to opening.
  - a. Use a linoleum knife and/or sandpaper to trim tile in acquiring a snug fit.

4. Apply adhesive.
  - a. Use a notched trowel or a notched wood paddle, spread adhesive over open area.
    - (1) Do not get adhesive on surrounding tile.
5. Install new tile.
  - a. Place tile in position.
  - b. Weight tile down.
6. Clean up work area.
  - a. Use detergent and rag as necessary - remove all excessive adhesive.
7. Check work with instructor.
  - a. Tile(s) must be laid top side up, must be cross-grained with surrounding tiles and all joints must be within 1/32".

NAVAL CONSTRUCTION TRAINING CENTER  
 PORT HUENEME, CALIFORNIA 93043  
 SPECIAL CONSTRUCTION BATTALION TRAINING (SCBT) 164.1

Classification: Unclassified

Topic: Accoustical Ceiling Tile

Average Time: 2 Periods (Class), 3 Periods (Pract)

Instructional Materials:

A. Texts: None.

B. References:

1. Fundamentals of Carpentry, Volume 2, W.E. Durbahn and E.W. Sundberg.
2. Complete Do-it-yourself Manual, Reader's Digest.

C. Tools, Equipment and Materials:

1. Measuring tape.
2. Chalk line.
3. Cross-cut saw.
4. Framing square.
5. Combination square.
6. Compass saw.
7. Step ladder.
8. 1/2" x 12" x 12" accoustical tile.

Terminal Objective: Upon completion of this unit the student will have completed finish carpentry projects involving wall board, plywood panel, composition floor tile and accoustical ceiling tile. All work is to be done by following procedures in accordance with job sheets and in meeting the specifications as stated on the job sheets.

Enabling Objectives: Upon completion of this topic the student will be able to layout, cut, prepare and install accoustical ceiling tile by following procedures in accordance with job sheet, SCBT 164.1 BU JS 1.2.4.1, "Laying Out, Cutting, Preparing and Installing Accoustical Ceiling Tile". The finished ceiling will be within job sheet specifications. Job sheet will be provided for each student.

Criterion Test: The student is to be tested on his ability to install accoustical ceiling tile such that the finish surface of the ceiling will be free of adhesive and hand prints, the corners of all tiles be laid within  $\pm 1/16$ " of alignment, and the end tiles wider than  $\bar{5}$ " at the narrowest point.

Homework: None

75

9. Putty knife.

10. Accoustical tile adhesive.

11. Sheet rock knife.

D. Training Aids and Devices:

1. Samples.

a. Accoustical tile.

b. Accoustical tile adhesive.

2. Locally Prepared Material:

a. Job sheet.

(1) SCBT 164.1 BU JS 1.2.4.1, "Laying  
Out, Cutting and Installing Accoustical  
Ceiling Tile".

E. Training Aids Equipment: None.

123

124



## OUTLINE OF INSTRUCTION

- I. Introduction to the lesson.
  - A. Establish contact.
    1. Name:
    2. Topic: Accoustical Ceiling Tile
  - B. Establish readiness.
    1. Purpose - accoustical tile does what it has been designed for and what its name implies. It helps cut down noise it also give a pleasant appearance. There are many types, designs and different application methods in accoustical tiles. We will be involved with just one type, the square edged type, and with one method of application, the adhesive method.
  - C. Establish effect.
    1. Value.
      - a. Pass course.
      - b. Perform better on the job.
      - c. Get advanced.
      - d. Be a better builder.
  - D. Overview.
    1. Job sheet.
      - a. SCBT 164.1 BU JS 1.2.4.1.

## INSIRUCIOR ACTIVITY

- I.A. Introduce self and topic.
- I.B. Motivate student by reading the statement on accoustical tile.
- I.C. State learning objectives.
  - a. Upon completion of this topic you will be able to install accoustical ceiling tile.

SCBT 164.1 BU IG 1.2.  
STUDENT ACTIVITY

76

OUTLINE OF INSTRUCTION

2. Pay close attention to the demonstration by the instructor.
3. Safety precautions.
4. Ask questions.

II. Presentation.

A. Introduce job sheet.

1. SCBT 164.1 BU JS 1.2.4.1, "Laying Out, Cutting and Installing Accoustical Ceiling Tile".

B. Ceiling materials.

1. 1/2" x 12" x 12" accoustical tile.
2. Accoustical tile cement.

C. Steps of procedure.

1. Tile placement layout.
  - a. Determine room dimensions.
  - b. Calculate width of end tile for length of the room.
    - (1) Calculate on using 12" x 12" tile.
    - (2) Stress that end tile should be at least 5" wide.
  - c. Calculate width of end tile for width of the room.

INSTRUCTOR ACTIVITY

II.A. Handout job sheet.

II.C.L. Give a lecture on end tile calculating technique. Use chalk board to demonstrate this technique - call student's attention to job sheet SCBT 164.1 BU JS 1.2.4.1.

SCBT 164.1 BU IG 1.2  
STUDENT ACTIVITY

II.C.1. Turn to job sheet and follow instruction/demonstration.

OUTLINE OF INSTRUCTION

INSTRUCTOR ACTIVITY

SCBI 164.1 BU IG 1.2  
STUDENT ACTIVITY

78

- d. Smooch cut edge with scrap ceiling tile.
- e. Apply adhesive and place tile in position.
- 5. General helpful comments.
  - a. Work with clean hands.
    - (1) Wash hands as often as necessary.
  - b. A white chalk is helpful in touch-up work.

III. Application.

- A. Student practice as a team member in laying out a room for ceiling tile placement, and laying out, cutting and placing of end tiles.

III.A. Assign student to a team and work area to lay out a room as a team member and for ceiling tile placement, and give tools, materials and work site to practice end tile placement.

IV. Summary.

- A. Ceiling tile materials.
  - 1. 1/2" x 12" x 12" accoustical tile.
  - 2. Accoustical tile cement.
- B. Procedures.
  - 1. Ceiling tile placement layout.
    - a. Calculating end tile for both width and length of room.
    - b. Calculating for guide lines.
      - (1) 3, 4, and 5 method.

OUTLINE OF INSTRUCTION

2. Determine tile placement guide lines.
  - a. At each end of the room (lengthwise) mark out the width of end tile for the width of the room.
  - b. Snap chalk line through these points.
  - c. Mark width of end tile for the length of the room at one end of the chalk line.
  - d. Use 3, 4, and 5 method and strike a perpendicular line to the chalk line at this point.
3. Prepare and lay tiles.
  - a. Apply adhesive to tile.
    - (1) Size of a walnut.
    - (2) At each corner - 1 1/2" away from the edges.
    - (3) Place and press tile in position.
4. Cut and lay end tiles.
  - a. Start from the center of wall - side and work outward.
  - b. Mark for both ends of tile.
  - c. Use cross-cut saw, cutting tile only on a downward stroke with slight undercut.

INSTRUCTOR ACTIVITY

II.C.2. Take class out to the training site and give a lecture/demonstration in the placing of guide lines.

SCBT 164.1 BU IG 1.2  
STUDENT ACTIVITY

79

131

(5 of 7)

132

OUTLINE OF INSTRUCTION

INSTRUCTOR ACTIVITY

SCBT 164.1 BU IG 1.2  
STUDENT ACTIVITY

80

2. Prepare for tile placement.
  - a. Adhesive the size of a walnut on four corners, 1 1/2" from the edge.
3. Preparation and placement of end tiles.
  - a. Work from the center outward.
  - b. Measure for each end of the tile.
  - c. Use cross-cut saw and cut only on a downward stroke.
  - d. Smooth cut edge with scrap of ceiling tile.
4. Helpful comments.
  - a. Work with clean hands.
  - b. White chalk to touch-up.

NAVAL CONSTRUCTION TRAINING CENTER  
PORT HUENEME, CALIFORNIA 93043  
SPECIAL CONSTRUCTION BATTALION TRAINING (SCBT) 164.1

JOB SHEET

TITLE: Laying Out, Cutting and Installing Accoustical Ceiling Tile

INTRODUCTION: This job sheet is to guide you in installing accoustical ceiling tile.

TOOLS AND EQUIPMENT:

1. Measuring tape.
2. Chalk line.
3. Cross-cut saw.
4. Framing square.
5. Combination square.
6. Compass saw.
7. Sheet rock knife.
8. Step ladder.

MATERIALS:

1. 1/2" x 12" x 12" accoustical tile.
2. Accoustical tile adhesive.

PROCEDURES:

1. Measure length and width of room.
2. Calculate for end tiles.
  - a. Divide length of room by 12" for number of full tiles.
  - b. Divide the remainder by 2 for width of end tiles for length of room.
  - c. If end tiles are less than 5", add a full tile (12") to the remainder and recalculate for end tiles.
  - d. In similar manner, determine end tiles for width of room.

3. Layout for tile laying.

- a. Divide the number of full tiles needed for the width of the room.
- b. Multiply this number by 12" and add the width of end tile for width of the room.
- c. Measure and mark this dimension at the ends of the room.
- d. Snap a chalk line through these points.
- e. Divide the number of full tiles needed for the length of the room.
- f. Multiply this number by 12" and add the width of the end tiles for the length of the room.
- g. Measure and mark this dimension on chalk line snapped in step 3d.
- h. At this point, use 3, 4 and 5 method to construct a line perpendicular to the chalk line.

4. Prepare and lay tiles.

- a. Apply tile adhesive approximately the size of a walnut to each corner of the tile (12 x 12), about 1 1/2" away from the edges.
- b. Place and press this tile in position such that two edges are aligned to the guide lines.
- c. Apply tile adhesive and place tiles until entire ceiling is covered except for the end tiles.

5. Cut and lay end tiles.

- a. Starting from the proximity of the center of wall - side, measure and mark necessary dimensions on both ends of end tile.
- b. Use straight edge and run a pencil line through these markings.
- c. Use cross-cut saw to cut along guide line - cut with a slight undercut and cut only on a downward stroke.
- d. If cut edge needs to be made smooth, use scrap ceiling tile as sanding block to touch up.

- e. Apply tile adhesive and place tile in position.
  - f. In like manner, cut and lay remainder of end tiles
6. Check work with instructor.
- a. All tile finish surfaces must be free of adhesive and hand prints, the corners of all tiles must not be more than  $\pm 1/16$ " out of alignment.

NOTE: Your hands must be clean to prevent hand prints from showing on tile surface. A white chalk will help if the surface needs to be touched up.



# CHAPTER 13 INTERIOR FINISH

The interior finish consists mainly of the finish covering applied to the rough walls, ceilings, and floors. Other major interior finish items are the inside door frames, the doors, the window sash, and the stairs.

Interior-finish items whose function is principally ornamental are classified under the general heading of INTERIOR TRIM. Interior trim includes inside door and window casings, window stools and aprons, baseboards, and molding trim.

The usual order of construction for the interior finish is as follows:

1. Ceiling covering
2. Wall covering
3. Stairs
4. Window sash
5. Window inside casings, stools, and aprons
6. Finish flooring
7. Inside door frames and casings
8. Baseboards
9. Molding trim.

## WALL AND CEILING COVERING

The two major types of wall and ceiling covering are PLASTER and DRY-WALL COVERING. Dry-wall covering is a general term applied to sheets or panels of wood, plywood, fiberboard, and the like.

### PLASTER

A PLASTER wall and/or ceiling covering requires the construction of a PLASTER BASE, or surface on which the plaster can be spread and to which it will adhere. A surface of this kind was formerly constructed by nailing wooden LATHS (thin, narrow strips usually 48 in. long) to the edges of studs and joists, or to wooden FURRING STRIPS anchored to concrete or masonry walls. In modern construction, wooden lath has been almost entirely superseded by GYPSUM lath, FIBERBOARD lath and METAL lath.

Gypsum lath usually consists of 16 in. by 48 in. sheets of GYPSUM BOARD, either solid or

perforated and usually squared-edged. It is applied horizontally to studs and at right angles to joists, and nailed to studs, joists, or furring strips with 1 1/8-in. flat-headed GYPSUM-LATH NAILS, 5 to each stud, joist or strip crossing.

Fiberboard lath consists of sheets of fiberboard, also usually 16 in. by 48 in. in size. It may be either square-edged or shiplap edged. It is applied in much the same manner as gypsum lath, except that 1 1/4-in. blued FIBERBOARD-LATH NAILS are used.

Metal lath consists of screen-like sheets of MESHED or RIBBED metal, usually 27 in. by 96 in. in size. To walls it is applied horizontally; to ceilings with the long dimension perpendicular to the line of the joists. It may be nailed to studs or to furring strips with regular metal-lath STAPLES, or with 8-penny nails driven part-way in and then hammered over. It may be similarly nailed to ceiling joists, or it may be tied up with wire ties to nails driven through the joists about 2 in. above the lower edges.

Before lath is applied to walls and ceilings, PLASTER GROUNDS are installed as called for in the working drawings. Plaster grounds are wood strips of the same thickness as the combined thickness of the lath and plaster. They are nailed to the framing members around doors and windows and to the studs along floor lines. They serve as a guide to the plasterers, to ensure that the plaster behind door casings, window casings, and baseboards will be of uniform and correct thickness. They also serve as nailing bases for the trim members mentioned.

Plastering is usually done in three coats, which form a combined thickness of about 5/8 in. The first coat is called the SCRATCH coat, because it is usually scored when partially set to improve the adhesion of the second coat. The second coat is called the BROWN coat, and the third the WHITE (also the SKIM or FINISH) coat. As gypsum or fiberboard lath provides the equivalent of a scratch coat, only the brown and finish coats of plaster are applied when these types of lath are used.

The basic ingredients for scratch-coat and brown-coat plaster are lime and sand. Proportions vary, but a scratch coat usually has about 1 part of lime to 2 parts of sand, by volume. The proportion of lime to sand in a brown coat is slightly smaller.

Plaster for an ordinary white coat usually consists of lime putty mixed with plaster-of-paris; a little marble dust may be included. Plaster for a high grade finish coat contains calcium sulphate instead of lime. KEENE'S CEMENT is a well-known variety of calcium sulphate finish plaster. A very superior hard-finish coat can be obtained by mixing 4 parts of Keene's cement with 1 part of lime putty.

Manufacturers of plaster usually furnish instruction sheets which set forth the recommended ingredient proportions and methods of application for their products. Follow these instructions closely. The actual application of plaster, especially to ceilings, is a skill which can be acquired only through practice. Additional information on plaster work may be found in chapter 14.

#### DRY-WALL FINISH

DRY-WALL FINISH is a general term applied to sheets or panels of various materials used for inside-wall and ceiling covering. The most common dry-wall finishes are GYPSUM-BOARD, PLYWOOD, FIBERBOARD, and WOOD.

##### Gypsum Board

Gypsum board usually comes in a standard size of 4' by 8'. However, on notice it can be obtained in any length up to 16 ft. It can be applied to walls, either vertically or horizontally. A 4-ft wide sheet applied vertically to studs 16 in. O.C. will cover 3 stud spaces. Five-penny cement-coated nails should be used with 1/2-in.-thick gypsum, 4-penny nails with 3/8-in.-thick gypsum. Nails should be spaced 6 to 8 in. O.C. for walls and 5 to 7 in. O.C. for ceilings.

Nail heads should be driven about one-sixteenth inch below the face of the board; this set can be obtained by using a crowned hammer. The indentations around nails away from edges are concealed by applying JOINT CEMENT. The nail indentations along edges are concealed with a perforated fiber JOINT TAPE set in joint cement. Edges are slightly recessed to bring the tape flush with the faces. Besides concealing

the nail indentations, the tape also conceals the joint.

The procedure for taping a joint is as follows:

1. Spread the joint cement along the joint with a 4- to 6-in. putty knife. Joint cement comes in powder form; the powder is mixed with water to about the consistency of putty.
2. Lay the tape against the joint and press it into the recess with the putty knife. Press until some of the joint cement is forced out through the holes in the tape.
3. Spread joint cement over the tape, and FEATHER (taper off) the outer edges.
4. Allow the cement to dry, then sand lightly. Apply a second coat, and again feather the edges.
5. Allow the cement to dry, and then sand the joint smooth.

For nail indentations away from edges, fill the indentations with cement, allow the cement to dry, and sand lightly. Apply another coat, allow to dry, and sand smooth.

##### Plywood

Plywood finish comes in sheets of various sizes which can be applied either vertically or horizontally. With horizontal application, lengths of stud stock called NAILERS are framed between the studs along the lines of horizontal joints. Panels can be nailed directly to studs and nailers, but a better method is to nail 2-in. furring strips to the studs and nailers and then glue and nail the panels to the strips. This method reduces joint movements caused by swelling or shrinking of the studs and nailers.

Joints between plywood panels can be finished in a variety of ways. For a tight butt joint, spread enough glue on the furring strip, stud, or nailer to provide a SQUEEZE of glue between the edges, allow the glue to dry, and then block-sand the joint smooth. Another smooth joint can be obtained by rabbeting the edges for shiplap.

Edges of panels can be smoothed and the joints left open for ornamental effect; or the edges can be beveled to form a V-groove joint when brought together; or joints can be left open and then filled with glued-in wooden splines. Outside corners between panels can be miter-joined, or the right angle between square edges at outside corners can be filled with quarter-round molding. Inside corners can be butted or mitered.

BUILDER 3 & 2

One-half inch plywood finish is nailed on with 1 1/4 in. finish nails spaced 6 in. O.C.

continuous surface of wood or plasterboard with a special type of adhesive.

Fiberboard

STAIRS

Fiberboard wall finish comes in 2 ft by 8 ft sheets which are applied horizontally. The long edges are usually rabbeted or tongue-and-grooved for joining. Fiberboard is nailed in place with finish nails, brads, or cadmium plated fiberboard nails. Use 1 1/2-in nails for 1/2-inch thick boards and 2-inch nails for 1-inch thick boards.

Fiberboard in small squares or rectangles is called TILEBOARD and each piece of tileboard is called a TILE. Common sizes are 12 inches by 12 inches, 12 inches by 24 inches, 16 inches by 16 inches, and 16 inches by 32 inches. Tiles can be nailed to studs, joists, and furring strips; usually, however, they are glued to a

There are many different kinds of stairs, but all have two main parts in common: the TREADS people walk on, and the STRINGERS (also called STRINGS, HORSES, and CARRIAGES) which support the treads. A very simple type of stairway, consisting only of stringers and treads, is shown in the left-hand view of figure 13-1. Treads of the type shown here are called PLANK treads, and this simple type of stairway is called a CLEAT stairway, because of the cleats attached to the stringers to support the treads.

A more finished type of stairway has the treads mounted on two or more sawtooth-edged stringers, and includes RISERS, as shown in the right-hand view of figure 13-1. The stringers

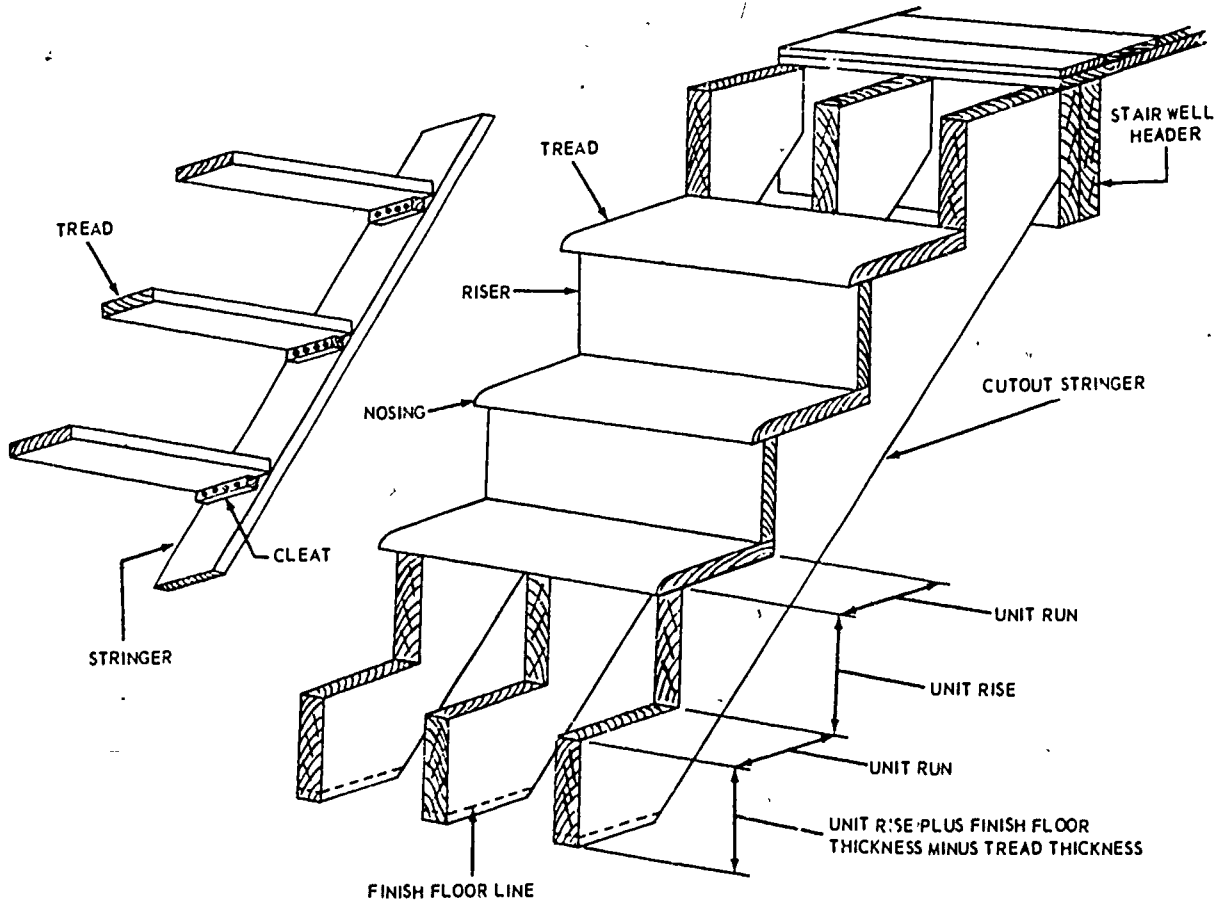

Figure 13-1.--Stairway nomenclature.

45.507

shown here are cut out of solid pieces of dimension lumber (usually 2 x 12), and are therefore called CUTOUT or SAWED stringers.

### STAIRWAY LAYOUT

The first step in stairway layout is to determine the UNIT RISE and UNIT RUN shown in figure 13-1. The unit rise is calculated on the basis of the TOTAL RISE of the stairway, and the fact that the customary permissible unit rise for stairs is in the vicinity of 7 inches.

The total rise is the vertical distance between the lower finish floor level and the upper finish floor level. This may be shown in the elevations; however, since the actual vertical distance as constructed may vary slightly from what it should have been, and since it is the actual distance you are dealing with, the distance should be measured.

At the time the stairs are to be laid out, the subflooring is laid but the finish flooring isn't. If both the lower and the upper floor are to be covered with finish flooring of the same thickness, the measured vertical distance from lower subfloor surface to the upper subfloor surface will be the same as the eventual distance between the finish floor surfaces, and therefore equal to the total rise of the stairway. But if you are measuring up from a finish floor (such as a concrete basement floor, for instance), then you must add to the measured distance the thickness of the upper finish flooring to get the total rise of the stairway. If the upper and lower finish floors will be of different thicknesses, then you must add the difference in thickness to the measured distance between subfloor surfaces to get the total rise of the stairway. Use a straight piece of lumber plumbed in the stair opening with a spirit level, or a plumb bob and cord, to measure the vertical distance.

Assume that the total rise measures 8 ft 11 in., as shown in figure 13-2. Knowing this, you can determine the unit rise as follows. First, reduce the total rise to inches—in this case it comes to 107 in. Next, divide the total rise in inches by the average permissible unit rise, which is 7 in. The result, disregarding any fraction, is the number of RISERS the stairway will have—in this case it is  $107/7$ , or 15. Now divide the total rise in inches by the number of risers—in this case, this is  $107/15$ , which comes to 7.13 in., or, rounded off to the nearest  $1/16$  in.,  $7\ 1/8$  in. This, then, is the unit rise, as shown in figure 13-2.

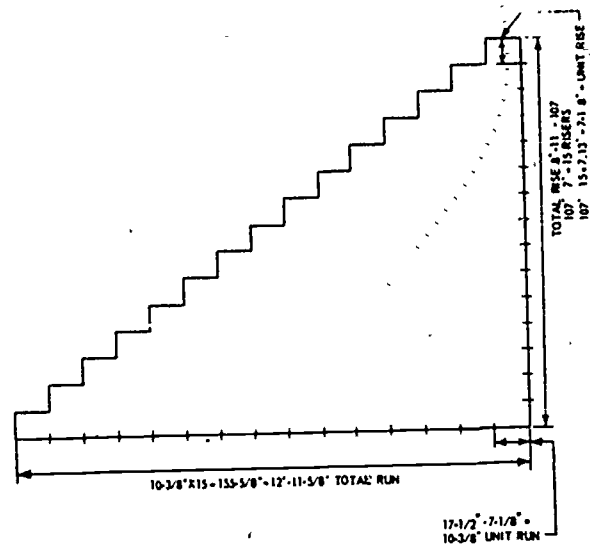

117.54

Figure 13-2.—Stairway layout computations.

The unit run is calculated on the basis of (1) the unit rise, and (2) a general architects' rule that the sum of the unit run and unit rise should be  $17\ 1/2$  in. In view of (2), if the unit rise is  $7\ 1/8$  in., the unit run is  $17\ 1/2$  in. minus  $7\ 1/8$  in., or  $10\ 3/8$  in.

You can now calculate the TOTAL RUN of the stairway. The total run is obviously equal to the product of the unit run times the total number of treads in the stairway. However, the total number of treads depends upon the manner in which the upper end of the stairway will be anchored to the header.

In figure 13-3, three methods of anchoring the upper end of a stairway are shown. In the first view there is a complete tread at the top of the stairway. This means that the number of complete treads will be the same as the number of risers. For the stairway shown in figure 13-1, there are 15 risers and 15 complete treads. Therefore, the total run of the stairway will be the product of the unit run times 15, or  $10\ 3/8$  in. x 15, or  $155\ 5/8$ ", or 12 ft 11 5/8 in., as shown.

In figure 13-3, second view, there is only part of a tread at the top of the stairway. If this method were used for the stairway shown in figure 13-2, the number of complete treads would be ONE LESS than the number of risers, or 14. The total run of the stairway would be the product of  $14 \times 10\ 3/8$ , PLUS THE RUN OF

88

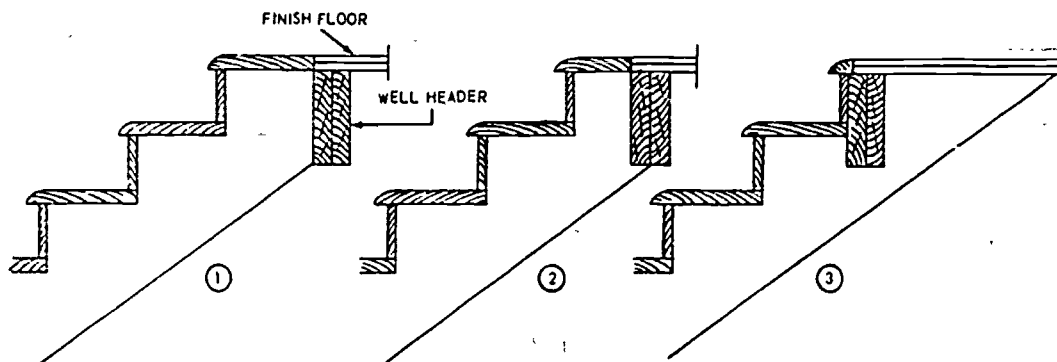

45.508

Figure 13-3.—Three methods of anchoring upper end of a stairway.

**THE PARTIAL TREAD AT THE TOP.** Suppose this run were 7 inches. Then the total run would be  $14 \times 10 \frac{3}{8} + 7$ , or  $152 \frac{1}{4}$  in., or 12 ft 8  $\frac{1}{4}$  in.

In figure 13-3, third view, there is no tread at all at the top of the stairway; the upper finish flooring serves as the top tread. In this case the total number of complete treads is again 14, but since there is no additional partial tread, the total run of the stairway is  $14 \times 10 \frac{3}{8}$ , or  $145 \frac{1}{4}$  in., or 12 ft 1  $\frac{1}{4}$  in.

When you have calculated the total run of the stairway, drop a plumb bob from the well head to the floor below and measure off the total run from the plumb bob. This locates the anchoring point for the lower end of the stairway.

Cutout stringers for main stairways are usually made from 2 x 12 stock. The first question is: About how long a piece of stock will you need? Let's assume that you are to use the method of upper-end anchorage shown in the first view of figure 13-3 to lay out a stringer for the stairway shown in figure 13-2. This stairway has a total rise of 8 ft 11 in. and a total run of 12 ft 11  $\frac{5}{8}$  in. The stringer must be long enough to form the hypotenuse of a triangle with sides of those two lengths. For an approximate length estimate, call the sides 9 and 13 ft long. The length of the hypotenuse, then, will equal the square root of  $9^2 + 13^2$ , or the square root of 250, or about 15.8 ft, or about 15 ft 9  $\frac{1}{2}$  in.

Figure 13-4 shows the layout at the lower end of the stringer. Set the framing square to the unit run on the tongue and the unit rise on the blade, and draw the line AB. This line represents the bottom tread. Then draw AD perpendicular to AB, in length equal to the unit rise.

This line represents the bottom riser in the stairway. Now, you've probably noticed that, up to this point, the thickness of a tread in the stairway has been ignored. This thickness is now about to be accounted for, by making an allowance in the height of this first riser, a process which is called **DROPPING THE STRINGER**.

As you can see in figure 13-1, the unit rise is measured from the top of one tread to the top of the next for ALL RISERS EXCEPT THE BOTTOM ONE. For this one, the unit rise is measured FROM THE FINISHED FLOOR SURFACE TO THE SURFACE OF THE FIRST TREAD. If AD were cut to the unit rise, the actual rise of the first step would be the sum of the unit rise plus the thickness of a tread. Therefore, the length of AD is shortened by the thickness of a tread, as shown in figure 13-4—or by the thickness of a tread less the thickness of the finish flooring. The first is done if the stringer will rest on a finish floor, such as concrete basement floor. The second is done if the stringer will rest on subflooring.

When you have shortened AD to AE, as shown, draw EF parallel to AB. This line represents the bottom horizontal anchor-edge of the stringer. Then proceed to lay off the remaining risers and treads to the unit rise and unit run, until you have laid off 15 risers and 15 treads. Figure 13-5 shows the layout at the upper end of the stringer. The line AB represents the top—that is, the 15th—tread. BC, drawn perpendicular to AE, represents the upper vertical anchor-edge of the stringer, which will butt against the stairwell header.





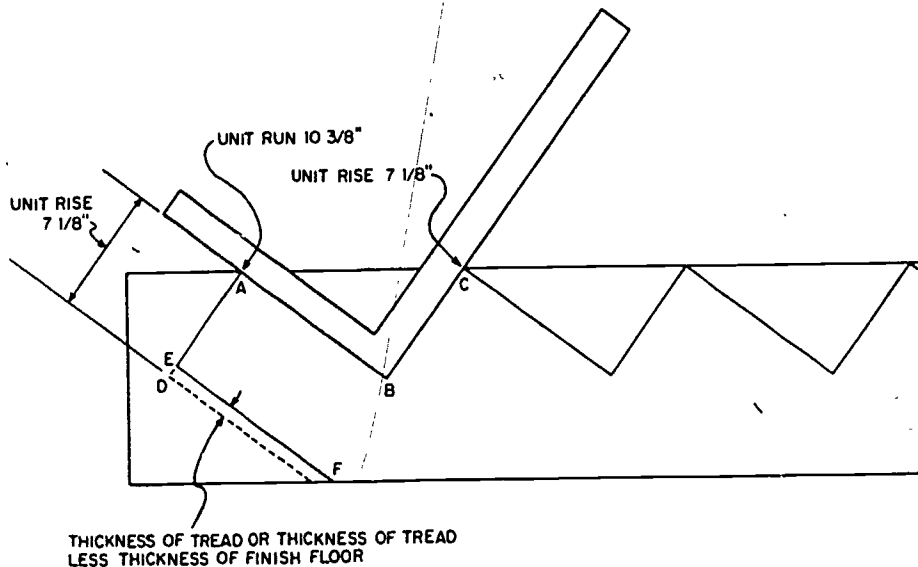

117.55

Figure 13-4.—Layout of lower end of cutout stringer.

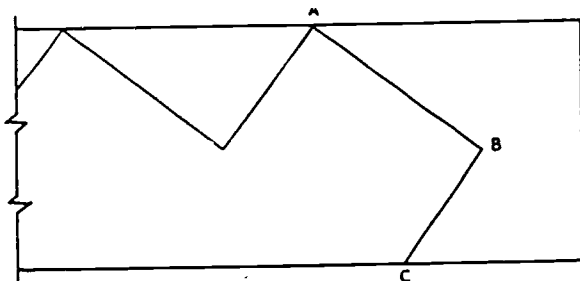

117.56

Figure 13-5.—Layout at upper end of cutout stringer.

### STAIRWAY CONSTRUCTION

We have been dealing with a common **STRAIGHT-FLIGHT** stairway, meaning one which follows the same direction throughout. When floor space is not extensive enough to permit construction of a straight-flight stairway, a **CHANGE** stairway is installed—meaning, one which changes direction one or more times. The most common types of these are **90-DEGREE** change and **180-DEGREE** change. These are usually **PLATFORM** stairways—that is, successive straight-flight lengths, connecting platforms at which the direction changes 90 degrees, or doubles back 180 degrees. Such

a stairway is laid out simply as a succession of straight-flight stairways.

The stairs in a structure are broadly divided into **PRINCIPAL** stairs and **SERVICE** stairs. Service stairs are porch, basement, and attic stairs. Some of these may be simple cleat stairways; others may be **OPEN-RISER** stairways. An open-riser stairway has treads anchored on cut-out stringers or stair-block stringers, but no risers. The lower ends of the stringers on porch, basement, and other stairs anchored on concrete are fastened with a **KICK-PLATE** like the one shown in figure 13-6.

A principal stairway is usually more finished in appearance. Rough cutout stringers are concealed by **FINISH** stringers like the one shown in figure 13-7. Treads and risers are often rabbet-joined as shown in figure 13-8. To prevent squeaking, triangular blocks may be glued into the joints, as shown in the same figure.

The vertical members which support a stairway handrail are called **BALUSTERS**. Figure 13-9 shows a method of joining balusters to treads. For this method, dowels shaped on the lower ends of the balusters are glued into holes bored in the treads.

Stringers should be toenailed to well headers with 10-penny nails, three to each side of the stringer. Those which face against trimmer joists should be nailed to the joist with at least three 16-penny nails apiece. At the bottom a

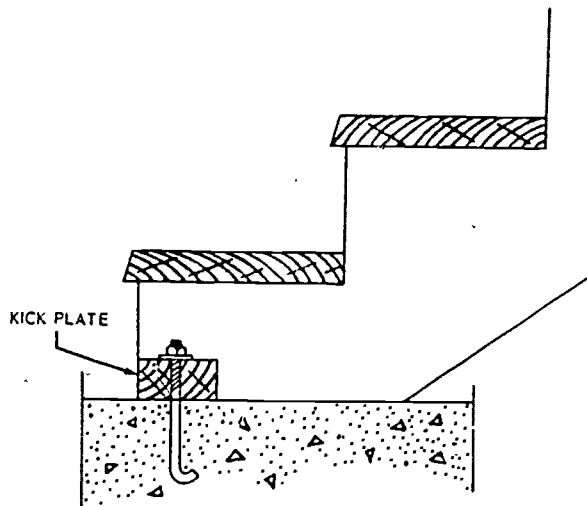

117.57  
 Figure 13-6.—Kick-plate for anchoring stairs to concrete.

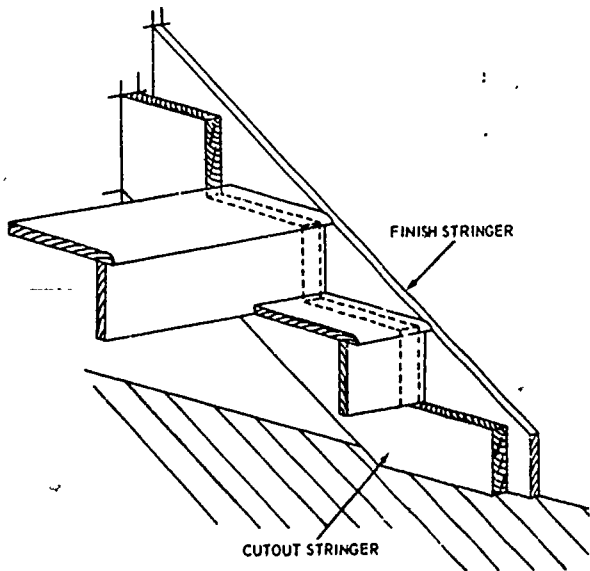

117.58  
 Figure 13-7.—Finish stringer.

stringer should be toenailed with 10-penny nails, 4 to each side, driven into the subflooring and if possible into a joist below.

Treads and risers should be nailed to stringers with 6-penny, 8-penny, or 10-penny finish nails, depending on the thickness of the stock.

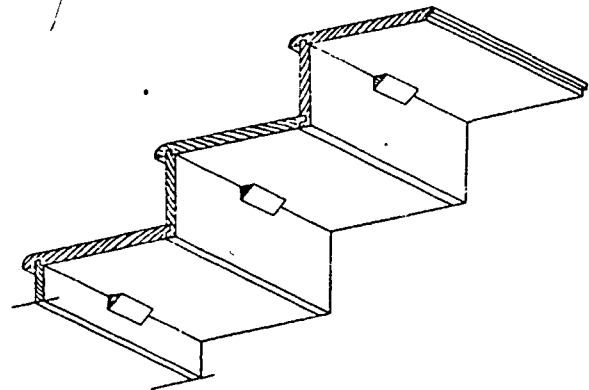

117.59  
 Figure 13-8.—Rabbet-joined treads and risers.

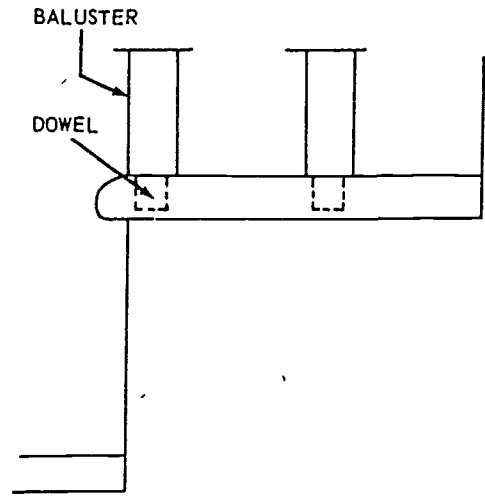

117.60.1  
 Figure 13-9.—One method of joining a baluster to the tread.

WINDOW SASH

A window frame is built to the dimensions of the window, as given on the window schedule. To prevent the sash from binding in the frame, it is necessary to apply a CLEARANCE ALLOWANCE when laying out the sash. Sash for a double-hung window is made 1/8 in. narrower and 1/16 in. shorter than the finished opening size; sash for wooden casements is made 1/8 in. narrower and 1/32 in. shorter than the opening size. Wooden sash is usually made from 1 3/8-in.-thick stock.

## INSTALLING WINDOW SASH

Casement sash is hung in about the same manner that a door is hung.

Double-hung sash consists of an upper and a lower sash, each of which can be slid up and down in a separate vertical runway. The upper sash slides in the outer runway, the lower sash in the inner runway. The inner side of the outer

runway is formed by the parting stop, the outer side by the blind stop, or by a SIDE STOP nailed to the faces of the jambs. The outer side of the inner runway is formed by the parting stop, the inner side by a side stop nailed to the faces of the side jambs. All this is shown in figures 13-10 and 13-11.

The weight of a double-hung sash may be counterbalanced by a couple of SASH WEIGHTS,

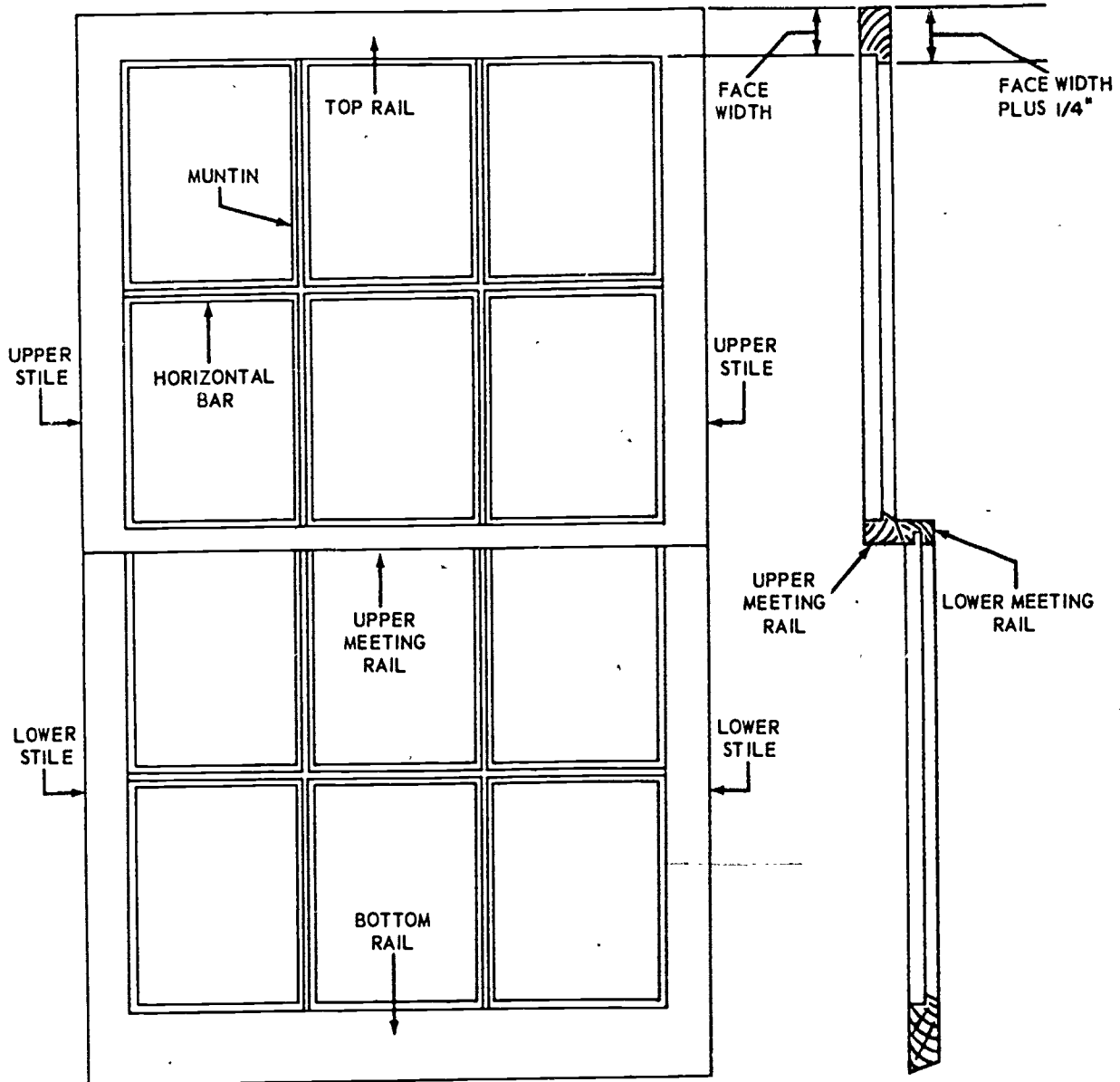

Figure 13-10.—Parts of a double-hung window sash.

45.509



92

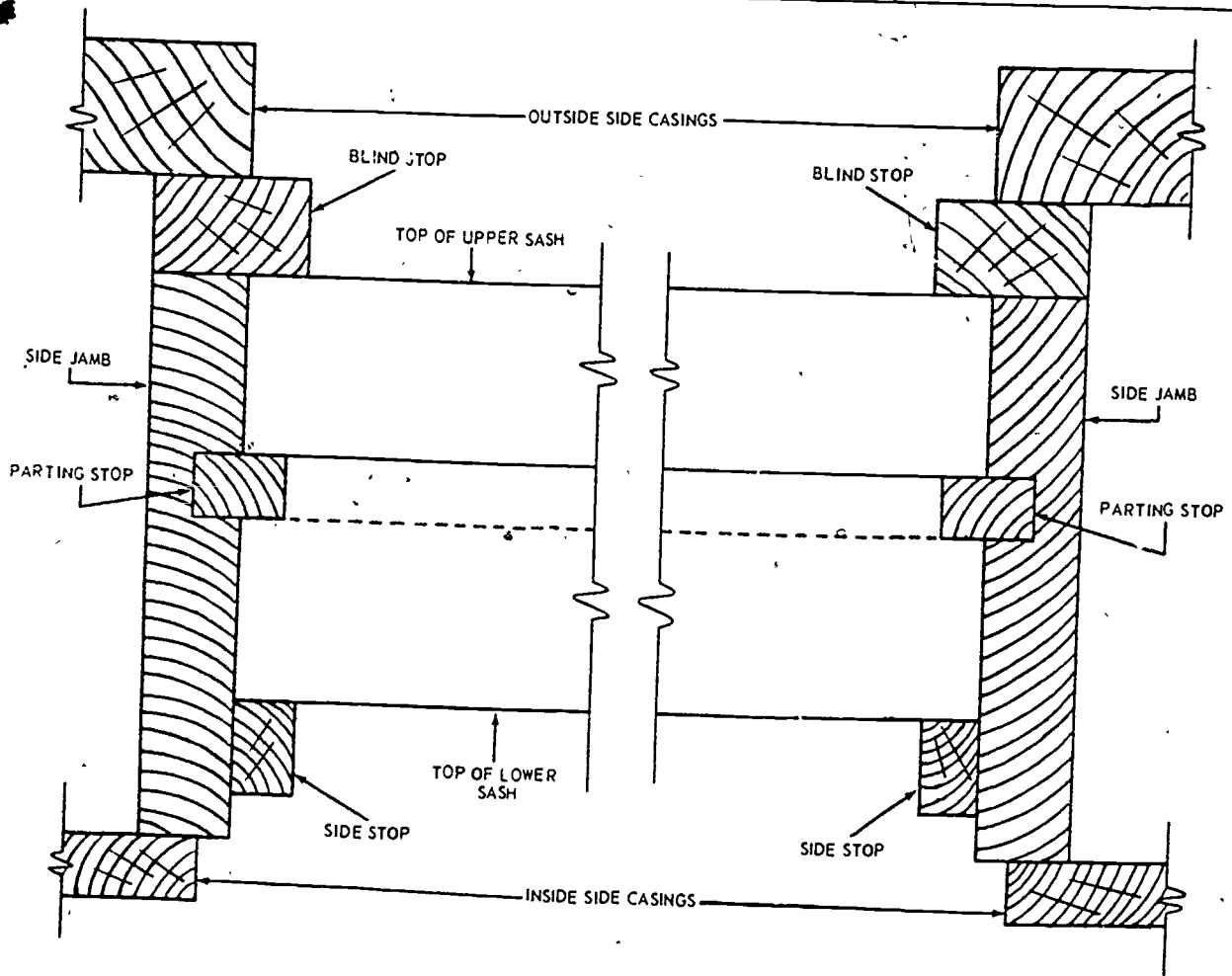

Figure 13-11.—Double-hung sash installed.

117.62

which hang in PULLEY POCKETS on either side of the frame, and which are connected to the tops of the upper and lower sash by lengths of SASH CORD running up and over pulleys at the top of the frame. SASH WEIGHTS HAVE BEEN LARGELY REPLACED, HOWEVER, BY VARIOUS SPRING DEVICES WHICH LIE INSIDE THE JAMBS AND DO NOT REQUIRE PULLEY POCKETS. For sash cord the outer edges of the stiles must be grooved about one-third of the way down from the top, and a hole must be cut at the end of each groove to contain a knot in the end of the cord. For some types of spring balances the stiles are not grooved; other types require a groove the full length of the stile.

Steps in fitting and hanging double-hung sash are as follows:

1. Try the upper sash in the frame for a fit; if necessary, plane down the stiles to get a clearance of 1/8 in.
2. Notch the ends of the meeting rails so the rails will fit around the parting stop as shown in figure 13-12. The depth of the notch is equal to the thickness of the parting stop, plus a 1/16-in. allowance for clearance. The width of the notch is the width of the parting stop, less the depth of the parting stop groove, plus a 1/16-in. allowance for clearance.
3. Remove the parting stop from the jambs, set the upper sash in its runway, and replace the parting stop. Run the upper sash all the way up and fasten it there with a nail tacked into each of the side jambs.

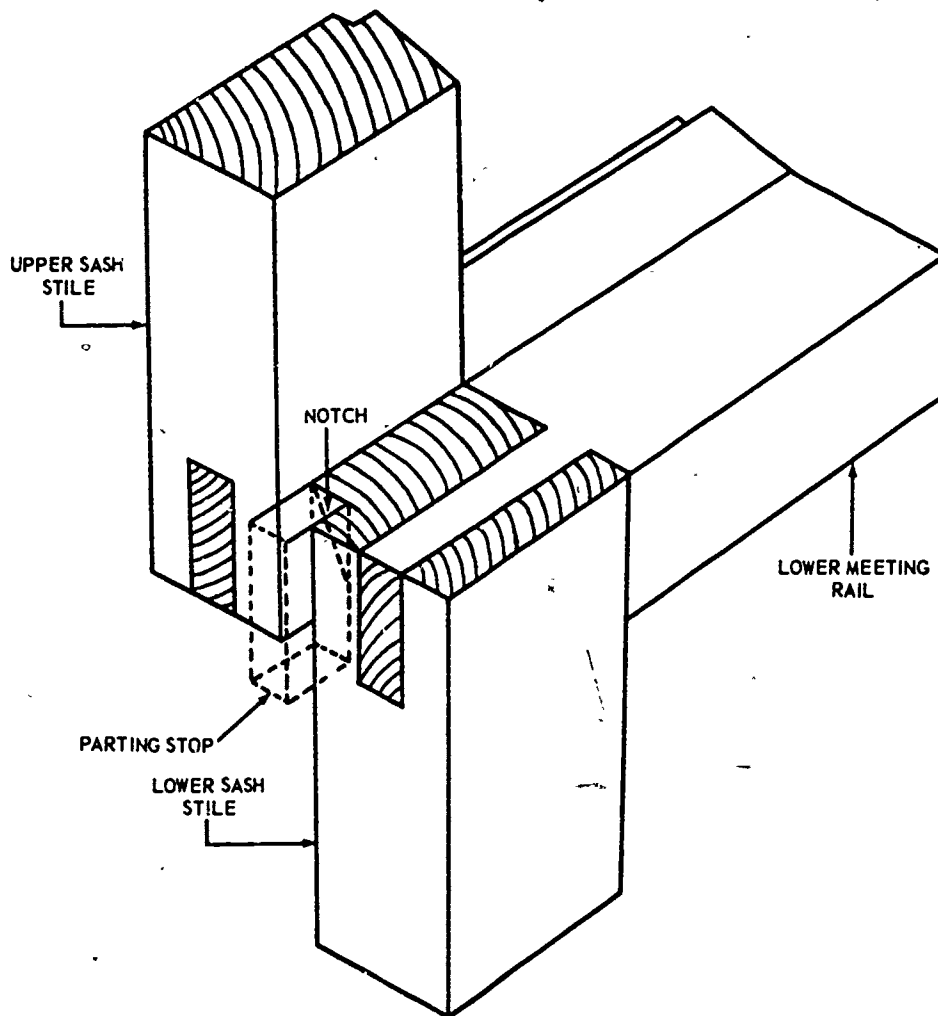

117.63

Figure 13-12.—Notching meeting rails for parting stop.

4. Try the lower sash for a fit, planing down the stiles as necessary.

5. Set the angle of the sill on the T-bevel by lining the handle of the bevel up with the parting stop and the blade with the sill. Lay off this angle on the bottom of the bottom rail and bevel the bottom of the rail to the angle.

6. Set the lower sash in its runway, all the way down, and measure the amount that the tops of the meeting rails are out of flush with each other. This is the amount that must be planed off the bottom rail to ensure that the meeting rails will be exactly flush when the window is closed. Plane down the bottom rail until the meeting rails come flush.

7. Remove the sash and the parting stop, and install or attach the counterbalance for the upper sash. Manufacturer's instructions for installing are usually included with **SPRING BALANCES**. To attach a sash weight, first run the end of the sash cord over the pulley into the sashweight pocket. Place the weight in the pocket and bend the cord to it with a round turn and two half-hitches through the eye of the weight. Set the sash in its runway, all the way down, and haul down on the sash cord until the weight is up to the pulley. Bring the cord against the stile, and cut it off about 4 in. below the hole at the end of the groove in the stile. This 4 in. is about the amount required to tie a figure-of-eight knot to set in the hole at the end of the groove.

371

147

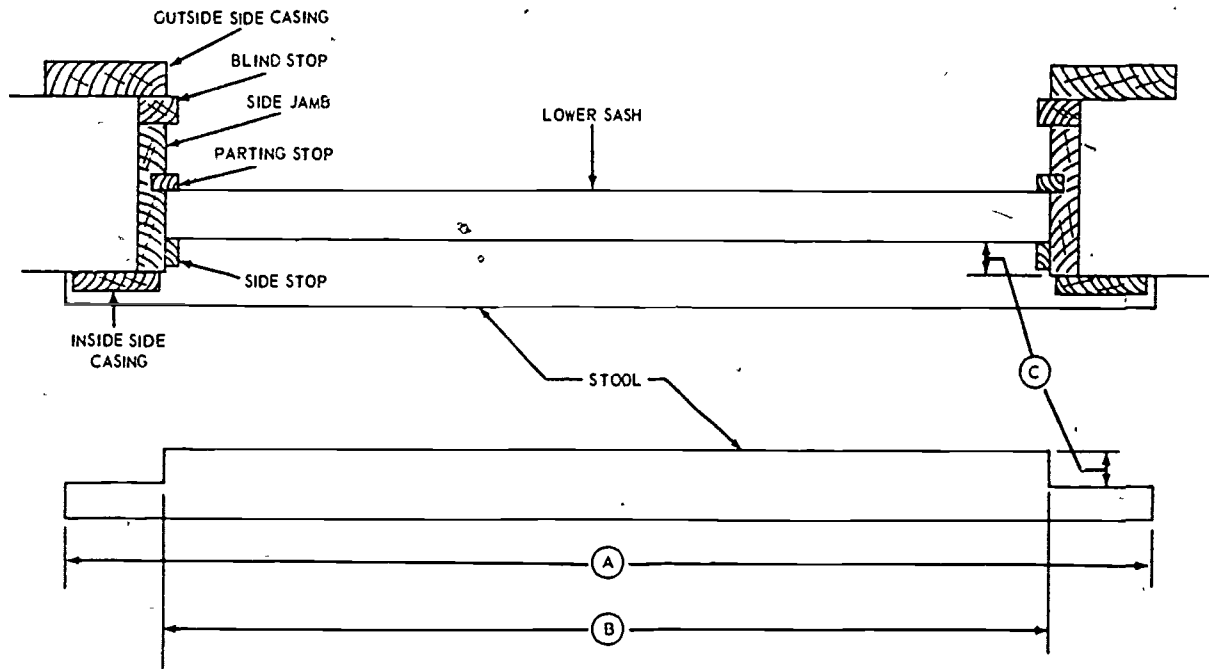

117.65

Figure 13-13.—Window stool layout.

When the counterbalances have all been prepared, set the upper sash in its runway, all the way up, and nail the parting stop into its groove with 8-penny finish nails spaced 12 in. O.C.

The side stop and the inside casings cannot be installed until after the STOOL and APRON have been installed. Figure 13-13 shows the general layout of a window stool; whereas figure 13-14 shows the assembled window stool and apron.

**METAL WINDOWS**

Either aluminum or steel windows will most likely be installed in a permanent type of building. Information on construction requirements and pointers on installing metal windows are given below.

Regardless of the type of window used, it should be of the size, combination, and type indicated or specified. Windows should be constructed to produce the results specified and to assure a neat appearance. Permanent joints should be formed by welding or by mechanical fastenings, as specified for each type window.

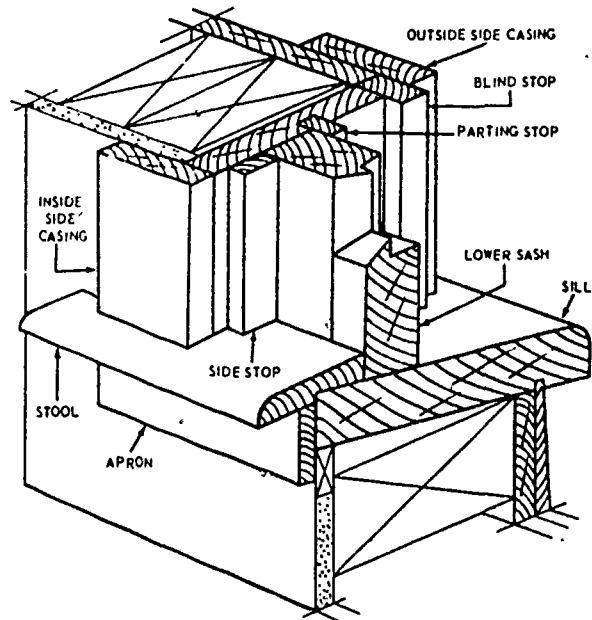

117.64

Figure 13-14.—Window stool and apron.

Joints should be of sufficient strength to maintain the structural value of members connected. Welded joints should be solid, have excess metal removed, and be dressed smooth on exposed and contact surfaces. The dressing should be done so that no discoloration or roughness will show after finishing. Joints formed with mechanical fastenings should be closely fitted and made permanently watertight. Frames and sash, including ventilators, come assembled as a unit with hardware unattached.

Hardware should be of suitable design and should have sufficient strength to perform the function for which it is used. It should be attached securely to the windows with noncorrosive bolts or machine screws; sheet metal screws should not be used. Where fixed screens are specified, the hardware should be especially adapted to permit satisfactory operation of ventilators.

Make sure you exercise care in handling windows to avoid dropping them. In addition, store windows upright on pieces of lumber to keep them off the ground, and cover them thoroughly to protect them from the elements.

Windows should be installed and adjusted by experienced and qualified Builders. Aluminum windows in concrete or masonry walls should be set in prepared openings. Unless indicated or specified otherwise, all other windows should be built-in as the work progresses, or they should be installed without forcing into prepared openings. Windows should be set at the proper elevation, location, and reveal. They should be set plumb, square, level, and in alignment. They should also be braced, strutted, and stayed properly to prevent distortion and misalignment. Ventilators and operating parts should be protected against accumulation of cement, lime, and other building materials, by keeping ventilators tightly closed and wired fast to the frame. Screws or bolts in sill members, joints at mullions, and contacts of windows with sills, built-in fins, or subframes should be bedded in mastic sealant of a type recommended by the window manufacturer. Windows should be installed in a manner that will prevent entrance of water.

Ample provision should be made for securing units to each other, to masonry, or to other adjoining or adjacent construction. Windows that are to be installed in direct contact with masonry must have head and jamb members designed to enter into masonry not less than 7/16 inch. Where windows are set in prepared masonry

openings, the necessary anchorage or fins should be placed during progress of wall construction. Anchors and fastenings should be built into, anchored, or bolted to the jambs of openings, and should be fastened securely to the windows or frames and to the adjoining construction. Unless indicated otherwise, anchors should be spaced not more than 18 inches apart on jambs and sills. Anchors and fastenings should have sufficient strength to hold the member firmly in position.

After windows have been installed and upon completion of glazing and painting, all ventilators and hardware should be adjusted to operate smoothly and to be weathertight when ventilators are closed and locked. Hardware and parts should be lubricated as necessary. Adjustments and tests should be as follows:

(a) Double-hung windows should have balances adjusted to proper tension, and guides waxed or lubricated.

(b) Casements equipped with rotary operators should be adjusted so that the top of the ventilator makes contact with the frame approximately 1/4 inch in advance of the bottom.

(c) Casements equipped with friction hinges, or friction holders, should be adjusted to proper tension.

(d) Projected sash should have arms or slides lubricated and adjusted to proper tension.

(e) Awning windows should have arms to ventilators adjusted so that the bottom edge of each ventilator makes continuous initial contact with frames when closed.

(f) Where windows are weatherstripped, the weatherstripping should make weathertight contact with frames when ventilators are closed and locked. The weatherstripping should not cause binding of sash, or prevent closing and locking of the ventilator.

After adjustment, all non-weatherstripped steel and aluminum windows, except security and commercial projected steel windows, should comply with prescribed feeler gage tests. Windows failing to comply with the tests should be removed and replaced with new windows, or should be corrected and restored to approved condition meeting the required tests. When ventilators are closed and locked, the metal-to-metal contacts between ventilators and their frames should conform to the following requirements:

Whenever conducting the feeler gage test on SIDE-HUNG VENTILATORS, the Builder should remember that it should not be possible to freely insert a steel feeler gage, 2 inches wide by 0.031 inch thick, at any point between the outside contacts of ventilator and frame; nor to freely insert a similar feeler gage, 0.020 inch thick, between more than 40 percent of such contacts.

Remember that for PROJECTED-OUT HORIZONTAL VENTILATORS, it should not be possible to freely insert a steel feeler gage, 2 inches wide by 0.031 inch thick, between the top rail inside contacts, or between the bottom and side rail outside contacts; nor to freely insert a similar feeler gage, 0.020 inch thick, between more than 40 percent of such contacts.

For PROJECTED-IN HORIZONTAL VENTILATORS, it should not be possible to freely insert a steel feeler gage, 2 inches wide by 0.031 inch thick, between the bottom rail outside contacts, or between the top and side rail inside contacts; nor to freely insert a similar feeler gage, 0.020 inch thick, between more than 40 percent of such contacts.

#### GLAZING

Glazing wood and metal sashes and doors consists of sash conditioning and placement of glass. Maintenance often involves only replacement of loose, deteriorated, or missing putty. When replacing glazing items in buildings and structures, use the same type materials as were used in the original work. Use replacement materials of improved quality only when justified by obvious inadequacy of the materials that have failed or by planned future utilization of the building or structure.

Wood sash may be glazed at the factory or on the job. In some instances it will reduce breakage and labor costs to have glazing done at the job site after sash is fitted. When a large number of stock-size wood sash are used, it is generally cheaper to have glazing done at the factory.

Steel sash are generally furnished open and glazing is performed on the job.

Cost of material varies with the size and kind of glass and whether glass is bedded in putty and face puttied, face puttied only, or set with wood or metal beads.

#### TYPES OF GLASS

Single strength glass is approximately 1/10 inch thick and used for small areas, never to exceed 400 square inches. Double strength glass

is approximately .133 thick and is used where high wind resistance is necessary. Window glass comes in three grades, (AA) or superior grade, (A) or very good, and (B) for general or utility grade.

Heavy sheet glass comes in various thicknesses from 3/16 inch to 1/4 inch and in sheet sizes up to 76 inches x 120 inches. Sheet glass is sometimes used for windows but is usually used for greenhouses. It is slightly wavy and may cause a slight distortion of images viewed through it.

Plate glass is manufactured in a continuous ribbon and cut into large sheets. Plate glass is ground and polished for high quality. It comes in thicknesses from 1/8 inch to 1 1/4 inches and is usually used for large windows, such as store fronts.

Tempered glass is glass that has been reheated to just below its melting point and suddenly cooled by oil bath method.

By cooling against metallic surface. Tempered glass cannot be cut or drilled after tempering and must be ordered to exact size. It will withstand heavy impacts and great pressures but if tapped near edge, will disintegrate into small pieces.

Heat strengthened glass is made of polished plate or patterned glass and is reheated and cooled to strengthen it.

It is used in curtain wall design as spandrel glazing of multistoried buildings.

Patterned glass is a rolled flat glass with an impressed design on one or both sides.

Wire glass is a regular rolled flat glass with either a hexagonal twisted or a diamond shaped welded continuous wire mesh as near as possible in the center of the sheet. The surface may be either patterned, figured or polished.

Heat absorbing glass is usually a heavy sheet glass, 1/8 inch or 1/4 inch thick, either a bluish or greenish color, has the ability to absorb the infra-red rays from the sun. More than 35 percent of the heat is excluded.

Insulating glass units are comprised of two or more sheets of glass separated by either 3/16 inch, 1/4 inch, or 1/2 inch air space. These units are factory sealed and the captive air is hydrated at atmospheric pressure. They are made of either window glass or polished plate glass. Special units may be obtained of varying combinations of heat absorbing, laminated patterned or tempered glass.

Glare reducing glass is available in double strength, in panes up to 60 inches x 80 inches,



and 3/16 inch, 7/32 inch and 1/4 inch in pines up to 72 inches x 120 inches in size. It is light gray in color, gives clear vision and is also slightly heat absorbent. One-fourth inch glass will exclude about 21 percent of the sun's heat rays.

Laminated glass is comprised of two or more sheets of glass with one or more layers of transparent vinyl plastic sandwiched between the glass. An adhesive applied with heat and pressure cements the layers into one unit. The elasticity of the plastic cushions any blow against the glass, preventing sharp pieces from flying. There is also laminated glaze reducing glass where the pigment in the vinyl plastic laminated provides the glare control quality.

### SASH PREPARATION

Attach the sash to structure so it will withstand the design load and to comply with the specifications. Adjust, plumb and square the sash to within 1/8 inch of nominal dimensions on shop drawings. Remove all rivet, screw, bolt or nail heads, welding fillets and other projections from specified clearances. Seal all sash corners and fabrication intersections to make the sash watertight. Primer paint all sealing surfaces of wood sash and carbon steel sash. Use appropriate solvents to remove grease, lacquers and other organic protecting finishes from sealing surfaces of aluminum sash.

### GLASS CUTTING

Insofar as possible, glass should be purchased and stocked in sizes that can be used without cutting. Glass of special sizes is cut in the shop. For glass sizes, measure all four sides of the sash and deduct 1/16 to 1/8 inch in the light size for irregularities in the sash. Minimum equipment required for glass cutting consists of a table, a common wood or metal T-square, and a glass cutter. The table should be about 4 feet square, with front and left-hand edges square. Mark off the surface of the table vertically and horizontally in inches. A thin coating of turpentine or kerosene on the glass line to be cut is helpful in lubricating the action of the cutter wheel. A sharp cutter must be carefully drawn only ONCE along the line of the desired cut. Additional strokes of the cutter may result in breakage.

Check dimensions related to sash openings to be sure that adequate clearances are maintained on all four sides of the perimeter. No

attempt should be made to change the size of heat strengthened, tempered or doubled glazed units since any such effort will result in permanent damage. All heat absorbing glass must be clean cut. Nipping to remove flares or to reduce oversized dimensions of heat-absorbing glass is not permitted.

### PREPARATION BEFORE GLAZING

Old wood sash. Clean all putty runs of broken glass fragments and glazier's points. Remove loose paint and putty by scraping. Wipe the surface clean with cloth saturated in mineral spirits or turpentine, prime the putty runs, and allow them to dry.

New wood sash. Remove dust, prime the putty runs, and allow them to dry. All new wood sash should be pressure treated for decay protection in accordance with Federal Specification TT-W-571.

Old metal sash. Remove loose paint or putty by scraping. Use steel wool or sandpaper to remove rust. Clean the surfaces thoroughly with a cloth saturated in mineral spirits or turpentine. Prime bare metal and allow it to dry thoroughly.

New metal sash. Wipe the sash thoroughly with a cloth saturated in mineral spirits or turpentine to remove dust, dirt, oil, or grease. Remove rust with steel wool or sandpaper. If the sash is not already factory primed, prime it with rust-inhibitive paint and allow it to dry thoroughly.

### SETTING GLASS IN WOOD AND METAL SASH

Do not glaze or reglaze exterior sash when the temperature is 40 degrees F or lower unless absolutely necessary. Sash and door members must be thoroughly cleaned of dust with a brush or cloth dampened with turpentine or mineral spirits. Lay a continuous 1/6-inch-thick bed of putty or compound in the putty run (fig. 13-15). The glazed face can be recognized as the size on which the glass was cut. If the glass has a bowed surface, it should be set with the concave side in. Wire glass is set with the twist vertical. Press the glass firmly into place so that the bed putty will fill all irregularities.

When glazing wood sash, insert two glazier's points per side for small lights and about 8 inches apart on all sides for large lights. When glazing metal sash, use the wire clips or metal glazing beads.

98

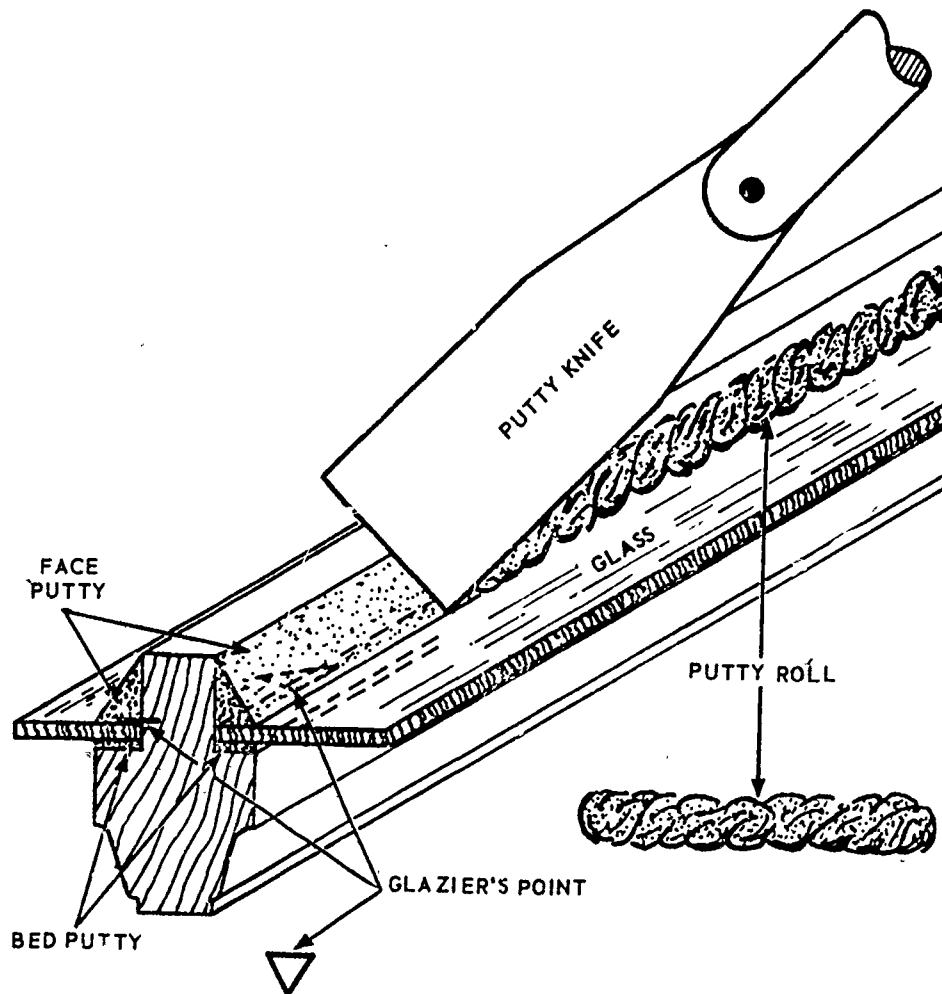

Figure 13-15.—Setting glass with glazier's points and putty.

133.160

After the glass has been bedded, lay a continuous bead of putty against the perimeter of the glass-face putty run. Press the putty with a putty knife or glazing tool with sufficient pressure to ensure its complete adhesion to the glass and sash. Finish with full, smooth, accurately formed bevels with clean cut miters. Trim up the bed putty on the reverse side of the glass. When glazing or reglazing interior sash and transoms, whether fixed or movable, and interior doors, use wood or metal glazing beads. Exterior doors and hinged transoms should have glass secured in place with inside wood or metal glazing beads bedded in putty. When setting wire glass for security purposes, set wood or metal glazing beads, secured with screws, on

the side facing the area to be protected. Wood sash putty should be painted as soon as it has surface-hardened. Do not wait longer than 2 months after glazing. Metal sash, Type I, elastic compound, should be painted immediately after a firm skin forms on the surface. Depending on weather conditions, the time for skinning over may be 2 to 10 days. Type II, metal sash putty, can usually be painted within 2 weeks after placing. This putty should not be painted before it has hardened because early painting may retard the set.

Clean the glass on both sides after painting. A cloth moistened with mineral spirits will remove putty stains. Ammonia, acid solutions, or water containing caustic soaps must not be used.

When scrapers are used, care should be exercised to avoid breaking the paint seal at the putty edge.

Handling and cutting glass creates a serious cutting hazard. Appropriate gloves and other personal protective equipment must be provided and adequate procedures for the disposal of cuttings and broken glass established.

### FINISH FLOORING

Before any finish flooring is laid the rough floor must be thoroughly cleaned. All plaster droppings must be removed, all protruding nail-heads driven flush, and all irregularities planed down or otherwise smoothed. The rough floor should then be carefully inspected for any loose boards or other imperfections.

### WOOD-STRIP FINISH FLOORING

Most wood-strip finish flooring is **SIDE-MATCHED** (tongue-and-grooved on the edges), and some is **END-MATCHED** (tongue-and-grooved on the ends) as well. Softwood flooring comes in face widths ranging from 2 1/4 to 5 in. The most widely used standard pattern of hardwood flooring has a face width of 2 1/4 in. Most wood-strip flooring is recessed on the lower face as shown in figures 13-16 and 13-17.

Wood subfloors are covered with building paper or with a layer of heavy felt before wood-strip finish flooring is applied. If the specifications call for furring strips between the subflooring and the finish flooring, the strips are nailed on top of the paper or felt. Furring strips are laid at right angles to the line of the finish flooring; they are usually spaced 12 or 16 in. O.C.

Wood-strip flooring is laid at right angles to the line of direction of the joists under the largest room on the floor. The first strip laid (which is called the **STARTER** strip) is laid parallel to and 5/8 in. away from the outer joist-end wall in the key room. This strip is placed with the side groove toward the wall, and face-nailed down with nails placed where they will be concealed by the **SHOE MOLDING** (molding placed in the angle between the baseboard and the floor) as shown in figure 13-16.

Subsequent strips are cut, fitted, and laid ahead of the nailing, about 6 or 8 courses (continuous wall-to-wall strips) at a time. A 3-man crew is convenient for wood-strip flooring, with one man cutting, the second fitting, and the third nailing. The cutter cuts strips of random

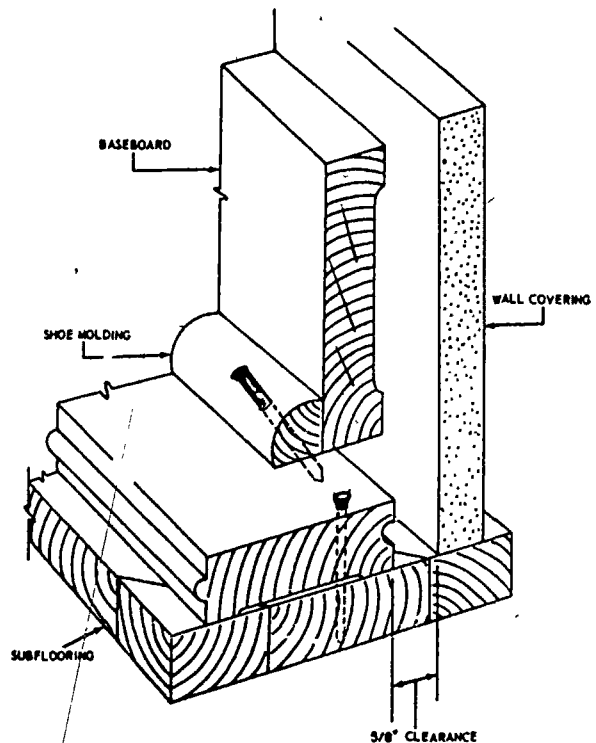

45.512

Figure 13-16.—Blind-nailing starter strip of wood finish flooring.

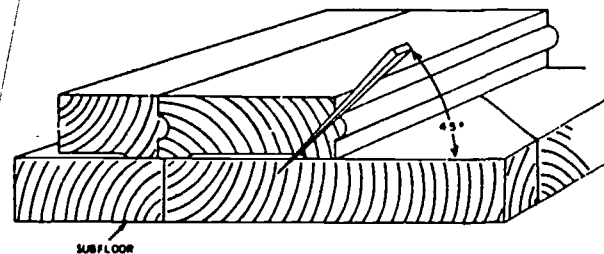

45.510

Figure 13-17.—Toenailing wood-strip flooring.

(various) lengths. The fitter lays out wall-to-wall strips, taking care to stagger end-joints in as uniform a manner as possible. The nailer drives strips up hard against previously nailed strips, using a piece of scrap flooring for the purpose, and then nails the strips down.

Courses which follow the starter course are toenailed down as shown in figure 13-17. Nails should be driven into joists, and it is a good idea to chalk-mark the lines of the joists on the



100

BUILDER 3 & 2

building paper before the floor-laying is started. For 25/32-in.-thick flooring use 8-penny cut flooring nails; for 1/2-in.-thick flooring use 6-penny wire casing nails; for 3/8-in.-thick flooring use 4-penny wire casing nails. Drive each nail down to the point where another blow or two might cause the hammer to damage the edge of the strip; then use a nail set to drive the nail the rest of the way home. Best nailing procedure is to stand on the strip, with toes in line with the outer edge, and strike the nail from a stooping position which will bring the hammer head square against the nail.

Sanding

Power-operated sanding machines are the most satisfactory means of preparing wood floors for finishing. The operator should wear an approved respirator or dust mask while sanding. Abrasive paper, commonly called sandpaper, is made with paper of fabric backing. For machine use, a fabric-backed or fabric-reinforced paper backing is recommended. The mineral cutting agent glued to the face of the paper may be flint (Federal Specification P-P-105), garnet (Federal Specification P-P-121, waterproof), or silicon carbide (Federal Specification P-P-101, waterproof). Cutting surfaces are designated close coat (cutting grits covering the entire face) or open coat (grits covering about half the cutting surface). Opencoat paper is recommended for sanding over materials, such as paint and varnish, that tend to clog spaces between the grits. Flint papers are made in at least 12 grades: 5/0 (very fine), 4/0, 3/0, 2/0, 0, 1/2, 1, 1 1/2, 2, 2 1/2, 3, 3 1/2 (very coarse). Flint (sand) papers having glue binders must not be stored where they will be subject to oil, moisture, or extreme heat and cold. Brittle paper can be softened by dampening the backing. The following table is a guide to sandpaper selection for floor furnishing.

| Grade     | Type  | Use  |
|-----------|-------|--|
| 3         | Open  | Used in place of No. 3 1/2 for surfaces of less resistance; is preferred if it does the required work.   |
| 2 1/2     | Open  | Preliminary roughing off of floor finishes such as shellac, wax, floor oils, alcohol stains, and lacquered surfaces.<br>Use as followup paper for floors roughed off with No. 3 1/2. |
| 2         | Close | Use instead of No. 2 and No. 2 1/2 open coat where surface permits cutting without gumming. Closed coat should be used in preference to open coat whenever practicable.              |
| 1 1/2     | Close | Use as a first paper on all new floors.  |
| 1         | Open  | Use as a followup for No. 2 and No. 2 1/2 in all cases.  |
| 1         | Close | Use the same as No. 1 open coat to provide a smooth floor finish.  |
| 1/2       | Close | Use a final finish on most floor work.   |
| 1/0 & 2/0 | Close | Use as a final finish on best hardwood floor work.   |
| 3/0 & 4/0 | Close | Use for finishing fine woodwork, such as furniture, and for rubbing down paint and varnish finishes.   |

| Grade | Type | Use   |
|-------|------|---|
| 3 1/2 | Open | Preliminary roughing off of stubborn varnish, shellac, floor oil, wax, and deep penetrating filler compounds.<br>Not to be used for cutting into wood surfaces. |

In exceptional cases, when old floor finishes cannot be removed by sanding or scraping with an abrasive, highly volatile liquids may be used. These liquids, as well as those used in floor finishing, include paint and varnish remover, varnish, liquid paint, and shellac, which have flashpoints as low as 40 degrees F. Finishing should be done only under expert supervision.



### Sealing

Seal wood floor by sealing and waxing them in the following manner: Apply liberally a sealer of light varnish that conforms to Federal Specification TT-S-176. Spread or spray it along the grain of the wood. After the sealer has dried completely, buff the floor with a floor-polishing machine, using No. 1 steelwool pads. If portions of the floor look lusterless, dry, or dead after the buffing, continue sealing and polishing until the floor surface has a uniform appearance. Apply two thin coats of water emulsion wax that conforms to Federal Specification P-W-155. Buff the wax after each application has thoroughly dried.

### RESILIENT FLOORING

In Navy construction, wood-strip flooring has been largely replaced by various types of RESILIENT flooring, most of which is applied in the form of 6 x 6-, 9 x 9-, or 12 x 12-in. squares called TILES. The types most frequently used are ASPHALT, VINYL, LINOLEUM, CORK, and RUBBER.

Manufacturers recommend that wood subfloors have an underlayment for resilient flooring, or that sheets of synthetic wood, such as plywood or tempered hardboard, be nailed over single subfloors. The subsurface must be carefully cleaned, smoothed, and inspected, and any cracks wider than 1/8 in. or holes larger than 1/4 in. must be filled. The subsurface is then covered with a felt backing, cemented down with adhesive. The tile is then laid on the felt.

Asphalt, and vinyl tile is set in an asphalt tile EMULSION, linoleum and cork tile in linoleum cement, and rubber tile in waterproof rubber cement. The manufacturer's instructions on proper methods of applying adhesive and laying tile are provided and should be carefully followed. All floors subjected to excessive moisture should be applied with a waterproof adhesive.

### ASPHALT AND VINYL TILES

Asphalt tile is a blended composition of asphaltic and/or resinous binders, asbestos fibers, and inert fillers or pigments. It can be installed satisfactorily over concrete floors in direct contact with the ground without the need to completely waterproof the concrete slab. It is quiet and safe to walk on, durable, and resistant to abrasion from foot traffic and common abuses

such as scuffing and cigarette burns. The tile is low in maintenance cost. Tiles are available in sizes of 4 by 4 inches, 9 by 9 inches, and 12 by 12 inches, in thicknesses of 1/8 and 3/16 inch. Tiles 9 by 9 inches are most commonly used in military construction.

Vinyl tiles are available in two types: vinyl asbestos tile, Federal Specification L-T-345, and flexible vinyl, Federal Specification L-F-450. Tiles are available in sizes of 6 by 6 inches, 9 by 9 inches, and 12 by 12 inches, and in thicknesses of 1/8 and 3/32 inch. Vinyl is also available in 54-inch sheets. Vinyl tile may be laid on a concrete floor in direct contact with the ground only if the slab is membrane-waterproofed. Vinyl tiles are durable and easy to keep clean. Vinyl plastic floorings have good resistance to abrasion, are impervious to water, and are outstanding in resistance to grease, oils, and alkalis.

Asphalt and vinyl tiles should be laid according to the manufacturer's recommendations, with or without lining felt as suitable for the application. Before the tile is laid, the floor area should be squared and the best method of laying the tile determined, depending on the shape of the room, location of fixed furnishings and equipment, and doorways. Tile should always be laid from the center of the room toward the walls so that border widths can be adjusted accordingly. Tiles should be stored for 24 hours before installation in a room heated to at least 70 degrees. Cold tiles may cause condensation on the underside and break down the cement bond. Cement should be spread at a uniform consistency ahead of the work and allowed to dry to a tacky state before tile is laid in it.

### CERAMIC AND QUARRY FLOOR TILE

Ceramic floor tile is glazed or unglazed, manufactured in small square, hexagonal, rectangular, and circular shapes about 1/4 inch thick, and often arranged in mosaic patterns. The pieces are usually factory-assembled (face side up) on paper sheets in the required pattern, laid on a mortar setting bed, pressed firmly on the mortar, and tamped true and even with the finished floor line. Grout is then forced into the joints, filling them completely, and is finished flush and level with the floor line.

Quarry tile is usually unglazed and manufactured in square and rectangular shapes, ranging from 2 3/4 inches to 9 inches in width, from 2 3/4 inches to 12 inches in length, and of

varying thicknesses. Tiles are laid individually on a mortar setting bed with joints about 1/2 inch wide.

In locations such as galleys and food preparation areas, where the floor is directly exposed to the effects of corrosion agents, use acid-resistant joint material to fill the joints. The acid-resistant mortars are proprietary products and should be mixed in accordance with the manufacturer's recommendations. They should be composed of powdered resin and liquid resin cement and be resistant to the effects of oils, fats, greases, organic and inorganic acids; salts, alkalies, and mineral solvents.

### DOORS

Inside door frames are constructed in several ways. The interior type is constructed like the outside type except that no casing is used on inside door frames. Hinge blocks are nailed to the inside wall finish, where the hinges are to be placed, to provide a nailing surface for the hinge flush with the door. Both the outside and inside door frames may be modified to suit a climatic condition.

### DOOR JAMBS

Door jambs (fig. 13-18) are the linings of the framing of door openings. Casings and stops are nailed to the door jambs and the door is hung from them. Inside jambs are made of 3/4-inch stock and outside jambs of 1 3/8-inch stock. The width of the stock will vary in accordance with the thickness of the walls. Inside jambs are built up with 3/8- by 1 3/8-inch stops nailed to the jamb, while outside jambs are usually rabbeted out to receive the door. Jambs are made and set in the following manner:

Regardless of how carefully rough openings are made, be sure to plumb the jambs and level the heads, when jambs are set.

Rough openings are usually made 2 1/2 inches larger in width and height than the size of the door to be hung. For example, a 2-foot 8-inch by 6-foot 8-inch door would need a rough opening of 2 feet 10 1/2 inches by 6 feet 10 1/2 inches. This extra space allows for the jambs, the wedging, and the clearance space for the door to swing.

Level the floor across the opening to determine any variation in floor heights at the point where the jambs rest on the floor.

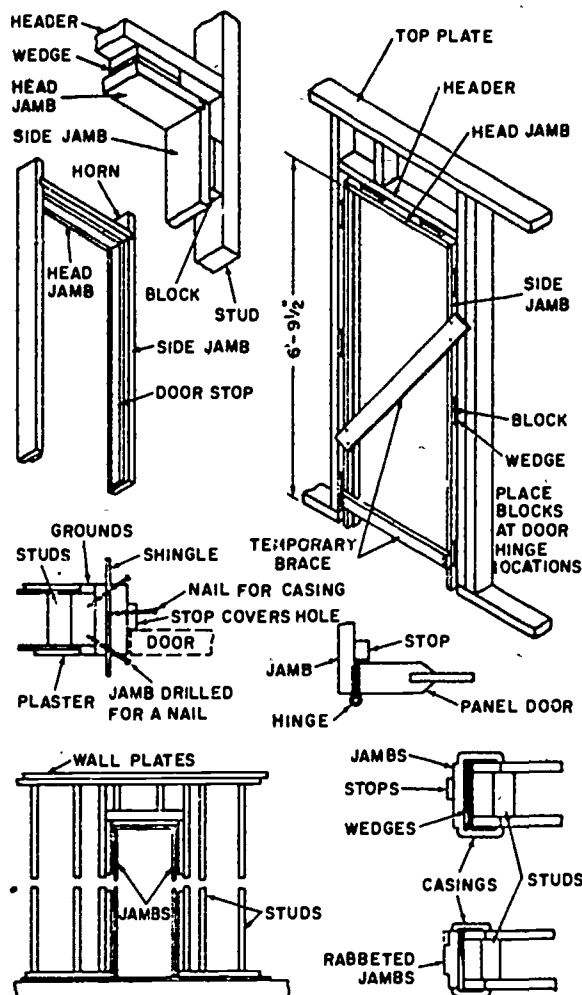

133.369

Figure 13-18.—Door jamb and door trim.

Now cut the head jamb with both ends square, having allowed width of the door plus the depth of both dados and a full 3/16 inch for door clearance.

From the lower edge of the dado, measure a distance equal to the height of the door plus the clearance wanted under it. Mark and cut square.

On the opposite jamb do the same, only make additions or subtractions for the variation in the floor, if any.

Now nail the jambs and jamb heads together with 8-penny common nails through the dado into the head jamb.

Set the jambs into the opening and place small blocks under each jamb on the subfloor just as

thick as the finish floor will be. This is to allow the finish floor to go under.

Plumb the jambs and level the jamb head.

Wedge the sides with shingles between the jambs and the studs, to align, and then nail securely in place.

Take care not to wedge the jamb unevenly.

Use a straightedge 5 or 6 feet long inside the jambs to help prevent uneven wedging.

Check jambs and head carefully, because jambs placed out of plumb will have a tendency to swing the door open or shut, depending on the direction in which the jamb is out of plumb.

#### DOOR TRIM

Door trim material is nailed onto the jambs to provide a finish between the jambs and the plastered wall. It is frequently called "casing" (fig. 13-18). Sizes vary from 1/2 to 3/4 inches in thickness, and from 2 1/2 to 6 inches in width. Most trim has a concave back, to fit over uneven plaster. In mitered work, care must be taken to make all joints clean, square, neat, and well fitted. (If the trim is to be mitered at the top corners, a miter box, miter square, hammer nail set, and block plane will be needed.) Door openings are cased up in the following manner:

Leave a margin of 1/4-inch from the edge of the jamb to the casing all around.

Cut one of the side casings square and even at the bottom, with the bottom of the jamb.

Cut the top or mitered end next, allowing 1/4-inch extra length for the margin at the top.

Nail the casing onto the jamb and even with the 1/4-inch margin line, starting at the top and working toward the bottom.

Use 4-penny finish nails along the jamb side and 6-penny or 8-penny case nails along the outer edge of the casings.

The nails along the outer edge will need to be long enough to go through the casing and plaster and into the studs.

Set all nailheads about 1/8 inch below the surface of the wood with a nail set.

Now apply the casing for the other side and then the head casing.

#### FITTING A DOOR

If a number of doors are to be fitted and hung, a DOOR JACK like the one shown in figure 13-19 should be constructed, to hold doors upright for the planing of edges and the installation of HARDWARE (hinges, locks, knobs, and other metal fittings on a door or window).

**NOTE:** The edge of the door can be beveled to prevent binding and to give a tighter fit.

The first step in fitting a door is to determine from the floor plan which stile is the hinge stile and which the lock stile, and to mark both the stiles and the corresponding jambs accordingly. Next, carefully measure the height of the finished opening ON BOTH SIDE JAMBS and the width of the opening AT BOTH TOP AND BOTTOM. The finished opening should be perfectly rectangular; but IT MAY NOT BE. Your job now is to fit the door accurately to the opening, regardless of the shape of the opening.

A well-fitted door, when hung, should conform to the shape of the finished opening, less a clearance allowance of 1/16 in. at the sides and on top. For an interior door without sill or threshold there should be a bottom clearance above the finished floor of from 3/8 to 1/2 in. This clearance is required to ensure that the door will swing clear of carpeting; if the carpeting is to be extra-thick, the bottom clearance will have to be greater than 1/2 in. For a door with a sill and no threshold, the bottom clearance should be 1/16 in. above the sill. For a door with a threshold, the bottom clearance should be 1/16 above the threshold. The sill and threshold, if any, should be set in place before the door is hung.

Lay off the measured dimensions of the finished opening, less allowances, on the door. Check the door jambs for trueness, and if you find any irregularities, transfer them to the door lines. Place the door in the jack and plane the edges to the lines, setting the door in the opening frequently to check the fit.

#### HANGING A DOOR

You will be dealing mainly with doors equipped with SIDE hinges (hinges located on the edges of one stile or the other). There are various types of side hinges, but yours will be mostly LOOSE-PIN BUTT MORTISE hinges like the one shown in figure 13-20. A loose-pin butt hinge consists of two rectangular LEAVES, pivoted on a PIN which is called a LOOSE PIN because it can be removed by simple extraction. The hinge is called a MORTISE hinge because the leaves are MORTISED into gains cut in the hinge stile of the door and the hinge jamb of the door frame.

The first step in hanging a door is to lay out the locations of the hinges on the hinge stile and the hinge jamb. Set the door in the frame, and



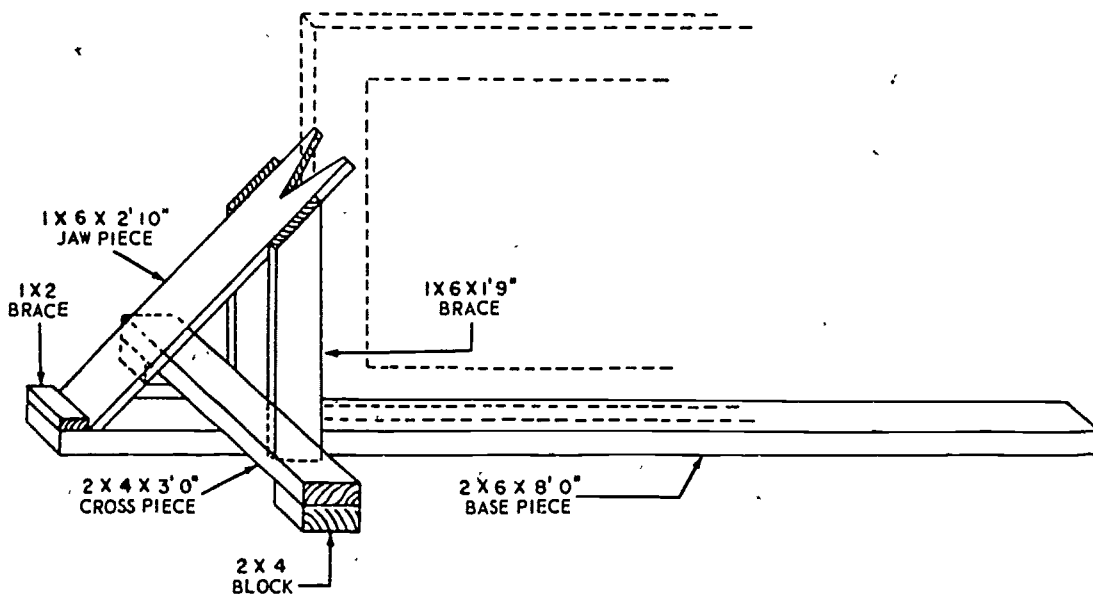

117.68

Figure 13-19.—Door jack.

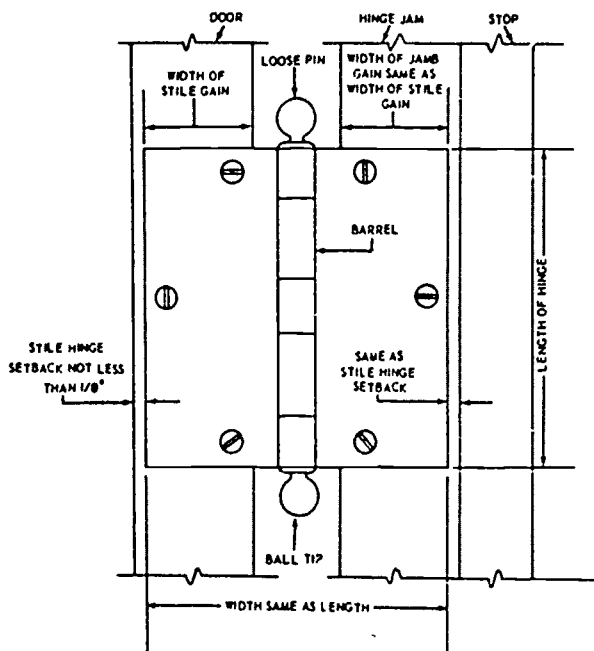

117.69

Figure 13-20.—Loose-pin butt mortise hinge.

force the hinge stile against the hinge jamb with the wedge marked A in figure 13-21. Then insert a 4-penny finish nail between the top rail

and the head jamb, and force the top rail up against the nail with the wedge marked B in the figure. Since a 4-penny finish nail has a diameter of 1/16 in. (which is the standard top clearance for a door), the door is now at the correct height.

Exterior doors usually have 3 hinges, interior doors, as a rule, only 2. The vertical distance between the top of the door and the top of the top hinge, and between the top of the finish floor and the bottom of the bottom hinge, may be specified. If not, the distances customarily used are those shown in figure 13-21. The middle hinge, if there is one, is usually located midway between the other two.

The size of a loose-pin butt mortise hinge is designated by the length (height) and by the combined width of the leaves in inches (height is always given first). The width varies with the requirements of setback, clearance, door thickness, etc., and is calculated individually for each door. Doors 1 1/8 to 1 3/8 in. thick and up to 32-in. wide take a 3 1/2-in. hinge. Doors 1 1/8 to 1 3/8 in. thick and from 32 to 37-in. wide take a 4-in. hinge. Doors more than 1 3/8 in. but not more than 1 7/8 in. thick and up to 32-in. wide take a 4 1/2 in. hinge; if more than 32 but not more than 37-in. wide they take a 5-in. hinge; if from 37 to 43-in. wide they take a 5-in. EXTRA HEAVY hinge. Doors thicker than 1 7/8

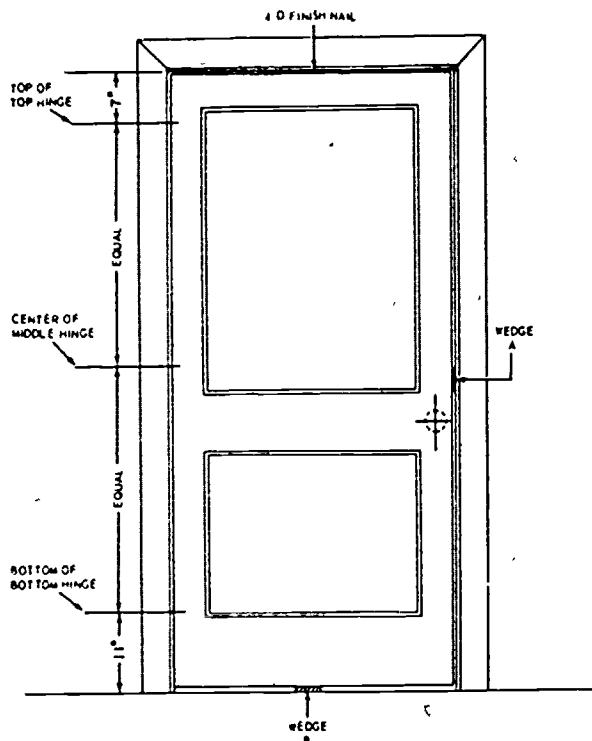

117.70

Figure 13-21.—Laying out hinge locations on a door.

in. and up to 43-in. wide take a 5-in. extra heavy hinge. Doors thicker than  $1\frac{7}{8}$  in. and wider than 43-in. take a 6-in. extra heavy hinge.

Place the door in the door jack and lay off the outlines of the gains on the edge of the hinge stile, using a hinge leaf as a marker. The **STILE HINGE SETBACK** (shown in fig. 13-20) should be not less than  $\frac{1}{8}$ -in. and is usually made about  $\frac{1}{4}$ -in. Lay out gains of exactly the same size on the hinge jamb, and then chisel out the gains to a depth exactly equal to the thickness of a leaf.

Separate the leaves on the hinges by extracting the loose pins, and screw the leaves into the gains, taking care to ensure that the loose pin will be up when the door is hung in place. Hang the door in place, insert the loose pins, and check the clearances at the side jambs. If the clearance along the hinge jamb is too large (more than  $\frac{1}{16}$ -in.) and that along the lock jamb too small (less than  $\frac{1}{16}$ ), remove the door, remove the hinge leaves from the gains, and slightly deepen the gains. If the clearance along the hinge jamb is too small and that along

the lock jamb too large, the gains are too deep. This can be corrected by shimming up the leaves with strips of cardboard placed in the gains.

### INSTALLING A CYLINDER LOCK

The parts of an ordinary cylinder LOCK for a door are shown in figure 13-22. The procedure for installing a lock of this type is as follows:

Open the door to a convenient working position and check it in place with wedges under the bottom near the outer edge.

Measure up 36 in. from the floor (the usual knob height), and square a line across the face and edge of the lock stile.

Use the template that is usually supplied with cylinder lock; place the template on the face of the door (at proper height and alignment with layout lines) and mark the centers of holes to be drilled. (See fig. 13-23.)

Drill the holes through the face of the door and then the one through the edge to receive the latch bolt. It should be slightly deeper than the length of the bolt.

Cut a gain for the latch-bolt mounting plate, and install the latch unit.

Install interior and exterior knobs.

Find the position of the strike plate and install it in the jamb.

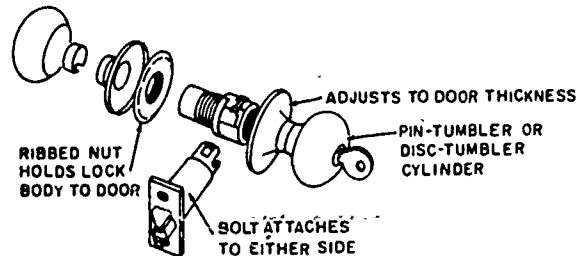

133.161

Figure 13-22.—Parts of a cylinder lock.

### INTERIOR TRIM

The casing around the doors and windows, the baseboard with its base mold and shoe mold, the picture mold, chair rail, cornice mold, and panel mold are the various trim members used in finishing the interior of a building.

Various types of wood can be used for interior trim, such as birch, oak, mahogany, walnut, white and yellow pine, and other available woods.

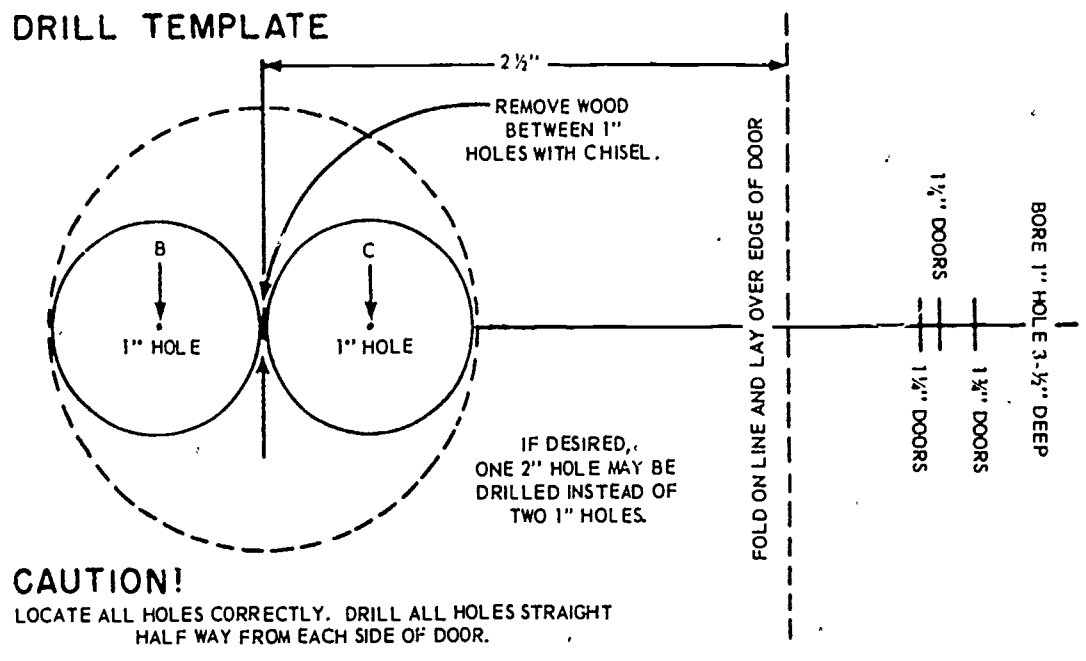

133.162

Figure 13-23.—One type of template.

A close-grain wood should be used when the trim is to be painted. However, harder woods free from pitch will provide a better paint surface.

**BASEBOARDS**

A trim member called a **BASEBOARD** is usually installed on the line along which the walls join the floors. Baseboard is nailed to the studs with two 6-penny finish nails at each stud crossing. The first step in installing baseboard, therefore, is to locate all the studs in the wall and mark the locations on the floor with light pencil marks.

Baseboard is miter-joined at outside corners and butt-joined at inside corners. Where baseboards cannot be miter-joined or butt-joined at corners, they should be capped. Since the walls at corner baseboard locations may not be perfectly vertical, inside and outside corners should be joined as follows:

To butt-join a piece of baseboard to another piece already in place at an inside corner, set the piece to be joined in position on the floor, bring the end against or near the face of the other piece, and take off the line of the face with a scriber as shown in figure 13-24. Use the

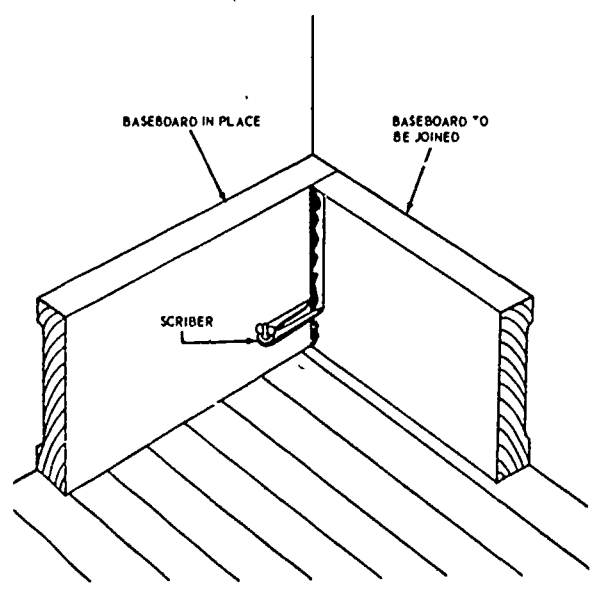

117.82

Figure 13-24.—Butt-joining baseboard at an inside corner.

same procedure when butting ends of baseboard against the side casings of doors.

For miter-joining at an outside corner, proceed as shown in figure 13-25. First set a

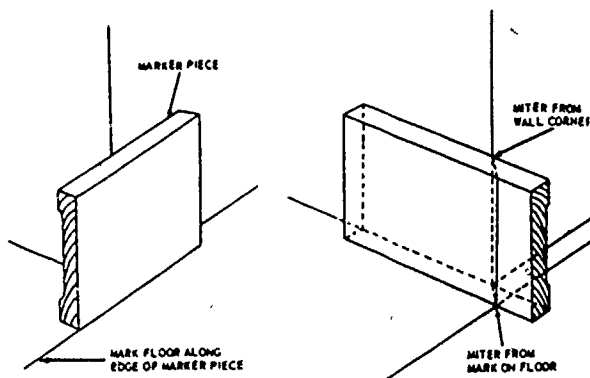

117.73

Figure 13-25.—Miter-joining baseboard at an outside corner.

**MARKER PIECE** of baseboard across the wall corner, as shown in the left-hand view and mark the floor along the edge of the piece. Then set the piece to be mitered in place, and mark the point where the wall corner intersects the top edge and the point where the mark on the floor intersects the bottom edge. Lay 45 degree lines across the edge from these points (for a 90-degree corner), connect these lines with a line across the face, and miter to the lines as indicated.

The line along which the baseboard joins the floor is usually covered by a strip of quarter-round molding called a **SHOE** molding. The shoe molding should be nailed to the floor, as shown in figure 13-16, and not to the baseboard. If it is nailed to the baseboard and the floor should

happen to settle, a space will appear between the bottom of the shoe molding and the floor surface.

The upper edges of baseboards are sometimes trimmed with a strip of molding called a **BASE CAP**.

### MISCELLANEOUS TRIM MEMBERS

The **PICTURE MOLD** is usually placed against the wall near the ceiling; however, at times you may prefer to lower it to 12 or 16 inches below the ceiling. **CORNICE MOLD** is usually a large cove mold fitted and nailed against both the wall and ceiling. The cornice mold of a room is sometimes ornamental and made up of several members. The **CHAIR RAIL** may be placed at various heights on the wall, usually around 48 inches up from the floor. The chair rail can be used to fasten fixtures. The **PANEL MOLD** is used to divide wall spaces into panels; this mold may be used horizontal or vertical. **SHELF CLEATS** make removal of shelves easier and they are very convenient for closets.

**CASINGS** and **STOPS** for doors and windows as well as **STOOLS** and **APRONS**, usually come in rough lengths. When this happens, it is a good plan to assort, select, and place the various members at each opening. When they come in random lengths, cut them to the rough lengths, and then assort them. Most base members and other moldings come in random lengths. Remember that the longest pieces should be reserved for the longest distances to be trimmed to avoid unsightly patching and piecing of trim.