

DOCUMENT RESUME

ED 206 328

PR 009 715

AUTHOR Wood, R. Kent; Woolley, Robert D.  
 TITLE An Overview of Videodisc Technology and Some Potential Applications in the Library, Information, and Instructional Sciences.  
 INSTITUTION - ERIC Clearinghouse on Information Resources, Syracuse, N.Y.  
 SPONS AGENCY National Inst. of Education (DHEW), Washington, D.C.  
 PUB DATE Dec 80  
 CONTRACT. 400-77-0015  
 NOTE 37p.  
 EDRS PRICE MF01/PC02 Plus Postage.  
 DESCRIPTORS Diagrams; Diffusion; \*Educational Technology; Equipment Manufacturers; Equipment Utilization; \*Information Science; \*Library Science; \*Videodisc Recordings; \*Video Equipment  
 IDENTIFIERS Fault Tree Analysis

ABSTRACT.

This discussion of several of the issues and systems of videodisc technology as applied to the library, information, and instructional sciences is based upon the Utah State University Videodisc Innovation Projects. Descriptions of the major marketed videodisc systems, as well as those soon to be marketed, are given. A critique of the ABC/NEA Schooldisc Program is also included. A 72-item list of references and selected bibliography is provided, which includes references dealing with fault tree analysis (sometimes referred to as "fault free analysis") as a recommended tool to assist with the smoothing out of the diffusion process for videodiscs. Library, information, and instructional specialists are seen to be in a position to play a major role in that diffusion process.  
 (Author/LLS)

\*\*\*\*\*  
 \* Reproductions supplied by EDRS are the best that can be made \*  
 \* from the original document. \*  
 \*\*\*\*\*

U S DEPARTMENT OF HEALTH  
EDUCATION & WELFARE  
NATIONAL INSTITUTE OF  
EDUCATION

THIS DOCUMENT HAS BEEN REPRO-  
DUCED EXACTLY AS RECEIVED FROM  
THE PERSON OR ORGANIZATION ORIGIN-  
ATING IT. POINTS OF VIEW OR OPINIONS  
STATED DO NOT NECESSARILY REPRESENT OFFICIAL NATIONAL INSTITUTE OF  
EDUCATION POSITION OR POLICY

AN OVERVIEW OF VIDEODISC TECHNOLOGY

AND SOME POTENTIAL APPLICATIONS IN THE LIBRARY, INFORMATION,  
AND INSTRUCTIONAL SCIENCES

by

R. Kent Wood

and

Robert D. Woolley

An  Information Analysis Product

December 1980

ERIC Clearinghouse on Information Resources  
Syracuse University

ED206328

R009715

Dr. R. Kent Wood received his master's degree in Librarianship from the University of Denver, an Educational Specialist Degree in Librarianship, and his doctorate in Higher Education Administration (with emphasis in Library, Information, and Instructional Sciences) from Brigham Young University. He is Professor of Instructional Media (Library Science and Instructional Systems Technology) and Director of the Videodisc Innovation Projects at Utah State University, Logan, Utah.

Mr. Robert D. Woolley received his master's degree in Instructional Media from Utah State University. He is Assistant Professor of Instructional Media, Systems Analyst for the Merrill Library and Learning Resources Program at USU, and serves as the Computer Specialist with the Videodisc Innovation Projects at Utah State University. In addition, he directs the Curriculum Materials Center.



This publication was prepared with funding from the National Institute of Education, U.S. Department of Education under contract no. NIE-400-77-0015. The opinions expressed in this report do not necessarily reflect the positions or policies of NIE or ED.

## ABSTRACT

This discussion of several of the issues and systems of videodisc technology as applied to the library, information, and instructional sciences is based upon the Utah State University Videodisc Innovation Projects and a paper delivered to the American Society for Information Sciences by Dr. R. Kent Wood in Minneapolis, Minnesota, October 16, 1979, with updating in the fall of 1980. Descriptions of the major marketed videodisc systems, as well as those soon to be marketed, are given. A critique of the ABC/NEA Schooldisc Program is a special feature. The 5-page list of references and selected bibliography which is provided includes references dealing with fault tree analysis (sometimes referred to as "fault free analysis") as a recommended tool to assist with the smoothing out of the diffusion process for videodiscs. Library, information, and instructional specialists are seen to be in a position to play a major role in that diffusion process.

## TABLE OF CONTENTS

Introduction .....	1
Library and Information Sciences .....	1
Videodisc Systems .....	3
Optical Reflective Laser Systems .....	3
Optical Transmissive Laser Systems .....	8
Capacitance or Stylus Systems .....	10
Combined Optical Capacitance Systems .....	11
Videodisc Is Not a Panacea .....	13
USU Center for Instructional Product Development .....	16
Review of Selected Videodisc Literature .....	18
ABC/NEA Schooldisc Program .....	21
Proposed Fault Tree Analysis .....	23
Conclusion .....	25
References and Selected Bibliography .....	28

### List of Figures

1. Media comparisons by formats .....	2
2. Optical videodisc and media storage capacity .....	4
3. Optical reflective videodisc system diagram .....	6
4. Data storage on videodisc .....	8
5. Optical transmissive videodisc system diagram .....	9
6. Capacitance videodisc system diagram .....	10
7. Combined optical/capacitance videodisc system diagram .....	12
8. Summary of major videodisc systems .....	14
9. Videodisc Innovations Project and logo .....	18
10. NATUL Project Fault Tree Apex .....	24
11. Swanson's 1964 projection compared with videodisc .....	25

## INTRODUCTION

Professionals in the library, information, and instructional sciences have become somewhat aware of the videodisc/microcomputer systems entering the market during the latter part of the decade of the 1970's. Magnavision (Philips of North America) was the early entry into the market in December of 1978, with MCA Discovision Associates (now a partnership of IBM and MCA Universal) entering the following year. Pioneer has been marketing its VP 1000 Laserdisc system since July 1980, and RCA has announced once again that it will enter the market in March 1981, rather than late 1980 as previously announced.

The many general questions received by the authors by telephone and mail include letters from as far away as the People's Republic of China, with such requests as "send me all the information you have on videodisc," or, in many cases, "on microcomputers," or both. This Information Analysis Product has been prepared for the ERIC Clearinghouse on Information Resources to provide a general introduction to this technology and its applications. More detailed information on specific topics will be furnished by a series of technical reports to be issued by the Utah State University Center for Instructional Development. Titles will include (1) Benchmark Data for the #7820 Discovision Associates Videodisc Player; (2) Pilot Language Documentation for the Special Education and Military Education Projects; (3) An Instructional Design Model for Developing Interactive Microcomputer/Videodisc Instruction; (4) Videodisc Premastering and Scripting Procedures; (5) Computer Interface Documentation; (6) Microcomputer Evaluations and Technical Specifications; (7) State-of-the-Art of Optical Disc Technology for Consumer and Educational Use; and (8) Criteria for the Development of an Educational/Industrial Videodisc Player.

## LIBRARY AND INFORMATION SCIENCES

Librarians are by nature and role definition evaluators, selectors, acquirers, and organizers of information. Because of recent advances in technology, that role has been added to, and, in many instances, specialized functions have been assumed by information scientists. The scholarly definition of technology as organized scientific knowledge applied to resolve practical problems fits in well with their tasks and roles. However, they should be aware that, although formats of information are manifestations of information/instructional technologies, machines and mechanization are not synonymous with technology.

Machines and mechanization are manifestations or spinoffs of technological advancement. The formats of information (software/courseware) are descriptors or reflectors of points in time of the library/information chronology. The shades of ancient clay tablets remain with us today in refined formats of microfiche, and the papyrus rolls from the old Egyptian temple libraries remain as microfilm and motion pictures. The computer drums and discs are a metamorphosis of stone cylinders of the distant past. The optical videodisc is an omnibus medium capable of storing all other information formats known to date, including the printed page (not taken directly from present books, but specially designed video book publishing), art prints, and static slides or the dynamic motion film or videotapes, as well as digitized or analog data.

## Media Comparisons by Formats

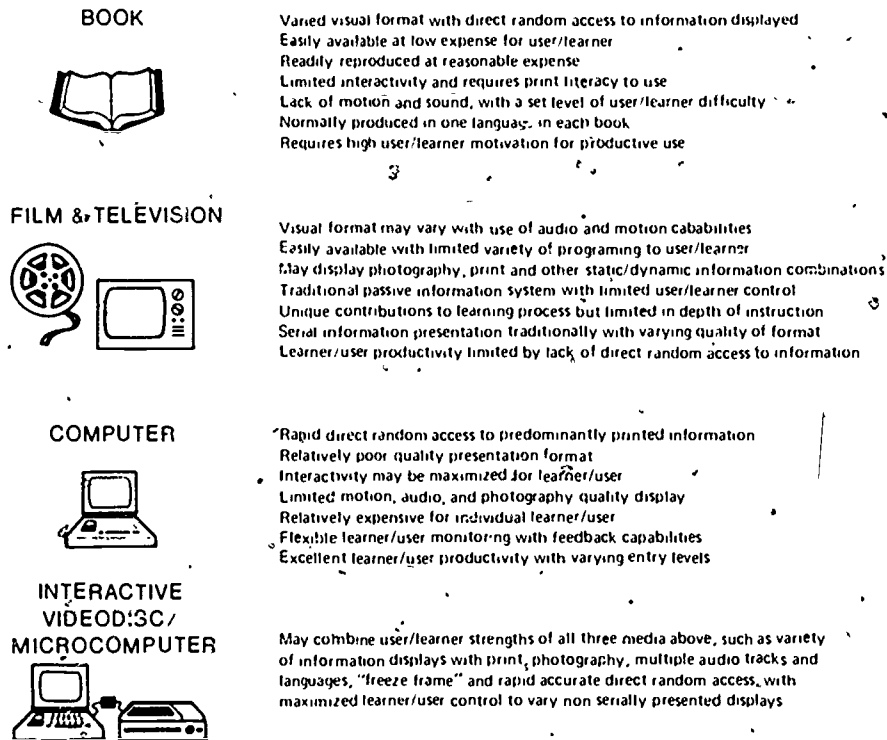

Figure 1. Media comparisons by formats. These brief comparisons of book, film/television, and computer formats suggest applications to library, information, and instructional sciences by combining the user/learner strengths of traditional media in the newer high technology formats of interactive videodisc microcomputer systems.

For librarians and information scientists, it is essential to gain appropriate and realistic perspectives of what videodisc alternatives exist and are available, as well as options that are likely to exist in the immediate future. As consumers in the sense of acquiring formats of information to perform tasks, library and information scientists should have a general understanding of what videodisc technology is and the present state-of-the-art, and become cognizant of the impending impact upon the library, information, and instructional sciences. Videodisc is not simply videotape on a disc!

Many authors agree that videodisc technology will greatly affect society generally. The videodisc interfaced to the personal microcomputer provides an "intelligent videodisc system" which holds even greater potential for use in information/instructional settings, such as library media centers. Some authorities have suggested that the impact will be equal to or greater than that of print technology some 500 years ago. Library, information, and instructional scientists should not make hasty judgements about the videodisc medium. Although it has roots reaching back 50 years, it has been a reality--and that on a limited basis--for less than

two years. Only in 1981 has the optical videodisc system become more generally available to the library/information/instructional communities with greater numbers and a wider range of software titles.

The indications of more optical videodisc software/courseware availability, through the cooperative efforts of Discovision Associates, Pioneer, Philips (Magnavox), and probably Sony Corporations working together in the Laser Vision/Optical Programming Associates' efforts to provide compatible optical videodisc programming for these three major laser based systems, will become evident just prior to RCA's Selectivision marketing efforts around March 1, 1981. This will be marked by a common logo and identification symbol:



## VIDEODISC SYSTEMS

Of the numerous videodisc systems either on the market or in advanced stages of research and development, several will be of major interest. These systems can be placed in four major categories:

1. Optical reflective laser systems.
2. Optical transmissive systems.
3. Capacitance or stylus systems.
4. Combined optical or capacitance systems.

### Optical Reflective Laser Systems

The accidental discovery by Philips and MCA that their research and development efforts were leading them to develop similar optical laser disc systems led to a gentleman's agreement to share in the development of the optical system which has been utilized by Philips in Europe (on different TV standards than the U.S.), Philips of North America through its subsidiary of Magnavox (Magnavision), and MCA Universal (Discovision). Similar systems have been developed by the Sony and Pioneer Electronics Corporations in Japan, and the MCA/Philips designation has become a generic identification of these optical reflective videodisc systems.

Discovision Associates, formed later, was a partnership entered into by IBM and MCA's subsidiary, Discovision, Inc., which to date has been the leader in the field. The DVA Videodisc Production Plant in Costa Mesa, California, has produced the great majority of the optical/reflective videodiscs available as software/courseware for the Magnavision, the Discovision, and the Pioneer Laserdisc systems. Nearly 400 titles are currently available, although not yet listed in the soon to be published catalog of videodisc programs compatible with the DVA, Magnavox, and Pioneer systems. Approximately 55 motion pictures are being reformatted to videodisc annually, with more than 100 training and educational programs being developed on videodisc each year. For example, IBM now uses 50 videodisc titles in the learning centers, and General Motors will have more than 100 titles in use in 1981. More recent discs will



include titles of Columbia Pictures and 20th Century Fox films, according to DVA spokesmen. Current titles include more entertainment features (i.e., Jaws, Smokey and the Bandit varieties) but also educational titles and other titles which may be used for educational purposes.

The IBM/MCA industrial and educational videodisc system, manufactured by Universal Pioneer as well as the Pioneer Laserdisc and the Magnavision systems, uses a helium-neon laser optics system which is directed onto and reflected from a 30 cm disc rotating in use at 1800 rpm. The disc has a capacity of 54,000 frames per side with a continuous playing time of 30 minutes per side. Using a technique called "constant linear velocity" (CLV), the optical videodisc can be extended to 60 minutes

### Optical Videodisc and Media Storage Capacity

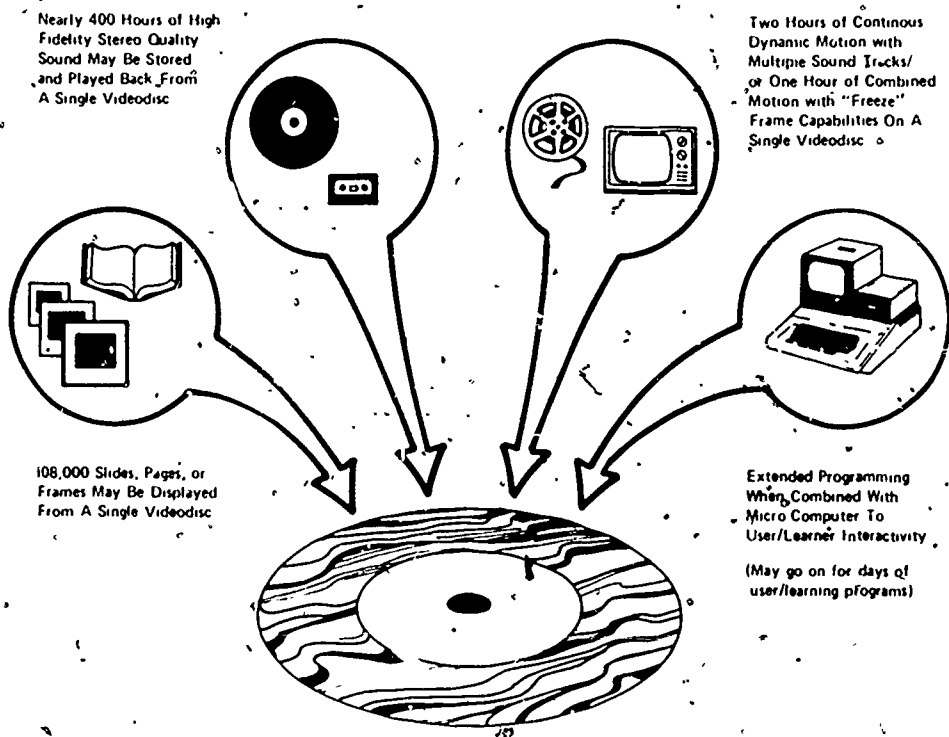

Figure 2. Optical videodisc and media storage capacity. Extensive media storage capacity of optical videodisc is summarized in this illustration. This illustrates the videodisc as something more than videotape in a disc format.

of continuous motion play on each side. This CLV format disallows using single image freeze frame and is primarily for motion pictures to be played on the optical videodisc systems of Pioneer, Magnavox, Sony, and Discovision Associates. It should be noted that the Sony system is not yet on the market and is reported to be only in the prototype stage. Current production techniques employed by Discovision Associates restrict the playing time to 27 minutes and 48,600 frames of visual information rather than the publicized 30 minute/54,000 frame capacity. However, when one analyzes the digital storage capacity as a computerized information storage device, the optical laser videodisc surpasses existing storage media, including the magnetic computer discs with more than 13 billion bits (gigabits) of information.

The Discovision Associates system provides a unique capability for external computer control (a computer interface port is standard on DVA model #7820, and the interface board developed at Utah State University with the VIP R&D efforts is readily available from Colony Productions of Tallahassee, Florida). The DVA system provides for dual audio-channels, variable slow motion, freeze frame, random direct access searching within a range of one to five seconds, fast forward and reverse, and a variety of user programmable functions implemented on the resident microcomputer which is also standard with the DVA #7820. A hand-held remote control device—similar to a hand-held calculator—allows a person direct control of the videodisc player by sending signals to the unit by infrared light or connected cable. The DVA industrial/educational videodisc system has been used for some time with the VIP and has been relatively maintenance-free. The U.S. Army has reported similar experience with the DVA system in very heavy use situations. The I/E DVA model sells at this time for about \$3,000, depending on how many players are ordered.

Magnavision (Philips of North America), one of the videodisc systems marketed for the home, uses essentially the same laser technology, minus the direct random access capabilities. Although the Magnavision must be manually searched, very much like a videotape player, it searches at a more rapid rate, taking roughly 27 to 30 seconds to search from frame 0 to the end of the standard videodisc. Some problems of maintenance have been reported in using the Magnavision players in educational settings, such as public and school library media centers; however, it should be remembered that the system was produced for the home entertainment market and was not designed for the heavy use and searching demanded in library and educational/training settings.

Pioneer's Model VP #1000 (introduced in June 1980, along with DVA's Model #D #1000 which is similar) is more compact than the DVA Model #7820 and should not be confused with it. The DVA Model #7820 is specifically designed for industrial/educational markets. The Pioneer player, however, is limited by the lack of a port for computer interface, and is four times slower in access time, although it provides a reasonable "less than 18 second" maximum search time for locating individual single video frames. It has a remote control unit available similar to the DVA control, but minus the programming keys. Neither the Pioneer VP #1000 nor the DVA Model #1000 contains a resident microprocessor with programmable memory, as does the DVA #7820. The Pioneer VP #1000 does provide direct random access, a feature not yet available on the Magnavision units. Because of Pioneer's reputation for its high fidelity ("bring it back alive") equipment, the company is emphasizing the player's stereo capability which is provided by playing both audio tracks in unison through plug-in stereo components. Pioneer has started a new subsidiary called Pioneer Artists, which will produce and acquire stereophonic musical performances for videodiscs. The Pioneer and DVA #1000 each sell for \$750, plus \$49 for the remote control.

### Optical Reflective Videodisc System

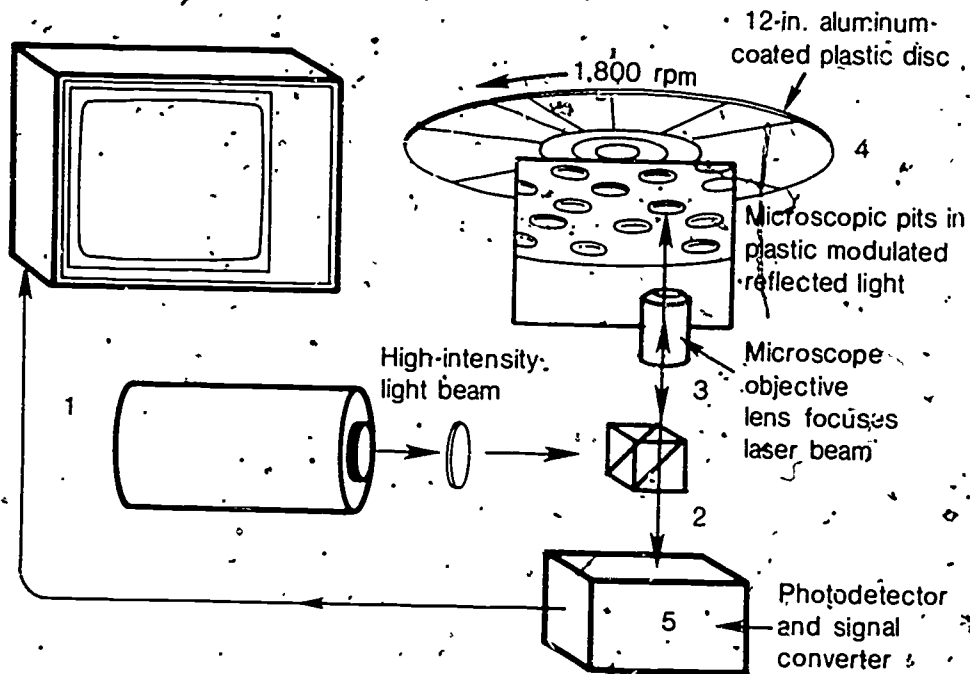

**Figure 3.** Optical reflective videodisc system diagram. Numbers one through five show the path of the laser beam from the high-intensity light beam to the surface of the optical reflective videodisc and the reflected beam through the lens to the signal converter for display and sound on a television receiver or monitor.

Videodisc mastering for the three optical videodisc systems (DVA, Pioneer, and Magnavision) is accomplished using master source materials, usually videotape or film. Final disc replication is accomplished by injection molding, making it possible to create large numbers of discs at low cost after front-end production expenditures. The replication of quality programs costs \$5.00 per disc in lots of as few as 50. Improved mastering techniques are now being developed which will improve both the quantity and quality of low cost videodisc mastering and replication. It is this improving replication and low cost that provides the potential of videodisc publishing, which may eventually prove to be less costly than the standard printed book of most libraries. Although books must be specifically designed for videodisc format, one 12-inch videodisc has the capacity to hold 300 such books with an average of 360 pages each.

The process for mastering videodiscs, and the demonstration of the Pioneer and DVA videodisc systems, are shown on videodiscs available from dealers in two versions. The DVA version is often referred to as the "Columbo" disc because a segment from the TV show is used to demonstrate dual language applications in English and Japanese. The second is called the "Mr. Wizard" disc because the explanation of the Pioneer system is given by the TV personality, Mr. Wizard, who has explained many other scientific phenomena to TV audiences in the past.

RCA has announced and demonstrated an optical disc system (not to be confused with their capacitance Selectavision home entertainment videodisc system) with recording and "direct read after write" (DRAW) capabilities (Bartolini, 1978). This system employs a laser technology with random access to digital data on the order of  $10^{11}$  bits of data within 250 milliseconds. Certainly the impact of this system is likely to be felt directly in the mass computer storage market. Magnavox and Philips have also announced a prototype DRAW system with a storage capacity of  $10^{10}$  to  $10^{11}$  bits, and access time of 70 milliseconds (Kenney, 1979; Bulthuis, 1979). These two systems yield an effective digital storage capacity of 500,000 typewritten pages on a single side of an optical disc. If these latter forms of disc technology become widely available, the impact on information storage and retrieval should be evident. Projected costs of data storage with these high density systems have been tentatively set at  $5 \times 10^{-8}$  cents per bit. This compares quite favorably to the present computer disc pack costs on large scale systems of  $5 \times 10^{-4}$  cents per bit.

With the recent partnership entered into by MCA and IBM to form Discovision Associates, it is to be expected that DVA will also explore the potential of videodisc as a computer storage device. DVA has already demonstrated the capabilities to store programs on the current videodiscs which download digital data into the microprocessor to run currently available programs. This digital data storage technique has been extensively used with the DVA General Motors Training and Sales Videodiscs. (General Motors is the single largest customer of DVA, having purchased more than 12,000 units as the initial order. The Caterpillar Heavy Equipment Company will soon use videodisc in direct sales work and probably for training.)

The high density read/write optical disc systems offer some unique advantages to those directly involved with information technology. Among these are:

1. Economy of data storage.
2. Data in a computer compatible form.
3. Rapid access to massive amounts of user data.
4. The capacity to fully integrate visual, print, audio, and other digital data in a single massive electronic archival file.

While the discs used with DRAW systems are not easily handled and require "clean room" environments, a technique of covering each disc in its own clear protective envelope has greatly reduced this environmental limitation. Tentative archival storage projections give the discs a reliable data storage file life of 10 years, as compared to two or three years of archival life with magnetic storage media.

### Data Storage on Videodisc

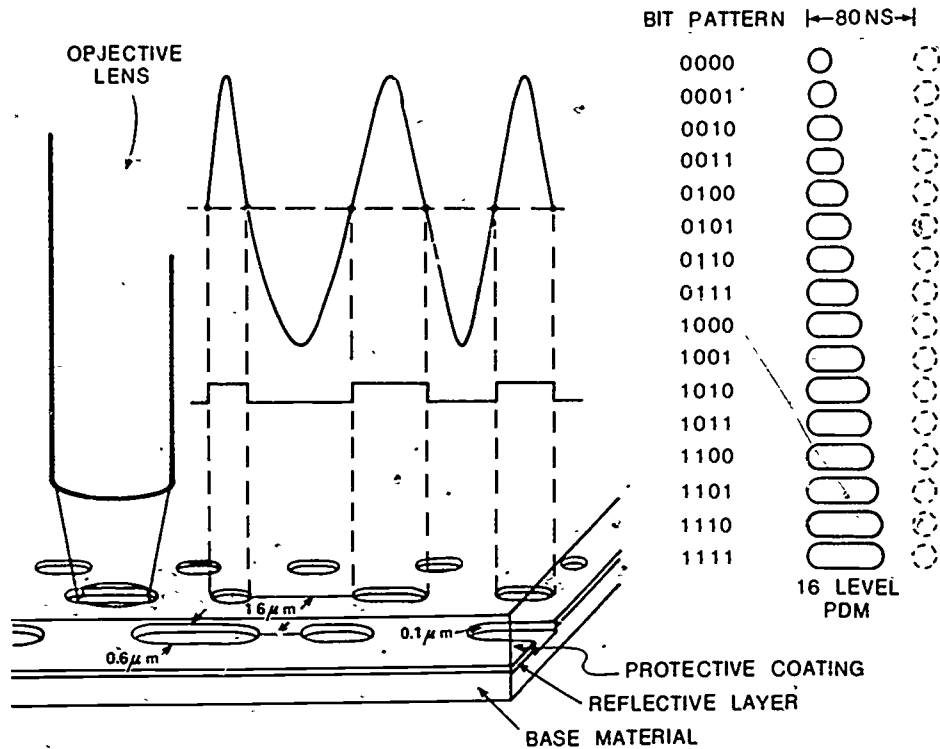

Figure 4. Data storage on videodisc. The bit patterns for storing digital data on optical videodisc are graphically represented here. Digital data storage on the optical videodisc makes it one of the most dense storage mediums at this time.

### Optical Transmissive Laser Systems

Thompson CSF (the giant French electronics firm), has produced an optical disc that, unlike the reflective laser systems, is flexible and can be optically read from either side without removing the disc from the player. In terms of features and overall storage capacity, the system is equal to that provided by the other laser read systems, i.e., 54,000 frame capacity on each side, and access time of approximately three seconds. In terms of software support, Thompson is not directly linked with any large base of entertainment or educational materials. Mastering and disc replication are reported to be inexpensive and reliable, and the discs may be played in especially rough and difficult environments, such as a moving army tank. Players have been used by such firms as Hughes, and institutions of higher education such as Florida State University. Dr. Alfred Bork of the University of California, Irvine—the person credited with creating the term "intelligent videodisc"—has also had experience with the Thompson players and expresses satisfaction with the units.

ARDEV (Atlantic Richfield Development, a subsidiary of Atlantic Richfield, Inc.) has a low cost film-based system in research and development stages. Dr. Peter Wohlmuth is directing most of the efforts with the ARDEV system; hence, the system seems to follow the same general plan as Wohlmuth developed with I/O Metrics, Inc. (now defunct) a few years ago. The ARDEV system is designed to handle analog or digital information and provide freeze frame, slow motion, and random access search capabilities. Video quality will probably not approach that of other optical videodisc systems, but disc replication and production costs could be much lower. The ARDEV system will use a transmissive disc somewhat like the Thompson CSF videodisc system. It would not be surprising to see the French firm of Thompson manufacture the ARDEV players in the future, based on what the authors view as similarities. The Thompson and the ARDEV systems are, by best guess, still two years away from large scale marketing. It is projected that the ARDEV system will likely be purchased by a company interested in training systems--e.g., Hughes or McDonald Douglas--rather than being marketed directly by Atlantic Richfield.

### Optical Transmissive Videodisc System

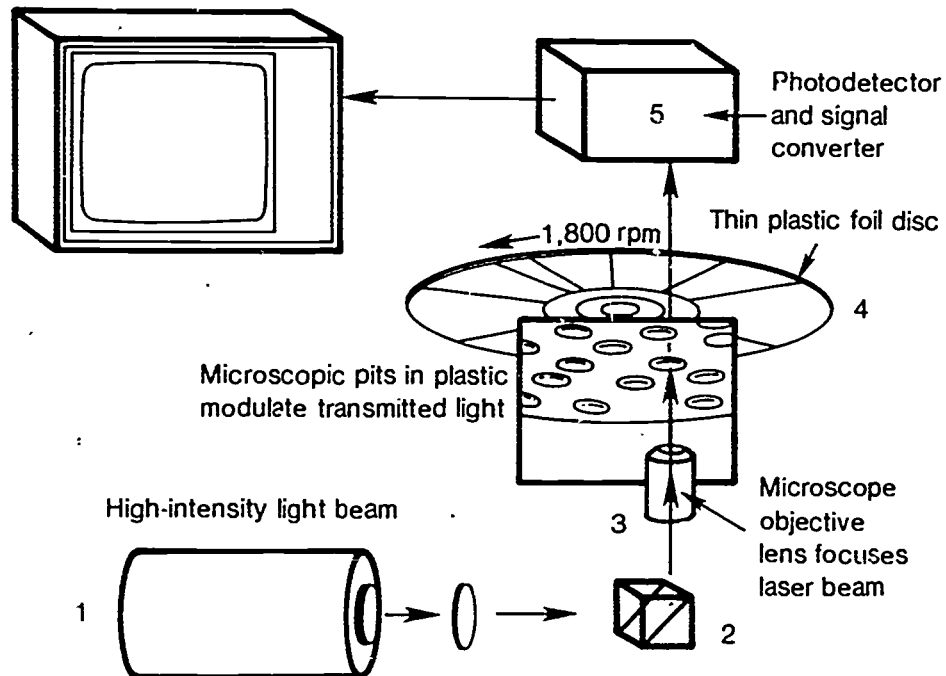
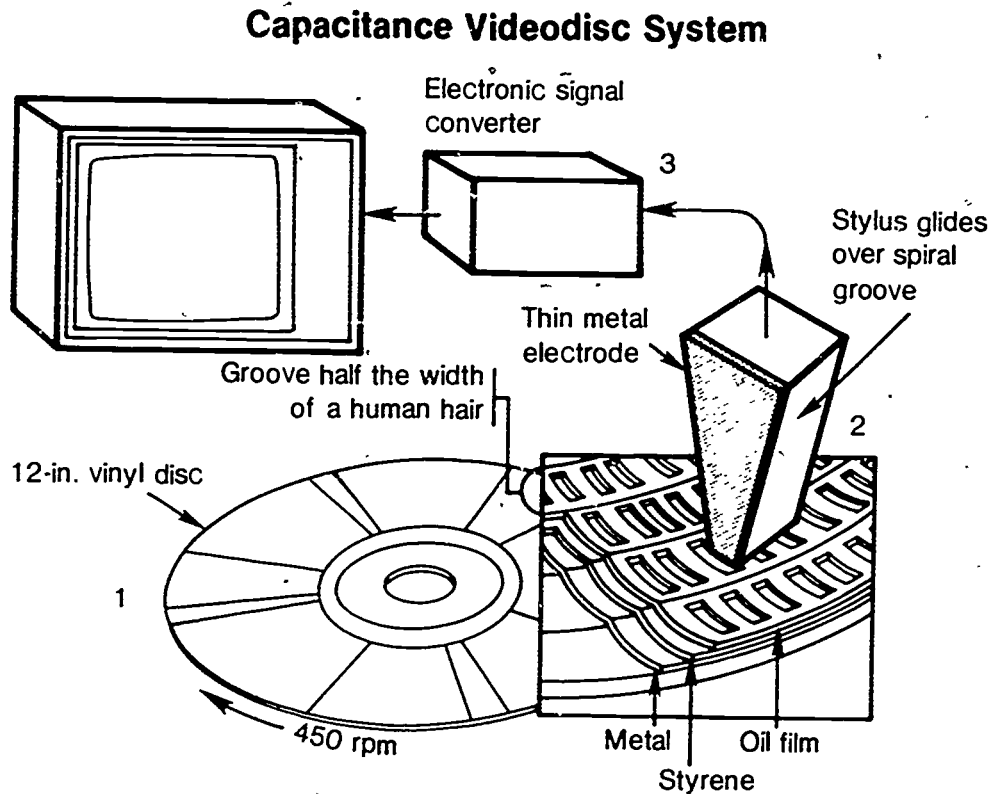

Figure 5. Optical transmissive system diagram. The high-intensity light beam in this system is not reflected, but rather passes through the transparent videodisc carrying the signal to the converter and to the television receiver or monitor. This system is very stable under conditions of movement or stress while it is in operation, e.g., in a military tank or other rough riding vehicle.

### Capacitance or Stylus Videodisc Systems

Another type of videodisc includes two major systems. These are the yet to be released to market RCA Selectavision and the first videodisc system to be introduced to the market some years ago, the TED (Telefunken/Decca) system. The TED system first introduced videodisc in a 10-minute disc format played on a machine very much like a phonograph player, including the stylus. The disc is a thin sheet of plastic foil, which allows discs to be produced inexpensively. Thus far, the system has not had any major impact on the market and simply does not offer the extensive features of the more sophisticated educational/industrial laser systems. It is likely, however, that a modified TED will become the "Videodisc Juke Box" of the future.



**Figure 6.** Capacitance videodisc systems diagram. The capacitance (mechanical stylus) system was earlier introduced on the TED videodisc systems, and most recently used with the RCA Selectavision Videodisc System to be introduced in 1981 to the general home video markets. It will produce an adequate video signal, but is limited in "search and freeze frame" because of the apparent wear on the disc when played other than linearly.

RCA has been issuing press releases for the last several years on a low cost capacitance system known as Selectavision, using the same name as their videotape recording system. The cost is to be under \$500 when it enters the market. RCA once more announced just before Christmas 1980, that they will enter the market in March of 1981. It appears that this time they mean business, and will commence a media blitz to capture the home market, if possible. The low price has appeal, but the Selectavision is a continuous playback system only, very similar to present record players, and, surprisingly, is only monaural--a real shock for those who expect stereo quality of the like given from laser systems. The RCA system may not be searched but will have a pause capability which appears to cause considerable wear when compared to the non-wearing laser-based videodisc systems. It will be unfortunate for the library, information, and instructional sciences if the RCA system floods the market and curtails the entrance of the information/educational laser-based videodisc systems into the home market, which will do much to set the tone and future of the library/information/instructional markets. An unsuspecting and less sophisticated segment of the American population will probably purchase the RCA system believing that "videodisc is videodisc," and learn too late the extreme limitations (in terms of library, information searching, and instructional uses) of this system. Nonetheless, RCA will have a major system on the market, with the content of vast software stores of CBS Television and Paramount Pictures by an agreement which has already been signed.

RCA and Zenith Radio have signed agreements to share each other's patented videodisc player developments, with the expected result that Zenith will also market a capacitance videodisc system for under \$500 about mid-1981. Librarians and other educators should be hopeful that the laser videodisc technology will be refined on a mass market basis, and that the lowering of prices will become possible to meet the low cost competition of the capacitance systems. This could move toward a standard for videodisc which would allow the more versatile laser-based systems to dominate the home market, which has such a great influence on the educational/industrial market.

The current videodisc companies fail to push hard enough in the research and development battles of the technologies, especially in the important software/courseware development and availability. The impact any of the videodisc systems will finally have will be in large part determined by the easy, inexpensive availability of educational and entertainment programming.

Library media personnel should be aware that 3M has a magnetic capacitance videodisc under development that could prove to be of major importance as an authoring medium for the laser optical videodisc systems. Because it is a magnetic system, it will be subject to the traditional storage and playback limitations of other magnetic storage media. The system should be available at relatively low cost and could make widely available some of the same features associated with magnetic disc systems used for instant replay on network broadcast TV. No reliable information is available concerning storage capacity or special features of the 3M system. Library media personnel should also be aware that 3M is setting up a videodisc replication center in the Minneapolis/St. Paul area which will deal with all videodisc formats.

#### Combined Optical/Capacitance Systems

J.V.C. (Victor Company of Japan) has announced a unique low cost videodisc system that will incorporate a stylus for continuous play application and laser optics technology to provide freeze frame, slow/fast motion, and rapid direct random access.



The Matsushita Company of Japan has adopted the JVC approach, making video/audio high density disc systems a very prominent part of the Japanese videodisc efforts. The JVC system is designed to be a low cost consumer system with probable educational applications.

Numerous other small developments are taking place in terms of disc players, new methods for disc replication, and totally new concepts for rapid access to visual and audio information. With change as the constant, standards are unlikely to be with us for some time. For example, a spin-off from the videodisc technology developments is the compact audio disc developed by Philips, and demonstrated in 1979. Philips claims the new system offers "an unprecedented improvement in sound quality

### Combined Optical/Capacitance Videodisc System

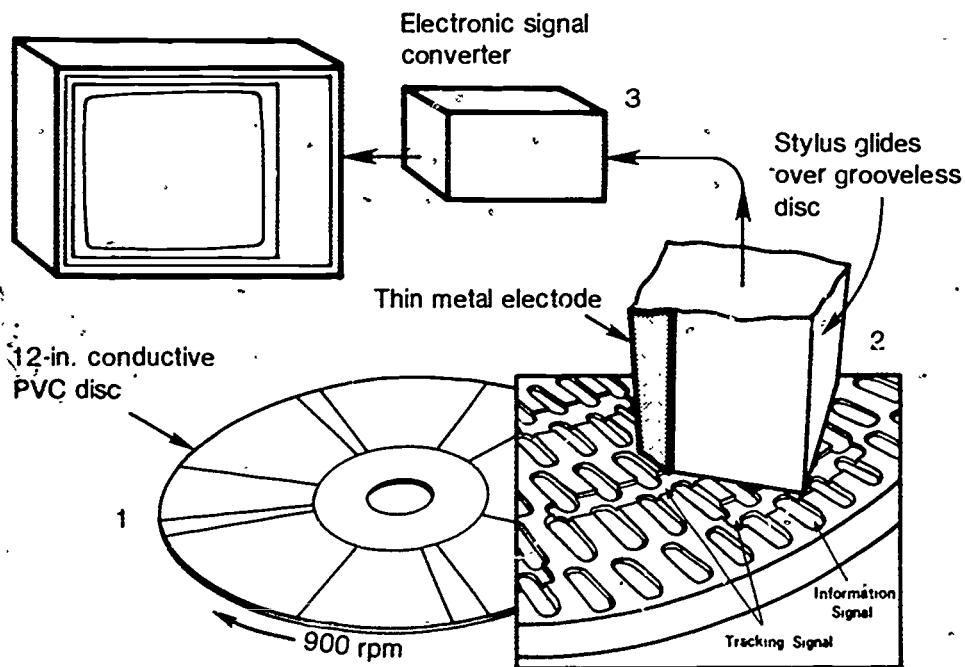

**Figure 7.** Combined optical/capacitance system diagram. The combined system has been used primarily by the Victor Company of Japan (JVC), and provides for a grooveless disc which is tracked by a laser and the signal taken from the disc by a mechanical stylus which "floats," making slight contact with the disc. This system has yet to be marketed in the United States but appears to be nearing release.

and realism." This new compact audio disc is based on digital recording rather than traditional analog sound recording techniques. The original sound waves are analyzed thousands of times each second, with the result that each sound wave is converted into 14-bit binary codes, which are then transferred into approximately six billion bits which are burned into the disc to be recorded by pits similar to those on videodiscs. A one-hour stereo audio disc recorded on one side is only 4½ inches in diameter and less than 1/16th inch in thickness (Gray, 1980). Philips has also experimentally placed more than 400 hours of high fidelity stereo sounds on a 12-inch disc.

Each of the systems described will have to meet the ultimate tests of the marketplace and succeed or fail as they will. Virtually all of the systems offer a potential revolution in communication and information technology. Multimedia materials may now be delivered on an inexpensive scale much as we now deal with printed information sources. With the increased costs of manufacturing the traditional book, the "generic book," further refined from the videodisc technology, may be a welcome advent in the library, information, and instructional sciences.

### VIDEODISC IS NOT A PANACEA

It may appear to library media specialists, as well as educational and instructional development specialists, that videodiscs could provide a solution to the multiple problems plaguing library media centers in terms of both cost factors and space management. Because videodiscs appear to be a universal medium, library media specialists might expect them to instantly replace the traditional book (or in some cases fear such replacement), as well as film, microtext, and video and audio recordings. Augmented computer storage systems could also be expected. However, the videodisc, in spite of its great promise, should not be regarded as a panacea.

It must be kept in mind that videodiscs, even when interfaced to the microcomputer (as has been successfully developed and demonstrated at Utah State University and other places), are not the ultimate replacement for all media, even though their unique characteristics will undoubtedly have a strong impact. Immediate overly optimistic expectations may be more harmful than helpful. Many LIS (library, information, and instructional sciences) professionals are from the "instant generation" identified a few years ago by S. L. Hayakawa, and they find it difficult to accept that the videodisc systems, together with a massive store of accompanying software/courseware, are not instantly available.

Along with the overly enthusiastic optimism, there is the more cautious reaction, e.g., "We are waiting for the technology to settle down, and then we will purchase and try it out." Other practitioners plan to consider purchase of videodisc when there is more courseware available. Some criticism is heard because hardware, software, and courseware are not instantly available and designed to specification. It seems more likely, however, that just as with the motion picture, television, microcomputer, and other communications technology, the introduction will come in the entertainment/home markets prior to the adoption in the educational community which will allow the new high communications technology to become "instructional technology." Those waiting for the videodisc to "settle down" may be waiting for what never was and never will be. It will probably continue to change constantly as the other media do.

The LIS professionals will determine in large part how the videodisc technology is diffused by the support they give it in the early stages, especially in the educational

market. It is not impossible that this medium could come in as a major information/educational tool, almost at the same time that it is being diffused in society as a home entertainment medium. One should perhaps view the "chicken and the egg" system, and recognize that "chickens" are the means by which "eggs" reproduce themselves. Which comes first may be more a point of view. It is evident that videodisc hardware must be in the field before large amounts of software and courseware will be developed and marketed. If the initial stock of software and courseware for distribution is not at a sufficient level to make the hardware/software combination alluring to library and instructional professionals for purchase, the technology will be doomed, regardless of its many capabilities and characteristics. Most development programs that fail do so, not because of their lack of potential, but because of lack of logistical support. A recognized principle appears to be that hardware systems

### MAJOR VIDEO DISC SYSTEMS AT A GLANCE

Name of System	Type of System	Available	Price
Discovision Associates	Optical Reflective	1978	\$2500-3000
Pioneer Laserdisc	Optical Reflective	1980	\$750-800
Philips	Optical Reflective	1978	\$2500-3000
Magnavision	Optical Reflective	1979	\$750-800
Thomson-CSF	Optical Transparent	1980	\$3000-4000
TED	Grooved Capacitance	1975	NA
RCA Selectavision	Grooved Capacitance	1981	\$400-500
JVC	Grooveless Capacitance	NA	NA
Sony	Optical Reflective	1980	\$2500-3000
Atlantic Richfield-ARDEV	Optical Transparent	NA	NA

Figure 8. Summary of major videodisc systems. The major videodisc systems are summarized on this chart. There are other videodisc systems undergoing research and development efforts. As noted earlier in this report, a number of changes may take place in the near future.

development always precedes the development of software/courseware. Each new medium of the past has produced mixed reactions, but a classic is a letter Thomas A. Edison wrote concerning the invention of the 'motion picture. He stated that, in his opinion, the film would become the "master medium":

...To me this is encouraging news, being indicative of an awakening of educators and of their inclination to avail themselves of modern developments. As you know, it has been my profound conviction for many years that education through the medium of the eye is more complete and convincing, and more easily acquired than by textbooks or oral teaching. I do not decry the latter, but think in the course of time they (books) will be used as supplementary only to motion picture teaching. (Reproduced in Wood and Smellie, 1980, p. 51)

LIS professionals must work together to maximize the utilization of videodisc systems if the technology is to realize its full potential in information/instructional settings. The library media professionals should be concerned with the aspects of selection, acquisition, storage, retrieval, distribution, utilization, and maintenance of materials and devices, i.e., the all important logistical support services. The systematic approach to design, production, evaluation, and utilization of complete systems of instruction, including all appropriate components and a management pattern for using them, is the important domain of the instructional development specialists. The generation of specifications for learning resources/instructional system components should be the concern of the instructional designer, while the instructional product development specialist is concerned with the design, production, and evaluation of isolated sets of instructional materials, devices, and techniques. The information/instructional system is a unique combination and arrangement of the elements of the information/instructional process designed to achieve predetermined objectives, as well as broader goal-free access to information. Mass media presentation formats of the printed page and broadcast media, as well as individual "user" information/instructional systems like videodisc/microcomputer technology that go beyond prescribed bounds of learning, should be of equal concern. The videodisc/microcomputer technology has great potential in these combined areas of interest within the broad scope of the library, information, and instructional sciences, and professionals in these fields should be alert to the key role they will play in its diffusion. The impact of this technology in the immediate future will likely be felt in the use of videodiscs as:

1. An inexpensive means of publishing information and instructional materials in all the traditional formats; e.g., books, films, and slides.
2. A medium (videodisc/microcomputer interfaced) which may be modified as an information/instructional storage and retrieval system, which will be far more versatile and eventually lower in cost than any of the traditional formats, including the book, microtext, or computer.
3. A medium which will capture all the existing media formats for storage (even books reformatted for video display); interlacing segments of motion/sound, mute frame-single image multiple language, or combinations of motion/sound mute/still images.

Videodisc has massive capacity, as yet relatively untapped, as an audio medium (400 hours+), as a computer storage medium (some 14 billion bits), or as a still image with sound (250 slide/sound programs of 80 images each (with up to 45 seconds of compressed sound with each image on current ARDEV developmental systems), or two hours of combined sound and motion, with two sound tracks for stereo effect, multiple language, or "dual pass" instruction (using the two sound tracks to contain different levels of audio information, similar to different reading levels, but with the same illustrations).

4. A low cost medium for media producers to disseminate the wide variety of information/instructional programs to library media markets on a much larger scale. Although the front end production costs will not be lessened, the distribution costs for a greatly expanded market provide the major projected future impact for the library, information, and instructional sciences.

Dr. Andrew R. Molnar of the National Science Foundation says:

Discoveries of fundamental importance are occurring in all areas of science at an incredible rate. However, continued growth and exploitation of information rests not only on science's ability to produce new knowledge, but also on society's ability to learn and apply knowledge in a productive way. If we are to continue to reap the advantages of the information explosion, we need new powerful intellectual tools to augment and expand human capacity to reason and work smarter.—The National Science Foundation has initiated a research and development thrust for a proof-of-concept demonstration of an intelligent videodisc system for science education in the hope that it will stimulate others to seek new instructional paradigms and to explore new technological innovations for use in the learning society. (Molnar, 1979, p. 11)

#### USU CENTER FOR INSTRUCTIONAL PRODUCT DEVELOPMENT

USU VIP staff are associated with the NSF Intelligent Videodisc Project with the University of Utah's Physics Department. It is for some of the reasons mentioned by Molnar that the Center for Instructional Product Development (CIPD) initiated the VIP at Utah State University with the financial and philosophical support of the University Provost and Vice President for Research, as well as the Dean and Associate Dean for Research of the College of Education. It is important that answers to the questions of what videodisc and microcomputer technologies offer librarians, educators, and trainers in business/education, government, military, and other information settings be found, and the present research and development efforts of the CIPD are concerned with how a videodisc random access system varies from a system based upon a videotape base; why mass distribution of videodiscs is likely to begin a new revolution in video publishing and programming; and what its impact will be upon industrial training, schools, colleges, and library/media/information centers.

The Center for Instructional Product Development was begun in 1977 as the Research and Development Laboratory of the Department of Instructional Media (Library Science and Instructional Systems Technology). The major goals of the Center are to enable graduate students who are involved in academic programs at the masters, specialists, and doctoral levels to have real life experiences with work and clients who contract with the CIPD to investigate, design, develop, and evaluate various aspects and phenomena involved in information/instructional media and technologies. The USU Videodisc Innovation Project (VIP) was one of those efforts, initiated locally because of the lack of financial interest from state and federal funding agencies or private industries in the early years and stages of R&D work with videodisc/microcomputer technologies.

The first major VIP project was the design, development, production, and evaluation of USU Videodisc #1, which was publicly shown and demonstrated with microcomputer interface at the AECT National Convention in New Orleans, Louisiana, in March 1979. More than 1,500 professional library, information, and instructional personnel participated in a National Interactive Videodisc Seminar, broadcast by satellite to more than 100 ground stations to share information learned from the VIP R&D efforts (Williamson, 1980).

Since the inception of the Videodisc Innovations Project, growing interest and new developments in the videodisc/microcomputer technologies have made it necessary to broaden the R&D base from a single project to the multiple efforts included in the USU Videodisc Innovation Projects. Several other major projects also doing research in this area are:

1. Control Data Corporation PLATO/Videodisc SIMTAB Project (Simulation and Training in Agri-Business) which will conclude in June of 1981.
2. The Interactive Microcomputer/Videodisc USAREUR Project (United States Army Education in Europe) with the University of Maryland.
3. National Science Foundation Intelligent Videodisc Demonstration of "Proof-of-Concept" Project with the University of Utah Physics Department.
4. Bureau of Education for the Handicapped, funded by the U.S. Department of Education.
5. The annual National Videodisc/Microcomputer Institute (NVMI), first funded by the U.S. Office of Education's Library Training Programs.

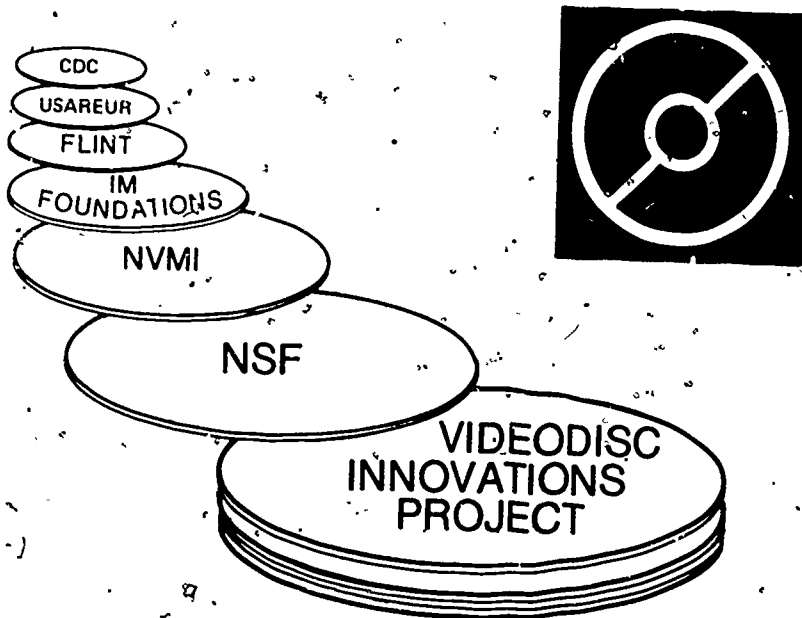

**Figure 9.** Videodisc Innovations Project and logo. Utah State University's Videodisc Innovations Project has been the basis for several research, development, and training efforts. It is to be hoped that this project, represented by the bold logo in the upper right-hand corner of this figure, will continue to provide leadership and shared expertise from future research, development, and training programs with videodisc/microcomputer projects.

---

**REVIEW OF SELECTED VIDEODISC LITERATURE TREATING LIBRARY,  
INFORMATION, AND INSTRUCTIONAL SCIENCES APPLICATIONS**

Published literature dealing directly with videodisc applications to libraries is rare. One of the earliest articles, which appears in *Utah Libraries* (Bradshaw, 1975), suggests the publication of "Videotextdiscs" which would contain a book in freeze-frame pages for reading, followed by the film or television producer's version of the same book for dynamic motion viewing. Other suggestions are made of what might be done to enhance more rapid acceptance of videodisc utilization in libraries. Another article suggested the use of videodiscs for library cataloging with the possibility of storing some four million catalog cards on seven videodiscs (Willocks, 1975). A paper

and slide presentation given at the national convention of the American Library Association by a representative of Philips of North America (Hensey, 1977) confirmed the compatibility of the Philips Magnavision and the MCA Discovision systems. Following that presentation, a spokeswoman for ALA wrote a pessimistic article entitled "Whatever Happened to the Videodisc?" which reflected the earlier mentioned impatience and skepticism of the new technology, as well as disgruntlement over premature announcements concerning the advent of the videodisc. The ALA article did, however, suggest applications for library reference services and information storage and retrieval with the caveat that such applications were far in the future (Boyle, 1977). More optimistic articles have since been authored by Boyle (1979a, 1979b) and others treating the videodisc as a medium with which to be knowledgeable and concerned (e.g., Cherry, 1980). An article featuring the USU VIP programs will appear in American Libraries in the April 1981.

Another writer and a library researcher working with videodiscs suggested a much more optimistic view of the videodisc technology as applied to educational settings, including libraries and videodisc publishing of journals and magazines, which would undoubtedly affect library/information/instructional specialists (Wood, 1976; Wood and Stephens, 1977, 1978). Other articles have appeared which forecast videodisc potential for school and public libraries (Gray, 1978) and reviewed the unique capabilities of videodisc and the anticipation of libraries eagerly awaiting the advent of the new medium because of its durability, accessibility, and capacity for massive storage of materials in visual, sound, and print formats (Rice, 1978).

A Futurist article which appeared in the spring of 1978 focused on videodisc combined with other technologies to form a major library information delivery system (Smith, 1978). By the fall of 1978, a prototype MCA Discovision microprocessor controlled random direct access videodisc system was demonstrated by a library information scientist (Wood) to a group of science and math educators meeting at a National Science Foundation Seminar in Salt Lake City, Utah (November 2, 1978). A general annotated bibliography on videodisc technology, including library applications, was published in late 1978 (Wood, 1978b) at almost the same time as an article describing the optical videodisc for data processing innovations (Gunther, 1978). The first national demonstration of the Utah State University Videodisc Innovations Project (VIP), directed by a library/information/instructional scientist, was reported in a special issue of Educational and Industrial Television (Wood, 1979c). The VIP demonstrations, sponsored by the National Association of Learning Laboratory Directors (NALLD), went on for a full day at the 1979 AECT national convention in New Orleans. This was followed by demonstrations during the next two days which included a joint presentation/demonstration with Tom Held of the National Library of Medicine's Lister Hill Biocommunications Center and Robert Woolley, a member of the USU VIP research team (Ackerman, 1979), as well as demonstrations by Smellie, Wood, and Woolley at the AECT "Showcase of Excellence." Other demonstrations were given by Thorkildsen to a congressional committee in April 1979 (U.S., Congress, Houses . . . , 1980, p. 236), and to the special educators attending AECT (Thorkildsen et al., 1979). Not even standing room was available for the VIP AECT presentation/demonstrations, an indication of the high degree of interest generated in the library media communities for videodisc, and especially for the microcomputer interface and touch panel control developed at USU.

The Utah State University Videodisc Innovations Project provided the basis for the first National Videodisc/Microcomputer Institute (NVMI), held on the USU Logan campus in June of 1979. This NVMI provided hands-on learning for 111 library media specialists from state libraries, state public education departments, and a few



representatives from military, religious, business, and industrial organizations (Patrick, 1979). It appears that the government of West Germany—through the Goethe Institute—will fund the May 1981 Videodisc/Microcomputer Institute as a seminar which will deal with video and microcomputer language learning systems. Participation in this conference will be by invitation only.

More coverage of the USU VIP appeared in a special issue of Information World (Armstrong, 1979). A VIP presentation and demonstration for the American Society for Information Science in Minneapolis, Minnesota (October 16, 1979) served as the starting point for the development of this ERIC publication. Another brief mention of the USU VIP appears in 1979 in a general survey article which describes the major U.S. videodisc projects (Merrill and Bennion, 1979).

Concern about copyright was expressed by librarians at the first NVMI because of the statement of copyright restrictions on the MCA produced videodiscs. The discs, which are distributed for playback on Magnavision, Discovision, and Pioneer laser-based videodisc systems, are labeled "For Home Use Only." The content of a letter dated April 23, 1979 to Robert Wedgeworth, Executive Secretary of the American Library Association, from legal counsel Newton N. Minow of the firm of Sidney & Austin, is quoted here:

You asked our opinion concerning a public library's use of videodiscs which bear a label "For Home Use Only."

We understand that libraries desire to purchase such videodiscs for normal library circulation and in-library use. Although the issue is a novel one and not entirely free from doubt, we believe that they may lawfully do so, that such use of these materials does not constitute copyright infringement or breach of contract. Libraries should not, however, exhibit the programs to a substantial audience.

A claim of copyright infringement would have to be based on unauthorized distribution or performance of the copyrighted work. The Copyright Revision Act of 1976, however, recognizes explicitly the right of the lawful owner of a copy of a copyrighted work "to sell or otherwise dispose of the possession" of such a copy without the copyright owner's authority (Section 109). Thus, libraries are free to loan the videodiscs to members of the public, just as they would a book.

Moreover, individual use of the videodiscs in the library or at home would not constitute an infringement of the copyright owner's exclusive right to perform the work publicly. While playing the videodisc at home is a performance, it is not "public" for purposes of the Act. To perform a work publicly means "to perform...at a place open to the public or at any place where a substantial number of persons outside of a normal circle of a family and its social acquaintances is gathered..." (Section 101). This clearly excludes home use, and we believe it also excludes an individual's viewing of a videodisc at the library, because the viewer typically will be in a private room and because a substantial number of persons would not be gathered for purposes of viewing the program. We suggest, however, that libraries not use videodiscs in programs for the public

at large, as in projecting a movie on a big screen in a meeting room, cultural center, or the like.

While there is thus little likelihood that a library's use of the videodiscs would constitute copyright infringement, it is possible that a copyright owner would attempt to prevent such use based on a contract theory. "For Home Use Only" could be read as simply a restatement of the copyright owner's exclusive performance rights as discussed above, or as a condition of the sale. If the videodiscs are sold to libraries by the manufacturer or his agent, it is unlikely that the legend could be held to be a condition of sale since library use would clearly be contemplated by the parties. Further, there is some case law which holds such restrictions to be invalid. In *RCA Mfg. Co., Inc. v. Whitman*, 114 F., 2nd 86, 90 (2nd Cir. 1940), the court held that the legend on records, "Not Licensed for Radio Broadcast," constituted an invalid "servitude upon the records," analogous to resale price restrictions and other antitrust violations. See also, *Universal Film Mfg. Co. v. Copperman*, 218 Fed. 577 (2nd Cir. 1914/condition on sale of film that it should not be sold or hired out outside of country where purchased held invalid). In both these cases, the courts found restrictions on use inconsistent with the concept of an outright sale. If possession of the videodiscs was transferred by lease or license, such restrictions possibly would be appropriate and legally binding.

While there is always the risk of legal action by the vendor of the videodiscs, we believe that the legal position regarding use of the videodiscs in the library or in patrons' homes is a sound and justifiable one.

We hope this is useful. Please let us know if we can be of further assistance. (1978-79 ALA Executive Board Document)

Two of the most informative general articles on videodisc systems appeared in Panorama (Lachenbruch, 1980a) and in Business Week (Videodiscs..., 1980). These two articles provide descriptions of the several videodisc systems with a projection of the market for sales and use in the next decade; however, both articles are more concerned with the features of hardware systems than with software/courseware.

#### ABC/NEA SCHOOLDISC PROGRAM

An exciting current project is the ABC/NEA Schooldisc Program. A description of this program by Wilhelms (1980) reports that 20 videodiscs of one-hour playing time will be released every two weeks during the 40-week school year of 1981. The first experimental disc was viewed in July 1980, and was disappointing in that it was intentionally and restrictively designed to avoid upstaging the teacher who may be using it, in an effort to motivate and enhance teacher use of the videodisc. Unfortunately, the concept is poorly conceived and not well executed. The first disc suffers from a mind set that videodisc is simply videotape in a different format and misses the mark in terms of effective use of its unique features and instructional power. Some of the preliminary decisions may account for criticisms that the materials are lacking in design:

1. Each hour of material would contain six 10-minute segments: one each in language skills, social studies, science, and the arts; in addition, one segment would always be devoted to current events, and one would be reserved for in-service messages to teachers.
2. The material would be recorded on videodiscs but will also be available on tape. (Wilhelms, 1980, p. 62GE)

It would seem the very conception of the project limits the design to a videotape on disc format, although the attempt may be more enterprising. The system will capture the videotape messages very well, but if that is the purpose, it would seem that the tape is the preferred medium, except for the cost of distribution. Teachers are serving as the designers for the Schooldiscs, apparently without assistance from professional instructional developers or designer specialists. This procedure would seem to limit the program's success in realizing a videodisc production, rather than a redone videotape anthology of ABC off-the-shelf materials reviewed by teachers. It appears that few totally new production segments will be done specifically for the Schooldiscs program.

In an article that appeared in the Phi Delta Kappan, Gough (1980) suggests that there are three major flaws in the program design. First, she points out that the target audience and content framework—at least for the four subject-matter-related segments—closely parallel the Agency for Instructional Television's "ThinkAbout," which was ready in September 1979 and is already in use in many classrooms in the U.S. and Canada. She considers the process of instructional design, which depends almost entirely on a handful of classroom teachers, to be an even more serious flaw. Five experienced, intermediate teachers selected by NEA met in January 1980 for one week to establish the grid of themes, subject matter content, and skills on which program production would be based. In February, these same teachers met to evaluate scripts and proposed visuals, and to write a teacher's guide for a pilot videodisc to be classroom tested in the fall of 1980. This same process took the developers of "ThinkAbout," who were already experienced in creating classroom television resources, more than two years. The fact that the instructional design of Schooldiscs will be totally teacher-developed—a fact stressed by ABC and NEA executives—underlines the lack of input from professional instructional designers and developers, which, together with the lack of adequate time and budgets, and the limited conceptualization of the program, is seen as a serious deterrent to the production of high quality materials. Gough also sees the distribution of the program as a package with the videodisc player at about \$700 and the discs at \$7.50 to \$10.00 as a major flaw.

We disagree with this last criticism. The cost of the programs is far less than for videocassette, and the hardware component in the package will be needed not only for the currently available Schooldiscs, but for any programs that will be produced in the future by the project. There are also a number of other programs on videodisc that can be used with the same systems. We also feel that this distribution of hardware and courseware in a single package will result in making videodisc more easily available to larger numbers of educators, thereby speeding up the diffusion process and adoption of the new technologies. Gough also points out some of the strengths of the program:

The ABC/NEA project does have some promising features, not the least of which is hardware...Videodiscs have two obvious advantages. First, they allow teachers to use programs at times convenient to them. Second, they will be cost effective, once the hardware is in place. If ABC and NEA manage to install videodisc playback equipment in a significant number of classrooms, other instructional television producers will no doubt retool immediately to take advantage of the fact. In that event, classroom television may never again be the same. (Videodisc technology seems likely to affect television use most profoundly in secondary schools, where inflexible schedules make the use of television broadcasts difficult.)

The current events segment of ABC/NEA Schooldiscs is another of the project's promising features. This segment will be developed by the ABC news staff, using commercial television footage. However, content will have to be chosen with care to avoid dated materials.

NEA, which has long pushed for more effective classroom use of television technology...will develop and control the content of the in-service Schooldisc segments and ABC/NEA Schooldiscs will demonstrate ABC's concern for children's programming... This collaboration is the first of its kind in the U.S., and the effort could significantly change classroom practice in the decade ahead. (1980)

In an earlier issue of Phi Delta Kappan, Wood and Stephens projected both the use of videodisc technology in education and its benefits to education in improving the quality of learning (1977). However, it will do little good for NEA's stamp of approval and ABC's cooperation if the flaws of the Schooldisc program are overly apparent in the finished products which will be scrutinized and criticized by so many who are watching videodisc. It could develop into one of the greatest setbacks (à la "I told you it wouldn't work better" syndromes) to the greatest advance in diffusion of this important technology. The subsequent impact of such a setback upon the library, information, and instructional sciences should be apparent.

In his review of the motivations and detriments to educational use of intelligent videodisc systems, Eastwood points out that many of the traditional barriers to acceptance are the same as those for other technologies (1978, 1978-79). However, the current library literature reflects a growing acceptance, at least to the point of "Try it, you'll like it" (Cherry, 1980).

#### PROPOSED FAULT FREE ANALYSIS

A spin-off from U.S. space research, Fault Free Analysis (usually called Fault Tree Analysis or FTA) has been used by Wood in such library, information, and instructional science research as the NATUL Project (National Needs Assessment of Teacher Use of Library Media Centers) and Project EAR (Educational Audiologist Research to Develop an Ed.D. curriculum at USU). The NATUL Project was reported at the ALA Library Research Round Table and reported in the 1977 Proceedings.

FTA is defined as a technique for increasing the probability of success in any system or organization by analyzing the most likely modes of failure that could occur. The objectives of FTA are to isolate and identify the failure events and thereby develop strategies and means to rectify or avoid them. A Fault Free Analysis would be useful to identify and prioritize the failure events of the diffusion process of videodisc technology to libraries, information agencies, and instructional and training settings so as to provide for a smoother process. (See Williamson, 1980; Wood, 1976, 1977a, 1978b; Wood et al., 1979.)

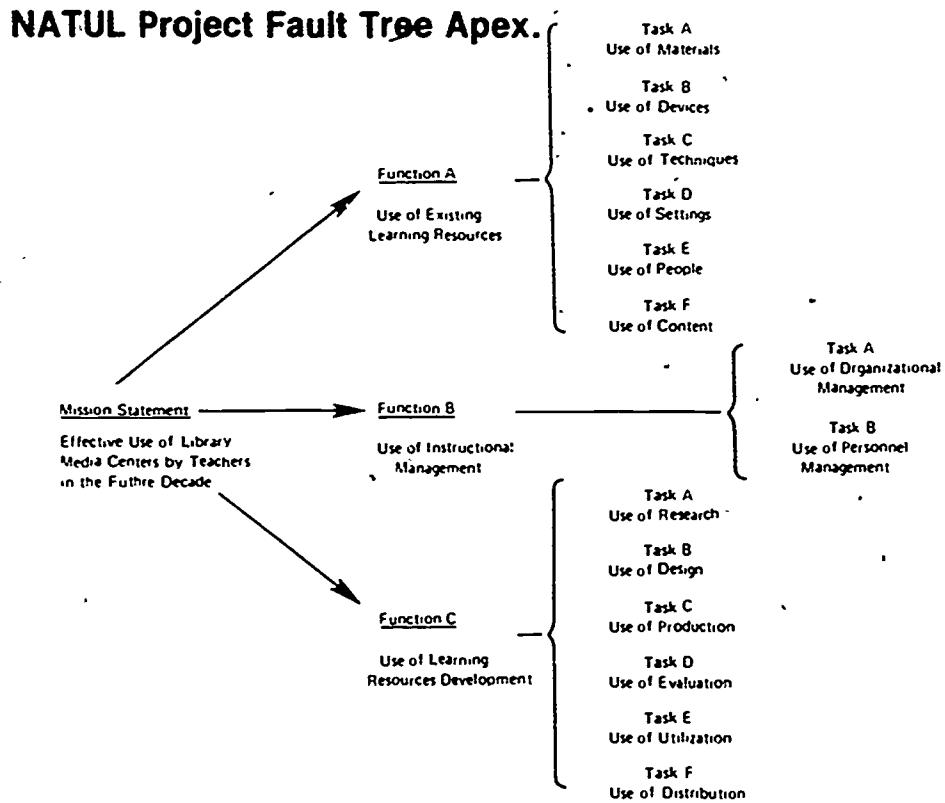

**Figure 10.** NATUL Fault Tree Apex. The NATUL Project was designed to determine particular problems associated with teacher use of library media centers. However, a similar methodology could be used to determine particular problems in other settings.

### CONCLUSION

In 1963, Don Swanson, former Dean of the University of Chicago's Graduate School of Library and Information Science, inferred in a talk on "Design Requirements for a Future Library" that a system which would have the capacity to hold 2,000 reels of high density magnetic tape to store  $10^{11}$  bits of information, and contain a future National Union catalog at the cost of 40 million dollars, with access time to any part within four minutes, would be cost effective (1964, p. 20). The present videodisc/microcomputer systems of 1981 could store the entire National Union Catalog on one disc using digitized data storage, and provide an average access time of 2.5 seconds, at a cost, including hardware, of less than \$5,000 after initial production costs of transfer to videodisc. Publication on videodisc systems would also appear to be feasible for large files with print, diagrams, or illustrations which are frequently searched, e.g., patent files.

### 1964 Projections and Videodisc System

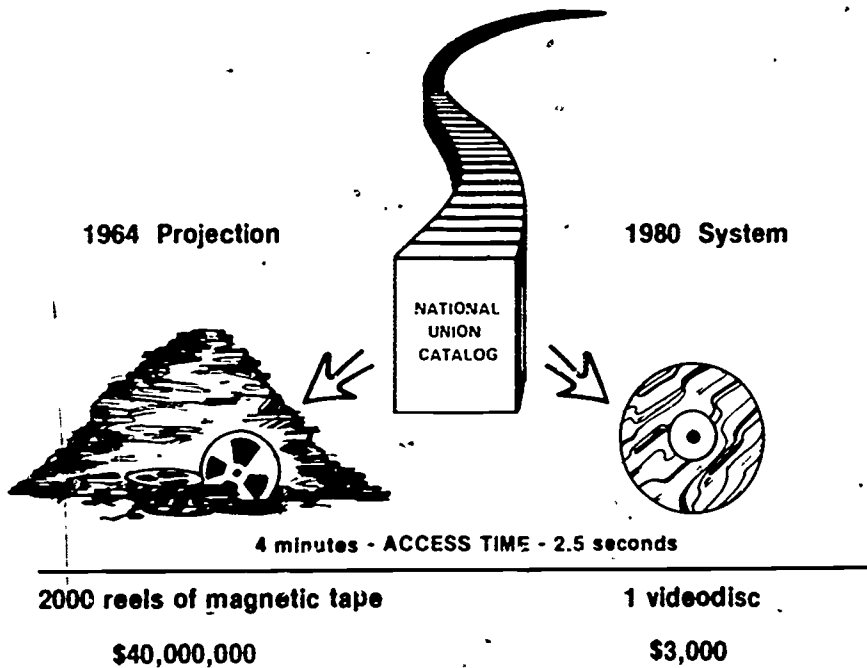

Figure 11. Swanson's 1964 projection compared with videodisc. Current videodisc systems may accomplish the tasks more cost effectively than was projected in 1964. The Library of Congress has been working with an experimental optical videodisc system which may test the feasibility of such a videodisc system. It appears that other large files could be effectively published on videodisc systems, such as patent files.

Alvin Toffler, in his recent book, The Third Wave (1980), speaks of "demassifying the media" and the future "electronic cottage" filled with easily accessed information devices. He suggests societal production will be decentralized as well as the dissemination of information.

This statement by Andrew R. Molnar of the National Science Foundation underlines the importance of the dissemination of information in a learning society:

Discoveries of fundamental importance are occurring in all areas of science at an incredible rate, and these developments have created a new body of knowledge that has significantly altered our society. In less than a generation, scientific knowledge has radically changed our concepts of the universe, the atom, the gene, and the continents upon which we live.

Much of this knowledge has been transformed into useful applications. Today, science-based information industries account for more than one-half of our nation's gross-national-product and over one-half of our jobs (Porat, 1977). It has been estimated that advances in knowledge are the largest single source of long-term economic growth, accounting for more than one-third of our economic output since World War II (National Science Board, 1976).

While the information explosion has expanded our understanding of the world about us and has, to date, brought us a high standard of living and economic prosperity, continued benefits will be directly related to our society's capacity to absorb new information and our ability to use it...

In the last session of Congress, a subcommittee of the House Committee on Science and Technology held hearings on "Computers in the Learning Society." They concluded that the Federal Government must be the primary source of funding for research in the computer based field and the Executive Branch must take the leadership in the development and implementation of a research strategy that will satisfy the requirements for compatibility between broad national goals and those of the country's highly autonomous school systems. They recommended that Federally sponsored research should be directed toward the goals of increasing our basic understanding of appropriate hardware, software, courseware, and instructional theories that would underpin cost effective computer-based educational systems...

Dr. Phillip Morrison of the Massachusetts Institute of Technology has said that "it is plain that American knowledge, like wealth, is skewed in its distribution. One percent of our citizens own a quarter of our wealth, and a similar peak applies in science" (National Academy of Sciences, 1977). In a learning society, it is clearly in the public interest to be sure that information is widely available to all of those who need it and want it.

In conclusion, if we are to reap the advantages of the information explosion, we will need to develop new, powerful technologies to

expand and increase human learning and reasoning. In the past, large investments in research greatly expanded the frontiers of science. The National Science Foundation has initiated a research thrust in this direction with the hope it will, in turn, stimulate others to seek new instructional paradigms and to explore new technological innovations for widespread use in the learning society. (Molnar, 1979, p. 11, 15)

The following bibliography is designed to provide an introduction to the growing literature in this field for practitioners, whether they are contemplating the use of videodisc in their organizations, planning for its incorporation into their programs, or already working with the new technologies.



## REFERENCES AND SELECTED BIBLIOGRAPHY

- Abbott, George L. Video disc: A selected bibliography of general review articles and proposed applications with separate section on technical and theoretical articles. Syracuse, NY: Information Yield, 1980. 34 pp.
- Ackerman, Helen V. Videodisc and computers highlight AECT conference. American Libraries, May 1979, p. 127. (Reports the first demonstration of the USU Videodisc Innovations Project, although not by name.)
- Armstrong, Anne A. Utah State's VIP. Information World, October 1979. (Special supplement on technologies, p. 11.)
- Bartolini, R. A. et al. Optical disc systems emerge. IEEE Spectrum, August 1978, pp. 20-28.
- Boyle, Deirdre. Disc fever sweeps Atlanta. Wilson Library Bulletin, March 1979(a), pp. 492-493.
- Boyle, Deirdre. Videodisc—the world on a silver platter? Wilson Library Bulletin, January 1979(b), p. 369.
- Boyle, Deirdre. Whatever happened to videodisc? American Libraries, February 1977, pp. 97-98.
- Bradshaw, H. Jerry. Videodisc—future shock. Utah Libraries, Spring 1975, pp. 10-16.
- Braun, Ludwig. Microcomputers and videodisc systems: Magic lamps for educators. Stony Brook, NY: State University of New York, 1977. 77pp. ERIC Document No. ED 154 839. (An abbreviated version of this report was published in People's Computers, January-February 1978.)
- Bulthuis, Kees et al. Ten billion bits on a disc. IEEE Spectrum, August 1979, pp. 26-33.
- Cherry, Susan Spaeth. Videodisc proves popular in pioneering libraries. American Libraries, September 1980, p. 509.
- DeBloois, Michael. Exploring new design models. Educational and Industrial Television, May 1979, pp. 34-36.
- Donath, Bob. The hustle of industrial visco. Industrial Marketing, April 1980, pp. 62-64.
- Eastwood, Lester F., Jr. Motivation and deterrents to educational use of intelligent videodisc systems. St. Louis, MO: Washington University, Center for Development Technology, 1978. 57 pp. ERIC Document No. ED 157 516. Also appeared in a special issue of the Journal of Educational Technology Systems (1978-79, 7, 303-335) together with other articles on videodisc technology by Andriessen, Branson, Bunderson, Holmgren, LaGow, Leveridge, Kribs, and Walker.
- Gelman, Morrie. Sony cool on viddisk future; prototype only. Variety, March 12, 1980, p. 1.

- Goldstein, Charles M. Videodisc—future storage medium. (Abstract of paper to be delivered at 3rd Online Information Meeting.) Online Review, December 1979, p. 415.
- Gough, Pauline B. ABC/NEA Schooldisc: Will apparent problems cancel out potential? Phi Delta Kappan, December 1980, pp. 247-249.
- Gray, Robert A. A technology spin-off: The compact audio disc. Instructional Innovator, December 1980, p. 38.
- Gray, Robert A. Videodisc technology: Its potential for libraries. School Library Journal, January 1978, pp. 22-24.
- Gunter, Greg. The optical videodisc. Bulletin of the American Society for Information Science, December 1978, p. 39.
- Hensey, June L. Philips and MCA optical videodisc system. A paper presented to the American Library Association, Detroit, MI, June 19, 1977. 8pp.
- Jacobson, Harlan. Pioneer enters videodisks; ally of MCA's system. Variety, April 2, 1980, p. 1.
- Jacobson, Harlan. Zenith to enter videodisc era next year via Selectivision tie. Variety, March 12, 1980, p. 50. (Describes the agreement between RCA and Zenith to share specifications on capacitance videodisc systems.)
- Kenney, George C. et al. An optical disc replaces 25 mag tapes. IEEE Spectrum, February 1979, pp. 33-38.
- Knoxville library showcases videodiscs. Library Journal, February 15, 1980, p. 464.
- Lachenbruch, David. The coming videodisc battle. Panorama, April 1980(a), pp. 57-60.
- Lachenbruch, David. Videodisc update. Radio-Electronics, August 1980(b), p. 4. (Notes RCA Selectivision announcement.)
- Merrill, Paul and Junius L. Bennion. Videodisc technology in education: The current scene. NSPI Journal, November 1979, pp. 18-26. (Describes the major videodisc projects in the U.S., including the USU Videodisc Innovations Project.)
- Molnar, Andrew R. Intelligent videodisc and the learning society. Journal of Computer Based Instruction, August 1979, pp. 11-16.
- National Academy of Science. Science: An American bicentennial view. Washington, DC: National Academy of Science, 1977, p. 6.
- National Science Board. Science indicators. Washington, DC: U.S. Government Printing Office, 1976.
- 1978-79 ALA executive document #74 (information). In Videoplay Report, June 11, 1979, p. 4. (Letter reproduced verbatim with letterhead.)
- Patrick, Lucy. Is there a videodisc in the house? Georgia Librarian, August 1979, p. 6. (One of the participants in the first National Videodisc/Microcomputer Institute at Utah State University reports her experiences.)

Porat, M. V. The information economy: Definition and measurement. U.S. Department of Commerce, Office of Telecommunications Special Publication 77-12 (9 vols.). Washington, DC: U.S. Government Printing Office, 1977.

Radding, Alan. Programming changes rapid. Advertising Age, July 23, 1980, pp. 10-13. (Analyzes changes in audiovisual formats with emphasis on videodisc.)

JVC's video disc. Radio-Electronics, May 1980. p. 4.

RCA to market videodisk system in 1981. Wilson Library Bulletin, January 1980, p. 279.

Rice, James, Jr. There's a videodisc in your future. Library Journal, January 15, 1978, pp. 143-144.

Rolph, Sarah. Computer graphics—seeing is believing. Datamation, August 1980(a), pp. 43-46. (An important article describing a spatial data management system based on videodisc.)

Rolph, Sarah. The disc revolution. Datamation, February 1980(b), p. 147.

Smellie, Don C. Videodisc in the classroom. Educational and Industrial Television, May 1979, p. 32.

Smith, Judson. An eye-opening glimpse at training's newest tool—the videodisc. Training, August 1979, pp. 21-22, 24.

Smith, Robert F. A funny thing is happening to the library on its way to the future. The Futurist, April 1978, pp. 85-91.

Sommer, Jeff. ...While videodisc players prepare to come into view. Advertising Age June 2, 1980, pp. 2, 8, 10. (Surveys recent RCA and other announcements of entering the videodisc market, predicting that lack of compatibility will slow sales.)

Swan, Paul and Grahame Naylor. Audio-visual: The latest developments. Marketing (British), February 1980, pp. 53-62. (Suggests a world-wide standard for videodisc may be coming with Philips, MCA, IBM, Grundig, Sharp, and Pioneer agreeing to produce compatible equipment.)

Swanson, Don R. Design requirements for a future library. In Libraries and Automation: Proceedings of the Conference on Libraries and Automation at Aarlie Foundation, Warrenton, Virginia, May 26-30, 1963, p. 20. Washington, DC: Library of Congress, 1964.

Thorkildsen, Ron et al. A microcomputer/videodisc CAI package to teach the retarded. Educational and Industrial Television, May 1979, pp. 40-42.

Toffler, Alvin. The third wave. New York: Morrow, 1980.

U.S. Congress, House, Committee on Science and Technology and Committee on Education and Labor. Information Technology in Education: Joint Hearings before the Subcommittee on Science, Research, and Technology and the Subcommittee on Select Education, 96th Congress, 2nd Sess., April 2-3, 1980, p. 236. Washington, DC: U.S. Government Printing Office, 1980.

- Videodisc: A three-way race for a billion-dollar jackpot. Business Week, July 7, 1980, pp. 72-81.
- Videodisc update: ALA legal counsel opinion. Videoplay, June 11, 1979, pp. 3-4.
- Walter, Gerard O. Will optical disk memory supplant microfilm? Journal of Micrographics, July-August 1980, pp. 31-34.
- Wilhelms, Fred T. The ABC/NEA Schooldisc program is underway. Today's Education, September-October 1980, pp. 61GE-63GE.
- Williamson, Rick. Anatomy of a national teleconference. Instructional Innovator, November 1980, pp. 27-28. (A participant in the First National Videodisc/Microcomputer Institute reports on Satellite Conference featuring Videodisc Innovations Project staff.)
- Willis, Barry D. Formats for the videodisc—what are the options? Educational and Industrial Television, May 1979, pp. 36-38.
- Willocks, R. Max. Special report: 4 million catalog cards on seven little platters: Library spinoffs from videodisc technology. American Libraries, December 1975, pp. 682-683.
- Wood, R. Kent. A fault-tree approach to systems analysis: An overview. Encyclia, Fall 1978(a), pp. 61-72. (A paper presented to the Library, Information, and Instructional Sciences Division of the Utah Academy of Sciences, Arts, and Letters.)
- Wood, R. Kent. A reader's guide to videodisc technology: A selected annotated bibliography. In Learning via telecommunications, pp. 15-20. Washington, DC: Association for Educational Communications and Technology, 1978(b).
- Wood, R. Kent. A status report on levels of library and information services in Utah libraries. Paper prepared for the Utah Governor's Conference on Library and Information Services, Salt Lake City, UT, April 9-11, 1979(a). 44pp. ERIC Document No. ED 169 885. (Suggests more widespread use of videodisc technology in libraries and media centers.)
- Wood, R. Kent. An introduction to fault tree analysis: The Natul Project. In ALA Library Research Round Table 1977 Research Forums: Proceedings with meetings held at the 96th Annual Conference of the American Library Association, Detroit, Michigan, July 17-23, 1977, pp. 137-160. Ann Arbor, MI: University Microfilms for the American Library Association, 1979(b). Also published on audiocassettes by the American Library Association as announced in American Libraries, January 1978.
- Wood, R. Kent. Success is easy when you know how to fail. Audiovisual Instruction, October 1978(c), p. 22.
- Wood, R. Kent. Using media centers in education. The Natul Project. Teacher use of library media centers in the future: A national needs assessment by use of delphi fault-tree analysis for instructional development. Logan, UT: Utah State University, Merrill Library and Learning Resources Program, 1976. 221 pp. ERIC Document No. ED 168 555. (An application of Fault Tree Analysis to library media centers.)

Wood, R. Kent. Utah State University's Videodisc Innovations Project. Educational and Industrial Television, May 1979(c), pp. 31-32. (Lead article in a special issue devoted to intelligent videodisc and the USU VIP.)

Wood, R. Kent. Videodisc in education. Video cassette, 3/4 inch, color, 23 minutes. The AECT Telecommunications Satellite Interactive Videodisc Conference featuring the USU VIP staff with script by R. Kent Wood with Don Smellie, Mike DeBlois, and Robert Woolley. (This cassette is available from the USU Center for Instructional Product Development (CIPD), Utah State University-UMC #30, Logan, UT 84322; \$50.00.)

Wood, R. Kent. Videodisc update '77. AAACE Quarterly, October-December 1977, pp. 18-24.

Wood, R. Kent and Don C. Smellie. Videodisc Innovation Projects. In Professional development and educational technology, pp. 49-56. Washington, DC: Association for Educational Communications and Technology, 1980.

Wood, R. Kent and Kent G. Stephens. An educator's guide to videodisc technology. Phi Delta Kappan, February 1977(a). Reprinted in People's Computers, February 1978.

Wood, R. Kent, Kent G. Stephens, and Bruce O. Barker. Fault tree analysis: An emerging methodology for instructional science. Instructional Science, December 1979, pp. 1-22.

Wood, R. Kent and Kent G. Stephens. Videodisc technology: An immediate future shock for educators. International Journal of Instructional Media, 1977(b), 4.

Wood, R. Kent and Robert D. Woolley. A consumer's guide for educators to microcomputer technology. Instructor, March 1980, pp. 86+.

Woolley, Robert D. A videodisc/portable computer system for information storage. Educational and Industrial Television, May 1979(a), pp. 38-40.

Woolley, Robert D. Microcomputers and videodiscs: New dimensions for computer-based education. Interface Age, December 1979(b), pp. 78-82. (Describes the early development of the VIP interface board now marketed by Colony Productions, 1248 Blouinstown Hwy., Tallahassee, FL 32304; 904/575-0691.)