

DOCUMENT RESUME

ED 205 368

SE 034 833

AUTHOR Coon, Herbert L.  
 TITLE Instructional Resources Monograph Series: Safety in Wastewater Treatment Systems. Selected Instructional Activities and References.  
 INSTITUTION Ohio State Univ., Columbus, Ohio. Information Reference Center for Science, Mathematics, and Environmental Education.  
 SPONS AGENCY Office of Water Program Operations (EPA), Cincinnati, Ohio. National Training and Operational Technology Center.  
 REPORT NO EPA-430/1/81-014  
 PUB DATE Jun 81  
 GRANT EPA-T-900710-03-0.  
 NOTE 183p. For related document, see ED 191 728. Contains occasional small print.  
 AVAILABLE FROM EPA Information Dissemination Project, 1200 Chambers Rd., 3rd Floor, Columbus, OH 43212 (\$5.50).  
 EDPS PRICE MF01/PC08 Plus Postage.  
 DESCRIPTORS Accident Prevention: Environmental Education: Instructional Materials: Postsecondary Education: \*Safety: \*Safety Education: \*Technical Education: \*Waste Disposal: Water Pollution: \*Water Resources

ABSTRACT

Described are instructional and reference materials that may be useful to managers, supervisors, foremen and others who are interested in the safety education of workers in wastewater systems. Emphasis is upon items relevant to the development and presentation of wastewater treatment training programs. Part I contains descriptions and excerpts from selected learning resources dealing with safety in wastewater treatment systems. In Part II, abstracts of additional films, slide-tape presentations, and print materials are presented. Part III describes the National Training and Operational Technology Center (NTOTC) and selected information sources. (Author/WB)

\*\*\*\*\*  
 \* Reproductions supplied by EDRS are the best that can be made  
 \* from the original document.  
 \*\*\*\*\*

United States  
Environmental Protection  
Agency

National Training  
and Operational  
Technology Center  
Cincinnati, OH 45268

EPA-430/1/81-014  
June 1981

Water



## Instructional Resources Monograph Series:

# Safety in Wastewater Treatment Systems

U.S. DEPARTMENT OF HEALTH,  
EDUCATION & WELFARE  
NATIONAL INSTITUTE OF  
EDUCATION

THIS DOCUMENT HAS BEEN REPRODUCED EXACTLY AS RECEIVED FROM THE PERSON OR ORGANIZATION ORIGINATING IT. POINTS OF VIEW OR OPINIONS STATED DO NOT NECESSARILY REPRESENT OFFICIAL NATIONAL INSTITUTE OF EDUCATION POSITION OR POLICY.

ED 205368

SE 034 833

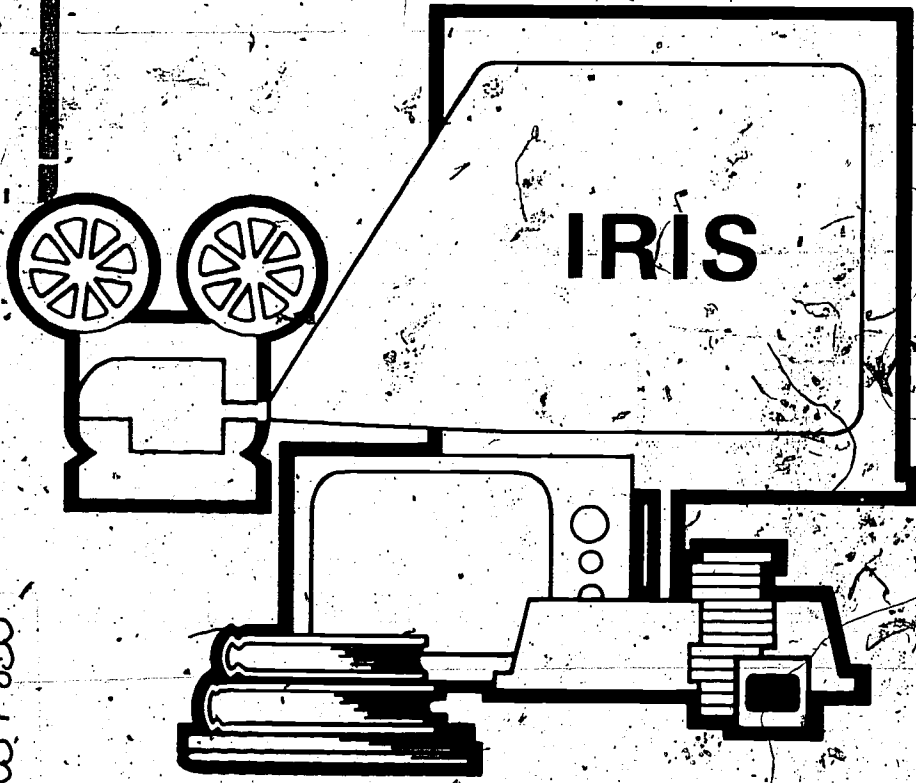

Monograph Series:  
SAFETY IN WASTEWATER TREATMENT SYSTEMS

Selected Instructional Activities  
and References

prepared by

EPA Information Dissemination Project  
SMEAC Information Reference Center  
1200 Chambers Road, Third Floor  
Columbus, Ohio 43212

Author - Herbert L. Coon

as part of

Grant No. T-900710-03-0

National Training & Operational Technology Center  
Office of Water Program Operations  
U.S. Environmental Protection Agency  
Cincinnati, Ohio 45268

June 1981

This monograph has been reviewed by the U.S. Environmental Protection Agency and approved for publication. Approval does not signify that the contents necessarily reflect the views and policies of the U.S. Environmental Protection Agency, nor does mention of trade names of commercial products constitute endorsement or recommendation for use.

This project has been financed (in part) with Federal funds from the U.S. Environmental Protection Agency, Office of Water Program Operations, National Training and Operational Technology Center, Cincinnati, Ohio, under grant identification number T-900710-03-0. The contents do not necessarily reflect the views and policies of the U.S. Environmental Protection Agency, nor does mention of trade names or commercial products constitute endorsement or recommendation for use.

## FOREWORD

The National Training and Operational Technology Center in cooperation with Ohio State University is developing an Instructional Resources Monograph Series. The monograph series is an extension of the information provided in the Instructional Resources Information System (IRIS) for water quality.

This document is one in the Instructional Resources Monograph Series. These documents will assist the professional in identifying and locating instructional and referenced materials related to various technical aspects of water quality control. Emphasis is given to items useful in the development and presentation of wastewater treatment training programs.

Each monograph reviews an aspect of wastewater treatment, provides representative examples of available instructional materials, and includes an annotated bibliography plus additional references.

Your comments and suggestions regarding these publications are invited.

Walter G. Gilbert  
Director  
NTOTC, US EPA  
Cincinnati, Ohio 45268

#### ABOUT THE AUTHOR

Herbert L. Coon is a Professor Emeritus in the Faculty of Science and Mathematics Education at The Ohio State University. Since 1973, he has been involved in developing and assembling learning resources for the ERIC Clearinghouse for Science, Mathematics, and Environmental Education. His experience includes directing numerous workshops aimed toward in-service education and curriculum development in this country and in overseas assignments.

#### CREDITS

Primary staff work for this publication completed by Mrs. Linda Shinn, Mrs. Janice Hingsbergen, Ms. Barbara Klaehn, Dr. Robert W. Howe, and several graduate student assistants.

Mr. Charles Feldmann, Chemist, Program Support Training Branch, National Training and Operational Technology Center, United States Environmental Protection Agency, Cincinnati, Ohio was particularly helpful in providing materials for Section VII.

## PREFACE

Safety education for employees in wastewater treatment systems is of critical importance. A survey conducted several years ago by the Water Pollution Control Federation found that wastewater systems had an injury rate substantially higher than most industries. Data collected by the National Safety Council in 1972 indicated that workers in sewage systems had an injury rate higher than that found in underground coal mining, a notoriously dangerous occupation.

The intent of this monograph is to assemble materials that may be useful to managers, supervisors, foremen and others who are interested in the safety education of workers in wastewater systems.

Despite their obvious interrelationships, eight separate aspects of safety have been identified and used as a framework to identify typical learning resources (Part I) and pertinent references (Part II). It is expected that such a format will facilitate the location of specific materials needed.

The learning resources are often small segments of illustrative materials on safety taken from a chapter or section of a publication or other learning resource that provides additional information. Bibliographic data concerning these resources are found in Part II.

For further information about these materials contact:

EPA Information Dissemination Project  
1200 Chambers Road, 3rd Floor  
Columbus, Ohio 43212

Phone: 614-422-6717

TABLE OF CONTENTS  
Safety in Wastewater Treatment Systems

PART I - DISCUSSION AND LEARNING RESOURCES . . . . .	1
Section I. SAFETY: Management-Supervisor-Worker Responsibilities . . . . .	3
Section II. SAFETY: The Individual Worker . . . . .	31
Section III. SAFETY: Plant Design and General Operation . . . . .	37
Section IV. SAFETY: Chemicals - Gases . . . . .	59
Section V. SAFETY: Electricity . . . . .	63
Section VI. SAFETY: Fire and Explosion . . . . .	89
Section VII. SAFETY: Laboratory Operation . . . . .	103
Section VIII. SAFETY: Manholes and Traffic . . . . .	125
PART II - ABSTRACTED REFERENCE MATERIALS . . . . .	147
Section I. SAFETY: Management-Supervisor-Worker Responsibilities . . . . .	149
Section II. SAFETY: The Individual Worker . . . . .	159
Section III. SAFETY: Plant Design and General Operation . . . . .	167
Section IV. SAFETY: Chemicals - Gases . . . . .	173
Section V. SAFETY: Electricity . . . . .	177
Section VI. SAFETY: Fire and Explosion . . . . .	179
Section VII. SAFETY: Laboratory Operation . . . . .	181
Section VIII. SAFETY: Manholes and Traffic . . . . .	185
PART III - THE NATIONAL TRAINING AND OPERATIONAL TECHNOLOGY CENTER AND SELECTED INFORMATION SOURCES . . . . .	187



PART I

Discussion and Learning Resources

SECTION I

**SAFETY: Management-Supervisor-Worker Responsibilities**

Safety for workers in wastewater treatment systems is a responsibility shared by management, supervisors, and workers. It is expected that individual workers will bring to their jobs positive attitudes regarding the importance of safety. Seldom will a new employee, even one who is generally concerned about safety, be aware of the many hazards related to work in wastewater treatment systems. Worker attitudes and behaviors are affected by knowledge about safety. The attitudes of management and supervisors toward safety are equally important.

Managers and supervisors must assume responsibility to develop safety education programs to meet the needs of their workers. They must open and use effective channels of communication between themselves and their employees. They must provide funds for safety education materials. They must provide on-the-job time for employees to learn more about safety needs and practices appropriate to their work. They must designate someone responsible to both management and workers for safety programs. They should develop, with input from workers, a variety of safety education strategies that will result in an increasingly safe workplace.

One result of a good safety education program is improved worker morale. He becomes motivated to take responsibility for his safety and for those with whom he works. He sees himself as an important part of the worker-supervisor-administration team concerned with all aspects of plant or system-wide safety.

Fortunately a large number of excellent teaching-learning materials are available that examine general aspects of safety such as motivation of workers, worker morale, roles of supervisors, roles of management and safety education programs. This section suggests a few learning resources that may be useful in this area of concern. The section of the publication citing abstracted reference materials (Part II) identifies many films, slide-tape presentations, and print materials that are available.

Learning Resource #1

"Why a Safety Program Works"

12 minutes

Water Pollution Control Federation

3900 Wisconsin Avenue

Washington, DC 20016

Good explanatory narration accompanies the 27 slides that deal with the ideas listed below. The material is designed to show management and supervisors, in broad general terms, that a safety program is a sound investment with excellent pay-back.

Slide number	Material presented in slide
1	Caption - "Why a Safety Program"
2	Wastewater system injury frequency rates compared with others.
3	Injured worker in hospital bed
4	Dollar costs
5	Injured worker in cave-in
6	Caption - "Safety is Efficiency"
7	Man surrounded by questions
8	Caption - "Safety is Knowledge"
9	News headline "Cave-in Kills 2"
10	Caption - "Safety is Good Public Relations"
11	Injured worker presenting bills to manager.
12	Caption - "Safety is Cost Control"
13	Injured employee and applicant in office waiting room.
14	Caption - "Safety is Good Employee Relations"
15	Listed results of good safety management
16	What is Your excuse?
17	Not enough time
18	Delegate and support safety responsibility
19	Injuries result in lost time
20	Results of good safety program
21	How to start a safety program
22	Role of safety consultants
23	Cost of safety program
24	Cost of accidents and related expenses
25	Man fishing in polluted stream
26	Man fishing in clean stream
27	The end

Learning Resource #2  
"Safety Program Guide"  
20 minutes

Water Pollution Control Federation  
3900 Wisconsin Avenue  
Washington, DC 20016

---

Good explanatory narration clarifies the ideas presented in the 39 slides listed below. The material offers specific suggestions as to how a safety program can be organized. Responsibility and roles to be assumed by managers and supervisors are illustrated.

<u>Slide number</u>	<u>Material presented in slide</u>
1	Caption - "Safety Program Guide"
2	Men developing safety policy
3	Publicizing safety policy
4	Workers reading safety policy
5	Bell Telephone Co. (model) safety policy
6	Manager handing worker job order
7	Manager wearing seat belt
8	Manager speaking for safety
9	Boss gets what he wants
10	Designating safety programs responsibility
11	Management safety committee
12	Work of safety committee
13	Employee - supervisor safety committee
14	Accident report form
15	Reason for accident
16	Accident record-keeping
17	U.S.A. Standard Institute
18	Injury frequency rate
19	Injury severity rate
20	Injured worker and investigator
21	Investigating accident cause
22	Unsafe acts, unsafe conditions
23	Protective device
24	Safety rules
25	Safety goggles
26	Safe work procedures
27	Learning on job
28	Off-hours management sponsored course
29	Safety meetings on company time
30	First-aid training
31	What to do when breathing stops
32	How to stop arterial bleeding
33	Treatment for shock
34	Important first-aid
35	Role of supervisors
36	Safety promotion
37	Factors promoting safety
38	Role of management
39	The end

Learning Resource #3  
Safety in Wastewater Works  
Water Pollution Control Federation  
3900 Wisconsin Avenue  
Washington, DC 20016

---

This 67 page pamphlet published in 1975 provides an excellent basic overview of the various aspects of safety that need to be considered by managers/supervisors and on-line workers in wastewater treatment systems.

The following Table of Contents identifies the many areas of concern that need to be included in a comprehensive safety education program.

TABLE OF CONTENTS

1. INTRODUCTION.....	1
2. RESPONSIBILITIES AND SAFETY PROGRAMS.....	4
2.1 Management Responsibilities.....	4
2.11 Employee Selection.....	5
2.12 Employee Training.....	6
2.13 Safety Committees.....	6
2.2 Operational and Maintenance Responsibilities.....	6
2.3 Reporting and Investigating Accidents and Illnesses.....	7
2.31 Reporting and Records.....	7
2.32 Investigation.....	8
2.4 Prevention of Injuries and Illnesses.....	10
2.41 Housekeeping.....	10
2.42 Illumination.....	10
2.43 Sanitation.....	10
2.44 Medical Services, First Aid, and Personal Protection Equipment.....	11
2.45 Mobile Equipment.....	11
2.46 Electrical and Power Generating Equipment.....	11
2.47 Safety Correction Methods.....	11
2.5 Security.....	12
2.51 General Security.....	12
2.52 Unauthorized Plant Entry.....	12
2.53 Sewer System Protection.....	12
2.54 Warning Devices.....	12
3. SAFETY IN OPERATIONS.....	13
3.1 Safety Work Rules and Procedures.....	13
3.2 Wastewater Facilities.....	13
3.21 Sewers.....	13
3.22 Wet and Dry Wells.....	16
3.23 Pumping Stations.....	18
3.24 Grit Chambers.....	18
3.25 Screens and Comminutors.....	19
3.26 Clarification and Aeration Facilities.....	19

3.27	Advanced Wastewater Treatment (Tertiary).....	20
3.28	Disinfection.....	20
3.29	Chemical Treatment of Sludge and Wastewater.....	22
3.30	Sludge Handling and Disposal.....	22
3.31	Lagoons and Ponds.....	24
3.32	Sampling.....	24
3.33	Radiological Hazards.....	25
3.34	Laboratory Operations.....	25
3.35	Buildings and Grounds.....	26
4.	SAFETY IN MAINTENANCE.....	28
4.1	General.....	28
4.2	Isolating Equipment.....	29
4.3	Electrical.....	30
4.301	General Rules.....	30
4.302	Working in Pairs on Energized Equipment.....	31
4.303	"Holding" and Locking out Electrical Circuits.....	31
4.304	Grounding Lines and Busses.....	31
4.305	Backfeed.....	31
4.306	Grounding of Portable Electrical Tools.....	31
4.307	Live Busses and Specialized Locations.....	31
4.308	Neutral Grounding.....	32
4.309	Metallic Objects in Work Area.....	32
4.310	Explosion-Proof Equipment.....	32
4.311	Current Transformers.....	32
4.312	High Voltage Equipment.....	32
4.4	Mechanical.....	33
4.41	General.....	33
4.42	Use of Lifting Equipment.....	33
4.43	Fork Lift Trucks.....	33
4.44	Material Handling.....	34
4.45	Engine Generators.....	34
4.46	Welding.....	34
4.47	Small Hand Tools.....	35
4.48	Air Powered Tools.....	36
4.49	Powder Actuated Tools.....	37
4.5	Housekeeping.....	37
5.	OXYGEN DEFICIENCY AND NOXIOUS GASES AND VAPORS.....	39
5.1	Public Utilities Practices.....	39
5.2	Hazardous Locations.....	40
5.3	Definition of Terms.....	40
5.31	Distinction Between Gas and Vapor.....	40
5.32	Specific Gravity or Vapor Density.....	40
5.33	Noxious Gases and Vapors.....	40
5.34	Explosive Limits and Explosive Range.....	41
5.35	Sewer Gas.....	42
5.36	Sludge Gas.....	42
5.4	Gases Encountered in Wastewater Works.....	42
5.41	Ammonia (NH <sub>3</sub> ), Class 2.....	42
5.42	Sulfur Dioxide (SO <sub>2</sub> ), Class 2.....	42
5.43	Acetylene (C <sub>2</sub> H <sub>2</sub> ), Class 1A.....	43
5.44	Ethane (C <sub>2</sub> H <sub>6</sub> ), Class 1A.....	43
5.45	Other Gases.....	43
5.46	Solvents.....	43

6. SAFETY EQUIPMENT.....	46
6.1 Description and Use of Oxygen Deficiency and Gas Detection Equipment.....	46
6.11 Oxygen Deficiency Indicator.....	46
6.111 Direct Reading Oxygen Indicators.....	47
6.12 Hydrogen Sulfide.....	47
6.121 Lead Acetate Paper.....	47
6.122 Hydrogen Sulfide Ampoules.....	47
6.123 Hydrogen Sulfide Detector.....	47
6.13 Combustible Gas Indicators.....	47
6.14 Carbon Monoxide.....	48
6.141 Indicator.....	48
6.142 Detector (Hoolomite).....	48
6.143 Indicating Tube.....	48
6.15 Chlorine Detection.....	48
6.16 Sulfur Dioxide Detector.....	48
6.17 Universal Test Kits.....	49
6.2 Respiratory Protective Apparatus.....	49
6.21 Canister Gas Mask.....	49
6.22 Universal Canister Gas Mask.....	50
6.23 Supplied Air Hose Mask.....	51
6.24 Compressed Air Mask.....	51
6.3 Safety Harness.....	51
6.4 Portable Lighting Equipment.....	52
6.5 Nonsparking Tools.....	52
6.6 Portable Blowers.....	52
6.7 Signs.....	52
6.8 Inhalators.....	53
7. SAFE PRACTICES.....	54
7.1 Fire Prevention.....	54
7.2 Sludge Gas Leak Investigations.....	54
7.3 Operation of Sludge Digestion Tanks.....	54
7.4 Operation of Sludge Pumps.....	55
7.5 Purging Gas Holders.....	55
7.6 Handling Chlorine Leaks.....	56
7.7 Enforcement of Local Ordinances.....	56
8. RESCUE PRACTICES.....	57
8.1 Gas Rescue Technique.....	57
8.2 Chlorine Poisoning.....	57
8.3 Resuscitation.....	57
9. APPENDIX.....	58
9.1 Accident Report.....	58
9.2 Accident Analysis and Disability Tabulation.....	60
9.3 Accident Analysis.....	61
9.4 Supervisor Accident Report.....	62
9.5 Report of Investigation.....	63
9.6 Safety Inspector's Investigation.....	64
9.7 Unsafe Condition Report.....	65
9.8 First Report of Injury to Dispatcher.....	66



10. REFERENCES.....

An example of the kinds of useful material found in this manual is found later in this publication in the section on safety related to electrical usage.

11  
217

Learning Resource #4

Plant Safety

Technical Publishing Company (TPC)

1301 So. Grove Avenue

Barrington, IL 60010

This trainee's guide includes material that covers many of the safety concerns of supervisors and workers in wastewater treatment plants. The material is presented in a form designed for self-study. Excellent suggestions are given to the trainee concerning how he can gain the most from the course of study. Helpful ideas regarding good study habits and improving reading skills are presented.

The 10 lessons (each 1½ - 2½ hours in length) contained in the guide are outlined below. All of the lessons are appropriate to the safety education needs of workers in wastewater treatment plants.

Lesson seven on Electrical Safety is reproduced, with permission, later in this publication in the section on safety related to electrical usage. That example indicates the format and usefulness of the TPC Training System materials.

TPC TRAINING SYSTEMS

PLANT SAFETY

Lesson 1 - MAKING SAFETY WORK - Responsibility for safety; Accidents and injuries; Hazards; Kinds of accidents and injuries; The accident chain; Interrupting the chain; The built-in hazards; Avoiding built-in hazards; The built-on hazards; Avoiding built-on hazards; Human influences on safety.

Lesson 2 - WORK AREA SAFETY - Safety where you work; Built-in hazards; Safety near moving machinery; Safety on roofs; Safety in extreme heat; Minimizing dangers in hot areas; Safety in enclosed areas; Safety in excavations and tunnels; Flammability and toxicity problems; Chemical safety; Utility maintenance safety; Exposure to penetrating radiation.

Lesson 3 - SAFE MATERIAL HANDLING - Handling materials; Material handling injuries; Cause of material handling injuries; Avoiding injuries; Manual lifting, carrying, setting; How to lift, carry, and set; Built-in material hazards; Team handling; Handling special shapes and sizes; Hand tools and accessories; Handtrucks, dollies, wheelbarrows; Power-assisted handtrucks; Powered industrial trucks; Industrial truck safety; Conveyors, chutes, troughs; Hoists and cranes; Receiving and storage; Storage safety; Chemicals and flammable liquids; Material handling and lighting.

Lesson 4 - TOOL AND EQUIPMENT SAFETY - Hand tools; Built-in hazards; Powered hand tools; Pneumatic tools; Tool bit safety; Gasoline-powered tools; Explosive powder tools; Portable ladders; Stepladders; Safe ladder practices; Fixed ladders; Ladder inspection; Scaffolds and working platforms.

Lesson 5 - MACHINERY SAFEGUARDS - Machine guards prevent accidents; Hazardous motions; Locking out power; Blocking moving parts; Point of operation machinery guarding; Barrier and enclosure guards; Controls and operating safety; Mechanical power transmission guards.

Lesson 6 - PERSONAL PROTECTION - Personal protective equipment; Head protection; Eye protection; Face protection; Ear protection; Foot protection; Respiratory protection; Processing air for respiration; Safety harnesses and lifelines; Gloves and special work clothing.

Lesson 7 - ELECTRICAL SAFETY - The nature of electricity; Electrical injuries; Preventing electrical accidents; Overcurrent protection; Grounding; Protection against ground faults; Hazardous locations; Portable power tool safety; Double-insulated tools; Electrical safety.

Lesson 8 - HAZARDOUS MATERIALS AND OPERATIONS - Material hazards and injuries; Hazardous liquids; Using solvents; Packaged materials; Normal exposures; Sudden, unexpected exposures; Dealing with unexpected exposure; Noise hazards; Welding hazards; Welding safety.

Lesson 9 - FIRE PREVENTION - How fires start; Fire and explosion hazards; Preventing fires; The four classes of fires; Fire-fighting agents; Portable fire extinguishers; Firehose handling and maintenance; How to use portable fire extinguishers.

Lesson 10 - UNDERSTANDING OSHA - What is OSHA; The purpose of OSHA; OSHA standards; Inspections by OSHA; Inspection results; The act and your job; Recordkeeping requirements; OSHA is "standardizing" safety; Safety and health institute (NIOSH); Important points relating to OSHA and you.

Learning Resources #5

"Safety for the Collection System Worker"

Chapter, IX, Operation and Maintenance of Wastewater Collection Systems: A Field Study Training Program, 1976

Kerri, Kenneth D. and Brady, John, Editors  
California State University, Sacramento  
6000 "J" Street  
Sacramento, CA 95819

This chapter of 63 pages provides a broad overview of the safety concerns important in wastewater collection systems. It identifies areas to be included in a safety education program and presents material designed to improve worker attitudes toward the knowledge about safety. As such it should be helpful to administrators-supervisors as they plan for safety education and also to those who do the routine work in the system.

Glenn Davis, author of this chapter, identifies its objectives as follows:

After completion of Chapter 9 you should be able to do the following:

1. Describe the importance of safe procedures and practices for the collection system worker.
2. Identify potential and existing hazards.
3. Test the atmospheres in confined spaces for oxygen deficiency, poisonous or toxic conditions, and explosive levels.
4. Properly ventilate confined spaces.
5. Drive safely.
6. Determine when shoring is required.
7. Recognize potential causes of cave-ins.
8. Outline procedures for safely entering confined spaces.
9. Route traffic around work areas in or near streets.
10. Prepare and present effective safety programs.
11. Extinguish fires.
12. Provide emergency first aid treatment.

The detailed material designed to accomplish the objectives listed above are shown in the following Table of Contents.

TABLE OF CONTENTS

CHAPTER 9. SAFETY FOR THE COLLECTION SYSTEM WORKER

by Glenn Davis

	<u>Page</u>
9.0 SAFETY.....	9-1
9.01 Survival.....	9-1
9.02 Professionalism.....	9-1
9.03 High Hazards.....	9-2
9.04 Other Industries by Comparison.....	9-5
9.05 A Definition of Safety.....	9-6
9.06 Hazards.....	9-6
9.07 Approved Procedures and Equipment.....	9-7
9.1 INFECTION AND INFECTIOUS DISEASES.....	9-8

9.2	GAS HAZARDS.....	9-11
	9.21 Poisonous or Toxic Gases.....	9-11
	9.22 Explosive Atmospheres.....	9-12
	9.23 Oxygen Deficient Atmospheres.....	9-14
	9.24 Detection of Hazardous Gases.....	9-15
	9.25 Protection Against Hazardous Gases.....	9-19
	9.26 Summary.....	9-19
9.3	DRIVING SAFETY = DEFENSIVE DRIVING.....	9-22
	9.31 Driving Safety.....	9-23
	9.32 Traffic Control.....	9-24
9.4	EXCAVATIONS AND TRENCH SHORING.....	9-29
	9.41 Causes of Cave-Ins.....	9-29
	9.42 Shoring Requirements.....	9-30
	9.43 Protection of Shoring.....	9-32
	9.44 Cooperation Between Workers and Supervisor.....	9-32
9.5	MANHOLES AND OTHER CONFINED SPACES.....	9-33
	9.51 Types of Hazards.....	9-33
	9.52 Safety Procedures.....	9-34
	9.53 Safety Harness.....	9-41
	9.54 Summary of Manhole Safety Steps.....	9-41
9.6	SAFETY ON THE JOB.....	9-44
	9.61 Construction.....	9-45
	9.62 Inspection.....	9-46
	9.63 Sewer Cleaning.....	9-46
	9.64 Lift Stations.....	9-47
9.7	ADDITIONAL JOB HAZARDS.....	9-51
	9.71 Radiological.....	9-51
	9.72 Electrical.....	9-51
	9.73 Noise.....	9-52
9.8	SAFETY ACTION.....	9-53
	9.81 Fire Fighting.....	9-53
	9.82 First Aid.....	9-54
9.9	SAFETY TRAINING PROGRAMS.....	9-57
	9.91 Safety Meetings.....	9-58
	9.92 Tail Gate Safety Sessions.....	9-59
	9.921 Formal Tail Gate Sessions.....	9-59
	9.922 Informal Tail Gate Sessions.....	9-60
	9.923 Scheduling Tail Gate Safety Sessions.....	9-62
	9.93 Safety Summary.....	9-62

9.10 RECORDS..... 9-63

9.11 ADDITIONAL READING..... 9-63

In this chapter, Mr. Davis identifies a series of questions that are answered in the textual material. These questions, reproduced below, deal with many of the important safety concerns of personnel working in wastewater collection systems. The reader will note that the numbering system of the questions parallels the numbering system used in the table of contents of the chapter.

- 9.0A. What is the First Law of Life for the collection system worker?
  - B. What skill most marks the professionalism of a collection system worker?
  - C. Why is a safe performance an important consideration for promotion?
  - D. How safe is the job of a collection system worker?
  - E. How can the poor safety statistics for collection system workers be improved?
  - F. What is safety?
- 9.1A. How can you determine if you have contacted a disease from your work?
  - B. How can the collection system worker be protected from pathogenic organisms?
- 9.2A. Why do gases found in sewers tend to be found in low level or underground structures?
  - B. What are the three basic classes of hazardous atmosphere?
  - C. What are some toxic gases that might find their way into a wastewater collection system?
  - D. Why is hydrogen sulphide especially dangerous?
  - E. What are possible ignition sources for an explosive atmosphere?
  - F. How can you try to locate possible sources of potential explosive hazards in your collection system?
  - G. Why is an oxygen deficient atmosphere hazardous?
  - H. Why should you attempt to measure the level of oxygen in a manhole before or immediately after the manhole cover is removed?
  - I. What would you do if you were required to work in an oxygen deficient atmosphere?
  - J. How can hydrogen sulphide be detected?
  - K. Prepare a list of dangerous gases encountered in wastewater collection systems and indicate how you would test for each gas.
- 9.3A. What is defensive driving?
  - B. Where should the truck be parked when working in traffic?
  - C. How can other people be warned that a truck is backing up?
  - D. Why are safety cones placed around a parked vehicle?
  - E. How can traffic be directed around a work site?
  - F. Where can you obtain additional training and guidance for the proper methods to route traffic around a job site?
- 9.4A. What is the purpose of shoring?
  - B. What causes excavation or trench sidewall cave-ins?
  - C. What is OSHA?
  - D. Can cave-ins be caused by vehicles and equipment operating near a recently excavated trench?
  - E. Why must care be taken when operating equipment near shoring?

- 9.5A. What kinds of hazards may be encountered when working in or around manholes?
- B. List the order for testing for combustible or toxic gases.
  - C. What do you do if the atmosphere in a confined space is still hazardous from a toxic gas or an oxygen deficiency after ventilation?
  - D. Even with a self contained breathing apparatus, you should never enter a confined space deemed hazardous because of combustible gas mixtures. True or False?
  - E. How long should a portable blower operate in a work area prior to permitting a worker to enter a confined space?
  - F. At the first signs of what kinds of feeling should a worker immediately leave a confined space and get into the open air as soon as possible.
- 9.6A. List at least five safety hazards around construction sites.
- B. What are the differences in safety hazards an inspector must watch out for between inspecting old and new wastewater collection systems?
  - C. What precautions must be taken when cleaning sewers?
- 9.7A. List three additional job hazards to collection system workers.
- B. Where do radioactive isotopes come from that get into wastewater sewers?
  - C. Electrical shock can occur under what kinds of conditions?
  - D. What safety precautions should be taken when electrical circuits and equipment are taken out of service for repair?
  - E. What sources of noises can cause permanent ear damage?
- 9.8A. What different types of materials can cause different types or classes of fires?
- B. How can each class or type of fire be extinguished?
  - C. How often should fire fighting equipment and extinguishers be inspected?
  - D. What would you do if a fellow worker badly cut his hand?
  - E. What would you do if you broke your arm?
- 9.9A. What types of meetings can be used for safety training programs?
- B. What factors have to be considered to have an effective safety meeting?
  - C. What is a tail gate safety session?
  - D. What kinds of topics should be covered in any type of safety meeting?
  - E. What do you think is the key or secret to a good safety meeting of any type?

Mr. Davis' suggested answers to the questions found above are as follows:

- 9.0A. The First Law of Life is Safety and Survival.
- B. The skill that most marks the professionalism of a collection system worker is the ability to carry out work assignments safely.
  - C. A reputation for a safe performance is an important professional characteristic. A safe performance will help you motivate, train and lead others which are supervisor characteristics that gain promotion.
  - D. The job of a collection system worker has many hazards for the careless worker. If you learn and practice safe procedures, your chances of injury can be minimized.
  - E. Safety statistics for collection system workers can be improved if everyone develops a desire to understand what causes accidents and how they can be prevented, coupled with a strong desire to work safely.

- F. Safety has been defined as "a means of thinking far enough ahead to do the job at hand with proper tools at the proper time and in the proper manner."
- 9.1A. The best indication that you might have contacted a disease from your work is that you don't feel well. If you have headaches, feel sick to your stomach, have diarrhea, feel feverish or sleepy, you should see your physician.
- B. The collection system worker must be constantly aware of the threat from pathogenic organisms. You can protect yourself by personal cleanliness, such as washing your hands, wearing gloves and proper clothing, and changing clothes before going home. Tetanus and polio immunizations are a must.
- 9.2A. Gases found in sewers usually concentrate in low level or underground structures because many of the gases are heavier than air and are produced in the low levels in deposits and slimes.
- B. The three basic classes of hazardous atmospheres are:
1. Poisonous or toxic
  2. Explosive
  3. Oxygen deficient
- C. Some toxic gases that might find their way into a wastewater collection system include carbon monoxide, ammonia, chlorine, and hydrogen sulfide ( $H_2S$ ).
- D. Hydrogen sulfide is especially dangerous because:
1. It is generated from the anaerobic decomposition of organic matter in collection lines,
  2. It is heavier than air, and
  3. Our noses tend to lose their sensitivity to hydrogen sulfide and become unreliable detectors.
- E. Possible ignition sources for an explosive atmosphere include a spark from an automobile, an improper tool, a shoe nail, a cigarette, or an open flame.
- F. Your local fire department and gas company personnel can be helpful in identifying potential dischargers of hazardous combustible materials.
- G. A shortage of oxygen to the worker produces a shortage of oxygen to the brain, which in turn makes the worker less alert to dangers that may result in death.
- H. Try to measure the oxygen level in manholes before any ventilation occurs by removing the manhole cover so existing conditions can be measured and expected conditions for the workers can be measured too.
- I. Before working in an oxygen deficient atmosphere, ventilate the space and wear an oxygen mask if necessary.
- J. Hydrogen sulfide can be detected by the nose, but the nose becomes tired of smelling hydrogen sulfide and is not reliable. Hydrogen sulfide indicating badges or  $H_2S$  ampoules are the most reliable methods.

K. Dangerous Gases

Method of Detection

Oxygen,  $O_2$   
 Gasoline Vapor  
 Carbon Monoxide, CO  
 Hydrogen,  $H_2$   
 Methane,  $CH_4$   
 Hydrogen Sulfide,  $H_2S$   
 Carbon Dioxide,  $CO_2$   
 Nitrogen,  $N_2$   
 Ethane,  $C_2H_6$   
 Chlorine,  $Cl_2$

Oxygen deficiency indicator  
 Combustible gas indicator  
 CO ampoules  
 Combustible gas indicator  
 Combustible gas indicator  
 $H_2S$  ampoules  
 Oxygen deficiency indicator  
 Oxygen deficiency indicator  
 Combustible gas indicator  
 Odor



- 9.3A. Defensive driving is careful driving to avoid accidents, while realizing all the special hazards that exist on the highway regardless of who has the legal right of way.
- B. When working in traffic, you should always park the truck with brakes set and roof light flashing in such a position that careless traffic must "plow" into the truck before it can "run over" the crew working in or around a manhole.
  - C. People can be warned of a truck backing up by having a passenger get out and direct the driver and by having the truck equipped with bells, horns or other types of alarms that sound off when the truck backs up.
  - D. Safety cones are placed around a vehicle to alert traffic of the location of the vehicle. When picking up traffic cones, look for tools not put away and hazards (children, toys) that might be run over when leaving the job site.
  - E. Traffic can be directed around a work site by use of safety cones, barricades, signs and flagmen.
  - F. Additional training and guidance regarding the proper methods to route traffic around a job site can be obtained by consulting the police or highway patrol.
- 9.4A. Shoring is used to prevent cave-ins from excavations that could bury and kill workers.
- B. Excavation or trench sidewall cave-ins can be caused by:
    1. Failure to shore, possibly because of a deliberate short cut to save time or expense.
    2. Inadequate shoring because of lack of knowledge or misjudgement of soil stability.
    3. Failure of shoring because of unsuspected bank loading caused by traffic or machinery vibration.
    4. Inadequate shoring maintenance or replacement after changes occur in the soils surrounding an excavation as a result of construction work or heavy rains.
    5. Failure of shoring material.
    6. Placement of spoil too near the trench edge.
    7. Trench wall undercutting.
  - C. OSHA stands for Occupational Safety and Health Act of 1970. OSHA standards describe measures that must be taken to provide workers with a safe environment and to protect them from accidents.
  - D. Yes. Special shoring requirements are necessary when vehicles or other equipment must operate near a recently excavated trench to prevent cave-ins.
  - E. Care must be taken when operating equipment near shoring to protect the bracing and shoring from damage by the equipment.
- 9.5A. Hazards that may be encountered when working in and around manholes include
1. Traffic. Both vehicular and pedestrian.
  2. Adverse atmospheres. Flammable and poisonous gases or a deficiency of oxygen.
  3. Physical and structural conditions. Loose or corroded rungs or dangerous liquids.
- B. Tests for combustible or toxic gases are to be conducted in the following order:
    1. Explosimeter Test for explosive conditions.
    2. Combustible gas-oxygen deficiency. Also test for oxygen deficiency.
    3. Hydrogen sulfide instrument or detector badge. Test for toxic gases.

- C. If the atmosphere in a confined space is still hazardous from a toxic gas or an oxygen deficiency after ventilation, contact your work station or supervisor immediately. If you must enter the confined space, wear a self-contained breathing unit or apparatus and be sure someone is standing by with another self-contained breathing unit or apparatus for rescue operations if necessary.
  - D. True. Never enter a confined space deemed hazardous because of combustible gas mixtures.
  - E. A portable blower should operate a minimum of 20 minutes in a work area prior to permitting a worker to enter a confined space.
  - F. At the first sign of nausea or loss of alertness, the worker should immediately get into the open air. The topside worker should be especially alert for problems because the worker in the confined space may not notice them.
- 9.6A. Safety hazards around construction sites include:

- 1. Children,
- 2. Traffic,
- 3. Construction equipment,
- 4. Drilling and blasting of rocks,
- 5. Trench and excavation cave-ins,
- 6. Underground utilities,
- 7. Overhead electrical lines.

B. An inspector must watch out for similar safety hazards when inspecting either old or new wastewater collection systems. Construction equipment and conditions may be an additional hazard for new systems. Gases found in sewers may be a more likely hazard around old wastewater collection systems.

C. When cleaning sewers, be careful:

- 1. Not to flood basements or homes,
- 2. To route traffic safely around job site,
- 3. To test for gases found in sewers, provide adequate ventilation and wear safety equipment before entering a manhole or confined space.

9.7A. Three additional job hazards to collection system workers include:

- 1. Radiological,
- 2. Electrical,
- 3. Noise.

B. Radioactive isotopes that enter wastewater collection systems come from hospitals, research labs and various industries.

C. Electrical shock can occur especially where the hazard of a ground and moisture are present.

D. Safety locks must be placed on all electrical circuits or equipment out of service for repair. Tags must indicate date of lock out and signature of person responsible for lock out.

E. Loud noises (over 85 decibels) from gas engines, air hammers, and other equipment can cause permanent ear damage.

9.8A. The different types of materials that can cause fires are ordinary combustibles, flammable liquids, electricity and metals.

B. The different types or classes of fires can be extinguished by the following methods:

<u>Class</u>	<u>Method of Extinguishing</u>
A	Water
B	Foam, carbon dioxide, dry chemicals
C	Carbon dioxide, dry chemicals
D	Carbon dioxide

- C. Fire fighting equipment and extinguishers should be inspected on a regular basis such as every 3 or 6 months and after each use.
  - D. For a badly cut hand, immediately cover wound with cleanest available cloth and try to stop bleeding. Call for medical help.
  - E. For a broken arm, try to support arm so it won't move and get to a doctor.
- 9.9A. Several types of meetings may be used in safety training programs. They can range from highly organized meetings to tail gate safety sessions to informal get togethers or bull sessions.
- B. Effective safety meetings result when:
    - 1. Everyone understands the basic safety concepts,
    - 2. Everyone participates and accepts their personal responsibility,
    - 3. Adequate safety equipment is available for demonstration and use,
    - 4. Everyone realizes that safety is a continuing learning and re-learning process,
    - 5. Accidents are studied and reviewed,
    - 6. Every appropriate detail of work is a subject for a safety discussion.
  - C. Tail gate safety sessions consist of a small group of workers gathered around the tail gate of a pickup or truck to discuss safety.
  - D. Topics covered in safety meetings should be simple and refer to subjects that the crew is involved in every day or a new or special job that the crew has been assigned.
  - E. Whatever you reply is the correct answer because it is your opinion.

The chapter also includes a list of general questions regarding safety of workers in wastewater treatment systems. It is suggested that personnel involved in the safety education program should develop written answers, in a safety notebook, to questions such as these.

1. Why is safety important?
2. How can the poor safety record of collection system workers in the past be improved?
3. Why is the job of a collection system worker hazardous?
4. How can collection system workers protect their health?
5. Why is the collection system worker confronted with gas hazards?
6. How can you protect yourself and your crew from gas hazards?
7. How can you avoid driving accidents?
8. Why have deep excavations killed so many workers?
9. How can you as a collection system worker protect yourself and your fellow workers from cave-ins?
10. What kinds of hazards are encountered by collection system workers in manholes?
11. What precautions would you take before entering a manhole?
12. What would you do if you discovered an explosive atmosphere in a manhole?
13. What kinds of hazards exist for children around a job site?
14. What would you do if you were an inspector on a construction job and observed both an unsafe condition and an unsafe act?

Learning Resource #6

Team Up For Safety in '81

The Industrial Commission of Ohio, Division of Safety and Hygiene  
in cooperation with The Society of Ohio Safety Engineers.  
246 North High Street  
P.O. Box 16512  
Columbus, OH 43215

-----  
This 47 page discussion guide provides the discussion leader with background material on the 15 topics listed below in the safety leader's check list. Reproduced also are suggestions for use of the discussion guide and finally the material dealing with preventing sprains and strains;

THE INDUSTRIAL COMMISSION  
OF OHIO  
Division of Safety and Hygiene

PATTERN FOR PROGRESS

Safety Leader's Check List

MONTH	TOPIC	5-MINUTE TALK	EMPLOYEE HANDOUT	STREAMERS UP	POSTERS UP
JANUARY	SLIPS				
FEBRUARY	ATTITUDE				
MARCH	ELECTRICAL HAZARDS				
APRIL	GOOD HOUSEKEEPING				
MAY	VACATION SAFETY				
JUNE	POWERED TOOLS				
JULY	BACK INJURIES				
AUGUST	MACHINE GUARDS				
SEPTEMBER	EYE PROTECTION				
OCTOBER	FIRE PREVENTION				
NOVEMBER	PINCH POINTS				
DECEMBER	PROTECTIVE EQUIPMENT				
ALTERNATE	OFFICE SAFETY				
ALTERNATE	INDUSTRIAL TRUCKS				
ALTERNATE	SKIN IRRITANTS				

### USE OF THE DISCUSSION GUIDE

This series of safety talks has been prepared for use by discussion leaders and covers many areas of accident prevention that apply to your workplace. The following are some suggestions to help you prepare for your safety meetings:

1. Set specific times and dates for your safety meetings. Publicize your meetings so that everyone involved will be sure to attend.
2. Review each month's topic in advance and become familiar with its content. You should be able to present the material in your own words and lead the discussion without reading the guide book.
3. Seating space is not absolutely necessary, but arrangements should be made so that those attending can easily see and hear the presentation.
4. Gather ahead of time whatever material and props you will need at the meeting. Try to use equipment used in your workplace to demonstrate your points. For example, bring protective eye wear to the eye safety discussion or use an actual fire extinguisher to demonstrate its use.

### DURING THE MEETING

1. Again, give the safety talk in your own words. Use the guide book merely as a reference. Make notes about safety points that pertain to your workplace so you can cover them.
2. The whole purpose of a safety meeting is to initiate discussion of safety problems among employees. Encourage participants to cite hazards they find on the job and to suggest corrections that could be made. Ask for specific comments that will improve the safety of your area.
3. Don't let the meeting turn into a gripe session about unrelated topics. As the discussion leader, it is your job to make sure the topic is safety. To allow discussion of other topics during the meeting wastes time and could destroy the effectiveness of your safety program.

### KNOW YOUR LIMIT—PREVENT SPRAINS AND STRAINS

July

Athletes in training know their abilities and their limitations, because going beyond what is physically possible leads to strained and sprained muscles and ligaments. Those injuries could put the athlete out of competition.

Your job may include lifting and carrying heavy material. You should be aware of how much you can do in order to avoid an injury that could put you on the bench for a while.

Sprains and strains can occur anywhere--in the workplace, during recreational and sporting events, and at home.

In order to understand these injuries, it is necessary to understand a little about the makeup of the human body. Now don't get too uptight about that; we aren't going to make physicians out of you.

The human body is designed with some very sound mechanical principles. It is a combination of a number of systems that complement each other. Today we are going to discuss just two of these--the skeletal and muscular systems. Because they are so closely related, physicians refer to them as the musculo-skeletal system.

The skeletal system consists of the 204 bones of the body. Don't worry, I'm not going to name all 204. The bones make up the framework of the body and determine its size. The skeletal system varies from individual to individual. Some people have short thick bones; others have long, rather thin bones. There are a few people who may be missing one bone or another, but in general the number of bones is 204.

This solid framework keeps the human body from being a blob, such as a jellyfish. The skeletal system acts as a support for the other systems in the body. It also serves as an anchor for the muscular system.

The muscular system is made up of all the muscles of the body. Muscles are the motors that move the bones and make it possible for the body to move and stand erect. There are many different muscles, but today we are going to discuss those that are most commonly sprained and strained.

When doctors talk of sprains and strains they speak of ligaments and tendons.

Ligaments are tough fibrous cord-like materials that connect bone to bone. Ligaments most commonly are associated with joints, with one bone connecting to another--at the elbow where the forearm is joined to the upperarm, at the knee, at the shoulder, at the wrist, at the hip. Wherever there is a joint you'll find ligaments. Tendons are of similar material, but their function is to attach muscle to bone.

Muscles of motion are almost always found in pairs and usually cross the joints of bones. When one muscle contracts to move a part of the body, its partner relaxes. You most likely have at one time or another experienced a cramp in your leg or foot. This occurs when the body is confused and contracts both muscles at the same time. Because they are balanced, each tries to overcome the other's resistance without success and this "ties you up in knots."

This background information will help you understand why sprains and strains happen. You probably all know about sprained ankles and strained elbows, but the back is an area where strains and sprains often occur. Back sprains and strains are also the most costly to the individual.

More than 24 bones make up the spine--seven in the neck area, 12 in the chest or trunk area, and five in the lower back. The bones are joined to each other by ligaments and muscles are attached for movement.

A strain occurs whenever a muscle is stretched beyond its limit. Muscles do a great deal of work. However, they must be conditioned if they are to perform in a given way. Professional athletes condition their muscles through rigorous training. We also must condition our muscles. A worker who is accustomed to manually handling a large number of pieces of material in a given workday can do so with ease. Those of us who have different duties would find it difficult to do that same amount of work without paying for it with aching muscles. If we should continue to do the work, however, we would soon be conditioned and be able to perform the job without pain.

However, even the conditioned athlete or worker cannot exceed the limitations of the muscles. When a muscle is stretched too much, the ligaments pull and sometimes even tear. Stretched ligaments and tendons are termed strains. A sprain is when tearing has occurred.

The industrial setting provides many opportunities for the occurrence of sprains and strains. The most common is material handling. We all handle material in one way or another. Even the office worker is involved with material handling when picking up a package, box or chair to move it.

Let's take a minute to consider all the operations in our area that might involve material handling and how they might cause a sprain or strain.

NOTE TO DISCUSSION LEADER:

Try to get employees to tell you about potential sprain and strain operations in their areas. Do not argue the point or dismiss any item; just list them.

Material handling strains and sprains often are caused by over exertion. You can see from the list we just made that we do have the potential for sprains and strains in our area.

Other movements can also cause sprains and strains--over reaching or extending a part of the body; reaching over something to pick up a load; or trying to reach a top shelf without using a proper stool or ladder. Can anyone give me an example of a strain or sprain case? It doesn't have to be work-related; remember these injuries also happen off the job.

NOTE TO DISCUSSION LEADER:

Try to get someone to tell about a sprain or strain injury. If necessary, tell of an injury yourself.

What can we do to minimize these injuries? Well, this meeting is a beginning. If we understand what causes sprains and strains, we are better equipped to prevent them. A few basic rules to remember are:

- Understand your limitations. Don't charge into a job cold. Warm up to it. Take a lesson from athletes; try to keep yourself in good condition and at your proper weight.
- Don't over-extend yourself--use a stepstool or a ladder when necessary.
- Lift with your legs, not with your back. Keep the load close. Don't twist your body while carrying a load.
- Be sure there are no slipping or tripping hazards in your work area or around your home. The sudden jerk caused by a slip or trip can cause a sprain or strain.

- Don't shy away from hard work because you fear a strain. Condition your body to do what is necessary.
- Look into ways to eliminate lifting and carrying or to keep it to a minimum. Is there a better way? Work smarter, not harder; it's easier and safer.

**NOTE TO DISCUSSION LEADER:**

If there have been sprain and strain accidents in your area, be prepared to discuss them with your employees. Listen to their ideas; they may have the answer you have been looking for.



Learning Resource #7  
"Safety in Water Utilities" by Julian Dyason  
Chapter 32 in Manual For Water Works Operators  
Southwest Section American Water Works Association  
Temple, TX 76501

---

In this chapter Mr. Dyason reviews the important role that must be assumed by management in setting up a safety program. He provides a list of responsibilities which are normally assigned to the person designated as safety director. The importance of supervisors and foremen is also stressed. The material cited below should be useful in planning or reviewing high level responsibilities for a safety education program.

#### SETTING UP THE PROGRAM

MANAGEMENT PARTICIPATION. Top management must take an active and interested part in the development and operation of a safety program. An executive's support can only be secured when he, himself, is convinced of the need of such a program. Conviction, on his part, will come to him only with full understanding of what his accident losses really are, how they affect efficiency, and what safety means in terms of production and personnel relationships.

If top management does not see the reasons for a sound and effective accident prevention program, then, no one else is likely to see them either. To start the program, then, it is essential that management issue a clear-but statement of policy for the guidance of all supervisors and employees. Such a statement should indicate management's viewpoint and should cover, in general, the basic elements. Furthermore, unless included in the statement of policy, the details of the program should be announced by management to the entire working force, through meetings, letters, or bulletins, foreman or bulletin board notices.

During the course of a year, top management should actively participate in the review of safety records. They should attend safety meetings on a regular basis, they should take personal action in the bad records of particular departments, they should periodically write letters for bulletin board posting, discussing the accident record in the operation and demonstrating management's interest and they, themselves, should set a good example by conforming with all safety regulations which apply to even the lowest person on the organizational chart.

In short then, if top management does not whole heartedly support the program, it has little chance of being effective.

SAFETY DIRECTOR. As a general "rule of thumb" in industry, full-time Safety Directors are usually hired in companies with over 400 employees. These persons will be charged with the entire responsibility of safety, of the implementation of the safety program and will answer only to top management. They will always be on a par with or ahead of all superintendents on the organizational chart. Their salaries should also be commensurate with this position on the management tree. For companies with less than 100 employees, they may employ their own full-time Safety Director; it is more frequent that the Safety Director is also a person who might be specifically charged with the responsibility for industrial relations or personnel or possibly is one of the vice-presidents of the company.

It is always best to give the safety responsibility to the highest possible ranking official. Such alignment gives the safety program the prestige and support necessary for success.

Where safety responsibility is delegated to an operating official, he assumes the responsibilities which would ordinarily belong to a Safety Director.

Some of the responsibilities of a Safety Director would include:

1. Complete responsibility for formulating, administering and making necessary changes in the accident prevention program.
2. Monthly or weekly reports on the status of safety to the person directly in charge of the particular department.
3. He should act in an advisory capacity in all matters pertaining to safety.
4. He should maintain an accident recording system that complies with the Federal Occupational Safety and Health Act.
5. He should personally investigate all serious accidents and make suggestions for corrective action to be taken by the supervisors to eliminate the accident causes.
6. He should participate in and supervise the training activities of all employees.
7. He should make personal inspections and supervise inspections by the foremen and supervisors for the purpose of discovering and correcting unsafe conditions or unsafe work practices before they cause accidents.
8. He should maintain outside professional contacts by which information may be exchanged with others and the program kept up to date.
9. He should stay abreast of the Occupational Safety and Health Act and its standards and make sure that they are being followed through in his organization.
10. He should initiate activities that will stimulate and maintain the interest of employees in safety.
11. He should use his insurance carrier to the fullest. Most insurance carriers have a safety or loss prevention department and this department's services are free to their insurance accounts.
12. He should set standards for safety equipment to be used by Company personnel.
13. He should recommend provisions for safety in plans and specifications of new buildings, new shops, pumping stations, etc.

Some Utility Companies have found it most beneficial to hire an outside Safety Consultant to conduct the accident prevention program. This plan can be most effective, but not without top management's support and participation. The outstanding advantage of this plan is economic. For an amount far less than would be paid to a full time employee, a company may receive experienced, professional services on a part-time basis.

If cooperation between the Company and the Safety Consultant is open and free, the program itself can also be most successful.

SUPERVISORS AND FOREMEN. The supervisors and foremen are the key in any safety program. To the worker, he is management. Most of what is thought up and planned by top management, high in the scale of authority, must sift through by way of the foremen, to the men and women running the machines, and doing the job. Safety must be so intimately related to each employee's temperament, his attitude toward his work and toward management, his idea of obedience and his sense of responsibility that the foreman is indispensable to good safety work, for his is the immediate contact and the immediate control. It is seldom feasible to hire foremen solely on the basis of their attitudes towards safety; consequently, the problem is one of enlisting the foreman's interest in it. Few better methods for creating interest in safety in all ranks of supervision can be found, than the one which persuaded the chief executive of the company to start the program in the first place. Usually, this reason is the identification of safety with efficiency and production.

In short then, a department or crew will be only as safe as its foreman or supervisor himself is. If the foreman exudes a safety attitude in everything he does, demands it of all personnel and trains all new personnel accordingly, the safety record of that crew will undoubtedly be one of the best.

SECTION II

SAFETY: The Individual Worker

Workers in wastewater treatment systems have had notoriously bad safety records. This condition has been attributed, in part, to the fact that municipalities and other governmental agencies who own wastewater treatment systems have given little attention to safety education. Certainly they have given less attention than is given by privately owned utilities whose insurance costs are affected by their safety records.

Wastewater system workers are exposed to many types of dangers. These situations encountered in their daily routine can result in injury to hands, feet, ears, back, and eyes. An examination of accident records of workers in these systems identifies strains (particularly to back), cuts, burns, contusions, broken bones, and maiming accidents as too common. Causes of such accidents are inherent in work around ladders, open pits, moving machinery, incinerators, slippery surfaces, and other conditions existing in treatment plants. Asphyxiation and drowning possibilities may be present. Excessive noise levels exist in some parts of wastewater treatment plants. Finally, infections from the sewage itself constitutes a hazard unique to workers in such plants.

Safety education materials that deal directly with protecting oneself from injury to eyes, hands, back, head, from asphyxiation or infection are of great interest to individual workers. Clearly most people are interested in protecting their own well-being.

A large number of teaching-learning materials are available that focus on specific aspects of safety such as protection of eyes, hands, the back against injury, and others. This section identifies only one learning resource that may be useful in the area of personal safety. The National Safety Council, DuPont, deNemours, Inc., and other agencies and companies have produced many films and other materials that deal with specific types of personal injury; their cause and prevention. These materials are reviewed and sources identified in Part II of this publication.

Learning Resource #8  
Basic Sewage Treatment Operation  
Topic: 10 Safety  
Ontario Ministry of the Environment, Toronto, CANADA

---

Supervisors may find the following material, reproduced from the publication cited above, useful in orienting new employees to safety measures that reduce the likelihood of dangers from infection.

Workers in treatment plants are exposed to the hazards of water-borne diseases, including Typhoid Fever, Amoebic Dysentery, Infectious Jaundice and other intestinal infections. Tetanus and skin infections must also be guarded against.

A majority of infections reach the body by way of the mouth, nose, eyes and ears. Therefore, washing your hands is a must before eating or smoking. Wear protective gloves where possible.

• Soap preparations requiring no water rinse are available for field use. The common drinking cup should be banned; each man should have and use his own.

Typhoid and Tetanus inoculations are recommended. These may be obtained free of charge from local Health Officers.

This hazard to plant personnel although very real and ever present can be largely reduced by the operator himself by following a few basic rules of personal hygiene. A few of these self applied rules are as follows:

1. Never eat your lunch or put anything into your mouth without first washing your hands.
2. Refrain from smoking while working in open tanks, on pumps, or cleaning out grit channels, etc. Remember, you inhale or ingest the filth that collects on the cigarette from dirty hands. Save your smoking time for lunch hours or at home.
3. A good policy is "never, put your hands above your collar when working on plant equipment."
4. Rubber or rubberized cotton gloves, rubber boots and coveralls are designed for body protection against dampness and contact with dirt, wear them at all times when working in tanks, etc.

5. Rubberized or rain suits can be worn in very wet or dirty places and can be washed off with a hose and brush, the same as rubber boots.
6. Always wear your rubber boots when working in tanks, washing down etc.; don't wear your street shoes.
7. Don't wear your rubber boots or coveralls in your car or at home.
8. Always wear rubber or plastic coated gloves when cleaning out pumps, handling hoses, etc.
9. Don't just wash your hands before going home, wash your face too, there is as much of your face to carry germs as there is of your hands.
10. Wear a hat when working around sludge tanks, cleaning out grit and other channels, don't go home with your head resembling a mop that just wiped up the floor around a cleaned out pump.
11. Keep your finger nails cut short and clean, they are excellent carrying places for dirt and germs.

SECTION III

SAFETY: Plant Design and General Operation

37

40



Safety in wastewater treatment systems, particularly in the treatment plant itself, is certainly related to the design of the plant. Design engineers, for various reasons, may or may not incorporate safety features such as those suggested in the Water Pollution Control Federation book Wastewater Treatment Plant Design published in 1977. A listing of the suggestions found in that publication are included in this section; the detailed list can be used as a checklist to identify needed safety provisions in existing plants as well as a guide in planning future construction.

Safety is related to many aspects of plant operation. A new plant with desirable safety features built into it can be operated in an unsafe manner by irresponsible personnel. Attention to good housekeeping practices is critically important in both new and old plants. Tripping over a hose or falling on a slippery floor can happen in either one.

Material including dangerous substances such as chlorine or strong acids must be handled and stored according to safety-tested procedures. Many back injuries have occurred when workers have attempted, single-handedly, to move heavy barrels or gas cylinders that should be moved by teams of workers, often with mechanical help.

Treatment plants, both new and old, face a continuing maintenance problem. Ladders become unsafe; guards on machinery may become loose; high pressure pumps need repair; and electric motors wear out. Careful attention to maintenance is an important ingredient in a safety program.

Persons interested in improving safety in wastewater treatment systems will find a very substantial amount of resource material available. A sample of the material dealing with the areas of plant design, plant operation, and maintenance is given in this section. Additional useful materials are reviewed later in this publication in the reference section.

Learning Resource #9  
Wastewater Treatment Plant Design  
Water Pollution Control Federation  
3900 Wisconsin Avenue  
Washington, DC 20016

---

A joint committee of the Water Pollution Control Federation and the American Society of Civil Engineers published Wastewater Treatment Plant Design, in 1977. This technical treatise written primarily for design engineers contains in Chapter Three a listing of factors to be considered in the areas of occupational health and physical safety when designing wastewater treatment plants. This extensive listing, reproduced below, can be useful to operating plant administrators/supervisors and workers in identifying safety hazards and needs that merit attention in their wastewater treatment system.

#### OCCUPATIONAL HEALTH

##### 1. Chemical.

- (a) Separate mechanical forced ventilation (with automatic timeclock operation) for influent room, wet well, dry well and screen or comminutor room. Some operations will require continuous ventilation.
- (b) Separation of the wet well and screen or comminutor room from other facilities, with separate outside access considered.
- (c) Pump station, where applicable, with a super-structure to facilitate entry and ventilation and to provide natural light.
- (d) Ventilation to force fresh air into wet well so that exhaust ventilator does not "pull in" sewer gases from influent sewer lines discharging to wet well.
- (e) An open channel provided immediately ahead of waste flow entry to influent structure to provide for venting of explosive gases and vapors.
- (f) Adequate ventilation in the grit chamber.
- (g) Chlorination, chlorine evaporator, and chlorine storage rooms separate, above ground, and each open only to outside air.
- (h) View windows to the chlorine evaporator and chlorine storage rooms for observation from the outside.
- (i) Forced mechanical ventilation that can be actuated automatically by light switches provided at chlorination rooms, chemical handling rooms, and laboratories.
- (j) Ventilation exhaust ports adequately dispersed and located to discharge where there will be no contamination of air inlets in other areas. Where general or space ventilation is utilized, a minimum of 15 complete air changes per hour are produced.
- (k) Light/vent switches located outside the chlorination rooms.
- (l) A photo-electric control to actuate ventilation and lighting when the light beam is interrupted on entrance to a room.
- (m) In special test areas of the laboratory, additional ventilation (explosion proof motor) with laboratory hoods.
- (n) The hood and room exhaust systems balanced so that a negative pressure is not created in the hoods.

- (o) Separate storage areas for dangerous chemicals.
- (p) Dust collectors on chemical elevators at loading points.
- (q) Liquid chlorine containers stored in well-ventilated fireproof structures with protection against direct exposure to the sun.
- (r) At the incinerator, satisfactory methods to handle dry pulverized sludge to preclude dust accumulation that results in potential dust explosion hazards.
- (s) Effective methods for the removal of dust, fly ash, and soot discharged from the stacks.
- (t) Exhaust facilities for permanent welding units.
- (u) Sludge storage tanks located upstream of vacuum filters with all safeguards against hazards of toxic and explosive gases.
- (v) Sludge pumps with pressure gauges to indicate build-up of gases when pumps are out of service.
- (w) All gas protective devices used with a digester in accordance with the manufacturer's recommendations.
- (x) Automatic gas alarm systems, both visual and audible, to detect explosive and/or combustible gases and vapors and to shut off all power in the area being protected except emergency (and explosion proof) ventilating and lighting equipment. Such alarms also in the screen or comminutor room, in the digester area, and elsewhere as needed.
- (y) Automatic chlorine leak detection devices (especially in large installations) to signal equipment failure and "fail-safe" shutoff flow of chlorine to evaporators and/or chlorinators.
- (z) The location of sensing devices for a signal transmittal in actuating emergency procedures.
- (aa) Sludge pump areas ventilated naturally and mechanically in a manner similar to that for wet wells.
- (bb) Both influent and discharge pipes to sludge pumps valved so that, if pumps are dismantled, sludge and gas cannot enter work area.
- (cc) Sludge pumps with quick closing type sampling valves.
- (dd) Washdown facilities for cleaning purposes wherever there is a possibility of spillage.
- (ee) Adequate drainage in all chemical storage and working areas.
- (ff) Piping and storage tanks coated to retard corrosive action.
- (gg) Full-chain or pedal-operated deluge showers with pedal-operated chest-level wash spouts and floor drain, where appropriate, in all areas where chemicals are being handled or stored.
- (hh) In hazardous areas, the use of a portable ladder rather than man-hole steps to discourage easy entry.
- (ii) Waste gas burners and vents located a safe distance from the building.
- (jj) Automatic shutdown controls to terminate the flow of hazardous waste materials to the incinerator in the event of a flame-out.
- (kk) For incinerator installations, fully automatic ignition start controls.
- (ll) A disinfection system selected to minimize handling and transportation problems.
- (mm) For liquid ferric chloride, sulfuric acid, and other corrosive liquid chemicals, acid-proof pumping equipment permanently installed for pumping liquid chemicals to the point of application.
- (nn) Gas outlets in the laboratory equipped with substantial handles and clearly identified.

- (oo) Dry hypochlorite stored in a cool dry area.
- (pp) Safeguards for facilities using sodium chlorite for disinfection.
- (qq) Safeguards for plants generating and/or using compressed gases.
- (rr) Adequate ventilation if methanol is used in plant processes.
- (ss) Materials and devices used for storing, transporting, or mixing hazardous chemicals to be compatible with the chemical(s) involved.
- (tt) Dikes or curbs capable of holding the stored volume plus a safety factor of 25 percent in each liquid chemical storage area.
- (uu) An acceptable "frequency of preparation" for chemicals used.
- (vv) Safety equipment, including portable ventilation equipment such as air blowers and adequate lengths of non-collapsible ducting; hydrogen sulfide, methane, chlorine, carbon monoxide, and oxygen deficiency indicators; industrial type vacuum cleaner; chlorine emergency repair kit; and proper self-contained air breathing apparatus.

## 2. Biological.

- (a) Fencing around all plant structures where unauthorized entry could result in personnel mishap or disruption of plant operation.
- (b) Provision for the safe collection of samples.
- (c) Pedal-operated laboratory sinks, toilets, and wash sinks.
- (d) Shower facilities with hot and cold running water for employee rooms.
- (e) Eating rooms separated from other facilities.
- (f) Two lockers for each plant employee (one for work clothes and another for street clothes).
- (g) An automatic washing machine for washing work clothes.
- (h) Washdown facilities for cleaning purposes wherever there may be spillage.
- (i) Disinfectant dispensers.
- (j) The potable water supply, where used for plant processes or other purposes such as washdown of equipment, protected by backflow preventers (or airbreak discharge).
- (k) Warning signs indicating non-potable water outlets.

## 3. Environmental.

- (a) Provisions affording protection against infrared radiation from combustion units, ultraviolet radiation from arcwelding, and ionization radiation from radioactive substances.
- (b) Equipment design for noise reduction.
- (c) A maximum permissible noise level during operation, expressed in decibels of sound under standard test conditions.
- (d) Air compressors, vacuum pumps for filter units, centrifuges, blowers, standby power units, and other similar equipment producing high noise levels located either in isolated buildings or rooms or within acoustically sound-proofed structures for maximum sound reduction.
- (e) A super-structure to provide natural light for the pump station.
- (f) Adequate lighting throughout the plant and particularly in areas of operational activities, including repair and servicing of equipment valves and controls.
- (g) Exterior floodlighting to provide for nighttime operation, maintenance, and inspection at each non-enclosed plant unit as well as for general illumination of plant operational areas.

- (h) Emergency battery-operated lights for interior areas, particularly in the vicinity of stairways.
- (i) Sludge pump areas well ventilated.
- (j) Both influent and discharge pipes to sludge pumps valved so that dismantling will not result in sludge entering the work area.
- (k) Sludge pumps with quick closing-type sampling valves.
- (l) The pump areas well-drained to facilitate hosing down for cleaning after pump dismantling.
- (m) Chlorination facilities with concrete floors and adequate but separate drainage from other facilities.
- (n) Incinerators with adequate temperature controls.
- (o) Heavy hatchway covers with spring assistance to prevent injury.
- (p) Hoists to lower and raise men and equipment into pit areas.
- (q) Chemical storage areas properly situated to eliminate the necessity of reaching beyond safe handling limits.
- (r) The applicability of handlift trucks for chemical handling.
- (s) Lifting associated with bags and drums of chemicals at a minimum level; discharge of chemicals preferably made through a floor chute with low curbing.
- (t) Safety equipment, including, radiological monitoring equipment, decibel meter noise analyzer, explosion proof flashlights, and portable lifting equipment.

#### PHYSICAL SAFETY

##### 1. Fire.

- (a) A fire alarm located at the plant.
- (b) Automatic firefighting systems.
- (c) Firefighting devices located in each separate structure at accessible points near the entrance to areas of likely conflagration.
- (d) Doors from potentially hazardous areas tight-fitting, self-closing to open out, and equipped with panic bars.
- (e) Laboratories and basement areas with two easily reached exits reasonably remote from each other.
- (f) Interior doors, where appropriate, to swing both ways and have wire glass panels.
- (g) Laboratory wall surfaces, ceilings, and furniture made of fire-resistant materials.
- (h) If oxygen is used for activated sludge aerators, detectors provided at points of possible leakage from supply tanks.
- (i) Waste gas burners and vents located a safe distance from buildings.
- (j) Proper safety transport for incoming chemical and fuel supplies.
- (k) Controls for the incinerator burner system to assure adequate purge time; interrupted pilot, flame scanner, and safety controls to prevent the possible lighting or re-lighting of a burner in a potentially hazardous atmosphere.
- (l) All electrical equipment adequately grounded.
- (m) Wiring properly insulated, grounded, and non-exposed.
- (n) Fire extinguishers suitable for the area and the equipment to be protected.
- (o) An emergency power supply for critical lighting and ventilation.

2. Burns.

- (a) Cages or guards around accessible hot exhaust piping.
- (b) Permanently installed acid-proof pumping equipment for liquid ferric chloride, sulfuric acid, or other liquid chemicals.
- (c) Pull-chain or pedal-operated deluge showers with pedal-operated chest-level wash spouts in all areas where chemicals are being handled or stored.
- (d) Laboratory sinks and wash sinks with pedal-operated faucets.

3. Explosion.

- (a) The screen room or comminutor room separated from other facilities and provided with separate outside access.
- (b) The wet well located either in a separate structure or accessible only from the outside.
- (c) The pump station with a super structure to facilitate ventilation.
- (d) Entry ways for the room holding a gas or oil fired heat exchanger to satisfy safety requirements.
- (e) Separate structures for standby engines used for emergency electrical power.
- (f) Sludge pump areas as well ventilated naturally and mechanically as wet wells.
- (g) Waste burners and vents located a safe distance from buildings.
- (h) Separate rooms for chlorinators, chlorine evaporators, and chlorine storage, with each above-ground opening only to outside air.
- (i) View windows to the chlorination facilities for observation from the outside.
- (j) Separate storage areas for dangerous chemicals.
- (k) An open channel immediately ahead of wastewater entry to influent structure to provide venting for explosive gases and vapors.
- (l) Sludge storage tanks upstream of vacuum filters with all safeguards against hazards of toxic and explosive gases.
- (m) Doors from potentially hazardous areas tight-fitting, self-closing, opening out, and equipped with panic bars.
- (n) Potentially explosive areas provided with blowout or rupture panels.
- (o) Separate mechanical forced ventilation (with automatic timeclock operation) for influent rooms, wet wells, dry wells, and screen or comminutor rooms.
- (p) Ventilation to force fresh air into the wet wells so that the exhaust ventilator does not "pull in" sewer gases from the influent sewer lines.
- (q) The grit chamber adequately ventilated.
- (r) Forced mechanical ventilation that will be automatically actuated by light switches for chlorination rooms, chemical handling rooms, and laboratories.
- (s) The ventilation exhaust ports adequately dispersed and located to discharge where there will be no contamination of air inlets in other areas.
- (t) Light/vent switches located outside the chlorination room.
- (u) A photo-electric control to actuate ventilation and lighting when the lightbeam is interrupted on entrance to a room.
- (v) In special test areas of the laboratory, additional ventilation with laboratory hoods.

- (w) The hood- and room-exhaust systems balanced so that a negative pressure is not created in the hoods.
- (x) Motors, switches, lights, and wiring explosion proof in screen area; grit chamber, wet well, digester area, laboratories, sludge pumping area, and wherever explosive gases may be present as a result of accident or malfunctions.
- (y) Switches, electrical equipment, and wiring associated with the wet well located in a non-hazardous area.
- (z) Dust collectors provided on chemical elevators at the loading point.
- (aa) Safety and relief devices on heat exchangers.
- (bb) All gas protective devices at the digester area provided in accordance with manufacturers' recommendations.
- (cc) At the incinerator, satisfactory methods to handle dry pulverized sludge to preclude dust accumulation that could result in dust explosion hazards.
- (dd) Sludge pumps with pressure gauges to indicate buildup of gases when pumps are out of service.
- (ee) Automatic gas alarm systems, both visual and audible, to detect explosive and/or combustible gases and vapors and shut off all power except to emergency and explosion proof ventilation and lighting equipment. Such systems provided in the screen or comminutor room, the digester area, and elsewhere as needed.
- (ff) An automatic chlorine lead detection device (especially in large installations) to signal equipment failure and to provide fail-safe shutoff of chlorine flow to evaporators and/or chlorinators.
- (gg) If oxygen is used for activated sludge aeration, oxygen leakage detectors at the points of possible leakage from the supply tanks.
- (hh) Automatic shutdown controls to terminate the flow of hazardous waste materials in the event of incinerator flame-outs.
- (ii) Fully automatic ignition start controls for the incinerator.
- (jj) A proper safety train on the incoming fuel supply of the auxiliary fuel system.
- (kk) Burner system controls to assure adequate purge time; interrupted pilot, flame scanner, and safety controls to prevent the possible lighting or relighting of a burner in a potentially hazardous atmosphere.
- (ll) Heat treatment processes with properly designed reactors and capacities.
- (mm) All medium and high voltage cables completely enclosed in either conduit or covered tray and adequately marked to warn personnel of contents.
- (nn) Laboratories with two easily reached exits reasonably remote from each other.
- (oo) Interior doors to swing both ways and have wire glass panels.
- (pp) Safety equipment to include explosion-proof flashlight, safety tools (non-sparking), and industrial-type vacuum cleaner.
- (qq) Safety harnesses for entering vaults or pits containing potentially harmful or explosive gases.
- (rr) Gas piping and pressure relief valves on digesters with adequate flame traps.
- (ss) Sediment and drip traps at low points in the gas system.
- (tt) Waste gas burners located in an open area for easy observation.
- (uu) Gas collection system to segregate as much of the piping and appurtenances as possible.

4. Electric Shock.

- (a) All electrical equipment adequately grounded.
- (b) All wiring properly insulated, grounded and unexposed.
- (c) Control circuit voltages not over 120 V.
- (d) All medium and high voltage cables completely enclosed in either conduit or covered tray and adequately marked to warn personnel of contents.
- (e) Switchboards with "dead front" and "dead rear."
- (f) In moist areas, where there is no possibility of flammable gas accumulation, moisture proof enclosures for switches, equipment, and lights.
- (g) Electrical "lock out" facilities to prevent accidental starts when machinery and equipment are being worked on or otherwise taken out of service.
- (h) An emergency shutoff switch, clearly labeled, at all machinery units.
- (i) Well-ventilated indoor control panels.
- (j) Appropriate control enclosures.
- (k) Safety equipment including safety tools.

5. Falls.

- (a) Rest landings on stairways.
- (b) Non-slip stair treads on landings and stairs.
- (c) Equal height and proper slope on stair risers.
- (d) A separate handrail where entrance is provided by ship's ladders or manhole steps. Ladder or manhole steps extending above entrance level also can provide a handhold for entering.
- (e) Fixed ladders more than one story high equipped with safety cages.
- (f) Tall ladders provided with rest or offset landings.
- (g) Use of non-slip surfaces (such as concrete floated smooth with broomed finish) or added non-slip covering for floors and ramps.
- (h) Ramps with a pitch commensurate with intended use.
- (i) In cold climates, gratings on outside stairs, and walkways on tanks wherever possible.
- (j) Where spillage is a problem, as in sludge pump and vacuum filter areas, sufficient faucets, adequate floor drainage, and water repellent wall surfaces provided for cleanup purposes.
- (k) Concrete floors with adequate drainage for chlorination facilities.
- (l) Durable, non-slip floor material in the laboratory.
- (m) Safe collection of wastewater and process flow samples.
- (n) Adequate width for tank walkways.
- (o) Process tanks with adequate railings, lifesaving devices, and interior ladders or manhole steps.
- (p) Lift-rings and grating locks flush-mounted to prevent tripping.
- (q) Elimination of "head-knockers" such as low pipes, valves, ceilings, and suspended equipment.
- (r) Double handrails or chains, fencing, or guards of proper height at floor and wall openings, pump wells, influent structures, open tanks, and above ground ramps.
- (s) A safe method for lamp replacement.
- (t) Emergency battery-operated lights for interior areas, particularly in the vicinity of stairways.
- (u) Exterior floodlighting for nighttime operation and maintenance and inspection of each non-enclosed plant unit as well as general illumination of plant operational area.
- (v) Adequate lighting in the grit chamber.



- (w) A super-structure at the pump station to facilitate entry and provide natural light.
  - (x) Proper painting to provide light color in darker areas and to distinguish walking areas, including steps, by contrasting colors.
  - (y) Metals, paints, and other materials selected to resist the corrosive effects of hydrogen sulfide and other sewer gases, greases, oils, and similar constituents frequently present in wastewater.
  - (z) Safety equipment to include ladders with non-skid feet.
6. Drowning.
- (a) Fencing around all plant structures where unauthorized entry could result in personal mishap or disruption of plant operations.
  - (b) Manholes, steps, or permanently attached ladders inside of tanks, basins, or wet wells, for entry or exit in cases of emergency.
  - (c) Life preservers attached to ropes and located near open tanks.
  - (d) Safety poles.
  - (e) Provision for lifelines along the internal walls above the water surface.
  - (f) Adequate widths for walkways in tanks.
  - (g) Safe sampling techniques.
  - (h) Adequate railings, lifesaving devices, interior ladders, or manhole steps in process tanks.
7. Impact.
- (a) Elimination of "head-knockers" created by low pipes, valves, ceilings, and suspended equipment.
  - (b) Equipment, piping, valves, and other appurtenances arranged for ease of access, uncrowded, and with ample walk areas.
  - (c) All commonly used passageway doors equipped with a glass panel to prevent accidental opening into another person.
  - (d) Stairways with kickplates around stairwell openings and with adequate railings.
  - (e) Hatchway covers with springs or positive locking devices to hold the covers open (unless they swing free of opening and lie flat).
  - (f) Well-planned, safe operations associated with incoming railroad cars.
8. Rotating Machinery Parts.
- (a) Equipment, piping, valves, and other appurtenances within structures arranged for ease of access, uncrowded, and provided with ample walk areas.
  - (b) Adequate space between machinery to permit maintenance in a safe manner.
  - (c) Cages around exposed rotating shafts and all other moving parts on machinery.
  - (d) Guards around long, exposed vertical shafts to safeguard the worker from contact or injury from "whipping" if the shaft breaks.
  - (e) Shafts with painted spiral or other markings to indicate running conditions.
  - (f) Positive displacement pumps with an air chamber and a pressure switch that will stop the pump at a pre-set pressure.
  - (g) Electrical "lockout" facilities with padlocks to prevent accidental starts when machinery and equipment are being worked on or otherwise taken out of service.

- (h) An emergency shutoff switch, clearly labeled, at all machinery units.
  - (i) Centralized control and malfunction warning systems.
  - (j) Running equipment equipped with indicator lights.
  - (k) Safety equipment to include a first-aid kit.
9. Materials Handling.
- (a) Fixed or portable electrical hoists with ceiling lifting devices for lifting heavy loads, including chemicals, pumps, motors, and equipment for repair or replacement.
  - (b) Lifting attachments such as hooks or eyes on heavy equipment.
  - (c) Hoists to lower and raise men and equipment into pit areas.
  - (d) The disinfection system selected for wastewater treatment to minimize handling and transportation problems.
  - (e) Chemical storage areas situated so personnel do not have to stretch beyond safe handling limits.
  - (f) Lifting associated with bags and drums of chemicals at a minimum level; discharge of chemicals preferably made through a floor chute with low curbing.
  - (g) The applicability of handlift trucks.
  - (h) Well-planned, safe operations associated with incoming railroad cars.
  - (i) Adequate space for equipment repair or replacement.
  - (j) Cleanout connections large enough for the operator to get hands and necessary tools through.
10. Pinning and Crushing.
- (a) Electrical "lockout" facilities with cylinder padlocks to prevent accidental starts when machinery and equipment are being worked on or otherwise taken out of service.
  - (b) An emergency shutoff switch, clearly labeled, at all machinery units.
  - (c) Centralized control and malfunction warning systems.
  - (d) Running equipment equipped with indicator lights.
  - (e) Special equipment bracing, where required.
11. Sensory Devices.
- (a) Sensing devices equipped with visual and audible alarms both nearby and at a centralized location, placed in all hazardous areas for combustible or explosive gases and vapors.
  - (b) Where oxygen is used in sludge aeration, oxygen leakage detectors at appropriate points on the supply tanks.
  - (c) Chlorine leak detection device to signal equipment failure in larger installations.
  - (d) A fire alarm at the plant.
  - (e) An automatic signal for incinerator flame-out.
  - (f) Centralized control and malfunction warning systems.
  - (g) Visual and audible alarms.
  - (h) Running equipment with indicator lights.
  - (i) Electrical lockout facilities with cylinder padlocks to prevent accidental starts when machinery and equipment are being worked on or otherwise taken out of service.
  - (j) Provisions to deal with infrared radiation from combustion units, ultraviolet radiation from arc welding, and ionizing radiation from radioactive materials.
  - (k) Pressure gauges at sludge pumps to indicate buildup of gases when the pumps are out of service.

- (l) Warning signs indicating dangers such as explosive gases, high pressure pipes, and underground utilities.
- (m) Warning signs, by each non-potable water outlet.
- (n) Standardized color coding of process piping and emergency equipment:
  - i. orange to designate dangerous parts of machines, or energized equipment, and flammable gas lines; ii. blue, potable water; iii. yellow, chlorine; iv. black, raw sludge; v. brown, treated sludge; vi. purple, radiation, hazards; vii. green, compressed air; viii. jade green, process or flushing water (non-potable); ix. gray, wastewater; x. orange with blue letters, steam; xi. white, traffic and housekeeping operations; and xii. red, fire protection equipment.
- (o) Safety equipment to include hydrogen sulfide, methane, chlorine, carbon monoxide, and oxygen deficiency indicators.

#### PERSONAL PROTECTIVE AND SAFETY EQUIPMENT

Even with the best of safety designs, unhealthy and unsafe conditions will be encountered. Hence, the need for protective and safety equipment. The design engineer should assume responsibility for specifying the equipment and its proper placement throughout the facility. He should consider personal protective equipment in the areas of head protection, ear protection, face and eye protection, protective respiratory equipment, foot and leg protectors, and protective clothing.

It should be noted that there are various categories of protective respiratory devices with specific application and limitation in the protection they afford. Respiratory devices are certified by the National Institute of Occupational Safety and Health. The design engineer should take care to locate safety equipment so that it is easily accessible in case of emergency. Essential safety equipment includes safety belts, harnesses, life-jackets, and lifelines. Storage facilities should also be specified for first-aid equipment.

Learning Resource #10

"Margin For Safety"

Slide-Cassette - 18 minutes

Water Pollution Control Federation

3900 Wisconsin Avenue

Washington D.C. 20016

Effective narration extends the ideas suggested by the 41 slides identified below. The presentation focuses on design, maintenance and operational factors that constitute the margin between safe and dangerous working conditions. It contains many practical suggestions that should prove to be useful to management, supervisors, and workers.

<u>Slide number</u>	<u>Material presented in slide</u>
1	Caption - "Margin For Safety"
2	Debris between buildings
3	Cluttered workbench
4	Tool housekeeping
5	Icy conditions
6	Salt for snow - ice removal
7	Safety treads
8	Handrails on steps -
9	Unguarded opening
10	Snow removal around valve
11	Care regarding grate removal
12	Very steep stairwell
13	Safety chain at steep stairwell
14	Safety chains at steep drywell
15	Flushing dryholes without handholds
16	No guardrails around deep tanks
17	Narrow walkways around deep tanks
18	Guardrails around deep tanks
19	Wearing life vests around deep wastewater
20	Guardrails at discharge opening
21	Guard at discharge opening
22	Mandatory use of safety equipment
23	Safety hats
24	Protecting against loud noise
25	Self-contained air pack
26	Use of air pack
27	Utility hose mask
28	Combustible gas indicators
29	Testing gas indicator
30	Oxygen deficiency meter
31	Metal toe guards
32	Eye protection
33	Fire extinguisher
34	Fire extinguisher check
35	Guarding moving parts
36	Guarding moving parts
37	Vehicular traffic danger
38	Vehicular traffic danger
39	Poor traffic warning
40	Worker attitude
41	The end

Learning Resource #11

"The Safe Way"

Slide-Cassette - 14 minutes

Water Pollution Control Federation

3900 Wisconsin Avenue

Washington, D.C. 20016

---

Good narration amplifies the ideas presented in the 38 slides identified below. The slide-cassette tape presentation is a general overview of the hazards and need for safety in wastewater treatment systems. As such it could be useful in an orientation session regarding safety with newly employed workers.

Slide number

Material presented in slide

1	Caption - "The Safe Way"
2	Sampling gas in manhole
3	Working around electrical switchboard
4	Taking sewage sample
5	Washing hands
6	Using waterless cleaners
7	Toe bars on pneumatic tools
8	Eye protection
9	Proper eye protection
10	Very steep stairway
11	Safe stairway procedures
12	Smoker entering manhole
13	Safe working in manhole
14	Lowering tools into manhole
15	Proper removal of manhole cover
16	Street hazards around manholes
17	Traffic warning devices
18	Street hazards
19	Working in trenches
20	Working in manholes
21	Importance of gloves
22	Washing down wet-well
23	Wire winch cable hazard
24	Injured hand
25	Importance of gloves
26	Unguarded moving parts
27	On-job communication
28	Bad housekeeping
29	Oily rags
30	Dirty rag container
31	Flammable material in welding area
32	Safe chemical storage
33	Safe chemical storage
34	Deluge shower and eyebath
35	Pipette safety
36	Bulb pipette
37	Importance of laboratory safety
38	The end

SECTION IV

SAFETY: Chemicals - Gases

Workers in wastewater treatment systems have safety concerns related to chemical usage. Highly corrosive acids are used in some cleaning operations. Employees unaccustomed to the hazards associated with the use of such chemicals require training to learn what to do in case of spillage, particularly if such chemicals get into eyes or on other exposed body surfaces. Employees should know of what to do immediately in the event of such an accident.

Large quantities of highly poisonous chlorine gas are used in modern sewage disposal plants. The routine use of several tons per month of this chemical may benumb workers to the danger inherent in this substance which was, in World War I, a battlefield weapon. Very careful training of all workers associated with transportation, storage, and use of chlorine is mandatory by OSHA standards and by common sense.

Gases such as hydrogen sulfide, carbon monoxide, methane, ammonia, and large amounts of carbon dioxide may be present in certain parts of wastewater treatment systems, particularly in manhole areas and in the wet-well entrance to the sewage treatment plant. Awareness of the dangers associated with these gases, tests available to determine their presence, and precautions to be taken when working around these substances are parts of a necessary safety education program.

Fortunately, many learning resources are available. Chemical companies such as DuPont, de Nemours, Inc. have prepared safety leaflets and other materials related to safe use of certain substances. A sample of material dealing with safety in chemical usage is given in this section. Additional materials are identified and reviewed in the reference section.

**Learning Resource #12**

**"Plant Safety and Good Housekeeping"**

**Chapter 14, Operation of Wastewater Treatment Plants: A Field Study Training Program Vol. II, 1980**

**Kerri, Kenneth D., Project Director  
California State University, Sacramento  
6000 "J" Street  
Sacramento, CA 95819**

---

The following Table duplicated from the reference cited above provides factual information on gaseous substances which may affect workers in wastewater treatment systems. The material can be used by supervisors or other personnel involved in a safety education program in many ways.

Discussion of sources, common properties, and physiological effects of the various gases can be made interesting and potentially very useful. Demonstrations of some methods of testing can be incorporated easily into a safety lesson on this area of concern.



**COMMON DANGEROUS GASES ENCOUNTERED IN WASTEWATER COLLECTION SYSTEMS AND AT WASTEWATER TREATMENT PLANTS<sup>1</sup>**

Name of Gas	Chemical Formulae	Specific Gravity of Vapor Density** (Air = 1)	Explosive Range (% by volume in air)		Common Properties (Percentages below are per cent in air by volume)	Physiological Effects (Percentages below are per cent in air by volume)	Most Common Sources in Sewers	Simplest and Cheapest Safe Method of Testing †
			Lower Limit	Upper Limit				
Oxygen (in Air)	O <sub>2</sub>	1.11	Not flammable		Colorless, odorless, tasteless, non-poisonous gas. Supports combustion.	Normal air contains 20.93% of O <sub>2</sub> . Man tolerates down to 12%. Below 5 to 7% likely to be fatal.	Oxygen depletion from poor ventilation and absorption or chemical consumption of available O <sub>2</sub> .	Oxygen deficiency indicator.
Gasoline Vapor	C <sub>8</sub> H <sub>18</sub> to C <sub>12</sub> H <sub>26</sub>	3.0 to 4.0	1.3	7.0	Colorless, odor noticeable in 0.03%. Flammable. Explosive.	Anesthetic effects when inhaled. 2.43% rapidly fatal. 1.1% to 2.2% dangerous for even short exposure.	Leaking storage tanks, discharges from garages, and commercial or home dry-cleaning operations.	1. Combustible gas indicator. 2. Oxygen deficiency indicator for concentrations over 30%.
Carbon Monoxide	CO	0.97	12.5	74.2	Colorless, odorless, non-irritating, tasteless, flammable. Explosive.	Hemoglobin of blood has strong affinity for gas causing oxygen starvation. 0.2 to 0.25% causes unconsciousness in 30 minutes.	Manufactured fuel gas.	CO ampoules.
Hydrogen	H <sub>2</sub>	0.07	4.0	74.2	Colorless, odorless, tasteless, non-poisonous, flammable. Explosive. Propagates flame rapidly; very dangerous.	Acts mechanically to deprive tissues of oxygen. Does not support life. A simple asphyxiant.	Manufactured fuel gas.	Combustible gas indicator.
Methane	CH <sub>4</sub>	0.55	5.0	15.0	Colorless, tasteless, odorless, non-poisonous. Flammable. Explosive.	See hydrogen.	Natural gas, marsh gas, fuel gas, sewer gas.	1. Combustible gas indicator. 2. Oxygen deficiency indicator.
Hydrogen Sulfide	H <sub>2</sub> S	1.19	4.3	46.0	Rotten egg odor in small concentrations but sense of smell rapidly impaired. Odor not evident at high concentrations. Colorless. Flammable. Explosive. Poisonous.	Death in few minutes at 0.2%. Paralyzes respiratory center.	Petroleum fumes, from blasting, sewer gas.	1. H <sub>2</sub> S analyzer. 2. H <sub>2</sub> S ampoules.
Carbon Dioxide	CO <sub>2</sub>	1.53	Not flammable		Colorless, odorless, non-flammable. Not generally present in dangerous amounts unless there is already a deficiency of oxygen.	10% cannot be endured for more than a few minutes. Acts on nerves of respiration.	Issues from carbonaceous strata. Sewer gas.	Oxygen deficiency indicator.
Nitrogen	N <sub>2</sub>	0.97	Not flammable		Colorless, tasteless, odorless. Non-flammable. Non-poisonous. Principal constituent of air (about 78%).	See hydrogen.	Issues from some rock strata. Sewer gas.	Oxygen deficiency indicator.
Ethane	C <sub>2</sub> H <sub>6</sub>	1.05	3.1	15.0	Colorless, tasteless, odorless, non-poisonous. Flammable. Explosive.	See hydrogen.	Natural gas.	Combustible gas indicator.
Chlorine	Cl <sub>2</sub>	2.5	Not flammable Not explosive		Greenish yellow gas, or amber color liquid under pressure. Highly irritating and penetrating odor. Highly corrosive in presence of moisture.	Respiratory irritant, irritating to eyes and mucous membranes. 30 ppm causes coughing. 40-60 ppm dangerous in 30 minutes. 1000 ppm apt to be fatal in few breaths.	Leaking pipe connections. Overdosage.	Chlorine detector. Odor, strong. Ammonia on swab gives off white fumes.

\*\* Gases with a specific gravity less than 1.0 are lighter than air; those more than 1.0 heavier than air.  
† The first method given is the preferable testing procedure.

1. Reprinted from Water and Sewage Works, August 1953.

Copied from "Manual of Instruction for Sewage Treatment Plant Operators," State of New York.

CH 7

Learning Resource #13

"Disinfection and Chlorination"

Chapter 10, Operation of Wastewater Treatment Plants: A Field Study Training Program Vol. I, 1980

Kerri, Kenneth D., Project Director  
California State University, Sacramento  
6000 "J" Street  
Sacramento, CA 95819

---

The following lesson duplicated from an earlier version (1976) of the reference cited above provides basic information about chlorine hazards and safety precautions that must be taken while working around this commonly used substance.

The lesson could be used during safety orientation of new employees or as a review of safety procedures to be followed by experienced workers.

CHAPTER 10, DISINFECTION AND CHLORINATION  
(Lesson 3 of 4 Lessons)

10.3 SAFETY AND FIRST AID

All persons handling chlorine should be thoroughly aware of its hazardous properties. Personnel should know the location and use of the various pieces of protective equipment and be instructed in safety procedures. For additional information on this topic, see the Water Pollution Control Federation's Manual of Practice No. 1, Safety in Wastewater Works, and the Chlorine Institute's Chlorine Manual, 4th edition.<sup>19</sup>

10.30 Chlorine Hazards

Chlorine is a gas, heavier than air, extremely toxic and corrosive in moist atmospheres. Dry chlorine gas can be safely handled in steel containers and piping, but with moisture must be handled in corrosion-resisting materials such as silver, glass, teflon, and certain other plastics. Chlorine gas at container pressure should never be piped in silver, glass, teflon, or any other plastic material. The gas is very irritating to the mucous membranes of the nose, to the throat, and to the lungs; a very small percentage in the air causes severe coughing. Heavy exposure can be fatal. (See Table 10-1.)

---

<sup>19</sup>Write to: Water Pollution Control Federation, 3900 Wisconsin Avenue, Washington, D.C. 20016; price to WPCF members, \$0.75; others, \$1.50. The Chlorine Institute, Inc., 342 Madison Avenue, New York, New York 10017; price \$0.75.

TABLE 10-1

PHYSIOLOGICAL RESPONSE TO CONCENTRATIONS OF CHLORINE GAS<sup>20</sup>

Effect	Parts of Chlorine Gas Per Million Parts of Air By Volume (ppm)
Slight symptoms after several hours' exposure	1
Detectable odor	3
60-minute inhalation without serious effects	4
Noxiousness	5
Throat irritation	15
Coughing	30
Effects dangerous to one-half to one hour	40
Death after a few deep breaths	1000

<sup>20</sup> Adapted from data in U.S. Bureau of Mines Technical Paper 248 (1955).

### 10.31 Why Chlorine Must be Handled with Care

You must always remember that chlorine is a hazardous chemical and must be handled with respect. Concentrations of chlorine gas in excess of 1000 ppm may be fatal after a few breaths.

Because the characteristic sharp odor of chlorine is noticeable even when the amount in the air is small, it is usually possible to get out of the gas area before serious harm is suffered. This feature makes chlorine less hazardous than gases such as carbon monoxide, which is odorless, and hydrogen sulfide, which impairs your sense of smell in a short time.

Inhaling chlorine causes general restlessness, panic, severe irritation of the throat, sneezing, and production of much saliva. These symptoms are followed by coughing, retching and vomiting, and difficulty in breathing. Chlorine is particularly irritating to persons suffering from asthma and certain types of chronic bronchitis. Liquid chlorine causes severe irritation and blistering on contact with the skin.

### 10.32 Protect Yourself From Chlorine

Every person working with chlorine should know the proper ways to handle it, should be trained in the use of self-contained breathing apparatus, and should know what to do in case of emergencies.

Here are some items you should always remember in order to protect yourself and others from possible injury:

- a. In an emergency, only authorized persons with adequate safety equipment should be in the danger area. Have your fire department examine your chlorine handling facilities and safety equipment so they will be aware of what you have and the possible dangers. They are well trained in the use of breathing apparatus and may be able to help you in an emergency, especially if they are familiar with chlorine hazards.
- b. In any chlorine atmosphere, short shallow breathing is safer than deep breathing. Recovery from exposure depends on the amount of chlorine inhaled, so it is important to keep that amount as small as possible.
- c. Clothing contaminated with liquid or gaseous chlorine continues to give off chlorine gas and irritate the body even after leaving a contaminated area. Therefore, contaminated clothing should be removed immediately and the exposed parts of the body washed with a large amount of cool water.

The use of a breathing apparatus is advisable during these operations. All caution should be taken to prevent any liquid from coming in contact with clothing not designed for protection, because the liquid can penetrate the cloth and cause skin problems.

- d. Learn the correct way of using the breathing apparatus, practice using it regularly, and take safety drills seriously. What you learn may save your life. The fire department is well trained in the use of breathing apparatus and can be very helpful in training.

- d. If you have found a chlorine leak and left the area before the leak was stopped, you should use an apparatus with a separate air supply when you return and repair the leak. Never rely on a cannister type mask for protection in repairing chlorine leaks. Cannister masks are not recommended because they do not supply oxygen. They only remove chlorine, if they are effective. Some agencies allow the use of cannister type masks; however, most operators who have had experience repairing chlorine leaks do not use cannister masks because of their short shelf life (approximately three to four months) and inability to provide adequate protection against high concentrations of chlorine. Extensive ventilation is recommended.
- e. Cooperate in taking care of all safety equipment, handling it carefully, and returning it to its proper storage place after use. Defective equipment, or equipment which you can't find when you need it, will not protect you.
- g. Always be sure that you know the location of first aid cabinets, breathing apparatus, showers, and other safety equipment. Review emergency instructions regularly to be sure you know them.
- h. Notify your police department that you need help if it becomes necessary to stop traffic on roads and to evacuate persons in the vicinity of a chlorine leak.

#### 10.33 First Aid Measures

- a. Be sure you know the location of breathing apparatus, first aid kits, and other safety equipment at all times.
- b. Remove clothing contaminated with liquid chlorine at once. Carry patient away from gas area--if possible to a room with a temperature 70°F. Keep patient warm, with blankets if necessary. Keep him quiet.
- c. Place patient on his back with his head higher than the rest of his body.
- d. Call a doctor and fire department immediately. Immediately begin appropriate treatment.
- e. Eyes. If even small quantities of chlorine have entered the eyes, hold the eyelids apart and flush copiously with lukewarm running water. Continue flushing for about fifteen minutes. Do not attempt any medication except under specific instructions from a physician.
- f. Skin. Get patient under a shower immediately, clothes and all. Remove clothing while the shower is running. Wash the skin with large quantities of soap and water. Do not attempt to neutralize chlorine with chemicals. Do not apply salves or ointments except as directed by a physician.

- g. Inhalation. If the patient is breathing, place him in a comfortable position; keep him warm and at rest until a physician arrives.

If breathing seems to have stopped, begin artificial respiration immediately. Mouth-to-mouth resuscitation or any of the approved methods may be used. Oxygen should be administered if equipment and trained personnel are available.

Automatic artificial respiration is considered preferable to manual, but only when administered by an experienced operator.

Rest is recommended after severe chlorine exposure.

- h. Throat Irritation. Drinking milk will relieve the discomforts of throat irritation from chlorine exposure. Chewing gum or drinking spirits of peppermint also will help reduce throat irritation. Follow emergency rules given by your physician. In the absence of such rules, the first aid steps above are suggested.

Taken in part from Chlorine Safe Handling Pamphlet, published by The Chemical Division of PPG Industries, Inc.

#### QUESTIONS

- 10.3A What are the hazards of chlorine gas?
- 10.3B What type of breathing apparatus is recommended when repairing a chlorine leak?
- 10.3C What first aid measures should be taken if a person comes in contact with chlorine?

SECTION V

SAFETY: Electricity

Enormous amounts of electricity are used in the process of pumping millions of gallons of water daily through a large wastewater treatment plant. Ventilation fans, conveyers, sludge scrapers, comminutors and many other electrical devices run continuously. The worker is often close to electric circuits that are dangerous or deadly.

While the electrical work in a treatment plant will almost always be done by well-trained licensed electricians, all workers in the plant should have a basic understanding of safety required around electricity. They should know that under certain conditions (wet footing and a current across the heart region) even low voltage electrical currents can kill. They should understand the critical nature of lock-out procedures that are designed to prevent the accidental starting of equipment while it is being cleaned or repaired. They should understand what they can do to prevent electrical accidents.

This section includes some exemplary lessons to help workers acquire safety understandings about electricity. The reference section identifies additional sources of useful information.



Learning Resource #14  
"Electrical Safety in Maintenance"  
Excerpted from Safety in Wastewater Works  
The Water Pollution Control Federation  
3900 Wisconsin Avenue  
Washington, DC 20016

-----

The following material can be useful as an outline to assist a supervisor in reviewing, with new employees, the safety measures that are important while working with electricity.

#### 4.3 ELECTRICAL

Ordinary 110V electricity may be fatal; however, lower voltages and low amperage electricity should not be underestimated. Extensive studies have shown that 0.005 amp will cause loss of muscle control and that 12V may, on good contact cause injury. Therefore, all voltages above 12V should be considered dangerous. Electrical systems at wastewater works operate at voltages from 120V to 4,000V or more. All electricity should be treated cautiously and without guessing as to the nature of the electrical circuit.

Electricity kills by paralyzing the nervous system and stopping muscular action. Frequently, electricity may hit the breathing center at the base of the brain and interrupt the transmission of the nervous impulses to the muscles responsible for breathing. In other cases, the electrical current directly affects the heart causing it to cease pumping blood. Death follows from lack of oxygen in the body. It cannot be determined which action has taken place, so it is essential that:

1. The victim be freed from the live conductor promptly by use of a dry stick or other nonconductor. Never use bare hands to remove a live wire.
2. Artificial respiration be supplied immediately and continuously until breathing is restored or until a doctor arrives.

4.301 General Rules:--The following are some general rules for electrical maintenance safety:

1. Do not ground yourself inadvertently to waterpiping or other metallic equipment when working on or in contact with electrical equipment or wiring. Do not pass tools to or otherwise touch a person who is grounded.
2. Allow only qualified and authorized people to work on electrical equipment or perform electrical maintenance.
3. Keep all electrical controls in safe working order, accessible, and well marked.
4. Keep wires from becoming a tripping hazard.
5. Never use metal ladders or metal tape measures around electrical equipment.

6. Unless a wire is positively known to be dead and it is impossible for it to become accidentally live again, handle it as though it were a live wire.

7. When working around electrical equipment, keep your mind on the hazard at all times.

8. Always work from a firm base. Loss of balance may cause a fall onto energized parts. When working over energized busses or parts, cover them with a good electrical insulator such as a rubber blanket.

9. No safety device should be made inoperative by removing guards, using oversized fuses, or blocking or bypassing protective devices unless it is absolutely essential to the repair or maintenance activity and then only after alerting the operating personnel and maintenance supervisor.

4.302 Working in Pairs on Energized Equipment:--One man should never work alone on energized equipment that operates at or above 440V. When two men work together, one can double check the other, and there is always one man available to de-energize circuits, apply first aid, or summon assistance in the event of a mishap. Usually, there is sufficient work so that both men may work simultaneously. There are cases in which an experienced electrician might safely work alone on equipment that operates at 440V. An example is work on a magnetic starter in a dead front motor control center, with a positive means of de-energizing the starter completely, if this motor control center is located in a clean, dry, well lighted area with good accessibility. However, contact with 440V may be lethal, and it is a good general practice to have two men work as a team on equipment and circuits at that or higher voltage.

4.303 Holding and Locking Out Electrical Circuits:--The most important safety requirement in electrical maintenance is to have and adhere to a good system for holding and locking out electrical circuits when equipment is being repaired.

This system should be developed to suit the needs of the maintenance organization of the particular wastewater works. It should be coordinated with the system for holding equipment out of service for mechanical maintenance. The chief requirements of any system are simplicity and responsibility which should be clear and should be assigned to the person who is actually involved in the locking out or releasing operation.

4.304 Grounding Lines and Busses:--Before any work is performed on a line or bus that operates at a voltage of 440 or above, in addition to being de-energized and locked out, it should be grounded. Of course, before grounding the line or bus, it should be made certain that it is in fact de-energized by testing it with a pre-tested voltmeter.

4.305 Backfeed:--Precautions should be taken to make certain that there is no possibility of a backfeed on a de-energized circuit. Backfeed can occur from the following sources:

1. A tie with another electrical source;
2. A control circuit that is interlocked with a control circuit fed from another source;

3. The high voltage side of a potential or control transformer that is not disconnected from the bus or the low voltage side of the transformer that becomes energized from an extraneous source acting as a step-up transformer and energizing the bus at a high voltage; or
4. Standby or emergency electrical power source.

4.306 Grounding of Portable Electrical Tools:--Each portable electrical tool that is not inherently double-insulated should be equipped with a separate electrical conductor (in or on the cord) that will effectively ground the metallic case of the tool. For 110V, single-phase tools, the present practice is to have a three-conductor cord, with the case-grounding conductor wired to a three-prong polarized plug (that is, the plug should be designed for insertion into the receptacle in only one way). The mating contact in the receptacle for this grounding plug is wired to a special grounding wire carried in the same conduit with the supply wires. This conductor is normally colored green and should be used only for equipment grounding.

Recently, double-insulated portable electrical tools have been manufactured, eliminating the need for the grounding conductor referred to above. Periodic checks should be made, however, to ensure that the integrity of the double insulation has not been damaged, with resulting dangerous electrical leakage. The cord should also be examined periodically to ensure against leakage caused by wear, cut, or abrasion. Extreme care should be used when work is performed in wet locations. Portable electrical tools should not be used where an explosive hazard exists. It is recommended that tools be tested with a portable ground fault interruptor before checking them out of a tool room.

4.307 Live Busses and Specialized Locations:--Before working inside switchboards, power cabinets, and other locations where there are exposed energized busses or parts, all conductors should be de-energized to the greatest degree practical. If some circuits remain energized, the following precautions should be taken to minimize the possibility of shock or short circuit:

1. All live busses should be covered with insulating blankets.
2. The greatest caution should be used to prevent accidental contact with live busses or parts within reach. Extra care should be taken to prevent dropping tools on live busses or falling against live busses or parts.
3. Live parts should be touched only when absolutely necessary and then only when standing on a dry insulating surface, clear of all other conductors or grounding surfaces. Rubber safety gloves in good tested condition and approved for use on the voltage should be worn. Touch a circuit with only one hand.
4. To prevent eye damage from possible high intensity arcing, protective goggles should be worn for all work inside energized switchgear.
5. Rings, watches, metal frame glasses, and all other jewelry should be removed before performing such work.

4.308 Neutral Grounding--The present general practice is to ground the neutral of plant distribution and utilization supply systems. This provides the following safety features:

1. The voltage between any of the phases and ground is limited to the neutral voltage phase (86.6 percent of line voltage).
2. In the event of any accidental ground in a piece of electrical equipment or wiring, ground fault current will flow, trip a circuit breaker, and thereby separate the faulted circuit from the system. (In many older plants, the neutral of the power utilization voltage is left ungrounded so that essential equipment may be kept in service temporarily, even though a single accidental ground exists. If such an ungrounded system exists, it is recommended that it be modified to a grounded system.) In such a system, however, there is nothing to limit the voltage that might appear between a phase conductor and ground, and this voltage may, in certain cases, reach several times the value of the system voltage. Thus, a man working on 440V equipment would be subject to a possible shock from several times this voltage.

For this reason, for such ungrounded systems, it is essential that the system be equipped with a ground detector and alarm to notify operating personnel immediately in the event of the occurrence of an accidental ground and that measures be taken to locate the ground and to disconnect the grounded equipment or circuit from the system immediately.

4.309 Metallic Objects in Work Area--A potential hazard in electrical work is small metallic objects, such as tools, flashlights, and jewelry, making contact with or shorting across live electrical parts. Pliers, screw drivers, wrenches, or other tools used in electrical work should have insulated handles. The uninsulated working surfaces of these tools should be as small as practicable to minimize the possibility of metal contacting live parts. Electrical tape or other insulating material may be used for this purpose, but its use should be discouraged; insulated tools are much more preferable. Metal flashlights should, of course, never be used. Jewelry of any kind should not be worn when working with or near electrical circuitry.

4.310 Explosion-Proof Equipment--Before breaking the seal on an explosion-proof enclosure, make certain that the work area has good ventilation. A gas check should be made. Nearby equipment and facilities should be shut down if practical. The area should be continually monitored for gas, and only nonsparking, nonferrous tools should be used. On completion of the work, make certain that the explosion-proof fittings have been adequately resealed.

4.311 Current Transformers--The secondary circuit of a current transformer should never be opened while the primary circuit is energized, because a very high voltage may thereby be set up in the secondary circuit. This high voltage may cause shock to personnel or may even result in failure of the insulation, which, in turn, could subject the secondary wiring to the high primary system voltage with dangerous consequence.

4.312 High-Voltage Equipments:--Many larger wastewater plants have electrical substations, transmissions lines, and switchgear operating at higher voltages, such as 2,400, 4,160, 6,900, or 12,000. For such equipment, the services of the public utility providing the service should be obtained. Usually such substations are furnished and installed by the public utility, and therefore, employees of the wastewater works should be prohibited from performing any work on them.

33

Learning Resource #15

Plant Safety

Technical Publishing Company (TPC)  
1301 So. Grove Avenue  
Barrington, IL 60010

---

Lesson seven of this trainee's guide on electrical safety is reproduced, with permission, below. As indicated earlier in section I, other lessons in the TPC guide on plant safety are equally promising for use in safety education of supervisors and workers in wastewater treatment systems.

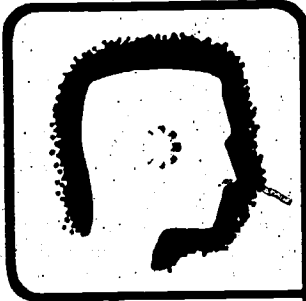

**Lesson Seven**

**Electrical Safety**

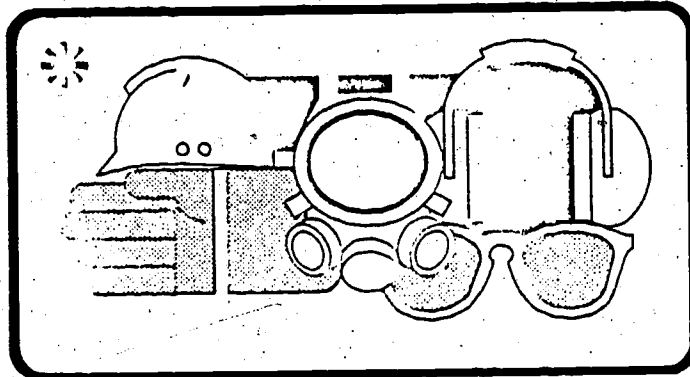

**TPC Training Systems**

**PLANT SAFETY**

**Lesson Seven – Electrical Safety**  
**CONTENTS**

	<b>Page</b>
Preface .....	99
The Nature of Electricity .....	99
Electrical Injuries .....	101
Preventing Electrical Accidents .....	102
Overcurrent Protection .....	103
Programed Exercises .....	104
Grounding .....	105
Protection Against Ground Faults .....	106
Hazardous Locations .....	107
Portable Power Tool Safety .....	107
Double-Insulated Tools .....	108
Electrical Safety .....	108
Programed Exercises .....	110
Self-Check Quiz .....	111
Answers to Self-Check Quiz .....	112

© Copyright by Technical Publishing Company,

A Division of Dun-Donnelley Publishing Corporation, A Dun & Bradstreet Company,  
Barrington, Illinois, 1974—all rights reserved, including those of translation.

No part of this material may be reproduced in any form or by any means, electronic or mechanical, including photocopying, recording, or by any information storage and retrieval system. Technical Publishing Company does not, by publication of data in this manual, ensure to anyone the use of such data against liability of any kind, including infringement of any patent. Publication of any data in this manual does not constitute a recommendation of any patent or proprietary right that may be involved.

Printed in the United States of America.



## Lesson Seven – Electrical Safety

### Preface

Normally, electricity is a useful source of power. However, when something goes wrong with a circuit or tool using it, or when it is handled with ignorance and disregard, electricity can become a deadly hazard. Injuries and death can result from direct contact with electrical current. You deal with electricity every time you turn on the lights, plug in and operate an electric tool or appliance, or start a machine. Thus, to avoid personal injury, you must know when, where, and how to avoid improper contact or use of devices through which electrical current is flowing.

This lesson explains what electricity is and how it can affect the human body. It also explains and illustrates some of the safe practices and uses of safety devices that can help you control, avoid, or eliminate electrical hazards with emphasis on safe use of portable power tools.

### The Nature of Electricity

7.01 Before you can protect yourself against the hazards of electricity, you must know something about it. Electricity is energy in the form of tiny, charged particles (electrons) which flow through a closed conducting path (a circuit) like water flowing through a pipe. Electrical current is the amount of electrons flowing past a given point in a given time and is measured in AMPERES (AM-peers). A pressure, electromotive force (emf), causes current flow. The pressure is measured in VOLTS. As the current flows through a circuit, it is being opposed. This opposition to current is called resistance, and is measured in OHMS.

7.02 The amount of current (amperes) flowing through a circuit is directly proportional to the electromotive force (volts) and inversely proportional to the resistance (ohms) of the circuit. This

relationship, is called OHM'S LAW and is expressed as:

$$I = \frac{E}{R}$$

where I = current in amperes  
E = electromotive force in volts  
R = resistance in ohms

In other words, the amount of electrical current is determined by dividing the force of the flow by the conductor's resistance. The result is current in amperes.

7.03 The energized conductor in an electrical circuit is often called the HOT wire. Electrical current flows to the loads such as portable tools and lights in a circuit through the hot and neutral (grounded)

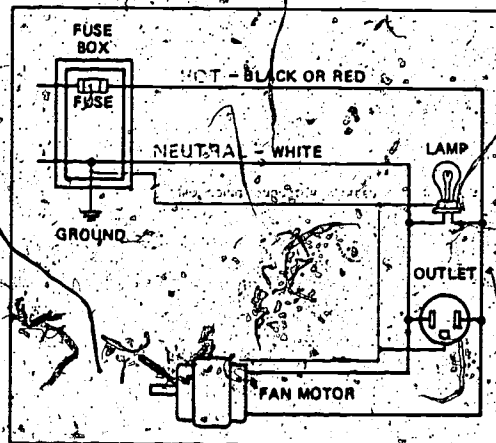

Fig. 7-1. Two-wire grounded-neutral electrical circuit.

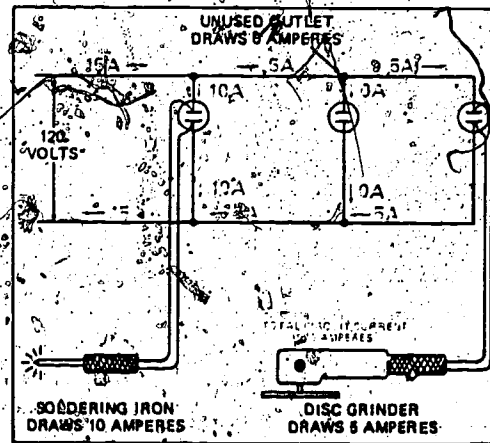

Fig. 7-2. Total current depends on total load.

wires. The wires are identified by the color of the insulation: black or red for the hot wires and white for the neutral wires, as illustrated in Fig. 7-1. Normally, current flows through the hot wire and the loads, returning through the neutral wire. An additional grounding conductor (green wire) provides grounding for the cases and frames of tools, outlets, and appliances. Electrical accidents and injuries can occur when a **SHORT CIRCUIT** (accidental connection between two points in an electrical circuit) or **ACCIDENTAL GROUND** (unintentional connection of a current-carrying conductor to ground) provide an alternate path through which current can flow.

7.04 Current will not flow through an open circuit, but some current will flow through every complete conducting path provided. Current divides itself among all the loads connected to a circuit according to their resistances. Total circuit current depends on the total load. For example, in a circuit where a soldering iron draws 10 amperes of current and a grinder draws 5 amperes, total circuit current is 15 amperes, divided as shown in Fig. 7-2.

7.05 If an electric drill is added to the circuit and draws an additional 7 amperes of current, the total circuit current will increase to 22 amperes. In other words, added loads cause total circuit current to increase. If you touch the hot conductor and any grounded conductor at the same time, your body

becomes an added load which also increases the total circuit current. The amount of current increase will be determined by the electrical resistance of your body at that particular time. The magnitude of current flowing through your body will determine the severity of shock and extent of injury.

7.06 Electrical circuits are referred to by their voltages. The most common voltages for residential and industrial applications are 120, 240, and 480. Circuits for ordinary lighting and small fractional-horsepower motors are usually 120 volts. For large motors and plant machinery, 240 and 480 volt circuits are common. The National Electrical Code defines high voltages as those exceeding 600 volts and low voltages as those between 24 and 600 volts. This can be misleading in terms of safety, however. Do not be deceived into thinking the term low voltage means low hazard, because you can receive a shock or burn from any energized circuit, no matter what the voltage may be.

7.07 "Safety" low voltages are those voltages lower than 24 volts, not because they eliminate shock hazards but because they reduce the severity of injury when shock occurs. Typical applications include hand lamps and portable electric tools powered by 6 to 12 volts. For a worker in a metal tank, shocks from a normal 120-volt circuit can be fatal. Due to the lower energy level in low voltage devices, a less severe shock is likely. Thus, safety low voltage devices are recommended for work inside metal tanks or in hazardous atmospheres.

## Electrical Injuries

7.08 The extent of injury received from an electric shock is determined by the amount of current that passes through your body, the path it takes, and the length of time you are in contact with the current. Voltage never killed anyone, it is current that does the damage.

7.09 Compared to the amount of current normally present in most circuits and appliances, the hazardous and fatal levels of current are very small—considerably less than one ampere (see Table 7-1). Note the current values are given in milliamperes (thousandths of an ampere), so 200 milliamperes equals 0.2 of an ampere. An ordinary 120-volt lighting circuit may have as much as 10 to 12 amperes of current flowing through it. That is many times more than enough to be fatal if the same amount of current flowed through your body.

7.10 Electrical shock occurs if your body becomes part of an electrical circuit. This can happen in three ways:

1. CONTACT WITH BOTH THE HOT AND NEUTRAL CONDUCTORS OF A CIRCUIT AT THE SAME TIME. Your body is then just like a light bulb filament or the windings in a motor. It, too, becomes a load between the conductors through which current will flow.
2. CONTACTING A CURRENT-CARRYING CONDUCTOR WHILE IT IS IN CONTACT WITH GROUND. This is unintentional grounding.
3. SHORT CIRCUITS. These occur when the hot conductor contacts metallic parts (handles or frames of a tool, for example), causing them to become energized. You can receive a shock if you are in contact with these energized parts when this happens.

7.11 Most fatal electrical shocks occur because the current flow is through or near the heart. For example, if the path is through both arms or an arm and a leg, as illustrated in Fig. 7-3, the current passes across the chest and either through or around the heart. A current of 100 milliamperes

CURRENT (Milliamperes)	EFFECTS
1 or less	No sensation - probably not even felt.
1 to 8	Shock is felt but not painful. Individual can let go at will. Muscular control is not lost.
8 to 15	Painful shock. Individual can let go at will because muscular control is not lost.
15 to 20	Painful shock. Muscular control is lost. Cannot let go.
20 to 50	Painful. Severe muscular contractions. Cannot let go.
50 to 200	Possible ventricular fibrillation. (A heart condition that results in death - no known emergency remedy available on the job.) Muscular contraction and nerve damage.
Over 200	Severe burns and severe muscular contractions - so severe that chest muscles clamp heart and stop it for the duration of the shock.

passing through the heart and lasting only one-third of a second can cause ventricular fibrillation (ven-TRIK-ya-lur fib-ril-LAY-shun) of the heart, a

Fig. 7-3. Fatal injuries can occur when shock current passes through your chest.

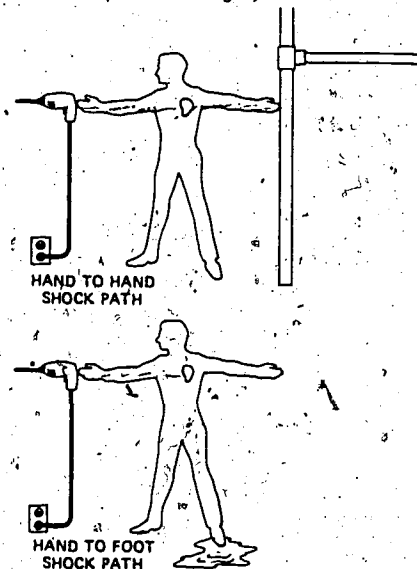

condition where the heart flutters uselessly and circulation stops. It usually results in death, because revival requires immediate use of a heart defibrillator by a medical technician. It is unlikely the equipment and the personnel will be available to aid every victim of fibrillation.

7.12 The effects of nonlethal amounts of current passing through the body range from a mild tingling sensation to severe pain and muscular contractions. The muscular reactions are particularly hazardous when you "freeze" or are unable to let go of the source of the shock. Other effects include burns, internal hemorrhaging (severe internal bleeding), and respiratory problems. In addition, secondary accidents can result when you suddenly pull back after receiving a shock.

7.13 Despite being in the lethal range, shocks from currents in excess of 200 milliamperes are not necessarily fatal. If the shock is severe enough, instead of causing fibrillation, the heart stops completely because the chest muscles contract. Then, if contact time is short and heart massage and mouth-to-mouth resuscitation are started immediately, it may be possible to restore normal heart action and circulation. When the heart stops, proper revival procedures must be administered within three to four minutes to save the victim. If delayed longer than 4 minutes, life cannot be restored.

7.14 Since speed is essential, start rescue and first aid measures as soon as it is safe to do so. *Do not, however, touch a shock victim while he is still in contact with the current.* If you cannot shut off power, drag or push the victim away from contact with a piece of dry rope, cloth, wood, or other nonconductive material. Be sure the item is dry because current can flow through wet rope, cloth, or wood. If "live" wires are lying on or near the victim, use a dry nonconductive object to lift them away or to pull the victim to safety. Then call for medical assistance and begin first aid immediately.

7.15 Your skin condition when you contact electricity greatly influences the severity of the shock. Dry skin has a very high electrical resistance, as indicated in Table 7-2, and significantly reduces shock effects. However, skin conditions change too often and rapidly to be depended on

Table 7-2. Typical electrical resistances.

Dry wood - 200,000 to 200,000,000 ohms per inch
Damp wood - 2,000 to 100,000 ohms per inch
No. 10 copper wire - 1 ohm per 1,000 ft
<b>HUMAN BODY:</b>
Dry skin - 100,000 to 500,000 ohms
Wet skin (perspiring) - down to 1,000 ohms
In water - down to 150 ohms
From hand to a foot - 400 to 800 ohms
Through the head, from ear to ear, approximately 100 ohms
<b>OHMS LAW:</b> $I = \frac{E}{R}$
<b>QUANTITY (AMPERES) = <math>\frac{\text{Pressure (volts)}}{\text{Resistance (ohms)}}</math></b>
<b>EXAMPLES:</b>
A. Dry skin: 120 volts ÷ 240,000 ohms = less than 0.5 milliamperes
B. Moist or wet skin: 120 volts ÷ 1,000 ohms = 120 milliamperes
C. Skin immersed or drenched: 120 volts ÷ 150 ohms = 800 milliamperes

for shock protection. With dry skin, a shock from a 120-volt circuit may be less than one milliamperé of current with little or no sensation. However, even a small amount of perspiration or moisture on the skin reduces resistance so drastically that shock current can suddenly reach lethal levels. Also, if you are standing in water or leaning against a wet surface, shock currents can reach 800 milliamperés, which is substantially above lethal levels.

#### Preventing Electrical Accidents

7.16 Electrical accident prevention is simply avoiding contact with energized circuits. While operating electric tools or equipment, insulate or isolate the current-carrying parts. During maintenance, repair, setup, or servicing of electrically powered devices, shut off power or, at least de-energize the circuit involved. Let local safety procedures and common sense dictate when to take electrical safety measures.

7.17 Electrical wires and cables are insulated with rubber or plastic to isolate the current-carrying conductors and are further protected by flexible or rigid conduit against damage. The insulation prevents contact between live wires except

where the insulation is damaged or stripped away to make circuit connections.

7.18 Wires with damaged or deteriorated insulation should be replaced. Only for emergency temporary repairs should these wires be wrapped with electrical tape. Where two or more wires are joined, the connection is normally taped, or capped with a thimble-like device called a wire nut, or coated with special "potting" compounds to prevent accidental contact with a bare conductor.

7.19 When current-carrying parts of an electrical circuit must be exposed during maintenance, shut off and lock out electrical power. This not only prevents accidental equipment operation during maintenance, but also prevents injuries if you should touch or fall against an exposed conductor nearby. Since it may not always be possible to deenergize all nearby circuits, you should know which circuits are energized and which are not before starting the job. If possible, place rubber sheets or plastic shields over and around exposed energized parts where contact can occur.

7.20 Always make sure you know what is behind or under material you are drilling or cutting with a power tool. Should the tool penetrate energized electrical wiring inside a wall or behind an obstruction, accidents and injuries can occur. Current from the energized circuit can flow through the tool you are holding and through your body to ground. Avoid such accidents by referring to electrical blueprints or consulting the electrical department to be sure no wiring is near where you must drill or cut.

#### Overcurrent Protection

7.21 Electrical circuits are designed to operate

below or at maximum rated current levels. For instance, many 120-volt circuits operate at or below 20 amperes. Should this current be exceeded, the circuit is subjected to an overcurrent condition (overload). FUSES and CIRCUIT BREAKERS, however, act as safety valves for electrical circuits and they open the circuit when overloads or short circuit conditions occur. They protect you by preventing operation of equipment with damaged or defective circuits which could produce shock hazards. They also protect equipment and circuit components from damage from excessive currents.

7.22 A "blown" fuse or "tripped" circuit breaker indicates something is wrong. Usually this is a short circuit or current overload. Do not attempt to reenergize the circuit until the problem is corrected. Normally, only electricians are allowed to replace fuses, reset circuit breakers, or make repairs to correct circuit problems. Also, often the electrical maintenance department is consulted before any circuit is energized or deenergized. Do not attempt any of these tasks unless you are authorized and trained to do so.

7.23 Fuses and circuit breakers normally provide adequate overcurrent protection, but are not dependable protection against shocks for two reasons. First, they only react to currents greater than their rated amperage. This means a 15 ampere fuse is not affected by a short circuit producing only 10 amperes of current, and that is more than enough to kill somebody. Second, fuses and circuit breakers do not react quickly enough. A shock current of 100 milliamperes for one-third of a second can be fatal. Yet it can take longer than that for a 15 ampere fuse or circuit breaker to open a circuit even when the current is in excess of 15 amperes.

Use these programmed exercises to help check your learning progress.

<p>7-1. Electric current in a circuit is measured in _____.</p>	<p>7-1. AMPERES REF: 7.01</p>
<p>7-2. Normal current flow in a circuit is through the hot wire and the loads, returning through the _____ wire.</p>	<p>7-2. NEUTRAL, WHITE, or GROUNDED REF: 7.03</p>
<p>7-3. High voltages are those exceeding _____ volts, and "safety" low voltages are below _____ volts.</p>	<p>7-3. 600 volts 24 volts REF: 7.06</p>
<p>7-4. Electric shocks are caused by _____ NOT by _____.</p>	<p>7-4. CURRENT VOLTAGE REF: 7.08</p>
<p>7-5. Electric shock is more likely to be fatal when the path of current is through or near the _____.</p>	<p>7-5. HEART REF: 7.11</p>
<p>7-6. To rescue a shock victim, first lift away "live" wires with a dry _____ object, then pull him to safety.</p>	<p>7-6. NONCONDUCTIVE object. Make sure the object is dry. REF: 7.14</p>
<p>7-7. Electrical accidents are prevented by avoiding _____ with energized circuits.</p>	<p>7-7. CONTACT REF: 7.16</p>
<p>7-8. Fuses and circuit breakers open electrical circuits when _____ or _____ conditions occur.</p>	<p>7-8. OVERLOADS or SHORT CIRCUIT conditions occur. They open the circuit whenever current exceeds the ratings of the fuses or circuit breakers. REF: 7.21</p>

## Grounding

7.24 A **GROUND** is any conducting connection between an electrical circuit and earth. Unplanned, unintentional connections to ground are **GROUND FAULTS**. Proper grounding helps keep voltages confined by avoiding dangerous differences in voltage levels between two conducting surfaces. In grounded-neutral power systems, the neutral conductor is connected to ground. This connection is referred to as the circuit ground.

7.25 **CIRCUIT GROUNDING** can be more easily understood by looking at low voltage secondary circuits found in most industrial plants. Such a circuit, 120-volts, 15-amps, with a 10-ohm circuit ground and ungrounded conduit is illustrated by the schematic in Fig. 7-4. When a short circuit occurs because of insulation failure, the ungrounded conduit becomes energized. The conduit now has the same potential (120 volts) as the ungrounded circuit conductor inside it, but no fault current can flow because the conduit is not grounded and the fuse doesn't blow. But anyone touching the conduit and ground will experience a shock which could be fatal.

7.26 Even if the conduit and the circuit are separately grounded, as in Fig. 7-5, there is still a risk of shock when a fault occurs. Under the conditions given in the illustration, 4 amperes of fault current flow from the conduit to ground, through the earth to circuit ground and back to the unfused conductor. The 4 amperes of current are not enough to blow the fuse, but more than enough to cause injury or death. In addition, there is an 80-volt potential between the conduit and ground.

7.27 Connecting the conduit and the neutral conductor to a *common ground*, as shown in Fig. 7-6, provides better shock protection than the other conditions just described. The conduit and the neutral wire are connected at the ground point. Thus, any fault between the hot conductor and the grounded conduit is the same as a short circuit between the hot and neutral conductors. A large fault current is created which quickly blows the fuse. A small amount of voltage appears momentarily on the conduit, but only for the short time it takes the fuse to blow.

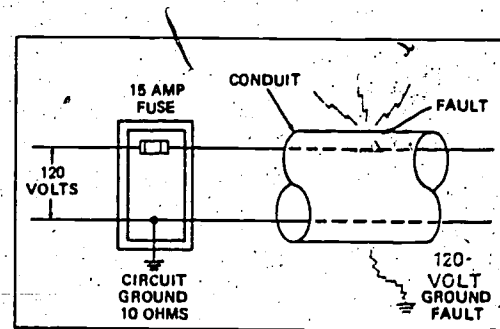

Fig. 7-4. Circuit grounded - conduit not grounded.

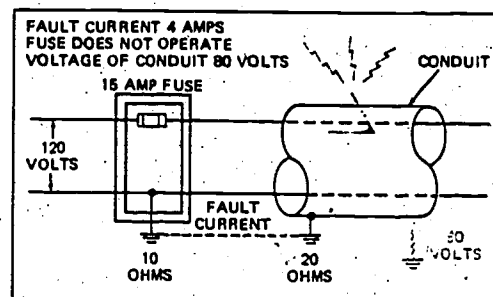

Fig. 7-5. Circuit and conduit grounded separately.

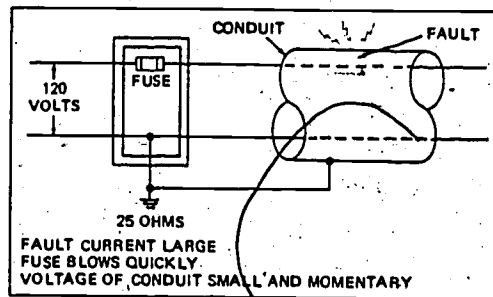

Fig. 7-6. Circuit and conduit connected to common ground.

7.28 **EQUIPMENT GROUNDING** is a method of shock protection for both portable and stationary electrical equipment. It uses an additional wire (green) to ensure the handle, case, frame, or other exposed metal parts of an appliance are connected to ground. As shown in Fig. 7-7, this grounding wire does not carry current except when a short circuit occurs and a fault current develops between the hot conductor and tool frame. If the fault current is large enough, it will blow the fuse or trip the circuit breaker. If not, the grounding wire at least provides an alternate path (instead of through

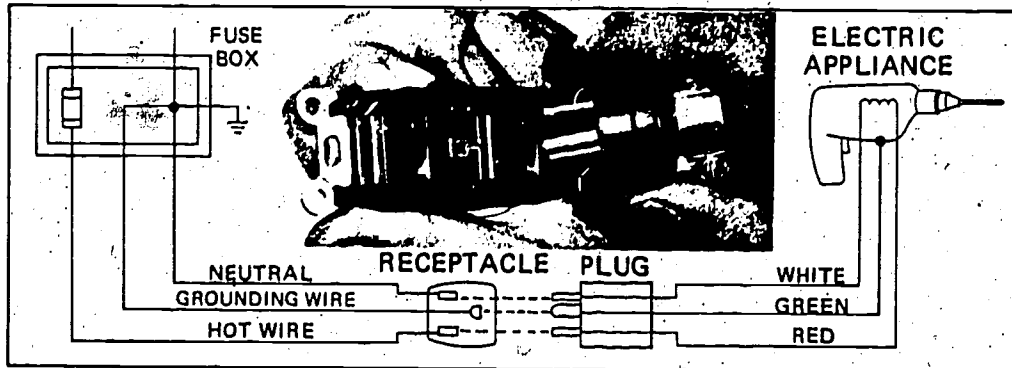

Fig. 7-7. Typical equipment grounding circuit.

your body) for carrying off a fault current.

7.29 The shape and arrangement of plug prongs and outlet slots prevent incorrect connections of the equipment grounding circuit. When a short circuit develops between the hot conductor and the frame of a two-wire ungrounded appliance, there is no alternate path for the fault current. Thus, if you touch the energized metal parts while in contact with ground, you will receive a shock. But, in three-wire grounded equipment, the short circuit current is carried off by the grounding wire.

7.30 The grounding wire must be in good condition and securely connected if equipment grounding is to be effective. A loose, corroded, or poorly connected ground connection can produce a high resistance to the flow of current. This can cause some of the fault current to flow through your body instead of being carried off by the grounding wire. For this reason, it is good practice to regularly check the condition and security of the grounding wire in tools and appliances that have equipment grounding provisions.

#### Protection Against Ground Faults

7.31 A GROUND FAULT is any path (circuit) established unintentionally between a current-carrying conductor and ground. Besides occurring in defective equipment, ground faults can result when serviceable equipment is abused, such as accidentally setting or dropping an energized electric tool in water. Depending on conditions and the nature of the contact, a ground fault has either high or low resistance. If it has low resistance, large

amounts of current flow, and the fuse blows or the circuit breaker trips to open the circuit.

7.32 Shock hazards are greater when the fault has a high resistance and not enough fault current flows to blow the fuse or trip the circuit breaker. In such cases, a GROUND FAULT CIRCUIT INTERRUPTER (GFCI) can protect you against shock. Under normal conditions when no ground fault exists, as in Fig. 7-8(A), the GFCI does nothing. However, the instant a ground fault occurs, there is an imbalance of current between the hot and neutral conductors, as shown in Fig. 7-8(B). The GFCI detects this imbalance and immediately opens the circuit before the fault current can reach a hazardous level.

Fig. 7-8. Ground fault circuit interrupters (GFCI).

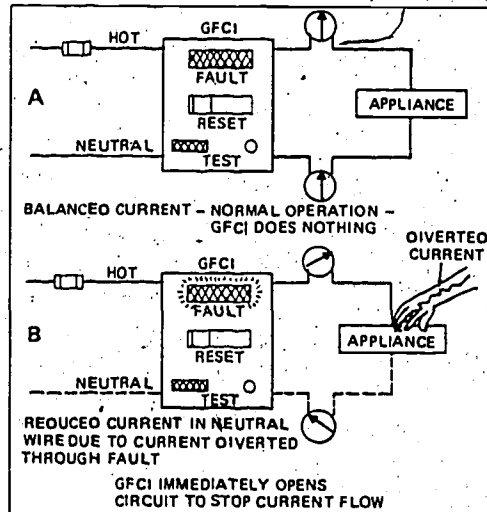



7.33 GFCI devices supplement the protection offered by fuses or circuit breakers because they react instantly to very small amounts of fault current. For example, some GFCIs react (trip to open the circuit) in only 0.025 of a second for a fault current of only 0.005 of an ampere (5 milliamperes). The GFCI reacts only to ground faults and not to short circuits (hot-to-neutral or line-to-line faults). However, short circuits often create a sufficient overload to trip circuit breakers and blow fuses.

7.34 Examples of portable GFCIs for protection at the point of use are illustrated in Fig. 7-9. Some plug-in units are small enough to be carried in a toolbox. For permanent applications, wired-in models and combination GFCI/circuit breakers can be installed in or near the distribution panel. Some outlets or receptacles also have built-in GFCIs. Because of the variety of GFCIs and the protection they provide, many plants are installing them in all normal duty, 120-volt electrical circuits, especially those for portable electric tools.

#### Hazardous Locations

7.35 Electrical equipment and wiring installed or used where flammable materials or explosive atmospheres exist require special safety measures. When the hazards cannot be limited or eliminated by ventilation, then local codes and regulations usually require the equipment and wiring to be intrinsically (inherently) safe and/or explosion proof.

That is, designed to prevent the ignition of a surrounding hazardous gas or vapor mixture.

7.36 Electrical equipment considered **INTRINSICALLY SAFE** is incapable of releasing enough electrical energy to ignite a hazardous atmosphere under normal or abnormal conditions. This generally applies to equipment with safety low voltage (less than 24 volts). However, the degree of safety provided depends on the nature and concentration of the hazardous material. For this reason, intrinsic safety is rated and specified for certain maximum proportions of various materials in air.

7.37 **EXPLOSION-PROOF** equipment is capable of containing an explosion within itself, so the explosion cannot ignite the surrounding atmosphere. The enclosures and guards placed over light bulbs in hazardous locations are explosion proof. The special, protected hand lamps used for temporary lighting in such areas is another example.

#### Portable Power Tool Safety

7.38 Never use faulty power tools. When tools or their cords are damaged or defective, replace them at once with tools in good condition. Damage to electric wiring and insulation can cause the metal parts of any tool, machine, or structure to become conductors of electrical current. Also, unless you are insulated from ground, you will receive

Fig. 7-9. GFCI devices at the point of use.



PORTABLE

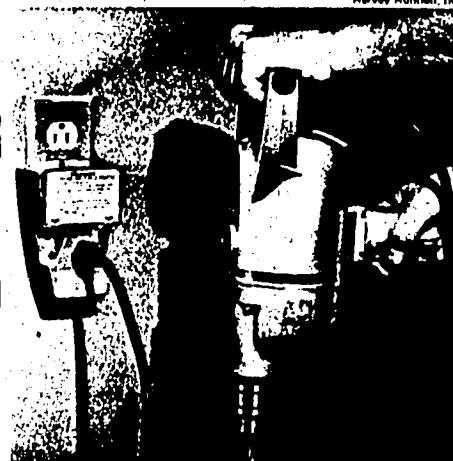

PLUG-IN

a shock when you contact the circuit. If equipment grounding is provided, the grounding wire will carry off most of the shock current. The grounding wire can make the shock current harmless if it is correctly designed and securely connected.

7.39 The reason for grounding tools and machines is because resistance limits current. More current flows through a low resistance conductor than through a high resistance one, so a low resistance path to ground provides a considerable amount of protection against shock by diverting the current. Clothing and dry skin offer some resistance and protection, but a properly connected green (grounding) wire in the three-wire grounding system provides a better path of very low resistance to ground.

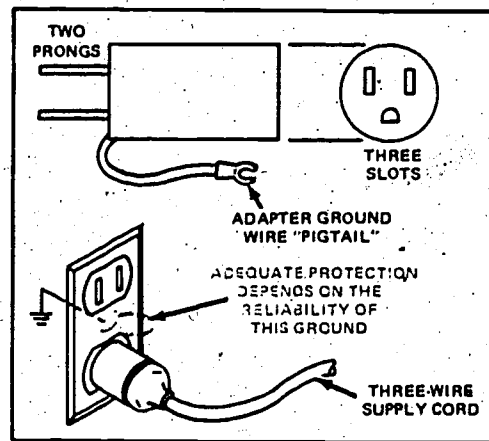

Fig. 7-10. Proper use of equipment grounding adapter.

7.40 Unfortunately, the three-wire grounding system is not foolproof because it can be ignored or evaded, and the results are accidents and injuries. A three-prong plug can be connected to a two-slot receptacle with an adapter, as shown in Fig. 7-10. The short "pigtail" wire completes the ground connection circuit. However, this pigtail is frequently ignored because it takes a little extra time and effort to connect it. Even when it is connected properly, the connection point has to be a reliable ground or protection is lost. If you use an adapter, you must connect the pigtail to a suitable ground.

7.41 Equipment grounding offers no protection if the grounding contact is broken off or bent over in an attempt to insert a three-contact plug into a two-contact receptacle. This is a *deliberately unsafe act* for which there is no excuse. Use either an adapter or a three-wire grounded extension cord to reach a source of power through which the grounding connection can be made.

7.42 Even when using a tool with the grounding protection properly connected, there is a chance of electric shock. This is because your body is grounded through the same grounding wire that is connecting exposed metal parts to ground. If you touch an ungrounded current-carrying conductor while you are grounded through the tool you are holding, you will receive a shock. So be aware you are grounded when holding the tool, and take special precautions to avoid contact with nearby energized circuits.

#### Double-Insulated Tools

7.43 Two-wire, DOUBLE-INSULATED tools are alternatives to the three-wire equipment grounding system. They are designed and constructed so the operator is insulated from possible shocks by a case or liner of insulating material.

7.44 All tools powered by electrical energy have FUNCTIONAL INSULATION: the normal insulation around wiring and other current-carrying parts. Double-insulated tools have an additional, independent insulation system called PROTECTIVE INSULATION. It protects the operator from shock if the functional insulation fails.

7.45 Some double-insulated tools have plastic housings similar to the plastic case of the portable sander in Fig. 7-11. Tools with metal exteriors are double-insulated with a plastic inner liner which surrounds and isolates any metal parts that might become energized if functional insulation fails. In addition, the housings of switches or controls are made of nonconductive materials and the tool shaft or arbor is fitted with an insulating sleeve.

#### Electrical Safety

7.46 Workers in every plant should take these precautions for electrical safety:

CONSIDER ALL ELECTRICAL CIRCUITS ENERGIZED AND DANGEROUS until you are certain they are not.

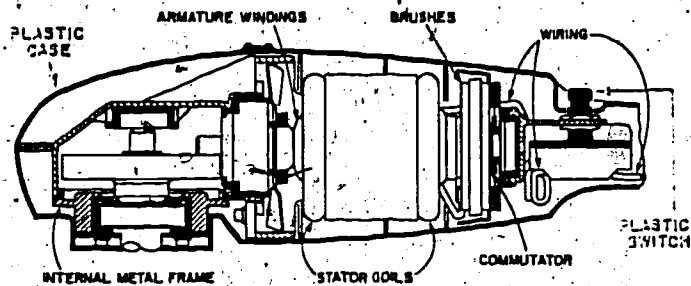

Fig. 7-11. A double-insulated tool.

**CHECK YOUR WORK-AREA** for puddles or wet surfaces, nearby energized circuits that must be avoided, and metal pipes or posts against which you could be grounded.

**DO NOT WEAR RINGS, WATCHES, or other metal jewelry items** when working near electrical circuits.

**DO NOT USE METAL LADDERS or uninsulated metal tools** on or near circuits.

**USE ONLY INTRINSICALLY SAFE OR EXPLOSION-PROOF TOOLS AND HAND LAMPS** in hazardous locations. Minimize shock hazards in metal tanks by using low voltage (6 or 12 volt) equipment.

**SHUT OFF AND LOCK OUT POWER** before repairing a circuit or attempting a mechanical repair near an exposed electrical hazard.

**EXAMINE ALL ELECTRICAL TOOLS AND EQUIPMENT** for signs of damage or deterioration.

**DO NOT ENERGIZE OR DEENERGIZE ANY ELECTRICAL CIRCUIT UNLESS:**

1. You are authorized to do so.
2. You are familiar with circuit controls and you know what is connected in the circuit.
3. All other workers are not in danger and have been specifically notified power is about to be turned on or off.

Use these programmed exercises to help check your learning progress.

<p>7-9. In an electrical circuit, any unplanned, unintentional connection to ground is a ground _____.</p>	<p><b>FAULT</b> REF: 7.24</p>
<p>7-10. In equipment grounding the green wire provides an alternate path for carrying off _____.</p>	<p>7-10. <b>FAULT CURRENT.</b> It provides shock protection when the case or frame of a tool is energized by a fault current. REF: 7.28</p>
<p>7-11. When a fault has a high resistance and fault current is not enough to blow the fuse, a _____ can protect you against electrical shock.</p>	<p>7-11. <b>GFCI</b> (ground fault circuit interrupter) REF: 7.32</p>
<p>7-12. Electrical equipment incapable of operating in a hazardous atmosphere or capable of containing an explosion within its enclosure is called _____ safe or _____ proof.</p>	<p>7-12. <b>INTRINSICALLY safe</b> or <b>EXPLOSION proof</b> REF: 7.35, 7.36, 7.37</p>
<p>7-13. The short "pigtail" wire on an adapter completes the _____ connection for a three-wire plug in a two-slot outlet.</p>	<p>7-13. <b>GROUND.</b> If the "pigtail" wire is not connected, the protection offered by the three-wire system is lost. REF: 7.40</p>
<p>7-14. On a three-prong plug, it is an unsafe act to _____ the grounding prong.</p>	<p>7-14. <b>BEND OVER</b> or <b>BREAK OFF.</b> This eliminates the protection offered by equipment grounding. REF: 7.41</p>
<p>7-15. A liner of insulating material in _____ tools protects the operator from shocks.</p>	<p>7-15. <b>DOUBLE-INSULATED</b> REF: 7.44</p>
<p>7-16. All electrical circuits should be considered _____ and dangerous until proven otherwise.</p>	<p>7-16. <b>ENERGIZED</b> REF: 7.46</p>

### SELF-CHECK QUIZ

- 7-1. What unit is used to measure the current flowing in an electrical circuit?
- Volt
  - Ohm
  - Ampere
  - Watt
- 7-2. Electric shocks are usually fatal if shock current exceeds
- 0.02 amperes
  - 0.02 milliamperes
  - 0.2 amperes
  - 0.2 milliamperes
- 7-3. Which of the following effects of electric shock require immediate attention by trained medical personnel?
- Muscular contractions
  - Ventricular fibrillation
  - Defibrillation
  - All of the above
- 7-4. When the insulation on current-carrying wires in a circuit is damaged or deteriorated, the wires should be
- replaced
  - separated
  - taped
  - stripped
- 7-5. What amount of current will cause a 15-ampere fuse in a 120-volt circuit to open (blow)?
- 1450 microamperes
  - 120 milliamperes
  - Current exceeding 15 amperes
  - All of the above
- 7-6. Why is it good practice to connect the neutral conductor and the metallic conduit of an electrical circuit to a common ground?
- Better shock protection
  - Eliminate ground faults
  - Reduce fault current
  - Improve circuit emf
- 7-7. The equipment grounding (green) wire does not carry current except when
- a fault current occurs
  - it is not grounded
  - the fuse blows
  - overheating occurs
- 7-8. A device that reacts to open the circuit when a fault current as small as 10 milliamperes occurs is called a/an
- circuit breaker
  - EMF detector
  - GFCI
  - fuse
- 7-9. The purpose of the short "pigtail" wire on an adapter for a three-prong plug is to
- eliminate static sparks
  - complete the grounding circuit
  - replace a GFCI
  - increase line-to-line resistance
- 7-10. When using double-insulated tools, protection against shocks is provided by the
- two-wire supply cord
  - three-wire supply cord
  - plastic case or liner
  - pigtail wire

### ANSWERS TO SELF-CHECK QUIZ

- 7-1. c. Ampere. REF: 7.01.
- 7-2. c. 0.2 amperes. REF: Table 7-1, 7.09.
- 7-3. b. Ventricular fibrillation. REF: 7.11.
- 7-4. a. Replaced. REF: 7.18.
- 7-5. c. A current exceeding 15 amperes. REF: 7.23.
- 7-6. a. Better shock protection. REF: 7.27.
- 7-7. a. A fault current occurs. REF: 7.28.
- 7-8. c. GFCI. REF: 7.33.
- 7-9. b. Complete the grounding circuit. REF: 7.40.
- 7-10. c. Plastic case or liner. REF: 7.43, 7.45.

TPC Training Systems, 1201 So. Olive Ave.  
Barrington, Illinois 60010-3123

SECTION VI

SAFETY: Fire and Explosion

Workers in wastewater treatment systems are subject to dangers associated with fires and explosions. Electrical fires are always a possibility in a plant that uses large amounts of electricity to power pumps, fans, conveyers, incinerators, and other equipment. Oil, grease, gasoline and other substances that can result in Class B fires are often stored in fairly large quantities. Instruction regarding various types of fires, how they can be extinguished, and still better how they can be prevented, is an important part of a safety program.

Explosion possibilities constitute a particularly dangerous hazard. Methane, the explosive gas responsible for many coal miner deaths, can be found in manholes, wet wells, and digester tanks. Hydrogen sulfide produced during sewage decomposition is another explosive hazard. Gasoline and other volatile carbon compounds often find their way into wastewater systems from leaking storage tanks, discharge from garages, commercial or home dry-cleaning operations, or from chemical-industrial plants.

Awareness of explosion hazards and mastery of techniques to be used in protecting oneself and colleagues from these dangers are important objectives of a safety education program for wastewater system workers.

This section includes some teaching-learning materials in this area. The reference section identifies additional resources.



Learning Resource #16

"Plant Safety and Good Housekeeping"

Chapter 14, Operation of Wastewater Treatment Plants: A Field Study Training Program Vol. II, 1980

Kerr, Kenneth D., Project Director  
California State University, Sacramento  
6000 "A" Street  
Sacramento, CA 95819

---

This chapter includes a short section on fire prevention which is reproduced below. The basic ideas of the section should be required knowledge for all workers in a wastewater treatment plant. Supervisors and workers must work constantly to implement the fundamental fire prevention practices listed in section 14.42.

#### 14.4 FIRE PREVENTION

Fires are a serious threat to the health and safety of the operator and to the buildings and equipment in a treatment plant. Fires may injure or cause the death of an operator. Equipment damaged by fire may no longer function properly, and your treatment plant may have difficulty adequately treating the influent wastewater.

Good safety practices with respect to fire prevention require a knowledge of:

1. Ingredients necessary for a fire
2. Fire control methods
3. Fire prevention practices

#### 14.40 INGREDIENTS NECESSARY FOR A FIRE

The three essential ingredients of all ordinary fires are:

1. FUEL - paper, wood, oil, solvents, and gas.
2. HEAT - the degree necessary to vaporize fuel according to its nature.
3. OXYGEN - normally at least 13 percent of oxygen in the air is necessary to sustain a fire. The greater the concentration, the brighter the blaze and more rapid the combustion.

To extinguish a fire, it is necessary to remove only one of the essentials

1. Cooling (temperature and heat control)
2. Smothering (oxygen control)
3. Isolation (fuel control)

Fires are classed as A-, B-, C-, or D-type fires, according to what is burning.

Class A fires (general combustibles such as wood, cloth, paper, or rubbish) are usually controlled by cooling - as by use of water to cool the material.

Class B fires (flammable liquids such as gasoline, oil, grease, or paint) are usually smothered by oxygen control - as by use of foam, carbon dioxide, or a dry chemical.

Class C fires (electrical equipment) are usually smothered by oxygen control - use of carbon dioxide or dry-chemical extinguishers - nonconductors of electricity.

Class D fires occur in combustible metals, such as magnesium, lithium, or sodium, and require special extinguishers and techniques.

Use carbon dioxide compressed gas extinguishers to control fires around electrical contacts. Do not use soda-acid type extinguishers because the electrical motor will have to be rewound and you could be electrocuted attempting to put out the fire.

Know where fire extinguishers and hoses are kept and know where yard hydrants are located, what each is for, and how to use them.

#### 14.42 FIRE PREVENTION PRACTICES

You can prevent fires by:

1. Maintaining a neat and clean work area, preventing accumulation of rubbish.
2. Putting oil- and paint-soaked rags in covered metal containers.
3. Observing all "no smoking" signs.
4. Keeping fire doors, exits, stairs, fire lanes, and firefighting equipment clear of obstructions.
5. Keeping all burnable materials away from furnaces or other sources of ignition.
6. Reporting any fire hazards you see that are beyond your control, especially electrical hazards which are the source of many fires.

Finally, here again are the things to remember:

1. Prevent fire by good housekeeping and proper handling of flammables.
2. Make sure that everyone obeys "no smoking" signs in all areas near explosive or flammable gases.
3. In case of fire, turn in the alarm immediately and make sure that the fire department is properly directed to the place of the fire.

4. Action during the first few seconds of ignition generally means the difference between destruction and control. Use the available portable fire-fighting equipment to control the fire until help arrives.
5. Use the proper extinguisher for that fire.
6. Learn how to operate the extinguishers.

If it is necessary to get out of the building, do not stop to get anything - just get out!

Can you prevent fires? You can if you try, so let's see what we can do to preserve our well-being and the water pollution control system.

If you guard against fires, you will be protecting your lives and your community.

#### 14.43 ACKNOWLEDGMENT

Material in this section on Fire Prevention appeared in the July 1970 issue of the Journal of the Water Pollution Control Federation, on pages 1426 and 1427, as a Wastewater Wisdom talk. Originally, the information appeared as a National Safety Council "5 Minute Safety Talk," published in the INDUSTRIAL SUPERVISOR.

Learning Resource #17

Team Up For Safety in '81

The Industrial Commission of Ohio, Division of Safety and Hygiene  
in cooperation with The Society of Ohio Safety Engineers  
246 North High Street  
P. O. Box 16512  
Columbus, OH 43215

---

This resource, described earlier in Section I, suggests that the safety education focus for one month in a facility such as a large wastewater treatment plant might be fire safety.

The following background material and teaching suggestions are offered.

**PUT OUT THE FIRE**

In 1978 fire claimed approximately 6,100 lives. The U.S. Fire Administration set property damage caused by fire during 1978 at approximately \$4.4 billion. The administration's figures also show that each day 153 manufacturing and basic industry installations were hit by fire and that 40 percent of these installations never resumed production. This means lost jobs, lost production and buildings that may never be replaced.

However, fire is an essential part of our lives. We cannot do without it, but we must prevent and stop unwanted fires that destroy our lives, jobs and buildings. We must put out the fire.

The achievement of such a goal requires the cooperation of all personnel. To prevent fires we must all work together. This also requires a commitment by top management to provide adequate training in the operation and maintenance of fire prevention devices.

Fire prevention devices and extinguishing agents have been available for years. In recent years important developments in fire prevention have reduced the problem to a great extent. Today, most industries offer fire prevention training through their employee safety education programs.

Effective fire prevention programs teach employees what causes ignition and what they can do to prevent ignition. Employees should learn how to use all portable fire extinguishers, understand the importance of using the proper extinguisher for each class of fire, know where fire extinguishers are located and be aware of the procedures to follow if a fire extinguisher needs to be recharged.

Many industries have their own fire brigades. The brigade should receive special training so all members are able to operate available firefighting equipment in order to cope with any firefighting problem that may be encountered.

**NOTE TO DISCUSSION LEADER:**

If your company has a fire brigade, describe the training they have received.

Special training also should be provided to employees who inspect and maintain fixed devices, such as water supplies, hydrants, automatic detection systems, sprinkler systems and manual firefighting apparatus.

Housekeeping is a very important part of any fire prevention program. Take the time to put waste paper in the noncombustible containers that are provided. Keep your work area clean. Trash, such as oily rags or paper that can cause spontaneous combustion, should not be allowed to accumulate.

Employees must comply with no smoking signs around painting areas, paint storage facilities, oxygen tanks and flammable liquid storage areas. Just one lighted cigarette could cause a fire that would destroy our buildings, jobs and possibly some lives.

In areas where fire hazards cannot be totally eliminated, we must work as a team and use every possible precaution to reduce the chance of fire.

**NOTE TO DISCUSSION LEADER:**

Bring a fire extinguisher to the meeting and show your employees how to use it. Review your company's fire record and discuss it with employees. Describe the fire protection available at your company, where fire extinguishers are located, and the evacuation procedures for employees in your area.

We all must be aware of the problems that can occur because of human error. Our plan covers all phases of a good fire prevention program and includes specific duties that are assigned to key personnel.

Together we can put out the fire before it starts. If we cooperate in this effort, we can make our fire prevention program work.

Learning Resource #18

Booklet: On-The-Job FIRE SAFETY

Channing L. Bete Co., Inc.  
200 State Road  
South Deerfield, MA 01373

This illustrated 14 page booklet presents the basic principles of fire safety. The booklet could be used by a supervisor to present initially or to review with his workers (1) the causes of industrial fires, (2) preventive measures, (3) what to do in case of fire, (4) different kinds of fire extinguishers, and (5) a fire safety checklist.

The booklet contains a large amount of information. Twelve common hazards that cause industrial fires are listed:

Open Flame	Portable Heaters
Spontaneous Ignition	Static Electricity
Hot Surfaces	Flammable Liquids
Mechanical Sparks	Chemicals
Electrical Equipment	Smoking
Friction	Welding and Cutting
	Arson

The example cited for each hazard, together with other sections of the booklet, provide material for a supervisor-worker discussion session on fire safety.

Learning Resource #19

Film "Using Extinguishers---The Right Way"

N.F.P.A. Film Library

470 Park Avenue South

New York, NY 10005

Mr. Keith McGrail, Film Librarian at the Ohio State Fire Academy, has prepared the following outline which should be useful when using this resource:

I. "Using Extinguishers---The Right Way"

A. Introduction to the Film

1. Emphasize that in the initial shots introducing subject matter of the film they intentionally show improper use of the extinguishers. This is done to show the importance of knowing how and when portable extinguishers should be used.

a) The improper use includes the following examples:

1. The wrong agents are introduced to the type of fire which is being attacked.
2. Improper application of correct agents are shown in the following manners:

- a) The agents are not directed to the base of the fire nearest the person using the extinguishers.
- b) The agents are introduced facing into the wind rather than with the wind at their backs. In this situation, the agent will not reach the fire and be able to do its' job.

2. Actual use of extinguishers under controlled situations should be a part of your training program. Local fire authorities in your jurisdiction can assist you in planning this part of your program.

3. An employee, upon leaving your training sessions should be properly trained and ready to act in case of a fire situation in your establishment. Their training should have them knowledgeable in the areas of:

- a) When the proper time to use a fire extinguisher is in relation to the fire. Too large a fire or a situation where the extinguisher does not sufficiently do the job intended for it requires immediate action to vacate the fire area immediately.
- b) Being ready to properly operate the extinguishers, including the following:

1. Knowing where the nearest extinguisher to their work area is and exactly how it operates.
2. Knowing how to properly remove the extinguisher from brackets and put it into operation.
3. Knowing proper procedures on what to do once your extinguisher has been used.

- 4) Knowing that we always call the fire department first before we begin any of the items just mentioned, many small fires become monsters we cannot control because we didn't call the fire department first. Use of an extinguisher doesn't always guarantee we will be successful in putting the fire out. We have a major problem on our hands if we are not successful and the fire department hasn't been called.

#### Film Content and Discussion

1. Classes of Fire Extinguishers
  - a) Class A- for use on ordinary combustibles (wood, paper, etc.)
  - b) Class B- for use on flammable liquid fires
  - c) Class C- for use on electrical fires
  - d) Class D- for use on metal fires such as magnesium
  - e) Classon intended for multiple uses
    1. Class B/C- for use on flammable liquid and electrical fires.
    2. Class A/B/C- for use on ordinary combustibles or flammable liquids or electrical fires.
2. Breakdown of different types of extinguishers in each class. This is explained extensively in the film.
3. Proper procedure to use in a fire situation
  - a) Call the Fire Department first before beginning any extinguishing activity.
  - b) Properly size up your situation--is your fire small enough to handle with a portable fire extinguisher?
    1. If not, exit the building immediately.
    2. If you feel it is small enough to attack, go to the following steps.
  - c) Be sure you know what type of extinguisher you have available to you and what fires it can be used on, as well as what type of fire you have. If you cannot determine either what type of fire you have or what type extinguishing agent you have, DO NOT USE YOUR EXTINGUISHER!! Introduction of the wrong agent on a fire can cause the fire to spread and build up, as well as possibly causing serious injury or death to the operator of the extinguisher. If you do use the extinguisher, keep yourself in a position where you have an exit from the building.
  - d) Once your extinguisher has been used, make sure it is marked to be refilled and recharged. Have a designated place for extinguishers in need of maintenance to restore it to operating condition. Even in the case where a small amount of the agent has been used, the extinguisher must be refilled and recharged prior to remounting and being put back into service. NEVER PUT AN EXTINGUISHER BACK IN SERVICE WITHOUT HAVING IT CHECKED FIRST IF THERE IS ANY DOUBT.

#### 4. Areas of Discussion With the Trainees



a) Fire escape plans and evacuation plans for work areas within the building.

1. Fire Wardens/Floor Wardens

a) What are their duties in conjunction with the fire plan?

b) All workers must know who their warden is and what the assigned task for their area is. A fire situation is no time to be finding out that employees don't know what to do.

1. Where is the designated exit for your area in case of fire?

2. Where is your alternate means of escape?

3. Do all employees under your leadership in the building know where their primary and secondary escapes are?

2. Necessary Information for Each Employee

a) Know where the planned exits for your work area are.

b) How does the fire extinguisher in your work area operate?

c) Where is the extinguisher and what type is it?

d) Do you know who the floor warden in your area is?

e) Do you have any other duties other than exiting the building in case of fire?

b) Questions For Use In Discussion Period With Your Group

1. Where is the nearest fire alarm from your office/desk?

2. Do you know how it operates?

3. Where is the nearest fire extinguisher from your desk/office?

4. Do you know how it operates?

5. What type of fire can your extinguisher be utilized on?

6. That means it is what class of extinguisher?

7. Do you know how you will exit your building in case of fire?

8. If your primary exit is blocked, where is your alternate means of escape?

9. Is it necessary to worry about having a means of escape from the fire when operating your extinguisher? why?

10. In detail in your own words, could you effectively relate to someone who has not operated your fire extinguisher the proper steps to put it to use?

11. Once your extinguisher has been used, especially if there is still a quantity of the agent remaining in the cylinder, can we put the extinguisher back into operation?

12. What if the extinguisher in question 11 is only removed from the bracket and doesn't feel as though it has been used?
13. Do you know, in enough detail, your place of employment's fire plan? If not, do you plan to learn about it?

SECTION VII

SAFETY: Laboratory Operation

Workers in the laboratory of a wastewater treatment plant are concerned with the safety problems inherent in working with chemicals and biological materials. Typically, laboratory personnel have had high school and probably college science courses; consequently they are aware of many aspects of laboratory safety.

These workers, however, probably have not had the responsibility of being in charge of a laboratory. They have not been responsible for organizing and operating a laboratory within state or federal safety standards.

If safety conditions in chemical/bacteriological/biological laboratory are to improve three things are required:

- A change in attitude
- An expenditure of funds
- The development of common sense

The first element is the most difficult to achieve. Workers often feel that because there have been no, or few, accidents in the past there is no reason to change. This is the most dangerous attitude of all. The underlying motivation for a laboratory safety program should be the prevention of accidents, not corrective action after the fact.

Installation of a safety shower is little consolation to the analyst who lost the use of an eye or been scarred for life by acid.

Getting experienced employees to think about safety as they carry out their laboratory work is all important. Use of safety posters, a talk by management, or even a system of reward for employee safety suggestions, are possible ways of bringing about attitude change. It is important that these efforts be part of a continuing program and not a "one shot" effort. For new employees, safety must be an integral, not separate, part of their training in carrying out laboratory procedures.

No expenditure of money for safety equipment such as eye wash fountains, fire extinguishers, safety showers, etc., will prevent accidents. And yet, this equipment is needed to lessen the effect of accidents should they occur. Safety equipment is expensive, and management may hesitate at the number of dollars needed. The cost is easily determined. Far more difficult to ascertain, however, is the cost of having an employee permanently disable, or in the hospital for several weeks. These costs are just as real as those for purchasing needed safety equipment. In almost all cases, dollars spent for ordinary laboratory safety equipment will be far less than those "spent" as a result of one serious accident. In addition, the safety equipment would have to be purchased anyway, as part of corrective action taken after the accident.

Common sense is somewhat difficult to define. The dictionary uses terms such as sound ordinary sense and good judgment. Everyone from laboratory managers to analysts is in favor of using common sense regarding safety. What that means in actual practice is another question, however. Perhaps the best concept is that if the two requirements above have been met, then common sense has been applied. In other words, common sense is inherent in the other requirements, not something apart from them.

Materials which might be useful to those conducting sessions on chemical/bacteriological/biological laboratory training may be obtained from many sources. This monograph describes only a part of what is available. Material referenced in this document was selected because it relates to laboratory work performed as part of water quality control programs.

Despite certain similarities, the materials were not intended to provide information to those carrying out university and college research studies. Information such as precautions to observe when working with carcinogenic compounds is beyond the scope of this monograph. It should be emphasized that no single document can provide all the information needed by someone presenting training in laboratory safety. The instructor will have to select several sources, and adapt relevant information to his/her specific needs.

This section provides examples of materials that can be used by supervisors and laboratory workers to determine the extent to which their laboratory and its personnel meet approved safety standards. Additional materials are cited in the reference section.

101

Learning Resource #20  
"Basic Laboratory Safety"  
Operator Training, Water and Wastewater Works  
Operating Training Committee of Ohio  
P.O. Box 626  
17 East Selby Blvd.  
Worthington, OH 43085

---

The following assignment and related questions may be useful to introduce safety concerns thought to be important by supervisors of workers in a wastewater treatment plant laboratory.

## BASIC LABORATORY

ASSIGNMENT #3

Name \_\_\_\_\_

Date \_\_\_\_\_

## SAFETY

## Objective:

To become acquainted with some of the hazards in the laboratory and to develop a positive attitude toward safety.

## Assignment:

Read Related Information contained in Assignment #3

## Related Information:

1. All chipped, cracked, or broken glassware should be placed in a special container for disposal. This special container should be marked plainly, "For Broken Glass Only." Do not put such material in wastebaskets or sinks where an injury can result from unseen broken glass. Do not pick up broken glass with bare hands. Use tongs for large pieces and wet cotton for small pieces. Never put excessive pressure on glassware with bare hands.
2. All chemicals should be labeled clearly.
3. When using volatile solvents, bases, or acids, the ventilation fan should be on and the work should be performed very carefully. For example, nitric acid, in addition to being injurious to the skin and eyes, is a strong oxidizer of organic materials. This oxidizing (or nitrating) of some organic materials may produce products, such as trinitrotoluol, tetryl, and nitroglycerin, with the possibility of fire or explosion. At least a face shield should be worn when using volatile solvents, bases, or acids. To assure safety, wear rubber gloves, a rubber apron, and acid-tight goggles.
4. Never handle any chemicals with the bare hands as toxic organic solvents can be absorbed through the skin. Use a spatula, spoon, or tongs.
5. Particular care is required when handling concentrated acids and bases. Concentrated acid should be added carefully to water, not water to acid; otherwise, this could cause an explosive force. When a person is splashed with acid, large volumes of water are required immediately to prevent serious burns. Avoid mixing of chemicals indiscriminately.

6. Never work in a poorly ventilated area. Toxic fumes even in mild concentrations can knock you out. Be sure you have adequate ventilation before you start work in the laboratory.
7. Suction bulbs on pipets are desirable to avoid possible contact of the mouth with the contaminated pipet. Safety pipets also may be used. Burets often can be substituted for pipets.
8. Smoking and eating should be avoided when working with infectious materials, such as sewage and sludge. Never use laboratory glassware for the serving of food.
9. Always use the proper type of equipment for handling hot containers, such as asbestos gloves, tongs, or cetera.
10. Keep oil, grease, mercury, volatile solvents, and strong acids out of the sinks. Many chemicals are incompatible with other chemicals. If you must flush one down the drain, use plenty of water. The drainage system can pocket vapors and cause an explosion hazard.
11. Use care in making rubber-to-glass connections. Lengths of glass tubing should be supported while they are being inserted into rubber. The ends of the glass should be fire polished and a lubricant, such as water or a water-soluble lubricating jelly, should be used. Never use grease or oil. Gloves should be held as close to the end being inserted as possible to prevent bending or breaking.
12. Where cylinders of oxygen or other compressed gases are used in the laboratory, they should be stored in separate and ventilated sections. They should be chained or clamped in an upright position while being used or stored. The protective caps should never be removed until the cylinder is set and clamped in place, ready for attachment of valve gauge and connections.



13. A carbon dioxide fire extinguisher is mounted on the inside wall of the control building beside the door.
14. Avoid blocking access to shutoff valves when setting up laboratory apparatus.
15. Never try to force rubber tubing or stoppers from glassware. Cut the material off.
16. Be sure that all gas, vacuum, and air jets as well as ovens, autoclaves, furnaces, hot plates, and other similar equipment are shut off at the end of each day's work.
17. Special explosion-proof cans should be used for the storage of solvents.
18. An eye wash fountain and shower should be readily available.
19. Laboratory personnel should be knowledgeable in first aid and rescue procedures.

Questions:

1. Accidents just happen. True \_\_\_\_\_ False \_\_\_\_\_
2. List three (3) causes of accidents in the laboratory.  
(a) \_\_\_\_\_  
(b) \_\_\_\_\_  
(c) \_\_\_\_\_
3. List three (3) items of protective gear you would expect to find in laboratories.  
(a) \_\_\_\_\_  
(b) \_\_\_\_\_  
(c) \_\_\_\_\_
4. List five (5) precautions that are to be observed in handling laboratory chemicals.

- (a) \_\_\_\_\_
- (b) \_\_\_\_\_
- (c) \_\_\_\_\_
- (d) \_\_\_\_\_
- (e) \_\_\_\_\_

5. List five (5) precautions to be used when handling laboratory glassware.

- (a) \_\_\_\_\_
- (b) \_\_\_\_\_
- (c) \_\_\_\_\_
- (d) \_\_\_\_\_
- (e) \_\_\_\_\_

6. List four (4) measures to observe in general housekeeping in the laboratory.

- (a) \_\_\_\_\_
- (b) \_\_\_\_\_
- (c) \_\_\_\_\_
- (d) \_\_\_\_\_

7. Are fire, rescue, and emergency procedures desirable for laboratory use?

Explain. \_\_\_\_\_  
\_\_\_\_\_

8. Should laboratory bottles be clearly labeled or is it sufficient to trust your memory.

Explain. \_\_\_\_\_  
\_\_\_\_\_

Learning Resource #31

"Health and Safety in The Lab"

Slide-Cassette - 15 minutes

US EPA

Environmental Research Center

Research Triangle Park, NC 27711

This presentation consisting of 63 slides and explanatory narration provides a general overview of health and safety problems found in chemical laboratories. Unsafe practices often found are depicted along with appropriate corrective measures. The material should be useful in reviewing, with recently hired laboratory employees, the importance of safety in wastewater treatment laboratories.

Material presented in slides and narration

Uncluttered hallways  
Unsafe acid pouring  
Safe acid pouring  
Mouth pipets  
Suction bulb pipets  
Unsafe insertion of glass tubing  
Safe insertion of glass tubing  
Chipped beakers  
No smoking in laboratory  
Drinking from chemical beaker  
Danger signs  
Unprotected eyes  
Safety shield  
Improper use of refrigerator storage  
Handling of flammable materials  
Storage of flammable materials  
Hazards of mixed storage of chemicals  
Handling of gas cylinders  
Laboratory clothing  
Chemical labeling  
Breathing apparatus  
Laboratory housekeeping  
Fire extinguishers  
Good housekeeping  
Using hood space for storage  
Eye wash  
Working alone in laboratory

Learning Resource #22  
Microbiological Methods For Monitoring The Environment  
Part V, Section C "Laboratory and Field Safety"  
Office of Research and Development  
U.S. EPA  
Cincinnati, OH 45268

---

This section, compiled from a number of available sources discusses the following:

1. Administration Considerations
2. Sources of Hazards
3. Field Guidelines
4. Laboratory Guidelines
5. Hazard Control
6. Safety Check List

Guidelines for laboratory safety cover: (1) personal conduct and clothing, (2) laboratory equipment, (3) disinfection/sterilization, (4) chemicals and gases, (5) handling glassware, (6) electrical equipment, and (7) emergency precautions.

These guidelines and a safety check list for microbiological water laboratories are reproduced below. These materials should be useful to supervisors and laboratory workers in wastewater treatment plants.

#### 4. Laboratory Safety Guidelines

The following safety rules are intended as guidelines. They were developed from the available safety literature (3-9) and have considered the Occupational Safety and Health Administration (OSHA) regulations (1,2). Using such source materials, the laboratory director, laboratory supervisor or senior professional should develop rules that are specific for the laboratory program and the organisms involved.

##### 4.1 Personal Conduct and Clothing

4.1.1 Store coats, hats, jackets, and other items of personal clothing outside of the microbiology laboratory. Do not mix laboratory and street clothes in the same locker.

4.1.2 Wear a non-flammable laboratory gown or coat in the laboratory. If clothing becomes contaminated, autoclave before laundering. Laboratory clothing should not be worn in clean areas or outside the building. Open-toed shoes, or extreme shoe styles should not be worn, since they provide little protection or are unstable.

4.1.3 Wear goggles or safety glasses to protect eyes from UV irradiation.

4.1.4 Wash hands carefully after laboratory and field duties, using a germicidal soap.

4.1.5 Use forceps or rubber gloves when there is a significant danger of contamination such as during the clean-up of pathogenic material.

4.1.6 Do not touch one's face, lick labels or put pencils and other materials in one's mouth.

4.1.7 Don't smoke, eat, drink or chew gum in the laboratory or while sampling. Do not keep food or drinks in the lab refrigerator or cold room. Do not brew coffee or tea in the laboratory area.

4.1.8 Keep conversation to an absolute minimum during bench work to prevent self-infection or loss of analytical data.

4.1.9 Keep reading matter, surplus materials and equipment out of the laboratory area.

4.1.10 Laboratory and field personnel handling polluted samples should be vaccinated against typhoid, tetanus and polio.

#### 4.2 Laboratory Equipment

4.2.1 Limit traffic through the work areas.

4.2.2 Treat all cultures and samples as if they are potentially pathogenic. The degree of risk is increased greatly in culture work because the microorganisms are produced in very large numbers.

4.2.3 Do not mouth-pipet polluted water, wastewater or other potentially infectious or toxic fluids; use a bulb or other mechanical device. See Part II-B, 1.8.2.

4.2.4 For potable waters, plug pipets with non-absorbent cotton. Do not use pipets with wet plugs.

4.2.5 Use a hooded bunsen burner or shielded electric incinerator to protect against splattering during culture work.

4.2.6 Maintain benches in a clear and uncluttered condition for maximum efficiency and safety.

4.2.7 Perform all culture work in a biohazard hood to protect cultures and workers.

4.2.8 Do not use the kitchen type blender for mixing materials containing infectious agents. Safety blenders are available in which infectious materials may be mixed without dissemination of infectious aerosols.

4.1.4 Wash hands carefully after laboratory and field duties, using a germicidal soap.

4.1.5 Use forceps or rubber gloves when there is a significant danger of contamination such as during the clean-up of pathogenic material.

4.1.6 Do not touch one's face, lick labels or put pencils and other materials in one's mouth.

4.1.7 Don't smoke, eat, drink or chew gum in the laboratory or while sampling. Do not keep food or drinks in the lab refrigerator or cold room. Do not brew coffee or tea in the laboratory area.

4.1.8 Keep conversation to an absolute minimum during bench work to prevent self-infection or loss of analytical data.

4.1.9 Keep reading matter, surplus materials and equipment out of the laboratory area.

4.1.10 Laboratory and field personnel handling polluted samples should be vaccinated against typhoid, tetanus and polio.

#### 4.2 Laboratory Equipment

4.2.1 Limit traffic through the work areas.

4.2.2 Treat all cultures and samples as if they are potentially pathogenic. The degree of risk is increased greatly in culture work because the microorganisms are produced in very large numbers.

4.2.3 Do not mouth-pipet polluted water, wastewater or other potentially infectious or toxic fluids; use a bulb or other mechanical device. See Part II-B, 1.8.2.

4.2.4 For potable waters, plug pipets with non-absorbent cotton. Do not use pipets with wet plugs.

4.2.5 Use a hooded bunsen burner or shielded electric incinerator to protect against splattering during culture work.

4.2.6 Maintain benches in a clear and uncluttered condition for maximum efficiency and safety.

4.2.7 Perform all culture work in a biohazard hood to protect cultures and workers.

4.2.8 Do not use the kitchen type blender for mixing materials containing infectious agents. Safety blenders are available in which infectious materials may be mixed without dissemination of infectious aerosols.

TABLE V-C-3

## Normal Use Concentration of Disinfectants

Compound	Use Concentration mg/liter
Organo-iodine Complexes	100-150
Quaternary Ammonium Compounds	700-800
Phenolics	1-1%
Alcohol, 70% w/v	water solution
Formaldehyde	8%
Formaldehyde in 70% Alcohol Solution	8%

4.3.6 Place used glassware in special cans marked for autoclaving. Keep broken glassware in a separate container. Place plastic items in separate cans to prevent fusing of plastic around glass items.

4.3.7 Mark contaminated items as Contaminated before removal from the laboratory for autoclaving. Use temperature-sensitive tapes which indicate exposure to heat. Pre-printed tapes or tags simplify this task.

4.3.8 Check autoclaves with the use of spore strips or spore suspensions of *B. stearothermophilus* and maximum-minimum recording thermometers. Ideally autoclaves are equipped with temperature recording devices so that a permanent record may be maintained.

Check hot air ovens and gas sterilizers periodically with spore strips or the indicator, *B. subtilis var. niger*.

4.3.9 Wet-mop floors weekly, using water containing a disinfectant. Dry or wet pickup vacuum cleaners with high-efficiency exhaust air filters are recommended. Wax floors with bacteriostatic floor waxes if available.

## 4.4 Chemicals and Gases

4.4.1 Label containers plainly and permanently. Dispose of material in unlabelled containers carefully. Wipe or rinse residual material from the external surfaces of reagent containers after use.

111

116

4.4.2 Store flammable solvents in an approved solvent storage cabinet or a well-ventilated area.

4.4.3 When opening bottles which may be under pressure i.e., hydrochloric acid, ammonium hydroxide, cover the bottle with a towel to divert chemical spray.

4.4.4 Use bottle carriers to transport bottles containing hazardous chemicals (acids, corrosives, flammable liquids). Large cylinders are transported only by means of a wheeled cart to which the cylinder is secured. Store and transport compressed gas cylinders with shipping caps on, in an upright position, always securely clamped or chained to a firm support and away from heat.

4.4.5 Reagents and chemical which might react in water drains or be dangerous to the environment must be disposed of in other ways. Examples are 1) sodium azide which reacts with metal drains to produce very explosive lead or copper azides and 2) mercury and its salts which should not be returned to the environment. Consult reference texts to determine the proper disposal procedure for each chemical (8,9).

#### 4.5 Handling Glassware

4.5.1 Discard broken, chipped or badly scratched glassware. Use gloves or sweep up broken glass, do not use bare hands. Pick up fine glass particles with wet paper towelling.

4.5.2 Fire polish tubing and rods.

4.5.3 Protect hands with gloves, towel, or tubing holder when inserting tubing into stoppers. Lubricate the tubing with water or glycerine. Handle tubing close to the stopper and out of line with end of the tube.

4.5.4 Use asbestos-centered wire gauze when heating glass vessels over a burner.

4.5.5 Do not attempt to catch falling glassware.

#### 4.6 Electrical Equipment

4.6.1 Keep materials, tools and hands dry while handling electrical equipment.

4.6.2 Use grounded outlets only.

4.6.3 Do not use electrical equipment near flammable solvents.

4.6.4 Use only carbon dioxide or dry powder fire extinguishers in case of fire in or near any electrical equipment.



#### 4.7 Emergency Precautions

4.7.1 Install and maintain both foam and carbon dioxide fire extinguishers within easy access of the laboratory.

4.7.2 Fire exits should be clearly marked and accessible.

4.7.3 Install and maintain a complete first aid kit and an oxygen respiration unit in the laboratory.

#### 5. Biohazard Control

##### 5.1 Safety Cabinets

5.1.1. The safety cabinet is the most important primary barrier available to the microbiologist for isolation and containment of microorganisms and for protecting the laboratory environment, and the surrounding area from contamination. Transfers of cultures especially pathogenic fungi, actinomycetes and yeasts should be conducted in the safety cabinets.

5.1.2 UV lamps are commonly used in biohazard hoods to maintain sterility of the work area. Goggles should be worn to protect the worker and cultures should be protected from undesirable exposure (see Part IV-A, 4 in this manual).

5.1.3 There are several types of ventilated cabinets available for use (10, 13):

##### (a) Partial Barrier Cabinet

The open or closed front cabinet is usually referred to as a partial barrier ventilated cabinet. This cabinet can be used with the glove panel removed, depending upon an inward flow of air of at least 100 linear ft. per min. to prevent escape of airborne particles. It can also be used with the glove panel in place and arm-length gloves attached, in which case it will be maintained under a reduced air pressure of about one inch of water gauge. When operated closed, the partial barrier needs an attached air lock for movement of materials. A third mode of operation consists of using a cabinet with glove panel attached, but with gloves removed.

##### (b) Absolute Barrier Cabinet

The second type of ventilated cabinet is the gas-tight cabinet system, referred to as an absolute barrier cabinet. Absolute barrier cabinets are connected to form a modular cabinet system with enclosed refrigerators, incubators, etc. Air is drawn into the cabinet system through ultrahigh efficiency filters and is exhausted through ultrahigh efficiency filters.

113

Safety Check List  
for Microbiological Water Laboratories

Survey By \_\_\_\_\_  
Laboratory: \_\_\_\_\_  
Location: \_\_\_\_\_  
Date: \_\_\_\_\_  
Code: S=Satisfactory, U=Unsatisfactory

1. Administrative Considerations

- (a) Laboratory has a formal documented safety program. \_\_\_\_\_
- (b) Each worker has a copy of the safety program. \_\_\_\_\_
- (c) Employees are aware of procedures for reporting accidents and unsafe conditions. \_\_\_\_\_
- (d) New employees are instructed on laboratory safety. \_\_\_\_\_
- (e) Joint supervisor-employee safety committee has been established to identify potential laboratory hazards. \_\_\_\_\_
- (f) Records are maintained of accidents and consequences. \_\_\_\_\_
- (g) Name and phone number of the supervisor and an alternate are posted at door of the laboratories so he may be contacted in case of an emergency. \_\_\_\_\_
- (h) Laboratory supervisor and at least one other permanent employee have attended appropriate first aid courses.  
If so, when: \_\_\_\_\_  
(date)
- (i) Emergency telephone numbers for fire, ambulance, health centers, and poison control center are placed in a conspicuous location near the telephone. \_\_\_\_\_
- (j) Employees know the location of first aid supplies. \_\_\_\_\_
- (k) Emergency first aid charts, and hazardous agents charts are posted in the laboratory. \_\_\_\_\_
- (l) Fire evacuation plan is established for the laboratory and is posted in a conspicuous location. \_\_\_\_\_

2. Personal Conduct

- (a) Personal clothing is stored outside of the microbiology laboratory. \_\_\_\_\_

- (b) Lab coats and street clothes are kept in separate lockers. \_\_\_\_\_
- (c) Laboratory coats are worn at all times in the laboratory. \_\_\_\_\_
- (d) Germicidal soap or medicated surgical sponges are available for employees' use. \_\_\_\_\_
- (e) Preparing, eating or drinking food and beverages are not permitted in the laboratory. \_\_\_\_\_
- (f) Smoking or chewing gum are not permitted in the laboratory. \_\_\_\_\_
- (g) Food or drink are not stored in laboratory refrigerators. \_\_\_\_\_
- (h) Reading materials are not kept in the laboratory. \_\_\_\_\_
- (i) Laboratory coats are not worn outside the lab. \_\_\_\_\_
- (j) Employees who have cuts, abrasions, etc. on face, hands, arms, etc. do not work with infectious agents. \_\_\_\_\_

**Laboratory Equipment**

- (a) Bulb or mechanical device is used to pipet polluted water, wastewater or other potentially infectious or toxic fluids. \_\_\_\_\_
- (b) Pipets are immersed in disinfectant after use. \_\_\_\_\_
- (c) Benches are maintained in clear and uncluttered condition. \_\_\_\_\_
- (d) Centrifuge cups and rubber cushions are in good condition. \_\_\_\_\_
- (e) A suitable disinfectant is available for immediate use. \_\_\_\_\_
- (f) Blender is used with sealed container assembly. \_\_\_\_\_
- (g) Microscopes, colony counters, etc. are kept out of the work area. \_\_\_\_\_
- (h) Water baths are clean and free of growth and deposits. \_\_\_\_\_
- (i) Employees are instructed in the operation of the autoclave and operating instructions are posted near the autoclave. \_\_\_\_\_

- (j) Autoclaves, hot air sterilizing ovens, water distilling equipment, and centrifuges are checked routinely for safe operation.

Give frequency and last date

Autoclave \_\_\_\_\_

Water still \_\_\_\_\_

Centrifuge \_\_\_\_\_

Hot Air Oven \_\_\_\_\_

- (k) No broken, chipped or scratched glassware are in use.

- (l) Broken glass is discarded in designated containers.

- (m) Electrical circuits are protected against overload with circuit breakers or ground-fault breakers.

- (n) Power cords, control switches and thermostats are in good working order.

- (o) Water taps are protected against back-siphoning.

4. Disinfection/Sterilization

- (a) Proper disinfectant is used routinely to disinfect table tops and carts before and after laboratory work.

- (b) Receptacles of contaminated items are marked.

- (c) Performance checks of autoclaves, gas sterilizers and hot air ovens are conducted with the use of spore strips, spore ampuls, indicators, etc.

Item	Frequency	Last Date
_____	_____	_____
_____	_____	_____
_____	_____	_____

- (d) Safety glasses are provided to employees.

- (e) Safety glasses are used with toxic or corrosive agents and during exposure to UV irradiation.

5. Biohazard Control

- (a) Biohazard tags or signs are posted in hazardous areas. \_\_\_\_\_
- (b) Safety cabinets of the appropriate type and class are provided. \_\_\_\_\_
- (c) Lab personnel are vaccinated for typhoid fever, tetanus and polio. \_\_\_\_\_
- (d) Floors are wet-mopped weekly with a disinfectant solution. \_\_\_\_\_
- (e) Personnel are trained in the proper procedures for handling lyophilized cultures where used. \_\_\_\_\_

6. General Handling and Storage of Chemicals and Gases

- (a) Containers of reagents and chemicals are labelled properly. \_\_\_\_\_
- (b) Flammable solvents are stored in an approved storage cabinet or well-ventilated area away from oil burners, hot plates, etc. \_\_\_\_\_
- (c) Bottle carriers are provided for hazardous substances. \_\_\_\_\_
- (d) Gas cylinders are securely clamped to a firm support. \_\_\_\_\_
- (e) Toxic chemicals are clearly marked poison or toxic. \_\_\_\_\_

7. Emergency Precautions

- (a) Foam and carbon dioxide fire extinguishers are installed within easy access to laboratory and are properly maintained. Frequency \_\_\_\_\_
- (b) Eye wash stations \_\_\_\_\_, showers \_\_\_\_\_, oxygen respirators \_\_\_\_\_, and fire blankets \_\_\_\_\_ are available within easy access. \_\_\_\_\_
- (c) Fire exits are marked clearly. \_\_\_\_\_
- (d) First aid kits are available and in good condition. \_\_\_\_\_
- (e) At least one full-time employee is trained in first aid. \_\_\_\_\_
- (f) Source of medical assistance is available and known to employees. \_\_\_\_\_

117

8. Suggested Areas of Improvement:

9. General Comments:

\_\_\_\_\_  
(Signature of Installation Officer) (date)

SECTION VIII

SAFETY: Manholes and Traffic

119

Activities at a wastewater treatment system that involve working in manholes and in traffic present singular safety problems. Explosive and noxious gases are constant potential dangers. The possibility of worker asphyxiation dictates certain approaches to the work that must be done.

The location of sewer lines and manholes, often in the center of main streets, demands that approved procedures be followed to protect the workers in the manholes and also the safety of automobile traffic that continues to use the street.

This section includes sample materials considered useful in teaching about manhole safety. Additional materials are cited in the reference section.



Learning Resource #23  
"Laboratory Safety Checklist"  
Lab Safety Supply Company  
P.O. Box 1363  
Janesville, WI 53545

---

The following checklist should be useful in identifying aspects of a laboratory or laboratory operation which do not meet OSHA regulations. Supervisor - laboratory worker review of the checklist in terms of its applicability to their specific laboratory can identify and correct unsafe conditions or practices. The material is reproduced with the permission of the Lab Safety Supply Company.

121

128

## LABORATORY SAFETY CHECKLIST

### YOUR LABORATORY AND THE OCCUPATIONAL SAFETY & HEALTH ACT (OSHA)

All employers in the United States, engaged in commerce, are covered by OSHA. In effect this means that employers and employees must follow certain safety related regulations set forth by OSHA. If, upon inspection, these regulations are not followed, the employer is subject to an immediate penalty of \$1000 for each violation. Due to the increased concern over health factors in laboratories, OSHA has increased their inspection of these facilities. Since there are over a half million words in the OSHA standards,\* we have tried to help you understand your legal requirements by making a checklist that summarizes some of the regulations that apply specifically to laboratories. The regulations have been edited and all applications have not been included in this summary. For a more complete explanation we refer you to actual OSHA standards.

\*The General Industry Safety & Health Standards  
 Superintendent of Documents  
 Government Printing Office  
 Washington, DC 20402  
 \$5.35 per copy

For additional copies of this  
 OSHA Check List write to:  
 Lab Safety Supply Co.  
 P. O. Box 1363  
 Janesville, WI 53545

©Copyright, 1977 Lab Safety Supply Co.

DO YOUR WALKING AND WORKING SURFACES MEET THESE REQUIREMENTS?	OSHA Section	Yes	No	Action Taken
1. Working areas, passageways, storerooms, service rooms in clean, orderly, and sanitary condition.	1910.22a1			
2. Workroom floors clean and dry. Drainage maintained and dry standing places provided.	1910.22a2			
3. Floors free from protruding nails, splinters, holes and loose boards.	1910.22a3			
4. Permanent aisles and passageways marked.	1910.22b2			
<b>DO YOUR EXITS MEET THESE REQUIREMENTS?</b>				
1. Sufficient exits for leaving in case of fire or other emergency, with alternate escape means provided.	1910.36b1			
2. Exits unobstructed and unlocked.	1910.36b4, 1910.36d1			
3. Exits marked and readily visible. Non-exits clearly marked.	1910.36b5, 1910.36b6			
4. Fire alarms provided where necessary.	1910.36b7			
5. More than one exit provided, sufficiently far apart.	1910.36b8			
* 6. Fire detection equipment, smoke alarms, sprinkler systems, lighted exit signs in good operating condition.	1910.36d2			
7. Exit doors, stairs, ramps, passageways, fire escapes, etc. approved by recognized testing laboratory.	1910.37a			
8. Exits should have a proper fire resistance rating and be protected by an approved self-closing fire door.	1910.37b			
9. Height, width and slope of means of egress meet OSHA specifications.	1910.37c			
10. Exits to be large enough for occupant load.	1910.37d			
11. Exits not through rooms that could be locked.	1910.37f			

	OSHA Section	Yes	No	Action Taken
12. Exits not concealed by hangings, draperies, mirrors.	1910.374			
13. Minimum width of exit no less than 28 inches (72 cm).	1910.376			
14. Exits shall discharge directly to street or open space.	1910.371			
15. Direction of egress clearly marked.	1910.372			
16. Exits maintained free of all obstructions and impediments.	1910.372			
17. Automatic sprinkler systems periodically inspected and tested.	1910.37m			
18. Alarm and fire protection systems inspected weekly.	1910.37n1			
19. Exits marked by readily visible signs and all non-exits clearly marked.	1910.37q			
<b>ARE YOUR HAZARDOUS MATERIALS ADEQUATELY PROTECTED?</b>				
1. Only approved containers and portable tanks to be used for storage of flammable and combustible materials.	1910.106d2i			
2. Containers to be of materials and sizes as specified by OSHA and DOT.	1910.106d2ii			
3. Storage cabinets to contain not more than 60 gallons (240 L) of flammable liquids or 120 gallons (450 L) of combustible liquids.	1910.106d3i			
4. Storage cabinets constructed to limit internal temperatures to no more than 325° F (163° C) in a ten minute fire test, with all joints and seams remaining tight and the door securely closed. Cabinets should be labeled "Flammable - Keep Fire Away"	1910.106d3ii			
5. Inside of storage rooms sufficiently fire resistant.	1910.106d4			
6. Flammable or combustible liquids stored in closed containers.	1910.106e2ii			
7. Places for transferring of flammable or combustible liquids at adequate distance from other operations and spill drainage and proper ventilation provided.	1910.106e2iii			
8. Flammable liquids kept in covered containers when not in use.	1910.106e2iv			
9. Portable fire extinguishers and control equipment provided for special hazards.	1910.106e5i			
10. Water available in volume and adequate pressure for extinguishing.	1910.106e5ii			
11. Adequate precaution taken to prevent ignition of flammable vapors.	1910.106e6i			
12. Flammable liquids dispensed into containers where nozzle and container are electrically connected. If floor plate is metal, receiving container should be properly grounded.	1910.106e6ii			
13. Storage of flammables is limited to use required for maintenance and operation. Such storage is kept in closed metal containers, storage cabinets or in an approved inside storage room.	1910.106e5iii			

	OSHA Section	Yes	No	Action Taken
14. The quantity of flammable liquid that is stored outside an inside storage room or cabinet in a building does not exceed: 25 gallons (25L) of Class IA liquids in containers 120 gallons (454L) of Class IB, IC, II or III liquid in containers 660 gallons (2495L) of Class IB, IC, II or III liquid in single portable tank	1910.106s2ib			
15. Flammable liquids having a flash point below 27°C (80°F) are stored in red container with a yellow band around the container or the contents identified in yellow.	1910.144kii			
16. The size of flammable liquid containers is in accordance with the following table:	1910.106d3iii			

**Flammable Liquids - Maximum Allowable Size of Containers**

Container type	Class I-A: flash point < -18°C, boiling point < 38°C	Class I-B: flash point < 23°C boiling point > 38°C	Class I-C: flash point > 23°C and < 38°C	Class II: flash point > 38°C and < 60°C	Class III: combustible liquids
Glass Approved high density poly- ethylene or metal	1 pt 1 gal	1 qt 5 gal	1 gal 5 gal	1 gal 5 gal	1 gal 5 gal
Safety cans Metal drums ICC specifi- cations (stor- age vaults only) Examples:	2 gal 60 gal  Ethyl ether Propylene oxide Pentane-n	5 gal 60 gal  Benzol Methyl alc. Gasoline Ethyl alc. Acetone Xylene Toluene	5 gal 60 gal  Ethyl mercaptan Turpentine Methyl alc. (30% in water)	5 gal 60 gal  Methyl amyl acetate Kerosene	5 gal 60 gal  Stoddard solvents Amyl alcohol Fuel oil

17. No more than 1100 gallons (4156L) of flammables or combustibles is located adjacent to buildings in approved storage building.	1910.1066ii			
18. A portable fire extinguisher rated 12-B is located not less than 10 feet nor more than 25 feet from any flammable storage room.	1910.1068iile			
19. Flammable liquids are kept in covered containers when not being used.	1910.10672iva			
20. Where flammable or combustible liquids are used provisions are provided for safe disposal of leakage or spills.	1910.10672ivb			
21. Class I liquids are used only when there are no open flames or other sources of ignition.	1910.10672ivc			
22. Transferring flammable liquids by means of air pressure is not permitted.	1910.10672ivd			
23. "No Smoking" signs shall be posted where hazards from flammable liquid vapors is normally present.	1910.10696			

ARE YOU USING THE PROPER EYE AND FACE PROTECTION?	OSHA Section	Yes	No	Action Taken
1. Eye and face protectors shall provide adequate protection against hazards.	1910.133a2i			
2. Eye and face protectors should be reasonably comfortable.	1910.133a2ii			
3. Eye and face protectors should fit snugly and not interfere with wearer's movements.	1910.133a2iii			
4. Eye and face protectors should be durable.	1910.133a2iv			
5. Eye and face protectors should be capable of being disinfected.	1910.133a2v			
6. Eye and face protectors should be easy to clean.	1910.133a2vi			
7. Eye and face protectors to be kept clean and in good repair.	1910.133a2vii			
8. Persons who require eye protection and also wear eye glasses, should wear eye protectors with optically corrected lenses, goggles that fit over corrective lenses, or goggles that incorporate corrective lenses mounted behind the protective lenses.	1910.133a3i, ii, iii			
9. Eye and face protectors should be marked to identify the manufacturer.	1910.133a4			
10. The user of eye and face protectors should be informed of their limits and precautions to take.	1910.133a5			
11. Eye and face protectors should comply with the American National Standard for Occupational and Educational Eye and Face Protection (ANSI Z87.1-1968)	1910.133a6			
<b>ARE YOU USING THE PROPER RESPIRATORS?</b>				
1. Respirators must be provided when necessary.	1910.134a2			
2. Respirators should be used in accordance with instructions and training received.	1910.134a3			
3. A written operating procedure for selection and use of respirators should be provided.	1910.134b1			
4. Respirators should be selected on the basis of the hazard present.	1910.134b2			
5. Respirators should be assigned to an individual for his exclusive use.	1910.134b4			
6. Respirators should be regularly cleaned and disinfected.	1910.134b5			
7. Respirators should be stored in a convenient, clean, and sanitary location.	1910.134b6			
8. Respirators should be inspected during cleaning and worn and deteriorated parts replaced.	1910.134b7			
9. Surveillance of work area conditions and degree of individual exposure or stress should be maintained.	1910.134b8			
10. Persons should not be assigned to tasks requiring respirators unless it has been determined that they are able to perform the work and use the equipment.	1910.134b10			

125

	OSHA Section	Yes	No	Action Taken
11. Respirators should be selected in accordance with ANSI regulation Z89.2 - 1969.	1910.134c			
12. Compressed air, compressed oxygen, liquid air, and liquid oxygen should be of high purity, at least meeting requirements of Compressed Gas Association Commodity Specification G.7.1 - 1966.	1910.134d			
13. Air may be supplied from cylinders or air compressors.	1910.134d2			
14. Standard procedures should be established for respirator use, including both emergency and routine uses.	1910.134e1			
15. The correct respirator should be specified for each job and marked to indicate to whom it is assigned and the date of issuance.	1910.134e2			
16. Written procedure for use of respirators in dangerous atmospheres should be provided.	1910.134e3			
17. Proper rescue equipment and a standby person should be present in case of respirator failure.	1910.134e3i			
<b>HOW IS YOUR WORKING ENVIRONMENT?</b>				
1. All work areas, including passageways, storerooms, and service rooms shall be kept clean, orderly, and sanitary.	1910.141a1			
2. Floors of all work areas shall be kept clean and dry as far as possible.	1910.141a1i			
3. Cleaning and sweeping should be done to minimize air contamination and as far as possible outside of working hours.	1910.141a1ii			
4. Expectorating on floors, walls, or stairs should be prohibited.	1910.141a2			
5. Receptacles for solid or liquid waste should not leak, be easy to clean, be maintained in a sanitary condition, and equipped with a tight fitting cover.	1910.141a3i			
6. All wastes should be removed without creating a nuisance or health menace and as often as necessary.	1910.141a3ii			
7. Work areas and other rooms should be constructed, equipped and maintained to prevent the entrance or harborage of rodents, insects and other vermin.	1910.141a4			
8. Potable water to be supplied for drinking, washing, etc.	1910.141b1			
<b>ARE YOU USING THE REQUIRED SIGNS AND TAGS?</b>				
1. All signs installed after August 30, 1971 must meet OSHA Standards.	1910.145a2			
2. Danger signs should be used only where immediate hazards exist. All such signs should not vary in design.	1910.145c1i			
3. All persons should be instructed that danger signs indicate immediate danger and therefore special precautions are necessary.	1910.145c1ii			
4. Caution signs should be used to warn of potential hazards or unsafe practices.	1910.145c2			

	OSHA Section	Yes	No	Action Taken
5. All persons should be instructed that caution signs indicate possible hazards.	1910.145c2ii			
6. Safety instruction signs should be used where there is a need for general information and suggestions relative to safety measures.	1910.145c3			
7. All signs should have rounded or blunt corners, be free of sharp edges, burrs, splinters, or other sharp projections. Fasteners should be located so as not to be hazardous and should be of a size meeting OSHA standards.	1910.145d1			
8. Danger signs must be red, black, and white and meet American National Standard Z53.1 - 1967.	1910.145d2i			
9. Radiation warning signs background must be yellow; panel magenta with yellow letters; the symbol magenta and letters on the background black.	1910.145d3i			
10. Caution signs should have a yellow background; and the panel, black with yellow letters.	1910.145d4i			
11. Safety instruction signs must be white and panel green with white letters; lettering on background black.	1910.145d6			
12. Directional signs must be white and panel black, with white arrow; any lettering must be black.	1910.145d7i			
13. Informational signs must be blue as background or panel.	1910.145d9			
14. Symbols on signs must follow recognized practices.	1910.145d11			
15. Wording on signs must meet OSHA regulations.	1910.145e1			
16. Tags may be used as a temporary warning until a positive means can be employed to eliminate the hazard.	1910.145f11			
17. Danger tags should not vary in design.	1910.145f4i			
18. Caution tags should warn only of potential hazards, or to caution against unsafe practices.	1910.145f5i			
19. Out-of-order tags should only indicate that a piece of equipment is out of order.	1910.145f6			
20. Biological hazard tags should be used to signify the potential or actual presence of a biohazard, to identify items contaminated with hazardous agents.	1910.145f8ii			
21. The term "biological hazard" shall refer only to those items presenting a potential risk to the well being of man.	1910.145f8iii			
<b>HOW ARE YOUR MEDICAL AND FIRST AID FACILITIES?</b>				
1. Medical personnel for advice and consultation should be available.	1910.151e			
2. A person trained to render first aid should be available if there is no infirmary, clinic or hospital nearby. First aid supplies approved by a consulting physician should be available.	1910.151b			
3. Facilities for drenching or flushing eyes or other parts of the body should be available in case of emergency.	1910.151c			

127

DO YOU HAVE THE RIGHT NUMBER & TYPE OF FIRE EXTINGUISHERS?	OSHA Section	Yes	No	Action Taken
1. Portable fire extinguishers should be kept fully charged and operable and kept in a designated place at all times when not in use.	1910.157a1			
2. Fire extinguishers should be readily accessible along normal paths of travel.	1910.157a2			
3. Extinguishers should not be obstructed or obscured from view.	1910.157a3			
4. Extinguishers for different classes of fire should be marked conspicuously to insure using the proper one.	1910.157a4			
5. Extinguishers should be installed on hangers or brackets, in cabinets, or on shelves.	1910.157a5			
6. Extinguishers weighing 40 lbs. (18 kg) or less should be installed so that the top is not more than 5 ft. (1.5m) above the floor. Those over 40 lbs. (18 kg) should be installed with the top no more than 3 1/2 ft. (1 m) above the floor.	1910.157a6			
7. Extinguishers in cabinets, wall recesses, or on shelves shall be placed with the instructions facing outward.	1910.157a7			
8. Extinguishers should be useable between 40° and 120° F. (5° and 50° C.)	1910.157a9			
9. Each fire extinguisher should have a tag attached showing maintenance or recharge date and person performing the service.	1910.157c3iv			
<b>HOW IS YOUR ELECTRICAL PROTECTION?</b>				
1. Electrical installations should conform to the National Electrical code NFPA 70 - 1971; ANSI C1-1971.	1910.309a			
2. All new electrical installations and all new utilization installed after March 15, 1972, and all replacements, modifications, and repairs on equipment installed before this date should meet the National Electrical Code NFPA 70 - 1971; ANSI C1 - 1971.	1910.309b			
<b>ARE YOU TAKING THE REQUIRED PRECAUTIONS WITH CARCINOGENS?</b>				
1. Exposure to the following carcinogens should be limited: a. Asbestos b. 4-nitrophenol c. Methyl chloromethyl ether d. 3,3'-dichlorobenzidine e. Alpha naphthylamine f. Bis-chloromethyl ether g. Beta naphthylamine h. Benzidine i. 4-aminodiphenyl j. Ethyleneimine k. Beta propiolactone l. 2-acetylaminofluorene m. 4-dimethylaminoazobenzene n. N-nitrosodimethylamine o. Vinyl chloride	1910.1001 to .1017			
2. Containers of vinyl chloride are labeled: Vinyl Chloride Extremely Flammable Gas Under Pressure Cancer Suspect Agent	1910.1017k1			
3. Containers of Carcinogens have labels "Cancer Suspect Agent" prominently displayed.	1910.93ee2iii			
4. Entrances to regulated area should have signs with the legend: Cancer Suspect Agent Authorized Personnel Only	1910.93ee			



	OSHA Section	Yes	No	Action Taken
5. Employees who work in regulated area should receive training with regard to working with carcinogens	1910.93ee5			
6. Regulated areas have a negative pressure with respect to nonregulated areas	1910.93d4			
7. Employees are required to wash hands, face, forearms and neck upon each exit from regulated area and shower at the end of the day	1910.93C2ii 1910.93C4vu			
8. Employees are provided with clean, full body protective clothing prior to entering regulated areas	1910.93p4ii			
9. Employees must remove protecting clothing when leaving regulated areas and at the end of the day place the clothing in an impervious container for decontamination or disposal	1910.93C4V			
10. All asbestos scrap, waste, debris and other products containing asbestos fibers must be labeled as follows: Caution Contains Asbestos Fibers Avoid Creating Dust Breathing Asbestos Dust May Cause Serious Bodily Harm	1910.1001			

129

**Learning Resource #24**  
**Traffic and Manhole Safety**  
**Chapter IV, Operation and Maintenance of Wastewater Collection**  
**Systems: A Field Study Training Program, 1976**  
**Kenneth D. Kerri and John Brady, Editors**  
**California State University, Sacramento**  
**Sacramento, CA 95819**

Chapter IV of this publication written by George Fraeland contains detailed information on manhole safety. It is designed to be used as a self-study program by persons training for work in wastewater treatment systems. It provides useful information to supervisors who may have the responsibility of maintaining safety around manhole operations.

The material dealing with manhole safety includes the following:

	<u>Page</u>
4.12 Manhole Safety.....	4-14
4.13 Classification and Description of Manhole Hazards.....	4-14
4.131 Atmospheric Hazards.....	4-15
4.132 Physical Injury.....	4-17
4.133 Infections and Diseases.....	4-18
4.134 Insects, Bugs and Rodents.....	4-18
4.135 Toxicants.....	4-19
4.136 Drowning.....	4-19
4.137 Summary.....	4-19
4.14 Safety Equipment and Procedures for Manhole Entry.....	4-20
4.140 Self-Contained Breathing Apparatus.....	4-20
4.141 Safety Harness with Lifeline.....	4-20
4.142 Portable Oxygen/Explosivity Alarm Unit.....	4-21
4.143 Ventilation Blower With Hose.....	4-21
4.144 Manhole Enclosure.....	4-21
4.145 Aluminum Ladders and Man Lifts.....	4-23
4.146 Ropes and Buckets.....	4-23
4.147 Hard Hats.....	4-23
4.148 Protective Clothing.....	4-25
4.149 Other Equipment and Procedures.....	4-25
4.15 Precautions for Manhole Entry.....	4-26
4.151 Immunizations.....	4-26
4.152 Disinfectants.....	4-26
4.153 Health Conditions of Workers.....	4-27
4.154 Insecticide.....	4-27
4.155 Wash Down.....	4-27
4.156 Required Tools, Materials and Equipment.....	4-28
4.157 Equipment Test.....	4-28
4.158 Briefing.....	4-28
4.16 Operations of Manhole Entry.....	4-29
4.17 While Worker is Down in the Manhole.....	4-31
4.18 Special Problems of Manhole Work.....	4-32
4.19 After Leaving Manhole.....	4-34
RESPONSIBILITY.....	4-35
Additional Reading.....	4-35

4.3	INSPECTION OF MANHOLES.....	4-45
4.31	Objective of Manhole Inspection.....	4-45
4.32	Safety.....	4-46
4.33	Equipment Required.....	4-46
4.34	Manpower.....	4-47
4.35	Procedure.....	4-47
4.36	Frequency of Manhole Inspections.....	4-50
4.37	Sample Inspection Forms.....	4-51

The organization, quality, and nature of the material presented by Froeland is shown in the following extensive citation on manhole safety (4.12) and classification and description of manhole hazards (4.13).

#### 4.12 Manhole Safety

Throughout this manual special safety precautions regarding specific jobs and procedures will be outlined. Everyone must recognize and understand the hazards encountered when entering a collection system manhole. Although the following discussion is brief, the collection system workers and their supervisors must become fully familiar with procedures discussed and apply them every time someone enters a manhole.

#### 4.13 Classification and Description of Manhole Hazards

There are six major categories of hazards a person may encounter when entering a manhole. These hazards are discussed in order of known frequency of accidents and deaths to workers - atmospheric, physical injury (slips, falls, falling objects, sharp objects, bumps and structural failures), infection and disease, insects and biting critters, toxic exposure, and drowning.

##### 4.131 Atmospheric Hazards

Atmospheric hazards consist of three major types - explosive or flammable, toxic atmospheres, and depletion or elimination of breathable oxygen. Do not allow unhealthy odors to distract your attention from the three major types of hazards that could kill you..

1. Explosive or flammable atmospheres can develop at any time in the collection system. Flammable gases or vapors may enter a sewer or manhole from a variety of legal, illegal or accidental sources. These conditions can be measured by the use of meters that indicate the explosive or flammable limits of the atmospheres.

131

- a. Methane gas is one of the products of waste decomposition. This gas can be produced almost anywhere in a collection system. Methane is also the major flammable gas in the natural gas piped under streets by utility companies. Leaks in these pipes will saturate a soil around a sewer pipe, and seepage will result in the gas entering the collection system and endangering workers in a manhole.
  - b. While methane and natural gases are lighter than air, a small portion of the gas will diffuse or escape from a manhole if there is natural ventilation. Propane, gasoline, solvents, and other explosive fuel gases may be as much as two-and-one-half times heavier than air and will tend to accumulate (if there is not ventilation) in the pockets of the lower portions of a collection system to form explosive mixtures or to displace air.
2. Toxic atmospheres (poisonous air) in wastewater collection systems or storm collection systems are most likely to be from the presence of hydrogen sulfide ( $H_2S$ ), a gas produced by the decomposition of certain materials containing sulfur. Hydrogen sulfide gas quickly mixes with air and goes wherever the air goes. If there is no ventilation or air movement,  $H_2S$  accumulates in the lower sections of a collection system. Hydrogen sulfide can be detected by the smell of rotten eggs or by the use of special test kits or instruments that measure the concentration of  $H_2S$ . Other toxic gases that may be encountered include chlorinated solvents and industrial toxins (poisons), depending on wastes discharged to the collection system.
  3. The amount of breathable oxygen present in a manhole can be decreased or eliminated by having the air mixed or replaced by the entry of another gas. Meters are available that measure the concentration of oxygen in the air.

Do not work in confined spaces where the atmosphere contains less than 19.5% oxygen. Always ventilate the manhole before entry and continuously during occupancy. Continuously test all levels of manhole for oxygen deficiencies and explosive and toxic conditions.

Concentrations of oxygen in a confined space may exceed the level in the air we normally breathe (21.9%) when pure oxygen ( $O_2$ ) is used to prevent septic conditions and the production

of hydrogen sulfide in the wastewater collection system (See Chapter 5, Section 5.6, Hydrogen Sulfide Control). If the manhole is continuously ventilated and the oxygen level continuously measured, no problems should develop. A higher than normal level of oxygen won't hurt you, but will increase the fire or explosive hazard.

#### 132 Physical Injury

Physical injury during manhole entry can occur from several causes. Workers in restricted spaces with uneven footing often have poor balance and decreased coordination. The manipulation of tools in restricted spaces often results in a worker being in an awkward position which can cause strained muscles or tendons, bruises or torn skin if the worker is not careful.

The use of heavy ladders for manhole entry and exit has been prohibited in many communities after these ladders have been dropped by accident while a worker is in a manhole. The practice of having metal rungs installed in manhole walls also has been discontinued by some agencies because the rungs or the concrete holding them was being eaten away and destroyed by the highly corrosive atmospheres of the collection system. Portable, lightweight, aluminum alloy ladders have proven satisfactory.

Dropping tools to workers in a manhole and tossing the tools back out has caused many physical injuries. In order for workers to see to catch a tool being dropped, they must look upward and into the brighter light, causing temporary loss of visual capacity. In addition to this, dust and debris from the street or manhole ring can fall into your eyes, again causing vision problems as well as possible eye infection if you attempt to wipe your eyes with a hand or glove that has been exposed to the wastewater environment. Tools should be lowered into and pulled out of manholes in a bucket or sling. Many collection system and treatment plant agencies use a truck winch to lower a worker and tools into a manhole. The man lift (Fig. 4.5, page 4-24) has a step, safety strap and snap, and a frame to avoid scrapes.

The use of spectacles or safety goggles in a manhole may be difficult because of their capacity to fog. These glasses also can become smeared by moisture in a manhole environment, thus resulting in decreased vision capacity by the wearer. Proper ventilation will reduce fogging problems. If a chipping gun or other tool is being used to chip concrete or pipe, safety glasses or goggles must be worn. A helmet and clear face shield worn by motorcyclists may be better than safety goggles.

When working in a manhole, beware of sharp objects that can cut or penetrate your skin and cause a serious infection. Typical sharp objects include razor blades, pins, hypodermic needles and broken pieces of glass and metal.

#### 4.133 Infections and Diseases

Infections are always potentially present when you enter a manhole. Every disease, parasite, infection, virus and illness of a community can end up in the wastewater collection system. Persons required to enter manholes are thus automatically exposed to these infections and diseases. Leptospirosis can be transmitted to workers through the urine and feces of rats living in sewers. This disease causes fever, headache, nausea, muscular pains, vomiting, and chills. Contact your safety officer or doctor regarding inoculations for typhoid, para-typhoid, polio and tetanus. Personal cleanliness is your best means of protection. If possible, have a commercial laundry service clean your uniform rather than wash your clothes at home with your family laundry.

#### 4.134 Insects, Bugs and Rodents

Insects, while less severe in danger to workers than infections and diseases, can be a source of danger. The black widow and the violin spider are examples of threats to your health. Many bites are associated with infections, for example, rat bites can cause rabies and mosquito bites can cause malaria. Following is a list of insects and bugs which have been found in manholes.

- Stinging insects such as wasps, mud daubers and bees
- Ticks
- Fleas
- Lice
- Mosquitos
- Houseflies
- Blowflies

Always inspect a manhole for insects, bugs and rodents before entering.

#### 4.135 Toxicants

Exposure to toxic acids, bases and other hazardous liquid or solid chemicals that can be discharged into the wastewater collection system by either accidental spills or deliberate action by industry or the public is always a potential health hazard. Proper boots and gloves are effective means of protection against these toxicants.

#### 4.136 Drowning

With the trend towards larger regional wastewater treatment plants, intercepting sewers are being constructed that convey large flows. These large diameter sewers and flows increase the chances of a worker drowning from an accidental slip or fall into the flowing wastewater. Watch your step at all times, especially when working near or in large flows to avoid drowning. Wear lift jackets and use lifelines if necessary.

#### 4.137 Summary

Manhole entry always must be considered a hazardous task due to the potential exposure to chemicals, toxic and explosive gases, insects and infectious conditions. Work in manholes can be done safely when the proper procedures are followed.

#### 4.14 Safety Equipment and Procedures for Manhole Entry

The pieces of equipment described below are recommended for use when workers are required to enter a collection system manhole.

##### 4.140 Self-Contained Breathing Apparatus

This apparatus consists of a face mask respirator and hose to the air supply. Air may be supplied either from a tank carried on the worker's back or from larger cylinders placed at a convenient location and not carried around by the worker. Use when ventilation is unable to provide a suitable atmosphere in a manhole or confined space.

##### 4.141 Safety Harness with Lifeline

The harness should be a parachute type which prevents a limp body from falling out of it. The lifeline connection should attach at the shoulders so as to suspend a body in the upright position. Tilting or doubling over of a body can prevent its rapid removal through the 24 inch manhole opening, or cause injury to a person while being removed in the doubled over or tilted position.

The harness and lifeline may be used to lower a worker into a confined space. Whenever a worker is underground (in a manhole), someone must be topside holding the lifeline and observing the actions of the worker in the harness. Do not tie the above ground end of the lifeline to any object that could be hit by a careless driver that could result in injury to the worker in the harness.

#### 4.16 Operations of Manhole Entry

The minimum crew for a worker to enter a collection system manhole is three workers: the worker who will go into the hole, the lifeline attendant and an assistant on the surface. The arrangement of the safety and other equipment is generally accomplished by the entire crew, however a support crew may be necessary to direct traffic and provide other needed assistance.

1. The manhole safety enclosure is placed around the manhole if necessary.

2. The portable explosivity/oxygen alarm system is calibrated BEFORE removing the manhole cover. Test the manhole from top to bottom for oxygen deficiency, explosive and toxic (hydrogen sulfide) gases. Test for explosive mixtures before removing the manhole cover because removal of the cover may produce a spark and cause an explosion. Also it is helpful to know conditions in the manhole before any ventilation occurs.

If an explosive atmosphere is discovered in a manhole:

- a. Immediately notify your supervisor that an explosive condition has been discovered and provide as many details as possible, including location. Request notification of police and fire departments.
- b. Do not remove the manhole cover.
- c. Turn off any running engines in the vicinity that could cause a spark.
- d. Route vehicles around manhole using cones, flags and barricades.
- e. Inspect upstream and downstream manholes for explosive conditions to determine the extent of the problem.
- f. Route traffic off the street to reduce potential for explosion.
- g. Notify industrial waste inspectors and wastewater treatment plant operators.
- h. Attempt to locate source of problem and correct situation.
- i. Cautiously ventilate system with a large blower to eliminate explosive hazard. Try ventilating from a safe upstream or downstream manhole in order to keep workers and equipment away from explosive conditions.
- j. Be sure there is NO SMOKING in the area.

3. Never use hands to remove or replace the manhole cover. Always use manhole lifts approved by the safety agency that regulates your activities.

4. Open manholes upstream and downstream from the work area to encourage natural ventilation of sewer. Cover open manholes with grating and place barricades around manholes to warn traffic and pedestrians.

5. The area immediately around the manhole opening, including the manhole ring and lid ledge, should be cleaned and all loose debris removed. Sweep the area before removing the manhole cover and clean the ring ledge after the cover has been removed.



6. The ventilation blower is started and the manhole atmosphere blown out prior to entry. The blower should be located in an area unwind of the manhole and at least ten feet from the manhole opening. If the blower has a gas driven engine, the exhaust must be downwind from the manhole. Place the air intake to the blower from two to five feet above the ground surface, depending on conditions (higher for dusty ground surfaces). Some agencies prefer to exhaust or pull air from the downstream manhole if possible.
7. Once the man going into the hole has donned the safety harness and has the lifeline attached, the other man on the crew or the foreman should check it for proper fit and attachment.
8. Continue to use the alarm system to test for the presence of an oxygen deficiency and explosive gases in the manhole atmosphere the entire time the worker is in the manhole.

#### 4.17 While Worker Is Down in the Manhole

1. The end of the lifeline must be held continuously by a crew member. This person shall perform no other function, but keep constant watch over the worker in the manhole. Tying the lifeline to prevent it from falling into the manhole is poor practice, especially if it is tied to an object that could be struck by a passing vehicle and cause injury to the worker in the manhole.
2. The safety enclosure will always contain one worker who holds the lifeline, observes the worker in the manhole, and calls for help if needed. Safety enclosures are not considered necessary by some agencies.

The worker holding the lifeline should be careful to secure any objects he has in his shirt or jacket pockets so that they will not fall into the manhole when he bends over it. Also he must be careful not to accidentally kick any tools or objects over the edge of the manhole.

3. As long as the worker is in the manhole, the worker holding the lifeline should carefully watch the worker and not distract him. Always listen and respond to the needs and condition of the worker in the manhole.
  - a. If there are any indications of trouble such as unusual behavior or warning signals from the gas/oxygen alarm system, immediately bring the worker up out of the manhole.

137

- b. Whenever a worker is in a manhole, continuously test the atmosphere for oxygen deficiency and for explosive and toxic (hydrogen sulfide) gases. Proper ventilation generally will prevent any problems with the manhole atmosphere from developing except during a dump up sewer. If the flammable gas level is within only 10 percent of the lower explosive limit (LEL), this is an indication that ventilation is ineffective.

Each major section concludes with questions the learner should be able to answer, such as the following, if he has really mastered the text material:

1. List the hazards you may encounter when entering a manhole.
2. What kinds of atmospheric hazards are encountered in manholes?
3. What are some of the causes of physical injuries in manholes?
4. How can you protect yourself from diseases when working in a manhole?
5. How can you protect yourself from insects when working in a manhole?
6. What kinds of preparations should be made before workers enter a manhole?
7. What are some of the health conditions of workers that should be considered before entering a manhole?
8. The briefing before manhole entering should discuss what topics?
9. What is the minimum size of a crew when someone enters a manhole?
10. What should the worker at the manhole entrance be doing while another worker is in the manhole?
11. What is the minimum level of oxygen in air for safe breathing?
12. What should a worker do after leaving a manhole?

Part II

Abstracted Reference Materials

## SECTION I

## Safety: Management - Supervisor - Worker Responsibilities

TITLE ACCIDENTS MADE EASY - SAFETY AWARENESS SERIES.  
 AVAIL NATIONAL SAFETY COUNCIL, 444 NORTH MICHIGAN AVENUE, CHICAGO, IL 60611 (\$250.00)  
 DESC \*ACCIDENT PREVENTION, ATTITUDES, \*AUDIOVISUAL AIDS, \*FILMS, \*INDUSTRIAL SAFETY, INSTRUCTIONAL FILMS, \*MANAGEMENT, POST SECONDARY EDUCATION, \*SAFETY  
 DESC NOTE (NO. 147.28-9) 16MM, 13 MIN., COLOR; THREE FILM SET (EW002805-EW002807) "SAFETY AWARENESS" SERIES  
 ABSTRACT VARIOUS EMPLOYEE ATTITUDES TOWARD SAFETY ARE UNCOVERED AS A RESULT OF A SERIES OF RECENT ACCIDENTS THAT COULD AND SHOULD HAVE BEEN AVOIDED. DIRECTED TO EMPLOYEES CONCENTRATING ON THEIR ATTITUDES ABOUT SAFETY IN RELATION TO THEIR JOBS, THEIR EMPLOYERS AND THEMSELVES.  
 INST-NAME NATIONAL SAFETY COUNCIL

TITLE ACCIDENT PREVENTION MANUAL FOR INDUSTRIAL OPERATION, 7TH ED.  
 AVAIL NATIONAL SAFETY COUNCIL, 444 NORTH MICHIGAN AVENUE, CHICAGO, IL 60611 (\$40.00)  
 DESC \*ACCIDENT PREVENTION, \*INDUSTRIAL SAFETY, INSTRUCTIONAL MATERIALS, \*MANUALS, POST SECONDARY EDUCATION, \*SAFETY  
 DESC NOTE 1536P. (NO. 121.38-9) PHOTOS, ILLUSTRATIONS, CHARTS, GRAPHS AND TABLES  
 ABSTRACT UP-TO-DATE INDUSTRIAL SAFETY SOURCEBOOK DESIGNED TO PROVIDE YOU WITH ALL THE ESSENTIAL INFORMATION NECESSARY TO CARRY OUT EFFICIENT ACCIDENT PREVENTION.  
 INST NAME NATIONAL SAFETY COUNCIL

TITLE ACCIDENT PREVENTION MANUAL FOR TRAINING PROGRAMS.  
 AUTHOR STRONG, M. S.  
 PUB DATE 75  
 AVAIL AMERICAN TECHNICAL SOCIETY, 848 EAST 58TH STREET, CHICAGO, IL 60637 (\$16.00)  
 DESC \*ACCIDENT PREVENTION, \*INSTRUCTION, \*INSTRUCTIONAL MATERIALS, LAWS, REGULATIONS, \*SAFETY  
 DESC NOTE 600P. (ISBN 0-8269-4517-1) 2ND ED.; ILLUSTRATION  
 ABSTRACT TWENTY RECOGNIZED EXPERTS HAVE POOLED THEIR KNOWLEDGE TO PRODUCE THIS MANUAL. FEDERAL REGULATIONS, OSHA, AND SAFETY PRACTICES HAVE UNDERScoreD THE NEED FOR THIS BOOK; EVERY EFFORT WAS MADE TO MAKE IT COMPLETE.

TITLE ARTIFICIAL RESPIRATION.  
 PUB DATE 73  
 AVAIL NATIONAL AUDIOVISUAL CENTER, REFERENCE SECTION, GENERAL SERVICES ADMINISTRATION, WASHINGTON, DC 20409 (PURCHASE PRICE: \$52.25)

DESC \*AUDIOVISUAL AIDS, \*ACCIDENT PREVENTION, ARTIFICIAL  
 RESPIRATION, FILMS, \*INSTRUCTIONAL FILMS, INSTRUCTIONAL  
 MATERIALS, POST SECONDARY EDUCATION, \*SAFETY  
 DESC NOTE (TITLE NO. 001994) (AGENCY NO. M-798) 16MM, 16 MIN., OPTICAL  
 SOUND, COLOR.  
 ABSTRACT TEACHES THE INDIVIDUAL HOW TO TAKE CARE OF MANY OF HIS MEDICAL  
 AND HEALTH NEEDS IN TIME OF DISASTER WHEN MEDICAL ASSISTANCE  
 MIGHT NOT BE READILY AVAILABLE.  
 INST NAME U.S. DEPARTMENT OF HEALTH, EDUCATION AND WELFARE.

TITLE ATTITUDES AND EMOTIONS.  
 AVAIL NATIONAL SAFETY COUNCIL, 444 NORTH MICHIGAN AVENUE, CHICAGO, IL  
 60611 (\$46.80)  
 DESC \*ACCIDENT PREVENTION, \*ATTITUDES, EMOTIONS, \*INDUSTRIAL SAFETY,  
 INSTRUCTIONAL MATERIALS, POST SECONDARY EDUCATION, \*SAFETY,  
 SLIDES, VISUAL AIDS  
 DESC NOTE (NO. 279.95-9) 30 (2X2) SLIDES, COLOR, SCRIPT  
 ABSTRACT DISCUSSES THESE IN RELATIONSHIP TO ACCIDENTS.  
 INST NAME NATIONAL SAFETY COUNCIL.

TITLE CONSIDERATIONS FOR PREPARATION OF OPERATION AND MAINTENANCE  
 MANUALS.  
 AUTHOR GREEN, R. L., AND OTHERS  
 PUB DATE 78  
 AVAIL SUPERINTENDENT OF DOCUMENTS, GOVERNMENT PRINTING OFFICE,  
 WASHINGTON, DC 20402 (\$3.10)  
 DESC \*COMMUNICATION SKILLS, EQUIPMENT MAINTENANCE, \*FACILITIES,  
 LABORATORY TESTING, \*MANUALS, PERMITS, PERSONNEL, \*PUMPING  
 STATIONS, SAFETY, STANDARDS, \*TRAINING MANUALS, UTILITIES,  
 WASTE DISPOSAL, \*WASTEWATER TREATMENT, WATER POLLUTION CONTROL  
 239P.  
 DESC NOTE THIS DOCUMENT PROVIDES CONSIDERATIONS FOR THE PREPARATION OF  
 ABSTRACT MUNICIPAL WATER TREATMENT PLANT OPERATION AND MAINTENANCE  
 MANUALS. TOPIC AREAS INCLUDE, (1) PERMITS AND STANDARDS, (2)  
 SLUDGE HANDLING, (3) PERSONNEL, (4) LABORATORY TESTING, (5)  
 SAFETY, (6) EMERGENCY OPERATIONS, AND (7) OTHER UTILITIES.  
 DETAILED DISCUSSIONS ON THE TYPE OF MANUAL ARE FOUND IN EACH  
 SECTION. A SUGGESTED MANUAL OUTLINE IS INCLUDED FOR TREATMENT  
 PLANTS AND FOR PUMPING STATIONS AND PIPELINES.

TITLE EVERYBODY'S DIFFERENT - HUMAN FACTORS IN SAFETY SERIES.  
 AVAIL NATIONAL SAFETY COUNCIL, 444 NORTH MICHIGAN AVENUE, CHICAGO, IL  
 60611 (\$185.00)  
 DESC \*ACCIDENT PREVENTION, \*ATTITUDES, AUDIOVISUAL AIDS, \*FILMS,  
 \*INDUSTRIAL SAFETY, INSTRUCTIONAL FILMS, \*MANAGEMENT, POST  
 SECONDARY EDUCATION, \*SAFETY  
 DESC NOTE (NO. 142.17-9) 16MM, 10 MIN., COLOR; FOUR-FILM SET  
 (EW002788-EW002791) "HUMAN FACTORS IN SAFETY" SERIES  
 ABSTRACT DEALS WITH THE HUMAN ELEMENT IN ACCIDENT PREVENTION: HOW THE  
 BEHAVIOR OF PEOPLE WITH OTHER PEOPLE CAN BE FACTORS IN CAUSING  
 OR AVOIDING ACCIDENTS; HOW PEOPLE DIFFER, PHYSICALLY AND  
 EMOTIONALLY; AND HOW THESE DIFFERENCES MAY AFFECT SAFETY  
 PERFORMANCES.  
 INST NAME NATIONAL SAFETY COUNCIL.

111

TITLE JOB TRAINING JOGGER.  
 AVAIL NATIONAL SAFETY COUNCIL, 444 NORTH MICHIGAN AVENUE, CHICAGO, IL  
 60611 (\$1.20)  
 DESC \*ACCIDENT PREVENTION, \*INDUSTRIAL SAFETY, \*INSTRUCTION,  
 INSTRUCTIONAL MATERIALS, POST SECONDARY EDUCATION, \*SAFETY,  
 \*TEACHING TECHNIQUES  
 DESC NOTE 20P. (NO. 193.21-9) MINIMUM ORDER OF 10  
 ABSTRACT A SAFETY INSTRUCTOR'S GUIDE COMBINING THE TESTED METHODS OF JOB  
 SAFETY ANALYSIS AND JOB INSTRUCTION TRAINING TO PRODUCE SOUND,  
 LOGICAL PROCEDURES FOR TEACHING SAFETY.  
 INST NAME NATIONAL SAFETY COUNCIL.

TITLE MAN AND HIS HABITS.  
 PUB DATE 69  
 AVAIL NATIONAL AUDIOVISUAL CENTER; REFERENCE SECTION; GENERAL  
 SERVICES ADMINISTRATION, WASHINGTON, DC 20409 (PURCHASE PRICE:  
 \$75.50)  
 DESC \*ACCIDENT PREVENTION, \*AUDIOVISUAL AIDS, \*FILMS, \*INSTRUCTIONAL  
 FILMS, \*INSTRUCTIONAL MATERIALS, \*POST SECONDARY EDUCATION,  
 \*SAFETY  
 DESC NOTE (TITLE NO. 003532) 16MM, 13 MIN., OPTICAL SOUND, COLOR.  
 ABSTRACT SHOWS HOW MAN'S HABITS MAY ENDANGER HIS SAFETY BY BECOMING  
 ROUTINE WHEN CARRIED OVER TO HIS WORK. BY VISUAL EXAMPLES, THE  
 WORKER IS SHOWN HOW TO ACQUIRE SAFE WORK HABITS BY PRACTICING  
 SAFETY AT HOME AND ON THE JOB.  
 INST NAME U.S. BUREAU OF MINES.

TITLE MANS SHORTCOMINGS.  
 PUB DATE 69  
 AVAIL NATIONAL AUDIOVISUAL CENTER, REFERENCE SECTION, GENERAL  
 SERVICES ADMINISTRATION, WASHINGTON, DC 20409 (PURCHASE PRICE:  
 \$75.50)  
 DESC \*ACCIDENT PREVENTION, AUDIOVISUAL AIDS, \*FILMS, \*INSTRUCTIONAL  
 FILMS, \*INSTRUCTIONAL MATERIALS, \*POST SECONDARY EDUCATION,  
 \*SAFETY, \*WORKER ATTITUDE  
 DESC NOTE (TITLE NO. 003533) 16MM, 13 MIN., OPTICAL SOUND, COLOR.  
 ABSTRACT DRAMATICALLY ENACTED SCENES SHOW HOW MAN'S PERSONALITY QUIRKS  
 MAY ENDANGER HIS AND OTHER WORKERS' SAFETY. SUGGESTIONS ARE  
 GIVEN TO AVOID OR CHANGE THIS MENTAL ATTITUDE AND PREVENT THESE  
 NONSENSIBLE ACTIONS.  
 INST NAME U.S. BUREAU OF MINES.

TITLE MOTIVATION: A MEANS TO ACCIDENT PREVENTION.  
 PUB DATE 69  
 AVAIL NATIONAL AUDIOVISUAL CENTER, REFERENCE SECTION. GENERAL  
 SERVICES ADMINISTRATION, WASHINGTON, DC 20409 (PURCHASE PRICE:  
 \$63.75)  
 DESC \*ACCIDENT PREVENTION, AUDIOVISUAL AIDS, \*FILMS, \*INSTRUCTIONAL  
 FILMS, \*INSTRUCTIONAL MATERIALS, \*POST SECONDARY EDUCATION,  
 \*SAFETY, \*WORKER ATTITUDE  
 DESC NOTE (TITLE NO. 003585) 16MM, 11 MIN., OPTICAL SOUND, COLOR.  
 ABSTRACT SHOWS HOW PROPER MOTIVATION PREVENTS ACCIDENTS AT HOME AND ON  
 THE JOB. THE REASONS THAT MOTIVATE THE STAFF ARE PRESENTED IN A  
 VISUALLY INTERESTING MANNER.  
 INST NAME U.S. BUREAU OF MINES.

TITLE NEW EMPLOYEE SAFETY TRAINING (NEST) - ENGLISH.  
 PUB DATE 67  
 AVAIL E.I. DUPONT DE NEMOURS & COMPANY, INC., EDUCATION & APPLIED TECHNOLOGY DIVISION, BRANDYWINE BLDG., WILMINGTON, DE 19898 (\$1.66)  
 DESC \*ACCIDENT PREVENTION, \*INDUSTRIAL SAFETY, \*INDUSTRY, \*INSTRUCTIONAL MATERIALS, \*POST SECONDARY EDUCATION, \*SAFETY  
 DESC NOTE 12P. COURSE NO. 500  
 ABSTRACT THE OBJECTIVE OF THIS TRAINING IS TO IMPROVE SAFETY PERFORMANCE BY ESTABLISHING WITH NEW EMPLOYEES A UNIFORM UNDERSTANDING OF SAFETY POLICIES.  
 INST NOTE E.I. DUPONT DE NEMOURS & COMPANY, INC.

TITLE OPERATION AND MAINTENANCE OF WASTEWATER COLLECTION SYSTEMS: A FIELD STUDY TRAINING PROGRAM.  
 PUB DATE 76  
 AVAIL DEPARTMENT OF CIVIL ENGINEERING, CALIFORNIA STATE UNIVERSITY AT SACRAMENTO, 6000 JAY STREET, SACRAMENTO, CA 95819 (\$30.00)  
 DESC EQUIPMENT, \*INSTRUCTIONAL MATERIALS, \*INSTRUMENTATION, \*MAINTENANCE, \*OPERATIONS (WASTEWATER), \*POST SECONDARY EDUCATION, \*PUMPS, RECORDS, SAFETY, TROUBLESHOOTING, WASTE DISPOSAL, \*WASTEWATER TREATMENT  
 DESC NOTE 1711P. 300 SLIDES, REVISED ANNUALLY, ALSO AVAILABLE ON ERIC MICROFICHE ED150007  
 ABSTRACT WRITTEN BY EXPERIENCED COLLECTION SYSTEM WORKERS (MAINTENANCE MEN) WITH THE INTENT OF PROVIDING COLLECTION SYSTEMS WORKERS WITH THE INFORMATION THEY NEED TO KNOW TO OPERATE AND MAINTAIN THEIR COLLECTION SYSTEMS AS SAFELY AND AS EFFICIENTLY AS POSSIBLE. TOPICS COVERED INCLUDE JOB SYSTEM, REVIEW OF PLANS AND SPECS, INSPECTION, TESTING, TELEVISIONING SEWERS, BALLING HIGH VELOCITY CLEANERS, SCOOTERS, KITES, RODDING, BUCKETS, REPAIRS, LIFT STATIONS, MAINTENANCE, RECORDS.

TITLE PEOPLE ARE ALL ALIKE - HUMAN FACTORS IN SAFETY SERIES.  
 AVAIL NATIONAL SAFETY COUNCIL, 444 NORTH MICHIGAN AVENUE, CHICAGO, IL 60611 (\$185.00)  
 DESC \*ACCIDENT PREVENTION, \*ATTITUDES, AUDIOVISUAL AIDS, EMOTIONS, \*FILMS, \*INDUSTRIAL SAFETY, INSTRUCTIONAL FILMS, \*MANAGEMENT, POST SECONDARY EDUCATION, \*SAFETY  
 DESC NOTE (NO. 142.16-9) 16MM, 10 MIN., COLOR; FOUR-FILM SET (EW002788-EW002791) "HUMAN FACTORS IN SAFETY" SERIES.  
 ABSTRACT DEALS WITH THE HUMAN ELEMENT IN ACCIDENT PREVENTION. HOW THE BEHAVIOR OF PEOPLE WITH OTHER PEOPLE CAN BE FACTORS IN CAUSING OR AVOIDING ACCIDENTS. DISCUSSES THE EMOTIONAL NEEDS, RESPONSES, CHARACTERISTICS THAT EVERYONE HAS IN COMMON.  
 INST NAME NATIONAL SAFETY COUNCIL

TITLE PLAN FOR PREVENTION - SAFETY MANAGEMENT SERIES.  
 AVAIL NATIONAL SAFETY COUNCIL, 444 NORTH MICHIGAN AVENUE, CHICAGO, IL 60611 (\$155.00)  
 DESC \*ACCIDENT PREVENTION, \*ACCIDENT REPORTING, AUDIOVISUAL AIDS, \*FILMS, \*INDUSTRIAL SAFETY, INSTRUCTIONAL FILMS, \*MANAGEMENT, POST SECONDARY EDUCATION, \*SAFETY  
 DESC NOTE (NO. 148.12-9) 16MM, 10 MIN., COLOR; EIGHT FILM SET (EW002796-EW002803) "SAFETY MANAGEMENT" SERIES

ABSTRACT TECHNIQUES OF GOOD ACCIDENT REPORTING.  
 INST NAME NATIONAL SAFETY COUNCIL

TITLE PLAN YOUR TALKS -- COMMUNICATING SAFETY SERIES.  
 AVAIL NATIONAL SAFETY COUNCIL, 444 NORTH MICHIGAN AVENUE, CHICAGO, IL 60611

DESC \*ACCIDENT PREVENTION, AUDIOVISUAL AIDS, COMMUNICATIONS, \*FILMS, \*INDUSTRIAL SAFETY, INSTRUCTIONAL FILMS, \*MANAGEMENT, POST SECONDARY EDUCATION, \*SAFETY

DESC NOTE 16MM, 10 MIN., COLOR; THREE FILM SET "COMMUNICATING SAFETY" SERIES NO. 147.20-9; PRICE: \$540.00 PER SET; SEE EW002785 AND EW002787

ABSTRACT TEACHES SUPERVISORY PERSONNEL HOW TO BRIDGE THE GAP OF POOR COMMUNICATION AND REALLY INSPIRE IMPROVED SAFETY PERFORMANCE FROM THEIR SUBORDINATES. DISCUSSES DEVICES FOR TURNING ANY ENCOUNTER INTO AN OPPORTUNITY FOR A SAFETY TALK..

TITLE PLANNING FOR SAFETY - INTRODUCTORY UNIT (COURSE).  
 AVAIL E.I. DUPONT DE NEMOURS & COMPANY, INC. EDUCATION & APPLIED TECHNOLOGY DIVISION, BRANDYWINE BLDG. WILMINGTON, DE 19898 (\$1.90)

DESC \*ACCIDENT PREVENTION, \*INDUSTRY, \*INSTRUCTIONAL MATERIALS, \*POST SECONDARY EDUCATION, \*SAFETY

DESC NOTE 32P. COURSE NO. 553

ABSTRACT TRAINEE WILL IDENTIFY THE STEPS IN AN ORGANIZED APPROACH TO SAFETY PLANNING ON HIS JOB AS HE GETS READY FOR THE JOB, AND PUTS AWAY WHEN THE JOB IS FINISHED. EACH EMPLOYEE WILL DEMONSTRATE ON THE JOB HOW HE IS USING "PLANNING FOR SAFETY."

INST NAME E.I. DUPOVT DE NEMOURS & COMPANY, INC.

TITLE PLANNING FOR SAFETY - INTRODUCTORY UNIT (LEADER'S GUIDE).  
 AVAIL E.I. DUPONT DE NEMOURS & COMPANY, INC., EDUCATION & APPLIED TECHNOLOGY DIVISION, BRANDYWINE BLDG. WILMINGTON, DE 19898 (\$1.90)

DESC \*INDUSTRY, \*INSTRUCTIONAL MATERIALS, \*POST SECONDARY EDUCATION, \*SAFETY, ACCIDENT PREVENTION, TEACHING GUIDES

DESC NOTE- 20P. ORDER NO. 552

ABSTRACT TRAINEE WILL IDENTIFY THE STEPS IN AN ORGANIZED APPROACH TO SAFETY PLANNING ON HIS JOB AS HE GETS READY FOR THE JOB, DOES THE JOB, AND PUTS AWAY WHEN THE JOB IS FINISHED. EACH EMPLOYEE WILL DEMONSTRATE ON THE JOB HOW HE IS USING "PLANNING FOR SAFETY".

INST NAME E.I. DEPONT DE NEMOURS & COMPANY, INC.

TITLE RUN THE TEAM - SAFETY MANAGEMENT SERIES.  
 AVAIL NATIONAL SAFETY COUNCIL, 444 NORTH MICHIGAN AVENUE, CHICAGO, IL 60611 (\$155.00)

DESC \*ACCIDENT PREVENTION, \*FILMS, \*INDUSTRIAL SAFETY, \*MANAGEMENT, \*SAFETY, \*SUPERVISION, AUDIOVISUAL AIDS, INSTRUCTIONAL FILMS, POST SECONDARY EDUCATION

DESC NOTE (NO. 148.11-9) 16MM, COLOR, 10 MIN. EIGHT FILM SET (EW002796 - EW002803) "SAFETY MANAGEMENT" SERIES



ABSTRACT BASIC FUNCTION OF THE FOREMAN IN SAFETY. PROVIDES THE FOREMAN AND SUPERVISORS WITH TRAINING IN BASIC AREAS OF ACCIDENT PREVENTION. THE FILM FOLLOWS A SAFETY DIRECTOR AND SUPERVISOR WHO ARE PLANNING A COURSE IN THE FUNDAMENTALS OF ACCIDENT PREVENTION. MOCK-UPS AND DEMONSTRATIONS ARE USED TO ILLUSTRATE MAJOR POINTS.

INST NAME NATIONAL SAFETY COUNCIL

TITLE S-T-O-P REFRESHER COURSE.

PUB DATE 68

AVAIL E.I. DUPONT DE NEMOURS & COMPANY, INC., EDUCATION & APPLIED TECHNOLOGY DIVISION, BRANDYWINE BLDG., WILMINGTON, DE 19898 (\$1.90)

DESC ACCIDENT PREVENTION, \*INDUSTRY, \*INSTRUCTIONAL MATERIALS, \*POST SECONDARY EDUCATION, \*REFRESHER COURSES, \*SAFETY, \*SUPERVISORS

DESC NOTE 20P. COURSE NO. 525

ABSTRACT REFRESHER COURSE FOR SUPERVISORY PERSONNEL CONCERNED WITH SAFETY.

INST NAME E.I. DUPONT DE NEMOURS & COMPANY, INC.

TITLE SAFETY ATTITUDES

AVAIL NATIONAL SAFETY COUNCIL, 444 NORTH MICHIGAN AVENUE, CHICAGO, IL 60611 (\$115.00)

DESC \*ACCIDENT PREVENTION, \*ATTITUDES, \*AUDIOVISUAL AIDS, \*FILMS, \*INDUSTRIAL SAFETY, INSTRUCTIONAL FILMS, POST SECONDARY EDUCATION, \*SAFETY

DESC NOTE (NO. 171.11-9) 16MM, 10MIN., COLOR

ABSTRACT GRAPHICALLY ILLUSTRATES HOW ATTITUDES CAN CAUSE OR PREVENT ACCIDENTS.

INST NAME NATIONAL SAFETY COUNCIL.

TITLE SAFETY ATTITUDES.

AVAIL NATIONAL SAFETY COUNCIL, 444 NORTH MICHIGAN AVENUE, CHICAGO, IL 60611 (\$46.80)

DESC \*ACCIDENT PREVENTION, \*ATTITUDES, \*INDUSTRIAL SAFETY, INSTRUCTIONAL MATERIALS, POST SECONDARY EDUCATION, \*SAFETY, SLIDES, VISUAL AIDS

DESC NOTE (NO. 176.01-9) 30 (2X2) SLIDES, COLOR, SCRIPT

ABSTRACT DESCRIBES THE CAUSES AND EFFECTS OF UNSAFE ATTITUDES AND TELLS HOW TO CHANGE THEM.

INST NAME NATIONAL SAFETY COUNCIL.

TITLE SAFE PRACTICE SERIES CARDS.

AVAIL E.I. DUPONT DE NEMOURS & COMPANY, INC.; EDUCATION & APPLIED TECHNOLOGY DIVISION, BRANDYWINE BLDG., WILMINGTON, DE 19898 (\$1.90)

DESC \*ACCIDENT PREVENTION, \*INDUSTRY, \*INSTRUCTIONAL MATERIALS, \*OPERATIONS, \*POST SECONDARY EDUCATION, \*SAFETY

DESC NOTE ORDER NO. 590

ABSTRACT REMINDER CARDS FOR SAFETY.

INST NAME E.I. DUPONT DE NEMOURS & COMPANY, INC.

TITLE SAFETY PRACTICE FOR WATER UTILITIES.

PUB DATE 71

145

AVAIL AMERICAN WATER WORKS ASSOCIATION, 6666 WEST QUINCY AVE.,  
 DENVER, CO 80235 (\$8.00)  
 DESC \*ACCIDENT PREVENTION, \*INSTRUCTIONAL MATERIALS, \*MANUALS,  
 OPERATIONS (WATER), \*POST SECONDARY EDUCATION, \*SAFETY,  
 UTILITIES, \*WATER TREATMENT  
 DESC NOTE 128P. PAPER BOUND, MANUAL NO. 30003 (M3)  
 ABSTRACT A MANUAL COVERING ALL ASPECTS OF EMPLOYEE ACCIDENT PREVENTION.  
 INST NAME AMERICAN WATER WORKS ASSOCIATION.

TITLE SAFETY PRINCIPLES - INTRODUCTORY UNIT 1 (COURSE).  
 AVAIL E.I. DUPONT DE NEMOURS & COMPANY, INC., EDUCATION & APPLIED  
 TECHNOLOGY DIVISION, BRANDYWINE BLDG., WILMINGTON, DE 19898  
 (\$1.90)  
 DESC ACCIDENT PREVENTION, \*INDUSTRY, \*INSTRUCTIONAL MATERIALS, \*POST  
 SECONDARY EDUCATION, \*SAFETY, \*SELF PACED INSTRUCTION  
 DESC NOTE COURSE NO. 551  
 ABSTRACT INSTRUCTIONAL MATERIAL FOR A COURSE IN SAFETY.  
 INST NAME E.I. DUPONT DE NEMOURS & COMPANY, INC.

TITLE SAFETY PRINCIPLES - INTRODUCTORY UNIT 1 (LEADER'S GUIDE).  
 AVAIL E.I. DUPONT DE NEMOURS & COMPANY, INC., EDUCATION & APPLIED  
 TECHNOLOGY DIVISION, BRANDYWINE BLDG., WILMINGTON, DE 19898  
 (\$1.90)  
 DESC ACCIDENT PREVENTION, \*INDUSTRY, \*INSTRUCTIONAL MATERIALS, \*POST  
 SECONDARY EDUCATION, \*SAFETY, SELF PACED INSTRUCTION, \*TEACHING  
 GUIDES  
 DESC NOTE ORDER NO. 550  
 ABSTRACT GUIDE FOR INSTRUCTOR TEACHING SAFETY PROGRAMS.  
 INST NAME E.I. DUPONT DE NEMOURS & COMPANY, INC.

TITLE SAFETY PROGRAM GUIDE.  
 PUB NO 69  
 AVAIL WATER POLLUTION CONTROL FEDERATION, 2626 PENNSYLVANIA AVE., NW,  
 WASHINGTON, DC 20037 (\$16.50)  
 DESC \*ACCIDENT PREVENTION, \*AUDIOVISUAL AIDS, EQUIPMENT (PLANT),  
 \*INDUSTRIAL SAFETY, \*INSTRUCTIONAL MATERIALS, POST SECONDARY  
 EDUCATION, RECORDS, \*SAFETY, \*SLIDES  
 DESC NO 20 MIN. TAPE, 39 SLIDES, AND SCRIPT, AVAILABLE ON LOAN FROM  
 NTOIC, 26 W ST CLAIR, CINCINNATI, OH 45268  
 ABSTRACT A GUIDE FOR ESTABLISHING AN EFFECTIVE SAFETY PROGRAM INCLUDING  
 THE ROLE OF MANAGEMENT, ORGANIZATION REQUIRED, RECORD-KEEPING,  
 ACCIDENT INVESTIGATION AND EVALUATION PROCEDURES, CAUSES OF  
 ACCIDENTS, PROTECTIVE EQUIPMENT REQUIRED, ESTABLISHING SAFETY  
 RULES AND PROCEDURES, ELEMENTS OF EMPLOYEE TRAINING PROGRAMS  
 AND SUGGESTIONS FOR MOTIVATING EMPLOYEES.

TITLE SELL SAFETY - SAFETY MANAGEMENT SERIES.  
 AVAIL NATIONAL SAFETY COUNCIL, 444 NORTH MICHIGAN AVENUE, CHICAGO, IL  
 60611 (\$155.00)  
 DESC \*ACCIDENT PREVENTION, AUDIOVISUAL AIDS, \*COMMUNICATIONS,  
 \*FILMS, \*INDUSTRIAL SAFETY, INSTRUCTIONAL FILMS, \*MANAGEMENT,  
 POST SECONDARY EDUCATION, \*SAFETY  
 DESC NO (NO. 148.18-9) 16 MM, 10 MIN., COLOR, EIGHT FILM SET  
 (EW002796-EW002803) "SAFETY MANAGEMENT" SERIES

ABSTRACT INST NAME SAFETY THROUGH GOOD COMMUNICATION.  
 NATIONAL SAFETY COUNCIL.

TITLE SHORT COURSE IN FIRST AID.  
 AVAIL THE LANSFORD PUBLISHING CO., DEPT. B, P.O. BOX 8711, SAN JOSE,  
 CA 95155 (\$89.95)

DESC \*FIRST AID, \*INSTRUCTIONAL MATERIALS, \*POST SECONDARY  
 EDUCATION, \*SAFETY, \*TRANSPARENCIES, \*VISUAL AIDS

DESC NO ORDER NO. W113; 15 TRANSPARENCIES  
 ABSTRACT BASIC FIRST AID KNOWLEDGE PRESENTED, INCLUDES: WHAT TO DO IF  
 BREATHING STOPS, MOUTH-TO-MOUTH RESUSCITATIONS, ARTIFICIAL  
 RESPIRATION, BLEEDING CHARACTERISTICS, HOW TO STOP BLEEDING,  
 SHOCK, WOUNDS, BURNS AND SCALDS, FRACTURES, AND OTHER PROBLEMS.

INST NAME THE LANSFORD PUBLISHING CO.

TITLE SUPERVISORS GUIDE TO HUMAN RELATIONS.  
 AUTHOR HANNAFORD, E. S.  
 AVAIL NATIONAL SAFETY COUNCIL, 444 NORTH MICHIGAN AVENUE, CHICAGO, IL  
 60611 (\$10.20)

DESC \*ACCIDENT PREVENTION, \*ATTITUDES, COMMUNICATIONS, \*INDUSTRIAL  
 SAFETY, INSTRUCTIONAL MATERIALS, MANAGEMENT, POST SECONDARY  
 EDUCATION, \*SAFETY, \*SUPERVISION

DESC NOTE 352P. (NO. 151.09-9)  
 ABSTRACT DEALS WITH THE HUMAN ELEMENTS OF SAFETY SUPERVISION AND  
 COMMUNICATIONS. PROVIDES PRACTICAL INFORMATION FOR SUPERVISORS  
 AND MIDDLE MANAGEMENT PERSONNEL. CONTAINS ACTUAL CASE  
 HISTORIES.

TITLE SUPERVISORS SAFETY MANUAL  
 AVAIL NATIONAL SAFETY COUNCIL, 444 NORTH MICHIGAN AVENUE, CHICAGO, IL  
 60611 (\$15.00)

DESC \*ACCIDENT PREVENTION, \*ATTITUDES, \*INDUSTRIAL SAFETY,  
 INSTRUCTIONAL MATERIALS, \*MANUALS, POST SECONDARY EDUCATION,  
 \*SAFETY, \*SUPERVISION

DESC NOTE 352P. (NO. 151.01-9)  
 ABSTRACT SHOWS SUPERVISORS HOW SAFETY RELATES TO EMPLOYEE SATISFACTION,  
 MORALE, AND HEALTH. ALSO COVERS JOB INSTRUCTION, INDUSTRIAL  
 HOUSEKEEPING, AND LOSS CONTROL.

INST NAME NATIONAL SAFETY COUNCIL.

TITLE SUPERVISOR'S SAFETY OBSERVATION HANDBOOK.  
 PUB 73  
 AVAIL NATIONAL SAFETY COUNCIL, 425 NORTH MICHIGAN AVE., CHICAGO, IL  
 60611

DESC \*ACCIDENT PREVENTION, EQUIPMENT UTILIZATION, EMERGENCY  
 PROGRAMS, \*INSTRUCTIONAL MATERIALS, JOB SKILLS, \*MANAGEMENT,  
 OSHA, POST SECONDARY EDUCATION, \*SAFETY, \*STANDARDS,  
 \*SUPERVISION, \*WORK ENVIRONMENT

DESC NOTE 19P.  
 ABSTRACT THIS HANDBOOK HIGHLIGHTS THE AREAS THAT SHOULD BE PART OF THE  
 SAFETY OBSERVATION PLAN OF PLANT SUPERVISORS. TOPIC AREAS  
 DISCUSSED INCLUDE: OBSERVATION OF WORK PRACTICES; HOUSEKEEPING;  
 LIGHTING; MATERIALS HANDLING; MACHINES AND EQUIPMENT;  
 PROTECTIVE EQUIPMENT; AND EMERGENCY PLANS. A SUGGESTED 31-DAY  
 SAFETY OBSERVATION PLAN IS INCLUDED.

INST NAME NATIONAL SAFETY COUNCIL.

**TITLE** TALK IT UP - COMMUNICATING SAFETY SERIES.  
**AVAIL** NATIONAL SAFETY COUNCIL, 444 NORTH MICHIGAN AVENUE, CHICAGO, IL 60611  
**DESC** \*ACCIDENT PREVENTION, AUDIOVISUAL AIDS, COMMUNICATIONS, \*FILMS, \*INDUSTRIAL SAFETY, INSTRUCTIONAL FILMS, \*MANAGEMENT, POST SECONDARY EDUCATION, \*SAFETY  
**DESC NOTE** 16MM, 10 MIN.; COLOR; THREE FILM SET "COMMUNICATING SAFETY" SERIES NO. 147.20-9; PRICE: \$490.00 PER SET. SEE EW002786 AND EW002787  
**ABSTRACT** TEACHES SUPERVISORY PERSONNEL HOW TO BRIDGE THE GAP OF POOR COMMUNICATION AND REALLY INSPIRE IMPROVED SAFETY PERFORMANCE FROM THEIR SUBORDINATES. EXPLORES METHODS OF COMMUNICATING SAFETY COMMITMENT TO EMPLOYEES.  
**INST NAME** NATIONAL SAFETY COUNCIL.

**TITLE** TEACHING SAFETY ON THE JOB - HUMAN FACTORS IN SAFETY SERIES.  
**AVAIL** NATIONAL SAFETY COUNCIL, 444 NORTH MICHIGAN AVENUE, CHICAGO, IL 60611 (\$185.00)  
**DESC** \*ACCIDENT PREVENTION, \*ATTITUDES, AUDIOVISUAL AIDS, \*FILMS, \*INDUSTRIAL SAFETY, INSTRUCTIONAL FILMS, \*MANAGEMENT, POST SECONDARY EDUCATION, \*SAFETY  
**DESC NOTE** (NO. 142.18-9) 16MM, 10 MIN., COLOR; FOUR-FILM SET (EW002788-EW002791) "HUMAN FACTORS IN SAFETY" SERIES  
**TITLE** DEALS WITH THE HUMAN ELEMENT IN ACCIDENT PREVENTION. HOW THE BEHAVIOR OF PEOPLE WITH OTHER PEOPLE CAN BE FACTORS IN CAUSING OR AVOIDING ACCIDENTS. HOW TO BUILD SAFETY INTO JOB TRAINING BY MAKING THE INSTRUCTION CLEAR AND BY PROPER FOLLOW-UP.  
**INST NAME** NATIONAL SAFETY COUNCIL

**TITLE** TEAMWORK FOR SAFETY - HUMAN FACTORS IN SAFETY SERIES.  
**AVAIL** NATIONAL SAFETY COUNCIL, 444 NORTH MICHIGAN AVENUE, CHICAGO, IL 60611 (\$185.00)  
**DESC** \*ACCIDENT PREVENTION, \*ATTITUDES, \*FILMS, \*INDUSTRIAL SAFETY, \*MANAGEMENT, \*SAFETY, AUDIOVISUAL AIDS, INSTRUCTIONAL FILMS, POST SECONDARY EDUCATION  
**DESC NOTE** (NO. 142.19-9) 16MM, 10 MIN. COLOR; FOUR-FILM SET (EW002788-EW002791) "HUMAN FACTORS IN SAFETY" SERIES  
**ABSTRACT** DEALS WITH THE HUMAN ELEMENT IN ACCIDENT PREVENTION. HOW THE BEHAVIOR OF PEOPLE WITH OTHER PEOPLE CAN BE FACTORS IN CAUSING OR AVOIDING ACCIDENTS. SHOWS HOW TO MAKE A GROUP OF PEOPLE FEEL LIKE PART OF A TEAM AND FUNCTION LIKE ONE.  
**INST NAME** NATIONAL SAFETY COUNCIL.

**TITLE** TOUGH ONES TAKE LONGER - COMMUNICATING SAFETY SERIES.  
**AVAIL** NATIONAL SAFETY COUNCIL, 444 NORTH MICHIGAN AVENUE, CHICAGO, IL 60611  
**DESC** \*ACCIDENT PREVENTION, \*ATTITUDES, \*FILMS, \*INDUSTRIAL SAFETY, \*MANAGEMENT, \*SAFETY, AUDIOVISUAL AIDS, INSTRUCTIONAL FILMS, POST SECONDARY EDUCATION  
**DESC NOTE** 16MM, 10 MIN. COLOR; THREE FILM SERIES "COMMUNICATING SAFETY" SERIES NO. 147.20-9; PRICE: \$540.00 PER SET; SEE EW002785 AND EW002786  
**ABSTRACT** HELPS SUPERVISORS RECOGNIZE AND COPE WITH PROBLEMS WITH PROBLEM PEOPLE SUCH AS THE WORRIER, THE CYNIC, THE PUT-OFF AND THE PREOCCUPIED WORKER.  
**INST NAME** NATIONAL SAFETY COUNCIL.

TITLE YOU AND WHAT YOU DO - SAFETY AWARENESS SERIES.  
AVAIL NATIONAL SAFETY COUNCIL, 444 NORTH MICHIGAN AVENUE, CHICAGO, IL  
60611 (\$195.00)  
DESC \*ACCIDENT PREVENTION, AUDIOVISUAL AIDS, \*FILMS, \*INDUSTRIAL  
SAFETY, INSTRUCTIONAL FILMS, \*MANAGEMENT, POST SECONDARY  
EDUCATION, \*SAFETY  
DESC NOTE (NO. 147.26-9) 16MM, 10 MIN., COLOR; THREE FILM SET  
(EW002805-EW002807) "SAFETY AWARENESS" SERIES  
ABSTRACT STUDIES THE DANGER INVOLVED WHEN PEOPLE AREN'T COMPLETELY  
TRAINED IN A PARTICULAR JOB...OR DON'T UNDERSTAND SPECIFIC  
INSTRUCTIONS.  
INST NAME NATIONAL SAFETY COUNCIL.

149

## SECTION II

## Safety: The Individual Worker

TITLE A NEW WAY TO LIFT.  
 AVAIL NATIONAL SAFETY COUNCIL, 444 NORTH MICHIGAN AVENUE, CHICAGO, IL 60611 (\$185.00)  
 DESC \*ACCIDENT PREVENTION, \*AUDIOVISUAL AIDS, \*FILMS, \*INDUSTRIAL SAFETY, INSTRUCTIONAL FILMS, \*LIFTING, POST SECONDARY EDUCATION, \*SAFETY  
 DESC NOTE (NO. 171.26-9) 16MM, 10 MIN., COLOR  
 ABSTRACT ILLUSTRATES A UNIQUE WAY TO LIFT LOADS OF ALL SIZES AND SHAPES  
 INST NAME NATIONAL SAFETY COUNCIL.

TITLE AVOIDING \* CONFINED SPACE HAZARDS IN WASTEWATER TREATMENT PLANTS.  
 AUTHOR NEW, BRUCE A.  
 AVAIL POLLUTION ENGINEERING, V 11 N8 P35-38 AUG 79  
 DESC \*ACCIDENT PREVENTION, \*SAFETY, EQUIPMENT, \*WORK ENVIRONMENT, \*FACILITIES, WATER POLLUTION CONTROL, \*WASTEWATER TREATMENT, STANDARDS  
 ABSTRACT DISCUSSED ARE THE HAZARDS COMMONLY ASSOCIATED WITH CONFINED ENTRY SPACES WITHIN WASTEWATER TREATMENT FACILITIES. RECOMMENDATIONS FOR SAFETY PROCEDURES AND PERSONNEL PROTECTION EQUIPMENT ARE PROVIDED.

TITLE BARE MINIMUM - SAFETY MANAGEMENT SERIES.  
 AVAIL NATIONAL SAFETY COUNCIL, 444 NORTH MICHIGAN AVENUE, CHICAGO, IL 60611 (\$155.00)  
 DESC \*ACCIDENT PREVENTION, AUDIOVISUAL AIDS, \*EQUIPMENT, \*FILMS, \*INDUSTRIAL SAFETY, INSTRUCTIONAL FILMS, \*MANAGEMENT, POST SECONDARY EDUCATION, PROTECTIVE EQUIPMENT, \*SAFETY  
 DESC NOTE (NO. 148.16-9) 16MM, 10 MIN., COLOR; EIGHT FILM SET (EW27960EW002803) "SAFETY MANAGEMENT" SERIES  
 ABSTRACT VALUE OF PERSONAL PROTECTIVE EQUIPMENT.  
 INST NAME NATIONAL SAFETY COUNCIL

TITLE BASIC HAND SAFETY (COURSE).  
 AVAIL E.I. DUPONT DE NEMOURS & COMPANY, INC., EDUCATION & APPLIED TECHNOLOGY DIVISION, BRANDYWINE BLDG., WILMINGTON, DE 19898 (\$1.90)  
 DESC \*ACCIDENT PREVENTION, \*HAND SAFETY, \*INSTRUCTIONAL MATERIALS, \*INDUSTRY, OPERATIONS, \*POST SECONDARY EDUCATION, \*SAFETY, SELF PACED INSTRUCTION  
 DESC NOTE COURSE NO. 569  
 ABSTRACT INSTRUCTIONAL MATERIALS ON USING ONE'S HANDS IN A SAFE WAY.  
 INST NAME E.I. DUPONT DE NEMOURS & COMPANY, INC.

TITLE BASIC SEWAGE TREATMENT OPERATION.  
 PUB DATE NOV 76  
 AVAIL PUBLICATIONS CENTRE, ONTARIO MINISTRY OF GOVERNMENT SERVICES, 880 BAY STREET, 5TH FLOOR, TORONTO, ONTARIO, CANADA M7A 1N8 (\$2.00; ORDERS MUST BE ACCOMPANIED BY CHECK OR MONEY ORDER PAYABLE TO "THE TREASURER OF ONTARIO")

\*BEHAVIORAL OBJECTIVES, \*ENVIRONMENTAL EDUCATION, ENVIRONMENTAL TECHNICIANS, JOB SKILLS, \*POLLUTION, SAFETY SAMPLING, WASTE DISPOSAL, \*WATER POLLUTION CONTROL, \*WORKSHOPS

ABSTRACT THIS MANUAL WAS DEVELOPED FOR USE AT WORKSHOPS DESIGNED TO INTRODUCE OPERATORS TO THE FUNDAMENTALS OF SEWAGE PLANT OPERATION. THE COURSE CONSISTS OF LECTURE-DISCUSSIONS AND HAND-ON ACTIVITIES. EACH OF THE LESSONS HAS CLEARLY STATED BEHAVIORAL OBJECTIVES TO TELL THE TRAINEE WHAT HE SHOULD KNOW OR DO AFTER COMPLETING THAT TOPIC. AREAS COVERED IN THIS MANUAL INCLUDE: INTRODUCTION TO SEWAGE TREATMENT, BACTERIOLOGY, PRIMARY TREATMENT, ACTIVATED SLUDGE PROCESS, SAMPLING AND RECORD KEEPING, SAFETY, AND SELECTED TESTS. A GLOSSARY OF TERMS IS INCLUDED FOR REFERENCE.

INST NAME ONTARIO MINISTRY OF THE ENVIRONMENT, TORONTO.

TITLE BODY MECHANICS.

PUB DATE 66

AVAIL NATIONAL AUDIOVISUAL CENTER, REFERENCE SECTION, GENERAL SERVICES ADMINISTRATION, WASHINGTON, DC 20409 (\$52.25)

DESC \*ACCIDENT PREVENTION, AUDIOVISUAL AIDS, \*FILMS, \*INSTRUCTIONAL FILMS, \*INSTRUCTIONAL MATERIALS, \*MANUAL LABOR, POST SECONDARY EDUCATION, \*SAFETY

DESC NOTE (TITLE NO. 181427), (AGENCY NO. M-1336), 16MM, 9 MIN., OPTICAL

ABSTRACT SOUND, COLOR  
SHOWS DO'S AND DON'TS OF LIFTING TECHNIQUES USED BY PHYSICAL THERAPISTS. EMPHASIZES USE OF PROPER BODY MECHANICS AS A PROTECTION TO BOTH PATIENT AND THERAPIST.

TITLE DOWN AND OUT.

AVAIL NATIONAL SAFETY COUNCIL, 444 NORTH MICHIGAN AVENUE, CHICAGO, IL 60611 (\$185.00)

DESC \*ACCIDENT PREVENTION, \*AUDIOVISUAL AIDS, \*FILMS, \*INDUSTRIAL SAFETY, INSTRUCTIONAL FILMS, \*MANAGEMENT, POST SECONDARY EDUCATION, \*SAFETY

DESC NOTE (NO. 171.20-9) 16MM, 10 MIN., COLOR

ABSTRACT DEMONSTRATES VARIOUS TYPES OF FALLS AND HOW TO AVOID THEM.

INST NAME NATIONAL SAFETY COUNCIL.

TITLE GUARD YOUR HANDS.

AVAIL NATIONAL SAFETY COUNCIL, 444 NORTH MICHIGAN AVENUE, CHICAGO, IL 60611 (\$39.60)

DESC \*ACCIDENT PREVENTION, \*HANDS, \*INDUSTRIAL SAFETY, \*PROTECTIVE CLOTHING, \*SAFETY, INSTRUCTIONAL MATERIALS, POST SECONDARY EDUCATION, SLIDES, VISUAL AIDS

DESC NOTE (NO. 176.16-9) 30 (2X2) SLIDES, COLOR, SCRIPT

ABSTRACT TELLS WHY IT IS SO IMPORTANT TO PROTECT HANDS AND EXPLAINS HOW TO AVOID HAND INJURIES.

INST NAME NATIONAL SAFETY COUNCIL.

151

TITLE GUARD YOUR SIGHT.  
AVAIL NATIONAL SAFETY COUNCIL, 444 NORTH MICHIGAN AVENUE, CHICAGO, IL  
60611 (\$39.60)  
DESC \*ACCIDENT PREVENTION, \*EYES, \*INDUSTRIAL SAFETY, INSTRUCTIONAL  
MATERIALS, POST SECONDARY EDUCATION, \*SAFETY, SLIDES, \*VISION,  
VISUAL AIDS  
DESC NOTE (NO. 176.08-9) 30 (2X2) SLIDES, COLOR, SCRIPT  
ABSTRACT EMPHASIZES THE NEED FOR EYE PROTECTION AND DEFEATS THE TYPICAL  
EXCUSES GIVEN FOR NOT WEARING SAFETY GLASSES.  
INST NAME NATIONAL SAFETY COUNCIL

TITLE HAND TOOLS.  
AVAIL NATIONAL SAFETY COUNCIL, 444 NORTH MICHIGAN AVENUE, CHICAGO, IL  
60611 (\$39.60)  
DESC \*ACCIDENT PREVENTION, \*EQUIPMENT, \*HAND TOOLS, \*INDUSTRIAL  
SAFETY, INSTRUCTIONAL MATERIALS, POST SECONDARY EDUCATION,  
\*SAFETY, SLIDES, VISUAL AIDS  
DESC NOTE (NO. 176.04-9) 30 (2X2) SLIDES, COLOR, SCRIPT  
ABSTRACT REVIEWS PROPER USE, CARE, AND MAINTENANCE OF HAND TOOLS; GIVES  
RULES FOR USAGE OF MOST COMMON TOOLS (WRENCHES, HAMMERS,  
CHISELS, OTHERS).  
INST NAME NATIONAL SAFETY COUNCIL.

TITLE HAND TRAPS.  
AVAIL NATIONAL SAFETY COUNCIL, 444 NORTH MICHIGAN AVENUE, CHICAGO, IL  
60611 (\$1.05)  
DESC \*ACCIDENT PREVENTION, \*HANDS, \*INDUSTRIAL SAFETY, INSTRUCTIONAL  
MATERIALS, POST SECONDARY EDUCATION, \*SAFETY  
DESC NOTE 8P. (NO. 195.13-9) MINIMUM ORDER OF 50 LEAFLETS  
ABSTRACT DESCRIBES THE FIVE BASIC MECHANICAL ACTIONS THAT CAN INJURE  
HANDS: ROTATING, IN-RUNNING NIP, SHEARING, SMASHING,  
PUNCTURING.  
INST NAME NATIONAL SAFETY COUNCIL.

TITLE HEAD PROTECTION.  
AVAIL NATIONAL SAFETY COUNCIL, 444 NORTH MICHIGAN AVENUE, CHICAGO,  
IL 60611 (\$46.80)  
DESC \*ACCIDENT PREVENTION, \*EQUIPMENT, HEAD PROTECTION, \*INDUSTRIAL  
SAFETY, INSTRUCTIONAL MATERIALS, POST SECONDARY EDUCATION,  
\*PROTECTIVE CLOTHING, \*SAFETY, SLIDES, VISUAL AIDS  
DESC NOTE (NO. 176.73-9) 30 SLIDES, COLOR, CASSETTS  
ABSTRACT IDEAL FOR CONSTRUCTION WORKERS AND OTHERS WHO WEAR HARD HATS.  
INST NAME NATIONAL SAFETY COUNCIL.

TITLE MANUAL LIFTING AND HANDLING.  
AVAIL NATIONAL SAFETY COUNCIL, 444 NORTH MICHIGAN AVENUE, CHICAGO, IL  
60611 (\$39.60)  
DESC \*ACCIDENT PREVENTION, \*INDUSTRIAL SAFETY, \*LIFTING, \*SAFETY,  
INSTRUCTIONAL MATERIALS, POST SECONDARY EDUCATION, SLIDES,  
VISUAL AIDS  
DESC NOTE (NO. 176.13-9) 30 (2X2) SLIDES, COLOR, SCRIPT  
ABSTRACT EXPLAINS HOW TO LIFT OBJECTS WITHOUT INJURING THE BACK AND HOW  
TO HANDLE OBJECTS OF VARYING SIZES AND SHAPES.  
INST NAME NATIONAL SAFETY COUNCIL



TITLE MESSAGE IN THE BOTTLE.  
AVAIL NATIONAL SAFETY COUNCIL, 444 NORTH MICHIGAN AVENUE, CHICAGO, IL  
60611 (\$39.60)  
DESC \*ACCIDENT PREVENTION, \*ALCOHOLIC BEVERAGES, ALCOHOLISM,  
\*INDUSTRIAL SAFETY, INSTRUCTIONAL MATERIALS, POST SECONDARY  
EDUCATION, \*SAFETY, SLIDES, VISUAL AIDS  
DESC NOTE (NO. 396.01-9) 30 (2X2)-SLIDES, COLOR, SCRIPT  
ABSTRACT EXPOSES THE AFFECT OF ALCOHOL ON ONE'S ABILITY TO PERFORM SUCH  
TASKS AS DRIVING, OPERATING MACHINERY, SWIMMING, CLIMBING A  
LADDER.  
INST NAME NATIONAL SAFETY COUNCIL

TITLE MULTIPLE CHOICE.  
PUB DATE 75  
AVAIL TECHNICAL LIBRARY, AMERICAN WATER WORKS ASSOCIATION, 6666  
QUINCY AVE., DENVER, CO 80235 RENTAL FEE - \$5.00  
DESC \*ACCIDENT PREVENTION, AUDIOVISUAL AIDS, \*CONSTRUCTION,  
\*EQUIPMENT OPERATION, FILMS, \*INSTRUCTIONAL MATERIALS, JOB  
SKILLS, \*SAFETY, \*WORK ENVIRONMENT  
DESC NOTE 25 MINUTE COLOR FILM-16MM.  
ABSTRACT THIS FILM PRESENTS SIX SITUATIONAL DRAMATIZATIONS OF JUDGMENTAL  
ERRORS MADE BY HEAVY EQUIPMENT OPERATORS. THE INFORMATION  
PROVDIES A BACKGROUND FOR CHOICES BETWEEN SAFETY AND DISASTER.  
INST NAME CATERPILLAR TRACTOR COMPANY, PEORIA, IL

TITLE OH MY ACHING BACK.  
AVAIL NATIONAL AUDIOVISUAL CENTER, REFERENCE SECTION, GENERAL  
SERVICES ADMINISTRATION, WASHINGTON, DC 20409 (PURCHASE PRICE:  
\$121.75)  
DESC \*ACCIDENT PREVENTION, AUDIOVISUAL AIDS, \*FILMS, \*INSTRUCTIONAL  
MATERIALS, INSTRUCTIONAL FILMS, \*INDUSTRIAL SAFETY, \*MANUAL  
LABOR, \*POST SECONDARY EDUCATION, \*SAFETY  
DESC NOTE (TITLE NO. 003550) 16MM, 21 MIN., OPTICAL SOUND, COLOR  
ABSTRACT SHOWS THE CORRECT METHOD OF LIFTING, INCLUDING GOOD POSTURE,  
POSITION, AND SMOOTH APPLICATION OF LIFTING POWER. ILLUSTRATES  
HOW STRAINS OCCUR AND HOW DISCS ARE PINCHED. EMPHASIZES THE  
NEED FOR PROPER LIFTING AND HANDLING OF WORKING TOOLS AND  
MATERIALS.

TITLE OH MY ACHING BACK.  
AVAIL NATIONAL SAFETY COUNCIL, 444 NORTH MICHIGAN AVENUE, CHICAGO, IL  
60611 (\$46.80)  
DESC \*ACCIDENT PREVENTION, \*INDUSTRIAL SAFETY, INSTRUCTIONAL  
MATERIALS, \*MANUAL LABOR, POST SECONDARY EDUCATION, \*SAFETY,  
SLIDES, VISUAL AIDS  
DESC NOTE (NO. 176.75-9) 30 SLIDES, COLOR, CASSETTE  
ABSTRACT EXPLAINS SOME OF THE COMMON CAUSES OF BACK PAIN AND SPRAINS.  
INST NAME NATIONAL SAFETY COUNCIL

153

TITLE ON EVERY HAND.  
 AVAIL NATIONAL SAFETY COUNCIL, 444 NORTH MICHIGAN AVENUE, CHICAGO, IL 60611 (\$185.00)  
 DESC \*ACCIDENT PREVENTION, \*AUDIOVISUAL AIDS, \*FILMS, \*INDUSTRIAL SAFETY, \*MATERIALS HANDLING, \*PROTECTIVE CLOTHING, \*PROTECTIVE EQUIPMENT, \*SAFETY, EQUIPMENT, INSTRUCTIONAL FILMS, POST SECONDARY EDUCATION  
 DESC NOTE (NO. 171.25-9) 16MM, 10 MIN. COLOR  
 ABSTRACT DEMONSTRATES PRECAUTIONS AND PROTECTIVE EQUIPMENT TO HELP PREVENT HAND INJURIES FROM CHEMICALS, IMPROPER USE OF TOOLS, MACHINES, ETC.  
 INST NAME NATIONAL SAFETY COUNCIL.

TITLE PERSONAL PROTECTIVE EQUIPMENT (COURSE).  
 AVAIL E.I. DUPONT DE NEMOURS & COMPANY, INC., EDUCATION & APPLIED TECHNOLOGY DIVISION, BRANDYWINE BLDG., WILMINGTON, DE 19898 (\$1.90)  
 DESC \*ACCIDENT PREVENTION, \*EQUIPMENT, \*INSTRUCTIONAL MATERIALS, \*OPERATIONS, \*POST SECONDARY EDUCATION, \*SAFETY, SELF PACED INSTRUCTION  
 DESC NOTE COURSE NO. 561  
 ABSTRACT INSTRUCTIONAL MATERIALS ON USE OF PERSONAL PROTECTIVE EQUIPMENT.  
 INST NAME E.I. DUPONT DE NEMOURS & COMPANY, INC.

TITLE SAFE WORK DRESS.  
 AVAIL NATIONAL SAFETY COUNCIL, 444 NORTH MICHIGAN AVENUE, CHICAGO, IL 60611 (\$46.80)  
 DESC \*ACCIDENT PREVENTION, \*INDUSTRIAL SAFETY, INSTRUCTIONAL MATERIALS, POST SECONDARY EDUCATION, \*PROTECTIVE CLOTHING, \*SAFETY, SLIDES, VISUAL AIDS  
 DESC NOTE (NO. 176.74-9) 30 SLIDES, COLOR, CASSETTE  
 ABSTRACT ILLUSTRATES IMPORTANCE OF PERSONAL PROTECTIVE CLOTHING.  
 INST NAME NATIONAL SAFETY COUNCIL.

TITLE SAFETY AFOOT.  
 AVAIL NATIONAL SAFETY COUNCIL, 444 NORTH MICHIGAN AVENUE, CHICAGO, IL 60611 (\$195.00)  
 DESC \*ACCIDENT PREVENTION, \*AUDIOVISUAL AIDS, EQUIPMENT, \*FILMS, \*INDUSTRIAL SAFETY, INSTRUCTIONAL FILMS, POST SECONDARY EDUCATION, \*PROTECTIVE CLOTHING, \*PROTECTIVE EQUIPMENT, \*SAFETY, \*SAFETY SHOES  
 DESC NOTE (NO. 171.12-9) 16MM, 10 MIN., COLOR  
 ABSTRACT CLEVER CLAY-ANIMATION "FOOT PEOPLE" DEPICT THE DANGERS OF NOT WEARING SHOES.  
 INST NAME NATIONAL SAFETY COUNCIL.

TITLE SAFETY PRECAUTIONS FOR ELECTRONICS PERSONNEL.  
 PUB DATE 76  
 AVAIL NATIONAL AUDIOVISUAL CENTER, REFERENCE SECTION, GENERAL SERVICES ADMINISTRATION, WASHINGTON, DC 20409 (PURCHASE PRICE: \$59.50)

DESC \*ACCIDENT PREVENTION, \*AUDIOVISUAL AIDS, \*ELECTRONICS  
 TECHNICIANS, ELECTRICITY, \*FILMS, \*INSTRUCTIONAL FILMS, \*POST  
 SECONDARY EDUCATION, \*SAFETY

DESC NOTE (TITLE NO. 661450) (AGENCY NO. MN06754) 16MM., 18 MIN., OPTICAL  
 SOUND, BLACK & WHITE.

ABSTRACT SHOW ELECTRICAL AND MECHANICAL HAZARDS WHICH ELECTRONICS  
 TECHNICIANS ENCOUNTER IN THEIR NORMAL WORK; STRESSES  
 PRECAUTIONS WHICH SHOULD BE EMPLOYED TO PREVENT ACCIDENTS:

INST NAME NAVAL FACILITIES ENGINEERING COMMAND.

TITLE SPOTLIGHT ON FALLS.  
 AVAIL NATIONAL SAFETY COUNCIL, 444 NORTH MICHIGAN AVENUE, CHICAGO, IL  
 60611 (\$0.11)

DESC \*ACCIDENT PREVENTION, \*INDUSTRIAL SAFETY, INSTRUCTIONAL  
 MATERIALS, MANAGEMENT, \*OBSERVATION, POST SECONDARY EDUCATION,  
 \*SAFETY, \*SUPERVISION

DESC NOTE 8P. (NO. 192.16-9) MINIMUM ORDER OF 50  
 ABSTRACT GUIDE TO HELP SUPERVISORS DEVELOP AN EFFECTIVE SAFETY  
 OBSERVATION PROGRAM TO FIT ANY OPERATION.

INST NAME NATIONAL SAFETY COUNCIL.

TITLE TECHNIQUES FOR LIFTING.  
 AVAIL NATIONAL SAFETY COUNCIL, 444 NORTH MICHIGAN AVENUE, CHICAGO, IL  
 60611 (\$195.00)

DESC \*ACCIDENT PREVENTION, \*AUDIOVISUAL AIDS, \*FILMS, \*INDUSTRIAL  
 SAFETY, INSTRUCTIONAL FILMS, \*LIFTING, POST SECONDARY  
 EDUCATION, \*SAFETY

DESC NOTE (NO. 171.14-9) 16MM, 10 MIN., COLOR  
 ABSTRACT CLAY-ANIMATION TECHNIQUE USES ABSTRACT CHARACTERS TO ILLUSTRATE  
 THE PROPER WAY TO LIFT LOADS OF VARIOUS SIZES AND SHAPES.

INST NAME NATIONAL SAFETY COUNCIL.

TITLE TIPS FOR NEW EMPLOYEES.  
 AVAIL NATIONAL SAFETY COUNCIL, 444 NORTH MICHIGAN AVENUE, CHICAGO, IL  
 60611 (\$39.60)

DESC \*ACCIDENT PREVENTION, \*INDUSTRIAL SAFETY, INSTRUCTIONAL  
 MATERIALS, POST SECONDARY EDUCATION, \*SAFETY, SLIDES, VISUAL  
 AIDS

DESC NOTE (NO. 176.10-9) 30 (2X2) SLIDES, COLOR, SCRIPT.  
 ABSTRACT OUTLINES BASIC SAFETY RULES OF INTEREST TO ALL NEW EMPLOYEES,  
 NO MATTER WHAT THEIR NEW JOBS ARE.

INST NAME NATIONAL SAFETY COUNCIL

TITLE TOOL HAZARDS (COURSE).  
 AVAIL E.I. DUPONT DE NEMOURS & COMPANY, INC., EDUCATION & APPLIED  
 TECHNOLOGY DIVISION, BRANDYWINE BLDG., WILMINGTON, DE 19898  
 (\$1.90)

DESC \*ACCIDENT PREVENTION, EQUIPMENT, \*HAND TOOLS, INDUSTRY,  
 \*INSTRUCTIONAL MATERIALS, OPERATIONS, \*POST SECONDARY  
 EDUCATION, \*SAFETY, \*SELF PACED INSTRUCTION

DESC NOTE COURSE NO. 573  
 ABSTRACT INSTRUCTIONAL MATERIAL ON USE OF HAND TOOLS.

INST NAME E.I. DUPONT DE NEMOURS & COMPANY, INC.

155

TITLE WE'LL SEE TOMORROW.  
AVAIL NATIONAL SAFETY COUNCIL, 444 NORTH MICHIGAN AVENUE, CHICAGO, IL  
60611 (\$185.00)  
DESC \*ACCIDENT PREVENTION, \*AUDIOVISUAL AIDS, EQUIPMENT, EYES,  
\*FILMS, \*INDUSTRIAL SAFETY, INSTRUCTIONAL FILMS; POST SECONDARY  
EDUCATION, \*SAFETY, \*VISION  
DESC NOTE (NO. 171.65-9) 16MM, 10 MIN., COLOR  
ABSTRACT SAFETY-CONSCIOUS EMPLOYEE FORGETS ABOUT EYE PROTECTION, JUST  
ONCE. INTERESTING AND DRAMATIC...INSPIRES CONTINUED USE OF  
PROTECTIVE EQUIPMENT.  
INST NAME NATIONAL SAFETY COUNCIL.

TITLE WORK AREA PROTECTION.  
AVAIL NATIONAL SAFETY COUNCIL, 444 NORTH MICHIGAN AVENUE, CHICAGO, IL  
60611 (\$19.20)  
DESC \*ACCIDENT PREVENTION, \*INDUSTRIAL SAFETY, INSTRUCTIONAL  
MATERIALS, POST SECONDARY EDUCATION, \*SAFETY, SLIDES, VISUAL  
AIDS  
DESC NOTE (NO. 129.19-9) 30 (2X2) SLIDES, COLOR, SCRIPT  
ABSTRACT OUTLINES BASIC SAFETY PROTECTION FOR ALL EMPLOYEES.  
INST NAME NATIONAL SAFETY COUNCIL.

TITLE YOU'RE IN THE ACT.  
AVAIL NATIONAL SAFETY COUNCIL, 444 NORTH MICHIGAN AVENUE, CHICAGO, IL  
60611 (\$.31)  
DESC \*ACCIDENT PREVENTION, \*INDUSTRIAL SAFETY, INSTRUCTIONAL  
MATERIALS, POST SECONDARY EDUCATION, \*SAFETY, \*SAFETY RULES  
DESC NOTE 36P. (NO. 192.15-9)  
ABSTRACT ILLUSTRATED BOOKLET FEATURES HUNDREDS OF SENSIBLE SAFETY RULES  
FOR NEARLY EVERY IMPORTANT PLANT ACTIVITY.  
INST NAME NATIONAL SAFETY COUNCIL.

TITLE YOUR BODY IS ONLY HUMAN - SAFETY AWARENESS SERIES.  
AVAIL NATIONAL SAFETY COUNCIL, 444 NORTH MICHIGAN AVENUE, CHICAGO, IL  
60611 (\$195.00)  
DESC \*ACCIDENT PREVENTION, \*AUDIOVISUAL AIDS, EQUIPMENT, \*FILMS,  
\*INDUSTRIAL SAFETY, INSTRUCTIONAL FILMS, \*MANAGEMENT, MATERIALS  
HANDLING, POST SECONDARY EDUCATION, \*SAFETY  
DESC NOTE (NO. 147.27-9) 16MM, 10 MIN., COLOR: THREE FILM SET  
ABSTRACT (EW02805-EW002807) "SAFETY AWARENESS" SERIES  
SPOTLIGHTS THE RELATIONSHIP BETWEEN MIND AND BODY IN  
ESTABLISHING SAFE WORK PATTERNS. MAN'S PHYSICAL LIMITATIONS ARE  
EXPLORED, AND THE PROPER USE OF TOOLS AND EQUIPMENT TO AUGMENT  
STRENGTH AND DEXTERITY ARE DESCRIBED.  
INST NAME NATIONAL SAFETY COUNCIL.

165 156

TITLE / YOUR FEET ARE YOUR FORTUNE.  
AVAIL NATIONAL SAFETY COUNCIL, 444 NORTH MICHIGAN AVENUE, CHICAGO, IL  
60611 (\$39.60)  
DESC \*ACCIDENT PREVENTION, \*INDUSTRIAL SAFETY, INSTRUCTIONAL  
MATERIALS, POST SECONDARY EDUCATION, \*PROTECTIVE CLOTHING,  
\*SAFETY, \*SAFETY SHOES, SLIDES, VISUAL AIDS  
DESC NOTE (NO. 176.19-9) 30 (2X2) SLIDES, COLOR, SCRIPT  
ABSTRACT TEACHES THE NEED FOR FOOT CARE AND PROTECTION AND DEMONSTRATES  
THE BENEFITS OF SAFETY SHOES.  
INST NAME NATIONAL SAFETY COUNCIL.

157

166

SECTION III

Safety, Plant Design and General Operation

TITLE AUDIO VISUAL TRAINING PROGRAM FOR WASTEWATER TREATMENT PLANT OPERATORS.  
PUB DATE 76  
AVAIL GREEN RIVER COMMUNITY COLLEGE, 12401 S.E. 320TH ST., AUBURN, WA 98002 PRICE: \$5.00, RENTAL, \$300.00 PURCHASE  
DESC AUDIOVISUAL AIDS, DISINFECTION, INDIVIDUALIZED INSTRUCTION, \*INSTRUCTIONAL MATERIALS, MAINTENANCE, \*OPERATIONS (WASTEWATER), RECORD KEEPING, SAFETY, SAMPLING, SEWAGE, \*WASTEWATER TREATMENT  
DESC NOTE 287P. 35MM SLIDES, 10 CASSETTES, WORKBOOKS, INSTRUCTOR'S MANUAL.  
ABSTRACT INCLUDES UNITS ON CHARACTERISTICS OF SEWAGE, NATURAL BIOLOGICAL TREATMENT PROCESSES, WASTE TREATMENT METHODS, DISINFECTION, TESTS AND SAMPLING, RECORD KEEPING, MAINTENANCE, AND SAFETY.

TITLE FIRST COURSE WORKBOOK FOR WATER TREATMENT PLANT OPERATORS.  
AUTHOR SHEETS, W. D.; BLANCHARD, D. A.  
PUB DATE 75  
AVAIL OPERATOR TRAINING COMMITTEE OF OHIO, INC., P.O. BOX 626, WORTHINGTON, OHIO 43085 (\$16.00)  
DESC EQUIPMENT, \*ENVIRONMENTAL TECHNICIANS, \*INSTRUCTIONAL MATERIALS, \*JOB SKILLS, MANPOWER DEVELOPMENT, \*OPERATIONS (WATER), \*POST SECONDARY EDUCATION, SAFETY, \*WATER POLLUTION CONTROL, WATER QUALITY, \*WATER TREATMENT  
ABSTRACT WORKBOOK FOR WATER TREATMENT PLANT OPERATIONAL PROBLEMS.

TITLE FUELS AND LUBRICANTS: SELECTING AND STORING.  
PUB DATE 73  
AVAIL AMERICAN ASSOCIATION FOR VOCATIONAL INSTRUCTIONAL MATERIALS, ENGINEERING CENTER, ATHENS, GA 30602  
DESC CONSUMER EDUCATION, DIESEL FUEL, \*FUELS, \*GAS, HYDRAULIC FLUID, \*INSTRUCTIONAL MATERIALS, \*LUBRICANTS, OIL, \*POST SECONDARY EDUCATION, SAFETY, \*SLIDES, \*VISUAL AIDS  
DESC NOTE ORDER NO. M102 (TRANSPARENCY, \$7.95), NO. S102 (SLIDES, \$29.85), NO. 102 (PRINTED, \$3.45)  
ABSTRACT AS THE SUPPLY OF PETROLEUM FUELS AND LUBRICANTS BECOMES SMALLER AND COST CONTINUES TO INCREASE, IT IS IMPORTANT THAT EVERYONE LEARN HOW TO SELECT THEM PROPERLY AND TO STORE THEM SAFELY. FROM THIS STUDY, A STUDENT WILL BE ABLE TO SELECT AND STORE THE FOLLOWING FUELS AND LUBRICANTS PROPERLY. GASOLINE, LP-GAS, DIESEL FUEL, CRANKCASE OIL, GEAR LUBRICANT, HYDRAULIC FLUID, GREASE.  
INST NAME AMERICAN ASSOCIATION FOR VOCATIONAL INSTRUCTIONAL MATERIALS.

TITLE HOUSEKEEPING MEANS SAFEKEEPING.  
AVAIL NATIONAL SAFETY COUNCIL, 444 NORTH MICHIGAN AVENUE, CHICAGO, IL 60611 (\$195.00)  
DESC \*ACCIDENT PREVENTION, \*AUDIOVISUAL AIDS, \*FILMS, INSTRUCTIONAL FILMS, \*MAINTENANCE, POST SECONDARY EDUCATION, \*SAFETY

DESC NOTE (NO. 171.36-9) 16MM, 10 MIN., COLOR  
 ABSTRACT FORCEFUL DRAMATIZATION OF THE PAINFUL CONSEQUENCES OF POOR  
 INDUSTRIAL HOUSEKEEPING.  
 INST NAME NATIONAL SAFETY COUNCIL.

TITLE HOW TO PREVENT FALLS.  
 AVAIL NATIONAL SAFETY COUNCIL, 444 NORTH MICHIGAN AVENUE, CHICAGO, IL  
 60611 (\$39.60)  
 DESC \*ACCIDENT PREVENTION, \*INDUSTRIAL SAFETY, INSTRUCTIONAL  
 MATERIALS, POST SECONDARY EDUCATION, \*SAFETY, \*SLIDES, VISUAL  
 AIDS  
 DESC NOTE (NO. 176.17-9) 30 (2X2) SLIDES, COLOR, SCRIPT  
 ABSTRACT TEACHES HOW TO SPOT HAZARDS THAT CAUSE FALLS AND HOW TO CORRECT  
 THESE HAZARDS.  
 INST NAME NATIONAL SAFETY COUNCIL.

TITLE IDENTIFY AND PREVENT CONFINED SPACE HAZARDS.  
 AUTHOR NEU, BRUCE A.  
 PUB DATE SEPT 79  
 AVAIL WATER AND WASTES ENGINEERING, V16 N9  
 DESC \*SAFETY, \*WORK ENVIRONMENT, \*SEWERS, \*OPERATIONS (WASTEWATER),  
 \*WASTEWATER TREATMENT, EQUIPMENT, ENGINEERING, \*ACCIDENT  
 PREVENTION  
 DESC NOTE 90-93  
 ABSTRACT THIS ARTICLE DISCUSSES THE HAZARDS ASSOCIATED WITH WASTEWATER  
 COLLECTION AND TREATMENT OPERATIONS AND PRECAUTIONS WHICH  
 SHOULD BE IMPLEMENTED TO INSURE OPERATOR SAFETY. MOISTURE,  
 TOXIC AND COMBUSTIBLE GASES, AND OTHER HAZARDS ARE COVERED.

TITLE INDUSTRIAL HOUSEKEEPING (COURSE).  
 AVAIL E.I. DUPONT DE NEMOURS COMPANY, INC., EDUCATION & APPLIED  
 TECHNOLOGY DIVISION, BRANDYWINE BLDG., WILMINGTON, DE 19898  
 (\$1.90)  
 DESC \*ACCIDENT PREVENTION, \*INDUSTRY, \*INSTRUCTIONAL MATERIALS,  
 MAINTENANCE, \*OPERATIONS, \*POST SECONDARY EDUCATION, \*SAFETY,  
 SELF PACED INSTRUCTION  
 DESC NOTE COURSE NO. 575  
 ABSTRACT INSTRUCTIONAL MATERIAL ON INDUSTRIAL HOUSEKEEPING.  
 INST NAME E.I. DUPONT DE NEMOURS & COMPANY, INC.

TITLE KEEP IT CLEAN FOR SAFETYS SAKE.  
 AVAIL NATIONAL SAFETY COUNCIL, 444 NORTH MICHIGAN AVENUE, CHICAGO, IL  
 60611 (\$115.00)  
 DESC \*ACCIDENT PREVENTION, \*AUDIOVISUAL AIDS, \*FILMS, \*INDUSTRIAL  
 SAFETY, INSTRUCTIONAL FILMS, \*MAINTENANCE, POST SECONDARY  
 EDUCATION, \*SAFETY  
 DESC NOTE (NO. 171.10-9) 16MM, 10 MIN., COLOR  
 ABSTRACT STOP-ACTION ANIMATION TECHNIQUE PROVIDES STEP-BY-STEP VISUAL  
 PRESENTATION OF THE NEED FOR GOOD PLANT HOUSEKEEPING.  
 INST NAME NATIONAL SAFETY COUNCIL.

159

168

TITLE MANUAL OF INSTRUCTION FOR PACKAGE PLANT OPERATORS.  
 AVAIL. EPA INFORMATION DISSEMINATION PROJECT, 1200 CHAMBERS RD., 3RD  
 FLOOR, COLUMBUS, OHIO 43212 (\$1.63)  
 DESC CHLORINATION, COST EFFECTIVENESS, ENGINEERING, FACILITIES,  
 \*INSTRUCTIONAL MATERIALS, \*JOB SKILLS, MAINTENANCE, \*WEST  
 VIRGINIA, \*PACKAGE TREATMENT PLANTS, \*OPERATIONS (WASTEWATER),  
 PRETREATMENT, SANITATION, SLUDGE, UTILITIES, \*WASTEWATER  
 TREATMENT, WATER POLLUTION CONTROL  
 DESC NOTE 21P  
 ABSTRACT THIS MANUAL PROVIDES BASIC INFORMATION NECESSARY TO PROPERLY  
 OPERATE AND MAINTAIN A WASTEWATER TREATMENT PACKAGE PLANT. THE  
 UNITS PRESENTED INCLUDE: (1) INSTALLATION; (2) PRETREATMENT;  
 (3) SLUDGE HOLDING TANKS; (4) CHLORINATION; (5) TROUBLE  
 SHOOTING; (6) SAFETY; AND (7) A SERVICE CHECK LIST.  
 INST NAME WEST VIRGINIA DEPARTMENT OF HEALTH, DIVISION OF SANITARY  
 ENGINEERING.

TITLE MARGIN FOR SAFETY.  
 PUB DATE 70  
 AVAIL. WATER POLLUTION CONTROL FEDERATION, 2626 PENNSYLVANIA AVE., NW,  
 WASHINGTON, DC 20037 (\$11.50)  
 DESC \*ACCIDENT PREVENTION, AUDIOVISUAL AIDS, EQUIPMENT, FIRE  
 EXTINGUISHERS, \*FIRE PROTECTION, \*INSTRUCTIONAL MATERIALS,  
 OPERATIONS (WASTEWATER), POST SECONDARY EDUCATION, \*SAFETY,  
 \*SLIDES, WASTE DISPOSAL, \*WASTEWATER TREATMENT  
 DESC NOTE 18 MIN. TAPE, 45 SLIDES, AND SCRIPT, AVAILABLE ON LOAN FROM  
 ABSTRACT WPIOTC, 26 W ST CLAIR, CINCINNATI, OH 45268  
 PROVIDING SAFE CONDITIONS FOR PERFORMANCE OF ROUTINE DUTIES IN  
 WASTEWATER WORKS. INCLUDES DETAILED DISCUSSIONS OF THE  
 IMPORTANCE OF GOOD HOUSEKEEPING, PREVENTING SLIPS OR FALLS,  
 PERSONAL PROTECTIVE EQUIPMENT, AND DEALING WITH FIRE  
 EXTINGUISHERS, MACHINERY WITH MOVING PARTS AND VEHICULAR  
 TRAFFIC IN WORK AREAS. ALSO EMPHASIZES SAFETY ATTITUDES.  
 INST NAME WATER POLLUTION CONTROL FEDERATION.

TITLE MIND OVER MATTER - SAFETY MANAGEMENT SERIES.  
 AVAIL. NATIONAL SAFETY COUNCIL, 444 NORTH MICHIGAN AVENUE, CHICAGO, IL  
 60611 (\$155.00)  
 DESC \*ACCIDENT PREVENTION, AUDIOVISUAL AIDS, \*FILMS, \*INDUSTRIAL  
 SAFETY, INSTRUCTIONAL FILMS, \*MANAGEMENT, MATERIALS HANDLING,  
 POST SECONDARY EDUCATION, \*SAFETY  
 DESC NOTE (NO. 148.14-9) 16MM, 10 MIN., COLOR: EIGHT FILM SET  
 (EW002796-EW002803) "SAFETY MANAGEMENT" SERIES  
 ABSTRACT HOW TO PREVENT MATERIALS HANDLING ACCIDENTS.  
 INST NAME NATIONAL SAFETY COUNCIL.

TITLE MOVING STORY.  
 AVAIL. NATIONAL SAFETY COUNCIL, 444 NORTH MICHIGAN AVENUE, CHICAGO, IL  
 60611 (\$0.095)  
 DESC \*ACCIDENT PREVENTION, \*INDUSTRIAL SAFETY, INSTRUCTIONAL  
 MATERIALS, \*MATERIALS HANDLING, POST SECONDARY EDUCATION,  
 \*SAFETY  
 DESC NOTE 8P. (NO. 195.61-9) (MINIMUM ORDER OF 50)  
 ABSTRACT TEACHES SAFE MATERIAL HANDLING.  
 INST NAME NATIONAL SAFETY COUNCIL.



**TITLE AVAIL** OFFICE SAFETY (COURSE);  
 E.I. DUPONT DE NEMOURS & COMPANY, INC., EDUCATION & APPLIED  
 TECHNOLOGY DIVISION, BRANDYWINE BLDG., WILMINGTON, DE 19898  
 (\$1.90)

**DESC** \*ACCIDENT PREVENTION, \*INSTRUCTIONAL MATERIALS, \*OFFICE SAFETY,  
 OPERATIONS, \*POST SECONDARY EDUCATION, \*SAFETY, \*SELF PACED  
 INSTRUCTION

**DESC NOTE** COURSE NO. 571  
**ABSTRACT** INSTRUCTIONAL MATERIAL ON SAFE PRACTICES IN THE OFFICE.  
**INST NAME** E.I. DUPONT DE NEMOURS & COMPANY, INC.

**TITLE AVAIL** OPERATION AND MAINTENANCE OF WASTEWATER COLLECTION SYSTEMS.  
 76  
 GREEN RIVER COMMUNITY COLLEGE, 12401 S.R. 320TH ST. AUBURN, WA  
 98002 PRICE: \$34.00

**DESC** ADMINISTRATION, AUDIOVISUAL AIDS, INDIVIDUALIZED INSTRUCTION,  
 INSTRUCTIONAL MATERIALS, INSPECTION, LIFT STATIONS,  
 \*MAINTENANCE, OPERATIONS (WASTEWATER), SAFETY, SEWERS,  
 \*WASTEWATER COLLECTION, WASTEWATER TREATMENT

**DESC NOTE** 143P. 35 MM SLIDES AND SLIDE NARRATIVE, INSTRUCTOR'S AND  
 STUDENT'S MANUALS.  
**ABSTRACT** INCLUDES UNITS ON INSPECTION, TESTING, CLEANING AND MAINTAINING  
 SEWERS, REPAIRS, LIFT STATIONS, SAFETY, ADMINISTRATION AND  
 ORGANIZATION.

**TITLE AVAIL** PORTABLE LADDERS.  
 NATIONAL SAFETY COUNCIL, 444 NORTH MICHIGAN AVENUE, CHICAGO, IL  
 60611 (\$39.60)

**DESC** \*ACCIDENT PREVENTION, \*EQUIPMENT, \*INDUSTRIAL SAFETY,  
 INSTRUCTIONAL MATERIALS, \*LADDERS, POST SECONDARY EDUCATION,  
 \*SAFETY, SLIDES, VISUAL AIDS

**DESC NOTE** (NO. 176.05-9) 30 (2X2) SLIDES, COLOR, SCRIPT  
**ABSTRACT** POINTS OUT MANY COMMON HAZARDS OF USING LADDERS AND TELLS HOW  
 TO HANDLE THEM SAFELY.  
**INST NAME** NATIONAL SAFETY COUNCIL.

**TITLE AVAIL** POWERED LIFT TRUCKS - OPERATOR TRAINING.  
 E.I. DUPONT DE NEMOURS & COMPANY, INC., EDUCATION & APPLIED  
 TECHNOLOGY DIVISION, BRANDYWINE BLDG., WILMINGTON, DE 19898  
 (\$16.50)

**DESC** COURSE CONTENT, \*EQUIPMENT, \*INSTRUCTIONAL MATERIALS,  
 MAINTENANCE, \*MECHANICAL EQUIPMENT, \*MOTOR VEHICLES, \*POST  
 SECONDARY EDUCATION, SAFETY, \*FORK LIFTS, \*POWERED LIFT TRUCKS

**DESC NOTE** ORDER NO. 135; 7 HRS. AVERAGE INSTRUCTION TIME  
**ABSTRACT** A FIVE-PART COURSE ON SAFE, ERROR FREE OPERATION OF THE POWERED  
 LIFT TRUCK INCLUDING: LOADS AND THEIR EFFECT, MAINTAINING  
 CONTROL, THE PROFESSIONAL OPERATOR, LIFT TRUCK OPERATION, LOAD  
 HANDLING. SAFE OPERATING RULES ARE ESTABLISHED FOR: LOAD  
 WEIGHT, LOAD CENTER, CARRYING POSITION, OPERATING SPEED,  
 DRIVING TECHNIQUES, PERSONAL SAFETY PRACTICES, OPERATING  
 PROCEDURES, AND INSPECTION PROCEDURES.  
**INST NAME** E.I. DUPONT DE NEMOURS & COMPANY, INC.

101

TITLE SAFE WAY.  
PUB DATE 70  
AVAIL WATER POLLUTION CONTROL FEDERATION, 2626 PENNSYLVANIA AVE., NW,  
WASHINGTON, DC 20037 (\$11.50)  
DESC \*ACCIDENT PREVENTION, AUDIOVISUAL AIDS, EQUIPMENT, FIRE  
PROTECTION, \*INSTRUCTIONAL MATERIALS, \*OPERATIONS (WASTEWATER),  
POST SECONDARY EDUCATION, \*SAFETY, \*SLIDES, WASTE DISPOSAL,  
\*WASTEWATER TREATMENT  
DESC NOTE 14 MIN. TAP, 39 SLIDES, AND SCRIPT, AVAILABLE ON LOAN FROM  
NIDIC, 26 W 8TH CLAIR, CINCINNATI, OH 45268  
ABSTRACT PERFORMING ROUTINE DUTIES IN WASTEWATER WORKS IN A SAFE WAY.  
DUTIES CONSIDERED INVOLVE MANHOLES, ELECTRICAL EQUIPMENT,  
SAMPLING, CONTAMINATED WATER, AIR TOOLS, STEEP PATHWAYS,  
VEHICULAR TRAFFIC, EXCAVATIONS, BAR SCREENS, WIRE ROPES,  
FLAMMABLE MATERIALS AND CHEMICALS.  
INST NAME WATER POLLUTION CONTROL FEDERATION.

TITLE SAFETY IN WASTEWATER WORKS.  
PUB DATE 75  
AVAIL WATER POLLUTION CONTROL FEDERATION, PUBLICATIONS DEPT., 3900  
WISCONSIN AVE., NW, WASHINGTON, DC 20016 (\$2.00)  
DESC \*ACCIDENT PREVENTION, \*INSTRUCTIONAL MATERIALS, MAINTENANCE,  
\*OPERATIONS (WASTEWATER), POST SECONDARY EDUCATION, \*SAFETY,  
\*WASTEWATER TREATMENT, \*WASTEWATER COLLECTION  
DESC NOTE 56P. MOP REPORT NO. 1  
ABSTRACT INCLUDES INFORMATION ON SAFE PRACTICES IN THE DESIGN,  
OPERATION, AND MAINTENANCE OF WASTEWATER COLLECTION AND  
TREATMENT SYSTEMS. AREAS DISCUSSED INCLUDE RESPONSIBILITIES,  
SAFETY PROGRAMS, OPERATIONS AND MAINTENANCE, NOXIOUS GASES AND  
VAPORS, OXYGEN DEFICIENCY, SAFETY PRACTICES, EQUIPMENT,  
ACCIDENT REPORTING, INVESTIGATION AND ANALYSIS.  
INST NAME WATER POLLUTION CONTROL FEDERATION.

TITLE SAFETY IS IN ORDER - SAFETY MANAGEMENT SERIES.  
AVAIL NATIONAL SAFETY COUNCIL, 444 NORTH MICHIGAN AVENUE, CHICAGO, IL  
60611 (\$155.00)  
DESC \*ACCIDENT PREVENTION, AUDIOVISUAL AIDS, \*FILMS, \*INDUSTRIAL  
SAFETY, INSTRUCTIONAL FILMS, MAINTENANCE, \*MANAGEMENT, POST  
SECONDARY EDUCATION, \*SAFETY  
DESC NOTE (NO. 148.15-9) 16MM, 10 MIN., COLOR; EIGHT FILM  
(EW002796-EW002803) "SAFETY MANAGEMENT" SERIES  
ABSTRACT HOW HOUSEKEEPING AND MAINTENANCE RELATE TO SAFETY AND  
EFFICIENCY.  
INST NAME NATIONAL SAFETY COUNCIL.

TITLE SECOND COURSE WORKBOOK FOR WATER TREATMENT PLANT OPERATORS.  
AUTHOR SHEETS, W. D.; HAGERTY, L. T.  
PUB DATE 75  
AVAIL OPERATOR TRAINING COMMITTEE OF OHIO, INC., P.O. BOX 626,  
WORTHINGTON, OHIO 43085 (\$20.00)

DESC EQUIPMENT, \*ENVIRONMENTAL, TECHNICIANS, \*INSTRUCTIONAL  
 MATERIALS, \*JOB SKILLS, MANPOWER DEVELOPMENT, \*OPERATORS  
 (WATER), \*POST SECONDARY EDUCATION, SAFETY, \*WATER POLLUTION  
 CONTROL, WATER QUALITY, \*WATER TREATMENT  
 ABSTRACT WORKBOOK FOR ADVANCED WATER TREATMENT PLANT OPERATIONAL  
 PROBLEMS.

TITLE WORKBOOK: QUESTIONS AND ANSWERS FOR WASTEWATER OPERATORS, 3RD  
 EDITION.

AUTHOR COVENTRY, F. L.  
 PUB DATES 74  
 AVAIL. F. L. COVENTRY, RT. 4, BOX 154 A, ROCKVILLE, IN 47072 (\$3.00)  
 DESC ACTIVATED SLUDGE, BIOLOGICAL TREATMENT, \*CERTIFICATION,  
 \*INSTRUCTIONAL MATERIALS, MAINTENANCE, \*OPERATIONS  
 (WASTEWATER), \*POST SECONDARY EDUCATION, \*STUDY QUESTIONS,  
 STABILIZATION LAGOONS, SAFETY, TRICKLING FILTERS, \*WASTEWATER  
 TREATMENT

DESC NOTE 64P. 520 QUESTIONS WITH ANSWERS  
 \* ABSTRACT THIS IS NOT A TECHBOOK ON WASTEWATER TREATMENT OPERATIONS. IT  
 IS A HANDBOOK. THE PLANT OPERATOR WHO CAN ANSWER THESE  
 QUESTIONS CORRECTLY WILL BE ABLE TO PASS MANY COMPREHENSIVE  
 CERTIFICATION TESTS.

133

## SECTION IV

## Safety: Chemicals - Gases

TITLE CHLORINE FACTS (FACT).  
 PUB DATE 69  
 AVAIL THE CHLORINE INSTITUTE, INC., 342 MADISON AVENUE, NEW YORK, NY 10017 (\$1.50)

DESC \*CHEMICAL INDUSTRY, \*CHLORINE, DISEASE CONTROL, \*ENVIRONMENTAL INFLUENCES, INDUSTRY, \*INSTRUCTIONAL MATERIALS, \*POST SECONDARY EDUCATION, \*PUBLIC HEALTH, \*SAFETY, WATER QUALITY, WATER TREATMENT.

DESC NOTE 24P.  
 ABSTRACT PRESENTS A QUICK SUMMARY OF CHLORINE'S HISTORY, MANUFACTURING PROCESSES, LOCATIONS OF PRODUCTION AND PACKAGING PLANTS, SHIPPING AND SAFETY PRACTICES, U.S. AND CANADIAN PRODUCTION TRENDS, A CHART OF END USES FOR CHLORINE AND A BIBLIOGRAPHY.

INST NAME THE CHLORINE INSTITUTE.

TITLE CHLORINE: HANDLE IT WITH CARE  
 PUB DATE JUN 79  
 AVAIL THE AMERICAN CITY & COUNTY, V94, N6, P55-56, JUN 79.

DESC \*SAFETY, CHEMICAL REACTIONS, WATER TREATMENT, PUBLIC HEALTH, \*JOB SKILLS, \*FIRST AID, \*CHLORINE

ABSTRACT STRESSED ARE SAFETY PRECAUTIONS TO BE UTILIZED BY PERSONNEL HANDLING CHLORINE. THE DO'S AND DON'TS OF CHLORINE SAFETY ARE EMPHASIZED AND FIRST AID PROCEDURES OUTLINED.

TITLE CHLORINE MANUAL  
 PUB DATE 69  
 AVAIL THE CHLORINE INSTITUTE, INC., 342 MADISON AVENUE, NEW YORK, NY 10017 (\$1.75)

DESC \*CHEMICAL REACTIONS, \*CHLORINE, DISEASE CONTROL, EQUIPMENT UTILIZATION, \*INSTRUCTIONAL MATERIALS, JOB SKILLS, \*POST SECONDARY EDUCATION, WATER TREATMENT, \*SAFETY

DESC NOTE 30P. NO. 1, 4TH ED.  
 ABSTRACT THIS MANUAL IS INTENDED TO BE A COMPENDIUM OF EXPERIENCE OF MATERIALS, EQUIPMENT AND PRACTICES THAT CONTRIBUTE TO SAFE HANDLING, STORAGE, SHIPMENT AND USE OF CHLORINE. IMPORTANT PROPERTIES OF CHLORINE ARE INCLUDED AS WELL AS PRACTICAL METHODS OF DEALING WITH EMERGENCIES THAT MAY BE ENCOUNTERED.

INST NAME THE CHLORINE INSTITUTE, INC.

TITLE FACILITIES AND OPERATING PROCEDURES FOR CHLORINE STORAGE.  
 AVAIL THE CHLORINE INSTITUTE, INC., 342 MADISON AVENUE, NEW YORK, NY 10017 (\$1.75)

DESC CHEMICAL INDUSTRY, \*CHLORINE, \*EQUIPMENT UTILIZATION, FACILITIES, INSTRUCTIONAL MATERIALS, \*POST SECONDARY EDUCATION, \*SAFETY

DESC NOTE 20P. INCLUDES DRAWINGS, NO. 5, 3RD ED.  
 ABSTRACT SUGGESTS GENERALLY APPLICABLE EQUIPMENT AND OPERATING  
 PROCEDURES FOR CHLORINE STORAGE FACILITIES.  
 INST NAME THE CHLORINE INSTITUTE, INC.

TITLE FACILITIES AND OPERATING PROCEDURES FOR CHLORINE STORAGE.  
 EDITION 3 REVISION 3. PAMPHLET 5.  
 PUB DATE OCT 77  
 AVAIL THE CHLORINE INSTITUTE, INC. 342 MADISON AVE NEW YORK, NY 10017  
 (\$2.00)

DESC / \*CHLORINE, \*CHEMICAL REACTIONS, \*CONSTRUCTION, DESIGN,  
 EQUIPMENT, FACILITIES, \*GUIDELINES, MAINTENANCE, \*STANDARDS,  
 \*SAFETY

DESC NOTE 20P  
 ABSTRACT THIS PAMPHLET PROVIDES BASIC INFORMATION REGARDING THE DESIGN,  
 CONSTRUCTION, LOCATION, INSTALLATION AND OPERATION OF CHLORINE  
 STORAGE SYSTEMS.  
 INST NAME CHLORINE INSTITUTE, INC.

TITLE FIRST AID AND MEDICAL MANAGEMENT OF CHLORINE EXPOSURES.  
 PUB DATE 75  
 AVAIL THE CHLORINE INSTITUTE, INC., 342 MADISON AVENUE, NEW YORK, NY  
 10017 (\$1.25)

DESC \*CHEMICAL REACTIONS, \*CHLORINE, \*FIRST AID, \*INSTRUCTIONAL  
 MATERIALS, \*POST SECONDARY EDUCATION, \*SAFETY

DESC NOTE 4P. NO. 63, 2ND ED.  
 ABSTRACT GIVES RECOMMENDATIONS ON FIRST AID AND MEDICAL MANAGEMENT OF  
 CHLORINE EXPOSURES. DEVELOPED BY THE INSTITUTE'S ENVIRONMENTAL  
 HEALTH COMMITTEE.  
 INST NAME THE CHLORINE INSTITUTE, INC.

TITLE LET'S INVENTORY YOUR CHLORINE HANDLING PRACTICES.  
 AUTHOR MCEWEN, ROBERT S.  
 PUB DATE NOV 70  
 DESC \*AUDIOVISUAL AIDS, CHEMISTRY, \*INSTRUCTIONAL MATERIALS,  
 POLLUTION, \*POST SECONDARY EDUCATION, \*SAFETY, \*WATER POLLUTION  
 CONTROL, \*CHLORINE, \*WASTEWATER TREATMENT, \*WATER TREATMENT

DESC NOTE INCLUDED IS A 32 MINUTE TAPE, 80 SLIDES, AND A SCRIPT.  
 ABSTRACT AVAILABLE ON LOAN FROM NTOIC, 26 W. ST. CLAIR, CINCINNATI, OH  
 45268  
 THIS MODULE IS DESIGNED FOR ALL PERSONNEL IN WATER SUPPLY AND  
 WASTEWATER TREATMENT PLANTS. IT DISCUSSES THE HANDLING OF  
 ELEMENTAL CHLORINE. THE PRINCIPLE DIVISIONS OF INFORMATION ARE  
 PHYSICAL AND CHEMICAL CHARACTERISTICS OF CHLORINE, SAFETY  
 REQUIREMENTS FOR THE SIX SEGMENTS OF TYPICAL CHLORINE FEED  
 SYSTEMS. CHLORINE EMERGENCY PROCEDURES, IN-PLANT OPERATING  
 PROCEDURES FOR SAFE HANDLING OF CHLORINE (15 ITEMS), AND  
 SOURCES OF ADDITIONAL INFORMATION.

TITLE OPERATION OF CHLORINE VAPORIZING EQUIPMENT.  
 PUB DATE 70  
 AVAIL THE CHLORINE INSTITUTE, INC., 342 MADISON AVENUE, NEW YORK, NY  
 10017 (\$1.75)

105

DESC CHEMICAL\* INDUSTRY, \*CHLORINE, ENVIRONMENTAL INFLUENCES,  
 \*EQUIPMENT UTILIZATION, HEALTH, \*INSTRUCTIONAL MATERIALS, JOB  
 SKILLS, \*POST SECONDARY EDUCATION, \*SAFETY  
 DESC NOTE 16P. NO.9, 2ND ED.  
 ABSTRACT CONTAINS INFORMATION INTENDED TO ASSIST IN THE SELECTION,  
 DESIGN AND SAFE OPERATION OF VAPORIZERS.  
 INST NAME THE CHLORINE INSTITUTE, INC.

TITLE SAFE HANDLING OF CHLORINE.  
 PUB DATE 70  
 AVAIL MODERN TALKING PICTURE SERVICE, 1687 ELMHURST ROAD, ELK GROVE  
 VILLAGE, IL 60007 (FREE RENTAL)

DESC \*ACCIDENT PREVENTION, \*AUDIOVISUAL AIDS, \*CHEMICAL INDUSTRY,  
 \*CHLORINE, \*FILMS, INDUSTRIAL SAFETY, INSTRUCTIONAL FILMS,  
 \*INSTRUCTIONAL MATERIALS, POST SECONDARY EDUCATION, \*SAFETY  
 DESC NOTE 16MM, 25 MIN., COLOR  
 ABSTRACT PROCEDURES FOR HANDLING CHLORINE CYLINDERS, TON CONTAINERS,  
 TANK CARS AND BARGES ARE OUTLINED IN THIS FILM. ALSO DISCUSSED  
 ARE APPROPRIATE MATERIALS OF CONSTRUCTION, PUMPING CHLORINE,  
 CHECKING STORAGE TANKS, OPERATING VAPORIZERS, REPACKING VALVES,  
 AND TRAINING OPERATORS TO HANDLE CHLORINE SAFELY.  
 INST NAME PITTSBURGH PLATE GLASS.

TITLE TANK ENTRY (COURSE).  
 AVAIL E.I. DUPONT DE NEMOURS & COMPANY, INC., EDUCATION & APPLIED  
 TECHNOLOGY DIVISION, BRANDYWINE BLDG., WILMINGTON, DE 19898  
 (\$1.90)  
 DESC \*ACCIDENT PREVENTION, \*CHEMICAL INDUSTRY, \*INSTRUCTIONAL  
 MATERIALS, OPERATIONS, \*POST SECONDARY EDUCATION, \*SAFETY, SELF  
 PACED INSTRUCTION, \*TANKS, \*TANK CLEANING, \*TANK INSPECTION  
 DESC NOTE COURSE NO. 567  
 ABSTRACT INSTRUCTIONAL MATERIAL ON TANK ENTRY.  
 INST NAME E.I. DUPONT DE NEMOURS & COMPANY, INC.

TITLE WALL CHART - SAFE HANDLING OF CHLORINE CONTAINERS (WC-1).  
 PUB DATE 64  
 AVAIL THE CHLORINE INSTITUTE, INC., 342 MADISON AVENUE, NEW YORK, NY  
 10017 (\$1.75)  
 DESC \*CHEMICAL INDUSTRY, CHEMICAL REACTIONS, \*CHLORINE, \*EQUIPMENT  
 UTILIZATION, \*FIRST AID, \*INSTRUCTIONAL MATERIALS, \*SAFETY,  
 \*WALL CHARTS  
 DESC NOTE CHART MEASURES 12 1/2 X 23 INCHES  
 ABSTRACT CONTAINS RECOMMENDATIONS FOR SAFE HANDLING OF CHLORINE  
 CYLINDERS AND TON CONTAINERS, EMERGENCY PROCEDURES AND  
 APPLICABLE PRINCIPLES OF FIRST AID.  
 INST NAME THE CHLORINE INSTITUTE, INC.

106

SECTION V

Safety: Electricity

TITLE ELECTRICAL SWITCH LOCKOUT PROCEDURE.  
AVAIL MANUFACTURING CHEMISTS ASSOCIATION, 1825 CONNECTICUT AVENUE,  
NW, WASHINGTON, DC 20009 (\$1.00)  
DESC \*ACCIDENT PREVENTION, \*ELECTRICAL SYSTEMS, \*INDUSTRIAL SAFETY,  
\*INSTRUCTIONAL MATERIALS, OPERATIONS (PLANT), \*POST SECONDARY  
EDUCATION  
DESC NOTE 4P. ORDER NO. SG-9  
ABSTRACT PROCEDURES FOR THE USE OF LOCKOUT BARS AND TAGS ARE DESCRIBED.  
INST NAME MANUFACTURING CHEMISTS ASSOCIATION

137

SECTION VI

Safety: Fire and Explosion

TITLE FIRE: CONCEPTS AND BEHAVIOR.  
AVAIL N.F.P.A. FILM LIBRARY, 40 PARK AVENUE, SOUTH, NEW YORK, NY  
PURCHASE PRICE \$295.00/RENTAL \$45.00 PER DAY  
DESC NOTE (COLOR/20 MIN. FILM)  
ABSTRACT THIS FILM IS FOR INDUSTRIAL FIRE BRIGADES, FIRE DEPARTMENTS  
AND FIRE SCIENCE STUDENTS. IT TEACHES FUNDAMENTAL PRINCIPLES  
OF FIRE SCIENCE AND GIVES PRACTICAL GUIDANCE ON HOW TO RELATE  
FIRE SCIENCE THEORY TO REAL LIFE FIRE SITUATIONS.

TITLE FLAMMABLES: ENGINEERING.  
AVAIL PROTECTOSEAL COMPANY, 225 WEST FOSTER AVENUE, BENSENVILLE, IL  
60106. PURCHASE PRICE \$150.00  
DESC NOTE (COLOR/26 MIN. FILM)  
ABSTRACT FOR USE AS A THREEFOLD PURPOSE: (1) DEMONSTRATES POTENTIAL  
HAZARDS IN THE MISHANDLING OF FLAMMABLE LIQUIDS; (2) EDUCATES  
PERSONNEL IN CORRECT TECHNIQUES AND METHODS IN THE HANDLING  
OF FLAMMABLE LIQUIDS; AND (3) STIMULATES INTEREST IN, AND  
COOPERATION WITH, SAFETY DEPARTMENTS IN SETTING UP FLAMMABLE  
LIQUID HANDLING PROCEDURES.

TITLE HAZARDOUS MATERIALS - EMERGENCY RESPONSE.  
AVAIL CORTER-MEDIA FIRE FILMS, 121 N.W. CRYSTAL ST., CRYSTAL RIVER,  
FL 32629. PURCHASE PRICE \$425.00/RENTAL \$55.00 - 3 DAYS.  
DESC NOTE (COLOR/30 MIN. FILM)  
ABSTRACT AN INTRODUCTION TO THE PROBLEMS ENCOUNTERED IN HAZARDOUS  
MATERIALS INCIDENTS. COMPREHENSIVE INTRODUCTION UTILITIES  
TV AND FILM COVERAGE OF 15 DIVERSIFIED INCIDENTS. THESE  
INCIDENTS INCLUDE ALL TYPES OF TRANSPORTATION ACCIDENTS AND  
STORAGE AND MANUFACTURING ACCIDENTS. SUBJECT AREAS INCLUDE:  
(1) CHEMICAL RECOGNITION, IDENTIFICATION, AND HAZARDS, (2)  
PROBLEMS WITH LEAKS, SPILLS, FIRES, AND EXPLOSIONS.

TITLE POLYMERS AND FIRES.  
AVAIL B. F. GOODRICH CHEMICAL CORPORATION, 6100 OAKTREE BLVD.,  
CLEVELAND, OH 44131. PURCHASE PRICE \$62.00  
DESC NOTE (COLOR/14 MIN. FILM)  
ABSTRACT HYDROCARBONS - WHAT MAKES UP POLYMERS (HYDROCARBONS) AND WHAT  
HAPPENS WHEN THEY BURN. IT TALKS ABOUT WHAT THE FIREFIGHTER  
CAN DO TO PROTECT HIMSELF FROM THE TOXIC GASES GIVEN OFF BY  
BURNING POLYMERS.

TITLE PROGNOSIS: FIRE.  
AVAIL FIRE PREVENTION THROUGH FILMS, INC., BOX II, NEWTON HIGHLANDS,  
MA 02161. PURCHASE PRICE \$260.00  
DESC NOTE (COLOR/20 MIN. FILM)



ABSTRACT THE MOST UP-TO-DATE TRAINING AID FOR TEACHING HEALTH CARE FACILITIES STAFF, INCLUDING NURSES, TECHNICIANS, HOUSE-KEEPING, OFFICE, MAINTENANCE STAFF AND OTHER PERSONNEL HOW TO KEEP THEIR FACILITY SAFE FROM FIRE. THE FILM PRESENTS EMPLOYEE'S RESPONSIBILITY FOR (1) FIRE PREVENTION: CAUSES OF FIRES, AND RECOGNIZING AND ELIMINATING HAZARDS; (2) FIRE CONTROL: KNOWING ABOUT FIRE DOORS AND OTHER BUILDING FEATURES; KNOWING ABOUT FIRE FIGHTING EQUIPMENT AND HOW AND WHEN TO USE IT; AND (3) EMERGENCY ACTION: PROCEDURES AND SEQUENCE OF REQUIRED ACTION; EVACUATION AND RELOCATION OF PATIENTS.

TITLE RUBBLE TROUBLE.  
 AVAIL FILM COMMUNICATORS, 1136 WEDDINGTON ST., NORTH HOLLYWOOD, CA 91601. PURCHASE PRICE \$275.00/RENTAL \$55.00-WEEK (COLOR/11 MIN. FILM)  
 DESC NOTE THIS LIVE-ACTION/ANIMATED FILM ON WASTE DISPOSAL FOR FIRE  
 ABSTRACT PREVENTION CAN KEEP YOUR PLANT OUT OF "RUBBLE TROUBLE." INDUSTRIAL WASTE, CARELESSLY SORTED, CAN BE FIRE'S BEST FRIEND. OILY RAGS, DUST, TRASH, AND RUBBISH WERE BORN TO BURN. ANY SOURCE OF IGNITION REACHING SUCH ITEMS CAN RESULT IN DISASTROUS AND COSTLY INDUSTRIAL HOLOCAUST. "RUBBLE TROUBLE" SHOWS THE MOST EFFICIENT METHODS OF ELIMINATING FIRE HAZARDS, IMPROVING WORKING CONDITIONS, INCREASING PLANT EFFICIENCY, AND INSTILLS THE BASIC PRINCIPLES OF INDUSTRIAL SAFETY.

TITLE THE SCIENCE OF FIRE.  
 AVAIL AMERICAN INSURANCE ASSOCIATION, 110 WILLIAM STREET, NEW YORK, NY. NO PRICE INFORMATION AVAILABLE.  
 DESC NOTE (COLOR/20 MIN. FILM)  
 ABSTRACT TELLS THE STORY OF FIRE, THE PRINCIPLES OF COMBUSTION, AND HOW FIRES CAN BE PREVENTED. COVERS FLASH POINTS, IGNITION, TEMPERATURES, VAPOR TRAVEL AND METHODS OF EXTINGUISHING.

TITLE USING EXTINGUISHERS THE RIGHT WAY.  
 AVAIL N.F.P.A., FILM LIBRARY, 470 PARK AVENUE, SOUTH, NEW YORK, NY. PURCHASE PRICE \$195.00/RENTAL \$20.00-DAY (COLOR/13 MIN. FILM)  
 DESC NOTE ACTUAL SHOTS AND NARRATION OF THE PEOPLE INVOLVED AT THE  
 ABSTRACT BEGINNING OF THIS FILM SHOWS WHAT CAN HAPPEN WHEN THE WRONG TYPE OF EXTINGUISHER IS USED ON A FIRE OR AN EXTINGUISHING AGENT IS IMPROPERLY APPLIED ON A FIRE. DEMONSTRATES WHAT IS NEEDED TO HAVE A FIRE, THE DIFFERENT TYPES OF EXTINGUISHERS AND WHAT FIRES THEY ARE USED ON, HOW TO OPERATE THEM, AND WHAT NEEDS TO BE DONE AFTER THEY ARE USED. ALSO SHOWS WHAT FIRE TO ATTACK AND WHICH TYPES TO STAY AWAY FROM.

109

## SECTION VII

## Safety: Laboratory Operation

TITLE BASIC LABORATORY TECHNIQUES FOR THE NATIONAL POLLUTION DISCHARGE ELIMINATION SYSTEM (NPDES)

AUTHOR BONNETTE, A. K., JENKINS, AND OTHERS

PUB DATE JUN 76

AVAIL ERIC INFORMATION ANALYSIS CENTER FOR SCIENCE, MATHEMATICS, AND ENVIRONMENTAL EDUCATION, THE OHIO STATE UNIVERSITY, 1200 CHAMBERS RD., 3RD FLOOR, COLUMBUS, OH 43212 (ON LOAN)

DESC EDUCATIONAL PROGRAMS, ENVIRONMENTAL EDUCATION, ENVIRONMENTAL TECHNICIANS, INDEPENDENT STUDY, \*INSTRUCTIONAL MATERIALS, \*LABORATORY TECHNIQUES, \*LEARNING MODULES, \*POLLUTION, POST SECONDARY EDUCATION, SAFETY, \*WATER POLLUTION CONTROL, \*WASTEWATER TREATMENT

DESC NOTE 479P.; CONTAINS OCCASIONAL LIGHT TYPE

ABSTRACT THIS MANUAL CONTAINS 24 SELF-STUDY MODULES FOR BASIC LABORATORY PROCEDURES FOR THE NATIONAL POLLUTION DISCHARGE ELIMINATION SYSTEM (NPDES) LABORATORY ANALYSES. AREAS OF STUDY INCLUDE SAFETY, IDENTIFICATION OF EQUIPMENT, HANDLING SOLIDS AND LIQUIDS, USE OF BALANCES, AND CARE AND USE OF EQUIPMENT. EVALUATION TESTS AND ANSWERS ARE PROVIDED FOR EACH MODULE.

INST NAME CLEMSON UNIV., S.C. COLL. OF ENGINEERING.

TITLE CHEMICAL HAZARDS

PUB DATE 72

AVAIL KALMIA COMPANY CONCORD, MA 01742 (PURCHASE PRICE: \$26.95 AND \$34.95)

DESC \*ACCIDENT PREVENTION, \*AUDIOVISUAL AIDS, \*CHEMICALS, CHEMICAL HAZARDS, FILMS, \*INSTRUCTIONAL FILMS, \*INSTRUCTIONAL MATERIALS, LABORATORY SAFETY, POST SECONDARY EDUCATION, \*SAFETY

DESC NOTE ORDER NO. 2900; 8MM AND 16MM, 3:42 MIN., COLOR

ABSTRACT ILLUSTRATES SEVERAL CHEMICAL HAZARDS AND APPROPRIATE PROCEDURES, ANTIDOTES, OR CORRECTIVE ACTIONS. HAZARDS INCLUDE CHEMICALS ON SKIN, DILUTION OF CONCENTRATED ACID, MERCURY SPILL, AND HANDLING SOLID ALKALI.

TITLE CHEMICAL LAB SAFETY

PUB DATE 61

AVAIL NATIONAL AUDIOVISUAL CENTER, REFERENCE SECTION, GENERAL SERVICES ADMINISTRATION, WASHINGTON, DC 20409 (RENTAL: \$12.50)

DESC \*ACCIDENT PREVENTION, AUDIOVISUAL AIDS, \*FILMS, \*INSTRUCTIONAL FILMS, \*INSTRUCTIONAL MATERIALS, \*LABORATORY SAFETY, \*SAFETY

DESC NOTE (TITLE NO. 211850), (AGENCY NO. M-0445), 16MM, 25 MIN., OPTICAL SOUND, COLOR

ABSTRACT SEVERAL SIMULATED CHEMICAL LAB ACCIDENTS ARE DEPICTED ALONG WITH SUGGESTIONS FOR THEIR PREVENTION AND TIPS FOR GENERAL SAFETY PRECAUTIONS IN ROUTINE LAB ACTIVITIES.

TITLE FIRE IN THE LABORATORY  
PUB DATE 72  
AVAIL KALMIA COMPANY CONCORD, MA 01742 (PURCHASE PRICE: \$26.95 AND  
and \$34.95)  
DESC \*ACCIDENT PREVENTION, \*AUDIOVISUAL AIDS, FILMS, \*FIRES,  
\*INSTRUCTIONAL MATERIALS, \*LABORATORY SAFETY, POST SECONDARY  
EDUCATION, \*SAFETY  
DESC NOTE ORDER NO. 2200; 8MM and 16MM, 3:30 MIN., COLOR  
ABSTRACT THREE TYPES OF LABORATORY FIRES AND CORRECT PROCEDURES FOR  
EXTINGUISHING THEM ARE SHOWN. SMALL FIRES ARE SMOTHERED. MEDIUM  
FIRES ARE PUT OUT WITH CO2 AND DRY POWDER EXTINGUISHERS. METAL  
FIRE IS SMOTHERED WITH SAND.

TITLE GUIDE FOR SAFETY IN THE CHEMICAL LABORATORY.  
PUB DATE 72  
DESC \*ACCIDENT PREVENTION, \*CHEMISTRY, \*FIRE PROTECTION,  
\*INSTRUCTIONAL MATERIALS, \*LABORATORY SAFETY, LABORATORY  
TECHNIQUES, \*POST SECONDARY EDUCATION, \*SAFETY  
DESC NOTE 506P.  
ABSTRACT HERE, FROM TODAY'S LEADING AUTHORITIES IN THE CHEMICAL  
INDUSTRY, IS QUICK REFERENCE HELP IN SAFELY HANDLING THE WIDE  
RANGE OF NEWLY DEVELOPED MATERIALS AND EQUIPMENT. A COOPERATIVE  
VENTURE OF THE INDUSTRY, THIS BOOK WAS PREPARED BY THE SAFETY  
AND FIRE PROTECTION COMMITTEE OF THE MCA. THE CONTRIBUTING  
AUTHORS REPRESENT FIRMS SUCH AS DOW, EASTMAN KODAK, AND DUPONT.  
TOGETHER THEY PROVIDE PROVEN SAFETY PROCEDURES DEVELOPED BY  
MANY INDIVIDUAL COMPANIES.

TITLE HANDBOOK FOR CHEMICAL TECHNICIANS.  
AUTHOR STRAUSS, HOWARD J.; KAUFMAN, MILTON  
PUB DATE 76  
AVAIL MCGRAW-HILL BOOK CO., MANCHESTER RD., MANCHESTER, MD 63011  
(\$17.20)  
DESC \*CHEMICAL REACTIONS, \*CHEMISTRY, ENGINEERING, ENVIRONMENTAL  
TECHNICIANS, \*FUNDAMENTAL CONCEPTS, \*INSTRUCTIONAL MATERIALS,  
\*LABORATORY PROCEDURES, \*MATHEMATICAL APPLICATIONS, ORGANIC  
CHEMISTRY, \*POST SECONDARY EDUCATION, SAFETY, WASTE DISPOSAL  
DESC NOTE 315P.  
ABSTRACT EACH OF THE TEN CHAPTERS OF THIS BOOK ADDRESSES AN IMPORTANT  
ASPECT OF CHEMICAL TECHNOLOGY. TOPICS INCLUDE MEASUREMENT  
PRINCIPLES, THERMAL, ELECTRICAL, AND MECHANICAL UNITS, CHEMICAL  
FUNDAMENTALS, ORGANIC CHEMISTRY, METALS, ALLOYS, AND METAL  
TESTING, FLUID MECHANICS, AND SAFETY PROCEDURES, FIRST AID, AND  
WASTE DISPOSAL. EXAMPLES OF CALCULATIONS ARE PROVIDED WITH  
STEP-BY-STEP EXPLANATIONS. THE TEXT IS INTERSPERSED WITH GRAPHS  
AND TABLES AS AN AID FOR DAILY LAB WORK. THE NECESSARY  
PRECAUTIONS FOR THE SAFE HANDLING AND DISPOSAL OF MATERIALS ARE  
DISCUSSED IN THE FINAL CHAPTER.

TITLE INTRODUCTORY LABORATORY TECHNIQUES.  
PUB DATE 70  
AVAIL KALMIA COMPANY CONCORD, MA 01742 (PURCHASE PRICE: \$26.95 AND  
\$34.95)

1.1

DESC NOTE ABSTRACT ORDER NO. 3100; 8MM AND 16MM, 3:35 MIN., COLOR DEMONSTRATIONS OF SAFETY-ORIENTED LABORATORY TECHNIQUES: POURING SOLIDS AND LIQUIDS AND HEATING LIQUIDS IN TEST TUBE AND EVAPORATING DISH. DANGERS OF SUPER-HEATED LIQUIDS AND CARELESS REMOVAL OF FLASK FROM FLAME ALSO SHOWN.

TITLE PERSONAL SAFETY.  
PUB DATE 72  
AVAIL KALMIA COMPANY CONCORD, MA 01742 (PURCHASE PRICE: \$26.95 AND \$34.95)

DESC \*ACCIDENT PREVENTION, \*AUDIOVISUAL AIDS, \*CHEMISTRY, FILMS, \*FIRES, \*INSTRUCTIONAL FILMS, \*INSTRUCTIONAL MATERIALS, POST SECONDARY EDUCATION, \*SAFETY

DESC NOTE ABSTRACT ORDER NO. 2100; 8MM OR 16MM 2:39 MIN., COLOR HOW TO ACT AND REACT IN THE LABORATORY. DEMONSTRATES EYE PROTECTION, TIEING BACK LONG HAIR, WEARING LOOSE INEXPENSIVE CLOTHING, WEARING LAB COAT OR APRON, AND WEARING PROTECTIVE SHOES. TECHNIQUES SHOWN FOR SMOTHERING CLOTHING FIRE WITH FIRE BLANKET AND LAB APRON.

TITLE AVAIL SAFETY EDUCATION DATA SHEET #23 - LABORATORY GLASSWARE.  
NATIONAL SAFETY COUNCIL, 444 NORTH MICHIGAN AVENUE, CHICAGO, IL 60611 (\$0.27)

DESC \*INDUSTRIAL SAFETY, \*INSTRUCTIONAL MATERIALS, \*LABORATORY EQUIPMENT, \*LABORATORY GLASSWARE, OPERATIONS, POST SECONDARY EDUCATION, \*SAFETY

DESC NOTE ABSTRACT 4P. (STOCK NO. 429.04-23) GENERAL REVIEW OF LABORATORY SAFETY.  
INST NAME NATIONAL SAFETY COUNCIL.

TITLE AUTHOR SAFETY IN THE LABORATORY.  
DISRAELI, R.  
PUB DATE 76  
AVAIL ASSOCIATED INSTRUCTIONAL MATERIALS, 324 DELAWARE AVE., OAKMONT, PA 15139, PRICE: \$5.00 (RENTAL, BLACK & WHITE), \$7.00 (RENTAL, COLOR)

DESC \*ACCIDENT PREVENTION, AUDIOVISUAL AIDS, \*CHEMISTRY, FILMS, INSTRUCTIONAL FILMS, \*INSTRUCTIONAL MATERIALS, \*LABORATORY SKILLS, \*LABORATORY SAFETY, POST SECONDARY EDUCATION, \*SAFETY

DESC NOTE ABSTRACT (DC-111) 16MM, 8MIN., COLOR. SAFETY PROCEDURES THAT SHOULD BE USED IN THE CHEMISTRY LABORATORY.

TITLE AVAIL SAFETY PIPETTING.  
NATIONAL AUDIOVISUAL CENTER REFERENCE SECTION, GENERAL SERVICES ADMINISTRATION, WASHINGTON, DC 20409 (PURCHASE PRICE: \$29.00)

DESC \*ACCIDENT PREVENTION, \*AUDIOVISUAL AIDS, \*FILMS, \*INSTRUCTIONAL MATERIALS, INSTRUCTIONAL FILMS, \*LABORATORY SAFETY, \*LABORATORY TECHNIQUES, \*POST SECONDARY EDUCATION, \*PIPETTES, \*SAFETY

DESC NOTE ABSTRACT (TITLE NO. 003328) (AGENCY NO. M-1160) 16MM, 5MIN., OPTICAL SOUND PRESENTS THREE INSTRUMENTS THAT ARE COMMONLY USED IN THE LABORATORY. THE OPERATION OF THESE INSTRUMENTS IS SHOWN IN DETAIL.

SECTION VIII

Safety: Manholes and Traffic

TITLE EXCAVATING NEAR UNDERGROUND UTILITIES.  
AVAIL \* NATIONAL SAFETY COUNCIL, 444 NORTH MICHIGAN AVENUE, CHICAGO, IL  
60611 (\$19.80)  
DESC \*ACCIDENT PREVENTION, \*EXCAVATION, \*INDUSTRIAL SAFETY,  
INSTRUCTIONAL MATERIALS, POST SECONDARY EDUCATION, \*SAFETY,  
SLIDES, \*UTILITIES, VISUAL AIDS  
DESC NOTE (NO. 129.18-9) 31 SLIDES, COLOR, SCRIPT  
ABSTRACT DISCUSSES THE HAZARDS OF WORKING NEAR UNDERGROUND UTILITY  
LINES.  
INST NAME NATIONAL SAFETY COUNCIL

TITLE MANHOLE SAFETY. TRAINING MODULE 3.330.1.77.  
PUB DATE SEP 77  
DESC \*INSTRUCTIONAL MATERIALS, \*POST SECONDARY EDUCATION, \*SAFETY,  
SECONDARY EDUCATION, \*TEACHING GUIDES, UNITS OF STUDY, \*SEWERS,  
\*WASTEWATER COLLECTION, WASTEWATER TREATMENT  
DESC NOTE 37P.  
ABSTRACT THIS DOCUMENT IS AN INSTRUCTIONAL MODULE PACKAGE PREPARED IN  
OBJECTIVE FORM FOR USE BY AN INSTRUCTOR FAMILIAR WITH THE USE  
OF SAFETY EQUIPMENT TO PREVENT ACCIDENTS, INJURY AND LOSS OF  
LIFE TO PERSONNEL WHILE INSPECTING OR WORKING IN SEWER MANHOLES  
OR IN CONFINED AREAS OF WASTEWATER TREATMENT PLANT. INCLUDED  
ARE OBJECTIVES, INSTRUCTOR GUIDES, STUDENT HANDOUTS, AND  
TRANSPARENCY MASTERS. THIS MODULE CONSIDERS PURPOSES AND TYPES  
OF MANHOLES, A SAFETY CHECKLIST, AND PROPER USE OF SAFETY  
EQUIPMENT.  
INST NAME KIRKWOOD COMMUNITY COLL., CEDAR-RAPIDS, IA.

PART III

The National Training and  
Operational Technology Center  
and Selected Information Sources

174

187

THE NATIONAL TRAINING AND OPERATIONAL  
TECHNOLOGY CENTER

The entire program responsibility for water pollution control training within the Environmental Protection Agency is assigned to the National Training and Operational Technology Center (NTOTC), located at EPA's Environmental Research Center in Cincinnati, Ohio.

The NTOTC is responsible for conducting training sessions, developing instructional materials and courses, providing training assistance, operating the Instructional Resources Center, and developing operational technology. The Center is also responsible for the management of the Section 104(g) operator training grant program, the academic training grant program, other training grant and contract programs, and related training activities.

As an instructional resource, NTOTC's purpose is to help regions, states, local governments, and educational institutions become knowledgeable about the Environmental Protection Agency's goals, regulations, and strategies, as well as the implications of EPA programs.

Activities encompass three categories: (1) instruction; (2) course development; and (3) information management.

Instruction

NTOTC offers a variety of training courses in water quality control. Such courses are taught at many locations, but most are presented at the Environmental Research Center in Cincinnati, Ohio. Area training centers will soon act as satellites to the NTOTC program, offering similar courses and instructional support. Select universities with broad pollution control curricula will act as area training centers within a region. As a result, more pollution control personnel will have access to needed specialized training.

Some courses are conducted at wastewater treatment plants, enabling USEPA to work directly with plant personnel to improve treatment plant effluent. While working on site at treatment plants, staff can diagnose and discuss particular problems and provide information on design and operation to many technicians within the local region.

Courses currently are offered in five general categories: wastewater treatment technology, treatment facility evaluation and inspection, water quality surveillance and monitoring, water quality analysis, and drinking water quality monitoring.

Students attend courses from all states, and from some foreign countries. The largest percentage represent federal, state, and municipal pollution control agencies. A relatively small number of college and university instructors attend these short courses which are typically one week in length. USEPA encourages more participation by the educational community so that current skills and knowledge will be transmitted to students to enable them to deal with pollution control problems as they

enter environmental occupations. Community college and university instructors may attend courses free of charge by following prescribed application procedures.

#### Course Development

NTOTC is active in the field of course development. As new educational and training needs are identified, appropriate instructional packages are developed. Almost all such development is based on current research and agency regulations. Materials include instructor guides, student manuals and supporting audiovisual materials. If USEPA'S pollution control training programs are to be successfully implemented, college and university staff from various departments must cooperate and integrate these instructional activities within their curricula, or students will not be adequately prepared, either theoretically or practically.

#### Information Management

The goal of USEPA's information management system is to support, in a comprehensive and systematic manner, those involved with pollution control education and training. A central location within the NTOTC facility is designed to provide a contact point and to coordinate assistance efforts.

Through the IRC, NTOTC maintains a central location to inventory, evaluate, catalog, and disseminate instructional materials in the areas of water pollution control, water supply, and pesticides. The IRC provides those involved in water quality control education and training with an information management system and acts as a primary communications link between the Environmental Protection Agency and educators at all post-secondary levels. Activities of IRC include:

#### IRIS

The focal point of the IRC is the Instructional Resources Information System (IRIS), a compilation of abstracts on print and non-print materials related to water quality and water resources education. Obtainable in paper, microfiche, and computer versions, the IRIS contains more than 5,500 entries from local, state, and federal government sources, as well as from private concerns and educational institutions. The system allows the user to discover what material can be utilized, the title, the author, cross references, and a brief abstract describing the content. IRIS users can also readily determine where the material can be obtained, whether it can be purchased, borrowed, or rented, and the cost. The IRIS is kept current through constant revision, adding new material as it becomes available and deleting outdated information.

IRIS can be scanned for a particular subject or author, both by hand and by computer. Any institution with appropriate computer terminals can access the search and retrieval capabilities of the system.



### Audiovisual Library

The IRC facilities include an audiovisual library equipped with individual study carrels for viewing movies, videocassettes, slide/tape presentations, filmstrips, and tape programs. Before determining curriculum requirements or making purchases, educators can use the library to review water quality-oriented materials for use in training courses.

Nearly 200 of these audiovisuals are also available to instructors for free, short-term loans. Not intended as self-instructional units, these materials are meant to be used as part of a complete training program. A catalog of audiovisual units can be obtained through the IRC.

### Workshops

The center also conducts a variety of water-related workshops each year. Designed for state and local agencies, as well as college and university educators, these seminars enable individuals to become familiar with USEPA developed and sponsored resources, descriptions of ongoing programs, and specific instructional techniques. Participants also assist NTOTC in determining instructional priorities.

### IRC Bulletin

The IRC maintains communications with its users through the IRC Bulletin. Published approximately six times a year and mailed to interested parties at no charge, the Bulletin provides current news on IRC events. It also includes descriptions of model programs, current instructional materials available, and education strategies. Articles for the Bulletin are accepted from various organizations, education institutions, and governmental agencies.

Interested persons are invited to Cincinnati to use IRC facilities for reviewing tapes, slides, films, and other materials before deciding about purchases or curriculum development requirements. IRC staff assist visitors by determining the most appropriate ways to use the Center's resources, or in determining educational and training program requirements and available resources. During the past year, universities and state and local governments have been assisted with curriculum design, course materials selection, and audiovisual support efforts.

1977

## THE INSTRUCTIONAL RESOURCES INFORMATION SYSTEM

### General Information about Materials in IRIS

The EPA Information Dissemination Project acquires, reviews, indexes, and makes available both print and non-print materials related to water quality and water resources education and instruction.

Before materials are entered into IRIS they are reviewed by the project staff. Availability of the material is checked, and the materials are abstracted and indexed. The abstract describes the contents of the material.

When items are processed they are entered on the IRIS computer tape maintained by the EPA Information Dissemination Project at The Ohio State University. These tapes are used for producing tapes for other information systems, publications, and for computer searches conducted at The Ohio State University.

Materials entered into the IRIS collection can be located by manual search or by computer. The first compilation contains resumes of selected materials processed for the previous IRIS collection and resumes of selected materials of items added to the IRIS collection during 1979. Quarterly updates of the IRIS compilation are available by subscription on a yearly basis.

A number of the materials processed for the IRIS system are entered into the ERIC system and announced in Resources in Education (RIE). Most of the materials announced in RIE are available on microfiche at various sites throughout the United States. Users can view these materials on site at many locations to identify what they believe will be useful to them at no cost.

### Description of Information in Resumes in IRIS

Two samples of resumes are provided to explain the data fields in the resumes. Sample resume #1 is a sample resume of an item not entered in ERIC. Sample resume #2 is a sample resume of an item entered into ERIC; a few additional data elements are in these resumes and are explained.

#### 1. Sample resume of materials not entered into ERIC

- a. IRIS NUMBER: EW003059
- b. PUBLICATION DATE: 1978
- c. TITLE: WATER POLLUTION MICROBIOLOGY, VOL. 2
- d. PERSONAL AUTHOR: MITCHELL, RALPH
- e. DESCRIPTOR: BIOCHEMISTRY; \*COLLEGE SCIENCE; DISEASE CONTROL; ECOLOGY; \*ENVIRONMENTAL INFLUENCES; \*INSTRUCTIONAL MATERIALS; \*MICROBIOLOGY; NATURAL RESOURCES; \*POLLUTION; \*PUBLIC HEALTH; \*WATER POLLUTION CONTROL; WATER QUALITY

- f. DESCRIPTIVE NOTE: 442P.
- g. ABSTRACT: THIS VOLUME CONTAINS INFORMATION FOR ENVIRONMENTAL AND SANITARY ENGINEERS, PUBLIC HEALTH SCIENTISTS AND MICROBIOLOGISTS CONCERNED WITH WATER POLLUTION. IT EXAMINES MICROORGANISMS AS CAUSITIVE AGENTS OF ECOLOGICAL AND PUBLIC HEALTH HAZARDS IN NATURAL WATERS, AND TREATS THE USE OF MICROORGANISMS IN POLLUTION CONTROL FROM A VARIETY OF PERSPECTIVES. (CS)
- h. AVAILABILITY: JOHN WILEY & SONS, ONE WILEY DR., SOMERSET NJ 08873 (\$24.95)

a. IRIS NUMBER--this is the identification number sequentially assigned to materials as they are processed. Gaps in numbers mean that some items have been deleted, are being processed to add new information, or have been delayed in processing for some reason.

b. PUBLICATION DATE--date material was published according to information on the material.

c. TITLE

d. PERSONAL AUTHOR--person or persons who wrote, compiled, or edited the material. Up to two personal authors can be listed.

e. DESCRIPTOR--subject terms which characterize substantive contents and form of the materials. The major terms are preceded by an asterisk. Terms used to index all resumes in this compilation can be reviewed in the Subject Index.

f. DESCRIPTIVE NOTE--various items of information may be contained in this section. For print materials the number of pages is usually listed.

g. ABSTRACT--some early materials entered into IRIS did not have abstract information. All materials currently being entered into IRIS have an informative abstract that describes the contents of the item.

h. AVAILABILITY--information in this field indicates where the material can be obtained and the price of the material quoted the last time information was received from the source. Please note: prices of nearly all materials are subject to changes and may not be accurate at the time a person orders a specific item.

179

2. Sample resume of material entered into ERIC  
(Resources in Education)

Item entered into ERIC (Resources in Education)  
will have a few additional data fields.

- IRIS NUMBER: EW002998
- a. ERIC NUMBER: ED151236  
PUBLICATION DATE: SEP 77  
TITLE: CHLORINATION. TRAINING MODULE 2.300.2.77.  
INSTITUTION CODE: BBB08399  
SPONSORING AGENCY CODE: BBB15379; FGK21436  
DESCRIPTOR: \*CHEMISTRY; \*INSTRUCTIONAL MATERIALS; \*POST SECONDARY  
EDUCATION; SECONDARY EDUCATION; \*TEACHING GUIDES; \*UNITS OF STUDY;  
WATER POLLUTION CONTROL; \*CHLORINATION; \*WASTE WATER TREATMENT;  
WATER TREATMENT
- b. EDRS PRICE: EDRS PRICE MF-\$0.83 HC-\$3.50 PLUS POSTAGE  
DESCRIPTIVE NOTE: FOR RELATED DOCUMENTS, SEE SE024 025-046
- c. ISSUE: RIEJUL78  
ABSTRACT: THIS DOCUMENT IS AN INSTRUCTIONAL MODULE PACKAGE  
PREPARED IN A FORM FOR USE BY AN INSTRUCTOR FAMILIAR WITH  
CHLORINE. THE INSTRUCTIONS FOR CHLORINATION AND SAFE OPERATION AND  
MAINTENANCE OF GASEOUS CHLORINE, DRY CALCIUM HYPOCHLORITE AND LIQUID  
SODIUM HYPOCHLORITE CHLORINATION SYSTEMS FOR WATER SUPPLY AND  
WASTEWATER TREATMENT FACILITIES ARE GIVEN. INCLUDED ARE  
OBJECTIVES, INSTRUCTOR GUIDES, STUDENT HANDOUTS AND TRANSPARENCY  
MASTERS. THE MODULE CONSIDERS PURPOSES OF CHLORINATION, PROPERTIES  
OF CHLORINE, METHODS OF CHLORINATION, SAFETY, MAINTENANCE OF  
CHLORINATION UNITS AND INTERPRETATION OF TEST RESULTS.  
(AUTHOR/RH)
- d. INSTITUTION NAME: KIRKWOOD COMMUNITY COLL., CEDAR RAPIDS, IOWA.  
SPONSORING AGENCY NAME: DEPARTMENT OF LABOR, WASHINGTON, D.C.;  
IOWA STATE DEPT. OF ENVIRONMENTAL QUALITY, DES MOINES.

How to Locate Desired Materials in IRIS

Users can identify materials of interest by scanning the resume  
listing, or using the Subject Index, Author Index, or Institution Index in  
the IRIS Compilation.

The Subject Index is designed to enable the user to search for  
information on either a broad subject or a narrow information concern. An  
EW number is included for each item listed under the subject heading. The  
EW number refers to the abstract entry in the resume section where complete  
bibliographic information, an abstract of the item, and availability  
information can be found.

A user can also coordinate a search by checking EW numbers that appear  
under two or more subject headings. For example, you could check all the EW  
numbers under Water Treatment and all the EW numbers under Films. EW  
numbers included under both subject headings would include information  
relevant to Water Treatment that were films. EW numbers under wastewater  
treatment and laboratory techniques would provide a list of materials  
related to laboratory techniques and to wastewater treatment. Similar  
techniques could be used to identify other information desired.

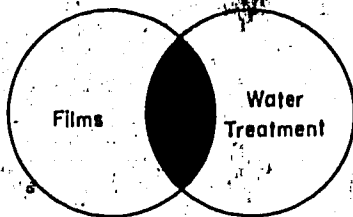

If you desire to locate a document by the name of the author, you can use the Author Index. EW numbers are provided under the author in the Author Index as in the Subject Index. Some documents do not have a listed author. These documents are listed under the name of the institution or organization responsible for developing the document in the Institution Index. Both sources can be used to help you locate documents.

#### The ERIC System

Another excellent source of educational information and materials is the ERIC system. ERIC is a national information system designed and developed by the U.S. Office of Education, and now supported and operated by the National Institute of Education (NIE), for providing ready access to descriptions of exemplary programs, research, instructional materials, teaching guides, and other related information that can be used to develop effective educational programs.

#### ERIC Clearinghouses

There are 16 clearinghouses in the nationwide ERIC network. Each clearinghouse has responsibility for collecting and analyzing materials related to their scope.

##### ADULT, CAREER, AND VOCATIONAL EDUCATION

The Ohio State University  
Center for Vocational Education  
1960 Kenny Road  
Columbus, Ohio 43210  
(614) 486-3655

##### COUNSELING AND PERSONNEL SERVICES

University of Michigan  
School of Education Building, Rm. 2108  
Ann Arbor, Michigan 48109  
(313) 764-3644

##### ELEMENTARY AND EARLY CHILDHOOD EDUCATION

University of Illinois  
College of Education  
805 W. Pennsylvania  
Urbana, Illinois 61801  
(217) 333-1386

**EDUCATIONAL MANAGEMENT**

University of Oregon  
Eugene, Oregon 97403  
(503) 686-5043

**HANDICAPPED AND GIFTED CHILDREN**

Council for Exceptional Children  
1920 Association Drive  
Reston, Virginia 22091  
(703) 620-3660

**HIGHER EDUCATION**

George Washington University  
One Dupont Circle, Suite 630  
Washington, DC 20036  
(202) 296-2597

**INFORMATION RESOURCES**

Syracuse University  
School of Education  
Syracuse, New York 13210  
(315) 423-3640

**JUNIOR COLLEGES**

University of California at Los Angeles  
Powell Library, Room 96  
Los Angeles, California 90024  
(213) 825-3931

**LANGUAGES AND LINGUISTICS**

3520 Prospect St., N.W.  
Washington, DC 20007  
(202) 298-9292

**READING AND COMMUNICATION SKILLS**

National Council of Teachers of English  
1111 Kenyon Road  
Urbana, Illinois 61801  
(217) 328-3870

**RURAL EDUCATION AND SMALL SCHOOLS**

New Mexico State University  
Box 3AP  
Las Cruces, New Mexico 88003  
(505) 646-2623

**SCIENCE, MATHEMATICS, AND ENVIRONMENTAL EDUCATION**

The Ohio State University  
1200 Chambers Road, Third Floor  
Columbus, Ohio 43212  
(614) 422-6717

**SOCIAL STUDIES/SOCIAL SCIENCE EDUCATION**

855 Broadway  
Boulder, Colorado 80302  
(303) 492-8434

**TEACHER EDUCATION**

American Association of Colleges for Teacher Education  
One Dupont Circle, NW, Suite 616  
Washington, DC 20036  
(202) 293-7280

**TESTS, MEASUREMENT, AND EVALUATION**

Educational Testing Services  
Princeton, New Jersey 08541  
(609) 921-9000, ext. 2176

**URBAN EDUCATION**

Box 40  
Teachers College, Columbia University  
525 W. 120th Street  
New York, New York 10027  
(212) 678-3437

193

197