

DOCUMENT RESUME

ED 204 583

CE 029 506

TITLE Calibrating a Respirable Dust Sampling Device. Module 24. Vocational Education Training in Environmental Health Sciences.

INSTITUTION Consumer Dynamics Inc., Rockville, Md.

SPONS AGENCY Office of Vocational and Adult Education (ED), Washington, D.C.

PUB DATE [81]

CONTRACT 300-80-0088

NOTE 36p.: For related documents see CE 029 482-507.

AVAILABLE FROM National Technical Information Service, U.S. Dept. of Commerce, 5285 Port Royal Rd., Springfield, VA 22161.

EDRS PRICE MF01/PC02 Plus Postage.

DESCRIPTORS \*Air Pollution: Competency Based Education: \*Educational Equipment: \*Environmental Education: \*Environmental Technicians: \*Equipment Maintenance: Learning Activities: Programed Instructional Materials: Public Health: Tests: Vocational Education

IDENTIFIERS \*Air Samplers: Air Sampling: \*Calibration: Environmental Health: Occupational Health: Respiration

ABSTRACT

This module, one of 25 on vocational education training for careers in environmental health occupations, contains self-instructional materials on calibrating a respirable dust sampling device. Following guidelines for students and instructors and an introduction that explains what the student will learn, are three lessons: (1) naming each part of the respirable dust sampling equipment and taking the equipment apart, cleaning it, and reassembling it; (2) assembling and preparing the calibration train, including a soapbubble meter, cyclone respirable dust sampling equipment and calibration container, and personal air sampling pump; and (3) calibrating a respirable dust sampling train using a soapbubble meter. Each lesson contains objectives, recommended methods and locations for practice, performance criteria, equipment and supplies to perform a task, detailed step-by-step instructions for learning a task, and performance exercises. Two performance tests cover assembling and preparing equipment for calibration, and calibrating a sampling train. (CT)

\*\*\*\*\*  
\* Reproductions supplied by EDRS are the best that can be made  
\* from the original document.  
\*\*\*\*\*

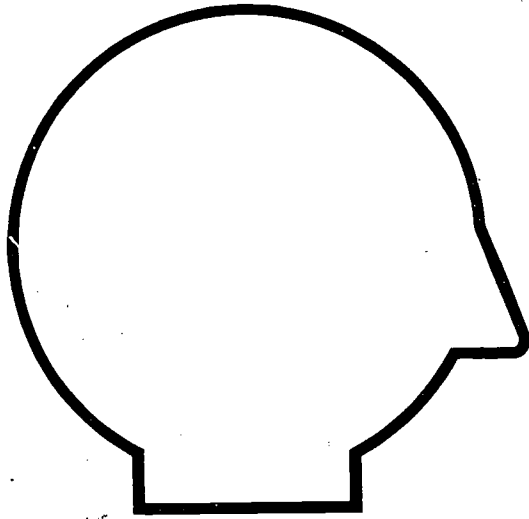

# Calibrating a Respirable Dust Sampling Device

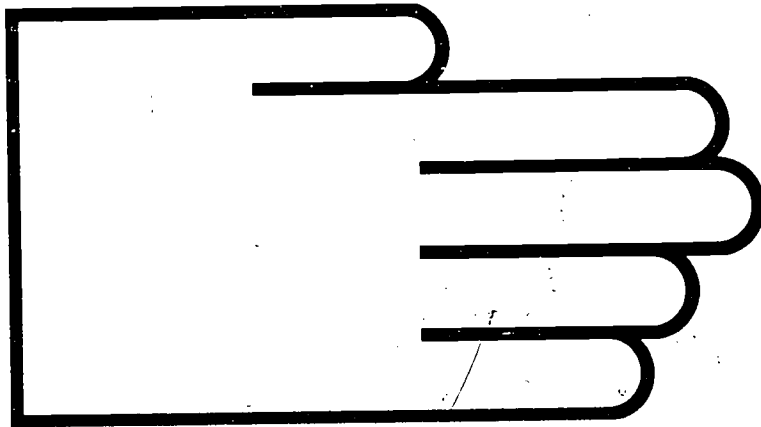

## Module 24

U.S. DEPARTMENT OF HEALTH  
EDUCATION & WELFARE  
NATIONAL INSTITUTE OF  
EDUCATION

THIS DOCUMENT HAS BEEN REPRODUCED EXACTLY AS RECEIVED FROM THE PERSON OR ORGANIZATION ORIGINATING IT. POINTS OF VIEW OR OPINIONS STATED DO NOT NECESSARILY REPRESENT THE OFFICIAL NATIONAL INSTITUTE OF EDUCATION POSITION OR POLICY.

OE029506

## FOREWORD

---

The Curriculum and Instruction Branch of the Office of Vocational and Adult Education, U.S. Department of Education, identified a need to improve the training opportunities for vocational education students interested in pursuing careers in environmental health. To fulfill that need, Consumer Dynamics, Inc., a Rockville, Maryland, based company, was awarded the contract to develop performance-oriented, competency-based modules in the environmental health sciences.

CALIBRATING A RESPIRABLE DUST SAMPLING DEVICE is one of the modules in the series, "Vocational Education Training in Environmental Health Sciences." The module content is based on selected materials in the environmental health field. The module is intended to supplement existing course materials.

# CONTENTS

---

FOREWORD .....	i
USING THESE SELF-INSTRUCTION MATERIALS .....	1
Guidelines For Students .....	1
Guidelines For Instructors .....	2
INTRODUCTION .....	4
Background.....	4
What You Will Learn .....	5
LESSON ONE .....	6
Objective .....	6
Where And How To Practice .....	6
How Well You Must Do .....	6
Things You Need .....	6
Getting There--Steps.....	8
Exercises .....	13
Other Reading .....	13
LESSON TWO .....	14
Objective .....	14
Where And How To Practice .....	14
How Well You Must Do .....	14
Things You Need .....	14
Getting There--Steps.....	16
Exercises .....	21
LESSON THREE .....	22
Objective .....	22
Where And How To Practice .....	22
How Well You Must Do .....	22
Things You Need .....	22
Getting There--Steps.....	23
Exercises .....	28
Other Reading .....	29
PERFORMANCE TEST .....	30
Assembling And Preparing Equipment For Calibration .....	30
Calibrating A Sampling Train.....	31
REFERENCES .....	33

## USING THESE SELF-INSTRUCTION MATERIALS

---

This self-instruction learning package or module is designed to allow both students and instructors flexibility of use. Although primarily intended for use in existing training programs, the module can be used by anyone interested in learning new skills or refreshing old ones. Therefore, two sets of guidelines are presented. One set is addressed to students and the other set is addressed to instructors. First, find out how you, the student, should use the materials in this book.

### GUIDELINES FOR STUDENTS

---

Take the Performance Test as a pretest.

When you pick up this book and work through it, your goal will not be a letter grade or a high score on an exam. Instead, you will work to develop skills that you can measure. You will not have to worry about how well someone else is doing. Before you start work on this book, you should, first, find out if you have sufficient skills to start training by reading through the section called PERFORMANCE TEST. If you think you can do all or most of the items in the test, ask your instructor to help you set up the equipment and obtain the accessories you will need to calibrate respirable dust sampling equipment. To calculate timing accuracy for setting flow rates, you will need to be able to work with metric units and to solve simple algebraic equations. To gain these skills, you should have taken a high school level course in algebra, geometry, or physics, or have gained the equivalent experience of working such problems on the job.

Work on parts you need to practice.

If you do everything well, according to the criteria in the Performance Test guidelines, you will not need to spend time working on this module. If, after taking the Performance Test you discover there are parts of the module you need to practice, follow the key to each item in FOR FURTHER STUDY.

## USING THESE SELF-INSTRUCTIONAL MATERIALS

---

Work straight through each lesson in the order presented.

Should you decide to completely work through this book, begin with the INTRODUCTION and go straight through each of the three lessons. The lesson begins with the OBJECTIVE of the training. Follow the instruction for each part in the order presented. Practice each step in a lesson until you can do it according to the criteria stated for the step. At the end of a lesson, do the EXERCISES. When there are audiovisuals listed at the end of a lesson, ask your instructor for help in obtaining them.

Take the Performance Test as a posttest.

Finally, after you have mastered the Exercises, ask your instructor to watch you calibrate a personal monitoring sampling train. The guidelines in the Performance Test can be used as a posttest to evaluate the quality of your performance. Turn now to the Performance Test.

## GUIDELINES FOR INSTRUCTORS

---

### Approach

The approach of these materials is to provide the student with (1) the nomenclature and uses of the components in the sampling train; (2) procedures for preparing the pump, sampling device, and bubble meter for calibration; and (3) procedures for calculating flow. The lessons are sequential in that the information presented in the previous lesson serves as a basis of skill development in a later lesson. Exercises are provided to guide the student's practice of the procedures presented in GETTING THERE--STEPS.

### Use of the Performance Test

A Performance Test is provided to serve as a guide to skill development progress. If a student is able to demonstrate skill development by meeting the criteria for performance given in each test item, further study is not needed. Therefore, the student should be given the option of entering training at any point. To determine at what point to start, the student should take the Performance Test as a pretest. At any time during the course of study, the student should also be allowed to test out of the remaining portions of training. Finally, the student's capability to accurately complete the entire task in a timely manner can be evaluated by using the Performance Test as a posttest.

## USING THESE SELF-INSTRUCTION MATERIALS

---

### Independent Study

This module is designed to enable the student to work independently under whatever time constraints you deem reasonable. However, depending on the skill level of the students with whom you are working, you may find it desirable to start a group together at the same time with a demonstration and informal presentation on the contents of the module.

### As A Laboratory Workbook

Alternatively, you may choose to use this module as a laboratory workbook in a structured laboratory session. With this option, you may allow students greater access to your assistance, especially in watching them perform the pre- and posttest portions of the training.

### General Instructions

Read through each lesson to anticipate what equipment and supplies you will need to make available for students to use. Also, order any audiovisuals or reading materials you think may present a complementary perspective to the training in this module. Use the guidelines presented in the Performance Test as the minimum requirements for gauging successful completion of training.

## INTRODUCTION

---

### BACKGROUND

---

Wherever workers manufacture or produce goods, the possibility exists that the air they breathe can become contaminated. Exposure over months and years to even very small amounts of some gases, vapors, mists, and particulates can cause irritation, dermatitis, or, in some cases, prolonged or serious illnesses, including cancer. The Occupational Safety and Health Administration (OSHA), under authority from Congress, passes laws in an effort to protect the workers from hazards that are not always obvious. These occupational safety and health laws often require that workers' exposures to airborne contaminants be measured using personal sampling equipment.

Healthy lungs can easily dispose of light concentrations of large dusts, 10 microns in diameter or more. But when workplace air becomes laden with even inactive dust of any size, injury to the lungs can occur. On the other hand, even light concentrations of small dusts, 10 microns in diameter or less, can easily become trapped in the tiny passages of the lungs. Because potentially hazardous levels of these smaller "respirable" dusts are nearly invisible to the naked eye, sampling of the dusts over a period of time is often the only way to detect respirable dusts.

To determine how much of the airborne contaminants a worker might breathe in during the usual 8-hour workday, a pump and sampling device are attached to the worker. The pump is set to draw air through a respirable dust sampling device at a specific flow rate. So that accurate measurements of a worker's exposure can be made, the pump and sampling device must be calibrated before and after sampling is done. The calibration is routinely performed by physically measuring how efficiently the pump can draw what volume of air in how much time. The rate of airflow per time is then calculated. The apparatus used to perform the calibration is a soapbubble meter consisting of a large laboratory buret and stand, flexible Tygon tubing, and soap solution.



## INTRODUCTION

---

### WHAT YOU WILL LEARN

---

When you finish working through the steps and exercises in this book, you will be able to identify the parts and functions of the cyclone respirable dust sampler; to clean the cyclone; and to calibrate a sampling train that includes a personal air sampling pump and cyclone sampling device.

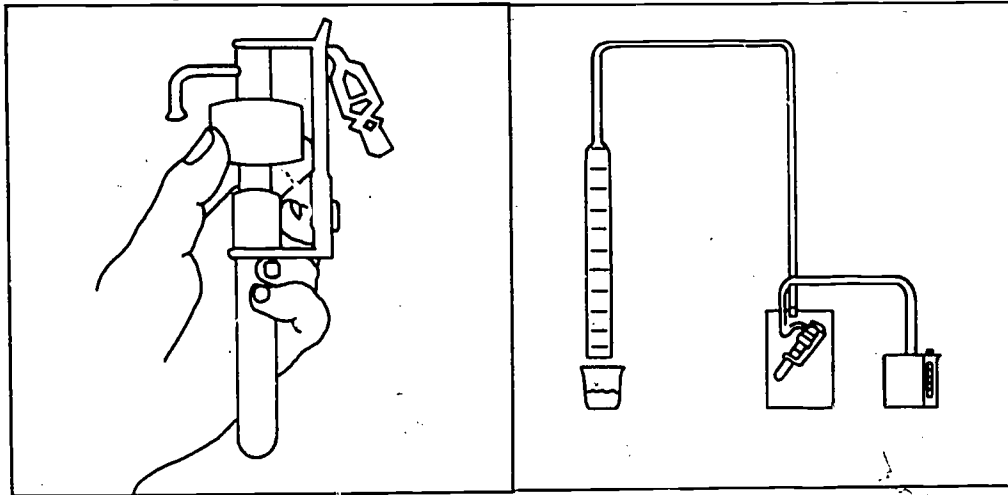

In the following three lessons, you will learn how to prepare the respirable dust sampling train for calibration and how to calibrate it using a soapbubble meter.

#### o Lesson One

You will be able to name each part of the respirable dust sampling equipment and how to take the equipment apart, clean it, and reassemble it.

#### o Lesson Two

You will be able to assemble and prepare the calibration train, including a soapbubble meter, cyclone respirable dust sampling equipment and calibration container, and personal air sampling pump.

#### o Lesson Three

You will be able to calibrate a respirable dust sampling train using a soapbubble meter.

## LESSON ONE

---

### OBJECTIVE

---

You will be able to name each part of the respirable dust sampling equipment and how to take the equipment apart, clean it, and reassemble it.

### WHERE AND HOW TO PRACTICE

---

You must practice this lesson in a clean room where visible dusts are not present. You should work at a table, laboratory bench, or any other clean, flat, sturdy surface on which to set the equipment. Tapwater and a 110-AC electric outlet should also be available. Practice labeling diagrams of the equipment to learn the names of each part and how it is used or functions. Work through each of the steps enough times so you can perform the procedures without referring to the lesson.

### HOW WELL YOU MUST DO

---

You must be able to name all the parts of the respirable dust sampling equipment and tell how each part functions or is used. You must be able to do this within 5 minutes. You must be able to disassemble, clean, and check the components for cracks, breaks, and changes in surface thickness or sizes of holes. Reassemble the device so that all parts fit together without leaking. Perform this task within 20 minutes (not including drying time.)

### THINGS YOU NEED

---

- o 10-mm nylon cyclone/holder assembly such as that manufactured by Mine Safety Appliances (MSA)\*
- o two-piece filter cassette containing preweighed membrane filter and backup pad
- o pipe cleaner
- o water (tap and distilled)
- o washing pan or sink

---

\*Use of a particular brand of equipment is not intended to be an endorsement of the product by the U.S. Department of Education.

LESSON ONE

---

THINGS YOU NEED (cont'd)

---

- o detergent, mild dishwashing
- o new paper towels
- o containers (2), clean, 1,000-ml capacity.

Instructions: Now turn to the next page and begin work on Lesson One, "Getting There--Steps."

GETTING THERE--STEPS

STEP 1

Pick up the cyclone/holder assembly. Using the illustration in the Key Point, identify each of the following parts:

- (1) flow connector assembly
- (2) upper bracket
- (3) filter holder/cassette
- (4) support screen
- (5) filter
- (6) coupler
- (7) sampling line
- (8) vortex finder
- (9) spring-clip assembly
- (10) crocodile clip
- (11) cyclone
- (12) lower bracket
- (13) grit pot
- (14) locking nut

KEY POINT 1

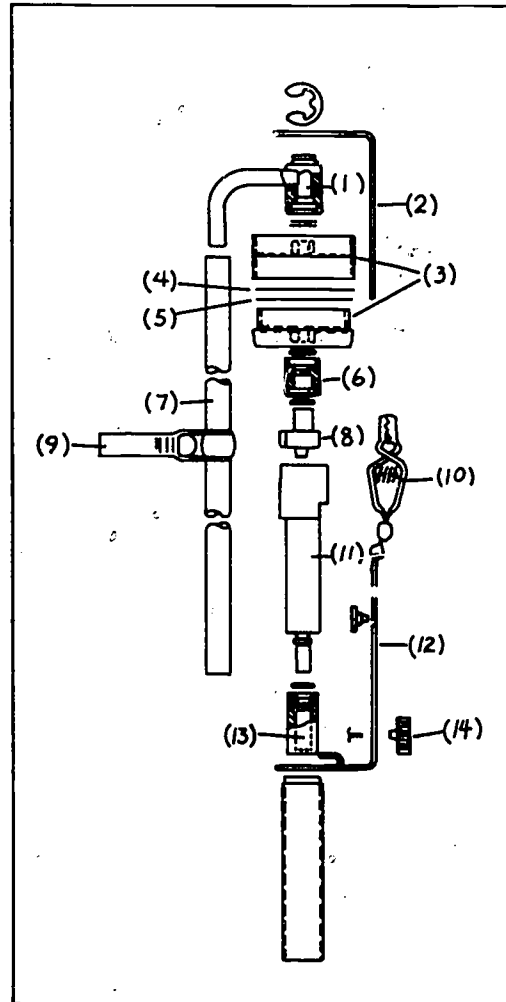

STEP 2

The cyclone is a respirable dust sampling device. When attached to a personal sampling pump via the sampling line, air containing dust particles is drawn into the cyclone through the vortex finder (1). The particles are swirled around through action created by the tapered sides. Particles that are about 10 microns or larger settle to the bottom of the cyclone in the grit pot (2). Particles that are about 10 microns or less in size are pulled upward against the membrane filter (3) in the filter holder or cassette. The lighter particles are considered respirable when they become trapped in the lungs.

KEY POINT 2

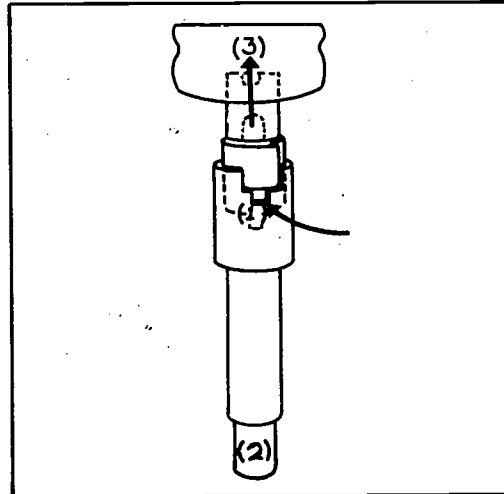

Lighter particles are drawn upward toward the filter, and heavier particles fall into the grit pot.

## LESSON ONE

### STEP 3

To begin disassembling the cyclone, loosen the locking nut (1) securing the upper bracket (2). Slide it up as far as it will go and tilt (3) the bracket back away from the filter cassette (4). Remove as one assembly (5) the filter cassette, coupler containing two O-rings, and vortex finder, and place them aside. Note the slit (6) formed when the vortex finder is seated in the top of the cyclone.

### KEY POINT 3

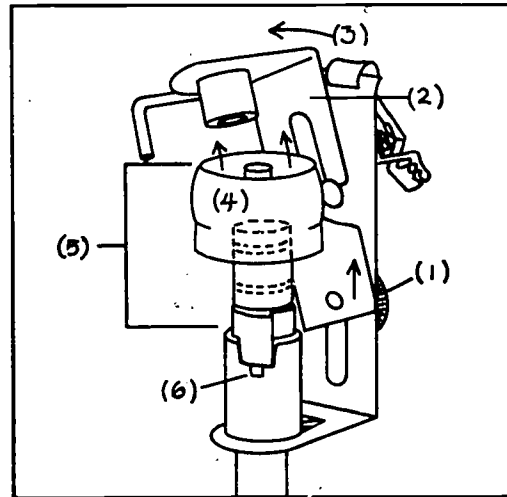

Remove the parts above the cyclone body.

### STEP 4

Next, slide the cyclone (1) and the attached grit pot (2) out of the metal sleeve and place them on the table.

### KEY POINT 4

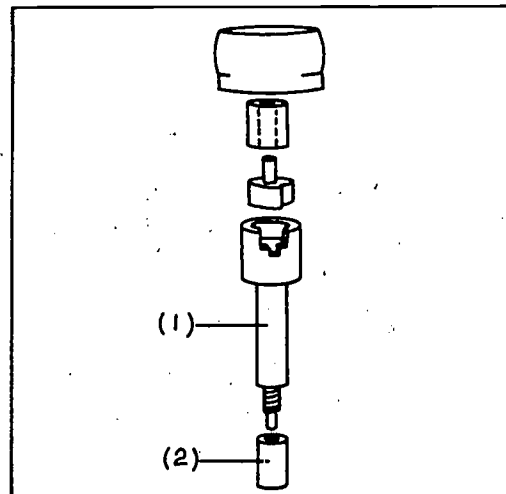

Remove the cyclone body from the holder.

## LESSON ONE

---

### STEP 5

Each part you just removed from between the metal brackets must be cleaned after each sampling period to prevent contamination of subsequent dust samples. Begin the cleaning process by filling a small clean container with about 1,000 ml (1 quart) of warm water. Add approximately 1 capful of dishwashing detergent. Fill another small clean container with warm water for rinsing.

### STEP 6

Pick up and separate the coupler from the filter cassette and the vortex finder. Before wetting the coupler and vortex finder, brush them out with a pipe cleaner. Brush out (do not tap out) particles. Turn the grit pot upside down and gently tap out any dirt or dust. Inspect the sampling line; clean it if necessary.

### KEY POINT 5

To prevent contamination, the components of the cyclone must be cleaned after each use.

### KEY POINT 6

Brush dirt out of the cyclone, coupler, and vortex finder. Tap particles out of the grit pot.

## LESSON ONE

---

### STEP 7

After removing the dust and dirt in Step 7, place the parts in the warm soapy water. With a cotton swab or pipe cleaner, carefully clean each part. Thoroughly rinse the parts, shake off excess water, and set them aside on clean paper towel- ing to dry. When all the parts have dried, inspect each for damage, including cracks and breaks, changes in thickness, damage to threads, and excessive wear in holes. Check the rubber O-rings in the coupler for roundness and integrity. Check also the inside walls of the cyclone body for scoring. If any of these defects are found, replace the part before using the cyclone again.

### STEP 8

Reassemble the cyclone. Screw the grit pot onto the cyclone body. Push the vortex finder into the coupler and replace them in the top of the cyclone. Check for proper sealing and snugness of fit. Make sure the inlet slit is formed. Slip the cyclone into the metal sleeve. Replace the upper bracket and loosely fasten the locking nut. Push the inlet side of a new filter cassette into the coupler. Resecure the cyclone by pushing the upper bracket down on the outlet side of the cassette until it is firmly seated. Make sure the inlet slit faces away (1) from the bracket. Tighten the locking nut.

### KEY POINT 7

Do not use the cyclone if any of its parts are damaged.

### KEY POINT 8

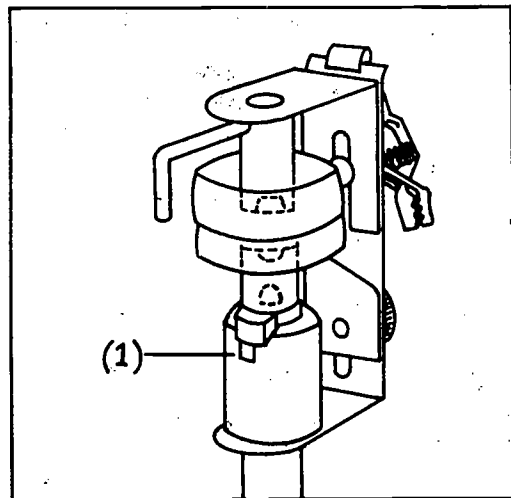

Make sure the cassette fittings are firmly seated and that the inlet slit is not obstructed.



EXERCISES

Instruction 1: With the respirable dust sampling equipment in front of you, practice naming each part and describing its function. Then label the following drawings to test your knowledge.

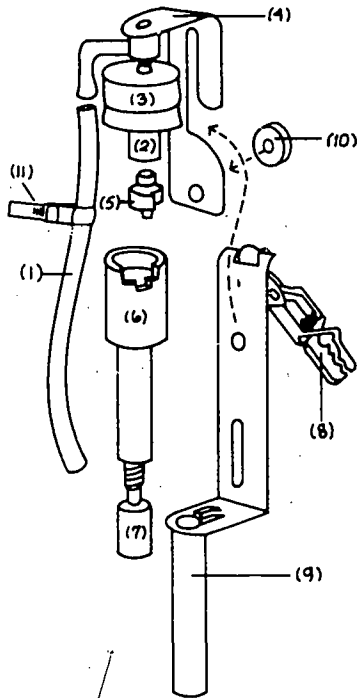

- (1) \_\_\_\_\_
- (2) \_\_\_\_\_
- (3) \_\_\_\_\_
- (4) \_\_\_\_\_
- (5) \_\_\_\_\_
- (6) \_\_\_\_\_
- (7) \_\_\_\_\_
- (8) \_\_\_\_\_
- (9) \_\_\_\_\_
- (10) \_\_\_\_\_
- (11) \_\_\_\_\_

Instruction 2: When you have correctly labeled each drawing and can tell the functions of each part, disassemble, clean, and reassemble the sampling device within 20 minutes (not including drying time), making sure all pieces fit snugly together and do not leak.

OTHER READING

MSA, "Instruction Manual for the Nylon Cyclone."

## LESSON TWO

---

### OBJECTIVE

---

You will be able to assemble and prepare the calibration train, including a soapbubble meter, cyclone respirable dust sampling equipment and calibration container, and personal air sampling pump.

### WHERE AND HOW TO PRACTICE

---

Use the same location as you did in Lesson One to practice the steps in this lesson. Read through the steps and exercises before working with the equipment. As you proceed through the lesson, make sure you understand a step before going on to the next.

### HOW WELL YOU MUST DO

---

You must be able to assemble the calibration train so there are no air leaks where tubing joins fittings, and so air flows without restrictions through the components. You must also be able to get a bubble to rise 1,000 ml in the soapbubble meter. After obtaining the equipment, you must be able to do this lesson within 20 minutes.

### THINGS YOU NEED

---

In addition to the equipment and supplies you used in Lesson One, you will need the following:

- o soapbubble meter
  - buret stand
  - buret clamps (2)
  - buret, 1,000 ml with base connections, cleaned and rinsed with water
  - beaker, wide-mouthed or flat-bottomed shallow dish (petri)
  - soap solution (1 capful of dishwashing liquid per 100 ml water) or child's soapbubble solution
  - 1-liter bottle with lid equipped with protruding intake and exhaust fittings (bottle must have 3-1/2-inch-diameter mouth or larger)

## LESSON TWO

---

### THINGS YOU NEED (cont'd)

---

- Tygon\* tubing, 1/4-inch (inside diameter): 3-, 8-, and 30-inch pieces
- o small screwdriver
- o personal sampling pump, MSA\* Model G or S or equivalent, previously calibrated using a 5.0-micron PVC filter.

Instructions: Now turn to the next page and begin work on Lesson Two, "Getting There--Steps."

---

\*Presentation of specific equipment models is not intended to be an endorsement by the U.S. Department of Education.

GETTING THERE--STEPS

STEP 1

The respirable dust sampling train consists of a portable pump (1) for drawing air through tubing (2) that connects the pump with the cyclone assembly (3). The calibration train also includes a soapbubble meter (4). The soapbubble meter is an inverted 1,000-ml buret and is considered a primary standard.

KEY POINT 1

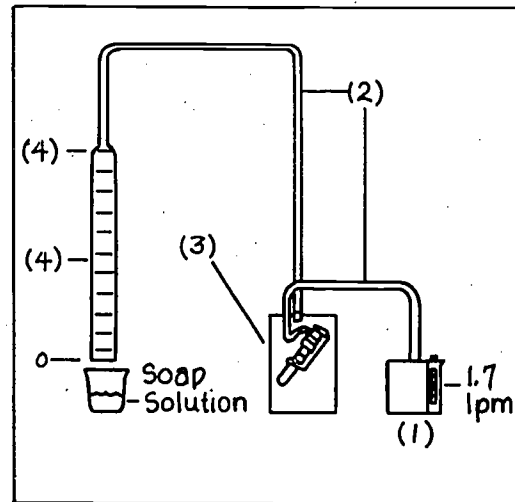

The sampling train is connected to the soapbubble meter for calibration. The sampling device is placed in a 1-liter bottle.

STEP 2

Before beginning calibration make sure the pump is fully charged and has run 5 minutes. Follow the manufacturer's instructions for operating the recharging unit. If there is a "high" and "low" setting on the unit, the high setting is used to fully recharge the battery. The low setting is used to maintain the battery at full charge when it is not in use.

KEY POINT 2

Fully recharge the pump battery before beginning calibration.

## LESSON TWO

### STEP 3

Place a new backup filter and pad into the cassette. Keep the filter clean and free from dust. The direction of airflow through the cyclone is shown in Key Point 3. When assembling the sampling train for actual dust collection, place a clean, pre-weighed filter and pad into the cassette.

### KEY POINT 3

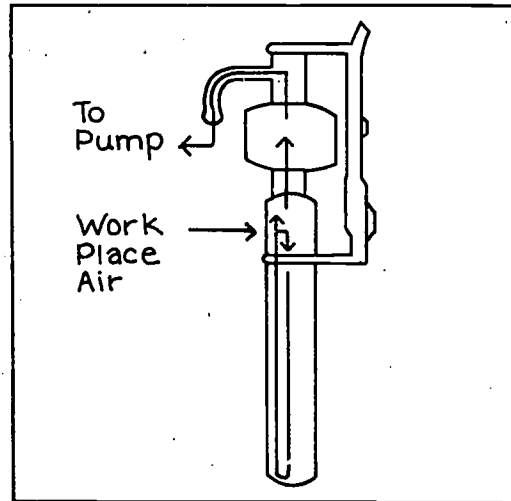

Insert a clean filter and pad into the cassette before calibrating the cyclone.

### STEP 4

Place the cyclone/holder assembly inside the 1-liter bottle (1). Attach one end of the 30-inch piece of tubing to the inlet (2) of the bottle, and the other end to the hose connection on the buret. Connect the 8-inch length of tubing between the inlet of the pump and the outlet (3) of the bottle. Finally, connect one end of the 3-inch-piece tubing to the outlet fitting (4) on the inside of the bottle lid and the other end (5) to the outlet of the sampling device. Check the tightness of the fittings and the integrity of the bottle seal.

### KEY POINT 4

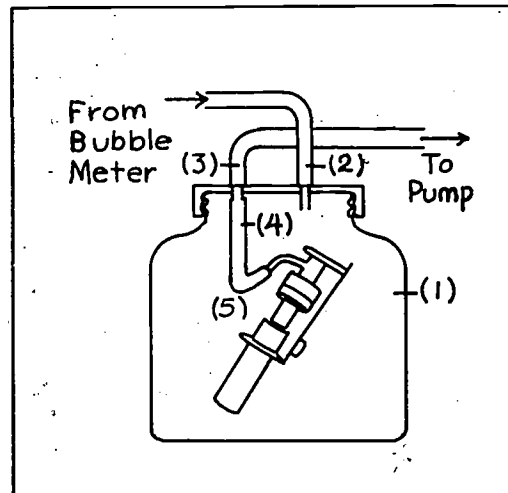

Observe the direction of flow when connecting up the calibration train. Make sure the bottle lid is tightly sealed.

STEP 5

Place the sampling pump in an upright position and turn it on. Adjust the airflow of the pump by turning the flow adjustment screw (1) so the rotameter ball is in line with an index mark on the rotameter scale you believe may correspond to an airflow of approximately 2.0 lpm. Since the object of calibrating the sampling train with the bubble meter is to find what marking on the rotameter scale corresponds to air flowing through the system, this initial alignment is only temporary. Keep the pump running for at least 5 minutes before beginning calibration.

STEP 6

Test for air leaks between fittings and tubing on the bubble meter, the 1-liter bottle, and the pump. Check the tubing size and push the tubing further onto the fittings if leaks are suspected.

KEY POINT 5

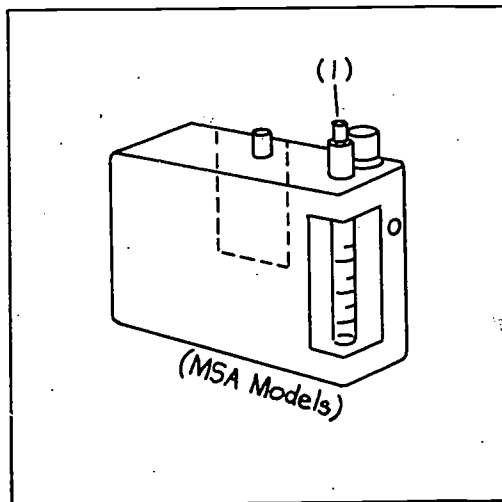

Index marks on the pump's rotameter scale do not indicate an actual flow setting.

KEY POINT 6

Check for fittings and tubing for tightness at each joint.

STEP 7

Check the tubing to make sure it is not kinked. Kinking could occur particularly at the joint (1) where the 30-inch tubing connects the 1,000-ml buret. If tubing is kinked at this point, tape it to the buret stand shaft (2) to keep the air line open.

KEY POINT 7

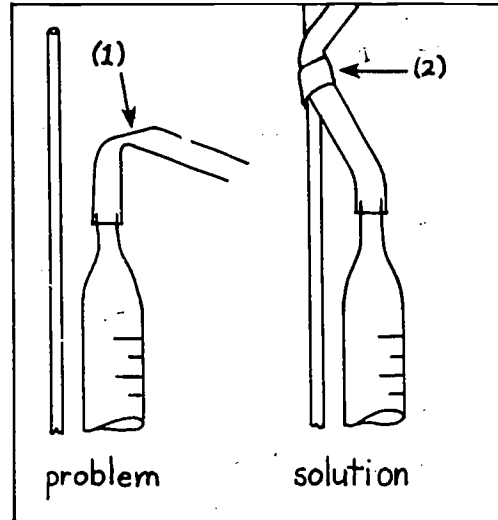

Remove the kink by supporting the tubing on the buret stand shaft.

STEP 8

Fill the soap solution container. Rinse the buret with soap solution before using. Form a bubble in the buret by raising the soap solution dish until the buret mouth is just below the surface of the solution (1). Quickly lower the dish (2). A bubble should have formed and begun to rise in the buret through the sucking action of the pump. Draw two or three bubbles up the buret to make sure that at least one bubble travels from the 0-ml mark to the 1,000-ml mark.

KEY POINT 8

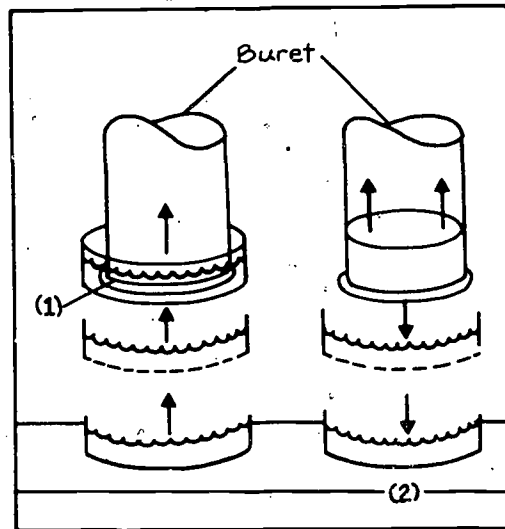

Submerge the buret mouth only briefly in the soap solution.

STEP 9

If you cannot get a bubble to rise to the 1,000-ml mark, wet the buret walls with soap solution. A stronger soap solution may also be needed. Try these remedies and repeat Step 8 until you can get two to three bubbles to rise to the 1,000-ml mark each time you try.

KEY POINT 9

If the bubbles do not rise, wet the buret with soap solution and/or make the solution stronger.



## LESSON TWO

---

### EXERCISES

---

Instructions: Practice connecting up the calibration train and testing it for leaks, and practice getting a bubble to rise 1,000 ml in the buret. When you can perform these procedures correctly in less than 20 minutes, turn to Lesson Three and begin work.

**OBJECTIVE**

---

You will be able to calibrate a respirable dust sampling train using a soapbubble meter.

**WHERE AND HOW TO PRACTICE**

---

Practice at the same location as in previous lessons. Practice each step in this lesson until you achieve the timing accuracy stated in "How Well You Must Do."

**HOW WELL YOU MUST DO**

---

For this lesson, your timing accuracy at 1.7 liters per minute (lpm) must be  $\pm 1$  second of the time the pump is expected to take to draw 1,000 ml. You should be able to calibrate the sampling train in less than 25 minutes.

**THINGS YOU NEED**

---

In addition to the equipment and supplies you have already used, you will need the following:

- o stopwatch
- o masking tape, 1/2-inch-wide
- o small notebook.

Instructions: Now turn to the next page and begin work on Lesson Three, "Getting There--Steps."

## LESSON THREE

---

### GETTING THERE--STEPS

---

#### STEP 1

The purpose of calibration is to adjust the pump when a particular flow rate is desired. The recommended flow rate for sampling with a cyclone is 1.7 lpm.

#### STEP 2

In the manufacturer's instructions, find the accuracy of the pump you are using. The accuracy is usually  $\pm 5-10$  percent of the volume the pump is expected to draw at any setting in the pumping range. Expressed in a different way, the pump operates with an allowable pumping error of 5-10 percent. The effect of this error on sampling efficiency is calculated after samples are collected. In calibrating the pump, the volume will remain for successive trial runs; however, timing of the bubble rise will be affected by the pumping error.

#### KEY POINT 1

The purpose of calibration is to adjust the pump to draw a desired volume of air.

#### KEY POINT 2

For many personal air sampling pumps, the allowable pumping error is between 5 and 10 percent.

STEP 3

Another error that is introduced is timing error. It is likely you will introduce timing error when you use the stopwatch to time the rise of the bubble in the buret. To minimize error during calibration, your timing accuracy must be  $\pm 1$  second at a flow setting of 1.7 lpm to be within 5 percent of the pumping error. Therefore, it should take 35 seconds  $\pm 1$  second for the bubble to rise 1,000 ml. The time calculated using the formula in Key Point 3 is based on the assumption that at 1.0 lpm it would take the bubble 60 seconds to rise 1.0 liter.

KEY POINT 3

Time for a bubble to rise  
1,000 ml at 1.7 lpm:

$$\frac{1.0 \times 60 \text{ sec}}{1.7 \text{ liters}} = 35 \text{ sec}$$

Because the timing accuracy is  $\pm 1$  second, the timing range at a 1.7 lpm setting is 34-36 seconds.

## LESSON THREE

---

### STEP 4

When the pump has run 5 minutes, pick up the stopwatch. With the pump running, form at least three bubbles as you did in Lesson Two. Pick a bubble to watch. Start the trial run when the bubble edge is in line with the 0-ml mark on the buret. Stop timing the instant the bubble reaches the 1,000-ml mark. Record the time for the trial run here:

\_\_\_\_\_.

If the time you recorded is greater than 37 seconds or less than 35 seconds, readjust the pump flow and repeat the step.

### STEP 5

Repeat Step 4 three more times at the setting at which you finally adjusted the pump. Record each timing here:

1st timing: \_\_\_\_\_ sec  
2nd timing: \_\_\_\_\_ sec  
3rd timing: \_\_\_\_\_ sec  
Average time: \_\_\_\_\_ sec

If the average is greater than 37 seconds or less than 35 seconds, readjust the pump flow and repeat this step.

### KEY POINT 4

Do a trial timing to obtain a coarse adjustment.

### KEY POINT 5

Obtain the average flow after three runs at the same adjustment.

## LESSON THREE

### STEP 6

At the final setting and with the pump still running, put a piece of masking tape (1) on the pump's rotameter scale close to the point where the rotameter ball is floating. Find the center (2) of the ball and draw a corresponding line (3) on the tape. The painted index mark on the rotameter scale may or may not correspond to the mark you make on the tape.

### KEY POINT 6

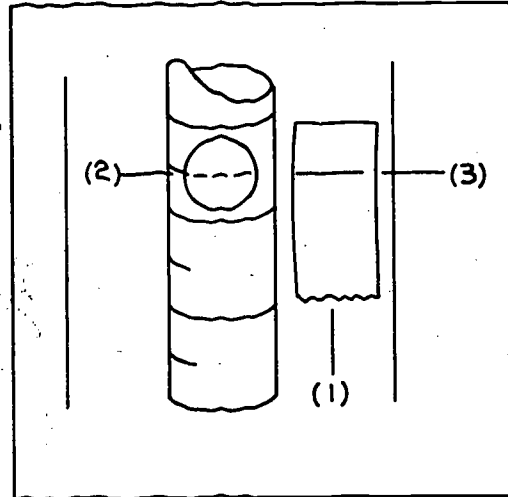

Make a mark on the tape to show where the center of the rotameter ball should be when the pump is drawing the desired flow rate.

## LESSON THREE

---

### STEP 7

Keep a complete record of the calibration procedure. In your notebook, record the date, time, serial number of the pump calibrated, and the description of the sampling device used in the sampling train.

### KEY POINT 7

Always document the calibration procedure.

LESSON THREE

EXERCISES

Instruction 1: Calculate and record, in the spaces provided, the time for a bubble to rise in a 1,000-ml buret at these flow rates:

1.0 lpm \_\_\_\_\_

1.5 lpm \_\_\_\_\_

2.0 lpm \_\_\_\_\_

Instruction 2: Adjust the flow so the pump draws at the flow rates listed in Instruction 1.

Instruction 3: Obtain timing data for a trial run (TR) and three consecutive runs (CR) for each of the flow rates in Instruction 1. Record the data here:

<u>1.0 lpm</u>		<u>1.5 lpm</u>	
<u>Seconds</u>		<u>Seconds</u>	
TR	_____	TR	_____
CR No. 1	_____	CR No. 1	_____
CR No. 2	_____	CR No. 2	_____
CR No. 3	_____	CR No. 3	_____
<u>2.0 lpm</u>			
<u>Seconds</u>			
TR	_____		
CR No. 1	_____		
CR No. 2	_____		
CR No. 3	_____		

Instruction 4: For each of the flow rates, 1.0, 1.5, and 2.0, place a piece of tape on the pump's rotameter scale at the point where the ball floats. Mark the tape each time you change the calibration flow.



## LESSON THREE/EXERCISES

Instruction 5: When you are able to calibrate the respirable dust sampling train within 25 minutes with a timing accuracy of 35 seconds  $\pm 1$  second, you are ready to demonstrate your skills by working through the Performance Test.

### OTHER READING

American Industrial Hygiene Association, AIHA Training Manual, Methods of Air Sampling and Analysis. (no date)

U.S. DHEW, No. 74-117, The Industrial Environment--Its Evaluation and Control, Washington, DC, 1973.

U.S. DOL, The Mine Safety and Health Administration, Maintenance and Calibration of Dust Sampling Equipment--Coal. Instruction Guide 36. (no date)

U.S. DOL, The Mine Safety and Health Administration, Standard Calibration and Maintenance Procedures for Wet Test Meters and Coal Mine Respirable Dust Samplers. Information Report 1121. (no date)

## PERFORMANCE TEST

---

Instructions: Check your skill level or progress by working through each of the items in this test. If you can perform each item as required, place a check in the space provided. When all of the items are checked, you are ready to demonstrate your skills to your instructor. You may use the following list if needed. You will be considered trained in a skill after your instructor approves your performance of each of the following items:

### ASSEMBLING AND PREPARING EQUIPMENT FOR CALIBRATION

---

- No. 1  Disassemble the respirable dust sampling equipment and clean the components by brushing the surfaces with a pipe cleaner, washing in a mild detergent solution, and rinsing in warm water; allow the components to air dry.
- No. 2  Inspect the surfaces of each component for signs of damage; replace damaged or defective parts before using.
- No. 3  Reassemble the cyclone so that all components are seated tightly; make sure the vortex finder is seated in the top of the cyclone to form the inlet slit.
- No. 4  Place a two-piece filter cassette containing uncontaminated filter media into the cyclone assembly.
- No. 5  Place the cyclone into a 1-liter container and attach tubing leading from the bubble meter to the pump; make the connections so that air is drawn through the bubble meter, the sampling pump, and the pump.
- No. 6  Check for air leaks in the sampling train.
- No. 7  Check and correct tubing for kinks.
- No. 8  Draw two or three bubbles from the 0-ml mark to the 1,000-ml mark.
- No. 9  Complete test items 1 through 8 above within 40 minutes.

### FOR FURTHER STUDY

If you could not perform one or more of the nine items above, review and practice the following lesson steps:

## PERFORMANCE TEST

---

No. 1  
Lesson One, Steps 3 through 7

No. 2  
Lesson One, Step 7

No. 3  
Lesson One, Step 8

No. 4  
Lesson Two, Step 3

No. 5  
Lesson Two, Step 4

No. 6  
Lesson Two, Step 6

No. 7  
Lesson Two, Step 7

No. 8  
Lesson Two, Steps 8 and 9

No. 9  
Practice all steps in Lessons One and Two.

## CALIBRATING A SAMPLING TRAIN

---

- No. 1 \_\_\_\_\_ Calculate the time for a bubble to rise from the 0-ml mark to the 1,000-ml mark in a bubble meter when the pump is adjusted to draw 1.7 lpm.
- No. 2 \_\_\_\_\_ Adjust the pump to draw 1.7 lpm so that the time the bubble travels from the 0-ml mark to the 1,000-ml mark is within  $\pm 1$  second of the time you calculated in the previous test item.
- No. 3 \_\_\_\_\_ After making the final flow adjustment, place a piece of tape on the rotameter scale next to where the rotameter ball floats; mark the tape to indicate the final flow setting.
- No. 4 \_\_\_\_\_ Record all calibration data in a notebook.

## PERFORMANCE TEST

---

### FOR FURTHER STUDY

If you could not perform one or more of the four items above, review and practice the following lesson steps:

No. 1  
Lesson Three, Step 3

No. 2  
Lesson Three, Step 4 and 5

No. 3  
Lesson Three, Step 6

No. 4  
Lesson Three, Step 7

## REFERENCES

---

U.S. DOL, Industrial Hygiene Field Operation Manual (IHFOM),  
OSHA Instruction CPL 2-2.20, April 2, 1979.