

DOCUMENT RESUME

ED 204 571

CE 029 494

TITLE Collecting Pests for Identification. Module 12. Vocational Education Training in Environmental Health Sciences.

INSTITUTION Consumer Dynamics Inc., Rockville, Md.

SPONS AGENCY Office of Vocational and Adult Education (ED), Washington, D.C.

PUB DATE [81]

CONTRACT 300-80-0088

NOTE 47p.: For related documents see CE 029 482-507.

AVAILABLE FROM National Technical Information Service, U.S. Dept. of Commerce, 5285 Port Royal Rd., Springfield, VA 22161.

EDRS PRICE MF01/PC02 Plus Postage.

DESCRIPTORS Competency Based Education; *Educational Equipment; *Entomology; *Environmental Education; *Environmental Technicians; Learning Activities; Programed Instructional Materials; Public Health; *Sanitation; Tests; Vocational Education

IDENTIFIERS Environmental Health; *Pests

ABSTRACT

This module, one of 25 on vocational education training for careers in environmental health occupations, contains self-instructional materials on collecting pests for identification. Following guidelines for students and instructors and an introduction that explains what the student will learn are three lessons: (1) identifying the parts and functions of rodent and anthropod traps and collection devices; (2) identifying locations suitable for collecting rodent, fly, and mosquito specimens; and (3) setting devices to collect pests, collecting the pests from the trap, labeling specimens, and preparing the specimens for shipment and analysis. Each lesson contains objectives, recommended methods and locations for practice, performance criteria, equipment and supplies to perform a task, detailed step-by-step instructions for learning a task, and performance exercises. Performance tests cover the subject matter of each lesson. (CT)

* Reproductions supplied by EDRS are the best that can be made
* from the original document.

ED204571

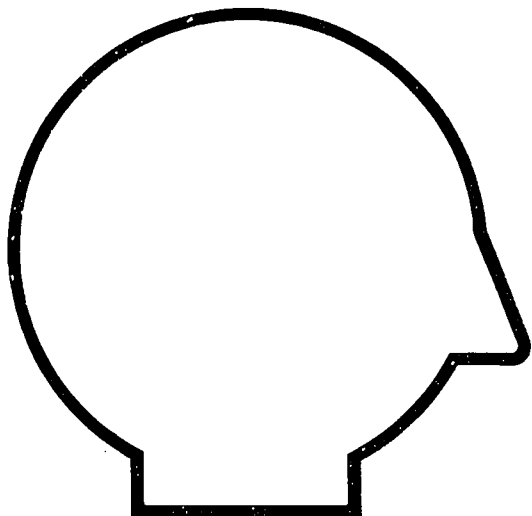

Collecting Pests for Identification

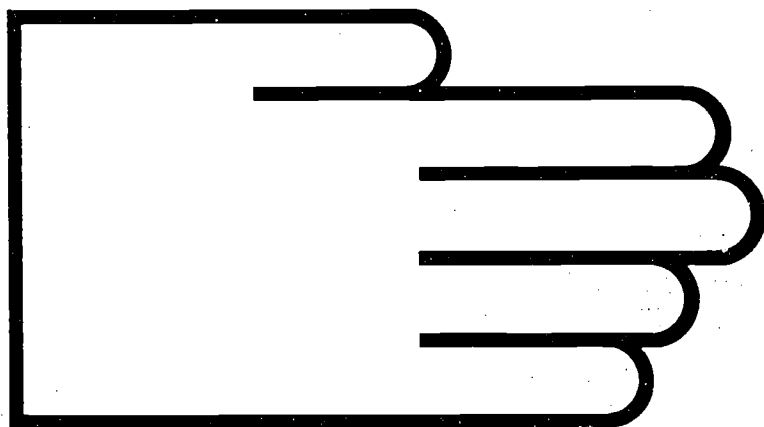

Module 12

U.S. DEPARTMENT OF HEALTH,
EDUCATION & WELFARE
NATIONAL INSTITUTE OF
EDUCATION

THIS DOCUMENT HAS BEEN REPRODUCED EXACTLY AS RECEIVED FROM THE PERSON OR ORGANIZATION ORIGINATING IT. POINTS OF VIEW OR OPINIONS STATED DO NOT NECESSARILY REPRESENT OFFICIAL NATIONAL INSTITUTE OF EDUCATION POSITION OR POLICY

U.S. DEPARTMENT OF EDUCATION, Office of Vocational and Adult Education

029 494

FOREWORD

The Curriculum and Instruction Branch of the Office of Vocational and Adult Education, U.S. Department of Education, identified a need to improve the training opportunities for vocational education students interested in pursuing careers in environmental health. To fulfill that need, Consumer Dynamics, Inc., a Rockville, Maryland, based company, was awarded the contract to develop performance-oriented, competency-based modules in the environmental health sciences.

COLLECTING PESTS FOR IDENTIFICATION is one of the modules in the series, "Vocational Education Training in Environmental Health Sciences." The module content is based on selected materials in the environmental health field. The module is intended to supplement existing course materials.

CONTENTS

FOREWORD	i
USING THESE SELF-INSTRUCTION MATERIALS	1
Guidelines For Students	1
Guidelines For Instructors	2
INTRODUCTION	4
Background	4
What You Will Learn	5
LESSON ONE	6
Objective	6
Where And How To Practice	6
How Well You Must Do	6
Things You Need	6
Getting There--Steps	7
Exercises	12
Films And Slide/Tape Programs	14
LESSON TWO	15
Objective	15
Where And How To Practice	15
How Well You Must Do	15
Things You Need	15
Getting There--Steps	16
Exercises	23
Other Reading	23
Films And Slide/Tape Programs	24
LESSON THREE	28
Objective	28
Where And How To Practice	28
How Well You Must Do	28
Things You Need	28
Getting There--Steps	30
Exercises	37
Films And Slide/Tape Programs	38
PERFORMANCE TEST	39
Identifying Locations For Collecting Pests	39
Collecting, Labeling, And Preparing Pests For Shipment And Analysis	40
REFERENCES	42

USING THESE SELF-INSTRUCTION MATERIALS

This self-instruction learning package or module is designed to allow both students and instructors flexibility of use. Although primarily intended for use in existing training programs, the module may be used by anyone interested in learning new skills or perfecting old ones. Therefore, two sets of guidelines are presented--one set addressed to students and the other set addressed to instructors. First, find out how you, the student, should use the materials in this book.

GUIDELINES FOR STUDENTS

Take the Performance Test as a pretest.

When you pick up this book and work through it, your goal will not be a letter grade or a high score on an exam. Instead, you will work to develop skills that you can measure. You will not have to worry about how well someone else is doing. Before you start work on this module, you should, first, find out if you have sufficient skills to start training by reading through the section called PERFORMANCE TEST. If you think you can do all or most of the items in this test, ask your instructor to obtain the necessary equipment and supplies. You should have had a course in high school biology, have knowledge of basic differences between flies and mosquitoes and other insects, have learned how to use a stereo microscope, and be enrolled in a vector control course in a 2- or 4-year technical school or college.

Work on parts you need to practice.

If you do everything well, according to the criteria in the Performance Test guidelines, you will not need to spend time working on this module. If after taking the Performance Test you discover there are parts you need to practice, follow the key to each item in FOR FURTHER STUDY.

Work straight through each lesson in the order presented.

Should you decide to completely work through this module, begin with the INTRODUCTION and go straight through each of the three lessons. The lesson begins with the OBJECTIVE of the training. Follow the instruction for each part in the order presented. Practice each step in a lesson until you can do it according to the criteria stated for the step. At the end of a lesson, do the EXERCISES. When there are audiovisuals listed at the end of a lesson, ask your instructor for help in obtaining them.

USING THESE SELF-INSTRUCTION MATERIALS

Take the Performance Test as a posttest.

Finally, after you have mastered all of the exercises in each lesson, ask your instructor to watch you do each item in the Performance Test. The items in the Performance Test are intended for use as a posttest to evaluate the quality of your performance. Turn now to the Performance Test.

GUIDELINES FOR INSTRUCTORS

Approach

The approach of these materials is to provide the student with the opportunity to learn skills for trapping rodents and for using traps and collection devices to obtain specimens of flies and mosquitoes. The equipment you have available may be somewhat different from that presented in the lessons. If such is the case, you may need to write supplementary instructions to point out the equipment differences. The skills tested on the Performance Test are designed for use with any make and model of instrumentation.

Independent Study

Students can work independently and at their own pace. Depending on the time frame you set for completing each lesson, you may want to start a group off in each lesson with a demonstration and informal presentation.

As a Laboratory Workbook

Alternatively, you may choose to use this module as a laboratory workbook in a structured laboratory session. With this option, you may allow students greater access to your assistance, especially in watching them perform the pre- and posttest portions of the training.

General Instructions

Read through each lesson to anticipate what equipment and supplies you will need to make available for students to use. Also, order any audiovisuals or reading materials you think may present a complementary perspective to the training in this module. Use the items in the Performance Test as the minimum requirements for gauging successful completion of the training.

USING THESE SELF-INSTRUCTION MATERIALS

Specific Instructions

In this module, students are asked to visit and return to areas where rodents, flies, and mosquitoes live and breed. Recommend several such areas so that small groups of three to five students can visit and not disturb the study environment. After each group has completed Lesson Two, have them visit a different study location. For Lesson Three, have the groups return to the first study location.

Students are to use killing jars for mosquito light traps. Only trained pest controllers or professional chemists should prepare these jars if they are to contain sodium cyanide and plaster of paris. Instead, obtain commercially prepared, poison-impregnated rubber strips that can be cut and placed in the bottom of the jars. Even though these strips are much safer to handle, students should avoid skin contact by wearing protective gloves and also should avoid inhaling vapors given off from the strips.

Students are required to kill specimens using chloroform. This substance should be used in a well-ventilated area; otherwise, students may succumb to dizziness, disorientation, and nausea.

Provide identification keys for two species of flies and mosquito adults predominant in your area. Keys are provided at the end of Lesson Two for some mosquito larvae and adults. Students will need to be able to identify these insects to complete the Exercises in Lesson Three.

INTRODUCTION

BACKGROUND

Throughout history, rats, mice, and various insects have competed with people for food, clothing, and shelter, and have affected their health and peace of mind. Through the centuries, an increasing number of pests have adapted to city and indoor life because of favorable temperatures, plentiful food and water, and abundant harborage.

Pests destroy billions of dollars worth of stored food annually in the United States. Insects and rodents damage clothing, rugs, books and paper, the wood in buildings, and many other items. When present in the kitchen or in restaurants, insects and rodents may repel customers and cause economic loss. Most important of all, certain species of insects and rodents carry and transmit germs that cause illnesses and diseases in people and in domestic animals.

Not until the 19th century were insects and rodents identified as the agents responsible for transmitting many devastating diseases. Worldwide, mosquitoes are responsible for the transmission of diseases to millions of people each year. These diseases include encephalitis, dengue, yellow fever, malaria, and filariasis. Domestic flies mechanically transmit organisms causing bacillary dysentery, infantile diarrhea, typhoid fever, paratyphoid fever, cholera, amoebic dysentery, pinworm, roundworm, and tapeworm infections. Native North American rodents act as reservoirs of many diseases transmissible to humans, such as plague in the western United States, tularemia, tickborne relapsing fever, spotted fever or tickborne typhus, human babesiasis, and some types of salmonellosis and leptospirosis.

The key to the population control of rodents and arthropods (vector control) does not lie in massive programs of spraying and poisoning, since these programs have been unsuccessful against the great reproductive and adaptive potential of the rodent and insect enemies. Control lies in affecting the growth and well-being of their populations. The first step in the control process is carried out through sampling and collection techniques, and is the responsibility of the sanitarian or environmental health technician.

INTRODUCTION

WHAT YOU WILL LEARN

When you finish working through the steps and exercises in this module, you will be able to collect pest specimens of rodents, flies, and mosquitoes, and to prepare the specimens for shipment to a laboratory for identification.

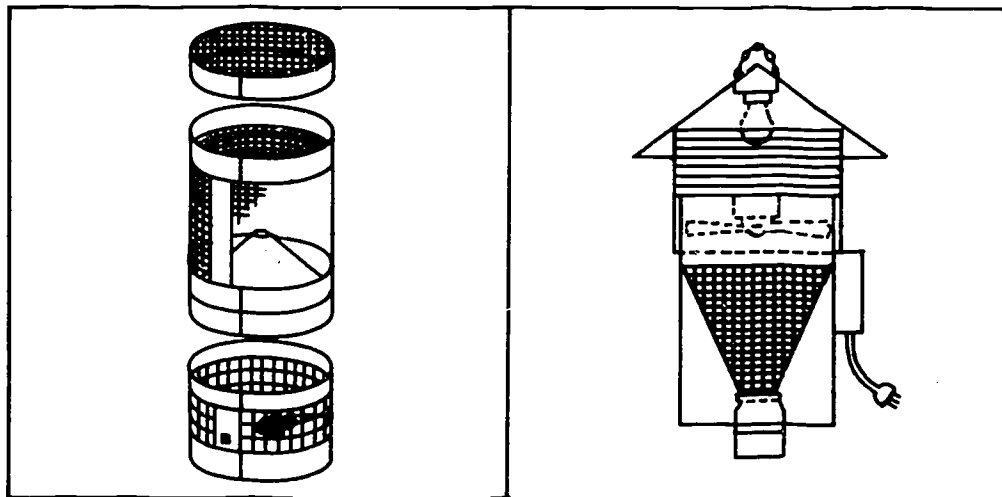

You will learn these skills in three lessons:

o Lesson One

You will be able to identify the parts and functions of rodent and arthropod traps and collection devices.

o Lesson Two

You will be able to identify locations suitable for collecting rodent, fly, and mosquito specimens.

o Lesson Three

You will be able to set devices to collect pests, collect the pests from the traps, label specimens, and prepare the specimens for shipment and analysis.

LESSON ONE

OBJECTIVE

You will be able to identify the parts and functions of rodent and arthropod traps and collection devices.

WHERE AND HOW TO PRACTICE

You should practice this lesson where there is room to spread out the collection devices and this module. Read through each step in the module and then refer to a part or parts of the equipment.

HOW WELL YOU MUST DO

You must be able to identify all the parts of each device and tell how a part or parts of each device functions. You must be able to complete the exercises in less than 20 minutes.

THINGS YOU NEED

You will need the following equipment and supplies:

- o snap traps, rodent and mice
- o metal live trap
- o baited fly trap
- o fly cone
- o collection tube, mosquitoes
- o light trap, mosquitoes
- o specimen killing jar
- o pencil and paper.

Instructions: Now turn to the next page and begin work on Lesson One, "Getting There--Steps."

GETTING THERE--STEPS

STEP 1

Place the rodent snap trap in front of you. It is the most effective device for trapping and killing rodents. Examine each of the following parts as you identify them in the Key Point:

- (1) base
- (2) baited-type trigger to activate the trap
- (3) expand-type trigger to activate the trap
- (4) spring snap to kill the rodent
- (5) trigger arm to set the trap
- (6) bait to attract the rodent
- (7) anchor to prevent the trap from being pulled away by the trapped but still living animal, or predators.

KEY POINT 1

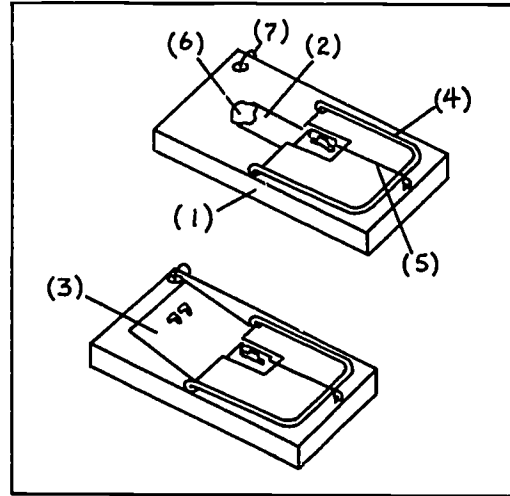

The snap trap is the most effective device for trapping and killing rodents.

STEP 2

Place the metal live trap in front of you. It is used if the captured animal is to be examined for fleas and diseases before it is killed. Examine each of the following parts as you identify them in the Key Point:

- (1) cage for enclosing the animal
- (2) trap door to close the cage
- (3) trigger and bait for releasing the trap door
- (4) anchor to prevent the cage from being dragged away by a predator.

KEY POINT 2

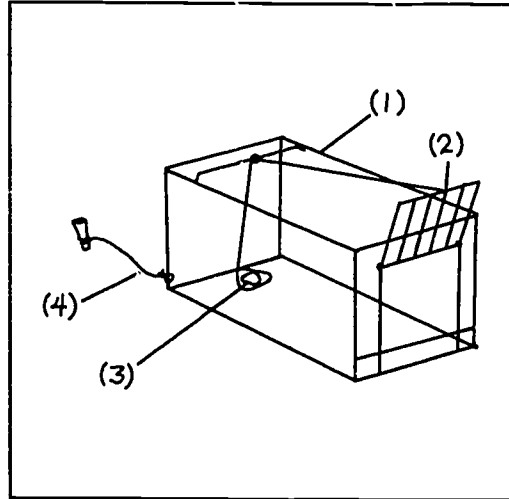

The live trap captures the animal for studies that cannot be done if the animal is killed by the trap.

STEP 3

Place the baited fly trap in front of you. It is used to determine the species and the number that live in the local area. This type of trap is used to catch live flies that are then killed in chloroform killing jars. Examine each of the following parts as you identify them in the Key Point:

- (1) bait
- (2) bait holder
- (3) pyramid opening to catch flies
- (4) cage
- (5) cover

KEY POINT 3

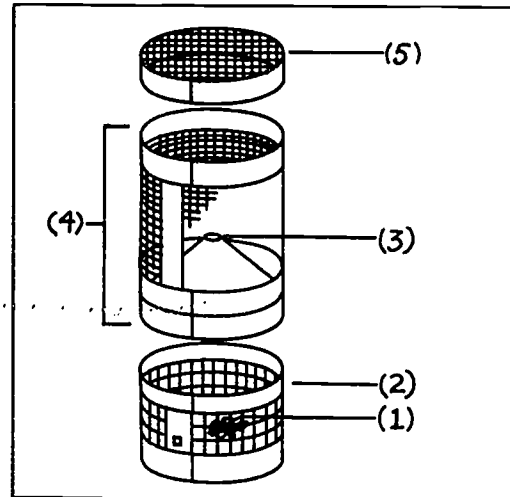

The baited fly trap is used to determine what species may be found in the area.

STEP 4

Place the fly cone in front of you. It is used to trap flies hovering over a natural attractant such as garbage or feces. Remove the cage (1) from the top of the #18 mesh screen wire cone (2). These are the only parts of this device.

KEY POINT 4

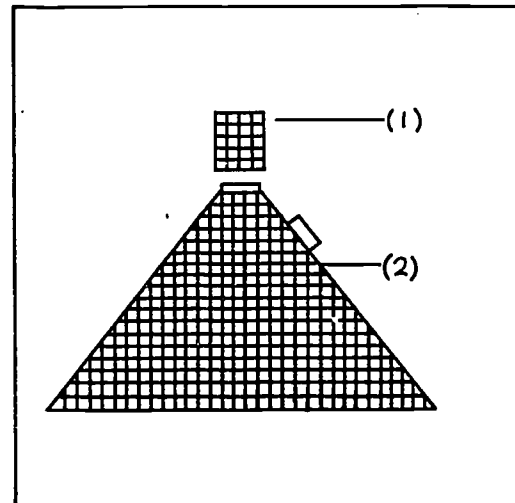

Fly cones are used to collect living specimens.

STEP 5

Place the collection tube mouth aspirator in front of you. It is used to collect adult mosquitoes resting on walls and in hard-to-reach places. The mosquito is sucked into the tube and then placed in a holding or killing jar to be sorted and identified or shipped to an entomology laboratory. Examine each of the following parts as you identify them in the Key Point:

- (1) glass mouthpiece
- (2) rubber or plastic hose
- (3) metal gauze to prevent the insect from being sucked into the hose
- (4) glass or plastic collection tube.

KEY POINT 5

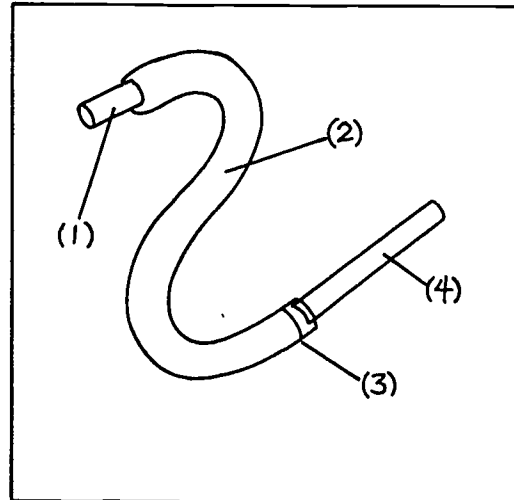

The collection tube is used to capture mosquitoes resting in hard-to-reach areas.

STEP 6

Place the mosquito light trap in front of you. This device allows sampling of adult mosquito populations between dusk and dawn. Examine each of the following parts as you identify them in the Key Point:

- (1) chain for hanging the trap
- (2) 25-watt electric light bulb for attracting the mosquitoes
- (3) mesh screening that is large enough for mosquitoes to enter the trap but small enough to prevent most larger insects from entering
- (4) fan for blowing mosquitoes downward
- (5) timer to turn the light on and off automatically
- (6) power cord, 110 VAC
- (7) mesh cone to guide mosquitoes into the killing jar
- (8) killing jar, containing poison-impregnated strips.

KEY POINT 6

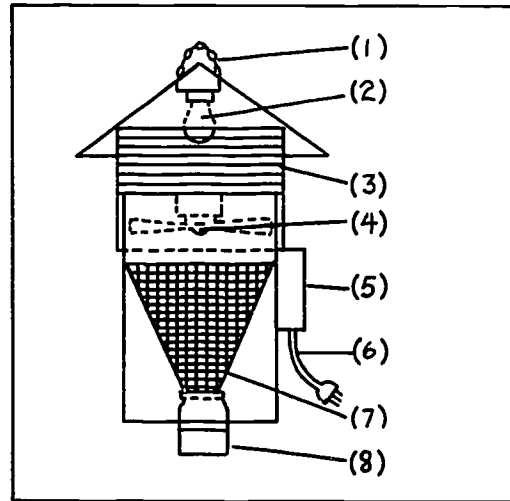

The mosquito light trap attracts and kills adult mosquitoes between dusk and dawn.

EXERCISES

Instructions: With the pest collection devices in front of you, practice naming the parts. Give the function of each part and label the following drawings to test your knowledge. You should be able to do this in less than 20 minutes.

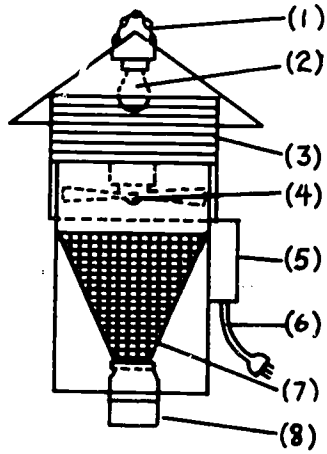

1. _____
2. _____
3. _____
4. _____
5. _____
6. _____
7. _____
8. _____

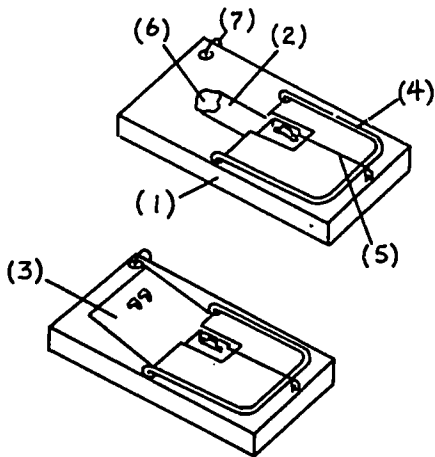

1. _____
2. _____
3. _____
4. _____
5. _____
6. _____
7. _____

LESSON ONE/EXERCISES

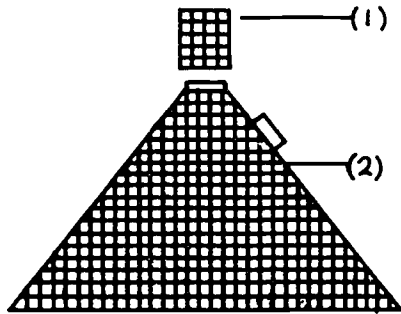

1. _____
2. _____

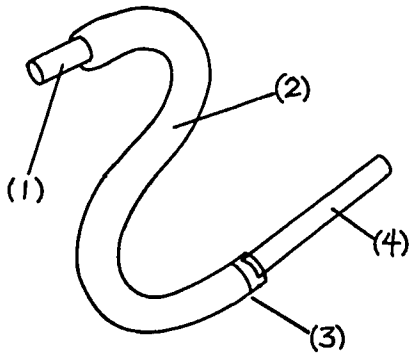

1. _____
2. _____
3. _____
4. _____

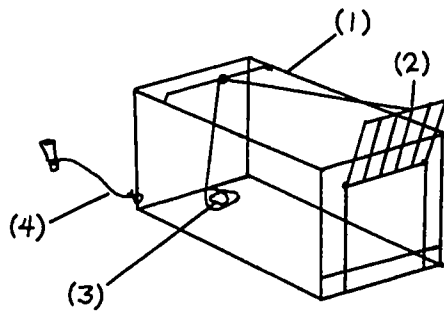

1. _____
2. _____
3. _____
4. _____

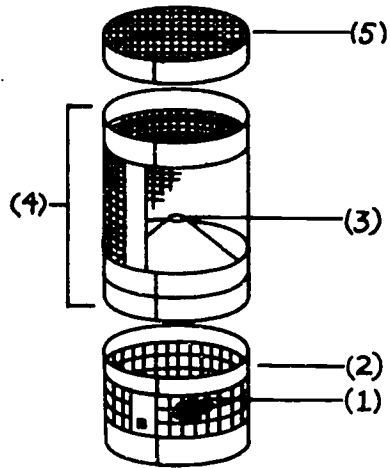

1. _____
2. _____
3. _____
4. _____
5. _____

FILMS AND SLIDE/TAPE PROGRAMS

American Institute of Biological Sciences. "How to Collect Insects By a Variety of Methods." Communication Skills Corporation, Tarrytown, NY, 1974.

This slide/tape presentation shows various methods for collecting insects.

LESSON TWO

OBJECTIVE

You will be able to identify locations suitable for collecting rodent, fly, and mosquito specimens.

WHERE AND HOW TO PRACTICE

You will need to go to the locations described in each of the steps to see firsthand where the pests live. Your instructor will point out breeding and feeding areas for rodents, flies, and mosquitoes. While you are at each location, point out the characteristics of the environment that make it attractive for the pest to live and breed. Describe the characteristics to your instructor or to another student, or write your descriptions in a small notebook. Since this lesson provides only a quick orientation to the different pest habitats, you will need to obtain additional information by reading through the references at the end of the chapter and by watching the films at the end of the lesson.

HOW WELL YOU MUST DO

In the appropriate environment, you must be able to point out at least two differences among the three major species of rodents (Norway and roof rats and the house mouse) that can be used to determine which rodent is present in a potential infestation. You also must be able to find the habitats of flies and mosquitoes, collect more than two types of flies, and collect more than two types of both adult and larva mosquito forms.

THINGS YOU NEED

You will need the following supplies:

- o pencil
- o notebook pad
- o old clothes, including long-sleeved shirt, long pants, sturdy walking shoes or boots, and hat (for the field trip)
- o Zip-loc bags to collect rodent feces
- o flashlight.

Instructions: Now turn to the next page and begin work on Lesson Two, "Getting There--Steps."

GETTING THERE--STEPS

STEP 1

Before you can set a snap trap or a live trap to catch a rodent, you must know where to look for rats and mice, and how to tell if they are active in a suspected area. Unless there are very heavy infestations, you will rarely see a rat and almost never see a mouse. You will, however, be able to detect the presence of a rodent by signs of its habitat and through the use of traps.

KEY POINT 1

To detect the presence of a rodent, look for signs of its habitat and use traps.

STEP 2

To find the common Norway rat (Rattus norvegicus), look at ground level, in burrows with 3-inch entryways into the ground and that run under foundations of buildings, and in rubbish dumps. Because they are semiaquatic (living half in and half out of water), also look for Norway rat burrows near streams, in marshy places, in sewers, and in rice fields.

KEY POINT 2

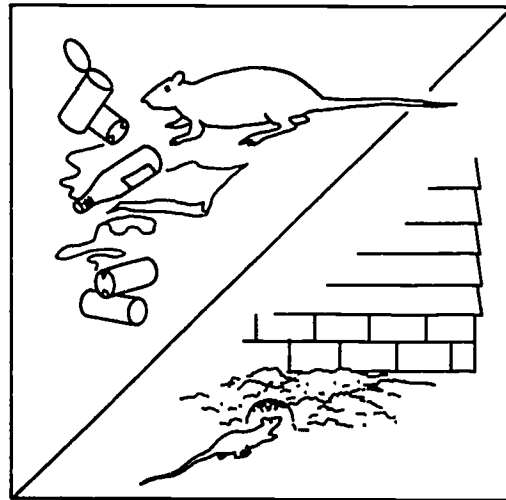

Look for the Norway rat at ground level, in burrows, rubbish dumps, and in semi-wet environments.

STEP 3

The roof rat (Rattus rattus), another very common rat in the United States, is smaller and more slender than the Norway rat. Look for the roof rat above ground; indoors in attics, between walls, and in enclosed spaces of cabinets; and outdoors in trees and in dense vine growth. Look for the roof rat at ground level when it is known that the Norway rat is absent.

KEY POINT 3

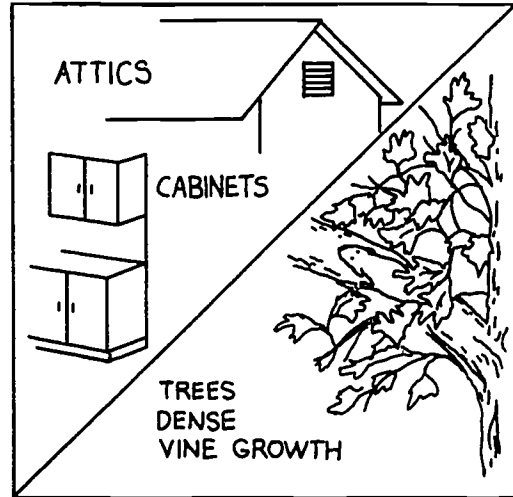

Look for the roof rat above and at ground level when the Norway rat is known to be absent.

STEP 4

The smallest of the domestic rodents is the house mouse (Mus musculus). As its name implies, look for this rodent primarily indoors in any convenient space in walls, cabinets, or furniture. When you see the house mouse, it usually will not be further than 10-30 feet from its nesting or harborage area.

KEY POINT 4

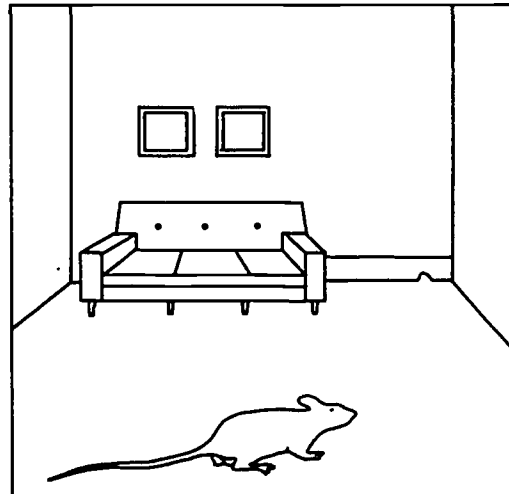

Look for the house mouse indoors at or above ground level.

STEP 5

To set an appropriate trap for a rodent, you must be able to detect the presence of each type of rat or mouse. When you first enter a suspected rodent-infested building, stand still. If rodents are present in large numbers, their activity may resume in several minutes. Listen for running, gnawing, scratching, and squealing from fighting rodents or nesting young. Roof rats or house mice will be present if you hear these sounds overhead or in the walls. Write in your notebook your observations when you first enter this building.

STEP 6

Once you have entered the building and have started to look for rodent signs, shine your flashlight under floor joists on an overhead beam for "swingmarks" (1). Swing marks are made when grease from the rodent's body rubs onto the side of the beam where the rodent has swung off the horizontal runway to get around the floor joist. Since mice do not leave rub marks, and Norway rats do not climb, the presence of swing marks is a pretty good sign that roof rats live, or have lived, in the building. In your notebook, make a list of what you see and where you see it.

KEY POINT 5

Listen for sounds of rodent activity just after entering a building suspected of being infested.

KEY POINT 6

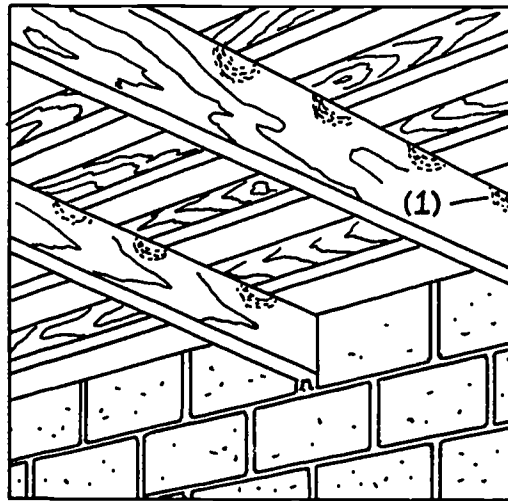

Roof rats leave swing marks on overhead beams.

LESSON TWO/RODENTS

STEP 7

There are other signs that indicate whether rodents are present. These include gnawings and tracks in dust. To determine if a runway is actively used, sprinkle some talc powder on a thin piece of cardboard and set it next to a wall. If you do not have talc powder, one of the best indicators of rodent infestation is the presence of feces along runways, near harborage, in secluded corners, and near food supplies.

KEY POINT 7

The presence of feces is one of the best indicators of the size and recentness of an infestation.

STEP 8

Collect samples of droppings from the areas mentioned in Step 7. By evaluating the size, shape, and freshness of rodent droppings, you can tell what species of rodents are present and whether there is a current or old, heavy or light infestation. Shown in the Key Point are drawings of droppings from the Norway and roof rats and the house mouse. Notice the difference in the relative size and shape for each rodent. Compare these differences with the samples you have collected. If there are different sizes of moist, shiny, dark droppings, several ages of rats probably are present, rather than different species of rodents; this indicates the presence of an extensive infestation. Old droppings look dull and grayish, and crumble when pressed. In your notebook, write your conclusions as to which rodents, and how many, may be present.

KEY POINT 8

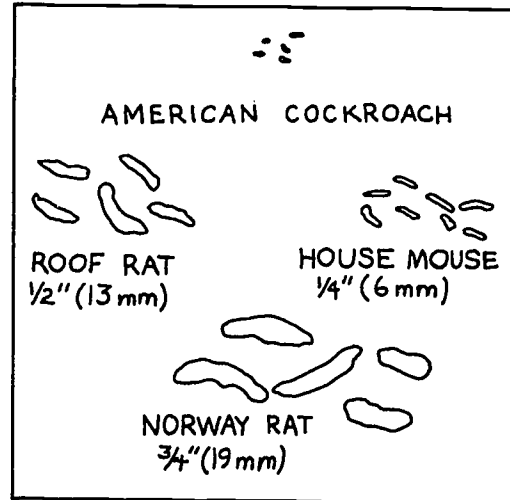

Rodent droppings can indicate species, size, and age of infestation.

STEP 9

Visit a garbage/refuse dump at any time of the year to look for signs of rodents, and during the warm months to look for fly breeding areas. In this area, the Norway rat may be dominant. If the Norway rat is absent, look for signs of the roof rat (it will dig burrows and live at ground level in any environment favorable to rats). If a wide range of decaying meat, vegetable, and fruit materials is present, you most likely will have a good opportunity to differentiate among several types of flies. Look for flies where there are substantial deposits of semisolid and liquid garbage materials.

KEY POINT 9

In the absence of Norway rats, roof rats may be found at ground level in any environment. Numerous types of flies will be found in garbage dumps, especially over semisolid, decaying materials.

STEP 10

During warm spring or summer months, visit a pond, backwater areas along a stream, or where there are tree holes, containers, old tires, shallow streams, and ditches and drains. Look for both larvae and adult forms of mosquitoes in such areas. Look for the larvae of such mosquitoes as Aedes, Culex, and Toxorhynchites in rain-filled containers or tree holes. Use the pictorial key at the end of the lesson as a guide to the identification of these larvae. Other species of mosquito larvae live along the edges of quiet pools or backwater areas flooded during heavy spring rains. Look for adult Aedes and other mosquito adult species resting in culverts, large holes in trees, abandoned houses, barns, and out-buildings.

KEY POINT 10

Mosquitoes breed well in still-water areas, including rain-filled containers, tree holes, and shallow backwater ponds.

EXERCISES

Instruction 1: Compare notes you took at each of the pest sites with those of other students in your group. Determine if you agree whether the same rats or mice are present and discuss why your findings lead you to different conclusions, if they do.

Instruction 2: In the classroom, write on the chalkboard what aspects of each pest site make it particularly attractive to the kind or species of pest you observed. Discuss how the habitats (living conditions) varied between locations for at least two species of each type of pest you encountered; e.g., the differences in the habitats of the Norway rat and the roof rat between Study Location A and Study Location B.

Instruction 3: Collect mosquitoes from the areas described in Step 10. Using a stereo microscope and the pictorial key provided at the end of this lesson, identify the genus and species of the mosquitoes you collected.

OTHER READING

Biological Factors in Domestic Rodent Control. U.S. Department of Health, Education, and Welfare, Public Health Service, Center for Disease Control, Atlanta, GA, 1977.

Household and Stored-food Insects of Public Health Importance, and Their Control. U.S. Department of Health, Education, and Welfare, Public Health Service, Center for Disease Control, Atlanta, GA, 1979.

Mosquitoes of Public Health Importance and Their Control. U.S. Department of Health, Education, and Welfare, Public Health Service, Center for Disease Control, Atlanta, GA, 1975.

Flies of Public Health Importance and Their Control. U.S. Department of Health, Education, and Welfare, Public Health Service, Center for Disease Control, Atlanta, GA, 1976.

FILMS AND SLIDE/TAPE PROGRAMS

U.S. National Medical Audiovisual Center. "Field Recognition of Domestic Rat Signs." U.S. National Audiovisual Center, Washington, DC 20409, 1968.

This 8-minute, 16-mm color film explains where to look for and recognize rat signs and how inspectors in the field can identify various species of rodents by the size and shape of their droppings.

U.S. National Medical Audiovisual Center. "Field Recognition of Mosquito Larvae." U.S. National Audiovisual Center, Washington, DC 20409, 1968.

This 6-minute, 16-mm color film shows Aedes aegypti and Culex larvae in motion.

PICTORIAL KEY TO UNITED STATES GENERA OF FEMALE MOSQUITOES
 Harry D. Pratt and Chester J. Stojanovich

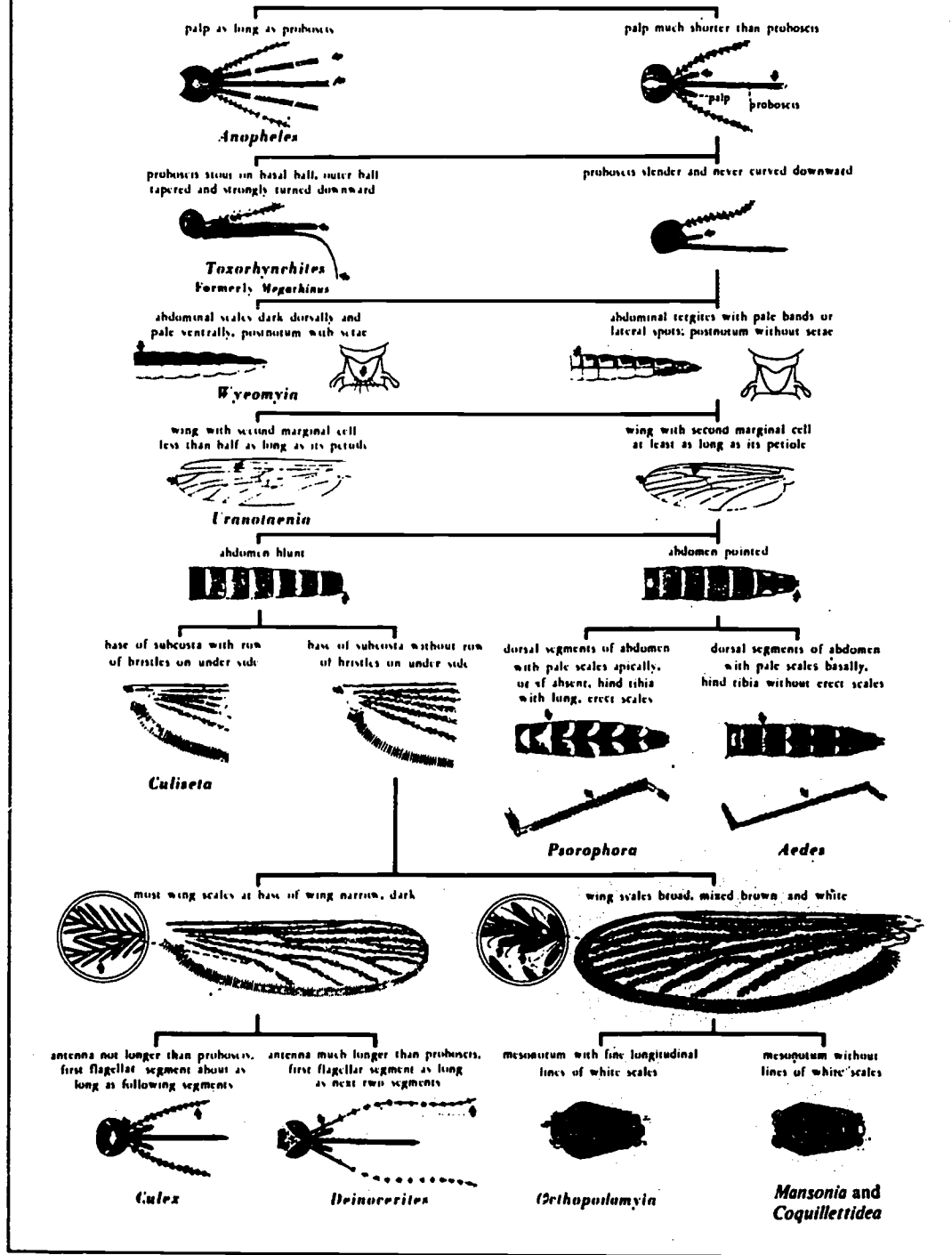

MOSQUITOES: PICTORIAL KEY TO SOME LARVAE
COMMONLY FOUND IN ARTIFICIAL CONTAINERS
Harry D. Pratt and Chester J. Stojanovich

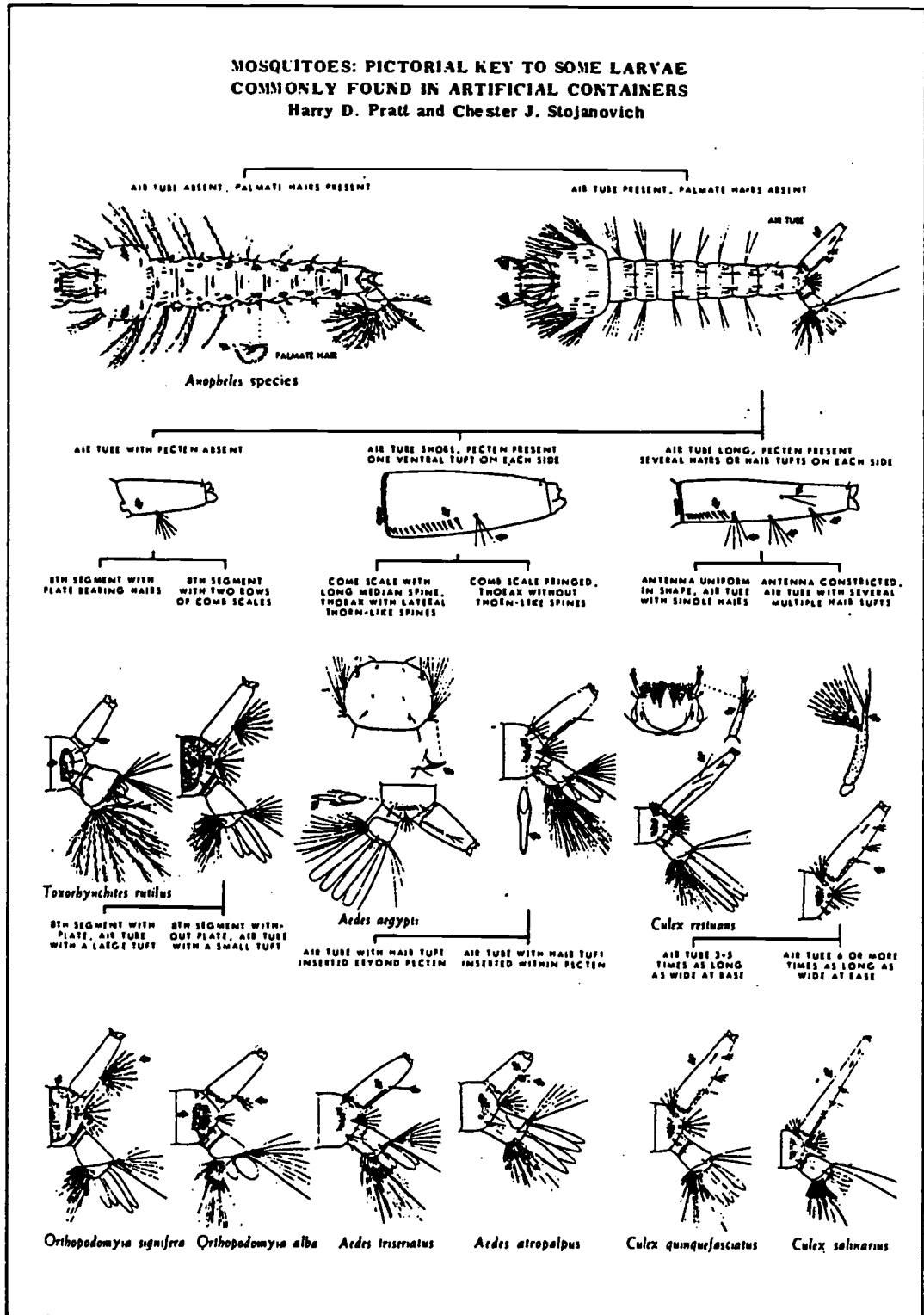

LESSON THREE

OBJECTIVE

You will be able to set devices to collect pests, collect the pests from the traps, label specimens, and prepare the specimens for shipment and analysis.

WHERE AND HOW TO PRACTICE

You will need to return to the same locations you visited in Lesson Two to practice using the pest trapping and collecting equipment. When you visit pest-infested areas, be sure to wear protective clothing to prevent insect bites to the extremities, face, and neck; wear protective gloves when handling any rodent. You will also need to work in a laboratory to prepare pests for shipment for further analysis.

HOW WELL YOU MUST DO

You must be able to keep records that will permit you to determine acceptable baits for rodents in each area you trap. You must be able to collect, process, and package flies and mosquitoes in a manner to prevent damage to the specimens; you also must be able to keep accurate enough records so that you can resample areas in which you previously collected flies and mosquito adults and larvae.

THINGS YOU NEED

In addition to the equipment you used in Lessons One and Two, you will need the following:

- o bait, including meat, fish, grain, vegetables, and fruits
- o string or chain to anchor the rodent traps
- o gloves (animal handler's, steel-reinforced)
- o Zip-loc bags
- o posterboard for signs
- o felt-tip pens for making signs
- o chloroform (reagent grade) and cottonballs

LESSON THREE

THINGS YOU NEED (cont'd)

- o large box for the baited fly trap
- o laboratory pan
- o boxes (two-lidded, small, mailable)
- o dark cloth, sized to fit around the fly cone
- o a pre-prepared killing jar, pint-sized with screw-on lid, for each light trap used
- o vials with screw cap, 70-mm-long (2-3/4-inch) X 21-mm-wide (3/4-inch)
- o 70 percent alcohol.

Instructions: Now turn to the next page and begin work on Lesson Three, "Getting There--Steps."

GETTING THERE--STEPS

STEP 1

Return to the potentially rodent-infested site you visited in Lesson Two. From the notes you made in your notebook, decide which species of rodents to set traps for. Obtain three snap traps that match the size and weight of the rodent to be trapped and small portions of bait, including meat, fish, and grain. Do not poison the foods. In normal practice you would set the bait a couple of times, find out which bait is acceptable, and then poison the foods.

STEP 2

Test the trigger mechanism on the trap before setting it. Bait the trigger before setting the trap, or use an expanded trigger (1) without bait for rat control. Expand the trigger by using screen wire. Place the trap across a runway or swing mark. Place a box or board (2) alongside of the runway to guide the rodent to the trap. Before leaving the baited trap, anchor it with string or chain to prevent the victim or a predator from hauling away the trap. Repeat this step in setting a live trap.

KEY POINT 1

Select rodent snap traps based on information you have gathered in a previous site visit.

KEY POINT 2

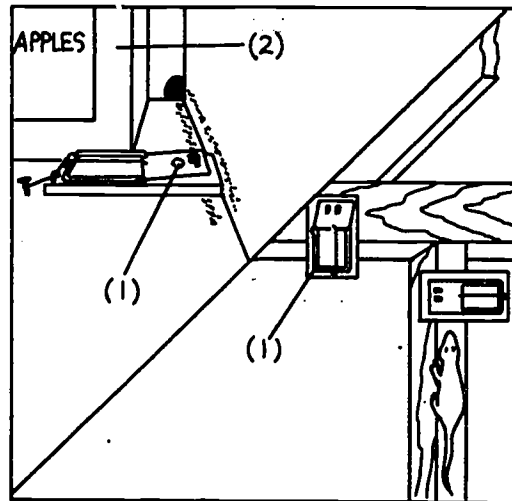

After placing a baited snap or live trap across a runway, anchor it with string or chain.

LESSON THREE/RODENTS AND FLIES

STEP 3

Record in your notebook where you placed each trap and what bait was used. Check each trap regularly and live traps every morning. Wearing protective gloves, remove a dead rodent from a trap and place the animal carcass in a Zip-loc bag. If rodents die in a live trap, the ectoparasites you have trapped the animal for will leave the body after a few hours. Transport a live animal in a cage. When handling live traps, use rodent handling gloves. Kill the rodent in the laboratory where you can immediately wash it and comb out the ectoparasites. Ask your instructor for detailed procedures to collect ectoparasites.

STEP 4

Obtain a baited fly trap. On the bait pan, place several attractants, including fish heads, chicken entrails, vegetables, and fruits. With the baited trap, return to the garbage/refuse site you visited in Lesson Two. Anchor the trap by tying it to a stake, tree, or large rock. Place a sign near the trap to identify the institution or department doing the sampling. Make a note in your notebook where you placed the trap.

KEY POINT 3

Make careful records of trap sites and baits. Check traps frequently.

KEY POINT 4

Anchor the baited fly trap and place an identification sign near it.

STEP 5

Check the trap at regular intervals. When a large enough number of flies have been trapped, return the trap to the classroom or laboratory. Remove the bait and place the trap in a large box or container that can be covered. Soak a wad of cotton with chloroform* and place it in the container with the trap.

KEY POINT 5

To kill the flies, place the trap in a closed container with a wad of chloroform-soaked cotton.

STEP 6

After covering the container, wait 10 minutes before removing the trap. Place the dead flies in a laboratory pan and dispose of the chloroform wad. Separate the flies from other insects. Place the flies in a single layer (1) in a cotton-lined (2) shipping box (3). Package the flies tightly enough so that they will not move in transit but not so tightly that they will be damaged. Label the box with the locality and date. On both the shipping document/specimen information sheet, also record information about the habitat, abundance, and weather conditions. Make a second record in your notebook. Include the date you shipped the specimens.

KEY POINT 6

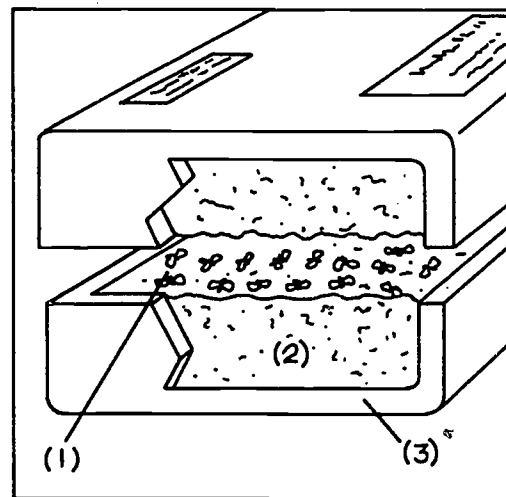

Package the specimens in such a way as to prevent damage during shipment.

*Use only in a well-ventilated area and under the instructor's supervision.

STEP 7

Obtain a fly cone and a piece of dark cloth that can be draped around it. Place or drop the cone over a natural attractant such as garbage or manure. Place the cloth (1) over the cone, leaving the cage (2) uncovered. Open the cage door (3) if it is not already open. Gently agitate the cone. This action will keep the flies from alighting on the sides of the trap and will cause them to fly upwards to the source of light. Once the cage is sufficiently full of flies, slide the cage door shut. Return the trap to the laboratory or classroom. Repeat the appropriate parts of Step 5 and all of Step 6 to prepare the flies for shipment.

KEY POINT 7

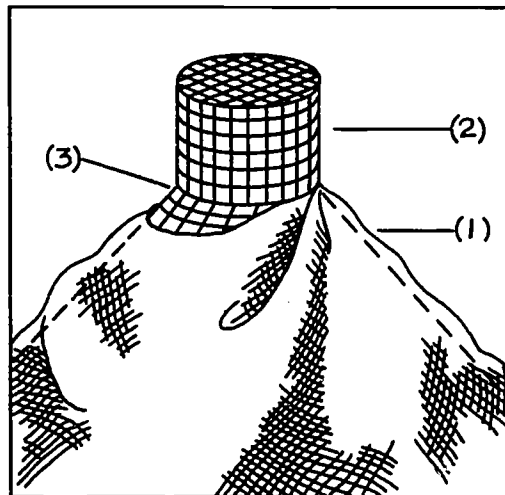

When the fly cone is covered with a dark cloth and agitated, flies seek the light coming through the cage.

STEP 8

Obtain adult mosquito specimens by using a collection tube and killing jar.* Return to the backwater areas of the stream you visited in Lesson Two. Using your flashlight find an adult mosquito resting area such as in a tree hollow or a vertical surface inside an outbuilding. Suck the mosquitoes into the tube and then blow them into the killing jar. To make sure the insects are dead and not just stunned, keep them in the covered killing jar for at least 2 minutes before carefully transferring them to a pill box lined with facial tissues or cotton. Label the box with the location, date, and time. Repeat this step for as many separate specimen samples as are needed.

KEY POINT 8

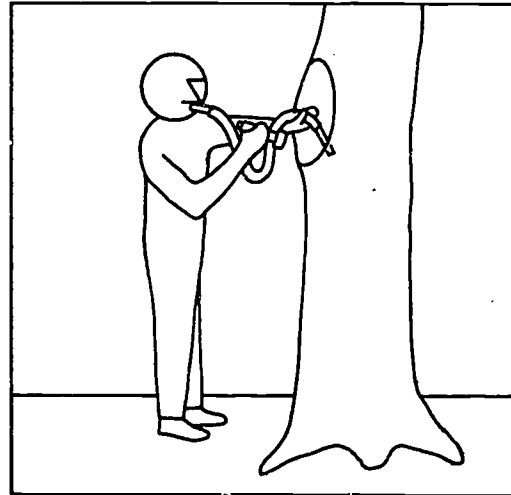

The mosquito collection tube allows sampling from hard-to-reach adult resting stations.

*Place a chloroform-soaked cotton ball in a covered vial.

STEP 9

Prepare the mosquito light trap for use; check the operation of the light, fan, and timer. Attach the pre-prepared killing jar* to the light trap. Hang it on a post supplied by 110 VAC unless, of course, the trap has its own power supply. Mount it so it is between 5 to 6 feet above ground, and no closer than 30 feet from buildings. If you have no choice about where to hang the trap, place it in an open area near trees and shrubs, away from lights, or in an area not subject to strong winds or pollution from an industrial plant. Adjust the timer on the trap to turn the light and fan on just before dark and off just after daylight. When you collect the trapped specimens, empty the killing jar into a bottle or cup fitted with a top. Label the top with the type of information given in Step 6.

KEY POINT 9

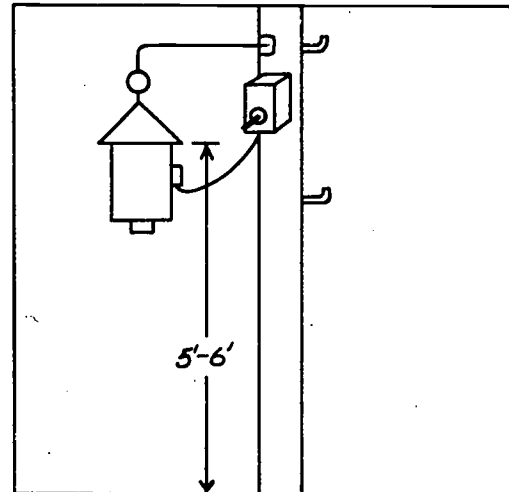

Hang the mosquito light trap near a 110-VAC source at a distance 6 feet above the ground.

*Described in the "Guidelines for Instructors."

LESSON THREE/MOSQUITOES

STEP 10

Obtain mosquito larvae by using a dipper, pan and handles, and preservative-containing vials.* Return to the backwater areas of the stream you visited in Lesson Two. Sample from shallow parts of stagnant waters in this area. Attaching an appropriately long handle to the dipper, skim the surface for such mosquitoes as Anopheles until the pan is half full. Let the pan float in the water. Using an eyedropper, remove the larvae from the pan and place them in small vials with screw tops. Number the vials and record in a notebook the location and conditions of sampling. When packaging the vials, make sure they are full and fit tightly in the shipping container. Each vial should be separated from the other with a piece of cardboard.

KEY POINT 10

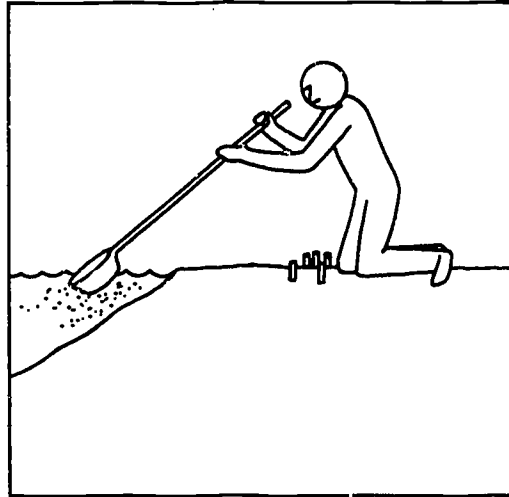

Collect larvae with a dipper. Put larvae into a vial containing 70 percent alcohol.

*The preservative should contain 70 percent ethyl alcohol.

EXERCISES

Instruction 1: Return to the first study site and set a rodent trap using what you have determined to be acceptable bait for the spot in which you are trapping. Compare the type and body characteristics, including weight, length, and age (young or fully grown), of the second rodent with the one you caught the first time. Compare your findings with others who set traps at the same study site. Keep accurate notes on the comparisons.

Instruction 2: Return to the first study site. Using the same kinds of bait you used the first time, set a baited fly trap in the same spot. In the laboratory, compare the numbers of two predominant types of flies from each trapping. Compare your findings with others. Determine if the numbers and types of flies were similar between specimen samples. Keep accurate notes on the comparisons.

Instruction 3: Return to the study area and draw a detailed map of that area. Pinpoint on the map each spot where baited fly traps were set. For each spot, compare the relative numbers of each fly type. If wide variations occur, compare the types of bait used and what types of flies seemed to be attracted to each trap.

Instruction 4: Repeat Instructions 2 and 3 using a fly cone.

Instruction 5: Repeat Instructions 2 and 3 using a mosquito light trap. Since bait is not used, ignore that part of Step 3.

Instruction 6: Repeat Instructions 2 and 3 using a larvae dipper. Since bait is not used, ignore that part of Step 4.

Instruction 7: Package at least two specimen samples you collected. After the packages are ready, shake them and then carefully reopen them. If they are damaged, repeat Step 6.

Note: Your instructor will help you identify two species of each pest you have collected.

LESSON THREE

FILMS AND SLIDE/TAPE PROGRAMS

U.S. Public Health Service. "Mosquito Survey Techniques." U.S. National Audiovisual Center, Washington, DC 20409, 1954.

This 15-minute, 16-mm color film shows mosquito survey methods under a variety of circumstances and for various mosquito species. It shows how to collect larvae and adult mosquitoes, and how to keep accurate records and evaluate results.

U.S. National Medical Audiovisual Center. "Listen to the Rat Man." U.S. National Audiovisual Center, Washington, DC 20409, 1970.

This 14-minute, 16-mm color film dramatizes the daily activities of a rodent control officer in an urban area.

American Institute of Biological Sciences. "How to Preserve Insects." Communication Skills Corporation, Tarrytown, NY 10591, 1974.

This slide/tape presentation shows the process for preserving insects.

PERFORMANCE TEST

Instructions: Check your skill level or progress by working through each of the items in this test. If you can perform each item as required, place a check in the space provided. When all of the items are checked, you are ready to demonstrate your skills to your instructor. You may use the following list if needed. You will be considered trained in a skill after your instructor approves your performance of each of the following items:

IDENTIFYING LOCATIONS FOR COLLECTING PESTS

- No. 1 _____ At the pest study site, point out signs that indicate the presence or absence of a rodent infestation, including freshness and abundance of fecal droppings, and evidence that runways are or are not being used.
- No. 2 _____ At the pest study site, point out at least two signs that indicate the presence of each of these rodents: the Norway rat, the roof rat, and the house mouse.
- No. 3 _____ At the pest study site, point out areas where conditions are favorable for fly habitats.
- No. 4 _____ At the pest study site, point out the conditions favorable for the development of two types of mosquito larvae.
- No. 5 _____ At the pest study site, point out areas or surfaces on which two types of adult mosquitoes are most likely to rest.

FOR FURTHER STUDY

If you could not perform one or more of the five items above, review and practice the following lesson steps:

No. 1
Lesson Two, Steps 7 and 8

No. 2
Lesson Two, Steps 1 through 8

No. 3
Lesson Two, Step 9

No. 4
Lesson Two, Step 10

No. 5
Lesson Two, Step 10

PERFORMANCE TEST

COLLECTING, LABELING, AND PREPARING PESTS FOR SHIPMENT AND ANALYSIS

- No. 1 _____ Bait, set, and anchor snap traps to which are attached acceptable baits to catch a Norway rat, a roof rat, and a house mouse.
- No. 2 _____ Keep records of where each rodent trap was set and what bait was used.
- No. 3 _____ Remove live rodents from a trap while wearing animal handler's gloves.
- No. 4 _____ Bait, set, and anchor a baited fly trap.
- No. 5 _____ Record the sampling location and condition during the period the baited fly trap was used.
- No. 6 _____ Use a fly cone to obtain fly specimens.
- No. 7 _____ Kill living flies in the laboratory and separate the flies from other insects.
- No. 8 _____ Package flies in single layers in shipping boxes to prevent damage to the insects; label the boxes and add information to your records regarding the number of specimens and where they were collected, and the date the specimens were shipped.
- No. 9 _____ Prepare a mosquito light trap for use, including preparing a killing jar, setting the timer for dusk to dawn, and locating it 6 feet above ground, no closer than 30 feet from buildings (lighted) in a windless clearing close to bushes and trees.
- No. 10 _____ Remove the mosquitoes from the trap, separate them from other insects, and prepare them for shipment as you prepared flies in No. 7.
- No. 11 _____ Use a dipper to obtain mosquito larvae. Place the larvae in vials containing 70 percent alcohol. Label and package the vials so that each sample can be properly identified.
- No. 12 _____ Use a mosquito collection tube to obtain adult mosquito specimens.

PERFORMANCE TEST

FOR FURTHER STUDY

If you could not perform one or more of the 12 items above, review and practice the following lesson steps:

No. 1
Lesson Three, Steps 1 through 3

No. 2
Lesson Three, Steps 1 through 3

No. 3
Lesson Three, Steps 1 through 3

No. 4
Lesson Three, Steps 4 and 5

No. 5
Lesson Three, Step 5

No. 6
Lesson Three, Step 7

No. 7
Lesson Three, Steps 5 and 6

No. 8
Lesson Three, Step 6

No. 9
Lesson Three, Step 9

No. 10
Lesson Three, Step 9

No. 11
Lesson Three, Step 10

No. 12
Lesson Three, Step 8

REFERENCES

Biological Factors in Domestic Rodent Control. U.S. Department of Health, Education, and Welfare, Public Health Service, Center for Disease Control, Atlanta, GA, 1977.

Biological Techniques: Collecting, Preserving, and Illustrating Plants and Animals. Jens Knudsen, Harper & Row, New York, 1966.

Control of Domestic Rats and Mice. U.S. Department of Health, Education, and Welfare, Public Health Service, Center for Disease Control, Atlanta, GA, 1976.

Environmental Health Specialist. Volume 1. AFSC 90750, Air University Extension Course Institute, 1974.

Household and Stored-food Insects of Public Health Importance and Their Control. U.S. Department of Health, Education, and Welfare, Public Health Service, Center for Disease Control, Atlanta, GA, 1979.

Mosquitoes of Public Health Importance and Their Control. U.S. Department of Health, Education, and Welfare, Public Health Service, Center for Disease Control, Atlanta, GA, 1977.