

DOCUMENT RESUME

ED 204 566

CE 029 489

TITLE Calibrating Personal Air Monitoring. Module 7. Vocational Education Training in Environmental Health Sciences.

INSTITUTION Consumer Dynamics Inc., Rockville, Md.

SPONS AGENCY Office of Vocational and Adult Education (ED), Washington, D.C.

PUB DATE [81]

CONTRACT 300-80-0088

NOTE 33p.: For related documents see CE 029 482-507.

AVAILABLE FROM National Technical Information Service, U.S. Dept. of Commerce, 5285 Port Royal Rd., Springfield, VA 22161.

EDRS PRICE MF01/PC02 Plus Postage.

DESCRIPTORS Competency Based Education; *Educational Equipment; *Environmental Education; *Environmental Technicians; Learning Activities; *Measurement Techniques; Programed Instructional Materials; *Public Health; Tests; Vocational Education

IDENTIFIERS Air Emissions; *Air Samplers; *Calibration; Environmental Health; Monitoring; Occupational Health

ABSTRACT This module, one of 25 on vocational education training for careers in environmental health occupations, contains self-instructional materials on calibrating personal air monitoring devices. Following guidelines for students and instructors and an introduction that explains what the student will learn are three lessons: (1) naming each part of the personal air monitoring assembly or sampling train, and the parts of the soapbubble meter calibration apparatus; (2) assembling and preparing the sampling train and soapbubble meter for calibration; and (3) calibrating a sampling train, including a personal air sampling pump and filter cassette. Each lesson contains objectives, recommended methods and locations for practice, performance criteria, equipment and supplies to perform a task, detailed step-by-step instructions for learning a task, and performance exercises. Two performance tests cover assembling and preparing equipment for calibration and calibrating a sampling train. (CT)

 * Reproductions supplied by EDRS are the best that can be made
 * from the original document.

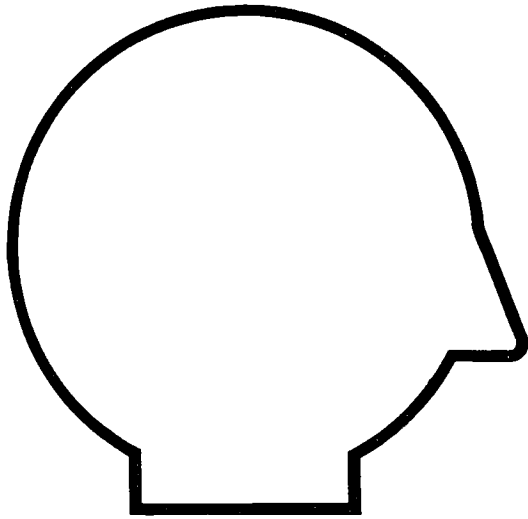

Calibrating Personal Air Monitoring Devices

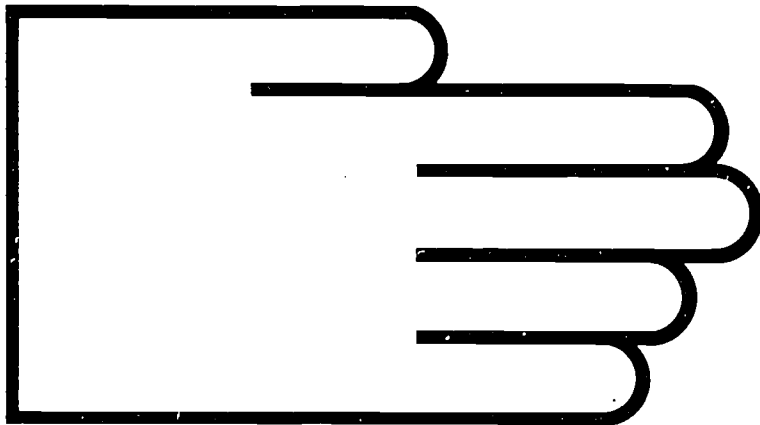

Module 7

U.S. DEPARTMENT OF HEALTH
EDUCATION & WELFARE
NATIONAL INSTITUTE OF
EDUCATION

THIS DOCUMENT HAS BEEN REPRODUCED EXACTLY AS RECEIVED FROM THE PERSON OR ORGANIZATION ORIGINATING IT. POINTS OF VIEW OR OPINIONS STATED DO NOT NECESSARILY REPRESENT OFFICIAL NATIONAL INSTITUTE OF EDUCATION POSITION OR POLICY.

FOREWORD

The Curriculum and Instruction Branch of the Office of Vocational and Adult Education, U.S. Department of Education, identified a need to improve the training opportunities for vocational education students interested in pursuing careers in environmental health. To fulfill that need, Consumer Dynamics, Inc., a Rockville, Maryland, based company, was awarded the contract to develop performance-oriented, competency-based modules in the environmental health sciences.

CALIBRATING PERSONAL AIR MONITORING DEVICES is one of the modules in the series, "Vocational Education Training in Environmental Health Sciences." The module content is based on selected materials in the environmental health field. The module is intended to supplement existing course materials.

CONTENTS

FOREWORD	i
USING THESE SELF-INSTRUCTION MATERIALS	1
Guidelines For Students	1
Guidelines For Instructors	2
INTRODUCTION	4
Background.....	4
What You Will Learn	5
LESSON ONE	6
Objective	6
Where And How To Practice	6
How Well You Must Do	6
Things You Need	6
Getting There--Steps.....	7
Exercises	10
LESSON TWO	11
Objective	11
Where And How To Practice	11
How Well You Must Do	11
Things You Need	11
Getting There--Steps.....	12
Exercises	17
LESSON THREE	18
Objective	18
Where And How To Practice	18
How Well You Must Do	18
Things You Need	18
Getting There--Steps.....	19
Exercises	24
PERFORMANCE TEST	26
Assembling And Preparing Equipment For Calibration	26
Calibrating A Sampling Train.....	28
REFERENCES	29

USING THESE SELF-INSTRUCTION MATERIALS

This self-instruction learning package or module is designed to allow both students and instructors flexibility of use. Although primarily intended for use in existing training programs, the module can be used by anyone interested in learning new skills or perking up old ones. Therefore, two sets of guidelines are presented--one set addressed to students and the other set addressed to instructors. First, find out how you, the student, should use the materials in this book.

GUIDELINES FOR STUDENTS

Take the Performance Test as a pretest.

When you pick up this book and work through it, your goal will not be a letter grade or a high score on an exam. Instead, you will work to develop skills that you can measure. You will not have to worry about how well someone else is doing. Before you start work on this book, you should, first, find out if you have sufficient skills to start training by reading through the section called PERFORMANCE TEST. If you think you can do all or most of the items in the test, ask your instructor to help you set up the equipment and obtain the accessories you will need to calibrate a personal air monitoring sampling train. To calculate timing accuracy for setting flow rates, you will need to be able to work with metric units and to solve simple algebraic equations. To gain these skills, you should have taken a high school level course in algebra, geometry, or physics, or have gained the equivalent experience of working such problems on the job.

Work on parts you need to practice.

If you do everything well, according to the criteria in the Performance Test guidelines, you will not need to spend time working on this module. If, after taking the Performance Test you discover there are parts of the module you need to practice, follow the key to each item in FOR FURTHER STUDY.

USING THESE SELF-INSTRUCTION MATERIALS

Work straight through each lesson in the order presented.

Should you decide to completely work through this book, begin with the INTRODUCTION and go straight through each of the three lessons. The lesson begins with the OBJECTIVE of the training. Follow the instruction for each part in the order presented. Practice each step in a lesson until you can do it according to the criteria stated for the step. At the end of a lesson, do the EXERCISES. When there are audiovisuals listed at the end of a lesson, ask your instructor for help in obtaining them.

Take the Performance Test as a posttest.

Finally, after you have mastered the Exercises, ask your instructor to watch you calibrate a personal monitoring sampling train. The guidelines in the Performance Test can be used as a posttest to evaluate the quality of your performance. Turn now to the Performance Test.

GUIDELINES FOR INSTRUCTORS

Approach

The approach of these materials is to provide the student with (1) the nomenclature and uses of the components in the sampling train; (2) procedures for preparing the pump, sampling devices, and bubble meter for calibration; and (3) procedures for actually calculating the flow of several sampling trains. The lessons are sequential in that the information presented in the previous lesson serves as a basis of skill development in a later lesson. Exercises are provided to guide the student's practice of the procedures presented in GETTING THERE--STEPS.

Use of the Performance Test

A Performance Test is provided to serve as a guide to skill development progress. If a student is able to demonstrate skill development by meeting the criteria for performance given in each test item, further study is not needed. Therefore, the student should be given the option of entering training at any point. To determine at what point to start, the student should take the Performance Test as a pretest. At any time during the course of study, the student should also be allowed to test out of the remaining portions of training. Finally, the student's capability to accurately complete the entire task in a timely manner can be evaluated by using the Performance Test as a posttest.

USING THESE SELF-INSTRUCTION MATERIALS

Independent Study

This module is designed to enable the student to work independently under whatever time constraints you deem reasonable. However, depending on the skill level of the students with whom you are working, you may find it desirable to start a group together at the same time with a demonstration and informal presentation on the contents of the module.

As a Laboratory Workbook

Alternatively, you may choose to use this module as a laboratory workbook in a structured laboratory session. With this option, you may allow students greater access to your assistance, especially in watching them perform the pre- and posttest portions of the training.

General Instructions

Read through each lesson to anticipate what equipment and supplies you will need to make available for students to use. Also, order any audiovisuals or reading materials you think may present a complementary perspective to the training in this module. Use the guidelines presented in the Performance Test as the minimum requirements for gauging successful completion of training.

Specific Instructions

Test the personal air sampling pumps the students will be using to make sure they are pumping within the manufacturer's allowable error range. If the pumping error is greater than this range, return the pump to the factory for maintenance. OSHA's IHFOM (see References) uses 5 percent as the allowable pumping error. Ensuring that pumps work within the allowable error will avoid possible problems the students may encounter in obtaining expected flow rates and in calculating timing accuracies.

INTRODUCTION

BACKGROUND

Wherever workers manufacture or produce goods, the possibility exists that the air they breathe can become contaminated. Exposure over months and years to even very small amounts of some gases, vapors, mists, and particulates can cause irritation, dermatitis, or, in some cases, prolonged or serious illnesses, including cancer. The Occupational Safety and Health Administration (OSHA), under authority from Congress, passes laws in an effort to protect the worker from hazards that are not always obvious. These occupational safety and health laws often require that workers' exposures to airborne contaminants be individually measured.

To determine how much of the airborne contaminants a worker might breathe in during the usual 8-hour workday, a pump and sampling device are attached to the worker. The pump is set to draw air through a sampling device at a specific flow rate. So that accurate measurements of a worker's exposure can be made, the pump and sampling device must be calibrated before and after sampling is done. The calibration is routinely performed by physically measuring how efficiently the pump can draw what volume of air in how much time. The rate of airflow per time is then calculated. The apparatus used to perform the calibration is a soapbubble meter consisting of a large laboratory buret and stand, flexible Tygon tubing, and soap solution.

INTRODUCTION

WHAT YOU WILL LEARN

When you finish working through the steps and exercises in this book, you will be able to calibrate any personal air monitoring pump using the soapbubble meter calibration method.

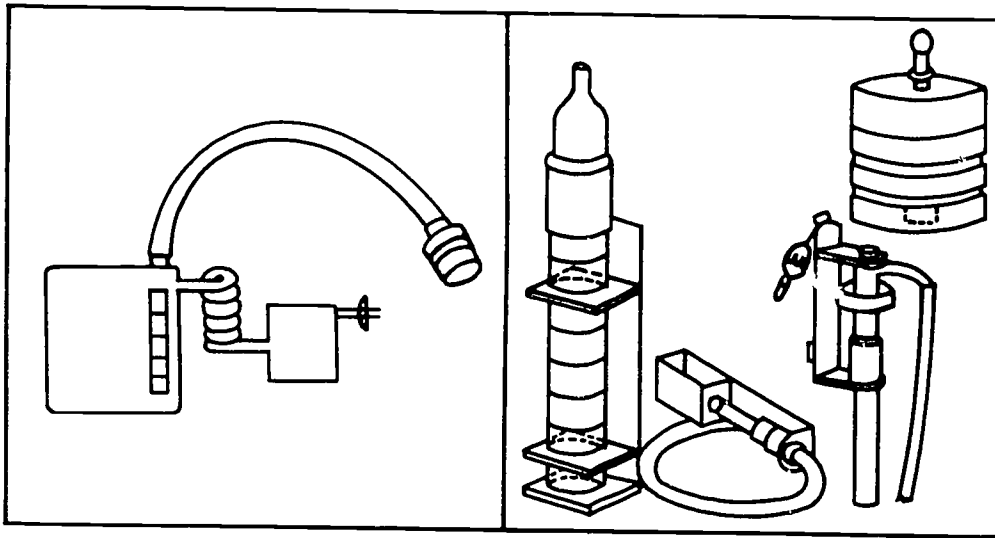

You will learn how to calibrate a personal sampling pump in three lessons:

o Lesson One

You will be able to name each part of the personal air monitoring assembly or sampling train, and the parts of the soapbubble meter calibration apparatus.

o Lesson Two

You will be able to assemble and prepare the sampling train and soapbubble meter for calibration.

o Lesson Three

Using a soapbubble meter, you will be able to calibrate a sampling train, including a personal air sampling pump and filter cassette.

LESSON ONE

OBJECTIVE

You will be able to name each part of the personal air monitoring assembly or sampling train, and the parts of the soapbubble meter calibration apparatus.

WHERE AND HOW TO PRACTICE

You will need a table, a laboratory bench, or any other flat, sturdy surface on which to set the equipment. Practice labeling diagrams of the equipment to learn the names of each part and how it is used in the sampling train.

HOW WELL YOU MUST DO

You must be able to correctly label each diagram in the exercises and to correctly tell how each part works or is used in the sampling train. You should be able to do this in less than 10 minutes.

THINGS YOU NEED

The availability of approved full range (25 milliliters to 4 liters) flow personal sampling pumps is increasing. However, several of the routinely used pumps are either low (25-200 ml) or high (1-4 liters) flow pumps. Therefore, you should learn how to use the full range, low, and high flow pumps, although it is not necessary to do so. If all of the pumps in the following list are available, practice using each one.

- o Personal air monitoring pumps with battery chargers
 - high flow such as the MSA Model G
 - low flow such as the MSA Model C-200
 - full flow range such as the Bendix BD44 and Sipin pump
- o Sampling devices and accessories
 - filter cassette containing preweighed filter and backup pad, 37-mm diameter
- o Soapbubble meter
 - buret stand
 - buret clamps (2)
 - buret, 1,000-ml with hose connection
 - beaker, flat-bottomed shallow dish (petri)
 - soap solution
 - Tygon tubing, 1/4-inch inside diameter; 2 pieces:
8 and 30 inches.

Instructions: Now turn to the next page and begin work on Lesson One, "Getting There--Steps."

GETTING THERE--STEPS

STEP 1

The personal air monitoring assembly or sampling train consists of a portable pump (1) for drawing air through tubing (2) that connects the pump with a sampling attachment or device (3). Before the pump is calibrated and used to monitor personal exposures, its electrical supply is recharged through use of a battery charger (4).

KEY POINT 1

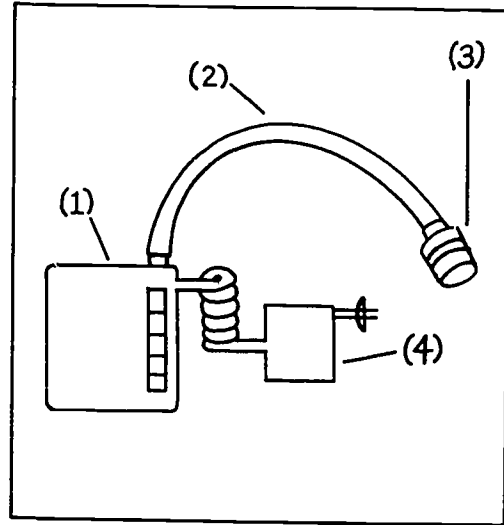

The sampling train has three components.

STEP 2

Pumps are designed to draw air through the sampling train at either a low rate volume or a high rate volume. Using a low flow pump, the flow can be adjusted to draw as little as 25 milliliters (ml) of air up to 200 ml. The high flow pump has a pumping range of 1-3 or 1-4 liters of air.

KEY POINT 2

The pumping range of low flow pumps is 25-200 ml and that of high flow pumps is 1-3 or 1-4 liters.

LESSON ONE

STEP 3

Find the following parts on the pump you are working with: the on-off switch (1), usually pushbutton operated; the air inlet fitting (2) to attach the sampling tube; the air outlet (3); the airflow indicator, a rotameter (4) or a digital readout meter (4a); the flow adjustment screw (5); the receptacle for the battery charger (6); and the belt fastener (7) for attaching the pump to the worker you are monitoring.

KEY POINT 3

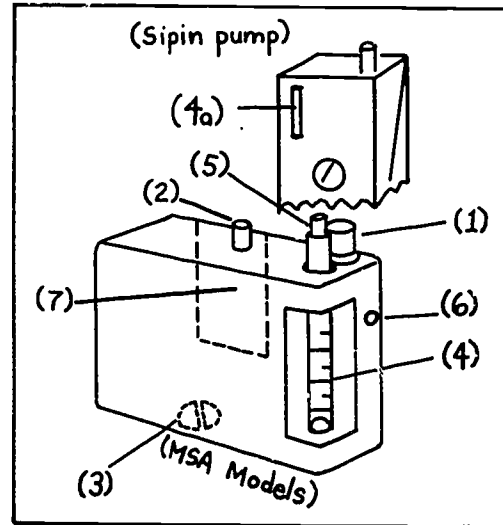

These features are common to most pumps. Refer to the operating instructions for more detail on your pump.

STEP 4

There are four types of sampling devices that can be used with the portable sampling or air monitoring pump: the charcoal tube and holder (1) for vapors; the respirable dust sampler (2) for sampling dusts that can become trapped in the lungs; the midget impinger (3) containing a liquid for collecting particles, gases, or vapors; and the plastic filter cassette (4) for collecting total dust samples.

KEY POINT 4

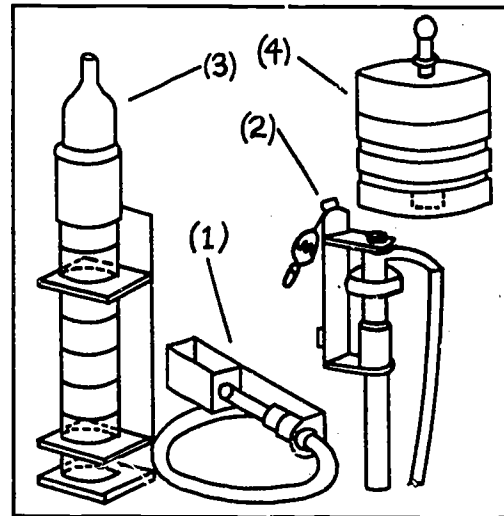

The size and shape of sampling devices may vary from manufacturer to manufacturer.

LESSON ONE

STEP 5

Tubing is the third major component of the sampling train. Usually, flexible Tygon tubing is used because it does not become brittle and break when substances in the air come in contact with it. Tubing should make a tight seal where it connects the pump with the sampling device.

STEP 6

The soapbubble meter consists of a buret stand (1); a 1,000-ml buret (2); two buret clamps (3); a beaker (4) or shallow, flat-bottomed dish such as a petri dish (5); and soap solution (6).

KEY POINT 5

Check tubing for leaks.

KEY POINT 6

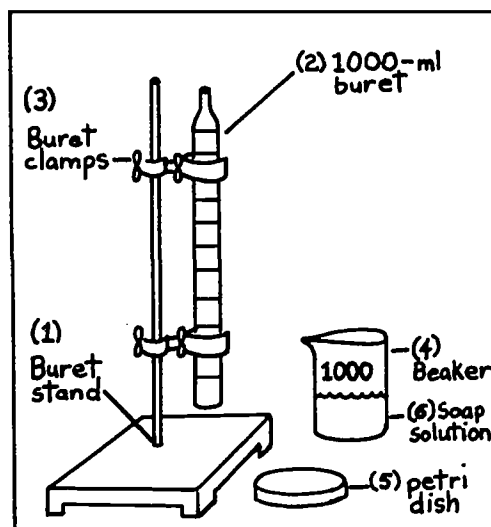

These are common components of a soapbubble meter.

LESSON ONE

EXERCISES

Instruction 1: With the sampling and calibration equipment in front of you, practice naming each part of each piece. Then label the following drawings to test your knowledge.

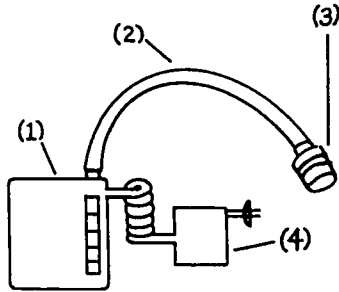

- (1) _____
- (2) _____
- (3) _____
- (4) _____

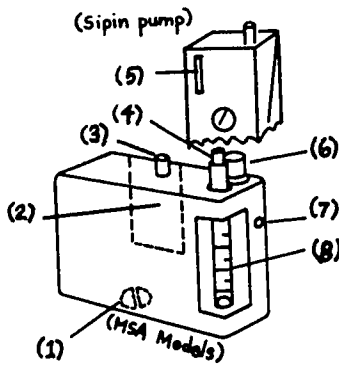

- (1) _____
- (2) _____
- (3) _____
- (4) _____
- (5) _____
- (6) _____
- (7) _____
- (8) _____

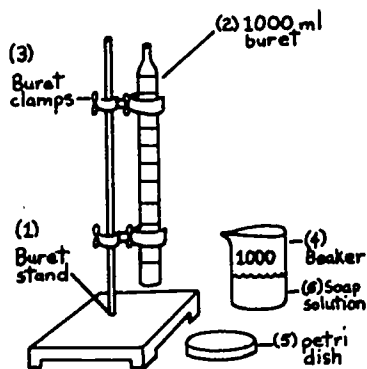

- (1) _____
- (2) _____
- (3) _____
- (4) _____
- (5) _____
- (6) _____

Instruction 2: When you can correctly label each part of each drawing in this exercise, you are ready to begin work on Lesson Two.

LESSON TWO

OBJECTIVE

You will be able to assemble and prepare the personal air monitoring sampling train and soapbubble meter for calibration.

WHERE AND HOW TO PRACTICE

Use the location specified in Lesson One to continue work presented in this lesson. A 110-AC outlet should be available to recharge the pump batteries. Read through the steps in Lesson Two and the exercises at the end of it before starting to work. As you go through the lesson, make sure you understand and can do each step before going on to the next one.

HOW WELL YOU MUST DO

You must be able to put the sampling train and soapbubble meter together so that all components needing support are firmly attached to prevent any air leaks from occurring where tubing joins components together into a system, and to prevent kinking of tubing. (You should be able to assemble a working sampling train within 15 minutes, using the equipment required in the lesson.) You must also be able to get a soapbubble to travel the entire length of the buret without breaking.

THINGS YOU NEED

You will need all of the equipment and supplies used in Lesson One.

Instructions: Now turn to the next page and begin work on Lesson Two, "Getting There--Steps."

GETTING THERE--STEPS

STEP 1

The day before you use any portable pump, recharge the pump's batteries. Follow the manufacturer's instructions for battery recharging time and for operating the charging unit. Many pumps need 16 hours for recharging. When recharging is complete, run the pump for 5 minutes to let it warm up before calibrating.

KEY POINT 1

Fully recharge the batteries of a portable pump before calibration.

STEP 2

Use a preweighed filter cassette containing a clean membrane filter and backup pad. Note the direction in which air flows through the cassette. Your instructor will assist you if the airflow is not clearly indicated.

KEY POINT 2

Be sure to use a preweighed filter cassette containing a clean filter and backup pad.

STEP 3

Assemble the soapbubble meter. Tighten the buret stand shaft by turning it into the base. Fasten two buret clamps on the shaft-- one at a point one-fourth of the way down the shaft (1) and the other at a point three-fourths of the way down the shaft (2).

KEY POINT 3

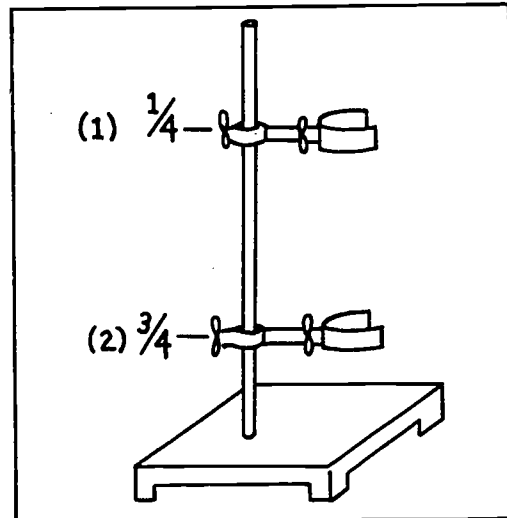

Fasten the support equipment tightly.

STEP 4

Prepare the buret for calibration. Completely rinse the inside of the buret with soap solution. Immediately turn it upside down. Note that in the inverted position the 0-ml mark will be the zeroing line, and the 1,000-ml mark will be the finishing line. Position the buret in the buret clamps so the mouth is about an inch above the soap solution. Adjust the clamps so the jaws keep the buret from falling, but not too tightly to cause it to crack.

KEY POINT 4

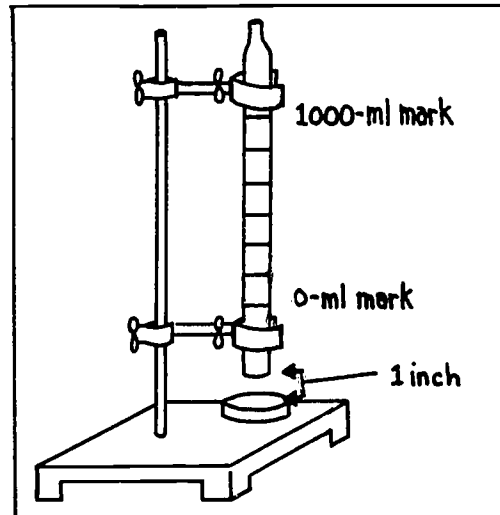

Rinse the buret and place it upside down.

LESSON TWO

STEP 5

Connect one end of a 30-inch piece of Tygon tubing to the inlet of the pump (1). Connect the other end to the outlet end of the closed filter cassette (2). The pump draws air through the sampling device. Air is exhausted through an outlet on the bottom of the pump (3). See item 3, Step 3, Lesson One.

KEY POINT 5

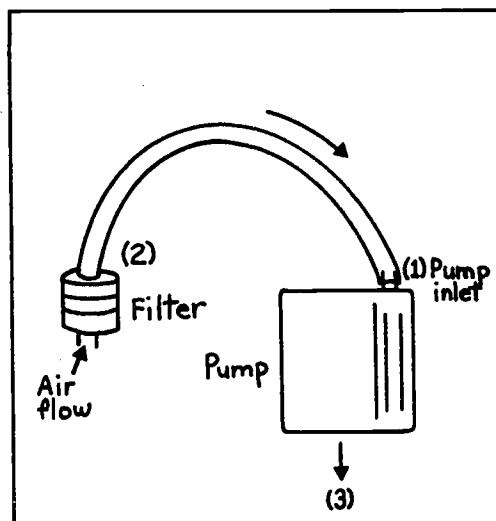

Connect the tubing so that air flows into the sampling device through the tubing and into the pump.

STEP 6

Attach one end of an 8-inch piece of Tygon tubing to the hose connection (1) of the buret and the other end to the inlet end (2) of the filter cassette.

KEY POINT 6

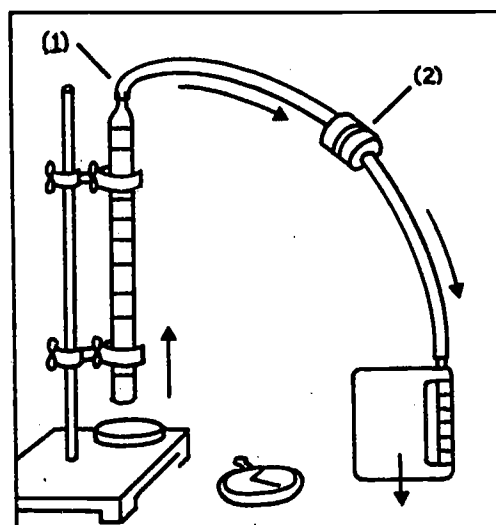

Make sure you correctly identify the inlet and outlet of each sampling train component.

LESSON TWO

STEP 7

Turn on the pump. Make sure the soap solution container is filled. Form a bubble in the buret by raising the soap solution dish until the buret mouth is just below the surface of the solution (1). Quickly lower the dish (2). A bubble should have formed and begun to rise in the buret through the sucking action of the pump. Draw two or three bubbles up the buret to make sure that at least one bubble makes it to the 1,000-ml mark.

KEY POINT 7

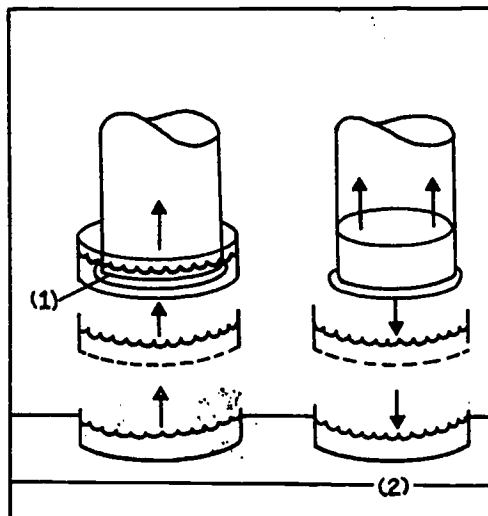

Submerge the buret mouth only briefly in the soap solution.

STEP 8

If you cannot get a bubble to rise to the 1,000-ml mark, wet the buret walls with soap solution. A stronger soap solution may also be needed. Try these remedies and repeat Step 9 until you can get two or three bubbles to rise to the 1,000-ml mark each time you try.

KEY POINT 8

If the bubbles do not rise, wet the buret with soap solution and/or make the solution stronger.

LESSON TWO

STEP 9

Test for air leaks between fittings and tubing on the bubble meter, the filter cassette, and the pump. Turn on the pump. Lift the flat dish to the mouth of the buret so that the lip is just in the solution. Quickly lower the dish and add a small amount of soap solution to each joint. If bubbles occur, turn off the pump. Check the tubing size and push the tubing further onto the fittings.

STEP 10

Check the tubing to make sure it is not kinked (1). Kinking could occur particularly at the joint where the 8-inch tubing connects the sampling device with the buret. If tubing is kinked at this point, tape it (2) to the buret stand shaft to keep the air line open.

KEY POINT 9

Check for air leaks between fittings and tubing at each joint.

KEY POINT 10

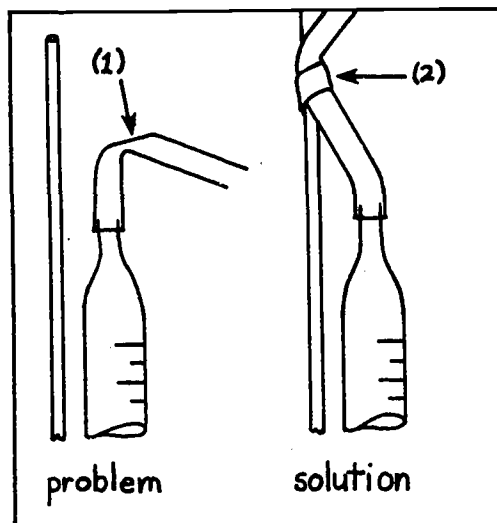

Remove the kink by supporting the tubing on the buret stand shaft.

LESSON TWO

EXERCISES

Instructions: Repeat all of the steps so that you can prepare the apparatus for calibration in less than 15 minutes.

LESSON THREE

OBJECTIVE

Using a soapbubble meter, you will be able to calibrate a personal air sampling train, including a personal air sampling pump and filter cassette.

WHERE AND HOW TO PRACTICE

Practice at the same location as in previous lessons. Practice each step in this lesson until you can achieve the timing accuracy stated in "How Well You Must Do."

HOW WELL YOU MUST DO

For this lesson, your timing accuracy at 2 liters per minute (lpm) must be ± 1 second of the time the pump is expected to take to draw the desired volume of air. You should be able to calibrate the sampling train in less than 25 minutes.

THINGS YOU NEED

In addition to the equipment and supplies you have already used, you will need the following:

- o stopwatch
- o small screwdriver
- o masking tape, 1/2-inch wide
- o small notebook.

Instructions: Now turn to the next page and begin work on Lesson Three, "Getting There--Steps."

GETTING THERE--STEPS

STEP 1

The purpose of calibration is to adjust the pump when a particular flow rate is desired. The recommended flow rate for sampling with a filter cassette is 1-2 lpm.

KEY POINT 1

The purpose of calibration is to adjust the pump to draw a desired volume of air.

STEP 2

In the manufacturer's instructions, find the accuracy of the pump you are using. The accuracy is usually $\pm 5-10$ percent of the volume the pump is expected to draw at any setting in the pumping range. Expressed in a different way, the pump operates with an allowable pumping error of 5-10 percent. This error is added to the error caused when samples are analyzed. In calibrating the pump, the volume will be the same for successive trial runs; however, timing of the bubble rise will be affected by the pumping error.

KEY POINT 2

For many personal air sampling pumps, the allowable pumping error is between 5 and 10 percent.

LESSON THREE

STEP 3

Another error that is introduced is timing error. It is likely you will introduce timing error when you use the stopwatch to time the rise of the bubble in the buret. To minimize error during calibration, your timing accuracy must be ± 1 second at a flow setting of 2.0 lpm to be within 5 percent of the pumping error. Therefore, it should take 30 seconds ± 1 second for the bubble to rise 1,000 ml. The time calculated using the formula in Key Point 3 is based on the assumption that at 1.0 lpm it would take the bubble 60 seconds to rise 1.0 liter.

STEP 4

Place the sampling pump in an upright position and turn it on. Adjust the airflow of the pump by turning the flow adjustment screw (1) so the rotameter ball is in line with an index mark on the rotameter scale you believe may correspond to an airflow of approximately 2.0 lpm. Since the object of calibrating the sampling train with the bubble meter is to find what marking on the rotameter scale corresponds to air flowing through the system, this initial alignment is only temporary. Keep the pump running for at least 5 minutes before beginning calibration.

KEY POINT 3

Time for a bubble to rise
1,000 ml at 2.0 lpm:

$$\frac{1.0 \times 60 \text{ sec}}{2.0 \text{ liters}} = 30 \text{ sec}$$

Because the timing accuracy is ± 1 second, the timing range at a 2.0 lpm setting is 29-31 seconds.

KEY POINT 4

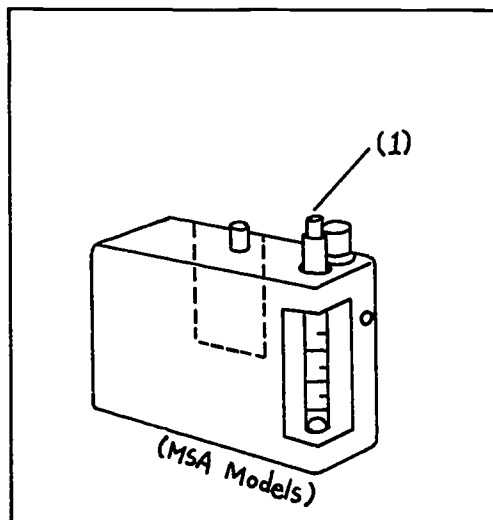

Index marks on the pump's rotameter scale do not indicate an actual flow setting.

LESSON THREE

STEP 5

Pick up the stopwatch. With the pump running, form at least three bubbles as you did in Lesson Two. Pick a bubble to watch. Start the trial run when the bubble edge is in line with the 0-ml mark on the buret. Stop timing the instant the bubble reaches the 1,000-ml mark. Record the time for the trial run here: _____.

If the time you recorded is greater than 31 seconds or less than 29 seconds, readjust the pump flow and repeat the step.

STEP 6

Repeat Step 5 three more times at the setting at which you finally adjusted the pump. Record each timing here:

1st timing: _____ sec
2nd timing: _____ sec
3rd timing: _____ sec
Average time: _____ sec

If the average is greater than 31 seconds or less than 29 seconds, readjust the pump flow and repeat this step.

KEY POINT 5

Do a trial timing to obtain a coarse adjustment.

KEY POINT 6

Obtain the average flow after three runs at the same adjustment.

LESSON THREE

STEP 7

At the final setting and with the pump still running, put a piece of masking tape (1) on the pump's rotameter scale close to the point where the rotameter ball is floating. Find the center (2) of the ball and draw a corresponding line (3) on the tape. The painted index mark on the rotameter scale may or may not correspond to the mark you make on the tape.

KEY POINT 7

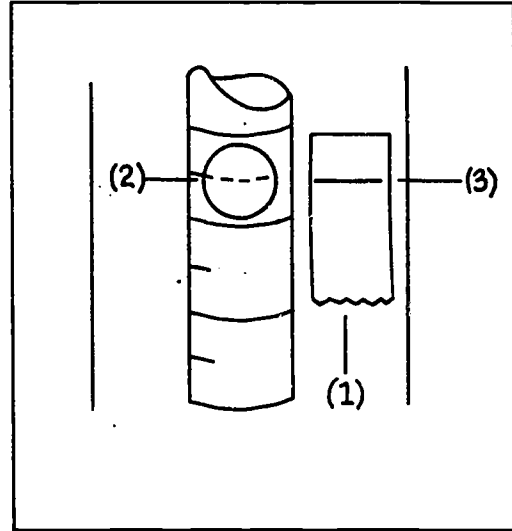

Make a mark on the tape to show where the center of the rotameter ball should be when the pump is drawing the desired flow rate.

LESSON THREE

STEP 8

Keep a complete record of the calibration procedure. In your notebook, record the date, time, serial number of the pump calibrated, and the description of the sampling device used in the sampling train. Then record the information you obtained in Step 6.

KEY POINT 8

Always document the calibration procedure.

EXERCISES

Instruction 1: Calculate and record, in the spaces provided, the time for a bubble to rise in a 1,000-ml buret at these flow rates:

1.0 lpm _____

1.5 lpm _____

2.0 lpm _____

Instruction 2: Adjust the flow so the pump draws at the flow rates listed in Instruction 1.

Instruction 3: Obtain timing data for a trial run (TR) and three consecutive runs (CR) for each of the flow rates in Instruction 1. Record the data here:

	<u>1.0 lpm</u>		<u>1.5 lpm</u>
	<u>Seconds</u>		<u>Seconds</u>
TR	_____	TR	_____
CR No. 1	_____	CR No. 1	_____
CR No. 2	_____	CR No. 2	_____
CR No. 3	_____	CR No. 3	_____
	<u>2.0 lpm</u>		
	<u>Seconds</u>		
TR	_____		
CR No. 1	_____		
CR No. 2	_____		
CR No. 3	_____		

Instruction 4: For each of the flow rates, 1.0, 1.5, and 2.0, place a piece of tape on the pump's rotameter scale at the point where the ball floats. Mark the tape each time you change the calibration flow.

LESSON THREE/EXERCISES

Instruction 5: Practice calibrating a sampling pump with a midget impinger and charcoal tube. Your instructor will have to give you directions for making up the fluid media for the impinger. Use a maximum flow rate of 1 lpm with the impinger. To calibrate the charcoal tube, you will need a 100-ml buret; use a flow rate between 0.05 and 0.2 lpm. For each flow rate determine the time it should take a bubble to travel the length of the calibration buret. Record the expected time next to the type of sampling device you will calibrate:

<u>Sampling Device</u>	<u>Expected Time</u>
a. charcoal tube	_____
b. midget impinger	_____

Instruction 6: In the following spaces, record the elapsed time for each trial run (TR) and consecutive run (CR):

a. charcoal tube	TR	_____
	CR No. 1	_____
	CR No. 2	_____
	CR No. 3	_____
b. midget impinger	TR	_____
	CR No. 1	_____
	CR No. 2	_____
	CR No. 3	_____

If you are having difficulty timing each run to within ± 1 second, practice timing each run at ± 1 second a few times. Ask your instructor for assistance if you are not able to do better. It is possible the pump is too badly worn to be accurately calibrated.

Instruction 7: Develop a complete record for each sampling device you calibrate.

PERFORMANCE TEST

Instructions: Check your skill level or progress by working through each of the items in this test. If you can perform each item as required, place a check in the space provided. When all of the items are checked, you are ready to demonstrate your skills to your instructor. You may use the following list if needed. You will be considered trained in a skill after your instructor approves your performance of each of the following items:

ASSEMBLING AND PREPARING EQUIPMENT FOR CALIBRATION

- No. 1 Allow a fully recharged pump to run 5 minutes before using.
- No. 2 Select a preweighed filter cassette containing uncontaminated membrane filter and pad.
- No. 3 Fasten two buret clamps at points one-fourth and three-fourths of the way down a tightened buret stand shaft.
- No. 4 Rinse the buret with soap solution and position it upside down 1 inch above the soap solution container.
- No. 5 Connect the sampling device to other components in the sampling train while observing the correct direction of flow.
- No. 6 Set up sampling trains for use with a closed filter cassette, charcoal tube, or midget impinger.
- No. 7 Check for air leaks in the sampling train.
- No. 8 Check and correct tubing for kinks.
- No. 9 Draw two or three bubbles through the entire length of the buret.
- No. 10 Complete items 1 through 9 in 25 minutes.

PERFORMANCE TEST

FOR FURTHER STUDY

If you could not perform one or more of the 10 items above, review and practice the following lesson steps:

No. 1
Lesson Two, Step 1

No. 2
Lesson Two, Step 2

No. 3
Lesson Two, Step 3

No. 4
Lesson Two, Step 4

No. 5
Lesson Two, Steps 2, 5, 6, 7

No. 6
Lesson Two, Steps 5 and 6

No. 7
Lesson Two, Step 8

No. 8
Lesson Two, Step 9

No. 9
Lesson Two, Steps 10 and 11

No. 10
Practice all Steps in Lesson Two.

PERFORMANCE TEST

CALIBRATING A SAMPLING TRAIN

- No. 1 _____ Calculate the time for a bubble to rise from the 0-ml mark to the 1,000-ml mark in a bubble meter when the pump is adjusted to draw 2.0 lpm.
- No. 2 _____ Adjust the pump to draw 2.0 lpm so that the time the bubble travels from the 0-ml mark to the 1,000-ml mark is within +1 second of the time you calculated in the previous test item.
- No. 3 _____ After making the final flow adjustment, place a piece of tape on the rotameter scale next to where the rotameter ball floats; mark the tape to indicate the final flow setting.
- No. 4 _____ Record all calibration data in a notebook.

FOR FURTHER STUDY

If you could not perform one or more of the four items above, review and practice the following lesson steps:

No. 1
Lesson Three, Step 3

No. 2
Lesson Three, Steps 4 through 6

No. 3
Lesson Three, Step 7

No. 4
Lesson Three, Step 8

REFERENCES

U.S. DOL, Industrial Hygiene Field Operation Manual (IHFOM), OSHA
Instruction CPL 2-2.20, April 2, 1979.