

ED 198 280

CE 027 916

AUTHOR Bruwelheide, Kenneth L.  
 TITLE Assisting the Physically Handicapped: An Identification and Development of Apparatus for Laboratory Shops. Phase I.  
 INSTITUTION Montana State Univ., Bozeman. Dept. of Agricultural and Industrial Education.  
 SPONS AGENCY Montana State Dept. of Public Instruction, Helena.  
 PUB DATE 79  
 NOTE 230p.

EDRS PRICE MF01/PC10 Plus Postage.  
 DESCRIPTORS \*Accessibility (for Disabled); Educational Legislation; Equipment Evaluation; \*Equipment Utilization; Federal Legislation; \*Hand Tools; Individualized Education Programs; Industrial Arts; Literature Reviews; Machine Tools; Mainstreaming; Metal Working; Mobility Aids; Models; \*Physical Disabilities; Safety Equipment; School Shops; Secondary Education; \*Shop Curriculum; Student Evaluation; Woodworking

## ABSTRACT

A study was conducted to identify and develop instructional aids in the form of physical apparatus that would permit students with physical handicaps and/or limitations to have greater access to laboratory-shop courses in Montana secondary schools. Steps taken in carrying out the study included the following: (1) identifying the physically handicapped population in public school; (2) summarizing legislation pertinent to public education of the handicapped; (3) developing apparatus that will permit physically handicapped students to use selected tools and equipment; (4) developing a set of working drawings of such apparatus; and (5) developing an assessment and implementation model of handicaps and programs for teacher use. Methodology included literature review, testing tools, and designing special apparatus with a group of handicapped students from Montana State University. Recommendations generated by the study include more teacher preservice and inservice education concerning working with handicapped students, testing with a broader range of handicaps, and testing a different or more complex set of tools. Appendixes include lists of tools used in the test and a teacher's guide to handicapped student assessment and apparatus implementation. (KC)

\*\*\*\*\*  
 \* Reproductions supplied by EDRS are the best that can be made \*  
 \* from the original document. \*  
 \*\*\*\*\*

ED198280

ASSISTING THE PHYSICALLY HANDICAPPED:  
AN IDENTIFICATION AND DEVELOPMENT OF  
APPARATUS FOR LABORATORY SHOPS  
PHASE I

By

KENNETH L. BRUWELHEIDE, Ed.D

Department of Agricultural and Industrial  
Education

MONTANA STATE UNIVERSITY  
Bozeman, Montana

1979

U.S. DEPARTMENT OF HEALTH,  
EDUCATION & WELFARE  
NATIONAL INSTITUTE OF  
EDUCATION

THIS DOCUMENT HAS BEEN REPRO-  
DUCED EXACTLY AS RECEIVED FROM  
THE PERSON OR ORGANIZATION ORIGIN-  
ATING IT. POINTS OF VIEW OR OPINIONS  
STATED DO NOT NECESSARILY REPRESENT OFFICIAL NATIONAL INSTITUTE OF  
EDUCATION POSITION OR POLICY

CE 027916

The findings in this report are the results of a research project sponsored by federal funds administered by the Office of Public Instruction of Montana. Grantees undertaking such projects are encouraged to express freely their professional judgement. Statements in the report do not, therefore, represent official OPI position or policy.

## ACKNOWLEDGEMENTS

I greatly appreciate the support given to this study by the Office of Public Instruction of the State of Montana, Helena, and, in particular, to Mr. Jim Golden, Vocational Special Needs Consultant of that office. Heartfelt thanks is extended to those members of Wheel-chairs, Crutches, and People, Montana State University, whose time, effort, and expertise made the applied research portion of this study possible.

Additional thanks is given to the Department of Agricultural and Industrial Education, Montana State University, and, in particular, to Dr. Max Amberson, Chairman, for continual supportive services and encouragement. And finally to Stuart L. Aasgaard my appreciation for his interest, insights and technical competence on building and testing the assistive apparatus developed in this project.

Kenneth L. Bruwelheide, Ed.D.

## TABLE OF CONTENTS

	Page
ACKNOWLEDGEMENTS. . . . .	ii
LIST OF TABLES. . . . .	vi
LIST OF FIGURES . . . . .	viii
 Chapter	
I. INTRODUCTION . . . . .	1
Statement of the Problem	
Purpose of the Study	
Procedure	
Sources of Data and Method of Study	
Limitations	
Definitions	
Summary	
II. REVIEW OF LITERATURE . . . . .	13
Introduction	
Part I: A Basis for Understanding the Physically Handicapped	
Who is Handicapped and What Does That Mean?	
Part II: Legislation for the Handicapped	
1954 - Brown vs. Board of Education	
The Vocational Education Act of 1963	
The Vocational Education Amendments of 1968	
The 1973 Vocational Rehabilitation Act	
The Education for All Handicapped Children Act of 1975	
Part III: Meeting the Educational Needs of The Handicapped Through Teacher Education	
Summary	
III. METHOD OF PROCEDURE. . . . .	64

## TABLE OF CONTENTS (Continued)

Chapter	Page
Introduction	
Review of Literature	
Selection of the Population	
Development of Assistive Apparatus	
Development of the Test Instrument	
Data Collection	
Analysis of Data	
Summary	
IV. PRESENTATION OF THE DATA . . . . .	71
Development of the Instrument	
Test Group Members	
Description of Test Group Members	
Presentation of the Data	
Measuring Tools	
Hand Tools	
Portable Electric Tools	
Stationary Power Tools	
Summary	
V. SUMMARY, CONCLUSIONS, AND RECOMMENDATIONS	109
Summary of the Study Need for the Study	
The Problem	
Purpose and Objectives	
Review of Literature	
Method of Procedure	
Summary of Findings	
Conclusions	
Recommendations	
Recommendations for Further Study	
BIBLIOGRAPHY . . . . .	123
APPENDICES . . . . .	128
Appendix A: Listing of Tools and Equipment Commonly Found in Industrial	

## TABLE OF CONTENTS (Continued)

## APPENDICES (Continued)

- Arts and Agricultural Mechanics  
Programs In Montana
- Appendix B: Test Instruments and Summary  
Sheets
- Appendix C: Listing of Tools and Equipment  
Selected for Laboratory Tests  
With Handicapped Test Groups
- Appendix D: Handicapped Student Assessment  
and Apparatus Implementation  
Information

## LIST OF TABLES

Table	Page
1. Public Law 94-142, The Education for All Handicapped Children Act of 1975, Provisions and Implications. . . . .	41
2. Tool Item 1, Combination Square . . . . .	78
3. Tool Item 2, Tri-Square . . . . .	79
4. Tool Item 3, 36" Rule . . . . .	79
5. Tool Item 4, Carpenters' Square . . . . .	80
6. Tool Item 5, Scratch Awl. . . . .	81
7. Tool Item 6, Tape Measure-Lockable. . . . .	81
8. Tool Item 7, Dividers . . . . .	82
9. Tool Item 8, Cross-Cut Saw. . . . .	83
10. Tool Item 9, Back -Saw . . . . .	84
11. Tool Item 10, Coping Saw. . . . .	85
12. Tool Item 11, Woodworking Bench Vise. . . . .	85
13. Tool Item 12, Hand Drill. . . . .	86
14. Tool Item 13, Bit and Brace . . . . .	87
15. Tool Item 14, Wood and/or Metal File. . . . .	87
16. Tool Item 15, Wood Rasp . . . . .	88
17. Tool Item 16, Sure-Form Rasp. . . . .	89
18. Tool Item 17, Block Plane . . . . .	89



## LIST OF TABLE (Continued)

Table	Page
19. Tool Item 18, Smooth-Plane. . . . .	90
20. Tool Item 19, Claw Hammer - 13 oz . . . . .	91
21. Tool Item 20, Nail Set. . . . .	91
22. Tool Item 21, Wood Chisel . . . . .	92
23. Tool Item 22, Spoke Shave . . . . .	93
24. Tool Item 23, Screwdriver . . . . .	93
25. Tool Item 24, Tin Snips . . . . .	94
26. Tool Item 25, Aviation Snips. . . . .	95
27. Tool Item 26, Pop Rivet Gun . . . . .	95
28. Tool Item 27, Slip Joint Pliers . . . . .	96
29. Tool Item 28, Hacksaw . . . . .	97
30. Tool Item 29, Electric Orbital Saw. . . . .	98
31. Tool Item 30, Portable Electric Drill ( $\frac{1}{4}$ " ). . . . .	99
32. Tool Item 31, Sabre Saw . . . . .	100
33. Tool Item 32, Belt Sander . . . . .	100
34. Tool Item 33, Router. . . . .	101
35. Tool Item 34, Table Saw . . . . .	102
36. Tool Item 35, Radial Arm Saw. . . . .	103
37. Tool Item 36, Drill Press . . . . .	104
38. Tool Item 37, Scroll Saw (Jig Saw). . . . .	104
39. Tool Item 38, Jointer (4"). . . . .	105
40. Tool Item 39, Wood Lathe. . . . .	106

LIST OF FIGURES

Figure	Page
1. Interdisciplinary Model for Teacher Education. . . . .	58

## CHAPTER I

### INTRODUCTION

Historically, the handicapped have been a misunderstood and somewhat hidden segment of our population. In the past, society has grouped all disabilities in one category labeled "handicapped" and due to a level of non-understanding has separated these individuals into groups for various activities. "Public education which would be able to do a great deal for the handicapped has in the past continued this separation of handicapped students from their peers and placed them in special classes." (Stewart, 1979).

In the arena of public education and subsequently, in society as a whole, there is now new hope for the handicapped or disabled individual. This new hope comes in the form of the Education For All Handicapped Children Act known officially as Public Law 94-142. This piece of federal legislation has been lauded as the most significant educational legislation of this century. The major thrust of P.L. 94-142 is to "guarantee a free appropriate public education for all handicapped children, ages 3 to 21." (Hull, 1977, p. 7). The ramifications of this legislation

both stated and implied are far-reaching and significant in their effect on public education and society as a whole. Every public law has accompanying regulations. Regulations are promulgated to carry out the intent of the law. On August 23, 1977, the final regulations for P.L. 94-142 were put in effect by public declaration; the regulations specific purposes are to (Strully, 1978, p. 55):

Insure that all handicapped children have available to them a free appropriate public education which includes special education and related services to meet their unique needs, to insure that the rights of handicapped children and their parents are protected, to assist states and localities to provide for the education of handicapped children, and to assess and insure the effectiveness of efforts to educate these children.

Both the law and the regulations are very clear on their intent; however, only the handicapped students, their parents, and professional educators working together will make the law a reality.

Implications of P.L. 94-142 for  
Industrial Arts and Vocational Education

In developing education programs for the handicapped, the following ideal, as stated by vocational teacher-educator Marc E. Hull (1977, p. 3) should be recognized:

If we can accept the premise that all persons

are vocationally limited (or handicapped), then denying any particular group access to appropriate vocational education solely on the basis of a handicap constitutes an act of discrimination. And, as many school districts have learned, or will ultimately learn, discrimination in any form is much too costly to perpetuate at public expense.

The major purpose of general education and, specifically, vocational education is to prepare our youth to function independently in and contribute to our society. "Education for the good life has been a basic philosophical tenant in the United States since the mid nineteenth century." (Young, et al., 1969). The good life has been defined differently by various groups over the years but a commonly held view is that independent, economic viability is basic to the good life of all individuals.

In relating to the role of vocational education in preparing for the food and independent life Phelps (1976, p. 1) indicates, "Education leading to an independent occupational role has been a major part of the educational endeavors in most free societies." Vocational education and the pre-vocational instructional areas of industrial arts education can play an integral role in preparing non-handicapped individuals as well as handicapped people for independent contributing lives in society. Supporting this premise Hull (1977, p. 3) states:

Possessing marketable vocational skills is one of the most impressive credentials that anyone can present to a prospective employer. For the handicapped, possessing marketable skills is proof of their ability to reduce the anxieties that employers express about hiring the handicapped. Participation in vocational education, therefore, could be viewed as an essential pathway to employment for many handicapped persons especially for individuals whose formal education will terminate with high school. Many handicapped persons have come to regard vocational preparation as a basic necessity, which is yet another appropriate rationale for serving the handicapped in vocational education.

The commitment to place handicapped individuals into regular school classroom settings is no longer one which school officials have the choice in making. The decision has been made through legislation. Administrators and teachers are now faced with the tasks of integrating, or main streaming, handicapped students into educational programs so that handicapped individuals may take advantage of the appropriate public education of their choice.

Barriers to this integration are many and varied in form. The most obvious of these are physical barriers such as stairs and multiple level school buildings which prohibit handicapped students from reaching classrooms and laboratories. Interestingly enough, these types of physical barriers are often the easiest to remove.

The greatest barriers may be those which are not immediately seen, those of administrator and teacher attitude, anxiety, and non-understanding of the handicapped individual. Barriers also extend to the laboratory-shop classroom setting where provisions must be made for proper and safe use of tools and equipment associated with determined skills in laboratory instruction.

#### Statement of the Problem

At the present time, there are many industrial arts and vocational education programs in Montana faced with the mandate of providing adequate and proper laboratory-shop skill instruction for the physically handicapped student. There is a need to identify and develop apparatus to assist the physically handicapped gain access to and develop skills in laboratory-shop programs.

#### Purpose of the Study

The purpose of this study was five-fold:

1. Identify that segment of the public school population known as the handicapped and specifically, the physically handicapped.

2. Summarize legislation pertinent to public education of the handicapped.
3. Design, develop, and test apparatus that will permit physically handicapped individuals to properly, safely, and independently use shop tools and equipment commonly identified in industrial arts and vocational agriculture curriculum guides.
4. Develop a set of working drawings of the aforementioned apparatus for distribution to teachers of industrial arts and vocational agriculture.
5. Develop a model for teacher assessment of physically handicapped student capabilities, their limitations, and the instructional integration with determined technical skill instruction.

#### Procedure

The following list illustrates the procedure for this study:

1. Review of literature.
2. Review and interpretation of legislation pertinent to education of handicapped students.
3. Review curriculum guides developed in coordination



with the Montana State Office of Public Instruction in the instructional areas of industrial arts and vocational agriculture education pertaining to:

- A. Shop hand tools and power equipment commonly in use.
  - B. Hierarchy of laboratory-shop skills present in both curricular areas.
4. Identify a population of physically handicapped individuals to:
- A. Identify skill operations with hand and power tools which are difficult for individuals with physical handicaps.
  - B. Assist in the development of help-apparatus.
  - C. Serve as a final testing body for the developed help-apparatus.
5. Formulate, develop, and construct apparatus to assist physically handicapped individuals in using selected shop tools and power equipment.
6. Develop a set of drawing-plans of the developed apparatus for printing and distribution to teachers.
7. Develop a model for assessment of physically handicapped students pertinent to determining

limitations and use of selected shop tools and equipment.

### Sources of Data and Method of Study

In addition to a search of the available literature, information and data were collected from:

1. Education specialists in the area of special needs education.
2. Curriculum guides developed in coordination with the Office of Public Instruction, Helena, Montana.
3. A sample population of physically handicapped individuals represented by members of Wheelchairs, Crutches and People, Montana State University.

### Limitations

This study determined the following as limitations:

1. Geographic Area: The State of Montana. Like other states, Montana has a school population of physically handicapped students capable of benefiting from industrial arts and vocational education classes.
2. Population: Administrators, instructors, and physically handicapped students involved in

secondary industrial arts and vocational agriculture education laboratory-shop activities.

3. Physically handicapped: An orthopedic impairment which adversely affects a child's educational performance.
4. Skills: Educational performance activities (shop skills) determined to be an appropriate part of an industrial arts or vocational agriculture curriculum.

#### Definitions

Aids and/or Apparatus: Assistive devices developed to permit the physically handicapped individual to use selected tools and equipment.

Capabilities: Physical abilities which the orthopedically impaired possess.

Drawing - Plans: The mechanical, orthographic drawings and material lists of the developed aids and apparatus developed and printed for distribution to Montana teachers of industrial arts, vocational agriculture, and other related vocational subject areas.

Equipment: Portable and stationary units of powered equipment selected as common to the skill development

goals of industrial arts and the mechanics portion of vocational agriculture education.

Handicapped Child: A child evaluated as mentally retarded, hard-of-hearing, deaf, speech-impaired, visually handicapped, emotionally disturbed, orthopedically impaired, other health impaired or as having specific learning disabilities, who because of those impairments, needs special education and related services.

Laboratory-Shop: Educational facility in which industrial arts or vocational agriculture mechanics subjects are taught.

Limitations: A material or immaterial point beyond which a physically handicapped person does not or cannot extend his physical capabilities.

Orthopedically Impaired - Physically Handicapped:  
A severe orthopedic impairment which adversely affects a child's educational performance. The term includes but is not limited to impairment caused by congenital anomaly, impairments caused by disease, and impairments from other causes such as accidents.

Special Education: Specially designed instruction, given at no cost to parents or guardian, to meet the unique needs of a handicapped child, including but not

limited to classroom instruction, instruction in vocational and practical arts education, home instruction, and instruction in hospitals and institutions. The term includes but is not limited to speech pathology, audiology, occupational therapy, and physical therapy.

Tools: Hand-held and operated tools selected as common in meeting the skill development goals of industrial arts and the mechanics portion of vocational agriculture education.

### Summary

When viewing the benefits of industrial arts instruction in public schools, the American Industrial Arts Association (1972:26) indicates:

Industrial Arts. . .provides unique opportunities for students to participate in representative experiences in industrial processes and occupations.

In further relating to discovery laboratory-shop learning activities, Buffer (1973, p. 3) quotes the American Industrial Arts Association by reviewing:

It (Industrial Arts) assists in the discovery and development of personal aptitudes, interests, creative technical abilities, self-reliance, sound judgment, resourcefulness, adaptability, problem solving, and expression in an industry-related environment. Industrial arts can bring about wholesome changes in the learner since it affects his habits, attitudes, understanding,

and his ability to function as a consumer, employer/employee, and citizen.

The key factor in the preceeding statement is that the involvement in laboratory-shop work activities pertaining to the field of pre-vocational industrial arts education experiences lead to positive student growth. Similar goals and results may also be applied to vocational agriculture mechanics instruction.

Physically handicapped students in our secondary industrial arts and vocational agriculture education school programs that have not benefited from these programs in the past have the right to such experiences. To guarantee this right of participation in any or all educational experiences Congress passed the Education For All Handicapped Children Act (Public Law 94-142). Schools now must offer appropriate educational experiences for all handicapped children.

This study is an attempt to identify and develop instructional aids in the form of physical apparatus that will permit students with physical handicaps and/or limitations to have greater access to laboratory-shop instructional programs.

## CHAPTER II

### REVIEW OF LITERATURE

#### Introduction

The purpose of this review of literature is three-fold. First, a summarization of the body of literature which deals with understanding the members of the population group designated as the physically handicapped will be developed. Second, a summarization of legislation pertinent to public education of the handicapped including the rationale and importance of Public Law 94-142 will be presented. Third, information leading to the fulfillment of educational needs of the handicapped through teacher education will be developed.

#### Part I: A Basis for Understanding the Physically Handicapped

##### Who is Handicapped and What Does That Mean

In recent years many segments of our society have accepted the challenge of serving the needs of the handicapped with a dedication and seriousness of great propor-

tion. The realm of public education is one of those societal segments that has accepted the challenge to do the most for the handicapped. This study deals with serving selected educational needs of the handicapped and, in particular, with serving that group known as the physically handicapped in their quest for attaining knowledge and skills in the industrial arts and vocational agriculture disciplines. It is appropriate, therefore, to establish who comprises the special needs group known as the physically handicapped.

In the specific instance of vocational education the noted special needs vocational educator, Katy Greenwood, (1977, p. 47) states that the handicapped are "those students who cannot succeed in regular vocational programs." The numbers of students which may comprise this group is considerable and is in itself, a topic for debate. Vocational administrator and researcher Cadar Parr notes that, "It has been estimated that over 25 percent of young people in schools today need some type of extra help in order to reach their full potential" (1975, p. 21). Parr's figure includes handicaps and disabilities of all kinds. A more realistic figure is presented by teacher-educator Dean Corrigan (1978, p. 12) as he speaks of those directly able to benefit from the provisions of



P.L. 94-142:

The beneficiaries of this act are approximately 12% of the human beings in the United States between the ages of 3 and 21 who have a handicap. . . .

When an examination is made of the numbers of handicapped students actually served by vocational education, a wide disparity in number is observed. Vocational teacher-educator Allen Phelps (1978, p. 14) observes that "the handicapped comprised less than 1.7% of the student enrollment in vocational education during the 1974-75 school year." This is a surprisingly low representative percentage for a group that may consider secondary or post-secondary vocational or career education to be their terminal educational experience. Phelps (1978, p. 15) continues by stating:

. . . This percentage is bound to increase because of the new legislation. . . . as the goal of providing educational opportunities to all of the handicapped is approached, increased emphasis must be given to the quality and appropriateness of those opportunities.

This research project deals specifically with providing selected Special Educational opportunities for the Handicapped Child, in particular the Physically Handicapped student. It is necessary at this juncture to define this group. (Stewart, 1979)

Special Education: Specially designed instruction, given at no cost to parents or guardians, to meet the unique needs of a handicapped child, including but not limited to classroom instruction, home instruction, and instruction in hospitals and institutions. The term includes but is not limited to speech pathology, audiology, occupational therapy and physical therapy.

Handicapped Child: A child evaluated as mentally retarded, hard-of-hearing, deaf, speech-impaired visually handicapped, emotionally disturbed, orthopedically impaired, or other health-impaired, or as having specific learning disabilities, who because of those impairments, needs special educational and related services.

Physically Handicapped or Orthopedically Impaired: A severe orthopedic impairment which adversely affects a child's educational performance. The term includes but is not limited to impairment caused by congenital anomaly, impairments caused by disease, or impairments from other causes such as accidents.

Other terminology used to describe physical handicaps are defined by special needs teacher-educator

Craig Stewart (March, 1979):

Static Handicaps - the handicap was there at birth, it is not changing, may be congenital. Persons born with a disability have a very different adjustment to make from someone who has not been handicapped and became so.

Trauma Induced - loss of a limb, tumor or accident induced disability. . . .was once whole and then disabled.

Degenerative Disease - Such as muscular dystrophy, cystic fibrosis and others which are 99% fatal.

It would not be possible to develop a composite physical profile of a handicapped individual. As in any other segment of our society, the physically handicapped come in many forms, ages, disabilities, and most importantly, abilities. However, one can elude to a somewhat limiting profile of characteristic emotional and psychological traits as they pertain to individual impairments and the psychological impact of those impairments to the total individual.

In continuing his discourse in describing the physically handicapped, Stewart (1979, March) further indicates:

Most handicapped students heretofore have been separated from their peers and placed in special classes. The amount of their adjustment in any new environment, i.e. regular school classes, depends upon how they are accepted by others and how they accept themselves.

Often the physically handicapped individual has a strong sensitivity regarding his handicap which may impede his abilities, progress, or success in a regular classroom setting with non-handicapped students. Therefore, in planning educational programs it is important that successful activities are experienced by the handicapped student:

Handicapped individuals need immediate success

in a new endeavor. This type of positive reinforcement (early success) enables him to handle failure later on. A handicapped person has experienced a disproportionate amount of failure in his lifetime. Success enhances increased acceptance by his peers.

(Stewart, 1979)

Great numbers of the physically handicapped have a sensitivity for their disability; however, this sensitivity includes their individual ability to overcome their disability to varying degrees. Many have an overwhelming need to succeed in "regular" endeavors. Success or progress has a special meaning because, often, success means a special effort in achievement. The self-fulfillment in success is a necessary goal that may in some way be compensating.

Achievement in the many aspects of industrial arts or vocational education is often a special accomplishment for the physically handicapped student. Many programs require special physical skills and dexterity often difficult for the non-physically handicapped student; thus skill attainment becomes almost impossible for the handicapped student. When accomplishments are made the results may be even more rewarding than others may perceive. It is, therefore, necessary to provide the opportunity for physically handicapped to obtain access to the industrial arts and vocational education laboratory-shop classroom.

## Part II: Legislation for the Handicapped

Federal legislation that has a direct impact on education for the handicapped has culminated with the passing of Public Law 94-142, or the Education For All Handicapped Children Act of 1975. One must realize that this act does not stand alone in efforts to provide educational opportunity for handicapped individuals. This is especially true when the many areas of vocational education are considered.

Education for the handicapped has evolved as our national social and educational climate has matured and progressed. The following is an overview of the litigation and legislation that affected education in general and vocational education in particular.

### 1954 - Brown vs. Board of Education

The single main point of this litigation was the supreme court's decision that "In the field of public education, the doctrine of separate but equal has no place." (Bauer, 1978, p. 49). Although this court case primarily concerned segregation of races, it heralded the

beginning of social feeling for the handicapped as well.

Special needs educator William Bauer (1978, p. 49) notes:

The separate but equal findings have been extended to include minorities other than racial. The analogies between the blacks and/or handicapped and the respective experiences in our society are quite similar, particularly in the area of social distance, stereotypes, negative attitude and segregation.

This litigation set the stage for future court cases and legislation which would make equal and appropriate public school education possible for the handicapped.

#### The Vocational Education Act of 1963

The case of Brown vs. Board of Education forwarded consideration of integrated educational opportunities for all students in all disciplines. Legislation affecting education for students wishing to pursue vocational education interests, and indirectly, the pre-vocational area of industrial arts, was founded in the 1963 Vocational Education Act.

Many factors led to the writing and passing of this legislation. Vocational education researcher Dennis Nystram (1973, p. 5) indicates, "the real importance of any historical legislative enactment exists in its relation to the national condition at the time of its passage and

in its effect on contemporary and future legislation." The Vocational Education Act of 1963 was significant as it reflected the educational and subsequent social concerns for the potential of handicapped individuals. This act was precipitated by President John F. Kennedy and his appointed body of vocational education specialists as they attempted to review and evaluate existing vocational education legislation and to make recommendations for improving and redirecting national vocational education programs.

Nystram (1973, p. 36) further states:

"Legislation, in particular occupational education legislation, is a process through which cultural need is identified, interpreted, and acted upon in a relationship with the various pressing economic, political, professional, and social factors characteristic of the society at a specific point in time."

The central theme, therefore, is manifested by a broadening of education for work and a real emphasis on serving the youth of this country. The new program and the amendments to Smith-Hughes and subsequent George-Barden legislation acted to remove much of the restrictiveness that had made these two acts somewhat obsolete. In the Declaration of Purpose of the 1963 Vocational Education Act, Section 1, the need for

program flexibility was emphasized by stating the need for, "vocational training or retraining which is of high quality, which is realistic in the light of actual or anticipated opportunities for gainful employment, and which is suited to their needs, interests, and ability to benefit from such training." (1963, Vocational Education Act, Section 1).

Another very important concept included in the recommendations set forth by President Kennedy's panel of consultants was that vocational education in America needed "programs for people." (Nystram, 1973, p. 37). The act further emphasized that a somewhat un-served segment of the population was comprised of handicapped individuals. At that time the committee labeled the handicapped as "Youth With Special Needs," (1963 Vocational Education Act, Section 4(A). Further definition of the law (Greenwood, 1975, p. 47) reveals that "Vocational Education shall be provided for persons who have academic, socioeconomic, or other handicaps that prevent them from succeeding in regular vocational education programs."

As in all educational legislation of this type, the main incentive for compliance is the allotment of funds. In the case of the 1963 Act, it was stated that 15% of the states' allotted funds would be spent in the area of



special needs. Some serious points are raised by Greenwood (1973, p. 47-48) as she states:

We in vocational education have complied with the federal laws as we should have; we have spent most of that money (the 15 percent) for the purpose intended; and yet, we must admit, that today, 12 years after that first mandate, we must face some uncomfortable facts:

- 1) Federal dollars have been the main source of incentive for providing support for students with special needs.
- 2) It is true that vocational education in some instances has failed to recruit and maintain large percentages of disadvantaged students into programs that could be helpful to them. Evidence can show that in some instances there has been an unwillingness on the part of vocational educators to provide flexibility in programs designed to meet those special needs of students.
- 3) And it is true that our main cadre of personnel are not prepared to deal with students with special needs - and university training programs do not seem to be moving rapidly to overcome this discrepancy.

So we have done what we should be doing in a sort of half-hearted, sometimes unwilling way, and the unspoken message has inferred: "This is not our real purpose. . . .we must not become the dumping ground for all of education's problems."

The inference made by Greenwood is that after a period of trial and evaluation, the 1963 Vocational

Education Act was not working as had been anticipated. Vocational programs have not met the original intent of the legislation:

The Vocational Education Act of 1963 was the first legislation to specifically charge vocational education with the responsibility for providing vocational programming for the handicapped and disadvantaged. This landmark legislation first identified special needs students as those individuals having academic, socioeconomic, or other handicaps that prevent them from succeeding in the regular vocational education program.

(Phelps, 1976, p. 3)

This legislation may have mandated too much of a change too quickly for traditional vocational educators, or perhaps, the financial incentives may not have provided enough motivation to cause this legislation to be implemented. Whatever the reason, the Vocational Education Act of 1963 did not work as anticipated and led to the enactment of further legislation including P.L. 94-142.

#### The Vocational Education Amendments of 1968

The failure of the 1963 Vocational Education Act began to produce change in opportunities for the handicapped. Phelps (1976, p. 3) verifies this failure by stating, "After four years had passed, however, this

general legislative change had produced few new opportunities for handicapped individuals."

Recognizing this failure, Congress required in the 1968 Amendments to the Vocational Act, that, each state spend 25% of its basic federal grant for vocational education exclusively to finance: "Special educational programs and services designed to enable disadvantaged and handicapped persons to achieve vocational education objectives that would otherwise be beyond their reach as a result of their handicapped condition" (Vocational Education Amendments of 1968, Part B). Of the basic grant, 15% was to be spent on programs for the disadvantaged, while 10% was to be spent on vocational programs serving the handicapped. The total value of these "set-aside" monies was approximately \$20 million each year for vocational education of the disabled.

The intent, then, of the 1968 Amendments Part B, pertaining to vocational education for the handicapped, was to increase the financial incentive to states for providing more vocational education opportunities. Additional implications of these amendments that affected educational programs for vocational education and industrial arts are found in the Acts General Provisions s noted by Nystram (1973, p. 41):

The first section deals with the Acts General Provisions; it declared the same purposes as the 1963 Act but emphasizes vocational education in post-secondary schools. The definition of vocational education also was broadened to bring it closer to general education.

Broadening the provisions of vocational education legislation would permit the inclusion or use of funds in areas not previously permitted, thereby, increasing the chances of acceptance of this act. Some latitude in the use of these monies was provided by making federal funding available to states with the approval of their State Plan by the Commissioner of Education.

The 1973 Rehabilitation Act

And

Section 504

During 1972, Congress began reviewing federally funded vocational rehabilitation programs for the handicapped to develop legislation which would expand services to the handicapped. Very early in these proceedings it was apparent that major changes in the law were necessary.

The major thrust of the resulting Vocational Rehabilitation Act of 1973, and, specifically, Section 504, was that handicapped persons cannot be discriminated against solely on the basis of their handicap. Thus,

Section 504 became the first federal civil rights law to protect the rights of handicapped persons.

The overall implications of the 1973 Rehabilitation Act for education are great. In addition to Section 504, other sections will also be of interest to local education agencies:

Section 502: Mandates the elimination of architectural barriers which make building inaccessible to the handicapped.

Section 503: Any federal contractor must take affirmative action to employ the handicapped.

(1973 Rehabilitation Act,  
502, 503)

The rules and regulations of Section 504 and the resulting implications for public education are very broad and encompassing. Selected portions of Sub-part D - Preschool, Elementary, and Secondary Education and their implications (1973 Rehabilitation Act, Section 504) are as follows:

PROPOSED RULES AND  
REGULATIONS FOR SEC. 504-  
REHABILITATION ACT OF 1973

IMPLICATIONS

Subpart D-Preschool, Elementary,  
and Secondary Education

PROPOSED RULES AND  
REGULATIONS FOR SEC. 504 -  
REHABILITATION ACT OF 1973  
CONTINUED

IMPLICATIONS CONT.

84.31 Application of this  
subpart

Subpart D applies to preschool, elementary, secondary, and adult education programs and activities that receive or benefit from federal financial assistance for the operation of such programs or activities.

84.32 Location and Noti-  
fication

A recipient which operates a public elementary or secondary education program shall annually:

- (a) Undertake to identify and locate every qualified handicapped person residing in the recipients' jurisdiction who is not receiving a public education; and
- (b) Take appropriate steps to notify handicapped persons and their parents or guardians of the recipients' duty under this subpart.

Child find programs must be implemented and maintained.

Parents must be notified of the state education agency and local education agency's responsibilities under Section 504.

84.33 Free Appropriate  
Public Education

PROPOSED RULES AND  
REGULATIONS FOR SEC. 504-  
REHABILITATION ACT OF 1973  
CONTINUED

IMPLICATIONS CONT.

(a) General

A recipient that operates a public elementary or secondary education program shall provide a free appropriate public education to each qualified handicapped person who is in (domicile or actual residence) the recipients' jurisdiction, regardless of the nature or severity of the person's handicap.

All qualified handicapped persons must be provided a free and appropriate education.

(b) Appropriate Education

(1) Regular or special education must be provided that is designed to meet the needs of handicapped persons as adequately as the needs of non-handicapped persons are met.

Handicapped individuals must be provided an educational program which is of the same quality as the program for non-handicapped individuals.

(2) Implementation of an individualized education program developed in accordance with the Education of the Handicapped Act is one means of providing an appropriate education.

Individual Education Program as required by P.L. 94-142 is not required but is one alternative strategy of providing appropriate education.

Compliance may require development of an in-service program to train or retrain personnel to deal with

PROPOSED RULES AND  
REGULATIONS FOR SEC. 504-  
REHABILITATION ACT OF 1973  
CONTINUED

IMPLICATIONS CONT.

- (3) Recipient remains responsible for handicapped person even if recipient refers such person to a program other than the one it operates.

students exhibiting specific handicapping conditions and make available appropriate materials and equipment.

State education agencies and local education agencies remain responsible which regardless of the agency provides services.

(c) Free Education

- (1) Education and related services must be provided without cost to the handicapped person except for those fees that are imposed on handicapped persons. Recipient still responsible for costs if it refers handicapped person to another program.
- (2) Recipient will be required to pay additional transportation costs if it refers handicapped person to another program.

Since recipient is responsible for costs, an interagency financial agreement will have to be consummated so that public agency (recipient), rather than handicapped individual and his/her family, will bear the costs for provision of education and related services.

Recipients will be responsible not only for educational costs but also transportation costs if handicapped child is referred to a private institution. Recipients will also be responsible for



PROPOSED RULES AND  
REGULATIONS FOR SEC. 504-  
REHABILITATION ACT OF 1973  
CONTINUED

IMPLICATIONS CONT.

room and board costs if referral is made to a residential program.

- (3) Recipient will be required to pay room board costs if it refers handicapped person to a residential program.
- (4) If recipient has conformed with this section and handicapped person chooses placement in a private school.

(d) Compliance

Recipients cannot exclude any qualified handicapped person from a public elementary or secondary education after June 3, 1977, and must be in full compliance with the other requirements at the earliest practicable time and in no event later than September 1, 1978.

Handicapped individuals cannot be excluded from public elementary or secondary education, and must be identified, evaluated, placed, and serve as soon as possible and in no event later than September 1, 1978.

84.34 Education Setting

(a) Academic Setting

A recipient shall educate each handicapped person in its jurisdiction with persons who are not handicapped to the maximum

State education agency must accommodate requirement that local education agencies provide education in

PROPOSED RULES AND  
REGULATIONS FOR SEC. 504-  
REHABILITATION ACT OF 1973  
CONTINUED

IMPLICATIONS CONT.

extent appropriate to the needs of the handicapped person.

the least restrictive environment. (To the maximum extent appropriate handicapped children must be educated with non-handicapped children).

Inservice training for regular education teachers and administrators will be necessary.

(b) Non-academic setting

Handicapped children must also be provided nonacademic services (meals, recess periods, etc.) in as integrated a setting as possible.

Re-examination of non-academic services for accessibility and non-discrimination may need to be undertaken.

(c) Comparable Facilities

If separate facilities and services for the handicapped are necessary, these facilities must be comparable to other facilities provided by the recipient.

Facilities, services, and activities for the handicapped students must be qualitatively comparable to those for non-handicapped.

84.35 Evaluation and Placement

- (a) Preplacement evaluation. A recipient may not take any action regarding the educational placement, denial of placement, or transfer of placement of a person who, because of

State must assure the appropriate number of qualified diagnostic staff are available to provide adequate assessment of student needs.

PROPOSED RULES AND  
REGULATIONS FOR SEC. 504-  
REHABILITATION ACT OF 1973  
CONTINUED

IMPLICATIONS CONT.

handicap, needs or is believed to need special education or related services without fully and individually evaluating such person's special educational needs.

- (b) Evaluation procedures. A recipient shall establish standards and procedures for the evaluation and placement of persons who, because of handicap, need or are believed to need special education or related services which ensure, at a minimum that:

- (1) Tests and other evaluation materials have been validated for the specific purpose for which they are used and are administered by trained personnel in conformance with the instructions provided by their producer.

State must examine evaluation materials currently used to ascertain their validity for specific populations to be assessed. This process shall include development of criteria by which to validate evaluation instruments and determine a level of test reliability for both manufactured and teacher-made assessment devices.

Staff training must be provided to develop staff competency to apply instruments.

PROPOSED RULES AND  
REGULATIONS FOR SEC. 504-  
REHABILITATION ACT OF 1973  
CONTINUED

IMPLICATIONS CONT.

(2) Tests and other evaluation materials include those tailored to assess specific areas of educational needs and not merely those which are designed to provide a single general intelligence quotient.

(3) Tests are selected and administered so as to best ensure that, when a test is administered to a student with impaired sensory, manual, or speaking skills, the test results accurately reflect the student's aptitude or achievement level or whatever other factor the test purports to measure, rather than reflecting the student's impaired sensory, manual or speaking skills (except where such skills are the factors which the test purports to measure).

(c) Placement Procedures. A recipient shall interpret evaluation data and make placement decisions by:

Multifactored assessment must take place before placement is required.

(1) Drawing upon information from a variety of sources, including aptitude and achievement tests, teacher

Training in the group decision-making placement process may be necessary.

PROPOSED RULES AND  
REGULATIONS FOR SEC. 504-  
REHABILITATION ACT OF 1973  
CONTINUED

IMPLICATIONS CONT.

recommendations, physical condition, social or cultural background, and adaptive behavior;

- (2) Establishing procedures to ensure that information obtained from all such sources is documented and carefully considered;
- (3) Ensuring that the placement decisions is made by a group of persons, including persons knowledgeable about the child, the meaning of the evaluation data, and the placement options, and;
- (4) Ensuring that the placement decision is made in conformity with 84.34
- (d) Re-evaluation. A recipient to which this section applied shall establish procedures, in accordance with paragraph (b) of this section, for periodic re-evaluation of students who have been provided special education and related services. A re-evaluation procedure consistent with the Education for the Handicapped Act is one means of meeting this requirement.
- Re-evaluation as required by P.L. 94-142 is an acceptable procedure.

PROPOSED RULES AND  
REGULATIONS FOR SEC. 504-  
REHABILITATION ACT OF 1973  
CONTINUED

IMPLICATIONS CONT.

84.36 Procedure Safeguards

A recipient shall establish and implement, with respect to actions regarding, the identification, evaluation, or educational placement of persons who, because of handicap, need or are believed to need special instruction or related services a system of procedural safeguards that includes notice, an opportunity for the parents or guardian of the person to examine relevant records, an impartial hearing with opportunity for participation by the person's parents or guardian and representation by counsel, and a review procedure. Compliance with the procedural safeguards of Section 615 of the Education of the Handicapped Act is one means of meeting this requirement.

Each recipient may establish its own system for insuring procedural safeguards. Procedural safeguards (Sec. 615 of Education for the Handicapped Act) provisions as stated in P.L. 94-142 are an acceptable alternative.

Establishment of state-wide due process procedures may make it easier for state education agencies to monitor local education agencies' compliance.

Training in interpretation of the Family Education Rights and Privacy Act and in monitoring its implementation may be necessary.

84.37 Non-Academic Services

(a) General

- (1) A recipient shall provide non-academic and extra-curricular services and activities in such a manner as is necessary to afford handicapped

Restructuring and planning for extra-curricular and non-academic services may be necessary to assure inclusion of handicapped

PROPOSED RULES AND  
REGULATIONS FOR SEC. 504-  
REHABILITATION ACT OF 1973  
CONTINUED

IMPLICATIONS CONT.

students an opportunity for participation in such services and activities.

in these activities.

- (2) Non-academic and extra-curricular services and activities may include counseling services, physical education, athletics, transportation, health services, recreational activities, special interest groups or clubs sponsored by the recipient, referrals to agencies which provide assistance to handicapped persons, and employment of students, including both employment by the recipient and assistance in making available outside employment.

Personnel working in non-academic and extra-curricular activities may need inservice training on methods for involving and integrating handicapped persons into activities.

- (b) Counseling services. A recipient which provides personal, academic, or vocational counseling, guidance of placement services to its students shall provide these services without discrimination on the basis of handicap. The recipient shall ensure that qualified handicapped students are not counseled toward more restrictive career objectives than are non-handicapped students with

School counselors may need inservice training in career education for the handicapped.

PROPOSED RULES AND  
REGULATIONS FOR SEC. 504-  
REHABILITATION ACT OF 1973  
CONTINUED

IMPLICATIONS CONT.

similar interests and abilities  
ities.

84.38 Preschool and Adult Educa-  
tion Programs

A recipient that operates a pre-  
school education or day care  
program or activity or an adult  
education program or activity may  
not, on the basis of handicap,  
exclude qualified handicapped persons  
from the program or activity and  
shall take into account the  
needs of such persons in determining  
the aid, benefits, or services  
to be provided under the program  
or activity.

Adequate planning for  
preschool and adult  
education programs will  
be necessary so as to  
include handicapped  
persons on the the basis  
of a handicapping condition.

Subpart E - Post-Secondary Educa-  
tion

84.41 Discrimination on the  
basis of handicap shall not  
take place in post-secondary  
education programs and activities,  
including those relating to  
post secondary vocational  
education, the following areas:

This is a multiple  
agency responsibility.  
The state education  
agency may be one of  
several public agencies  
to insure that post-  
secondary education  
programs meet the re-  
quirements of Section  
504.

84.42 Admissions

84.43 Treatment

84.44 Academic Adjustments

The 1973 Rehabilitation Act was a step closer to



providing proper educational opportunities for handicapped individuals. The major fault with this act and Section 504 was that compliance was mandated but difficult under existing funding structure. Thus, the enabling relationship between that Act and the subsequent P.L. 94-142 legislation is that the later constitutes basic compliance abilities of Section 504.

In review of Section 504, Secretary of Health, Education, and Welfare, Joseph Califano, (April 29, 1977) stated:

The 504 Regulation attacks the discrimination, the demeaning practices and the injustices that have afflicted the nation's handicapped citizens. It reflects the recognition of the Congress that most handicapped persons can lead proud and productive lives, despite their disabilities. It will usher in a new era of equality for the handicapped individuals in which unfair barriers to self-sufficiency and decent treatment will begin to fall before the force of the law.

The Education for All Handicapped Children Act of 1975

(P.L. 94-142)

Public Law 94-142, or the Education for All Handicapped Children Act, was signed into law in November of 1975 by President Ford. While this legislation was the follow-up and guardian to many other pieces of legislation, both educational and social, President Ford signed the bill

reluctantly. The basic premise for his reluctance was that while this act supported previous legislation and while he and others agreed on the basic purpose of the law, "The bill promises more than the Federal Government can deliver and its good intention could be thwarted by the many unwise provisions it contains." (Ford, November 28, 1975).

No one can disagree with the basic purpose of the law, that of providing educational opportunities to the handicapped. The question asked by school officials in regard to their planning schedules and budgets is "We must do what, to whom, by when?" When projecting the implementation of P.L. 94-142 to vocational education an interesting question develops out of the multitude of rules and regulations: "Are we doing what we ought to be doing?" (Greenwood, 197, p. 48).

These types of questions may develop and may be generated by feelings of not wanting to change. The point is that the law exists, and it is necessary for all to make the required social, political, economic, and educational reforms to make the law work. P.L. 94-142 holds many regulations and subsequent implications for public education. A brief review of these regulations and implications is appropriate at this time.

## Table 1

Public Law 94-142The Education for All Handicapped Children Act of 1975

## Provisions and Implications

## A Synopsis

<u>Purpose</u>	<u>Implications</u>
To assure that all handicapped children have available to them a free, appropriate public education which emphasizes special education and related services designed to meet their unique needs, to assure that children and parents' rights are protected, to assist states and localities, and to assure effectiveness for efforts.	Full service.
<u>Definition</u>	<u>General Implication</u>
Handicapped children includes orthopedically impaired and specific learning disabilities.	
Special Education: free, specially designed instruction to meet a handicapped child's unique needs including instruction in the classroom, physical education, home, hospitals, and institutions.	Training of institutional personnel in special education administration and curriculum.
Related Services; transportation and supportive services	Federal dollars may be used for medical or

Definition

including speech, audiology, psychological, physical and occupational therapy, recreation and medical and counseling (medical for diagnostic and evaluative purposes only) and can include identification and assessment of handicapping conditions.

Free, appropriate public education means special education and related services which are at public expense, meet SEA standards, include preschool and an individualized education program.

Individualized education program: (written statement developed by LEA representative, teacher, parents and child, when appropriate)

- Child's present level of educational performance.
- Annual goals and short term objectives.
- Specific education services to be provided.
- Extent to which child will be able to participate in the regular classroom
- Projected date for initiation and duration of services to be provided the child.
- Objective criteria and evaluation procedures.
- Schedule for determining whether instructional objectives are

General Implication

paramedical services, for diagnostic and evaluative purposes.

More inclusive definition requires additional services and training efforts.

Training of administrators and teachers.

DefinitionGeneral Implications

being achieved (must be re-viewed at least annually).

Excess costs: costs in excess of annual APPE in LEA during preceding school year after deducting funds from Title I (ESEA), Title VII (ESEA), State and local funds expended for programs under this part or Title I, VII.

Excess cost will vary from district to district throughout the state.

Administrator training.

Native language: language normally used by child or child's parents (Bilingual Education Act).

Intermediate education unit: SEA supervised agency providing free public special education and related education on a regional basis.

Intermediate treated as LEA.

(Education for All Handicapped Children Act of 1975)

Financial Entitlements and Allocations of P.L. 94-142

The financial provisions of P.L. 94-142 make both the law itself as well as former acts significant pieces of legislation. Entitlements to the states are based on the number of handicapped children served, ages 3-21. This number is not to exceed 12% of the total number of all children aged 5-17 in the state. Initially, funding will start (FY 1978) at \$387 million and increase to a

total of \$3.16 billion (FY 1982).

One of the financial implications of the Act is that states are required to implement and maintain personnel development systems for teachers and administrators. This includes the development of preservice and inservice activities.

Funding responsibility and formulation is quite complex. Formulation takes into consideration the relationship that exists between the federal government, state education agencies, and the local education agency. Financial sharing is quite specific to each category, although the balance of allotments may be quite different between categories.

#### Eligibility, P.L. 94-142

Under the requirements of Section 612 of P.L. 94-142, in order to be eligible a state must meet specific conditions. These conditions and the general implications are found below.

#### Eligibility Requirements P.L. 94-142

##### Requirements

##### Implications

1) A policy which assures

In some cases State

(Eligibility Req. P.L. 94-142 Cont.)

RequirementsImplications

a free appropriate public education to all handicapped children.

policy may have to be redirected.

- 2) Develop a plan which meets the criteria set in 94-142 and submit the plan to BEH no later than August 21, 1975. The plan should be amended to insure that:

- A. Full educational opportunity is available to all handicapped children

A detailed timetable is set for accomplishing such a goal.

SEA timetable will have to meet minimum criteria of 94-142.

Description is provided of the kind and number of facilities, personnel, and services necessary throughout the State to meet the goal.

Training SEA staff in data collection procedures, needs assessment, and program planning.

- B. By September 1, 1978, availability of a free, appropriate public education for all handicapped children between the ages of 3 and 18.

Full service date certain.

By September 1, 1980, all handicapped children between the ages of 3 and 21.

Requirement does not apply to 3-5 or 18-21 population

Special education programs required if

(Eligibility Req. P.L. 94-142 Cont.)

RequirementsImplications

if inconsistent with State law practice or court order.

public education is provided for normal or handicapped children in 3-5 age range.

- |    |  |   |
|----|--|---|
| C. | All children in need of special education are identified, located and evaluated.   | Child find.   |
| D. | The State assures the protection or confidentiality of personally identifiable information.  | Training in interpretation of Buckley amendments and implementation of guidelines.  |
| E. | Amendments to State plan shall be available to public 30 days prior to when the plan is submitted to Commissioner.   | SEA must make plan a public document.   |
| 3) | State must set priorities for service to handicapped children:   |   |
| A. | Handicapped children not receiving an education.<br><br>Handicapped children with the most severe handicaps within each disability area receiving an inadequate education. | Child find and initiation of new services.<br><br>Inservice training of administrators and teachers in education of the severely handicapped. |
| 4) | Each LEA will maintain, review, and revise as needed, but no less than once yearly, an individualized education program for each handicapped child.                        | Requires that LEAs have a written individualized educational plan for each handicapped child at the beginning of each school year which       |



(Eligibility Req. P.L. 94-142 Cont.)

Requirements

Implications

- |    |   |   |
|----|---|---|
|    |   | would be reviewed at least once yearly. SEA would be required to evaluate the individualized educational plans in accordance with criteria established with the U.S. Commissioner of Education. |
| 5) | A. State has established procedural safeguards.   |   |
|    | B. State assures that handicapped children will be educated with non-handicapped children to the maximum extent appropriate.  | Training in process of least restrictive environment - "mainstreaming."   |
|    | C. State assures that non-discriminatory testing practices are in force.  | Culturally biased tests will not be considered valid.   |
| 6) | SEA will assure that all educational programs for the handicapped, including program administered by any other State or local agency, will be under the general supervision of the SEA and will meet SEA standards. | Educational programs for the handicapped within state government but out of SEA authority must meet SEA standards.<br><br>Provisions may conflict with state law.                               |
| 7) | A. State will assure that procedures are established for consultation with individuals concerned with education of the handicapped, including handicapped individuals.  |   |

(Eligibility Req. P.L. 94-142 Cont.)

Requirements

Implications

- |   |  |
|---|--|
| <p>B. Prior to adoption of policy, an opportunity for public comment and hearings will be available with adequate notice provided for such a hearing.</p> | <p>Training in procedures for SEA personnel.</p> |
|---|--|

(Education for All Handicapped Children Act, 1975)

This review of P.L. 94-142 has included the purpose, definitions, financial entitlements and allotments, and eligibility requirements. Other regulation sections include the state plan, application guidelines for the local education agency, procedural safeguards, judicial review, and evaluation criteria.

Additional Implications for Schools

The Education for All Handicapped Children Act identifies the regular classroom as the "least restrictive environment" unless another setting is prescribed as more appropriate to meet a child's special needs. If other settings are used, they must be fully justified. Corrigan (1978, p. 12) states:

The implications of using regular classrooms

are enormous, not the least of which is that all educators--teachers, counselors, administrators, and other support personnel - must be educationally prepared to work with handicapped persons. This calls for a change in roles of all education personnel, particularly special educators who will join and share their expertise with instructional teams as well as students. . . .

On the topic of individuality and labeling Corrigan

(1978, p. 12) further indicates:

American schools must be based now on the principle of "no rejects;" every human being has a right to be treated as a person - not an object, or a symbol on a chart, or a category in a student grouping structure. The labeling and classification of children, and the social stigma that this labeling produces, must be eliminated. . . .

The individualization requirement calls for a continuous progress reporting system with diagnostic profiles describing each student's human variability, exceptionality, and intellectual-personal growth. However, the current marking system and the illegitimate comparisons it makes, the pressure it creates and the failure it produces, must go the way of all outmoded practices. It will do little good to place children with handicaps in regular classrooms and flunk them, or deny them a high school diploma based on standardized competency tests.

The Education for All Handicapped Children Act calls on educators to, "reaffirm some fundamental premises of American education" (Corrigan, 1978, p. 14). The implications are that all children have a right to an educational experience that enables them to develop to their fullest potential.

Part III: Meeting the Educational Needs of  
The Handicapped Through Teacher Education

Perhaps the greatest educational implication calling for change is in the area of teacher education. The dualism in thought and teacher education preparation regarding "Special vs. Regular" teacher education must be re-examined. The education time lag that exists between teacher education and classroom practice will be one of the major obstacle to realizing the goals of P.L. 94-142. In a somewhat idealistic manner Corrigan (1978, p. 14) exclaims:

This reform is not an impossible challenge. Nor is the teacher education situation one that can be corrected by minor tinkering. As the AACTE Bicentennial Commission Report states, 'What the teaching profession needs is a totally new set of concepts regarding the nature of the emerging human services society, its educational demands, the kinds of delivery systems necessary to provide public access to continuing educational opportunity, and the types of professional personnel and training required to reform public education.'

. . . .A major shakeup is needed in the form and substance of teacher education from the first introduction through the teacher's entire career. Financial and personal resources must be directed toward strategies that link schools seeking to change with teacher education institutions seeking to break out of established patterns.

Out of the basic contest of P.L. 94-142 comes the statement (Corrigan, 1978, p. 11) that:

The Education for All Handicapped Children Act identifies the regular classroom as the "least restrictive environment," unless another setting is prescribed as more appropriate to meet a child's special needs. If other settings are used, they must be justified.

Fulfilling this responsibility places every classroom teacher in the position of having to deal with the special needs student on a daily basis.

The implication for teacher education is that through inservice and preservice activities institutions of higher learning must prepare the classroom teacher to effectively serve the handicapped student. In the long run this preparation may be difficult to provide. It is fully recognized that teacher education is the fundamental place to start. In speaking to the needs of vocational educators, Greenwood (1975, p. 52) states, "Probably the most significant way of providing for the disadvantaged in vocational education is that of staff development, and personnel development."

The dilemma faced by teacher education as a whole is stated by Martin (1974, p. 152), ". . . efforts to provide training and experience for regular classroom teachers are not keeping pace with the efforts to mainstream." This has been brought about because while P.L. 94-142

is specific to mandate to individual states and, subsequently, to the local school districts, time-frame mandates to the institutions of higher learning who provide teachers are not as clear. In support of this statement teacher-educator Maynard Reynolds (1978, p. 28) writes:

The legal force of P.L. 94-142 is directed to school districts and their employees. Teacher-educators have not been enjoined directly in any legal sense in these developments, although the regulations in the amendments to Section 504 of the Federal Rehabilitation Act that affect college environments are having effects.

Teacher education should be the area that takes the lead in the implementation of P.L. 94-142.

If teacher education is to take the leading role, many attitudes must change. One of the major changes required is the reluctance of teachers to accept the handicapped individual. In reviewing a national assessment study of vocational educators, Phelps (1976, p. 7) cites an Olympus Research Corporation study:

One of the most often mentioned constraints limiting the expansion of vocational education programs for the handicapped was the reluctance of teachers in regular classrooms to accept the handicapped, or the inability of teachers to instruct handicapped students. Thus, teacher training in special education techniques was considered a necessity, not only to help affect program expansion, but also to improve program quality.

Preservice and inservice teacher education is the place to

begin to reduce this reluctance, real or perceived anxiety, and general non-understanding of the handicapped student.

An additional concern is that many classroom teachers fear that they will be forced into a disproportional amount of training and day by day classroom activities when they must deal with handicapped students. In response to this expressed fear Haisly and Gilbert (1978, p. 30) write:

Many educators have viewed the requirements of P.L. 94-142 and the implied competencies necessary to teach children with learning problems, together with the requirement of due process, as some new conspiracy against them. We believe that good teachers have always used the essential teaching competencies required for successful implementation of P.L. 94-142.

The implication here is that good teachers will be able to accept the challenge of the handicapped students while other teachers may have to evaluate their basic professional philosophies on education and improve their classroom techniques, abilities, and understanding.

The consequences that P.L. 94-142 will bring to the classroom teacher are not entirely clear, teacher educators Schlechty and Turnbull (1978, p. 34) offer the following:

What is not clear, however, is precisely how the implementation of P.L. 94-142 will affect the teacher's role. Two possibilities are suggested. First, the implementation of P.L. 94-142 will

further bureaucratize schools and classrooms and lead to a consequent diminution of the classroom teacher's power and authority--perhaps to the point that the regular teacher will become nothing more (or less) than a technician carrying out the directives of individuals with expertise in the area of special education. An example of such expertise is the diagnosis and remediation of learning difficulties.

The alternative outcome is that P.L. 94-142 will enhance the status of the classroom teacher as a professional and bestow upon him or her authority to make pedagogical decisions that require specified performance from others (e.g., diagnosticians, special educators, curriculum specialists, evaluators, and parents). P.L. 94-142 has the potential of making the classroom teacher first among equals in the area of planning and implementing instructional programs for youngsters. The response teacher-educators develop to P.L. 94-142 will go far toward determining which of these consequences will come about.

Teacher education, therefore, has an important role to play in the success of P.L. 94-142. With adequate preparation more teachers will develop attitudes that are essential to the objectives of P.L. 94-142.

So, it may be inferred that while teacher education directed toward the end of successfully implementing P.L. 94-142 will cause some change in structure, much of the foundation for competency development already exists. Of necessity, however, teacher education programs may have to improve their basic programs, materials, and procedures. In planning this phase of P.L. 94-142



implementation, Haisly and Gilbert (1978, p. 33) make the following suggestions for teacher education in general:

A first step toward change should be inservice training for college faculty so that they too are knowledgeable about P.L. 94-142 and its implications for changing organizational patterns in local schools. A second step should be toward integrating the knowledge and skills of regular and special educators so that they are better prepared to teach preservice students. Third, and finally, we teacher-educators should become involved with school programs and the children in our schools for whom the law was intended.

Continuing this thought, Reynolds (1978, p. 29) concludes:

Much inservice teacher education on P.L. 94-142 is devoted to the superficialities of "filling out the forms" and like matters. Teacher educators need to examine the situation for its fundamental requirements and, as quickly as possible, direct their activities beyond mere surface requirements. They have a responsibility for providing leadership to identify the pivotal ideas and skills needed to implement P.L. 94-142, and to help organize training activities that penetrate to the fundamentals.

Special Skills Needed by  
Vocational Educators to Implement  
P.L. 94-142

Guidelines which should be followed by teacher education programs preparing teachers to implement P.L. 94-142 come from all areas. In reviewing the many models, several points seem to show a degree of commonality.

"Initially it may be said that teachers need to establish a basis of educational knowledge and skills." (Haisly, 1978, p. 30). Knowledge in this instance is a base of information needed by all school personnel while skills may pertain to working with specific school groups such as elementary or secondary.

Basic to classroom teachers, no matter what the grade level or discipline, is an understanding of the due process aspects of P.L. 94-142. These aspects of the laws' implementations are vital to its success and to staying within the legal parameters of the Act. Teacher education programs, therefore, should understand and articulate these portions for complete understanding by their prospective teacher students.

One of the major questions to be answered by teacher-educators is "How can current programs be restructured to provide the exceptional new teacher so much in demand," (Brown and Reece, 1978, p. 51). Many authors reflect an interdisciplinary approach of educating all teacher education candidates. This approach may draw from the specialists that exist in any teacher education program to provide the basic knowledge and skills required to work with the handicapped. The candidates would then

receive instruction particular to their own discipline from specialists in those areas. There are many factors supporting this interdisciplinary curriculum approach as noted by teacher-education curriculum specialists Brown and Reece (1978, p. 51):

1. Integration of disciplines is necessary for problem solving because of the complex nature of social problems in our world societies. The information explosion, coupled with changing truths as new information is discovered, reveals the need for shared brain power in resolving the intractable problems of mankind. Additionally, survival in an increasingly interdependent world and humanitarian compassion and responsibility of "have's" for "have-not's" is best stressed through interdisciplinary education.
2. Integration of disciplines for problem-solving purposes yields two facets: (a) the teacher, regardless of the setting in which he/she works, must resolve various problems related to motivation for learning and developing a classroom atmosphere supportive of learning, and (b) knowledge must be organized in such a way as to provide for relevant, effective and efficient learning.
3. Integration of disciplines is needed to enable teachers to cope effectively with the increasing complexity of the teaching role. Greater parent and community involvement, the broadened concept of career involvement, the broadened concept of career education, and implementation of community education programs are areas which necessitate re-directing and enhancing teacher skills and competencies.

These concepts may be graphically placed in a model, see Figure 1 on the following page.

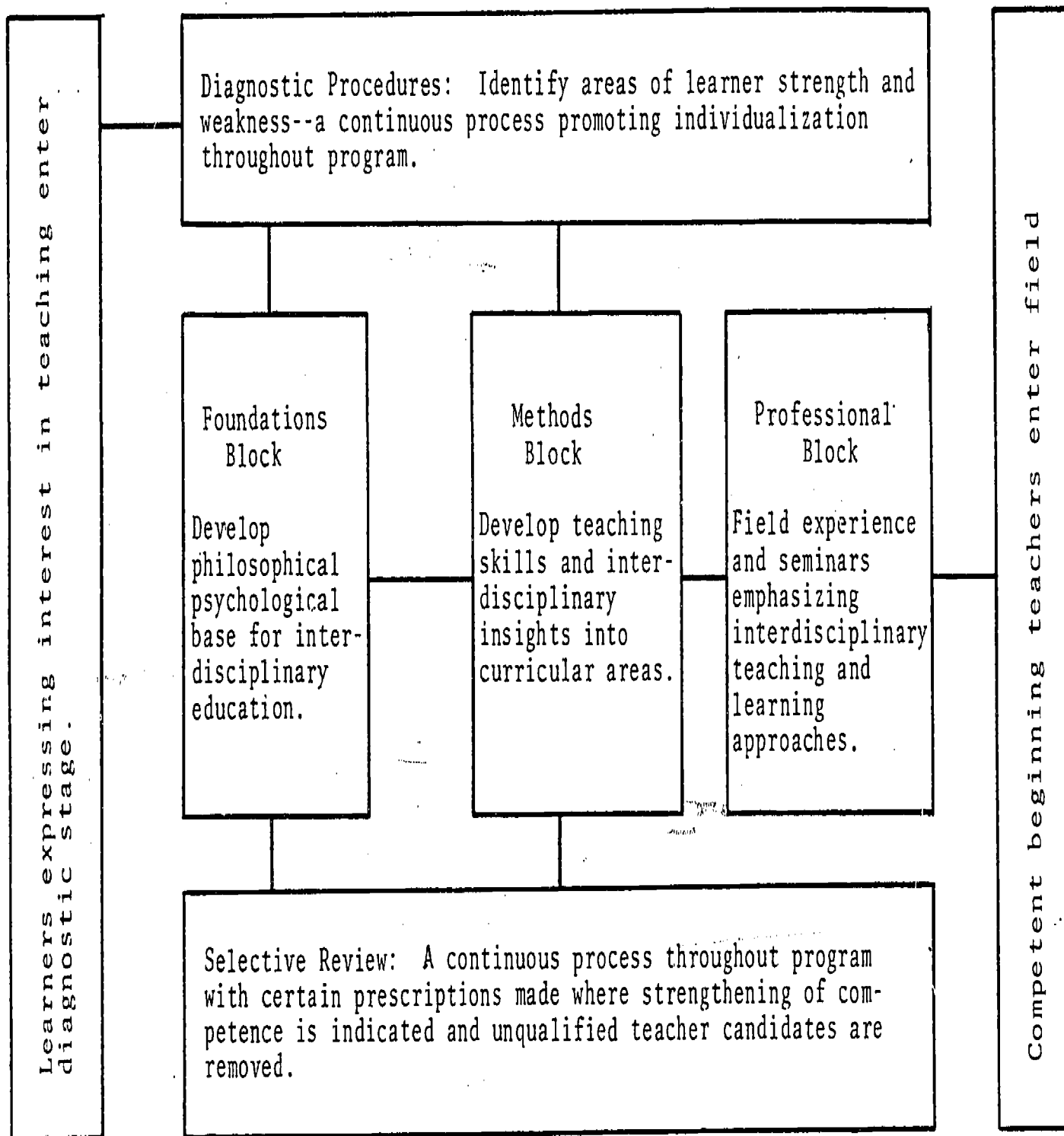

Figure 1. Interdisciplinary model for teacher education

(Brown and Reece, 1978, p. 52)

This model is comprised of five main elements: Diagnostic Procedures; Selective Review; Foundations Block; Methods Block; and Professional Block. Each of these elements may be so constructed as to permit subject area specialists to relate to the needs of the handicapped student in their discipline while also viewing the total or interdisciplinary profile of the student's entire educational experience and needs. The specific content of each block is reviewed by Brown and Reece (1978, p. 51-52):

Diagnostic Procedures. Upon expressing interest in entering the teacher preparatory program, the student undergoes diagnostic evaluation to identify strengths and weaknesses which form the basis for developing individualized learning prescriptions. These prescriptions provide the initial base data for curricular decisions made by the instructional teams.

However, diagnosis must be a continuous process throughout each block in order to maintain relevant, individualized learning experiences. Therefore, diagnostic evaluation will be conducted at intervals with specific emphasis on the cognitive and affective goals. Data so gained will provide the basis for curricular decision making by the instructional team for that particular group of learners.

Selective Review. Since employment opportunities primarily exist for individuals who are well prepared, who exhibit unusual insights and capabilities, and who can give direction to innovative programs, it is important that a selective review process be established

as a continuing component of the proposed model. The review's purposes are to identify areas in which individuals require extensive remediation and to recognize, as early as possible, those individuals who do not develop necessary commitment or do not have the potential for developing them. Such individuals may then be counseled into other areas without undue loss of time and finances.

Selective review committee members are representatives of the instructional teams, cooperating public school faculties, and the peer group. It is important that the selective review process be an effective part of the teacher preparation model, but it should also provide a model for the profession. The writers propose that peers of the teacher candidates serve on the committee.

Foundations Block. The initial learning block in the model occurs at the sophomore level. Its primary purpose is to develop a philosophical and psychological base for interdisciplinary education. Facets include aspects of life philosophies, philosophies of education, and educational psychology as reflected by the philosophical elements. Relationships between the components of special education, early childhood, bilingual-multicultural, elementary, middle school, and high school education will be emphasized. Instruction will be in the form of rotation seminars designed by teaching teams composed of representatives expert in the respective areas. Selected field experiences, including observation and participation at the elementary, middle, and high school levels, are essential to reinforce concepts presented.

Methods Block. The intermediate learning block in the model occurs at the junior level. Its primary purpose is to develop at the junior level. Its primary purpose is to develop interdisciplinary curriculum guides similar to the actual process which could be implemented in a school setting. Instructional methods and materials in the various disciplines will be

included, but concurrent seminars will emphasize interdisciplinary planning of teaching. An interdisciplinary instructional plan will utilize rotating seminars, learning centers of multilevel field experiences to emphasize related concepts.

Professional Block. The culminating learning block occurs at the senior level. Its primary purpose is to enhance further the development of competencies required of entry-level teachers. Primary emphasis will be on field experience. Weekly seminars will emphasize disciplinary interrelationships and interdisciplinary potential encountered in field assignments. Opportunities in cross-disciplinary teaching will form the basis for selecting field placement. Supervisory teams will be composed of university specialists in disciplinary areas and instructional techniques plus a public school master teacher. The supervisory team will be responsible for both individual and joint observations, followed by conferences with the teacher candidate.

This model embodies a great deal of flexibility which will make it suitable for implementation in almost any teacher education setting. Its implementation would provide latitude for the specifics of any discipline plus the provisions of P.L. 94-142.

Teacher education must head the cry for improvement of their product and the successful implementation of P.L. 94-142. In support of this need, the AACTE Board of Directors issued the following statement (1978, p. 44):

Our profession has a continuing commitment to improve the quality of education. This commitment is exemplified by our advocacy of equal opportunity, unlimited access, unconditional acceptance, and total responsiveness to individ-

ual differences. Our support for the education of all exceptional individuals is not simply an endorsement of a mandate which is the culmination of a singular struggle in behalf of a neglected minority; it is a present part of our continuing quest for quality education to maximize the potential of each individual.

The mandate implicit in recent court decisions and legislation serves as still another catalyst for evolutionary change, one which can ultimately guarantee the rights of all children and youth to an appropriate education. The importance of this mandate centers on the inequities which it corrects. Its significance is also embedded in the nature of responses required of educators, parents, and the general public.

Without substantive changes in attitudes, instructional programming, and in the priorities for allocating resources, this movement will neither benefit the individuals it is intended to serve, nor have an impact on the larger society.

### Summary

The literature suggests that society in general and the realm of public education in particular has a high level of misunderstanding about those individuals known collectively as the handicapped. Congress has given public education the charge of providing appropriate educational opportunities services and experience for all handicapped children through the auspices of the 1975 Education for All Handicapped Children Act (Public Law 94-142). The role of teacher education in the success of the implementation



of P.L. 94-142 is crucial. Only through well-developed and implemented preservice and inservice teacher education programs will classroom teachers develop the insights and skills necessary to properly educate the handicapped.

-- 03224

## Chapter III

### Method of Procedure

#### Introduction

The purposes of this study were to identify that segment of our school-aged population known as the handicapped and to review legislation pertaining to the background and understanding of P.L. 94-142, the Education for All Handicapped Children Act of 1975. In addition, other purposes were to develop apparatus that would permit the physically handicapped to use selected shop equipment and to develop assessment model that will enable teachers of shop subjects to integrate physically handicapped students into secondary laboratory-shop courses. This chapter describes the methodology and procedures used in this investigation and subsequent report.

#### Review of Literature

The review of literature completed for this study was of particular significance. From the review of literature an understanding of who comprises the population

group referred to as the physically handicapped was developed. It was also determined that the educational needs of the handicapped could be provided for under the auspices of P.L. 94-142 and other preceding legislation.

Public Law 94-142 has been lauded as the most important education legislation to be invoked in this century. The implications of this legislation for teacher education are great. The agent that may have the greatest effect on successful public education for the handicapped is teacher education. Efforts to educate and/or upgrade classroom teachers to effectively work with the handicapped rest, in part, on the success of teacher education to develop and implement appropriate preservice and inservice education programs for all teachers who must deal with handicapped students.

### Selection of the Population

Two samplings were made for this study. First: competencies and skills represented by tools and equipment common to suggested state curriculum guides in industrial arts and vocational agriculture mechanics were selected. Achievement of these competencies and skills are reflected in the correct use of selected tools and equipment. This

achievement in part, was made possible through the use of assistive apparatus developed for that purpose.

Second: Physically handicapped individuals were selected to test the use of selected tools and equipment to determine the level of difficulty in use and to help in the development of assistive apparatus. These individuals were selected due to the nature of their physical handicaps and because they had little, if any, former shop experience. These individuals were identified from a group of physically handicapped college students. Additionally, they are disabled by physical handicaps representative of handicaps found in other population groups. This test population would approximate student abilities and disabilities found with other physically handicapped students in the secondary school sector, definitively meaning:

- A. Physically handicapped; or disabled, to a degree but possessing some freedom of mobility.
- B. Physically handicapped only, not limited in any mental or psychological capacity.
- C. Having the potential of being self-sufficient in the laboratory-shop setting with the help of assistive devices.

- D. Very little if any prior experience with laboratory-shop skills or equipment.

Findings and conclusions derived from this study selection, development, and testing have implications for other similar groups of physically handicapped individuals and school settings. This application is possible since similar groups elsewhere may be categorized by grade level, instructional discipline and objectives, and handicapped category rather than geographic area. The selection of these competencies, skills, tools, and equipment was based on the following factors:

1. Commonality to both industrial arts and vocational agriculture mechanics. (Appendix A).
2. Representation of shop skills and competencies found in all basic laboratory-shop programs, urban or rural.
3. Similarity of these shop skills and competencies taught in other geographic areas to both handicapped and non-handicapped students.

#### Development of Assistive Apparatus

Numerous assistive apparatus were developed and help aids identified. These apparatus and aids were those

found helpful in achieving competencies and skills identified as common basic skills to both industrial arts and vocational agricultural mechanics. Throughout the process of development, physically handicapped individuals were consulted as to the appropriateness of the apparatus. Final testing of the apparatus was conducted by the test group for final apparatus development and impact.

#### Development of the Test Instrument

One instrument was developed to facilitate the collection of pertinent data. (See Appendix B). This instrument, an information category check sheet, was devised to accumulate information on the difficulties encountered by the physically handicapped in using selected hand tools, portable power tools, and stationary power equipment. Members of the testing groups responded individually to exercises developed to indicate:

- A. Success or failure in the use of the selected tools and equipment.
- B. Level of difficulty encountered in the use of selected tools and equipment.
- C. Suggestions on aids to facilitate the use of tools and equipment.

Members of the test group had very little if any prior experience with laboratory-shop tools and/or equipment and therefore simulated secondary-school students in their first experience in such an environment.

### Data Collection

Data collected from performance testing of the physically handicapped test group with selected tools, equipment, and subsequent competencies was done in a laboratory-shop setting. Tools and equipment used in testing were structured to simulate actual laboratory-shop instruction by one qualified instructor with one physically handicapped student at a time.

### Analysis of Data

Data generated by laboratory testing of the achievement in the use of correct tool and machine useage and the subsequent competency attainment was analyzed by data test sheets and photographic records to determine:

- A. Level of difficulty in tool and equipment use.
- B. Modifications on aids needed for their use.
- C. Teaching methods and skills needed for the

assessment--matching of disabilities and skill development.

### Summary

Following the selection of a common group of skills, competencies, tools, and equipment from suggested Montana curriculum guides for industrial arts and vocational agriculture mechanics, one instrument was used to collect data pertinent to the purpose of this study. From this data an overall description of the use of selected tools, equipment, and subsequent competency development by physically handicapped students was presented. The results and supplemental information on the handicapped obtained from the review of literature was used to develop an assessment and implementation model for teachers permitting handicapped students to receive instruction in the use of identified tools and equipment.



## Chapter IV

### Presentation of Data

The design of the applied research portion of this study centered around several major considerations:

- A. Identification of laboratory-shop tools and equipment and the subsequent competencies common to both industrial arts and vocational agriculture mechanics subject areas.
- B. Identification of a test group population of physically handicapped individuals.
- C. Determination of the degree of difficulty encountered by the test group in the use of identified tools and equipment.
- D. Development of a complement of apparatus which will serve as help aids to permit the physically handicapped to properly use selected shop tools and equipment.
- E. Acquisition of information pertinent to the physically handicapped and their use of shop tools and equipment, the development of guidelines for the implementation of the apparatus and integration

of physically handicapped students into secondary school-shop settings.

Data collected and presented in this chapter will pertain to these considerations.

### Development of the Instrument

The test sampling of tools and equipment and the subsequent competency development for this study consisted of those identified as common to both industrial arts and the mechanics portion of vocational agriculture education. These tools and equipment were identified from state curriculum guides in those respective instructional disciplines developed through the auspices of the Office of Public Instruction, Helena, Montana. Included in this sampling were hand tools, portable power tools, and stationary power tools.

The selection of tools and equipment for this study was on the basis of:

1. Commonality of tools and equipment found in both industrial arts and vocational agriculture mechanics.
2. Representation of basic skills, introductory shop instruction, tools, and equipment. (Physically

handicapped students probably have not had any prior shop experience and, therefore, will encounter basic equipment first.)

3. Similarity of the selected tools and equipment to those used in basic skills laboratory-shop programs in other geographic areas.

A complete listing of tools and equipment appears in Appendix A.

The instrument constructed to test tool and equipment usage was a simple information sheet that included the following information categories:

1. Test group member.
2. Name of tool or piece of equipment.
3. Level of difficulty. Ranked from easy (1) to impossible (5).
4. Specific Difficulty. From the viewpoint of the test group member, the specific problem in use.
5. Suggestions for correction. Possible provisions that might be made for the physically handicapped to use this tool or piece of equipment.

In reporting the results of the testing, each tool or piece of equipment will be presented separately with mean ( $\bar{x}$ ) difficulty level given for the use of each. The

mean will be derived from the numerical scores given by the test group members on difficulty level of use for each item. Review of Specific Difficulty and Suggestions for Correction categories will be composites of information given by test group members.

#### Test Group Members

The test group selected for this study consisted of four (4) physically handicapped individuals. At the time of this study these individuals were students at Montana State University. This group was selected for the following reasons:

1. Availability for testing purposes.
2. Previous levels of experience with laboratory-shop tools and equipment. These individuals have had very little, if any, previous experience and, therefore, would be similar in background to secondary school students entering laboratory-shop classes for the first time.
3. Physical handicaps possessed by this group are representative of those in groups of physically handicapped secondary school students who will be taking laboratory-shop subjects for the

first time.

4. Test group members are physically handicapped and do not in any way suffer any psychological impairment.

Specific information about test group members disabilities is important since inferences will be drawn from their ability to use tools and equipment and their suggestions for corrective-adaptive apparatus.

#### Descriptions of Test Group Members

Test Group Member A: Female, Age 21.

Specific Disability: Para-pelegic-paralysis from upper waist down; damage to vertebrae T-6, gunshot wound at 10 years of age.

Mobility: Confined to wheelchair, arm strength good; cannot exert much pulling motion but can push against chair well. Limited in activities of varying heights.

Test Group Member B: Male, Age 21.

Specific Disability: Cerebral Palsy; since birth; muscular coordination difficulty.

Mobility: Slight overall mobility limitation; can work sitting or standing, can work well

when pressure movement is required; coordination difficulty when little or no muscle pressure is required.

Test Group Member C: Female, Age 19.

Specific disability: Amputee-- right arm gone at shoulder.

Mobility: All other muscle functions are normal.

This individual is slight of stature but has developed added degree of compensating strength in left arm.

Test Group Member D: Male, Age 28.

Specific disability: Paralysis - partial in right side of body and total in the left due to spinal injury experienced at age 24. Prior to an accident, this individual was a fine all-around athlete.

Mobility: Needs aided support of crutch to walk.

Must complete all activities totally with limited right side mobility. Must either sit down or stand, tires very easily.

#### Presentation of Data

The data is presented in the general order of items

appearing in the listing of tools and equipment (see Appendix C). Presentation of information about tools and/or equipment will begin with Item #1 appearing on Table 2.

It should be noted at this point that the findings and conclusions of this study depend upon the assessments made and information and suggestions given by the test group members. Test group members were tested individually and test sessions were presented as equal and alike as possible. Every attempt was made to erase all variables except individual handicaps.

The following is a review of tools and equipment items tested and responses of test group members to difficulty level, specific difficulty, and suggestions for correction in the use of tested tool and equipment items. The items tested began with simple hand tools, progressed to hand-held portable power tools, and finished with stationary power machinery. The order was simple to complex. Whenever difficulty was encountered suggestions from test members were used to develop corrective devices.

Testing was completed by subjecting test group members to simulated skill exercises with all tools. A complete photographic record was kept so that additional study may be made of data from all test members using all tools and pieces of equipment.

Measuring Tools

Tool Item 1, Table 2.

Tool: Combination Square

## LEVEL OF DIFFICULTY RATING

TEST GROUP MEMBERS				
A	B	C	D	$\bar{X}$
1	2	2	3	2

Specific Difficulty:

1. Difficult to hold in place, especially with one hand.
2. Impossible to use in vertical position.

Suggestions for Correction:

Some type of holding device or use on large flat surface.



Tool Item 2, Table 3.

Tool: Tri-Square

LEVEL OF DIFFICULTY RATING

TEST GROUP MEMBERS				
A	B	C	D	$\bar{X}$
1	2	2	3	2

Specific Difficulty:

Difficult to hold steady, need both hands. Cannot be used in vertical position.

Suggestions for Correction:

Use on large flat surface, develop some type of clamp to hold in position.

Tool Item 3, Table 4.

Tool: 36" Rule

LEVEL OF DIFFICULTY RATING

TEST GROUP MEMBERS				
A	B	C	D	$\bar{X}$
1	1	2	2	1.5

Table 4 Continued.

Specific Difficulty:

Hard to balance with one hand, cannot make long straight line unaided. Must be used in horizontal position.

Suggestions for Correction:

Use shorter scale, use in horizontal position.

Tool Item 4, Table 5.

Tool: Carpenters Square

LEVEL OF DIFFICULTY RATING

TEST GROUP MEMBERS				
A	B	C	D	$\bar{X}$
1	2	2	3	2

Specific Difficulty:

Hard to balance, square is too heavy, must use on a horizontal surface.

Suggestions for Correction:

Use smaller, lighter square, provide large flat surface for work.

Tool Item 5, Table 6.

Tool: Scratch Awl

LEVEL OF DIFFICULTY RATING

TEST GROUP MEMBERS				
A	B	C	D	$\bar{X}$
1	2	2	1	1.5

Specific Difficulty:

Need guide to use, must hold or secure material.

Suggestions for Correction:

Clamp stock to bench, develop a guide.

Tool Item 6, Table 7.

Tool: Tape Measure - Lockable

LEVEL OF DIFFICULTY RATING

TEST GROUP MEMBERS				
A	B	C	D	$\bar{X}$
1	1	2	2	1.5

Table 7 continued.

Specific Difficulty:

Material being measured may move.

Suggestions for Correction:

Make sure object to be measured is held securely. Develop table clamp.

Tool Item 7, Table 8.

Tool: Dividers

LEVEL OF DIFFICULTY RATING

TEST GROUP MEMBERS				
A	B	C	D	$\bar{X}$
1	3	3	1	2

Specific Difficulty:

Requires fine motor control, material moves.

Suggestions for Correction:

Develop some type of clamp.

Analysis of the Use of Measuring Tools

Although the rated difficulty level for the use of measuring tools was not high, some implications of use were very evident. The physically handicapped test group members showed considerable frustration and difficulty with fine motor control. Difficulty in using all of the measuring tools was compounded by the test members inability to precisely move the tool or the accompanying marking pencil.

Hand Tools

Tool Item 8, Table 9

Tool: Cross-Cut Saw

LEVEL OF DIFFICULTY RATING

TEST GROUP MEMBERS				
A	B	C	D	$\bar{X}$
5	3	3	3	3

Specific Difficulty:

Too flexible, blade, perhaps, is too coarse, difficult to control and push.

Table 9, continued.

Suggestions for Correction:

Hold stock securely, use finer toothed blade, use lighter weight saw, use more rigid saw.

Tool Item 9, Table 10

Tool: Back-saw

LEVEL OF DIFFICULTY RATING

TEST GROUP MEMBERS				
A	B	C	D	$\bar{X}$
1	2	1	2	1.5

Specific Difficulty:

Requires fine motor control, hard to start through wood.

Suggestions for Correction:

Use small and lightweight back-saw, file a notch at beginning point.

Tool Item 10, Table 11.

Tool: Coping Saw

LEVEL OF DIFFICULTY RATING

TEST GROUP MEMBERS				
A	B	C	D	$\bar{X}$
2	4	1	2	2.25

Specific Difficulty:

Angle of pull is awkward, requires fine motor control, work must be clamped to bench securely, blade must be tight.

Suggestions for Correction:

Clamp securely to bench, perhaps clamp material so that pulling of saw is in the horizontal position.

Tool Item 11, Table 12.

Tool: Woodworking Bench Vise

LEVEL OF DIFFICULTY RATING

TEST GROUP MEMBERS				
A	B	C	D	$\bar{X}$
1	1	2	3	1.75

Table 12, continued.

Specific Difficulty:

Vise mechanism may be too stiff or hard to operate, long pieces of stock are hard to hold while working vise. Need height block to adjust depth of vise grab.

Suggestions for Correction:

Develop stop on bench front to hold material when clamping, lubricate vise mechanical components, develop depth block.

Tool Item 12, Table 13.

Tool: Hand Drill

LEVEL OF DIFFICULTY RATING

TEST GROUP MEMBERS				
A	B	C	D	$\bar{X}$
1	2	5	3	2.75

Specific Difficulty:

Adjust level of drilling, requires fine motor control, cannot be used with one hand, hard or impossible to put drill bit in chuck.

Suggestions for Correction:

Use in horizontal position, provide larger handle, lubricate mechanism.



Tool Item 13, Table 14.

Tool: Bit and Brace

LEVEL OF DIFFICULTY RATING

TEST GROUP MEMBERS				
A	B	C	D	$\bar{X}$
3	1	5	2	2.75

Specific Difficulty:

A great deal of strength is needed to work bit and brace, hard to balance, cannot use with one hand, impossible to put bit into brace chuck with one hand.

Suggestions for Correction:

Make sure that height is adjusted for horizontal drilling from wheel chair or stool, perhaps a "Breast Drill" with shoulder plate would be a more appropriate tool allowing for the use of the entire body to control inward pressure rather than just arms.

Tool Item 14, Table 15.

Tool: Wood and/or Metal File

LEVEL OF DIFFICULTY RATING

TEST GROUP MEMBERS				
A	B	C	D	$\bar{X}$
1	1	1	1	1

Table 15 continued.

Specific Difficulty:

Accuracy is somewhat affected when used with one hand, change height of work to a comfortable position which permits proper angle for pressure.

Suggestions for Correction:

Use fine file.

Tool Item 15, Table 16.

Tool: Wood Rasp

LEVEL OF DIFFICULTY RATING

TEST GROUP MEMBERS				
A	B	C	D	$\bar{X}$
2	3	1	1	1.75

Specific Difficulty:

Due to coarseness rasp is hard to push, requires fine motor control, hard to use with one hand.

Suggestions for Correction:

Use finer toothed rasp-file, practice, smaller rasp.

Tool Item 16, Table 17.

Tool: Sure-Form Rasp

LEVEL OF DIFFICULTY RATING

TEST GROUP MEMBERS				
A	B	C	D	$\bar{X}$
2	1	1	1	1.25

Specific Difficulty:

Level of work and tool.

Suggestions for Correction:

Use smaller tool for easier handling. Easiest of all file-type tools to use.

Tool Item 17, Table 18.

Tool: Block Plane

LEVEL OF DIFFICULTY RATING

TEST GROUP MEMBERS				
A	B	C	D	$\bar{X}$
2	1	3	1	1.75

Table 18, continued.

Specific Difficulty:

Length of work surface vs. length of reach, balance of individual, hard to start on cut.

Suggestions for Correction:

Adjust for fine depth of cut, tilt cut on angle to cut, adjust-level of work so that it may be easily reached, keep sharp.

Tool Item 18, Table 19.

Tool: Smooth-Plane

LEVEL OF DIFFICULTY RATING

TEST GROUP MEMBERS				
A	B	C	D	$\bar{X}$
2	1	3	3	2.25

Specific Difficulty:

Length of required stroke is greater than reach, too much strength is required, hard to start, balance required.

Suggestions for Correction:

Adjust height of work, cannot be easily used with one arm use smaller lighter plane.

Tool Item 19, Table 20.

Tool: Claw Hammer - 13 oz.

LEVEL OF DIFFICULTY RATING

TEST GROUP MEMBERS				
A	B	C	D	$\bar{X}$
3	3	2	4	3.0

Specific Difficulty:

Difficult to maintain fine motor control and consistency of blows, some type of control necessary to hold nails requires balance and aim.

Suggestions for Correction:

Use heavier hammer, need some device to hold nails in place, lower work, and match weight of hammer with individual 16 oz.

Tool Item 20, Table 21..

Tool: Nail Set

LEVEL OF DIFFICULTY RATING

TEST GROUP MEMBERS				
A	B	C	D	$\bar{X}$
1	4	5	5	3.75

Table 21, continued.

Specific Difficulty:

Requires fine motor control, tool requires high degree of accuracy for proper use, cannot maintain aim and balance.

Suggestions for Correction:

Not recommended for use by individuals with motor control problems.

Tool Item 21, Table 22.

Tool: Wood Chisel

LEVEL OF DIFFICULTY RATING

TEST GROUP MEMBERS				
A	B	C	D	$\bar{X}$
2	2	4	3	2.75

Specific Difficulty:

Level of work, strength and motor control required, hard to control with limited strength and balance.

Suggestions for Correction:

Keep tool sharp, use larger chisel for easier control.

Tool Item 22, Table 23.

Tool: Spoke Shave

LEVEL OF DIFFICULTY RATING

TEST GROUP MEMBERS				
A	B	C	D	$\bar{X}$
1	1	4	5	2.75

Specific Difficulty:

Length of stroke, must have two hands.

Suggestions for Correction:

Keep tool sharp, adjust for fine depth of cut.

Tool Item 23, Table 24.

Tool: Screwdriver

LEVEL OF DIFFICULTY RATING

TEST GROUP MEMBERS				
A	B	C	D	$\bar{X}$
2	1	2	1	1.5

Table 24, continued.

Specific Difficulty:

Angle of work and screwdriver length, requires fine motor control, difficult to use with one hand.

Suggestions for Correction:

Use large screwdriver handle/short shank, make sure screwdriver is sharpened correctly, use pilot hole for wood screws, magnetic screwdriver top, screwball driver works very well.

Tool Item 24, Table 25.

Tool: Tin Snips

LEVEL OF DIFFICULTY RATING

TEST GROUP MEMBERS				
A	B	C	D	$\bar{X}$
3	4	2	1	2.5

Specific Difficulty:

Requires physical strength and coordination, metal must be clamped down, fine motor control necessary.

Suggestions for Correction:

Increase leverage, secure work.



Tool Item 25, Table 26.

Tool: Aviation Snips (Straight Cut)

LEVEL OF DIFFICULTY RATING

TEST GROUP MEMBERS				
A	B	C	D	$\bar{X}$
2	2	2	1	1.75

Specific Difficulty:

Requires fine motor control.

Suggestions for Correction:

Use will improve with practice, much easier than tin snips.

Tool Item 26, Table 27.

Tool: Pop Rivet Gun

LEVEL OF DIFFICULTY RATING

TEST GROUP MEMBERS				
A	B	C	D	$\bar{X}$
1	2	5	5	3.25

Table 27, continued.

Specific Difficulty:

Requires fine motor control and strength, cannot be used with one hand.

Suggestions for Correction:

Make sure pop rivet holes are drilled correctly.

Tool Item 27, Table 28.

Tool: Slip-Joint Pliers

LEVEL OF DIFFICULTY RATING

TEST GROUP MEMBERS				
A	B	C	D	$\bar{X}$
1	1	1	1	1

Specific Difficulty:

Requires some fine motor control, otherwise, easy to use.

Tool Item 28, Table 29.

Tool: Hacksaw

LEVEL OF DIFFICULTY RATING

TEST GROUP MEMBERS				
A	B	C	D	$\bar{X}$
2	1	1	2	1.5

Specific Difficulty:

Blade too coarse, requires fine motor control.

Suggestions for Correction:

Use finer than usual blade.

Analysis of the Use of Hand Tools

Although specific difficulties were encountered in the use of certain hand tools, overall, test group members could successfully use most of the hand tools. Comments of test group members revealed that skill levels would certainly rise with additional practice.

Consolations were necessary with some hand tools. The pop rivet gun and nail set were extremely difficult for

the test group members to master due to strength and fine motor control requirements, respectively. Adjustments in the type of tool used proved to be of great help. The standard cross cut saw was replaced by the smaller, more rigid back saw, aviation snips were much easier to use than the standard tin snips, and the 16 ounce hammer proved more satisfactory than the 13 ounce hammer--small changes which made it possible for the physically handicapped to use hand tools.

Portable Electric Tools

Tool Item 29, Table 30.

Tool: Electric Orbital Sander (Rockwell 505)

LEVEL OF DIFFICULTY RATING

TEST GROUP MEMBERS				
A	B	C	D	$\bar{X}$
1	1	1	1	1

Specific Difficulty:

Material should be secured.

Table 30, continued.

Suggestions for Correction:

No problem in use.

Tool Item 30, Table 31.

Tool: Portable Electric Drill ( $\frac{1}{4}$ " )

LEVEL OF DIFFICULTY RATING

TEST GROUP MEMBERS				
A	B	C	D	$\bar{X}$
1	1	1	1	1

Specific Difficulty:

Hard to put bits in chuck.

Suggestions for Correction:

Use lightweight tool, drill in horizontal position.

Tool Item 31, Table 32

Tool: Sabre Saw

LEVEL OF DIFFICULTY RATING

TEST GROUP MEMBERS				
A	B	C	D	$\bar{X}$
1	1	1	1	1

Specific Difficulty:

Sawdust obstructs line, cannot see.

Suggestions for Correction:

Make sure work is secured.

Tool Item 32, Table 33.

Tool: Belt Sander

LEVEL OF DIFFICULTY RATING

TEST GROUP MEMBERS				
A	B	C	D	$\bar{X}$
4	1	2	1	2.0

Table 33, continued.

Specific Difficulty:

Produced anxiety, pulls away and is hard to control from wheelchair, somewhat heavy, requires fine motor control.

Suggestions for Correction:

Use lighter weight machine, make sure work is secured.

Tool Item 33, Table 34.

Tool: Router

LEVEL OF DIFFICULTY RATING

TEST GROUP MEMBERS				
A	B	C	D	$\bar{X}$
5	4	5	5	4.75

Specific Difficulty:

Danger from torque and rotational speed, need both hands and a high degree of motor control.

Suggestions for Correction:

Not recommended for use by the physically handicapped with motor control difficulty. Develop some type of router table-- completed x of use = 1. Became very safe, accurate, and easy to use.

Analysis of the Use of Portable Electric Tools

Among the selection of portable electric tools, all could be used with safety and relative ease by test group members. The exception was the router. While simple enough to use, to maintain a level of safety, the router required a combined degree of fine motor control and strength beyond the ability of the test group members. To accommodate the use of the router, a simple router table was constructed. While router tables are not a new idea, this design has some unique features which were recommended by test group members (see plans in Appendix D).

Stationary Power Tools

Tool Item 34, Table 35.

Tool: Table Saw

LEVEL OF DIFFICULTY RATING

TEST GROUP MEMBERS				
A	B	C	D	$\bar{X}$
5	5	5	5	5



Table 35, continued.

Specific Difficulty:

Not recommended for use due to fine motor control and strength requirements and safety precautions--recommend all crosscutting be done on radial arm saw.

Tool Item 35, Table 36.

Tool: Radial Arm Saw/Clamping Table Attachment

LEVEL OF DIFFICULTY RATING

TEST GROUP MEMBERS				
A	B	C	D	$\bar{X}$
1	1	1	1	1

Specific Difficulty:

No problem/clamping device.

Suggestions for Correction:

Make sure radial arm saw head has return spring for safety.

Tool Item 36, Table 37.

Tool: Drill Press/Hold Down Table

LEVEL OF DIFFICULTY RATING

TEST GROUP MEMBERS				
A	B	C	D	$\bar{X}$
3/1	3/1	2/1	3/1	2.75/1

Specific Difficulty:

Long stock will not balance on small table, stock may catch and spin if not clamped down, danger at eye level, elevate wheelchair.

Suggestions for Correction:

Use larger table and/or hold down clamps, Appendix D.

Tool Item 37, Table 38.

Tool: Scroll Saw (Jigsaw)/Large Table Assembly

LEVEL OF DIFFICULTY RATING

TEST GROUP MEMBERS				
A	B	C	D	$\bar{X}$
4/1	3/1	4/1	4/1	3.73/1.0

Table 38, continued.

Specific Difficulty:

Hard to hold large work pieces, table height too high for wheelchair-bound individual.

Suggestions for Correction:

Raise wheelchair, develop large table. No problem/table, Appendix D.

Tool Item 38, Table 39.

Tool: Jointer (4")

LEVEL OF DIFFICULTY RATING

TEST GROUP MEMBERS				
A	B	C	D	$\bar{X}$
2	1	5	5	3.25

Specific Difficulty:

Length of reach required from wheelchair, large boards may be cumbersome, requires fine motor control.

Suggestions for Correction:

Make sure all guards are in place - - may be dangerous for limited control individual.

Tool Item 39, Table 40.

Tool: Wood Lathe

LEVEL OF DIFFICULTY RATING

TEST GROUP MEMBERS				
A	B	C	D	$\bar{X}$
3	5	5	5	4.5

Specific Difficulty:

Limited motor control, cannot put forth the required strength.

Suggestions for Correction:

Not recommended for use by the motor control impaired individual.

Analysis of the Use of Stationary Power Tools

The use of stationary power tools by test group members proved to be very challenging from an access and safety standpoint. Input from test groups members as well as experienced laboratory instructors produced a series of devices which could be attached to the test equipment to permit safe and correct use by the physically handicapped members of the test group.

It should be noted that the developed devices all fall into the category of clamping or holding devices. Mobility and strength limitations of the handicapped proved the necessity for this type of device generally to secure the material being worked with or to give added support to the work space.

The stationary tools selected for use proved to be suitable for use by our test group with two exceptions:

- A. Table Saw - Dexterity, strength, and reach requirements proved to be too great for test group members. If user must sit in a wheelchair or on a stool to operate machinery, the table saw presents an access problem.
- B. Wood Lathe - Due to dexterity, strength, and fine motor control requirements, it is recommended that this machine not be used by those with physical handicaps of the upper body or handicaps that affect stance and/or balance.

A complete listing of these devices and plans for their construction appears in Appendix D.

Summary

This chapter has presented an analysis of data accumulated through laboratory-shop testing of identified tools and/or equipment by a group of physically handicapped individuals. This testing revealed levels of difficulty, specific difficulty, and suggestions for correction that would permit physically handicapped students to properly use the selected tools and equipment.

## Chapter V

### Summary, Conclusions and Recommendations

The purpose of this chapter is to summarize the study which was an identification and development of apparatus to assist the physically handicapped in obtaining access to laboratory-shops. The need, purpose, and specific objectives are briefly reviewed; the techniques and procedures employed while conducting the study are briefly considered; the major findings are summarized; and conclusions are set forth. Finally, on the basis of the findings and conclusions of the study, recommendations for further study of areas relative to this subject are presented.

#### Summary of the Study

##### Need for the Study

We live in a time when a great deal of concern and emphasis is placed on the rights and opportunities of disadvantaged and handicapped individuals. This overall concern and resulting emphasis naturally extends to public education where disadvantaged and handicapped individuals may have the opportunity to acquire knowledge

and develop skills that will enable them to compensate for their disabilities and cope more effectively in society.

Specific to the concerns of this study is the placement of physically handicapped individuals into laboratory-shop classroom setting in educational programs of secondary industrial arts and vocational agriculture. These are educational scenes that have, in many instances, been closed to the physically handicapped either because of fear, teacher and administrator anxiety, or the lack of teacher skill in working with the handicapped student.

The passing of the Education for All Handicapped Children Act of 1975 (P.L. 94-142) removed the question of whether or not public schools should or should not develop educational programs for the handicapped: Physically handicapped students will now be integrated into "regular" secondary school laboratory-shop programs.

#### The Problem

Thus, at present, many industrial arts and vocational agriculture education programs in Montana faced with the mandate of providing adequate and proper laboratory-shop skill instruction for the physically handicapped student. There is a need to identify and develop apparatus



to assist the physically handicapped in both obtaining access and developing skills in laboratory-shop programs.

### Purpose and Objectives

#### Purpose

The purpose of this study was to determine how physically handicapped students in Montana secondary industrial arts and vocational agriculture programs could obtain access to laboratory-shop programs, their tools and equipment and subsequent skill development as mandated by Public Law 94-142.

#### Objectives

In order to accomplish the major purpose of this study, specific objectives were formulated:

1. Identify that segment of the public school population known as the handicapped and specifically the physically handicapped.
2. Summarize legislation pertinent to public education of the handicapped.
3. Develop apparatus that will permit physically handicapped students to properly use selected

tools and/or equipment.

4. Develop a set of working drawings of the aforementioned apparatus.
5. Develop an assessment and implementation model of handicaps and programs for teacher use.

### Review of Literature

A review of pertinent literature suggests that there is a great deal of misinformation and misunderstanding about the handicapped and, specifically, the physically handicapped. As in the past, disabled individuals of all types have grouped into one category labeled "handicapped", and due to a level of non-understanding, these individuals have been separated from many activities.

In recent years, legislators have attempted to aid the handicapped individual. Legislation serves the handicapped primarily through the arena of public education, and then, subsequently, into society as a whole. Until recently litigation and legislation, however, has not always been successful in opening doors for the handicapped. New hope comes in the form of the Education For All Handicapped Children Act known officially as Public Law 94-142. While this legislation stands out as unique it does not stand alone. Public Law 94-142 may be viewed

as the implementation and financing law enabling previous legislation as well as new statutes to be implemented for the benefit of the handicapped. The context and major purpose of this legislation is simply to give the handicapped individual an appropriate and equal educational opportunity when possible.

Education is the key area that can serve the handicapped first and foremost. The areas of industrial arts and vocational education can uniquely serve the handicapped by providing instruction in skill development that will enable the handicapped where appropriate, to develop careers of various types for self support. The important term in the legislation is "appropriate education." Not all handicapped individuals will be able to benefit from regular or special educational experiences, but those that can should have the opportunity.

#### Method of Procedure

The study was focused upon five major purposes: first, to identify that segment of the public school population known as the handicapped, and specifically, the physically handicapped; second, to summarize legislation pertinent to public education of the handicapped; third,

to design, develop, and test apparatus that will permit physically handicapped individuals to properly, safely, and independently use shop tools and equipment commonly identified in industrial arts and vocational agriculture curriculum guides; fourth, to develop a set of working drawings of the aforementioned apparatus for distribution to teachers of industrial arts and vocational agriculture; fifth, to develop a model for both teacher assessment of physically handicapped student capabilities/limitations and the instructional integration of determined technical skill instruction.

The identification of tools and equipment commonly in use was completed by reviewing curriculum guides in both industrial arts and vocational agriculture disciplines developed cooperatively by the Montana State Office of Public Instruction, Helena, and the Department of Agriculture and Industrial Education, Bozeman. Tools and equipment selected are basic to both industrial arts and vocational agriculture disciplines and represent introductory skills.

The test group of physically handicapped individuals was selected from members of a handicapped student's group at Montana State University: Wheelchairs, Crutches,

and People. This test group approximates student abilities and disabilities found with other physically handicapped students in the secondary school sector, specifically:

- A. Physically handicapped, or disabled, to a degree but possessing some freedom of mobility.
- B. Physically handicapped only, not limited in any mental or psychological capacity.
- C. Having the potential of being self-sufficient in the laboratory-shop setting with the help of assistive devices.
- D. Very little, if any, prior experience with laboratory-shop skills or equipment.

Information on the use of tools and equipment by the test group was collected through individual laboratory-exercise testing with information compiled on an information category check sheet. This data as well as input from test group members was used to develop assistive apparatus and devices which permit the handicapped to correctly and safely use the identified shop tools and equipment.

Information gathered from the review of literature and legislation, as well as the developed assistive devices were compiled into a guide for teachers. It is hoped that the use of this guide will enable teachers

of laboratory-shop subjects to better assess student handicaps and develop instruction appropriate for those handicapped individuals in meeting goals and objectives of their respective disciplines.

### Summary of Findings

To satisfy the major objectives of the study, this investigator used many resources. Data and information were obtained from curriculum guides developed cooperatively by the Office of Public Instruction and the Department of Agricultural and Industrial Education, Montana State University. Additionally, a thorough review of literature pertinent to the topic was conducted and a group of physically handicapped individuals was utilized for their information on handicaps and their overall expertise.

Representative tools and equipment were selected for laboratory-exercise testing by the physically handicapped test group. The results of this testing were completed on an information category check sheet. A presentation of this testing data appears in Chapter IV:

The data indicates that the population (handicapped test group members), viewed collectively, have a high degree of similarity in problems encountered using the

selected tools and equipment. Although their handicaps were of different types, each individual experienced difficulty with fine motor control, dexterity, reach, and body position when using tools and equipment. It may also be noted that while varying degrees of difficulty existed in the use of tools and equipment, test group members felt they could use all but a few tools very well with practice.

Interestingly, some tools which were perceived to be simple to use prior to testing proved to be difficult or impossible to use during the test, and conversely. Specifically, the common hammer, cross-cut saw, and nail set were much more difficult to use than anticipated, and the nail set was almost impossible to use by the test group members. While tools such as the large belt sander were simple to operate, the router and radial arm saw proved easy to operate with simple assistive devices.

As in any new skill experience, the test group members experienced a lack of knowledge about the tools, equipment, and their use. The point to be made here is that this is the same situation that physically handicapped students in the secondary school sector will face. Of particular note is that all test group members were able to use the tools and equipment, with few exceptions,

after basic use and safety instruction was given.

This investigator viewed the tool and equipment useage situation prior to testing in order to develop exercise situations that would be appropriate for all individuals. This led to some speculation on strength and mobility limits of individual test group members. It was discovered that the best source of information on the specific limitations of any one disability is the handicapped individual who possesses it.

An overwhelming attitude which prevailed during all testing sessions and in all encounters was that while non-handicapped individuals may look at disabilities, members of this test group were always searching for ways to utilize their positive abilities. This is a compensating motive to be sure, but one that does effect student performance.

### Conclusions

Data analysis and the findings of this study warrant the following conclusions:

1. The detailed descriptive data derived from the review of literature pertaining to the physically handicapped in general may be



applied to physically handicapped students enrolled in secondary laboratory-shop programs in Montana.

2. Regular classroom teachers may experience a high degree of anxiety when faced with providing appropriate educational experiences for the handicapped. The most effective way to implement the statutes of legislation pertaining to providing these educational experiences for the physically handicapped is through pre-service and in-service teacher education.
3. Based on the information revealed through laboratory testing of selected tool and equipment use by a group of physically handicapped individuals, it is apparent that:
  - A. Physically handicapped individuals with little or no prior laboratory-shop experience can master many of the basic skills required to correctly use introductory shop tools and equipment.
  - B. The physically handicapped, as a collective group, share common difficulties related to the use of laboratory tools and

equipment. These are difficulties related to physical strength, mobility, and fine motor control.

- C. Where tool and equipment use and safety is a problem, assistive apparatus and/or devices can easily be constructed to provide safe and proper use, (see Appendix D). These devices generally will fall into the category of holding or clamping devices.
- D. Assistive apparatus to aid the physically handicapped may be developed by the laboratory-shop instructor quickly and inexpensively, and from locally available materials.
- E. Assistive apparatus and devices constructed to aid the physically handicapped with shop skills may also make those skill operations easier and safer for non-handicapped students.

#### Recommendations

On the basis of the data, findings, and conclusions

of this study, the investigator believes the following recommendations merit consideration:

1. The Montana State Office of Public Instruction and, specifically, the Office of the Director of Vocational Education continue to provide school district superintendents, secondary school principals and area supervisors with information particular to their position and role in providing appropriate educational experiences for the handicapped student.
2. Teachers of laboratory-shop subjects be brought up to date on the classroom statute responsibilities and implications of legislation pertaining to the free and appropriate education of the handicapped.
3. Montana teachers of industrial arts and vocational laboratory-shop classes attend workshops conducted by the Department of Agricultural and Industrial Education, Montana State University, cooperatively with the Office of Public Instruction. The purpose of these workshops would be to give the regular classroom teacher information on the practical assessment of physically handicapped students in light of attaining

appropriate educational objectives.

### Recommendations for Further Study

This study was limited to an investigation of laboratory-shop usage of basic hand tools, portable power tools, and stationary power equipment by a selected group of physically handicapped individuals. However, the study is suggestive of additional areas of needed research pertaining to the integration and skill development of other handicapped individuals into industrial arts and vocational education laboratory-shop courses:

1. Testing with a broader range of physically handicapped individuals.
2. Testing of skill attainment with tools and equipment or a more complex and higher skill level, leading to the development of assistive devices for those tools and pieces of equipment.
3. An investigation of the integration of the multiple handicapped student into industrial arts and vocational laboratory-shop classes.

## BIBLIOGRAPHY

## Books

- Bauer, William R. 1978. Mainstreaming - Toward More Than Mainschooling. Children in Contemporary Society. Pittsburgh Area Pre-School Association, Pittsburgh, Penna. (ERIC Document No. ED 153-381).
- Buffer, James J. 1973. Review and Synthesis of Research on Industrial Arts for Students With Special Needs. Information Series No. 69. Center for Vocational and Technical Education, Ohio State University, Columbus, Ohio. (ERIC Document No. ED 090-394).
- Chisman, Arlington W., Novak, Kathy 1977. Planning Vocational Education Program for the Disadvantaged and Handicapped. Virginia Polytechnic Institute and State University, Blacksburg, Virginia. (ERIC Document No. ED 145-123).
- Corrigan, Dean C. 1978. "Political and Moral Contexts That Produced P.L. 94-142." Journal of Teacher Education, November-December 1978, Vol xxix, Number 6: pp. 10-14.
- Department of Health, Education and Welfare 1975. Region VI Inservice Training for Vocational Technical Personnel. EPD Consortium D. Conference Report, Richardson, Texas. (ERIC Document No. ED 147-501).
- The Education for All Handicapped Children Act of 1975. The National Association of State Directors of Special Education, Washington, D.C.
- Education of the Handicapped Litigation Brought Under P.L. 94-142 and Section 504 1978. The National Association of State Directors of Special Education, Washington, D.C.
- Greenwood, Katy 1975. Vocational Education for the Disadvantaged: Compliance or Commitment? Department of Health, Education and Welfare. Region VI, Inservice Training for Vocational Technical Personnel, EPD Consortium D, Conference Report, Richardson, Texas, (ERIC Document No. ED 147-501).

- Haisley, Fay B., Gilberts, Robt. D. 1978. "Individual Competencies Needed to Implement P.L. 94-142." Journal of Teacher Education. Vol. XXIX, No. 6.
- Hull, Marc E. 1977. Vocational Education For The Handicapped - A Review of Information, Series #19. Texas A&M College Station, Texas.
- Martin, Edwin W. 1978. "Education of the Handicapped Act and Teacher Education." Journal of Teacher Education. Vol. XXIX, No. 6.
- Martin, E. W. 1974. "Some Thoughts On Mainstreaming." Exceptional Children Magazine, No. 41.
- McPhie, Walter E. 1978. "A Teacher Educating Dilemma: Practical Application vs. Theory." Journal of Teacher Education, Vol. XXIX, No. 6.
- Messerschmidt, Dale H. 1976. "Industrial Arts In Special Education." American Industrial Arts Association, Des Moines, Iowa. (ERIC Document No. Ed. 133-439).
- Nystram, Dennis C. 1973. Occupation and Career Education Legislation. Howard W. Sams & Co., Inc., New York, New York.
- Parr, Cadar 1975. State Effort For Meeting The Needs of Special Populations In Vocational Technical Education. Department of Health, Education, and Welfare, Region VI, Inservice Training for Vocational Technical Personnel, EPD Consortium D, Conference Report, Richardson, Texas. (ERIC Document No. ED 147-501).
- Phelps, Allen L. 1978. A Review and Analysis of Vo-Ed Programs for Handicapped Individuals In the United States. First World Congress on Future Special Education, Sterling, Scotland. (ERIC Document No. ED 157-297).
- Pittsburg Pre-School Association 1978. Eight Papers On Mainstreaming. Pittsburg, Pennsylvania. (ERIC Document No. ED 153-381).

- Rehabilitation Act The, An Analysis of the Section 504 Regulation and Its Implications for State and Local Education Agencies 1977. National Association of State Directors of Special Education, Washington, D.C.
- Sargent, Laurence R. 1978. "State Certification Requirements." Journal of Teacher Education, Vol. XXIX No. 6.
- Schlechty, Phillip C., Turnbull, Ann P. 1978. "Bureaucracy or Professionalism: Implications of P.L. 94-142." Journal of Teacher Education. Vol. XXIX, No. 6.
- Strully, Jeffery L. 1978. "Shawntell, Children In Contemporary Society." Pittsburg Area Pre-School Association. Pittsburg, Penna. (ERIC Document No. ED 153-381).
- Weisenstein, Meredith, Gall, Damiem 1978. "Adapting Teacher Education to Include Mainstreaming: Dean's Grant Projects." Journal of Teacher Education. Vol. XXIX, No. 6.
- Weisgerber, R.A., Smith, C.A. 1977. Improving Vocational Education Services for Handicapped Students, Final Report. American Institutes for Research in the Behavioral Sciences, Palo Alto, California. (ERIC Document No. ED 142-774).
- Winnick, Joseph P., Jansma, Paul 1977. Physical Education Inservice Resource Manual, State University College, Brockport, New York.
- Young, E.B., et. al. 1970. Vocational Education for Handicapped Persons: Handbook for Program Implementations. Washington, D.C., Government Printing Office.

### Curriculum Guides

- Industrial Arts Curriculum Guide for Montana Secondary School 1978. Office of Public Instruction, Helena, Montana; Department of Agricultural and Industrial Education, Montana State University, Bozeman, Montana.



Two-Year Core Curriculum In Vocational Agriculture Education 1975. Office of Public Instruction, Helena, Montana; Department of Agricultural and Industrial Education, Montana State University, Bozeman, Montana.

Additional

Stewart, Craig. Director of Basic Education for the Handicapped In Physical Education. Montana State University, Bozeman, Montana.

## APPENDICES

APPENDIX A  
LISTING OF TOOLS AND MACHINES COMMON  
TO BOTH INDUSTRIAL ARTS AND VOCATIONAL AGRICULTURE  
MECHANICS CURRICULUM GUIDES IN MONTANA

## LISTING OF COMMON TOOLS IN BOTH IA AND VO. AG

## I Metalworking

Hand Tools

1. Layout tools: tape measure, steel rule, steel square, combination square, scriber, scratch awl, wing dividers, inside caliper, outside caliper, hermaphrodite caliper, center punch, prick punch, ball peen jammer.
2. Hacksaw
3. Files
4. Hand drill and twist bits
5. Cold chisels
6. Taps
7. Dies
8. Adjustable wrench
9. Open end wrench
10. Box end wrench
11. Socket wrench sets
12. Vise-grip wrench
13. Pipe wrench
14. Allen wrenches

15. Combination plier
16. Needle nose plier
17. Box joint utility plier
18. Machinist vise
19. C-clamps
20. Common screwdriver
21. Phillips screwdriver

#### Portable Power Tools

1. Electric hand drill
2. Portable electric grinder

#### Stationary Power Tools

1. Drill press
2. Bench grinder
3. Band saw
4. Power hacksaw

### II Sheetmetal

#### Hand Tools

1. Layout tools: scratch awl, scribe, steel rule,

- combination square, wing dividers, center punch, prick punch, ball peen hammer.
2. Cutting sheetmetal with shears, tin snips, aviation snips, cold chisel, and nibbler.
  3. Hacksaw
  4. Files
  5. Drilling with hand drill and twist bits
  6. Punching holes using a solid punch, hollow punch, and hand punch
  7. Assembling sheetmetal components with pop riveter and setting rivets by hand
  8. Soldering using soldering copper, iron, and gun.

#### Portable Power Tools

1. Electric hand drill
2. Electric jig saw

#### Stationary Power Tools

1. Drill press
2. Bending sheetmetal with a finger brake, a folder, a hand brake, and a press brake
3. Using forming rolls to form stove pipe

4. Cutting sheetmetal with a squaring shear
5. Punching holes in sheetmetal with a punch press
6. Cutting notches in sheetmetal using a notcher

### III Welding

#### Hand Tools

1. Layout tools: tape measure, steel rule, steel square, combination square, scribe, scratch awl, dividers, center punch, prick punch, ball peen hammer, inside and outside calipers, hermaphrodite calipers.
2. Hacksaw
3. Files
4. Clipping hammer
5. Wire brush
6. C-clamps
7. Vise-grip wrench
8. Cold chisel
9. Drilling with hand drill

#### Portable Power Tools

1. Electric hand drill
2. Portable electric grinder

### Stationary Power Tools

1. Drill press
2. Bench grinder
3. Band saw
4. Power hacksaw
5. Oxy-acetylene welding equipment
6. Arc welding equipment

## IV Woodwork & Carpentry

### Hand Tools

1. Layout tools: tape measure, steel rule, tri-square, framing square, combination square, sliding T-bevel, marking gage, wing dividers, scratch awl, trammer points, carpenters' level, plumb bob and chalk line, inside calipers, outside calipers, hermaphrodite calipers, center square
2. Sawing tools: crosscut saw, rip saw, back-saw, compass saw, keyhole saw, coping saw
3. Edge cutting tools: smooth, jack block planes, chisels, surfboard tool, rasps, gouges, spokeshave, cabinet scraper, lathe tools



4. Drilling and boring tools: brace, hand drill, yankee drill, auger bit, twist bit
5. Claw hammer
6. Nail set
7. Hand screw clamp, bar clamp, c-clamp
8. Screwdriver

#### Portable Power Tools

1. Electric hand drills
2. Electric jig saw
3. Router
4. Builders' saw
5. Belt sander
6. Orbital sander

#### Stationary Power Tools

1. Drill press
2. Scroll saw
3. Table saw
4. Radial arm saw
5. Band saw
6. Wood lathe

7. Jointer
8. Surfacer
9. Shaper
10. Sanding machine
11. Paneling saw

### V Crafts

#### Hand Tools

1. Layout tools: steel rule, scriber, scratch awl, dividers, tri-square, combination square
2. Shears
3. Utility knife
4. Swivel knife
5. Tin snips
6. Aviation snips
7. Center punch
8. Leather tools: camouflage, shaders, bevelers, stops, veiners, seeders, background tools
9. Solid and hollow punches
10. Leather mallet
11. Ball peen hammer
12. Hand drill

13. Coping saw
14. Jewclers saw
15. Files
16. Hacksaw
17. Cold chisel
18. Soldering copper, iron, and gun

#### Portable Power Tools

1. Electric hand drill
2. Electric jig saw

#### Stationary Power Tools

1. Drill press
2. Scroll saw
3. Table saw
4. Bench grinder
5. Band saw

## HIERARCHY OF SKILLS

## I Woodwork

Hand Tools

1. Measuring tools: tape measure, steel rule, framing square, combination square, tri-square
2. Layout tools: scribe, scratch awl, tri-square, combination square, marking gage, wing dividers, inside caliper, outside caliper, hermaphrodite caliper, plum bob and chalk line, sliding T-bevel, center square, trammel points
3. Hammers
4. Screwdrivers
5. Saws: crosscut, rip, back, coping, keyhole, compass
6. Chisels
7. Files and rasps
8. Planes: smooth, jack, block
9. Cabinet scraper
10. Spokeshave
11. Yankee drill
12. Hand drill

13. Brace
14. Clamps

### Portable Power Tools

1. Electric hand drill
2. Electric orbital sander
3. Electric jig saw
4. Belt sander
5. Builders' saw
6. Power planer
7. Router

### Stationary Power Tools

1. Scroll saw
2. Bank saw
3. Sanding machine
4. Drill press
5. Wood lathe
6. Jointer
7. Surfacer
8. Table saw
9. Radial arm saw
10. Mortiser & tenouer

## 11. Shaper

## Metalwork

Hand Tools

1. Measuring tools: tape measure, steel rule, combination square, steel square
2. Layout tools: scribe, scratch awl, combination square, steel square, dividers, inside and outside calipers, hermaphrodite caliper, center punch, prick punch
3. Hammers
4. Screwdrivers
5. Pliers (combination, needlenose, box joint)
6. Wrenches (open end, box end, adjustable)
7. Vise-grips
8. Hacksaw
9. Cold chisels
10. Clamps
11. Dies
12. Taps
13. Hand drill

Portable Power Tools

1. Electric hand drill
2. Portable electric grinder

Stationary Power Tools

1. Bench grinder
2. Band saw
3. Drill press
4. Power hacksaw
5. Arc welder
6. Oxy-acetylene welding equipment

## Sheetmetal

Hand Tools

1. Layout tools: scribe, scratch awl, tape measure, steel rule, steel square, combination square, dividers, center punch, prick punch
2. Hammers
3. Hack'saw
4. Files
5. Cold chisel

6. Nibbler
7. Punches (solid, hollow, hand punch)
8. Tin snips
9. Aviation snips
10. Hand drill
11. Riveting (Hand and pop riveter)
12. Soldering using soldering copper, iron and gun

#### Portable Power Tools

1. Electric hand drill

#### Stationary Tools

1. Squaring shear
2. Notcher
3. Brake
4. Bar folder
5. Box and pan brake
6. Press brake
7. Forming rolls
8. Turning machine
9. Wiring machine
10. Burring machine



11. Drill press
12. Band saw

## Crafts

### Hand Tools

1. Layout tools: steel rule, scriber, scratch awl, dividers, tri-square, combination square, center punch
2. Hammers: ball peen, leather mallet
3. Utility knife, swivel knife
4. Shears
5. Tin snips
6. Aviation snips
7. Solid and hollow punches
8. Cold chisel
9. Leather tools - camouflage, shaders, bevelers, stops, veiners, seeders, background tools
10. Saws: coping and jewelers, hacksaw
11. Files
12. Hand drill
13. Soldering with soldering copper, iron and gun

Portable Power Tools

1. Electric hand drill
2. Electric jig saw

---

Stationary Power Tools

1. Bench grinder
2. Scroll saw
3. Band saw
4. Drill press
5. Table saw

APPENDIX B  
TEST INSTRUMENT  
AND  
SUMMARY SHEETS

TEST GROUP MEMBER \_\_\_\_\_

SCHOOL	DIFFICULTY LEVEL	SPECIFIC DIFFICULTY	SUGGESTIONS FOR CORRECTION

Table:

Tool:

LEVEL OF DIFFICULTY RATING

TEST-GROUP MEMBERS				
A	B	C	D	$\bar{X}$

Specific Difficulty:

Suggestions for Correction:

APPENDIX C  
LISTING OF TOOLS AND EQUIPMENT SELECTED FOR  
LABORATORY TESTS/HANDICAPPED INDIVIDUALS

Measuring Tools

Combination Square  
 Tri-Square  
 36" Rule  
 Carpenters Square

Scratch Awl  
 Locakable Tape Measure  
 Dividers

Hand Tools

Cross Cut Saw  
 Back-Saw  
 Coping Saw  
 Woodworking Vise  
 Hand Drill  
 Bit and Brace  
 Wood File  
 Wood Rasp  
 Sure Form Tool  
 Block Plane  
 Smooth Plane

Claw Hammer  
 Nail Set  
 Wood Chisel  
 Spoke Shave  
 Screwdriver  
 Tin Snips  
 Aviation Snips  
 Pop Rivet Gun  
 Pliers  
 Hack Saw

Portable Power Tools

Orbital Sander  
 Electric Drill  
 Sabre Saw

Belt Sander  
 Router

Stationary Power Tools

Table Saw  
 Radial Arm Saw  
 Drill Press

Jig Saw  
 Jointer  
 Wood Lathe

APPENDIX D  
HANDICAPPED STUDENT ASSESSMENT  
AND  
APPARATUS IMPLEMENTATION INFORMATION  
A TEACHERS GUIDE



ASSISTING THE PHYSICALLY HANDICAPPED:  
AN IDENTIFICATION AND DEVELOPMENT OF  
APPARATUS FOR LABORATORY SHOPS  
PHASE I

Handicapped Student Assessment  
And Apparatus Implementation  
Information

By

KENNETH L. BRUWELHEIDE, Ed.D

Department of Agricultural and Industrial  
Education

MONTANA STATE UNIVERSITY  
Bozeman, Montana

1979

In Cooperation With  
Montana State Office of Public Instruction  
Helena, Montana

## Introduction

Historically, the handicapped have been a misunderstood and somewhat hidden segment of our population. In the past, society has grouped all disabilities in one category labeled "handicapped" and due to a level of non-understanding has separated these individuals into groups for various activities. "Public education which would be able to do a great deal for the handicapped has in the past continued this separation of handicapped students from their peers and placed them in special classes." (Stewart, 1979).

In the arena of public education, and subsequently in society as a whole, there is now new hope for the handicapped or disabled individual. This new hope comes in the form of the Education For All Handicapped Children Act of 1975, known officially as Public Law 94-142. This highly acclaimed act, "guarantees a free appropriate public education for all handicapped children, ages 3 to 21." (Hull, 1977, p. 7). The specific encompassing regulation of P.L. 94-142 that this study deals with is (Strully, 1978, p. 55):

To insure that all handicapped children have available to them a free appropriate public education which includes special education and related services to meet their unique needs, to insure that the rights of handicapped children and their parents are protected, to assist states and localities to provide for the education of handicapped children, and to assess and insure the effectiveness of efforts to educate these children.

Briefly stated P.L. 94-142 means that teachers of all disciplines will have handicapped students in their classrooms. No longer will public school administrators or teachers ponder the question of whether or not to provide services for these individuals, the decision has been mandated. Having handicapped students in ones' classes can be an exciting, as well as professionally and personally rewarding challenge to those teachers willing to meet that challenge.

It is the aim of this study to provide information and methods of meeting the challenge of integrating physically handicapped students into industrial arts and vocational agriculture laboratory-shops.

### Statement of the Problem

At the present time there are many industrial arts

and vocational agriculture programs in Montana faced with the mandate of providing adequate and proper laboratory-shop skill instruction for the physically handicapped student. There is a need to identify and develop apparatus to assist the physically handicapped in both obtaining access and developing skills in laboratory-shop programs.

#### Purpose of the Study

The major purpose of this study, and the resulting information for teachers and administrators, is to provide teachers with instructions concerning physically handicapped students and the process of providing educational opportunities for them in laboratory-shop programs.

#### Who Are The Handicapped

When the word "handicapped" is applied most individuals envision a person with some sort of disabling mental or physical abnormality. In speaking of students who teachers may encounter in industrial arts and vocational education areas, the definition may be somewhat narrowed to "those students who cannot succeed in

regular vocational programs." (Greenwood, 1977, p. 47). The numbers of students which may comprise this group is considerable, and in itself, a topic for debate. A very realistic figure of the numbers of handicapped students who will be able to directly benefit from the provisions of P.L. 94-142 is about 12% of the population of the United States between the ages of 3 and 21.

The aforementioned percentage reflects the number of students with special needs. The actual number of students who are to benefit from educational experiences deemed "appropriate" for them under the statutes of P.L. 94-142 will vary from district to district. The key wording, to teachers of laboratory-shop subjects, is appropriate. The implied parameters of appropriateness will be the severity of individual handicaps in regard to safety and other considerations.

In order to establish some common ground, it is necessary to present definitions pertaining to handicapped students and their educational experience.

Special Education: Specially designed instruction given at no cost to parents or guardians, to meet the unique needs of a handicapped child, including but not limited to classroom instruction, home instruction, and hospitals.

Handicapped Child: A child evaluated as being mentally retarded, hard of hearing, deaf, speech-

impaired, visually handicapped, emotionally disturbed, orthopedically impaired, or other health-impaired, or as having specific learning disabilities, who because of those impairments needs special education and related services.

Physically Handicapped or Orthopedically Impaired: Severe orthopedic impairment which adversely affects a child's educational performance.

(Stewart, 1979)

Other terminology used to more specifically define the physically handicapped and their impairments are as follows:

Static Handicaps: The handicap was there at birth, it is not changing, may be congenital. Persons born with a disability have a very different adjustment to make from someone who had not been handicapped and has become so.

Trauma Induced: Loss of a limb, trauma, or accident induced disability; was once whole, then was maimed.

Degenerative Disease: Such as muscular dystrophy, cystic fibrosis, and others which are 99% fatal.

In continuing a description of the physically handicapped as a group, special teacher-educator Craig Stewart (March, 1979) continues by stating:

Most handicapped students heretofore have been separated from their peers and placed in special classes. The amount of their adjustment in any new environment, i.e., regular school classes, depends upon how they are accepted by others and how they accept themselves.

Often, the physically handicapped individual has a strong sensitivity regarding his handicap which may impede his abilities, progress, or success in a regular classroom setting with non-handicapped students. Therefore, in planning educational programs it is important that successful activities are experienced by the handicapped student:

Handicapped individuals need immediate success in a new endeavor. This type of positive reinforcement (early success) enables him to handle failure later on. A handicapped person has experienced a disproportionate amount of failure in his lifetime. Success enhances increased acceptance by his peers.

(Stewart, 1979)

It would not be possible to develop a composite physical profile of a handicapped individual. As in any other segment of our society, the physically handicapped come in many forms, ages, disabilities, and most importantly, abilities. However, one can elude to a somewhat limited profile of characteristic emotional and psychological traits as they pertain to individual impairments and the psychological impact of those impairments to the total individual.

Great numbers of the physically handicapped have a sensitivity for their disability, however, this sensitivity includes a great pride in their individual ability to

overcome their disability to varying degrees. Many have an overwhelming need to succeed in "regular" endeavors. Success or progress has a special meaning because often success means a special effort in achievement. The self-fulfillment in success is a necessary goal that may in some small way be compensating.

Achievement in the many aspects of industrial arts or vocational education is often a special accomplishment for the physically handicapped student. Many of these programs require special physical skills and dexterity often difficult for the non-physically handicapped student. When accomplishments are made the results may be even more rewarding than others may perceive. It is, therefore, necessary to provide the opportunity for physically handicapped to obtain access to the industrial arts and vocational education laboratory-shop classroom.

The importance of the classroom teachers in the success of providing appropriate and meaningful educational experiences for the handicapped student cannot be overstated. All assessment, planning, teaching, and evaluation would be to no avail if the individual classroom teacher is not dedicated to the process and to the students with special needs. "Successful implementation of P.L. 94-142 ultimately depends on well-educated



teachers." (Winnick, 1977, p. 1) Aside from the idealism of thought, such programs require hard work.

A Guide for Working With The  
Physically Handicapped In Industrial Arts  
And Vocational Agriculture Education

The following material may serve as a general information base when dealing with physically handicapped students wishing to participate in secondary laboratory-shop programs in industrial arts, vocational agriculture, and other vocationally oriented programs. Information will be presented in several major sections:

- I. Teacher Characteristics
- II. Teacher Competencies
- III. Student Assessment
- IV. Development of Individual Education Programs (IEP)
- V. The Identification and Development of Apparatus To Assist The Physically Handicapped In Laboratory-Shops

I Teacher Characteristics

Many practicing teachers have the basic skills needed to be successful classroom teachers, e.g., a practicing knowledge of educational foundations, subject matter and curriculum. Following these, the characteristi

most needed is that of constructive teacher attitudes towards the handicapped student. Teacher attitudes have been formed over years of experience as pointed out by special educator Eileen Brady (1977, p. 9):

The attitudes of teachers today have been strongly influenced by the low visibility of handicapped individuals in the past. The stress on education for the exceptional child has been slowly increasing over the years. However, many teachers have not been involved in this phenomenon. This lack of experience must not hinder the opportunity for special children to take advantage of their own potential in least restrictive educational environment.

Probably the greatest barrier to the handicapped student is the attitude barrier. Teachers can assist in the reduction of attitude barriers by leading their classes with a proper and positive attitude towards the handicapped. A major step by teachers in the reduction of attitude barriers is to focus on abilities rather than disabilities.

Another important teacher characteristic is that of realistically accepting handicapped students for what they are and by refraining from attempting to make them well. If teachers do not accept the ultimate limits of handicapped ability, then, these educators probably experience some degrees of failure.

## II Teacher Competencies

Much has been written about the competencies required by teachers who work with the disadvantaged and handicapped. The categories of these competencies range from simple clerical skills to the very skillful psychological management of the emotionally disturbed. Throughout the various studies pertaining to competencies, categorical groupings of competencies can be devised and are applicable to those listed by many authors. As indicated by vocational teacher educator V.O. Scott (Phelps, 1976, p. 34) these groupings include:

1. Proficiency in dealing with rapidly changing situations that arise in the classroom.
2. Perceptiveness and capability in meeting psychological needs of students.
3. Skill in modifying learning experiences in the content areas.
4. Responsiveness to situations that arise in the classroom to help students acquire and practice social skills.
5. Flexibility in decision making.

The aforementioned competencies relate to the operational classroom level of teacher action. Before such action occurs as the result of the integration of

the handicapped students in the least restrictive classroom environment, more basic knowledge and/or competencies are needed. "The area in which educational personnel are least knowledgeable and skilled is the legal provisions established by P.L. 94-142." (Haisly & Gilbert, 1978, p. 30). The legal requirements of all handicapped students must be understood and implemented before classroom activity is possible and the classroom competencies noted by Scott (Phelps, 1976, p. 34) are required. The overriding implication to be remembered is that learning experiences and environment for the handicapped should be appropriate. To assure this appropriateness a sound understanding of the due process requirements of P.L. 94-142 is necessary.

#### What Education Personnel Should Know

Some aspects of due process are of special interest to education personnel.

1. Parents must be notified in writing that their child has been referred for evaluation and is under consideration for educational placement, or that their request for evaluation has been denied.
2. After a diagnostic process has been completed and a considered course of action proposed, parents must be informed of that decision in writing. (During this process, parent and student involvement in planning and decision making is essential).

3. Final placement decisions must be provided to the parents, they should also be given information on their "due process rights," should they wish to contest the decision at a formal hearing.
4. Most states allow parents to have the child evaluated by an independent agent at the agency's expense if a mutually acceptable evaluator can be identified prior to the initial hearing.
5. Any required hearing is usually held at the local agency level and presided over by an impartial designee of that agency.
6. Most systems allow parents legal representation at such hearings. Prior to the hearing, full access must be provided to relevant school records. Additional evidence can be presented at a hearing, and persons involved in the original decision can be compelled to attend, to be confronted, and to be cross examined.
7. Usually an appeal of the final decision to the state educational agency is provided for.

Special education provisions in virtually all states have due process regulations which bind state plans submitted under the Education of All Handicapped Children Act. State guidelines or regulations to implement these requirements are in various stages of development.

#### Skills Educators Should Develop

Education personnel should be able to complete:

1. Articulate information and implications related to recent court decisions.
2. Prepare placement recommendations and program justifications adequately supported by documentation in a complete but concise and logical manner.

3. Develop skills in the use of procedures necessary to conduct a contested case hearing in an appropriate manner.
4. Maintain a professional posture as an expert witness in circumstances that may be threatening.
5. Accept an external review process with good grace. This ability comes from an understanding of the philosophy behind the requirement and a sense of security in the process.

(Haisly and Gilbert, 1978, p. 31-32).

A checklist to test the level of understanding of individual teachers of P.L. 94-142 may be of value in self-evaluation. If teachers are not knowledgeable about the procedures of P.L. 94-142 then some type of in-service education is necessary.

CHECKLIST-KNOWLEDGE BASE			
What teachers need to know about P.L. 94-142	What level of competence do you expect of your trainees?		
	Can identify source	Can define	Can elaborate
1. Knowledge of laws regarding the handicapped.			
2. Knowledge of handicapping conditions.			
3. Knowledge of P.L. 94-142-terminology and definitions (e.g., "least restrictive environment," "free appropriate public education").			
4. Understanding of appropriate instructional settings for the handicapped.			
5. Knowledge of child evaluation procedures.			
6. Knowledge of procedural safeguards.			
7. Knowledge of IEP (individualized education program) development and implementation.			
8. Knowledge of state and local guidelines for implementation of 94-142.			
9. Knowledge of least restrictive placement possibilities.			
10. Knowledge about related services and their availability.			

(Haisly and Gilberts, 1978, p. 31)



### III Student Assessment

The education assessment of individual students is the process of analyzing the present level of functioning in light of determined objectives. One of the keys to assessment is, first, deciding what objectives should be attainable in light of the disability. In answering the question of what can be done with the handicapped, industrial arts specialist, Dale Messerschmidt, indicates (1976, p. 3-4):

What do we attempt to do with special education students in industrial arts? The answer is relatively simple. We attempt to fulfill the usual goals stated for industrial arts.

This statement embodies the essence of P.L. 94-142, that of providing the handicapped with as near to normal educational experiences as possible.

Assessment of handicapped students must take place on an individual basis according to the due process procedure. Classroom teachers will not stand alone in this process. Assisting them will be state and school district specialists who will aid in the evaluation of the present level of handicapped student's functioning. The teachers role in the assessment of the handicapped is to:

1. Provide requirements necessary to meet objectives.
2. Provide safety in the laboratory-shop.
3. Agree with assessment specialist and parents on an individual education program for each student.
4. Assume an active role in carrying out the individual education program.

It is not appropriate to suggest a standardized test which will evaluate all physically handicapped students. However, a general method which will assist laboratory-shop teachers in assessing disabilities as well as important abilities is advisable.

#### Recommended Assessment Method

1. Provide an interruption-free time period in the laboratory-shop area where the physically handicapped student will be working.
- \*2. Include in this activity the school district special needs teacher, specialist, or consultant if appropriate.
3. From the listing of regular class objectives select a set which is representative of all areas of instruction as well as tools and machinery used.
4. Develop tool and machinery (skill) exercise which will be representative of those needed to accomplish the goals and objectives of the course of study.
5. Arrange these tasks in order of simple to

difficult.

6. Ask the physically handicapped student to "walk through" the developed exercises to ascertain if they are physically possible. If possible, are they safe due to strength, coordination, or mobility limitations?
- \*\*7. Each student can now be generally assessed as to abilities and disabilities.
  - \* Special needs personnel should be included in test periods as they may lend valuable information to the appropriateness of various conditions and safety requirements.
  - \*\* It is important that testing for handicapped student assessment be carried out in a private session and not during regular class hours.

Following the individual testing and assessment the teacher, special needs school specialist, and parents will have information necessary to compile the Individual Education Program for the student in question for the laboratory-shop instructional area.

#### IV Development of the Individual Education Program (IEP)

Among the provisions of the Education for All Handicapped Children Act - P.L. 94-142 is the development of an individual education program (IEP) for each handicapped student. According to P.L. 94-142 regulation each IEP must be written to include:

1. A picture of the student's current level of education performance.
2. A statement of yearly goals which include short-term objectives.
3. A statement of specific special education and related services to be provided to the child.
4. The projected dates for supportive services.
5. The extent to which the child will be able to participate in regular programs.
6. The anticipated evaluation procedures, criteria and time tables for determining at least yearly whether short-term educational objectives are being attained.

Various agencies and individuals have responsibilities to carryout in the development of the IEP. These agencies and individuals as well as their responsibilities are as follows:

1. A representative of the local education agency, other than the child's teacher, who is qualified to provide or to supervise the provisions of special education.
2. The child's teacher or teachers, special, or regular, or both who have a direct responsibility for implementing the child's individualized education program.
3. One or both of the child's parents, guardians, or surrogate parents.
4. When, appropriate, the child.
5. Other individuals, at the discretion of the parent or agency.

### The Teachers' Role

The following information and suggestions pertaining to the classroom teachers' role in the development and implementation of the IEP is derived from the Physical Education Inservice Resource Manual (Winnick & Jansma, 1977, p. 19) as Linda Furrall, special needs educator, interprets P.L. 94-142:

The teacher plays an instrumental part in developing and monitoring the status of the IEP. Hill (1977, p. 1) states that since the classroom teachers is usually the primary IEP implementor, it is the teacher's role not only to set up parent-teacher conferences and record a summary of those meetings, but also to:

State the student's present levels of functioning.  
Plan cooperatively with the parents and develop a mutually acceptable education plan including: short-term instructional goals, supportive services and materials to be provided to the student, a projected date for initiation, expected duration and a review annually of these goals.

Monitor progress and evaluate the Individualized Education Plan cooperatively with the parents.

In addition, Stein (1978) stresses that if the need exists, the teacher should specially design the classes.

The teacher must also face the fact that it may be increasingly necessary to devote planning periods and even time after school to IEP related activities, planning conferences or

recording for documentation. In addition, Torres (1977) suggests that participation in the IEP process also may require inservice training in order to learn new skills to use or interpret formal or informal tests, to write appropriate annual goals and short-term objectives, to write lesson plans which reflect annual goals and short-term instructional objectives, and to know public relations skills to use with parents. Furthermore, regular class teachers will probably be faced with the task of appropriately combining handicapped and non-handicapped students in his or her class.

Lastly, the teacher should realize that the IEP is not a legally binding contract, rather it is only a guide to direct the student's education. Hayes and Higgins (1978) indicate that parents cannot necessarily litigate in the courts if short-term instructional objectives and annual goals are not met. The good teacher should outline a realistic plan of instructional action and be able to explain the reason for lack of progress if such is the case. The conscientious teacher need not fear liability issues and become intimidated at the expense of the handicapped child.

#### V The Identification and Development of Apparatus To Assist The Physically Handicapped in Laboratory-Shops

It is understood that the physically handicapped student will need some assistance in attaining the goals and objectives set by the IEP. It is also understood that each school or school district may not have the resources to completely renovate shop facilities and equipment for a handful of physically handicapped students. Pertaining to the process of accomodating the physically handicapped

student it is necessary to make the following assumptions:

- A. School district financial resources will be limited.
- B. Teacher time to adapt the shop facility will be limited.
- C. Rural schools may not have local sources of special material or supplies to construct adaptive equipment.
- D. Adaptive changes in the physical environment of the laboratory-shop should not hinder other non-handicapped students.

The following section makes suggestions and provides information on partially accomodating the physically handicapped students in laboratory-shop programs by providing the following:

1. Listings of tools, portable power tools, and stationary power equipment which are common to basic skill instruction in the industrial arts and vocational agriculture mechanics skill areas.
  2. A listing of a hierarchy of skill achievement from simple to complex.
  - \*3. Drawings and material lists of assistive apparatus developed to aid the physically handicapped in attaining access to laboratory-shops.
- \* These devices were developed to enable the physically handicapped to use "regular" shop tools and equipment, and to be made easily from readily available materials.

SECTION I

Tools, Portable Power Tools, and Stationary Power Equipment  
Common To Basic Skill Instruction In Industrial Arts And  
Vocational Agriculture Mechanics



## LISTING OF COMMON TOOLS IN BOTH IA AND VO. AG

## I Metalworking

Hand Tools

1. Layout tools: tape measure, steel rule, steel square, combination square, scriber, scratch awl, wing dividers, inside caliper, outside caliper, hermaphrodite caliper, center punch, prick punch, ball peen jammer.
2. Hacksaw
3. Files
4. Hand drill and twist bits
5. Cold chisels
6. Taps
7. Dies
8. Adjustable wrench
9. Open end wrench
10. Box end wrench
11. Socket wrench sets
12. Vise-grip wrench
13. Pipe wrench
14. Allen wrenches

15. Combination plier
16. Needle nose plier
17. Box joint utility plier
18. Machinist vise
19. C-clamps
20. Common screwdriver
21. Phillips screwdriver

#### Portable Power Tools

1. Electric hand drill
2. Portable electric grinder

#### Stationary Power Tools

1. Drill press
2. Bench grinder
3. Band saw
4. Power hacksaw

## II Sheetmetal

#### Hand Tools

1. Layout tools: scratch awl, scribe, steel rule,

- combination square, wing dividers, center punch, prick punch, ball peen hammer
2. Cutting sheetmetal with shears, tin snips, aviation snips, cold chisel, and nibbler
  3. Hacksaw
  4. Files
  5. Drilling with hand drill and twist bits
  6. Punching holes using a solid punch, hollow punch, and hand punch
  7. Assembling sheetmetal components with pop riveter and setting rivets by hand
  8. Soldering using soldering copper, iron, and gun

#### Portable Power Tools

1. Electric hand drill
2. Electric jig saw

#### Stationary Power Tools

1. Drill Press
2. Bending sheetmetal with a finger brake, a folder, and hand brake, and a press brake
3. Using forming rolls to form stove pipe

4. Cutting sheetmetal with a squaring shear
5. Punching holes in sheetmetal with a punch press
6. Cutting notches in sheetmetal using a notcher

### III Welding

#### Hand Tools

1. Layout tools: tape measure, steel rule, steel square, combination square, scriber, scratch awl, dividers, center punch, prick punch, ball peen hammer, inside and outside calipers, hermaphrodite calipers
2. Hacksaw
3. Files
4. Clipping hammer
5. Wire brush
6. C-clamps
7. Vise-grip wrench
8. Cold chisel
9. Drilling with hand drill

#### Portable Power Tools

1. Electric hand drill
2. Portable electric grinder

### Stationary Power Tools

1. Drill press
2. Bench grinder
3. Band saw
4. Power hacksaw
5. Oxy-acetylene welding equipment
6. Arc welding equipment

## IV Woodwork & Carpentry

### Hand Tools

1. Layout tools: tape measure, steel rule, tri-square, framing square, combination square, sliding T-bevel, marking gage, wing dividers, scratch awl, trammer points, carpenters' level, plumb bob and chalk line, inside calipers, outside calipers, hermaphrodite calipers, center square
2. Sawing tools: crosscut saw, rip saw, back-saw, compass saw, keyhole saw, coping saw
3. Edge cutting tools: smooth, jack block planes, chisels, surforn tool, rasps, gouges, spokeshave, cabinet scraper, lathe tools

4. Drilling and boring tools: brace, hand drill, yankee drill, auger bit, twist bit
5. Claw hammer
6. Nail set
7. Hand screw clamp, bar clamp, c-clamp
8. Screwdriver

#### Portable Power Tools

1. Electric hand drills
2. Electric jig saw
3. Router
4. Builders' saw
5. Belt sander
6. Orbital sander

#### Stationary Power Tools

1. Drill press
2. Scroll saw
3. Table saw
4. Radial arm saw
5. Band saw
6. Wood lathe

7. Jointer
8. Surfacer
9. Shaper
10. Sanding machine
11. Paneling saw

## V Crafts

### Hand Tools

1. Layout tools: steel rule, scribe, scratch awl, dividers, tri-square, combination square
2. Shears
3. Utility knife
4. Swivel knife
5. Tin snips
6. Aviation snips
7. Center punch
8. Leather tools: camouflage, shaders, bevelers, stops, veiners, seeders, background tools
9. Solid and hollow punches
10. Leather mallet
11. Ball peen hammer
12. Hand drill

13. Coping saw
14. Jewelers saw
15. Files
16. Hacksaw
17. Cold chisel
18. Soldering copper, iron, and gun

#### Portable Power Tools

1. Electric hand drill
2. Electric jig saw

#### Stationary Power Tools

1. Drill press
2. Scroll saw
3. Table saw
4. Bench grinder
5. Band saw



## HIERARCHY OF SKILLS

## I Woodwork

Hand Tools

1. Measuring tools: tape measure, steel rule, framing square, combination square, tri-square
2. Layout tools: scribe, scratch awl, tri-square, combination square, marking gage, wing dividers, insides caliper, outside caliper, hermaphrodite caliper, plum bob and chalk line, sliding T-bevel, center square trammel points
3. Hammers
4. Screwdrivers
5. Saws: crosscut, rip, back, coping, keyhole, compass
6. Chisels
7. Files and rasps
8. Planes: smooth, jack, block
9. Cabinet scraper
10. Spokeshave
11. Yankee drill
12. Hand drill

13. Brace
14. Clamps

#### Portable Power Tools

1. Electric hand drill
2. Electric orbital sander
3. Electric jig saw
4. Belt sander
5. Builders' saw
6. Power planer
7. Router

#### Stationary Power Tools

1. Scroll saw
2. Band saw
3. Sanding machine
4. Drill press
5. Wood lathe
6. Jointer
7. Surfacer
8. Table saw
9. Radial arm saw
10. Mortiser & tenouer

## 11. Shaper

## Metalwork

Hand Tools

1. Measuring tools: tape measure, steel rule, combination square, steel square
2. Layout tools: scribe, scratch awl, combination square, steel square, dividers, inside and outside calipers, hermaphrodite caliper, center punch, prick punch
3. Hammers
4. Screwdrivers
5. Pliers (combination, needlenose, box joint)
6. Wrenches (open end, box end, adjustable)
7. Vise-grips
8. Hacksaw
9. Files
10. Cold chisels
11. Clamps
12. Dies
13. Taps
14. Hand drill

Portable Power Tools

1. Electric hand drill
2. Portable electric grinder

Stationary Power Tools

1. Bench grinder
2. Band saw
3. Drill press
4. Power hacksaw
5. Arc welder
6. Oxy-acetylene welding equipment

## Sheetmetal

Hand Tools

1. Layout tools: scribe, scratch awls, tape measure, steel rule, steel square, combination square, dividers, center punch, prick punch
2. Hammers
3. Hacksaw
4. Files
5. Cold chisel

6. Nibbler
7. Punches (solid, hollow, hand punch)
8. Tin snips
9. Aviation snips
10. Hand drill
11. Riveting (hand and pop riveter)
12. Soldering using soldering copper, iron, and gun

#### Portable Power Tools

1. Electric hand drill

#### Stationary Power Tools

1. Squaring shear
2. Notcher
3. Brake
4. Bar folder
5. Box and pan brake
6. Press brake
7. Forming rolls
8. Turning machine
9. Wiring machine
10. Burring machine

11. Drill press
12. Band saw

## Crafts

### Hand Tools

1. Layout tools: steel rule, scribe, scratch awl, dividers, tri-square, combination square, center punch
2. Hammers - ball peen, leather mallet
3. Utility knife, swivel knife
4. Shears
5. Tin snips
6. Aviation snips
7. Solid and hollow punches
8. Cold chisel
9. Leather tools - camouflage, shaders, bevelers, stops, veiners, seeders, background tools
10. Saws: coping, jewelers, hacksaw
11. Filers
12. Hand drill
13. Soldering with soldering copper, iron and gun

Portable Power Tools

1. Electric hand drill
2. Electric jig saw

Stationary Power Tools

1. Bench grinder
2. Scroll saw
3. Band saw
4. Drill press
5. Table saw

SECTION II

Listing of Evaluated Tools and The Mean ( $\bar{x}$ ) Difficulty  
Use Level Indicated by Test Group Member



The following listing of tools and equipment represents those items which test group members encountered in a laboratory-shop use evaluation. The numerical score recorded is the mean ( $\bar{x}$ ) of the ratings given by individual test group members. Ratings were given on the basis of one (1), easy to use, to five (5), impossible to use.

Measuring Tools

	$\bar{x}$		$\bar{x}$
Combination Square	2	Scratch Awl	1.5
Tri-Square	2	Lockable Tape Measure	1.5
36" Rule	1.5	Dividers	2
Carpenters Square	2		

Hand Tools

	$\bar{x}$		$\bar{x}$
Cross Cut Saw	3	Claw Hammer	3.0
Back Saw	1.5	Nail Set	3.75
Coping Saw	2.25	Wood Chisel	2.75
Woodworking Vise	1.75	Spoke Shave	2.75
Hand Drill	2.75	Tin Snips	2.5
Bit and Brace	2.75	Aviation Snips	1.75
Wood File	1.0	Pop Rivet Gun	3.25
Wood Rasp	1.75	Pliers	1.0
Sure Form Tool	1.25	Hacksaw	1.5
Block Plane	1.75	Smooth Plane	2.25

Portable Power Tools

	$\bar{x}$		$\bar{x}$
Orbital Sander	1.0	Belt Sander	2.0
Electric Drill	1.0	Router	4.75
Sabre Saw	1.0		

Stationary Power Tools

	$\bar{x}$		$\bar{x}$
Table Saw	5.0	Jig Saw	3.75
Radial Arm Saw	1.0	Jointer	3.25
Drill Press	2.75	Wood Lathe	4.5

SECTION III

Drawings and Material Lists of Assistive Apparatus Developed  
to Aid the Physically Handicapped In Attaining Access to the  
Laboratory-Shop.

The following drawings and plans are to serve as a suggested guide for laboratory-shop teachers and supervisors who wish to adapt the physical shop setting and machinery to accomodate the physically handicapped student. These sample devices were developed to fit specific instances and pieces of machinery. It should be noted that while much of the equipment present in laboratory-shop classes is similar individual design changes will be necessary to fit specific pieces of equipment.

Materials used for these assistive devices is of the type readily available at building supply and hardware stores. All of the following devices were made in-house with a minimum amount of teacher effort and school expense.

An important feature is that these devices were found to be of great assistance to non-handicapped students. This fact may be of consideration when considering the construction of such devices.

Laboratory Workbench  
For the Handicapped

Material:

1. 2x4 - Fir, Laminated for Top.
2. 3" Channel Iron.
3.  $\frac{1}{2}$ " Plate Steel.
4.  $2\frac{1}{2}$ " I.D. Black Steel Pipe.
5. 2" I.D. Black Steel Pipe.

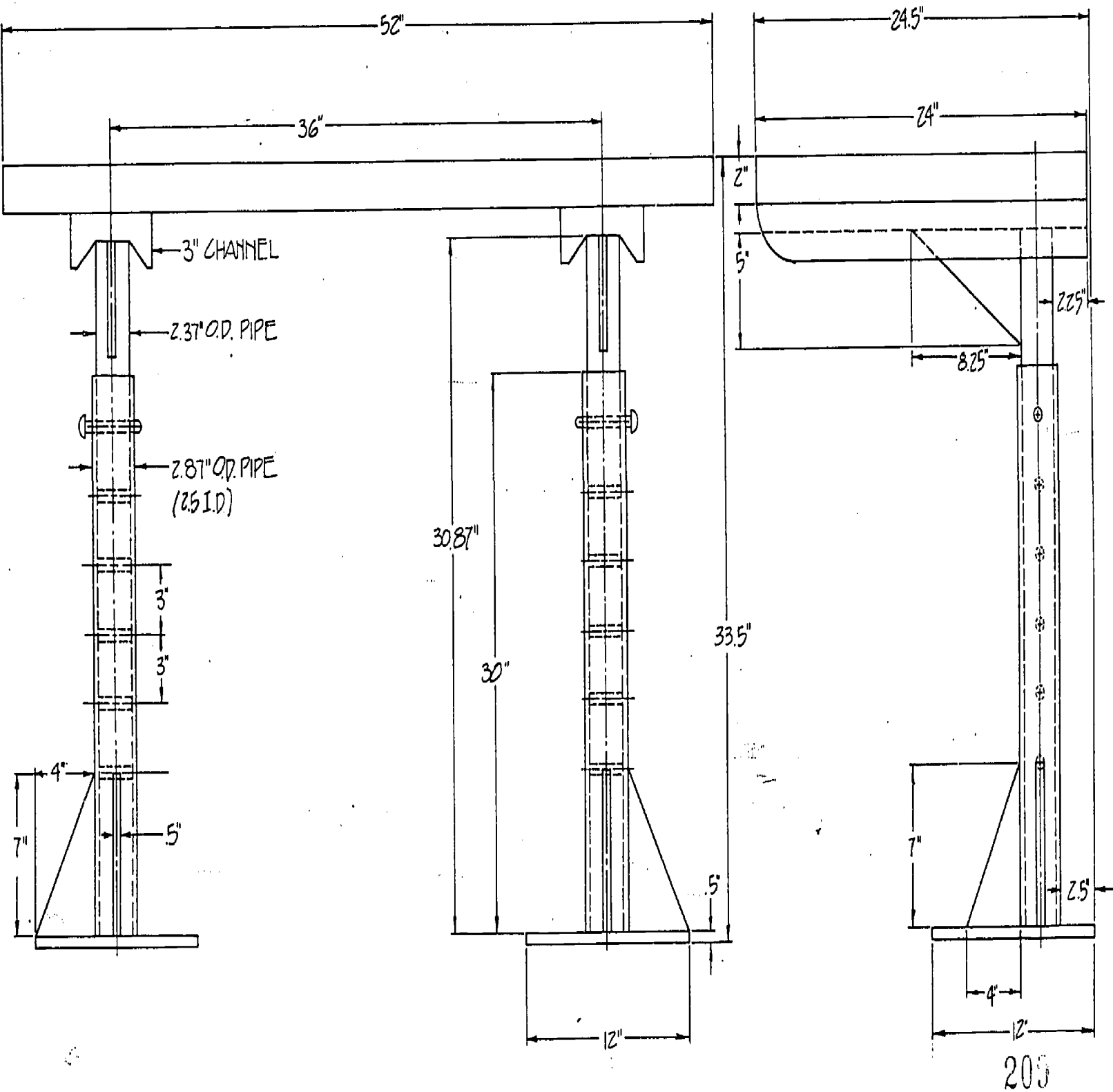

208

APPARATUS FOR THE HANDICAPPED PROJECT		DWG 1 OF
DEPT. OF AGRICULTURAL & INDUSTRIAL EDUCATION MERIC STATE UNIVERSITY BOZEMAN, MONTANA	OFFICE OF PUBLIC INSTRUCTION HELENA, MONTANA	
SCALE:	TITLE: WORKBENCH	

Radial Arm Saw - Cutting Platform  
For The Handicapped

Material:

1. 3/4" Birch Plywood.
2. 1" Birch Solid Stock.
3. 2 each - 8" C-Clamps.
4. Assorted Hardware.



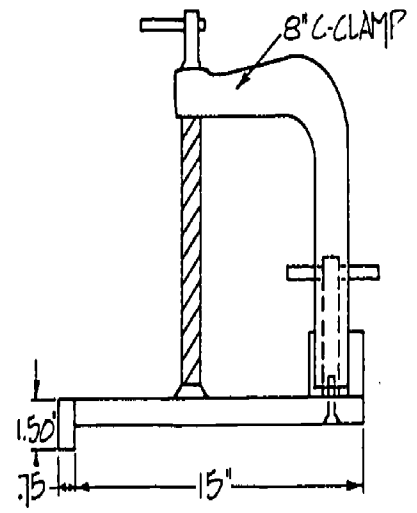
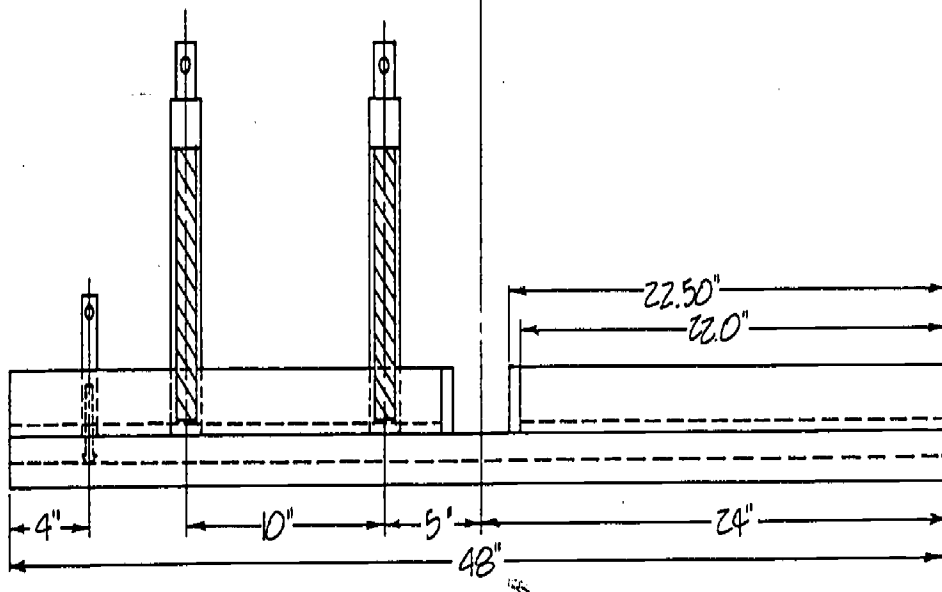
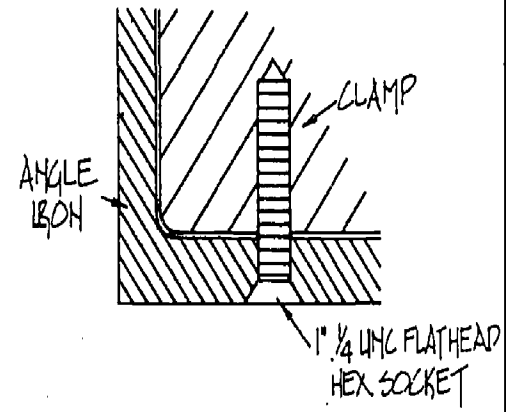
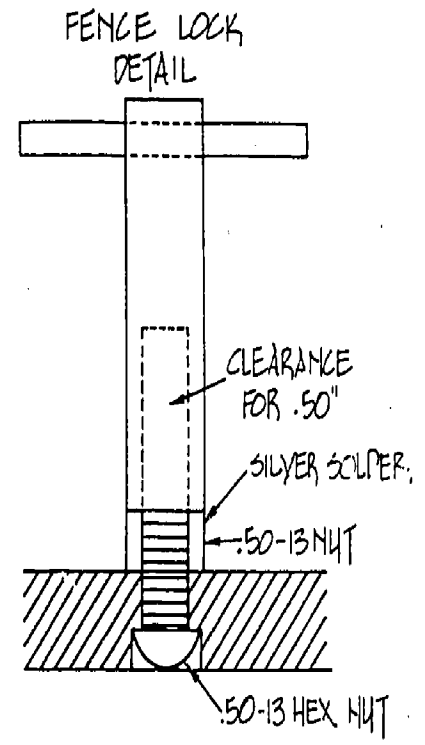
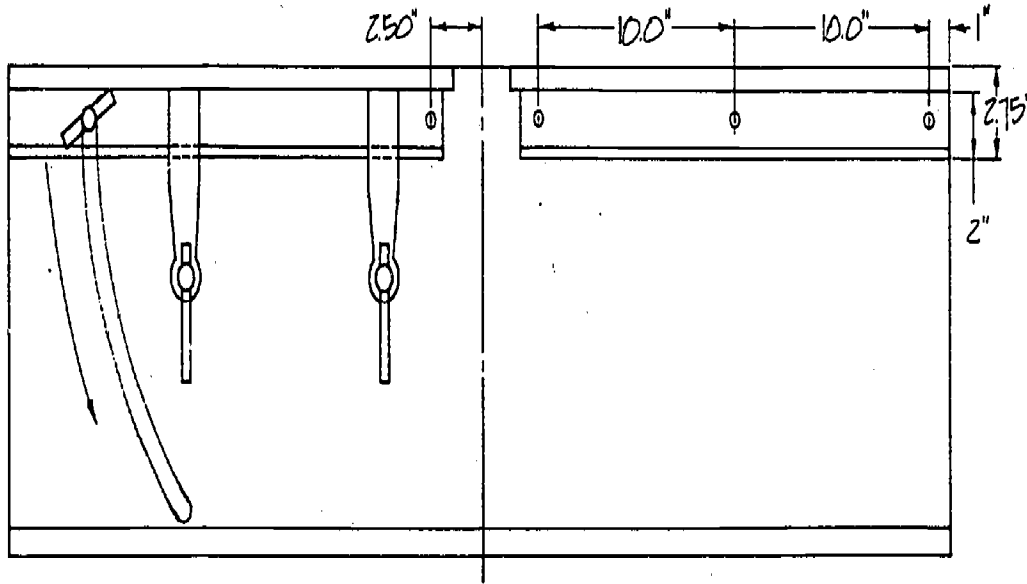

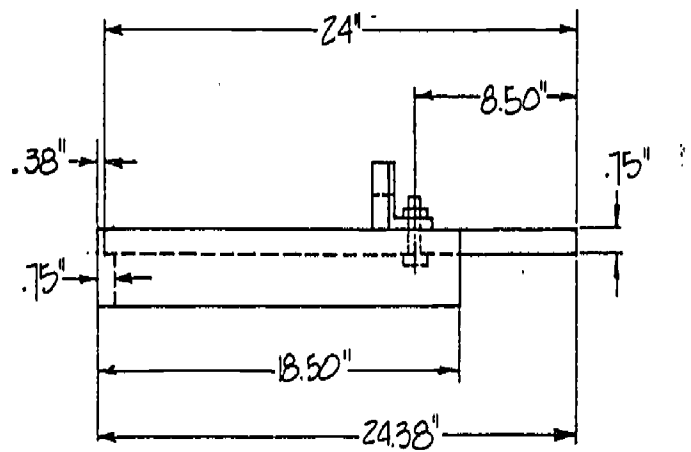
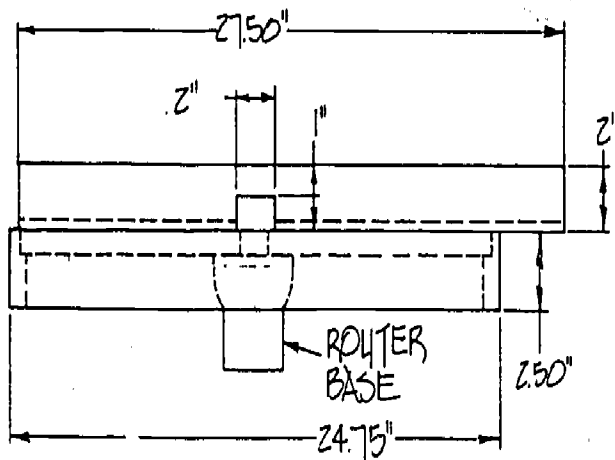
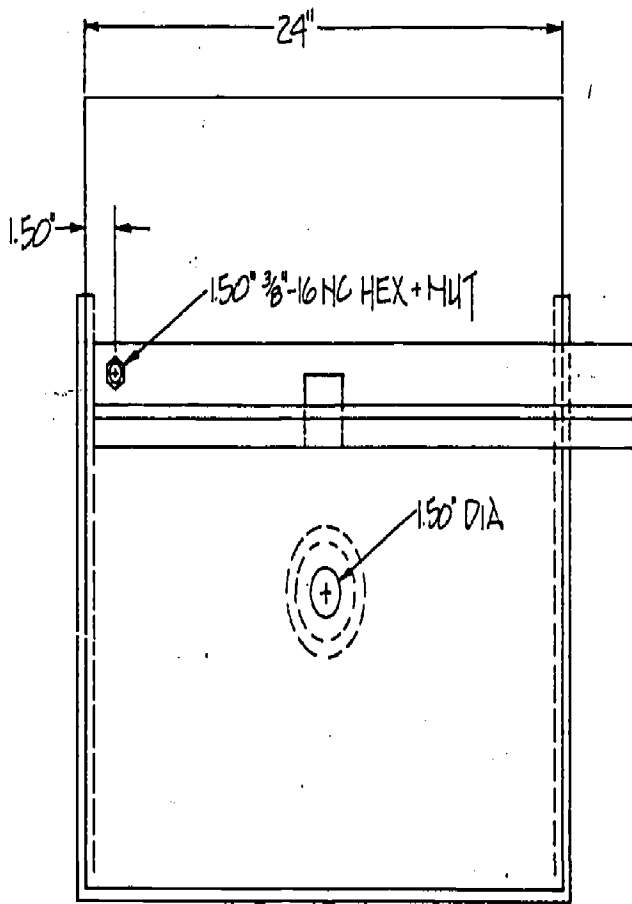

APPARATUS FOR THE HANDICAPPED PROJECT

DEPT. OF AGRICULTURAL & INDUSTRIAL EDUCATION  
MONTANA STATE UNIVERSITY BOZEMAN, MONTANA

OFFICE OF PUBLIC INSTRUCTION  
HELENA, MONTANA

DWG  
1

TITLE: ROUTER TABLE

Adaptive Drill Press Table  
For The Handicapped

Material:

1. 3/4" Birch Plywood.
2. 1" Solid Birch Stock.
3. 2 each - 5" C-Clamps.
4. Assorted Hardware.

K.L. Bruwelheide

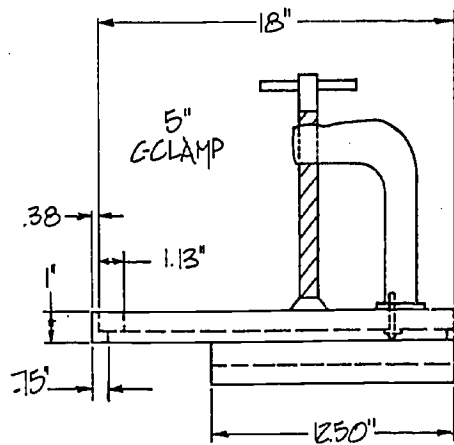
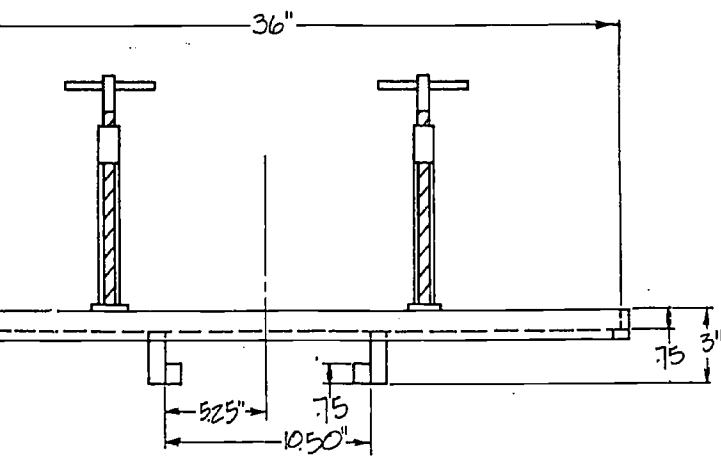
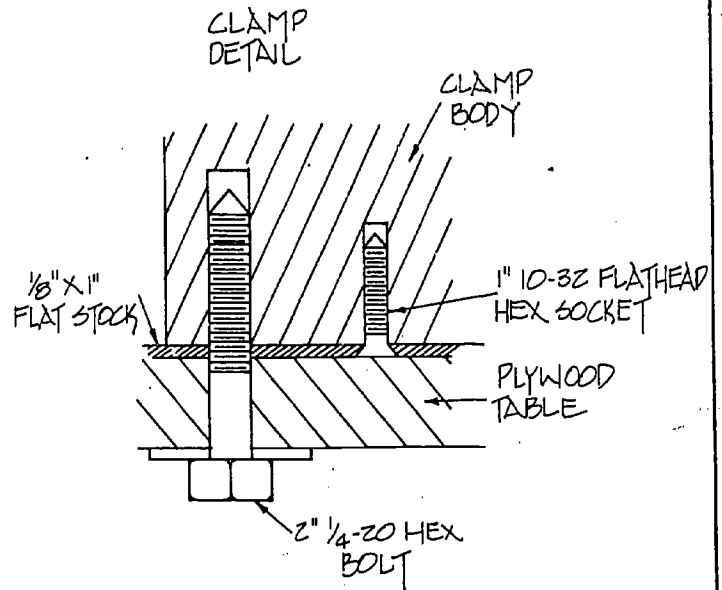
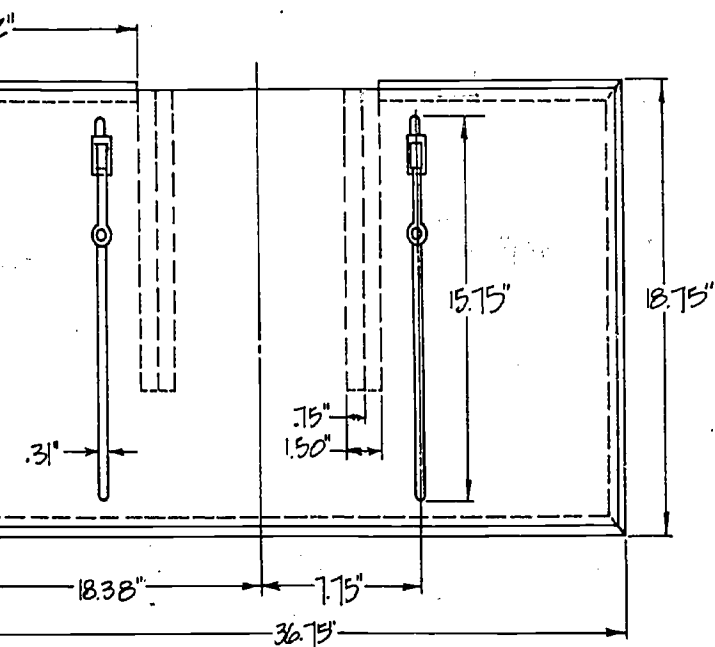

FOR THE HANDICAPPED PROJECT  
CULTURAL & INDUSTRIAL EDUCATION  
THE UNIVERSITY BOZEMAN, MONTANA  
TITLE: DRILL PRESS FIXTURE

OFFICE OF PUBLIC INSTRUCTION  
HELENA, MONTANA

DWG  
1

217

Adaptive Jig Saw Fixture  
For the Handicapped

Material:

1. 3/4" Birch Plywood.
2. 1" Solid Birch Stock.
3. Assorted Hardware.



Wheelchair Platform and Ramp  
For The Handicapped

Material:

1. 3/4" Plywood.
2. 2 x 4 Fir or Pine.
3. 1/2 x 2 Hot Rolled Steel.
4. 2 each - 3" Locking Casters.
5. 2 each - 26" Bicycle Wheels, Tires, and Axles.
6. 3/4" Electrical Conduit.
7. Assorted Hardware.

The purpose of this wheelchair platform and accompanying ramp is to elevate the wheelchair bound student high enough to permit proper machine use. Due to construction provisions it also provides for independent mobility.

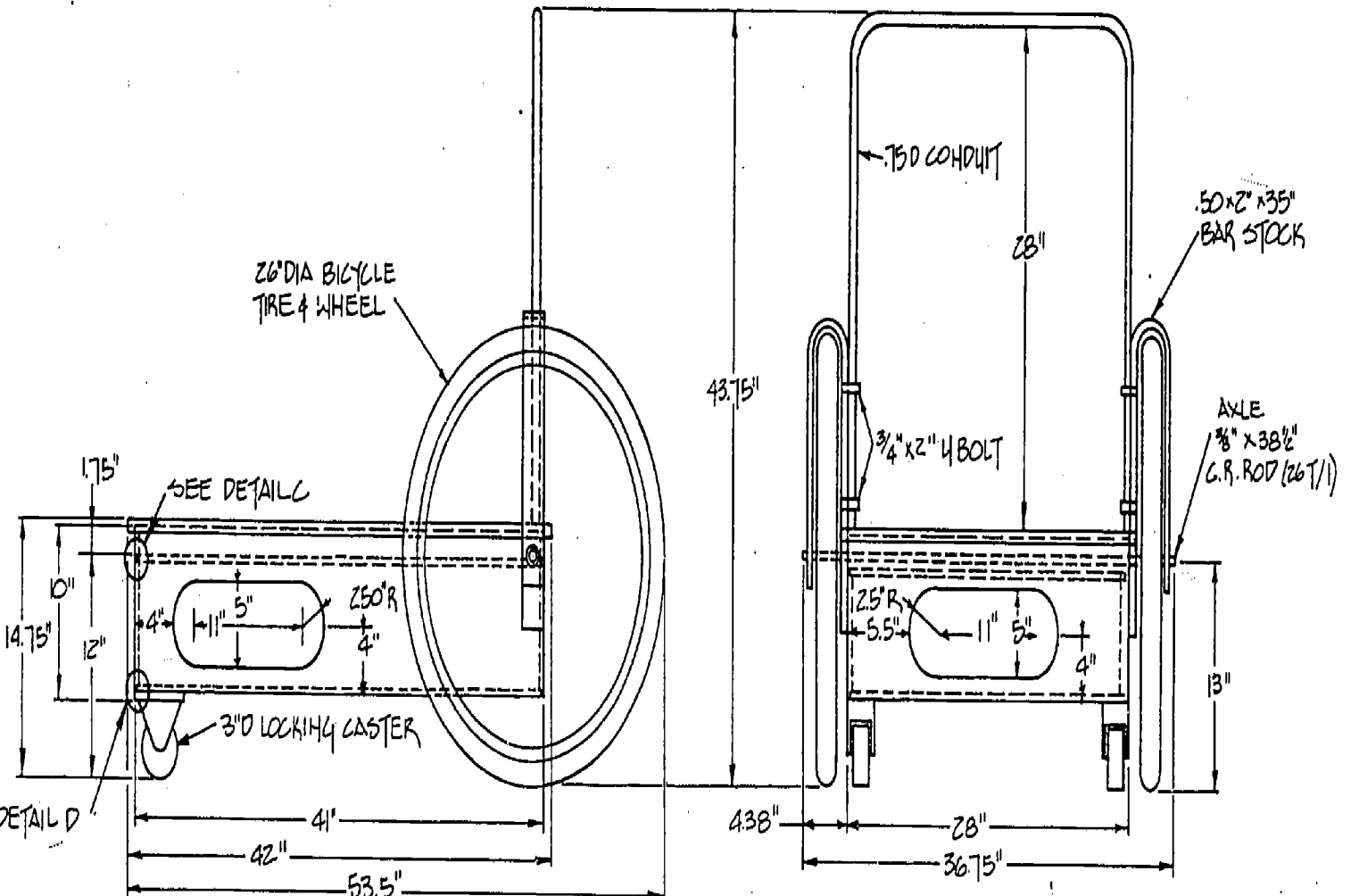
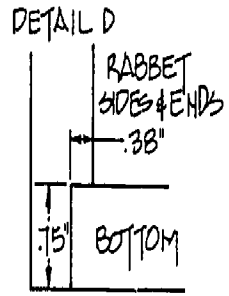
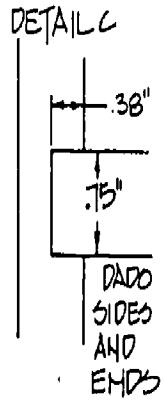
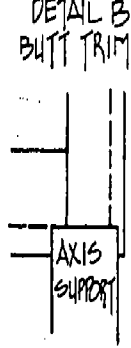
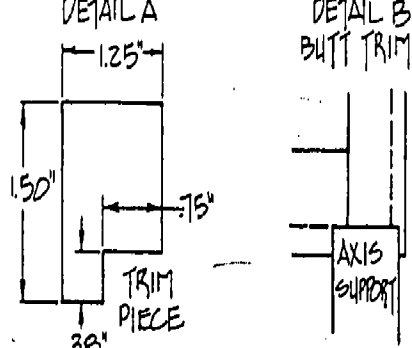
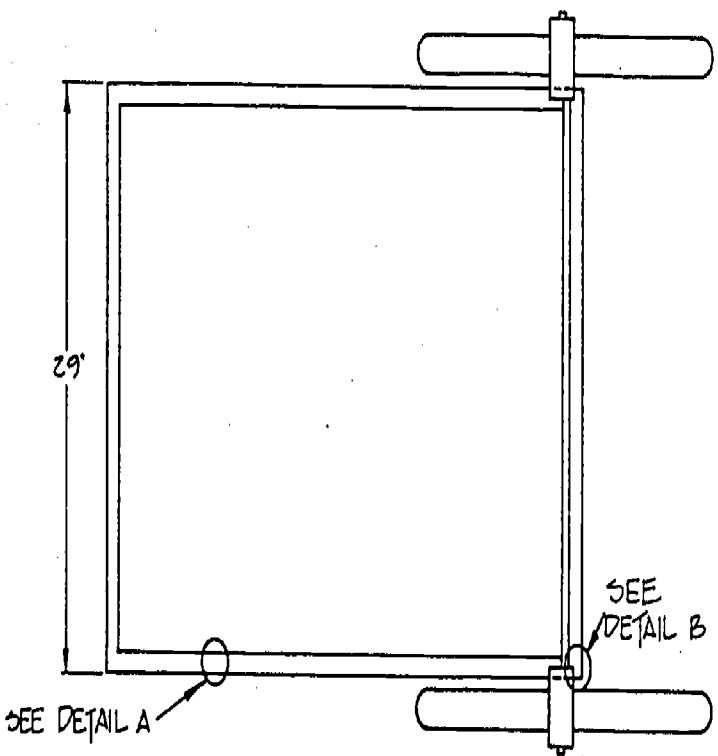

APPARATUS FOR THE HANDICAPPED PROJECT

DEPT. OF AGRICULTURAL & INDUSTRIAL EDUCATION  
MONTANA STATE UNIVERSITY BOZEMAN, MONTANA

OFFICE OF PUBLIC INSTRUCTION  
HELENA, MONTANA

DWG  
1



TITLE: WHEEL CHAIR CART



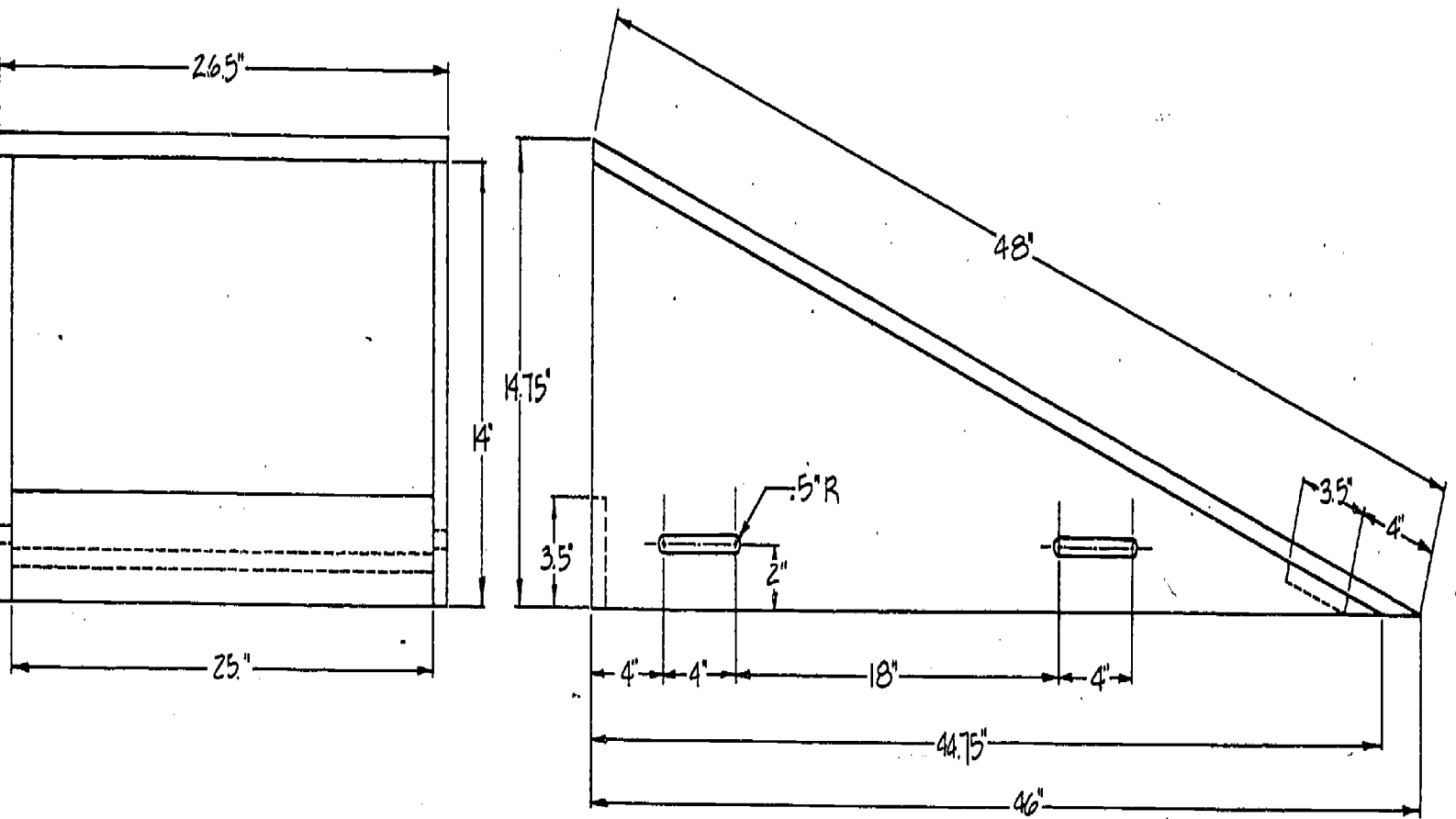

APPARATUS FOR THE HANDICAPPED PROJECT

DEPT. OF AGRICULTURAL & INDUSTRIAL EDUCATION  
 MONTANA STATE UNIVERSITY BOZEMAN, MONTANA

OFFICE OF PUBLIC INSTRUCTION  
 HELENA, MONTANA

TITLE: WHEEL CHAIR RAMP

DWG  
 1  
 OF

## BIBLIOGRAPHY

## Books

- Bauer, William R. 1978. Mainstreaming - Toward More Than Mainschooling. Children in Contemporary Society. Pittsburg Area Pre-School Association, Pittsburg, Penna. (ERIC Document No. ED 153-381).
- Buffer, James J. 1973. Review and Synthesis of Research on Industrial Arts for Students With Special Needs. Information Series No. 69. Center for Vocational and Technical Education, Ohio State University, Columbus, Ohio. (ERIC Document No. ED 090-394).
- Chisman, Arlington W., Novak, Kathy 1977. Planning Vocational Education Program for the Disadvantaged and Handicapped. Virginia Polytechnic Institute and State University, Blacksburg, Virginia. (ERIC Document No. ED 145-123).
- Corrigan, Dean C. 1978. "Political and Moral Contexts That Produced P.L. 94-142." Journal of Teacher Education, November-December 1978, Vol xxix, Number 6: pp. 10-14.
- Department of Health, Education and Welfare 1975. Region VI Inservice Training for Vocational Technical Personnel. EPD Consortium D. Conference Report, Richardson, Texas. (ERIC Document No. ED 147-501).
- The Education for All Handicapped Children Act of 1975. The National Association of State Directors of Special Education, Washington, D.C.
- Education of the Handicapped Litigation Brought Under P.L. 94-142 and Section 504 1978. The National Association of State Directors of Special Education, Washington, D.C.
- Greenwood, Katy 1975. Vocational Education for the Disadvantaged: Compliance or Commitment? Department of Health, Education and Welfare. Region VI, Inservice Training for Vocational Technical Personnel, EPD Consortium D, Conference Report, Richardson, Texas, (ERIC Document No. ED 147-501).

- Haisley, Fay B., Gilberts, Robt. D. 1978. "Individual Competencies Needed to Implement P.L. 94-142." Journal of Teacher Education. Vol. XXIX, No. 6.
- Hull, Marc E. 1977. Vocational Education For The Handicapped - A Review of Information, Series #19. Texas A&M College Station, Texas.
- Martin, Edwin W. 1978. "Education of the Handicapped Act and Teacher Education." Journal of Teacher Education. Vol. XXIX, No. 6.
- Martin, E. W. 1974. "Some Thoughts On Mainstreaming." Exceptional Children Magazine, No. 41.
- McPhie, Walter E. 1978. "A Teacher Educating Dilemma: Practical Application vs. Theory." Journal of Teacher Education, Vol. XXIX, No. 6.
- Messerschmidt, Dale H. 1976. "Industrial Arts In Special Education." American Industrial Arts Association, Des Moines, Iowa. (ERIC Document No. ED 133-439).
- Nystram, Dennis C. 1973. Occupation and Career Education Legislation. Howard W. Sams & Co., Inc., New York, New York.
- Parr, Cadar 1975. State Effort For Meeting The Needs of Special Populations In Vocational Technical Education. Department of Health, Education, and Welfare, Region VI, Inservice Training for Vocational Technical Personnel, EPD Consortium D, Conference Report, Richardson, Texas. (ERIC Document No. ED 147-501).
- Phelps, Allen L. 1978. A Review and Analysis of Vo-Ed Programs for Handicapped Individuals In the United States. First World Congress on Future Special Education, Sterling, Scotland. (ERIC Document No. ED 157-297).
- Pittsburg Pre-School Association 1978. Eight Papers On Mainstreaming. Pittsburg, Pennsylvania. (ERIC Document No. ED 153-381).

- Rehabilitation Act The, An Analysis of the Section 504 Regulation and Its Implications for State and Local Education Agencies 1977. National Association of State Directors of Special Education, Washington, D.C.
- Sargent, Laurence R. 1978. "State Certification Requirements." Journal of Teacher Education, Vol. XXIX No. 6.
- Schlechty, Phillip C., Turnbull, Ann P. 1978. "Bureaucracy or Professionalism: Implications of P.L. 94-142." Journal of Teacher Education. Vol. XXIX, No. 6.
- Strully, Jeffery L. 1978. "Shawntell, Children In Contemporary Society." Pittsburg Area Pre-School Association. Pittsburg, Penna. (ERIC Document No. ED 153-381).
- Weisenstein, Meredith, Gall, Damiem 1978. "Adapting Teacher Education to Include Mainstreaming: Dean's Grant Projects." Journal of Teacher Education. Vol. XXIX, No. 6.
- Weisgerber, R.A., Smith, C.A. 1977. Improving Vocational Education Services for Handicapped Students, Final Report. American Institutes for Research in the Behavioral Sciences, Palo Alto, California. (ERIC Document No. ED 142-774).
- Winnick, Joseph P., Jansma, Paul 1977. Physical Education Inservice Resource Manual, State University College, Brockport, New York.
- Young, E.B., et. al. 1970. Vocational Education for Handicapped Persons: Handbook for Program Implementations. Washington, D.C., Government Printing Office.

### Curriculum Guides

- Industrial Arts Curriculum Guide for Montana Secondary School 1978. Office of Public Instruction, Helena, Montana; Department of Agricultural and Industrial Education, Montana State University, Bozeman, Montana.

Two-Year Core Curriculum In Vocational Agriculture Education 1975. Office of Public Instruction, Helena, Montana; Department of Agricultural and Industrial Education, Montana State University, Bozeman, Montana.

Additional

Stewart, Craig. Director of Basic Education for the Handicapped In Physical Education. Montana State University, Bozeman, Montana.