

DOCUMENT RESUME

ED 198 245

CE 026 254

AUTHOR Levine, Jerrold M.  
 TITLE Trainability of Abilities. Final Report, March 15, 1977-March 15, 1980.  
 INSTITUTION Advanced Research Resources Organization, Bethesda, Md.  
 SPONS AGENCY Office of Naval Research, Arlington, Va. Personnel and Training Research Programs Office.  
 REPORT NO ARRO-3010-FR  
 PUB DATE Jun 80  
 CONTRACT N00014-77-C-0268  
 NOTE 52p.: For related documents see ED 150 428, ED 167 840, and ED 183 954.

EDRS PRICE MF01/PC03 Plus Postage.  
 DESCRIPTORS \*Ability: Educational Research: Feasibility Studies: Higher Education: Perceptual Development: Performance: \*Performance Factors: \*Sensory Training: Spatial Ability: \*Transfer of Training: Visualization: Visual Perception

ABSTRACT

A program investigated the feasibility of training selected abilities so as to facilitate transfer among tasks requiring these abilities and thus reduce training time and increase personnel flexibility. An extensive review of relevant literature was a first step in this investigation. Undergraduate college students were used as subjects in an initial and a followup study, both of which used experimental and control groups and a pretest/posttest experimental design. The first experiment examined the abilities of spatial scanning and flexibility of closure both for increase in the abilities as a result of training and for transfer of training to a criteria task requiring those abilities. Spatial scanning ability improved, flexibility of closure did not, and no transfer of training occurred. The second experiment attempted to train a single ability--spatial visualization--for transfer to two different criterion tasks. No improvement in spatial visualization could be inferred as a result of training, and no transfer of training occurred. Results suggested that (1) length and type of training may be critical factors, (2) some abilities may be more amenable to training than others, and (3) alternative training strategies should be considered. (YLB)

\*\*\*\*\*  
 \* Reproductions supplied by EDRS are the best that can be made \*  
 \* from the original document. \*  
 \*\*\*\*\*



ED198245

ARRO-3010-FR

# TRAINABILITY OF ABILITIES

Jerrold M. Levine

FINAL REPORT

Prepared under Contract to the  
Personnel and Training Research Programs  
Psychological Sciences Division  
Office of Naval Research  
Department of the Navy

Contract No. N00014-77-C-0268

NR No. 154-400

Approved for public release; distribution unlimited.  
Reproduction in whole or in part is permitted for  
any purpose of the United States Government.

ADVANCED RESEARCH RESOURCES ORGANIZATION

June 1980

U.S. DEPARTMENT OF HEALTH,  
EDUCATION & WELFARE  
NATIONAL INSTITUTE OF  
EDUCATION

THIS DOCUMENT HAS BEEN REPRO-  
DUCED EXACTLY AS RECEIVED FROM  
THE PERSON OR ORGANIZATION ORIGIN-  
ATING IT. POINTS OF VIEW OR OPINIONS  
STATED DO NOT NECESSARILY REPRESENT OFFICIAL NATIONAL INSTITUTE OF  
EDUCATION POSITION OR POLICY

CE 026 254

REPORT DOCUMENTATION PAGE		READ INSTRUCTIONS BEFORE COMPLETING FORM								
1. REPORT NUMBER	2. GOVT ACCESSION NO.	3. RECIPIENT'S CATALOG NUMBER								
4. TITLE (and Subtitle)  Trainability of Abilities		5. TYPE OF REPORT & PERIOD COVERED Final Report 15 Mar 77 - 15 Mar 80								
		6. PERFORMING ORG. REPORT NUMBER ARRO-3010-FR								
7. AUTHOR(s)  Jerrold M. Levine		8. CONTRACT OR GRANT NUMBER(s)  N00014-77-C-0268								
9. PERFORMING ORGANIZATION NAME AND ADDRESS Advanced Research Resources Organization 4330 East-West Highway, Suite 900 Washington, D.C. 20014		10. PROGRAM ELEMENT, PROJECT, TASK AREA & WORK UNIT NUMBERS 61153N, RR042-06 RR042-06-01, NR 154-400								
11. CONTROLLING OFFICE NAME AND ADDRESS Personnel and Training Research Programs Office of Naval Research (Code 458) Arlington, Virginia 22217		12. REPORT DATE June 1980								
		13. NUMBER OF PAGES 34								
14. MONITORING AGENCY NAME & ADDRESS (if different from Controlling Office)		15. SECURITY CLASS. (of this report) Unclassified								
		15a. DECLASSIFICATION/DOWNGRADING SCHEDULE								
16. DISTRIBUTION STATEMENT (of this Report)  Approved for public release; distribution unlimited.										
17. DISTRIBUTION STATEMENT (of the abstract entered in Block 20, if different from Report)										
18. SUPPLEMENTARY NOTES										
19. KEY WORDS (Continue on reverse side if necessary and identify by block number)										
<table border="0"> <tr> <td>Training</td> <td>Spatial Visualization</td> </tr> <tr> <td>Transfer of Training</td> <td>Ability Training</td> </tr> <tr> <td>Abilities</td> <td>Electronic Trouble-shooting</td> </tr> <tr> <td>Spatial Scanning</td> <td>Flexibility of Closure</td> </tr> </table>			Training	Spatial Visualization	Transfer of Training	Ability Training	Abilities	Electronic Trouble-shooting	Spatial Scanning	Flexibility of Closure
Training	Spatial Visualization									
Transfer of Training	Ability Training									
Abilities	Electronic Trouble-shooting									
Spatial Scanning	Flexibility of Closure									
20. ABSTRACT (Continue on reverse side if necessary and identify by block number)										
<p>The feasibility of training selected abilities so as to facilitate transfer among tasks requiring these abilities and therefore reduce training time and increase personnel flexibility was investigated. Undergraduate college students participated in several studies of from one to five days duration. Experimental subjects received extensive practice with feedback provided on a set of tasks known to require the ability of being trained. Control subjects received no practice. All subjects were tested on transfer tasks which were dissimilar to the training tasks but which had earlier been demonstrated to require for successful task</p>										

Continued from Block 20--Abstract

performance the abilities being trained. Results indicated that training significantly enhanced one of three of the abilities as measured by a standard ability test administered before and after training. There was no evidence that performance on the transfer tasks was affected significantly as a result of training (i.e., there was no transfer of training).

## ABSTRACT

The feasibility of training selected abilities so as to facilitate transfer among tasks requiring these abilities and thereby reduce training time and increase personnel flexibility was investigated. A review of the literature relevant to ability training and nonspecific transfer produced mixed support for ability training, and only indirect support for nonspecific transfer. An experiment was conducted to train the abilities of flexibility of closure and spatial scanning for transfer to an electronic trouble-shooting task. While the spatial scanning ability improved with training, flexibility of closure did not, and no transfer of training occurred. A second experiment attempted to train a single ability--spatial visualization--for transfer to two different criterion tasks. No improvement in spatial visualization as a result of training could be inferred, and no transfer of training occurred. The implications of these results are discussed in terms of alternative training strategies which might increase the likelihood of successful ability training and transfer.

## INTRODUCTION

Personnel training requirements in the Navy have altered considerably in recent years, due to the impact of a number of variables. Increased automation in man-machine systems has reduced the number of personnel manning the systems, but enhanced the responsibility of those personnel. Fewer billets, smaller crew sizes, and the increased complexity of Navy tasks have all affected the demands placed on a training program. Simultaneously training costs have increased reducing the cost-effectiveness of direct training for each of the varied and complex skills required of the personnel. What may be needed is training focused on general ability requirements of the jobs. Such a program would increase personnel flexibility since the trained ability would apply to a number of skills and tasks.

The identification of general human abilities accounting for individual differences in cognitive, perceptual, and motor performance has been the subject of extensive research (cf. Fleishman, 1964, 1972; French, Eckstrom, & Price, 1963; Guilford, 1967). As a result of these efforts, abilities have been conceptualized as broad capacities underlying performance on a variety of human tasks (Fleishman, 1967, 1972). Typically, abilities are identified through correlational studies of human performance, in which the fact of individual differences is exploited to gain insights about common processes required to perform different groups of tasks. This is contrasted with skills, which define levels of proficiency in a particular task. Clearly, if training a general ability increased the level of skill on several tasks, then

ability training would provide an extremely cost-effective alternative to specific skill training.

The initial difficulty is to determine whether or not it is possible to modify or increase the level of a given ability possessed by an individual. In the traditional conceptualization, abilities are considered to be the product of early learning and genetic factors (Ferguson, 1956; Gagné & Fleishman, 1959). and the ability remains relatively stable and unchanging in the adult (Fleishman, 1972). There is some evidence, however, to indicate that abilities can be modified through appropriate experience even in adult life. For example, Brinkmann (1966) provided extensive training in the behaviors thought to be involved in spatial visualization ability (i.e. discrimination, recognition, organization, and orientation). He found that the trained group improved their performance on a spatial relations criterion test to a significant degree, while an untrained control group did not improve.

The potential gains in terms of personnel flexibility and reduced training cost mandate exploratory investigation of the feasibility of ability training. As a first step in this investigation, an extensive review of the relevant literature was conducted (Hogan, 1978). This review provided the bases for an initial experimental investigation, in which the abilities of spatial scanning and flexibility of closure were systematically examined, both for increases in the abilities as a result of training, and for transfer of training to a criterion task requiring those abilities (Levine, Brahlek, Eisner, & Fleishman, 1979). A

follow-up to this study employed a refined design to investigate the potential for training spatial visualization ability and obtaining transfer to multiple criterion tasks (Levine, Schulman, Brahlek, & Fleishman, 1980). Each of these three activities in the investigation of ability training is summarized below, followed by conclusions and implications drawn from the investigations.



## BACKGROUND

The research relevant to training and transfer of abilities can be considered in three major groupings: early laboratory research of direct relevance; later, more sophisticated laboratory research of less import; and applied research. Each of these research areas provides us with clues regarding the potential trainability of abilities.

### Early Research

One of the first attempts to train an ability was conducted by William James (1890). He tried to improve a subject's memory ability by training them to memorize the poetry of one author, and transferring them to memorization of a different author's verse. James obtained no positive transfer, and indeed his failure to use a training control would have rendered the results difficult to evaluate in any case. Several later attempts were apparently more successful, however. Sleight (1911) reported work by Ebert and Meumann which employed a variety of training materials and criteria, trained over a nine-month period, and employed pretest controls. Their results showed a general improvement in memory ability overall and indicated that the amount of improvement was generally proportional to the degree of similarity between training task and criterion test. Others (Winch, 1910) obtained similar results, but methodological problems such as inequality of pre- and posttest conditions continued to plague the research.

Similar research interest carried over to the potential for training learning. Some speculation concerning the existence of a "g" or general factor in intelligence sparked considerable research. The

conclusion of much of this research was similar to that based on the memory training research, however; little acceptable evidence for a general factor, and considerable evidence to suggest that similarity between training and criterion was the prime determinant of transfer. The conclusion that specificity was an accurate assumption reduced interest in nonspecific transfer. The early research warned of some of the methodological pitfalls in assessing nonspecific transfer, and hinted at the importance of varied training programs and the crucial role of the nature of the criterion task in determining transfer. However, little scientifically acceptable support for nonspecific transfer was produced by this research.

#### Later Research

Although interest in nonspecific transfer per se waned as a result of the conclusion of specificity, later learning research produced results relevant to nonspecific transfer. Two areas in particular are of relevance: warmup effects and learning to learn. Warmup refers to the fact that neutral activity prior to criterion performance results in better performance, while learning to learn refers to the acquisition of learning skills or sets through unrelated practice.

Warmup is a special case of nonspecific transfer, since the warmup activity is neutral with respect to both the training and the criterion materials. Evidence suggests that the amount of warmup activity and its temporal contiguity to the criterion test are both positively related to amount of transfer. The result was originally assumed to be due to activation of postural and orientation sets which facilitated

criterion performance. More recent investigations have attributed warmup to the preparation of performance support systems such as attention and expectancy, thus facilitating performance. In either case, the temporal relationship is critical, and warmup effects will tend to dissipate quickly.

Learning to learn effects, on the other hand, tend to be more enduring. Learning to learn occurs when training on a task unrelated to the criterion results in improved performance. The implication is that subjects do not acquire skills directly related to criterion performance, instead they acquire strategies or learning skills useful in solving even unrelated problems. The potential relevance to ability training is clear.

Learning to learn phenomena are not the only instance in which acquisition of a general strategy appears to play a role in facilitating positive transfer. Edmonds and Evans (1966) demonstrated that training in a visual pattern recognition task facilitated transfer to a memory reproduction task, if the visual patterns contained some redundancy. No transfer occurred when random visual patterns were used in training. The strategy employed to perceive and remember redundant patterns appeared to be helpful, therefore, in the performance of the memory reproduction task.

In summary, while little research has been conducted to examine specifically the conditions of nonspecific transfer, some support for nonspecific transfer may be inferred from a variety of phenomena. These include warmup and learning to learn, as well as the general phenomenon

of developing a strategy in one learning situation which facilitates performance in another.

### Applied Research

It might be expected that the potential for nonspecific transfer of training would have been thoroughly examined by applied researchers, since its potential value is clear. Here, too, however, much of the evidence about nonspecific transfer is inferential in nature. For example, when simulation devices are employed in training, it is assumed that higher fidelity (i.e., greater specificity) will result in greater transfer to on-the-job performance. Contradictory evidence exists, however. Voss (1969) showed that pilot training with a physically similar device produced no better transfer than training in reduced conditions. It has been suggested (Wheaton, Rose, Fingerman, Korotkin, & Holding, 1974) that transfer can be obtained from training in devices lacking in physical similarity, if there is sufficient task fidelity.

Educational researchers have attempted to train general abilities such as originality and creativity, as well as cognitive abilities. For example, Maltzman (1960) reviewed a programmatic attempt at originality training. Typically, subjects were trained to produce different responses to the same stimulus word. Facilitation of originality occurred as a result at this training, and persisted for as long as two days. Similarly, some success has been obtained in training creativity (Parnes & Noller, 1972). Attempts to train cognitive abilities in pre-school children have been made, but are impossible to evaluate due to inadequate experimental control. Indeed, this criticism applied to much of the educational research on ability training.

No direct support of scientific adequacy appears to exist for the notion of nonspecific transfer. There are, however, tantalizing hints suggesting that such transfer is possible. Phenomena such as warmup and learning to learn may be considered special instances of nonspecific transfer. Moreover, training may result in the development of a mediating strategy which proves useful in a variety of unrelated tasks. Suggestions of positive transfer from general simulation devices also question the need for specificity in training, and evidence favoring general ability training may be inferred cautiously from educational research. It is clear that to understand transfer, task requirements and learner strategies must be considered, as well as learner abilities. Moreover, it appears that task characteristics are more important than training materials per se in facilitating transfer, and variability of training within a class of response types increases the likelihood of transfer. Such evidence supports and encourages a systematic attempt at general ability training.

## STUDY I

Based on the review of the literature on nonspecific transfer, a careful study of the feasibility of training selected abilities for transfer to Navy tasks was undertaken.

The abilities selected for training were: (1) flexibility of closure, defined as the ability to identify or detect a known pattern which is hidden in background material, and (2) spatial scanning, defined as speed in exploring visually a wide or complicated visual field to detect or identify objects. The Kit of Factor-Referenced Cognitive Tests provides the "Hidden Patterns Test" for flexibility of closure, and "Choosing a Path" for spatial scanning, as tests of the level of these abilities.

Several criteria were used for the selection of training materials. They needed to be diverse and varied, allowing the subject to develop appropriate strategies in a variety of contexts. They had to be difficult enough to challenge subjects so that learning could take place. They had to be as dissimilar as possible from the criterion task, while still requiring the same abilities, so that nonspecific transfer might be evaluated. Finally, they had to be easy to administer and provide built-in feedback. The training paradigm consisted of structured practice with nine self-administered pencil and paper tests selected on the above criteria. Six of these tasks involved flexibility of closure; the other three involved spatial scanning. The nine tasks constituting the training program are listed below:

- Task 1 -- "Hidden Figures" (flexibility of closure)  
Subjects were presented with a series of five geometric figures and a complex design in which one of the figures was embedded. The task was to visually search the design and identify which figure was contained within it, at the same time outlining the embedded figure.
- Task 2 -- "Copying" (flexibility of closure)  
In this task subjects copied a series of asymmetrical line drawings, composed of connecting line segments, onto grids formed of dots. Subjects' drawings had to be in the exact proportions and positions as the originals.
- Task 3 -- "Puzzles" (spatial scanning)  
Subjects were to solve line diagram puzzles by tracing over all the lines of the diagram with a continuous line (i.e., without tracing any line twice).
- Task 4 -- "Hidden Letters" (flexibility of closure)  
This task required subjects to search for capital letters outlined in dots and surrounded by random dot patterns.
- Task 5 -- "Inspection" (flexibility of closure)  
Subjects visually searched graphic designs for irregular lines, i.e., lines with breaks.
- Task 6 -- "Embedded Figures" (flexibility of closure)  
The task was to locate a particular figure which could be hidden within any of four patterns.

- Task 7 -- "Map Planning" (spatial scanning)

The task was to identify the shortest route between two locations on a schematized map.

- Task 8 -- "Mazes" (spatial scanning)

The task was to solve a series of mazes by tracing a path from the starting point to the goal.

- Task 9 -- "Altair Designs" (flexibility of closure)

Subjects were presented with computer-generated graphics and were to locate specific designs hidden within the overall designs.

The criterion or transfer task was an electronic troubleshooting task. It consisted of a series of problems in which subjects were required to locate malfunctions in diagrams of electric circuits. A digital logic circuit was employed, in which one faulty wire was identified. The subject's task was to find that wire by inserting a hypothetical probe (a "light bulb") at various locations (sockets) and depressing the appropriate switches to turn the light on. If the light went on, that part of the circuit was not faulty and the subject had to check the rest of the circuits. If it failed to go on, additional tests were required in that part of the circuit. Each test ideally divided the number of potential break locations in half (see Figure 1). Four separate configurations with three levels of difficulty for each configuration were employed. This task had previously been shown to load heavily on the abilities of flexibility of closure and spatial scanning (Rose, Fingerman, Wheaton, Eisner, & Kramer, 1974).



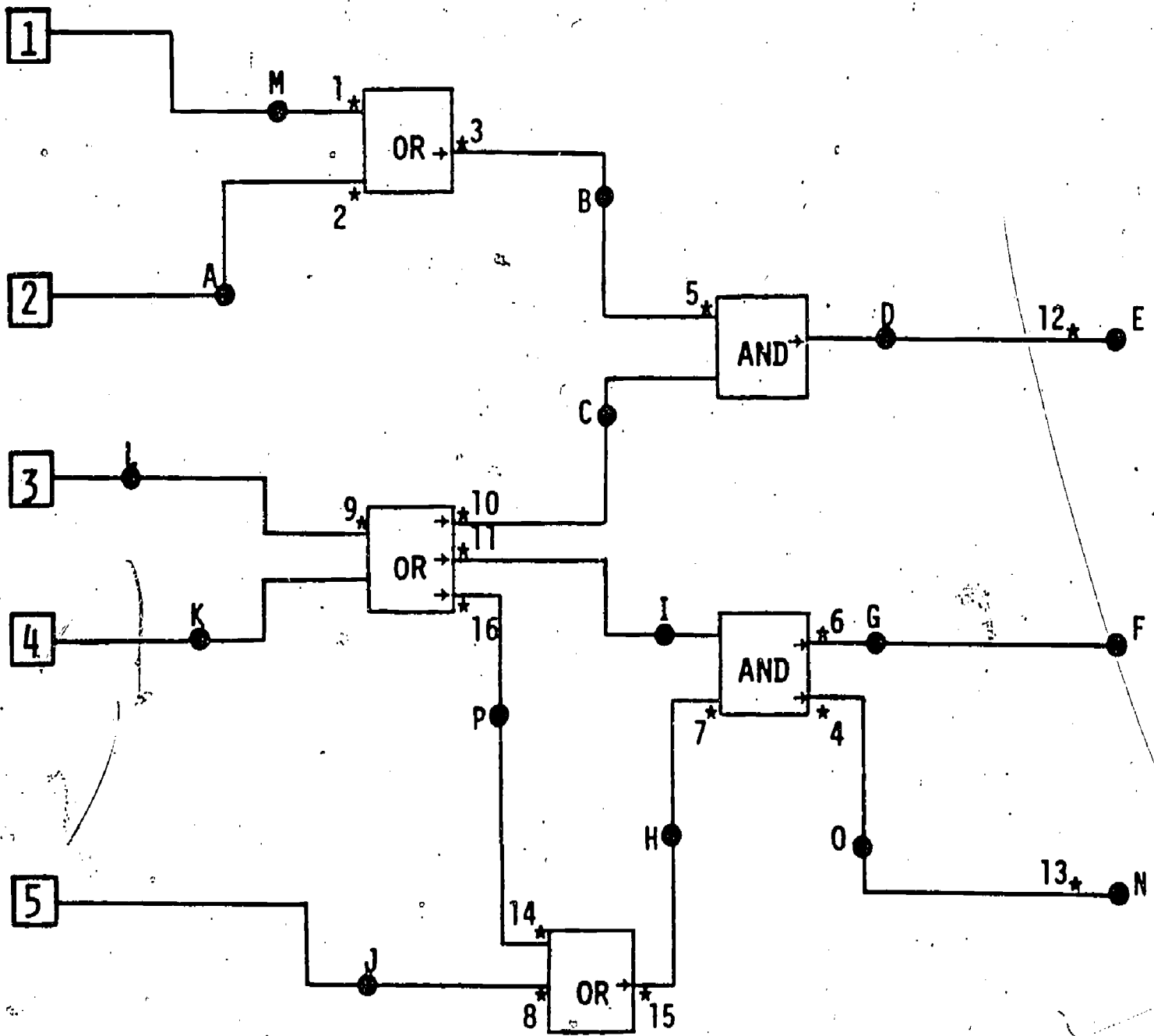

Figure 1. Example of troubleshooting problem at simplest level of problem difficulty. (Circles A-P represent light sockets--i.e., locations where subject can place probe. Numbered stars are potential breakpoints.)

## Experimental Design and Procedures

A number of methodological issues had to be considered when designing this study. It was, of course, necessary to provide a comparison between an experimental group receiving ability training and a control group receiving none. Moreover, a pretest/posttest design was necessary to assess transfer from training to the criterion task. However, since the pretest itself might serve as a form of practice, additional groups of subjects who received no pretest were required so that any effect could be unambiguously attributed to the training regimen.

These considerations led to a design employing five groups of subjects:  $E_1$ , who received the following sequence--pretest, ability test, training, ability test, and posttest.  $E_2$  received the same sequence without the pretest. The  $C_1$  control group was identical to  $E_1$  except no ability tests or training were administered, and  $C_2$  was identical to  $E_2$  except without ability tests or ability training. A final control group,  $C_3$ , received only the ability tests, spaced by a period equivalent to the training period. This control group received no pre- or posttest and no training. Table 1 provides a graphic representation of this design. The design allowed the two key questions to be addressed; i.e., were the abilities trained, and did transfer occur?

Within this design, subjects were randomly assigned to one of the five groups and participated in one experimental session per day, for up to five days. On the first day, the pretest on the troubleshooting task was introduced and administered. Days two, three, and four constituted the training phase of the study, in a single five-hour session each

TABLE 1  
Experimental Design

Group	Day 1 Pretest	Days 2-4 Train	Day 5 Posttest	n
E <sub>1</sub>	A	T <sub>1</sub> B T <sub>2</sub>	A	(15)
C <sub>1</sub>	A	X	A	(10)
E <sub>2</sub>	X	T <sub>1</sub> B T <sub>2</sub>	A	(15)
C <sub>2</sub>	X	X	A	(10)
C <sub>3</sub>		T <sub>1</sub> X T <sub>2</sub>		(10)

X = No Activity

A = Criterion Task

B = Training Tasks

T = Test of Abilities

day. The training was preceded and followed by the ability tests. On the fifth day, the posttest on the troubleshooting task was administered. This test consisted of 18 problems varying in form and difficulty, and different from the problems presented on the pretest. This procedure was modified as necessary to fit the design requirements for each group.

### Results and Conclusions

Analyses were conducted on the ability test scores and the troubleshooting test. The four performance measures collected on the troubleshooting task were: (1) accuracy, (2) number of tests to solution, (3) time to solution, and (4) number of erroneous tests.

The analyses of the ability tests involved comparison of the trained groups ( $E_1$  and  $E_2$ ) to the appropriate control ( $C_3$ ) to evaluate change in ability as a function of training. For the spatial scanning test, both  $E_1$  and  $E_2$  showed significant improvement, while  $C_3$  showed no improvement, indicating that the spatial scanning ability had been successfully trained. On the flexibility of closure test,  $E_1$  and  $E_2$  again improved significantly, but so did  $C_3$ , so the change in ability could not be unambiguously attributed to training.

To evaluate transfer, a mixed design analysis of variance was conducted on troubleshooting scores, using groups as a between-subjects variable, and trial blocks and problem difficulty as within-subjects variables. Time to solution was the only measure of troubleshooting performance which differentiated among groups. The analysis indicated that there was no difference between trained and untrained groups (i.e.,  $E_1$  and  $E_2$  equaled  $C_1$  and  $C_2$ ). Rather, the presence of the pretest affected

posttest performance (i.e.,  $E_1$  and  $C_1$  were faster than  $E_2$  and  $C_2$ ). In addition, groups interacted with problem difficulty, such that  $E_1$  was faster than  $E_2$  at all levels of difficulty, whereas  $C_1$  was faster than  $C_2$  only on the most difficult problems. These results lend no support to the hypothesis that ability training will transfer to a dissimilar criterion task.

In an effort to discern whether the impact of training upon transfer is a function of initial ability level, an analysis of covariance was carried out with initial pretest scores as the covariate for groups  $E_1$  and  $C_1$ . No significant differences emerged. Since training might be effective only for subjects starting out with a low level of the abilities being trained, an analysis of covariance was carried out using only the five highest scoring and five lowest scoring subjects for each ability test. Again, no significant differences were obtained. Overall, transfer ranged from -3.4% to 14.3% on the different measures, and no evidence supported the suggestion of enhanced transfer as a function of training.

Several conclusions may be drawn from this study. The training regimen did improve spatial scanning scores, and while we cannot conclude that training improved flexibility of closure, it is possible. This is so, due to the nature of the ability tests employed. The Hidden Patterns Test, though a valid and reliable measure of flexibility of closure, was so simple that there were few wrong answers. The simplicity of this test suggests that training might well have been effective, but the test was simply not sensitive enough to detect the improvement. Still the results for training abilities are relatively encouraging.

This is even more encouraging when the number of potentially important variables regarding the training regimen are considered. Three five-hour sessions of massed, self-paced practice with feedback were employed in the present study. More extensive or distributed practice might well increase ability improvement as a result of training, though these alternatives were not logistically feasible in the current study. Similarly, it was decided to use tasks requiring the ability in question as training materials; it might be that a training program developed around the specific behaviors required in the criterion task would be more effective.

There is less encouragement regarding the possibility of nonspecific transfer from ability training. None of the analyses performed offers support for such transfer. This is confusing, since at least one ability--spatial scanning--was successfully trained. One possible explanation lies in the ability structure required to perform the criterion task; although the abilities trained in this task account for the largest single portion of variance in the troubleshooting task, over 70% of the variance in performance is still unaccounted for (cf. Rose, et al., 1974). Overall, these results suggested further investigation, refined somewhat by the findings of this initial study.

## STUDY II

The results of an initial attempt to train the abilities of flexibility of closure and spatial scanning for transfer to an electronic troubleshooting task were mixed, but provided modest encouragement. Some evidence for trainability of abilities had been produced, and although this training did not transfer to the criterion task, a more "sensitive" criterion task or tasks might easily demonstrate such transfer (cf., Levine, Brahlek, Eisner, & Fleishman, 1979). A second study was therefore conducted, employing essentially the same methodology as the first, but modified to take advantage of the knowledge acquired in the first study.

For this study, the ability of spatial visualization was chosen as the subject for training. Spatial visualization requires representation of visual stimuli in short-term memory, and requires that, in addition, the representation be restructured into components for manipulation and comparison. It is thus distinct from spatial orientation, which requires only a transformation of the represented stimulus configuration.

A principal difference in this investigation was that two transfer tasks were chosen, so that the effect of different levels of involvement of the ability in the criterion tasks could be examined, and the issue of generalizability of transfer could be addressed. The transfer tasks were: (1) Assembly, obtained from the Flanagan Aptitude Classification Tests. In this task, subjects are given a diagram of an array of machinery-type parts, labeled to indicate how they fit together, and are required to visualize the assembled product and select it from five presented alternatives; and (2) Designs, developed for this study by ARRO staff. In this

task, subjects are presented with a 4 x 4 matrix of red and white squares and triangles, and are required to reproduce the "flipped" (i.e., turned end over end) version of each design. An independent analysis of the contribution of seven perceptual abilities to performance on this task indicated substantial contribution by spatial visualization, a lesser contribution by perceptual speed, and no other significantly involved abilities.

The ability test chosen for this study was the "Surface Development" test from the Kit of Factor-Referenced Cognitive Tests. This test is speeded, with scores adjusted for guessing. In addition, the task is difficult enough to hope to avoid the problems evident with the ability test for flexibility of closure in the previous study.

The training materials consisted of nine tasks involving spatial visualization:

- Task 1 -- "Copying"

In this task subjects copied a series of asymmetrical line drawings onto graph paper grids. Subjects' drawings had to be in the exact proportions and positions as the originals.

- Task 2 -- "Paperwork"

For each item, successive drawings illustrated two or three folds made in a square sheet of paper. The final drawing of the folded paper showed where a hole was punched in it.

The subject drew holes in a blank square to represent where the punched holes would be when the paper was unfolded.



Subjects were provided with paper and hole punches with which they were to check their answers.

● Task 3 -- "Puzzles"

This task consisted of four different problems, each with its own instructions and each requiring a different type of solution. In general, the problems required subjects to mentally rearrange objects into different patterns or to mentally rotate two-dimensional drawings in order to arrive at a solution.

- Problem No. 1 was a figure made up of eight squares. The task was to fill the squares with the numbers one through eight so that no two consecutive numbers were adjacent horizontally, vertically, or diagonally.
- Problem No. 2 was a schematic representation of a plot of land containing 12 houses. Subjects were to divide it into six plots of the same size and shape, and each containing two houses, by drawing only four lines.
- Problem No. 3 presented subjects with a drawing of four pieces of chain, each containing three links. The task was to make a closed loop by opening and re-attaching only three links.
- In Problem No. 4, subjects were shown three two-dimensional sketches of rectangular solids composed of cubes. They were to imagine that a hole had been drilled

diagonally from one corner to another and then were to indicate which cubes the drill passed through.

- Task 4 -- "Formboard"

In this task, subjects viewed pictures of geometric shapes which had been cut into pieces, and were to imagine how the pieces would fit together to form the original shape. Each problem contained two figures--one representing the original shape, and the other, the shape after it had been cut. Subjects were instructed to carefully study the outline shape and the pieces, then mentally rotate and reposition the pieces within the outline until they could determine how the pieces fit together.

- Task 5 -- "Pattern Orientation"

Subjects located a given pattern of circles within a large circle which (the pattern) had been rotated from its original position. Subjects then determined which of several points within the large circle had the same spatial relationship to the pattern as a particular point did to the original unrotated pattern.

- Task 6 -- "Upside Down Copying"

This task was similar to Task 1, except that subjects were to copy patterns as they would appear if turned upside down.

- Task 7 -- "Stick Problems"

Groups of "sticks" were laid out to form patterns comprised of squares (pictorial representation). In part I of this task, subjects were to remove a specified number of sticks in such a manner that a specified number of squares remained. In part II, subjects were instructed to move a certain number of sticks into new positions so that a certain number of squares resulted.

- Task 8 -- "Thinking in Three Dimensions"

Dimension, shape, and surface and interior colors of geometric solids were described to subjects. Various cutting manipulations were then described, and subjects were to answer questions about the number and colors of the resulting pieces.

- Task 9 -- "On the Square"

This task required subjects to determine how abstract geometric shapes could be dissected and then reassembled to form squares. Subjects were presented with a series of paper shapes, each of which was constructed from pieces of a square. The task was to cut each shape into as few pieces as necessary, then reassemble the pieces into a square. The resulting pieces would form a square only if the shape had been cut in a certain pattern.

## Design and Procedure

The design of this study employed essentially the same logic as the first. An experimental group ( $E_1$ ) received a pretest on the criterion task, a pre-training ability test, training, a post-training ability test, and finally the post-training criterion task. The effect of training on criterion performance was assessed by comparison with a control group ( $C_1$ ) which received only the pretest and posttest on the criterion task. The effect of pretesting in biasing posttest performance on the criterion was controlled by the presence of a second experimental group ( $E_2$ ) which was identical to  $E_1$ , except no pretest on the criterion task was given. Finally, the effect of training on ability level was assessed by comparing the experimental groups to a second control group ( $C_2$ ) which received only the ability tests, with no training or criterion task testing.

Some differences between this study and the initial one are apparent, however. In the present study, only a single ability was trained, so the practice is more extensive than for either ability in the initial study. Two criterion tasks were employed, allowing questions of the generalizability of transfer to be addressed. The design allowed for a substantial increase in the number of subjects per group. Finally, a second transfer posttest was administered to some members of Groups  $E_1$  and  $C_1$ , nearly three months after the training period. This addition allowed the examination of long-term impact of training on performance. The design for this study is depicted in Table 2.

TABLE 2  
Experimental Design

Group	N	Day 1 Pretests	Days 2-4 Train	Day 5 Posttests	Day 85* Posttests
E <sub>1</sub>	20	A	T <sub>1</sub> B T <sub>2</sub>	A	A
C <sub>1</sub>	20	A	X	A	A
E <sub>2</sub>	20	X	T <sub>1</sub> B T <sub>2</sub>	A	
C <sub>2</sub>	20		T <sub>1</sub> X T <sub>2</sub>		

X = No Activity

A = Transfer Tasks (Designs and Assembly)

B = Training Tasks

T = Test of Ability

\* = Only 9 of 20 subjects in E<sub>1</sub> and C<sub>1</sub> returned for testing.

The procedure for this study was also similar to that of the initial study, with some modifications. Since two criterion tasks were employed, the pre- and post-training test sessions were slightly longer and required that the order in which the criterion tasks were given be counterbalanced across groups. The nine training tasks were administered three per day, with no repetitions, and only a single ability test was administered before and after training. Because of this, the training sessions were somewhat shorter.

Subjects in group  $E_1$  participated in groups of five. On Day 1 they received the two criterion task pretests in counterbalanced order. On Day 2 they received the ability test, followed by self-paced training on Tasks 1-3. On Day 3 they received training on Tasks 4-6, and on Day 4 training on Tasks 7-9, followed by the ability test again. On Day 5 and on Day 85 they received the two criterion tasks in counterbalanced order. Group  $E_2$  followed a similar procedure, except the Day 1 pretest and the Day 85 posttest. Group  $C_1$  received the Day 1 pretest, Day 5 posttest, and Day 85 posttest, and Group  $C_2$  received only the Day 2 and Day 4 ability tests.

### Results and Conclusions.

In order to determine whether spatial visualization improved with training, changes in ability test scores for Groups  $E_1$  and  $E_2$  were compared to those of the untrained control Group  $C_2$ . All groups showed some improvement in scores, but none of the improvements were statistically significant.

For both transfer tasks, time to solution was the only reliable performance measure. For the Assembly task, a groups x order x trial blocks analysis of variance carried out on the experimental groups revealed no significant group main effects, and only a significant groups x blocks interaction indicating that Group  $E_2$  took longer than  $E_1$  to solve problems in the final block. No other effect of the pretest on transfer was apparent. In order to assess whether training had any effect on transfer, an analysis of covariance was carried out on Groups  $E_1$  and  $C_1$ , using pretest scores as the covariate. No group effects were apparent in this analysis. Similarly, no group differences in long-term retention between Groups  $E_1$  and  $C_1$  were revealed.

A parallel set of analyses was carried out on the Designs test. The analysis of variance concerned the variables of groups, order, trial blocks, and problem difficulty. The only group effect to emerge in this analysis was the group x difficulty interaction, indicating that Group  $E_2$ , with no pretest experience with the Designs task, took longer to solve more difficult problems. Both the covariance analysis and the retention analysis revealed no significant group differences.

This study provided no evidence that spatial visualization could be trained. However, previous attempts at training spatial visualization had met with at least mixed success (Brinkmann, 1966), so it may be important to examine different training methods. Similarly, no evidence for transfer of training emerged, with either criterion task, in spite of the fact that spatial visualization was nearly the only ability required to perform the tasks. Many alternative strategies exist which might

potentially succeed in training an ability and transferring to a dissimilar, criterion task, but practical limitations precluded investigation of all alternatives. The amount and type of training needed to improve spatial visualization is an empirical issue which has not yet been addressed.



## CONCLUSIONS

In this project we were concerned with initial evaluation of the potential for training general human abilities to transfer to a variety of Navy-type tasks. A literature review concluded that no direct evidence existed regarding the potential for ability training, but that indirect evidence from nonspecific transfer research provided some, albeit mixed, support for the possibility. An experiment was conducted to train the abilities of spatial scanning and flexibility of closure for transfer to an electronic troubleshooting task. Only the spatial scanning ability improved through training, and no transfer to the troubleshooting task occurred. A second study trained a single ability--spatial visualization--for transfer to two criterion tasks. In this study there was no evidence for ability improvement and no transfer of training.

It appears that the critical issue is ability training, for transfer cannot be evaluated until training can be shown to be effective. The current project successfully trained one of the three abilities attempted, which suggests that it is, in fact, possible. The number of factors affecting training effectiveness is large, however. For example, the current study used 12-15 hours of practice, 4-5 hours per day on three consecutive days. It may well be that longer practice, or more distributed practice, would have resulted in greater improvement. Such variations were not feasible within the scope of the current project.

Secondly, the type of training may be critical. The current project employed structured practice with tasks known to require the ability in question. While this is a feasible approach, it seems possible that subjects are unfocused and have an inadequate concept of their learning goal. Since the training tasks typically require more than just the ability in question for performance, this form of training may become too diffuse to be effective.

Another question raised by the current results is the possibility that some abilities are simply more amenable to training than others. Since spatial scanning was trained, it is premature to conclude that ability training per se is impossible. Rather it becomes a question of examining several abilities for trainability. In addition, several variations of training programs should be employed, since it seems reasonable to suggest that different training regimens may be more effective with different abilities. While results of the current project showed no differences in trainability as a result of the initial ability level of the subject, the nature of the ability itself may cause it to interact differently with different training programs.

One potentially important source of alternative training strategies comes from current cognitive psychological research, which has tended to break down abilities into the component information processing operations needed for performance. For example, Just and Carpenter (1976) recorded eye movements during performance of a spatial visualization task, and were able to discern three processes occurring in this task. They labeled these processes "search," "transform," and

"confirm." These processes can be supported both by the eye movement data and through independent reaction-time data.

It seems possible that training aimed at improving the application of these component processes might very well result in improved overall ability level as well as transfer to a criterion task. Indeed, Brinkmann's (1966) relatively successful attempt to train spatial abilities focused on components such as orientation, discrimination, etc. This does not solve all the difficulties, however. Specifying the appropriate components for training and an appropriate training regimen are still necessary. While the current project provides some answers, many questions remain to be dealt with before the question of the potential for training general human abilities may be satisfactorily answered.

## REFERENCES

- Brinkmann, E. H. Programmed instruction as a technique for improving spatial visualization. Journal of Applied Psychology, 1966, 50(2), 179-184.
- Edmonds, E. M. & Evans, S. H. Schema learning without a prototype. Psychonomic Science, 1966, 5, 247-248.
- Ferguson, G. A. On transfer and the abilities of man. Canadian Journal of Psychology, 1956, 10, 121-131.
- Fleishman, E. A. The structure and measurement of physical fitness. Englewood Cliffs, N.J.: Prentice Hall, 1964.
- Fleishman, E. A. Performance assessment based on an empirically derived task taxonomy. Human Factors, 1967, 9, 349-366.
- Fleishman, E. A. On the relation between abilities, learning and human performance. American Psychologist, 1972, 27, 1017-1032.
- French, J. W., Eckstrom, R. B., & Price, L. A. Manual for kit of reference tests for cognitive factors. Princeton, New Jersey: Educational Testing Service, June 1963.
- Gagné, R. M. & Fleishman, E. A. Psychology and human performance: An introduction to psychology. New York, N.Y.: Henry Holt, 1959.
- Guilford, J. P. The nature of human intelligence. New York, N.Y.: McGraw-Hill, 1967.
- Hogan, J. C. Trainability of abilities: A review of non-specific transfer issues relevant to ability training. (ARRO Technical Report R78-1). Washington, D.C.: Advanced Research Resources Organization, January 1978.

- James, W. Principles of psychology: I. New York, N.Y.: Holt, 1890.
- Just, M. A. & Carpenter, P. A. Eye fixations and cognitive processes. Cognitive Psychology, 1976, 8, 441-480.
- Levine, J. M., Brahlek, R. E., Eisner, E. J., & Fleishman, E. A. Trainability of abilities: Training and transfer of abilities related to electronic fault-finding. (ARRO Technical Report 3010/R79-2). Washington, D.C.: Advanced Research Resources Organization, March 1979.
- Levine, J. M., Schulman, D., Brahlek, R. E., & Fleishman, E. A. Trainability of abilities: Training and transfer of spatial visualization. (ARRO Technical Report 3010/R80-3). Washington, D.C.: Advanced Research Resources Organization, April 1980.
- Maltzman, I. On the training of originality. Psychological Review, 1960, 67, 229-242.
- Parnes, S. J. & Noller, R. B. Applied creativity: The creative studies project: II. Results of the two-year program. Journal of Creative Behavior, 1972, 6, 164-186.
- Rose, A. M., Fingerman, P. W., Wheaton, G. R., Eisner, E., & Kramer, G. Methods for predicting job-ability requirements: II. Ability requirements as a function of changes in the characteristics of an electronic fault-finding task. Washington, D.C.: American Institutes for Research, Technical Report R74-6, August 1974.
- Sleight, W. G. Memory and formal training. British Journal of Psychology, 1911, 4, 386-457.
- Voss, H. A. Fidelity of simulation and pilot performance. Technical Report NAVTRADEVCEP P-1300-46, Life Sciences, Inc., 1969.

Wheaton, G. R., Rose, A. M., Fingerman, P. W., Korotkin, A. L., & Holding, D. H. Evaluation of the effectiveness of training devices: I. Literature review and preliminary model. Technical Report. Contract DAHC 19-73-0049, Army Research Institute, 1974.

Winch, C. H. The transfer of improvement in memory in school children. British Journal of Psychology, 1910, 3, 386-405.

DISTRIBUTION LIST

NAVY

1 Dr. Larry Dean, LT, MSC, USN  
Psychology Department  
Naval Submarine Medical Research Lab  
Naval Submarine Base  
Groton, CT 06340

1 LT Steven D. Harris, MSC, USN  
Code 6021  
Naval Air Development Center  
Warminster, Pennsylvania 18974

1 Dr. Richard Elster  
Department of Administrative Sciences  
Naval Postgraduate School  
Monterey, CA 93940

1 Dr. Patrick R. Harrison  
Psychology Course Director  
Leadership & Law Dept. (7b)  
Div. of Professional Development  
U.S. Naval Academy  
Annapolis, MD 21402

1 Dr. Pat Federico  
Navy Personnel R&D Center  
San Diego, CA 92152

1 CDR Charles W. Hutchins  
Naval Air Systems Command Hq  
AIR-340F  
Navy Department  
Washington, DC 20361

1 Mr. Paul Foley  
Navy Personnel R&D Center  
San Diego, CA 92152

1 CDR Robert S. Kennedy  
Head, Human Performance Sciences  
Naval Aerospace Medical Research Lab  
Box 29407  
New Orleans, LA 70189

1 Dr. John Ford  
Navy Personnel R&D Center  
San Diego, CA 92152

1 Dr. Norman J. Kerr  
Chief of Naval Technical Training  
Naval Air Station Memphis (75)  
Millington, TN 38054

1 Dr. Richard Gibson  
Bureau of Medicine and Surgery  
Code 3C13  
Navy Department  
Washington, DC 20372

1 Dr. William L. Maloy  
Principal Civilian Advisor for  
Education and Training  
Naval Training Command, Code OOA  
Pensacola, FL 32508

1 Dr. Kneale Marshall  
Scientific Advisor to DCNO(MPT)  
OPOIT  
Washington, DC 20370

1 CAPT Richard L. Martin, USN  
Prospective Commanding Officer  
USS Carl Vinson (CVN-70)  
Newport News Shipbuilding  
and Drydock Co.  
Newport News, VA 23607

1 Dr. William Montague  
Navy Personnel R&D Center  
San Diego, CA 92152

1 Commanding Officer  
U.S. Naval Amphibious School  
Coronado, CA 92155

1 Library  
Naval Health Research Center  
P. O. Box 85122  
San Diego, CA 92138

1 Naval Medical R&D Command  
Code 44  
National Naval Medical Center  
Bethesda, MD 20014

1 Ted M. I. Yellen  
Technical Information Office  
Code 201  
Navy Personnel R&D Center  
San Diego, CA 92152

1 Library, Code P201L  
Navy Personnel R&D Center  
San Diego, CA 92152

1 Technical Director  
Navy Personnel R&D Center  
San Diego, CA 92152

6 Commanding Officer  
Naval Research Laboratory  
Code 2627  
Washington, DC 20390

1 Psychologist  
ONR Branch Office  
Bldg. 114, Section D  
666 Summer Street  
Boston, MA 02210



1

Psychologist  
ONR Branch Office  
536 S. Clark Street  
Chicago, IL 60605

1

LT Frank C. Petho, MSC, USN (Ph.D)  
Code L51  
Naval Aerospace Medical Research Lab  
Pensacola, FL 32508

1

Office of Naval Research  
Code 441  
800 N. Quincy Street  
Arlington, VA 22217

1

Roger W. Remington, Ph.D  
Code L52  
NAMRL  
Pensacola, FL 32508

5

Personnel & Training Research Programs  
(Code 458)  
Office of Naval Research  
Arlington, VA 22217

1

Dr. Bernard Rimland (03B)  
Navy Personnel R&D Center  
San Diego, CA 92152

1

Psychologist  
ONR Branch Office  
1030 East Green Street  
Pasadena, CA 91101

1

Dr. Worth Scanland  
Chief of Naval Education and Training  
Code N-5  
NAS, Pensacola, FL 32508

1

Office of the Chief of Naval Operations  
Research Development & Studies Branch  
(OP-115)  
Washington, DC 20350

1

Dr. Robert G. Smith  
Office of Chief of Naval Operations  
OP-987H  
Washington, DC 20350

1

Captain Donald F. Parker, USN  
Commanding Officer  
Navy Personnel R&D Center  
San Diego, CA 92152

1

Dr. Alfred F. Smode  
Training Analysis & Evaluation Group  
(TAEG)  
Dept. of the Navy  
Orlando, FL 32813



1 Dr. Richard Sorensen  
Navy Personnel R&D Center  
San Diego, CA 92152

1 Dr. Robert Wisner  
Code 309  
Navy Personnel R&D Center  
San Diego, CA 92152

1 W. Gary Thomson  
Naval Ocean Systems Center  
Code 7132  
San Diego, CA 92152

1 Dr. Martin F. Wiskoff  
Navy Personnel R&D Center  
San Diego, CA 92152

ARMY

1 Technical Director  
U.S. Army Research Institute for the  
Behavioral and Social Sciences  
5001 Eisenhower Avenue  
Alexandria, VA 22333

1 Dr. Milton S. Katz  
Training Technical Area  
U.S. Army Research Institute  
5001 Eisenhower Avenue  
Alexandria, VA 22333

1 HQ USAREUE & 7th Army  
ODCSOPS  
USAAREUE Director of GED  
APO New York 09403

1 Director  
U.S. Army Human Engineering Labs  
Attn: DRXHE-DB  
Aberdeen Proving Ground, MD 21005

1 Dr. Ralph Dusek  
U.S. Army Research Institute  
5001 Eisenhower Avenue  
Alexandria, VA 22333

1 Dr. Harold F. O'Neil, Jr.  
Attn: PERI-OK  
Army Research Institute  
5001 Eisenhower Avenue  
Alexandria, VA 22333

1 Dr. Michael Kaplan  
U.S. Army Research Institute  
5001 Eisenhower Avenue  
Alexandria, VA 22333

1 Dr. Robert Sasmor  
U.S. Army Research Institute for the  
Behavioral and Social Sciences  
5001 Eisenhower Avenue  
Alexandria, VA 22333

1 Commandant  
U.S. Army Institute of Administration  
Attn: Dr. Sherrill  
Ft Benjamin Harrison, IN 46256

1 Dr. Joseph Ward  
U.S. Army Research Institute  
5001 Eisenhower Avenue  
Alexandria, VA 22333

1 Dr. Frederick Steinheiser  
U.S. Army Research Institute  
5001 Eisenhower Avenue  
Alexandria, VA 22333

AIR FORCE

1 Air Force Human Resources Lab  
AFHRL/MPD  
Brooks AFB, TX 78235

1 Dr. Genevieve Haddad  
Program Manager  
Life Sciences Directorate  
AFOSR  
Bolling AFB, DC 20332

1 U.S. Air Force Office of Scientific  
Research  
Life Sciences Directorate, NL  
Bolling Air Force Base  
Washington, DC 20332

1 Dr. Ronald G. Hughes  
AFHRL/OTR  
Williams AFB, AZ 85224

1 Air University Library  
AUL/LSE 76/443  
Maxwell AFB, AL 36112

1 Research and Measurement Division  
Research Branch, AFMPC/MPCYPR  
Randolph AFB, TX 78148

1 Dr. Earl A. Alluisi  
HQ, AFHRL (AFSC)  
Brooks AFB, TX 78235

1 Dr. Marty Rockway (AFHRL/TT)  
Lowry AFB  
Colorado 80230

1 Dr. Frank Schufletowski  
U.S. Air Force  
ATC/XPTD  
Randolph AFB, TX 78148

1 Jack A. Thorpe, Maj., USAF  
Naval War College  
Providence, RI 02846

2 3700 TCHTW/TTGH Stop 32  
Sheppard AFB, TX 76311

### MARINES

1 H. William Greenup  
Education Advisor (E031)  
Education Center, MCDEC  
Quantico, VA 22134

1 Special Assistant for Marine  
Corps Matters  
Code 100M  
Office of Naval Research  
800 N. Quincy St.  
Arlington, VA 22217

1 Headquarters, U.S. Marine Corps  
Code MPI-20  
Washington, DC 20380

1 Dr. A. L. Slafkosky  
Scientific Advisor (Code RD-1)  
HQ U.S. Marine Corps  
Washington, DC 20380

### OTHER DOD

12 Defense Technical Information Center  
Cameron Station, Bldg 5  
Alexandria, VA 22314  
Attn: TC

1 Military Assistant for Training and  
Personnel Technology  
Office of the Under Secretary of  
Defense for Research & Engineering  
Room 3D129, The Pentagon  
Washington, DC 20301

1 Dr. Dexter Fletcher  
Advanced Research Projects Agency  
1400 Wilson Blvd.  
Arlington, VA 22209

CIVIL GOVERNMENT

1 Dr. Susan Chipman  
Learning and Development  
National Institute of Education  
1200 19th Street NW  
Washington, DC 20208

1 Personnel R&D Center  
Office of Personnel Management  
1900 E Street NW  
Washington, DC 20415

1 Dr. Joseph I. Lipson  
SEDR W-638  
National Science Foundation  
Washington, DC 20550

1 Dr. H. Wallace Sinaiko  
Program Director  
Manpower Research and Advisory  
Services  
Smithsonian Institution  
801 North Pitt Street  
Alexandria, VA 22314

1 William J. McLaurin  
Rm. 301, Internal Revenue Service  
2221 Jefferson Davis Highway  
Arlington, VA 22202

1 Dr. Frank Withrow  
U.S. Office of Education  
400 Maryland Ave. SW  
Washington, DC 20202

1 Dr. Andrew R. Molnar  
Science Education Dev. and Research  
National Science Foundation  
Washington, DC 20550

1 Dr. Joseph L. Young, Director  
Memory & Cognitive Processes  
National Science Foundation  
Washington, DC 20550

NON GOVERNMENT

1 Dr. John R. Anderson  
Department of Psychology  
Carnegie Mellon University  
Pittsburgh, PA 15213

1 Dr. John Annett  
Department of Psychology  
University of Warwick  
Coventry CV4 7AL  
England

1 Dr. Michael Atwood  
Science Applications Institute  
40 Denver Tech. Center West  
7935 E. Prentice Avenue  
Englewood, CO 80110

1 Psychological Research Unit  
Department of Defense (Army Office)  
Campbell Park Offices  
Canberra ACT 2600  
Australia

1 Dr. Alan Baddeley  
Medical Research Council  
Applied Psychology Unit  
15 Chaucer Road  
Cambridge CB2 2EF  
England

1 Dr. Patricia Baggett  
Department of Psychology  
University of Denver  
University Park  
Denver, CO 80208

1 Dr. Jackson Beatty  
Department of Psychology  
University of California  
Los Angeles, CA 90024

1 Dr. Nicholas A. Bond  
Department of Psychology  
Sacramento State College  
600 Jay Street  
Sacramento, CA 95819

1 Dr. Lyle Bourne  
Department of Psychology  
University of Colorado  
Boulder, CO 80309

1 Dr. Robert Brennan  
American College Testing Programs  
P. O. Box 168  
Iowa City, IA 52240

1 Dr. C. Victor Bunderson  
Wicat, Inc.  
University Plaza, Suite 10  
1160 S. State Street  
Orem, UT 84057

1 Dr. John B. Carroll  
Psychometric Lab  
University of North Carolina  
Davie Hall 013A  
Chapel Hill, NC 27514

1 Dr. William Chase  
Department of Psychology  
Carnegie Mellon University  
Pittsburgh, PA 15213

1 Dr. Norman Cliff  
Department of Psychology  
University of Southern California  
University Park  
Los Angeles, CA 90007

1 Dr. Lynn A. Cooper  
Department of Psychology  
Uris Hall  
Cornell University  
Ithaca, NY 14850

1 Dr. Richard L. Ferguson  
The American College Testing Program  
P. O. Box 168  
Iowa City, IA 52240

1 Dr. Meredith P. Crawford  
American Psychological Association  
1200 17th Street, N.W.  
Washington D.C. 20036

1 Dr. John R. Frederiksen  
Bolt Beranek & Newman  
50 Moulton Street  
Cambridge, MA 02138

1 Dr. Kenneth B. Cross  
Anacapa Sciences, Inc.  
P. O. Drawer Q  
Santa Barbara, CA 93102

1 Dr. Alinda Friedman  
Department of Psychology  
University of Alberta  
Edmonton, Alberta  
Canada T6G 2E9

1 Dr. Marvin D. Dunnette  
N492 Elliott Hall  
Department of Psychology  
University of Minnesota  
Minneapolis, MN 55455

1 Dr. R. Edward Geiselman  
Department of Psychology  
University of California  
Los Angeles, CA 90024

1 LCol. J. C. Eggenberger  
Directorate of Personnel Applied Rsrch.  
National Defence HQ  
101 Colonel By Drive  
Ottawa, Canada K1A 0K2

1 Dr. Robert Glaser  
LRDC  
University of Pittsburgh  
3939 O'Hara Street  
Pittsburgh, PA 15213

1 ERIC Facility - Acquisitions  
4833 Rugby Avenue  
Bethesda, MD 20014

1 Dr. Marvin D. Glock  
217 Stone Hall  
Cornell University  
Ithaca, NY 14853

1 Dr. Daniel Gopher  
Industrial & Management Engineering  
Technion-Israel Institute of Technology  
Haifa  
ISRAEL

1 Ms. Glenda Greenwald, Ed.  
"Human Intelligence Newsletter"  
P. O. Box 1163  
Birmingham, MI 48012

1 Dr. James G. Greeno  
LRDC  
University of Pittsburgh  
3939 O'Hara Street  
Pittsburgh, PA 15213

1 Dr. Lloyd Humphreys  
Department of Psychology  
University of Illinois  
Champaign, IL 61820

1 Dr. Harold Hawkins  
Department of Psychology  
University of Oregon  
Eugene, OR 97403

1 Library  
HumRRO/Western Division  
27857 Berwick Drive  
Carmel, CA 93921

1 Dr. Barbara Hayes-Roth  
The Rand Corporation  
1700 Main Street  
Santa Monica, CA 90406

1 Dr. Earl Hunt  
Department of Psychology  
University of Washington  
Seattle, WA 98105

1 Dr. Frederick Hayes-Roth  
The Rand Corporation  
1700 Main Street  
Santa Monica, CA 90406

1 Dr. Douglas H. Jones  
Room T-255  
Educational Testing Service  
Princeton, NJ 08450

1 Dr. James R. Hoffman  
Department of Psychology  
University of Delaware  
Newark, DE 19711

3 Journal Supplement Abstract Service  
American Psychological Association  
1200 17th Street, N.W.  
Washington, D.C. 20036



1 Dr. Wilson A. Judd  
McDonnell-Douglas Astronautics Co. -  
St. Louis  
P. O. Box 30204  
Lowry AFB, CO 80230

1 Dr. Charles Lewis  
Faculteit Sociale Wetenschappen  
Rijksuniversiteit Groningen  
Oude Boteringestraat  
Groningen  
NETHERLANDS

1 Dr. Steven W. Keele  
Department of Psychology  
University of Oregon  
Eugene, OR 97403

1 Dr. Robert R. Mackie  
Human Factors Research, Inc.  
5775 Dawson Avenue  
Goleta, CA 93017

1 Dr. Mazie Knerr  
Litton-Mellonics  
Box 1286  
Springfield, VA 22151

1 Dr. Allen Munro  
Behavioral Technology Laboratories  
1845 Elena Ave., Fourth Floor  
Redondo Beach, CA 90277

1 Dr. Stephen Kosslyn  
Harvard University  
Department of Psychology  
33 Kirkland Street  
Cambridge, MA 02138

1 Dr. Donald A. Norman  
Department of Psychology, C-009  
Univ. of California, San Diego  
La Jolla, CA 92093

1 Dr. Alan Lesgold  
Learning R & D Center  
University of Pittsburgh  
Pittsburgh, PA 15260

1 Dr. Melvin R. Novick  
356 Lindquist Center for Measurement  
University of Iowa  
Iowa City, IA 52242

1 Dr. Michael Levine  
Dept. of Educational Psychology  
210 Education Bldg.  
University of Illinois  
Champaign, IL 61801

1 Dr. Jesse Orlansky  
Institute for Defense Analyses  
400 Army Navy Drive  
Arlington, VA 22202

1 Dr. James A. Paulson  
Portland State University  
P. O. Box 751  
Portland, OR 97207

1 Mr. Luigi Petruccio  
2431 N. Edgewood Street  
Arlington, VA 22207

1 Dr. Martha Polson  
Department of Psychology  
University of Colorado  
Boulder, CO 80309

1 Dr. Peter Polson  
Department of Psychology  
University of Colorado  
Boulder, CO 80309

1 Dr. Diane M. Ramsey-Klee  
R-K Research & System Design  
3947 Ridgemont Drive  
Malibu, CA 90265

1 Minrat M. L. Rauch  
P II 4  
Bundesministerium Der Verteidigung  
Postfach 1328  
D-53 Bonn 1,  
GERMANY

1 Dr. Mark D. Reckase  
Educational Psychology Dept.  
University of Missouri-Columbia  
4 Hill Hall  
Columbia, MO 65211

1 Dr. Andrew M. Rose  
American Institutes for Research  
1055 Thomas Jefferson St., NW  
Washington, DC 20007

1 Dr. Ernst Z. Rothkopf  
Bell Laboratories  
600 Mountain Avenue  
Murray Hill, NJ 07974

1 Prof. Fumiko Samejima  
Department of Psychology  
University of Tennessee  
Knoxville, TN 37916

1 Dr. Irwin Sarason  
Department of Psychology  
University of Washington  
Seattle, WA 98195

1 Dr. Walter Schneider  
Department of Psychology  
University of Illinois  
Champaign, IL 61820

1 Dr. Robert J. Seidel  
Instructional Technology Group  
HumRRO  
300 N. Washington St.  
Alexandria, VA 22314

1 Dr. David Stone  
ED 236  
SUNY, Albany  
Albany, NY 12222

1 Committee on Cognitive Research  
c/o Dr. Lonnie R. Sherrod  
Social Science Research Council  
605 Third Avenue  
New York, NY 10016

1 Dr. Patrick Suppes  
Institute for Mathematical Studies  
in the Social Sciences  
Stanford University  
Stanford, CA 94305

1 Dr. Richard Snow  
School of Education  
Stanford University  
Stanford, CA 94305

1 Dr. Kikumi Tatsuoka  
Computer Based Education Research  
Laboratory  
252 Engineering Research Laboratory  
University of Illinois  
Urbana, IL 61801

1 Dr. Kathryn T. Spoehr  
Department of Psychology  
Brown University  
Providence, RI 02912

1 Dr. Perry Thorndyke  
The Rand Corporation  
1700 Main Street  
Santa Monica, CA 90406

1 Dr. Robert Sternberg  
Department of Psychology  
Yale University  
Box 11A, Yale Station  
New Haven, CT 06520

1 Dr. Douglas Towne  
Univ. of Southern California  
Behavioral Technology Labs  
1845 S. Elena Ave.  
Redondo Beach, CA 90277

1 Dr. Albert Stevens  
Bolt Beranek & Newman, Inc.  
50 Moulton Street  
Cambridge, MA 02138

1 Dr. J. Uhlner  
Perceptronic, Inc.  
6271 Variel Avenue  
Woodland Hills, CA 91364

1 Dr. Benton J. Underwood  
Department of Psychology  
Northwestern University  
Evanston, IL 60201

1 Dr. Keith T. Wescourt  
Information Sciences Dept.  
The Rand Corporation  
1700 Main Street  
Santa Monica, CA 90406

1 Dr. Willard S. Vaughan, Jr.  
Oceanautics, Inc.  
422 Sixth Street  
Annapolis, MD 21403

1 Dr. Susan E. Whitely  
Psychology Department  
University of Kansas  
Lawrence, KS 66044

1 Dr. Thomas Wallsten  
Psychometric Laboratory  
Davie Hall 013A  
Univ. of North Carolina  
Chapel Hill, NC 27514

1 Dr. Christopher Wickens  
Department of Psychology  
University of Illinois  
Champaign, IL 61820

1 Dr. Phyllis Weaver  
Graduate School of Education  
Harvard University  
200 Larsen Hall, Appian Way  
Cambridge, MA 02138

1 Dr. Arthur J. Woodward  
Department of Psychology  
University of California  
Los Angeles, CA 90024

1 Dr. David J. Weiss  
N660 Elliott Hall  
University of Minnesota  
75 E. River Road  
Minneapolis, MN 55455

1 Dr. Gershon Weltman  
Perceptronic, Inc.  
6271 Variel Ave.  
Woodland Hills, CA 91367