

DOCUMENT RESUME

ED 198 004

SE 034 290

AUTHOR Hogarth, Peter T.: And Others
 TITLE The Energy-Wise Homebuyer: A Guide to Selecting an Energy-Efficient Home.
 INSTITUTION Technology and Economics, Inc., Cambridge, Mass.
 SPONS AGENCY Department of Energy, Washington, D.C.; Department of Housing and Urban Development, Washington, D.C. Office of Policy Development and Research.
 REPORT NO HUD-PDR-412(2)
 PUB DATE Mar 79
 CONTRACT H-2648
 NOTE 65p.
 AVAILABLE FROM Superintendent of Documents, U.S. Government Printing Office, Washington, DC 20402 (no price quoted).
 EDRS PRICE MF01/PC03 Plus Postage.
 DESCRIPTORS Adults; Building Systems: *Consumer Education: *Energy: *Energy Conservation: *Heating: Housing: *Housing Industry: Money Management
 IDENTIFIERS *Home Improvement; Insulation

ABSTRACT

Presented is a guide for purchasers of new or used homes who wish to make informed comparisons of energy costs. Included are 12 energy features to look for, detailed energy checklists, and charts for calculating energy expenses. Among the considerations discussed are heating systems, insulation, thermostats, caulking and weatherstripping, and improvements to existing homes. Also provided are tips on energy-conscious living, a glossary of terms related to energy efficiency, and a list of further sources of information.

(WB)

 * Reproductions supplied by EDRS are the best that can be made *
 * from the original document. *



U.S. Department of Housing and Urban Development
 In Cooperation with the
 U.S. Department of Energy

U.S. DEPARTMENT OF HEALTH,
 EDUCATION & WELFARE
 NATIONAL INSTITUTE OF
 EDUCATION

THIS DOCUMENT HAS BEEN REPRODUCED EXACTLY AS RECEIVED FROM THE PERSON OR ORGANIZATION ORIGINATING IT. POINTS OF VIEW OR OPINIONS STATED DO NOT NECESSARILY REPRESENT OFFICIAL NATIONAL INSTITUTE OF EDUCATION POSITION OR POLICY.

The Energy-Wise Home Buyer

A Guide to Selecting an Energy Efficient Home

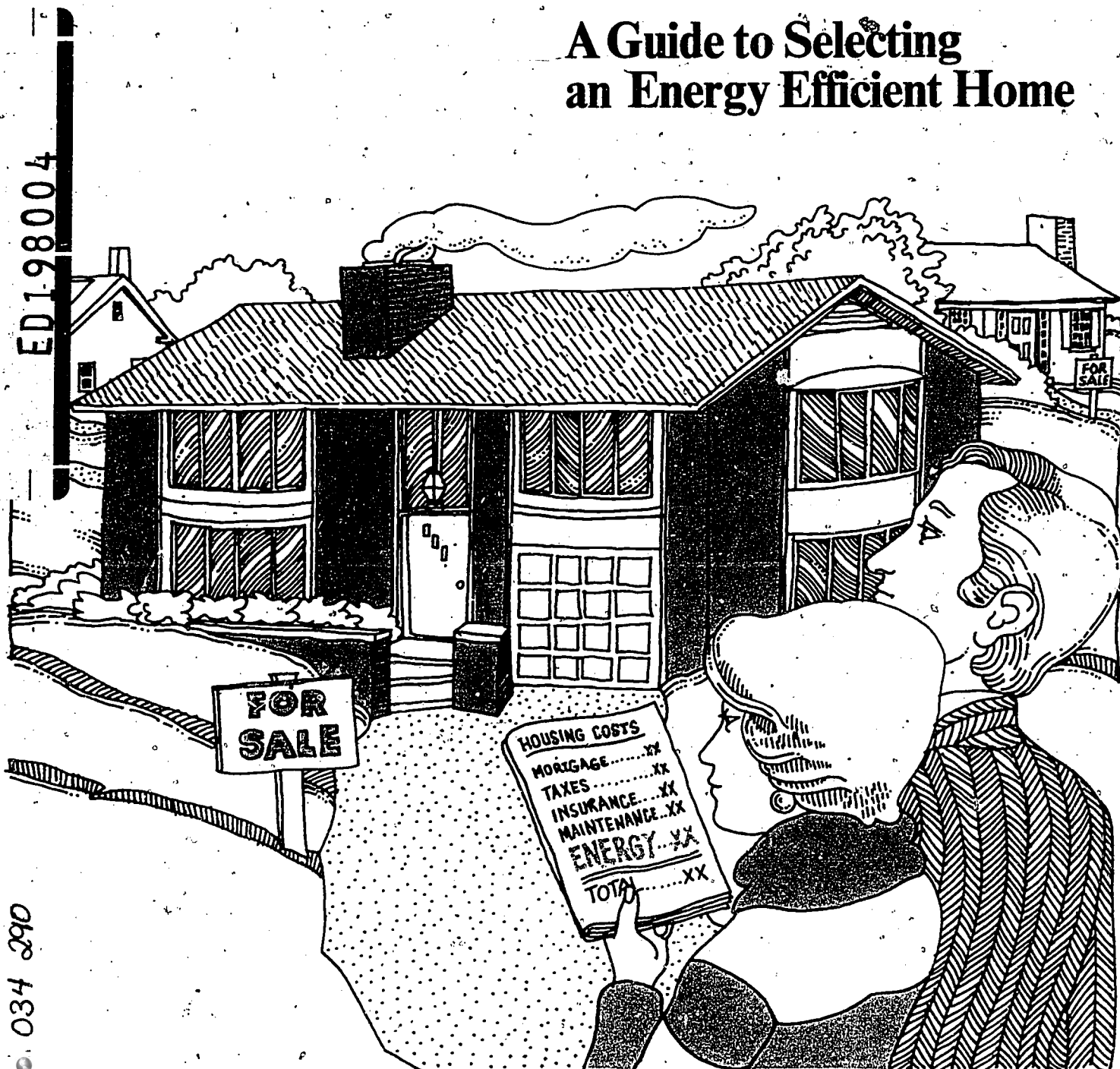

034 290

THE WHITE HOUSE

WASHINGTON

May 2, 1979

Dear Homebuyer:

All Americans are aware of the rising costs of homeownership. While taxes, mortgage rates, maintenance, insurance, and energy costs are all rising, energy costs seem to be taking a larger and larger share of the homeowner's budget. The Department of Housing and Urban Development and the Department of Energy have produced the enclosed booklet to help citizens deal with the problems of housing costs and energy consumption.

Whether you are thinking of buying a newly constructed home or an existing home, this guide will help you in your purchasing decisions. It shows you how a house uses energy, how you can estimate your energy costs, and how you can evaluate the energy efficiency of a variety of homes. In addition, a number of tips on how to save energy after you move in are included.

With the benefits of recent tax credits by the Government, and better information programs for homeowners about energy conservation, we as individuals and families can contribute to our national goal of becoming energy independent.

Sincerely,

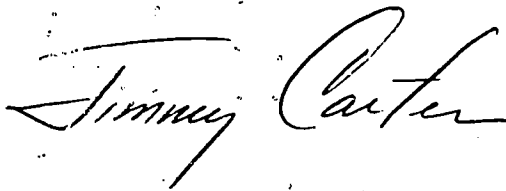

Prepared under Inter-Agency Agreement No. EC 77-A-31-1039 for the

**Division of Energy, Building Technology,
and Standards—**

**Office of Policy Development
and Research—**

**U.S. Department of Housing
and Urban Development**

Washington, D.C.

**Office of Buildings and
Community Systems—**

**Office of Conservation and
Solar Applications—**

U.S. Department of Energy

Under HUD Contract No. H-2648 by

**Technology + Economics, Inc.
Cambridge, Massachusetts**

March 1979

This report was prepared under contract to the U.S. Department of Housing and Urban Development. The findings and conclusions are those of the contractor, and do not necessarily reflect the policy or views of the U.S. Department of Housing and Urban Development.

For sale by the Superintendent of Documents, U.S. Government Printing Office
Washington, D.C. 20402

How to use this guide	1
------------------------------	---

Twelve energy-efficiency features to look for in a new home	5
1. Proper levels of insulation	8
2. Caulking and weatherstripping	10
3. Storm windows and doors	11
4. Type of heating system	12
5. Heat pumps	12
6. An air conditioning unit with high energy efficiency ratio (EER)	13
7. Ducts and pipes	14
8. Well installed attic insulation	15
9. Clock thermostats, individual room controls, and zoned heating systems	16
10. Proper orientation and shading of windows	17
11. Band joist insulation	17
12. Outside combustion air intakes	18
How to check for the twelve features when you visit a home	18
Energy cost estimates by builders	20
Making your decision	21
New homes energy checklist	22

Past energy bills—determining the energy costs of used homes	26
Improving the used home	28
Financing the improvements	29
How much room for improvement? Inspecting the home	29
Repairs, caulking, and weatherstripping	30
Storm windows and doors	32
Insulation	33
Ducts and pipes in unheated spaces	36
Heating and cooling equipment	36
Making your homebuying choice	38
Used homes energy checklist	40

After you move in: energy-conscious living	43
Energy-saving maintenance	45
More low-cost energy savers	46
Some bigger energy-savers	49
Other things to look for when you buy a home	52
A detailed reference list of home energy-efficiency features	54
Glossary 56; For further reference 58; Index 59; Acknowledgements 60	

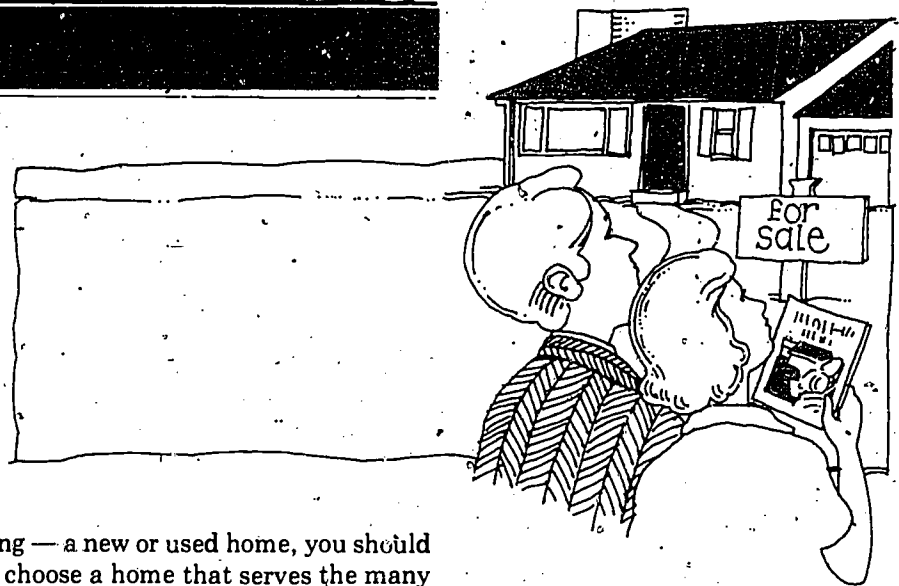
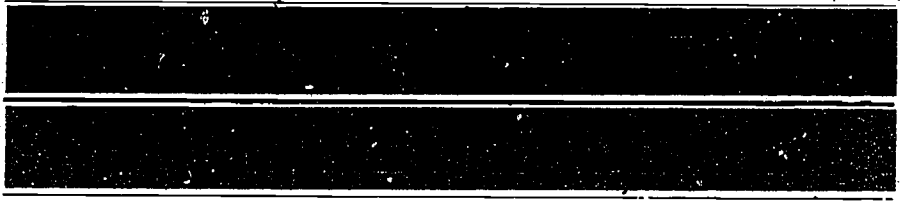

If you are buying — or thinking of buying — a new or used home, you should read this Guide. It will tell you how to choose a home that serves the many needs of your family and at the same time is efficient to heat and cool. A few minutes spent using this Guide and following its recommendations will help save you money, perhaps a great deal of money.

In examining a home, you will obviously want to consider many factors. The cost of heating and cooling the home may not be one of the more “glamorous” factors, but it should be among the most relevant. Energy costs have risen considerably in recent years, much more rapidly than the rate of inflation, and future energy costs promise to be even higher. Which home you select may make a difference of thousands of dollars in terms of your total energy costs. So don’t ignore energy costs in making this most important purchase decision. *The Energy-Wise Homebuyer* will help you to make an informed decision.



This Guide is divided into three main parts — you need only read the parts that apply to you:

- Part 1 is for buyers of new homes, and starts on the next page.
- Part 2 is for buyers of used or existing homes, and starts on page 25.
- Part 3 is for buyers of both new and existing homes. It provides a more detailed, in-depth look at the energy-efficiency features of any home and also contains tips on energy-efficient living. Part 3 starts on page 43.

We suggest that you read through Part 1 or Part 2 before you go to visit any homes. Then, take this Guide with you when you visit homes, and use it as a reference. “Energy Checklists” are provided at the ends of Part 1 and Part 2, where you can make note of the energy features of each home you visit.

At the back of this Guide, starting on page 56, there is a glossary of energy-efficiency terms. Also, on page 58, there is a list of sources of further information on home energy efficiency.

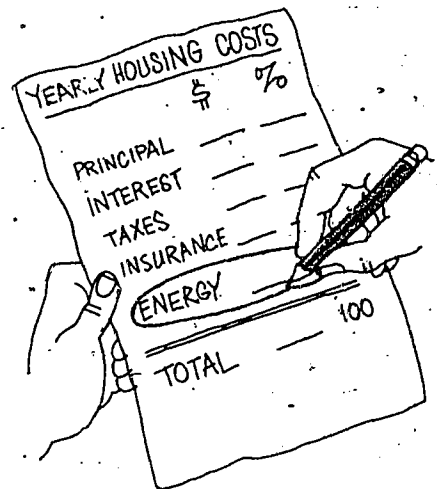

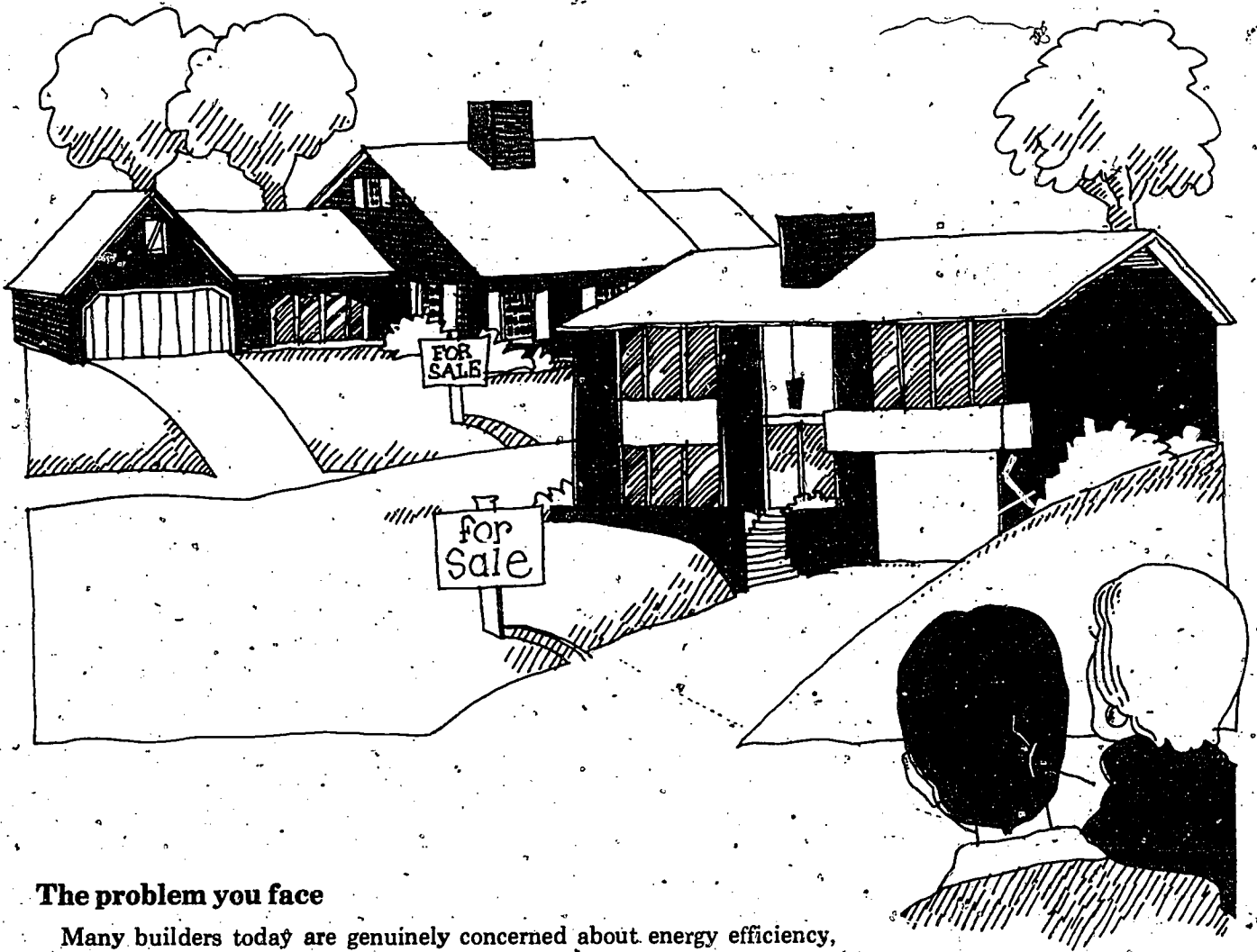

The problem you face

Many builders today are genuinely concerned about energy efficiency, and many new homes built today are very energy-efficient. **But don't take energy efficiency for granted in a new home.** Don't assume that a home is energy-efficient just because it is new. Don't assume that all new homes will have the same energy costs.

There are no ironclad guarantees of energy efficiency in new homes. Codes and standards to help assure that new homes will be energy-efficient are just beginning to be implemented, and at the present time, not all new homes comply with them. In addition, present-day codes and standards do not cover some energy-efficiency features that are important and worth looking for. Nevertheless, it is possible for you to evaluate different new homes and make a wise, energy-efficient choice. This part of *The Energy-Wise Homebuyer* shows you how.

How to shop for energy efficiency in a new home

How can you, a concerned homebuyer, be sure of choosing a new home that is energy-efficient?

There are two methods for you to use. They are to

1. Look at the energy-efficiency features of each home.
2. Look at energy cost estimates from builders and dealers.

Important energy-efficiency features include proper insulation, protection against air leaks, and efficient heating and cooling equipment. This Guide highlights twelve important energy efficiency features to look for in a new home. Starting on the next page, the Guide explains what these features are and how to select the home with the best combination of features.

Estimates of the costs of heating and cooling a home are often provided by builders and dealers, based on past experience or on engineering calculations. Pages 20 and 21 of this Guide explain how to obtain these estimates and how to use them correctly.

We suggest that you use both these methods. That way, one method can serve as a check on the accuracy of the other.

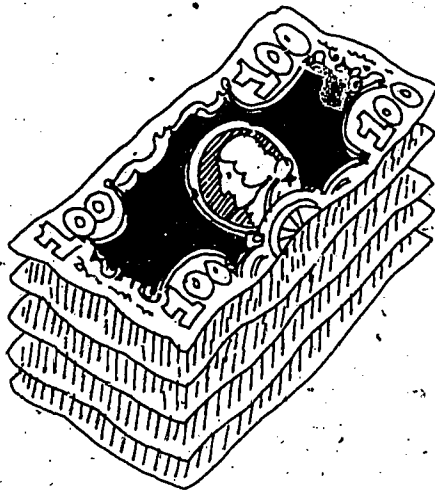

To sum up

Don't take energy efficiency for granted in new homes. Look at their energy-efficiency features before you make your choice. Also, obtain energy cost estimates and carefully evaluate them.

When you go out to look at a home, take *The Energy-Wise Homebuyer* with you as a reference guide. If you like, use the New Homes Energy Checklist (pages 22 and 23) to note the features of the home.

Remember, if you choose the right home, you could save literally hundreds of dollars each year — and have improved comfort and livability as well.

These twelve energy-efficiency features are selected out of all the possible ones for you to look for. All of these twelve features are important. You should become familiar with each of these features so that you will be best able to evaluate the energy efficiency of the homes that you visit. They are features that you can either ask the builder or seller about or easily investigate for yourself. If present, they will all result in significantly lowered energy bills.

The twelve features are divided into two categories:

- Six major features
- Six quality checks

Six major features

The six major features are the first six illustrated on the next two pages and are numbered 1 through 6. These features include proper levels of insulation; caulking and weatherstripping, storm sash in cooler climates, and proper choices of heating and cooling equipment.

Not every home should have every one of these features — for example, not every home should have a heat pump, storm windows, or large amounts of attic insulation. But every home *should* have a proper combination of these features — suitable for the local climate, and suitable for the types of energy available in your area. If you want your new home to be as economical as possible, be familiar with these six features, know which are recommended for your area and choice of fuels, and make sure that the home you choose has as many of the recommended features as possible.

The next two pages illustrate these features. Pages 8 through 14 explain them in detail.

Six quality checks

These six features will also increase the energy efficiency of a home. They should be checked to determine the general quality of construction and the builder's concern for energy conservation.

The quality of construction of a home — particularly its tightness against air leaks and the quality of installation of insulation — greatly affects its energy efficiency. Many small features go to make-up quality of construction. Many are hidden from sight. But the six items here are representative of these many small features. If they are there, chances are that many other energy-efficiency features are present also.

These "Six Quality Checks" are shown on the next two pages and are described in detail on pages 14 through 18.



Six Major Features

1

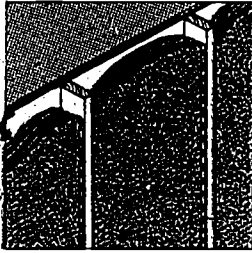

- 1. Proper levels of insulation:**
- In ceilings and attics.
 - In walls.
 - In floors, crawl space or basement walls and slab foundation perimeters.
- AN ESSENTIAL FEATURE.**
See page 8 for details.

2

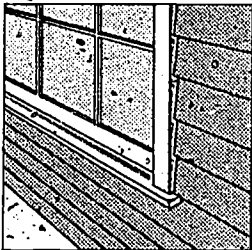

- 2. Caulking and weatherstripping:**
- Caulking of window and door frames, and of cracks and joints on the outside of the house.
 - Windows weatherstripped and adjusted so that you can't rattle them.
- See page 10 for details.*

3

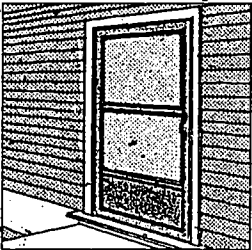

- 3. Storm windows and doors (or insulating glass and thermal doors) in climates where they are needed.**
See page 11 for details.

4

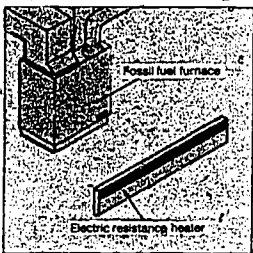

- 4. Type of heating system.**
See page 12.

5

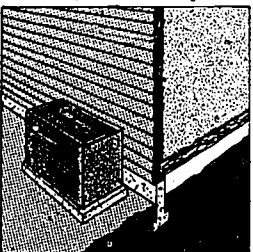

- 5. A heat pump instead of electric resistance heat, if gas or oil is not available. A good feature in some — but not all — climates and areas of the country.**
See page 12.

6

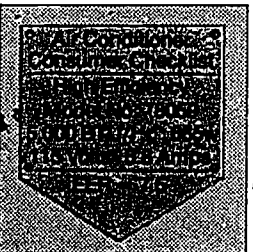

- 6. An air conditioning unit with high Energy Efficiency Ratio (EER). Or, no central air conditioning at all in cooler climates.**
See page 13.

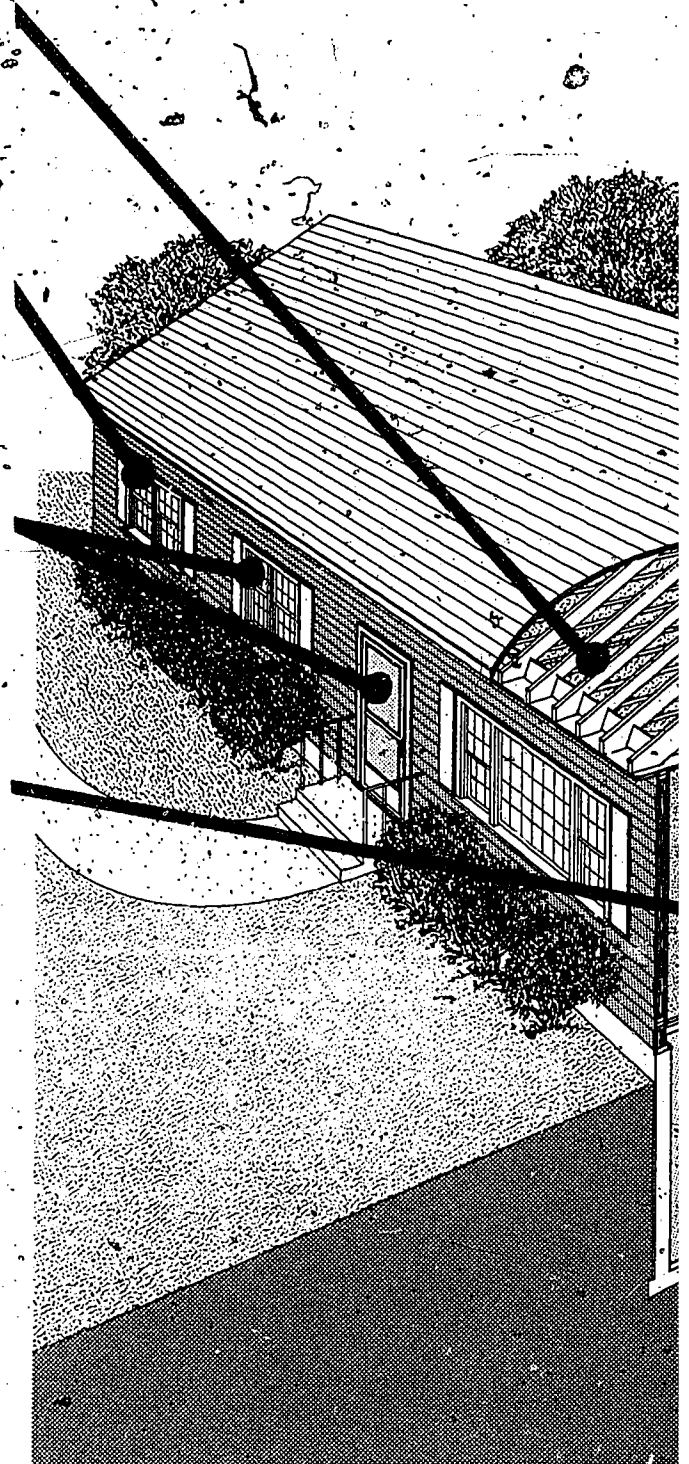

Six Quality Checks

7. Ducts and pipes located in the heated space of the home if possible; or, if in unheated spaces, tightly sealed and insulated. See page 14 for details.

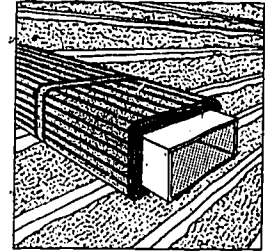

7

8. Quality installation of attic insulation.

- Even installation — no holes or gaps, except around vents and light fixtures; no thin spots.
 - Attic access that is weatherstripped and insulated.
- See page 15.

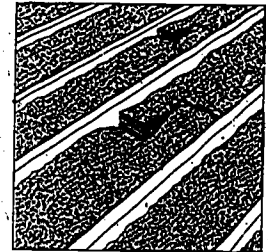

8

9. A clock thermostat for central heating and air conditioning systems (not recommended for heat pumps in winter).

Individual room controls for electric resistance baseboard heat.

See page 16 for details.

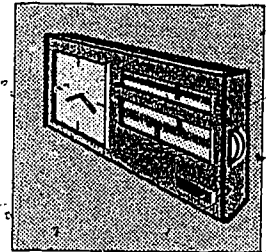

9

10. Proper orientation and shading of windows. A maximum of windows to the south with summer shading. Fewer windows to the north, east, and west. Shading for east and west windows if possible.

See page 17 for details.

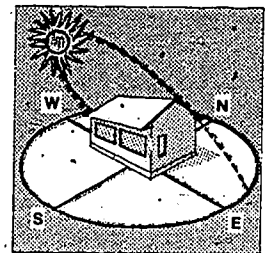

10

11. Band joist insulation.

See page 17.

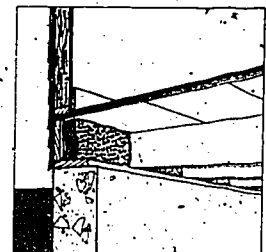

11

12. Outside combustion air intakes for furnaces and fireplaces.

See page 18.

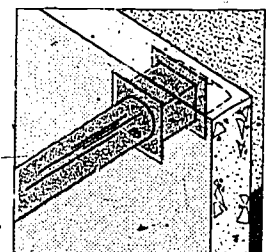

12

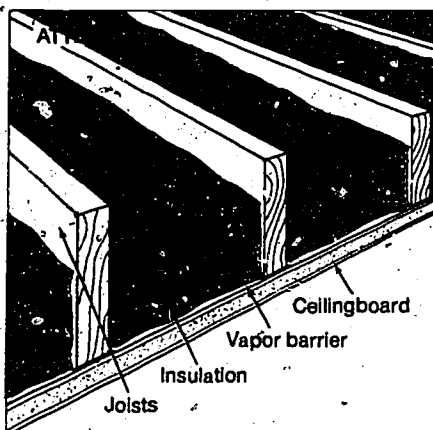

Attic insulation.

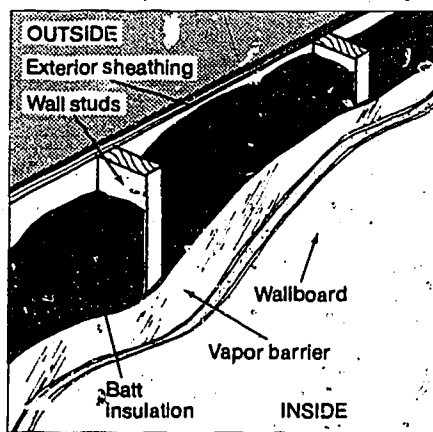

Wall insulation.

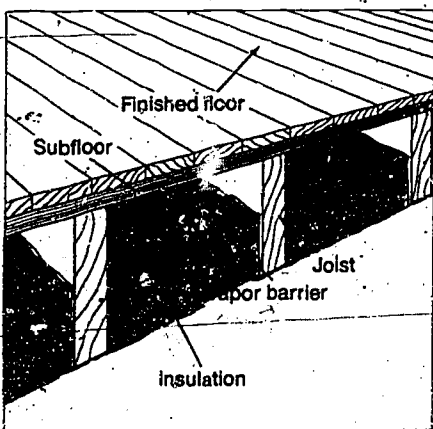

Crawl space insulation

It is essential that a home have adequate amounts of insulation, in its

- ceiling or attic
- walls
- crawl space or basement walls, floors, or slab foundation perimeters.

How much insulation you need depends on your climate and your cost of energy. The tables below present suggested guidelines. These guidelines are in line with the new Minimum Property Standards being developed by the U.S. Department of Housing and Urban Development.

To understand these tables, you need to understand the term "R-value." "R-values," as shown in the tables, such as R-11, R-19, etc., are measures of the insulating value of insulation. The higher the R-value, the higher the insulating value of the insulation. For example, an R-11 glass fiber insulating batt is about 3½ inches thick; an R-19 glass fiber batt is about 6 or 6½ inches thick. Other types of insulation have greater or lesser insulating value per inch of thickness.

Look at the map on the accompanying page to see which climate zone you are in — A, B, C, D, or E. Now refer to the appropriate column of each table. Note that Table 1 is for homes with all types of heating except electric resistance, and Table 2 is specifically for homes with electric resistance heat. For easier reference, circle the column on each table for your climate zone.

Table 1: For homes heated with oil, gas or heat pumps*

Feature	Zone A	Zone B	Zone C	Zone D	Zone E
1. Ceiling Insulation	R-19	R-19	R-26	R-30	R-38
2. Wall Insulation†	R-11	R-11	R-13	R-13	R-19
3. Floors Over Unheated Spaces	none	none	R-11	R-11	R-19
4. Foundation Walls of Heated Spaces	none	none	R-6	R-11	R-11
5. Slab Foundation Perimeter	none	R-2	R-5	R-5	R-7.5

Table 2. For homes heated with electric resistance heat*

Feature	Zone A	Zone B	Zone C	Zone D	Zone E
1. Ceiling Insulation	R-19	R-22	R-30	R-30	R-38
2. Wall Insulation†	R-11	R-13	R-19	R-19	R-19
3. Floors Over Unheated Spaces	none	R-11	R-19	R-19	R-19
4. Foundation Walls of Heated Spaces	none	none	R-6	R-11	R-11
5. Slab Foundation Perimeter	none	R-5	R-7.5	R-7.5	R-7.5

*Based on the May 1979 revisions to the HUD Minimum Property Standards.

†Does not apply to masonry walls, which should comply with local standards.

These are the basic requirements that a new home should meet. When you talk to the dealer, it is a good idea to specifically ask about the insulation levels in each part of the home — ceiling, walls, and floor. Make sure that these insulation levels are reasonably close to what is recommended here.

Proper levels of insulation:

- An essential feature.
- An important feature.
- A good quality check.
- Something you or the builder can add or improve at time of purchase.

*But only in some cases and for certain parts of the home.

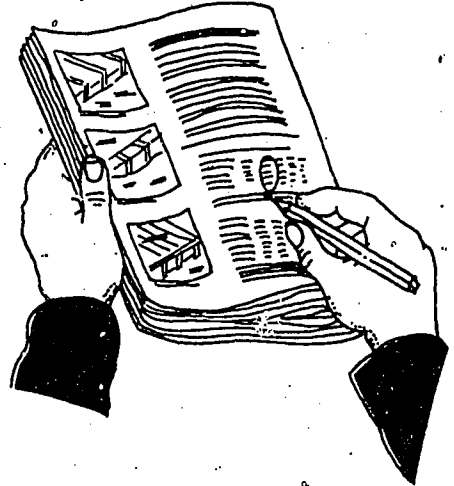

Climate Zones of the U.S.

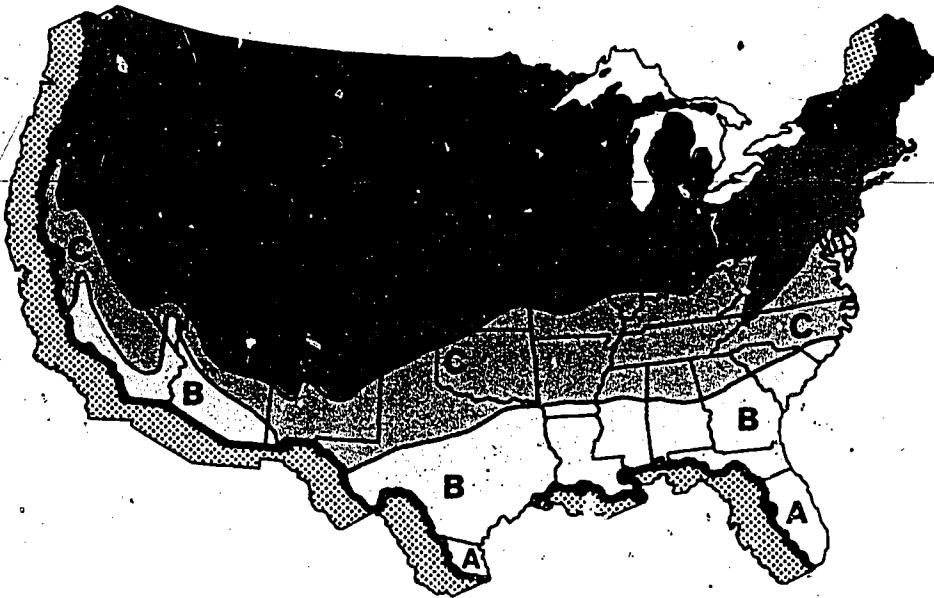

Caulking and weatherstripping

Caulking and weatherstripping are essential features of a home. Their presence and quality of installation are also good indicators of the overall quality of construction.

“Caulking” consists of a flexible-sealing compound. All outside cracks and joints outside of the house should be caulked. If a home is not properly caulked it will not be energy-efficient. You should either not purchase it, or if you do purchase it, caulk it yourself or have the builder caulk it as soon as possible.

Check for good caulking job by looking at the places indicated in the illustrations:

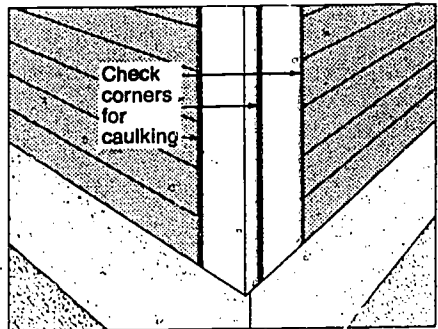

Corners on the outside of the house and around exterior chimneys

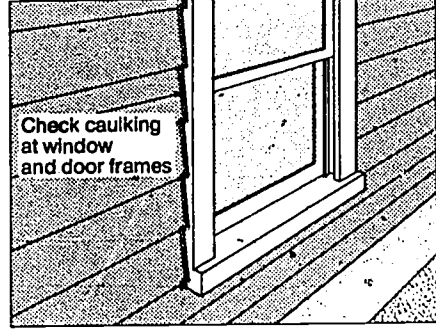

Around the window and door frames on the outside of the house

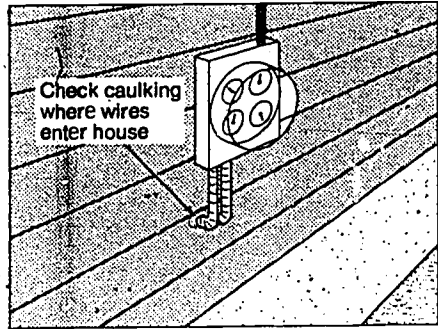

Places where pipes and wires enter the house

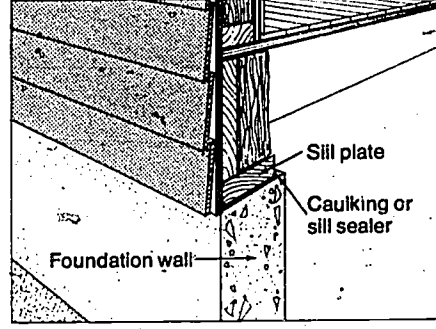

Between the foundation and the sill plate.

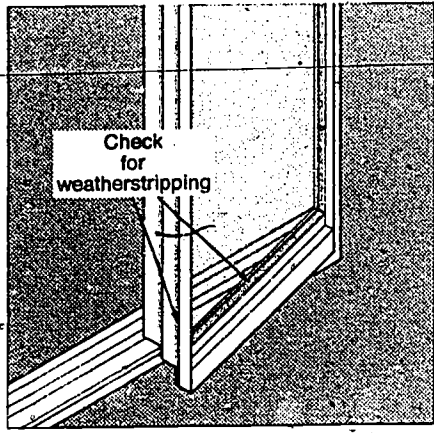

Weatherstripping.

“Weatherstripping” consists of seals made of metal, foam, or vinyl strips around the edges of the moving parts of doors and windows. Nearly all new homes are weatherstripped, but some jobs are better than others. You can check the quality of weatherstripping by rattling a few windows when they are locked. Good quality windows, when properly installed and adjusted, will operate easily but not rattle significantly.

Caulking and weatherstripping:

- An essential feature.
- An important feature.
- A good quality check.
- Something you or the builder can add or improve at time of purchase.

In cooler climates, windows should have two or even three layers of glass, and exterior doors either should be thermal doors¹ or should have storm doors.

The windows in a house can have two layers of glass by either using storm windows or insulating glass. (Insulating glass consists of two layers of glass in a single window frame, separated by a small air space.) Three layers of glass are usually obtained by combining storm windows with permanently installed windows of insulating glass.

Table 3: For homes heated with oil, gas or heat pumps*

Feature	Zone A	Zone B	Zone C	Zone D	Zone E
1. Number of Glass Layers for Windows	1	1	1	2	3
2. Storm Door or Thermal Door	No	No	No†	No†	Yes

Table 4: For homes heated with electric resistance heat*

Feature	Zone A	Zone B	Zone C	Zone D	Zone E
1. Number of Glass Layers for Windows	1	2	2	3	3
2. Storm Door or Thermal Door	No	No†	No†	Yes	Yes

*Based on the May 1979 revisions to the HUD Minimum Property Standards.

†Storm door or thermal door is recommended if primary door is hollow or is over 25% glass.

The most energy-efficient windows are either wood-framed windows (plain or vinyl-covered), or metal framed windows with a "thermal break" of insulating material between the inner and outer portions of the frame (see illustration).

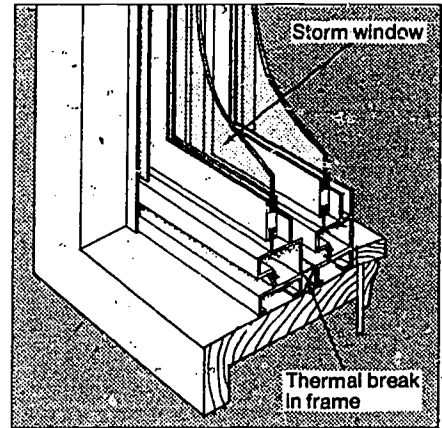

Insulating glass with thermal break.

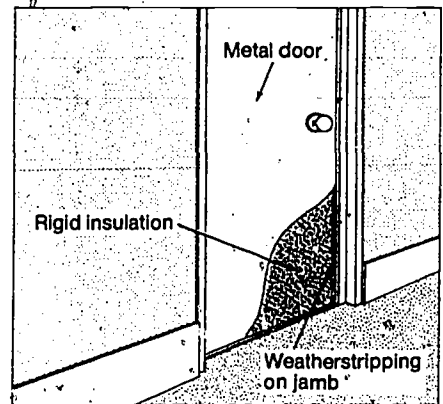

Thermal door.

Storm windows and doors
(or insulating glass and thermal doors):

- An essential feature.
- An important feature.
- A good quality check.
- Something you or the builder can add or improve at time of purchase.

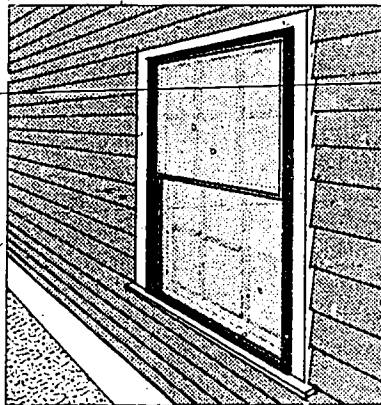

Storm window.

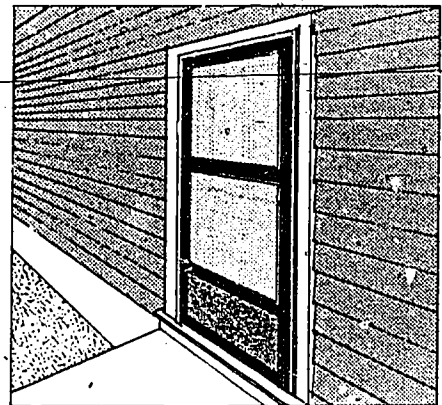

Storm door.

¹A thermal door has a core of high-efficiency insulating material, and high-quality weatherstripping.

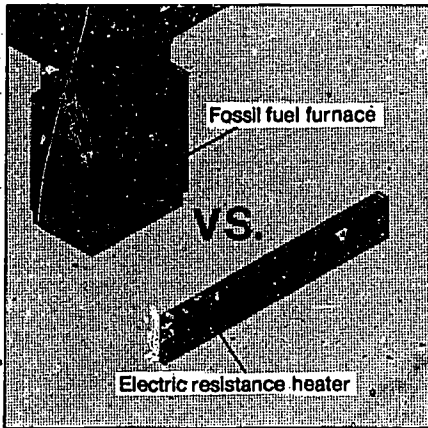

An oil or gas furnace is usually more economical than electric resistance heat.

Energy costs with electric resistance heat are in most cases higher than those with gas or oil heat. A gas or oil heating system, while more expensive to purchase, will usually be more economical in the long run.

In some areas gas or oil heat is not available for new homes. An electric heat pump will offer savings in some of these locations, but in others it will not be economical (See item no. 5 below, "Heat pumps"). Thus, sometimes electric resistance heat is the only choice.

There are three common kinds of electric resistance heating methods: *individual baseboard units* located in each room, *radiant ceiling panels*, and central "*electric furnaces*" from which hot air is distributed to all parts of the home. If you buy a home with electric resistance heat, you can lower your energy costs if you choose baseboard units or radiant ceiling panels with individual thermostatic controls in each room. Individual controls let you turn down the heat when the room is not in use. Electric furnaces do not have individual thermostatic room controls, and are less desirable for this reason.

Note: Electrically heated homes should have thicker insulation than other homes. Look very carefully at an electrically heated home to be sure that it has the required insulation and as many of the other recommended features as possible -- refer back to the tables on pages 8 and 11.

Type of heating system:

- An essential feature.
- An important feature.
- A good quality check.
- Something you or the builder can add or improve at time of purchase.

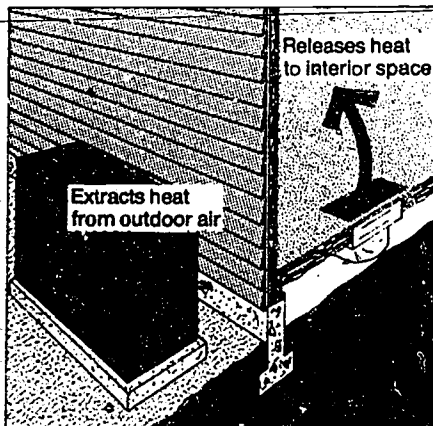

Heat pump system; heating mode

A "heat pump" is like an air conditioner that can both heat and cool. An air conditioner takes heat from indoors and moves it outdoors. A heat pump extracts heat from the *outdoor* air and moves it *indoors* -- and does so even though the outdoor air is colder than the indoor air.

In the summer, the heat pump reverses itself and works like an ordinary air conditioner.

How do you tell whether you should consider a heat pump? A heat pump system usually costs more than a conventional heating system plus central air conditioning. Thus, if a heat pump is to be chosen, the energy savings from it must be large enough to pay for the added initial cost. Whether or not it will pay for its added cost depends on your climate and the relative costs of different fuels.

In general, if the choice is between a *heat pump* on the one hand, and *gas or oil heat* with central air conditioning on the other, gas or oil heat are likely to be lower in cost both to purchase and to operate.

If the choice is between a heat pump and electric resistance heat, a heat pump *may* be your more cost-effective choice -- but only if compared to

electric resistance heat with accompanying central air conditioning. (A heat pump is always *less* cost-effective than electric resistance heating without air conditioning.)

When considering a heat pump instead of electric resistance heat we suggest that you ask the advice of your local electric company. They can give you exact information regarding heat pump operating costs in your area.

In general, heat pumps are most cost-effective in moderate climates. They are not recommended in warm climates. In cold climates, such as Zone E on the climate map (page 9), only high-performance heat pumps (Coefficients of Performance greater than about 2.4) should be considered.

A heat pump instead of electric resistance heat:

- An essential feature.
- An important feature.
- A good quality check.
- Something you or the builder can add or improve at time of purchase.



The "energy efficiency ratio" or "EER" of an air conditioner is a measure of the amount of cooling power it provides for each unit of electricity it uses. The higher the EER, the less it will cost to operate. The EER ratings of air conditioners vary all the way from 6.0 to 9.0 or more. An air conditioner with an EER of 9.0 uses only two-thirds as much energy as one with an EER of 6.0. This could mean a savings of \$100 per year in a typical home in a warm climate.^{2, 3}

²The Air Conditioning and Refrigeration Institute (ARI) publishes a directory giving the EERs of nearly all air conditioning models. Most air conditioning contractors have a copy of this directory and can tell you the EER of a unit if you tell them the exact make and model number. The ARI will also answer mail or telephone inquiries about specific models. Their address and telephone number are the following:

Air Conditioning and Refrigeration Institute
 1815 North Fort Myer Drive
 Arlington, VA 22209
 Telephone: 703/524-8800

³You can calculate the EER for yourself from the information on the nameplate of the unit (probably on the outdoor part of the unit). The nameplate will show the rated output in BTUs (British Thermal Units), and will also show the rated amps and voltage of power use, plus whether the unit uses single-phase or three-phase power. The EER may be calculated as follows:

- For single-phase power:
$$EER = \frac{BTUs}{.85 \times \text{Amps} \times \text{Volts}}$$
- For three-phase power:
$$EER = \frac{BTUs}{1.73 \times \text{Amps} \times \text{Volts}}$$

For example, a 24,000 BTU unit using single-phase power and rated at 32 amps and 110 volts has an EER of
$$\frac{24,000}{.85 \times 32 \times 110} = 8.0$$

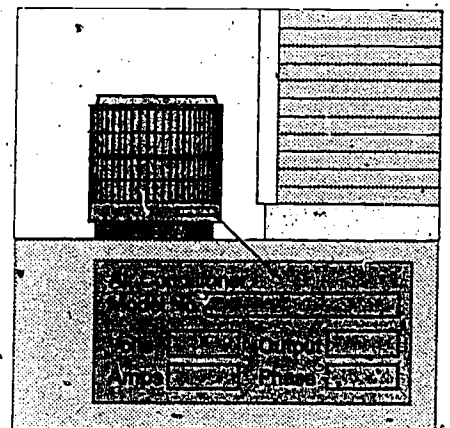

Central air conditioner: outdoor unit.

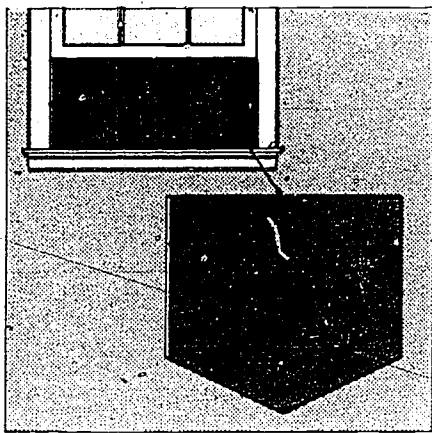

Room air conditioner.

All new *room* air conditioners have EER labels. It is expected that starting sometime in 1979, new *central* air conditioners, as well, will be labelled with estimated yearly energy costs.

If you are buying or ordering a home that is not yet completed, or if you are buying a home in which a central air conditioning unit is not yet installed, you can specify that you want a high-EER unit — 8.0 or more. An air conditioning contractor can help you in selecting an appropriate unit, and can show you the complete manufacturer's specifications.

One more point about air conditioning: In many climates, you should consider living without an air conditioning unit. With wise use of natural ventilation and shading, and with a whole-house exhaust fan system, you can still be comfortable — and save both the cost of the air conditioning unit and the cost of operating it.

Air conditioning unit with high EER:

- An essential feature.
- An important feature.
- A good quality check.
- Something you or the builder can add or improve at time of purchase.

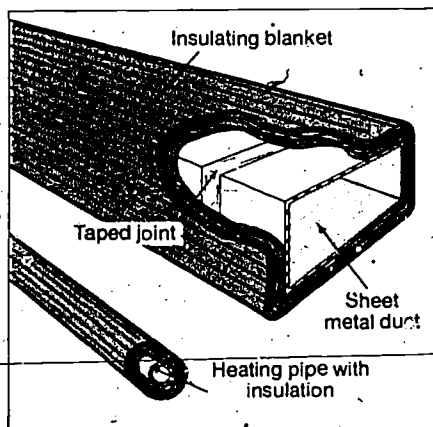

Properly insulated duct and pipe.

Air ducts and heating pipes can be major sources of heat loss unless they are either located inside the heated space or insulated. The best method is to place ducts and heating pipes inside the heated space of the house. If they are located inside the heated space, they need not be insulated since any heat leakage will be beneficial to the house.

Often, though, ducts and heating pipes are located in unheated attics and crawl spaces. If so, they must be insulated. Ducts should be covered by insulating blankets at least two inches thick — or by rigid insulation at least one inch thick. Even thicker insulation is recommended in colder climates. Heating pipes should have at least one-half inch of insulation, and an inch or more in colder climates. Pipes carrying air conditioning refrigerant should also be insulated.

The quality of installation of the insulation is also important, especially for ducts. Ducts should be tightly sealed so that no air leakage occurs outside the heated space of the house. Ducts used for air conditioning should have a vapor barrier on the outside of the insulation. Duct and pipe insulation should be continuous, that is, without gaps, and securely fastened to the ducts and pipes.

It is not necessary for pipes carrying hot tap water to be insulated, since these pipes are not in use a large percentage of the time.

Ducts and pipes located in the heated space, or insulated in unheated spaces:

- An essential feature.
- An important feature.
- A good quality check.
- Something you or the builder can add or improve at time of purchase.

Attic insulation must be installed evenly, without holes or gaps, in order to be fully effective. Even small gaps damage performance.

Look for the following features:

- Blanket-type insulation should be snugly fitted around joints and irregularities.
- If loose-fill insulation is used, it should extend evenly out to the edges — but not cover the eaves beyond the ceiling. Inspect the whole attic, not just the area right next to the attic access.
- Insulation should not block ventilation slots at the eaves. If loose fill insulation is used, baffles or other means should be provided to prevent insulation from spilling into the eave area.
- Insulation should not be installed closer than three inches to recessed ceiling light fixtures.
- The attic access should have a thick layer of insulation fastened to it — extending out to the edges — and be weatherstripped around the edges to make a tight seal when closed.
- There should be a tight seal around where ducts descend into the living space, and around flues and chimneys. Gaps around flues and chimneys must be filled only with non-burning material.

Note: All attics should have adequate natural ventilation. Look for vents at the gable, along the eaves, and/or along the ridge. See Part 3, page 48, for more details.

Well installed attic insulation:

- An essential feature.
- An important feature.
- A good quality check.
- Something you or the builder can add or improve at time of purchase.

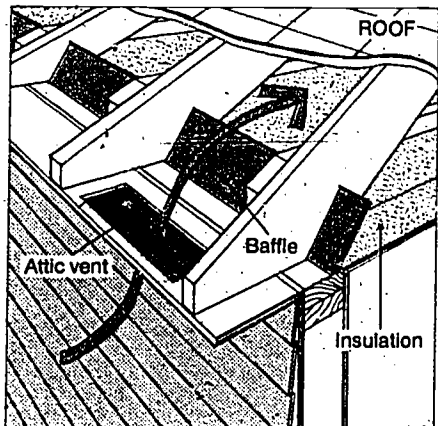

Well-installed attic insulation.

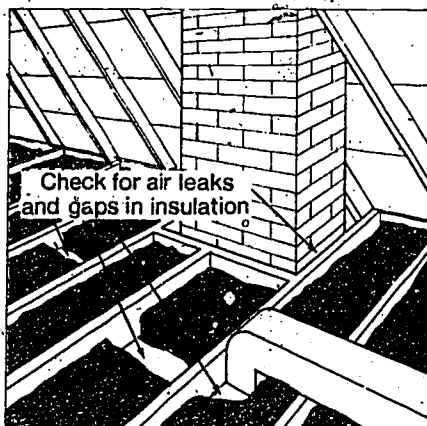

Poorly-installed attic insulation.

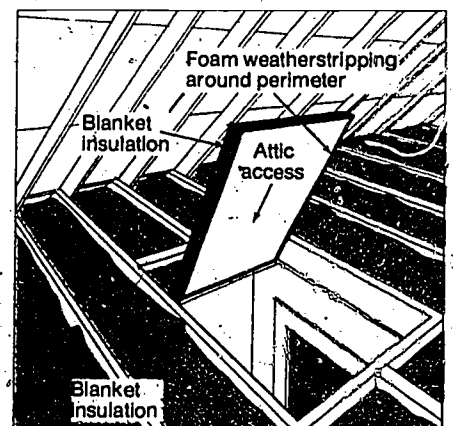

Well-installed attic insulation and weather-stripped access.

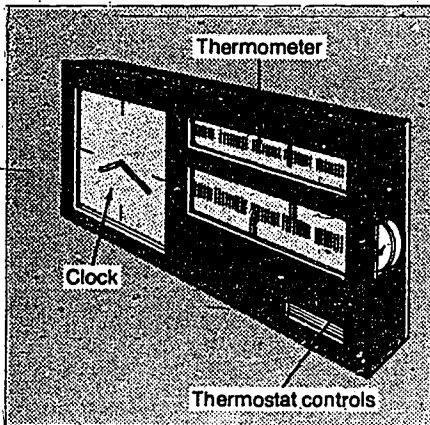

Clock thermostat.

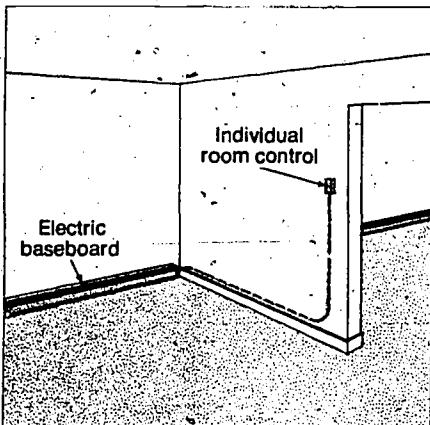

Individual room control for electric heating unit.

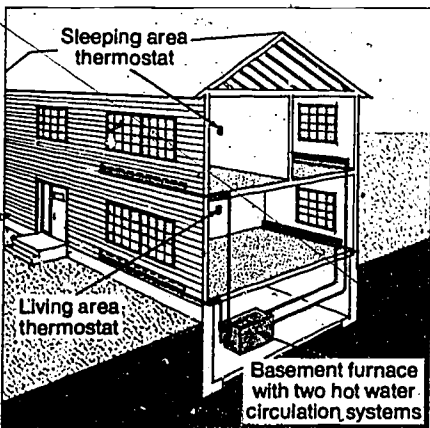

Zoned heating system.

Clock thermostats

Clock thermostats automatically turn back the thermostat setting for one or more periods each day — such as at night or when the house is empty. Clock thermostats are a good feature for energy savings.

You can achieve the same energy savings by remembering always to turn back the thermostat at appropriate times. But for most people, the convenience and reliability of an automatic clock thermostat makes it worth the small added investment. If a new home has a clock thermostat, this indicates an energy-conscious attitude on the part of the builder. If there is no clock thermostat, consider adding one when you move in.

Whenever you set back the thermostat, you will be saving a significant amount of money. Setting the thermostat back 10 degrees each night can save from 10 to 16 percent of your heating bill.

The two common types of clock thermostats are single setback and dual setback. The single setback type turns the heat back for one period, the dual setback for two periods. Families that leave the home completely unoccupied in the day should consider a dual setback unit, that will turn the heat down in the daytime as well as at night.

If there is central air conditioning, the clock thermostat should also automatically turn up the cooling setting in the summer.

Note: Clock thermostats and thermostat setbacks are not recommended in the winter with electric heat pumps.

Individual Room Controls

With electric resistance heating, a good feature is to have baseboard heating units (not an electric furnace) with individual thermostatic controls in every room. This allows you to turn back the thermostat in each room whenever it is not in use.

Zoned Heating Systems

If a hot water heating system is used, a *zoned* control system is a good feature. In a typical zoned system it is possible to have the bedrooms at one temperature and the living area at another. The living area can be turned back 10 degrees or more at night, and the sleeping area can be similarly turned back during the day. Two clock thermostats can be installed — one for each zone — to do this automatically.

Zoning is not recommended for forced air heating systems because of the high cost of the necessary equipment.

Clock thermostats, individual room controls, zoned heating systems:

- Essential features.
- Important features.
- Good quality checks.
- *Something you or the builder can add or improve at time of purchase.

*clock thermostat only.

A south-facing window with a storm window or double glass can capture sunlight in the winter and help to heat the house. A south-facing window with *triple* glass will let in more heat in the daytime than it loses at night.

In the summer, the same window can be shaded so that direct sunlight does not enter it and heat up the house.

Other things being equal, you should select the house with the best window and shading design.

A home should have as much of its window area as possible facing south, and as little of its window area as possible facing east, west, and north. In addition, some type of summer shading should be provided for windows that face south, east, or west.

If the home is in a warm climate and there is no outdoor shading available, then it is not desirable for the windows to face south: it is more important in warm climates to keep the summer sun out than to let the winter sun in. If good shading is not available, then it is better to have the most window area to the *north*.

Shading can be provided by roof overhangs, working shutters, sunscreens and awnings, and by deciduous trees, shrubs, and hedges. See page 52 for more information on shading devices.

For maximum energy efficiency, it is important that large, south-facing windows have blinds or curtains that are open on sunny winter days and closed at other times when it is cold or hot outside.

Proper orientation and shading of windows:

- An essential feature.
- An important feature.
- A good quality check.
- Something you or the builder can add or improve at time of purchase.

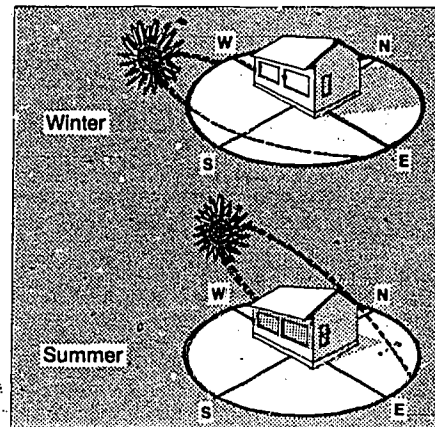

Ideal orientation and shading.

The "band joist" (or "rim joist") is shown in the accompanying illustration. A carefully insulated band joist is a good energy-efficiency feature and also indicates good general quality of construction — it takes extra labor to cut insulation so that it fits well in all the spaces.

When you inspect the band joist, look for thick insulation (R-11 to R-19 — or 3 to 6 inches thick) carefully cut to size and installed between each of the floor joists. If floor insulation has been installed, the ends of the insulation runs should be turned up or down so that the band joist is covered. If the band joist is not visible because a finished ceiling is installed on the lower level, ask the builder if the band joist is insulated. Also, for a two story house, ask if the band joist between the first and second stories is insulated.

Band joist insulation:

- An essential feature.
- An important feature.
- A good quality check.
- Something you or the builder can add or improve at time of purchase.

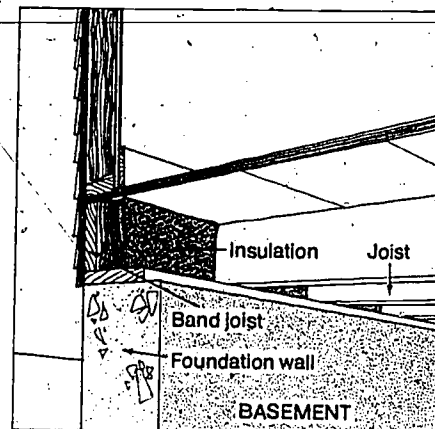

Band joist insulation.

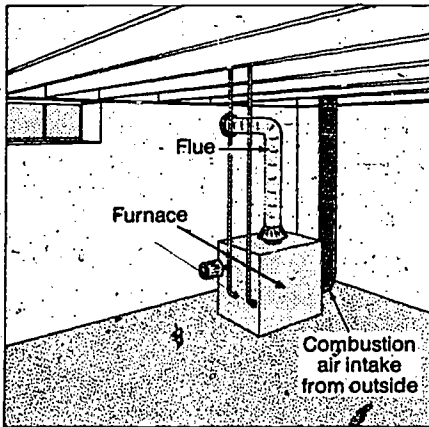

Outside combustion air intake for furnace.

Furnaces that burn gas or oil and are located in heated spaces, as well as all fireplaces, should have outside combustion air intakes. An "outside combustion air intake" is a duct leading from outside the house to the furnace or fireplace. It draws air directly from outdoors into the furnace or fireplace. Without an outside combustion air intake, warm air is drawn from the house, and cold air is drawn into the house from outside to replace it. An outside combustion air intake increases both efficiency and comfort.

Outside combustion air intakes:

- An essential feature.
- An important feature.
- A good quality check.
- Something you or the builder can add or improve at time of purchase.

It's easy to check for the twelve features highlighted here. Many of them are things that you can directly ask the builder or salesperson. A knowledgeable salesperson should be able to tell you about these seven features:

- Feature no. 1. Proper levels of insulation. *(Check the features of the home against the tables on page 8).*
- Feature no. 3. Storm windows and doors. *(Check the features of the home against the tables on page 11).*
- Feature no's. 4 & 5. Type of heating equipment. *(pages 12-13).*
- Feature no. 6. Air conditioning with high EER. *(Unfortunately, not all dealers know the EER, but you can find out for yourself if necessary, as shown on page 13).*
- Feature no. 9. Clock thermostats, zone controls, or individual room controls *(page 16).*
- Feature no. 12. Outside combustion air intakes *(above).*

A knowledgeable and conscientious salesperson will be eager to answer your questions about these energy-efficient features — and will tell you about other energy features of the home as well. Ask the salesperson to give you a rundown of the energy-efficiency features offered in new homes.

Don't be shy about asking all the questions about energy features that you want to ask. If the salesperson can't or won't answer them, it's a sign that he or she may not be knowledgeable enough or concerned enough about energy to market an energy-efficient home.

The other five items are things that you should check for yourself — although the salesperson can help you locate what you are looking for. These five items, again, are:

- Feature no. 2. Presence and quality of protection against air leaks — weatherstripping, caulking, seals and gaskets *(Page 10).*

- Feature no. 7. Ducts and pipes: their location, and the quality and thickness of their insulation (page 14).
- Feature no. 8. Well-installed attic insulation (page 15).
- Feature no. 10. Orientation and shading (page 17).
- Feature no. 11. Presence and quality of band joist (rim joist) insulation (page 17).

Using the new homes checklist

It's a good idea to take notes to help remember the answers. The New Homes Checklist on pages 22 and 23 will help to do just that. To use the checklist, bring it with you when you visit each home. Check off the features that each home has or does not have. There's space to score three different homes.





So far, this Guide has focused on the twelve features as one way to estimate the energy efficiency of new homes. Now the Guide will focus on a second approach — looking at the energy cost estimates provided by builders.

Past energy cost information

Many builders now keep track of the energy costs for homes they built in previous years as well as testimonials they have received from homeowners pleased with the energy performance of their new homes. These builders are happy to provide you with this information. In particular, they can show you records of actual past energy costs for homes like the one you are interested in buying. Or, they can show you calculated predictions of energy use for heating and cooling.

This information helps you in two ways:

First, it lets you compare energy costs of different homes built by different builders.

Second, it helps you estimate your likely energy costs for budgeting purposes.

Interpreting these estimates

Be sure that you understand what these energy cost estimates mean and what factors may affect them. There are two factors in particular to bear in mind:

1. The past utility records should be for a home of size and type similar to the model for sale.
2. The past utility records should be for a home that uses the same fuels and the same types of heating and cooling systems as the model for sale.

Bear in mind that energy costs for different families can vary by 50 percent or more due to other factors, such as the size of the family or its living habits. These factors may explain why a particular energy cost estimate seems unusually low. If an estimate seems unusually low, look at the energy efficiency features of the home to see if they are unusually good; otherwise, take the figures with a grain of salt.

If the past records do not meet these tests, then they are of little use. But if they *do* meet these tests, then you can use them as guidelines to compare different homes and to estimate what your future energy costs will be.

Other types of energy cost information

Another type of information that builders sometimes have consists of energy-cost estimates supplied by the local utility company. Some builders, after completing their first homes of a particular model, may ask an energy analyst from the utility company to inspect a sample home and calculate its expected energy consumption. Or, the builder may provide predicted energy use figures based on his own calculations. Information such as this, like actual past energy bills for sample homes, is only an estimate of what your family's energy use would be with this home model. But if it is

available, it is another good guideline for comparing different homes and estimating future energy costs.

Use the checklist

In summary, it's a good idea to ask builders and sellers for energy cost estimates for the home models you visit. For your convenience, there are spaces on the checklist for you to note down the information they give you.

Your homebuying decision will be complex and will involve many factors besides energy. You may not choose to buy the home that is the most energy-efficient. It is important, however, to weigh energy in your decision.

The twelve energy-efficiency features we highlight here, along with energy cost predictions, will help you to make an intelligent decision. Other things being equal, you should choose the home that has the largest number of energy-efficiency features, along with the lowest predicted energy bill. Here are some points that will help you:

1. If you have filled out the **Energy checklist**, add up the number of "yeses" you have checked for each home. The total number of "yeses" is a crude "energy score" for the home.
2. However, note that some of the features are more important than others. The first six of the twelve features are the most important. In particular, feature no. 1 — "Proper levels of insulation" — is essential. The other five of the first six features are only slightly less important. The "six additional features" — nos. 7-12 — are less important. Count the first six features most heavily in your decision.
3. If you have energy cost predictions, compare these predictions for the different homes. See if the energy cost predictions and the "scores" of energy-efficiency features both show that the same home is most economical. If the two methods disagree as to which home is more economical, and if the differences are large, find out why. Possible reasons for differences include the following:
 - One home may be larger or of a different design than another, so that its predicted energy costs are higher even though both have similar efficiency features.
 - One home may be of higher construction quality, or may have efficiency features that you did not notice in your first inspection.
 - The energy cost predictions for one home may be deceptive or calculated in a different way than the predictions for the other home. (Refer again to the previous page.)

You may not always get clear answers as to why these differences exist, but they may tip you off about problems in a home that you might otherwise not have noticed.

To summarize: Take into account the "energy score" (number of energy-efficiency features) as part of your total home-buying decision. If you have energy cost predictions for the homes, take these into account as well. If you do this, you can confidently make an energy-wise home-buying choice.





This scoresheet is an optional part of *The Energy-Wise Homebuyer*. It is a convenient way to note down the energy saving features of the homes you visit. There is space to score up to three different homes, and a finished sample. Simply check off the items that the home does or does not have. These twelve energy-efficiency items are the same twelve illustrated and explained on the previous pages.

Refer to the previous page for guidelines in interpreting this information. Even if you decide not to use this scoresheet, these items are things you should be familiar with in making a wise home purchase choice.

SAMPLE	FIRST HOME	SECOND HOME	THIRD HOME	
<i>Beauty Home II</i> model J. Doe builder or dealer 851 Any St. location Heating System <input type="checkbox"/> gas <input type="checkbox"/> oil <input checked="" type="checkbox"/> heat pump <input type="checkbox"/> electric baseboards or radiant panels <input type="checkbox"/> electric furnace Central Air Conditioning YES NO <input checked="" type="checkbox"/> <input type="checkbox"/>	model builder or dealer location Heating System <input type="checkbox"/> gas <input type="checkbox"/> oil <input type="checkbox"/> heat pump <input type="checkbox"/> electric baseboards or radiant panels <input type="checkbox"/> electric furnace Central Air Conditioning YES NO <input type="checkbox"/> <input type="checkbox"/>	model builder or dealer location Heating System <input type="checkbox"/> gas <input type="checkbox"/> oil <input type="checkbox"/> heat pump <input type="checkbox"/> electric baseboards or radiant panels <input type="checkbox"/> electric furnace Central Air Conditioning YES NO <input type="checkbox"/> <input type="checkbox"/>	model builder or dealer location Heating System <input type="checkbox"/> gas <input type="checkbox"/> oil <input type="checkbox"/> heat pump <input type="checkbox"/> electric baseboards or radiant panels <input type="checkbox"/> electric furnace Central Air Conditioning YES NO <input type="checkbox"/> <input type="checkbox"/>	
1. Does the home have proper levels of insulation, in • ceilings and attics? • walls? • floors, crawl space or basement walls, or slab foundation perimeters? An Essential Feature — See page 8 for details.	<input checked="" type="checkbox"/> <input type="checkbox"/> <input checked="" type="checkbox"/> <input type="checkbox"/> <input checked="" type="checkbox"/> <input type="checkbox"/>	<input type="checkbox"/> <input type="checkbox"/> <input type="checkbox"/> <input type="checkbox"/> <input type="checkbox"/> <input type="checkbox"/>	<input type="checkbox"/> <input type="checkbox"/> <input type="checkbox"/> <input type="checkbox"/> <input type="checkbox"/> <input type="checkbox"/>	<input type="checkbox"/> <input type="checkbox"/> <input type="checkbox"/> <input type="checkbox"/> <input type="checkbox"/> <input type="checkbox"/>
2. Does the home have: • Caulking and plugging of window and door frames, and of holes, cracks and joints on the outside of the house? • Caulking on the inside, sill sealer, or a tight fit where sill and foundation meet? • Windows and doors weatherstripped and adjusted so that you can't rattle them? See page 10 for details.	<input checked="" type="checkbox"/> <input type="checkbox"/> <input checked="" type="checkbox"/> <input type="checkbox"/> <input checked="" type="checkbox"/> <input type="checkbox"/>	<input type="checkbox"/> <input type="checkbox"/> <input type="checkbox"/> <input type="checkbox"/> <input type="checkbox"/> <input type="checkbox"/>	<input type="checkbox"/> <input type="checkbox"/> <input type="checkbox"/> <input type="checkbox"/> <input type="checkbox"/> <input type="checkbox"/>	<input type="checkbox"/> <input type="checkbox"/> <input type="checkbox"/> <input type="checkbox"/> <input type="checkbox"/> <input type="checkbox"/>
3. Does the home have (if needed in your climate): • Storm windows (or insulating glass)? • Storm doors (or thermal doors)? See page 11 for details.	<input checked="" type="checkbox"/> <input type="checkbox"/> <input checked="" type="checkbox"/> <input type="checkbox"/>	<input type="checkbox"/> <input type="checkbox"/> <input type="checkbox"/> <input type="checkbox"/>	<input type="checkbox"/> <input type="checkbox"/> <input type="checkbox"/> <input type="checkbox"/>	<input type="checkbox"/> <input type="checkbox"/> <input type="checkbox"/> <input type="checkbox"/>
4. Does the home have gas or oil heat instead of electric resistance heat, if gas or oil is available? See page 12.	<input checked="" type="checkbox"/> <input type="checkbox"/>	<input type="checkbox"/> <input type="checkbox"/>	<input type="checkbox"/> <input type="checkbox"/>	<input type="checkbox"/> <input type="checkbox"/>
5. If gas or oil heat is not available, is a heat pump recommended instead of electric resistance heat in your area? <input type="checkbox"/> YES <input type="checkbox"/> NO Does the home comply with this recommendation? See page 12.	<input checked="" type="checkbox"/> <input type="checkbox"/>	<input type="checkbox"/> <input type="checkbox"/>	<input type="checkbox"/> <input type="checkbox"/>	<input type="checkbox"/> <input type="checkbox"/>

<p>6. Does the air conditioning unit have a high Energy Efficiency Ratio (EER) — 7.5 or more? OR — is there no central air conditioning at all if the home is in a cooler climate? See page 13.</p>	<input checked="" type="checkbox"/> <input type="checkbox"/>	<input type="checkbox"/> <input type="checkbox"/>	<input type="checkbox"/> <input type="checkbox"/>	<input checked="" type="checkbox"/> <input checked="" type="checkbox"/>
<p>7. Ducts and pipes:</p> <ul style="list-style-type: none"> • Are all ducts and heating system pipes located inside heated space? • OR — is thick, well-fitted insulation (1" rigid, 2" or thicker blanket-type) used on ducts located in unheated spaces? • AND — are heating system pipes and air conditioning refrigerant pipes insulated with 1/2" to 1" of insulation? An important feature. See page 14. 	<input checked="" type="checkbox"/> <input type="checkbox"/> <input checked="" type="checkbox"/> <input type="checkbox"/>	<input type="checkbox"/> <input type="checkbox"/> <input type="checkbox"/> <input type="checkbox"/>	<input type="checkbox"/> <input type="checkbox"/> <input type="checkbox"/> <input type="checkbox"/>	<input type="checkbox"/> <input type="checkbox"/> <input type="checkbox"/> <input type="checkbox"/>
<p>8. Is attic insulation well installed? Check for:</p> <ul style="list-style-type: none"> • Even installation — no holes or gaps, except around vents and light fixtures; no thin spots. • An attic access that is weatherstripped and insulated. See page 15. 	<input checked="" type="checkbox"/> <input type="checkbox"/> <input checked="" type="checkbox"/> <input type="checkbox"/>	<input type="checkbox"/> <input type="checkbox"/> <input type="checkbox"/> <input type="checkbox"/>	<input type="checkbox"/> <input type="checkbox"/> <input type="checkbox"/> <input type="checkbox"/>	<input type="checkbox"/> <input type="checkbox"/> <input type="checkbox"/> <input type="checkbox"/>
<p>9. Is there a clock thermostat for central heating and air conditioning systems? (Note: not recommended for heat pumps in winter.) OR — are there individual room controls for electric resistance heat? See page 16 for details.</p>	<input checked="" type="checkbox"/> <input type="checkbox"/>	<input type="checkbox"/> <input type="checkbox"/>	<input type="checkbox"/> <input type="checkbox"/>	<input type="checkbox"/> <input type="checkbox"/>
<p>10. Are windows properly oriented and shaded? That is, are there a maximum of windows to the south with summer shading, and fewer windows to the north, east, and west? Is there a minimum of south-facing windows without summer shading? See page 17 for details.</p>	<input checked="" type="checkbox"/> <input type="checkbox"/>	<input type="checkbox"/> <input type="checkbox"/>	<input type="checkbox"/> <input type="checkbox"/>	<input type="checkbox"/> <input type="checkbox"/>
<p>11. Does the home have thick, well-fitted band joist (rim joist) insulation? See page 17.</p>	<input checked="" type="checkbox"/> <input type="checkbox"/>	<input type="checkbox"/> <input type="checkbox"/>	<input type="checkbox"/> <input type="checkbox"/>	<input type="checkbox"/> <input type="checkbox"/>
<p>12. Are there outside combustion air intakes for furnaces and fireplaces? See page 18.</p>	<input checked="" type="checkbox"/> <input type="checkbox"/>	<input type="checkbox"/> <input type="checkbox"/>	<input type="checkbox"/> <input type="checkbox"/>	<input type="checkbox"/> <input type="checkbox"/>
<p>Total "yeses" (items 1-12)</p>	<input type="checkbox" value="19"/>	<input type="checkbox"/>	<input type="checkbox"/>	<input type="checkbox"/>
<p>Energy bill estimates from salesperson</p> <p>Here is space to record information that a salesperson may provide about energy costs of this or a similar home.</p>	<input type="text" value="\$ XX.XX"/> monthly bill <input type="text" value="\$ XXX.XX"/> yearly bill	<input type="text" value="\$"/> monthly bill <input type="text" value="\$"/> yearly bill	<input type="text" value="\$"/> monthly bill <input type="text" value="\$"/> yearly bill	<input type="text" value="\$"/> monthly bill <input type="text" value="\$"/> yearly bill

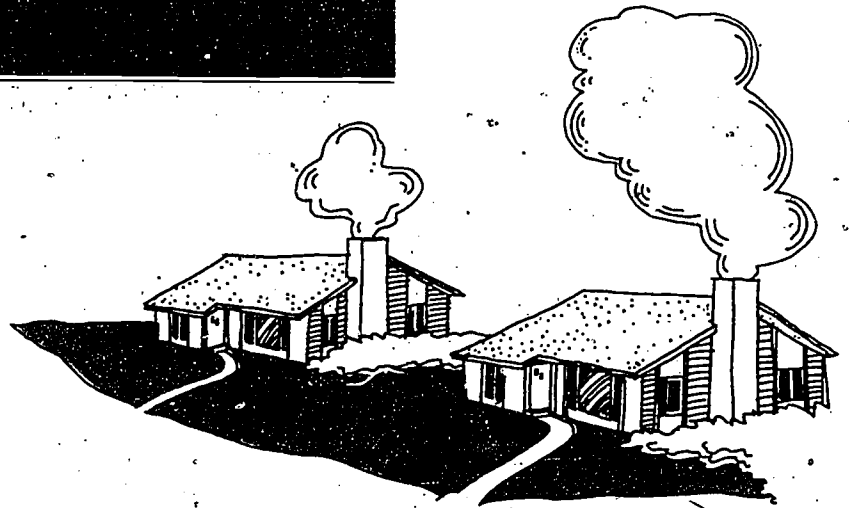
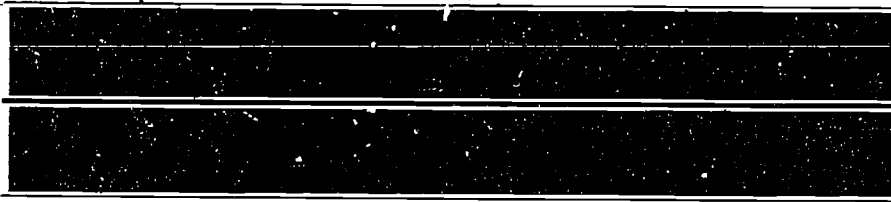

Introduction

Read this section if you are planning to buy an existing or used home. Energy costs for used homes are even more important than for new homes. Here are three reasons why:

- Most used homes cost more to heat and cool than similar new homes.
- The energy costs of different used homes can vary widely — as much as 100 percent or more between homes of the same general size and type.
- Some used homes can be improved by the buyer to reduce their energy bills. It is important to know which homes can and cannot be improved.

When you look at used homes, remember that choosing the right home could save you hundreds of dollars each year in energy costs.



Part 2 covers the following important topics:

1. Past energy bills (pages 26 to 28)

This first section shows you how to get past energy cost information for a home. Past energy costs are the most important information you need to make a wise homebuying decision.

2. Improving a used home (pages 28 to 37)

Many used homes that are not very energy-efficient can be improved at a cost that is small compared to the long-term savings that will result. This section shows you how to inspect a home for possible improvements.

3. The Energy Checklist for used homes (pages 40 and 41)

The Energy Checklist allows you to record past energy bills for homes and to note possible energy-efficiency improvements.

Note: Part 3 of *The Energy-Wise Homebuyer* contains information on additional features of used homes, and on maintenance and energy-efficient living.



How can you tell if a used home is energy-efficient or not?

If all you could do was to look at the home — its size, shape, windows, furnace, insulation, and so forth — it would be a very difficult job to accurately estimate its energy costs. Fortunately, there's an easier way — *instead of looking at the home itself, look at the energy bills of the previous occupants for the past year or two.*

Your future energy bills in a particular home may differ from those of the previous owner because of different family size or living habits. Nevertheless, past utility bills are the best, most practical way to get a handle on what your energy bills would be in a home you buy. In fact, the basic energy-wise rule for used home buying is: *Don't buy a used home until you have seen an accurate, documented record of its past energy costs.*

When you visit a home for the first time and only want to look at it quickly, it's enough to rely on the seller's word about energy costs. But when you get seriously interested in a particular home, it's much better to see written proof. Certainly, you should never make a commitment to purchase a particular home based on the seller's word alone.

How to get the numbers you need

There are two main ways of getting accurate written information on past energy costs.

1. The first way is to look at copies of the energy bills for the past year. Request these from the seller or real estate agent. Remember, it's wise to look at all the bills for an *entire* year — not just for the heating season or the air conditioning season. Otherwise, you might miss a large bill at the beginning or end of the season. Also, some utility companies — particularly for homes with electric heat — offer a monthly payment plan where a customer pays twelve equal payments — even though most of the energy use for heating is in the winter. When you look at this information, sit down, take your time, check its completeness, and take written notes of either the monthly bills or the total yearly bill. **The Energy Checklist** on pages 40 and 41 will help you do this. Column C of the **Checklist** is a handy place to record the documented yearly energy bills for up to three homes.
2. Sometimes a homeseller does not have complete records of his energy bills for a whole year. If this is the case, you can still find out the year's energy bills — directly from the gas, oil, or electric company. The way to do this is to ask the seller to write a request letter to the utility. A utility will not release this information without the written permission of the occupant. The accompanying illustration shows a sample form for the request letter, which the seller can copy. The utility can mail the information to the seller, to the seller's real estate agent, or directly to you.

Seller's address
Very nice street
Anywhere, U.S.A.

To: Utility Company
Billing Department

Dear Utility Company:

Please send me a complete listing of my past year's energy bills, for my home, at the above address. My account number is _____.

Sincerely,

[seller's signature]

Which bills to look at

Which energy bills do you need to look at — oil, gas, electricity, or a combination? It's basically a matter of common sense — you have to know about every major source of heat and air conditioning. Here are two useful guidelines:

1. Be sure you include *all* major sources of heat — sometimes, for example, a large home has oil or gas heat, but it also has electric heaters as the main heat source in several rooms. If so, you need to look at both kinds of bills.
2. If a home has central air conditioning, along with gas or oil heat, you need to look at the year's electric bills along with the gas or oil bills.

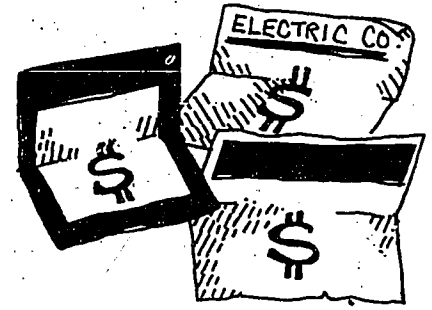

Points to keep in mind

There are two additional points to keep in mind about these past energy cost figures that you are obtaining:

1. Because of steadily rising energy prices, your energy costs in any home you move into will tend to be higher than the costs for the previous occupant. To get a better picture of what your actual energy costs will be for the coming year, we suggest that you increase the previous year's cost figures by 10 percent, like this:

Example

Previous occupant's yearly energy cost	=	\$460
Add 10% $460 \times .10$	=	46
Your estimated cost for next year	=	\$506

Column C of the **Energy Checklist** (pages 40 and 41) provides space for you to do this. If the energy bills are two years old, increase them by 20 percent instead of by 10 percent.



2. The past energy-use figures for the home are for a different family with different living habits from your family. Your energy use could be somewhat different from the energy use of the previous occupants. It could be *very* different if any of the following are true:
 - a. The home was unoccupied for long periods during the year, especially in the winter.
 - b. The previous family was much larger or smaller than yours.
 - c. The previous family used a thermostat setting for heating that was unusually high (above 74 degrees) or unusually low (below 65 degrees).
 - d. The previous winter or summer was unusually severe or mild.

When you compare homes, it's good to ask about and make a note of any conditions, such as these, that would make a difference. Unfortunately, there is no easy way to put these factors into exact dollars and cents. However, if you are aware of these factors, you won't be misled when you encounter an unusually high or unusually low utility bill because of them.



What do the numbers mean?

Your homebuying decision will be complex and will include many factors. We hope that you will be sure to include energy costs as one of these factors. Bear the following points in mind when you make your decision:

1. If at all possible, don't buy a particular home until you have complete, written documentation of its past energy costs.
2. Don't buy a particular home unless you are sure that you can afford to pay its energy costs — in addition to the other costs of mortgage, taxes, insurance, and upkeep that together make up the total costs of homeownership. Be particularly careful if the energy costs are on the high side or if the home seems to be in poor condition.
3. The home you select will not necessarily be the one with the lowest energy costs, because of the many other factors you have to weigh. You should aim at achieving the best balance of all the major factors.
4. Many older homes offer the opportunity for energy-saving improvements. Even if the energy costs of the previous occupants seem high, you may be able to lower your energy costs by making energy-saving improvements at the time that you move in. This is the topic of the next section of *The Energy-Wise Homebuyer*.

This section of *The Energy-Wise Homebuyer* shows how to make energy-saving improvements to a home at the time you move in. Consider the following examples:

- It may happen that you like a particular home, but its energy bills are very high. The energy costs for this home could be quite reasonable if you make the proper improvements at the time of purchase.
- A home might already have low energy bills — but still have room for improvement. With the right energy-saving improvements, such a home can become a real bargain.
- You might find two similar homes with comparable past energy bills — one offering many opportunities for improvement, the other having fewer opportunities. Which is the better, more "energy-wise" purchase? *Provided that the past energy bills are correct* the home with the *most* room for improvement is the better purchase, because when you make the improvements, its energy bill should be lower.

It is important to know when you can and can't improve the home — if you find out that you can't improve it after you've already moved in, you're stuck with higher energy bills than you were expecting.

All of the improvements recommended here involve some investment of time or money, but all of them have been carefully selected so that in the long run they will save you more than they cost you.

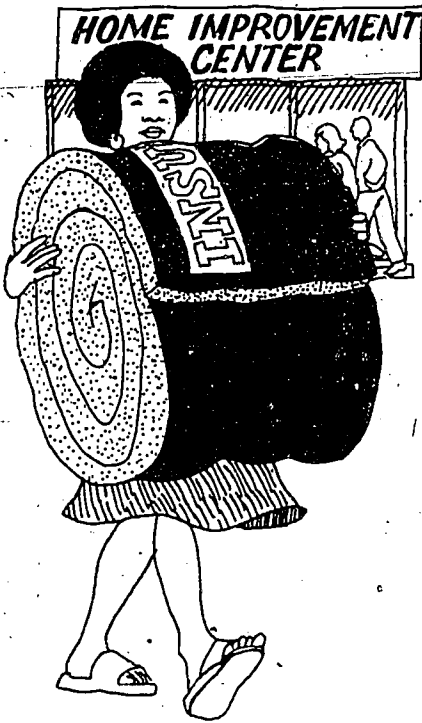

Your lender may be willing to finance major energy improvements at the time of sale, either as part of the mortgage or through a separate loan. If major energy improvements are needed, ask your lender about this possibility. Remember, these improvements make the home a better risk for the lender as well as a better buy for you. When the costs of needed energy improvements are added to the mortgage or financed by a long-term loan, the monthly energy savings are often actually larger than the added monthly payments.

A Federal Income Tax Credit is now available for energy-conserving home improvements. The credit allows you to deduct 15 percent of your improvement costs from your income tax, up to a maximum of \$300. For full details, including a list of the improvements that qualify for the tax credit, consult your local Internal Revenue Service Office.

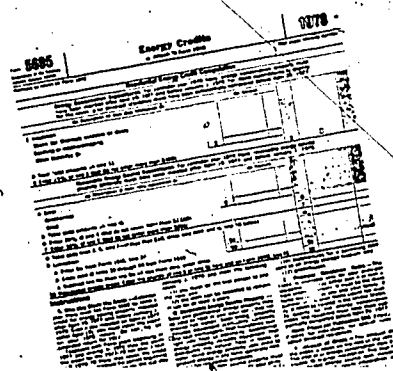

Get your tax credit!

The inspection procedure recommended here is optional to *The Energy-Wise Homebuyer*. If you are very short of time, it is better just to use past energy bill information. But if you have time, it is good to inspect the energy-efficiency features of a home before you purchase it. It will further help you to choose the right home, and it will often save you significant amounts on your future energy bills.

This section of *The Energy-Wise Homebuyer* will make the inspection as easy and accurate as possible. It will take you about a half hour to inspect each home. You don't need to look in detail at the energy-efficiency features in every home you visit. Instead, first narrow down your purchase decision to the one or two homes you are most interested in. Then, inspect just these one or two homes.

For further help . . .

If you don't want to do the inspection yourself, but still want accurate information about the energy efficiency of the home, you can have a qualified professional engineer or energy specialist do the inspection for you. Some gas and electric companies offer energy inspection services, either for free or at minimum cost. If you have not actually bought the home yet, you will probably have to get the seller to request the inspection for you. In some cities, private energy companies will perform detailed inspections for a fee. Your state energy office may be able to assist you in locating a qualified and reputable service.

The inspection procedure

The inspection procedure is essentially very simple. The following pages present specific information about the main energy-efficiency features of the home:

- repairs, caulking, and weatherstripping
- storm windows and doors
- ceiling, wall, and floor insulation
- duct and pipe insulation
- heating and cooling equipment



Each of these areas of the home has a separate section explaining what the feature is, where it is located, and how to inspect it.

It will be helpful to read through these pages before visiting the home. Look also at the **Energy Checklist** on pages 40 and 41. The scoresheet has space for you to make a systematic record of your inspections for up to three homes. When you visit the home, take this Guide with you. Refer to these pages as you inspect the home, and check the condition of each part.

Look for these energy-saving features in each home and note the condition of each feature. If an item is in poor condition or is incomplete, mark it as "missing" or "below minimum" on the checklist. If you buy the home, the checklist will be your reference guide to items needing attention.

Repairs

Minor repairs and small changes can produce large savings. Look for needed repairs in the areas shown in the illustrations.

If a home requires a significant number of repairs, note this on the Checklist, column D, page 40.

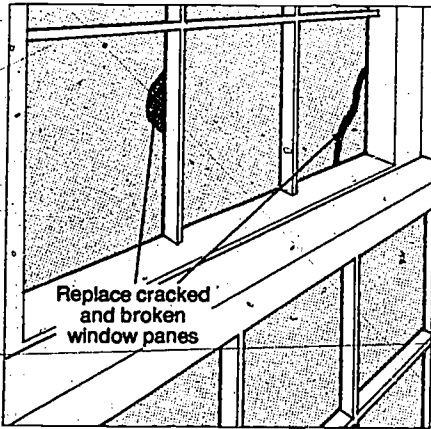

Badly cracked or broken window panes.

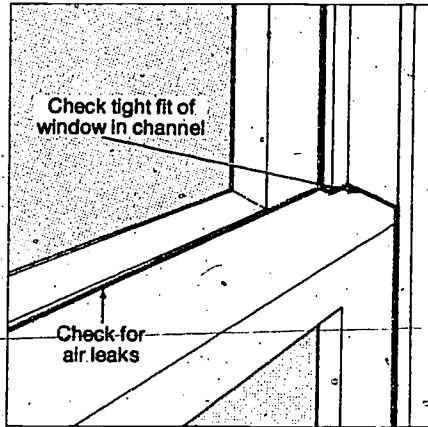

Doors, windows, and storm windows that do not close tightly.

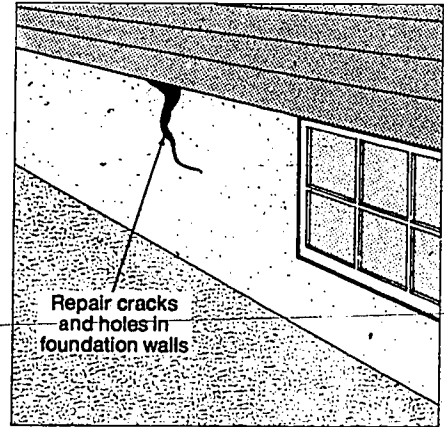

Holes in the outer walls and around the foundation.

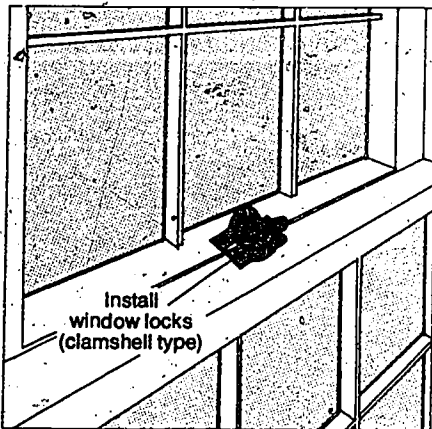

Missing or poorly adjusted window locks. Note: Window locks should be of a kind (such as the clamshell kind) that pulls the window together at the meeting rail rather than forces it apart.

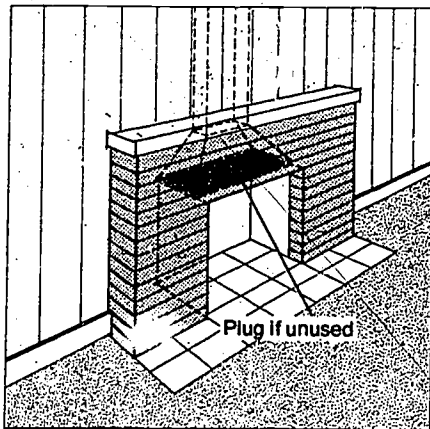

Fireplace dampers that are missing or will not close. If there is no damper in an unused fireplace, a removable plywood plug can be made to fit tightly in the opening from the fireplace into the chimney.

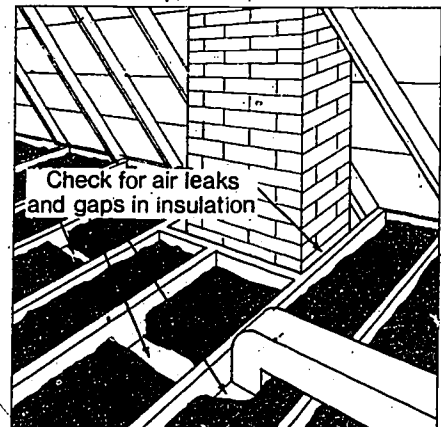

Air leaks between the attic and the heated space — for example, around chimneys and flues (fill gap with non-burning material), and around where ducts descend to the heated space. Also — gaps in the insulation.

Caulking and puttying

Caulking should be present at all cracks on the exterior of the home, and should be tight and in good condition. If it is loose, deteriorated, or missing, it should be replaced. This is a good do-it-yourself job that pays for itself quickly. Areas to check for caulking or a tight seal are shown in the illustrations.

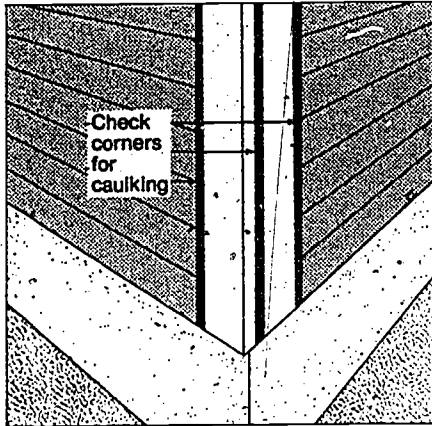

Corners of the house on the outside, and around exterior chimneys.

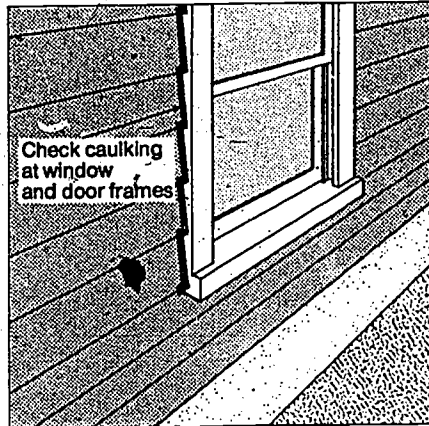

Window and door trim on the outside of the house.

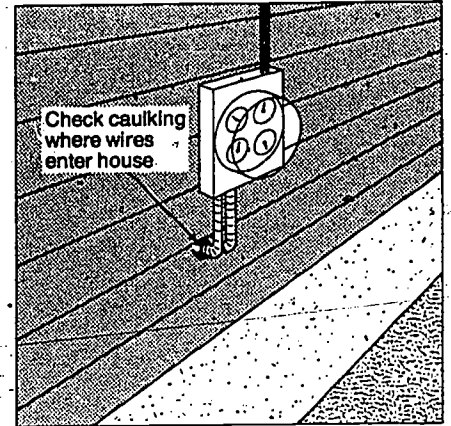

Places where pipes and wires enter the house.

If significant amounts of caulking are required, note this on the Checklist, Column D, page 40.

Weatherstripping

"Weatherstripping" consists of strips of metal, vinyl, or foam that provide a weather-tight seal between the frame and the moving parts of doors and windows. It is another very good way to cut energy loss. (Don't forget to check infrequently used doors and latches such as those leading to an unheated cellar or attic; they also need weatherstripping.) If the weatherstripping around some or all of the doors and windows of the home is not making a tight seal, note this on Column D of the Checklist, page 40.

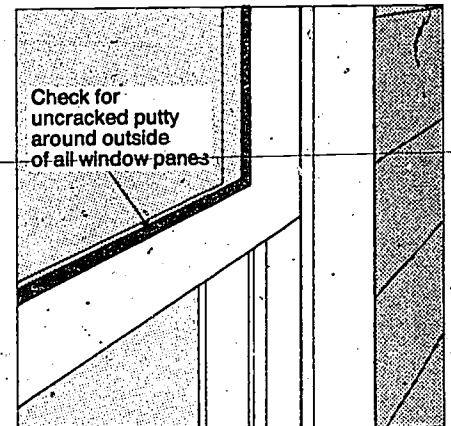

Window panes (all panes should have uncracked putty around them).

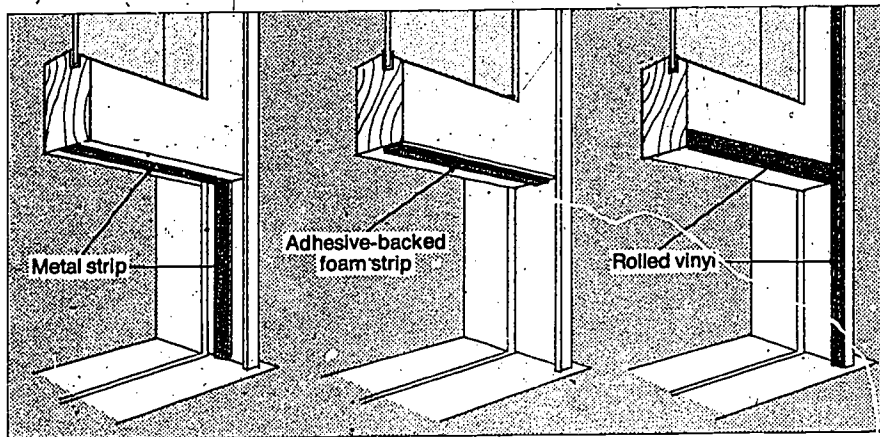

Different types of weatherstripping

In many parts of the country a home should have storm windows, and in the coldest parts of the country, a home should also have storm doors.

To find out if a home in your area should have storm windows or storm doors, first look at the map to see which climate zone you are in. Then look at the recommendations in the table below for that zone. Note the stricter recommendations for homes with electric resistance heat.

Requirements for storm windows and doors*

	Zone A	Zone B	Zone C	Zone D	Zone E
Storm windows recommended? (or insulating glass)	no	no†	yes	yes††	yes††
Storm doors recommended? (or thermal doors)	no	no	no†	no†	yes

*Based on May 1979 revisions to the HUD Minimum Property Standards.

†“yes” in these cases if the home has electric resistance heat.

††Triple glass recommended if the home has electric resistance heat.

If storm windows and doors are recommended for your location, but some or all of them are missing or in poor repair, note this in Column E of the Checklist, page 41.

If you do not want the expense of permanent metal-framed storm windows, you can install flexible or rigid sheet plastic over your windows at a much lower cost.

If a home has insulating glass, then storm windows are not necessary.⁴ “Insulating glass” simply means two layers of glass, separated by a small air space, built into a single window frame.

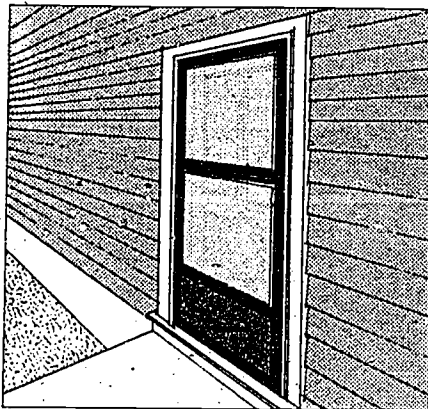

Storm door.

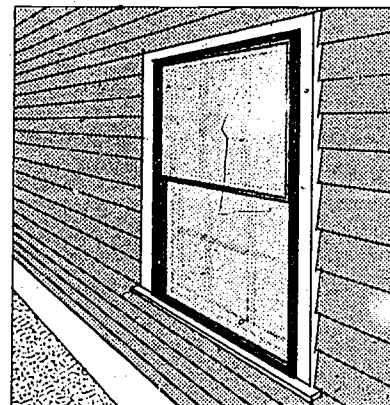

Storm window.

If a thermal door is installed, a storm door is not needed. A “thermal door” looks like a regular door, but it is metal and is filled with a foam insulating material. In addition, it is usually weatherstripped with a magnetic or other good quality weatherstrip or gasket that sticks to the edges of the door when it is closed.

⁴Except in Zones D and E, with electric resistance heat.

Climate Zones of the U.S.

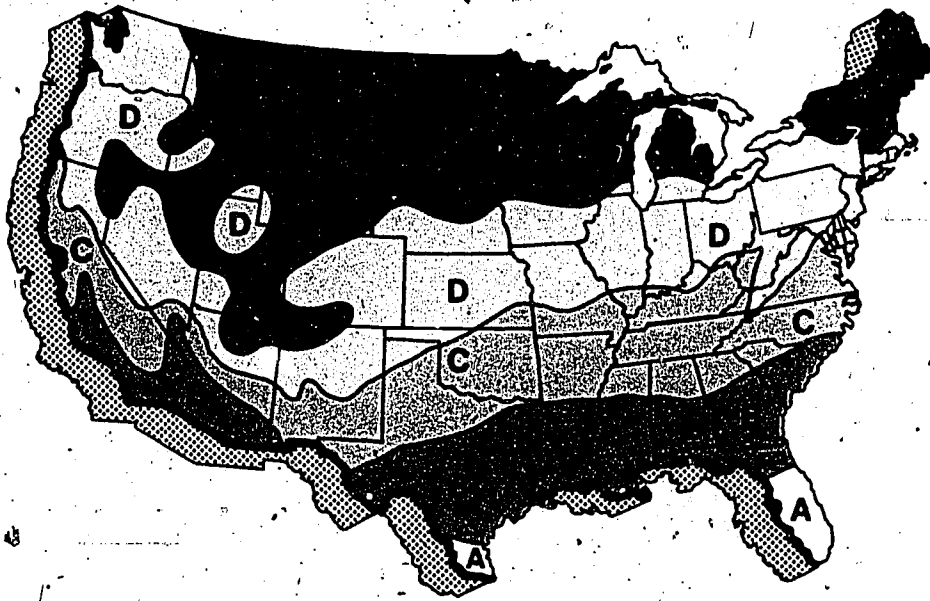

Many existing homes do not have enough insulation in their ceilings, floors, walls and basement walls. If this is the case in an existing home that you are purchasing, then it is well worth your while to add the needed insulation.

How much insulation?

Different amounts of insulation are needed in different climates. Also, there are different, stricter requirements for homes that are heated with electric resistance heat instead of oil, gas or a heat pump.

The tables on the next page show how much insulation a home in your area should have. To determine your insulation requirements, first look at the map above to see which climate zone you are in. Then, refer to the column in each table for that climate zone. Circle that column in each of the two tables so that you can refer back to the tables easily.

The tables give two R-values for each type of insulation: "minimum" and "recommended." The meaning of these numbers is as follows.

- If the work would be done by a contractor, and if the home has *more* than the "minimum" level of insulation, then it is probably not worthwhile to add more insulation.
- If a home has less than the "minimum" level of insulation, then more insulation should be added. But when you add the insulation, add it all the way up to the "Recommended" level (not just to the "minimum").
- With do-it-yourself work, it is worthwhile to install the "recommended" level of insulation regardless of how much insulation is already there.

Insulation requirements

Table 1. For oil heat, gas heat, or heat pump*

		<i>Climate Zone (see map on previous page)</i>				
		A	B	C	D	E
Ceilings	<i>minimum**</i>	R-3†	R-3†	R-6†	R-9	R-9
	<i>recommended</i>	R-19	R-19	R-19	R-30	R-38
Frame walls	<i>minimum**</i>	none	none	none	none	none
	<i>recommended</i>	none	fill cavity	fill cavity	fill cavity	fill cavity
Walls of heated basements and crawl spaces	<i>minimum**</i>	none	none	none	none	none
	<i>recommended</i>	none	none	R-3	R-11	R-11
Floors over unheated spaces	<i>minimum**</i>	none	none	R-6	R-6	R-6
	<i>recommended</i>	none	none	R-11	R-11	R-19

Table 2. For electric resistance heat*

		<i>Climate Zone (see map on previous page)</i>				
		A	B	C	D	E
Ceilings	<i>minimum**</i>	R-6†	R-6†	R-9	R-9	R-11
	<i>recommended</i>	R-19	R-22	R-30	R-30	R-38
Frame walls	<i>minimum**</i>	none	none	none	R-3††	R-3††
	<i>recommended</i>	none	fill cavity	fill cavity	fill cavity	fill cavity
Walls of heated basements and crawl spaces	<i>minimum**</i>	none	none	none	none	none
	<i>recommended</i>	none	none	R-6	R-11	R-11
Floors over unheated spaces	<i>minimum**</i>	none	R-6	R-6	R-6	R-6
	<i>recommended</i>	none	R-11	R-19	R-19	R-19

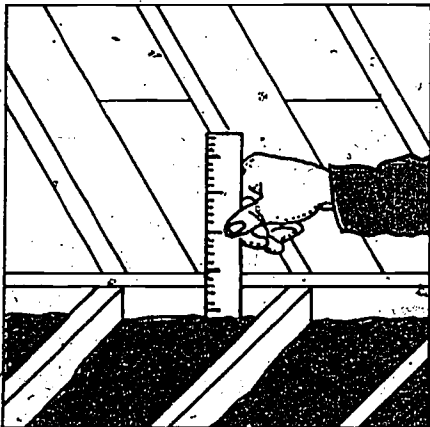

Checking thickness of attic insulation.

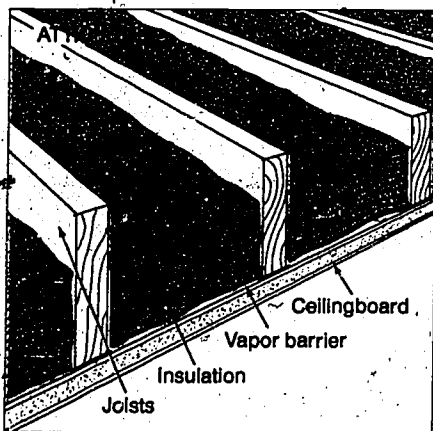

Attic insulation.

*"Recommended" levels are based on the May 1979 revisions to the HUD Minimum Property Standards. The "minimum" levels in the tables are approximate.

**See previous text for explanation.

†R-9 if the home has central air conditioning.

††See text on page 35.

Note: The numbers in the tables such as R-6, R-11, R-30, etc., refer to the "R-values" of insulation. The "R-value" measures the effectiveness of a layer of insulation: the higher the R-value, the better the insulation. Existing insulation may be assumed to have an R-value of approximately 3.0 per inch. Thus, three inches of existing insulation has an R-value of approximately 9.

Ceilings

If you find some or all of the ceiling insulation to be below the minimum given in the table, note that it is "below minimum" on Column F of the Checklist, page 41.

Note: All attics should have adequate ventilation, both to remove moisture that might otherwise condense in the insulation, and for cooling in the summer. When you inspect attic insulation, also check for ventilation. For more on attic ventilation, see Part 3, page 48.

Frame walls

Insulation can often be added to the cavities of existing frame walls through small holes drilled from the outside. But the house must meet two conditions for this to be possible:

1. There should be *no* existing insulation at all inside the wall. New insulation can only be added to empty wall cavities. If an inch or two of existing insulation is already there, it will interfere with the process of adding new insulation, and will reduce the savings achieved by the new insulation. The exception is that ureaformaldehyde foam can sometimes be installed in a minimally insulated wall cavity. This is cost-effective for electrically heated homes in Zones D and E, if the existing insulation is not more than an inch thick. Consult a local installer.
2. The outside of the walls should be wood clapboards, wood or asphalt shingles, or vinyl or metal siding. These can be removed to expose the inner sheathing, and then replaced without harming the appearance of the home. While it may be possible in some cases to reinsulate walls with other types of outer surfaces (brick, stone, stucco, or asbestos shingles), it is generally too expensive to be worth the cost.

Many homes in the north without wall insulation meet these favorable preconditions. If so, adding wall insulation will reduce heating and cooling costs. If the seller or real estate agent cannot tell you whether the home already has wall insulation, the following test will sometimes show that insulation is present:

- Take the cover off a light switch or receptacle on an outside wall. (*Turn off the power first, at the central electrical box.*) Shine a flashlight into the space between the switchbox and the wall material and see if there is any insulation. Note, however, that in some homes with existing wall insulation, the insulation is not installed immediately adjacent to the switches.

If you have further questions about insulating the walls of a home, ask a local insulation contractor for advice. If the home's frame walls are not insulated, and if the tables on page 34 indicate that they should be, note this in Column G of the Checklist, page 41.

Walls of heated basements and crawl spaces

It is usually more cost-effective to insulate the walls of a heated basement or enclosed crawl space, rather than the floor above it. If either the floor above an enclosed crawl space, or the basement or crawl space walls fail to meet the minimum requirements shown in the tables (page 34), note this in Column H of the Checklist, page 41.

Floors over unheated spaces

"Unheated spaces" include garages, porches, and open crawl spaces that do not have air outlets or radiators specifically intended to heat them. If an unheated space below the floor of a heated space cannot be sealed off from the cold outdoor air and insulated, then the floor should be insulated according to the recommendations shown in the tables (page 34). Note that this recommendation also includes that portion of floors of overhanging (cantilevered) stories that are exposed to the outside air. If floor insulation is needed, note this in the Checklist, Column H.

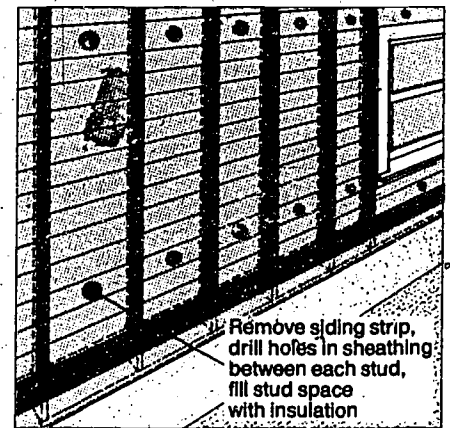

Reinsulating a wall.

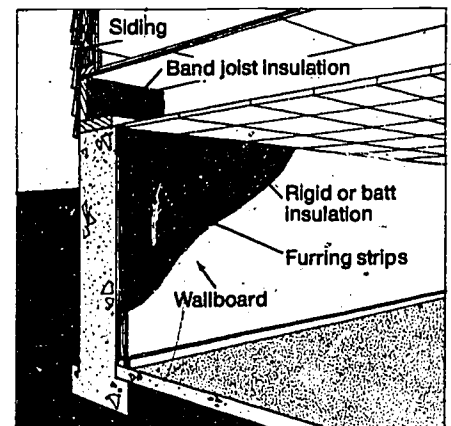

Basement wall insulation.

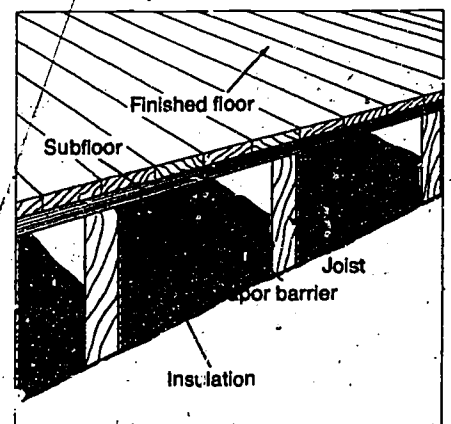

Crawl space insulation.

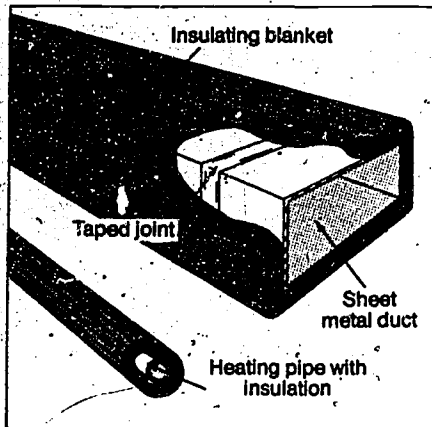

Properly insulated duct and pipe

Hot water heating pipes, steam pipes, and warm air ducts should be insulated wherever they run through an unheated part of the home, regardless of the climate zone. Pipes carrying air conditioning refrigerant should also be insulated. Pipes should have at least ½ inch of insulation; air ducts should have at least 1 inch of insulation. In colder climates (Zones D and E), double these amounts should be used. If any heating or air conditioning pipes or ducts outside the heated space have no insulation, note this on the Checklist, Column I.

To be effective, duct and pipe insulation should be in good condition, without holes or gaps. Any damage should be repaired when you move into the home. Also, ducts and duct insulation should be tightly taped to seal against air leaks. Check that the connections of ducts to the furnace are tight. Ducts and pipes used for air conditioning should have vapor barriers on the outside of the insulation.

It is not necessary to insulate pipes for domestic hot water (tap water) since these are not used a large percentage of the time.

If there are pipes or ducts outside the heated space that have no insulation, or if there are poorly sealed, leaky ducts, note this in the Column I of the Checklist, page 41.

The condition and efficiency of heating and cooling equipment is important to a home's overall energy efficiency.

Oil and gas furnaces

It is desirable to check the condition and efficiency of a gas or oil furnace if a home has one. Unfortunately, there is no easy way for you to judge the condition of a furnace just by looking at it. Therefore, it is a good idea to have a qualified technician from the local oil or gas company inspect the furnace. This is particularly true of oil furnaces that are more than about eight years old. It is less true for gas furnaces, since they have fewer parts needing maintenance or adjustment.

Often, even older oil and gas furnaces can heat a home efficiently if they are in good repair. Don't replace an old furnace unless there is a definite problem that cannot be repaired, or unless it is substantially "oversized". (An "oversized" furnace is one with excessive heating capacity. For a full discussion of furnace sizing, see page 46.)

If you have the furnace inspected, have the technician test its efficiency. An oil-fired unit's efficiency as measured by stack gas analysis should be between 70 and 80 percent. Gas units should be between 75 and 85 percent efficient. If the furnace measures significantly lower than these guidelines — i.e., below 65 percent efficiency — you should consider repairing, modifying, or replacing it.

You may find a tag stating the results of a past efficiency test attached to the furnace. Check it to see if the efficiency is in the proper range (70-80 percent for oil, 75-85 percent for gas). Also check the date: for the test to be useful it should not be more than two years old for an oil furnace, or three years old for a gas furnace. If a recent test shows that the unit was performing efficiently, then you can assume it is in good condition.

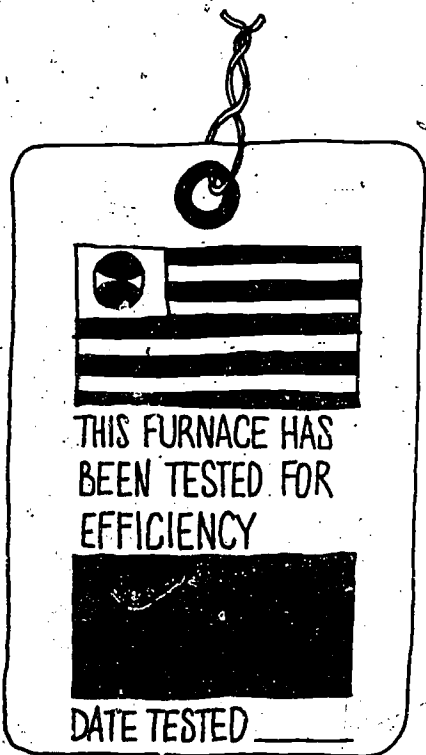

Furnace efficiency tag.

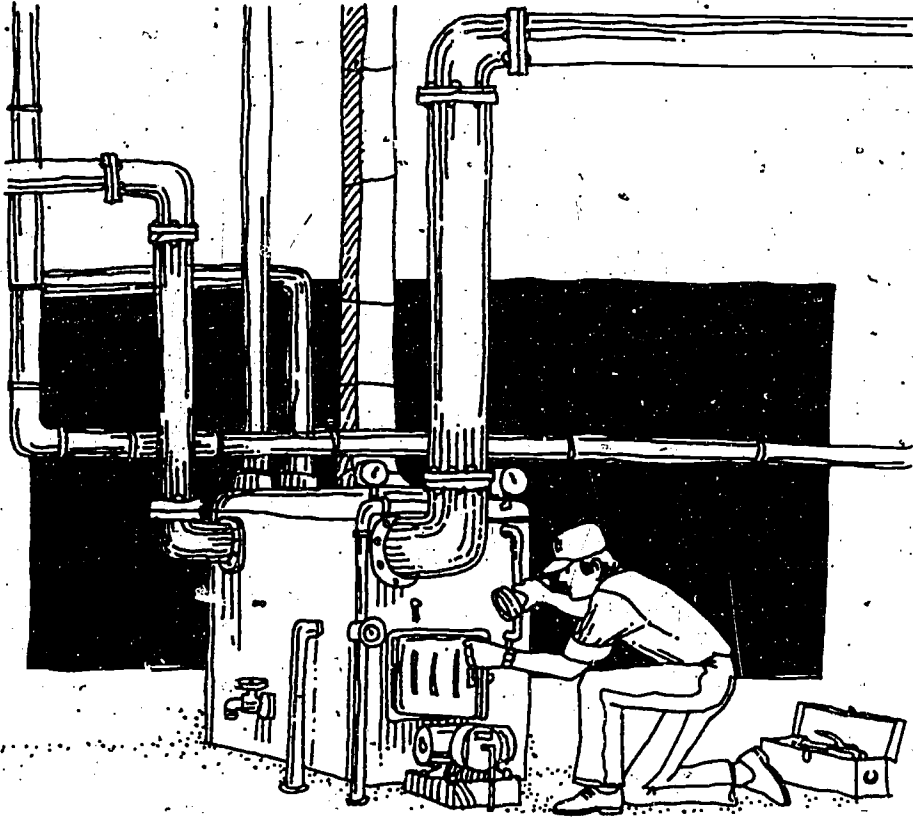

Important note: After you move in, and particularly if you make energy-saving improvements to the home, you should check at the first opportunity to see that the furnace is properly sized for your heating needs. See page 46.

There is space for you to note the condition and efficiency of the furnace on the **Checklist**, Column J.

Thermostats

A **clock thermostat** automatically reduces the house temperature during sleeping hours or during hours when the house is unoccupied. A clock thermostat replacing the regular thermostat is a wise investment for most families living in homes with central heating systems. Although you could achieve the same energy savings by remembering always to turn back the thermostat at appropriate times, most people prefer the convenience and reliability of an automatic clock thermostat. Different models allow either one or two different setbacks each day. If you leave your home unoccupied during the day, consider the dual-setback kind. Special models are available for use with central air conditioning.

If the home is heated by individual electric resistance heaters in each room, then **individual thermostats** in each room for each heater are more energy efficient than a clock thermostat. Individual thermostats let you turn back the heat in a room whenever it is not in use.

Note that clock thermostats for winter temperature setbacks are not recommended for use with heat pumps.



When you have filled out the **Checklist** (pages 40-41) you will have a quick summary of the condition of each home you have inspected. There are two ways to put this information to use:

1. *Before* making a purchase decision — to help you decide which home is your "best buy" for energy efficiency.
2. *After* your purchase decision — to help you make energy-efficiency improvements needed for the home.

If you have inspected two or more homes before you finally purchase a home, you may have found that the homes differ quite a bit in their past energy costs or in the opportunities they offer for improvements. Here are some points to help you evaluate these factors:

- a. If you are choosing between two homes that are both relatively high in cost to heat and cool — according to *documented* past energy bill information — then the one with the *most* features needing improvements is the one that offers the greatest potential savings: that is, if both homes start off costing about the same to heat and cool, the one to which the greatest number of energy-saving improvements are made will have the greatest savings and will end up with the lowest energy bills.
- b. If you are choosing between two homes that are both relatively *low* in cost to heat and cool, then the one with the most features needing improvement could become even lower in energy costs if the improvements are made.
- c. But if you are buying a home with many possible improvements, and plan to lower its energy bills by making those improvements, make sure that you have accurate and documented past energy bill information for the home. Make sure that the past energy bills are not deceptively low. They might be if the home was unoccupied for long periods or if the thermostat was set very low in the winter.
- d. To check the accuracy and reliability of past energy bill information, examine the list of possible energy-saving improvements which can be made in a home. If two homes have similar energy bills, but one needs many more improvements than the other, find out why. Perhaps the past energy bills for the home needing improvements are misleading, or perhaps the home that seems to need fewer improvements actually has hidden flaws. For example, there might be a major air leak that you did not notice, or a furnace that is operating inefficiently. Large discrepancies should be looked into: Either you should inspect the home more carefully yourself, or you should call in a qualified professional engineer or energy specialist.

With these points in mind you can make the purchase choice that will end up saving you the most on energy costs.

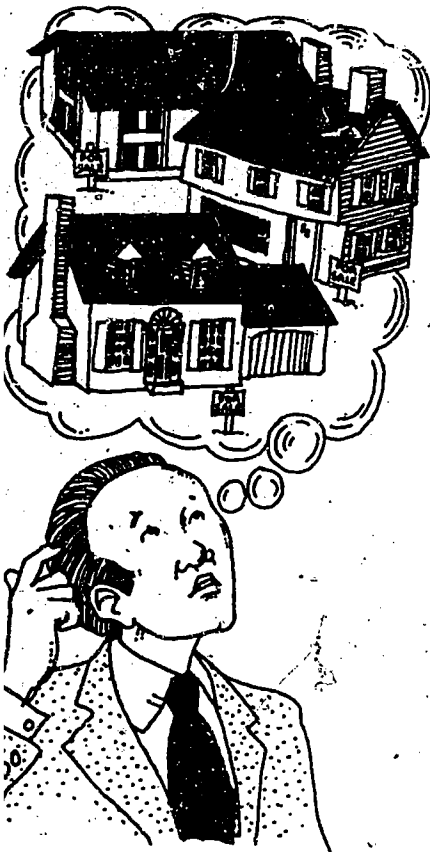

After you move in

If you purchase a home needing energy-saving improvements, the information from your inspection of the home will help you make the improvements by reminding you of what you have done and what still needs to be done.

Before you actually make any energy improvements to the home, you may want estimates of their costs and probable savings. *In The Bank . . . Or Up The Chimney?* is a 72-page guide prepared by the Department of Housing and Urban Development precisely for that purpose. *In The Bank . . . Or Up The Chimney?* also provides detailed, illustrated instructions for doing the work, and it has advice on choosing the right contractor for work you want done for you.⁵ Similar publications are available in bookstores.



⁵For ordering information, see page 58.

Recommended Section (A-C)

The "recommended" section — Columns, A, B, and C — of the scoresheet provides the basic information you need to assess the energy efficiency of a used home. Obtain and note down the actual documented information for the two or three homes that you are most seriously interested in. Refer to pages 26-28 regarding past energy bills.

A Address of home		B Heating and cooling systems		C Past energy bills use "Per Year" figures (see text for explanation)		D Repairs Caulking Weatherstripping	
FIRST HOUSE	Name of development (if applicable)	Heating <input type="checkbox"/> Gas <input type="checkbox"/> Oil <input type="checkbox"/> Heat Pump <input type="checkbox"/> Electric Baseboards or Radiant Panels <input type="checkbox"/> Electric Furnace Central air conditioning <input type="checkbox"/> Yes <input type="checkbox"/> No	Estimated Total \$ <input type="text"/>	Actual and Documented \$ <input type="text"/> Gas		Carpentry/Repairs <input type="checkbox"/> OK <input type="checkbox"/> Required	
	No. Street			\$ <input type="text"/> Oil		Caulking <input type="checkbox"/> OK <input type="checkbox"/> Required	
	City			+ \$ <input type="text"/> Electricity		Weatherstripping <input type="checkbox"/> OK <input type="checkbox"/> Required	
	Realtor or Seller			\$ <input type="text"/> Total \$ <input type="text"/> Add 10% or 20% (see page 27) \$ <input type="text"/> Adjusted Total			
SECOND HOUSE	Name of development (if applicable)	Heating <input type="checkbox"/> Gas <input type="checkbox"/> Oil <input type="checkbox"/> Heat Pump <input type="checkbox"/> Electric Baseboards or Radiant Panels <input type="checkbox"/> Electric Furnace Central air conditioning <input type="checkbox"/> Yes <input type="checkbox"/> No	Estimated Total \$ <input type="text"/>	Actual and Documented \$ <input type="text"/> Gas		Carpentry/Repairs <input type="checkbox"/> OK <input type="checkbox"/> Required	
	No. Street			\$ <input type="text"/> Oil		Caulking <input type="checkbox"/> OK <input type="checkbox"/> Required	
	City			+ \$ <input type="text"/> Electricity		Weatherstripping <input type="checkbox"/> OK <input type="checkbox"/> Required	
	Realtor or Seller			\$ <input type="text"/> Total \$ <input type="text"/> Add 10% or 20% (see page 27) \$ <input type="text"/> Adjusted Total			
THIRD HOUSE	Name of development (if applicable)	Heating <input type="checkbox"/> Gas <input type="checkbox"/> Oil <input type="checkbox"/> Heat Pump <input type="checkbox"/> Electric Baseboards or Radiant Panels <input type="checkbox"/> Electric Furnace Central air conditioning <input type="checkbox"/> Yes <input type="checkbox"/> No	Estimated Total \$ <input type="text"/>	Actual and Documented \$ <input type="text"/> Gas		Carpentry/Repairs <input type="checkbox"/> OK <input type="checkbox"/> Required	
	No. Street			\$ <input type="text"/> Oil		Caulking <input type="checkbox"/> OK <input type="checkbox"/> Required	
	City			+ \$ <input type="text"/> Electricity		Weatherstripping <input type="checkbox"/> OK <input type="checkbox"/> Required	
	Realtor or Seller			\$ <input type="text"/> Total \$ <input type="text"/> Add 10% or 20% (see page 27) \$ <input type="text"/> Adjusted Total			

Optional Section (D-J)

The "optional" section of the scoresheet (Columns D-J) will help you to determine the energy-efficiency features of a used home. With this information you can make important improvements on many existing homes that will substantially lower your energy costs and your total housing costs. We suggest you fill out these columns for the one or two homes you are most seriously interested in buying. Refer to the previous pages to fill out columns D through J.

E Storm windows and doors	F Ceiling or attic insulation	G Frame wall insulation	H Crawl space, basement wall, floor insulation	I Ducts and heating pipes in unheated spaces	J Oil or gas furnace
<p>Storm Windows</p> <input type="checkbox"/> OK <input type="checkbox"/> Missing but required	<p>R- <input type="text"/></p> <input type="checkbox"/> at or above minimum acceptable level <i>(see table, page 34)</i> <input type="checkbox"/> below minimum, upgrade to	<p>Frame Walls</p> <p>Type of outside wall surface:</p> <input type="checkbox"/> at or above minimum acceptable level <i>(see table, page 34)</i> <input type="checkbox"/> below minimum, upgrade to	<p>Floors over unheated spaces</p> <input type="checkbox"/> at or above minimum <i>(see table, page 34)</i> <input type="checkbox"/> below minimum <i>(from table, page 34)</i>	<p>Ducts</p> <input type="checkbox"/> Already insulated <input type="checkbox"/> Not insulated; Upgrade to R-8 (more in coldest climates). <input type="checkbox"/> Taping and sealing required.	<p>Oil or gas</p> <input type="checkbox"/> In good repair. <input type="checkbox"/> Repairs required. <input type="checkbox"/> Replacement required. <input type="checkbox"/> Might be substantially oversized <i>(see page 36)</i>
<p>Storm Windows</p> <input type="checkbox"/> OK <input type="checkbox"/> Missing but required	<p>R- <input type="text"/></p> <input type="checkbox"/> at or above minimum acceptable level <i>(see table, page 34)</i> <input type="checkbox"/> below minimum, upgrade to	<p>Frame Walls</p> <p>Type of outside wall surface:</p> <input type="checkbox"/> at or above minimum acceptable level <i>(see table, page 34)</i> <input type="checkbox"/> below minimum, upgrade to	<p>Floors over unheated spaces</p> <input type="checkbox"/> at or above minimum <i>(see table, page 34)</i> <input type="checkbox"/> below minimum <i>(from table, page 34)</i>	<p>Ducts</p> <input type="checkbox"/> Already insulated <input type="checkbox"/> Not insulated; Upgrade to R-8 (more in coldest climates). <input type="checkbox"/> Taping and sealing required.	<p>Oil or gas</p> <input type="checkbox"/> In good repair. <input type="checkbox"/> Repairs required. <input type="checkbox"/> Replacement required. <input type="checkbox"/> Might be substantially oversized <i>(see page 36)</i>
<p>Storm Windows</p> <input type="checkbox"/> OK <input type="checkbox"/> Missing but required	<p>R- <input type="text"/></p> <input type="checkbox"/> at or above minimum acceptable level <i>(see table, page 34)</i> <input type="checkbox"/> below minimum, upgrade to	<p>Frame Walls</p> <p>Type of outside wall surface:</p> <input type="checkbox"/> at or above minimum acceptable level <i>(see table, page 34)</i> <input type="checkbox"/> below minimum, upgrade to	<p>Floors over unheated spaces</p> <input type="checkbox"/> at or above minimum <i>(see table, page 34)</i> <input type="checkbox"/> below minimum <i>(from table, page 34)</i>	<p>Ducts</p> <input type="checkbox"/> Already insulated <input type="checkbox"/> Not insulated; Upgrade to R-8 (more in coldest climates). <input type="checkbox"/> Taping and sealing required.	<p>Oil or gas</p> <input type="checkbox"/> In good repair. <input type="checkbox"/> Repairs required. <input type="checkbox"/> Replacement required. <input type="checkbox"/> Might be substantially oversized <i>(see page 36)</i>

This part of *The Energy-Wise Homebuyer* provides additional information about energy efficiency and the home. It is intended for buyers of both new and used homes. There are six sections:

After you move in: energy conscious living (page 43).

Energy-saving maintenance (page 45).

More low-cost energy-savers (page 46).

Low- to moderate-cost features to look for when you buy a home, or add to a home after you buy it.

Some bigger energy-savers (page 49).

Higher-cost (but higher-saving) features to look for in a home, or add to it.

Other things to look for when you buy a home (page 52).

Important design features to look for when you buy a home.

A detailed reference list of home energy-efficiency features (pages 54-55). This list summarizes all the items discussed in the Guide, and indicates in which climate zones they are applicable.

Low energy bills come not only from the efficiency of your home, but also from energy-conscious living habits.

Energy-conscious living is easy and it usually costs you nothing. But it can reduce your energy bills substantially.

Here are six important tips for energy-conscious living. The most important items are listed first.

1. Turn back the thermostat

Turn your heating thermostat down in winter and your cooling thermostat up in summer as much as is comfortable. Significant savings can be realized by just a few degrees difference.

- A no-cost item
- A low-cost item
- An easy-to-do item
- IMPORTANT** — Large savings in relation to cost or effort





Closing drapes at night.

2. Close off unused rooms

Don't heat or cool unused rooms. Shut off radiators or vents and close the doors to rooms that are not being used.

- A no-cost item
- A low-cost item
- An easy-to-do item
- IMPORTANT** — Large savings in relation to cost or effort

*Modifications may be required if the home has a hot water or steam heating system. A heating system specialist can suggest cost-effective modifications.

3. Use drapes and blinds

Close drapes and blinds at night in winter. Open them in the daytime where they will allow direct sunlight to enter.

In the summer, close drapes and blinds of windows exposed to direct sunlight.

- A no-cost item
- A low-cost item
- An easy-to-do item
- IMPORTANT** — Large savings in relation to cost or effort

4. Close fireplace dampers

Close the fireplace damper when the fireplace is not in use. If there is no damper, a plug can be made to fit inside the entry to the chimney. See the illustration.

- A no-cost item
- A low-cost item
- An easy-to-do item
- IMPORTANT** — Large savings in relation to cost or effort

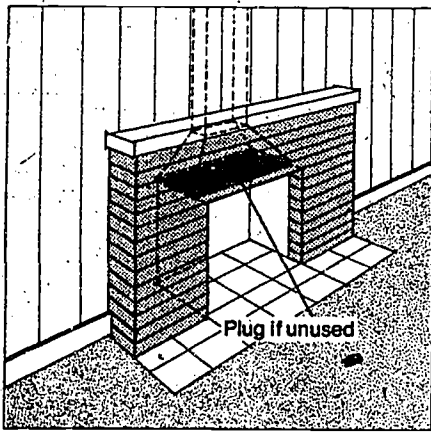

Fireplace dampers that are missing or will not close. If there is no damper in an unused fireplace, a removable plywood plug can be made to fit tightly in the opening from the fireplace into the chimney.

5. Turn down the water heater.

Set the water heater thermostat to the minimum possible temperature (usually about 120 degrees F).

- A no-cost item
- A low-cost item
- An easy-to-do item
- IMPORTANT** — Large savings in relation to cost or effort

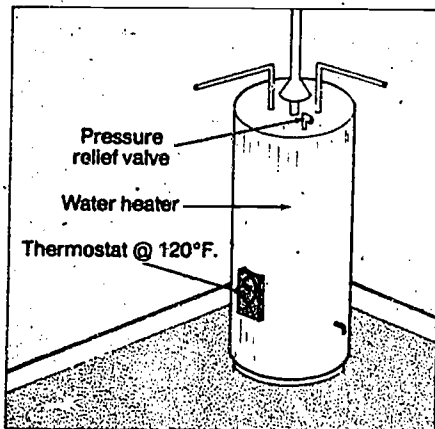

Turning back the water heater.

6. Use your vestibule

If you have a door with a vestibule, use this entrance in cold and hot weather rather than doors opening directly into living areas.

- A no-cost item
- A low-cost item
- An easy-to-do item
- IMPORTANT** — Large savings in relation to cost or effort

For maximum energy efficiency, keep the energy-related parts of your home in top condition. Here is a checklist of six important maintenance items. Many of them are things you can take care of yourself, at very low cost. The more important items are listed first.

1. The yearly inspection

Inspect your home at the start of each heating season. Repair or replace broken or missing caulking and weatherstripping around doors, windows, storm windows, and foundation walls. Replace broken or badly cracked window panes — including storm window glass. These measures will greatly reduce energy loss due to infiltration of cold air.

- A no-cost item
- A low-cost item
- An easy-to-do item
- IMPORTANT — Large savings in relation to cost or effort

2. Servicing the heating and cooling system.

Keep your heating system in top operating condition. Oil furnaces and central air conditioning systems should be serviced every year and gas furnaces every two years. A qualified specialist should be called for this service.

- A no-cost item
- A low-cost item
- An easy-to-do item
- IMPORTANT — Large savings in relation to cost or effort

3. Changing air filters

Changing the air filters in a forced air heating system is something you can easily learn to do yourself. Change them or clean them by vacuuming as often as required to keep them clean and free of obstruction — at least twice a year, or, if you have central air conditioning, four times a year. In dusty climates they may need changing even more often than this.

- A no-cost item
- A low-cost item
- An easy-to-do item
- IMPORTANT — Large savings in relation to cost or effort

4. Exhaust fan dampers

Exhaust fan dampers should be regularly inspected to make sure they are opening and closing smoothly, and that they shut tightly when the fan is not running. Check roof-mounted dampers in particular, since these tend to become clogged with leaves.

- A no-cost item
- A low-cost item
- An easy-to-do item
- IMPORTANT — Large savings in relation to cost or effort

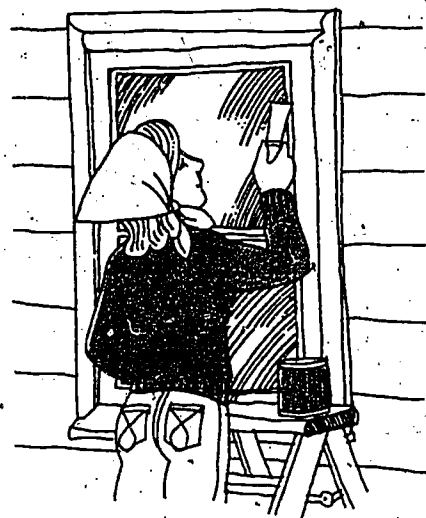

Yearly repairs.



Servicing the heating system.

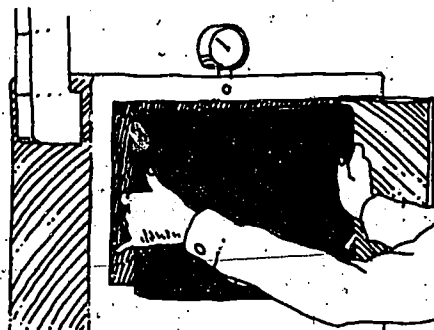

Changing the air filter.

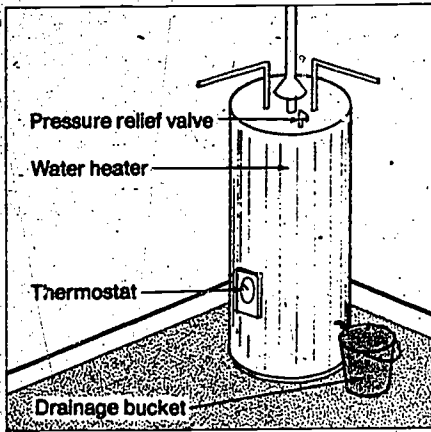

Draining sediment from the water heater.

5. The water heater

Drain a bucket of water from the water heater tank every three months to remove collected sediment. Sediment causes the heater to operate inefficiently, and waste energy. There is a valve at the bottom of the heater for doing this.

- A no-cost item
- A low-cost item
- An easy-to-do item
- IMPORTANT** — Large savings in relation to cost or effort

6. The outdoor air conditioning unit

Keep the outdoor unit of your air conditioner or heat pump clean and free of obstructions. This includes trimming back bushes, flowers and weeds from around the unit.

- A no-cost item
- A low-cost item
- An easy-to-do item
- IMPORTANT** — Large savings in relation to cost or effort



Here are eight energy-saving features of low to moderate cost that were not discussed in detail in the previous sections of this Guide. These features are things to look for when you buy a home — and things you can add to a home after you buy it. They are all cost-effective when installed and used properly. The most important and cost-effective items are listed first.

1. Oil furnace capacity adjustment

Be sure that the heating capacity of your oil furnace is properly matched to the size of your heating needs. Many units are "oversized," meaning that they burn fuel too fast, so that they switch on for only brief periods in all but the coldest weather. Such units are inefficient.

The capacity or "size" of an oil furnace can usually be reduced up to 20 percent by changing the burner nozzle. You can check your furnace for proper size on any very cold winter night. On a very cold winter night the furnace should run most of the time — at least 40 minutes out of every hour. If it runs less than this, its capacity should be reduced. Your oil company can change the nozzle.

It is particularly important to check or recheck furnace capacity whenever you have carried out a major energy conservation improvement, such as insulating the ceiling or walls, or adding storm windows. These changes will tend to make the heating system oversized, which, unless corrected, will reduce the savings you achieve from the improvements.

If the "size" of the unit cannot be sufficiently reduced by this simple modification — or if you have a severely over-sized gas unit, it may be cost-effective to replace it. See page 50.

- Something to look for in a new home
- Something to look for in a used home
- Something you can do after purchase
- Low in cost to install
- IMPORTANT — Highly cost-effective**

2. Hot water savers

Water-saving devices, such as "low-flow" showerheads and sink aerators, can reduce your hot water use significantly. In particular, a water-saving showerhead can greatly reduce your hot water use — while still providing a satisfying shower. An efficient showerhead can pay for itself in a matter of weeks.

- Something to look for in a new home
- Something to look for in a used home
- Something you can install after purchase
- Low in cost to install
- IMPORTANT — Highly cost-effective**

3. Blinds and drapes

Blinds and drapes can be important energy-savers. In the winter, they can be closed at night to greatly reduce heat loss through windows. In the summer, they can be closed in the daytime — particularly when the window is exposed to direct sunlight — to reduce the load on the air conditioner.

Some kinds of blinds and drapes are more energy-efficient than others. Look for blinds that have a tight seal around all edges and blinds and drapes that are made of insulating materials.

- Something to look for in a new home
- Something to look for in a used home
- Something you can install after purchase
- Low in cost to install
- IMPORTANT — Highly cost-effective**

4. Whole-house fans

Whole-house fans that exhaust air from the house (usually out through the attic) are recommended. These fans differ from power attic ventilators (see no.5 below) in that they exhaust air from the *house*, not from the *attic*. At many times of the year they allow you to be comfortable in your home without using air conditioning.

Important: Seal and insulate the fan opening each winter.

- Something to look for in a new home
- Something to look for in a used home
- Something you can install after purchase
- Low in cost to install
- IMPORTANT — Highly cost-effective**

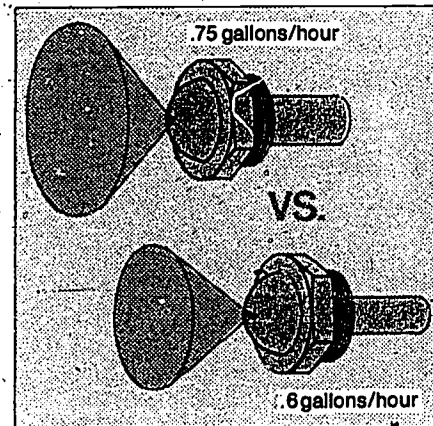

Oil furnace capacity adjustment.

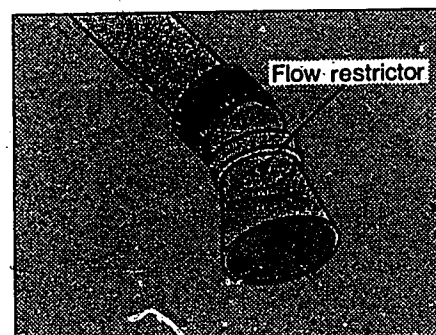

Water-saving showerhead.

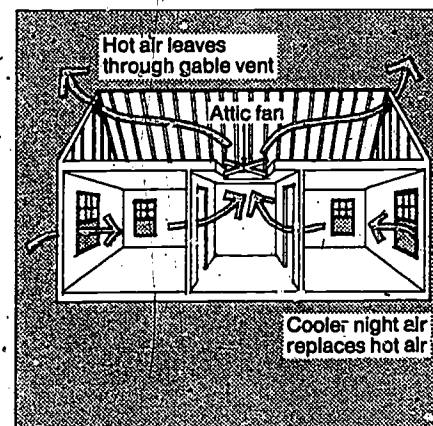
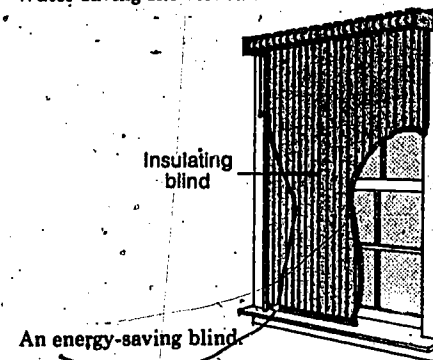

Whole-house fan.

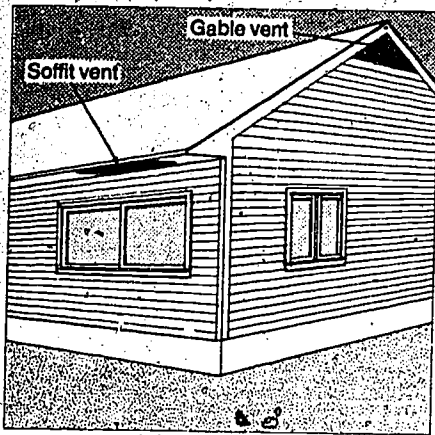

Attic vents.

5. Attic ventilation

Attic ventilation removes moisture from the attic and cools it in the summer. All homes should have some method of attic ventilation. If a home in a cooler climate already has some ventilation, you can assume that it is adequate if there are no signs of moisture condensation in the insulation. If there is no ventilation, you should provide it.

A good rule of thumb for the minimum ventilation requirement is that the ventilator area should be 1/150th of the floor area of the attic. Thus, a 1500 square-foot attic should have 10 square feet of clear, unobstructed ventilation area. If attic insulation with a vapor barrier facing the interior of the house is installed, then this ventilation area can be reduced by half. Roofs covered with slate or wood shakes, without solid sheathing, do not need special ventilators.

Attic ventilation works best if two or more vents are used, to permit circulation of air. If possible, there should be a combination of high and low vents — such as eave or soffit vents at the bottom of the roofline, and gable or ridge vents in the upper part of the roof.

Ventilation in warm climates is not a substitute for adequate amounts of ceiling insulation — insulation with an R-value of 19 or more should be provided if the home is air conditioned. (See the tables on pages 8 or 34.)

Power ventilators that exhaust air from the attic are not recommended. Recent studies have shown that even in the warmest climates the energy savings from having a cooler attic often do not cover the added electricity cost of operating the fan.

- Something to look for in a new home
- Something to look for in a used home
- Something you can install after purchase
- Low in cost to install
- IMPORTANT — Highly cost-effective

6. Exhaust fans

Exhaust fans are very desirable in air conditioned homes in the kitchen, bathrooms, and laundry room. They should be used in the summer whenever moisture is being produced by cooking, showers, or laundry. In order to effectively cool a home, an air conditioner must remove moisture from the air. Excessive moisture in the home increases the amount of work the air conditioner has to do — and increases the cost of running it. Some new homes are built so tightly that moisture must be exhausted in both winter and summer to prevent moisture build-up and condensation problems indoors.

Exhaust fans should have dampers that automatically shut tightly when the fan is not running. The damper should be inspected periodically to make sure that it is working properly. This is particularly important for roof-mounted dampers, which tend to become clogged with leaves.

Clothes dryers should always be directly vented to the outdoors.

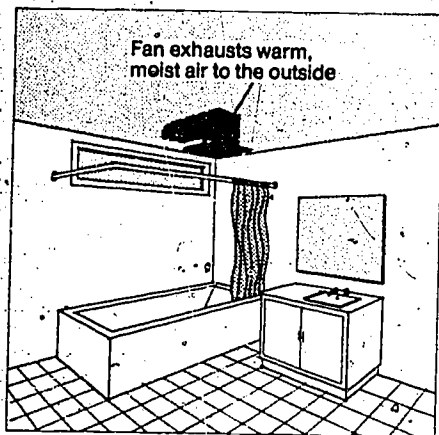

Exhaust fan.

- Something to look for in a new home
- Something to look for in a used home
- Something you can install after purchase
- Low in cost to install
- IMPORTANT — Highly cost-effective

7. Hot water tank insulating jacket.

A jacket consisting of one or two inches of insulation can be installed on an older water heater, and will significantly reduce its heat loss. Insulation kits sold in some hardware stores make this an easy do-it-yourself project. This measure is recommended in the following cases:

- In colder climates (Zones C, D, and E on the map on page 9 or 33) when the water heater is *outside* the heated portion of the home.
- In warmer climates (Zones A and B) when the home is air conditioned and the water heater is *inside* the air conditioned portion of the home.

Note: Do not insulate the top or bottom of gas-burning models.

- Something to look for in a new home
- Something to look for in a used home
- Something you can install after purchase
- Low in cost to install
- IMPORTANT — Highly cost-effective

8. Fluorescent lights

Fluorescent lights should be installed instead of incandescent (light bulb) lights wherever practical — for example, in the kitchen, bathrooms, laundry, and work spaces. They use about a fourth of the power used by ordinary incandescent lights.

- Something to look for in a new home
- Something to look for in a used home
- Something you can install after purchase
- Low in cost to install
- IMPORTANT — Highly cost-effective

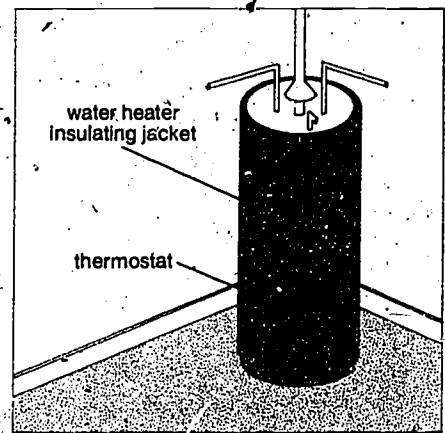

Hot water tank insulating jacket.

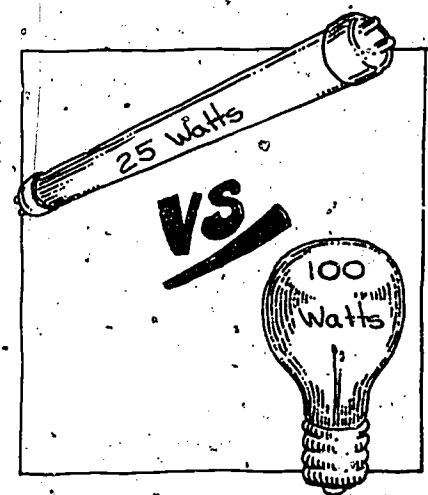

These six energy-saving measures cost more than the previous eight, but they also save more than the items described above. Seek expert advice before investing in one of these features if you feel at all uncertain about it. The six measures are listed in approximate order of importance and probable cost-effectiveness, with the most important first.

1. Protection from the wind

Protection from the wind can be provided by trees, bushes, and hedges. Dense shrubbery around a home can cut heating costs by over 20 percent. Evergreens make the best windbreaks. They should be placed in the direction of the prevailing winter wind (most often from the north, northeast, or northwest). Garages and similar structures are also best placed to the north.

- Something to look for in a new home
- Something to look for in a used home
- Something you can install after purchase
- Low in cost to install
- IMPORTANT — Highly cost-effective

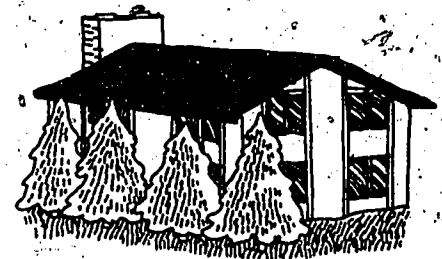

Evergreens as windbreaks.

2. Replacement of heating and cooling equipment

An oil or gas furnace that is substantially oversized or that is unable to achieve an efficiency of about 65 percent in continuous operation should probably be replaced.

The capacity, or "size", of an oil furnace can be reduced up to 20 percent by installing a smaller burner nozzle. Larger reductions, or any reductions in gas furnace capacity, generally involve purchasing a new unit. Furnace sizing, and a simple test for determining whether a furnace is properly sized, are described on page 46. Remember, when you upgrade an older home to substantially reduce its heating requirements, you are likely to make the furnace oversized in relation to the new, smaller heating load. This reduces the savings you are getting from other energy-saving improvements, and may make replacement of the furnace a worthwhile investment.

Furnace efficiency can be checked by a qualified oil or gas company serviceman. A modern unit when properly adjusted can achieve a 75 to 80 percent steady-state efficiency; 65 percent efficiency or lower is too low, and you should consider replacing the unit.

For older oil furnaces, as an alternative to replacing the whole unit, a qualified technician can install a flame retention burner in the existing unit. This will reduce heating bills by about 10 percent.

If your home has central air conditioning and is located in a warm climate (Zones A and B in the map on page 9 or 33), you should consider replacing the air conditioning unit if you undertake other major energy-efficiency improvements. After the improvements, the unit will be oversized, and also, if it is more than a few years old, its EER (energy-efficiency ratio) is probably much lower than the EER's available today. If you do replace the unit, be sure to get a model with a high EER (that is, 8.0 or greater).

In making decisions about whether to replace a furnace or an air conditioner, seek the advice of qualified servicemen and dealers in your area.

One further note: Devices are available that reduce flue gas heat losses when the furnace is not operating; recover heat from stack gas before it enters the chimney; and lower boiler water temperatures when the outside temperature is mild. Your oil or gas company can help you determine whether these energy efficiency devices can be used in your heating system, as well as the expected fuel savings.

- Something to look for in a new home
- Something to look for in a used home
- Something you can install after purchase
- Low in cost to install
- *IMPORTANT— Highly cost-effective**

*In some cases—consult your oil or gas company.

3. Solar water heating

Solar energy systems to heat domestic hot water will reduce water heating costs. Some are complete systems, while others are added to existing water heaters. Their cost-effectiveness varies according to your geographic location and the amount of sunlight available there, and according to energy prices in your area. Obtain and evaluate as much information as you can about the performance of a solar water heating system before purchasing it, or before giving great weight to this feature in a home you are considering. See page 58 for where to call for general information and information on federal tax credit eligibility.

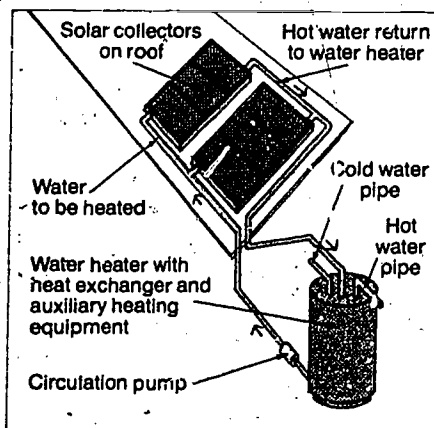

Solar hot water heating system.

The National Solar Heating and Cooling Information Center has a toll-free hotline to answer questions about solar water heating and applicable tax information. The number is 800/523-2929.

- Something to look for in a new home
- Something to look for in a used home
- Something you can install after purchase
- Low in cost to install
- IMPORTANT — Highly cost-effective

4. Energy-efficient appliances

Energy-efficient appliances for kitchen and laundry can save you money. Check to see if the refrigerator, washer, dryer, and water heater are labeled or sold as "energy-efficient." The savings from these particular energy-efficient appliances justifies their slightly higher cost.

- Something to look for in a new home
- Something to look for in a used home
- Something you can install after purchase
- Low in cost to install
- IMPORTANT — Highly cost-effective

5. Vestibules

A vestibule, breezeway, or other "air-lock" type entry between the outdoors and the living area will reduce air infiltration and reduce air changes when you leave and enter your home. Be sure to enter and leave your home through this entryway during peak heating and cooling months.

- Something to look for in a new home
- Something to look for in a used home
- Something you can install after purchase
- Low in cost to install
- IMPORTANT — Highly cost-effective

6. Fireplaces and wood stoves

Fireplaces and wood stoves used in conjunction with standard heating systems can sometimes offer significant energy savings (if firewood can be obtained inexpensively), but only if the unit is of closed combustion design with an outside combustion air intake. "Closed combustion design" means that the wood is burned in an enclosed space that is not directly exposed to the room. In the case of a fireplace, this means that it will have a closed glass front along with an outside combustion air intake. An "outside combustion air intake" allows the fireplace or stove to draw cold air from outdoors instead of air from indoors that has already been heated. Ordinary stoves and fireplaces are inefficient because they draw large amounts of heated indoor air up the chimney.

- Something to look for in a new home
- Something to look for in a used home
- Something you can install after purchase
- Low in cost to install
- IMPORTANT — Highly cost-effective

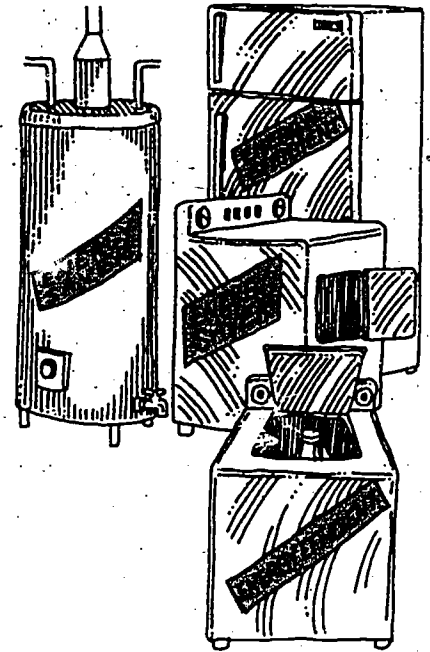

Energy-efficient appliances.

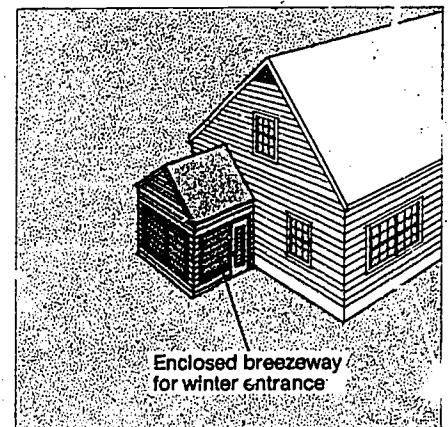

Adding a vestibule.

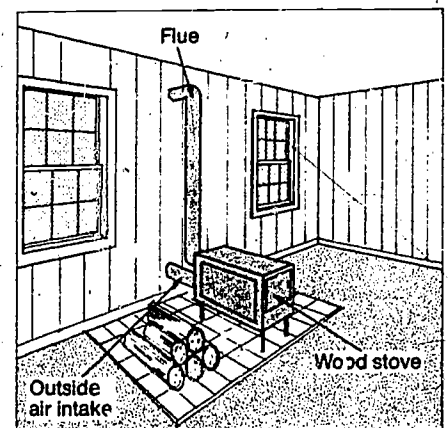

An energy-efficient wood-stove.

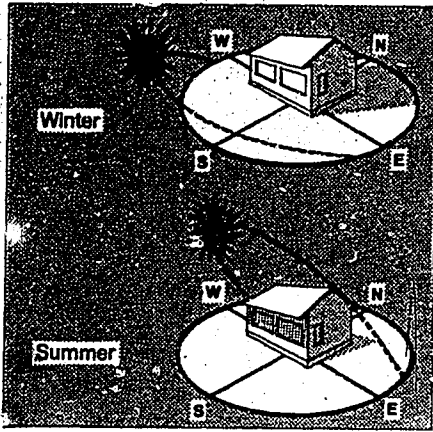

Ideal orientation and shading.



Deciduous tree: summer.



Deciduous tree: winter.

The items covered here have to do with the shape, orientation, and placement of the home. They are **not** things that you can easily change about a home after you buy it. Since you can't do much about them later on, it is a good idea to pay attention to them **now**, before you settle on a particular home.

The cost-effectiveness of these items is hard to evaluate, and can vary from very high to relatively low.

1. Shading and orientation

Control of the sun will significantly increase the energy-efficiency of a home. The most important features are the direction in which windows face, and proper shading of those windows. Look for a home

1. that has as much of its window area as possible on the south side, and the minimum window area required for light and ventilation on the north, east, and west sides, *and*
2. that has summer shading for the south-facing windows consisting of deciduous trees, properly designed overhangs, or movable awnings or shutters to block the summer sun.

Note that south-facing glass *without* summer shading is not desirable. A home built without regard to the direction its windows face should have the minimum glass area necessary for light and ventilation.

The possible shading methods are as follows:

- **Roof overhangs** are effective shading devices. They must be of the correct depth in order to be effective. The accompanying table shows, for selected U.S. cities, the depth of overhang required to adequately shade the upper six feet of a wall. If the windows extend down more than six feet, the overhang should be proportionately increased.

Amount of overhang required to shade six feet of wall

Cities	Approx. latitude	Direction window faces		
		South	Southeast	East West
Duluth, MN/Seattle, WA	47°	3'3"	6'0"	7'2"
New York, NY/Chicago, IL	42°	2'8"	5'2"	7'2"
Washington, DC/Denver, CO	39°	2'3"	4'10"	7'2"
Atlanta, GA/Dallas, TX/Los Angeles, CA	34°	1'7"	4'3"	7'2"
Jacksonville, FL/Houston, TX	30°	1'1"	3'9"	7'2"
Tampa, FL/Corpus Christi, TX	28°	10"	3'5"	7'2"

- **Deciduous trees** (trees that lose their leaves in the winter) are very good summer "shading devices" because they provide shade exactly when it is needed in the summer and let sunlight through when it is needed in the winter. If a home is completely shaded by trees in the summer, its air conditioning bill may be reduced by half.

- *Awnings and exterior shutters* can also be used for summer shading. Awnings have the disadvantages that they have to be removed and replaced each fall and spring in order to provide full winter heating, and that they are subject to deterioration from the weather.
- *Inside blinds, shades and draperies* help to cut summer sun, but they are the least satisfactory way to do so, since they do not stop the sun's rays until they are already inside the glass. See page 47.

In warm climates, the *least* desirable direction for windows to face is east or west. In the summer, these windows receive the low rays of the early morning and late afternoon sun, and cannot be easily shaded by overhangs. If a home in a warm climate has large west-facing windows you should consider providing some type of shading to block the afternoon summer sun.

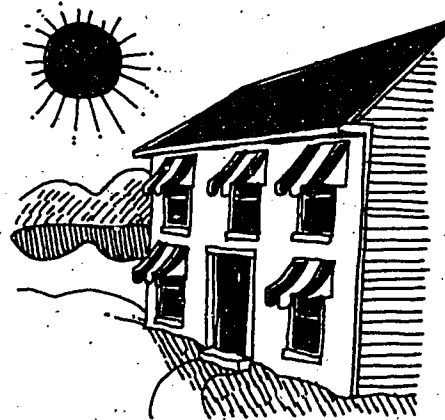

Awnings can be used for summer shading.

- Something to look for in a new home
- Something to look for in a used home
- Something you can install after purchase
- Low in cost to install
- IMPORTANT — Highly cost-effective

2. Efficient shape

Shape and height of the home affects its heat loss characteristics. The most important factor is the shape of the floor plan of the home: a simple, compact, rectangular home is more energy-efficient than an equivalent home with a complicated L-, T- or H-shape, because its wall area is smaller even though it has the same floor area.

It makes less difference whether a house is one or two stories. Although a two-story house has less total exterior surface compared to its floor area, it usually has *more* wall area compared to its floor area, and walls normally are less energy-efficient than ceilings and floors.

Town houses and row houses that share party walls *may* be more energy-efficient than detached houses because of the reduced exterior wall area. However, party walls are sometimes constructed in a way that results in significant heat loss.

Shorter walls also result in reduced heat loss. Walls that are 7 feet, 6 inches high lose less heat than eight-foot walls.

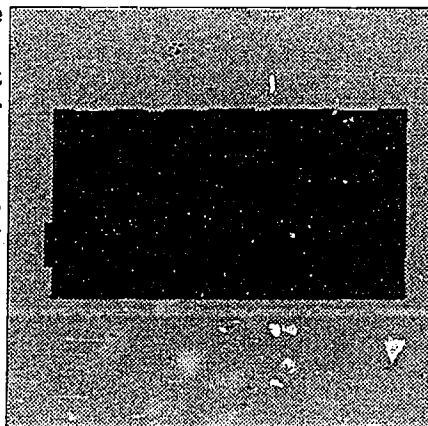

Energy-efficient floor plan.

- Something to look for in a new home
- Something to look for in a used home
- Something you can install after purchase
- Low in cost to install
- IMPORTANT — Highly cost-effective

3. Solar space heating

Solar energy systems for space heating are covered by a variety of specialized books on the subject. For assistance in this area and information on tax credits, call the National Solar Center toll-free at 800/523-2929.

- Something to look for in a new home
- Something to look for in a used home
- Something you can install after purchase
- Low in cost to install
- IMPORTANT — Highly cost-effective

Checklist for the Buyer of a Home - Energy-Related Features

These pages provide a reference list to assist buyers of both new and used homes who want to take a more careful, detailed look at a home. This Guide presents recommendations concerning 40 different features of a home. For each of the five climate zones, the checklist tells you whether the feature is definitely recommended, of no value, or definitely not recommended. This list of features overlaps the "twelve features for new homes" and the items to be inspected in used homes. Many additional features, however, are also covered.

The features are presented here with only brief descriptions. All of them are explained in detail elsewhere in *The Energy-Wise Homebuyer*, and page references are included.

Feature	Page(s)	Zone 1	Zone 2	Zone 3	Zone 4	Zone 5
Ceiling Insulation	8, 34	R-19	R-19	R-19	R-30	R-38
Wall Insulation (except for masonry walls)	8, 35	R-11	R-11	R-13	R-13	R-19
Floor Insulation (Floors over unheated spaces)	8, 35	no	not needed	R-11	R-11	R-19
Walls of Heated Basements	8, 35	no	not needed	R-6	R-11	R-11
Insulation Around Edge of Concrete Slab Floor	8	no	R-2	R-5	R-7.5	R-7.5
No. Layers of Glass	11, 32	1	1	1	2	3
Storm Doors or Thermal Doors	11, 32	no	no	no	no	yes
Heating and Cooling Equipment						
Electric Furnace as Main Heat Source	12	OK	avoid	avoid	avoid	avoid
Electric Room Heaters With Individual Room Controls	16	OK	OK	OK	OK	OK
Oil or Gas Furnace	12	not needed	yes	yes	yes	yes
Air Conditioning Recommended	13	OK	OK	OK	maybe not	avoid
If Central Air Conditioning Used, Is Heat Pump Recommended Instead of Electric Resistance Heat?	12	no ²	maybe ²	maybe ²	maybe ²	no ²
Suggested Minimum EER ³ of Air Conditioning Equipment	13	8.0	8.0	8.0	7.5	7.5
Ducts and Heating Pipes Inside Heated Space	14	yes	yes	yes	yes	yes
Ducts Insulated If Outside Heated Space	14, 36	R-4	R-4	R-6	R-10	R-10
Heating Pipes Insulated If Outside Heated Space	14, 36	R-2	R-2	R-3	R-3	R-4
Outside Combustion Air Intake for Furnace	18	yes	yes	yes	yes	yes
Zoned Heating System	16	no	yes	yes	yes	yes
Whole House Ventilating Fan	47	yes	yes	yes	maybe	possibly
Clock Thermostat(s) (Except With Heat Pump)	16	only if central A/C		yes	yes	yes

¹Follow the recommendations in Table 2, page 8 and Table 4, page 11, if electric resistance heat is used.

²Check with local power company for precise information for your area

³"Energy Efficiency Ratio"

Shape of Heated Space	53	yes	yes	yes	yes	yes
Maximum Windows to South; South East & West Windows Shaded in Summer; Deciduous Shade Trees	17, 52	no	yes	yes	yes	yes
Minimum Total Window Area if Windows Not Facing in the Right Direction, or Not Properly Shaded	52	yes	yes	yes	yes	yes
Low Walls — 7½ ft. instead of 8 ft. or more	53	yes	yes	yes	yes	yes
Vestibule Entryway	51	not needed	not needed	not needed	yes	desirable
Windbreaks (e.g., evergreen shrubs or hedges) in Direction of Winter Wind	49	not needed	not needed	not needed	yes	desirable
Recommended Attic Vent Area as Fraction of Total Attic Floor Area	48	1/150	1/150	1/150	1/150	1/150
Recommended Attic Vent Area if Vapor Barrier Provided Under Ceiling Insulation	48	1/300	1/300	1/300	1/300	1/300
Attic Power Vents (Exhausts Air From Attic)	48	no	no	no	no	no
Fireplace or Wood Stove — Sealed Combustion Unit with Outside-Air Intake — If lowcost firewood available	51	no value	no value	maybe	maybe	yes
Fireplace or Stove — Not Sealed or With no Outside Combustion Air Intake	51	no	no	no	no	no
Efficient Waterheater (heavy insulation jacket)				if A/C provided	maybe	little value
a. if inside heated and cooled space	49	yes	yes			
b. if outside heated and cooled space	49	not needed	not needed	maybe	yes	yes
Solar-Assisted Water Heater	50	maybe	maybe	maybe	possible	doubtful
Water-Saving Faucets and Showerheads	47	yes	yes	yes	yes	yes
Fluorescent Lighting where possible	49	yes	yes	yes	yes	yes
Heavy Draperies, Shades, Shutters on Windows	44, 47, 52	yes	yes	yes	yes	yes
High-Efficiency Refrigerator, Washer, Dryer	51	yes	yes	yes	yes	yes
Exhaust fans in Bathroom, Kitchen, Laundry	48	if A/C provided	if A/C provided	if A/C provided	if A/C provided	no
Look for quality and completeness of the following:						
Caulking and Weatherstripping	10, 30	yes, all zones				
Band Joist (Rim Joist) Insulation	17	yes, all zones				
Well-Installed Ceiling Insulation; Attic Access Insulated and Weatherstripped	15	yes, all zones				
Sill Sealing Insulation, — Caulking of Sill, or Tight Fit	10	yes, all zones				

Band Joist, Rim Joist

The board, set on edge on the sill plate, that runs around the outer edge of the underfloor structure.

Batt Insulation

Pieces of glass fiber or rock wool insulation, 16 or 24 inches wide and 4 or 8 feet long.

Blanket Insulation

Long rolls of glass fiber or rock wool insulation.

Blown-In Insulation

Loose insulation injected into a wall cavity or attic by means of a special machine.

British Thermal Unit (Btu)

A measure of heat energy: One Btu is the amount of heat required to raise the temperature of a pound of water by one degree Fahrenheit.

Caulking

A flexible material used to fill gaps where two different surfaces of the house meet.

Cellulosic Fiber Insulation

A loose insulation manufactured from wood or paper products and usually chemically treated for fire resistance. All such material used in homes should comply with General Services Administration specifications to assure fire resistance.

Clock Thermostat

A thermostat that automatically raises and lowers the indoor temperature at specified times of the day or night.

Coefficient of Performance (COP)

A measure of the efficiency of a heat pump or air conditioner. The COP is defined as the number of Btu's of heat that are moved between indoors and outdoors by each Btu of input energy used to operate the unit. A unit with a higher COP is more efficient. The COP is proportional to the EER (see below).

Cost-Effectiveness

A measure of the degree to which an energy-efficiency measure results in savings that pay for its original purchase cost. A measure with high cost-effectiveness, other things being equal, is a better investment than one with low cost-effectiveness.

Degree Day

A measure of winter climate severity: One degree day is one degree Fahrenheit difference between the average outdoor temperature for the day and a standard temperature of 65° Fahrenheit. Yearly heating costs are roughly proportional to yearly heating degree days.

Electric Furnace

A centrally-located device which heats air with electric resistance heating elements for distribution throughout the house.

Electric Resistance Heat

Heat produced by the flow of electricity through high-resistance wire, tape, or film.

Energy Efficiency Ratio (EER)

A measure of air conditioner efficiency. The EER is defined as the number of Btu's of heat removed from the house by an air conditioner per watt of electrical energy used to operate the unit. A unit with a higher EER is more efficient. See page 13 for how to calculate EER's.

Expanded Polystyrene ("bead board")

A rigid plastic insulating material.

Extruded Polystyrene ("Styrofoam")

A rigid plastic insulating material.

Glass Fiber Insulation ("Fiberglass")

Insulation made out of thin strands of glass fiber, either in the form of batts, blankets or rolls, or loose-fill.

Heat Pump

A device, similar in operation to an air conditioner, which extracts heat from the outdoor air in winter and moves it indoors. It is electrically operated but is more efficient than electric resistance heat under most climate conditions. In the summer, a heat pump operates to provide cooling like an ordinary central air conditioner.

Infiltration

The leakage of air through cracks in the surface components of a building.

Insulating Glass

Two layers of glass with an air space in between, manufactured as a single unit.

Joists

The beams that support a floor or ceiling.

Loose-fill Insulation

Insulation in the form of short fibers or granules that can be poured, or blown into place by a special machine.

Outside Combustion Air Intake

A duct to a furnace or fireplace that draws cold air from the outside for use in the combustion process.

R-value

A measure of the insulating value of a substance. A higher R-value means a higher insulating ability.

Retrofit

Alteration of a home or addition of materials or devices to improve its energy performance.

Sealed Combustion Unit

A furnace or fireplace which shuts out air except at controllable vents.

Sill Plate

The horizontal board, lying flat on top of the foundation, on which the outer wall rests.

Sill Sealing Insulation

Insulation placed between foundation and sill to prevent air leakage.

Sizing (of Furnace)

The heating capacity of an oil or gas furnace. A furnace with too large a capacity ("oversized") is inefficient. Furnace sizing can often be reduced through minor modifications. See page 46.

¹Registered trademark of the Dow Chemical Company

Thermal Break

A layer of insulating material between the inner and outer frames of a metal-framed window.

Thermal Door

A tightly sealing door manufactured with an insulating core encased within an outer shell.

Ureaformaldehyde Foam

An insulating foam primarily used for injection into existing walls.

Urethane Foam

A plastic insulating material available as rigid boards, or for spraying onto building surfaces.

Vapor Barrier

A thin sheet of plastic or specially treated paper that resists penetration by moisture. Such a layer should normally be located on the side of a layer of insulation facing the interior of the house.

Weatherstripping

Flexible metal, vinyl, foam or felt material for preventing air leaks around the moving parts of windows and doors.



- *In The Bank . . . or Up The Chimney?*
A Dollars and Cents Guide to Energy-Saving Home Improvements, Second Edition, 1977
By the U. S. Department of Housing and Urban Development. Complete information on how to choose the most cost-effective energy conservation improvements for any home, plus detailed, illustrated how-to instructions. 72 pages.
For sale by the Superintendent of Documents, U. S. Government Printing Office, Washington, DC 20402. Price \$1.70. Specify Stock Number 023-000-00411-9.
- *Thermal Performance Guidelines for One and Two Family Dwellings, 1977*
By the National Association of Home Builders. Detailed information on the most cost-effective levels of insulation and other energy-saving features for new homes, for your exact climate and energy prices.
For sale by the National Association of Home Builders, 15th and M Streets, NW, Washington, DC 20005. Price \$10.00. NAHB Publication No. 560.02.
- *Solar Hot Water and Your Home*
By the National Solar Heating And Cooling Information Center. Detailed information on all aspects of solar domestic hot water heating. 20 pages.
Free from the National Solar Center: call toll-free 800/523-2929.
- The National Solar Center's toll-free number, 800/523-2929, is a hotline for all types of federal information resources on solar heating and cooling.

air conditioner efficiency	13-14
air conditioner maintenance	45, 46
air filters	45
appliances	51
attic insulation	8-9, 15, 33-34
attic ventilation	48
band joist insulation	17
caulking	10, 30-31
climate zones	9, 33
clock thermostat	16, 37
drapes	44, 47
duct insulation	14, 36
electric resistance heating	12-13
energy cost estimates	20-21, 26-28
energy efficiency ratio (EER)	13-14
fans	47-48
financing	29
fireplaces	18, 44, 51
floor insulation	8-9, 33-35
fluorescent lights	49
fuel cost estimates	20-21, 26-28
furnace efficiency	36-37, 50
furnace maintenance	45, 46-47
gas furnaces	12, 36-37
heat pumps	12-13
heating pipe insulation	14, 36
hot water tank	44, 46
hot water tank insulation	49
individual room controls	16, 37
insulating glass	11, 32
insulation requirements	8-9, 33-36
oil furnaces	12, 36-37
rim joist insulation	17
R-value	8, 34
solar orientation	17, 52-53
solar space heating	53
solar water heating	50-51
storm doors	11, 32
storm windows	11, 32
thermal doors	11, 32
utility bills	20, 26-27
wall insulation	8-9, 33-35
water saving devices	47
weatherstripping	10, 31
windbreaks	49
window blinds	44, 47
woodburning stoves	51
zoned heating systems	16

This manual has been prepared by Technology + Economics, Inc. under Contract No. H-2648 for the Division of Energy, Building Technology and Standards, Office of Policy Development and Research, U.S. Department of Housing and Urban Development, and was supported by funds from the Office of Buildings and Community Systems, Office of Conservation and Solar Applications, U.S. Department of Energy.

The authors wish to thank Mary Ann Eichenberger of the Division of Energy, Building Technology, and Standards at HUD for her untiring support and assistance throughout the course of the project. Her efforts on this project provided us with invaluable service.

The authors also wish to thank Mary-Lynn Wrabel and Gerald Leighton at the Department of Energy, and Joseph Sherman and Robert Jones, Jr., AIA at the Department of Housing and Urban Development, and many others at both agencies for their professional assistance throughout the project.

This manual was reviewed by a committee composed of members from various governmental, industrial, and academic organizations. Their comments and suggestions provided valuable advice in ensuring the technical accuracy and proper orientation of this booklet. The members of the Review Committee were:

William J. Angell of the University of Minnesota; Charles H. Burkhardt of the New England Fuel Institute; G. Paul Carr of the American Bankers Association; Don L. Gilchrist of the National Association of Home Manufacturers; Saul B. Klamon of the National Association of Mutual Savings Banks; Lloyd P. Kuehn of the National Association of Realtors; Carol B. Meeks of Cornell University; Harold B. Olin of the United States League of Savings Associations; and Paul Smith of the American Gas Association

Principal authors:	Subcontractors:	Project staff:
Peter T. Hogarth, <i>Project Manager</i>	NAHB Research Foundation, Ralph J. Johnson	Eric S. Brown Claire J. Morton
David J. MacFadyen	Designworks, Jennie Bush	Douglas Peterson
Frank Spain	Steve Johnson, <i>Technical Illustrator</i>	Robert F. Stone Michael E. White
	George Ulrich, <i>Illustrator</i>	Geoffrey Young

Disclaimer:

The research and studies forming the basis for this manual were conducted pursuant to a contract with the U.S. Department of Housing and Urban Development (HUD) and were supported by funds from the U.S. Department of Energy (DOE). The statements and conclusions contained herein are those of the contractor and do not necessarily reflect the views of the U.S. Government in general or HUD or DOE in particular. This manual is not an official standard, and neither the United States, nor HUD nor DOE, nor the contractor makes any warranty, expressed or implied, or assumes responsibility for the accuracy or completeness of the information herein. However, HUD and DOE emphasizes that this manual may be reproduced freely by any interested party, so long as no material contained in the manual is changed or deleted in such reproduction, and so long as proper credit is given to HUD and DOE in such reproduction.