

DOCUMENT RESUME

ED 197 148

CE 027 777

AUTHOR Schramm, C.; Osland, Walt
 TITLE Mountain Plains Learning Experience Guide: Automotive Repair. Course: Brake Systems.
 INSTITUTION Mountain-Plains Education and Economic Development Program, Inc., Glasgow AFB, Mont.
 SPONS AGENCY Office of Vocational and Adult Education (ED), Washington, D.C.
 BUREAU NO 49BMH90008
 PUB DATE Mar 76
 CONTRACT 300-79-0153
 NOTE 232p.: Not available in paper copy due to light print. For related documents, see CE 027 766, CE 027 768-775, CE 027 777-780.

EDRS PRICE MF01 Plus Postage. PC Not Available from EDRS.
 DESCRIPTORS Adult Education: *Auto Mechanics; Disadvantaged: Family Programs: *Individualized Instruction: Instructional Materials: Learning Activities: Learning Modules: Motor Vehicles; Postsecondary Education: Skilled Occupations: *Vocational Education

IDENTIFIERS *Brake Services: Mountain Plains Program

ABSTRACT

One of twelve individualized courses included in an automotive repair curriculum, this course covers theory, operation, and repair of drum brakes, disc brakes, and brake system components. The course is comprised of six units: (1) Fundamentals of Brake Systems, (2) Master Cylinder, (3) Drum Brakes, (4) Disc Brakes, (5) Power Brakes, and (6) Emergency Brakes. Each unit begins with a Unit Learning Experience Guide that gives directions for unit completion. The remainder of the unit consists of Learning Activity Packages (LAP) that provide specific information for completion of a learning activity. Each LAP is comprised of the following parts: objective, evaluation procedure, resources, procedure, supplemental sheets, study guide, and a LAP test with answers. The course is preceded by a pretest which is designed to direct the student to units and performance activities. (LRA)

ED197148

MOUNTAIN PLAINS LEARNING EXPERIENCE GUIDE:

Automotive Repair.

Course: Brake Systems.

CE027777

U S DEPARTMENT OF HEALTH,
EDUCATION & WELFARE
NATIONAL INSTITUTE OF
EDUCATION

THIS DOCUMENT HAS BEEN REPRO-
DUCED EXACTLY AS RECEIVED FROM
THE PERSON OR ORGANIZATION ORIGIN-
ATING IT. POINTS OF VIEW OR OPINIONS
STATED DO NOT NECESSARILY REPRESENT
OFFICIAL NATIONAL INSTITUTE OF
EDUCATION POSITION OR POLICY

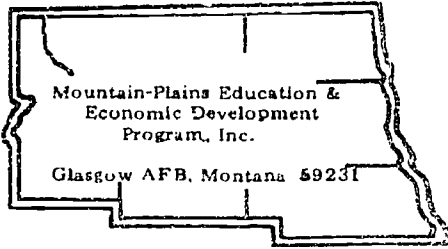

Learning Experience Guide

COURSE: BRAKE SYSTEMS

DESCRIPTION:

Brake Systems includes theory, operation and repair of drum brakes, disc brakes and brake system components.

RATIONALE:

The automobile depends on the brake system for stopping its motion or slowing it down. Periodic maintenance and repair work is required to maintain a margin of safety. The mechanic who performs brake work has the responsibility of doing the best possible job, and this course gives the mechanic the training.

PREREQUISITES:

MATH SKILLS - Level E or higher as determined by the specific requirement of the particular job titles.

COMMUNICATION SKILLS - Level E or higher as determined by the specific requirement of the particular job titles.

OBJECTIVE:

Inspect, service and repair automotive brake systems.

RESOURCE:

A resource list is attached.

GENERAL INSTRUCTIONS:

This course has six units. Each unit has a Unit Learning Experience Guide (LEG) that gives directions for unit completion. Each unit consists of Learning Activity Packages (LAPs) that provide specific information for completion of a learning activity. Pretesting results direct the student to units and performance activities.

Principal Author(s):

C. Schramm/W. Osland

GENERAL INSTRUCTIONS: (cont.)

The general procedure for this course is as follows:

- (1) Read the assigned unit LEG for this course.
- (2) Begin and complete the first assigned LAP.
 - a. Take and score the LAP test.
 - b. Turn in the LAP test answer sheet.
 - c. Determine the reason for any missed items on the LAP test.
 - d. Proceed to the next assigned LAP in the unit.
 - e. Complete all required LAPs for the unit by following steps (a) through (d).
- (3) Take the unit tests as described in the Unit LEG "Evaluation Procedures".
- (4) Proceed to the next assigned unit in this course.
- (5) Follow steps 1 through 4 for all required units for this course.
- (6) Proceed to the next assigned course..

You will work independently unless directed to do otherwise. When questions or problems arise, you are expected to discuss them with the instructor. At all times remember to follow correct safety procedures during the performance activity.

UNIT TITLES:

- .01 Fundamentals of Brake Systems
- .02 Master Cylinder
- .03 Drum Brakes
- .04 Disc Brakes
- .05 Power Brake
- .06 Emergency Brakes

EVALUATION PROCEDURE:

Course evaluation is by pre and post testing using a multiple-choice type of test.

In this course, the course test is used as a pretest to determine which units, if any, the student may be able to validate. The student is considered validated for a particular unit if 4 out of 5 items are correctly answered for each LAP part on the course pretest and that particular unit does not have a performance test requirement.

For those units with performance test requirements, the student must also satisfactorily complete the performance test to validate that unit. Unit performance test validation procedures are given in the "Evaluation Procedure" section of the unit Learning Experience Guide (LEG)

The course test will also be taken by the student as a post test to determine any changes resulting from taking all or part of the course. **Score at least 80% on the course post test.**

FOLLOW-THROUGH:

Go to the first Learning Experience Guide (LEG) listed on your Student Progress Record (SPR).

RESOURCE LIST

Printed Materials

1. Auto Mechanics Fundamentals. Martin W. Stockel, Goodheart-Willcox Company, Inc.
2. Auto Service and Repair. Martin W. Stockel, Goodheart-Willcox Company, Inc.
3. Automotive Service and/or Repair Manuals such as Motor Repair Manual. The Hearst Corporation, 1972, or the equivalent.
4. Manufacturer's Specifications for brake systems.
5. Operator's Manual, Lathe.
6. Operator's Manual, Pressure Bleeder.
7. Time and Parts Manual.

Audio/Visuals

Super 8 Sound Films: Brake Work Filmstrips

DCA Educational Products, Inc.

1. Assembly Procedures (#FAA172).
2. Assembly Procedures (#FAA192).
3. Disassembly Procedures (#FAA162).
4. Disassembly Procedures (#FAA182).
5. Nomenclature and Adjustments (#FAA152).

Universal Education and Visual Arts

6. Dual Master Cylinder Assembly, Part III (FL-7773).
7. Dual Master Cylinder Cleaning and Honing, Part II (#FL-7772).
8. Dual Master Cylinder Disassembly (#FL-7771).
9. Installing the Pads (#FL-7778).
10. Removing the Pads (#FL-7777).
11. Single Piston Caliper Assembly (#FL-7776).
12. Single Piston Caliper Cleaning and Inspection (#FL-7775).
13. Single Piston Caliper Disassembly (#FL-7774).

Equipment

1. Automobile or system to be diagnosed, serviced and repaired (automobile with: disc brakes, drum brakes, emergency brake, and power brakes)
2. Projector, AVT Systems Super 8 mm Instant Film Loop Player.
3. Replacement parts: brake drums
brake linings
brake pads
brake shoes
cups and seals for caliper
disc brake rotor
power brake replacement parts
repair kits: caliper, wheel cylinder, and master cylinder

4. Safety equipment: gloves
goggles
jack stands
5. Supplies: brake fluid
6. Tools, basic hand: chisel and punch set
5/32" pin punch
3/16" solid
gauge, feeler (.002" - .025")
hammer, ball peen
hammer, plastic tip
handle, speed
hex key set
pliers, diagonal cutting
pliers, needle nose
scraper, gasket
screwdriver, standard (set)
screwdriver, Phillips (set)
screw starter
socket set (3/8" drive)
extension (3")
ratchet
socket set (1/4" drive)
extension (")
handle (6" flex)
ratchet
socket, spark plug
extension (6")
wrench, combination (set)
wrench, combination ignition (set)
7. Tools, general: fender cover
jacks or lift
8. Tools, brake systems: brake adjusting tool
brake bleeder
brake spoon
retainer spring tool

7/23/75

INDEX/LEP FOOT THAT ANOTHER INDEX: FUNDAMENTALS OF HOME SYSTEMS

- 1. c
- 2. c
- 3. c
- 4. c
- 5. c
- 6. c
- 7. d
- 8. c
- 9. c
- 10. d
- 11. c
- 12. a
- 13. c
- 14. c
- 15. d
- 16. a
- 17. a
- 18. ~~18~~
- 19. c
- 20. c
- 21. c
- 22. c
- 23. a
- 24. a
- 25. d
- 26. d
- 27. c
- 28. c
- 29. c
- 30. c
- 31. c
- 32. c
- 33. a
- 34. a
- 35. d
- 36. c
- 37. c
- 38. c
- 39. c
- 40. c
- 41. d
- 42. c
- 43. c
- 44. c
- 45. c
- 46. c
- 47. c
- 48. c
- 49. c
- 50. c
- 51. c
- 52. c
- 53. c
- 54. c
- 55. c
- 56. c
- 57. c
- 58. c
- 59. c
- 60. c
- 61. c
- 62. c
- 63. c
- 64. c
- 65. c
- 66. c
- 67. c
- 68. c
- 69. c
- 70. c
- 71. c
- 72. c
- 73. c
- 74. c
- 75. c
- 76. c
- 77. c
- 78. c
- 79. c
- 80. c
- 81. c
- 82. c
- 83. c
- 84. c
- 85. c
- 86. c
- 87. c
- 88. c
- 89. c
- 90. c
- 91. c
- 92. c
- 93. c
- 94. c
- 95. c
- 96. c
- 97. c
- 98. c
- 99. c
- 100. c

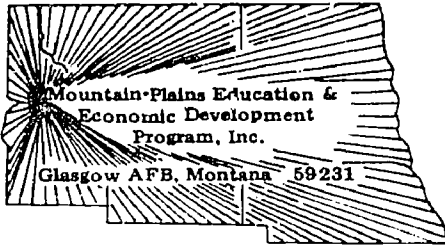

COURSE TEST: BRAKE SYSTEMS

37.09.01.01

1. The modern auto uses:
 - a. hydraulic over mechanical brakes.
 - b. hydraulic brakes as a stopping medium.
 - c. mechanical brakes as a stopping medium.
 - d. mechanical over hydraulic brakes.

2. The greatest advantage of a dual master cylinder is:
 - a. a more even application of brake fluid to each wheel.
 - b. less brake fluid loss due to evaporation.
 - c. the prevention of total brake loss if one wheel cylinder fails.
 - d. greater breaking power at the wheel cylinders.

Identify the components of the pictured cylinder. *(questions # 3 and 4).

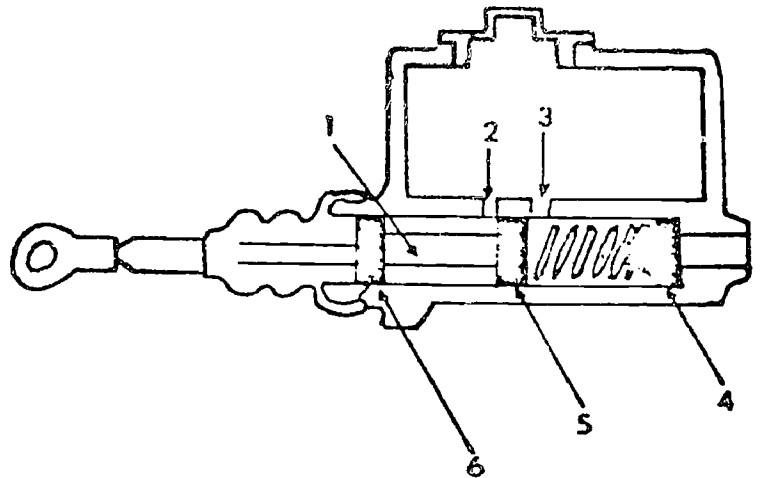

3. Part #3 is called:
 - a. compensating port.
 - b. air vent port.
 - c. reservoir drain.
 - d. fluid inlet port.

4. Part #6 is called:
 - a. secondary cup.
 - b. dust boot.
 - c. piston.
 - d. primary cup.

*(Adapted from Auto Mechanics Fundamentals, Stockel, Goodheart-Wilcox, 1969, page 336, Figures 18-10).

37.09.01.01 (continued)

5. The brake shoe that faces the front bumper of the vehicle is referred to as the:
- important shoe.
 - secondary shoe.
 - primary shoe.
 - servo acting shoe.

37.09.01.02

6. Often because of corrosion, bleeder screws must be:
- tapped out.
 - replaced.
 - re-drilled.
 - removed and cleaned.
7. The greatest danger of brake fluid is that it:
- has a highly acid effect.
 - is flammable.
 - will ruin paint.
 - is highly toxic.

37.09.01.03

8. Brake line ends for flaring should be:
- rounded off.
 - single flared.
 - compress fitted.
 - double flared.
9. To prevent vibration damage, brake lines are:
- rubber suspended.
 - rubber covered.
 - securely mounted.
 - double lined.
10. Copper tubing may be used on:
- lines where greater bending routes are necessary to follow:
 - no brake lines at any time.
 - lines that have minimal flexing.
 - lines until the proper line can be obtained.

37.09.01.03 (continued)

11. Brake line connection should use:

- a. double flared ends.
- b. single compression fittings.
- c. single flare end.
- d. double compression fitting.

12. Brake lines are made up of:

- a. steel.
- b. aluminum.
- c. galvanized iron.
- d. copper.

37.09.01.04

13. The first point to start bleeding is at the:

- a. line connection at the master cylinder itself.
- b. closest wheel from the master cylinder.
- c. farthest wheel from the master cylinder.
- d. first junction box connection.

14. The most common way air can enter the system through the master cylinder is:

- a. through a leaking check valve.
- b. through a damaged master cylinder boot.
- c. by a cracked master cylinder.
- d. by allowing fluid to be too low in the reservoir.

15. The "spongy" feeling of the brake pedal reveals the:

- a. softening of the rubber cups in the master cylinder.
- b. effectiveness of weakened shoe return springs.
- c. presence of air in the system.
- d. existence of water in the brake fluid.

37.09.01.05

16. A brake drum that is cracked should be:

- a. turned down on the brake drum lathe.
- b. carefully welded and then smoothed on the brake lathe.
- c. discarded.
- d. destroyed.

17. Proper free pedal travel for manual brakes is about:

- a. 0 to 1 inch.
- b. 1/2 to 2 inches.
- c. 1/4 to 1/2 inches.
- d. no free play should exist.

37.09.01.05 (continued)

18. When brake lining becomes overheated, it loses a great amount of its efficiency. This occurrence is called:
- grabbing.
 - lining heat loss.
 - brake loss.
 - brake fade.
19. Heat checking (which is not excessive) on a brake drum shoe surface:
- cannot be removed and the drum should be replaced.
 - is normal wear and can be reused as it is.
 - can be removed on a brake lathe.
 - can be polished out with emery cloth.
20. Signs of wetness on the outside of the front backing plate and inside surface of the front tire reveals leakage at the:
- front wheel grease seal.
 - master cylinder.
 - front grease seal and wheel cylinder.
 - wheel cylinder.

37.09.02.01

21. Fluid is entrapped in the cylinder bore as soon as the primary cup passes the:
- secondary cup.
 - check valve.
 - compensating port.
 - fluid inlet port.
22. The serious drawback of the single unit master cylinder is:
- that a power booster cannot be adopted to the master cylinder.
 - that it has braking pressure efficiency.
 - that brakes cannot be pumped up effectively.
 - total loss of brakes if a brake line is ruptured.
23. Which of the following is developed primarily in the master cylinder:
- brake fluid.
 - static pressure.
 - hydraulic pressure.
 - friction.
24. If hard pressure is held on the pedal and the brake pedal slowly lowers itself but there is no evidence of fluid loss, then the:
- filled over half of its capacity.
 - filled to the top.
 - filled 1 to $\frac{1}{2}$ inches from the top.
 - filled $\frac{1}{2}$ to $\frac{1}{4}$ inches from the top.

37.09.02.01 (continued)

25. If hard pressure is held on the pedal and the brake pedal slowly lowers itself but there is no evidence of fluid loss, then the:
- check valve is not operating.
 - secondary cup is leaking.
 - primary cup is leaking.
 - compensating port is blocked.

37.09.02.02

26. On one-only open end master cylinder (single) the check valve is usually the:
- first part to come out of the cylinder bore.
 - last part to come out of the cylinder bore.
 - part that follows in between the primary cup and spring during disassembly.
 - only part that has to be pressed out.
27. Minor or very light scratches and corrosion can be removed with:
- emery cloth.
 - crocus cloth.
 - sand paper.
 - machinist-file.
28. Clearance between the piston and the cylinder bore must not exceed:
- .001
 - .0005
 - .050
 - .005
29. During reassembly of new parts, all parts should be:
- measured.
 - lubricated with denatured alcohol.
 - tested.
 - lubricated with fluid.
30. Before reassembly of cleaned and new parts the mechanic should thoroughly clean his hands with:
- clean, fresh solvent.
 - brake fluid.
 - soap and water.
 - denatured alcohol.

37.09.02.03

31. A check valve is not used in a dual master cylinder on a:
- truck with the master cylinder located beneath the floor.
 - vehicle equipped with front disc brakes.
 - vehicle equipped with full disc brakes.
 - light duty truck.
32. The stop bolt located at the bottom of the dual master cylinder must be removed to release the:
- brake pedal push rod.
 - check valve.
 - floating piston.
 - primary piston.
33. Bleeding of the dual master cylinder should be done at the:
- primary side first.
 - same time on both sides.
 - secondary side first.
 - does not matter which side first.
34. Pits and scratches can be removed from a master cup cylinder by:
- honing.
 - machining.
 - sand paper.
 - emery cloth.
35. The holes in the cup-end of the piston are for:
- fluid to readily flow to the secondary cup.
 - allowing fluid to quickly flow through and past the cup lips on brake application.
 - allowing fluid to quickly flow through and past the cup lips on release.

37.09.03.01

36. For a self-centered shoe to operate, it must have:
- double anchor.
 - single anchor.
 - no anchor.
 - center anchor.
37. The most popular drum brake design in use today is the:
- total contact, center plane, non-servo.
 - truck type brakes.
 - single anchor-duo-servo
 - non-servo.

37.09.03.01 (continued)

38. Some brake shoes center themselves upon application. To do this they must be able to move outward as well as:
- inward.
 - up and down.
 - in and out.
 - right and left.
39. The brake springs, shoes, and hardware are all fastened to the:
- drum plate.
 - wheel hub.
 - drum.
 - backing plate.
40. Brake shoes can be arranged so that one shoe helps the other. This set up is referred to as:
- total contact, center plane, non-servo brake.
 - self adjusting brake.
 - eccentric brake.
 - servo brake.

37.09.03.02

41. Wheel cylinder bores can be reconditioned by:
- emery cloth.
 - sand paper.
 - honing.
 - machining.
42. The most widely used cylinder of today is the:
- double-stepped cylinder.
 - stepped cylinder.
 - single-piston cylinder.
 - double-end straight cylinder.
43. When it is desired to transmit more pressure to one shoe than the other, it is recommended to use:
- a double-end straight cylinder.
 - a single-piston cylinder.
 - a stepped cylinder.
 - a stronger return spring.
44. Final cleansing of the wheel cylinder (whenever possible) should be done with:
- clean brake fluid.
 - fresh solvent.
 - denatured alcohol.
 - soap and water.

37.09.03.02 (continued)

45. Identification of part #2 is*:

- a. housing plug.
- b. fastener screw.
- c. bleeder screw.
- d. grease fitting.

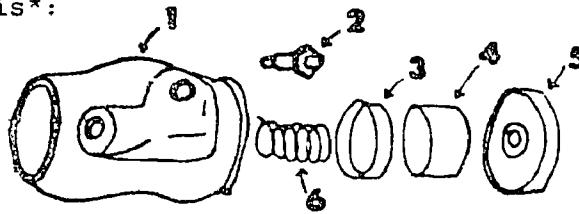
37.09.04.01

46. If the star adjuster fails to rotate then:

- a. oil or lubricant should be squirted on the adjuster threads to soak and free the adjuster to turn.
- b. the drum should be removed, the star adjuster should be cleaned and released to turn.
- c. the mechanic should inform the customer that he needs a brake overhaul.
- d. the mechanic should go on to the other wheels.

47. Brake shoe adjustment requires the wheel to be:

- a. off the floor.
- b. in good shape.
- c. on the floor evenly.
- d. at proper air pressure.

48. The correct brake shoe adjustment is to:

- a. adjust the shoes out until a heavy drag is evident on the wheel as it is turned.
- b. adjust the shoes out until a light scraping sound is heard while turning the wheel.
- c. turn the adjuster until it starts to bind and back off two notches.
- d. adjust the shoes out to lock the wheel, then back off until wheel is free to move without scraping.

49. If the shoe lining is adjusted too close to the drum:

- a. the brakes will drag, heat up, and possibly lock.
- b. the brakes will drag.
- c. the brakes will heat up and crack the drum.
- d. the anchor pin will be sheared off eventually.

*(Adapted from Auto Mechanics Fundamentals, Stockel, Goodheart-Wilcox, 1969, page 342, Figure 18-22).

37.09.03.03 (continued)

50. What presents difficulty in backing off the star-adjuster through the adjusting slot on a self-adjusting brake?
- lever spring.
 - star adjuster spring.
 - trip lever.
 - star adjuster one-way ratchet.

37.09.03.04

51. The shoe that moves away from the anchor (single-anchor type) upon brake forward application is the:
- reverse shoe.
 - primary.
 - secondary.
 - center.
52. Before removal of the brake shoe spring and shoes, it is recommended that you:
- lock the brake pedal.
 - bleed off the cylinder fluid pressure.
 - inspect for cylinder leakage.
 - install a wheel cylinder clamp.
53. To match the new lining to the circumference of the old drum:
- the shoes should be concentric ground.
 - a drum gauge should be used.
 - the shoes should be adjusted out tightly against the drum.
 - the drum should be "turned down" on a lathe.
54. After removal of the drum and before disassembly of the shoe assembly, it is recommended that you:
- test the wheel cylinder for leakage.
 - study the shoe arrangement.
 - wash all parts with solvent.
 - bleed off the fluid.
55. The brake shoe that usually bears the most lining is the:
- primary shoe.
 - secondary shoe.
 - center shoe.
 - all bear the same amount of lining.

37.09.04.01

56. As the wheel cylinder transmits the fluid pressure in drum brakes, the disc brake uses a unit called:
- a disc.
 - a pad.
 - rotor.
 - caliper.
57. Unlike drum brakes, a disc brake fluid system does not maintain which of the following in the lines:
- self-centering.
 - single unit master cylinder
 - static pressure.
 - dual master cylinder.
58. Compared to conventional brakes, disc brakes require:
- more frequent brake lining replacement.
 - low temperature brake fluid.
 - longer stopping distances.
 - higher hydraulic pressure.
59. The stopping friction against the disc is created by forcing which of the following into the disc:
- caliper.
 - rotor.
 - pads.
 - shoes.
60. A valve placed in the rear drum brake fluid line that is installed to prevent rear wheel brake lockup, is the:
- proportioning valve.
 - check valve.
 - metering valve.
 - sensor valve.

37.09.04.02

61. When pad wear is what fraction of an inch to the base plate, it should be replaced
- 1/8 inch.
 - 1/16 inch.
 - 1/4 inch.
 - 1/32 inch.

37.09.04.02 (continued)

62. To effectively remove the pads from the installed caliper, it may be necessary to:
- hammer lightly on the disc.
 - loosen the disc to shift it side to side.
 - hammer lightly on the caliper.
 - force the piston back into their bores.

37.09.04.03

63. In removing the caliper, what needs to be pushed back for additional clearance?
- brake lining.
 - pads.
 - piston.
 - disc.
64. If one of the two calipers which can be separated is damaged, then:
- the damaged half should be replaced.
 - both halves should be replaced.
 - the damaged half should be machined.
 - the calipers of both wheels should be fully exchanged.
65. A typical caliper piston utilizes:
- one seal and one dust boot.
 - two seals.
 - no seals and one dust boot.
 - one cylinder cup and one seal.
66. To force the piston out of the caliper, it may be necessary to utilize a:
- hydraulic press.
 - hydraulic pump or air pressure.
 - hammer and long punch.
 - mechanical puller.
67. Wheel-bearing tension adjustment on a disc brake is difficult because of the:
- resistance drag of the pads.
 - excessive weight of the disc.
 - off-center placement of the caliper.
 - varied thicknesses of the disc.

37.09.04.04

68. Run-out of a disc can be effectively measured with a(n):
- drum micrometer.
 - outside micrometer.
 - dial indicator.
 - inside micrometer.

37.09.04.04 (continued)

69. The spacing holes between the two disc surfaces have what primary purpose?
- reduction in weight.
 - effective cooling.
 - reduction in production costs.
 - a cushioning effect when brakes are extremely applied.
70. What measure tool should be used to insure correct and careful cutting down of the reusable rotor?
- dial indicator.
 - outside micrometer.
 - drum micrometer.
 - thickness gauges.

37.09.05.01

71. The vacuum control valve regulates vacuum at the:
- atmosphere inlet.
 - manifold vacuum outlet.
 - booster vacuum inlet.
 - master cylinder.
72. The brake power booster uses a vacuum on both sides of the diaphragm in the:
- released position.
 - applied position.
 - rested position.
 - retarded position.
73. The power booster operates off:
- engine vacuum and power steering vacuum.
 - engine vacuum and distributor vacuum.
 - engine vacuum and atmospheric pressure.
 - atmospheric pressure and power steering vacuum.

37.09.05.02

74. When the engine is off:
- the vacuum should slowly drop off.
 - the brakes will not operate.
 - vacuum should not exist in the lines.
 - vacuum should remain in the lines.

37.09.05.02 (continued)

75. Often a defective power booster can only be repaired by:
- a. installation of power booster kit.
 - b. replacement of the entire unit.
 - c. patching the damaged diaphragm.
 - d. none of the above.

37.09.06.01

76. The reason parking brakes will firmly hold in the forward position and not in the reverse position is because of the:
- a. secondary shoe.
 - b. primary shoe.
 - c. servo action.
 - d. uneven strut rod.
77. An emergency brake not only can be located at the wheel, but also at the:
- a. car end.
 - b. front wheel.
 - c. drive shaft.
 - d. fly wheel.
78. The emergency park brake utilizes both brakes of one wheel by the use of a:
- a. movable cam.
 - b. connecting rod.
 - c. chain link.
 - d. strut rod.

37.09.06.02

79. If the parking brake doesn't release completely and it is set up too tight, it will:
- a. cause the self adjuster to malfunction.
 - b. weaken the return spring of the park brake.
 - c. effect wheel cylinder performance.
 - d. increase park brake pedal or lever application travel.
80. If a brake cable is sticking, it should be:
- a. replaced.
 - b. lubricated.
 - c. soaked.
 - d. disassembled and inspected.

UNIT TEST ANSWER SHEET

Occupational Area:
 File Code:
 Name:
 Family Pay Number:

Automotive
37.09

Sex: M F (Circle 1)

ANSWERS

- | | | | | | |
|------|--------------|------|--------------|------|--------------|
| 0101 | 1. <u>B</u> | 0201 | 21. <u>C</u> | 0302 | 41. <u>C</u> |
| | 2. <u>C</u> | | 22. <u>D</u> | | 42. <u>D</u> |
| | 3. <u>A</u> | | 23. <u>C</u> | | 43. <u>C</u> |
| | 4. <u>A</u> | | 24. <u>D</u> | 0303 | 44. <u>C</u> |
| | 5. <u>C</u> | | 25. <u>C</u> | | 45. <u>C</u> |
| 0102 | 6. <u>D</u> | 0202 | 26. <u>B</u> | | 46. <u>B</u> |
| | 7. <u>C</u> | | 27. <u>B</u> | | 47. <u>A</u> |
| 0103 | 8. <u>D</u> | | 28. <u>D</u> | | 48. <u>D</u> |
| | 9. <u>C</u> | | 29. <u>D</u> | 0304 | 49. <u>C</u> |
| | 10. <u>B</u> | | 30. <u>C</u> | | 50. <u>C</u> |
| | 11. <u>A</u> | 0203 | 31. <u>C</u> | | 51. <u>A</u> |
| | 12. <u>A</u> | | 32. <u>C</u> | | 52. <u>A</u> |
| 0104 | 13. <u>C</u> | | 33. <u>A</u> | | 53. <u>B</u> |
| | 14. <u>D</u> | | 34. <u>A</u> | 0305 | 54. <u>D</u> |
| | 15. <u>C</u> | | 35. <u>C</u> | | 55. <u>B</u> |
| 0105 | 16. <u>D</u> | 0301 | 36. <u>B</u> | 0401 | 56. <u>D</u> |
| | 17. <u>C</u> | | 37. <u>C</u> | | 57. <u>C</u> |
| | 18. <u>D</u> | | 38. <u>B</u> | | 58. <u>D</u> |
| | 19. <u>C</u> | | 39. <u>D</u> | | 59. <u>C</u> |
| | 20. <u>D</u> | | 40. <u>D</u> | | 60. <u>A</u> |

UNIT TEST ANSWER SHEET

Occupational Area:

Automotive

File Code:

37.09

Name:

ANSWERS

0402	61.	<u>A</u>	81.	<u> </u>	101.	<u> </u>
	62.	<u>D</u>	82.	<u> </u>	102.	<u> </u>
0403	63.	<u>C</u>	83.	<u> </u>	103.	<u> </u>
	64.	<u>B</u>	84.	<u> </u>	104.	<u> </u>
	65.	<u>C</u>	85.	<u> </u>	105.	<u> </u>
	66.	<u>B</u>	86.	<u> </u>	106.	<u> </u>
	67.	<u>A</u>	87.	<u> </u>	107.	<u> </u>
0404	68.	<u>C</u>	88.	<u> </u>	108.	<u> </u>
	69.	<u>B</u>	89.	<u> </u>	109.	<u> </u>
	70.	<u>B</u>	90.	<u> </u>	110.	<u> </u>
0501	71.	<u>C</u>	91.	<u> </u>	111.	<u> </u>
	72.	<u>A</u>	92.	<u> </u>	112.	<u> </u>
	73.	<u>C</u>	93.	<u> </u>	113.	<u> </u>
0502	74.	<u>D</u>	94.	<u> </u>	114.	<u> </u>
	75.	<u>B</u>	95.	<u> </u>	115.	<u> </u>
0601	76.	<u>C</u>	96.	<u> </u>	116.	<u> </u>
	77.	<u>C</u>	97.	<u> </u>	117.	<u> </u>
	78.	<u>D</u>	98.	<u> </u>	118.	<u> </u>
	79.	<u>A</u>	99.	<u> </u>	119.	<u> </u>
	80.	<u>B</u>	100.	<u> </u>	120.	<u> </u>

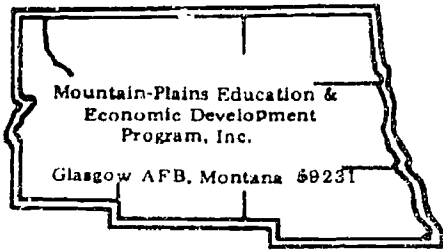

Learning Experience Guide

UNIT: FUNDAMENTALS OF BRAKE SYSTEMS

RAIIIONALE:

The fundamentals and procedures in this unit enable you to diagnose components and determine the operation of the brake system to meet the manufacturers' specifications and bleed the brake system.

PREREQUISITES:

MATH SKILLS - Level E

COMMUNICATION SKILLS - Level E

OBJECTIVES:

Recognize the components and the operation of the brake system, lines, switches and equalizers. Describe precautions and limitations of brake fluid uses. Perform bleeding of a brake system and brake inspection.

RESOURCES:

Auto Service and Repair. Stockel, Goodheart-Willcox Company, Inc.
Manufacturers' specification checklist for brake systems.
Operator's Manual, Pressure Bleeder.
Repair Manual for year and model of car to be assigned to you.
Auto Mechanics Fundamentals. Stockel, Goodheart-Willcox Company, Inc.

Brake Work Filmstrips:

Assembly Procedures (FAA: 172). DCA Educational Products, Inc.
Disassembly Procedures (#FAA: 162). DCA Educational Products, Inc.
Nomenclature and Adjustments (#FAA: 152). DCA Educational Products, Inc.

Automobile to be given brake inspection
 Brake fluid
 Fender Covers
 Jacks
 Jack stands
 Projector, AVT Systems Super 8 mm Film Loop Player

Principal Author(s):

C. Schramm/W. Osland

RESOURCES: Equipment (cont.)

Tools, Basic Hand:

Chisel and Punch Set
 5/32" Pin Punch
 3/16" Solid

Gauge, feeler (.002" - .025")

Hammer, ball peen
 Hammer, plastic tip
 Handle, speed
 Hex Key Set

Pliers, diagonal cutting
 Pliers, needle nose

Scraper, gasket
 Screwdriver, standard (Set)
 Screwdriver, phillips (Set)
 Screw starter

Socket Set (3/8" drive)
 extension (3")
 ratchet

Socket Set (1/4" drive)
 extension (3")
 handle (6" flex)
 ratchet

Socket, spark plug
 extension (6")

Wrench, combination (Set)
 Wrench, combination ignition (Set)
 Wrench, combination ignition (set)

GENERAL INSTRUCTIONS:

This unit consists of five Learning Activity Packages (LAPs). Each LAP will provide specific information for completion of a learning activity.

The general procedure for this unit is as follows:

- (1) Read the first assigned Learning Activity Package (LAP).
- (2) Begin and complete the first assigned LAP.
- (3) Complete all required LAPs for the unit.
- (4) In this unit, the LAP and unit tests are combined. This combined test is taken after completing the last LAP in the unit.
- (5) Take the Unit/LAP tests as described in the Unit LEG "Evaluation Procedures".
- (6) Proceed to the next assigned unit.

PERFORMANCE ACTIVITIES:

- .01 Basic Brake Operation
- .02 Brake Fluids
- .03 Hydraulic Lines, Switches and Equalizers
- .04 Bleeding of Brake Systems
- .05 Brake Inspection

EVALUATION PROCEDURE:

Score 4 out of 5 correct answers for each LAP in the unit on the unit post test.
Perform the brake inspection in accordance with the checklist on the unit/performance test.

FOLLOW-THROUGH:

Go to the first Learning Activity Package (LAP) listed on your Student Progress Record (SPR).

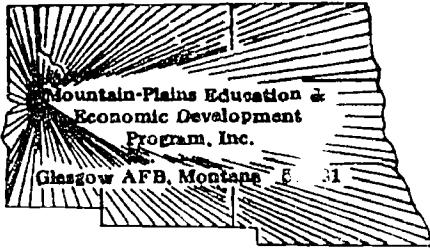

UNIT/LAP PRETEST: FUNDAMENTALS OF BRAKE SYSTEMS

37.09.01.01.

1. When a liquid is confined and placed under pressure:

- a. it can easily be compressed.
- b. it cannot be compressed.
- c. it can be reduced in volume.
- d. it's force can be multiplied.

2. Part no. 1 in the illustration* below is called a:

- a. piston.
- b. plunger.
- c. push rod.
- d. cylinder bore.

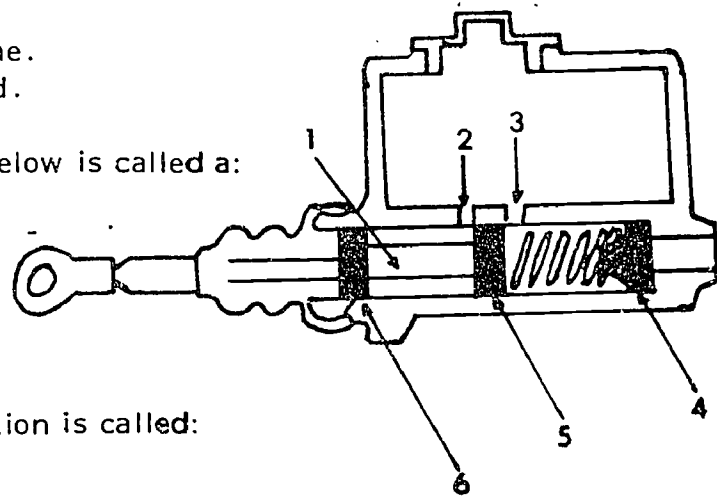

3. Part no. 4 of the same illustration is called:

- a. piston.
- b. residual check valve.
- c. primary cup.
- d. secondary cup.

*(Adapted from Auto Mechanics Fundamentals, Stockel, Goodheart-Willcox, 1974, p. 336, Fig. 18-10.)

4. Liquids can increase force:

- a. by transmitting a small piston force onto a large piston.
- b. by transmitting a large piston force onto a small piston force.
- c. (not possible with liquids).
- d. by shortening the length of fluid route lines.

5. Copper tubing can be used (on brakes):

- a. in places where line flexibility is needed for bending.
- b. (never for brake lines).
- c. where vibration occurs.
- d. from the master cylinder to the first-line junction box.

37.09.01.02.

6. Oil can not be substituted for brake fluid because:
 - a. oil is flammable.
 - b. it will not lubricate moving parts as effectively.
 - c. oil is too thick to flow readily.
 - d. it will deteriorate rubber parts.
7. Disc brakes require a brake fluid that:
 - a. is resistant to dust.
 - b. is highly resistant to heat.
 - c. will not break down under constant braking vibration.
 - d. is the same as drum brake fluid.
8. Quality brake fluid must be non-flammable because of:
 - a. spilled brake fluid on the floor near possible flames.
 - b. an open brake fluid container in the shop.
 - c. the high temperature of braking.
 - d. the boiling temperature of the engine heat.
9. Brake fluid must be of high quality to prevent:
 - a. corrosion.
 - b. loss of fluid.
 - c. settling.
 - d. leaking.

37.09.01.03.

10. Flexible brake lines are made of:
 - a. double thickness hose.
 - b. single layer hose.
 - c. multiple-ply construction hose.
 - d. flame-resistant hose.
11. To prevent vibration damage, brake lines are:
 - a. rubber suspended.
 - b. rubber covered.
 - c. securely mounted.
 - d. double lined.
12. Brake line ends for flaring should be:
 - a. rounded off.
 - b. single flared.
 - c. compress fitted.
 - d. double flared.

37.09.01.03. cont.

13. Brake lines are made up of:
- steel.
 - aluminum.
 - galvanized iron.
 - copper.
14. Brake line connections should use:
- double flared ends.
 - single compression fittings.
 - single flare end.
 - double compression fittings.

37.09.01.04.

15. The "spongy" feeling of the brake pedal reveals the:
- softening of the rubber cups in the master cylinder.
 - effectiveness of weakened shoe return springs.
 - presence of air in the system.
 - existence of water in the brake fluid.
16. The most common way air can enter the system through the master cylinder is:
- by allowing fluid to be too low in the reservoir.
 - by a cracked master cylinder.
 - through a damaged master cylinder boot.
 - through a leaking check valve.
17. The first point to start bleeding is at the:
- line connection at the master cylinder itself.
 - closest wheel from the master cylinder.
 - farthest wheel from the master cylinder.
 - first junction box connection.
18. Close observation must be paid to which of the following as the brakes are being bled.
- amount of fluid being discharged.
 - wheel cylinder fluid level.
 - position of the brake pedal.
 - master cylinder fluid level.
19. When bleeding tandem master cylinders, first bleed the wheels that are served by the:
- non-disc brake.
 - secondary piston.
 - primary piston.
 - disc brake.

37.09.01.04. cont.

20. Before bleeding the brakes:

- a. the master cylinder push rod should be lengthened.
- b. the emergency brake should be inspected.
- c. the shoe travel should be checked and adjusted up properly.
- d. the brake pedal push rod should be shortened.

37.09.01.05.

21. A spongy feeling brake pedal reveals what possible problem?

- a. low on fluid in the master cylinder reservoir.
- b. air entrapped in the brake lines.
- c. a flex line is weakened to the point that it swells with pressure applied.
- d. brake shoe travel needs to be adjusted.

22. On vehicle wheel cylinder leakage inspection is performed by:

- a. applying brake pedal pressure (drum off) while observing wheel cylinder for leakage.
- b. examining the backing plate for signs of fluid leakage.
- c. pulling back the dust boot lips and looking for leakage.
- d. examining the master cylinder reservoir for fluid loss.

23.

24. Leakage of the secondary cup on a single unit master cylinder is revealed by:

- a. loss of brake pedal pressure.
- b. the vehicle will pull to one side upon braking.
- c. fluid wetness at the plunger rod end of the master cylinder.
- d. fluid wetness around the master cylinder filter cap.

25. Out-of-round allowance of a drum should not exceed:

- a. .005.
- b. .010.
- c. .060.
- d. .080.

UNIT/LAP PRETEST ANSWER KEY: FUNDAMENTALS OF BRAKE SYSTEMS

LAP .01

1. b
2. a
3. b
4. a
5. b

LAP .02

6. d
7. b
8. c
9. a

LAP .03

10. c
11. c
12. d
13. a
14. a

LAP .04

15. c
16. a
17. c
18. d
19. c
20. c

LAP .05

21. b
22. c
23. d
24. c
25. b

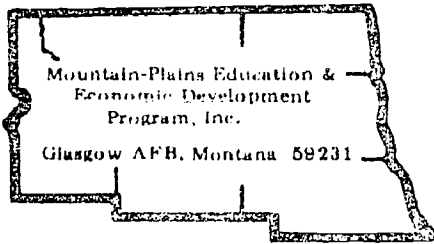

Learning Activity Package

Student: _____

Date: _____

PERFORMANCE ACTIVITY: Basic Brake Operation

OBJECTIVES:

Given a number of alternate solutions, identify the brake system components and determine its operation.

EVALUATION PROCEDURE:

Correctly answer 8 out of 10 items on a Unit/LAP test after completion of LAP 37.09.01.05.

RESOURCES:

Auto Mechanics Fundamentals, Stockel.

Filmstrips:

Assembly Procedures -- FAA:172
Disassembly Procedures -- FFA:162
Nomenclature and Adjustments -- FAA:152.

PROCEDURE:

1. Read Chapter 18, pages 337-363, in Auto Mechanics Fundamentals.
2. Study Figures 18-1 through 18-53 in Auto Mechanics Fundamentals.
3. On a separate sheet of paper, answer questions 1 through 42, pages 363, in Auto Mechanics Fundamentals.
4. Upon completion, return the answer sheet to the instructor.
5. Return the textbook.
6. Obtain and view the filmstrips listed above in "Resources".
7. Return the filmstrips.
8. Go to the next LAP.

Principal Author(s): J. Anderson
W. Osland

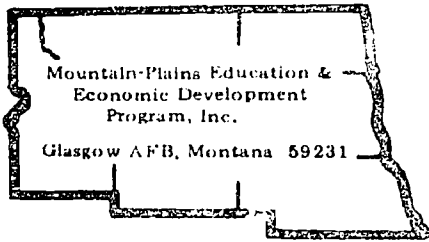

Learning Activity Package

Student: _____

Date: _____

PERFORMANCE ACTIVITY: Brake Fluids

OBJECTIVE:

Correctly identify the precautions and limitations of quality brake fluid.

EVALUATION PROCEDURE:

Evaluation will be after completing LAP 37.09.01.05.

RESOURCES:

Auto Service and Repair, Stockel.

PROCEDURE:

1. Read Chapter 29, pages 29-25 and 29-8, in Auto Service and Repair.
2. On a separate sheet of paper, answer questions 11 and 32 at the end of Chapter 29 in Auto Service and Repair.
3. ~~Give~~ your answer sheet to the instructor for evaluation.
4. Proceed to the next LAP.

Principal Author(s):

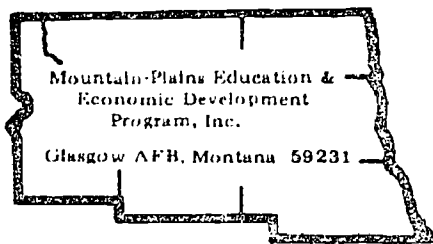

Learning Activity Package

Student: _____

Date: _____

PERFORMANCE ACTIVITY: Hydraulic Lines, Switches, and Equalizers

OBJECTIVES:

Recognize the hydraulic lines, switches and equalizers components and each of their operations.

EVALUATION PROCEDURE:

Correctly answer 8 out of 10 items on a multiple-choice objective test.

RESOURCES:

Auto Service and Repair, Stockel.

PROCEDURE:

1. Read Chapter 5, pages 5-2 through 5-13, in Auto Service and Repair.
2. Study Figures 5-1A through 5-27 in Auto Service and Repair.
3. Read "Power Steering and Brake Hose", page 5-13, in Auto Service and Repair.
4. Study Figures 5-51 and 5-52 in Auto Service and Repair.
5. On a separate sheet of paper, answer questions 1, 5, 7, 8, 9, 10, 11, 13, 15, 16, 18, 20, 21, 25 and 38 in Auto Service and Repair.
6. Read Chapter 29, page 29-24, "Stoplight Switch" in Auto Service and Repair.
7. Study Figure 29-54 in Auto Service and Repair.
8. Read "Proportioning Valve", pages 29-30 and 29-31, in Auto Service and Repair.
9. Study Figure 29-72, page 29-31, in Auto Service and Repair.
10. Give your answer sheet to the instructor for evaluation.
11. Return the textbook to the proper shelf.

Principal Author(s):

J. Anderson/W. Osland

34

PROCEDURE: (cont.)

12. Obtain a copy of the LAP test from the instructor. Answer all of the questions and return the test to the instructor for evaluation.
13. Upon successful completion of the LAP test, ask the instructor for the Unit/Lap Post Test 37.03.05. Answer all of the questions and return the answer sheet to the instructor for evaluation.
14. Upon successful completion, proceed to the next LAP.

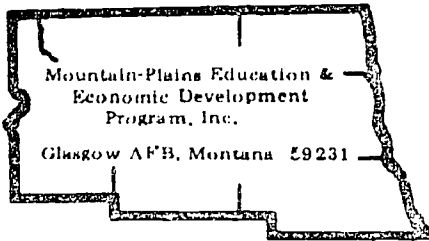

Learning Activity Package

Student: _____

Date: _____

PERFORMANCE ACTIVITY: Bleeding of Brake Systems

OBJECTIVE:

Recognize the correct procedure for bleeding the brake system.

EVALUATION PROCEDURE:

Evaluation will be after completing LAP 37.09.01.05.

RESOURCES:

Operator's Manual, Pressure Bleeder.
Repair Manual for the year and model of the car to be assigned to you.

Automobile needing brake bleeding.
Brake bleeder.
Brake fluid.
Fender covers.
Jack.
Jack stands.
Tools, Basic Hand (listed on the Unit LEG)

PROCEDURE:

Key Points

Refer to the repair manual for the recommended procedure of bleeding the vehicle that you are working on.

On some automobiles, it is necessary to adjust the brake shoe travel to correct excessive brake pedal action.

1. Place fender covers on the vehicle.
2. Check master cylinder fluid level.
3. Attach pressure bleed to the master cylinder. Refer to Operator's Manual for correct hook-up and operation.

Principal Author(s):

J. Anderson/W. Osland

PROCEDURE: (cont.)

4. Activate bleeder and bleed each wheel cylinder to remove air from the system.
5. Deactivate bleeder and remove from the master cylinder.
6. Add brake fluid to the master cylinder as required.
7. Ask the instructor to evaluate the brake pedal travel and feel.
8. Clean and return all tools and equipment.
9. Clean work area.
10. Proceed to the next LAP.

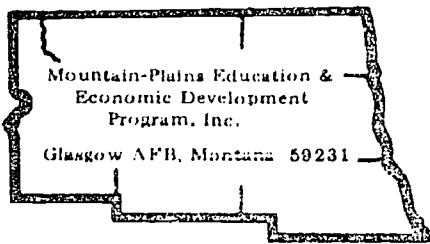

Learning Activity Package

Student: _____

Date: _____

PERFORMANCE ACTIVITY: Brake Inspection

OBJECTIVES:

Recognize the correct procedure of brake inspections. Perform brake inspection.

EVALUATION PROCEDURE:

80% correct brake inspection using an actual car brake inspection checkoff sheet with the instructor observing. Correctly answer 8 out of 10 items on a multiple-choice objective test.

RESOURCES:

Automobile to be given brake inspection.
Brake fluid.
Fender covers.
Jacks.
Jack stands.
Tools, Basic Hand (listed on the Unit LEG)

PROCEDURE:

1. Safely place the vehicle up on jack stands.
2. Remove the drum to inspect the brake shoes.
3. Obtain a brake inspection sheet and read it carefully. Fill in all results as each inspection is completed for each step.
4. Record shoe inspection results on work order. Measure and record amount of lining material left.
5. Inspect the flexible brake lines. Record condition on work order.
6. Inspect each wheel cylinder for signs of leakage or rubber boot deterioration. Record results.

Principal Author(s):

J. Anderson/W. Osland

PROCEDURE: (cont.)

7. Inspect brake fluid condition (clean, dirty, etc.). Record results on work order.
8. Inspect the master cylinder fluid level.
9. Explain your results to the instructor and show the malfunctioning parts to him.
10. Reinstall the brake drum.
11. Close off the master cylinder. Correct fluid level if necessary.
12. Lower car to floor.
13. Check brake pedal travel. Record the results. When the brake inspection sheet is completed, have the instructor evaluate it and approve it with his signature.
14. Clean and return all tools and equipment.
15. Clean work area.
16. Upon successful completion of the Unit/LAP test, proceed to the next unit.

*Mountain-Plains Education & Economic Development Program, Inc.***BRAKE INSPECTION SHEET**

(Attach to Shop Record Copy of Completed Work Order)

Vehicle _____ Year _____ Date _____

Mileage _____ Brake Model or Type _____

1. BRAKE PEDAL CHECK:

Pedal Movement = smooth _____ free _____ binding _____ needs repair _____
 Pedal Free-play = amount _____ required amount _____ needs adjustment _____
 Pedal Feel = spongy _____ firm _____ full travel _____ needs repair _____ needs bleeding _____

COMMENTS:

2. MASTER CYLINDER INSPECTION:

Needs Repair _____

Signs of Leakage = _____
 Condition of Fluid = clean _____ dirty _____ low _____ added _____ needs flushing _____

COMMENTS:

3. POWER BRAKE INSPECTION:

Not Equipped _____

Amount of Vacuum Supplied = _____
 Pedal Movement on Engine Start Test = satisfactory _____ unsatisfactory _____

COMMENTS:

4. PARKING BRAKE INSPECTION:

Needs Adjustment _____ Adjusted _____ Needs Repair _____
 Pedal Travel (from start) = 1/4 _____ 1/3 _____ 1/2 _____ 2/3 _____ 3/4 _____ floor _____
 Condition of Cable = poor _____ good _____ needs replacement _____
 Brake Effectiveness = holds forward _____ does not hold _____

COMMENTS:

5. DRUM BRAKE INSPECTION:

Drum Condition = scored _____ out-of-round _____ worn beyond limits _____
 " = cracked _____ heat-checked _____ needs replacement _____
 Return Springs = tight _____ loose _____ bent _____ need replacement _____
 Self Adjusters = none _____ operating _____ inoperable _____ need replacement _____
 Wheel Cylinders = leakage _____ dry _____ boot condition _____
 Axle Fluid Seals = leaking _____ dry _____ need replacement _____

COMMENTS:

6. BRAKE SHOE INSPECTION:

Amount of Remaining Lining = _____ need replacement _____
 Shoe Condition = metal rubbing drum _____
 Lining Condition = cracked _____ wet _____ decomposed _____ glazed _____

COMMENTS:

7. CHASSIS INSPECTION:

Shocks = leaking _____ good _____ broken _____ needs replacement _____
 Springs = sagging _____ broken _____ needs replacement _____
 Alignment = satisfactory _____ needs adjustment _____

LIST WORN SUSPENSION PARTS(if any):

8. BRAKE LINES:

Metal Lines = properly fastened _____ satisfactory _____ need repair _____
 Flex Hoses = cracked _____ frayed _____ leaking _____ need replacement _____

COMMENTS:

9. WHEEL BEARINGS:

Condition = need repacking _____ clean & repacked _____ need replacement _____
 Tightness = loose _____ too tight _____ adjusted _____ need adjustment _____

COMMENTS:

10. TIRE CONDITION:

= sufficient tread _____ poor tread _____ damaged _____ need replacement _____
 = incorrect air pressure _____ adjusted _____

COMMENTS:

FINAL SUMMARY:

Repairman _____ Date _____ Instructor Approval _____

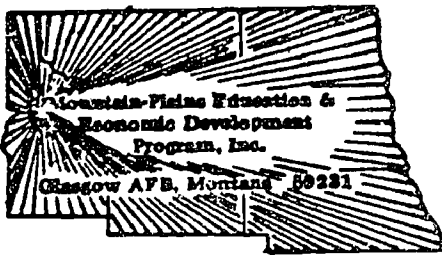

UNIT/LAP POST TEST: FUNDAMENTALS OF BRAKE SYSTEMS (A)

37.09.01.01.

- 1. The modern auto uses:
 - a. mechanical over hydraulic brakes.
 - b. mechanical brakes as a stopping medium.
 - c. hydraulic brakes as a stopping medium.
 - d. hydraulic over mechanical brakes.

- 2. Item 2 in this illustration* is the:
 - a. breather
 - b. plunger
 - c. compensator part
 - d. bleeder

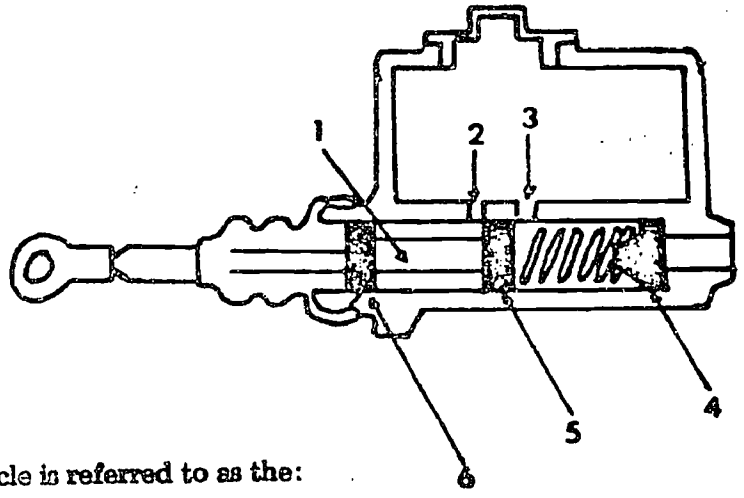

- 3. The brake shoe that faces the front of the vehicle is referred to as the:
 - a. servo acting shoe
 - b. primary shoe
 - c. secondary shoe
 - d. best shoe

- 4. Item 4 in the illustration is the:
 - a. piston
 - b. residual check valve
 - c. primary cup
 - d. secondary cup

- 5. Fluid is returned to the reservoir of the master cylinder upon brake pedal release by the:
 - a. vacuum pressure created when the fluid is pumped.
 - b. return spring on the brake pedal.
 - c. brake shoe retractor springs at the wheel assembly.
 - d. self-adjustment springs of the wheel assembly.

- 6. Oil cannot be substituted for brake fluid because:
 - a. oil is flammable.
 - b. it will not lubricate moving parts as effectively.
 - c. oil is too thick to flow readily.
 - d. it will deteriorate rubber parts.

*Adapted from Auto Mechanics Fundamentals
Stockel, Goodheart-Wilcox, 1969, p. 336
Fig. 18-10.

37.09.01.01. (cont'd)

7. Disc brakes require a brake fluid that:
- is resistant to dust.
 - is highly resistant to heat.
 - will not break down under constant braking vibration.
 - is the same as drum brake fluid.

37.09.01.02.

8. The greatest danger of brake fluid is that it:
- has a highly acid effect.
 - is flammable.
 - will ruin paint.
 - is highly toxic.
9. If brake fluid enters the eye, it is recommended to:
- lie the victim down on his back to rest.
 - gently rub the eye with a soft absorbent towel.
 - flush the eye with warm water and consult a doctor.
 - apply eye drops.
10. Often because of corrosion, bleeder screws must be:
- tapped out.
 - replaced.
 - redrilled.
 - removed and cleaned.
11. Quality brake fluid must be nonflammable because of the:
- fire hazard from brake fluid spilled on the floor near sparks or flames.
 - fire hazard from open brake fluid containers.
 - high temperatures developed during severe braking.
 - high underhood temperatures.
12. Brake fluid should be able to prevent:
- corrosion
 - fluid compression
 - separation
 - leaks

37.09.01.03.

13. Flexible brake lines are made of:
- double thickness hose.
 - single layer hose.
 - multiple-play construction hose.
 - flame-resistant hose.

87.09.01.03, (cont'd)

14. To prevent vibration damage, brake lines are:
- rubber suspended.
 - rubber covered.
 - securely mounted.
 - double lined.
15. Brake line ends for flaring should be:
- rounded off.
 - single flared.
 - compress fitted.
 - double flared.
16. A stop light switch could keep the brake pedal from releasing completely:
- true
 - raise
17. Brake lines are made of:
- steel
 - aluminum
 - galvanized iron
 - copper
18. Brake line connections should use:
- double flared ends.
 - single compression fittings.
 - single flare end.
 - double compression fittings.
19. A car will stop more quickly if the wheels are:
- locked.
 - rolling freely.
 - just short of locking.
 - makes no difference.
20. When the brake warning light comes on with a dual system:
- the brake fluid is low.
 - the linings are worn out.
 - one-half of system has failed.
 - there is air in the lines.

37.09.01.04.

21. Bleeding the brakes is the process of:
- removing air from the fluid lines.
 - draining some fluid from the wheel cylinders.
 - grinding the lining to fit the drum.
 - grinding the lining to fit the drum and reduce the shoe travel within the drum.
22. Having the bleeder hose in a container of fluid is to:
- save the fluid so that it may be reused.
 - determine the quality of the fluid.
 - reduce the fire hazard from fluids spilled on the floor.
 - determine when the air has been removed from the system.
23. Rapid pumping of the pedal while bleeding will cause the fluid to become:
- aerated
 - hot
 - evaporated
 - expanded
24. A one-man bleeding operation can be easily done with the:
- use of a pressure bleeder.
 - application of a clear bottle and hose.
 - bleeder "cracked" open and slowly pumping the pedal.
 - master cylinder full and allowing a "trickle" to flow through with all the bleeder screws open.
25. When bleeding disc brakes, what is recommended to be done while bleeding the caliper to remove clinging air bubbles?
- tap the disc pads to center the piston.
 - apply heavier pressure on the pedal than drum brakes.
 - slowly pump the pedal with even strokes.
 - rap the caliper with a plastic hammer.
26. Because of one of its qualities, bled brake fluid:
- should be quickly discarded in a fire-proof container.
 - can be saved and reused after the air bubbles settle out.
 - can be stored and used as rubber lubricant.
 - can be replaced back into the master cylinder if it is low.

37.09.01.05.

27. On vehicle wheel cylinder leakage, inspection is performed by:
- applying brake pedal pressure (drum off) while observing wheel cylinder leakage.
 - examining the backing plate for signs of fluid leakage.
 - pulling back the dust boot lips and looking for leakage.
 - examining the master cylinder reservoir for fluid loss.

37.09.01.05. (cont'd)

28. Heat checking on a brake drum shoe surface:
- a. cannot be removed and the drum should be replaced.
 - b. is normal wear and can be reused as it is.
 - c. can be removed on a brake lathe.
 - d. can be polished out with emery cloth.
29. Proper free pedal travel for manual brakes is about:
- a. 0 to 1 inches.
 - b. 1/2 to 2 inches.
 - c. 1/4 to 1/2 inches.
 - d. no free play should exist.
30. Brake drum out-of-round is measured with a/an:
- a. outside micrometer.
 - b. drum adjusting gauge.
 - c. depth gauge.
 - d. drum micrometer.
31. Out-of-round allowance of a drum should not exceed:
- a. .005
 - b. .010
 - c. .060
 - d. .080

UNIT/LAP POST TEST ANSWER SHEET: FUNDAMENTALS OF BRAKE SYSTEMS **A**

- | | |
|--------------------|---------|
| 1. c | 24. a |
| 2. a | 25. d |
| 3. b | 26. c |
| 4. b | 27. c |
| 5. c | 28. c |
| 6. d | 29. c |
| 7. b | 30. d |
| 8. c | 31. a / |
| 9. c | |
| 10. d | |
| 11. c | |
| 12. a | |
| 13. c | |
| 14. c | |
| 15. d | |
| 16. a | |
| 17. a | |
| 18. b A | |
| 19. c | |
| 20. c | |
| 21. a | |
| 22. d | |
| 23. a | |

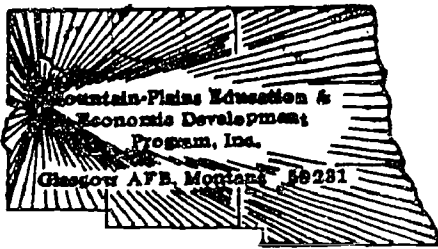

UNIT/LAP POST TEST: FUNDAMENTALS OF BRAKE SYSTEMS (B)

37.09.01.01

1. Disc brakes require a brake fluid that:
 - a. is resistant to dust
 - b. is highly resistant to heat
 - c. will not break down under constant braking vibration
 - d. is the same as drum brake fluid

2. Oil cannot be substituted for brake fluid because:
 - a. oil is flammable
 - b. it will not lubricate moving parts as effectively
 - c. oil is too thick to flow readily
 - d. it will deteriorate rubber parts

3. Fluid is returned to the reservoir of the master cylinder upon brake pedal release by the:
 - a. vacuum pressure created when the fluid is pumped
 - b. return spring on the brake pedal
 - c. brake shoe retractor springs at the wheel assembly
 - d. self-adjustment springs of the wheel assembly

4. Item 4 in the illustration is the:

- a. piston
- b. residual check valve
- c. primary cup
- d. secondary cup

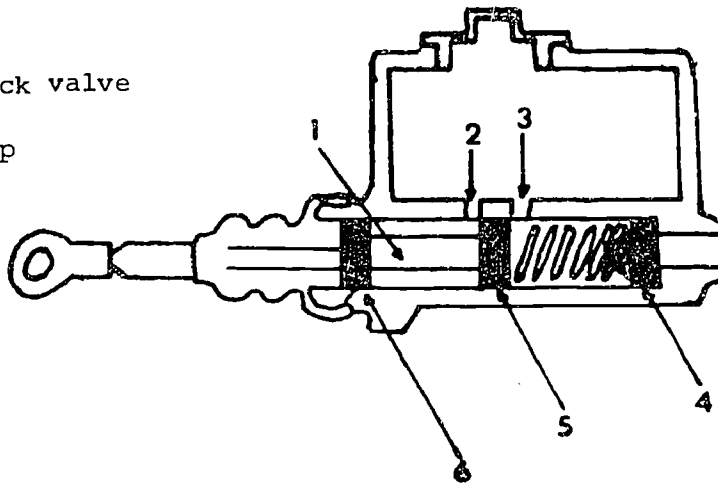

5. The brake shoe that faces the front of the vehicle is referred to as the:
 - a. servo acting shoe
 - b. primary shoe
 - c. secondary shoe
 - d. best shoe

37.09.01.01 cont.

6. Item 2 in the illustration* is the:
- breather
 - plunger
 - compensator part
 - bleeder
7. The modern auto uses:
- mechanical over hydraulic brakes
 - mechanical brakes as a stopping medium
 - hydraulic brakes as a stopping medium
 - hydraulic over mechanical brakes

37.09.01.02

8. Brake fluid should be able to prevent:
- corrosion
 - fluid compression
 - separation
 - leaks
9. Quality brake fluid must be nonflammable because of the:
- fire hazard from brake fluid spilled on the floor near sparks or flame
 - fire hazard from open brake fluid containers
 - high temperatures developed during severe braking
 - high underhood temperatures
10. Often because of corrosion, bleeder screws must be:
- tapped out
 - replaced
 - redrilled
 - removed and cleaned
11. If brake fluid enters the eye, it is recommended to:
- lie the victim down on his back to rest
 - gently rub the eye with a soft absorbent towel
 - flush the eye with warm water and consult a doctor
 - apply eye drops
12. The greatest danger of brake fluid is that it:
- has a highly acid effect
 - is flammable
 - will ruin paint
 - is highly toxic

*Adapted from Auto Mechanics Fundamentals, Stockel, Goodheart-Wilcox, 1969, p./336
Fig. 18-10

37.09.01.03

13. When the brake warning light comes on with a dual system:
- the brake fluid is low
 - the linings are worn out
 - one-half of system has failed
 - there is air in the lines
14. A car will stop quickly if the wheels are:
- locked
 - rolling freely
 - just short of locking
 - makes no difference
15. Brake line connections should use:
- double flared ends
 - single compression fittings
 - single flare end
 - double compression fittings
16. Brake lines are made of:
- steel
 - aluminum
 - galvanized iron
 - copper
17. A stop light switch could keep the brake pedal from releasing completely:
- true
 - false
18. To prepare a brake line end for flaring it should be:
- rounded off
 - single flared
 - compress fitted
 - double flared
19. To prevent vibration damage, brake lines are:
- rubber suspended
 - rubber covered
 - securely mounted
 - double lined.
20. Flexible brake lines are made of:
- double thickness hose
 - single layer hose
 - multiple-play construction hose
 - flame-resistant hose

37.09.01.04

21. Because of one of its qualities, bled brake fluid:
- should be quickly discarded in a fire-proof container
 - can be saved and reused after the air bubbles settle out
 - can be stored and used as rubber lubricant
 - can be replaced back into the master cylinder if it is low
22. When bleeding disc brakes, what is recommended to be done while bleeding the caliper to remove clinging air bubbles?
- tap the disc pads to center the piston
 - apply heavier pressure on the pedal than drum brakes
 - slowly pump the pedal with even strokes
 - rap the caliper with a plastic hammer
23. A one-man bleeding operation can be easily done with the:
- use of a pressure bleeder
 - application of a clear bottle and hose
 - bleeder "cracked" open and slowly pumping the pedal
 - master cylinder full and allowing a "trickle" to flow through with all the bleeder screws open
24. Rapid pumping of the pedal while bleeding will cause the fluid to become:
- aerated
 - hot
 - evaporated
 - expanded
25. Having the bleeder hose in a container of fluid is to:
- save the fluid so that it may be reused
 - determine the quality of the fluid
 - reduce the fire hazard from fluids spilled on the floor
 - determine when the air has been removed from the system
26. Bleeding the brakes is the process of:
- removing air from the fluid lines
 - draining some fluid from the wheel cylinders
 - grinding the lining to fit the drum
 - grinding the lining to fit the drum and reduce the shoe travel within the drum

37.09.01.05

27. Out-of-round allowance of a drum should not exceed:
- .005
 - .010
 - .060
 - .080

37.09.01.05 cont.

28. Brake drum out-of-round is measured with a/an:
- outside micrometer
 - drum adjusting gauge
 - depth gauge
 - drum micrometer
29. Proper free pedal travel for manual brakes is about:
- 0 to 1 inches
 - 1/2 to 2 inches
 - 1/4 to 1/2 inches
 - no free play should exist
30. Heat checking on a brake drum shoe surface:
- cannot be removed and the drum should be replaced
 - is normal wear and can be reused as it is
 - can be removed on a brake lathe
 - can be polished out with emery cloth
31. On vehicle wheel cylinder leakage, inspection is performed by:
- applying brake pedal pressure (drum off) while observing wheel cylinder leakage
 - examining the backing plate for signs of fluid leakage
 - pulling back the dust boot lips and looking for leakage
 - examining the master cylinder reservoir for fluid loss

UNIT/LAP POST TEST ANSWER SHEET: FUNDAMENTALS OF BRAKE SYSTEMS (B)

- | | |
|--------------------|--------------------|
| 1. B | 26. A |
| 2. D | 27. A B |
| 3. C | 28. D |
| 4. B | 29. C |
| 5. B | 30. C |
| 6. A | 31. C |
| 7. C | |
| 8. A | |
| 9. C | |
| 10. D | |
| 11. C | |
| 12. C | |
| 13. C | |
| 14. C | |
| 15. B A | |
| 16. A | |
| 17. A | |
| 18. D | |
| 19. C | |
| 20. C | |
| 21. C | |
| 22. D | |
| 23. A | |
| 24. A | |
| 25. D | |



UNIT/LAP POST TEST: FUNDAMENTALS OF BRAKE SYSTEMS (C)

37.09.01.01

1. The modern auto uses:

- a. mechanical over hydraulic brakes
- b. mechanical brakes as a stopping medium
- c. hydraulic brakes as a stopping medium
- d. hydraulic over mechanical brakes

2. Item 4 in the illustration is the:

- a. piston
- b. residual check valve
- c. primary cup
- d. secondary cup

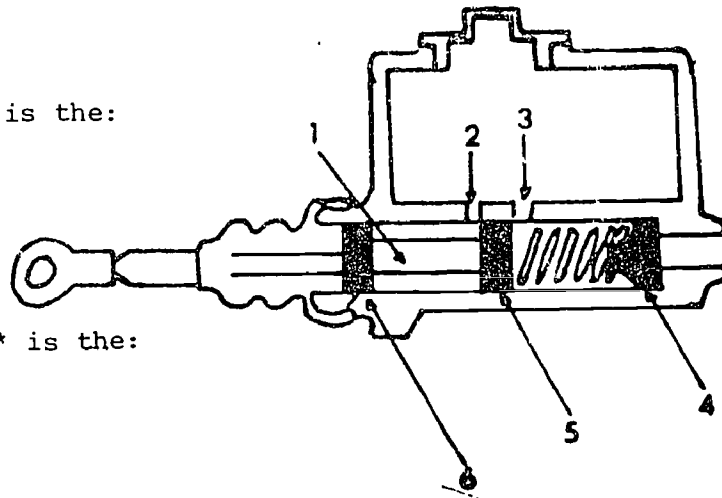

3. Item 2 in the illustration* is the:

- a. breather
- b. plunger
- c. compensator part
- d. bleeder

4. Fluid is returned to the reservoir of the master cylinder upon brake pedal release by the:

- a. vacuum pressure created when the fluid is pumped
- b. return spring on the brake pedal
- c. brake shoe retractor springs at the wheel assembly
- d. self-adjustment springs of the wheel assembly

5. Oil cannot be substituted for brake fluid because:

- a. oil is flammable
- b. it will not lubricate moving parts as effectively
- c. oil is too thick to flow readily
- d. it will deteriorate rubber parts

6. The brake shoe that faces the front of the vehicle is referred to as the:

- a. servo acting shoe
- b. primary shoe
- c. secondary shoe
- d. best shoe

*Adapted from Auto Mechanics Fundamentals, Stockel, Goodheart-Wilcox, 1969, p. 336
 Fig. 18-10

37.09.01.01 cont.

7. Disc brakes require a brake fluid that:
- is resistant to dust
 - is highly resistant to heat
 - will not break down under constant braking vibration
 - is the same as drum brake fluid

37.09.01.02

8. The greatest danger of brake fluid is that it:
- has a highly acid effect
 - is flammable
 - will ruin paint
 - is highly toxic
9. Brake fluid should be able to prevent:
- corrosion
 - fluid compression
 - separation
 - leaks
10. Quality brake fluid must be nonflammable because of the:
- fire hazard from brake fluid spilled on the floor near sparks or flame
 - fire hazard from open brake fluid containers
 - high temperatures during severe braking
 - high underhood temperatures
11. Often because of corrosion, bleeder screws must be:
- tapped out
 - replaced
 - redrilled
 - removed and cleaned
12. If brake fluid enters the eye, it is recommended to:
- lie the victim down on his back to rest
 - gently rub the eye with a soft absorbent towel
 - flush the eye with warm water and consult a doctor
 - apply eye drops

37.09.01.03

13. Flexible brake lines are made of:
- double thickness hose
 - single layer hose
 - multiple-ply construction hose
 - flame-resistant hose

37.09.01.03 cont.

14. To prevent vibration damage, brake lines are:
- rubber suspended
 - rubber covered
 - securely mounted
 - double lined
15. Brake line connections should use:
- double flared ends
 - single compression fittings
 - single flare end
 - double compression fittings
16. A stop light switch could keep the brake pedal from releasing completely:
- true
 - false
17. To prepare a brake line end for flaring it should be:
- rounded off
 - single flared
 - compress fitted
 - double flared
18. When the brake warning light comes on with a dual system:
- the brake fluid is low
 - the linings are worn out
 - one-half of system has failed
 - there is air in the lines
19. Brake lines are made of:
- steel
 - aluminum
 - galvanized iron
 - copper
20. A car will stop more quickly if the wheels are:
- locked
 - rolling freely
 - just short of locking
 - makes no difference

37.09.01.04

21. Because of one of its qualities, bled brake fluid:
- should be quickly discarded in a fire-proof container
 - can be saved and reused after the air bubbles settle out
 - can be stored and used as rubber lubricant
 - can be replaced back into the master cylinder if it is low

37.09.01.04 cont.

22. When bleeding disc brakes, what is recommended to be done while bleeding the caliper to remove clinging air bubbles?
- tap the disc pads to center the piston
 - apply heavier pressure on the pedal than drum brakes
 - slowly pump the pedal with even strokes
 - rap the caliper with a plastic hammer
23. A one-man bleeding operation can be easily done with the:
- use of a pressure bleeder
 - application of a clear bottle and hose
 - bleeder "cracked" open and slowly pumping the pedal
 - master cylinder full and allowing a "trickle" to flow through with all the bleeder screws open
24. Rapid pumping of the pedal while bleeding will cause the fluid to become:
- aerated
 - hot
 - evaporated
 - expanded
25. Bleeding the brakes is the process of:
- removing air from the fluid lines
 - draining some fluid from the wheel cylinders
 - grinding the lining to fit the drum
 - grinding the lining to fit the drum and reduce the shoe travel within the drum
26. Having the bleeder hose in a container of fluid is to:
- save the fluid so that it may be reused
 - determine the quality of the fluid
 - reduce the fire hazard from fluids spilled on the floor
 - determine when the air has been removed from the system

37.09.01.05

27. Proper free pedal travel for manual brakes is about:
- 0 to 1 inches
 - 1/2 to 2 inches
 - 1/4 to 1/2 inches
 - no free play should exist
28. Brake drum out-of-round is measured with a/an:
- outside micrometer
 - drum adjusting gauge
 - depth gauge
 - drum micrometer

37.09.01.05 cont.

29. On vehicle wheel cylinder leakage, inspection is performed by:
- a. applying brake pedal pressure (drum off) while observing wheel cylinder leakage
 - b. examining the backing plate for signs of fluid leakage
 - c. pulling back the dust boot lips and looking for leakage
 - d. examining the master cylinder reservoir for fluid loss
30. Out-of-round allowance of a drum should not exceed:
- a. .005
 - b. .010
 - c. .060
 - d. .080
31. Heat checking on a brake drum shoe surface:
- a. cannot be removed and the drum should be replaced
 - b. is normal wear and can be reused as it is
 - c. can be removed on a brake lathe
 - d. can be polished out with emery cloth

UNIT/LAP POST TEST ANSWER SHEET: FUNDAMENTALS OF BRAKE SYSTEMS (C)

- | | |
|-------------------|------------------|
| 1. C | 26. D |
| 2. B | 27. C |
| 3. A | 28. D |
| 4. C | 29. C |
| 5. D | 30. B |
| 6. B | 31. C |
| 7. B | |
| 8. C | |
| 9. A | |
| 10. C | |
| 11. D | |
| 12. C | |
| 13. C | |
| 14. C | |
| 15. BA | |
| 16. A | |
| 17. D | |
| 18. C | |
| 19. A | |
| 20. C | |
| 21. C | |
| 22. D | |
| 23. A | |
| 24. A | |
| 25. A | |

Student: _____ File Code: 37.09.01.00.B1-5

Date: _____ Date Published: 5/12/76

Family Pay Number: _____ Sex: M F (Circle 1)

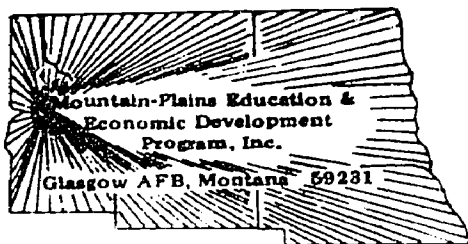

UNIT PERFORMANCE TEST: BRAKE SYSTEMS

OBJECTIVE:

Inspect brakes on any make and model car, according to the attached checklist.

TASK:

The student will be asked to perform a brake inspection on a car to be chosen at the time of the test. He will compare the condition of the brake system to the manufacturer's specifications for that system.

ASSIGNMENT:

CONDITIONS:

The student may use the service manual and time and parts manual. The student may not receive any help from the instructor or other students. The test will be taken in an environment similar to that of a repair garage.

RESOURCES:

Safety equipment - goggles
Repair manual
Time and Parts manual
Work order
Ruler
Jacks
Jack stand
Fender covers

RESOURCES: Equipment (cont.)

Tools, Basic Hand:

Chisel and Punch Set
5/32" Pin Punch
3/16" Solid

Gauge, feeler (.002" - .025")

Hammer, ball peen
Hammer, plastic tip
Handle, speed
Hex Key Set

Pliers, diagonal cutting
Pliers, needle nose

Scraper, gasket
Screwdriver, standard (Set)
Screwdriver, phillips (Set)
Screw starter

Socket Set (3/8" drive)
extension (3")
ratchet

Socket Set (1/4" drive)
extension (3")
handle (6" flex)
ratchet

Socket, spark plug
extension (6")

Wrench, combination (Set)
Wrench, combination ignition (Set)

Student: _____

File Code: 37.09.01.00.B1-5

Date: _____

Date Published: 5/12/76

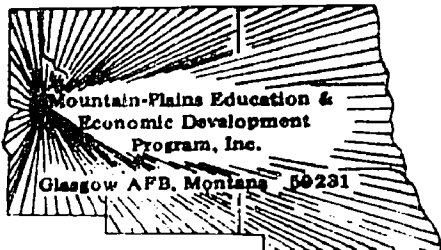

Family Pay Number: _____

Sex: M F (Circle 1)

PERFORMANCE CHECKLIST:

OVERALL PERFORMANCE: Satisfactory _____ Unsatisfactory _____

	CRITERION	
	Met	Not Met
Objective 1:		
1. Checks condition of pads or linings.		
Criterion: Measures lining and compares with manufacturer's specifications and checks for heat damage.		
2. Checks condition of wheel cylinder or caliper.		
Criterion: Student must check wheel cylinder or caliper seals for leakage and check dust seals for cracks or damage.		
3. Checks condition of master cylinder.		
Criterion: Student must check for seal leakage and hold pressure on pedal for one minute to see if there is any pedal fade.		
4. Checks condition of power brake unit.		
Criterion: Student must check for the following:		
(a) Vacuum diaphragm does not leak;		
(b) Vacuum hoses not cracked or oil soaked;		
(c) Check atmospheric air filter;		

(Checklist continued)

	CRITERION	
	Met	Not Met
(d) Put pressure on pedal. Start engine, if pedal goes down		
to apply brakes, unit okay.		
5. Checks condition of emergency brake system.		
Criterion: Student must check to see that cables move freely, pedal		
adjusted correctly (2-3" free pedal), secondary rear brake shoes		
meet with manufacturer's limits.		
6. Checks condition of fluid and lines.		
Criterion: Student must check to see that fluid is clean, hoses not cracked,		
and lines are not damaged.		
7. Correctly adjusts the brakes		
Criterion: Pedal has 1-3/4" to 3/4" free play.		
8. Checks each item against manufacturer's specifications.		
Criterion: Lists actual measurements and manufacturer's specifications.		
9. Lists the parts of the brake system needing repair.		
Criterion: Student must select the parts that deviate from manufacturer's		
specifications.		
10. Uses tools correctly.		
Criterion: Student must use appropriate tools to the job and in such a way		
as to not cause any damage to auto parts or himself. Cleans tools		
after use. Returns tools and equipment.		

(Checklist continued)

	CRITERION	
	Met	Not Met
11. Makes brake inspection in allotted time.		
Criterion: Completes job in flat rate time.		
Student must satisfactory complete all line items for an overall score of		
satisfactory.		



WORK SHEET

	Actual Specifications	Manufacturer's Specifications
Pads or linings		
Wheel cylinder		
Master cylinder		
Power brake unit		
Emergency brake system		
Fluid and lines		
Pedal level		

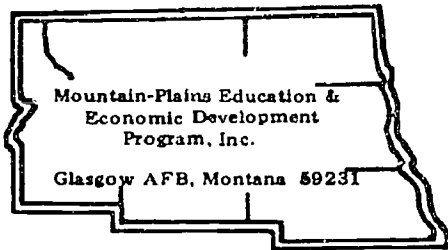

Learning Experience Guide

UNIT: MASTER CYLINDER

RATIONALE:

The fundamentals and techniques in this unit will enable you to diagnose and overhaul the master cylinder.

PREREQUISITES:

MATH - Level E

COMMUNICATION - Level E

OBJECTIVE:

Recognize the components and operation of the master cylinder. Perform an overhaul of the master cylinder.

RESOURCES:

Printed Material

Auto Service and Repair. Stockel, Goodheart-Willcox Company, Inc.

Repair Manual for year and model of car to be assigned to you.

Audio/Visuals

Filmstrips:

Dual Master Cylinder Assembly Part III (#7773). Universal Education & Visual Arts
Dual Master Cylinder Cleaning and Honing Part II (#7772). Universal Education & Visual Arts.
Dual Master Cylinder Disassembly (#7771). Universal Education & Visual Arts.

Equipment

Automobile with a dual master cylinder.
 Automobile with a single master cylinder.
 Brake fluid.
 Fender covers.
 Master cylinder repair kit.
 Projector, AVI Systems Super 8 mm Instant Film Loop Player.

Principal Author(s):

RESOURCES: Equipment (cont.)

Tools, Basic Hand:

Chisel and Punch Set

5/32" Pin Punch

3/16" Solid

Gauge, feeler (.002" - .025")

Hammer, ball peen

Hammer, plastic tip

Handle, speed

Hex Key Set

Pliers, diagonal cutting

Pliers, needle nose

Scraper, gasket

Screwdriver, standard (Set)

Screwdriver, phillips (Set)

Screw starter

Socket Set (3/8" drive)

extension (3")

ratchet

Socket Set (1/4" drive)

extension (3")

handle (6" flex)

ratchet

Socket, spark plug

extension (6")

Wrench, combination (Set)

Wrench, combination ignition (Set)

GENERAL INSTRUCTIONS:

This unit consists of three Learning Activity Packages (LAPs). Each LAP will provide specific information for completion of a learning activity.

The general procedure for this unit is as follows:

- (1) Read the first assigned Learning Activity Package (LAP).
- (2) Begin and complete the first assigned LAP.
- (3) Take and score the LAP test.
- (4) Turn in the LAP test answer sheet.
- (5) Determine the reason for any missed items on the LAP test.
- (6) Proceed to and complete the next assigned LAP in the unit.
- (7) Complete all required LAPs for the unit by following steps 3 through 6.
- (8) Take the unit tests as described in the Unit LEG "Evaluation Procedures".
- (9) Proceed to the next assigned unit.

PERFORMANCE ACTIVITIES:

- .01 Fundamentals of Master Cylinders
- .02 Overhauling a Single Master Cylinder
- .03 Overhauling a Dual Master Cylinder

EVALUATION PROCEDURE:

When pretesting:

1. The student takes the unit multiple-choice pretest.
2. Successful completion is 4 out of 5 items for each LAP part of the pretest.
3. The student then takes a unit performance test if the unit pretest was successfully completed.
4. Satisfactory completion of the performance test is meeting the criteria listed on the performance test.

When post testing:

1. The student takes a multiple-choice unit post test and a unit performance test.
2. Successful unit completion is meeting the listed criteria for the performance test.

Score 4 out of 5 correct answers for each LAP in the unit on the unit post test.
Perform master cylinder overhaul in accordance with the master cylinder checklist.

FOLLOW-THROUGH:

Go to the first Learning Activity Package (LAP) listed on your Student Progress Record (SPR).

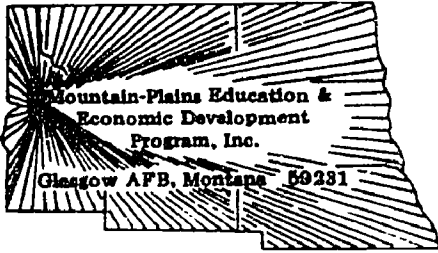

UNIT PRETEST: MASTER CYLINDER

37.09.02.01.

1. The secondary piston of the dual master cylinder is moved by:
 - a. the primary to secondary contact rod
 - b. the secondary push rod
 - c. the primary piston stop rod
 - d. hydraulic pressure from the primary piston
2. Failure of either the front or rear system of the dual master cylinder will be first evidenced by a:
 - a. greater need of foot pressure to apply the brake
 - b. sudden increase in brake pedal travel
 - c. loss of brake fluid on the master cylinder
 - d. failure of the brake to hold
3. A faulty check valve within the master cylinder can be noticed by:
 - a. minor fluid loss at the reservoir
 - b. failure to maintain brake pressure when activated
 - c. excessive pedal travel
 - d. excessive fluid loss
4. Residual pressure can be checked by:
 - a. measuring the amount of brake pedal pressure
 - b. removing the valve and checking it with a light
 - c. measuring the amount of fluid returning to the reservoir
 - d. applying and releasing the brake, then cracking open a bleeder screw
5. When released, pressured fluid returns to the reservoir from the cylinder bore through the:
 - a. compensating port
 - b. inlet port
 - c. breather port
 - d. reservoir vent

37.09.02.02.

6. Fluid leakage evident within the master cylinder dust boot reveals leakage at the:
 - a. master cylinder seal
 - b. secondary cup
 - c. boot damage
 - d. primary cup

7. Brake lines should be disconnected with:
 - a. box-end wrench
 - b. pipe wrench
 - c. open-end wrench
 - d. flare nut wrench

8. After the master cylinder is removed, before disassembling, it should:
 - a. have the exterior cleaned thoroughly
 - b. be soaked in solvent for a period of time
 - c. have the remaining fluid pumped out
 - d. be bench tested

- 9.

10. What should be done to a single unit master cylinder before re-installing?
 - a. pumped several times
 - b. thoroughly rinsed
 - c. soaked in fluid
 - d. pressure tested

37.09.02.03.

11. After honing, cleaning, rinsing, and drying, the bore should be:
 - a. inspected with a light
 - b. soaked in brake fluid
 - c. soaked in denatured alcohol
 - d. measured for clearance

12.

13. The "floating piston" of the dual master cylinder is:

- a. referring to the secondary piston
- b. sometimes called the primary piston
- c. the same as the check valve
- d. located between the primary and secondary pistons

14. What holds the cups of the dual master in place when in the "released" position?

- a. return springs of the shoe assembly
- b. piston springs
- c. static pressure of the master cylinder
- d. return spring for the brake pedal

15. Over-lengthening of the master-cylinder push rod will cause what possible problem?

- a. covering up the compensating port which won't allow build-up-fluid to return to the reservoir and will cause brakes to lock-up
- b. covering up of the breather port allowing no fluid to reach the check valve
- c. covering up of the compensating port allowing no fluid to enter the cylinder bore area
- d. a greater stroke of fluid will create too much fluid to flow into the wheel cylinder causing possible leakage

UNIT PRETEST ANSWER KEY: MASTER CYLINDERS

LAP .01

1. d
2. b
3. c
4. d
5. a

LAP .02

6. b
7. d
8. a
9. d
10. d

LAP .03

11. d
12. d
13. a
14. b
15. a

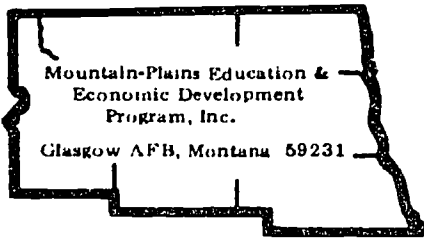

Learning Activity Package

Student: _____

Date: _____

PERFORMANCE ACTIVITY: Fundamentals of Master Cylinders**OBJECTIVES:**

Given a number of alternate solutions, identify the master cylinder components. Determine the master cylinder operation.

EVALUATION PROCEDURE:

Correctly answer 8 out of 10 items on a multiple-choice objective test.

RESOURCES:

Auto Service and Repair, Stockel.

Repair Manual for year and model of car to be assigned to you.

Filmstrips:

Dual Master Cylinder Assembly Part III -- #7773.

Dual Master Cylinder Cleaning and Honing Part II -- #7772.

Dual Master Cylinder Disassembly -- #7771.

PROCEDURE:

1. Read Chapter 29, pages 29-4 to 29-8, in Auto Service and Repair.
2. Study Figures 29-5 through 29-12 and 29-14 through 29-15 in Auto Service and Repair.
3. Obtain and view the filmstrips listed above in "Resources".
4. Return the filmstrips.
5. On a separate sheet of paper, answer questions 1 through 6, pages 29-36, in Auto Service and Repair.
6. On completion, return the answer sheet to the instructor.
7. Return the textbook.

Principal Author(s):

J. Anderson/W. Osland

PROCEDURE: (cont.)

7. Take the LAP test, score it and return the answer sheet.
8. If the score is less than 80%, review the material.
9. Upon successful completion, proceed to the next LAP.

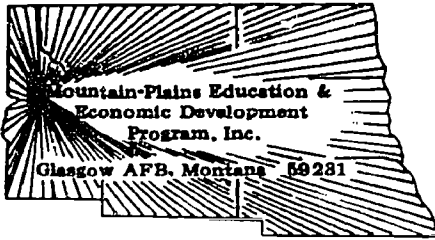

LAP TEST: FUNDAMENTALS OF MASTER CYLINDERS

1. Fluid is entrapped in the cylinder bore as soon as the primary cup passes the:
 - a. fluid inlet port
 - b. compensating port
 - c. check valve
 - d. secondary cup

2. Fluid passes quickly by the lips of the primary cup when the brakes are:
 - a. released
 - b. applied
 - c. leaking at the wheel cylinders
 - d. in the "rested" position

3. The serious drawback of the single unit master cylinder is:
 - a. that the brakes cannot be pumped up effectively
 - b. total loss of brakes if a brake line is ruptured
 - c. that a power booster cannot be adapted to the master cylinder
 - d. that it has braking pressure efficiency

4. The secondary piston of the dual master cylinder is moved by:
 - a. the primary to secondary contact rod
 - b. the secondary push rod
 - c. the primary piston stop rod
 - d. hydraulic pressure from the primary piston

5. Failure of either the front or rear system of the dual master cylinder will be first evidenced by a:
 - a. greater need of foot pressure to apply the brake
 - b. sudden increase in brake pedal travel
 - c. loss of brake fluid in the master cylinder
 - d. failure of the brake to hold

6. If hard pressure is held on the pedal and the brake pedal slowly lowers itself but there is no evidence of fluid loss, then the:
- check valve is not operating
 - secondary cup is leaking
 - primary cup is leaking
 - compensating port is blocked
7. A faulty check valve within the master cylinder can be noticed by:
- minor fluid loss at the reservoir
 - failure to maintain brake pressure when activated
 - excessive pedal travel
 - excessive fluid loss
8. Residual pressure can be checked by:
- measuring the amount of fluid returning to the reservoir
 - removing the valve and checking it with a light
 - measuring the amount of fluid returning to the reservoir
 - applying & releasing the brakes, then cracking open a bleeder screw
9. When released, pressured fluid returns to the reservoir from the cylinder bore through the:
- compensating port
 - Inlet port
 - breather port
 - reservoir vent
10. Recommended fluid level of the master cylinder is:
- filled over half of its capacity
 - filled to the top
 - filled 1 to $\frac{1}{2}$ inches of the top
 - filled $\frac{1}{2}$ to $\frac{1}{4}$ inches of the top

LAP TEST ANSWER KEY: FUNDAMENTALS OF MASTER CYLINDERS

1. b
2. a
3. b
4. d
5. b
6. c
7. c
8. d
9. a
10. d

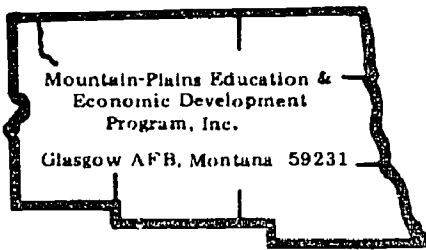

Learning Activity Package

Student: _____

Date: _____

PERFORMANCE ACTIVITY: Overhauling a Single Master Cylinder.

OBJECTIVE:

Overhaul a single master cylinder to meet manufacturer's specifications.

EVALUATION PROCEDURE:

Operation of the completed master cylinder must meet manufacturer's specification check list. Correctly answer 8 out of 10 items on a multiple-choice objective test to be taken at the end of this unit.

RESOURCES:

Repair Manual for year and model of car to be assigned to you.

Automobile with a single master cylinder.

Brake fluid.

Fender covers.

Master cylinder repair kit.

Tools, Basic Hand (listed on the Unit LEG).

PROCEDURE:

CAUTION: Brake fluid will ruin paint!

1. Place fender covers.
2. Remove master cylinder. Follow correct removal procedure from the repair manual.
3. Disassemble master cylinder on a clean bench area. Follow the disassembly procedure recommended in the repair manual.
4. Inspect the master cylinder bore for damage. Hone, if necessary, to recondition cylinder bore.
5. Replace defective parts with the new parts.
6. Clean all parts thoroughly and lubricate internal parts with brake fluid.

Principal Author(s):

J. Anderson/W. Osland

PROCEDURE: (cont.)

7. Carefully reassemble master cylinder.
8. Place cylinder in vice and bleed before reinstallations.
9. Carefully install master cylinder.
10. Correct master cylinder fluid level.
11. Bleed brakes using the correct procedure.
12. Check fluid level.
13. Have the instructor test the brake pedal for approval.
14. Clean and return all tools and equipment.
15. Clean work and bench area.
16. Go to the next LAP.

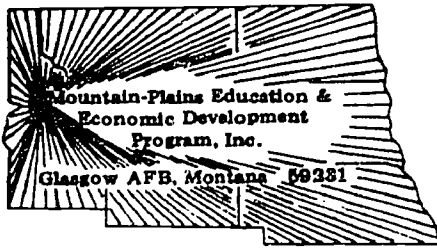

LAP TEST: OVERHAULING SINGLE MASTER CYLINDERS

1. Brake lines should be disconnected with:
 - a. box-end wrench
 - b. pipe wrenches
 - c. open-end wrenches
 - d. flare nut wrench

2. After the master cylinder is removed, before disassembling, it should:
 - a. have the exterior cleaned thoroughly
 - b. be soaked in solvent for a period of time
 - c. have the remaining fluid pumped out
 - d. be bench tested

3. On an open-end master cylinder (single) the check valve is usually the:
 - a. first part to come out of the cylinder bore
 - b. last part to come out of the cylinder bore
 - c. part that follows in between the primary cup and spring during disassembly
 - d. only part that has to be pressed out

4. Clearance between the piston and the cylinder bore must not exceed:
 - a. .001
 - b. .0005
 - c. .050
 - d. .005

5. Minor or very light scratches and corrosion can be removed with:
 - a. emery cloth
 - b. crocus cloth
 - c. sand paper
 - d. machinist file

6. The brake warning light warns the driver of:
 - a. Low fluid level in the master cylinder.
 - b. Air in the brake system.
 - c. failure of the front or rear brake system.
 - d. lack of power brake assist.

7. During re-assembly of new parts, all parts should be:
 - a. tested.
 - b. lubricated with fluid
 - c. measured.
 - d. lubricated with denatured alcohol.

8. Before re-assembly of cleaned and new parts the mechanic should thoroughly clean his hands with:
 - a. soap and water.
 - b. denatured alcohol.
 - c. clean fresh solvent.
 - d. brake fluid.

9. The drum type brake shoes on each wheel are designed so that:
 - a. both shoes apply equal braking effort.
 - b. the brake effort is totally dependent on the pedal pressure.
 - c. the secondary shoe increases the braking effort of the primary shoe.
 - d. none of the above.

10. If a self-adjusting brake system is not losing fluid but pedal travel is constantly increasing, the most likely cause is:
 - a. the master cylinder is defective.
 - b. the self-adjusters are not functioning properly.
 - c. brake pedal travel needs adjusting.
 - d. the parking brakes are wearing out.

LAP TEST ANSWER KEY: OVERHAULING SINGLE MASTER CYLINDERS

1. D
2. A
3. B
4. D
5. B
6. C
7. B
8. A
9. ~~A~~ B
10. B

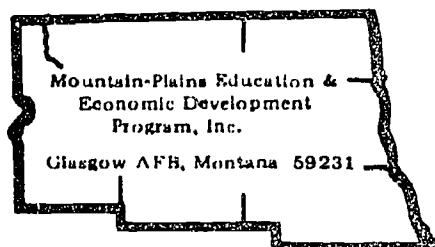

Learning Activity Package

Student: _____

Date: _____

PERFORMANCE ACTIVITY: Overhauling Dual Master Cylinder

OBJECTIVE:

Overhaul a dual master cylinder to meet manufacturer's specifications.

EVALUATION PROCEDURE:

Perform master cylinder overhaul in accordance with manufacturer's specifications and manufacturer's check list.

Correctly answer 8 out of 10 items on a multiple-choice objective test.

RESOURCES:

Repair Manual for year and model of car to be assigned to you.

Filmstrips: : 1000 1000 1000 1000 1000

Dual Master Cylinder Assembly Part III -- #7773.

Dual Master Cylinder Cleaning and Honing Part II -- #7772.

Dual Master Cylinder Disassembly -- #7771.

Automobile with a dual master cylinder.

Brake fluid.

Fender covers.

Master cylinder repair kit.

Tools, Basic Hand (listed on the Unit LEG).

PROCEDURE:

CAUTION: Brake fluid will ruin paint!

1. View filmstrips. ~~Return filmstrips when finished viewing.~~
2. Place fender covers on car.
3. Remove master cylinder following repair manual removal procedures.
4. Place master cylinder on bench for disassembly.

Principal Author(s):

J. Anderson/W. Osland

PROCEDURE: (cont.)

5. Disassemble master cylinder and lay out parts in sequence. Follow the disassembly procedure of the repair manual.
6. Inspect and clean all parts.
7. Inspect cylinder bore for damage or excessive wear. Hone cylinder bore if necessary.
8. Clean cylinder bore.
9. Replace worn parts with master cylinder repair kit.
10. Lubricate all internal parts with brake fluid and reassemble the master cylinder.
11. Bleed cylinder by placing it in a vice and pumping cylinder piston.
12. Install master cylinder back in the vehicle.
13. Correct the fluid level in the master cylinder.
14. Bleed brakes using the correct procedure.
15. Correct the fluid level again.
16. Have instructor inspect completed work and test the brake pedal.
17. Clean and return all tools and equipment.
18. Clean work bench and work area.
19. Obtain a copy of the LAP test.
20. After completion of the test, score it and return the answer sheet.
21. If the score is less than 80%, review the material.
22. After successful completion of the LAP test, ask the instructor for a copy of the Unit Post test 37.09.02. Answer all of the questions and return the test to the instructor for evaluation.
23. Upon successful completion, proceed to the next Unit.

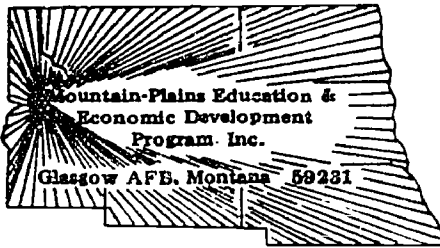

LAP TEST: OVERHAULING DUAL MASTER CYLINDERS

1. Pits and scratches can be removed from a master cylinder by:
 - a. emery cloth
 - b. machining
 - c. sand paper
 - d. honing

2. After honing, cleaning, rinsing and drying, the bore should be:
 - a. inspected with a light
 - b. soaked in brake fluid
 - c. soaked in denatured alcohol
 - d. measured for clearance

3. Bleeding of the master cylinder should be done at the:
 - a. primary side first
 - b. secondary side first
 - c. same time on both sides
 - d. does not matter which side first

4. The dual master cylinder utilizes:
 - a. no check valves in the system
 - b. two check valves, one located in each piston reservoir
 - c. one check valve centered between each unit
 - d. two check valves, one located in each tube seat

5. The "floating piston" of the dual master cylinder is:
 - a. referring to the secondary piston
 - b. sometimes called the primary piston
 - c. the same as the check valve
 - d. located between the primary and secondary piston

6. The stop bolt located at the bottom of the dual master cylinder must be removed to release the:
 - a. primary piston
 - b. floating piston
 - c. check valve
 - d. brake pedal push rod

7. A check valve is not used in a dual master cylinder on a:
 - a. truck with the master cylinder located beneath the floor
 - b. vehicle equipped with front disc brakes
 - c. vehicle equipped with full disc brakes
 - d. light duty truck

8. The holes in the cup-end of the pistons are for:
 - a. fluid to readily flow to the secondary cup
 - b. allowing fluid to quickly flow through and past the cup lips on brake application
 - c. better placement holding of the cups onto the pistons to prevent slippage
 - d. allowing fluid to quickly flow through and past the cup lips on release

9. What holds the cups of the dual master in place when in the "released" position?
 - a. return springs of the shoe assembly
 - b. piston springs
 - c. static pressure of the master cylinder
 - d. return spring for the brake pedal

10. Over-lengthening of the master cylinder push rod will cause what possible problem?
 - a. covering up the compensating port which won't allow build-up fluid to return to the reservoir and will cause brakes to lock-up
 - b. covering up of the breather port allowing no fluid to reach the check valve
 - c. covering up of the compensating port allowing no fluid to enter the cylinder bore area
 - d. a greater stroke of fluid will create too much fluid to flow into the wheel cylinders causing possible breakage

LAP TEST ANSWER KEY: OVERHAULING DUAL MASTER CYLINDERS

1. d
2. d
3. a
4. d
5. a
6. b
7. c
8. d
9. b
10. a

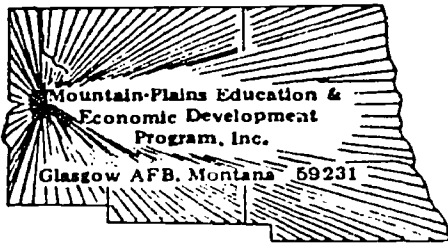

UNIT POST TEST: MASTER CYLINDERS (A)

37.09.02.01.

1. Fluid is entrapped in the cylinder bore as soon as the primary cup passes the:
 - a. fluid inlet port
 - b. compensating port
 - c. check valve
 - d. secondary cup
2. The tandem master cylinder divides the braking power between:
 - a. rear left and front right
 - b. right and left
 - c. front left and rear right
 - d. front and back
3. Failure of either the front or rear system of the dual master cylinder will be first evidenced by a:
 - a. greater need of foot pressure to apply the brake
 - b. sudden increase in brake pedal travel
 - c. loss of brake fluid in the master cylinder
 - d. failure of the brakes to hold
4. Residual pressure can be checked by:
 - a. measuring the amount of brake pedal pressure
 - b. removing the valve and checking it with a light
 - c. measuring the amount of fluid returning to the reservoir
 - d. applying and releasing the brakes, then cracking open a bleeder screw
5. Recommended fluid level of the master cylinder is:
 - a. filled over half of its capacity
 - b. filled to the top
 - c. filled 1 to $\frac{1}{2}$ inches of the top
 - d. filled $\frac{1}{2}$ to $\frac{1}{4}$ inches of the top

37.09.02.02.

6. Fluid leakage evident within the master cylinder dust boot reveals leakage at the:
- master cylinder seal
 - secondary cup
 - boot damage
 - primary cup
7. After the master cylinder is removed, before disassembling, it should:
- have the exterior cleaned thoroughly
 - be soaked in solvent for a period of time
 - have the remaining fluid pumped out
 - be bench tested
8. On drum-type brakes, which of the following can cause pedal rising on successive brake applications with all brakes dragging?
- Insufficient free travel or clearance between master cylinder push rod and piston.
 - Master cylinder piston not returning to stop.
 - Both A and B.
 - Neither A nor B.
9. During reassembly of new parts, all parts should be:
- tested.
 - lubricated with fluid
 - measured
 - lubricated with denatured alcohol
10. Bleeding after installation of brake lines may not be necessary if:
- no fluid was lost from the disconnected lines
 - bleeding is always necessary after line work
 - the master cylinder was kept full during installation
 - there were no leaks elsewhere in the brake system

37.09.02.03

11. Pits and scratches can be removed from a master cylinder by:
- emery cloth
 - machining
 - sand paper
 - honing
12. After honing, cleaning, rinsing and drying, the bore should be:
- inspected with a light
 - soaked in brake fluid
 - soaked in denatured alcohol
 - measured for clearance

13. The stop bolt located at the bottom of the dual master cylinder must be removed to release the:
- primary piston
 - floating piston
 - check valve
 - brake pedal push rod
14. A check valve is not used in a dual master cylinder on a:
- truck with the master cylinder located beneath the floor
 - vehicle equipped with front disc brakes
 - vehicle equipped with full disc brakes
 - light duty truck
15. Over - lengthening of the master cylinder push rod will cause what possible problem?
- covering up the compensating port which won't allow built-up-fluid to return to the reservoir and will cause brakes to lock-up
 - covering up of the breather port allowing no fluid to reach the check valve
 - covering up of the compensating port allowing no fluid to enter the cylinder bore area
 - a greater stroke of fluid will create too much fluid to flow into the wheel cylinder causing possible leakage

UNIT POST TEST ANSWER KEY: MASTER CYLINDER (A)

LAP 01

1. B
2. D
3. B
4. D
5. D

LAP 02

6. B
7. A
8. C
9. B
10. B

LAP 03

11. D
12. D
13. B
14. C
15. A



UNIT POST TEST: MASTER CYLINDERS (B)

37.09.02.01

1. Recommended fluid level of the master cylinder is:
 - a. filled over half of its capacity
 - b. filled to the top
 - c. filled 1 to 1/2 inches of the top
 - d. filled 1/2 to 3/4 inches of the top

2. Residual pressure can be checked by:
 - a. measuring the amount of brake pedal pressure
 - b. removing the valve and checking it with a light
 - c. measuring the amount of fluid returning to the reservoir
 - d. applying and releasing the brakes, then cracking open a bleeder screw

3. Failure of either the front or rear system of the dual master cylinder will be first evidenced by a:
 - a. greater need of foot pressure to apply the brake
 - b. sudden increase in brake pedal travel
 - c. loss of brake fluid in the master cylinder
 - d. failure of the brakes to hold

4. The tandem master cylinder divides the braking power between:
 - a. rear left and front right
 - b. right and left
 - c. front left and rear right
 - d. front and back

5. Fluid is entrapped in the cylinder bore as soon as the primary cup passes the:
 - a. fluid inlet port
 - b. compensating port
 - c. check valve
 - d. secondary cup

37.09.02.02

6. Bleeding after installation of brake lines may not be necessary if:
 - a. no fluid was lost from the disconnected lines
 - b. bleeding is always necessary after line work
 - c. the master cylinder was kept full during installation
 - d. there were no leaks elsewhere in the brake system

37.09.02.02 (continued)

7. During reassembly of new parts, all parts should be:
 - a. tested
 - b. lubricated with fluid
 - c. measured
 - d. lubricated with denatured alcohol

8. On drum-type brakes, which of the following can cause pedal rising on successive brake applications with all brakes dragging?
 - a. Insufficient free travel or clearance between master cylinder push rod and piston.
 - b. Master cylinder piston not returning to stop.
 - c. Both a and b.
 - d. Neither a nor b.

9. After the master cylinder is removed, before disassembling, it should:
 - a. have the exterior cleaned thoroughly.
 - b. be soaked in solvent for a period of time.
 - c. have the remaining fluid pumped out
 - d. be bench tested.

10. Fluid leakage evident within the master cylinder dust boot reveals leakage at the:
 - a. master cylinder seal.
 - b. secondary cup.
 - c. boot damage.
 - d. primary cup.

37.09.02.03

11. Over-lengthening of the master cylinder push rod will cause what possible problem?
 - a. covering up the compensating port which won't allow built-up-fluid to return to the reservoir and will cause brakes to lock up.
 - b. covering up of the breather port allowing no fluid to reach the check valve.
 - c. covering up of the compensating port allowing no fluid to enter the cylinder bore area.
 - d. a greater stroke of fluid will create too much fluid to flow into the wheel cylinder causing possible leakage.

12. A check valve is not used in a dual master cylinder on a:
 - a. truck with the master cylinder located beneath the floor.
 - b. vehicle equipped with front disc brakes.
 - c. vehicle equipped with full disc brakes.
 - d. light duty truck.

37.09.02.03 (continued)

13. The stop bolt located at the bottom of the dual master cylinder must be removed to release the:
 - a. primary piston.
 - b. floating piston.
 - c. check valve.
 - d. brake pedal push rod.

14. After honing, cleaning, rinsing and drying, the bore should be:
 - a. inspected with a light.
 - b. soaked in brake fluid.
 - c. soaked in denatured alcohol.
 - d. measured for clearance.

15. Pits and scratches can be removed from a master cylinder by:
 - a. emery cloth.
 - b. machining.
 - c. sand paper.
 - d. honing.

UNIT POST TEST ANSWER KEY: MASTER CYLINDER (B)

LAP 01

1. D
2. D
3. B
4. D
5. B

LAP 02

6. B
7. B
8. C
9. A
10. B

LAP 03

11. A
12. C
13. B
14. D
15. D

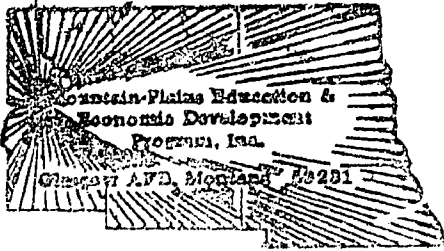

UNIT POST TEST: MASTER CYLINDERS (C)

37.09.02.01

1. Fluid is entrapped in the cylinder bore as soon as the primary cup passes the:
 - a. fluid inlet port
 - b. compensating port
 - c. check valve
 - d. secondary cup
2. Failure of either the front or rear system of the dual master cylinder will be first evidenced by a:
 - a. greater need of foot pressure to apply the brake
 - b. sudden increase in brake pedal travel
 - c. loss of brake fluid in the master cylinder
 - d. failure of the brakes to hold
3. Recommended fluid level of the master cylinder is:
 - a. filled over half of its capacity
 - b. filled to the top
 - c. filled 1 to 1/4 inches of the top
 - d. filled 1/4 to 1/2 inches of the top
4. The tandem master cylinder divides the braking power between:
 - a. rear left and front right
 - b. right and left
 - c. front left and rear right
 - d. front and back
5. Residual pressure can be checked by:
 - a. measuring the amount of brake pedal pressure
 - b. removing the valve and checking it with a light
 - c. measuring the amount of fluid returning to the reservoir
 - d. applying and releasing the brakes, then cracking open a bleeder screw
6. Fluid leakage evident within the master cylinder dust boot reveals leakage at the:
 - a. master cylinder seal
 - b. secondary cup
 - c. boot damage
 - d. primary cup

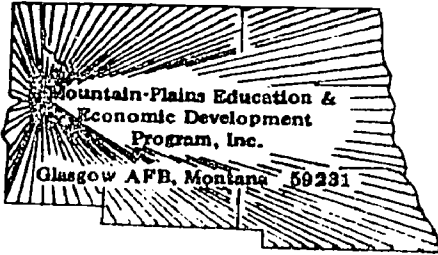

Family Pay Number: _____ Sex: M F (Circle 1)

PERFORMANCE CHECKLIST:

OVERALL PERFORMANCE: Satisfactory _____ Unsatisfactory _____

CRITERION
Met Not Met

	Met	Not Met
Objective 1:		
1. Remove steering gear box.		
Criterion: Does not damage car or gear box.		
2. Disassembles and inspects gear box components.		
Criterion: Follows service manual procedure and compares parts to manufacturer's specifications.		
3. Assembles steering gear box.		
Criterion: Must meet manufacturer's specifications.		
Objective 2:		
4. Adjusts end play.		
Criterion: Must meet manufacturer's specifications.		
5. Adjusts l.g.n. point or through point.		
Criterion: Must meet manufacturer's specifications.		
6. Completes test in allotted time for assigned vehicle.		

CRITERION
Met Not Met

Criterion: Must meet flat rate for assigned vehicle.

The student must complete 5 out of 6 line items to achieve an overall score of satisfactory.

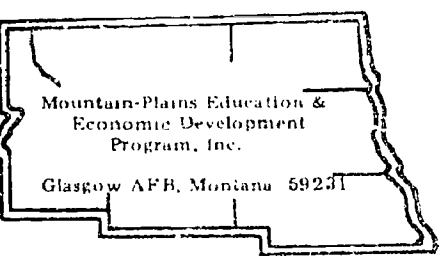

Learning Experience Guide

UNIT: POWER STEERING

RATIONALE:

The fundamentals and techniques in this unit will enable one to diagnose and overhaul power steering components.

PREREQUISITES:

Math Skills at Level F
Communication Skills at Level F

OBJECTIVES:

Recognize the components and proper operation of power steering. Use the proper procedure for overhaul of power steering components.

RESOURCES:

Printed Materials

Auto Mechanics Fundamentals. Martin W. Stockel, Goodheart-Willcox Company, Inc.
Auto Service and Repair. Martin W. Stockel, Goodheart-Willcox Company, Inc.
Motor's Auto Repair Manual. Motor, The Hearst Corporation. 1972 or equivalent.

Equipment

Automobile with power steering
Drain pan
Fender covers
Power steering fluid
Replacement parts as needed
Tools, Basic Hand:

- Chisel and Punch Set
 - 5/32" Pin Punch
 - 3/16" Solid
- Gauge, feeler (.002" - .025")
- Hammer, ball peen
- Hammer, plastic tip
- Handle, speed
- Hex Key Set
- Pliers, diagonal cutting
- Pliers, needle nose

Resources: Equipment: Continued

Scraper, gasket
 Screwdriver, standard (Set)
 Screwdriver, phillips (Set)
 Screw starter

Socket Set (3/8" drive)
 extension (3")
 ratchet

Socket Set (1/4" drive)
 extension (3")
 handle (6" flex)
 ratchet

Socket, spark plug
 extension (6")

Wrench, combination (Set)
 Wrench, combination ignition (Set)

GENERAL INSTRUCTIONS:

This unit consists of four Learning Activity Packages (LAPs). Each LAP will provide specific information for completion of a learning activity.

The general procedure for this unit is as follows:

- (1) Read the first assigned Learning Activity Package (LAP).
- (2) Begin and complete the first assigned LAP.
- (3) Take and score the LAP test.
- (4) Turn in the LAP test answer sheet.
- (5) Determine the reason for any missed items on the LAP test.
- (6) Proceed to and complete the next assigned LAP in the unit.
- (7) Complete all required LAPs for the unit by following steps 3 through 6.
- (8) In this Unit, there are some LAPs that have tests combined with other LAP tests. These combined tests are taken after completing the last LAP covered by the test.
- (9) Take the unit tests as described in the Unit LEG "Evaluation Procedures".
- (10) Proceed to the next assigned unit.

PERFORMANCE ACTIVITIES:

- .01 Fundamentals of Power Steering
- .02 Overhaul of Power Steering Pumps
- .03 Overhaul of Power Steering Control Units
- .04 Overhaul of Power Steering Cylinders

EVALUATION PROCEDURE:

When pretesting:

1. The student takes the unit multiple-choice pretest.
2. Successful completion is 4 out of 5 items for each LAP part of the pretest.
3. The student then takes a unit performance test if the unit pretest was successfully completed.
4. Satisfactory completion of the performance test is meeting the criteria listed on the performance test.

When post testing:

1. The student takes a multiple-choice unit post test and a unit performance test.
2. Successful unit completion is meeting the listed criteria for the performance test.

FOLLOW-THROUGH:

Go to the first assigned Learning Activity Package (LAP) listed on your Student Progress Record (SPR).

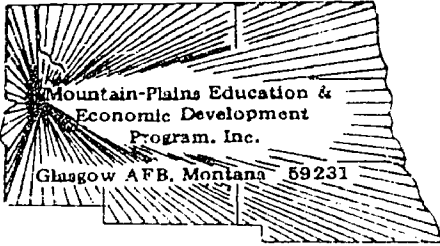

UNIT PRETEST: POWER STEERING

37.10.03.01.

1. A hydraulic pump power steering unit is generally operated by:
 - a. a belt driven by the engine.
 - b. a power piston.
 - c. an electric motor running off of the battery.
 - d. a universal shaft, generally six (6) feet long.

2. What is meant by a self-contained power steering unit?
 - a. it is the same as the slipper vane unit and roller vane unit.
 - b. the power cylinder and control valve are in separate units.
 - c. the oil reservoir is mounted directly on top of the power steering unit.
 - d. the control valve mechanism, power piston, and gears are in an integral unit.

3. Oil, in a power steering unit under pressure from the pumps, enters the valve body by way of:
 - a. the back pressure valve.
 - b. the inlet passage.
 - c. the lower cylinder head.
 - d. the power chamber.

4. When no pressure is being applied to the steering wheel, the spool valve is:
 - a. in a neutral position.
 - b. straight up and down.
 - c. compressed or engaged by the pivot lever.
 - d. vibrating profusely along with the pivot lever.

5. The center thrust bearing can move up or down with the worm shaft, but not:
 - a. when there is an excess of lubricating oil.
 - b. while under pressure.
 - c. while having pressure on it and the spool valve is in the left position.
 - d. around with it.

37.10.03.02.

6. The pump pulley should be removed with a:
- puller.
 - press.
 - plastic hammer.
 - slide hammer.
7. To replace a leaking drive shaft seal:
- the pulley can be removed, pry the seal out and install a new one without further disassembly.
 - the entire unit must be removed and disassembled.
 - it is best to overhaul the entire pump.
 - the pump should be fully tested for additional leaks.

37.10.03.03.

8. A power steering control valve regulates oil under pressure to:
- the worm.
 - the reservoir.
 - the right or left of the rack-piston nut.
 - the sector shaft.

37.10.03.04.

9. When overhauling a power steering cylinder, it is important to:
- know where the reservoir is located.
 - avoid nicking parts and to keep all parts clean.
 - keep the oil full at all times.
 - have the ball nut connected directly to the power piston.
10. When reinstalling the steering gear, misalignment can:
- correct itself over a period of time.
 - cause bindings and premature wear.
 - affect the reservoir and pump.
 - affect the steering pump cooler.

UNIT PRETEST ANSWER KEY: POWER STEERING

LAP .01

1. a
2. d
3. b
4. a
5. d

LAP .02

6. a
7. a

LAP .03

8. c

LAP .04

9. b
10. b

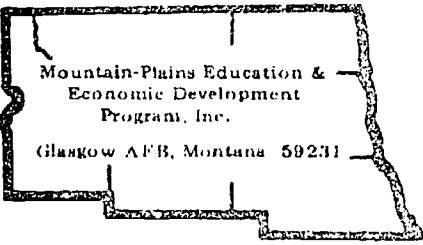

Learning Activity Package

Student: _____

Date: _____

PERFORMANCE ACTIVITY: Fundamentals of Power Steering

OBJECTIVE:

Recognize components and proper operation of the power steering system.

EVALUATION PROCEDURE:

Score 80% correct on LAP study questions.

Eight correct responses to a ten-item multiple choice objective test.

RESOURCES:

Auto Mechanics Fundamentals, Stockel.

PROCEDURE:

Steps

1. Obtain text copy and secure a quiet place to study.
2. From Chapter 17, beginning with "Power Steering" page 326, read through to "Quiz" page 336.
3. Study figures 17-32 through 17-52.
4. On separate paper, neatly answer questions 22 through 32 on page 336.
5. Give answer sheet to instructor for evaluation.
6. Return text to shelf.
7. Take and score the LAP test.
8. Upon successful completion, proceed to the next LAP.

Principal Author(s): J. Anderson/W. Osland

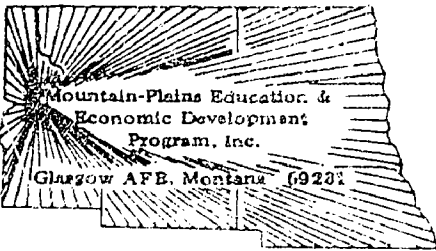

LAP TEST: FUNDAMENTALS OF POWER STEERING

1. A power steering unit is designed:
 - a. to reduce the steering wheel turning effort.
 - b. for women primarily.
 - c. for racing when quick turning is needed.
 - d. to be used in the more sophisticated cars.

2. The feeling imparted to the steering wheel by the wheels of a car in motion is called:
 - a. phantom pressure.
 - b. power steering.
 - c. turning effort.
 - d. road feel.

3. To maintain road feel, power steering systems require:
 - a. them to be mounted somewhat loosely.
 - b. some wheel effort.
 - c. them to be self-contained.
 - d. them to have rack and pinion steering gearbox.

4. A hydraulic pump power steering unit is generally operated by:
 - a. a belt driven by the engine.
 - b. a power piston.
 - c. an electric motor running off of the battery.
 - d. a universal shaft, generally (6) six feet long.

5. What is meant by a self-contained power steering unit?
 - a. it is the same as the slipper vane unit and roller vane unit.
 - b. the power cylinder and control valve are in separate units.
 - c. the oil reservoir is mounted directly on top of the power steering unit.
 - d. the control valve mechanism, power piston, and gears are in an integral unit.

6. Oil, in a power steering unit under pressure from the pump, enters the valve body by way of:
 - a. the back pressure valve.
 - b. the inlet passage.
 - c. the lower cylinder head.
 - d. the power chamber.

7. The center thrust bearing can move up or down with the worm shaft, but not:
 - a. when there is an excess of lubricating oil.
 - b. while under pressure.
 - c. while having pressure on it and the spool valve is in the left position.
 - d. around with it.
8. If the spool valve is in a neutral position, oil is fed:
 - a. to the pitman shaft by the power piston.
 - b. nowhere.
 - c. only to the steering column connection.
 - d. to both sides of the power piston and to the reaction rings.
9. Oil leakage in the power steering pump is prevented by:
 - a. neoprene rubber rings that ride in grooves.
 - b. a brass bushing.
 - c. a collar.
 - d. a back pressure valve.
10. The worm shaft must be connected to the steering shaft to allow for:
 - a. movement on the end of the pitman shaft.
 - b. play in the steering shaft.
 - c. play in the steering column.
 - d. movement on the end of the worm shaft.

LAP TEST ANSWER KEY: FUNDAMENTALS OF POWER STEERING

LAP .01

1. a
2. d
3. b
4. a
5. d
6. b
7. d
8. d
9. a
10. d

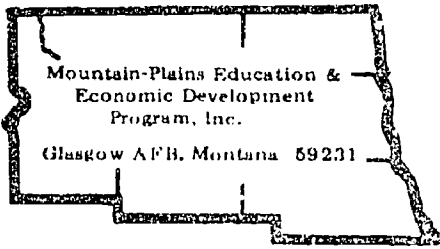

Learning Activity Package

Student: _____

Date: _____

PERFORMANCE ACTIVITY: Overhaul of Power Steering Pumps

OBJECTIVE:

Use the proper procedure for overhaul of power steering pumps.

EVALUATION PROCEDURE:

80% correct on performance checklist.
LAP test after completing LAP 37.10.03.04.

RESOURCES:

Auto Service and Repair, Stockel.
Motor's Auto Repair Manual.

Automobile with power steering pump
Fender covers
Power steering fluid
Replacement parts as needed
Tools, Basic Hand (see Unit LEG)

PROCEDURE:

NOTE: Review pages 31-15 through 31-17 in Auto Service and Repair.

1. Place fender covers.
2. Remove power steering pumps. Follow removal procedure of repair manual.
3. Drain remaining fluid out of pumps.
4. Disassemble the pump. Refer to disassembly procedure of manual. Lay all parts out in removal order on a clean area of the work bench.
5. Inspect all parts for wear and damage.
6. Replace all damaged parts. Replace all worn parts with the new replacement parts.
7. Lubricate all new parts and reassemble the pump. Refer to assembly procedure of manual.
8. Re-install pump in vehicle.

Principal Author(s): J. Anderson/W. Osland

9. Fill fluid level with power steering fluid.
10. Test power steering by turning the wheels full right and left for positive assistance.
11. When satisfactorily operational, ask the instructor to inspect the completed work for evaluation.
12. Clean and return all tools and equipment.
13. Clean work areas.
14. Proceed to next LAP.

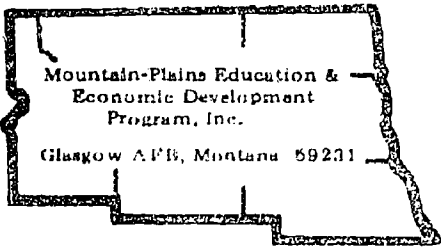

Learning Activity Package

Student: _____

Date: _____

PERFORMANCE ACTIVITY: Overhaul of Power Steering Control Units

OBJECTIVE:

Use the proper procedure for the overhaul of power steering control unit.

EVALUATION PROCEDURE:

80% correct on performance checklist.
LAP test after completing LAP 37,10,03,04.

RESOURCES:

Auto Service and Repair, Stockel.
Motor's Auto Repair Manual.

Automobile with power steering control unit
Drain pan
Fender covers
Power steering fluid
Replacement parts as needed
Tools, Basic Hand (see Unit LEG)

PROCEDURE:

NOTE: Review pages 31-7 through 31-15 in Auto Service and Repair.

1. Place fender covers.
2. Examine power steering fluid level.
3. Diagnose power steering problem.

NOTE: Prediagnosis aids the inspection of the disassembled unit in locating the defective part. Operate the steering full left and right while listening and feeling for noticeable problems. Refer to manual for diagnosis procedure. Record diagnosis results on work order.

4. Place drain pan below control unit to catch leaking fluid during removal from vehicle.
5. Remove control unit from vehicle. Refer to removal procedure of manual.

Principal Author(s): J. Anderson/W. Osland

6. Drain remaining fluid from control unit.
7. Disassemble control unit on a clean bench. Follow closely the disassembly procedure outlined in the manual. CAUTION: Extreme care must be taken to insure correct reassembly of control unit. Place all parts in the removal sequence on the bench.
8. Clean and inspect all parts for wear and damage.
9. Replace the worn parts with the new replacement parts.
10. Lubricate the parts with power steering fluid and reassemble. Follow re-assembly procedure of repair manual closely.
11. Remount control unit in the vehicle. Refer to manual for proper steering centering procedure.
12. Correct fluid level with power steering fluid.
13. Operate steering full left and right turns for positive assistance and assurance of repair of the problem. Check for leaks.
14. Ask the instructor to evaluate the completed work.
15. Clean work areas.
16. Clean and return all tools and equipment.
17. Proceed to next LAP.

”

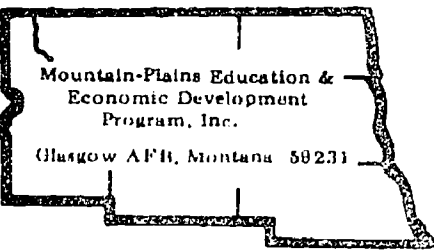

Learning Activity Package

Student: _____

Date: _____

PERFORMANCE ACTIVITY: Overhaul of Power Steering Cylinders

OBJECTIVE:

Overhaul a power steering cylinder.

EVALUATION PROCEDURE:

80% correct on performance checklist.

Eight correct responses to a ten-item multiple choice objective test.

RESOURCES:

Repair Manual for make and model of car assigned

Automobile with power steering cylinder

Drain pan

Fender covers

Power steering fluid

Replacement parts as needed

Tools, Basic Hand (see Unit LEG)

PROCEDURE:

Steps

1. Place fender covers.
2. Correct fluid level if needed.
3. Test operate the power steering to diagnose problem of the defective steering. Refer to diagnose procedure of manual. Record results on work order.
4. Remove cylinder from vehicle. Refer to removal procedure of the repair manual. Use drain pan to catch leaking fluid.
5. Clean excessive dirt and grease from the cylinder exterior.
6. Disassemble cylinder on a clean bench. Refer to the manual for disassembly procedure. Keep all parts in order of removal.
7. Clean and inspect all parts for damage and wear.
8. Replace worn parts with the new replacement parts.

Principal Author(s): J. Anderson/W. Gsland

9. Lubricate all the parts with power steering fluid and reassemble. Refer to assembly procedure of manual.
10. Install cylinder on vehicle.
11. Correct fluid level.
12. Test operate power steering for satisfactory operation. Check for any signs of leakage.
13. Ask the instructor to evaluate the completed work.
14. Clean and return all tools and equipment.
15. Clean work areas.
16. Take and score the LAP test.

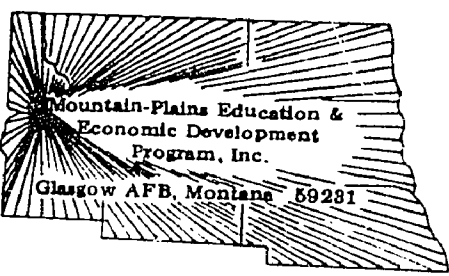

LAP TEST: OVERHAULING POWER STEERING PUMPS, CONTROL UNITS AND CYLINDERS

37.10.03.02.

1. To replace a leaking drive shaft seal:
 - a. the pulley can be removed, pry the seal out and install a new one without further disassembly.
 - b. the entire unit must be removed and disassembled.
 - c. it is best to overhaul the entire pump.
 - d. the pump should be fully tested for additional leaks.
2. Over-tightening of the pump belt will usually result in:
 - a. premature failure of the pump.
 - b. premature failure of the shaft bearing.
 - c. premature failure of the belt.
 - d. misalignment of the pump pulley.
3. The majority of power steering pumps are:
 - a. not equipped with any pressure control device.
 - b. partial flow.
 - c. pressure-relieved when the wheels are straight ahead.
 - d. constant pressure flow.

37.10.03.03.

4. You should record diagnosis results on:
 - a. the power steering unit.
 - b. top of the air cleaner so you won't forget.
 - c. nothing, it is not necessary.
 - d. a work order.
5. Prior to reassembly of the power steering unit, you should:
 - a. lubricate the parts with 30 weight oil.
 - b. lubricate the parts with a light grease.
 - c. clean them thoroughly and put them together dry.
 - d. lubricate the parts with power steering fluid.
6. To completely drain a power steering control unit you could:
 - a. turn the housing in every angle and it will drip completely dry.
 - b. put an air hose on the end of the pressure port seat.
 - c. remove the hoses from the pressure port seat and let it drain overnight.
 - d. drain it by turning the stub shaft on the rack piston several times.

37.10.03.04.

7. When overhauling a power steering cylinder, it is important to:
 - a. know where the reservoir is located.
 - b. avoid nicking parts and to keep all parts clean.
 - c. keep the oil full at all times.
 - d. have the ball nut connected directly to the power piston.

8. When reinstalling the steering gear, check for proper alignment with the:
 - a. worm.
 - b. steering shaft.
 - c. shift rods.
 - d. shim.

9. When reinstalling the steering gear, misalignment can:
 - a. correct itself over a period of time.
 - b. cause bindings and premature wear.
 - c. affect the reservoir and pump.
 - d. affect the steering pump cooler.

10. To admit oil pressure to the power cylinder, the pitman arm:
 - a. forces the tie rod to pump the oil into the cylinder.
 - b. turns off the shut-off valve.
 - c. moves the control valve to the open position.
 - d. develops five pounds of back pressure.

LAP TEST ANSWER KEY: OVERHAULING POWER STEERING PUMPS, CONTROL UNITS AND CYLINDERS

LAP .02

1. a
2. b
3. d

LAP .03

4. d
5. d
6. d

LAP .04

7. b
8. b
9. b
10. c

UNIT POST TEST ANSWER KEY: POWER STEERING(A)

LAP .01

1. c
2. c or b
3. a
4. d
5. c

LAP .02

6. b
7. c

LAP .03

8. c
9. c

LAP .04

10. a

37.10.03.02.

6. The slipper pump uses what to keep the slippers out against the wall?
 - a. oil pressure.
 - b. springs.
 - c. centrifugal force.
 - d. balanced weights.

7. A vibrating flow control valve in the pump usually indicates:
 - a. overfilled with fluid.
 - b. sticking valve.
 - c. low on fluid in the reservoir.
 - d. leaking pressure within the pump.

37.10.03.03.

8. A power steering control valve regulates oil under pressure to:
 - a. the worm.
 - b. the reservoir.
 - c. the right or left of the rack-piston nut.
 - d. the sector shaft.

9. When adjusting the worm to rack-piston preload, you receive a mild preload from:
 - a. the damper seal.
 - b. the reservoir tank.
 - c. the worm groove which is ground with a high point in the center.
 - d. the pressure port seat.

37.10.03.04.

10. When putting a power steering unit together again, you have how many basic adjustments on an in-line power steering gear?
 - a. 3
 - b. 5
 - c. 2
 - d. 4

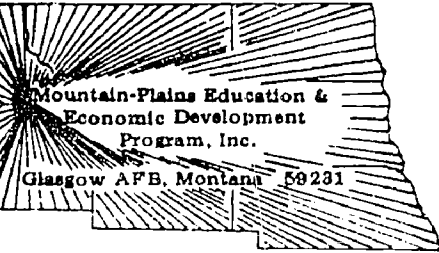

UNIT POST TEST: POWER STEERING (B)

37.10.03.01

1. In a rotary valve action unit, when the steering wheel is moved to the right, a turning force is applied to the stub shaft and through the pin to the:
 - a. pitman shaft.
 - b. spool valve.
 - c. torsion bar.
 - d. check valve.
2. In a self-contained, offset, power steering gear, the additional force offered by the pressurized oil is applied to:
 - a. the right turn power chamber only.
 - b. the spool valve.
 - c. the left turn power chamber only.
 - d. the pitman shaft.
3. Oil leakage in the power steering pump is prevented by:
 - a. neoprene rubber rings that ride in grooves.
 - b. a brass bushing.
 - c. a collar.
 - d. a back pressure valve.
4. The worm shaft is connected to the steering shaft by a:
 - a. brass bushing.
 - b. universal joining.
 - c. flexible connector.
 - d. spool valve.
5. The two forces on the center thrust bearing "fight" against the driver's turning force on the wheel and produce:
 - a. a vibration in the front-end which can cause you to lose control of your car.
 - b. a hazard when driving.
 - c. road feel.
 - d. no feel at all if you have a good power steering unit.

37.10.03.02

6. A vibrating flow control valve in the pump usually indicates:
 - a. overfilled with fluid.
 - b. sticking valve.
 - c. low on fluid in the reservoir.
 - d. leaking pressure within the pump.

37.10.03.02 (continued)

7. The slipper pump uses what to keep the slippers out against the wall?
- oil pressure.
 - springs.
 - centrifugal force.
 - balanced weights.

37.10.03.03

8. When adjusting the worm to rack-piston preload, you receive a milk preload from:
- the damper seal.
 - the reservoir tank.
 - the worm groove which is ground with a high point in the center.
 - the pressure port seat.
9. A power steering control valve regulates oil under pressure to:
- the worm.
 - the reservoir.
 - the right or left of the rack-piston nut.
 - the sector shaft.

37.10.03.04

10. When putting a power steering unit together again, you have how many basic adjustments on an in-line power steering gear?
- 3
 - 5
 - 2
 - 4

UNIT POST TEST ANSWER KEY: POWER STEERING (B)

1. C
2. D
3. A
4. C or B
5. C
6. C
7. B
8. C
9. C
10. A

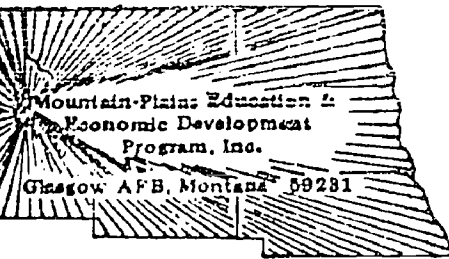

UNIT POST TEST: POWER STEERING (C)

37.10.03.01

1. In a self-contained, offset, power steering gear, the additional force offered by the pressurized oil is applied to:
 - a. the right turn power chamber only.
 - b. the spool valve.
 - c. the left turn power chamber only.
 - d. the pitman shaft.
2. Oil leakage in the power steering pump is prevented by:
 - a. neoprene rubber rings that ride in grooves.
 - b. a brass bushing.
 - c. a collar.
 - d. a back pressure valve.
3. In a rotary valve action unit, when the steering wheel is moved to the right, a turning force is applied to the stub shaft and through the pin to the:
 - a. pitman shaft.
 - b. spool valve.
 - c. torsion bar.
 - d. check valve.
4. The two forces on the center thrust bearing "fight" against the driver's turning force on the wheel and produce:
 - a. a vibration in the front-end which can cause you to lose control of your car.
 - b. a hazard when driving.
 - c. road feel.
 - d. no feel at all if you have a good power steering unit.
5. The worm shaft is connected to the steering shaft by a:
 - a. brass bushing.
 - b. universal joint.
 - c. flexible connector.
 - d. spool valve.

37.10.03.02

6. The slipper pump uses what to keep the slippers out against the wall?
 - a. oil pressure.
 - b. springs.
 - c. centrifugal force.
 - d. balanced weights.

37.10.03.02 (continued)

7. A vibrating flow control valve in the pump usually indicates:
- overfilled with fluid.
 - sticking valve.
 - low on fluid in the reservoir.
 - leaking pressure within the pump.

37.10.03.03

8. A power steering control valve regulates oil under pressure to:
- the worm.
 - the reservoir.
 - the right or left of the rack-piston nut.
 - the sector shaft.
9. When adjusting the worm to rack-piston preload, you receive a milk preload from:
- the damper seal.
 - the reservoir tank.
 - the worm groove which is ground with a high point in the center.
 - the pressure port seat.

37.10.03.04

10. When putting a power steering unit together again, you have how many basic adjustments on an in-line power steering gear?
- 3
 - 5
 - 2
 - 4

Date: _____

Date Published: 6-20-77

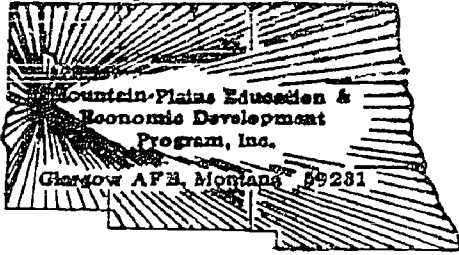

UNIT POST TEST: POWER STEERING (C)

37.10.03.01

1. In a self-contained, offset, power steering gear, the additional force offered by the pressurized oil is applied to:
 - a. the right turn power chamber only.
 - b. the spool valve.
 - c. the left turn power chamber only.
 - d. the pitman shaft.

2. Oil leakage in the power steering pump is prevented by:
 - a. neoprene rubber rings that ride in grooves.
 - b. a brass bushing.
 - c. a collar.
 - d. a back pressure valve.

3. In a rotary valve action unit, when the steering wheel is moved to the right, a turning force is applied to the stub shaft and through the pin to the:
 - a. pitman shaft.
 - b. spool valve.
 - c. torsion bar.
 - d. check valve.

4. The two forces on the center thrust bearing "fight" against the driver's turning force on the wheel and produce:
 - a. a vibration in the front-end which can cause you to lose control of your car.
 - b. a hazard when driving.
 - c. road feel.
 - d. no feel at all if you have a good power steering unit.

5. The worm shaft is connected to the steering shaft by a:
 - a. brass bushing.
 - b. universal joint.
 - c. flexible connector.
 - d. spool valve.

37.10.03.02

6. The slipper pump uses what to keep the slippers out against the wall?
 - a. oil pressure.
 - b. springs.
 - c. centrifugal force.
 - d. balanced weights.

37.10.03.02 (continued)

7. A vibrating flow control valve in the pump usually indicates:
- overfilled with fluid.
 - sticking valve.
 - low on fluid in the reservoir.
 - leaking pressure within the pump.

37.10.03.03

8. A power steering control valve regulates oil under pressure to:
- the worm.
 - the reservoir.
 - the right or left of the rack-piston nut.
 - the sector shaft.
9. When adjusting the worm to rack-piston preload, you receive a milk preload from:
- the damper seal.
 - the reservoir tank.
 - the worm groove which is ground with a high point in the center.
 - the pressure port seat.

37.10.03.04

10. When putting a power steering unit together again, you have how many basic adjustments on an in-line power steering gear?
- 3
 - 5
 - 2
 - 4

UNIT POST TEST ANSWER KEY: POWER STEERING (C)

1. D
2. A
3. C
4. C
5. C or B
6. B
7. C
8. C
9. C
10. A

Student: _____ File Code: 37.10.03.00.B1-5

Date: _____ Date Published: 13/10/76

Family Pay Number: _____ Sex: M F (Circle 1)

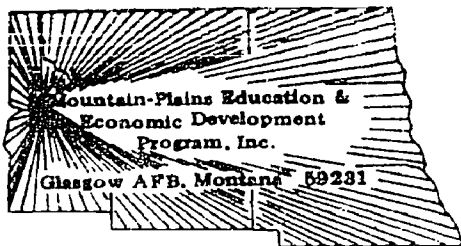

UNIT PERFORMANCE TEST: POWER STEERING

OBJECTIVE 1:

Overhaul power steering units.

TASK:

The student will be assigned a vehicle on which he must overhaul the power steering pump and control units.

ASSIGNMENT:

CONDITIONS:

The student must perform the test using only those materials provided for the test and complete the test in the auto shop.

RESOURCES:

Service Manual
Parts and Time Manual
Parts if Needed
Snap Ring Pliers
Hoses if needed
Power Steering Fluid
Overhaul Gasket Set

RESOURCES: (Cont.)

Jack
Jack Stands
Fender Covers
Combination Ignition wrench set
Combination Wrench Set
Standard Screwdriver Set
Phillips Screwdriver Set
Feeler gauge - .002 through .025 inch
Hex Key Set
Diagonal Cutting Pliers
Needle Nose Plier
1/4" Drive Socket Set
Ratchet - 3" and 6" extensions - 6" flex handle
Ball Peen hammer
Plastic Tip Hammer
Screw Starter
Chisel and Punch Set
5/32" Pin Punch - 3/16" Solid
Gasket scraper
3/8" Drive Ratchet
3" Extension
Spark Plug Socket
6" Extension
Speed Handle
3/8" Drive Socket Set

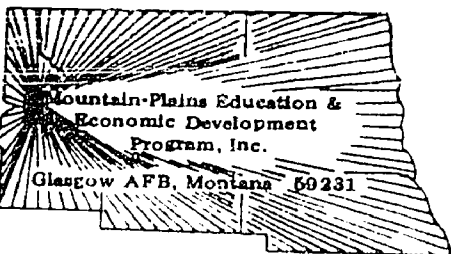

Student: _____ File Code: 37.10.03.00.81-5

Date: _____ Date Published: 3/10/76

Family Pay Number: _____ Sex: M F (Circle 1)

PERFORMANCE CHECKLIST:

OVERALL PERFORMANCE: Satisfactory _____ Unsatisfactory _____

	CRITERION	
	Met	Not Met
Objective 1:		
1. Remove power steering pump.		
Criterion: Does not damage pump or vehicle.		
2. Disassemble and inspect pump components.		
Criterion: Compares parts to manufacturer's specifications.		
3. Assembles pump.		
Criterion: Must follow service manual procedures and meet manufacturer's specifications.		
4. Remove power steering control unit.		
Criterion: Does not damage unit or vehicle.		
5. Disassembles and inspects power steering control unit.		
Criterion: Compares parts to manufacturer's specifications.		
6. Assembles and installs power steering control unit.		

CRITERION
Met Not Met

	Met	Not Met
Criterion: Must meet manufacturer's specifications.		
7. Tests power steering system.		
Criterion: Must meet manufacturer's specifications.		
8. Must complete test in allotted time.		
Criterion: Must meet flat rate on assigned vehicle.		
Student must satisfactorily complete 7 out of 8 line items		
to achieve an overall score of satisfactory.		



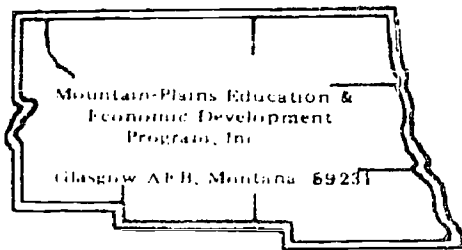

Learning Experience Guide

UNIT: FUNDAMENTALS OF SUSPENSION

RATIONALE:

The fundamentals in this unit will familiarize you with the components of front-end suspension and enable you to properly replace front-end components.

PREREQUISITES:

Math Skills at Level E for LAP 1
 Math Skills at Level F for LAPs 2-4
 Communication Skills at Level E for LAP 1
 Communication Skills at Level F for LAPs 2-4

OBJECTIVE:

Recognize the components and proper operation of front-end suspension and the correct procedure for replacement of front-end components. Replace front-end components.

RESOURCES:

Auto Mechanics Fundamentals. Martin W. Stockel, Goodheart-Willcox Company, Inc.
Auto Service and Repair. Martin W. Stockel, Goodheart-Willcox Company, Inc.
Motor's Auto Repair Manual. Motor, The Hearst Corporation, 1972 or equivalent.

Automobile needing replacement for: ball joint
 control arm bushing
 idler arm
 tie rod

Cotter key
 Creeper
 Grease
 Jacks (or lift)
 Jack stands
 Projector
 Replacement parts
 Special installation tools for ball joints

Principal Author(s): C. Schramm/W. Osland

RESOURCES: Equipment (cont.)

Tools, Basic Hand:

Chisel and Punch Set
 5/32" Pin Punch
 3/16" Solid

Gauge, feeler (.002" - .025")

Hammer, ball peen
 Hammer, plastic tip
 Handle, speed
 Hex Key Set

Pliers, diagonal cutting
 Pliers, needle nose

Scraper, gasket
 Screwdriver, standard (Set)
 Screwdriver, phillips (Set)
 Screw starter

Socket Set (3/8" drive)
 extension (3")
 ratchet

Socket Set (1/4" drive)
 extension (3")
 handle (6" flex)
 ratchet

Socket, spark plug
 extension (6")

Wrench, combination (Set)
 Wrench, combination ignition (Set)

GENERAL INSTRUCTIONS:

This unit consists of five Learning Activity Packages (LAPs). Each LAP will provide specific information for completion of a learning activity.

The general procedure for this unit is as follows:

- (1) Read the first assigned Learning Activity Package (LAP).
- (2) Begin and complete the first assigned LAP.
- (3) Take and score the LAP test.
- (4) Turn in the LAP test answer sheet.
- (5) Determine the reason for any missed items on the LAP test.
- (6) Proceed to and complete the next assigned LAP in the unit.
- (7) Complete all required LAPs for the unit by following steps 3 through 6.
- (8) Take the unit tests as described in the Unit LEG "Evaluation Procedures".
- (9) Proceed to the next assigned unit.

PERFORMANCE ACTIVITIES:

- .01 Fundamentals of Front-End Suspension
- .02 Replacing Ball Joints
- .03 Replacement of Tie-Rod Ends
- .04 Replacement of Idler Arms
- .05 Replacement of Control Arm Bushings

EVALUATION PROCEDURE:

When pretesting:

1. The student takes the unit multiple-choice pretest.
2. Successful completion is 4 out of 5 items for each LAP part of the pretest.
3. The student then takes a unit performance test if the unit pretest was successfully completed.
4. Satisfactory completion of the performance test is meeting the criteria listed on the performance test.

When post testing:

1. The student takes a multiple-choice unit post test and a unit performance test.
2. Successful unit completion is meeting the listed criteria for the performance test.

FOLLOW-THROUGH:

Go to the first assigned Learning Activity Package (LAP) listed on your Student Progress Record (SPR).

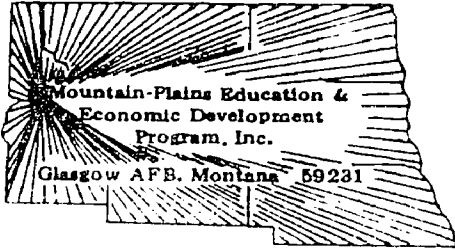

UNIT PRETEST: FUNDAMENTALS OF SUSPENSION

37.10.04.01.

1. The integral type frame is constructed as a:
 - a. part of the body.
 - b. separate unit from the body.
 - c. part of the main suspension.
 - d. separate steel frame.

2. Spring oscillation is:
 - a. the forward and backward movement of the springs caused by the wheel hitting a bump.
 - b. the up and down movement of the spring caused by the wheel hitting a bump.
 - c. the upward movement of the spring caused by the wheel hitting a bump.
 - d. the downward motion of the spring caused by the wheel hitting a bump.

3. Independent front suspension:
 - a. lets each front wheel turn independently.
 - b. allows the car to turn freely on corners.
 - c. allows either front wheel to move up and down independently.
 - d. allows the front wheels to move up and down at the same time.

4. The use of ball joints on the independent front suspension replaces the use of:
 - a. rubber bushing and gromets.
 - b. spindle and wheel bearings.
 - c. springs and shackles.
 - d. threaded bushings and kingpins.

5. The stabilizer bar is used to:
 - a. stabilize lower control arm.
 - b. overcome spring oscillations.
 - c. overcome unsprung weight.
 - d. overcome the tendency for car's body to lean on corners.

6. When lubricating the suspension system, never grease:
 - a. ball joints.
 - b. kingpins.
 - c. tie rod ends.
 - d. rubber gromets and bushings.

37.10.04.01. cont.

7. Positive camber is tipping the tops of the wheels:
- in.
 - out.
 - back.
 - forward.
8. When removing coil springs that are under pressure:
- lower the complete front-end.
 - stand clear as the last bolt is loosened.
 - keep the weight on the spring.
 - use a coil spring compressor.
9. A long bar of strong steel that is used to support suspension weight is referred to as a:
- strut bar.
 - stabilizer bar.
 - torsion bar.
 - tie rod bar.
10. The term used for the weight of all parts of the car that are supported by the suspension system is:
- drop-weight.
 - unsprung weight.
 - out-of-balance.
 - sprung weight.

37.10.04.02.

11. To check the ball joint wear effectively:
- the wheel bearings must be loose.
 - the wheel must not be off the floor.
 - the pressure must be released.
 - the front shocks must be removed.
12. _____
13. Riveted mounted ball joints are replaced with:
- bolts.
 - new rivets.
 - welding into place.
 - screw in ball joints.

37.10.04.02. cont.

14. When lowering the disconnected ball joint arm with a jack, the jack should be:
- a quick release hydraulic hand jack.
 - parallel with the frame.
 - directly below the spring on the arm.
 - parallel with the length of the suspension arm.
15. After installation of the joint into the spindle:
- a lock washer and nut should be quickly installed.
 - the nut should be hand tightened as much as possible and pinned.
 - the nut should be torqued.
 - the joint nut and a lock nut should be installed.

37.10.04.03.

16. Before tie-rod-end removal:
- the tie rod should be checked for being bent.
 - the length of the tie rod should be measured and recorded.
 - the tie-rod-end should be threaded out of the sleeve.
 - the steering wheel should be locked into position.

37.10.04.04.

17. The function of the idler arm is to:
- support front-end suspension weight.
 - move the steering linkage to turn the wheels.
 - carry the steering linkage movement.
 - move the pitman arm in the direction necessary to turn.

18.

37.10.04.05.

19. When one arm bushing is worn:
- both bushings of that arm should be replaced.
 - it should be replaced only to save time and expense.
 - replace the one and measure the other for amount of extended life.
 - the entire control arm should be replaced.

20.

UNIT/LAP PRETEST ANSWER KEY: FUNDAMENTALS OF SUSPENSION

LAP .01

1. a
2. b
3. c
4. d
5. d
6. d
7. b
8. d
9. c
10. d

LAP .02

11. c
12. d
13. a
14. d
15. c

LAP .03

16. b

LAP .04

17. c
18. d

LAP .05

19. a
20. b

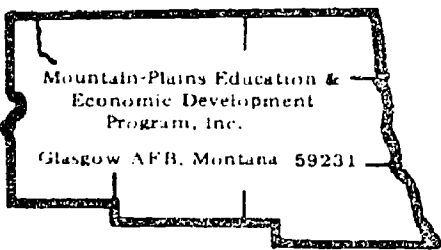

Learning Activity Package

Student: _____

Date: _____

PERFORMANCE ACTIVITY: Fundamentals of Front-End Suspension

OBJECTIVE:

Recognize the operation of each component of a suspension system.

EVALUATION PROCEDURE:

80% correct on LAP study questions.

Eight correct responses to a ten-item multiple-choice objective test.

RESOURCES:

Auto Mechanics Fundamentals, Stockel.

Auto Service and Repair, Stockel.

PROCEDURE:

1. Do the following assignments using Auto Mechanics Fundamentals:
 - a. Read Chapter 15, "Frames, Bodies, Springs, Suspension Systems," pages 283-301.
 - b. Study all schematic drawings thoroughly.
 - c. Answer quiz questions 1-35 on pages 300, 301.
 - d. Read Chapter 17, "Front Wheel Alignment, Steering System," pages 313-336.
 - e. Study all the schematic drawings thoroughly.
 - f. Answer quiz questions 1-17 on page 336.
 - g. Return text to shelf and turn quiz answers over to the instructor for evaluation.

2. Do the following assignments using Auto Repair and Service:
 - a. Read Chapter 31, "Steering Suspension Systems Service," pages 31.20 through 31.38.
 - b. Study all the schematic drawings.
 - c. Familiarize yourself with "Problem Diagnosis," pages 31.38 through 31.40.
 - d. Complete answers to quiz questions 23-42 on page 31.41.
 - e. Read Chapter 30, "Wheels, Bearings, Tires," pages 30.1 through 30.20.

Principal Author(s):

J. Anderson/W. Osland

Procedure: continued

- f. Study all the schematic drawings on page 30.20.
 - g. Read the "Problem Diagnosis" section, page 30.26 through page 30.29.
This information will be helpful in actual work diagnosing.
 - h. Answer quiz questions 1-24 on pages 30.29 and 30.30.
 - i. Return text to shelf and turn your quiz answers over to the instructor for evaluation.
3. Take and score the LAP test.
 4. If the score is less than 80%, review the material.

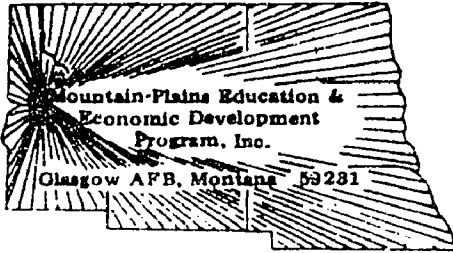

LAP TEST: FUNDAMENTALS OF FRONT-END SUSPENSION

1. The integral type frame is constructed as a:
 - a. part of the body.
 - b. separate unit from the body.
 - c. part of the main suspension.
 - d. separate steel frame.

2. Spring oscillation is:
 - a. the forward and backward movement of the springs caused by the hitting a bump.
 - b. the up and down movement of the spring caused by the wheel hitting a bump.
 - c. the upward movement of the spring caused by the wheel hitting a bump.
 - d. the downward motion of the spring caused by the wheel hitting a bump.

3. Independent front suspension:
 - a. lets each front wheel turn independently.
 - b. allows the car to turn freely on corners.
 - c. allows either front wheel to move up and down independently.
 - d. allows the front wheels to move up and down at the same time.

4. The use of ball joints on the independent front suspension replaces the use of:
 - a. rubber bushing and gromets.
 - b. spindle and wheel bearings.
 - c. springs and shackles.
 - d. threaded bushings and kingpins.

5. The stabilizer bar is used to:
 - a. stabilize lower control arm.
 - b. overcome spring oscillations.
 - c. overcome unsprung weight.
 - d. overcome the tendency for car's body to lean on corners.

6. When lubricating the suspension system, never grease:
 - a. ball joints.
 - b. kingpins.
 - c. tie rod ends.
 - d. rubber gromets and bushings.

37.10.04.01. cont.

7. Positive camber is tipping the tops of the wheels:
 - a. in.
 - b. out.
 - c. back.
 - d. forward.

8. When removing coil springs that are under pressure:
 - a. lower the complete front-end.
 - c. keep the weight on the spring.
 - d. use a coil spring compressor.

9. A long bar of strong steel that is used to support suspension weight is referred to as a:
 - a. strut bar.
 - b. stabilizer bar.
 - c. torsion bar.
 - d. tie rod bar.

10. The term used for the weight of all parts of the car that are supported by the suspension system is:
 - a. drop-weight.
 - b. unsprung weight.
 - c. out-of-balance.
 - d. sprung weight.

LAP TEST ANSWER KEY: FUNDAMENTALS OF FRONT-END SUSPENSION

1. a
2. b
3. ~~a~~ C
4. ~~b~~ D
5. d
6. ~~a~~ D
7. b
8. d
9. ~~a~~ C
10. ~~a~~ D

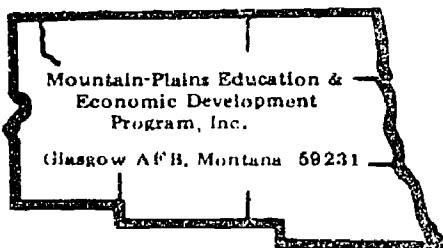

Learning Activity Package

Student: _____

Date: _____

PERFORMANCE ACTIVITY: Replacing Ball Joints

OBJECTIVE:

Identify the correct procedure for removing and replacing the ball joints. Replace a set of ball joints.

EVALUATION PROCEDURE:

80% correct on performance checklist.
LAP test after completion of LAP 37,10,04,03.

RESOURCES:

Auto Service and Repair, Stockel.
Motor's Auto Repair Manual.

Automobile needing new ball joints
Jack
Jack stands

Replacements parts
Special tools for installation of
ball joints
Tools, Basic Hand: (see Unit LEG)

PROCEDURE:

NOTE: Review pages 31-23 through 31-28 in Auto Service and Repair.

CAUTION: Extreme caution must be observed because of the coil springs.

1. Raise vehicle and secure it safely with jack stands.
2. Remove wheel and assembly.
3. Clean suspension parts and ball joints of dirt and grease to improve working conditions.
4. Obtain manual for the specific directions to follow for the particular make, model and year of the car being worked on.

NOTE: Due to the variety of suspension systems, the mechanic must learn to use the manual in working independently with each individual automobile.

Principal Author(s): J. Anderson/W. Osland

5. Follow the directions in the manual for changing the ball joints.
6. Return manual, tools and all equipment to their proper places after lowering the car.
7. Be sure new ball joints have a sufficient amount of grease before leaving the shop.
8. Upon completion, the instructor will inspect the job. If satisfactory, proceed to the next LAP.

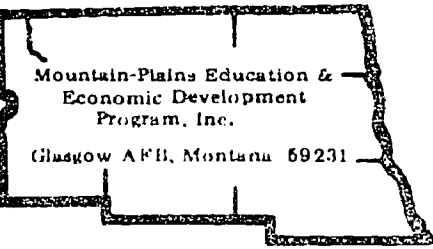

Learning Activity Package

Student: _____

Date: _____

PERFORMANCE ACTIVITY: Replacement of Tie-Rod Ends

OBJECTIVE:

Demonstrate the correct procedure for replacement of tie-rod ends.

EVALUATION PROCEDURE:

80% correct on performance checklist.
Eight correct responses to a ten-item multiple choice objective test.

RESOURCES:

Automobile needing tie-rod replacement
Cotter keys
Grease
Jack
Jack stands
New Tie-Rod Ends
Tools, basic hand (See Unit LEG)

Auto Service and Repair, Stockel.
Motor's Auto Repair Manual.

PROCEDURE:

NOTE: Review pages 31-21 through 31-22 in Auto Service and Repair.

1. Raise front of vehicle and secure with jack stands.
2. Remove tie-rods. Refer to manual for correct removal procedure.
3. Compare new tie-rod end to the old one to be sure of exact replacement.
4. Install the new tie-rod end following the procedure from the repair manual.
5. Ask the instructor to evaluate your work.
6. Lower vehicle.
7. Clean and return all tools and equipment.
8. Clean work areas.
9. Take and score the LAP test.
10. Upon successful completion, proceed to the next LAP.

Principal Author(s): J. Anderson/W. Osland

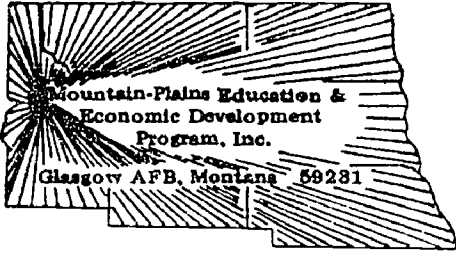

LAP TEST: REPLACEMENT OF BALL JOINTS AND TIE-ROD-ENDS

37.10.04.02

1. Often the factory installed joints (original equipment):
 - a. are riveted into place and must be cut.
 - b. are pressed into place and must be cut out.
 - c. can only be replaced by replacing the entire control arm assembly.
 - d. must be cut out entirely with a torch.
2. In replacing a balljoint with the spring on the upper control arm:
 - a. the spring must be removed.
 - b. the weight of the car must be supported by the upper control arm.
 - c. a block or a support wedge should be used between the upper control arm and the frame.
 - d. a hydraulic jack must be used to lower the control arm after the ball stud nut is loosened.
3. Riveted mounted ball joints are replaced with:
 - a. bolts.
 - b. new rivets.
 - c. welding into place.
 - d. screw in ball joints.
4. Pressed ball joints are removed from the spindle:
 - a. with a special tool and a hammer.
 - b. with a special tool.
 - c. with a hammer.
 - d. by the use of heat.
5. After installation of the joint into the spindle:
 - a. a lock washer and nut should be quickly installed.
 - b. the nut should be hand tightened as much as possible and pinned.
 - c. the nut should be torqued.
 - d. the joint nut and a lock nut should be installed.
6. After ball joint installation, camber should be checked and adjusted on:
 - a. shim adjusting vehicles.
 - b. eccentric adjusting vehicles.
 - c. all types of suspension systems.
 - d. sliding slot adjustment vehicles.

37.10.04.02 (continued)

7. After joint installation:

- a. the new joint should be checked for amount of free play.
- b. the joint should be tested.
- c. the jack should be lowered slowly in releasing the car weight.
- d. the joint should be lubricated.

37.10.04.03

8. After first torquing the tie-rod-end nut to specifications:

- a. install a cotter key and bend the ends down flat.
- b. it is recommended to rap the spindle arm and retorque.
- c. adjust the tie rod sleeve to the correct length.
- d. also tighten the tie rod sleeve locking clamps.

9. The tie-rod-end should be threaded into the sleeve:

- a. at any time convenient.
- b. after installation into the tapered hole.
- c. by turning the sleeve.
- d. before installation into the tapered hole.

10. Toe-in adjustment can be almost unnecessary if the:

- a. the tie rod sleeve is measured before disassembly.
- b. tie rod sleeve is marked.
- c. tie rod length is measured before disassembly.
- d. the wheel and steering wheel are locked in the straight ahead position.

LAP TEST ANSWER KEY: REPLACEMENT OF BALL JOINTS AND TIE-ROD-ENDS

LAP .02

1. A or C
2. C
3. A
4. A or B
5. C
6. All
7. D

LAP .03

8. B or A
9. D
10. C

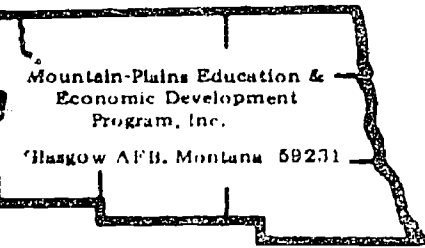

Learning Activity Package

Student: _____

Date: _____

PERFORMANCE ACTIVITY: Replacement of Idler Arms

OBJECTIVE:

Recognize the correct procedure for the removal and replacement of idler arms.

EVALUATION PROCEDURE:

80% correct on performance checklist.
LAP test after completion of LAP 37.10.04.05.

RESOURCES:

Automobile needing idler arm replacement
Cotter key
Creeper
Idler arm
Jack
Jack stands
Tools, Basic Hand: (See Unit LEG)

Auto Service and Repair, Stockel.
Motor's Auto Repair Manual.

PROCEDURE:

NOTE: Review page 31-22 in Auto Service and Repair.

1. Raise vehicle and secure stands.
2. Remove defective idler arm. Refer to repair manual for procedure.
3. Compare defective idler arm to the new idler arm to insure exact replacement.
4. Install new idler arm and cotter key.
5. Ask the instructor to evaluate your completed work.
6. Clean and return all tools and equipment.
7. Clean work area.
8. Proceed to next LAP.

Principal Author(s): J. Anderson/W. Osland

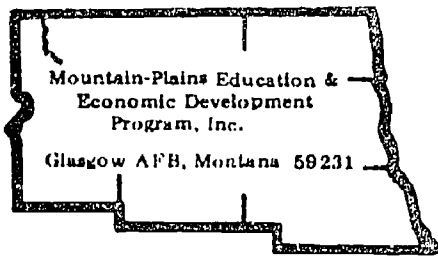

Learning Activity Package

Student: _____

Date: _____

PERFORMANCE ACTIVITY: Replacement of Control Arm Bushings

OBJECTIVE:

Demonstrate correct procedure for replacement of control arm bushings.

EVALUATION PROCEDURE:

80% correct on performance checklist.

Eight correct responses to a ten-item multiple choice objective test.

RESOURCES:

Automobile needing control arm bushing replacement
 Jack
 Jack stand
 New control arm bushings
 Tools, Basic Hand: (See Unit LEG)

Auto Service and Repair, Stockel.
Motor's Auto Repair Manual.

PROCEDURE:

NOTE: Review page 31-30 through 31-31 in Auto Service and Repair.

1. Raise front of vehicle and secure jack stands.
2. Remove front wheels for easier access to bushings.
3. Locate removal procedure in manual and follow the procedure step-by-step to safely and properly remove and replace the control arm bushings.

NOTE: Because of the variety of vehicles and safety precautions, it is mandatory to refer to a repair manual.

4. Ask the instructor to evaluate your work.
5. Lower car.
6. Clean and return all tools and equipment to tool room.
7. Clean work area.
8. Take and score the LAP test.

Principal Author(s): J. Anderson/W. Osland

9. Upon completion of LAP test obtain a copy of unit post test. Answer all of the questions and return test to the instructor for evaluation.
10. Upon successful completion of unit test, proceed to the next unit.

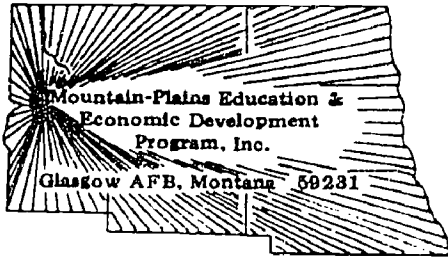

LAP TEST: REPLACEMENT OF IDLER ARMS AND CONTROL ARM BUSHINGS

37.10.04.04

1. The function of the idler arm is to:
 - a. support front-end suspension weight.
 - b. move the steering linkage to turn the wheels.
 - c. carry the steering linkage movement.
 - d. move the pitman arm in the direction necessary to turn.
2. The idler arm is bolted to:
 - a. the frame and linkage.
 - b. the frame and the pitman arm.
 - c. the pitman and the linkage.
 - d. the tie rod and tie rod center link.
3. Idler arm replacement can be done with:
 - a. pickle fork, hand tools, hammer.
 - b. hand tools, hammer.
 - c. hand tools, press, hammer.
 - d. hand tools, hydraulic hand jack.
4. For easier installation of idler arm repair kit components, a:
 - a. rubber lubricant can be used on the sliding bushings.
 - b. light coat of oil can be used on the sliding bushings.
 - c. light coat of heavy grease can be used on the sliding bushings.
 - d. application of clean solvent can be used.
5. As part of the installation, idler arms should be:
 - a. aligned.
 - b. oiled.
 - c. adjusted.
 - d. torqued.

37.10.04.05

6. If an upper control arm bushing is worn:
 - a. replace only the worn bushing.
 - b. replace both bushings.
 - c. replace upper and lower arm bushings.
 - d. it is necessary to replace the entire control arm assembly.

37.10.04.05 (continued)

7. While pressing the new bushings in the control arm pad to prevent collapsing the control arm around the bushing, it is recommended to use:
 - a. extreme caution.
 - b. a tube support.
 - c. a press ram.
 - d. a spacer block.

8. To install bushings into a double arm bushing control arm with a press, it is necessary to use what to prevent distortion?
 - a. spacer block.
 - b. stiffener plate.
 - c. tube.
 - d. puller.

9. In removing the control arm from the coil spring mounted type, it is mandatory to use:
 - a. a hydraulic floor jack.
 - b. a coil spring compressor.
 - c. a safety chain.
 - d. a jack stand on the control arm.

10. On a control arm bushing, the movement of the arm (up and down) is accomplished by:
 - a. the bushing outer sleeve rotating in the arm.
 - b. the bushing inner part rotating on the bolt.
 - c. the twisting of the rubber.
 - d. the pivot bolt rotating in the control arm.

LAP TEST ANSWER KEY: REPLACEMENT OF IDLER ARMS AND CONTROL
ARM BUSHINGS

LAP 04

1. C

2. A

3. ~~B~~ A 4/20 1/3

4. A

5. D

LAP 05

6. B

7. D

8. B

9. B

10. ~~X~~ C 9/13 X 8



UNIT POST TEST: FUNDAMENTALS OF SUSPENSION (A)

37.10.04.01

1. The integral type frame is constructed as a:
 - a. part of the body.
 - b. separate unit from the body.
 - c. part of the main suspension.
 - d. separate steel frame.
2. Spring oscillation is:
 - a. the forward and backward movement of the springs caused by the wheel hitting a bump.
 - b. the up and down movement of the spring caused by the wheel hitting a bump.
 - c. the upward movement of the spring caused by the wheel hitting a bump.
 - d. the downward motion of the spring caused by the wheel hitting a bump.
3. The purpose of the shock absorber is to:
 - a. eliminate swaying of the car.
 - b. keep the tires from bouncing.
 - c. fasten the body to the axles.
 - d. overcome spring oscillations.
4. Independent front suspension:
 - a. lets each front wheel turn independently.
 - b. allows the car to turn freely on corners.
 - c. allows either front wheel to move up and down independently.
 - d. allows the front wheels to move up and down at the same time.
5. When lubricating the suspension system, never grease:
 - a. ball joints.
 - b. kingpins.
 - c. tie rod ends.
 - d. rubber gromets and bushings.
6. Caster angle, as applied to the steering system, is the:
 - a. amount each tire points in at the front.
 - b. inward and outward tilt of the kingpin or ball joint at the top.
 - c. forward or backward tilt of kingpin or ball joint at the top.
 - d. amount each tire points out at the front.

37.10.04.01 (continued)

7. Positive camber is tipping the tops of the wheels:
 - a. in.
 - b. out.
 - c. back.
 - d. forward.

8. When removing coil springs that are under pressure:
 - a. lower the complete front-end.
 - b. stand clear as the last bolt is loosened.
 - c. keep the weight on the spring.
 - d. use a coil spring compressor.

9. The term used for the weight of all parts of the car that are supported by the suspension system is:
 - a. drop-weight.
 - b. unsprung weight.
 - c. out-of-balance.
 - d. sprung weight.

10. The disadvantage of solid axle front-ends is:
 - a. difficulty in aligning the front-ends.
 - b. costly front-end repairs.
 - c. bump action of the road will effect the other wheel.
 - d. leaf springs will sag under excessive weight.

37.10.04.02

11. To test a ball joint with the spring against the upper control arm, the mechanic would need a:
 - a. support wedge.
 - b. smaller jack.
 - c. spring compressor.
 - d. ball joint wrench.

12. When replacing a ball joint with the spring on the lower control arm and the ball joint stud loose in the knuckle:
 - a. place a safety stand under the lower control arm.
 - b. chain up the upper control arm.
 - c. remove the coil spring with a spring compressor.
 - d. lower the lower control arm carefully with a hydraulic jack.

13. Which of the following statements is true about a McPherson strut front suspension:
 - a. upper and lower control arms are used.
 - b. two ball joints are used.
 - c. camber and caster is adjusted by shimming the upper control arm.
 - d. the shock absorber is built into the strut.

37.10.04.02 (continued)

14. When lowering the disconnected ball joint arm with a jack, the jack should be:
- a quick release hydraulic hand jack.
 - parallel with the frame.
 - directly below the spring on the arm.
 - parallel with the length of the suspension arm.
15. After installation of the joint into the spindle:
- a lock washer and nut should be quickly installed.
 - the nut should be hand tightened as much as possible and pinned.
 - the nut should be torqued.
 - the joint nut and a lock nut should be installed.

37.10.04.03

16. Before tie-rod-end removal:
- the tie rod should be checked for being bent.
 - the length of the tie rod should be measured and recorded.
 - the tie-rod-end should be threaded out of the sleeve.
 - the steering wheel should be locked into position.

37.10.04.04

17. After installation, idler arms should be:
- aligned.
 - greased.
 - adjusted.
 - torqued.
18. Idler arm movement for wear testing can be done by:
- telescoping gauge.
 - use of a dial indicator.
 - eye observation.
 - torque wrench.

37.10.04.05

19. To install bushings into a double arm bushing control arm with a press, it is necessary to use what to prevent distortion?
- spacer block.
 - stiffener plate.
 - tube.
 - puller.
20. When replacing suspension arm bushings:
- replace the one needed.
 - always replace both bushings.
 - replace them with cast iron bushings.
 - replace upper and lower bushings.

POST TEST ANSWER KEY: FUNDAMENTALS OF SUSPENSION (A)

LAP .01

1. A
2. B
3. D
4. C
5. D
6. C
7. B
8. D
9. D
10. C

LAP .02

11. A
12. D
13. D
14. D
15. C

LAP .03

16. B

LAP .04

17. D
18. C

LAP .05

19. B
20. B

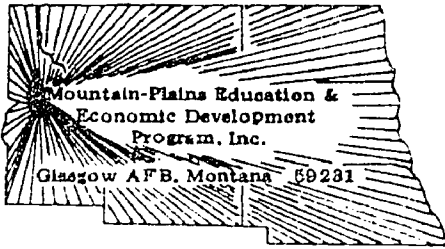

UNIT POST TEST: FUNDAMENTALS OF SUSPENSION (B)

37.10.04.01

1. The disadvantage of solid axle front-ends is:
 - a. difficulty in aligning the front-end.
 - b. costly front-end repairs.
 - c. bump action of the road will effect the other wheel.
 - d. leaf springs will sag under excessive weight.

2. The term used for the weight of all parts of the car that are supported by the suspension system is:
 - a. drop-weight.
 - b. unsprung weight.
 - c. out-of-balance.
 - d. sprung weight.

3. When removing coil springs that are under pressure:
 - a. lower the complete front-end.
 - b. stand clear as the last bolt is loosened.
 - c. keep the weight on the spring.
 - d. use a coil spring compressor.

4. Positive camber is tipping the tops of the wheels:
 - a. in.
 - b. out.
 - c. back.
 - d. forward.

5. Caster angle, as applied to the steering system, is the:
 - a. amount each tire points in at the front.
 - b. inward and outward tilt of the kingpin or ball joint at the top.
 - c. forward or backward tilt of kingpin or ball joint at the top.
 - d. amount each tire points out at the front.

6. When lubricating the suspension system, never grease:
 - a. ball joints.
 - b. kingpins.
 - c. tie rod ends.
 - d. rubber grommets and bushings.

37.10.04.01 (continued)

7. Independent front suspension:
 - a. lets each front wheel turn independently.
 - b. allows the car to turn freely on corners.
 - c. allows either front wheel to move up and down independently.
 - d. allows the front wheels to move up and down at the same time.

8. The purpose of the shock absorber is to:
 - a. eliminate swaying of the car.
 - b. keep the tires from bouncing.
 - c. fasten the body to the axles.
 - d. overcome spring oscillations.

9. Spring oscillation is:
 - a. the forward and backward movement of the springs caused by the wheel hitting a bump.
 - b. the up and down movement of the spring caused by the wheel hitting a bump.
 - c. the upward movement of the spring caused by the wheel hitting a bump.
 - d. the downward motion of the spring caused by the wheel hitting a bump.

10. The integral type frame is constructed as a:
 - a. part of the body.
 - b. separate unit from the body.
 - c. part of the main suspension.
 - d. separate steel frame.

37.10.04.02

11. After installation of the joint into the spindle:
 - a. a lock washer and nut should be quickly installed.
 - b. the nut should be hand-tightened as much as possible and pinned.
 - c. the nut should be torqued.
 - d. the joint nut and a lock nut should be installed.

12. When lowering the disconnected ball joint arm with a jack, the jack should be:
 - a. a quick release hydraulic hand jack.
 - b. parallel with the frame.
 - c. directly below the spring on the arm.
 - d. parallel with the length of the suspension arm.

13. When replacing a ball joint with the spring on the lower control arm and the ball joint stud loose in the knuckle:
 - a. place a safety stand under the lower control arm.
 - b. chain up the upper control arm.
 - c. remove the coil spring with a spring compressor.
 - d. lower the lower control arm carefully with a hydraulic jack.

37.10.04.02 (continued)

14. Which of the following statements is true about a McPherson strut front suspension?
- upper and lower control arms are used.
 - two ball joints are used.
 - camber and caster is adjusted by shimming the upper control arm.
 - the shock absorber is built into the strut.
15. To test a ball joint with the spring against the upper control arm, the mechanic would need a:
- support wedge.
 - smaller jack.
 - spring compressor.
 - ball joint wrench.

37.10.04.03

16. Before tie-rod-end removal:
- the tie rod should be checked for being bent.
 - the length of the tie rod should be measured and recorded.
 - the tie-rod-end should be threaded out of the sleeve.
 - the steering wheel should be locked into position.

37.10.04.04

17. Idler arm movement for wear testing can be done by:
- telescoping gauge.
 - use of a dial indicator.
 - eye observation.
 - torque wrench.
18. After installation, idler arms should be:
- aligned.
 - greased.
 - adjusted.
 - torqued.

37.10.04.05

19. When replacing suspension arm bushings:
- replace the one needed.
 - always replace both bushings.
 - replace them with case iron bushings.
 - replace upper and lower bushings.
20. To install bushings into a double arm bushing control arm with a press, it is necessary to use what to prevent distortion:
- spacer block.
 - stiffener plate.
 - tube.
 - roller.

UNIT POST TEST: FUNDAMENTALS OF SUSPENSION

LAP .01

1. C
2. D
3. D
4. B
5. C
6. D
7. C
8. D
9. B
10. A

LAP .02

11. C
12. D
13. D
14. D
15. A

LAP .03

16. B

LAP .04

17. C
18. D

LAP .05

19. B
20. B

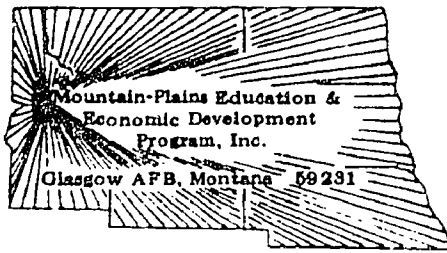

UNIT POST TEST: FUNDAMENTALS OF SUSPENSION (C)

37.10.04.01

1. The integral type frame is constructed as a:
 - a. part of the body.
 - b. separate unit from the body.
 - c. part of the main suspension.
 - d. separate steel frame.
2. The disadvantage of solid axle front-ends is:
 - a. difficulty in aligning the front-end.
 - b. costly front-end repairs.
 - c. bump action of the road will effect the other wheel.
 - d. leaf springs will sag under excessive weight.
3. When removing coil springs that are under pressure:
 - a. lower the complete front-end.
 - b. stand clear as the last bolt is loosened.
 - c. keep the weight on the spring.
 - d. use a coil spring compressor.
4. Caster angle, as applied to the steering system, is the:
 - a. amount each tire points in at the front.
 - b. inward and outward tilt of the kingpin or ball joint at the top.
 - c. forward or backward tilt of kingpin or ball joint at the top.
 - d. amount each tire points out at the front.
5. The purpose of the shock absorber is to:
 - a. eliminate swaying of the car.
 - b. keep the tires from bouncing.
 - c. fasten the body to the axles.
 - d. overcome spring oscillations.
6. The term used for the weight of all parts of the car that are supported by the suspension system is:
 - a. drop-weight.
 - b. unsprung weight.
 - c. out-of-balance.
 - d. sprung weight.

37.10.04.01 (continued)

7. When lubricating the suspension system, never grease:
- ball joints.
 - kingpins.
 - tie rod ends.
 - rubber gromets and bushing.
8. Positive camber is tipping the tops of the wheels:
- in.
 - out.
 - back.
 - forward.
9. Spring oscillation is:
- the forward and backward movement of the springs caused by the wheel hitting a bump.
 - the up and down movement of the spring caused by the wheel hitting a bump.
 - the upward movement of the spring caused by the wheel hitting a bump.
 - the downward motion of the spring caused by the wheel hitting a bump.
10. Independent front suspension:
- lets each front wheel turn independently.
 - allows the car to turn freely on corners.
 - allows either front wheel to move up and down independently.
 - allows the front wheels to move up and down at the same time.

37.10.04.02

11. To test a ball joint with the spring against the upper control arm, the mechanic would need a:
- support wedge.
 - smaller jack.
 - spring compressor.
 - ball joint wrench.
12. After installation of the joint into the spindle:
- a lock washer and nut should be quickly installed.
 - the nut should be hand tightened as much as possible and pinned.
 - the nut should be torqued.
 - the joint nut and a lock nut should be installed.
13. When lowering the disconnected ball joint arm with a jack, the jack should be:
- a quick release hydraulic hand jack.
 - parallel with the frame.
 - directly below the spring on the arm.
 - parallel with the length of the suspension arm.

37.10.04.02 (continued)

14. When replacing a ball joint with the spring on the lower control arm and the ball joint stud loose in the knuckle:
- place a safety stand under the lower control arm.
 - chain up the upper control arm.
 - remove the coil spring with a spring compressor.
 - lower the lower control arm carefully with a hydraulic jack.
15. Which of the following statements is true about a McPherson strut front suspension?
- upper and lower control arms are used.
 - two ball joints are used.
 - camber and caster is adjusted by shimming the upper control arm.
 - the shock absorber is built into the strut.

37.10.04.03

16. Before tie-rod-end removal:
- the tie rod should be checked for being bent.
 - the length of the tie rod should be measured and recorded.
 - the tie-rod-end should be threaded out of the sleeve.
 - the steering wheel should be locked into position.

37.10.04.04

17. After installation, idler arms should be:
- aligned.
 - greased.
 - adjusted.
 - torqued.
18. Idler arm movement for wear testing can be done by:
- telescoping gauge.
 - use of a dial indicator.
 - eye observation.
 - torque wrench.

37.10.04.05

19. To install bushings into a double arm bushing control arm with a press, it is necessary to use what to prevent distortion?
- spacer block.
 - stiffener plate.
 - tube.
 - puller.
20. When replacing suspension arm bushings:
- replace the one needed.
 - always replace both bushings.
 - replace them with cast iron bushings.
 - replace upper and lower bushings.

UNIT POST TEST ANSWER KEY: FUNDAMENTALS OF SUSPENSION (C)

LAP .01

1. A
2. C
3. D
4. C
5. D
6. D
7. D
8. B
9. B
10. C

LAP .02

11. A
12. C
13. D
14. D
15. D

LAP .03

16. B

LAP .04

17. D
18. C
19. B
20. B

Student: _____ File Code: 37.10.04.00.B1-5

Date: _____ Date Published: 3/10/76

Family Pay Number: _____ Sex: M F (Circle 1)

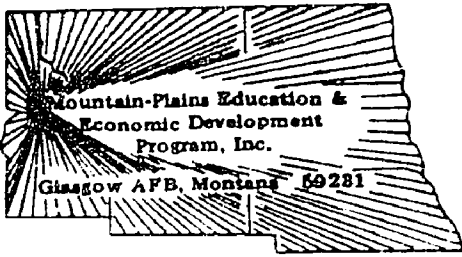

UNIT PERFORMANCE TEST: FRONT-END REPAIR

OBJECTIVE 1:

Inspect all front end parts as per checklist.

OBJECTIVE 2:

Repair front end parts as per checklist.

TASK:

The student will be assigned a vehicle needing front end repair. He will inspect ball joints, tie rod ends, idler arm, pitman arm, connecting link, control arm bushings, and stabilizer bushings for wear. He will replace those parts worn beyond specifications.

ASSIGNMENT:

CONDITIONS:

The student will use only those materials provided for the test and perform the activity in the auto shop.

RESOURCES:

Car needing repairs
New parts as needed.
Jacks
Fender covers
Alignment Tables
Alignment gauge
Chalk
Tire pressure gauge
Pickle Fork
Air Chisel
Lug Wrench
Jack Stands
Combination Ignition wrench set
Combination Wrench Set
Standard Screwdriver Set
Phillips Screwdriver Set
Feeler gauge - .002 through .025 inch
Hex Key Set
Diagonal Cutting Pliers
Needle Nose Plier
1/4" Drive Socket Set
Ratchet - 3" and 6" extensions - 6" flex handle
Ball Peen hammer
Plastic Tip Hammer
Screw Starter
Chisel and Punch Set
5/32" Pin Punch - 3/16" Solid
Gasket scraper
3/8" Drive Ratchet
3" Extension
Spark Plug Socket
6" Extension
Speed Handle
3/8" Drive Socket Set

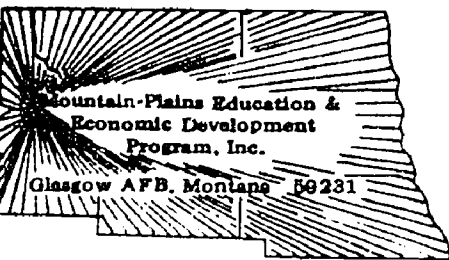

Family Pay Number: _____ Sex: M F (Circle 1)

PERFORMANCE CHECKLIST:

OVERALL PERFORMANCE: Satisfactory _____ Unsatisfactory _____

	CRITERION	
	Met	Not Met
Objective 1:		
1. Inspect ball joints.		
Criterion: Compares to manufacturer's specifications.		
2. Inspect idler arm.		
Criterion: Compares to manufacturer's specifications.		
3. Inspect center link.		
Criterion: Compares to manufacturer's specifications.		
4. Inspect tie rod ends.		
Criterion: Compares to manufacturer's specifications.		
5. Inspect Pitman arm.		
Criterion: Compares to manufacturer's specifications.		
6. Inspect control arm bushings.		
Criterion: Compares to manufacturer's specifications.		
7. Inspect stabilizer bar bushings.		
Criterion: Compares to manufacturer's specifications.		

	CRITERION	
	Met	Not Met
Objective 2:		
8. Repair ball joints.		
Criterion: Must meet manufacturer's specifications.		
9. Repairs idler arm.		
Criterion: Must meet manufacturer's specifications.		
10. Repairs center link.		
Criterion: Must meet manufacturer's specifications.		
11. Repairs tie rod ends.		
Criterion: Must meet manufacturer's specifications.		
12. Repairs Pitman arm.		
Criterion: Must meet manufacturer's specifications.		
13. Repairs control arm bushings.		
Criterion: Must meet manufacturer's specifications.		
14. Repairs stabilizer bar bushings.		
Criterion: Must meet manufacturer's specifications.		
The student must complete 12/14 line items to pass test.		

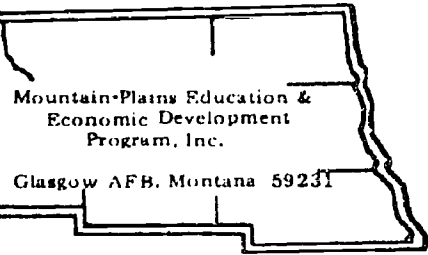

Learning Experience Guide

UNIT: FRONT-END ALIGNMENT

RATIONALE:

The techniques in this unit will enable one to align front-ends.

PREREQUISITES:

Math at Level F
Communication at Level F

OBJECTIVE:

Recognize the components and use proper procedure for front-end alignment.

RESOURCES:

Printed Materials

Auto Service and Repair. Martin W. Stockel, Goodheart-Willcox Company, Inc.
Motor's Auto Repair Manual. Motor, The Hearst Corporation. 1972 or equivalent.
Operator's Manual for Alignment Equipment.

Audio/Visuals

Super 8 Sound Films: Wheel Alignment

DCA Educational Products, Inc.

Adjusting Torsion Bar Suspension (#FAA142).
Caster Camber Adjustment, Cam Assembly (#FAA102).
Caster Camber Adjustment, Shim (#FAA112).
Caster Camber Adjustment, Slide (#FAA122).
Checking Camber (#FAA072).
Checking Toe and Centering Steering (#FAA092).
Set Up and Suspension Checks (#FAA062).
Toe and Center Steering Adjustments (#FAA132).

Equipment

Alignment equipment
Automobile needing: toe adjustment
shim type wheel alignment
slide type adjustment
eccentric type adjustment
eccentric and strut adjustment

Fender covers
Jack & jack stands

Principal Author(s): C. Schramm/W. Osland

Scribe
Special tools
Tools, Basic Hand:

Chisel and Punch Set
5/32" Pin Punch
3/16" Solid

Gauge, feeler (.002" - .025")

Hammer, ball peen
Hammer, plastic tip
Handle, speed
Hex Key Set

Pliers, diagonal cutting
Pliers, needle nose

Scraper, gasket
Screwdriver, standard (Set)
Screwdriver, phillips (Set)
Screw starter

Socket Set (3/8" drive)
extension (3")
ratchet

Socket Set (1/4" drive)
extension (3")
handle (6" flex)
ratchet

Socket, spark plug
extension (6")

Wrench, combination (Set)
Wrench, combination ignition (Set)

Tire pressure guage

GENERAL INSTRUCTIONS:

This unit consists of six Learning Activity Packages (LAPs). Each LAP will provide specific information for completion of a learning activity.

The general procedure for this unit is as follows:

- (1) Read the first assigned Learning Activity Package (LAP).
- (2) Begin and complete the first assigned LAP.
- (3) Take and score the LAP test.
- (4) Turn in the LAP test answer sheet.
- (5) Determine the reason for any missed items on the LAP test.
- (6) Proceed to and complete the next assigned LAP in the unit.
- (7) Complete all required LAPs for the unit by following steps 3 through 6.

- (8) In this Unit, there are some LAPs that have tests combined with other LAP tests. These combined tests are taken after completing the last LAP covered by the test.
- (9) Take the unit tests as described in the Unit LEG "Evaluation Procedures".
- (10) Proceed to the next assigned unit.

PERFORMANCE ACTIVITIES:

- .01 Adjusting Camber
- .02 Adjusting Caster
- .03 Adjusting Toe-In
- .04 Adjusting Caster-Camber (eccentric and strut)
- .05 Adjusting Caster-Camber (eccentric)
- .06 Adjusting Caster-Camber (slide)

EVALUATION PROCEDURE:

When pretesting:

1. The student takes the unit multiple-choice pretest.
2. Successful completion is 4 out of 5 items for each LAP part of the pretest.
3. The student then takes a unit performance test if the unit pretest was successfully completed.
4. Satisfactory completion of the performance test is meeting the criteria listed on the performance test.

When post testing:

1. The student takes a multiple-choice unit post test and a unit performance test.
2. Successful unit completion is meeting the listed criteria for the performance test.

FOLLOW-THROUGH:

Go to the first assigned Learning Activity Package (LAP) listed on your Student Progress Record (SPR).

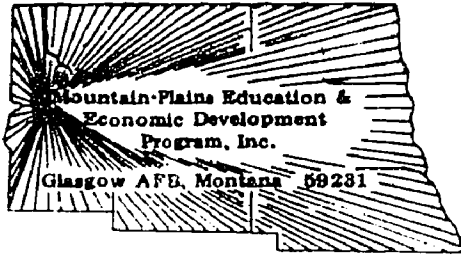

UNIT PRETEST: FRONT-END ALIGNMENT

37.10.05.01.

1. After shims are reshuffled and the bolts are tightened:
 - a. the car must be bounced and camber reread.
 - b. the caster must be adjusted.
 - c. the toe-in must be checked.
 - d. the camber must be reread.
2. Loose wheel bearings will least affect which alignment reading?
 - a. caster.
 - b. riding height.
 - c. camber.
 - d. toe-in.
3. Negative camber is increased by moving the top of the wheel towards the:
 - a. engine.
 - b. fender opening.
 - c. headlight.
 - d. taillight.
- 4.

37.10.05.02.

5. The vehicle manufacturer who has utilized caster-shim adjustment is:
 - a. American Motors.
 - b. Ford Motors Company.
 - c. General Motors.
 - d. Chrysler Corporation.
6. What holds the installed shim in place?
 - a. the placement groove on the suspension.
 - b. the slotted ends of the shims.
 - c. the tightened bolt.
 - d. the threaded wire through the shims.

37.10.05.02.

7. The removed shims after the alignment should be:
- cleaned and refiled.
 - discarded in the trash.
 - discarded in the scrap metal storage.
 - returned to the car owner.

37.10.05.03.

8. Standard tires have the toe reading usually set at:
- 1/8 to 1/4 toe-in.
 - 0 toe-in.
 - 0 to 1/16 toe-in.
 - 1/8 to 1/4 toe-out.
9. Radial tires have the toe reading usually set at:
- 0 toe-in.
 - 1/16 to 1/8 toe-in.
 - 1/16 toe-out
 - 1/8 toe-in.
10. Toe-in adjustment is accomplished by:
- adjusting the pitman arm.
 - turning one of the tie rod sleeves.
 - adjusting the steering knuckle.
 - changing the idler arm angle.
11. The adjusting tie rod sleeve tool is effective for turning the sleeve because it:
- is the only tool that can be used to turn the sleeve.
 - easily fits the sleeve.
 - is compact and fits into close working quarters.
 - spreads the sleeve as it grips it for turning.
12. Toe-in of the tires is desired over no toe-in because of the:
- resistance of the tires to roll.
 - crown of the highway.
 - vehicle's weight.
 - vehicle's speed capability.

37.10.05.04.

13. The eccentric strut rod adjustment is usually considered the:
- same as the others for ease of adjustment.
 - most difficult of the front-end adjustments.
 - easiest method of the front-end adjustments.
 - most time-consuming of all of the adjustments.

37.10.05.04. cont.

14. Adjustment of the strut rod with one hand tool would be a(n):
- box-end wrench.
 - open-end wrench.
 - deep socket.
 - vehicle overload.

37.10.05.05.

15. The eccentric adjuster is shaped somewhat:
- like a wedge.
 - oval.
 - octagonally.
 - like a cam lobe.
16. What must sometimes be done to turn a difficult eccentric?
- raise the wheel of the vehicle.
 - heat the eccentric.
 - use a power impact wrench.
 - hammer the eccentric head.
17. Eccentrics are held in place after alignment by:
- torqued lock bolts.
 - new lock bolts.
 - cotter keyed bolts.
 - pinned eccentrics.

37.10.05.06.

18. The slide adjustment type is usually found more often on the:
- Ford Motor cars.
 - General Motors cars.
 - American Motors cars.
 - Chrysler Corporation cars.
19. By moving the front slide in and the back slide out, you achieve more:
- negative camber.
 - positive camber.
 - positive caster.
 - negative caster.
20. By moving the front slide out and the back slide in, you achieve more:
- positive camber.
 - negative camber.
 - negative caster.
 - positive caster.

UNIT PRETEST ANSWER KEY: FRONT-END ALIGNMENT

LAP .01

1. a
2. a
3. a
4. a

LAP .02

5. c
6. c
7. a

LAP .03

8. a
9. a
10. b
11. d
12. a

LAP .04

13. c
14. b

LAP .05

15. d
16. a
17. a

LAP .06

18. a
19. d
20. d

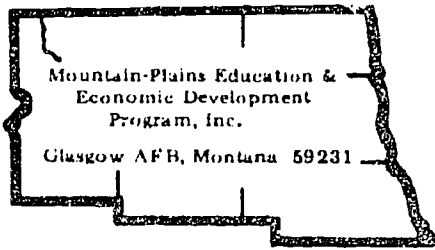

Learning Activity Package

Student: _____

Date: _____

PERFORMANCE ACTIVITY: Adjusting Camber (Shim)

OBJECTIVE:

Use correct procedure for adjustment of camber (shim type).

EVALUATION PROCEDURE:

30% correct on performance evaluation.
LAP test after completing LAP 37.10.05.02.

RESOURCES:

Auto Service and Repair, Stockel.
Operator's Manual for Alignment Equipment.

Filmstrips:

Caster Camber Adjustments, (Shim)--FAA112.
Checking Camber--FAA072.
Checking Caster--FAA082.
Set Up and Suspension Checks--FAA062.

Automobile needing wheels aligned - Shim type
Alignment equipment
Alignment specifications

Fender covers
Tire pressure gauge
Tools, Basic Hand: (See Unit LEG)

PROCEDURE:

NOTE: Review pages 30-26 through 30-29 in Auto Service and Repair.

1. Place vehicle evenly on alignment rack.
2. Diagnose cause of defective wear on tire. Record diagnosis on work order.
Record what adjustments would be needed to correct the problem.

NOTE: Always determine what is the exact cause(s) of the abnormal tire wear. Check for unbalance, improper tire pressure, incorrect camber, incorrect toe-in, poor shocks, worn or damaged suspension components. Be sure to measure the amount of ball joint free-play wear. Also, test and adjust the wheel bearing tightness before continuing further with gauge attachment.
Record all test and diagnosis on the work order.

Principal Author(s): J. Anderson/W. Osland

3. Discuss your diagnosis with the instructor for evaluation.
4. Check tire inflation of the tires. Correct as necessary.
5. Measure standing height of vehicle to insure vehicle's natural stance. See manual for specifications and procedure of measuring.
6. Carefully attach alignment equipment. Follow set-up procedure of the equipment's operator's manual.
7. Measure the camber and record readings on work order.
8. Compare readings to camber specifications to determine how the adjustment should be made to meet the manufacturer's recommended specifications.
9. Study the shim adjustment of the upper control arm to determine if shims need to be added or subtracted. Refer to the repair manual if a problem occurs in adjustment procedure.
10. Adjust the camber.
11. After the adjustment is completed, ask the instructor to inspect your work for approval.
12. With approval, proceed to the next LAP.

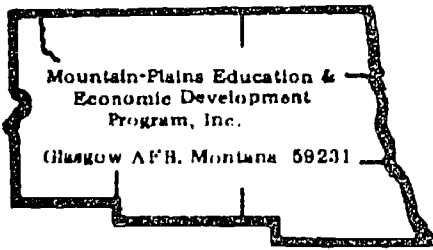

Learning Activity Package

Student: _____

Date: _____

PERFORMANCE ACTIVITY: Adjusting Caster (shim)

OBJECTIVE:

Use the correct procedure for adjustment of caster (shim type).

EVALUATION PROCEDURE:

80% correct on performance checklist.

Eight correct responses to a ten-item multiple choice objective test.

RESOURCES:

Alignment equipment
 Automobile needing caster adjustment--shim type
 Fender covers
 Tools, Basic Hand (see Unit LEG)
 Operator's Manual for Alignment Equipment.
Motor's Auto Repair Manual.

PROCEDURE:

NOTE: An Alignment Specification Chart comes with the alignment equipment or can be found in Motor's Auto Repair Manual.

1. Follow the instructions with the alignment equipment and install on the vehicle.
2. Follow the Alignment Specification Chart to obtain the present caster reading of the left wheel. Record results.
3. Compare readings to manufacturer's specifications and analyze how the adjustment should be made without affecting the camber.
4. Make the adjustment.
5. Obtain another reading of the caster to see if the adjustment is satisfactory. Readjust if necessary.
6. Ask the instructor to evaluate your completed adjustment.
7. Repeat the steps to adjust the right wheel. Record present reading before adjustment.
8. Ask the instructor to evaluate the completed adjustments.

Principal Author(s): J. Anderson/W. Osland

9. Clean and return all tools and equipment.
10. Clean work area.
11. Take and score the LAP test.
12. Proceed to the next LAP.

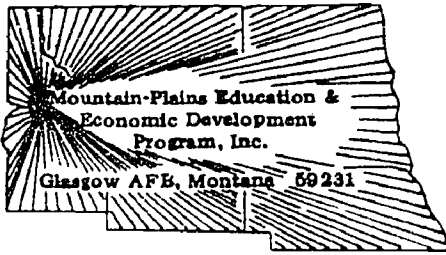

LAP TEST: ADJUSTING CAMBER/CASTER (SHIM)

37.10.05.01

1. To change the camber without affecting the caster, shims:
 - a. should be removed or added from the forward bolt.
 - b. must be subtracted from one bolt and added to the other bolt.
 - c. must be added or subtracted in the same amounts on both bolts.
 - d. should be removed or added from the rear bolt.
2. After shims are reshuffled and the bolts are tightened:
 - a. the car must be bounced and camber reread.
 - b. the caster must be adjusted.
 - c. the toe-in must be checked.
 - d. the camber must be reread,
3. Loose wheel bearings will least affect which alignment reading?
 - a. caster.
 - b. toe-out.
 - c. camber.
 - d. toe-in.
4. During alignment setup process, which component is not part of front-end check:
 - a. "U" joints.
 - b. ball joints.
 - c. tie-rod-ends.
 - d. control arm bushings.
5. Which vehicle manufacturer utilizes the shim's adjustment most?
 - a. General Motors.
 - b. Ford Motors.
 - c. American Motors.
 - d. Chrysler Corporation.

37.10.05.02

6. What steering factor is used in the steering suspension system to reduce the need for excessive positive camber?
 - a. caster.
 - b. toe-in.
 - c. steering axis inclination.
 - d. toe-out on turns.

7. Positive caster is with the top of the wheel moved in the direction of the:
 - a. fender opening.
 - b. engine.
 - c. taillight.
 - d. headlight.

8. To reduce the tendency of the car to wander, you can increase the:
 - a. positive camber.
 - b. negative camber.
 - c. negative caster.
 - d. positive caster.

9. The normal weight of the car tends to cause the front wheels to move toward:
 - a. negative caster.
 - b. negative camber.
 - c. positive camber.
 - d. positive caster.

10. What holds the installed shims in place?
 - a. the placement groove on the suspension.
 - b. the slotted ends of the shims.
 - c. the tightened bolt.
 - d. the threaded wire through the shims.

LAP TEST ANSWER KEY: ADJUSTING CAMBER/CASTER (SHIM)

LAP 01

1. C
2. A
3. A
4. A
5. A

LAP 02

6. C
7. C
8. D
9. B
10. C

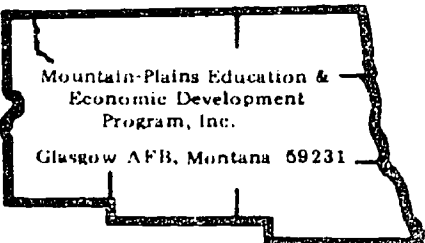

Mountain-Plains Education &
Economic Development
Program, Inc.

Glasgow AFB, Montana 59231

Learning Activity Package

Student: _____

Date: _____

PERFORMANCE ACTIVITY: Adjusting Toe-In

OBJECTIVE:

Use the correct procedures to adjust toe-in and toe-out.

EVALUATION PROCEDURE:

80% correct on performance evaluation.
Eight correct responses to a ten-item multiple-choice objective test.

RESOURCES:

Automobile needing toe adjustment
Jack
Jack stands
Scribe
Special tools
Tire pressure guage
Tools, basic hand (see Unit LEG)

Auto Service and Repair, Stockel.
Motor's Auto Repair Manual.

Super 8 filmstrips:

Adjusting Torsion Bar Suspension--FAA042.
Checking Toe and Centering Steering--FAA092.
Toe and Center Steering Adjustments--FAA132.

PROCEDURE:

NOTE: Review pages 30-7 through 30-10 in Auto Service and Repair.

- NOTE:**
- A. Determine first if the tires are radial or non-radial. Remember: Radial tires are set for zero toe-in unless otherwise specified by either the tire or vehicle manufacturer.
 - B. Examine and feel the flat surface of the tire to locate a "flathead edge." This feel will indicate if toe-in adjustment is needed, also the direction of needed adjustment.
 - C. Examine the tread surface for abnormal wear due to incorrect air pressure. Remember:
 1. Low pressure causes extreme wear of the sides of the tire and not in the center.
 2. High pressure causes extreme wear of the center of the tire and not on the sides.
 - D. Test and adjust tire air pressure as needed to correct wear pattern.

Remember: Record all information and adjustment on the work order in the "comments" section.

1. Raise front tires off floor and place jack stands.
2. With a scribe or thin marker, make a clean line along the tread of the tire. Brace the marker against the tire and turn the tire around to make the complete even line.
3. Repeat this on the other front tire.
4. Refer to the manual to find the recommended toe.
5. With assistance, measure from line to line on the front part of the tire, at an even height from the floor. Record measurement.
6. Now, measure the rear part of the tire. Record measurement.
7. Subtract the front measurement from the rear measurement. The difference should match the recommended toe from the specifications.
8. Adjust if required.
9. Ask the instructor to evaluate your work.
10. Clean and return all tools and equipment.
11. Clean work area.
12. Take and score the LAP test.
13. Upon successful completion, proceed to the next LAP.

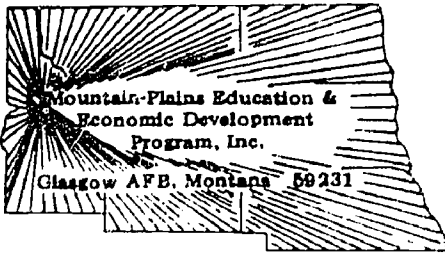

LAP TEST: ADJUSTING TOE-IN

1. Standard tires have the toe reading usually set at:
 - a. 1/8 to 1/4 toe-in.
 - b. 0 toe-in.
 - c. 0 to 1/16 toe-in.
 - d. 1/8 to 1/4 toe-out.
2. Tires with excessive toe-out will have the "feather edge" to:
 - a. both sides of the tire.
 - b. the tire's inside.
 - c. the tire's center.
 - d. the tire's outside.
3. Tires which have excessive toe-in will result with the "feather edge" on:
 - a. the outside.
 - b. the inside.
 - c. the tire center.
 - d. both sides of the tire.
4. Toe-in adjustment is accomplished by:
 - a. adjusting the pitman arm.
 - b. turning one of the tie rod sleeves.
 - c. adjusting the steering knuckle.
 - d. changing the idler arm angle.
5. Before adjusting the toe-in, the what should be centered?
 - a. front tires.
 - b. right tire.
 - c. left tire.
 - d. steering wheel.
6. After toe-in is adjusted, the front-end should:
 - a. be bounced and measured again.
 - b. be measured again.
 - c. test driven.
 - d. greased.
7. If alignment equipment is not available, what can be used to easily set toe?
 - a. tape measure.
 - b. yardstick.
 - c. string.
 - d. a steel rod

8. Setting toe with a measurement tool (not regular alignment equipment) requires measuring from the tire's:
 - a. circular scribed lines.
 - b. outside edges.
 - c. center tread marks.
 - d. inside rim edge.

9. Toe measurement and adjustment (to be satisfactory,) must be done with:
 - a. the vehicle front up on two jack stands.
 - b. the vehicle sitting normally on a flat surface.
 - c. the vehicle up on four jack stands.
 - d. the vehicle jacked up on an alignment rack.

10. Toe-in of the tires is desired over no toe-in because of the:
 - a. resistance of the tires to roll straight down the road.
 - b. crown of the highway.
 - c. vehicle's weight.
 - d. vehicle's speed capability.

LAP TEST ANSWER KEY: ADJUSTING TOE

LAP .03

1. a
2. d
3. b
4. b
5. d
6. a
7. a
8. a
9. b
10. a

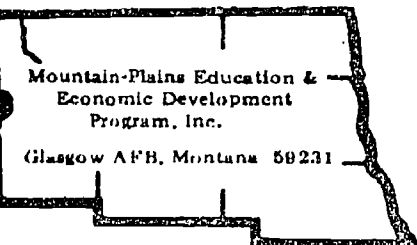

Learning Activity Package

Student: _____

Date: _____

PERFORMANCE ACTIVITY: Adjusting Caster-Camber (eccentric and strut)

OBJECTIVE:

Use the correct procedure for adjustment of 'caster-camber' (eccentric and strut).

EVALUATION PROCEDURE:

80% correct on performance checklist.

Eight correct responses to a ten-item multiple choice objective test.

RESOURCES:

Motor's Auto Repair Manual. (as assigned)

Alignment equipment
Automobile with eccentric and strut adjustment
Fender covers
Tire pressure gauge
Tools, Basic Hand (see Unit LEG)

PROCEDURE:

Steps

1. Center the vehicle properly on the alignment area.
2. Diagnose the tire wear to determine what adjustments are needed. Record results on work order.
3. Check tire pressure. Correct as necessary.
4. Inspect vehicle stand height for unevenness of suspension.
5. Attach and adjust the alignment equipment.
6. Obtain the vehicle's present readings of caster and camber. Record on work order.
7. Obtain the manufacturer's specifications from the manual and record on work order.
8. Place fender covers.

Principal Author(s): J. Anderson/W. Osland

9. Refer to the repair manual for the correct procedure of adjusting the cam and strut-rod to obtain the correct alignment readings.
 10. Complete the necessary adjustments to have the vehicle caster and camber meet the manufacturer's specifications.
 11. When the adjustments are completed, ask the instructor to evaluate your work.
 12. Clean and return all tools and equipment.
 13. Clean alignment area.
 14. Proceed on to next LAP.
-

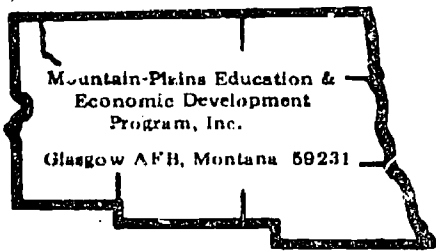

Learning Activity Package

Student: _____

Date: _____

PERFORMANCE ACTIVITY: Adjusting Caster-Camber (eccentric)

OBJECTIVE:

Use the correct procedure for adjustment of caster-camber (eccentric and strut).

EVALUATION PROCEDURE:

80% correct on performance checklist.
LAP test after the completion of LAP 37.10.05.06.

RESOURCES:

Motor's Auto Repair Manual.

Alignment equipment
Automobile with eccentric and street adjustment
Fender covers
Tire pressure guage
Tools, Basic Hand (see Unit LEG)

PROCEDURE:

Steps

1. Center vehicle on alignment area.
2. Inspect tire wear to determine needed adjustment. Record on work order.
3. Check tire air pressures. Adjust if necessary.
4. Inspect vehicle curb height for proper suspension setting level.
5. Attach and adjust alignment equipment.
6. Obtain and record the present camber and caster readings.
7. Obtain the alignment specifications from the reference manual and record on work order.
8. Refer to the repair manual for the proper procedure of adjusting the eccentric cams.
9. Place fender covers.

Principal Author(s): J. Anderson/W. Osland

10. Complete the caster and camber adjustments as needed to meet the manufacturer's specifications.

NOTE: The caster and camber are adjusted by the same eccentric cams. Care must be taken not to disturb one adjustment while making the other.

11. When the adjustments are completed, ask the instructor to evaluate your work.
12. Clean and return all tools and equipment.
13. Clean alignment area.
14. Proceed to next LAP.

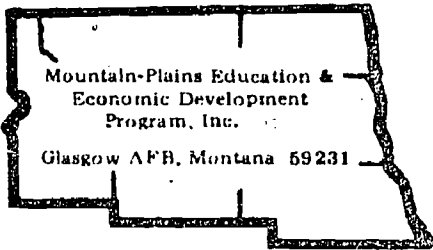

Learning Activity Package

Student: _____

Date: _____

PERFORMANCE ACTIVITY: Adjusting Caster-Camber (slide)

OBJECTIVE:

Use the correct procedure for adjustment of caster-camber (slide type).

EVALUATION PROCEDURE:

80% correct performance checklist.

LAP test.

RESOURCES:

Operator's Manual for Alignment Equipment: signed to you
Motor's Auto Repair Manual: alignment equipment

Filmstrips:

Caster Camber Adjustment, Cam Assembly--FAA102.
Caster Camber Adjustment, Slide--FAA122.

Alignment equipment

Automobile with slide adjustment

Fender covers

Tire pressure guage

Tools, Basic Hand (see Unit LEG)

PROCEDURE:

1. Locate vehicle properly on alignment stall.
2. Examine tire wear to determine adjustments needed.
3. Check tire air pressure. Adjust to correct pressure if necessary.
 NOTE: Determine if abnormal wear is caused by improper tire air pressure, unbalanced tires, poor shocks, incorrect camber or toe-in, worn or damaged suspension components. Record diagnosis on work order.
4. Check curb height of vehicle to be sure of level suspension.
5. Attach and adjust alignment equipment. (Follow the instructions with the alignment equipment.)
6. Obtain alignment specifications from reference manual and record on work order.
7. Obtain the present readings of camber and caster.
8. Place fender covers.

Principal Author(s): J. Anderson/W. Osland

9. Make the necessary adjustments to meet the alignment specifications. Loosen the retaining lock bolt enough to use the slide tool to move the upper control arm to the direction of required adjustment. Tighten bolt to prevent slipping when slide tool is released.

NOTE: Caster and camber are adjusted by this slide procedure. In some cases, it is necessary to loosen both retaining lock bolts.

10. After adjustments are completed, ask the instructor to evaluate your work.
11. Clean and return all tools and equipment.
12. Clean alignment area.
13. Proceed to next LAP.

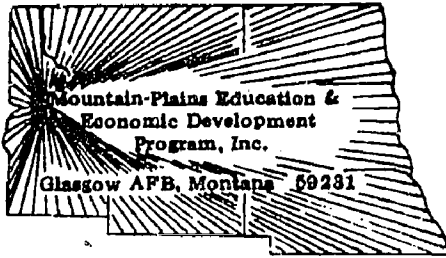

LAP TEST: ADJUSTING CASTER/CAMBER (SLIDE, ECCENTRIC, STRUT)

37.10.05.06

1. By moving both slides out the same amount, you achieve more:
 - a. positive caster.
 - b. negative caster.
 - c. positive camber.
 - d. negative camber.
2. By moving the front slide in and the back slide out, you achieve more:
 - a. negative camber.
 - b. positive camber.
 - c. positive caster.
 - d. negative caster.
3. In moving the slide adjustment, it is easier to:
 - a. loosen bolts enough to move both slides at the same time.
 - b. loosen one bolt a little to pivot and loosen the other more to slide.
 - c. loosen only the one slide that you intend to move.
 - d. loosen one and tap the other with a hammer.

37.10.05.05

4. Camber is adjusted by moving the eccentrics (without affecting caster):
 - a. one at a time in opposite directions.
 - b. in opposite directions at the same amount.
 - c. in the same direction and the same amount.
 - d. in the same direction, but move the back 1/3 farther than the other.
5. Before the eccentric can be turned, what must be done?
 - a. oil the eccentric slide surface.
 - b. loosen the lock bolt.
 - c. remove the cotter key.
 - d. loosen the lock nut.
6. Eccentrics are held in place after alignment by:
 - a. lock nuts.
 - b. new lock bolts.
 - c. cotter keyed bolts.
 - d. pinned eccentrics.

37.10.05.04

7. Of the eccentric and strut adjustment, camber is usually adjusted by:
- the eccentric and strut rod.
 - the strut rod?
 - the eccentrics.
 - the slide bolt.
8. Of the eccentric and strut adjustment, caster is usually adjusted by:
- the strut rod.
 - the eccentric.
 - eccentric and strut rod.
 - the slide bolt.
9. The eccentric strut rod adjustment is usually considered the:
- same as the others for ease of adjustment.
 - most difficult of the front-end adjustments.
 - easiest method of the front-end adjustments.
 - most time-consuming of all the adjustments.
10. Adjusting the caster (strut rod):
- has no affect upon camber.
 - has no affect upon the toe-in.
 - will change the camber slightly.
 - will change steering axis inclination.

LAP TEST ANSWER KEY: ADJUSTING CASTER/CAMBER (SLIDE, ECCENTRIC, STRUT)

1. C
2. D
3. B
4. C
5. D
6. A
7. C
8. A
9. C
10. C

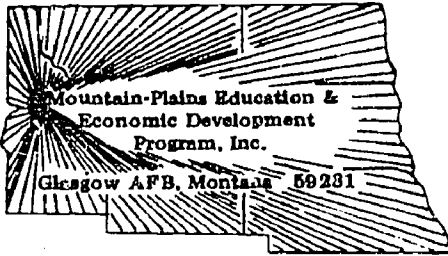

UNIT POST TEST: FRONT-END ALIGNMENT (A)

37.10.05.01

1. Which of the following is not part of alignment precheck?
 - a. air pressure
 - b. shocks
 - c. trunk weight
 - d. riding height

2. The turn tables are not necessary to adjust the:
 - a. caster
 - b. riding height
 - c. camber
 - d. toe-in

3. Negative camber is increased by moving the top of the wheel towards the:
 - a. engine
 - b. fender opening
 - c. headlight
 - d. taillight

4. Positive camber is increased by moving the tops of the wheel towards the:
 - a. engine
 - b. headlight
 - c. fender opening
 - d. taillight

37.10.05.02

5. Negative caster is with the top of the wheel moved in the direction of the:
 - a. fender opening
 - b. headlight
 - c. engine
 - d. rear taillight

6. If the specifications call for a difference between the left and right wheel camber settings it would be to compensate for:
 - a. engine torque
 - b. road resistance
 - c. drivers weight
 - d. road crown

37.10.05.02 cont.

7. Which of the following is most responsible for steering stability on a level road?
- caster
 - camber
 - steering axis inclination
 - toe-out

37.10.05.03

8. Radial tires have the toe reading usually set at:
- 0 toe-in
 - 1/16 to 1/8 toe-in
 - 1/16 toe-out
 - 1/8 toe-in
9. Proper toe-in will allow the tires to move forward without:
- setting up a wheel tramp
 - a scrubbing, scraping action between tire and road
 - going into a wheel shimmy
 - causing a front-end vibration
10. Toe-in adjustment is accomplished by:
- adjusting the pitman arm
 - turning one of the tie rod sleeves
 - adjusting the steering knuckle
 - changing the idler arm angle
11. The adjusting tie rod sleeve tool is effective for turning the sleeve because it:
- is the only tool that can be used to turn the sleeve
 - easily fits the sleeve
 - is compact and fits into close working quarters
 - spreads the sleeve as it grips it for turning
12. Setting toe with a measurement tool (not regular alignment equipment) requires measuring from the tire's:
- circular scribed lines
 - outside edges
 - center tread marks
 - inside rim edge

37.10.05.04

13. A car may have a tendency to pull to the side having:
- more positive caster
 - less positive caster
 - less negative caster
 - less positive camber

37.10.05.04 cont.

14. It is best to start out by adjusting the:
- strut rod
 - camber first
 - caster-camber together
 - caster first
15. Strut rod adjustment can vary from each other to allow for:
- road crown
 - road resistance
 - vehicle weight
 - vehicle overload

37.10.05.05

16. Which reading can be observed at the same time it is being adjusted?
- negative caster
 - caster
 - camber
 - positive caster
17. What must sometimes be done to turn a difficult eccentric?
- raise the vehicle off the wheel
 - heat the eccentric
 - use a power impact wrench
 - hammer the eccentric head

37.10.05.06

18. A car has a strut rod from the front of the frame to the lower control arm. Which of the following is true about this system?
- shortening the rod changes camber
 - the length of the rod will not affect caster or camber
 - the rod acts as a stabilizer bar
 - lengthening the rod reduces positive caster
19. By moving the front slide in and the back slide out, you achieve more:
- positive camber
 - negative camber
 - negative caster
 - positive caster
20. What prevents the slides from moving when the alignment is completed?
- cotter pinned slide bolts
 - torqued down sliding bolts
 - lock nuts on the slide bolts
 - the weight of the car

UNIT POST TEST ANSWER KEY: (4)

Lap .01

1. B
2. B
3. A
4. C

Lap .02

5. B
6. D
7. A

Lap .03

8. A
9. B
10. B
11. D
12. A

Lap .04

13. C
14. D
15. A

Lap .05

16. C
17. A

Lap .06

18. D
19. C
20. B

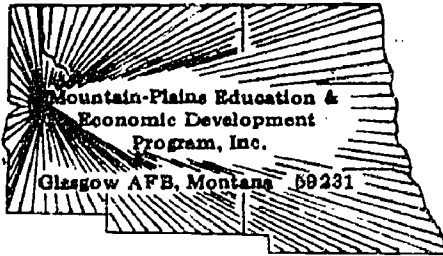

UNIT POST TEST: FRONT-END ALIGNMENT (B)

37.10.05.01

1. Positive camber is increased by moving the tops of the wheel towards the:
 - a. engine
 - b. headlight
 - c. fender opening
 - d. taillight
2. Negative camber is increased by moving the top of the wheel towards the:
 - a. engine
 - b. fender opening
 - c. headlight
 - d. taillight
3. The turn tables are not necessary to adjust the:
 - a. caster
 - b. riding height
 - c. camber
 - d. toe-in
4. Which of the following is not part of alignment precheck?
 - a. air pressure
 - b. shocks
 - c. trunk weight
 - d. riding height

37.10.05.02

5. Which of the following is most responsible for steering stability on a level road?
 - a. caster
 - b. camber
 - c. steering axis inclination
 - d. toe-out
6. If the specifications call for a difference between the left and right wheel camber settings, it would be to compensate for:
 - a. engine torque
 - b. road resistance
 - c. driver's weight
 - d. road crown

37.10.05.02 (continued)

7. Negative caster is with the top of the wheel moved in the direction of the:
- fender opening
 - headlight
 - engine
 - rear taillight

37.10.05.03

8. Setting toe with a measurement tool (not regular alignment equipment) requires measuring from the tire's:
- circular scribed lines
 - outside edges
 - center tread marks
 - inside rim edge
9. The adjusting tie rod sleeve tool is effective for turning the sleeve because it:
- is the only tool that can be used to turn the sleeve
 - easily fits the sleeve
 - is compact and fits into close working quarters
 - spreads the sleeve as it grips it for turning
10. Toe-in adjustment is accomplished by:
- adjusting the pitman arm
 - turning one of the tie rod sleeves
 - adjusting the steering knuckle
 - changing the idler arm angle
11. Proper toe-in will allow the tires to move forward without:
- setting up a wheel tramp
 - a scrubbing, scraping action between tire and road
 - going into a wheel shimmy
 - causing a front-end vibration
12. Radial tires have the toe reading usually set at:
- 0 toe-in
 - 1/16 to 1/8 toe-in
 - 1/16 toe-out
 - 1/8 toe-in

37.10.05.04

13. Strut rod adjustment can vary from each other to allow for:
- road crown
 - road resistance
 - vehicle weight
 - vehicle overload

37.10.05.04 (continued)

14. It is best to start out by adjusting the:
- strut rod
 - camber first
 - caster-camber together
 - caster first
15. A Car may have a tendency to pull to the side having:
- more positive caster
 - less positive caster
 - less negative caster
 - less positive camber

37.10.05.05

16. What must sometimes be done to turn a difficult eccentric?
- raises the vehicle off the wheel
 - head the eccentric
 - use a power impact wrench
 - hammer the eccentric head
17. Which reading can be observed at the same time it is being adjusted?
- negative caster
 - caster
 - camber
 - positive caster

37.10.05.06

18. What prevents the slides from moving when the alignment is completed?
- cotter pinned slide bolts
 - torqued down sliding bolts
 - lock nuts on the slide bolts
 - the weight of the car
19. By moving the front slide in and the back slide out, you achieve more:
- positive camber
 - negative camber
 - negative caster
 - positive caster
20. A car has a strut rod from the front of the frame to the lower control arm. Which of the following is true about this system?
- shortening the rod changes camber
 - the length of the rod will not affect caster or camber
 - the rod acts as a stabilizer bar
 - lengthening the rod reduces positive caster

UNIT POST TEST ANSWER KEY: FRONT-END ALIGNMENT (B)

LAP 01

1. c
2. a
3. b
4. b

LAP 02

5. a
6. d
7. b

LAP 03

8. a
9. d
10. b
11. b
12. a

LAP 04

13. a
14. d
15. ~~b~~c

LAP 05

16. a
17. c

LAP 06

18. b
19. c
20. d

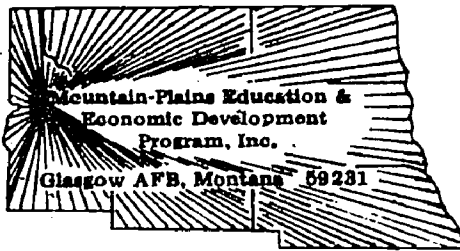

UNIT POST TEST: FRONT-END ALIGNMENT (C)

37.10.05.01

1. Negative camber is increased by moving the top of the wheel towards the:
 - a. engine
 - b. fender opening
 - c. headlight
 - d. taillight
2. Which of the following is not part of alignment precheck?
 - a. air pressure
 - b. shocks
 - c. trunk weight
 - d. riding height
3. The turn tables are not necessary to adjust the:
 - a. caster
 - b. riding height
 - c. camber
 - d. toe-in
4. Positive camber is increased by moving the tops of the wheel towards the:
 - a. engine
 - b. headlight
 - c. fender opening
 - d. taillight

37.10.05.02

5. If the specifications call for a difference between the left and right wheel camber settings, it would be to compensate for:
 - a. engine torque
 - b. road resistance
 - c. driver's weight
 - d. road crown
6. Negative caster is with the top of the wheel moved in the direction of the:
 - a. fender opening
 - b. headlight
 - c. engine
 - d. rear taillight

37.10.05.02 (continued)

7. Which of the following is most responsible for steering stability on a level road?
- caster
 - camber
 - steering axis inclination
 - toe-out

37.10.05.03

8. Radial tires have the toe reading usually set at:
- 0 toe-in
 - 1/16 to 1/8 toe-in
 - 1/16 toe-out
 - 1/8 toe-in
9. Setting toe with a measurement tool (not regular alignment equipment) requires measuring from the tire's:
- circular scribed lines
 - outside edges
 - center tread marks
 - inside rim edge
10. The adjusting tie rod sleeve tool is effective for turning the sleeve because it:
- is the only tool that can be used to turn the sleeve
 - easily fits the sleeve
 - is compact and fits into close working quarters
 - spreads the sleeve as it grips it for turning
11. Proper toe-in will allow the tires to move forward without:
- setting up a wheel tramp
 - a scrubbing, scraping action between tire and road
 - going into a wheel shimmy
 - causing a front-end vibration
12. Toe-in adjustment is accomplished by:
- adjusting the pitman arm
 - turning one of the tie rod sleeves
 - adjusting the steering knuckle
 - changing the idler arm angle

37.10.05.04

13. It is best to start out by adjusting the:
- strut rod
 - camber first
 - caster-camber together
 - caster first

37.10.05.04 (continued)

14. A car may have a tendency to pull to the side having:
- more positive caster
 - less positive caster
 - less negative caster
 - less positive camber
15. Strut rod adjustment can vary from each other to allow for:
- road crown
 - road resistance
 - vehicle weight
 - vehicle overload

37.10.05.05

16. Which reading can be observed at the same time it is being adjusted?
- negative caster
 - caster
 - camber
 - positive caster
17. What must sometimes be done to turn a difficult eccentric?
- raise the vehicle off the wheel
 - heat the eccentric
 - use a power impact wrench
 - hammer the eccentric head

37.10.05.06

18. By moving the front slide in and the back slide out, you achieve more:
- positive camber
 - negative camber
 - negative caster
 - positive caster
19. What prevents the slides from moving when the alignment is completed?
- cotter pinned slide bolts
 - torqued down sliding bolts
 - lock nuts on the slide bolts
 - the weight of the car
20. A car has a strut rod from the front of the frame to the lower control arm. Which of the following is true about this system?
- shoring the rod changes camber
 - the length of the rod will not affect caster or camber
 - the rod acts as a stabilizer bar
 - lengthening the rod reduces positive caster

UNIT POST TEST ANSWER KEY: FRONT END ALIGNMENT (C)

LAP 01

1. a
2. b
3. **eb**
4. c

LAP 02

5. d
6. b
7. a

LAP 03

8. a
9. a
10. d
11. b
12. b

LAP 04

13. d
14. **ac**
15. a

LAP 05

16. c
17. a

LAP 06

18. c
19. b
20. d

Student: _____ File Code: 37.10.05.00.B1-5

Date: _____ Date Published: 3/10/76

Family Pay Number: _____ Sex: M F (Circle 1)

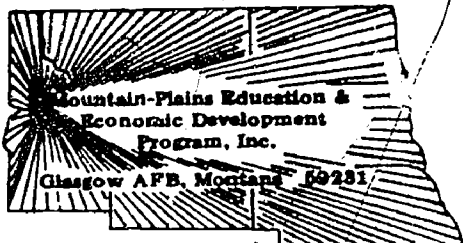

UNIT PERFORMANCE TEST: FRONT END ALIGNMENT

OBJECTIVE 1:

Align front end.

TASK:

The student will be assigned a vehicle on which he must align the front end by adjusting camber, caster, and toe.

ASSIGNMENT:

CONDITIONS:

The student will perform the test using only those materials provided for the test and perform the test in the auto shop.

RESOURCES:

Alignment Machine
Special Alignment Wrenches
Service Manual
Parts and Time Guide
Jack
Scribe or Chalk

RESOURCES: (Cont)

Combination Ignition wrench set
Combination Wrench Set
Standard Screwdriver Set
Phillips Screwdriver Set
Feeler gauge - .002 through .025 inch
Hex Key Set
Diagonal Cutting Pliers
Needle Nose Plier
1/4" Drive Socket Set
Ratchet - 3" and 6" extensions - 6" flex handle
Ball Peen hammer
Elastic Tip Hammer
Crew Starter
Chisel and Punch Set
3/32" Pin Punch - 3/16" Solid
Gasket scraper
3/8" Drive Ratchet
3" Extension
Spark Plug Socket
5" Extension
Speed Handle
3/8" Drive Socket Set

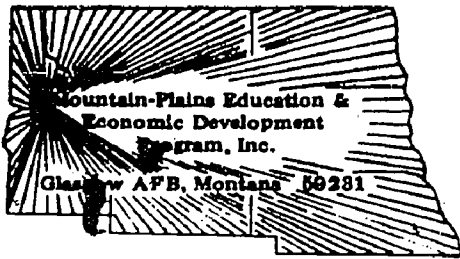

Family Pay Number: _____ Sex: M F (Circle 1)

PERFORMANCE CHECKLIST:

OVERALL PERFORMANCE: Satisfactory _____ Unsatisfactory _____

	CRITERION	
	Met	Not Met

Objective 1:		
1. Inspect front end for wear.		
2. Adjust caster.		
3. Adjust camber.		
4. Adjust toe.		
Criterion: Must meet manufacturer's specifications.		
5. Road test.		
Criterion: Must drive straight with no wander or shimmy.		
6. Must perform test in allotted time.		
Criterion: Must meet flat rate for assigned vehicle.		
Student must meet all 6 line items to achieve an overall		
score of satisfactory.		

Student: _____

File Code: 37.12.01.00.81-5

Date: _____

Date Published: 3/4/76

Family Pay Number: _____

Sex: M F (Circle 1)

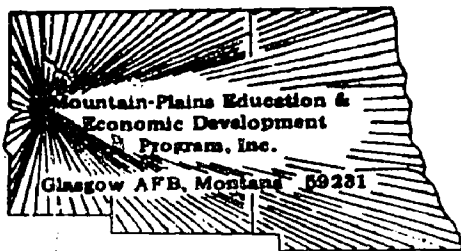

UNIT PERFORMANCE TEST: DETAILING AND SERVICING

OBJECTIVE:

Detail and service a vehicle.

TASK:

The student will be assigned a vehicle on which he must change oil and filter, clean windshield, check water in battery and radiator, check air filter, vacuum interior, check all belts, check power steering fluid, and lubricate door hinges.

ASSIGNMENT:

CONDITIONS:

The student will use only those materials provided for the test and perform the test in the auto shop.

RESOURCES:

Windshield cleaner
Lubrication sticker
Oil
Oil filter
Service manual
Time and parts manual
Oil filter wrench
Drain pan
Fender covers
Jack
Jack stands

RESOURCES: (Continued)

Combination Ignition wrench set
Combination Wrench Set
Standard Screwdriver Set
Phillips Screwdriver Set
Feeler gauge - .002 through .025 inch
Hex Key Set
Diagonal Cutting Pliers
Needle Nose Plier
1/4" Drive Socket Set
Ratchet - 3" and 6" extensions - 6" flex handle
Ball Peen hammer
Plastic Tip Hammer
Screw Starter
Chisel and Punch Set
5/32" Pin Punch - 3/16" Solid
Gasket scraper
3/8" Drive Ratchet
3" Extension
Spark Plug Socket
6" Extension
Speed Handle
3/8" Drive Socket Set

Student: _____

File Code: 37.12.01.00.81-5

Date: _____

Date Published: 3/4/76

Family Pay Number: _____

Sex: M F (Circle 1)

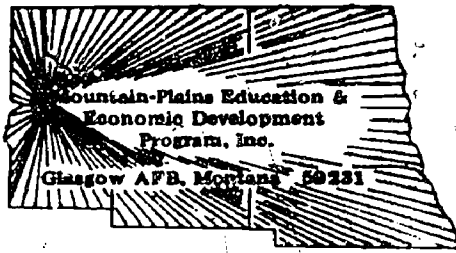

PERFORMANCE CHECKLIST:

OVERALL PERFORMANCE: Satisfactory _____ Unsatisfactory _____

	CRITERION	
	Met	Not Met
Objective:		
1. Change oil and filter.		
Criterion: Read full on dip stick, no leaks on drain plug or filter.		
2. Clean windshield and interior.		
Criterion: Be clean for instructor inspection.		
3. Inspect under hood.		
Criterion: Note any problems on work order; have belts tight.		
4. Complete test in allotted time.		
Criterion: Complete in one hour.		
Student must satisfactorily complete 3 of 4 line items to pass test.		