

DOCUMENT RESUME

ED 197 144

CE 027 772

AUTHOR Osland, Walt
 TITLE Mountain Plains Learning Experience Guide: Automotive Repair. Course: Automotive Fuel Systems.
 INSTITUTION Mountain-Plains Education and Economic Development Program, Inc., Glasgow AFB, Mont.
 SPONS AGENCY Office of Vocational and Adult Education (ED), Washington, D.C.
 PUBAN NO 498MH90008
 PUB DATE Oct 77
 CONTACT 309-79-0153
 NOTE 182p.; For related documents, see CE 027 766, CE 027 678-775, CE 027 777-780.

EDRS PRICE MF01/PC08 Plus Postage.
 DESCRIPTORS Adult Education: *Auto Mechanics: Disadvantaged: Family Programs: Fuel Consumption: *Fuels: *Individualized Instruction: Instructional Materials: Learning Activities: Learning Modules: Motor Vehicles: Postsecondary Education: Skilled Occupations: *Vocational Education
 IDENTIFIERS *Automotive Fuel Systems: Mountain Plains Program

ABSTRACT

One of twelve individualized courses included in an automotive repair curriculum, this course covers the theory, operation, and repair of the carburetor, fuel pump, and other related fuel system components and parts. The course is comprised of six units: (1) Fundamentals of Fuel Systems, (2) Fuel Pumps, (3) Fuel Lines and Filters, (4) Carburetors, (5) Fuel Characteristics, and (6) Automatic Chokes. Each unit begins with a Unit Learning Experience Guide that gives directions for unit completion. The remainder of the unit consists of Learning Activity Packages (LAP) that provide specific information for completion of a learning activity. Each LAP is comprised of the following parts: objective, evaluation procedure, resources, procedure, supplemental sheets, study guide, and a LAP test with answers. The course is preceded by a pretest which is designed to direct the student to unit and performance activities. (LRA)

 * Reproductions supplied by EDRS are the best that can be made *
 * from the original document. *

ED197144

MOUNTAIN PLAINS LEARNING EXPERIENCE GUIDE:

Automotive Repair.

Course: Automotive Fuel Systems.

CE 027772

U S DEPARTMENT OF HEALTH,
EDUCATION & WELFARE
NATIONAL INSTITUTE OF
EDUCATION

THIS DOCUMENT HAS BEEN REPRO-
DUCED EXACTLY AS RECEIVED FROM
THE PERSON OR ORGANIZATION ORIGIN-
ATING IT. POINTS OF VIEW OR OPINIONS
STATED DO NOT NECESSARILY REPRESENT
OFFICIAL NATIONAL INSTITUTE OF
EDUCATION POSITION OR POLICY

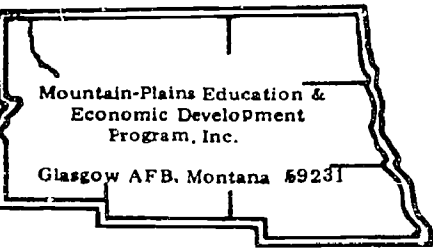

Learning Experience Guide

COURSE: AUTOMOTIVE FUEL SYSTEMS

DESCRIPTION:

Automotive Fuel Systems covers the theory, operation and repair of the carburetor, fuel pump and other related fuel system components and parts.

RATIONALE:

The theory and techniques taught in this course will enable you to perform the activities required of you when working on the fuel system of an automobile.

OBJECTIVE:

Diagnose and repair automotive fuel systems, components and parts.

RESOURCES:

A resource list is attached.

GENERAL INSTRUCTIONS:

This course has six units. Each unit has a unit Learning Experience Guide (LEG) that gives directions for unit completion. Each unit consists of Learning Activity Packages (LAPs) that provide specific information for completion of a learning activity. Pretesting results direct the student to units and performance activities.

The general procedure for this course is as follows:

- (1) Read the assigned unit LEG for this course.
- (2) Begin and complete the first assigned LAP.
 - a. Take and score the LAP test.
 - b. Turn in the LAP test.
 - c. Determine the reason for any missed items on the LAP test.
 - d. Proceed to the next assigned LAP in the unit.
 - e. Complete all required LAPs for the unit by following steps (a) through (d).
- (3) Take the unit tests as described in the unit LEG "Evaluation Procedures."

Principal Author(s): W. Osland

GENERAL INSTRUCTIONS: (continued)

- (4) Proceed to the next assigned unit in this course.
- (5) Follow steps 1 through 4 for all required units for this course.
- (6) Proceed to the next assigned course.

You will work independently unless directed to do otherwise. When questions or problems arise, you are expected to discuss them with the instructor. At all times, remember to follow correct safety procedures during the performance activity.

UNIT TITLES:

- .01 Fundamentals of Fuel Systems
- .02 Fuel Pumps
- .03 Fuel Lines and Filters
- .04 Carburetors
- .05 Fuel Characteristics
- .06 Automatic Chokes

EVALUATION PROCEDURE:

Course evaluation is by pre and post testing using a multiple-choice type of test.

In this course, the course test is used as a pretest to determine which units, if any, the student may be able to validate. The student is considered validated for a particular unit if 4 out of 5 items are correctly answered for each LAP part on the course pretest and that particular unit does not have a performance test requirement.

For those units with performance test requirements, the student must also satisfactorily complete the performance test to validate that unit. Unit performance test validation procedures are given in the "Evaluation Procedure" section of the unit Learning Experience Guide (LEG).

The course test will also be taken by the student as a post test to determine any changes resulting from taking all or part of the course. Score 80% correct on the post test.

FOLLOW-THROUGH:

Go to the first assigned unit Learning Experience Guide (LEG) listed on your Student Progress Record (SPR).

RESOURCE LIST

Printed Materials

1. Automotive Encyclopedia, Toboldt and Johnson, Goodheart-Wilcox Company, Inc.
2. Auto Mechanics Fundamentals, Martin W. Stockel, Goodheart-Wilcox Company, Inc., 1969.
3. Auto Service and Repair, Martin W. Stockel, Goodheart-Wilcox Company, Inc., 1969.
4. Motor's Auto Repair Manual, Motor, The Heart Corporation. (1972 or equivalent)
5. Specification's Manual — Fuel Filter/Fuel Pump

Equipment

1. Automobile needing: dash pot clearance adjustment
carburetor idle adjustment
air/fuel ration mixture adjustment
2. Automobile equipped with: choke, automatic
choke, mechanical
fuel pump, defective
fuel system, defective
3. Replacement parts: fuel filter
fuel pump
push rods
4. Carburetor and repair kits: single throat
dual barrel
four barrel
quadrajet
thermoquad
5. Safety equipment: jack or lift
jack stands
fender covers
6. Supplies: carburetor cleaner
compressed air
gaskets
gasket cement
soft cloth
tray
wire basket
exhaust hoses
7. Test equipment: tachometer
vacuum gauge and adapter fitting

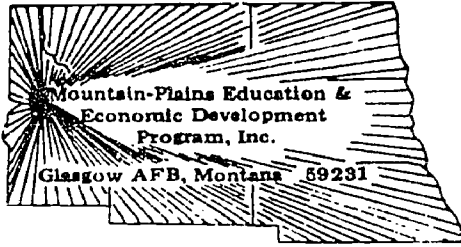

COURSE TEST: AUTOMOTIVE FUEL SYSTEM

37.05.01.01

1. Alcohol is added to gasoline primarily to:
 - a. absorb moisture.
 - b. prevent the free passage of fuel.
 - c. provide easier starting.
 - d. increase the volatility of the fuel.
2. What characteristic of fuel affects easy starting?
 - a. heptane.
 - b. octane.
 - c. volatility.
 - d. lead.
3. The vaporizing ability of any liquid is called its:
 - a. heptane.
 - b. volatility.
 - c. cetane.
 - d. benzol.
4. If the percentage of volatile fuel is too high, what condition will occur?
 - a. carbon build up.
 - b. flooding.
 - c. vapor lock.
 - d. gas leak.
5. The ability of a fuel to resist detonation is measured by its:
 - a. sulfur rating.
 - b. lubrication ability.
 - c. octane rating.
 - d. pre-ignition rating.

37.05.01.02

6. Internal baffles in a gas tank are used to:
 - a. prevent water build-up in the gas.
 - b. collapse of tank from pressure.
 - c. present sloshing of gas.
 - d. reinforce tank for strength.

37.05.01.02 (continued)

7. What is the most common type of fuel pump?
 - a. electrical.
 - b. mechanical.
 - c. rotor.
 - d. gear.

8. Gas contamination in the gas tank is caused from:
 - a. poor grades of gas.
 - b. additives in gas.
 - c. condensation.
 - d. low octane gas.

9. A gas tank is usually constructed of:
 - a. aluminum.
 - b. thin sheet metal.
 - c. gage steel.
 - d. galvanized metal.

10. A difficult task for the fuel system is to:
 - a. supply enough gasoline to the carburetor.
 - b. consistently deliver the proper air-fuel mixture.
 - c. discharge waste gases.
 - d. clean the gas before it enters the carburetor.

37.05.01.03:

11. When removing a dent from a gas tank, before applying air pressure to the tank you should:
 - a. be sure there is adequate ventilation in tank.
 - b. put safety bands around tank.
 - c. fill tank with water.
 - d. heat tank where dent is.

12. When you are inspecting a gas tank and find a leak, you should clean it thoroughly and then:
 - a. bronze it.
 - b. weld it.
 - c. solder it.
 - d. glue it.

13. If gas is not coming to the fuel pump very well, it could be:
 - a. the carburetor is flooded.
 - b. water in the gas.
 - c. the carburetor is not drawing air properly.
 - d. a plugged fuel filter.

37.05.01.03 (continued)

14. When inspecting and testing a fuel pump, you should check for leaks, output pressure and:
- air loss.
 - air pressure.
 - volume
 - the fuel gage assembly for accuracy.
15. An average fuel-air ratio is 1 part of the fuel to how many parts of air?
- 3
 - 15
 - 10
 - 5

37.05.02.01

16. Filters should be cleaned:
- periodically.
 - never.
 - annually.
 - semiannually.
17. The current trend in filters is toward:
- paper filters.
 - polyurethane filters.
 - disposable filters.
 - fine screen.
18. Fuel lines should not be too close to the engine for what reason?
- to prevent collapse of the line.
 - to prevent fire.
 - to prevent vapor lock.
 - so more air can be transferred through the line along with the gas.
19. The sintered bronze fuel filter is positioned where on almost all vehicles?
- on the tip of the fuel pump.
 - on the bottom of the fuel pump.
 - on the carburetor.
 - on the pick-up pipe.
20. How many filters are found in the fuel system?
- 2
 - 3
 - 1
 - 4

37.05.02.02

21. When you have a metal case around a filter, to inspect the fuel filter you must:
- take the case off gently.
 - leave it on until you have 100,000 miles on it.
 - cut it off with a hacksaw.
 - replace with a new one.
22. When checking fuel filters, they should be replaced every:
- 5,000 miles.
 - 50,000 miles.
 - 100,000 miles.
 - 10,000 to 20,000 miles.
23. What major precaution must be double checked after every fuel filter replacement?
- that there is a pulsator test performed.
 - that there are no leaks.
 - that there is proper ventilation.
 - that there are more filters to change.

37.05.02.03

24. What type of filter will allow fuel to be forced through it under pressure?
- the filter from the pick-up pipe.
 - a porous bronze filter on the carburetor.
 - the filter on the bottom of the fuel pump.
 - filter on top of the fuel pump.
25. When installing a fuel filter, it is important that you:
- get the thinnest filter possible.
 - get the heaviest filter possible.
 - install it in the right direction.
 - get a porous bronze filter.

37.05.03.01

26. Vapor lock in a car can be caused from:
- lines too short.
 - lines too long.
 - lines too close to the intake manifold.
 - lines too close to the exhaust manifold.

37.05.03.01 (continued)

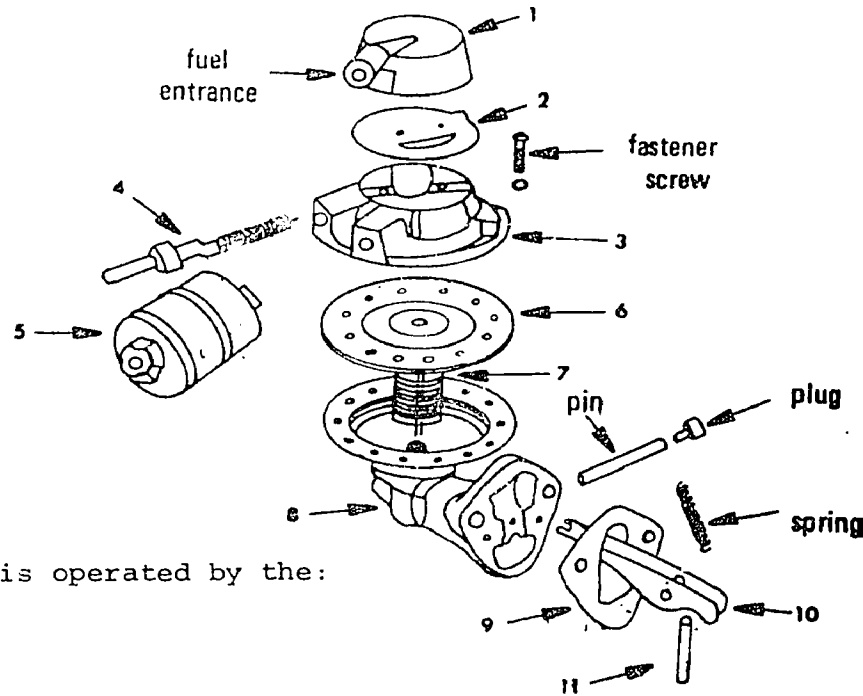

27. In the diagram* above, number 11 is operated by the:

- timing gear.
- fan belt.
- crankshaft.
- camshaft.

28. In the diagram above, number 9 is:

- the pulsator diaphragm.
- the gasket.
- the lower fuel filter.
- the upper fuel filter.

29. In the diagram above, what is number 4?

- fuel inlet.
- fuel outlet.
- diaphragm return spring.
- vapor return valve.

30. In the diagram above, number 5 is:

- the fuel outlet valve.
- the vapor return valve.
- the fuel inlet valve.
- fuel filter.

* (From Auto Mechanics Fundamentals, Stockel, Goodheart-Wilcox, 1969, page 120, Figure 6-134).

37.05.03.02

31. What is the average vacuum developed by a vacuum pump that is built into a fuel pump?
- a. 7½ inches.
 - b. 5 inches.
 - c. 10 inches.
 - d. 18 inches.
32. In 45 seconds, how much fuel should be pumped by the average mechanical type fuel pump?
- a. 1 pint
 - b. 2 pints
 - c. 3 pints
 - d. 32 ounces
33. When you pump gas into a pint container to measure how long it takes, it is called what kind of test?
- a. a vacuum test.
 - b. a pressure test.
 - c. a discharge test.
 - d. a capacity test.

37.05.03.03

34. When attaching fuel lines, it is important that you:
- a. start with fingers.
 - b. use a box-end wrench.
 - c. get them as tight as you can.
 - d. use an adjustable wrench.
35. When replacing a fuel pump, you should always replace what gasket?
- a. diaphragm gasket.
 - b. head gasket.
 - c. mounting gasket.
 - d. pulsator gasket.

37.05.04.01

36. When the engine is warming up, it is necessary to idle the engine somewhat faster to prevent stalling. This is accomplished by connecting the choke shaft to the:
- a. choke piston cylinder.
 - b. fast idle cam.
 - c. engine manifold vacuum.
 - d. choke stone tube.

37.05.04.01 (continued)

37. Hot engine operating temperature affects which of the following?
- hot idle compensating valve.
 - secondard throttle valve.
 - power valve piston assembly.
 - secondary air valve.
38. Engine speed is controlled by the position of what, in the carburetor?
- main metering jet.
 - inlet ball check.
 - throttle valve.
 - main discharge jet.
39. How many types of idle speed-up controls are there when air conditioning is running?
- 1
 - none
 - 2
 - 3
40. A venturi tube does what?
- causes a vacuum.
 - discharges gas from the fuel bowl.
 - gives gas to the fuel bowl.
 - decreases vapor lock in a carburetor.

37.05.04.02

41. Single barrel carburetors are usually found on engines with how many cylinders?
- 8 cylinders.
 - diesel engines with 6 cylinders.
 - 12 cylinders.
 - 6 cylinders.
42. When disassembling a carburetor, you should lay parts:
- on a clean bench.
 - on a rag.
 - on a piece of paper.
 - in a clean can.

37.05.04.03

43. Two-barrel carburetors utilize how many airfuel screws?
- 0
 - 4
 - 3
 - 2

... except for which system?

... you should:

... each ...

...

... a four barrel carburetor?

- ... carburetor.
- ... carburetor.
- ... carburetor.
- ... carburetor.

... drop on all Quadrajet carburetors

... a part used to maintain a higher idel ...

...

37.05.04.06

51. The main body of a thermo-quad carburetor is made of:
- cast iron.
 - molded phenolic resin.
 - all metal.
 - aluminum.
52. You can identify a specific thermo-quad carburetor by:
- the metal tag fastened to air horn.
 - the fuel inlet valve.
 - disassembling it.
 - the vacuum diaphragm.

37.05.04.07

53. When placing a new gasket on a manifold, you should be careful not to:
- put too much glue on the surface.
 - put it on dry.
 - place it upside down.
 - put it on clean.
54. When a new carburetor is installed, you should make all of the tests and then:
- clean the engine.
 - record results.
 - take it for a test drive.
 - return it to owner.
55. Parts not to be placed in a carburetor solution are:
- those made of aluminum.
 - those made of rubber.
 - the outside parts of a carburetor.
 - the throttle valves.

37.05.04.08

56. When installing idel-mixture screws, how many turns should they be backed off after they have been turned all the way in?
- depends on type, make, and year of carburetor.
 - 1½ turns.
 - 3½ turns.
 - 2 turns.
57. When connecting the tachometer you set it for:
- number of cylinders and on low range.
 - number of cylinders and on high range.
 - on low range.
 - number of cylinders.

37.05.04.09

58. When adjusting dashpot, it should just contact the:
- accelerating lever.
 - choke control cable bracket assembly.
 - throttle lever.
 - throttle plate.
59. The function of the dashpot is to:
- make sure the idle speed-up air passage is always open.
 - prevent stalling when linkage returns to idle.
 - enrich fuel mixture when needed.
 - have a high idle when engine is cold.

37.05.04.10

60. Some mixture screws have external limiters to control the amount that screws may be adjusted. This also helps:
- to prevent backfiring inside of the carburetor.
 - to prevent excess air entry into the air horn.
 - keep exhaust emission down.
 - exhaust emission to rise.

37.05.05.01

61. A choke stove is:
- heating compartment.
 - air storage space.
 - choke valve inside of the air horn.
 - vacuum passage to the intake manifold.
62. How many normal sections of a carburetor are there?
- 3
 - 5
 - 2
 - 4
63. An automatic choke has a spring which is made of:
- aluminum.
 - two dissimilar metals.
 - copper.
 - light tin.
64. A fuel bowl on a carburetor is used to:
- mix the air and gas together.
 - collect sediment from the gas lines.
 - hold a supply of gas.
 - vaporize gas so it can be ignited.

37.05.05.01 (continued)

65. The air entering the carburetor opens the choke slightly, and the vacuum piston will also pull the choke open a little. When these two forces work together, it is called:
- a balanced condition.
 - a room air induction.
 - a thermodynamic air convulsion.
 - a dual action.

37.05.05.02

66. When reassembling the automatic choke, the thermostatic spring is positioned correctly when it engages the:
- secondary throttle shaft.
 - vacuum diaphragm choke break.
 - fast idle cam.
 - choke shaft lever.
67. Automatic chokes have a valve in the air horn which is actuated by a:
- camshaft.
 - thermostatic coil in manifold.
 - throttle linkage.
 - crankshaft.

37.05.05.03

68. On an electric automatic choke, the electrical circuit is controlled through operation of the:
- offset position of the choke valve.
 - thermostatic coil.
 - vacuum operated choke piston.
 - starter switch.
69. The heat for operating the thermostatic spiral spring on an electric automatic choke is provided by:
- an exhaust manifold.
 - recycling of exhaust emissions.
 - an electric heating element.
 - a heat stove.

37.05.05.04

70. When adjusting the choke vacuum "break" (piston type) you would do so by:
- adjusting the idle mixture screw.
 - installing a smaller diaphragm.
 - an adjusting nut or bending linkage.
 - bending the thermostatic spring.

COURSE PRETEST ANSWER KEY: AUTOMOTIVE FUEL SYSTEM

Occupational Area:

File Code:

Name:

Family Pay Number

 37.05.00.00 B1-2

Sex M F (Circle 1)

ANSWERS

.01.01	1. D _____	37.05.02.02	21. B _____	37.05.04.02	41. B _____
	2. B _____		22. A _____		42. B _____
	3. A _____		23. D _____	37.05.04.03	43. D _____
	4. C _____	37.05.02.03	24. B _____		44. D _____
	5. A _____		25. A _____		45. A _____
4.01.02	6. D _____	37.05.03.01	26. D _____	37.05.04.04	46. C _____
	7. B _____		27. C _____		47. D _____
	8. B _____		28. D _____		48. B _____
	9. C _____		29. B _____	37.05.04.05	49. A _____
	10. B _____		30. D _____		50. A _____
5.01.03	11. D _____	37.05.03.02	31. C _____	37.05.04.06	51. B _____
	12. C _____		32. A _____		52. C _____
	13. C _____		33. C _____	37.05.04.07	53. B _____
	14. B _____	37.05.03.03	34. C _____		54. C _____
	15. B _____		35. A _____		55. C _____
05.02.01	16. C _____	37.05.04.01	36. A _____	37.05.04.08	56. D _____
	17. C _____		37. C _____		57. B _____
	18. C _____		38. B _____	37.05.04.09	58. C _____
	19. A _____		39. C _____		59. A _____
	20. A _____		40. A _____	37.05.04.10	60. C _____

Occupational Area:

File Code:

Name:

37.05.00.00.B1-2

ANSWERS

05.05.01	61. A	_____	81.	_____	101.	_____
	62. B	_____	82.	_____	102.	_____
	63. C	_____	83.	_____	103.	_____
	64. A	_____	84.	_____	104.	_____
	65. A	_____	85.	_____	105.	_____
05.05.02	66. B	_____	86.	_____	106.	_____
	67. D	_____	87.	_____	107.	_____
05.05.03	68. A	_____	88.	_____	108.	_____
05.05.04	69. D	_____	89.	_____	109.	_____
	70. A	_____	90.	_____	110.	_____
	71.	_____	91.	_____	111.	_____
	72.	_____	92.	_____	112.	_____
	73.	_____	93.	_____	113.	_____
	74.	_____	94.	_____	114.	_____
	75.	_____	95.	_____	115.	_____
	76.	_____	96.	_____	116.	_____
	77.	_____	97.	_____	117.	_____
	78.	_____	98.	_____	118.	_____
	79.	_____	99.	_____	119.	_____
	80.	_____	100.	_____	120.	_____

UNIT TEST ANSWER SHEET

Occupational Area: Automotive
 File Code: 37.05
 Name: _____
 Family Pay Number: _____

Sex: M F (Circle 1)

ANSWERS

- | | | | | | |
|------|--------------|------|--------------|------|--------------|
| 10 | 1. <u>A</u> | 0202 | 21. <u>D</u> | 0402 | 41. <u>D</u> |
| | 2. <u>C</u> | | 22. <u>D</u> | | 42. <u>C</u> |
| | 3. <u>B</u> | | 23. <u>B</u> | 0402 | 43. <u>D</u> |
| | 4. <u>C</u> | 0203 | 24. <u>B</u> | | 44. <u>D</u> |
| | 5. <u>C</u> | | 25. <u>C</u> | | 45. <u>D</u> |
| 0102 | 6. <u>C</u> | 0301 | 26. <u>D</u> | 0404 | 46. <u>A</u> |
| | 7. <u>B</u> | | 27. <u>D</u> | | 47. <u>B</u> |
| | 8. <u>C</u> | | 28. <u>B</u> | | 48. <u>D</u> |
| | 9. <u>B</u> | | 29. <u>D</u> | 0405 | 49. <u>C</u> |
| | 10. <u>B</u> | | 30. <u>D</u> | | 50. <u>D</u> |
| 0103 | 11. <u>C</u> | 0302 | 31. <u>C</u> | 0406 | 51. <u>B</u> |
| | 12. <u>C</u> | | 32. <u>A</u> | | 52. <u>A</u> |
| | 13. <u>D</u> | | 33. <u>D</u> | 0407 | 53. <u>C</u> |
| | 14. <u>C</u> | 0303 | 34. <u>A</u> | | 54. <u>C</u> |
| | 15. <u>B</u> | | 35. <u>C</u> | | 55. <u>B</u> |
| 0201 | 16. <u>A</u> | 0401 | 36. <u>B</u> | 0408 | 56. <u>A</u> |
| | 17. <u>C</u> | | 37. <u>A</u> | | 57. <u>B</u> |
| | 18. <u>C</u> | | 38. <u>C</u> | 0409 | 58. <u>C</u> |
| | 19. <u>C</u> | | 39. <u>C</u> | | 59. <u>B</u> |
| | 20. <u>A</u> | | 40. <u>A</u> | 0410 | 60. <u>C</u> |

UNIT TEST ANSWER SHEET

Occupational Area:

File Code:

Name:

Automotive

37.05

ANSWERS

- 61. A
- 62. A
- 63. B
- 64. C
- 65. A
- 66. D
- 67. B
- 68. D
- 69. C
- 70. C
- 71.
- 72.
- 73.
- 74.
- 75.
- 76.
- 77.
- 78.
- 79.
- 80.

- 81.
- 82.
- 83.
- 84.
- 85.
- 86.
- 87.
- 88.
- 89.
- 90.
- 91.
- 92.
- 93.
- 94.
- 95.
- 96.
- 97.
- 98.
- 99.
- 100.

- 101.
- 102.
- 103.
- 104.
- 105.
- 106.
- 107.
- 108.
- 109.
- 110.
- 111.
- 112.
- 113.
- 114.
- 115.
- 116.
- 117.
- 118.
- 119.
- 120.

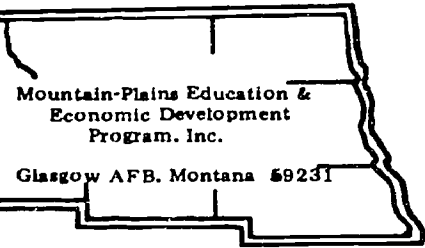

Learning Experience Guide

UNIT: FUNDAMENTALS OF FUEL SYSTEMS

RATIONALE:

The fundamentals and techniques in this unit will enable you to recognize the fuel system components and diagnose the fuel system problems.

PREREQUISITES:

None

OBJECTIVES:

Recognize the components of the fuel system.

Use the proper procedure for fuel system inspection.

RESOURCES:

Printed Materials

Auto Mechanics Fundamentals. Martin W. Stockel, Goodheart-Wilcox Company, Inc.

Auto Service and Repair. Martin W. Stockel, Goodheart-Wilcox Company, Inc.

Manufacturer's Specifications.

Equipment

Automobile with fuel system problem

Jack or lift

Jack stands

GENERAL INSTRUCTIONS:

This unit consists of two Learning Activity Packages (LAPs). Each LAP will provide specific information for completion of a learning activity.

Principal Author(s):

The general procedure for this unit is as follows:

1. Read the first assigned Learning Activity Package (LAP).
2. Begin and complete the first assigned LAP.
3. Complete all required LAPs for the unit.
4. In this unit, the LAP and unit tests are combined. This combined test is taken after completing the last LAP in the unit.
5. Take the unit/LAP test as described in the unit LEG "Evaluation Procedures."
6. Proceed to the next assigned unit.

PERFORMANCE ACTIVITIES:

- .01 Overview of Fundamentals
- .02 Inspecting Fuel System

EVALUATION PROCEDURE:

When pretesting:

1. The student takes the unit multiple-choice pretest.
2. Successful completion is 4 out of 5 items for each LAP part of the pretest.
3. The student then takes a unit performance test if the unit pretest was successfully completed.
4. Satisfactory completion of the performance test is meeting the criteria listed on the performance test.

When post testing:

1. The students takes a multiple-choice unit post test and a unit performance test.
2. Successful unit completion is meeting the listed criteria for the performance test.

FOLLOW-THROUGH

Go to the first assigned Learning Activity Package (LAP) listed on your Student Progress Record (SPR).

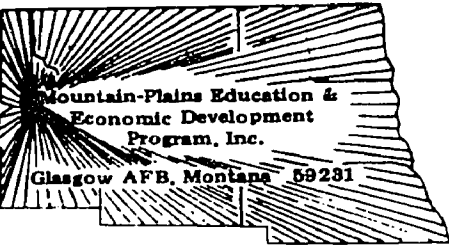

UNIT/LAP PRETEST: FUNDAMENTALS OF FUEL SYSTEMS

37.05.01.01.

1. Iso-octane and what other material are used to determine the octane rating of a fuel?
 - a. heptane.
 - b. cetane.
 - c. benzol.
 - d. propane.

2. Cetane number of a diesel fuel is a measure of:
 - a. viscosity.
 - b. engine deposits in combustion chamber.
 - c. time between fuel injection and ignition.
 - d. volatility.

3. The three stages that are sometimes termed formation or nucleus of flame, hatching out, and propagation make up what process?
 - a. octane rating process.
 - b. normal combustion in a combustion chamber.
 - c. distillation process.
 - d. cetane rating process.

4. If the percentage of volatility is too high, what condition will occur?
 - a. vapor lock.
 - b. carbon build up.
 - c. flooding.
 - d. gas leak.

5. Sulfur content of a fuel should be:
 - a. an average amount along with other additives.
 - b. does not matter.
 - c. low as possible.
 - d. high as possible.

6. Liquid petroleum gas is a mixture of:
 - a. butane and heptane.
 - b. hetane and cetane.
 - c. butane and propane.
 - d. benzol and heptane.

37.05.01.01. cont.

7. Lead is an important part of fuel because it:
- helps prevent detonation.
 - oxidizes hydro-carbon.
 - is used as a lubrication.
 - helps prevent carbon build-up.
8. The ability of a fuel to resist detonation is measured by its:
- octane rating.
 - pre-ignition rating.
 - sulfur rating.
 - lubricating ability.
9. The vaporizing ability of any liquid is called its:
- heptane.
 - cetane.
 - benzol.
 - volatility.
- 10.

37.05.01.02.

11.

12.

13. Internal baffles in a gas tank are used to:
- prevent water build-up.
 - reinforce tank for strength.
 - prevent sloshing of gas.
 - collapse of tank from pressure.

37.05.01.02. cont.

14. A difficult task for the fuel system is to:
- discharge waste gases.
 - consistently deliver the proper air-fuel mixture.
 - clean the gas before it enters the carburetor.
 - supply enough gasoline to the carburetor.
15. An air chamber divided in half by a diaphragm is called a:
- check valve.
 - anti-percolater valve.
 - fuel pump.
 - carburetor.

37.05.01.03.

16. When inspecting and testing a fuel pump, you should check for leaks, output pressure and:
- air loss.
 - inlet vacuum.
 - air pressure.
 - fuel gage assembly for accuracy.
- 17.
18. When checking or making an inspection, you should:
- make sure you at least write it down on paper.
 - depend on your memory.
 - tell the owner when you see something wrong.
 - put your results on a work order.
19. When checking the fuel line from tank to pump, you should look for leaks and check:
- to make sure that it is insulated where it touches the frame.
 - the pressure build-up in the line.
 - for a "flat spot" in the carburetor.
 - connections for tightness.
20. When removing a dent from a gas tank, before applying air pressure to the tank you should:
- be sure there is adequate ventilation in tank.
 - put safety bands around tank.
 - fill tank with water.
 - heat tank where the dent is?

UNIT/LAP PRETEST ANSWER KEY: FUNDAMENTALS OF FUEL SYSTEMS

LAP .01

1. a
2. c
3. b
4. a
5. c
6. c
7. a
8. a
9. d
10. a

LAP .02

11. d
12. c
13. c
14. b
15. c

LAP .03

16. b
17. a
18. d
19. d
20. c



Learning Activity Package

Student: _____

Date: _____

PERFORMANCE ACTIVITY: Fundamentals of Fuel Characteristics

... and limitations of fuel.

PROCEDURE:

... on LAP study questions. Eight correct responses to a ten-item multiple choice objective test.

RESOURCES

Automotive Encyclopedia, Toboldt

PROCEDURE:

1. Do the following assignments using Automotive Encyclopedia:
 - a. Read "Automotive Fuels" on pages 229-235.
 - b. On a separate sheet of paper, neatly answer questions 1-14 on page 235.
 - c. Return the answer sheet to the instructor for evaluation.
2. Take and score the Unit/LAP post test.
3. Upon successful completion, go to the next assigned unit.

Principal Author(s): J. Anderson, W. Osland

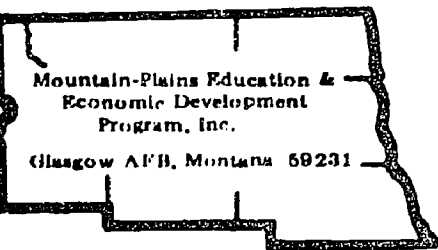

Learning Activity Package

Student: _____

Date: _____

PERFORMANCE ACTIVITY: Overview of Fundamentals

OBJECTIVE:

Recognize the components of the fuel system and how they perform to operate a fuel system.

EVALUATION PROCEDURE:

80% correct on LAP study questions.
Eight correct responses to a ten-item multiple-choice objective test to be taken after completing the LAP.

RESOURCES:

Auto Mechanics Fundamentals, Stockel.
Super 8 Sound Film Loops:
Projector

PROCEDURE:

1. Do the following assignments using Auto Mechanics Fundamentals:
 - a. Read Chapter 6, "Fuel Systems," paragraphs - first six.
 - b. Read "Air Cleaners," four paragraphs.
 - c. Study the fuel system picture - far figure 6-33.
 - d. Answer Review questions 1,2,3 and 33 on a separate sheet of paper.
2. Return the textbook to the proper shelf.
3. Return your answer sheet to the instructor.
4. Go to the next LAP.

Principal Author(s): W. Osland

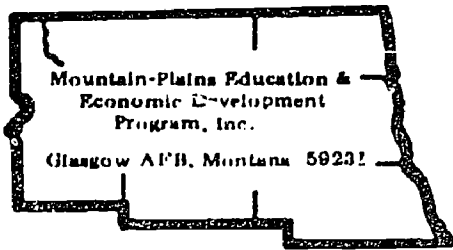

Learning Activity Package

Student: _____

Date: _____

PERFORMANCE ACTIVITY: Inspecting Fuel System

OBJECTIVE:

Recognize and use the correct procedure to inspect the complete fuel system on the automobile to determine its present condition.

EVALUATION PROCEDURE:

Eight correct responses to a ten-item multiple-choice objective test.

RESOURCES:

Auto Service and Repair, Stockel.
 Manufacturer' Specifications
 Automobile with a fuel system problem
 Jacks or lift
 Jack stands

PROCEDURE:

NOTE: Read the first 5 paragraphs of Chapter 22 subject "Fuel Systems".

1. Raise the vehicle and secure with safety stands for easy access during inspection.
2. Inspect the fuel tank:
 - a. for any leaks due to damage.
 - b. tightness of the fuel line connection into the tank.
 - c. check sending unit float.
 - d. check sending unit wire connection into the tank.
 - e. check mounting straps for tightness.
 (Record all results on the work order)
3. Inspect the fuel line to the pump:
 - a. for any leaks due to damage.
 - b. connections for tightness.
 - c. line mounting brackets for proper fit, alignment and tightness.
 - d. flex line at pump for damage, leakage and tightness.

Principal Author(s): W. Osland

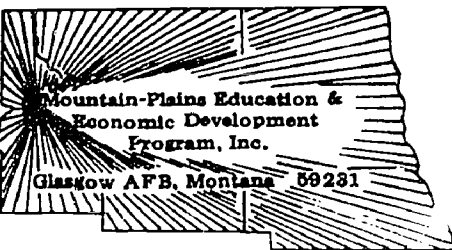

UNIT/LAP POST TEST: FUNDAMENTALS OF FUEL SYSTEMS A

37.05.01.01

1. For maximum power and economy of operation, what content in fuel is required?
 - a. low volatility and high heat content
 - b. high sulfur content and high heat content
 - c. low viscosity and low heat content
 - d. high sulfur content

2. Liquid petroleum gas is a mixture of:
 - a. benzol and heptane.
 - b. butane and propane.
 - c. butane and heptane.
 - d. heptane and cetane.

3. Immediately after ignition, combustion chamber temperatures may reach a temperature of:
 - a. 7,5000 degrees.
 - b. 2,5000 degrees.
 - c. 1,5000 degrees.
 - d. 5,5000 degrees.

4. Alcohol is added to gasoline primarily to:
 - a. provide easier starting.
 - b. prevent the free passage of fuel.
 - c. absorb moisture.
 - d. increase the volatility of the fuel.

5. Sulfur content of a fuel should be:
 - a. an average amount along with other additives.
 - b. does not matter.
 - c. low as possible.
 - d. high as possible.

6. The vaporizing ability of any liquid is called its:
 - a. volatility.
 - b. heptane.
 - c. benzol.
 - d. cetane

37.05.01.01 (continued)

7. The three stages that are sometimes termed formation or nucleus of flame, hatching out, and propagation make up what process?
- distillation process
 - octane rating process
 - cetane rating process
 - normal combustion is a combustion chamber
8. What characteristic of fuel affects easy starting?
- volatility
 - lead
 - heptane
 - octane
9. Iso-octane and what other material are used to determine the octane rating of a fuel?
- cetane
 - propane
 - heptane
 - benzol
10. If the percentage of volatility is too high, what condition will occur?
- flooding
 - carbon buildup
 - gas leak
 - vapor lock

37.05.01.02

11. Internal baffles in a gas tank are used to:
- prevent water buildup in the gas.
 - prevent sloshing of gas.
 - collapse of tank from pressure.
 - reinforce tank for strength.
12. Gas contamination in the gas tank is caused from:
- low octane gas.
 - condensation.
 - poor grades of gas.
 - additives in gas.
13. The two most common fuel pumps that are used are:
- mechanical and electrical.
 - mechanical and ram induction.
 - mechanical and gravitational.
 - siphon and gravitational.

37.05.01.02 (continued)

14. When the engine is first started, the choke valve:

- a. is closed.
- b. is open.
- c. can be either open or closed.
- d. is part way open.

15. A fuel pump delivers fuel to the:

- a. cylinders.
- b. air chamber.
- c. carburetor.
- d. spark plug.

37.05.01.03

16. If gas is not coming to the fuel pump very well, it could be:

- a. the carburetor is flooded.
- b. water in the gas.
- c. a plugged fuel filter.
- d. the carburetor is not drawing air properly.

17. When checking or making an inspection, you should:

- a. tell the owner when you see something wrong.
- b. depend on your memory.
- c. make sure you at least write it down on paper.
- d. put your results on a work order.

18. When checking the fuel line from tank to pump, you should look for leads and check:

- a. for a "flat spot" in the carburetor.
- b. to make sure that it is insulated where it touches the frame.
- c. the pressure buildup in the line.
- d. connections for tightness.

19. An air chamber divided in half by a diaphragm is called a:

- a. check valve.
- b. anti-pereolater valve.
- c. fuel pump.
- d. carburetor.

20. When you are inspecting a gas tank and find a leak, you should clean it thoroughly and then:

- a. solder it.
- b. glue it.
- c. weld it.
- d. bronze it.

UNIT/LAP POST TEST ANSWER KEY: FUNDAMENTALS OF FUEL SYSTEMS *A*LAP .01

1. a
2. b
3. d
4. c
5. c
6. a
7. d
8. a
9. c
10. d

LAP .02

11. b
12. b
13. a
14. a
15. c

LAP .03

16. c
17. d
18. d
19. ~~a~~ c
20. a

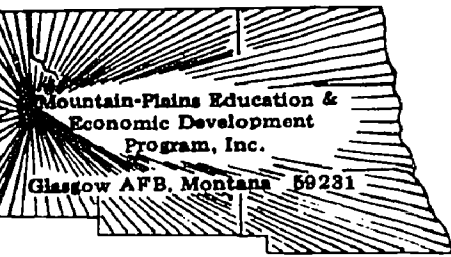

UNIT/LAP POST TEST: FUNDAMENTALS OF FUEL SYSTEMS (B)

37.05.01.01

1. The vaporizing ability of any liquid is called its:
 - a. volatility
 - b. heptane
 - c. benzol
 - d. centane

2. Sulfur content of a fuel should be:
 - a. an average amount along with other additives
 - b. does not matter
 - c. low as possible
 - d. high as possible

3. Alcohol is added to gasoline primarily to:
 - a. provide easier starting
 - b. prevent the free passage of fuel
 - c. absorb moisture
 - d. increase the volatility of the fuel

4. Immediately after ignition, combustion chamber temperatures may reach a temperature of:
 - a. 7,500 degrees
 - b. 2,500 degrees
 - c. 1,500 degrees
 - d. 5,500 degrees

5. Liquid petroleum gas is a mixture of:
 - a. benzol and heptane
 - b. butane and propane
 - c. butane and heptane
 - d. heptane and cetane

6. For maximum power and economy of operation, what content in fuel is required?
 - a. low volatility and high heat content
 - b. high sulfur content and high heat content
 - c. low viscosity and low heat content
 - d. high sulfur content

37.05.01.01 cont.

7. If the percentage of volatility is too high, what condition will occur?
 - a. flooding
 - b. carbon build up
 - c. gas leak
 - d. vapor lock

8. Iso-octane and what other material are used to determine the octane rating of a fuel?
 - a. cetane
 - b. propane
 - c. heptane
 - d. benzol

9. What characteristic of fuel affects easy starting?
 - a. volatility
 - b. lead
 - c. heptane
 - d. octane

10. The three stages that are sometimes termed formation or nucleus of flame, hatchingout, and propagation make up what process?
 - a. distillation process
 - b. octane rating process
 - c. cetane rating process
 - d. normal combustion in a combustion chamber

37.05.01.02

11. A fuel pump delivers fuel to the:
 - a. cylinders
 - b. air chamber
 - c. carburetor
 - d. spark plug

12. When the engine is first started, the choke valve:
 - a. is closed
 - b. is open
 - c. can be either open or closed
 - d. is part way open

13. The two most common fuel pumps that are used are:
 - a. mechanical and electrical
 - b. mechanical and ram induction
 - c. mechanical and gravitational
 - d. siphon and gravitational

37.05.01.02 cont.

14. Gas contamination in the gas tank is caused from:

- a. low octane gas
- b. condensation
- c. poor grades of gas
- d. additives in gas

15. Internal baffles in a gas tank are used to:

- a. prevent water build-up in the gas
- b. prevent sloshing of gas
- c. collapse of tank from pressure
- d. reinforce tank for strength

37.05.01.03

16. When you are inspecting a gas tank and find a leak, you should clean it thoroughly and then:

- a. solder it
- b. glue it
- c. weld it
- d. bronze it

17. When checking the fuel line from tank to pump, you should look for leaks and check:

- a. for a "flat spot" in the carburetor
- b. to make sure that it is insulated where it touched the frame
- c. the pressure build up in the line
- d. connections for tightness

18. When checking or making an inspection, you should:

- a. tell the owner when you see something wrong
- b. depend on your memory
- c. make sure you at least write it down on paper
- d. put your results on a work order

19. If gas is not coming to the fuel pump very well, it could be:

- a. the carburetor is flooded
- b. water in the gas
- c. a plugged fuel filter
- d. the carburetor is not drawing air properly

UNIT/LAP POST TEST ANSWER KEY: FUNDAMENTALS OF FUEL SYSTEMS

LAP 01

1. a
2. c
3. c
4. d
5. b
6. a
7. d
8. c
9. a
10. d

LAP 02

11. c
12. a
13. a
14. b
15. b

LAP 03

16. a
17. d
18. d
19. c

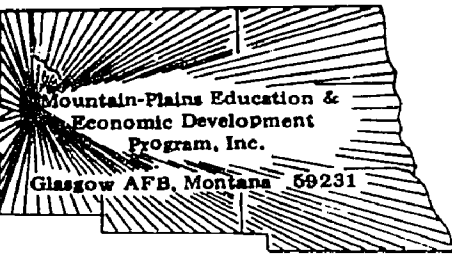

UNIT/LAP POST TEST: FUNDAMENTALS OF FUEL SYSTEMS (C)

37.05.01.01

1. Iso-octane and what other material are used to determine the octane rating of a fuel?
 - a. cetane
 - b. propane
 - c. heptane
 - d. benzol

2. Sulfur content of a fuel should be:
 - a. an average amount along with other additives
 - b. does not matter
 - c. low as possible
 - d. high as possible

3. The three stages that are sometimes termed formation or nucleus of flame, hatchingout, and propagation make up what process?
 - a. distillation process
 - b. octane rating process
 - c. cetane rating process
 - d. normal combustion in a combustion chamber

4. If the percentage of volatility is too high, what condition will occur?
 - a. flooding
 - b. carbon build up
 - c. gas leak
 - d. vapor lock

5. The vaporizing ability of any liquid is called its:
 - a. volatility
 - b. heptane
 - c. benzol
 - d. cetane

6. Alcohol is added to gasoline primarily to:
 - a. provide easier starting
 - b. prevent the free passage of fuel
 - c. absorb moisture
 - d. increase the volatility of the fuel

37.05.01.01. cont.

7. Liquid petroleum gas is a mixture of:
- benzol and heptane
 - butane and propane
 - butane and heptane
 - heptane and cetane
8. For maximum power and economy of operation, what content in fuel is required?
- low volatility and high heat content
 - high sulfur content and high heat content
 - low viscosity and low heat content
 - high sulfur content
9. Immediately after ignition, combustion chamber temperatures may reach a temperature of:
- 7,500 degrees
 - 2,500 degrees
 - 1,500 degrees
 - 5,500 degrees
10. What characteristic of fuel affects easy starting?
- volatility
 - lead
 - heptane
 - octane

37.05.01.02

11. Gas contamination in the gas tank is caused from:
- low octane gas
 - condensation
 - poor grades of gas
 - additives in gas
12. When the engine is first started, the choke valve:
- is closed
 - is open
 - can be either open or closed
 - is part way open
13. A fuel pump delivers fuel to the:
- cylinders.
 - air chamber
 - carburetor
 - spark plug

37.05.01.02. cont.

14. Internal baffles in a gas tank are used to:
- prevent water build-up in the gas
 - prevent sloshing of gas
 - collapse of tank from pressure
 - reinforce tank for strength
15. The two most common fuel pumps that are used are:
- mechanical and electrical
 - mechanical and ram induction
 - mechanical and gravitational
 - siphon and gravitational

37.05.01.03

16. If gas is not coming to the fuel pump very well, it could be:
- the carburetor is flooded
 - water in the gas
 - a plugged fuel filter
 - the carburetor is not drawing air properly
17. When checking the fuel line from tank to pump, you should look for leaks and check:
- for a "falt spot" in the carburetor
 - to make sure that it is insulated where it touches the frame
 - the pressure build up in the line
 - connections for tightness
18. When you are inspecting a gas tank and find a leak, you should clean it thoroughly and then:
- solder it
 - glue it
 - weld it
 - bronze it
19. When checking or making an inspection, you should:
- tell the owner when you see something wrong
 - depend on your memory
 - make sure you at least write it down on paper
 - put your results on a work order

UNIT/LAP POST TEST ANSWER KEY: FUNDAMENTALS OF FUEL SYSTEMS (C)

LAP 01

1. c
2. c
3. d
4. d
5. a
6. c
7. b
8. a
9. d
10. a

LAP 02

11. b
12. a
13. c
14. b
15. a

LAP 03

16. c
17. d
18. a
19. d

Student: _____

File Code: 37.05.01.00.B1-5

Date: _____

Date Published: 3/4/76

Family Pay Number: _____

Sex: M F (Circle 1)

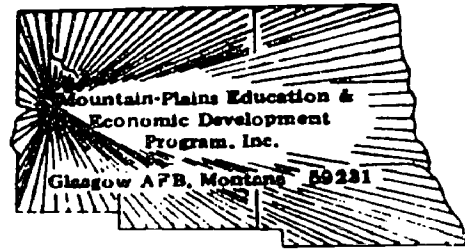

UNIT PERFORMANCE TEST: AUTOMOTIVE FUEL SYSTEMS

OBJECTIVE 1:

Test and inspect fuel system.

TASK:

The student will be assigned a vehicle on which he must inspect fuel tank, lines, filter, fuel pump, and carburetor.

ASSIGNMENT:

CONDITIONS:

The student will use only those materials provided for the test and perform the test in the auto shop.

RESOURCES:

Vehicle
Time and Parts Manual
Repair Manual
Fuel Pump Tester
Fender Covers
Jacks
Jack Stands

RESOURCES: (Cont.)

Combination Ignition wrench set
Combination Wrench Set
Standard Screwdriver Set
Phillips Screwdriver Set
Feeler gauge - .002 through .025 inch
Hex Key Set
Diagonal Cutting Pliers
Needle Nose Plier
1/4" Drive Socket Set
Ratchet - 3" and 6" extensions - 6" flex handle
Ball Peen hammer
Plastic Tip Hammer
Screw Starter
Chisel and Punch Set
5/32" Pin Punch - 3/16" Solid
Gasket scraper
3/8" Drive Ratchet
3" Extension
Spark Plug Socket
6" Extension
Speed Handle
3/8" Drive Socket Set

Student: _____

File Code: 37.05.01.00.B1-5

Date: _____

Date Published: 3/4/76

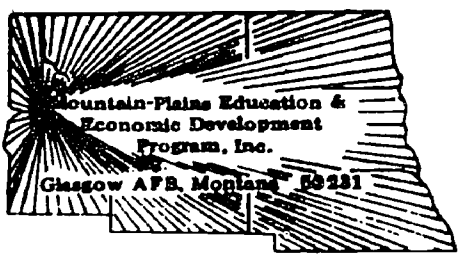

Family Pay Number: _____

Sex: M F (Circle 1)

PERFORMANCE CHECKLIST:

OVERALL PERFORMANCE: Satisfactory _____ Unsatisfactory _____

	CRITERION	
	Met	Not Met
Objective 1:		
1. Inspect tank and fuel lines.		
Criterion: No visual leaks.		
2. Inspect fuel filter.		
Criterion: Must pass flow test as per manufacturer's specifications.		
3. Test fuel pump.		
Criterion: Must meet manufacturer's specifications on flow and pressure.		
4. Test carburetor.		
Criterion: Must meet manufacturer's specifications.		
5. Complete test in allotted time.		
Criterion: Must meet flat rate on assigned vehicle.		
Must satisfactorily complete 4 out of 5 line items to pass test.		

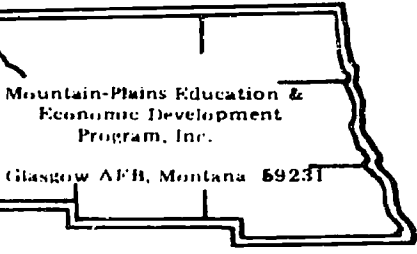

Learning Experience Guide

UNIT: FUEL LINES AND FILTERS

RATIONALE:

The fundamentals and techniques in this Unit will enable you to diagnose and replace automotive fuel lines and filters.

PREREQUISITES:

None

OBJECTIVES:

- Recognize the components and proper operation of fuel filters.
- Use proper procedure for fuel line and filter inspection and replacement.

RESOURCES:

Printed Material

Auto Service and Repair. Martin W. Stockel, Goodheart-Willcox Company, Inc.

Equipment

- Automobile with defective fuel system
- Fender covers
- Fuel filter replacement
- Tools, Basic Hand: Chisel and Punch Set
- 5/32" Pin Punch
- 3/16" Solid
- Gauge, feeler (.002" - .025")
- Hammer, ball peen
- Hammer, plastic tip
- Handle, speed
- Hex Key Set
- Pliers, diagonal cutting
- Pliers, needle nose

Scraper, gear

Principal Author(s): C. Schramm/W. Osland

Scraper, gasket
Screwdriver, standard (Set)
Screwdriver, phillips (Set)
Screw starter

Socket Set (3/8" drive)
extension (3")
ratchet

Socket Set (1/4" drive)
extension (3")
handle (6" flex)
ratchet

Socket, spark plug
extension (6")

Wrench, combination (Set)
Wrench, combination ignition (Set)

GENERAL INSTRUCTIONS:

This Unit consists of three Learning Activity Packages (LAPs). Each LAP will provide specific information for completion of a learning activity.

The general procedure for this Unit is as follows:

1. Read the first assigned Learning Activity Package (LAP).
2. Begin and complete the first assigned LAP.
3. Complete all required LAPs for the Unit.
4. In this Unit, the LAP and Unit test is combined. This combined test is taken after completing the last LAP in the Unit.
5. Take the Unit/LAP test as described in the Unit LEG "Evaluation Procedures".
6. Proceed to the next assigned unit.

PERFORMANCE ACTIVITIES:

- .01 Overview of Fundamentals
- .02 Inspection of Fuel Lines
- .03 Replacing Fuel Filters

EVALUATION PROCEDURE:

When pretesting:

1. The student takes the unit multiple-choice pretest.
2. Successful completion is 4 out of 5 items for each LAP part of the pretest.
3. The student then takes a unit performance test if the unit pretest was successfully completed.
4. Satisfactory completion of the performance test is meeting the criteria listed on the performance test.

Evaluation Procedure: continued

When post testing:

1. The student takes a multiple-choice unit post test and a unit performance test.
2. Successful unit completion is meeting the listed criteria for the performance test.

FOLLOW-THROUGH:

Go to the first assigned Learning Activity Package (LAP) listed on your Student Progress Record (SPR).

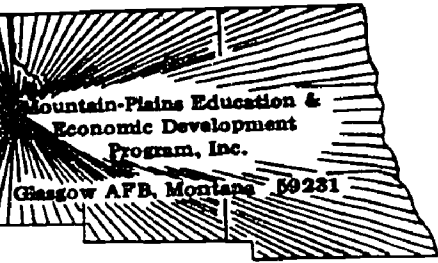

UNIT/LAP PRETEST: FUEL LINES AND FILTERS

37.05.02.01

1. On some filters, which are nonserviceable, when they plug up from dirt:
 - a. they can be taken apart and cleaned by carbon tetrachloride.
 - b. they can be cleaned by reversing them on the line.
 - c. gas bypasses the filter.
 - d. they don't pass any gas at all.
2. Filters should be cleaned:
 - a. semiannually.
 - b. annually.
 - c. never.
 - d. periodically.
3. The current trend in fuel filters is toward various:
 - a. fine meshed screens only.
 - b. china and ceramic.
 - c. porous bronze only.
 - d. disposable filters.
4. Fuel lines should not be too close to the engine for what reason?
 - a. to prevent fire.
 - b. to prevent collapse of the line.
 - c. so more air can be transferred through the line along with the gas
 - d. to prevent vapor lock.

37.05.02.02

5.

37.05.02.02 continued:

6. When inspecting fuel filters, a restricted or dirty filter can be spotted when giving:
 - a. a bleeding air test.
 - b. a hydrometer test.
 - c. a vacuum test.
 - d. a fuel flow test.

7. When you have a metal case around a filter, to inspect the fuel filter you must:
 - a. take off gently.
 - b. take a hacksaw and cut it in half.
 - c. replace with a new one.
 - d. leave it on till you have 100,000 miles on it.

8. What major precaution must be double checked after every fuel filter replacement?
 - a. that there are no leaks.
 - b. that there are more filters to change.
 - c. that there is proper ventilation.
 - d. that there is a pulsator test performed.

37.05.02.03

9. Which filter will allow fuel to be forced through it under pressure:
 - a. filter on top of the fuel pump.
 - b. on the filter from the pick-up pipe.
 - c. a porous bronze filter on the carburetor.
 - d. on the filter on the bottom of the fuel pump.

10. Fuel filters installed near a heat source can result in:
 - a. better gas mileage.
 - b. a fire.
 - c. bad gas mileage.
 - d. vapor lock.

UNIT/LAP PRETEST ANSWER KEY: FUEL LINES AND FILTERS

LAP

- | | |
|----|-------|
| 01 | 1. D |
| | 2. D |
| | 3. D |
| | 4. D |
| 02 | 5. A |
| | 6. D |
| | 7. C |
| | 8. A |
| 03 | 9. C |
| | 10. D |

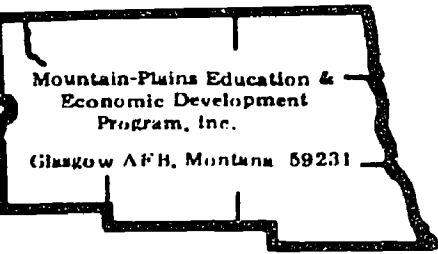

Learning Activity Package

Student: _____

Date: _____

PERFORMANCE ACTIVITY: Overview of Fundamentals

OBJECTIVE:

Recognize the parts and correct operation of the different types of fuel filters.

EVALUATION PROCEDURE:

Eight correct responses to a ten-item multiple choice objective test to be taken after LAP #37.05.02.03.

RESOURCES:

Auto Service and Repair, Stockel.

PROCEDURE:

1. Read pages 20-13 through 20-15 "Fuel Filter Service" in Auto Service and Repair.
2. Return the textbook to the proper shelf.
3. Upon satisfactory completion of this LAP, go to the next LAP.

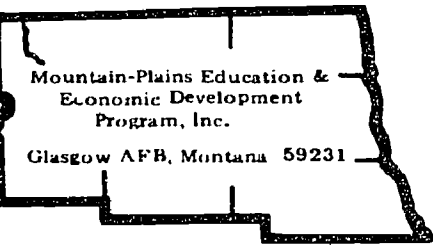

Learning Activity Package

Student: _____

Date: _____

PERFORMANCE ACTIVITY: Inspection of Fuel Filters

Objecti :
OBJECTIVE:

Recognize and use the correct procedure for inspecting the fuel filter to determine its condition.

EVALUATION PROCEDURE:

Eight correct responses to a ten-item multiple-choice objective test to be taken after completing LAP 37.05.02.03.

RESOURCES:

Auto Service and Repair, Stockel.
Motor's Auto Repair Manual.
Automobile with defective fuel system
Tools, Basic Hand: (See Unit LEG)

PROCEDURE:

NOTE: Review pages 20-13 through 20-14 in Auto Service and Repair. Refer to repair manual if necessary.

1. Locate the filter.
2. If it is made of a "see-through" material (glass, plastic) look to see if there is an over-amount of deposits which may block the fuel flow.
NOTE: Metal filter cases cannot be checked by vision.
3. Check mileage by checking the service sticker to see the date of installation and mileage.
NOTE: A gas filter should be serviced or replaced every 10,000 miles.
4. A fuel flow test of the fuel pump (LAP 37.05.03.02.B1) giving a low reading may indicate a restricted or dirty filter.
Test the fuel filter if none of the visual checks give satisfactory results. Check these results against the recommended factory results.
5. (a) Record all results on the work order. Show these results to the instructor for evaluation.
(b) Ask your instructor to then check the filter for proper installation.
6. Upon satisfactory completion of this LAP, proceed to the next LAP. The LAP test will be taken after LAP # 37.05.02.03.

Principal Author(s): W. Osland

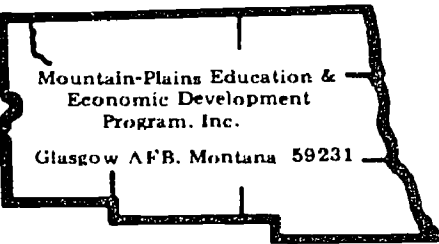

Learning Activity Package

Student: _____

Date: _____

PERFORMANCE ACTIVITY: Replacing Fuel Filters

OBJECTIVE:

Recognize and use the correct procedure for removing and replacing the fuel filter.

EVALUATION PROCEDURE:

Eight correct responses to a ten-item multiple-choice objective test.

RESOURCES:

Auto Service and Repair, Stockel.

Automobile needing fuel filter replacement

Fender covers

Tools, Basic Hand: (See Unit LEG)

PROCEDURE:

NOTE: Review pages 20-13 through 20-14 in Auto Service and Repair. Study the illustration on page 20-14.

1. Place fender covers on fenders.
2. Place container under fuel filter.
3. Remove filter clamps.
4. Remove filter.
5. To replace, put clamps loosely on fuel lines.
6. Put filter in place and slip on lines. NOTE: Make sure filter is in correct direction. Some filters have a "front" and a "back".
7. Tighten clamps.
8. Start engine and check for leaks.
9. Remove container, tools and fender covers.
10. Instructor will check to see that filter was replaced properly and that there are no leaks.
11. Take and score the LAP test.

Principal Author(s):

W. Osland

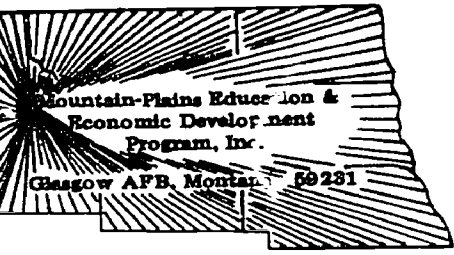

UNIT/LAP POST TEST: FUEL LINES AND FILTERS **A**

37.05.02.01

1. Filters should be cleaned:
 - a. semiannually.
 - b. annually.
 - c. periodically.
 - d. never.

2. The sintered bronze fuel filter is positioned where on almost all vehicles?
 - a. on the pick-up pipe.
 - b. on the top of the fuel pump.
 - c. on the bottom of the fuel pump.
 - d. in the carburetor.

3. How many filters are there usually from the tank to the carburetor?
 - a. 1
 - b. 3
 - c. 4
 - d. 2

4. Using high volatile gasoline during hot weather can cause:
 - a. fires, because it is highly explosive.
 - b. combustion in the gas tank.
 - c. vapor lock.
 - d. pinging of engine.

37.05.02.02

5. What major precaution must be double checked after every fuel filter replacement?
 - a. that there are no leaks.
 - b. that there is proper ventilation.
 - c. that there are more filters to change.
 - d. that there is a pulsator test performed.

37.05.02.02 continued:

6. In general, on the fuel system, how many filters or screens are there?
- a. 4 to 5
 - b. 1 to 2
 - c. 3 to 4
 - d. 2 to 3
- 7.
8. When you have a metal case around a filter, to inspect fuel filter you must:
- a. replace with a new one.
 - b. take off gently.
 - c. leave it on till you have 100,000 miles on it.
 - d., take a hacksaw and cut it in half.

37.05.02.03

9. When installing a fuel filter, it is important that you:
- a. get the heaviest filter possible.
 - b. install it in the right direction.
 - c. get a porous bronze filter.
 - d. get the thinnest filter possible.
10. Which filter will allow fuel to be forced through it under pressure:
- a. on the filter on the bottom of the fuel pump.
 - b. on the filter from the pick-up pipe.
 - c. filter on top of the fuel pump.
 - d. a porous bronze filter on the carburetor.

UNIT/LAP POST TEST ANSWER KEY: FUEL LINES AND FILTERS. A

LAP

- | | |
|----|-----------------|
| 01 | 1. C |
| | 2. D |
| | 3. D |
| | 4. C |
| 02 | 5. A |
| | 6. D |
| | 7. A |
| | 8. A |
| 03 | 9. B |
| | 10. D |

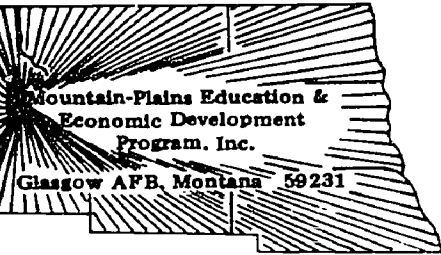

UNIT/LAP POST TEST: FUEL LINES AND FILTERS B

37.04.02.01

1. Using high volatile gasoline during hot weather can cause:
 - a. fires, because it is highly explosive
 - b. combustion in the gas tank
 - c. vapor lock
 - d. pinging of engine
2. How many filters are there usually from the tank to the carburetor?
 - a. 1
 - b. 3
 - c. 4
 - d. 2
3. The sintered bronze fuel filter is positioned where on almost all vehicles?
 - a. on the pick-up pipe
 - b. on the top of the fuel pump
 - c. on the bottom of the fuel pump
 - d. in the carburetor
4. Filters should be cleaned:
 - a. semiannually
 - b. annually
 - c. periodically
 - d. never

37.05.02.02

5. When you have a metal case around a filter, to inspect a fuel filter you must:
 - a. replace with a new one
 - b. take off gently
 - c. leave it on till you have 100,000 miles on it
 - d. take a hacksaw and cut it in half
6. In general, on the fuel system, how many filters or screens are there?
 - a. 4 to 5
 - b. 1 to 2
 - c. 3 to 4
 - d. 2 to 3

37.05.02.02

7. What major precaution must be double checked after every fuel filter replacement?
- a. that there are no leaks
 - b. that there is proper ventalation
 - c. that there are more filters to change
 - d. that there is a pulsator test performed

37.05.02.03

8. Which filter will allow fuel to be forced through it under pressure:
- a. on the filter on the bottom of the fuel pump
 - b. on the filter from the pick-up pipe.
 - c. filter on top of the fuel pump
 - d. a porous bronze filter on the carburetor
9. When installing a fuel filter, it is important that you:
- a. get the heaviest filter possible
 - b. install it in the right direction
 - c. get a porous bronze filter
 - d. get the thinnest filter possible

UNIT/LAP TEST ANSWER KEY: FUEL LINES AND FILTERS (B)

LAP 01

1. c
2. d
3. d
4. c

LAP 02

5. a
6. d
7. ~~a~~

LAP 03

8. ~~a~~
9. b

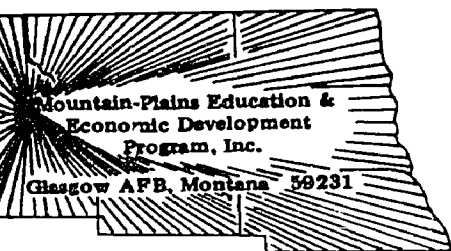

UNIT/LAP POST TEST: FUEL LINES AND FILTERS (C)

37.05.02.01

1. The sintered bronze fuel filter is positioned where on almost all vehicles?
 - a. on the pick-up pipe
 - b. on the top of the fuel pump
 - c. on the bottom of the fuel pump
 - d. in the carburetor

2. How many filters are there usually from the tank to the carburetor?
 - a. 1
 - b. 3
 - c. 4
 - d. 2

3. Using high volatile gasoline during hot weather can cause:
 - a. fires, because it is highly explosive
 - b. combustion in the gas tank
 - c. vapor lock
 - d. pinging of engine

4. Filters should be cleaned:
 - a. semiannually
 - b. annually
 - c. periodically
 - d. never

37.05.02.02

5. What major precaution must be double checked after every fuel filter replacement?
 - a. that there are no leaks
 - b. that there is proper ventalation
 - c. that there are more filters to change
 - d. that there is a pulsator test performed

6. When you have a metal case around a filter, to inspect fuel filter you must:
 - a. replace with a new one
 - b. take off gently
 - c. leave it on till you have 100,000 miles on it
 - d. take a hacksaw and cut it in half

37.05.02.02 cont.

7. In general, on the fuel system, how many filters or screens are there?
- a. 4 to 5
 - b. 1 to 2
 - c. 3 to 4
 - d. 2 to 3

37.05.02.03

8. When installing a fuel filter, it is important that you:
- a. get the heaviest filter possible
 - b. install it in the right direction
 - c. get a porous bronze filter
 - d. get the thinnest filter possible
9. Which filter will allow fuel to be forced through it under pressure:
- a. on the filter on the bottom of the fuel pump
 - b. on the filter from the pick-up pipe
 - c. filter on top of the fuel pump
 - d. a porous bronze filter on the carburetor

UNIT/LAP POST TEST ANSWER KEY: FUEL LINES AND FILTERS

LAP 01

1. D
2. D
3. C
4. C

LAP 02

5. A
6. A
7. D

LAP 03

8. B
9. D

Student: _____ File Code: 37.05.02.00.B1-5

Date: _____ Date Published: 3/4/76

Family Pay Number: _____ Sex: M F (Circle 1)

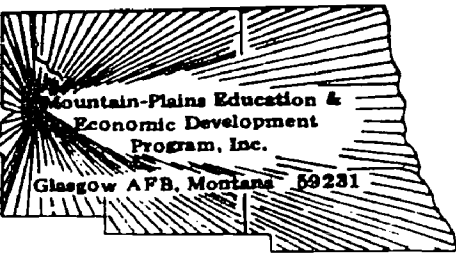

UNIT PERFORMANCE TEST: FUEL LINES AND FILTERS

OBJECTIVE 1:

Replace fuel filter and inspect lines.

TASK:

The student will be assigned a vehicle on which he must replace the fuel filter and inspect fuel lines.

ASSIGNMENT:

CONDITIONS:

The student may use only those materials provided for the test and perform the test in the auto shop.

RESOURCES:

Auto needing Filter Replacement
New Fuel Filter
Fender Covers
Drain Pan
Service Manuals
Parts and Time Guide

RESOURCES: (Cont.)

Combination Ignition wrench set
Combination Wrench Set
Standard Screwdriver Set
Phillips Screwdriver Set
Feeler gauge - .002 through .025 inch
Hex Key Set
Diagonal Cutting Pliers
Needle Nose Plier
1/4" Drive Socket Set
Ratchet - 3" and 6" extensions - 6" flex handle
Ball Peen hammer
Plastic Tip Hammer
Screw Starter
Chisel and Punch Set
5/32" Pin Punch - 3/16" Solid
Gasket scraper
3/8" Drive Ratchet
3" Extension
Spark Plug Socket
6" Extension
Speed Handle
3/8" Drive Socket Set

Student: _____

File Code: 37.05.02.00.B1-5

Date: _____

Date Published: 3/4/76

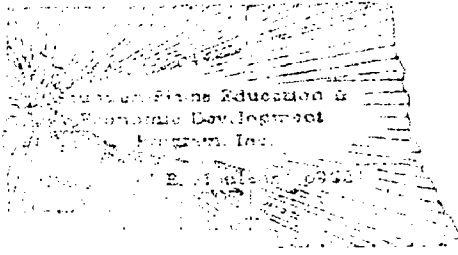

Family Pay Number: _____

Sex: M F (Circle 1)

PERFORMANCE CHECKLIST:

PERFORMANCE: Satisfactory _____ Unsatisfactory _____

	CRITERION	
	Met	Not Met
1. Replace fuel filter.		
Criterion: Must not leak and must pass manufacturer's flow test.		
2. Inspect fuel lines.		
Criterion: No leaks.		
3. Complete test in allotted time.		
Criterion: Meet flat rate on assigned vehicle.		
Not satisfactorily complete 2 out of 3 line items to pass		

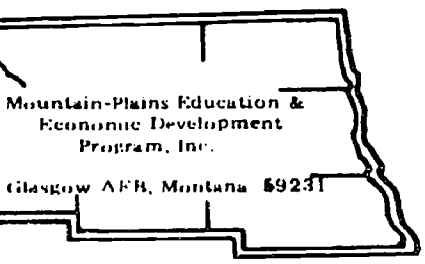

Learning Experience Guide

UNIT: FUEL PUMPS

RATIONALE:

The fundamentals and techniques in this Unit enable you to diagnose and replace automotive fuel pumps.

PREREQUISITES:

None

OBJECTIVES:

- Recognize the components of the fuel pump.
- Remove, test and replace the fuel pump.

RESOURCES:

Printed Materials

- Auto Mechanics Fundamentals. Martin W. Stockel, Goodheart-Willcox Company, Inc.
- Auto Service and Repair. Martin W. Stockel, Goodheart-Willcox Company, Inc.
- Motor's Auto Repair Manual. Motor, The Hearst Corporation. (1972 or equivalent)
- Specification Manual--Fuel Pump

Equipment

- Automobile with fuel pump to be tested and/or replaced
- Fender covers
- Fuel pump, replacement
- Gasket cement
- Push rods, replacement
- Test Equipment, fuel pump: hose
pint container
pressure gauge
- Tools, Basic Hand: Chisel and Punch Set
5/32" Pin Punch
3/16" Solid
- Gauge, feeler (.002" - .025")

Principal Author(s): C. Schramm/W. Osland

Hammer, ball peen
Hammer, plastic tip
Handle, speed
Hex Key Set

Pliers, diagonal cutting
Pliers, needle nose

Scraper, gasket
Screwdriver, standard (Set)
Screwdriver, phillips (Set)
Screw starter

Socket Set (3/8" drive)
extension (3")
ratchet

Socket Set (1/4" drive)
extension (3")
handle (6" flex)
ratchet

Socket, spark plug
extension (6")

Wrench, combination (Set)
Wrench, combination ignition (Set)

GENERAL INSTRUCTIONS:

This Unit consists of three Learning Activity Packages (LAPs). Each LAP will provide specific information for completion of a learning activity.

The general procedure for this Unit is as follows:

- (1) Read the first assigned Learning Activity Package (LAP).
- (2) Begin and complete the first assigned LAP.
- (3) Take and score the LAP test.
- (4) Turn in the LAP test answer sheet.
- (5) Determine the reason for any missed items on the LAP test.
- (6) Proceed to and complete the next assigned LAP in the unit.
- (7) Complete all required LAPs for the unit by following steps 3 through 6.
- (8) In this Unit, there are some LAPs that have tests combined with other LAP tests. These combined tests are taken after completing the last LAP covered by the test.
- (9) Take the unit tests as described in the Unit LEG "Evaluation Procedures".
- (10) Proceed to the next assigned unit.

PERFORMANCE ACTIVITIES:

- .01 Overview of Fundamentals
- .02 Testing a Fuel Pump
- .03 Replacement of Fuel Pump

EVALUATION PROCEDURE:

When pretesting:

1. The student takes the unit multiple-choice pretest.
2. Successful completion is 4 out of 5 items for each LAP part of the pretest.
3. The student then takes a unit performance test if the unit pretest was successfully completed.
4. Satisfactory completion of the performance test is meeting the criteria listed on the performance test.

When post testing:

1. The student takes a multiple-choice unit post test and a unit performance test.
2. Successful unit completion is meeting the listed criteria for the performance test.

FOLLOW-THROUGH:

Go to the first assigned Learning Activity Package (LAP) listed on your Student Progress Record (SPR).

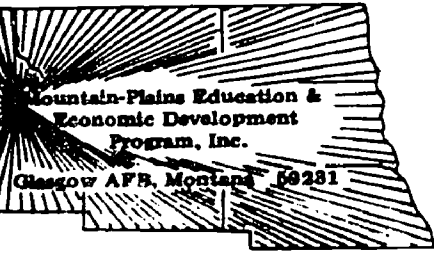

UNIT PRETEST: FUEL PUMPS

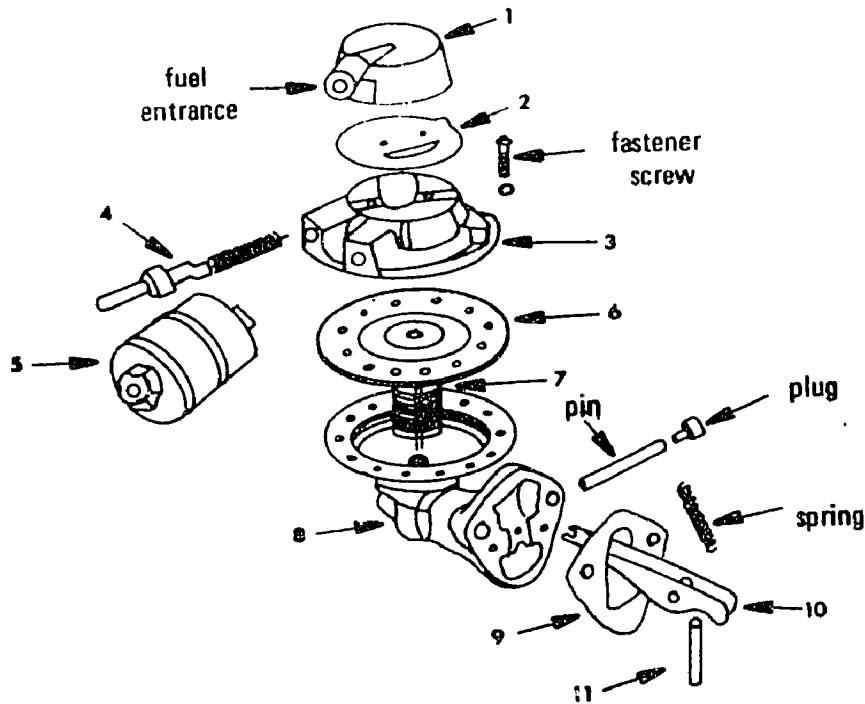
37.05.03.01 .

1. In the diagram^{*} above, number 5 is:
 - a. fuel filter.
 - b. fuel outlet valve.
 - c. vapor return valve.
 - d. fuel inlet valve.

2. In the diagram above, number 11 is operated by the:
 - a. fan belt.
 - b. timing gear.
 - c. camshaft.
 - d. crankshaft.

^{*}(From Auto Mechanics Fundamentals,
 Stockel, Goodheart-Willcox, 1974
 p. 120. Fig. 6-134.)

37.05.03.01 continued:

3. In the diagram number 8 is the:
- roller pin housing.
 - small casting.
 - lower housing.
 - valve body.
4. In the diagram number 10 is the:
- rocker arm.
 - rod assembly unit.
 - push rod assembly.
 - roller pin assembly.
5. In the diagram number 6 is the:
- pulsator diaphragm.
 - vapor return valve.
 - diaphragm.
 - fuel filter.

37.05.03.02

6. What is the average vacuum developed by a vacuum pump that is built into a fuel pump?
- 7-1/2 inches.
 - 18 inches.
 - 5 inches.
 - 10 inches.
7. When you pump gas into a pint container to measure how long it takes, it is called what kind of a test?
- a pressure test.
 - a capacity test.
 - a vacuum test.
 - a discharge test.

37.05.03.02 continued:

8. How much pressure should the conventional mechanical type fuel pump develop?
- a. 5 lbs.
 - b. 10 lbs.
 - c. 15 lbs.
 - d. 8 lbs.
9. For what purpose is the vacuum pump built into some types of fuel pumps?
- a. to operate the windshield wipers.
 - b. to operate the pistons in automatic chokes.
 - c. to cause the outlet valve to close.
 - d. to aid in pumping fuel.
10. What is the cause of excessive fuel pump pressure on a mechanical type fuel pump?
- a. insufficient flexing of the diaphragm.
 - b. clogged fuel cleaners.
 - c. clogged line to the fuel supply tank.
 - d. too much flexing of the diaphragm.

37.05.03.03

11.

12. After installing a new pump, you should test it for:
- a. cam clearance.
 - b. pinched lines.
 - c. leaks and warpage.
 - d. pressure and volume.

37.05.03.03 continued:

13. When attaching fuel lines, it is important that you:
- use a box-end wrench.
 - get them as tight as you can.
 - use an adjustable wrench.
 - start with fingers.
14. When installing a fuel pump, you should be sure the cam or eccentric bears against the:
- rocker arm **contact**.
 - pull rod.
 - valve housing.
 - diaphragm.
- 15.

UNIT PRETEST ANSWER KEY: FUEL PUMPS

LAP

- | | |
|----|-------|
| 01 | 1. A |
| | 2. C |
| | 3. C |
| | 4. A |
| | 5. C |
| 02 | 6. D |
| | 7. B |
| | 8. A |
| | 9. A |
| | 10. A |
| 03 | 11. A |
| | 12. D |
| | 13. D |
| | 14. A |
| | 15. A |

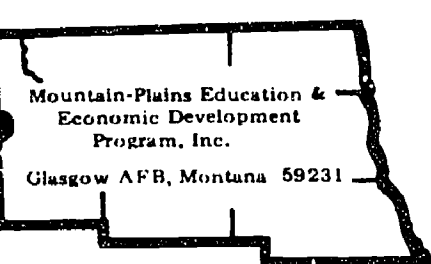

Learning Activity Package

Student: _____

Date: _____

PERFORMANCE ACTIVITY: Overview of Fundamentals

OBJECTIVES:

Identify the parts of the fuel pump and recognize how they are essential to the operation of the fuel pump.

EVALUATION PROCEDURE:

Correctly answer LAP study questions.
Eight correct responses to a ten-item multiple-choice objective test.

RESOURCES:

Auto Mechanics Fundamentals, Stockel.

PROCEDURE:

1. Do the following assignments using Auto Mechanics Fundamentals:
 - a. Read Chapter 6, "How Gas Leaves The Gasoline Tank," pages 121-126.
 - b. Answer quiz questions 4, 5, 6, 7 and 8 on page 156 on a separate sheet of paper.
2. Return the textbook to the proper shelf.
3. Return your answer sheet to the instructor.
4. Take and score the LAP test.
5. Upon satisfactory completion, go to the next LAP.

Principal Author(s):

W. Osland

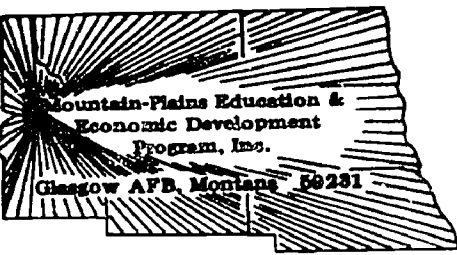

LAP TEST: OVERVIEW OF FUNDAMENTALS

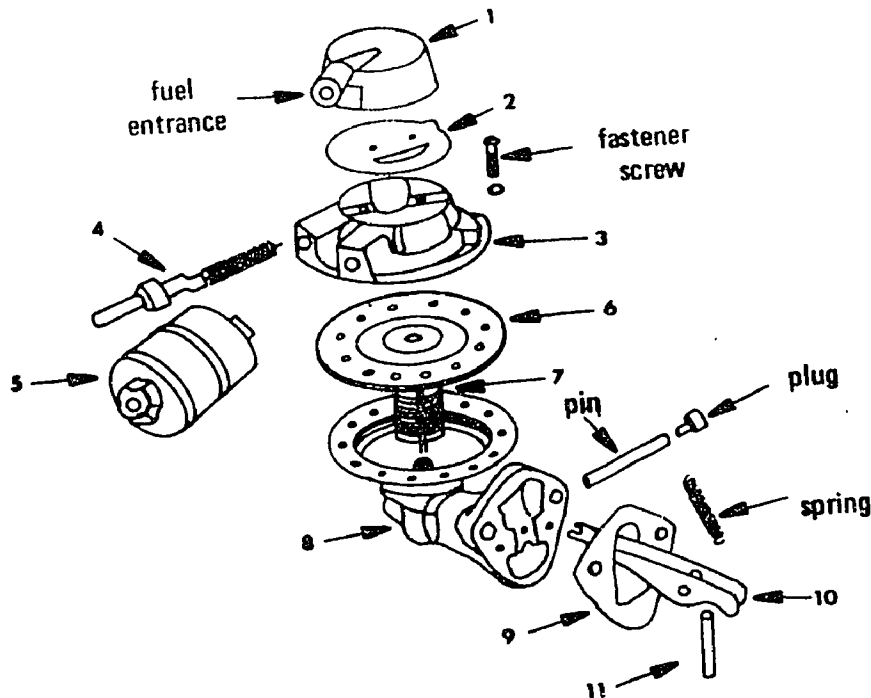

1. In the diagram ^{*} number 11 is operated by the:
 - a. camshaft.
 - b. crankshaft.
 - c. fan belt.
 - d. timing gear.

2. Fuel pump repair kits are of two basic types; one is a complete repair kit and the other is:
 - a. a pin, bushing kit.
 - b. a rocker arm kit.
 - c. a gasket kit.
 - d. a diaphragm kit.

^{*}(From Auto Mechanics Fundamentals,
Stockel, Goodheart-Willcox, 1974
p. 120, Fig. 6-134.)

3. In the diagram number 5 is:
 - a. fuel inlet valve.
 - b. vapor return valve.
 - c. fuel filter.
 - d. fuel outlet valve.

4. In the diagram number 6 is the:
 - a. diaphragm.
 - b. fuel filter.
 - c. pulsator diaphragm.
 - d. vapor return valve.

5. Vapor lock in a car can be caused from:
 - a. lines too short.
 - b. lines too close to the exhaust manifold.
 - c. lines too long.
 - d. lines too close to the intake manifold.

6. In the diagram what is number 1?
 - a. filter.
 - b. top cover.
 - c. fuel inlet valve.
 - d. valve body.

7. In the diagram number 9 is:
 - a. the upper fuel filter.
 - b. a gasket.
 - c. the pulsator diaphragm.
 - d. the lower fuel filter.

8. In the diagram number 8 is the:
 - a. side housing.
 - b. lower housing.
 - c. roller pin housing.
 - d. valve body.

9. In the diagram number 2 is the:
- a. pulsator diaphragm.
 - b. filter.
 - c. butterfly valve.
 - d. vacuum diaphragm.
10. In the diagram number 3 is the:
- a. valve body.
 - b. intake jet.
 - c. jet system.
 - d. vacuum diaphragm.

LAP TEST ANSWER KEY: OVERVIEW OF FUNDAMENTALS

1. A
2. D
3. C
4. A
5. B
6. B
7. B
8. B
9. A
10. A

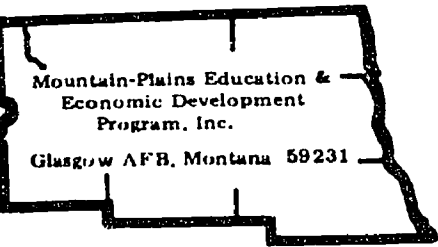

Learning Activity Package

Student: _____

Date: _____

PERFORMANCE ACTIVITY: Testing A Fuel Pump

OBJECTIVE:

Recognize and use the correct procedure for testing the fuel pump for pressure and volume.

EVALUATION PROCEDURE:

Eight correct responses to a ten-item multiple-choice objective test to be taken after completing LAP 37.05.03.03.

RESOURCES:

Auto Service and Repair, Stockel.
Motor's Auto Repair Manual.

Automobile assigned to you
 Fender covers

Testing equipment: hose
 pint container
 pressure gauge

Tools, Basic Hand: (See Unit LEG)

PROCEDURE:

NOTE: Read pages 20-3 through 20-3 in Auto Service and Repair. Refer to the repair manual if necessary.

1. Place fender covers on fenders.
2. Look up specifications for engine being tested and record pressure and volume.
3. Disconnect the fuel line at the carburetor inlet.
 NOTE: Use two wrenches -- one on fitting on carburetor and other on line fitting.
4. Attach pressure gauge and hose between the carburetor inlet and the disconnected fuel pipe.
5. Start engine and take the pressure reading with the engine running.
6. Stop the engine and note the pressure reading.
 NOTE: Pressure should remain constant or return very slowly to zero.
7. Check the pressure against the figures you listed on procedure number two.
8. Connect the hose so that the pump will deliver gasoline into the pint container.
 NOTE: The container should be held at carburetor level.

Principal Author(s): W. Osland

9. Start engine and run at idle RPM.
CAUTION: Be careful not to spill gasoline.
10. Note the time it takes to fill the pint container .
11. Turn the engine off.
12. Check the volume figures against the specifications you listed in procedure number two.
13. Replace pump if either tests were below specifications .
14. Disconnect pressure gauge.
15. Install the fuel line fittings with your fingers , hand tight.
NOTE: If you try to start the fittings with a wrench, you may strip the threads.
16. Tighten fittings with flare nut wrenches .
17. Start engine and check for leaks .
18. Stop engine .
19. Remove tools , equipment and fender covers . Put them away .
20. Have instructor check your work order .
21. Upon completion of LAP, proceed to the next LAP. The LAP test will be taken after the LAP 37.05.03.03.

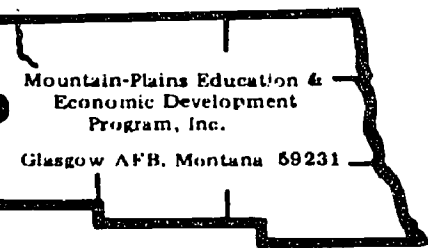

Learning Activity Package

Student: _____

Date: _____

PERFORMANCE ACTIVITY: Replacement of Fuel Pump

OBJECTIVE:

Recognize and use the correct procedure for removing and replacing fuel pump.

EVALUATION PROCEDURE:

Eight correct responses to a ten-item multiple-choice objective test.

RESOURCES:

Auto Service and Repair, Stockel.
 Specification's Manual--Fuel Pump
 Automobile needing a new fuel pump installed
 Fuel pump
 Fender covers
 Gasket cement
 Tools, Basic Hand: (See Unit LEG)

PROCEDURE:

NOTE: Read page 20-13 in Auto Service and Repair. Refer to the specification manual for fuel pump if necessary.

1. Place fender covers on fenders.
2. Remove pump heat shield if so equipped.
3. Disconnect vacuum lines if a double action pump.
4. Disconnect fuel lines.
 NOTE: Use two wrenches, one for holding the fitting next to the pump and one for turning the fuel line fitting.
5. Remove the nut or cap screws that hold the pump to the block.
6. Remove the fuel pump.
 NOTE: If pump is activated by a push rod, remove rod and measure it. Compare length with specifications. Replace push rod if it is shorter than recommended.
7. Clean block surface and fuel pump.

Principal Author(s): W. Osland

8. Cement gasket in place and install pump.
NOTE: If the pump will not fit flat against the block rotate the engine until the cam eccentric is down.
9. Tighten cap screws of bolts evenly.
10. Install the fuel line fittings with your fingers hand tight.
NOTE: If you try to start the fittings with a wrench, you may strip the threads.
11. Install vacuum pump lines.
NOTE; Be sure lines are attached to correct fittings.
12. Tighten all fittings with flare-nut wrench.
13. Start engine and check for leaks.
14. Remove tools and fender covers.
15. The instructor will check completed work for proper installation of the fuel pump.
16. Take and score the LAP test.

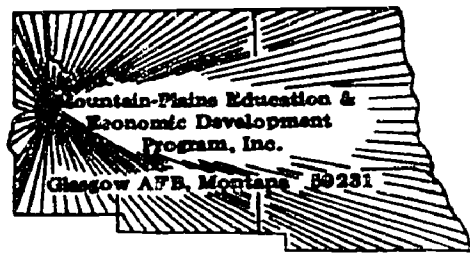

LAP TEST: TESTING AND REPLACEMENT OF FUEL PUMP

37.05.03.02

1. What is the average vacuum developed by a vacuum pump that is built into a fuel pump?
 - a. 10 inches.
 - b. 18 inches.
 - c. 7-1/2 inches.
 - d. 5 inches.

2. For what purpose is the vacuum built into some types of fuel pumps?
 - a. to cause the outlet valve to close.
 - b. to operate the pistons in automatic chokes.
 - c. to operate the windshield wipers.
 - d. to aid in pumping fuel.

3. What is the cause of excessive fuel pump pressure on a mechanical type fuel pump?
 - a. clogged fuel cleaners.
 - b. too much flexing of the diaphragm.
 - c. clogged line to the fuel supply tank.
 - d. insufficient flexing of the diaphragm.

4. How much pressure should the conventional mechanical type fuel pump develop?
 - a. 10 lbs.
 - b. 8 lbs.
 - c. 5 lbs.
 - d. 15 lbs.

5. When you pump gas into a pint container to measure how long it takes, it is called what kind of a test?
 - a. a discharge test.
 - b. a pressure test.
 - c. a vacuum test.
 - d. a capacity test.

37.05.03.03

6. When replacing a fuel pump, you should always replace what gasket?
 - a. pulsator gasket.
 - b. head gasket.
 - c. diaphragm gasket.
 - d. mounting.

7. When attaching fuel lines, it is important that you:
 - a. use an adjustable wrench.
 - b. get them as tight as you can.
 - c. start with fingers.
 - d. use a box-end wrench.

8. After installing a new pump, you should test it for:
 - a. warpage.
 - b. cam clearance.
 - c. pressure and volume.
 - d. pinched lines.

9. When installing a fuel pump, you should be sure the cam or eccentric bears against the:
 - a. pull rod.
 - b. diaphragm.
 - c. rocker arm contact.
 - d. valve housing.

- 10.

LAP TEST ANSWER KEY: TESTING AND REPLACEMENT OF FUEL
PUMP

LAP

- 02 1. A
 2. C
 3. D
 4. C
 5. D
- 03 6. D
 7. C
 8. C
 9. C
~~10. A~~

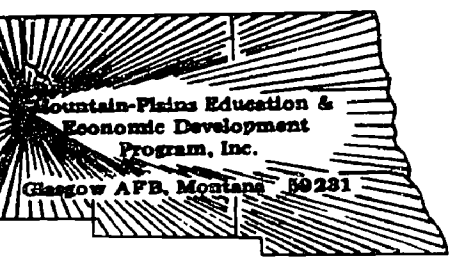

UNIT POST TEST: FUEL PUMPS *A*

37.05.03.01

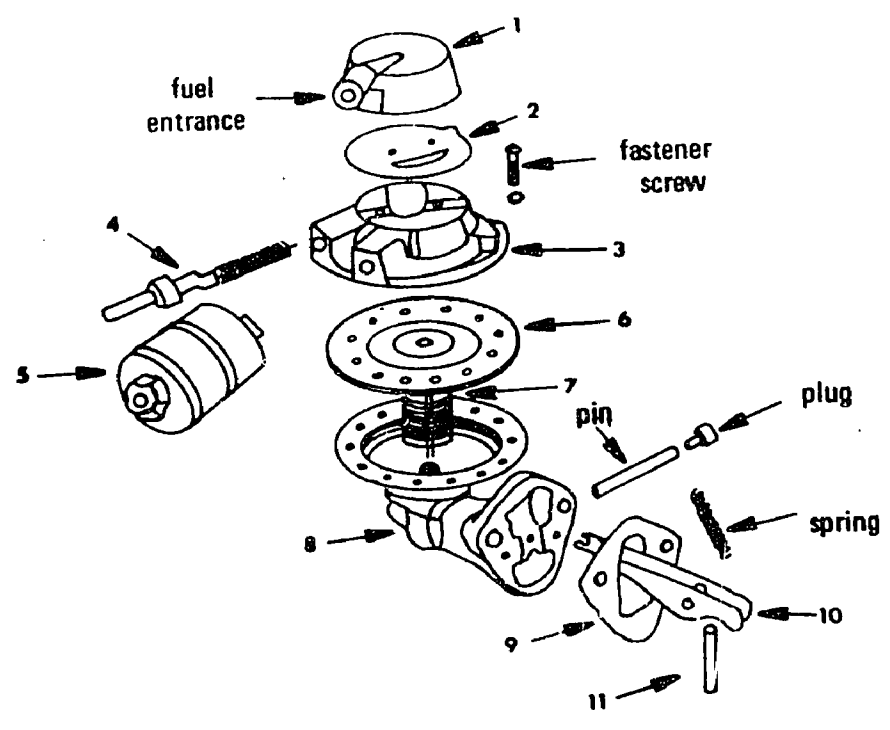

1. In the diagram* above, number 7 is the:
 - a. pulsator diaphragm return spring.
 - b. vacuum diaphragm spring.
 - c. vapor return valve spring.
 - d. push rod return spring.

2. In the diagram above, number 3 is the:
 - a. vacuum diaphragm.
 - b. valve body.
 - c. intake jet.
 - d. jet system.

* (From Auto Mechanics Fundamentals, Stockel, Goodheart-Wilkcox, 1974 p. 120, Fig. 6-134.)

37.05.03.01 continued:

3. In the diagram number 10 is the:
- rocker arm.
 - push rod assembly.
 - roller pin assembly.
 - rod assembly unit.
4. Vapor lock in a car can be caused from:
- lines too long.
 - lines too close to the intake manifold.
 - lines too close to the exhaust manifold.
 - lines too short.
5. In the diagram number 2 is the:
- vacuum diaphragm.
 - pulsator diaphragm.
 - butterfly valve.
 - filter.

37.05.03.02

6. In 45 seconds, how much fuel should be pumped by the average mechanical type of fuel pump?
- 3 pints.
 - 2 pints.
 - 32 ounces.
 - 1 pint.
7. For what purpose is the vacuum pump built into some types of fuel pumps?
- to operate the windshield wipers.
 - to operate the pistons in automatic chokes.
 - to cause the outlet valve to close.
 - to aid in pumping fuel.
8. You can test the vacuum of a pump without a gauge by using what instead?
- the size of your camshaft.
 - the compression in your pistons.
 - the windshield wipers.
 - the size of your crankshaft.

37.05.03.02 . continued:

9. What is the average vacuum developed by a vacuum pump that is built into a fuel pump?
- 10 inches.
 - 7-1/2 inches.
 - 18 inches.
 - 5 inches.
10. When you pump gas into a pint container to measure how long it takes, it is called what kind of a test?
- a capacity test.
 - a pressure test.
 - a vacuum test.
 - a discharge test.

37.05.03.03.

11. When replacing a fuel pump, you should always replace what gasket?
- mounting.
 - diaphragm gasket.
 - head gasket.
 - pulsator gasket.
12. When removing a fuel pump with the lines already disconnected, it must be removed with caution:
- to prevent fuel loss.
 - so you don't bend the lines.
 - so you won't start a fire from the battery.
 - to prevent dirt entering the system.
13. When installing a fuel pump, you should be sure the cam or eccentric bears against the:
- pull rod.
 - valve housing.
 - rocker arm contact.
 - diaphragm.

37.05.03.03 continued:

14.

15. When attaching fuel lines, it is important that you:

- a. use an adjustable wrench.
- b. start with fingers.
- c. use a box-end wrench.
- d. get them as tight as you can.

UNIT POST TEST ANSWER KEY: FUEL PUMPS

LAP

- 01 1. B
 2. B
 3. A
 4. C
 5. B
- 02 6. D
 7. A
 8. C
 9. A
 10. A
- 03 11. A
 12. D
 13. C
 ~~14. B~~
 15. B

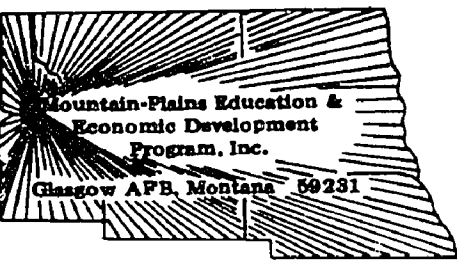

UNIT POST TEST: FUEL PUMPS (B)

37.05.03.01

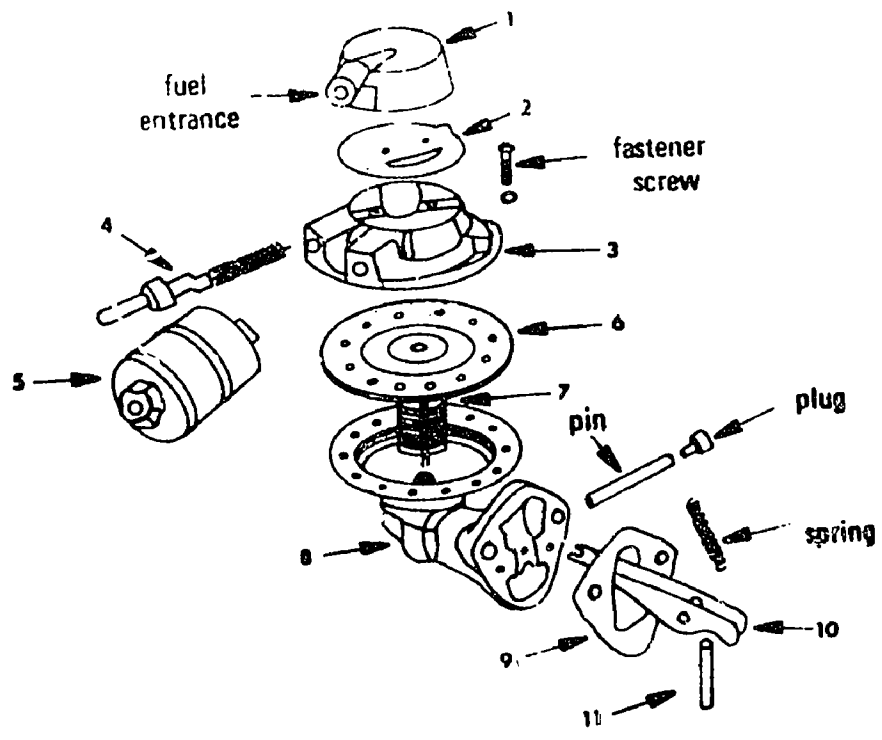

1. In the diagram number 2 is the:
 - a. vacuum diaphragm
 - b. pulsator diaphragm
 - c. butterfly valve
 - d. filter

2. Vapor lock in a car can be caused from:
 - a. lines too long
 - b. lines too close to the intake manifold
 - c. lines too close to the exhaust manifold
 - d. lines too short

* (From Auto Mechanics Fundamentals, Stockel, Goodheart-Wilcox, 1969 p. 120, Fig. 6-134)

37.05.03.01 cont.

3. In the diagram number 10 is the:
- rocker arm
 - push rod assembly
 - roller pin assembly
 - rod assembly unit
4. In the diagram above, number 3 is the:
- vacuum diaphragm
 - valve body
 - intake jet
 - jet system
5. In the diagram number 7 is the:
- pulsator diaphragm return spring
 - vacuum diaphragm spring
 - vapor return valve spring
 - push rod return spring

37.05.03.02

6. When you pump gas into a pint container to measure how long it takes, it is called what kind of a test?
- a capacity test
 - a pressure test
 - a vacuum test
 - a discharge test
7. What is the average vacuum developed by a vacuum pump that is built into a fuel pump?
- 10 inches
 - 7-1/2 inches
 - 18 inches
 - 5 inches
8. You can test the vacuum of a pump without a gauge by using what instead?
- the size of your camshaft
 - the compression in your pistons
 - the windshield wipers
 - the size of your crankshaft

37.05.03.02 cont.

9. For what purpose is the vacuum pump built into some types of fuel pumps?
- to operate the windsheild wipers
 - to operate the pistons in automatic chokes
 - to cause the outlet valve to close
 - to aid in pumping fuel
10. In 45 seconds, how much fuel should be pumped by the average mechanical type of fuel pump?
- 3 pints
 - 2 pints
 - 32 ounces
 - 1 pint

37.05.03.03

11. When attaching fuel lines, it is important that you:
- use an adjustable wrench
 - start with fingers
 - use a box-end wrench
 - get them as tight as you can
12. When installing a fuel pump, you should be sure the cam or eccentric bears against the:
- pull rod
 - valve housing
 - rocker arm contact
 - diaphragm
13. When removing a fuel pump with the lines already disconnected, it must be removed with caution:
- to prevent fuel loss
 - so you don't bend the lines
 - so you won't start a fire from the battery
 - to prevent dirt entering the system
14. When replacing a fuel pump, you should always replace what gasket?
- mounting
 - diaphragm gasket
 - head gasket
 - pulsator gasket

UNIT POST TEST ANSWER KEY: FUEL PUMPS

LAP 01

1. B
2. C
3. A
4. B
5. B

LAP 02

6. A
7. A
8. C
9. A
10. D

LAP 03

11. B
12. C
13. D
14. A

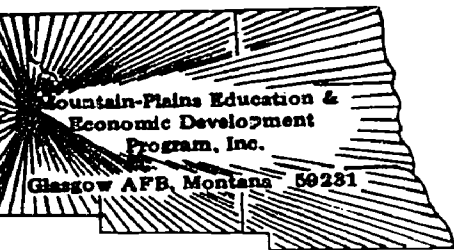

UNIT POST TEST: FUEL PUMPS (C)

37.05.03.01

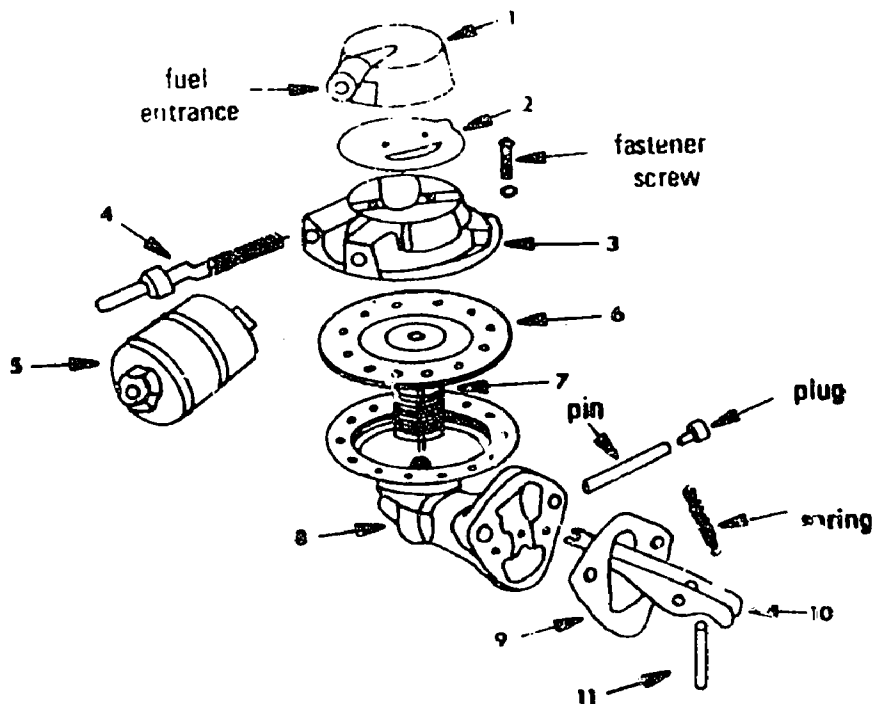

1. In the diagram number 10 is the:
 - a. rocker arm
 - b. push rod assembly
 - c. roller pin assembly
 - d. rod assembly unit

2. In the diagram* above, number 7 is the:
 - a. pulsator diaphragm return spring
 - b. vacuum diaphragm spring
 - c. vapor return valve spring
 - d. push rod return spring

* (From Auto Mechanics Fundamentals, Stockel, Goodheart-Wilcox, 1969, p. 120, Fig. 6-134.)

37.05.03.01 cont.

3. In the diagram number 2 is the:
 - a. vacuum diaphragm
 - b. pulsator diaphragm
 - c. butterfly valve
 - d. filter

4. Vapor lock in a car can be caused from:
 - a. lines too long
 - b. lines too close to the intake manifold
 - c. lines too close to the exhaust manifold
 - d. lines too short

5. In the diagram above, number 3 is the:
 - a. vacuum diaphragm
 - b. valve body
 - c. intake jet
 - d. jet system

37.05.03.02

6. In 45 seconds, how much fuel should be pumped by the average mechanical type of fuel pump?
 - a. 3 pints
 - b. 2 pints
 - c. 32 ounces
 - d. 1 pint

7. When you pump gas into a pint container to measure how long it takes, it is called what kind of a test?
 - a. a capacity test
 - b. a pressure test
 - c. a vacuum test
 - d. a discharge test

8. What is the average vacuum developed by a vacuum pump that is built into a fuel pump?
 - a. 10 inches
 - b. 7-1/2 inches
 - c. 18 inches
 - d. 5 inches

37.05.03.02 cont.

9. You can test the vacuum of a pump without a gauge by using what instead?
- the size of your camshaft
 - the compression in your pistons
 - the windshield wipers
 - the size of your crankshaft
10. For what purpose is the vacuum pump built into some types of fuel pumps?
- to operate the windshield wipers
 - to operate the pistons in automatic chokes
 - to cause the outlet valve to close
 - to aid in pumping fuel

37.05.03.03

11. When replacing a fuel pump, you should always replace what gasket?
- mounting
 - diaphragm gasket
 - head gasket
 - pulsator gasket
12. When attaching fuel lines, it is important that you:
- use an adjustable wrench
 - start with fingers
 - use a box-end wrench
 - get them as tight as you can
13. When installing a fuel pump, you should be sure the cam or eccentric bears against the:
- pull rod
 - valve housing
 - rocker arm contact
 - diaphragm
14. When removing a fuel pump with the lines already disconnected, it must be removed with caution:
- to prevent fuel loss
 - so you don't bend the lines
 - so you won't start a fire from the battery
 - to prevent dirt entering the system

UNIT POST TEST ANSWER KEY: FUEL PUMPS (C)

LAP 01

1. a
2. b
3. b
4. c
5. b

LAP 02

6. d
7. a
8. a
9. c
10. a

LAP 03

11. a
12. b
13. c
14. d

Student: _____ File Code: 37.05.03.00.B1-5

Date: _____ Date Published: 3/4/76

Family Pay Number: _____ Sex: M F (Circle 1)

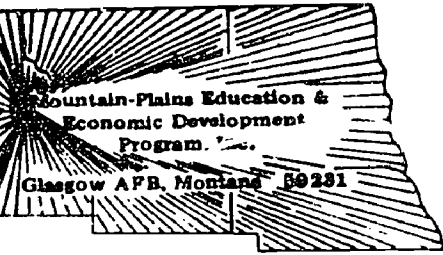

UNIT PERFORMANCE TEST: FUEL PUMPS

OBJECTIVE 1:

Replace fuel pump.

TASK:

The student will be assigned a vehicle on which he must replace the fuel pump.

ASSIGNMENT:

CONDITIONS:

The student may use only those materials provided for the test and perform the test in the auto shop.

RESOURCES:

New Fuel Pump
Car needing pump replacement
Fender covers
Fuel Pump Tester

RESOURCES: (Cont.)

Combination Ignition wrench set
Combination Wrench Set
Standard Screwdriver Set
Phillips Screwdriver Set
Feeler gauge - .002 through .025 inch
Hex Key Set
Diagonal Cutting Pliers
Needle Nose Plier
1/4" Drive Socket Set
Ratchet - 3" and 6" extensions - 6" flex handle
Ball Peen hammer
Plastic Tip Hammer
Screw Starter
Chisel and Punch Set
5/32" Pin Punch - 3/16" Solid
Gasket scraper
3/8" Drive Ratchet
3" Extension
Spark Plug Socket
6" Extension
Speed Handle
3/8" Drive Socket Set

Student: _____

File Code: 37.05.03.00.B1-5

Date: _____

Date Published: 3/4/76

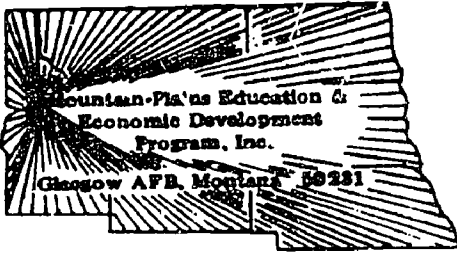

Family Pay Number: _____

Sex: M F (Circle 1)

PERFORMANCE CHECKLIST:

OVERALL PERFORMANCE: Satisfactory _____ Unsatisfactory _____

CRITERION
Met Not Met

	Met	Not Met
Objective 1:		
1. Test old fuel pump.		
Criterion: Compares to manufacturer's specifications.		
2. Replace fuel pump.		
Criterion: Follows service manual procedures and pump works with no leaks.		
3. Test new fuel pump.		
Criterion: Must meet manufacturer's specifications.		
4. Complete test in allotted time.		
Criterion: Meet flat rate on assigned vehicle.		
Must satisfactorily complete 3 out of 4 line items to pass test.		

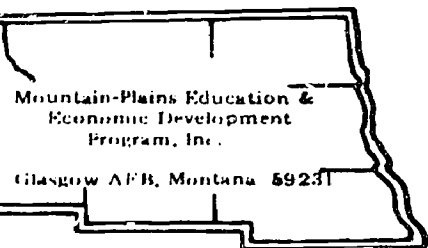

Learning Experience Guide

UNIT: CARBURETORS

RATIONALE:

Most engines run by the use of a carburetor which supplies fuel (fuel injection is another system). It is vital to know the theory and operation of the carburetor.

PREREQUISITES:

Units: .01 Fundamentals of Fuel Systems
 .02 Fuel Pump
 .03 Fuel Lines and Filters

OBJECTIVE:

Diagnose and repair carburetors.

RESOURCES:

Printed Materials

Auto Service and Repair. Martin W. Stockel, Goodheart-Willcox Company, Inc.
Auto Mechanics Fundamentals. Martin W. Stockel, Goodheart-Willcox Company, Inc.
Motor's Auto Repair Manual. Motor, The Hearst Corporation. (1972 or equivalent)

Equipment

Adapter

Automobile needing engine idle adjustment - dash pot

Automobile needing engine idle adjustment - mechanical stop

Butcher paper

Carburetors and repair kits: dual barrel
 four barrel
 quadrajet
 single throat
 thermoquad

Principal Author(s):

W. Osland

Resources: Equipment continued

Carburetor cleaner

Compressed air

Fender covers

Projector, AVT System Super 8 mm Instant Film Loop Player

Replacement parts as needed

Tachometer

Tools, Basic Hand: Chisel and Punch Set

5/32" Pin Punch

3/16" Solid

Gauge, feeler (.002" - .025")

Hammer, ball peen

Hammer, plastic tip

Handle, speed

Hex Key Set

Pliers, diagonal cutting

Pliers, needle nose

Scraper, gasket

Screwdriver, standard (Set)

Screwdriver, phillips (Set)

Screw starter

Socket Set (3/8" drive)

extension (3")

ratchet

Socket Set (1/4" drive)

extension (3")

handle (6" flex)

ratchet

Socket, spark plug

extension (6")

Wrench, combination (Set)

Wrench, combination ignition (Set)

Tray

Wire basket

Vacuum gauge and adapter fitting

GENERAL INSTRUCTIONS:

This Unit consists of ten Learning Activity Packages (LAPs). Each LAP will provide specific information for completion of a learning activity.

The general procedure for this Unit is as follows:

- (1) Read the first assigned Learning Activity Package (LAP).
- (2) Begin and complete the first assigned LAP.
- (3) Take and score the LAP test.

General Procedure: continued

- (4) Turn in the LAP test answer sheet.
- (5) Determine the reason for any missed items on the LAP test.
- (6) Proceed to and complete the next assigned LAP in the unit.
- (7) Complete all required LAPs for the unit by following steps 3 through 6.
- (8) In this Unit, there are some LAPs that have tests combined with other LAP tests. These combined tests are taken after completing the last LAP covered by the test.
- (9) Take the unit tests as described in the Unit LEG "Evaluation Procedures".
- (10) Proceed to the next assigned unit.

PERFORMANCE ACTIVITIES:

- .01 Fundamentals of the Carburetor
- .02 Overhaul of Single Barrel Carburetor
- .03 Overhaul of 2 Barrel Carburetor
- .04 Overhaul of 4 Barrel Carburetor
- .05 **Overhaul of Quadrajet Carburetor**
- .06 Overhaul of Thermoquad Carburetor
- .07 Replacement of Carburetor and Gasket
- .08 Adjustment of Fuel Air Mixture
- .09 Idle Adjustment - Dash Pot
- .10 Idle Adjustment - Mechanical Stop

EVALUATION PROCEDURE:

When pretesting:

1. The student takes the unit multiple-choice pretest.
2. Successful completion is 4 out of 5 items for each LAP part of the pretest.
3. The student then takes a unit performance test if the unit pretest was successfully completed.
4. Satisfactory completion of the performance test is meeting the criteria listed on the performance test.

When post testing:

1. The student takes a multiple-choice unit post test and a unit performance test.
2. Successful unit completion is meeting the listed criteria for the performance test.

FOLLOW-THROUGH:

Go to the first assigned Learning Activity Package (LAP) listed on your Student Progress Record (SPR).

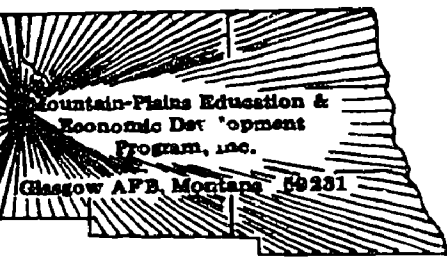

UNIT PRETEST: CARBURETORS

37.05.04.01

1. When the engine is warming up, it is necessary to idle the engine somewhat faster to prevent stalling. This is accomplished by connecting the choke shaft to the:
 - a. choke piston cylinder.
 - b. engine manifold vacuum.
 - c. fast idle cam.
 - d. choke stove tube.

- 2.

3. When the throttle valve is thrown open, the engine will seem to die; this is a:
 - a. plugged main jet.
 - b. plugged fuel line.
 - c. plugged main inlet valve.
 - d. flat spot.

4. In the offset choke valve, what closes it?
 - a. the vacuum piston.
 - b. the throttle linkage.
 - c. air entering the carburetor.
 - d. the cold thermostatic coil.

5. The slow down device placed on the carburetor for when the throttle is suddenly returned to idle is called a(n):
 - a. reduction diaphragm.
 - b. idle speed-up air passage.
 - c. hot idle compensator.
 - d. dashpot.

37.05.04.02

6. A single-barrel carburetor has how many air-mixture screws?
- 2
 - 4
 - 3
 - 1
7. Whenever it becomes necessary to dismantle a carburetor be sure to account for what parts that are found under pump plungers?
- gaskets.
 - guides.
 - seals.
 - ball checks.

37.05.04.03

8. A two-barreled carburetor has how many outlets to the intake manifold?
- 5
 - 2
 - 4
 - 0
9. To prevent damage to throttle plates or valves you should:
- attach repair legs to carburetor.
 - put carburetor on cardboard or something soft.
 - mount on a board.
 - put carburetor on a towel.

37.05.04.04

10. Prior to taking off a carburetor, you should:
- disconnect battery cable.
 - order carburetor repair kit.
 - disconnect intake manifold.
 - remove surface dirt.

37.05.04.04 . continued:

11. The four-barrel carburetor is divided into how many sides?
- a. 8
 - b. 2
 - c. 6
 - d. 4
12. When you lay out parts on paper in the order of disassembly, you should:
- a. put a clean rag on top.
 - b. use only a white plastic-coated paper.
 - c. wash parts first.
 - d. mark parts on the paper.

37.05.04.05

13.

14. Mounted on the side of carburetor is a part used to maintain a higher idle speed when engine is running; it is called a(n):
- a. curb idle speed switch.
 - b. throttle lever.
 - c. idle speed solenoid.
 - d. accelerator pump plunger linkage.

37.05.04.06

15. The main body of a thermoquad carburetor is made of:
- a. any kind of metal.
 - b. cast iron.
 - c. molded phenolic resin.
 - d. aluminum.

37.05.04.07

16. When a new carburetor is installed, you should make all of the tests and then:
- return it to owner.
 - clean the engine.
 - record results.
 - take it for a test drive.

37.05.04.08

17. Fuel-air adjustment must be done at normal engine temperature with what in "full open" position?
- engine manifold vacuum.
 - float.
 - air horn.
 - automatic choke.
18. When installing new idle mixture screws, you should screw in gently to prevent damage to the:
- vacuum diaphragm unit.
 - air horn.
 - fuel inlet fitting.
 - seat.

37.05.04.09

19. A dashpot on a carburetor is on cars with what kind of transmission?
- automatic.
 - manual only.
 - turbo hydra-matic only.
 - transmissions with a torque converter only.

37.05.04.10

20. When you move the idle air-adjusting screw in, it:
- increases R.P.M.'S.
 - restricts the pulsator diaphragm.
 - leans mixture.
 - enriches mixture.

UNIT PRETEST ANSWER KEY: CARBURETORS

LAP

- | | |
|----|-------|
| 01 | 1. C |
| | 2. C |
| | 3. D |
| | 4. D |
| | 5. D |
| 02 | 6. D |
| | 7. D |
| 03 | 8. B |
| | 9. A |
| 04 | 10. D |
| | 11. B |
| | 12. D |
| 05 | 13. B |
| | 14. C |
| 06 | 15. C |
| 07 | 16. D |
| 08 | 17. D |
| | 18. D |
| 09 | 19. A |
| 10 | 20. D |

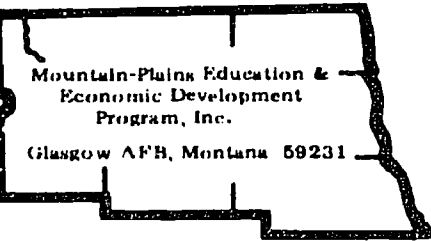

Learning Activity Package

Student: _____

Date: _____

PERFORMANCE ACTIVITY: Fundamentals of the Carburetor

OBJECTIVE:

Recognize the theory and proper operation of the carburetor.

EVALUATION PROCEDURE:

Score 80% correct on LAP study questions.
Eight correct responses to a ten-item multiple-choice objective test.

RESOURCES:

Auto Service and Repair, Stockel.
Auto Mechanics Fundamentals, Stockel.

PROCEDURE:

1. Do the following assignments using Auto Mechanics Fundamentals:
 - a. Read pages 126-149 "The Carburetor".
 - b. Study the carburetor (disassembled view) on page 147.
 - c. Answer quiz questions 9, 10, 11, 12, 13, 14, 16, 17, 18, 19, 20, 21, 23, 24, 25, 26 and 27 on page 152 on a separate sheet of paper. These questions must be correct to complete this LAP.
 - d. Return the textbook to the proper shelf.
 - d. Return the answer sheet to the instructor for evaluation.
2. Read pages 180-185 through 20-29 in Auto Service and Repair.
3. Take and score LAP test.

Principal Author(s):

J. Anderson, W. Osland

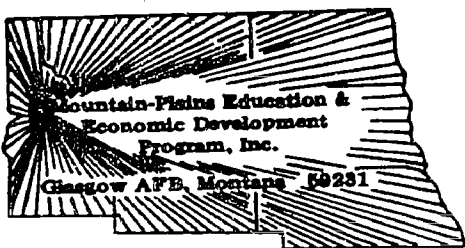

LAP TEST: FUNDAMENTALS OF THE CARBURETOR

1. Hot engine operating temperature affects which of the following?
 - a. secondary air valve.
 - b. secondary throttle valve.
 - c. hot idle compensating valve.
 - d. power valve piston assembly.

2. In the offset choke valve, what closes it?
 - a. the throttle linkage.
 - b. the vacuum piston.
 - c. air entering the carburetor.
 - d. the cold thermostatic coil.

3. How many types of idle speed-up controls are there when air conditioning is running?
 - a. 2
 - b. 3
 - c. 1
 - d. none

4. The function of the fuel bowl is to:
 - a. smooth out the gas flow going to the pulsator diaphragm.
 - b. filter the gas going into the inlet valve.
 - c. mix the fuel with the air.
 - d. hold a supply of gasoline.

5. A venturi tube does what?
 - a. decreases vapor lock in a carburetor.
 - b. causes a vacuum.
 - c. gives gas to the fuel bowl.
 - d. discharges gas from the fuel bowl.

6. The drag placed on the throttle lever when the throttle is suddenly returned to idle is called a:
 - a. dashpot.
 - b. reduction diaphragm.
 - c. idle speed-up air passage.
 - d. hot idle compensator.

7. The hollow float that is in a carburetor controls:
 - a. the fuel outlet valve.
 - b. the needle valve.
 - c. the fuel diaphragm.
 - d. the output of gas into the pulsator diaphragm.

8. When the engine is warming up, it is necessary to idle the engine somewhat faster to prevent stalling. This is accomplished by connecting the choke shaft to the:
 - a. engine manifold vacuum.
 - b. choke piston cylinder.
 - c. fast idle cam.
 - d. choke stone tube.

9. Engine speed is controlled by the position of what, in the carburetor?
 - a. the main metering jet.
 - b. the inlet ball check.
 - c. the main discharge jet.
 - d. the throttle valve.

10. To obtain more fuel for the high speed range it may be necessary to:
 - a. get a larger fuel inlet valve.
 - b. open the secondary throttle valve.
 - c. lift the metering rod up.
 - d. open the auxiliary throttle valve.

LAP TEST ANSWER KEY: FUNDAMENTALS OF THE CARBURETOR

1. C
2. D
3. A
4. D
5. B
6. A
7. B
8. C
9. D
10. C

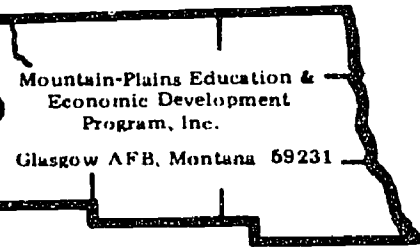

Learning Activity Package

Student: _____

Date: _____

PERFORMANCE ACTIVITY: Overhaul of Single Barrel Carburetor

OBJECTIVE:

Use the correct procedure for overhauling a single throat carburetor.

EVALUATION PROCEDURE:

Eight correct responses to a ten-item multiple-choice objective test to be taken after completing LAP 37.05.04.03.

RESOURCES:

Motor's Auto Repair Manual.

Carburetor cleaner

Butcher paper

Compressed air

Single throat carburetor

Single throat carburetor repair kit

Tray

Tools: Basic Hand: (see Unit LEG)

Wire basket

PROCEDURE:

Overhaul the carburetor to manufacturer's specifications by following the steps listed below:

1. Remove surface dirt from the outside of carburetor.
2. Locate overhaul procedures in the specific shop repair manual.
3. Lay butcher paper in tray.
4. Disassemble according to instructions in repair manual.
5. Lay out parts on paper in the order of disassembly.
6. Mark the parts on the paper in the order of disassembly.
7. Put parts in a wire cleaning basket. NOTE: Do not put neoprene leather, or plastic parts in basket.

Principal Author(s): J. Anderson, W. Osland

8. Submerge basket in carburetor cleaner for 20 to 45 minutes. NOTE: Time depends on how dirty the parts are.
9. Remove the parts from the cleaner and let drain.
10. Rinse parts with water or solvent. NOTE: Check recommendations on the cleaner.
11. Dry all parts with air pressure and force air through carburetor passages.
12. Lay out all parts on a sheet of paper.
13. Open a repair kit and replace old parts with the new ones.
14. Assemble carburetor according to instructions. NOTE: Be sure to adjust float with kit gauge.
15. Upon assembly, move all the linkages to check for satisfactory operation.
16. Return carburetor to car for remounting.
17. See LAP's - 8, 9, and 10 for proper finish adjustments.
18. When finished, have the instructor check the carburetor for satisfactory operation on a running engine.
19. Upon completion of this LAP, proceed to the next LAP. The LAP test will be taken after LAP :37.05.04.03.

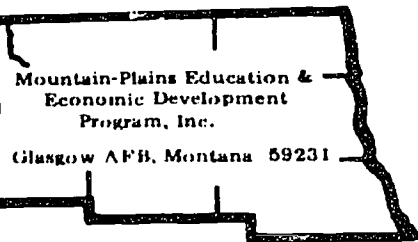

Learning Activity Package

Student: _____

Date: _____

PERFORMANCE ACTIVITY: Overhaul of 2 Barrel Carburetor

OBJECTIVE:

Use the correct procedure for overhauling a dual-barrel carburetor.

EVALUATION PROCEDURE:

Eight correct responses to a ten-item multiple-choice objective test.

RESOURCES:

~~RESOURCES~~

Motor's Auto Repair Manual.

Butcher paper
Carburetor cleaner
Compressed air
Dual barrel carburetor
Dual barrel carburetor repair kit
Fender covers
Tools, Basic Hand: (see Unit LEG)
Tray

PROCEDURE:

Overhaul the carburetor to manufacturer's specifications by following the steps listed below:

1. Remove surface dirt from the outside of carburetor.
2. Locate overhaul procedures in the specific shop repair manual.
3. Lay butcher paper in tray.
4. Disassemble according to instructions in repair manual.
5. Lay out parts on paper in the order of disassembly.
6. Mark the parts on the paper with a pencil.
7. Put parts in a wire cleaning basket. NOTE: Do not put neoprene, leather, or plastic parts in basket.
8. Submerge basket in carburetor cleaner for 20 to 45 minutes. NOTE: Time depends on how dirty the parts are.

Principal Author(s): J. Anderson, W. Osland

9. Remove the parts from the cleaner and let drain.
10. Rinse parts with water or solvent. NOTE: Check recommendations on the cleaner.
11. Dry all parts with air pressure and force air through carburetor passages.
12. Lay out all parts on a sheet of paper.
13. Open a repair kit and replace old parts with the new ones.
14. Assemble carburetor according to instructions. NOTE: Be sure to adjust float with kit gauge.
15. Upon assembly, move all the linkages to check for satisfactory operation.
16. Return carburetor to car for remounting.
17. See LAP's - 08, 09, and 10 for proper finish adjustments.
18. When finished, have the instructor check the carburetor for satisfactory operation on a running engine.
19. Take and score the LAP test.
20. Upon successful completion, go to the next LAP.

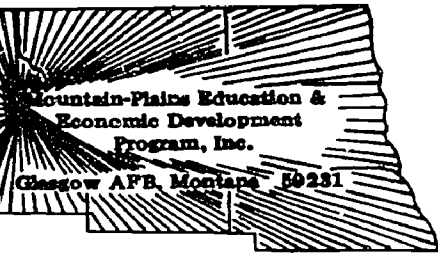

LAP TEST: OVERHAUL OF SINGLE BARREL AND
2 BARREL CARBURETORS

37.05.04.02.

1. Single-barrel carburetors are usually found on engines with how many cylinders?
 - a. 8 cylinder.
 - b. 6 cylinder.
 - c. with 6 cylinders.
 - d. 12 cylinder.

2. Float adjustment on a single-barrel carburetor is done by:
 - a. a single screw.
 - b. fuel inlet nut.
 - c. bending the float arm.
 - d. two screws.

3. A single-barrel carburetor has how many air-mixture screws?
 - a. 3
 - b. 4
 - c. 2
 - d. 1

- 4.

5. Whenever it becomes necessary to dismantle a carburetor, be sure to account for what parts that are found under pump plungers?
 - a. gaskets.
 - b. guides.
 - c. seals.
 - d. ball checks.

37.05.04.03

6. With a dual carburetor, each barrel supplies gas to what?
- all of the cylinders.
 - fuel pump.
 - alternating cylinders.
 - exhaust manifold.
7. How many fuel discharge ports does the conventional idle system have on a two-barrel carburetor?
- 3
 - 1
 - 2
 - 6
8. A two-barrel carburetor usually has two of every system except for what system?
- high-speed.
 - power.
 - float.
 - idling.
9. Two-barrel carburetors utilize how many air screws?
- 2
 - 3
 - 0
 - 4
10. To prevent damage to a two-barrel carburetor when cleaning, you should:
- use a drill bit of the same size.
 - use a thin wire and then air blast.
 - use air blast only.
 - wash out with gasoline and let dry.

LAP TEST ANSWER KEY: OVERHAUL OF SINGLE BARREL AND
2 BARREL CARBURETORS

LAP

- 02 1. B or C
 2. C
 3. D
 ~~4. B~~
 5. D
- 03 6. C
 7. C
 8. C
 9. A
 10. C

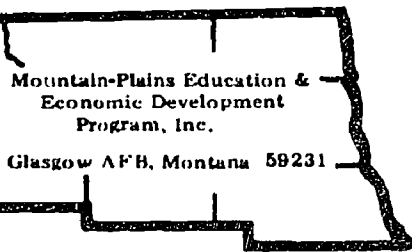

Learning Activity Package

Student: _____

Date: _____

PERFORMANCE ACTIVITY: Overhaul of 4 Barrel Carburetor

OBJECTIVE:

Use the correct procedure for overhauling a four-barrel carburetor.

EVALUATION PROCEDURE:

Eight correct responses on a ten-item multiple-choice objective test to be taken after completing LAP 37.05.04.06.

RESOURCES:

Motor's Auto Repair Manual.

Butcher paper
Carburetor cleaner
Compressed air
Fender covers
Four barrel carburetor
Four barrel carburetor repair kit
Tools, Basic Hand: (See Unit LEG)
Tray

PROCEDURE:

Overhaul the carburetor to manufacturer's specifications by following the steps listed below:

1. Remove surface dirt from the outside of carburetor.
2. Locate overhaul procedures in the specific shop repair manual.
3. Lay butcher paper in tray.
4. Disassemble according to instructions in the repair manual.
5. Lay out parts on paper in the order of disassembly.
6. Mark the parts on the paper with a pencil.
7. Put parts in a wire cleaning basket. NOTE: Do not put neoprene, leather, or plastic parts in basket.

Principal Author(s): J. Anderson, W. Osland

8. Submerge basket in carburetor cleaner for 20 to 45 minutes. NOTE: Time depends on how dirty the parts are.
9. Remove the parts from the cleaner and let drain.
10. Rinse parts with water or solvent. NOTE: Check recommendations on the cleaner.

11. Dry all parts with air pressure and force air through the carburetor passages.
12. Inspect all parts for cleanliness and condition.
13. Lay out all parts on sheet of paper.
14. Open repair kit and replace old parts with the new ones.
15. Assemble carburetor according to instructions. NOTE: Be sure to adjust float with kit gauge.
16. Upon assembly move all the linkages to check for satisfactory operation.
17. Return carburetor to car and remount.
18. See LAP's - 08, 09, 10 for proper finish adjustments.
19. Have the instructor check the carburetor for satisfactory operation on a running engine when completed for evaluation.
20. Upon completion of this LAP, proceed to the next LAP. The LAP test will be taken after LAP #37.05.04.06.

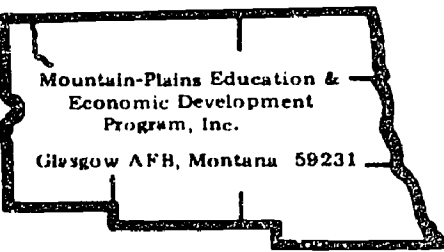

Learning Activity Package

Student: _____

Date: _____

PERFORMANCE ACTIVITY: Overhaul of Quadrajets Carburetor

OBJECTIVE:

Use the correct procedure for overhauling a quadrajets carburetor.

EVALUATION PROCEDURE:

Eight correct responses to a ten-item multiple-choice objective test to be taken after completing LAP 37.05.04.06.

RESOURCES:

Motor's Auto Repair Manual.

Butcher paper
Carburetor cleaner
Compressed air
Quadrajets carburetor
Quadrajets carburetor repair kit
Fender covers
Tools, Basic Hand: (See Unit LEG)
Tray
Wire basket

PROCEDURE:

Overhaul the carburetor to manufacturer's specifications by following the steps listed below:

1. Remove surface dirt from the outside of carburetor.
2. Locate overhaul procedure in the specific shop repair manual.
3. Lay butcher paper in tray.
4. Disassemble according to instructions in repair manual.
5. Lay out parts on paper in the order of disassembly.
6. Mark the parts on the paper with a pencil.
7. Put parts in a wire cleaning basket. NOTE: Do not put neoprene, leather, or plastic parts in basket.

Principal Author(s): J. Anderson, W. Osland

8. Submerge basket in carburetor cleaner for 20-45 minutes. NOTE: Time depends on how dirty the parts are.
9. Remove the parts from the cleaner and let drain.
10. Rinse parts with water or solvent. NOTE: Check recommendations on the cleaner
11. Dry all parts with air pressure and force air through the carburetor passages.
12. Inspect all parts for cleanliness and condition.
13. Lay out all parts on sheet of paper.
14. Open repair kit and replace old parts with the new ones.
15. Assemble carburetor according to instructions. NOTE: Be sure to adjust float with kit gauge.
16. Upon assembly move all the linkages to check for satisfactory operation.
17. Return carburetor to car and remount.
18. See LAP's - 08, 09, 10 for proper finish adjustment.
19. Have the instructor check the carburetor for satisfactory operation on the running engine when completed for evaluation.
20. Upon completion of this LAP, proceed to the next LAP. Take the LAP test after completing LAP# 37.05.04.06.

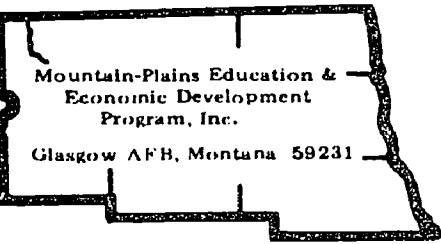

Learning Activity Package

Student: _____

Date: _____

PERFORMANCE ACTIVITY: Overhaul of Thermoquad Carburetor

OBJECTIVE:

Use the correct procedure for overhauling a thermoquad carburetor.

EVALUATION PROCEDURE:

Eight correct responses to a ten-item multiple-choice objective test.

RESOURCES:

Motor's Auto Repair Manual.

Butcher paper
Carburetor cleaner
Compressed air
Thermoquad carburetor
Thermoquad carburetor repair kit
Fender covers
Tools, Basic Hand: (See Unit LEG)
Tray
Wire basket

PROCEDURE:

Overhaul the carburetor to manufacturer's specifications by following the steps listed below:

1. Remove surface dirt from the outside of carburetor.
2. Locate overhaul procedures in the specific shop repair manual.
3. Lay butcher paper in tray.
4. Disassemble according to instructions in repair manual.
5. Lay out parts on paper in the order of disassembly.
6. Mark the parts on the paper with a pencil.
7. Put parts in the wire cleaning basket. **NOTE:** Do not put neoprene, leather, or plastic parts in basket.

Principal Author(s): J. Anderson, W. Osland

8. Submerge basket in carburetor cleaner for 20-45 minutes. NOTE: Time depends on how dirty the parts are.
9. Remove the parts from the cleaner and let drain.
10. Rinse parts with water or solvent. NOTE: Check recommendations on the cleaner.
11. Dry all parts with air pressure and force air through the carburetor passages.
12. Inspect all parts for cleanliness and condition.
13. Lay out all parts on sheet of paper.
14. Open repair kit and replace old parts with the new ones.
15. Assemble carburetor according to instructions. NOTE: Be sure to adjust float with kit gauge.
16. Upon assembly move all the linkages to check for satisfactory operation.
17. Return carburetor to car and remount.
18. See LAP's - 08, 09, 10 for proper finish adjustment.
19. When completed, have the instructor check the carburetor for satisfactory operation on a running engine.
20. Take and score the LAP test.
21. Upon successful completion, go to the next LAP.

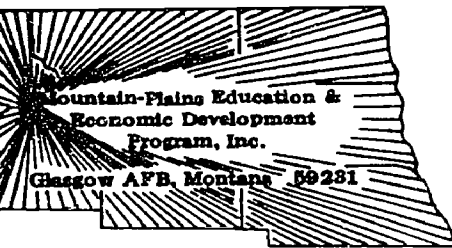

LAP TEST: OVERHAUL OF 4 BARREL CARBURETOR,
QUADRAJET CARBURETOR, AND
THERMOQUAD CARBURETOR

37.05.04.04

1. When you lay out parts on paper in the order of disassembly, you should:
 - a. wash parts first.
 - b. use only a white plastic-coated paper.
 - c. mark parts on the paper.
 - d. put a clean rag on top.
2. When cleaning parts, you should let them soak:
 - a. overnight.
 - b. 20 to 45 minutes.
 - c. not less than an hour.
 - d. not more than 5 minutes.
3. Prior to taking off a carburetor, you should:
 - a. disconnect intake manifold.
 - b. order carburetor repair kit.
 - c. disconnect battery cable.
 - d. remove surface dirt.
4. Large venturi tubes are located where on a four-barrel carburetor?
 - a. on the alternate side of the carburetor.
 - b. on the throttle side of the carburetor.
 - c. on the primary side of the carburetor.
 - d. on the secondary side of the carburetor.

37.05.04.05

5. Before removing a carburetor, you should:
 - a. remove outside dirt.
 - b. tune up engine.
 - c. disconnect fuel pump line from gas tank.
 - d. remove battery cable.

LAP TEST ANSWER KEY: OVERHAUL OF 4 BARREL CARBURETOR,
QUADRAJET CARBURETOR, AND THERMOQUAD
CARBURETOR

LAP

- | | |
|----|-----------------|
| 04 | 1. C |
| | 2. B |
| | 3. D |
| | 4. D |
| 05 | 5. A |
| | 6. B |
| | 7. B |
| | 8. B |
| | 9. C |
| 06 | 10. A |

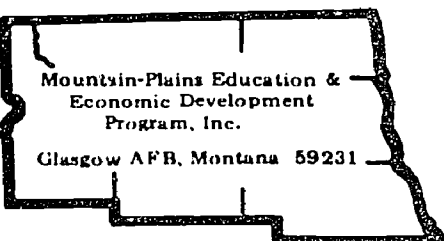

Learning Activity Package

Student: _____

Date: _____

PERFORMANCE ACTIVITY: Replacement of Carburetor and Gasket

OBJECTIVE:

Use the correct procedure for replacing a carburetor and gasket.

EVALUATION PROCEDURE:

Eight correct responses to a ten-item multiple-choice objective test to be taken after completing LAP 37.05.04,10

RESOURCES:

Auto Service and Repair, Stockerl.

Motor's Auto Repair Manual.

Automobile needing carburetor and gasket replacement

Fender covers

Replacement parts as needed

Tools, Basic Hand: (See Unit LEG)

Vacuum gauge

PROCEDURE:

NOTE: Review page 20-29 "Carburetor Installation" in Auto Service and Repair. Refer to the repair manual if necessary.

Replace the carburetor and gasket by following the steps listed below:

1. Place fender covers on fenders.
2. Remove air cleaner.
3. Disconnect fuel line at carburetor.
4. Remove vacuum line tube or hose.
5. Disconnect automatic heat controls.
6. Remove any electrical connections.
7. Disconnect throttle linkage.
8. Remove carburetor hold-down nuts from manifold studs.
9. Lift carburetor straight up and off. **NOTE:** Be careful not to damage studs, fuel lines, etc.

Principal Author(s): J. Anderson, W. Osland

10. Remove base gasket.
11. Scrape manifold gasket area clean.
12. Service carburetor as necessary.
13. Place new gasket on manifold. NOTE: Be sure gasket is not upside down. It must match the opening of carburetor and manifold.
14. Set the carburetor on the manifold. NOTE: Align carburetor so studs will not be damaged.
15. **Replace the carburetor hold-down nuts** on the studs.
16. Connect the fuel line to the carburetor inlet.
17. Connect the vacuum line to the carburetor. NOTE: Be sure these lines are air tight.
18. Connect automatic choke controls.
19. Connect electrical circuits.
20. Connect throttle linkage.
21. Replace carburetor air cleaner.
22. Test for vacuum leaks and adjust with a vacuum gauge.
23. Have instructor check carburetor operation.
24. Remove all tools, equipment and fender covers. Put them away.
25. Proceed to the next LAP. The LAP test will be taken after LAP #37.06.04.10.

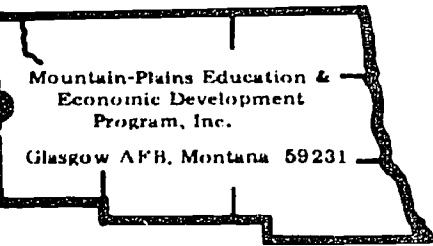

Learning Activity Package

Student: _____

Date: _____

PERFORMANCE ACTIVITY: Adjustment of Fuel-Air Mixture

OBJECTIVE:

Use the correct procedure for adjusting the idle mixture of a carburetor.

EVALUATION PROCEDURE:

Eight correct responses to a ten-item multiple-choice objective test to be taken after completing LAP 37.05.04.10

RESOURCES:

Auto Service And Repair, Stockel.
Motor's Auto Repair Manual.

Exhaust hoses
Fender covers
Soft cloth
Tachometer
Tools, Basic Hand: (See Unit LEG)
Vacuum gauge and adapter fitting

PROCEDURE:

NOTE: Review pages 20-16 through 20-26 in Auto Service and Repair. Refer to the repair manual if necessary.

Adjust the carburetor idle air/fuel ration mixture using the vacuum gauge and tachometer. Follow the steps listed below:

1. Place fender covers on fenders and connect up exhaust removal hoses.
2. Attach vacuum gauge adaptor fitting to intake manifold.
3. Attach vacuum gauge to adaptor fitting.
4. Remove idle mixture screw(s). NOTE: Two and four barrel carburetors have two idle mixture screws.
5. Clean the screws with a soft cloth.
6. Blow out screw holes with air.
7. Install Idle mixture screws in until they seat. NOTE: Screw in gently to prevent damage to seat.
8. Back screws off $1\frac{1}{2}$ turns.

9. Connect tachometer. NOTE: Set for number of cylinders and set up high scale range.
10. Start engine and run until warm. NOTE: Automatic choke should be fully open.
11. Set the idle speed screw first if it is necessary to get proper idle rpm.
12. Turn the idle mixture screws until the highest vacuum reading is reached.
NOTE: All three screws may have to be adjusted to get a smooth idle at the proper rpm.
13. Have an instructor check the carburetor for proper operation.
14. Disconnect tachometer, vacuum gauge and adaptor. NOTE: Be sure fitting or plug is firm in intake manifold.
15. Remove fender covers, tools and equipment. Put them away.
16. Proceed to the next LAP. The LAP test will be taken after completing LAP # 37.05.04.10.

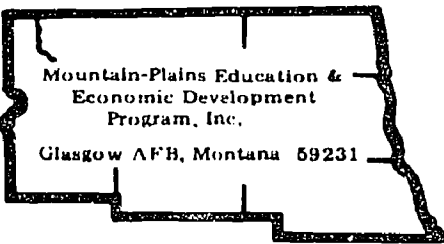

Learning Activity Package

Student: _____

Date: _____

PERFORMANCE ACTIVITY: Idle Adjustment - Dash Pot

OBJECTIVE:

Use the correct procedure for adjusting the dash pot.

EVALUATION PROCEDURE:

Eight correct responses to a ten-item multiple-choice objective test that is to be taken after completing LAP 37.05.04.10

RESOURCES:

Auto Service and Repair, Stockel.
Motor's Auto Repair Manual.

Automobile needing dash pot adjustment
Exhaust hoses
Fender covers
Tachometer
Tools, Basic Hand: (See Unit LEG)

PROCEDURE:

NOTE: Review pages 20-23 through 20-25 in Auto Service and Repair. Refer to the repair manual if necessary.

Adjust dash pot clearance to manufacturer's specifications by following the steps listed below:

1. Place fender covers on fenders.
2. Connect tachometer.
3. Connect up exhaust discharge hose.
4. Start engine.
5. Accelerate engine, allowing throttle to snap shut.
6. Check tachometer reading.
7. Repeat steps 4 and 5 several times.
8. Check linkage for binding or sticking.
9. Set carburetor fast idle cam on high step.
10. Adjust dashpot to just contact throttle lever.
11. Repeat steps 4 and 5 several times. **NOTE:** If engine speed does not return to the same rpm each time, replace dashpot.
12. Remove tachometer and fender covers.
13. Upon completion of this LAP, proceed to the next LAP. The LAP test will be taken after LAP #:37.05.04.10

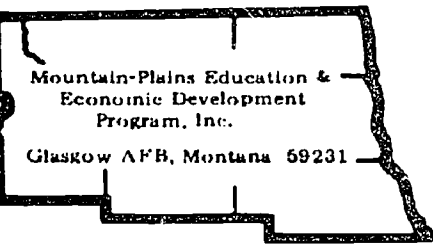

Learning Activity Package

Student: _____

Date: _____

PERFORMANCE ACTIVITY: Idle Adjustment - Mechanical Stop

OBJECTIVE:

Use the correct procedure for adjusting the idle adjustment.

EVALUATION PROCEDURE:

Eight correct responses to a ten-item multiple-choice objective test.

to be taken after

RESOURCES:

Motor's Auto Repair Manual.

Automobile needing engine idle adjustment - mechanical stop
 Fender covers
 Tachometer
 Tools, Basic Hand: (See Unit LEG)

PROCEDURE:

NOTE: Refer to ~~repair~~ repair manual if necessary.

Adjust engine idle rpm to specifications using a tachometer and following the steps listed below:

1. Place fender covers on fenders.
2. Normalize engine. (Run engine at normal operating temperature).
3. Connect tachometer. CAUTION: Be sure leads are clear of fan.
4. Set tachometer to correct number of cylinder and to the high rpm scale.
5. Start engine.
6. Turn tachometer control to low rpm scale.
7. Read rpm and compare with specifications.
8. Adjust idle speed screw to get correct rpm. NOTE: Be sure throttle linkage is not on fast idle cam.
9. Remove tachometer and fender covers. Put them away.
10. Take and score the LAP test.

Principal Author(s): J. Anderson, W. Osland

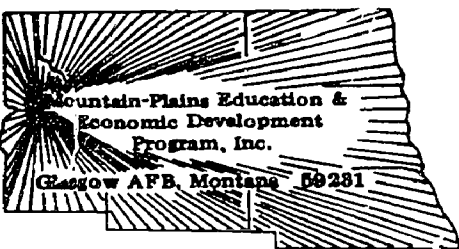

LAP TEST: REPLACEMENT CARBURETOR/GASKET;
ADJUSTMENT OF FUEL AIR MIXTURE;
IDLE ADJUSTMENT - DASHPOT/
MECHANICAL STOP

37.05.04.07

1. Parts not to be placed in a carburetor solution are:
 - a. those made of rubber.
 - b. those made of aluminum.
 - c. the outside parts of a carburetor.
 - d. the throttle valves.

2. When new carburetor is installed, you should make all of the tests and then:
 - a. return it to owner.
 - b. clean the engine.
 - c. take it for a test drive.
 - d. record results.

3. When placing a new gasket on a manifold, you should be careful so as not to:
 - a. put too much glue on the surface.
 - b. place it upside down.
 - c. put it on dry.
 - d. put it on clean.

37.05.04.08

4.

37.05.04.08. continued:

5. How many idle screws do two and four-barrel carburetors have?
- 4
 - 2
 - 1
 - 3
6. When connecting the tachometer, you set it for:
- the number of cylinders and on high range.
 - the number of cylinders and on low range.
 - low range.
 - the number of cylinders.
7. You turn the idle mixture screw(s) until:
- the engine starts to lope.
 - they are all the way in.
 - the highest vacuum reading is reached.
 - the lowest vacuum reading is reached without the engine stalling.

37.05.04.09.

8. A dashpot on a carburetor is found on cars with what kind of transmission?
- automatic only.
 - standard only.
 - turbo-hydromatic only.
 - only those transmissions that have torque convertors.

37.05.04.10 .

9.

10.

LAP TEST ANSWER KEY: REPLACEMENT CARBURETOR/GASKET;
ADJUSTMENT FUEL AIR MIXTURE; IDLE
ADJUSTMENT DASHPOT/MECHANICAL STOP

LAP

- 07 1. A
 2. C
 3. B

- 08 ~~4. A~~
 5. B
 6. A
 7. C

- 09 8. A

- 10 ~~9. B~~
 ~~10. A~~

37.05.04.02.

6. When too much air is entering the intake manifold below the throttle plate causing all engine performances to be bad, it could be caused from:
- a worn pulsator diaphragm.
 - a loose flange nut.
 - a worn air horn gasket.
 - a worn vacuum inlet valve assembly.
7. Single-barrel carburetors are usually found on engines with how many cylinders?
- 8 cylinder.
 - with 6 cylinders.
 - 12 cylinder.
 - 6 cylinder.
- 8.

37.05.04.03.

9. How many fuel discharge ports does the conventional idle system have on a two-barrel carburetor?
- 2
 - 4
 - 1
 - 3
10. With a dual carburetor each barrel supplies gas to what?
- fuel pump.
 - exhaust manifold.
 - alternating cylinders.
 - all of the cylinders.

37.05.04.04.

11. Choke valves on four-barrel carburetor are located where?
- in the primary barrels only.
 - in the secondary barrels only.
 - in all barrels.
 - in the alternate barrels only.

37.05.04.05.

12. When cleaning parts, you should:
- use a light oil.
 - not put neoprene parts in cleaner.
 - let parts set overnight at the minimum cleaning period.
 - put plastic and leather parts in cleaner.
13. Before removing a carburetor, you should:
- tune up engine.
 - remove outside dirt.
 - remove battery cable.
 - disconnect fuel pump line from gas tank.

37.05.04.06.

14. When installing new throttle valves to throttle shaft, you secure them by:
- tapping valves in place and center punching them.
 - neoprene seals.
 - screws and staking them.
 - reinstalling new limiter caps.
15. The main body of a thermoquad carburetor is made of:
- cast iron.
 - aluminum.
 - molded phenolic resin.
 - any metal.

37.05.04.07.

16.

37.05.04.08.

17. How many idle screws do two and four-barrel carburetors have?

- a. 3
- b. 4
- c. 1
- d. 2

18. You turn the idle mixture screw(s) until:

- a. they are all the way in.
- b. the lowest vacuum reading is reached without the engine stalling.
- c. the highest vacuum reading is reached.
- d. the engine starts to lope.

37.05.04.09.

19. When adjusting the dashpot, it should just contact the:

- a. accelerating lever.
- b. throttle plate.
- c. throttle lever.
- d. choke control cable bracket assembly.

37.05.04.10.

20. Some mixture screws have external limiters to control amount screws may be adjusted. This also helps:

- a. to prevent excess air entry into the air horn.
- b. exhaust emission to rise.
- c. to prevent backfiring inside of the carburetor.
- d. to keep exhaust emission down.

UNIT POST TEST ANSWER KEY:

CARBURETORS *A*LAP

- 01 1. C
 2. D
 3. B
 ~~4. B~~
 5. A
- 02 6. B
 7. D or B
 ~~8. B~~
- 03 9. A
 10. C
- 04 11. A
- 05 12. B
 13. B
- 06 14. C
 15. C
- 07 ~~16. C~~
- 08 17. D
 18. C or D
- 09 19. C
- 10 20. D

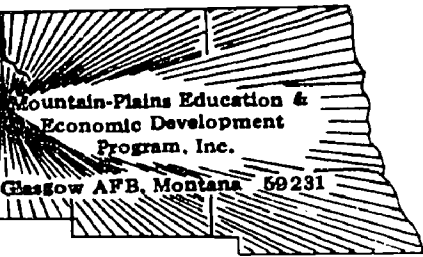

UNIT POST TEST: CARBURETORS (B)

37.05.04.01

1. Engine speed is controlled by the position of what, in the carburetor?
 - a. throttle valve
 - b. main discharge jet
 - c. main metering jet
 - d. inlet ball check

2. Hot engine operating temperature affects which of the following?
 - a. secondary throttle valve
 - b. hot idle compensating valve
 - c. power valve piston assembly
 - d. secondary air valve

3. A venturi tube does what?
 - a. gives gas to the fuel bowl.
 - b. discharges gas from the fuel bowl
 - c. decreases vapor lock in a carburetor
 - d. causes a vacuum

4. To increase vacuum in the carburetor air horn, what is used?
 - a. a diaphragm
 - b. a metering rod
 - c. a venturi
 - d. a throttle valve

37.05.04.02

5. Single-barrel carburetors are usually found on engines with how many cylinders?
 - a. 8 cylinder
 - b. with 6 cylinders
 - c. 12 cylinder
 - d. 6 cylinder

37.05.04.02 cont.

6. When too much air is entering the intake manifold below the throttle plate causing all engine performances to be bad, it could be caused from:
- a worn pulsator diaphragm
 - a loose flange nut
 - a worn air horn gasket
 - a worn vacuum inlet valve assembly

37.05.04.03

7. With a dual carburetor each barrel supplies gas to what?
- fuel pump
 - exhaust manifold
 - alternating cylinders
 - all of the cylinders
8. How many fuel discharge ports does the conventional idle system have on a two-barrel carburetor?
- 2
 - 4
 - 1
 - 3

37.05.04.04

9. Choke valves on four barrel carburetor are located where?
- in the primary barrels only
 - in the secondary barrels only
 - in all barrels
 - in the alternate barrels only

37.05.04.05

10. Before removing a carburetor, you should:
- tune up engine
 - remove outside dirt
 - remove battery cable
 - disconnect fuel pump line from gas tank
11. When cleaning parts you should:
- use a light oil
 - not put neoprene parts in cleaner
 - let parts set overnight at the minimum cleaning period
 - put plastic and leather parts in cleaner

37.05.04.06

12. The main body of a thermoquad carburetor is made of:
- cast iron
 - aluminum
 - molded phenolic resin
 - any metal
13. When installing new throttle valves to throttle shaft, you secure them by:
- tapping valves in place and center punching them
 - neoprene seals
 - screws and staking them
 - reinstalling new limiter caps

37.05.04.08

14. You turn the idle mixture screws(s) until:
- they are all the way in
 - the lowest vacuum reading is reached without the engine stalling
 - the highest vacuum reading is reached
 - the engine starts to lope
15. How many idle screws do two and four-barrel carburetors have?
- 3
 - 4
 - 1
 - 2

37.05.04.09

16. When adjusting the dashpot, it should just contact the:
- accelerating lever
 - throttle plate
 - throttle lever
 - choke control cable bracket assembly

37.05.04.10

17. Some mixture screws have external limiters to control amount screws may be adjusted. This also helps:
- to prevent excess air entry into the air horn
 - exhaust emission to rise
 - to prevent backfiring inside of the carburetor
 - to keep exhaust emission down

UNIT POST TEST ANSWER KEY: CARBURETORS (B)

1. A
2. B
3. D
4. C
5. D
6. B
7. C
8. A
9. A
10. B
11. B
12. C
13. C
14. C
15. D
16. C
17. D

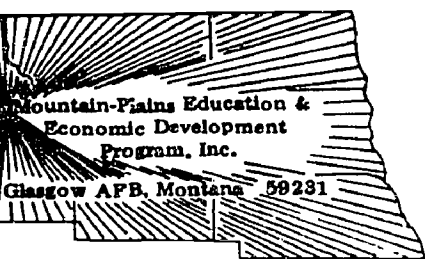

UNIT POST TEST: CARBURETORS (C)

37.05.04.01

1. Hot engine operating temperature affects which of the following?
 - a. secondary throttle valve
 - b. hot idle compensating valve
 - c. power valve piston assembly
 - d. secondary air valve

2. Engine speed is controlled by the position of what, in the carburetor?
 - a. throttle valve
 - b. main discharge jet
 - c. main metering jet
 - d. inlet ball check

3. To increase vacuum in the carburetor air horn, what is used?
 - a. a diaphragm
 - b. a metering rod
 - c. a venturi
 - d. a throttle valve

4. A venturi tube does what?
 - a. gives gas to the fuel bowl
 - b. discharges gas from the fuel bowl
 - c. decreases vapor lock in a carburetor
 - d. causes a vacuum

37.05.04.02

5. When too much air is entering the intake manifold below the throttle plate causing all engine performances to be bad, it could be caused from:
 - a. a worn pulsator diaphragm
 - b. a loose flange nut
 - c. a worn air horn gasket
 - d. a worn vacuum inlet valve assembly

37.05.04.02 cont.

6. Single-barrel carburetors are usually found on engines with how many cylinders?
- a. 8 cylinder
 - b. with 6 cylinders
 - c. 12 cylinder
 - d. 6 cylinder

37.05.04.03

7. How many fuel discharge ports does the conventional idle system have on a two-barrel carburetor?
- a. 2
 - b. 4
 - c. 1
 - d. 3
8. With a dual carburetor each barrel supplies gas to what?
- a. fuel pump
 - b. exhaust manifold
 - c. alternating cylinders
 - d. all of the cylinders

37.05.04.04

9. Choke valves on four-barrel carburetor are located where?
- a. in the primary barrels only
 - b. in the secondary barrels only
 - c. in all barrels
 - d. in the alternate barrels only

37.05.04.05

10. When cleaning parts, you should:
- a. use a light oil
 - b. not put neoprene parts in a cleaner
 - c. let parts set overnight at the minimum cleaning period
 - d. put plastic and leather parts in cleaner
11. Before removing a carburetor, you should:
- a. tune up engine
 - b. remove outside dirt
 - c. remove battery cable
 - d. disconnect fuel pump line from gas tank

37.05.04.06

12. When installing new throttle valves to throttle shaft, you secure them by:
- tapping valves in place and center punching them
 - neoprene seals
 - screws and staking them
 - reinstalling new limiter caps
13. The main body of a thermoquad carburetor is made of:
- cast iron
 - aluminum
 - molded phenolic resin
 - any metal

37.05.04.08

14. How many idle screws do two and four-barrel carburetors have?
- 3
 - 4
 - 1
 - 2
15. You turn the idle mixture screw(s) until:
- they are all the way in
 - the lowest vacuum reading is reached without the engine stalling
 - the highest vacuum reading is reached
 - the engine starts to lope

37.05.04.09

16. When adjusting the dashpot, it should just contact the:
- accelerating lever
 - throttle plate
 - throttle lever
 - choke control cable bracket assembly

37.05.04.10

17. Some mixture screws have external limiters to control amount screws may be adjusted. This also helps:
- to prevent excess air entry into the air horn
 - exhaust emission to rise
 - to prevent back firing inside of the carburetor
 - to keep exhaust emission down

UNIT POST TEST ANSWER KEY: CARBURETORS (C)

1. B
2. A
3. C
4. D
5. B
6. D
7. A
8. C
9. A
10. B
11. B
12. C
13. C
14. D
15. C
16. C
17. D

Student: _____ File Code: 37.05.04.00.B1-

Date: _____ Date Published: 3/4/76

Family Pay Number: _____ Sex: M F (Circle 1)

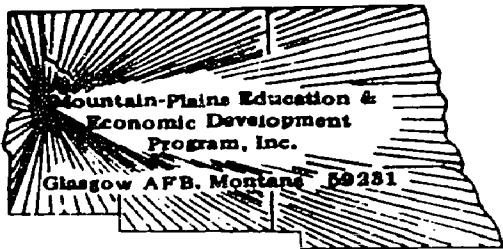

UNIT PERFORMANCE TEST: CARBURETORS

OBJECTIVE 1:

Overhaul a carburetor.

TASK:

The student will be assigned a vehicle on which he must overhaul the carburetor.

ASSIGNMENT:

CONDITIONS:

The student may use only those materials provided for the test and perform the test in the auto shop.

RESOURCES:

- Vehicle with carburetor
- Carburetor repair kit
- Carburetor Cleaner
- Fender Covers
- Service Manuals
- Time and Parts Manuals

RESOURCES: (Cont.)

Combination Ignition wrench set
Combination Wrench Set
Standard Screwdriver Set
Phillips Screwdriver Set
Feeler gauge - .002 through .025 inch
Hex Key Set
Diagonal Cutting Pliers
Needle Nose Plier
1/4" Drive Socket Set
Ratchet - 3" and 6" extensions - 6" flex handle
Ball Peen hammer
Plastic Tip Hammer
Screw Starter
Chisel and Punch Set
5/32" Pin Punch - 3/16" Solid
Gasket scraper
3/8" Drive Ratchet
3" Extension
Spark Plug Socket
6" Extension
Speed Handle
3/8" Drive Socket Set

Student: _____

File Code: . 37.05.04.00.81-5

Date: _____

Date Published: 3/4/76

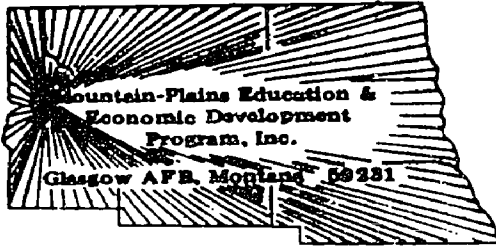

Family Pay Number: _____

Sex: M F (Circle 1)

PERFORMANCE CHECKLIST:

OVERALL PERFORMANCE: Satisfactory _____ Unsatisfactory _____

	CRITERION	
	Met	Not Met

Objective 1:		
1. Remove and disassemble carburetor		
Criterion: Follows service manual procedure, sketches carburetor parts for correct location.		
2. Cleans and inspects carburetor parts.		
Criterion: All parts clean and compares parts to Manufacturer's specifications.		
3. Assembles and installs carburetor.		
Criterion: Functions to manufacturer's specifications.		
4. Completes test in allotted time.		
Criterion: Meets flat rate time on assigned vehicle.		
Must satisfactorily meet 3 out of 4 line items to pass test.		

Pliers, diagonal cutting
Pliers, needle nose

Scraper, gasket
Screwdriver, standard (Set)
Screwdriver, phillips (Set)
Screw starter

Socket Set (3/8" drive)
extension (3")
ratchet

Socket Set (1/4" drive)
extension (3")
handle (6" flex)
ratchet

Socket, spark plug
extension (6")

Wrench, combination (Set)
Wrench, combination ignition (Set)

GENERAL INSTRUCTIONS:

This Unit consists of four Learning Activity Packages (LAPs). Each LAP will provide specific information for completion of a learning activity.

The general procedure for this Unit is as follows:

- (1) Read the first assigned Learning Activity Package (LAP).
- (2) Begin and complete the first assigned LAP.
- (3) Take and score the LAP test.
- (4) Turn in the LAP test answer sheet.
- (5) Determine the reason for any missed items on the LAP test.
- (6) Proceed to and complete the next assigned LAP in the unit.
- (7) Complete all required LAPs for the unit by following steps 3 through 6.
- (8) In this Unit, there are some LAPs that have tests combined with other LAP tests. These combined tests are taken after completing the last LAP covered by the test.
- (9) Take the unit tests as described in the Unit LEG "Evaluation Procedures".
- (10) Proceed to the next assigned unit.

PERFORMANCE ACTIVITIES:

- .01 Overview of Fundamentals
- .02 Overhaul Automatic Chokes
- .03 Adjusting Automatic Electric Chokes
- .04 Adjustment of the Mechanical Type

EVALUATION PROCEDURE:

When pretesting:

1. The student takes the unit multiple-choice pretest.
2. Successful completion is 4 out of 5 items for each LAP part of the pretest.
3. The student then takes a unit performance test if the unit pretest was successfully completed.
4. Satisfactory completion of the performance test is meeting the criteria listed on the performance test.

When post testing:

1. The student takes a multiple-choice unit post test and a unit performance test.
2. Successful unit completion is meeting the listed criteria for the the performance test.

FOLLOW-THROUGH:

Go to the first assigned Learning Activity Package (LAP) listed on your Student Progress Record (SPR).

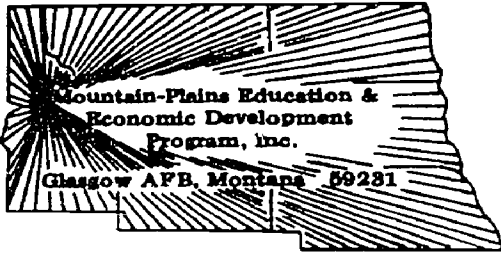

UNIT PRETEST: AUTOMATIC CHOKES

37.05.05.01

1. The electric choke is activated by the:
 - a. vacuum pressure.
 - b. ignition switch.
 - c. air pressure.
 - d. field windings.

- 2.

3. An automatic choke has a spring which is made of:
 - a. copper.
 - b. aluminum.
 - c. bimetallic metal.
 - d. light tin.

4. What happens to the automatic choke immediately upon starting?
 - a. it will be forced shut.
 - b. it will open and close.
 - c. it will completely open.
 - d. it will open partially.

5. A choke stove is a(n):
 - a. heating compartment.
 - b. vacuum passage to the intake manifold.
 - c. choke valve inside of the air horn.
 - d. air storage space.

37.05.05.02

6. When reassembling the automatic choke, if the thermostatic spring is positioned correctly, it engages the:
- secondary throttle shaft.
 - choke shaft lever.
 - fast idle cam.
 - vacuum diaphragm choke break.

37.05.05.03 Adjusting Automatic Electric Chokes

7. The heat for operating the thermostat spiral spring is provided by a(n):
- electric heating element.
 - exhaust manifold.
 - recycling of exhaust emissions.
 - heat stove.

37.05.05.04

8.

9.

10.

UNIT PRETEST ANSWER KEY: AUTOMATIC CHOKES

LAP

- | | |
|----|-------|
| 01 | 1. B |
| | 2. D |
| | 3. C |
| | 4. D |
| | 5. A |
| 02 | 6. B |
| 03 | 7. A |
| 04 | 8. D |
| | 9. D |
| | 10. A |

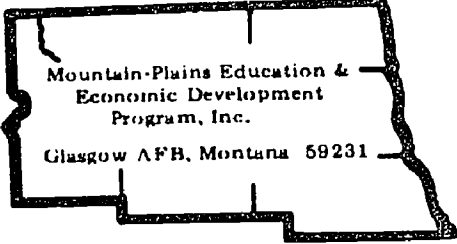

Mountain-Plains Education &
Economic Development
Program, Inc.

Glasgow AFB, Montana 59231

Learning Activity Package

Student: _____

Date: _____

PERFORMANCE ACTIVITY: Overview of Fundamentals

OBJECTIVE:

Use the components and proper operation of the different types of automatic chokes.

EVALUATION PROCEDURE:

Eight correct responses to a ten-item multiple-choice objective test.

RESOURCES:

Auto Mechanics Fundamentals, Stockel.

PROCEDURE:

1. Read "Solution - Automatic Choke Circuit" on pages 136 through 140 in Auto Mechanics Fundamentals.
2. Take and score the LAP test.
3. Upon successful completion, go to the next LAP.

Principal Author(s):

W. Osland

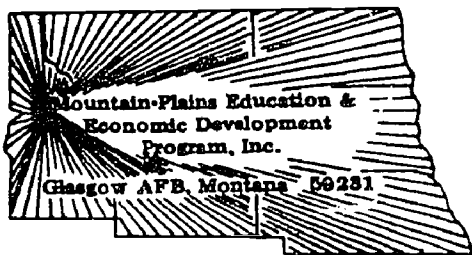

LAP TEST: OVERVIEW OF FUNDAMENTALS

- 1.
- 2.
3. A small vacuum operated piston in the automatic choke has the function of:
 - a. shutting off gas and making the fuel mixture leaner.
 - b. closing the choke.
 - c. opening the choke.
 - d. pumping gas into the air horn.
4. A "choke unloader" is used when the engine:
 - a. stalls out from lack of gas.
 - b. gets too much gas in the fuel bowl.
 - c. choke sticks open.
 - d. floods.
5. The electric choke is activated by the:
 - a. air pressure.
 - b. field windings.
 - c. ignition switch.
 - d. vacuum pressure.

6. How many normal sections of a carburetor are there?
- a. 4
 - b. 5
 - c. 2
 - d. 3
7. What happens to the automatic choke immediately upon starting?
- a. it will completely open.
 - b. it will open partially.
 - c. it will open and close.
 - d. it will be forced shut.
- 8.
9. A fuel bowl on a carburetor is used to:
- a. collect sediment from the gas lines.
 - b. hold a supply of gas.
 - c. mix the air and gas together.
 - d. vaporize gas so it can be ignited.
- 10.

LAP TEST ANSWER KEY: OVERVIEW OF FUNDAMENTALS

~~1. D~~

~~2. D~~

3. C

4. D

5. C

6. D

7. B

~~8. A~~

9. B

~~10. C~~

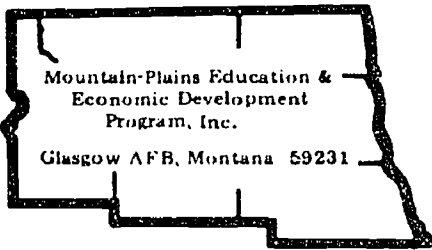

Learning Activity Package

Student: _____

Date: _____

PERFORMANCE ACTIVITY: Overhaul Automatic Chokes

OBJECTIVE:

Use the correct procedure for overhauling an automatic choke.

EVALUATION PROCEDURE:

Eight correct responses to a ten-item multiple-choice objective test to be taken after completing BAP 37.05.05.04.

RESOURCES:

Auto Service and Repair, Stockel.
Motor's Auto Repair Manual.

Automobile with an automatic choke
Carburetor cleaner
Fender covers
Tools, Basic Hand: (See Unit LEG)

PROCEDURE:

NOTE: Review pages 20-21 through 20-23 in Auto Service and Repair.

1. Place fender covers over the car's fenders.
2. Obtain the proper manual for the year and make of the automobile.
3. Locate the carburetor section of Automatic Choke Repair in the manual.
4. Follow the step-by-step procedure of removal, cleaning, adjustment and testing recommended for that particular carburetor.
5. Have the instructor check the choke operations after completion.
6. Go to the next assigned LAP.

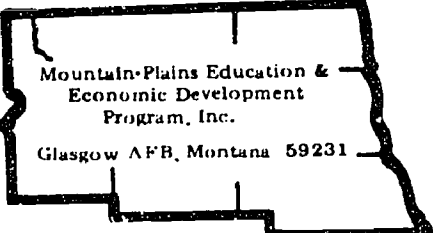

Mountain Plains Education &
Economic Development
Program, Inc.

Glasgow AFB, Montana 59231

Learning Activity Package

Student: _____

Date: _____

PERFORMANCE ACTIVITY: Adjusting Automatic Electric Chokes

OBJECTIVE:

Use the correct procedure for adjusting an electric automatic choke.

EVALUATION PROCEDURE:

Eight correct responses to a ten-item multiple-choice objective test to be taken after completing LAP 37.05.05.04.

RESOURCES:

Motor's Auto Repair Manual.

Automobile with an electric choke
Fender covers
Tools, Basic Hand: (See Unit LEG)

PROCEDURE:

NOTE: Refer to the repair manual if necessary.

1. Place fender covers on fenders.
2. Remove air cleaner.
3. Set throttle about $\frac{1}{4}$ open.
4. Move choke lever until the hole in the shaft aligns with the slot in the bearing boss.
5. Insert a tight fitting nail in the hole. NOTE: Nail should engage the notch in the flanged base of the ~~thermostat~~ housing.
6. Loosen clamp bolt on automatic choke lever.
7. Push lever up until choke valve is just closed.
8. Hold lever in this position and tighten the bolt clamping the choke lever to the shaft.
9. Remove nail and test action to see that the choke valve does not bind.
10. Remove any gum or carbon deposits from choke mechanism. NOTE: Acetone will quickly remove deposits.
11. Return throttle to idle position.
12. Replace air cleaner.
13. Remove fender covers.
14. Upon completion, the instructor will check the work to see if the choke works properly.
15. Go to the next assigned LAP.

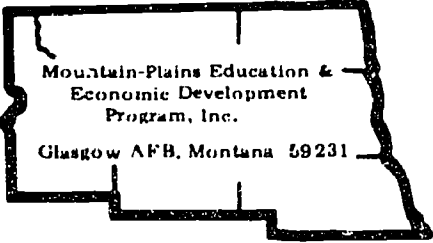

Mountain-Plains Education &
Economic Development
Program, Inc.

Glasgow AFB, Montana 59231

Learning Activity Package

Student: _____

Date: _____

PERFORMANCE ACTIVITY: Adjustment of the Mechanical Type

OBJECTIVE:

Use the correct procedure for adjusting an automatic choke.

EVALUATION PROCEDURE:

Eight correct responses to a ten-item multiple-choice objective test.

RESOURCES:

Auto Service and Repair, Stockel.
Motor's Auto Repair Manual.

Automobile with mechanical choke
Fender covers
Tools, Basic Hand: (See Unit LEG)

PROCEDURE:

NOTE: Review "Choke Adjustment" on page 20-20 in Auto Service and Repair.

1. Place the fender covers on the car fenders.
2. Inspect the choke linkage for freeness and proper movement.
3. (a) Obtain the proper manual for the year and model.
(b) Locate the carburetor section.
(c) Locate the automatic choke adjustment procedure for the particular carburetor that you are working on.
(d) Locate the specification page for carburetor choke adjustments.
4. Following the recommended step-by-step procedure, make all the adjustments according to specifications.
5. Have the instructor check your adjustments when completed to be sure they are correct and that it operates properly.
6. Take and score the LAP test.

Principal Author(s):

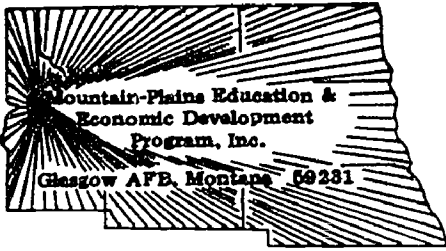

LAP TEST: OVERHAUL OF AUTOMATIC CHOKES;
ADJUSTING AUTOMATIC ELECTRIC/
MECHANICAL TYPE CHOKES

37.05.05.02 : OVERHAUL OF AUTOMATIC CHOKES

1.

2. When reassembling the automatic choke; if the thermostatic spring is positioned correctly, it engages the:

- a. vacuum diaphragm choke break.
- b. fast idle cam.
- c. secondary throttle shaft.
- d. choke shaft lever.

3. The choke valve should be where when the engine is cold?

- a. closed.
- b. almost closed.
- c. almost open.
- d. open.

4. The positioning of the choke housing and cover index marks adjust:

- a. the level of the float.
- b. the dashpot adjustment.
- c. choke vacuum break diaphragm.
- d. the tension to the thermostatic spring.

37.05.05.03 : ADJUSTING AUTOMATIC ELECTRIC CHOKES

5. The heat for operating the thermostatic spring is provided by a(n):
- electric heating element.
 - heat stove.
 - exhaust manifold.
 - recycling of exhaust emissions.
6. On an electric automatic choke, the electrical circuit is controlled through operation of the:
- ignition switch.
 - vacuum operated choke piston.
 - thermostatic coil.
 - offset position of the choke valve.

37.05.05.04 : MECHANICAL TYPE CHOKES

7. To adjust an anti-stall dashpot (internal type) you would adjust by:
- the fast idle screw.
 - dashpot adjusting screw.
 - adjusting the dashpot mounting.
 - the vacuum diaphragm.
8. Accelerator pump adjustment is done by:
- fast idle screw.
 - adjusting screw.
 - adjusting the fast idle cam.
 - bending linkage.
9. When adjusting the choke vacuum "break" (piston type) you would do so by:
- bending the thermostatic spring.
 - installing a smaller diaphragm.
 - adjusting the idle mixture screw.
 - adjusting nut or bending linkage.
10. Setting the float drop can be done by:
- adjusting float inlet needle.
 - bending of the float stop lip.
 - bending float spring to desired tension.
 - bending float arm.

LAP TEST ANSWER KEY: OVERHAUL OF AUTOMATIC CHOKES;
ADJUSTING AUTOMATIC ELECTRIC/
MECHANICAL TYPE CHOKES

LAP

- 02 ~~1. C~~
 2. D
 3. A
 4. D
- 03 5. A
 6. A
- 04 7. B
 8. D
 9. D
 10. B

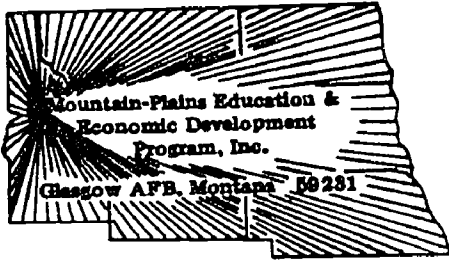

UNIT POST TEST: AUTOMATIC CHOKES *A*

37.05.05.01.

1.

2.

3.

4. A small vacuum operated piston in the carburetor has the function of:

- a. closing the choke.
- b. opening the choke.
- c. shutting off gas and making the fuel mixture cleaner.
- d. pumping gas into the air horn

5.

37.05.05.02

6. Automatic chokes have a valve in the air horn which is actuated by a:
 - a. thermostatic coil in manifold.
 - b. camshaft.
 - c. crankshaft.
 - d. throttle linkage.
7. Sluggish action or sticking of the choke will cause:
 - a. defective fuel pump operations.
 - b. vapor lock.
 - c. excessive fuel consumption.
 - d. carburetor idle limiters to fail.
8. The positioning of the choke housing and cover index marks adjust:
 - a. the dashpot adjustment.
 - b. choke vacuum break diaphragm.
 - c. the tension to the thermostatic spring.
 - d. the level of the float.

37.05.05.03

9. On an electric automatic choke, the electrical circuit is controlled through operation of the:
 - a. vacuum operated choke piston.
 - b. thermostatic coil.
 - c. ignition switch.
 - d. offset position of the choke valve.

37.05.05.04

10. When adjusting the choke vacuum "break" (piston type), you would do so by:
 - a. an adjusting nut or bending linkage.
 - b. bending the thermostatic spring.
 - c. adjusting the idle mixture screw.
 - d. installing a smaller diaphragm.

UNIT POST TEST ANSWER KEY: AUTOMATIC CHOKES

LAP

- 01 ~~1. Q~~
 ~~2. A~~
 ~~3. D~~
 4. B
 ~~5. B~~
- 02 6. A
 7. C
 8. C
- 03 9. C
- 04 10. A

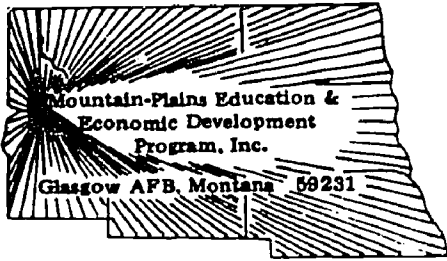

UNIT POST TEST: AUTOMATIC CHOKES (B)

37.05.05.01

1. A small vacuum operated piston in the carburetor has the function of:
- a. closing the choke
 - b. opening the choke
 - c. shutting off gas and making the fuel mixture cleaner
 - d. pumping gas into the air horn

37.05.05.02

2. The positioning of the choke housing and cover index marks adjust:
- a. the dashpot adjustment
 - b. choke vacuum break diaphragm
 - c. the tension to the thermostatic spring
 - d. the level of the float
3. Sluggish action or sticking of the choke will cause:
- a. defective fuel pump operations
 - b. vapor lock
 - c. excessive fuel consumption
 - d. carburetor idle limiters to fail
4. Automatic chokes have a valve in the air horn which is actuated by a:
- a. thermostatic coil in manifold
 - b. camshaft
 - c. crankshaft
 - d. throttle linkage

37.05.05.03

5. On an electric automatic choke, the electrical circuit is controlled through operation of the:
- a. vacuum operated choke piston
 - b. thermostatic coil
 - c. ignition switch
 - d. offset position of the choke valve

37.05.05.04

6. When adjusting the choke vacuum "break" (piston type), you would do so by:
- a. an adjusting nut or bending linkage
 - b. bending the thermostatic spring
 - c. adjusting the idle mixture screw
 - d. installing a smaller diaphragm

UNIT POST TEST: AUTOMATIC CHOKES (B)

1. B
2. C
3. C
4. A
5. C
6. A

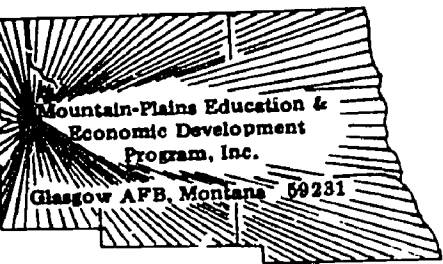

UNIT POST TEST: AUTOMATIC CHOKES (C)

37.05.05.01

1. A small vacuum operated piston in the carburetor has the function of:
- a. closing the choke
 - b. opening the choke
 - c. shutting off gas and making the fuel mixture cleaner
 - d. pumping gas into the air horn

37.05.05.02

2. Automatic chokes have a valve in the air horn which is actuated by a:
- a. thermostatic coil in manifold
 - b. camshaft
 - c. crankshaft
 - d. throttle linkage
3. The positioning of the choke housing and cover index marks adjust:
- a. the dashpot adjustment
 - b. choke vacuum break diaphragm
 - c. the tension to the thermostatic spring
 - d. the level of the float
4. Sluggish action or sticking of the choke will cause:
- a. defective fuel pump operations
 - b. vapor lock
 - c. excessive fuel consumption
 - d. carburetor idle limiters to fail

37.05.05.03

5. On an electric automatic choke, the electrical circuit is controlled through operation of the:
- a. vacuum operated choke piston
 - b. thermostatic coil
 - c. ignition switch
 - d. offset position of the choke valve

37.05.05.04

6. When adjusting the choke vacuum "break" (piston type), you would do so by:
- a. an adjusting nut on the linkage
 - b. bending the thermos tatic spring
 - c. adjusting the idle mixture screw
 - d. installing a smaller diaphragm

UNIT POST TEST: AUTOMATIC CHOKES (C)

1. b
2. a
3. c
4. c
5. c
6. a

Student: _____

File Code: 37.05.05.00.B1-5

Date: _____

Date Published: 3/4/76

Family Pay Number: _____

Sex: M F (Circle 1)

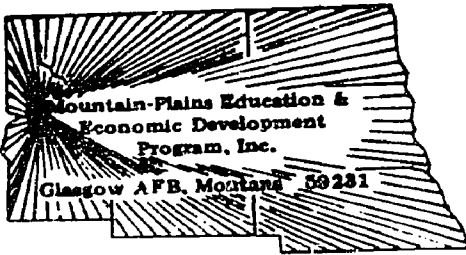

UNIT PERFORMANCE TEST: AUTOMATIC CHOKES

OBJECTIVE 1:

Overhaul automatic choke.

TASK:

The student will be assigned a car on which he must overhaul and adjust the automatic choke.

ASSIGNMENT:

CONDITIONS:

The student may use only those materials provided for the test and must perform the test in the auto shop.

RESOURCES:

Car with Automatic Choke
Repair Manual
Time and Parts Manual
Fender Covers
Choke Cleaner
Repair parts if Needed

RESOURCES: (Cont.)

Combination Ignition wrench set
Combination Wrench Set
Standard Screwdriver Set
Phillips Screwdriver Set
Feeler gauge - .002 through .025 inch
Hex Key Set
Diagonal Cutting Pliers
Needle Nose Plier
1/4" Drive Socket Set
Ratchet - 3" and 6" extensions - 6" flex handle
Ball Peen hammer
Plastic Tip Hammer
Screw Starter
Chisel and Punch Set
5/32" Pin Punch - 3/16" Solid
Gasket scraper
3/8" Drive Ratchet
3" Extension
Spark Plug Socket
6" Extension
Speed Handle
3/8" Drive Socket Set

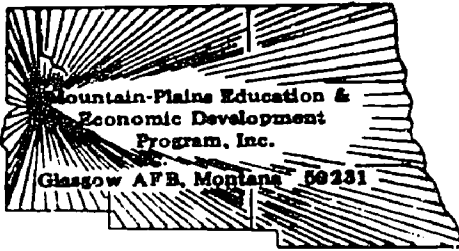

Family Pay Number: _____ Sex: M F (Circle 1)

PERFORMANCE CHECKLIST:

OVERALL PERFORMANCE: Satisfactory _____ Unsatisfactory _____

	CRITERION	
	Met	Not Met
Objective 1:		
1. Test automatic choke.		
Criterion: Must compare to manufacturer's specifications.		
2. Disassemble and clean automatic choke.		
Criterion: All parts clean and moving freely.		
3. Assembles and adjusts choke.		
Criterion: Meets manufacturer's specifications.		
4. Completes test in allotted time.		
Criterion: Meets flat rate time on assigned vehicle.		
Must satisfactorily complete 3 out of 4 line items to pass test.		