

DOCUMENT RESUME

ED 193 502

CE 026 958

AUTHOR Godbey, Frank W.
 TITLE Occupational Safety and Health in Vocational Education: A Guide for Administrators, Faculty, and Staff.
 INSTITUTION National Inst. for Occupational Safety and Health (DHEW/PHS), Cincinnati, Ohio. Div. of Technical Services.
 REPORT NO NIOSH-79-138
 PUB DATE Feb 79
 NOTE 192p.: Small print accompanying some illustrations will not reproduce well.
 AVAILABLE FROM Superintendent of Documents, U.S. Government Printing Office, Washington, DC 20402

EDRS PRICE MF01/PC08 Plus Postage.
 DESCRIPTORS Accident Prevention; Administrator Guides; Checklists; Evaluation Methods; Guidelines; Health Materials; *Needs Assessment; *Program Development; Program Evaluation; *Program Implementation; Safety; *School Safety; *Vocational Education; Work Environment
 IDENTIFIERS *Occupational Safety and Health

ABSTRACT

This guide is intended to help administrators at schools having vocational education programs assess their occupational safety and health needs and establish a program to ensure a safer and more healthful work environment. It consists of three sections: (1) administrative guidelines, (2) technical-regulatory guidelines, and (3) a self-evaluation instrument for use in assessing total school environment. Covered in the first section are a general philosophy for occupational safety and health (OSH); forming objectives for, supporting, and organizing an OSH program; OSH maintenance; generating employee cooperation; emergency plans; and selecting and handling machine and hand tools. Items discussed in the second section include walking surfaces, ladders, stairs, guardrails, and scaffolds; such OSH concerns as noise, ventilation, harmful materials and processes; medical and first aid; fire protection; and machinery. A checklist for these items constitutes the twenty-four page self-evaluation instrument contained in the third section. A brief discussion of information sources and a bibliography conclude the guide. (MN)

 * Reproductions supplied by EDRS are the best that can be made *
 * from the original document. *

ED193502

OCCUPATIONAL SAFETY AND HEALTH IN VOCATIONAL EDUCATION

A Guide for Administrators, Faculty, and Staff

Frank W. Godbey

U S DEPARTMENT OF HEALTH,
EDUCATION & WELFARE
NATIONAL INSTITUTE OF
EDUCATION

THIS DOCUMENT HAS BEEN REPRO-
DUCED EXACTLY AS RECEIVED FROM
THE PERSON OR ORGANIZATION ORIGIN-
ATING IT. POINTS OF VIEW OR OPINIONS
STATED DO NOT NECESSARILY REPRESENT
OFFICIAL NATIONAL INSTITUTE OF
EDUCATION POSITION OR POLICY

U. S. DEPARTMENT OF HEALTH, EDUCATION, AND WELFARE
Public Health Service
Center for Disease Control
National Institute for Occupational Safety and Health
Division of Technical Services
Cincinnati, Ohio
February 1979

CF ORG 958

For sale by the Superintendent of Documents, U.S. Government
Printing Office, Washington, D.C. 20402

NOV 7 1980

DISCLAIMER

Mention of company names or products does not constitute endorsement by the National Institute for Occupational Safety and Health.

DHEW (NIOSH) Publication No. 79-138

3

ii

ABSTRACT

This guide has been developed to assist schools having vocational education programs in assessing their occupational safety and health needs and in establishing a comprehensive program to ensure a safer and more healthful work environment. It is directed to the school person(s) having administrative and technical responsibility for the occupational safety and health of employees.

This document presents the areas to be considered in organizing and implementing an occupational safety and health program and the need to provide it with adequate administrative, employee, and financial support. It discusses selected basic functional activities necessary to render an effective program. It also provides technical information regarding the identification and handling of basic potential hazard areas as well as a self-evaluation instrument for use in assessing the total school environment.



CONTENTS

ABSTRACT, iii
ACKNOWLEDGMENT, xi
INTRODUCTION, 1
ADMINISTRATIVE GUIDELINES, 5
General Philosophy for Safety and Health, 5
Occupational Safety and Health Program, 5
Formulating Program Objectives, 7
Obtaining Administrative Support, 8
Assigning Responsibility, 9
OSH Program Functions, 10
Conducting On-Site Inspections, 10
Taking Corrective Action, 12
Written Rules and Regulations, 13
Safety and Health Training, 15
Recordkeeping and Reporting Requirements, 17
Accident Investigation and Reporting, 19
Monitoring and Evaluation of Program Activities, 21
OSH Committees, 22
Generating Employee Cooperation, 24
Emergency Plans, 26
OSH Maintenance, 27
Routine Corrective Maintenance, 28
Preventive Maintenance, 29
Selection, Procurement, and Placement of Machine Tools and Hand Tools, 30
Placement of Equipment, 31
Special Hazards, 32
TECHNICAL—REGULATORY GUIDELINES, 35
Walking and Working Surfaces, 35
Fixed Ladders, 36
Portable Ladders, 37
Fixed Industrial Stairs, 38
The Standard Guardrail and Toeboard, 39
Where a Standard Guardrail is Required, 40

General Requirements for All Scaffolds, 41	
Rolling Scaffolds, 43	
Safety Belts, Lifelines, Lanyards, and Nets, 43	
Excavating and Trenching, 44	
Exits and Exit Markings, 46	
General Requirements, 46	
Size and Placement of Signs, 46	
Occupational Health and Environmental Controls, 47	
Occupational Noise Exposure, 49	
Ventilation, 50	
Chemical Handling, 52	
Entry to Confined Spaces, 53	
Tank Entry and Cleaning, 53	
Entry and Cleaning of Sewers, 54	
Harmful Materials and Processes, 55	
Acetic Acid, 56	
Adhesives, 56	
Ammonia, 56	
Asbestos, 56	
Beryllium, 57	
Body Fillers, 57	
Cadmium, 58	
Carbon Dioxide (CO ₂), 58	
Carbon Monoxide, 58	
Caustics and Other Corrosive Chemicals, 59	
Chlorine, 59	
Chromium, 59	
Cutting Fluids, 60	
Dermatitis, 60	
Drain Cleaners, 61	
Wood Dust, 61	
Grain Dust, 61	
Other Dust, 62	
Electroplating, 62	
Epoxy Resins, 63	
Fibrous Material (Asbestos, Glass, etc.), 63	
Formaldehyde, 64	
Formic Acid, 64	
Fumigants, 64	
Heat and Cold, 65	
Hydrochloric Acid, 65	
Hydrogen, 65	
Hydrogen Sulfide, 66	
Insecticides, 66	
Insulating Foam, 67	
Lactic Acid, 67	
Lead Fumes or Dusts, 67	

Lime, 68
 Mercury, 68
 Metal Fumes and Dust, 69
 Methane, 69
 Microwaves, 69
 Oxalic Acid, 70
 Oxygen Deficient Atmosphere, 70
 Paints, Lacquers, Stains, and Solvents, 70
 Perchloroethylene, 71
 Phenol, 71
 Polyvinyl Chloride, 72
 Radiation, 72
 Refrigerants, 72
 Rodents, Snakes, Animals, Parasites, and
 Infectious Diseases, 73
 Soaps and Detergents, 73
 Soda Ash, 73
 Sodium Hydroxide, 74
 Sodium Sulfide, 74
 Solvents, 75
 Styrene, 76
 Sulfuric Acid, 76
 Ultraviolet Radiation, 76
 Welding, Burning, and Soldering—Hot Work
 Operations, 76
 Zinc Oxide Fumes, 77
 Hazardous Materials, 77
 Flammable and Combustible Liquids, 77
 Storage Cabinets, 79
 Inside Storage, 80
 Outside Storage, 81
 Gasoline Storage, 81
 Liquefied Petroleum Storage Area, 81
 Spray Painting, 82
 General Requirements, 82
 Spray Areas, 83
 Spray Booths, 83
 Paint Drying Apparatus, 84
 Personal Protective Equipment, 84
 Eye and Face Protection, 84
 Goggles, 85
 Spectacles, 86
 Helmets and Hand Shields, 87
 Face Shields, 88
 Care and Disinfection of Eye Protection, 88
 Hearing Protection, 89
 Head Protection, 89

Foot Protection,	90
Gloves, Aprons, and Other Protective Clothing,	90
Gloves and Hand Leathers,	91
Aprons,	91
Coveralls and Overalls,	91
Shop Coats,	91
Respiratory Protection,	92
Respiratory Cleaning,	92
General Environmental Controls,	93
Sanitation,	93
Signs and Tags,	94
Signs,	94
Tags,	95
Medical and First Aid,	95
Fire Protection,	97
Fire Alarm System,	98
Emergency Procedures,	99
Building Evacuation,	99
Notification and Training,	99
Good Housekeeping,	99
Fire Extinguishers,	100
Automatic Sprinkler Systems,	101
Sprinkler Alarms,	102
Compressed Air Equipment,	102
Materials Handling and Storage,	104
Manual Handling,	104
Powered Industrial Trucks,	104
Hoisting Equipment,	106
Slings,	107
Rigging Equipment,	108
Hydraulic Lift Skid Trucks,	109
Hand Trucks,	109
Safe Storage,	109
Space Layout,	110
Materials Handling Hazards,	111
Storage of Materials and Tools,	111
Location of Storage Facilities,	112
Construction Considerations,	112
Storage Methods,	113
Tool Storage,	113
Material Storage,	113
Flammable Liquids and Finishing Supplies,	113
Machinery and Machine Guarding,	114
General Requirements of Machine Guarding,	115
The Four Main Methods of Guarding,	115
Enclosure Guards,	115
Interlocking Guards,	116

- Automatic Guards, 117
- Remote Control, Placement, Feeding, Ejecting, 117
- The Techniques of Mechanical Guarding, 118
 - Cutting Action, 118
 - Rotating, Reciprocating, and Transverse Motion, 119
 - In-Running Nip Points, 120
 - Punching, Shearing, and Bending Action, 120
- General Requirements for Safe Operation of Equipment, 121
- Specific Requirements for Woodworking Equipment, 122
 - Rip Saws, 122
 - Table Saws, 122
 - Radial Saws, 124
 - Bandsaws and Band Resaws, 125
 - Swing Cutoff Saws and Sliding Cutoff Saws, 126
 - Jointers, 127
 - Tenoning Machines, 128
 - Wood Shapers and Similar Equipment, 128
 - Planing, Molding, Sticking, and Matching Machines, 129
 - Boring and Mortising Machines, 130
 - Miter Saws, 131
 - Portable Circular Saws, 131
 - Sanding Machines, 132
 - Lathes, 132
 - Router, 133
 - Alligator Shears and Notchers, 133
 - Guillotine Shears (Metal), 134
 - Shredders (Metal and Paper Scrap), 134
 - Compactors and Balers (Metal and Paper Scrap), 135
 - Grinders, 135
 - Fans, 136
 - Air Compressors, 136
 - Conveyors, 136
 - Rotating Screw Conveyors, 137
- Hand and Portable Powered Tools, 137
 - Safety Requirements for Powder-Actuated Tools, 139
 - Safety Rules for Operating Power Tools, 142
- Welding, Cutting, and Brazing, 142
 - General, 142
 - Gas Welding, 145
 - Electric Arc Welding, 146
- The National Electrical Code (NEC), 147
 - Electrical Requirements, 147
 - Wet Locations, 148
 - Damp or Wet Locations, 148
 - Temporary Lights, 149
 - Arcing Parts, 149

SELF-EVALUATION INSTRUMENT (SEI), 151
Checklist, 151
Walking and Working Surfaces, 151
Buildings and Yards, 151
Storage Lofts, Second Floors, etc., 152
Stairs, 152
Ladders, 153
Scaffolding, 153
Excavating—Trenching, 154
Exits and Exit Markings, 154
Occupational Health and Environmental Control, 155
Occupational Noise Exposure, 156
Hazardous Materials, 157
Flammable and Combustible Liquids, 157
Spray Painting, 159
Personal Protective Equipment, 160
General Environmental Controls, 161
Sanitation, 161
Medical and First Aid, 162
Fire Protection, 163
Automatic Sprinkler, 163
Compressed Air, 164
Materials Handling and Storage, 164
Cranes, 165
Machinery and Machine Guarding, 166
Abrasive Wheel Machinery (Grinders), 169
Hand and Portable Powered Tools, 169
Jacks, 170
Lifts, 170
Welding, Cutting, and Brazing, 170
National Electrical Code, 172
Electrical Wiring, 172
Recordkeeping, 173
INFORMATION SOURCES, 175
NIOSH Regional Offices, 176
OSHA Regional Offices, 177
Educational Resource Centers, 178
Bibliography, 180

ACKNOWLEDGMENTS

The author expresses gratitude to Merle E. Strong, Ph.D., Professor, Educational Administration, University of Wisconsin, to George LaPatka, Technical and Industrial Coordinator, Willmar Area Vocational-Technical Institute, to Homer Edwards, Vocational and Technical Education Program Officer, U.S. Office of Education, DHEW, to Joseph Gliem, Ph.D., Department of Agricultural Engineering, Ohio State University, to Oliver Oberlander, Department of Industrial Education, Central Michigan University, to Jack McElroy, Vocational Education, University of Kentucky, to Arthur Ballou, Supervisor for Trade and Industrial Education, Dade County School System, to James M. Cogdell, Assistant Director, Vocational Industrial Education, Texas Education Agency, and to Robert B. Gates, Assistant Director, Vocational Education, Ohio Department of Education for their expert input and guidance into the development of this guide.

The author also expresses thanks to R. F. Espenschied, Ph.D., Department of Agricultural Engineering, University of Illinois, and Chairman of the American Vocational Association-National Safety Council Joint Safety Committee, to Lowell A. Burkett, Executive Director, American Vocational Association, and to James L. Reid, Executive Director, National Association of State Directors of Vocational Education, for their encouragement and assistance in this project.

Special thanks are conveyed to the following NIOSH personnel who have devoted time and expertise in preparing this document: Division of Technical Services, Marshall E. LaNier, Director, Alphonse Schaplowsky, Deputy Director, Loren L. Hatch, D.O., Ph.D., Medical Officer; Technical Information Development Branch, Gerald Karches, Chief, Lorraine Ede, Section Chief, Thomas R. Davis, Writer Editor; Technical Reviewers, Austin Henschel, Ph.D., Physiologist, John M. Blankenhorn, Industrial Hygienist, Norbert Berberich, Ph.D., Chemist, Walter E. Ruch, Ph.D., Regional Consultant; Secretarial Support, Gayla Osborne and Ann Battistone.

INTRODUCTION

From the beginning of vocational programs in schools, vocational educators have been concerned for the safety of their students and fellow employees. More recently, a great deal of interest has also been focused on the potential health problems in their shops and laboratories. Vocational educators, through their special knowledge, can make a unique contribution to the various elements of a comprehensive occupational safety and health (OSH) program. In addition, they can readily translate this information into the education and training of young men and women to work safely and successfully in today's technological society.

The importance of this training was aptly expressed by Dr. Eula Bingham, Assistant Secretary for Labor, in a recent interview, "... it is very important to start educating workers when they're still in the training stage. For example, in high schools where individuals are learning vocational skills, they must learn how to do the job safely. We must start even earlier than that in terms of changing attitudes. I believe that every child should grow up to adulthood expecting to have a safe and healthy workplace. . . .

"We have to change attitudes so that people expect as their right a safe and healthful workplace. That's the ultimate goal."

Although recent federal and state legislation in the occupational safety and health area does not generally recognize students per se as employees and, therefore, does not provide direct protection, the application of these requirements to the school program will ultimately and effectively benefit the students.

Also, there should be ascertained whether any state laws have been enacted specifically to cover vocational students as, for example, in use of eye protection safety lenses.

Because of this recent legislation and the number of vocational schools and occupational program areas, occupational safety and health must be considered a priority and reempha-

sized in the vocational education program. The magnitude of the concern becomes apparent when one considers the fact that approximately 18,000 secondary schools (60% of all secondary schools) and 12,000 postsecondary schools offer vocational education programs. Although these programs range from the relatively nonhazardous to the potentially extremely hazardous, they all have certain potential hazards which can be controlled through a comprehensive occupational safety and health program.

All occupational programs are generally grouped from the 170 occupational fields into seven major groups of occupational training as follows:

Agri-Business	Health
Marketing and Distribution	Home Economics
Business and Office	Trade and Industrial
Technical	

From a review of these program areas, it is obvious that vocational schools need occupational safety and health from a wide spectrum of occupational and other potential hazard areas. It is imperative that vocational schools use all pertinent information to develop a comprehensive OSH program.

The William-Steiger "Occupational Safety and Health Act of 1970" (OSH Act) was passed into law "to assure safe and healthful working conditions for working men and women. . ." This Act established the National Institute for Occupational Safety and Health (NIOSH) in the Department of Health, Education, and Welfare and the Occupational Safety and Health Administration (OSHA) in the Department of Labor. The Act provides for research, informational programs, education, and training in the field of occupational safety and health and authorizes the enforcement of standards. As part of these activities, surveys have been made by NIOSH to determine the most common safety and health problems in schools. This guide was developed to assist you in dealing with those potential problems and in developing a comprehensive OSH program.

While the aim of this guide is to assist you in providing a safe and healthful workplace by describing safe practices and helping to identify some of the more frequently encountered violations of the safety and health standards, it is not intended to provide total information in all areas of compliance. Additional information can be found in the

General Industry Standards (Code of Federal Regulations, Title 29, Part 1910 — Occupational Safety and Health Standards) and Construction Standards (Code of Federal Regulations, Title 29, Part 1926 — Occupational Safety and Health Standards).

In some states, the federal government has delegated enforcement authority for occupational safety and health to the state government. Although state standards sometimes differ from federal standards, they must be at least as effective as the federal standards.

Every private school and some public ones are covered either by the federal or state safety and health standards. Public schools in states where the federal government has not approved the state's enforcement of standards are not subject to any direct safety and health regulations under the OSH Act. They are, however, subject to public pressures to conform and may be liable if they have deviated from recognized OSH standards and an accident occurs. Public schools do come under state jurisdiction in those states whose OSH plan has been approved by the federal government.

Although the list of approved state plans is subject to change, the following were included as of this writing: Alaska, Arizona, California, Hawaii, Indiana, Iowa, Kentucky, Maryland, Michigan, Minnesota, Nevada, North Carolina, Oregon, South Carolina, Tennessee, Utah, Vermont, Virginia, Washington, Wyoming, Virgin Islands, and Puerto Rico.

On the last few pages of the guide are listed addresses of NIOSH and OSHA regional offices where additional information and materials can be obtained.

ADMINISTRATIVE GUIDELINES

GENERAL PHILOSOPHY FOR SAFETY AND HEALTH

Through the use of a safety and health program and with the participation of employees and students, existing unsafe acts or conditions should become apparent. For many of these, there will not be specific standards. Nevertheless, it is important to find a solution to all recognized problems.

During the analysis of the workplace for safety and health problems, it may also become apparent that the "letter of the law" is not being met. This may be particularly noticeable where dimensions are given for ladders, stairs, railings, etc. If the intent of the law is being met, a variance from the regulations may be requested instead of making changes. The decision whether to make changes must be made on the basis of the OSHA determination concerning the request for variance.

When new buildings are being constructed, renovations are being made, or new equipment is obtained, the standards must be followed.

Even where a citation is issued, it is desirable that the school have demonstrated a willingness to comply with the law by operating safety and health programs, by correcting imminent dangers in the workplace, by maintaining records of purchases and installations, and by other activities promoting compliance. Therefore, after an OSHA compliance visit and a citation, the school can substantiate its "good faith" intent to provide a safe and healthful workplace by producing records which document this intent (see regulation 29 CFR 1903.15(b)).

OCCUPATIONAL SAFETY AND HEALTH PROGRAM

Hazardous conditions or practices not covered in the OSHA standards are covered under the general duty clause of the

Act, which states, "Each employer shall furnish to each of his employees employment and a place of employment which are free from recognized hazards that are causing or are likely to cause death or serious physical harm to his employees."

The most effective method of providing for a safe and healthful environment is through a comprehensive, formal occupational safety and health (OSH) program, consisting of top level administrative support, assignment of responsibilities, and well-defined activities. The purpose of such a program is to identify, evaluate, and control hazards and potential hazards in the school.

Administrators should be aware of both the benefits and the school's responsibilities relating to the development of a comprehensive, effective OSH program. From a cost benefit standpoint, money used to initiate and maintain such a program can result in considerable cost savings. For an OSH program to be judged effective, it should be responsible for reducing the number and severity of occupational illnesses and injuries in the school. This reduction can affect both direct and indirect costs. Direct costs such as insurance premiums often are based on the school's accident rate and are lowered when the claims frequency drops. Other direct costs affected by the frequency of hazards and accidents are OSHA (and other agency) fines, repair costs, and court and investigation costs. The indirect costs would involve such factors as lowered productivity, time lost from work, and possible replacement costs. In addition to these cost factors, an administrator should consider the humanitarian aspects of creating safe and healthful working conditions. Such conditions, in addition to resulting in fewer accidents, also help employee and student morale and instill a pride of achievement among employees.

Today, a school also has both legal and moral responsibilities toward its employees. No longer is the school under the protection of statutory or sovereign immunity. A school now may be liable in the case of an accident and can be sued for negligence. Schools also must now comply with a number of federal, state, and local regulations regarding safety and health standards. At the state and local levels, schools must take into account worker's compensation, fire safety laws, building and construction codes, sanitation requirements, and a variety of other regulations. At the federal level, the OSHA regulations are the most comprehensive safety and health

requirements facing employers. All private institutions and many public ones are under OSHA (at either the federal or state level). Even if a school is not under OSHA, per se, there may still be on-site OSHA inspections covering any private services offered within the school complex, such as food commissaries. The school may then become inadvertently involved if violations are found. A comprehensive OSH program with good documentation is effective in dealing with these areas of potential liability and noncompliance.

To be considered a formal program, the OSH effort must exhibit certain characteristics. First, it must be recognized and supported by the top level administration (preferably including the board) of the school. Without this recognition and support, it cannot compete for resources, exert authority, or initiate activities which involve the school as a whole. Second, in order to be a program, some planned activities must occur which lead toward defined program objectives. A program is successful only by virtue of what it accomplishes. Third, someone must be designated as being responsible and accountable for the program. Program objectives cannot be achieved without proper direction and coordination of program activities. All three of these criteria must be fulfilled for a school to qualify as having a formal OSH program.

Formulating Program Objectives

A program is an effort directed at achieving an objective. Thus, one of the first steps in setting up an OSH program should be to define exactly what the program will achieve. The administration must make specific decisions in advance regarding what they intend to do and how they plan to carry it out. This can be called the "planning process".

The overall goal of any OSH program is "to improve the safety and health of the school work environment." In more functional terms, this goal can be restated as "to reduce the number and severity of occupational illnesses and injuries." While all OSH program activities are aimed at achieving this goal, such a goal is too general to use in organizing a program. To provide a better framework, clear and measurable objectives should be developed. Well-formulated objectives provide the foundation for organizing activities, allocating staff and funds efficiently, monitoring performance, assessing program effectiveness, and communicating information about the program to others. These objectives are established by program planners and administrators.

Many different objectives could be pursued in the course of achieving the goal. Because program staff and other resources are limited, assess your current situation before deciding which course of action would bring about the greatest progress toward the goal, given the available resources. For instance, if the largest number of occupational illnesses and injuries occur in laboratories, perhaps the program should allocate extra resources to eliminate hazards, upgrade safety equipment, and train laboratory personnel in safe work practices.

One way to begin formulating objectives for a OSH program is to consider the basic functions that are part of an effective OSH program. These functions, discussed in more detail later, are as follows:

- Conducting on-site inspections to uncover hazards;
- Correcting or controlling these hazards;
- Developing written rules and regulations;
- Providing safety and health training;
- Investigating accidents;
- Maintaining illness/injury records; and
- Monitoring and evaluating the program's performance against its objectives.

Obtaining Administrative Support

A key element in any OSH program is obtaining and publicizing the administration's endorsement. There are two reasons this support is important. First, without the actual commitment of top administration, the program will be unable to compete with other endorsed programs for a share of the school's resources. Second, without the visibility of top administration support, the program will be hard-pressed to enlist the cooperation of other members of the school behind the OSH effort.

The administration's support for an OSH program may be based on various interests: the cost/benefit advantages of OSH, ethical responsibilities to employees and students, compliance with OSHA and other legislated directives, or taking a position of leadership within the community. Whatever the motivation, it is important that the administrators of the school visibly endorse the OSH program.

When this endorsement is obtained, a brief policy statement is usually issued by the administrator of the school. Basically, this policy statement indicates the administration's

endorsement of, and general expectations for, the OSH program with delegation of responsibility for the program. Such policy statements are usually quite brief as they are mainly statements of endorsement. Also, if the statement is basic and general, it allows greater flexibility to make program changes without going through the board for approval.

To be effective, an OSH program policy statement must meet the following criteria:

- It is issued by the Administrator of the school, with the endorsement of the board;
- It formally initiates the program and indicates its purpose;
- It names the person who will be responsible for the program;
- It lists the major program elements to be undertaken to the extent they are known at the time the policy statement is issued;
- It requests the cooperation of all school personnel and conveys the Administrator's intent to enforce the program; and
- It is distributed to all school personnel.

The precise form of the written policy is not as important as its clarity in stating the administration's sincere desires for a sound safety and health program.

This visible support is very important to the success of the program, since the control of occupational safety and health hazards requires the cooperation of all individuals in the school: students, faculty, subcontractors, and non-academic employees. It is well documented in organizational studies that individuals will not adhere to policies, programs, or directives unless it is clear that those in authority give the policies full support and are willing to enforce them.

Assigning Responsibility

A successful OSH program must have a Program Administrator who is responsible for the program and who can represent it at the administrative level. Continuing top-level administrative support is best achieved by appointing someone from top administration in this capacity.

The Program Administrator's relationship to the School Administrator is a primary factor in determining how much

management support the program will receive. The Program Administrator's status can have a similar impact on the way the OSH program is perceived by employees. Generally, the higher the position of the Program Administrator, the more important the program is assumed to be. Because the functions of the OSH program cross all organizational lines, major directives must come from the top. The Program Administrator serves not only as the program advocate at the top administrative level but also as the ultimate authority behind the major directives of the program.

The Program Administrator should be someone with an active interest and some experience in the field of occupational safety and health, committed to the success of the program, and with the attributes of leadership, diligence, diplomacy, and administrative competency. In some instances, the newly appointed individual will need to take additional training to develop the necessary expertise in the field. The Educational Resource Centers (ERC), funded by NIOSH training project grants, provide various training programs in OSH and should be able to assist in this area. (See Information Sources.)

OSH Program Functions

As listed before, the basic functions of an effective OSH program are conducting on-site inspections, correcting hazardous conditions, developing written rules and regulations, providing training to employees, investigating accidents, keeping illness and injury records, and monitoring and evaluating the program's efforts.

While some of these functions are not required by OSHA regulations, together they represent the cumulative experience of OSH professionals regarding the activities that must be conducted for a program to be successful.

Conducting On-Site Inspections

Inspections should be conducted not only to uncover physical hazards and to assure compliance with OSHA regulations and other federal, state, and local codes, but also to examine unsafe practices among employees. Besides detecting safety and health problems, these inspections can measure how well a supervisor or department is progressing in ensuring that conditions remain safe.

The supervisor is directly responsible for environmental conditions and for employee safety and (with the assistance of the Program Administrator) should also be made responsible

for locating and reducing hazards. Inspections performed by the Program Administrator are then basically used to audit the supervisor's effectiveness.

Formal inspections of all campus facilities should be conducted at least once a year. More frequent inspections should be conducted in high risk environments, such as laboratory, physical plant, and food service areas.

Inspections should be conducted by the Program Administrator, by supervisors, and sometimes by outside experts. The frequency and type of inspections conducted by each depend upon the organizational structure and staffing of the OSH program. With a well-established and adequately staffed OSH program, the Program Administrator should conduct most of the formal inspections. Operating supervisors should conduct the informal daily or weekly inspections. At a school with no full-time Program Administrator, the part-time Program Administrator must concentrate on policy and procedures development and evaluation of effort, covering only some of the inspection areas. Here the OSH program must rely on supervisors to conduct many of the formal inspections and submit reports on results to the Program Administrator.

When the program must rely this way upon supervisors, it is often helpful to arrange occasional inspections of work areas by other supervisors. This compensates for the loss of objectivity inherent in asking a supervisor to check his or her own OSH performance. The Program Administrator must be very diplomatic in initiating these arrangements to avoid conflicts among the parties involved.

The services of outside experts may be needed occasionally to supplement the skills available in the school and to achieve objectivity, particularly when there is no full-time OSH professional to conduct inspections and recommend procedures. This service can sometimes be obtained from local safety councils, insurance companies, governmental agencies, or local corporations.

All supervisors should conduct daily or weekly informal inspections. During the inspections, notes should be taken on all unsafe conditions and activities in order to ensure immediate corrective action. Such action might include on-the-job training of an employee, repair of a machine guard, restocking of first aid supplies, or a variety of activities. The supervisor should note the date of the inspection, the problems identified, and the corrective actions taken. These records are

valuable in guarding both the supervisor and the institution against both federal and state compliance violations or court action.

No discussion of inspections could be complete without mention of the Self-Evaluation Instrument (SEI). The SEI is a time-honored tool in the safety and health field and is useful in any OSH program for two reasons. First, an SEI identifies areas which should be checked thoroughly during inspections. Second, it provides guidance to supervisors who are not as familiar with the legal requirements and the proposed safety and health procedures as the Program Administrator. An SEI is included in the back of this guide which can be customized to fit the needs of your program.

SEI's do have shortcomings, however, as they cannot cover all standards and procedures without becoming too large. Moreover, the standards which are easily included in an SEI tend to be concerned with equipment and facilities. A thorough inspection of any area should consider a variety of factors: people, processes, equipment, materials, and the environmental conditions. This requires a thorough knowledge of OSH theory and accepted practices, as well as with all relevant regulations. It requires looking beyond the immediate violations to the causes of those violations in order to eliminate both the violation and the cause. Thus, care must be taken not to become overly dependent on the use of Self-Evaluation Instruments.

Taking Corrective Action

After an inspection is conducted, a report should be sent to the Program Administrator listing the problems which were identified, an estimate of the severity of each hazard, and the recommended corrective actions. If the supervisor intends to correct any problems personally, this should be reported.

The Program Administrator must summarize the necessary remedies for the problems identified through inspections and through accident investigations.

In developing the summary, the Program Administrator verifies the supervisor's estimate of the severity of the hazard; that is, whether it is an imminent danger violation, a serious violation, or a non-serious violation. The violations are arranged on the summary form in the order of severity. The corrective action(s) required for each, the estimated cost of the corrective action, and the earliest date the corrective action

could be completed are listed. This summary is then processed as a request for funds or administration support for the corrective actions. The Program Administrator determines which actions should be undertaken immediately. Generally, imminent danger and serious violations must be corrected immediately, because they could result in serious injuries or illnesses. Nonserious violations can, if necessary, be allowed a longer time period for corrections.

The Program Administrator generally must negotiate with others to get the corrective actions carried out. This entails getting them to use their funds, allocating general funds for the project, or devising some other means to get the hazard corrected. The Program Administrator summarizes the results of all of these actions in the correction plan. The plan lists each corrective action that will be undertaken, the individual who is responsible for the action, the date by which it should be completed, and the estimated cost of the project. The Program Administrator then sends a copy of the applicable portions of the plan to each work unit or department. The plan guides the activities of those carrying out the corrective actions and also serves as a basis for the Program Administrator to monitor the progress of these activities.

Written Rules and Regulations

OSH rules and regulations must be written, published, and communicated to employees to provide a consistent and easily administered approach for ensuring safe work practices in all school activities. The development of these rules serves three important functions for an OSH program. First, the involvement of employees in the formulation of rules and regulations is an excellent way of motivating them to follow the procedures. Second, a school, by developing its own rules and regulations, is forced to pull together all of the relevant federal, state, and local standards, as well as all of the rules it has developed on its own. Finally, these written documents set standards for safe work practices and establish a basis for disciplinary action against employees who fail to meet the standards.

However, for these OSH rules to be effective and enforceable, they must be well-conceived, realistic, fair, and presented in language and a form which can be easily understood by all. The development of such rules and regulations is not a simple task that can be accomplished overnight; it takes time and thought, and should involve the input of OSH professionals and possibly consultants.

The ultimate responsibility for developing all rules and regulations should rest with the Program Administrator. General OSH rules and regulations can be formulated, however, using any one or a combination of the following groups of school personnel: the personnel department, special rules-making committees, departmental committees of supervisors and employees, or employee safety committees.

General rules and regulations should include the following information:

- An overview of the existing OSH program including the school policy statement;
- A description of the various administrative functions responsible for the program;
- A list of those rules and procedures, including disciplinary actions, applicable to all personnel;
- An explanation of the responsibilities of the individual employee regarding the school OSH program; and
- A list of emergency telephone numbers to keep on hand.

Specific OSH procedures or rules will be required for particular operations or jobs. In this case, the personnel who are directly involved with these specific tasks should be given the opportunity to develop the instructions. Any involvement of employees in developing the rules and regulations in this matter draws upon their knowledge of a particular department or operation and, at the same time, motivates them to adhere to the rules that have been developed.

All available resource materials should be reviewed prior to writing the standards, but information should be limited to only those areas which are directly related to activities performed at the school.

After the rules and regulations have been written in draft form, they should be posted on school bulletin boards, so that employees may comment on them. The notice should indicate why the rules were developed, their proposed adoption date, and the cut-off date for comments. Labor unions or other such groups also may be asked to review the rules and their comments solicited. It is important to emphasize that allowing employees to react to rules that apply to them, giving them an opportunity to express their opinions and comment from their own experiences, should encourage acceptance and cooperation when the rules are made, distributed, and enforced.

Each employee should receive a copy of those general safety and health rules that apply to all personnel. In addition, employees performing hazardous tasks should receive copies of the specific rules and regulations developed for those tasks.

Once the rules have been issued in final form, a review mechanism should be developed to provide employees and supervisors with the opportunity to suggest any additions, deletions, or alterations that should be made to the existing instructions. As modifications are needed or new rules are developed, updated versions of the rules and regulations must be issued.

Safety and Health Training

Many accidents and injuries that occur in schools result from employee oversight or failure to abide by published safety and health rules. Unsafe practices among maintenance or physical plant employees, for example, include failure to use personal protective equipment, improper lifting and carrying, and unsafe use of materials and equipment. Often these unsafe practices can be related directly to the training of individual employees and to a lack of knowledge of the hazards to which they are exposed and of how to handle these potential dangers. Thus, safety and health training is a vital element of the school OSH program.

Care must be taken to ensure that employees receive and assimilate safety and health information and that they are motivated to act on this information. This calls for a formal, fully organized, documented program—a program designed to develop an awareness of safe and healthful practices as they apply to each employee.

The importance of such training is recognized under OSHA, which contains a number of regulations requiring that training be provided. These regulations are described in the OSHA publication, *Training Requirements of the OSHA Standards*, which can be obtained from OSHA regional offices. While the regulations specify some functional areas in which training is required (e.g., operation of materials handling equipment, welding equipment, and power presses), they do not specify the type of training that must be given, nor do they identify all types of training which may be needed. Basically, the responsibility for identifying and meeting OSH training needs rests with each individual school.

Employees should be trained to maintain their own safety and the safety of others whenever they need to acquire new knowledge, to learn new skills, or to take a refresher course in specific information. In general, this need will arise in the following situations:

- when a new employee is hired;
- when the employee transfers to another job;
- when new equipment is installed or a new task is assigned; and
- at any time when the lack of employee knowledge or skill is creating accidents or potential hazards.

Training should be based upon assessed needs. If lack of employee skill or knowledge is thought to be at the root of a hazard or potential problem, the training should be planned by determining what the employee needs to know or should be able to do by the end of the training session. Assessing what employees need to know in terms of safety procedures takes into account some type of analysis of the job itself, the equipment being used, any operating or behavioral problems, and an overall appraisal of the individual's job performance.

Once needs have been determined, training objectives must be developed and written down. These objectives must be stated in terms of what the employee should know and be able to do by the end of the training. Examples of these objectives are:

- The employee shall be able to describe the procedure to follow in case of emergency (fire, chemical spill, etc.).
- The employee shall be able to effectively lock power machinery prior to performing maintenance or repair operations.
- The employee shall be able to demonstrate an ability to satisfactorily clean and use the respiratory protective equipment.

The use of these objectives make it easier to determine if the employees have really obtained the necessary skills or knowledge at the end of the training. Once the objectives have been defined, the training content and method should be decided. If this approach is used, determining content and method is simplified and the trainer can focus on the kinds of experiences to be provided so that the employee will achieve the desired behavior. For example, to achieve the fire prevention objective stated above, a full-scale fire drill may be necessary. The content and method suggested by the second objective, on the other hand, might consist of showing employees how

machinery is locked out and letting them practice this procedure.

Most training will occur on the job, with the supervisor as trainer. In some instances, training will involve other persons, such as the Program Administrator or outside consultants. A variety of training tools—movies, slides, posters, and manuals—can be used. Some of these are already developed and can be purchased from various safety organizations and commercial companies.

Recordkeeping and Reporting Requirements

It is wise to document all training, medical examinations, inspections, accident investigations, and other tasks conducted by your OSH program. When money or manpower are expended on any effort, it is worth the extra time required to document that effort. This documentation will be valuable not only in demonstrating good faith to OSHA personnel, but also in defending the school against court actions. In addition, it can be used to monitor the effectiveness of your program, analyze problem areas and trends, and justify program expenditures to your administration.

OSHA requires that employers keep certain basic records on occupational injuries and illnesses. These records provide employers with a measure for evaluating the success of their health and safety activities and for identifying high risk areas of their business to which attention should be directed. Federal regulations require that employers with 11 or more employees at any time during the previous calendar year complete OSHA Form 101 (or its equivalent) and Form 200 during the current calendar year. OSHA Form 200 must also be kept current to within 6 days. These records must be maintained for 5 years, excluding the current year.

The types of work-related injuries and illnesses that must be recorded are those involving fatalities; lost workdays; or any others that require medical treatment, job transfer, or termination or that result in loss of consciousness.

Any occurrence of a work-related fatal accident or an accident requiring the hospitalization of five or more employees must be reported to OSHA within 48 hours. The annual summary for the preceding year, Form 200, must be posted for the entire month of February. Employers must also post (at all times) one of the full size versions (10 x 16) of the OSHA Job Safety and

Health Protection posters or a state-approved poster where required. (See illustration.)

Employers are required to maintain accurate records of certain potentially toxic or harmful physical agents that must be monitored or measured and to promptly advise any employee of any excessive exposure and the action taken to prevent a recurrence of such exposure. Examples are asbestos and ionizing radiation.

For more detailed information, the booklet "Recordkeeping Requirements Under the Williams-Steiger Occupational Safety and Health Act of 1970" is available from OSHA.

job safety and health protection

"The conditions which give rise to occupational safety and health hazards are created through the process of labor and capital working together through the labor-management relationship. It is the responsibility of both to create and maintain safe and healthful working conditions."

Employers Each employer shall furnish to each of his employees employment and a place of employment which has been recognized hazards that are causing or may lead to serious illness or death in particular terms of his employees and shall comply with occupational safety and health standards issued under the Act.

Employers Each employer shall comply with all occupational safety and health standards, rules, regulations and orders issued under the Act that apply to his own business and conduct on the job.

Inspection The Occupational Safety and Health Administration is part of the Department of Labor and the primary responsibility for administering the Act is placed upon the Occupational Safety and Health Administration. The Act requires that a representative of the employer and a representative authorized by the employee be present at all inspections. It is the responsibility of the employer to provide the necessary information to the representative of the employee.

Complaint If there is a complaint from the employee, the employer and the representative of the employee, the representative of the employee should be notified of the complaint. The Act requires that the employer and the representative of the employee be notified of the complaint. The Act requires that the employer and the representative of the employee be notified of the complaint.

Citation "After inspection of a place of employment has revealed that there is a serious violation, the citation shall be issued to the employer. The citation shall specify the nature of the violation, the standard which has been violated, and the date by which the violation must be corrected."

Proposed Penalty: "The Act provides for monetary penalties imposed on employers of up to \$1,000 for each serious violation and for repeated violations of up to \$5,000 for each willful violation. Penalties of up to \$1,000 per day may be assessed for failure to comply with any citation which requires the employer to take any action to abate a violation. Penalties of up to \$1,000 for each violation are also provided for the failure to comply with any citation which requires the employer to take any action to abate a violation. Penalties of up to \$1,000 for each violation are also provided for the failure to comply with any citation which requires the employer to take any action to abate a violation."

Voluntary Activity "The Act provides for the establishment of a voluntary activity program. The Act provides for the establishment of a voluntary activity program. The Act provides for the establishment of a voluntary activity program."

More Information Additional information and details of the Act are available from the Occupational Safety and Health Administration. Additional information and details of the Act are available from the Occupational Safety and Health Administration.

Agency Offices
 Atlanta, Georgia
 Boston, Massachusetts
 Chicago, Illinois
 Dallas, Texas
 Denver, Colorado
 Kansas City, Missouri
 New York, New York
 Philadelphia, Pennsylvania
 San Francisco, California
 Seattle, Washington

Department of Labor
 Occupational Safety and Health Administration
 200 Constitution Avenue, N.W.
 Washington, D.C. 20330

U.S. Department of Labor

Accident Investigation and Reporting

A valuable part of any OSH program is the accident investigation and reporting system. Data helpful in program evaluation and improvement as well as data required by OSHA can be collected this way. Such information can be used for many purposes, including:

- identifying and controlling specific high-risk accident situations;
- indicating where a change, substitution, or elimination of materials, methods, processes or operations should be made;
- identifying trends in the severity of accidents, types of injuries, volume of property damage, location of accidents, causes of accidents, etc.;
- providing safety performance information to work groups to enable them to compare their present performance to their own past performance and that of other work groups;
- justifying program expenditures to the administration by documenting program accomplishments;
- identifying group and individual training needs;
- serving as a basis for award and incentive programs to motivate and stimulate employee cooperation with the OSH program; and
- developing defenses for the institution against court actions.

An effective accident investigation and reporting system can help reduce the number and severity of accidents by uncovering the causes of accidents, by initiating corrective actions, and by increasing supervisor involvement in the OSH program. The system is based on understanding and following through on three basic principles of accident investigation.

First, the system should investigate all accidents including those which result in injuries requiring only first aid or only in property damage. Any accident, no matter how serious or trivial, could point to a flaw in the OSH program. Minor accidents should be reported and investigated because they sometimes are symptomatic of hazardous conditions or practices that could lead to future serious accidents. Moreover, these accidents often result in heavy property damage and other costs to the school.

The second principle is that the reporting system must be easy to use if it is to be successful in collecting information on all

accidents. Therefore, the proposed system uses only one form for collecting all of the information needed.

The third principle is recognition that the key person in any accident prevention program is the supervisor. For the OSH program to be successful, it must have the full cooperation and support of each supervisor. Therefore, all efforts by the Program Administrator should be conducted in conjunction with the supervisors. It is generally the supervisor who is responsible for conducting the initial accident investigation and filling out the accident reporting form for any employee.

The first step in setting up this system is designing the accident investigation and reporting form. Since this will be the basis for the entire system, care must be taken to require all necessary information, using a form that supervisors will be able to complete with a minimum of effort.

Your accident reporting form should be analyzed to make sure that it will contain all of the information required by the OSHA 101 form and the state workers' compensation form. In addition, the form should require all other information necessary for any internal reports required by the OSH program.

Finally, the accident investigation and reporting form should include space for the supervisor's analysis of the causes of the accident, covering all information regarding the injured person (what the person was supposed to be doing, what the person actually was doing, and training and past performance and accident records) and an examination or inspection of the equipment being used and the physical environment at the time of the accident. The supervisor also should recommend the steps to be taken to prevent similar accidents from occurring. In this manner, the accident investigation and reporting form aids in examining more closely the causes of the accident and in considering the follow-up action to be taken.

As explained above, the Program Administrator provides guidance, but the immediate supervisor — dealing directly with employees—is the key person in any OSH program. Therefore, the supervisor is responsible for ensuring that the work environment is hazard-free and that employees are adequately trained in safe working procedures. The supervisor must enforce, on a daily basis, any efforts initiated by the OSH program. This includes accident investigation and reporting.

The supervisor not only must be thoroughly familiar with the accident reporting system but also must believe in the need to report all accidents. The most important part of the supervisor's accident reporting duties is investigating the accident. The supervisor must be trained to get the answers to two questions: (1) What happened to cause the accident or illness? and (2) What can be done to prevent it from happening again?

Based on the results of the accident investigation, the conditions which caused the accident should be eliminated or controlled as soon as possible.

After the supervisor has completed his initial investigation and filled out the accident investigation and reporting form, the form should be forwarded to the Program Administrator for processing and analysis. The Program Administrator should be responsible for determining whether the accident must be reported to OSHA or the state workers' compensation office.

The Program Administrator also should review that portion of the form describing the accident, the causes of the accident, and the control measures that were instituted or recommended by the supervisor to prevent a similar accident from occurring. If the investigation, actions, and report filed by the supervisor are adequate and do not indicate serious future hazards, the Program Administrator could simply code the information for use in the various internal summary reports.

Monitoring and Evaluation of Program Activities

Monitoring is the day-to-day review of program activities to determine the extent of progress toward program objectives. The purpose of monitoring is to identify actual and potential problems early, so corrective action can be taken. Evaluation, on the other hand, is the periodic review of the direction, effectiveness, and efficiency of a program.

The Program Administrator is responsible for monitoring the activities of the OSH program to make sure they are carried out as planned. This is an important function of a successful program because it is quite easy to let projects slide if no one is concerned enough to check the program's status.

Specifically, monitoring should ensure that the following activities are performed:

- routine inspections of work areas and equipment are conducted at the agreed-upon frequencies;
- reinspections are conducted to check progress toward compliance in areas where violations were uncovered;
- all accidents and incidents are investigated thoroughly and reported in writing;
- employees receive OSH training when hired and as needed thereafter;
- rules and regulations are updated to encompass new campus activities and changes in the requirements;
- OSHA-required records are kept up to date and accurate;
- each new employee receives a pre-employment medical examination and periodic examinations are performed later as needed;
- exposure levels for industrial hygiene hazards are checked periodically;
- OSH committees meet regularly; and
- any other activities of your program are conducted in a timely fashion.

Merely monitoring some activities may be sufficient to keep them on schedule. Other activities may prove to be chronically behind schedule or inadequately performed. This calls for reassessment on the part of the Program Administrator. Appropriate remedial action follows naturally from a clear understanding of why the problem exists.

Data on occupational illnesses and injuries can provide valuable feedback for the OSH program. They are a direct measure of the program's success or failure in achieving its overall objective—a reduction in the number and severity of occupational illnesses and injuries. These data can be used to develop summary reports comparing the present OSH situation in your school with the situation in the past. Such reports can be invaluable in pointing out areas of program success or failure and can be used to plan for improved program effectiveness.

OSH COMMITTEES

In some instances, program planners and administrators may wish to consider establishing a committee or committees to serve as an adjunct to the actual program organization. For example, they may wish to obtain the input or advice of specialists or to obtain the visible support and endorsement of departments or individuals who may not be directly involved in the OSH program. Sometimes, also, there is a need for short-

term input while planning or starting up the OSH program which is not expected to continue when the program is underway. In both instances, a committee may be an appropriate device.

In considering whether to establish an OSH committee, it is worthwhile to consider those activities which committees can and should do, and those which they are incapable of doing. The basic function of a safety and health committee is to encourage compliance with OSH rules by fellow employees—a vital function in the academic community. As such, it may meet regularly to conduct inspections of operations and facilities, review accident reports, and recommend corrective measures. Its role is basically advisory and supportive. Committees should neither dictate policy nor relieve those in line of authority of their direct responsibility.

Thus, a committee should never be used in place of, or as a supplement to, a Program Administrator. They are not appropriate for functioning at the day-to-day operational level. For example, a committee may pass approval on new employees, but it should not be expected to supervise them. It may ratify budget submissions, but should not be expected to prepare them. It may develop policies, but should not be expected to actively enforce them. Since committee members are removed from the operational level, they may not be interested in investing much of their time and energy in the program effort. Committees seek consensus; therefore, by their very nature, they are time-consuming.

On the other hand, the establishment of safety and health committees can fulfill a number of necessary and worthwhile purposes for the school OSH program:

- They can provide representation from a diversity of functions, specialties, and departments.
- They can provide visibility and top-level endorsement.
- They can provide authority and general leadership influence.
- They can share the burden of responsibility for unpopular actions.

The need for committees will vary from school to school and situation to situation. Usually an *ad hoc* committee is preferable when a specific problem requires the diversity of opinion and influence that a committee can provide. This type of committee can easily be formed and then disbanded after the

project has been completed. Standing committees, however, may also be required to assure continued representation, even though a standing committee may have a greater tendency to polarize or to get "bogged down" in details or because committee members are not able to sustain continuing involvement due to other work pressures. The usual basic approach and goal regarding standing committees is to have one central safety and health committee and subcommittees for special hazard areas, if necessary.

OSH program committees or subcommittees can draw members from a number of different groups: administration, faculty, physical plant, service area, etc., such committees may have different purposes as well. Generally, committees consist of (1) individuals representing employees who are exposed to OSH hazards, (2) individuals representing school officials responsible for hazard abatement, and (3) individuals knowledgeable about particular hazard classes. The Program Administrator should be included as a member of any OSH committee. However, it is best that the role of chairperson go to someone other than the Program Administrator—someone outside the OSH program, goal-oriented, and influential.

Whenever representatives of the school administration are included, they should be of as high a level within the administration as possible, in order to assure that committee recommendations reflect the thinking of the school administration. The inclusion of high level administrators also reflects the administration's support for the overall program.

For greatest effectiveness, committees should meet as frequently as possible. In most cases, monthly meetings are best; quarterly meetings are the minimum acceptable. It is important that meetings be held on schedule. A major contributor to the deterioration of committees is infrequent meetings, particularly if periodic schedules are not met.

GENERATING EMPLOYEE COOPERATION

When the OSH program has been established, it is necessary to assure that all school employees (particularly those for whom OSH responsibilities are secondary to other job duties) participate and cooperate in carrying out the program.

One method of gaining employee support is involvement in the program. For instance, employees can be given responsibility for identifying and correcting hazards in their own work areas

by conducting routine inspections. They also can be asked to participate in writing rules and regulations for their jobs, thereby recognizing their knowledge. The committee concept can be used as a formal mechanism for gaining input from employees.

A second, more formal approach directed at employee involvement is the modification of written job descriptions to indicate the addition of OSH program responsibilities. This is advisable whenever OSH responsibilities constitute a significant modification of or addition to the employee's present duties.

Another means of increasing employee cooperation is through training. Often poor cooperation is due to a lack of understanding and skill on the part of the employee. Increased knowledge and skill generally go hand in hand with increased acceptance of the OSH program.

A fourth and most powerful influence on an employee's willingness to cooperate is the behavior and attitude of the employee's supervisor. The supervisor generally is responsible for training the employee on the job and for communicating the wishes and values of the administration. The supervisor sets the example. Therefore, supervisors must be convinced that carrying out the safety and health program is in their interest, so that they will convey this message to their subordinates. There are three basic ways the behavior and attitude of supervisors can be improved. First, supervisors can be given authority for carrying out OSH program activities in the area under their control. Second, part of the supervisor's performance evaluation can be dependent upon the extent of cooperation offered the program by their areas. Third, the OSH efforts of the supervisor should be adequately rewarded through recognition or additional responsibility when OSH goals are achieved. In these three ways, the supervisor's attitude and behavior with regard to the OSH program can be improved and, consequently, greater cooperation can be generated among other employees.

There is a fifth way to generate employee cooperation. Employees should be made aware of the fact that following OSH procedures are a condition of their employment. Formal procedures should be developed to discipline employees who do not obey school OSH regulations. Taking such measures may protect the institution from OSHA citations for violations resulting from employee negligence. Under the OSH Act, it is

quite clear that the responsibility for complying with safety and health regulations rests with the employer, even if the violation resulted from employee negligence. However, some organizations have been successful in contesting OSHA citations and penalties resulting from employee negligence when they were able to prove that adequate OSH procedures were developed, that sufficient training was provided, and that the disciplining of employees for failure to follow OSH procedures was fair and consistent.

In considering various methods for generating employee cooperation, the OSH program planners, administrators, and staff should use existing channels of communication and work within the organization. If certain employee groups are unionized, then changes in working procedures must be carefully worked out with employee representatives. It will be advantageous to stress the benefits of the OSH program to employees and specify the changes it may require in working procedures.

EMERGENCY PLANS

Emergency plans to cope with natural disasters (e.g., tornado conditions, earthquakes, and hurricanes), gas leaks, fires, bomb threats, public disturbances, and other emergency situations are desirable. Protection of employees, students, and visitors is essential. Good preparation and training can be valuable in averting panic and enhancing rapid and safe evacuation.

Emergency operation plans should be written. This requires clear and thorough planning and coordination so that people aren't working at cross purposes during an emergency.

The written plan should delegate specific responsibilities so that everyone knows exactly what is expected of them. The written plan also provides a permanent record for periodic reference. Above all, you should test the plan before it is needed. It is too late when the disaster strikes.

These are some items you may want to include on your disaster program checklist:

- a written policy statement
- types of disaster expected
- school layout
- relationships with disaster and welfare agencies

- emergency organization chart
- description of school warning system
- emergency shutdown procedures
- evacuation routes, including directional signs
- shelters for employees
- participation in mutual aid associations
- alternate school headquarters
- utility repairs

OSH MAINTENANCE

Maintenance is an important aspect of an OSH Program which is often overlooked. In addition to assuring maximum operation of equipment and facilities at minimum cost, proper maintenance will provide the safest possible working conditions for employees. Unsafe conditions are often due to insufficient or improper maintenance and result in accidents causing injuries, costly property damage, or both. Instances in which poor maintenance can lead to accidental injury or damage to equipment are numerous. The following are typical examples:

- Rough or slippery floors and floors with holes, splinters, and poor patching contribute heavily to the sources of injuries that are most common — namely, handling, slipping, tripping, and falling. Such defects also often contribute to “machinery” injuries.
- The condition of all portable equipment that persons climb or stand on or work from is important from a safety standpoint. This equipment includes portable ladders, steps, saw horses, scaffolds, planks, etc.
- Defective tools are prolific sources of injury. This applies not only to familiar hand tools such as chisels and wrenches, but also, because of their increased use, to powered hand tools such as grinders and drills.
- Unless properly maintained, machine guards and safety devices not only fail to protect but also give a false sense of security, which may be worse than no protection at all.
- A higher standard of maintenance than is necessary for educational purposes may be vital to safety. For instance, clutch wear may cause a machine to start unexpectedly.
- Electric wiring becomes unsafe not only from use, but from temporary repairs, alterations, or additions. “Temporary” jobs tend to become permanent unless carefully limited to necessities and immediately made standard when the emergency has passed.

- Windows, lights, and reflectors may become dirty, and light bulbs may be burned out.
- The ventilation for the shop or laboratory may not be properly adjusted, with screen filters not replaced or the ventilator overloaded.

Maintenance can operate in two ways: (1) routine corrective maintenance necessary on a day-by-day basis to keep equipment clean and operating, and (2) preventive maintenance which involves overhaul of equipment on a predetermined schedule before breakdown occurs. These two approaches to maintenance differ only in the way they operate, and some overlapping is usually involved.

Routine Corrective Maintenance

Routine corrective maintenance is required primarily to keep equipment and the working area in the same operating condition without a major change. Routine maintenance is intended to preserve the status quo, rather than to detect and correct conditions which may cause future trouble. If the conditions are good, maintenance keeps them that way; if conditions are not good, routine maintenance will not improve them. When a condition is uncovered which points to future breakdown, it should be routinely repaired, but all too often repairs are made only after the breakdown occurs. Routine maintenance involves a variety of things - oiling of machinery, disposal of scrap, inspecting condition of tools, a general clean-up, minor repairs of machines and equipment after a breakdown, and similar activities.

The fact that maintenance is routine does not detract from its importance, either in maintaining a training program or preventing injuries. It is an important activity and will assist in creating an efficient, safe working environment. But a good maintenance program should be planned and organized in the same way as any other activity. In planning and organizing, consideration should be given to at least these five steps:

- Develop effective procedures to cover all maintenance activities.
- Formulate schedules to cover repetitive operations, such as lubrication of machines, cleaning windows and lighting fixtures, and disposal of scrap.
- Establish a procedure for handling nonrepetitive jobs, such as repairs or installation of machines.
- Arrange to have frequently needed spare parts on hand for equipment repair.

- Develop a follow-up system to assure that procedures and schedules are followed.

The importance of routine maintenance should not be underestimated. When properly planned and organized, it can be a positive factor in controlling accidents in school shops and laboratories.

Preventive Maintenance

Preventive maintenance has a different purpose than routine maintenance. It aims to prevent conditions from arising which could result in costly delays due to the breakdown of equipment. Such conditions can be detected through inspection and prevented by periodic overhaul or replacement. The inspection or overhaul provides a sound basis for scheduling work to avoid rush handling of emergency jobs involving excessive overtime.

Preventive maintenance may be defined as an orderly, uniform, continuous, and scheduled procedure to prevent breakdown and prolong the useful life of equipment and buildings. Some advantages to be gained from preventive maintenance include decrease of "down time" of equipment due to breakdown, reduced repair costs, increase in the life of the equipment, more training time on the equipment available, and safer working conditions.

In determining whether a system of preventive maintenance is worthwhile, the following questions need to be considered:

- Does the cost in inspection exceed the cost of repair and the value of down time?
- Will the normal life of the equipment exceed what is required without preventive maintenance?
- Does the good condition of the equipment contribute to safe working conditions?
- Is the equipment critical to the training process?
- Is standby equipment available for continuing the training process in case of failure?

If the answer to questions 1, 2, or 5 is yes, the need for preventive maintenance is doubtful. If the answer to 3 or 4 is yes, the need is at once apparent. Under most conditions, preventive maintenance is necessary to maintain training facilities, and it is almost always necessary to eliminate dangerous conditions involving mechanical equipment.

Successful preventive maintenance in school shops and laboratories involves at least the following factors:

- Regular systematic inspections of all machines, equipment, and the premises.
- A program of periodic replacement of essential equipment or parts.
- Keeping records of inspections, replacements, and findings.
- Repairs and replacements made as indicated from inspections or in accordance with replacement schedules.
- Periodic evaluation of the progress of the maintenance program.

A preventive maintenance program, rather than a simple repair system, will result in considerable savings in training time. It will also reduce the number of accidents. Many school injuries are charged to training hazards, but the true cause may often be poor maintenance; proper maintenance would have eliminated the hazard and, consequently, the resulting accident. But preventive maintenance does more than reduce injuries due to accidents. It promotes orderly and economic training; it controls equipment losses; it helps improve training methods generally. Good maintenance also promotes proper use of tools, equipment, and machines. Adequate tool storage with inspection and dispensing procedures assures the use of the right tool for a job, one properly dressed or sharpened and in overall satisfactory condition. When safe and properly maintained tools are issued, workers have an added incentive to give the tools better care. Preventive maintenance is a conservation program at the training level, a systematic method of saving which will return dividends in training and in accident prevention.

SELECTION, PROCUREMENT, AND PLACEMENT OF MACHINE TOOLS AND HAND TOOLS

Because of highly competitive marketing, some manufacturers of machine tools find it advantageous to list safety devices designed for the protection of operators as auxiliary equipment. School shop personnel must be familiar with such items and assure that they are included in the original purchase order. If adequate guarding is not provided on machinery by the manufacturer, this does not relieve the school of its responsibility for proper guarding.

Attention must also be given to the quality of materials and construction of the many hand tools purchased for the school shop. A quality-built tool is the safe tool, and quality must not be sacrificed for the sake of the budget. Electric hand tools must be equipped with ground wires, and connections, plugs, terminals, and wires should be checked to see that all are of approved construction.

In general, the safest machine is the best machine available to do the job. A safety checklist for use in selecting machine tools might well include the following points:

- Is the machine designed so that it is impossible for the operator to be exposed to the point-of-operation or any other hazard point while the machine is operating?
- Is the machine designed so that, wherever possible, all corners are rounded and no sharp corners or edges are exposed?
- Are the machine controls located so that the operator will not be near the point-of-operation while operating the controls?
- Are the controls placed so that the operator will not have to reach excessively or be off-balance to operate the machine?
- Are the power transmission and drive mechanism built in as integral parts of the machine?
- Are overload devices built into the machine?
- Is the machine designed for mechanical rather than manual holding devices?
- Are all electrical components of the machine grounded?

Placement of Equipment

The importance of providing adequate space around equipment has already been noted. However, care must be taken to locate equipment in such a way that there is no interference between the operations and the operators. Machines should be placed at a 45° angle to window walls in order to secure the maximum effect from natural light. The angular placement also places operators out of alignment with the revolving spindles of machines adjacent to them and thereby reduces the danger from accessories or materials which may be thrown from neighboring equipment.

The maximum size of materials to be worked in a machine should be determined, since additional space may be needed.

A lathe to be used for machining long bars fed through the head stock obviously needs more space to the left of the machine than one which is to be used only for chuck work. Certain machines, such as the metal working planer and shaper, need to be placed so that sufficient clear space remains when tables or rams are operating at their maximum distances. All heavy equipment should be leveled and securely fastened to floors. The placement of felt, cork, rubber, or other shock-absorbing material under machines is recommended in order to reduce the noise level. Certain machines, such as cutoff saws and shears, should be placed near the material storage areas in order to reduce hazards from handling large pieces of stock.

Methods used in placement of equipment usually involve scaled drawings of floor plans indicating fixed obstructions such as supporting pillars in walls, window and door openings, and the relationship of the room to other service areas. Showing the relative location of all equipment and facilities on a drawing is known as the "single dimension method." The "two-dimensional method" is probably most frequently used and involves arranging flat patterns on the floor plan drawing. The patterns are to scale and in the shape of the floor area required for each item of equipment. A more revealing technique is to make use of three-dimensional scale models of equipment set up on a drawn-to-scale floor plan. Some equipment manufacturers furnish models upon request, and other models may be carved from soft wood, or made from cardboard. The planner should make several alternative layouts before deciding which will be implemented. The introduction of a single item of equipment may demand the rearrangement of the entire floor plan, but additional equipment or a change in emphasis or procedure will require adjustment of the layout without jeopardizing the safety considerations already in effect.

Special Hazards

In almost every shop there are certain pieces of equipment, kinds of materials, or specific processes that deserve extra attention for the protection of workers. In many instances, special shielding of certain equipment and isolation of hazardous processes are required. Welding areas must be isolated to protect nearby persons from flash, burns, and fumes. Foundry and heat-treating areas should be located so as to avoid injury. Hand chipping of metal and machining operations that result in flying chips require isolation or special shielding. Areas

such as electroplating and etching, where acids and chemicals are used, need precautionary treatment. Paint and spray areas demand an efficient exhaust ventilation system, as well as an isolated location. An exhaust system is also needed wherever auto or other engines are running. The relatively high speeds of portable and stationary grinding machines and the possibility of the wheel breaking require the segregation of these machines from others in the shop.

TECHNICAL-REGULATORY GUIDELINES

This section is a review of OSHA regulations which apply to general conditions and operations. The important points of each standard are summarized and, where possible, are listed in the same sequence as the OSHA safety and health standards (29 CFR 1910). Note that recognized hazards which are not yet covered by these regulations must still be controlled, even though there are no specific standards governing them. Also, while some of these standards may not apply to your particular school, additional standards (depending on the specific programs and materials you use) may be applicable.

The control methods discussed in this section are only suggestions as to how hazards may be corrected. Further assistance may be obtained from your state occupational safety and health agency, NIOSH regional consultant, or OSHA area office. Consultation with OSHA compliance officers anywhere off your school site (including an OSHA office), or with NIOSH regional industrial hygienists onsite or elsewhere, is encouraged and will not trigger a compliance inspection of your facility. The addresses and phone numbers for the NIOSH and OSHA regional offices are listed at the end of this booklet. For detailed information on control of noise or air contaminant levels, machine guarding, etc. — where specific designs are sought — you may need the services of a professional consultant.

WALKING AND WORKING SURFACES

All work areas, passageways, storerooms, and service rooms must be kept clean, orderly, sanitary, and as dry as possible. All spills should be cleaned up promptly. Floors in work areas must be kept free of scrap, chips, oil and coolant spills, and other debris.

Constantly wet areas should have nonslip surfaces or mats where employees must walk or work.



Every floor, working place, and passageway must be maintained free from protruding nails, splinters, holes, and loose boards.

Where mechanical handling equipment such as a lift truck is used, sufficient safe clearance must be provided for foot and vehicular traffic.

No obstruction that could create a hazard is permitted in the aisles.

All permanent aisles must be easily recognizable.

FIXED LADDERS

Fixed ladders must be designed to withstand a single concentrated load of at least 200 pounds.

Rungs of metal ladders must have a minimum diameter of $\frac{3}{4}$ inch. Rungs of wood ladders must have a minimum diameter of $1\frac{1}{2}$ inches.

Rungs must be at least 16 inches wide, be spaced no more than 12 inches apart, and be free of splinters and burrs.

Ladders, when their construction and location so requires, must be treated with a preservative to resist deterioration. Note that paint will not adequately preserve a wooden ladder.

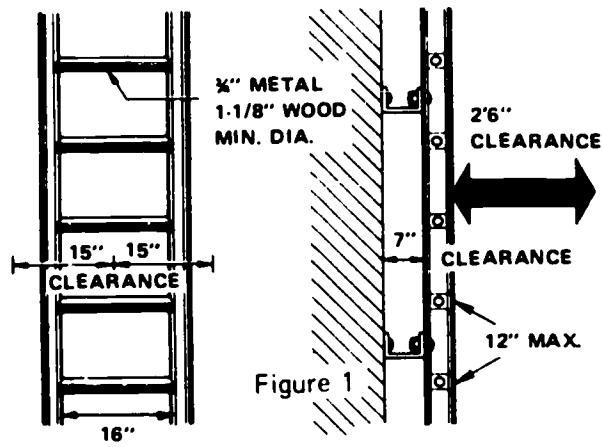

The preferred pitch for safe descent is 75° to 90°. Unless caged, or equipped with a ladder safety device, ladders with 90° pitch must have a 2½ foot clearance on the climbing side.

There must be at least a 7-inch clearance in back of the ladder to provide adequate toe space.

Vertical ladders must have either cages or a ladder safety device if they are more than 20 feet long.

Unless a ladder safety device is used, landing platforms must be provided on ladders greater than 20 feet long. A platform is required every 30 feet for caged ladders and every 20 feet for unprotected ladders (when no ladder safety device is used).

PORTABLE LADDERS

Portable ladders must be maintained in good condition at all times with tight joints, securely attached hardware and fittings, and freely operating moveable parts. They should be kept coated with a suitable protective material. (OSHA may eliminate the preservative requirement. Check with your OSHA area or regional office for details.)

They must be inspected frequently. Defective ladders must be tagged "Dangerous - Do Not Use" and removed from service for repair or destruction. Ladders with broken or missing

steps, rungs, or cleats, cracked or broken side rails, or other faulty equipment must not be used.

Ladders must not be used near energized electrical equipment.

All ladders must be placed so that they have a secure footing. They may not be placed on boxes, barrels, boards, bricks, or other unstable bases to obtain additional height. Nonslip bases should be used.

Any purchase order for ladders should include the requirement that they meet OSHA standards.

FIXED INDUSTRIAL STAIRS

Riser height and tread width must be uniform throughout any flight of stairs.

All treads must be reasonably slip-resistant.

Vertical clearance above any stair tread to any overhead obstruction must be at least 7 feet, measured from the leading edge of the tread.

The minimum permissible width is 22 inches. (If the stairs are a means of exit access, they must be at least 28 inches wide.)

The angle to the horizontal made by the stairs must be between 30° and 50° .

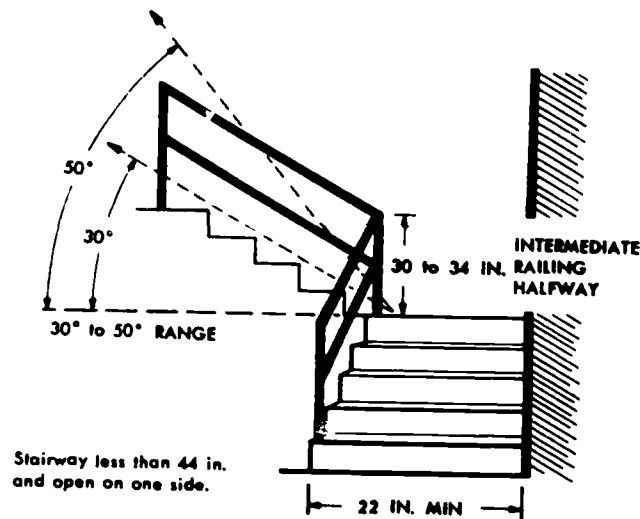

17

38

All stairs should be adequately lighted.

If the tread is less than 9 inches wide, the risers should be open.

If the flight of stairs has four or more risers:

- a stair railing on each open side is required;
- a handrail on each enclosed side is required if greater than 44 inches wide;
- if both sides are enclosed on a stairway less than 44 inches wide, at least one handrail is required, preferably on the right side descending; and
- if the stairway is 88 or more inches wide, an intermediate stair railing located midway is required.

The vertical height of the railing must be 30 to 34 inches. The construction must be similar to the standard guardrail described later in this section.

THE STANDARD GUARDRAIL AND TOEBOARD

A standard guardrail consists of a top rail, intermediate rail, and posts. The distance from the upper surface of the top rail to the floor, platform, runway, or ramp must be 42 inches. The intermediate rail must be approximately halfway between the top rail and the floor.

A standard guardrail can be of any configuration and construction that meets the basic dimension requirements (42 inches high with midrail) and can withstand 200 pounds applied in any direction at any point on the top rail. For wood railings, the rails and posts must be at least 2- by 4-inch stock, with posts spaced not more than 6 feet apart. For pipe railings, rails and posts must be at least 1½ inch outside diameter pipe, with posts spaced not more than 8 feet apart. Structural steel railings and posts must be of 2- by 2- by ¼-inch angles or other metal shapes of equivalent strength, with posts spaced not more than 8 feet apart.

The standard toeboard must be approximately 4 inches high from the floor to its top edge, with no more than a quarter-inch gap between the toeboard and the floor. It may be constructed of any substantial material—either solid or perforated—as long as any openings are smaller than 1 inch.

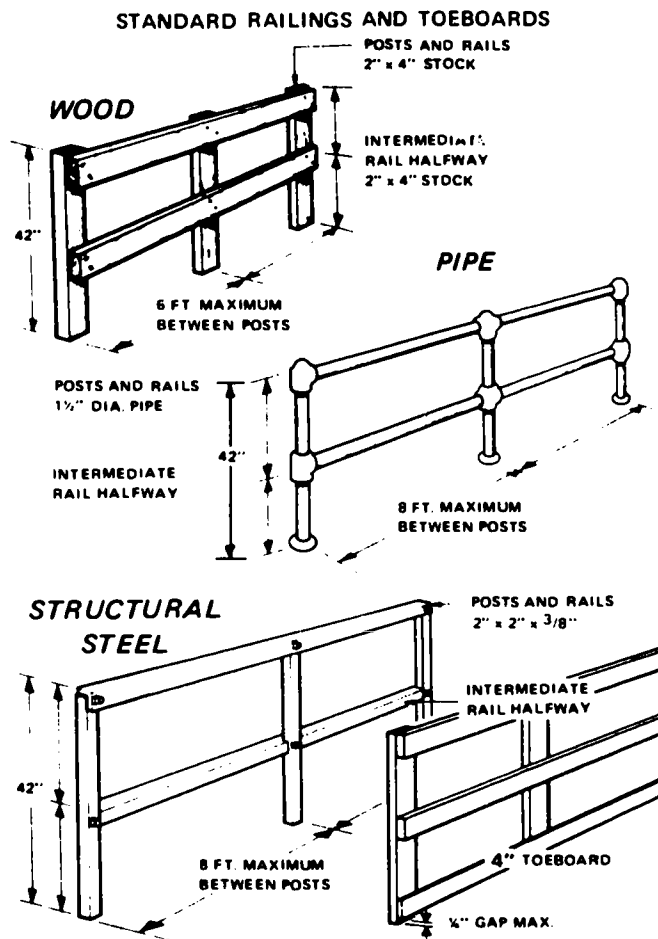

WHERE A STANDARD GUARDRAIL IS REQUIRED

A standard guardrail is required at—

Every open-sided floor or platform 4 feet or more above the adjacent floor or ground level must be railed on all open sides, except where there is entrance to a ramp, stairway, or fixed ladder.

Every stairway floor opening must be guarded on all open sides, except the entrance to the stairway.

Every ladderway floor opening must be guarded by a standard railing and toeboard on all sides, with passage through the railing constructed so as to prevent a person from walking directly into the opening.

Every runway or catwalk four feet or more above ground level must have railings on all open sides.

As a general condition, a standard toeboard and guardrail are required wherever people walk beneath the open sides of a platform or under similar structures or where things could fall from the structure (for example, into machinery below).

GENERAL REQUIREMENTS FOR ALL SCAFFOLDS

All scaffolding must have solid footing or anchoring capable of holding the intended load without settling or shifting. Unstable objects such as barrels, loose bricks, blocks, or boxes must not be used to support scaffolds or planks.

Guardrails and toeboards must be used on all open sides and ends of platforms which are more than 10 feet above the ground

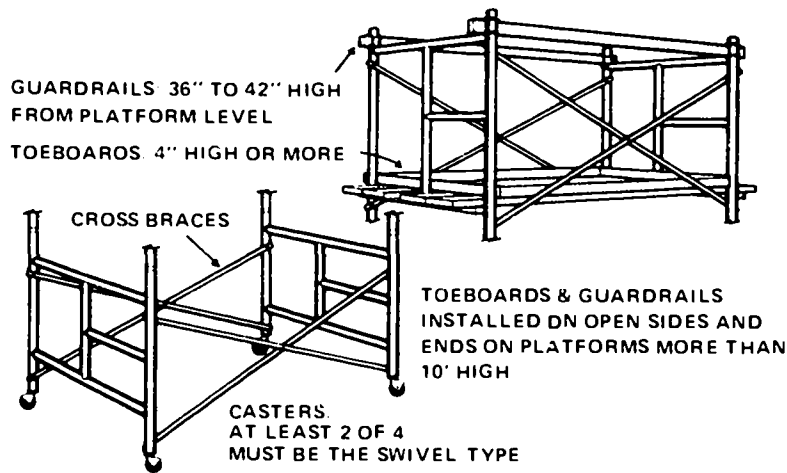

or floor (except needle beam scaffolds and floats). Scaffolds 4 to 10 feet high which are less than 45 inches wide must also have guardrails.

Scaffolds and their components must be able to support at least four times the maximum intended load. Wire or fiber rope used for scaffold suspension must be capable of supporting at least six times the intended load.

All planking or platforms must be overlapped at least 12 inches or secured from movement.

Planks must extend over the end supports not less than 6 inches or more than 18 inches (not more than 12 inches at construction sites), and should be secured from falling off the platform.

Planks must not be placed on guardrails to obtain greater heights.

Scaffolds must be secured when in use and must not be moved when in use or occupied.

All scaffolds must be maintained in a safe condition at all times. Unsafe scaffolds should be removed from the site for disposal or the defective parts immediately replaced or repaired.

The poles, legs, or uprights of scaffolds must be plumb and securely and rigidly braced to prevent swaying and displacement.

Planking must be scaffold grade for the species of wood used. The maximum permissible spans for 2- by 10-inch or wider planks are as follows:

MATERIAL					
	Full thickness undressed lumber			Nominal thickness lumber	
Working load (p.s.f.)	25	50	75	25	50
Permissible span (ft.)	10	8	6	8	6
The maximum permissible span for 1½ x 9 inch or wider plank of full thickness is four feet, with medium loading of 50 p.s.f.					

ROLLING SCAFFOLDS

When free-standing mobile scaffolds are used, the height must not exceed four times the minimum base dimension.

Rolling scaffolds must be properly braced by cross bracing and horizontal bracing.

Casters must be properly designed for strength and have locking devices. At least two of the four casters or wheels on rolling scaffolds must swivel.

Platforms must be tightly planked for the full width of the scaffold (except for the entrance opening) and the planks must be secured in place.

A ladder or stairway built into or affixed to the rolling scaffold is required for proper access and exit and a landing platform must be provided at intervals not to exceed 35 feet.

Rolling scaffolds must rest upon suitable footing when in use, with the locking devices on casters in the locked position.

As a general rule, no one should be allowed to ride on manually propelled scaffolds.

SAFETY BELTS, LIFELINES, LANYARDS, AND NETS

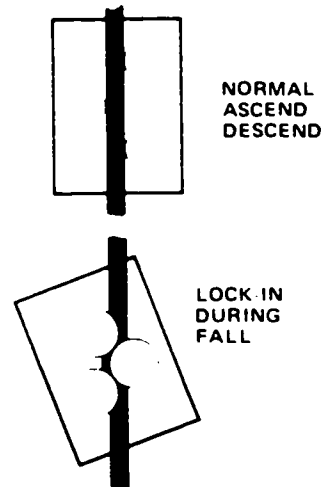
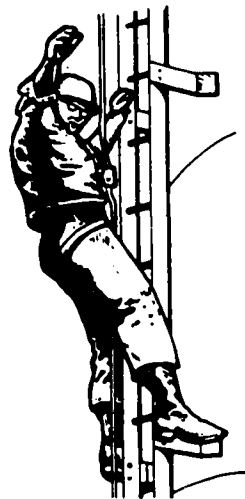

All safety belts, lifelines, and lanyards must have a breaking strength of 5,400 pounds and the hardware be capable of withstanding a minimum tensile loading of 4,000 pounds without breaking, ripping, or any permanent deformation. Such equipment must be anchored to a structural member capable of supporting 5,400 pounds of dead weight.

Where the use of scaffolds, ladders, safety lines, or belts is impractical, safety nets must be provided when persons are exposed to heights greater than 25 feet.

Operations where nets are required must not be undertaken until the net is in place and tested.

EXCAVATING AND TRENCHING

Prior to excavation, any underground utilities in the area must be located and protected during the operation. Utility companies or local regulatory agencies, as appropriate, must be contacted for advice on location and protection and for appropriate permits or approvals necessary prior to excavation.

The walls and faces of excavations and trenches over 5 feet deep, where workers may be exposed to danger, must be guarded by a shoring system, sloping of the ground, or some other equivalent means. Trenches less than 5 feet deep with hazardous soil conditions also must be effectively protected.

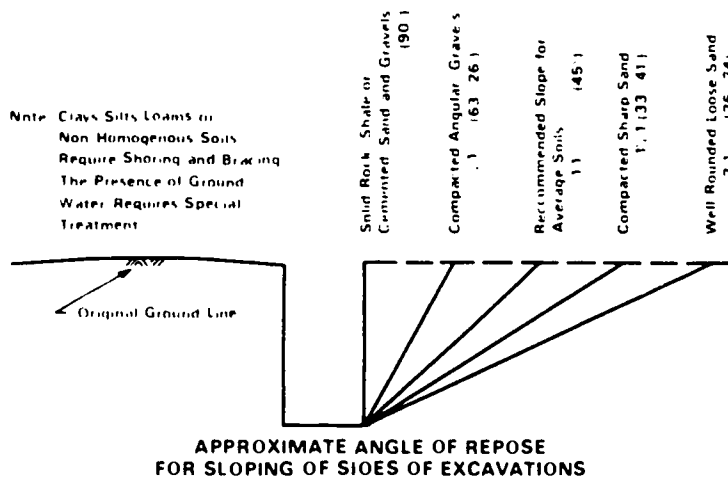

Appropriate trench boxes or shields may be used in lieu of shoring or sloping to prevent cave-ins and entrapment.

Tools, equipment, and excavated material must be kept 2 feet or more from the lip of the trench to avoid the dangers of falling and wall instability.

Daily inspections must be made of trenches and excavations by a competent person to assure adequate slopes, shoring, and bracing, and to check for evidence of possible slides or cave-ins. More frequent inspections may be necessary as work progresses or after inclement weather conditions, such as rain.

Ladders or steps must be located so as to require no more than 25 feet of lateral travel in trenches 4 feet deep or more.

Any runways and sidewalks must be kept free of debris and, if undermined, must be adequately shored to prevent a cave-in from any maximum loading.

Appropriate barricades and warning signs must be provided to prevent anyone from falling into excavations.

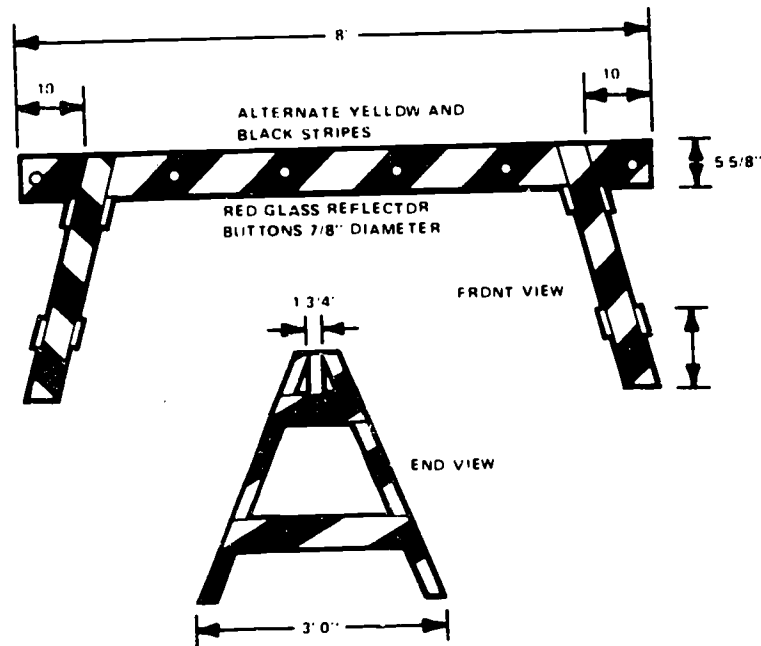

Example of Acceptable Barricade

EXIT AND EXIT MARKINGS

General Requirements

The exit route must lead to a public way.

Areas around exit doors and passageways leading to and from the exit must be kept free of obstructions.

Exit access must be arranged so that it is unnecessary to travel toward any area of high hazard potential in order to reach the nearest exit (unless the path of travel is effectively shielded by suitable partitions or other barriers).

A door from a room to an exit, or to a way of exit access, must be of the side-hinged, swinging type. It must swing out in the direction of travel if 50 or more persons occupy the room or if it is an exit from an area of high hazard potential.

No lock or fastening may be used which prevents escape from inside the building.

Exits must be readily accessible at all times. Where exits are not immediately accessible from an open area, every occupant of that area must have access to two exits by separate paths. These paths must be through safe passageways, aisles, or corridors which lead directly to the exits.

Size and Placement of Signs

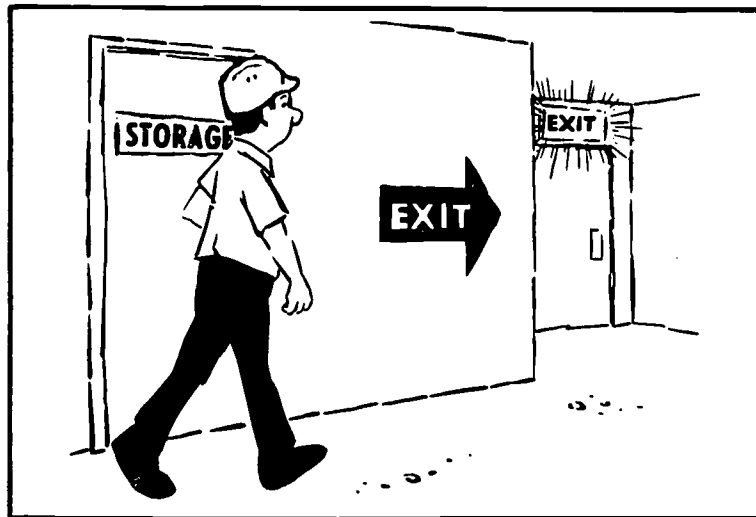

Every exit must be marked with the word "EXIT" in plain, legible letters not less than 6 inches high with the strokes of the letters not less than 1/4 inch wide.

The visibility of the sign must not be impaired by decoration, furnishings, or other signs.

Doors, passageways, or stairways which are neither exits nor ways to an exit, but may be mistaken for an exit, must be clearly marked "NOT AN EXIT" or with a sign indicating their actual use, e.g., "STORAGE ROOM" or "TO BASEMENT."

In areas where the direction to the nearest exit may not be apparent, an exit sign with a directional arrow must be used.

Exit signs must be illuminated by a reliable light source if occupancy is permitted at night, or if normal lighting levels are reduced at times during working hours.

OCCUPATIONAL HEALTH AND ENVIRONMENTAL CONTROLS

In some cases, health hazards are not recognized because some materials used are identified only by trade names. Also, some materials contain mixtures of substances, making identification still more difficult. If the composition of a material cannot be determined, the information should be requested from the manufacturer or supplier. In many instances, they can provide Material Safety Data Sheets for the products. These sheets contain information such as the hazardous concentration level and physical characteristics of the substance, requirements of personal protective equipment, emergency procedures, and reactivities with other substances.

In identifying occupational health hazards, job hazard analyses should be made showing the substances used, the number of workers at risk, products formed, and any byproducts generated. The form of the products and byproducts should be noted, i.e., a liquid, dust, vapor, mist, gas, or fume. The most likely routes of entry should also be noted, i.e., by mouth, skin, or inhalation. Methods of controlling exposure should then be noted.

A job hazard analysis may be made of each operation, or for the department as a whole. The survey should evaluate present conditions. Related activities, such as maintenance and service

operations, should also be examined for health hazard potential. Some examples of unsuspected hazards are:

- Welding performed around chlorinated materials (e.g., trichloroethylene). This may cause the formation of toxic gases in addition to welding fumes.
- Generation of carbon monoxide and other hazardous exhaust gases by forklift trucks with internal combustion engines.
- Formation of chlorine and other poisonous gases when certain cleaning agents are mixed.

After completing the job survey, evaluate all exposure substances listed for their hazard potential. You should also determine if present controls are adequate. Measuring air contaminant levels and evaluating controls (particularly ventilation) may require outside consultation in some cases. After the evaluation is completed, any required controls should be provided.

The following job health hazard analysis illustrates a survey of a paint spray operation.

JOB HEALTH HAZARD ANALYSIS ¹					
Operation: Spray painting			Page: 1		
Date: 8/8/77					
Number of employees	Job Title	Exposure Substance	Form ¹	Route of entry ²	Control ³
5	Spray painters (in spray booth)	No. 413 Spray paint	L	S	G (rubber)
			V	I	LV
			M	I	LV
		Toluene	L	S	G (rubber)
			V	I	LV
			M	I	LV
Spray painters (assembly line)	No. 212 Orange	L	S	G (rubber)	
		V	I	R (organic filter)	
		M	I	R (organic filter)	

1) Form: D = dust, L = liquid, V = vapor, G = gas, F = fume, M = mist
 2) Route of entry: S = skin, I = inhalation
 3) Control: LV = local ventilation, GV = general ventilation, R = respirator (type)
 G = gloves (type), F = face protection, O = other protection (type)

Various control methods can be used to prevent or reduce employee exposures. Some of these methods, which can be used singly or in combination, are:

- Substitution of less toxic materials — use of fiber glass for asbestos as insulation.
- Change of a process—e.g., automating a manual operation. Isolation — placing the hazardous process in a separate room or in a corner of the building to reduce the number of persons exposed.
- Ventilation—either local exhaust ventilation where contaminants are removed at the point of generation, or, if the air contaminant has a low order of toxicity, general dilution ventilation. (See "Ventilation.")
- Administrative controls—as a temporary measure, limiting the total amount of time an individual is exposed to a health hazard and rotating two or more workers.
- Training and education—telling workers what hazards they are exposed to and how to reduce or limit exposure.
- Personal hygiene—this cannot be over-emphasized. Workers should wash their hands before eating and they should not be permitted to eat around toxic chemicals or in contaminated areas. If chemicals such as caustics, epoxies, and resins get on the skin, they should be washed off immediately. Clothing should be changed and washed daily if it becomes contaminated with toxic chemicals, dusts, fumes, or liquids.
- Personal protective equipment—use of such items as respirators, hearing protection devices, protective clothing, and protective equipment.

Occupational Noise Exposure

Excessive noise is one of the most commonly violated standards and can cause permanent hearing damage. It is management's responsibility to make sure no one is exposed to noise levels in excess of the standards. The current standard is 90 decibels A-weighted (dBA) for an 8-hour exposure. Even at this noise level, hearing damage can be expected in some individuals. It may soon be a requirement, and it is considered good practice, to give annual hearing tests to all persons exposed to 85-90 dBA noise levels for 8 hours daily. If no hearing loss is observed, ear protection is not required.

At greater than 90 dBA exposures (8 hours per day) or for higher noise levels in excess of the allowable times (e.g., 100 dBA for more than 2 hours), an effective hearing conservation program must be administered. The following table gives

estimates of noise levels and the maximum allowable exposure times. It is necessary that either engineering controls, such as enclosing noisy equipment, or administrative controls, such as limiting time of exposure, be used to reduce noise levels or the exposure time to comply with the standard. If these control measures are not feasible, effective personal protective equipment is required. There are many forms and types of ear protection that can be considered, from ear muffs to ear plugs. Some are more useful than others, depending on the noise level, the frequency of the noise, and how well they fit the individual. It is necessary to provide protection that is effective and reasonably comfortable to the wearer.

If reference to the accompanying table indicates that levels and times of exposure are such that corrective action is needed, professional help should be sought to correct the problem. A noise survey by adequately equipped and trained personnel should be made before implementing engineering and administrative controls or setting up a hearing conservation program.

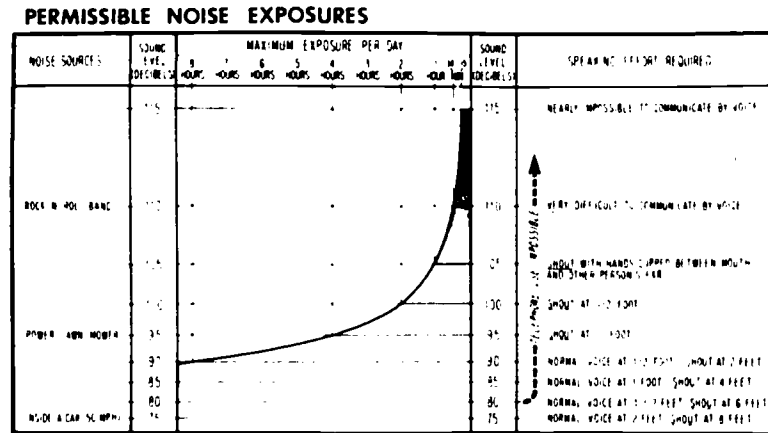

Ventilation

Mechanical exhaust ventilation is, in most cases, the first choice for control of air contaminants which are potential health hazards. A properly designed local exhaust or dilution ventilation system will either remove air contaminants which may be present, or lower the concentration of fumes, vapors,

dusts, mists, or other contaminants generated in the working environment to reduce or eliminate health or fire hazards.

Local exhaust ventilation removes the hazardous materials at or near their point of origin and prohibits them from being drawn through the breathing zone of the worker. Local exhaust ventilation is the preferred type as it usually performs more efficiently and prevents air contaminants from being circulated through the entire work area.

General dilution ventilation depends upon pulling a sufficient volume of air through the work area to dilute the contaminants to a lower, or nonhazardous, level. Dilution ventilation requires a greater volume of air movement for efficient operation than does a local exhaust system.

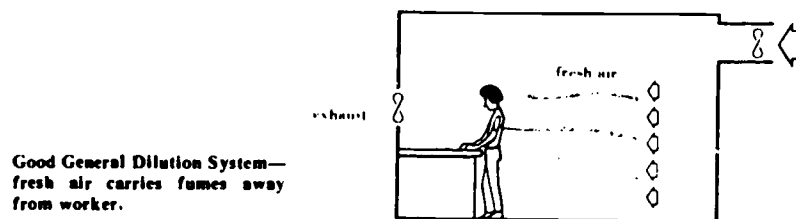
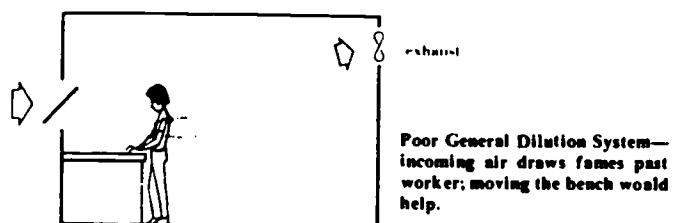

Local exhaust systems should be installed wherever a large volume of air contaminant is generated or where a particularly hazardous substance is used. Some operations which usually require the use of local exhaust ventilation are welding, spray painting, woodworking, and processes involving the use of lead, mercury, resins, asbestos, beryllium, and flammable liquids.

General dilution ventilation is an effective control for areas generating low concentrations of hazardous substances. It may effectively be used in some flammable liquid storage areas or with low hazard potential substances.

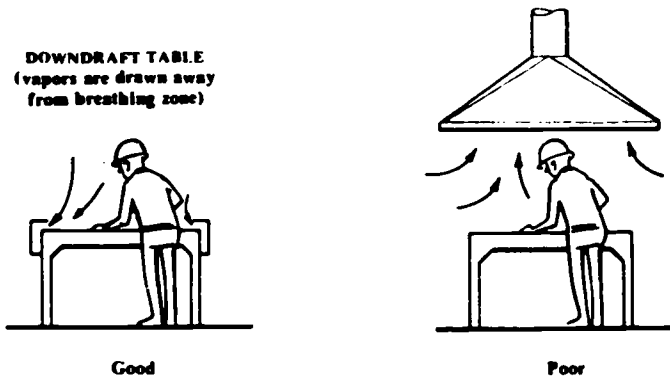

The design of ventilation systems is somewhat detailed, involving determination of the volume of air which needs to be moved, the type of fan which will adequately exhaust the air volume, the placement of the exhausts, makeup air, and the positioning of the system. A mechanical engineer should be consulted to assist in providing an effective environmental control through the use of a ventilation system.

Chemical Handling

Whenever hazardous chemicals are used, certain precautionary measures should be adopted to reduce the hazard to persons who work with or around them. The most important point is to limit or avoid contact with chemicals as much as possible—to prevent direct skin contact, inhalation of vapors, dusts or mists, and to prevent ingestion.

A training program should be established as the first step in controlling exposure. Environmental controls, process controls, personal protective equipment, and emergency eye wash and shower facilities are also important in areas where chemicals are used extensively.

An effective training program should include the following points:

- the physical characteristics of the chemicals used, their possible reactivity with other substances, and their flammability
- toxic properties, symptoms and effects of overexposure
- proper techniques and practices for handling, storing, mixing, and disposal of hazardous chemicals

- good personal hygiene habits necessary to limit effects of exposure (e.g., changing splashed clothing immediately and frequent washing of exposed skin surfaces)
- the types of personal protective equipment that may be needed, the reasons for its use, and how to use and maintain it properly
- correct emergency procedures to follow in case a splash or spill occurs.

Local exhaust and general dilution ventilation systems operate as environmental controls to reduce the amount of chemical contaminants in the air of the work area, to remove vapors, dusts, and mists at or near their point of origin, and to reduce fire and explosion hazards.

Process controls include enclosing operations and covering and guarding open tanks, pits, and vats.

Personal protective equipment may be used as an additional method of protection. The equipment chosen must suit the individual exposure. If the hazard is primarily through skin contact, then aprons, gloves, and sleeves will be required; if there is the danger of splashes to the eyes, goggles and a face shield are needed; if the chief hazard is through inhalation, then respirators must be used. The proper type of equipment is also important. Rubber is impervious to acids but may be ineffective for organic solvent exposure. Respirators which are suitable for dust control are not at all effective for mists or vapors of solvents. In some cases, a supplied-air respirator must be used.

The degree of hazard a chemical presents (its toxicity) also influences the type and amount of personal protective equipment required. Those having more severe effects require the use of more equipment.

Eye wash and shower facilities must be readily available for immediate emergency use. They must be located throughout the work areas where hazardous chemicals are used, and persons must be instructed in correct emergency procedures to follow.

Entry to Confined Spaces

Tank Entry and Cleaning

The following general rules apply whenever anyone must enter vats, tanks, or other confined spaces:

- Completely drain the tank of all contents.
- Flush the tank thoroughly by filling with water and, if necessary, hose down with steam to remove particulate matter (e.g., fats).
- Close and lock all valves leading to the tank.
- Forced-air ventilation is usually required, and should preferably be applied from the bottom.
- Test for the presence of toxic gases or explosive atmosphere.
- Test for sufficient oxygen.

When it has been determined that the atmosphere within the tank is free of toxic or explosive gases and contains sufficient oxygen, these procedures should be followed for tank entry:

- Written permission to enter the tank must be obtained from the supervisor and posted at the entrance to the tank.
- All electrical equipment, belt drives, mixers, and agitators connected to the tank must be locked out.
- Forced-air ventilation must be applied through the tank.
- The person entering the tank must be equipped with a safety harness and lifeline, a supplied-air respirator, and other necessary personal protective equipment.
- There must be another worker on stand-by, equipped with a self-contained respirator and familiar with emergency procedures.
- The worker in the tank must be visible at all times to the person on stand-by.

All persons who either enter confined spaces or serve as stand-by workers must be thoroughly trained in the standard procedures as well as emergency procedures.

Entry and Cleaning of Sewers

From time to time, it may be necessary to enter sewers to clean them of waste products. As this organic matter decays, it produces toxic gases such as hydrogen sulfide, methane, and carbon monoxide. These products of decomposition replace the oxygen which may be present and the result is an oxygen-deficient atmosphere. Other toxic gases and vapors may also be present from the solvents and chemicals used in processes.

Whenever possible, sewers should be cleaned from the outside by pumping or dredging.

When it is necessary to enter a sewer for cleaning or repair, the following procedure should be used:

- If possible, flush the sewer with water or steam.
- Close and lock out all inlets to the sewer.
- Written permission from the supervisor to enter the sewer must be obtained and the permit posted.
- All flames and sparks or spark-producing equipment in the area of the cover must be extinguished or turned off.
- Only nonsparking tools may be used until tests have proven there are no explosive gases present in the sewer.
- Once the manhole cover is removed, a movable standard guardrail must be placed around the floor opening.
- Forced-air ventilation should be blown through the sewer.
- The sewer must be tested for the presence of combustible gases (use a combustible indicator).
- Test for the presence of hydrogen sulfide near the bottom of the sewer (hydrogen sulfide detector).
- Test to see if there is sufficient oxygen present (oxygen deficiency lamp or indicator).
- Test for the presence of carbon monoxide.

These tests must be performed at various levels in the sewer. For example, methane gas (explosive) is lighter than air and is usually found near the top. Solvent vapors, which may also be explosive, are heavier than air and will be found near the bottom. The oxygen deficiency and carbon monoxide tests must also be performed at various levels.

Only when tests have shown that there are no toxic or combustible gases present may the workers enter the sewer. Anyone who enters the sewer must be equipped with air-line (supplied-air) respirators and lifelines. Stand-by personnel must be equipped with self-contained respirators. Testing of the atmosphere in the sewer for combustible gases, toxic gases, and oxygen deficiency must be repeated at regular intervals, as long as anyone is working in the sewer. As they work, they may release hazardous gases into the air from under accumulated waste, or as waste is shoveled or hosed.

Harmful Materials and Processes

The following is a discussion of some of the harmful materials and processes which may be encountered in the school environment. For more information on chemicals, or for information on chemicals which are not listed, contact the manufacturer or supplier. They will frequently provide Material Safety Data Sheets which discuss the hazards a chemical may present, specific precautions to take when handling, storing, or using the substance, suggested control methods, and emergency and first aid procedures.

Acetic Acid

Acetic acid (sometimes called glacial acetic acid) is a colorless liquid with a sharp, vinegar odor and taste. It burns the skin quickly on contact, raises blisters, and can be injurious to the eyes if splashed into them. Breathing the vapors can cause coughing, chest pain, and irritation of the nose and throat. Flammable or explosive vapors may be formed as the result of heating acetic acid.

Eye wash fountains and safety showers must be provided in the areas where acetic acid is handled or used. Local exhaust ventilation may be necessary to remove vapors. Persons exposed to the hazard of splashes must wear a face shield and safety glasses. Protective clothing such as gloves, sleeves, and aprons may also be required.

Adhesives

Synthetic adhesives containing formaldehyde, neoprene, and epoxy resins may constitute a skin or respiratory hazard. Persons should be protected by ventilation systems and provided with suitable personal protective devices.

Ammonia

Ammonia is a colorless liquid or gas which has a characteristic odor and sharp taste and is used as a cleaning agent or as a refrigeration gas. Skin contact with ammonia produces burns; the vapors are irritating to the eyes, nose, throat, and lungs. Gas exposure occurs most often from refrigeration compressor leaks or when equipment is torn down for repair.

Local exhaust ventilation systems must be used to remove ammonia vapors at the point of origin. Persons who handle ammonia must be provided with protective clothing such as gloves, sleeves, and aprons, and proper eye and face protection (safety glasses and face shields) if they are exposed to the hazard of splashes of liquid. Approved respirators may be needed in some areas to control exposure to the vapors. A source of clean running water (for use as eye wash and safety shower) must be readily available in all areas where ammonia is handled.

Asbestos

Where individuals spend most of the day repairing brakes or machine linings to fit drums, they may be exposed to excess asbestos, unless precautions are taken.

Inhalation of excess asbestos fibers over a prolonged period of time can result in the development of a form of pneumoconiosis known as asbestosis. Primary symptoms of advanced asbestosis include variable cough, dyspnea, substernal chest pains, decreased chest expansion, weakness, clubbed finger tips, and curved fingernails. There is some evidence that persons exposed to asbestos for long periods have an increased incidence of lung and other cancers.

Prevention of asbestosis-related diseases depends upon preventing exposure to concentrations of dust. Persons should not wear contaminated clothing home and should never clean their clothes with compressed air. Clean-up of dust should be conducted in a manner which prevents the dust from becoming airborne.

Persons must not be exposed to unsafe levels of airborne asbestos. Asbestos waste and debris must be collected in impermeable bags or containers. All asbestos and asbestos-bearing materials must be labeled. Special clothing and approved respirators must be worn when handling asbestos. Employees handling asbestos must be given regular physical checkups.

Methods to limit exposure to asbestos include isolation and ventilation of dust producing operations and wetting the material before handling.

WARNING: Asbestos workers who smoke have an almost 90 times greater risk of cancer than the nonsmoking public.

Beryllium

Beryllium, which has many desirable alloying properties, is also extremely toxic. A single excessive exposure may result in respiratory effects ranging from a mild inflammation of the nose and throat to a severe chemical pneumonitis, possibly resulting in death. Chronic exposure to lower concentrations may result in tightness of the chest, shortness of breath, chronic cough, loss of weight, and general weakness. Work areas should be monitored to limit and control levels of exposure. Respirators and protective clothing should be worn by all persons to protect against exposure in excess of the standard.

Body Fillers

Plastic body fillers are the most popular type of materials used to repair auto bodies. When handling the raw materials (before

they have dried or cured), rubber gloves should be worn. If any gets on the skin, it should be promptly washed off with soap and water.

Cadmium

The brownish-yellow fume, cadmium oxide (CdO), produced when cutting cadmium-containing metals, can be an extremely hazardous health problem. This fume may, however, be masked by other metal fumes given off simultaneously. Cadmium-plated or alloy steel may look like zinc-coated steel.

Excessive cadmium oxide exposure causes no marked initial discomfort. However, acute symptoms occur a few hours later. These symptoms include dry cough, irritation of the throat and tightness of the chest leading to extreme difficulty in breathing, chest pains, and possible death from pulmonary edema (fluid in the air spaces of the lungs). Lesser exposure may cause lung and kidney damage. Employees should be provided with respiratory protection and protective clothing to prevent harmful exposure.

Carbon Dioxide (CO₂)

CO₂ is an asphyxiant—that is, it replaces the oxygen in the blood and may reduce the amount of oxygen to dangerously low levels. CO₂ is both odorless and colorless. Inhalation of CO₂ causes an increase in the breathing rate and may cause shortness of breath, dizziness, and vomiting.

In any area where a high concentration of CO₂ is suspected, persons should wear supplied-air or self-contained respirators. General dilution ventilation is usually an adequate control for low levels of CO₂. In areas of higher concentrations, local exhaust ventilation may be necessary. Areas where CO₂ is used should be monitored to ensure that levels are kept within the acceptable limits. CO₂ does not diffuse readily and may collect in confined spaces. (See "Entry to Confined Spaces.")

Carbon Monoxide

Internal combustion equipment (e.g., forklifts, autos, mowers, and space heaters) and some hot work operations, such as welding, produce carbon monoxide. It is a tasteless, odorless gas and a poison. If allowed to accumulate, it may produce unconsciousness and death in a matter of minutes. Auto exhaust should be removed from the work area by:

- mechanical exhaust ventilation in the repair room,

- connecting hoses to the tailpipe and exhausting directly outside, or
- using mechanical ventilation connected to the tailpipe.

There is less loss of building heat from direct connection and such methods are more efficient in removing exhaust.

Space heaters should be inspected to make sure they are adequately ventilated and not blocked. Welding area exposure should be controlled through the use of local exhaust or general dilution ventilation systems.

Caustics and Other Corrosive Chemicals

Caustics, such as sodium hydroxide, and some acids are used for cleaning metal parts in dip tanks. Strong caustic solutions are often used for cleaning reusable filters of range, grill, and broiler exhaust hoods. Controlled procedures are necessary for such cleaning and protective clothing and equipment must be provided and used. Skin contact with the cleaning solution will cause severe burns. Rubber gloves and a face shield or goggles should be worn when handling caustics. Any caustics that contact the skin must be washed off immediately. A safety shower and eye wash fountain should be installed where caustics are handled.

Chlorine

Chlorine is used in swimming pools and in wash and rinse water. It may be purchased in liquid form, as a powder or granules, or as a compressed gas. Respiratory protection should be available where compressed chlorine gas is used or stored.

Chromium

Chromium (chromic acid, sodium dichromate, and chromium compounds) causes the formation of burns known as "chrome holes" on the hands and forearms as the result of skin contact with the acid or dust. Inhalation of chromium dusts or acid mists may cause irritation of the mucous membranes and the formation of ulcers in the nose and mouth.

Local exhaust ventilation is required to remove airborne concentrations of the acid mist, dusts, and fumes. Persons must wear goggles and rubber gloves to prevent skin contact. If skin contact does occur, the area must be thoroughly washed with clean running water. Good personal hygiene habits must be stressed, and employees who handle chromium compounds should have periodic physical examinations.

Cutting Fluids

Contact dermatitis (skin rash or irritation) caused by oils or additives is the main problem resulting from exposure to cutting fluids. It may be prevented by limiting skin contact through the use of barrier creams and lotions.

Prolonged inhalation of oil mists can cause irritation of the mucous membranes of the nose and throat. If airborne concentrations are high enough, the oil may accumulate in, and block, the small air passages of the lungs. Enclosure of processes or local exhaust ventilation is recommended.

Dermatitis

Skin disorders are among the most common of occupational illnesses. Dermatitis can range from an itch or a rash to severe blistering, cracking, and actual damage to the skin. It can be caused by contact or exposure to chemicals, microorganisms, foods, or other substances.

Primary irritants cause dermatitis by direct contact with the skin. Acids, alkalies, solvents, and some oils are primary irritants.

Sensitizers produce severe allergic reactions after repeated exposures to the sensitizing agent. Contact with even a small amount of the sensitizer at a later time will produce the same severe reaction.

Eliminating or reducing skin contact with chemicals is the most important step in preventing occupational dermatitis. This may be accomplished by enclosing a process or through the use of proper personal protective clothing and equipment.

Good personal hygiene habits and practices must be explained and encouraged. Workers should be instructed in how to effectively remove contaminants from the skin and of the need for prompt removal of contaminated clothing.

Protective clothing and equipment may be used to prevent contact with potential irritants. Gloves, sleeves, aprons, boots, face shields, and goggles may be required.

Protective ointments and barrier creams also offer some protection, depending on the type of exposure. Workers should be instructed to apply them to clean skin, to wash them away frequently (especially before eating, smoking, or using the toilet), and to reapply to the clean skin before returning to

work. Barrier creams do not offer as much protection as clothing or equipment, but they are especially effective for the exposed skin of the face and neck, which may be difficult to keep covered.

Drain Cleaners

Drain cleaners cause skin burns and are harmful when splashed in the eyes. When using drain cleaners, rubber gloves and goggles or a face shield should be worn.

Wood Dust

Wood dust, if not removed at the source of generation, can present a health hazard. Some dusts are toxic or cause allergic responses in workers. Excessive dust makes good housekeeping difficult and also increases the fire potential.

The best control for wood dust is local exhaust ventilation with subsequent collection by cyclones or bag houses.

If local exhaust ventilation is installed, some maintenance is required:

- The duct velocity should be maintained at a minimum of 3500 feet per minute to prevent dust from accumulating and plugging the system.
- The ducts should be checked and cleaned at regular intervals.
- Dust collectors should be cleaned and maintained regularly.
- If a bag house is used, it should be shaken regularly. Check V-belts on the drive units of the exhaust fan for slipping or breaks.
- Check for loose, damaged, or broken ducts.

Respirators may be worn by individuals to prevent inhalation of the wood dust. For more information regarding respirators, see "Personal Protective Equipment."

Grain Dust

Exposure to grain dust must not exceed the 8-hour time-weighted average limit of 5 milligrams of respirable dust in 1 cubic meter of air or 15 milligrams of total dust in 1 cubic meter of air in any 8-hour work shift of a 40-hour work week. Good housekeeping will help reduce the dust problem by reducing the scattering of settled dust. However, a technique (e.g., vacuuming) should be used that will not itself create a dust

problem. Increased ventilation in specific areas would also improve the situation.

There are a number of inexpensive dust respirators on the market which would reduce the exposure problem to employees.

Other Dust

Activities such as sanding, paints, primers, and body fillers all produce large quantities of dust. Dust is also a problem in brake overhaul. Dust is created in preparing tire casings for recap; local exhaust systems and personal protective equipment may be required.

Electroplating

Electroplating is used extensively to provide tarnish-resistant finishes and for decorative purposes. The chief hazards of electroplating are exposures to toxic chemicals and strong acids and alkalis. Emergency eye wash and shower facilities are required where corrosive materials are handled and used.

Chrome plating requires the use of chromic acids. Breathing chromic acid vapor or mist may cause irritation of the respiratory tract; skin contact causes dermatitis and burns known as "chrome holes." Local exhaust ventilation should be used with all chromic acid tanks. The recommended exhaust volume is a minimum of 150 cubic feet per minute, per square foot of tank surface. Employees who work with chromic acids must have periodic medical examinations of the mouth, nose, and other parts of the body to detect the first stages of ulceration produced by contact with chromic acid.

Copper plating baths are both acid and alkaline types. The cyanide salts in the alkaline bath are the greatest hazard in copper plating. These salt particles may become airborne when the tanks are charged. Cyanide solutions are readily absorbed, and skin contact must be avoided. Local exhaust ventilation systems are required to draw off the vapors, respirators may be needed, and workers must limit skin contact through the use of gloves which the cyanide cannot penetrate. Good personal hygiene practices must be stressed, including frequent washing of exposed skin areas, particularly before eating or smoking.

If a cyanide salt solution is mixed with acid, deadly hydrogen cyanide gas can result. All traces of acid must be rinsed away

from parts before they are immersed in the cyanide vat. An extra rinse step between the acid and cyanide tanks is strongly recommended. Local exhaust ventilation is necessary.

Zinc and cadmium plating operations also use cyanide baths. As with copper plating, care must be exercised to avoid contact with the cyanide solution and to prevent a cyanide/acid mix. Local exhaust ventilation is required. It is recommended that zinc and cadmium plating baths be operated at room temperature and low current density, which will lessen the air flow rate required for effective exhaust ventilation.

Epoxy Resins

Wet or uncured epoxy resins and the chemicals used to harden, thin, strengthen, or make the resin flexible should be regarded and handled as hazardous materials. Dermatitis, an inflammation of the skin, is the disease that most often attacks workers handling epoxy resins and the chemicals used to manufacture them. In addition, sanding or polishing epoxy surfaces sometimes causes dermatitis due to the epoxy or the polishes. The use of impervious plastic gloves and similar protection over other skin areas can help prevent this condition. Some of the symptoms of dermatitis are redness, itching, swelling, and blisters. Oozing, crusting, and scaling of the skin can also occur.

Respiratory, nose, and throat irritation, headache, nausea, intestinal upsets, and other conditions may result from breathing the vapors or dust from the various epoxy manufacturing processes. The eyes may also be affected by vapors or by direct contact.

Outbreaks of dermatitis and other diseases can be avoided by following these basic rules:

- Inform workers of possible hazards.
- Provide ventilation to control vapors produced while mixing the resins and hardeners as well as to control the glass and epoxy particulates.
- Maintain plant and personal hygiene through good housekeeping procedures, appropriate hand cleansers, protective clothing and, where needed, protective creams.

Fibrous Material (Asbestos, Glass, etc.)

The installation or modification of insulation around piping, boilers, and ventilation systems may generate toxic amounts of airborne fibrous materials. Perhaps the most hazardous is

asbestos which may result in asbestosis or lung cancer. (See the section on "Asbestos.") Glass and other fibrous materials which are less hazardous have recently replaced asbestos, but good protection (i.e., respirators, ventilation) is still required when there is a possibility of the fibers becoming airborne.

Formaldehyde

Formaldehyde (formalin) is a colorless liquid with a characteristic pungent odor. It is irritating to the skin, the mucous membrane, and the eyes. Its chief effect is on the upper respiratory system where continued exposure produces nasal congestion and a feeling of tightness in the chest. Prolonged exposure may have an effect on the kidneys.

Local exhaust or dilution ventilation must be used to control the concentration of formaldehyde vapors. Persons must be instructed to avoid breathing the vapors and to prevent all skin contact. All containers must be kept tightly closed.

Gloves, sleeves, aprons, and protective skin creams may be needed to prevent skin contact. Face shields must be worn where there is the chance of sprays or splashes.

Workers should change their work clothes at least daily and whenever they are splashed. Adequate washing facilities must be provided.

Approved respirators may be used to control intermittent exposures, but ventilation systems must be used for routine operations.

Formic Acid

Formic acid has a characteristic pungent odor. Inhalation of high concentrations of vapors may cause irritation of the nasal passages, nausea, and vomiting. Some formic acid compounds are highly flammable. Skin contact can cause burns and severe irritation.

Local exhaust ventilation must be used to control concentrations of formic acid vapors. Persons who handle the acid and who may be exposed to skin and eye contact must wear gloves, aprons, and proper eye and face protection. Facilities for flushing the eyes and skin must be readily available.

Fumigants

The grain fumigants used to kill pests that infest grain in trucks, rail cars, and elevators may be present as contaminants

in grain operations. Some of the fumigant compounds and the major health effects are as follows:

- Methyl bromide is a colorless, transparent liquid or gas, with a chloroform-like odor. It is a central nervous system depressant and is toxic to the liver.
- Carbon tetrachloride is a colorless liquid with a heavy ethereal odor. It has a narcotic action and may produce unconsciousness in persons exposed to high concentrations.
- Ethylene dichloride is a colorless liquid with a sweetish odor. It is a central nervous system depressant and produces injury to the lungs, liver, and kidneys from high concentrations.
- Phosphine is a colorless gas released from moist phosphide fumigants. It is odorless at safe concentrations but has an odor similar to decayed fish at high concentrations. Chronic poisoning may produce intestinal upset, jaundice, and loss of appetite.

Heat and Cold

Heat stress may be a problem in kitchen areas. High heat levels can cause heat-related illnesses and persons should be made aware of the symptoms of heat disorders and the need for water and salt replacement.

Provisions should be made to keep employees' temperature within narrow limits when they are exposed to extreme heat and cold. Such exposure can result in fatigue, discomfort, job inefficiency, collapse, and other health problems

Hydrochloric Acid

Hydrochloric acid causes severe burns when splashed into the eyes, and skin contact may produce burns or ulcers. Inhalation of the acid mist or vapor is irritating to the respiratory tract.

Protective clothing (gloves, aprons, boots), eye and face protection, and perhaps respirators must be worn when hydrochloric acid is handled. Eye wash fountains and safety showers must be available in the immediate area, and any person who splashes the acid into the eyes should be referred to a physician after the eyes are thoroughly flushed with water.

Hydrogen

Battery charging operations produce hydrogen gas and an explosive atmosphere may result unless adequate ventilation is provided. "NO SMOKING" signs must be posted.

Hydrogen Sulfide

Hydrogen sulfide is a colorless, highly toxic, and flammable gas, produced by the decomposition of sulfur-containing organic material. It may be found in enclosed spaces such as unventilated basements, or in pits, tanks, or vats which formerly contained organic matter.

The gas has a characteristic "rotten egg" odor. However, the use of odor as a warning of its presence is not reliable because continued exposure to the gas causes a loss of sensitivity of the sense of smell.

Hydrogen sulfide is both an irritant (in low concentrations) and an asphyxiant. Exposure to low concentrations produces irritation of the eyes, a "burning" sensation in the nasal passages and respiratory tract, headaches, and dizziness. If small amounts are absorbed, the gas acts as a nervous system depressant. Inhalation of high concentrations of the gas can be immediately fatal, as it causes paralysis of the respiratory center and results in suffocation.

Hydrogen sulfide is a dangerous fire hazard when exposed to heat and flame.

When persons detect the faintest odor of hydrogen sulfide (a "rotten egg" smell), they should immediately leave the area. Local exhaust ventilation is required to remove the gas at its source, and forced-air ventilation should be used in the area. Supplied-air (air line) respirators must be worn by persons working in atmospheres containing even small amounts of hydrogen sulfide gas. All tanks, vats, pits, and other enclosed spaces which have contained organic matter (e.g., hair, fat, skin, sludge) must be tested for the presence of hydrogen sulfide before workers begin cleaning operations. Even if they do not enter the area, but work from an opening in the top, it is a good idea to test for the presence of the gas. (See "Entry to Confined Spaces.")

Insecticides

Insecticides may be compounds of various toxic chemicals, and all are health hazards. Inhalation of dusts, mists, or liquid vapors, direct skin contact, and ingestion (eating) are the ways the chemical can enter the bodies of persons exposed to insecticides.

The best control is to limit all contact with the insecticides as much as possible. Workers should be instructed to avoid skin

contact and breathing of dusts and vapors. Personal protective clothing and equipment such as gloves, aprons, boots, goggles or glasses, and face shields must be worn by all who work around insecticides. Ventilation may be needed to limit airborne concentrations, and respirators may also be required. Safety showers, eye washes, and changes of clothing should be provided. Workers should be encouraged to change work clothing that may become splashed, and to take a shower at the end of the shift.

Insulating Foam

Some prefabricated buildings have foam insulation installed in the shop which can involve the use of isocyanates. Generally, isocyanates are irritating to the eyes, skin, and respiratory tract and can produce sensitivity reactions with asthma-like symptoms at very low levels. They should be used only in areas with adequate general and local exhaust ventilation. Since skin contact should be avoided, protective clothing is recommended.

Lactic Acid

Lactic acid presents the general health hazards associated with acids: possible dermatitis from direct skin contact, burns as the result of contact with concentrated solutions, and irritation of the nasal passages from inhalation of the acid mists.

Persons who handle lactic acid must wear protective goggles, gloves, and aprons. They must be instructed to wash exposed skin areas thoroughly after handling the acid.

Lead Fumes or Dusts

Fumes are very small particles formed by the vaporization of metal during welding or cutting operations. Metal dust is generated by grinding. Lead poisoning may occur through the inhalation or accidental ingestion of lead fumes or dust.

The symptoms of lead poisoning include loss of appetite, metallic taste in the mouth, anemia, headache, nervous irritability, muscle and joint pains, and abdominal cramps. Chronic lead poisoning is slow and vague in its beginning and the signs and symptoms are not well defined.

No one symptom indicates the occurrence of lead poisoning. At first, one may experience a general ill-feeling, fatigue, exhaustion, irritability, loss of appetite and weight, vague abdominal discomfort, and a yellow discoloration of the skin.

Later there may be colic, constipation, and disturbance of sleep. A blue line on the gums is indicative of lead poisoning, as may be the premature loss of teeth. In the advanced stages of chronic lead poisoning, several body functions and such organs as the liver and kidneys may be affected.

There is the potential for being exposed to excessive quantities of airborne lead particulate whenever welding or cutting is performed on materials coated with leaded paints or containing lead (e.g., galvanized steel contains lead and zinc).

Good personal hygiene practices on the part of all lead workers must be stressed. Those who work with lead should wash their hands thoroughly before eating. Lead-contaminated gloves should be removed and hands washed before eating or smoking to prevent additional lead exposure. Eating must not be allowed in areas where the welding or cutting of lead is performed. Care should be taken that worker exposure to lead fumes and dust is limited through the use of exhaust ventilation or respirators and eye protection.

Lime

Lime (quick lime, caustic lime, calcium oxide) is a caustic and can rapidly burn the skin and eyes on contact. If pulverized lime is moistened, it forms calcium hydrate which generates heat. Flammable or combustible materials must not be stored near pulverized lime as they may be ignited from the heat produced.

Workers must wear goggles and gloves when handling lime. Eye wash and emergency shower facilities must be available in the immediate area. "Hydrated pulverized lime" may be substituted for pulverized lime as it is not heat reactive, and is therefore less of a fire hazard.

Mercury

Mercury is highly toxic and exposures to mercury should be kept to a minimum. In chronic mercury poisoning, psychic and emotional disturbances are characteristic. Fine tremors may affect the hands, head, lips, or jaw. Excess salivation, gingivitis, and digestive disturbances are also common. Although inhalation is the main route of absorption, mercury can also be absorbed through skin contact and ingestion. Mercury and its salts are skin irritants.

To keep employee exposures to mercury at a minimum, the following precautions should be taken:

- The most important control measure is good housekeeping. All spills should be cleaned up immediately and workers should be instructed to prevent mercury spills and to avoid skin or eye contact.
- Waste mercury should be stored in airtight, nonmetallic containers until disposed of.
- Workers should be instructed in proper personal hygiene when using mercury, i.e., washing hands prior to eating and smoking (which should be done away from work areas).

Metal Fumes and Dust

Fumes are very small particles formed by the vaporization of metal during torch-cutting, burning, or welding operations, whereas metal dust is generated by grinding. Special precautions such as exhaust ventilation and the wearing of respirators and eye protection need to be taken when cutting, burning, or grinding scrap containing alloys of the more toxic metals, such as lead, zinc, cadmium, or beryllium.

Methane

Methane is a colorless, odorless, tasteless gas produced by decomposing organic material. Methane may be found in tank, pit, sump, or drain cleaning operations, or wherever decaying organic material has accumulated.

Methane gas is highly flammable, and is also an explosion hazard. It is a simple asphyxiant, replacing the oxygen in the blood to cause suffocation. Symptoms of methane exposure are an increase in respiration rate, impaired muscular coordination, and diminished mental alertness. Nausea and vomiting may occur, as well as loss of consciousness and possible death.

All enclosed spaces which contain organic matter must be tested before workers enter. (See "Entry to Confined Spaces.") The atmosphere must also be tested while they work, as cleaning operations may release methane into the atmosphere.

Forced-air ventilation must be blown through the area, and workers must use supplied-air respirators where methane is present.

Microwaves

Microwave ovens are becoming a standard item in food service operations. Microwaves are very hazardous to the eyes. As the

oven ages, hinges and catches become loose and microwaves may leak out. If the interlock system fails, the unit may not shut off when the door is open. Units should be checked periodically for leaks and proper working order by properly equipped and trained personnel. They should be cleaned regularly and whenever food is spilled.

Oxalic Acid

Oxalic acid has the appearance of lump sugar. It is a strong poison if ingested and also can cause severe burns to the eyes, skin, and nasal passages.

Chemical workers' goggles must be worn by persons who handle oxalic acid. Impervious gloves will help to prevent skin contact. Workers should be instructed to wash their hands and faces after handling the acid.

Oxygen Deficient Atmosphere

If proper precautions are not observed, many operations, such as the repair and cleaning of tanks and entry into manholes, sewers, and other confined spaces, can be very dangerous. Not only may a person be exposed to various toxic gases, but the atmosphere may also be deficient in oxygen, which would be immediately dangerous to life. Such entries should be made only when there are adequate procedures delineating the proper precautions and safeguards (e.g., air line respirator, lifeline, buddy system, etc.) to be followed. (See "Entry to Confined Spaces.")

Paints, Lacquers, Stains, and Solvents

Thinners used in most paints will have a narcotic effect on workers and a long-term exposure may cause irreparable liver and lung damage. Respirators should be worn in the spray area or paint booth, in addition to the ventilation provided. (See Respirators under "Personal Protective Equipment.")

Some of the newer paints contain hardeners and other additives that can cause skin rashes and dermatitis.

Do not permit persons to wash their hands in the thinners and solvents because they take the fats out of the skin, increasing the chance for skin rashes, and can, in some cases, be absorbed through the skin. Solvent-resistant gloves and long-sleeved shirts worn while painting will prevent the paints or stains from contacting the skin in those areas. If paints or stains do get on the skin, they should be removed with waterless hand cleaners.

Chemicals used in the coating and staining of wood products are potentially hazardous to health. All organic solvents have some effect on the central nervous system and the skin.

Principle modes of exposure causing health problems from industrial use of solvents are skin contact and inhalation of vapors.

Exposure may result in damage to the skin, blood, lungs, liver, kidneys, and gastrointestinal system. Exposures are controlled by engineering controls (e.g., ventilation), good work practices, and personal protection devices.

Perchloroethylene

Perchloroethylene is used in the dry cleaning machines found in some schools. Avoid breathing the vapors and avoid skin contact. A respirator should be available for use when spills occur or when cleaning out the residue. Perchloroethylene is often found in spray cans and is used as a spot remover or furniture cleaner.

Phenol

Phenol (Carbolic Acid) is highly poisonous even in a diluted state. It is readily absorbed through the skin. Initial skin contact produces a tingling and then a burning feeling, followed by an anesthetic effect and possible discoloration. Dilute concentrations of phenol can cause dermatitis. Phenol also attacks the eyes and mucous membranes of the nose and throat.

Phenol may be absorbed through inhalation or ingestion and it attacks the lungs and gastrointestinal system. Liver and kidney damage may be so extensive as to cause death.

Acute exposure affects the central nervous system and may also disrupt breathing, causing death. Some symptoms of phenol absorption are weakness, headache and dizziness, irregular breathing, vision effects, a ringing in the ears, and possible loss of consciousness.

Where possible, phenol should be handled or used in a closed system. In all cases, exposure to phenol must be kept at a minimum through process controls, ventilation, and personal protective equipment.

Where exposed to phenol, workers must wear goggles and face protection, and rubber gloves, boots, and aprons. A supplied-air

respirator should be worn by persons who may be exposed to phenol vapors.

Safety showers and eye wash facilities must be available in the immediate area. Workers should be instructed to immediately shower off any skin area splashed with phenol, and to use soap to wash the skin. Since poisoning may result from contact with splashed clothing, changes of clothing must be readily available. Workers should be thoroughly familiar with emergency procedures.

Polyvinyl Chloride

Polyvinyl chloride (PVC) is used in many products, including containers and packaging films. Heat-sealing and hot-wire cutting of PVC films produces irritating vapors that produce a condition called "meat wrappers' asthma." Although vinyl chloride, now considered a carcinogen (cancer-causing agent), is used in the production of PVC resin, exposure to vinyl chloride gas is not a hazard associated with heat-sealing or hot-wire cutting of PVC film. However, because of the irritating effects of PVC vapors, these activities must be performed in well-ventilated areas.

Radiation

Ionizing radiation is prevalent from radiographic machines producing X-rays or using radioactive materials as a source of gamma or other radiations. These machines are used to check welds, pipes, joints, etc. Lasers are used for alignment of pipes and produce intense nonionizing radiation.

Welding produces ultraviolet light which is hazardous to the eyes and skin. If proper safeguards are not observed, both ionizing and nonionizing radiation can be very hazardous. Only qualified and trained persons should be assigned to use such equipment and it may be necessary to obtain approval or licenses from federal, state, or local authorities for the equipment, user, and use of such equipment.

Refrigerants

Problems which may occur during installation, modification, or repair of refrigeration units are leaks and, very infrequently, fire or explosion. Refrigerants may be considered in the following classes:

- Nonflammable substances where the toxicity is slight, such as some fluorinated hydrocarbons (Freon).

Although considered fairly safe, these refrigerants may decompose into highly toxic gases (e.g., hydrochloric acid, chlorine, phosgene, etc.) upon exposure to hot surfaces (sweating, welding, etc.) or open flames.

- Toxic and corrosive refrigerants (e.g., methyl chloride and ammonia) may be flammable in concentrations exceeding 3.5 percent by volume. Ammonia is the most common refrigerant in this category, and is very irritating to the eyes, skin, and respiratory system. In large releases of ammonia, the area must be evacuated. Re-entry may be made wearing appropriate respiratory protective devices and protective impervious clothing. As ammonia is readily soluble in water, it may be necessary to spray water in the room via a water mist-type nozzle to lower concentrations of ammonia.
- Highly flammable or explosive substances (propane, ethylene, etc.) must be used with strict controls, safety equipment, and administrative controls.

If a refrigerant escapes, action should be taken for removal of the contaminant from the premises. If ventilation is used, exhaust from the floor area must be provided for heavier-than-air gases and from the ceiling for lighter-than-air gases.

Rodents, Snakes, Animals, Parasites, and Infectious Diseases

Some construction sites (e.g., installation or modification of sewers) present health problems which may not be common in schools. However, bites from rats, snakes, and animals can lead to a very badly infected wound or disease, such as rabies. Cuts and abrasions become infected and parasitic infections may, upon occasion, be a problem. Bacteria may also infect cuts and abrasions which may then need medical treatment, even if the original wound did not require first aid. General protective measures (e.g., rodent control, personal hygiene and clothing, and vaccination) should be used to control such problems.

Soaps and Detergents

Soaps and detergents may cause contact dermatitis (skin rashes) or throat irritation may occur from inhalation of soap dust. Disposable respirators (face masks) may be needed by persons who are sensitive to the dust.

Soda Ash

Soda ash has no marked effect on dry skin. However, it is caustic to the eyes and can burn the respiratory tract if inhaled.

Suitable eye protection (e.g., chemical workers' goggles) must be worn by workers who handle soda ash. Where there is potential for inhaling soda ash, an approved respirator is required. There must be an eye wash facility readily available in the work area.

Sodium Hydroxide

Sodium hydroxide (caustic soda or lye) in dilute concentrations produces dermatitis as the result of skin contact. Ulcerations and burns may result from contact with concentrated solutions.

Inhalation causes irritation of the respiratory tract, and possible damage to lung tissue. Ingestion of even a small amount of lye will result in possibly fatal poisoning.

Splashes or particles in the eye will cause extremely severe burning of the eye tissue.

Ventilation systems should be used to reduce the amount of sodium hydroxide vapors present. Workers who prepare lye solutions or who work around tanks of lye must wear rubber protective equipment including gloves, sleeves, aprons, and footwear. Gas-tight chemical workers' goggles are required as eye protection. Workers in mixing operations must also wear face shields. If respirators are needed, they must be approved for sodium hydroxide exposure.

Safety showers and eye wash facilities are required in all areas where lye is handled. Because of the ease with which lye may be ingested, workers must be instructed to wash exposed areas frequently, particularly before eating.

Sodium Sulfide

Sodium sulfide has caustic physical effects similar to those of sodium hydroxide (lye). The chief hazard of sodium sulfide is that it readily forms the toxic gas hydrogen sulfide when it contacts acid.

A good ventilation system is required in areas where sodium sulfide is used. This is especially important in areas where there is the possibility of forming hydrogen sulfide. Workers must wear protective clothing such as rubber gloves, aprons, and boots, and chemical workers' goggles when working near or handling sodium sulfide. Emergency eye wash facilities and showers are required in the work area.

Solvents

Solvents have many applications, and exposure presents a potential threat to the health of workers. All organic solvents have some effect on the central nervous system and the skin. The principal modes of exposure are inhalation of vapors and skin contact. Excessive solvent vapor inhalation may have no discernible effects on health, causing only a lack of coordination and drowsiness, but this may increase the risk of accidents. In other cases, exposure may result in serious damage to the blood, lungs, liver, kidney, and gastrointestinal system.

Skin contact may cause dermatitis, ranging in severity from a simple irritation to actual damage to the skin. Even the most inert solvents can dissolve the natural protective barriers of fats and oils, leaving the skin unprotected. When these natural lubricants are removed, the skin becomes subject to disabling and possibly disfiguring dermatitis and opens the way to serious infection.

Measures to control solvent exposure include the substitution of a less toxic solvent, local exhaust ventilation, and the use of protective clothing.

Substitution of a less toxic or less volatile solvent has been effective in controlling solvent exposure and in reducing the hazard potential. For example, the substitution of methyl chloroform for carbon tetrachloride has worked efficiently and effectively in many cleaning and degreasing operations. The substitution of a less toxic solvent does not imply that a health hazard has been *eliminated*; it only means that a person is less likely to suffer ill effects.

The use of closed systems and local exhaust ventilation is an effective way of preventing solvent vapors from entering the breathing zone of the worker. Containers of flammable solvents must be covered when not in use. Local exhaust ventilation can remove vapors at their point of origin and thus prevent toxic concentrations in the workplace.

Good personal hygiene is essential whenever solvents are used. The skin should always be protected from contact with solvents. Gloves, face shields, goggles, and other protective clothing may be used. Similarly, barrier creams may offer some degree of protection. The skin should never be washed with any raw organic solvent. Although some solvents are less

toxic than others, good safety practices dictate that care be exercised in the use of *all* organic industrial solvents.

Styrene

Styrene is used in a number of processes including the manufacture of fiberglass-reinforced products (polyester resins), packaging, and insulating materials. Styrene is irritating to the eyes and lungs at low air concentrations, and may cause nausea, headache, and dizziness at higher concentrations. It may be necessary to provide ventilation in areas where styrene is used extensively. Because styrene is also very flammable, care must be taken to prevent fire or explosions.

Sulfuric Acid

Sulfuric acid (vitriol, dipping acid) rapidly and severely burns the skin and eyes on contact. Ingestion of the acid will cause internal poisoning. Inhalation of the fumes and acid mists results in inflammation of the mucous membranes of the respiratory tract and possible damage to the lungs.

Proper local exhaust ventilation must be provided for all processes in which sulfuric acid is used. The vapors must be drawn off as they are generated to prevent exposure. Prevent all skin contact with sulfuric acid through the use of proper personal protective equipment: rubber gloves, sleeves, aprons, and boots; goggles and face shields where there is the danger of splashing. Respirators may be used for short-term exposure, such as during dispensing or mixing. Eye wash and emergency showers must be located in the immediate area. Containers of sulfuric acid should be kept tightly closed or sealed and stored in a dry, well-ventilated area. Good personal hygiene must be encouraged.

Ultraviolet Radiation

Ultraviolet radiation can be harmful to the skin and eyes. Examples of low-intensity ultraviolet radiation sources are low-pressure mercury vapor lamps and black-light lamps. Individuals should wear eye protection and protective clothing.

Welding, Burning, and Soldering—Hot Work Operations

Fumes from welding and other hot work operations contain the metals being welded together (e.g., cadmium, zinc, lead, iron, copper), the filler material, flux, and the coating on the welding

rods. Such operations may also generate other gases (carbon monoxide, arsine, ozone, etc.) at concentrations which may be hazardous to the health of workers. When extensive hot work, particularly in confined areas, is done, there could be an excessive fume exposure to these materials. Ventilation or respiratory protection may be needed for certain operations. Protection for the welder (eye glasses) and for other persons (curtain, etc.) working near the welding operation should be provided, due to the ultraviolet light produced during such operations. Engineering controls, such as local exhaust ventilation, are required before personal protective equipment is acceptable as a control measure. When effective engineering controls are not feasible or while they are being instituted, personal protective equipment is required.

Zinc Oxide Fumes

Excessive exposure to zinc oxide (ZnO) is the most frequent cause of an illness known as metal fume fever. This malady may also be known as zinc chills, shakes, or "Monday morning" fever and is the result of inhalation of fumes from the torch-cutting of zinc-containing alloys such as galvanized steel. Metal fume fever may also follow excessive exposure to fumes of a number of other metals, including iron, cadmium, copper, lead, or nickel. The symptoms are similar to those of influenza and usually occur a few hours after exposure. The symptoms include a metallic taste in the mouth, dryness of the nose and throat, weakness, fatigue, muscular and joint pain, fever, chills, and nausea. These symptoms usually last less than 24 hours and a temporary immunity follows. Therefore, workers are more susceptible on Mondays or on workdays following a holiday than on other workdays. (See "Welding, Cutting, and Brazing".)

HAZARDOUS MATERIALS

Flammable and Combustible Liquids

Flammable and combustible liquids are categorized by their ease of ignition. Flammable liquids are more easily ignited than combustible ones. Examples of flammables are gasoline, acetone, lacquer, and thinner. Examples of combustibles are kerosene, fuel oil, and Stoddard solvent.

Connections on all drums and pipes containing flammable and combustible liquids must be vapor- and liquid-tight.

**CLASSIFICATION OF SOME TYPICAL FLAMMABLE
AND COMBUSTIBLE PRODUCTS**

Class	FLAMMABLES	Flash Point	Boiling Point
I	A Gasoline (some) Pentane	Lower than 73°F	Lower than 100°F
	B Acetone Denatured Alcohol Gasoline (some) Naphtha, VM and P Toluene	Lower than 73°F	At or Above 100°F
	C Xylene	At or Above 73°F	
II	COMBUSTIBLES Kerosene Mineral Spirits Naphtha Stoddard Solvent	At or Above 100°F	
III	Asphalt Brake Fluid Fuel Oil #4 Fuel Oil #5 Fuel Oil #6	At or Above 140°F	

When flammable liquids are transferred from one container to another (for example, from one bulk container to another), they must be effectively bonded and grounded. This practice prevents electrical discharge (e.g., sparks) from the accumulation of static charge because of the transfer process.

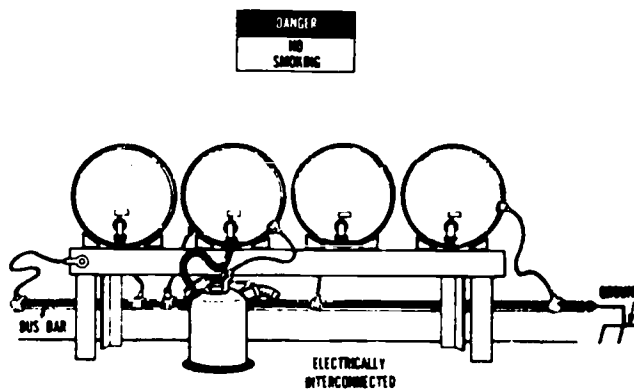

Drums grounded and bonded to receiving container

All spills of flammable or combustible liquids must be cleaned up promptly.

Supplies of flammable and combustible liquids must be stored in approved fire-resistant safety containers. These containers can be purchased from an industrial supply house.

All flammable liquids must be kept in closed containers when not in use.

Combustible waste materials, such as oily shop rags or paint rags, must be stored in covered metal containers and be disposed of daily.

Storage Cabinets

Storage cabinets must be distinctly marked "FLAMMABLE —KEEP FIRE AWAY." Storage cabinets must meet National Fire Protection Association test requirements. Cabinets constructed in the following manner will meet these requirements:

- Metal cabinets must be constructed of at least No. 18 gauge sheet iron, double-walled with tight joints and a 1½ inch air space between. Doors must have three-point locks with a sill raised at least 2 inches above the cabinet floor.
- Wooden cabinets must be constructed of at least 1-inch plywood with rabbeted joints fastened in two directions with flathead screws.

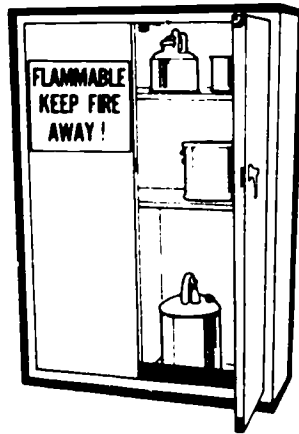

Inside Storage

Open flames and smoking must not be permitted in flammable or combustible liquid storage areas. Openings to other rooms or buildings must be provided with self-closing fire doors and noncombustible, liquid tight, raised sills or ramps at least 4 inches high. A permissible alternative to a sill or ramp is an open-grated trench which drains to a safe location.

General exhaust ventilation (either gravity or mechanical) which provides for a complete change of air within a room at least six times each hour is required for inside storage rooms. Explosion-proof lights are required in flammable liquid storage areas.

STORAGE IN INSIDE ROOMS

Fire protection* provided	Fire resistance	Maximum size	Total allowable quantities (gals./sq. ft. floor area)
Yes.....	2 hours.....	500 sq. ft.....	10
No	2 hours.....	500 sq. ft.....	4
Yes.....	1 hour	150 sq. ft.....	5
No	1 hour	150 sq. ft.....	2

*Fire protection system shall be sprinkler, water spray, carbon dioxide, or other system.

INDOOR CONTAINER STORAGE

Class liquid	Storage level	Protected storage Maximum per pile		Unprotected storage Maximum per pile	
		Gallons	Height	Gallons	Height
I-A...	Ground and upper floors.....	2,750 (50)	3 ft. (1)	660 (12)	3 ft. (1)
	Basement.....	Not permitted		Not permitted	
I-B...	Ground and upper floors.....	5,500 (100)	6 ft. (2)	1,375 (25)	3 ft. (1)
	Basement.....	Not permitted		Not permitted	
I-C...	Ground and upper floors.....	16,500 (300)	6 ft. (2)	4,125 (75)	3 ft. (1)
	Basement.....	Not permitted		Not permitted	
II.....	Ground and upper floors.....	16,500 (300)	9 ft. (3)	4,125 (75)	9 ft. (3)
	Basement.....	5,500 (100)	9 ft. (3)	Not permitted	
III.....	Ground and upper floors.....	55,000 (1,000)	15 ft. (5)	13,750 (250)	12 ft. (4)
	Basement.....	8,250 (150)	9 ft. (3)	Not permitted	

NOTE 1: When 2 or more classes of materials are stored in a single pile, the maximum gallonage permitted in that pile shall be the smallest of 2 or more separate maximum gallonages.

NOTE 2: Aisles shall be provided so that no container is more than 12 ft. from an aisle. Main aisles shall be at least 8 ft. wide and side aisles at least 4 ft. wide.

NOTE 3: Each pile shall be separate from each other by at least 4 ft. (Numbers in parentheses indicate corresponding number of 55-gal. drums.)

Outside Storage

If flammable and combustible liquids are stored outside, the area should be graded so that spills are diverted away from any building. The storage area should be kept free of combustible material not necessary for storage, such as weeds and other debris. Smoking must be prohibited.

OUTDOOR CONTAINER STORAGE

1	2	3	4	5
Class	Maximum per pile (see note 1)	Distance between piles (see note 2)	Distance to property line that can be built upon (see notes 3 and 4)	Distance to street, alley, public way (see note 4)
	gal	ft	ft	ft
IA	1,100	5	20	10
IB	2,200	5	20	10
IC	4,400	5	20	10
II	8,800	5	10	5
III	22,000	5	10	5

NOTE 1: When 2 or more classes of materials are stored in a single pile, the maximum gallons in that pile shall be the smallest of the 2 or more separate gallonages.

NOTE 2: Within 200 ft. of each container, there shall be a 12-ft. wide access way to permit approach of fire control apparatus.

NOTE 3: The distances listed apply to properties that have protection for exposures as defined. If there are exposures and such protection for exposures does not exist, the distances in column 4 shall be doubled.

NOTE 4: When total quantity stored does not exceed 50 percent of maximum per pile, the distances in columns 4 and 5 may be reduced 50 percent, but not less than 3 ft.

Gasoline Storage

If gasoline is stored on the premises in less than 60-gallon quantities, storage must be in approved containers. Quantities greater than 60 gallons must be stored in tanks located underground or in specially designed enclosures.

Gasoline dispensing pumps must have at least one fire extinguisher having a minimum approved classification of B, C, located within 75 feet of the pump. As a visible reminder, signs reading "NO SMOKING" must be conspicuously posted.

Liquefied Petroleum Storage Area

"NO SMOKING" signs must be present on the storage tank.

Units to be fueled must be turned off while filling.



The LP tank must be guarded to protect it from vehicular damage.

Electrical connections, pumps, switches, etc., must be vapor- and explosion proof.

SPRAY PAINTING

General Requirements

Portable lamps must be removed during spraying.

Low flash-point thinners (less than 100° F) may be used for cleaning purposes only if used in a well-ventilated area such as a spray booth.

The fire control sprinkler heads must be kept clean and free of paint build-up.

“NO SMOKING” signs must be posted wherever flammable liquids are sprayed or stored.

Parts to be painted should be arranged so that overspray and fumes are not drawn through the breathing zone.

Protective clothing such as gloves, apron, and a cloth cap should be worn.

Respirators must be cleaned and maintained regularly.

There should never be more than one day's supply of paint outside of storage rooms or cabinets.

Spray Areas

The spray area must be at least 20 feet from flames, sparks, electric motors (unless explosion-proof), or other ignition sources.

The spray area must be free from hot surfaces, such as heat lamps.

Electric lights in the spray area must be covered and guarded from accidental breakage.

The spray area must be kept clean of combustible residue.

Mechanical ventilation must be provided and kept operating to remove vapors during the painting.

Spray Booths

Spray booths must be made of metal, masonry, or other suitable noncombustible material and be smooth on the inside to aid in cleaning.

Floors and baffles must be noncombustible and easily cleaned.

Spray booth lights must be explosion-proof or enclosed in sealed panels.

Mechanical ventilation must be installed and operating during spraying.

The ventilation rate must be at least 100 linear feet per minute over the open face of the booth.

Electric motors for the exhaust fans must be outside the booth or ducts and the belts and pulleys fully enclosed.

Air exhausted from the paint booth must be discharged outside where it cannot reenter the building.

Ducts connected to the booth must have access doors to allow for cleaning.

Air supply must be maintained for paint booth.

Plugged overspray filters must be replaced.

When temperatures are below 55°, the make-up air must be heated to at least 65° except where adequate and safe means of radiant or general building heating maintains a minimum temperature of 65° with the exhaust system in operation.

The heater of the make-up air must be located outside the spray booth.

Paint Drying Apparatus

Mechanical ventilation must be left on while the paint is drying. A warning sign to this effect must be attached to the drying apparatus.

The area used for drying with portable heaters or lights must be kept clean of overspray products.

Heat sources must be kept out of the spray area during spray operations.

All electrical drying apparatus must be properly grounded.

PERSONAL PROTECTIVE EQUIPMENT

Personal protective equipment should never be considered the "first line of defense." Equipment of this nature is only back-up protection for the unexpected or the unusual. It may not be used as a substitute for feasible engineering or administrative controls. If such control methods are not feasible, or while they are being implemented, personal protective equipment is required if persons are exposed to harmful levels of physical agents or toxic substances. Personal protective clothing and equipment must be of safe design and construction for the work to be performed, and be maintained in a sanitary and reliable condition.

Eye and Face Protection

One of the best starting points for establishing the habit of using personal protective equipment is the use of eye and face protection. Eye protection or face shields must be provided and workers must wear this equipment where there is a reasonable probability of injury from flying objects, glare, injurious radiation or splashes from liquids such as caustics and solvents. The equipment must be designed to provide adequate

protection against the particular hazards to which the person is exposed and distinctly marked to identify the manufacturer. Administrators should establish an eye protection program in shops and laboratories in which every person, including the teacher and visitors, must wear the required eye protection at all times while in the shop or laboratory. Only protective eye wear of industrial quality, as specified by the American National Standards Institute (ANSI) or equivalent should be used. The ANSI standards cover such important features of protective eye wear as lens thickness, lens penetration, lens retention, optical quality, flame resistance of the frame, sterilizability, warp resistance, and so on. In selecting the equipment, consideration should be given to the kind and degree of hazard, and the protection should be selected on that basis. Where there is a choice of protectors, the degree of protection required should govern the selection. Where the degree of protection required is not an important issue, comfort may be a deciding factor.

A brief description of various types of eye and face protectors, along with suggestions for their use and information on their limitations, follows:

Goggles

Goggles consist of a pair of contour-shaped eyecups with glass or plastic lenses. They are held in place by a headband for the protection of eyes and the eye sockets. There are several types of goggles:

Eyecup goggles. Each eyecup is provided with a lens retainer bearing evenly on the lens with sufficient pressure to retain fragments in the event of lens breakage. The design readily permits removal or replacement of lenses. Lens retainers for welders and cutters are made to accommodate a filter lens, filter gasket, and cover lens.

Flexible-fitting goggles. Flexible-fitting goggles protect against fine dust, fumes, liquids, splashes, mists, and sprays. The frame is composed of a flexible, chemical-resistant, nontoxic, nonirritating, slow-burning material forming a lens holder. The flexible-fitting goggles are usually ventilated to prevent fogging. In some cases, the ventilation is designed to make the goggles splash-proof. Since the frame is of nonrigid material, they offer less protection against impact than do eyecup goggles.

Plastic eyeshield goggles. Plastic eyeshield goggles provide protection against light flying objects and, when so designed, against glare and injurious radiation. They are acceptable for light chipping or grinding operations, for use around woodworking machines, for spot welding, for babbitting, and for protection against glare or injurious radiation in low concentrations. They should not be used for protection against severe flying object hazards or for welding.

Foundrymen's goggles. Foundrymen's goggles consist of a mask made of flexible, nonirritating, and noncombustible or slow-burning material, metal lens holders, lenses, and a positive means of support on the face. The edge of the mask in contact with the face is provided with a binding of corduroy or other suitable material. These goggles are used to provide protection against impact and hot metal splash hazards encountered in foundry operations, such as melting, pouring, chipping, babbitting, grinding, and riveting. They are also designed to provide protection against dust.

Spectacles

Safety spectacles are patterned after conventional eyeglasses but are of more substantial construction, either with or without side shields and with impact-resistant lenses. Clip-on side shields are available for easy conversion of spectacles for front *and* side protection. Lenses may be clear or filtered, glass or plastic. Corrective safety lenses may also be mounted in spectacles with safety frames, provided the lenses are tempered to meet the proper impact standards. Two types of spectacles are described below:

Metal, plastic, or combination frame spectacles. Spectacles are intended to provide protection from flying objects, glare, and injurious radiation. Spectacles without side shields provide frontal eye protection only. Where side protection is also necessary, the spectacles should be provided with side shields made of metal or slow-burning plastic materials. Spectacles are used for light chipping operations, for grinding, for machine tool operations, and for other jobs involving flying object hazards. When provided with filter lenses, they may be used for furnace operations, molten metal handling, spot welding, and work adjacent to welding.

Plastic eyeshield spectacles. Plastic eyeshield spectacles have similar features and are used under the same conditions as plastic or metal frame spectacles, although they are not as durable as the latter.

Persons who require vision correction should be encouraged to obtain prescription safety glasses. When they wear prescription spectacles which do not have safety lenses in safety frames, an appropriate cover goggle should be worn over their regular glasses as protection against shattering of the unhardened lenses. Because of their added cost, prescription safety glasses should be protected against pitting during grinding operations by a face shield, cover goggles, or lightweight disposable plastic clip-ons.

Most cover goggle frames are molded in either a flexible or rigid vinyl or soft rubber material. Headbands consist of an elastic adjustable strap which can be replaced at a very nominal cost.

Helmets and Hand Shields

Helmets and hand shields are designed to provide protection against intense radiant energy not only for the eyes, but also for the face, ears, and neck. Typical operations which require helmets or hand shields include various kinds of arc welding and heavy gas cutting. Two types are described below:

Helmets. Because of the area to be protected, the helmet body is of such size and shape as to protect the face, top of the head, and the neck to a vertical line back of the ears. It has an opening or openings in the front for a filter plate and cover plate. The helmet body is supported so that it does not come in contact with any part of the head and can be lifted up from in front of the face to allow the welder to examine the weld. The helmet body is made of vulcanized fiber, reinforced plastic, or other suitable heat- and flame-resistant material, opaque to visible ultraviolet and infrared radiations and able to be disinfected. Rivets or other metal parts, if terminating on the inside surface, are insulated.

Hand shields. Hand shields are used in some welding operations or for observing the welding process. A handle made of nonconducting, noncombustible, or slow-burning material is provided. The materials used for hand shields are similar to those used for helmets. The lens mounting arrangement and filter and cover plates are the same as for the helmet.

Face Shields

Face shields are designed to provide protection to the face from flying particles and sprays of hazardous liquids and, in addition, to provide antiglare protection when needed. Plastics used in the manufacture of face shields combine a high degree of mechanical strength with low weight, are nonirritating to the skin when exposed to perspiration, and are capable of withstanding frequent disinfection. Plastic materials should be slow-burning. Clear or colored plastic materials used in windows should be of an optical grade to provide equivalent performance with the optical, physical, and radiant energy requirements specified for other eye protectors. When face shields are to be used in atmospheres or working areas requiring special conditions of nonconductivity or nonsparking, all materials used should be made to meet these requirements and plainly and permanently labeled as "nonconductive face shield" or "nonsparking face shield." Some typical uses for face shields include woodworking operations where chips and particles fly; metal machining causing flying particles; buffing, polishing, wire brushing, and grinding operations where flying particles or objects may strike the face; spot welding; and handling of hot or corrosive materials. They are not acceptable for protection against heavy flying objects, for welding and cutting, or against intense radiant energy. In such cases, where facial protection is needed, the face shield should be worn over appropriate goggles.

Care and Disinfection of Eye Protection

Good eye protective devices require clean lenses. Dirty lenses will blur vision and will eventually cause eye strain. Lenses should be cleaned daily with a solution of warm water and soap (or a cleaning solution) and wiped dry. Pitted or scratched lenses can also reduce vision and should be replaced with new lenses whenever possible. The molded plastic frames of protective covers readily permit lens replacement. Spectacle-type frames require professional skill to replace, and replacement of the entire safety goggle should be considered. Keeping goggles in their cases when not in use will extend their life span. The plastic bag or box in which they are shipped provides an ideal dust-proof container for protection.

If a protective device is worn by more than one person, it will require a means of disinfection. The most effective method of disinfecting eye protective equipment is 1) thorough cleansing

with soap and warm water and 2) careful drying with tissue. A complete immersion in disinfecting solution for 10 minutes is another means of disinfection. After such treatment, the protective devices should be allowed to dry at room temperature, because wiping will destroy the germicidal residue which otherwise retains its effectiveness while in use. Disinfection under ultraviolet light is not recommended, because this causes rapid deterioration of plastic and rubber parts.

Hearing Protection

Noise levels in some areas may be above the 90 dBA legal limit. While noise controls are being implemented, workers must be provided and directed to wear hearing protection. (See "Occupational Health and Environmental Control.") Ear protectors are designed to filter out and absorb harmful noise of both high and low frequency. Ear plugs alone significantly reduce noise at the eardrum. Ear muffs seal out noise by providing a tight fit around the ear. Ear plugs should be individually fitted to the wearer. They are somewhat difficult to detect from a distance and regular inspections should be made to ensure that they are being worn where needed. The protection from noise by ear plugs is generally somewhat less than that by ear muffs. Ear muffs may be foam-filled or grease-filled. The latter cost somewhat more but are the most effective in reducing sound levels. Ear muffs are substantially more expensive than ear plugs and are more bulky, but are sometimes more comfortable to wear.

Head Protection

Hard hats are required in situations where persons may be struck in the head by falling or flying objects.

This head protection must meet the recommendations in ANSI Z89.1-1969 for protection against the type of hazard expected. It must be one of the following types and of one of the following classes*:

- Type 1 - Helmet, full brim
- Type 2 - Helmet, brimless, with peak
- Class A - Limited voltage protection
- Class C - No voltage protection
- Class D - Limited voltage protection, fire fighters' service, Type 1 only

*Class B—High voltage protection, not included in this standard

Each helmet must be identified on the inside of the shell in letters not less than 1/8 inch high, with the name of the manufacturer and the ANSI designation and class.

For example: Manufacturer's name
ANSI Z89.1 - 1969
Class A

Foot Protection

Safety shoes are recommended to prevent injury to the feet from falling objects and other hazards. They should be worn particularly where heavy stock is handled. They should also be worn where there are parts-handling, shipping, and receiving operations.

This foot protection must meet the recommendations in ANSI Z41.1-1967 for protection against the type of hazard expected. Safety footwear is organized into three classes, according to its ability to meet minimum requirements for both compression and impact tests:

Classification	Compression (Pounds)	Impact (Foot-Pounds)	Clearance (Inches)
75	2,500	75	16/32
50	1,750	50	16/32
30	1,000	30	16/32

When classified according to ANSI performance requirements, at least one of each pair of footwear must be clearly and legibly stamped on the inside quarter, or the shank of the outsole, shank of the insole, or tongue, and enclosed in a border. The identification must read as follows: USAS* followed by the designation Z41.1 - 1967/75, Z41.1 - 1967/50, or Z41.1 - 1967/30, depending on the results of the impact and compression testing. Numbers and letters must be 3/16 inch high or larger.

Example: USAS
Z41.1 - 1967/75

Gloves, Aprons, and Other Protective Clothing

Gloves, aprons, and other protective clothing may be necessary for some operations (e.g., welding), depending on the nature of the hazard generated.

*USAS (United States of American Standards) now ANSI (American National Standards Institute).

Gloves and Hand Leathers

Gloves and arm protectors should be used to prevent lacerations from handling objects with sharp edges, to prevent contact with chemicals, or to prevent burns.

Canvas or heavy cotton work gloves are usually worn if the main hazard is blisters due to friction. Such protection is inexpensive and easily procured. When heat is involved, such as in foundry work, a more protective type of glove or mitten must be worn. For welding, a leather glove extending well over the wrist is recommended. Some of the more durable ones are made of cowhide or horsehide. Hand guards or leathers are usually of a special design to reduce hazards when handling material with sharp edges, such as sheet metal or steel. They consist of a pad of leather which covers the palm of the hand and fingers, yet permits maximum hand flexibility. For protection against acids, caustics, solvents, and petroleum products, an appropriate impermeable glove, available in various types of rubber or plastic, should be used. Such gloves can be purchased in wrist or gauntlet length. The gauntlets vary in length and extend to a few inches above the wrist or to the entire length of the arm, as required. Gloves should not be worn around moving machinery.

Aprons

Aprons, available in a variety of materials, may be either the bib type covering from the chest down to the knees or ankles or of the waist type. Aprons protect against sparks, hot metal splashes, and splashing liquids, depending on the material from which they are made. Loose aprons are extremely hazardous around revolving or reciprocating machinery and should not be permitted.

Coveralls and Overalls

Coveralls cover the body except for the hands, head, and feet. Overalls include a "bib," but do not have sleeves as provided in coveralls. They are usually made from a rugged material to withstand hard and long wear. Coveralls and overalls provide body protection and are recommended for building construction jobs.

Shop Coats

Shop coats give general body protection. Frequently, they are used to safeguard against grease and dirt. More specifically,

they serve as protection from chemicals and hot substances. Coats with sleeves should not be used when working around moving machinery. The short-sleeve wraparound knee or hip length serves well for general laboratory or shop use.

Respiratory Protection

Approved respirators must be provided by the school when the workplace air is contaminated with excessive concentrations of harmful dusts, fumes, mists, gases, or vapors. Respirators may be used as a control only when engineering or administrative controls are not feasible, or while they are being implemented.

If respirators are used, a written respirator program must be established and must include the following:

The respirators selected for use must be designed to protect against the specific hazards to which people are exposed.

Written instructions covering the selection and use of respirators must be available.

Workers must be trained in the use and limitations of respirators as well as their proper fitting and maintenance.

Respirators should be cleaned at the end of each use. They should be taken apart, washed, dried, and defective parts replaced.

If a respirator is used by two persons, it must be cleaned and disinfected after each use.

When the respirator is worn, all straps must be adjusted and tied.

To ensure proper function of the respirator, a good face seal is necessary. Beards, long sideburns, and glasses may interfere with the fit.

The filter, cartridge, or canister must be replaced when they have been used for the specified lifetime, when the wearer can smell vapors in the mask, or if breathing becomes difficult.

Respiratory Cleaning

The following procedure is suggested for cleaning and disinfecting respirators:

Remove any filters, cartridges, or canisters.

Wash facepiece and breathing tube in a cleaner-disinfectant solution. Use a hand brush to facilitate removal of dirt.

Rinse completely in clean, warm water.

Air dry in a clean area.

Clean other respirator parts as recommended by the manufacturer.

Inspect valves, headstraps, and other parts; replace with new parts if defective.

Insert new filters, cartridges, or canisters; make sure seal is tight.

Place in a plastic bag or other container for storage.

GENERAL ENVIRONMENTAL CONTROLS

Sanitation

Safe drinking water must be provided in all places of employment. The use of a common drinking cup is forbidden.

Receptacles for waste food must be covered and kept in a clean and sanitary condition.

Restrooms must be kept in a clean and sanitary condition.

Separate toilet facilities must be provided for each sex. If only one person at a time uses a toilet room and the door can be locked from the inside, separate facilities are not required.

One toilet must be provided for approximately every 15 employees.

Each lavatory must have hot and cold or tepid running water, hand soap, and individual hand towels or warm air blowers.

Beverages or food must not be stored or consumed in a toilet room or in any area exposed to toxic materials.

Persons working with toxic substances should wash and, where necessary, change from contaminated clothing before eating, drinking, or smoking.

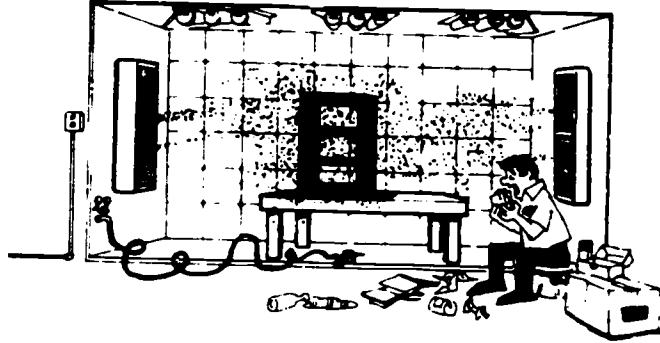

In any establishment where food is handled, processed, or sold, sanitation of the highest order should be maintained:

Any container used for solid or liquid waste that may spoil must be made leakproof, easy to clean, and be kept clean. The container must have a tight fitting cover, unless it can be maintained in a sanitary condition without a cover.

Every enclosed work place and personal service room must be constructed, equipped, and maintained, so far as reasonably practicable, in such a manner as to prevent the entrance or harborage of rodents, insects, and vermin of any kind.

Signs and Tags

The construction safety and health regulations require the use of signs and tags as described below:

Signs

Signs that warn of real or potential hazards must be visible to all persons and promptly removed or covered when the hazard no longer exists.

“DANGER” signs must be used when an immediate hazard exists.

“CAUTION” signs are to be used to warn against potential hazards or unsafe practices.

Construction areas must have legible traffic signs at hazardous points. Safety instruction signs and directional signs are other types of signs used.

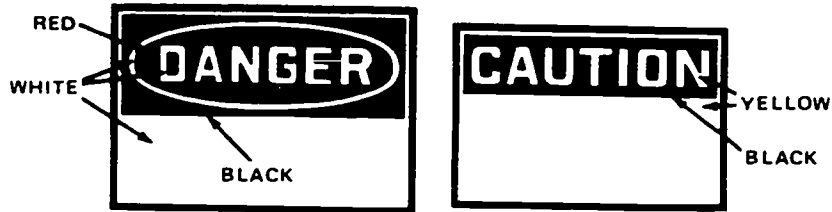

Tags

Accident prevention tags differ from signs in that they are used as a temporary means of warning persons of existing hazards, such as defective tools or equipment. They may not be used in place of accident prevention signs. The above illustrations are examples of preferred accident prevention tags, although similar tags are acceptable.

It is recommended that locks be used in combination with tags to lock out controls, switches, etc., which if not locked out may lead to an accident; for example, if electrical maintenance is being done.

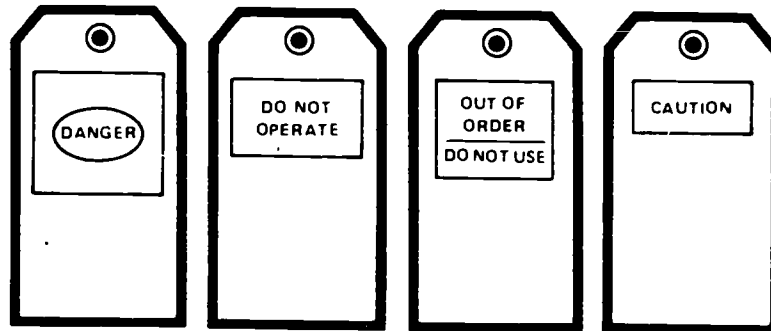

White tag - White letters on red square

White tag - White letters on red oval with a black square

Yellow tag - Yellow letters on a black background

White tag - White letters on black background

TAGS

MEDICAL AND FIRST AID

The administrator who is interested in maintaining service, preventing loss of work time, receiving efficient work performance and creating good morale among employees should adopt ways to maintain the health of the employees. A

good practice is to require preplacement medical examinations to ensure that prospective employees are physically able to do the specific work. As a minimum, an occupational toxic exposure history should be recorded for each employee and placed on file. (See "Occupational History of Potential Hazard Exposure.")

Eye care is especially critical in vocational education programs. Often overlooked in an occupational safety and health program is the wearing of contact lenses. Contact lenses should never be worn in a work setting. In order to be effective and to assure compliance, not even office employees can be exempted. Small particles of carbon, talc, dust and dirt, chemical fumes, excessive heat, or other hazards often affect contact lenses and can destroy vision. If a person is splashed with a corrosive chemical, eyesight may be damaged by the time the contact lens is removed. An unconscious worker's contact lenses cannot be removed. Even protective safety goggles do not always protect contact lenses.

Emergency phone numbers must be posted near telephones. The Emergency Information Chart (printed inside the back cover of this guide) may be helpful. Stretchers and blankets should be available for prompt transportation of injured or ill employees to a hospital.

If no infirmary, clinic, or hospital, which is used for treatment of all injured employees, is near the school, the following are required:

- At least one and preferably more employees on each shift must be adequately trained to render first aid. The American Red Cross, some insurance carriers, local safety councils, and others with OSHA-approved programs provide acceptable training.
- First aid supplies approved by a consulting physician must be readily available. The supplies should be in sanitary containers with individually sealed packages for material such as gauze, bandages, and dressings that must be sterile. Other items often needed are adhesive tape, triangular bandages (to be used as slings), inflatable plastic splints, scissors, and mild soap for cleansing of wounds or cuts.
- Suitable facilities for quick drenching or flushing of the eyes and body must be provided within the work area when a person may be exposed to corrosive material.

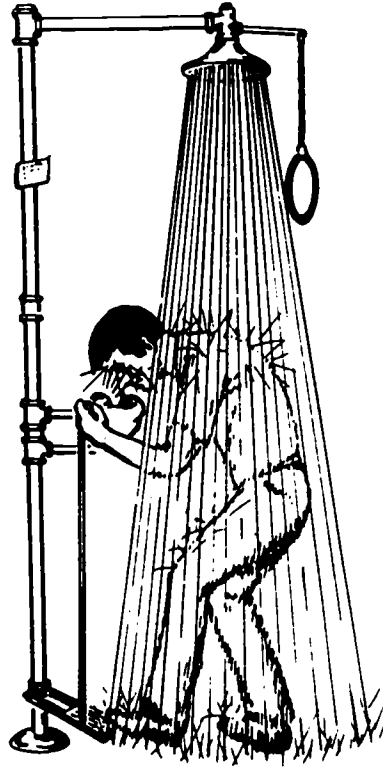

Some states have laws concerning medical practice which establish limits on first aid given by the lay person. Trained employees should understand where first aid ends and professional medical treatment begins.

NOTE: First aid is immediate, temporary treatment given in the event of accident or illness—before the doctor arrives. Immediate first aid (within 4 minutes) may prevent permanent impairment or death, and may lead to complete recovery.

FIRE PROTECTION

Everything necessary to start a fire is present in schools: *fuel*, such as gasoline, hydrogen generated during battery charging, packing and cleaning materials, paints and solvents, plastics, trash, and many other items; *oxygen* from the air; and *ignition*

sources, in the form of flames, sparks, heating systems, welding, hot metal, spontaneous combustion, and electrical equipment. The basic principle of preventing fire in your school is to keep these three elements separated.

Scheduled maintenance checks of electrical machinery and ventilation systems, good housekeeping, periodic facility inspection, and proper storage and disposal of combustible sweeping compounds, oil mops and rags, and flammable solvents rank as the best safeguards against fire. However, even the best maintained facility can have a fire.

Of primary concern in the event of a fire is the safe evacuation of people from the scene of the fire. Regardless of size, each school should be equipped with a fire alarm system and have an emergency evacuation plan in case of fire.

Fire Alarm System

The fire alarm system, once installed, must be under the supervision of a qualified individual. The system must be tested and inspected weekly. Generally, the fire alarm system includes three subsystems:

Detection system. The fire alarm system must include detection devices—each designed for the area it is to protect. Typical detection devices are smoke detectors, flame detectors, and heat detectors. The decision regarding the type of detector to use should be made in consultation with the local fire department.

Extinguishing system. The extinguishing system, activated by the detection system, can be a water system (e.g., automatic sprinkler system), a gas system (e.g., carbon dioxide), or powder system (e.g., sodium bicarbonate). The type of system to use may vary from one area to another depending on the type of fire likely to break out. Consultation with the local fire department is advised.

Warning system. The warning system should include warning bells or buzzers and wall-mounted fire alarm activators at strategic locations throughout the facility. The warning system should be connected into the local fire department.

Emergency Procedures

In case of fire, make sure the local fire department is notified before any attempt is made to fight the fire, regardless of any arrangements made previously with the fire department.

While the fire department is being notified, an orderly evacuation from the facility should begin.

Building Evacuation

A plan for orderly evacuation should include the following:

- an evacuation signal
- a well-planned evacuation route for all areas of the facility
- designation of an assembly area for persons well away from the school
- an accounting procedure for all persons after assembly (a daily list of those absent should be made to simplify accounting)
- a search of the building to assure complete evacuation. Floor or area "wardens" should be designated to cover all areas.

Notification and Training

- A list of telephone numbers for local fire departments should be posted in prominent places throughout the school and all employees advised of this posting. (See Emergency Information on the inside back cover.)
- Floor plans for designated areas should be posted showing locations of fire alarm activators, fire extinguishers, and exits.
- Several employees in each area of the facility should be trained in the use of fire extinguishers.

Good Housekeeping

Maintaining a clean and orderly school reduces the danger of fires. Combustible material of any type should be kept only in places which are isolated by fire-resistant construction.

Rubbish should be disposed of regularly. If it is necessary to store combustible waste materials, a covered metal receptacle is suggested.

The materials used for cleaning can also create hazards. Combustible sweeping compounds, such as oil-treated

workshop can be a fire hazard. Floor mats containing low flash point solvents can be dangerous especially near sources of ignition. All oil rags and rags must be stored in closed metal containers.

Some common causes of fires in all vehicles are:

- Electrical malfunctions
- Oil leaks
- Engine failure
- Sparks
- Oil surfaces
- Smoking

Proper maintenance and frequent inspections through a safety program can reduce these hazards.

And while some good housekeeping contributes to a safer workplace by reducing the potential for fire, it also reduces accidents caused by slips, trips and falls. Falls are one of the most contributors to injury. Accumulations of waste and scrap and spills of slippery materials must be cleaned up promptly so that they do not constitute a hazard.

Good housekeeping also contributes to increased safety during materials handling and storage. An orderly vehicle with unobstructed aisles and passages can significantly reduce accidents.

Fire Extinguishers

Fire extinguishers must meet the following requirements:

• Be kept fully charged and in their designated places.

• Be located along normal paths of travel.

• Not be obstructed or obscured from view.

• Be inspected for storage until in a designated person at least monthly to ensure that they:

- Are in their designated place
- Have not been tampered with or actuated, and
- Do not have corrosion or other impairments.

• Be examined at least yearly and recharged or repaired to ensure operability and safety. A tag must be attached to show the

maintenance or recharge date and signature or initials of the person performing the service. (OSHA is also considering eliminating these standards.)

Be hydrostatically tested. Extinguisher sales representatives usually will perform this service at appropriate intervals.

Be selected on the basis of type of hazard, degree of hazard, and area to be protected.

Type of hazard	Basic minimum extinguisher rating	Maximum travel distance to extinguishers (feet)
Light	4B	50
Ordinary	8B	50
Extra	12B	50

Basic minimum extinguisher rating for area specified	Maximum travel distance to extinguishers (feet)	Areas to be protected per extinguisher		
		Light hazard occupancy (square feet)	Ordinary hazard occupancy (square feet)	Extra hazard occupancy (square feet)
1A	75	3,000
2A	75	6,000	3,000	Note 1
3A	75	9,000	4,500	3,000
4A	75	11,250	6,000	4,000
6A	75	11,250	9,000	6,000

Be placed so that the maximum travel distances, unless there are extremely hazardous conditions, do not exceed 75 feet for Class A fires or 50 feet for Class B fires.

A chart showing fire extinguishers by class, and how to use them, is located in the back of this booklet.

Automatic Sprinkler Systems

When automatic sprinkler systems are provided, they must meet design requirements of the National Fire Protection Association's Standard for the Installation of Sprinkler Systems (NFPA No. 13-1969), as well as OSHA requirements.

Every automatic sprinkler system must have at least one automatic water supply of adequate pressure, capacity, and reliability.

One or more fire department connections through which the fire department can pump water is required.

The school is responsible for the condition of the sprinkler system and must keep it in good operating order. Functional tests are required at least once each year.

The clearance between sprinkler deflectors and the top of combustible storage normally must be at least 36 inches. If the material is in solid piles of less than 15 feet high or in piles less than 12 feet high with horizontal channels, a minimum clearance of 18 inches is allowed. Also, commodities containing only small amounts of combustible materials may be stored up to 18 inches from the sprinkler deflectors.

Alarm systems, audible to all persons, must be provided on all automatic sprinkler installations.

Sprinkler Alarms

A sprinkler alarm is designed to sound an alarm whenever there is any flow of water from a sprinkler system equal to or more than the amount of flow from a single sprinkler.

Such waterflow alarms must be provided on all sprinkler installations.

All alarms must be located where they are accessible for inspection, removal, and repair.

Under conditions of variable water pressure, a retarding device must be installed. The installation must have valves that allow repair or removal without shutting off the sprinklers. The valves must be arranged so that they may be locked or sealed in the open position.

COMPRESSED AIR EQUIPMENT

Workers should be familiar with the air compressor's operation and maintenance instructions.

New air tanks must be constructed in accordance with the American Society of Mechanical Engineers (ASME) Boiler and

Pressure Vessel Code, Section VIII. The ASME Code requires this information to be permanently stamped on the air tank.

The drain valve on the air tank should be opened frequently to prevent excessive accumulation of liquid.

Air tanks must be protected by adequate safety-relief valve(s). These valves must be tested at regular intervals to be sure they are in good operating condition.

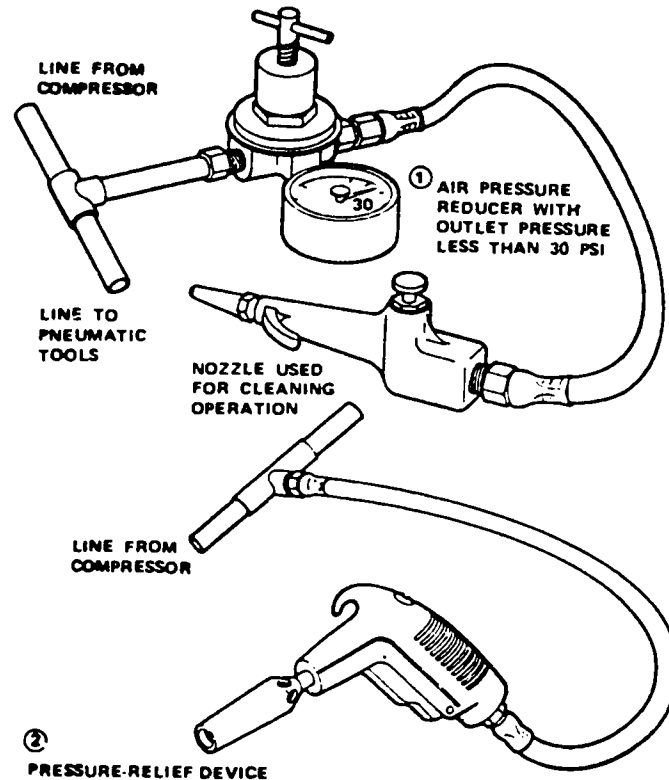
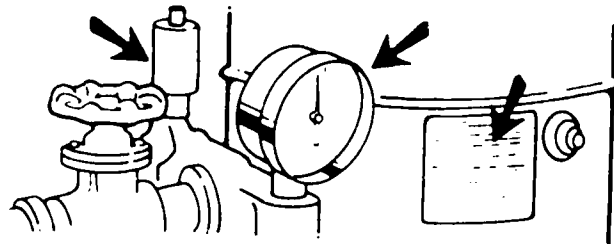

The pressure controller and gauge must be maintained in good operating condition.

There must be no valves between the air tank and the safety valve.

It is common practice to use compressed air for cleaning areas, individual machines, workbenches, and clothing. However, it is *never* a good practice to use compressed air for these purposes. Vacuuming or brushing are much safer methods. If compressed air is the only feasible way of cleaning, the pressure must be reduced to below 30 psi whenever the nozzle is dead-ended, and effective chip guarding and eye and face protection must be used. Even at this pressure, workers should never be permitted to blow material from their person or clothing.

MATERIALS HANDLING AND STORAGE

Manual Handling

Accidents in manual handling of materials are primarily the result of unsafe working habits—improper lifting, carrying too heavy a load, incorrect gripping, and failing to wear personal protective equipment. Training in safe work habits, analysis of operations, and adequate supervision can help to reduce the number of accidents.

“It’s not what you lift but how you lift it.” This applies to the lifting, lowering, or moving of heavy equipment or loads. Periodic demonstrations should be given in “how to lift safely,” using the procedure described in the lifting chart in the back of this book.

When two or more persons must carry a single heavy object, they should be similar in size and physique. One acting as a leader should position himself so that he can watch and coach the others. He should use predetermined signals to control the lifting, carrying, and lowering of the object. All persons should act together so that no extra burden will be placed suddenly upon one.

When two persons carry long sections of pipe or lumber, they should carry at the same level and walk in step.

Powered Industrial Trucks

Powered industrial trucks are classified into categories for the purpose of determining what type of truck may be used in a

certain location. The type of hazard in a location determines whether diesel, electric, gasoline, or LP-gas powered trucks may be used and what additional safeguards must be present. Suppliers can assist in the proper selection.

High-lift rider trucks must be fitted with an overhead guard to protect the operator from falling objects.

Methods must be developed and used to effectively train operators in the safe operation of powered industrial trucks, and only trained and authorized employees may operate the truck.

When a powered industrial truck is left unattended (the operator is 25 feet or more away or the truck is not in view), the forks must be fully lowered, the control lever positioned in neutral, the power shut off, and the brakes set. The wheels must be blocked, if parked on an incline.

Industrial trucks must be examined daily before being placed into service for any conditions adversely affecting the safety of the vehicle. If the truck is used around the clock, it must be inspected after each shift.

If the load being carried obstructs forward view, the operator is required to travel with the load trailing.

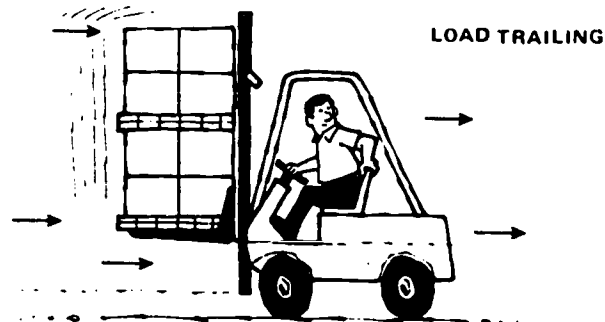

When unloading or loading from trucks, trailers, or railroad cars with forklift trucks, provision must be made for securing the truck, trailer, or railroad car by setting the brakes and placing wheel chocks under the rear wheels. Portable dock boards must be secured in position with devices which will prevent their slipping during loading and unloading.

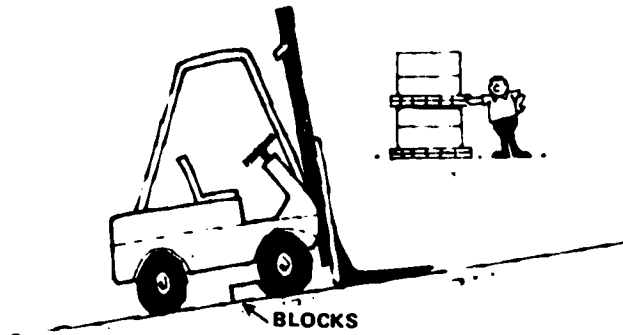

If battery-operated equipment is used, the battery charging area is to be designated as a "NO SMOKING" area due to the hydrogen gas emitted during charging.

Hoisting Equipment

Although the information provided in this section pertains specifically to cranes, these requirements should be applied to all hoisting equipment.

Only persons designated as qualified by the school are permitted to operate cranes.

The rated load capacity must be legibly marked on each side of the hoist. Operators should be aware of the weight of the load.

Hand signals to operators should be those prescribed by the applicable ANSI standard for the type of crane in use (see foldout in back of guide).

The hoist must be equipped with a self-setting brake applied to the motor shaft or some part of the gear train.

For powered hoists, holding brakes must be applied automatically when power is off.

Hooks, ropes, chains, brakes, and all functional operating mechanisms must be inspected daily for indications of damage and excessive wear. Written and signed inspection reports must be made monthly on critical items such as brakes, hooks, and ropes and must be readily available.

115

Loads must not be carried over the heads of people.

Hoisting, lowering, swinging, or traveling is not permitted while anyone is on the load or hook.

The operator must test the brakes each time a near-capacity load is handled. This test is done by raising the load a few inches and applying the brakes.

The hoist rope or chain must be free from kinks or twists and must not be wrapped around the load.

The operator must not leave his position at the controls while the load is suspended.

All cranes using a lifting magnet must have a switch in the magnet circuit with provisions for locking the switch in the open position.

When the hook is in the extreme low position, at least two complete wraps of rope must remain on the drum. Rope ends must be safely and securely attached to the drum by means of a clamp or socket arrangement approved by the crane or rope manufacturer.

When making a hook-up, the hook must be centered over the load to prevent swinging.

The trip-setting of hoist limit switches must be determined by tests with an empty hook.

Slings

Each day before use, the sling and all fastenings and attachments must be inspected by a competent person designated by the school. A thorough inspection of alloy steel chain slings must be made at regular intervals not to exceed 12 months and a record kept. Each new, repaired, or reconditioned alloy steel chain sling must be proof-tested before use and a certificate of the proof test must be kept.

Whenever a sling is used, the following safe practices must be observed:

Slings that are damaged or defective must not be used.

Slings must not be shortened with knots, bolts, or other makeshift devices.

Sling legs must not be kinked.

Slings must be securely attached to their loads and must not be loaded in excess of their rated capabilities.

Slings must be padded or protected from the sharp edges of their loads.

Suspended loads must be kept clear of all obstructions and all persons must be kept clear of loads about to be lifted or already suspended.

Shock loading is prohibited.

A sling must not be pulled from under a load while the load is resting on the sling.

Rigging Equipment

The following are cautions for avoiding hazards in using rigging equipment.

Hooks must have no cracks or other deformation.

The rated capacity of the hooks must be equal to that of the chain.

It is not permitted to use job (i.e., shop) hooks or makeshift fasteners constructed from bolts, rods, etc.

Rope slings, including end connections, may not have excessive wear, broken wires, kinks, or twists.

Rigging equipment, when not in use, must be removed from the immediate work area.

All hoisting equipment, slings, webbing, and rope cable must be inspected visually every day for unusual wear and serviceability. A monthly, itemized inspection report must be written for all lifting equipment.

Protruding ends of strands in splices or slings and bridles must be coffered or blunted.

It is not permitted to tie or secure wire rope with knots.

An eye splice made in any wire rope may not have less than three full tucks.

When used for eye splices, the 'U' bolt must be applied so that the 'U' section is in contact with the dead end of the wire rope.

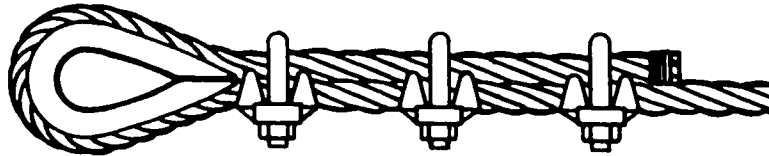

Manila rope must be used in accordance with manufacturer's recommendations. Knots may not be used in lieu of splices.

Synthetic webbing (nylon, polyester, and polypropylene) must be coded to show the name or trademark of the manufacturer, rated capacities for the type of hitch, and the type of material. (The rated capacity must not be exceeded.)

Hydraulic Lift Skid Trucks

A hydraulic lift truck that leaks should be taken out of service until repaired. The leaking can cause the load to settle after it is raised, thereby becoming a hazard.

Hand Trucks

Operators of hand trucks should wear gloves and safety shoes. The most frequent injuries to hands and feet may then be avoided. Also, hand trucks should be fitted with knuckle guards to prevent jamming hands into obstructions.

Safe Storage

The primary problem confronting the person responsible for the storage area is maintaining a neat and orderly area for both temporary and permanent storage. Proper planning of material storage areas demands that the material not obstruct fire extinguishers, fire alarm boxes, sprinkler system controls, electric switches, lights, first aid equipment, or exits. Safe clearances must be allowed for aisles, at loading docks, through doorways, and whenever turns or passage must be made. All permanent aisles and passageways must be appropriately marked, preferably with lines on the floor. Proper drainage must be provided and clearance limits shall be

marked. (OSHA may eliminate the drainage requirement. Contact your OSHA area or regional office for more information.)

Space Layout

When laying out storage space, the following safety factors should be considered:

Nature of material—

Hazardous commodities, including flammable and toxic materials, should be kept segregated from each other and other kinds of supplies. Pallets loaded with cardboard boxes do not stack evenly and will become unstable.

Floorloads—

The floorload capacity is the maximum weight of stored supplies which can be safely supported by the floor, expressed in pounds per square foot of storage space. When this information is not available and when floorload capacity is in doubt, consult a competent engineer to determine the maximum floorload capacity. These floorload capacities must be posted in a readily visible location. (OSHA is considering the elimination of this posting requirement. Check with your OSHA area or regional office for more information.)

Doors—

Doors should be of sufficient height and width to readily accommodate the safe use of materials handling equipment.

Loading facilities—

Adequate space for safe loading and unloading of materials is a must. This includes maintaining sufficient aisle space leading to the loading dock.

Stack clearance—

Standard regulations on stack clearance should be observed, keeping in mind the requirement for clearance below fire protection sprinkler heads (see "Fire Protection.")

Layout of aisles—

Safe operations within the storage areas require considerable attention to space layout for aisles. There must be enough operating space for handling and stacking materials safely.

Aisles should be planned to provide easy access to exits and fire control equipment. They should be straight and clear of obstructions.

A clear space should be maintained around fire protection equipment and the location of such equipment should be well marked.

Floors and stairways—

Floors, stairways, and loading areas must be kept clear of slipping and tripping hazards, such as oil spills or splintered or damaged floors.

All drums should be kept tightly sealed. If leaks occur, the damaged container must be removed and any fire or slipping hazard eliminated.

Materials Handling Hazards

Remove all protruding nails from boxes before unpacking or carrying.

Keep scrap material clear of operating area.

Cylindrical objects that are stored in a horizontal position should be nested and blocked to prevent rolling.

Flammable packing materials should be placed in closed metal containers to prevent fire hazards.

Enforce "NO SMOKING" regulations in hazardous areas.

Storage of Materials and Tools

The safe storage of materials and tools is directly related to effective instruction, good housekeeping, fire prevention, and other elements of a safe school shop environment. Inadequate or unsafe storage procedures and practices frequently create conditions dangerous to persons working in the shop and create fire or explosion hazards that might damage the building. Lack of storage facilities invites unsatisfactory housekeeping practices and increases the difficulty of handling materials, tools, and projects. This increases the number of hazards in the shop.

Safe storage facilities for materials and tools must be provided in school shops for several reasons. The primary purpose is to protect persons working in the shop from accidents. Adequate

storage facilities are also needed to protect tools and materials from theft, unauthorized use, improper or unsafe handling, damage, and deterioration. Lack of adequate storage areas for tools and materials creates many unsafe conditions. Unsafe acts may be committed by shop workers because of insufficient storage space. Efficient storage practices will permit accurate, up-to-date inventory of materials and supplies in shop.

No one storage method or procedure is best for all shop conditions, but from the standpoint of efficiency and safety, one can follow certain general considerations in arranging for the safe storage of shop tools and materials.

Location of Storage Facilities

The general location of storage rooms may depend upon the size of the shop or laboratory, the nature of the activities, class enrollments, and nature of the materials and tools. Generally, storage rooms should be located adjacent to the work area and close to places where the materials are needed. Supply storage areas should be located in or near the shop, so that there is easy access to materials without having to cross the paths or traffic patterns of others. Safety and ease of storage, delivery of supplies, and the issuing of materials should be considered when planning the location of storage facilities. It is desirable to have an outside door or unloading ramp near the storage room. Storage areas should be arranged and located to reduce traffic and eliminate congestion during the class period. Crowded areas are prolific accident producers. Tool panels and cabinets should be located away from hazardous machinery. Supplies of flammable liquids should be stored in an area apart from the main building. The storage facility for flammable liquids and other materials should be located so that the sun's rays and other sources of heat do not reach them. Chemicals which may react with one another if spilled should be stored separately in compatible groups.

Construction Considerations

Shelves, racks, bins, and cabinets should be designed and constructed to hold the maximum number of tools and items safely without the danger of collapsing. Storage racks constructed with steel or pipe are usually safer than those built of wood and create fewer fire hazards. Extra strength racks may be needed for large portable tools and other heavy items. Racks should be designed so that heavy items are stored on the lower shelves.

Storage Methods

All materials, tools, parts, and accessories should be stored safely and neatly and arranged in an orderly and accessible way in the places provided, regardless of the specific storage method. Those items used most frequently should be stored within easy reach on the lower shelves. Storage areas must be clean, orderly, ventilated, and well-lighted. Containers, bins, shelves, and drawers which contain caustics, acids, solvents, and bundles of materials should never be stored on the tops of lockers or cabinets, because there is always the danger of objects falling from these places. Generally, vertical storage of long pieces of material creates greater hazards than horizontal storage.

Tool Storage

Many different methods and techniques have been devised for storing hand and portable tools. The most common tool storage methods are tool panels, centralized tool cribs, wall cabinets, bench drawers, and movable racks. Regardless of the methods selected, tool storage facilities should be designed and arranged to provide maximum protection from hazards caused by tools falling from overhead, by knives and other sharp tools being carried in pockets, and by chisels laid loosely in tool boxes.

Material Storage

The average shop contains hundreds of different hardware items and supplies. Each presents a different storage problem. Regardless of the system used, the storage facilities should be located for convenience and safety. Many schools use the closed storage method, in which all supplies and materials are kept locked in the storeroom or cabinets. Others use the open storage method, where persons are permitted to use supplies as they are needed. A combination of the open and closed systems of materials storage is used by most. For safety reasons, some materials, particularly hazardous chemicals, should be in locked storage areas and used only under immediate supervision.

Flammable Liquids and Finishing Supplies

The storage of flammable liquids, such as gasoline, thinners, and other liquids, presents many problems from the standpoint of health, convenience, fire control and prevention, and explosions. The storage of such materials can be very troublesome and dangerous unless flammable liquid storage

areas are carefully planned and provisions made to safely care for the various types of flammable materials. (See Hazardous Materials.)

MACHINERY AND MACHINE GUARDING

Machine guarding is of the utmost importance in protecting persons from the hazards associated with operating machinery. In fact it could be said that the degree to which machines are guarded in an establishment is a reflection of management's interest in providing a safe workplace.

People cannot always be relied upon to act safely enough around machinery in motion to avoid accidents. From time to time they will react differently to the same environment because of physical, mental or emotional changes—sometimes reacting safely, sometimes not. It follows that even the well-coordinated and highly trained person may at times perform unsafe acts which could lead to injury and death. Proper guarding will allow the worker to work safely and at the same time perform assigned tasks.

Hazards are created wherever there are rotating, reciprocating, and transverse motions, in running nip points, cutting and punching, shearing, and bending actions. Some of these motions may be at the point of operation (point where work is performed upon material in process) or other moving parts of the machine.

It is not adequate to consider the safety of the machine operator only, but others in the machine area must be safeguarded.

The most common methods of guarding a hazard or hazardous machine operation are:

- enclosing the operation (the preferred method)
- interlocking devices
- moving barriers
- removal devices
- remote control
- two-hand tripping devices
- electronic safety devices

A booklet entitled "The Principles and Techniques of Mechanical Guarding," OSHA 2057, can be obtained by writing to OSHA regional offices listed in the back of this book. Many equipment representatives can assist in obtaining the necessary protective devices.

General Requirements for Machine Guarding

One or more methods of machine guarding must be provided to protect the operator and others in the machine area from hazards.

Guards must be attached to the machine if possible. The guard should not itself be a hazard.

All fixed machines must be secured to prevent movement.

The guarding device must conform to appropriate standards, or if no standards exist, be designed and made to prevent the operator from having any part of his body in the danger zone during the operating cycle.

All belts, pulleys, chains, sprockets, and gears must be effectively guarded.

All belts, chain drives, shafting, couplings, keys, collars, and clutches located 7 feet or less above the ground, floor, or working platform must be guarded to prevent accidental contact. V-belts and chain drives must be completely enclosed.

Certain guarding methods are not necessarily preferable to others, but the type of operation, the size or shape of stock, the method of handling, the physical layout, the type of material, and the job requirements or limitations may present important considerations. A certain flexibility in operations may also determine the practicability of the method to be used. It is when guarding the point-of-operation, where work is being done on an object, that the most effective and practical of several means of guarding must be selected.

The Four Main Methods of Guarding

Enclosure Guards

Fixed enclosure guards should be used in preference to all other types. They prevent access to dangerous parts at all times by enclosing the hazardous operation completely. They also restrain bursting machine parts from flying about. They admit the stock but will not admit hands into the danger zone because of limited feed opening size. They may be constructed so as to be adjustable to different sets of tools or dies, but once adjusted, they should be fixed.

Enclosure guards may be installed at the point where material is being processed, and at other places where there may be

a hazard when inserting or manipulating stock. They may also be used to prevent contact with rotating, reciprocating, and transverse motion of machine members away from the point of operation.

Interlocking Guards

When a fixed enclosure guard is not practicable, an interlocking enclosure or barrier should be considered as the first alternative.

An interlocking enclosure guard is not fixed and may be opened or removed as the operation requires. However, due to an electrical or mechanical interlocking connection with the operating mechanism, the operation position and the operator can no longer reach the point of danger.

An interlocking enclosure guard should do three things:

- Shut off or disengage the power to prevent the starting of the machine when the guard is open.
- Guard the danger point before the machine can be operated.
- Keep the guard closed until the dangerous part is at rest, or stop the machine when the guard is opened.

When gate guards or hinged enclosure guards are used with interlocks, they should be so designed as to completely enclose the point of operation before the operating clutch can be engaged.

An interlocking barrier quickly stops the machine or prevents application of injurious pressure when any part of the operator's body contacts the barrier. The barrier may be a bar, a rod, a wire, or some similar device (not an enclosure), extended across the danger zone and interlocked electrically or mechanically with a braking mechanism. Electrical interlocking devices should be so designed that if they fail, they fail safe, making the guarded machine inoperative.

Another type of interlocking barrier may be in the form of an electric-eye beam or a magnetic, radiation, or similar type circuit so designed and installed that when the the operator's hand or any part of the body is in the danger zone, the machine cannot be operated, or if the hand or any part of the body is inserted while the machine is in motion, it will immediately activate a braking mechanism.

Automatic Guards

When neither an enclosure guard nor an interlocking guard is practicable, an automatic guard may be used.

An automatic guard acts independently of the operator, repeating its cycle as long as the machine is in motion. This type of guard removes the operator's hands, arms, or body from the danger zone as the ram, plunger, or other tool closes on the piece upon which work is being done. It is operated by the machine itself through a system of linkages connected to the operating mechanism.

Common types of automatic guards are sweep and pushaway devices, which are moving barriers crossing the danger zone when the machine is activated, and pull-away devices, consisting of hand and arm attachments which pull the operator away from the danger zone.

Sweep and pushaway devices should be designed to prevent the operator from reaching behind or across the protective device into the danger zone before the machine has completed its closing cycle. The device itself should not offer a hazard by creating a shear point between the moving guard and a stationary or moving part of the machine.

Automatic pressure release or pivoting arm devices provide utility, yet protect the in-running nip point situation.

Remote Control, Placement, Feeding, Ejecting

Although they are not guards in the technical sense, there are certain methods which can be used to accomplish the same effect, that is, of protecting the operator from the hazardous point of operation. They may be used to complement one of the other types of guards.

Two-handed operating devices may be used to activate the machine. These devices require simultaneous action of both hands of the operator on electrical switch button, air control valves, or mechanical levers. On presses with a non-interrupting stroke, two-handed operating devices should require manual operation until a point is reached in the cycle at which the hazard ceases. Hand controls may be interconnected with foot controls to permit operation of the machine. The actuating controls should be so located as to make it impossible for the operator to be able to move his hands from the controls to the danger zone before the machine has completed its closing cycle. The two-handed controls should be so designed as

to prevent the blocking, tying down, or holding down of one control to allow one hand free access to the point of operation. When more than one person is working a machine, additional controls should be installed and designed so that all persons must simultaneously activate the starting mechanism for remote locations.

Automatic or semiautomatic feeding mechanisms such as rolls, plungers, chutes, slide and dial feeds, and revolving dies may be used in conjunction with ram enclosures. Special soft metal hand tools may be used to place or remove parts in conjunction with an enclosure, interlocking, or automatic guard. Special jigs, holding devices, and dies may be used to manipulate stock at the point of operation, yet keep hands safe. Mechanical or air-operated ejecting mechanisms may be used to remove any parts, thus eliminating the need for the hands to be placed in the danger zone.

The theory behind these methods is that if for good reason it is impossible to completely enclose or isolate the hazard, the next device or combination of devices should be used to keep the exposure to a minimum.

The Techniques of Mechanical Guarding

It is recognized that a given situation—a hazard-creating motion or action—may frequently be guarded in a number of satisfactory ways.

The selection of guarding method to be used may depend upon a number of things. Space limitations, size of stock, frequency of use, and still other factors may be important in making the final decision. It is not the intent of this guide to suggest which method of guarding is the best for a given situation, but rather to show that there are a number of ways to guard each different condition. This will be done by illustrating typical situations which may be guarded by a variety of methods.

In the illustrations, various motions and actions are shown and typical guards illustrate the various guarding techniques. It is not possible to apply all of the guarding techniques to all of the motions or actions, but an effort has been made to show examples of those that are frequently found in schools.

Cutting Action

Cutting action results when rotating, reciprocating, or transverse motion is imparted to a tool so that material being removed is in the form of chips. The danger of cutting action

exists at the movable cutting edge of the machine as it approaches or comes in contact with the material being cut. Such action takes place at the point of operation in cutting wood, metal, or other materials as differentiated from punching, shearing, or bending by press action.

Typical examples of mechanisms involving cutting action include band and circular saws, milling machines, planing or shaping machines, turning machines, boring or drilling machines, and grinding machines.

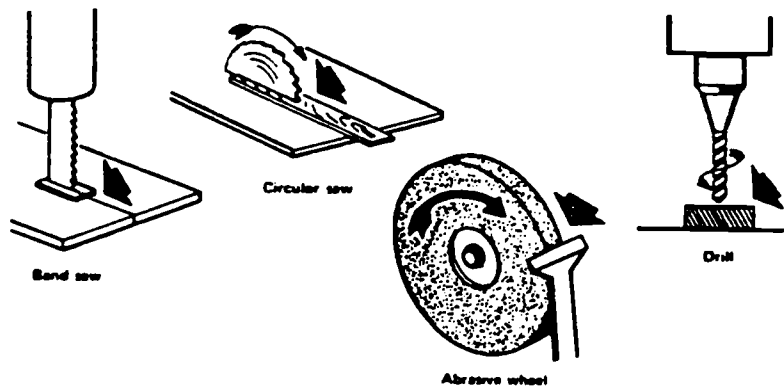

Rotating, Reciprocating, and Transverse Motion

Rotating, reciprocating, and transverse motions create hazards in two general areas—at the point of operation where work is being done and at the point where power or motion is being transmitted from one part of a mechanical linkage to another. Even smooth, slowly rotating shafts can grip clothing or hair or, through mere skin contact, force an arm or hand into a dangerous position.

Collars, couplings, cams, clutches, flywheels, shaft ends, spindles, rotating bar stock, lead screws, and horizontal or vertical shafting are typical examples of common rotating mechanisms which are hazardous. The danger increases when bolts, oil cups, nicks, abrasions, and projecting keys or screw threads are exposed when rotating.

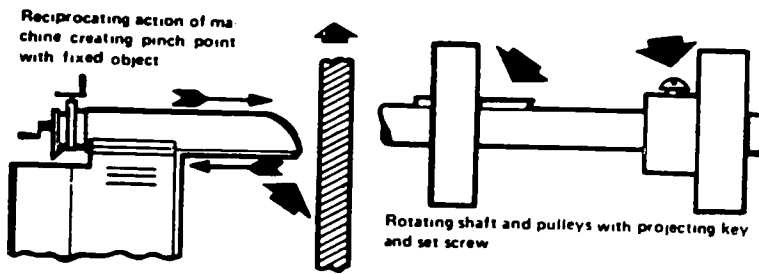

In-Running Nip Points

In-running nip points are a special danger existing only through action of rotating objects. Whenever machine parts rotate toward each other, or where one rotates toward a stationary object, an in-running nip point is formed. Objects or parts of the body may be drawn into this nip point and be bruised and crushed.

The in-running side of rolling mills and calenders, or rolls used for bending, printing, corrugating, embossing or feeding and conveying stock, the in-running side of a chain and sprocket, belt and pulley, a gear rack, a gear and pinion, and a belt conveyor terminal are typical examples of nip point hazards.

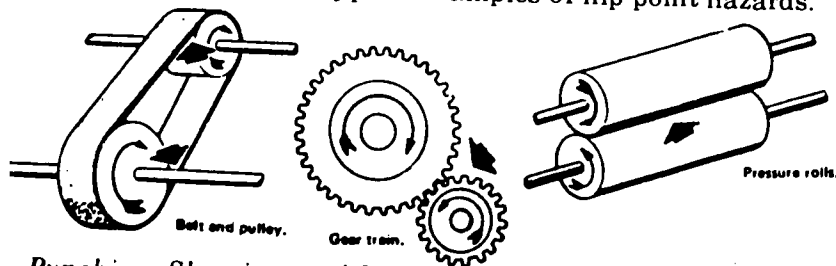

Punching, Shearing, and Bending Action

Punching, shearing, or bending action results when power is applied to a ram (plunger) or knife for the purpose of blanking, trimming, drawing, punching, shearing, or stamping metal or other materials as differentiated from removing the material in the form of chips. The danger of this type of action lies at the point of operation where stock is actually inserted, maintained, and withdrawn.

Typical examples of equipment involving punching, shearing, or bending action include power presses, foot and hand presses, bending presses or brakes, as well as squaring, guillotine, and alligator shears.

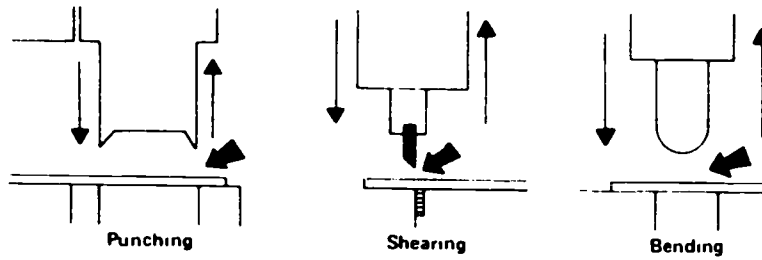

General Requirements for Safe Operation of Equipment

“Stop” switch— Every machine must have a “stop” switch within easy access of the operator (preferably in front and clearly identified). Machines requiring more than one operator must have “stop” switches handy to each operator.

Master switch— Every machine must be provided with a means of keeping the machine inoperative while repairs or adjustments are being made. A disconnect switch that can be locked in the “off” position is recommended.

Cutting tools— Sharp cutting tools are safer and more efficient. Dull tools tend to “grab” and create a hazardous condition.

Guards and other safety devices— Safe operations require proper guarding of the point of operation, drivetrain, V-belts, etc., and the proper use of all devices and methods promoting safety.

Scrap and waste— The working surface of machinery must be kept clear of scrap material to prevent possible serious injuries should scrap come in contact with saw or cutter blades.

The following pages contain examples of specific equipment that must be guarded. Generally, all powered equipment must be safeguarded to prevent employees from the various dangers caused by moving parts.

Specific Requirements for Woodworking Equipment

Rip Saws

Rip saws must have a hood that covers the saw at all times, to the depth of the teeth.

The hood must adjust itself automatically to the thickness of and remain in contact with the material being cut.

A spreader and non-kickback device must be provided.

The exposed part of the saw underneath the table must be guarded.

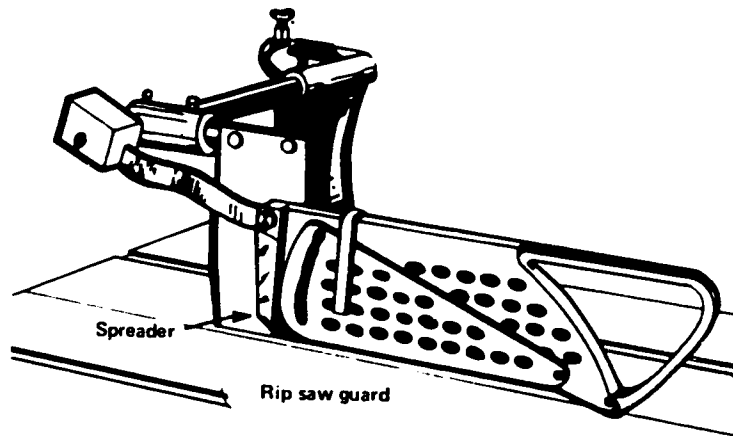

Table Saws

Table saws must be provided with a hood that covers the saw at all times.

The standard hood guard may be impractical when rabbetting and dadoing. In this case, an effective guarding procedure is to use a jig to hold the work, keeping the hands away from the blade.

Table saws do not have to be equipped with a spreader or non-kickback device, unless used as a rip saw.

The exposed part of the saw underneath the table must be guarded.

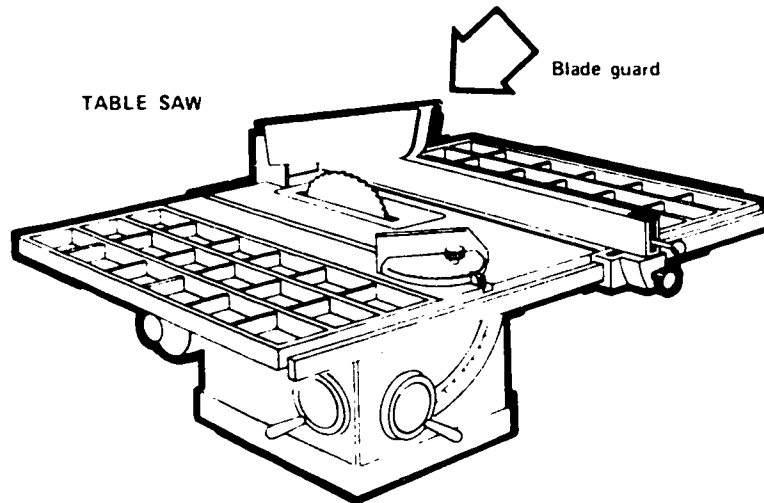

When feeding a table saw, hands must be kept out of the line of the cut. Since no guard is entirely foolproof, it could allow a person's hands to follow the stock into the saw. When ripping with the fence gauge near the saw, a push stick must always be used to complete the cut.

The saw must be adjusted to expose the least saw blade area above the table; the lower the blade, the less chance for kickbacks. Hence, it is also good practice to stand out of the line of the stock being ripped. A heavy leather apron or other guard for the abdomen is recommended.

Never saw freehand with a circular table saw. Such freehand sawing is always dangerous. The stock must always be held against a gauge.

The saw must be appropriate for the job. For instance, it is an unsafe practice to rip with a crosscut saw or to crosscut with a rip saw.

The dangerous practice of removing a hood guard because of narrow clearance on the gauge-side can be avoided by clamping a filler board to the table between the gauge and the saw and using it to guide the stock.

Crosscutting long boards on a table saw should be avoided because the operator is required to use considerable hand

pressure near the saw blade. Also, boards extending beyond the table may be struck by people or trucks. Long stock should be crosscut on a swing pull saw.

Work that should be done on special power-fed machines should not be done on general purpose hand-fed machines.

To set the table saw gauge without taking off the guards, a permanent mark should designate the line of cut on the table top.

The saw or fence gauge should never be adjusted while the saw is running.

A brush or stick should be used to clean sawdust and scrap from a saw.

Radial Saws

Radial saws must be provided with the following features:

An upper hood to enclose the top portion of the blade down to a point that will include the end of the saw arbor. The sides of the lower exposed portion of the blade must be guarded to the full diameter of the blade by a device that automatically adjusts to the thickness of the stock being cut.

Nonkickback dogs on both sides on the saw designed to provide adequate holding power for all thicknesses of material being cut, if used for ripping.

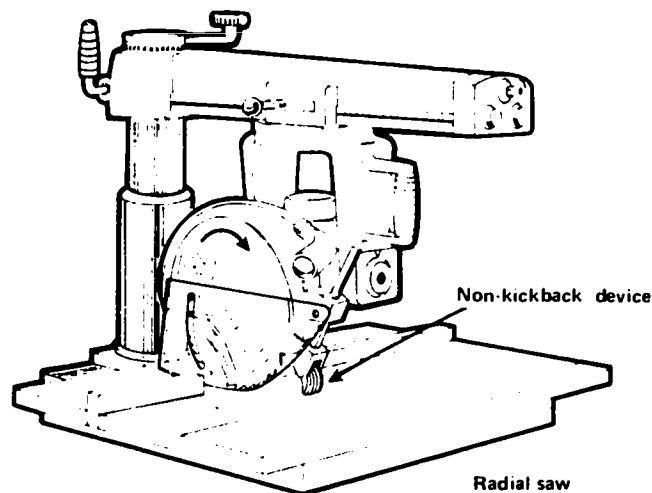

133

124

An adjustable stop, limiting forward travel of the blade to the distance necessary to complete a cut in repetitive operations.

A head which automatically returns to its starting position.

Marking on the hood showing the direction of saw rotation. In addition, a permanent label must be affixed to the rear of the guard reading: "DANGER. DO NOT RIP OR PLOUGH FROM THIS END."

Bandsaws and Band Resaws

OSHA regulations require these safety devices:

An enclosure for the entire blade except for the working portion.

An enclosure for wheels.

A tension control device.

A suitable guard on in-running feed rolls.

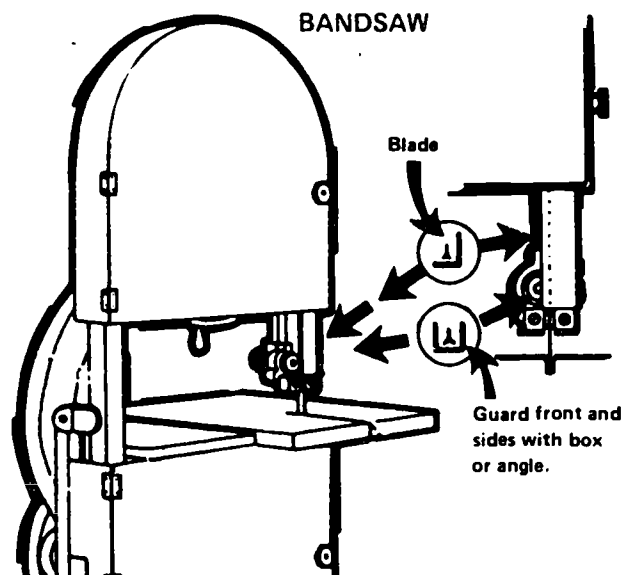

Band or band resaw wheels **MUST** be completely enclosed and all portions of the blade **MUST** be guarded, except that portion between the guide rolls and the table.

***Swing Cutoff Saws and Sliding Cutoff Saws
(mounted above the table)***

The following features are required:

A hood completely enclosing the upper half of the saw, the arbor end, and the point of operation at all positions on the saw. The hood must be designed to automatically cover the lower part of the blade. When the saw is returned to the back of the table, the hood must rise on top of the fence. When moved forward, the hood must drop and remain in contact with the table top or the material being cut.

An effective device to return the saw automatically to the back of the table when released.

Limit chains or other equally effective devices to prevent the saw from swinging beyond the front or back edges of the table or beyond a forward position where the gullets of the lowest saw teeth can be above the table top.

(Inverted swing cutoff saws require a hood that covers the portion of the saw protruding above the table or above the material being cut. It must automatically adjust to the thickness of, and remain in contact with, the material being cut.)

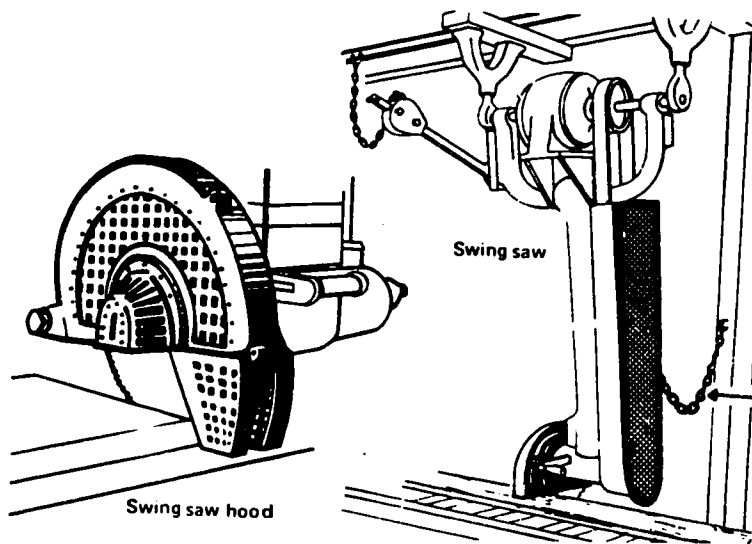

Jointers

OSHA requirements for jointers include the following:

Hand-fed with horizontal head—A cylindrical cutting head with knife projecting no more than $\frac{1}{8}$ inch beyond the cylinder.

Table openings—Clearances between rear table and cutter head must be $\frac{1}{8}$ inch maximum. Table throat opening (when tables are set with each other for zero cut) must be $2\frac{1}{2}$ inches maximum.

Horizontal head—An automatic guard covering the head on the working side of the fence or gauge, and a guard covering the head back of the fence or gauge.

Vertical head—An exhaust hood or other guard completely enclosing the revolving head except for a slot of width necessary to perform the work.

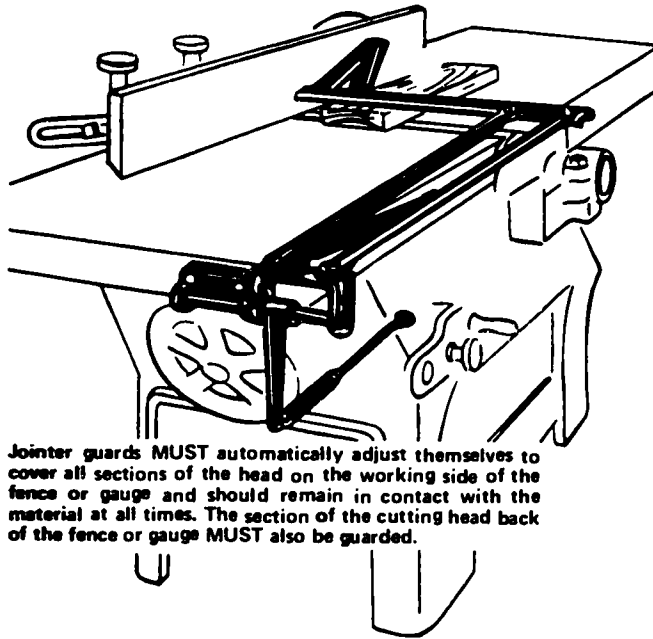

Jointer guards MUST automatically adjust themselves to cover all sections of the head on the working side of the fence or gauge and should remain in contact with the material at all times. The section of the cutting head back of the fence or gauge MUST also be guarded.

Tenoning Machines

Feed chains and sprockets of all double end tenoning machines must be enclosed except for the portion necessary to convey stock.

Unused part of all cutting heads and saws must be covered by metal guards (1/16-inch minimum sheet metal or 3/16-inch minimum cast iron.) If an exhaust system is used, the guard must form all or part of the hood and it must be constructed with metal as thick as specified above.

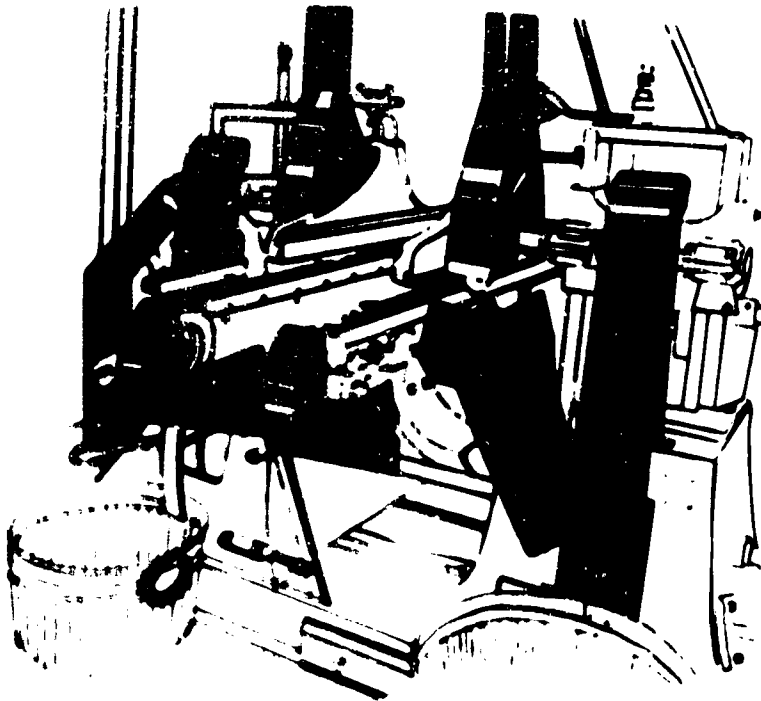

Double end tenoner.

Wood Shapers and Similar Equipment

Cutting heads must be enclosed with cage or adjustable guards of a diameter at least as great as the diameter of the cutter. Warning devices of leather or other material attached to the spindle are not acceptable.

Single cutter knives in shaper heads must be properly balanced.

Double spindle shapers require a starting and stopping device for each spindle.

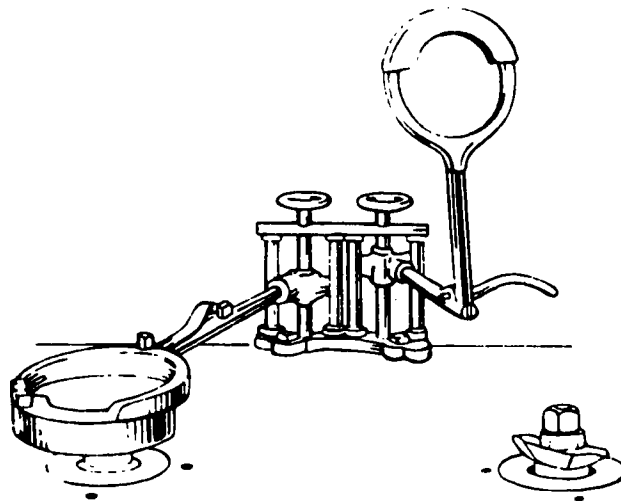

Shaper guards

Planing, Molding, Sticking, and Matching Machines

Cutting heads and saws must be guarded with metal—minimum 1/16-inch thick if sheet metal or minimum 3/16-inch thick if cast iron.

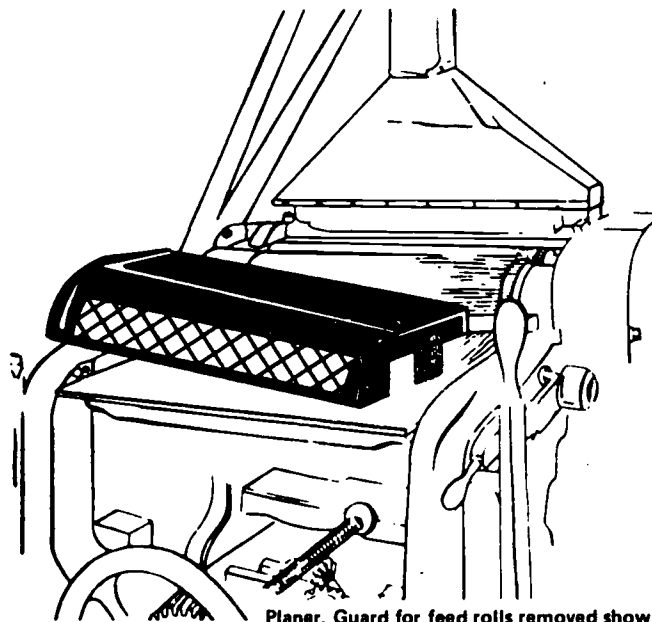

Planer. Guard for feed rolls removed showing substantial construction.

Feed rolls must be guarded by a hood or suitable guard to prevent the operator's hands from coming in contact with the in-running rolls.

Surfacers or planers which can accept multiple pieces of wood simultaneously must be provided with either sectional infeed rolls that provide contact pressure on feed stock or suitable section kickback finger devices at the infeed end.

Boring and Mortising Machines

Requirements for boring and mortising machines are—

Safety bit chucks with no projecting setscrews.

Boring bits and chucks completely enclosed above material being worked.

Top of cutting chain and driving mechanism enclosed.

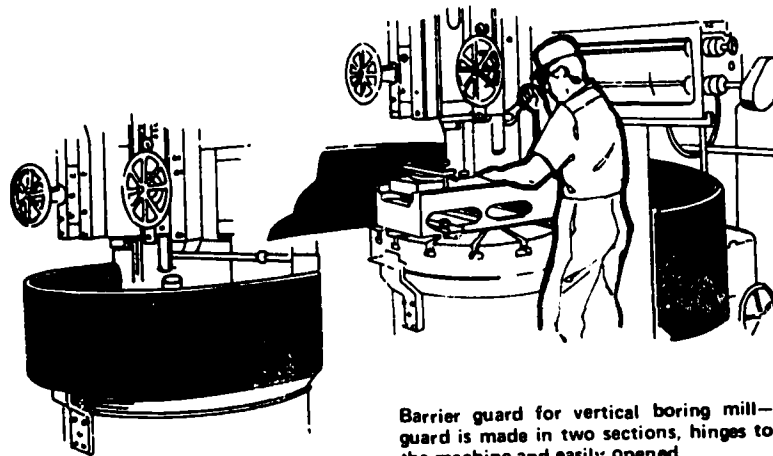

Barrier guard for vertical boring mill—guard is made in two sections, hinges to the machine and easily opened.

Counterweight, with acceptable means to prevent its dropping:

- Bolt through both bar and counterweight.
- Bolt through extreme end of bar.
- Safety chain attached if counterweight does not encircle bar.

- Counterweight suspended by chain or wire rope must travel in pipe or other enclosure.
- Universal joints on spindles of boring machines completely enclosed.
- Foot treadle protected from accidental tripping by inverted U-shaped metal guard.

Miter Saws

The hood must enclose the upper part of the blade.

The lower part of the blade must be adequately guarded.

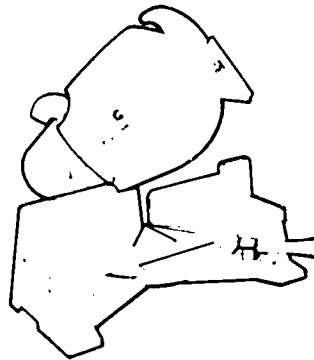

Portable Circular Saws

The blade must be guarded above and below the base plate or shoe.

When the saw is withdrawn from the work, the lower guard must automatically and instantly return to the covered position.

The saw must be equipped with a dead-man switch.

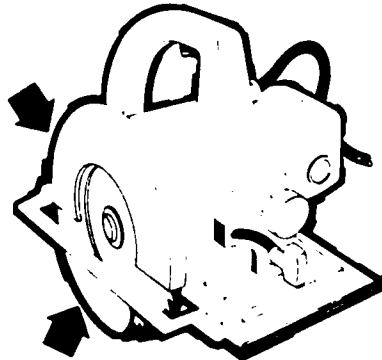

Sanding Machines

Self-feed sanding machines require a semicylindrical guard to protect operator's hands from the in-running rolls. The guard must be of heavy material well secured to the frame carrying the rolls so as to stay in adjustment for any thickness of stock. The bottom of the guard should come down to within $\frac{3}{8}$ inch of the contact face of the feed roll where it touches the stock.

Drum sanders require an exhaust hood (or other guard if no exhaust system is necessary) and a guard to enclose the revolving drum, except that portion of the drum above the table.

Disc sanders require an enclosed disc, except for the portion of the disc above the table.

Belt sanders require guards at each nip point where the sanding belt runs onto a pulley. The unused part of the sanding belt must be guarded against accidental contact.

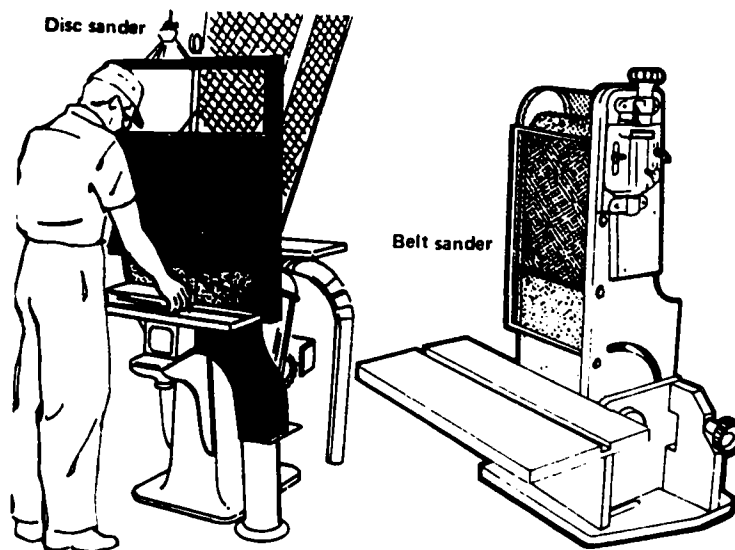

Lathes

Wood-turning lathes: cutting heads must be covered as completely as possible by hoods or shields hinged to the machines so they can be thrown back for adjusting.

Shoe last and spoke lathes, doweling machines, and wood heel turning lathes of the rotating knife type must have hoods covering the cutter blades, except contact points.

Lathes used for turning long pieces of stock held only between the two centers must have long curved guards extending over the top of the lathe to prevent work pieces from being thrown out of the lathe if they become loose.

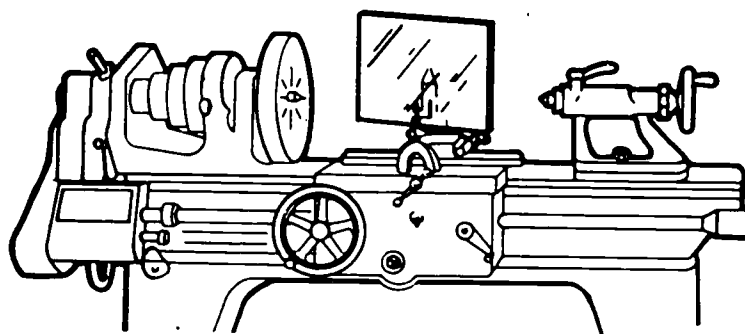

Router (other than hand-held)

The tops and sides of the router must be covered.

Alligator Shears and Notchers

A guard must be provided at the point of operation to prevent the worker from inserting a hand into the area. A typical point of operation guard is shown in the figure below. This type of guard is adaptable to most alligator shears and modes of use. It can be designed to fit with a clearance of from 1 to 2 inches between the moving arm and the guard. Workers should be trained by supervisors or other experienced personnel in the techniques of handling small parts in holding-tools and in the manipulation of the shear's controls.

The operator and others in the vicinity must wear protective goggles or face shields as a protection against flying fragments.

On foot-operated hydraulic alligator shears, the pedal should have a protective guard to prevent unplanned operation caused by falling objects or someone's accidentally stepping on it.

A hold down device at the infeed side should be provided, capable of restraining the material from being forced upward during the shearing stroke.

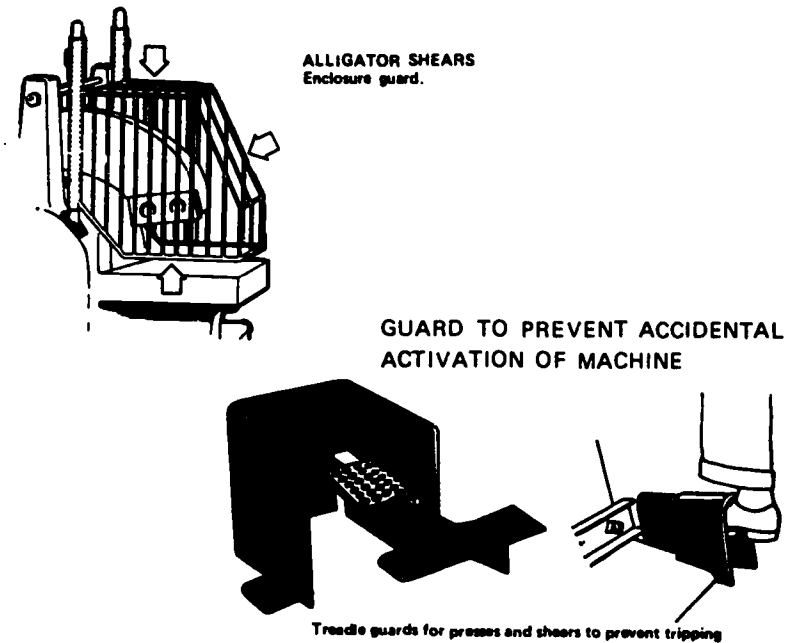

Guillotine Shears (metal)

The operator should have all auxiliary personnel clearly within his view at all times.

All affected workers in the shearing area must be protected by curtains or deflectors capable of intercepting ejected parts, or the area should be roped or fenced off or otherwise restricted to worker entry.

Hand-fed or conveyor-fed guillotine shears should have an electrical interlock-type gate that will exclude personnel from the point of operation by preventing the shear's operation until the gate is closed.

Shredders (metal and paper scrap)

When shredders that may throw random pieces of material back toward the inlet opening are used, flexible shields should be installed as protection for loaders or passersby. Alternatively, the hazardous area could be roped or fenced off, to restrict entry into the danger zone.

Warning signs should be posted.

Where conveyors are used to load the shredder, there should be "STOP" controls within easy and quick access to workers on the line.

Compactors and Balers (metal and paper scrap)

All balers or scrap-compressing equipment must be guarded so that the ram of the compacting device cannot be activated until workers are out of the danger area. On paper balers, where the scrap is put into a pit prior to compression, an interlocking device which will allow operation of the ram only after loading gates are closed and in place should be used. On large metal compactors, the operator must have a clear, unobstructed view of the loading, compacting, and unloading areas to be sure that all personnel are safely clear of the operating area.

Grinders

Wheel safety guard must cover the spindle end, nut, and flange projections. The exposed area of the grinding wheel should not exceed more than one-fourth of the area of the entire wheel. When the guard opening is measured, the visors and other accessory equipment are not included as part of the guard unless they are as strong as the guard.

Work or tool rests must be of strong construction and must be adjustable to compensate for wheel wear. Work rests must be kept closely adjusted to the wheel to prevent the work from becoming jammed between the wheel and the work rest. The maximum clearance allowed is $\frac{1}{8}$ inch.

Tongue guards (upper peripheral guards) must be constructed so that they adjust to the wheel as it wears down. A maximum clearance of $\frac{1}{4}$ inch is allowed between the wheel and the tongue guard.

Goggles or a face shield must be worn by grinder operators.

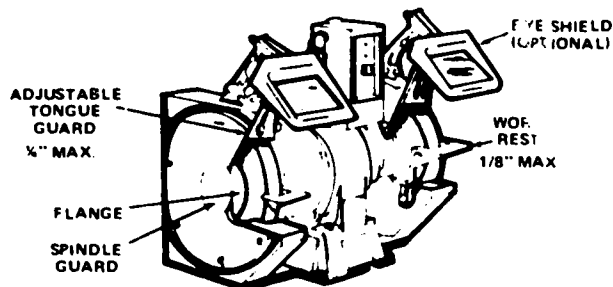

Fans

If fans are located within 7 feet of the floor, they must be guarded with grille or mesh, limiting openings to not more than $\frac{1}{2}$ inch (least dimension).

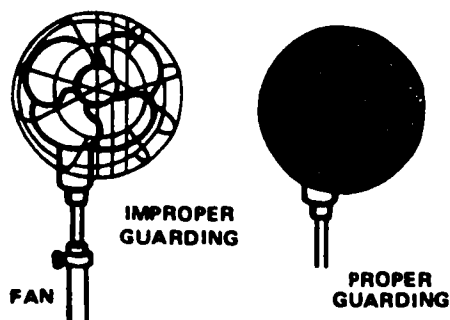

Air Compressors

The pulleys and drive belts of air compressors must be fully enclosed.

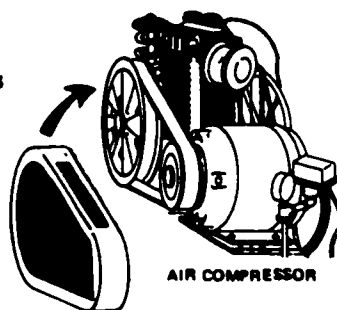

Conveyors

Conveyors of many varieties are widely used and cause numerous injuries. By implementing the following rules, many of these can be avoided.

Conveyors should not exceed their maximum rated speed or capacity. (The rated speed and capacity should be conspicuously posted.)

Employees should not ride conveyors.

Each conveyor must be kept clear of accumulations of materials which could inhibit its safe operation.

Nip and shear points on conveyors, as in all other locations, must be guarded.

145136

Guards must be kept in place at all times, except when the electrical power is off and the conveyor is locked out.

After a conveyor has been repaired, tested, or serviced, it must not be operated until all guards and safety devices have been reinstalled and all maintenance equipment removed.

A visual inspection of the entire conveyor and the immediate area should be made by the operator before putting the conveyor into operation. The inspection should assure the following:

- unblocked feed and discharge points
- proper functioning of brakes
- proper functioning of limit switches
- presence of all guards and switches
- no employees exposed to moving conveyor parts

Rotating Screw Conveyors

A rotating screw mechanism consists of a rotating screw (worm) or agitator blades or paddles located within a stationary case or shell. These are hazardous because in the back and forth or straight-line action, a worker may be struck or caught in a pinch or shear point between the fixed and moving parts. The principle of the rotating screw is used in most meat grinders. Fingers and hands must be prevented from reaching into the point of operation.

Screw conveyors should be guarded by enclosure guards. Hinged or removable covers on the enclosures will still allow access to the worm for cleaning.

HAND AND PORTABLE POWERED TOOLS

The following is a partial list of regulations governing use of hand tools.

The school is responsible for the safe condition of all tools and equipment used, including individually-owned tools and equipment.

Hammers with broken or cracked handles, chisels and punches with mushroomed heads, or bent or broken wrenches should not be used.

Wrenches with sprung jaws must not be used.

Most hand-held electrical power tools must be equipped with a “dead man” or “quick-release” control, so that the power is automatically shut off whenever the operator releases the control.



Portable circular saws must be equipped with guards above and below the base plate or shoe. The lower guard must retract when the blade is in use, and automatically recover the guarding position when the tool is withdrawn from the work.

All hand-held portable electrical equipment must have its frame grounded or be double-insulated and identified as such.

All tools must be used with appropriate shields, guards, and attachments and in accordance with recommendations by the manufacturers. Workers must be trained concerning the use of power tools and safety requirements.

The rated load of any jack must be permanently marked on the jack.

Jacks must be inspected at least once every 6 months.

Jacks must be appropriately blocked or cribbed when necessary to provide a firm foundation.

Pneumatic power tools must be positively secured to the hose to prevent the tool from becoming disconnected; also, a tool retainer must be used to prevent the attachment from being expelled.

Nailers, staplers, and similar equipment with autofeed should have a muzzle to prevent the tool from ejecting material unless the muzzle is in contact with the work surface.

Safety Requirements for Powder-Actuated Tools

Only persons who have been trained in the operation of the particular tool in use must be allowed to operate a powder-actuated tool.

The tool must be tested each day before loading to see that safety devices are in proper working condition. The testing method must be in accordance with the manufacturer's recommended procedure.

Any tool found not in proper working order, or that develops a defect during use, must be immediately removed from service and not used until properly repaired.

Tools must not be loaded until just prior to the intended firing time. Neither loaded nor empty tools are to be pointed at anyone. Hands must be kept clear of the open barrel end.

Loaded tools must not be left unattended.

Fasteners must not be driven into very hard or brittle materials, including, but not limited to, cast iron, glazed tile, surface-hardened steel, glass block, live rock, face brick, or hollow tile.

Driving into easily penetrated materials must be avoided unless such materials are backed by a substance that will prevent the pin or fastener from passing completely through. The pin could fly through with enough force to cause serious injury.

No fastener is to be driven into an area fragmented by an unsatisfactory fastening.

Tools must not be used in an explosive or flammable atmosphere.

All tools must be used with the correct shield, guard, or attachment recommended by the manufacturer.

Powder-actuated tools must meet all other applicable requirements of American National Standards Institute, A10.3-1970, Safety Requirements for Explosive-Actuated Fastening Tools.

In many states, a license is required before a worker can operate powder-actuated tools.

Safe use of powder-actuated tools requires operators to:

- Never fasten closer than 3 inches from the edge in concrete.
- Never fasten closer than $\frac{1}{2}$ inch from the edge in steel.

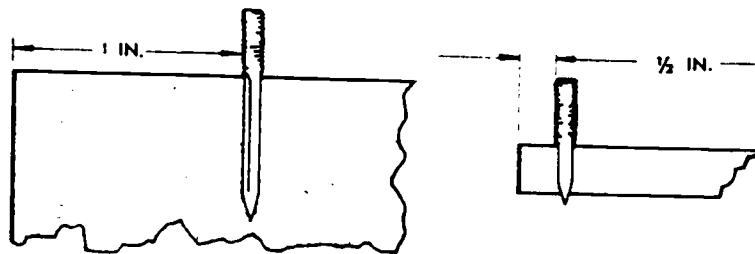

- Not attempt fastenings into brittle, weak, or hollow material.

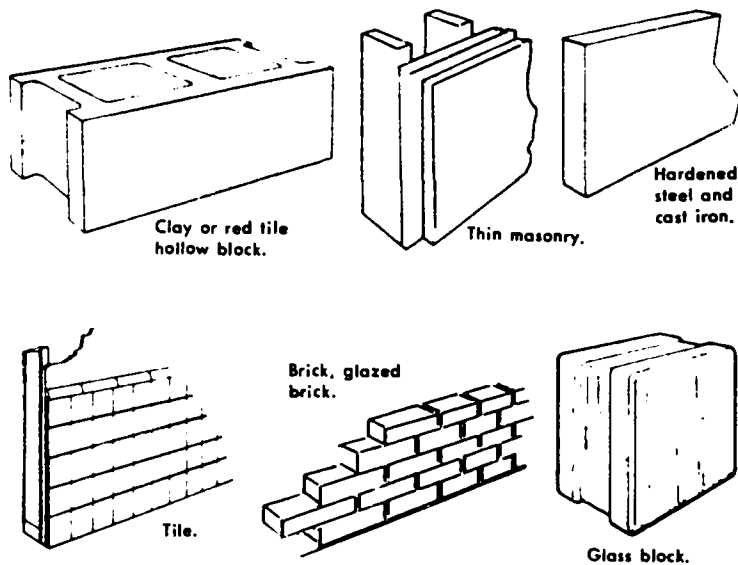

- Always keep head and body behind the tool when firing.
- Keep other workers out of the line of fire.
- Always wear safety goggles and a hard hat.

- Always check for cracks when fastening into the edge of concrete.
- Lean on the tool when firing to keep it at right angles to the work surface.
- Clean and lubricate the tool daily.
- Always know the material being fastened into, especially in older buildings where base material may be concealed.
- Backup the work with a ½ inch steel plate and clear the area of all persons when fastening into thin material.

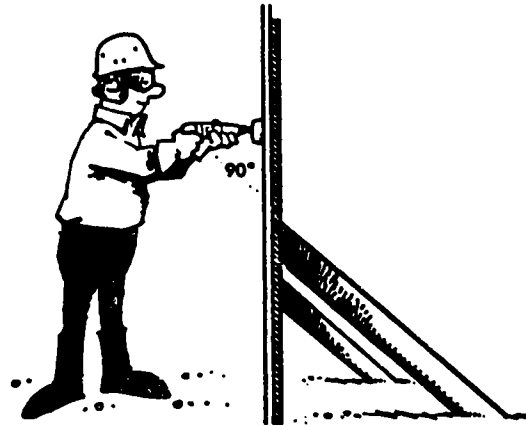

- Never use the tool in an explosive atmosphere.
- Always store cartridges in a container used for cartridges only and do not carry cartridges in pockets or mixed with other objects.
- Never use powder tool cartridges in firearms.
- Use ear plugs when fastening in confined areas such as small rooms, tanks.
- Be sure the bore of the tool is clear before loading.
- Never fasten where the standard guard will not give protection. Special guards are available for such applications.
- Never attempt to fasten through a pre-drilled hole unless the tool is equipped with a hole locator.

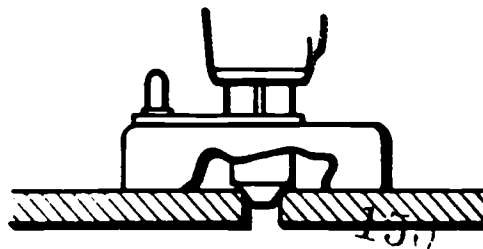

- Never clean or service a powder-actuated tool unless adequate instruction has been received

In case of a misfire, the employee must use the following procedure:

- Hold the tool in place for 30 seconds (count slowly).
- Pull the trigger again. If it still does not fire, wait another 30 seconds. Keep tool in place while opening mechanism.
- Remove the cartridge
- Put the cartridge in a bucket of water. Never put unfired cartridges in trash that will be burned or leave cartridges where children can get to them.
- Return unfired cartridge to supervisor for disposal.

Safety Rules for Operating Power Tools

Operators should be instructed to:

- Know the application, limitations, and potential hazards of the tool used
- Select the proper tool for the job.
- Remove adjusting keys and wrenches before turning on tools
- Not use tools with frayed cords, or loose or broken switches
- Keep guards in place and in working order.
- Have ground prongs in place, or use tools marked "double insulated"
- Maintain working areas free of clutter.
- Keep alert to potential hazards in the working environment such as damp locations or the presence of highly combustible materials.
- Dress properly to prevent loose clothing from catching in moving parts.
- Use safety glasses, dust or face masks, or other protective clothing and equipment when necessary.
- Not surprise or distract anyone using a power tool.

WELDING, CUTTING, AND BRAZING

General

Areas for cutting and welding must be established based on fire potentials for the facility. Special procedures must be established for welding and cutting in high hazard locations. Preferably, cutting or welding should be done in an area with

no surrounding combustible material. If combustibles in the immediate vicinity are unavoidable, guards must be used to protect against the fire hazards from heat and sparks. Suitable fire extinguishing equipment (pails of water, buckets of sand, a hose, or a portable extinguisher) must be maintained for instant use.



Torch cutters and welders must be trained in the safe operation of their equipment. Printed rules and instructions (supplied by the manufacturers) covering operation of equipment must be strictly enforced.

No welding, cutting, or other hot work may be performed on used drums, barrels, tanks, or other containers until they have been cleaned so thoroughly as to make absolutely certain that there are no flammable materials present or any substances such as greases, tars, acids, or other materials which, when subjected to heat, might produce flammable or toxic vapors.

The atmosphere in the welding area must be free of flammable gases, liquids, and vapors.

Goggles or other suitable eye protection (e.g., helmets or hand shields) must be used during welding or cutting to guard against sparks and debris.

Persons adjacent to the welding areas must be protected from ultraviolet rays by noncombustible or flameproof screens or shields, or they must be required to wear appropriate goggles.

Persons exposed to hazards created by cutting and welding must be protected by personal protective equipment.

The potential health hazard to a welder or cutter from gases or metal fumes depends on the toxicity of the materials involved (types of metals, fluxes, coatings, etc.), the duration and location of the process, and ventilation.

There are specific requirements concerning ventilation and respirators when welding or cutting is performed on the following:

- stainless steel, lead, zinc, or cadmium
- metals coated with lead- or mercury-containing materials, such as paint
- fluxes or other materials containing fluorides

These requirements are summarized here:

REQUIREMENTS FOR VENTILATION AND RESPIRATORS WHEN WELDING OR CUTTING

Welding or cutting on materials containing or coated with	Location of operation		
	Confined spaces	Indoors	Outdoors
Lead	A or B	A	C
Zinc	A or B	A	
Cadmium†	A or B	A or B	C
Beryllium†	A and B	A and B	A and B
Mercury†	A or B	A or B	C
Fluorine†	A or B		
Stainless steels	A	A	A

*A = Mechanical local exhaust ventilation by means of either hoods or booths with sufficient airflow to maintain a velocity, away from the worker, of at least 100 linear feet per minute.

B = NIOSH approved supplied-air respirator.

C = NIOSH approved respiratory protective equipment.

†Unless atmospheric tests under the most adverse conditions have established that the workers' exposures are within acceptable concentrations defined by 1910.1000.

Mechanical ventilation must be provided when welding or cutting is done on metals not covered in the table when the volume of space per welder is less than 10,000 cubic feet, or the ceiling is less than 16 feet high, or work is done in confined spaces.

Such mechanical ventilation must be at the minimum rate of 2,000 cubic feet per minute per welder, unless hoods or booths are provided with sufficient airflow to maintain a velocity, away from the worker, of at least 100 linear feet per minute. Alternatively, approved supplied-air respirators must be used.

Gas Welding

General requirements governing gas welding:

All cylinders must be stored and used away from radiators and other sources of heat.

All cylinders stored inside buildings must be located in a well-protected, well-ventilated, dry location at least 20 feet from highly combustible materials and away from elevators, stairs, or gangways. They must not be kept in unventilated enclosures such as lockers and cupboards.

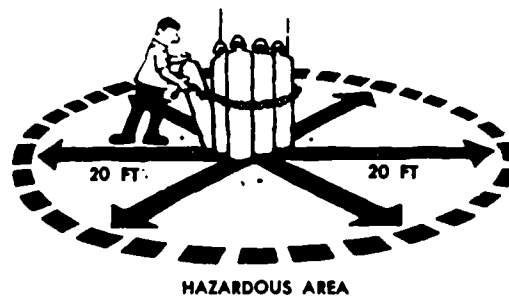

Valve protection caps must be used where the cylinder is designed to accept a cap, except when cylinders are in use or connected for use.

Stored oxygen cylinders must be kept separated from stored fuel gas cylinders or combustible materials (especially oil or grease) by a minimum distance of 20 feet or by a noncombustible barrier at least 5 feet high and having a ½-hour fire resistance rating.



All cylinder valves must be closed when work is finished. Where a special wrench is required, it must be left in position on the stem of the valve while the cylinder is in use so that the fuel-gas flow can be quickly turned off in case of emergency. In the case of manifolded or coupled cylinders, at least one such wrench must always be available for immediate use.

All cylinders must be legibly marked to identify contents.

No cylinder should be permitted to stand alone without being secured with lashing or chain to prevent it from toppling over.

Acetylene must not be used at a pressure in excess of 15 psi gauge (or 30 psi absolute). Above this pressure, acetylene may become unstable.

Indoor storage of fuel gas is limited to a total capacity of 2,000 cubic feet or 300 pounds of liquefied petroleum gas.

Hoses showing leaks, burns, or worn places which render them unfit for service must be replaced or repaired.

Electric Arc Welding

If the welding machine is wet, it must be thoroughly dried and tested before it is used again.

Coiled welding cable must be spread out and the ground lead must be firmly attached to the work.

Cables must be inspected for damage and loss of insulation and be repaired immediately.

Ground and electrode cables may only be joined together with connectors specifically designed for that purpose.

155

Cables with splices within 10 feet of the operator may not be used; neither may the operator coil cables around his body.

Welding helmets or hand shields must be worn by the operator. Persons close by must wear eye protection.

Shields or screens must protect others in the vicinity from arc welding rays.

Arc welders should wear clean, fire-resistant gloves and clothing with collars and sleeves buttoned.

Electrode holders which are not in use must be placed in a safe place away from conductive objects.

THE NATIONAL ELECTRICAL CODE (NEC)

Electrical Requirements

More fires are caused by electrical malfunction than any other cause, and standards pertaining to electrical equipment and its use in all industries have been cited as violations more frequently than any others.

The National Electrical Code (NFPA 70-1971, ANSI C1-1971) has been adopted as a national consensus standard by OSHA (refer to "Information Sources"). The purpose of the NEC is the practical safeguarding of persons, buildings, and property from hazards arising from the use of electricity. The code contains minimum provisions considered necessary for safety. Your electrician should be familiar with these requirements. For example:

Each disconnecting means (e.g., circuit breaker or fuse box) must be legibly marked to indicate its purpose unless its purpose is evident.

Frames of electrical motors, regardless of voltage, must be grounded.

Exposed noncurrent-carrying metal parts of fixed equipment that may become energized under abnormal conditions must be grounded under any of the following circumstances:

- **in wet or damp locations**
- **if in electrical contact with metal**

- if operated in excess of 150 volts to ground
- when in a hazardous location

Exposed noncurrent-carrying metal parts of the following plug-connected equipment, which are liable to become energized, must be grounded or double-insulated and distinctly marked:

- portable hand-held motor-operated tools
- appliances
- any equipment operated in excess of 150 volts to ground

Outlets, switches, junction boxes, etc., must be covered.

Flexible cords may not be:

- used as a substitute for fixed wiring
- run through holes in walls, ceilings, or floors
- run through doors, windows, etc.
- attached to building surfaces

Flexible cord must be fastened so that there is no pull on joints or terminal screws. It must be replaced when frayed or when the insulation has deteriorated.

All splices in flexible cord must be executed by brazing, welding, or soldering, or by joining the conductors with suitable splicing devices. Any splices, joints, and the free ends of conductors must be properly insulated.

Wet Locations

A switch or circuit breaker in a wet location or outside of a building must be enclosed in a weatherproof enclosure.

Damp or Wet Locations

In damp or wet locations, cabinets and cutout boxes of the surface type must be weatherproof and so placed or equipped as to prevent moisture or water from entering and accumulating within the cabinet or cutout box. They must also be mounted so there is at least ¼ inch of air space between the enclosure and the wall or other supporting surface. It is recommended that boxes of nonconductive material be used with nonmetallic-sheathed cable.

In locations where walls are frequently washed or where there are **surfaces** of absorbent materials, such as damp paper or **wood**, the entire wiring system, including all boxes, fittings, **conduits**, and cable, must be mounted so that there is at least a **1/4-inch** air space between it and the wall or supporting surface.

Temporary Lights

Exposed bulbs on temporary lights and sockets must be **guarded** to prevent accidental contact except if deeply recessed **in the reflector** or otherwise inaccessible.

Temporary lights must not be suspended by their electrical **cords** unless they are designed for that use.

Arcing Parts

Parts of electrical equipment which in ordinary operation **produce arcs, sparks, etc.**, must be enclosed unless they are **separated** and isolated from all combustible materials.

SELF-EVALUATION INSTRUMENT (SEI)

Since the success of an occupational safety and health program depends on identifying hazards and taking immediate remedial action, inspections of the school are a necessity.

Using an SEI, the Program Administrator or a representative can make periodic inspections (preferably at least once each month) and identify problem areas so that corrective action may be taken.

References made in the SEI subtitles refer to appropriate sections of the Occupational Safety and Health Standards (Code of Federal Regulations, Title 29, Part 1910, which are the OSHA "General Industry Standards," and Code of Federal Regulations, Title 29, Part 1926, which are the OSHA "Construction Standards.")

The SEI questions have been designed so that a "yes" answer indicates satisfactory performance whereas a "no" answer indicates unsatisfactory or no performance in the area.

CHECKLIST

Walking and Working Surfaces (29 CFR 1910.22-.27, 1926.451, 1926.650-652)

Buildings and Yards

	Yes	No
Are all the areas of the school kept clean and orderly?	()	()
Are floors, aisles, and inside passageways kept clean and dry and all spills cleaned up immediately?	()	()
Are floor holes, such as drains, covered?	()	()

- Are yards maintained so as to minimize tripping and falling hazards? () ()
- Are permanent aisles appropriately marked? () ()
- Are wet or greasy areas covered with nonslip materials? () ()
- Are floor mats (rubber and wood) in good repair? () ()
- Are steam pipes and hot vats guarded or insulated where employees could contact them? () ()
- Are broken dishes picked up immediately? () ()

*Storage Lofts, Second Floors, etc.
(29 CFR 1910.22, .23)*

- | | Yes | No |
|---|-----|-----|
| Are signs showing floorload capacity present? | () | () |
| Are platforms, storage lofts, balconies, etc. that are more than 4 feet above the floor protected with standard guardrails? | () | () |
| Are all platforms, lofts, and balconies (above where people or machinery could be exposed to falling objects) guarded with standard 4-inch toeboards? | () | () |

*Stairs
(29 CFR 1910.24)*

- | | Yes | No |
|--|-----|-----|
| Are there handrails on all stairways having four or more risers? | () | () |
| Are all stairways at least 22 inches wide? | () | () |
| Do stairs have at least a 7-foot overhead clearance? | () | () |
| Do stairs angle no more than 50% and no less than 30%? | () | () |

Ladders

(29 CFR 1910.25, .26, .27)

	Yes	No
Have defective ladders (e.g., broken rungs, side rails, etc.) been tagged as "DANGEROUS, DO NOT USE" and removed from service for repair or destruction?	()	()
Is the use of the top of an ordinary stepladder as a step prohibited?	()	()
Do fixed ladders have at least 3½ feet of extension at the top of the landing?	()	()
Is the distance between the centerline of rungs on a fixed ladder and the nearest permanent object in back of the ladder at least 7 inches or more?	()	()
Do all fixed ladders have a pitch of 75° to 90°?	()	()
Do portable ladders have nonslip bases?	()	()

Scaffolding

(29 CFR 1926.451)

	Yes	No
Are scaffolds erected, moved, dismantled or altered only under the supervision of a competent person?	()	()
Is scaffolding placed on solid footing and are unstable objects such as boxes, barrels, and concrete blocks prohibited for supporting scaffolding?	()	()
Are standard guardrails and toeboards installed on all scaffolds when required?	()	()
If persons are required to pass or work under a scaffold, is a screen of No. 18 gauge U.S. standard wire or its equivalent properly installed?	()	()
Is scaffold planking of approved grades?	()	()
Is scaffold planking overlapped a minimum of 12 inches or secured from movement?	()	()

Does scaffold planking extend over its end supports between 6 and 12 inches? () ()

Are scaffolds capable of supporting at least four times the intended load without failure? () ()

Excavating—Trenching
(29 CFR 1926.650—652)

Prior to excavation, is a check made for underground installation (i.e., sewer, telephone, water, fuel, electric lines, etc.)? Yes No
() ()

Are the walls and faces of all excavations in which people may be endangered by moving ground shored up, sloped, or guarded by some equivalent means? () ()

Are excavations inspected by a competent person after every rainstorm or other occurrence which may increase the hazard? () ()

Is excavated or other material stored at least 2 feet from the edge of the excavation? () ()

Do trenches more than 5 feet deep have ladders or steps located within 25 feet of workers? () ()

Exits and Exit Markings
(29 CFR 1910.36-.37)

Are all exits marked with an exit sign and illuminated by a reliable source? Yes No
() ()

Is the lettering at least 6 inches high with the principal letter strokes at least 3/4 of an inch wide? () ()

Is the direction to exits, when not immediately apparent, marked with visible signs? () ()

Are doors or other passageways, that are neither exits nor ways to an exit and which may be mistaken for an exit appropriately marked "NOT AN EXIT," "TO BASEMENT," "STOREROOM," etc? () ()

- Are exit doors side-hinged?** () ()
- Are all doors that must be passed through to reach an exit or way to an exit always free to access with no possibility of a person being locked inside?** () ()
- Are all exit routes always kept free of obstructions?** () ()
- Can all cooler doors be opened quickly from the inside?** () ()

Occupational Health and Environmental Control
(29 CFR 1910.1000, .94, .95) Yes No

- Is management aware of the potential health hazards caused by the various operations in the facility?** () ()
- Is exposure kept within the acceptable levels?** () ()
- Are all containers, such as vats, storage tanks, etc., labeled as to their contents?** () ()
- If internal combustion engines are used, is carbon monoxide kept within acceptable levels?** () ()
- Is exposure to hazardous substances controlled by ventilation, use of respirators, limiting exposure time, or other means?** () ()
- Are persons required to wear eye and skin protection when handling solvents and caustics?** () ()
- Are eye wash fountains and safety showers provided in areas where chemicals, such as caustics, are handled?** () ()
- Is adequate ventilation provided to minimize exposure to wood dust?** () ()
- Is dust removed by vacuuming whenever possible, rather than by blowing or sweeping?** () ()
- Is a regular clean-up procedure outlined to remove accumulated dust on rafters and other equipment?** () ()

- Is exposure to welding fumes controlled by ventilation, use of respirators, exposure time, or other means? () ()
- Have procedures been set for cleanup of solvent spills? () ()
- Are exhaust ventilation systems in working order, for example, to remove exhaust from automobiles, boats, snowmobiles, and so forth? () ()
- Are the tailpipe exhaust systems in good working order (not plugged, no broken hoses, etc.)? () ()
- Are engines turned off except when using the tailpipe exhaust system? () ()
- Are the gas space heaters properly vented? () ()
- Are employees properly protected during dusty and noisy work processes? () ()
- Are solvent-soaked, greasy, or oily rags and combustible materials disposed of in covered metal containers and emptied daily? () ()

**Occupational Noise Exposure
(29 CFR 1910.95)**

- | | Yes | No |
|--|-----|-----|
| If a noise problem is suspected, have noise levels been accurately measured? | () | () |
| If a noise problem exists, have plans to reduce the noise levels by engineering methods been formulated (e.g., enclosure, maintenance, different methods of processing)? | () | () |
| If engineering controls cannot reduce the noise to safe levels: | | |
| •Have administrative controls, such as limiting exposure in a given area, been started? | () | () |
| •Are affected persons given annual audiometric tests, if necessary? | () | () |

103



- Do all persons in high-noise areas wear hearing protection? () ()
- Are annual noise surveys made to reevaluate the problem? () ()

Hazardous Materials

Flammable and Combustible Liquids

(29 CFR 1910.106)

Yes No

Are all connections on drums and piped systems of flammable and combustible liquids both vapor- and liquid-tight? () ()

Are flammable liquids kept in closed containers when not in use (e.g., parts cleaning tanks, pans)? () ()

Are all spills of flammable or combustible liquids cleaned up promptly? () ()

Is combustible waste material (such as oily rags) stored in covered metal receptacles and disposed of daily? () ()

Are bulk drums of flammable liquids grounded and bonded to containers during dispensing? () ()

Are gasoline and other flammable liquids stored in approved containers? () ()

Do storage rooms for flammable and combustible liquids have explosion-proof lights? () ()

Do storage rooms for flammable and combustible liquids have mechanical or gravity ventilation (at least six air changes per hour)? () ()

Are storage cabinets for flammable liquids labeled "FLAMMABLE — KEEP FIRE AWAY"? () ()

Are storage areas for flammables prominently posted as "NO SMOKING" areas? () ()

Is there never more than one day's supply of flammable liquids outside of approved storage cabinets or rooms? () ()

- In fueling areas for internal combustion engines:**
- are smoking or open flames not allowed? () ()
 - are engines of vehicles being fueled turned off? () ()
 - is a fire extinguisher located within 75 feet? () ()
- Are gas tanks of vehicles for repair drained upon arrival? () ()
- After draining and plugging all gas tank openings, are tanks removed only with wrenches or bolt cutters? () ()
- Are LP-gas storage tanks guarded to prevent damage from vehicles? () ()
- Are "NO SMOKING" signs posted on LP-gas tanks? () ()
- Are all paints, lacquers, or thinners kept for more than 30 days stored in approved metal or wooden cabinets or in storage rooms? () ()
- Do metal cabinets meet the following requirements?
- 18 gauge sheet iron (minimum) () ()
 - Double wall with 1½ inches air space () ()
 - Three-point lock on the door () ()
 - Door sill at least 2 inches above bottom of cabinet () ()
- Do wood cabinets meet the following requirements? () ()
- One-inch plywood that will not break down or delaminate under fire conditions () ()
 - All joints rabbeted () ()
 - If more than one door is used, at least a 1-inch rabbeted overlap () ()

**Spray Painting
(29 CFR 1910.107)**

	Yes	No
Are portable lamps removed during spray operations?	()	()
Do solvents used for cleaning have high flash points (not less than 100°F)?	()	()
Are fire control sprinkler heads kept clean?	()	()
Are "NO SMOKING" signs posted in the spray area, paint room, paint booth, and paint storage area?	()	()
Are the electric motors for exhaust fans placed outside booths or ducts?	()	()
Are belts and pulleys inside the booth fully enclosed?	()	()
Do ducts have access doors to allow cleaning?	()	()
At low temperatures (below 55°), is make-up air heated to at least 65°?	()	()
Is the make-up air heater located outside the spray booth?	()	()
Do all drying spaces have adequate ventilation?	()	()
Is the spray area at least 20 feet from flame, sparks, electric motors, or other ignition sources?	()	()
Is the spray area free of hot surfaces?	()	()
Is the spray area kept clean of combustible residue?	()	()
Are spray booths constructed of metal, masonry, or other substantial noncombustible material?	()	()
Are spray booth floors and baffles noncombustible and easily cleaned?	()	()
Do spray booths have explosion-proof lights or are they lighted through sealed clear panels?	()	()

- Is mechanical ventilation on during spray operations? () ()
- Is infrared drying apparatus kept out of the spray area during spraying operations? () ()
- Is the spray area completely ventilated before using the drying apparatus? () ()
- Is the electric drying apparatus properly grounded? () ()
- Is personal protective equipment provided, used, and maintained wherever it is necessary? () ()
- Is the ventilation rate across the face of the paint spray booth at least 100 linear feet per minute? () ()

**Personal Protective Equipment
(29 CFR 1910.132-.137)**

- | | Yes | No |
|--|-----|-----|
| Is personally owned personal protective equipment, such as gloves, protective shoes, etc., adequate and properly maintained? | () | () |
| Is eye and face protection required to prevent injury from molten metal, flying debris, sparks, or chips during grinding, welding, cutting, etc? | () | () |
| Are leggings, aprons, gloves, etc., worn as protection from flames, sparks, and flying chips? | () | () |
| Are ear plugs or muffs provided and worn during noisy conditions? | () | () |
| Are respirators provided and used when necessary? | () | () |
| Are there written standard operating procedures for the selection and use of respirators? | () | () |
| Where practicable, are respirators assigned for use by one person only? | () | () |
| Are respirators inspected and disinfected after use? | () | () |

Are respirators stored in a convenient, clean, and sanitary location? () ()

Are respirators checked for proper fit (especially on workers who wear eyeglasses or beards)? () ()

Is the proper respirator in use for the hazards present? (For example, dust masks do not protect against solvent vapors.) () ()

Are approved respirators provided and worn during chemicals handling, grinding, buffing, etc? () ()

Are routinely-used respirators inspected during cleaning? () ()

Is foot protection provided and worn to prevent injuries from punctures and falling objects? () ()

Are gloves provided and worn where necessary to help avoid cuts? () ()

Are hard hats required where falling objects could be a hazard? () ()

Is proper personal protective equipment provided, used, and maintained wherever it is needed? () ()

Is slip-resistant footwear worn? () ()

Is eye protection used when working under vehicles? () ()

Is heavy cloth placed over the radiator cap when opening it to protect hands and face from steam and hot coolant? () ()

Is a battery carrier strap used when handling batteries? () ()

**General Environmental Controls
(29 CFR 1910.141)**

Sanitation

	Yes	No
Are restrooms and washrooms kept in clean and sanitary condition?	()	()

Are covered receptacles for waste food kept in clean and sanitary condition? () ()

Are all outlets for water that is not suitable for drinking clearly posted as "UNSAFE FOR DRINKING, WASHING, OR COOKING"? () ()

Are persons prohibited from eating in areas where toxic materials are present? () ()

Has pest control been exercised? () ()

If persons are permitted to eat on the premises, are they provided with a suitable space for that purpose? () ()

Is all drinking, washing, and cooking water suitable for drinking? () ()

Are covered receptacles for sanitary napkins provided in the women's restrooms? () ()

**Medical and First Aid
(29 CFR 1910.151)**

Yes No

Are adequate first aid supplies (approved by a consulting physician) readily available, inspected, and replenished? () ()

Is at least one person on each shift currently qualified to render first aid in the absence of a nearby clinic or hospital? (Some states require first aid trained persons regardless of nearby clinics or hospitals.) () ()

Are medical personnel readily available for advice and consultation on matters of health? () ()

Are emergency phone numbers posted? () ()

Where persons may be exposed to injurious corrosive materials (for example, battery acid), are they provided with quick-drenching and flushing facilities for immediate emergency use? () ()

Fire Protection

(29 CFR 1910.157-161)

Yes No

Are extinguishers selected for the types of combustibles and flammables in the areas where they are to be used?

() ()

- Class A Ordinary combustible material fires.**
- Class B Flammable liquid or grease fires.**
- Class C Energized electrical equipment fires.**

Are extinguishers fully charged and kept in designated places?

() ()

Are extinguishers located along normal paths of travel?

() ()

Are extinguisher locations not obstructed or blocked?

() ()

Is the clearance between sprinkler deflectors and the top of storage at least 18 inches?

() ()

Are heads or nozzles pointed in the direction of the potential-fire areas?

() ()

Have all extinguishers been serviced, maintained and tagged at intervals not exceeding one year?

() ()

Are all extinguishers checked monthly (by management or a designated person) to see if they are in place, if they have been discharged, etc.?

() ()

Have all extinguishers been hydrostatically tested according to schedules set for the type of extinguisher?

() ()

Automatic Sprinkler (if applicable)

Yes No

Is there at least one automatic water supply of adequate pressure, capacity, and reliability?

() ()

Are water-flow alarms provided on all sprinklers?

() ()

Are the sprinkler systems periodically inspected and continuously maintained?

() ()

**Compressed Air
(29 CFR 1910.169)**

	Yes	No
Are pulleys and belts on compressors and motors completely guarded?	()	()
Are flexible cords or plugs on electric motors periodically checked and replaced if deteriorated?	()	()
Do the relief valves operate properly?	()	()
Are air tanks drained regularly?	()	()
Are the pressure-relief device and gauge in good operating condition?	()	()

**Materials Handling and Storage
(29 CFR 1910.176-184, 1926.550)**

	Yes	No
Is there safe clearance for equipment through aisles and doors?	()	()
Is stored material stable and secure?	()	()
Are storage areas free from tripping hazards?	()	()
Are only trained operators allowed to operate powered lift trucks?	()	()
Are appropriate overhead guards installed on powered lift trucks?	()	()
Is battery charging performed only in designated areas?	()	()
Are "NO SMOKING" signs posted near battery charging units?	()	()
Are all vehicles shut off prior to loading?	()	()
Are dock boards (bridge plates) used when loading or unloading from dock to truck?	()	()
Is a means for anchoring the dock plates provided?	()	()
Is all storage secured against sliding or collapsing?	()	()

Have aisles been designated and kept clear to allow unhindered passage? () ()

Are containers of combustibles or flammables, when stacked one upon another, always separated by dunnage sufficient to provide stability? () ()

Are racks and platforms loaded only within the limits of their capacity? () ()

If motorized equipment, such as lift trucks, is used, are aisles permanently marked to provide sufficient clearance for passage of the equipment? () ()

Are motorized vehicles and mechanized equipment inspected daily or prior to use? () ()

Are wrecker booms, chain hoists, ropes, and slings adequate for the load? () ()

Are the brakes set and the rear wheels chocked to prevent highway trucks from moving while being boarded by powered lift trucks? () ()

Are chain hoists, ropes, and slings adequate for the job? () ()

On units using internal combustion engines, do the exhaust gases in the room not exceed allowable limits for carbon monoxide? () ()

Are specifications posted for maximum loads approved for any floor, roof of a building, or other structure? () ()

Is there no combustible material piled next to lights or piled so that it would cause interference with the sprinkler system? () ()

Is bar stock stored properly and neatly in the work area? () ()

Cranes

(29 CFR ~ 1926.550, 1910.179-180)

Yes No

Are operators properly trained and are they following the manufacturer's specifications and limitations for the equipment? () ()

- Are proper hand signals being used? () ()
- Are special hazard warnings or instruction posted on equipment and visible to the operator? () ()
- Has equipment been inspected and any deficiencies corrected prior to use? () ()
- Are barricades adequate around the swing radius of revolving superstructures? () ()
- Is the equipment 10 feet or more away from any line of 50 kV or more (an additional 0.4 inches for each 1kV over 50)? () ()
- Have appropriate precautions been taken (e.g., deenergizing line) for work which is close to power lines? () ()

**Machinery and Machine Guarding
(29 CFR 1910.212-.219)**

- | | Yes | No |
|--|-----|-----|
| Are belts, pulleys, and rotating shafts guarded? | () | () |
| Are chains, sprockets, and gears properly guarded? | () | () |
| Are all in-going nip points properly guarded? | () | () |
| Are rotating shafts that are not smooth properly guarded? | () | () |
| Are all rotating parts recessed or covered with collars? | () | () |
| Are all pieces of equipment with an electric motor or any electrical connection effectively grounded? | () | () |
| Is all fixed machinery securely anchored to prevent movement? | () | () |
| Are alligator shears and notchers provided with guards at the point of operation to prevent the employee's hands from being inserted into the danger zone? | () | () |

Are the pedals of foot-operated hydraulic shears guarded to prevent accidental operation? () ()

Are sprockets and belt drives completely enclosed where they are within reach of platforms and passageways or less than 7 feet from the floor? () ()

Is the hot wire on the wrapping machine kept taut and the roller kept so that the wrapping film is held tight to provide a quick, clean cut (the least amount of fumes)? () ()

Are screw conveyors covered or otherwise guarded (e.g., an intergral part of meat grinder)? () ()

Are there proper guards on all:

Rip saws? () ()

Table saws? () ()

Radial arm saws? () ()

Swing saws? () ()

Miter saws? () ()

Band saws? () ()

Skill saws? () ()

Jointers? () ()

Planers? () ()

Tenoning machines? () ()

Disc sanders? () ()

Belt sanders? () ()

Drum sanders? () ()

Shapers? () ()

Routers? () ()

Other specialty equipment? () ()

167 175

Are there limit chains or stops on:

- Swing saws?** () ()
- Radial arm saws?** () ()
- Are saws used for ripping equipped with antikickback dogs?** () ()
- Are all surfacers or planers that run stock of varying thickness equipped with yielding sectional rolls or antikickback fingers at the infeed end?** () ()
- Does every machine have a master switch to keep it inoperative during repairs or adjustments?** () ()
- Are splitting saws equipped with "dead man" switches to interrupt power if the switch is released?** () ()
- Are there stop switches handy to each operator on machines requiring more than one operator?** () ()
- Are all saws properly guarded and are spreaders, jigs, and combs used where appropriate?** () ()
- Are all saw blades and other cutting tools regularly inspected for sharpness and other conditions affecting safe operation?** () ()
- Have swing cut-off saws and radial saws been properly designed or modified to return automatically to the back of the table when released?** () ()
- Do band saws have a tension control device?** () ()
- Are all hoods, guards, and antikickback dogs designed and installed to properly function with material being cut?** () ()
- Are blade guards on meat saws always lowered to the height of the piece being cut?** () ()
- Are fans guarded when less than 7 feet above floor, with guards having openings of ½ inch or less?** () ()

Abrasive Wheel Machinery (Grinders)
(29 CFR 1910.215)

	Yes	No
Is the work rest used and kept adjusted to within $\frac{1}{8}$ inch of wheel?	()	()
Is the adjustable tongue on the top side of the grinder used and kept adjusted to within $\frac{1}{4}$ inch of the wheel?	()	()
Do side guards cover the spindle, nut, and flange and 75% of the wheel diameter?	()	()
Are bench and pedestal grinders permanently mounted?	()	()
Are goggles or face shields always worn when grinding?	()	()

Hand and Portable Powered Tools
(29 CFR 1910.242, .244)

	Yes	No
Are tools and equipment (both school- and individually-owned) in good condition?	()	()
Have chisels, punches, etc., with mushroomed heads been reconditioned or replaced if necessary?	()	()
Have broken hammer handles been replaced?	()	()
Have worn or bent wrenches been replaced?	()	()
Have workers been instructed that the use of compressed air to blow debris from their clothing or body is prohibited because the air can enter the body and cause serious harm?	()	()
Have deteriorated air hoses been replaced?	()	()
Have workers been made aware of the hazards caused by faulty or improperly used hand tools?	()	()
Has compressed air used for cleaning been reduced to 30 psi when dead-ended?	()	()

Are portable abrasive wheels appropriately guarded? () ()

Are meat-cutting knives properly stored (in openings on the side or in back of cutting table) when not being used? () ()

Jacks

Are jacks checked periodically to see if they are in good condition? Yes No () ()

Are cars on jacks cribbed, blocked, or secured at once? () ()

Are support stands always used after the vehicle has been raised with a hydraulic jack? () ()

Lifts

Do employees stand to one side of vehicles when directing them into position over the lift? Yes No () ()

Are hoist controls manually operated and not blocked into the open or shut position? () ()

Are loads squarely engaged, and neither the lift nor adapter overloaded? () ()

If a lift is equipped with a mechanical locking device, is it made certain that the device is in place when the lift is up? () ()

When a lift malfunctions, is it removed from service and repaired immediately? () ()

**Welding, Cutting, and Brazing
(29 CFR 1910.252)**

Are fuel gas cylinders and oxygen cylinders in storage separated by 20 feet or a barrier 5 feet high having a ½-hour fire resistance rating? Yes No () ()

Are cylinders secured and stored where they cannot be knocked over? () ()

- Are valve protective caps in place except when the cylinder is in use?** () ()
- Are compressed gas cylinders kept away from sources of heat, elevators, stairs, or gangways?** () ()
- Are only persons who are judged competent allowed to use oxygen or fuel gas equipment?** () ()
- Do all cylinders (except those with fixed hand wheels) have nonadjustable wrenches, keys, or handles in place on valve stems while they are in use?** () ()
- Is welding or cutting always conducted at a safe distance from flammable liquids?** () ()
- Are all compressed gas cylinders legibly marked to identify their contents?** () ()
- Are the valves shut off when the cylinder is not in use?** () ()
- Are precautions taken to be sure that barrels, tanks, or other containers have been cleaned thoroughly to remove all flammable vapors or residues before cutting, welding, or other hot work is permitted on them?** () ()
- Is eye protection (goggles, helmets, hand shields) provided and worn as a protection against sparks or other debris?** () ()
- Is appropriate protective clothing (gloves, aprons, leggings, etc.) worn as a protection against sparks and other debris?** () ()
- Are electrode holders stored away from conducting objects when not in use?** () ()
- Is there a fire extinguisher nearby?** () ()
- Are nearby workers protected from welding flash?** () ()
- Are employee exposures to cutting and welding fumes kept within acceptable limits?** () ()

In confined spaces, is local exhaust ventilation or are approved supplied-air respirators provided and used when cutting or welding on metals containing or coated with:

- Lead? () ()
- Cadmium (also for indoor work)? () ()
- Zinc? () ()
- Mercuric compounds? () ()
- Fluorine (certain fluxes)? () ()

Is mechanical ventilation or are supplied-air respirators provided when cutting on other metals (copper, iron, nickel, etc.):

- in a space of less than 10,000 cubic feet per person? () ()
- in a room having a ceiling height less than 16 feet? () ()
- in confined spaces? () ()
- in any location where persons are exposed to toxic levels of contaminants? () ()

**National Electrical Code
(29 CFR 1910.308, .309)**

Electrical Wiring

- | | Yes | No |
|--|-----|-----|
| Have exposed wires, frayed cords, and deteriorated insulation been repaired or replaced? | () | () |
| Are flexible cords and cables not attached to building surfaces? | () | () |
| Are electrical equipment controls accessible? | () | () |
| Are all conduit connections intact? | () | () |

- Do all extension cords being used have a ground wire? () ()
- Are all extension cords in use of appropriate wiring to carry the current being drawn? () ()
- Are multiple plug adapters not used? () ()
- Are junction boxes, outlets, switches, and fittings covered? () ()
- Is all metal fixed electrical equipment grounded? () ()
- Are flexible cords and cables fastened so that there is no direct pull on joints or terminal screws? () ()
- Are flexible cords and cables never substituted for fixed wiring? () ()
- Do flexible cords and cables not run through holes in wall or ceiling or through doorways or windows? () ()
- Do flexible cords and cables have properly executed splices or taps? () ()
- Does all equipment connected by cord and plug have grounded connections? () ()
- Are electrical appliances such as vacuums, polishers, and vending machines grounded? () ()
- Are all portable electrical hand tools grounded? (Double-insulated tools are acceptable without grounding.) () ()
- Are breaker switches identified as to their use? () ()

Recordkeeping
(29 CFR 1903.2 - 1904.8)

- | | Yes | No |
|---|-----|-----|
| Is employee poster (OSHA or equivalent state poster) prominently displayed? | () | () |

Is a summary of all occupational injuries and illnesses compiled at the conclusion of each calendar year and recorded on OSHA Form No. 200? Is form 200 posted during the month of February? () ()

Have all OSHA records been retained for a period of 5 years, excluding the current year? () ()

Have occupational injuries or illnesses, except minor injuries requiring only first aid, been recorded on OSHA forms No. 200 and 101, or equivalent? () ()

Are OSHA forms No. 200 and 101 kept current to within 6 days? () ()

INFORMATION SOURCES

American National Standards Institute (ANSI)
1430 Broadway
New York, New York 10018

National Fire Protection Association (NFPA)
470 Atlantic Avenue
Boston, Massachusetts 02210

National Safety Council
444 North Michigan Avenue
Chicago, Illinois 60611

Health and Safety Consultants
For a list of health and safety consultants write to:
American Industrial Hygiene Association
c/o William E. McCormick,
Managing Director
475 Wolf Ledges
Akron, Ohio 44311

American Vocational Association
1510 H. Street, N. W.
Washington, D. C. 20005

**National Association of State Directors
of Vocational Education**
1510 H. Street, N. W.
Washington, D. C. 20005

NIOSH and OSHA regional directors, Educational Resource Centers, trade associations, and insurance companies can also provide useful information. The Small Business Administration will provide information on economic assistance for compliance with OSHA Standards (if needed).

NIOSH and OSHA Regional Offices
The following pages list NIOSH and OSHA regional offices which can provide information on the Occupational Safety and

Health Act including questions on standards interpretations, voluntary compliance information, copies of the OSHA Standards, OSH Act, Employee Rights Posting Notice, and publications.

NIOSH Regional Offices

DHEW, Region I
Government Center (JFK Fed. Bldg.)
Boston, Massachusetts 02203
Tel.: 617/223-6668/9

DHEW, Region II—Federal Building
26 Federal Plaza
New York, New York 10007
Tel.: 212/264-2485/8

DHEW, Region III
3525 Market Street, P.O. Box 13716
Philadelphia, Pennsylvania 19101
Tel.: 215/596-6716

DHEW, Region IV
50 Seventh Street, N.E.
Atlanta, Georgia 30323
Tel.: 404/526-5474

DHEW, Region V
300 South Wacker Drive
Chicago, Illinois 60607
Tel.: 312/886-3651

DHEW, Region VI
1200 Main Tower Building, Room 1700-A
Dallas, Texas 75245
Tel.: 214/655-3081

DHEW, Region VII
601 East 12th Street
Kansas City, Missouri 64106
Tel.: 816/374-5332

DHEW, Region VIII
19th and Stout Streets
9017 Federal Building
Denver, Colorado 80202
Tel.: 303/837-3979

184
176

DHEW, Region IX
50 Fulton Street (223 FOB)
San Francisco, California 94102
Tel.: 415/556-3781

DHEW, Region X
1321 Second Avenue (Arcade Bldg.)
Seattle, Washington 98101
Tel.: 206/442-0530

OSHA Regional Offices

Region I
U. S. Department of Labor
Occupational Safety and Health Administration
JFK Building, Room 1804
Boston, Massachusetts 02203
Tel.: 617/223-6712/3

Region II
U. S. Department of Labor
Occupational Safety and Health Administration
1515 Broadway (1 Astor Plaza), Room 3445
New York, New York 10036
Tel.: 212/971-5941/2

Region III
U. S. Department of Labor
Occupational Safety and Health Administration
15220 Gateway Center, 3535 Market Street
Philadelphia, Pennsylvania 19104
Tel.: 215/596-1201

Region IV
U. S. Department of Labor
Occupational Safety and Health Administration
1375 Peachtree Street, N.E., Suite 587
Atlanta, Georgia 30309
Tel.: 404/526-3573/4 or 2281/2

Region V
U. S. Department of Labor
Occupational Safety and Health Administration
230 S. Dearborn, 32nd Floor
Chicago, Illinois 60604
Tel.: 312/353-4716/7

Region VI
U. S. Department of Labor
Occupational Safety and Health Administration
555 Griffin Square Building, Room 602
Dallas, Texas 75202
Tel.: 214/749-2477/8/9 or 2567

Region VII
U. S. Department of Labor
Occupational Safety and Health Administration
Federal Building, Room 3000, 911 Walnut Street
Kansas City, Missouri 64106
Tel.: 816/374-5861

Region VIII
U. S. Department of Labor
Occupational Safety and Health Administration
Federal Building, Room 15010, 1961 Stout Street
Denver, Colorado 80202
Tel.: 303/837-3883

Region IX
U.S. Department of Labor
Occupational Safety and Health Administration
9470 Federal Building, 450 Golden Gate Avenue
Post Office Box 36017
San Francisco, California 94102
Tel.: 415/556-0584

Region X
U.S. Department of Labor
Occupational Safety and Health Administration
6048 Federal Office Building, 909 First Avenue
Seattle, Washington 98174
Tel.: 206/442-5930

Educational Resource Centers

The University of Texas Health
Science Center
P.O. Box 20186
Houston, Texas 77025
(713) 792-4300

The Johns Hopkins University
School of Hygiene & Public Health
615 North Wolfe Street
Baltimore, Maryland 21205
(301) 935-3720 or 3537

Department of Environmental Sciences
and Engineering
School of Public Health
University of North Carolina
Chapel Hill, North Carolina 27514
(919) 966-1023

Department of Environmental Health
University of Washington
Seattle, Washington 98195
(206) 543-6991

Department of Environmental Health
University of Cincinnati
College of Medicine
3223 Eden Avenue
Cincinnati, Ohio 45267
(513) 872-5701

Harvard University
School of Public Health
665 Huntington Avenue
Boston, Massachusetts 02115
(617) 732-1260

University of Minnesota
School of Public Health
420 Delaware Street, S.E.
Minneapolis, Minnesota 55455
(612) 373-8080

Department of Family & Community
Medicine
University of Arizona Health
Sciences Center
Tucson, Arizona 85724
(602) 882-6244

179
187

School of Public Health
University of Illinois at the
Medical Center
P.O. Box 6998
Chicago, Illinois 60680
(312) 996-7811

University of Utah
Medical Center
Room BC 106 DFCM
Salt Lake City, Utah 84132
(801) 581-8719



















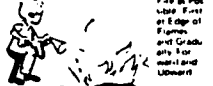

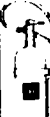

Mt. Sinai School of Medicine
1 Gustav Levy Place
New York, New York 10029
(212) 650-6174

Selected Bibliography

- Berberich, N., Blankenhorn, J., and Yonker, J. Occupational Injury Control. In: Occupational Safety and Health Symposia, 1975. NIOSH Publ. No. 76-136. National Institute for Occupational Safety and Health, Cincinnati, Ohio 45226. 1976.
- Campbell, E. A. Safety Manual for the Graphic Arts Industries. National Safety Council, Chicago, Illinois 60611. 1972.
- Cohen, M. L., Newman, J. W., and Hutchison, M. K. Occupational Health in a Health Service Area: Handbook for Planning. NIOSH Publ. No. 78-203. National Institute for Occupational Safety and Health, Cincinnati, Ohio 45226. 1978.
- Dade County Public Schools. Safety Manual for Teachers of Industrial Education Subjects. Bulletin No. 125. Industrial Arts Department and the Division of Vocational-Technical and Adult Education, Dade County Public Schools, Miami, Florida.
- Godbey, F., and Hatch, L. L. Occupational Safety and Health Program Guidelines for Colleges and Universities. NIOSH Publ. No. 79-108. National Institute for Occupational Safety and Health, Cincinnati, Ohio 45226. 1978.
- Hardy, H., and Hamilton, A. Industrial Toxicology. Third Edition, Publishing Sciences Group, Inc. Acton, Massachusetts. 1974.

- Hatch, L. L. Problems in Occupational Health Programming. In: Occupational Safety and Health Symposia, 1977. NIOSH Publ. No. 78-169. National Institute for Occupational Safety and Health, Cincinnati, Ohio 45226. 1978.
- Hatch, L.L., Rentos, P. G., Godbey, F. W., and Schrems, E. L. Self-Evaluation of Occupational Safety and Health Programs. NIOSH Publ. No. 78-187. National Institute for Occupational Safety and Health, Cincinnati, Ohio 45226. 1978.
- Jacknow, D., and Silver, R. An Employer's Basic Guide to Occupational Health Services. Detroit Industrial Clinic. Detroit, Michigan.
- Key, M. M., Henschel, A., Butler, J., Ligo, R. N., Tabershaw, I. R., and Ede, L. Occupational Diseases—A Guide to Their Recognition. NIOSH Publ. No. 77-181. National Institute for Occupational Safety and Health, Cincinnati, Ohio 45226. 1977.
- LaNier, M. How to do a Walk Through Survey: The Industrial Hygienist's Viewpoint. In: Occupational Safety and Health Symposia, 1976. NIOSH Publ. No. 77-179. National Institute for Occupational Safety and Health, Cincinnati, Ohio 45226. 1977.
- Lee, J. The New Nurse in Industry. NIOSH Publ. No. 78-143. National Institute for Occupational Safety and Health, Cincinnati, Ohio 45226. 1978.
- McKell, W. E., et al. A Safety Guide for Industrial Education. Granite School District, Salt Lake City, Utah. 1966.
- Maloney, C. NIOSH Publications Catalog. Second edition. NIOSH Publ. No. 78-123. National Institute for Occupational Safety and Health, Cincinnati, Ohio 45226. 1978.
- Olishifski, J., and McElroy, F. E. Fundamentals of Industrial Hygiene. Occupational Health Series. National Safety Council, Chicago, Illinois 60611. 1971.
- Patty, F. A. Industrial Hygiene and Toxicology. Interscience Publishers, Inc., New York, New York. 1963.
- Prakken Publications. Modern School Shop Planning. 6th edition, revised. Prakken Publications, Inc., Ann Arbor, Michigan. 1971.
- Rentos, P. G., Godbey, F. W., Hatch, L. L., and Schrems, E. L. Self-Evaluation Instrument—The Electric Utility Industry. NIOSH Publ. No. 78-207. National Institute for Occupational Safety and Health, Cincinnati, Ohio 45226. 1978.

- Schapiro, J.** Radiation Protection; A Guide for Scientists and Physicians. Harvard University Press, Cambridge, Massachusetts. 1972.
- Schrems, E.** Worker's Compensation Experience Rating as a Safety Evaluation Tool. *Journal of Occupational Medicine*, 18(4):4 April 1976.
- Shashack, W. F.,** editor. Occupational Safety and Health Act Handbook for Vocational and Technical Education Teachers. (Directed by Dr. J. Stern.) Rurban Education Developmental Laboratory, Department of Vocational and Technical Education, University of Illinois at Urbana, Urbana, Illinois 61801. 1974.
- State Department of Education.** Safety in Industrial Arts Laboratories. Bulletin 76 H-1. Florida State Department of Education, Tallahassee, Florida. 1969.
- State Department of Education of Vermont.** Guide to Safety for Industrial Arts. Division of Elementary and Secondary Education, Vermont State Department of Education, Montpelier, Vermont. 1974.
- Strong, M. E.,** editor. Accident Prevention Manual for Training Programs. American Technical Society, Chicago, Illinois 60637. 1975.
- U.S. Department of Health, Education, and Welfare.** An Accident Prevention Program for School Shops and Laboratories. U.S. Department of Health, Education, and Welfare, Washington, D.C. 1967.
- U.S. Department of Labor, Occupational Safety and Health Administration.** Occupational Safety and Health: A Bibliography. National Technical Information Service, Springfield, Virginia 22151. 1974.
- Utah State Board for Vocational Education.** Industrial Arts Safety Guide. Utah State Board for Vocational Education, Salt Lake City, Utah. 1969.
- Williams, W. A.** An Accident Prevention Program for School Shops and Laboratories. National Safety Council, Chicago, Illinois 60611.

KIND OF FIRE		APPROVED TYPE OF EXTINGUISHER							HOW TO OPERATE	
DECIDE THE CLASS OF FIRE YOU ARE FIGHTING...	... THEN CHECK THE COLUMNS TO THE RIGHT OF THAT CLASS	MATCH UP PROPER EXTINGUISHER WITH CLASS OF FIRE SHOWN AT LEFT							<p>FOAM Don't Poy Stream into the Burning Liquid. Allow Foam to Fall Lightly on Fire.</p> 	
		FOAM Solution of Aluminum Sulfate and Boric Acids in Water	CARBON DIOXIDE Carbon Dioxide Gas Under Pressure	SODA ACID Bicarbonate of Soda Solution and Sulfuric Acid	PUMP TANK Plain Water	GAS CARTRIDGE Water Emulsified by Carbon Dioxide Gas	MULTI-PURPOSE DRY CHEMICAL	ORDINARY DRY CHEMICAL		
<p>CLASS A FIRES</p> <p>USE THESE EXTINGUISHERS</p> <p>ORDINARY COMBUSTIBLES</p> <ul style="list-style-type: none"> WOOD PAPER CLOTH, ETC. 			X							<p>CARBON DIOXIDE Direct Discharge in Cone to Top of Pool. First at Edge of Flames and Gradually Move Inward and Upward.</p> 
<p>CLASS B FIRES</p> <p>USE THESE EXTINGUISHERS</p> <p>FLAMMABLE LIQUIDS, GREASE</p> <ul style="list-style-type: none"> GASOLINE PAINTS OILS, ETC. 				X	X	X			<p>SODA ACID CARTRIDGE Direct Stream at Base of Flame.</p> 	
<p>CLASS C FIRES</p> <p>USE THESE EXTINGUISHERS</p> <p>ELECTRICAL EQUIPMENT</p> <ul style="list-style-type: none"> MOTORS SWITCHES, ETC. 		X		X	X	X			<p>PUMP TANK Place Foot on Footrest and Direct Stream at Base of Flames.</p> 	
		X	X	X	X	X			<p>DRY CHEMICAL Direct at the Base of the Flames. In the Case of Class A Fires Follow Up by Directing the Dry Chemical at Remaining Material That is Burning.</p> 	

NATIONAL INSTITUTE FOR OCCUPATIONAL SAFETY AND HEALTH

**STANDARD
HAND
SIGNALS FOR
CONTROLLING
CRAWLER,
LOCOMOTIVE
AND TRUCK
CRANE
OPERATIONS**



HOIST Right forearm extended, hand open, palm facing forward, fingers spread, thumb pointing upward.



LOWER Right arm extended forward, palm facing forward, fingers spread, thumb pointing downward.



USE MAIN HOIST To use on hand, then use right to repeat.



SWING Arms extended, palm and fingers in direction of swing of boom.



STOP Arms extended, palm down, hand position rigidly held.



EMERGENCY STOP Arms extended, palm down, more hand rigidly held.



USE SHOT-DRUM Left hand raised, palm facing forward, fingers spread.



RAISE BOOM Arm extended, palm facing forward, thumb pointing upward.



LOWER BOOM Arm extended, palm facing forward, thumb pointing downward.



TRAVEL Arm extended forward, hand open and slightly raised, make walking motion in direction of travel.



DO EVERYTHING One hand in front of body.



TRAVEL Right hand in front of body, making a walking motion about face while indicating direction of travel, forward or backward (for greater crane body).



MOVE SLOWLY Use one hand to give any necessary signal and place other hand on front of head, using the middle finger, thumb pointing upward.



RAISE THE BOOM AND LOWER THE LOAD Right arm extended, thumb pointing up, then fingers in and out in form of hand movement is desired.



LOWER THE BOOM AND RAISE THE LOAD Right arm extended, thumb pointing down, then fingers in and out in form of hand movement is desired.

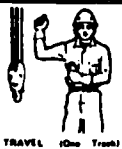

TRAVEL (One Hand) Left hand raised, palm indicated by raised foot. The right hand is held in all motion indicated by arm for motion of other hand, extended vertically in front of body. (For greater crane body).



EXTEND BOOM (Two-Handing Signal) Both feet in front of body with thumbs pointing outward.



RETRACT BOOM (Two-Handing Signal) Both feet in front of body with thumbs pointing toward each other.



RETRACT BOOM (Two-Handing Signal) One hand flat in front of other, thumb pointing outward and heel of flat up, palm down.



EXTEND BOOM (Two-Handing Signal) One hand flat in front of other, thumb pointing outward and heel of flat up, palm down.