

DOCUMENT RESUME

ED 192 143

CE 026 771

AUTHOR Welch, Frederick G., Ed.  
 TITLE Trade and Industrial Education Course of Study for Appliance Repair.  
 INSTITUTION Pennsylvania State Dept. of Education, Harrisburg. Bureau of Vocational and Technical Education.; Pennsylvania State Univ., University Park. Div. of Occupational and Vocational Studies.  
 PUB DATE Jun 80  
 NOTE 411p.  
 EDRS PRICE MF01/PC17 Plus Postage.  
 DESCRIPTORS Adult Education; Appliance Repairers; \*Appliance Repairing; Course Objectives; Course Organization; Curriculum Guides; \*Electrical Appliances; Hand Tools; \*Home Furnishings; Job Analysis; Job Skills; Learning Activities; Postsecondary Education; \*Refrigeration; Secondary Education; Skill Analysis; Skilled Workers; Task Analysis; \*Trade and Industrial Education

ABSTRACT

Designed for use by instructors of appliance repair to help establish a uniform curriculum, this manual presents a basic course of study. Individual instructors can add or delete jobs or lessons to suit their particular teaching situations. Contents include the course philosophy, listing of course objectives and activities to achieve them, plan of instructional practice, listing of appliance repair reference materials, bibliography, listing of resources for visual aids, and course outline. These seven units are included: orientation, basic electricity, basic shop tools, laundry equipment, kitchen equipment, and refrigeration. Job sheets, operation sheets, information sheets, and assignment sheets are provided. Job sheets (student practice in developing skill competencies) define materials and tools needed, competence procedures/steps cross-indexed to related operation sheet(s), and method of evaluation. Operation sheets, supplementing job sheets and indicating how to perform skill competency operation necessary to complete assigned jobs, include competency, objective, and competence-procedures/steps. Information sheets supplement job sheets and provide the student with information necessary for completing the assigned jobs with the highest possible degree of understanding. Sample assignment sheets provide the student with mental activities necessary to learn the "knowing" that accompanies the "doing" of a trade. (YIB)

\*\*\*\*\*  
 \* Reproductions supplied by EDRS are the best that can be made \*  
 \* from the original document. \*  
 \*\*\*\*\*

ED192143

# ARTS AND INDUSTRIAL EDUCATION

## COURSE OF STUDY

FOR

# APPLIANCE REPAIR

U.S. DEPARTMENT OF HEALTH,  
EDUCATION & WELFARE  
NATIONAL INSTITUTE OF  
EDUCATION

THIS DOCUMENT HAS BEEN REPRODUCED EXACTLY AS RECEIVED FROM THE PERSON OR ORGANIZATION ORIGINATING IT. POINTS OF VIEW OR OPINIONS STATED DO NOT NECESSARILY REPRESENT OFFICIAL NATIONAL INSTITUTE OF EDUCATION POSITION OR POLICY.

"PERMISSION TO REPRODUCE THIS MATERIAL HAS BEEN GRANTED BY

B. Ford

TO THE EDUCATIONAL RESOURCES INFORMATION CENTER (ERIC)."

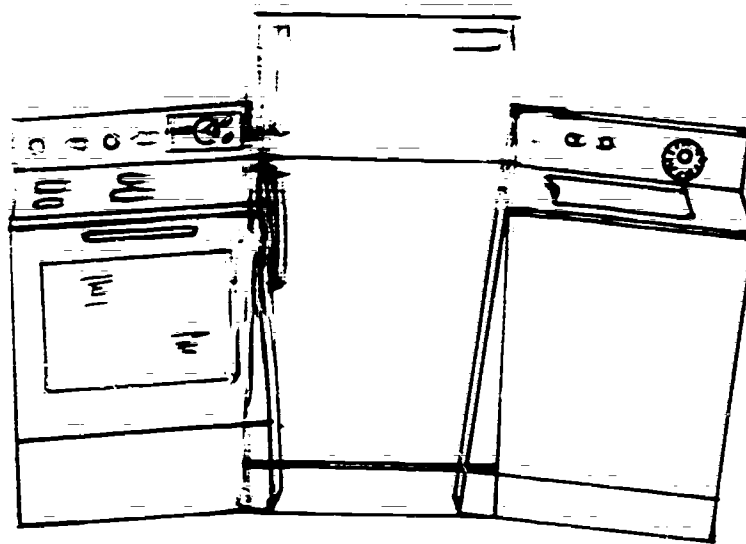

Pennsylvania Department of Education

1980

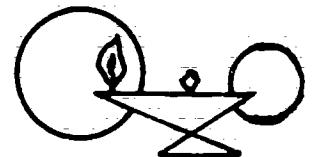

CE 026 771

## APPLIANCE REPAIR

This manual is designed for use by instructors of Appliance Repair to help establish a uniform curriculum in this area of vocational education instruction. It is developed so the individual instructor can add or delete jobs or lessons to suit their particular teaching situations.

The manufacturer's of appliances use various methods of construction. Therefore, the job sheets are written using general steps. You, as the instructor, will be required to supply the necessary information and manufacturer's manuals needed to do the jobs.

EDITED BY

Frederick G. Welch  
The Pennsylvania State University

ASSISTED BY

Jane Jantzer  
The Pennsylvania State University

Roger Keith  
Jefferson County-DuBois Area Vocational-Technical School

ART WORK BY

James Albert  
The Pennsylvania State University

Paul Albert  
The Pennsylvania State University

COMPILED BY

Robert W. Allen (Primary Consultant)  
Lehigh County Area Vocational-Technical School

John Loomis  
Lancaster County - Willow Street Area Vocational-Technical School

Howard E. Matthews  
Lawrence County Area Vocational-Technical School

IN COOPERATION WITH

Division of Occupational and Vocational Studies  
College of Education  
The Pennsylvania State University

AND

Department of Education  
Bureau of Vocational Education  
Harrisburg, Pennsylvania

June 1980

Commonwealth of Pennsylvania  
Richard Thornburgh, Governor

Department of Education  
Robert Scanlon, Secretary

Office of Basic Education  
Ronald Lewis, Commissioner

Bureau of Vocational Education  
Robert Edwards, Acting Director

Vocational Program Development Division  
T. Dean Witmer, Chief

Trade and Industrial Education  
John W. Brandt, Supervisor

Pennsylvania Department of Education  
333 Market Street  
Harrisburg, PA 17126

## TABLE OF CONTENTS

<del>PREFACE</del> . . . . .	iii
<del>COURSE</del> PHILOSOPHY . . . . .	1
<del>GENERAL</del> COURSE OBJECTIVES . . . . .	3
<del>PLAN OF</del> INSTRUCTIONAL OBJECTIVES . . . . .	5
<del>APPENDIX</del> REPAIR REFERENCE MATERIALS . . . . .	7
<del>APPENDIX</del> . . . . .	11
RESOURCES FOR VISUAL AIDS . . . . .	17
<del>COURSE</del> OUTLINE	
. Occupational Description and Major Discussions . . . . .	27
. Skill Competency Development Jobs . . . . .	28
. Skill Competencies and Information Lessons . . . . .	28
. Assignments . . . . .	28
<del>WRITEN</del> INSTRUCTIONAL AIDS	
. Introduction . . . . .	39
. Job Sheets . . . . .	39
. Operation Sheets . . . . .	353
. Information . . . . .	607
. Assignment Sheet (Samples) . . . . .	655

## PREFACE

In recent years, we have planned and constructed the finest of vocational education facilities and have placed fine equipment in these facilities. Our attention must be directed to provide the teacher with the basic tools for instruction to assist in providing quality instruction.

This basic course of study is intended to be used as a teaching and learning guide. The information provides the essentials of the occupation, insuring that the students who successfully complete the course will have sufficient competencies for initial employment and ample orientation for growth and advancement. The teacher who uses this course may find it necessary to modify and supplement the material to meet the needs of specific student and the local industrial community.

This material has been prepared by a committee of teachers under the general direction of the staff of the Division of Occupational and Vocational Studies at the Pennsylvania State University in cooperation with the Trade and Industrial Education staff of the Bureau of Vocational Education of the Department of Education.

John W. Brandt  
Supervisor  
Trade and Industrial Education  
Bureau of Vocational Education

Frederick G. Welch  
Professor in Charge  
Division of Occup. & Voc. Studies  
The Pennsylvania State University

1980

## COURSE PHILOSOPHY

In keeping with the overall philosophy of vocational education, the Appliance Repair course will contribute to the development of individual students by providing them the opportunity to master basic skills, acquire knowledge, and develop favorable attitudes in the areas which the course emphasizes.

The relationship of mathematics, science and communications skills should be emphasized. Student awareness of responsibility to others must be emphasized. The student must be cognizant of changes within the industry and their effect on society and technology. The contribution of audio-visual media to society will be stressed.

A student should develop pride in his own work, a respect for those who labor and appreciation of the heritage that is his. As these concepts are developed, the student should gain a better understanding of responsibilities and duties of citizenship as well as rewards in this field of endeavor.



## GENERAL COURSE OBJECTIVES

### Objectives

1. To develop specific skills and ~~related~~ information associated with the occupation.
2. To develop understanding of labor and management.
3. To develop good work habits.
4. To develop occupational safety habits and understandings.
5. To develop the ability to work cooperatively with fellow workers.

### Activities to Achieve Objectives

1. Series of appropriate individual and group practice jobs.
  2. Use of job, operation, information and assignment sheets for individual students.
1. Readings in trade magazines and periodicals.
  2. Talks by representatives of labor and management.
  3. Discussion of problems related to employee-management-trade union transactions.
1. Set specific criteria for success in each job.
  2. Allow for student planning.
  3. Maintain a clean, well-organized shop, noting how this is conducive to effective learning.
  4. Objective evaluation of students' jobs, methods and ideas.
  5. Good work habits and how they are related to job stability and/or advancement.
1. Displaying safety posters.
  2. Safety warning devices for hazardous materials and/or work areas.
  3. Demonstration of correct safety practices.
  4. Safety and the effect on the production dollar, due to time lost.
  5. Student participation in a safety program.
  6. Showing of motion pictures and slides that are safety oriented.
1. Set up a maximum of class and group projects.
  2. Encouragement of team work.
  3. Provide for student planning committees.
  4. Assignment of student specialist to assist students needing help.

## Objectives

6. Stimulation and development of leadership abilities.
7. Development of good citizenship.

## Activities to Achieve Objectives

1. To provide opportunity for students to plan, assign, and evaluate their jobs and those of other students.
2. Student participation in VICA.
1. Provide for student participation in school-related citizenship activities.

## PLAN OF INSTRUCTIONAL PRACTICE

The effectiveness of instruction depends on the careful organization and control of the routine details concerning the management of the pupil, equipment, teaching methods and the physical laboratory arrangement. The teacher must determine the best management practices and formulate a very definite statement of the basic standards to be followed in teaching the course to bring about the attainment of the learning goals.

### Length of Course

The course of study is designed as a three-year curriculum involving approximately 1500 hours of class and laboratory instruction, primarily for beginning students who are interested in securing employment in the occupation. Where job entry is the goal, the entire course of study would be appropriate. In adults programs, it may be found that a single thrust is the student's goal, therefore, the course content may be restricted to a single major division.

### Use of This Course of Study

The material has been arranged in major divisions of the trade. In most cases, the material contained in the first division must be learned before progressing to the next division. The nature of some trade areas permit entry into random divisions after the introductory basic material is covered. Some divisions of the occupation can be taught separately.

The content of this course material consists of job sheets (yellow) and skill competency sheets (white). The skill competency sheets are simply written and highly illustrated. These sheets outline the manipulative handling of tools and materials that make up the doing part of the occupation. The sequence of the skill competency sheets (SC) is based on the organization of the job sheets. Notice that job number one incorporates the basic skill competencies and job number two includes additional skill competencies. This cumulative reuse of the skill competencies continues throughout the entire job sheet collection. After a number of jobs have insured that the student has been sufficiently exposed to a skill competency, no further reference to that skill competency is made.

The job sheets are arranged in an order that gradually exposes the skill competencies. The purpose of the job sheet is to insure the introduction of each operation or skill competency in a controlled manner. Look at this group of jobs as a framework that can be added to, by you, to meet local needs. You may decide to design new or different jobs that will be inserted between or replace any of the suggested jobs. In time you will be able to custom design a course of study for your own needs. There will be little or no need to vary the skill competency sheets.

## Teaching Methods

The following procedures are offered as the most productive in achieving the desired results in this course:

1. Demonstrations--Operations and procedures will be demonstrated while the students observe. The purpose is to show how things are done correctly and safely.
2. Class Discussion--A method of teaching in which the students and the teacher take part, directed and controlled by the teacher to a predetermined objective. Technical and related information common to a class or group of students will be presented in this manner. Evaluation of the material presented in this manner should be done by objective testing.
3. Laboratory Talks--Short, informal talks by the instructor during laboratory activities to convey information pertinent to the activity in progress. Not scheduled and not timed, this activity should occur at any appropriate time and for periods of varying duration.
4. Observation and Input--This teacher activity should take place at all times when students are performing psychomotor skills. The purpose is to reinforce a previously given demonstration, class discussion, or laboratory talk, or to update the students' skills by further demonstration and/or further disclosures of technical and related information.

## Vehicles of Instruction

The application phase of this course will consist of work assignments kept as close to industrial conditions as a shop situation permits. Job, operation and information sheets will be provided, so that students of different levels of skill and ability can understand them. The students will be encouraged to progress as rapidly as possible, and achieve the standard set of the course. Special attention will be given to the unique student, offering special assistance so that slow as well as fast students may progress at their own rate of speed.

## Items to be Developed by Teacher

The following items are peculiar to the local school situation and need to be developed by each local instructor.

- . Standards of attainment required
- . Pupil work evaluation
- . Shop controls and regulations
- . Pupil personnel organization
- . Method of tool check
- . Records and forms
- . Information lessons

MANUFACTURERS

<u>COMPANY</u>	<u>ADDRESS</u>
Admiral Corporation	3800 West Cortland Street Chicago 47, Illinois
Amana Refrigeration Company, Inc.	Amana, Iowa
A.O. Smith Corporation	P.O. Box 28 Kankakee, Illinois
Blackstone Corporation	1111 Allen Street Jamestown, New York
Carrier Corporation	Carrier Parkway Syracuse 1, New York
Chrysler Corporation Air Temp Division	P. O. Box 1037 Dayton 1, Ohio
Fedders Corporation	58-01 Grand Avenue Maspeth 78, New York
Frigidaire Division of General Motors Corporation	300 Taylor Street Dayton 1, Ohio
General Electric Company Major Appliance Division	Louisville, Kentucky
Gibson Refrigeration Company Division of Hupp Manufacturing Corporation	Greenville, Michigan
Hamilton Manufacturing Company	Two Rivers, Wisconsin
Hoover Company	East Maple Street North Canton, Ohio
Hotpoint, Inc. Division of General Electric	5600 West Taylor Street Chicago, Illinois
In Sink-Erator Manufacturing Company	1225 14th Street Racine, Wisconsin
Ironrite Corporation	25th and Smallman Streets Pittsburgh, Pennsylvania

Kitchen Aid Home Dishwasher  
Division of Hobart Manufacturing  
Company

711 Pennsylvania Avenue  
Troy, Ohio

Magic Chef, Inc.

King Edward Avenue  
Cleveland, Tennessee

The Maytag Company, Inc.

Newton, Iowa

National Rubber Machinery Company  
Plumbing Equipment Division

920 Lafayette Road  
Medina, Ohio

Norge Corporation  
Division of Borg-Warner Corporation

Merchandise Mart Plaza  
Chicago 54, Illinois

O'Keefe and Merritt

3700 East Olympic Blvd.  
Los Angeles 23, California

Pennsylvania-Bradford Appliance  
Corporation

24th and Ellsworth  
Philadelphia 46, Pennsylvania

Philco, Inc.  
Division of the Ford Motor Company

Fort Washington Industrial Park  
Fort Washington, Pennsylvania

Quiet Kool  
Division of Emerson Radio, Inc.

14th and Coles  
Jersey City 2, New Jersey

Revco, Inc.

Deerfield, Michigan

Speed Queen, Inc.  
Division of McGraw Edison

Ripon, Wisconsin

Thermadore Electrical Manufacturing Co.  
Division of Norris Thermadore  
Corporation

5119 District Blvd.  
Los Angeles, California

Tappan Company

250 Wayne Street  
Mansfield, Ohio

Waste King Company

3300 East 50th Street  
Los Angeles 58, California

Welbilt Corporation

Welbilt Square  
Maspeth 78, New York

Westinghouse Electric Corporation  
Major Appliance Division

P.O. Box 2199  
Columbus, Ohio

Whirlpool Corporation

Benton Harbor, Michigan

York Corporation  
Division of Borg-Warner Corporation

Grantley Road  
York, Pennsylvania

Youngstown Kitchens  
Division of Mullins Manufacturing  
Corp.

Salem, Ohio

## BIBLIOGRAPHY

- Anderson, E. P. Air Conditioning.  
Howard W. Sams Company, 1975.
- Anderson, E. P. Commercial Refrigeration.  
Howard W. Sams Company, 1975.
- Anderson, E. P. Home Appliance and Air Conditioning.  
Howard W. Sams Company, 1975.
- Anderson, E. P. Home Appliance Service Guide.  
Howard W. Sams Company, 1976.
- Anderson, E. P. Wiring Diagrams for Light and Power.  
Howard W. Sams Company, 1970.
- Althouse & Turnquist. Modern Refrigeration and Air Conditioning.  
Homewood, Illinois: Goodheart-Wilcox, 1975.
- Althouse & Turnquist. Modern Refrigeration and Air Conditioning. (Job Sheets)  
Homewood, Illinois: Goodheart-Wilcox, 1968.
- Brockwell, P. T. How to Repair Household Appliances.  
Maple Press Company, 1957.
- Brockwell, P. T. Major Appliance Servicing.  
McGraw-Hill Book Company, Inc.
- Brockwell, P. T. Small Appliance Servicing.  
McGraw-Hill Book Company, Inc., 1957.
- Buban & Schmidt. Understanding Electricity and Electronics.  
Brodhead Garrett.
- Burkhardt, Charles H. Residential and Commercial Air Conditioning.  
McGraw-Hill Book Company.
- Carr, Clifford. American Electricians Handbook.  
New York: McGraw-Hill Book Company, Inc., 1961.
- Collings. Projects in Electricity.  
Brodhead Garrett.
- Darr, Jack. How to Repair Major Appliances.  
Howard W. Sams Company, 1966.
- Darr, Jack. How to Repair Small Appliances - Volume I.  
Howard W. Sams Company, 1974.
- Darr, Jack. How to Repair Small Appliances - Volume II.  
Howard W. Sams Company, 1973.



- Dragoo and Porter. General Shop Electricity.  
Brodhead Garrett.
- Duff. Alternating Current Fundamentals #68 (lab manual available #69;  
teacher manual available #70). Delmar. 1963.
- Gerrish, Howard H. Electricity.  
Brodhead Garrett.
- Gerrish, J. J. Electricity Manual.  
Homewood, Illinois: Goodheart-Wilcox, 1964.
- Goliber. Refrigeration Servicing #9.  
Delmar.
- Graf, Rudolf F. Modern Dictionary of Electronics.  
Brodhead Garrett.
- Graham, Kennard C. Interior Electrical Wiring Residential (study guide  
available). American Technical Society.
- Graham, Kennard C. Fundamentals of Electricity (study guide available).  
American Technical Society.
- Graham, Kennard C. National Electrical Code and Blueprint Reading.  
American Technical Society.
- Graham, Kennard C. Understanding and Servicing Fractional Horsepower Motors  
(guide available). American Technical Society.
- Heine, Gilbert; Dunlop, Carl H. & Jones, C. S. How to Read Electrical  
Blueprints (study guide available). American Technical Society.
- Herrington, D. Dictionary of Electronic Terms.  
Editors and Engineers, 1965.
- Herrington, D. How to Read Schematic Diagrams.  
Howard W. Sams Company, 1962.
- Jones, E. W. General Electricity.  
McKnight & McKnight.
- Lang. Principles of Air Conditioning.  
Albany- New York: Delmar Publishing Co., 1972.
- Langley, Betty C. Refrigeration and Air Conditioning.  
Reston Publishing Co., 1978.
- Loper. Direct Current Fundamentals #71 (lab manual available #72; teacher  
manual available #73). Delmar Publishing Co., 1963.
- March, Warren and Olivio, Thomas. Principles of Refrigeration #7 (study guide  
available #8), Delmar Publishing Co., 1966.

- Marcus, Abraham. Basic Electricity.  
Prentice Hall, Inc.
- McPortland, Joseph and Novak, Wm. Practical Electricity.  
McGraw-Hill.
- Newham, R. W. Small Appliance Repairs.  
New York: McGraw-Hill Book Company, 1967.
- Noll, Edward M. Science Projects in Electricity.  
Brodhead Garrett.
- Oldfield, R. L. Practical Dictionary of Electricity & Electronics.  
American Technical Society.
- Schure, Alexander. A Programmed Course in Basic Electricity.  
McGraw-Hill.
- Steinberg, Wm. and Ford, Walter B. Basic Electricity and Electronics (study  
guide available). American Technical Society.
- Stetka, F. & Brandon. NEPA - Handbook of the NEC.  
New York: McGraw-Hill Book Company, 1965.
- Thwarts, Russel. Fundamentals of Electricity.  
McGraw-Hill.
- Tinnell, Richard W. Experiments in Electric AC.  
McGraw-Hill.
- Wiggins, D. Automotive Air Conditioning #11 (instructor guide available #10).  
Delmar.
- Zbar and Schillakraut. Basic Electricity Laboratory Manual.  
Brodhead Garrett.
- ABC's of Electricity.  
Howard Sams Staff, Brodhead & Garrett.
- Automotive Air Conditioning and Heating Service Manual.  
Mitchell Manuals, Inc. 1979 Supplement.
- A.S.A. Wiring Diagrams.  
Whirlpool Corporation, 1965.
- Basic Electrical Power Distribution.  
Picture Training Books, Brodhead Garrett.
- Basic Electricity.  
Navy Training Course, NAVPENS 10086-A, U.S. Govt. Printing Office.
- Basic Electricity, Vols. 1, 2, 3, 4, 5.  
Picture Training Books, Brodhead Garrett.
- Basic Electricity and Electronics.  
Howard W. Sams Company, 1964.

Calibration of Oven Thermostats.

Ozs. and Electric, 1963 & 1964.

Commercial and Industrial Refrigeration.

New York: McGraw-Hill Book Company, 1952.

Doolin's Trouble Shooters--Bible of Air Conditioning, Heating & Refrigeration.

Doolco Incorporation, 1963.

Electric Motor Control #88 (lab manual available #89; instructor guide available #90). Delmar.

Electricity I #77 (answer book #78)

Delmar.

Electricity II #79 (answer book #80).

Delmar.

Electricity III #81 (answer book #82).

Delmar.

Electricity IV #83 (answer book #84).

Delmar.

Learning Electricity Fundamentals.

Howard W. Sams Company, 1957.

Machinists's Maze 3 & 2

NAVEDTRA 10524-E U.S. Govt. Printing Office, 1978.

Mathematics for Electricians.

New York: McGraw-Hill Book Company, 1958.

National Electrical Code Handbook.

New York: McGraw-Hill Book Company, 1954.

101 Ways to Use Your VOM and VTVM.

Brodhead Garrett.

Practical Heat.

New York: McGraw-Hill Book Company, 1939.

Programmed Basic Electricity Course.

Brodhead Garrett.

Refrigeration and Air Conditioning.

Air Conditioning and Refrigeration Institute, Printice Hall, Inc., 1979.

Related Information Electricity.

Albany, New York: Delmar Publishing Company, 1962.

Servicing Small Appliances.

New York: McGraw-Hill Book Company, 1957.

Simplified Electricity for Utility Workers #85. (teacher manual #86).  
Delmar.

Westinghouse Maintenance Hints.  
Westinghouse, 1966.

## Resources for Visual Aids

Aids Catalog	IDE Air Equipment, Inc. P.O. Box E No. End Station Wilkes-Barre, PA 18705
Bibliography of Training Aids (Catalog available for \$1.00)	Compiled by: Air-Conditioning & Refrigeration Institute 1815 North Fort Meyer Drive Arlington, Virginia 22209
Bucks County Film Library	West & Ashland Sts., Doylestown, PA
Bucks County Regional Inst. Material Center	280 Red Cedar Drive, Levittown, PA
City College of New York, A/V Center Commonwealth of Pennsylvania	17 Lexington Ave., New York, NY 10010 Dept. of Public Education Harrisburg, PA
Du Art Film Laboratories, Inc.	245 W. 55th St., N.Y., N.Y. 10019
Encyclopedia Britannica Films	202 E. 44th St., N.Y., N.Y. 10017
Films (Catalog Available Free)	General Services Administration National Archives & Records Service National Audiovisual Center Washington, DC 20409
Film Strips & Cassette Tapes	Whirlpool Corporation Literature Dept., 229 Factory St. La Porte, Indiana 46350
Ideal Pictures	41 No. 11th St., Phila., PA 19107
J. P. Lilley & Sons, Inc.	Box 3035, 928 W. Third St. Harrisburg, PA 17105
Pennsylvania State University	University Park, PA
Society for Visual Education, Inc.	1345 W. Diversey Pkwy. Chicago, ILL 60614
U.S. Air Force Film Library	8900 S. Broadway, St. Louis, MO 63125
U.S. Army, First Army	Governors Island, N.Y., N.Y. 10004
U.S. Govt. Film Service	245 W. 55th St., N.Y., N.Y. 10019

U. S. Navy	4th Navy Dist., Phila., PA 19100
University of Illinois, V/A Center	704 S. 6th St., Champaign, IL
University of Michigan, A/V Center	Frieze Bldg., Ann Arbor, MI
Westinghouse Electric Co.	Visual Communications Dept. 3 Gateway Center Pittsburgh, PA 15230
Wholesome Films Center, Inc.	20 Melrose St., Boston, Mass. 02116

Reference Material Suppliers

American Technical Society	848 E. 58th St., Chicago, IL
Brodhead Garrett	4560 E. 71st St., Cleveland, Ohio
Delmar Publishing Co.	Mountainview Ave., Albany, NY
Goodheart-Willcox Co., Inc.	Homewood, IL
McGraw-Hill Book Co.	330 W. 42 St., N.Y., N.Y.
McKnight & McKnight Publishing Co.	Bloomington, IL
Prentice Hall, Inc.	Englewood Cliffs, N.J.
U.S. Govt. Printing Office	Washington 25, DC

Films

Title	Color	Time (Min)	Sound	Supplier (L-Loan) (R-Rent) (B-Buy)
ABC of Hand Tools, Part I, Part II	No	33	Yes	L - Commonwealth of Pa.
Adding and Removing Refrigerant	No	17	Yes	B - Du Art Film Lab
"A is For Atom"	Yes	16		Pa. Power & Light Co. Marketing Department Allentown, PA
Ampere, Volt and Ohm	No	8	Yes	L - U.S. Air Force Film Library Center. B - Du Art Film Lab.
An Introduction to the Electron	No	16	Yes	B - Du Art Film Lab.
Basic Electricity	Yes	19	Yes	L - U.S. Air Force R - Wholesome Film Center B - Du Art Film Lab.
Checking the Refrigerator Electrical System	No	17	Yes	B - Du Art Film Lab.
Checking the Refrigeration System General Procedures	No	17	Yes	B - Du Art Film Lab.
Checking the Refrigeration System Troubleshooting	No	17	Yes	B - Du Art Film Lab.
Circuits: Series/Parallel	No	8	Yes	L - U.S. Navy, 4th Dist.
"The Dawn of Better Living"	Yes	20		Pa. Power & Light Co. Marketing Department Allentown, PA
"Eddie, Inc."	Yes	30		Pa. Power & Light Co. Marketing Department Allentown, PA
Electrical Circuit Faults	No	19	Yes	B - Du Art Film Lab.
Electrical Conductors & Resistors	Yes	15	Yes	R - Univ. of Penna.
Electricity: How It Is Generated	No	11	Yes	L - Bucks Film Library Bucks County R.I.M.
Electricity: Principles of Safety	No	11	Yes	R - Ideal Pictures



## Films

Title	Color	Frames	Sound	Supplier (R-Rent) (B-Buy)
Ampere, Volt, and Ohm	No	?	No	R - U.S. Air Force B - Du Art Film Lab.
Basic Principles of Refrigeration	Yes	71	No	B - Du Art Film Lab.
Electrical Circuits	No	57	No	B - Du Art Film Lab.
Electrical Circuits: Types of and Measurement of volts, amps and ohms	Yes	57	No	B - Soc. for Visual Educ
Electric Magnet	No	47	No	B - Soc. for Visual Educ
Electricity, Characteristics	No	48	No	B - Soc. for Visual Educ
Heat and How It Is Measured	No	52	No	B - Soc. for Visual Educ
Joining Solid Conductors	No	?	No	B - Du Art Film Lab
The Principles of Electric Motors and Generators	No	68	No	B - Soc. for Visual Educ
Split Phase Motor Principles	No	?	No	B - Du Art Film Lab. R - City College of NY
Static Electricity	No	65	No	B - Soc. for Visual Educ
Wire Sizes and Voltage Drop	No	?	No	B - Du Art Film Lab



Title	Color	Time (Min)	Sound	(L-Loan)
				Supplier (R - Rent) (B - Buy)
Electricity Works For Us	No	12	Yes	L - Bucks Film Library Bucks County R.I.M.
Electric Power & Common Sense	Yes	26		Pa. Power & Light Co. Marketing Department Allentown, PA
Electromagnets	No	11	Yes	R - Univ. of Michigan
The Electron	No	11	Yes	L - Commonwealth of PA
Elements of Electrical Circuits	No	11	Yes	Rent or Buy - Encyclopedia Britanica; L - Commonwealth of PA R - Univ. of Michigan
Elements of Electricity (molecular construction)	No	15	Yes	L - U.S. Army, First B - Du Art Film Lab.
Hand Soldering	No	20	Yes	B - Du Art Film Lab.
Heating & Air Conditioning	No	11	Yes	L - Commonwealth of PA
Home Electrical Appliances	No	11	Yes	R - Penna. State Univ.
Home is Where The Heart Is	Yes	12		Pa. Power & Light Co. Marketing Department Allentown, PA
How to Keep A Job	No	10	Yes	L - Commonwealth of PA
How to Produce Electrical Current with Magnets	No	11	Yes	R - Univ. of Michigan
How to Test and Locate Electrical Circuit Faults	No	19	Yes	R - Univ. of Michigan B - Du Art Film Lab.
How Transformers Work	Yes	15	Yes	R - Univ. of Michigan
Introduction to Electricity	Yes/No	11	Yes	B/R - J.P. Lilley & Son L - Bucks County R.I.M.
Joining Solid Conductors	No	22	Yes	B - Du Art Film Lab.
Just Plug It In	Yes	25		Pa. Power & Light Co. Marketing Department Allentown, PA
Keep-em Protected	Yes	15	Yes	L - Westinghouse Elec. Co.

Title	Color	Time (Min)	Sound	(L - Loan)
				Supplier (R - Rent) (B - Buy)
Learning About Electrical Current	No	8	Yes	R - Penna. State Univ.
Living Unlimited	Yes	14		Pa. Power & Light Co. Marketing Department Allentown, PA
Locating and Repairing Refrigerant Leaks	No	17	Yes	B - Du Art Film Lab.
Magnetism	No	10	Yes	R - Penna. State Univ. L - Bucks County
Magnetism	No	16	Yes	L - Bucks Film Library Bucks County R.I.M.
Making & Repairing Tubing Connections	No	18	Yes	B - Du Art Film Lab.
Measurement of Electricity	Yes	11	Yes	R - Univ. Of Michigan
More Dangerous Than Dynamite	No	11	Yes	L - Commonwealth of Pa.
The Nature of Heat	No	10	Yes	L - Bucks Film Library Bucks County R.I.M.
Principles of Current Electricity	No	22	Yes	R - Penna. State Univ. L - Commonwealth of Pa.
Principles of Current Generation	No	20	Yes	L - Commonwealth of Pa.
Principles of Electrical Measurements	No	22	Yes	R - Penna. State Univ.
Principles of Electrical Measurement: Part I and II	No	20	Yes	L - Commonwealth of Pa.
Principles of Electricity	Yes	20		Pa. Power & Light Co. Marketing Department Allentown, Pa.
Principles of Electromagnetism	No	20	Yes	L - Commonwealth of Pa.
Principles of Magnetism	No	20	Yes	L - Commonwealth of Pa.
Principles of Magnetism	No	22	Yes	R - Penna. State Univ.
Principles of Refrigeration	No	20	Yes	B - Du Art Film Lab.

Title	Color	Time (Min)	Sound	(L-Loan)
				Supplier (R-Rent) (B-Buy)
Principles of Safety with Electricity	Yes/No	11	Yes	B/R - J. P. Lilley & Son
Quieting a Noisy Refrigerator	No	16	Yes	B - Du Art Film Lab.
Reddy Made Magic	Yes	8		Pa. Power & Light Co. Marketing Department Allentown, PA
Refrigeration & Air Conditioning	Yes/No	11	Yes	B/R - J.P. Lilley & Son
Removing & Installing Compressor or Condenser	No	17	Yes	B - Du Art Film Lab.
Removing & Installing a Cooling Unit	No	19	Yes	B - Du Art Film Lab.
Rotating Magnetic Fields	No	13	Yes	B - Du Art Film Lab.
Safety With Electricity	Yes	10	Yes	R - Univ. of Illinois
Safety in the Shop	No	12	Yes	B - Du Art Film Lab.
Series & Parallel Circuits	No	11	Yes	R - Penna. State Univ.
The Shocking Truth	Yes	26	Yes	L - Commonwealth of PA
So You Want To Be A Home Appliance Service Technician	Yes	11		Vocational Films 111 Euclid Avenue Park Ridge, IL 60068
Split Phase Motor Principles	No	17	Yes	R - City College of NY B - Du Art Film Lab
Squirrel-Cage Rotor Principles	No	10	Yes	B - Du Art Film Lab.
Starting Characteristics of Common Induction Motors	Yes	15	Yes	R - Univ. of Michigan
The Symbol of Better Living	Yes	18		Pa. Power & Light Co. Marketing Department Allentown, PA
Three-Wire Service Entrances	No	24	Yes	B - Du Art Film Lab.
Volts and Amperes	No	14	Yes	R - Univ. of Michigan
Wire Sizes and Voltage Drop	No	13	Yes	B - Du Art Film Lab. L - U.S. Govt. Film Service

## Transparencies

NOTE: Supplier for all - Brodhead Garrett

<u>Title</u>	<u>Code</u>	<u>Cost</u>
AC Current and Voltage in Phase	E 55	5.40
AC Generator	E 44	5.40
AC Generator Cycle	E 46	5.40
Ampere Left Hand Rule	E 35	3.65
Back EMF in a Motor	E 51	6.35
Bar Magnet	E 30	6.35
Charging by Conduction	E 5	7.80
Charging by Induction	E 6	6.65
Comparison of DC and AC Power	E 56	5.65
Condition for Induced EMF	E 40	7.80
Dry Cell	E 19	6.35
The Effect of a Coil on an Induced Current	E 41	5.95
Effect of Shape of a Conductor	E 10	5.40
Effective Value of an AC Current	E 57	5.40
Electric Charges	E 1	5.40
Electric Circuit	E 12	6.35
The Electric Field	E 8	7.80
Electrostatic Charge	E 9	4.65
Hand Rules for the Motor Effect	E 50	10.20
Heating Effects	E 24	5.40
Horseshoe Magnet	E 31	5.40
Hot Wire Meter	E 59	7.80
Inductance	E 52	6.65
Induction Coil	E 53	4.55
Inductive Circuits	E 61	5.65

Title	Code	Cost
Iron Vane Meter	E 58	5.40
Left Hand Generator Rule	E 45	4.65
Left Hand Rule for Coil	E 37	7.10
Magnetic Field About a Current Loop	E 36	4.65
The Motor Effect	E 49	4.95
Ohms Law (Parallel)	E 22	6.45
Ohms Law (Resistance in Series)	E 21	6.65
Pith Ball Experiment	E 2	7.80
Simple Voltaic Cell	E 16	5.65
Temporary Charge by Induction	E 3	7.80
Thermocouple	E 15	4.65
The Transformer	E 54	5.40
The Watt Hour Meter	E 60	4.35

## COURSE OUTLINE

Instructional Title: Appliance Repair

Code: 17.0200

---

---

### Occupation Description

Classroom and shop experiences concerned with the theory of electrical circuitry, simple gearing, linkages, and lubrication in the operation, maintenance, and repair of components including relays, time switches, pumps and agitators used in appliances such as washers, dryers, vacuum cleaners, toasters, water heaters, and stoves. Related training is provided in the use of familiar tools, test equipment, and service manuals, and in making cash estimates for repairs.

---

---

### Major Divisions of the Occupation

- I. Orientation
  - II. Basic Electricity
  - III. Basic Shop Tools
  - IV. Laundry Equipment
  - V. Kitchen Equipment
  - VI. Refrigeration
-

## APPLIANCE REPAIR COURSE OF STUDY

### OUTLINE OF JOB, SKILL COMPETENCY AND INFORMATION SHEET TITLES

#### Skill Competency Development Jobs (J)

These are suggested typical jobs to provide experiences to assist the student to learn the skill competencies of the occupation. The Jobs are denoted with a (J) before the number. The numbers preceding each title correspond with the identifying numbers found on the JOB SHEETS which follow:

#### Skill Competencies (SC)

These are tasks or operations workers perform in the occupation. These competencies should be demonstrated by the teacher and practiced by the student. The SKILL COMPETENCIES are denoted with an (SC) before the number. The numbers preceding each title correspond with the identifying numbers found on the OPERATION SHEETS which follow:

#### Information Lessons (IL)

These lessons make up the general technical information and knowledge needed to perform the skill competencies or jobs. These items represent the common information taught on a group instruction basis. Additional information will emerge to be taught on an individual student basis as pupils work on the skill competencies and jobs. The Information Lessons are denoted with an (IL) before the number. The numbers preceding each title correspond with the identifying numbers found on the INFORMATION SHEETS which follow:

#### Assignments (AS)

These sheets reinforce the students' learning with mental activities. A few samples have been included for the instructor. Additional assignment sheets will have to be developed by the instructor to meet the needs of the students and the local industry. The Assignment Sheets are denoted with an (AS) before the number. The numbers preceding each title correspond with the identifying numbers found on the ASSIGNMENT SHEETS which follow:

#### UNIT I: Orientation

#### UNIT II: Basic Electricity

- J-2-1 Lay Out for a Fixture Placement
  - SC-2-1 Measure and Mark Stock to Length With Steel Tape
  - SC-2-1A Measure and Mark Stock to Length with the Folding Rule
  - SC-2-1B Square a Line on Stock with the Try Square or Combination Square
  - SC-2-1C Square a Line on Stock with the Framing Square
- J-2-2 Drill Holes in Panel to Mount
  - SC-2-2 Put Drill Bit in a Drill Motor Chuck
  - SC-2-2A Drill with an Electric Hand Drill (3/8)

UNIT II:	Basic Electricity
J-2-3	Mount the Fixtures
SC-2-3	Tighten Nuts and Bolts
J-2-4	Lay Out Wiring
SC-2-4	Cut Wire with Side Cutters or Diagonals
J-2-5	Skin Wires
SC-2-5	Skin a Conductor with a Knife
J-2-6	Bend Loops on the Ends of Wire
SC-2-6	Bend an Eye on a Wire with a Needle Nose Pliers
J-2-7	Install Wires
SC-2-7	Connect Devices Using Screws
J-2-8	Skin Power Cord
SC-2-8	Strip Cable or Cord
J-2-9	Skin and Solder Wire
SC-2-8A	Clean a Stranded Wire Using a Knife
SC-2-9	Solder Connections with a Solder Gun
IL-2-1	Solder Gun Maintenance
J-2-10	Install a Cord
SC-2-10	Adjust and Use the Adjustable Wrench
J-2-11	Bend and Dress Wires
SC-2-11	Dress Solid Wire
J-2-12	Check a Circuit
IL-2-2	Series Circuits
AS-2-1	Check a Circuit
J-2-13	Lay Out and Wire a Parallel Circuit
J-2-14	Make Wire Splices
SC-2-12	Twist a Two Wire Tap Using Pliers
J-2-15	Solder and Tape Splices
SC-2-13	Tape Conductors
J-2-16	Check the Parallel Circuit
IL-2-3	Parallel Circuits
AS-2-2	Check the Parallel Circuit
J-2-17	Lay Out and Wire a Series-Parallel Circuit
SC-2-14	Remove Insulation Leaving a Lead
J-2-18	Prepare Wire for Lead Splice
SC-2-15	Make a Two Wire Lead Splice



UNIT II:	Basic Electricity
J-2-19	Make a Lead Splice
J-2-20	Install a Wire Nut and Complete Wiring a Circuit
SC-2-16	Install Wire Nuts
J-2-21	Check a Series-Parallel Circuit
IL-2-4	Series-Parallel Circuits
AS-2-3	Checking the Series-Parallel Circuit
J-2-22	Build a Series-Parallel Circuit for Use with Volt-Ohmmeter
J-2-23	Measure Voltage with a Volt-Ohm Meter
IL-2-5	Volt-Ohm Meter
J-2-24	Build a Series-Parallel Circuit for Use With the Volt-Ohm Meter
SC-2-17	Set Up Volt-Ohm Meter to Measure Voltages
IL-2-5A	Using the Volt-Ohm Meter to Check Voltage to a Component
SC-2-18	Set Up Volt-Ohm Meter to Measure Continuity
IL-2-5B	Using the Volt-Ohm Meter to Check Continuity of a Component or Circuit
J-2-25	Read Continuity with a Volt-Ohm Meter
J-2-26	Read Resistances on Various Parts Using the Ohm Meter
SC-2-19	Set Up Volt-Ohm Meter to Measure Resistances
J-2-27	Build and Check a Parallel Circuit to Use With a Clamp-On Amp-Meter
SC-2-20	Set Up the Clamp-On Amp-Meter to Measure Current Flow
IL-2-6	Clamp-On Amp-Meter
IL-2-6A	Clamp-On Amp-Meter (Conclusions)
J-2-28	Build and Check a Parallel Circuit Using a Volt-Watt Meter
SC-2-21	Set Up Volt-Watt Meter for Use
IL-2-7	Volt-Watt Meter
IL-2-7A	Volt-Watt Meter (Conclusions)
J-2-29	Build a Twin Lamp Tester
SC-2-22	Strip Wire with Wire Strippers
J-2-30	Check a Fuse Circuit 120/240
SC-2-23	Use a Twin Lamp Tester to Test a Circuit
J-2-31	Check a Fuse Circuit with a Volt-Ohm Meter
J-2-32	Check a Fuse Using an Ohm Meter
J-2-33	Lay Out, Mount and Cut Wires for Fixtures for Three Way Switches
SC-2-24	Skin Romex with Skinner
SC-2-24A	Strip Romex with Knife

UNIT II: Basic Electricity

- J-2-34 Install Lock Nuts in Boxes for 3-Way Connector  
SC-2-25 Remove a Knockout  
SC-2-26 Install Connectors
- J-2-35 Install Wires and Fixtures for Three Way Switch  
SC-2-27 Install a Grounding Clip
- J-2-36 Lay Out, Mount Fixture Boxes, and Install Connectors, Cut and  
Install BX Wires (Four Way Project)  
SC-2-28 Cut B.X. Cable  
SC-2-28A Strip B.X. Cable
- J-2-37 Wire, Install the Fixtures and Check Circuit with the Volt-Ohm  
Meter (Four Way Project)  
SC-2-29 Install an Anti-Short

UNIT III: Basic Shop Tools

- J-3-1 Scrape Clean a (Whirlpool-Kenmore) Transmission  
SC-3-1 Use a Putty Knife
- J-3-2 Wash and Clean a (Whirlpool-Kenmore) Transmission  
SC-3-2 Use a Parts Cleaner  
SC-3-2A Use an Air Gun
- J-3-3 Remove Control Magnet (Wigwag Solenoid)  
SC-3-3 Use a Socket Wrench
- J-3-4 Remove (Whirlpool-Kenmore) Drive Pulley  
SC-3-4 Tighten and Loosen Fasteners with Allen Wrenches  
SC-3-5 Use Pulley Puller
- J-3-5 Remove (Whirlpool-Kenmore) Transmission Cover  
SC-3-6 Use a Socket Wrench With a Ratchet
- J-3-6 Remove and Clean Gears  
SC-3-7 Use Tru Arc Pliers
- J-3-7 Reassemble the (Whirlpool-Kenmore) Transmission  
SC-3-8 Use a Torque Wrench
- J-3-8 Clean a Part Using a Hand Wire Brush  
SC-3-9 Clean Corrosion Using Hand Wire Brush
- J-3-9 Clean a Part Using a Wire Wheel  
SC-3-10 Clean Corrosion Using a Wire Wheel
- J-3-10 Clean and Polish an Appliance Using a Buffer Wheel  
SC-3-11 Clean and Polish an Appliance Using a Buffer Wheel
- J-3-11 Prepare Stock to Drill Holes with a Drill Press  
SC-3-12 Use a Center Punch

UNIT III: Basic Shop Tools

J-3-12 Mount Stock for Drilling with a Drill Press Vise  
SC-3-13 Tighten and Loosen Fasteners with an Open End Wrench

J-3-13 Drill Holes in Stock  
SC-3-14 Drill Holes in Stock Using a Drill Press

J-3-14 Prepare the Stock For Taping Holes  
SC-3-15 Secure Stock to a Surface with "C" Clamps

J-3-15 Tap Holes Using 10/32 Tap  
SC-3-16 Tap Threads in Metal Stock

J-3-16 Secure Stock in Vise for Cutting

J-3-17 Cut Round Stock to Length  
SC-3-17 Secure Stock in Bench Vise  
SC-3-18 Cut Metal with a Hack Saw

J-3-18 Prepare Stock for Threading  
SC-3-19 Shape and Smooth Surfaces with a File

J-3-19 Thread Rod Using Die  
SC-3-20 Cut External Threads with a Die

J-3-20 Dress a Straight Blade Screwdriver  
SC-3-21 Set Up Bench Grinder

J-3-21 Sharpen a Drill Bit  
SC-3-22 Install and Use Drill Bit Sharpening Guide

J-3-22 Remove a Broken Bolt  
SC-3-23 Remove a Bolt with a Screw Extractor  
IL-3-1 Using a Growler

J-3-24 Disassemble an Electric Motor and Clean Parts  
SC-3-24 Clean Parts Using the Air Nozzle

J-3-25 Move Washer Using Appliance Hand Truck  
SC-3-25 Attach Hand Truck to an Appliance

UNIT IV: Laundry Equipment

J-4-1 Install Inlet Hoses  
SC-4-1 Use a Pump Pliers

J-4-2 Install an Automatic Washer Drain Hose Using Spring Clamp  
SC-4-2 Use the Hose Clamp Pliers

J-4-3 Install an Automatic Washer Drain Hose Using Worm Clamp  
SC-4-3 Join Flexible Plastic or Rubber Tubing

- UNIT IV: Laundry Equipment
- J-4-4            Level Automatic Washer  
           SC-4-4            Use the Level
- J-4-5            Install Cord on Dryer  
           SC-4-5            Install Wire in Lugs
- J-4-6            Install Dryer Vent Using Flexible Tubing  
           SC-4-6            Cut with the Utility Knife
- J-4-7            Fit Window Plate for Dryer Vent  
           SC-4-7            Cut Thin Metal with Tin Shears
- J-4-8            Mark Vent Opening on Window Plate  
           SC-4-8            Mark Stock Using a Compass
- J-4-9            Cut Hole in Plate  
           SC-4-9            Cut Metal with Chisel
- J-4-10           Cut Circular Hole in Window Plate  
           SC-4-10           Make an Inside Curved Cut with Hand Shears
- J-4-11           Install Window Plate in Wooden Sash  
           SC-4-11           Install Glazing Points (Push Points)
- J-4-12           Install Dryer Vent Hood  
           SC-4-12           Rivet with a Pop Rivet Gun
- J-4-13           Install Dryer (Level and Clean)  
           SC-4-13           Clean a Painted Surface
- J-4-14           Polish a Dryer  
           SC-4-14           Polish a Painted Surface
- J-4-15           Check Blower Operation and Vent Damper  
           IL-4-1            Check Blower Operation
- J-4-16           Remove Belt for Dryer Blower  
           SC-4-15           Remove "V" Belt from Pulley
- J-4-17           Remove, Clean and Inspect the Blower Assembly  
           SC-4-16           Clean, Using the Shop Vacuum Cleaner  
           IL-4-2            Setting Up the Shop Vacuum Cleaner
- J-4-18           Lubricate and Reassemble Blower Assembly  
           SC-4-17           Lubricate a Shaft and Sleeve Bearing
- J-4-19           Install Spade Terminal Using Crimping Tool  
           SC-4-18           Skin Wire With a Crimping Tool  
           SC-4-18A          Crimp Wire to Terminal with Crimping Tool
- J-4-20           Check Dryer for Proper Heating  
           SC-4-19           Calibrate and Use a Temperature Tester Robinair #12850

- UNIT IV: Laundry Equipment
- J-4-21            Repair a Water Seal Leak on a Frigidaire Automatic Washer Pump  
 SC-4-20            Use an Inserting Tool and Plastic Head Hammer
- J-4-22            Remove a Stuck Agitator on an Automatic Washer Using a Puller  
 SC-4-21            Use an Agitator Puller
- J-4-23            Remove Tub Locknut  
 SC-4-22            Use an Adjustable Spanner Wrench
- J-4-24            Remove Tight Screw or Bolt Using Impact Tool  
 SC-4-23            Use Impact Tool
- J-4-25            Check Spin Speed on an Automatic Washer Using a Hand Tachometer  
 SC-4-24            Use a Hand Tachometer
- J-4-26            Check the Water Supply Pressure Using a Water Pressure Gauge  
 SC-4-25            Install a Water Pressure Gauge Onto a Water Supply Faucet
- J-4-27            Check Clutch Clearance  
 SC-4-26            Use a Feeler Gauge
- J-4-28            Lubricate a Water Pump or Shaft  
 SC-4-27            Lubricate Using a Hand Grease Gun
- J-4-29            Remove and Install Bearings in Motor  
 SC-4-28            Set Up and Operate Arbor-Bearing Press
- J-4-30            Remove Spin Tub on Frigidaire Automatic Washer to Inspect and  
                          Clean Outer Tub  
 SC-4-29            Use a Hammer and Chisel
- J-4-31            Evaluate Dryer Timer Performance
- J-4-32            Replace a Start Switch on a Dryer
- J-4-33            Replace the Temperature Selection Switch on an Electric Dryer
- J-4-34            Replace a Thermostat on an Electric Dryer
- J-4-35            Replace a Heating Element on an Electric Dryer
- J-4-36            Replace Motor on an Electric Dryer
- J-4-37            Replace Timer on an Electric Dryer
- J-4-38            Check Door Switch Operation
- J-4-39            Replace Inlet Valve on an Automatic Washer
- J-4-40            Replace a Water Pump on an Automatic Washer

UNIT V: Kitchen Equipment

J-5-1                  Replace a Push Button Switch on an Electric Range  
        SC-5-1              Use a Screw Starter

J-5-2                  Check the Operation of a Five Heat Switch  
        SC-5-2              Attach a Twin Lamp Tester

J-5-3                  Test an Infinite Switch Using a Test Lamp

J-5-4                  Test Oven Temperature

J-5-5                  Clean an Oven  
        SC-5-3              Apply Paste Type Oven Cleaner

J-5-6                  Install an Oven Door Spring Using Brake Spring Pliers  
        SC-5-4              Use Brake Spring Pliers to Install a Coil Spring

J-5-7                  Replace Door Panel on Appliance Using Offset Screwdriver  
        SC-5-5              Tighten or Loosen Fasteners with an Offset Screwdriver (Blade  
   or Phillips Head)  
        SC-5-6              Adjust, Tighten and Remove Fasteners with a Phillips Head  
   Screwdriver

J-5-8                  Replace Oven Timer

J-5-9                  Rewire Open Heating Elements  
        SC-5-7              Use the Lock Grip Pliers

J-5-10                 Replace Surface Elements

J-5-11                 Replace a Rotary Switch

J-5-12                 Replace Water Heater Thermostat

J-5-13                 Replace Wrap Around Type Water Heater Element

J-5-14                 Replace Immersion Type Water Heater Element

J-5-15                 Install a Garbage Disposal Body  
        SC-5-8              Tighten Pipes and Fittings with Pipe Wrenches

J-5-16                 Install a Garbage Disposal Drain  
        SC-5-9              Light a Soldering Torch

J-5-17                 Install a Garbage Disposal Electrically  
        SC-5-10             Use Knock Out Punches

J-5-18                 Replace an ON/OFF Switch on a Garbage Disposal

J-5-19                 Replace a Motor Relay on a Garbage Disposal

J-5-20                 Install a Dishwasher

J-5-21                 Replace a Water Inlet Valve on a Dishwasher

- UNIT V: Kitchen Equipment
- J-5-22 Replace a Dishwasher Timer
- J-5-23 Replace a Water Level Switch on a Dishwasher
- J-5-24 Replace Heating Element on a Dishwasher
- J-5-25 Replace a Dispenser on a Dishwasher
- UNIT VI: Refrigeration
- J-6-1 Cut Tubing to Length and Ream  
 SC-6-1 Cut and Ream Copper Tubing  
 SC-6-1A Enlarging a Hole with a Tapered Reamer
- J-6-2 Flare Tubing  
 SC-6-2 Flare Copper Tubing
- J-6-3 Install a Compression Fitting Onto Copper Tubing for Part One (P-1)  
 SC-6-3 Tighten Tubing Nut with Tubing Wrench
- J-6-4 Cut and Swedge Tubing from D-6-1 for Part Two (P-2)  
 SC-6-4 Swedge Copper Tubing
- J-6-5 Clean the Tubing for Soldering  
 SC-6-5 Clean Outside of Tubing with Sandpaper  
 SC-6-5A Clean Inside of Tubing with Wire Brush
- J-6-6 Assemble the Tubing and Set Up to Silver Solder P-2  
 SC-6-6 Set Up and Light Prestolite Torch  
 SC-6-6A Light and Adjust the Prestolite Torch
- J-6-7 Silver Solder and Assemble P-2 to P-1  
 SC-6-7 Silver Solder
- J-6-8 Make Loop for Part Three (P-3), Assemble and Silver Solder to P-1 and P-2  
 SC-6-8 Bend Copper Tubing with a Bending Spring
- J-6-9 Cut, Assemble and Attach Part Four (P-4) to P-1, 2 or 3  
 SC-6-9 Solder with 95/5 Solder
- J-6-10 Install a Process Adapter on Tubing  
 SC-6-10 Install a Process Adapter
- J-6-11 Check for Leaks Using Nitrogen and Liquid Detector  
 SC-6-11 Test with Liquid Leak Detector  
 IL-6-1 Portable Vacuum Pump - Robinair #12496
- J-6-12 Evacuate Tubing Assembly Using a Portable Vacuum Pump

UNIT VI:

- J-6-13 Charge and Leak Test Tubing with a Prestolite Leak Detector  
SC-6-12 Check for Leaks Using a Prestolite Leak Detector  
IL-6-2 Using the Prestolite Leak Detector
- J-6-14 Check for Leaks Using an Electronic Leak Detector  
IL-6-3 The Electronic Leak Detector
- J-6-15 Pinch Off and Solder the Process Tubing  
SC-6-13 Seal Process Tubing with a Pinch Off Tool
- J-6-16 Repair a Leak and Recharge a Refrigerator  
IL-6-4 The Charging Cylinder - Robinair #12206  
IL-6-4A Getting the Charging Cylinder (Robinair #12206) Ready for Use
- J-6-17 Take a Temperature Reading of the Evaporator of the Refrigerator  
IL-6-5 The Temperature Tester
- J-6-18 Check Temperature Using a Temperature Recorder  
IL-6-6 The Temperature Recorder
- J-6-19 Replace Light Switch  
SC-6-14 Remove Light Switch Using Removing Tool
- J-6-20 Replace a Starting Relay on a Compressor
- J-6-21 Replace a Defrost Timer
- J-6-22 Replace a Defrost Heater
- J-6-23 Replace a Temperature Control  
SC-6-15 Attach a Fish Wire to a Capillary Tube
- J-6-24 Remove and Replace Refrigerator - Freezer Doors
- J-6-25 Remove and Replace Door Gasket
- J-6-26 Align a Refrigeration-Freezer Door
- J-6-27 Straighten Fins on an Air Conditioner Condenser  
SC-6-16 Straighten Fin on an Air Conditioner Condenser or Evaporator
- J-6-28 Check a Capacitor  
IL-6-7 The Capacitor Analyzer



## WRITTEN INSTRUCTIONAL AIDS

### Introduction

Instruction sheets are aids used in developing the most effective and efficient teaching-learning situation that is possible. Four types of sheets are generally used including job sheets, operation sheets, information sheets and assignment sheets.

### JOB SHEETS

THE JOB involves a sequential performance of operations by the learner to "try out" and develop the skill competencies (operations) of the occupation resulting in a product or service. It is the vehicle of instruction or the media by which the student practices and develops a series of skill competencies (operations).

JOB SHEETS indicate to the student what to do in performing the various jobs assigned by the instructor. The following (yellow) sheets are the job sheets that will be used as vehicles of instruction in this course. Remember additional job sheets can be added or deleted to provide a course better in meeting the local needs.

JOB: Lay Out for a Fixture Placement

JOB SHEET  
IDENTIFICATION CODE

UNIT II: Basic Electricity

JOB NUMBER: J-2-1

COURSE: Appliance Repair

MATERIAL: (3) Cleat Sockets  
(1) S. P. - SW. Surface Mount  
(1) Insulated Mounting Stud  
18 X 24 Box

TOOLS: Foot Rule  
Pencil  
Square

COMPETENCE - PROCEDURES/STEPS The student will be able to:	TEACHING/LEARNING ACTIVITIES
---	------------------------------

1. Measure and mark board as shown on drawing.
2. Number and place the fixtures on lines as per drawing.
3. Mark holes to be drilled.

. SC-2-1 through SC-2-1C

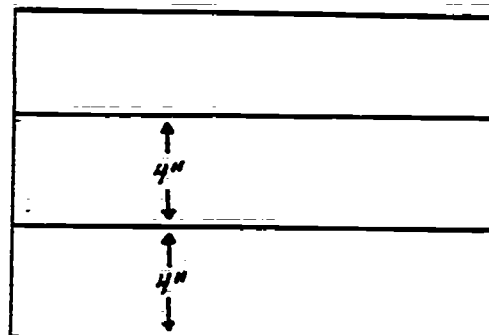

NOTE: Save material for  
J-2-2.

METHOD OF EVALUATION:

1. Measurements are within tolerance.

JOB: Drill Holes in Panel to Mount  
Fixtures

JOB SHEET  
IDENTIFICATION CODE

UNIT II: Basic Electricity

JOB NUMBER: J-2-2

COURSE: Appliance Repair

MATERIAL: Use J-2-1

TOOLS: 3/8" Drill  
1/4" Bit

SAFETY PRECAUTIONS:

Wear safety glasses

---

COMPETENCE - PROCEDURES/STEPS The student will be able to:	TEACHING/LEARNING ACTIVITIES
1. Insert 1/4" drill bit in drill.	. SC-2-2
2. Drill hole at marks.	. SC-2-2A

---

NOTE: Save material for  
J-2-3.

---

METHOD OF EVALUATION:

1. Holes are drilled straight.
2. Holes are as marked.

JOB: Mount the Fixtures

JOB SHEET  
IDENTIFICATION CODE

UNIT II: Basic Electricity

JOB NUMBER: J-2-3

COURSE: Appliance Repair

MATERIAL: (3) Cleat Sockets  
(1) S. P. - SW. Surface Mount  
(1) Insulated Mounting Stud

Use J-2-2

TOOLS: Straight Blade Screwdriver  
Nutdriver Set

SAFETY PRECAUTIONS:

Wear safety glasses

COMPETENCE - PROCEDURES/STEPS The student will be able to:	TEACHING/LEARNING ACTIVITIES
1. Place one cleat socket at second drilled area.	. SC-2-3  NOTE: Each socket must be mounted separately.
2. Insert the bolts and attach nuts.	NOTE: Do not tighten too securely.
3. Repeat step #2 for the other sockets.	
4. Place the switch at the first drilled area.	
5. Insert the bolt and tighten the nut.	
6. Install the insulated stud, 1/2 on top of board.	
7. Tighten all nuts.	NOTE: Do not over tighten nuts.  NOTE: Save material for J-2-4

METHOD OF EVALUATION:

1. Fixtures are mounted tight.
2. Fixtures are mounted at proper location.

JOB: Lay Out Wiring

JOB SHEET  
IDENTIFICATION CODE

UNIT II: Basic Electricity

JOB NUMBER: J-2-4

COURSE: Appliance Repair

MATERIAL: #14 TW Wire (Black and White)  
Use J-2-3

TOOLS: Diagonal Pliers  
Foot Rule

SAFETY PRECAUTIONS:

Wear safety glasses

---

COMPETENCE - PROCEDURES/STEPS	TEACHING/LEARNING ACTIVITIES
The student will be able to:	
1. Measure the distance between each terminal allowing enough for connections.	: SC-2-4
2. Cut wires to length.	

---

NOTE: Save material for J-2-5.

---

METHOD OF EVALUATION:

1. Wires are cut to fit between terminals with enough slack for connections.

JOB: Skin Wires

JOB SHEET  
IDENTIFICATION CODE

UNIT II: Basic Electricity

JOB NUMBER: J-2-5

COURSE: Appliance Repair

MATERIAL: Use J-2-4

TOOLS: Electrician's Knife

SAFETY PRECAUTIONS:

Wear safety glasses

---

COMPETENCE - PROCEDURES/STEPS The student will be able to:	TEACHING/LEARNING ACTIVITIES
1. Skin both ends of the wire.	. SC-2-5

---

NOTE: Save material for  
J-2-6.

---

METHOD OF EVALUATION:

1. Wires are not nicked.
2. Insulation is removed as needed for connection.

JOB: Bend Loops on the Ends of Wire

JOB SHEET  
IDENTIFICATION CODE

UNIT II: Basic Electricity

JOB NUMBER: J-2-6

COURSE: Appliance Repair

MATERIAL: Use J-2-5

TOOLS: Needle Nose Pliers

SAFETY PRECAUTIONS:

Wear safety glasses

---

COMPETENCE - PROCEDURES/STEPS  
The student will be able to:

---

TEACHING/LEARNING ACTIVITIES

1. Bend a loop on end of each wire.

. SC-2-6

NOTE: Make sure the loops  
are made in the right  
direction for screw.

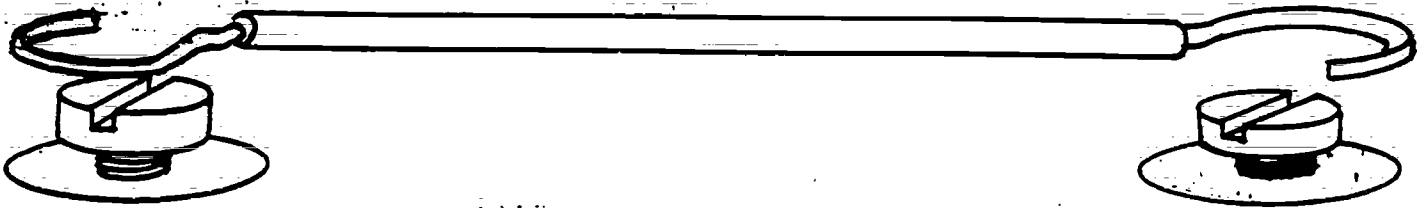

NOTE: Save material for  
J-2-7.

---

METHOD OF EVALUATION:

1. Bends are the correct size and length to fix the screw.

JOB: Install Wires

JOB SHEET  
IDENTIFICATION CODE

UNIT II: Basic Electricity

JOB NUMBER: J-2-7

COURSE: Appliance Repair

MATERIAL: Use J-2-6  
Use Terminals from J-2-3

TOOLS: Screwdriver  
Needle Nose Pliers

SAFETY PRECAUTIONS:

Wear safety glasses

---

COMPETENCE - PROCEDURES/STEPS The student will be able to:	TEACHING/LEARNING ACTIVITIES
1. Loosen screws on first cleat socket.	. SC-2-7
2. Place wire loop over screw in the direction shown.	
3. Tighten screw, holding loop snugly.	
4. Repeat hook-up as shown in drawing.	

---

METHOD OF EVALUATION:

1. Wires are connected to the proper terminal.
2. Connections are tight.



JOB: Skin Power Cord

JOB SHEET  
IDENTIFICATION CODE

UNIT II: Basic Electricity

JOB NUMBER: J-2-8

COURSE: Appliance Repair

MATERIAL: 18/2 S. J. Cord with Male Plug

TOOLS: Electrician's Knife  
Foot Rule  
Diagonal Pliers

SAFETY PRECAUTIONS:

Wear safety glasses

---

COMPETENCE - PROCEDURES/STEPS The student will be able to:	TEACHING/LEARNING ACTIVITIES
1. Remove the outer covering of the cord 6" from the end of the cord.	SC-2-8
2. Remove the paper and filler around the wires.	

---

NOTE: Save material for J-2-9.

---

METHOD OF EVALUATION:

1. The proper amount of outer covering has been removed.

JOB: Skin and Solder Wire

JOB SHEET  
IDENTIFICATION CODE

UNIT II: Basic Electricity

JOB NUMBER: J-2-9

COURSE: Appliance Repair

MATERIAL: Use J-2-8

TOOLS: Electrician's Knife  
Solder Gun  
60/40 Rosin Core Solder  
Needle Nose Pliers

SAFETY PRECAUTIONS:

Wear safety glasses.

---

<u>COMPETENCE - PROCEDURES/STEPS</u> The student will be able to:	<u>TEACHING/LEARNING ACTIVITIES</u>
1. Skin the wire ends.	. SC-2-5; SC-2-6 & SC-2-8A
2. Clean the wire strands by scraping the knife edge over the skinned end.	. SC-2-9
3. Twist the strands together tightly.	. IL-2-1
4. Apply solder to the bare wire ends.	
5. Bend the wire ends to form a loop as you did with the solid wire.	

---

NOTE: Save material for J-2-10.

---

METHOD OF EVALUATION:

1. Solder joints are coated.
2. Connection is solid mechanically.

JOB: Install a Cord  
UNIT II: Basic Electricity  
COURSE: Appliance Repair  
MATERIAL: Use J-2-9  
TOOLS: Screwdriver  
Crescent Wrench  
Nutdriver Set

JOB SHEET  
IDENTIFICATION CODE

JOB NUMBER: J-2-10

---

COMPETENCE - PROCEDURES/STEPS The student will be able to:	TEACHING/LEARNING ACTIVITIES
1. Loosen screw on left side of switch. 2. Attach loop of the black wire to the screw and tighten. 3. Remove the top nut of the insulation stud. 4. Remove one flat washer. 5. Place loop over the bolt. 6. Install the washer on top of loop. 7. Install and tighten nut.	. SC-2-10

---

NOTE: Save for J-2-12.

---

METHOD OF EVALUATION:

1. Cord is installed to proper terminals.
2. Connections are tight.

JOB: Bend and Dress Wires

JOB SHEET  
IDENTIFICATION CODE

UNIT II: Basic Electricity

JOB NUMBER: J-2-11

COURSE: Appliance Repair

MATERIAL: Scrap Wire

SAFETY PRECAUTIONS:

Wear safety glasses

---

COMPETENCE - PROCEDURES/STEPS The student will be able to:	TEACHING/LEARNING ACTIVITIES
1. Bend and dress wires to appear neat with right angle (90°) bends and straight runs.	. SC-2-11

---

METHOD OF EVALUATION:

1. Wire looks neat.
2. 90° angles and straight wiring runs.

JOB: Check a Circuit  
UNIT II: Basic Electricity  
COURSE: Appliance Repair  
MATERIAL: (3) 60 Watt 120 Volt Lamps

JOB SHEET  
IDENTIFICATION CODE

JOB NUMBER: J-2-12

---

COMPETENCE - PROCEDURES/STEPS The student will be able to:	TEACHING/LEARNING ACTIVITIES
1. Install the lamps.	. IL-2-2
2. Turn the switch to the <u>off</u> position.	. AS-2-1
3. Plug in the power cord.	
4. Turn the switch to the <u>on</u> position.	NOTE: The lamps should be on.
5. Turn the switch on and off a few times to check circuit and switch.	
6. Do (AS-2-1).	

---

METHOD OF EVALUATION:

1. Circuit operates properly.

JOB: Lay Out and Wire a Parallel Circuit

JOB SHEET  
IDENTIFICATION CODE

UNIT II: Basic Electricity

JOB NUMBER: J-2-13

COURSE: Appliance Repair

DRAWING NO: D-2-13

MATERIAL: (3) Cleat Sockets  
(3) 60 Watt 120 Volt Lamps  
14 T. W. Wire (Black & White)  
(1) S.P. Surface Switch  
Power Cord--18/2 S.J. with  
Male Plug  
8 Mounting Bolts--1" X 1/4"  
With Nuts  
(1) Insulated Terminal  
(1) 18" X 24" Panel Board  
from J-2-12

TOOLS: 3/8" Drill - 1/4" Bit  
Screwdriver  
Solder Gun  
Nutdriver Set  
Crescent Wrench

Needle Nose Pliers  
Solder 60/40  
Tape  
Foot Rule  
Diagonal Pliers

SAFETY PRECAUTIONS:

Wear safety glasses

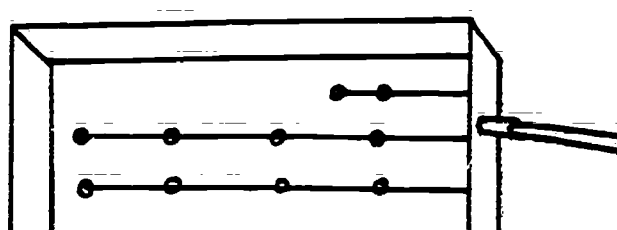
<u>COMPETENCE - PROCEDURES/STEPS</u> The student will be able to:	<u>TEACHING/LEARNING ACTIVITIES</u>
<ol style="list-style-type: none"><li>1. Drill new holes for the wires to go under board.</li><li>2. Cut wires to proper length for all the fixtures.</li><li>3. Skin one end of the wires and bend the hooks.</li><li>4. Install the wires on the terminals as per the diagram.</li><li>5. Attach the power cord.</li></ol>	<p>SC-2-1 thru SC-2-11</p> <p>NOTE: All wires are to be run through the board and splices made underneath as shown.</p> 

METHOD OF EVALUATION:

1. Layout is according to drawing.
2. Measurements are within tolerances.

# PARALLEL CIRCUIT

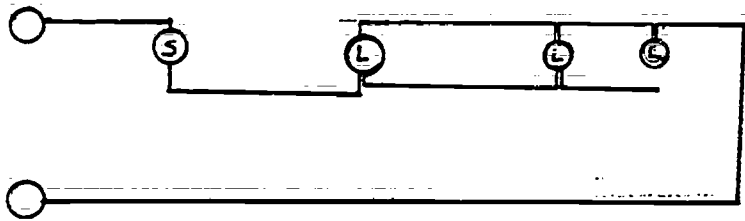

JOB: Make Wire Splices

JOB SHEET  
IDENTIFICATION CODE

UNIT II: Basic Electricity

JOB NUMBER: J-2-14

COURSE: Appliance Repair

MATERIAL: 14 T.W. Wire(Black & White)

TOOLS: Diagonal Pliers  
Duck Bill Pliers or Electrician's  
Pliers  
Electrician's Knife

SAFETY PRECAUTION:

Wear safety glasses

---

COMPETENCE - PROCEDURES/STEPS The student will be able to:	TEACHING/LEARNING ACTIVITIES
1. Skin the wires.	. SC-2-5
2. Twist wires together to hook up as per diagram.	. SC-2-12
3. Check that all splices are tight.	

---

METHOD OF EVALUATION:

1. Splices are tight.



JOB: Solder and Tape Splices

JOB SHEET  
IDENTIFICATION CODE

UNIT II: Basic Electricity

JOB NUMBER: J-2-15

COURSE: Appliance Repair

MATERIAL: Electrical Tape--60/40 Solder

TOOLS: Solder Gun

SAFETY PRECAUTIONS:

Wear safety glasses

---

COMPETENCE - PROCEDURES/STEPS The student will be able to:	TEACHING/LEARNING ACTIVITIES
1. Solder all splices.	. SC-2-9
2. Tape all the connections.	. SC-2-13

NOTE: Have the instructor check connections before taping.

---

METHOD OF EVALUATION:

1. Solder joints are solid.
2. Tape is neat and tight.

JOB: Check the Parallel Circuit

JOB SHEET  
IDENTIFICATION CODE

UNIT II: Basic Electricity

JOB NUMBER: J-2-16

COURSE: Appliance Repair

MATERIAL: (3) 60 Watt-120 Volt Lamps

SAFETY PRECAUTIONS:

Wear safety glasses

---

COMPETENCE - PROCEDURES/STEPS The student will be able to:	TEACHING/LEARNING ACTIVITIES
1. Install the lamps.	. IL-2-3
2. Turn the switch of the OFF position.	. AS-2-2
3. Plug the line cord into the receptacle.	
4. Turn the switch to the ON position.	NOTE: Are all the lamps lit?
5. Turn the switch off and on a few times to check operation.	
6. Do AS-2-2.	NOTE: Leave fixtures in place for next job.
7. Remove all wires.	

---

METHOD OF EVALUATION:

1. Circuit works.

JOB: Lay Out and Wire a Series-Parallel Circuit

UNIT II: Basic Electricity

COURSE: Appliance Repair

MATERIAL: Power Cord 18/2 S.O. with Male Plug  
 (3) Cleat Sockets  
 #14 T.W. Wire (Black & White)  
 (2) S.P. Surface Switches  
 (3) 60 Watt-120 Volt Lamps  
 (4) Insulated Studs  
 10 Mounting Bolts--1" X 1/4" With Nuts  
 (1) Panel Board  
 Tape  
 Solder 60/40

JOB SHEET  
 IDENTIFICATION CODE

JOB NUMBER: J-2-17

TOOLS:  
 Screwdriver  
 Nutdriver  
 Crescent Wrench  
 Diagonal Pliers  
 Knife  
 Solder Gun  
 Duck Bill Pliers  
 Electrician's Pliers  
 Needle Nose Pliers

**SAFETY PRECAUTIONS:**

Wear safety glasses

COMPETENCE - PROCEDURES/STEPS The student will be able to:	TEACHING/LEARNING ACTIVITIES
---	------------------------------

1. Lay out and drill holes to mount switch and insulated studs.
2. Mount the switch.
3. Drill the holes for wires to go under board.
4. Mount the insulated stud.
5. Measure and cut the wires.

Use panel board with fixture mounted from prior jobs. An extra switch and 3 more insulated studs are needed.

. SC-2-1 thru SC-2-15

NOTE: Circuit to be wired underneath board.

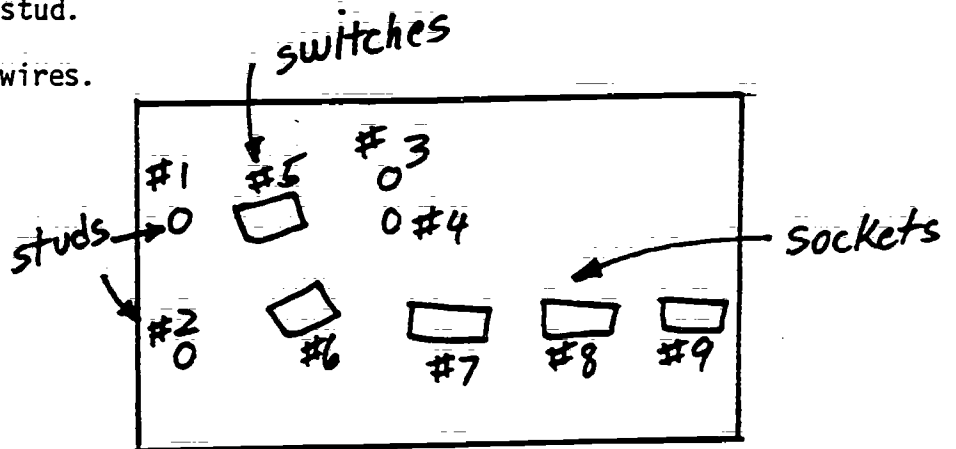

6. Skin and bend loops on one end of the wires.
7. Install the wires through the holes.
8. Connect the loops to the terminals.

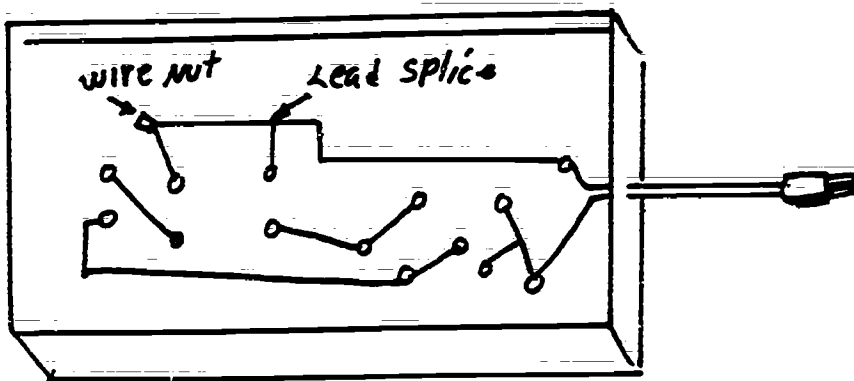

NOTE: The fixtures are numbered to clarify answers to questions on AS-2-3.

METHOD OF EVALUATION:

1. Lay out is correct. (As per drawing).
2. All connections are tight.

JOB: Prepare Wire for Lead Splice

JOB SHEET  
IDENTIFICATION CODE

UNIT II: Basic Electricity

JOB NUMBER: J-2-18

COURSE: Appliance Repair

TOOLS: Electrician's Knife

SAFETY PRECAUTIONS:

Wear safety glasses

---

COMPETENCE - PROCEDURES/STEPS	TEACHING/LEARNING ACTIVITIES
-------------------------------	------------------------------

---

1. Locate where a lead splice will be used.

. SC-2-5, SC-2-14

NOTE: Use a lead splice whenever it is necessary to connect a wire to another wire as it goes to another terminal or splice.

2. Prepare the wire for splicing.

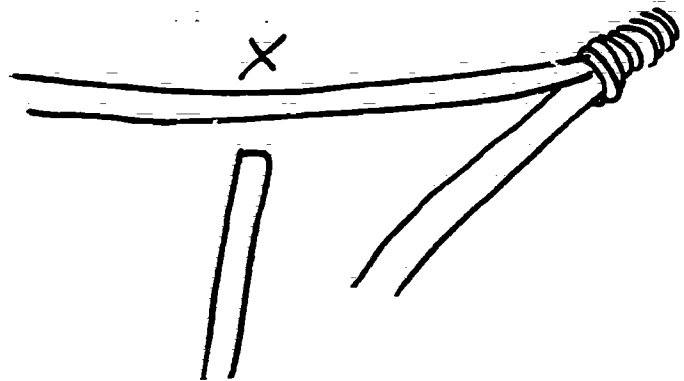

---

METHOD OF EVALUATION:

1. Wire is not nicked.
2. Insulation is removed at the proper place.

JOB: Make a Lead Splice

JOB SHEET  
IDENTIFICATION CODE

UNIT II: Basic Electricity

JOB NUMBER: J-2-19

COURSE: Appliance Repair

TOOLS: Duck Bill Pliers or Electrician's  
Pliers

SAFETY PRECAUTIONS:

Wear safety glasses

---

COMPETENCE - PROCEDURES/STEPS The student will be able to:	TEACHING/LEARNING ACTIVITIES
1. Skin wire to be attached to lead wire.  2. Twist wire as per instructions.  3. Solder and tape the connection.	. SC-2-13, SC-2-15  NOTE: Have instructor inspect the splice before soldering and taping.

---

METHOD OF EVALUATION:

1. Splice is tight.

JOB: Install a Wire Nut and Complete Wiring a Circuit

JOB SHEET  
IDENTIFICATION CODE

UNIT II: Basic Electricity

JOB NUMBER: J-2-20

COURSE: Appliance Repair

MATERIAL: Wire Nut

SAFETY PRECAUTIONS:

Wear safety glasses

---

COMPETENCE - PROCEDURES/STEPS The student will be able to:	TEACHING/LEARNING ACTIVITIES
1. Locate one connection to install a wire nut.	. SC-2-12
2. Skin the wires.	. SC-2-8 . SC-2-13 . SC-2-16
3. Install the wire nut.	NOTE: Allow instructor to evaluate the operation before continuing.
4. Tape wire nut to wire.	
5. Splice, solder and tape the remaining connections.	

---

METHOD OF EVALUATION:

1. Connection is tight.
2. No copper shows behind wire nut.
3. Wire nut is taped securely preventing possibility of back-off.

JOB: Check a Series-Parallel Circuit

JOB SHEET  
IDENTIFICATION CODE

UNIT II: Basic Electricity

JOB NUMBER: J-2-21

COURSE: Appliance Repair

MATERIAL: (3) 60 Watt-120 Volt Lamps

SAFETY PRECAUTIONS:

Wear safety glasses

---

COMPETENCE - PROCEDURES/STEPS The student will be able to:	TEACHING/LEARNING ACTIVITIES
1. Install lamps in the sockets.	. IL-2-4
2. Turn both switches to the OFF position.	. AS-2-3
3. Plug the line cord into the receptacle.	
4. Turn on switch #5, then switch #6.	
5. Check to see if all lamps are on.	
6. Do AS-2-3.	

---

METHOD OF EVALUATION:

1. Circuit works.



JOB: Build a Series-Parallel Circuit  
for Use With Volt-Ohmmeter

JOB SHEET  
IDENTIFICATION CODE

UNIT II: Basic Electricity

JOB NUMBER: J-2-22

COURSE: Appliance Repair

MATERIAL: See J-2-16 through J-2-20

EQUIPMENT: See J-2-16 through J-2-20

TOOLS: See J-2-16 through J-2-20

SAFETY PRECAUTIONS:

Wear safety glasses

---

COMPETENCE - PROCEDURES/STEPS The student will be able to:	TEACHING/LEARNING ACTIVITIES
1. Lay out and mount fixtures.	. SC-2-1 through SC-2-11
2. Wire the circuit.	. SC-2-12 & SC-2-13
3. Check the circuit for proper operation.	. SC-2-14 through SC-2-16

---

NOTE: Save finished job  
for J-2-23.

---

METHOD OF EVALUATION:

1. All connections are solid.
2. Circuit works.

JOB: Measure Voltage with a Volt-Ohm Meter

JOB SHEET  
IDENTIFICATION CODE

UNIT II: Basic Electricity

JOB NUMBER: J-2-23

COURSE: Appliance Repair

MATERIAL: Use J-2-22

EQUIPMENT: Volt-Ohm Meter

SAFETY PRECAUTIONS:

Wear safety glasses

COMPETENCE - PROCEDURES/STEPS The student will be able to:	TEACHING/LEARNING ACTIVITIES
1. Unplug the power cord.	IL-2-5
2. Remove the cleat socket insulators, switch covers, and turn switches off.	NOTE: Use IL-2-3 for schematic to get the test point numbers.
3. Set the volt-ohm meter to the VAC 250 scale.	
4. Plug in the power cord.	
5. Attach one test lead to the line side of socket #7.	
6. Attach the other test lead to the line side of switch side of switch #5.	NOTE: There is a voltage reading.
7. Move the test lead from the line side of switch #5 to the load side of switch #5.	NOTE: There is no voltage reading because the switch is open.
8. Turn the switch #5 to the ON position.	NOTE: There is a voltage reading, and lamps #8 and #9 light.
9. Move the test lead from the line side of lamp #7 to the line side of switch #5.	NOTE: There is no voltage reading across the switch.

COMPETENCE - PROCEDURES/STEPS	TEACHING/LEARNING ACTIVITIES
10. Move the test leads from the line and load side of switch #5 to the line and load side of switch #6.	NOTE: There is a voltage reading.
11. Turn the #6 switch to the ON position.	NOTE: There is no voltage reading, and lamp #7 lights.
12. Unscrew lamp #7, attach one test lead to the line side of the lamp socket and the other test lead to the load side of the lamp socket.	NOTE: There is a voltage reading.
13. Screw the lamp into #7 socket.	NOTE: There is a voltage reading.

---

METHOD OF EVALUATION:

1. Procedure is correct.

JOB: Build a Series-Parallel Circuit  
for Use With the Volt-Ohm Meter

JOB SHEET  
IDENTIFICATION CODE

UNIT II: Basic Electricity

JOB NUMBER: J-2-24

COURSE: Appliance Repair

MATERIAL: See J-2-16 through J-2-20

EQUIPMENT: See J-2-16 through J-2-20

TOOLS: See J-2-16 through J-2-20

SAFETY PRECAUTIONS:

Wear safety glasses

COMPETENCE - PROCEDURES/STEPS The student will be able to:	TEACHING/LEARNING ACTIVITIES
1. Lay out and mount fixtures.	. SC-2-1 through SC-2-11
2. Wire the circuit.	. SC-2-12 & SC-2-13
3. Check the circuit for proper operation.	. SC-2-14 through SC-2-16
4. Measure continuity with volt-ohm meter.	. SC-2-18

METHOD OF EVALUATION:

1. Circuit works.
2. Connections are solid.

JOB: Read Continuity with a  
Volt-Ohm Meter

JOB SHEET  
IDENTIFICATION CODE

UNIT II: Basic Electricity

JOB NUMBER: J-2-25

COURSE: Appliance Repair

MATERIAL: J-2-24

EQUIPMENT: Volt-Ohm Meter

SAFETY PRECAUTIONS:

Wear safety glasses

COMPETENCE - PROCEDURES/STEPS	TEACHING/LEARNING ACTIVITIES
1. Unplug the power cord.	NOTE: All ohm checking is done with no voltage in the circuit.
2. Turn both #5 and #6 switches to the ON position.	
3. Set the volt-ohm meter to the R X 1 scale.	
4. Touch the two test leads together, and zero the meter.	
5. Attach one test lead to the #1 insulated stud. Attach the other test lead to the #2 insulated stud.	NOTE: The needle moves to the zero end of the scale, and this means the entire circuit has continuity, and it is complete.
6. Turn the #5 and #6 switch to the OFF position.	NOTE: There is no continuity in the circuit, because there is a break in the circuit.
7. Move the one test lead from the #1 insulated stud to the #4 insulated stud.	NOTE: This is now checking the continuity through lamps #8 and #9.

COMPETENCE - PROCEDURES/STEPS	TEACHING/LEARNING ACTIVITIES
8. Remove the #8 lamp	NOTE: There is no continuity.
9. Install the #8 lamp.	NOTE: There is continuity.
10. Remove #7 lamp.	NOTE: This does not affect the continuity.
11. Move the one test lead from the #4 insulated stud to the #3 insulated stud.	NOTE: There is no continuity.
12. Install the #7 lamp.	NOTE: There is continuity.
13. Attach one test lead to the line side of switch #5.	
14. Attach the other test lead to the load side of switch #5.	NOTE: Then the switch is in the OFF position, there is no continuity.
15. Turn #5 switch to the ON position.	NOTE: There is continuity.

METHOD OF EVALUATION:

1. Circuit check out with meter.

70

JOB: Read Resistances on Various  
Parts Using the Ohm Meter

JOB SHEET  
IDENTIFICATION CODE

UNIT II: Basic Electricity

JOB NUMBER: J-2-26

COURSE: Appliance Repair

MATERIAL: MU-15 Chromolox Surface Element  
TGA-1157 Chromolox Water Heater  
Element  
E775 Rodale Heating Element  
Ballast--(IL-20W)  
Spin Solenoid (Speed Queen)  
MC-45 Chromolox Surface Element  
Water Inlet Valve (Auto Washer)

TOOLS: Ohm-Meter

SAFETY PRECAUTIONS:

Wear safety glasses

COMPETENCE - PROCEDURES/STEPS The student will be able to:	TEACHING/LEARNING ACTIVITIES
1. Write the numbers one through nine on a piece of paper.	. IL-2-5 . SC-2-19
2. Set the volt-ohm meter to the R X 1 scale and zero the meter.	
3. Attach one test lead to each of the element screw terminals on the MU-15 Chromolox surface element.	
4. Take an ohm reading and write this reading on the piece of paper.	
5. Zero the meter and attach one test lead to each of the screw terminals on the TGA-1157 Chromolox water heater element.	
6. Take an ohm reading then write this on the piece of paper next to #2.	
7. Zero the meter, attach one test lead to the base shell of the #E775 Rodale cone type heating element and the other test lead to the center base terminal of the cone heating element.	

8. Take an ohm reading and write this reading next to #3 on the paper.
9. Zero the meter and attach one test lead to each of the wires on the one light 20 watt flourescent ballast.
10. Take an ohm reading and write this reading next to #4 on the paper.
11. Zero the meter and attach one test lead to each of the spade terminals of the Speed Queen #20058 solenoid.
12. Take an ohm reading and write this reading next to #5 on the paper.
13. Zero the meter, attach one test lead to the common terminal of the MC 45 Chromolox surface element and the other test lead to the terminal for the outer coil of the surface element.
14. Take an ohm reading and write this reading next to #6 on the paper.
15. Move the test lead from the outer coil terminal to the inner coil terminal.
16. Take an ohm reading and write this next to #7 on the paper.
17. Zero the meter and attach one test lead to each spade terminal of one solenoid of the Speed Queen #21714 water inlet valve.
18. Set the meter to the Rx 10 scale and zero the meter.
19. Re-attach the test leads to one solenoid terminal.
20. Take an ohm reading and write this reading next to #8 on the paper.
21. Move the test leads to the other solenoid on the inlet valve.
22. Take an ohm reading and write this reading next to #9 on the paper.

NOTE: It is hard to read the meter accurately.

NOTE: Do not forget to multiply the reading by ten.



23. Turn the selector switch to the OFF position.

NOTE: This turns off the battery that supplies voltage for the meter.

24. Compare one's resistance readings with the following:

NOTE: Reading may vary approx. 15%.

a. 37 ohms

b. 38 ohms

c. 12 ohms

d. 22 ohms

e. 4 ohms

f. 64 ohms

g. 85 ohms

h. 360 ohms

i. 360 ohms

NOTE: If one's readings do not compare within a few ohms, double check readings, then check with the instructor.

---

METHOD OF EVALUATION:

1. Readings are within tolerance.

73

JOB: Build and Check a Parallel  
Circuit to Use With a Clamp-On  
Amp-Meter

JOB SHEET  
IDENTIFICATION CODE

UNIT II: Basic Electricity

JOB NUMBER: J-2-27

COURSE: Appliance Repair

MATERIAL: See J-2-13 through J-2-16  
(2) E77-S Heating Elements  
(Rodale Cone Type)

TOOLS: See J-2-13 through J-2-16

SAFETY PRECAUTIONS:

Wear safety glasses

---

COMPETENCE - PROCEDURES/STEPS The student will be able to:	TEACHING/LEARNING ACTIVITIES
1. Build up a parallel circuit.	. SC-2-20
2. Plug in the power cord and check that the circuit works properly.	. SC-2-1 through SC-2-13
3. Turn the switch to the OFF position.	. IL-2-2
4. Clamp the amp-meter around the wire that feeds the line side of the switch.	. IL-2-6 & IL-2-6A
5. Set the selector switch to the highest scale if the ammeter has a scale selector.	NOTE: There is no amp reading.
6. Turn the circuit switch to the ON position.	
7. If the amp-meter has a scale selector, turn the selector switch to a lower scale until the meter is easily read.	NOTE: The amp reading should be about 1 1/2 amps.
8. Turn the circuit switch to the OFF position.	
9. Unscrew the middle lamp and install the cone type heating element.	

---

**COMPETENCE - PROCEDURES/STEPS**

---

**TEACHING/LEARNING ACTIVITIES**

10. Set the selector switch to the highest scale if the amp-meter has a scale selector.
11. Turn the circuit switch to the ON position and turn the selector switch to a lower scale until the meter is easily read.  
NOTE: The amp reading should be about 10 amps.
12. Turn the circuit switch to the OFF position.
13. Unscrew the end lamp and insert another cone type heating element.
14. Set the selector switch to the highest scale if the amp-meter has a scale selector.
15. Turn the circuit switch to the ON position and turn the selector switch to a lower scale until the meter is easily read.  
NOTE: The amp reading should be about 20 amps.
16. Turn the circuit switch to the Off position.
17. Clamp the amp-meter around one of the feed wires to the end lamp socket.
18. Turn the circuit switch to the ON position.
19. Take an amp reading.  
NOTE: It should be about 9 amps.
20. Move the amp-meter and clamp it around one of the feed wires to the middle socket.
21. Take an amp reading.  
NOTE: It should be about 18 amps.
22. Turn the circuit switch to the OFF position and unplug the power cord.

---

**METHOD OF EVALUATION:**

75

1. Meter readings are within tolerance.

JOB: Build and Check a Parallel  
Circuit Using a Volt-Watt Meter

JOB SHEET  
IDENTIFICATION CODE

UNIT II: Basic Electricity

JOB NUMBER: J-2-28

COURSE: Appliance Repair

MATERIAL: See J-2-13 through J-2-16  
(2) E77 Rodale Cone Heating  
Elements

TOOLS: See J-2-13 through J-2-16

SAFETY PRECAUTIONS:

Wear safety glasses

---

COMPETENCE - PROCEDURES/STEPS  
The student will be able to:

TEACHING/LEARNING ACTIVITIES

---

- |  |  |
|--|--|
| 1. Build and check a parallel circuit.   |  |
| 2. Check to see if the circuit is working properly then turn the circuit switch to the OFF position. | . SC-2-21<br>. IL-2-7 & IL-2-7A              |
| 3. Set the volt-watt meter voltage switch to the 130 position.                                       |  |
| 4. Set the volt-watt meter wattage switch to the 0-5000 scale.                                       |  |
| 5. Plug in the power cord of the volt-watt meter.  | NOTE: There is a voltage reading.            |
| 6. Plug in the power cord of the circuit and turn the circuit switch to the ON position.             |  |
| 7. Turn the wattage selector switch to the 0-5000 scale and take a wattage reading.                  | NOTE: The reading should be about 180 watts. |
| 8. Turn the circuit switch to the OFF position.  |  |
| 9. Unscrew the first lamp and install one cone heater in the socket.                                 |  |
| 10. Turn the wattage selector switch to the 0-5000 scale.  |  |

11. Turn the circuit switch to the ON position.
12. Take a wattage reading.
13. Turn the circuit switch to the OFF position.
14. Unscrew the middle lamp and install the other cone heater.
15. Turn the circuit switch to the ON position.
16. Take a wattage reading.
17. Unplug the power cords.

NOTE: The reading should be about 720 watts.

NOTE: The reading should be about 1260 watts.

---

METHOD OF EVALUATION:

1. Meter readings are within tolerance.

JOB: Build a Twin Lamp Tester

JOB SHEET  
IDENTIFICATION CODE

UNIT II: Basic Electricity

JOB NUMBER: J-2-29

COURSE: Appliance Repair

MATERIAL: 2 Weatherproof Pig Tail Sockets  
2 25-40 Watt Lamps (230 Volt)  
3 Insulated Type Alligator Clips  
3 Pieces of #18 Stranded Wire  
4" Long  
Electrical Tape  
Solder

TOOLS: Electrician's Knife  
Diagonal Pliers  
Wire Stripper  
Solder Gun and Solder

SAFETY PRECAUTIONS:

Wear safety glasses

COMPETENCE - PROCEDURES/STEPS The student will be able to:	TEACHING/LEARNING ACTIVITIES
1. Cut the pig tail socket leads to an even length (about 4").	
2. Remove about 1/2" of insulation from each lead.	. SC-2-22
3. Remove about 1/2" of insulation from each end of the #18 wires.	
4. Connect one lead from each pig tail socket to one end of a #18 wire.	
5. Solder and tape this connection.	
6. Connect one piece of #18 wire to the 2 remaining leads of the pig tail sockets.	
7. Solder and tape these connections.	
8. Attach an alligator clip to each of the #18 wires.	
9. Insert the lamps, and the tester is ready for use.	

---

METHOD OF EVALUATION:

1. Tester works.
2. Connections are solid.
3. Tape is tight.

79

JOB: Check a Fuse Circuit 120/240

JOB SHEET  
IDENTIFICATION CODE

UNIT II: Basic Electricity

JOB NUMBER: J-2-30

COURSE: Appliance Repair

MATERIAL: 240 Volt Safety Switch Circuit  
with One Bad Fuse (Plug or  
Cartridge Type)

EQUIPMENT: Twin Lamp Tester

SAFETY PRECAUTIONS:

Wear safety glasses

---

COMPETENCE - PROCEDURES/STEPS The student will be able to:	TEACHING/LEARNING ACTIVITIES
<ol style="list-style-type: none"><li>1. Turn off the power.</li><li>2. Attach the double test lead to the neutral block.</li><li>3. Attach one of the test leads to the load side terminal of line #1.</li><li>4. Attach the remaining test lead to the load side terminal of line #2.</li><li>5. Turn on the power.</li><li>6. The one lamp lights but the other one does not.</li><li>7. Is the fuse bad?</li><li>8. Go to J-2-31 to double check with a volt-ohm meter.</li></ol>	. SC-2-23

---

METHOD OF EVALUATION:

1. Proper procedure was used.



JOB: Check a Fuse Circuit with a Volt-Ohm Meter

JOB SHEET  
IDENTIFICATION CODE

UNIT II: Basic Electricity

JOB NUMBER: J-2-31

COURSE: Appliance Repair

MATERIAL: 240 Volt Safety Switch Circuit with One Bad Fuse

EQUIPMENT: Volt-Ohm Meter

SAFETY PRECAUTIONS:

Wear safety glasses

COMPETENCE - PROCEDURES/STEPS The student will be able to:	TEACHING/LEARNING ACTIVITIES
1. Open the switch door and turn on the switch.	
2. Set the volt-ohm meter to the VAC 250 scale.	
3. Attach the one test lead to the neutral terminal strip.	
4. Touch the other test lead to the red line terminal.	NOTE: The voltage reading should be 120 volts.
5. Touch the test lead to the black line terminal.	NOTE: The voltage reading should be 120 volts.
6. Touch the test lead to the red load terminal.	NOTE: The voltage reading should be 120 volts. If there is no reading, the fuse is defective and should be replaced.
7. Touch the test lead to the black load terminals.	NOTE: The voltage reading should be 120 volts. If there is no reading, the fuse is defective and should be replaced.
8. Turn off the power switch.	
9. Remove the defective fuse.	
10. Do J-2-32.	

SI

---

METHOD OF EVALUATION:

1. Safe procedures were used.
2. Logical approach.

82

JOB: Check a Fuse Using an Ohm meter

JOB SHEET  
IDENTIFICATION CODE

UNIT II: Basic Electricity

JOB NUMBER: J-2-32

COURSE: Appliance Repair

MATERIAL: A Defective Fuse - Plug Fuse  
A Defective Fuse - Cartridge

EQUIPMENT: Volt-Ohm Meter

SAFETY PRECAUTIONS:

Wear safety glasses

---

COMPETENCE - PROCEDURES/STEPS	TEACHING/LEARNING ACTIVITIES
-------------------------------	------------------------------

---

PLUG FUSE

- |  |                     |
|--|---------------------|
| 1. Remove the fuse from the circuit.               | : SC-2-18 & SC-2-19 |
| 2. Set up the volt-ohm meter to the RX-1 scale.    | . IL-2-5B           |
| 3. Zero the meter.                                 |                     |
| 4. Attach one lead to the base of the fuse.        |                     |
| 5. Attach the other lead to the shell of the fuse. |                     |
| 6. The meter reads infinity ( $\infty$ ), or open. |                     |

CARTRIDGE FUSE

1. Attach one test lead to each end of the fuse.
2. The meter reads infinity ( $\infty$ ), or open.

---

METHOD OF EVALUATION:

1. Proper procedure was used.
2. Correct diagnosis.

83

JOB: Lay Out, Mount and Cut Wires for  
Fixtures for Three Way Switches

JOB SHEET  
IDENTIFICATION CODE

UNIT II: Basic Electricity

JOB NUMBER: J-2-33

COURSE: Appliance Repair

MATERIAL: (2) 3 Way Flush Switches  
(2) Utility or Handy Boxes  
Project  
Box  
(4) Wire Nuts  
Power Cord  
1/2 Romex with Ground

3" or 4" Round Box  
3" or 4" Keyless Socket  
Romex Connectors  
50W Lamp  
Toggle Plates  
(6) 1/4" X 1" Nuts and Bolts  
1/2 Romex with Ground

EQUIPMENT: Volt-Ohm Meter

TOOLS: Screwdriver  
Nutdriver Set  
Electric Drill  
Diagonal Pliers

Foot Rule  
5/16" Twist Drill Bit  
Electrician Knife  
Needle Nose Pliers  
Romex Skinner

SAFETY PRECAUTIONS:

Wear safety glasses

COMPETENCE - PROCEDURES/STEPS Student will be able to:	TEACHING/LEARNING ACTIVITIES
1. Lay out fixtures and mark holes for drilling.	: SC-2-1 through SC-2-4
2. Drill holes and mount fixtures.	. SC-2-24
3. Cut and skin romex to meet requirements.	. SC-2-24A

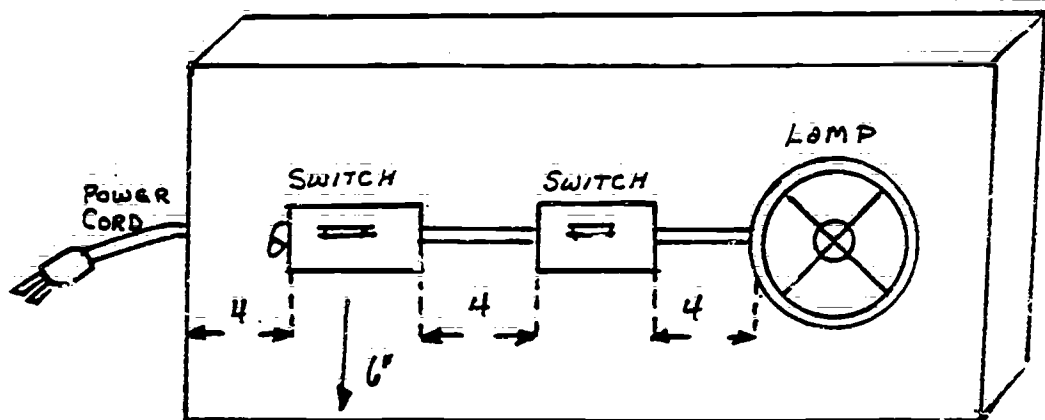

METHOD OF EVALUATION:

1. Layout correct.
2. Fixtures mounted as per drawing.

JOB: Install Lock Nuts in Boxes for  
3-Way Connector

JOB SHEET  
IDENTIFICATION CODE

UNIT II: Basic Electricity

JOB NUMBER: J-2-34

COURSE: Appliance Repair

MATERIAL: 5-Romex Connectors

TOOLS: Ball Peen Hammer

SAFETY PRECAUTIONS:

Wear safety glasses

---

COMPETENCE - PROCEDURES/STEPS  
The student will be able to:

TEACHING/LEARNING ACTIVITIES

---

1. Remove the needed knockouts as per drawing.
2. Install connectors and tighten lock nuts.

. SC-2-25 & SC-2-26

---

METHOD OF EVALUATION:

1. Locknuts tight.
2. Clamp screws clear of panel

JOB: Install Wires and Fixtures for  
Three Way Switch

JOB SHEET  
IDENTIFICATION CODE

UNIT II: Basic Electricity

JOB NUMBER: J-2-35

COURSE: Appliance Repair

MATERIAL: (3) Grounding Clips

SAFETY PRECAUTIONS:

Wear safety glasses

---

COMPETENCE - PROCEDURES/STEPS The student will be able to:	TEACHING/LEARNING ACTIVITIES
1. Install the romex cables and tighten into the connectors.	. SC-2-5 through SC-2-9 . SC-2-11
2. Dress ground wires and fasten them with the grounding clips.	. SC-2-27
3. Skin the wires, bend loops and attach the wires to the fixtures.	NOTE: Use wire nuts for any splicing.
4. Attach the power cord.	
5. Install the lamp.	
6. Test the circuit continuity with the volt-ohm meter.	
7. Mount the fixtures to the boxes.	
8. Install the switch covers.	
9. Re-test the circuit with the volt-ohm meter.	
10. Plug in the power cord and test the circuit.	

---

METHOD OF EVALUATION:

1. Romex not pinched.
2. Wiring neat.
3. Ground clips in place.
4. Circuit works.

86

JOB: Lay Out, Mount Fixture Boxes, and  
Install Connectors, Cut and  
Install BX Wires (Four Way  
Project)

JOB SHEET  
IDENTIFICATION CODE

JOB NUMBER: J-2-36

UNIT II: Basic Electricity

COURSE: Appliance Repair

MATERIAL: (2) 3 Way Switches (Flush) 50 Watt Lamp  
4 Way Switch (Flush) (3) Toggle Plate Covers  
3" or 4" Round Box (3) Utility Boxes  
3" or 4" Keyless Socket Power Cord  
(7) BX Connectors Project Box  
(7) BX Red Sleeves 14/2 BX Wire Ground  
(8) 1/4" X 5/16" Nuts and Bolts 14/3 BX Wire Ground  
(4) Grounding Clips (6) Wire Nuts

EQUIPMENT: Volt-Ohm Meter

TOOLS: Screwdriver, 6" and 8" Nutdriver Set  
Ball Peen Hammer Diagonal Pliers  
Electric Drill BX Cutter  
5/16" Bit Electrician's Knife  
Needle Nose Plier

SAFETY PRECAUTION:

Wear Safety glasses

---

<u>COMPETENCE - PROCEDURES/STEPS</u> The student will be able to:	<u>TEACHING/LEARNING ACTIVITIES</u>
1. Place and mark the fixture boxes to drill holes as per drawing.	. SC-2-1 through SC-2-4
2. Drill holes and mount the fixture boxes.	. SC-2-25 through SC-2-28A
3. Install the BX connectors.	
4. Cut and install the BX cable into the boxes.	
5. Dress the ground wires and install the grounding clips.	

---

METHOD OF EVALUATION:

1. Wiring neat.
2. Connections solid.
3. Ground clips in place.

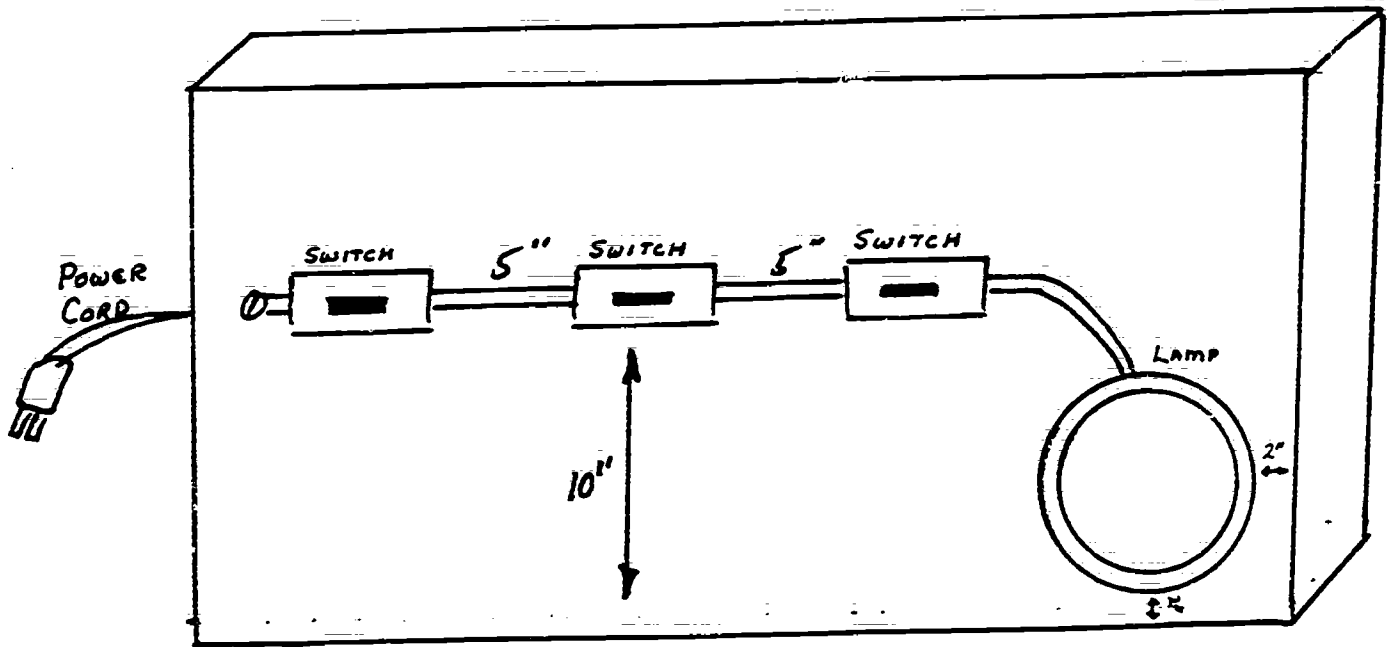



JOB: Wire, Install the Fixtures and  
Check Circuit with the Volt-Ohm  
Meter (Four Way Project)

JOB SHEET  
IDENTIFICATION CODE

JOB NUMBER: J-2-37

UNIT II: Basic Electricity

COURSE: Appliance Repair

MATERIAL: See J-2-36

SAFETY PRECAUTIONS:

Wear safety glasses

COMPETENCE = PROCEDURES/STEPS The student will be able to:	TEACHING/LEARNING ACTIVITIES
1. Install the power cord.	. SC-2-16
2. Make the necessary connections to the fixtures.	. IL-2-4, SC-2-17
3. Make the necessary splices.	. SC-2-5 through SC-2-9
4. Install the lamp.	. SC-2-11
5. Plug in the power cord.	. SC-2-29
6. Turn on one switch if the lamp is not already on.	NOTE: The instructor should check student procedure for checking circuit.
7. Trace the voltage with the volt-ohm meter from the power cord to the lamp.	NOTE: Make sure the meter is set up properly.
8. Turn off the power.	
9. Install the fixtures into the boxes.	
10. Install the switch covers.	
11. Recheck the circuit.	

METHOD OF EVALUATION:

1. Splices tight.
2. Connections solid.
3. Circuit works.
4. Logical procedure was used to check the circuit.

JOB: Scrape Clean a (Whirlpool-Kenmore) Transmission

JOB SHEET  
IDENTIFICATION CODE

UNIT III: Basic Shop Tools

JOB NUMBER: J-3-1

COURSE: Appliance Repair

MATERIAL: Whirlpool-Kenmore Automatic Washer Transmission

TOOLS: Putty Knife

SAFETY PRECAUTIONS:

Wear safety glasses

---

COMPETENCE - PROCEDURES/STEPS  
The student will be able to:

TEACHING/LEARNING ACTIVITIES

1. Remove clip and springs holding the clutch assembly plate.
2. Remove the basket drive assembly.
3. Use the putty knife to scrape off the grease and grime.

. SC-3-1

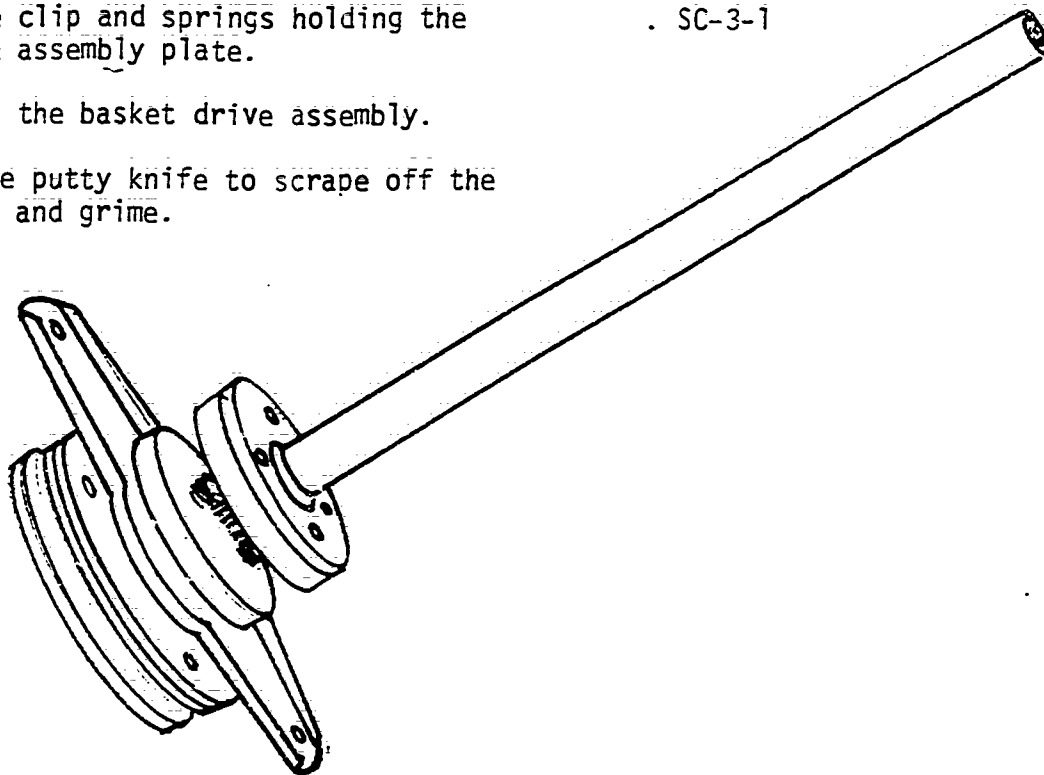

---

METHOD OF EVALUATION:

1. Heavy grease and grime was removed.

JOB: Wash and Clean a (Whirlpool-Kenmore) Transmission

JOB SHEET  
IDENTIFICATION CODE

UNIT III: Basic Shop Tools

JOB NUMBER: J-3-2

COURSE: Appliance Repair

MATERIAL: Whirlpool-Kenmore Automatic Washer Transmission

TOOLS: Parts Washer  
Brush  
Putty Knife

SAFETY PRECAUTIONS:

Wear safety glasses

---

COMPETENCE - PROCEDURES/STEPS The student will be able to:	TEACHING/LEARNING ACTIVITIES
1. Clean the outer transmission case.	. SC-3-2  NOTE: Do not immerse in the cleaning tank.
2. Blow dry parts with an air blow gun.	. SC-3-2A  NOTE: Allow to dry by draining those parts not able to be blown dry.

---

METHOD OF EVALUATION:

1. Transmission is clean.

JOB: Remove Control Magnet (Wigwag Solenoid)

JOB SHEET  
IDENTIFICATION CODE

UNIT III: Basic Shop Tools

JOB NUMBER: J-3-3

COURSE: Appliance Repair

MATERIAL: See J-3-1

TOOLS: Socket Set (Shallow)  
Breaker Bar

COMPETENCE - PROCEDURES/STEPS The student will be able to:	TEACHING/LEARNING ACTIVITIES
1. Locate the control magnet solenoid.	SC-3-3
2. Locate the mounting bolt.	
3. Remove the bolt.	

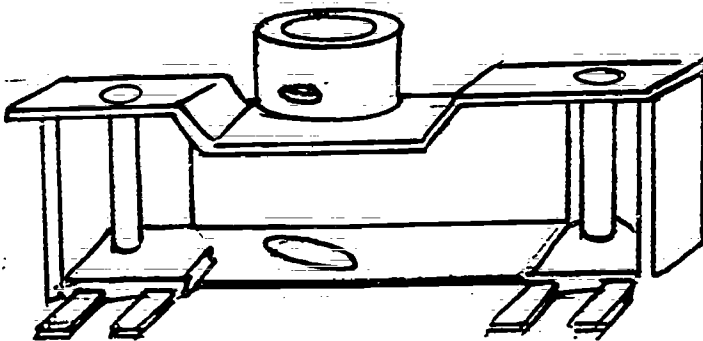

NOTE: Bolt must be completely removed in order to take the control magnet off.

METHOD OF EVALUATION:

1. Part is removed without damage.

JOB: Remove (Whirlpool-Kenmore) Drive Pulley

JOB SHEET  
IDENTIFICATION CODE

UNIT III: Basic Shop Tools

JOB NUMBER: J-3-4

COURSE: Appliance Repair

EQUIPMENT: See J-3-1

TOOLS: Hex or Allen Wrench Set  
Pulley Puller

SAFETY PRECAUTIONS:

Wear safety glasses

COMPETENCE - PROCEDURES/STEPS The student will be able to:	TEACHING/LEARNING ACTIVITIES
1. Locate the drive pulley mounting screw. (Hex or Allen type)	: SC-3-4
2. Remove the allen screw.	: SC-3-5
3. Remove the pulley.	NOTE: If it does not slip off use a pulley puller.

METHOD OF EVALUATION:

1. Part removed undamaged.

JOB: Remove (Whirlpool-Kenmore)  
Transmission Cover

JOB SHEET  
IDENTIFICATION CODE

UNIT III: Basic Shop Tools

JOB NUMBER: J-3-5

COURSE: Appliance Repair

MATERIAL: See J-3-1

TOOLS: Ratchet Handle  
Shallow Socket Set

SAFETY PRECAUTIONS:

Wear safety glasses

---

COMPETENCE - PROCEDURES/STEPS The student will be able to:	TEACHING/LEARNING ACTIVITIES
1. Remove the transmission cover bolts.	. SC-3-3
2. Insert the putty knife blade between the transmission cover and the gasket.	. SC-3-6
3. Continue the above operation completely around the transmission.	
4. Lift off the transmission case.	
5. Drain the oil.	

---

METHOD OF EVALUATION:

1. Cover removed undamaged.

JOB: Remove and Clean Gears

JOB SHEET  
IDENTIFICATION CODE

UNIT III: Basic Shop Tools

JOB NUMBER: J-3-6

COURSE: Appliance Repair

MATERIAL: See J-3-1

TOOLS: Tru-Arc Pliers

SAFETY PRECAUTIONS:

Wear safety glasses

COMPETENCE - PROCEDURES/STEPS The student will be able to:	TEACHING/LEARNING ACTIVITIES
1. Locate the worm gear lock ring.	. SC-3-7
2. Remove the lock ring using the tru-arc pliers.	. SC-3-2
3. Remove the gears.	
4. Clean, dry and inspect the gears and shaft.	
5. Clean, dry and inspect the gear case.	
6. Replace any defective parts.	

METHOD OF EVALUATION:

1. Gear clean
2. Proper judgement made as to wear.

JOB: Reassemble the (Whirlpool-Kenmore) Transmission

JOB SHEET  
IDENTIFICATION CODE

UNIT III: Basic Shop Tools

JOB NUMBER: J-3-7

COURSE: Appliance Repair

MATERIAL: Whirlpool-Kenmore Automatic Washer Transmission

TOOLS: Torque Wrench  
Socket Wrench

SAFETY PRECAUTIONS:

Wear safety glasses

COMPETENCE - PROCEDURES/STEPS The student will be able to:	TEACHING/LEARNING ACTIVITIES
1. Install new oil.	NOTE: See manufacturer's specifications.
2. Install new gasket.	: SC-3-8
3. Install the gear case cover.	: SC-3-4
4. Install the gear case bolts and torque them 10 to 12 pounds per square inch.	: SC-3-6
5. Install the drive pulley and tighten allen set screw.	: SC-3-7
6. Install the control magnet assembly.	
7. Install the basket drive assembly.	
3. Have the instructor check the transmission for proper operation.	

METHOD OF EVALUATION:

1. Assembled properly.
2. Transmission turns freely.



JOB: Clean a Part Using a Hand Wire Brush

JOB SHEET  
IDENTIFICATION CODE

UNIT III: Basic Shop Tools

JOB NUMBER: J-3-8

COURSE: Appliance Repair

MATERIAL: Any Slightly Corroded Part

TOOLS: Hand Wire Brush

SAFETY PRECAUTIONS:

Wear safety glasses

---

COMPETENCE - PROCEDURES/STEPS  
The student will be able to:

TEACHING/LEARNING ACTIVITIES

---

1. Remove any parts that could be damaged by the wire brush.
2. Grasp handle of wire brush firmly and push the bristle end over areas to be cleaned.
3. Continue cleaning until corrosion is brushed away.

SC-3-9

---

METHOD OF EVALUATION:

1. Part clean.

JOB: Clean a Part Using a Wire Wheel

JOB SHEET  
IDENTIFICATION CODE

JOB III: Basic Shop Tools

JOB NUMBER: SC-3-9

COURSE: Appliance Repair

MATERIAL: Corroded Part

TOOLS: Wire Wheel

SAFETY PRECAUTIONS:

Safety glasses  
Gloves

COMPETENCE - PROCEDURES, STEPS The student will be able to:	TEACHING/LEARNING ACTIVITIES
1. Remove any parts that could be damaged by the wire wheel.	SC-3-10
2. Clean corroded part(s) with wire wheel.	

METHOD OF EVALUATION

1. Part clean

98

JOB: Clear and Polish an Appliance  
Using a Buffer Wheel

JOB SHEET  
IDENTIFICATION CODE

UNIT TITLE: Basic ~~Shop~~ Tools

JOB NUMBER: J-1-10

COURSE: Appliance Repair

MATERIAL: Any Chrome Finish Appliance -  
Toaster - Iron, etc.

TOOLS: Buffer Wheel

SAFETY PRECAUTIONS:

Wear safety glasses and gloves

---

COMPETENCE - PROCEDURES/STEPS  
The student will be able to:

TEACHING/LEARNING ACTIVITIES

1. Remove any parts such as controls - knobs -  
etc. that could be damaged.
2. Polish the appliance using a buffer  
wheel.

SC-3-11

---

METHOD OF EVALUATION:

1. Appliance cleaned and polished without damage.

99

JOB: Prepare Stock to Drill Holes  
with a Drill Press

JOB SHEET  
IDENTIFICATION CODE

UNIT III: Basic Shop Tools

JOB NUMBER: J-3-11

COURSE: Appliance Repair

MATERIAL: Cold Rolled Steel 2" x 6" x 1/2"

EQUIPMENT: Drill Press

TOOLS: Drill Bits  
Drill Press Vise

SAFETY PRECAUTIONS:

Wear safety glasses

---

COMPETENCE - PROCEDURES/STEPS The student will be able to:	TEACHING/LEARNING ACTIVITIES
1. Mark stock for drilling with a center punch.	. SC-3-12
2. Select proper drill bit.	
3. Install drill bit into chuck.	NOTE: Instructor will demonstrate the set-up and operation of the drill press.

---

METHOD OF EVALUATION:

1. Proper bit selected.
2. Bit installed correctly.

100

JOB: Mount Stock for Drilling with a Drill Press Vise

JOB SHEET  
IDENTIFICATION CODE

UNIT III: Basic Shop Tools

NUMBER: J-3-12

COURSE: Appliance Repair

MATERIAL: Stock From J-3-11  
Bed Bolts

TOOLS: Drill Press Vise  
Open End Wrenches

SAFETY PRECAUTIONS:

Wear safety glasses

---

COMPETENCE - PROCEDURES/STEPS  
The student will be able to:

---

LEARNING ACTIVITIES

1. Mount the stock in the vise.
2. Position stock for drilling.
3. Install bolts to hold vise.
4. Tighten bolts using an open end wrench.

NOTE: Instructor will demonstrate the set-up and operation of the drill press.

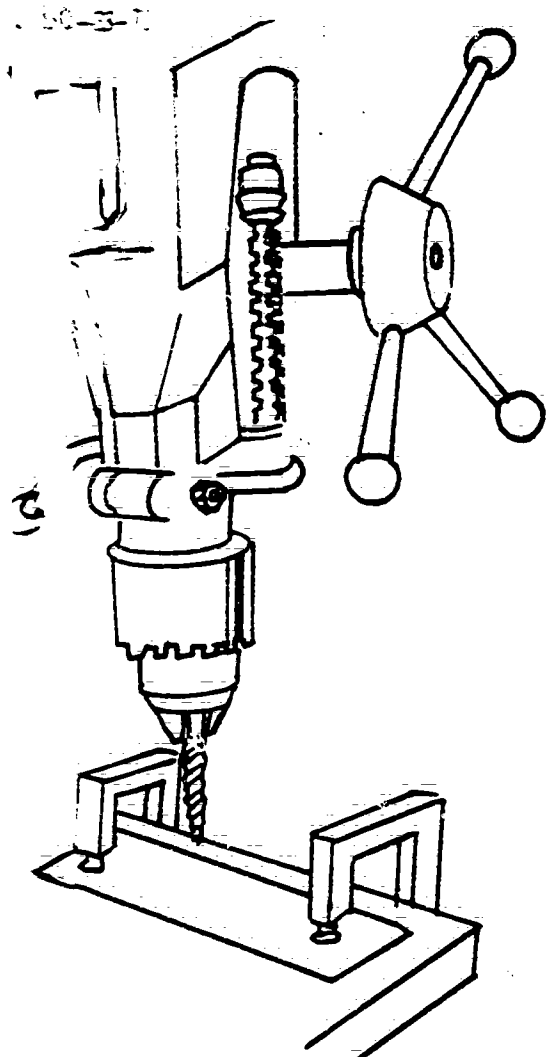

---

METHOD OF EVALUATION:

1. Stock mounted at the proper position.

101

Drill Holes in Stock

JOB SHEET  
IDENTIFICATION CODE

TITLE: Basic Shop Tools

JOB NUMBER: J-3-13

COURSE: Appliances Repair

MATERIAL: Stock From J-3-11  
Cutting Oil

EQUIPMENT: Drill Press

SAFETY PRECAUTIONS:

Wear safety glasses

---

COMPETENCE - PROCEDURES/STEPS  
The student will be able to:

---

TEACHING/LEARNING ACTIVITIES

1. Turn on drill press.
2. Adjust the bit speed.
3. Drill one hole.
4. Turn off the drill press.
5. Reposition the stock to drill second hole.
6. Drill the second hole.
7. Turn off the drill press.
8. Reposition the stock to drill the third hole.
9. Drill the third hole.
10. Turn off the drill press.
11. Remove the stock.
12. Clean the stock.

. SC-3-14

NOTE: Instructor will demonstrate drill press operation.

NOTE: Drill three holes for 10/32 tap.

---

METHOD OF EVALUATION:

1. Holes drilled within tolerances.
2. Holes drilled at proper location.

JOB: Prepare the Stock For Taping  
Holes

JOB SHEET  
IDENTIFICATION CODE

UNIT: Basic Shop Tools

JOB NUMBER: J-3-14

COURSE: Appliance Repair

MATERIAL: Stock From J-3-11

EQUIPMENT: Work Bench

TOOLS: "C" Clamp

SAFETY PRECAUTIONS:

Wear safety glasses

---

COMPETENCE - PROCEDURES/STEPS The student will be able to:	TEACHING/LEARNING ACTIVITIES
1. Secure the stock to the work bench using "C" clamps.	: SC-3-15
2. Check drilled holes for metal chips and clean if necessary.	

---

METHOD OF EVALUATION:

1. Stock clamped securely.

JOB: Tap Holes Using 10/32 Tap

JOB SHEET  
IDENTIFICATION CODE

UNIT III: Basic Shop Tools

JOB NUMBER: J-3-15

COURSE: Appliance Repair

MATERIAL: Stock From J-3-11  
Cutting Oil

TOOLS: Tap and Die Set

SAFETY PRECAUTIONS:

Wear safety glasses

---

COMPETENCE - PROCEDURES/STEPS The student will be able to:	TEACHING/LEARNING ACTIVITIES
1. Tap the threads in the first hole.	SC-3-16
2. Use a 10/32 bolt to check the tapping job on the first hole.	
3. Repeat the above operations for tapping the second and third hole.	
4. Clean the stock and work area.	

---

METHOD OF EVALUATION:

1. Threads are cut to the proper depth.
2. Threads are clean.



JOB: Secure Stock in Vise For Cutting

JOB SHEET  
IDENTIFICATION CODE

UNIT III: Basic Shop Tools

JOB NUMBER: J-3-16

COURSE: Appliance Repair

MATERIAL: Round Cold Rolled Stock For  
10/32 Threading

EQUIPMENT: Bench Vise

SAFETY PRECAUTIONS:

Wear safety glasses

---

COMPETENCE - PROCEDURES/STEPS The student will be able to:	TEACHING/LEARNING ACTIVITIES
1. Place stock in bench vise with enough clearance past the mark to saw.	. SC-3-17

---

METHOD OF EVALUATION:

1. Location of stock in vise is within tolerance.

JOB: Cut Round Stock to Length

JOB SHEET  
IDENTIFICATION CODE

UNIT III: Basic Shop Tools

JOB NUMBER: J-3-17

COURSE: Appliance Repair

MATERIAL: Round Cold Rolled Stock For  
10/32 Die

EQUIPMENT: Bench Vise

TOOLS: Hack Saw

SAFETY PRECAUTIONS:

Wear safety glasses

COMPETENCE - PROCEDURES/STEPS The student will be able to:	TEACHING/LEARNING ACTIVITIES
1. Place stock in vise allowing 2" clearance for marking.	. SC-3-17
2. Measure and mark stock to length of 3 1/2".	. SC-3-18
3. Cut stock with a hack saw.	
4. Cut three pieces of stock to length.	

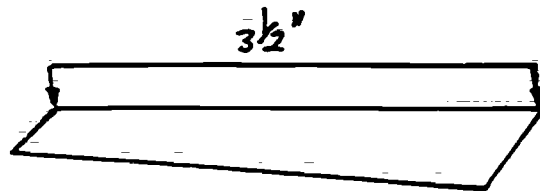

METHOD OF EVALUATION:

1. Cut is straight.
2. Cut is within tolerance.

106

JOB: Prepare Stock For Threading

JOB SHEET  
IDENTIFICATION CODE

UNIT III: Basic Shop Tools

JOB NUMBER: J-3-18

COURSE: Appliance Repair

MATERIAL: Cut Rods From J-3-17

EQUIPMENT: Bench Vise

TOOLS: Flat File

SAFETY PRECAUTIONS:

Wear safety glasses

---

COMPETENCE - PROCEDURES/STEPS The student will be able to:	TEACHING/LEARNING ACTIVITIES
1. Place stock in vise vertically.	. SC-3-17
2. File end until it is flat.	. SC-3-19
3. File edge to remove burrs.	
4. Repeat operations on opposite end.	

---

METHOD OF EVALUATION:

1. Stock is filed smooth.
2. Burrs are removed.

197

JOB: Thread Rod Using Die

JOB SHEET  
IDENTIFICATION CODE

UNIT III: Basic Shop Tools

JOB NUMBER: J-3-19

COURSE: Appliance Repair

MATERIAL: Cut Rods from J-3-17  
Cutting Oil

EQUIPMENT: Bench Vise

TOOLS: Tap and Die Set

SAFETY PRECAUTIONS:

Wear safety glasses

---

COMPETENCE - PROCEDURES/STEPS  
The student will be able to:

TEACHING/LEARNING ACTIVITIES

- |   |           |
|---|-----------|
| 1. Secure rod in vise, vertically.            | . SC-3-17 |
|   | . SC-3-20 |
| 2. Thread rods 1 1/2".                        |           |
| 3. Clear rods and area.                       |           |
| 4. Insert rods into tapped plate from J-3-11. |           |

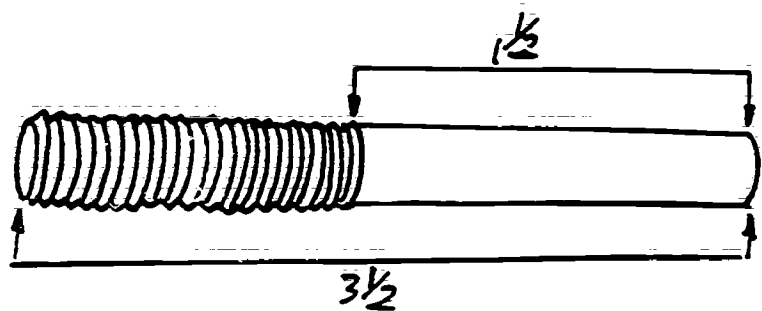

---

METHOD OF EVALUATION:

1. Threads are clean.
2. Thread length is within tolerance.

108

UNIT III: Basic Shop Tools

JOB NUMBER: J-3-20

COURSE: Appliance Repair

EQUIPMENT: Bench Grinder

TOOLS: Straight Blade Screwdriver with  
Bad Tip

SAFETY PRECAUTIONS:

Wear safety glasses

---

COMPETENCE - PROCEDURES/STEPS The student will be able to:	TEACHING/LEARNING ACTIVITIES
---	------------------------------

---

1. Grind blade edge straight.

. SC-3-21

NOTE: Use water to cool  
blade.

2. Grind side taper equally to get the  
proper blade thickness.

3. Clean and inspect.

---

METHOD OF EVALUATION:

1. Blade is ground to proper angle.

2. Taper is ground to proper angle.

109

UNIT III: Basic Shop Tools

JOB NUMBER: J-3-21

COURSE: Appliance Repair

MATERIAL: Dull Drill Bits

EQUIPMENT: Bench Grinder

TOOLS: Drill Bit Holder

SAFETY PRECAUTIONS:

Wear safety glasses

---

COMPETENCE - PROCEDURES/STEPS The student will be able to:	TEACHING/LEARNING ACTIVITIES
1. Set up grinder.	. SC-3-21 . SC-3-22
2. Install drill guide.	
3. Sharpen drill bit.	
4. Clean and inspect.	

---

METHOD OF EVALUATION:

1. Drill bit cuts correctly.
2. Drill sharpened to proper angle for materials to be drilled.

JOB: Remove a Broken Bolt

JOB SHEET  
IDENTIFICATION CODE

UNIT III: Basic Shop Tools

JOB NUMBER: J-3-22

COURSE: Appliance Repair

MATERIAL: Part with Broken Bolt

EQUIPMENT: Electric Drill  
Drill Bits

TOOLS: Easy Out Screw Extractor  
Center Punch

Tap Handle

---

COMPETENCE - PROCEDURES/STEPS The student will be able to:	TEACHING/LEARNING ACTIVITIES
1. Apply rust solvent to the bolt area.	. SC-3-23
2. Make a center punch mark in the center of the bolt.	
3. Drill the proper size hole in the bolt to fit the screw extractor.	
4. Insert the screw extractor into the hole.	
5. Remove the bolt by turning the screw extractor counter clockwise.	

---

METHOD OF EVALUATION:

1. Bolt is removed without damage to stock threads.

111

JOB: Remove and Check an Armature

JOB SHEET  
IDENTIFICATION CODE

UNIT III: Basic Shop Tools

JOB NUMBER: J-3-23

COURSE: Appliance Repair

MATERIAL: Any Power Tool Armature  
(Good or Bad)

TOOLS: Hack Saw Blade Only

SAFETY PRECAUTIONS:

Wear safety glasses

---

COMPETENCE - PROCEDURES/STEPS Student will be able to:	TEACHING/LEARNING ACTIVITIES
1. Ground test the armature.	. IL-3-1
2. Short test the armature.	
3. Test the armature for open circuit.	NOTE: If the armature fails any of the above tests it should be replaced.

---

METHOD OF EVALUATION:

1. Proper diagnosis.



JOB: Disassemble an Electric Motor  
and Clean Parts

JOB SHEET  
IDENTIFICATION CODE

UNIT III: Basic Shop Tools

JOB NUMBER: J-3-24

COURSE: Appliance Repair

MATERIAL: Rags  
Sand Cloth

EQUIPMENT: Used Motor

TOOLS: Basic Hand Tools  
Center Punch  
Air Nozzle

SAFETY PRECAUTIONS:

Wear safety glasses

---

COMPETENCE - PROCEDURES/STEPS  
The student will be able to:

TEACHING/LEARNING ACTIVITIES

---

1. Clean the outer case of the motor with a rag.
2. Mark the end bells of the motor using a center punch and align the three punch marks on the end bells with the three punch marks on the motor frame.
3. Remove the motor pulley. (if used)
4. Use a file to remove any burrs on the pulley shaft.
5. Remove the motor case bolts.
6. Remove the end bell opposite the motor terminal board.
7. Remove the motor rotor.
8. Loosen the end bell at the motor terminal end of the motor.
9. Clean and inspect all parts and use the air hose and nozzle to remove dirt and lint.
10. Clean the oily parts with solvent in a parts washer.

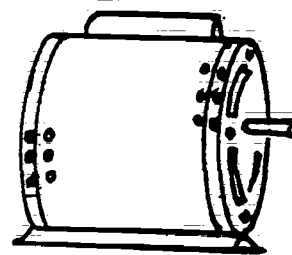

SC-3-19

NOTE: Do not remove or damage the wiring.

SC-3-24

113

11. Replace any defective parts.
12. Reassemble motor and test.

---

METHOD OF EVALUATION:

1. Motor disassembled without damage.
2. Motor turns freely after assembly.
3. Motor works.

114

JOB: Move Washer Using Appliance  
Hand Truck

JOB SHEET  
IDENTIFICATION CODE

UNIT III: Basic Shop Tools

JOB NUMBER: J-3-25

COURSE: Appliance Repair

EQUIPMENT: Automatic Washer

TOOLS: Hand Truck

SAFETY PRECAUTIONS:

Wear safety glasses

---

COMPETENCE - PROCEDURES/STEPS The student will be able to:	TEACHING/LEARNING ACTIVITIES
1. Locate the assigned washer.	. SC-3-25
2. Attach the hand truck to the washer.	
3. Move washer to assigned area.	
4. Remove the hand truck.	

---

METHOD OF EVALUATION:

1. The appliance is moved to proper location without damage to appliance or area.

JOB: Install Inlet Hoses

JOB SHEET  
IDENTIFICATION CODE

UNIT IV: Laundry Equipment

JOB NUMBER: J-4-1

COURSE: Appliance Repair

MATERIAL: (2) Inlet Hoses with Washers

EQUIPMENT: Automatic Washer

TOOLS: Pump Pliers

SAFETY PRECAUTIONS:

Wear safety glasses

COMPETENCE - PROCEDURES/STEPS The student will be able to:	TEACHING/LEARNING ACTIVITIES
1. Locate inlet valve.	. SC-4-1
2. Locate hot side.	
3. Screw one end of hose fitting onto the threaded inlet valve (hot side).	NOTE: Check for a rubber washer in each fitting.
	NOTE: Be careful not to cross thread the fittings.
4. Using the pump pliers, tighten the hose fitting.	NOTE: Usually 3/4 to 1 turn is all that is needed.
5. Install the other end of the hose to the hot water faucet.	
6. Repeat the operation using the cold hose.	
7. Turn on the water supply and check for leaks.	

METHOD OF EVALUATION:

1. Hoses installed without leaks.

116

JOB: Install an Automatic Washer  
Drain Hose Using Spring Clamp

JOB SHEET  
IDENTIFICATION CODE

UNIT IV: Laundry Equipment

JOB NUMBER: J-4-2

COURSE: Appliance Repair

MATERIAL: Drain Hose  
Spring Clamp

EQUIPMENT: Automatic Washer

TOOLS: Hose Clamp Pliers

SAFETY PRECAUTIONS:

Wear safety glasses

---

COMPETENCE - PROCEDURES/STEPS The student will be able to:	TEACHING/LEARNING ACTIVITIES
1. Locate the drain hose fitting on the rear of the washer.	. SC-4-2
2. Select the proper drain hose.	
3. Select the proper size spring clamp.	
4. Slide the spring clamp over drain hose.	
5. Slide drain hose over drain fitting.	
6. Position spring clamp and release tension.	

---

METHOD OF EVALUATION:

1. Clamp installed at the proper place.
2. Hose does not leak.

117

JOB: Install an Automatic Washer  
Drain Hose Using Worm Clamp

JOB SHEET  
IDENTIFICATION CODE

UNIT IV: Laundry Equipment

JOB NUMBER: J-4-3

COURSE: Appliance Repair

MATERIAL: Drain Hose  
Worm Clamp

EQUIPMENT: Automatic Washer

TOOLS: Screwdriver

SAFETY PRECAUTIONS:

Wear safety glasses

---

COMPETENCE - PROCEDURES/STEPS The student will be able to:	TEACHING/LEARNING ACTIVITIES
1. Locate the drain hose fitting on the rear of the washer.	. SC-4-3
2. Select the proper drain hose.	
3. Select the proper worm clamp.	
4. Slide the clamp over the drain hose.	
5. Slide the drain hose onto the drain fitting.	
6. Position the worm clamp.	
7. Tighten the worm clamp.	

---

METHOD OF EVALUATION:

1. Clamp installed at the proper location.
2. Hose does not leak.

JOB: Level Automatic Washer

JOB SHEET  
IDENTIFICATION CODE

UNIT IV: Laundry Equipment

JOB NUMBER: J-4-4

COURSE: Appliance Repair

EQUIPMENT: Automatic Washer

TOOLS: Level  
Open End Wrench  
Pump Pliers

---

COMPETENCE - PROCEDURES/STEPS The student will be able to:	TEACHING/LEARNING ACTIVITIES
1. Locate the leveling legs of the washer.	. SC-4-4
2. Check to see if they are touching the floor.	
3. Place level across the top front of washer.	
4. Adjust the legs to level the washer from left to right.	
5. Place level on left side of the washer (front to back).	
6. Adjust the legs to level the washer.	
7. Place the level on the right side of the washer (front to back).	
8. Adjust the legs to level the washer.	
9. Check the washer to make sure all the legs are touching the floor and the washer is level and solid.	
10. Lock the adjusting legs in place with the lock nuts.	

---

METHOD OF EVALUATION:

1. Washer is solid on the floor.
2. Washer is level within tolerance. 119

JOB: Install Cord on Dryer

JOB SHEET  
IDENTIFICATION CODE

UNIT IV: Laundry Equipment

JOB NUMBER: J-4-5

COURSE: Appliance Repair

MATERIAL: Dryer Cord

EQUIPMENT: Electric Dryer

TOOLS: Screwdriver  
Nutdriver

SAFETY PRECAUTIONS:

Wear safety glasses

---

COMPETENCE - PROCEDURES/STEPS The student will be able to:	TEACHING/LEARNING ACTIVITIES
1. Locate the terminal block cover.	. SC-4-5
2. Remove the cover.	
3. Insert cord into the knockout hole.	
4. Fasten the cord to the terminal block (middle wire to middle terminal).	
5. Install the cord connector.	
6. Install the terminal block cover.	

---

METHOD OF EVALUATION:

1. Cord is wired to the proper terminals.
2. Connections are sealed.
3. Cord clamp properly tightened.

120



JOB: Install Dryer Vent Using Flexible Tubing

JOB SHEET  
IDENTIFICATION CODE

UNIT IV: Laundry Equipment

JOB NUMBER: J-4-6

COURSE: Appliance Repair

MATERIAL: (4") Flexible Vent Tubing  
(2) Worm Clamps  
Electric Dryer

TOOLS: Utility Knife  
Diagonal Pliers  
Foot Rule

---

COMPETENCE - PROCEDURES/STEPS The student will be able to:	TEACHING/LEARNING ACTIVITIES
<ol style="list-style-type: none"><li>1. Locate dryer vent pipe.</li><li>2. Measure length of vent tubing needed.</li><li>3. Mark and cut the tubing to length.</li><li>4. Slip the worm gear clamp over both ends.</li><li>5. Insert the vent tubing over the vent pipe of the dryer.</li><li>6. Tighten the worm clamp.</li></ol>	<p>. SC-4-6</p> <p>NOTE: Use a diagonal pliers to cut the metal band.</p>

---

METHOD OF EVALUATION:

1. Vent is installed neatly.
2. Clamps are tight.

121

JOB: Fit Window Plate for Dryer Vent

JOB SHEET  
IDENTIFICATION CODE

UNIT IV: Laundry Equipment

JOB NUMBER: J-4-7

COURSE: Appliance Repair

MATERIAL: Aluminum Plate  
Wooden Sash

TOOLS: Folding Rule  
Straight Snips (Tin Shears)

SAFETY PRECAUTIONS:

Wear safety glasses

---

COMPETENCE - PROCEDURES/STEPS The student will be able to:	TEACHING/LEARNING ACTIVITIES
1. Measure and mark the window plate to fit the window opening.	. SC-4-7
2. Cut the window plate to size.	

---

METHOD OF EVALUATION:

1. Window plate cut to size - within tolerance (Tolerance opening size minus 1/16").

122

JOB: Mark Vent Opening on Window Plate

JOB SHEET  
IDENTIFICATION CODE

UNIT IV: Laundry Equipment

JOB NUMBER: J-4-8

COURSE: Appliance Repair

MATERIAL: Window Plate from J-4-7  
Soft Board

TOOLS: Compass  
Center Punch

SAFETY PRECAUTIONS:

Wear safety glasses

COMPETENCE - PROCEDURES/STEPS The student will be able to:	TEACHING/LEARNING ACTIVITIES
---	------------------------------

1. Place the window plate on a soft board.
2. Mark the center of the opening with a center punch mark.
3. Adjust the opening of the compass to 1/2 the desired width of hole opening.
4. Draw the circle on the plate.

. SC-4-8

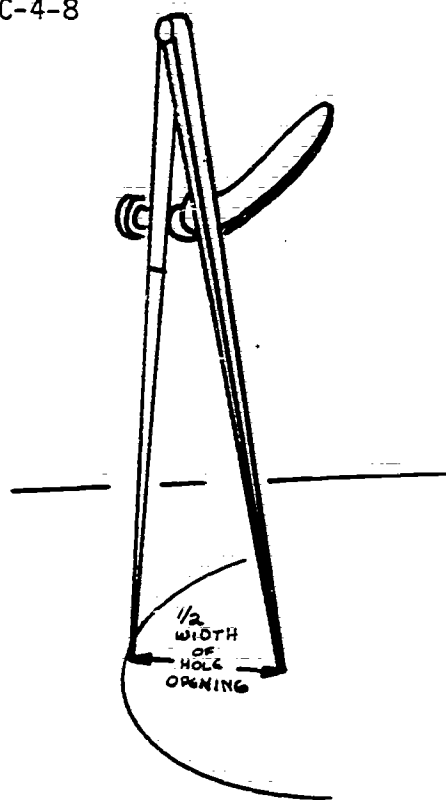

METHOD OF EVALUATION:

1. Circle marked to within tolerance.

123

JOB: Cut Hole in Plate

JOB SHEET  
IDENTIFICATION CODE

UNIT IV: Laundry Equipment

JOB NUMBER: J-4-9

COURSE: Appliance Repair

MATERIAL: Window Plate from J-4-8

TOOLS: Hammer  
Chisel

SAFETY PRECAUTIONS:

Wear safety glasses

---

COMPETENCE - PROCEDURES/STEPS	TEACHING/LEARNING ACTIVITIES
The student will be able to:	
<hr/> <ol style="list-style-type: none"><li>1. Place the window plate on soft board.</li><li>2. Select an area between the center mark and the outer edge of the circle and cut a hole through the plate.</li></ol>	<p>. SC-4-9</p> <p>NOTE: The hole should be large enough to accept the tin shear blade.</p>

---

METHOD OF EVALUATION:

1. Hole is large enough.

124

JOB: Cut Circular Hole in Window Plate

JOB SHEET  
IDENTIFICATION CODE

UNIT IV: Laundry Equipment

JOB NUMBER: J-4-10

COURSE: Appliance Repair

MATERIAL: Window Plate from J-4-9

TOOLS: Curved Blade Hand Shears

SAFETY PRECAUTIONS:

Wear safety glasses

---

COMPETENCE - PROCEDURES/STEPS The student will be able to:	TEACHING/LEARNING ACTIVITIES
1. Insert shears into hole.	. SC-4-10
2. Cut circular hole.	
3. Trim any rough edges.	

---

METHOD OF EVALUATION:

1. Hole is cut to within tolerance.
2. Edges are smooth.

125

JOB: Install Window Plate in Wooden Sash

JOB SHEET  
IDENTIFICATION CODE

UNIT IV: Laundry Equipment

JOB NUMBER: J-4-11

COURSE: Appliance Repair

MATERIAL: Glazing Points  
Window Plate from J-4-8

EQUIPMENT: Wooden Window

TOOLS: Hammer

SAFETY PRECAUTIONS:

Wear safety glasses

---

COMPETENCE - PROCEDURES/STEPS The student will be able to:	TEACHING/LEARNING ACTIVITIES
1. Place window plate into frame.	: SC-4-11
2. Fasten the plate to the frame with glazing points.	

---

METHOD OF EVALUATION:

1. Window plate is securely mounted.

*120*

JOB: Install Dryer Vent Hood

JOB SHEET  
IDENTIFICATION CODE

UNIT IV: Laundry Equipment

JOB NUMBER: J-4-12

COURSE: Appliance Repair

EQUIPMENT: Pop Rivets

TOOLS: Pop Rivet Gun

SAFETY PRECAUTIONS:

Wear safety glasses

COMPETENCE - PROCEDURES/STEPS The student will be able to:	TEACHING/LEARNING ACTIVITIES
1. Insert the vent hood into window plate.	. SC-4-3
2. Measure and mark the 4 corners for drilling.	. SC-4-2
3. Center punch the marks for drilling.	
4. Drill the 4 holes.	NOTE: Use the proper size drill bit for the pop rivets.
5. Install the pop rivets (rivets face the outside).	
6. Caulk or putty the holes in the pop rivets.	
7. Install the vent tubing to the vent hood.	
8. Tighten the worm clamp.	

METHOD OF EVALUATION:

1. Pop rivets are tight.
2. Holes are sealed.

127

JOB: Install Dryer (Level and Clean)

JOB SHEET  
IDENTIFICATION CODE

UNIT IV: Laundry Equipment

JOB NUMBER: J-4-13

COURSE: Appliance Repair

MATERIAL: Cleaning Solution  
Rags

TOOLS: Level  
Open End Wrench

SAFETY PRECAUTIONS:

Wear safety glasses

---

COMPETENCE - PROCEDURES/STEPS The student will be able to:	TEACHING/LEARNING ACTIVITIES
1. Level the dryer.	. SC-4-4
2. Clean the dryer.	. SC-4-13

---

METHOD OF EVALUATION:

1. Dryer is level and solid on the floor.
2. Dryer is clean.

100



JOB: Polish a Dryer

JOB SHEET  
IDENTIFICATION CODE

UNIT IV: Laundry Equipment

JOB NUMBER: J-4-14

COURSE: Appliance Repair

MATERIAL: Rags  
Polish

SAFETY PRECAUTIONS:

Wear safety glasses

---

COMPETENCE - PROCEDURES/STEPS The student will be able to:	TEACHING/LEARNING ACTIVITIES
<ol style="list-style-type: none"><li>1. Apply polish.</li><li>2. Remove excess polish.</li><li>3. Buff surface.</li></ol>	<p>NOTE: All surfaces to be polished should be thoroughly cleaned first.</p> <p>. SC-4-14</p>

---

METHOD OF EVALUATION:

1. Dryer is clean and polished.

129

JOB: Check Blower Operation and Vent Damper

JOB SHEET  
IDENTIFICATION CODE

UNIT IV: Laundry Equipment

JOB NUMBER: J-4-15

COURSE: Appliance Repair

SAFETY PRECAUTIONS:

Wear safety glasses

---

COMPETENCE - PROCEDURES/STEPS The student will be able to:	TEACHING/LEARNING ACTIVITIES
1. Check for closed damper before starting dryer.	. IL-4-1
2. Plug in the power cord.	
3. Start the dryer.	
4. Check for proper air circulation.	NOTE: Damper should open.
5. Check for noise and vibrations in the blower assembly.	
6. Check the vent piping for vibrations.	

---

METHOD OF EVALUATION:

1. Diagnosis is correct.

130

JOB: Remove Belt for Dryer Blower Assembly

JOB SHEET  
IDENTIFICATION CODE

UNIT IV: Laundry Equipment

JOB NUMBER: J-4-16

COURSE: Appliance Repair

MATERIAL: Electric Dryer (any dryer with the blower assembly mounted on the rear assembly)

TOOLS: Basic Hand Tools

SAFETY PRECAUTIONS:

Wear safety glasses

---

COMPETENCE - PROCEDURES/STEPS The student will be able to:	TEACHING/LEARNING ACTIVITIES
1. Turn off the power source.	. SC-4-15
2. Remove the inspection panel.	
3. Remove any tension springs.	
4. <u>Loosen</u> the motor bolts.	NOTE: DO NOT remove the bolts.
5. Remove the belt or belts.	

---

METHOD OF EVALUATION:

1. Belt is removed without damage to the appliance.

JOB: Remove, Clean and Inspect the Blower Assembly

JOB SHEET  
IDENTIFICATION CODE

UNIT IV: Laundry Equipment

JOB NUMBER: J-4-17

COURSE: Appliance Repair

MATERIAL: Electric Dryer from J-4-16

EQUIPMENT: Vacuum Cleaner

TOOLS: Basic Hand Tools

SAFETY PRECAUTIONS:

Wear safety glasses

---

COMPETENCE - PROCEDURES/STEPS The student will be able to:	TEACHING/LEARNING ACTIVITIES
1. Remove the blower housing.	. SC-4-16
2. Remove the drive pulley.	. IL-4-2
3. Remove the blower fan from the housing.	
4. Clean the lint and dirt from the parts.	
5. Inspect the parts of the blower for defects.	

---

METHOD OF EVALUATION:

1. Disassembled without damage.
2. Parts cleaned.

132

JOB: Lubricate and Reassemble Blower  
Assembly

JOB SHEET  
IDENTIFICATION CODE

UNIT IV: Laundry Equipment

JOB NUMBER: J-4-18

COURSE: Appliance Repair

MATERIAL: Turbine Oil  
Electric Dryer from J-4-16

TOOLS: Basic Hand Tools

SAFETY PRECAUTIONS:

Wear safety glasses

---

COMPETENCE - PROCEDURES/STEPS	TEACHING/LEARNING ACTIVITIES
The student will be able to:	
1. Coat the blower shaft with a thin layer of turbine oil.	. SC-4-17
2. Apply a small amount of turbine oil to the inner surface of the sleeve bearings.	
3. Reassemble the blower assembly.	
4. Install the blower assembly.	
5. Check for proper operation.	

---

METHOD OF EVALUATION:

1. Blower works and turns freely.

JOB: Install Spade Terminal Using  
Crimping Tool

JOB SHEET  
IDENTIFICATION CODE

UNIT IV: Laundry Equipment

JOB NUMBER: J-4-19

COURSE: Appliance Repair

MATERIAL: #12 Stranded Wire  
Spade Terminal (Female)

TOOLS: Knife  
Diagonal Pliers  
Crimping Tool

SAFETY PRECAUTIONS:

Wear safety glasses

---

COMPETENCE - PROCEDURES/STEPS The student will be able to:	TEACHING/LEARNING ACTIVITIES
1. Strip and clean insulation from wire, about 1/4".	. SC-4-18
2. Insert wire into terminal.	
3. Crimp terminal onto wire by squeezing terminal in hole of crimping tool.	. SC-4-18A

NOTE: Crimping action is  
the same as the pliers.

---

METHOD OF EVALUATION:

1. Connection is solid.

134

JOB: Check Dryer for Proper Heating

JOB SHEET  
IDENTIFICATION CODE

UNIT IV: Laundry Equipment

JOB NUMBER: J-4-20

COURSE: Appliance Repair

MATERIAL: Gas or Electric Dryer

EQUIPMENT: Temperature Tester

SAFETY PRECAUTIONS:

Wear safety glasses

---

COMPETENCE - PROCEDURES/STEPS The student will be able to:	TEACHING/LEARNING ACTIVITIES
1. Install the dryer in assigned location.	. SC-4-1 <sup>a</sup>
2. Check the dryer for proper operation.	
3. Install temperature tester lead into exhaust duct.	
4. Take temperature readings and compare.	

---

METHOD OF EVALUATION:

1. Dryer heats to manufacturer's specifications.
2. Readings are within tolerance.

135

JOB: Repair a Water Seal Leak on a  
Frigidaire Automatic Washer Pump

JOB SHEET  
IDENTIFICATION CODE

UNIT IV: Laundry Equipment

JOB NUMBER: J-4-21

COURSE: Appliance Repair

MATERIAL: Frigidaire Automatic Washer -  
New Pump Seal

TOOLS: Basic Hand Tools  
Seal Inserting Tool  
Drift Punch  
Plastic Head Hammer

SAFETY PRECAUTIONS:

Wear safety glasses

---

COMPETENCE - PROCEDURES/STEPS The student will be able to:	TEACHING/LEARNING ACTIVITIES
1. Remove the inspection panel.	
2. Remove the drain hoses.	
3. Remove the screws from the pump cover.	. SC-4-20
4. Remove the pump cover.	
5. Remove the pump impeller.	
6. Remove the screws from the pump base.	
7. Remove the pump base.	
8. Drive out the old seal using a drift punch and hammer.	. SC-3-12
9. Clean the pump base and cover.	
10. Install the new seal.	
11. Install the pump base and tighten the mounting screws.	
12. Install the new impeller.	
13. Install the new gasket and pump cover.	
14. Install the drain hose.	

136



---

COMPETENCE - PROCEDURES/STEPS

TEACHING/LEARNING ACTIVITIES

---

15. Hook up the washer and check for proper operation.
16. Install the inspection panel.

---

METHOD OF EVALUATION:

1. Pump does not leak.

JOB: Remove a Stuck Agitator on an Automatic Washer Using a Puller

JOB SHEET  
IDENTIFICATION CODE

UNIT IV: Laundry Equipment

JOB NUMBER: J-4-22

COURSE: Appliance Repair

MATERIAL: Rust Solvent  
Automatic Washer with Standard Agitator

TOOLS: Agitator Puller  
Basic Hand Tools  
Rubber Mallet

SAFETY PRECAUTIONS:

Wear safety glasses

COMPETENCE - PROCEDURES/STEPS The student will be able to:	TEACHING/LEARNING ACTIVITIES
1. Remove agitator cap or collar.	. SC-4-21
2. Apply rust solvent to the torque block.	
3. Hit the top of the agitator with the rubber mallet.	
4. Install agitator puller.	
5. Hit the top and sides of the agitator as the pressure is increased on the puller.	NOTE: If this does not remove the agitator it may have to be broken using a chisel and hammer. Check with your instructor.

METHOD OF EVALUATION:

1. Agitator is removed without damage to appliance.

JOB: Remove Tub Locknut

JOB SHEET  
IDENTIFICATION CODE

UNIT IV: Laundry Equipment

JOB NUMBER: J-4-23

COURSE: Appliance Repair

MATERIAL: Automatic Washer - Kenmore-  
Whirlpool-Maytag

TOOLS: Adjustable Spanner Wrench  
Taper Punch  
Ball Peen Hammer

SAFETY PRECAUTIONS:

Wear safety glasses

---

COMPETENCE - PROCEDURES/STEPS The student will be able to:	TEACHING/LEARNING ACTIVITIES
1. Turn off the power.	
2. Remove the agitator.	. SC-4-22
3. Locate the tub locknut.	
4. Apply rust solvent.	
5. Loosen locknut using spanner wrench.	
6. Remove the tub and inspect the inner and outer tubs.	
7. Clean both tubs.	
8. Apply lubricant to the threads for the locknut.	
9. Install the tub.	
10. Tighten the locknut.	

---

METHOD OF EVALUATION:

1. Locknut removed within prescribed time.

JOB: Remove Tight Screw or Bolt  
Using Impact Tool

JOB SHEET  
IDENTIFICATION CODE

UNIT IV: Laundry Equipment

JOB NUMBER: J-4-24

COURSE: Appliance Repair

MATERIAL: Rust Solvent  
Automatic Washer

TOOLS: Impact Tool  
Soft Face Hammer

SAFETY PRECAUTIONS:

Wear safety glasses

---

COMPETENCE - PROCEDURES/STEPS The student will be able to:	TEACHING/LEARNING ACTIVITIES
1. Locate the tight screw or bolt to be loosened.	. SC-4-23
2. Apply rust solvent.	
3. Select the proper socket or bit for impact tool.	
4. Install the socket or bit on the impact handle.	
5. Loosen the screw or bolt.	

---

METHOD OF EVALUATION:

1. Screw or bolt removed without damage to the appliance.

JOB: Check Spin Speed on an Automatic Washer Using a Hand Tachometer

JOB SHEET  
IDENTIFICATION CODE

UNIT IV: Laundry Equipment

JOB NUMBER: J-4-25

COURSE: Appliance Repair

MATERIAL: Automatic Washer

TOOLS: Hand Tachometer

SAFETY PRECAUTIONS:

Wear safety glasses

COMPETENCE - PROCEDURES/STEPS The student will be able to:	TEACHING/LEARNING ACTIVITIES
1. Install and level washer.	. SC-4-24
2. Turn timer knob to spin cycle.	
3. Plug in power supply.	NOTE: Check if machine will spin with lid open, (by-pass lid switch if necessary).
4. Hold tachometer onto the agitator cap or shaft surface.	
5. Read the meter scale.	
6. Take two readings and compare with the manufacturer's specifications.	

METHOD OF EVALUATION:

1. Speed readings are within tolerance.

141

JOB: Check the Water Supply Pressure  
Using a Water Pressure Gauge

JOB SHEET  
IDENTIFICATION CODE

UNIT IV: Laundry Equipment

JOB NUMBER: J-4-26

COURSE: Appliance Repair

TOOLS: Water Pressure Gauge

SAFETY PRECAUTIONS:

Wear safety glasses

---

COMPETENCE - PROCEDURES/STEPS The student will be able to:	TEACHING/LEARNING ACTIVITIES
1. Attach the pressure gauge on the cold faucet.	. SC-4-25
2. Turn on the cold faucet.	NOTE: Make sure faucet is off before attaching or removing pressure gauge.
3. Take a gauge reading.	
4. Attach the pressure gauge on the hot faucet.	
5. Turn on hot faucet.	
6. Take a gauge reading.	NOTE: Compare the readings with standard specifications.

---

METHOD OF EVALUATION:

1. Gauge readings are within tolerance.

112

JOB: Check Clutch Clearance

JOB SHEET  
IDENTIFICATION CODE

UNIT IV: Laundry Equipment

JOB NUMBER: J-4-27

COURSE: Appliance Repair

MATERIAL: Automatic Washer - Kenmore-  
Whirlpool

TOOLS: Feeler gauge  
Basic Hand Tools

SAFETY PRECAUTIONS:

Wear safety glasses

COMPETENCE - PROCEDURES/STEPS The student will be able to:	TEACHING/LEARNING ACTIVITIES
1. Disconnect power supply.	. SC-4-26
2. Remove rear cover.	
3. Plug in the power cord.	
4. Start the machine in any position other than spin.	
5. Disconnect power supply.	
6. Lay the machine on the front.	NOTE: Use a blanket or mat to protect the finish.
7. Locate the clutch plate.	
8. Check the clutch clearance using a feeler gauge.	NOTE: Compare the clutch clearance to the manufacturer's specifications.
9. Adjust the clutch if necessary.	

METHOD OF EVALUATION:

1. Readings are correct.
2. Clutch adjusted to correct tolerance.

JOB: Lubricate a Water Pump or Shaft

JOB SHEET  
IDENTIFICATION CODE

UNIT IV: Laundry Equipment

JOB NUMBER: J-4-28

COURSE: Appliance Repair

MATERIAL: Automatic Washer - Speed Queen,  
Norge, or Others That Have  
Grease Fittings

TOOLS: Basic Hand Tools  
Grease Gun

SAFETY PRECAUTIONS:

Wear safety glasses

---

COMPETENCE - PROCEDURES/STEPS The student will be able to:	TEACHING/LEARNING ACTIVITIES
1. Disconnect the power supply.	. SC-4-27
2. Remove the inspection panel.	
3. Locate the grease fitting.	
4. Clean the grease fitting.	
5. Install the grease gun.	
6. Pump in the required amount of grease.	NOTE: For amount of grease see the manu- facturer's specifications.

---

METHOD OF EVALUATION:

1. Proper procedure followed.

114



JOB: Remove and Install Bearings  
in Motor

JOB SHEET  
IDENTIFICATION CODE

UNIT IV: Laundry Equipment

JOB NUMBER: J-4-29

COURSE: Appliance Repair

MATERIAL: Bearings  
Used Motor

EQUIPMENT: Arbor-Bearing Press

TOOLS: Basic Hand Tools

SAFETY PRECAUTIONS:

Wear safety glasses

COMPETENCE - PROCEDURES/STEPS The student will be able to:	TEACHING/LEARNING ACTIVITIES
1. Disassemble the motor.	. SC-4-28
2. Clean the motor parts.	
3. Inspect the motor shaft.	NOTE: If shaft is worn notify your instructor.
4. Remove the old bearings using the arbor bearing press.	
5. Install the new bearings using the arbor-bearing press.	NOTE: The bearings should be checked for fit on the motor shaft before installing them into the end bell.
6. Reassemble the motor.	
7. Check the motor for proper operation.	

METHOD OF EVALUATION:

1. Motor turns freely.
2. Motor operates.

115

JOB: Remove Spin Tub on Frigidaire Automatic Washer to Inspect and Clean Outer Tub

JOB SHEET  
IDENTIFICATION CODE

UNIT IV: Laundry Equipment

JOB NUMBER: J-4-30

COURSE: Appliance Repair

MATERIAL: Frigidaire Automatic Washer

TOOLS: Basic Hand Tools  
Socket Set with Extensions  
Ball Peen Hammer  
Chisel

SAFETY PRECAUTIONS:

Wear safety glasses

COMPETENCE - PROCEDURES/STEPS The student will be able to:	TEACHING/LEARNING ACTIVITIES
1. Turn off the power supply.	
2. Remove the top assembly.	NOTE: Refer to manufacturer's manual for removal steps.
3. Remove the outer tub cover.	NOTE: Refer to manufacturer's manual for removal steps.
4. Remove the pulsator assembly.	
5. Locate the lock nut and lock tab.	
6. Straighten the lock tab.	. SC-4-29
7. Remove the lock nut.	. SC-4-22
8. Remove the spanner nut.	
9. Lift out the inner tub.	
10. Clean and inspect the outer tub.	NOTE: The instructor will check the tub.
11. Reassemble and check the machine for proper operation.	

116

---

METHOD OF EVALUATION:

1. Parts were removed without damage.
2. Proper reassembly and machine operation.

117

JOB: Evaluate Dryer Timer Performance

JOB SHEET  
IDENTIFICATION CODE

UNIT IV: Laundry Equipment

JOB NUMBER: J-4-31

COURSE: Appliance Repair

MATERIAL: Electric Dryer

SAFETY PRECAUTIONS:

Wear safety glasses

COMPETENCE - PROCEDURES/STEPS The student will be able to:	TEACHING/LEARNING ACTIVITIES
1. Turn timer to the time dry position.	NOTE: Set at approximately the 30 minute setting.
2. Take a temperature test of the vented air after a few minutes of operation.	NOTE: Compare with manufacturer's specifications.
3. Manually advance the timer to the 10 minute position on the dial and check that the cool-off cycle operates.	NOTE: Check that the timer advances properly.
4. Manually turn the timer to the automatic cycle.	
5. Check that the timer advances properly after the operating thermostat shuts off the dryer heat.	
7. Manually turn the timer to the air fluff cycle.	NOTE: The heat should not be on.

METHOD OF EVALUATION:

1. Diagnosis correct.

JOB: Replace a Start Switch on a  
Dryer

JOB SHEET  
IDENTIFICATION CODE

UNIT IV: Laundry Equipment

JOB NUMBER: J-4-32

COURSE: Appliance Repair

MATERIAL: Electric Dryer

TOOLS: Basic Hand Tools

SAFETY PRECAUTIONS:

Wear safety glasses

---

COMPETENCE - PROCEDURES/STEPS The student will be able to:	TEACHING/LEARNING ACTIVITIES
<ol style="list-style-type: none"><li>1. Turn off the supply line.</li><li>2. Remove the access panel.</li><li>3. Remove the electrical connections.</li><li>4. Make a drawing showing connections, color and location.</li><li>5. Remove the knob or button.</li><li>6. Remove the mounting screws or bolts and remove the defective switch.</li><li>7. Position the new switch and tighten the mounting screws or bolts.</li><li>8. Replace the knob or button.</li><li>9. Replace the electrical connections.</li><li>10. Replace the access panel.</li><li>11. Check for proper operation.</li></ol>	<p>NOTE: Some switches do not have removable knobs or buttons.</p>

---

METHOD OF EVALUATION:

1. Switch operates.

149

JOB: Replace the Temperature Selection Switch on an Electric Dryer

JOB SHEET  
IDENTIFICATION CODE

UNIT IV: Laundry Equipment

JOB NUMBER: J-4-32

COURSE: Appliance Repair

MATERIAL: Electric Dryer

TOOLS: Basic Hand Tools

SAFETY PRECAUTIONS:

Wear safety glasses

---

COMPETENCE - PROCEDURES/STEPS The student will be able to:	TEACHING/LEARNING ACTIVITIES
1. Turn off the supply line.	
2. Remove the access panel.	
3. Remove the electrical connections noting their color and location.	
4. Remove the knob.	
5. Remove the mounting screws or bolts and remove the defective switch.	
6. Position the new switch and tighten the mounting screws or bolts.	
7. Replace the knob.	
8. Replace the electrical connections.	
9. Replace the access panel.	
10. Check for proper operation.	

---

METHOD OF EVALUATION:

1. Selector switch connections tight.
2. Mounted correctly.
3. Dryer operates.

150

JOB: Replace a Thermostat on an Electric Dryer

JOB SHEET  
IDENTIFICATION CODE

UNIT IV: Laundry Equipment

JOB NUMBER: J-4-34

COURSE: Appliance Repair

MATERIAL: Electric Dryer

TOOLS: Basic Hand Tools

SAFETY PRECAUTIONS:

Wear safety glasses

---

COMPETENCE - PROCEDURES/STEPS  
The student will be able to:

---

TEACHING/LEARNING ACTIVITIES

#### CAPILLARY TYPE THERMOSTAT

1. Turn off the power source.
2. Remove the inspection cover.
3. Remove the line and load wires from the thermostat.
4. Remove the knob and the thermostat mounting screw.
5. Remove the capillary tube clamp.
6. Install a new thermostat and tighten the thermostat mounting screws.
7. Position and clamp the capillary tubing.
8. Replace the line and load wiring.
9. Replace the inspection cover.
10. Turn on the power source.
11. Check the dryer operation.

NOTE: Make a drawing noting their color and location.

NOTE: Use drawing.

#### MECHANICAL TYPE THERMOSTAT

1. Turn off the power source.
2. Remove the inspection cover.

151

---

COMPETENCE - PROCEDURES/STEPS	TEACHING/LEARNING ACTIVITIES
3. Remove the line and load wires, noting their color and location.	
4. Remove the mounting screws.	
5. Install a new thermostat and tighten the thermostat mounting screws.	
6. Replace the line and load wires.	
7. Replace the inspection cover.	
8. Turn on the power source.	
9. Check the dryer operation.	

---

METHOD OF EVALUATION:

1. Dryer operates.
2. Dryer heats properly.



JOB: Replace a Heating Element on an Electric Dryer

JOB SHEET  
IDENTIFICATION CODE

UNIT IV: Laundry Equipment

JOB NUMBER: J-4-35

COURSE: Appliance Repair

MATERIAL: Electric Dryer

TOOLS: Basic Hand Tools

SAFETY PRECAUTIONS:

Wear safety glasses

---

COMPETENCE - PROCEDURES/STEPS  
The student will be able to:

TEACHING/LEARNING ACTIVITIES

---

1. Turn off the power source.
2. Remove the inspection panel.
3. Remove the wires to the element, noting their color and location.
4. Remove the element mounting screws.
5. Clean the line out of the heating duct.
6. Install the new element and tighten the mounting screws.
7. Replace the wires to the element.
8. Replace the inspection panel.
9. Turn on the power source.
10. Check the operation.

---

METHOD OF EVALUATION:

1. Wire terminal tight.
2. Insulators not broken.
3. Dryer heats.

153

JOB: Replace Motor on an Electric Dryer

JOB SHEET  
IDENTIFICATION CODE

UNIT IV: Laundry Equipment

JOB NUMBER: J-4-36

COURSE: Appliance Repair

MATERIAL: Electric Dryer

TOOLS: Basic Hand Tools

SAFETY PRECAUTIONS:

Wear safety glasses

COMPETENCE - PROCEDURES/STEPS The student will be able to:	TEACHING/LEARNING ACTIVITIES
<ol style="list-style-type: none"><li>1. Turn off the supply line.</li><li>2. Remove the access panel.</li><li>3. Remove the electrical connections noting their color and location.</li><li>4. Remove the centrifugal switch mounting screws and remove defective switch.</li><li>5. Position the new centrifugal switch and tighten.</li><li>6. Replace the electrical connections and go to step 11.</li><li>7. Loosen and remove the motor mounting screws or bolts.</li><li>8. Remove the defective motor.</li><li>9. Position the new motor and tighten the screws or bolts.</li><li>10. Replace the electrical connections.</li><li>11. Replace the access panel.</li><li>12. Check for proper operation.</li></ol>	<p>NOTE: If the motor has an external centrifugal switch do step 4, 5 and 6. If the centrifugal switch is the internal type, go to step 7.</p>

154

---

METHOD OF EVALUATION:

1. Bolts tight.
2. Proper belt alignment.
3. No vibrations:

155

JOB: Replace Timer on an Electric  
Dryer

JOB SHEET  
IDENTIFICATION CODE

UNIT IV: Laundry Equipment

JOB NUMBER: J-4-37

COURSE: Appliance Repair

MATERIAL: Electric Dryer

TOOLS: Basic Hand Tools

SAFETY PRECAUTIONS:

Wear safety glasses

---

COMPETENCE - PROCEDURES/STEPS  
The student will be able to:

TEACHING/LEARNING ACTIVITIES

---

1. Make sure the power source is turned off.
2. Remove the inspection cover.
3. Remove the wires from the timer noting their color and location.
4. Remove the timer knob.
5. Remove the timer mounting screws.
6. Install a new timer and tighten the mounting screws.
7. Replace the knob.
8. Replace the wires.
9. Replace the inspection cover.
10. Turn on the power source.
11. Check the dryer operation.

---

METHOD OF EVALUATION:

1. Connection properly made
2. Connection tight.
3. Timer operates dryer.

156

JOB: Check Door Switch Operation

JOB SHEET  
IDENTIFICATION CODE

UNIT IV: Laundry Equipment

JOB NUMBER: J-4-38

COURSE: Appliance Repair

MATERIAL: Electric Dryer

TOOLS: Basic Hand Tools

SAFETY PRECAUTIONS:

Wear safety glasses

COMPETENCE - PROCEDURES/STEPS The student will be able to:	TEACHING/LEARNING ACTIVITIES
DOOR SWITCH CHECKING STEPS	. SC-2-18
<ol style="list-style-type: none"><li>1. Turn off the power source.</li><li>2. Remove the door switch mounting screws.</li><li>3. Remove the door switch wires, noting their color and location.</li><li>4. Set a volt-ohm meter to the R X 1 scale.</li><li>5. For two wire type:<ol style="list-style-type: none"><li>a. attach one test lead to each terminal.</li><li>b. Push the button in and hold it.</li></ol></li><li>6. For three wire type:<ol style="list-style-type: none"><li>a. attach one test lead to the terminal that feeds the drum light (#3 on this switch).</li><li>b. attach the other test lead to the common terminal (usually the single terminal) on one end of the switch (#1 on this switch).</li><li>c. attach one test lead to the terminal that feeds the timer (#2 on this switch).</li></ol></li></ol>	<p>NOTE: There should be NO continuity.</p> <p>NOTE: There should be continuity. If there is no continuity, the switch is defective.</p> <p>NOTE: There should be continuity, if there is no continuity the switch is defective.</p>

157

---

COMPETENCE - PROCEDURES/STEPS	TEACHING/LEARNING ACTIVITIES
d. attach the other test lead to the common terminal (#1 on this switch). e. Press the button in and hold it in.	NOTE: There should be no continuity. NOTE: There should be continuity. If there is no continuity, the switch is defective.

---

METHOD OF EVALUATION:

1. Diagnosis correct.

158

JOB: Replace Inlet Valve on an Automatic Washer

JOB SHEET  
IDENTIFICATION CODE

UNIT IV: Laundry Equipment

JOB NUMBER: J-4-39

COURSE: Appliance Repair

MATERIAL: Automatic Washer

TOOLS: Basic Hand Tools

SAFETY PRECAUTIONS:

Wear safety glasses

---

COMPETENCE - PROCEDURES/STEPS The student will be able to:	TEACHING/LEARNING ACTIVITIES
<ol style="list-style-type: none"><li>1. Unplug the power cord.</li><li>2. Remove the access panel.</li><li>3. Turn off the water supply.</li><li>4. Remove the inlet hoses.</li><li>5. Remove the electrical connections noting their color and location.</li><li>6. Remove the tub fill hose.</li><li>7. Remove the inlet valve mounting screws or bolts.</li><li>8. Position the new inlet valve and tighten the mounting screws or bolts.</li><li>9. Replace the tub fill hose.</li><li>10. Connect the electrical wiring.</li><li>11. Replace the inlet hoses.</li><li>12. Turn on the water supply and check for leaks.</li><li>13. Replace the access panel.</li><li>14. Check for proper operation.</li></ol>	

---

---

METHOD OF EVALUATION:

1. Valve mounting bolt tight.
2. Valve doesn't leak.
3. Wired correctly.

160



JOB: Replace a Water Pump on an Automatic Washer

JOB SHEET  
IDENTIFICATION CODE

UNIT IV: Laundry Equipment

JOB NUMBER: J-4-40

COURSE: Appliance Repair

MATERIAL: Automatic Washer

TOOLS: Basic Hand Tools

SAFETY PRECAUTIONS:

Wear safety glasses

---

COMPETENCE - PROCEDURES/STEPS  
The student will be able to:

TEACHING/LEARNING ACTIVITIES

---

1. Unplug the power cord.
2. Remove the access panel.
3. Remove the pump hoses.
4. Remove the pump mounting bolts.
5. Position the new pump and tighten the mounting bolts.
6. Attach the hoses.
7. Adjust the belt.
8. Replace the access panel.
9. Check for proper operation.

---

METHOD OF EVALUATION:

1. Mounting bolts tight.
2. Belt alignment proper.
3. Nose connections do not leak.

181

JOB: Replace a Push Button Switch  
on an Electric Range

JOB SHEET  
IDENTIFICATION CODE

UNIT V: Kitchen Equipment

JOB NUMBER: J-5-1

COURSE: Appliance Repair

MATERIAL: Electric Range (with Push Button  
Switches)

TOOLS: Basic Hand Tools  
Screw Starter

SAFETY PRECAUTIONS:

Wear safety glasses

COMPETENCE - PROCEDURES/STEPS The student will be able to:	TEACHING/LEARNING ACTIVITIES
1. Turn off the power supply.	
2. Remove the switch panel inspection cover.	
3. Remove the wires.	NOTE: Make a drawing of their location and color.
4. Using regular screwdriver, loosen the switch mounting screws.	
5. Install the screw starter on to the switch mounting screws.	. SC-5-1
6. Remove the mounting screws.	
7. Remove the switch.	
8. Position the new switch.	
9. Insert the switch mounting screws and turn them into position.	NOTE: Do not tighten the screws with the screw starter as this may damage the holding devise.
10. Tighten the mounting screws, using regular screwdriver.	
11. Install the wires as per the drawing from step 3.	
12. Reinstall the inspection panel.	
13. Check for correct operation.	

162

---

METHOD OF EVALUATION:

1. Switch installed without damage.
2. Connection solid.
3. Range operates.

153

JOB: Check the Operation of a Five Heat Switch

JOB SHEET  
IDENTIFICATION CODE

UNIT V: Kitchen Equipment

JOB NUMBER: J-5-2

COURSE: Appliance Repair

MATERIAL: Electric Range with Five Heat Switches

EQUIPMENT: Twin Lamp Tester From J-2-29

TOOLS: Basic Hand Tools

SAFETY PRECAUTIONS:

Wear safety glasses

---

COMPETENCE - PROCEDURES/STEPS  
The student will be able to:

TEACHING/LEARNING ACTIVITIES

---

1. Turn off power.
2. Attach the twin lamp tester to the terminals on the surface element.
3. Turn on the power.
4. Set the switch to the high position.
5. Check the remaining positions.

. SC-5-2

NOTE: Make sure the alligator clamps are not touching each other.

NOTE: Both lamps should be on.

NOTE: Refer to the manufacturer's specifications for proper operation.

NOTE: Most switches operate as follows:  
High - Both lamps bright.  
Second - One lamp bright.  
Third - Both lamps dull.  
Low - One lamp dull.  
Warm - Both lamps dim.

---

METHOD OF EVALUATION:

1. All five settings on switch were properly diagnosed.

JOB: Test an Infinite Switch Using a Test Lamp

JOB SHEET  
IDENTIFICATION CODE

UNIT V: Kitchen Equipment

JOB NUMBER: J-5-3

COURSE: Appliance Repair

MATERIAL: Electric Range with Infinite Switches

EQUIPMENT: Twin Lamp Tester

SAFETY PRECAUTIONS:

Wear safety glasses

COMPETENCE - PROCEDURES/STEPS The student will be able to:	TEACHING/LEARNING ACTIVITIES
1. Turn off the power supply.	. SC-5-2
2. Attach the test lamp alligator clamps of one lamp to the surface element.	NOTE: Tape the remaining alligator clamp to avoid shock hazards.
3. Turn on the power supply.	
4. Set the switch to the low position.	NOTE: The lamp should be bright.  NOTE: This switch will not operate unless current flows through the element.  NOTE: Wait a few seconds and the lamp should go off. The lamp will continue to go on and off.
5. Continue observing lamp.	

METHOD OF EVALUATION:

1. Diagnosis accurate.

JOB: Test Oven Temperature

JOB SHEET  
IDENTIFICATION CODE

UNIT V: Kitchen Equipment

JOB NUMBER: J-5-4

COURSE: Appliance Repair

MATERIAL: Electric Range

EQUIPMENT: Temperature Tester

SAFETY PRECAUTIONS:

Wear safety glasses

COMPETENCE - PROCEDURES/STEPS The student will be able to:	TEACHING/LEARNING ACTIVITIES
<ol style="list-style-type: none"><li>1. Put the oven rack in the center of oven.</li><li>2. Turn the selector switch to BAKE.</li><li>3. Set the thermostat to 250°.</li><li>4. Place the thermocouple test lead on the oven rack (in the center).</li><li>5. Let the oven heat through a cycle at least twice.</li><li>6. Check oven temperature.</li></ol>	<p>. SC-4-19</p> <p>NOTE: The thermostat must go on and off twice.</p> <p>NOTE: When the oven heat goes off, the temperature should be about 230° and it should slowly rise to between 240° and 260°.</p> <ol style="list-style-type: none"><li>a. If these readings are over 50° or more off calibration, replace the thermostat.</li><li>b. If the readings are within 40°, most thermostats can be re-calibrated.</li></ol>

METHOD OF EVALUATION:

1. Adjustment correct.
2. Diagnosis accurate.

166

JOB: Clean an Oven

JOB SHEET  
IDENTIFICATION CODE

UNIT V: Kitchen Equipment

JOB NUMBER: J-5-5

COURSE: Appliance Repair

MATERIAL: Oven Cleaner  
Rags  
Range with Dirty Oven

SAFETY PRECAUTIONS:

1. Wear full face safety shield
2. Wear rubber gloves

COMPETENCE - PROCEDURES/STEPS The student will be able to:	TEACHING/LEARNING ACTIVITIES
1. Remove the oven racks.	. SC-5-3  NOTE: The oven racks can also be cleaned with the oven cleaner.
2. Remove the oven elements if the elements are plug in type.	
3. Apply the oven cleaner solution.	NOTE: Allow time for the solution to react.
4. Remove all oven cleaning solution from the oven wall with a damp rag.	
5. Replace the oven elements.	
6. Turn on the oven and heat the oven to dry the oven walls.	
7. Install the cleaned oven racks.	

METHOD OF EVALUATION:

1. Oven clean.

167

JOB: Install an Oven Door Spring Using  
Brake Spring Pliers

JOB SHEET  
IDENTIFICATION CODE

UNIT V: Kitchen Equipment

JOB NUMBER: J-5-6

COURSE: Appliance Repair

MATERIAL: Oven Door Spring  
Range with Oven Spring Removed

TOOLS: Brake Spring Pliers  
Basic Hand Tools

SAFETY PRECAUTIONS:

Wear safety glasses

---

COMPETENCE - PROCEDURES/STEPS The student will be able to:	TEACHING/LEARNING ACTIVITIES
1. Remove the drawers.	. SC-5-4
2. Remove the spring inspection cover over the spring chamber.	NOTE: Some ranges will require the removal of a side panel to locate the spring chamber.
3. Remove the broken spring.	
4. Install the new spring.	
5. Check for proper operation.	
6. Reassemble the parts.	

---

METHOD OF EVALUATION:

1. Adjustment correct.
2. Door operates.



JOB: Replace Door Panel on Appliance  
Using Offset Screwdriver

JOB SHEET  
IDENTIFICATION CODE

UNIT V: Kitchen Equipment

JOB NUMBER: J-5-7

COURSE: Appliance Repair

MATERIAL: Range - (Handle that has a screw  
with low overhead clearance)

TOOLS: Offset Screwdriver  
Basic Hand Tools

SAFETY PRECAUTIONS:

Wear safety glasses

---

COMPETENCE - PROCEDURES/STEPS The student will be able to:	TEACHING/LEARNING ACTIVITIES
1. Open the door to the broil stop.	. SC-5-5
2. Locate the panel mounting screws.	. SC-5-6
3. Remove the screws.	
4. Install the new panel.	

---

METHOD OF EVALUATION:

1. Panel replaced and adjusted with no damage to equipment.

JOB: Replace Oven Timer

JOB SHEET  
IDENTIFICATION CODE

UNIT V: Kitchen Equipment

JOB NUMBER: J-5-8

COURSE: Appliance Repair

MATERIAL: Electric Range

TOOLS: Basic Hand Tools  
Offset Screwdrivers

SAFETY PRECAUTIONS:

Wear safety glasses

<u>COMPETENCE - PROCEDURES/STEPS</u> The student will be able to:	<u>TEACHING/LEARNING ACTIVITIES</u>
1. Turn off the power source.	. SC-5-5
2. Remove the switch panel inspection cover.	. SC-5-6
3. Remove the wires to the timer terminals.	NOTE: Make a drawing to show their color and location.
4. Remove the timer knobs.	
5. Remove the timer mounting screws and remove the old timer.	
6. Install the new timer and tighten the mounting screws.	
7. Attach the wires to the proper terminals.	NOTE: Use the drawing to check the hook up.
8. Turn on the power source and check the operation.	
9. Replace the switch panel inspection cover.	

METHOD OF EVALUATION:

1. Connections solid.
2. Timer operates.

170

JOB: Rewire Open Heating Elements

JOB SHEET  
IDENTIFICATION CODE

UNIT V: Kitchen Equipment

JOB NUMBER: J-5-9

COURSE: Appliance Repair

MATERIAL: Element Wire  
Open Wire Broil or Bake Element  
Rust Solvent  
Thin Wire or String  
Emory Cloth

TOOLS: Basic Hand Tools  
Lock Grip Pliers  
Smooth File

SAFETY PRECAUTIONS:

Wear safety glasses

COMPETENCE - PROCEDURES/STEPS The student will be able to:	TEACHING/LEARNING ACTIVITIES
1. Remove the element screws at the terminals.	. SC-5-7  NOTE: Most screws will be rusted. Apply rust solvent.
2. Make a drawing, noting the element path through the insulators.	
3. Remove the old element wire.	
4. Inspect the insulators.	
5. Replace any cracked or broken insulators.	
6. Use the drawing and run the string or wire through the insulators to get the length of travel.	
7. Mark the string or wire as to length.	
8. Remove the string or wire.	
9. Clamp the string or wire to one end of the new element wire using the lock grip pliers.	
10. Stretch the new element wire to within 2" of the required length.	

171

---

COMPETENCE - PROCEDURES/STEPS

TEACHING/LEARNING ACTIVITIES

---

11. Clean the terminals with a file or emory cloth.
12. Thread the new element wire through the insulators, starting at the center and working to one end.
13. Attach the element wire to one terminal.
14. Repeat steps #12 and 13 on the other end.

---

METHOD OF EVALUATION:

1. Connections solid.
2. Insulators not cracked.
3. No hot spots.

172

JOB: Replace Surface Elements

JOB SHEET  
IDENTIFICATION CODE

UNIT V: Kitchen Equipment

JOB NUMBER: J-5-10

COURSE: Appliance Repair

MATERIAL: Electric Range

TOOLS: Basic Hand Tools  
Offset Screw Driver  
Lock Grip Pliers  
Screw Starter

SAFETY PRECAUTIONS:

Wear safety glasses

COMPETENCE - PROCEDURES/STEPS The student will be able to:	TEACHING/LEARNING ACTIVITIES
1. Make sure the voltage source is turned off.	. SC-5-1 . SC-5-6 . SC-5-7
2. Remove the element wires.	NOTE: Note their color and location.
3. Attach the wire to the new element.	NOTE: Make sure the common wire is on the common terminal. If the element has a ground wire, attach it to the proper terminal.
4. Install the element in the range.	
5. Turn on the voltage supply.	
6. Turn the switch to the <u>high</u> position.	NOTE: Make sure the element heats properly.

METHOD OF EVALUATION:

1. Connections clean.
2. Connections solid.
3. Element works.

173

JOB: Replace a Rotary Switch

JOB SHEET  
IDENTIFICATION CODE

UNIT V: Kitchen Equipment

JOB NUMBER: J-5-11

COURSE: Appliance Repair

MATERIAL: Electric Range

TOOLS: Basic Hand Tools  
Offset Screwdriver  
Screw Starter

SAFETY PRECAUTIONS:

Wear safety glasses

COMPETENCE - PROCEDURES/STEPS The student will be able to:	TEACHING/LEARNING ACTIVITIES
1. Turn off the voltage source.	. SC-5-1
2. Remove the inspection cover.	. SC-5-6
3. Remove the line and load wires.	NOTE: Make a drawing to note their color and location on the switch.
4. Remove the mounting screws that hold the switch.	
5. Install a new switch and tighten the mounting screws.	
6. Replace the line and load wires.	NOTE: Check your drawing.
7. Replace the inspection cover.	
8. Turn the switch to the OFF position.	
9. Turn on the voltage supply.	
10. Check the switch operation to see that it heats properly.	

METHOD OF EVALUATION:

1. Connections solid.
2. Switch operates.

174

JOB: Replace Water Heater Thermostat

JOB SHEET  
IDENTIFICATION CODE

UNIT V: Kitchen Equipment

JOB NUMBER: J-5-12

COURSE: Appliance Repair

MATERIAL: Electric Water Heater

TOOLS: Basic Hand Tools

SAFETY PRECAUTIONS:

Wear safety glasses

COMPETENCE - PROCEDURES/STEPS The student will be able to:	TEACHING/LEARNING ACTIVITIES
1. Turn off the power source.	. SC-5-1
2. Remove the inspection cover.	. SC-5-6
3. Remove the wires from the thermostat terminals.	. SC-5-7 NOTE: Note their color and location. Make a drawing if necessary.
4. Remove the thermostat mounting bolts.	NOTE: Some thermostats are held in place by a spring clip.
5. Install the new thermostat and tighten the mounting bolts.	
6. Inspect the wires and terminals for corrosion and replace them if necessary.	
7. Connect the wires and terminals to the new thermostat.	
8. Replace the inspection cover.	
9. Turn on the power source and check the operation.	

METHOD OF EVALUATION:

1. Connections tight.
2. Thermostat operates.

175

JOB: Replace Wrap Around Type Water  
Heater Element

JOB SHEET  
IDENTIFICATION CODE

UNIT V: Kitchen Equipment

JOB NUMBER: J-5-13

COURSE: Appliance Repair

MATERIALS: Rust Solvent  
Gasket Cement  
8 ft. #14 solid wire  
Electric Water Heater (with  
wrap around element)

TOOLS: Basic Hand Tools  
Lock Grip Pliers  
3/8" Drive Socket Set  
Ball Peen Hammer

SAFETY PRECAUTIONS:

Wear safety glasses

COMPETENCE - PROCEDURES/STEPS The student will be able to:	TEACHING/LEARNING ACTIVITIES
1. Turn off the voltage supply.	. SC-5-7
2. Remove the inspection covers.	
3. Remove the insulation covering the element terminals.	
4. Disconnect the wires from the element terminals.	
5. Loosen the bolts on the element mounting clamp.	<u>NOTE: Do not remove the bolts.</u>
6. Attach an 8' piece of #14 wire to one element terminal.	
7. Attach the lock grip pliers to the other element terminal.	
8. Using the lock grip pliers, pull out the defective element.	<u>NOTE: Pull it until about 2" of the attached wire is seen.</u>
9. Disconnect the wire and attach it to one terminal of the new element.	
10. Use the wire to pull in the new element.	

176



---

**COMPETENCE - PROCEDURES/STEPS**

---

**TEACHING/LEARNING ACTIVITIES**

11. Tighten the bolts on the element mounting clamp.
12. Remove the #14 wire from the element terminal.
13. Attach the supply wires to the element terminals.
14. Replace the insulation and the inspection covers.
15. Turn on the voltage supply.
16. Check the operation.

---

**METHOD OF EVALUATION:**

1. Connections solid.
2. Clamp tight.
3. Element operates.

JOB: Replace Immersion Type Water  
Heater Element

JOB SHEET  
IDENTIFICATION CODE

UNIT V: Kitchen Equipment

JOB NUMBER: J-5-14

COURSE: Appliance Repair

MATERIAL: Rust Solvent  
Gasket Cement  
Electric Water Heater with  
Immersion Elements

TOOLS: Basic Hand Tools  
3/8" Drive Socket Set  
Ball Peen Hammer  
50' Piece of Garden Hose

SAFETY PRECAUTIONS:

Wear safety glasses

COMPETENCE - PROCEDURES/STEPS The student will be able to:	TEACHING/LEARNING ACTIVITIES
1. Turn off the voltage supply.	. SC-5-7
2. Turn off the cold water supply valve.	
3. Attach a garden hose to the water heater drain valve.	
4. Open the drain valve and open a hot water faucet anywhere above the water heater.	
5. Wait until the tank is drained.	
6. While waiting, put liquid wrench on the element mounting bolts and remove the wires from the element terminal.	
7. Remove the element mounting bolts.	
8. Insert a straight screwdriver blade between the element flange and the tank.	
9. Tap the screwdriver with a hammer in order to pry the element loose.	
10. Clean away any old gasket material around the flange opening.	
11. Coat the area with gasket cement.	

178

COMPETENCE - PROCEDURES/STEPS	TEACHING/LEARNING ACTIVITIES
12. Coat the inside of the element flange with gasket cement.	
13. Install the element and gasket.	NOTE: Start the bolts and turn them as far as possible by hand. Then, tighten the bolt with a socket wrench making sure to tighten the bolts equally.
14. Remove the drain hose and close the drain valve.	
15. Open the cold water supply valve.	
16. While waiting for the tank to fill, attach the voltage supply wires to the element terminals.	
17. When the water flows out of the hot water spigot, close the spigot.	NOTE: The tank is full.
18. Check for water leaks around the element gasket.	
19. Replace the insulation and the inspection covers.	
20. Turn on the voltage supply and check the operation.	

METHOD OF EVALUATION:

1. Connections tight.
2. Element operates.
3. Does not leak.

179

JOB: Install a Garbage Disposal Body

JOB SHEET  
IDENTIFICATION CODE

UNIT V: Kitchen Equipment

JOB NUMBER: J-5-15

COURSE: Appliance Repair

MATERIAL: Putty  
Garbage Disposal

TOOLS: Basic Hand Tools  
Pipe Wrenches  
3/8" Socket Set  
Hex Wrenches  
Hacksaw

SAFETY PRECAUTIONS:

Wear safety glasses

---

COMPETENCE - PROCEDURES/STEPS	TEACHING/LEARNING ACTIVITIES
The student will be able to:	
1. Disassemble the existing drain piping to below the trap level of the sink.	SC-5-8
2. Remove the crumb cup and strainer assembly.	
3. Attach the disposal to the sink following the manufacturer's installation instructions.	

---

METHOD OF EVALUATION:

1. Water piping and old disposal removed without damage to sink.

180

JOB: Install a Garbage Disposal Drain

JOB SHEET  
IDENTIFICATION CODE

UNIT V: Kitchen Equipment

JOB NUMBER: J-5-16

COURSE: Appliance Repair

MATERIAL: 1 1/4 Trap  
50/50 Solder  
Garbage Disposal from J-5-15  
Flux

EQUIPMENT: Propane Torch

TOOLS: Basic Hand Tools  
Pipe Wrenches  
Hacksaw

SAFETY PRECAUTIONS:

1. Wear safety glasses
2. Wear gloves

---

COMPETENCE - PROCEDURES/STEPS The student will be able to:	TEACHING/LEARNING ACTIVITIES
1. Align and mark the drain trap and drain tubing to be cut.	. SC-5-9 . SC-3-18
2. Cut the tubing to size.	
3. Attach the drain trap and tubing to the disposal.	
4. Solder the drain tubing to the drain line where necessary.	

---

METHOD OF EVALUATION:

1. Drain does not leak.
2. Trap properly installed.
3. No damage to equipment.

ISI

JOB: Install a Garbage Disposal Electrically

UNIT V: Kitchen Equipment

COURSE: Appliance Repair

MATERIAL: 12/2 W.G. Cable  
Connectors  
Garbage Disposal from J-5-15

EQUIPMENT: Electric Drill 3/8

TOOLS: Basic Hand Tools  
Knock Out Punch Set  
Adjustable Wrench  
Foot Rule

JOB SHEET  
IDENTIFICATION CODE

JOB NUMBER: J-5-17

SAFETY PRECAUTIONS:

Wear safety glasses

COMPETENCE - PROCEDURES/STEPS The student will be able to:	TEACHING/LEARNING ACTIVITIES
1. Measure and mark the spot to cut a hole through the sink base for the electrical cable.	. SC-2-2A . SC-5-1
2. Drill the pilot hole in the sink base for the knock out punch.	. SC-5-7 . SC-5-10
3. Cut hole in sink base with a knockout punch ("1/2").	
4. Drill a hole through the wood floor if necessary to run the cable to the supply panel.	
5. Attach the cable to the disposal connection box and make the proper connections.	
6. Run the cable to the supply panel and make the proper connections.	

METHOD OF EVALUATION:

1. Disposal works.
2. Electric connection solid.

192

JOB: Replace an ON/OFF Switch on a  
Garbage Disposal

JOB SHEET  
IDENTIFICATION CODE

UNIT V: Kitchen Equipment

JOB NUMBER: J-5-18

COURSE: Appliance Repair

MATERIAL: On/Off Switch  
Lubriplate Grease  
Garbage Disposal

TOOLS: Basic Hand Tools  
Screw Starter  
Offset Screwdriver

**SAFETY PRECAUTIONS:**

Wear safety glasses

COMPETENCE - PROCEDURES/STEPS The student will be able to:	TEACHING/LEARNING ACTIVITIES
1. Turn off the voltage supply.	. SC-5-1
2. Remove the inspection cover.	. SC-5-6
3. Remove the wires on the switch.	NOTE: Make a drawing noting their color and location.
4. Remove the switch mounting screws.	
5. Remove the switch push rod and lubricate it.	
6. Install the new switch.	
7. Reconnect the wires.	NOTE: Use the drawing.
8. Replace the inspection cover.	
9. Turn on the voltage supply.	
10. Check the operation.	

**METHOD OF EVALUATION:**

1. Electric connections are tight.
2. Switch operates.

10.

JOB: Replace a Motor Relay on a  
Garbage Disposal

JOB SHEET  
IDENTIFICATION CODE

UNIT V: Kitchen Equipment

JOB NUMBER: J-5-19

COURSE: Appliance Repair

MATERIAL: Motor Relay  
Garbage Disposal

TOOLS: Basic Hand Tools  
Offset Screwdrivers  
Screw Starters

SAFETY PRECAUTIONS:

Wear safety glasses

---

COMPETENCE - PROCEDURES/STEPS The student will be able to:	TEACHING/LEARNING ACTIVITIES
1. Turn off the power supply.	. SC-5-1
2. Remove the motor cover in order to locate the relay.	. SC-5-6
3. Remove the wires to the relay.	NOTE: Indicate color and location of wires with a drawing.
4. Remove the relay mounting screws.	
5. Install the new relay and tighten the mounting screws.	
6. Attach the wires to the relay.	
7. Replace the motor cover.	
8. Turn on the power supply and check the operation.	

---

METHOD OF EVALUATION:

1. Relay mounted properly.
2. Electrical connections are solid.

194



JOB: Install a Dishwasher

JOB SHEET  
IDENTIFICATION CODE

UNIT V: Kitchen Equipment

JOB NUMBER: J-5-20

COURSE: Appliance Repair

MATERIAL: 1 1/4 Drain Trap  
12/2 W.G. Cable  
Dishwasher

EQUIPMENT Propane Torch  
Electric Hand Drill and Bits

TOOLS: Basic Hand Tools  
Pipe Wrenches  
Hacksaw  
Foot Rule  
Level  
Lock Grip Plier

---

COMPETENCE = PROCEDURES/STEPS The student will be able to:	TEACHING/LEARNING ACTIVITIES
---	------------------------------

---

- |   |  |
|---|--|
| 1. Turn off the voltage supply.                                       | . SC-5-7 through SC-5-10                         |
| 2. Turn off the hot water supply.                                     |  |
| 3. Measure and cut holes for electrical wire, water, and drain pipes. | NOTE: See the manufacturer's installation sheet. |
| 4. Remove the front inspection panel.                                 |  |
| 5. Position and level the dishwasher.                                 |  |
| 6. Connect the hot water supply pipe to the inlet valve.              |  |
| 7. Connect the drain pipe to the dishwasher pump or drain valve.      |  |
| 8. Connect the voltage supply to the dishwasher terminal block.       |  |
| 9. Turn on the hot water supply and check for leaks.                  |  |
| 10. Turn on the voltage supply.                                       |  |
| 11. Replace the front inspection panel.                               |  |
| 12. Clean and polish the dishwasher.                                  |  |
| 13. Check the operation.  |  |

197

---

COMPETENCE - PROCEDURES/STEPS

TEACHING/LEARNING ACTIVITIES

---

---

METHOD OF EVALUATION:

1. Piping does not leak.
2. Electrical connections are tight.
3. Dishwasher operates.

186

JOB: Replace a Water Inlet Valve on  
a Dishwasher

JOB SHEET  
IDENTIFICATION CODE

UNIT V: Kitchen Equipment

JOB NUMBER: J-5-21

COURSE: Appliance Repair

MATERIAL: Water Inlet Valve  
Dishwasher

EQUIPMENT: Propane Torch

TOOLS: Basic Hand Tools  
Screw Starter  
Lock Grip Pliers

Pipe Wrenches  
Offset Screwdriver

SAFETY PRECAUTIONS:

Wear safety glasses

COMPETENCE - PROCEDURES/STEPS The student will be able to:	TEACHING/LEARNING ACTIVITIES
1. Turn off the voltage supply.	. SC-5-1
2. Turn off the hot water supply	. SC-5-6 through SC-5-9
3. Remove the inspection panel.	
4. Remove the wires to the inlet valve solenoid.	
5. Loosen the piping to the inlet valve.	
6. Remove the mounting bolts on the inlet valve.	
7. Remove the piping to the inlet valve.	
8. Install the new inlet valve and tighten the mounting bolts.	
9. Reconnect the piping to the inlet valve.	
10. Attach the wires to the inlet valve solenoid.	
11. Turn on the hot water supply and check for leaks.	
12. Turn on the voltage supply.	
13. Check the operation.	

14. Reinstall the inspection panel.

---

METHOD OF EVALUATION:

1. No leaks.
2. Electrical connections are tight.

183

JOB: Replace a Dishwasher Timer

JOB SHEET  
IDENTIFICATION CODE

UNIT V: Kitchen Equipment

JOB NUMBER: J-5-22

COURSE: Appliance Repair

MATERIAL: Timer  
Dishwasher

TOOLS: Basic Hand Tools  
Screw Starter  
Offset Screwdrivers

SAFETY PRECAUTIONS:

Wear safety glasses

COMPETENCE - PROCEDURES/STEPS The student will be able to:	TEACHING/LEARNING ACTIVITIES
1. Turn off the voltage supply.	. SC-5-1
2. Remove the inspection panel.	. SC-5-6
3. Remove the timer knob and the mounting screws.	
4. Move the timer to one side, and transfer the wires from the old timer to the new timer.	NOTE: Each wire terminal is numbered or lettered. Be sure to transfer each one to the right place.
5. Mount the new timer and tighten the mounting screws.	
6. Turn on the voltage supply and check the operation.	
7. Replace the inspection panel.	

METHOD OF EVALUATION:

1. Electrical connections are solid.
2. Dishwasher works.

JOB: Replace a Water Level Switch  
on a Dishwasher

JOB SHEET  
IDENTIFICATION CODE

UNIT V: Kitchen Equipment

JOB NUMBER: J-5-23

COURSE: Appliance Repair

MATERIAL: Water Level Switch  
Gasket Sealant  
Dishwasher

TOOLS: Basic Hand Tools  
Screw Starter  
Offset Screwdrivers

SAFETY PRECAUTIONS:

Wear safety glasses

<u>COMPETENCE - PROCEDURES/STEPS</u> The student will be able to:	<u>TEACHING/LEARNING ACTIVITIES</u>
1. Turn off the voltage supply.	. SC-5-1
2. Remove the inspection panel.	. SC-5-6
3. Remove the wires to the water level switch.	
4. Remove the switch mounting screws.	
5. Remove the pressure tube or hose.	
6. Install the new switch, and tighten the mounting screws.	
7. Replace the wires to the switch.	
8. Examine the pressure tube or hose for leaks and install a new one if necessary.	
9. Attach the pressure tube or hose.	
10. Replace the inspection panel.	
11. Turn on the voltage supply.	
12. Check the operation.	

---

METHOD OF EVALUATION:

1. Electrical connections are tight.
2. No leaks

191

JOB: Replace a Heating Element on a Dishwasher

JOB SHEET  
IDENTIFICATION CODE

UNIT V: Kitchen Equipment

JOB NUMBER: J-5-24

COURSE: Appliance Repair

MATERIAL: Heating Element  
Gasket Sealant  
Rust Solvent  
Dishwasher

TOOLS: Basic Hand Tools  
Screw Starter  
Offset Screwdrivers  
Pipe Wrench  
Lock Grip Pliers

COMPETENCE - PROCEDURES/STEPS The student will be able to:	TEACHING/LEARNING ACTIVITIES
1. Turn off the voltage supply.	. SC-5-1
2. Remove the inspection panel.	. SC-5-6 through SC-5-8
3. Remove the wires to the heating element.	
4. Remove the heating element mounting screws.	
5. Install the new heating element, seal and fasten the mounting bolts.	
6. Re-attach the wires to the heating element.	
7. Turn on the voltage supply.	
8. Dial the timer to the WASH cycle and check for water leaks.	
9. Dial the timer to the DRY cycle and check the operation.	
10. Replace the inspection panel.	

METHOD OF EVALUATION:

1. No water leaks.
2. Wiring is secure.

192



JOB: Replace a Dispenser on a Dishwasher

JOB SHEET  
IDENTIFICATION CODE

UNIT V: Kitchen Equipment

JOB NUMBER: J-5-25

COURSE: Appliance Repair

MATERIAL: Dispenser  
Gasket Sealant  
Dishwasher

TOOLS: Basic Hand Tools  
Offset Screwdrivers  
Screw Starters

SAFETY PRECAUTIONS:

Wear safety glasses

COMPETENCE - PROCEDURES/STEPS The student will be able to:	TEACHING/LEARNING ACTIVITIES
1. Turn off the power source.	. SC-5-1
2. Locate and remove the dispenser inspection panel.	. SC-5-6
3. Remove the dispenser mounting bolts.	
4. Disconnect the wires from the dispenser assembly.	NOTE: Take note of color and location of wires.
5. Clean the dispenser mounting area, so that the new dispenser and gasket will fit properly.	
6. Attach the wires to the new dispenser.	
7. Mount the new dispenser and tighten the mounting bolts.	
8. Replace the dispenser inspection panel.	
9. Turn on the power source and check the operation.	

METHOD OF EVALUATION:

1. Electrical connections are tight.
2. No water leaks.
3. Dispenser operates properly.

193

JOB: Cut Tubing to Length and Ream

JOB SHEET  
IDENTIFICATION CODE

UNIT VI. Refrigeration

JOB NUMBER: J-6-1

COURSE: Appliance Repair

MATERIAL: 1/4" Copper Tubing (O.D.)

TOOLS: Tubing Cutter  
Foot Rule

SAFETY PRECAUTIONS:

1. wear safety glasses

COMPETENCE - PROCEDURES/STEPS The student will be able to:	TEACHING/LEARNING ACTIVITIES
1. Measure and mark tubing (1 piece 2' long).	SC-6-1
2. Cut tubing at mark.	SC-6-1A
3. Ream tubing.	Note: If tubing is too small to use reamer blade, use alternate method on SC-6-1A.

METHOD OF EVALUATION:

1. Tubing cut to tolerance
2. Tubing was properly reamed

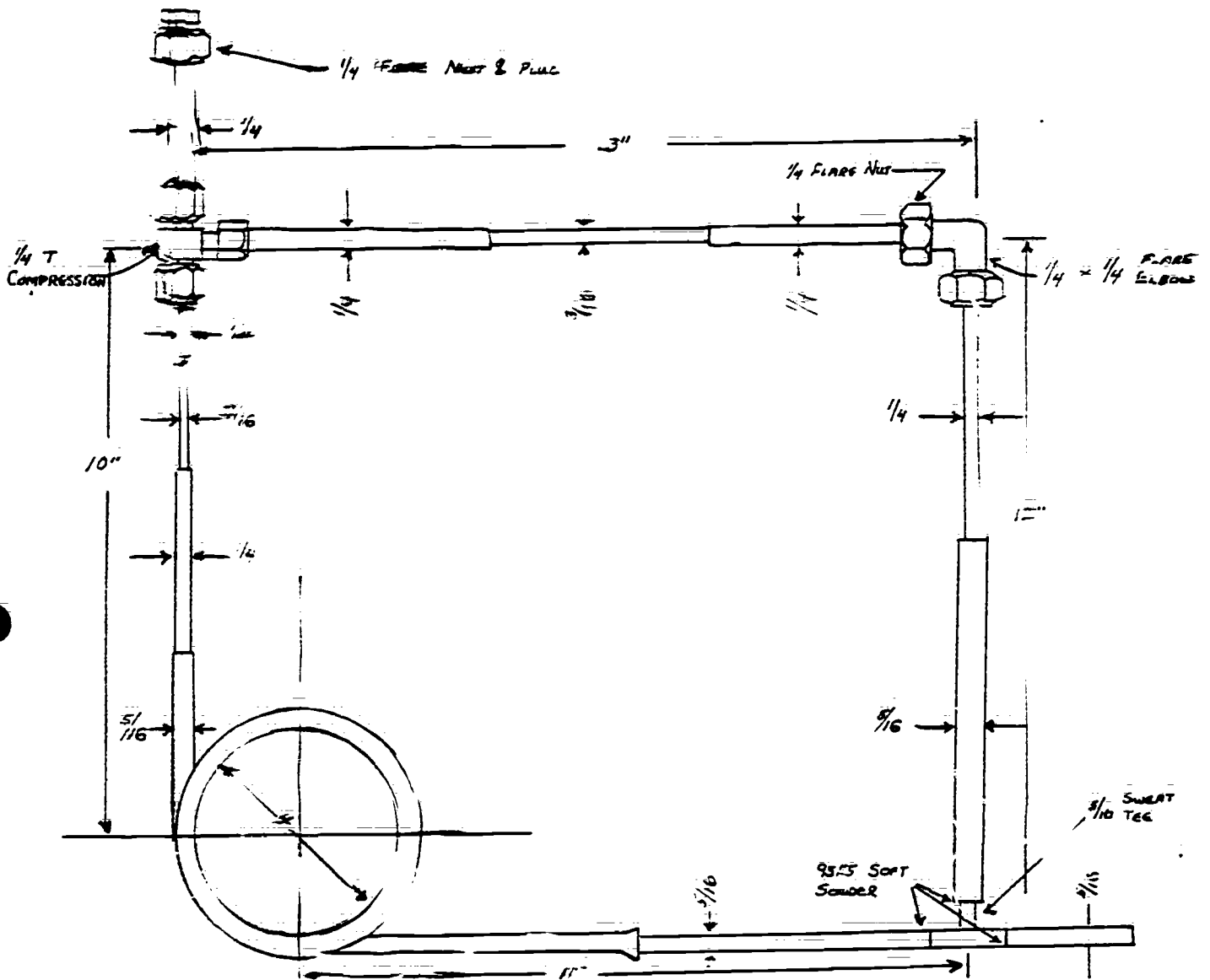

JOB: Flare Tubing  
 UNIT VI: Refrigeration  
 COURSE: Appliance Repair  
 MATERIAL: 1/4" Tubing from J-6-1  
 EQUIPMENT: Flare Block  
 Yoke  
 SAFETY PRECAUTIONS:  
 1. Wear safety glasses

JOB SHEET  
 IDENTIFICATION CODE  
 JOB NUMBER: J-6-2

COMPETENCE - PROCEDURES/STEPS The student will be able to:	TEACHING/LEARNING ACTIVITIES
1. Place the flare nut over the tubing.	. SC-6-2
2. Place the tubing into the flare block.	
3. Flare the tubing.	

METHOD OF EVALUATION:

1. Flare is within tolerance.

JOB: Install a Compression Fitting Onto  
Copper Tubing for Part One (P-1)

JOB SHEET  
IDENTIFICATION CODE

UNIT VI: Refrigeration

JOB NUMBER -6-3

COURSE: Appliance Repair

MATERIAL: 1/4" Tubing From J-6-1  
1/4" Compression "T"  
1/4" Flare Plug

TOOLS: Tubing Wrench  
Open End Wrench

SAFETY PRECAUTIONS:

1. Wear safety glasses

COMPETENCE - PROCEDURES/STEPS  
The student will be able to:

TEACHING/LEARNING ACTIVITIES

1. Install flare nut onto the flared end of the 1/4" tubing.
2. Install the compression nut onto the other end of the tubing.
3. Place the compression sleeve on the end of the tubing.
4. Insert the tubing and sleeve into the compression "T" as shown.
5. Tighten the compression nut.
6. Install 1/4" flare plug.

NOTE: Allow of tubing to protrude

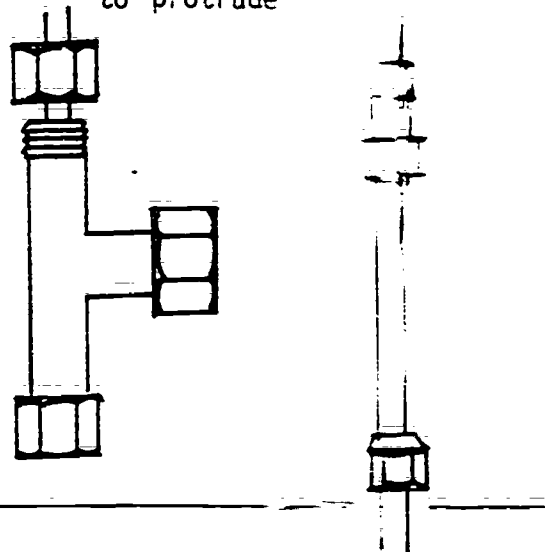

METHOD OF EVALUATION:

1. Fitting was assembled correctly.

197

3: ~~and~~ Swedge Tubing from D-6-1  
~~Part Two~~ (P-2)

JOB SHEET  
IDENTIFICATION CODE

UNIT VI: Refrigeration

JOB NUMBER: J-6-4

COURSE: ~~Refrigeration~~ Repair

MATERIALS: 1/4" Tubing  
3/16" Tubing  
1/4" Flare

EQUIPMENT: Flare Block and Yoke

TOOLS: Tubing Cutter  
Swaging Tool  
Flared Reamer

COMPETENCE - PROCEDURES/STEPS  
The student will be able to:

TECHNIQUE/LEARNING ACTIVITIES

1. Measure and mark two pieces of 1/4" tubing  
1 1/2" long. SC-6-4
2. Cut and ream these pieces to length.
3. Measure and mark 1 piece of 3/16" tubing  
1 1/2" long.
4. Cut and ream this piece to length.
5. Flare one 1/4" piece.
6. Place flare nut onto the tubing.
7. Swedge the opposite end to 3/16" size.
8. Swedge one end of the other piece of  
1/4" tubing.

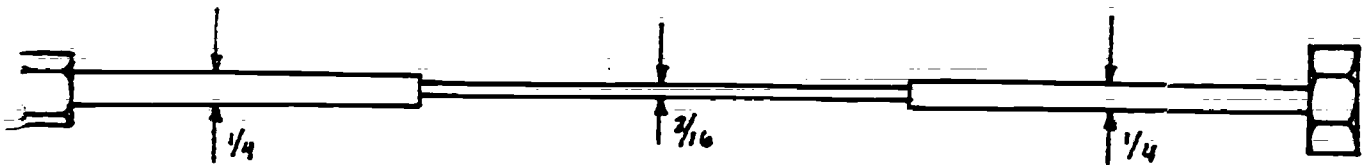

METHOD OF EVALUATION:

1. Cut to length within tolerance.
2. Tubing was properly swedged to size.

JOB: Clean the Tubing for Soldering

JOB SHEET

UNIT IV: Refrigeration

IDENTIFICATION CODE

COURSE: Appliance Repair

JOB NUMBER: J-6-5

MATERIAL: 1/4" Tubing from J-6-4  
3/16" Tubing from J-6-4  
Sandpaper

TOOLS: Interline Brush

SAFE PRECAUTIONS:

1. Wear safety glasses

---

COMPETENCE - PROCESSES/STEPS	TEACHING/LEARNING ACTIVITIES
The student will be able to:	
1. Clean the 3/16" tubing on the outside about 1" on each end with sandpaper.	: SC-6-5 : SC-6-5A
2. Clean the inside of the 1/4" tubing using the wire brush.	NOTE: Clean both ends.

---

METHOD OF EVALUATION:

1. Tubing was properly cleaned.

JOB: Assemble the Tubing and Set Up to  
Silver Solder P-2

JOB SHEET  
IDENTIFICATION CODE

UNIT VI: Refrigeration

JOB NUMBER: J-6-6

COURSE: Appliance Repair

MATERIAL: Copper Tubing from P-2

EQUIPMENT: Prestolite Torch

TOOLS: Striker

SAFETY PRECAUTIONS:

1. Wear safety glasses

---

COMPETENCE - PROCEDURES/STEPS The student will be able to:	TEACHING/LEARNING ACTIVITIES
1. Place the 1/4" tubing with the flare nut into the vise.	. SC-6-6, SC-6-A
2. Clamp the vise jaws onto the flare nut.	NOTE: Do not clamp the tubing too tightly. The 1/4" tubing should be held in a horizontal position.
3. Put the 3/16" tubing into the 1/4" tubing.	NOTE: Place one 1/4" tubing on each side of the 3/16" tubing.
4. Set up and light the prestolite torch.	

---

METHOD OF EVALUATION:

1. Tubing is assembled correctly.
2. Prestolite torch was set up safely.



JOB: Silver Solder and Assemble P-2 to P-1

JOB SHEET  
IDENTIFICATION CODE

UNIT VI: Refrigeration

JOB NUMBER: J-6-7

COURSE: Appliance Repair

MATERIAL: Silver Solder  
Silver Solder Flux  
Sandpaper

EQUIPMENT: Prestolite Torch

TOOLS: Striker

SAFETY PRECAUTIONS:

1. Wear safety glasses
2. Wear gloves

---

COMPETENCE - PROCEDURES/STEPS	TEACHING/LEARNING ACTIVITIES
The student will be able to:	

---

- |   |          |
|---|----------|
| 1. Clean around the joints with sandpaper.              | : SC-6-7 |
| 2. Apply the flux.                                      |          |
| 3. Light the prestolite torch.                          |          |
| 4. Silver solder the two joints.                        |          |
| 5. Clean and inspect the joints after the tubing cools. |          |
| 6. Connect the compression fitting to the "T" on P-1.   |          |

METHOD OF EVALUATION:

1. Joint was properly soldered without damage to tubing.

201

JOB: Make Loop for Part Three (P-3),  
Assemble and Silver Solder to  
P-1 and P-2

JOB SHEET  
IDENTIFICATION CODE

UNIT VI: Refrigeration

JOB NUMBER: J-6-8

COURSE: Appliance Repair

DRAWING NO: D-6-8

MATERIAL: 5/16" Tubing  
1/4" Tubing  
3/16" Tubing  
Silver Solder

TOOLS: 5/16" Bending Spring  
5/16" Swedging Tool  
1/4" Swedging Tool

Foot Rule  
3/16" Swedging Tool

SAFETY PRECAUTIONS:

1. Wear safety glasses

---

COMPETENCE - PROCEDURES/STEPS  
The student will be able to:

TEACHING/LEARNING ACTIVITIES

---

1. Measure and mark the tubing, (approx. 3/4"). . SC-6-1
2. Cut to length and ream. . SC-6-3 through SC-6-8
3. Bend loop as per drawing in Fig. 1.
4. Swedge a 4" end to 1/4" opening.
5. Swedge a 5" end to 5/16" opening.
6. Measure and mark two pieces of 1/4" tubing,  
one 2" long and one 3" long.
7. Cut and ream the 3/16" piece.
8. Measure and mark one 3" piece of  
3/16" tubing.
9. Cut and ream the 3/16" piece.
10. Swedge one end of each 1/4" piece to  
a 3/16" opening.
11. Clean and assemble as per D-6-8.
12. Silver solder all necessary joints.

202

---

**COMPETENCE - PROCEDURES/STEPS****TEACHING/LEARNING ACTIVITIES**

---

13. Attach the compression fitting and tighten the nut.
14. Measure and mark a 5" piece of 5/16" tubing.
15. Cut and ream the tubing.
16. Clean the tubing.
17. Silver solder the 5/16" joint.
18. Clean all solder joints.

---

**METHOD OF EVALUATION:**

1. Loop is within tolerance.
2. Pieces were assembled correctly, as per drawing.

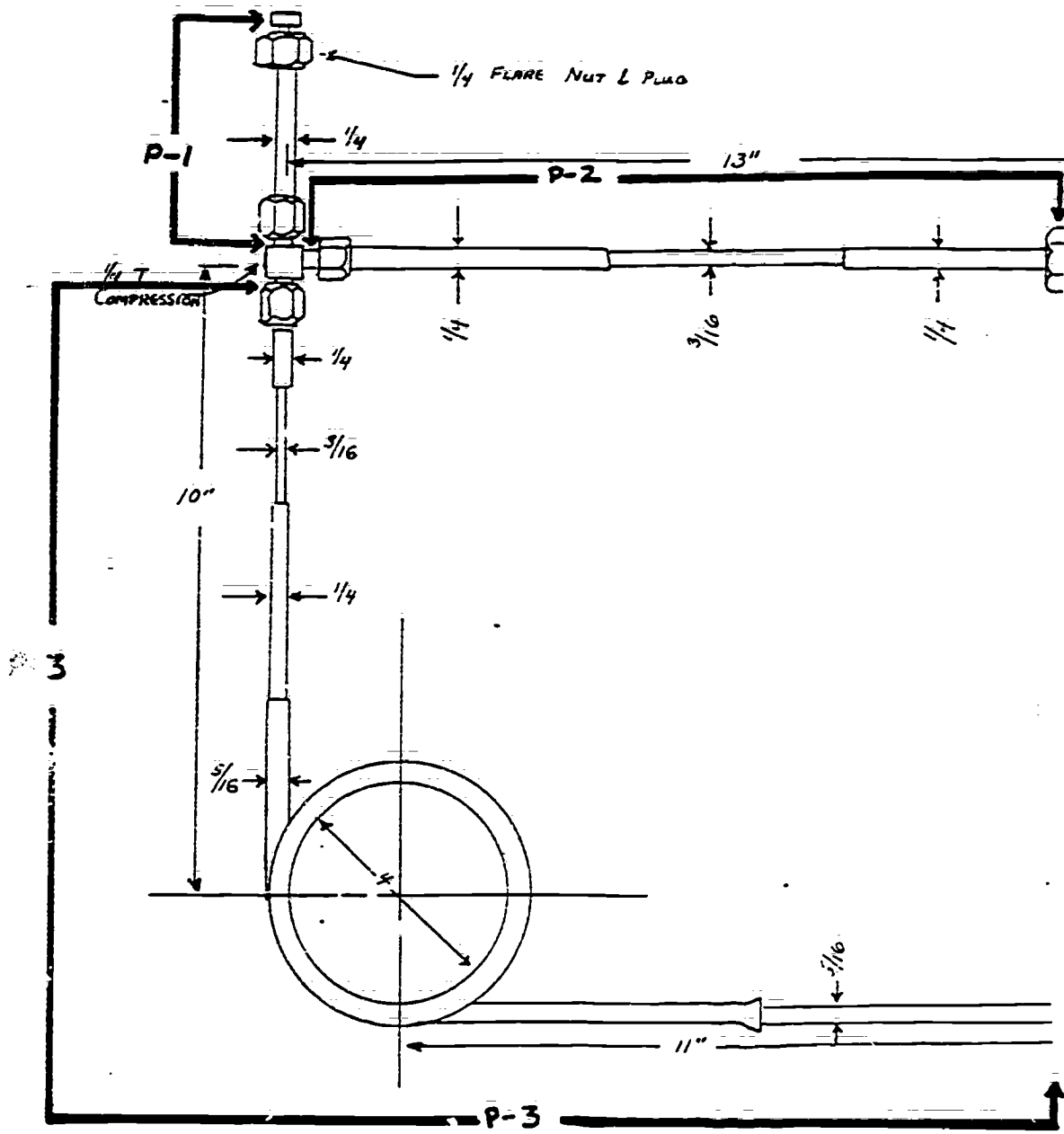

UNIT VI: Refrigeration  
COURSE: Appliance Repair

JOB NUMBER: J-6-9

DRAWING NO: D-6-9

MATERIAL: 1/4" Tubing  
5/16" Tubing  
5/16" Sweat Tee

Silver Solder and Flux  
1/4" Flare Elbow  
95/5 Solder and Flux

TOOLS: Foot Rule  
Flaring Tool  
Swedging Tool, 1/4"

SAFETY PRECAUTIONS:

1. Wear safety glasses

COMPETENCE - PROCEDURES/STEPS The student will be able to:	TEACHING/LEARNING ACTIVITIES
1. Measure and mark one piece of 1/4" tubing 6" long.	. SC-6-9 . SC-6-1 through SC-6-7
2. Cut and ream the tubing.	
3. Measure and mark one piece of 5/16" tubing 6" long.	
4. Cut and ream the tubing.	
5. Flare one end of the 1/4" tubing as per figure 1.	
6. Swedge one end of the 5/16" tubing as per figure 1.	
7. Attach the 1/4" flare elbow to P-2.	
8. Attach the 1/4" flare tubing of P-4 to the 1/4" flare elbow.	
9. Tighten the flare nuts on the 1/4" elbow.	
10. Clean the 1/4" to 5/16" joint.	
11. Silver solder the 1/4" tubing to the 5/16" tubing.	
12. Cut and ream a 5/16" tubing to 6" length.	
13. Clean the 5/16" sweat tee and the 5/16" tubing.	

295

14. Assemble the 5/16" tee to join the ends together.

15. Apply 95/5 flux to the sweat tee connections.

16. Solder the joints.

NOTE: Allow the joints to cool and inspect.

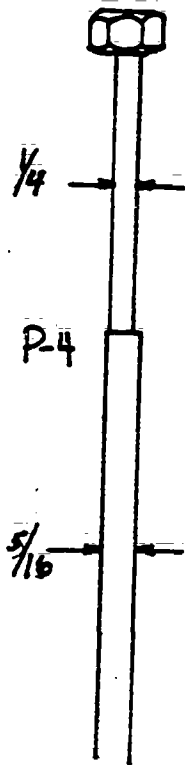

---

METHOD OF EVALUATION:

1. Tubing was properly cut to tolerance.
2. Pieces were properly assembled as per drawing.
3. Soldered joints are solid.

296

ALL JOINTS - SWAGED & SILVER SOLDERED

UNLESS OTHERWISE NOTED

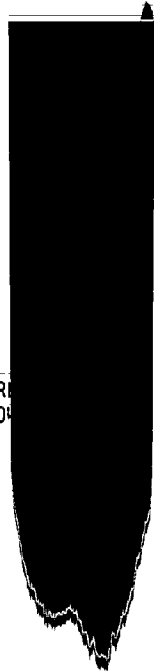
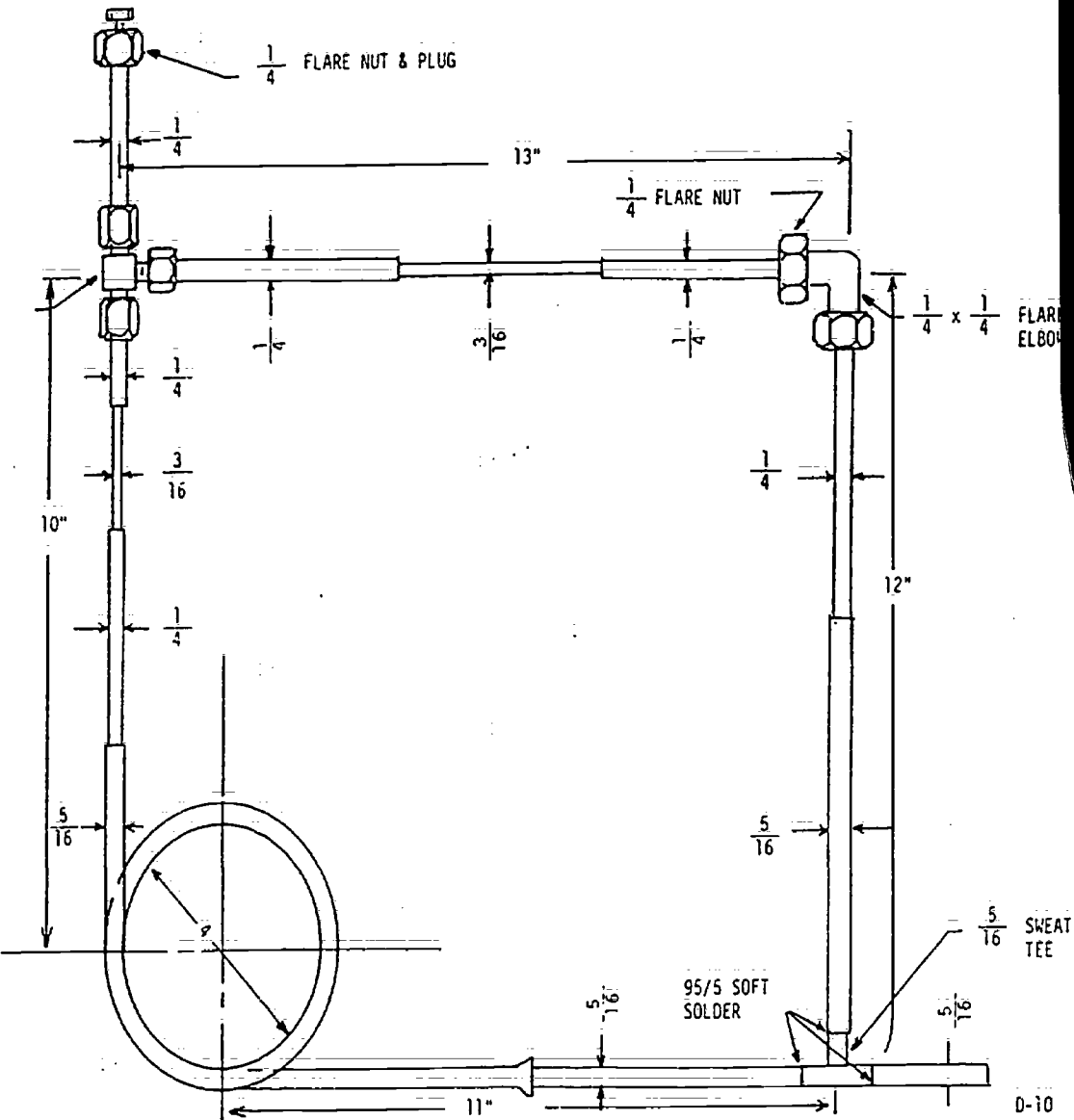

207

298

	D-6-9
--	-------

JOB: Install a Process Adapter on Tubing

JOB SHEET  
IDENTIFICATION CODE

UNIT VI: Refrigeration

JOB NUMBER: J-6-10

COURSE: Appliance Repair

MATERIAL: Robinair Process Adapter  
Tubing Assembly from J-6-1

SAFETY PRECAUTIONS:

1. Wear safety glasses

---

<u>COMPETENCE - PROCEDURES/STEPS</u> The student will be able to:	<u>TEACHING/LEARNING ACTIVITIES</u>
1. Select the 5/16" process adapter washers and seal.	: SC-6-10
2. Install the process adapter onto the tubing.	

---

METHOD OF EVALUATION:

1. Adapter was assembled properly.

209



JOB: Check for Leaks Using Nitrogen and  
Liquid Detector

JOB SHEET  
IDENTIFICATION CODE

UNIT VI: Refrigeration

JOB NUMBER: J-6-11

COURSE: Appliance Repair

MATERIAL: Tubing Assembly from J-6-1  
Liquid Leak Detector Solution

EQUIPMENT: Nitrogen Tank and Regulator

SAFETY PRECAUTIONS:

1. Wear safety glasses

---

COMPETENCE - PROCEDURES/STEPS The student will be able to:	TEACHING/LEARNING ACTIVITIES
1. Move the nitrogen tank with regulator to the work area.	NOTE: Use the appliance hand truck.
2. Attach the hose from the regulator to the tubing assembly process adapter.	. SC-3-26
3. Open the nitrogen tank valve.	. SC-6-11
4. Apply liquid leak detector solution to all the connections and check for leaks.	. IL-6-1
5. Turn off the nitrogen tank valve.	
6. Loosen the hose connection at the regulator and allow the nitrogen to slowly bleed out.	

---

METHOD OF EVALUATION:

1. No leaks.
2. Nitrogen tank hooked up safely.

210

JOB: Evacuate Tubing Assembly Using a Portable Vacuum Pump

JOB SHEET  
IDENTIFICATION CODE

UNIT VI: Refrigeration

JOB NUMBER: J-6-12

COURSE: Appliance Repair

MATERIAL: Tubing Assembly from J-6-9

EQUIPMENT: Vacuum Pump  
Manifold Gauges

SAFETY PRECAUTIONS:

1. Wear safety glasses

COMPETENCE - PROCEDURES/STEPS	TEACHING/LEARNING ACTIVITIES
The student will be able to:	
<ol style="list-style-type: none"><li>1. Attach center hose of the manifold gauge to the tubing assembly process fitting.</li><li>2. Start the vacuum pump.</li><li>3. Open the left hand valve of the manifold gauge.</li><li>4. Open the valve of the vacuum pump.</li><li>5. Close the left hand valve of the manifold gauge.</li><li>6. Close the valve of the vacuum pump.</li><li>7. Shut off the power to the vacuum pump motor.</li></ol>	<p>NOTE: The gauge will move toward the 30" mark on the manifold gauge.</p> <p>NOTE: When the tubing is evacuated continue with step 5.</p>

METHOD OF EVALUATION:

1. Vacuum pump is hooked up safely.

211

JOB: Charge and Leak Test Tubing with a Prestolite Leak Detector

JOB SHEET  
IDENTIFICATION CODE

UNIT VI: Refrigeration

JOB NUMBER: J-6-13

COURSE: Appliance Repair

MATERIAL: Tubing Assembly from J-6-9 with Vacuum and Manifold Gauges

EQUIPMENT: Prestolite Leak Detector  
Refrigerant Cylinder

TOOLS: Valve Wrench  
Striker

SAFETY PRECAUTIONS:

1. Wear safety glasses

---

COMPETENCE - PROCEDURES/STEPS The student will be able to:	TEACHING/LEARNING ACTIVITIES
1. Attach a charging hose from the refrigerant cylinder to the right hand manifold gauge.	. SC-6-6
2. Open the valve on the refrigerant cylinder and purge the hose.	. SC-6-12 . IL-6-2
3. Open the valve on the right hand manifold gauge.	NOTE: Purging is done by loosening the fitting on the hose at the manifold.
4. Install the leak detector head to the presto-lite hose.	
5. Light the leak detector.	
6. Test for leaks.	

---

METHOD OF EVALUATION:

1. Hose hooked up correctly.
2. Tubing charged properly.

212

JOB: Check for Leaks Using an Electronic Leak Detector

JOB SHEET  
IDENTIFICATION CODE

UNIT VI: Refrigeration

JOB NUMBER: J-6-14

COURSE: Appliance Repair

MATERIAL: Tubing Assembly from J-6-12

EQUIPMENT: Electronic Leak Detector

SAFETY PRECAUTIONS:

1. Wear safety glasses

---

COMPETENCE - PROCEDURES/STEPS The student will be able to:	TEACHING/LEARNING ACTIVITIES
1. Set up the leak detector as per manufacturer's instructions.	. IL-6-3
2. Test for leaks in tubing assembly.	

---

METHOD OF EVALUATION:

1. Proper leak detector procedure was followed.

JOB: Pinch Off and Solder the Process Tubing

JOB SHEET  
IDENTIFICATION CODE

UNIT VI: Refrigeration

JOB NUMBER: J-6-15

COURSE: Appliance Repair

MATERIAL: Tubing Assembly from J-6-9  
95/5 Solder and Flux

EQUIPMENT: Prestolite Torch

TOOLS: Pinch Off Tool

SAFETY PRECAUTIONS:

1. Wear safety glasses

---

COMPETENCE - PROCEDURES/STEPS	TEACHING/LEARNING ACTIVITIES
-------------------------------	------------------------------

---

- |   |   |
|---|---|
| 1. Attach the pinch off tool as close to the process adapter as possible. | . SC-6-6  |
|   | . SC-6-9  |
| 2. Tighten the pinch off tool until the tubing is sealed.                 | . SC-6-10   |
| 3. Remove the process adapter.  | . SC-6-13   |
| 4. Solder the tubing to seal it.  | NOTE: The solder must completely fill the tubing. |
| 5. Remove the pinch off tool.   |   |
| 6. Test the seal for leaks.   |   |

---

METHOD OF EVALUATION:

1. Pinch off does not leak.

JOB: Repair a Leak and Recharge a Refrigerator

JOB SHEET  
IDENTIFICATION CODE

UNIT VI: Refrigeration

JOB NUMBER: J-6-16

COURSE: Appliance Repair

MATERIAL: Silver Solder and Flux  
95/5 Solder and Flux  
1/4" Copper Tubing  
5/16" Copper Tubing  
Schaffer Brushes

Evaporator Epoxy  
Liquid Leak Detector  
Refrigerant R-12  
Sandpaper

EQUIPMENT: Flaring Block  
Prestolite Torch  
Vacuum Pump  
Manifold Gauges

Process Adapters  
Charging Cylinder  
Hoses

TOOLS: Hammer  
Swedging Tools  
Diagonal Pliers

Triangle File  
Tubing Cutter  
Pinch Off Tool

---

COMPETENCE - PROCEDURES/STEPS  
The student will be able to:

TEACHING/LEARNING ACTIVITIES

---

1. Locate the process tubing stump and cut a small hole near the pinch.
2. Cut the tubing when the refrigerant is out of the system.
3. Attach an 8" piece of tubing to the process stump.
4. Install a process adapter to the process tubing and pressurize the system with nitrogen or refrigerant.
5. Locate the leak.
6. Depressurize the system and repair the leak.
7. Cut the old dryer out of the system and install a new dryer.
8. Recheck the system for leaks.
9. Depressurize the system and evacuate.
10. Recharge the system, use the charging cylinder for proper charge.

NOTE: Use a diagonal pliers.

. SC-6-1

. SC-6-4 through SC-6-7

. SC-6-9 through SC-6-13

. IL-6-4

. IL-6-4A

11. Pinch off and seal system.
12. Plug in refrigerator and check.

---

METHOD OF EVALUATION:

1. Leak is properly repaired.
2. Proper charge was put into equipment.
3. Equipment operates properly with no leaks.

JOB: Take a Temperature Reading of the Evaporator of the Refrigerator

JOB SHEET  
IDENTIFICATION CODE

UNIT VI: Refrigeration

JOB NUMBER: J-6-17

COURSE: Appliance Repair

MATERIAL: Repaired Refrigerator from J-6-16

EQUIPMENT: Temperature Tester

SAFETY PRECAUTIONS:

1. Wear safety glasses

---

COMPETENCE - PROCEDURES/STEPS The student will be able to:	TEACHING/LEARNING ACTIVITIES
1. Set up the temperature tester.	. IL-6-5
2. Place the probe into the evaporator.	
3. Take a temperature reading when the compressor shuts off.	
4. Check the reading with the manufacturer's specifications.	

---

METHOD OF EVALUATION:

1. Reading is within tolerance.



JOB: Check Temperature Using a Temperature Recorder

JOB SHEET  
IDENTIFICATION CODE

UNIT VI: Refrigeration

JOB NUMBER: J-6-18

COURSE: Appliance Repair

MATERIAL: Repaired Refrigerator from J-6-16

EQUIPMENT: Temperature Recorder

SAFETY PRECAUTIONS:

1. Wear safety glasses

---

COMPETENCE - PROCEDURES/STEPS The student will be able to:	TEACHING/LEARNING ACTIVITIES
1. Set up the temperature recorder.	. IL-6-6
2. Attach the probe near the thermostat sensor.	
3. Compare the cut-in and cut-off with the manufacturer's specifications.	

---

METHOD OF EVALUATION:

1. Recorder was properly hooked up.
2. Readings are within tolerance.

218

JOB: Replace Light Switch

JOB SHEET  
IDENTIFICATION CODE

UNIT VI: Refrigeration

JOB NUMBER: J-6-19

COURSE: Appliance Repair

MATERIAL: Door Switch  
Refrigerator

TOOLS: Switch Removing Tool

SAFETY PRECAUTIONS:

1. Wear safety glasses

---

COMPETENCE - PROCEDURES/STEPS The student will be able to:	TEACHING/LEARNING ACTIVITIES
<ol style="list-style-type: none"><li>1. Disconnect the power cord.</li><li>2. Open the door and locate the light switch.</li><li>3. Remove the switch.</li><li>4. Disconnect the wires.</li><li>5. Reconnect the wires to the new switch.</li><li>6. Push the switch into the hole.</li><li>7. Check the switch operation.</li></ol>	. SC-6-14

---

METHOD OF EVALUATION:

1. Electrical connections are solid.
2. Connections were replaced with no damage to equipment.
3. Switch operates properly.

JOB: Replace a Starting Relay on a Compressor

JOB SHEET

UNIT VI: Refrigeration

IDENTIFICATION CODE

COURSE: Appliance Repair

JOB NUMBER: J-6-20

MATERIAL: Relay  
Any Refrigeration Equipment with a Relay

TOOLS: Basic Hand Tools

SAFETY PRECAUTIONS:

1. Wear safety glasses

---

COMPETENCE - PROCEDURES/STEPS  
The student will be able to:

TEACHING/LEARNING ACTIVITIES

---

1. Disconnect the power cord.
2. Locate the compressor and remove the terminal cover.
3. Locate the relay and remove the wires.
4. Remove the relay mounting screws.
5. Install the new relay.
6. Connect the wires to the relay.
7. Reinstall the terminal cover.
8. Check the operation.

NOTE: Make a drawing to show the wire locations.

---

METHOD OF EVALUATION:

1. Mounting screws are tight.
2. Electrical connection is solid.
3. Relay operates properly.

220

JOB: Replace a Defrost Timer  
UNIT VI: Refrigeration  
COURSE: Appliance Repair  
MATERIAL: Defrost Timer  
Frost Free Refrigerator  
TOOLS: Basic Hand Tools

JOB SHEET  
IDENTIFICATION CODE

JOB NUMBER: J-6-21

SAFETY PRECAUTIONS:

1. Wear safety glasses

---

COMPETENCE - PROCEDURES/STEPS The student will be able to:	TEACHING/LEARNING ACTIVITIES
---	------------------------------

---

1. Disconnect the power cord.
2. Locate the defrost timer and remove the mounting screws.
3. Remove the wires.
4. Install the wires to the new timer.
5. Secure the timer with the mounting screws.
6. Check the operation.

NOTE: Make a drawing to show their color and location.

---

METHOD OF EVALUATION:

1. Electrical connections are tight.
2. Timer operates properly.

221

JOB: Replace a Defrost Heater

JOB SHEET  
IDENTIFICATION CODE

UNIT VI: Refrigeration

JOB NUMBER: J-6-22

COURSE: Appliance Repair

MATERIAL: Defrost Heater  
Frost Free Refrigerator

TOOLS: Basic Hand Tools

SAFETY PRECAUTIONS:

1. Wear safety glasses

---

COMPETENCE - PROCEDURES/STEPS  
The student will be able to:

TEACHING/LEARNING ACTIVITIES

---

1. Disconnect the power cord.
2. Remove the trim covers as necessary according to manufacturer's service manual.
3. Remove the mounting screws and clips from the defrost heater and evaporator.
4. Disconnect the wires.
5. Connect the wires to the new defrost heater.
6. Fasten the defrost heater to the evaporator.
7. Reassemble the trim covers.
8. Check the operation.

---

METHOD OF EVALUATION:

1. No damage to trim.
2. Electrical connections are water tight.
3. Heater works properly.

222

JOB: Replace a Temperature Control

JOB SHEET  
IDENTIFICATION CODE

UNIT VI: Refrigeration

JOB NUMBER: J-6-23

COURSE: Appliance Repair

MATERIAL: Temperature Control  
Refrigerator

TOOLS: Basic Hand Tools

SAFETY PRECAUTIONS:

1. Wear safety glasses

COMPETENCE - PROCEDURES/STEPS The student will be able to:	TEACHING/LEARNING ACTIVITIES
1. Disconnect the power cord.	. SC-6-15
2. Locate the temperature control and remove the knob.	
3. Remove the mounting screws.	
4. Disconnect the wires.	NOTE: Make a drawing of their color and location.
5. Locate the capillary tube clamp and loosen it.	
6. Slide the capillary tube out of the clamp.	NOTE: If the capillary tube is routed behind the wall of the product attach a "fish" wire to the defective temperature control capillary. When the defective control has been removed, attach the "fish" wire to the new control capillary tube.
7. Remove the control and pull the capillary tube and "fish" wire out until there is enough "fish" wire to reconnect to the new control.	
8. Remove the "fish" wire and attach it to the new control capillary tube.	
9. Pull the new capillary tube into place with the "fish" wire.	
10. Remove the "fish" wire.	
11. Clamp the capillary tube in place.	

12. Connect the wires to the new control.
13. Install the mounting screws.
14. Install the trim frame and knob.
15. Check the operation.

---

METHOD OF EVALUATION:

1. No damage to equipment.
2. Electrical connections are solid.
3. Thermostat works properly.

224

JOB: Remove and Replace Refrigerator - Freezer Doors

JOB SHEET  
IDENTIFICATION CODE

UNIT VI: Refrigeration

JOB NUMBER: J-6-24

COURSE: Appliance Repair

MATERIAL: Refrigerator or Upright Freezer

EQUIPMENT: Moving Pad

TOOLS: Basic Hand Tools

SAFETY PRECAUTIONS:

1. Wear safety glasses

---

COMPETENCE - PROCEDURES/STEPS	TEACHING/LEARNING ACTIVITIES
<hr/>	
1. Disconnect the power cord.	
2. Check for wiring leading into the door and disconnect.	
3. Remove the top hinge.	
4. Lift door off bottom hinge or remove bottom hinge.	
5. Place door on moving pad to make necessary repairs.	
6. After making repairs to the door replace by reversing procedures.	
7. Realign door and check seal.	NOTE: If door does not seal properly see J-6-25.
8. Check operation.	

---

METHOD OF EVALUATION:

1. Door was properly aligned.
2. Gasket properly seals.
3. No damage to equipment.



JOB: Remove and Replace Door Gasket  
 UNIT VI: Refrigeration  
 COURSE: Appliance Repair  
 MATERIAL: Door Gasket  
 Refrigerator or Upright Freezer  
 Perma Gum  
 EQUIPMENT: Moving Pad  
 TOOLS: Basic Hand Tools  
 SAFETY PRECAUTIONS:

JOB SHEET  
 IDENTIFICATION CODE

JOB NUMBER: J-6-25

1. Wear safety glasses

COMPETENCE - PROCEDURES/STEPS The student will be able to:	TEACHING/LEARNING ACTIVITIES
<ol style="list-style-type: none"> <li>1. Disconnect the power cord.</li> <li>2. Remove the door.</li> <li>3. Place door on a flat well padded surface.</li> <li>4. Remove the screws or clips from the inner door panel and gasket.</li> <li>5. Remove the defective gasket.</li> <li>6. Place the new gasket in position.</li> </ol>	<p>NOTE: Allow new gasket to reach room temperature to facilitate proper installation.</p>
<ol style="list-style-type: none"> <li>7. Install screws and clips to hold the gasket in place.</li> </ol>	<p>NOTE: Add perma gum sealant if needed to seal gasket to door.</p>
<ol style="list-style-type: none"> <li>8. Tighten the screws evenly around the door.</li> </ol>	<p>NOTE: Do not tighten the screws until all the screws are in place.</p>

---

COMPETENCE - PROCEDURES/STEPS

TEACHING/LEARNING ACTIVITIES

---

9. Remount the door and check the seal.
10. Align the door if necessary.

NOTE: If alignment is necessary, see J-6-26.

---

METHOD OF EVALUATION:

1. Door properly seals.
2. No damage to equipment.

227

JOB: Align a Refrigeration-Freezer Door  
UNIT VI: Refrigeration  
COURSE: Appliance Repair  
MATERIAL: Refrigerator-Freezer  
TOOLS: Basic Hand Tools

JOB SHEET  
IDENTIFICATION CODE

JOB NUMBER: J-6-26

SAFETY PRECAUTIONS:

1. Wear safety glasses

---

COMPETENCE - PROCEDURES/STEPS  
The student will be able to:

TEACHING/LEARNING ACTIVITIES

---

1. Sight along the door to locate the misalignment.
2. Open the door and loosen the screws under the gasket as shown.
3. If the misaligned area is at the top, hold the bottom of the door in place with foot and apply a pulling pressure to the top of the door.
4. If the misalignment is at the bottom, hold the bottom of the door with foot and apply a pushing pressure to the top of the door.
5. Tighten the screws and check the operation.

NOTE: Loosen screws about 1/2" turn only where shown. Do not loosen screws along hinge side.

NOTE: Apply only enough pressure to twist the door according to the adjustment needed.

NOTE: Apply only enough pressure to twist the door according to the adjustment needed.

---

METHOD OF EVALUATION:

1. Door properly fits and gasket seals.

JOB: Straighten Fins on an Air  
Conditioner Condenser

JOB SHEET  
IDENTIFICATION CODE

UNIT VI: Refrigeration

JOB NUMBER: J-6-27

COURSE: Appliance Repair

MATERIAL: Air Conditioner with Damaged Condenser Fins

TOOLS: Fin Tool

SAFETY PRECAUTIONS:

1. Wear safety glasses
2. Wear gloves

---

COMPETENCE - PROCEDURES/STEPS The student will be able to:	TEACHING/LEARNING ACTIVITIES
1. Select the proper fin tool.	. SC-6-16
2. Locate the damaged area.	
3. Insert the fin tool at the damaged area.	NOTE: Start to work the area by using only 1/2 the fin tool on the damaged area and the other 1/2 on a good area. This will give the proper fin alignment.
4. Work the fin tool up and down through the damaged area.	
5. Repeat the operation until the total area is repaired.	

---

METHOD OF EVALUATION:

1. Fins are straight.
2. No damage to fins or tool.

JOB: Check a Capacitor

JOB SHEET  
IDENTIFICATION CODE

UNIT VI: Refrigeration

JOB NUMBER: J-6-28

COURSE: Appliance Repair

MATERIAL: Capacitor

EQUIPMENT: Capacitor Analyzer

SAFETY PRECAUTIONS:

1. Wear safety glasses

---

COMPETENCE - PROCEDURES/STEPS	TEACHING/LEARNING ACTIVITIES
The student will be able to:	

---

1. Disconnect the power cord.

: IL-6-7

2. Locate the capacitor.

3. Remove the mounting screws.

4. Disconnect the wires.

NOTE: Make a drawing to show the color and location.

5. Test the capacitor and replace if necessary.

6. Reassemble the product.

7. Check the operation.

METHOD OF EVALUATION:

1. Diagnosis correct.
2. Readings are within tolerance.

230

## OPERATION SHEETS

OPERATIONS are the subdivisions in the breakdown of a job. Each operation represents a process, way of doing or how to perform the particular skill competency or operation.

OPERATION SHEETS supplement the job sheets and indicate to the student how to perform the many skill competency operations necessary to complete the assigned jobs. The following (white) sheets are the operation sheets that will be used as vehicles of instruction in this course. Additional operation sheets can be added or deleted as needed.

COMPETENCY: Measure and Mark Stock to Length  
With Steel Tape

COURSE: Appliance Repair

UNIT II: Basic Electricity

OBJECTIVE: The student will be able to  
properly measure and mark stock  
to specifications without error

Page 1 of 1 page

COMPETENCE - PROCEDURES/STEPS	TEACHING/LEARNING ACTIVITIES
The student will be able to:	

1. Hook the end of the tape onto the end of the stock and extend the tape by pulling on the case.

NOTE: The tape should lay parallel to the edge of the stock.

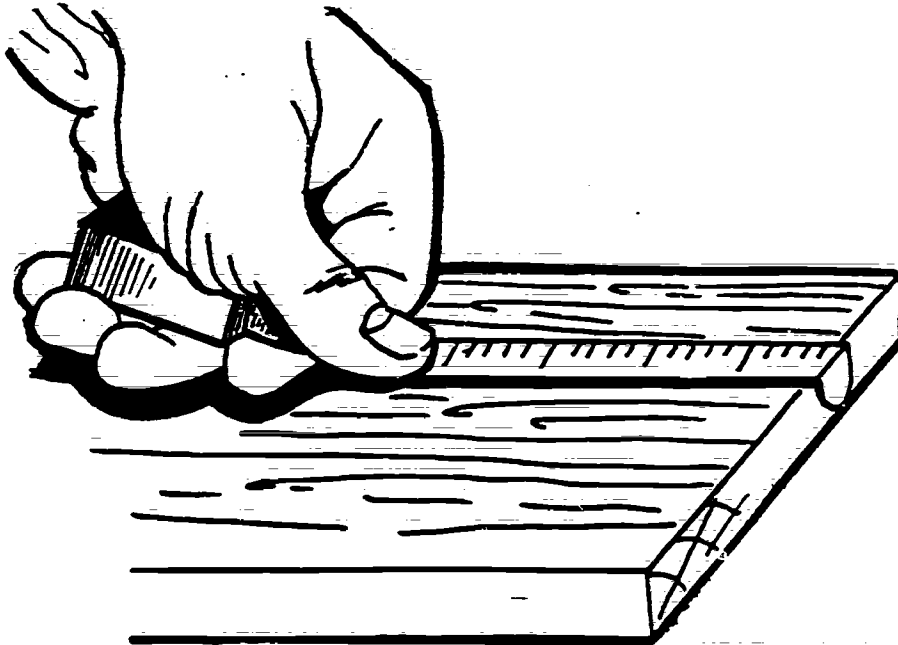

2. Place a mark on the stock close to the edge of the tape at the desired dimension.

NOTE: A "V" mark is used by many carpenters with the point of the "V" indicating the exact measurement.

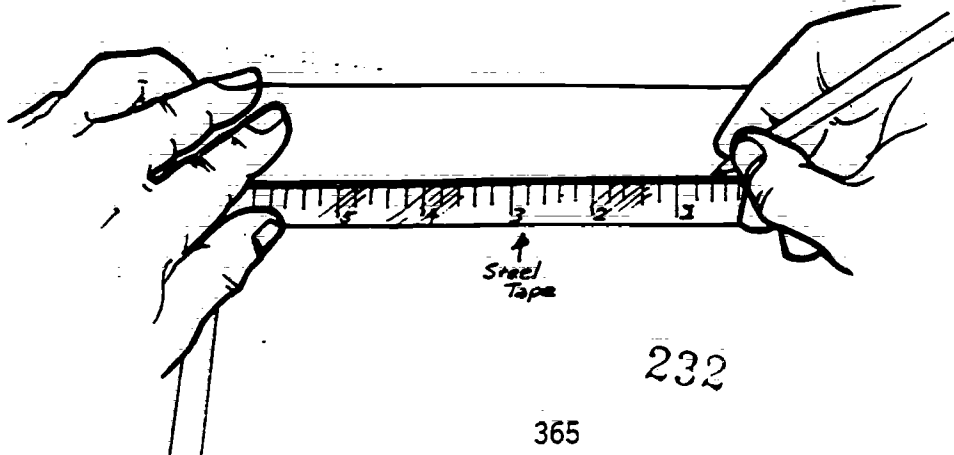

232

COMPETENCY: Measure and Mark Stock to Length with the Folding Rule

COURSE: Appliance Repair

UNIT II: Basic Electricity

OBJECTIVE: The student will be able to lay out stock to specifications with the folding rule

Page 1 of 1 page

COMPETENCE - PROCEDURES/STEPS  
The student will be able to:

TEACHING/LEARNING ACTIVITIES

1. Open enough sections of the rule to take the measurement.
2. Place the rule flat on the stock, parallel to the edge and the end of the rule even with the end of the stock.

NOTE: More accurate measurements can be taken with the rule held on edge.

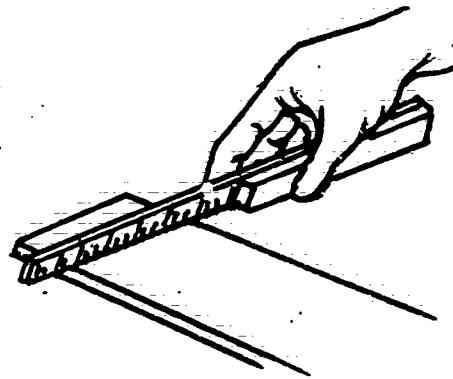
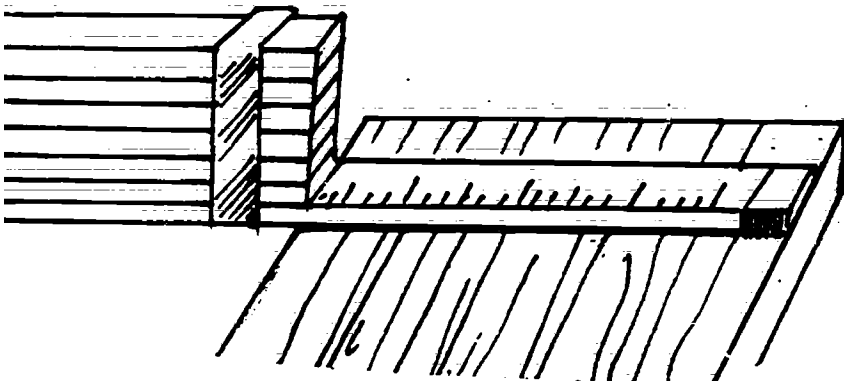

3. Place a mark on the stock close to the edge of the rule as with a steel tape.

NOTE: Another method commonly used when using the folding rule is to place the rule in position so the desired dimension is even with the end of the stock; then place a mark at the end of the rule.

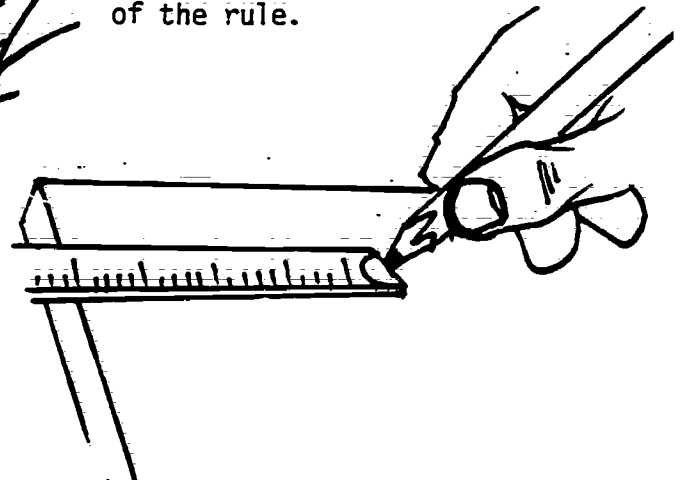
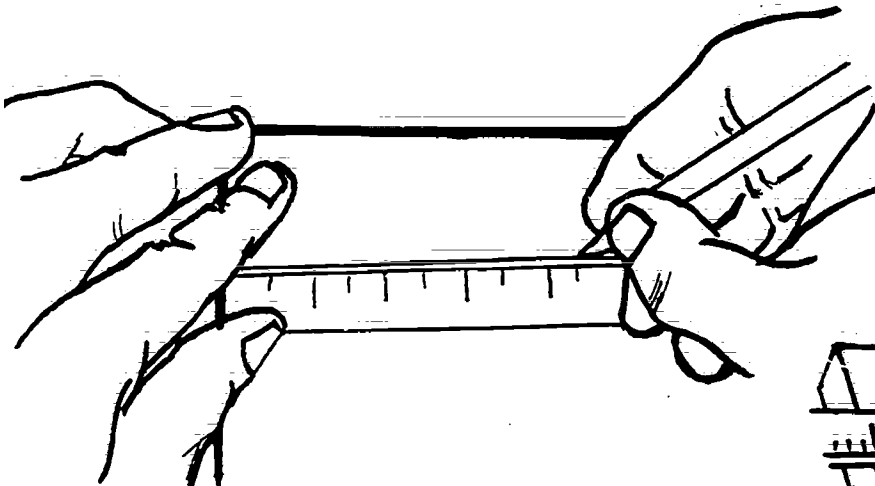



COMPETENCY: Square a Line on Stock with the Try Square or Combination Square

COURSE: Appliance Repair

UNIT II: Basic Electricity

OBJECTIVE: The student will be able to properly square a line on stock without error

Page 1 of 1 page

---

COMPETENCE - PROCEDURES/STEPS

The student will be able to:

TEACHING/LEARNING ACTIVITIES

---

1. Place the head of the square against the edge of the stock.
2. Slide the square along the edge of the stock until the edge of the blade is aligned with the mark to be squared.

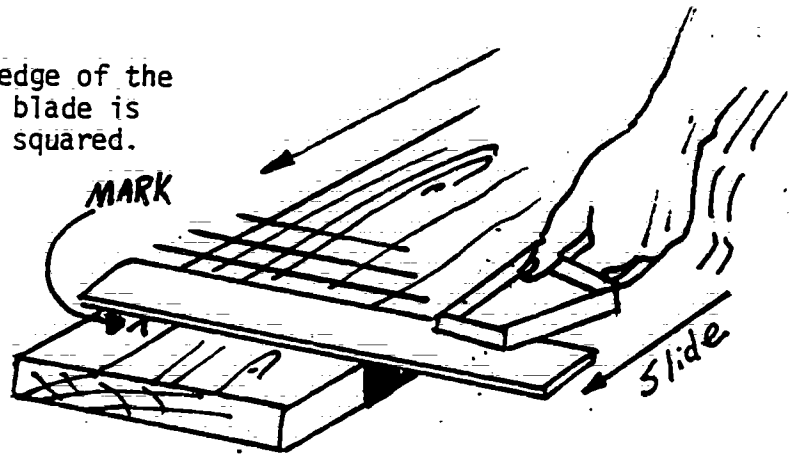

3. Mark a line along the edge of the blade with a sharp pencil.

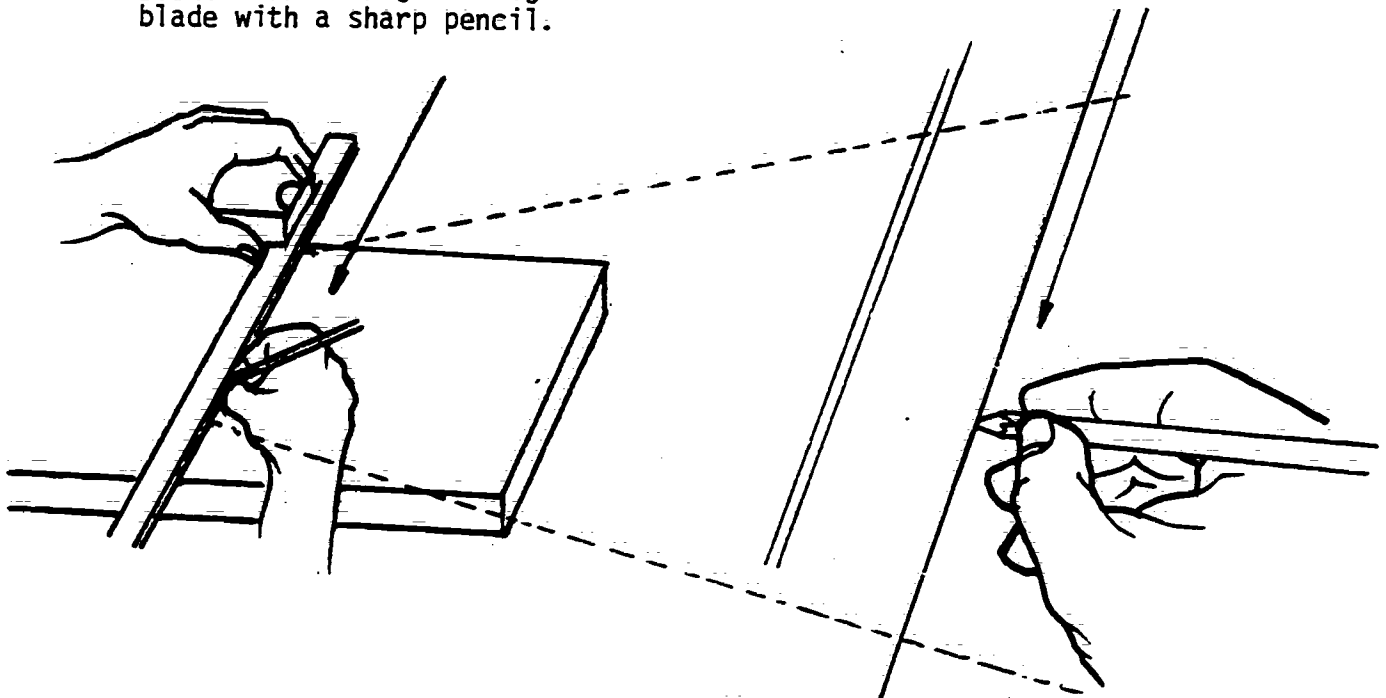

234

OPERATION SHEET

SC-2-1C

COMPETENCY: Square a Line on Stock with the Framing Square

COURSE: Appliance Repair

UNIT II: Basic Electricity

OBJECTIVE: The student will be able to accurately square a line on stock with the framing square.

Page 1 of 1 page

COMPETENCE - PROCEDURES/STEPS  
The student will be able to:

TEACHING/LEARNING ACTIVITIES

1. Place the inside edge of the blade against the edge of the stock.
2. Slide the square along the stock until the edge of the tongue is aligned with the mark to be squared.

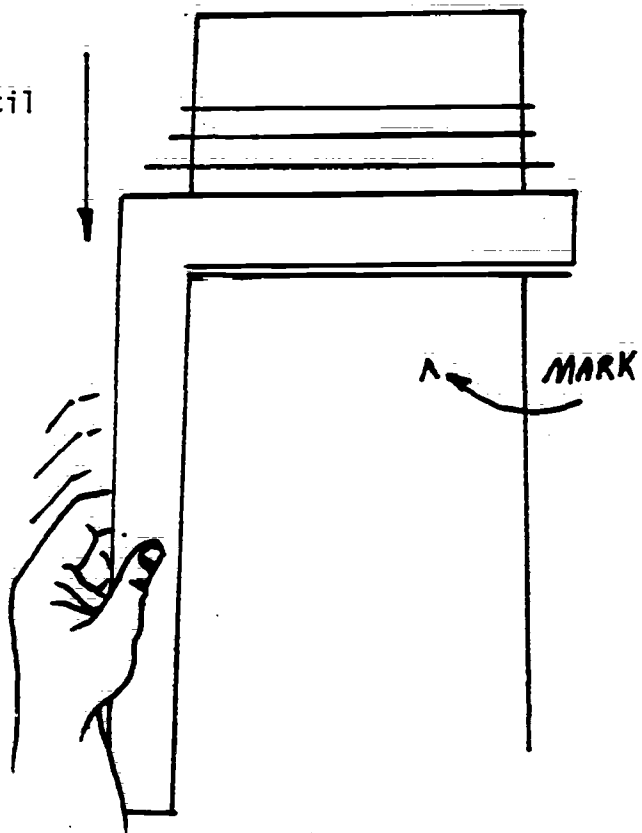

3. Mark along the edge of the tongue.

NOTE: A square line may be laid out on wider stock by placing the tongue of the framing square against the edge of the stock and marking along the blade.

When squaring a line on thin material, align the outer edge of the blade even with the edge of the material and mark along the tongue.

235

COMPETENCY: Put Drill Bit in a Drill Motor  
Chuck

COURSE: Appliance Repair

UNIT II: Basic Electricity

OBJECTIVE: The student will be able to install drill bit--acceptable  
to safety standards

Page 1 of 2 pages

---

COMPETENCE - PROCEDURES/STEPS

The student will be able to:

TEACHING/LEARNING ACTIVITIES

---

1. Open the chuck by turning it counter-clockwise with fingers.

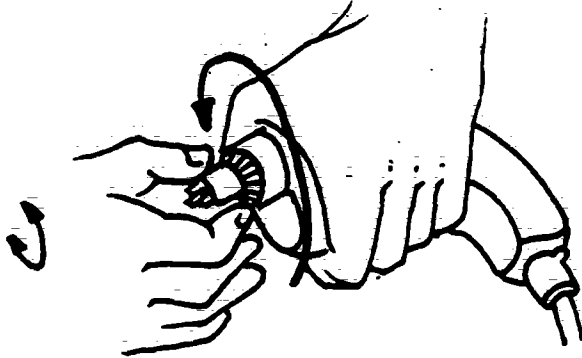

2. Push the blunt end of the bit into the chuck until it bottoms.

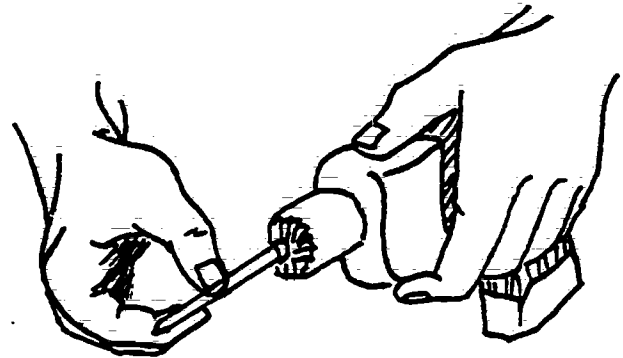

3. Hold the bit in the center of the chuck and turn the chuck clockwise by hand.

NOTE: Make sure the bit is centered in the chuck.

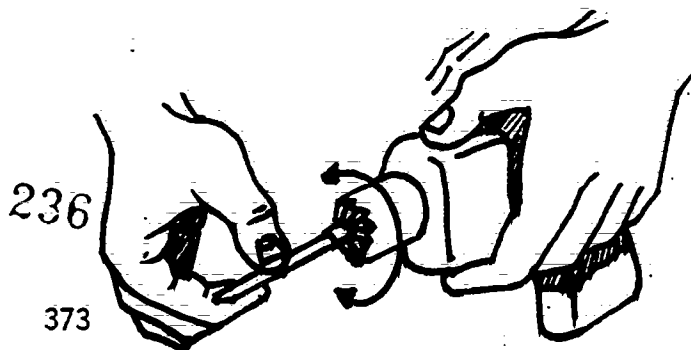

COMPETENCE - PROCEDURES/STEPS	TEACHING/LEARNING ACTIVITIES
-------------------------------	------------------------------

4. Tighten the chuck by turning the chuck key clockwise until it is tight.
5. Move the key to the next key guide and tighten it the same way.

NOTE: Move to, and tighten each key guide.

NOTE: Remove the key before using the drill.

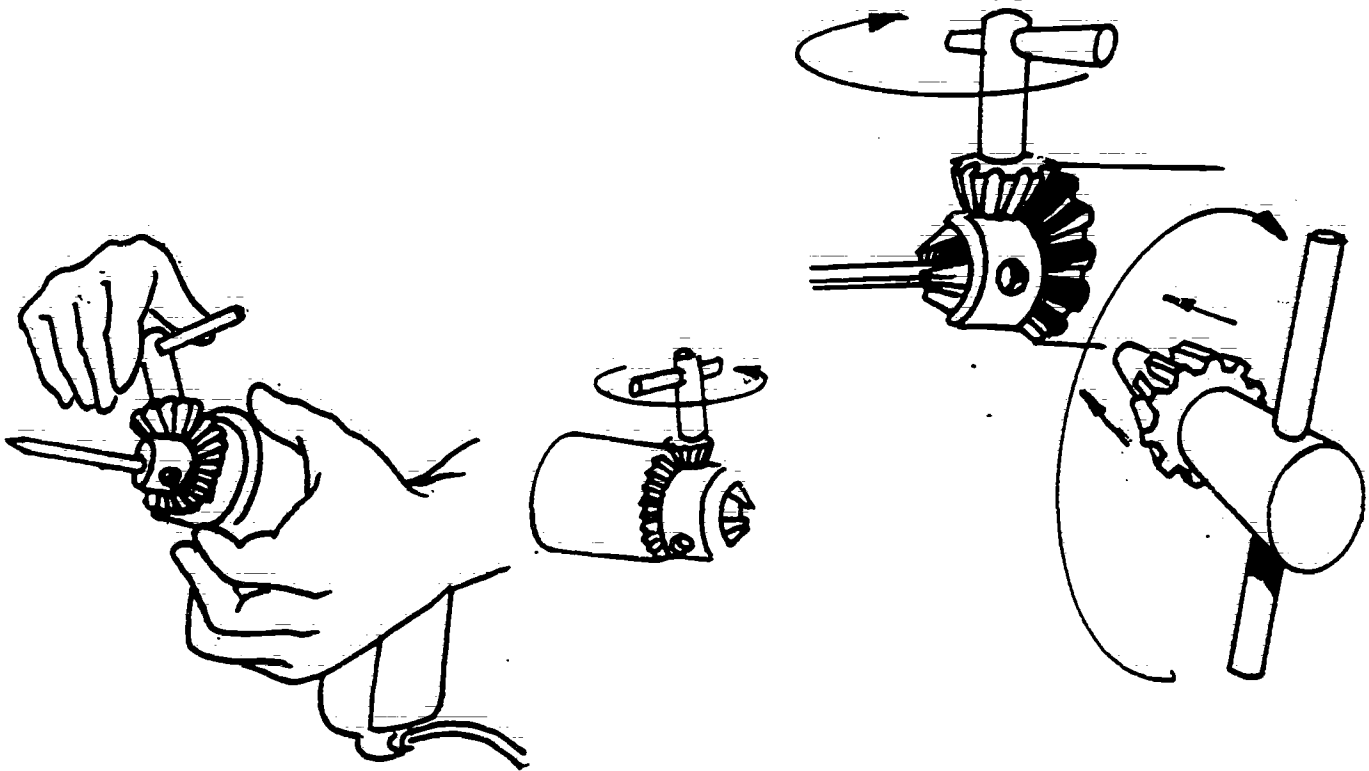

6. Plug the drill into an outlet and squeeze the trigger until the drill starts.

NOTE: The bit should run true and not wobble. If the bit wobbles, go back to step 1 and start again.

COMPETENCY: Drill with an Electric Hand  
Drill (3/8)

COURSE: Appliance Repair

UNIT II: Basic Electricity

OBJECTIVE: The student will be able to properly drill holes with  
the electric hand drill

Page 1 of 1 page

---

COMPETENCE - PROCEDURES/STEPS  
The student will be able to:

---

TEACHING/LEARNING ACTIVITIES

---

1. Place drill bit on punch mark.

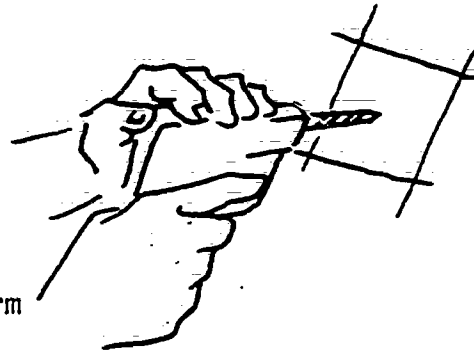

2. Squeeze the trigger and apply firm pressure to drill.

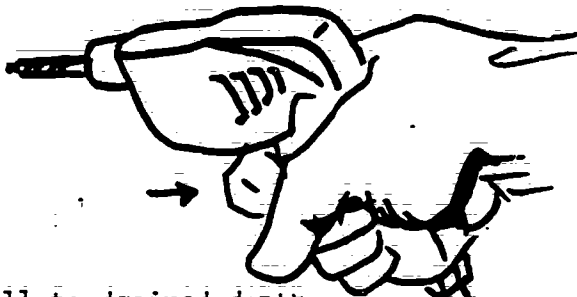

NOTE: Apply oil occasion-  
ally when needed.

3. Drill to desired depth.

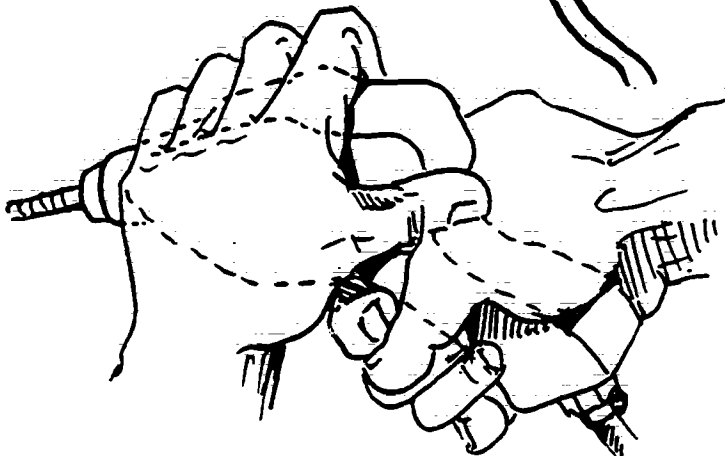

COMPETENCY: Tighten Nuts and Bolts

COURSE: Appliance Repair

UNIT II: Basic Electricity

OBJECTIVE: The student will be able to properly tighten nuts and bolts using screwdriver and nutdriver.

Page 1 of 1 page

---

COMPETENCE - PROCEDURES/STEPS  
The student will be able to:

TEACHING/LEARNING ACTIVITIES

---

1. Hold the screwdriver blade in bolt slot with one hand.

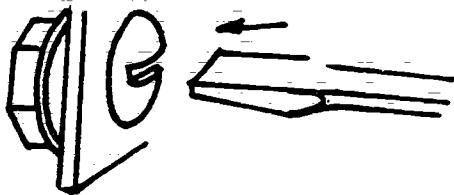

2. Hold the nutdriver over the nut with other hand.

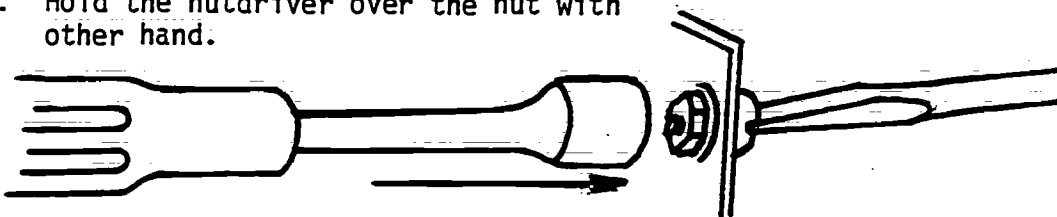

3. Hold firmly with the screwdriver and firmly tighten the nut with the nutdriver.

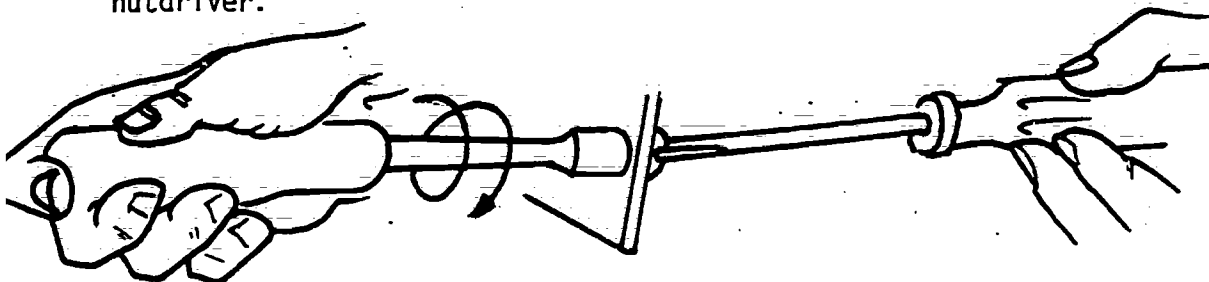

COMPETENCY: Cut Wire with Side Cutters or  
Diagonals

COURSE: Appliance Repair

UNIT II: Basic Electricity

OBJECTIVE: The student will be able to safely cut wire and bend with  
the side cutting pliers

Page 1 of 1 page

---

COMPETENCE - PROCEDURES/STEPS  
The student will be able to:

TEACHING/LEARNING ACTIVITIES

---

1. Hold the side cutters in the hand as shown.

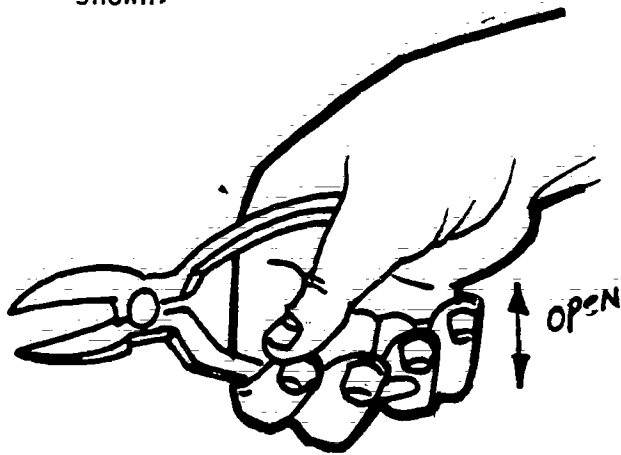

2. Grip wire with cutters.

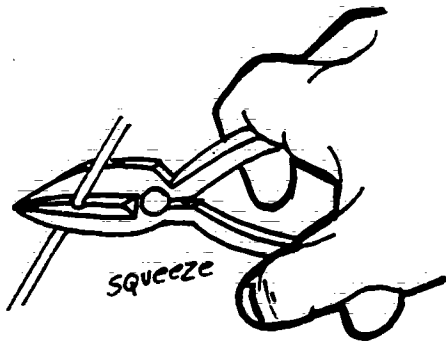

NOTE: The tip of the cutter is used for close work.

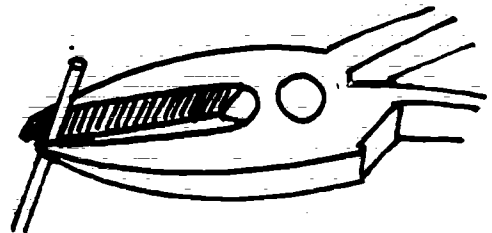

3. Make cut.

240

COMPETENCY: Skin a Conductor with a Knife

COURSE: Appliance Repair

UNIT II: Basic Electricity

OBJECTIVE: The student will be able to remove the insulation acceptable to the shop standards pre-set by the instructor

Page 1 of 1 page

---

COMPETENCE - PROCEDURES/STEPS  
The student will be able to:

TEACHING/LEARNING ACTIVITIES

---

1. Hold the insulated wire in one hand and the knife in the other.
2. Place the knife blade about 1 1/4" from the end of the wire.
3. Push the knife forward carefully so as not to nick the conductor.

CAUTION: Never cut toward oneself when using a knife; always turn the blade away.

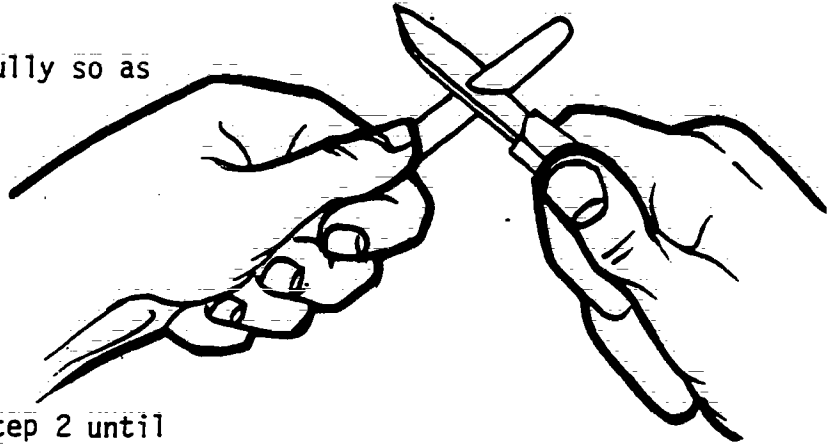

4. Rotate the wire and repeat step 2 until all the insulation is removed.

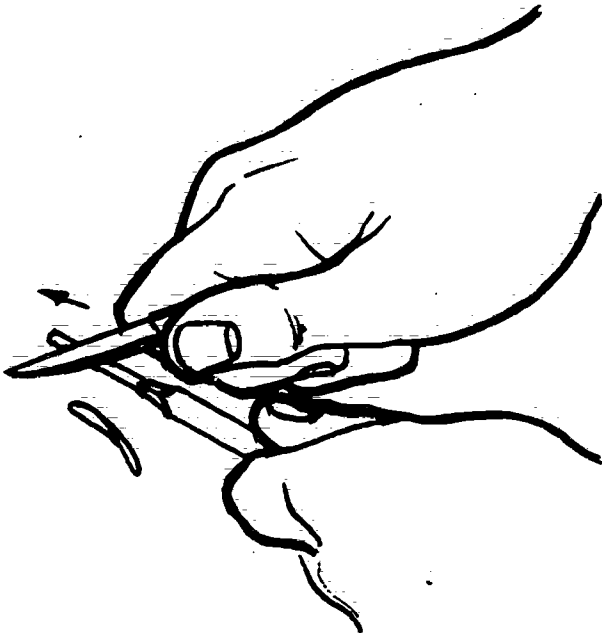

241



COMPETENCY: Bend an Eye on a Wire with a  
Needle Nose Pliers

COURSE: Appliance Repair

UNIT II: Basic Electricity

OBJECTIVE: The student will be able to prepare wire for use in wiring  
a switch, receptacle, etc.

Page 1 of 1 page

---

COMPETENCE - PROCEDURES/STEPS  
The student will be able to:

TEACHING/LEARNING ACTIVITIES

---

1. Hold wire in one hand.
2. Hold needle nose pliers in the other hand  
and grasp wire as shown.

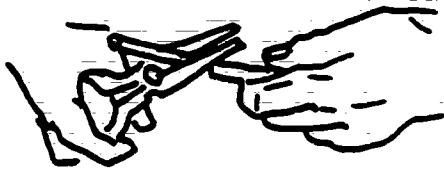

3. Bend wire up, slip needle nose to the  
end of the wire and twist loop.

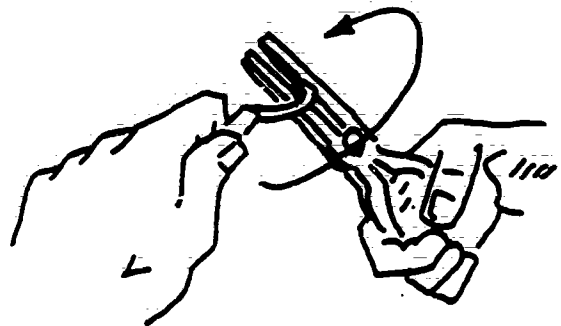
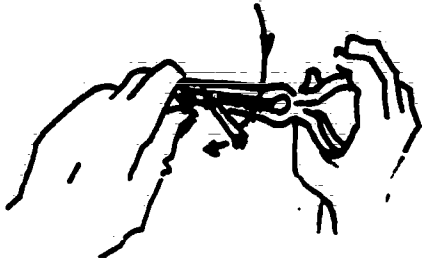

242

OPERATION SHEET

SC-2-7

COMPETENCY: Connect Devices Using Screws

COURSE: Appliance Repair

UNIT II: Basic Electricity

OBJECTIVE: The student will be able to connect the wires to the devices acceptable to the shop standards pre-set by the instructor .

Page 1 of 1 page

---

COMPETENCE - PROCEDURES/STEPS  
The student will be able to:

TEACHING/LEARNING ACTIVITIES

---

1. Use a screwdriver to loosen the screws on the device.

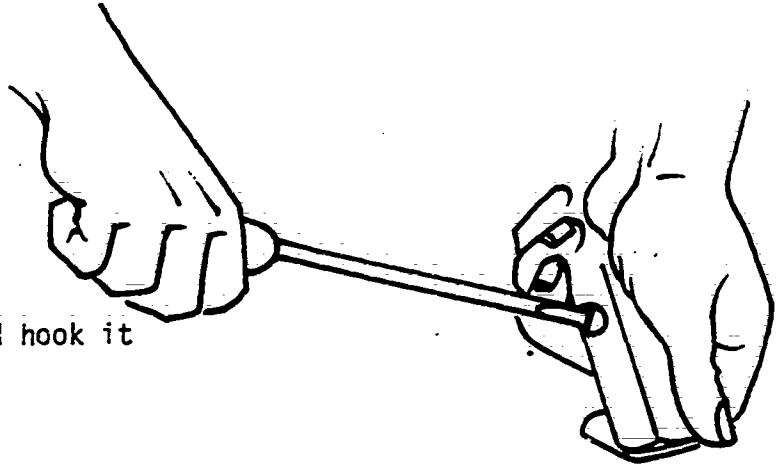

2. Bend a hook on the wire and hook it around the screw clockwise.

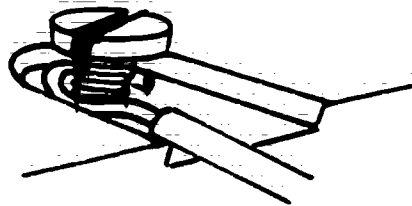
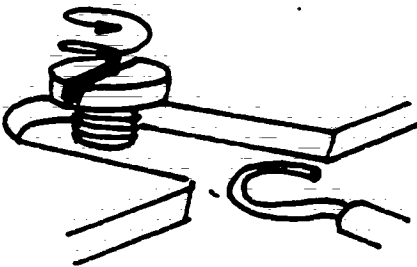

3. Turn the screw clockwise until it is tight.

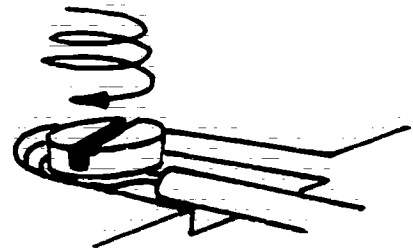

COMPETENCY: Strip Cable or Cord

COURSE: Appliance Repair

UNIT II: Basic Electricity

OBJECTIVE: The student will be able to strip the cable acceptable to the standards set by N.E.C.

Page 1 of 2 pages

---

COMPETENCE - PROCEDURES/STEPS  
The student will be able to:

---

TEACHING/LEARNING ACTIVITIES

1. Place the cable on a flat surface.
2. Anchor the cable with one hand as shown.
3. Using the other hand, place the knife blade in the middle of the cable.
4. Pushing slightly, pull the knife down the length of the cable slitting the outside covering.

NOTE: Be careful not to cut through the cable covering.

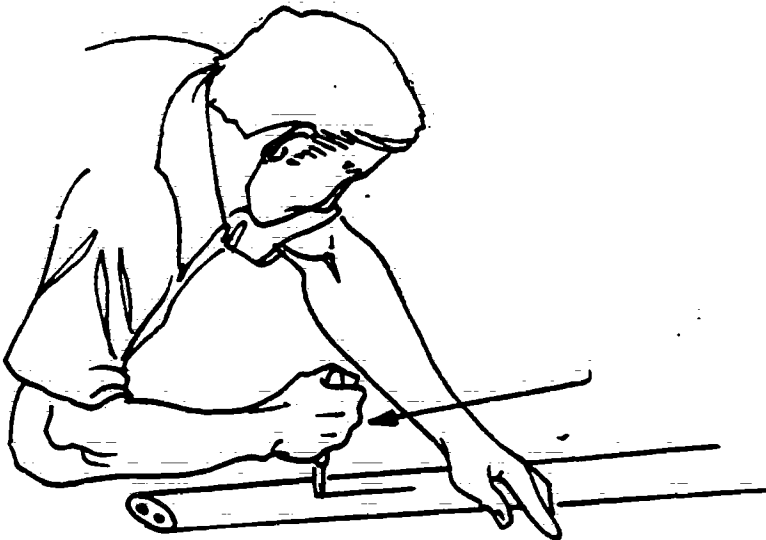

5. Hold the cable and cut completely around the outside covering.

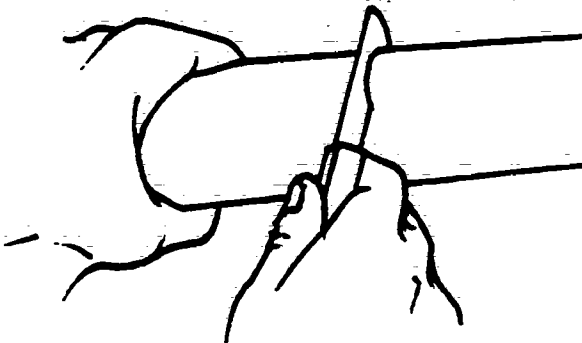

214

---

COMPETENCE - PROCEDURES/STEPS

TEACHING/LEARNING ACTIVITIES

---

6. Tear off the covering along the marked line.

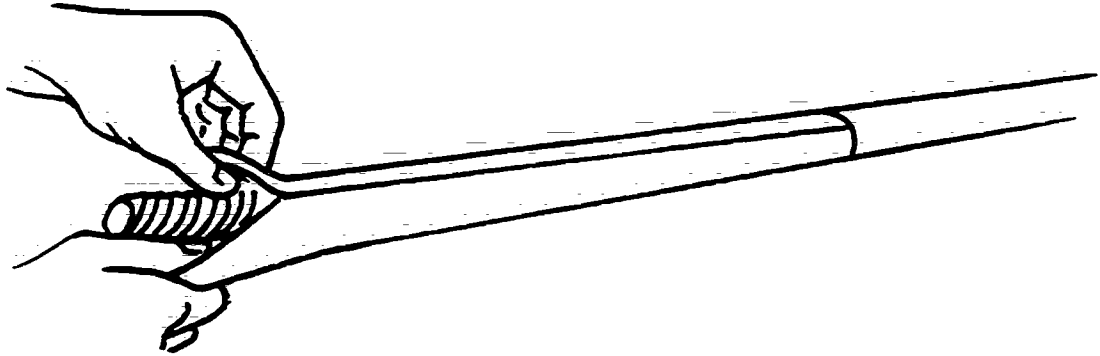

7. Use a pocket knife to cut off any paper that may be around the cable.

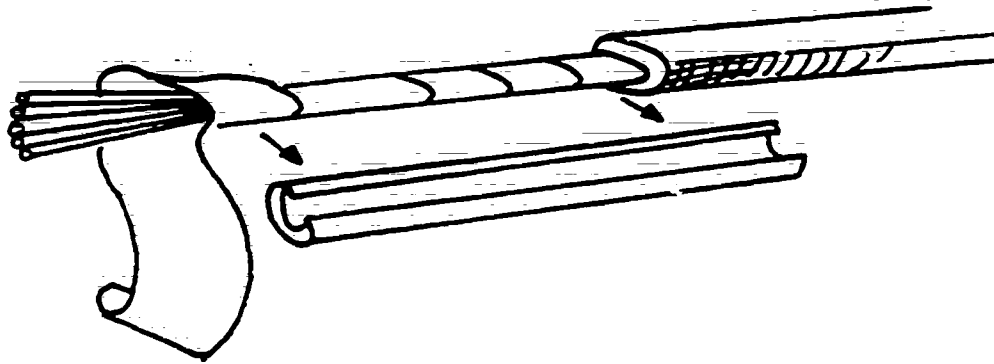

COMPETENCY: Clean a Stranded Wire Using  
a Knife

COURSE: Appliance Repair

UNIT II: Basic Electricity

OBJECTIVE: The student will be able to  
scrape a stranded wire clean  
using a knife edge

Page 1 of 1 page

---

COMPETENCE - PROCEDURES/STEPS  
The student will be able to:

TEACHING/LEARNING ACTIVITIES

---

1. Place skinned wire on a flat surface.
2. Scrape the wire using the knife blade edge across the wire strands until they are clean.

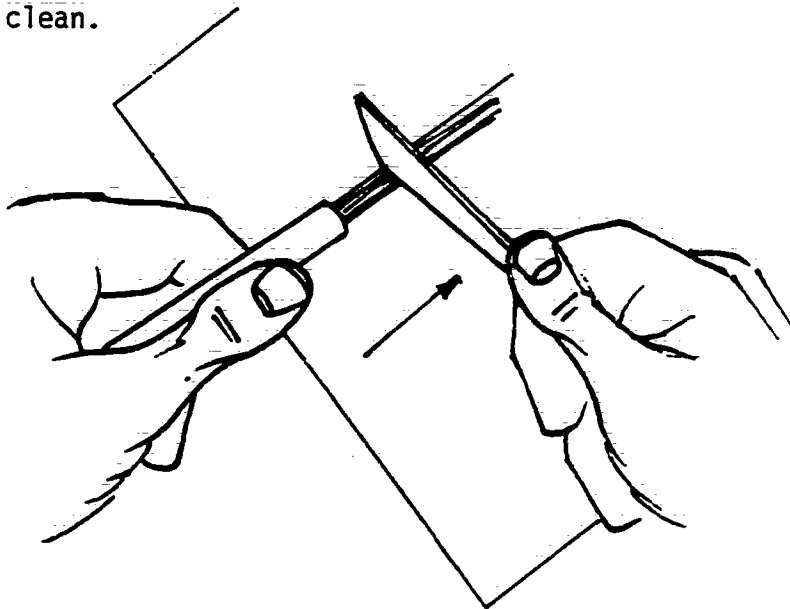

NOTE: After wire is cleaned,  
twist wire strands back  
together.

COMPETENCY: Solder Connections with a Solder Gun

COURSE: Appliance Repair

UNIT II: Basic Electricity

OBJECTIVE: The student will be able to solder connection acceptable to the shop standards pre-set by the shop instructor

Page 1 of 2 pages

COMPETENCE - PROCEDURES/STEPS  
The student will be able to:

TEACHING/LEARNING ACTIVITIES

1. Unroll about 6" of solder.

CAUTION: Never touch the tip of the gun. It remains hot after the gun is turned off and can cause serious burns.

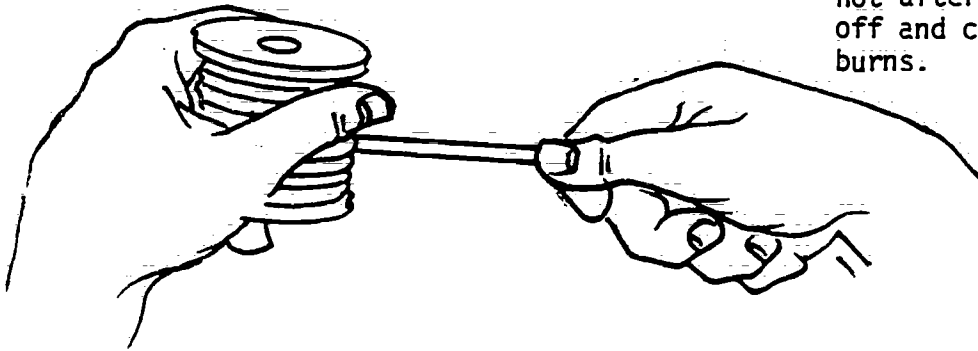

2. Plug the solder gun into an outlet.
3. Hold the gun in hand and squeeze the trigger all the way in.

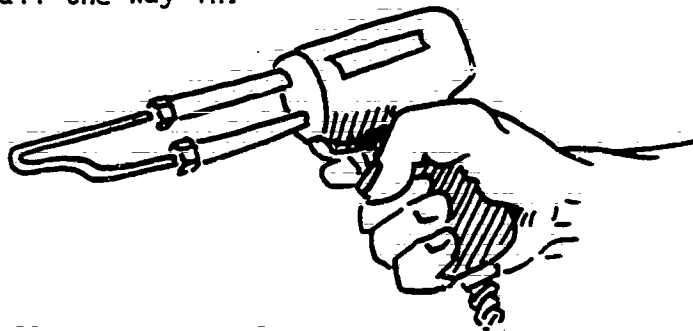

4. Put a small amount of solder on the tip.

CAUTION: BE CAREFUL not to let any hot solder fall on oneself. It can cause serious burns.

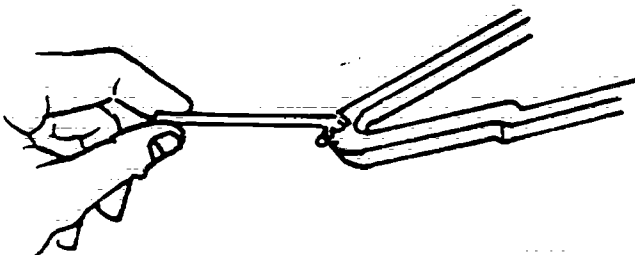

246

COMPETENCE - PROCEDURES/STEPS	TEACHING/LEARNING ACTIVITIES
-------------------------------	------------------------------

5. Hold the rag in one hand and brush it across the tip of the solder gun.

NOTE: Apply some pressure but do not hold onto the tip. Keep brushing until the tip looks shiny.

6. Apply 3/8" of solder to the tip.
7. Put the solder tip on the bottom of the connection making sure that the tinned part of the tip is touching the connection.
8. Place the end of the solder near the beginning of the connection and apply light pressure.

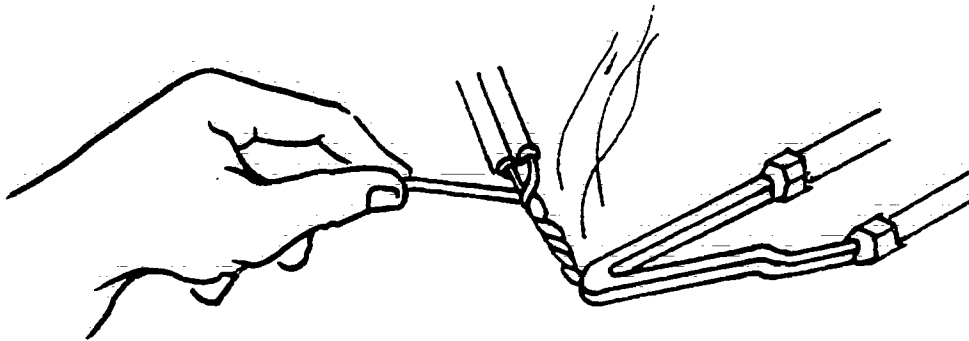

9. Allow the solder to start melting, then continue to feed solder on the beginning of the connection until the solder flows to the end.
10. Remove the solder gun from the connection and then remove the solder.

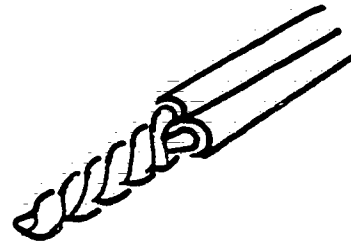

217

COMPETENCY: Adjust and Use the Adjustable Wrench

COURSE: Appliance Repair

UNIT II: Basic Electricity

OBJECTIVE: The student will be able to adjust and use the wrench in an efficient manner

Page 1 of 1 page

COMPETENCE - PROCEDURES/STEPS  
The student will be able to:

TEACHING/LEARNING ACTIVITIES

1. Hold the adjustable wrench in hand with thumb on the knurled worm gear.

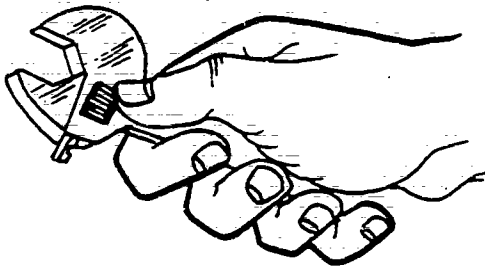

2. Roll the gear with thumb to open or close the jaw of the wrench.

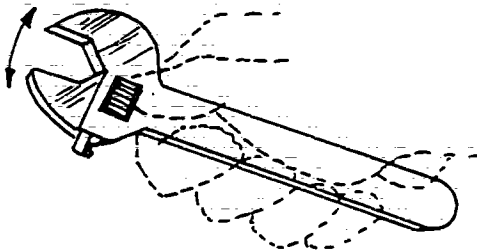

3. Open wrench jaw large enough to fit over the bolt, nut or stud.
4. Close jaw on bolt head until it is tight.

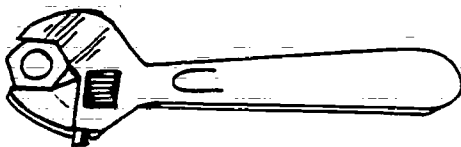

5. Turn nut or bolt to tighten or loosen.

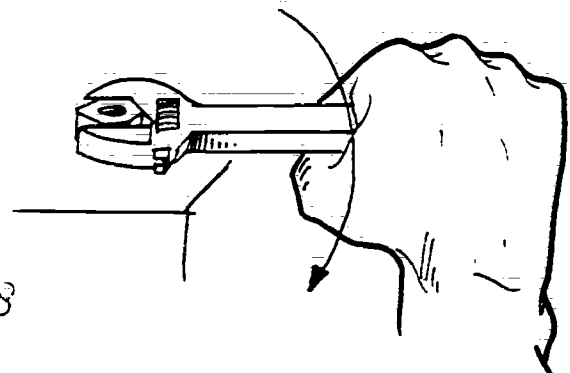

248



COMPETENCY: Dress Solid Wire

COURSE: Appliance Repair

UNIT II: Basic Electricity

OBJECTIVE: The student will be able to dress solid wire

Page 1 of 1 page

---

COMPETENCE - PROCEDURES/STEPS  
The student will be able to:

---

TEACHING/LEARNING ACTIVITIES

1. Grasp the wire with both hands and bend an angle (where necessary).

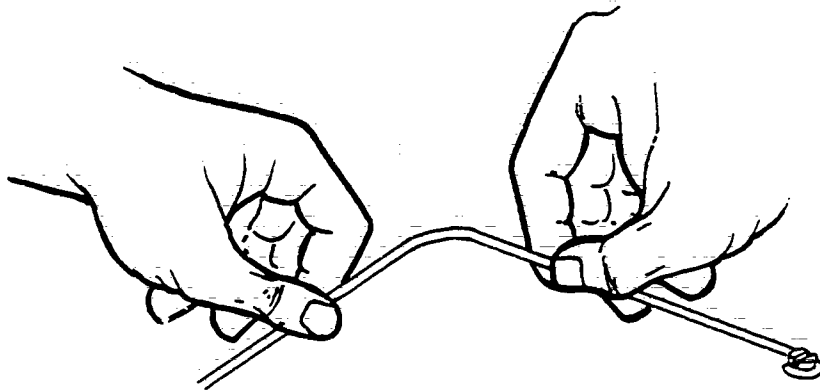

2. Grasp the wire with both hands and straighten wire as shown.

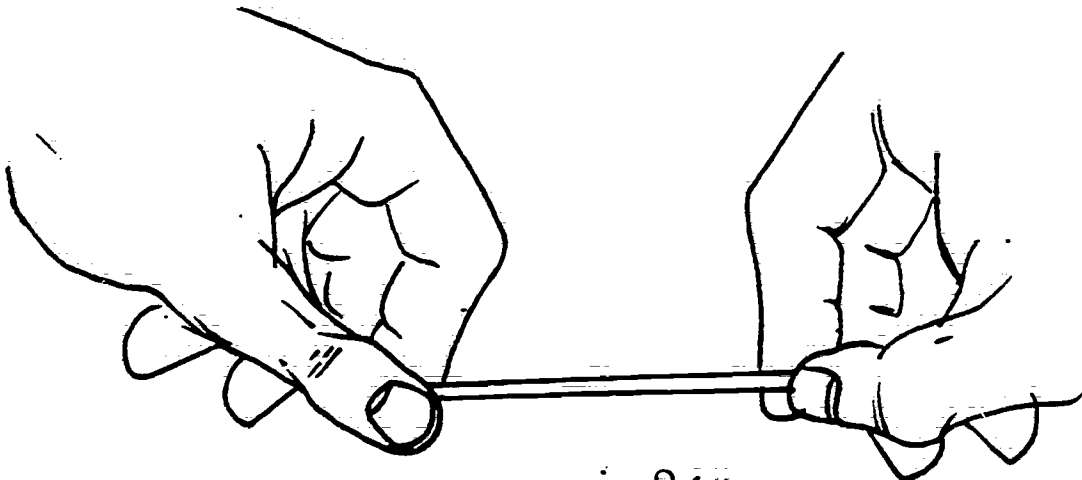

COMPETENCY: Twist a Two Wire Tap Using Pliers

COURSE: Appliance Repair

UNIT II: Basic Electricity

OBJECTIVE: The student will be able to twist 2 wire taps acceptable to the shop standards pre-set by the instructor.

Page 1 of 2 pages

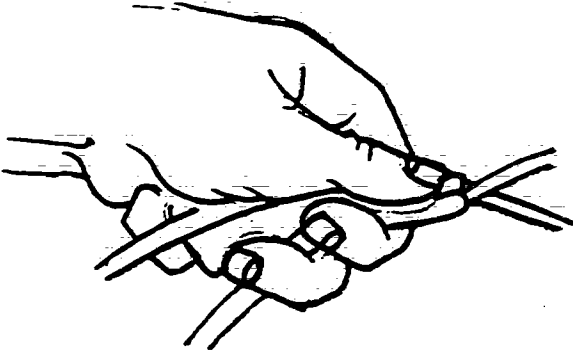
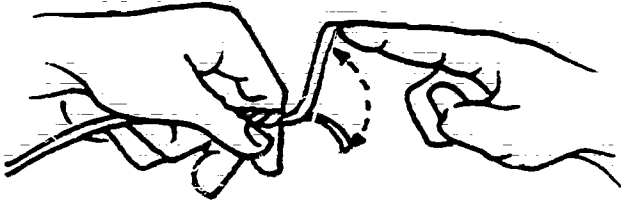
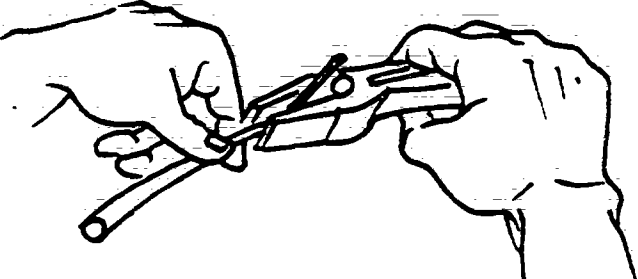
COMPETENCE - PROCEDURES/STEPS	TEACHING/LEARNING ACTIVITIES
The student will be able to:	
<p>1. Hold both wires in one hand and cross them about 1/4" from the insulation.</p>	
<p>2. Push the wires with index finger and bend them slightly.</p>	
<p>3. Place the wires between the jaws of pliers and turn them with the pliers 1/4 turn clockwise.</p>	<p>NOTE: Only the bare wires should twist. Squeezing the pliers too tightly will make the insulated part of the wire twist.</p>
	

---

COMPETENCE - PROCEDURES/STEPS

TEACHING/LEARNING ACTIVITIES

---

4. Remove the pliers and place them back on the wires about 1/2" from the twist and turn them a full turn clockwise.

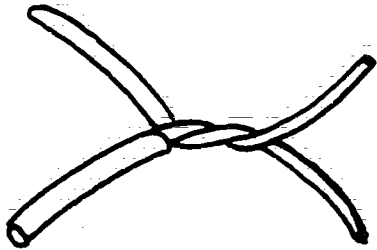

5. Repeat step 4 until the wires are completely twisted together.

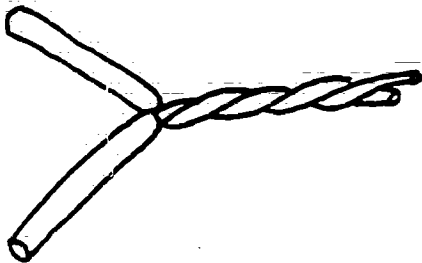

6. Use the side cutter to snip off any excess and make ends of wires even.

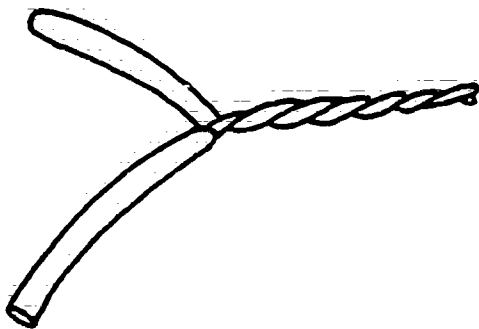

251

COMPETENCY: Tape Conductors

COURSE: Appliance Repair

UNIT II: Basic Electricity

OBJECTIVE: The student will be able to tape the conductors acceptable to the shop standards pre-set by the instructor

Page 1 of 2 pages

---

COMPETENCE - PROCEDURES/STEPS  
The student will be able to:

TEACHING/LEARNING ACTIVITIES

---

1. Unroll about 8" of tape.
2. Hold hands with thumbs and index fingers together on the tape and squeeze the tape very tightly, then twist one hand clockwise and the other hand counter-clockwise very quickly to tear off the tape.

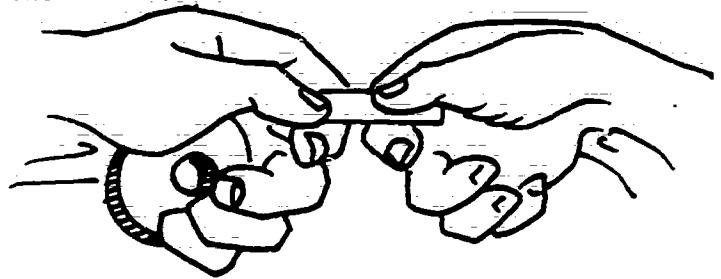
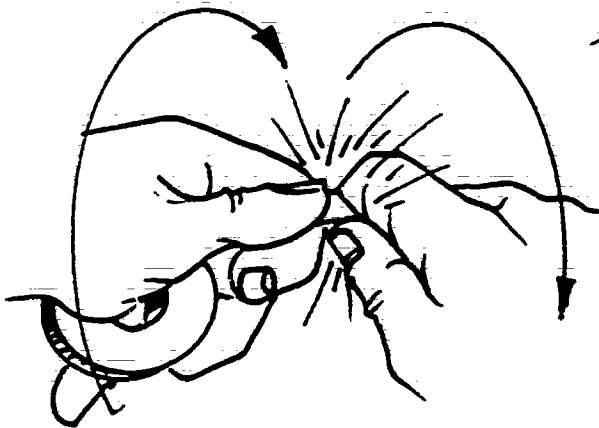

3. Begin to tape, placing one full width of the tape on the insulation.

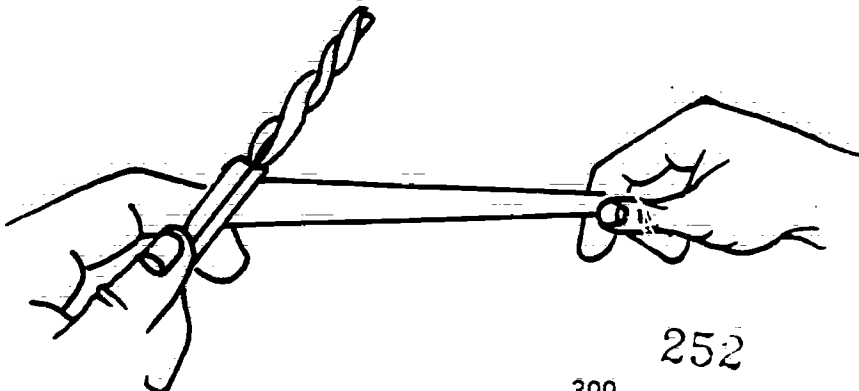

## COMPETENCE - PROCEDURES/STEPS

## TEACHING/LEARNING ACTIVITIES

4. Keep tension on the tape and wrap it spirally clockwise toward the end of the conductor in 1/4" spirals until the tape is one full width of the tape past the end.

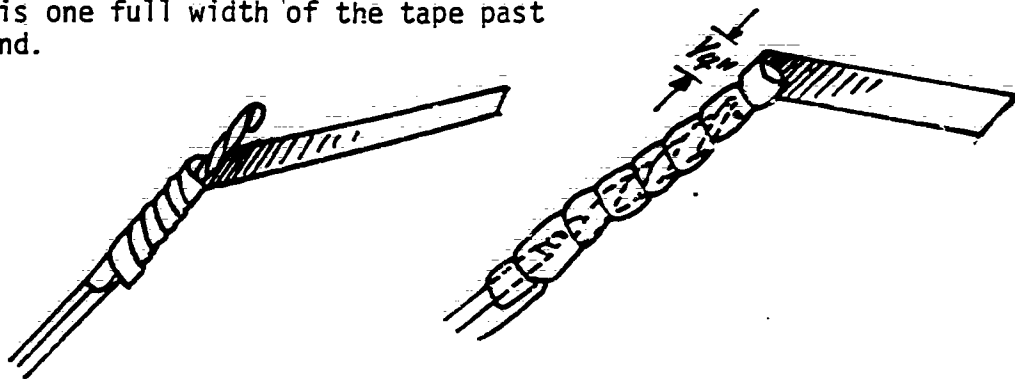

5. Fold the 1/2" of spiral back over the conductor and wrap the tape counter-clockwise back on the conductor to where the tape started.

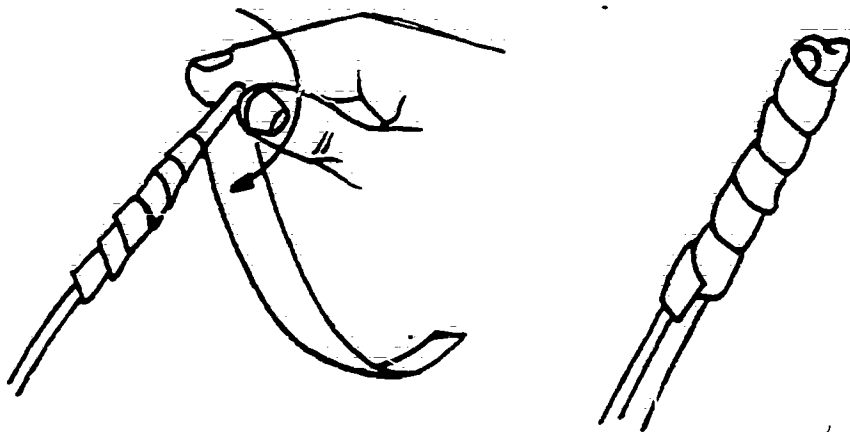

6. Cut/tear off the extra tape.

COMPETENCY: Remove Insulation Leaving a Lead

COURSE: Appliance Repair

UNIT II: Basic Electricity

OBJECTIVE: The student will be able to remove part of the insulation leaving a lead acceptable to the standards pre-set by the instructor

Page 1 of 2 pages

---

COMPETENCE - PROCEDURES/STEPS  
The student will be able to:

TEACHING/LEARNING ACTIVITIES

---

1. Hold the knife in one hand and the wire in the other.
2. Hold the knife against the wire and push gently on the insulation by squeezing it with thumb and index finger.

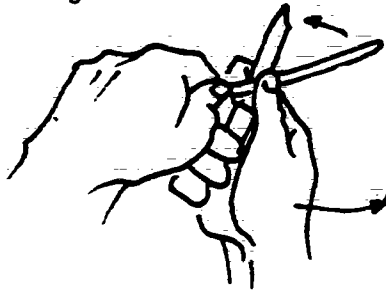

3. Make complete cut around wire.

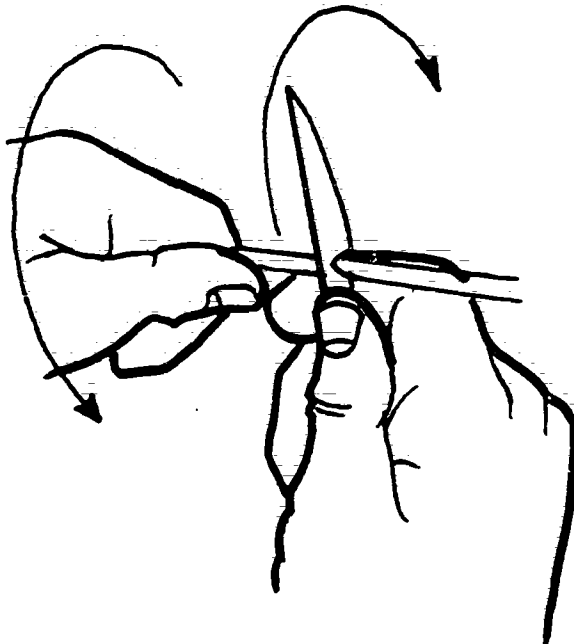

NOTE: Be careful to just cut the insulation and not the wire.

---

COMPETENCE - PROCEDURES/STEPS

TEACHING/LEARNING ACTIVITIES

---

4. Make a second cut repeating steps 2 and 3 at point where insulation is to be removed.

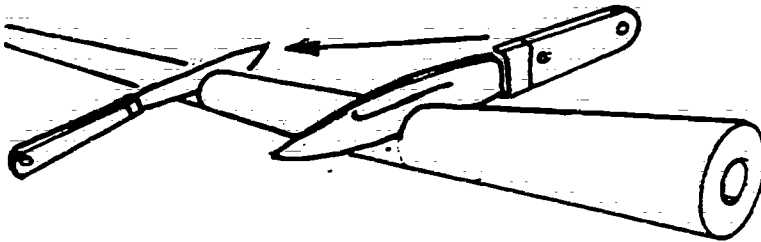

5. Hold the wire tightly and place the knife at a 45° angle to the wire at the point where insulation was cut.

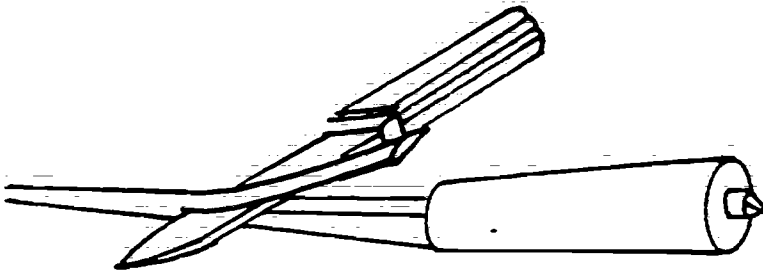

6. Push the back of the blade with thumb until the other cut around the insulation is reached.

CAUTION: CUT CAREFULLY.  
The knife could easily slip.

7. Lay the knife down and pull the rest of the insulation off.

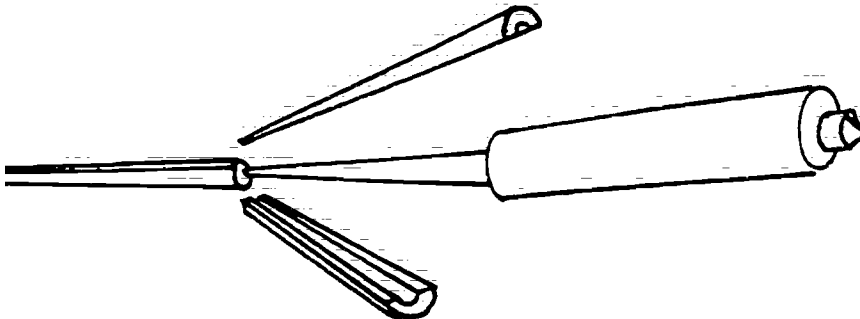

COMPETENCY: Make a Two Wire Lead Splice

COURSE: Appliance Repair

UNIT II: Basic Electricity

OBJECTIVE: The student will be able to twist 2-wire taps leaving a lead acceptable to the shop standards pre-set by the instructor

Page 1 of 2 pages

---

COMPETENCE - PROCEDURES/STEPS  
The student will be able to:

---

TEACHING/LEARNING ACTIVITIES

1. Cross the wires and keep the insulation on both of them even and squeeze them tightly between thumb and index finger.

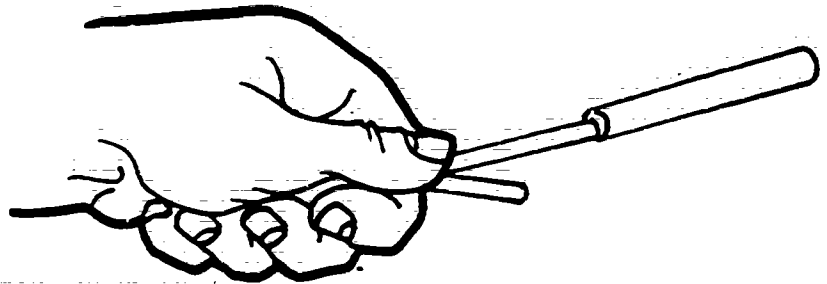

2. With the other index finger, push the wires to bend them slightly.

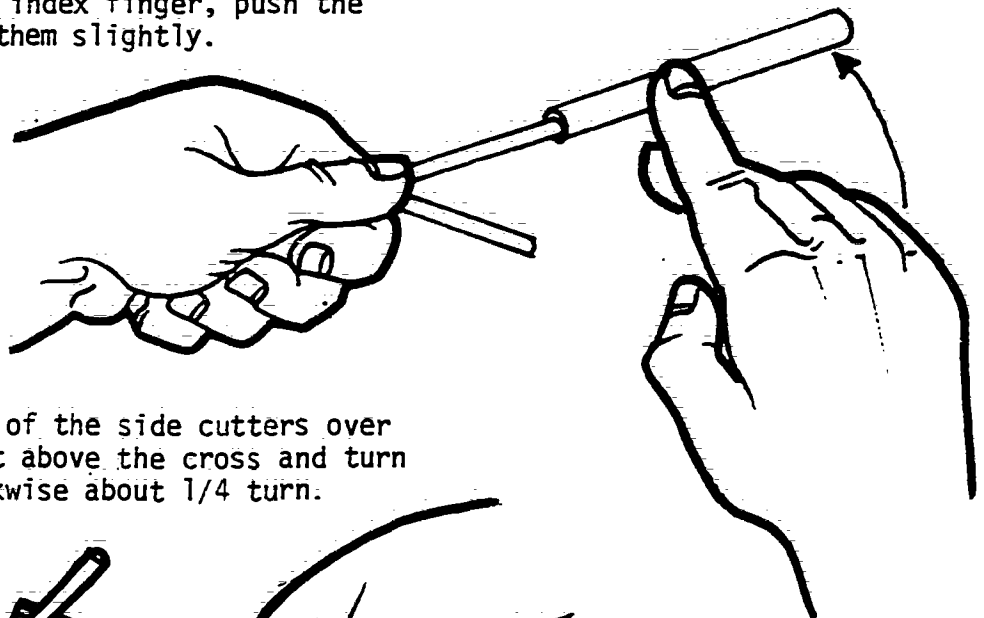

3. Place the jaws of the side cutters over both wires just above the cross and turn the wires clockwise about 1/4 turn.

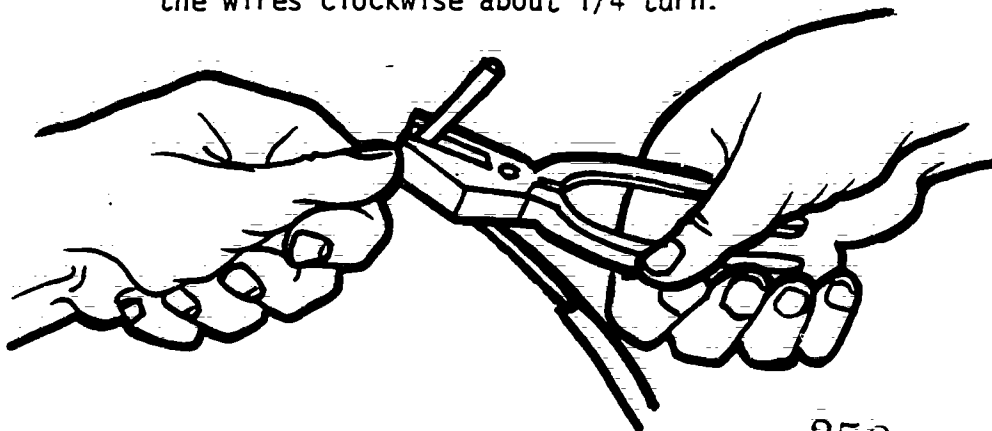



COMPETENCE - PROCEDURES/STEPS

TEACHING/LEARNING ACTIVITIES

4. Remove the side cutters, turn them back, place them back on the wires just above the twist and turn them a full turn clockwise.

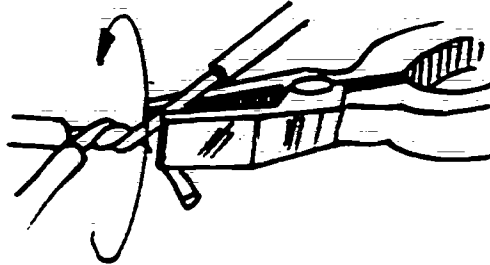
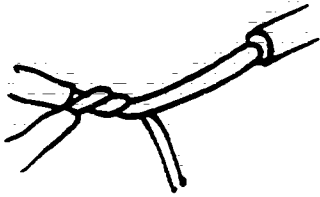

5. Repeat step 4 until the wires are twisted to the end.

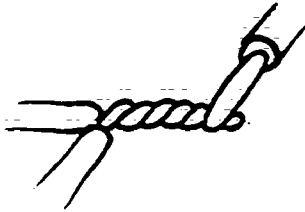

NOTE: If the insulation has slipped back on the wire, slide it back in place by putting one hand near the tap and pushing the insulation with the other hand.

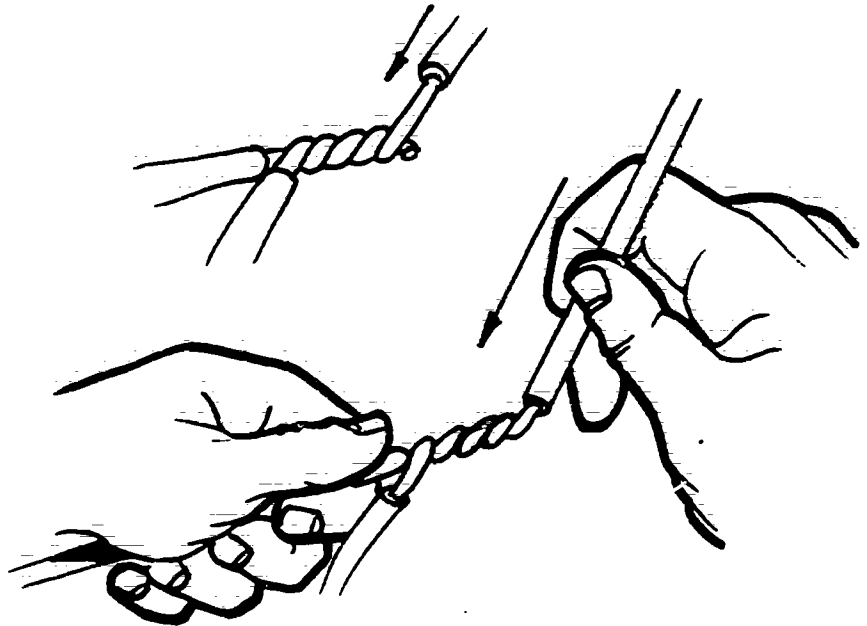

257

COMPETENCY: Install Wire Nuts

COURSE: Appliance Repair

UNIT II: Basic Electricity

OBJECTIVE: The student will be able to install wire nuts acceptable to the shop standards pre-set by the instructor

Page 1 of 1 page

---

COMPETENCE - PROCEDURES/STEPS  
The student will be able to:

---

TEACHING/LEARNING ACTIVITIES

1. Hold the wires in one hand and the wire nut in the other hand between the thumb and the index finger.

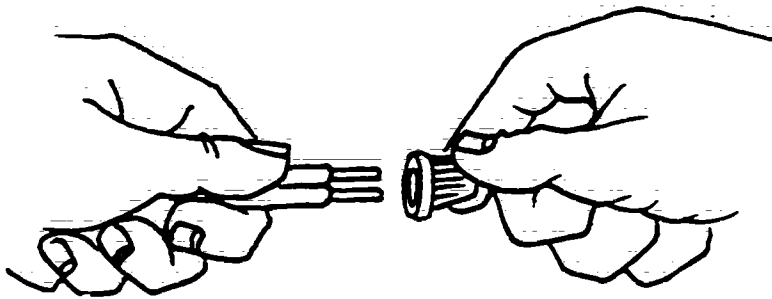

2. Push the wire nut onto the wires and begin to twist it clockwise.

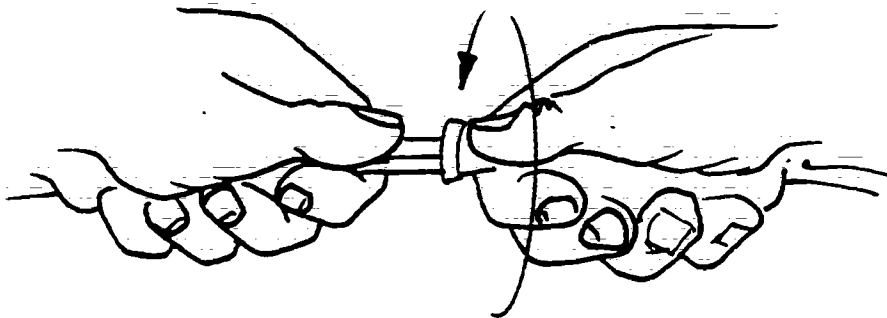

3. Continue to turn the wire nut until it bottoms.

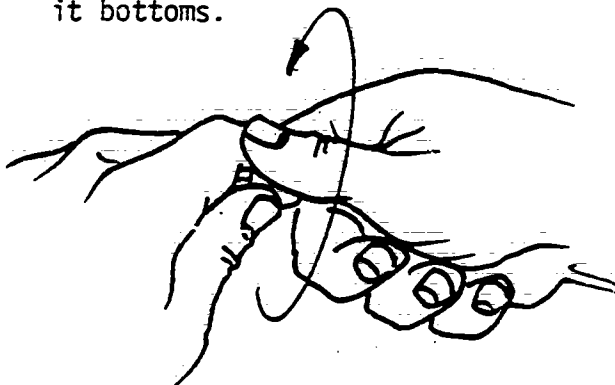

NOTE: The wire nut has bottomed when the insulation begins to twist.

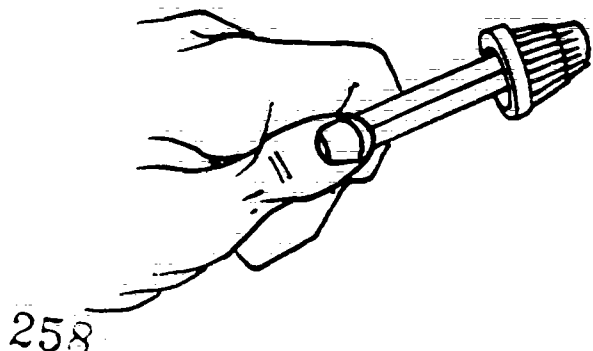

258

COMPETENCY: Set Up Volt-Ohm Meter to Measure Voltages

COURSE: Appliance Repair

UNIT II: Basic Electricity

OBJECTIVE: The student will be able to properly use the test probes using a volt-ohm meter (Robinair #12723)

Page 1 of 1 page

COMPETENCE - PROCEDURES/STEPS The student will be able to:	TEACHING/LEARNING ACTIVITIES
1. Open cover and fasten cover with strap clips.	. IL-2-5A
2. Locate the 2 test probes.	NOTE: They are insulated handles with metal tips.
3. Set the selector scale to the proper position (VAC-250AC), then attach or place probes at the two wanted places to get a meter reading.	

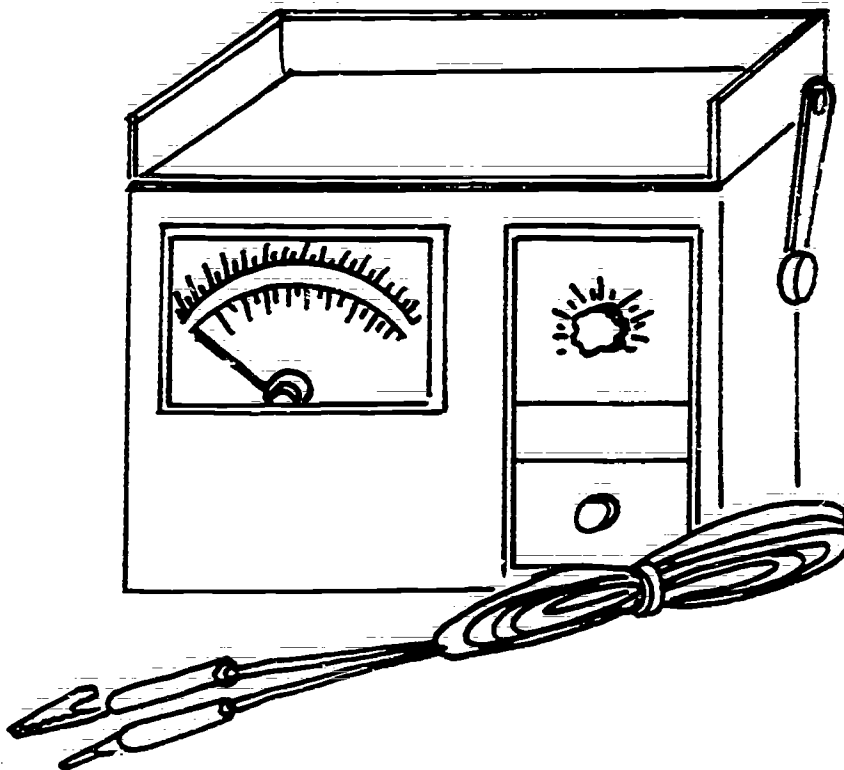

OPERATION SHEET

SC-2-18

COMPETENCY: Set Up Volt-Ohm Meter to  
Measure Continuity

COURSE: Appliance Repair

UNIT II: Basic Electricity

OBJECTIVE: The student will be able to properly use the volt-ohm meter  
test probe for continuity testing (Robinair #12723)

Page 1 of 1 page

COMPETENCE - PROCEDURES/STEPS The student will be able to:	TEACHING/LEARNING ACTIVITIES
1. Open the lid and fasten the locking straps.	. IL-2-5B
2. Locate the two probes.	
3. Set the meter to the R X 1 scale.	
4. Touch the two probes together.	
5. Adjust the meter needle to zero using the "zero adjust" knob.	NOTE: If the needle does not move to zero when the knob is turned all the way to the right the battery must be replaced.
	NOTE: Notify instructor upon completion of operation.

OPERATION SHEET

SC-2-19

COMPETENCY: Set Up Volt-Ohm Meter to  
Measure Resistances

COURSE: Appliance Repair

UNIT II: Basic Electricity

OBJECTIVE: The student will be able to make accurate resistance readings  
using the volt-ohm meter (Robinair #12723)

Page 1 of 1 page

---

COMPETENCE - PROCEDURES/STEPS  
The student will be able to:

TEACHING/LEARNING ACTIVITIES

---

1. Open the lid and fasten the locking straps.
2. Locate the two test probes.
3. Set the meter to the R x 1 scale.
4. Touch the two probes together.
5. Zero adjust the meter.
6. Touch the probes across the part of circuit to be measured.

261

OPERATION SHEET

SC-2-20

COMPETENCY: Set Up the Clamp-On Amp-Meter  
to Measure Current Flow

COURSE: Appliance Repair

UNIT II: Basic Electricity

OBJECTIVE: The student will be able to correctly use the amp-meter

Page 1 of 1 page

---

COMPETENCE - PROCEDURES/STEPS	TEACHING/LEARNING ACTIVITIES
The student will be able to:	
1. Remove the meter from the case.	
2. Set the needle reading at zero.	NOTE: Have the instructor zero the meter if needed.
3. Select the proper scale if more than one scale is available.	NOTE: Make sure the jaws open and close properly.
4. Locate the wire to be checked.	
5. Clamp the jaws around the wire.	CAUTION: Make sure not to touch any LIVE wiring.
6. Take the meter reading.	

---

262

OPERATION SHEET

SC-2-21

COMPETENCY: Set Up Volt-Watt Meter for Use

COURSE: Appliance Repair

UNIT II: Basic Electricity

OBJECTIVE: The student will be able to properly use the volt-watt meter to check a circuit or appliance

Page 1 of 1 page

COMPETENCE - PROCEDURES/STEPS	TEACHING/LEARNING ACTIVITIES
- The student will be able to:	
1. Open the lid and fasten the locking straps.	
2. Set the toggle switch to the proper voltage setting 130/260.	
3. Set the selector dial to the highest scale. (5000).	
4. Plug in the cord that is attached to the meter case.	
5. Plug the cord of the appliance to be checked into the receptacle located below the toggle switch.	
6. Take a meter reading of the wattage scale.	NOTE: If necessary, dial the selector to a lower scale for easier reading.

COMPETENCY: Strip Wire with Wire Strippers

COURSE: Appliance Repair

UNIT II: Basic Electricity

OBJECTIVE: The student will be able to strip the wire to the proper length acceptable to the shop standards pre-set by the instructor

Page 1 of 2 pages

---

COMPETENCE - PROCEDURES/STEPS  
The student will be able to:

TEACHING/LEARNING ACTIVITIES

---

1. Hold wire stripper in one hand as shown.

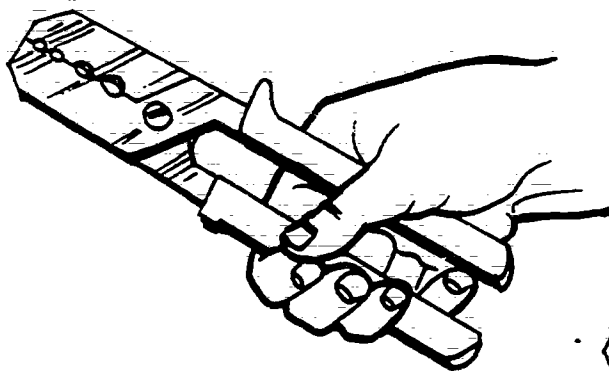

2. Open cutter by pushing bottom handle with little finger and letting other three fingers open at the same time.

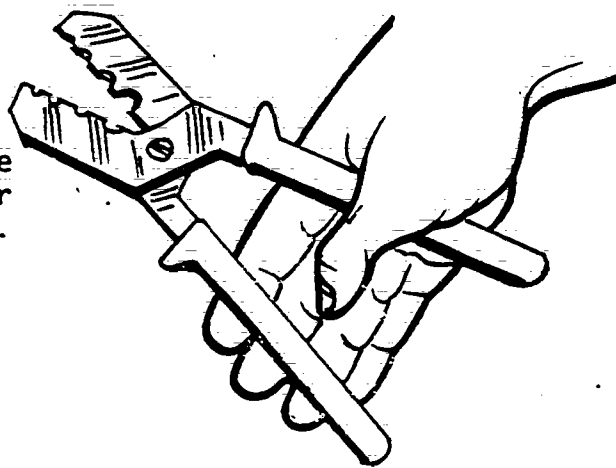

3. Place wire in proper hold with other hand. (#14 wire in #14 hole, #12 wire in #12 holes, etc.)

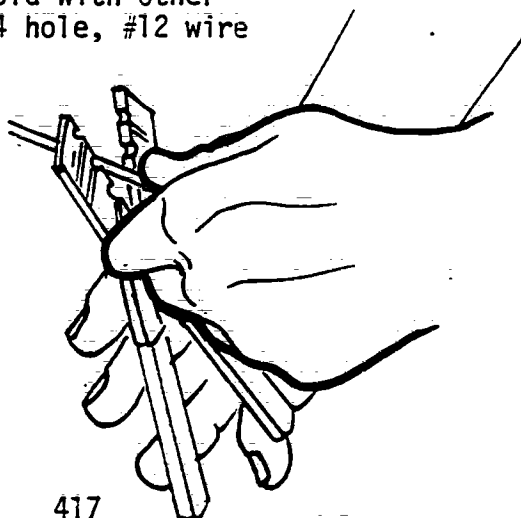



---

COMPETENCE - PROCEDURES/STEPS

TEACHING/LEARNING ACTIVITIES

---

4. Squeeze stripper until one feels the insulation start to cut.
5. Keep pressure on wire and wrapping little finger around handle, squeeze stripper shut.

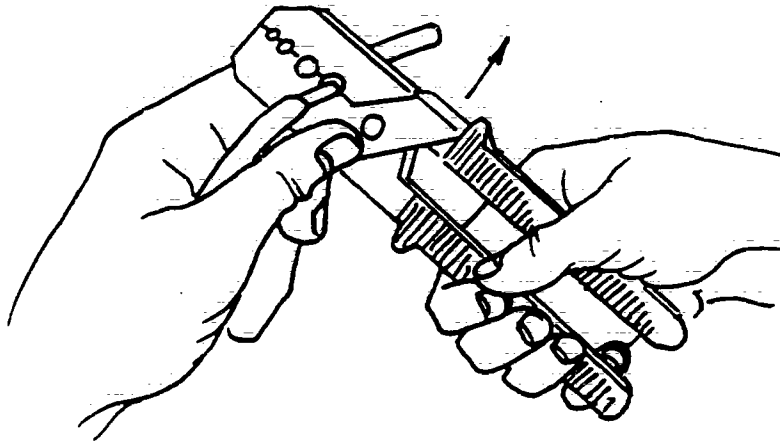

6. Hold wire tightly with fingers and place thumb on side of stripper.
7. Push stripper with thumb and pull wire with fingers.

295

COMPETENCY: Use a Twin Lamp Tester to Test  
a Circuit

COURSE: Appliance Repair

UNIT II: Basic Electricity

OBJECTIVE: The student will be able to properly use a twin lamp tester  
to check a fuse panel or appliance 120/240

Page 1 of 1 page

---

COMPETENCE - PROCEDURES/STEPS  
The student will be able to:

TEACHING/LEARNING ACTIVITIES

---

### 120 Volt Test

1. Turn off the power.
2. Attach the double lead alligator clip to the neutral wire or terminal.
3. Attach one other alligator clip to the check point on terminal.
4. Turn on the power and the lamp should light.

### 240 Volt Test

1. Turn off the power.
2. Attach the double lead alligator clip to the neutral wire or terminal.
3. Attach each of the remaining alligator clips one to line #1 power, one to line #2 power.
4. Turn on the power and both lamps should light.

COMPETENCY: Skin Romex with Skinner

COURSE: Appliance Repair

UNIT II: Basic Electricity

OBJECTIVE: The student will be able to strip romex acceptable to shop standards pre-set by the instructor

Page 1 of 2 pages

---

COMPETENCE - PROCEDURES/STEPS

The student will be able to:

TEACHING/LEARNING ACTIVITIES

---

NOTE: Be sure that all conductors are cut evenly and that one has not been bent in a hook. The hook could tear one's hand when the wire stripper is used.

1. Insert the cable through the stripper.

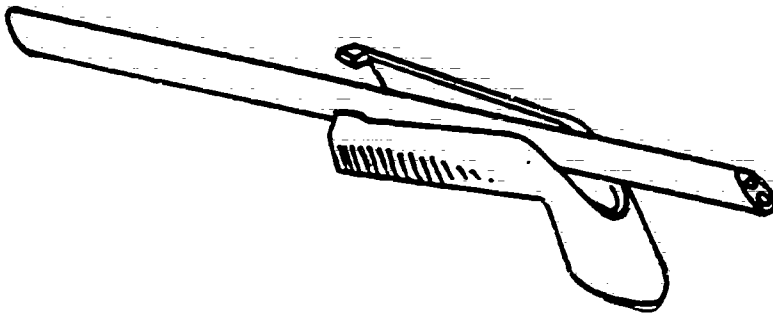

2. Grasp the cable with one hand and the stripper with the other, then press on the stripper until the cutting blade cuts the outer covering of the cable.

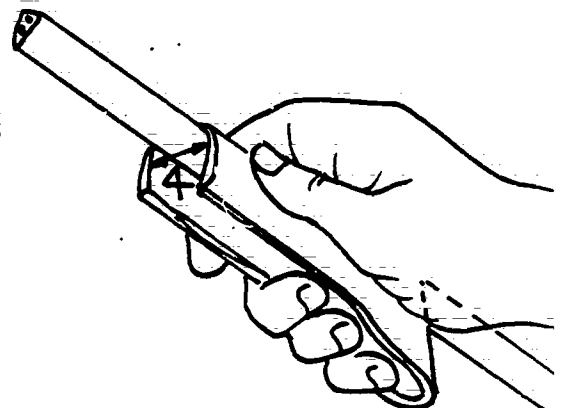

267

---

COMPETENCE - PROCEDURES/STEPS

TEACHING/LEARNING ACTIVITIES

---

3. Pull the stripper off the end of the cable.

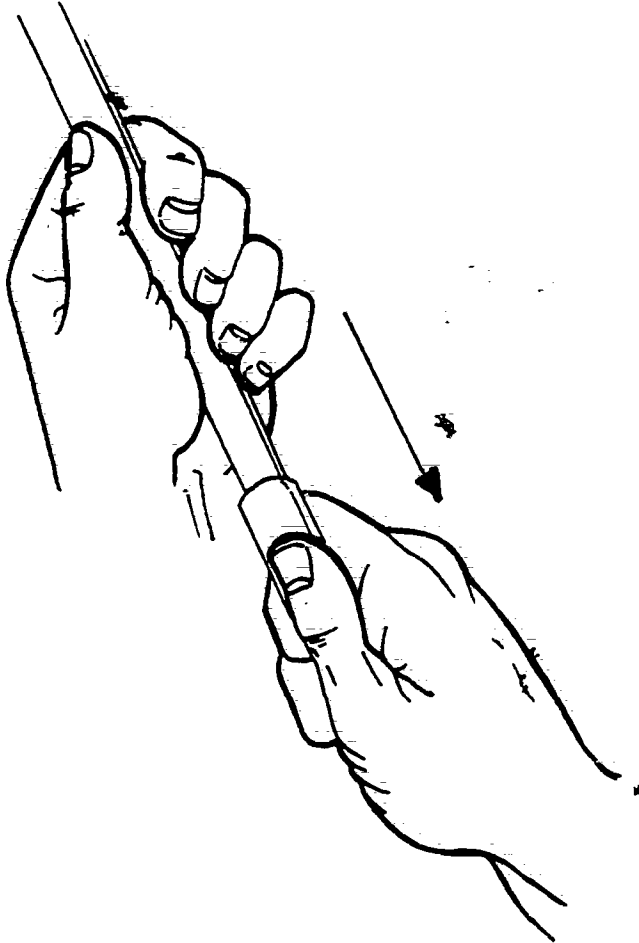

4. Peel off the split cover and trim the outer covering neatly with a knife.

NOTE: Be careful not to cut the conductor insulation.

253

COMPETENCY: Strip Romex with Knife

COURSE: Appliance Repair

UNIT II: Basic Electricity

OBJECTIVE: The student will be able to strip the romex acceptable to the standards set by N.E.C.

Page 1 of 2 pages

---

COMPETENCE - PROCEDURES/STEPS  
The student will be able to:

TEACHING/LEARNING ACTIVITIES

---

1. Place the romex on a flat surface.
2. Anchor the romex with one hand and with the other hand place the knife blade in the middle of the romex as shown.
3. Push slightly and pull the knife down the length of the romex.

NOTE: Be careful not to cut through the romex covering.

4. Hold the romex and cut completely around it.

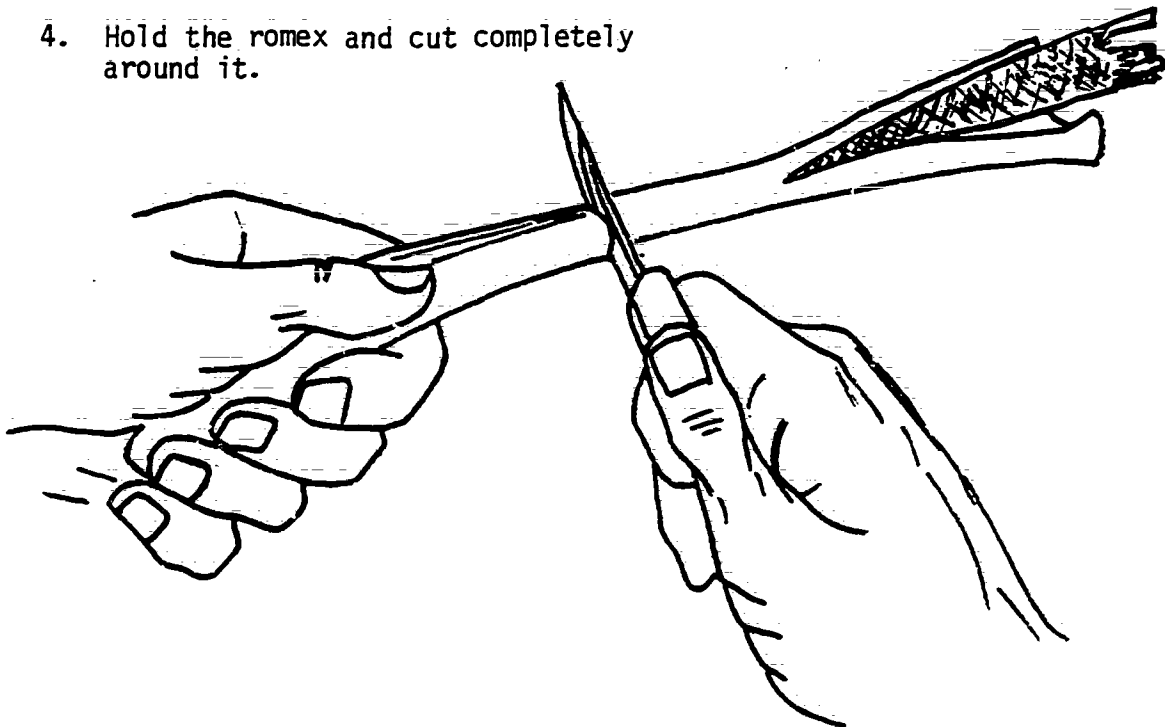

COMPETENCE - PROCEDURES/STEPS

TEACHING/LEARNING ACTIVITIES

5. Tear off the covering along the marked line.
6. Use a pocket knife, cut off any paper that may be around the romex.

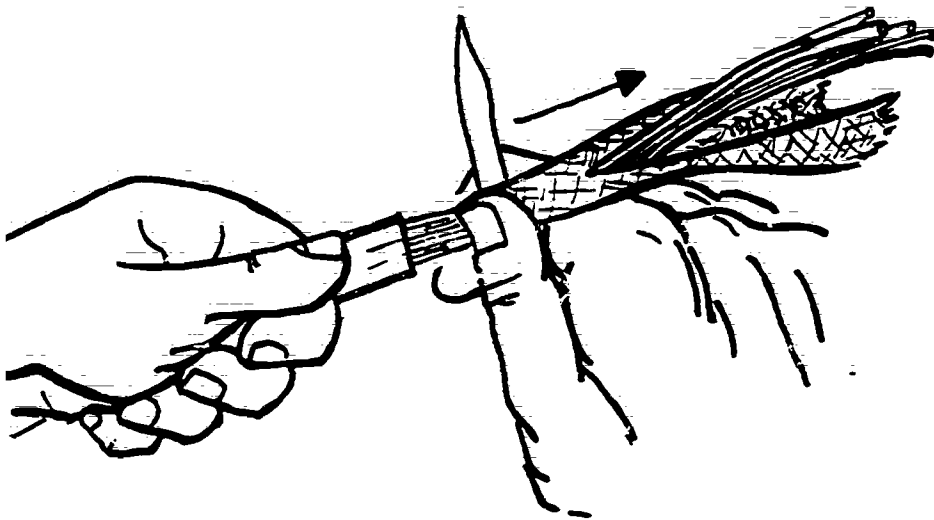
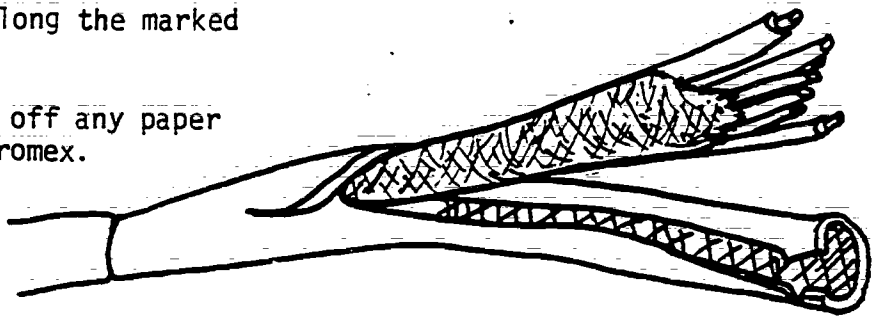

270

COMPETENCY: Remove a Knockout

COURSE: Appliance Repair

UNIT II: Basic Electricity

OBJECTIVE: The student will be able to properly remove the knockout (K.O.) without removing the larger ones around it or damaging other nearby surfaces

Page 1 of 1 page

---

COMPETENCE - PROCEDURES/STEPS The student will be able to:	TEACHING/LEARNING ACTIVITIES
---	------------------------------

---

1. Place the punch at the point on the K.O. across from the tie.
2. Strike the punch with the hammer so the K.O. is pushed inward.

CAUTION: Wear safety glasses.

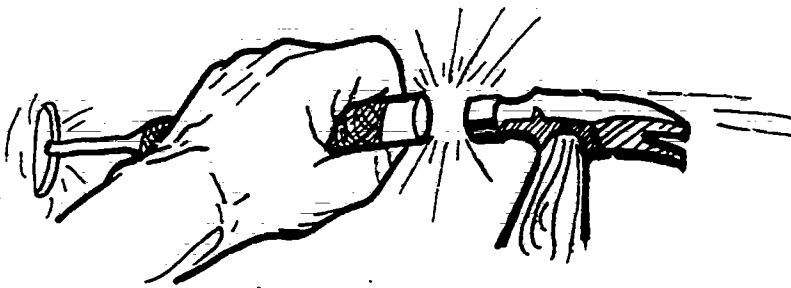

3. Using linemans pliers, bend K.O. back and forth until it breaks off.

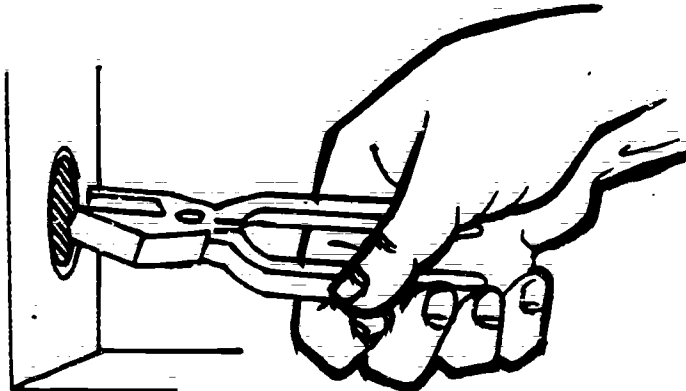

COMPETENCY: Install Connectors

COURSE: Appliance Repair

UNIT II: Basic Electricity

OBJECTIVE: The student will be able to install connectors acceptable to the N.E.C.

Page 1 of 2 pages

COMPETENCE - PROCEDURES/STEPS	TEACHING/LEARNING ACTIVITIES
The student will be able to:	

1. Hold the connector and unscrew the lock nut.



2. Place the connector in the K.O. hole with one hand and with the screw faced as shown.

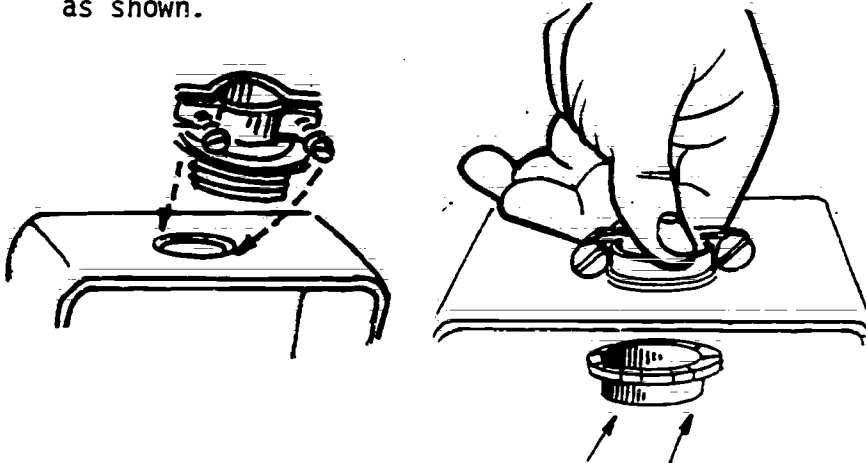

3. With the other hand, screw the lock nut on finger tight.

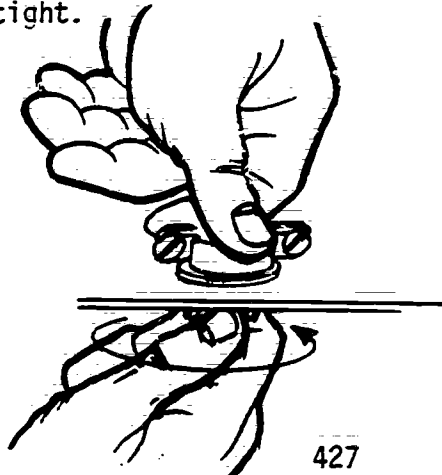

NOTE: Make sure that the serrated teeth on the lock nut are pointed upward.



COMPETENCE - PROCEDURES/STEPS

TEACHING/LEARNING ACTIVITIES

4. Place the punch in the teeth of the lock nut and drive the lock nut on tight in a clockwise direction.

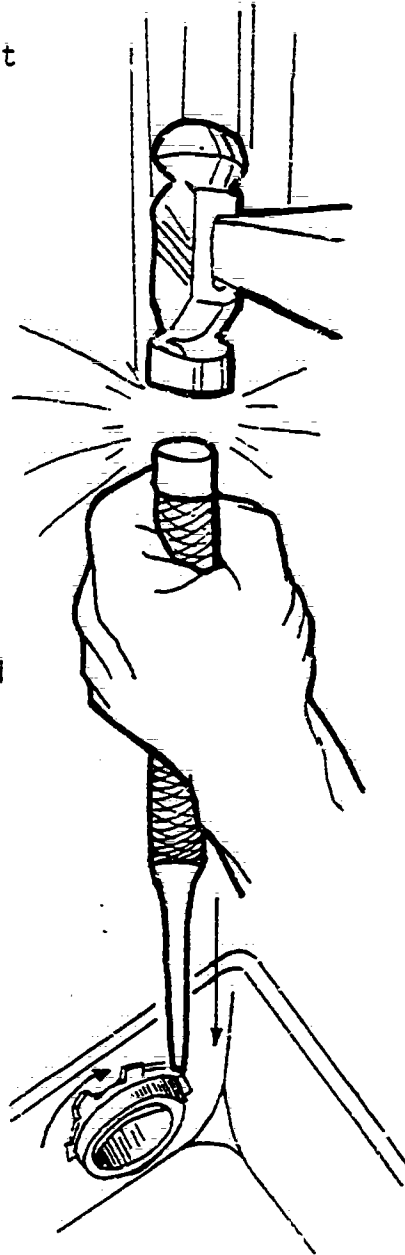

5. Continue to tighten the lock nut until a scratch line is formed on the box where the teeth have dug in.

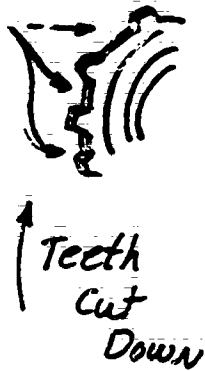

273

COMPETENCY: Install a Grounding Clip

COURSE: Appliance Repair

UNIT II: Basic Electricity

OBJECTIVE: The student will be able to properly install ground clips

Page 1 of 1 page

---

COMPETENCE - PROCEDURES/STEPS  
The student will be able to:

TEACHING/LEARNING ACTIVITIES

---

1. Dress the ground wire or wires along the bottom and side of the box.
2. Cut wires to the proper length.
3. Place ground clip, with tab inside, in the proper area of the box.
4. Slide the ground wires into the clip.
5. Press the ground clip in place.

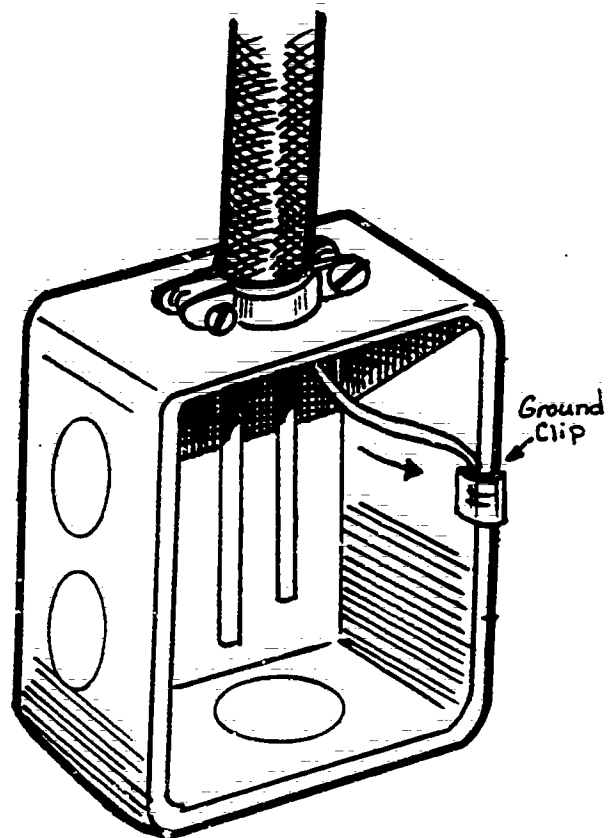

COMPETENCY: Cut B.X. Cable

COURSE: Appliance Repair

UNIT II: Basic Electricity

OBJECTIVE: The student will be able to cut the cable acceptable to shop standards pre-set by the instructor

Page 1 of 2 pages

COMPETENCE - PROCEDURES/STEPS

The student will be able to:

TEACHING/LEARNING ACTIVITIES

1. Hold B.X. cable in hands and squeeze the cable until the outer metal covering breaks open.

2. Place the B.X. cable in the hands, and get a good tight grip on it so the cable does not slip.

3. Twist left hand counterclockwise and right hand clockwise until the outer metal covering forms a loop as shown.

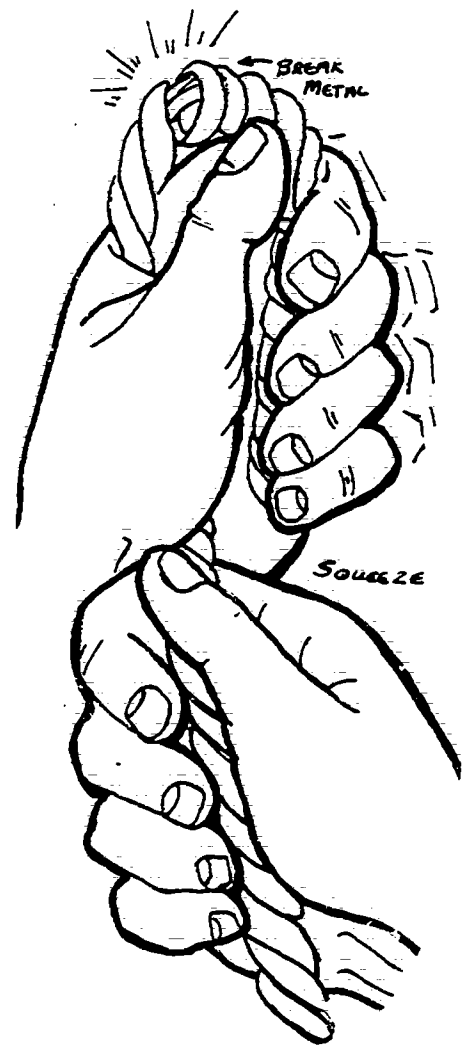
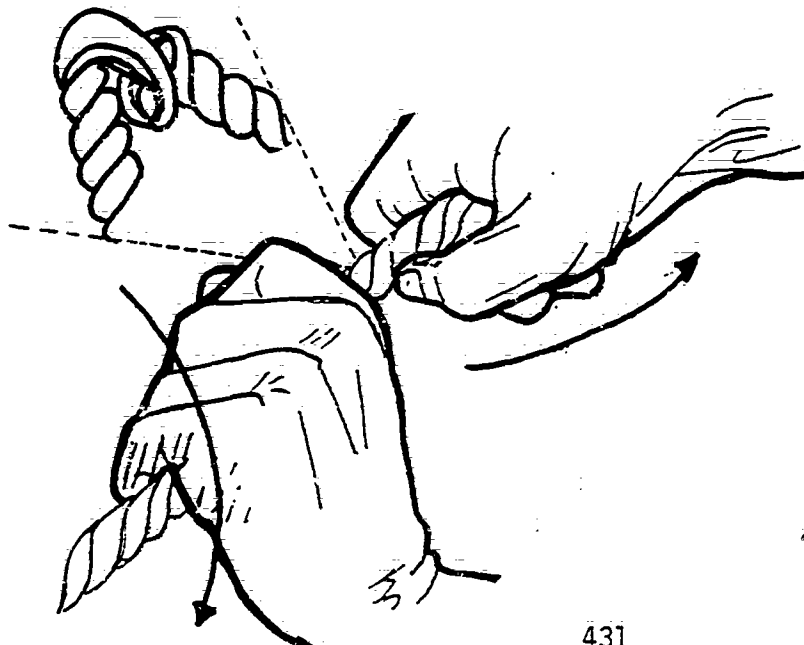

275

COMPETENCE - PROCEDURES/STEPS

TEACHING/LEARNING ACTIVITIES

4. With B.X. cutters, cut the loop as shown.

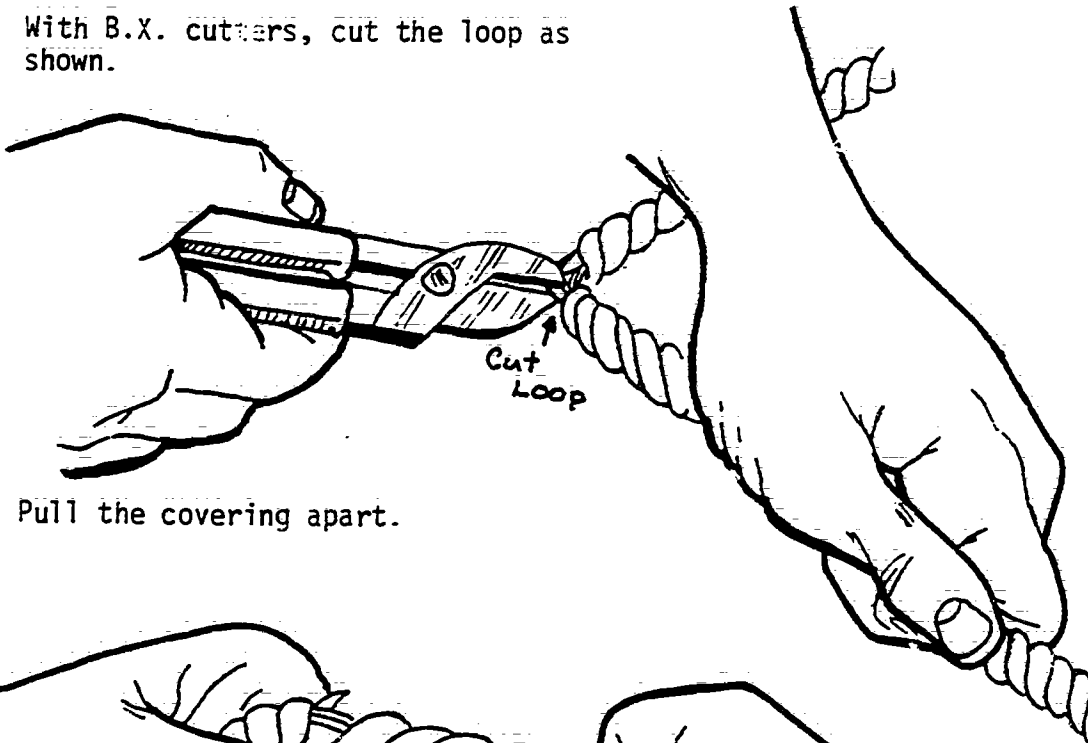

5. Pull the covering apart.

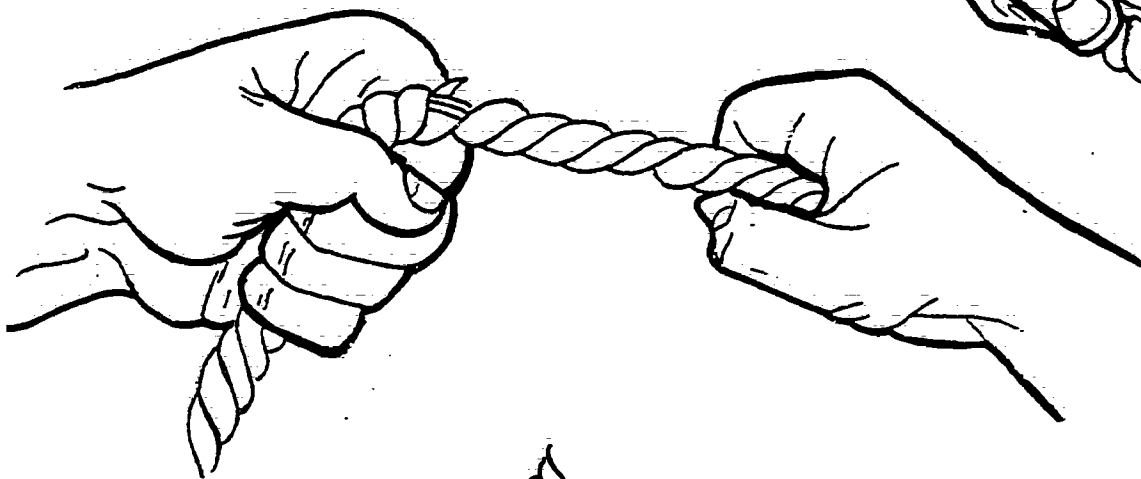

6. Cut the wires.

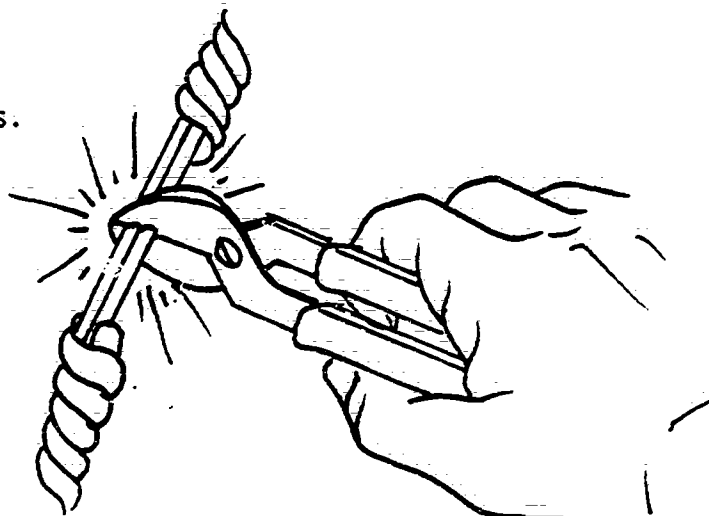

COMPETENCY: Strip B.X. Cable

COURSE: Appliance Repair

UNIT II: Basic Electricity

OBJECTIVE: The student will be able to strip the cable acceptable to the N.E.C.

Page 1 of 2 pages

COMPETENCE - PROCEDURES/STEPS

The student will be able to:

TEACHING/LEARNING ACTIVITIES

1. Hold B.X. cable in the hands and squeeze the cable until the outer metal covering breaks open.
2. Place the B.X. cable in the hands, and get a good, tight grip on it so the cable does not slip.
3. Twist left hand counterclockwise and right hand clockwise until the outer metal covering forms a loop as shown.



COMPETENCE - PROCEDURES/STEPS

TEACHING/LEARNING ACTIVITIES

4. With B.X. cutters, cut the loop as shown in Fig. A and remove the outer covering as shown in Fig. B.

NOTE: Be careful not to damage the insulation on the conductor with the B.X. cutters.

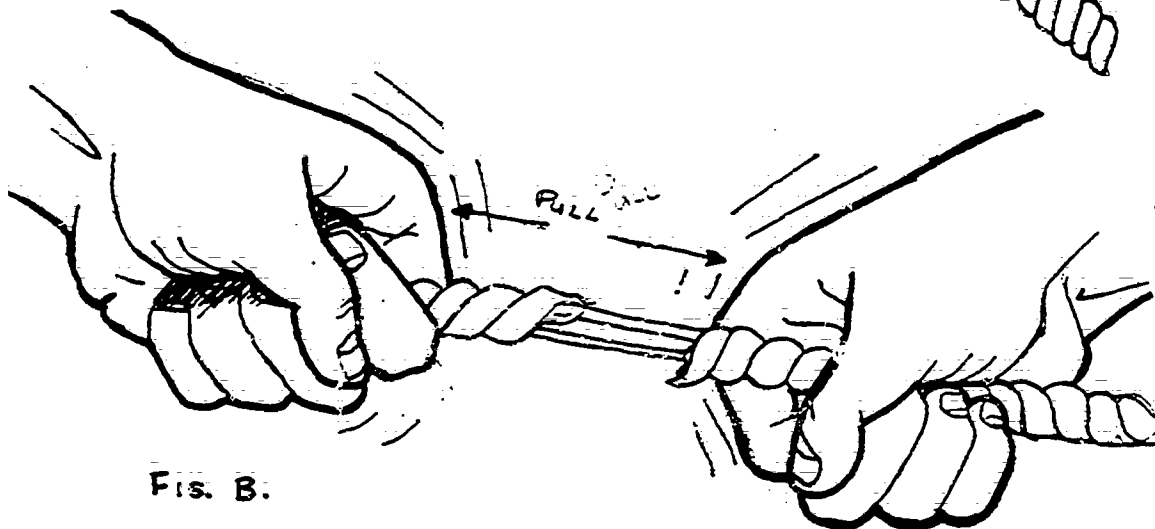
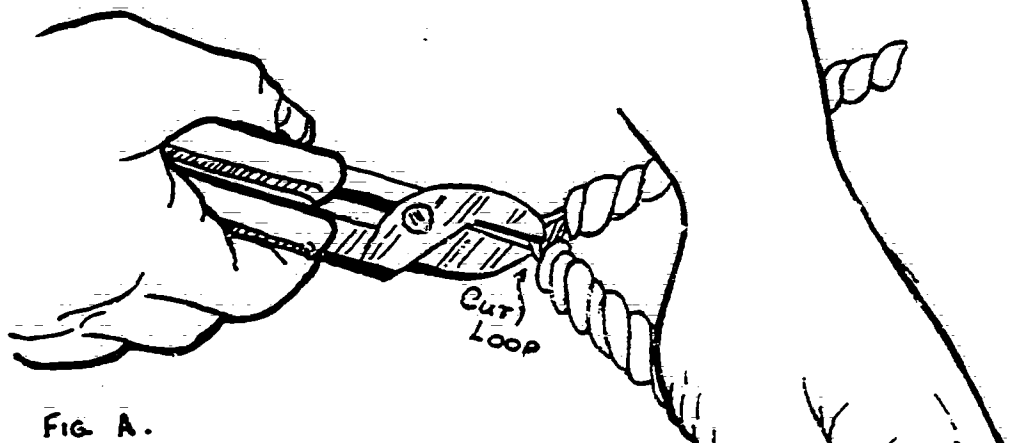

278

COMPETENCY: Install an Anti-Short

COURSE: Appliance Repair

UNIT II: Basic Electricity

OBJECTIVE: The student will be able to install anti-shorts acceptable to N.E.C.

Page 1 of 2 pages

---

COMPETENCE - PROCEDURES/STEPS

The student will be able to:

TEACHING/LEARNING ACTIVITIES

---

1. Place the anti-short between the conductors and the armored covering.
2. Turn the anti-short so that the open part is opposite the point where the cable was cut.

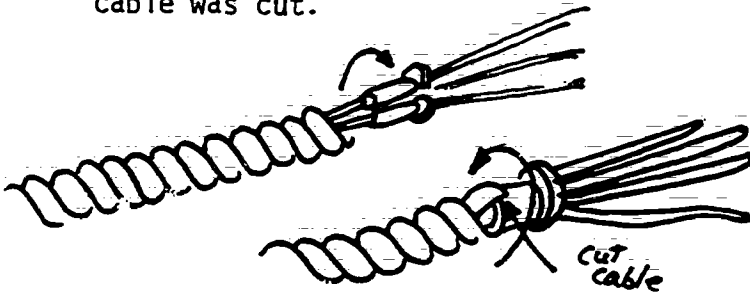

3. Use the fingers to push the anti-short in to proper depth.

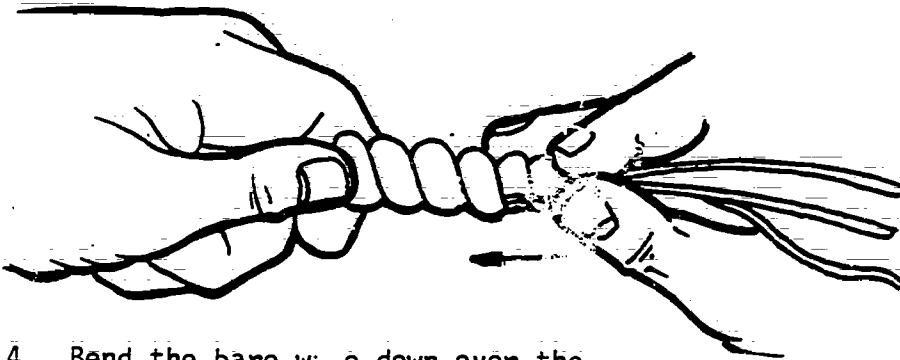

4. Bend the bare wire down over the armored cable at the point where the cable was cut.

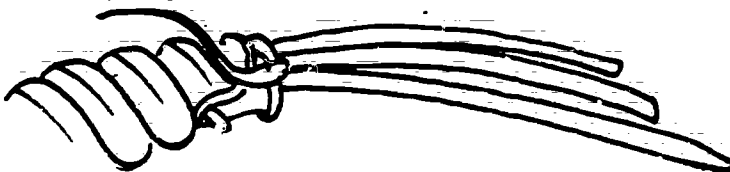

---

COMPETENCE - PROCEDURES/STEPS

TEACHING/LEARNING ACTIVITIES

---

5. Twist the bare wire around the cable about four turns in the grooves of the armored covering.

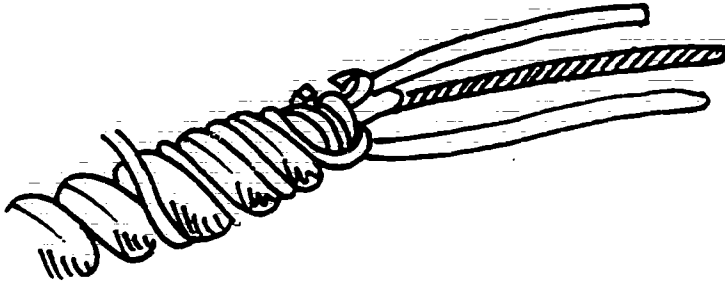

6. Use the B.X. cutters to clip off the extra wire.

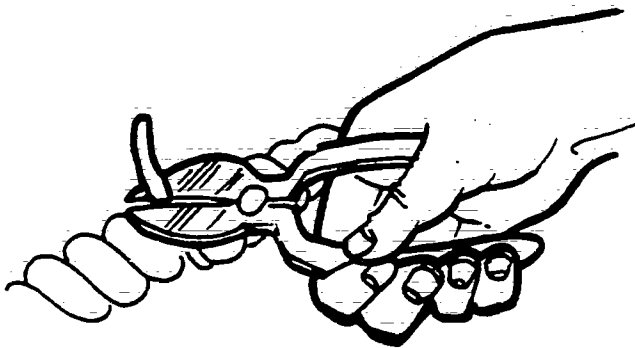

7. Use the thumb, or the back of the B.X. cutter to bend around the loose end.

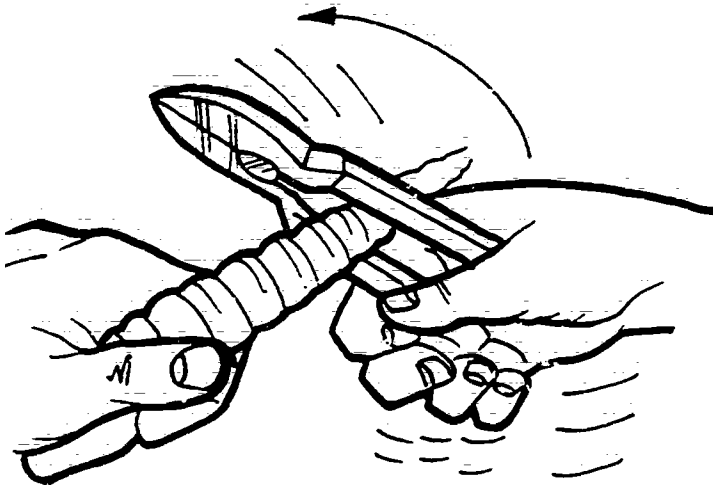

280



OPERATION SHEET

SC-3-1

COMPETENCY: Use a Putty Knife

COURSE: Appliance Repair

UNIT III: Basic Shop Tools

OBJECTIVE: The student will be able to properly use a putty knife to clean grease and grime from a part

Page 1 of 1 page

---

COMPETENCE - PROCEDURES/STEPS  
The student will be able to:

TEACHING/LEARNING ACTIVITIES

---

1. Grasp the handle firmly.

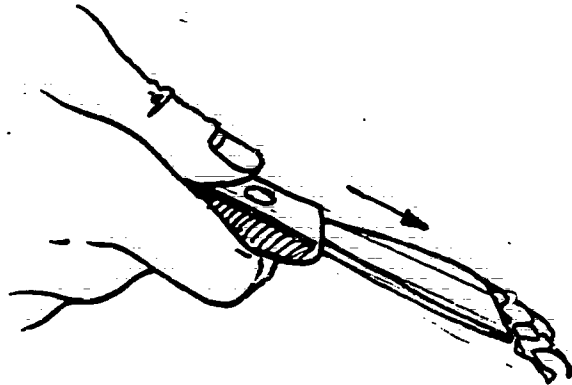

2. Press down on the blade edge and scrape along the surface to remove the grease and grime.

NOTE: Do not use the point of the blade because it will scratch the surface.

281

OPERATION SHEET  
SC-3-2

COMPETENCY: Use a Parts Cleaner

COURSE: Appliance Repair

UNIT III: Basic Shop Tools

OBJECTIVE: The student will be able to use the parts cleaner for removing dirt and grease from parts

Page 1 of 1 page

COMPETENCE - PROCEDURES/STEPS  
The student will be able to:

TEACHING/LEARNING ACTIVITIES

1. Place the part or parts into the cleaner rack.
2. Select the flexible or movable rubber spray method and turn the selector valve for the one being used.

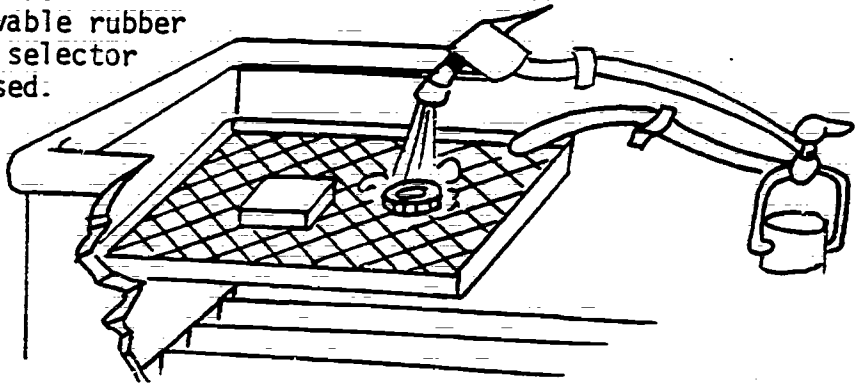

3. Use one hand and direct the spray over the item to be cleaned.

NOTE: A scraper or brush can be used with the other hand to remove dirt and grease.



4. Continue to scrape or brush while rinsing or washing, until part is cleaned.

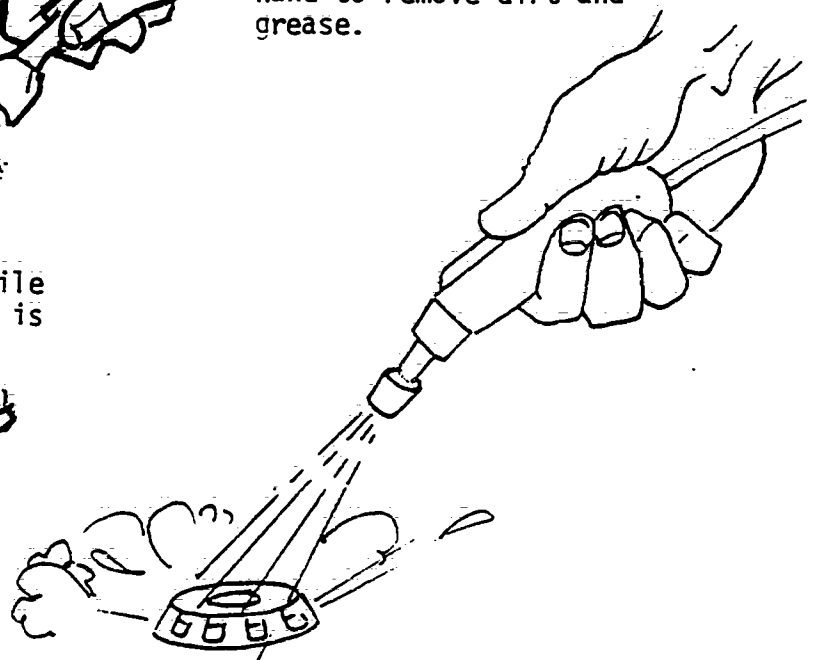

282

OPERATION SHEET

SC-3-2A

COMPETENCY: Use an Air Gun

COURSE: Appliance Repair

UNIT III: Basic Shop Tools

OBJECTIVE: The student will be able to use the air gun to properly clean, dry and remove dust and dirt from parts

Page 1 of 1 page

---

COMPETENCE - PROCEDURES/STEPS  
The student will be able to:

---

TEACHING/LEARNING ACTIVITIES

NOTE: Clean parts in parts washer to remove most of the foreign matter.

1. Place parts to be cleaned in work area.
2. Hold part to be cleaned in one hand and depressing button on air gun nozzle with the other hand, direct air spray onto part to be cleaned.

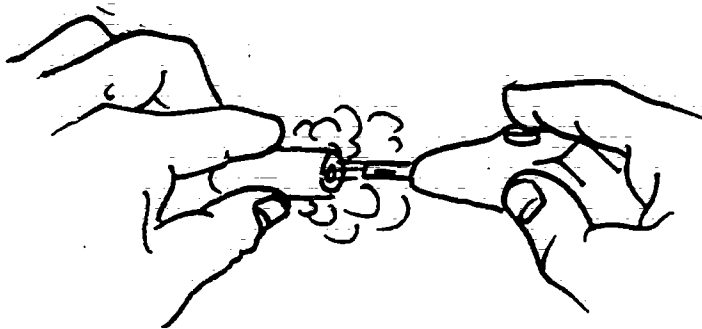

3. Continue spraying until part is cleaned.

NOTE: Student must wear full face shield when using air compressor and air nozzle.

COMPETENCY: Use a Socket Wrench

COURSE: Heating

OBJECTIVE: The student will be able to properly tighten and loosen fasteners with a socket

COMPETENCE - PROCEDURES/STEPS  
The student will be able to:

TEACHING/LEARNING ACTIVITIES

1. Snap desired socket onto tool.

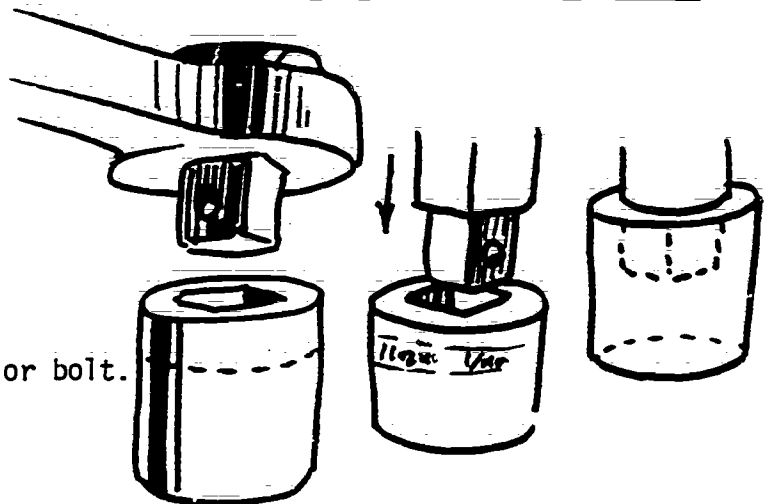

2. Place socket over hex head nut or bolt.

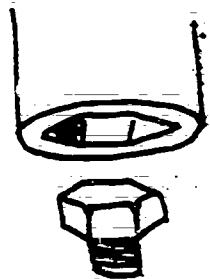

3. Hold socket in place with one hand.

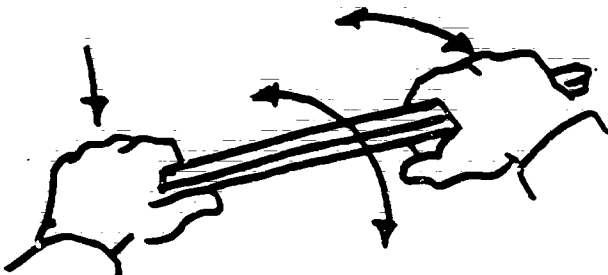

4. Turn tool to remove or tighten the fastener.

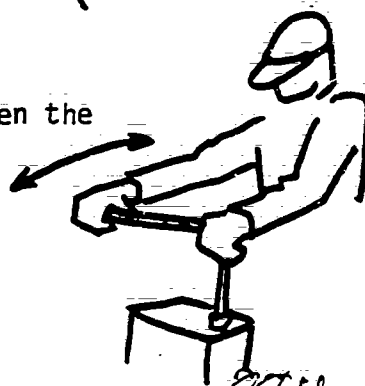

COMPETENCY: Tighten and Loosen Fasteners  
with Allen Wrenches

COURSE: Appliance Repair

UNIT III: Basic Shop Tools

OBJECTIVE: The student will be able to use allen wrenches in a safe,  
efficient manner

Page 1 of 1 page

COMPETENCE - PROCEDURES/STEPS  
The student will be able to:

TEACHING/LEARNING ACTIVITIES

1. Insert proper wrench into hex hole in fastener.

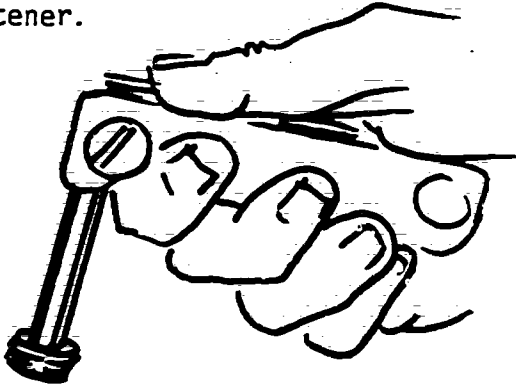

2. Tighten or remove by turning fastener clockwise or counterclockwise.

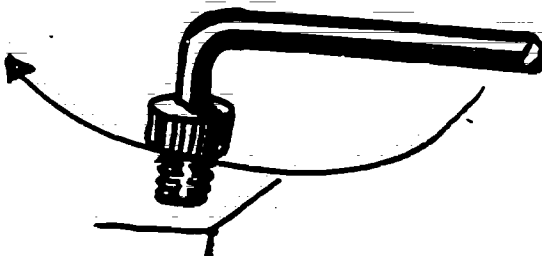

3. Insert the short end for more leverage and the long end for hard to reach places.

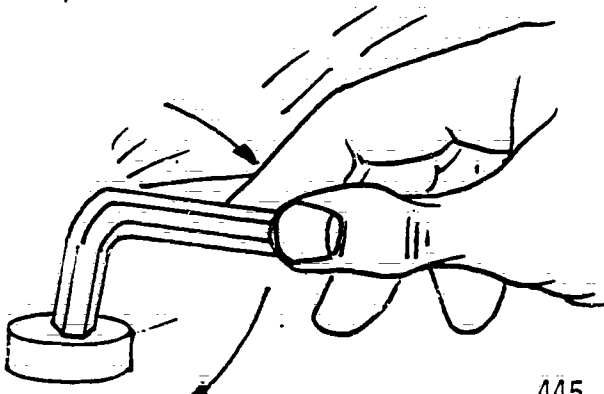

NOTE: If the fit is sloppy, use a larger size.

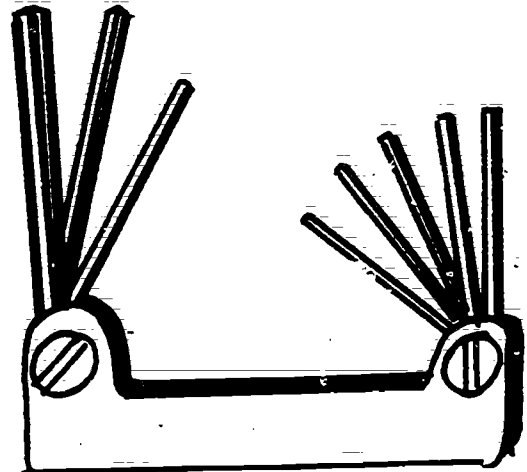

OPERATION SHEET  
SC-3-5

COMPETENCY: Use Pulley Puller

COURSE: Appliance Repair

UNIT III: Basic Shop Tools

OBJECTIVE: The student will be able to properly use a pulley to remove a pulley

Page 1 of 1 page

---

COMPETENCE - PROCEDURES/STEPS  
The student will be able to:

TEACHING/LEARNING ACTIVITIES

---

1. Select the proper size pulley.
2. Spread the jaws to fit over the pulley and hook it over the other edge.
3. Screw drive the bolt down until it hits the center of the pulley shaft.
4. Continue turning the drive bolt until the pulley is removed.

CAUTION: Do not bend the pulley.

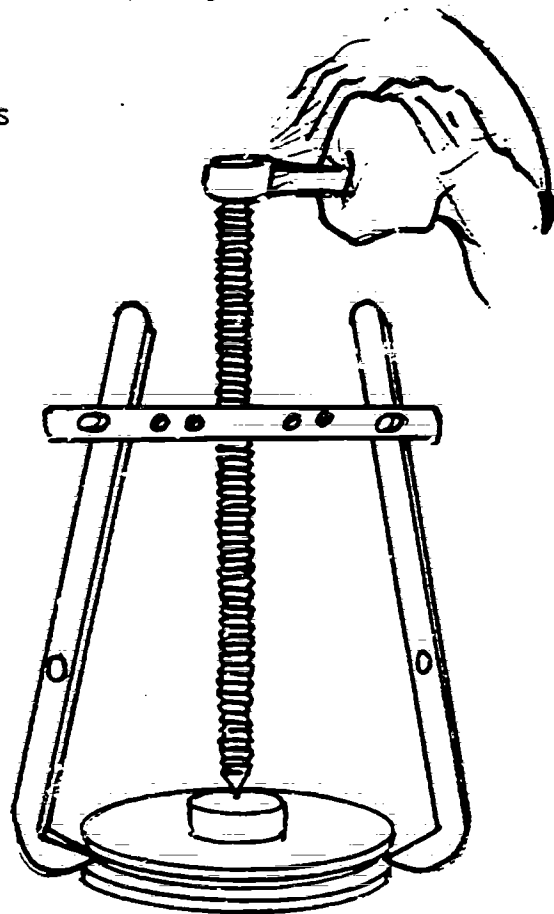

OPERATION SHEET

SC-3-6

COMPETENCY: Use a Socket Wrench With a Ratchet

COURSE: Appliance Repair

UNIT III: Basic Shop Tools

OBJECTIVE: The student will be able to use the socket and ratchet effectively and safely

Page 1 of 1 page

---

COMPETENCE - PROCEDURES/STEPS  
The student will be able to:

---

TEACHING/LEARNING ACTIVITIES

1. Snap the socket onto the ratchet end.
2. Place the socket over the hex nut or bolt.
3. Hold the socket in place with the one hand.
4. With the other hand, turn the ratchet reversing knob, tightening the bolt.

NOTE: Remove a bolt by turning the ratchet and reversing knob the other way.

287

COMPETENCY: Use Tru Arc Pliers

COURSE: Appliance Repair

UNIT III: Basic Shop Tools

OBJECTIVE: The student will be able to assemble and disassemble parts that are held in place with snap rings

Page 1 of 1 page

COMPETENCE - PROCEDURES/STEPS  
The student will be able to:

TEACHING/LEARNING ACTIVITIES

NOTE: Squeezing action of pliers: some open when the handles are squeezed,

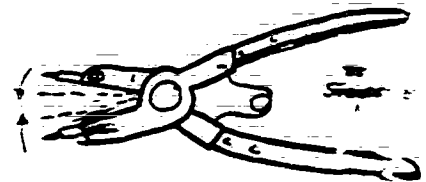
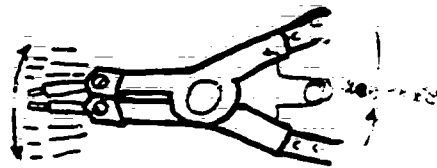

Some use when the handles are squeezed.

1. Insert tips of plier into holes in snap ring.



2. Squeeze and slide ring into locking groove.



3. Relax plier, remove tips from holes.
4. Reverse procedure to remove snap ring.

NOTE: There are inside and outside snap rings of several different styles.

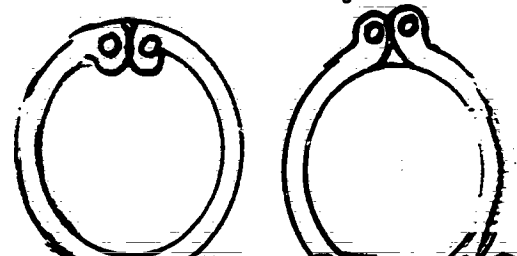

288



## OPERATION SHEET

SC-3-8

COMPETENCE: Use a Torque Wrench

COURSE: Small Engine Repair

UNIT III: Basic Shop Tools

OBJECTIVES: The student will be able to properly use a torque wrench for tightening to manufacturer's specifications

Page 1 of 1 page

COMPETENCE - PROCEDURES/STEPS	TEACHING/LEARNING ACTIVITIES
The student will be able to:	
1. Select proper torque wrench range and size.	
2. Select proper socket size and attach to torque wrench.	
3. Determine correct torque specifications as given by manufacturer's specifications.	
4. Grasp the torque wrench in the correct manner and with an even, steady pulling motion tighten nut or bolt to correct torque as indicated on the torque wrench scale.	

299

OPERATION SHEET

SC-3-9

COMPETENCY: Clean Corrosion Using Hand  
Wire Brush

COURSE: Appliance Repair

UNIT III: Basic Shop Tools

OBJECTIVE: The student will be able to use a hand wire brush properly

Page 1 of 1 page

---

COMPETENCE - PROCEDURES/STEPS

The student will be able to:

TEACHING/LEARNING ACTIVITIES

---

1. Grasp the handle firmly and push the wire bristles over the area to be cleaned.
2. Continue operation until the part is cleaned.

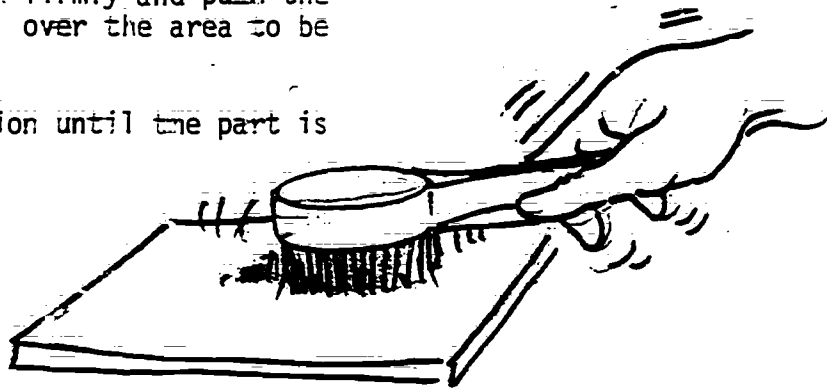

290

OPERATION SHEET

SC-3-10

COMPETENCY: Clean Corrosion Using a Wire Wheel

COURSE: Appliance Repair

UNIT III: Basic Shop Tools

OBJECTIVE: The student will be able to use a wire wheel properly

Page 1 of 1 page

COMPETENCE - PROCEDURES/STEPS The student will be able to:	TEACHING/LEARNING ACTIVITIES
<ol style="list-style-type: none"><li>1. Check to see that the wire wheel is clean and turns freely.</li><li>2. Adjust the guard if necessary.</li><li>3. Turn on the power.</li><li>4. Hold the part firmly.</li><li>5. Bring the part up against the wire wheel applying pressure to the part.</li></ol>	<p>NOTE: Safety glasses and gloves must be worn.</p>
<ol style="list-style-type: none"><li>6. Continue the operation until the part is clean.</li></ol>	

291

OPERATION ~~SECRET~~

SC-3-11

COMPETENCY: Clean and Polish an Appliance Using a Buffer Wheel

COURSE: Appliance Repair

UNIT III: Basic Shop Tools

OBJECTIVE: The student will be able to clean and polish a chrome finish on an appliance

Page 1 of 1 page

COMPETENCE - PROCESSES/STEPS The student will be able to:	TEACHING/LEARNING ACTIVITIES
1. Check to see that the buffer wheel is clean and to <del>free</del> .	NOTE: Safety glasses and gloves must <del>be</del> worn.
2. Turn on the power.	
3. Apply rouge to the wheel.	
4. Hold the appliance firmly and press it against the wheel.	NOTE: Apply rouge as needed.
5. Continue operation until appliance is polished.	

OPERATION SHEET

SC-3-12

COMPETENCY: Use a Center Punch

COURSE: Appliance Repair

UNIT III: Basic Shop Tools

OBJECTIVE: The student will be able to mark a stock for drilling holes with a center punch

Page 1 of 1 page

---

COMPETENCE - PROCEDURES/STEPS	TEACHING/LEARNING ACTIVITIES
-------------------------------	------------------------------

---

1. Slide punch across stock to where mark is to be made.

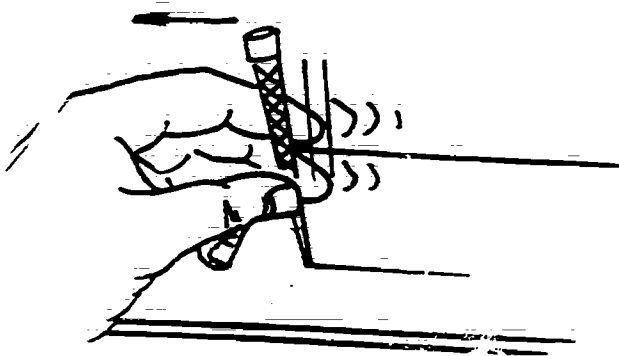

2. With hammer, strike back of punch to mark stock.

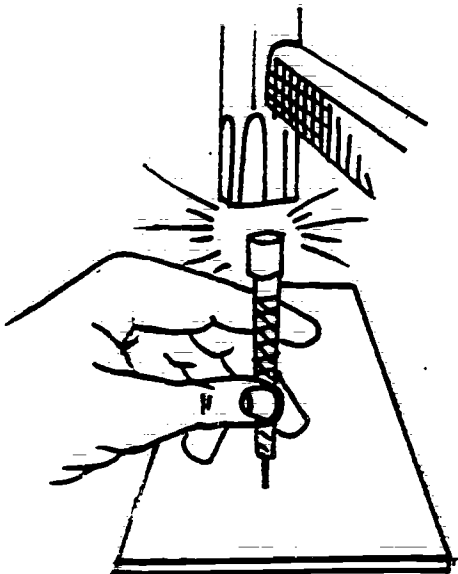

293

COMPETENCY: Tighten and Loosen Fasteners  
with an Open End Wrench

COURSE: Appliance Repair

UNIT III: Basic Shop Tools

OBJECTIVE: The student will be able to safely and effectively use the open end wrench

COMPETENCE - PROCEDURES/STEPS	TEACHING/LEARNING ACTIVITIES
-------------------------------	------------------------------

The student will be able to:

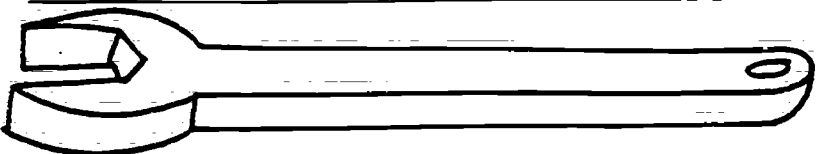

NOTE: The open end wrench is designed to slip straight onto the fastener.

1. Place the open end wrench over the fastener.

NOTE: Be sure of a good fit.



2. Pull the wrench handle to tighten or loosen the fastener.

NOTE: Tightening is usually clockwise, loosening is usually counterclockwise.

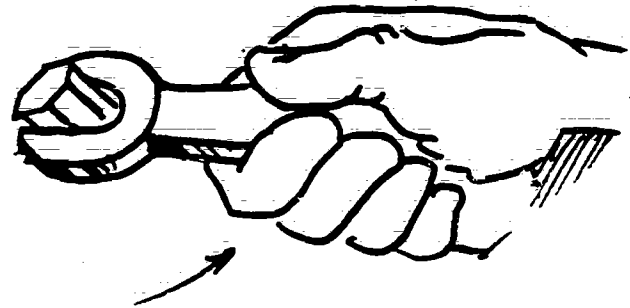
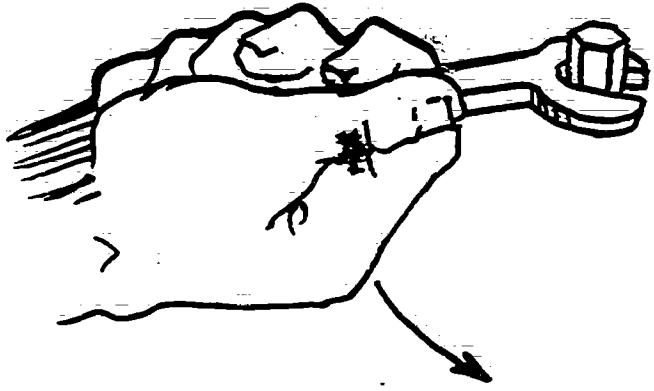

COMPETENCE - PROCEDURES/STEPS

TEACHING/LEARNING ACTIVITIES

3. Position oneself so that it is always possible to pull instead of push.

NOTE: Final tightening or original loosening may require the use of two hands.

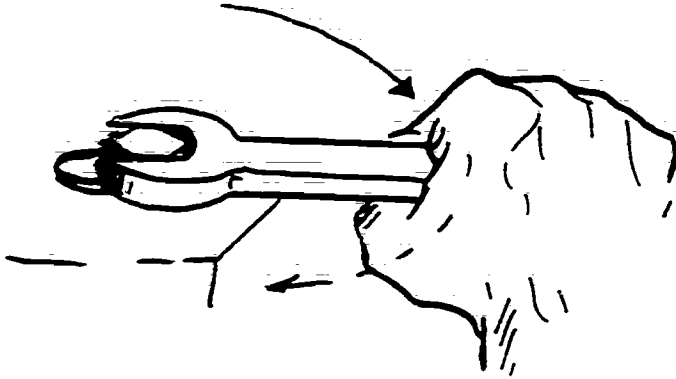

205

COMPETENCY: Drill Holes in Stock Using a Drill Press

COURSE: Appliance Repair

UNIT III: Basic Shop Tools

OBJECTIVE: Drill holes to the proper size and depth

Page 1 of 1 page

COMPETENCE - PROCEDURES/STEPS  
The student will be able to:

TEACHING/LEARNING ACTIVITIES

1. Turn on the power and adjust bit speed.
2. Lower the bit using the shaft control arm.
3. Apply pressure as needed to drill the hole.
4. Supply cutting oil to the drill bit as needed.

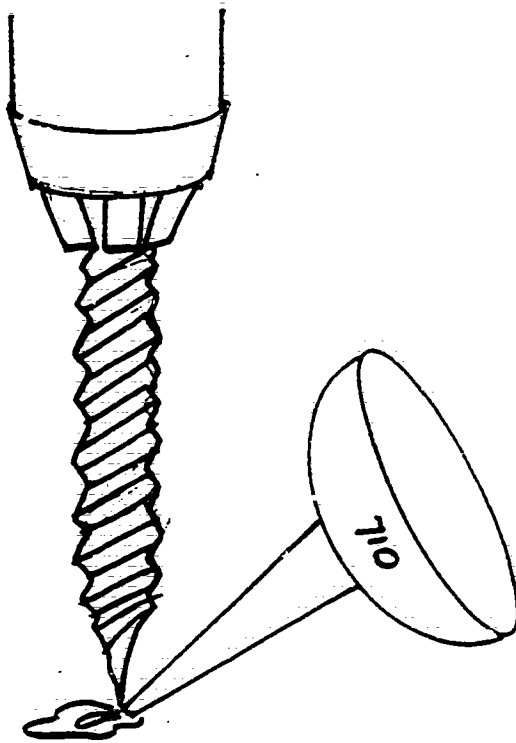
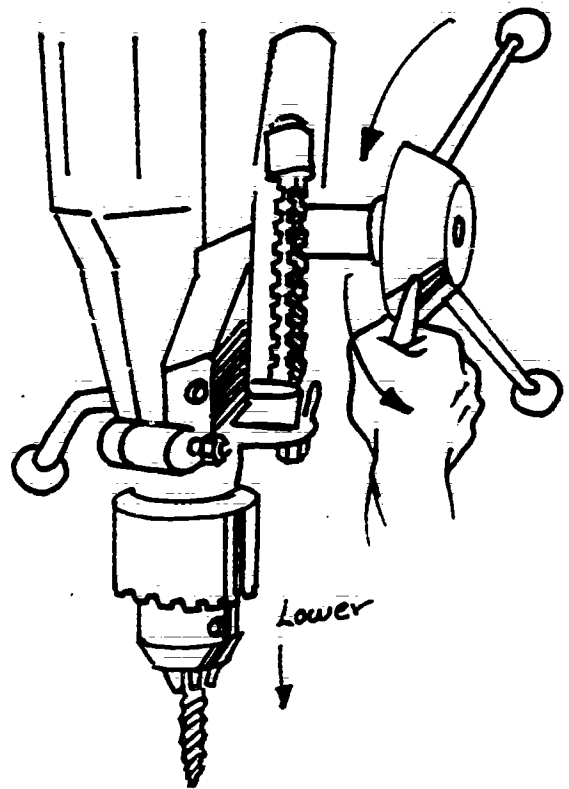

5. Release pressure on drill press arm and allow the drill bit to return to the up position.
6. Turn off power.

NOTE: When finished clean up chips and the surrounding area.



COMPETENCY: Secure Stock to a Surface with  
"C" Clamps

COURSE: Appliance Repair

UNIT III: Basic Shop Tools

OBJECTIVE: The student will be able to clamp stock to the surface to insure safe working procedures

Page 1 of 1 page

COMPETENCE - PROCEDURES/STEPS  
The student will be able to:

TEACHING/LEARNING ACTIVITIES

1. Place stock at the corner of the work bench.
2. Open one "C" clamp large enough to fit over stock and work bench edge by turning thumb screw counterclockwise.

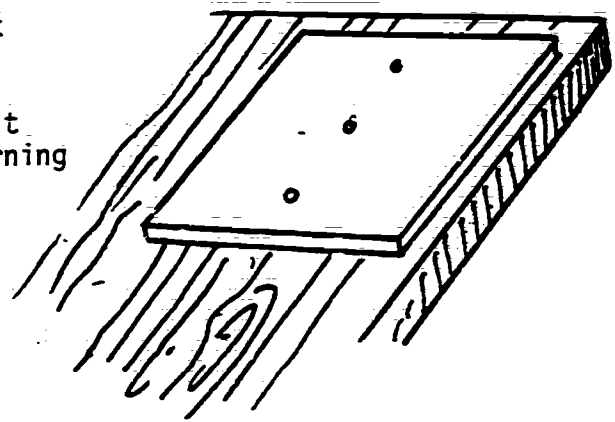

3. Position the "C" clamp at the corner of the stock.
4. Fasten the "C" clamp by turning the thumb screw clockwise but do not tighten.
5. Repeat steps 3 and 4 with the other clamp for the other end as shown.
6. Tighten both clamps:

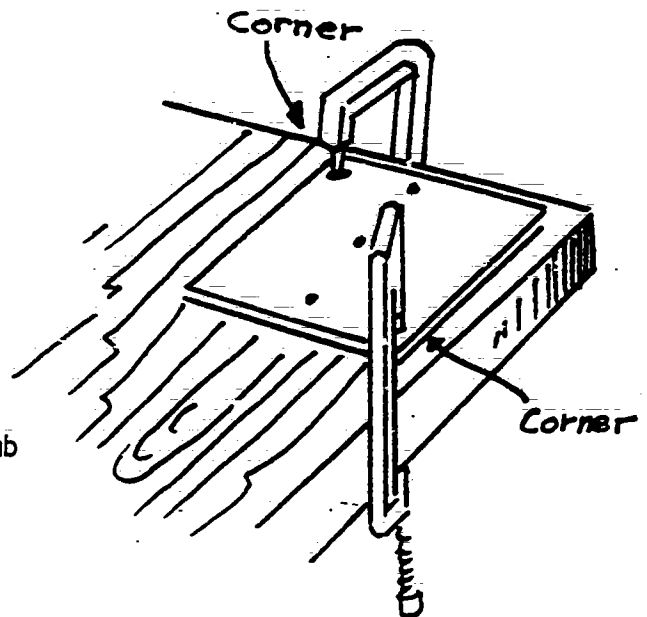

COMPETENCY: Tap Threads in Metal Stock

COURSE: Appliance Repair

UNIT III: Basic Shop Tools

OBJECTIVE: The student will be able to tap threads in metal stock to proper specifications

Page 1 of 2 pages

COMPETENCE - PROCEDURES/STEPS

The student will be able to:

TEACHING/LEARNING ACTIVITIES

1. Select 10/32 tap.
2. Install onto tap handle.
3. Insert tap into drilled hole.

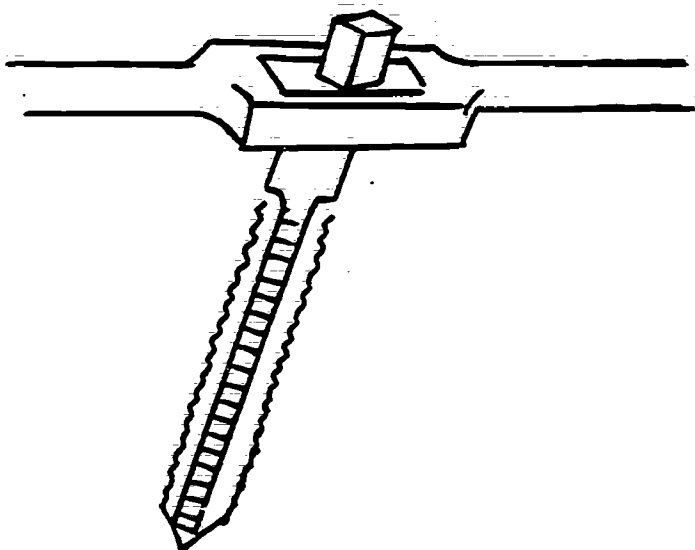
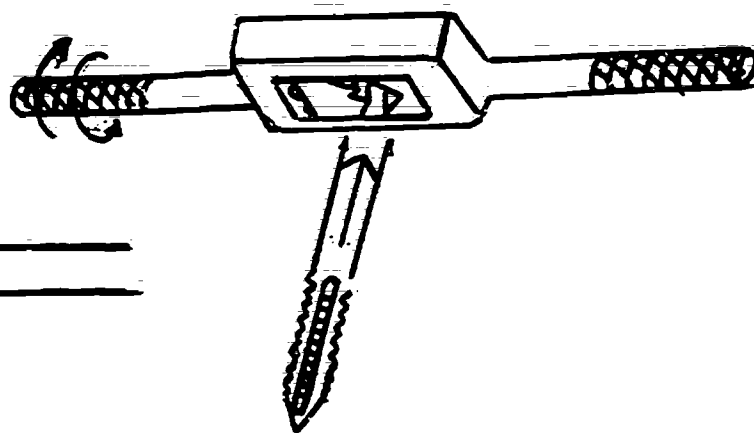

4. Turn tap handle clockwise.

NOTE: Make sure tap is held straight.

Turn tap handle backwards if the tap binds.

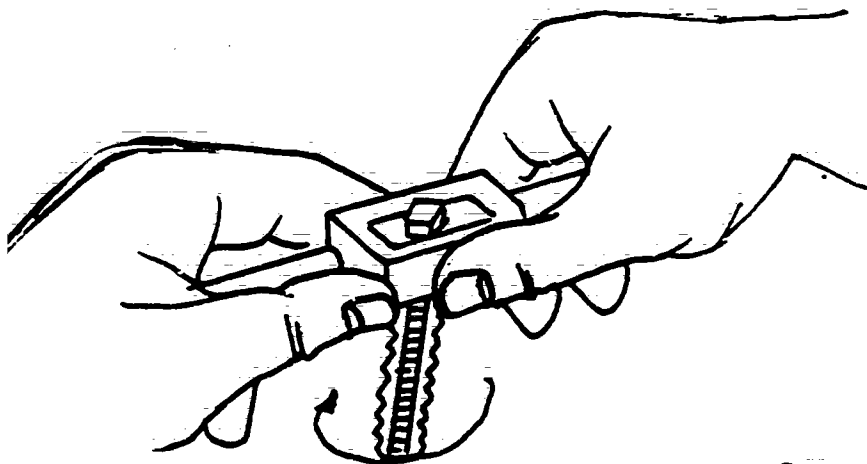

COMPETENCE - PROCEDURES/STEPS	TEACHING/LEARNING ACTIVITIES
-------------------------------	------------------------------

5. Apply cutting oil as needed.
6. Turn tap handle until tap has seated or until it is through the hole.
7. Remove tap (turn counterclockwise).
8. Clean the tap and stock.

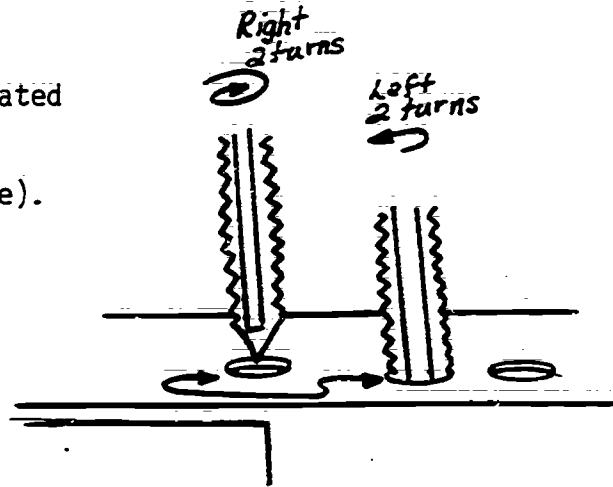

239

COMPETENCY: Secure Stock in Bench Vice

COURSE: Appliance Repair

UNIT III: Basic Shop Tools

OBJECTIVE: The student will be able to clamp material securely using a bench vise

Page 1 of 1 page

---

COMPETENCE - PROCEDURES/STEPS  
The student will be able to:

TEACHING/LEARNING ACTIVITIES

---

1. Open vise jaws by turning handle counter clockwise until the stock fits between jaws.

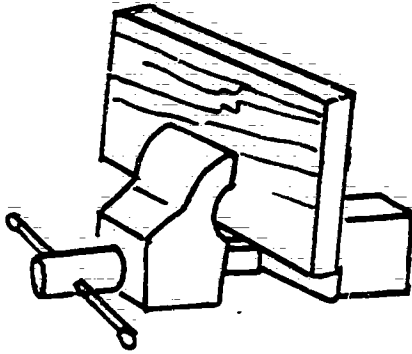

2. Position the stock between the jaws.
3. Turn the handle clockwise until the stock is firmly clamped into position.

COMPETENCY: Cut Metal with a Hack Saw

COURSE: Appliance Repair

UNIT III: Basic Shop Tools

OBJECTIVE: The student will be able to cut short lengths of metal stock

Page 1 of 2 pages

COMPETENCE - PROCEDURES/STEPS  
The student will be able to:

TEACHING/LEARNING ACTIVITIES

1. Fasten material to be cut in a vise or support it firmly on a workbench.

NOTE: Before beginning to make the cut check to see that the blade has the proper tension and that the teeth point away from the handle.

2. Guiding the saw with thumb, start an accurate cut by sawing with short strokes.

NOTE: The procedure listed is for heavier metal stock. When cutting thinner metals such as sheet metal or aluminum siding, the cut is usually made with one hand while using the other hand to hold the material.

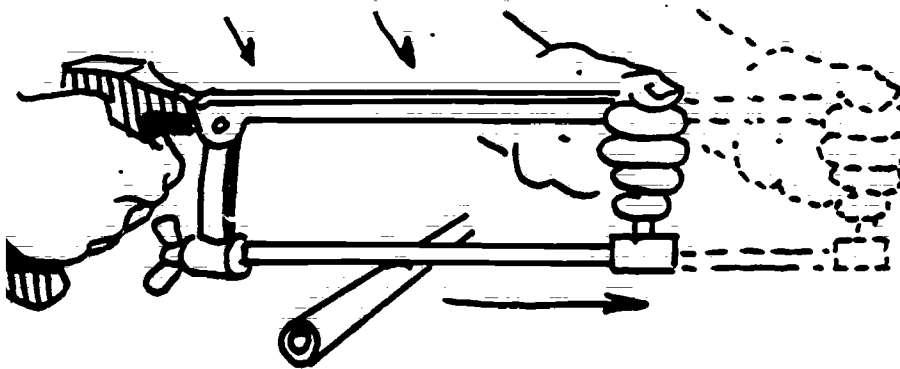

3. Stand at ease facing work with feet at least 12" apart.
4. Holding the handle with one hand, firmly grip the front of the saw frame with the other hand.

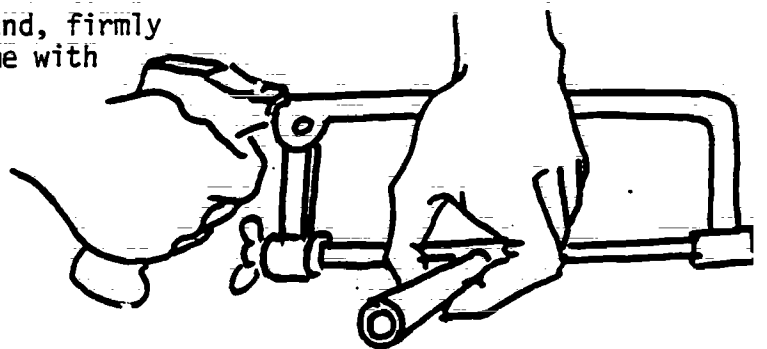

301

## COMPETENCE - PROCEDURES/STEPS

## TEACHING/LEARNING ACTIVITIES

5. Applying pressure, make the forward stroke.

NOTE: Do not allow the teeth of the saw to slip over the work as this will dull the blade.

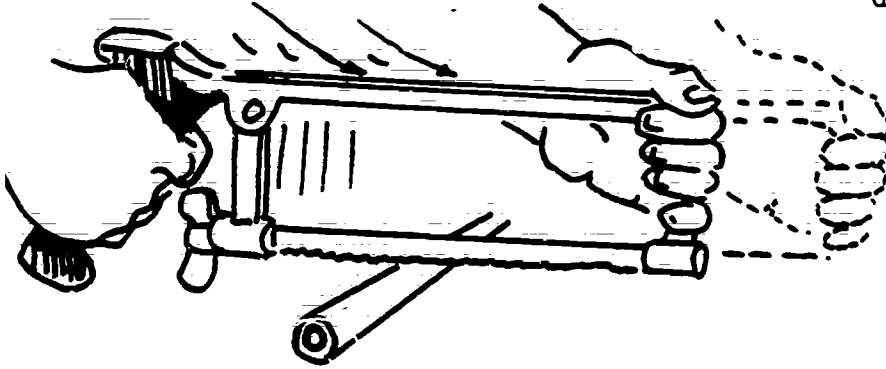

6. Return stroke, lifting the blade slightly.

NOTE: Do not lift the blade out of the cut.

7. Continue cutting with about 40-60 strokes a minute.

NOTE: On heavy work apply more pressure. In addition to the arm movement, a slight swaying of the body in the direction of the cut will help.

8. Ease up on the forward pressure as the cut is completed to avoid slipping and injury.

NOTE: Move hand from front of saw frame to hold rod while cut is completed.

305

COMPETENCY: Shape and Smooth Surfaces with  
a File

COURSE: Appliance Repair

UNIT III: Basic Shop Tools

OBJECTIVES: The student will be able to properly use the file while shaping  
or smoothing surfaces

Page 1 of 1 page

COMPETENCE - PROCEDURES/STEPS  
The student will be able to:

TEACHING/LEARNING ACTIVITIES

1. Hold the handle of the file in one hand with the index finger stretched out on top the file and hold the point of the file with the thumb and first two fingers of the other hand.

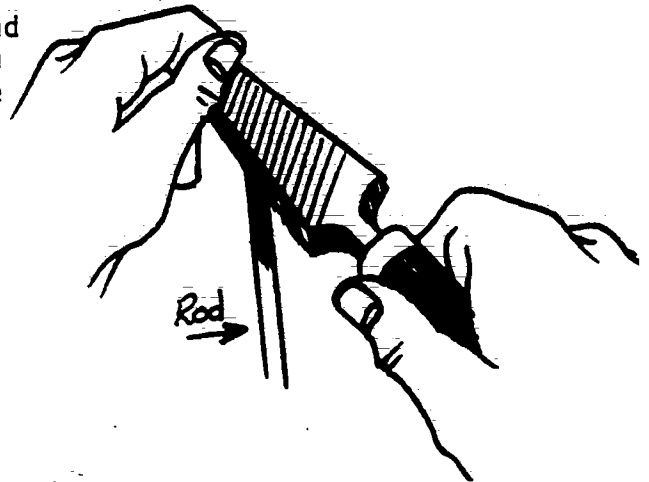

2. File with forward strokes diagonally across the work.

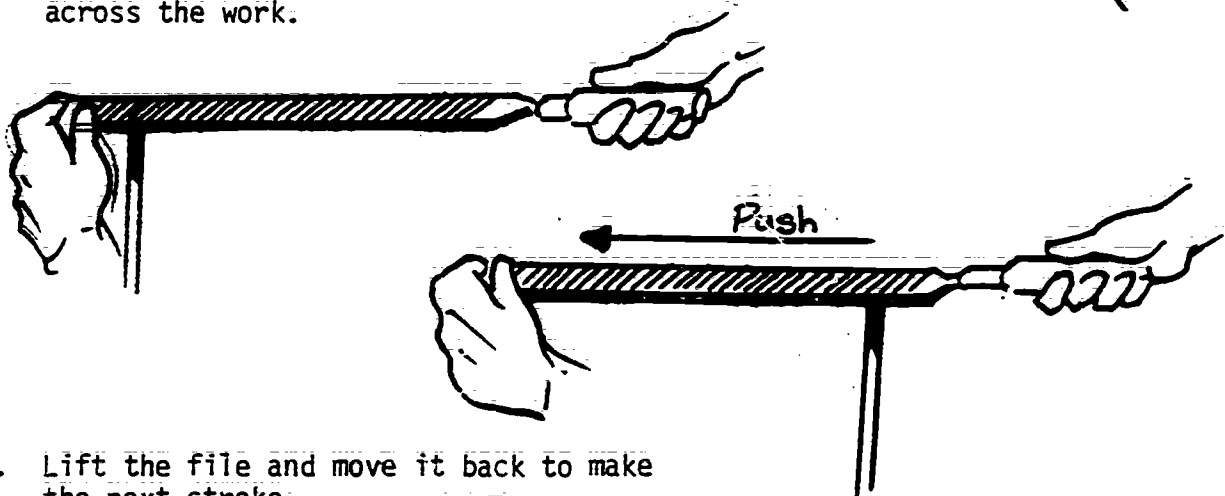

3. Lift the file and move it back to make the next stroke.

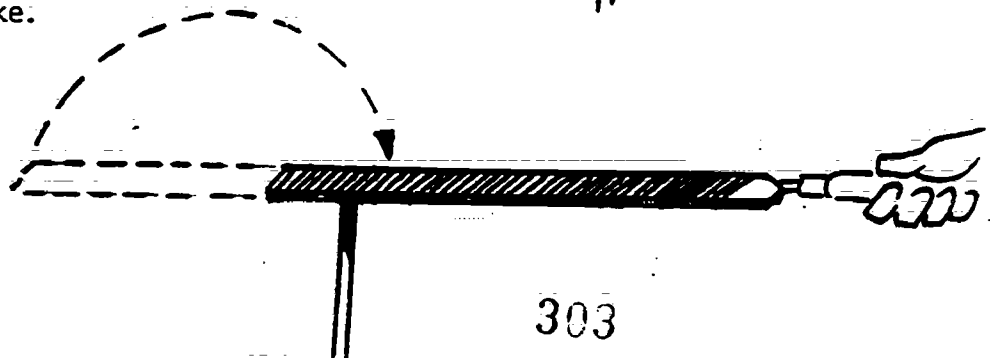

COMPETENCY: Cut External Threads with a Die

COURSE: Appliance Repair

UNIT III: Basic Shop Tools

OBJECTIVE: The student will be able to cut external threads using the proper die

Page 1 of 1 page

---

COMPETENCE - PROCEDURES/STEPS

The student will be able to:

TEACHING/LEARNING ACTIVITIES

---

1. Place the bolt or stud in the vise.
2. Place the die in the die holder with the side marked "starting side" facing out.

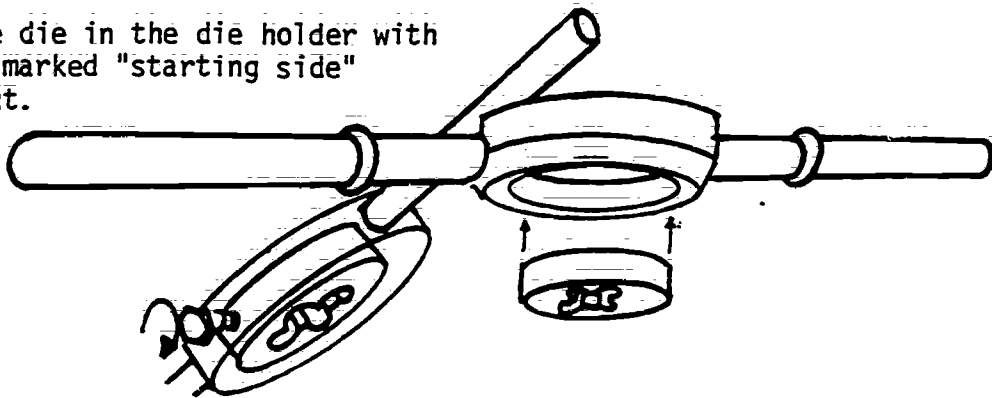

3. Position the die on top of the bolt or stud and turn the handle one turn clockwise.
4. Turn the handle back counterclockwise to clean out the threads as they are cut.
5. Drop some cutting oil on the cutting tool.

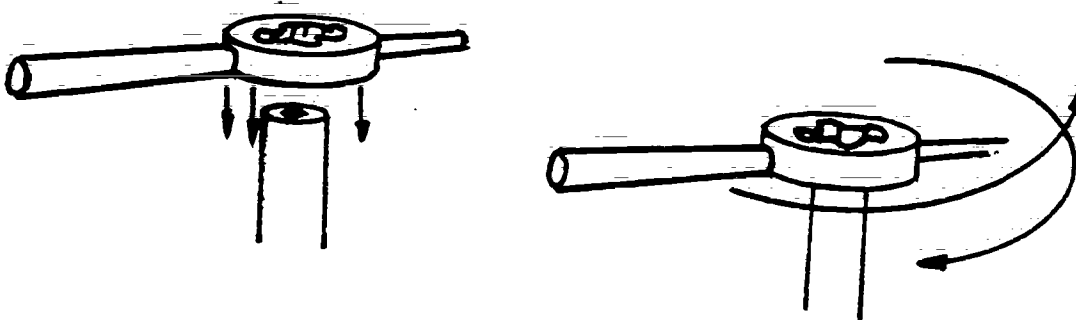



OPERATION SHEET

SC-3-21

COMPETENCY: Set up Bench Grinder

COURSE: Appliance Repair

UNIT III: Basic Shop Tools

OBJECTIVE: The student will be able to set up and use bench grinder to sharpen or shape metal parts

Page 1 of 1 page

COMPETENCE - PROCEDURES/STEPS

The student will be able to:

TEACHING/LEARNING ACTIVITIES

1. Turn wheel by hand to inspect the wheel for clearance and damage.
2. Adjust the grinder window shield.
3. Adjust the tool rest for proper clearance.
4. Turn on the power.
5. Hold the item to be shaped against the wheel.

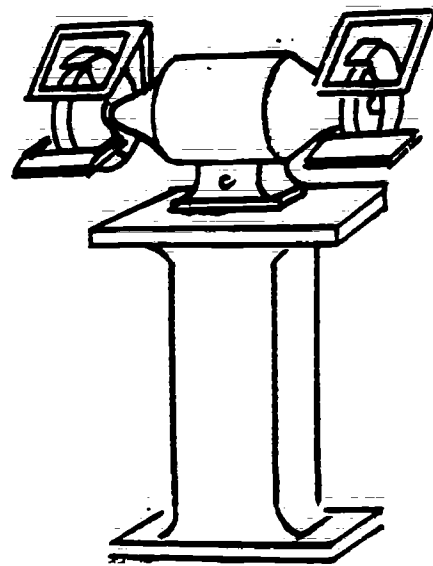
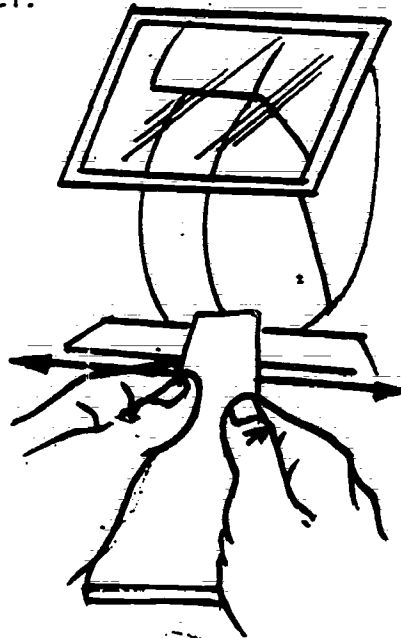

NOTE: Do not exert too much pressure.

NOTE: If the item is small use a pliers or other holding device.

NOTE: Cool the item with water.

6. Move the item back and forth across wheel.
7. Continue the operation until the item is properly formed.

OPERATION SHEET

SC-3-22

COMPETENCY: Install and Use Drill Bit  
Sharpening Guide

COURSE: Appliance Repair

UNIT III: Basic Shop Tools

OBJECTIVE: The student will be able to sharpen a drill bit

Page 1 of 1 page

COMPETENCE - PROCEDURES/STEPS The student will be able to:	TEACHING/LEARNING ACTIVITIES
<ol style="list-style-type: none"><li>1. Insert the sharpening guide into the holder provided on the grinder.</li><li>2. Set the angle adjustment for the proper angle needed.</li><li>3. Adjust the clearance.</li><li>4. Turn on the power.</li><li>5. Put the drill bit on the drill bit guide.</li><li>6. Push the drill bit against the wheel lightly.</li><li>7. Turn the drill bit slowly 1/2 turn as the drill guide is moved from side to side.</li><li>8. Repeat the grinding operation until the drill bit is sharpened.</li></ol>	<p>NOTE: It should have 1/16" at the point.</p>

COMPETENCY: Remove a Bolt with a Screw Extractor

COURSE: Appliance Repair

UNIT III: Basic Shop Tools

OBJECTIVE: The student will be able to effectively remove a bolt with a screw extractor

Page 1 of 1 page

COMPETENCE - PROCEDURES/STEPS The student will be able to:	TEACHING/LEARNING ACTIVITIES
---	------------------------------

1. Drill a hole into the center of the bolt to be removed.

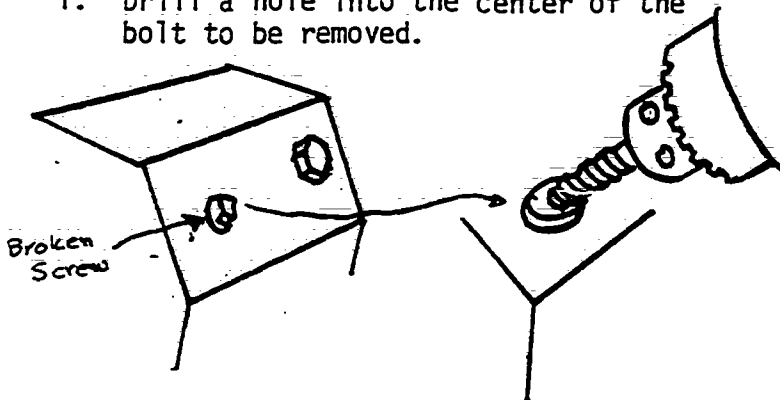

NOTE: Select the proper size drill bit for the size of extractor to be used.

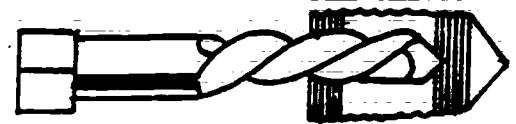

2. Insert the extractor into the hole as far as it will go.
3. Use the tap holder to turn the screw extractor and extract the screw.

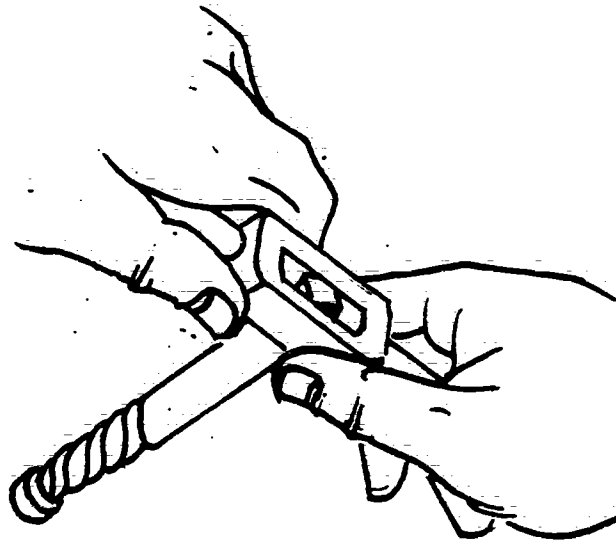

OPERATION SHEET

SC-3-24

COMPETENCY: Clean Parts Using the Air Nozzle

COURSE: Appliance Repair

UNIT III: Basic Hand Tools

OBJECTIVE: The student will be able to safely use the air nozzle to clean parts

Page 1 of 1 page

COMPETENCE - PROCEDURES/STEPS The student will be able to:	TEACHING/LEARNING ACTIVITIES
---	------------------------------

1. Install nozzle into air hose.
2. Turn on the air supply.
3. Adjust the air pressure regulator by setting it to 100 pounds.
4. Aim nozzle toward the part to be cleaned.
5. Press nozzle button and move nozzle tip back and forth across the area to be cleaned.
6. Repeat process until part is free of dirt and lint.

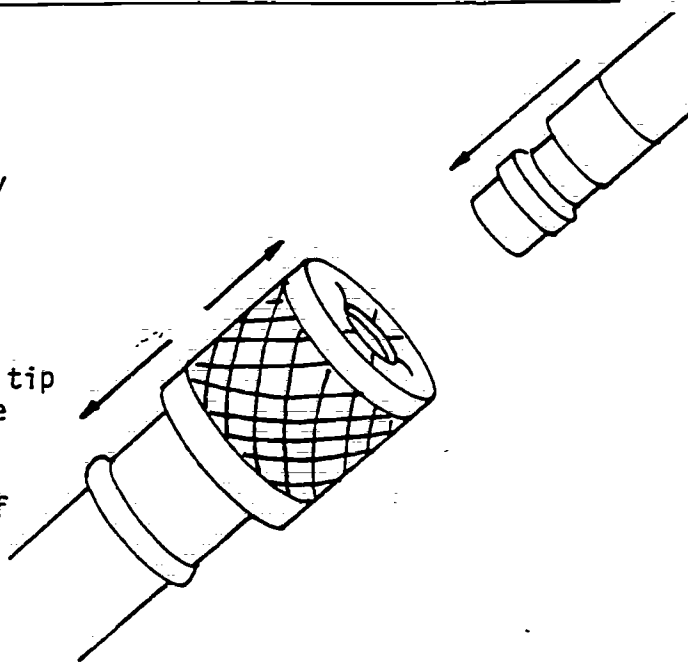

308

COMPETENCY: Attach Hand Truck to an Appliance

COURSE: Appliance Repair

UNIT III: Basic Hand Tools

OBJECTIVE: The student will be able to attach the appliance hand truck to an appliance

---

COMPETENCE - PROCEDURES/STEPS  
The student will be able to:

TEACHING/LEARNING ACTIVITIES

---

1. Place the hand truck at the rear of the appliance.

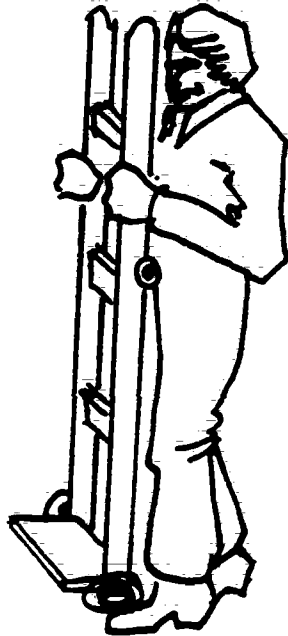

2. Tilt the appliance forward.

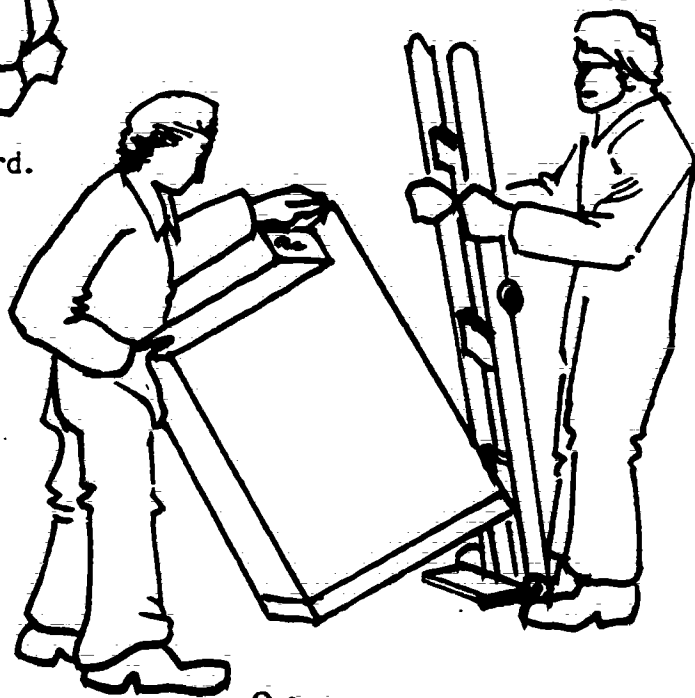

COMPETENCE - PROCEDURES/STEPS

TEACHING/LEARNING ACTIVITIES

3. Slide the hand truck blade under the appliance.
4. Allow the appliance to return to the upright position.

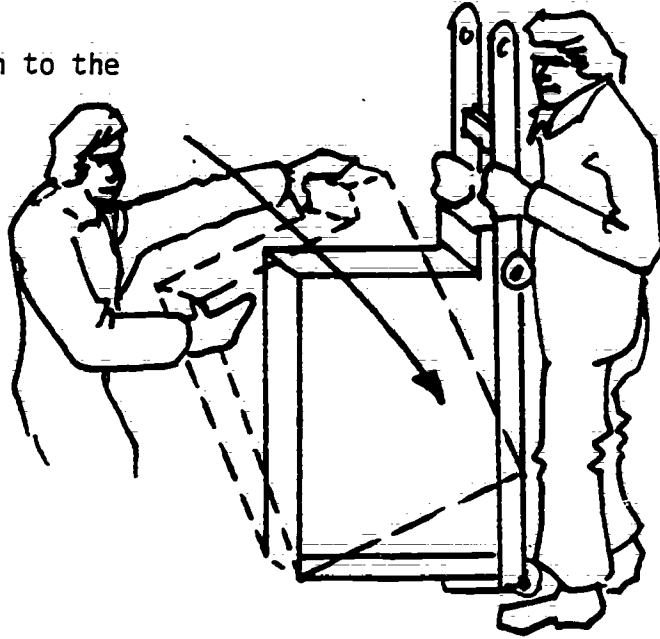

5. Place the strap around the appliance.



6. Tilt the appliance back onto the truck until it is in balance.
7. Move appliance to desired location.

310

OPERATION SHEET

SC-4-1

COMPETENCY: Use a Pump Pliers

COURSE: Appliance Repair

UNIT IV: Laundry Equipment

OBJECTIVE: The student will be able to install and properly tighten hose fittings with the pump pliers

Page 1 of 1 page

---

COMPETENCE - PROCEDURES/STEPS The student will be able to:	TEACHING/LEARNING ACTIVITIES
<ol style="list-style-type: none"><li>1. Hold pliers as shown.</li><li>2. Open jaws of plier and place jaws over hose fitting to be tightened.</li><li>3. Tighten hose fittings as needed, usually 3/4 to 1 turn is all.</li></ol>	<p>NOTE: Do not use excessive force to start the threading process. It will cause cross threading.</p>

---

COMPETENCY: Use the Hose Clamp Pliers

COURSE: Appliance Repair

UNIT IV: Laundry Equipment

OBJECTIVE: The student will be able to use the hose clamp pliers to properly install a spring clamp

Page 1 of 1 page

COMPETENCE - PROCEDURES/STEPS

The student will be able to:

TEACHING/LEARNING ACTIVITIES

1. Align indentations on the tip of the pliers so that the tips engage the clamp from opposite sides.

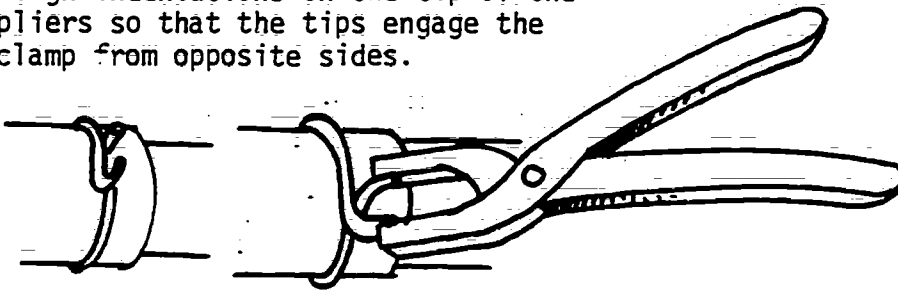

2. Firmly grasp pliers and squeeze plier handles.

NOTE: Make sure the tip of the pliers grasp the hose clamp correctly.

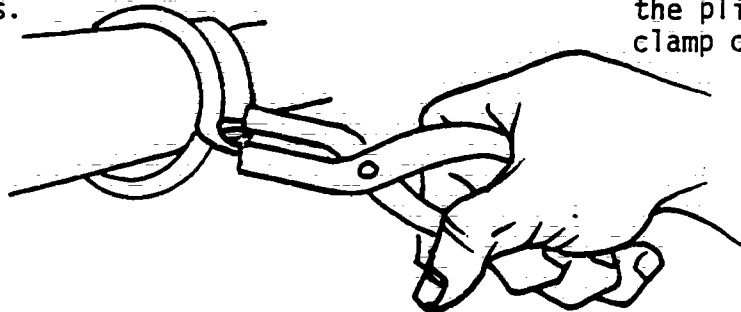

3. While maintaining pressure on the handles, slide the clamp from hose to fitting.

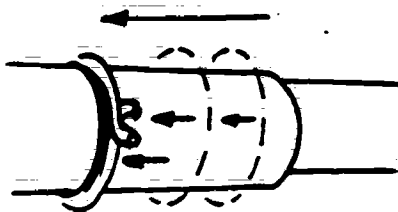

4. Release pressure on plier handles and remove pliers.

NOTE: To remove clamp, repeat steps 1 and 2 to release clamp then slide the clamp back on the hose until the clamp is clear of the fitting.



COMPETENCY: Join Flexible Plastic or Rubber Tubing

COURSE: Appliance Repair

UNIT IV: Laundry Equipment

OBJECTIVE: The student will be able to join flexible plastic or rubber tubing using inert fittings and stainless steel clamps

Page 1 of 1 page

COMPETENCE - PROCEDURES/STEPS  
The student will be able to:

TEACHING/LEARNING ACTIVITIES

1. Slide a clamp over the end of the hose.

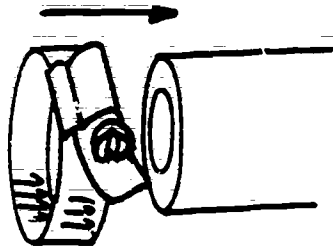

2. Place the hose onto the hose fitting using a twisting, pushing motion.

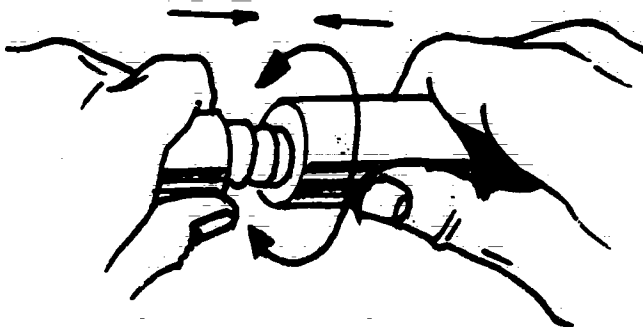
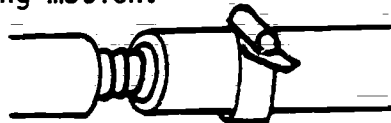

3. Slide the stainless steel clamp into position, approximately 1/2" from the end.
4. Tighten the clamp using a screwdriver.

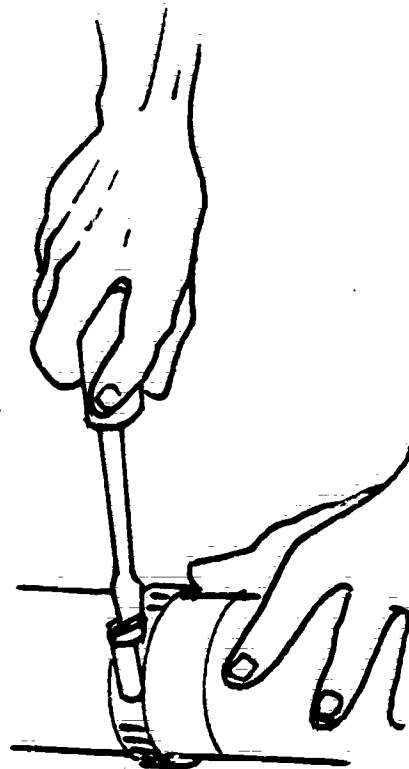
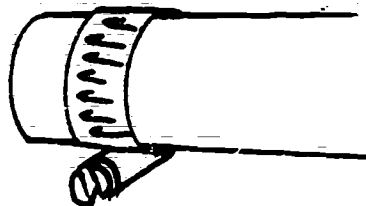

313

493

COMPETENCY: Use the Level

COURSE: Appliance Repair

UNIT IV: Laundry Equipment

OBJECTIVE: The student will be able to properly use the level to obtain accurate readings

Page 1 of 2 pages

---

COMPETENCE - PROCEDURES/STEPS  
The student will be able to:

TEACHING/LEARNING ACTIVITIES

---

1. Lay the edge of the level on surface; parallel to the edges of the surface.

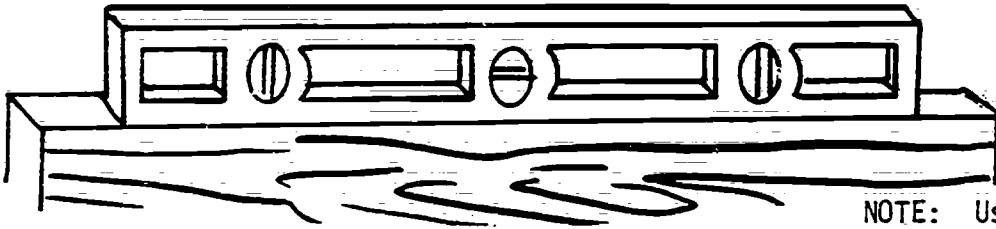

NOTE: Use only the best and most accurate level. Inaccurate tools are frequent causes of inaccurate work.

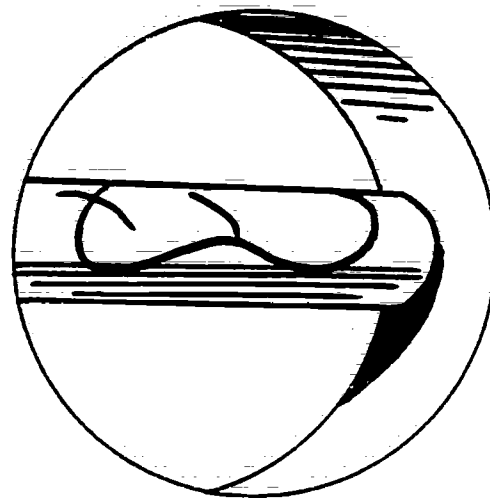

## COMPETENCE - PROCEDURES/STEPS

## TEACHING/LEARNING ACTIVITIES

2. Raise or lower one end of surface until bubble is centered between the reference lines.

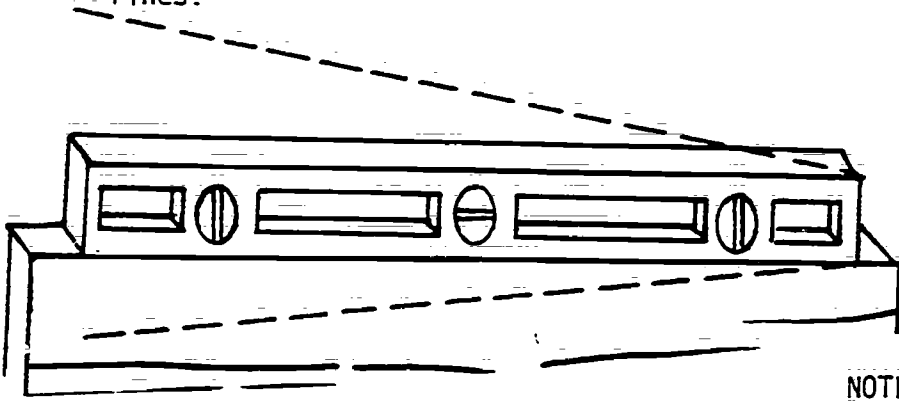

NOTE: Some levels have two lines / / of which the bubble should be centered. Some have one line / at which the bubble should be centered.

CAUTION: Do not drop or jar this instrument, it could cause it to become inaccurate.

NOTE: Always use as large a leveling tool as possible. Your reading will always be more accurate.

NOTE: On a long surface, use a true straight edge between the level and the surface.

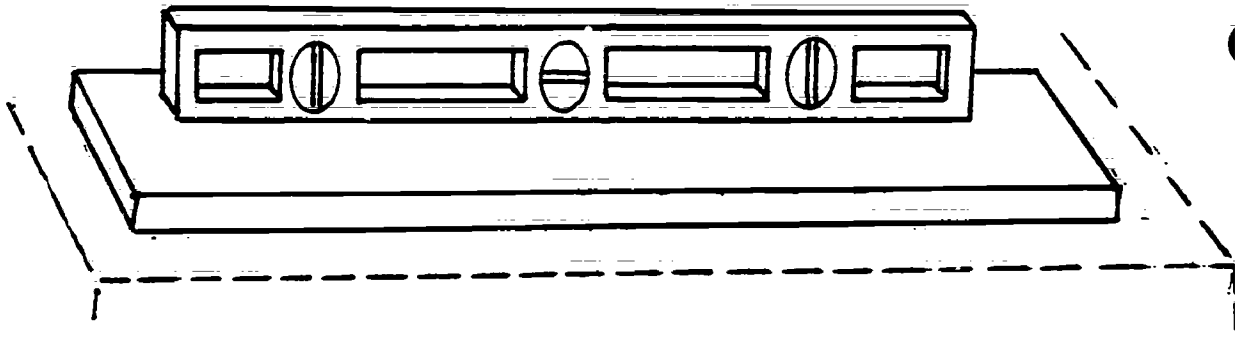

315

COMPETENCY: Install Wire in Lugs

COURSE: Appliance Repair

UNIT IV: Laundry Equipment

OBJECTIVE: The student will be able to install wire in a lug to meet the standards pre-set by industry

Page 1 of 1 page

---

COMPETENCE - PROCEDURES/STEPS  
The student will be able to:

TEACHING/LEARNING ACTIVITIES

---

1. Loosen the screws.

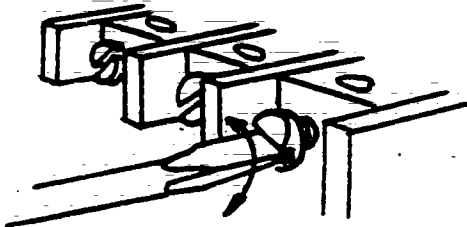

2. Push the wire in the lugs.

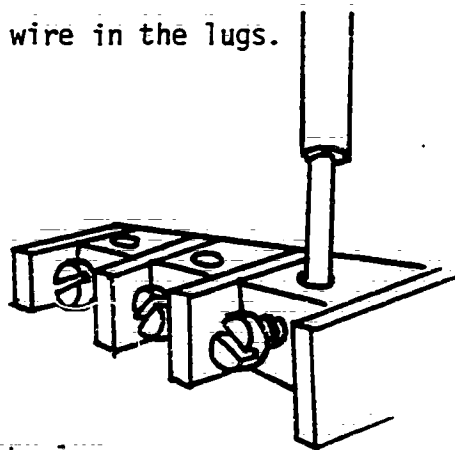

NOTE: Make sure the wire is in to the bottom of the lug.

3. Tighten the lug.

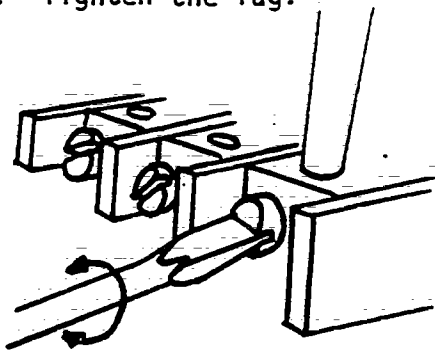

COMPETENCY: Cut with the Utility Knife

COURSE: Appliance Repair

UNIT IV: Laundry Equipment

OBJECTIVE: The student will be able to properly and safely cut insulation with a utility knife

Page 1 of 1 page

---

COMPETENCE - PROCEDURES/STEPS

The student will be able to:

TEACHING/LEARNING ACTIVITIES

---

1. Push button on knife handle to expose blade.

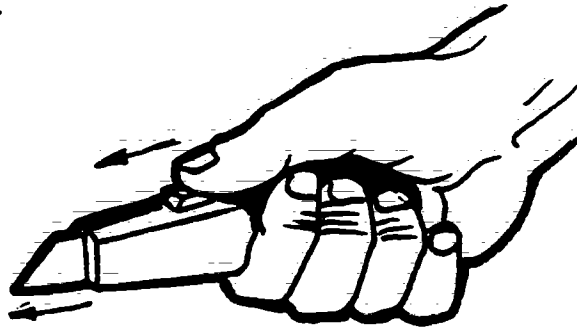

2. Applying pressure down and pulling knife, cut along the desired mark.

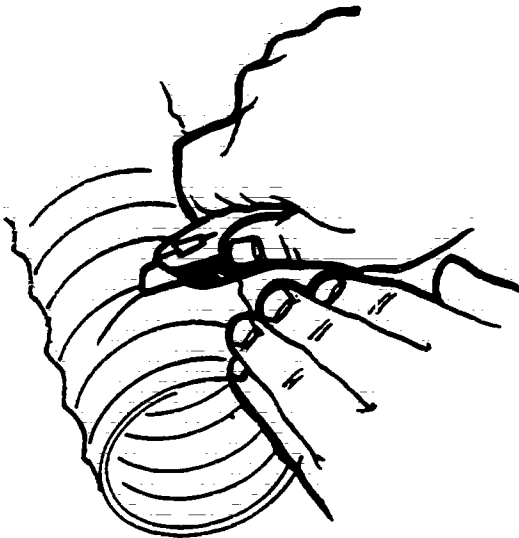

3. When the cut is finished, pull the button to cover the blade.

COMPETENCY: Cut Thin Metal With Tin Shears

COURSE: Appliance Repair

UNIT IV: Laundry Equipment

OBJECTIVE: The student will be able to cut thin metal with tin shears

Page 1 of 1 page

COMPETENCE - PROCEDURES/STEPS  
The student will be able to:

TEACHING/LEARNING ACTIVITIES

1. Grasp the snips with one hand and hold the shorter side of the sheet metal in the other.

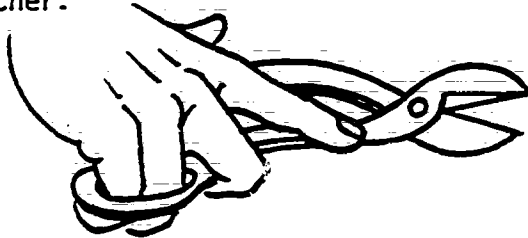

2. Open the blades wide and start the cut at the edge of the sheet metal.

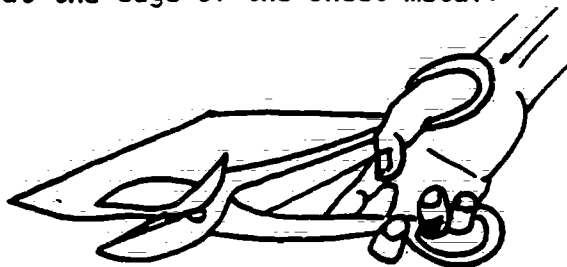

NOTE: Hold the blades of the snips at a right angle to the sheet metal.

3. Start the next cut at the end of the one before.

NOTE: Close shear blades just short of their full length to avoid getting jagged edges on sheet metal.

4. Finish the cut.

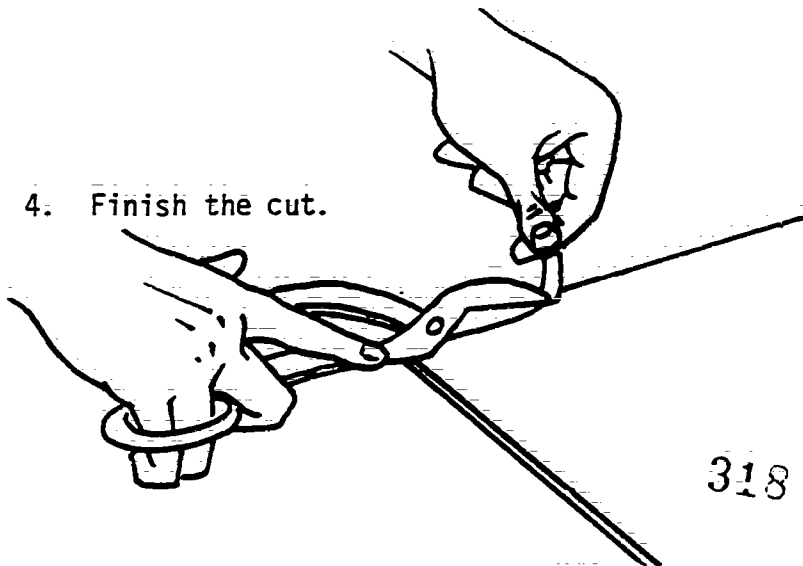

NOTE: Keep the snips on the cutting line by changing the angle of the cut if necessary.

COMPETENCY: Mark Stock Using a Compass

COURSE: Appliance Repair

UNIT IV: Laundry Equipment

OBJECTIVE: The students will be able to mark stock accurately using a compass

Page 1 of 1 page

---

COMPETENCE - PROCEDURES/STEPS  
The student will be able to:

TEACHING/LEARNING ACTIVITIES

---

1. Place pointed end of compass onto the center mark.

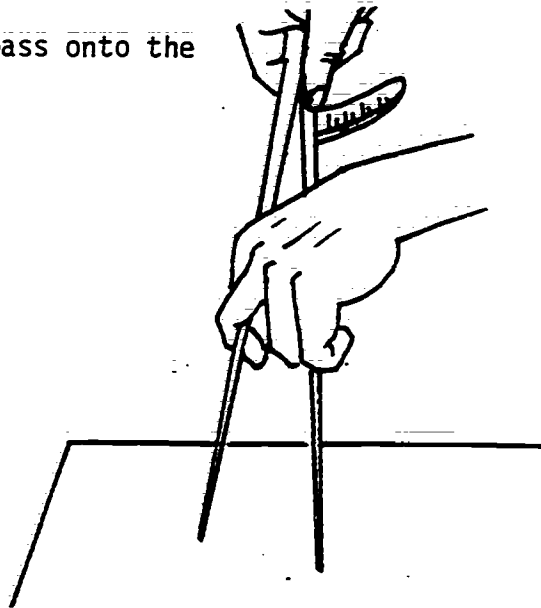

2. Swing the other end of the compass around until a circle is clearly marked.

NOTE: Make sure the center point end of the compass does not move out of the mark.

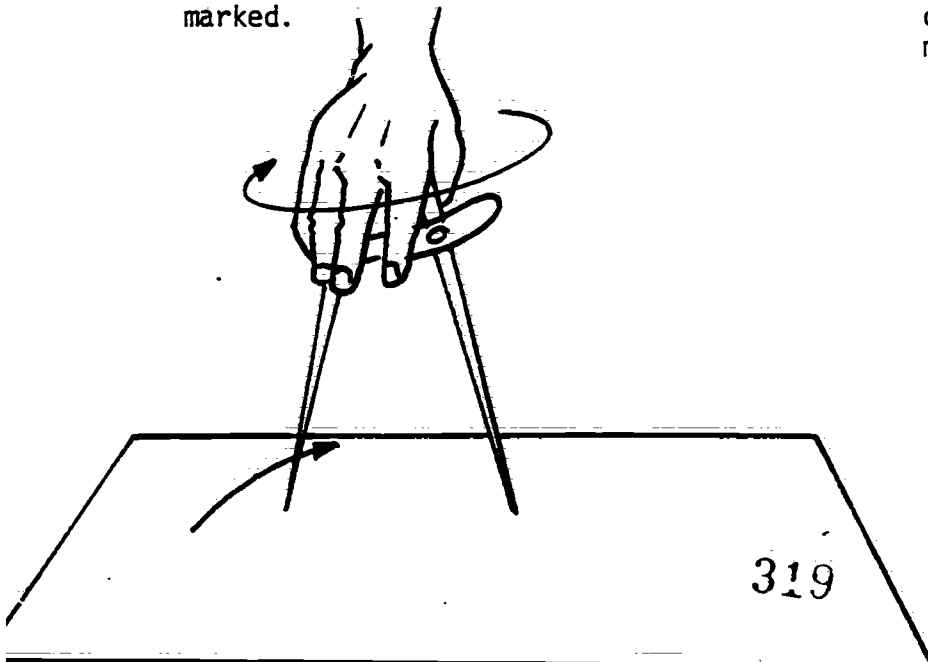

COMPETENCY: Cut Metal with Chisel

COURSE: Appliance Repair

UNIT IV: Laundry Equipment

OBJECTIVE: The student will be able to use a hammer and chisel to cut a hole in sheet metal

Page 1 of 1 page

---

COMPETENCE - PROCEDURES/STEPS  
The student will be able to:

TEACHING/LEARNING ACTIVITIES

---

1. Place metal stock onto soft board.

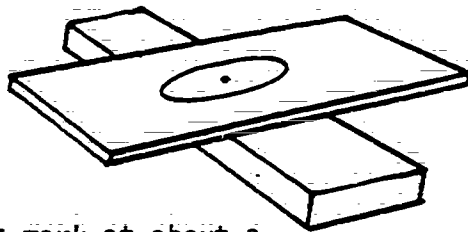

2. Hold chisel against mark at about a 45° angle.

3. Strike the head of the chisel with the hammer.

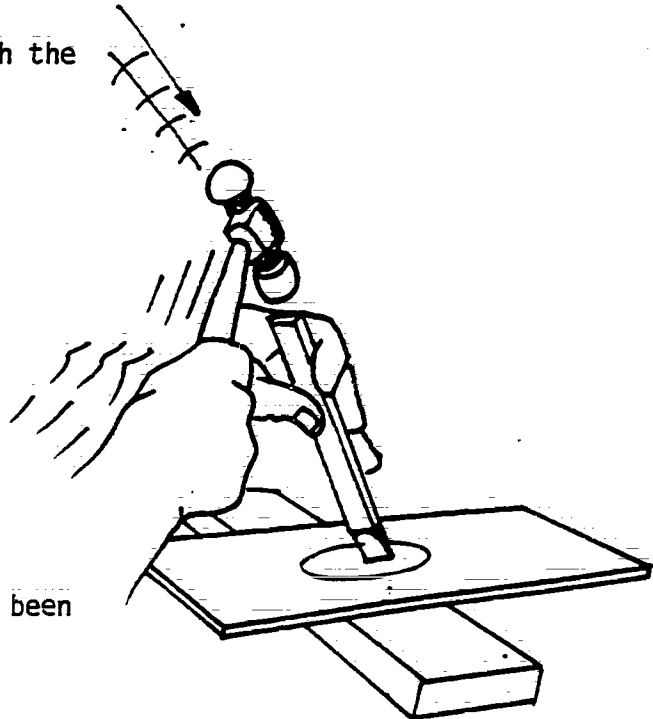
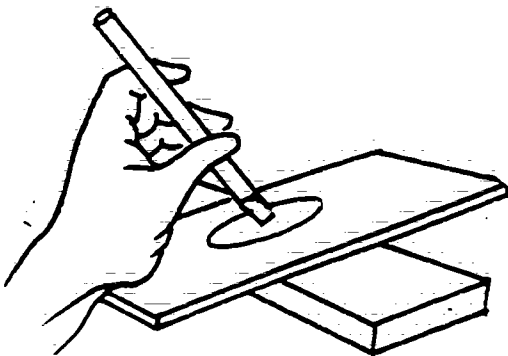

4. Repeat step #3 until the hole has been cut to the desired size.



COMPETENCY: Make an Inside Curved Cut with Hand Shears

COURSE: Appliance Repair

UNIT IV: Laundry Equipment

OBJECTIVE: The student will be able to properly cut out an inside circle using the hand shears

Page 1 of 1 page

COMPETENCE - PROCEDURES/STEPS  
The student will be able to:

TEACHING/LEARNING ACTIVITIES

1. Insert one blade of the shears in the starting hole.

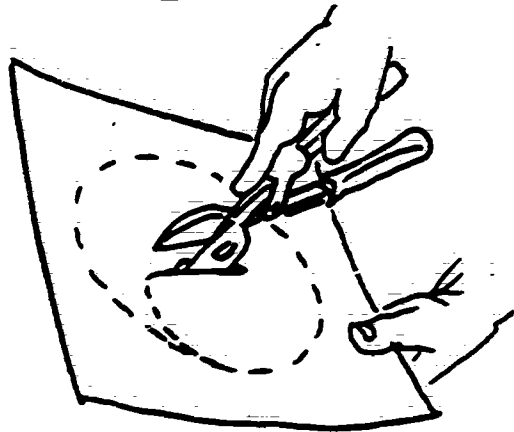
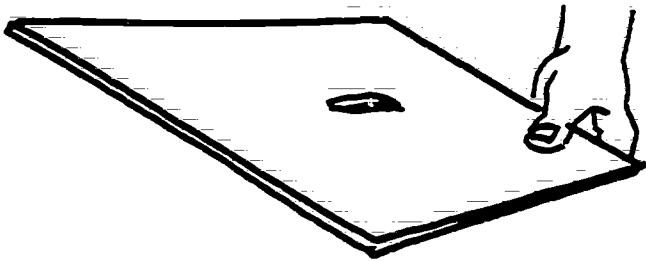

2. Start the cut by squeezing the shears.

NOTE: Relax hand and they will open automatically.

3. Keep the blades of the shears vertical and cut an arc to the scribed circle.

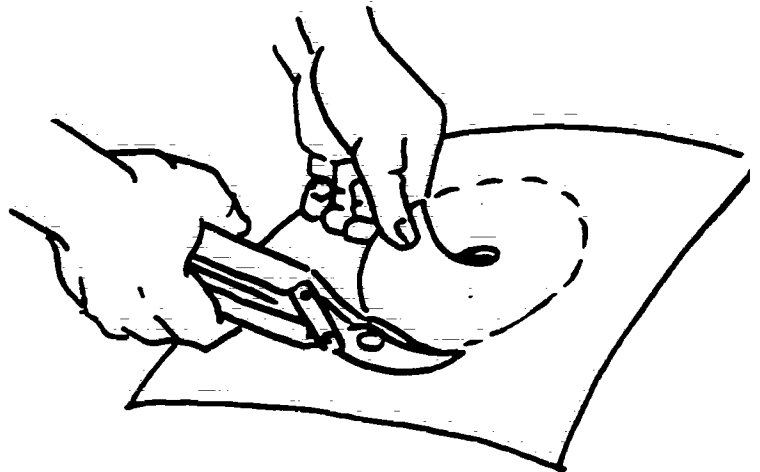

4. Cut until the circle is complete.

NOTE: Work the shears with one hand and at the same time turn the metal with the other hand.

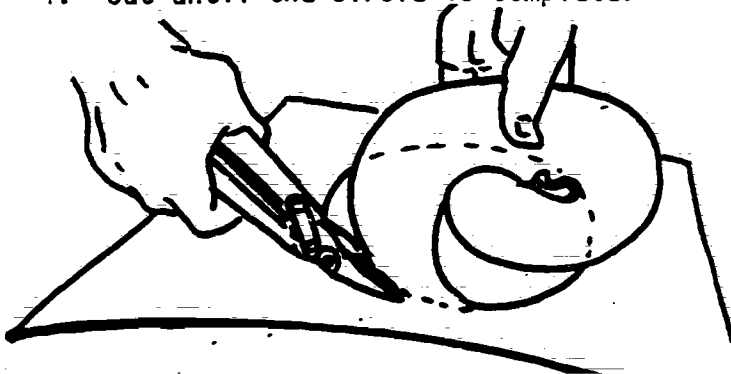

321

COMPETENCY: Install Glazing Points  
(Push Points)

COURSE: Appliance Repair

UNIT IV: Laundry Equipment

OBJECTIVE: The student will be able to fasten material in a window frame using glazing points

Page 1 of 1 page

COMPETENCE - PROCEDURES/STEPS

The student will be able to:

TEACHING/LEARNING ACTIVITIES

1. Position the push point at the point to be installed.
2. Holding the push point with the index finger of one hand, use a putty knife against the back edge of the push point tab.
3. Push the point into the sash until the tab is solidly against the side of the rabbet.

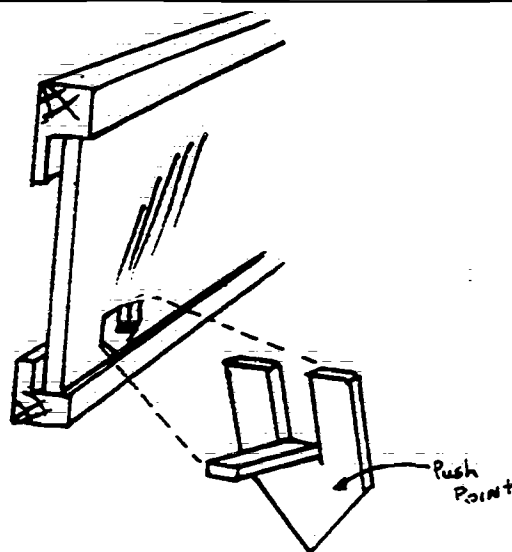
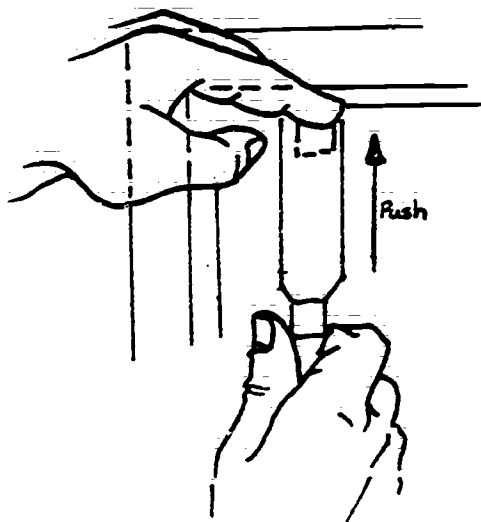

NOTE: Install a glazing point around the rabbet at intervals of every 4" to 6".

COMPETENCY: Rivet with a Pop Rivet Gun

COURSE: Appliance Repair

UNIT IV: Laundry Equipment

OBJECTIVE: The student will be able to properly apply rivets with the pop rivet gun

Page 1 of 2 pages

COMPETENCE - PROCEDURES/STEPS  
The student will be able to:

TEACHING/LEARNING ACTIVITIES

1. Open handle completely.
2. Insert rivet mandrel into nosepiece until rivet head is in contact with face of nosepiece.

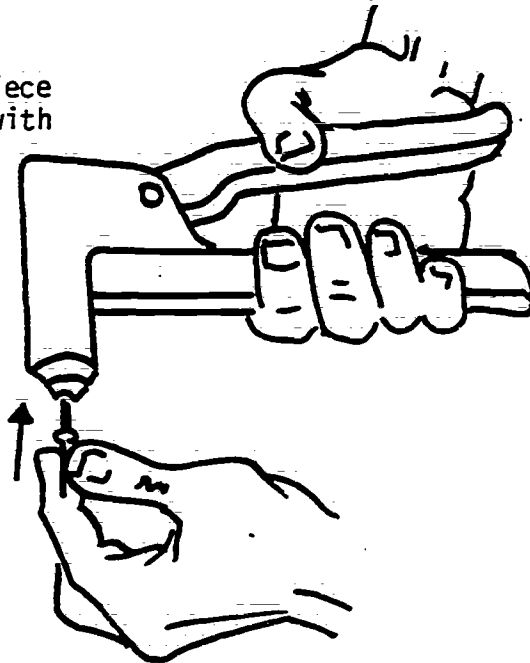

3. Close handle lightly until contact is made between rivet mandrel and riveter jaw.
4. At this point using riveter as a guide, insert rivet into hole of unit to be riveted.

NOTE: Both top and bottom face of rivet head and outer surface of unit to be riveted must be in contact at this time.

323

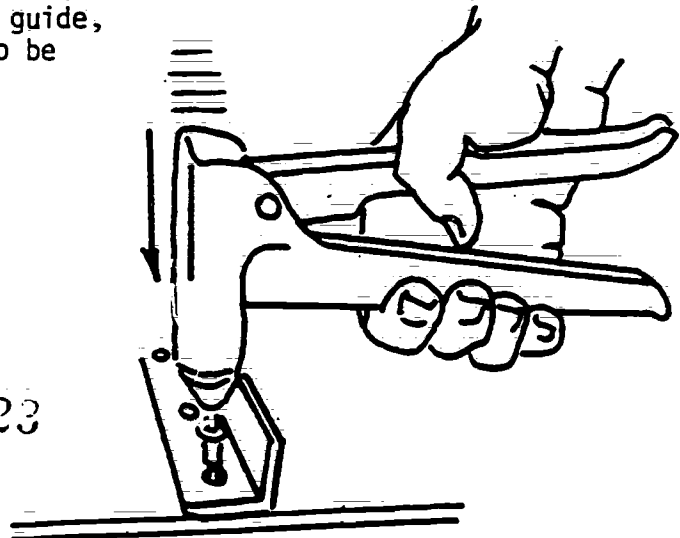

5. Squeeze movable handle down until rivet is set.

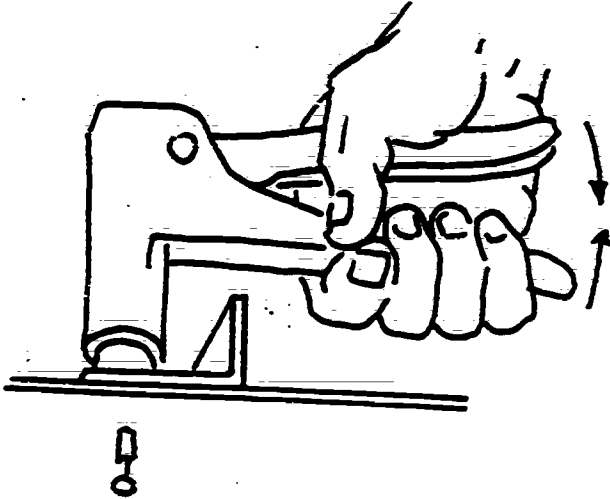

324

OPERATION SHEET

SC-4-13

COMPETENCY: Clean a Painted Surface

COURSE: Appliance Repair

UNIT IV: Laundry Equipment

OBJECTIVE: The student will be able to clean a painted surface properly

Page 1 of 1 page

---

COMPETENCE - PROCEDURES/STEPS	TEACHING/LEARNING ACTIVITIES
-------------------------------	------------------------------

---

1. Spray the area to be cleaned with cleaning solution.
2. Allow the solution to activate.
3. Using a rag, wipe surface clean.
4. Repeat steps #1,2,3 until surface is cleaned.

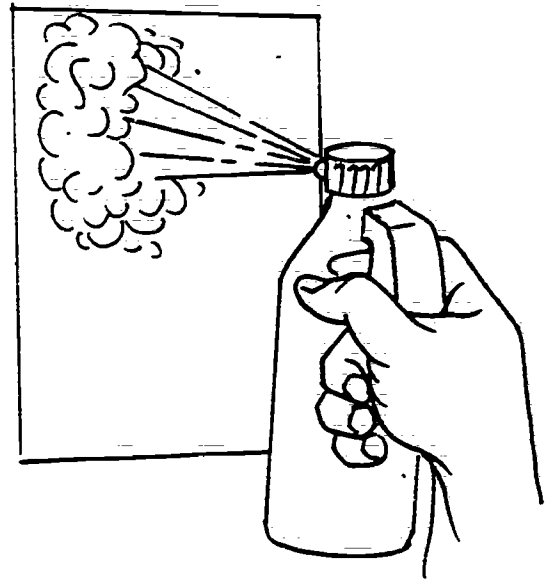

COMPETENCY: Polish a Painted Surface

COURSE: Appliance Repair

UNIT IV: Laundry Equipment

OBJECTIVE: The student will be able to polish a painted surface

Page 1 of 1 page

---

COMPETENCE - PROCEDURES/STEPS	TEACHING/LEARNING ACTIVITIES
-------------------------------	------------------------------

---

1. Pour a small quantity of polish onto a rag.
2. Using a circular motion, apply an even coat of polish onto the painted surface.
3. In circular motion, rub off the polish with a clean rag. (buffing)
4. Continue buffing surface for a good shine.

NOTE: Allow the polish to dry thoroughly before buffing a shine.

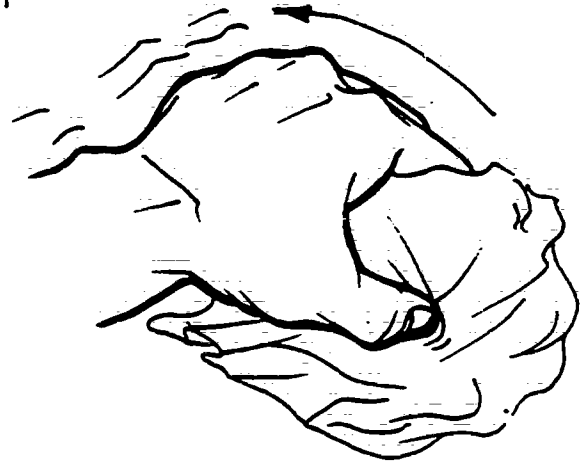

COMPETENCY: Remove "V" Belt from Pulley

COURSE: Appliance Repair

UNIT IV: Laundry Equipment

OBJECTIVE: The student will be able to safely remove a V-belt from pulley

Page 1 of 1 page

COMPETENCE - PROCEDURES/STEPS

The student will be able to:

TEACHING/LEARNING ACTIVITIES

1. Locate the largest pulley.
2. Grasp the V-belt with one hand and twist it so that the V points away from the groove of the pulley.

NOTE: Make sure tension springs are removed and motor bolts are loosened.

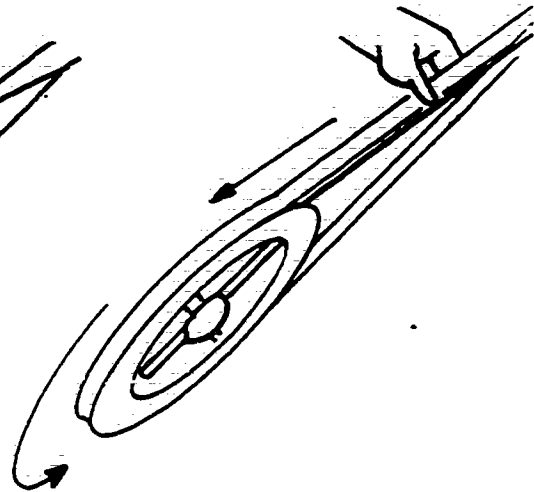
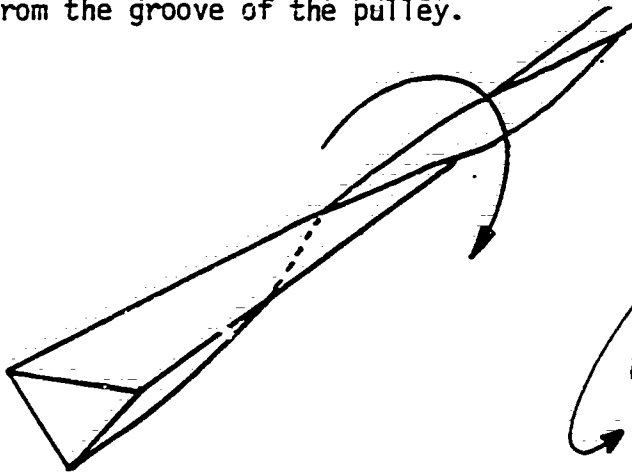

3. Pull the belt away from the pulley groove.
4. Slowly rotate the pulley so the belt moves out of the pulley groove.

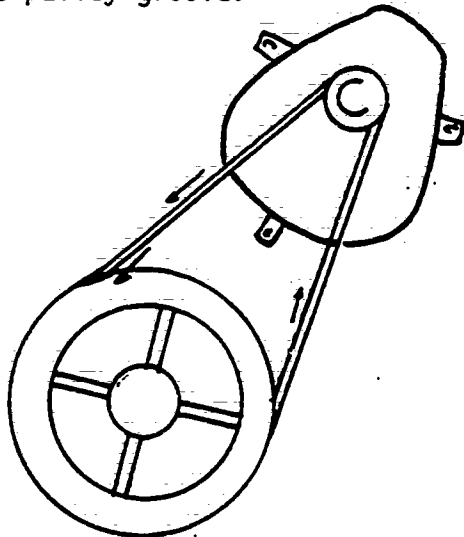

COMPETENCY: Clean, Using the Shop Vacuum Cleaner

COURSE: Appliance Repair

UNIT IV: Laundry Equipment

OBJECTIVE: The student will be able to correctly use a shop vacuum cleaner

Page 1 of 1 page

---

COMPETENCE - PROCEDURES/STEPS The student will be able to:	TEACHING/LEARNING ACTIVITIES
---	------------------------------

---

1. Turn on the vacuum cleaner. . IL-4-2
2. Place cleaning tool at the area to be cleaned.
3. Using a stroking motion back and forth or from side to side, clean the area.

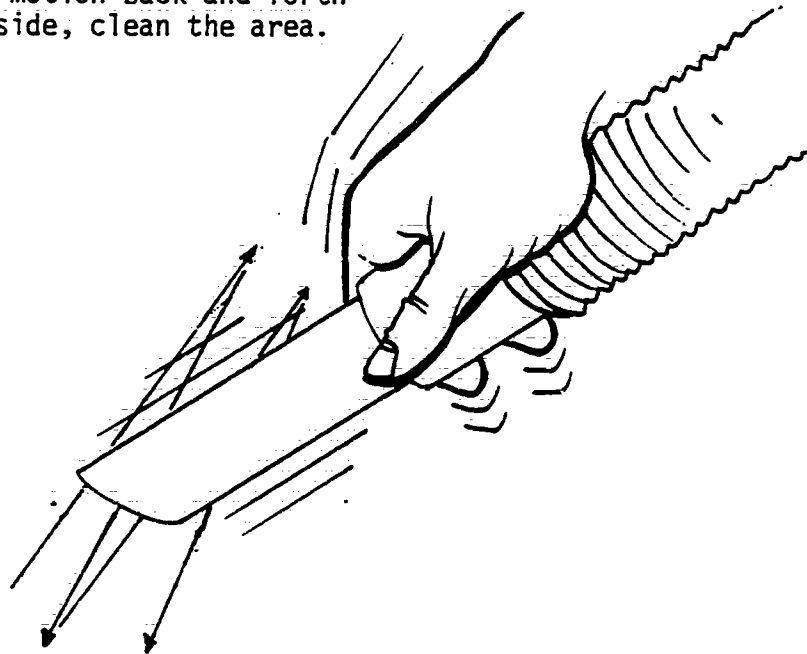



COMPETENCY: Lubricate a Shaft and Sleeve Bearing

COURSE: Appliance Repair

UNIT IV: Laundry Equipment

OBJECTIVE: The student will be able to properly lubricate a shaft and sleeve bearing

Page 1 of 1 page

---

COMPETENCE - PROCEDURES/STEPS  
The student will be able to:

TEACHING/LEARNING ACTIVITIES

---

1. Soak a Q Tip with lubricant.

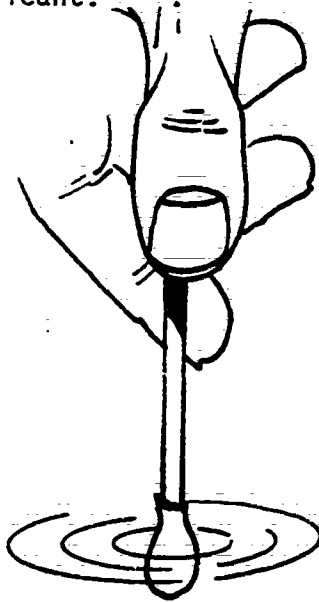

NOTE: See factory specifications for the proper lubricant for the job.

2. Rub the Q Tip over the entire surface to be lubricated.

329

3. Repeat steps 1 and 2 as needed.

521

COMPETENCY: Skin Wire with a Crimping Tool

COURSE: Appliance Repair

UNIT IV: Laundry Equipment

OBJECTIVE: The student will be able to skin-clean wire using a crimping tool

Page 1 of 1 page

COMPETENCE - PROCEDURES/STEPS  
The student will be able to:

TEACHING/LEARNING ACTIVITIES

1. Insert wire into skinning hole.

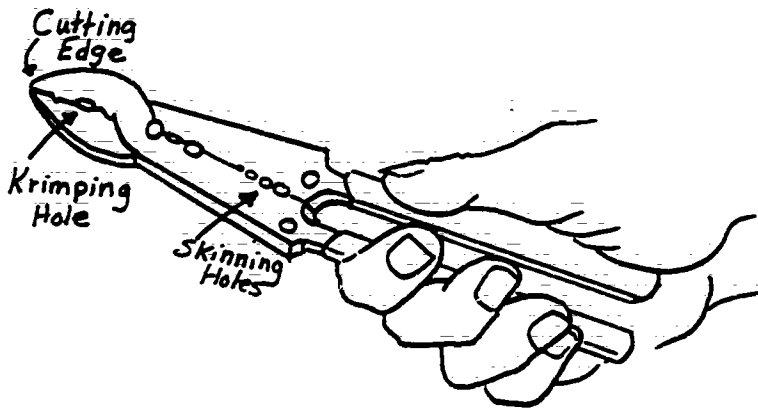

NOTE: Use correct hole for size of wire.

NOTE: Allow about 1/4" of wire to protrude from hole.

2. Squeeze handles of crimping tool closed.
3. Rotate crimping tool around the wire to insure a clean cut.
4. Hold the wire firmly with one hand and pull the crimping tool and the wire apart.

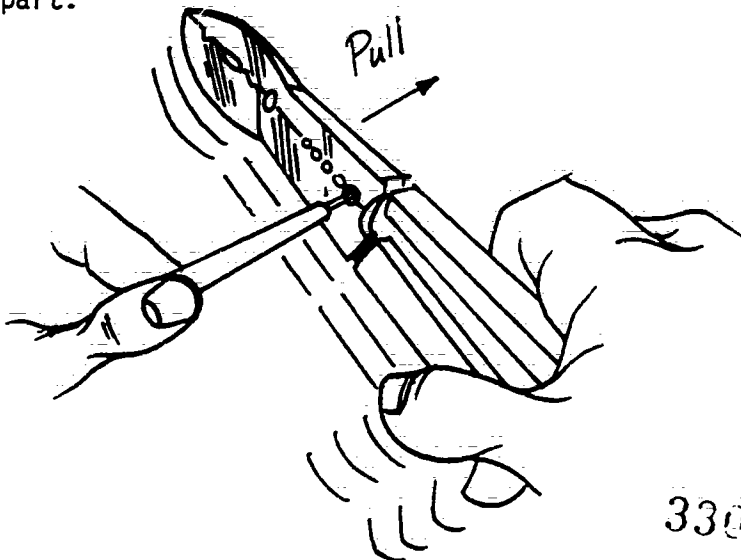
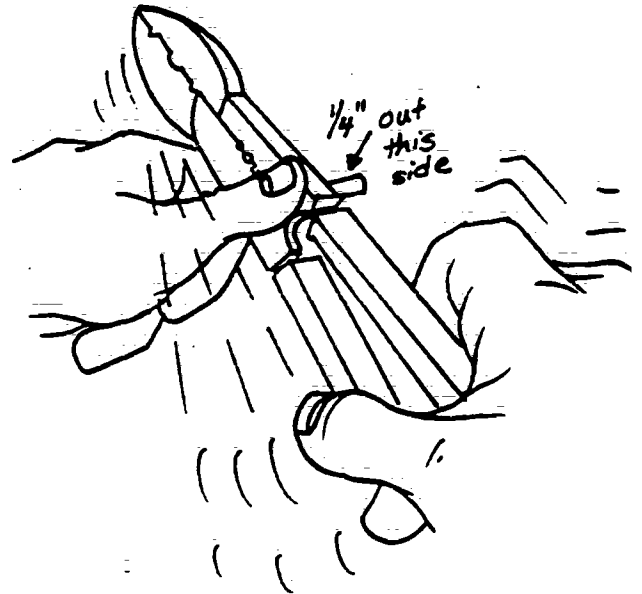

330

COMPETENCY: Crimp Wire to Terminal with Crimping Tool

COURSE: Appliance Repair

UNIT IV: Laundry Equipment

OBJECTIVE: The student will be able to properly crimp wire to the terminal using a crimping tool

COMPETENCE = PROCEDURES/STEPS The student will be able to:	TEACHING/LEARNING ACTIVITIES
---	------------------------------

1. Insert wire into terminal end.

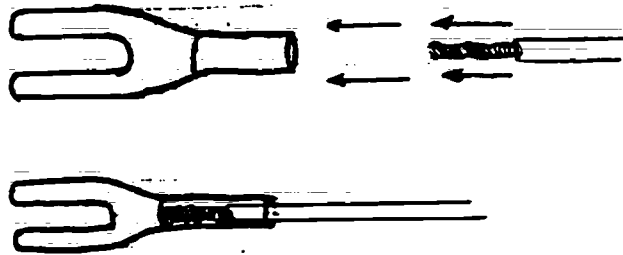

2. Place jaws of crimping tool around terminal end.

NOTE: Use proper crimping hole.

3. Close crimping tool around terminal end.

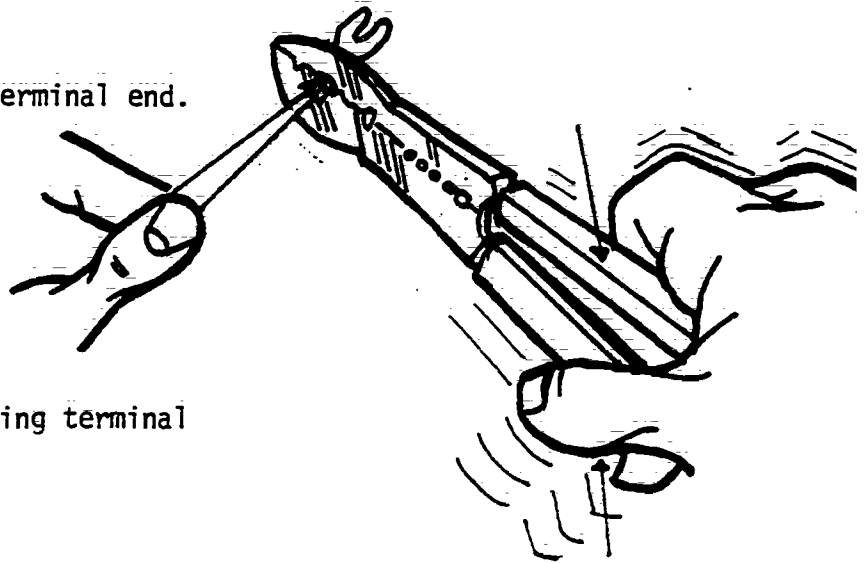

4. Tightly squeeze handles closing terminal end around wire.

OPERATION SHEET

SC-4-19

COMPETENCY: Calibrate and Use a Temperature Tester  
Robinair #12850

COURSE: Appliance Repair

UNIT IV: Laundry Equipment

OBJECTIVE: The student will be able to accurately calibrate and read the temperature tester.

Page 1 of 1 page

---

COMPETENCE - PROCEDURES/STEPS The student will be able to:	TEACHING/LEARNING ACTIVITIES
---	------------------------------

---

1. Unsnap the cover straps.
2. Attach the cover straps to hold the cover in the open position.
3. Plug in the test lead.
4. Place the opposite end of the test lead near a room thermometer.
5. Calibrate the needle to the room temperature using a small screwdriver.

NOTE: Allow a few minutes for the test lead and meter to stabilize.

NOTE: The adjusting screw is located at the bottom center of the meter--clockwise lowers the reading--counterclockwise raises the reading.

332

COMPETENCY: Use an inserting Tool and Plastic Head Hammer

COURSE: Appliance Repair

UNIT IV: Laundry Equipment

OBJECTIVE: The student will be able to install a seal using a seal inserting tool and plastic head hammer

COMPETENCE - PROCEDURES/STEPS  
The student will be able to:

TEACHING/LEARNING ACTIVITIES

1. Place seal on the opening.



NOTE: Select the proper size inserting tool; tool must fit over and fit on edge of seal.

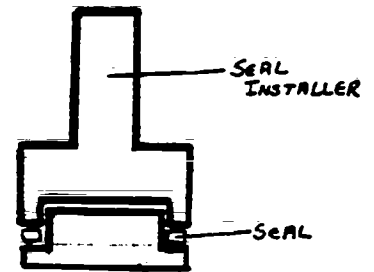

2. Place inserting tool over seal.
3. Tap the inserting tool with a plastic head hammer.



4. Continue tapping the inserting tool until the seal is seated.

OPERATION SHEET

SC-4-21

COMPETENCY: Use an Agitator Puller

COURSE: Appliance Repair

UNIT IV: Laundry Equipment

OBJECTIVE: The student will be able to use an agitator puller to remove a stuck agitator

Page 1 of 1 page

---

COMPETENCE - PROCEDURES/STEPS	TEACHING/LEARNING ACTIVITIES
The student will be able to:	
<hr/>	
<ol style="list-style-type: none"><li>1. Remove agitator cap or collar.</li><li>2. Place agitator puller arms over the agitator.</li><li>3. Insert the bent ends of the arms under the agitator.</li><li>4. Turn the "T" handle clockwise until it contacts the center of the shaft.</li><li>5. Continue to increase pressure until the agitator pulls free.</li></ol>	

---

334

COMPETENCY: Use an Adjustable Spanner Wrench

COURSE: Appliance Repair

UNIT IV: Laundry Equipment

OBJECTIVE: The student will be able to properly use an adjustable spanner wrench to remove large locknuts

Page 1 of 1 page

COMPETENCE - PROCEDURES/STEPS The student will be able to:	TEACHING/LEARNING ACTIVITIES
1. Clean and check the notches.	
2. Insert wrench hook into a notch.	NOTE: Select a notch that is flat so that the wrench hook will fit securely.
3. Pull handle around to the opposite side of the locknut.	
4. Hold hook end in the notch and pull the handle to loosen the nut.	NOTE: If the nut does not turn, it may be necessary to loosen it by using a large taper punch and ball peen hammer. See your instructor.

COMPETENCY: Use Impact Tool

COURSE: Appliance Repair

UNIT IV: Laundry Equipment

OBJECTIVE: The student will be able to properly use an impact tool to loosen screws on bolts

Page 1 of 1 page

COMPETENCE - PROCEDURES/STEPS The student will be able to:	TEACHING/LEARNING ACTIVITIES
---	------------------------------

1. Place the socket or bit onto the bolt or screw to be removed.

NOTE: Select the proper socket or bit to fit the item to be removed.

2. Apply a turning pressure to the handle.

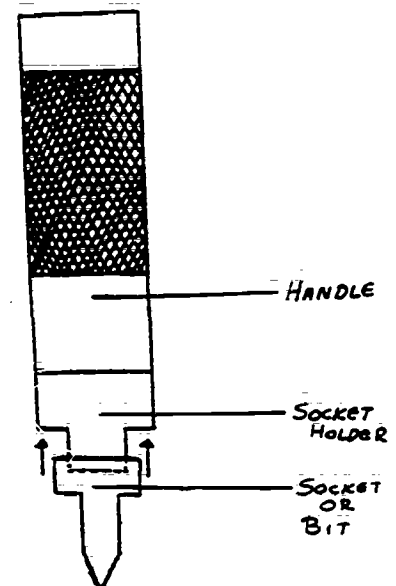

3. Strike the handle using a soft face hammer.

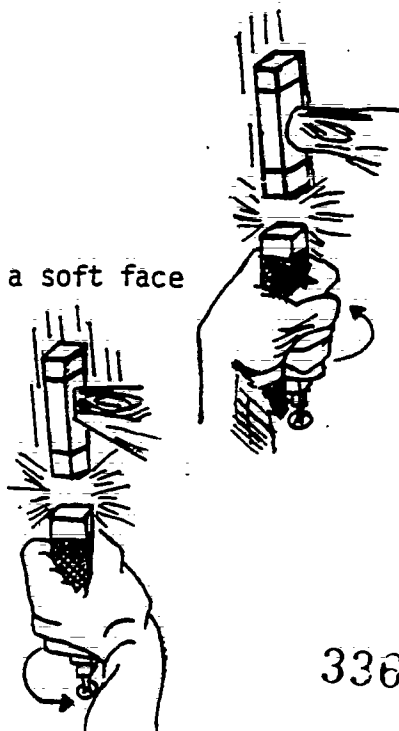



COMPETENCY: Use a Hand Tachometer

COURSE: Appliance Repair

UNIT IV: Laundry Equipment

OBJECTIVE: The student will be able to safely use a hand tachometer and accurately read the meter to check shaft speed

Page 1 of 1 page

---

COMPETENCE - PROCEDURES/STEPS  
The student will be able to:

TEACHING/LEARNING ACTIVITIES

---

1. Grasp the tachometer as shown with fingers around the meter.
2. Place the tip of the tachometer against the spinning shaft of the item to be checked.
3. Take a meter reading.
4. Remove the tachometer tip from the shaft.
5. Repeat the above steps and take a second reading.

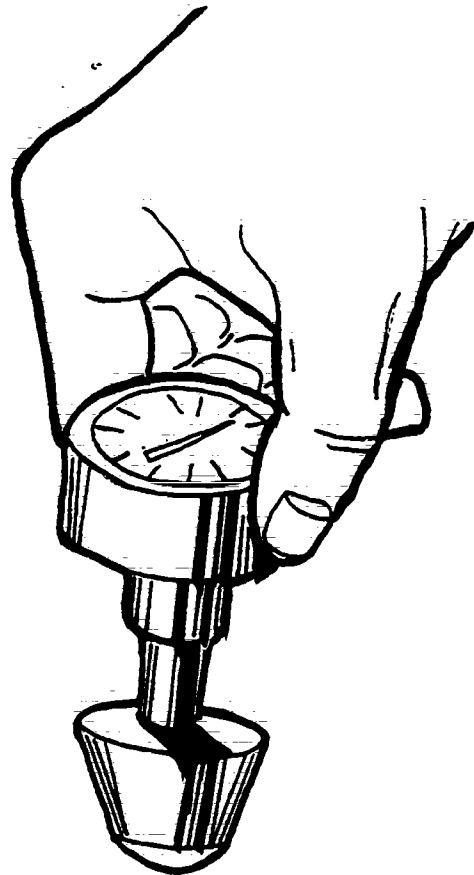

OPERATION SHEET

SC-4-25

COMPETENCY: Install a Water Pressure Gauge Onto a Water Supply Faucet

COURSE: Appliance Repair

UNIT IV: Laundry Equipment

OBJECTIVE: The student will be able to properly install a water pressure gauge

Page 1 of 1 page

---

COMPETENCE - PROCEDURES/STEPS The student will be able to:	TEACHING/LEARNING ACTIVITIES
<ol style="list-style-type: none"><li>1. Check that the gauge needle reads "zero".</li><li>2. Screw the swivel hose fitting onto the faucet.</li></ol>	<p>NOTE: Make sure rubber washer is in the swivel hose fitting.</p>

---

COMPETENCY: Use a Feeler Gauge

COURSE: Appliance Repair

UNIT IV: Laundry Equipment

OBJECTIVE: The student will be able to properly use and read a feeler gauge

Page 1 of 1 page

COMPETENCE - PROCEDURES/STEPS  
The student will be able to:

TEACHING/LEARNING ACTIVITIES

1. Fan out the gauge blades as shown.

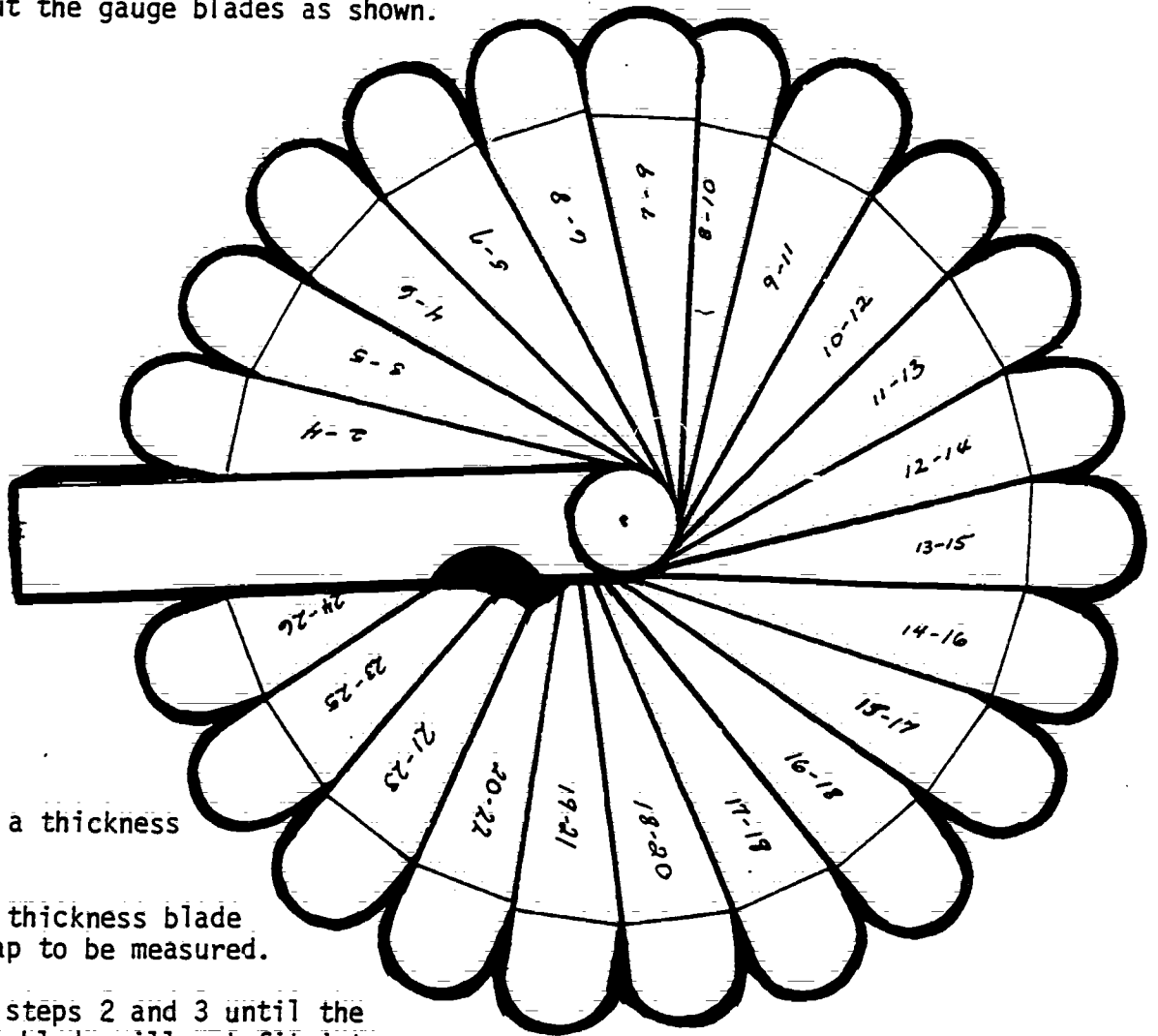

2. Select a thickness blade.
3. Insert thickness blade into gap to be measured.
4. Repeat steps 2 and 3 until the thicker blade will not fit into gap and the next thinner blade fits.

339

OPERATION SHEET

SC-4-27

COMPETENCY: Lubricate Using a Hand Grease Gun

COURSE: Appliance Repair

UNIT IV: Laundry Equipment

OBJECTIVE: The student will be able to install and use a hand grease gun

Page 1 of 1 page

---

COMPETENCE - PROCEDURES/STEPS	TEACHING/LEARNING ACTIVITIES
-------------------------------	------------------------------

---

1. Clean grease fitting.
2. Push grease gun hose fitting onto the grease fitting.
3. Move the grease gun handle up and down until the proper amount of grease has been added.

340

OPERATION SHEET

SC-4-28

COMPETENCY: Set Up and Operate Arbor-Bearing Press

COURSE: Appliance Repair

UNIT IV: Laundry Equipment

OBJECTIVE: The student will be able to safely set up and operate an arbor-bearing press

Page 1 of 1 page

COMPETENCE - PROCEDURES/STEPS	TEACHING/LEARNING ACTIVITIES
The student will be able to:	
1. Turn the worm shaft handle counter-clockwise until there is enough clearance to place the part being worked on underneath.	
2. Place the part on the work bed.	NOTE: Elevate if necessary for bottom clearance.
3. Install the press tool onto the tool holder.	NOTE: Use the proper size press tool to fit the job.
4. Turn the worm shaft clockwise until the press tool meets the job.	
5. Align the press tool with the job.	
6. Continue turning the worm shaft until the pressing operation is finished.	

341

COMPETENCY: Use a Hammer and Chisel

COURSE: Appliance Repair

UNIT IV: Laundry Equipment

OBJECTIVE: The student will be able to use a hammer and chisel to straighten lock tabs

Page 1 of 1 page

---

COMPETENCE - PROCEDURES/STEPS  
The student will be able to:

---

TEACHING/LEARNING ACTIVITIES

---

1. Hold the chisel in left hand.
2. Place the chisel between the lock tab and the nut.

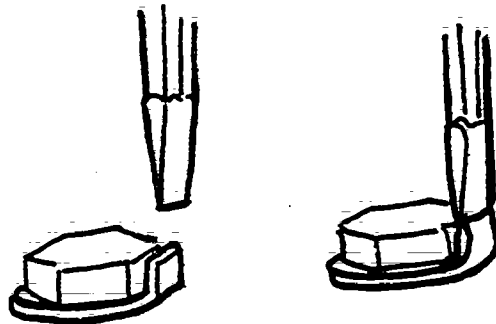

3. Grasp the hammer in right hand.

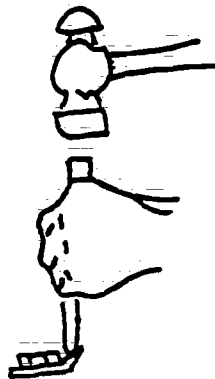

4. Strike the head of the chisel with the hammer.
5. Repeat step 4 until the tab is straightened.



312

OPERATION SHEET

SC-5-1

COMPETENCY: Use a Screw Starter

UNIT V: Kitchen Equipment

COURSE: Appliance Repair

OBJECTIVE: The student will be able to properly use a screw starter

Page 1 of 1 page

COMPETENCE - PROCEDURES/STEPS	TEACHING/LEARNING ACTIVITIES
The student will be able to:	
<ol style="list-style-type: none"><li>1. Rotate the sleeve of the screwstarter to the cocked position, with fingers.</li><li>2. Insert the screwstarter tip into the screw slot.</li></ol>	
<ol style="list-style-type: none"><li>3. Push the screwstarter firmly against the screw.</li></ol>	<p>NOTE: This will engage the screw and the screwstarter.</p>
<ol style="list-style-type: none"><li>4. Turn the screw into the hole in a clockwise direction.</li></ol>	<p>NOTE: After the screw has been partially threaded into the hole, use a screwdriver to complete the tightening operation.</p>
	<p>NOTE: The other end of the screwstarter may have a magnet on it which can be used for picking up screws or small parts.</p>

OPERATION SHEET

SC-5-2

COMPETENCY: Attach a Twin Lamp Tester

COURSE: Appliance Repair

UNIT V: Kitchen Equipment

OBJECTIVE: The student will be able to properly attach a twin lamp tester

Page 1 of 1 page

---

COMPETENCE - PROCEDURES/STEPS

The student will be able to:

TEACHING/LEARNING ACTIVITIES

---

1. Attach the middle alligator clamp to the common terminal.
2. Attach the other two alligator clamps to the 2 other terminals.

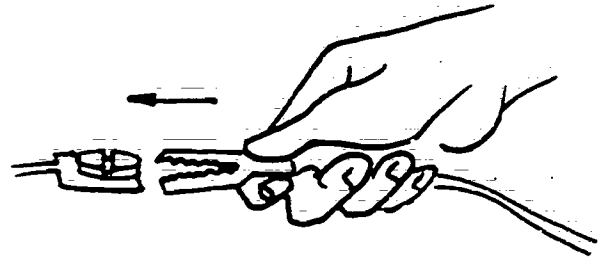

344



COMPETENCY: Apply Paste Type Oven Cleaner

COURSE: Appliance Repair

UNIT V: Kitchen Equipment

OBJECTIVE: The student will be able to safely mix and apply oven cleaning solution

Page 1 of 1 page

COMPETENCE - PROCEDURES/STEPS The student will be able to:	TEACHING/LEARNING ACTIVITIES
1. Read the directions on jar.	SAFETY NOTE: Full face shield and rubber gloves must be worn.
2. Unscrew the jar cap.	
3. Mix the solution.	NOTE: Use the applicator brush or stick.
4. Apply the solution to the walls of the oven.	

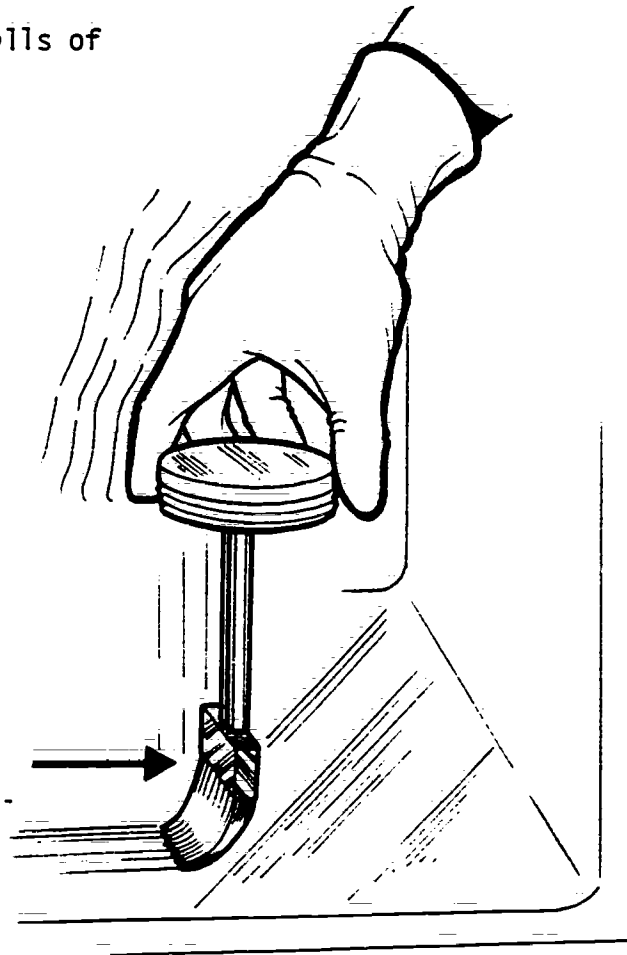

OPERATION SHEET  
SC-5-4

COMPETENCY: Use Brake Spring Pliers to  
Install a Coil Spring

COURSE: Appliance Repair

UNIT V: Kitchen Equipment

OBJECTIVE: The student will be able to use brake spring pliers

Page 1 of 1 page

---

COMPETENCE - PROCEDURES/STEPS	TEACHING/LEARNING ACTIVITIES
-------------------------------	------------------------------

---

- The student will be able to:
1. Place the straight jaw of the spring pliers into the area where the spring will be anchored.
  2. Hook the curved jaw of the spring pliers on to the spring.
  3. Squeeze the handles of the pliers together until the spring can be hooked into the anchor point.

316

COMPETENCY: Tighten or Loosen Fasteners with  
an Offset Screwdriver (Blade or  
Phillips Head)

COURSE: Appliance Repair

UNIT V: Kitchen Equipment

OBJECTIVE: The student will be able to properly use the offset screwdriver  
to loosen and tighten screws or bolts

Page 1 of 1 page

---

COMPETENCE - PROCEDURES/STEPS  
The student will be able to:

---

TEACHING/LEARNING ACTIVITIES

1. Guide blade into position with one hand while holding offset screwdriver with the other.

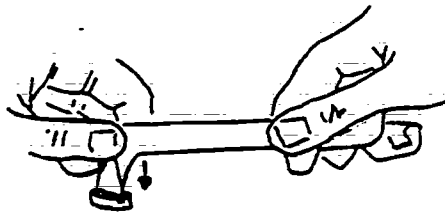

2. Pull or push the offset screwdriver about 1/4 turn while holding in position with the free hand.

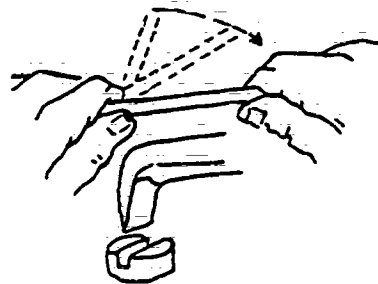

3. Remove driver and turn end for end and repeat another 1/4 turn.

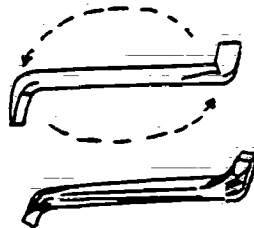

4. Continue this until the fastener is tightened or removed.

317

COMPETENCY: Adjust, Tighten and Remove Fasteners with a Phillips Head Screwdriver

COURSE: Appliance Repair

UNIT V: Kitchen Equipment

OBJECTIVE: The student will be able to remove or replace machine screws with phillips head screwdriver

Page 1 of 1 page

COMPETENCE - PROCEDURES/STEPS The student will be able to:	TEACHING/LEARNING ACTIVITIES
---	------------------------------

1. Place tip of phillips screwdriver into slotted fastener - firmly - squarely.

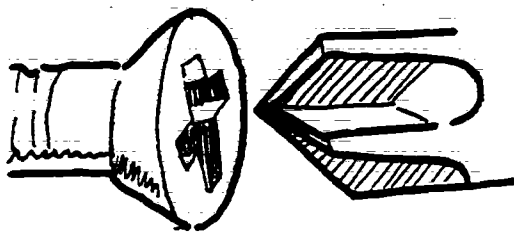

NOTE: Be sure to hold the screwdriver straight; if the tip slips out of the slots, the screw will be damaged and serious injury is possible.

2. Twist phillips screwdriver to the left to remove fastener or to the right to tighten the fastener.

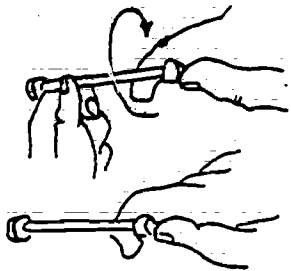

NOTE: Phillips head screwdrivers come in a wide variety of sizes.

3. Continue turning until the fastener is completely tightened or removed.

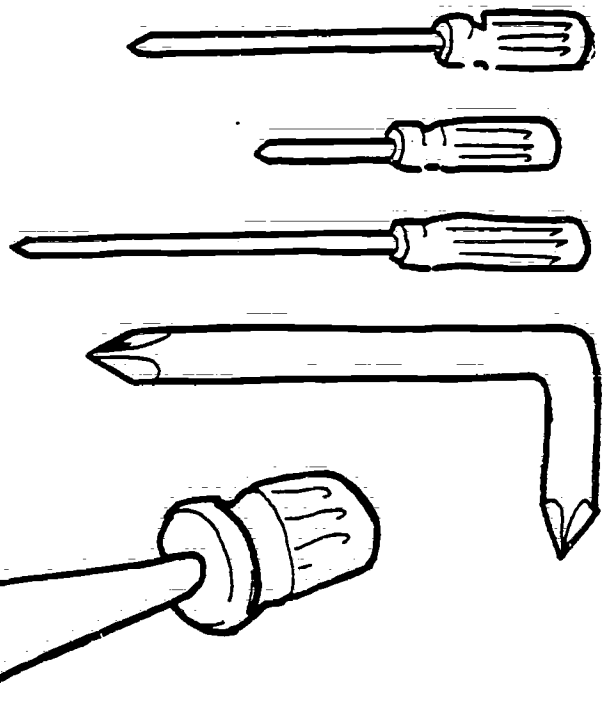

COMPETENCY: Use the Lock Grip Pliers

COURSE: Appliance Repair

UNIT V: Kitchen Equipment

OBJECTIVES: The student will be able to use a lock grip pliers to hold or loosen bolts and nuts

Page 1 of 1 page

COMPETENCE - PROCEDURES/STEPS  
The student will be able to:

TEACHING/LEARNING ACTIVITIES

1. Release the tension with the release lever.
2. Open the jaws by pulling the handles apart.

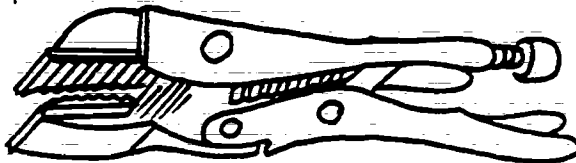

3. Place the jaws over the item to be held and close the handles.

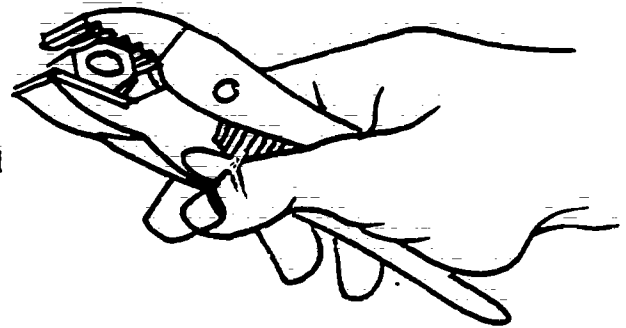

4. Adjust the adjusting screw until the plier locks.

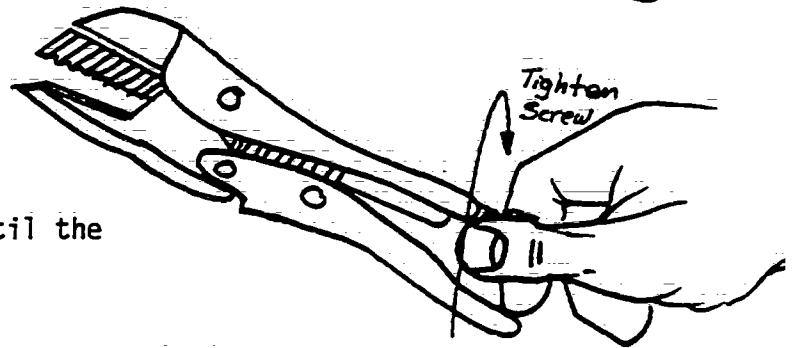

5. Release the release lever and open the jaws.
6. Turn the adjusting screw 1/2 turn clockwise.
7. Place jaws on item to be held, close the jaws and squeeze until the jaws lock.

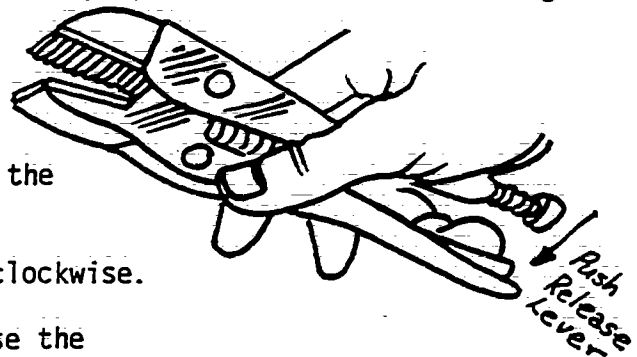

COMPETENCY: Tighten Pipes and Fittings  
With Pipe Wrenches

COURSE: Appliance Repair

UNIT V: Kitchen Equipment

OBJECTIVE: The student will be able to connect and disconnect pipes using pipe wrenches

Page 1 of 1 page

COMPETENCE - PROCEDURES/STEPS  
The student will be able to:

TEACHING/LEARNING ACTIVITIES

1. Place the pipe wrench on the pipe about 2" from the end in a counterclockwise position.
2. Place another pipe wrench on the fitting in a clockwise position.

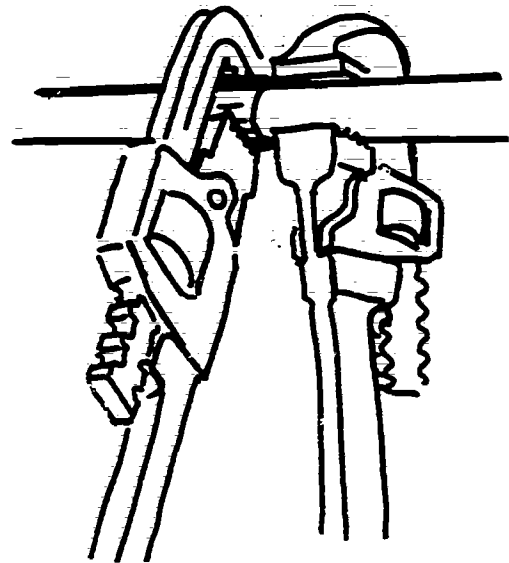

3. Hold the wrench on the pipe steady with one hand.
4. With the other hand, ratchet-on the fitting until it is snug or until it is in line with the connection.

NOTE: Because the threads taper, about one turn is needed to "wrench tighten" a pipe fitting.

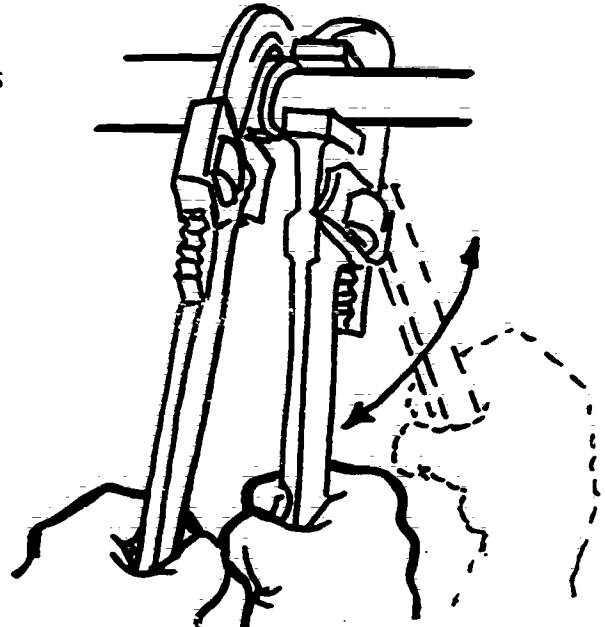

350

COMPETENCY: Light a Soldering Torch

COURSE: Appliance Repair

UNIT V: Kitchen Equipment

OBJECTIVE: The student will be able to light the torch 10 out of 10 times

Page 1 of 2 pages

COMPETENCE - PROCEDURES/STEPS  
The student will be able to:

TEACHING/LEARNING ACTIVITIES

1. Put the head on the torch.
2. Turn the head clockwise until it is hand tight.

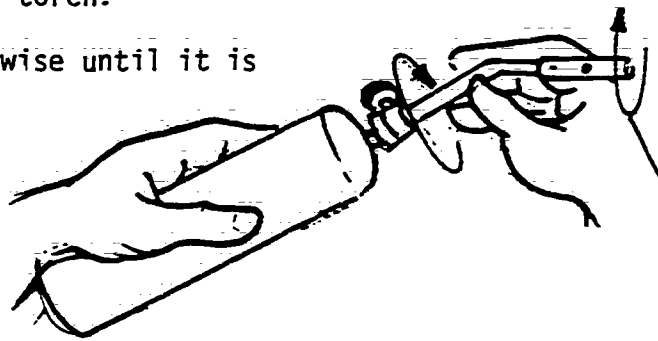

3. Turn the flame adjusting screw about 1/2 turn counterclockwise.

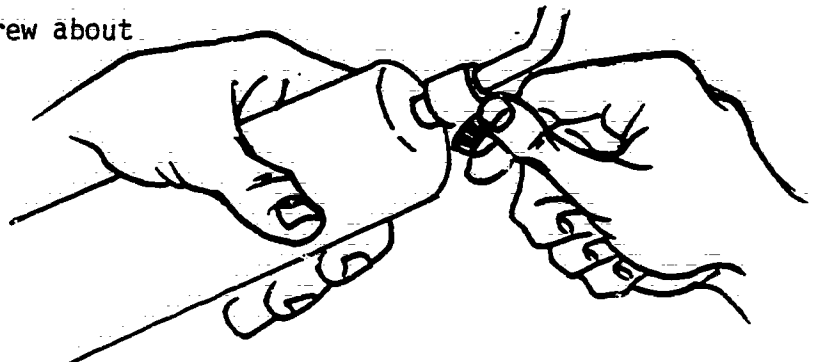

4. Holding striker hood over torch tip, squeeze handle allowing the sparks to light the gas mixture.

CAUTION: Keep fingers away from in front of the torch tip when you are lighting it or after it is lit.

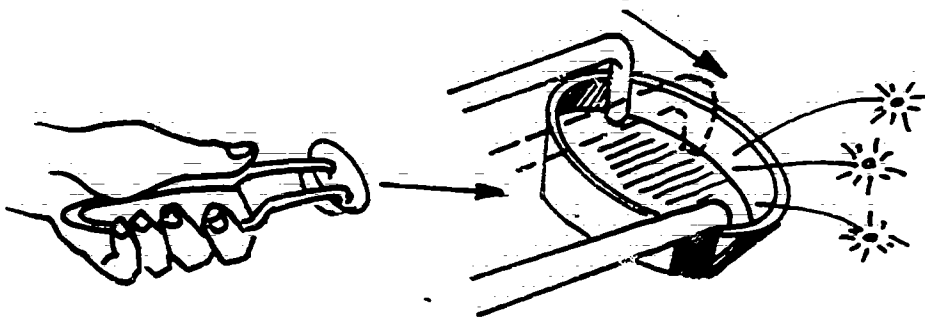

351

---

COMPETENCY - PROCEDURES/STEPS

TEACHING/LEARNING ACTIVITIES

---

5. After the torch is lit, turn the flame adjusting screw in either direction until the desired flame is reached.

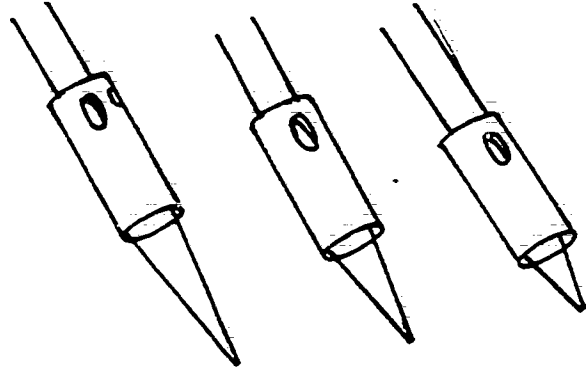

6. To turn the torch off, turn the flame adjusting screw clockwise until it is tight. (The flame will keep burning for about 5 seconds).

CAUTION: The neck of the torch remains hot for a while after the torch is turned off so be careful not to touch it.



COMPETENCY: Use Knock Out Punches

COURSE: Appliance Repair

UNIT V: Kitchen Equipment

OBJECTIVE: The student will be able to cut a hole in metal to proper size

Page 1 of 2 pages

---

COMPETENCE - PROCEDURES/STEPS  
The student will be able to:

TEACHING/LEARNING ACTIVITIES

---

1. Unscrew the knock out punch.

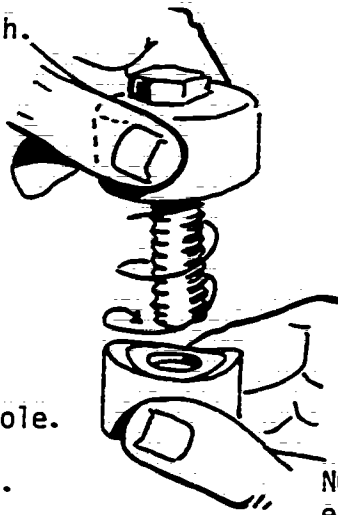

2. Put the bolt through the hole.
3. Screw the bottom cutter on.
4. Tighten it finger tight.

NOTE: Make sure the cutting edge is toward the metal.

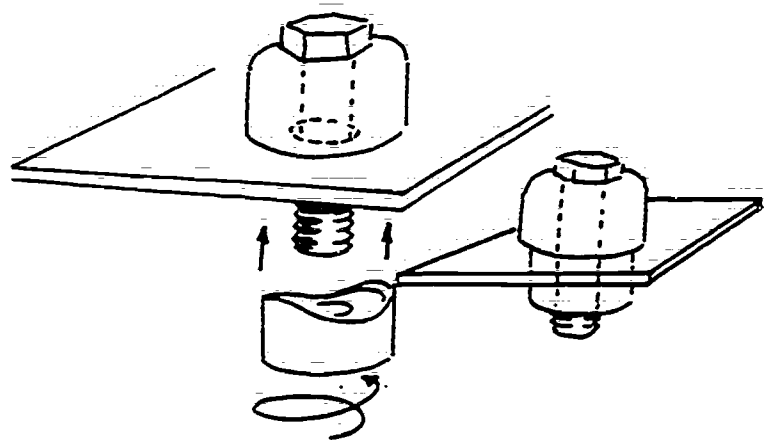
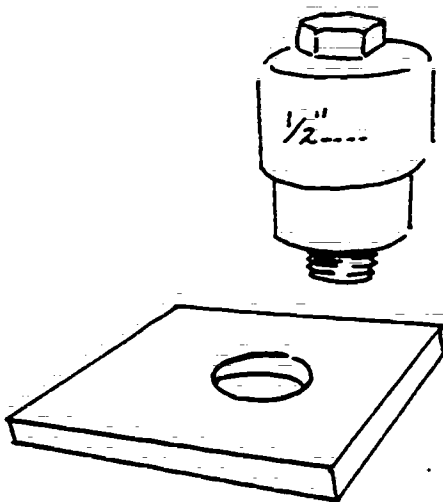

---

COMPETENCE - PROCEDURES/STEPS

---

---

TEACHING/LEARNING ACTIVITIES

---

5. Tighten the bolt with a crescent wrench until two clicks can be heard and felt.

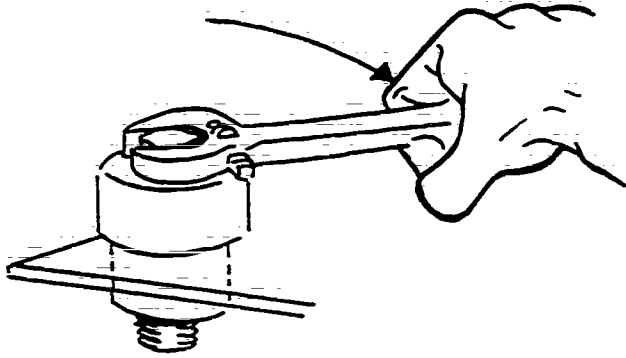

NOTE: The K.O. will lift right out.

NOTE: Remove the metal by removing the bolt and taking apart the punch.

COMPETENCY: Set Up and Light Prestolite Torch

COURSE: Appliance Repair

UNIT VI: Refrigeration

OBJECTIVE: The student will be able to set up a prestolite torch for safe operation

Page 1 of 2 pages

---

COMPETENCE - PROCEDURES/STEPS  
The student will be able to:

TEACHING/LEARNING ACTIVITIES

---

1. Attach regulator to tank.

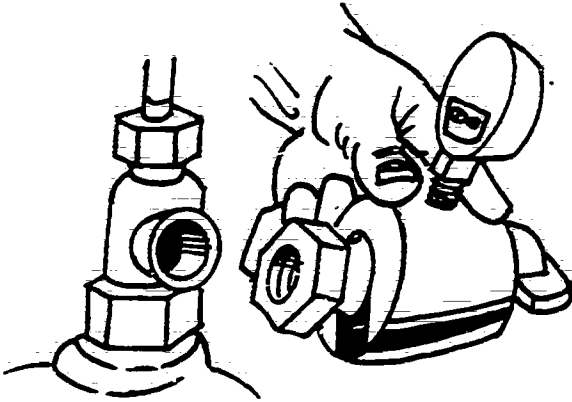

2. Tighten nut with wrench.

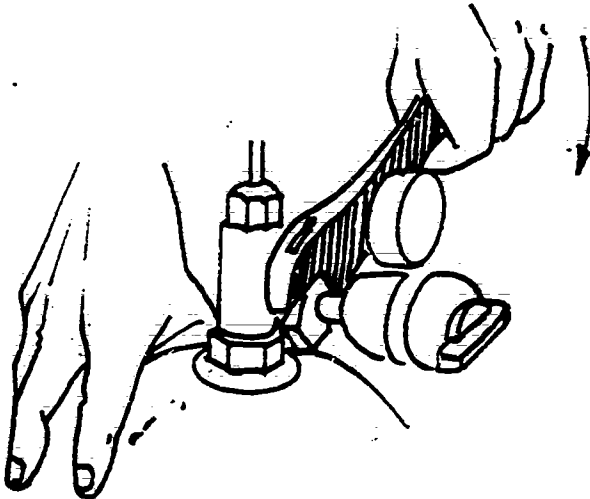

3. Attach hose assembly to regulator and handle.

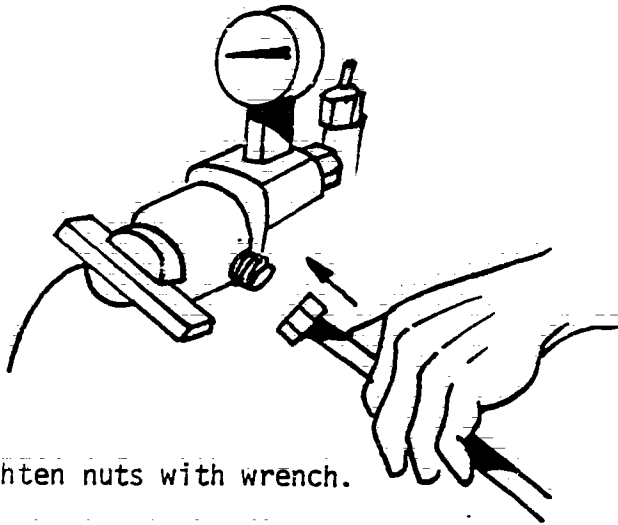

4. Tighten nuts with wrench.
5. Attach stem to handle.
6. Tighten the connection nut with fingers.

350

OPERATION SHEET

SC-6-1

COMPETENCY: Cut and Ream Copper Tubing

COURSE: Appliance Repair

UNIT VI: Refrigeration

OBJECTIVE: The student will be able to neatly cut copper tubing and properly ream edges

Page 1 of 1 page

---

COMPETENCE - PROCEDURES/STEPS The student will be able to:	TEACHING/LEARNING ACTIVITIES
---	------------------------------

---

1. Measure and mark tubing to be cut.
2. Open tubing cutter as required to fit over tubing.
3. Place cutter over tubing with cutter wheel on cutting mark.
4. Close tubing cutter on tubing and rotate cutter completely around tubing.
5. Continue to rotate cutter on tubing and tighten handle about 1/4 turn after each rotation to increase the pressure on the cutting wheel.
6. Continue step 5 until tubing separates.

NOTE: Avoid turning handle too hard and applying too much pressure on the tubing.

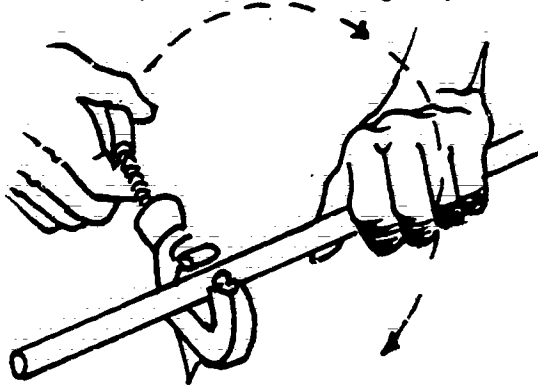

7. Insert reamer blade into newly cut end of tubing.
8. Apply slight pressure while turning reamer in a clockwise direction.
9. Continue step 8 until all burrs are removed.

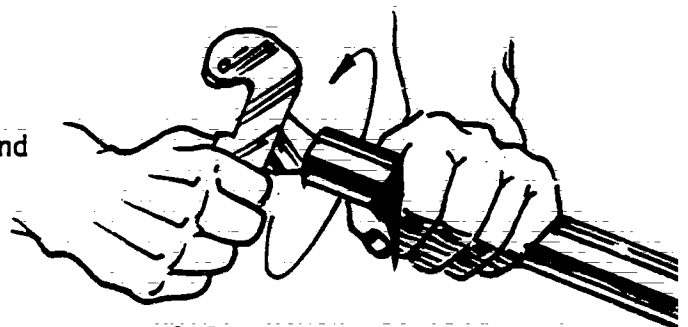

NOTE: Never use fingers to check if burrs are removed.

COMPETENCY: Enlarging a Hole with a Tapered Reamer

COURSE: Appliance Repair

UNIT VI: Refrigeration

OBJECTIVE: The student will be able to enlarge hole to proper size

Page 1 of 1 page

---

COMPETENCE - PROCEDURES/STEPS  
The student will be able to:

TEACHING/LEARNING ACTIVITIES

---

1. Hold reamer "T" handle as shown.

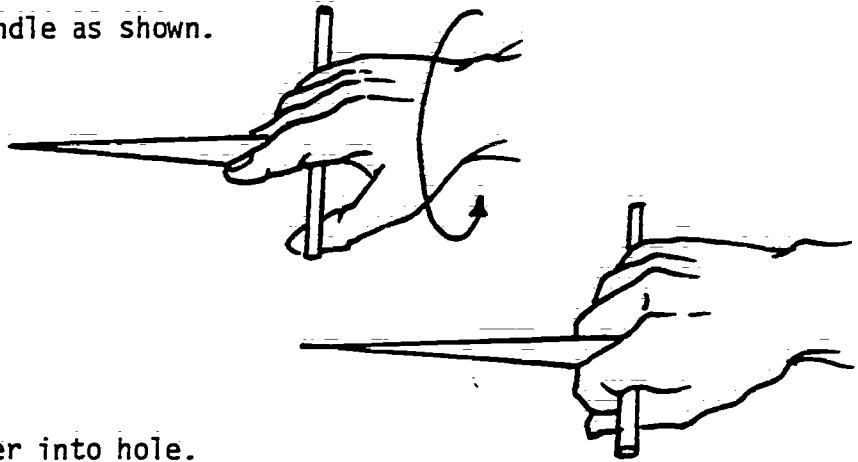

2. Insert end of reamer into hole.

3. Push and turn reamer until hole enlarges to desired size.

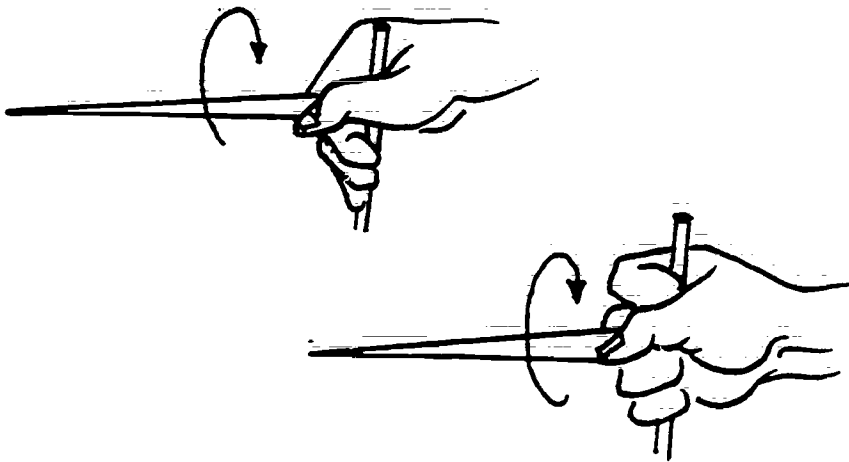

COMPETENCY: Flare Copper Tubing

COURSE: Appliance Repair

UNIT VI: Refrigeration

OBJECTIVE: The student will be able to flare copper tubing to uniform bevel

Page 1 of 2 pages

COMPETENCE - PROCEDURES/STEPS

The student will be able to:

TEACHING/LEARNING ACTIVITIES

1. Loosen the wing nuts and open the flare block.

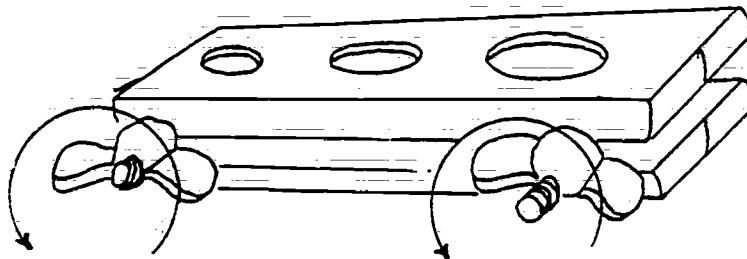

2. Insert the tubing into the proper size hole.

NOTE: Allow enough tubing to protrude through the flare block so that the flare yoke can press it against the taper flange.

3. Place the flare yoke over the flange block.

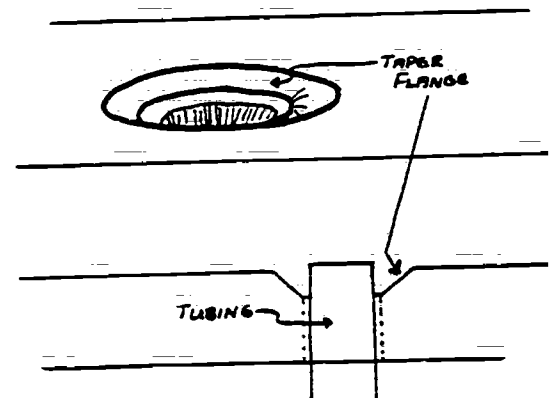
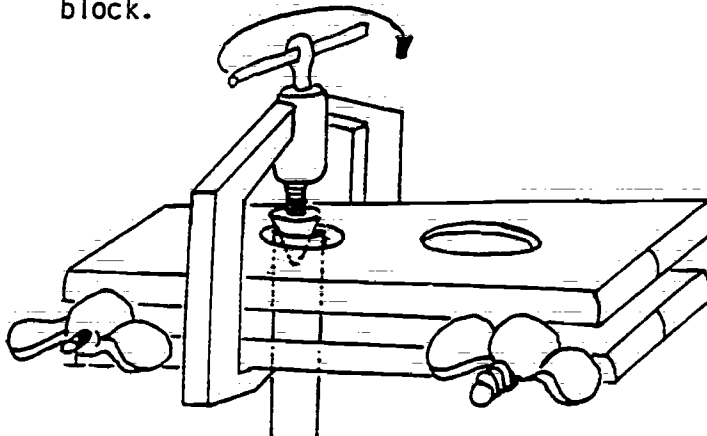

4. Turn the "T" handle of the flare yoke until the cone fits into the center of the tubing.
5. Continue turning the "T" handle until the flare cone has seated.

---

COMPETENCE - PROCEDURES/STEPS

TEACHING/LEARNING ACTIVITIES

---

6. Turn the "T" handle the opposite direction until it can be removed from the flare block.
7. Loosen the wing nuts on the flare block and remove the tubing.

360



COMPETENCY: Tighten Tubing Nut with Tubing Wrench

COURSE: Appliance Repair

UNIT VI: Refrigeration

OBJECTIVE: The student will be able to properly tighten or loosen flare nut with flare nut wrench

Page 1 of 1 page

COMPETENCE - PROCEDURES/STEPS

The student will be able to:

TEACHING/LEARNING ACTIVITIES

1. Select correct size wrench.
2. Place wrench over tubing and move it forward until wrench fits over nut.
3. Tighten by turning clockwise.

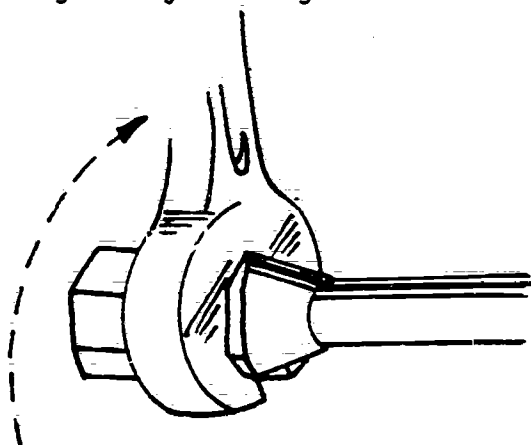
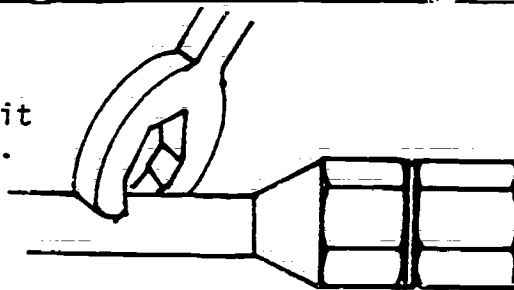

4. Loosen by turning counterclockwise.
5. Remove wrench.

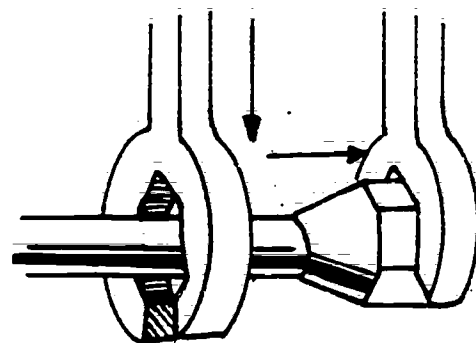

COMPETENCY: Swedge Copper Tubing

COURSE: Plumbing

UNIT VI: Refrigeration

OBJECTIVE: The student will be able to properly swedge 3/16" to 3/8" copper tubing

Page 1 of 2 pages

COMPETENCE - PROCEDURES/STEPS The student will be able to:	TEACHING/LEARNING ACTIVITIES
---	------------------------------

1. Insert one end of the tubing in the proper slot of a flaring tool block with the end extended through the block.
2. Tighten the flaring tool block wing nuts and fasten the block in a vice, or hold in hand.

NOTE: The distance between A & B will govern the length of tubing extending above the block. (See illustration)

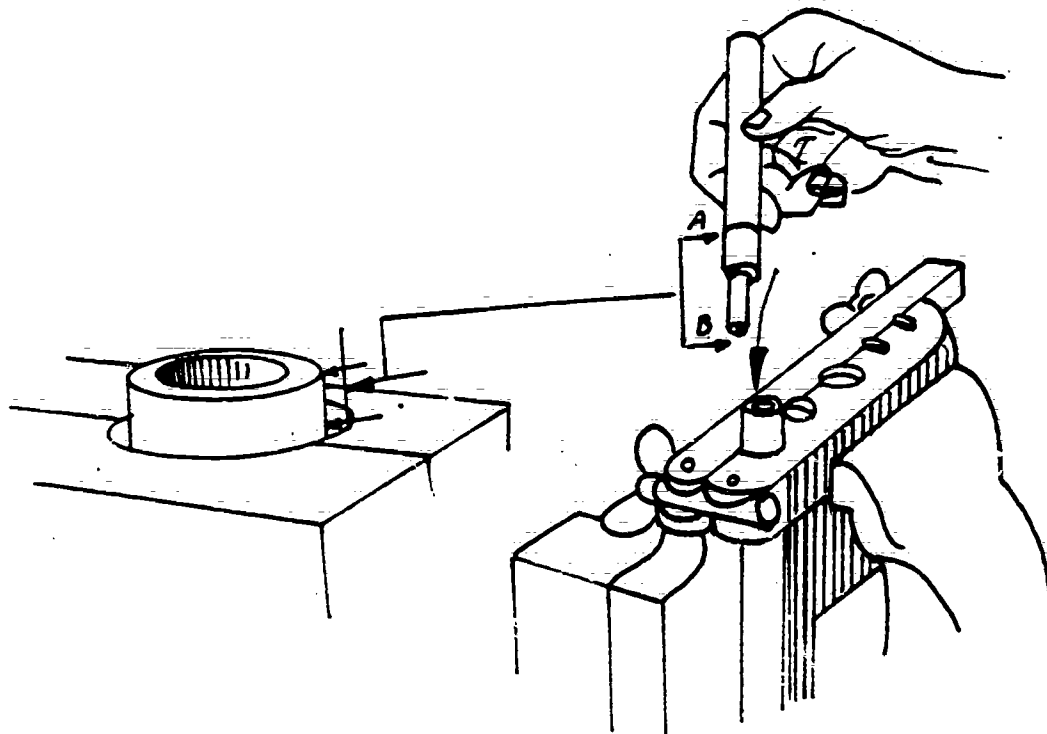

3. Insert the swedging tool in the open end of the extended tubing.

362

COMPETENCE - PROCEDURES/STEPS

TEACHING/LEARNING ACTIVITIES

4. Drive the swedging tool into the tubing using a hammer, until the tubing is expanded to the proper depth.

NOTE: Use a turning motion as shown.

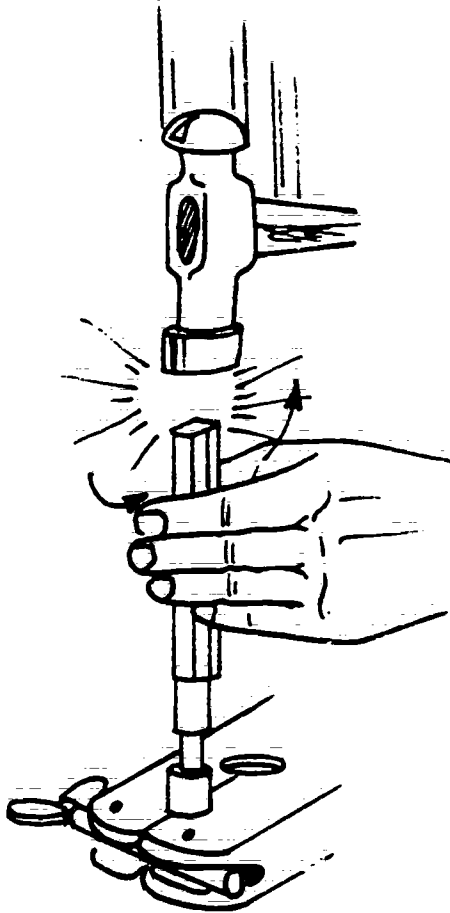

5. Tap the swedging tool lightly while exerting a pulling and twisting force to remove it from the finished joint.

353

COMPETENCY: Clean Outside of Tubing with Sandpaper

COURSE: Appliance Repair

UNIT VI: Refrigeration

OBJECTIVE: The student will be able to prepare tubing for soldering

Page 1 of 1 page

---

COMPETENCE - PROCEDURES/STEPS  
The student will be able to:

---

TEACHING/LEARNING ACTIVITIES

1. Hold strip of sandpaper in both hands.
2. Place strip over end of tubing.

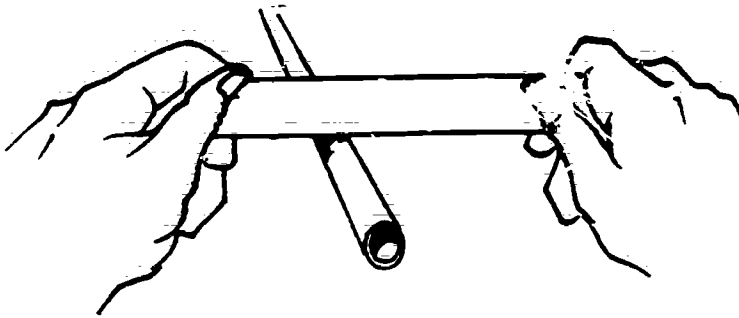

3. Pull strip of sandpaper over tubing until clean as shown.

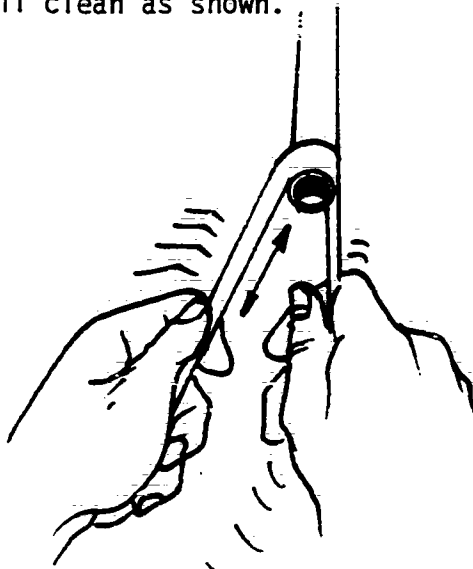

364

COMPETENCY: Clean Inside of Tubing with Wire Brush

COURSE: Appliance Repair

UNIT VI: Refrigeration

OBJECTIVE: The student will be able to clean the inside of tubing in preparation for soldering

Page 1 of 1 page

---

COMPETENCE - PROCEDURES/STEPS  
The student will be able to:

TEACHING/LEARNING ACTIVITIES

---

1. Hold the tubing firmly in one hand.
2. Insert the wire brush into the tubing using a clockwise turning action.
3. Turn the brush at least three complete revolutions.

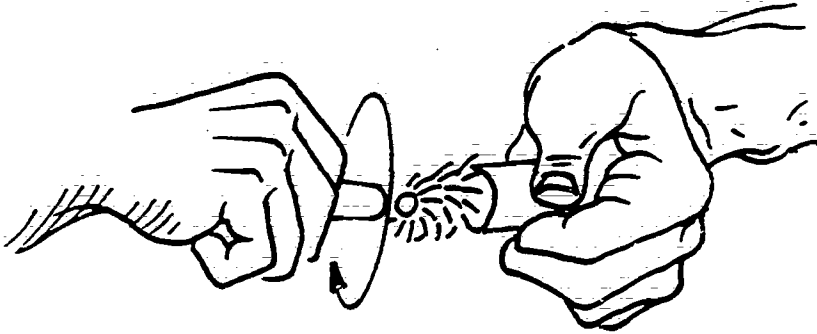

4. Continue turning the brush in a clockwise direction and pull the wire brush out of the tubing.

COMPETENCY: Light and Adjust the Prestolite Torch

COURSE: Appliance Repair

UNIT VI: Refrigeration

OBJECTIVE: The student will be able to properly use the prestolite torch observing all safety rules

Page 1 of 2 pages

COMPETENCE - PROCEDURES/STEPS  
The student will be able to:

TEACHING/LEARNING ACTIVITIES

1. Place the tank key on the tank valve and open the tank so gas can go through the regulator into the hoses.

NOTE: Leave the key on the tank valve.

2. Open the gas valve on the torch handle, approximately 1/4 to 1/2 turn.
3. Use friction lighter and strike in front of the torch tip.
4. As soon as the torch lights, open the valve on the torch handle to full flame.

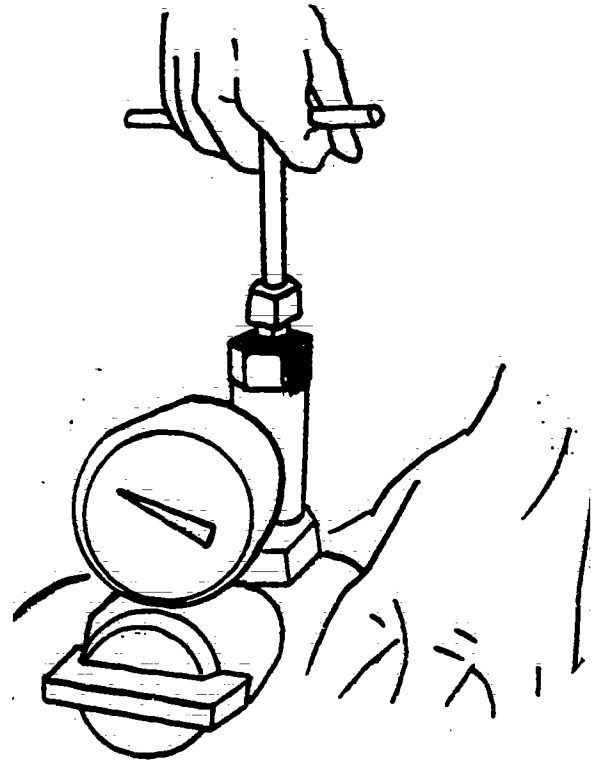

NOTE: When lighting torch be sure to hold the torch tip away from you.

NOTE: If flame is large and maintains a blue-green color tank has proper gas.

CAUTION: Always check hoses, valves and gages for damage or leaks. If any are located close tank, replace faulty piece with new.

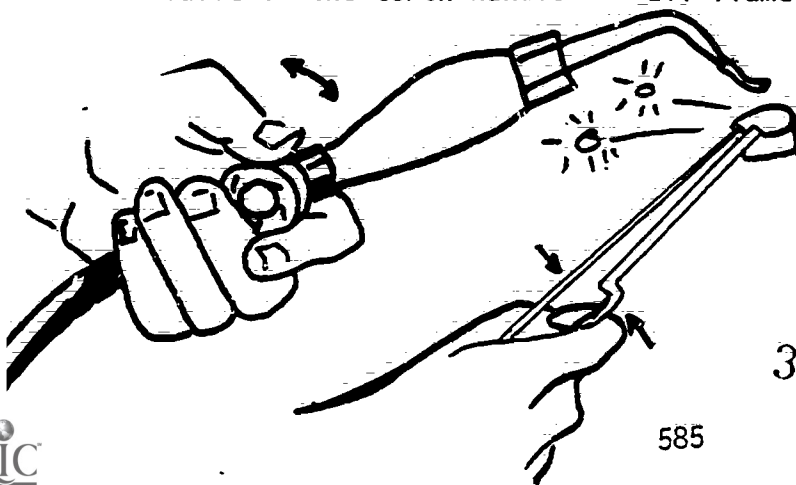

356

585

5. Close regulator valve until the inner flame cone is approximately 1/4" to 1/2".

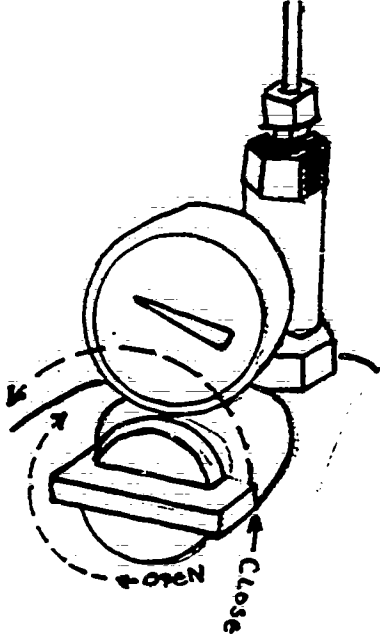

357

COMPETENCY: Silver Solder

COURSE: Appliance Repair

UNIT VI: Refrigeration

OBJECTIVE: The student will be able to safely apply the flame and silver solder tubing

Page 1 of 1 page

---

COMPETENCE - PROCEDURES/STEPS  
The student will be able to:

---

TEACHING/LEARNING ACTIVITIES

1. Apply flux to the outside of the joint.
2. Hold the torch tip as shown so that the blue flame is about 1/4" away from the joint.

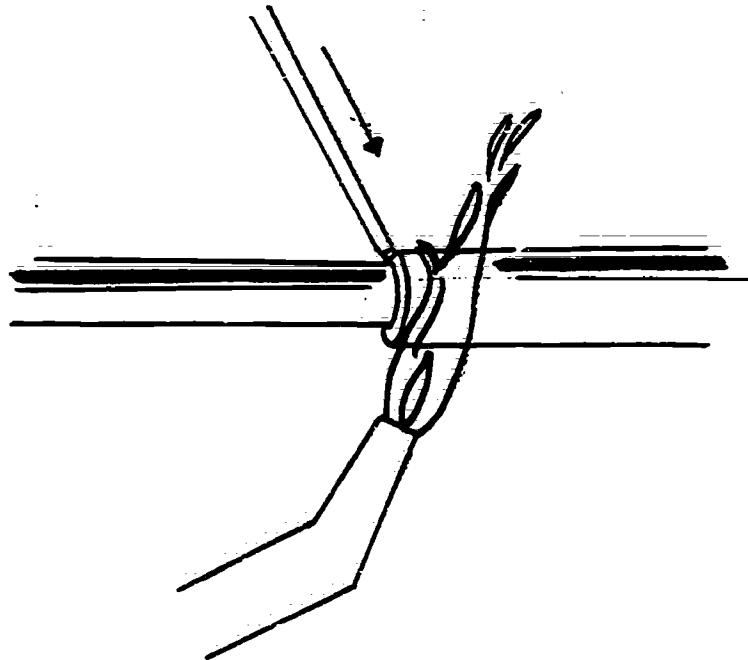

3. Apply the silver solder when the tubing at the joint becomes red and the flux turns clear.
4. Pull the flame and solder away when the silver solder flows around the joint.

NOTE: Always apply the silver solder to the opposite side of the tubing from the torch flame.



COMPETENCY: Bend Copper Tubing with a Bending Spring

COURSE: Appliance Repair

UNIT VI: Refrigeration

OBJECTIVE: The student will be able to properly bend copper tubing using a bending spring

Page 1 of 1 page

COMPETENCE - PROCEDURES/STEPS  
The student will be able to:

TEACHING/LEARNING ACTIVITIES

1. Slide bending spring over tubing to the proper position.

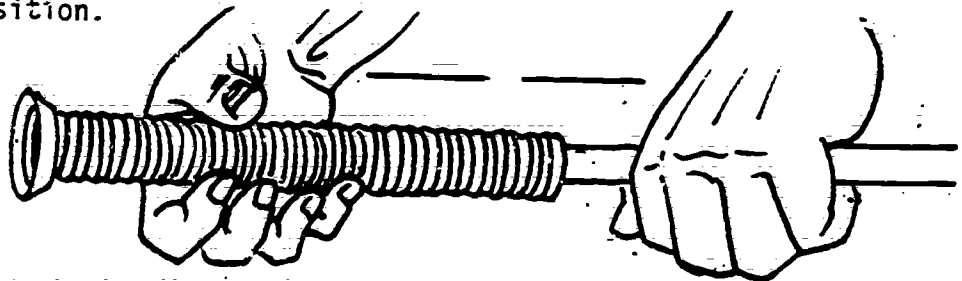

2. Hold one end of the bending spring firmly in one hand, and pull the opposite end toward your body to the approximate angle desired.

NOTE: Since the bending spring is not a precision tool, experience and judgement will greatly help in acquiring accuracy.

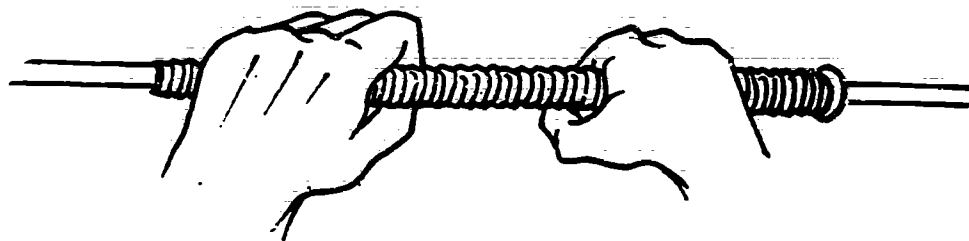

3. Remove the spring with a turn-pulling motion.

NOTE: Check bend for accuracy.

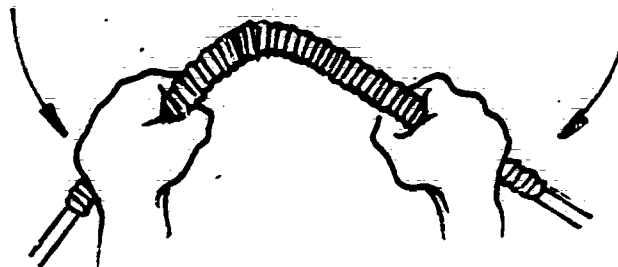

4. Repeat steps until desired offset is made.

COMPETENCY: Solder with 95/5 Solder

COURSE: Appliance Repair

UNIT VI: Refrigeration

OBJECTIVE: The student will be able to solder copper tubing with 95/5 solder

Page 1 of 1 page

COMPETENCE - PROCEDURES/STEPS

The student will be able to:

TEACHING/LEARNING ACTIVITIES

1. Adjust the torch regulator to produce a soft flame.

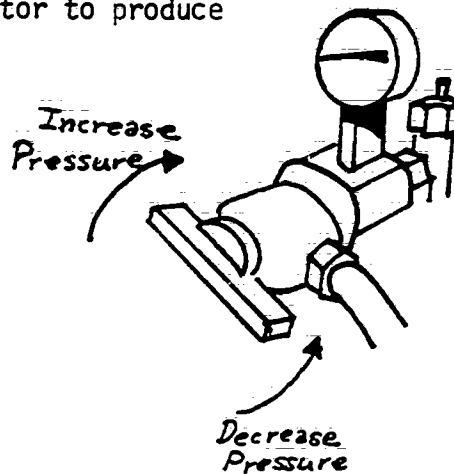

2. Place the flame at the joint so that the flame surrounds the joint.
3. Apply the solder to the joint when the flux starts to bubble.

NOTE: Decrease pressure to produce a soft flame for soft solder. Increase pressure to produce a harsh flame for silver solder.

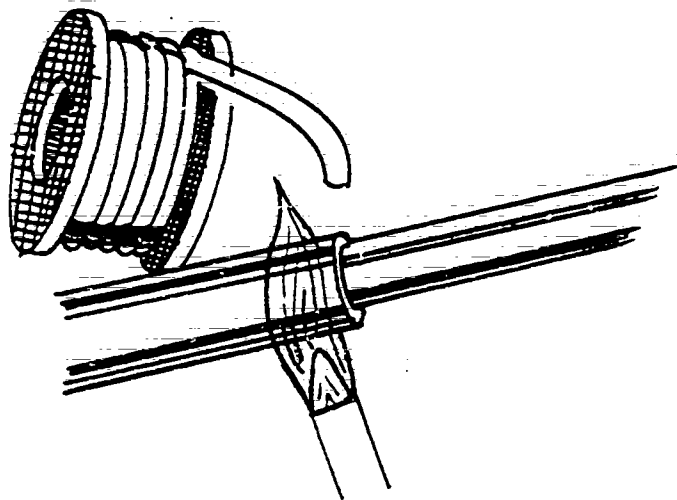

4. Remove the solder and the flame from the joint when the solder has traveled completely around the joint.

370

OPERATION SHEET

SC-6-10

COMPETENCY: Install a Process Adapter

COURSE: Appliance Repair

UNIT VI: Refrigeration

OBJECTIVE: The student will be able to properly install a process adapter

Page 1 of 1 page

---

COMPETENCE - PROCEDURES/STEPS	TEACHING/LEARNING ACTIVITIES
The student will be able to:	

---

1. Slide the rear plate over the tubing.
2. Place one metal washer on the tubing, flat side toward the rear plate.
3. Push the rubber seal on to the tubing.
4. Place the second metal washer on the tubing, flat side toward the end of the tubing.
5. Put the front plate on the tubing.
6. Slide the rear plate toward the front plate.
7. Hold the rear plate and turn the front plate clockwise.
8. Continue turning the front plate until the adapter assembly is tightly clamped onto the tubing.

371

COMPETENCY: Test with Liquid Leak Detector

COURSE: Appliance Repair

UNIT VI: Refrigeration

OBJECTIVE: The student will be able to test for refrigerant leaks safely and efficiently

Page 1 of 1 page

COMPETENCE - PROCEDURES/STEPS	TEACHING/LEARNING ACTIVITIES
The student will be able to:	

1. Mix proper amount of liquid and water and place it in small container.

NOTE: Liquid detergent can be used.



2. Using a brush, apply the liquid to the joint.

NOTE: See that the liquid is brushed the whole way around the joint.

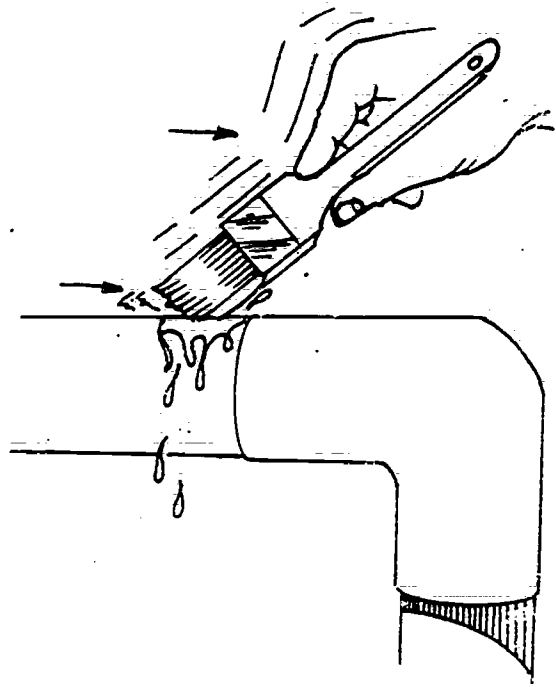

3. Check for leaks by watching the liquid for air bubbles.

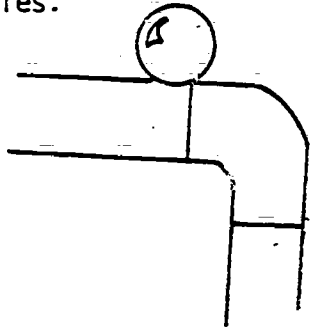

4. Repeat steps 2 through 4 at each joint.

NOTE: Repair or replace any leaking joint or fittings.

372

OPERATION SHEET

SC-6-12

COMPETENCY: Check for Leaks Using a Prestolite Leak Detector

COURSE: Appliance Repair

UNIT VI: Refrigeration

OBJECTIVE: The student will be able to find a leak using a prestolite leak detector

Page 1 of 1 page

---

COMPETENCE - PROCEDURES/STEPS  
The student will be able to:

TEACHING/LEARNING ACTIVITIES

---

1. Attach the leak detector head to the torch handle.
2. Light and adjust the flame.
3. Search for leaks by moving sensor hose along the fittings and joints, noting the color of the flame.

NOTE: Cupping your hand around the tubing or fitting will increase the efficiency of the detector.

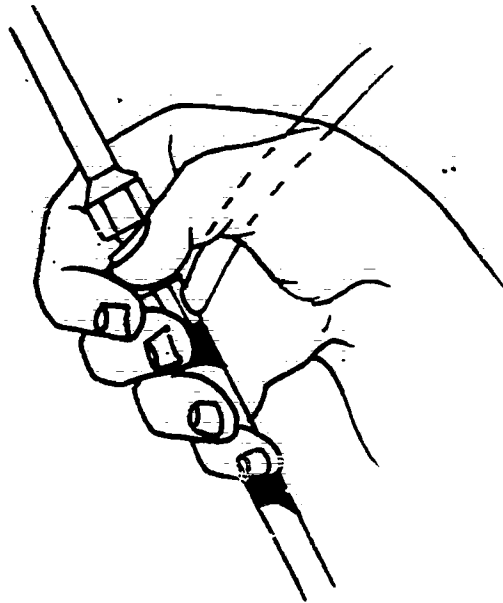

373

COMPETENCY: Seal Process Tubing with a Pinch Off Tool

COURSE: Appliance Repair

UNIT VI: Refrigeration

OBJECTIVE: The student will be able to seal a process tube

Page 1 of 1 page

---

COMPETENCE - PROCEDURES/STEPS  
The student will be able to:

TEACHING/LEARNING ACTIVITIES

---

1. Turn the handle counterclockwise and place the pinch off tool on the tubing.
2. Turn the handle clockwise to pinch the tubing until it seals.

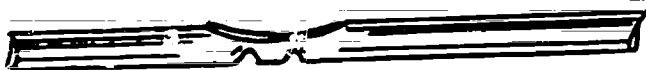
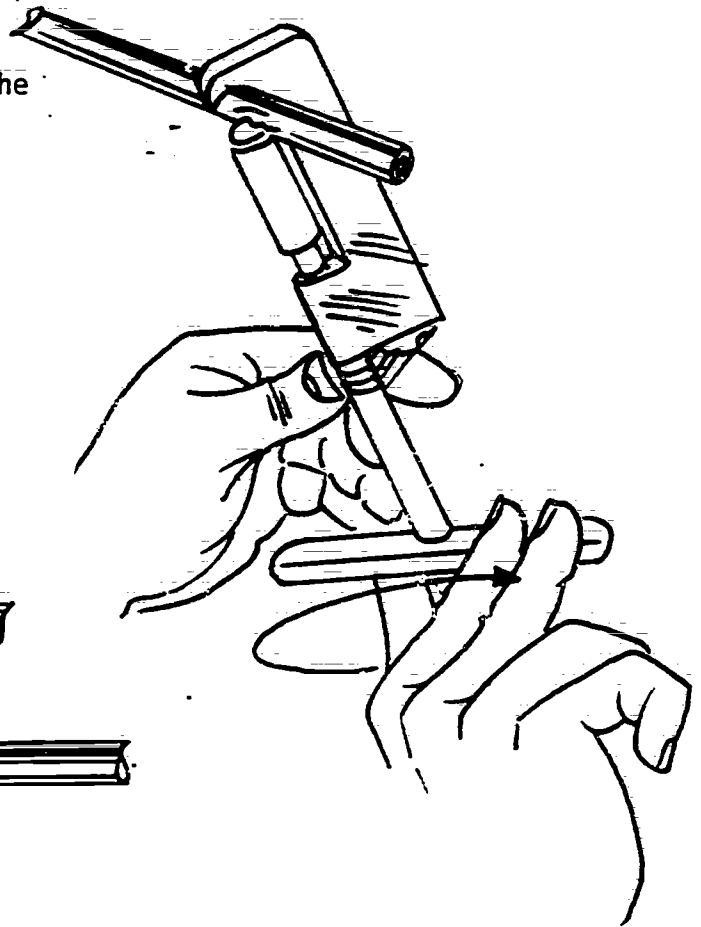

COMPETENCY: Remove Light Switch Using Removing Tool

COURSE: Appliance Repair

UNIT VI: Refrigeration

OBJECTIVE: The student will be able to remove a light switch using a switch removal tool

Page 1 of 1 page

---

COMPETENCE - PROCEDURES/STEPS  
The student will be able to:

TEACHING/LEARNING ACTIVITIES

---

1. Locate the door switch.
2. Press the blade ends under the switch collar.

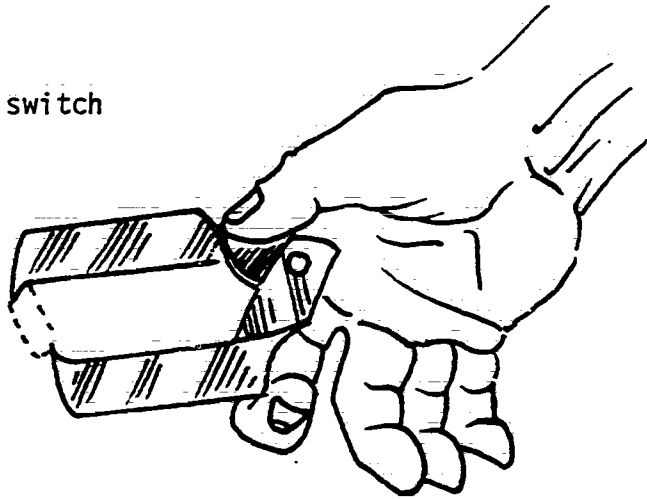

3. Squeeze the blades together and pull the switch out.

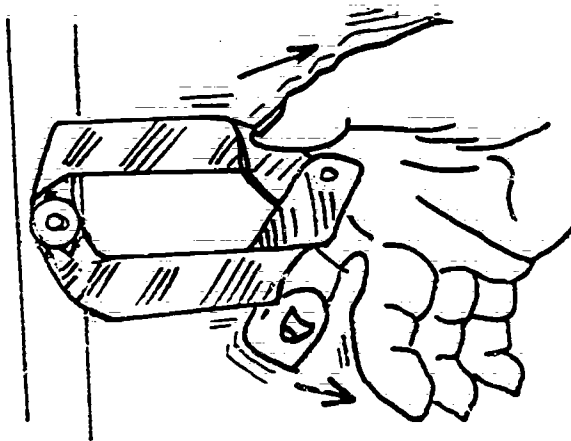

375

601

COMPETENCY: Attach a Fish Wire to a Capillary Tube

COURSE: Appliance Repair

UNIT VI: Refrigeration

OBJECTIVE: The student will be able to attach a fish wire to a capillary tube without damage to it

Page 1 of 1 page

COMPETENCE - PROCEDURES/STEPS	TEACHING/LEARNING ACTIVITIES
The student will be able to:	

1. Skin about 5" of insulation off a length of #14 or #12 stranded wire.
2. Wrap the wire around the capillary tube in a spiral, leaving a gap between the turns.

NOTE: Wrap at least 3 turns, then reverse the spiral and fill in the gaps back to the start.

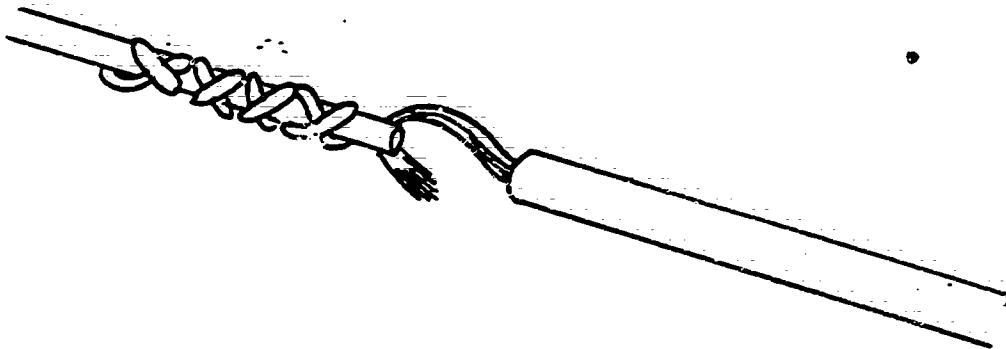

3. Tape the connection.

NOTE: Extend the tape beyond the spiral connection area (at least 2").

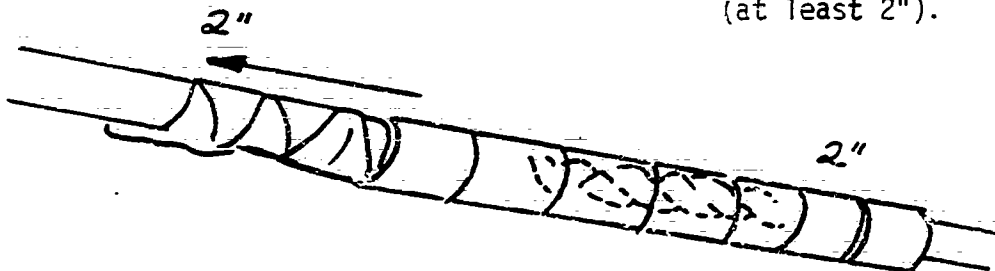



OPERATION SHEET

SC-6-16

COMPETENCY: Straighten Fin on an Air Conditioner Condenser or Evaporator

COURSE: Appliance Repair

UNIT VI: Refrigeration

OBJECTIVE: The student will be able to straighten a condenser or evaporator or an air conditioner

Page 1 of 1 page

---

COMPETENCE - PROCEDURES/STEPS  
The student will be able to:

TEACHING/LEARNING ACTIVITIES

---

1. Select the proper fin spacing to fit the tool.
2. Insert the tool.
3. Work up or down along the damaged area using a rocking action as shown.

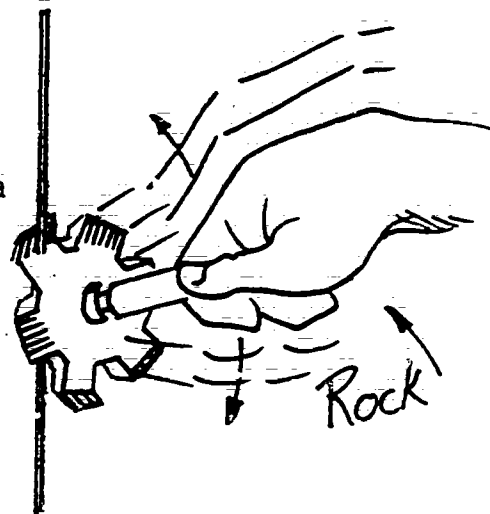

377

### INFORMATION SHEETS

INFORMATION SHEETS supplement the job sheets and provide the student with information necessary for completing the assigned jobs with the highest possible degree of understanding. The following (pink) sheets are the information sheets that will be used to supplement the job sheets, where necessary. Additional information will have to be written as needed to fit the local needs.

378

TITLE: Solder Gun Maintenance

Page 1 of 1 page

COURSE: Appliance Repair

UNIT II: Basic Electricity

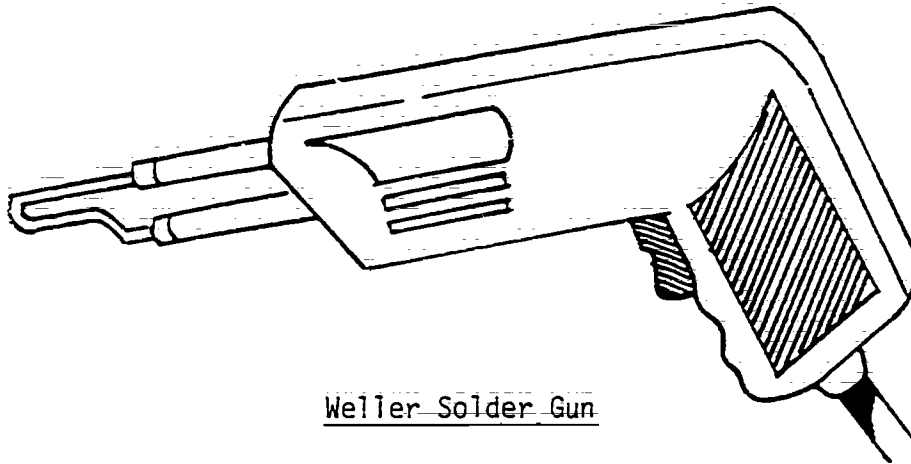

Weller Solder Gun

The solder gun tip must be clean to do a proper solder job. To clean the tip:

1. Heat the tip and dip it into solder flux.
  2. Wipe the dirt off with a clean rag.
  3. If the tip is very corroded use a file to clean it.
- NOTE: The nuts must be tight for proper heating.

When the tip cannot be cleaned or if the tip is broken follow these steps for replacement:

1. Remove the nuts holding the tip in place.
2. The tip can now be removed from the gun.
3. Straighten the tip ends to remove the nuts.
4. Slide the nuts over the new tip ends.
5. Bend the new tip ends to fit into the gun.
6. Start the nuts into the gun. Be careful not to cross thread the nuts.
7. Tighten the nuts.
8. Heat the gun and dip the tip into solder flux.  
NOTE: Only 1/2" of the tip is to be dipped.
9. Apply solder to the tip.
10. Wipe the excess solder off with a clean rag.

TITLE: Series Circuits

Page 1 of 1 page

COURSE: Appliance Repair

UNIT II: Basic Electricity

The first circuit we will discuss will be the series circuit. If you remember the old series string Christmas tree lights, you will recall that when one light burned out, all the lights went off. This is typical of a series circuit.

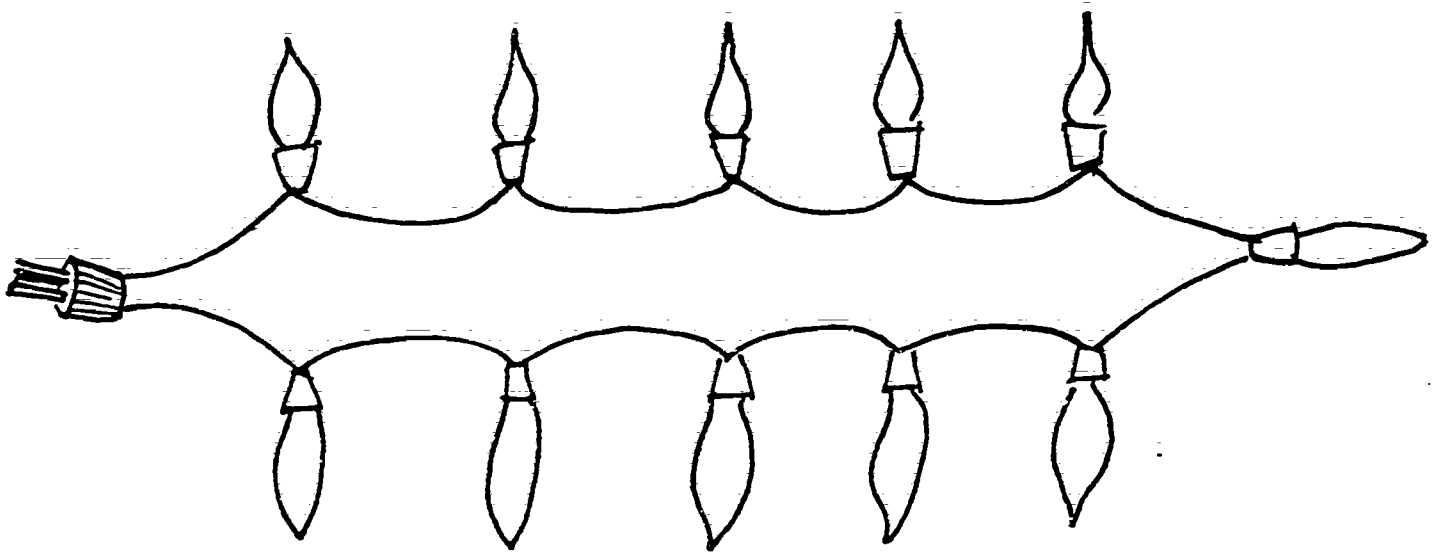

have built a series circuit using the "Series Circuit Job Sheet". Now you are able to see how a series circuit works and why it is a valuable circuit for control wiring of electrical appliances.

This circuit is used when two or more controls are needed to control one component.

NOTE: Leave all fixtures on the board, but remove all wiring. You will need the fixtures and board for J-2-12 and J-2-13.

TITLE: Parallel Circuits

Page 1 of 1 page

COURSE: Appliance Repair

UNIT II: Basic Electricity

The word parallel means equal to or side by side. Picture two roads running along side each other, going on and on but never joining.

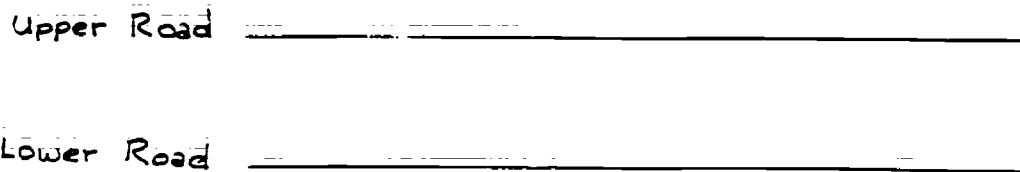

Now put small connecting roads between the two roads as places to go from the upper road to the lower road.

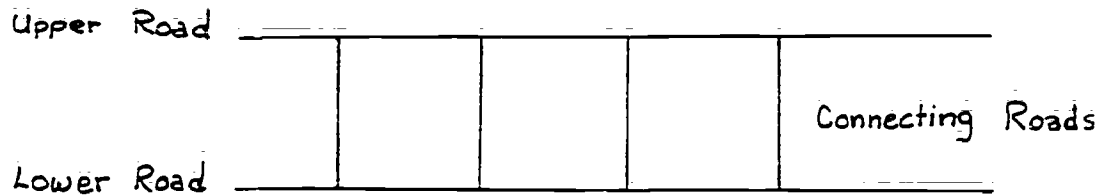

We can see that if we remove any of these connecting roads, it does not break the main path of travel.

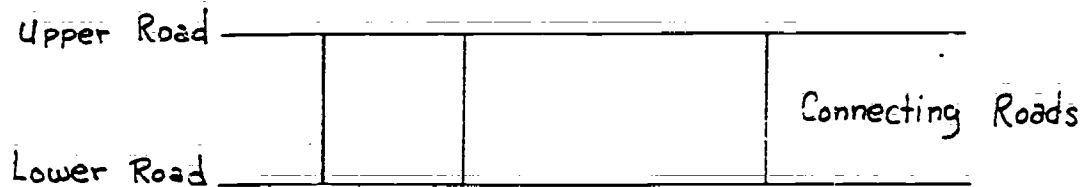

The same is true in a parallel circuit. If any of the lamps that are connected across the main wires should burn out, it would not cause the other lamps to go out.

TITLE: Series-Parallel Circuits

Page 1 of 1 page

COURSE: Appliance Repair

UNIT II: Basic Electricity

This circuit is a combination of a series circuit and a parallel circuit. A series-parallel circuit can be used in many appliances on control and safety circuits. The series-parallel circuit can be used for any number of control and component operations.

Series-Parallel Schematic

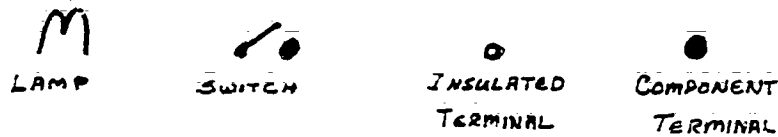
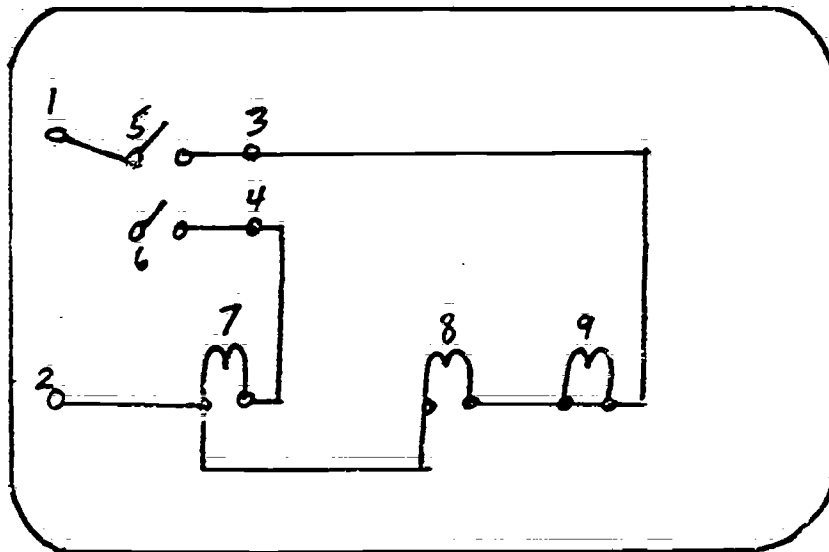

TITLE: Volt-Ohm Meter  
COURSE: Appliance Repair

Page 1 of 2 pages

UNIT II: Basic Electricity

The volt-ohm meter is a multi-purpose testing instrument. It measures the pressure, in volts, of a power source, both AC and DC. It also measures the resistance, in ohms, of a circuit.

The meter has two control knobs. One is a scale selector switch that allows the user to select the proper setting to get an accurate reading. The other is used to zero ohm adjust the meter. When voltage is measured with the volt-ohm meter, the voltage in the circuit moves the meter needle.

When measuring the resistance of a circuit, the circuit must be disconnected from the power source.

The volt-ohm meter has a battery to supply voltage to the test leads. The current flow moves the meter needle. When the test leads are attached to the circuit, voltage is applied to that circuit. If there is no resistance in the circuit, the needle moves to the right, or the zero end, of the meter. If there is resistance in the circuit, the meter needle will not move as far to the right. Therefore, as the resistance in a circuit decreases, the meter needle moves farther toward the zero.

When reading the resistance of a circuit, the selector switch should be set so that the needle is to the right of center of the meter. This is because the meter is easier to read on the right end of the scale.

Whenever the selector switch is moved to a different ohm scale, the meter needle must be adjusted. This operation is termed "zero adjust the meter".



TITLE: Using the Volt-Ohm Meter to  
Check Voltage to a Component

Page 1 of 1 page

COURSE: Appliance Repair

UNIT 11: Basic Electronics

### Conclusions

1. When the test leads were attached to the line and load side of lamp #7 socket with the lamp removed, there was a voltage reading. This means there was voltage to the lamp socket.
2. When the lamp was installed, it lighted up. There was a voltage reading. This means that if voltage is applied to a component socket with or without the component inserted, there will be a voltage reading.
3. However, when the test leads were attached across the line and load sides of switch #5, there was a voltage reading with the switch in the OFF position and there was no voltage reading when the switch was in the ON position.

Volts are very lazy and will follow the path of least resistance. Therefore, when the switch was off, the voltage will have one path to follow and that was through the meter. When the switch was on, the switch contacts offered less resistance than the meter so the voltage went through the switch.

4. This testing series should point out that a control component, such as a switch, can be checked with a volt-ohm meter to see if it is good or bad. If the control component is good, there will be no voltage reading across the line and load terminals. If the control component is bad, there will be a voltage reading.
5. This test will be accurate and can be used to check fuses, switches, thermostats and also to check for a broken wire in a circuit. This is done by attaching the test lead across the component. One test lead to the line side and the other lead to the load side.

TITLE: Using the Volt-ohm Meter to  
Check Continuity of a Component  
or Circuit

Page 1 of 1 page

COURSE: Appliance Repair

UNIT II: Basic Electricity

Conclusions

1. The volt-ohm meter can check a component or circuit without voltage being supplied.
2. Continuity in a circuit means there is no break in the circuit and current can flow.
3. Continuity in a component means the component is good and can control the current flow.
4. No continuity in a circuit means there is a break in the circuit and current cannot flow. The reading on the meter will be at infinity. The symbol  $\infty$  on the left side of the meter means infinity.

TITLE: Clamp-On Amp-Meter

Page 1 of 2 pages

COURSE: Appliance Repair

UNIT II: Basic Electricity

The clamp-on type meter is used to measure the current ampere flow through a circuit. It can be used to check total or partial loads in a home or industrial circuit. The main use of the amp-meter is to check for overloaded conductors. It can also be used to check the amperage of individual appliances.

The meter of the amp-meter is driven by the magnetic force field around the wire. As more current flows through the wire, the magnetic force field becomes stronger.

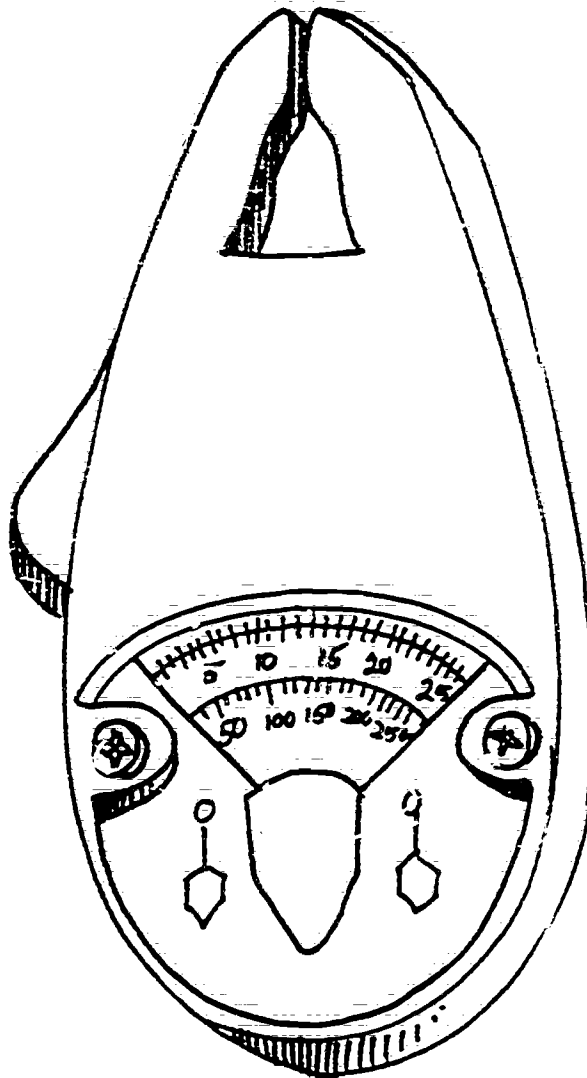

A clamp-meter is designed to clamp around a single wire. It may have a selector switch which lets the user vary the scale and make the meter easier to read. The selector switch should always be set to the highest scale. The user should then turn the selector switch until the meter pointer reads near mid-scale.

Some clamp-on amp-meters have an adapter which enables the amp-meter to measure the current flow through a covered two-wire cord. The adapter is designed to plug into a receptacle. The adapter cord plugs into the receptacle contained in the adapter. The clamp-on amp-meter clamps around the loop hole in the adapter. The amp-meter is operated the same way if it is clamped around a single wire or through the loop hole in the adapter. Some models can also be used as a voltmeter. A two wire adapter plugs into the side of the meter case. The other end of the adapter has test probes. The test probes can then be used to take voltage readings.

TITLE: Clamp-On Amp-Meter  
(Conclusions)

Page 1 of 1 page

COURSE: Appliance Repair

UNIT II: Basic Electricity

1. There was no current flow with the circuit switch in the OFF position.
2. Notice that the current flow increased when one cone type heating element was installed.
3. Notice that the circuit with one cone type heating element should be protected with a 10 to 15 amp fuse. A circuit with ~~two~~ lamps could be fused with as low as 2 to 5 amp fuses.
4. Notice that when two cone type heating elements were installed, the current flow was too high in amperes. It should be fused at 10 to 15 amps.
5. Notice that by using an amp-meter to check the current flow in a circuit, the following can be determined:
  - a. If the circuit is fused properly in relation to the current flow.
  - b. If the current flow is too high in relation to the elements used in the circuit.
  - c. The amount of current flow through part of a circuit.
  - d. The amount of current flow through the whole circuit.

TITLE Volt-Watt Meter  
COURSE Appliance Repair

Page 1 of 2 pages

UNIT II: Basic Electricity

This testing instrument is designed to check the voltage supply to the appliance and the wattage used by the appliance. Most testers have two meters. One measures the voltage, and one measures the wattage.

The volt-meter can measure either 130 volts or 260 volts. A switch is used to set up the volt-meter scale. This is a two position switch. It can be set either to the 130 volt or 260 volt position. A power cord supplies voltage to the tester. The appliance power cord plugs into a receptacle mounted on the tester.

The watt-meter is connected to this receptacle. When the appliance is in operation, the watt-meter measures the wattage used by the appliance. A selector switch is used to set the various wattage scale readings.

With this tester, the user can read both the voltage and the wattage at the same time. Most testers have adapter leads to use when checking a 250 volt appliance.

GENERAL OPERATING INFORMATION

1. Turn the voltage switch to the proper position (110 volt or 250 volt).
2. Plug in the tester power cord. The volt-meter should show a reading.
3. Turn the wattage selector switch to the highest scale (0-5000).
4. Plug the appliance power cord into the tester receptacle.
5. Start the appliance. The volt and watt-meter should show a reading.

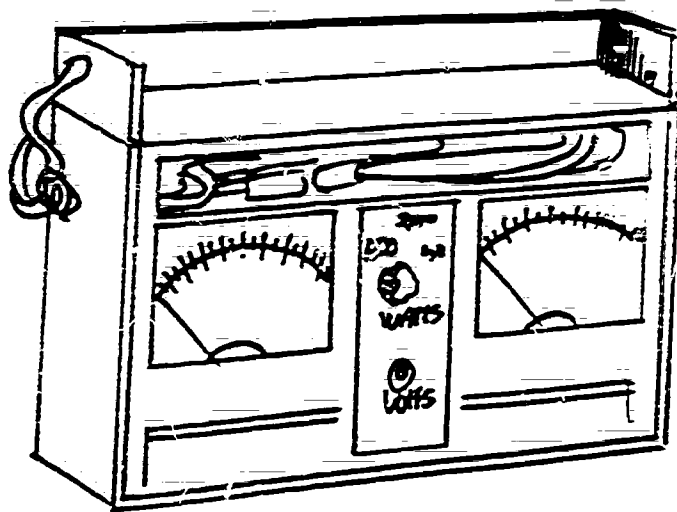

321

7

TITLE: Volt-Watt Meter (Conclusions)

Page 1 of 1 page

COURSE: Appliance Repair

UNIT II: Basic Electricity

1. The volt-meter and the watt-meter work independently.
2. The volt-meter operates as soon as the tester is plugged into a receptacle.
3. The watt-meter operates only when current flows through a circuit or an appliance is attached to the tester.
4. If the wattage of a circuit is not known, always set the selector switch to the highest scale. Then turn the selector to a lower scale until the meter is easily read.
5. If the voltage of a circuit is not known, always turn the voltage switch to the 220 volt position. When the voltage is known, turn the switch to the proper position.
6. When the wattage increased in the circuit, it did not affect the voltage.
7. To find the amperage of the circuit when using the volt-watt meter, the wattage is divided by the voltage.



TITLE: Using a Growler

Page 1 of 3 pages

COURSE: Appliance Repair

UNIT III: Basic Shop Tools

GROUNDING CIRCUIT TEST

Plug the armature cord into an AC outlet, place the armature between the growler jaws, and set the selector switch in the GRD or the Continuity position (depending on the brand of growler used.)

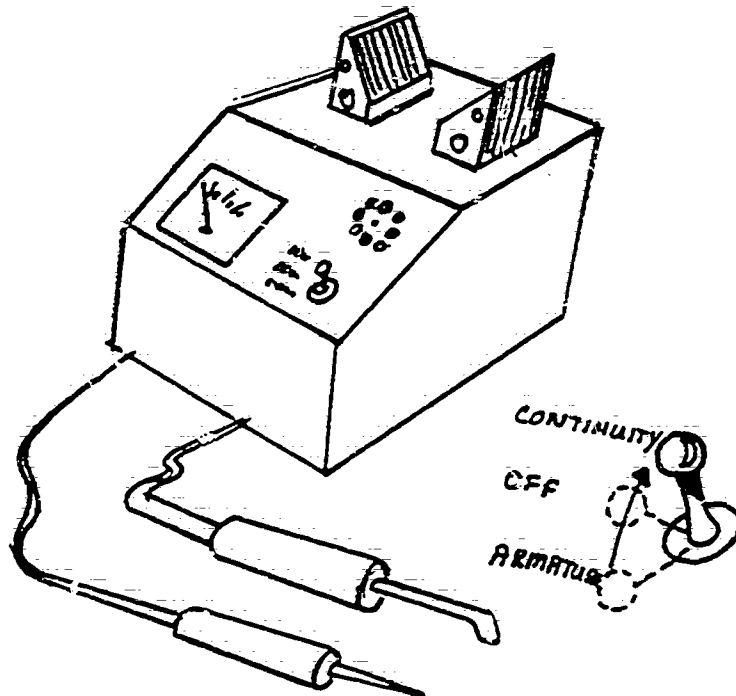

Hold the test prod on any commutator bar and the other prod on the armature poles.

NOTE: If the light flashes, the commutator or the windings are grounded. Replace the armature.

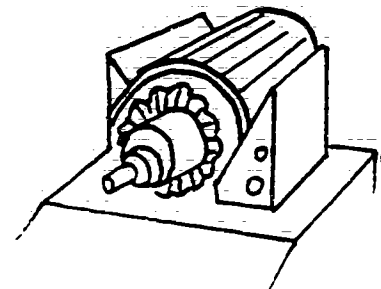
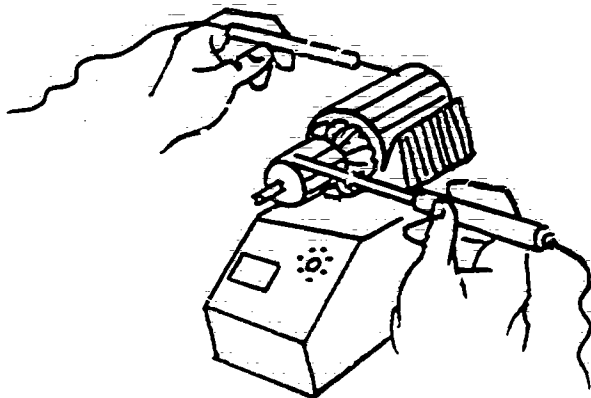

SHORTED CIRCUIT TEST

Plug the armature cord into an AC outlet, place the armature between the growler jaws, and set the selector switch to ON or armature position (depending on the brand of growler used).

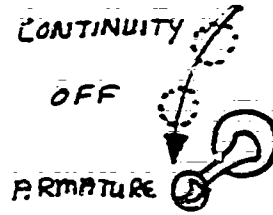

Rotate the armature slowly in the growler jaws and hold a hacksaw blade parallel and against the top of the armature.

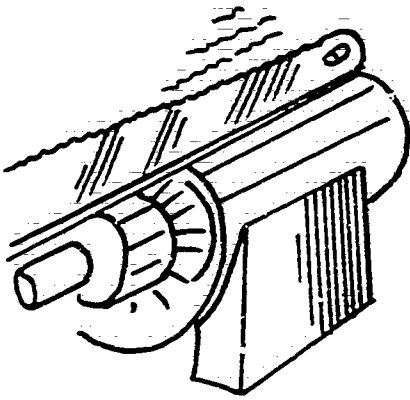

NOTE: The steel blade will be attracted to the armature core and will vibrate when a shorted armature coil is located. Replace the armature.

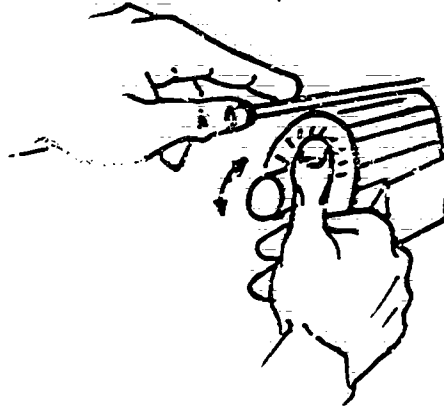

### OPEN CIRCUIT TEST

Plug the armature cord into an AC outlet, place the armature between the growler jaws, and set the selector switch in the GRD or the Continuity position (depending on the brand of growler used).

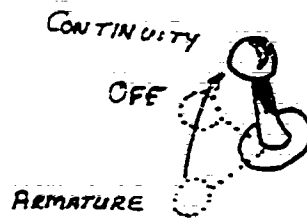

Hold the test prod on any commutator bar and touch an adjoining bar with the prod.

NOTE: The light will flash at each bar if armature is operational.

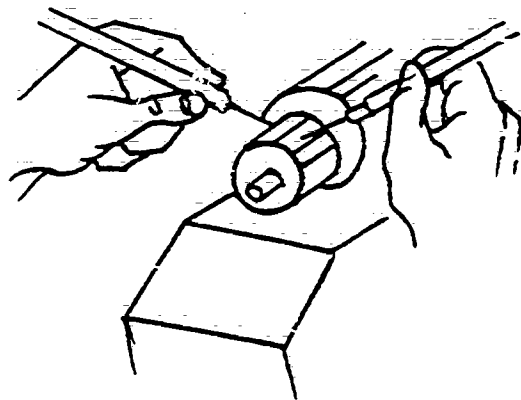

TITLE: Check Blower Operation

Page 1 of 1 page

COURSE: Appliance Repair

UNIT IV: Laundry Equipment

Proper blower operation in dryer is essential for adequate drying and proper operation.

Before starting the dryer, vent damper should be closed.

After starting dryer there should be sufficient air circulation to open the dryer's vent damper

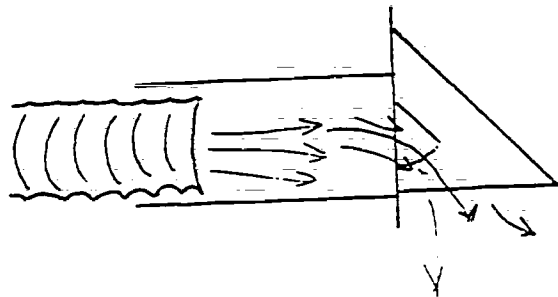

If the air volume is low:

- a. Shut off dryer and check filter.
- b. Remove inspection panel and check blower chamber and belt.

TITLE: Setting Up the Shop Vacuum Cleaner

Page 1 of 2 pages

COURSE: Appliance Repair

UNIT IV: Laundry Equipment

1. Unlock the cleaner lid clamps.
2. Remove the lid and check to be sure filter and tank are clean.

NOTE: Clean if necessary.

3. Replace the lid assembly and reclamp it.
4. Plug in the power cord.
5. Turn on the power switch.
6. Hold hand over intake hole of cleaner to check suction.

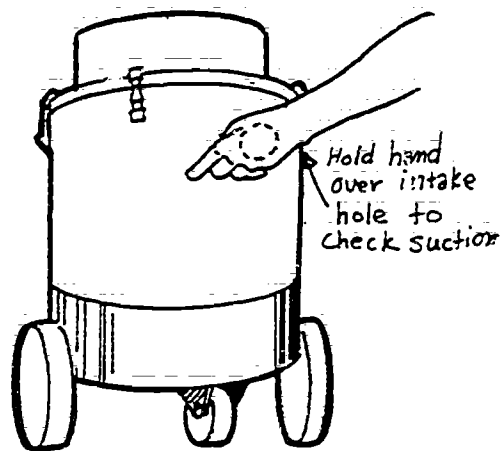

7. Install the hose onto the intake hole.

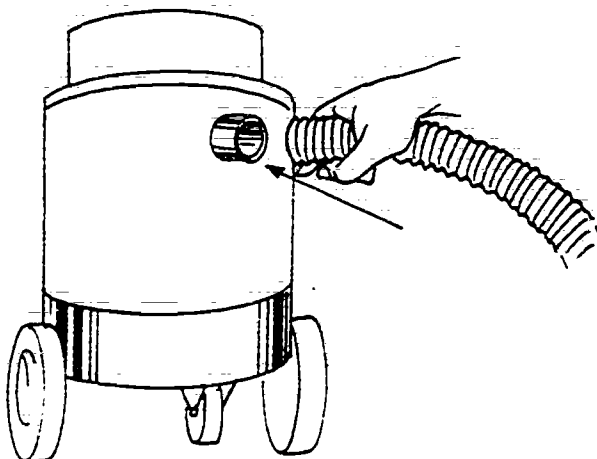

397

8. Install one of the tools onto the other end of the hose.

NOTE: The brush is usually used for dusting.

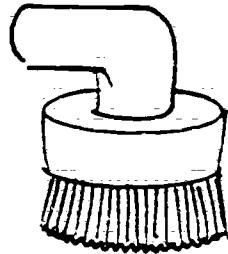

NOTE: The crevis tool is used to reach into tight spots.

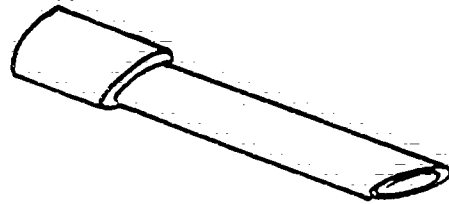

9. Hold hand over end of tool to check suction through hose and tool.

You are now ready for the cleaning operation.

TITLE: Portable Vacuum Pump - Robinair #12496 Page 1 of 1 page  
COURSE: Appliance Repair UNIT VI: Refrigeration

This rotary vane vacuum pump will pull down a refrigerant system to within 3" of barometric pressure (29.62" of Mercury). According to a standard steam table, water will boil at this level if the room temperature is above 55°F. The vacuum pump will remove air and moisture from a sealed refrigeration system after the leak has been repaired.

This unit design includes a motor overload protector and a three-way starting switch to provide the desired protection of the motor windings. A hand valve with a Teflon seat assures a positive shut-off. This model also has a manifold, gauges, and charging lines.

To start the vacuum pump the switch must be turned to the right and held at the start position until the motor starts. When the switch released it will spring back to the left to the run position.

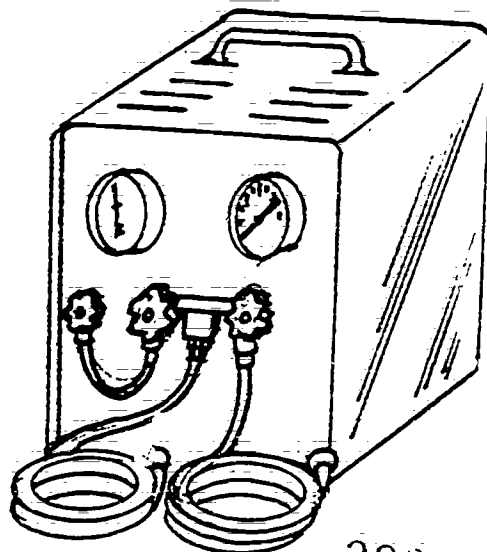

399

TITLE: Using the Prestolite Leak Detector

Page 1 of 1 page

COURSE: Appliance Repair

UNIT VI: Refrigeration

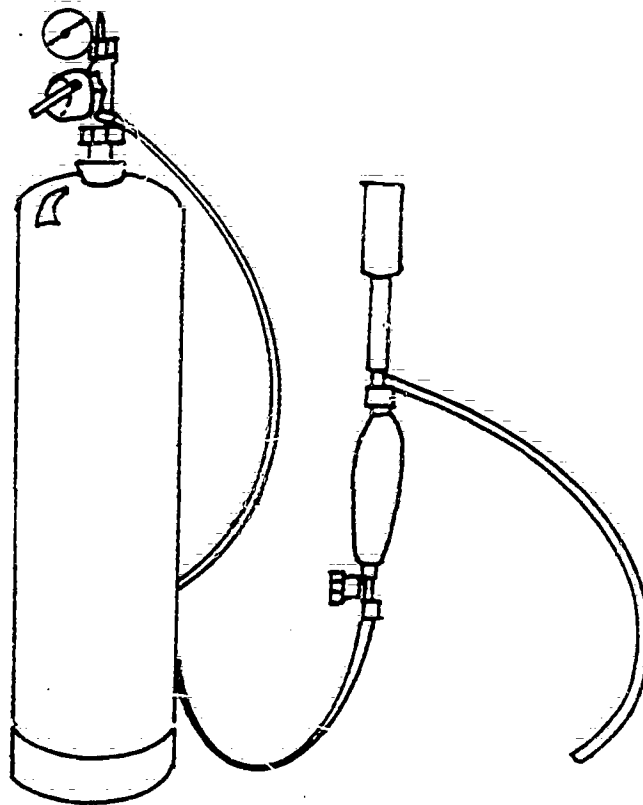

This tester is an adapter assembly made to attach to the Prestolite Brazing Kit. The adapter operates on acetylene. When acetylene burns it produces a colorless to a light blue flame. This flame burns in a shielded housing and heats a plate. A hose is attached to the shielded housing. This hose is placed near where a leak is suspected. If there is a leak, the color of the flame changes to a light green. A bright blue flame will indicate a large leak. A violet flame will indicate a very large leak.



TITLE: The Electronic Leak Detector

Page 1 of 1 page

COURSE: Appliance Repair

UNIT VI: Refrigeration

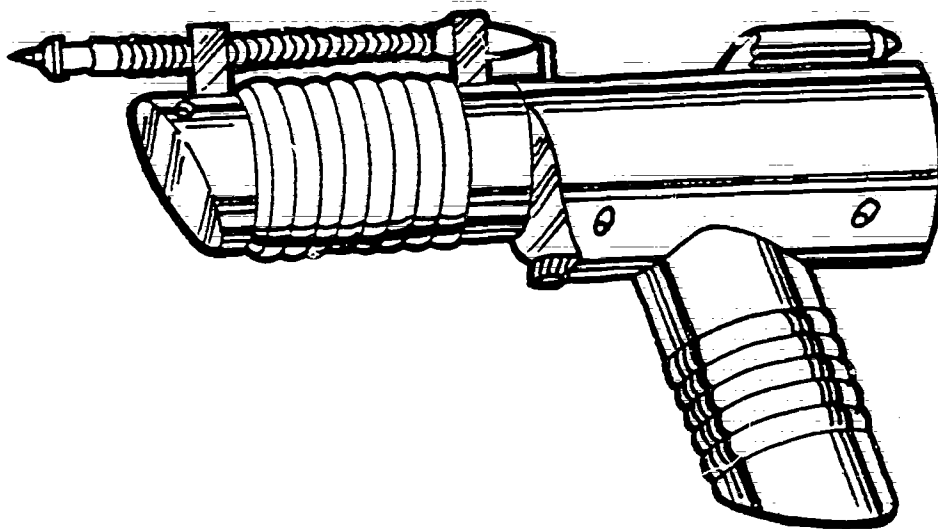

The electronic leak detector is a highly sensitive unit. It should only be used when a leak can not be found with the liquid or prestolite detector. Always follow the set up procedures listed by the manufacturer of the tester. The sensing tip should be moved along the tubing at a speed of about 1" per second. When a leak is found a signal will be present (a flashing light or a sound).

TITLE: The Charging Cylinder - Repair #12206

Page 1 of 1 page

COURSE: Appliance Repair

UNIT VI: Refrigeration

Charging cylinders eliminate wasted refrigerant and permit the serviceman to buy refrigerant in economical drums. The charging cylinder helps the serviceman accurately charge a system and eliminate call backs.

This type of charging cylinder quickly compensates for volume fluctuations caused by temperature differences. Temperature regulates pressure, and pressure regulates volume when dealing with refrigerants. This charging cylinder has a round plastic shroud with calibrating numbers. A pressure gauge is mounted on the top of the cylinder. Dialing the plastic shroud containing the calibrations to correspond with the pressure gauge reading, makes the cylinder ready for use.

The charging cylinder has a shut off valve at the bottom. This valve is used when filling the cylinder or when charging a system. The valve on the top of the charging cylinder is used to purge off the air in the cylinder.

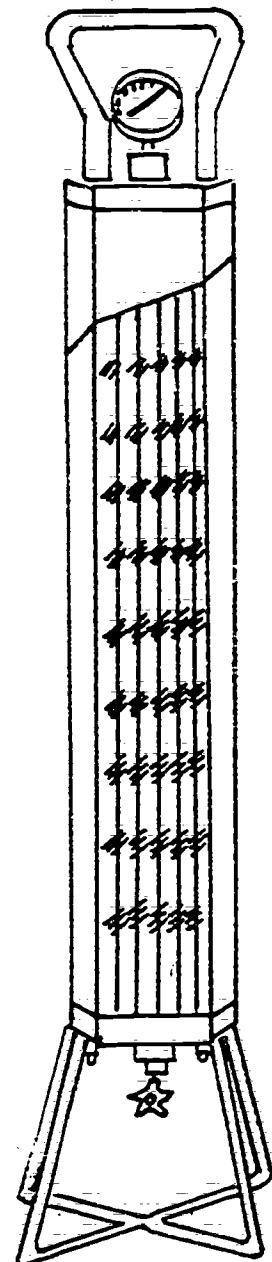

402

TITLE: Getting the Charging Cylinder  
Ready for Use

Page 1 of 1 page

COURSE: Appliance Repair

UNIT VI: Refrigeration

1. Determine the refrigerant needed. Refer to the appliance service manual or the model number plate on the appliance. (Example: The appliance plate states that F 12 refrigerant is used. The plate also states that less than 2 pounds of refrigerant is used. However, the service manual will state the type of refrigerant and the exact charge needed.)
2. Turn the refrigerant drum upside down, and attach a charging hose from the drum to the charging cylinder.
3. Turn the drum valve open and loosen the charging hose at the charging cylinder. When the liquid refrigerant is at the loosened hose connection, tighten the connection.
4. Open the charging cylinder valve and fill the cylinder to the 30 ounce line.
5. Turn off the drum valve and the charging cylinder valve.
6. Remove the charging hose from the refrigerant drum.
7. Dial the shroud calibration to the pressure dial reading.

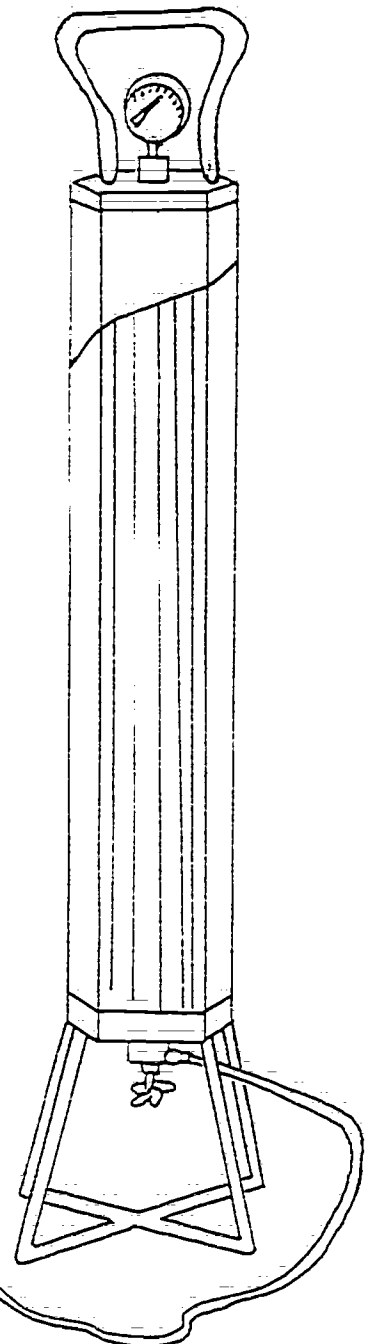
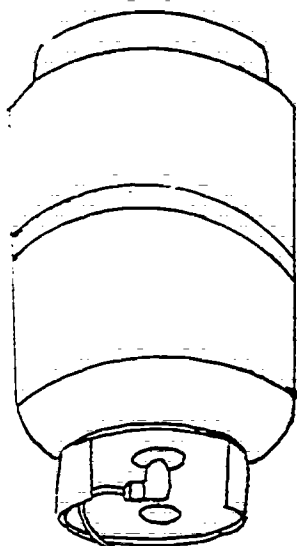

8. The charging cylinder is now ready for use.

TITLE: The Temperature Tester  
COURSE: Appliance Repair

Page 1 of 1 page

UNIT VI: Refrigeration

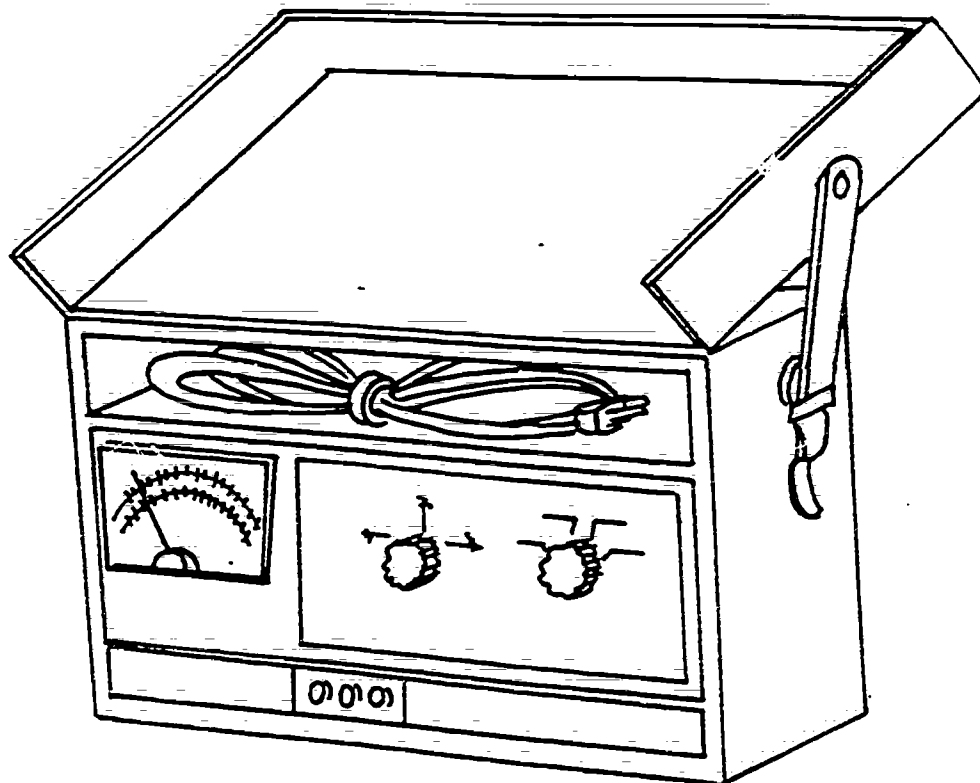

The refrigeration temperature tester is designed to test temperatures from  $-50^{\circ}\text{F}$  to  $+150^{\circ}\text{F}$ . This unit has three probes that can be used in different areas. The meter will read the temperature at each probe as the probe selector knob is turned from the 1, 2 or 3 position. The meter must be adjusted before taking a reading. Set the position knob to the adjust position and turn the adjusting screw so that the needle aligns with the marking on the meter dial. The position knob can then be set to the high or low scale.

TITLE: The Temperature Recorder  
COURSE: Appliance Repair

Page 1 of 1 page  
UNIT VI: Refrigeration

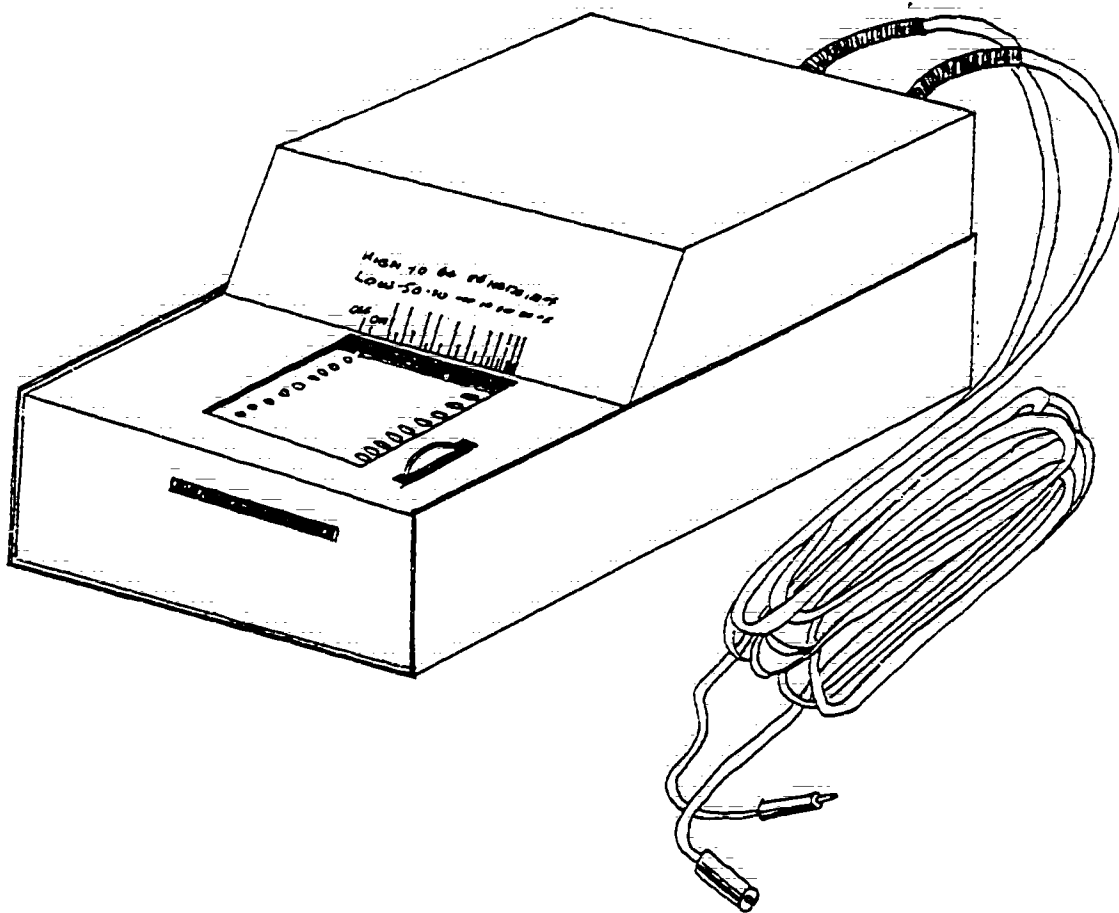

The temperature recorder is designed to give the technician a visual record of the cut-in and cut-off temperatures of the product. The probe should always be placed in the same location as the sensor of the thermostat. This allows the technician to compare the cut-in and cut-off temperatures to the manufacturer's specifications. The temperature recorder also allows the technician to check how the product reacts to various conditions throughout the day or night.

TITLE: The Capacitor Analyzer

Page 1 of 2 pages

COURSE: Appliance Repair

UNIT VI: Refrigeration

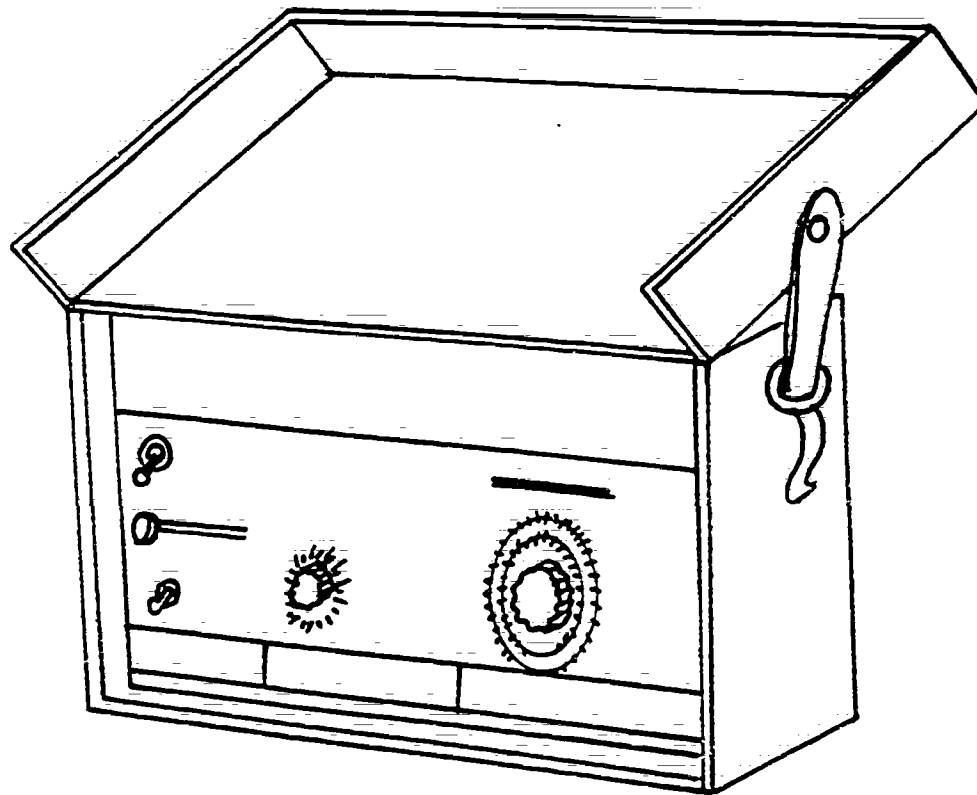

The capacitor analyzer is an instrument that measures both capacitance and power factor. To operate this instrument follow these steps.

1. Plug in the power cord and wait until the tube-eye indicator lights.
2. Attach the capacitor to be checked to the alligator clamps.
3. Set the range switch to the proper range for the capacitor.
  - Range 1 - 1 to 20 MFD.
  - Range 2 - 21 to 49 MFD.
  - Range 3 - 50 to 5000 MFD.
4. Set power factor to "0".
5. Move the sweep scale counterclockwise to the open position.
6. Push the switch to the "test" position and hold it.
7. Move the sweep scale knob clockwise until the eye tube opens to the widest gap.
8. Read the capacitance indicated at the sweep pointer.

Conclusions;

1. If the pointer is near the rated capacitance of the capacitor it is good.
2. If the pointer is moved to the end, clockwise, the capacitor is open.
3. If the eye tube stays at one open position the capacitor is shorted.

40.

## ASSIGNMENT SHEETS

ASSIGNMENT SHEETS are to supplement the other sheets in this course as well as any textbook should it be used. They provide the student with mental activities necessary to learn the "knowing" that accompanies the "doing" of a trade. The student is assigned related studies or technical information to be "sought out" by the student on an individual basis through the use of problems or "exercises." Due to the variety of informational sources and one's local needs, we have not written a series of assignment sheets. The following sheet is a sample of an assignment sheet to provide direction for any assignment sheets to be written.



TITLE: Checking a Circuit

Page 1 of 1 page

COURSE: Appliance Repair

UNIT II: Basic Electricity

REFERENCE: J-2-12

1. Unscrew the first lamp.

a. What happens to lamp #2? \_\_\_\_\_

b. What happens to lamp #3? \_\_\_\_\_

2. Replace lamp #1. Unscrew lamp #2.

a. What happens to lamp #1? \_\_\_\_\_

b. What happens to lamp #3? \_\_\_\_\_

3. Why do you think this happens?

\_\_\_\_\_  
\_\_\_\_\_  
\_\_\_\_\_

4. Is this the same action as a switch? \_\_\_\_\_

5. How can you check to see if it is?

\_\_\_\_\_  
\_\_\_\_\_

6. Can you recall any series circuits you may have seen? Where?

a. \_\_\_\_\_

b. \_\_\_\_\_

c. \_\_\_\_\_

d. \_\_\_\_\_

e. \_\_\_\_\_

ASSIGNMENT SHEET

AS-2-2

TITLE: Check the Parallel Circuit

Page 1 of 1 page

COURSE: Appliance Repair

UNIT II: Basic Electricity

REFERENCE: J-2-16

1. What happens when you unscrew lamp #2? \_\_\_\_\_  
\_\_\_\_\_
2. What will happen if you unscrew lamps #2 and #3? \_\_\_\_\_  
\_\_\_\_\_
3. What is different between this and a series circuit?  
\_\_\_\_\_  
\_\_\_\_\_
4. Does the switch do anything? \_\_\_\_\_
  - a. What? \_\_\_\_\_  
\_\_\_\_\_
  - b. Why? \_\_\_\_\_  
\_\_\_\_\_
5. Can you recall ever seeing a parallel circuit? Where?
  - a. \_\_\_\_\_
  - b. \_\_\_\_\_
  - c. \_\_\_\_\_
  - d. \_\_\_\_\_
  - e. \_\_\_\_\_

TITLE:       Checking the Series-Parallel  
              Circuit

Page 1 of 1 page

COURSE:     Appliance Repair

UNIT II:    Basic Electricity

REFERENCE:  J-2-21

1. How many lamps go off when switch #6 is turned off? \_\_\_\_\_
2. How many lamps does switch #5 control? \_\_\_\_\_
3. What lamps would go out if lamp #8 were unscrewed? \_\_\_\_\_
4. Would lamp #8 and #9 go out if lamp #7 were unscrewed? \_\_\_\_\_
5. Must both switches be turned on to light the #8 and #9 lamps? \_\_\_\_\_
6. Which section is a parallel circuit.  
\_\_\_\_\_
7. Which section is a series circuit?  
\_\_\_\_\_
8. What can be done to make all lamps operate with either switch?  
\_\_\_\_\_  
\_\_\_\_\_  
\_\_\_\_\_  
\_\_\_\_\_