

ED 191 986

CE 024 396

**TITLE** Military Curricula for Vocational & Technical Education. Metals Processing Specialist, Blocks V and VI, Classroom Course 13-7.

**INSTITUTION** Chanute AFB Technical Training Center, Ill.; Ohio State Univ., Columbus. National Center for Research in Vocational Education.

**PUB DATE** Sep 75

**NOTE** 288p.; Sections will not reproduce well due to light and broken type. For related documents see CE 024 394-397.

**EDRS PRICE** MF01/PC12 Plus Postage.

**DESCRIPTORS** \*Aviation Mechanics; Behavioral Objectives; Course Descriptions; Curriculum Guides; High Schools; Learning Activities; Lesson Plans; Metals; \*Metal Working; Postsecondary Education; \*Repair; Secondary Education; Skilled Occupations; \*Trade and Industrial Education; Units of Study; \*Welding

**IDENTIFIERS** \*Aircraft; Military Curriculum Project.

**ABSTRACT**

These curriculum materials are the third section of a four-part, secondary-postsecondary-level course in metals processing. The course is one of a number of military-developed curriculum packages selected for adaptation to vocational instruction and curriculum development in a civilian setting. Block V, Inert Gas Shielded Welding of High Performance Aircraft Metals, has nine lessons containing eighty-eight hours of instruction: Inert Gas Shielded Welding, Joints of Heat and Corrosion Resistant Ferrous Alloys, Position Welding of Heat and Corrosion Resistant Ferrous Alloys, Joints of Aluminum and Aluminum Alloy Sheet and Plate, Butt Joints of Magnesium, Joints of A-286 Alloy, Joints of Chromoly, Butt Joints of Nickel Base Alloys, and Butt Joints of Titanium and Titanium Alloy Sheet. Block VI, Pipe, Tubing, and Aircraft Exhaust and Jet Engine Hot Section Repair, has six lessons covering fifty-eight hours of instruction: Joints of Heat and Corrosion Resistant Ferrous Alloy Pipe, Joints of Aluminum Alloy Pipe and Tubing, Butt Patches on Jet Engine Hot Section Parts, Fillet Patches on Jet Engine Hot Section Parts, Reciprocating Engine Exhaust Manifold Repair, and Welding of Carbon and Alloy Steel Tubular Assemblies. Instruction materials include a course chart, detailed lesson plans, and a plan of instruction containing the units of instruction, criterion objectives, and additional materials needed. Student materials include a study guide for each block with objectives, information, review exercises, and references for each lesson. Suggested audiovisuals are not provided. (YLB)

\*\*\*\*\*  
 \* Reproductions supplied by EDRS are the best that can be made \*  
 \* from the original document. \*  
 \*\*\*\*\*



## MILITARY CURRICULUM MATERIALS

The military-developed curriculum materials in this course package were selected by the National Center for Research in Vocational Education Military Curriculum Project for dissemination to the six regional Curriculum Coordination Centers and other instructional materials agencies. The purpose of disseminating these courses was to make curriculum materials developed by the military more accessible to vocational educators in the civilian setting.

The course materials were acquired, evaluated by project staff and practitioners in the field, and prepared for dissemination. Materials which were specific to the military were deleted, copyrighted materials were either omitted or approval for their use was obtained. These course packages contain curriculum resource materials which can be adapted to support vocational instruction and curriculum development.

# The National Center Mission Statement

The National Center for Research in Vocational Education's mission is to increase the ability of diverse agencies, institutions, and organizations to solve educational problems relating to individual career planning, preparation, and progression. The National Center fulfills its mission by:

- Generating knowledge through research
- Developing educational programs and products
- Evaluating individual program needs and outcomes
- Installing educational programs and products
- Operating information systems and services
- Conducting leadership development and training programs

## FOR FURTHER INFORMATION ABOUT Military Curriculum Materials

### WRITE OR CALL

Program Information Office  
The National Center for Research in Vocational  
Education  
The Ohio State University  
1960 Kenny Road, Columbus, Ohio 43210  
Telephone: 614/486-3655 or Toll Free 800/  
848-4815 within the continental U.S.  
(except Ohio).



THE NATIONAL CENTER  
FOR RESEARCH IN VOCATIONAL EDUCATION  
The Ohio State University, 1960 Kenny Road, Columbus, Ohio 43210  
Call 614/486-3655  
Call 800/848-4815

# Military Curriculum Materials for Vocational and Technical Education

## Information and Field Services Division

The National Center for Research  
in Vocational Education





# Military Curriculum Materials Dissemination Is . . .

# What Materials Are Available?

# How Can These Materials Be Obtained?

an activity to increase the accessibility of military-developed curriculum materials to vocational and technical educators.

This project, funded by the U.S. Office of Education, includes the identification and acquisition of curriculum materials in print form from the Coast Guard, Air Force, Army, Marine Corps and Navy.

Access to military curriculum materials is provided through a "Joint Memorandum of Understanding" between the U.S. Office of Education and the Department of Defense.

The acquired materials are reviewed by staff and subject matter specialists, and courses deemed applicable to vocational and technical education are selected for dissemination.

The National Center for Research in Vocational Education is the U.S. Office of Education's designated representative to acquire the materials and conduct the project activities.

## Project Staff:

Wesley E. Budke, Ph.D., Director  
National Center Clearinghouse

Shirley A. Chase, Ph.D.  
Project Director

One hundred twenty courses on microfiche (thirteen in paper form) and descriptions of each have been provided to the vocational Curriculum Coordination Centers and other instructional materials agencies for dissemination.

Course materials include programmed instruction, curriculum outlines, instructor guides, student workbooks and technical manuals.

The 120 courses represent the following sixteen vocational subject areas:

Agriculture	Food Service
Aviation	Health
Building & Construction	Heating & Air Conditioning
Trades	Machine Shop
Clerical Occupations	Management & Supervision
Communications	Meteorology & Navigation
Drafting	Photography
Electronics	Public Service
Engine Mechanics	

The number of courses and the subject areas represented will expand as additional materials with application to vocational and technical education are identified and selected for dissemination.

Contact the Curriculum Coordination Center in your region for information on obtaining materials (e.g., availability and cost). They will respond to your request directly or refer you to an instructional materials agency closer to you.

## CURRICULUM COORDINATION CENTERS

### EAST CENTRAL

Rebecca S. Douglass  
Director  
100 North First Street  
Springfield, IL 62777  
217/782-0759

### NORTHWEST

William Daniels  
Director  
Building 17  
Airdustrial Park  
Olympia, WA 98504  
206/753-0879

### MIDWEST

Robert Patton  
Director  
1515 West Sixth Ave.  
Stillwater, OK 74704  
405/377-2000

### SOUTHEAST

James F. Shail, Ph.D.  
Director  
Mississippi State University  
Drawer DX  
Mississippi State, MS 39762  
601/325-2510

### NORTHEAST

Joseph F. Kelly, Ph.D.  
Director  
225 West State Street  
Trenton, NJ 08625  
609/292-6562

### WESTERN

Lawrence F. H. Zane, Ph.D.  
Director  
1775 University Ave.  
Honolulu, HI 95822  
808/948-7834

METALS PROCESSING SPECIALIST, BLOCKS V AND VI

## Table of Contents

Course Description	Page 1
Course Chart	Page 3
Plan of Instruction	Page 4
Lesson Plans	Page 19
Block V - Inert Gas Shielded Welding Of High Performance Aircraft Metals	
<u>Inert Gas Shielded Welding Of High Performance Aircraft Metals - Study Guides</u>	Page 127
Block VI - Pipe, Tubine, And Aircraft Exhaust And Jet Engine Hot Section Repair	
<u>Pipe, Tubing, And Aircraft Exhaust And Jet Engine Hot Section Repair - Study Guides</u>	Page 193

D

Developed by:  
United States Air Force

Development and  
Review Dates:  
September 23, 1975

D.O.T. No.:  
812.884  
Occupational Area:  
Machine Shop  
Target Audiences:  
Grades 11-adult

Print Pages:  
280

Cost:  
\$5.75

Availability:  
Military Curriculum Project, The Center  
for Vocational Education, 1960 Kenny  
Rd., Columbus, OH 43210

Contents:

Block V

*Inert Gas Shielded Welding of High  
Performance Aircraft Metals*

Block VI

*Pipe, Tubing, and Aircraft Exhaust and  
Jet Engine Hot Section Repair*

Type of Materials:

Lesson Plans:	Programmed Text:	Student Workbook:	Handouts:	Text Materials:	Audio-Visuals:

Instructional Design:

Performance Objectives:	Tests:	Review Exercises:	Additional Materials Required:

Type of Instruction:

Group Instruction:	Individualized:

\* Materials are recommended but not provided.

Expires July 1, 1978



2

Course Description:

This is the third section of a four-part course on metals processing. Training for the entire course includes fabrication of welded structures and metal weld repairs; principles, techniques and processes of welding, cutting, soldering, brazing, and hard surfacing of various types of metals used in the fabrication and repair of equipment; blueprint reading; heat treating, hardness testing, identification and prevention of corrosion; use of hand and measuring tools; and operation and maintenance of welding, heat treating, test equipment and power machinery such as grinders, drill presses, power saws, and metal cutting shears. Safety is emphasized throughout the course. This section deals with inert gas shielded welding of high performance aircraft metals, pipe, tubing, and aircraft exhaust and jet engine hot section repair. This section contains two blocks of instruction covering 146 hours. Students should complete Metals Processing Specialist, Blocks II and IV, (3-6), before beginning this third part of the course.

Block V — *Inert Gas Shielded Welding of High Performance Aircraft Metals* has nine lessons containing 88 hours of instruction. The lesson topics and hours follow:

- Inert Gas Shielded Welding (2 hours)
- Joints of Heat and Corrosion Resistant Ferrous Alloys (24 hours)
- Position Welding of Heat and Corrosion Resistant Ferrous Alloys (6 hours)
- Joints of Aluminum and Aluminum Alloy Sheet and Plate (12 hours)
- Butt Joints of Magnesium (6 hours)
- Joints of A-286 Alloy (10 hours)
- Joints of Chromoloy (12 hours)
- Butt Joints of Nickel Base Alloys (6 hours)
- Butt Joints of Titanium and Titanium Alloy Sheet (10 hours)

Block VI — *Pipe, Tubing, and Aircraft Exhaust and Jet Engine Hot Section Repair* has six lessons covering 58 hours of instruction.

- Joints of Heat and Corrosion Resistant Ferrous Alloy Pipe (8 hours)
- Joints of Aluminum Alloy Pipe and Tubing (8 hours)
- Butt Patches on Jet Engine Hot Section Parts (18 hours)
- Fillet Patches on Jet Engine Hot Section Parts (12 hours)
- Reciprocating Engine Exhaust Manifold Repair (6 hours)
- Welding of Carbon and Alloy Steel Tubular Assemblies (6 hours)

This section contains both teacher and student materials. Printed instructor materials include a course chart; detailed lesson plans; and a plan of instruction including the units of instruction, the criterion objectives, the duration of the lessons, and additional materials needed. Student materials include a study guide for each block which contains objectives, information, review exercises and references for each lesson.

Text materials are provided in the student study guides, however, several commercial texts and military technical manuals are referenced throughout the course. Audiovisuals suggested for use in the entire course include 188 slides, 8 films, 2 videotapes, and 9 transparency sets. The audiovisuals are not provided. This course can be used as advanced study in both welding and aviation repair courses. It requires previous welding experience and skills.



<p>9</p> <p>10</p> <p>11</p>	<p><u>Course Material - UNCLASSIFIED</u> 120 Hours TT</p> <p><b>BLOCK V - Inert Gas Shielded Welding of High Performance Aircraft Metals</b></p> <p>Inert Gas Shielded Welding (2 hrs); Joints of Heat and Corrosion Resistant Ferrous Alloys (24 hrs); Position Welding of Heat and Corrosion Resistant Ferrous Alloys (6 hrs); Joints of Aluminum and Aluminum Alloy Sheet and Plate (12 hrs); Butt Joints of Magnesium (6 hrs); Joints of A-286 Alloy (10 hrs); Joints of Chromoloy (12 hrs); Butt Joints of Nickel Base Alloys (6 hrs); Butt Joints of Titanium and Titanium Alloy Sheet (10 hrs); Measurement and Critique (2 hrs).</p> <p>(Equipment Hazards and Personnel Safety Integrated with Above Subjects)</p> <p>60 Hours C/L</p>	<p>30 Hours CTT</p>
------------------------------	---	---------------------

ATC FORM APR 73

449A

PREVIOUS EDITION OBSOLETE.

73-24978

<p>12</p> <p>13</p>	<p><u>Course Material - UNCLASSIFIED</u> 78 Hours TT</p> <p><b>BLOCK VI - Pipe, Tubing, and Aircraft Exhaust and Jet Engine Hot Section Repair</b></p> <p>Joints of Heat and Corrosion Resistant Ferrous Alloy Pipe (8 hrs); Joints of Aluminum Alloy Pipe and Tubing (8 hrs); Butt Patches on Jet Engine Hot Section Parts (18 hrs); Fillet Patches on Jet Engine Hot Section Parts (12 hrs); Reciprocating Engine Exhaust Manifold Repair (6 hrs); Welding of Carbon and Alloy Steel Tubular Assemblies (6 hrs); Measurement and Critique (2 hrs).</p> <p>(Equipment Hazards and Personnel Safety Integrated with Above Subjects)</p> <p>60 Hours C/L</p>	<p>8 Hours CTT</p> <p>2 Hours RT</p> <p>10 Hours CTT</p>
---------------------	---	--



PLAN OF INSTRUCTION	COURSE TITLE Metals Processing Specialist	
BLOCK TITLE Inert Gas Shielded Welding of High Performance Aircraft Metals		
UNITS OF INSTRUCTION AND CRITERION OBJECTIVES	DURATION (HOURS) 2	SUPPORT MATERIALS AND GUIDANCE 3
<p>1. Inert Gas Shielded Welding</p> <p>a. Without reference, select principles and operation of inert gas shielded welding equipment with 75% accuracy.</p> <p>b. Given inert gas shielded welding machine, set up and make correct apparatus settings IAW TO 34W4-41-1.</p>	<p>2</p>	<p><u>Column 1 Reference</u></p> <p>1a 1b</p> <p><u>STS Reference</u></p> <p>23a(1) ✓ 23a(2)</p> <p><u>Instructional Materials</u></p> <p>3ABRS3131-SG-501, Inert Gas Shielded Welding Modern Welding (Chapters 11 and 12) TO 34W4-41-1, Operator Service and Repair - Inert Gas Shielded Arc Welding Machine</p> <p><u>Audio Visual Aids</u></p> <p>Film: FLC 9-233, Industrial Gases and Shielded Arc Welding Chart: Arc Welding Machine Controls</p> <p><u>Training Equipment</u></p> <p>Inert Gas Shielded Welding Equipment consisting of: Arc Welding Machine, Protective Equipment, Torch with Hoses and Cables, and Welding Tables (1) Toolkit (1)</p> <p><u>Training Methods</u></p> <p>Discussion/Demonstration (1.5 hrs) Performance (.5 hr)</p> <p><u>Instructional Environment/Design</u></p> <p>Classroom (1.5 hrs) Laboratory (.5 hr)</p> <p><u>Instructional Guidance</u></p> <p>Have each student respond to the written items in the lesson. Emphasize the importance of correct current settings for TIG welding. Make outside assignment to read 3ABRS3131-SG-502 and Chapter 18, Modern Welding. Instructor will use "Quality and Reliability Assurance Handbook H-56, Arc Welding" (Chapter 5), as an additional reference throughout Block V.</p>
PLAN OF INSTRUCTION NO. 3ABRS3131	DATE 23 September 1975	BLOCK NO. V PAGE NO. 33

PLAN OF INSTRUCTION (Continued)

1 UNITS OF INSTRUCTION AND CRITERION OBJECTIVES	2 DURATION (HOURS)	3 SUPPORT MATERIALS AND GUIDANCE										
<p>2. Joints of Heat and Corrosion Resistant Ferrous Alloys</p> <p>a. Given inert gas shielded welding equipment and heat and corrosion resistant ferrous alloy specimens, set up and weld edge joints, free of undercut and overlap for a total combined distance of no less than 3/4 of the length of the specimen, excluding the first 1/2 inch start and the last 1/2 inch finish. All shop safety, good housekeeping, and fire prevention measures must be observed.</p>	<p>32 (24/8)</p> <p>(3)</p>	<p>Caution students not to mark or write on any training literature as it is to be reused by subsequent classes.</p> <table border="0"> <tr> <td><u>Column 1 Reference</u></td> <td><u>STS Reference</u></td> </tr> <tr> <td>2a</td> <td>3a, 3b, 23a(3)</td> </tr> <tr> <td>2b</td> <td>3a, 3b, 23a(5)</td> </tr> <tr> <td>2c</td> <td>3a, 3b, 23a(4)</td> </tr> <tr> <td>2d</td> <td>3a, 3b, 23a(6)</td> </tr> </table> <p><u>Instructional Materials</u> 3ABR53131-SG-502, Joints of Heat and Corrosion Resistant Ferrous Alloys Modern Welding (Chapter 18)</p> <p><u>Training Equipment</u> Inert Gas Shielded Welding Equipment Complete (1) Power Shears (6) Toolkit (1) Trainer: Tungsten Inert Gas (TIG) Shielded Welding Specimens, 4404 (12)</p> <p><u>Training Methods</u> Discussion/Demonstration (2.5 hrs) Performance (21.5 hrs) Outside Assignment (8 hrs)</p> <p><u>Instructional Environment/Design</u> Classroom (2 hrs) Laboratory (22 hrs)</p>	<u>Column 1 Reference</u>	<u>STS Reference</u>	2a	3a, 3b, 23a(3)	2b	3a, 3b, 23a(5)	2c	3a, 3b, 23a(4)	2d	3a, 3b, 23a(6)
<u>Column 1 Reference</u>	<u>STS Reference</u>											
2a	3a, 3b, 23a(3)											
2b	3a, 3b, 23a(5)											
2c	3a, 3b, 23a(4)											
2d	3a, 3b, 23a(6)											
<p>b. Given inert gas shielded welding equipment and heat and corrosion resistant ferrous alloy specimens, set up and weld lap joints, free of excessive penetration, undercut, and overlap, for a total combined distance of no less than 3/4 of the length of the specimen, excluding the first 1/2 inch start and the last 1/2 inch finish. All shop safety, good housekeeping, and fire prevention measures must be observed.</p> <p>c. Given inert gas shielded welding equipment and heat and corrosion resistant ferrous alloy specimens, set up and weld butt joints with 100% penetration, free of undercut and overlap, for a total combined distance of no less than 3/4 of the length of the specimen excluding the first 1/2 inch start and the last 1/4 inch finish. All shop safety, good house-keeping, and fire prevention measures must be observed.</p>	<p>(5)</p> <p>(7)</p>	<p><u>Instructional Guidance</u> Emphasize welding safety and weld requirements for edge, lap, butt, tee, and corner joints. Make outside assignment to read 3ABR53131-SG-503 and Chapters 11 and 18, Modern Welding. Administer appraisal test upon completion of this assignment. Emphasize conservation of heat and corrosion resistant ferrous alloys and filler rods.</p>										

PLAN OF INSTRUCTION NO. 3ABR53131	DATE 23 September 1975	BLOCK NO. V	PAGE NO. 34
-----------------------------------	------------------------	-------------	-------------

PLAN OF INSTRUCTION (Continued)

UNITS OF INSTRUCTION AND CRITERION OBJECTIVES	DURATION (HOURS)	SUPPORT MATERIALS AND GUIDANCE	
<p>d. Given inert gas shielded welding equipment and heat and corrosion resistant ferrous alloy specimens, set up and weld tee and corner joints, free of excessive penetration, overlap, and undercut, for a total combined distance of no less than 3/4 of the length of the specimen, excluding the first 1/2 inch start and the last 1/2 inch finish. All shop safety, good housekeeping, and fire prevention measures must be observed.</p>	(9)		
<p>3. Position Welding of Heat and Corrosion Resistant Ferrous Alloys</p> <p>a. Given inert gas shielded welding equipment and heat and corrosion resistant ferrous alloy specimens, set up and weld butt joints in the horizontal position with 100% penetration, free of overlap and undercut, for a total combined distance of no less than 3/4 of the length of the specimen, excluding the first 1/2 inch start and the last 1/2 inch finish. All shop safety, good housekeeping, and fire prevention measures must be observed.</p> <p>b. Given inert gas shielded welding equipment and heat and corrosion resistant ferrous alloy specimens, set up and weld butt joints in the vertical position with 100% penetration, free of overlap and undercut, for a total combined distance of no less than 3/4 of the length of the specimen, excluding the first 1/2 inch start and the last 1/2 inch finish. All shop safety, good housekeeping, and fire prevention measures must be observed.</p>	<p>8 (6/2)</p>	<p><u>Column 1 Reference</u> 3a, 3b</p> <p><u>STS Reference</u> 3a, 3b, 23a(7)</p> <p><u>Instructional Materials</u> 3ABR53131-SG-503, Position Welding of Heat and Corrosion Resistant Ferrous Alloys Modern Welding (Chapter 18)</p> <p><u>Training Equipment</u> Inert Gas Shielded Welding Station Complete (1) Power Shears (6) Toolkit (1)</p> <p><u>Training Methods</u> Discussion/Demonstration (1 hr) Performance (5 hrs) Outside Assignment (2 hrs)</p> <p><u>Instructional Environment/Design</u> Classroom (.5 hr) Laboratory (5.5 hrs)</p> <p><u>Instructional Guidance</u> Emphasize welding safety-applicable to horizontal and vertical welding and explain welding requirements for butt joints. Make outside assignment to read 3ABR53131-SG-504 and Chapter 18, Modern Welding. Administer appraisal test upon completion of this assignment. Emphasize proper joint set-up and flowmeter adjustment to conserve argon gas.</p>	
PLAN OF INSTRUCTION NO. 3ABR53131	DATE 23 September 1975	BLOCK NO. V	PAGE NO. 35



PLAN OF INSTRUCTION (Continued)

UNITS OF INSTRUCTION AND CRITERION OBJECTIVES	DURATION (HOURS)	SUPPORT MATERIALS AND GUIDANCE
<p>4. Joints of Aluminum and Aluminum Alloy Sheet and Plate</p> <p>a. Given inert gas shielded welding equipment and aluminum and aluminum alloy sheet specimens, set up and weld lap joints, free of excessive penetration, overlap, and undercut, for a total combined distance of no less than 3/4 of the length of the specimen, excluding the first 1/2 inch start and the last 1/2 inch finish. All shop safety, good housekeeping, and fire prevention measures must be observed.</p> <p>b. Given inert gas shielded welding equipment and aluminum and aluminum alloy plate specimens, set up and weld butt joints with 100% penetration, free of overlap and undercut, for a total combined distance of no less than 3/4 of the length of the specimen, excluding the first 1/2 inch start and the last 1/2 inch finish. All shop safety, good housekeeping, and fire prevention measures must be observed.</p> <p>c. Given inert gas shielded welding equipment and aluminum and aluminum alloy sheet specimens, set up and weld tee joints, free of excessive penetration, overlap, and undercut, for a total combined distance of no less than 3/4 of the length of the specimen, excluding the first 1/2 inch start and the last 1/2 inch finish. All shop safety, good housekeeping, and fire prevention measures must be observed.</p>	<p>16 (12/4)</p> <p>(2)</p> <p>(5)</p> <p>(5)</p>	<p><u>Column 1 Reference</u> 4a, 4b, 4c</p> <p><u>STS Reference</u> 3a, 3b, 23a(9)</p> <p><u>Instructional Materials</u> 3ABR53131-SG-504, Joints of Aluminum and Aluminum Alloy Sheet and Plate Modern Welding (Chapter 18)</p> <p><u>Audio Visual Aids</u> Film: FLC 2360, Welding Aluminum</p> <p><u>Training Equipment</u> Inert Gas Shielded Welding Station Complete (1) Power Shears (6) Toolkit (1)</p> <p><u>Training Methods</u> Discussion/Demonstration (2 hrs) Performance (10 hrs) Outside Assignment (4 hrs)</p> <p><u>Instructional Environment/Design</u> Classroom (1.5 hrs) Laboratory (10.5 hrs)</p> <p><u>Instructional Guidance</u> Emphasize welding safety and welding requirements for aluminum. Make outside assignment to read 3ABR53131-SG-505 and Chapter 18, Modern Welding. Administer appraisal test upon completion of this assignment. Instructor will use MIL-HDBK-694A(MR), Aluminum and Aluminum Alloys, as an additional reference. Emphasize conservation of aluminum and aluminum alloy sheet, plate, and filler rod.</p>

PLAN OF INSTRUCTION NO. 3ABR53131

DATE 23 September 1975

BLOCK NO. V

PAGE NO. 36

PLAN OF INSTRUCTION (Continued)

UNITS OF INSTRUCTION AND CRITERION OBJECTIVES	DURATION (HOURS)	SUPPORT MATERIALS AND GUIDANCE
<p>5: Butt Joints of Magnesium</p> <p>a. Given inert gas shielded welding equipment and magnesium specimens, set up and weld butt joints with 100% penetration, free of overlap and undercut, for a total combined distance of no less than 3/4 of the length of the specimen, excluding the first 1/2 inch start and the last 1/2 inch finish. All shop safety, good housekeeping, and fire prevention measures must be observed.</p>	<p>8 (6/2)</p>	<p><u>Column 1 Reference</u>      <u>STS Reference</u>  5a                              3a, 3b, 33a(9)</p> <p><u>Instructional Materials</u>  3ABR53131-SG-505, Butt Joints of Magnesium  Modern Welding (Chapter 18)</p> <p><u>Training Equipment</u>  Inert Gas Shielded Welding Station Complete (1)  Cleaning Equipment (12)  Power Shears (6)  Toolkit (1)</p> <p><u>Training Methods</u>  Discussion/Demonstration (1 hr)  Performance (5 hrs)  Outside Assignment (2 hrs)</p> <p><u>Instructional Environment/Design</u>  Classroom (.5 hr)  Laboratory (5.5 hrs)</p> <p><u>Instructional Guidance</u>  Emphasize welding safety and fire prevention, applicable to magnesium. Make outside assignment to read 3ABR53131-SG-506. Administer appraisal test upon completion of this assignment. Instructor will use MIL-HDBK-693A, Magnesium and Magnesium Alloy Handbook and MIL-STD-409A, Alloy Nomenclature and Temper Designation System for Magnesium Base Alloys, as an additional reference. Emphasize conservation of magnesium sheet and filler rod.</p>
<p>PLAN OF INSTRUCTION NO. 3ABR 53131</p>	<p>DATE 23 September 1975</p>	<p>BLOCK NO. V      PAGE NO. 37</p>



PLAN OF INSTRUCTION (Continued)

UNITS OF INSTRUCTION AND CRITERION OBJECTIVES 1	DURATION (HOURS) 2	SUPPORT MATERIALS AND GUIDANCE 3	
<p>6. Joints of A-286 Alloy</p> <p>a. Given inert gas shielded welding equipment and A-286 alloy specimens, set up and weld butt joints with 100% penetration, free of overlap and undercut, for a total combined distance of no less than 3/4 of the length of the specimen, excluding the first 1/2 inch start and the last 1/2 inch finish. All shop safety, good housekeeping, and fire prevention measures must be observed.</p> <p>b. Given inert gas shielded welding equipment and A-286 alloy specimens, set up and weld tee joints free of excessive penetration, overlap, and undercut, for a total combined distance of no less than 3/4 of the length of the specimen, excluding the first 1/2 inch start and the last 1/2 inch finish. All shop safety, good housekeeping, and fire prevention measures must be observed.</p>	<p>14 (10/4) (6)</p> <p>(4)</p>	<p><u>Column i Reference</u>      <u>STS Reference</u> 6a                                  3a, 3b, 23a(4) 6b                                  3a, 3b, 23a(6)</p> <p><u>Instructional Materials</u> 3ABR53131-SG-506, Joints of A-286 Alloy</p> <p><u>Training Equipment</u> Inert Gas Shielded Welding Station Complete (1) Cleaning Equipment (12) Power Shears (6) Toolkit (1)</p> <p><u>Training Methods</u> Discussion/Demonstration (1 hr) Performance (9 hrs) Outside Assignment (4 hrs)</p> <p><u>Instructional Environment/Design</u> Classroom (1 hr) Laboratory (9 hrs)</p> <p><u>Instructional Guidance</u> Emphasize shop safety and explain welding requirements for A-286 alloy. Make outside assignment to read 3ABR53131-SG-507. Administer appraisal test upon completion of this assignment. Emphasize conservation of A-286 alloy sheet and filler rod.</p>	
PLAN OF INSTRUCTION NO. 3ABR53131	DATE 23 September 1975	BLOCK NO. V	PAGE NO. 38



PLAN OF INSTRUCTION (Continued)

UNITS OF INSTRUCTION AND CRITERION OBJECTIVES	DURATION (HOURS)	SUPPORT MATERIALS AND GUIDANCE
<p>8. Buttt Joints of Nickel Base Alloys</p> <p>a. Given inert gas shielded welding equipment and nickel base, alloy specimens, set up and weld buttt joints with 100% penetration, free of overlap and undercut, for a total combined distance of no less than 3/4 of the length of the specimen, excluding the first 1/2 inch start and the last 1/2 inch finish. All shop safety, good housekeeping, and fire prevention measuras must be observed.</p>	<p>10 (6/4)</p>	<p><u>Column 1 Reference</u> 8a</p> <p><u>STS Reference</u> 3a, 3b, 23a(11)</p> <p><u>Instructional Materials</u> 3ABR53131-SG-508, Buttt Joints of Nickel Base Alloys</p> <p><u>Training Equipment</u> Inert Gas Shielded Welding Station Complete (1) Cleaning Equipment (12) Power Shears (6) Toolkit (1)</p> <p><u>Training Methods</u> Discussion/Demonstration (1 hr) Performance (5 hrs) Outside Assignment (4 hrs)</p> <p><u>Instructional Environment/Design</u> Classroom (.5 hr) Laboratory (5.5 hrs)</p> <p><u>Instructional Guidance</u> Emphasize welding safety and explain the welding requirements for nickel base alloys. Make outside assignment to read 3ABR53131-SG-509 and Chapter 24, Modern Welding. Administer appraisal test upon completion of this assignment. Emphasize conservation of nickel base alloy sheet and filler rod.</p>
<p>PLAN OF INSTRUCTION NO. 3ABR53131</p>	<p>DATE 23 September 1975</p>	<p>BLOCK NO. 7</p> <p>PAGE NO. 40</p>

PLAN OF INSTRUCTION (Continued)

1 UNITS OF INSTRUCTION AND CRITERION OBJECTIVES	2 DURATION (HOURS)	3 SUPPORT MATERIALS AND GUIDANCE		
<p>9. <u>Butt Joints of Titanium and Titanium Alloy Sheet</u></p> <p>a. <u>Given inert gas shielded welding equipment and titanium and titanium alloy specimens, set up and weld butt joints with 100% penetration, free of overlap and undercut, for a total combined distance of no less than 3/4 of the length of the specimen, excluding the first 1/2 inch start and the last 1/2 inch finish. All shop safety, good housekeeping, and fire prevention measures must be observed.</u></p>	<p>12 (10/2)</p>	<p><u>Column 1 Reference</u> 9a</p> <p><u>Instructional Materials</u> 3ABR53131-SG-509, Butt Joints of Titanium and Titanium Alloy Sheet Modern Welding (Chapter 24)</p> <p><u>Audio Visual Aids</u> Film: FLC 8/60, How to Weld Titanium</p> <p><u>Training Equipment</u> Inert Gas Shielded Welding Station Complete (1) Rectangular Dri Bel Bubble (2) Cleaning Equipment (12) Toolkit (1)</p> <p><u>Training Methods</u> Discussion/Demonstration (2 hrs) Performance (8 hrs) Outside Assignment (2 hrs)</p> <p><u>Instructional Environment/Design</u> Classroom (1.5 hrs) Laboratory (8.5 hrs)</p> <p><u>Instructional Guidance</u> Emphasize welding safety and welding requirements applicable to titanium and titanium alloys. Make outside assignment to read 3ABR53131-SG-601. Administer appraisal test upon completion of this assignment. Instructors will demonstrate using the open welding jig and the rectangular Dri Bel bubble when welding titanium butt joints. Each student will complete butt joints utilizing both methods. Instructor will use MIL-HDBK-697(MR), Titanium and Titanium Alloys, as an additional reference. Emphasize conservation of titanium and titanium alloy sheet and filler rod.</p>	<p><u>STS Reference</u> 3a, 3b, 23a(10)</p>	
<p>10. <u>Measurement and Critique</u></p>	<p>2</p>			
<p>PLAN OF INSTRUCTION NO. 3ABR53131</p>		<p>DATE 23 September 1975</p>	<p>BLOCK NO. V</p>	<p>PAGE NO. 41</p>



PLAN OF INSTRUCTION		COURSE TITLE Metals Processing Specialist	
BLOCK TITLE Pipe, Tubing, and Aircraft Exhaust and Jet Engine Hot Section Repair			
UNITS OF INSTRUCTION AND CRITERION OBJECTIVES	DURATION (HOURS)	SUPPORT MATERIALS AND GUIDANCE	
1. Joints of Heat and Corrosion Resistant Ferrous Alloy Pipe  a. Given inert gas shielded welding equipment and heat and corrosion resistant ferrous alloy pipe specimens, set up and weld butt joints with 100% penetration, free of overlap and undercut, for a total combined distance of no less than 3/4 of the length of the weld. All shop safety, good housekeeping, and fire prevention measures must be observed.  b. Given inert gas shielded welding equipment and heat and corrosion resistant ferrous alloy pipe specimens, set up and weld tee joints with 30% to 80% penetration, free of overlap and undercut, for a total combined distance of no less than 3/4 of the length of the weld. All shop safety, good housekeeping, and fire prevention measures must be observed.	10 (8/2)  (5)  (3)	<u>Column 1 Reference</u> <u>STS Reference</u> 1a                             3a, 3b, 27a 1b                             3a, 3b, 27a  <u>Instructional Materials</u> 3ABRS3131-SG-601, Joints of Heat and Corrosion Resistant Ferrous Alloy Pipe TO 00-25-224, Welding High Pressure and Cryogenic Systems  <u>Audio Visual Aids</u> Chart: Pipe Welding - Welding Sequences  <u>Training Equipment</u> Inert Gas Shielded Welding Station Complete (1) Cleaning Equipment (12) Grinder (4) Power Saw (12) Toolkit (1)  <u>Training Methods</u> Discussion/Demonstration (2 hrs) Performance (6 hrs) Outside Assignment (2 hrs)  <u>Instructional Environment/Design</u> Classroom (1.5 hrs) Laboratory (6.5 hrs)  <u>Instructional Guidance</u> Emphasize welding safety and explain welding requirements for heat and corrosion resistant ferrous alloy pipe. Make outside assignment to read 3ABRS3131-SG-602. Administer appraisal test upon completion of this assignment. Caution students not to mark or write on any training literature as it is to be reused by subsequent classes. Emphasize cutting and reuse of pipe.	
PLAN OF INSTRUCTION NO. 3ABRS3131	DATE 23 September 1975	BLOCK NO. VI	PAGE NO. 43

PLAN OF INSTRUCTION (Continued)

1 UNITS OF INSTRUCTION AND CRITERION OBJECTIVES	2 DURATION (HOURS)	3 SUPPORT MATERIALS AND GUIDANCE	
<p>2. Joints of Aluminum Alloy Pipe and Tubing</p> <p>a. Given inert gas shielded welding equipment and aluminum alloy pipe and tubing specimens, set up and weld butt joints with 100% penetration, free of overlap and undercut, for a total combined distance of no less than 3/4 of the length of the weld. All shop safety, good housekeeping, and fire prevention measures must be observed.</p> <p>b. Given inert gas shielded welding equipment and aluminum alloy pipe and tubing specimens, set up and weld tee joints with 30% to 80% penetration, free of overlap and undercut, for a total combined distance of no less than 3/4 of the length of the weld. All shop safety, good housekeeping, and fire prevention measures must be observed.</p>	<p>12 (3/4) (4)</p> <p>(4)</p>	<p><u>Column 1 Reference</u></p> <p>2a 2b</p> <p><u>Instructional Materials</u></p> <p>3ABR53131-SG-602, Joints of Aluminum Alloy Pipe and Tubing TO 00-25-224</p> <p><u>Audio Visual Aids</u></p> <p>Chart: Pipe Welding - Welding Sequences</p> <p><u>Training Equipment</u></p> <p>Inert Gas Shielded Welding Station Complete (1) Power Saw (12) Toolkit (1) Cleaning Equipment (12)</p> <p><u>Training Methods</u></p> <p>Discussion/Demonstration (2 hrs) Performance (6 hrs) Outside Assignment (4 hrs)</p> <p><u>Instructional Environment/Design</u></p> <p>Classroom (1.5 hrs) Laboratory (6.5 hrs)</p> <p><u>Instructional Guidance</u></p> <p>Emphasize welding safety and explain welding requirements for aluminum pipe and tubing. Stress proper joint set-up and welding current requirements. Make outside assignment to read 3ABR53131-SG-603. Administer appraisal test upon completion of this assignment. Emphasize cutting and reuse of aluminum alloy pipe and tubing.</p>	<p><u>STS Reference</u></p> <p>3a, 3b, 27b 3a, 3b, 27b</p>
<p>PLAN OF INSTRUCTION NO. 3ABR53131</p>	<p>DATE 23 September 1975</p>	<p>BLOCK NO. VI</p>	<p>PAGE NO. 44</p>



PLAN OF INSTRUCTION (Continued)

UNITS OF INSTRUCTION AND CRITERION OBJECTIVES	DURATION (HOURS)	SUPPORT MATERIALS AND GUIDANCE								
<p>3. Butt Patches on Jet Engine Hot Section Parts</p> <p>a. Without reference, state the functions of jet engine hot section parts with 75% accuracy.</p> <p>b. Given TO, identify location and service requirements pertaining to jet engine hot section parts without error.</p> <p>c. Given technical orders, select cleaning methods, repair procedures, and techniques for weld repair without error.</p> <p>d. Given inert gas shielded welding equipment and jet engine hot section parts, set up and make butt patch weld repairs with 100% penetration, free of overlap and undercut, for a total combined distance of no less than 3/4 of the length of the weld excluding the 1/2 inch at the start and finish. All shop safety, good housekeeping, and fire prevention measures must be observed.</p>	<p>22 (18/4)</p> <p>(1)</p> <p>(.5)</p> <p>(1.5)</p> <p>(15)</p>	<table border="0"> <tr> <td><u>Column 1 Reference</u></td> <td><u>STS Reference</u></td> </tr> <tr> <td>3a</td> <td>25a</td> </tr> <tr> <td>3b</td> <td>25b</td> </tr> <tr> <td>3c</td> <td>3a, 3b, 25c</td> </tr> </table> <p><u>Instructional Materials</u> 3ABR53131-SG-603, Butt Patches on Jet Engine Hot Section Parts TO 2J-1-13, Turbojet Engines or Gas Turbine Cleaning TO 2J-6 Series, Field Maintenance Instructions</p> <p><u>Training Equipment</u> Inert Gas Shielded Welding Station Complete (1) Pneumatic Grinder (1) Toolkit (1) Trainer: 3215 Jet Engine Repair (12) Selected Condemned/Defective Part(s) (1) Cleaning Equipment (1)</p> <p><u>Training Methods</u> Discussion/Demonstration (2 hrs) Performance (16 hrs) Outside Assignment (4 hrs)</p> <p><u>Instructional Environment/Design</u> Classroom (1.5 hrs) Laboratory (16.5 hrs)</p> <p><u>Instructional Guidance</u> Emphasize welding safety applicable to hot section repair. Have each student respond to all written items in the lesson. Make outside assignment to read 3ABR53131-SG-604. Administer appraisal test upon completion of this assignment. Emphasize conservation of butt patch material.</p>	<u>Column 1 Reference</u>	<u>STS Reference</u>	3a	25a	3b	25b	3c	3a, 3b, 25c
<u>Column 1 Reference</u>	<u>STS Reference</u>									
3a	25a									
3b	25b									
3c	3a, 3b, 25c									
PLAN OF INSTRUCTION NO. 3ABR53131	DATE 23 September 1975	BLOCK NO. VI PAGE NO. 45								



PLAN OF INSTRUCTION (Continued)

UNITS OF INSTRUCTION AND CRITERION OBJECTIVES	DURATION (HOURS)	SUPPORT MATERIALS AND GUIDANCE
<p>4. Fillet Patches on Jet Engine Hot Section Parts</p> <p>a. Given inert gas shielded welding equipment and jet engine hot section parts, set up and make fillet patch weld repairs free of excessive penetration, overlap, and undercut, for a total combined distance of no less than 3/4 of the length of the weld, excluding the 1/2 inch at the start and finish. All shop safety, good housekeeping, and fire prevention measures must be observed.</p>	<p>16 (12/4)</p>	<p><u>Column 1 Reference</u>      <u>STS Reference</u> 4a                                      3a, 3b, 25c</p> <p><u>Instructional Materials</u> JABRS3131-SG-604, Fillet Patches on Jet Engine Hot Section Parts TO 2J-1-13 TO 2J-6-Series</p> <p><u>Training Equipment</u> Inert Gas Shielded Welding Station Complete (1) Pneumatic Grinder (1) Toolkit (1) Trainer: 3215 Jet Engine Repair (12) Selected Condemned/Defective Part(s) (1) Cleaning Equipment (12)</p> <p><u>Training Methods</u> Discussion/Demonstration (2 hrs) Performance (10 hrs) Outside Assignment (4 hrs)</p> <p><u>Instructional Environment/Design</u> Classroom (1.5 hrs) Laboratory (10.5 hrs)</p> <p><u>Instructional Guidance</u> Emphasize welding safety applicable to hot section repair. Make outside assignment to read JABRS3131-SG-605. Administer appraisal test upon completion of this assignment. Emphasize conservation of fillet patch material.</p>
<p>PLAN OF INSTRUCTION NO. JABRS3131</p>	<p>DATE 23 September 1975</p>	<p>BLOCK NO. VI                      PAGE NO. 46</p>

PLAN OF INSTRUCTION (Continued)

UNITS OF INSTRUCTION AND CRITERION OBJECTIVES	DURATION (HOURS)	SUPPORT MATERIALS AND GUIDANCE								
<p>5. Reciprocating Engine Exhaust Manifold Repair</p> <p>a. Given technical orders, select cleaning methods, repair procedures, and techniques for weld repair without error.</p> <p>b. Given a list of materials, select materials required for repair of reciprocating engine exhaust manifold parts and assemblies with 75% accuracy.</p> <p>c. Given inert gas shielded welding equipment and reciprocating engine exhaust and manifold assemblies, set up and make weld repairs free of excessive penetration, overlap, and undercut, for a total combined distance of no less than 3/4 of the length of the weld, excluding the first 1/2 inch start and the last 1/2 inch finish. All shop safety, good housekeeping, and fire prevention measures must be observed.</p>	<p>8 (6/2)</p>	<table border="0"> <tr> <td><u>Column 1 Reference</u></td> <td><u>STS Reference</u></td> </tr> <tr> <td>5a</td> <td>25b</td> </tr> <tr> <td>5b</td> <td>25d</td> </tr> <tr> <td>5c</td> <td>3a, 3b, 25e</td> </tr> </table> <p><u>Instructional Materials</u> 3ABR53131-SG-605, Reciprocating Engine Exhaust Manifold Repair TO 2RA Series, Engine Exhaust Assembly Systems</p> <p><u>Audio Visual Aids</u> Chart: Layout for a Butt Patch on Edge of Exhaust Stack System</p> <p><u>Training Equipment</u> Inert Gas Shielded Welding Station Complete (1) Sandblast Machine (12) Power Shears (5) Slip Rolls (12) Buffer and Polishing Machine (4) Throatless Shears (6) Work Bench (4) Toolkit (1) Selected/Condemned Defective Part(s) (1)</p> <p><u>Training Methods</u> Discussion/Demonstration (2 hrs) Performance (4 hrs) Outside Assignment (2 hrs)</p> <p><u>Instructional Environment/Design</u> Classroom (1.5 hrs) Laboratory (4.5 hrs)</p> <p><u>Instructional Guidance</u> Emphasize welding safety and monitor all students during cleaning and preparation of parts for welding. Have each student respond to the written items in the lesson. Make outside assignment to read 3ABR53131-SG-606 and Modern Welding (Chapter 18). Administer appraisal test upon completion of this assignment. Emphasize conservation of cleaning materials, shielding gas, and filler rod.</p>	<u>Column 1 Reference</u>	<u>STS Reference</u>	5a	25b	5b	25d	5c	3a, 3b, 25e
<u>Column 1 Reference</u>	<u>STS Reference</u>									
5a	25b									
5b	25d									
5c	3a, 3b, 25e									
<p>PLAN OF INSTRUCTION NO. 3ABR53131</p>	<p>DATE 23 September 1975</p>	<p>BLOCK NO. VI</p> <p>PAGE NO. 47</p>								

PLAN OF INSTRUCTION (Continued)

UNITS OF INSTRUCTION AND CRITERION OBJECTIVES	DURATION (HOURS)	SUPPORT MATERIALS AND GUIDANCE	
<p>6. Welding of Carbon and Alloy Steel Tubular Assemblies</p> <p>a. Given materials, tools, and required equipment, lay out and fabricate tubular joints and assemblies without error.</p> <p>b. Given oxyacetylene welding equipment and tubular specimens; set up and weld tubular joints free of excessive penetration, overlap, and undercut for a total combined distance of no less than 3/4 of the length of the weld. All shop safety, good housekeeping, and fire prevention measures must be observed.</p>	<p>8 (6/2)</p>	<p>Column 1 Reference    STS Reference 6a                            12c 6b                            3a, 3b, 12e</p> <p><u>Instructional Materials</u> 3ABR53131-SG-606, Welding Carbon and Alloy Steel Tubular Assemblies Modern Welding (Chapter 18)</p> <p><u>Audio Visual Aids</u> Charts: Tubular Assemblies</p> <p><u>Training Equipment</u> Oxyacetylene Welding Station Complete (1) Trainer: 3216 Steel Tubing Weld (12) Toolkit (1)</p> <p><u>Training Methods</u> Discussion/Demonstration (1 hr) Performance (5 hrs) Outside Assignment (2 hrs)</p> <p><u>Instructional Environment/Design</u> Classroom (.5 hr) Laboratory (5.5 hrs)</p> <p><u>Instructional Guidance</u> Emphasize welding safety applicable to fabrication and welding of tubular joints. Have student read 3ABR53131-SG-701. Emphasize conservation of oxyacetylene welding gases and filler rod. Use TO 1-1A-1 as an additional reference.</p>	
<p>7. Related Training (identified in course chart).</p>	<p>2</p>		
<p>8. Measurement and Critique</p>	<p>2</p>		
<p>PLAN OF INSTRUCTION NO. 3ABR53131</p>	<p>DATE 23 September 1975</p>	<p>BLOCK NO. VI</p>	<p>PAGE NO. 48</p>



APPROVAL OFFICE AND DATE TWSTI 8/21/75	INSTRUCTOR Lesson Plans 13-7 19
COURSE NUMBER 3ABR53131	COURSE TITLE Metals Processing Specialist
BLOCK NUMBER V	BLOCK TITLE Inert Gas Shielded Welding of High Performance Aircraft Metals

LESSON TITLE  
Inert Gas Shielded Welding

LESSON DURATION		
CLASSROOM/Laboratory D & D 1.5 hrs/Perf .5 hr	Complementary None	TOTAL 2 hrs

POI REFERENCE		
PAGE NUMBER 33	PAGE DATE 23 Sep 1975	PARAGRAPH 1

STS/CIS REFERENCE	
NUMBER STS 531X1	DATE 31 May 1975

SUPERVISOR APPROVAL			
SIGNATURE	DATE	SIGNATURE	DATE

PRECLASS PREPARATION			
EQUIPMENT LOCATED IN LABORATORY	EQUIPMENT FROM SUPPLY	CLASSIFIED MATERIAL	GRAPHIC AIDS AND UNCLASSIFIED MATERIAL
1. Inert Gas Shielded Welding Equipment consisting of: Arc Welding Machine, Protective Equipment, Torch with Hoses & Cables and Welding Table	Consolidated Toolkit	None	1. 3ABR53131-SG-501 2. Modern Welding (Chapters 11 & 12) 3. TO 34W4-41-1 4. Film: FLC 9-233 Industrial Gases and Shielded Arc Welding 5. Charts: ARC Welding Machine Controls

CRITERION OBJECTIVES AND TEACHING STEPS

a. Without reference, select principles and operation of inert gas shielded welding equipment with 75% accuracy.

b. Given inert gas shielded welding machine, set up and make correct apparatus setting IAW TO 34W4-41-1.

Teaching steps are listed in Part II.





INTRODUCTION

Time: 10 min

Attention:

Review:

Overview: Students will at the completion of this lesson, understand the principles of inert gas shielded welding and operation of various types of equipment.

Motivation:

BODY

Time: 1 hr 40 min

Day 1

Presentation:

(Refer to objectives 1a, 1b)

1. Principles of inert gas shielded welding and operation of various types of equipment.

SHOW FILM FLC 9-233  
(Industrial Gases and  
Shielded Arc Welding)

a. Tungsten Inert Gas:

(1) Inert Gas Shielded Welding

(a) Process which utilizes an inert gas to protect the weld zone from atmospheric oxidation which contaminates the weld.

(b) Inert gas is a colorless, odorless, nontoxic and nonflammable gas, chemically inactive and one which will not combine with any other element.

(2) Source of Power

(a) Current may be supplied through either a welding generator, DC or AC.

(b) Unit should have good current control at the lower end of its current range.

show CHARTS EC74-225  
ARC WELDING MACHINE  
CONTROLS

- (c) Superimposed high frequency is used in some machines to permit starting the arc without touching the electrode to the work.

(3) Welding Current

(a) Direct current straight polarity

1. Electrode made negative and the work positive
2. This current gives a deep narrow weld because heat is concentrated on work piece.
3. Less chance of arc blow.
4. Used when welding stainless steel, copper or brasses.

(b) Direct current reverse polarity

1. Electrode made positive and the work negative
2. This current gives a wide shallow weld because electrode consumes most of the heat.
3. A larger diameter electrode should be used, since it absorbs a large amount of heat, to help protect it from burning off and also contamination.
4. Can be used for magnesium

(c) Alternating Current

1. Combination of DCSP and DCRP
2. Foreign matter such as moisture, oxides or scale found on the surface of the plate, tend to prevent (partially or completely) the flow of current in the reverse polarity direction.

3 To prevent this from occurring superimposed high frequency is used.

a With 60 cycles alternating current there are 120 changes of current flow direction per second

b With superimposed AC there are 120,000 changes of current flow per second

4 Advantages of AC.

a Arc may be started without touching electrode to work

b Longer arc is possible

c Electrodes have longer life

5 Metals which give excellent results are magnesium and mag. castings, aluminum and alum. castings

#### (4) Shielding Gas

##### (a) General Information

1 Argon, helium or a mixture of the two are generally preferred for use as shielding gas

2 Many other gases and gas mixtures have been tried but for general use all have been found to have marked deficiencies such as rapid electrode deterioration, porosity in welds or arc stability

3 Some have been found useful for certain purposes, the reactive gas nitrogen can be used as the shielding gas in welding copper

(b) Argon

23

- 1 Used more extensively because it is cheaper
- 2 Cylinder markings are gray with a white horizontal band
- 3 Nonferrous metals, such as aluminum and magnesium are sensitive to impurities and are best welded with high purity gas, producing excellent welding results. Argon and helium gases which are commercially available from most sources are of high purity and average well over 99.95% pure
- 4 Argon is generally used for all alternating current welding applications, such as aluminum, magnesium or copper
- 5 The tendency of burn through is less with argon, therefore it is good for welding thin gauge material

(c) Helium

- 1 High arc voltage and power are desirable for welding thick material and metals with high heat conductivity therefore, helium is used in these applications because of its higher arc voltage characteristics
- 2 Helium is usually used with DC welding machines, using DCSP
- 3 Helium is used to weld magnesium using DCRP
- 4 Cylinders are gray with light brown top

(5) Regulator Flowmeter

- (a) Steps down the high pressure in the cylinder or manifold cylinders, to a lower working pressure
- (b) The lower pressure is received by the flow meter, the required gas flow to the apparatus is controlled by the amount of manual adjustment of the throttle valve
- (c) This flow is indicated on the flowmeter tube and is controlled by the manual adjustment of the throttle valve

(6) Torches

- (a) Two types are air-cooled and water-cooled
  - 1 Air cooled is excellent for repairing this gauge material
    - a It can operate continuously on AC or DC up to 100 amps
  - 2 Water cooled is designed to operate higher current ratings above 100 amps to 300 amps
    - a Water requirements are from one to two pints per minute
    - b A special fuse of 45 amps is installed in the power lead line to the torch to protect the equipment from overheating in case of water stoppage
    - c Water stoppage may result from an accumulation of dirt in the small passages of the torch



be corrected by disconnecting the water lines and reversing the flow of water

(b) Three basic parts of the torch are collet, cup and electrode

- 1 Collet is used to hold the electrode in place
- 2 Electrodes used for gas shielded welding are:
  - a Commercially pure tungsten
  - b 1% Thoriated
  - c 2% Thoriated
  - d Zirtung
- 3 Thoriated tungsten electrodes are superior to pure tungsten because of their higher electron flow, better arc starting and stability and they are less likely to become contaminated
- 4 Tungsten electrodes that become contaminated should be ground off or break off contaminated end with pliers
- 5 Tungsten electrodes may be identified by color markings on either the box or the electrode itself
  - a Green - Pure tungsten
  - b Yellow - 1% Thoriated
  - c Red - 2% Thoriated
  - d Brown - Zirtung

(7) Safety

- (a) Wear gloves when using AC high frequency
- (b) Proper shade lens
- (c) Shut off machines and gases when not in use

Application:

1. Student will set up and make apparatus settings without error with instructor assistance

Evaluation:

1. Student will answer 75% of the following questions correctly

26  
EQUIPMENT USED: INERT GAS  
SHIELDED WELDING EQUIPMENT  
CONSISTING OF ARC WELDING  
MACHINE, PROTECTIVE EQUIPMENT  
TORCH WITH CABLES + HOSES  
AND WELDING TABLE.

CONCLUSION

Time: - 10 min

1. Summary

- a. Review principles of Inert Gas Shielded Welding Operation
- b. Advantage of gas shielded welding for various types of metal
- c. Set up and adjust apparatus for heat and corrosion resistant ferrous alloys

2. Remediation

3. Assignment NONE

APPROVAL OFFICE AND DATE TWSTL <i>9/23/75</i>	INSTRUCTION
COURSE NUMBER 3ABR53131	COURSE TITLE Metals Processing Specialist
BLOCK NUMBER V	BLOCK TITLE Inert Gas Shielded Welding of High Performance Aircraft Metals
LESSON TITLE Joints of Heat and Corrosion Resistant Ferrous Alloys	

LESSON DURATION		
CLASSROOM / Laboratory D & D 2.5 hrs/Perf 21.5 nrs	Complementary 6 hrs	TOTAL 30 hrs

POI REFERENCE		
PAGE NUMBER 34 and 35	PAGE DATE 23 Sep 1975	PARAGRAPH 2

STS. CTS REFERENCE	
NUMBER STS 531X1	DATE 31 May 1975

SUPERVISOR APPROVAL			
SIGNATURE	DATE	SIGNATURE	DATE

PRECLASS PREPARATION			
EQUIPMENT LOCATED IN LABORATORY	EQUIPMENT FROM SUPPLY	CLASSIFIED MATERIAL	GRAPHIC AIDS AND UNCLASSIFIED MATERIAL
<ol style="list-style-type: none"> <li>Inert Gas Shielded Welding Equipment Complete</li> <li>Power Shears</li> <li>Trainer: Tungsten Inert Gas (TIG) Shielded Welding Specimens, 4404</li> </ol>	Consolidated Toolkit	None /	<ol style="list-style-type: none"> <li>3ABR53131-SG-502</li> <li>Modern Welding (Chapter 18)</li> </ol>

CRITERION OBJECTIVES AND TEACHING STEPS	
a.	Given inert gas shielded welding equipment and heat and corrosion resistant ferrous alloy specimens, set up and weld edge joints, free of undercut and overlap for a total combined distance of no less than 3/4 of the length of the specimen, excluding the first 1/2 inch start and the last 1/2 inch finish. All shop safety, good housekeeping and fire prevention measures must be observed.
b.	Given inert gas shielded welding equipment and heat and corrosion resistant ferrous alloy specimens, set up and weld lap joints, free of excessive penetration, undercut, and overlap for a total combined distance of no less than 3/4 of the length of the specimen, excluding the first 1/2 inch start and the last 1/2 inch finish. All shop safety, good housekeeping and fire prevention measures must be observed.
c.	Given inert gas shielded welding equipment and heat and corrosion resistant ferrous alloy specimens, set up and weld butt joints with 100% penetration, free of undercut and overlap, for a total combined distance of no less than 3/4 of the length of the specimen excluding the first 1/2 inch start and the last 1/2 inch

## CRITERION OBJECTIVES AND TEACHING STEPS (Continued)

finish. All shop safety, good housekeeping, and fire prevention measures must be observed.

- d. Given inert gas shielded welding equipment and heat and corrosion resistant ferrous alloy specimens, set up and weld tee and corner joints, free of excessive penetration, overlap and undercut for a total combined distance of no less than  $3/4$  of the length of the specimen, excluding the first  $1/2$  inch start and the last  $1/2$  inch finish. All shop safety, good housekeeping and fire prevention measures must be observed.

Teaching steps are listed in Part II.

1. Attention:
2. Review: In the last lesson you learned the principles of Inert Gas Shielded Welding and Operation of various types of equipment.
3. Overview: At the completion of this lesson you will have learned how to weld butt, lap, tee, corner and edge joints in heat and corrosion resistant ferrous alloys.
4. Motivation:

## BODY

Time: 29 hrs 40 min

## PRESENTATION:

(Refer to objectives 2a, b, 2c)

## 1. Corrosion Resistant Steel

## a. General Information

(1) The coefficient of expansion for stainless steel is greater than carbon steel

(a) To resist the tendency of warpage during welding, joint edges must be correctly aligned and properly tacked

(2) Carbide precipitation is another important factor to consider when welding stainless steel:

(a) This effect is less when using the inert gas method because the heat is concentrated to a smaller area

(b) Carbide precipitation usually occurs near fusion line. It can be overcome by confining the arc heat to as small an area as possible

← Show TRAINER 4404  
TUNGSTON INERT GAS (TIG)  
Shielded Welding Specim



- (c) This means you should use a smaller electrode, higher amperage and a faster welding speed

(3) Weld back up

- (a) On light gauge material backing is usually used to protect the underside of the weld from atmospheric contamination resulting in possible weld porosity or poor surface appearance
- (b) Weld back up on heavier material prevents the weld from melting through excessively by conducting some of the heat away from the joint edges
- (c) Flat metal backup plates may be used only on flange type joints
- (d) Explain the groove in the backup plates

2. Weld edge joints of heat and corrosion resistant ferrous alloys to Modern Welding Handbook specifications.

a. Welding Edge Joints

- (1) One of the easiest joints to weld
- (2) Edge joints are used primarily on light gauge material, where there is little or no direct tension or bending stresses applied on the finished weld
- (3) Using metal up to .030, no filler rod is required
- (a) Very close fit-up is necessary when not using filler rod

3. Weld butt joints of heat and corrosion resistant ferrous alloy to Modern Welding Handbook specifications

a. Butt Joint

- (1) Butt joints are easy joints to prepare and can be welded with or without filler rod material, depending on the thickness of the metal.
  - (a) Metal up to .030 can be welded without filler rod
- (2) Joint fit-up for a square edge butt joint should always be true enough to permit 100% penetration with good fusion.
  - (a) On metal up to .030, no spacing is necessary
- (3) Metal preparation and set up
  - (a) Metal should always be free of burrs
  - (b) Joint edges must be cleaned of all foreign material
  - (c) Fixtures are used for metal alignment, but the main purpose is to dissipate excess heat
  - (d) For butt joints of a thickness greater than .030 inch the work should be set up with the edges spaced very slightly
  - (e) When welding butt joints outside of a fixture, the joint edges should be aligned parallel, spaced approximately the thickness of the metal
- (4) Machine setting and equipment adjustment
  - (a) Current - DC straight polarity

(b) Argon flow - 4-6 liters  
(15-20 PSI)

(c) Electrode - 2% Throiated tungsten

(d) Electrode should extend 1/4 to 5/16" beyond the edge of the cup

(e) Water flow - 1-2 pints per minute

(5) Welding Application

(a) If electrode becomes contaminated strike the arc on a piece of copper plate until the erratic tendency of the arc smooths out. If this does not work, grind the contamination off on the grinder

(b) Use the foot control to adjust the arc to desired heat required

(c) Travel should be the fore-hand method adding filler rod to the forward edge of the molten pool as you travel along.

(d) When terminating the weld the foot control should be swung to the low position, the arc broken and the shielding gas allowed to flow over the weld area until it has cooled

(e) In order to prevent overlap when restarting a weld, the arc is struck approximately 1/4" ahead of the terminated weld and then moved back to the end of the weld so as to bring it to the molten state before adding filler rod

(f) Weld specifications are:  
Bead width - 2 to 3 T  
Penetration - 100%  
Reinforcement - 5 to 30%

(6) Defects to be avoided

32

- (a) Undercut caused by poor set up, improper backing or excessive heat
- (b) Overlap caused by insufficient heat or adding too much filler rod
- (c) Too wide a bead caused by traveling too slow
- (d) Insufficient penetration caused by inadequate spacing of the pieces prior to welding or insufficient heat or traveling too fast
- (e) Smoky oxidized appearance caused by insufficient flow of shielding gas or improper

4. Weld lap joints of heat and corrosion resistant ferrous alloys to Modern Welding Handbook specifications

- a. Lap joints are used to join two overlapping sheet, can also be used where you have poor fitup
- b. Three types of lap joints
  - (1) Doubled
  - (2) Single
  - (3) Joggled
- c. Doubled welding of lap joints is the strongest
- d. Single welded lap joints are usually sufficient for most applications, but a single welded lap joint in sheet metal will not develop the full strength of the base metal
- e. Stainless steel lap welds made by the heli arc process in light gauge metals up to .060 can be set up and welded without filler rod
  - (1) The electrode is so directed as to melt the upper edge of the joint, giving a smooth, slightly convex weld

- (1) Pieces to be lap welded should be sheared leaving a square edge free of burrs and warpage
  - (2) Joint edges must be thoroughly cleaned of all foreign material
  - (3) No fluxing is necessary
- g. Machine and equipment adjustments are the same as the butt joint

h. Welding Application

- (1) Use forehand method melting back about 1 to 2 T of the top plate

i. Weld specifications

- (1) Bead width - 2 to 3 T
- (2) Upper Leg - equals 1 T
- (3) Lower Leg - equals 1 1/2 T
- (4) Penetration - 25 to 80%

J. Defects to avoid

- (1) Undercut
- (2) Too wide a bead
- (3) Excessive Burning back of the top plate
- (4) Smoky oxidized weld
- (5) Excessive penetration

k. Inspection (Visual)

- (1) Reinforcement should not extend above the thickness of the upper sheet
- (2) The contour of the bead should be slightly convex
- (3) The surface appearance should be from a dark bronze to a light purple



## 5. Welding Handbook Specifications

34

- a. Tee joints are frequently made to join sheets of unequal thickness
- b. Tee joints are made to join plates at approximately 90 degrees of each other

### c. Specifications for tee joint

- (1) Legs -  $1 \frac{1}{2} T$
- (2) Penetration - 25 to 85%
- (3) Bead width - 2 to 3 T
- (4) Bead should be slightly concave to convex

### d. Machine setting and equipment

- (1) DCSP
- (2) Water flow is from 1 to 2 pints per minute
- (3) Argon flow should be about 15 to 20 psi

### e. Welding application

- (1) Strike and adjust arc on the copper plate
- (2) Hold torch to bisect the angle as near to perpendicular to the axis of the weld as practical
- (3) Add the filler rod at the root of the joint and fore-edge of the molten pool
- (4) Let the inert gas cool the weld when the weld is terminated

### f. Defects

- (1) Undercut
- (2) Too little filler rod
- (3) Wrong torch angle

### g. Characteristics of good welds

- (1) No overlap or undercut

h. Corner joint

(1) Used mainly on boxes, frames, etc.

(2) Specifications

(a) Legs are equal to T

(b) Throat equal to T

(c) Penetration - 100%

(3) Machine setting

(a) DCSP

(b) Argon flow should be 15 to 20 psi

(c) Water flow - 1 to 2 pints per minute

(4) Welding applications

(a) Torch angle 75 to 90°

(b) Strike arc and stabilize on copper plate

(c) Allow shielding gas to flow over terminated weld

(5) Defects to avoid

(a) Undercut

(b) Overlap

(c) Excessive penetration

(d) Wrong torch angle

i. Utilize health and safety equipment

(1) Machinery guards

(2) Proper eye protection

(3) Protective clothing (gloves, etc.)

1. Students will perform the following:

- a. Preparation of metal
- b. Set up of joint
- c. Weld Edge joint
- d. Observe all safety precautions during the accomplishment of the project

Equipment used in lesson, Inert Gas Shielded Welding Station Complete Power Shears.

36

**Evaluation:**

1. Student will be checked for proper welding techniques in welding edge joints
2. Assistance will be given when necessary

**Summary:**

**END OF DAY SUMMARY Day 1**

1. Preparation of material
2. Set up of edge joint and lap joint
3. Setting and adjustment of equipment
4. Weld back ups
5. Safety
1. Read 3ABR53131-SG-502 and answer questions at end of chapter.

**CTT**

Assignment-POI Objective 2C  
POI Time 2 hours

**INTRODUCTION TO NEW DAY INSTRUCTION Day 2**

1. Remotivation
2. Review Evaluate CTT Assignment & Critique Missed Items Study Guide 502
  - a. Preparation of metal
  - b. Set up of edge and lap joint
  - c. Setting up and adjustment of equipment
  - d. Back ups
  - e. Techniques of welding edge and lap joint

Application: Objectives 2a, b, c

Equipment used throughout lesson,  
Inert Gas Shielded Welding Station.  
Complete Power Shears.

1. Students will perform the following:
  - a. Preparation of metal
  - b. Set up of joint
  - c. Weld edge, lap and butt joints
  - d. Observe all safety precautions during the accomplishment of the project.

Evaluation:

1. Student will be checked for proper welding techniques in welding butt joints
2. Assistance will be given when necessary

Summary:

END OF DAY SUMMARY

DAY 2

1. Preparation of material
2. Set up of edge, lap and butt joint
3. Setting and adjustment of equipment
4. Weld back ups
5. Safety
1. None

Assignment:

INTRODUCTION TO NEW DAYS INSTRUCTION

DAY 3

1. Remotivation
2. Review
  - a. Types of butt joints

- c. Setting up and adjustment of equipment
- d. Techniques in welding lap joints
- e. Safety

38

Overview: Welding Butt joints of heat & Corrosion resistant ferrous alloys

Application:

1. Student will perform the following:
  - a. Preparation of metal
  - b. Set up of joints
  - c. Welding of butt joints
  - d. Observe all shop safety rules

Equipment used: Inert Gas Shielded  
Welding Station Complete Power  
Shears.

Evaluation:

1. Student will be checked for procedures and techniques in welding butt joints
2. Assistance will be given when necessary

Summary:

CTT Assignment: Poi Objective 2d  
Poi Time 2 hrs.

END OF DAY SUMMARY DAY 3

1. Types of butt joints
2. Preparation of metal
3. Setting up and adjustment of equipment
4. Techniques in welding butt joints
5. Safety
1. Read Modern Welding Handbook Chapter 18 Para 18-1 Thru 18-19

INTRODUCTION TO NEW DAY'S INSTRUCTION DAY 4

1. Remotivation
2. Review
- a. Evaluate CTT Assignment & Critique missed items (Modern Welding Chap.18)
- b. Preparation of Material.



- c. Set up of Metal
  - d. Weld tee and corner joints to Modern Welding Handbook specifications
  - e. Observe all shop safety practices
3. Overview: Welding Tee and corner joints of heat and corrosion resistant ferrous alloys.

Application: Refer to initial application step page 6, part II L/P for equipment used. Inert Gas Shielded Welding Equipment Complete, Power Shears

- 1. Student will perform the following:
  - a. Preparation of metal
  - b. Set up of metal
  - c. Weld tee and corner joints to Modern Welding Handbook specifications

Evaluation:

- 1. Student will be checked for proper procedure and techniques for welding tee and corner joints of heat and corrosion resistant ferrous alloys.
- 2. Assistance will be given when necessary.

END OF DAY SUMMARY DAY 4

Summary:

- 1. Types of tee and corner joints
- 2. Preparation of metal
- 3. Setting up and adjustment of equipment
- 4. Techniques in welding tee and corner joints
- 5. Safety

CTT Assignment: POI Objective  
POI Time 2 hrs.

- 1. Read 3ABR53131-SG-503 and Answer questions at end of Chapter.

INTRODUCTION TO NEW DAYS INSTRUCTION DAY 5 2 hours

- 1. Remotivation
- 2. Review- Evaluate CTT Assignment and critique missed items (SG503)
  - a. Types of tee and corner joints



- b. Preparation of material
- c. Setting up and adjustment of equipment
- d. Techniques in welding tee and corner joints

Safety

Application:

- 1. Student will perform the following:
  - a. Preparation of metal
  - b. Set up of metal
  - c. Weld tee and corner joints to Modern Welding Handbook specifications
  - d. Observe all shop safety practices

Equipment used, Inert gas, shielded welding station complete, power shears

Evaluation:

- 1. Student will be checked for proper procedure and techniques for welding tee and corner joints of heat and corrosion resistant ferrous alloys.
- 2. Assistance will be given when necessary.

CONCLUSION

Time: 10 Min.

Day 5, 2 hrs.

- 1. Summary:
  - a. Set up of edge, butt, lap, tee and corner joints of heat and corrosion resistant ferrous alloys
  - b. Preparation of metal for all joints
  - c. Techniques for welding all joints
  - d. Shop safety procedures

2. Assignment: None

3. Remotivation:

4. Closure.

APPROVAL OFFICE AND DATE TWSTI   8/27/75 [Signature]		INSTRUCTOR	
COURSE NUMBER 3ABR53131		COURSE TITLE Metals Processing Specialist	
BLOCK NUMBER V		BLOCK TITLE Inert Gas Shielded Welding of High Performance Aircraft Metals	
LESSON TITLE Position Welding of Heat and Corrosion Resistant Ferrous Alloys			
LESSON DURATION			
CLASSROOM/Laboratory D & D 1 hr/Perf 5 hrs		Complementary 2 hrs	TOTAL 8 hrs
POI REFERENCE			
PAGE NUMBER 35		PAGE DATE 23 Sep 1975	PARAGRAPH 3
STS/CIS REFERENCE			
NUMBER STS 531X1		DATE 31 May 1975	
SUPERVISOR APPROVAL			
SIGNATURE		DATE	SIGNATURE
PRECLASS PREPARATION			
EQUIPMENT LOCATED IN LABORATORY	EQUIPMENT FROM SUPPLY	CLASSIFIED MATERIAL	GRAPHIC AIDS AND UNCLASSIFIED MATERIAL
1. Inert Gas Shielded Welding Station Complete 2. Power Shears	Consolidated Toolkit	None	1. 3ABR53131-SG-503 2. Modern Welding (Chapter 18)
CRITERION OBJECTIVES AND TEACHING STEPS			
<p>a. Given inert gas shielded welding equipment and heat and corrosion resistant ferrous alloy specimens, set up and weld butt joints in the horizontal position with 100% penetration, free of overlap and undercut, for a total combined distance of no less than 3/4 of the length of the specimen, excluding the first 1/2 inch start and the last 1/2 inch finish. All shop safety, good housekeeping and fire prevention measures must be observed.</p> <p>b. Given inert gas shielded welding equipment and head and corrosion resistant ferrous alloy specimens, set up and weld butt joints in the vertical position with 100% penetration, free of overlap and undercut, for a total combined distance of no less than 3/4 of the length of the specimen, excluding the first 1/2 inch start and the last 1/2 inch finish. All shop, safety, good housekeeping and fire prevention measures must be observed.</p>			
Teaching steps are listed in Part II.			

42

**INTRODUCTION**

Time: 10 Min

1. **Attention:**
2. **Review:** Evaluate CTT assignment and critique missed items.
3. **Overview:** At the completion of the lesson you will have learned the position welding of heat and corrosion resistant ferrous alloys.
4. **Motivation:**

**BODY**

Time: 5 Hrs 40 Min

**Presentation:**

(Refer to objectives 3a, b)

1. **Set up and make correct apparatus settings for welding heat and corrosion resistant ferrous alloys**
  - a. **Machine setting**
    - (1) DCSP
    - (2) Low range - 90%
    - (3) High frequency start
    - (4) Water flow - 1-2 pts per min
    - (5) Gas flow - 15-20 liter/min
  - b. **Metal set-up**
    - (1) Use back up with fixtures (5 cu ft/hr)
    - (2) Tack weld if fixtures are not used
    - (3) Metal (joint) must be at least a 75 degree angle

2. Position welding of heat and corrosion resistant ferrous alloys to Modern Welding Handbook specifications.

a. Vertical Butt Joint

- (1) Due to the force of gravity the bead has a tendency to run down
- (2) Torch angle should be an angle of 45 degrees upward
- (3) Filler rod should be added to forward leading edge of molten pool
- (4) A downward flow will form a good bead and a good blending into the parent metal
- (5) Proper heat control is very important to insure 100% penetration

b. Weld specifications

- (1) Bead width - 2 to 3 T
- (2) Bead height - 5 to 30%
- (3) Penetration - 100%

c. Defects to Avoid

- (1) Undercut
- (2) Overlap
- (3) Too little or too much penetration

3. Position weld heat and corrosion resistant ferrous alloys (vertical and horizontal)

a. Horizontal weld butt joint

- (1) Gravity pulls the molten pool downward
- (2) Torch angle should be as close to 90 degrees as possible

(3) Filler rod is added to forward leading edge of molten pool

(4) 100% penetration is necessary

b. Weld specifications are the same as vertical butt joint

c. Practice shop safely

Application:

Refer to objectives 3a, b)

Students will use equipment in shop. Inert gas shielded welding station complete, power shears

Student will perform the following:

1. Preparation of metal
2. Set up of joint
3. Weld butt joints of heat and corrosion resistant ferrous alloys in the vertical and horizontal positions
4. Observe all safety precautions during the accomplishment of the project

Evaluation:

1. Student will be checked for the proper procedures and techniques in welding butt joints in the vertical and horizontal positions
2. Assistance will be given when necessary

Summary:

END OF DAY SUMMARY

DAY 5

1. Preparation of metal
2. Set up of joints to be welded
3. Weld specifications
4. Observe safety precautions

Assignment: POI Objective 4a, POI Time 2 hrs.

Read 3ABR53131-SG-504 and answer questions at end of chapter



INTRODUCTION TO NEW DAY'S INSTRUCTION

- 1. Remotivation
- 2. Review: Evaluate CTT Assignment and Critique missed items (SG 504)
  - a. Welding procedures for vertical and horizontal butt joints
  - b. Practice shop safety
  - c. Check on homework assignment

Overview: Position welding butt joints (horizontal position)

Application:

(Cont, Refer to objectives 3b

Students will use equipment in shop. Inert gas shielded welding station complete; power shears

- 1. Student will perform the following:
  - a. Preparation of metal
  - b. Set up of joint
  - c. Weld butt joint in horizontal position to specifications
  - d. Observe all safety precautions

Evaluation:

- 1. Student will be checked for proper procedures and techniques in welding a horizontal butt joint
- 2. Assistance will be given when necessary

CONCLUSION

Time: 10 Min

- 1. Summary
  - a. Preparation of metal and material
  - b. Set up of joint
  - c. Weld specifications
  - d. Observe all safety precautions

46

ABR53131 Metals Processing Specialist

BLOCK NUMBER V BLOCK TITLE Inert Gas Shielded Welding of High Performance Aircraft Metals

LESSON TITLE Joints of Aluminum and Aluminum Alloy Sheet and Plate

CLASSROOM/Laboratory D & D 2 hrs/Perf 10 hrs LESSON DURATION Complementary 4 hrs TOTAL 16 hrs

PAGE NUMBER 36 PAGE DATE 23 Sep 1975 PARAGRAPH 4

NUMBER STS 531X1 DATE 31 May 1975

SUPERVISOR APPROVAL table with columns for SIGNATURE and DATE.

PRECLASS PREPARATION

Table with 4 columns: EQUIPMENT LOCATED IN LABORATORY, EQUIPMENT FROM SUPPLY, CLASSIFIED MATERIAL, and GRAPHIC AID AND UNCLASSIFIED MATERIALS.

CRITERION OBJECTIVES AND TEACHING STEPS

- a. Given inert gas shielded welding equipment and aluminum and aluminum alloy sheet specimens, set up and weld lap joints, free of excessive penetration, overlap, and undercut, for a total combined distance of no less than 3/4 of the length of the specimen, excluding the first 1/2-inch start and the last 1/2 inch finish. All shop safety, good housekeeping, and fire prevention measures must be observed.
b. Given inert gas shielded welding equipment and aluminum and alluminum alloy plate specimens, set up and wel butt joints with 100% penetration, free of overlap and undercut for a total combined distance of no less than 3/4 of the length of the specimen, excluding the first 1/2 inch start and the last 1/2 inch finish. All shop safety, good housekeeping, and fire prevention measures must be observed.
c. Given inert gas shielded welding equipment and aluminum and aluminum alloy sheet specimens, set up and weld tee joints, free of excessive penetration, overlap, and undercut, for a total combined distance of no less than 3/4 of the length of the specimen, excluding the first 1/2 inch start and the last 1/2 inch finish. All shop safety, good housekeeping, and fire prevention measures must be observed.

Teaching steps are listed in Part II.

ATC 170



## INTRODUCTION

47  
Time: 10 Min

1. Attention:
2. Review: Evaluate GTT assignment and critique missed items SS9504
3. Overview: At the completion of this lesson you will have the Introduction and Welding of Butt, Lap, Tee of Aluminum.
4. Motivation:

## BODY

Time: 11 hrs. 40 min.

### Presentation

(Refer to objectives 4a, b)

1. Factors such as thickness or gauge, design of parts, finish and appearance desired, and available equipment must be considered in selection of the heli arc welding method to be used in joining aluminum.
2. TIG is used for welding aluminum section which is less than 1/8" in thickness.
  - a. Welding fixtures are sometimes necessary and should be used when welding thin gauge material to prevent warpage.
3. The arc is established between a nonconsumable tungsten electrode and the parts to be welded.
4. Flux is not required in inert gas welding because the action of the arc breaks up the oxide film.
5. Power Source
  - a. AC high frequency is recommended for welding of aluminum
  - b. DCRP may be used if AC isn't available for aluminum

Show Trainer 4404 Tugston  
Inert Gas (TIG) Shielded  
Welded Specimens  
Students Issued 3ABR53131  
SG501 Modern Welding  
Handbook  
at the end of Blk. IV.

## 6. Explain alternating current

- a. AC is a combination of DCSP and DCRP
- b. When high frequency is superimposed upon AC welding current a continual flow of electrons is jumping the gap between the electrode and the work piece, piercing the oxide film and forming a path for the welding current to follow.

## 7. Aluminum alloy most widely used

- a. 1100, 3003, 4043, 5052, 6061, 7075 and 2024
- b. 1100-pure aluminum  
3003-manganese-can be heat treated but must be annealed before welding  
4043-aluminum silicon  
5052-magnesium-heat treatable and weldable  
6061-magnesium silicon-weldable

7075-zinc-heat treatable,  
nonweldable  
2024-copper-heat treatable  
non weldable

Show Film: FLC-2360  
(Welding Aluminum)

## 8. Welding equipment

- a. For welding above 100 amps a water cooled torch is used
- b. Water used to cool the welding torch should be clean to prevent clogging or flow restriction.
  - (1) Overheating can melt the silver brased metal joints in the torch and the plastic water tube which sheaths the electric cable

- (2) Some welding equipment is provided with solenoid valves and valve timing controls to control the flow of water and gas during welding.
- (3) When welding is stopped, the timer allows the water and gas to flow for a sufficient length of time to allow the tungsten electrode to cook, thus preventing contamination when exposed to air.

c. Recommend electrode sizes for various ranges of welding current.

9. Filler material

- a. Additional filler metal is not necessary in TIG welding when enough parent metal is provided by the joint design to form the weld bead.
- b. The filler rod should always be within the inert gas shield and at the leading edge of the weld pool.
- c. Too large a rod disturbs and often freezes the pool, while a rod too small in size forces the welder to feed too fast for steady operation.

10. Preparation of metal

- a. Cleaning of the surfaces to be welded is of major importance in all aluminum joining regardless of the welding process.
- b. Oxide, grease or oil film remaining on the edges to be joined will cause unsound welds.



c. Mild alkaline solutions and commercial degreasers that do not give off toxic fumes during welding are used successfully to remove surface contaminants before welding.

(1) Acetone-alkaline solution-explosive

(2) Alcohol-alkaline solution-explosive

d. Oxide film can also be removed by mechanical means

(1) Aluminum wool

(2) Stainless steel brush

## 11. Joint Requirement

a. The choice of joint design and root openings required for its welding are determined by the structural requirements of the weld.

b. The basic types of joint designs are the butt, lap, corner and edge.

(1) Almost any fabrication will have one or a combination of two or more of these basic types, depending upon the physical properties desired, type of material being welded, the size, shape and appearance of the assembly.

## 12. Weld specifications

a. Butt joint

(1) Metal up to and including  $1/8$  can be welded with no edge preparation other than removing burrs and cleaning.



- (2) Welding is done from one side only, on metal of 1/8" or less
- (3) On material over 1/8" and up to 1/4" thickness a square edge butt joint can be used if the joint is to be welded from both sides
- (4) A single-vee butt joint is used on metal 1/8: to 1/2" thickness where welding is done from one side only
- (5) Metal over 1/2" is prepared with a double-vee or double-u
  - (a) Vee or U joints are filled with filler rod
- (6) Specification for Butt Joint
  - (a) Penetration-100%
  - (b) Width-2 to 3 T
  - (c) Height-5% to 30% T

### 13. Lap joint

- a. A lap joint needs no metal preparation, other than cleaning and removing burrs
- b. Plates must be in close contact along the joint edges, to prevent burning away of the upper plate.
- c. On material up to 1/4" thick, a lap joint can be made with or without filler rod

- (1) Lap joints are not recommended on metal over  $\frac{1}{2}$ " thick except for rough fit up
- (2) Three types of lap joints
  - (a) Single welded lap
  - (b) Doubled welded lap
  - (c) Joggled lap
- (3) Specifications for lap joint
  - (a) Lower leg -  $1 \frac{1}{2} T$
  - (b) Upper leg -  $T$
  - (c) Width bead 2 to 3  $T$
  - (d) Penetration - 25 to 80% of  $T$

#### 14. Tee Joints

- a. The plain tee joint, which is used on material up to  $\frac{1}{8}$ " thickness, needs to have special preparation other than cleaning the edge of the vertical sheet and the surface of the horizontal sheet where the weld is to be made.
- b. Welds made on metal having a thickness of  $\frac{1}{8}$ " or more require beveling of the vertical sheet.
  - (1) A single bevel is used on metal up to  $\frac{1}{2}$ " where welding is done from one side only.
  - (2) A double bevel is used where the joint can be welded from both sides.

- (1) Lower leg-1 1/2 T
- (2) Upper leg-1 T
- (3) Width bead-2 to 3 T
- (4) Penetration-25 to 80% T

15. Welding procedures

- a. Back up plates are recommended wherever possible to control weld penetration and permit faster welding speeds.
- b. Tack weld at about 1" to 1 1/2" intervals, they should be neat and small.
- c. The arc is started by bringing electrode close to the work surface.
  - (1) Electrodes do not have to touch the work surface.
- d. Hold long arc
  - (1) Between 1/8" to 3/16"
- e. Keep filler rod fairly flat to work surface.
  - (1) Between 10-20 degrees

Application:  
(Refer to objectives 4a, 4b)

EVALUATION:

- 1. Student will be checked for proper welding procedure
- 2. Assistance will be given when necessary

Students will use equipment in shop. Inert gas shielded welding station complete, power shears

1. Preparation of material
2. Welding procedures and techniques
3. Aluminum alloy most widely used
4. Alternating current
5. Lap AND BUTT JOINT SPECIFICATIONS

CTT Assignment

Read Modern Welding Handbook. POI objective 4b, 4c  
 Para 18-35, para 23-21 POI time 2 hrs.  
 and para 24-21

INTRODUCTION TO NEW DAY'S INSTRUCTION

Day 7

1. Evaluate CTT and critique missed items. (Modern Welding - para 18-35 para 23-21 and para 24-21).
2. Remotivation:
3. Review:
  - a. Preparation of material
  - b. Set up of joint
  - c. Welding procedures and techniques
  - d. Safety

Overview: Tee joints of aluminum.

Application:

(Refer to objectives 4c)

Students will use equipment in shop  
 Inert gas shielded welding station  
 complete (power shears)

Student will perform the following:

1. Preparation of material
2. Set up and tack
3. Weld tee joint to student guide specifications
4. Observe all safety precautions during accomplishment of project

Evaluation:

1. Student will be checked for proper welding procedures.
2. Assistance will be given when necessary.

Summary:

END OF DAY SUMMARY

Day 7/

1. Preparation of material
2. Welding procedures and techniques
3. Aluminum alloy most widely used
4. Alternating current
5. Tee joint specifications

CTT Assignment: Read 3ABR53131 SG-505 Answer  
Questions at end of chapter  
Read chapter 18 Modern Welding

POI Objective 5a  
POI Time 2 hrs.

INTRODUCTION TO NEW DAY'S INSTRUCTION

Day 8, 2 hrs.

1. Remotivation:
2. Review: Evaluate CTT Assignment and critique missed items (SG 505)
  - a. Preparation of material
  - b. Set up of joint
  - c. Welding procedures and techniques
  - d. Safety
3. Overview: Tee joints of aluminum.

Application: (Cont'd) ←

Students will use equipment  
in shop inert gas shielded  
welding station complete  
(Power Shears)

Student will perform the following:

1. Preparation of metal
2. Set up of joint
3. Welding procedures and techniques  
for lap and tee joints

Evaluation:

1. Student will be checked for proper  
procedures and techniques.
2. Assistance will be given when  
necessary.

## 1. Summary

- a. Preparation of material
- b. Welding procedures and techniques of butt, lap and tee joints
- c. Specifications for butt, lap and tee joints
- d. Safety

2. Assignment - *NONE*

## 3. Remotivation:

## 4. Closure:



APPROVAL OFFICE AND DATE TWSI 80-0725-15 checked		INSTRUCTOR	
COURSE NUMBER 3ABR53131		COURSE TITLE Metals Processing Specialist	
BLOCK NUMBER V		BLOCK TITLE Inert Gas Shielded Welding of High Performance Aircraft Metals	
LESSON TITLE Butt Joints of Magnesium			
LESSON DURATION			
CLASSROOM/Laboratory D & D 1 hr/Perf 5 hrs		Complementary 2 hrs	TOTAL 8 hrs
POI REFERENCE			
PAGE NUMBER 37		PAGE DATE 23 Sep 1975	PARAGRAPH 5
SIS/CTS REFERENCE			
NUMBER STS 531X1		DATE 31 May 1975	
SUPERVISOR APPROVAL			
SIGNATURE	DATE	SIGNATURE	DATE
PRECLASS PREPARATION			
EQUIPMENT LOCATED IN LABORATORY	EQUIPMENT FROM SUPPLY	CLASSIFIED MATERIAL	GRAPHIC AIDS AND UNCLASSIFIED MATERIAL
1. Inert Gas Shielded Welding Station Complete 2. Cleaning Equipment 3. Power Shears 4. TRAINER 4404 TUNGSTEN INERT GAS (TIG) shielded welding	Consolidated Toolkit	None	1. 3ABR53131-SC-505 2. Modern Welding (Chapter 18)
CRITERION OBJECTIVES AND TEACHING STEPS			
<p>a. Given inert gas shielded welding equipment and magnesium specimens, set up and weld butt joints with 100% penetration, free of overlap and undercut, for a total combined distance of no less than 3/4 of the length of the specimen, excluding the first 1/2 inch start and the last 1/2 inch finish. All shop safety, good housekeeping and fire prevention measures must be observed.</p> <p>Teaching steps are listed in Part II.</p>			

INTRODUCTION

Time: 10 Min

- 1. Attention:
- 2. Review: In the last block you learned how to set up and prepare for welding aluminum butt, lap and tee joints using the gas shielded process. Evaluate GIT assignment and critique missed items.
- 3. Overview: Upon completion of this lesson, you will learn and apply proper procedures for welding magnesium butt joints.
- 4. Motivation:

BODY

Time: 7 Hrs 40 Min

Presentation:  
(Refer to Objective 5a)

- 1. General information ← Show trainer 4404 Tungsten Inert Gas (TIG) shielded welding specimens
  - a. World's lightest structural metal
    - (1) Aluminum is 1 1/2 times as heavy, iron and steel are 4 times as heavy and copper and nickel alloys are 5 times as heavy.
  - b. Magnesium is alloyed with other metals including aluminum, zinc, manganese and others.
    - (1) Magnesium containing Thorium and radioactive.
  - c. Uses of magnesium are divided into two types - structural and nonstructural
    - (1) Structural uses include, fuselages, wings, landing wheels, engine parts and accessories.
    - (2) Nonstructural uses are its use as an alloying element in aluminum, lead, zinc and other nonferrous alloys.

**Welding butt joints of Magnesium to  
Modern Welding Handbook specifications**

59

**a. Numbering System**

- (1) Two letters followed by two or three numbers

**b. Welding machines and torches**

- (1) Direct Current machines and alternating current machines with a high frequency current superimposed
- (2) For thin gauge material, both types of machines are used, but on material over 3/16" thick, AC machines are preferred because of penetrating power.

**c. Shielded gas**

- (1) Helium and argon are both suitable for welding of magnesium
- (2) Argon is used with alternating current, helium is used with reverse polarity.

**d. Surface preparation**

- (1) Magnesium alloys are usually supplied with an oil coating or chrome pickle finish for surface protection during shipment and storage.
- (2) Oil coating
  - (a) Preferred for materials to be welded since they are easier to clean.
  - (b) Parts to be painted after welding should be made from chrome pickled metal.
- (3) Cleaning
  - (a) Chemicals

- 1 Vapor degreaser
- 2 Acetone
- 3 Hot alkaline solution

(B) Mechanical

- 1 Emery cloth
- 2 Stainless steel wool
- 3 Wire brush

c. Joint Preparations

- (1) Edges should be free from loose pieces or pits which may contain contamination such as oil or oxides
  - (a) Milled, sawed, sanded, routed or filed edges are satisfactory.
- (2) Fit - up should be 1/16" gap or less for butt joints.
- (3) Welding fixtures are necessary when welding thin gauge material to prevent the plates from overlapping and to dissipate excessive heat.

f. Welding polarity

- (1) DCRP is used when there is no ACHF available.
- (2) Alternating current with high frequency superimposed is normally used.
  - (a) Electrode is held flush or slightly below the surface of the work for maximum penetration
  - (b) Torch angle should be from 75 to 90°



61

3. Practice Safety in Performance of required tasks

- a. Remove all jewelry
- b. Wear protective clothing
- c. Check water, gas, power cables and water cables

4. Demonstration

5. Practice good housekeeping consistent with safety and fire prevention

Overview: Welding butt joints of magnesium

Application: ←

1. Student will be given material and equipment for welding butt joints of magnesium.

- a. Prepare joints for welding
- b. Weld joints to specifications
- c. Observe all safety precautions

Students will use equipment in shop. Inert gas shielded welding station complete, cleaning equipment power shears.

Evaluation:

1. Student will be given assistance when necessary
2. Welds will be visually inspected for height, width, overlap, undercut, and penetration

Summary:

END OF DAY SUMMARY

DAY 8

1. Preparation of metal
2. Welding procedures for butt joints of magnesium
3. Specifications for joint

CIT Assignment: POI objective 6a POI time 2 hrs.

1. Read SG 3ABR53131-SG-506 and answer questions at end of chapter.
2. Read chapter 18 Modern Welding Para 18-20 Thru 18-22

INTRODUCTION TO NEW DAY'S INSTRUCTION

DAY 9 |

- 1. Remotivation
- 2. Review: Evaluate CTT Assignment and critique missed items (SG 506) |
  - a. Preparation of metal
  - b. Welding procedures and specification: for butt joint
- 3. Overview: Welding butt joints of magnesium.

Application: (Cont)

Students will use equipment in shop. Inert gas shielded welding station complete, cleaning equipment power shears

Student will perform the following:

- 1. Preparation of metal
- 2. Set up of joint
- 3. Weld butt joint to specifications in the Modern Welding Handbook

Evaluation:

- 1. Student will be checked for proper welding procedures
- 2. Assistance will be given when necessary

CONCLUSION

Time: 10 Min

- 1. Summary
  - a. Set up and preparation of butt joints of magnesium for welding.
  - b. Use of proper welding procedures and techniques.
  - c. Joint to be welded to specifications in the Modern Welding Handbook.
- 2. Remotivation
- 3. Assignment None





**LESSON PLAN ( Part I, General)**

APPROVAL OFFICE AND DATE <i>STC 10/25/75 Sec 101</i>		INSTRUCTOR	
COURSE NUMBER <b>3ABR51131</b>		COURSE TITLE <b>Metals Processing Specialist</b>	
BLOCK NUMBER <b>V</b>		BLOCK TITLE <b>Inert Gas Shielded Welding of High Performance Aircraft Metals</b>	
LESSON TITLE <b>Joints of A-286 Alloy</b>			
LESSON DURATION			
CLASSROOM/Laboratory <b>D &amp; D 1 hr/Perf 9 hrs</b>	Complementary <b>4 hrs</b>	TOTAL <b>14 hrs</b>	
PAGE REFERENCE			
PAGE NUMBER <b>38</b>	PAGE DATE <b>23 Sep 1975</b>	PARAGRAPH <b>6</b>	
STIS/CIS REFERENCE			
NUMBER <b>STS 531X1</b>	DATE <b>31 May 1975</b>		
SUPERVISOR APPROVAL			
SIGNATURE	DATE	SIGNATURE	DATE
PRECLASS PREPARATION			
EQUIPMENT LOCATED IN LABORATORY	EQUIPMENT FROM SUPPLY	CLASSIFIED MATERIAL	GRAPHIC AIDS AND UNCLASSIFIED MATERIAL
<ol style="list-style-type: none"> <li>1. Inert Gas Shielded Welding Station Complete</li> <li>2. Cleaning Equipment</li> <li>3. Power Shears</li> <li>4. <b>TRAINER 4404 TUNGSTEN INERT GAS (TIG) shielded welding</b></li> </ol>	<b>Consolidated Toolkit</b>	None	<b>I. 3ABR53131-SG-506</b>
CRITERION OBJECTIVES AND TEACHING STEPS			
<p>a. Given inert gas shielded welding equipment and A-286 alloy specimens, set up and weld butt joints with 100% penetration, free of overlap and undercut, for a total combined distance of no less than 3/4 of the length of the specimen, excluding the first 1/2 inch start and the last 1/2 inch finish. All shop safety, good housekeeping and fire prevention measures must be observed.</p> <p>b. Given inert gas shielded welding equipment and A-286 alloy specimens, set up and weld tee and corner joints free of excessive penetration, overlap and undercut, for a total combined distance of no less than 3/4 of the length of the specimen, excluding the first 1/2 inch start and the last 1/2 inch finish. All shop safety, good housekeeping and fire prevention measures must be observed.</p>			
Teaching steps are listed in Part II.			

1. Attention
2. Review: In the last lesson you learned how to prepare and set up for welding magnesium butt joint in accordance with specifications. Evaluate CTR assignment and critique missed items.
3. Overview: Upon completion of this lesson student will learn and apply proper procedures for welding A-286 butt and tee joint to specifications.
4. Motivation:

## BODY

Time: 13 hrs. 40 min.

## Presentation:

(Refer to objectives 5a, 6a)

## 1. General Information:

## a. A-286

Show trainer 4404 Tungsten,  
Inert Gas (TIG) Shielded  
Welding specimens.

- (1) Designed for parts requiring high strength up to 1300 degrees F and oxidation resistance up to 1500 degrees F
- (2) Should be welded in the solution-treated condition
- (3) Strees relieve (1650° F  
1 hr - air cooled)
- (4) Chemical composition
  - (a) Chromium
  - (b) Nickel
  - (c) Iron

## b. Only properly trained men will perform welding on aircraft parts

- (1) Specification MIL-T-5021 outlines welding qualifications for aircraft welders

## c. TIG welding is the best suited welding process for repairing or welding A-286 alloy

## d. The possibility of A-286 cracking is more critical than that of stainless steel

## 2. Welding equipment and materials

- a. Welding machine-AC-DC rectifier with foot control rheostat
- b. Light weight (inert gas) are welding torch

- c. 2% thoriated tungsten electrode
- d. Shielding gas (argon or helium)
- e. Welding lense (No. 8, 9 or 10)
- f. Light weight gloves
- g. Filler material
  - (1) Hastelloy "W"
  - (2) A-286 sheared stock

### 3. Welding procedure

- a. Vapor degrease the part or remove all grease, oil or other organic material
  - (1) Area to be welded may be cleaned with cloth soaked in acetone or petroleum benzine
- b. Grit blast may be used to remove dirt, scale, carbon, rust or other inorganic matter
  - (1) Stainless steel power driven rotary brush or emery cloth may also be used
- c. Where a crack is suspected:
  - (1) Red dye check to determine exact location
  - (2) Inspect both sides of the area to determine exact location if crack penetrates the material
- d. Prepare cracks for welding as follows:
  - (1) Up to 0.045" thick grind to a depth of 50% of parent metal thickness
  - (2) 0.045 to 0.090" thick grind to 75% of parent metal thickness
  - (3) Over 0.090" thick grind to within 0.030" of opposite side
- e. Set current for thickness of material to be welded
- f. Check all tacks, (tacks that are cracked will be ground completely out and made over)
- g. Use copper tab to start arc on whenever possible
- h. Keep filler rod under gas shield
- i. Grind out point where weld was terminated, before restarting
- j. Eliminate crater cracks
- k. Multipass welding- each bead shall be thoroughly cleaned by grinding or rotary-filing, followed by the wire brushing to completely remove all oxide

1. Clean repair welds with fine emery cloth and dye check

67

4. Weld requirements:

a. Butt joints

- (1) Penetration-100% T
- (2) Reinforcement - 5-30% T
- (3) Width - 2-3 T

b. Tee joints

- (1) Penetration - 25-80% T
- (2) Leg width - 1 1/2 T
- (3) Width - 2-3 T

Application: (Refer to objectives 6a)

Evaluation:

1. Student will be checked for proper welding procedures.
2. Assistance will be given when necessary

Students will use equipment in shop: Inert gas shielded welding station complete (2) cleaning equipment (3) power power shears

END OF DAY SUMMARY

DAY 9

Summary:

1. Welding equipment and material
2. Welding procedures
3. Weld requirements

CTT Assignment: 1. Read Modern Welding Para. 22-1 thru 22-5  
POI Objective 6b  
POI Time 2 hours

INTRODUCTION TO NEW DAY'S INSTRUCTION

1. Remotiva
2. Review: Evaluate CTT Assignment and critique missed items
  - a. Welding procedures
  - b. Welding equipment and material

3. Overview: Welding butt joints of A-286

Application: (Continued)  
(Refer to objectives 6a)

Students will use equipment in shop. Inert gas shield welding station complete  
Cleaning equipment, power shears

Student will perform the following:

1. Preparation of material
2. Set up and tack
3. Weld joints to student guide specifications
4. Observe all safety precautions during accomplishment of project

Evaluation:

1. Student will be checked for proper welding procedures
2. Assistance will be given when necessary

CONCLUSION

DAY 10

Time: 10 min.

1. Summary

- a. Preparation of metal
- b. Shop safety

2. CTT assignment: POI objective 7a POI time 2 hours

- a. Review notes taken during class
- b. Read 3ABR53131-SG-507 and answer questions at end of chapter.

3. Remotivation:

4. Closure:

LESSON PLAN (Part I, General)

APPROVAL OFFICE AND DATE TWSTI 20 Sep 75 [Signature]	INSTRUCTOR 69
COURSE NUMBER 3ABR53131	COURSE TITLE Metals Processing Specialist
BLOCK NUMBER V	BLOCK TITLE Inert Gas Shielded Welding of High Performance Aircraft Metals

LESSON TITLE  
Joints of A-286 Alloy

CLASSROOM; Laboratory		LESSON DURATION Complementary	TOTAL
D & D 1 hr/ Perf 9 hrs		4 hrs.	14 hrs.

PAGE NUMBER 38	PAGE DATE 23 Sep 1975	PARAGRAPH 6
-------------------	--------------------------	----------------

NUMBER STS 531X1	DATE 31 May 1975
---------------------	---------------------

SUPERVISOR APPROVAL			
SIGNATURE	DATE	SIGNATURE	DATE

PRECLASS PREPARATION

EQUIPMENT LOCATED IN LABORATORY	EQUIPMENT FROM SUPPLY	CLASSIFIED MATERIAL	GRAPHIC AIDS AND UNCLASSIFIED MATERIAL
Inert Gas Shielded Welding Station Complete Cleaning Equipment Power Shears Trainer 4404 Tungsten inert gas (TIG) shielded welding s.	Consolidated Toolkit	None	1. 3ABR53131-SG-506

CRITERION OBJECTIVES AND TEACHING STEPS

- a. Given inert gas shielded welding equipment and A-286 alloy specimens, set up and weld butt joints with 100% penetration, free of overlap and undercut, for a total combined distance of no less than 3/4 of the length of the specimen, excluding the first 1/2 inch start and the last 1/2 inch finish. All shop safety, good housekeeping and fire prevention measures must be observed.
- b. Given inert gas shielded welding equipment and A-286 alloy specimens, set up and weld tee and corner joints free of excessive penetration, overlap and undercut, for a total combined distance of no less than 3/4 of the length of the specimen, excluding the first 1/2 inch start and the last 1/2 inch finish. All shop safety, good housekeeping and fire prevention measures must be observed.

Teaching steps are listed in Part II.



INTRODUCTION

Time: 10 min

1. Attention
2. Review: In the last lesson you learned how to prepare and set up for welding magnesium butt joint in accordance with specifications. Evaluate CTT assignment and critique missed items.
3. Overview: Upon completion of this lesson student will learn and apply proper procedures for welding A-286 butt and tee joint to specifications.
4. Motivation:

BODY

Time: 13 hrs 40 min

Presentation:

(Refer to objectives 5a, 6a)

1. General Information

a. A-286

show TRAINER 4404 TUNGSTEN INERT GAS (TIG) shielded Welding Specimens.

- (1) Designed for parts requiring high strength up to 1300 degrees F and oxidation resistance up to 1500 degrees F
- (2) Should be welded in the solution-treated condition
- (3) Stress relieve (1650° F 1 hr - air cooled)
- (4) Chemical composition
  - (a) Chromium
  - (b) Nickel
  - (c) Iron

b. Only properly trained men will perform welding on aircraft parts

- (1) Specification MIL-T-5021 outlines welding qualifications for aircraft welders



1 Acetone may be used

(b) Grit-blasting may be used to remove dirt, rust and scale.

1 If grit blast is used, the surface shall be polished with a rotary stainless steel brush to remove blast residue from the surface.

b. Prepare crack for welding

- (1) Completely grind out any crack that does not penetrate the material.
- (2) For through cracks frind out to a depth of 50% of metal thickness, keeping width to a minimum.
- (3) Weld immediately after pre-heating (700-800) degrees F and stress relieve immediately afterward.
- (4) Check for cracks

c. Welding equipment and material

- (1) AC-DC rectifier welder
- (2) Water cooled torch
- (3) Tungsten electrode—2% Thoriated
- (4) Argon gas for primary shielding, helium for back up shielding
- (5) Filler rod
  - (a) Sheared stock
  - (b) Copper coated filler wire - to protect wire from corrosion

d. Joint preparation

- (1) Remove sharp edges or burrs
- (2) Spacing 2T
- (3) Sheilding gas - 12 cu. ft/hr.
- (4) Back up gas - 3-5 cu. ft./hr.
- (5) Torch angle
  - (a) Butt - 75-90 degrees
  - (b) Tee - 45 degrees

e. Weld specifications

- (1) Butt joint
  - (a) Penetration - 100% T



3. Practice safety in performance of required tasks
  - a. Remove all jewelry before operation of equipment
  - b. Wear protective clothing
  - c. Check water, gas, power cables and water cables
4. Demonstration
5. Practice good housekeeping consistent with safety and fire prevention.

Application:

Student will be given material and equipment for welding butt, lap, and tee joints of chromoly.

Students will use equipment in shop. Inert gas shielded welding station complete, cleaning equipment power shears.

1. Prepare joints for welding.
2. Weld joints to specifications.
3. Observe all safety precautions.

Evaluation:

1. Student will be given assistance when necessary.
2. Welds will be visually inspected for height, width, overlap, undercut and penetration

Summary

END OF DAY SUMMARY

DAY 11

1. Preparation of metal
2. Welding procedure
3. Shop safety

CTI Assignment:

1. Read Modern Welding Para 22-6 thru 22-4

INTRODUCTION TO NEW DAY'S INSTRUCTION

DAY 12

Evaluate CTI and critique missed items.

1. Remotivation
2. Review
  - a. Welding equipment and materials
  - b. Welding procedures
  - c. Weld requirements
3. Check on home assignment

Note: Page 72 has been omitted. However, all material is included.

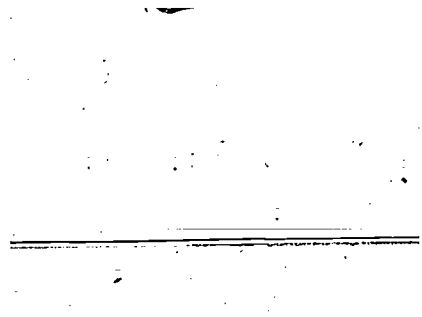

3. Overview: Welding, butt and tee joints of chromoloy (Objective 7b, c)

74

APPLICATION: (Cont)

Students will use equipment in shop. Inert Gas Shielded Welding station complete, cleaning equipment, power shears.

Student will be given material and equipment for welding required joints.

1. Prepare joints for welding.

2. Observe all shop safety.

EVALUATION:

1. Student will be checked for proper welding procedure

2. Assistance will be given when necessary

CONCLUSION

Time: 10 min

1. Summary

a. Preparation of metal

b. Shop safety

2. CTT assignment: POI Objective 8a POI time 2 hours

a. Read 3ABR53131-SG-508 and answer questions at end of chapter.

b. Review notes taken in class

3. Remotivation:

4. Closure:

LESSON PLAN ( Part I, General)

APPROVAL OFFICE AND DATE TWSTI <i>80/1/75</i>	INSTRUCTOR
COURSE NUMBER 3ABR53131	COURSE TITLE Metals Processing Specialist
BLOCK NUMBER V	BLOCK TITLE Inert Gas Shielded Welding of High Performance Aircraft Metals
LESSON TITLE Butt Joints of Nickel Base Alloys	

LESSON DURATION		
CLASSROOM/Laboratory D & D 1 hr/Perf 5 hrs	Complementary 2 hrs	TOTAL 10 hrs

POI REFERENCE		
PAGE NUMBER 40	PAGE DATE 23 Sep 1975	PARAGRAPH 8

STS/CTS REFERENCE	
NUMBER STS 531X1	DATE 31 May 1975

SUPERVISOR APPROVAL			
SIGNATURE	DATE	SIGNATURE	DATE

PRECLASS PREPARATION			
EQUIPMENT LOCATED IN LABORATORY	EQUIPMENT FROM SUPPLY	CLASSIFIED MATERIAL	GRAPHIC AIDS AND UNCLASSIFIED MATERIAL
1. Inert Gas Shielded Welding Station Complete 2. Cleaning Equipment 3. Power Shears 4. TRAINER 4404 TUNGSTEN INERT GAS (TIG) shielded welded specimens.	<i>Consolidated Tools</i>	None	1. 3ABR53131-SG-508

CRITERION OBJECTIVES AND TEACHING STEPS

a. Given inert gas shielded welding equipment and nickel base, alloy specimens, set up and weld butt joints with 100% penetration, free of overlap and undercut, for a total combined distance of no less than 3/4 of the length of the specimen excluding the first 1/2 inch start and the last 1/2 inch finish. All shop safety, good housekeeping and fire prevention measures must be observed.

Teaching steps are listed in Part II.



1. Attention:
2. Review: In the last lesson you learned how to set up and weld Chromoloy butt, tee and lap joints to specifications. Evaluate CTT assignment and critique missed items.
3. Overview: Upon completion of this lesson, you will learn and apply proper procedures for welding nicke base butt, tee and lap joints.
4. Motivation:

## BODY

Time: 5 hrs 40 min

DAY 13

## Presentation:

(Refer to objective 8a)

1. General information
  - a. Good mechanical properties (strength and ductility)
  - b. Coefficient of thermal expansion of inconel is about the same as that of carbon steels
    - (1) Warpage and stress resulting from the application of heat will be approximately the same
    - (2) Welding fixtures should be used wherever possible to help dissipate heat
2. Weld butt joints of nicke base alloy (TIG) to study guide specifications
  - a. Metal preparation
    - (1) Chemical cleaning
      - (a) Vapor degreaser
      - (b) Acetone
    - (2) Mechanical cleaning
      - (a) Sand blaster
      - (b) Stainless steel wire brush
      - (c) Grinder

Show Trainer 4404 Tungsten Inert GAS (TIG) shielded welding specimens

b. Welding equipment

- (1) AC-DC rectifier welder
- (2) Inert gas (argon)
- (3) 2% Thoriated tungsten electrode
- (4) Welding fixture

c. Current and filler rod

- (1) DCSP
- (2) Amperage depends on thickness of material
- (3) Filler rod
  - (a) Inconel 62 or 69
  - (b) Sheared stock

d. Torch angle

- (1) 75-90 degrees
- (2) Upon completion of weld, leave torch in place until gas flow stops

3. Butt joint specifications

- a. Penetration - 100% T
- b. Bead width - 2-3 T
- c. Reinforcement - 5-30% T

4. Practice safety in performance of required tasks

5. Practice good housekeeping consistent with safety and fire prevention

- a. Remove all jewelry before operation of equipment
- b. Wear protective clothing
- c. Check water, gas, power cables and water lines



6. Demonstration

APPLICATION: ← \_\_\_\_\_

Students will use equipment in shop.

Student will be given material and equipment for welding butt joints of nickel base alloys

- 1. Inert gas shielded welding station complete
- 2. Cleaning equipment
- 3. Power shears

- 1. Prepare joints for welding
- 2. Weld joints to specifications
- 3. Observe all safety precautions

EVALUATION:

- 1. Student will be given assistance when necessary
- 2. Welds will be visually inspected for height, width, overlap, undercut and penetration

CONCLUSION

Time: 10 min

DAY 13

1. Summary:

- a. Preparation of joint
- b. Weld specifications
- c. Welding procedures

2. CTT Assignment: POI Objective 9a POI time 2 hours

- a. Read 3ABR53131-SG-509 and answer questions at end of chapter.
- b. Read Chapter 24 Para 24-26 }  
Modern Welding Handbook

3. REMOTIVATION:

4. CLOSURE:

LESSON PLAN ( Part I, General)

APPROVAL OFFICE AND DATE TWSTI <i>20 Oct 76 Bill Bell</i>	INSTRUCTOR
COURSE NUMBER 3ABR53131	COURSE TITLE Metals Processing Specialist
BLOCK NUMBER V	BLOCK TITLE Inert Gas Shielded Welding of High Performance Aircraft Metals

LESSON TITLE  
Butt Joints of Titanium and Titanium Alloy Sheet

LESSON DURATION		
CLASSROOM/Laboratory D & D 2 hrs/Perf 8 hrs	Complementary 2 hrs	TOTAL 12 hrs

POI REFERENCE		
PAGE NUMBER 41	PAGE DATE 23 September 1975	PARAGRAPH 9

STS/CIS REFERENCE	
NUMBER STS 531X1	DATE 31 May 1975

SUPERVISOR APPROVAL			
SIGNATURE	DATE	SIGNATURE	DATE

PRECLASS PREPARATION			
EQUIPMENT LOCATED IN LABORATORY	EQUIPMENT FROM SUPPLY	CLASSIFIED MATERIAL	GRAPHIC AIDS AND UNCLASSIFIED MATERIAL
<ol style="list-style-type: none"> <li>Inert Gas Shielded Welding Station Complete</li> <li>Rectangular Dri Bel Bubble</li> <li>Cleaning Equipment</li> <li>Trainer 4404</li> <li>Tungsten Inert Gas (TIG) Shielded Welded Specimen</li> </ol>	<i>Consolidated Toolkit</i>	None	<ol style="list-style-type: none"> <li>3ABR53131-SG-509</li> <li>Modern Welding (Chapter 24)</li> <li>Film: FIG 8/60 How to Weld Titanium</li> </ol>

CRITERION OBJECTIVES AND TEACHING STEPS

1. Given inert gas shielded welding equipment and titanium and titanium alloy specimens, set up and weld butt joints with 100% penetration, free of overlap, and undercut, for a total combined distance of no less than 3/4 of the length of the specimen, excluding the first 1/2 inch start and the last 1/2 inch finish. All shop safety, good housekeeping and fire prevention measures must be observed.

Teaching steps are listed in Part II.

1. Attention:
  2. Review: In the last lesson you learned how to set up and weld butt joints of nickel base alloys, according to specifications. Evaluate CTT assignment and critique missed items.
  3. Overview: Upon completion of this lesson, you will learn and properly apply procedures for welding butt joints of titanium and titanium alloy sheet.
- 
4. Motivation:

## BODY

Time: 9 hrs 40 min

## Presentation:

(Refer to objective 9a)

## 1. General information

- a. Melting point of commercially pure titanium 3140 - 3270 F
- b. Discovered in 1795

## 2. Identification

- a. Grinds very slow and gives off bright, white sparks with traces ending in brilliant white bursts. (Spark Test)

Show Trainer 4404 Tungsten  
Inert (TIG) shielded welding  
specimens

- b. Aircraft parts fabricated of titanium are identified by the word "titanium" etched or stamped on the part.
- c. Identified by manufacturers code and specification number stamped on sheet, bar, plate and tubing stock.

## 3. Hydrochloric acid test

- (1) Used to distinguish between commercially pure titanium and its alloys
- (2) Put piece to be identified in 50cc of hydrochloric acid (solution will become violet after 1 hour)
- (3) To 5cc of solution, add 3% of hydrogen peroxide
  - (a) Commercially pure strip will turn orange-yellow
  - (b) An alloy of titanium will turn a deep red-orange

3. Characteristics

a. Light weight

- (1) Compares favorably to stainless steel at temperatures below 800-900 degrees F
- (2) Lighter than stainless steel and slightly heavier than aluminum

b. Corrosion resistant

- (1) Greater corrosion resistance than aluminum
- (2) It appears that titanium will replace aluminum in aircraft where high strength and resistance to sea water are prime considerations

4. Some uses of titanium

- a. Aircraft skins
- b. Frames
- c. Hydraulic lines

5. Composition

- a. Commercially pure (4900 & 4901)
- b. Alloyed with aluminum, manganese, iron, chromium and carbon

6. Welding techniques

- a. Most weldments are made with commercially pure titanium
- b. Stronger alloys are not suitable for welding because of brittleness along the heat affected zone. (Alpha and Beta types)

Show Film: FLC 8160

How to Weld Titanium

c. TIG or MIG is the only process recommended for welding titanium

- (1) Reason-controlled atmosphere (argon & helium)
- (2) Can also be spot welded or silver soldered
  - (a) Only used for glueing applications
  - (b) Cannot be used to obtain strength of base metal because of absence of inert gas
- (3) Argon or helium or a mixture of the two are used to dispell oxygen and nitrogen, allowing welds to be made that reach base metal strength

d. Purge chambers

- (1) Impractical for air force use
- (2) Waste gas, bulky and expensive

7. Weld butt joints of titanium to Modern Welding Specifications

a. Preparation of metal

- (1) Solvent degreasing (Vapor degreaser)
  - (a) Hot trichloroethylene (180 degrees F)
  - (b) Used to remove organic contaminants (Grease, oil, etc)
- (2) Chemical Pickling
  - (a) Time - 1-20 min
  - (b) 80-160 degrees
  - (c) Rinsed in hot water
  - (d) Alkaline dip used to remove organics (Grease, oil, etc)

(3) Grit Blasting

(a) Used to remove inorganics  
(Rust, scale & oxides)

(4) Grinding, Wire Brushing & Emery Cloth

b. Welding titanium

(1) Non-consumable or consumable inert gas shielded welding may be used

(2) Shielding Gases

(a) Argon or helium or both

1 Argon gives a more stable arc than helium

2 Argon is heavier than helium and is preferred for open-air welding because of its blanketing effect

(b) Filler rod should be kept under gas shield to avoid oxidation of hot filler rod

(c) Trailing shields

1 Extend behind torch

2 Porous diffusion of gas (argon & atmosphere)

(d) Baffles

1 Helps keep gas around weld area

2 Helps keep atmosphere away from weld area

(3) Current

(a) Direct current straight polarity

(4) TIG - 2% thoriated tungsten electrode (helps keep a steady arc)

c. Joint Preparation

- (1) Remove sharp edges or burrs
- (2) Torch angle - 75-90 degrees
- (3) Position gas shielding and back-up gas (use generous cup size)

d. Weld specifications

- (1) Penetration - 100% T
- (2) Bead width - 2-3 T
- (3) Reinforcement - 5-30% T

3. Practice safety in performance of required tasks

- a. Remove all jewelry before operating equipment
- b. Wear protective clothing.
- c. Check water, gas, power cables and water cables

4. Demonstration

5. Practice good housekeeping consistent with safety and fire prevention

APPLICATION:

Students will use equipment in shop.

- 1. Student will be given material and welding equipment for welding butt joints of titanium
- 2. Prepare joints for welding
- 3. Weld joints to specifications
- 4. Observe all safety precautions

- 1. Inert Gas shielded welding station complete
- 2. Rectangular dri bel bubble, (3) cleaning equipment.

EVALUATION:

- 1. Student will be given assistance when necessary
- 2. Welds will be visually inspected for height, width; overlap, undercut and penetration



1. Preparation of metal
2. Set up of joint
3. Shielding gas
4. Welding procedures

## Assignment:

1. None

INTRODUCTION TO NEW DAY'S INSTRUCTION

DAY 15

1. Remotivation
2. Review
  - a. Preparation of metal
  - b. Set up of joint
  - c. Weld specifications

Overview: Welding butt joints of titanium and titanium alloy sheet.

## Application: (Continued)

1. Given material and equipment for welding titanium butt joint, student will:
  - a. Prepare joint
  - b. Set up of joint
  - c. Weld joint to specifications

Students will use equipment in shop:

1. Inert gas shielded welding station complete
2. Rectangular Dr. bell bubble
3. Cleaning equipment

## Evaluation:

1. Student will be checked during the accomplishment of the project
2. Assistance will be given when necessary

CONCLUSION

Time: 10 min

86

1. Summary:

- a. Preparation of metal
- b. Set up of joint
- c. Shielding gas

2. CTT Assignment: POI objective 1a POI time 2 hours

Read 3ABR53131-SG-601 and answer questions at end of chapter.

3. Remediation:

4. Closure:

LESSON PLAN (Part I, General)

APPROVAL OFFICE AND DATE: <i>INSTI 8E 8775 J. J. ...</i>	INSTRUCTOR
COURSE NUMBER 3ABR53131	COURSE TITLE Metals Processing Specialist
BLOCK NUMBER V	BLOCK TITLE Inert Gas Shielded Welding of High Performance Aircraft Metals

LESSON TITLE  
Joints of Chromoloy

LESSON DURATION		
CLASSROOM/Laboratory D & D 1 hr/Perf 11 hrs	Complementary 4 hrs	TOTAL 16 hrs

POI REFERENCE		
PAGE NUMBER 39	PAGE DATE 23 Sep 1975	PARAGRAPH 7

STS/CTS REFERENCE	
NUMBER STS 531X1	DATE 31 May 1975

SUPERVISOR APPROVAL			
SIGNATURE	DATE	SIGNATURE	DATE

PRECLASS PREPARATION

EQUIPMENT LOCATED IN LABORATORY	EQUIPMENT FROM SUPPLY	CLASSIFIED MATERIAL	GRAPHIC AIDS AND UNCLASSIFIED MATERIAL
1. Inert Gas Shielded Welding Station Complete 2. Cleaning Equipment 3. Power Shears 4. TRAINER 4404 TUNGSTEN INERT GAS Shielded WELDING SPEC	Consolidated Toolkit	None	1. 3ABR53131-SG-507

CRITERION OBJECTIVES AND TEACHING STEPS

- a. Given inert gas shielded welding equipment and chromoloy specimens, set up and weld lap joints free of excessive penetration, overlap, and undercut for a total combined distance of no less than 3/4 of the length of the specimen, excluding the first 1/2 inch start and the last 1/2 inch finish. All shop safety, good housekeeping and fire prevention measures must be observed.
- b. Given inert gas shielded welding equipment and chromoloy specimens, set up and weld butt joints with 100% penetration, free of overlap and undercut, for a total combined distance of no less than 3/4 of the length of the specimen, excluding the first 1/2 inch start and the last 1/2 inch finish. All shop safety, good housekeeping and fire prevention measures must be observed.
- c. Given inert gas shielded welding equipment and chromoloy specimens, set up and weld tee joints free of excessive penetration, overlap, and undercut for a total combined distance of no less than 3/4 length of the specimen, excluding the first 1/2 inch start and the last 1/2 inch finish. All shop safety, good housekeeping, and fire prevention measures must be observed.  
Teaching steps are listed in Part II.

1. Attention:
2. Review: In the last class you learned how to prepare and set up for welding A-286 metal according to specifications. Your application included welding a butt joint and tee joint and learning about the characteristics of A-286.  
Evaluate CTT assignment and critique missed items.
3. Overview: Upon completion of this lesson, students will learn and apply proper procedures for welding chromoloy butt, lap and tee joints in the flat position according to specifications.
4. Motivation:

## BODY

Time: 11 hrs 40 min

## Presentation

(Refer to Objectives 7a, b)

Show trainer: 4404 Tungsten  
Inert gas (TIG) shielded  
welding specimens

## 1. General Information

- a. Weld repairs on chromoloy parts should be performed by certified welders.
  - b. Iron base
  - c. Meets the medium-high temperature service requirements needed in the jet engine turbine section.
  - d. Normalized at 1725 degrees F for 2 hrs then air cooled.
  - e. Chromoloy is one of the easiest of the super alloys to weld.
2. Weld butt, tee and lap joints of chromoloy to specifications.
    - a. Preparation of chromoloy for welding.
      - (1) Cleaning
        - (a) Vapor degrease to remove grease and oil.

- (2) Clean area to be welded
- (3) Tack and check alignment
- (4) Run root or penetration pass
- (5) Use stringer beads for filling  
vee
- (6) DCSP

d. Good Housekeeping

- (1) Safety measures
- (2) Fire prevention

APPLICATION:

1. Students will weld stainless steel pipe butt joint IAW TO 34W4-1-5 and SG-601.
2. Students will weld stainless steel tee joint IAW 34W4-1-5 and SG-601.
3. All safety rules and good housekeeping will continue to be observed at all times.

EVALUATION:

1. Instructor will assist and check each student for proper welding procedures and for their observance of good housekeeping and safety.

END OF DAY SUMMARY

Summary:

1. Types of stainless steel
2. Types of filler rod
3. Welding procedures for butt joint
4. Good housekeeping and shop safety

CTT Assignment:  
POI item la, lb, 2 hrs

1. 3ABR53230-SG-602 and answer questions.

INTRODUCTION TO NEW DAY'S INSTRUCTION

(Day 2, 2 hrs)

1. Remotivation: Restate previous
2. Review:
  - a. Evaluate CTT assignment critique missed items.
  - b. Types of stainless steel pipe
  - c. Types of filler rod
  - d. Welding procedures and techniques
  - e. Safety
3. Objectives to be covered
  - i. Welding stainless steel tee joint

Application: (cont)

1. Students will continue welding stainless steel pipe specimens in accordance with TO 34W4-1-5 and SG-601. Instructor will assist when necessary.
2. All safety rules and good housekeeping will continue to be observed at all times.

EVALUATION:

1. Students will turn completed butt and tee joints of stainless steel pipe, provided they meet all required criteria. Performance of students in shop safety and fire prevention will be considered.
2. Given a series of questions concerning welding procedures and techniques of stainless steel pipe welding, students are required to select correct responses with a minimum of 75% accuracy.

CONCLUSION:

Time: 10 min

1. Summary:
  - a. Type of stainless steel pipe

- b. Type of filler rod
- c. Weld procedures for tee joint
- d. Good housekeeping and shop safety

2. CTT Assignment:

- a. Read 3ABK53230-SG-602, and answer questions.
- b. POI Item 2a, 2b, (4 hrs)

3. Remotivation

4. Closing statement



LESSON PLAN ( Part I, General)

91A

APPROVAL OFFICE AND DATE: TWSTI 14C 2775 Richard  
 INSTRUCTOR:

COURSE NUMBER: 3ABR53131  
 COURSE TITLE: Metals Processing Specialist.

BLOCK NUMBER: VI  
 BLOCK TITLE: Pipe, Tubing, and Aircraft Exhaust and Jet Engine Hot Section Repair

LESSON TITLE: Joints of Heat and Corrosion Resistant Ferrous Alloy Pipe

CLASSROOM/Laboratory: D & D 2 hrs/Perf 6 hrs  
 LESSON DURATION: Complementary 2 hrs  
 TOTAL: 10 hrs

PAGE NUMBER: 43  
 PAGE DATE: 23 Sep 75  
 PARAGRAPH: 1

STS/CYS REFERENCE NUMBER: STS 531X1  
 DATE: 31 May 1975

SUPERVISOR APPROVAL			
SIGNATURE	DATE	SIGNATURE	DATE

PRECLASS PREPARATION			
EQUIPMENT LOCATED IN LABORATORY	EQUIPMENT FROM SUPPLY	CLASSIFIED MATERIAL	GRAPHIC AIDS AND UNCLASSIFIED MATERIAL
1. Inert Gas Shielded Welding Station Complete 2. Cleaning Equipment 3. Grinder 4. Power Saw	Consolidated Toolkit	None	1. 3ABR53131-SG-601 2. TO 00-25-224 3. Charts: CAFB 63-502, Pipe Welding - Welding Sequences

- CRITERION OBJECTIVES AND TEACHING STEPS
- a. Given inert gas shielded welding equipment and heat and corrosion resistant ferrous alloy pipe specimens, set up and weld butt joints with 100% penetration, free of overlap and undercut, for a total combined distance of no less than 3/4 of the length of the weld. All shop safety, good housekeeping and fire prevention measures must be observed.
  - b. Given inert gas shielded welding equipment and heat and corrosion resistant ferrous alloy pipe specimens, set up and weld tee joints with 30% to 80% penetration, free of overlap and undercut, for a total combined distance of no less than 3/4 of the length of the weld. All shop safety, good housekeeping, and fire prevention measures must be observed.

Teaching steps are listed in Part II.

114

INTRODUCTION

TIME: 10 min

- 1. Attention: Welcome to Block VI
- 2. Review: Cover aspects and procedures of heli-arc welding which students learned in Block V and relate them as important for the skilled welder to know in the field. Evaluatate CTT assignment. Critique missed items.
- 3. Overview: Upon completion of this lesson, students will set up and weld stainless steel pipe while observing all rules of good house-keeping and safety.
- 4. Motivation: You now are proficient in welding S/S sheet so we now will try S/S pipe, with 360° welds.

BODY

TIME: 7 hr 40 min

PRESENTATION:

Ref. Objective #1

- 1. Students will participate in discussion of various procedures for welding stainless steel pipe in the vertical position.
  - a. Types of stainless steel for welding pipe.
    - (1) 321 - titanium stabilized stain- less steel
    - (2) 347 - columbium stabilized stain- less steel
    - (3) Extra low carbon stainless steel
  - b. Types of filler rod for stainless steel pipe
    - (1) 321
    - (2) 347
  - c. Welding Procedure
    - (1) Form pipe bevel to a standard vee

1 Acetone may be used

(b) Grit-blasting may be used to remove dirt, rust and scale.

1 If grit blast is used, the surface shall be polished with a rotary stainless steel brush to remove blast residue from the surface.

b. Prepare crack for welding

- (1) Completely grind out any crack that does not penetrate the material.
- (2) For through cracks grind out to a depth of 50% of metal thickness, keeping width to a minimum.
- (3) Weld immediately after pre-heating (700-800) degrees F and stress relieve immediately afterward.
- (4) Check for cracks

c. Welding equipment and material

- (1) AC-DC rectifier welder
- (2) Water cooled torch
- (3) Tungsten electrode--2% Thoriated
- (4) Argon gas for primary shielding, helium for back up shielding
- (5) Filler rod
  - (a) Sheared stock
  - (b) Copper coated filler wire-  
to protect wire from corrosion

d. Joint preparation

- (1) Remove sharp edges or burrs

- (2) Spacing 2 T
- (3) Shielding gas - 12 cu. ft./hr.
- (4) Back up gas - 3-5 cu. ft./hr.
- (5) Torch angle
  - (a) Butt- 75-90 degrees
  - (b) Tee - 45 degrees

e. Weld specifications

- (1) Butt joint
  - (a) Penetration - 100% T
  - (b) Width - 2-3 T
  - (c) Reinforcement - 5-30% T
- (2) Tee joint
  - (a) Legs -  $1\frac{1}{2}$  T
  - (b) Penetration - 100% T
  - (c) Bead shape - slightly concave to slightly convex

3. Practice safety in performance of required tasks

- a. Remove all jewelry before operation of equipment
- b. Wear protective clothing
- c. Check water, gas, power cables and water cables

4. Demonstration

5. Practice good housekeeping consistent with safety and fire prevention.

Application: ← \_\_\_\_\_

Student will be given material and equipment for welding butt, lap, and tee joints of chromoly.

Students will use equipment in shop. Inert gas shielded welding station complete, cleaning equipment, power shears.

1. Prepare joints for welding.
2. Weld joints to specifications.
3. Observe all safety precautions.

Evaluation:

1. Student will be given assistance when necessary.
2. Welds will be visually inspected for height, width, overlap, undercut and penetration.

Summary

END OF DAY SUMMARY

DAY 11

1. Preparation of metal
2. Welding Procedure
3. Shop safety

CTT Assignment:

1. Read Modern Welding Para 22-6 thru 22-11

INTRODUCTION TO NEW DAY'S INSTRUCTION

DAY 12

Evaluate CTT and critique missed items:

1. Remotivation
2. Review
  - a. Welding equipment and materials
  - b. Welding procedures
  - c. Weld requirements
3. Check on home assignment

3. Overview: Welding, butt and tee joints of chromoloy (Objective 7b, c) 91F

APPLICATION: (Cont) ←

Student will be given material and equipment for welding required joints.

Students will use equipment in shop. Inert gas shielded welding station complete, cleaning equipment, power shears.

- 1. Prepare joints for welding.
- 2. Observe all shop safety.

EVALUATION:

- 1. Student will be checked for proper welding procedure
- 2. Assistance will be given when necessary

CONCLUSION

Time: 10 min

1. Summary

- a. Preparation of metal
- b. Shop safety

2. CTT assignment:

POI objective 8a

POI time 2 hours

- a. Read 3ABR53131-SG-508 and answer questions at end of chapter.
- b. Review notes taken in class

3. Remotivation:

4. Closure:

LESSON PLAN ( Part I, General)			
APPROVAL OFFICE AND DATE <b>TWSTI</b>		INSTRUCTOR	
COURSE NUMBER <b>3ABR53131</b>		COURSE TITLE <b>Metals Processing Specialist</b>	
BLOCK NUMBER <b>VI</b>		BLOCK TITLE <b>Pipe, Tubing, and Aircraft Exhaust and Jet Engine Hot Section Repair</b>	
LESSON TITLE <b>Joints of Aluminum Alloys Pipe and Tubing</b>			
LESSON DURATION			
CLASSROOM/Laboratory <b>D &amp; D 2 hrs/Perf 6 hrs</b>	Complementary <b>4 hrs</b>		TOTAL <b>12 hrs</b>
POI REFERENCE			
PAGE NUMBER <b>44</b>	PAGE DATE <b>23 Sep 1975</b>	PARAGRAPH <b>2</b>	
STS/CTS REFERENCE			
NUMBER <b>STS 531X1</b>		DATE <b>31 May 1975</b>	
SUPERVISOR APPROVAL			
SIGNATURE	DATE	SIGNATURE	DATE
PPECLASS PREPARATION			
EQUIPMENT LOCATED IN LABORATORY	EQUIPMENT FROM SUPPLY	CLASSIFIED MATERIAL	GRAPHIC AIDS AND UNCLASSIFIED MATERIAL
<ol style="list-style-type: none"> <li>1. Inert Gas Shielded Welding Station Complete</li> <li>2. Power Saw</li> <li>3. Cleaning Equipment</li> </ol>	<b>Toolkit</b>	<b>None</b>	<ol style="list-style-type: none"> <li>1. 3ABR53131-SG-602</li> <li>2. TO 00-25-224</li> <li>3. Charts: CAFE 63-502, Pipe Welding - Welding Sequences</li> </ol>
CRITERION OBJECTIVES AND TEACHING STEPS			
<p>a. Given inert gas shielded welding equipment and aluminum alloy pipe and tubing specimens, set up and weld butt joints with 100% penetration, free of overlap and undercut, for a total combined distance of no less than 3/4 of the length of the weld. All shop safety, good housekeeping, and fire prevention measures must be observed.</p> <p>b. Given inert gas shielded welding equipment and aluminum alloy pipe and tubing specimens, set up and weld tee joints with 30% to 80% penetration, free of overlap and undercut, for a total combined distance of no less than 3/4 of the length of the weld. All shop safety, good housekeeping, and fire prevention measures must be observed.</p>			
Teaching steps are listed in Part II.			





INTRODUCTION

TIME: 10 min

1. Attention: Stainless pipe wasn't hard now for alum.
2. Review: Discuss important points of ferrous alloy pipe welding covered in previous lesson. Evaluate CTT Assignment. Critique missed items.
3. Overview: Upon completion of this lesson, students will set up and TIG weld specimens of aluminum alloy pipe. Joints to be welded are butt and tee welds.
4. Motivation: Alum is not hard to weld neither.

BODY

TIME: 7 hr 40 min

PRESENTATION:

Ref. Objective #1 and 2

1. Students will discuss procedures involved in welding butt joints of aluminum alloy pipe in the vertical position.
  - a. Types of aluminum for welding pipe.
    - (1) 3003
    - (2) 5052
    - (3) 6061-F
  - b. Filler rod for aluminum:
    - (1) 4043 - alloyed with silicon
    - (2) Shear stock or base metal rod
  - c. Welding Procedure:
    - (1) Form pipe bevel to a standard vee
    - (2) Clean area to be welded

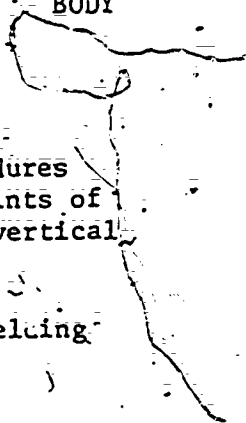

- (3) Preheat with TIG torch
- (4) Tack at 3 or more locations - make them small with 100% penetration
- (5) Weld root or penetration pass
- (6) Use stringer beads for filling vee
- (7) Cover beads can be either stringer beads or weave beads.
- (8) ACHF

**APPLICATION:**

- 1. Students will weld butt joints of aluminum alloy pipe in the vertical position, while observing good housekeeping, shop safety and fire prevention.

**EVALUATION:**

- 1. Instructor will check for proper welding procedures, and insure that all rules of good housekeeping, safety and fire prevention are being followed.
- 2. Students will turn in a butt joint of aluminum alloy pipe, which will meet requirements prescribed in the criterion checklist.

END OF DAY SUMMARY

**Summary:**

- 1. Types of aluminum pipe
- 2. Filler rod
- 3. Welding Procedures for butt joint

**CTT Assignment:**

POI Item 2a, 2b. 2 hrs

- 1. Read 3ABR53230-SG-602, Answer questions

(Day 3, 4 hrs)

1. Remotivation KIA
2. Review:
  - a. Evaluate CTT assignment.  
Critique missed items.
  - b. Types of aluminum pipe
  - c. Filler rod
  - d. Welding procedures
3. Objectives to be covered
  - a. Weld procedures

PRESENTATION (Cont)

Ref. Objectives # 1 & 2

1. Students will discuss characteristics of a pipe tee joint of aluminum alloy and the procedures involved in proper set-up and welding.
  - a. Welding procedure
    - (1) Insure proper bevel and fit-up of pipe specimens for the tee joint
    - (2) Clean area to be welded.
    - (3) Preheat entire joint set-up with TIG torch.
    - (4) Tack evenly and check for proper alignment
    - (5) Weld stringer beads, observing all proper specifications.
    - (6) ACHF

APPLICATION:

1. Students will weld aluminum alloy pipe tee joints in accordance with TO 34W4-1-5 and SG-602.

2. All safety precautions, fire prevention and good housekeeping will be observed at all times.

96

EVALUATION:

1. Instructor will check for proper welding procedures, and insure that all rules of good housekeeping and fire prevention are being followed. Assistance will be given as needed.
2. Students will weld and turn in a tee joint of aluminum alloy pipe, which will meet all required specifications and criteria.
3. Given a series of questions regarding aluminum alloy pipe welding, shop safety and fire prevention, students will answer correct responses with 75% minimum accuracy.

CONCLUSION:

TIME: 10 min.

1. Summary:
  - a. Types of aluminum pipe
  - b. Filler rod
  - c. Set up of joints
  - d. Welding procedures for tee joint
2. CTT Assignment  
POI Items 3a,3b,3c,3d, 4 hrs
  - a. Read 3ABR53230-SG-603, Answers and Questions
3. Remotivation
4. Closing statement

4

LESSON PLAN ( Part I, General)

APPROVAL OFFICE AND DATE TWSTI <i>10/2/75</i>	INSTRUCTOR
COURSE NUMBER 3ABR53131	COURSE TITLE Metals Processing Specialist
BLOCK NUMBER VI	BLOCK TITLE Pipe, Tubing, and Aircraft Exhaust and Jet Engine Hot Section Repair
LESSON TITLE Butt Patches on Jet Engine Hot Section Parts	

LESSON DURATION		
CLASSROOM /Laboratory D & D 2 hrs/Perf 16 hrs	Complementary 4 hrs	TOTAL 22 hrs

POI REFERENCE		
PAGE NUMBER 45	PAGE DATE 23 Sep 1975	PARAGRAPH 3

STS/CTS REFERENCE	
NUMBER STS 531X1	DATE 31 May 1975

SUPERVISOR APPROVAL			
SIGNATURE	DATE	SIGNATURE	DATE

PRECLASS PREPARATION			
EQUIPMENT LOCATED IN LABORATORY	EQUIPMENT FROM SUPPLY	CLASSIFIED MATERIAL	GRAPHIC AIDS AND UNCLASSIFIED MATERIAL
1. Inert Gas Shielded Welding Station Complete 2. Pneumatic Grinder 3. Trainer 3215 4. Cleaning Equipment 5. Selected Condemned/Defective Part(s)	Toolkit	None	1. 3ABR53131-SG-603 2. TO 2J-6 Series 3. TO 2J-1-13

CRITERION OBJECTIVES AND TEACHING STEPS
<p>a. Without reference, state the functions of various jet engine hot section parts with 75% accuracy.</p> <p>b. Given TO, identify location and service requirements pertaining to jet engine hot section parts without error.</p> <p>c. Given technical orders, select cleaning methods, repair procedures, and techniques for weld repair without error.</p> <p>d. Given inert gas shielded welding equipment and jet engine hot section parts, set up and make butt patch weld repairs with 100% penetration, free of overlap, and undercut, for a total combined distance of no less than 3/4 of the length of the weld excluding 1/2 inch at the start and finish. All shop safety, good housekeeping, and fire prevention measures must be observed.</p>

Teaching steps are listed in Part II.

## INTRODUCTION

TIME: 10 min

1. Attention: What is a butt patch?
2. Review: Briefly mention the important skills learned in pipe welding. Evaluate CTT assignment, critique missed items.
3. Overview: Upon completion of this lesson, students will be familiar with jet engine hot section components, know how to use the applicable tech orders, and weld patches on the various hot section parts.
4. Motivation: Now is the time to start on Jet Engine parts.

## BODY

TIME: 17 hr 40 min

## PRESENTATION

1. Students will participate in discussion concerning the location, function, and service requirements of the various hot section parts.
  - a. Area of hot section;  
Between compressor and turbine section.
  - b. Parts composing the hot section:
    - (1) Transition duct
    - (2) Combustion liner assemblies
    - (3) Inner combustion casing
    - (4) Outer combustion casing
    - (5) First stage turbine nozzle

c. Function of the hot section:

- (1) Fuel is injected and air is forced into combustion liners through the transition duct.
- (2) Fuel-air mixture is then supported and ignited in the hot section.
- (3) Resulting gases rush from hot section to turbine, thus driving the compressor and accessory drive section.

d. Service Requirements:

- (1) Weld repair of parent metal cracks
- (2) Repair or replacement of burned and eroded metal
- (3) Repair of buckles and bulges

APPLICATION:

1. Obtain the proper -6 series Tech Order
2. Know the proper nomenclature of the part and look it up in the table of contents or index.
3. Locate part in Tech Order.
4. Turn to the appropriate page and paragraph, and check for instructions and further references given such as:
  - a. Serviceable/repairable table for the particular component.

EVALUATION:

1. Conducted throughout lesson. EODS



## END OF DAY SUMMARY

Day 3

SUMMARY:

REVIEW:

1. Function of jet engine hot section parts.
  2. Identify location and service requirements of jet engine hot section parts.
  3. Cleaning methods, repair procedures, and welding techniques.
- 
1. Review 3ABR53131-SG-603
  2. Review - TO 2J-1-13

CTT Assignment:  
POI items 3a, 3b, 2 hrs

### INTRODUCTION TO NEW DAY'S INSTRUCTION

(Day 4, 6 hrs)

1. Evaluate CTT assignment critique missed items.
2. Remotivation
3. Review
  - a. Jet engine hot section components
  - b. Use of tech orders
4. Overview
  - a. Cleaning methods
  - b. Repair procedures
  - c. Welding techniques

BODY

### PRESENTATION

- a. Weld Data Table
- b. Cleaning methods requirements
- c. Acid etching; (if applicable to the part)
- d. Welding Procedure
  - (1) Current Setting

- (2) Back-up and shielding gas flow
- (3) Other important data such as cautions and suggestions.

d. Weld Specifications

- (1) Bead height and width
  - (2) Penetration
  - (3) Pneumatic grinding and tolerances allowed.
  - (4) Stress relieving requirements, if any
1. Use tech data at all times.
  2. Make sure patch repair metal is the same type and thickness as prescribed in tech order.
  3. When making patch:
    - a. Cut out defective area with a hack saw and in accordance with the TO.
    - b. Make template for shaping the patch and form to contour and size according to tech order specifications.
  4. Clean the area as outlined in the tech order.
  5. When using the pneumatic grinder:
    - a. Make sure wheel with proper RPM rating is used.

- b. Check wheel and grinder for defects.
  - c. Always use a face shield.
  - d. No jewelry or improper clothing.
  - e. Never tap grinder on part while grinding.
  - f. Never hold grinder in one place on the part for too long.
  - g. Keep grinder moving smoothly and evenly, avoiding nicking edges, louvers, etc.
  - h. Always disconnect air from grinder when not using it.
6. When welding the patch, insure full compliance with the appropriate tech order as to:
- a. Proper current setting.
  - b. Proper shielding and back up gas pressure.
  - c. Proper filler wire and tungsten type and size.
  - d. Proper spacing and tolerances, if any.
  - e. Applicable specifications, suggestions and precautions.
7. Observe all measures of safety, good housekeeping and fire prevention.

#### APPLICATION

1. Given the appropriate TO 2J-6 series, students will use this

publication to determine cleaning methods, repair procedures and techniques for weld repair without error.

- 2. While observing all measures of good housekeeping, safety, and fire prevention, students will set up and weld butt patches on jet engine hot section parts on full accordance with TO 2J-6 series.

EVALUATION

Instructor will check each student for proper compliance with the TO 2J-6 series, correct welding procedures, specifications, observance of good housekeeping, fire prevention and safety. Assistance will be given as needed.

END OF DAY SUMMARY

Summary:

- 1. Use of tech data
- 2. Patch repair
- 3. Use of pneumatic grinder
- 4. Welding procedures for patch repair

CTT Assignment: POI items 3c, 3d (2 hrs)

- 1. Review 3ABR53230-SG-603
- 2. Review TO 2J-1-13

(Day 5, 6 hrs)

INTRODUCTION TO NEW DAY'S INSTRUCTION

- 1. Evaluate CTT assignment  
Critique missed items
- 2. Remotivation
- 3. Review:
  - a. Tech data
  - b. Patch repair
  - c. Use of pneumatic grinder
  - d. Welding procedures for patch repair
- 4. Overview:
  - a. Cleaning methods
  - b. Repair procedures
  - c. Weld repair techniques

APPLICATION: (con't)  
Ref. objectives #1, 2 & 3

- 1. Students will continue to use the appropriate TO 2J-6 series to determine



cleaning methods, repair procedures and techniques for weld repair without error.

2. Students will continue to set up and weld butt patches on jet engine hot section parts in full accordance with the TO 2J-6 Series. All rules of good housekeeping, safety and fire prevention will be observed.

END OF DAY SUMMARY

Summary:

- 1. Use of tech data
- 2. Patch repair
- 3. Use of pneumatic grinder
- 4. Welding procedures for patch repair.

Assignment:

- 1. Read 3ABR53230-SG-004, Answer questions.
- 2. Read TO 2J-1-13

INTRODUCTION TO NEW DAY'S INSTRUCTION

(Day 6 4 hrs)

- 1. Evaluate CTT assignment, critique missed items.
- 2. Remotivation
- 3. Review:
  - a. Use of tech data
  - b. Patch repair
  - c. Use of pneumatic grinders
  - d. Welding procedures for patch repair.
- 4. Overview:
  - a. Cleaning methods
  - b. Repair procedures
  - c. Weld repair techniques

APPLICATION: (con't)

Refer objectives #1, 2, & 3

1. Students will continue to use the appropriate TO 2J-6 series to determine cleaning methods, repair procedures and techniques for weld repair without error.

2. Students will continue and complete their work in setting up and welding butt patches on jet engine hot section parts in full compliance with TO 2J-6 series. All rules of good housekeeping, shop safety and fire prevention will be observed.

EVALUATION

1. Students will complete and turn in their butt patch welds, which will meet all standards of the criterion checklist, and all specifications and requirements contained in the appropriate TO 2J-6 series.

2. Instructor will check each student for proper compliance with TO 2J-6 series, correct welding procedures, specifications, observance of good housekeeping, fire prevention and shop safety, Assistance will be given as needed.

3. Administer appraisal test.

Conclusion

Time: 10 Min

1. Summary

- a. function of hot section
- b. parts of hot section
- c. use of -6 series TOs
- d. welding procedures
- e. patch repair
- f. weld specifications
- g. use of pneumatic grinders
- h. shop safety

2. CTT assignment: POI item 4a, 4 hrs

- a. Read 3ABR53230-SG-604, Answer questions
- b. Review TO 2J-1-13

3. Remotivation

4. Closing statement



LESSON PLAN (Part I. General)

106

APPROVAL OFFICE AND DATE TWSTI 14 Oct 15 Richard	INSTRUCTOR
COURSE NUMBER 3ABR53131	COURSE TITLE Metals Processing Specialist
BLOCK NUMBER VI	BLOCK TITLE Pipe, Tubing, and Aircraft Exhaust and Jet Engine Hot Section Repair
LESSON TITLE Fillet Patches on Jet Engine Hot Section Parts	

LESSON DURATION		
CLASSROOM/Laboratory D & D 2 hrs/Perf 10 hrs	Complementary 4 hrs	TOTAL 16 hrs

POI REFERENCE		
PAGE NUMBER 46	PAGE DATE 23 Sep 1975	PARAGRAPH 4

STS. CTS REFERENCE	
NUMBER STS 531X1	DATE 31 May 1975

SUPERVISOR APPROVAL			
SIGNATURE	DATE	SIGNATURE	DATE

PRECLASS PREPARATION			
EQUIPMENT LOCATED IN LABORATORY	EQUIPMENT FROM SUPPLY	CLASSIFIED MATERIAL	GRAPHIC AIDS AND UNCLASSIFIED MATERIAL
1. Inert Gas Shielded Welding Station Complete 2. Pneumatic Grinder 3. Trainer 3215 4. Cleaning Equipment 5. Selected Condemned/Defective Part(s)	Toolkit	None	1. 3ABR53131-SG-604 2. TO 2J-1-13 3. TO 2J-6 Series

CRITERION OBJECTIVES AND TEACHING STEPS

a. Given inert gas shielded welding equipment and jet engine hot section parts, set up and make fillet patch weld repairs free of excessive penetration, overlap, and undercut for a total combined distance of no less than 3/4 of the length of the weld, excluding the 1/2 inch at the start and finish. All shop safety, good housekeeping, and fire prevention measures must be observed.

Teaching steps are listed in Part II.



INTRODUCTION

TIME: 10 min

107

1. Attention: Conserve, conserve, conserve!!!
2. Review: Cover important aspects of butt patch repair learned in lesson 3ABR53230-603. Evaluate CTT assignment critique missed items.
3. Overview: Upon completion of this lesson, students will set up and make fillet weld repairs on jet engine hot section parts. Work will be done only in full accordance with the appropriate TO 2J-6 Series, while all rules of shop safety, good housekeeping, and fire prevention are observed.
4. Motivation: By using proper Tech Data will keep your ass in a safe place  
Appropriate -6 TO

BODY

TIME-11 hrs 40 min

PRESENTATION:

Ref-objective #1

1. Obtain the proper -6 series tech order.
2. Know the proper nomenclature of the part and look it up in the table of contents or index.
3. Turn to the appropriate page and paragraph, and check for instructions and further references given such as:
  - a. Serviceable/repairable table for the particular component.
  - b. Weld data table
  - c. Cleaning methods and requirements
  - d. Acid etching; (if applicable to the part)

- e. Welding procedure
  - (1) Current Setting
  - (2) Shielding gas flow
  - (3) Other important data such as precautions and suggestions.

- f. Weld specifications
  - (1) Bead height, width and contour
  - (2) Penetration
  - (3) Pneumatic Grinding and tolerances allowed
  - (4) Stress relieving requirements, if any.

4. Make sure patch repair metal type and thickness corresponds with that prescribed in the tech order, and the part to be welded.

5. When making patch:
- a. Remove defective patch or metal in compliance with the tech order.
  - b. Etch test as necessary
  - c. Prepare patch to prescribed size, shape and contour according to tech order specifications.



- 6. Clean the area as outlined in the tech order.
- 7. When welding the patch, insure full compliance with the appropriate tech order as to:
  - a. Proper current setting
  - b. Proper shielding gas pressure
  - c. Correct filler wire and tungsten type and size.
  - d. Proper spacing, placement and tolerances if any.
  - e. Applicable specifications, suggestions and precautions.
- 8. Observe all measures of safety, good housekeeping and fire prevention as follows:
  - a. Insure maximum safety when using the pneumatic grinder.
    - (1) Faceshield
    - (2) Correct RPM rating of wheel to grinder
    - (3) No jewelry or improper clothing.
    - (4) Never tap grinder on part, or bind wheel in tight areas.
    - (5) Always disconnect air from grinder when not using it.



- b. Careful handling and use of acetone or other cleaning agents.
- c. Wear gloves when using etching solution-always add acid to water, never water to acid.
- d. Dispose of oily rags in metal container with lid.
- e. Using power shear, no jewelry and one man at a time on machine.
- f. Be safety conscious when using all shop equipment, and keep all areas clean.

**APPLICATION**

1. While observing all measures of good housekeeping, safety and fire prevention, students will set up and weld fillet patches on jet engine hot section parts in full accordance with TO 2J-6 series.

**EVALUATION:**

2. Instructor will check each student for proper compliance with TO 2J-6 Series, correct welding procedures, specifications, observance of good housekeeping, fire prevention and shop safety. Assistance will be given as needed.

END OF DAY SUMMARY

**Summary**

- 1. Use of tech data
- 2. Serviceable/repairable parts
- 3. Welding procedures
- 4. Weld specifications

5. Patch repair
6. Good housekeeping and shop safety.

CTT Assignment: Students will read/review the following assignment after completion of the assignment students will be able to answer questions with 75% accuracy. 1. POI item 4a, POI Time 2 hrs. Read. 3ABR53131-SG-604

(Day 8, 4 hrs) INTRODUCTION TO NEW DAY'S INSTRUCTION

1. Evaluate CTT Assignment Critique missed items.
2. Remotivation when is FMS you will daily work with A/C parts.
3. Review:
  - a. use of tech data
  - b. serviceable/repairable parts
  - c. welding procedures
  - d. weld specifications
  - e. patch repair
4. Overview
  - a. Set up and weld fillet patches.

APPLICATION (cont)

1. Students will continue to set up and weld fillet patches on jet engine hot section parts in full compliance with TO 2J-6 Series. All rules of good housekeeping, safety and fire prevention will be observed.

EVALUATION:

1. Instructor will check each student for proper compliance with the TO 2J-6 Series, correct welding procedures, specifications, observance of good housekeeping, fire prevention and shop safety. Assistance will be given as needed.

## END OF DAY SUMMARY

112

### Summary:

1. use of tech data
2. welding procedures
3. weld specifications
4. patch repair
5. good housekeeping and shop safety

**CTT Assignment:** Students will read/review following assignment after completion of assignment will be required to answer questions with 75% accuracy.

POI Item 6a, ( 2 hrs)

## INTRODUCTION TO NEW DAY'S INSTRUCTION

1. Evaluate - CTT assignment  
Critique missed items.
2. Remotivation
3. Review
  - a. tech data
  - b. welding procedures
  - c. weld specifications
  - d. patch repair
4. Overview
  - a. Set up and complete welding fillet patches

### APPLICATION

1. Students will continue and complete their work in setting up and welding fillet patches on jet engine hot section parts in full compliance with TO 2J-6 Series. All rules or good housekeeping, shop safety and fire prevention will be observed.

### EVALUATION

1. Students will complete and turn in their best fillet patch welds, which will meet all standards of the criterion checklist, and all specifications and requirements contained in the appropriate 2J-6 Series tech order.

**CONCLUSION****1. Summary:**

- a. tech data
- b. weld procedures
- c. weld specification
- d. patch repair

**2. CTT Assignment:** Students will read/review following assignment after assignment will answer questions with 75% accuracy. Read:  
3ABR53131-SG-605

**3. Remotivation****4. Closing Statement**



APPROVAL OFFICE AND DATE TWSTI 11/20/75 Richard	INSTRUCTOR
COURSE NUMBER 3ABR53131	COURSE TITLE Metals Processing Specialist
BLOCK NUMBER VI	BLOCK TITLE Pipe, Tubing, and Aircraft Exhaust and Jet Engine Hot Section Repair

LESSON TITLE  
Reciprocating Engine Exhaust Manifold Repair

LESSON DURATION		
CLASSROOM/ Laboratory/ D & D 2 hrs/Perf 4 hrs/	Complementary 2 hrs.	TOTAL 8 hrs.

POI REFERENCE		
PAGE NUMBER 47	PAGE DATE 23 Sep 1975	PARAGRAPH 5

STS/CTS REFERENCE	
NUMBER STS 531X1	DATE 31 May 1975

SUPERVISOR APPROVAL			
SIGNATURE	DATE	SIGNATURE	DATE

PRECLASS PREPARATION			
EQUIPMENT LOCATED IN LABORATORY	EQUIPMENT FROM SUPPLY	CLASSIFIED MATERIAL	GRAPHIC AIDS AND UNCLASSIFIED MATERIAL
1. Inert Gas Shielded Welding Station Complete 2. Sandblast Machine 3. Power Shears 4. Slip Rolls 5. Throatless Shears 6. Buffer & Polishing Machine	Toolkit	None	1. 3ABR53131-SG-605 2. TO 2RA Series 3. Chart: CC 74-217

CRITERION OBJECTIVES AND TEACHING STEPS

- a. Given technical orders, select cleaning methods, repair procedures, and techniques for weld repair without error.
- b. Given a list of materials, select materials required for repair of reciprocating engine exhaust manifold parts and assemblies with 75% accuracy.
- c. Given inert gas shielded welding equipment and reciprocating engine exhaust and manifold assemblies, set up and make weld repairs free of excessive penetration, overlap, and undercut, for a total combined distance of no less than 3/4 of the length of the weld, excluding the first 1/2 inch start and the last 1/2 inch finish. All shop safety, good housekeeping, and fire prevention measures must be observed.

Teaching steps are listed in Part II.



INTRODUCTION

TIME: 10 Min

115

1. Attention: Now that recip's are on the way out, we will learn how to weld on them.
2. Review: Fillet welds on jet engine hot section parts. Evaluate CTT assignment critique missed items.
3. Overview: Students will set up and weld butt and lap joint repairs on reciprocating engine manifolds in accordance with the TO 2RA Series.
4. Motivation: You may have to someday work on recip's.

BODY

TIME: 5 Hr. 40 Min.

PRESENTATION:

Ref Objectives #1, 2, 3

1. Cleaning methods in accordance with TO 2RA series
  - a. Degrease all exhaust assembly components using a solution of compound-carbon removal.
  - b. Rinse with hot water under pressure
  - c. Inspect all exhaust assembly components for hard carbon deposits.
  - d. After degreasing, clean components in a 15%, by weight, solution of caustic soda solution and water.
  - e. Steam clean all parts thoroughly and rinse in cold water.
  - f. Clean both inside and outside of cracked areas with a stainless steel brush or very light sand blasting.

2. Minor crack repair - cracks less than one inch long:
  - a. Apply flux to underside of crack
  - b. Heliarc weld using 19-9WX or 18-8 type 347 weld rod
3. Major weld repair - cracks longer than one inch, or holes requiring patches:
  - a. Cracks longer than one inch
    - (1) Level edges
    - (2) Tack weld every  $\frac{1}{2}$  inch before attempting final weld repair.
    - (3) Start welding from ends of crack, working both ways toward the center.
4. Patch repair of thinned areas and holes:
  - a. Cut away thinned area and smooth stack body material edges.
  - b. Make patch  $\frac{1}{2}$  inch larger than removed body material using same gauge material as the original material.
  - c. Insure minimum radius of  $\frac{1}{4}$  on all corners
  - d. Form patch to fit contour of stack
  - e. Insure  $\frac{1}{4}$  overlap of patch over damaged area
  - f. Make sure area to be welded is clean on both sides and then heliarc weld.
5. Welding Current
  - a. DCSP
  - b. 50-60 amperes

- 6. Torch gas = 10-15 cubic feet per hour
- 7. Materials required for repair of aircraft parts and assemblies
  - a. Vapor degreaser
  - b. Sand blaster
  - c. Hand tools for cleaning and joint preparation
  - d. Appropriate tech data
  - e. Various gauges and types of metal for patch weld repair
  - f. Appropriate weld rods according to tech data
  - g. Complete heliarc weld station and accessories
  - h. Safety items
  - i. Flux
  - j. Heat treating furnace

APPLICATION:

- 1. Given inert gas shielded welding equipment and exhaust manifolds, while observing all shop safety and fire prevention measures, set up and make weld repairs in accordance with TO 2RA Series.

EVALUATION:

- 1. Instructor will check students for proper weld procedures as outlined in TO 2RA Series, and see that all measures of good housekeeping, fire prevention and safety are being observed. Assistance will be given as needed.
- 2. Given the applicable publications, use technical orders to determine cleaning methods, repair procedures and techniques for weld repair without error.



Summary:

1. Cleaning methods
2. Minor crack repair
3. Major crack repair
4. Patch repair
5. Materials required for repair of aircraft parts.

CTT Assignment: The students will read/review the following assignment, after completion of the assignment students will be able to answer questions with 75% accuracy.

POI items 5abc, Time 2 hrs

Read 3ABR53131-SG-605

(Day 9 4 hrs)

INTRODUCTION TO NEW DAY'S INSTRUCTION

1. Evaluate CTT Assignment  
Critique missed items
2. Remotivation:
3. Review:
  - a. Cleaning methods
  - b. Minor crack repair
  - c. Major crack repair
  - d. Patch repair
  - e. Shop safety
4. Overview
  - a. Weld repairs on reciprocating engine exhaust manifolds.

APPLICATION: (Cont)

1. Students will continue to set up and weld repairs on exhaust manifolds in accordance with TO 2RA Series, while observing all measures of good housekeeping, fire prevention and safety.

EVALUATION:

1. Given the applicable publications, use technical orders to determine cleaning methods, repair procedures and techniques for weld repair without error.

2. Given a series of questions concerning the materials required for repair of aircraft parts and assemblies, select the correct responses for 75% of the questions.
3. Students will complete and turn in weld repairs performed on engine exhaust manifolds, which will meet all requirements outlined in TO 2RA Series and the criterion checklist. This includes individual observance of all rules of good housekeeping, fire prevention and safety.

**CONCLUSION**

**TIME:**

1. Summary:
  - a. Cleaning methods
  - b. Minor crack repair
  - c. Major crack repair
  - d. Patch repair
  - e. Material required for repair of aircraft parts
2. CTT Assignment: Students will read/review following assignment, after completion of the assignment students will be able to answer questions with 75% accuracy.  
POI Item 6a, 6b, time 2 hrs    Read: 3ABR53131-SG-606  
and answer questions
3. Remotivation
4. Closing statement



LESSON PLAN (Part I, General)

120

APPROVAL OFFICE AND DATE TWSTI 14 Oct 75 <i>Richard</i>		INSTRUCTOR	
COURSE NUMBER 3ABR53131		COURSE TITLE Metals Processing Specialist	
BLOCK NUMBER VI		BLOCK TITLE Pipe, Tubing, and Aircraft Exhaust and Jet Engine Hot Section Repair	
LESSON TITLE Welding of Carbon and Alloy Steel Tubular Assemblies			
LESSON DURATION			
CLASSROOM/Laboratory D & D 1 hr/Perf 5 hrs	Complementary 2 hrs	TOTAL 8 hrs	
POI REFERENCE			
PAGE NUMBER 48	PAGE DATE 23 Sep 1975	PARAGRAPH 6	
STS/CTS REFERENCE			
NUMBER STS 531X1	DATE 31 May 1975		
SUPERVISOR APPROVAL			
SIGNATURE	DATE	SIGNATURE	DATE
PRECLASS PREPARATION			
EQUIPMENT LOCATED IN LABORATORY	EQUIPMENT FROM SUPPLY	CLASSIFIED MATERIAL	GRAPHIC AIDS AND UNCLASSIFIED MATERIAL
1. Oxyacetylene Welding Station Complete 2. Trainer 3216	Toolkit	None	1. 3ABR53131-SG-606 2. Charts: CC 74-208, CC 74-209, CC 74-210, CC 74-211, CC 74-212, CC 74-213 3. Modern Welding (Chapter 18)
CRITERION OBJECTIVES AND TEACHING STEPS			
<p>a. Given materials, tools, and required equipment, lay out and fabricate tubular joints and assemblies without error.</p> <p>b. Given oxyacetylene welding equipment and tubular specimens, set up and weld tubular joints free of excessive penetration, overlap, and undercut for a total combined distance of no less than 3/4 of the length of the weld. All shop safety, good housekeeping, and fire prevention measures must be observed.</p> <p>Teaching steps are listed in part II.</p>			

118



INTRODUCTION

TIME: 10 Min.

1. Attention: Used on engine mounts and some maintenance stands.
2. Review: Briefly cover what was learned concerning welding of reciprocating manifolds.
3. Overview: Students will cut out and fit up tubular assemblies and splice repairs and oxyacetylene weld them according to TO 1-1A-1.
4. Motivation: Last joint before blocking out.

BCDY

TIME: 5 Hrs. 40 Min.

PRESENTATION:

Ref Objectives a and b.

1. Consult TO 1-1A-1 for tubular welding for the:
  - a. Type of metal being welded and means of identification
    - (1) Chemical composition
    - (2) Tensile and yield strength
    - (3) Heat and quench test
  - b. Factors concerning the type of metal to be welded in this case 4130 chromoloy steel tubing.
    - (1) Preheating temperature and requirements
    - (2) Weldability
    - (3) Stress Relieving and other forms of heat treating, temperatures, factors and requirements
    - (4) Required cooling methods
2. Lay out and fabricate tubular joints and assemblies
  - a. Tools to be used

- (1) Files - round and half-round types
- (2) Hacksaw - adjustable type with flexible blade
- (3) Combination set with square or protractor head

b. Layout and assembly of station joint

- (1) 1 inch and 1 1/8 inch OD 4130 chromoloy tubing is used.
- (2) Length of tubing as given in study guide:
  - (a) A-tube is 2 3/4" long 1" OD
  - (b) B-tube is 5 1/2" long, 1 1/8" OD
  - (c) C-tubes are 4 1/2" long, 1" OD
  - (d) D - gusset plates are 0.093" X 3/4" X 2 1/2"
- (3) Proper fit of tubing
  - (a) Square B tube at both ends to a 90 degree angle.
  - (b) Square A tube at one end to 90 degree angle. Rough grind other end of the tube to fit contour of B tube. Finish contour fit with files.
  - (c) Square one end of C tube to a 90 degree angle. Rough grind other end to fit contour of B tube. Finish contour fit with files.

c. Layouts and fabrication of scarf and fish-mouth splices

- (1) Both splices may be used where partial replacement of a damaged member is necessary.



- (2) Splices are never placed in middle 1/3 portion of a member.
- (3) Only one splice per single tubular member.
- (4) Angle of cut on both splices is 30 degrees.
- (5) Length of fishmouth splice is  $4\frac{1}{2}D$
- (6) Length of scarf splice is  $6\frac{1}{2}D$

3. Welding specifications and procedures

a. Penetration - most important factor.

- (1) On 1/8" T or greater, bevel edges to a 45 degree angle to eliminate need for spacing.
- (2) Use neutral flame for best results and to prevent changing metal properties.

b. Overlap - caused by fear of burning through thus adding filler rod too rapidly.

c. Shallow welds - lack of filler metal - thickness of weld should be greater than parent metal.

d. Burning - 4130 melts at approximately 2600 degrees F; 300-400 degrees above this point may endanger any of its properties.

e. Undercutting

- (1) Strength is reduced
- (2) Torch is at improper angle
- (3) Eliminated by angling the flame more directly at the edge that is being undercut.

f. Uniformity of bead



- (1) Last and probably least most important
- (2) Uniformity of the width is more important than uniformity of the surface.

g. Changing rod

- (1) Necessitates most of the stopping and starting
- (2) Flame envelope should continue to play upon the solidified puddle to prevent oxidation.

h. Finishing Welds

- (1) Lap over distance of  $1/8-1/4$ "
- (2) The crater should always be filled.
- (3) The flame should be withdrawn (usually ahead of the puddle) and the puddle allowed to solidify.
- (4) Pinholes, caused by contracting of surrounding metal, should be rewelded just enough to get rid of the hole. If necessary a drop of rod should be added.

END OF DAY SUMMARY

Summary:

1. Metal identification
2. Layout and fabricate tubular assemblies
3. Welding specifications and procedures.

CTT Assignment  
POI Items 6a, 6b (2 hrs)

1. Review 3ABR53131-SG-606
2. Review Modern Welding Chapter 18.

(Day 10-4 hrs)

INTRODUCTION TO NEW DAY'S INSTRUCTION

1. Evaluate CTT assignment  
Critique missed items.
2. Remotivation: Restate previous
3. Review:
  - a. Metal identification
  - b. Factors concerning the type of metal to be welded.
  - c. Lay out and fabrication of tubular joints.
  - d. Welding of tubular assemblies.
4. Overview
  - a. Layout and fabricate tubular joints
  - b. Weld tubular joints.

APPLICATION (Cont)

1. Students will continue to lay out and fabricate tubular joints and assemblies.
2. While observing all shop safety, good housekeeping and fire prevention measures, students will continue to set up and weld tubular joints.

EVALUATION:

1. Student performance in the laboratory on the layout, fabrication and welding of tubular joints and assemblies will be evaluated by the instructor. Proper observance of good housekeeping, fire prevention and shop safety will be considered.
2. Students will complete and turn in their work on tubular joints. Joints must meet all specifications of the criterion checklist.

CONCLUSION

TIME: 10 Min.

1. Summary:
  - a. Metal identification
  - b. Factors concerning the type of metal to be welded
  - c. Lay out and fabrication of tubular joints.
  - d. Welding tubular assemblies
2. Assignment:
  - a. Read 3ABR53131-SG-701 and 702 answer questions.
  - b. Read TO 1-1A-9, para 2-43 thru 2-57, pages 2-8 - 2-11
3. Remotivation
4. Closing statement





Technical Training

Metals Processing Specialist

BLOCK V  
INERT GAS SHIELDED WELDING OF  
HIGH PERFORMANCE AIRCRAFT METALS

3 September 1974



13-7

CHAMUTE TECHNICAL TRAINING CENTER

This supersedes 3ABR53230-SG-500, 28 November 1972.

OPR: TWS

DISTRIBUTION: X

TWS - 200; TTOC - 2

Designed For ATC Course Use

DO NOT USE ON THE JOB

Study Guides and Workbooks are training publications authorized by Air Training Command (ATC) for student use in ATC courses.

The STUDY GUIDE (SG) presents the information you need to complete the unit of instruction or makes assignments for you to read in other publications which contain the required information.

The WORKBOOK (WB) contains work procedures designed to help you achieve the learning objectives of the unit of instruction. Knowledge acquired from using the study guide will help you perform the missions or exercises, solve the problems, or answer questions presented in the workbook.

The STUDY GUIDE AND WORKBOOK (SW) contains both SG and WB material under one cover. The two training publications may be combined when the WB is not designed for you to write in, or when both SG and WB are issued for you to keep.

Training publications are designed for ATC use only. They are updated as necessary for training purposes, but are NOT to be used on the job as authoritative references in preference to Technical Orders or other official publications.

### TABLE OF CONTENTS

UNIT	TITLE	PAGE
501	Inert Gas Shielded Welding	1
502	Joints of Heat and Corrosion Resistant Ferrous Alloys	13
503	Position Welding of Heat and Corrosion Resistant Ferrous Alloys	25
504	Joints of Aluminum and Aluminum Alloy Sheet and Plate	29
505	Butt Joints of Magnesium	37
506	Joints of A-286 Alloy	43
507	Joints of Chromoloy	47
508	Butt Joints of Nickel Base Alloys	51
509	Butt Joints of Titanium and Titanium Alloy Sheet	55



### INERT GAS SHIELDED WELDING

#### OBJECTIVES

After completing this study guide and your classroom instruction, you will be able to:

1. Understand and apply the principles of inert gas shielded welding for fabricating different types of joints on various types of metal.

#### INTRODUCTION

Inert gas shielded welding is a welding process which uses an inert gas to protect the weld zone from atmospheric oxidation which would contaminate the weld. It produces welds that are stronger, more ductile, and more corrosion resistant than welds made with ordinary metallic arc welding. The protective shield that envelops the weld enables the joints to be fabricated without the use of flux, thus eliminating the corrosion due to flux entrapment, and also expensive postwelding operations. The entire welding operation takes place without spatter, sparks, or fumes.

#### INFORMATION

##### MANAGEMENT OF DEFENSE ENERGY AND RESOURCES

While you are in Block V, there is to be no writing in training literature provided you. This is due to redistribution to subsequent classes. Also, while you are on regular scheduled breaks, you will leave lights on in the classroom unless you will be out of the classroom for 20 minutes or more.

During clean-up of classroom and other areas, use of cleaning materials should be kept to a minimum in order to reduce cost. These procedures should be followed throughout Block V.

#### TIG WELDING

There are many inert gas shielded welding processes. The process that you are going to become familiar with is the tungsten inert gas (TIG), figure 1. Tungsten inert gas uses a nonconsumable tungsten electrode.

The tungsten inert gas shielded welding process is especially adapted for welding light gage work requiring the highest quality and/or finish because of the exceptional concentration of heat, precise heat control, and the ability to weld with or without filler metal. It is one of the few processes which permits the rapid welding of tiny or light-walled objects.

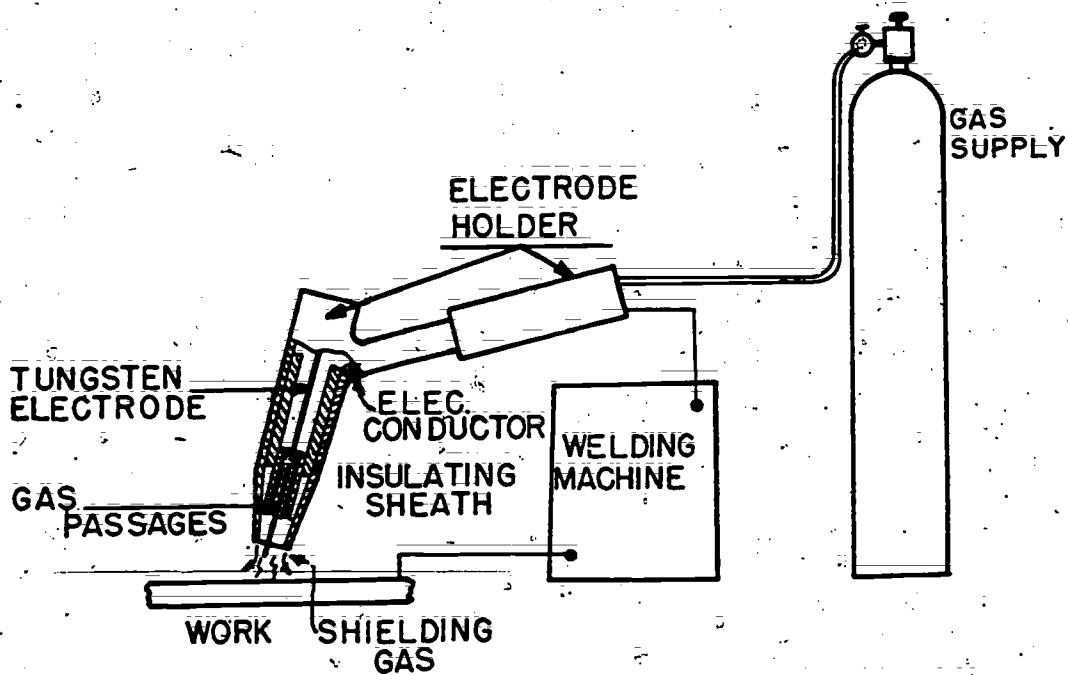

Figure 1. Inert-Gas Shielded Process (Nonconsumable-Electrode) TIG.

An arc from the tungsten electrode in the atmosphere of inert gas provides an intense source of heat which is very clean and operates very quietly. The inert gases provide an almost ideal shielding cover in which to melt most metals for welding, refining, or casting. Because of this, the inert gas process is generally adapted for welding a wide range of materials.

Most metals or alloys which do not vaporize under the heat of the arc, and which solidify without cracking, can be welded. Some of the metals that can be satisfactorily welded by this method are most grades of carbon steel alloys, stainless steels, aluminum and aluminum alloys, magnesium and its alloys, copper, copper-nickel, phosphor bronze, tin bronzes of various types, brasses, nickel, monel, inconel, high temperature alloys, titanium, zirconium, gold, and silver.

The basic requirements for inert gas shielded arc welding consist of a power unit, gas-shielded welding torch, shielding gases, auxiliary equipment, and protective welding equipment.

#### Power Source

The welding current may be supplied through either a welding generator, DC rectifier, or an AC transformer. It is important that the unit have good current control at the lower end of the current range. Standard DC welding machines are employed and selected on the basis of the current output and the range necessary to meet the requirements of the work. Superimposed high frequency is used in some machines to permit starting the arc without the electrode contacting the work.

## Torch

There are several types and models of gas shielded welding torches being used today. The operation and design are basically the same with the exception of the manner in which they are cooled.

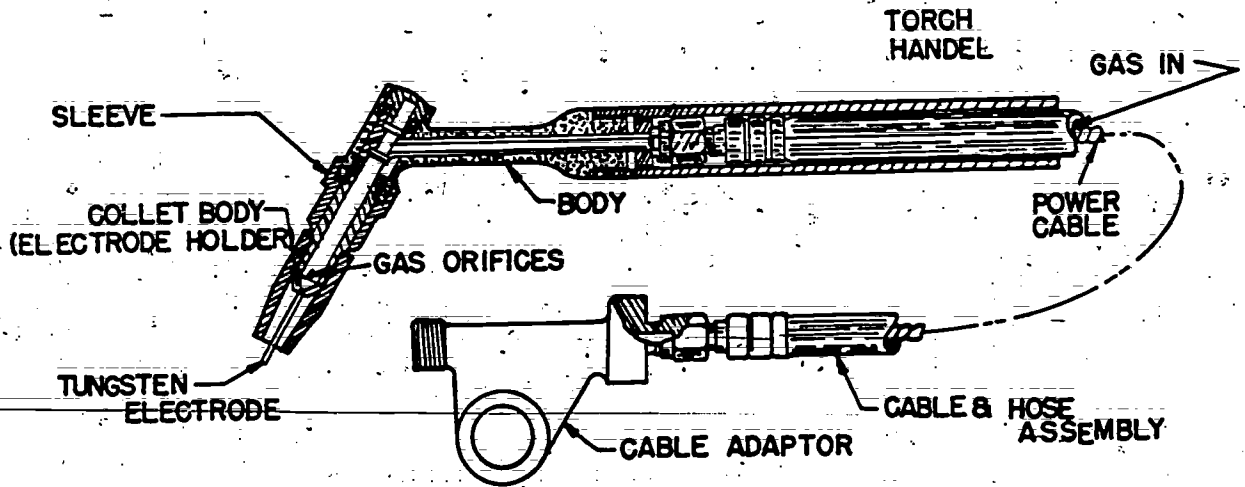

Figure 2. Air-Cooled, Gas Shielded Arc Welding Torch.

The air-cooled torch, figure 2, is designed for manual welding of high thin gage materials and is excellent for weld repairing thin section jet engine parts. This torch can be used for welding with high-frequency stabilized alternating current or straight polarity direct current, depending on the job requirements. It can perform continuously on AC or DC current up to 100 amperes.

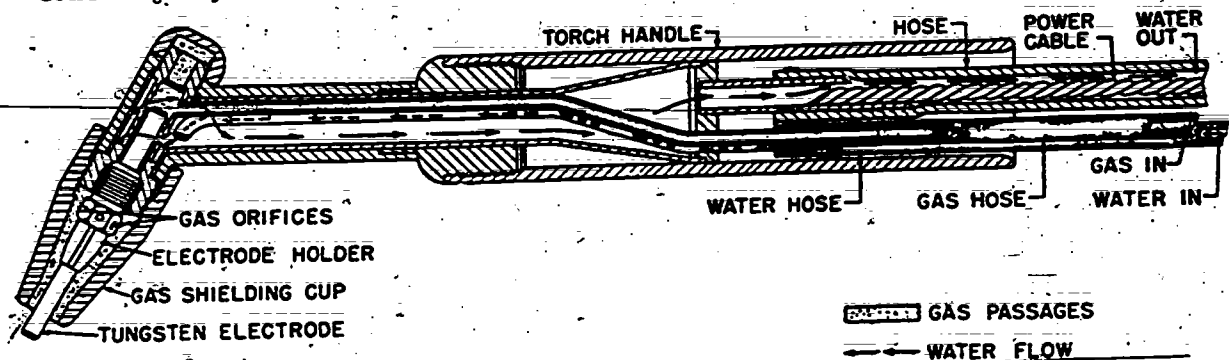

Figure 3. Water-Cooled, Inert-Gas Shielded Arc Welding Torch.

The water-cooled torch, figure 3, is designed to operate at higher current ratings above 100 amperes and up to 300 amperes current capacity. Water-cooling of the torch and power cable for inert gas shielded welding makes possible the use of lightweight parts capable of carrying the rated current without danger of overheating. The power cable is located in the water discharge hose. Water requirements are from one to two pints per minute. A special fuse of about 45 amperes is installed in the power lead line to the torch to protect the equipment from overheating in case of water stoppage. The torch head basically consists of three parts: the collet or electrode

holder, the gas shielding cup, and the tungsten electrode. The shielding gas enters through a plastic hose fitted to the rear of the torch handle, passes through the body and emerges from the gas orifices in the torch head. It is then guided down toward the weld or molten pool by the gas shielding cup that surrounds the electrode.

The tungsten electrode is held firmly in place by a replaceable electrode holder (collet) that screws into the torch head. The threaded end that screws into the torch head is split into four parts. When the electrode holder is tightened, a clamping action takes place on the electrode and holds it in place. The holders are made in various sizes and hold electrodes from .020 to 1/4 inch in diameter and from 3 to 12 inches long.

Gas shielding cups are made from plastic, metal, and ceramic tile. They are made in various sizes and the size selected depends on the size of the electrode to be used. The cup number indicates the diameter of the cup opening in 1/16ths of an inch. Continued use of the torch at high amperage tends to deteriorate the shielding gas cup. For this reason, metal water-cooled cups are used with currents above 100 amperes.

#### Hose

Rubber or plastic hose is used to circulate water for cooling the torch and power cable lead. The bare flexible lead cable is enclosed in the water outlet hose. A separate hose is used for the water inlet and another for feeding the shielding gas to the torch. In case of water stoppage, welding must be stopped to prevent damage to the welding equipment.

Water stoppage may result from an accumulation of dirt in the small passages of the torch. This condition can usually be corrected by disconnecting the water lines and momentarily reversing the flow of water. Three possible causes of leakage in water lines are: an excessive high water pressure, mistreatment of equipment, and improperly sealed hose connection. If leaking occurs in the torch handle, soldered repairs may be necessary. When the hose is damaged near a connection, it is only necessary to cut away the broken section and reinstall it to the fitting. Rubber cement or a hose clamp may be used for securing a leakproof joint. When repairing the water outlet hose, it is necessary to remove an equal length of electrical cable.

The argon or helium hose must be gastight. If the molten pool becomes cloudy or the tungsten electrode turns blue on cooling, it is an indication of a leak in the hose or hose connections. If, for any reason, the plastic hose is subjected to temperatures above 125 degrees, it becomes soft and loses its strength. It should be protected carefully and not allowed to come in contact with hot metal. Hose that has been burned or broken should be replaced because it cannot be effectively repaired. Leaks cause the shielding gas to become diluted with air and causes contamination of the molten pool and the adjacent metal.

## Tungsten Electrodes

Four types of tungsten electrodes are used for gas shielded welding. They are commercially pure tungsten, 1% thoriated tungsten, 2% thoriated tungsten, and tungsten containing thirty to fifty percent zirconium. The thoriated tungsten electrodes are superior to pure tungsten electrodes because of their higher electrode flow, better arc starting and stability, high current carrying capacity, and higher resistance to contamination. The tungsten electrodes containing zirconium have been refined and improved to make them better than the thoriated tungsten electrodes but are considered to be too expensive for normal Air Force use.

The tungsten electrodes are color coded for easier selection. Pure tungsten has a green end, 1% thoriated has a yellow end, 2% thoriated has a red end, and the zirconium tungsten has a brown end.

Tungsten electrodes are practically nonconsumable, but when the electrode unintentionally touches the molten pool, a small ball forms on the end, which may cause an erratic arc. This metal pickup should be removed by grinding or breaking it off with a pair of pliers. Electrode loss due to oxidation can be prevented by leaving the gas on a short time after the arc is broken, allowing it to cool in the protective atmosphere of the shielding gas. Tungsten electrodes are available in diameters of .020 to 1/4 inch and in lengths of 3 to 12 inches. The diameter of the electrode to be used depends upon the current setting used in welding.

## Foot Control

The foot control is a foot-operated rheostat which is installed in the field circuit of the welding machine to change the arc for varying thicknesses of metal. This control enables you to start and stop the machine, and provides a convenient method of making current settings during welding. Another disadvantage is that the control shuts off the welding current and at the same time allows the gas to flow, which protects the weld during cooling, and helps to control crater cracking.

## Gas Regulator

A combination regulator-flowmeter, figure 4, has been developed to control the flow of shielding gases. It steps down the high pressure in the cylinder or manifold to lower working pressures. The gas flow to the apparatus is indicated on a flowmeter tube. In operations in which the gas consumption is high, a central cylinder manifold system can be installed and the gas piped to the various welding stations. The flowmeter is equipped with a manual throttle valve for gas flow adjustment and the welder can set the gas flow required. The flowmeter tube is calibrated at a positive pressure which normally exceeds any back pressure produced by the equipment. This makes a true reading of the gas pressure possible.

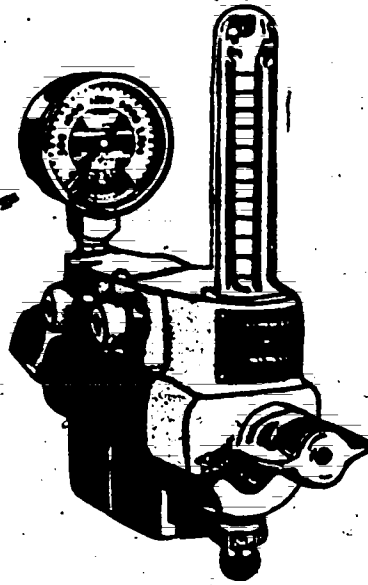

Figure 4. Argon Regulator Flowmeter.

For economic reasons and for ease in handling, both manual and mechanical shutoff valves are made available in the power unit. Electric solenoid valves are installed in the unit, allowing the flow of shielding gas and water to be turned on automatically when the foot control is used. These valves are designed in such a manner that they can be timed to allow the gas and water to flow before the arc is struck. When the foot control is used to stop the arc, the gas and water continue to flow for a specified time. The flowing of gas and water after the arc is stopped permits cooling of the electrode and the molten pool, protecting them from atmospheric contamination.

### Welding Current

**DIRECT CURRENT.** The welding circuit may be connected up as either straight or reverse polarity. The choice of polarity depends upon the type of metal to be welded.

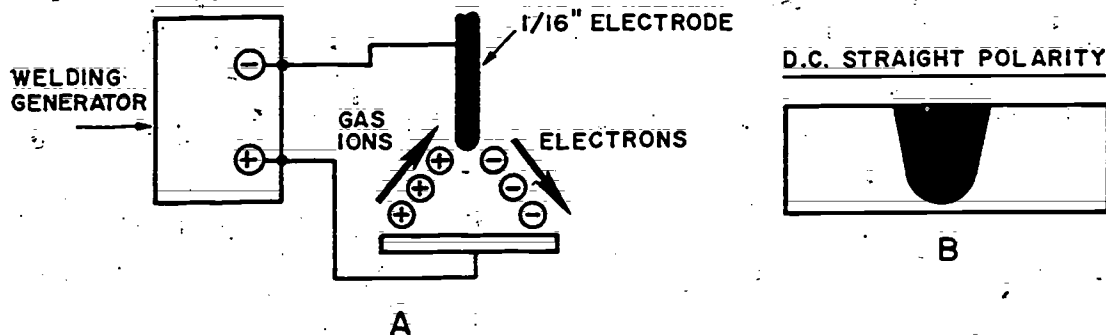

Figure 5. Welding Current.



In direct current straight polarity (DCSP) welding, the electrode is negative and the work is positive, as shown in A of figure 5. In straight polarity welding, the electrons strike the plate at high velocity, producing a concentration of heat effect upon the plate. The heat not only influences the welding action, but the shape of the weld also. DCSP produces a deep narrow weld, as shown in B of figure 5.

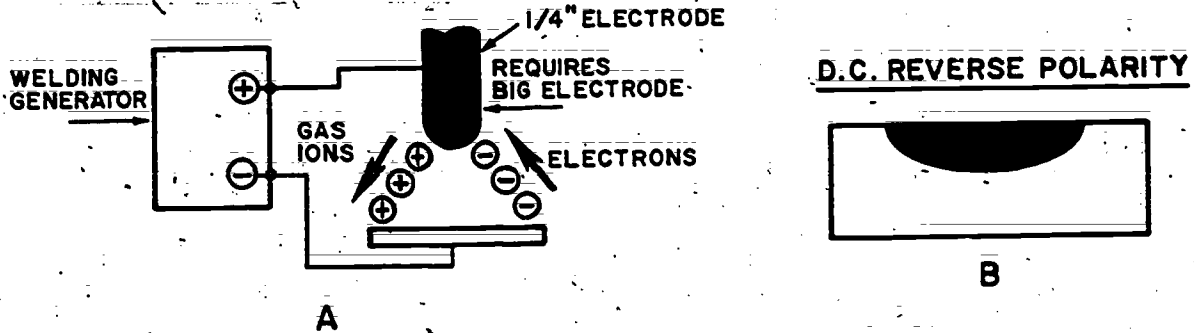

Figure 6. Direct Current - Reverse Polarity.

In direct current reverse polarity (DCRP) welding, the electrode is positive and the work is negative, as shown in A of figure 6. In reverse polarity welding, the electrons are flowing from the plate to the electrode. This requires the use of large diameter electrodes to absorb the extra heat generated and helps to prevent the electrode from burning off. DCRP produces a wide, shallow weld, as shown in B of figure 6. For any given welding current, DCRP requires a larger diameter electrode than DCSP.

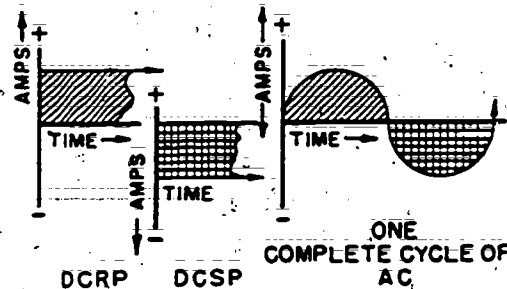

Figure 7. AC Wave.

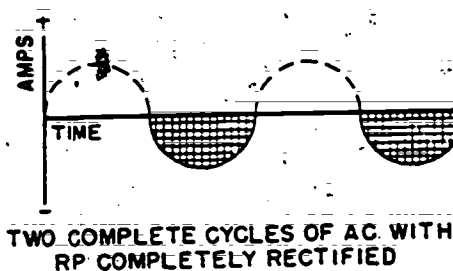

Figure 8. Rectified AC Wave.

**ALTERNATING CURRENT.** Alternating current (AC) welding is a combination of DCSP and DCRP welding current. One half of each complete cycle is DCSP and the other half is DCRP, as shown in figure 7. Foreign matter, such as moisture, oxides, or scale on the surface of the plate, tends to prevent the flow of current in the reverse polarity direction. If no current flows in the reverse direction, rectification is taking place and the current wave would look like figure 8. To prevent this from occurring, it is common practice to superimpose high voltage, high frequency additional current on the standard welding current. When high frequency is superimposed upon AC welding current, a continual flow of electrons is jumping the gap between the electrode and the work piece, piercing the oxide film and forming a path for the welding current to follow. Some advantages that are obtained from using high frequency current are starting the arc without touching the electrode to the work piece, better arc starting and stability, a longer arc is possible, welding electrodes have a longer life, and wider current ranges can be used. A typical weld contour produced with high frequency stabilized AC is shown in figure 9, with DCSP and DCRP welds for comparison.

WELD RESULT-SUMMARY



Figure 9. Comparison of Weld Contours.

**Shielding Gas**

Although there are several inert gases which may be used for gas shielded welding, argon and helium are the two most commonly used. The main reasons for this is the complete chemical inertness and insolubility in molten metals; electrical characteristics that are favorable to smooth, quiet arc action, and efficient metal transfer at high current density. Whether argon or helium is used for the shielding gas depends on the distinctive characteristics required to produce the desired results. Argon is used in most cases, but helium is used when more heat per ampere of welding current is needed. This characteristic of helium becomes a disadvantage when welding very light gages of metal, 1/32 inch or less.

The term "inert gas" suggests a chemically inactive gas, one which will not combine with any other element. The two gases produce different effects upon the materials to be welded due to arc voltage, argon producing a narrow bead with deep center penetration, while helium produces a wide bead with comparatively shallow penetration. These differences often make one or the other of the two gases, or a mixture of the two, preferable for specific applications.



Many other types of gases and gas mixtures have been tested, but all have some deficiency which prevented them being used, such as causing rapid deterioration of the electrode, porosity in welds, and arc instability. Some have been found quite useful for specific purposes, such as nitrogen, which is used as a shielding gas for welding copper. Also, mixtures of argon, helium, and hydrogen have been used in welding heat and corrosion resistant ferrous alloys and some nickel-bearing alloys, such as monel. Both gases are plentiful, but due to the difference in weight, three times as much helium is required for shielding as argon.

**ARGON.** Argon is a colorless, odorless, nontoxic, and nonflammable inert gas, which is somewhat heavier than air. It is supplied in cylinders similar in size and shape to oxygen cylinders, carrying pressure between 2000 to 2500 pounds per square inch. The cylinder may be identified by the distinctive color markings of gray with a white band painted horizontally around the cylinder. The cylinder is considered empty when the pressure is reduced to 40 pounds per square inch and should be replaced with a full cylinder.

Gas purity may have considerable bearing on welding, depending upon the extent to which materials are affected by impurities. Stainless steel, as a rule, is not significantly affected by metals, such as aluminum or magnesium, are relatively sensitive to impurities and are best welded with high-purity gas. The argon and helium gases which are commercially available from most sources are of high purity and average well over 99.95% pure.

Argon is generally used for all alternating current welding applications, such as welding aluminum, magnesium, or copper. The arc is relatively hard to start in helium gas shielding when very low welding current is used. This difficulty is not encountered with argon and the low arc voltage characteristic is particularly helpful in the welding of thin material, because the tendency toward burn-through is reduced.

**HELIUM.** Helium is a colorless, odorless, nontoxic, and tasteless inert gas. It is much lighter than air, being the second lightest of all gases. Helium is nonflammable and is placed under pressure in cylinders, like argon, with 2000 to 2500 pounds per square inch. The cylinder may be identified by the distinctive color markings of gray with a buff top (light brown). The cylinder is considered empty when the pressure is reduced to 25 pounds per square inch and should be replaced with a full cylinder.

Helium is used mainly with direct current welding machines, using DCSP. This shielding gas is used to weld magnesium using DCRP. High arc voltage and current settings are desirable for welding thick metallic materials which have high heat conductivity.

## WELDABILITY OF VARIOUS TYPES OF METALS

## Heat and Corrosion Resistant Ferrous Alloys

Heat and corrosion resistant ferrous alloys are probably the most easily welded of all metals by the gas shielded process. They are generally welded with direct current straight polarity, using argon as the shielding gas. These factors give maximum heat input, resulting in deep penetration and fast welding speeds. This technique minimizes carbide precipitation in nonstabilized heat and corrosion resistant ferrous alloys and helps reduce distortion on thin sections.

## Aluminum

Aluminum and aluminum alloys, along with heat and corrosion resistant ferrous alloy, make up the bulk of the metals joined by inert gas shielded welding. The welding method preferred is alternating current, high frequency stabilization, with argon as the shielding gas. Aluminum can also be welded with direct current reverse polarity.

## Magnesium

Magnesium was largely responsible for the development of the gas shielded welding process because it is virtually the only process that can be successfully used to weld magnesium. Magnesium alloys can be welded using AC or DC current. If DC machines are used, reverse polarity with helium gas for shielding is used. When AC machines with high frequency stabilization are used, argon is used as the shielding gas.

## Monel and Inconel

Monel and inconel are both readily weldable by gas shielded welding. The basic procedure is the same as for the heat and corrosion resistant ferrous alloys, using direct current straight polarity and argon as the shielding gas.

## A-286

A-286 is best fabricated or repaired by tungsten inert gas shielded welding (TIG). Argon is the preferred shielding gas on the lighter gage metals and helium for the heavier gage metals. During welding, the heat input should be kept as low as possible while still obtaining proper fusion. Welding A-286 is more critical than welding other similar types of alloys. If A-286 is not properly shielded, or if it is permitted to burn through without a backup of either shielding gas or a copper backup plate, there is a high probability that the weld will crack.

## Chromoloy

Direct current straight polarity is used in the fabrication and repair of this material. This new alloy is being used in our

present day aircraft and missiles because it meets the medium-high temperature service requirements needed in the jet engine turbine sections. Chromoloy is one of the easiest to weld of the new alloys and should present no problem to you as a welder.

### QUESTIONS

Note: Answer the questions at the end of this chapter on a separate sheet of paper.

1. Define an inert gas.
2. How do welds made by the inert gas method compare to those made by metallic arc welding?
3. List five metals which can be satisfactorily welded by the TIG process.
4. What is the purpose of the 45 amp fuse installed in the power lead line?
5. From what material are gas shielding cups made?
6. Why are thoriated electrodes more superior to the pure tungsten electrodes?
7. What determines the choice of welding polarity?
8. Why are large diameter electrodes required for welding with DCRP?
9. What are the weld characteristics produced when welding with DCRP? DCSP? AC?
10. What is the purpose of the foot control?

### REFERENCE

1. Althouse/Turnquist/Bowditch, Modern Welding Handbook, Chapters 11 and 18, 1967.

## JOINTS OF HEAT AND CORROSION RESISTANT FERROUS ALLOYS

### OBJECTIVES

After completing this study guide and your classroom instruction, you will be able to:

1. Apply the techniques and procedures for welding joints of heat and corrosion resistant ferrous alloys using the TIG welding process.

### INTRODUCTION

Inert gas shielded welding is used very extensively for the fabrication and repair of jet engine aircraft parts because it prevents oxidation of the weld, maintains the maximum of corrosion resistance in the welded part, and helps keep warpage to a minimum. The use of special welding fixtures, close control of current settings, and the application of certain welding techniques and welding speeds, assist in producing welds of a highest quality.

### INFORMATION

#### MANAGEMENT OF DEFENSE ENERGY AND RESOURCES

When welding heat and corrosion resistant ferrous alloys, the bead will be completed with a minimum amount of filler rod. After completing a weld, you will cut the specimen as close to the bead as possible, and utilize the remainder of the specimen.

#### FACTORS PERTAINING TO WELDING OF HEAT AND CORROSION RESISTANT FERROUS ALLOYS

The coefficient of expansion for heat and corrosion ferrous resistant alloys is approximately 60% greater than for carbon steels, and special precautions are a necessity. To resist the tendency to warp during welding, joint edges must be correctly aligned and properly spaced. Tack welds must be closely spaced in accordance with metal thickness. Thin gage metals offer less resistance to warpage when heat is applied and must, therefore, be tack welded at closer intervals than heavy gage metals.

Carbide precipitation is another important factor to consider in welding heat and corrosion resistant ferrous alloys. When the metal is kept at an elevated temperature for any length of time, the carbon combines with chromium and forms chromium carbide. In



the region of this carbide formation, a loss of corrosion resistance results and the tensile strength and ductility are reduced. This usually occurs near the fusion line in the welding of heat and corrosion resistant ferrous alloys. The effect can be reduced to a minimum by confining the arc or heat to as small an area as possible. This means that best results are obtained by the use of smaller electrodes, higher amperages, and faster welding speeds. Inert gas shielded welding is very adaptable in this respect as the tungsten electrode has a very high melting point, allowing the use of high amperages with smaller diameter electrodes. This permits higher welding speeds, a narrow heat affected zone and more rapid cooling of the metal.

On some gas shielded welding applications, the joint edges should be backed up to obtain best results. On light gage material, backing is usually used to protect the underside of the weld from oxidation.

### CORNER AND EDGE JOINTS

Corner and edge joints are the easiest types of joints to weld. With proper setup, no filler rod is needed on metal up to 1/8 inch thick. Very close fitup is necessary so the edges will fuse together without the use of filler rod. The different types of joints and setup are shown in figure 10.

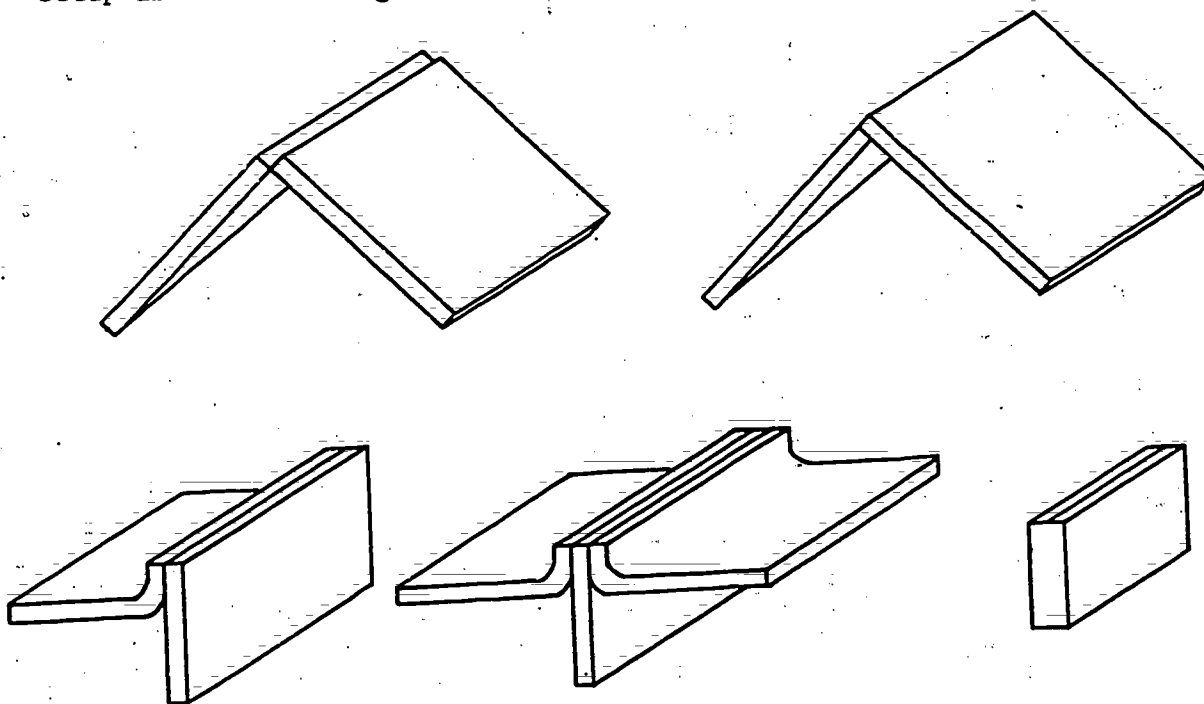

Figure 10. Types of Corner and Edge Joints.

### Metals Preparation and Setup

The preparation of an edge or corner joint is simple. Clean the edges thoroughly to remove all foreign material and make sure

that the edges fit together evenly and that all burrs have been removed. A very close fitup is necessary for the edges to fuse together without the use of filler rod.

General Welding Procedures

1. Strike and hold an arc until a molten pool develops.
2. Hold the electrode as nearly vertical to the joint as possible.
3. Regulate the speed of travel to produce a uniform bead.
4. To terminate the weld, swing the foot control to the low position to break the arc and permit the shielding gas to flow over the weld area until it has cooled.
5. A slow welding speed will cause molten metal to roll off the edge of the metal.
6. Irregular or rapid speed of travel will produce a rough or uneven surface.

WELDING BUTT JOINTS

The square butt joint is an easy joint to prepare and can be welded with or without filler material, depending upon the thickness of the pieces being welded. Joint fitup for a square-edge butt joint should always be true enough to assure 100% penetration with good fusion. In welding light-gage material without adding filler metal, extreme care should be taken to avoid low spots and burn-through. The heavier thicknesses will generally require filler metal to provide adequate reinforcement.

Metal Preparation and Setup

Light gage sheet stock to be butt welded must be accurately sheared and free of burrs. Joint edges must be thoroughly cleaned of all foreign material. A fixture, such as shown in figure 11, may be used for holding the pieces in alignment. For butt welding a thickness of .030 inch or less in a fixture, the work may be set up with the edges butted together, and clamped tightly in the fixture. For butt joints of a thickness greater than .030 inch, the work should be set up with the edges spaced very slightly. The backing plate for metal above .051 inch should have a V-shaped groove equal in depth to the metal thickness and about 1/8 inch wide. The clamping bars should be set as close to the joint edges as will permit manipulation of the electrode without the shielding cup touching.

When welding butt joints outside of a fixture, the joint edges should be aligned parallel, spaced approximately the thickness of the metal and tack welded, as shown in figure 12.





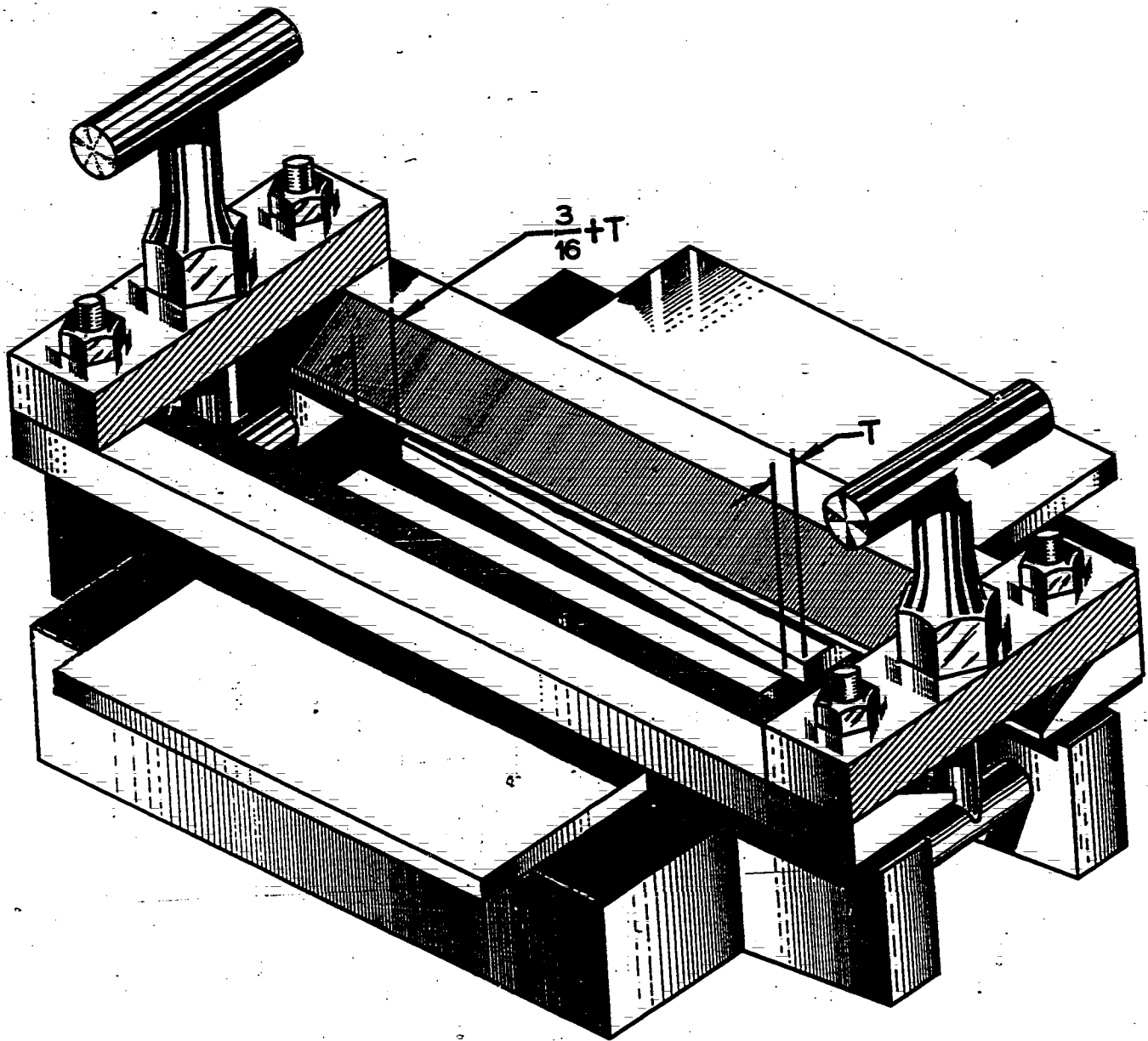

Figure 11. Butt Welding Fixture.

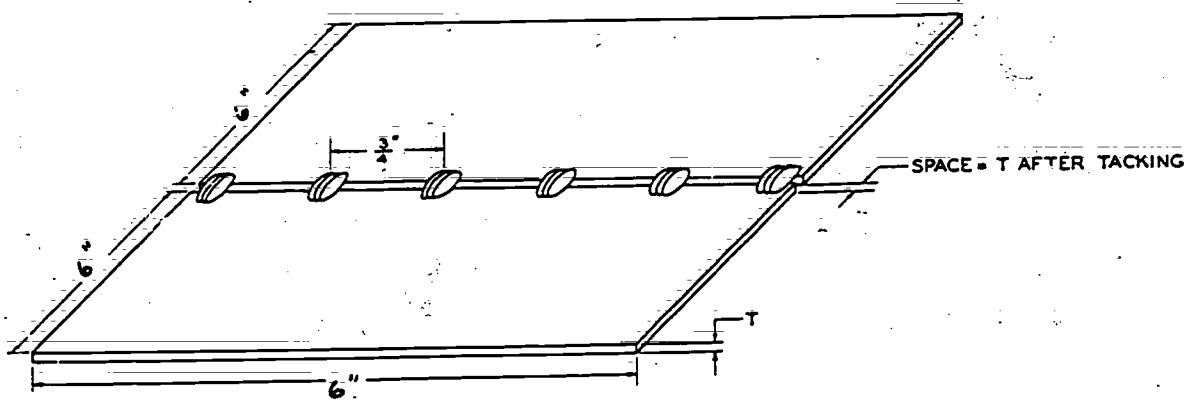

Figure 12. Tack Welded Butt Joint.

### Machine Setting and Equipment Adjustment

For metal thicknesses ranging from .030 to .081 of an inch, the following approximate settings can be slightly altered to fit the individual thickness of metal. The fact that the metal is being welded in a fixture which dissipates heat from the weld area also may affect the current setting.

1. Current - DC straight polarity, 15 to 90 amperes.
2. Argon flow - 12 to 15 cubic feet per hour (cfh).
3. Electrode - tungsten - .040 to 3/32 inch.
4. Electrode adjustment - To extend 1/4 to 5/16 inch beyond edge of gas shielding cup.
5. Water flow - Approximately 1 pint per minute.

### General Welding Procedures

1. Strike and hold an arc near the joint edges.
  2. If the tungsten electrode becomes contaminated, strike the arc on a piece of copper plate until the erratic tendency of the arc "smooths out."
  3. Use the foot control rheostat to adjust the arc to the approximate desired heat.
  4. Move the arc to the joint edges and travel steadily along (forehand), holding the electrode as nearly vertical to the joint as possible.
  5. Filler rod should be added at the forward edge of the pool.
- Note: Manipulation of the torch is not necessary to obtain the proper width of weld in light gage metals.
6. To terminate the weld, the foot control should be swung to the low position, the arc broken, and the shielding gas permitted to flow over the weld area until it has cooled to a black heat.
  7. In order to avoid overlap in restarting a weld, strike the arc ahead of the terminated weld (approximately 1/4 inch) and then move it back to the end of the weld so as to bring it to the molten state before adding filler rod.
  8. Weld specifications of penetration, reinforcement, and width of bead are shown in figure 13. These specifications are approximations of acceptable variations for heat and corrosion resistant ferrous alloy welds on jet aircraft parts.





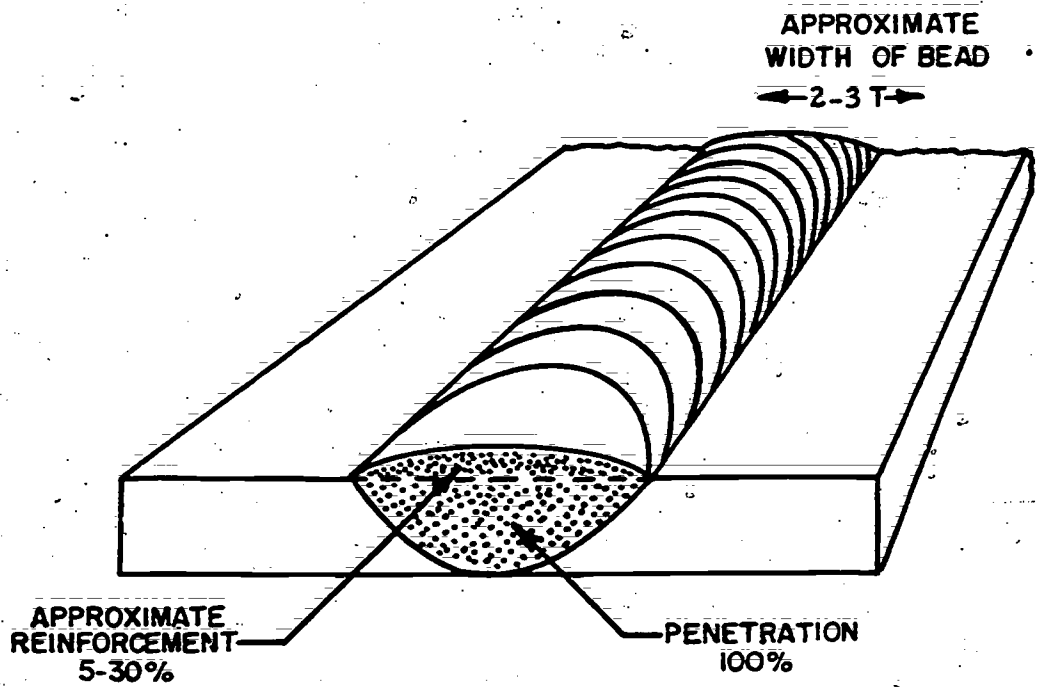

Figure 13. Butt Weld Specifications.

9. Defects to be avoided are:

- a. Undercut - Caused by poor setup, improper backing or excessive heat.
- b. Overlap - Caused by insufficient heat or adding too much filler rod.

Weld Requirements

Heat and corrosion resistant ferrous alloy butt welds made with the inert gas shielded welding process may be narrower with less reinforcement because the highly effective shielding of the inert gas results in a weld of high ductility and tensile strength. The high amperage carried by a small electrode permits a narrow weld having fusion equal to that of wider welds made by oxyacetylene or metallic arc welding process.

- 1. Penetration through the joint should be slightly in excess of 100%.
- 2. Reinforcement for light gages of heat and corrosion resistant ferrous alloys can vary between 5 to 30% of T (T = base metal thickness).
- 3. Width of bead can vary from 2 to 3 T.
- 4. Surface appearance should be a dark bronze to a light purple color.
- 5. The weld metal should taper smoothly into the base metal with no undercut or overlap.

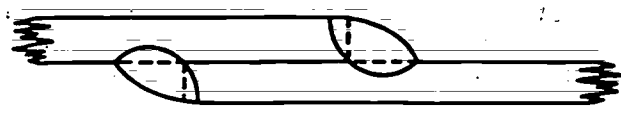

A. DOUBLE WELDED LAP



B. SINGLE WELDED LAP

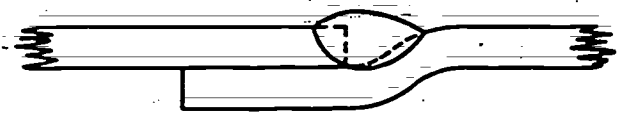

C. JOGGLED LAP

Figure 14. Type of Lap Joints.

WELDING LAP JOINTS

Lap joints are used to join two overlapping sheets so that the edge of one sheet is welded to the surface of the other, as shown in figure 14. When the joint design does not permit welding from both sides, the joint may be welded from one side only. For some applications, such as tubular splices, a single welded lap is satisfactory. However, a single welded lap joint in sheet metal will not develop the full strength of the base metal. Lap joints are used extensively in the repair of weldable jet and conventional aircraft parts because of the ease of preparation and welding. Heat and corrosion resistant ferrous alloy lap welds made by the inert gas shielded process in light gage metals (up to .0625) can be set up and welded with no addition of filler rod. The electrode is so directed as to melt the upper edge of the joint, resulting in a smooth, slightly convex weld bead.

Machine and Equipment Adjustment

For metal thickness ranging from .031 to .081 inches, the following approximate settings can be slightly altered to fit the individual thickness of the metal. The fact that it is being welded in a fixture which dissipates the heat from the weld area also may affect the current setting.

1. Current - DC straight polarity - 20 to 90 amperes.
2. Argon flow - 12 to 15 cubic feet per hour (cfh).
3. Electrode - tungsten .040 to 3/32 inch.

4. Electrode adjustment - To extend  $1/4$  inch to  $5/16$  inch beyond edge of gas shielding cup.

5. Water flow approximately 1 pint per minute.

### Metal Preparation and Setup

Pieces to be lap welded should be sheared, leaving a square edge free of burrs and warpage. Joint edges must be thoroughly cleaned of all foreign materials. Steel wool may be used for this purpose. Fluxing is not necessary for inert gas shielded welding of heat and corrosion resistant ferrous alloy lap joints. Pieces to be welded in a fixture are set up as shown in figure 15. The clamping bars should be set up as close to the joint edge as will permit manipulation of the torch without striking the shielding cup to the clamping bars. To avoid a binding of the clamping bars and possible gapping of the joint to be welded, pieces of shim stock of appropriate thickness are placed with fixtures as shown in figure 15.

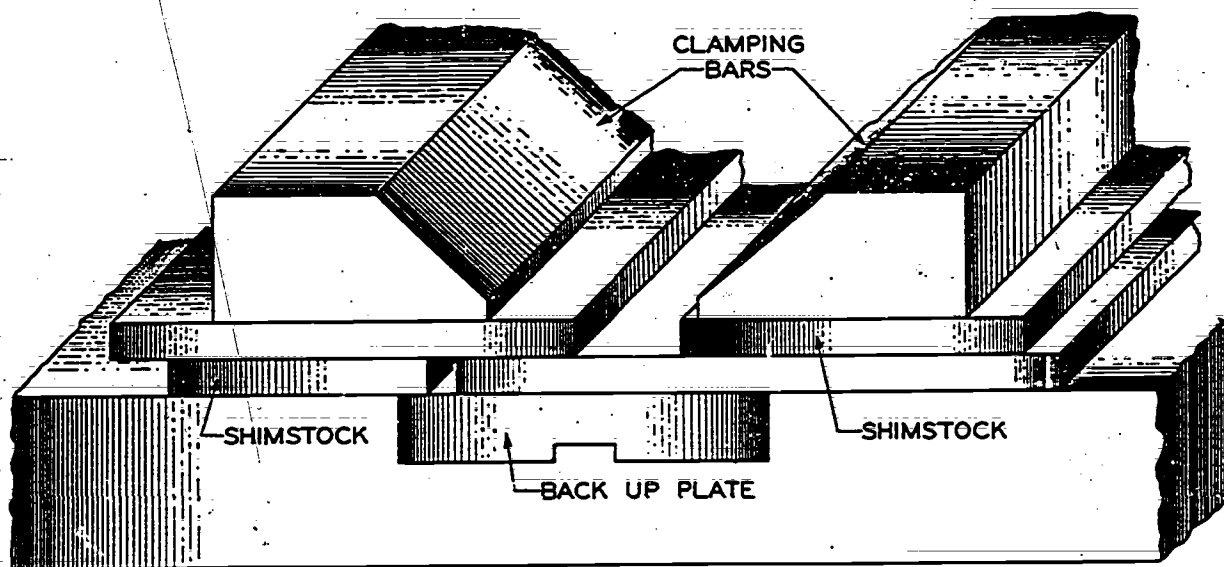

Figure 15. Fixture Setup For Lap Welding.

### General Welding Procedures

1. Strike an arc on a copper sheet with the foot control rheostat set in a "high" position. Immediately upon establishing the arc, swing the foot control toward the "low" position and back again toward "high," fluctuating the current intensity to study the characteristics of the arc and the functioning of the foot control.

Note: The foot control rheostat controls the amount of heat in the arc by changing the open circuit voltage.

2. Strike an arc on the joint edge and move steadily along (forehand) melting back approximately 1 to 2 thicknesses of the top sheet.

3. Ordinarily manipulation (weaving of the torch) is not necessary for lap welding of light gage stainless steel sheet. The torch head is tilted slightly toward the root of the joint and in the direction of travel.

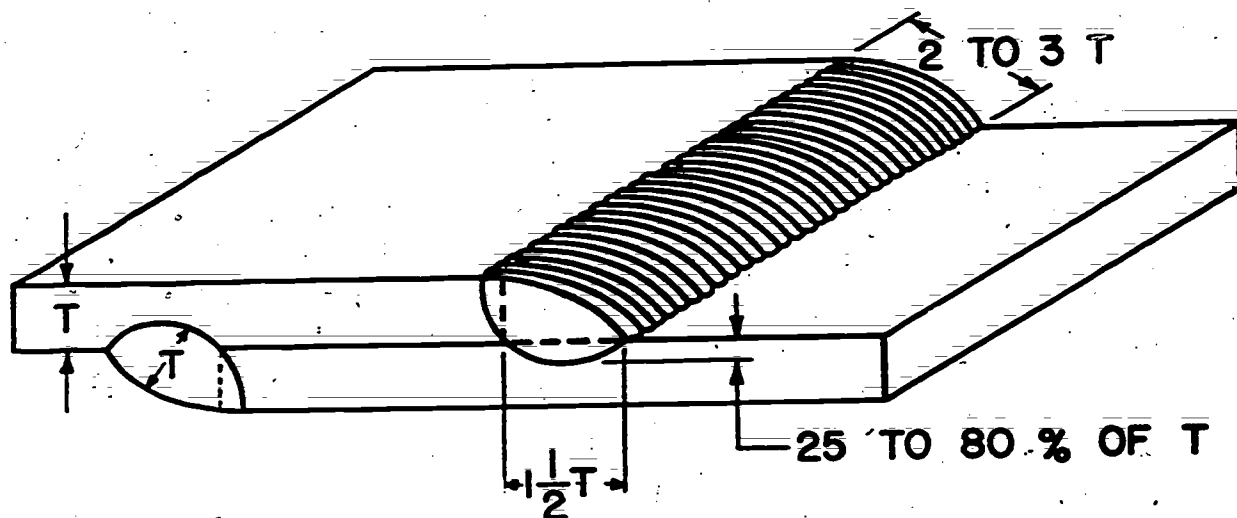

Figure 16. Lap Weld Specifications.

4. Weld specifications of penetration, width of bead, depth of throat, and length of upper and lower leg are shown in figure 16. These specifications are approximations of acceptable variations for welds on aircraft jet engine parts.

5. Defects to be carefully avoided are:

- a. Undercut - Caused by poor setup, improper angling, or failure to melt back enough of the top plate.
- b. Too wide a bead - Caused by excessive heat, traveling too slow or unnecessary weaving of the torch.
- c. Excessive melting back of the top sheet - Caused by a gap between the two sheets.
- d. Smoky oxidized appearance of the weld - Caused by insufficient flow of shielding gas or improper current setting.
- e. Excessive penetration of the lower sheet - Caused by improper backing, traveling too slow, or too high a current setting.

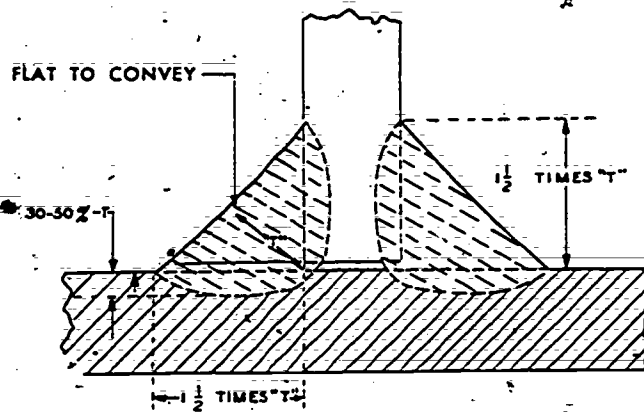

Figure 17. Throat and Leg Dimensions.

### TEE JOINTS

The tee joint, shown in figure 17, is used to join two plates whose surfaces are at an angle of approximately 90 degrees to each other. Welding can be done from one or both sides, depending upon the position and strength required.

When both pieces of the base metal are the same thickness, the upper and lower leg specification should be  $1\frac{1}{2}T$ . If one piece is thinner than the other, the thinner piece determines the leg length or height. Penetration should be from 25% to 80% of "T." The throat thickness should be "T."

Tee joints used in the fabrication or repair of heat and corrosion resistant ferrous alloy aircraft jet engine parts are frequently made to join sheets of unequal thickness. Although they are generally welded from one side only, the technique used requires skillful control of the arc to obtain good fusion into the heavy gage sheet and to avoid undercut of the light gage sheet.

### Machine and Equipment Adjustment

The following approximated settings are for instances where both sheets to be joined are of the same thickness. For metal thicknesses ranging from .031 to .081, the following settings can be altered to match the operator's skill and the thickness of the metal with consideration for the quenching effect.

1. Current - DC straight polarity, 20 to 90 amperes.
2. Argon flow - 12 to 15 cubic feet per hour (cfh).
3. Electrode - tungsten .040 to 3/32 inch.
4. Electrode adjustment - 3/8 - 1/2 inch for tee welds; 1/4 - 5/16 inch for corner.

Note: Above measured from edge of gas shielding cup.

5. Water flow, approximately 1 pint per minute.

### Metal Preparation and Setup

Heat and corrosion resistant ferrous alloy sheet stock used for tee joints should be sheared leaving a square edge free of burrs and warpage. Joint edges must be thoroughly cleaned.

Note: Up to .0625 of an inch, no edge preparation other than cleaning and square shearing is necessary. Metal over .0625 is sometimes prepared for a single "V" tee or a double "V" tee when the joint can be welded from one side or when maximum strength is necessary.

Spacing of tee joints for inert gas shielded arc welding is not necessary because the concentrated heat of the arc enables the operator to obtain proper fusion and penetration without spacing.

### General Procedures

The following listed steps are general procedures to be used when welding tee joints.

1. Strike and hold an arc on a piece of copper plate using the foot control rheostat to establish a stable arc of the approximate required heat.
2. Strike an arc on the joint edge and make a series of tack welds about 1-1/2 inches apart.
3. Hold the torch in such a manner as to bisect the included angle made by the two pieces being welded and as near perpendicular to the axis of the weld as practical.

Note: In welding sheets of unequal thickness, preheat the heavy sheet with a long arc and direct most of the heat on the heavy sheet during the actual welding operation.

4. Add the filler rod at the root of the joint and forward edge of the molten pool.
5. The molten pool and end of the filler rod should be protected by the shielding gas during the entire welding operation.
6. In terminating the weld, the foot control should be swung to the low position, the arc broken, and the shielding gas permitted to flow over the weld area until it has cooled to a black heat.

QUESTIONS

Note: Answer the questions at the end of this chapter on a separate sheet of paper.

- 1. Why is inert gas shielded welding used extensively on heat and corrosion resistant ferrous alloys?
- 2. What is the coefficient of expansion for heat and corrosion resistant ferrous alloys, compared to carbon steel?
- 3. Why is tungsten material usually used when welding light gage materials?
- 4. What is the current setting range and argon flow range?
- 5. When welding a thin square edge butt joint with TIG process, what is the requirement for penetration?
- 6. List the three different types of lap joints.
- 7. What should the color be for a properly welded joint of corrosion resistant ferrous alloy?
- 8. What should the penetration be on a tee joint?
- 9. What type of current is used when inert gas shielded welding heat and corrosion resistant ferrous alloys?

REFERENCE

- 1. Althouse/Turnquist/Bowditch, Modern Welding Handbook, (Chapters 11 and 18), 1967.





POSITION WELDING OF HEAT AND CORROSION  
RESISTANT FERROUS ALLOYS

OBJECTIVES

After completing this study guide and your classroom instruction, you will be able to:

1. Apply techniques and procedures for position welding heat and corrosion resistant ferrous alloys.

INTRODUCTION

Although welding procedures change from time to time because of changing requirements, the positions remain the same. Since you can't turn an aircraft or a power unit over or stand them on end, you have to weld cracks and joints where they are found. It seems that the larger the part, the more it cracks vertically or in a horizontal position. This is why you need to know how to weld in the vertical and horizontal positions using the inert gas shielded procedure.

INFORMATION

MANAGEMENT OF DEFENSE ENERGY AND RESOURCES

While welding heat and corrosion resistant ferrous alloys, you will utilize proper specimen setup and flowmeter adjustment to conserve argon gas.

POSITION WELDING

At first, it may seem that position welding with the inert gas process is just as difficult as position welding is with oxyacetylene and the metallic arc. Even though the basic procedures are the same, the techniques are a little different. The biggest problem has always been to control the molten pool to keep it to a manageable size. With the smaller electrode of the inert gas shielded torch and the foot controlled rheostat, it is very easy to control the molten pool. The bead contour may be a little higher due to the force of gravity but the weld specifications are just as easy to obtain as they were in the flat position.

After you have set up the torch, make sure that you have turned on the water and gas. If the water is not turned on, it can cause the torch to overheat and burn out the safety fuse in the power lead. If the gas is not turned on, you do not have proper shielding and weld becomes contaminated and may fail.



In previous blocks when you had to change the position of the weld, you also had to change the type of current and the electrode. This is not the case in this block. You use the same current for welding heat and corrosion resistant ferrous alloys in the vertical and horizontal position as you did to weld them in the flat position. DCSP gives you the deep penetration and faster welding speed you need to control the molten pool and minimize carbide precipitation. It also helps you to control warpage and distortion in thin sections.

### Equipment

To weld heat and corrosion resistant ferrous alloys in the vertical and horizontal position, you need an AC-DC welder, an inert gas welding torch, a 2% thoriated tungsten electrode, lightweight leather gloves, and a welding lens dark enough to protect your eyes from the intense light of the arc.

### Filler Rod

The filler rod should be 1/16" in diameter and as close to the composition of the base metal as possible. It should be cleaned by using emery cloth to remove any surface contamination, such as dirt or rust, and then dipped in acetone to remove any grease or oil that may still be on it. Once the filler rod has been cleaned, do not touch it with your fingers as this will put oil from your skin back on the rod.

There may be times when the proper filler rod is not available. In this case, you can use what is known as "shear stock." This is a very thin or narrow strip of material cut from a sheet of metal that has the same composition as the metal to be welded.

### Metal Cleaning

Clean all grease or oil from the metal, using a cleaner such as acetone, naphtha, alcohol, or trichloroethylene in a vapor degreaser. Rust, scale, and corrosion can be removed by using a wire brush or emery cloth. Use a file to remove burrs from the edges of the metal. A sandblaster should never be used to clean heat and corrosion resistant ferrous alloys because it pits the metal and causes contamination.

### Tacking

The type of joint to be welded determines the number of tack welds you need. Butt joints are tacked every 1-1/2 to 2 inches, lap joints are tacked every 2 inches, and tee joints are tacked every 1-1/2 inches.

### Safety

Wear gloves while you are handling the metal. Serious cuts could result in handling the metal bare-handed. Be sure to wear gloves during welding to avoid getting shocked.

Wear a face shield while you are buffing the metal or grinding the electrode. The tungsten electrode is very hard and brittle and has a tendency to shatter if it is fed into the grinding wheel too fast or too hard.

Be sure your helmet has the proper shade lens for you. The wrong shade lens can cause you to strain your eyes if it is too dark or to burn them if it is too light. The recommended shades are 8, 9, or 10.

Wear clothing that can protect you from the infrared and ultraviolet light rays generated in the arc. Exposure to these rays may cause first and second degree burns, depending on the exposure time.

### APPLICATION

#### Welding Horizontal Butt Joints

**WELD SPECIFICATIONS.** The weld specifications for any given joint are determined by the type of joint and not by the position. The horizontal butt joint should have 100% penetration. The weld reinforcement should be 5% to 30% with a bead width of 2 to 3 T.

**TECHNIQUES.** The bead of the vertical butt joint has a tendency to run down due to the force of gravity. To control this, maintain a 45 degree upward angle of the torch to the surface plate. Use the minimum amount of heat necessary to form the molten pool. Once the bead is started, add the filler rod to the leading edge of the molten pool. Continue to move along the joint. Do not hesitate at any one spot because the excess heat may cause you to burn through or allow the bead to sag.

**GENERAL PROCEDURES.** The following listed steps are general procedures to use when welding vertical butt joints.

1. Clean two pieces of metal.
2. File the burrs off the edges of the metal.
3. Clean the filler rod.
4. Set up the torch. Be sure to turn on the water and gas.
5. Set the machine on DCSP, the current on the low range, and the start adjustment on 2.
6. Tack the joint and set it up in the vertical position.
7. Start the arc and weld the joint.



## QUESTIONS

Note: Answer the questions at the end of this chapter on a separate sheet of paper.

1. What is the biggest problem encountered in position welding?
2. Why should a face shield be worn when grinding a tungsten electrode?
3. What determines the weld specifications for a given joint?
4. Name the two types of rays generated by the arc when TIG welding.
5. Which joint is considered the most difficult to weld, the horizontal or vertical butt? Why?

## REFERENCE

1. Althouse/Turnquist/Bowditch, Modern Welding Handbook, (Chapters 11 and 18), 1967.

### JOINTS OF ALUMINUM AND ALUMINUM ALLOY SHEET AND PLATE

#### OBJECTIVES

After completing this study guide and your classroom instruction, you will be able to:

1. Understand and apply the techniques and procedures of welding joints of aluminum and aluminum alloy, using the tungsten inert gas (TIG) process.

#### INTRODUCTION

Although aluminum is the most abundant metallic element in the earth's surface, it only ranks fifth among the common metals used today. It was not until the discovery of a heat treatable aluminum alloy that aluminum assumed any commercial importance. Today, aluminum and its alloys are the most abundant materials used in aircraft construction.

#### INFORMATION

##### MANAGEMENT OF DEFENSE ENERGY AND RESOURCES

While welding specimens of aluminum and aluminum alloy sheet and plate, you will complete all welded joints with a minimum amount of filler rod. After you have completed a weld, cut the specimen as close to the bead as possible, and utilize the remainder of the specimen to conserve materials.

##### ALUMINUM AND ALUMINUM ALLOYS

Pure aluminum weighs approximately 1/3 that of steel. It is a very good conductor of electricity, has a high resistance to corrosion, and is a good conductor of heat. It is easily formed by rolling, drawing, hammering, pressing, etc., into any of the many shapes required. It has very good casting qualities by the die cast, permanent mold, or sand casting method. In spite of these desirable properties, aluminum in its pure or nearly pure form has very low strength characteristics. This factor makes unalloyed aluminum useless for structural aircraft parts.

Aluminum alloy can be made as strong as low carbon steel. In fact, some fully heat-treated, cold worked, and artificially aged aluminum has the highest weight-strength ratio of any structural alloy known. Although the aluminum alloys, as such, possess higher strength characteristics than the pure metal, most of the aluminum

alloys have lower corrosion resistance qualities than the pure aluminum. For this reason, most alloys possess a clad or alclad coating of pure aluminum or some more corrosion resistant alloy than the base metal. On metal parts where this clad coating is not present to protect the base metal other corrosion preventive treatment, such as painting, anodizing, etc., is used to induce high surface corrosion resistance. Heat treatment may increase or decrease the corrosion resistance of aluminum alloys.

### WELDING BUTT, LAP, AND TEE JOINTS OF ALUMINUM ALLOYS

Tungsten inert gas (TIG) arc welding process is considered the best method of welding aluminum. The process uses a chemically inert gas (argon or helium, or mixtures of both) to keep the atmosphere away from the electrode and the molten weld pool. The shielding gas does not in any way interfere with the visibility needed by the welder to do a good manual welding job in making neat and sound welds.

Aluminum and aluminum alloys that can be welded by the TIG welding process include 1100, 3003, 3004, 5005, 5050, 5052, 5154, 5083, 6061, 6062, and 6063. Welding of work hardened nonheattreatable alloys reduces their higher strength. Heat treated alloy in the "as welded condition" can be expected to develop about 40 to 60 percent of strength of the heat treated alloy.

### TIG WELDING PROCESS

Tungsten inert gas process is preferred for welding aluminum sections which are less than 1/8 inch in thickness. Welding fixtures are sometimes necessary and should be used in welding thin gage material to prevent warpage. TIG may also be used to weld heavier section. In the TIG process, the arc is established between a nonconsumable tungsten electrode and the parts to be welded with a shield of inert gas enveloping the arc and weld pool. The arc melts the base metal and a bare filler rod of suitable alloy is manually added to the molten pool. Welding can be done rapidly from all positions. Flux is not required in TIG welding because the action of the arc breaks up the oxide film and allows good weld metal to flow. A shield of inert gas surrounds the electrode and the weld pool to prevent oxidation during welding. TIG welding is faster than gas welding due to the heat of the tungsten arc concentrated in a small area. Distortion in TIG welds are less than for gas welds.

#### Power Source

For any welding process, heat must be supplied to the base metal and the filler metal (if used) to fuse the component parts. The source of heat in the TIG process is the electric arc maintained between the electrode and the workpiece.

Alternating current is recommended for TIG welding of aluminum. For some welding applications, direct current reverse polarity (DCRP) is used successfully. To better understand why alternating current is recommended for TIG welding applications, direct current straight polarity (DCSP) and DCRP are to be considered first. In DCSP welding, the electrode is negative and the work positive, so that the electrons go from the electrode to the plate. In DCRP, the electrons flow from the plate to the electrode. In DCSP welding, there is considerable heating of the base plate, which is receiving electrons, while the electrode stays relatively cool. During DCRP welding, the opposite is true. As the electrode receives the heat from the electron transfer, it is overheated at quite low currents. This limits DCRP for TIG welding, since there is likely to be tungsten burn-off and contamination of the weld.

Alternating current is widely used for it offers both the advantages of DCSP and DCRP welding. Theoretically, AC welding can be called a combination of DCSP and DCRP welding.

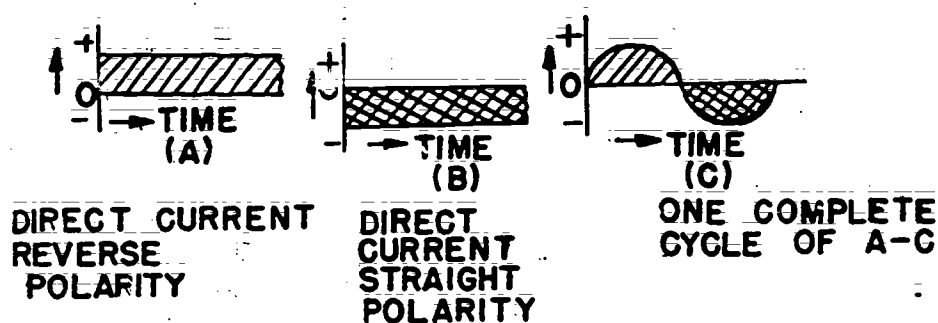

Figure 18. Current Flow in AC Welding.

In AC welding, when the current passes through zero, figure 18, the arc is broke. To restart the arc, high voltage, high frequency (120,000 cycles) low power additional current is superimposed on the welding current. Low frequency AC is difficult to start and maintain the arc. In using high frequency, a path is established for the current to follow when the arc is struck at zero current. After the arc is started and stabilized, the high frequency is automatically cut off.

### Welding Equipment

In addition to the AC power source, the required equipment is as follows:

1. TIG welding torch.
2. Inert gas supply, regulator-flowmeter, hose, and fittings.
3. Filler metal.
4. Water supply and fittings.

5. Helmet or eye shielding, and protective clothing.
6. Welding fixtures or backup plates.

For currents above 100 amperes, cooling the torch and power cable is necessary because of heat generated by the arc and the current passing through the cable. For welding currents below 100 amperes, air-cooled torches are satisfactory.

Water used to cool the welding gun should be clean to prevent clogging or flow restriction. Overheating can melt the silver brazed metal joints in the gun and the plastic water tube which sheaths the electric cable. A control mechanism is available which does not allow the welding current to start unless the water is flowing. Some TIG welding equipment is provided with solenoid valves and valve timing controls to control the flow of water and gas during welding. When the welding is stopped, the timer allows the water and gas to flow for a sufficient length of time to allow the tungsten electrode to cool, thus preventing contamination when it is exposed to air. The tungsten must cool bright and shiny. Any bluing or blackening of the tungsten indicates a lack of gas coverage.

The TIG welding torch carries the welding current and directs the inert gas to the weld area. The torch must be properly insulated for the maximum current ranges to ensure operational safety. Current is transmitted from the AC transformer through the power cable to a collet holding the tungsten electrode. Gas ports surrounding the electrode permit the inert gas to enter the nozzle or cup which is directed upon the surface to be welded.

The electrode should extend beyond the end of the gas shielding cup a distance equal to its diameter for butt welding and slightly further (1/8 to 3/16 inch) for fillet welding. Selecting the right size electrode for each job is important in preventing electrode damage (pure tungsten melts at 6125°F) and causing poor welds by too high or too low a current. Excessive current will cause tungsten particles to transfer to the weld while insufficient current allows the arc to wander erratically over the end of the electrode. Recommended electrode sizes for various ranges of welding current are shown in table 1.

#### Filler Material

Additional filler metal is not necessary in TIG welding when enough parent metal is provided by the joint design to form the weld bead. For other welds it is often necessary to add filler metal. Filler metal in the form of straight length, bare rod, is used for manual welding. The filler rod should always be placed within the inert gas shield and at the leading edge of the weld pool. Too large a rod disturbs and often freezes the pool, while



Electrode Dia In.	Gas Cup No.	Welding Current (Amperes)		
		AC	DCSP	DCRP
.040	6	10-40	10-40	
1/16	6	20-60	20-75	10-20
3/32	6-7-8	30-100	30-100	15-20
1/8	6-7-8	150	100-150	25-40
3/16	7-8	200	125-200	40-80

Table 1. Selection of Electrode Diameter, Gas Cup and Current Setting.

a rod too small in size forces the welder to feed too fast for steady hand operation. Care must be taken to see that a compatible filler may result. Dirty rods will contaminate the weld and every effort should be made to use only clean rods.

Metal Preparation

Cleaning the surfaces to be welded is of major importance in all aluminum joining regardless of the welding process. Oxide, grease, or oil film remaining on the edges to be joined cause unsound welds. Mild alkaline solutions and commercial degreasers that do not give off toxic fumes during welding are used successfully to remove surface contaminants before welding. All welding surfaces should be thoroughly dry after cleaning to prevent porosity in the weld metal. Oxide film should be removed from the surface of the aluminum by using aluminum wool or brushing with a clean stainless steel wire brush.

JOINT DESIGN

The choice of joint design and root openings required for TIG welding are determined by the structural requirements of the weldment. On relatively thin materials, 1/16 to 3/16 inch thickness, the square butt joint is usually satisfactory for the TIG process. Design varies from the square butt for 1/8 inch sheet to 60 degree included angle vee joint for 1/2 inch plate. The basic types of joint designs are the butt, lap, tee, corner, and edge. Almost any fabrication will have one or a combination of two or more of these basic types, depending upon the physical properties desired, type of metal being welded, the size, shape, and appearance of the assembly. Weld specifications vary slightly as to the type of metal and physical properties desired.





### Butt Joint

The square edge butt joint can be welded with or without filler rod, depending upon the thickness of the pieces being welded. Metal up to and including 1/8 inch can be welded with no edge preparation other than removing burrs and cleaning. Welding is done from one side only, on metal of 1/8 inch thickness or less. On metal 1/8 to 1/4 inch thickness, a square edge butt joint can be used if the joint is to be welded from both sides, as shown in figure 19. A single vee butt joint is used on metal 1/8 to 1/2 inch thickness when welding is done from one side only. Metal over 1/2 inch is prepared with a double vee or double U, as shown in figure 20. Filler rod must be used to fill the vee or U.

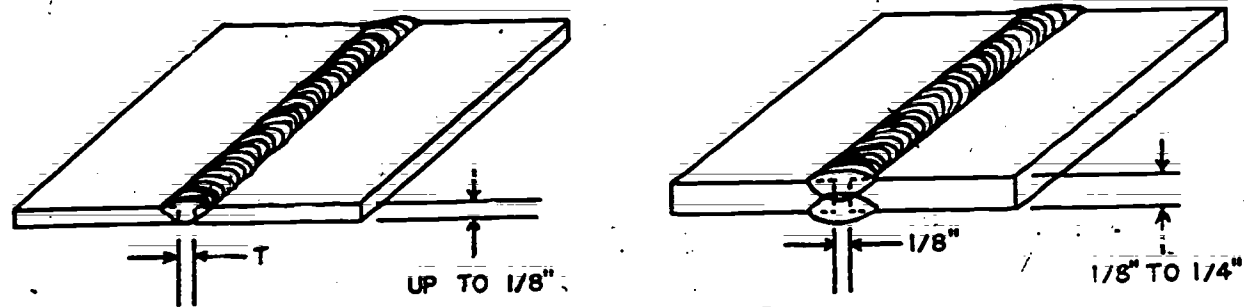
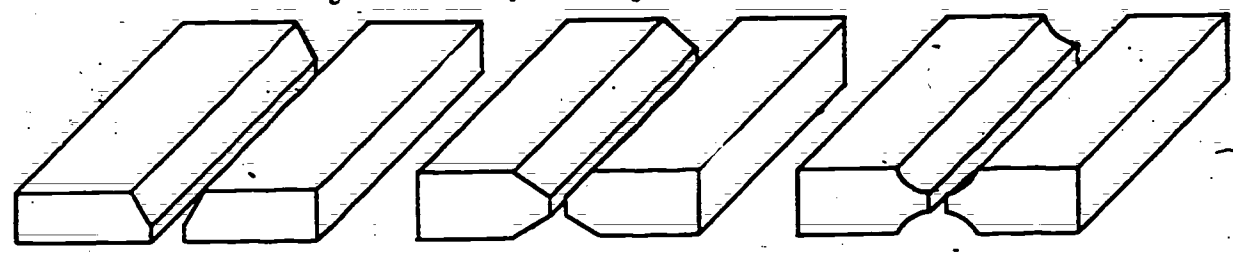

Figure 19. Square Edge Butt Joints.



Single-Vee

Double-Vee

Double-U

Figure 20. Single-Vee, Double-Vee and Double-U Butt Joints.

### Lap Joints

A lap joint needs no metal preparation other than cleaning and removing burrs. The plates must be in close contact along the joint edges, to prevent burning away of the upper plate. On material up to 1/4 inch thick, a lap joint can be made with or without filler rod. Lap joints are not recommended on metal over 1/4 inch thick except for rough fitup. Three kinds of lap welds are the single welded lap, double welded lap, and the joggled lap. In figure 21, the double welded lap is the only lap joint that will develop the full strength of the base metal.



Figure 21. Types of Lap Joints.

### Tee Joints

The plain tee joint, which is used on metal up to 1/8 inch in thickness, needs no special preparation other than cleaning the edge of the vertical sheet and the surface of the horizontal sheet where the weld is to be made. Welds made on metal having a thickness of 1/8 inch or more requires beveling of the vertical sheet. A single bevel is used on metal up to 1/2 inch where welding is done from one side only. A double bevel is used when the joint can be welded from both sides. Joint preparation is shown in figure 22.

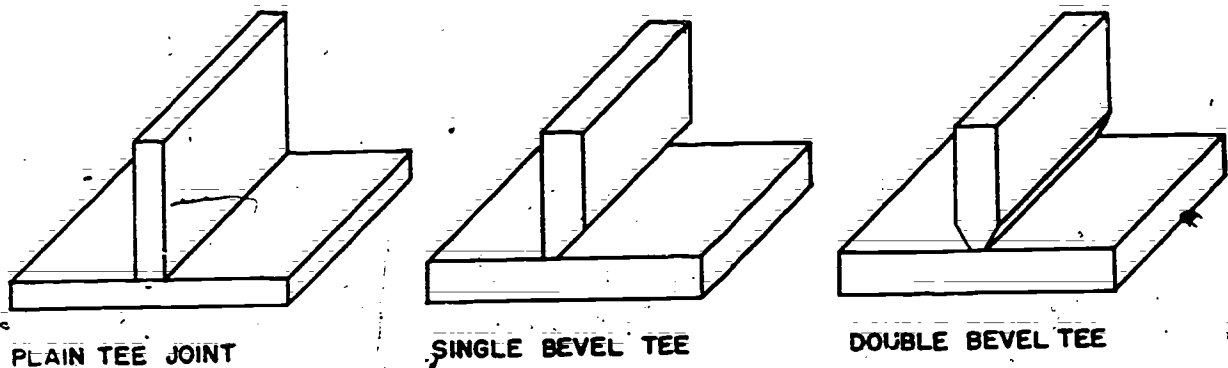

Figure 22. Types of Tee Joints.

### WELDING SETUP AND APPLICATION

On relatively thin materials, up to 1/8 inch thickness, the square butt joint is satisfactory. The weld should be supported by a backup bar or plate when feasible, except when welding is done from both sides. This backup bar may be copper, steel, or aluminum. Copper and steel backups should be removable. When an aluminum backup bar or plate is used, it should be compatible with the parent metal. Backup plates are recommended whenever possible to control weld penetration and permit faster welding speeds. Inert gas backup can be used when high quality welding is necessary.

1. Place the pieces of metal in a fixture and butt edges to check for fitup and alignment. Clamp the pieces for alignment and spacing. Good joint fitup makes welding easier.
2. Adjust the current setting and argon flow for the thickness of the metal being welded.
3. Tack weld at about 1 to 1-1/2 inch intervals; the tacks should be neat and small.

4. Start the arc by bringing the tungsten electrode close to the work surface. The electrode does not have to touch the work surface because the high frequency current forms a path to the work piece.
5. Adjust the arc to the desired length, between 1/8 to 3/16 inch.
6. Hold the arc at the starting point until the metal liquifies and a molten pool is established.
7. Add the filler rod manually to the front edge of the molten pool, melting a small amount and withdrawing the rod.
8. Point the torch in the direction of travel with a 10 - 20 degree angle from the vertical position.
9. Keep the filler rod fairly flat to the work surface between 15 - 30 degrees from horizontal position.
10. Advance steadily along the line of weld, keeping a uniform bead with evenly spaced ripples.
11. To terminate the weld, release pressure off the foot control switch, keeping the torch directed on the molten pool. Gas and ar will continue to flow for a few seconds, cooling the weld, preventing contamination of the metal and tungsten electrode.

QUESTIONS

Note: Answer the questions at the end of this chapter on a separate sheet of paper.

1. How does the weight of aluminum compare to steel?
2. How does the corrosion resistance of aluminum alloys compare to the pure metal?
3. How does the strength properties of aluminum alloys compare to low carbon steel?
4. List the aluminum and aluminum alloys that may be welded by the TIG welding process?
5. What does a bluing or blackening of the tungsten indicate?
6. What happens if a too large filler rod is used for TIG welding aluminum? Too small filler rod?

REFERENCE

1. Althouse/Turnquist/Bowditch, Modern Welding Handbook, (Chapters 11 and 18), 1967.



## BUTT JOINTS OF MAGNESIUM

### OBJECTIVES

After completing this study guide and your classroom instruction, you will be able to:

1. Explain the composition of magnesium and magnesium alloys and some of its uses.
2. Weld butt joints.

### INTRODUCTION

Magnesium and magnesium alloys are the lightest structural metals. Pure magnesium melts at 1202°F and catches fire very easily at a slightly higher temperature. It burns with a flame temperature of over 8000°F. It is lightweight, easy to machine, highly corrosion resistant, and has high strength. It is alloyed with small quantities of other metals, such as aluminum, manganese, zinc, and zirconium to obtain desired properties. It can be welded by most of the welding processes. Because magnesium oxidizes rapidly when it is heated to the melting point in air, a protective inert gas shield should be used in TIG welding to control oxidation.

### INFORMATION

#### MANAGEMENT OF DEFENSE ENERGY AND RESOURCES

While inert gas shielded welding magnesium sheet, you will complete all beads with minimum amount of filler rod. After you have completed a weld, cut the specimen as close to the bead as possible and utilize remainder of the specimen to conserve materials.

#### MAGNESIUM AND MAGNESIUM ALLOYS

In the wrought form, commercially pure magnesium has a tensile strength of approximately 35,000 psi. It is nonmagnetic and has a relatively high thermal conductivity, which is desirable when rapid dissipation of heat is required. Most cold forming operations are impossible because the slip planes present in most metals do not exist in magnesium. For these reasons, hot forming must be performed between 400° and 600°F. The height of the temperature depends upon the thickness of the metal and degree of bend required. Magnesium and magnesium alloys maintain their structural strength and are unaffected by heat up to 200°F. Above this temperature, the metal or alloy tends to expand. The amount of expansion and loss of strength depends upon the type of alloy and the type of heat treatment.

Magnesium alloys do not corrode in dry air, but retain their light silvery metallic luster. They are not severely attacked by corrosion in ordinary moist air encountered in inland areas. In ordinary moist air, the alloy develops a thin gray film of magnesium oxide and carbonate. In a salty atmosphere, the chlorides tend to increase the tendency to corrode when concentration of the salts in the air are sufficient to encourage corrosion. Even when a slightly salty air is present, the gray film tends to retard corrosion and prevent dangerous corrosive attack for several months. Magnesium is resistant to corrosive attack by most alkalines, many organic chemicals, pure chromic acid, concentrated hydrofluoric acid, solutions of alkali metal arsenates, fluorides, chromates, and dichromates. Oxalic acid and salt solutions corrode magnesium to varying degrees. The amount of corrosion depends upon the conditions of service, as well as the kind of chemicals attacking the part. For this reason, magnesium parts are usually coated with a chemical treatment or some form of paint primer. In addition to atmospheric and chemical corrosion, magnesium products may be subject to galvanic corrosion during fabrication operations and in actual use because of:

1. Rubbing against steel.
2. Cleaning with wire brush, steel wool, or emery cloth.
3. Shot blasting or sand grit blasting.
4. Gas welding.

Magnesium products are supplied in the best condition possible and maximum care should be exercised during fabrication to prevent contamination. Magnesium alloys are also subject to stress corrosion cracking. This type of corrosion takes place when the metal is under stress in the presence of a corrosive medium. It takes place when a part under stress begins to crack and the cracking causes new surfaces to be opened up to corrosion. The corrosion then begins to follow the crack and weakens the part further, which results in more cracking and corrosion, until failure of the part results.

Magnesium alloys are produced and used in many shapes and forms, such as castings, extruded bars, rods, tubing, sheets and plate, and forgings. They are suitable for varied applications. Their inherent strength, light weight, shock and vibration resistance are factors which make their use desirable. The weight for an equal volume of magnesium is approximately two-thirds that of aluminum and one-fifth of steel.

MAGNESIUM IDENTIFICATION

Number System

The current system used to identify magnesium alloys is a two letter, and two or three digit number designation. The letters designate the major alloying elements, arranged in decreasing percentage order,



or in alphabetical order if the elements are of equal amounts, followed by the respective digital percentages of these elements. The percentage is rounded off to the nearest whole number, or if a tolerance range of the alloy is specified, the mean of the range (rounded off to the nearest whole number) is used. A letter following the percentage digits denotes the latest qualified version of the alloy. For example: Alloy designation AZ92A would consist of 9% (mean value) aluminum and 2% (mean value) zinc as the major alloying elements. The suffix "A" indicates this is the first qualified alloy of this type. One exception to the use of the letter is that an "X" indicates that the impurity content is controlled to a low limit. Some of the letters used to designate various alloying elements are:

A . . . . Aluminum	E . . . . Rare Earth
H . . . . Thorium	K . . . . Zirconium
M . . . . Manganese	Z . . . . Zinc

METAL PREPARATION

Edges that are to be welded must be smooth and free of loose pieces and cavities that might contain contaminating agents, such as oil or oxides.

Cleaning

An oil-coating or chrome-pickle finish is usually provided on magnesium alloys for surface protection during shipment and storage. This oil, together with other foreign matter and metallic oxides, must be removed from the surface prior to welding. Chemical cleaning is preferred, because it is faster and more uniform in its action. Mechanical cleaning can be used if chemical cleaning facilities are not available. A final bright chrome-pickle finish is recommended for parts that are to be welded.

Grease should be removed by the vapor degreasing method in which trichlorethylene is used or with a hot alkaline cleaning compound. Grease may also be removed by dipping small parts in dry cleaning solvent or mineral spirits paint thinner. Mechanical cleaning can be done satisfactorily with 160 to 240 grits aluminum oxide abrasive cloth, stainless steel wool, or by wire brushing. Immediately after the grease, oil, and other foreign materials have been removed from the surface, the metal should be dipped for three minutes in a hot solution with the following compositions:

- Chromic acid (CR 24 oz O<sub>3</sub>).
- Sodium nitrate (N<sub>a</sub> 4 oz NO<sub>3</sub>).
- Calcium or magnesium fluoride 1/8 oz.
- Water . . . . . to make 1 gallon.





Note: The bath should be operated at 70° to 90°F. The work should be removed from the solution, thoroughly rinsed with hot water, and air dried. The welding rod should also be cleaned to obtain the best results.

ety Precautions

Goggles, gloves, and other equipment designed to protect the s and skin of the welder should be worn.

The possibility of fire caused by welding magnesium metal is y remote because the temperature of beginning fusion must be reached ore solid magnesium ignites and sustained burning occurs only this temperature is maintained. Finely divided magnesium particles, h as grinding dust, filings, shavings, borings, and chips present e hazrd, since they ignite readily if proper precautions are taken. Magnesium scrap of this type is not common to welding ration. If a magnesium fire does start, it can be extinguished h dry sand, dry powdered soapstone, or dry cast iron chips. The ferred extinguishing agents for magnesium fires are graphite e powders.

WELDING PROCEDURES

Because of its rapid oxidation when magnesium is heated to melting point, an inert gas (argon or helium) is used to shield metal during TIG welding.

Direct current machines of the stable arc type operating on erse polarity (electrode positive) and alternating current machines, h a high frequency current superimposed on the normal welding rent, are used on magnesium. Both alternating and direct current hines are used for thin gage material. However, because of better etrating power, alternating current machines are used on material r 3/16 inch thick. Helium is more practical than argon for use h direct current reverse polarity; however, three times as much ium by volume as argon is required for a given amount of welding. on is used with alternating current.

The electrodes, which are composed of tungsten, are held in ater-cooled torch equipped with required electrical cables and tings and an inlet and nozzle for the inert gas.

The two magnesium alloys, in the form of sheet, plate, and rusion, that are most commonly used for applications involving ding are ASTM-1A (Federal Specification QQ-M-54), which is alloyed h manganese, and ASTM-AZ31A (Federal Specification QQ-M-44), which alloyed with aluminum, manganese, and zinc.

Less preparation is required for welding with alternating current i with direct current because of the greater penetration obtained. ets up to 1/4 inch thickness may be welded from one side with uare butt joint. Sheets over 1/4 inch thick should be welded





from both sides when the nature of the structure permits, as sounder welds may be obtained and less warpage results. For a double V joint, the included angle should extend from both sides to leave a minimum 1/16 inch root face in the center of the sheets. In welding a double V joint, the back of the first bead should be chipped out, using a chipping hammer fitted with a cape chisel, to remove oxide film, dirt, and incompletely fused areas, before the second bead is added. In this manner maximum soundness is obtained.

The gas should start flowing a fraction of a second before the arc is struck. With direct current, the arc is struck by brushing the tungsten electrode over the surface. With alternating current, the arc should be started and stopped by means of a remote control switch. The average arc length should be about 1/8 inch in using helium and 1/16 inch in using argon.

In welding with alternating current, maximum penetration is obtained when the end of the electrode is held flush with or slightly below the surface of the work. The torch should be held nearly perpendicular to the surface of the work and the welding rod added from a position as nearly parallel with the work as possible.

Welding should progress in a straight line at a uniform speed, with no rotary or weaving motion of the rod or torch, except for large corner joints or fillet welds. The welding can be fed either continuously or intermittently, but care should be taken to avoid withdrawing the heated end from the protective gaseous atmosphere during the welding operation. Forehand welding, in which the welding rod precedes the torch in the direction of welding, is preferred. If stops are necessary, the weld should be started about 1/2 inch back from the end of the weld when welding is resumed.

Because of the high coefficient of thermal expansion and conductivity, the control of distortion in the welding of magnesium presents some difficulties, but rigid fixing, small beads, and selected sequence in welding minimize distortion. Magnesium parts can be straightened by holding them in position with clamps and heating to 300° to 400°F. If this heating is done by local torch application, care must be taken not to overheat the metal and thereby destroy its properties.

If cracking is encountered during the welding of certain magnesium alloys, starting and stopping plates may be used to overcome this difficulty. These plates consist of scrap pieces of magnesium stock butted against opposite ends of the joint to be welded, as shown in A of figure 23. The weld is started in one of the abutting plates, continued across the junction, along the joint to be welded, and stopped on the opposite abutting plate. If a V groove is used, the abutting plates should also be grooved. An alternate method is to start the weld in the middle of the joint and weld to each edge (item B, figure 23). Cracking may also be minimized by preheating the plate and fixture to 200° to 400°F, and sometimes, by increasing the speed of the weld.

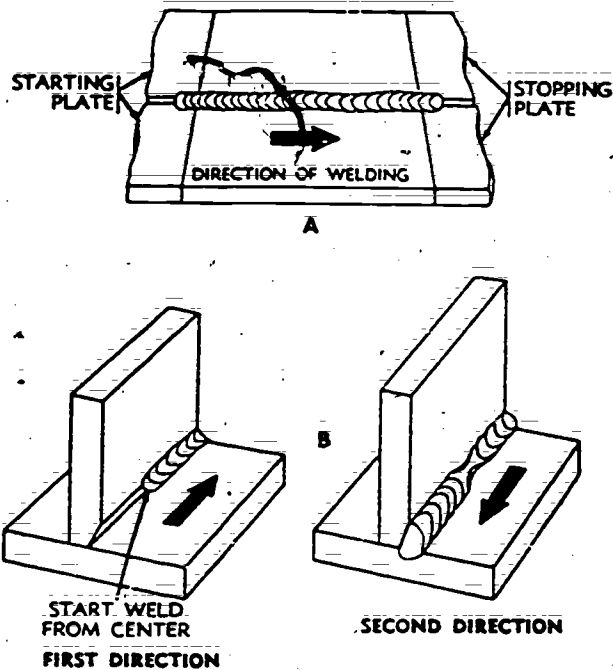

Figure 23. Minimizing Cracking During Welding.

## QUESTIONS

Note: Answer the questions at the end of this chapter on a separate sheet of paper.

1. Name some extinguishing agents used for magnesium fires.
2. How is maximum penetration obtained when welding magnesium with AC?
3. How is cracking minimized when welding magnesium?
4. List three ways to minimize distortion when welding magnesium.
5. What is the major alloying elements in AZ92A magnesium?

## REFERENCES

1. Althouse/Turnquist/Bowditch, Modern Welding Handbook, (Chapters 11 and 18), 1967.
2. TO 34W4-1-5, Welding Theory and Application, Chapter 7.

## JOINTS OF A-286 ALLOY

## OBJECTIVES

After completing this study guide and your classroom instruction, you will be able to:

1. Apply the proper welding techniques to weld joints in A-286 alloy.

## INTRODUCTION

A-286 is an iron base alloy used in the construction of the newer jet engines. It is in the work hardenable chromium-nickel austenitic stainless steel group and is nonmagnetic. It develops hardness by titanium precipitation with a smaller hardening effect produced by molybdenum. A-286 is able to withstand more than 10,000 pounds per square inch (stress rupture) for 100 hours at temperatures ranging from 1200° to 2000°F and is able to retain its strength up to 1400°F.

The A-286 alloy is a superalloy and is rather difficult to weld until the technique is mastered. The weld requirements on A-286 material is very critical and all weld repairs on aircraft jet engine parts must be accomplished by metals processing technicians who have been trained and certified on A-286 metal.

## INFORMATION

## MANAGEMENT OF DEFENSE ENERGY AND RESOURCES

While inert gas shielded welding A-286 alloy sheet, you will complete all beads with minimum amount of filler rod. After you have completed a weld, cut the specimen as close to the bead as possible, and utilize the remainder of the specimen to conserve materials.

## WELDING A-286

TIG welding has been found to be the best suited fusion welding process for repairing or welding A-286 alloy. Argon gas shielding is preferred on material of light gage, with helium being used on heavier material. The welding of A-286 alloy is more critical than other alloys of this type in that there is a greater danger of cracking if the weld is not properly shielded or if it is permitted to burn through without a backup of either shielding gas or a copper backup block.

### Requirements

The welding requirements of A-286 alloy are critical and in order to produce full metal strength, the proper penetration and reinforcement must be maintained. The weld specifications for the butt and tee joints are given below.

1. Butt joint - 100% penetration and 5% to 30% reinforcement.
2. Tee joint - 25% to 80% penetration.

### Butt Joint Preparation

1. Low current setting of 35 to 40 amperes (DC - straight polarity).
2. Remove sharp edges or burrs with file.
3. Clean weld area using stainless steel brush or wool. If emery cloth is used, remove dust before welding.
4. Position gas shield backup or close-fitting copper plate.
5. Spacing: 0.020 inch.
6. Backup gas rate: 3 to 10 cubic feet per hour (cfh).
7. Gas shielding rate: 12 to 15 cubic feet per hour (cfh).
8. Tungsten electrode: Grind to a needle point and extend approximately 3/16 to 1/4 inch beyond gas cup.
9. Torch angle: 75° to 90°.
10. Edge preparation: Sheet heavier than .060 inch, "v" edges to 50% T.

### Tee Joint Preparation

1. Tacking: three places on the backside.
2. End tacks at least 1/8 inch from ends.
3. Clean weld area with emery paper and remove dust before welding.
4. Thinner coupon or stock used as lower plate.
5. Keep electrode pointed.

## Welding Procedures

The following listed steps are general procedures to follow when welding A-286 alloy:

1. Clean all parts thoroughly before welding. All scale, grease, and foreign material must be removed from the area to be welded.
2. Set current for thickness of material to be welded.
3. Check all tacks for cracks before welding over them.
4. Use copper tabs to start and finish the arc whenever possible.
5. Keep the filler wire under the gas protective shield at all times.
6. If it is necessary to stop and start again, grind out the point where the weld was stopped before restarting.
7. To stop the weld, use the foot control rheostat to help eliminate crater cracks. Do not terminate welds on sharp corners. There is danger of cracks occurring if you terminate welds on sharp corners.
8. When it is necessary, welding should be sequenced to minimize stress introduced during welding.
9. To avoid distortion, copper and argon backup shields should be used whenever possible. If it is possible to use both, do so; but every effort should be made to use at least one.

## QUESTIONS

Note: Answer the questions at the end of this chapter on a separate sheet of paper.

1. What is the base metal for A-286?
2. To what group of stainless steel does A-286 belong?
3. How is A-286 hardened?
4. Why are welds on A-286 sometimes sequence welded?
5. When multipass welding, what should be done to each bead welded?

## REFERENCE

1. Aithouse/Turnquist/Bowditch, Modern Welding Handbook, (Chapters 11 and 18), 1967.

Metal & NDI Branch  
Chanutte AFB, Illinois

3ABR53230-SG-507

JOINTS OF CHROMOLOY

OBJECTIVES

After completing this study guide and your classroom instruction, you will be able to:

1. Apply the correct techniques and procedures for welding chromoloy.

INTRODUCTION

Chromoloy is one of the many new alloys being used in our present day aircraft. This alloy meets the medium high temperature service requirements of jet engine turbine sections. It must be free of all defects, such as laps, seams, seals, cracks, hard spots, and any other defect which may be detrimental to the use of the material.

INFORMATION

MANAGEMENT OF DEFENSE ENERGY AND RESOURCES

While inert gas shielded welding chromoloy sheet, you will complete all beads with minimum amount of filler rod. After you have completed a weld, cut the specimen as close to the bead as possible, and utilize remainder of the specimen to conserve materials.

CHROMOLOY

Chromoloy is processed in the annealed condition. After a part has been fabricated by welding, it is normalized at 1725°F for two hours, and then air-cooled. This produces a hardness of approximately RC 36-40. If it is tempered at 1200°F for two hours and air-cooled, the minimum hardness will be approximately RC 30.

Since chromoloy is a new alloy, you should become familiar with its properties, characteristics, and the welding procedures used to repair it. The actual welding technique used to weld chromoloy should present no problem for you. Chromoloy is one of the easiest to weld of the new alloys used in the aircraft field.

WELDING CHROMOLOY

The following equipment and materials are used to ensure production of quality welds in chromoloy:

1. Welding machine - AC-DC rectifier with foot control rheostat.
2. Lightweight (inert gas) arc welding torch.



- 3. Two percent thoriated tungsten electrode.
- 4. Argon gas for protective shielding.
- 5. Argon gas for backup gas (copper plate).
- 6. Welding lens: Use number 8, 9, or 10. Anything over 10 is not recommended.
- 7. Lightweight gloves.
- 8. Copper-coated chromoloy filler wire or sheared stock for inert gas welding.

The following steps are general procedures to be used when welding chromoloy:

- 1. Low current setting: 45 to 55 amperes, DC, straight polarity.
- 2. Remove sharp edges or burrs on material with file.
- 3. Clean the weld area, using stainless steel brush or wool. If emery cloth is used, remove dust before welding.
- 4. Position gas shield backup or close fitting copper plate.
- 5. Spacing: 0.020 inch.
- 6. Backup gas rate: 3 to 10 cubic feet per hour (cfh).
- 7. Gas shielding rate: 12 to 15 cubic feet per hour (cfh).
- 8. Tungsten electrode: Grind to a needle or sharp point and extend approximately 3/16 to 1/4 inch beyond gas cup.
- 9. Torch angle: 75 to 90.
- 10. Remove all of the copper coating from the filler rod prior to welding.

QUESTIONS

Note: Answer the questions at the end of this chapter on a separate sheet of paper.

- 1. In what condition is chromoloy processed?
- 2. What type filler wire is used for welding chromoloy?
- 3. What is the current setting recommended when welding chromoloy?
- 4. Explain the electrode preparation for welding chromoloy.
- 5. Explain the use of chromoloy on aircraft.





## REFERENCE

1. Althouse/Turnquist/Bowditch, Modern Welding Handbook, (Chapters 11 and 18), 1967.

Metal & NDI Branch  
Chanute AFB, Illinois

3ABR53230-SG-508

### BUTT JOINTS OF NICKEL BASE ALLOYS

#### OBJECTIVES

After completing this study guide and your classroom instruction, you will be able to:

1. Apply the techniques and procedures to weld nickel base alloys.

#### INTRODUCTION

Inconel is a nickel base alloy used in the hot section of jet engines. Although it reacts to heat much the same as carbon steel, it maintains its strength at temperatures of 1400° to 1800°F.

#### INFORMATION

##### MANAGEMENT OF DEFENSE ENERGY AND RESOURCES

While inert gas shielded welding nickel base alloy sheet, you will complete all beads with minimum amount of filler rod. After you have completed a weld, cut the specimen as close to the bead as possible, and utilize remainder of the specimen to conserve materials.

#### NICKEL BASE ALLOYS

Generally, good mechanical properties, strength and ductility are inherent in welded joints in all nickel and high nickel alloys. Similar to the welding of other metals, the weld joint area should be clean. All preservatives, dirt, grease, oil, scale, paint, crayon marks, etc., must be removed before starting the welding operation. Inconel is susceptible to embrittlement by sulfur and lead which may be contained in the residual contaminants during the welding process.

The coefficient of thermal expansion of inconel is about the same as that of the carbon steels and consequently, warpage and stress resulting from heating will be approximately the same. Welding fixtures should be used wherever possible to help dissipate excessive heat, thus eliminating some warpage. Also, the same joint designs used for carbon steels are used to weld inconel.

#### WELDING INCONEL

The equipment used to weld inconel is the same as for the other superalloys. You need a good AC-DC welding machine, an inert gas welding torch, a foot control, and a 2% thoriated tungsten electrode.

The current for welding inconel should be DC strength polarity. The current setting depends upon the thickness of the material you are welding. After you have selected the current setting for a particular piece of material, further adjustments can be made with the foot control. The foot control also helps protect the weld after the current is shut off by allowing the gas to continue to flow until the weld has cooled. This helps to prevent oxidation of the weld surface.

The electrode should be ground to a sharp tapering point. Be careful not to allow it to touch the molten pool or the filler rod. This causes it to become contaminated so that it has to be reground. The electrode should not extend more than 1/2 inch beyond the end of the gas cup.

Be sure that the gas cup is the proper size for the work. It should be large enough to maintain adequate gas coverage when you are adding filler rod. A cup smaller or larger may allow the surrounding atmosphere to contact the hot weld and cause oxidation.

Whenever possible, the weld should be made in a still atmosphere, free from air currents or drafts. It should be protected with shielding gas from both sides. If a backup gas cannot be used, gas welding flux may be used to protect the underside of the weld.

The following steps are general procedures to follow when welding inconel:

1. Clean the edges of the joint and remove all burrs with a file.
2. Select the proper current setting.
3. Check to be sure the cooling water and cover gas are on.
4. Select the proper filler rod.
5. Set the shielding and backup gas to the proper pressure.
6. Start the arc and weld the joint, keeping a torch angle of 75° to 90°.

#### QUESTIONS

Note: Answer the questions at the end of this chapter on a separate sheet of paper.

1. What is the base metal in inconel?
2. What two elements cause brittleness in welds when welding inconel?

3. What material is used to protect the weld if a backup gas cannot be used?
4. How does the coefficient of expansion in inconel compare to carbon steel?
5. Explain electrode preparation for welding inconel.

#### REFERENCE

1. Althouse/Turnquist/Bowditch, Modern Welding Handbook, (Chapter 11), 1967.

## BUTT JOINTS OF TITANIUM AND TITANIUM ALLOY SHEET

### OBJECTIVES

After completing this study guide and your classroom instruction, you will be able to:

1. Apply the techniques and procedures used to weld titanium.

### INTRODUCTION

Titanium is an abundant metal, occurring in the earth's crust to the extent of .064 percent and is fourth in order of abundance of the chemical agents. It is found in all soils combined with other elements. Its ore are rutile (TiO<sub>2</sub>) and ilmenite (Fe TiO<sub>3</sub>), among others, and they occur in widely distributed areas. Known ore reserves in the United States and Mexico are estimated at 350 million tons of refined metal.

### INFORMATION

#### MANAGEMENT OF DEFENSE ENERGY AND RESOURCES

While inert gas shielded welding titanium and titanium alloy sheets, you will complete all beads with minimum amount of filler rod. After you have completed a weld, cut the specimen as close to the bead as possible and utilize the remainder of the specimen to conserve materials.

#### TITANIUM AND TITANIUM ALLOYS

Titanium, a light, strong, corrosion resistant and ductile metal, fills the gap between aluminum and stainless steel so far as weight and strength at intermediate temperatures are concerned. It is considerably lighter than stainless steel (18-8) and somewhat heavier than aluminum. Its strength compares favorably to stainless steel at temperatures below 950°F. Above this temperature it absorbs atmospheric gases and becomes extremely brittle. Titanium is not suitable for applications in hot sections of jet or reciprocating engines and cannot replace stainless steel except in application of intermediate or low temperature service.

Some aluminum alloys are stronger than titanium per unit of weights, but lose this advantage in the low temperature range. Titanium has a greater corrosion resistance than aluminum, but this advantage is offset somewhat by its greater density and lesser workability and weldability. Titanium is replacing aluminum in aircraft where high strength and resistance to sea water are prime considerations.

Aluminum holds its own in low stressed parts and assemblies where the characteristics of titanium cannot be fully used and where its greater weight is a disadvantage. Table 2, Comparison of Titanium with Other Aircraft Metals, is based upon comparative studies and presents some comparative data with stainless steels and 75-S aluminum alloy.

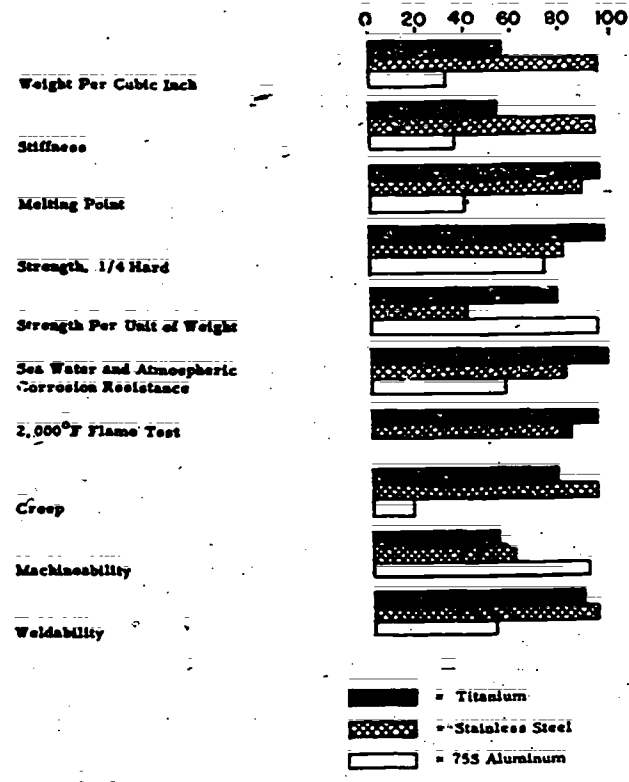

Table 2: Comparison of Titanium With Other Aircraft Metals.

Here are some new and contemplated uses of titanium. You can visualize some requirements of the part from its name and location.

1. Aircraft skins.
2. Engine shrouds.
3. Fire walls.
4. Longerons.
5. Frames.
6. Landing gear doors.
7. Hydraulic lines.
8. Fittings.
9. Access doors.

- 10. Air ducts.
- 11. Fasteners.
- 12. Ribs.
- 13. Spars.
- 14. Flaps.
- 15. Slat tracks.
- 16. Shear pins.
- 17. Wing tips.

DESIGNATION	COMPOSITION	YIELD STRENGTH	ULTIMATE TENSILE STRENGTH*
AMS 4900	Comm. Pure	55000 psi	65000 psi
4901	Comm. Pure	70000	80000
4908	8% Mn Alloy	110000	120000
4925	4%Al-4%Mn Alloy	130000	140000
Spec. MIL-T-9047 C12	1.5%Fe 2.7%Fe	130000	140000
Spec. MIL-T-9047 C13	3%Al-5%Cr	140000	160000

\* These are typical strengths and may not conform to manufacturer's specifications.

Table 3. Titanium Tensile and Yield Strengths.

Commercially pure titanium, AMS 4900 and 4901, have minimum yield strengths of 55,000 and 70,000 psi respectively (table 3). Tensile strengths are 65,000 and 80,000 respectively. They can be cold worked, however, to reach substantially higher strengths but with a consequent loss of ductility.

The titanium manganese alloy (AMS 4908) has a yield strength of 110,000 and a tensile strength of 120,000 psi in the annealed condition. This alloy can be effectively heat treated, but the precise methods have not been clearly established and agreed upon by the leading research laboratories. The titanium manganese aluminum alloy has a yield strength of 130,000 and a tensile strength of 140,000 psi. This alloy is identified by Specification AMS 4925. It is considered an excellent alloy for forgings, as well as for sheet. Other alloys have been developed containing various percentages of aluminum, manganese, iron, chromium, and carbon. Some of them develop well over 200,000 psi, but are generally hard and have poor work and weldability. Grades AMS 4900 and 4901, on the other hand, have good ductility and are weldable.





IDENTIFICATION OF TITANIUM

<u>PRODUCERS</u>	<u>DESIGNATION</u>	<u>COMPOSITION</u>	<u>AMS SPEC NO.</u>
Rem Cru	RC-55 (Old Code)	Commercially Pure	4900
	A-55 (Current Code)		
Rem Cru	RC-70 (Old Code)	Commercially Pure	4901
	A-70 (Current Code)		
Rem Cru	RC-130A (Old Code)	8% Mn Alloy	4908
	C-110M (Current Code)		
Rem Cru	RC-130B (Old Code)	4 AL-4MN Alloy	4925
	C-130 AM (Current Code)		
Republic Steel	RS-55	Commercially Pure	4900
Republic Steel	RS-70	Commercially Pure	4901
Republic Steel	RS-110-A	8% Mn Alloy	4908
Republic Steel	RS-130	4Al-4Mn Alloy	4925
Titanium Metals	Ti-55A	Commercially Pure	4900
Titanium Metals	Ti-75A	Commercially Pure	4901
Mallory-Sharon	Grade III	Commercially Pure	4900
Mallory-Sharon	Grade III	Commercially Pure	4901
Mallory-Sharon	8% Mn Alloy	8% Mn Alloy	4908
Mallory-Sharon	4Mn-4Al Alloy	4Mn-4Al Alloy	4925

Table 4. Identification of Titanium by Code and Specification Numbers.

Titanium, in the commercially pure form, is silvery-gray in appearance resembling unpolished stainless steel, but with slight more luster. It is nonferrous and nonmagnetic. It weighs 0.163 pounds per cubic inch as compared to 0.283 pounds per cubic inch for steel. It grinds very slowly and gives off bright, white sparks with traces ending in brilliant white bursts. About 90 percent of these traces terminate in bushy bursts within 10 inches of the grinding wheel. The remaining 10 percent may reach a distance of six feet depending upon wheel speed and pressure applied against the wheel. This spark color and behavior is unique and, therefore, reliable as a quick, easy shop test. Moistened titanium leaves a gray-white mark when it is rubbed on glass. This mark is clearly discernible and resists efforts to remove it by rubbing with the hands. Titanium is also identified by the manufacturer's code stock, as shown in table 4. Aircraft parts fabricated of titanium are identified by the word "titanium" etched or stamped in a conspicuous place.

Some difficulty may arise in trying to distinguish pure titanium from its alloys. This can be done by using a simple chemical test. This test does not require any special laboratory equipment and may be performed in the shop.



Cut a small test strip off both pieces to be identified and reflux them separately for one hour in 50cc of concentrated hydrochloric acid. Both solutions will become purple or violet in color after one hour. Decant the solutions separately and to about 5cc of each solution, add an equal volume of three percent hydrogen peroxide. If one solution contained a pure titanium test strip, it will become orange-yellow in color; if the other solution contained an alloy, it will become deep red-orange in color. There remains, however, the problem of determining whether the alloy so identified is titanium manganese, titanium manganese aluminum, or some other combination. This problem too can be solved by chemical tests, but the process is rather involved. If quantitative analysis must be made, the alloy in question should be sent to a laboratory.

The procedures for welding titanium and titanium alloys are similar to other metals. Some processes, however, such as oxyacetylene or arc welding processes using active gases, cannot be used due to the high chemical activity and sensitivity of titanium to embrittlement by contamination. Processes that are satisfactory for welding titanium and titanium alloys include inert gas shielded metal arc welding and spot, seam, and flash welding. All of these processes provide for shielding of the molten weld metal and heat affected zones that would be affected by active elements. Prior to welding, titanium and its alloys should be free of all scale and other material that might cause weld contamination.

### WELDING TITANIUM

Most weldments are made with commercially pure titanium. Unfortunately the stronger alloys (alpha-beta types) are not suitable for welding because of brittleness that develops along the heat affected zone adjacent to the weld. These alloys are easily welded and the weld tensile strength is good, but the heat affected zone is weak.

Inert gas arc, either consumable electrode or tungsten, is the only fusion process recommended for pure titanium. The reason is titanium's affinity for atmospheric gases at the welding heat. The use of argon or helium, or a mixture of the two, dispels oxygen and nitrogen and allows welds to be made that reach base metal strength. The gas shield must be dense and both sides of the joint must be protected. A plate of copper or brass may be used for this backup plate, provided it is designed to afford a high degree of protection. An auxiliary stream of inert gas directed against this back side has also been found to be effective. A good measure of weld protection is the extent of oxide coloring in the weld area. With a normal argon flow of five liters per minute, the weld and weld area will range in color from gold to blue-green to purple. Sufficient protection will not have been attained until these colors disappear and the weld and weld area is practically identical to the base metal color. A flow through the torch of 20 cubic feet per hour is usually sufficient in welding thin sheet at a slow speed of travel. As sheet thickness and/or travel is increased, shielding of the hot metal trailing the arc becomes a problem. An auxiliary stream of gas, or an apron, should be used that provides an inert shield for a distance of at least two inches (depending on weldment thickness) behind the arc.



Some manufacturers are using closed welding containers to provide protection. In this process, the welding equipment and weldment are placed in a collapsible or rigid chamber, sealed, purged free of air, and then filled with inert gas. This process has many disadvantages so far as aircraft repair is concerned. The size of titanium parts and the inaccessibility of cracks dictates the use of conventional equipment with slight modifications to improve gas protection.

Several such modifications and improvised methods have been reported. One effective and very simple method is to tape a strip of paper over the penetration side of the joint with provisions for a stream of helium to enter one end and escape at the other. Steel, copper, and aluminum backup plates are also used, some grooved, with an inert atmosphere filling the groove, and some plain and close fitting.

### Surface Preparation

Surface cleaning is important in preparing titanium and its alloys for welding. Proper surface cleaning prior to welding reduces contamination of the weld due to surface scale or other foreign materials.

Several cleaning procedures are used, depending on the surface condition of the base and filler metals. Surface conditions most often encountered are as follows:

1. Scale-free (as received from the mill).
2. Light scale (after hot forming or annealing at intermediate temperature; i.e., less than 1300°F).
3. Heavy scale (after hot forming, annealing, or forging at high temperature).

Metals that are scale-free can be cleaned by simple degreasing. Metals with light oxide scale should be cleaned by acid pickling. In order to minimize hydrogen pickup, pickling solutions for this operation should have a nitric acid concentration greater than twenty percent. Metals to be welded should be pickled for 1 to 20 minutes at a bath temperature from 80° to 160°F. After pickling, the parts are rinsed in hot water.

Metals with a heavy scale should be cleaned with sand, grit, vaporblasting, molten sodium hydride salt baths, or molten caustic baths. Sand, grit, or vaporblasting is preferred if it is applicable. Hydrogen pickup may occur with molten bath temperature and pickling time. Bath temperature should be held at about 750° to 850°F. Parts should not be pickled any longer than necessary to remove scale. After heavy scale is removed, the metal should be pickled.

Surfaces of metals that may have undergone oxyacetylene flame-cutting operations have a very heavy scale and may contain micro cracks due to excessive contamination or the metallurgical characteristics of the alloys. The best cleaning method for flame-cut surfaces is to remove the contaminated layer and any cracks that may be present by machining operations. Certain alloys can be stressed immediately after cutting to prevent the propagation of these cracks into the heat affected base metal. This stress relief is usually made in conjunction with the cutting operation.

## Shielding

Very good shielding conditions are necessary to produce arc welded joints with maximum ductility and toughness. To obtain these conditions, the amount of air or other active gases which contact the molten weld metals and adjacent heated zones must be very low.

*INERT GASES.* Both helium and argon are used as shielding gases. With helium as the shielding gas, higher welding speeds and better penetration are obtained than with argon, but the arc is more stable in argon. For "open-air" welding operations, most welders prefer argon as the shielding gas because its density is greater than that of air. Mixtures of argon and helium also are used. With mixtures, the arc characteristics of both helium and argon are obtained. The mixtures usually vary in composition from about 20 to 80 percent argon. They often are used with consumable electrode process. To provide adequate shielding for the face and root sides of welds, special precautions often are taken. These precautions include the use of baffles, trailing shields, and special backing fixtures in open-air welding and the use of inert gas-filled welding chambers.

*WELDING CHAMBERS.* For some applications, inert gas-filled welding chambers are used. The advantage of using such chambers is that good shielding may be obtained for the root and face of the weld without the use of special fixtures. Also, the surface appearance of such welds is a fairly reliable measure of shielding conditions. The use of chambers is especially desirable when complex joints are being welded. However, chambers are not required for many applications and their use may be limited.

Welding chambers vary in size and shape, depending on their use and the size of assemblies to be welded. The inert atmospheres may be obtained by evacuating the chamber and filling it with helium or argon, purging the chamber with inert gas, and collapsing the chamber to expel air and refilling the chamber with an inert gas. Plastic bags have been used in this latter manner. When the atmospheres are obtained by purging or collapsing the chambers, inert gas usually is supplied through the welding torch to ensure complete protection of the welds.

**OPEN AIR WELDING.** In open air welding operations, the methods used to shield the face of the weld vary with joint design, welding conditions, and the thickness of the materials being joined. The most critical area in regard to shielding is the molten weld puddle. Impurities diffuse into the molten metal very rapidly and remain in solution. The gas flowing through a standard welding torch is sufficient to shield the molten zone. Because of the low thermal conductivity of titanium, however, the molten puddle tends to be larger than in other metals. For this reason, and because of the very good shielding conditions required in welding titanium, larger nozzles are used on the welding torch, with proportionally higher gas flows than are required for other metals. Also, chill bars often are used to limit the size of the puddle.

The primary sources of contamination in the molten weld puddle are turbulence in the gas flow from the welding torch, oxidation of hot filler rods, insufficient gas flow, small nozzles on the welding torch, and impure shielding gases.

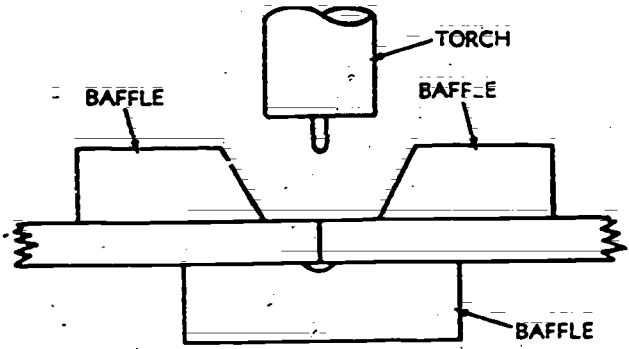

A. FLAT BUTT OR LAP WELDS

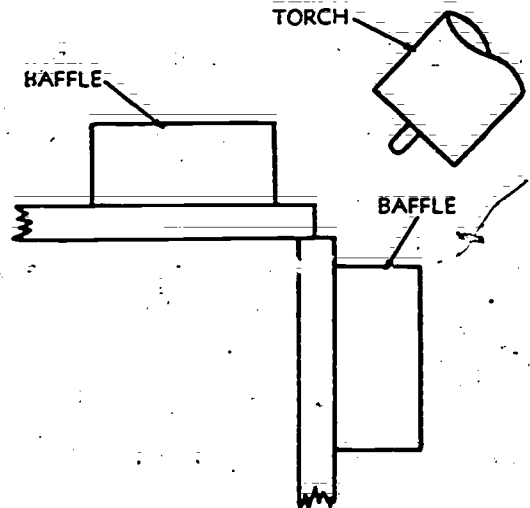

B. CORNER WELDS

Figure 24. Baffle Arrangements Used to Improve Shielding for the Face of Welds.

If turbulence occurs in the gas flowing from the torch, air will be absorbed by the metal and contamination will result. Turbulence is generally caused by excessive amounts of gas flowing through the torch, long arc lengths, air currents blowing across the weld, and joint design. Contamination from this source can be minimized by adjusting gas flows and arc lengths and by placing baffles alongside the welds. Baffles protect the weld from drafts and tend to retard the flow of shielding gas from the joint area. Chill bars or the clamping toes of the welding fixture can serve as baffles (figure 24). Baffles are especially important for making corner type welds.

General Information

In manual welding operations with the tungsten arc process, oxidation of the hot filler metal is a very important source of contamination. To control it, the hot end of the filler wire must be kept within the gas shield of the welding torch. The welder must be trained to keep the filler wire shielded in welding titanium and its alloys. Even with proper manipulation, however, contamination from this source probably cannot be eliminated completely.

Weld contamination which occurs in the molten weld puddle is especially hazardous because the impurities go into solution and do not cause discoloration. Although discolored welds may have been improperly shielded while molten, weld discoloration is caused by contamination which occurs after the weld has solidified.

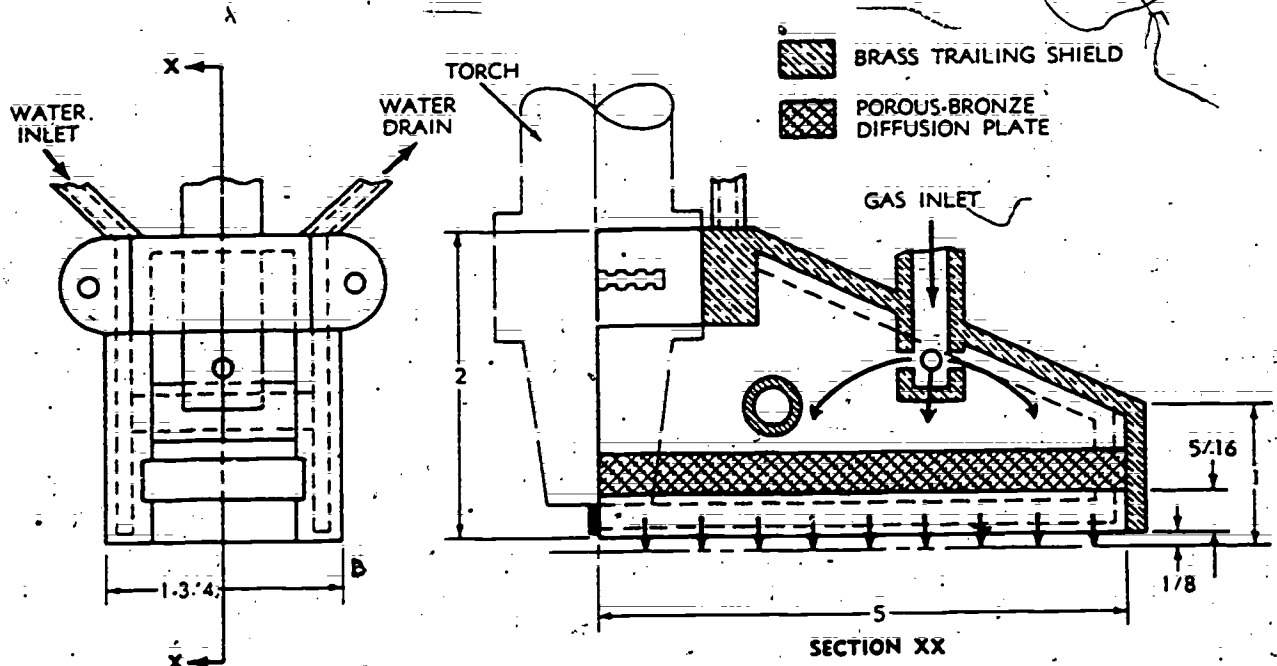

NOTE ALL DIMENSIONS SHOWN ARE IN INCHES

RA.PD 258187

Figure 25. Trailing Shield.



Most of the auxiliary equipment used on torches to weld titanium is designed to improve shielding conditions for the welds as they solidify and cool. However, if the welding heat input is low and the welds cool to temperatures below about 1200° to 1000°F, while they are shielded by the gas flowing from the welding torch, auxiliary shielding equipment is not required. If the welds are at excessively high temperatures after they are no longer shielded by the welding torch, then auxiliary shielding should be supplied

Trailing shields often are used to supply auxiliary shielding. These shields extend behind the welding torch and vary considerably in size, shape, and design. Sometimes they are incorporated into special cups which are used on the welding torch. They may consist only of tubes or hoses attached to the torch or manipulated by hand to direct a stream of inert gas on the welds. Figure 25 shows a drawing of one type of trailing shield currently in use. Important features of this shield are that the porous diffusion plate allows an even flow of gas over the entire shield area and prevents turbulence in the gas stream, and the shield fits on the torch so that a continuous gas stream between the torch and shield is obtained.

Baffles also are beneficial in improving shielding conditions for welds by retarding the flow of shielding gas from the joint area. Baffles may be placed alongside the weld, over the top, or at the ends of the weld. In some instances, they may actually form a chamber around the arc and molten weld puddle. Also, chill bars may be used to increase weld cooling rates and may make auxiliary shielding unnecessary.

In open air welding operations, a means must be provided for shielding the root or back of the welds. Backing fixtures often are used for this purpose. In one type, an auxiliary supply of inert gas is provided to shield the back of the weld. In the other, a solid or grooved backup bar fits tightly against the back of the weld and provides the required shielding. Fixtures which provide an inert gas shield are preferred, especially in manual welding operations with low welding speeds. Figures 26 and 27 show backup fixtures used in butt welding flat heavy plate and thin sheet, respectively. Similar types of fixtures are used for other joint designs. However, the design of the fixture varies with the design of the joints. For fillet welds on tee joints, shielding should be supplied for two sides of the weld in addition to shielding the face of the weld.

For some applications, it may be easier to inclose the back of the weld, as in a tank, and supply inert gas for shielding purposes. This method is necessary in welding tanks, tubes, or other inclosed structures where access to the back of the weld is not possible. Also, in some weldments, it may be necessary to machine holes or grooves in the structures in order to provide shielding gas for the back or root of the welds.





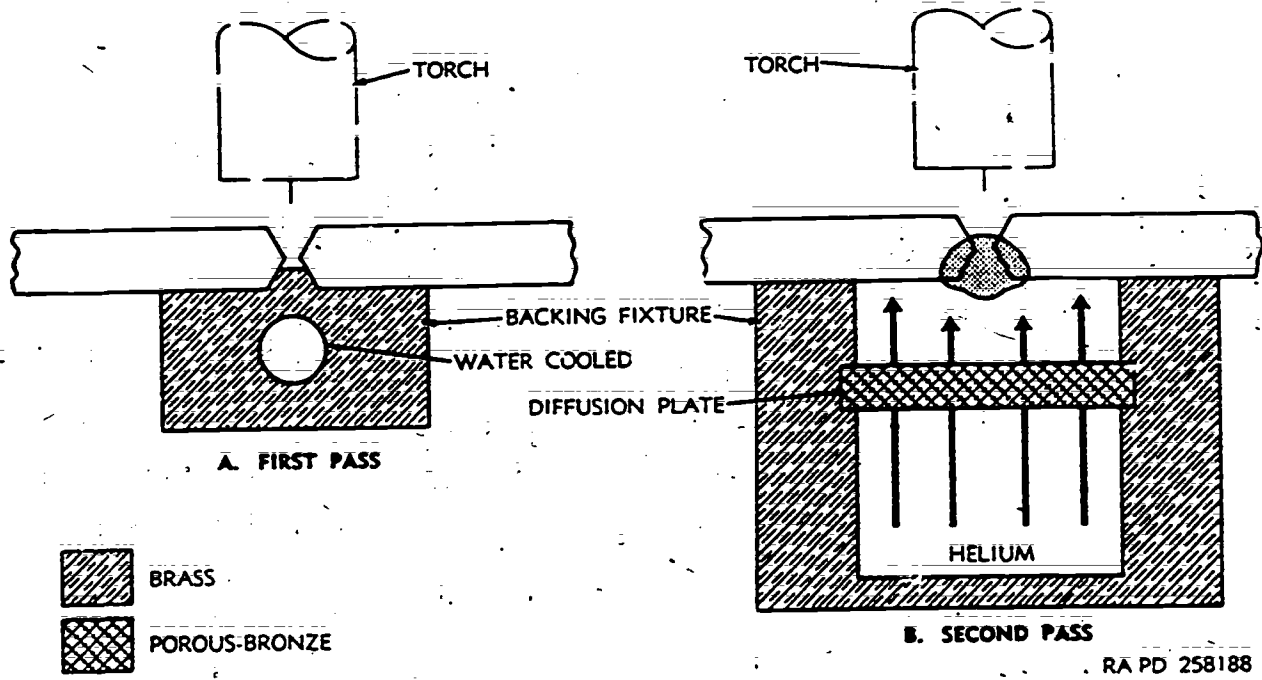

Figure 26. Backing Fixtures for Welding Heavy Titanium Plate.

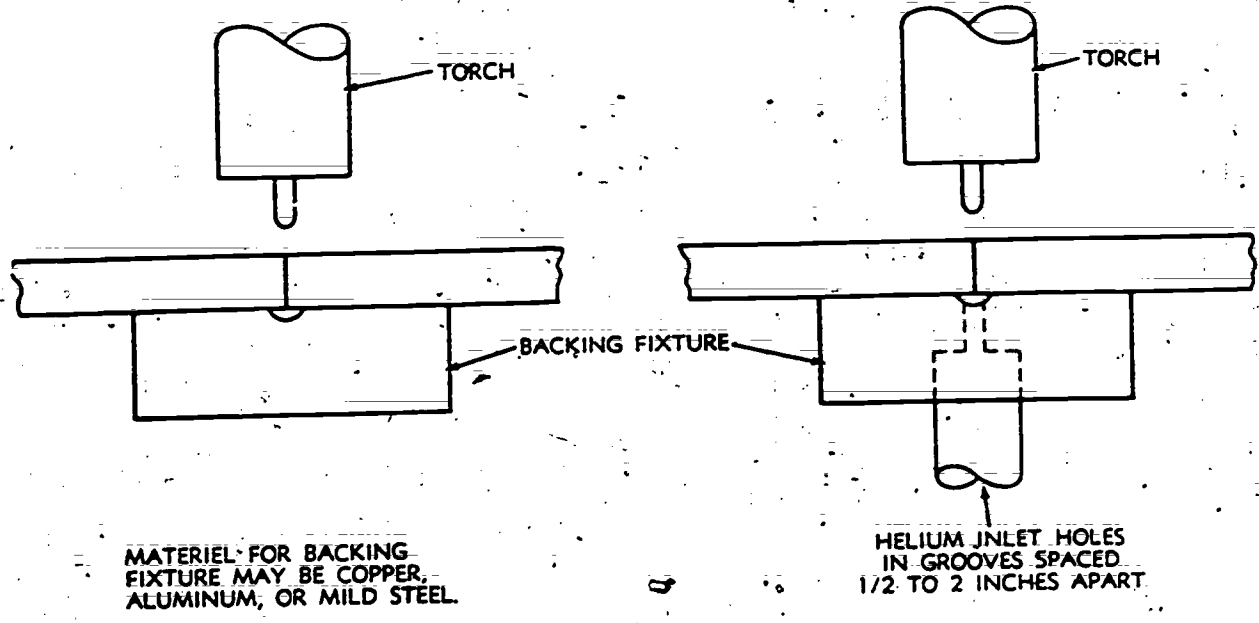

Figure 27. Backing Fixtures for Welding Thin Sheets.

In circumferential welds, distortion may result in a loose fitup between the material being welded and the backing fixture. This condition may cause excessive weld contamination. One method of overcoming this problem is to use backing fixtures that will provide an inert gas shield for the weld, even when there is a gap between the backing fixture and metal being welded. The type of backing fixture shown in figure 26 will work in this manner. Also, a flexible backing fixture which would conform to the weld as it distorts would overcome this problem.

Bend or notch-toughness tests are the best methods for evaluating shielding conditions, but visual inspection of the weld surface, which is not an infallible method, is the only nondestructive means for evaluating weld quality at the present time. With this method, the presence of a heavy gray scale with a nonmetallic luster on the weld bead indicates that the weld has been contaminated badly and has low ductility. Also, the weld surface may be shiny but have different colors, ranging from grayish-blue to violet to brown. This type of discoloration may be found on several contaminated welds or may be due only to surface contamination. If the discoloration is due only to surface contamination, the weld may be satisfactory. However, the quality of the weld cannot be determined without a destructive test. With good shielding procedures, weld surfaces are shiny and show no discoloration. However, if the weld is improperly shielded in the high temperature zone around the arc and adequately shielded at lower temperatures, a severely contaminated weld with a shiny surface can be produced.

Joint Design

Joint designs for titanium are about the same as those used for other metals. For welding a thin sheet, the tungsten arc process generally is used. With this process, butt welds may be made with or without filler rod, depending on the thickness of the joint and fitup. Special shearing procedures sometimes are used so that the root opening does not exceed 8 percent of the sheet thickness. If fitup is this good, filler rod is not required. If fitup is not this good, filler metal is added to obtain full thickness joints. In welding thicker sheet (greater than about 0.090 inch), both the tungsten arc and consumable electrode processes are used with single V butt or square butt joints with a root opening. For welding titanium plates, bars, or forgings, both the tungsten arc and consumable electrode processes also are used with single and double V joints. In all cases, good weld penetration may be obtained without excessive "drop-through." However, penetration and drop-through are controlled more easily by the use of proper backing fixtures. Because of the low thermal conductivity of titanium, weld beads tend to be wider than normal. However, the width of the beads is generally controlled by using short arc lengths or by placing chill bars or the clamping toes of the fixture close to the sides of the joints.



## Welding Variables

Welding speed and current for titanium alloys depend on the process used, shielding gas, thickness of the material being welded, design of the backing fixtures, and the spacing of chill bars or hold-down bars in the welding jig. Welding speeds vary from about 3 to 40 inches per minute. The highest welding speeds are obtained with the consumable electrodes process. In most cases, direct current is used with straight polarity for the tungsten arc process and reverse polarity for the consumable electrode process.

In setting up arc welding operations for titanium, the welding conditions should be evaluated on the basis of weld joint properties and appearance. Radiographs will show if porosity or cracking is present in the weld joint. A simple bend test or notch-toughness test will show whether or not the shielding conditions are adequate, and a visual examination of the weld will show if the weld penetration and contour are satisfactory. After adequate procedures are established, careful controls are desirable to ensure that the shielding conditions are not changed.

## Weld Defects

Defects in arc welded joints in titanium alloys consist mainly of porosity and cold cracks. Weld penetration can be controlled by adjusting welding conditions.

**POROSITY.** Weld porosity is rapidly becoming a major problem in arc welding titanium alloys. Although acceptable limits for porosity in arc welded joints have not been established, porosity has been observed in tungsten arc welds in practically all of the alloys which appear suitable for welding operations. It does not extend to the surface of the weld but has been detected in radiographs. It usually occurs close to the fusion line of the welds. Weld porosity may be reduced by agitating the molten weld puddle and adjusting welding speeds. Also, remelting the weld will eliminate some of the porosity present after the first pass. However, the latter method of reducing weld porosity tends to increase weld contamination.

**CRACKS.** With adequate shielding procedures and suitable alloys, cracks should not be a problem. However, cracks have been troublesome in welding some alloys. Weld cracks are attributed to a number of causes. In commercially pure titanium, weld metal cracks are believed to be caused by excessive oxygen or nitrogen contamination. These cracks are observed usually in weld craters. In some of the alpha-beta alloys, transverse cracks in the weld metal and heat-affected zones are believed to be due to the low ductility of the weld zones. However, cracks in these alloys also may be due to contamination. Cracks also have been observed in alpha-beta welds made under restraint and with high external stresses. These cracks are sometimes attributed to the hydrogen content of the alloys. If weld cracking is due to contamination, it may be controlled by improving shielding conditions. However, repair welding on excessively contaminated welds is not practical in many cases.

Cracks which are caused by the low ductility of welds in alpha-beta alloys can be prevented by heat treating or stress relieving the welded piece in a furnace immediately after welding. Oxyacetylene torches also have been used for this purpose. However, care must be taken so that the welded parts are not overheated or excessively contaminated by the torch heating operation. Cracks due to hydrogen may be prevented by vacuum-annealing treatments prior to welding.

## QUESTIONS

Note: Answer the questions at the end of this chapter on a separate sheet of paper.

1. Describe the sparks given off when grinding titanium.
2. How are aircraft parts made of titanium identified?
3. Most weldments are made of what type of titanium?
4. Why is welding titanium in a purge chamber considered impractical?
5. Which type of shielding gas is preferred for open air welding of titanium? Why?
6. What is the purpose of the trailing shield?
7. What is the baffle used for when welding titanium?

## REFERENCES

1. Aithouse/Turnquist/Bowditch, Modern Welding Handbook, (Chapter 11), 1967.
2. TO 34W4-1-5, Welding Theory and Application, Chapter 7.



Technical Training

Metals Processing Specialist

BLOCK VI  
PIPE, TUBING, AND AIRCRAFT EXHAUST AND JET ENGINE  
HOT SECTION REPAIR

10 September 1974



13-7

CHANUTE TECHNICAL TRAINING CENTER (ATC)

This supersedes 3ABR53230-SG-600, 7 May 1973.

OPR: TWS

DISTRIBUTION: X

TWS - 200; TIOC - 2

Designed For ATC Course Use

DO NOT USE ON THE JOB

Study Guides and Workbooks are training publications authorized by Air Training Command (ATC) for student use in ATC courses.

The STUDY GUIDE (SG) presents the information you need to complete the unit of instruction or makes assignments for you to read in other publications which contain the required information.

The WORKBOOK (WB) contains work procedures designed to help you achieve the learning objectives of the unit of instruction. Knowledge acquired from using the study guide will help you perform the missions or exercises, solve the problems, or answer questions presented in the workbook.

The STUDY GUIDE AND WORKBOOK (SW) contains both SG and WB material under one cover. The two training publications may be combined when the WB is not designed for you to write in, or when both SG and WB are issued for you to keep.

Training publications are designed for ATC use only. They are updated as necessary for training purposes, but are NOT to be used on the job as authoritative references in preference to Technical Orders or other official publications.

### CONTENTS

UNIT	TITLE	PAGE
601	Joints of Heat and Corrosion Resistant Ferrous Alloy Pipe	1 through 11
602	Joints of Aluminum Alloy Pipe and Tubing	13 through 19
603	Butt Patches on Jet Engine Hot Section Parts	21 through 31
604	Fillet Patches on Jet Engine Hot Section Parts	33 through 38
605	Reciprocating Engine Exhaust Manifold Repair	39 through 51
606	Welding of Carbon and Alloy Steel Tubular Assemblies	53 through 69

Metals & NDI Branch  
Chanute AFB, Illinois

3ABR53230-SG-601

## JOINTS OF HEAT AND CORROSION RESISTANT FERROUS ALLOY PIPE

### OBJECTIVES

After completing this study guide and your classroom instruction, you will apply shop safety, good housekeeping and fire prevention measures while welding pipe joints of heat and corrosion resistant ferrous alloys in accordance with the criterion checklist.

### INTRODUCTION

You are about to study one of the more difficult welding operations you will be required to perform, welding joints of heat and corrosion resistant ferrous alloy pipes. The alloy isn't new to you but pipe is. It is considered difficult to weld because you have 360 changes of direction to complete one pass. This will be the major difficulty to overcome.

### INFORMATION

#### MANAGEMENT OF DEFENSE ENERGY AND RESOURCES

While you are in Block VI, do not write in the training literature provided you. This is due to redistribution to subsequent classes.

Also, while you are on regular scheduled breaks, you will leave lights on in the classroom unless the break is for a period of 20 minutes or more.

During clean-up of classrooms and other areas, use of cleaning materials should be kept to a minimum in order to reduce cost in this area. These procedures should be followed throughout Block VI.

All weld beads must be completed and pipe cut so as to fully utilize all training material. After completing the weld, turn off the argon back-up gas to help conserve material.

#### PIPE WELDING TACTICS

TIG pipe welding is different from oxyacetylene welding. The highly concentrated heat of the arc produces a weld puddle which is smaller and easier to control than the weld puddles obtained with other processes. In addition, the weld penetration is deeper with the TIG process, and welding speeds are faster than with other methods. Because of these differences, special techniques have been worked out for TIG pipe welding. Even though you may have had experience in oxyacetylene or covered electrode welding, or even in TIG welding of other materials, you will find that you must learn a new set of skills for TIG pipe welding. You will have to be able to "read" the weld puddle and understand what it tells you about the





penetration and weld bead contour inside the pipe. When you are able to respond automatically to these indications without taking the time to think about them, you will have mastered the technique of TIG pipe welding, and you will be able to produce high quality welds in any joint design and in any position.

## TIG WELDING EQUIPMENT

### Electrodes

A suitable supply of 1/16 inch or 3/32 inch diameter electrodes, with collets to hold them, should be available. Two percent thoriated tungsten electrodes are preferred. Grind the electrode to a point, in order to concentrate the energy of the arc in one spot.

### Shielding Gas

Welding grade argon in cylinders or from an argon manifold system is required. If cylinders are used, two cylinders, supplied with argon regulators and flowmeters, should be used; one for the gas supply to the torch, the other as a source of gas backing. If argon is supplied from a manifold, two flowmeters are used to meter the argon flow for the torch and for the gas backing.

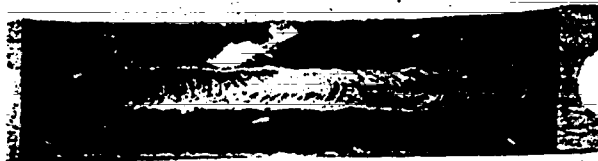

Figure 1. Comparison of Welds Made With an Argon Backing (Upper) and Without an Argon Backing (Lower).

### Gas Backing

Argon is recommended as a backing gas for pipe welding, since it is the most effective in preventing oxidation of the backside of the weld. Figure 1 illustrates the pronounced improvement of the weld bead when an argon backing is used on carbon steel pipe. The lower weld was made without gas backing; the upper weld used argon as a gas backing. Notice the irregularities and oxides on the lower weld, and the smoothness and uniformity of the upper weld. Even though the weld made without a gas backing is irregular, it is still a great improvement over welds made with covered electrodes or by the oxyacetylene process. The argon backing may be confined to the weld areas by paper baffles, by completing filling the pipe or by the use of a removable backing device. The backside of the weld should first

be purged with six volumes of argon for each volume between the baffles of the backing device. Therefore, a gas flow of 3 to 10 cubic feet per hour should be maintained during welding. Higher flow rates may be required if a joint spacing is used between the pipe sections. Nitrogen has been used as a gas backing for the welding of stainless steel pipe, and carbon dioxide has been tried. If nitrogen or carbon dioxide are used as a gas backing in welding, the backside of the weld may be adversely affected due to chemical reactions of these gases with the weld puddle.

### Welding Power Supply

Direct current, straight polarity is used for welding all grades of steel pipes. With straight polarity, the electrode is negative and the work piece is positive. The power supply may be a DC rectifier-type, of at least 300 ampere capacity. If a welding generator is used, be sure to set it for maximum open circuit voltage, to minimize changes in current which occur with changes in arc length. Rectifier-type power supplies usually do not have an open circuit voltage adjustment. The 300-ampere rectifier is recommended so that the operating point during welding will be at the steepest part of the volt-ampere curve. When this occurs, changes in arc length will produce only very small changes in current.

### Other Supplies

A welder's helmet with a number 10 or number 12 shielding glass is needed to protect the operator's face and eyes. A pair of light leather or cotton gloves should be worn. Avoid the use of the heavier chrome-leather or asbestos gloves, since they interfere with the "feel" of the welding rod and torch during welding. A hand wire brush, or power wire brush, should be available for removing any oxide or surface contamination before tack welding. Stainless steel welding rod to match the stainless steel pipe being welded should be used. Rod of 1/16 inch diameter will generally be found acceptable. Rod of 3/32 inch may be used, but new operators tend to use too low a current and welding speed with this size rod.

### TIG WELDING STAINLESS STEEL PIPE

The vee-groove joint has been widely accepted as a standard joint design for pipe welding. The standard vee joint may be butted together and welded without filler rod on the root pass. However, for higher quality welds, or where porosity may be a problem, a joint spacing of 1/16 to 3/32 inch should be used. Filler rod is then used on the root pass. The three standard pipe joints are shown in figure 2.

### Tack Welding

The purpose of the tack weld is to hold the pipe sections in alignment, and minimize the amount of contraction that may occur during welding. If you are going to use filler rod for the root pass weld, you should use filler rod for the tack weld. The sharp vee joint and the standard vee joint with joint spacing, as shown in figure 2, both require filler rod for the root pass and the tack

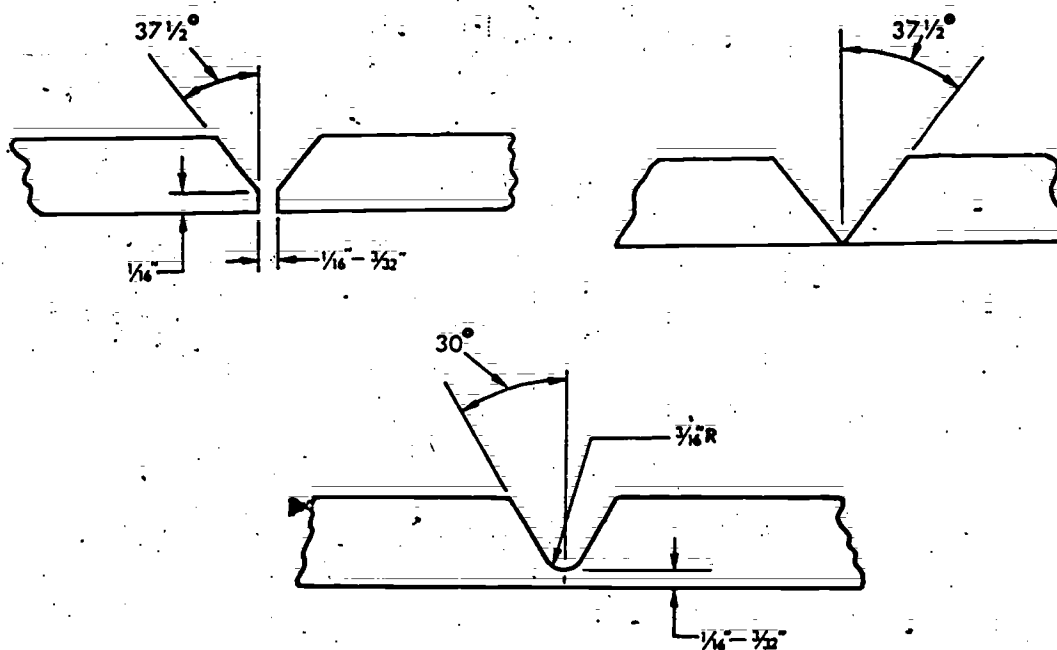
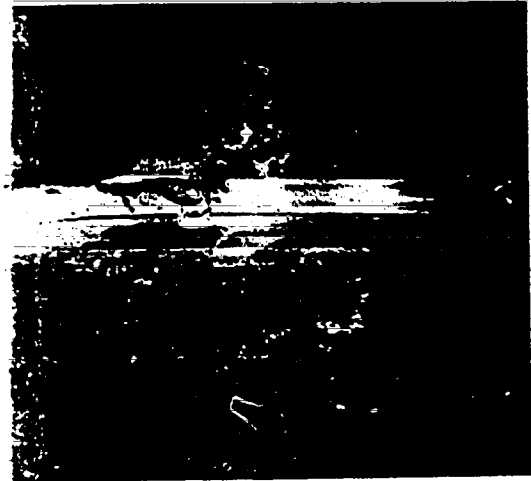

Figure 2. Types of Pipe Joints.

welds. On these joints, make your tack welds about 3/8 to 1/2 inch long and space them evenly around the pipe, about four to six tacks per joint, depending on the pipe size. When you make the root pass, you may either weld right over the tack weld (re-fusing the tack weld), or you may simply tie into the edges of the tack weld, and allow the tack weld to serve as part of the root pass. To stop a tack weld, maneuver the weld puddle to one side of the pipe joint and increase the welding speed. This will decrease the size of the weld puddle. Break the arc when the weld puddle has disappeared or decreased to a rather small size. This technique is used to prevent any cracking which may occur in the weld crater itself, since the heavy pipe wall section will chill the small weld puddle very quickly, and eliminate any crater cracks which could later spread through the tack weld. If filler rod is not to be used on the root pass (such as with the U-joint, figure 2) no filler rod should be used on the tack weld. This time the tack welds should be relatively small, about 1/8 inch long, but space them about every 2 to 2-1/2 inches around the pipe. Terminate the tack weld exactly as before, by carrying the puddle to the side and increasing the welding speed. Figure 3 shows a tack weld in a standard vee joint with joint spacing. Filler rod was used for this weld. Figure 4 shows a tack weld made without filler rod on a U-joint. Notice on both welds the way the weld was carried off to the side of the joint before the arc was broken.

### Starting and Stopping Weld Beads

In TIG pipe welding, all welds starts are "touch starts." Simply touch the electrode to the work piece and then withdraw the torch about 1/16 inch to "draw" the arc. Do not let the electrode touch



*Figure 3. Tack Weld on Standard Vee Joint With Spacing.*



*Figure 4. Tack Weld on U-Joint.*

the puddle during welding, since it may become contaminated. Contamination of the electrode can be prevented by adjusting the electrode extension beyond the gas cup, so that the gas cup will keep the electrode from touching the puddle. If you do let the cup ride on the pipe joint during welding, use a very light torch pressure. Never use a carbon block for starting the arc, as the electrode will become contaminated and cause an erratic, wandering arc. If the electrode is contaminated; you will have to retaper the point on a grinding wheel. In picking up a weld bead that was interrupted, begin the puddle 1/4 inch or more back from the end of the previous bead to ensure good fusion of the two beads, figure 5. Take special care to obtain complete penetration when tying in or welding over tack welds, or where weld beads overlap. When approaching the tack weld, or the overlap bead, do not add filler rod for the last 1/8 inch of the weld. When the tack weld or bead is reached, it will melt and flow back over the 1/8 inch space and give complete penetration.

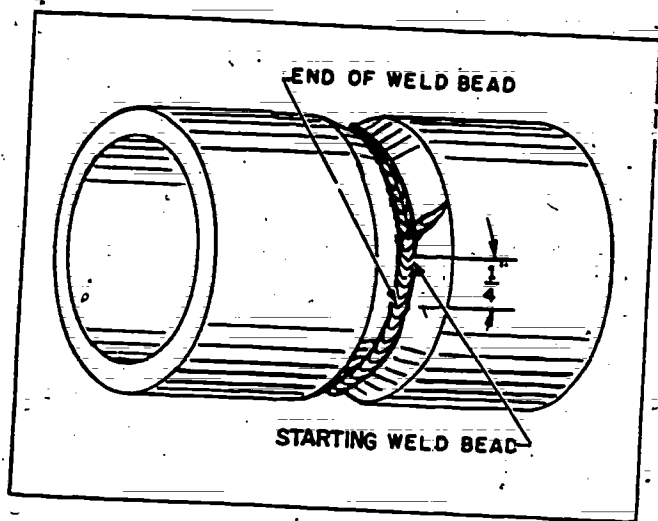

Figure 5. Starting and Stopping a Weld Bead.

Stopping a weld bead is accomplished in the same way the tack weld was interrupted. Carry the puddle to the side of the pipe joint, increase the welding speed, and when the puddle disappears or becomes very small, break the arc by withdrawing the torch from the work, as shown in figure 5.

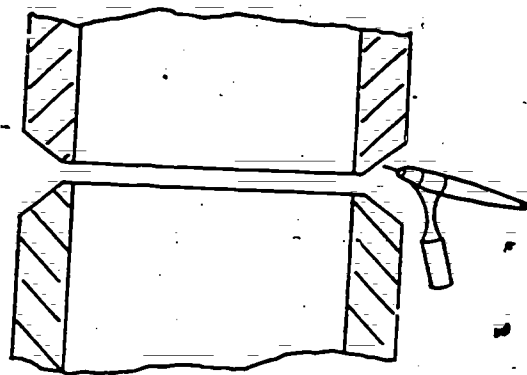

Figure 6. Torch Position For Welding Pipe in the Vertical Position.

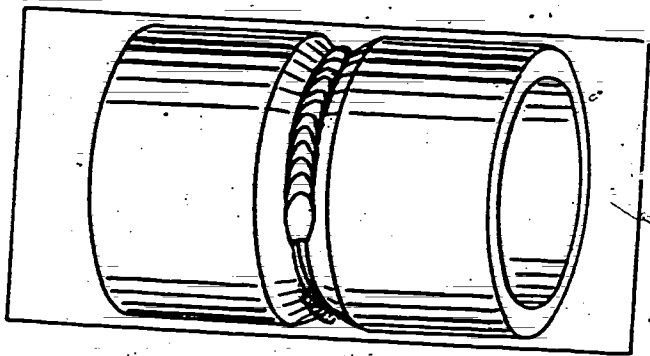

Figure 7. Correct Puddle Shape For Standard Vee With Joint Spacing.

### Standard Vee with Joint Spacing

After the joint has been properly tacked and placed in position for welding, strike an arc on the side of the joint and carry it to the bottom of the joint. Let the arc dwell on the bottom of the joint until a small weld puddle forms on each side of the vee. Then add filler rod to the front of the weld puddle until the puddle bridges the joint opening. (Do not put the filler rod directly into the arc.) When you add the filler rod, the rod should be almost tangent to the pipe surface, and the torch should be slanted about 15 to 20 degrees toward the rod with an arc length of about 1/16 inch, figure 6. When the puddle increases to about 1/8 inch thick, remove the rod and hold the torch stationary. The weld puddle will now begin to flatten out in front, forming a thin front edge and will take a wedge shape, with rounded corners extending to the bottom of the joint. This wedge shape means that penetration is complete. Figure 7 illustrates the correct puddle shape for complete penetration on this joint. As soon as penetration is complete, as shown by the puddle shape, add filler rod and advance the TIG torch simultaneously. Keep advancing the correct puddle shape to complete the pass. It will be necessary for you to remove the rod about every 1/8 inch to observe the puddle shape. When you have mastered the technique, you will be able to keep the height of the puddle even and about 1/8 inch thick (depending on the pipe size). If the welding speed is too slow, you will have excessive penetration inside the pipe. The weld puddle will then have a rounded opening at the front, which will be wider than the joint opening (keyhole shape). This shape is very similar to the shape of the weld puddle for correct penetration on sharp vee joint. Be careful not to confuse the two. Remember that a keyhole-shaped puddle for a spaced joint shows excessive penetration, since too much of the edges are being melted back. To overcome excessive penetration, add more filler rod to the puddle, slant the torch sharply toward the filler rod so more rod is melted, and increase your welding speed. The effect will be to put more heat into the filler rod and less into the pipe itself. This will close the enlarged opening at the front of the puddle.

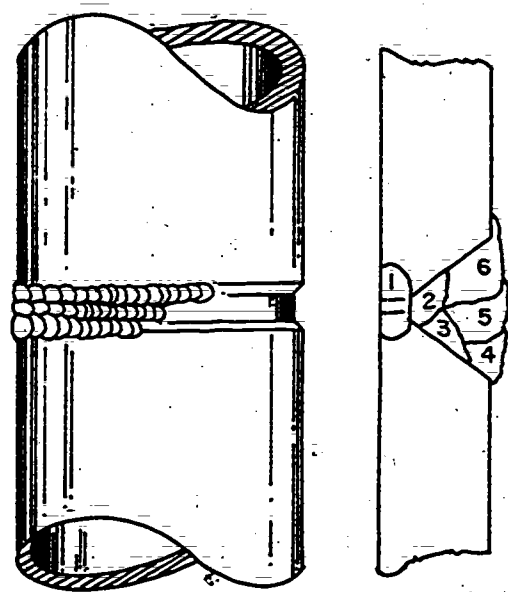

Figure 8. Filler Passes with Stringer Beads (Left) and Welding Sequence (Right).



## Filler Pass Welding

Filler passes are used to fill the pipe joint to within approximately 1/16 inch of the top surface. Larger weld puddles can be used for the filler pass on rolled pipe than for the fixed position welds, since the weld puddle will have no tendency to sag out of the joint because of gravity.

## Filler-Pass Welding Stainless Steel Pipe

For welding stainless steel pipe in any position, the stringer bead technique should be used. The stringer beads on stainless steel should be kept as small as possible, since the small weld bead will solidify quickly and prevent precipitation of carbides in these steels. Small beads also reduce the tendency for hot-short cracking. Figure 8 shows the sequence for making stringer beads on vertical-fixed position pipe.



Figure 9. TIG Pipe Weld Made With Stringer-Bead Technique.

## Adding Filler Rod

Place the filler rod in the bottom of the joint and keep feeding it into the weld puddle rather than into the arc. As the filler rod is added, move the torch to each side of the rod to tie the edges of the weld puddle to the sides of the pipe joint. It is not necessary to remove the rod from the puddle to observe penetration, but the weld puddle must be kept thin in front and should blend evenly into the sides of the joint. Be careful that the puddle does not become thick in front and appear to be poured into the joint. This will result in cold shuts, where fluid metal is deposited on pipe which is not molten. Another means of judging filler pass penetration on carbon and low alloy steel pipes is by watching for a very slight film of molten oxides ahead of the weld puddle. This thin film is more reddish in color than the weld puddle, and as long as it can be seen, penetration is complete. Smooth, uniform finish passes can only be made if the filler passes are also smooth, and the pipe is filled to a uniform level. Care spent in making smooth filler passes will result in finished welds of excellent appearance as well as quality. As in making filler passes, either stringer bead or weave beads may be used for carbon and low alloy



steel pipes in the rolled and horizontal position. Stringer beads must be used for carbon or low alloy steel pipe in the vertical position, or for stainless steel in any position. Finished welds should be about 1/8 inch wider than the joint, with the overlap evenly spaced on each side of the joint. The weld bead height should be about 1/16 inch above the surface of the pipe and should increase evenly from the edges to the center. Weld edges should be straight and without any undercutting, figure 9.

#### Procedure for Welding Stainless Steel Pipe Butt Joint

1. Deburr, clean, and align pipe.
2. Set welder for DCSP.
3. Make sure your torch angle is 75 to 90 degrees.
4. Make sure your filler rod angle is 15 to 20 degrees.
5. Tack weld joints.
  - a. Tacks 3/8 to 1/2 inch long.
  - b. 4 to 6 tacks per joint spaced evenly.
  - c. Penetration of 100 percent.
6. Weld root pass.
  - a. Penetrate 100 percent.
  - b. If contamination occurs, clean weld and regrind tungsten to a point.
7. Use stringer beads for filling vee.

#### Welding a Tee Joint

The tee joint on pipe, as on plate, is a fillet-type of weld. The end of the vertical pipe must be grooved out to fit the horizontal pipe. This type of fit-up is called a saddle. After the pipe fit-up has been made, clean the edges thoroughly and remove all burrs. All metal that is to be fused during welding must be absolutely clean. Avoid sharp corners, or sudden changes in size or contour, since they might lead to concentrations of stress. Maintain joint alignment by the use of fixtures and with adequate tack welds. Tack welds, when used for alignment and holding, should be of sufficient size to support the joint throughout the welding operations. The spacing between the parts to be joined should be carefully considered. The edges should fit snugly. The root opening between the welding edges for a given thickness of metal must permit the gap to be bridged without difficulty. The torch should be held at the center of the joint and moved in small circles to obtain complete fusion at the edges of the weld and also obtain the correct penetration. The completed weld

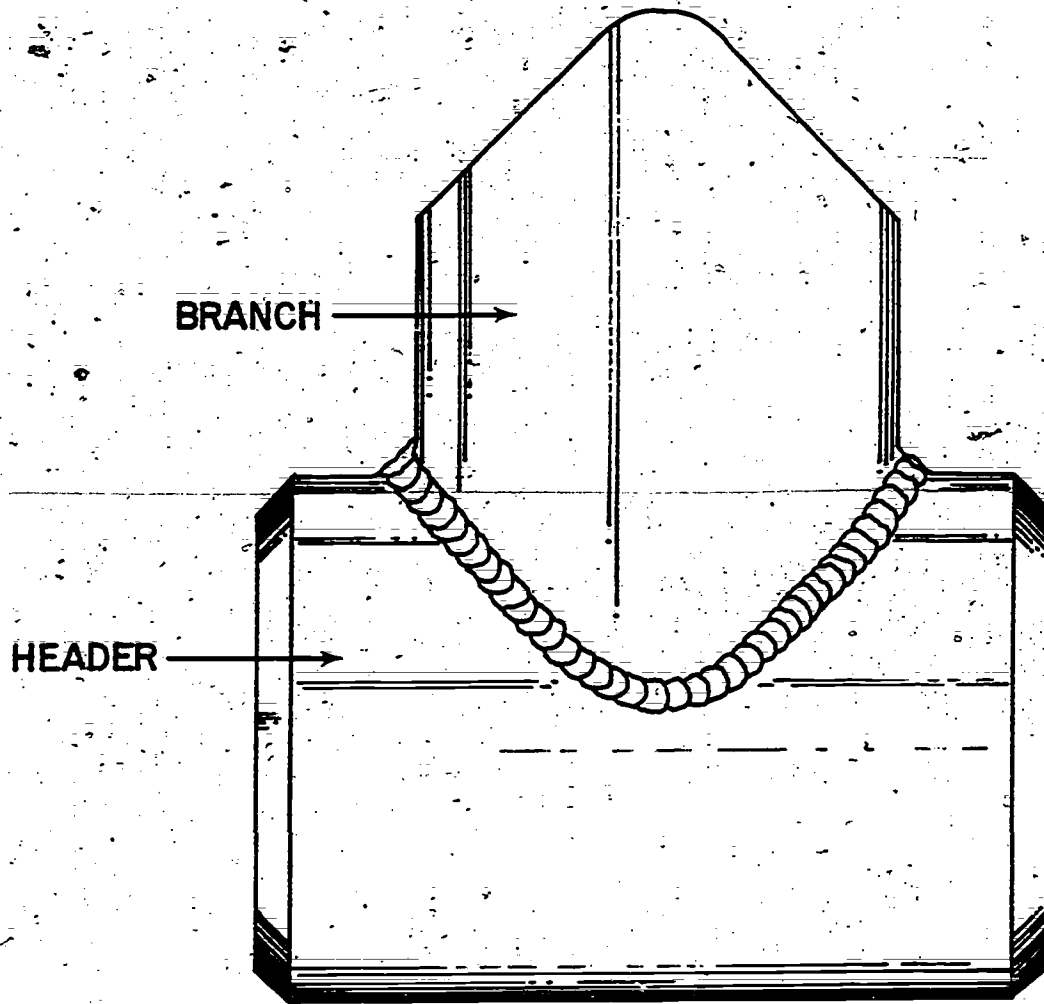

Figure 10. Stainless Steel Tee Joint.

should have leg dimensions of not less than 1-1/2 times the wall thickness, 15 to 85 percent penetration, and the face should be flat to slightly convex, as shown in figure 10.

#### Procedure for Welding a Tee Joint

1. Fit one pipe to straddle the other pipe.
2. Clean and deburr the pipe.
3. Set the welder from AC current with high frequency.
4. Tack weld the pipe at no less than three spots evenly around the pipe with the tack welds not exceeding one inch in length.
5. Check joint for alignment.
6. Weld the joint to the proper specifications.

You have now completed this study guide.

Note: Answer the questions at the end of this chapter on a separate sheet of paper.

QUESTIONS

1. Why should the tungsten electrode be ground to a point when TIG welding heat and corrosion resistant ferrous alloys?
2. What type gas is recommended for backing gas for welding pipe joints? Why?
3. What is the angle for a standard vee bevel?
4. What is the joint spacing for welding pipe butt joints?
5. Explain the correct procedure for stopping a weld bead when welding pipe butt joints.
6. What advantages do small weld beads have over large weld beads when welding pipe butt joints?
7. How many tacks are required when welding pipe butt joints?
8. What is the purpose of tack welds?

REFERENCES

1. TO 34W4-1-5, Welding Theory and Application.
2. Althouse, Turnquist, Bowditch, Modern Welding, 1967.

## JOINTS OF ALUMINUM ALLOY PIPE AND TUBING

### OBJECTIVES

After completing this study guide and your classroom instruction, you will apply shop safety, good housekeeping and fire prevention measures while welding pipe and tubing joints of aluminum alloy in accordance with the criterion checklist.

### INTRODUCTION

You have just completed a lesson on welding stainless steel pipe and you are now going to study joints of aluminum alloy pipe and tubing. Aluminum, because of its "hot start" characteristic, may give you a few more problems. However, if you follow the procedures and use the information in this study guide you should have very little problem.

### INFORMATION

#### MANAGEMENT OF DEFENSE ENERGY AND RESOURCES

All weld beads must be completed, and pipe cut so as to fully utilize all training material. To help conserve resources, there will be no argon backup gas used during this exercise.

#### TIG PIPE WELDING

TIG pipe welding is different from oxyacetylene welding. The highly concentrated heat of the arc produces a weld puddle which is smaller and easier to control than the weld puddles obtained with other processes. In addition, the weld penetration is deeper with the TIG process, and welding speeds are faster than with other methods. Because of these differences, special techniques have been worked out for TIG pipe welding. Even though you may have had experience in oxyacetylene or covered electrode welding, or even in TIG welding of other materials, you will find that you must learn a new set of skills for TIG pipe welding. You will have to be able to "read" the weld puddle and understand what it tells you about the penetration and weld bead contour inside the pipe. When you are able to respond automatically to these indications without taking the time to think about them, you will have mastered the technique of TIG pipe welding, and you will be able to produce high quality welds in any joint design and in any position.

#### TIG WELDING EQUIPMENT

##### Electrodes

A suitable supply of 3/32 inch diameter electrodes, with collets to hold them, should be available. Two percent thoriated tungsten electrodes are preferred. Grind the electrode to a spherical shape.

## Shielding Gas

Welding grade argon in cylinders or from an argon manifold system is required. If cylinders are used, two cylinders supplied with argon regulators and flowmeters should be used; one for the gas supply to the torch, the other as a source of gas backing. If argon is supplied from a manifold, two flowmeters are used to meter the argon flow for the torch and for the gas backing.

## Gas Backing

Argon is recommended as a backing gas for pipe welding, since it is the most effective in preventing oxidation of the back side of the weld. The argon backing may be confined to the weld areas by the use of baffles, by completely filling the pipe, or by the use of a removable backing device. The backside of the weld should first be purged with six volumes of argon for each volume between the baffles of the backing device. Thereafter, a gas flow of 3 to 10 cubic feet per hour should be maintained during welding. Higher flow rates may be required if a joint spacing is used between the pipe sections.

## Welding Power Supply

Alternating current, high frequency is used in welding all grades of aluminum and aluminum alloy pipe and tubing. This current is used because it produces a good cleaning action, which is very important when welding aluminum or aluminum alloy. The power supply may be an ac or dc rectifier type, or it could also be an ac transformer.

## Other Supplies

A welder's helmet with a number 10 or number 12 shielding glass is needed to protect the operator's face and eyes. A pair of light leather or cotton gloves should be worn. Avoid the use of the heavier chrome-leather or asbestos gloves, since they interfere with the "feel" of the welding rod and torch during welding. The gloves will also protect you from getting a mild shock while using the high frequency and ac current. Cleaning supplies will also be needed. These will include rags soaked in acetone, files, and either a hand wire brush, or a power wire brush. Aluminum welding rod to match the aluminum pipe being welded should be used. Rod of 1/16 inch diameter will generally be found acceptable. Rod of 3/32 inch may be used, but new operators tend to use too low a current and welding speed with this size rod.

## TIG WELDING ALUMINUM PIPE

### Preparation of Edges

All butt joints must be melted through their full thickness to obtain a complete penetration weld. This can be done by using the same joints as were discussed for stainless steel pipe welding.

### Cleaning

Joints must be thoroughly cleaned to remove all foreign substances before welding. Oil, grease, dirt, paint, and other substances

will burn in the arc and generate gases which will contaminate the inert gas and interfere with the clean, smooth flow of weld metal. These materials can also cause porosity, incomplete fusion, inadequate penetration, and undercutting, in addition to tough welds of poor appearance.

Joint edges can be cleaned with solvent soaked rags to remove surface oil, grease, and dirt. This should be sufficient cleaning for most joints. Suitable solvents include naphtha, alcohol, and acetone. When solvent soaked rags will not remove imbedded dirt, it will then be necessary to employ files, chisels, wire brushes, or metal scrapers. These should be clean and free from oil.

### Tack Welding

After the edges have been cleaned, assemble the joint. When the joint has been properly aligned, tack weld at three or more locations. The tack weld should be fully penetrated and rather flat; that is, not built up and should not exceed one inch in length. Three such welds placed equal distance around the joint will usually maintain alignment.

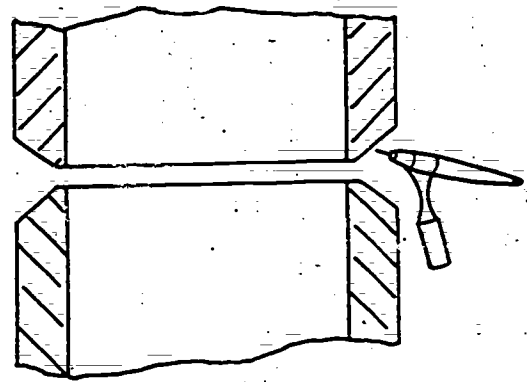

Figure 11. Torch Position For Welding Pipe in the Vertical Position.

### Welding a Butt Joint

The butt joint will be welded in the vertical fixed welding position so, therefore, will be welded in the horizontal welding position. Special techniques are required to compensate for the sagging of the puddle due to the force of gravity. Position the torch as shown in figure 11, and form the weld puddle on the upper side of the joint, keeping it slightly above the centerline of the joint. Move the torch in small circles, from the top of the puddle around the puddle to the bottom, and then up the other side to the top. Do not permit the arc to dwell too long on the bottom, but permit it to dwell longer on the top of the weld. This circular motion will insure fusion of the bottom of the joint with the filler rod and yet will not undercut the upper side of the weld bead. Preventing contamination of the weld is very important when welding aluminum and aluminum alloys. If the electrode becomes contaminated, regrind it to a dull point and as you are welding it will form a ball





Figure 12. Finished Horizontal Weld Bead.

on the end. This is what is desired. The contamination will also have to be cleaned off the weld in order to obtain a good weld. The butt joint should have 100 percent penetration and the finished weld should be about  $1/8$  inch wider than the joint, with the overlap spaced evenly on both sides of the joint. The weld bead height should be about  $1/16$  inch above the surface of the pipe and should increase evenly from the edges to the center. Weld edges should be straight and without any undercut, as shown in figure 12.

#### Procedure for Welding a Butt Joint

1. Clean and deburr the pipe.
2. Align the pipe to check the fit-up.
3. Set the welder for ac current with high frequency.
4. Tack weld the pipe.
  - a. Three or more tacks not to exceed one inch in length.
  - b. Tack must be fully penetrated and flat.
5. Check your pipe for alignment and contamination.
6. Weld the pipe, obtaining full penetration and good fusion without any contamination.



BRANCH

HEADER



Figure 13. Tee Joint.

- 7. Fill joint with stringer beads.

Welding a Tee Joint

The tee joint on pipe, as on plate, is a fillet-type of weld. The end of the vertical pipe must be grooved out to fit the horizontal pipe. This type of fit-up is called a saddle. After the pipe fit-up has been made, clean the edges thoroughly and remove all burrs. All metal that is to be fused during welding must be absolutely clean. Avoid sharp corners, or sudden changes in size or contour, since they might lead to concentrations of stress. Maintain joint alignment by the use of fixtures and with adequate tack welds. Tack welds, when used for alignment and holding, should be of sufficient size to support the joint throughout the welding operation. The spacing between the parts to be joined should be carefully considered. The edges should fit snugly. The root opening between the welding edges for a given thickness of metal must permit the gap

to be bridged without difficulty. The torch should be held at the center of the joint and moved in small circles to obtain complete fusion at the edges of the weld and also obtain the correct penetration. The completed weld should have leg dimensions of not less than 1-1/2 times the wall thickness, 15 to 85 percent penetration, and the face should be flat to slightly convex, as shown in figure 13.

When welding aluminum pipe, it is most satisfactory to point the electrode toward the center or axis of the pipe. This is more satisfactory than trying to modify the angle of the electrode along the length of the weld. The arc should be maintained at a controllable length, usually about 1/4 inch or just long enough to prevent contamination of the electrode when the welding rod is added. Short arcs do not contribute to ease of application or improvement of weld soundness or appearance. The inert gas should be adjusted to flow at a rate which will provide good cleaning. A welding rod should be used for all passes and should be used in such a manner that it does not interfere with the stability of the arc. The best way to accomplish this is to introduce the welding rod nearly tangent to the pipe at the location of the arc; make sure that the first contact is between the end of the welding rod and the leading edge of the pool. Smooth, uniform forward motion of the arc and addition of the filler rod will contribute to best results; short, jerky movements will be reflected in inclusions, rough appearance, non-uniform penetration, and difficulty in application.

#### Procedure for Welding a Tee Joint

1. Fit one pipe to straddle the other pipe.
2. Clean and deburr the pipe.
3. Set the welder for ac current with high frequency.
4. Tack weld the pipe at no less than three spots evenly around the pipe with the tack welds not exceeding one inch in length.
5. Check joint for alignment.
6. Weld the joint to the proper specifications.

You have now completed this section of the study guide.

Note: Answer the questions at the end of this chapter on a separate sheet of paper.

#### QUESTIONS

1. What type point is recommended for the tungsten electrode when welding aluminum pipe?
2. Explain the term "land" in association with welding pipe.
3. What type gloves should be worn when welding aluminum pipe?

Why?

4. What must be done to keep alignment when welding pipe joints?
5. What is the purpose of the high frequency current when welding aluminum alloys?
6. Explain the term "fillet."

#### REFERENCES

1. TO 34W4-1-5, Welding Theory and Application.
2. Althouse, Turnquist, Bowditch, Modern Welding, 1967.

## BUTT PATCHES ON JET ENGINE HOT SECTION PARTS

### OBJECTIVES

After completing this study guide and your classroom instruction, you will identify: jet engine hot section parts; their location, repairs necessary; cleaning method; and the repair procedures and techniques for weld repair. Also, you will apply shop safety, good housekeeping and fire prevention measures while making butt patch weld repairs in accordance with the criterion checklist.

### INTRODUCTION

If you are assigned to a field maintenance squadron, you will be responsible for repairing many different jet engine hot section components. Most of these repairs involve cracks in different areas of these components.

### INFORMATION

#### MANAGEMENT OF DEFENSE ENERGY AND RESOURCES

Lay out patch repair on aircraft part in such a manner as to get the maximum amount of training time on each part.

Conserve patch material by laying out the repair patch with a minimum amount of waste.

To conserve argon gas, use a copper back-up strip.

#### TIG WELD REPAIRS

The inert gas-shielded arc welding process is used almost exclusively for repair of jet engine parts. Welds made by this method are smaller and have the required physical properties which are so critical for jet engine parts. Most of the weld repairs are made on the "hot section" of the engine. Repairs on the J-79 jet engine should be made by the inert gas-shielded arc process. An alternate process can be used only if allowed by the technical order.

Repair of a hot section part is not a guesswork procedure. Step-by-step procedures are outlined in the TO covering repair of the particular jet engine you may be working on. The TO gives you the base metal of any component, the welding process to use, and the type or types of filler rod needed. This is, of course, if a repair is authorized to begin with. You may even find that although a part may have a crack, the TO tells you it is not necessary to repair it. The TO that pertains to a specific repair is always the final authority, except in cases of extreme emergency.

The TO to consult for assistance in this lesson is TO 2J-J79-66. This TO covers the J-79 engine from the smallest nut and bolt to the largest of the engine's components.

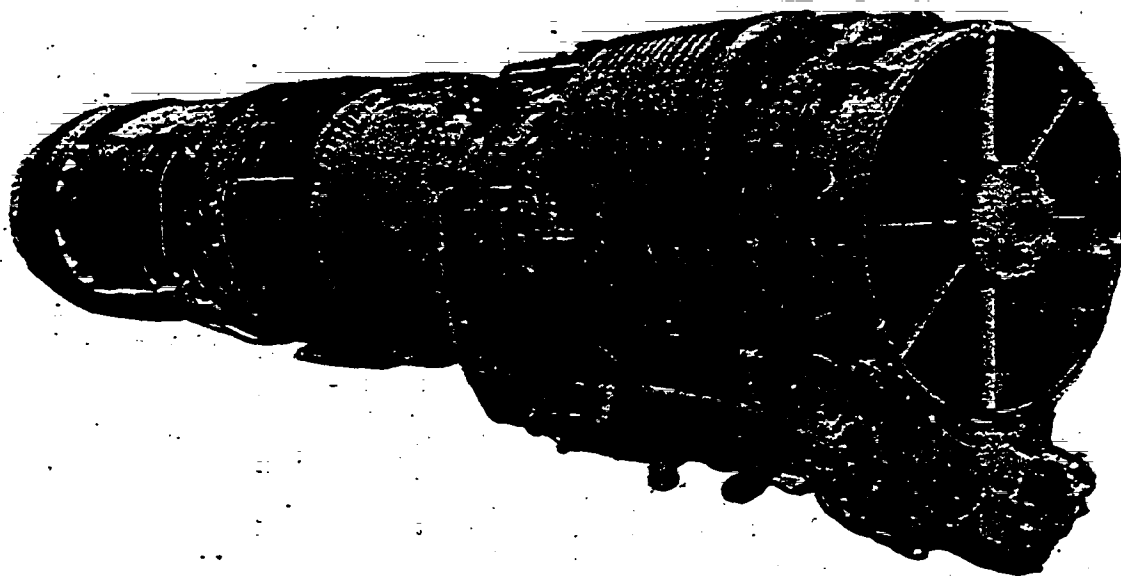

Figure 14. J-79 Engine.

#### J-79 ENGINE

The J-79-GE-19 engine is a lightweight, high-thrust, axial-flow turbojet engine with variable afterburner thrust. It incorporates a 17-stage compressor, in which the angles of the inlet guide vanes and the first six stages of vanes are variable; a combustion system consisting of ten combustion liners located between an inner and outer casing; a three-stage turbine rotor that is coupled directly to the compressor rotor; and an afterburner system that provides thrust variation by means of fuel flow scheduling and actuation of the variable area exhaust nozzle. The J-79 engine is illustrated in figure 14.

Below is a list of alloys used in making component parts of the J-79-GE-5B, 5C, and 7A model engines.

- |                      |                  |
|----------------------|------------------|
| a. Aluminum alloy    | g. Hastelloy-X   |
| b. Magnesium thorium | h. R-41          |
| c. Chromoloy         | i. R-235         |
| d. A-286             | j. N-155         |
| e. Incoloy-T         | k. 321 Stainless |
| f. L-605             | l. Inconel       |

Nearly all of these alloys are repairable at field level; however, you may not remember the various types of alloys that the manufacturer uses for the construction of the engine. You are not expected to remember the alloys used in the construction or the procedure used

to repair a "hot section," and this is why technical orders are used. TO 2J-J79-66 is the technical order to consult on the J-79 engine.

### CLEANING OF HOT SECTION PARTS

All parts that require weld repair should be cleaned thoroughly enough to allow making good welds and allow visual inspection to determine the extent of the damage. Cleaning of jet engine parts prior to welding is outlined in TO 2J-1-13 and the -16 for the particular engine.

#### Caustic Soda Solution Cleaning

Sufficient water should be used to completely cover the parts while soaking in the solution. As caustic soda is highly active, the tank should be made of stainless steel, supported by an outside wood shell covering. The solution strength, for effective cleaning, should contain from 10 to 14 ounces of caustic soda per gallon of water. The solution may be used either hot or cold; however, cleaning is most effective when the solution is heated to 180° - 200°F. When used at room temperature, a longer soaking time is required. After the part is clean, it should be rinsed in hot water to remove all traces of the cleaning solution.

#### Hydro-Steam Cleaning

An alternate cleaning method is by hydro-steam cleaning. The solution used is a mixture of one part cleaning compound formula C to 25 gallons of water. This solution is sprayed on the part under steam pressure of 100 psi. Removal of heavy carbon deposits is then made by applying a carbon remover solution. These cleaning solutions are listed in AF supply catalog.

#### Blast Cleaning

There are two types of blast cleaning which may be used to remove hard carbon or lead deposits from engine components. The two types are "Vapor Blasting" and "Soft Grit Blasting." Using either type, the engine part must first be degreased or put through a decarbonizing solution and then rinsed and dried thoroughly.

#### Mechanical Cleaning

Parts not having deposits of carbon can be cleaned of surface oxide by mechanical cleaning. This cleaning is best accomplished with abrasive cloth (80-100 grit), steel wool, or a peach stone blast.

### COMBUSTION SECTION

The combustion section of the J-79 engine, shown in figure 15, is also known as the "hot section" of the engine because this is where the fuel is burned. This section is also where most of the repair work is done. The section consists of four parts: outer



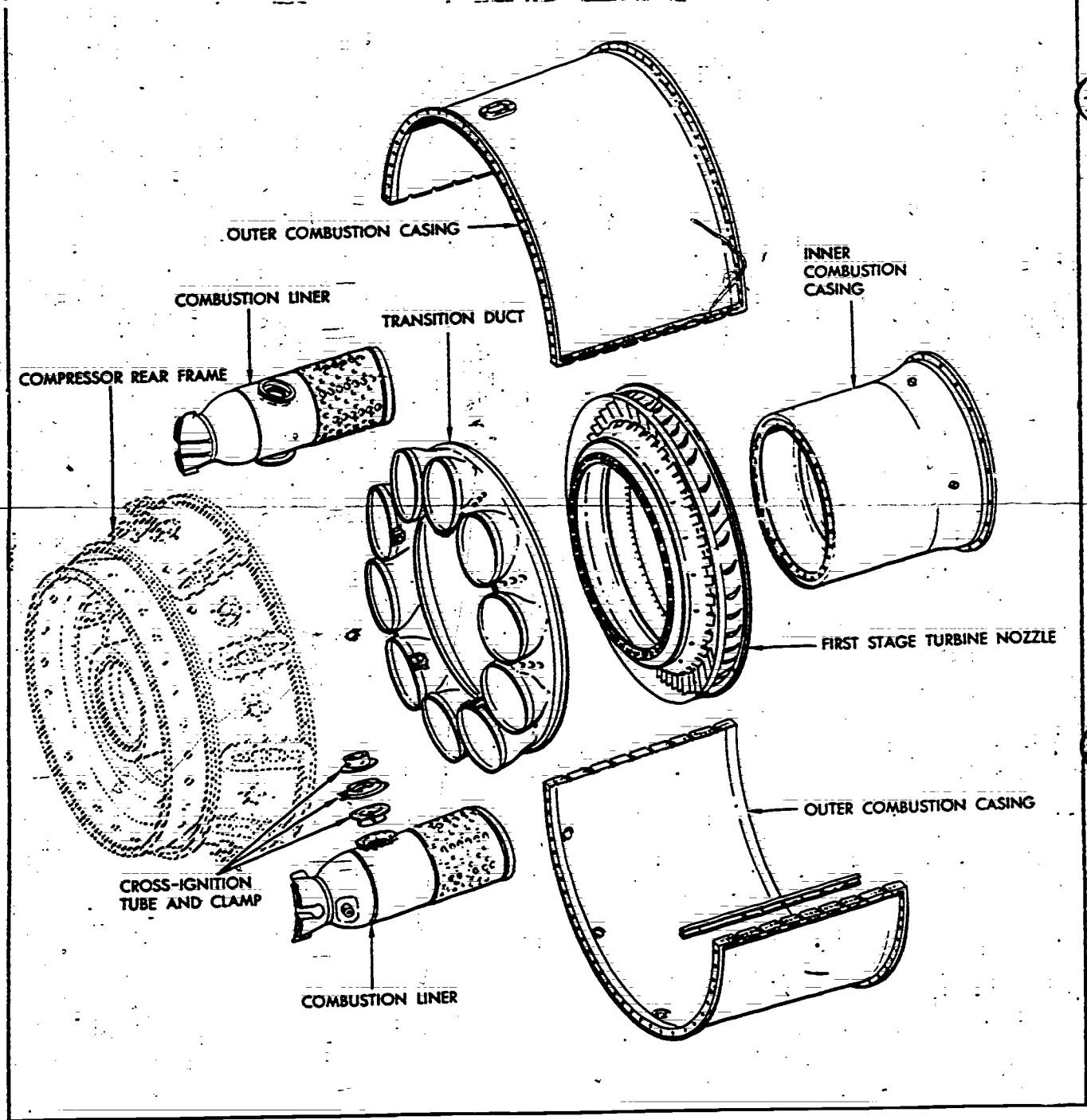

Figure 15. Combustion Section.

combustion casing, inner combustion casing, combustion liners, and a transition duct.

Outer Combustion Casing

The outer combustion casing is split on the horizontal line to permit removal of half of the casing for inspection and removal of the liners. The upper half contains a port at the 12 o'clock position for extraction of anti-icing air. The lower half contains two spark plug bosses, for numbers 4 and 5 combustion liners, and a combustion system drain. A port near the rear flange lets air



flow from the combustion casing to the torch igniter. A locking strip, which fits along the inside of the horizontal flange, strengthens the flange and prevents air leakage. The outer combustion casing is an assembly of matched halves; therefore, the entire casing must be replaced when replacement of either half is necessary.

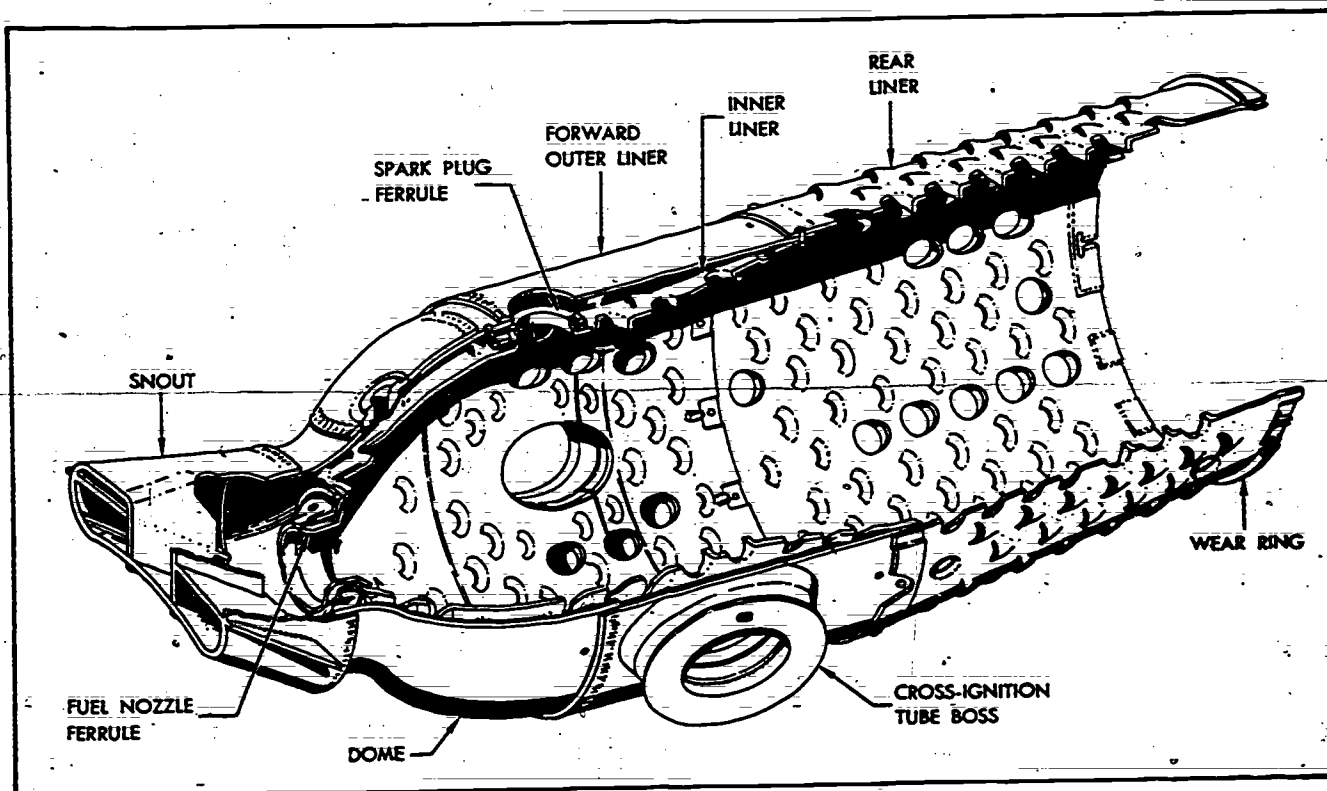

Figure 16. Combustion Liner.

### Combustion Liners

Each combustion liner consists of three parts riveted together. They are: an inner liner, an outer liner, and a rear liner, as shown in figure 16. The outer liner incorporates a snout which scoops compressor discharge air into the liner. Vanes in the snout distribute air uniformly around the dome of the inner liner. A slot in the snout permits the fuel nozzle to extend into the inner liner dome. The number 4 and 5 liners have spark plug holes through the outer and inner liners.

The rear liners are oval-shaped and oblique at the rear to facilitate their removal. A wear ring is riveted to the end of the rear liner. The liners fit into the inlet ports of the transition duct and are supported by it. The liners have thimble holes, through which air is introduced to complete the combustion, and louvers that provide a flow of cooling air along the inner surface of the liner.

The adjacent combustion liners are joined near the front end by cross-ignition tubes. The flanges of adjacent liners are held

by V-band clamps to form a sturdy assembly. The liners are restrained by retaining bolts in the compressor rear frame.

### Inner Combustion Casing

The inner casing is an internally stiffened cylinder that bolts between the compressor rear frame and the transition liner and first-stage turbine nozzle. It absorbs the torque developed on the turbine nozzle and confines the combustion airflow to an annular passage around the liners. Holes near the front of the casing permit air to flow into the chamber around the turbine shaft to cool the shaft.

### Transition Duct

The transition duct provides a ring of ten oval inlet ports and an annular exit that has an area approximately one-half that of the total area of the ten inlets to accelerate the gases into the first-stage nozzle. The duct is supported and is held in place by five pin-bolts near the rear flanges of the inner combustion casing.

The inlet ports of the transition duct support the rear end of the combustion liners. Small louvers between the inlet ports admit cooling air.

### WELDING PROCEDURE

You must be qualified, in accordance with MIL-T-5021, before making repair welds on engine components. You must also use the inert gas-shielded arc welding process to repair all engine components unless otherwise specified by the pertaining TO. When welding on engine components, you must also be aware of residual magnetism. Residual magnetism is induced by electrical current flow through a part and if it becomes strong enough, it may attract metallic particles which, if introduced into an operating bearing, can cause severe damage. You can minimize the strength of the residual magnetism, however, by placing the ground cable as close to the work as possible.

### Chromoloy Engine Parts

Vapor degrease the part or clean the repair area with a lint-free cloth soaked in acetone or benzine to remove any oil or grease on the part. Make sure the part is clean down to the bare metal in the repair area. Carbon, scale, or rust may be cleaned from the metal surface by using a power-driven stainless steel rotary wire brush, by using emery grit roll, or by grit blasting. Cover or plug all openings prior to grit blasting. Polish the surface with a stainless steel rotary brush or emery grit roll after grit blasting to remove residual grit. Inspect both surfaces of the repair area, if possible, to determine if cracks extend completely through the metal. Remove rivets if cracks extend under the rivet heads.

Completely grind out all cracks, except for through cracks. Grind approximately 1/8 inch beyond the ends of all cracks. For through cracks, grind to depths depending on thickness of the parent



metal. Metals up to 0.045 inch thick should be ground out to 50 percent of the metal thickness. Metals from 0.045 to 0.090 inch thick should be ground out to 0.30 inch of the opposite surface. After all cracks have been grouped out, the part should be reinspected to be certain all but through cracks have been removed. If no cracks are in evidence, clean the area with lint-free cloth soaked in acetone or benzine to remove any residual inspection fluid.

The back surface of the repair area should be protected with shielding gas. If the area is accessible, position a contoured copper block containing gas grooves, or a gas cup containing a suitable diffuser, against this surface. Direct about ten cubic feet per hour of welding grade argon or helium into the block or cup. The block or cup should provide even, nonturbulent gas flow. The gas grooves in the copper block should be about 1/8 inch wide and the outlet aperture should be recessed 0.060 to 0.090 inch below the contoured surface of the block. The gas cup diffuser should be recessed about 1/4 inch below the open end of the cup. If the back surface of the repair area is not accessible, seal the cavity behind the repair area, except for a gas inlet and outlet. Direct welding grade argon or helium into the cavity until it is completely purged of air.

The welding machine should incorporate arctrol or equivalent. It should be set for dc straight polarity. The electrode should be 1/16 inch diameter tungsten, two percent thoriated. The end of the electrode should be pointed. The torch gas should be argon adjusted to 10 to 15 cubic feet per hour. Filler rod should be chromoloy 1/32-, 1-16-, or 3/32-inch diameter wire, depending upon the size of the crack to be welded. Adjust the current for metal thickness as listed below:

Up to 0.045	35 to 45 amperes
0.045 to 0.060	50 to 60 amperes
0.060 to 0.080	65 to 75 amperes
0.080 to 0.100	80 to 90 amperes
0.100 to 0.125	90 to 100 amperes (multipass)
0.125 and up	80 to 100 amperes (multipass)
Castings	80 to 100 amperes

Clean the filler wire immediately before use by wiping with acetone. Start the arc on a copper strip if the welding machine does not have a high-frequency arc starting circuit. Weld the crack and locally stress relieve each boss or gusset assembly before proceeding to the next repair area. If you are making a multipass weld, clean the bead after each pass by grinding or grooving. Polish with a stainless steel wire brush to remove oxides before welding another bead. If you are welding from both sides of a repair area, grind or groove the root of the first weld to sound metal and inspect for cracks. Remove any residual grit with a

Lint-free cloth soaked in acetone or benzine and polish with a stainless steel rotary brush before making additional welds.

Stress relieve no more than two linear inches of weld heat-affected zone at a time. Use an oxyacetylene torch to locally heat the area, using a neutral or slightly reducing flame. To insure that the heat-affected zone is heated to the correct temperature, use temperature-sensitive crayons of the proper temperature range. Mount a locally manufactured shield along the edges of the heat-affected zone to prevent exposure of the adjacent parent metal to the torch flame. Slowly bring the metal temperature of the heat-affected zone up to 1200°F by intermittent application of the torch flame. Control the rate of temperature rise so that one minute is required to reach this temperature. Hold the metal temperature between 1105° and 1250°F for five minutes. Time this interval accurately, starting when the temperature reaches 1200°F. The temperature may exceed 1250°F for a maximum total time of one minute, but it must not exceed 1300°F. The temperature may go below 1150°F for a maximum total of two minutes, but must not go below 1100°F. The temperature and the time must be carefully controlled during stress relieving to insure satisfactory welds. Polish the stress-relieved area with a stainless steel rotary wire bursh to remove all oxides, scale, and temperature-sensitive crayon residue. Inspect the repair to insure that no cracks remain.

#### A-286, Incoloy-T, L-605, Hastelloy-X, and 321 Stainless Steel

You should follow the same procedures for cleaning and preparing these metals for welding as you do for chromoloy engine parts. However, after all cracks have been ground and grooved out, the area should be treated with acid etch to remove any smeared metal. The acid etching solution is prepared as follows:

77cc	water
15cc	sulfuric acid (95-98 percent)
180cc	hydrochloric acid (36.5-38 percent CP grade)
55cc	nitric acid (69-71 percent CP grade)
75cc	acetic acid (99.7 percent)
45 grams	ferric chloride ( $\text{FeCl}_3 \cdot 6\text{H}_2\text{O}$ )

Apply the etching solution with clean cotton swabs. One minute after applying the etching solution, thoroughly wash the etched area with tap water and dry with clean, lint-free cloth or filtered compressed air. Do not permit the etching solution to contact the skin, since severe burns will result.

After acid etching, reinspect the repair area to insure that all but the through cracks have been removed. Regrind, acid etch, and reinspect if any cracks are found. Clean the repair area with

lint-free cloth soaked in acetone or benzine before starting the weld. Provide gas backing to the repair area by the same procedure as outlined for welding chromoloy.

All the engine parts fabricated from these alloys are welded with inert-gas tungsten arc, using dc, straight polarity. The electrode should be 1/16-inch diameter tungsten, two percent thoriated, and ground to a point. The torch gas should be argon, adjusted to 10-15 cubic feet per hour. Refer to the TO in selecting the filler rod to be used with each alloy engine part. Adjust the current for metal thickness as listed below:

Up to 0.045	30-40 amperes
0.045 to 0.065	50-60 amperes
0.065 to 0.090	60-80 amperes
0.090 and up	60-80 amperes (multipass)
Castings	60-80 amperes

Clean the filler wire immediately before use by wiping with acetone. Start the arc on a copper strip if the welding machine does not have a high frequency arc starting circuit. If you are making multipass welds, clean the bead after each pass. If welding from both sides of the repair area, grind or groove the root of the first weld to sound metal, acid etch, and inspect for cracks. Clean the area with a lint-free cloth soaked in acetone and polish with a stainless steel rotary brush before making additional welds. After all welding has been completed, polish the area with a stainless steel rotary wire brush to remove all oxides and scale. Inspect the area to insure that all cracks are repaired. Clean the repair area with acetone or benzine prior to returning the part to service.

### Aluminum Alloy

You must be trained and qualified to weld aluminum alloy engine parts. Clean aluminum alloy engine parts by vapor degreasing or wiping the front and back surfaces of the repair area with a lint-free cloth soaked in acetone or benzine to remove oil or grease. Paint, dirt, scale, or carbon deposits must be removed from the front and back surfaces of the repair area by using a stainless steel rotary wire brush. Remove all chemical or anodic protective coating from the front and back surfaces within one-half inch of the weld area, using #160 or #180 grit emery roll, disc, or sheet. Inspect the front and back surfaces of the repair area to determine the exact location and extent of cracks.

Completely groove out all cracks except through cracks. Groove to approximately 1/8 inch beyond the ends of cracks. Use a carbide or high-speed rotary steel rotary file to groove out cracks. Do not use grinding wheels. When cracks go completely through the part, they should be grooved out as indicated: up to 0.045 inch, 50 percent of metal thickness; 0.045 to 0.090 inch, 75 percent of



metal thickness; and 0.090 inch and thicker, to 0.030 inch of the back surface. Groove the back surface of the weld area to blend any sharp edges, resulting from through cracks, to smooth contours.

After the cracks have been grooved, acid etch the repair area, using an etching solution consisting of water and 5 percent (by volume) of sodium hydroxide. Apply the etching solution to the area with clean cotton swabs. Permit the etching solution to remain on the area for 50 to 60 seconds; then wash the area thoroughly with water and dry with a clean lint-free cloth or filtered compressed air. Reinspect the repair area to be certain that all cracks have been removed. If any cracks are in evidence, they must be grooved out and etched before the welding is started. The back surface of the repair area should be protected with shielding gas, using the same procedure as for chromoloy.

The welding machine should incorporate a foot-operated current control device. The process for welding aluminum engine parts is inert-gas tungsten-arc, using ac with high frequency. The electrode should be two percent thoriated tungsten, 3/32 to 1/8-inch in diameter. Use argon for the torch gas, adjusted to 10 to 15 cubic feet per hour; however, if increased penetration is required, helium may be used. Use filler rod as designated for aluminum engine parts in TO. Use a 1/16- to 1/8-inch diameter filler rod, depending upon the size of the crack to be welded. The current can be adjusted to the approximate setting by the following formula: for metal thickness up to 1/8-inch, use 1000 amperes times the metal thickness. Example: 1000 x 0.045 inch metal thickness equals 45 amperes. For metal thicknesses 1/8-inch or greater, use 125 amperes. Reduce current 25 to 33-1/3 percent when you use helium torch gas.

Clean the filler rod immediately before use. If the filler rod is old, polish it with stainless steel wool to remove surface oxides. Wipe the filler rod with a lint-free cloth soaked in acetone.

When you make multipass welds, clean the bead with a stainless steel rotary wire brush after each pass. When you weld from both sides of the parent metal, groove the root of the first weld to sound metal and acid etch before inspecting for the exact crack location. After inspecting the area and identifying the crack location, clean the area with a lint-free cloth soaked in acetone or benzine before making additional welds. After all welding has been completed, inspect the complete weld area for evidence of cracks; if none are found, clean the weld with acetone or benzine prior to placing the part in service.

Note: Answer the questions at the end of this chapter on a separate sheet of paper.

QUESTIONS

- 1. What is the function of each of the following:
  - a. Transition Duct (Inlet Ports)
  - b. Combustion Liner



(1) Louvers

(2) Thimble Holes

c. Inner Combustion Casing

d. Outer Combustion Casing (Top Half)

2. The series TO for maintenance and repair of jet engines is the \_\_\_\_\_.

3. What are the two types of cleaning processes and give examples of each?

4. Why is a lead pencil not used to mark damaged areas on hot section parts?

5. Explain the preparation necessary for welding cracks on jet engine parts.

#### REFERENCES

1. TO 2J-6 Series, Field Maintenance Instructions.
2. TO 2J-1-13, Turbo Jet Engine or Gas Turbine Cleaning.



Metals & NDI Branch  
Chanute AFB, Illinois

3ABR53230-SG-604

## FILLET PATCHES ON JET ENGINE HOT SECTION PARTS

### OBJECTIVES

After completing this study guide and your classroom instruction, you will apply shop safety, good housekeeping and fire prevention measures while making fillet patches on jet engine hot section parts in accordance with the criterion checklist.

### INTRODUCTION

Fillet patches are not used in a major repair of a hot section component. However, there are many parts that can only be repaired by this method. An improperly applied fillet weld or patch can do more damage to a jet engine hot section than no repair at all.

### INFORMATION

#### MANAGEMENT OF DEFENSE ENERGY AND RESOURCES

In order to conserve some of our resources, do not use argon gas for back-up purposes. Use a copper back-up strip. After completion of the exercise return the copper strip to your instructor, for use by subsequent classes.

#### FILLET WELDS

Fillet patches are used on hot section parts to replace components, such as crossover tubes and heat shields of combustion chambers. These parts normally require replacement due to chafing wear at the crossover tube outlet because it has rubbed against the tube of an adjoining chamber.

Prior to repairing or replacing a fillet weld or patch, consult the appropriate TO to be sure that the repair is authorized.

#### JET ENGINE COMPONENTS

Field repair by fusion welding of cracks in steel parts in J-57 engines becomes a special problem. A large percentage of these parts are fabricated from 13 percent corrosion-resistant chromium steel which is susceptible to air hardening. The high temperature at which fusion weld repairs are made and the subsequent air cooling of parts from these temperatures usually result in an increase in hardness and a loss in ductility. Parts on which fusion weld repairs have been made have a tendency to crack because the steel structure has become unstable and highly stressed. The structures can be improved by reheating parts and controlling their cooling.

Most repairs on the J-57 engine will be made in the combustion section illustrated in figure 17. The combustion section is located in the "hot section" and starts at the aft end of the compressor section and extends to the end of the afterburner. It gets

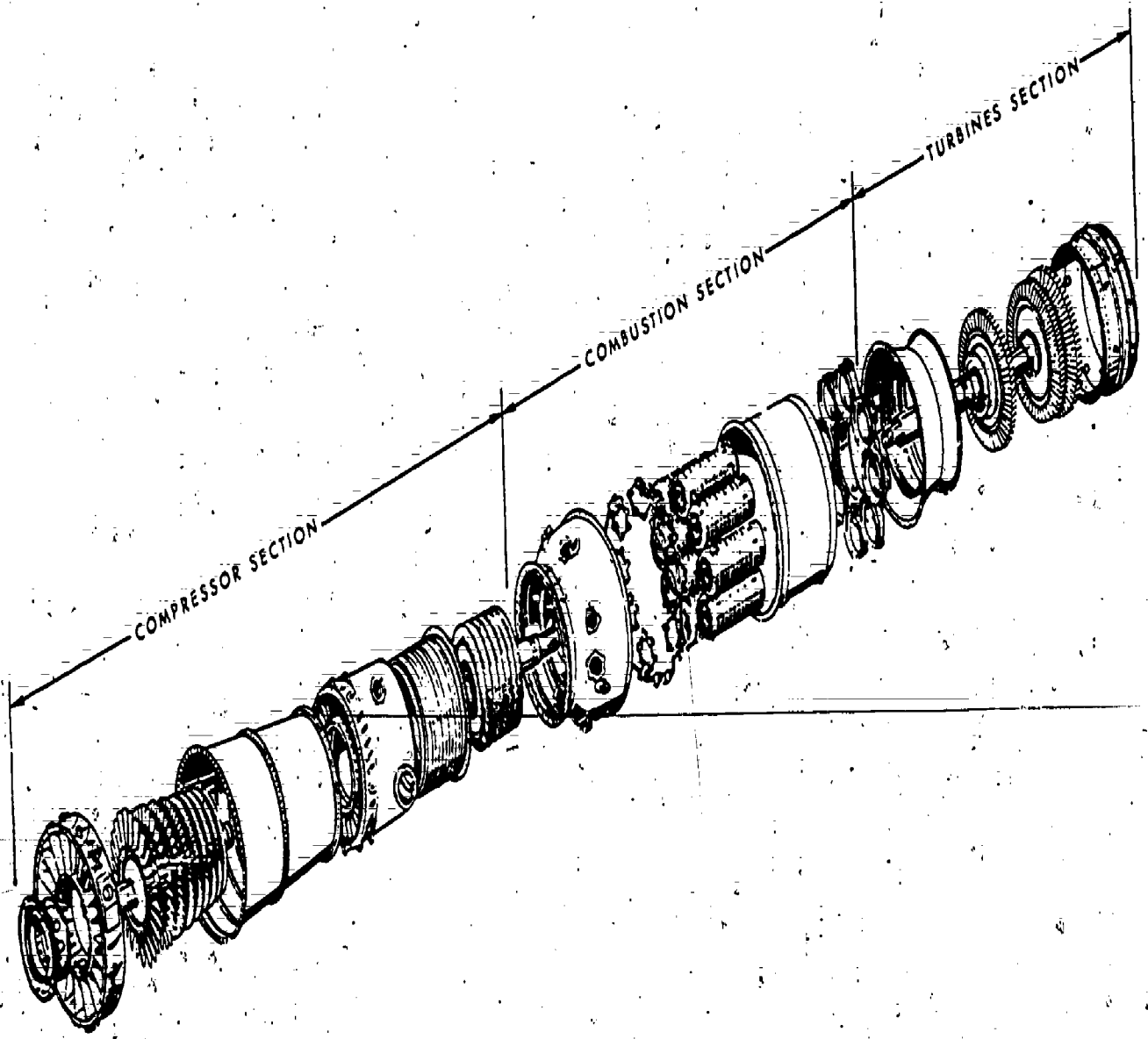

Figure 17. Exploded View - J-57 Engine.

the name combustion section because this is where the fuel is burned. As the fuel is burned, the temperature rises to approximately 5000°F and this causes great stress upon the metal, which eventually causes cracks. There are many repairs which may be made on a hot section, but before you can make the repairs, you must first clean the parts.

### CLEANING HOT SECTION PARTS

Cleaning is normally done on hot section parts prior to their arrival in the welding shop. There may be times when further cleaning is required. There are four types of cleaning you can use to remove corrosion or contamination.

#### Degreasing

Removing all oil or grease from parts is necessary to prevent contamination of cleaning agents during follow-up cleaning.

*EMULSION TYPE CLEANERS.* These cleaners are safe for all metals since they are neutral and noncorrosive.

*CHLORINATED SOLVENTS.* These solvents are usually used in the vapor condensate method. Parts degreased by this method are absolutely dry and if they are not to be subjected to further cleaning, must be sprayed immediately with a corrosion preventive.

*PETROLEUM SOLVENT.* These solvents may be used in a dip tank or as a spray. When used as a spray, they should be used in a spray booth that has positive ventilation to the outside. Although the flash point of these solvents is relatively high, proper fire precautions should be taken.

#### Decarbonizing

Engine parts which have carbon deposits may be cleaned by soaking in a carbon removing solution. Since carbon removing solutions are dangerous to skin and eyes, goggles, rubber gloves, and aprons should be worn by personnel handling these solutions.

#### Vapor Blasting

Vapor blasting is used to clean certain parts of hard carbon and lead deposits. This cleaning is normally done after the part has been degreased or put through a decarbonizing solution.

#### Soft Grit Blasting

This is also used to remove hard carbon or lead deposits. Many types of grit, such as ground corn, apricot or peach pits, walnut shells, clover seed, and cracked wheat may be used. Some types of grit leave a light greasy film on the part. This should be removed if you have to inspect it with a fluorescent penetrant.

### FILLET WELDS ON HOT SECTIONS

Welds on the J-57 engine, hot section, are made using the inert gas-shielded arc welding process. All the welding that is done on the hot section, however, is not guess work. There is a technical order which details the complete procedure for cleaning and repairing each part. The TO that pertains to the J-57 engine is TO 2J-J57-76.

The following repairs are just some of the repairs which require fillet welds on the hot section of a J-57 engine.

#### Combustion Chamber Fireseal Assembly

The fireseal assembly is made from AMS 5510, and all weld repairs on this weldment must be made by inert gas fusion welding using filler rod AMS 5680. Cracks occurring along the outer area of bolt holds cannot be repaired. This weldment must not be stress relieved.

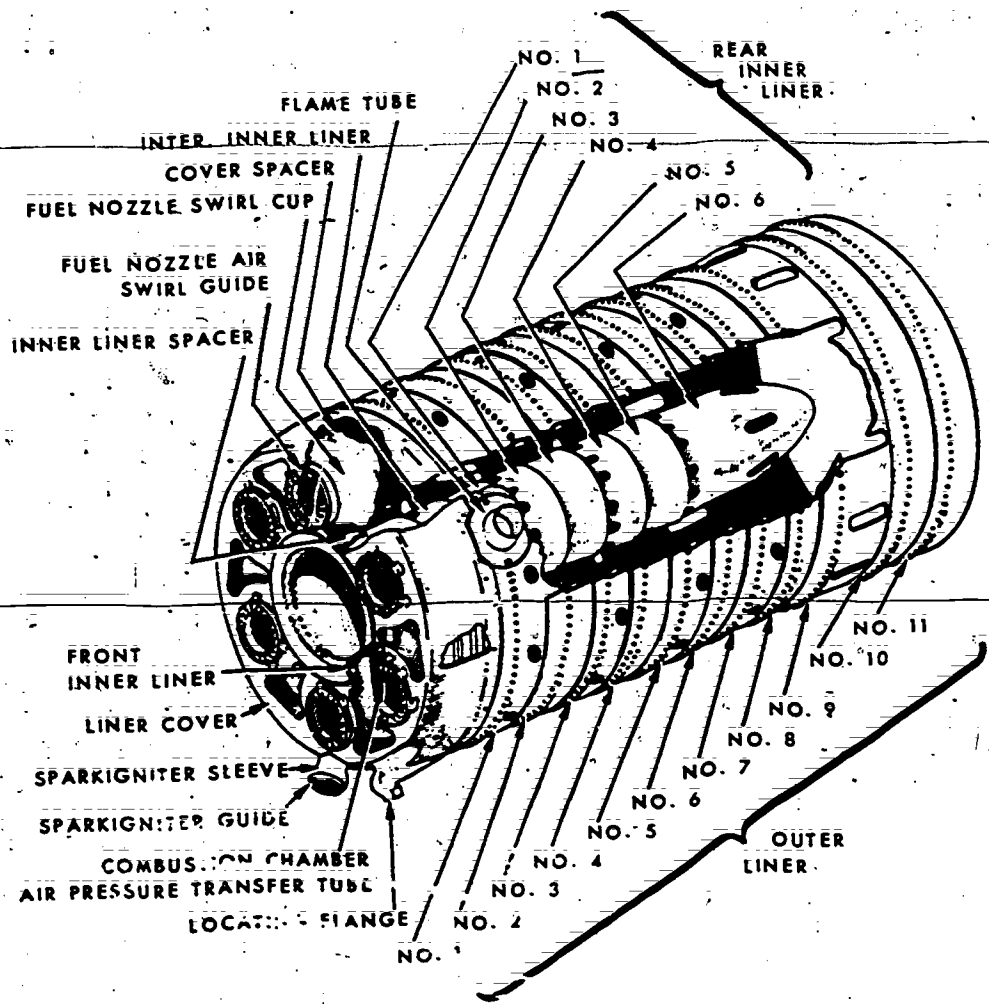

Figure 18. Combustion Liner Component Nomenclature.

## Combustion Chambers

The combustion chamber is located in the hot section, and its purpose is to ignite and produce complete combustion of fuel. This produces a temperature around 5000°F. The expansion and contraction caused by this temperature produced cracks in various areas of the chamber and must be repaired in accordance with TO 2J-J57-76. The nomenclature of the combustion chamber is shown in figure 18.

## Diffuser Case Weld Repair Installed on Engine

This procedure provides a method for authorized jet engine field maintenance activities to weld the diffuser case while it is installed on the engine. It should be used with discretion, since it will not produce a repair of the same quality as can be obtained by removing the case from the engine. This type of repair is restricted by the absolute necessity of not being able to remove the case.

Cracks up to a maximum of three inches long are repairable by inert gas fusion welding. Not more than one crack is permitted to be repaired at each strut location and no crack or repair is permitted at the gearbox tower shaft strut. "V" out the section to be repaired and weld with filler rod AMS 5680 or AMS 5681. Cracks cannot be repaired more than once. If a crack repair weld develops a crack, repair must be made at overhaul. All repairs to these cracks must be locally stress relieved at 550° to 660°F for one hour. The stress relieved area must overlap and extend three inches in all directions from the crack.

## Turbine Nozzle Assembly

Circumferential cracks (figure 19) not to exceed three inches in length and axial cracks not to exceed three-fourths inch in length are acceptable as long as normal progression will not result in a piece of metal breaking out. When breakout of a piece of metal appears likely, the piece may be removed as long as only one layer of metal is affected. Total accumulation of these cracks must not exceed 10 inches, and no attempt should be made to repair the part if the metal has deteriorated because of burning. Inert gas-shielding arc welding must be used on this assembly and stress relieving is not required.

Note: Answer the questions at the end of this chapter on a separate sheet of paper.

## QUESTIONS

1. When are fillet welds used on hot sections of jet engines?
2. After reading the appropriate TO, what is the first thing you should do prior to welding?
3. List four (4) types of cleaning used to remove corrosion and contamination.

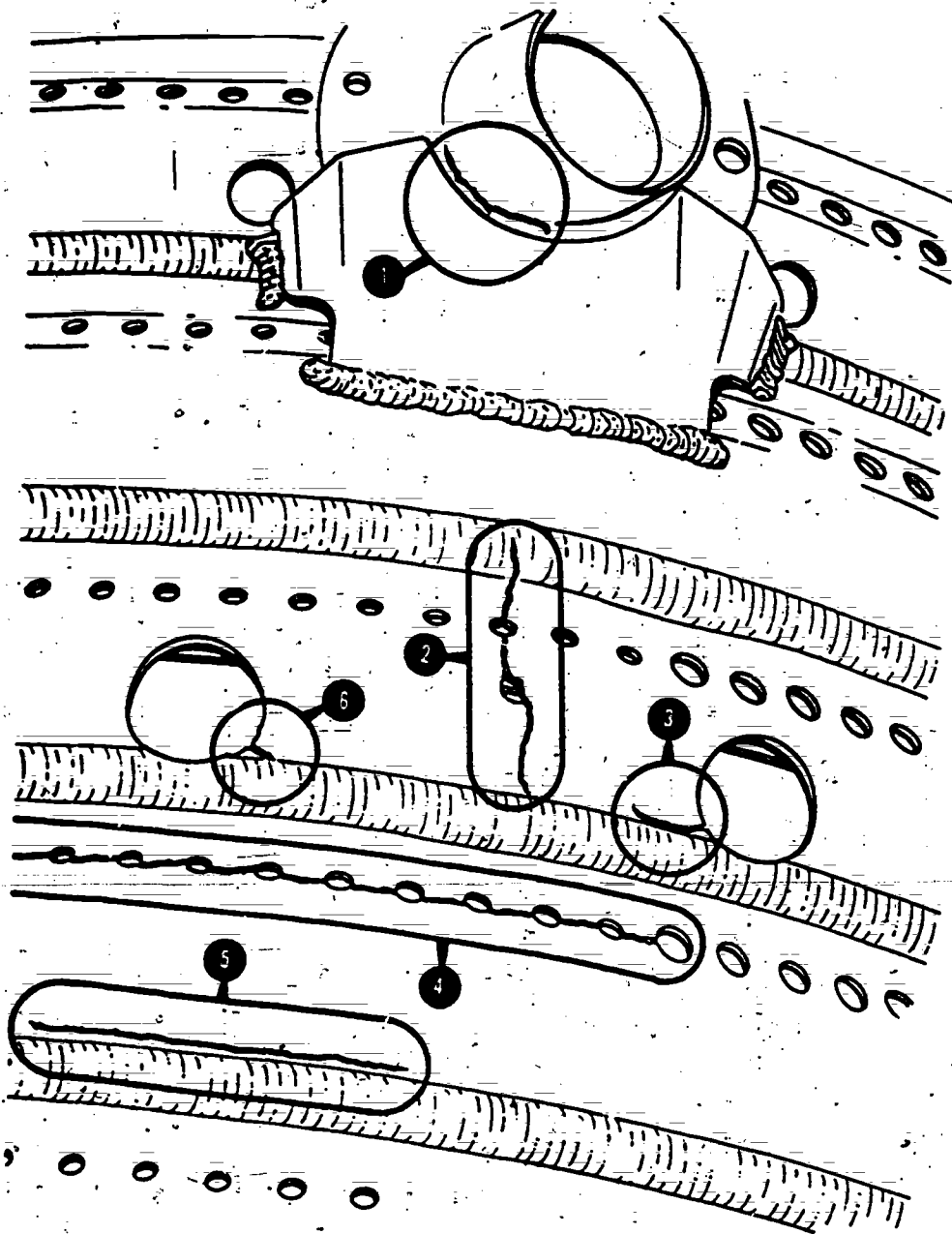

Figure 19. Circumferential Cracks in Outer Liner Material Adjacent and Parallel to Outer Liner Seam.

4. What is the main cause of combustion cracks in a combustion chamber?
5. Where are fillet patches most often used on jet engine hot section parts?
6. What is the purpose of the combustion chamber on the jet engine?

#### REFERENCES

1. TO 2J-1-13, Turbojet Engine or Gas Turbine Cleaning.
2. TO 2J-6 Series, Field Maintenance Instructions.



Metals & NDI Branch  
Chanute AFB, Illinois

3ABR53230-SG-605

## RECIPROCATING ENGINE EXHAUST MANIFOLD REPAIR

### OBJECTIVES

After completing this study guide and your classroom instruction, you will: determine cleaning methods, repair procedures and techniques, and the materials required for repair on reciprocating engine exhaust manifolds; apply shop safety, good housekeeping and fire prevention measures while making weld repairs on reciprocating engine exhaust manifolds in accordance with the criterion checklist.

### INTRODUCTION

The use of welding in aircraft construction is now recognized as a most satisfactory means of joining both structural and non-structural parts and assemblies, depending, of course, on the type of materials, joint efficiency, cost, and other factors. There was a time, prior to World War II, when welding was not considered as being generally satisfactory for the light metals and was limited to as few applications as possible in the heavy or ferrous metals group. Today's designers and engineers have a different philosophy and take advantage of every opportunity to use welding in all its various forms. This philosophy may appear to apply also to the repair of aircraft parts and lead to the false conclusion that welding should be the standard method for joining anything and everything. It must be understood, however, that welding is not to be used as the standard fabrication method for any and all aircraft parts that fail or rupture. A high degree of prudence and common sense must be exercised in determining the applicability of welding and the appropriate process for a given job. Printed instructions appear in technical orders, commercial literature, Air Force manuals, and various welding reference books. These printed instructions, though, do not, and cannot, cover every circumstance with which you will be faced. This student study guide is concerned with some sources of information and some procedures you can use in determining weldability of aircraft parts.

### INFORMATION

#### MANAGEMENT OF DEFENSE ENERGY AND RESOURCES

When laying out the patch repair on the exhaust manifold, do so in such a manner as to fully utilize the specified area.

Layout patch on repair metal to cut waste down to a minimum.

#### FACTORS CAUSING MANIFOLD REPAIRS

Aircraft reciprocating engines have hot sections made of heat and corrosion resistant steel and inconel. These high temperature service parts must be weld repaired frequently. Exhaust manifolds are particularly subject to cracks and worn spots caused by high.



METAL	ALLOY ELEMENTS %	PRINCIPAL AIRCRAFT USES	WELDABILITY BY METHOD					
			GAS	ARC	SPOT	INERT-GAS ARC	SILVER SOLDERING	BRAZING
Pure Aluminum (Commercial)		Air Foils, Scoops, Tubing, Non-Stressed Parts	Good		Good	Good		
Aluminum Alloys	2.5 Mg, 0.25 Cr	Parts (Sheet) of Intermediate Strength	Fair		Fair	Good		
	Clad, 4.5 Cu, 1.5 Mg, 0.6 Mn	Stressed Skin High Strength Parts Exposed to Corrosive Agents			Good			
	5.6 Zn, 2.5 Mg, 1.6 Cu	Propellers, High Strength			Good			
	1.2 Mn	Low Stressed Parts	Good		Fair	Good		
	4.0 Cu, 0.5 Mg, 0.5 Mn	Structural Members, Rods, Bars, Angle, Extrusions			Good			
	5.7 Si	Castings	Good			Good		
Magnesium Alloys	1.5 Mn, Sheet	Ducts, Tanks, Interior Furnishings	Good		Fair	Fair		
	6.0 Al, 3.0 Zn, 0.2 Mn	Castings				Good		
	3.0 Al, 1.0 Zn	Tubing	Fair		Fair	Fair		
Ferrous Metals	0.50 Mn, 0.90 Cr, 0.20 Mo	Engine Mounts, Landing Gears, Struts, Tubing	Good	Good	Good	Good	Good	Good
Stainless Steel	18 Cr, 8Ni	Exhaust Stacks, Hot Section of Jet Engines	Good	Good	Good	Good	Fair	
Nickel Steel	3Ni, 0.30 C	Bolts, Rods, Struts	Good	Good	Good	Good	Good	Good
Chrome-Nickel-Moly	Up to 6 Cr, Ni, Mo	Used as Substitute For Chrome-Moly	Good	Good	Good	Good	Good	Good
Inconel	78 Ni, 14 Cr, 8 Fe	Exhaust Stacks and Surfaces Exposed to Hot Gases	Good	Good	Good	Good	Fair	
Incoloy	0.04 C; 13.0 Cr; 2.4 Ti; 42.0 Ni; 6.0 Mo; Fe bal	Combustion Liners, Cross Ignition Tubes				Good		
A-286	0.06 C; 14.8 Cr; 25.5 Ni; 1.3 Mo; 0.3 V; 2.0 Ti; 0.003 B; Fe bal	Turbine Nozzle Frame, Stator Assembly		Good		Good		
Chromoloy	18 Cr; .04 Mn; 80 Cr; .80 Mo; .08 V	Compressor Stator Frame and Rear Casing				Good		

Table 1. Weldability of the Common Aircraft Metals.

temperatures and excessive vibration of the engine. These hot section parts are also subjected to continuous heating and cooling which, of course, causes repeated expansion and contraction. These severe operating conditions introduce stresses that result in cracks around welded fittings, holes, lugs, clamps, and open-end sections. Frequently, a section of an exhaust manifold is burned so severely that part of it must be cut out and a butt or lap patch welded in place. This study guide is concerned with repair problems and procedures common to these hot sections of aircraft reciprocating engines.

## WELD REPAIR

### Examination of Parts

The construction of an aircraft part should be examined in reference to its ability to carry structural loads. If, for instance, it was riveted in the initial construction, there is a good possibility that it is heat treated or nonweldable or both. If welding was used in its fabrication, then there is a good possibility that it can be safely repaired by welding. This, of course, will be governed by any heat treatment or cold working that might have been given the part after the welding used in its construction was completed. If the part is joined to its supporting fittings by sheet metal screws or snap-type fasteners, or by any other low stress device, that fact should be noted as it indicates that the part was not designed to carry heavy loads. The probability that it has not been heat treated or cold worked is good, therefore, welding may be entirely satisfactory.

In the final analysis, technical orders must be used to dispel any doubt. In some cases, it may be necessary to research the Air Force, military, or federal specifications before you are absolutely sure of the correct procedure to follow. In such a circumstance, by all means be sure. The time spent in research is unimportant compared to the cost and the tragedy that might occur should a welded part fail in flight.

Table 1 lists the principal metals used in aircraft construction and an adjective description of their weldability by the several welding methods. This table can be used as a guide only, as many metals with excellent weldability become nonweldable through heat treatment, plating, cold working, or by the type of service to which they are subjected.

You may arrive at the identification of metal used in the construction of an aircraft part by one of several methods. Visual examination may be sufficient. Technical orders, blueprints, and specifications may be necessary. The shop methods of grinding, chipping, hardness, and acid testing may also be necessary. No sure, short-cut formula for metal identification exists outside the laboratory. But welding success depends upon correct identification and that can be made by one of several methods or by the collective application of several methods. Don't attempt to weld repair an

Test	Purpose	Procedure	Results
Acid	To identify stainless steel from Inconel	Make solution of 100cc HCl and 10 gr $\text{CuCl}_2$ . Place a few drops on a clean spot; allow to stand for a few minutes. Add a few drops of water and wipe off solution.	If a copper spot shows, the metal is stainless steel. A white spot indicates Inconel.
Spark	To identify carbon steels and ferrous castings.	Have a sample of each known metal on a panel. Compare the spark of unknown with the known by testing on grinding wheel.	Metal can be identified by comparing: a. Length of stream. b. Color of spark. c. Shape of spark. d. Density of spark.
Flame	To identify magnesium alloy from aluminum or aluminum alloy.	Obtain a chip of metal from the fractured area to be repaired, making sure it is clean. Apply the torch to chip.	Magnesium will burn upon becoming molten. Aluminum "balls up" upon becoming molten.
Caustic Soda	To identify the non-heat-treated aluminum alloys from the heat-treated aluminum or the weldable from the nonweldable.	Obtain sample and place in a solution of 10% caustic soda and allow to stand for a few minutes.	The weldable will stay the same color. The non-weldable will turn black. Alclad core will turn black. (cross section).
Heat & Quench	To identify low carbon steel tubing from X4130	Heat sample to red heat and quench in water, then strike with a hammer.	Low carbon steel will bend or flatten out. X4130 will shatter.

Table 2: Shop Tests for Identification of Metals.

aircraft part unless you can identify the metals, since this determines whether it can be repaired and how to repair it.

Identification of Weldable Parts

The coming of the jet engine has introduced many new problems. Alloys used in its construction must be super metals to withstand the severe and prolonged service to which they are subjected. The very nature of the engine and its parts make precision welding necessary. No longer can we "suppose" that a given welding method is sufficient or that a given filler rod will do. Years of research and study of welding principles and techniques are used by laboratory technicians to determine the procedure and technique to use in repairing the new metals being manufactured. Repairs made by the welder must be as strong as welding can make it. It will not be that strong if we attempt to do a job without knowing all about it; its service requirements, its strength, its corrosion resistance, its composition and the effects that welding heat will produce.

Earlier we discussed the composition of metal as to its being ferrous or nonferrous and its original fabrication. After these simple facts are known, you should turn to technical orders and find the name and function of the part, where it is located, and establish its relative importance and service requirements. Knowing this, you should research the dash six (-6), Field Maintenance and Replacement Technical Orders, for any reference to the failure of that part. If directions are given, follow them to the letter. If none are given, then turn to the several shop methods of metal identification, shown in table 2. If it is aluminum, you can check it with the caustic soda solution, give it a hardness test, and establish it as pure or as an alloy. This same procedure applies, of course, to the ferrous metals. The spark and hardness tests will quickly establish their approximate composition and degree of hardness. In some cases, it may be necessary to weld a heat treated part and then reheat treat it. If this becomes necessary, you must be certain that the correct filler rod or electrode is used and that adequate facilities exist for the reheat treatment.

Blueprints are a source of information for identification of the part or assembly. They are, or should be, on file in the line maintenance or engineering office. The type of material, condition, and finish are indicated on the drawing. Suppose, for example, that the drawings specifies chrome-moly (4130) in the annealed condition. The fact that it is annealed is justification for welding repair, assuming, of course, that contrary directions for its repair do not exist in technical orders.

Hot section parts for today's jet engines are being made of various superalloy metals. Some of these are A-286, Chromoloy, N-155, L-605, Incoloy, and 321 Stainless Steel. These superalloys are being used due to the necessity for metals which can withstand intense heat and pressures of more than 10,000 psi (stress rupture) for long periods of operation at temperatures ranging from 1200°F to 200°F. The weldability of superalloys depend more on the individual alloy and its welding characteristics, than on the group to which they belong. The field maintenance and replacement technical orders should be your welding Bible in the repair of aircraft engines using high performance superalloys.



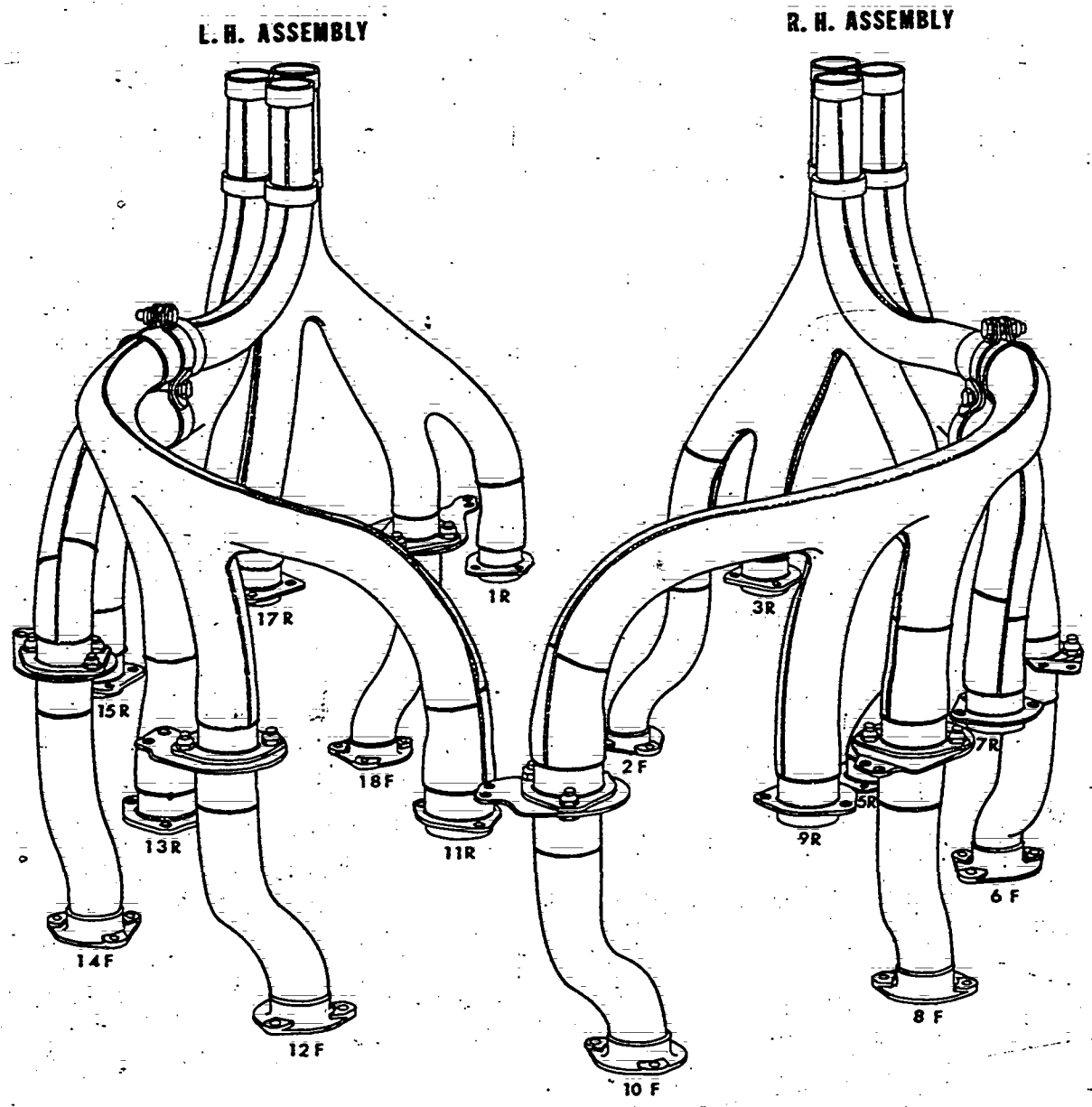

Figure 20. Engine Exhaust System Assembly, Complete.

The engine exhaust system assembly consists of two groups of trimese exhaust stack assemblies which are connected to port extensions on the front cylinders and directly attached to the engine exhaust port pads on the rear cylinders. The exhaust stacks are supported by figure-eight type clamps, as shown in figure 20.

### WELDING CRACKS IN EXHAUST MANIFOLDS

Although apparently simple, this is one of the most difficult welds to make. It becomes even more difficult if the crack leads to an open end that must telescope into, or over, another exhaust section. These cracks, of course, form butt joints. Penetration must



reach, but not exceed 100%, and the bead face must be flat without undercut. Welding on high temperature parts is further complicated by their oxidized condition and by a ceramic coating caused by the exhaust gases and prolonged heating. This coating makes the components very difficult to clean.

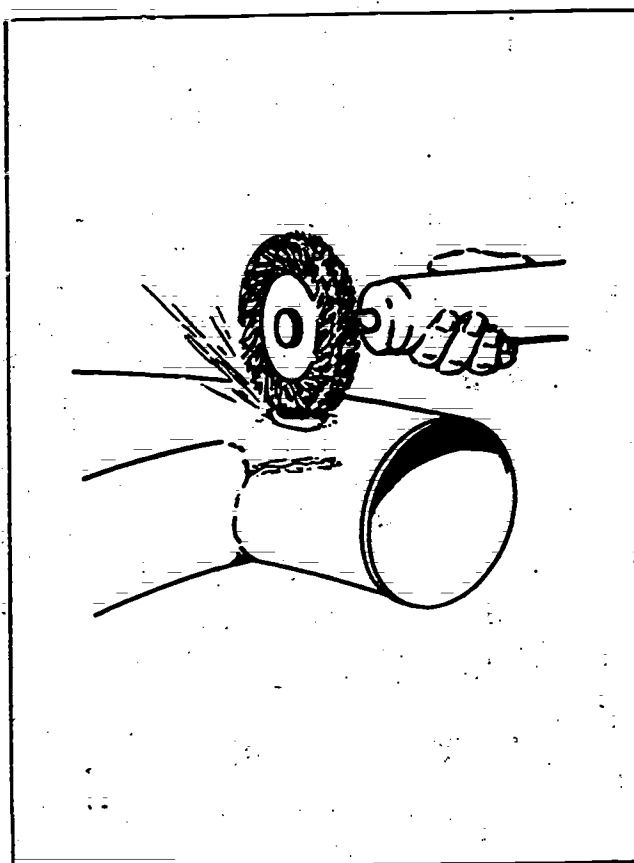

Figure 21. *Cleaning.*

To clean the components, you must soak them in a carbon removing compound. The parts must be soaked from one to five hours depending on the solution strength. The cleaning must be accomplished in a well ventilated area due to the toxic and irritating effects of the solution vapors. Rinse the parts with hot water, under pressure. If parts are not thoroughly clean, soak in a solution of caustic soda for one to three hours, then steam clean thoroughly and rinse in cold water. Clean the cracked area both inside and outside using a stainless steel brush or very light sandblast, as shown in figure.21.

Figure 22 illustrates the setup for welding cracks leading to an open end. The C-clamp is used to maintain alignment of the joint edges during tack welding. Sufficient spacing and sound tack welds are needed to minimize warping and overlapping of the joint edges during welding. To prevent oxidation, introduce back-up gas to the back edge of the joint. Tack welds are then made from the fixed to the open end and spaced about one-half inch apart. They must be sound, with 100 percent penetration and small, to permit easy, uninterrupted welding over them. Start at the fixed end and progress



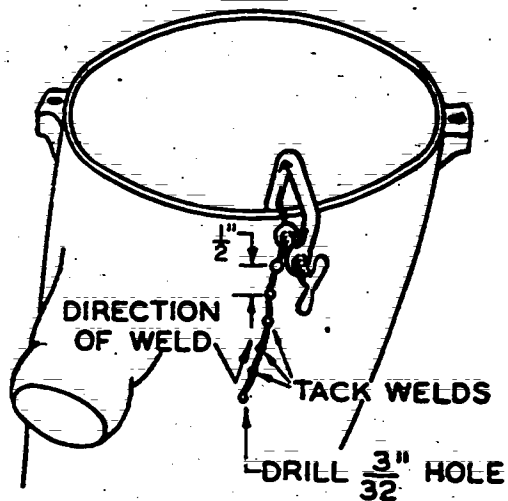

Figure 22. Set-Up for Open End Crack.

to the open end. Do not stop the weld before it is finished, as oxidation is likely to occur at the point of stopping and starting.

Where considerable welding has been done on the manifolds, residual stress may be relatively high. This condition, if allowed to remain, will cause cracks to reoccur in the stress area and particularly along the heat-affected zone adjacent to welds. This stress can be removed by heating the manifold unit to a temperature of 1900-2000 degrees F, and cooling slowly. This step is not considered necessary when only one or two short cracks have been welded.

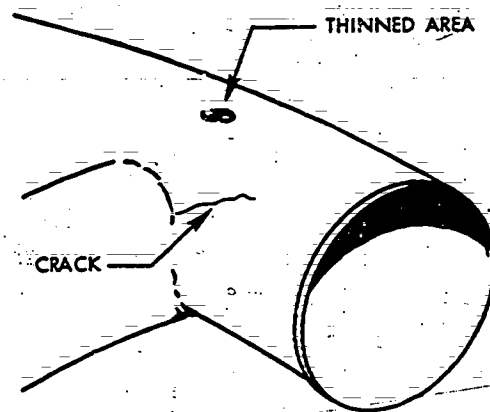

Figure 23. Damaged Part.

Figure 23 illustrates a damaged part which requires both a crack repair and a patch repair over the thinned area.

The crack must be cleaned both inside and outside whenever possible. The edge of the crack should then be leveled and tack welded



every half-inch before attempting final weld repair. To complete the final weld, start welding from the ends of the crack and work both ways toward the center. During the welding procedure, avoid overheating the material and keep the weld face flat or slightly convex on the welding side. Penetration of the weld should be, and not to exceed, 100 percent. Again, the applicable TO must be followed to assure proper post treatment of the weld and possibility of grinding the weld to meet specifications of the part for assembly.

### LAP PATCH

To repair a hole or a thinned area, a patch must be used. The TO will again give you the specifications you need for performing this repair.

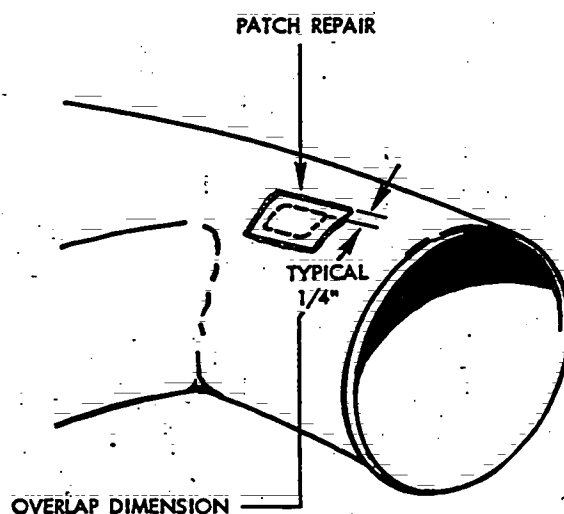

Figure 24. Patch Repair.

Cut away all the thinned area and smooth out the stack body material edges. Make sure the corners do not have less than one-quarter inch radius. Cut the patch 1/4-inch larger than the removed material, as shown in figure 24. Use the same gauge material as the original stack body is and formfit the patch to the contour of the stack body.

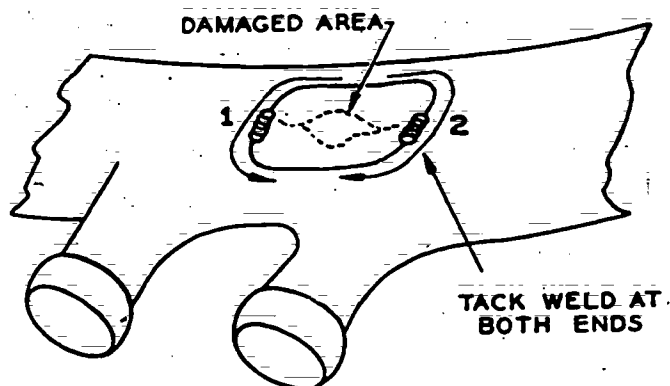
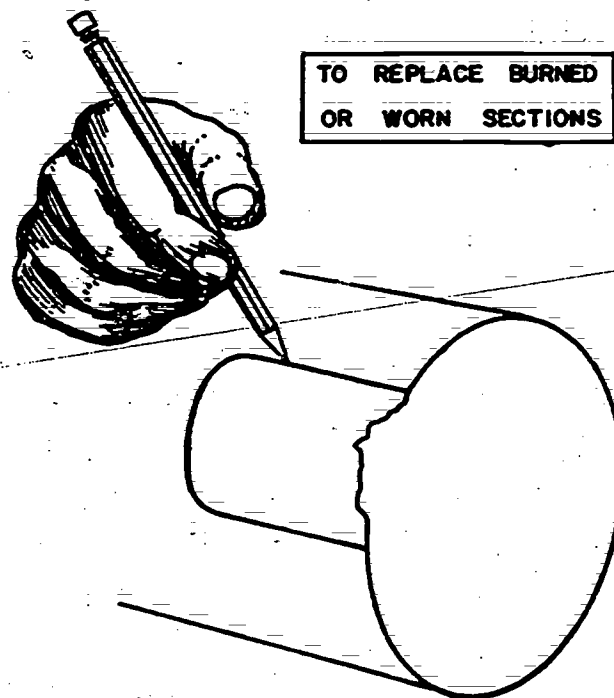

Figure 25. Set-Up for Lap Patch.

Set the patch in position and tack weld in two places, as shown in figure 25. Figure 25 also shows the correct welding procedure for a patch repair. Start at the center of edge not tacked and weld 180°, then go back to the start and weld in the opposite direction 180°, completing the weld.

### BUTT PATCH

This repair is quite simple, but, like welding cracks, requires careful preparation of the patch and the area of the manifold to which it will be welded. The extent of damage must be carefully determined in order to remove all the damaged area. The design of the patch will, of course, depend upon the shape of the section removed. In all cases, the inside corners of the section should be rounded to permit a more even distribution of stresses. As in all repairs on aircraft parts, the metal for the patch must be the same type and thickness as that used in the fabrication of the manifold.



*Figure 26. Layout of Section to be Removed.*

The outline of the section to be removed may be marked with a pencil, as shown in figure 26. The section is then removed with a hacksaw or welding torch. The welding torch method is a melting process rather than one of cutting. The flame should be directed toward the section being removed so that the excess slag will be blown onto the section to be discarded. A hacksaw will produce a smoother edge and should be used when possible. Finishing of the rough edges may be done with a file.

A template for the patch can be made by placing paper on light cardboard inside the manifold and tracing the cutaway area. The

template should then be cut 1/64 inch smaller on all sides to provide proper spacing. The patch is then cut to the shape of the template and formed to the proper contour in a slip roll former or by bending it over the horn of an anvil.

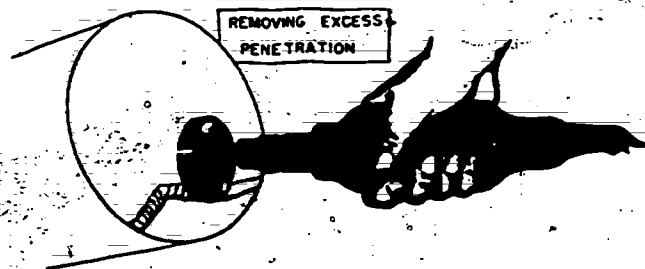

Figure 27. Pneumatic Grinder Used to Remove Excess Penetration.

In welding this patch, it must be uniformly spaced and properly tack welded. The spacing should equal the metal thickness on all sides to permit complete penetration and to limit distortion and residual stress. The first tack weld should be made at the back center of the patch and then tack welds are made alternately from side to side. "C" clamps can be used to hold the patch in position during welding. After tacking, the underside of the joint should be gas shielded, as in the preceding instruction on welding cracks, to prevent oxidation. The weld is then made in two steps by starting at the back center tack weld and welding continuously to the end of that half of the joint. The weld is completed by starting again at the back center tack weld and welding the remaining half. Welding from the back center to the open end in this manner helps to prevent cracks or stress in the weld area and possible loss of spacing caused by contraction of the weld metal. Again, excessive penetration or reinforcement should be avoided to permit the telescoping sections to fit properly. The weld face and excess penetration can be ground flush with a pneumatic grinder (14,000 rpm), as shown in figure 27. Grinding wheels, designed specifically for use on stainless steel, are available in many sizes.

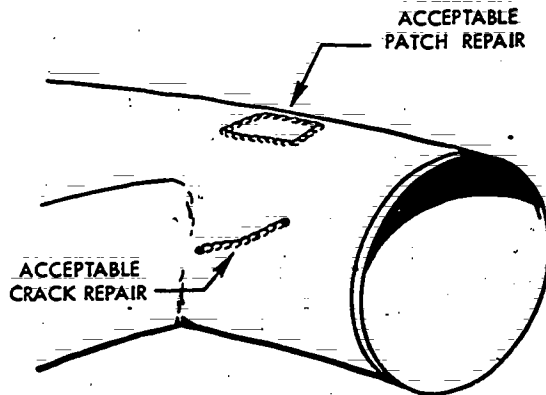

Figure 28. Acceptable Part.

Figure 28 shows acceptable repair of an exhaust manifold when done according to prescribed procedures.

### WELDING CRACKS

1. Make a saw cut (if no crack exists) from the end of a manifold to represent a crack.
2. Clean the inside and outside of the stack in the immediate area of the crack.



Figure 29. Drilling Hole in Preparation for Welding a Crack.

3. Locate the end of the crack and drill a small hole slightly (1/16 inch) beyond it, figure 29.
4. Align the edges and tack weld the joint.
5. Weld the crack, starting at the drilled hole and working forward to the outside edge. Make a flat bead to avoid excessive grinding.

### WELDING A LAP PATCH

1. Prepare a hole in a stack to receive a lap patch.
2. Cut a stainless steel patch of the same thickness as the rest of the stack, round the corners, and fit it to the contour of the stack. It should overlap the hole 1/4 inch.
3. Tack weld the patch in two spots, opposite of each other.
4. Weld the joint in two steps: (1) halfway around in one direction from center of the side not tack welded, then (2) in the opposite direction from the start point to finish the weld.

### WELDING A BUTT PATCH

1. Use a hacksaw or a welding flame to remove a simulated worn or damaged part of the stack.

2. Smooth the edges of the cut-out with a file and clean the area for welding.
3. Make a paper template of the cut-out area and use it to lay out a patch of the same thickness of stainless steel as the stack.
4. Roll or bend the patch to fit the contour of the stack.
5. Clamp the patch in position and tack weld it at the back center.
6. Make successive tack welds on alternate sides, 1/2 to 1 inch apart.
7. Weld the joint in two stages from the back center tack weld to the front edge in both stages.

You have now completed this section of the study guide.

Note: Answer the questions at the end of this chapter on a separate sheet of paper.

#### QUESTIONS

1. What is the first step when cleaning reciprocating engine parts? The second step?
2. Explain stop drilling.
3. What TO should be researched to decide a part's importance and service requirements?
4. Give four (4) superalloys that hot section parts are made of.
5. Why is mechanical cleaning discouraged when cleaning metal parts?

#### REFERENCES

TO 2RA Series, Engine Exhaust Assembly Systems.

Metals & NDI Branch  
Chanute AFB, Illinois

3ABRS3230-SG-606

## WELDING OF CARBON AND ALLOY STEEL TUBULAR ASSEMBLIES

### OBJECTIVES

After completing this study guide and your classroom instruction, you will lay out and fabricate tubular joints and assemblies and you will apply shop safety, good housekeeping, and fire prevention measures while welding tubular assemblies of carbon and alloy steel in accordance with the criterion checklist.

### INTRODUCTION

Tubular assemblies are used throughout the Air Force in maintenance stands, boarding ramps, and various places where the strength, light weight, and ease of construction of pipe or tubular assemblies would be advantageous.

### INFORMATION

#### MANAGEMENT OF DEFENSE ENERGY AND RESOURCES

Measure and lay out splices to keep waste to a minimum and reduce the number of hacksaw cuts required.

Tack weld and finish weld in rapid sequence so as to conserve oxygen and acetylene gas.

Fully use all welding rods within the limits of safety.

#### TUBULAR SPLICES

The initial step in the manufacture of an assembly is to make a plan or drawing showing the location of the various parts and where they are to be joined. In most cases, the drawing gives only the location and dimensions of the finished assembly.

Tubular members may be spliced by partial tube replacement used with internal or external reinforcing steel sleeves or by the use of an externally telescoping tube replacement of the next larger diameter tubing. Each type of splice has its particular advantage or function and the methods involved are essentially the same.

Two types of splice welds are permitted; the scarf and the fishmouth. The fishmouth, being the stronger of the two, is preferred over the scarf weld. However, the nature and location of the damage will determine which type must be used. Splices may not be made in the middle third of a tube section and only one partial replacement tube can be inserted in one section of a structural member. When new tubes are used to replace bent or damaged tubes, the original alignment of the structure must be checked and maintained.

The exact dimensions can be obtained from a blueprint of the part or by measuring the distance between points of corresponding members or undamaged, identical sections of the part. The strength of the repair must be equal to the original strength of the part. Maximum strength of the part can be assured by the selection of the proper type and size of materials, locating and dimensioning the sleeves properly and the application of proper welding procedures.

### CHROME-MOLYBDENUM ALLOY STEELS

Chrome-molybdenum alloy steels, commonly known and referred to as chrome-moly alloy steels, may be welded satisfactorily by all methods and processes. The oxyacetylene flame is generally preferred for welding thin-walled tubing and light-gage sheet, particularly where the metal cannot be backed up on the side opposite that from which the weld is to be made. For materials greater than 3/32 inch in thickness, the electric arc is preferred, because the heat zone will be narrower, and, as a result, heat stresses will be lower and the base metal less heat-affected. This is an advantage, especially where the part is too large to be heat-treated to relieve stresses produced by the welding operation.

The welding technique with the oxyacetylene flame is about the same as that required for plain-carbon steels. The area surrounding the weld, however, should be preheated to between 300° and 800°F, depending on the thickness of the metal; this is necessary, because a sudden application of flame without preliminary heating might cause the formation of cracks in the heated area. The flame should be directed on the metal at such an angle that preheating takes place ahead of the weld.

A copper-coated low-carbon welding rod is used for general welding of this metal with the oxyacetylene flame. Chrome-molybdenum or high strength-rods may be used for joints requiring high strength. The strength of parts welded with these rods can be increased by heat treatment after welding.

A soft (neutral or slightly carburizing) flame must always be used. An oxidizing flame burns the steel and weakens it and a weld made with this flame may crack on cooling if contraction is restrained. A highly carburizing flame makes the metal brittle and will also cause cracking on cooling. The volume of flame should be just large enough to melt the base metal and to obtain good fusion.

Overheating will result in severe stresses being set up and will cause excessive grain growth. This condition produces low strength in the welds and the adjacent area of the base metal.

The weld should be protected from the air as much as possible while hot, to avoid scaling and rapid cooling. When available, a jet of hydrogen directed on the metal from the side opposite to the weld will reduce scaling caused by oxidation and will add strength to the finished part by eliminating air hardening around the weld.



When fixtures are used to hold the part to be welded, they should be designed to allow a maximum amount of movement of the part. This is done to avoid distortion or cracking due to contraction as the metal cools.

### REPAIR OF TUBULAR STRUCTURES

Repairs to structural tubes consist of smoothing small nicks, scratches and dents; reinforcing cracked members; reinforcing dented areas; splicing damaged members; replacing damaged members when splicing is impractical; and correcting minor distortion. When inspecting for possible damage, the structure surrounding any visual damage must be carefully examined to insure that no secondary damage remains undetected. Secondary damage may be produced in some structure remote from the location of the primary damage by the transmission of the damaging stress along the tube. Damage of this nature usually occurs where the most abrupt change in load travel is experienced. If this damage remains undetected, loads applied in the normal course of operation may cause failure of the part. Some forms of damage to tubular structures may be considered negligible. Such damage may take the form of slight indentations, scratches, or minor bowing. Smooth dents not exceeding one-twentieth of the tube diameter in depth, without cracks, fractures, or sharp corners, and not in the middle third of the length of the member may be disregarded, except to satisfy appearance. Tubular members should be carefully examined for the presence of sharp nicks and deep scratches. These nicks and scratches produce stress concentrations that may cause failure of the part.

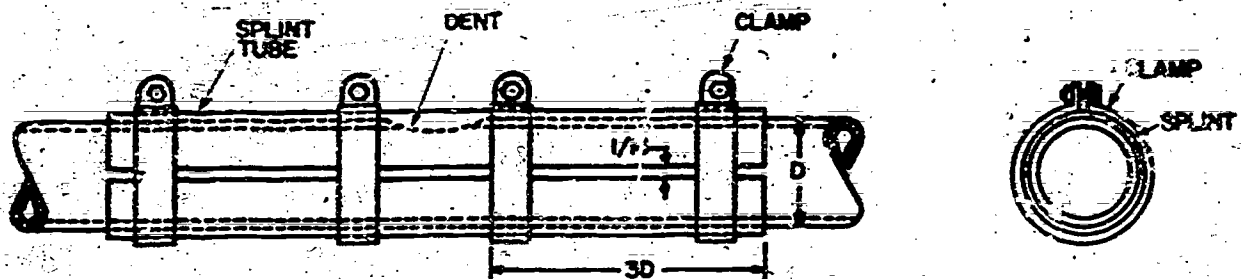

Figure 30. Reinforcement of Dent in Heat-Treated Tubular Member.

#### Sharp Dents or Cracks in Steel Tubes

If a crack or sharp dent is located in the length of a steel tube, it may be repaired with a reinforcement sleeve tube. Heat treated members are repaired by means of a split tube clamped in place over the damaged section, as shown in figure 30. The split tube must extend approximately three diameters beyond the edge of the dent or crack, and be of an equal wall thickness to the tube being repaired. The clamps must be secured sufficiently to prevent the clamps or sleeve from loosening in service.

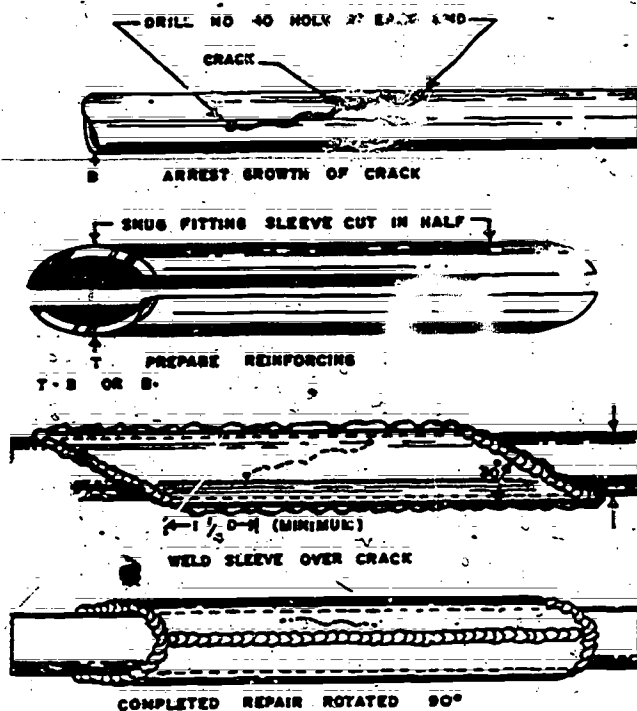

Figure 31. Reinforcing a Dent or Crack in Steel Tubing by Welding.

Dents or cracks in tubular members which are not heat treated may be reinforced as shown in figure 31. This method is satisfactory for short tubes or long members where the injury is not located in the middle one-third of the member. The reinforcing tube should have an inside diameter approximately equal to the outside diameter of the tube being repaired, and of the same wall thickness. The tube should extend beyond the damaged area not less than 1-1/4 times the tube diameter. The ends of the sleeve may be cut diagonally at both ends to a 30-degree angle or to a fishmouth form of cut. In the case of a crack in the damaged tube, a small hole should be drilled at each end to prevent spreading of the crack. The tube is then cut in half, placed over the damaged area, and then welded along the length of the two sides and each end, as shown in figure 31.

#### Outer Sleeve Repair

The damaged section of tubing is removed by a square cut across the tube. Removal of the tube is made so the welded sleeves will not be made in the middle third of the member. A stub end of sufficient length must be maintained to permit the proper positioning of the sleeve. A new tube is selected which is the same type of metal used in the original fabrication of the part. This tube must have the same outside diameter, wall thickness and length as the removed section. The maximum gap between the ends of the stub and replacement tube is 1/32 inch. All burrs are removed from the inside and outside wall of the stub and replacement tube to permit movement of the outer sleeves into position. To prevent corrosion on the inside of the the replacement tube, it is dipped into hot (165°F) raw linseed oil. The excess oil is wiped from the outside wall of the tube.

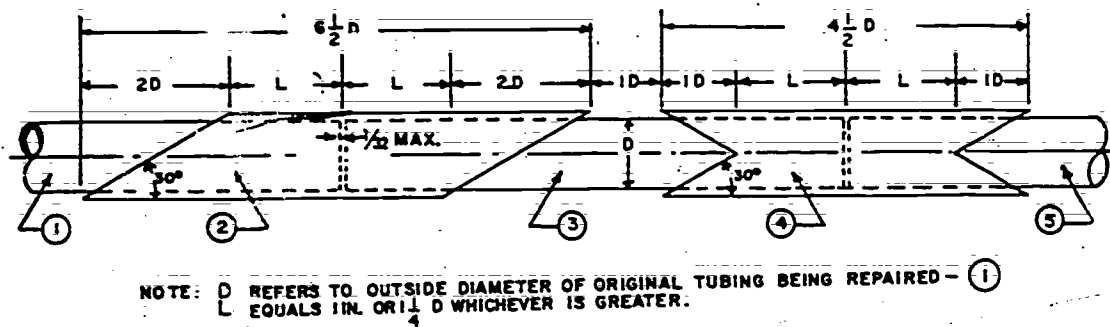

Figure 32. Dimensions of Scarf and Fishmouth Splices.

The outer sleeve splice, either the scarf or fishmouth sleeve, is fabricated to the specifications and dimensions shown in figure 32. Figure 33 illustrates the method used in positioning the sleeves to permit movement over the area they are to reinforce. The sleeves are telescoped over the replacement tube and the square ends of this tube are lined up with the original tube stubs. The sleeves are then moved over the center of each joint. Position the sleeves to telescope the inside tubes to proper dimensions and adjust the sleeve ends to provide maximum reinforcement.

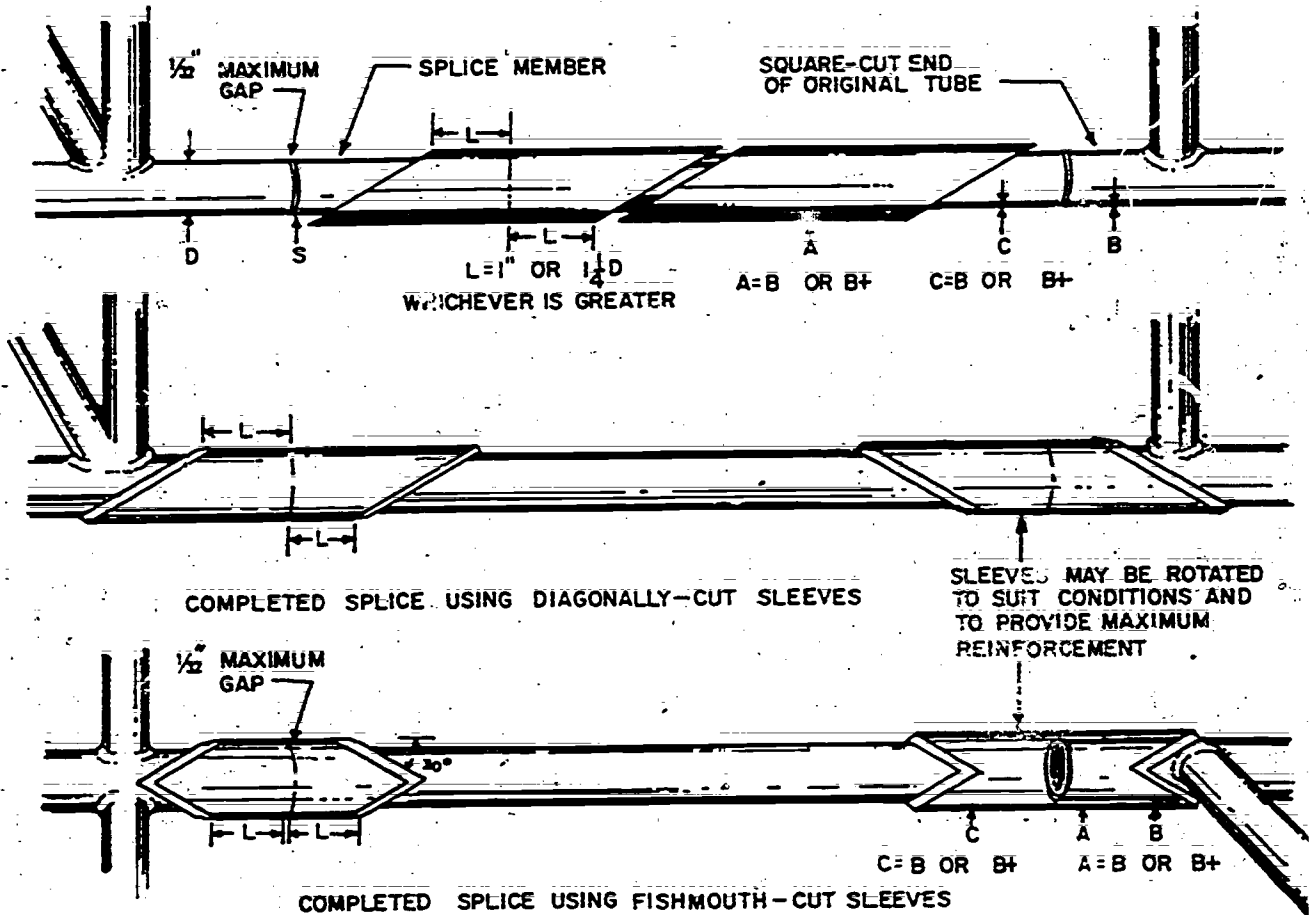

Figure 33. Steel Tube Outer Sleeve Splice Repair.

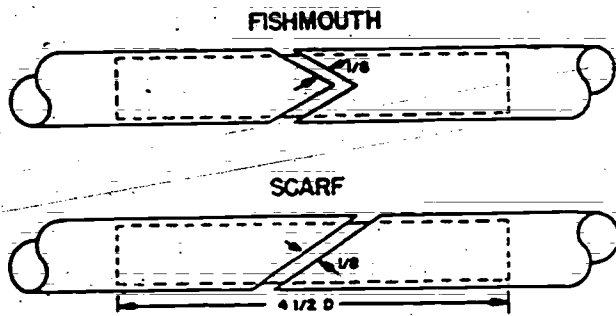

Figure 34. Scarf and Fishmouth Inner Sleeve Splices.

### Inner Sleeve Repair

The scarf and fishmouth inner sleeve splices, shown in figure 34, may be used where partial replacement of a damaged member is necessary. Although they are more difficult to set up than the outer sleeve splices, they must be used where the original outside diameter of the tube being repaired must be maintained. Splices of this type have about the same resistance to bending as the outer sleeve splices and will develop the full strength of the tube. The scarf inner sleeve splice is always used in preference to the fishmouth. The fishmouth ends require considerably more time in forming the ends of the stub member and the replacement tube. Welding of the fishmouth inner sleeve is also more difficult. The scarf inner sleeve splice is dimensioned and fabricated to the form shown in figure 35. The length of cut is the same as for the scarf outer sleeve, which is two times the diameter of the tube being repaired. This gives an angle of approximately 30 degrees. The length of the inner sleeve is  $4\frac{1}{2} D$ . When repairing a one-inch diameter tube, this permits the sleeve to extend the distance "L," which is 1 inch or  $1\frac{1}{4} D$ , whichever is greater, beyond the nearest cut of the scarf angle. To obtain maximum strength, the reinforcing tube, which is the inner sleeve, must be of the same wall thickness and have an outside diameter approximately equal to the inside diameter of the damaged tube. The maximum tolerance is  $\frac{1}{64}$  of an inch.

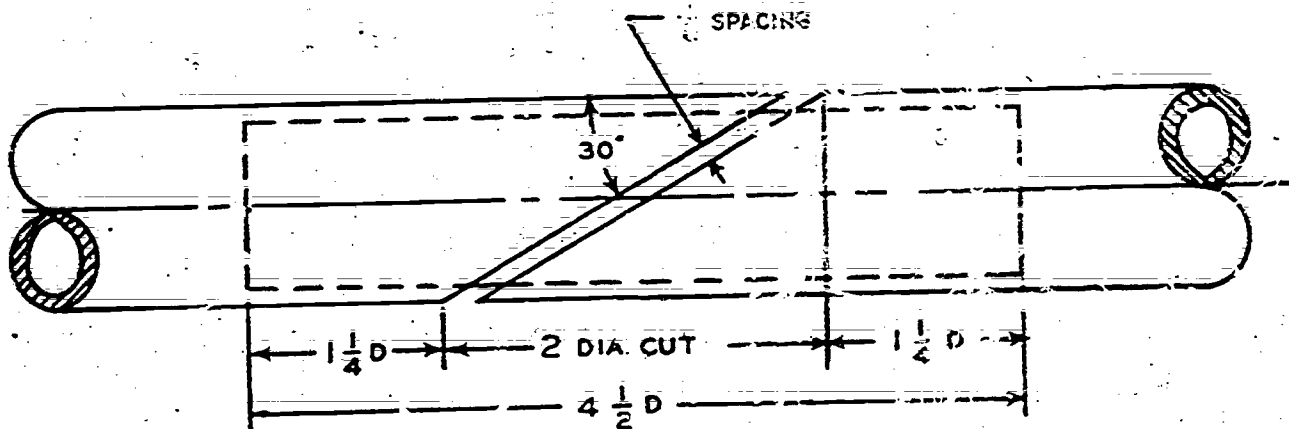

Figure 35. Scarf Inner Sleeve Splice Dimensions.

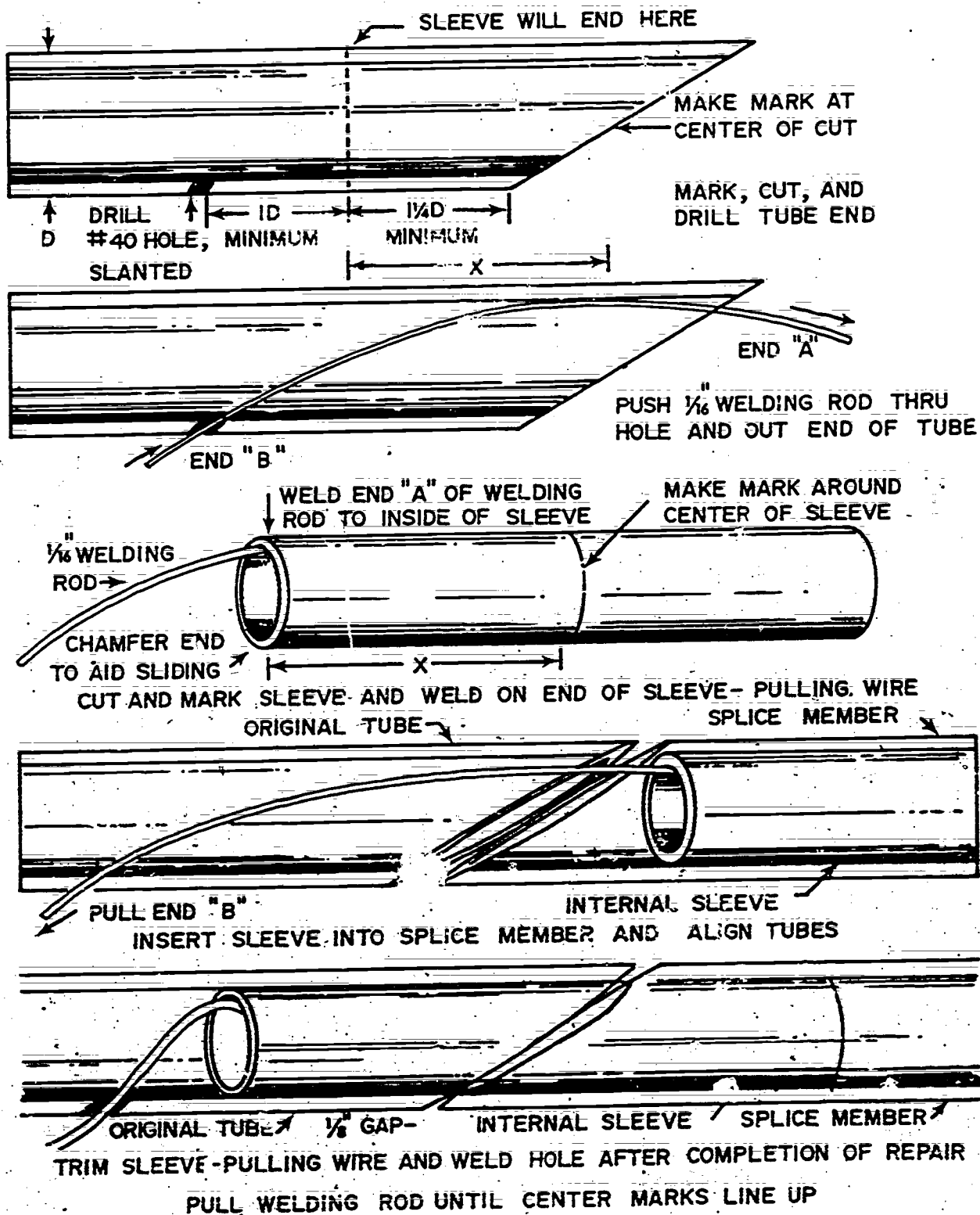

Figure 38. Centering Inner Sleeve in Stub and Replacement Tubes.

The damaged section of tubing is removed by cutting a scarf angle; locating the cuts away from the middle third of the damaged tube section. The burrs must be removed by filing to permit the tube to telescope the inner sleeves. The new section of tubing must be of the same diameter, wall thickness and length as the removed section of the damaged tube. At each end of the replacement tube, a scarf cut is made to the same dimensions as the stub members, allowing a 1/8-inch space between the scarf butt ends of the stub member and replacement tube. If the spacing is less than 1/8-inch at the scarf joint, fusion to the inner sleeve will not take place. The inner sleeve must be fused to the outer sleeve to prevent it from slipping away from the area it is to reinforce.

Figure 36 illustrates the procedure for centering the inner sleeve tube into the replacement tube at the scarf joint. The center of the scarf cut is located on the stub member near the edge of the joint. At a minimum distance of  $2\frac{1}{2} D$  from the nearest end of the scarf cut, center punch the tube and drill a number 40 hole. The hole should be drilled at an angle of 30 degrees to permit the sleeve-pulling wire to move freely with the inner sleeve tube. A length of 1/16 inch welding or brazing rod is then inserted into the hole and through the end of the stub tube. The wire is then welded to the inside wall of the reinforcing inner sleeve.

This inner sleeve should be chamfered and all burrs removed from the inside of the stub and replacement tubes to facilitate sliding the inner sleeve into position. The center of the sleeve is marked, as an aid in centering the sleeve into the scarf joint. The inner sleeve tube is inserted into the replacement tube 180 degrees from the drilled hole. If the fit between the two tubes is too tight, polishing the inner sleeve with emery cloth is necessary. Align the stub ends of the original tubes with the scarf angles of the replacement tube. Pull the exposed end of the sleeve-pulling wire until the center mark on the sleeve is directly in line with the center mark on the scarf cut, figure 36. The pulling wire is then bent sharply to hold the sleeve in position. A final check on the overall dimensions can then be made and one of the scarf tubes tack welded in position. The opposite end is free to move as the first point is being welded. The weld is made through the 1/8-inch spacing between the butt ends of the scarf joint. This first weld is then permitted to cool completely, making it possible to allow for contraction of the welds at the last joint. The section is then jacked apart 1/16-inch over the dimensions desired. The last scarf joint is tack welded and the jack and clamp removed to permit the section to expand and contract freely. Then the weld is made; upon cooling completely, the station will contract to the approximate desired dimensions. The sleeve-pulling wires are then cut flush with the surface of the tube and the holes welded.

#### SCARF SPLICE

1. Cut (hacksaw) a length of .058" wall tubing sufficient to splice a 7/8" OD tube. Allow an extra 1/4" for filing.
2. Remove all burrs.



3. Apply a coat of layout dye for a distance of two inches on both ends of the tube.

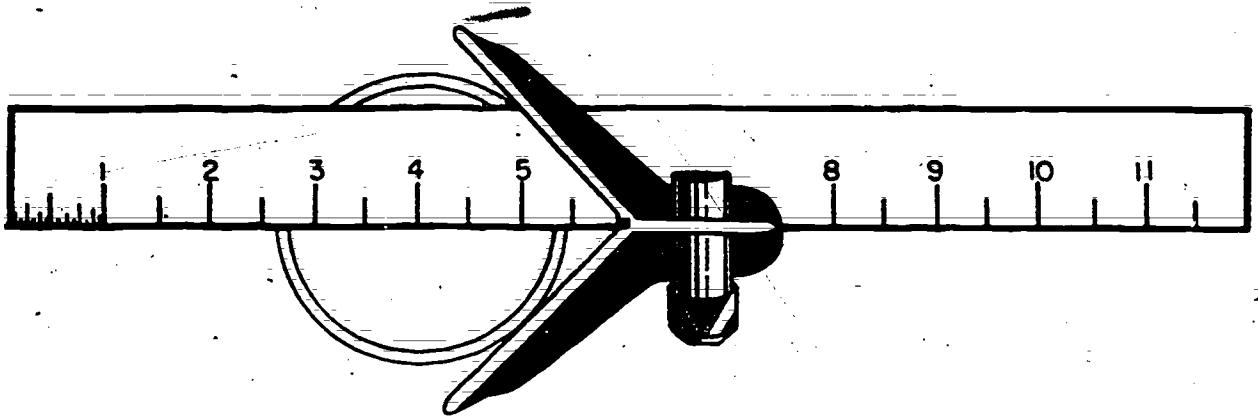

Figure 37. Scribing Round Stock with Centering Head.

4. Insert the 12" blade in the centering head and scribe the tubing wall at opposite (180°) sides, figure 37.

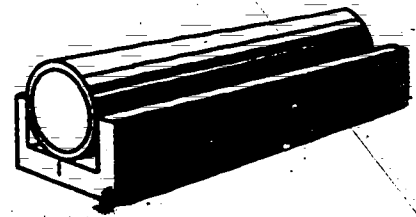

Figure 38. Aligning One of Marks on End of Tube with Top Edge of Block.

5. Place the tube in a centering block and align one mark on the end of the tube with the top edge of the block, figure 38. Scribe a line the entire length of the tube.

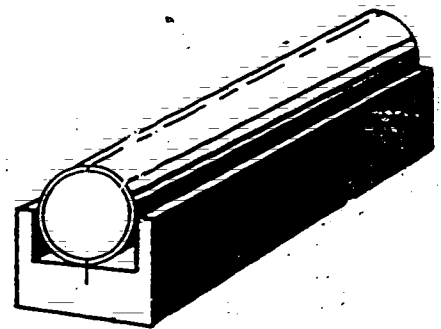

Figure 39. Aligning Mark on End of Tube with Mark at V at Bottom of Block.

6. Rotate the tube 90° or until one mark on the end of the tube lines up with the notch or V at the bottom of the centering block, figure 39.



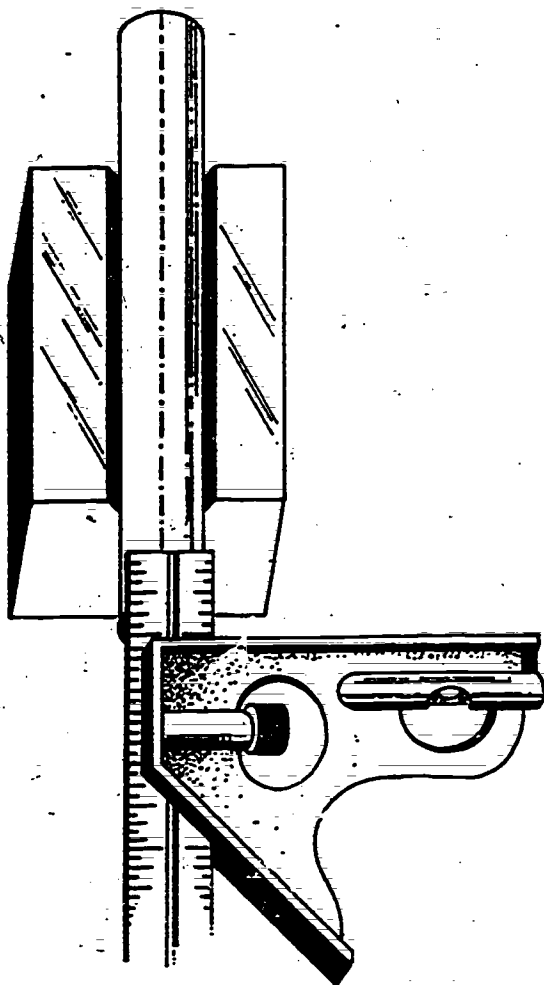

Figure 40. Scribing a Line at Right Angles to the Longitudinal Line.

7. Insert the 12" blade in the square head and scribe a short line one diameter from end of tube and at right angles to the longitudinal line, figure 40.

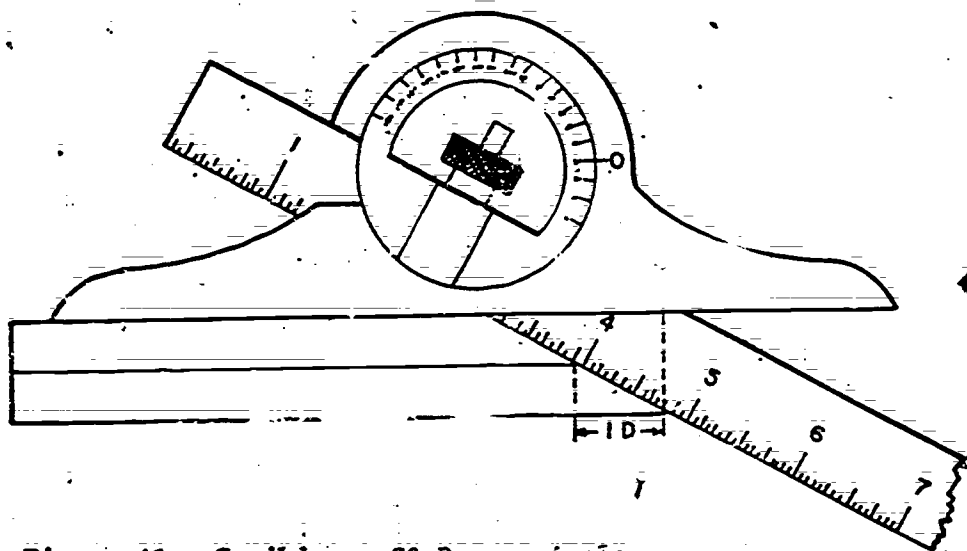

Figure 41. Scribing a 30-Degree Angle.

8. Insert the blade in the protractor head, set it at  $30^\circ$  and scribe a short line that bisects the  $90^\circ$  angle, figure 41.

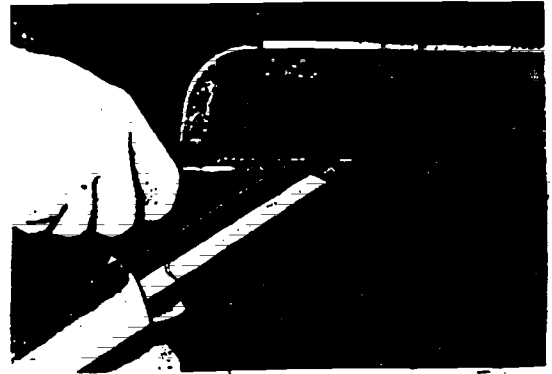

Figure 42. Cutting Tubing with a Hacksaw.

9. Place tubing in clamp and vise and cut the  $30^\circ$  angles, figure 42.

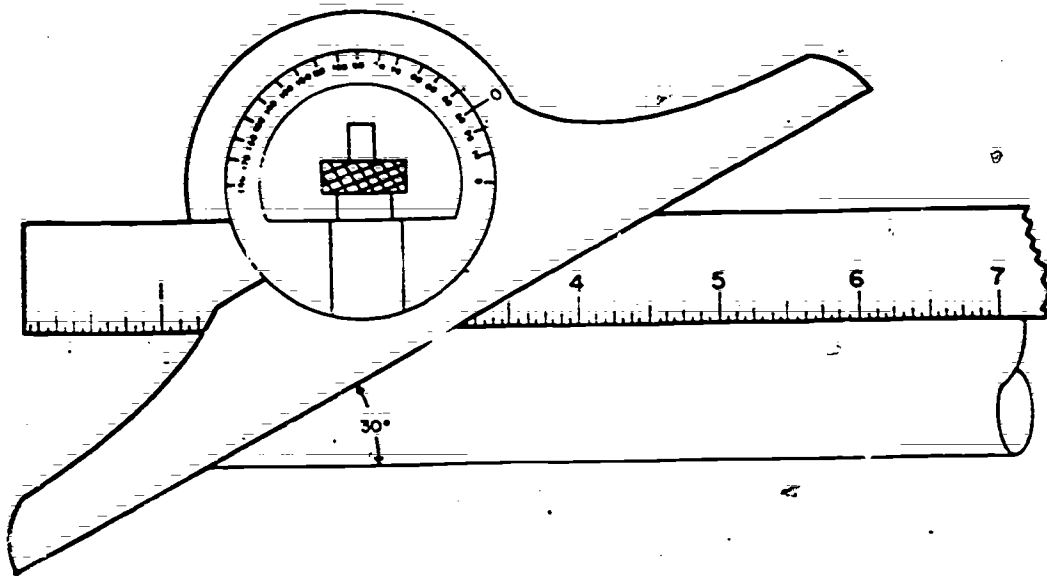

Figure 43. Checking Angle with the Protractor.

10. Check the angles with a protractor, figure 43, and file them to the correct dimensions.

#### FISHMOUTH SPLICE

1. Cut a rectangular piece of paper equal in length to the desired finished length of the splice and equal in width to the circumference of the splice.
2. Fold the paper into four equal sections. Unfold it and draw a line along each crease, figure 44.

FOLD THE PAPER INTO FOUR EQUAL SECTIONS AND DRAW A LINE ALONG EACH FOLD.

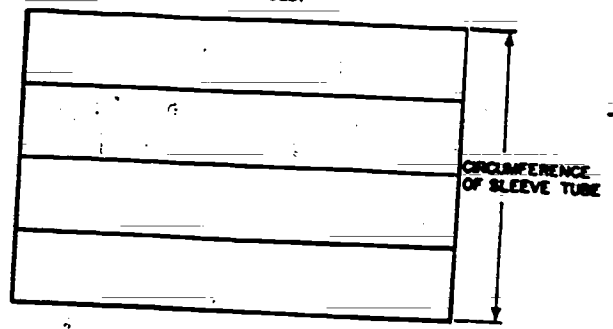
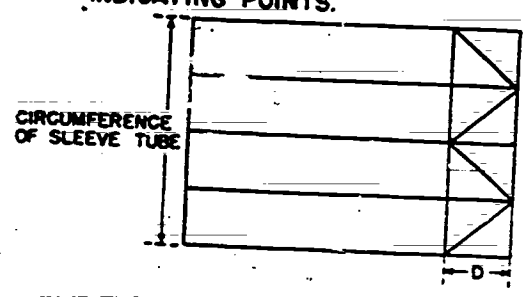

Figure 44. Making a Template, Step 1.

3. Draw lines at right angles to the creases and one diameter from each end of the template, figure 45. Connect the points as shown to form three equilateral triangles and two right triangles at each end.

DRAW TRIANGLE BY CONNECTING THE INDICATING POINTS.



"D" IS THE DIAMETER OF THE TUBE BEING REPAIRED

Figure 45. Making a Template, Step 2.

CUT AWAY THE AREA OUTSIDE THE TWO TRIANGLES.

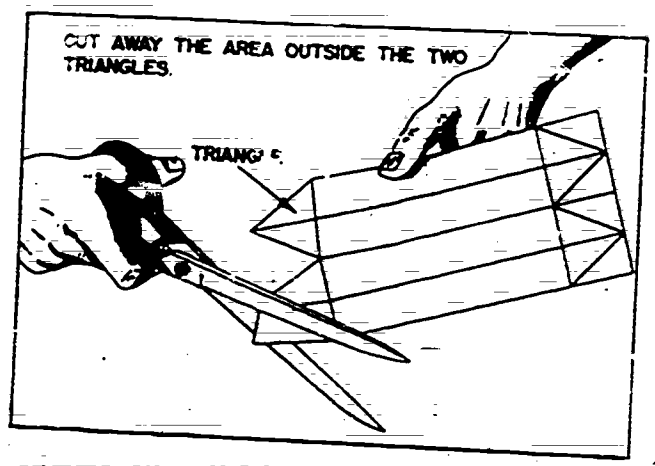

Figure 46. Making a Template, Step 3.

4. Cut out the two right angle triangles and the center equilateral triangle, figure 46.

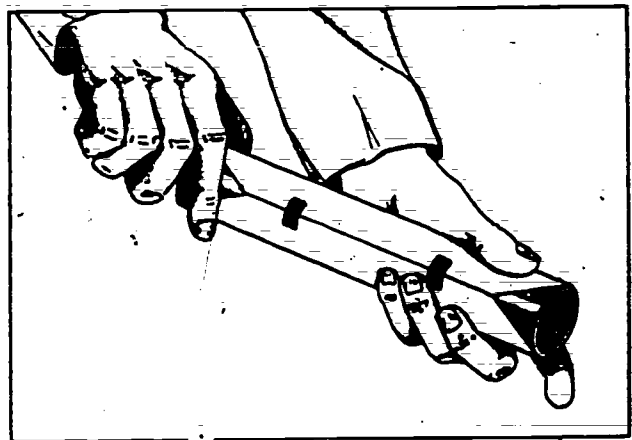
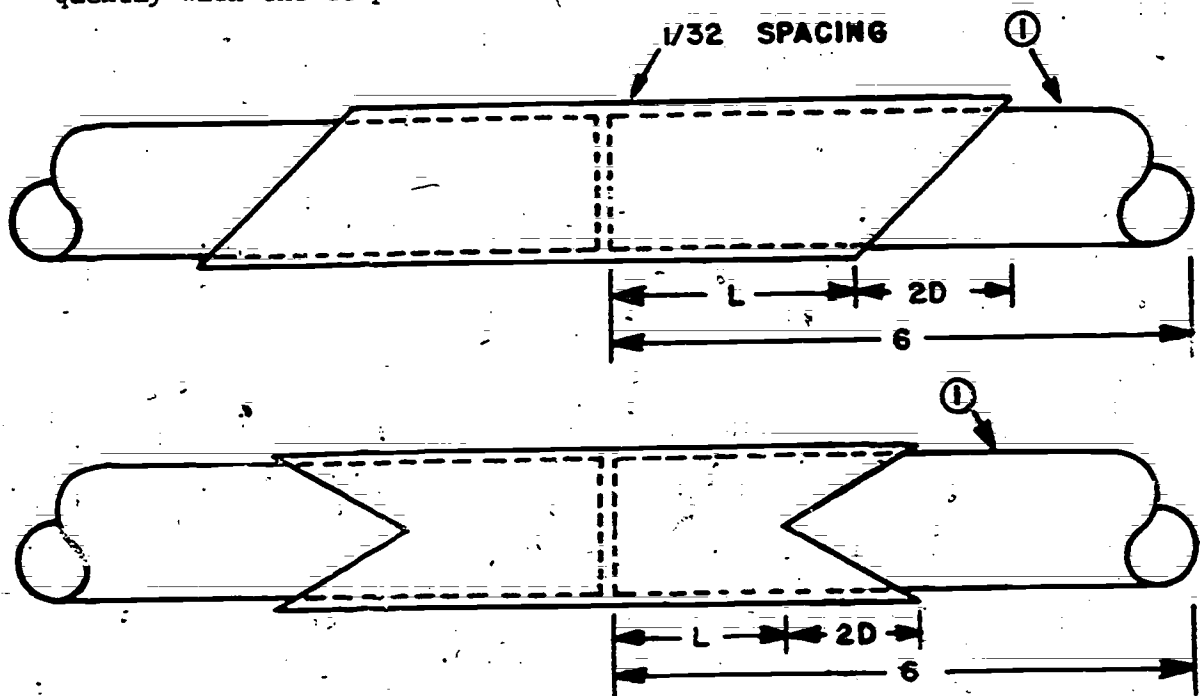

Figure 47. Wrap a Template Around Tube and Secure it with Masking Tape.

5. Wrap the template around the splice and secure it with masking tape, figure 47. Mark the tube with a pencil or by exposing the ends of the carbon or soot of an acetylene flame.

6. Remove the template, place the splice in a tubing clamp, and make four separate cuts on each end.

7. File the splice to correct dimensions, checking it frequently with the template.



NOTE: D EQUALS DIAMETER OF TUBE BEING REPAIRED—①  
L EQUALS 1 IN. OR  $\frac{1}{4}$  D WHICHEVER IS GREATER

Figure 48. Scarf and Fishmouth Outer Sleeve Splices.

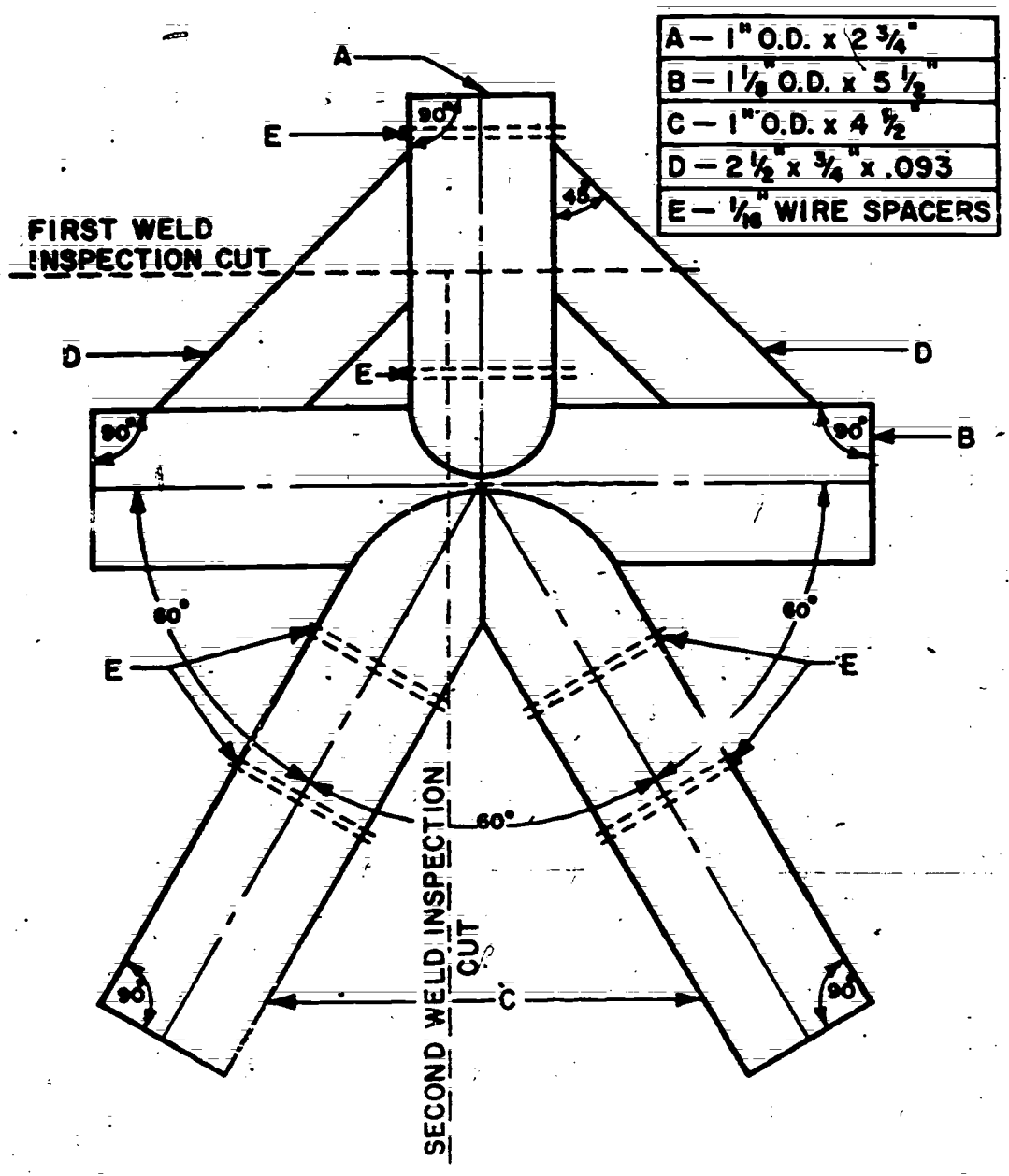

Figure 49. Station Joint.

### WELDING SCARF AND FISHMOUTH SLEEVE (Figure 48)

Note: Use sleeves fabricated.

1. Select four tubes 6" long of proper diameter which will telescope into the outer sleeve.
2. Position sleeves so as to allow 1/32" spacing between the square ends of the inside tubes.
3. Tack weld splices into position, making sure sleeves are properly aligned.
4. Weld splices in the flat position, rotating tubes for ease of welding.
5. Allow the welds to cool slowly to room temperature.
6. Remove all burrs from inside of tube ends. Your instructor will check the appearance of the welds and then tensile pull each to determine strength of each welded splice.

### STATION JOINT

1. Cut material for figure 49 with hacksaw.
  - a. 1-"A" tube 2-3/4" long.
  - b. 1-"B" tube 5-1/2" long.
  - c. 2-"C" tubes 4-1/2" long.
  - d. 2-"D" gusset plates - 0.93 x 3/8" x 2-1/2" long.
2. Square "B" tube at both ends to a 90-degree angle.
3. Square "A" tube at one end to a 90-degree angle. Rough grind the other end of tube to fit contour of "B" tube. Finish contour fit with a half-round file.
4. Square one end of "C" tubes at a 90-degree angle. Rough grind the other ends to fit contour of "B" and "C" tubes. Finish contour fit with a half-round file.
5. All tubing centerlines should meet at one central point to equalize the stress load on any one tube in proportion to size.
6. Gusset plates are cut at 45-degree angles on each end to fit angle of "A" and "B" tubes.

### Butt Welds

1. Clean and deburr the ends of the tube.
2. Align the tubing in V blocks, allowing about 3/64" spacing.

## A. PLAIN BUTT WELD

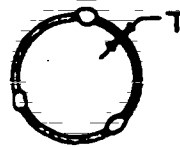
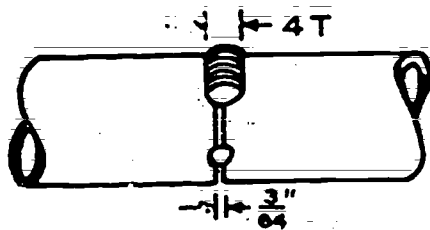

TACKING PROCEDURE

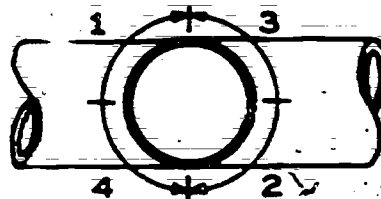
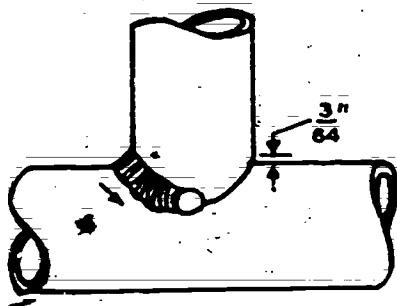

B. TEE JOINT

C. WELDING PROCEDURE, TEE JOINT

Figure 50. Butt and Tee Joint Weld.

3. Tack weld in three places indicated in figure 50.
4. Using forehand welding, carry the weld upward as much as possible.
5. After the weld is completed, check it for proper specifications and the tube for alignment.

## Tee Welds

1. Grind or file the end of one tube to conform to the curvature of the other tube. Be sure to remove all burrs.
2. After this joint fits within 1/16", set up and tack weld.
3. Follow the welding procedure for a T-joint, as indicated in figure 50.

## Station Joint

1. Place tubing in fixture and use proper tacking procedure to maintain tubular alignment. (Do not tack gussets in-place at this time)
2. Remove from fixture and use proper weld sequence to complete tube to tube structure.



3. Tack and weld gusset plates to tubing.
4. When joint has cooled, cut through inspection areas and prepare cut for acid etch.
5. Etch each cross section weld for penetration between tube and plate.

Note: Answer the questions at the end of this chapter on a separate sheet of paper.

### QUESTIONS

1. How should 4130 tubing be cooled after welding? Why?
2. What is the joint spacing for an outer fishmouth splice?
3. What is the proper angle to be cut when making all splices?
4. What is the correct length for a fishmouth splice?
5. How is the length of all splices determined?
6. When welding 4130, what is the correct flame used when oxyacetylene welding?
7. Why is chrome-molybdenum alloy steel tubing preheated before welding?
8. What will the result be if the tubing is overheated while welding?
9. How does a fishmouth splice differ from a scarf? Which is most preferred? Why?

### REFERENCE

TO 1-1A-1, General Manual for Structural Repair