

DOCUMENT RESUME

ED 191 149

EA 012 888

AUTHOR Gilmartin, Kevin J.  
 TITLE The Status of Women and Minorities in Education: A Social Indicator Feasibility Study.  
 INSTITUTION American Institutes for Research in the Behavioral Sciences, Palo Alto, Calif.  
 SPONS AGENCY National Center for Education Statistics (DHEW), Washington, D.C.  
 PUB DATE Apr 80  
 CONTRACT 300-70-0150  
 NOTE 80p.: Paper presented at the Annual Meeting of the American Educational Research Association (Boston, MA, April 7-11, 1980). Some figures may be marginally legible.

EDRS PRICE MF01/PC04 Plus Postage.  
 DESCRIPTORS Academic Achievement: Access to Education: Administrators: Annotated Bibliographies: Attendance: Curriculum: Data Collection: Elementary Secondary Education: \*Equal Education: Feasibility Studies: \*Females: Graduate Study: Higher Education: Literature Reviews: \*Minority Groups: Postsecondary Education: \*Social Indicators: Status: Student Motivation: Students: Teachers

ABSTRACT

The purpose of this report is to determine the feasibility of and need for a series of social indicator reports on the status of women and disadvantaged minorities in education, as students, teachers, and administrators. Further, it addresses questions concerning the form, issues to be covered, and data that should be used if such reports are created. The first section presents overviews of the past and present status of women and minorities in education. The overviews are followed by a discussion of various concepts of equality of educational opportunity and their implications for developing and presenting educational indicators in a social indicator report. The section introducing the conceptual frameworks to be used divides the subject matter into eight content areas (aspiration, enrollment, retention, resources, achievement, subject matter, teachers, and administrators), each with a set of related issues (research questions) and a focused literature review. The study discusses the data sources available and those that should be created. It ends with the recommendation that three reports on the status of minorities and two on the status of women be produced. (Author/IRT)

\*\*\*\*\*  
 \* Reproductions supplied by EDRS are the best that can be made \*  
 \* from the original document. \*  
 \*\*\*\*\*

ED191149



AMERICAN INSTITUTES FOR RESEARCH  
IN THE BEHAVIORAL SCIENCES

P.O. Box 1113, 1791 Arastradero Rd., Palo Alto, Ca 94302 • 415/493-3550

U.S. DEPARTMENT OF HEALTH,  
EDUCATION & WELFARE  
NATIONAL INSTITUTE OF  
EDUCATION

THIS DOCUMENT HAS BEEN REPRO-  
DUCED EXACTLY AS RECEIVED FROM  
THE PERSON OR ORGANIZATION ORIGIN-  
ATING IT. POINTS OF VIEW OR OPINIONS  
STATED DO NOT NECESSARILY REPRESENT  
OFFICIAL NATIONAL INSTITUTE OF  
EDUCATION POSITION OR POLICY

THE STATUS OF WOMEN AND MINORITIES IN EDUCATION:  
A SOCIAL INDICATOR FEASIBILITY STUDY

Kevin J. Gilmartin

Social Indicators Research Program  
American Institutes for Research  
P.O. Box 1113  
Palo Alto, California 94302

This work was done under Contract No. 300-78-0150 with the National Center for Education Statistics, Department of Health, Education, and Welfare. The content does not necessarily reflect the position or policy of either agency, however, and no official endorsement should be inferred.

April 1980

"PERMISSION TO REPRODUCE THIS  
MATERIAL HAS BEEN GRANTED BY

K. J. Gilmartin

2

An Equal Opportunity Employer

TO THE EDUCATIONAL RESOURCES  
INFORMATION CENTER (ERIC)."

EA 012 888  
ERIC  
Full Text Provided by ERIC

THE STATUS OF WOMEN AND MINORITIES IN EDUCATION:  
A SOCIAL INDICATOR FEASIBILITY STUDY

Context

In spite of the fact that education is funded largely by government agencies, it is still distributed relatively unequally among the United States population. Among individuals who reached the age of six shortly before World War I, the most-educated fifth received 30% of the schooling (measured simply as years in school), and the least-educated fifth received about 10% (Duncan, 1968). There has been less inequality of distribution of education in more recent cohorts, with the most-educated fifth receiving 27% of the schooling and the least-educated fifth receiving 14%.\* Of course, this inequality is less than inequalities seen in other sectors of society. Consider income distribution, for example; among family units, the fifth paid the highest income receives 45% of the aggregate family personal income and the lowest paid fifth receives only 5% of the family income. Nevertheless, inequality in education is particularly insidious because it perpetuates and accentuates class differences from one generation to the next.

The primary concern with equitable distribution of education, however, is not that all persons receive the same amount of education but rather that the distribution not be a function of irrelevant personal characteristics, such as sex and racial/ethnic group. The purpose of this feasibility report is to determine whether a series of social indicator reports on the status of women and disadvantaged minorities in education, as students, teachers, and administrators, can and should be produced, and if so, in what form, addressing which issues, and using what data.

---

\*It could be argued that the inequality with which education is distributed is understated because the unit is a grade completed. The cost of providing a year's schooling increases with the grade level, and therefore the inequality of distribution would increase if a dollar value were associated with each grade completed.

In this section on the context, overviews are presented of the past and present status of women and minorities in education. The overviews are followed by a discussion of various concepts of equality of educational opportunity and their implications for developing and presenting educational indicators in a social indicator report. In the section introducing the conceptual frameworks, the subject matter is divided into eight content areas (aspirations, enrollment, retention, resources, achievement, subject matter, teachers, and administrators), each with a set of related issues (i.e., research questions) and a more focused literature review.

#### Overview of the Status of Women in Education

Inequality of education between the sexes has been severest at the postsecondary level. During the first two centuries of higher education in the United States, women were simply barred from college attendance. From the founding of Harvard in 1636 to the opening of Oberlin in 1837, a woman could not attend college in this country (Graham, 1970). By the mid-1800s, some American colleges had begun to admit women to their classes, and other colleges were established exclusively for women. The impetus for higher education for women came from two sources. First, contemporaneous with the abolition movement, the ideological conviction that women were entitled to the same educational opportunities as men gained support. Second, the latter half of the nineteenth century was a time of dire economic need for many colleges because of shrinking enrollments. For this reason, college trustees and presidents began considering women as potential sources of tuition revenues that would permit colleges to remain open (Graham, 1970).

As indexed by mean grades completed, the sex differential in schooling has been modest throughout this century, and the direction of the differential has reversed over time. At the turn of the century, women averaged 0.3 more grades of schooling than men; in the cohorts born around 1915, the two sexes received equal amounts of schooling; by the time that the cohorts born in the 1930s had completed their educations, a difference in favor of men had increased to 0.4 grades (Duncan, 1968). Continuation ratios between successive grades have

been higher for females than for males in the elementary grades. Although less consistently, this has also been true for the secondary grades. There has been a consistent trend toward convergence of the continuation ratios for males and females at both grade levels, however. In contrast, continuation ratios into and throughout higher education have been higher for males, and until recently this sex difference had tended to widen over time.

By 1920, women constituted 47% of the undergraduates in the country and were receiving 15% of the Ph.Ds. These percentages were relatively constant until the late 1940s, when the proportion of 18- to 21-year-olds in higher education increased much more rapidly for men than for women. In 1940, 17% of the men and 12% of the women in that age group were enrolled in higher education; by 1950, 34% of the men and only 17% of the women were enrolled (Ferriss, 1969). Although the percentage of women receiving doctorates rose gradually from a low in the late 1950s and early 1960s, it has only recently surpassed the high attained in the late 1920s. Today, 43% of bachelor's degrees, 46% of master's degrees, 16% of first professional degrees (e.g., D.D.S., M.D., L.L.B.), and 23% of doctoral degrees are awarded to women (Brown, 1978a, 1978b, 1978c, 1978d). Much of the progress of women relative to men in higher education has occurred in this decade.

There are several explanations for the sex differences in higher educational attainment that have been observed in the United States over the last century.

First, it is argued, a family is more likely to invest in a son's education than in a daughter's, in the belief that the son must be able to find a job, but the daughter may not have to. Second, even if the daughter intends to work, most jobs open to her do not require a college degree: skills necessary for secretarial, clerical, and operative positions can be learned on the job. And third, so the argument goes, the daughter will undoubtedly get married and have children, and will in any case stop her education at that point. Indeed, marriage and childbearing have traditionally been considered sufficient reasons for women to terminate their schooling, though the parallel roles for men (husband and father) did not, in general, preclude a man from continuing to be a student as well. [Van Dusen & Sheldon, 1976, p. 108]

Cultural trends in the late 1960s and the 1970s are rapidly removing these causes of sex differences in educational attainment. Increasing numbers of women are the sole wage earners for their families or are economically independent. In 1973, 42% of women in the labor force were single, widowed, divorced, or separated, and another 19% of the female labor force were married to men earning less than \$7,000 annual income. Increasingly, women are facing the likelihood that at some point in their lifetime they will have to support themselves or contribute to the family income. Women are bringing more education to their traditional jobs and thus have made that additional training a requirement of the positions (e.g., most secretaries are now expected to have some college training), and in increasing numbers women have been challenging the barriers to traditionally male blue-collar jobs and therefore have had to acquire the prerequisite educational background for entrance. Finally, increasing numbers of women do not choose to abandon their educational careers upon marriage and the arrival of children (Van Dusen & Sheldon, 1976).

#### Overview of the Status of Minorities\* in Education

Whites born in the United States around 1900 received 3.1 more years of schooling on the average than did nonwhites born at the same time (Duncan, 1968). As indexed by mean grades completed, the white-nonwhite differential in attainment has narrowed appreciably during this century. For the cohorts born around 1930, the difference had decreased to 1.5 grades.

Until relatively recently, the sharpest differences between the continuation ratios for whites and nonwhites have occurred at the lower

---

\*The term "minorities" will be used to refer to disadvantaged ethnic and racial minorities: blacks, Mexican-Americans, Puerto Ricans, and American Indians. Other minority groups that do not appear to be educationally disadvantaged relative to white males (e.g., Chinese, Japanese) are not being considered and should be separated, when possible, from other nonwhite or non-Anglo groups in data analyses and reports. Unfortunately, many data sources have been disaggregated into "white" and "nonwhite". The educational status of nonwhites (because the category includes Orientals) tends to be better than the educational status of disadvantaged minorities.

grade levels. During most of this century, nonwhites were much more likely to drop out of school during fifth or sixth grades than were whites. It was not until 1960 that the largest difference in continuation ratios between whites and nonwhites occurred at as high a grade level as between twelfth and thirteenth grades (Duncan, 1968). However, the problem of the nonwhite elementary-school dropout continues to be acute in the South.

Measures of educational attainment, especially up through secondary education, indicate that differences between whites and blacks have been narrowing in recent years. In 1950, blacks completed a median of 8.6 years of education, with only 20% graduating from high school. By 1977, blacks were completing a median of 12.6 years of education (the national median was 12.9), and 75% were graduating from high school (the national average was 86%).

Large inequalities in the content and quality of the educational experiences of whites and blacks remain, however. More black students have low grade point averages in school than white students, and they are suspended more often and for longer spells than whites (Chadima & Wabnick, 1977). While on the average black children start first grade at an earlier age than whites, they tend to lose the advantage of their earlier start, drawing even with whites in terms of median grade placement at about age nine and then falling behind. By age 16, median grade placement for blacks is about a third of a grade behind whites. The main reason for this is that black children are about twice as likely as white children to repeat a grade. Among white 17-year-old males, 35% are either not enrolled in school or are enrolled below the modal grade; among black 17-year-old males, 57% are in this category (Ferriss, 1978). By age 18, the proportions of white and black males educationally below the modal grade level (including high school graduates who have not continued their education) increases to 52% and 82%, respectively.

#### The Concept of Equality of Educational Opportunity\*

Although there is wide agreement in the United States that our society accepts and supports the fundamental value of equal opportunity,

---

\*Many of the concepts in this section are described in greater detail in Coleman (1968).



when it comes to areas of specific application there is considerable disagreement over its meaning. Several alternative interpretations of the concept of equality of educational opportunity are advocated by various groups in the United States today. These alternative interpretations are not merely of academic interest. They lead to the advocacy of different educational policies and different standards for judging the current extent of educational equality and, in turn, to the use of different social indicators and analyses in social reports on the status of women and minorities in education.

In preindustrial Europe, the extended family, as the basic unit of social organization, had complete authority over the children and complete responsibility for them. A child's education or training was whatever seemed necessary to maintain the family's productivity. In that kind of society, the concept of equality of educational opportunity had no relevance at all. The fixed stations in life that most families occupied precluded any idea of opportunity and, even less, equality of opportunity.

With the industrial revolution, economic organizations developed outside the household, and children began to be occupationally mobile outside their families. The training that children received came to be of interest to all in the community, since the economic stability of the community depended on the types and levels of skills possessed by community members. Private education grew with the expansion of the mercantile class, but the idea of general educational opportunity for all children by means of public education arose only in the nineteenth century. In England, private schools run by churches were not supplemented by a state-supported system until the Education Act of 1870. The class system directly manifested itself through the schools. The state-supported schools became the schools of the laboring lower classes with a sharply different curriculum from the church-run schools, which served the middle and upper classes. Only the latter schools provided the curriculum and examinations that permitted admission to higher education. The United States, which did not have a strong traditional class structure, saw universal education in free public schools become widespread in the early nineteenth century. The public schools were attended by representatives of all classes and provided a common educational experience for most American children--excluding



only Indians and southern Negroes, who were without schools, and some of the poor who did not attend available schools.

In the United States, the first concept of equality of educational opportunity consisted of (1) providing a free education up to a given level, (2) providing a common curriculum for all children, (3) providing that children from diverse backgrounds attended the same school, and (4) providing equality of resources within a given locality, since local taxes supported the schools. This conception of equality of opportunity is still held by many, but there are some assumptions in it that are not obvious. First, it does not deal with inequality of resources across localities. Second, it assumes that the existence of free schools eliminates economic sources of inequality of opportunity. Many families could not allow their children to attend school beyond an early age, however, because their labor was necessary to the family. Economic sources of inequality of opportunity have now become small up through secondary education, but at one time they were a major source of inequality, and for higher education they remain so, even with the existence of "free" state colleges. Third, this concept of equality of opportunity assumes that opportunity lies in exposure to a given curriculum. The school's role is passive, providing an opportunity by being available, while the child's role is active, achieving through use of the opportunity.

A second concept of equality of educational opportunity challenged the second premise of the first concept: that providing a common curriculum for all children would provide equal opportunities for all children to realize their potential through education. Many schools began taking career development into account and diversified their curricula on the assumption that children who are not going to attend college will have greater equality of educational opportunity if they have a specially designed curriculum than if they must take the curriculum designed for college entrance. A major difficulty with this concept, however, is that it takes as given what is actually problematic--that a given child is going into a given postsecondary occupational or educational path. This is a true dilemma, and one that no educational system has fully solved.

A third stage in the development of the concept of equal educational opportunity was made official in 1896 when the Supreme Court

upheld the southern states' notion of "separate but equal" facilities, rejecting the third premise of the first concept--providing that children attend the same school. This stage ended in 1954 when the Supreme Court ruled that legal separation by race inherently constitutes inequality of opportunity. In developing what was to become a fourth concept of equality of educational opportunity, the Supreme Court tried to articulate the source of inequality in "separate but equal" facilities: that the effects of such separate schools were likely to be different. In particular, one's fellow students were viewed as contributors to the quality and effects of one's education. Thus, a concept of equality of opportunity that focused on effects of schooling began to take form. This concept may be defined in terms of consequences of the school for individuals with equal backgrounds and abilities: equality of educational opportunity requires equality of results, given the same individual input. (A more sophisticated version of this concept, equality of results relative to each student's potential for learning, is presented in Pugh, Killalea, and Loatman [1978].)

A fifth concept is now emerging, defined in terms of consequences of the school for individuals with unequal backgrounds and abilities: equality of educational opportunity requires equality of results, even given different individual inputs. Such a definition implies that educational equality is reached only when the results of schooling (achievement and attitudes) are the same for racial and ethnic minorities as for the majority group. There are currently serious questions about this last definition of equality of opportunity. It assumes that other factors, such as the family and community environments, are not as influential as the school environment in affecting achievement over the years attending school, even though these factors may differ greatly for the two population groups. Such an assumption seems highly unrealistic, especially in view of the importance of family background for achievement. If such possibilities are acknowledged, however, then how much can the results be different before there is inequality of educational opportunity? The relative intensity of the convergent school influences and the divergent out-of-school influences determine the effectiveness of the educational system in providing equality of educational opportunity. In this perspective, complete

equality of opportunity can be reached only if all the divergent out-of-school influences vanish or are entirely compensated for by the schools; given continuing divergent influences during the school years, equality of opportunity can only be approached and never fully reached.

Originally, the role of the school was passive, providing an opportunity by being available, and the role of the student was active, achieving through constructive use of the opportunity. The evolution of the concept of educational opportunity has reversed these roles: when equality is judged in terms of results, the responsibility to create achievement lies with the educational institution, not the student. The school's responsibility has shifted from increasing and distributing equally its resources to increasing the quality of students' achievements. This change in expectations will have strong consequences for the practice of education in future years.

The goal of equal results is distinct from and partially conflicts with the goal of equal opportunity coupled with fair competition (meritocracy), since the outcomes of a competitive system will be unequal individual results (Bell, 1972; Levine, 1975). Through inherited advantage, those unequal results may limit the opportunity of succeeding generations. But the relevant question is why those results are unequal. Inequality of outcomes is held to be acceptable if it results from fair competition. The decision of which characteristics are considered to be fair advantages (competence? dedication? seniority? inherited wealth?) is primarily a question of a society's value system. Americans tend to agree that advantages based solely on racial, ethnic, and sexual characteristics are unfair. The uncertainties and difficulties of the recent value shift from equal processes to equal results should not be minimized, however. In time, this value shift may lead to basic revisions in the social basis of reward systems and in the concepts of individual merit (Levine, 1975).

The reason for this discussion of the concept of equality of educational opportunity is that the various senses of this concept would lead one to develop different social indicators when assessing the status of women and minorities in education. Ignoring the third sense of this concept ("separate but equal" education for minorities),

the other four viable senses are (in simplified form) (1) identical resources, (2) equal but differentiated resources to fit students' differing needs, (3) equally effective resources to ensure equal results given equal student characteristics, and (4) unequal resources to ensure equal results by compensating for unequal student characteristics. Examples of an indicator of equal educational status for women and minorities that would be congruent with each concept are, respectively, (1) equal attendance (exposure to the curriculum) in the public schools by men and women, blacks and whites; (2) equal expenditures per pupil for men and women, blacks and whites, spent for resources that fit the educational, career, and family paths of the students; (3) equal achievement scores and educational attainment for men and women, blacks and whites, who come from similar socioeconomic backgrounds and who have similar attitudes, IQs, and specific abilities; and (4) equal ability scores and educational attainment for men and women, blacks and whites, regardless of background and personal characteristics.

Recent disagreements concerning "bias" in the presentation of education statistics comparing black and white students (e.g., Higher Education Daily, 12 June 1978, p. 3) have been based on different senses of equality of educational opportunity. Persons accepting a concept based on equal opportunity and meritocracy would advocate correcting statistics for differing abilities of the students--are black and white high school graduates with equal SAT scores continuing to college at the same rates? On the other hand, those using a sense of the concept based on equal results would advocate reporting the percentages of blacks and whites going to college without correcting for abilities or past educational performance. In preparing a social report on the status of women and minorities in education, it will be important to indicate clearly which social indicators and analyses are based on which senses of the concept of equal opportunity.

#### Conceptual Frameworks

A social report on the status of women and minorities in education concerns at least 105 populations of interest (not including white males, who will often serve as a comparison group). The populations

are displayed in Figure 1: sexual/ethnic/racial group (women, blacks, Mexican-Americans, Puerto Ricans, American Indians) by educational role (student, teacher, administrator) by level of education (preschool, elementary, secondary, noncollegiate postsecondary, college, graduate, adult). The cells in Figure 1 would be approximately nonintersecting except for the intersection of sex with racial/ethnic group (so, more properly, the space is four-dimensional with race and sex as separate dimensions). Each issue discussed below concerns some, but not all, of the populations of interest. Accordingly, each issue is accompanied by the coordinates in Figure 1 of the populations for which it is most relevant. For example, Issue 2, presented on page 18 (enrollment at the beginning of an educational stage), concerns students beginning preschool, noncollegiate postsecondary education, college, graduate programs, and adult education--rows A1 and A4 through A7. These cells are marked with dots in Figure 1. During data access and analysis for each issue, an effort should be made to include relevant statistics for all the appropriate populations.

We have identified from the literature eight issue areas. For students, educational aspirations supply the motivation for school attendance and achievement. Enrollment in the next educational stage and retention and dropout rates together determine educational attainment. Educational resources and school environments may affect educational achievement. Various groups of students are more or less likely than white males to take particular subject matters, which partially determines the occupations they enter. Finally, employment as teachers and employment as administrators of educational institutions completes the cycle by allowing members of a group to serve as role models and encourage other members of the group who are students.

Disparities in these eight issue areas when compared to white males differ for women and for minorities. Women tend to have somewhat lower educational aspirations, especially beyond the bachelor's degree, and their aspirations fall during college attendance, while male students' aspirations rise. Women enroll almost as frequently as men at all educational stages except doctoral programs and first professional degree programs (e.g., medical school, law school). Women are more likely than men to drop out of college, especially after becoming

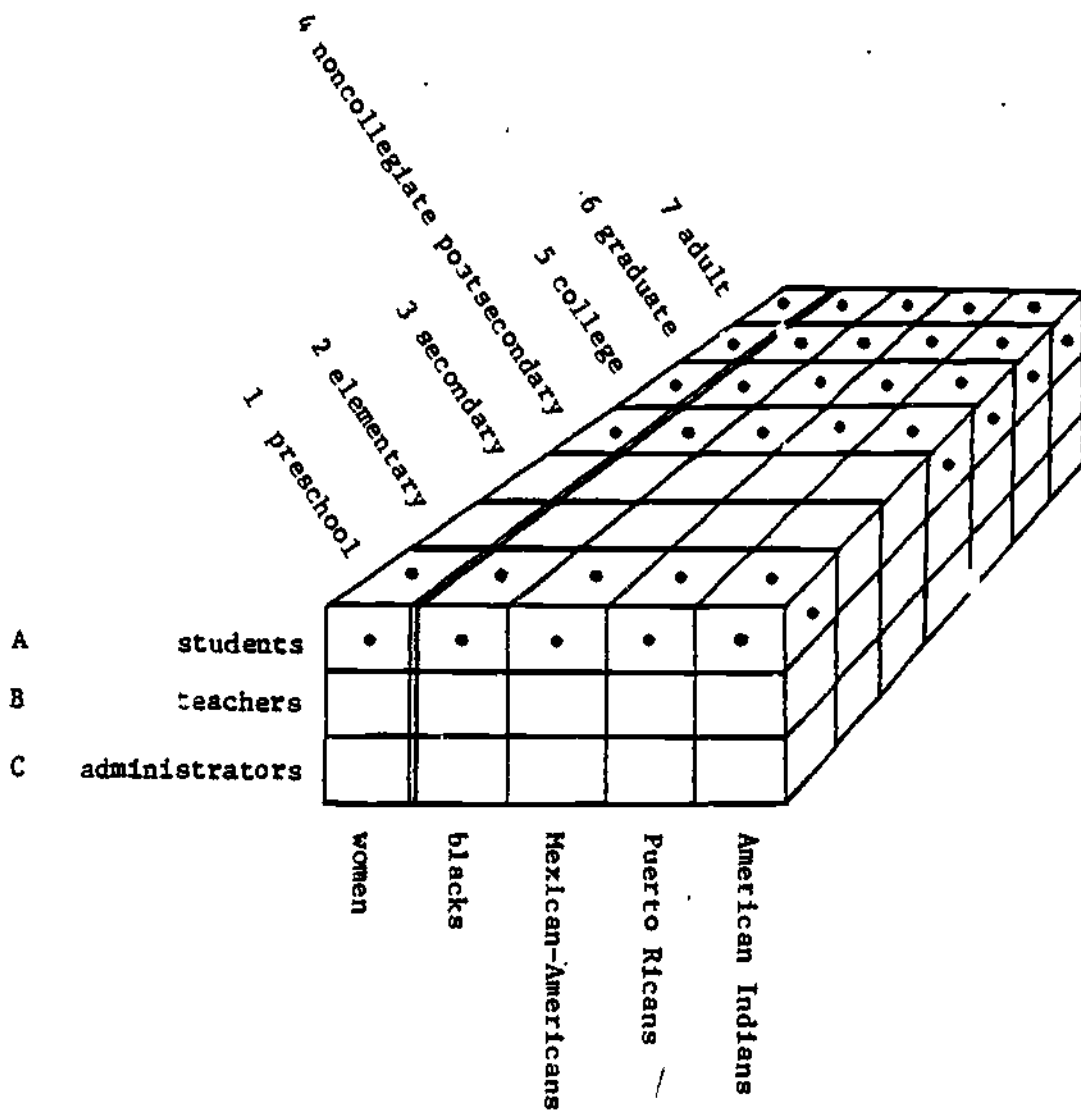

Figure 1. The 105 populations of interest: sexual/ethnic/racial group by educational role by level of education. (Note: The double boundary between women and blacks indicates that sex and ethnic/racial group are two independent dimensions. The cubes with dots on their sides are the populations of interest for Issue 2 (Rows A1 and A4 through A7.)



married. Except for the advantages and disadvantages of women's colleges, women experience the same school environments as men. Women achieve higher grades than men in high school and college, and they tend to take different subjects, more often specializing in the humanities and arts and less often taking math and science. Women are overrepresented as elementary and secondary teachers and underrepresented as college and university faculty members, especially at the higher ranks. Women are underrepresented as educational administrators at all levels of education.

The educational disparities for minorities are more severe. Although their educational aspirations are often as high as the aspirations of whites, they are much less likely to achieve their aspirations. Minorities are less likely than whites to enroll in college (and therefore in all higher degree programs also), although when SES and academic aptitude are controlled, blacks may be more likely to enroll in college than whites. Minority dropout rates are higher than for whites at all educational levels, including elementary school. Because elementary and secondary schools and colleges are still often racially segregated and even more often segregated by social class and because tracking tends to increase this segregation, minorities do not experience the same school environments as whites. The greatest disparity between minorities and whites is in terms of educational achievement. Although minorities are less likely to take science and math than whites and are more likely to major in education, the subject matter disparities are not as great as for women. Finally, minorities are underrepresented as teachers and as administrators at all educational levels.

For each of the eight issues, a social indicator report should aim to answer the following questions:

- How is the status of women and minorities different from the status of white males?
- What are possible or probable causes of these differences?
- Which of these causes can be legitimately labeled "barriers" (i.e., someone's freedom of action has been limited), and how can these barriers be diminished or removed?

- What are the recent trends, and what are their implications for the near future?

These questions are not repeated under each issue discussed below but nevertheless are assumed to apply.

### Educational Aspirations

Issue 1: What are the educational plans and expectations of students? At what rates are these plans being met or exceeded? (Rows A3 through A7 in Figure 1.)

There is substantial motivation among all groups of students to attend school beyond high school. While the percentage of high school seniors with plans to attend college dropped between 1972 and 1974, it rose again in 1975 to 73% (Chadima & Wabnick, 1977). More black high school seniors planned to attend college than white seniors, but the white students were more sure of their plans. Enrollment rates the next year indicated that 69% of the white students and only 60% of the black students had fulfilled the first step of their plans. Among high school graduates 18 to 24 years old not in school, proportionally more blacks and Hispanics than whites are interested in attending school (Golladay & Noell, 1978), indicating that their educational aspirations have not been met. It is interesting to note that this proportion increases with decreasing family income; financial difficulties may be the direct or indirect cause of many of these unfulfilled plans.

Female high school seniors are more likely to plan to go to college than their male counterparts (Ferriss, 1978), and among college freshmen, women are as likely as men to plan on earning a master's degree (A. W. Astin, 1978). There was a dramatic increase between 1966 and 1976 in the percentages of female freshmen planning to earn a degree beyond the master's: an increase from 5% to 8% planning to earn a Ph.D. or Ed.D., from 2% to 6% planning to earn an M.D. or D.D.S., and from virtually none to 4% planning to earn an L.L.B. or J.D. Although rapidly approaching the rates of male freshmen's plans, women were still not as likely to have educational plans beyond the master's degree; the rates of plans by males for the three classes of degrees listed above were 10%, 8%, and 6%, respectively. In addition,

women's aspirations for higher degrees decline slightly after the freshman year, while men's aspirations increase during the undergraduate years.

Some of the factors associated with educational plans in high school are (1) community (students in metropolitan areas other than the central city are more likely to plan to go to college), (2) region (students in the West are more likely to have college plans), and (3) whether or not an older sibling has attended college (Ferriss, 1978). In addition, educational plans may be affected by the economy (i.e., the unemployment rate and therefore the chances of finding a job if one did not go to college), and the decrease in the college plans of males but not females during the early 1970s may partially have been the result of the changing military draft laws.

Educational aspirations do not appear to be a factor in lower enrollment rates for women, blacks, and Hispanics up through college enrollment; however, lower educational aspirations may be related to lower attainment beyond college for these groups. It is possible that a national program to increase the proportion of college women planning to earn a doctorate degree would be the most cost-effective policy for increasing the proportions of female Ph.D.s, M.D.s, and J.D.s. It is less likely that similar policies alone would be as effective for minorities, whose major problems are not merely motivational.

Figure 2 displays the major variables related to the educational aspirations of women and minorities. A social indicator report on the educational status of women and minorities should contain a chapter on educational aspirations, how they have changed over time, what factors may have influenced them to rise or fall in successive cohorts, and what effects on educational attainment can be attributed to educational aspirations. For large numbers of young people (especially women), motivation and other personal considerations are what limit educational attainment, not a lack of ability. Many female dropouts have tested ability levels that indicate that they could have succeeded easily at the next educational level (Wise, McLaughlin, & Gilmartin, 1977). Educational aspirations can also determine what subjects and what levels of courses are taken in high school and college; not taking certain courses (e.g., science, math, college preparatory courses) can

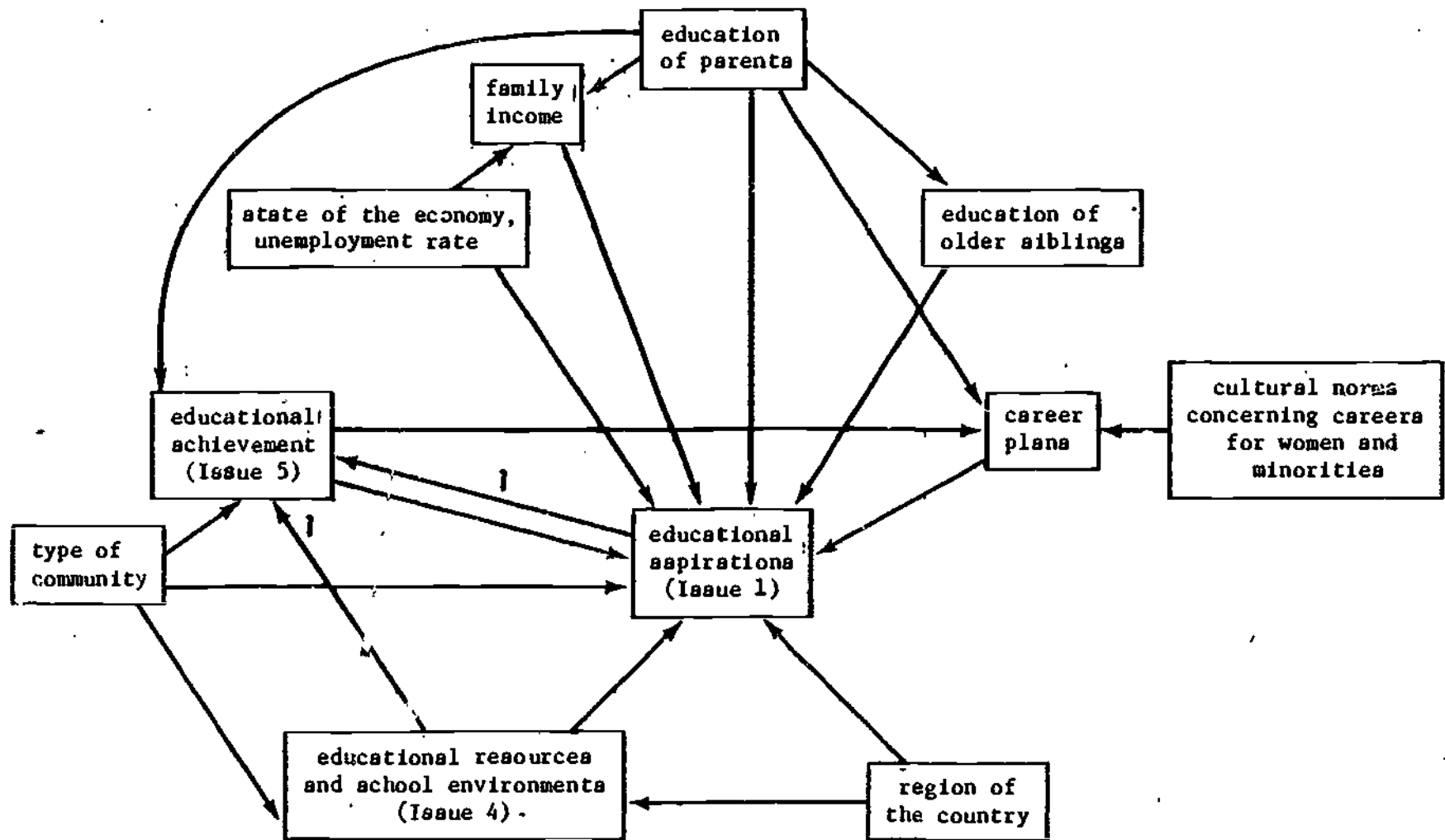

Figure 2. Major variables related to the educational aspirations of women and minorities.

effectively close the door to certain educational and career paths. Finally, the effects of differences in aspirations will have to be known and accounted for in later chapters of the social report on enrollment, retention, and possibly achievement.

### Enrollment

Issue 2: Among those qualified to enroll, what proportion enroll at each successive educational stage-(in particular, preschool, non-collegiate postsecondary education, college, master's programs, doctoral programs, and adult education)? (Rows A1 and A4 through A7 in Figure 1.)

Preschool. The preprimary enrollment rate (nursery school and kindergarten) is directly associated with the child's family income, increasing as income increases ( $r=.75$ ), and is as strongly associated among whites as among blacks (Ferriss, 1978). The average family income of enrollees in private preprimary schools is approximately 30% greater than the family income of enrollees in public preprimary schools. A social report should explore the degree to which preprimary enrollment and the type of preprimary school are related to later educational achievement and the implications of recent changes in preprimary enrollment rates for the various groups of interest.

College. The proportion of college enrollees who are black has increased from 5% in 1966 to 11% in 1976 (Golladay & Noell, 1978). However, a disproportionately large number of minority students attend low-cost institutions (Spurlock, 1977). College enrollment rates have declined among males and increased among females in all groups since 1967, and they are now higher for females than males (43% vs. 35%). Much of the increase in female enrollment has been in the older age groups, as a higher proportion of women decide to enter college after having children. In the over-35 age category, the absolute number of women enrolled exceeds that of men (Tittle & Denker, 1977). During the period of 1970 to 1974, part-time enrollment in college increased 50%, compared with a 10% increase in the number of full-time students (Van Dusen & Sheldon, 1976). Minorities and women are more likely to be part-time students than are white males. The social report should explore the reasons for these higher part-time enrollment rates and the special needs or disadvantages of part-time students.

For the causes of any disparities in college enrollment, one must take into account variation on many dimensions; the question of "fairness" of disparities must deal with these dimensions. College enrollment within four years of high school graduation is highly related to ability (low, 31% enroll in college; middle, 57%, high, 85%), educational aspirations (high school or less, 14% enroll in college; vocational-technical, 32%; 2-year college, 73%; 4-year college, 92%; graduate school, 94%), and socioeconomic status (low, 37% enroll in college; middle, 54%; high, 86%). In comparison, college enrollment is only slightly related to racial/ethnic group (Hispanic, 52% enroll in college; black, 53%; white, 59%) (Golladay & Noell, 1978).

Hansen, Gold, and Labovitz (1972) explored the interrelations of several variables related to college enrollment: sex, race, IQ, grade point average, neighborhood SES, SES of other students in the school, and educational plans. They found that college entry is affected by the socioeconomic contexts of students' neighborhood and school only through the intervening influence upon manifest ability, as indicated by IQ scores and grade point averages, and upon college aspirations. Given equal ability and aspiration, rates of college entry are approximately equal among those from differing SES backgrounds, but differing SES backgrounds are associated with differing distributions of ability and college plans, which in turn are associated with differing rates of college entry. The moderate relation of sex with college entry added little to the other control variables. The stronger relation of race to college entry was found to be largely accounted for by neighborhood SES, IQ, and educational plans.

A congruent finding is that the narrowing gap in average years of schooling between whites and minorities is largely due to a narrowing of the gap in their social and economic experiences. Although the relation between racial/ethnic group and education is declining, the relation between family SES and education persists for all population groups and continues to explain 55%-70% of the variance in educational attainment (Chadima & Wabnick, 1977).

In an extensive literature review, Tittle and Denker (1977) identified a number of classes of barriers that have in the past affected the entry (more specifically the re-entry) of women into



postsecondary education. Institutional barriers that exclude women from postsecondary education include (1) sex and age quotas in admission practices, (2) financial aid practices, (3) regulations requiring full-time course loads or completion of studies within a particular time period, coupled with females' greater need for part-time enrollment, (4) inflexibility in time and location of courses, coupled with females' greater need for flexible hours, (5) no provision of child care facilities, (6) faculty and staff discouragement of women students from graduate study, (7) less help in job placement for females, and (8) counseling that reflects sex stereotypes and masculine expectations about women's life styles. Situational barriers include (1) negative attitudes of husband and other family members toward a college education for women, especially in lower SES groups, (2) lack of knowledge of available educational opportunities, and (3) the strain of being simultaneously a student, a homemaker, and possibly a parent. Dispositional barriers include (1) women's views of appropriate sex roles and their ambivalence about education, intellectual activity, and careers; (2) differences from men in motivation for entering college; (3) personality characteristics less compatible with independent action and competition; and (4) the tendency of both males and females to undervalue the work of a woman. In spite of these factors that Tittle and Denker identified as barriers for women, female enrollment is as high in college and almost as high in master's programs as male enrollment. Their literature review was focused on the re-enrollment of women in postsecondary education, however, and some of these factors may influence older women more than 18-year-olds. Not all of these variables have policy importance, and maybe those factors that cannot be directly affected by policy decisions need not be included in a social report. The institutional barriers and some of the situational barriers are most amenable to governmental influence.

Graduate school. Women face additional barriers when attempting to enroll in graduate school, according to Centra (1974). Graduate education for women is more controversial than college education because it is considered to be a commitment to a professional career and is less useful outside of a career (e.g., in raising a family). A major reservation about accepting women into doctoral programs has

been that women do not remain professionally active long enough to justify the expenditure of talent and money necessary to train them. Longitudinal studies of women doctorates tend to indicate that this is not a valid reservation (Centra, 1974). In any case, it is only at the advanced degree level that women as students remain greatly under-represented.

Adult education. Some of the educational disadvantage of minorities in elementary and secondary grades may be reduced by their over-representation in adult education. In 1976, 47% of the participants in adult basic and secondary education were black, Hispanic, or American Indian. The effects of enrollment in adult educational programs on lifetime educational attainment should be discussed in the social report, and these enrollment rates should be discussed in relation to educational needs.

Figure 3 displays the major variables related to the enrollment of women and minorities. Since the continuation ratios of women and minorities tend to be especially low relative to the continuation ratios of white males at the points of enrollment into the next educational stage (college for minorities, doctoral and professional degree programs for women), the social indicator report should contain a chapter devoted to enrollment rates. Particular attention should be paid to barriers to enrollment that can be reduced through government policies.

#### Retention

Issue 3: What are the dropout rates prior to completing each educational stage (in particular, high school, noncollegiate post-secondary programs, college, and graduate programs)? (Rows A3 through A6 in Figure 1.)

Figures 4, 5, 6, and 7 show the typical education flow patterns of black, Mexican-American, Puerto Rican, and American Indian students relative to white students (from Aronson, 1976). The figure in each box is the percentage of students from the previous educational stage who continue their studies. When black students are compared to white students, the overall picture is one of a persistent decrement in retention at nearly every stage of education. There are no points of

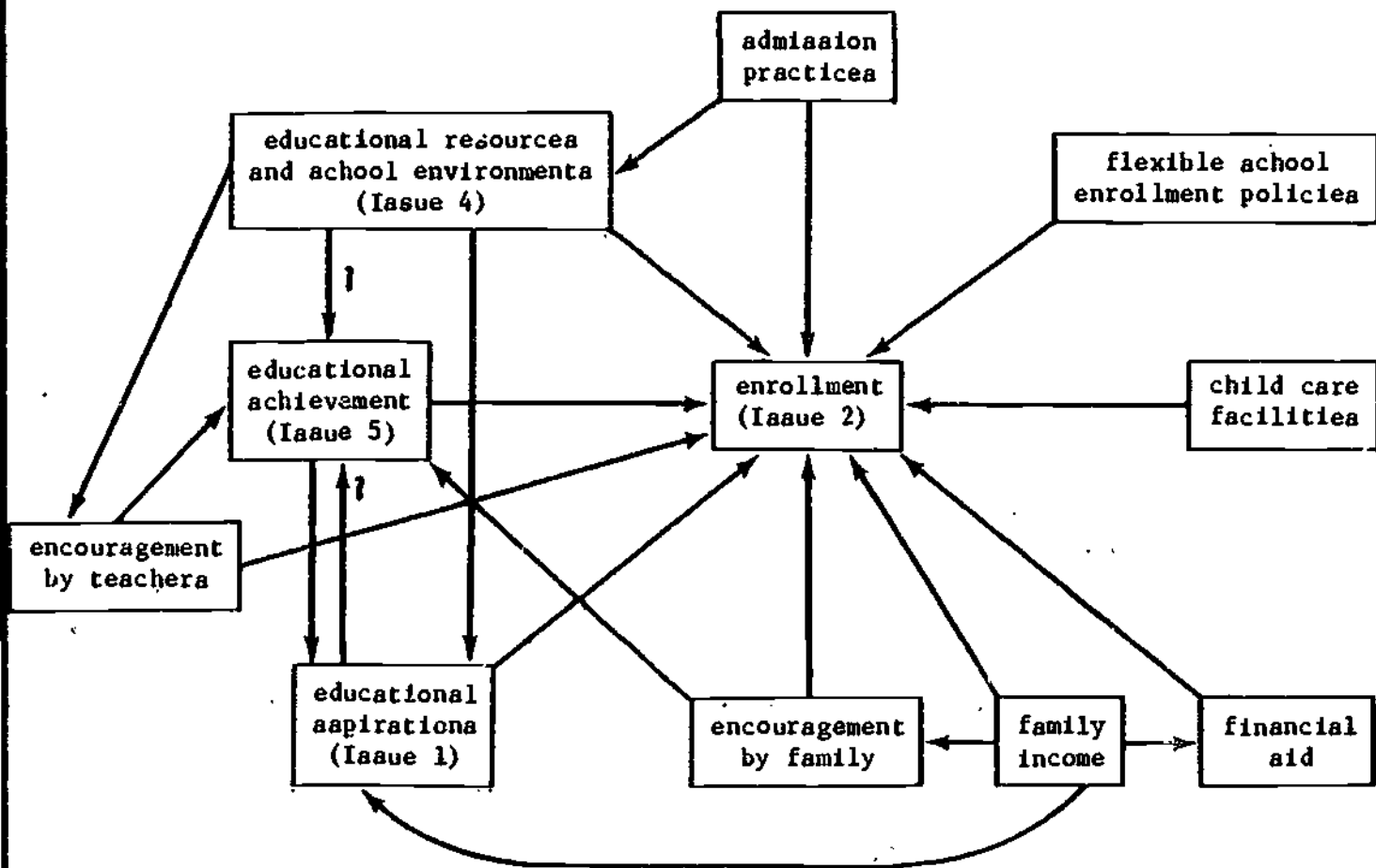
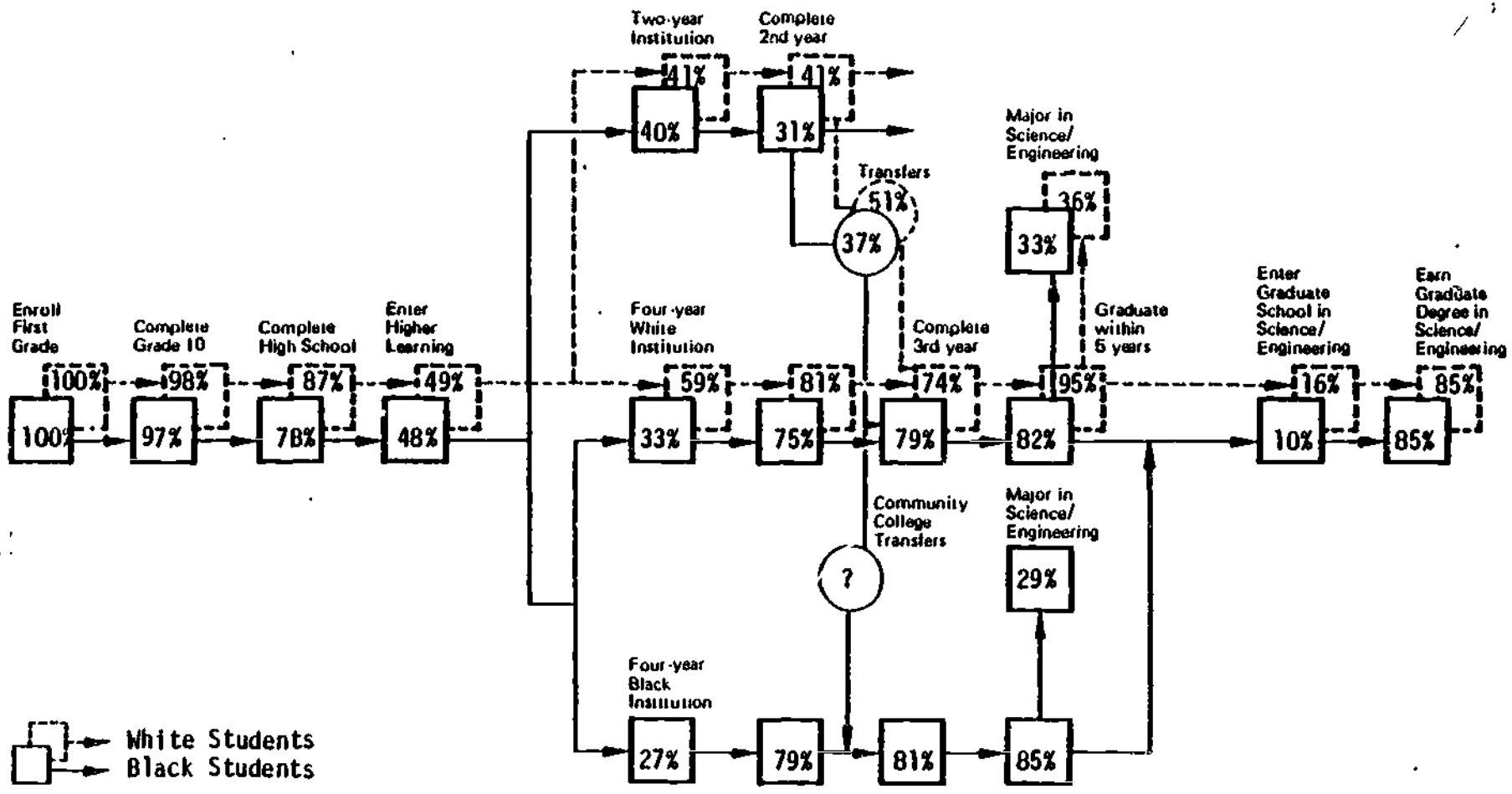
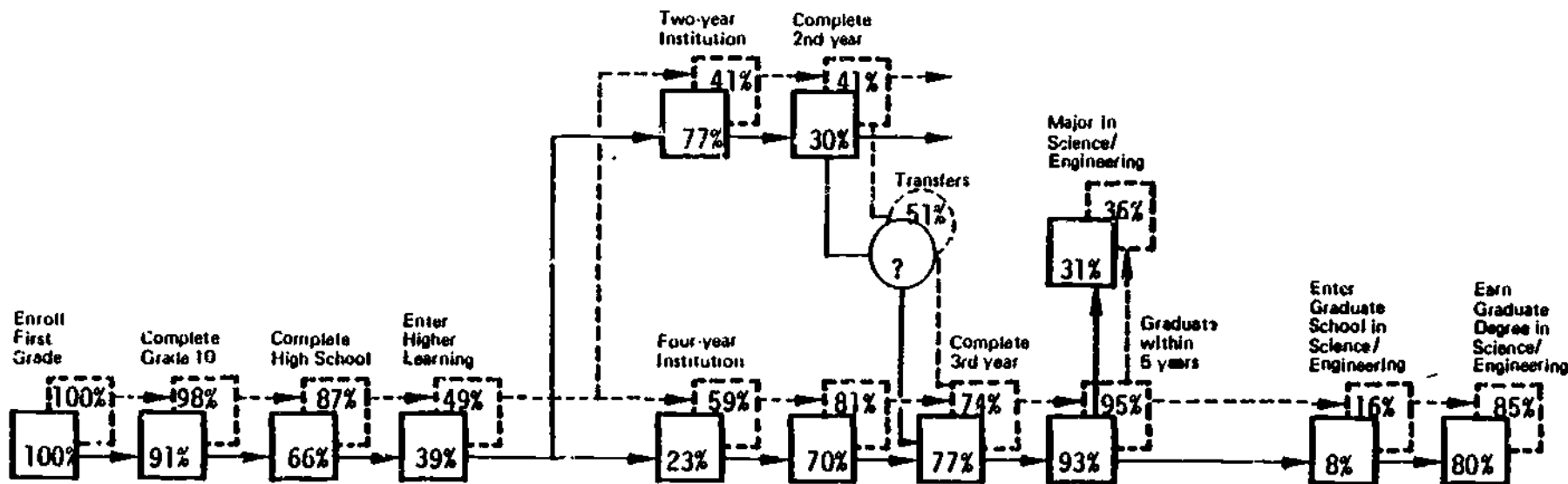

Figure 3. Major variables related to the enrollment of women and minorities.



NOTE Each figure represents the proportion of students from the previous stage who continue their studies.

Figure 4. Typical education flow pattern: black and white students (from Aronson, 1976).



White Students
   
 Mexican American Students

NOTE Each figure represents the proportion of students from the previous stage who continue their studies.

Figure 5. Typical education flow pattern: Mexican-American and white students (from Aaronson, 1976).

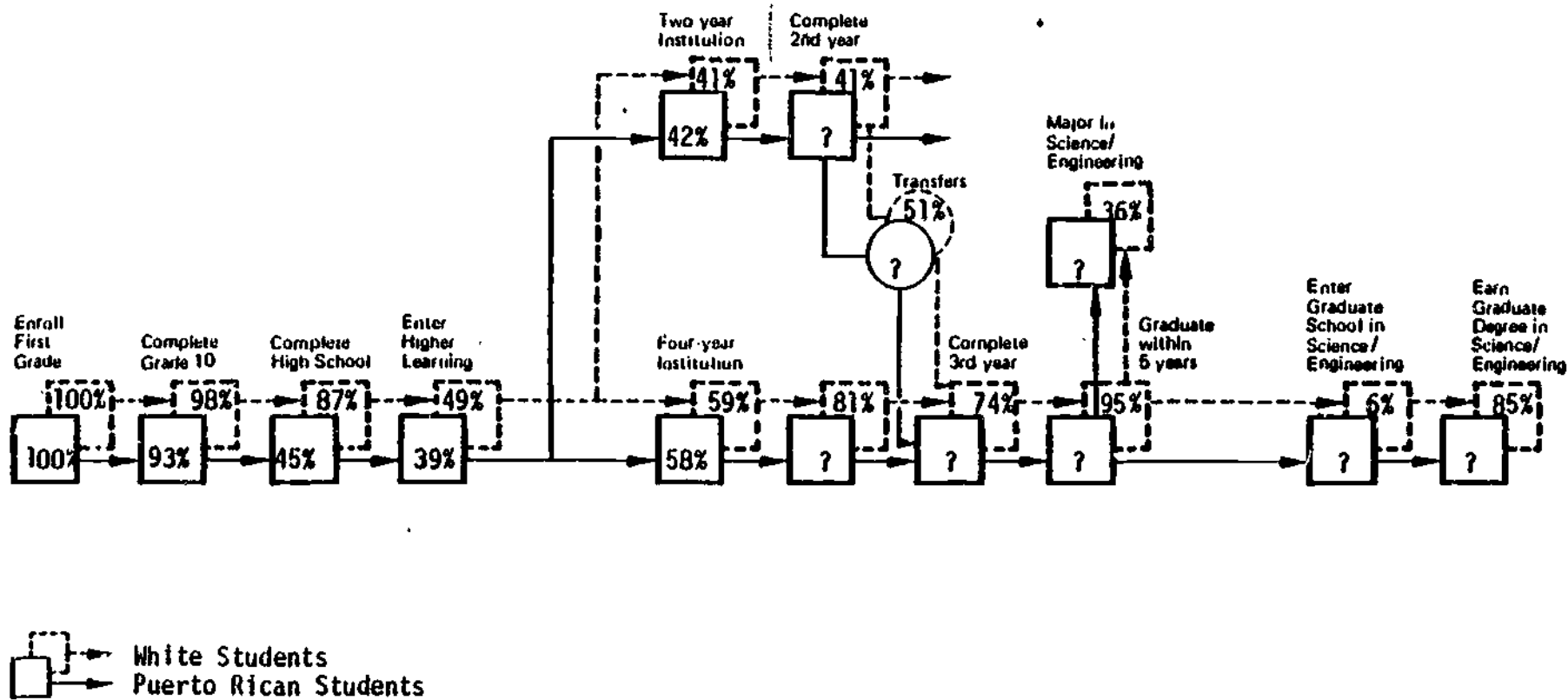

NOTE: Each figure represents the proportion of students from the previous stage who continue their studies

Figure 6. Typical education flow pattern: Puerto Rican and white students (from Aronson, 1976).



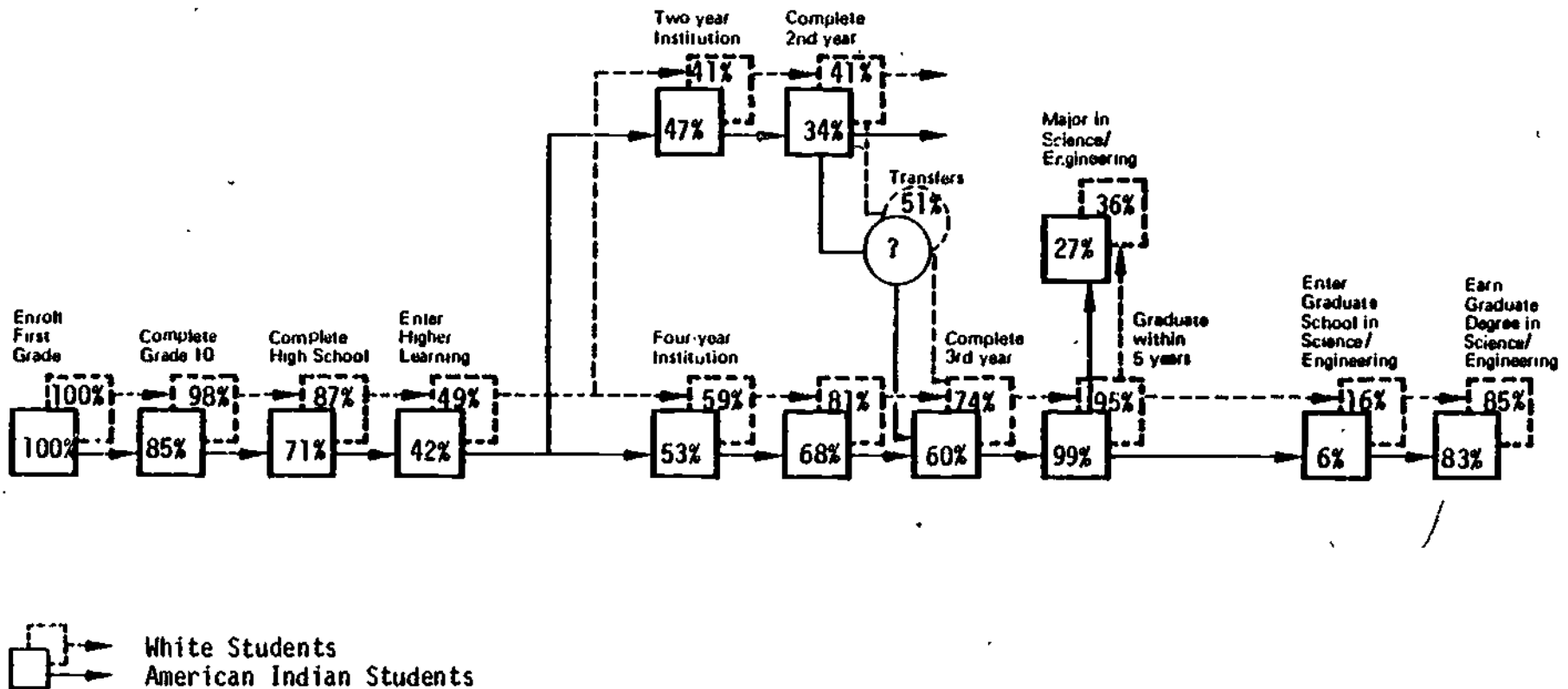

NOTE. Each figure represents the proportion of students from the previous stage who continue their studies

Figure 7. Typical education flow pattern: American Indian and white students (from Aronson, 1976).

large-scale divergence, though there is still an important difference in the high school completion rate. Compared to the experiences of black students, the educational experiences of the three less numerous minority groups are even more divergent from the educational experience of white students. Many American Indians drop out of the educational process prior to the completion of 10th grade. Among Puerto Rican students, the lowest retention rate occurs at the point of high school completion. Mexican-American students are also lost at a fairly high rate at that point. The three groups have approximately equal rates of entry into higher education after completion of high school, but less than half as many Mexican-Americans attend four-year institutions as do students from other groups (possibly because of the large number of community colleges in California), and American Indians have a high dropout rate during their years of higher education.

High school. Economic factors seem to influence retention rates in high school (and probably do so for postsecondary enrollment also). The enrollment rates of minority males vary inversely with business conditions (i.e., minority males were more likely to remain in school during periods of high unemployment than during periods of low unemployment) (Chadima & Wabnick, 1977). White males do not appear on the average to respond to changes in business conditions. The enrollment rates of both white and minority females, on the other hand, decrease during periods of high unemployment. This may be because women often enter the labor market in search of additional sources of family income during high unemployment cycles.

College. Women's higher dropout rates in college are attributable in part to their greater tendency to marry during their undergraduate years (A. W. Astin, 1978). Women are substantially more likely to get married during college than men, even after their initially stronger marriage plans are taken into account. Marriage has opposite effects on the retention rates of men and women: marriage has a negative effect on a woman's chances of finishing college and a positive effect on a man's chances. Women tend to drop out of college for personal, nonscholastic reasons, while men tend to drop out mainly for scholastic reasons (Wilson & Wise, 1975; Wise, McLaughlin, & Gilmartin, 1977; Pantages & Creedon, 1978). For both, however, financial reasons rank

high in importance. Women who drop out have been less likely to re-enroll later and get their degree than men who drop out, possibly for some of the reasons identified by Tittle and Denker (1977) and discussed under the previous issue.

Spurlock (1977) analyzed the causes of low retention rates for minorities in colleges and graduate programs. He found that at the undergraduate level better remedial programs and more psychosocial support are needed, and minorities are disproportionately represented in the groups with these needs. Even at community colleges, which have generally been the most active institutions in providing remedial services, faculty acceptance of remedial programs as integral parts of the curriculum has been reluctant at best. Effective counseling services are also needed by minority college students. The insensitivity of white faculty members and administrators to the cultural backgrounds of minority students is frequently cited by these students as a major cause of disenchantment and withdrawal. At many predominantly white institutions, a large proportion of minority withdrawals occur for reasons other than academic failure. A. W. Astin (1972) found that dropout rates of black students attending white colleges are slightly lower than would be predicted from their high school grades and test scores.

Graduate school. At the graduate and professional school level, selective admissions, disagreement among graduate faculty members over the propriety of remediation at this level, and unclear policies on financially disadvantaged status for graduate students are all major influences on minority retention (Spurlock, 1977). Because many faculty find it difficult to view a baccalaureate holder as educationally disadvantaged, the concept of remedial programs for graduate and professional students strikes an antagonistic chord. In addition, unwillingness to acquire more loans that simply increase the debt incurred during undergraduate education is a principal barrier to participation in further education by minority college graduates because of their low SES backgrounds.

Figure 8 displays the major variables related to retention and dropout rates for women and minorities. These influences on staying in school should be analyzed in a chapter on dropout rates in the

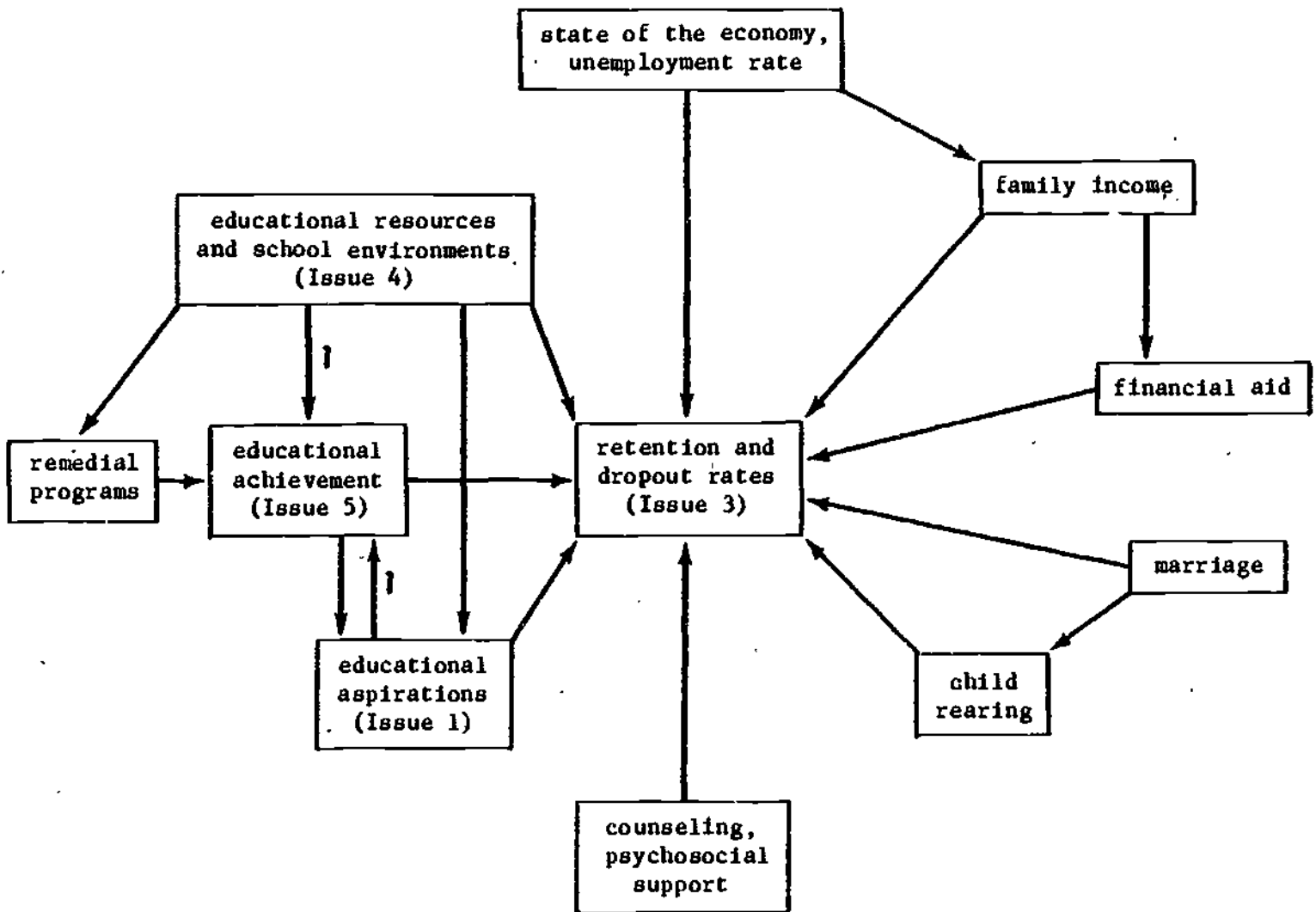

Figure 8. Major variables related to retention and dropout rates for women and minorities.

social indicator report, with an eye toward policies that would reduce the dropout rates for women and minorities at various educational levels. Retention of enrolled students is especially important for two reasons. First, in terms of occupational opportunities and income, getting a diploma or degree is crucial for receiving reasonable returns from an educational investment. Employers tend to consider a high school graduate much more favorably than someone who dropped out during twelfth grade; it is not clear that someone with a year or two of college is better off than a high school graduate with an equivalent amount of on-the-job experience; and going to graduate school is not a good investment of time and money (in terms of financial returns) unless one receives a certificate or degree. The second reason why retention is an important topic for a social indicator report is that enrolled students are already in frequent contact with faculty and support staff at an educational institution and therefore are more easily helped by policy decisions than unenrolled young people no longer in contact with an educational institution. Future federal influence on the educational status of women and minorities will be greatest for those who are persuaded not to drop out and with whom lines of communication have already been established.

#### Educational Resources and School Environments

Issue 4: What are the quantities and qualities of available educational resources, and what are the characteristics of the school environments? What is the extent of ethnic/racial, sex, and socio-economic integration (i.e., to what extent do different groups experience the same school environments)? What are the strengths and weaknesses of women's colleges and black colleges? (Rows A1 through A7 in Figure 1.)

Elementary and secondary schools. The gap between blacks and whites in available school resources has widened in recent years. The reason for this is that local revenues constitute a large share of local budgets and local revenues have shown increasing disparities based on differences in property value. The importance of reporting resource differentials in a social indicator report, however, depends on the relation of resources to educational outcomes. Although the

effects of differential school resources on student outcomes have been widely studied, the results are inconclusive. The two most extensively reported and debated studies, the "Coleman Report" (Coleman, 1966) and Inequality (Jencks, Smith, Acland, Bane, Cohen, Gintis, Heyns, & Michelson, 1972), found little evidence to suggest that school resources make a measurable difference in student achievement. (It should be noted that the Coleman data were used extensively in the Jencks study. For a critique of the methodology and conclusions of Jencks et al. [1972], see Harvard Educational Review [1973] and Levine [1975].) Other studies, particularly those of intervention programs such as compensatory education, have found effects of resource variation (Chadima & Wabnick, 1977). Even these, however, have not shown strong correlations between level of funding and student outcomes but simply that the occurrence of certain interventions has improved student achievement.

Integration. Integration is one way of trying to ensure that minorities and whites receive similar educational resources and experience similar school environments. Integration has progressed very slowly in this decade. In 1970, 71% of black elementary and secondary students attended schools in which blacks were the majority; by 1974, the proportion had decreased to 67% (Golladay & Noell, 1978). Integration was most extensive and was increasing most rapidly in the South and the border states; education was most racially segregated in the Midwest. The majority of studies of students in desegregated schools have found positive effects on the achievement of black children and no measurable effect on the learning of white children (Chadima & Wabnick, 1977). One of the most extensive studies of this type was a 1973 evaluation of the federal Emergency School Assistance Program (ESAP, later superceded by ESAA). ESAP aimed to provide financial assistance to meet the special needs of school districts undergoing desegregation. Researchers found that the achievement scores of black male high school students attending ESAP schools were half a grade level higher than their counterparts in non-ESAP schools by the end of the period examined. These differences were attributed to improvements in the racial climate and to the skill and support of understanding school personnel, which affected the motivation of the students.



Tracking. In about half the high schools in the United States, the method for handling diverse student populations is through some sort of tracking system (Schafer, Olexa, & Polk, 1970). Under this arrangement, the entire student body is divided into two or more relatively distinct career lines with such titles as college preparatory, vocational, technical, industrial, business, general, basic, and remedial. While students on different tracks may take some courses together in the same classroom, they are usually separated into entirely different courses or into different sections of the same course. Socioeconomic and racial background are related to the track to which a student is assigned. Even after controlling for achievement in junior high school and ability as measured by IQ scores, children from low income and minority group families are found to be overrepresented in noncollege-bound tracks (Schafer, Olexa, & Polk, 1970; Jones, Erickson, & Crowell, 1972). Track position is related to whether a student's academic performance improves or deteriorates during high school. The grade point average of college preparatory students tends to rise during high school, while the grade point average of other students declines, even after correcting for the effects of IQ, social class, and previous performance. Noncollege-bound students are more likely to be suspended from school, and they are much more likely to drop out of school, even after controlling for social class background, IQ, and past performance. It is conceivable, although not proven, that the detrimental effects on those with lower intelligence scores of segregation based upon intellect are similar to the known detrimental effects on blacks of schools segregated on the basis of class or race. Tracking may be another means by which minorities are systematically denied equal educational opportunity.

Women's colleges and black colleges. The pattern of intellectual and educational development for the typical undergraduate woman varies somewhat if she attends a women's college rather than a coeducational college. At a women's college, she is more likely to attain positions of leadership, to complete the degree, to aspire to higher degrees, and to enter a graduate or professional school (A.W. Astin, 1978). Here segregation apparently has a positive effect on the "disadvantaged" group. A suggestion of similar results for blacks exists. Of the 27%

of black students who attend a black four-year college, 54% graduate, while 49% of those who attend a white four-year college graduate (Aronson, 1976; see Figure 4). The positive and negative effects of racially or sexually segregated college education should be explored in the social indicator report.

Figure 9 displays the major variables related to educational resources and school environments for women and minorities. Although research on the effects of school resources and environments on educational achievement has been inconclusive, discussion of equality of educational opportunity has often concerned the provision of identical or equivalent resources. The peer group is a major component of the school environment, and consequently racial and social (and sexual?) segregation between schools or within a school, intended or unintended, may have deleterious effects on the less able group of students (possibly including segregated white students taking physical education and segregated males taking English). Regardless of what causal links between schooling and achievement research has or has not been able to demonstrate, differences in educational environments experienced by various groups are automatically suspect. A chapter of the social indicator report should explore trends over time in educational resource differentials between groups and the causes of those differentials. Many of the factors that affect educational resources and school environments can be influenced by policy decisions at some level of government.

#### Educational Achievement

Issue 5: What are the levels of educational achievement in terms of functional ability in various areas (e.g., reading, writing, arithmetic) and tested academic achievement? What are the levels of direct educational benefits other than cognitive development? (Rows A1 through A7 in Figure 1.)

There has been little change in the gap between white and minority elementary and secondary students between 1965 and 1975 in achievement in reading, vocabulary, math, and science. Blacks and Hispanics have consistently performed below the national mean on achievement tests in social studies, science, math, career and occupational development,

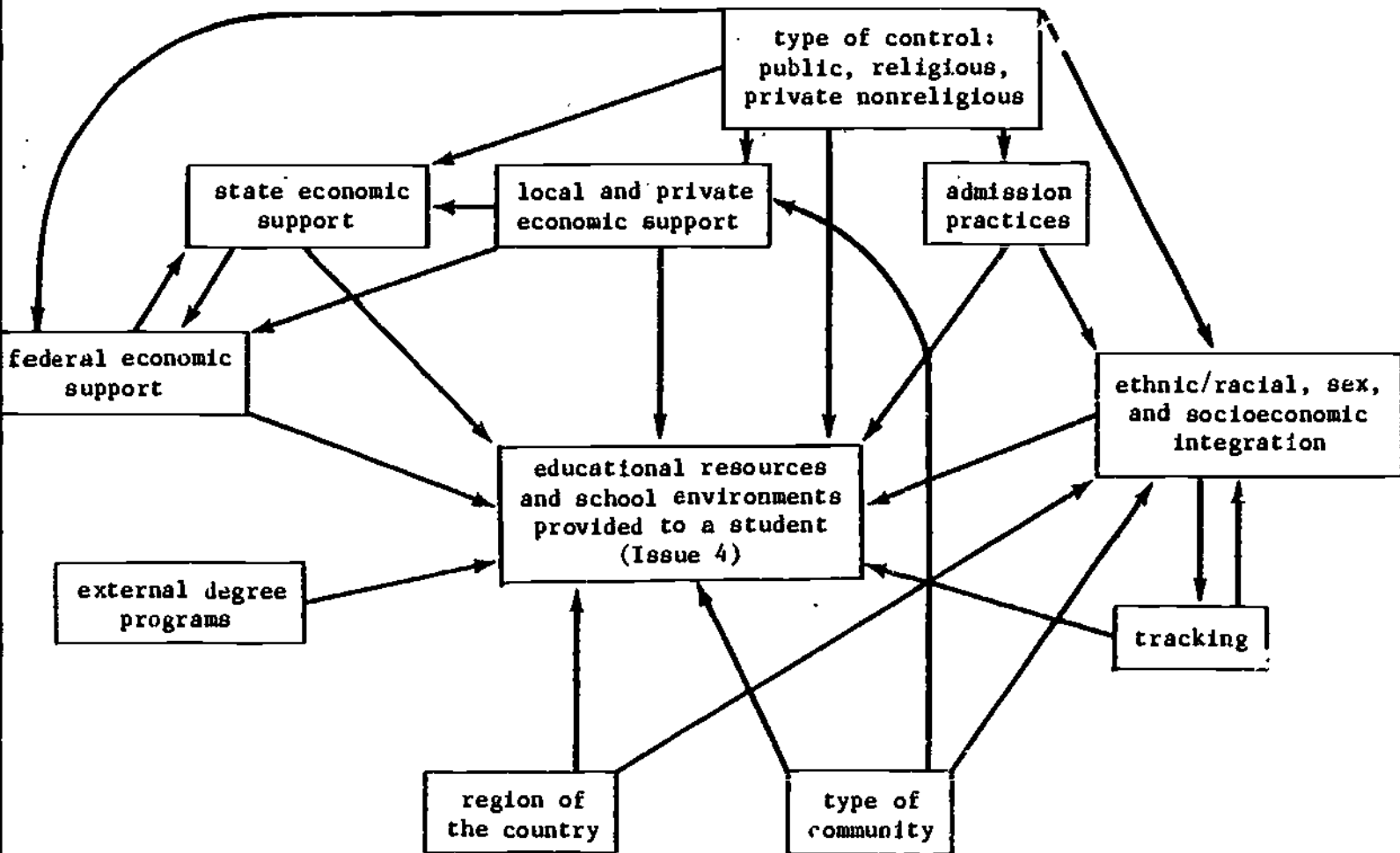

Figure 9. Major variables related to educational resources and school environments for women and minorities.

and reading (Golladay & Noell, 1978). Over the various content areas and age groups (9, 13, and 17), Hispanics scored approximately 11 percentile points below the national mean, and blacks scored approximately 15 percentile points below the national mean. White students were 2 to 4 percentile points above the national mean.

Although overall the achievement of white students on these dimensions exceeds the achievement of minority students, the white-minority difference in ability among persons who terminate their schooling at the same grade level is much less. The mean cognitive development of minority adults does not differ substantially from that of white adults who have terminated their schooling at the same grade level (Duncan, 1968). In fact, the number of grades completed has often been used as an indirect indicator of educational achievement. Arguments that grades completed is an adequate indicator of academic achievement across cohorts have contradicted each other. Some argue that a grades-completed measure overstates change over time in education because high school graduates were a more select group in the past, while others argue that a grades-completed measure understates gains in education because school quality and in-classroom time per grade have increased over time. In order to use grades completed as an indicator, it may be necessary to correct for changes in selectivity and the length of the school year.

Research has consistently shown that women get higher grades than men both in high school and in college (A. W. Astin, 1978). When comparing the average high school grades of men and women entering college, women with grades of B+ or higher outnumber men by nearly three to two, whereas men with grades below B- outnumber women by nearly two to one. Between 1966 and 1976, there was a substantial inflation of high school grades among college entrants, even though mean SAT scores were falling during this same period. The grade inflation occurred for both sexes but appeared to be greater for men than for women. Use of grades as an indicator of educational achievement over time will require correction for grade inflation.

Figure 10 displays the major variables related to educational achievement of women and minorities. Achievement is especially important for analyzing the educational status of minorities, because the

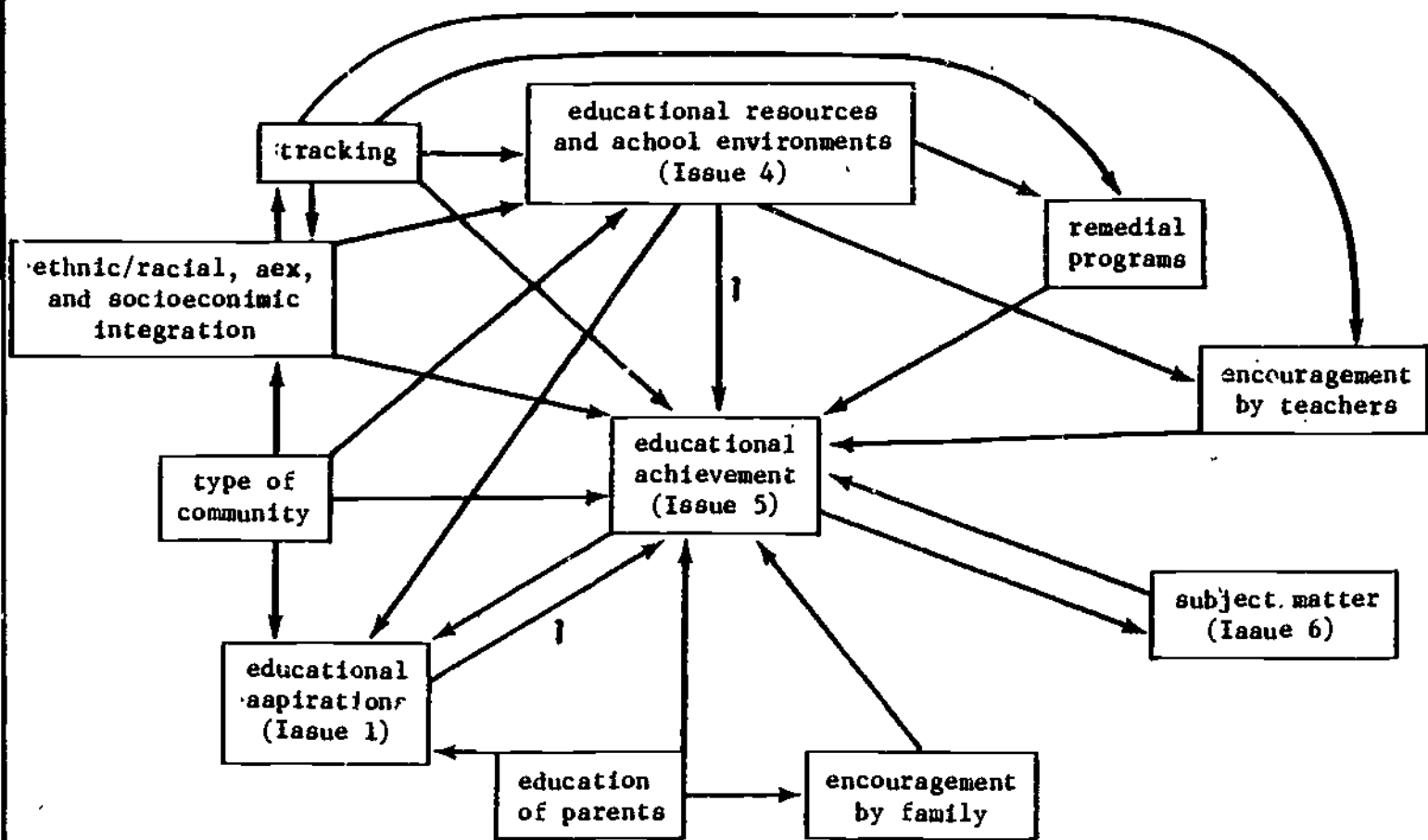

Figure 10. Major variables related to educational achievement of women and minorities.

differential between minorities and whites is greater for achievement than for average attainment. The variance in achievement is greater in the minority groups than for whites, and a larger proportion of minorities do not achieve basic literacy, even when they stay in school through ten or eleven grades. Since basic skills in reading, writing, arithmetic, direction following, and information usage are absolutely essential for citizens in a modern country, the chapter in the social indicator report on educational achievement should explore functional literacy rates before considering higher level and more refined measures of achievement. Unfortunately, many of the factors related to low achievement (e.g., characteristics of the student's community and family) are not very amenable to governmental intervention, and therefore the social indicator report should aim to identify viable policy decisions that have the greatest likelihood for increasing the achievement of certain groups of students.

#### Subject Matter

Issue 6: What subject matters are students taking and specializing in (especially students in secondary, noncollegiate postsecondary, college, and graduate education)? Which of these subject matters is more likely to lead to employment with higher prestige and higher pay than average for a given amount of education (as measured by the salaries of white males)? (Rows A3 through A6 in Figure 1.)

Surveys of entering college students show that women are increasingly motivated to pursue careers in professional fields that have traditionally been dominated by men (Gilmartin, McLaughlin, Wise, & Rossi, 1976; A. W. Astin, 1978). Women are still much more likely to major in fields like literature and the arts, however, whereas men more often major in the sciences and engineering. Brown (1978a, 1978b, 1978c, 1978d) reports that virtually the same pattern of subject matter by sex can be found among undergraduates, master's candidates, and doctoral candidates: more than 70% of the degrees in home economics, library science, education, and the health professions (at the undergraduate level) are awarded to women, and more than 80% of the degrees in agriculture, architecture, business, computer science, engineering, law, and the physical sciences are awarded to men. Very few women are

earning first professional degrees in any field (e.g., a medical field, law): only in pharmacy are more than 20% of the degrees awarded to women.

In undergraduate and master's programs, increasing numbers of women have been taking subjects that have been dominated by male students in the past. In professional and doctoral programs, however, the increase in female degree recipients has been greatest in those subjects in which women were already well represented. The correlations between the proportions of degrees awarded to women in 1976 and the changes in those proportions between 1971 and 1976 for the subject matters reported by Brown are  $-.61$  for bachelor's degrees,  $-.43$  for master's degrees,  $.77$  for professional degrees, and  $.50$  for doctoral degrees. Thus, up through the master's degree, where women are well represented, specialization has become less sexually stereotyped in this decade, but at higher-level graduate degrees, where women are still very underrepresented, specialization has become more sexually stereotyped since 1971.

The long-term financial returns from investment in education vary as a function of subject matter as well as by ethnic group and sex. The fields into which women and minorities most often go tend to be fields with low average salary and prestige. (In part, the salaries and prestige may be low because many women and minorities are in those fields.) In addition to the differential salaries of women and minorities relative to white males at the same job with the same education, the salary implications of the occupational fields entered by women and minorities should be analyzed. It is quite possible that, if there were perfect equality of educational attainment and no salary discrimination between the sexes for equal work and equal ability, there would still be a residual difference in mean salary and prestige between men and women caused by differences in the fields in which they have specialized.

Figure 11 displays the major variables related to the subject matters chosen by women and minorities. Cultural norms concerning the sexes (and to a lesser degree minority groups) are directly or indirectly the major cause of group differences in discipline specialization. Lower achievement by females and minorities in high school



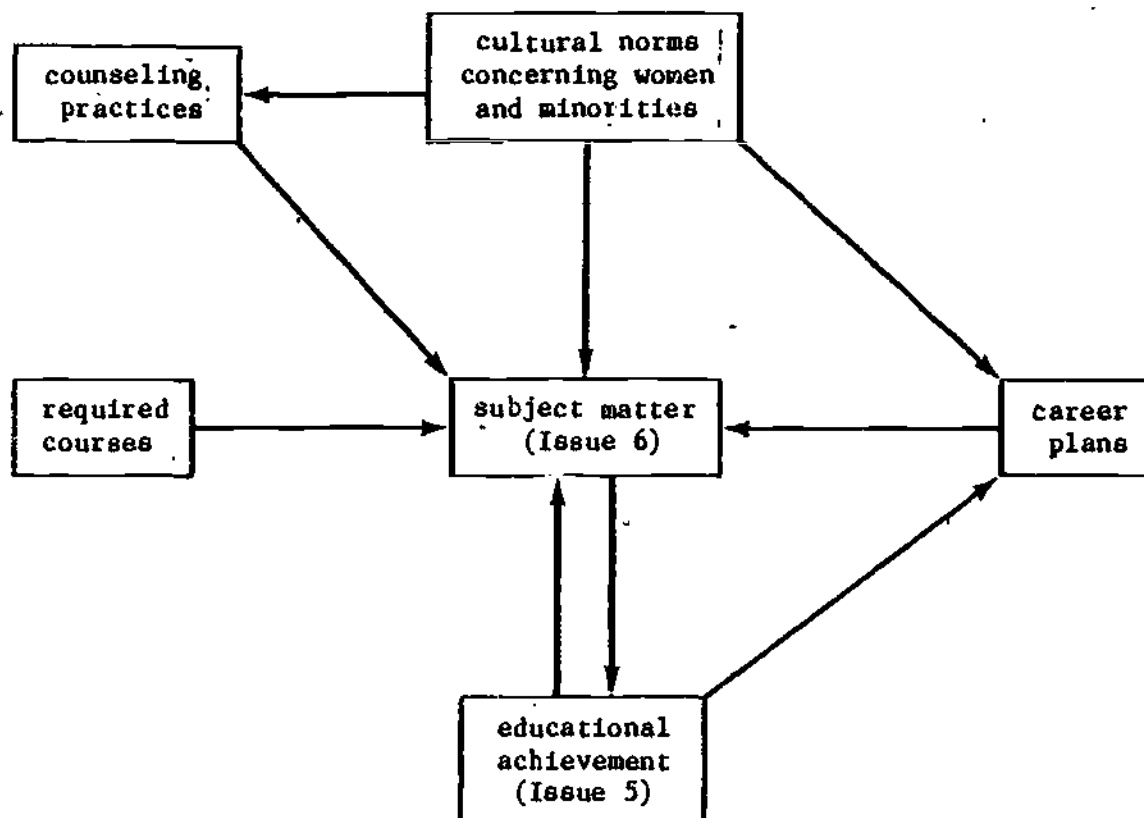

Figure 11. Major variables related to the subject matters chosen by women and minorities.

math and science courses and lower achievement by males in high school English courses are also major factors. Requiring certain courses for all students reduces stereotypic specialization. The social indicator report should explore the extent to which choices of subject matter in high school and college unduly restrict later educational and occupational alternatives for various groups and the extent to which counseling practices mitigate or exacerbate group differences.

### Teachers

Issue 7: What proportions of college graduates become teachers? With how much training beyond college, teaching at what levels of education, in what subjects, with what academic ranks, at what salaries, in what kinds of schools, and with what work environments? (Rows B1 through B7 in Figure 1.)

Elementary and secondary schools. Elementary and secondary teachers have primarily been women. The proportion of elementary and secondary teachers who were female reached a low in 1880 at 57%, peaked in 1920 and again in 1944 at 85%, and has since declined to approximately 67% (Ferriss, 1969).

Colleges and universities. Women constitute 24% of the faculty members of institutions of higher learning, a proportion that has declined since 1939. Female faculty members tend to have fewer advanced degrees, and they tend to cluster in the lower academic ranks, in the less prestigious institutions, at lower salary levels, and in the "softer" academic disciplines (e.g., education, social service, home economics, and nursing) (Graham, 1970; Faia, 1977; Gordon & Kerr, 1978). Particularly since 1972, the federal government, both by statute and executive order, has moved to check employment discrimination against women in higher education (Divine, 1976).

Sixty-one percent of male faculty members in higher education have tenure compared with 42% of the female faculty (Golladay & Noell, 1978). Women are 28% of the assistant professors, 17% of the associate professors, and only 10% of the full professors. Women constitute a higher proportion of the faculty at two-year colleges than at four-year colleges or universities, and women at the higher academic ranks are especially likely to be at community colleges. In general, the rate

at which women achieve the status of full professor is slower than for men, the average lag varying from two to five years in the biological sciences to as much as a decade in the social sciences (Graham, 1970). Using the Carnegie Commission on Higher Education classification of institutions of higher education, Gordon and Kerr (1978) found that the percentage of women among full professors is smallest in the most prestigious group, Research Universities I, and tends to rise with the declining prestige of the universities. The percentage of women among full professors varies directly with the percentage of women among the students at the school or in the department. There is recent evidence, however, that institutions with the smallest percentage of female full professors are making special efforts to hire women at lower levels (Gordon & Kerr, 1978). By the early 1980s, we should have a better indication of whether the recent upsurge in the proportion of women among assistant professors will result in more women moving into the higher ranks.

Average salaries of female full-time faculty members are lower than those of males at all ranks in every type of college and university. The disparity in income increases with rank: female assistant professors are paid 4% less than male assistant professors, female associate professors 5% less, and female full professors 10% less (Golladay & Noell, 1978). Centra (1974) has also reported that the salaries of male and female faculty with Ph.D.s diverge as the number of years of full-time experience since the doctorate increases. (Since Centra's study was not longitudinal, length of experience is confounded with cohort, and his findings could be interpreted as indicating a decrease of sex discrimination in starting salary over time.) Studies have estimated the proportion of the salary difference due to sex discrimination by applying to female faculty members an equation with coefficients derived through multiple regression analysis of male salaries (Bayer & Astin, 1975; Faia, 1977). The estimation takes into account the fact that part of the salary difference between males and females is due to "legitimate" factors such as differences in rank, scholarly productivity, and the type of school at which the person teaches. If female faculty members were rewarded for their experience, abilities, and other characteristics in exactly the same degree as men, their

average salary would increase by about one-seventh of the present difference in salaries between the sexes (Faia, 1977). These findings deserve an important caveat: the prediction of "discrimination-free" female salaries by means of the male salary equation involves a conservative estimate of the kind and degree of sex discrimination operating in academia, since some of the factors that influence salary (e.g., rank, scholarly productivity, type of school) may be influenced by discrimination.

The reasons for sex differences in rank and income have been the subject of much speculation and research. The following is a list of possible factors: (1) women may be more willing to settle for lower salaries, particularly if their mobility is restricted by their husbands' careers, (2) women may seek lower-paying jobs at two-year and four-year colleges instead of universities, (3) women are less likely to have earned Ph.D.s, (4) in the age range when assistant professors are achieving the record that will determine their success in gaining promotion, ages 25 to 35, married women are likely to be bearing and rearing their children, (5) women tend to specialize in subjects in which faculty members are paid less (e.g., home economics instead of business), (6) women may be ambivalent about the desirability of combining career and family responsibilities, (7) women may have lower career aspirations and expectations in our culture, (8) women tend to be more interested in teaching than in research (which is more highly rewarded in academia), (9) women are more likely to teach undergraduate courses rather than graduate courses, (10) women publish fewer articles and books, (11) a woman may be unemployed for a while or have to take a less desirable position because of the nepotism rule, written or unwritten, at most colleges and universities, (12) women may lose seniority because pregnancy and maternity leave is not recognized as legitimate, (13) more men than women move into higher paying administrative positions at colleges and universities, (14) men are more likely to supplement their salaries with royalties, consulting activities, summer employment, or a second part-time job, and (15) schools may be less willing to pay women comparable salaries and to promote them (sex discrimination) (Graham, 1970; Centra, 1974; A. W. Astin, 1978; Gordon & Kerr, 1978). See H. S. Astin (1978) for a review of

factors affecting women's scholarly productivity and, therefore, indirectly affecting their ranks and salaries. All of these factors should be considered, both as causes and as effects, in an overall model and analysis of practices in the hiring, pay, and promotion of women as teachers.

The career opportunity costs for women may be greater than for men. Studies using census data have shown that there are sharp differences between males and females in the relationship between marriage rates and various measures of status, such as occupational prestige (Faia, 1977). For males, the higher the prestige, the higher the marriage rate; for females, the higher the prestige, the lower the marriage rate. For fertility, too, much the same pattern emerges: married male faculty members are much more likely than married female faculty members to have two or more children. Among males, there is no systematic relationship between educational attainment and marriage. Among females, however, the percentage unmarried increases steadily as one moves up the educational scale, with a majority of female Ph.D.s either never married or else divorced (54% vs. 10% for males). This striking contrast suggests that in order to achieve high educational and occupational status females must often forgo marriage and reduce childbearing. If reduced marriage rates and low fertility can be considered as opportunity costs, then they constitute a form of investment that is rewarded in terms of educational attainment and occupational prestige. What is significant, of course, is that this particular investment-reward connection does not exist for males. Measures of marriage rates and child rearing should be included in models of the career development process of faculty members.

Minorities (other than Orientals) make up 6% of the full-time faculty in institutions of higher education (Golladay & Noell, 1978). Minorities are 7% of the assistant professors, 4% of the associate professors, and 3% of the full professors, which may indicate that greater numbers of minorities have been hired as faculty members in the past few years. Among minorities, women are better represented than among whites: 40% of the minority faculty are women (as opposed to 24% of the white faculty).

For those minority students who have progressed through the educational system to the point of being hired into a college faculty, the first years of teaching often include a major disadvantage relative to white faculty members--a work overload caused by multiple responsibilities related to minority student guidance and other minority issues in addition to the regular duties of a new faculty member (Spurlock, 1977). Promotion based on conventional evaluation methods is more difficult to obtain when extraprofessional activities take excessive time.

Figure 12 displays the major variables related to the employment of women and minorities as teachers. It should be noted in the figure that the proportions of faculty members and students who are women and minorities may be causally related both ways. Schools and departments with higher proportions of women and minorities among their students may be more likely to hire and promote similar faculty members, and schools and departments with more female and minority faculty members may draw more female and minority students. It is even possible that female and minority faculty members increase the number of similar students who enroll in college or graduate school and decrease the number who drop out. (Of course, the correlation between the proportions of students and faculty members may not be the result of any direct causal link.) The amount of underrepresentation among faculty members is especially striking for women, considering that almost as many women as men graduate from college and earn master's degrees. Various potential barriers to the hiring and career development of women and minorities as faculty members should be explored in the social indicator report, and policy implications of the findings should be clearly specified.

#### Administrators

Issue 8: What proportion of college graduates become administrators at educational institutions? With how much training beyond college, with what ranks or job labels, at what salaries, and in what kinds of schools? (Rows C1 through C7 in Figure 1.)

Traditionally, the major source of administrators for colleges and universities has been the faculty, so it should not be surprising

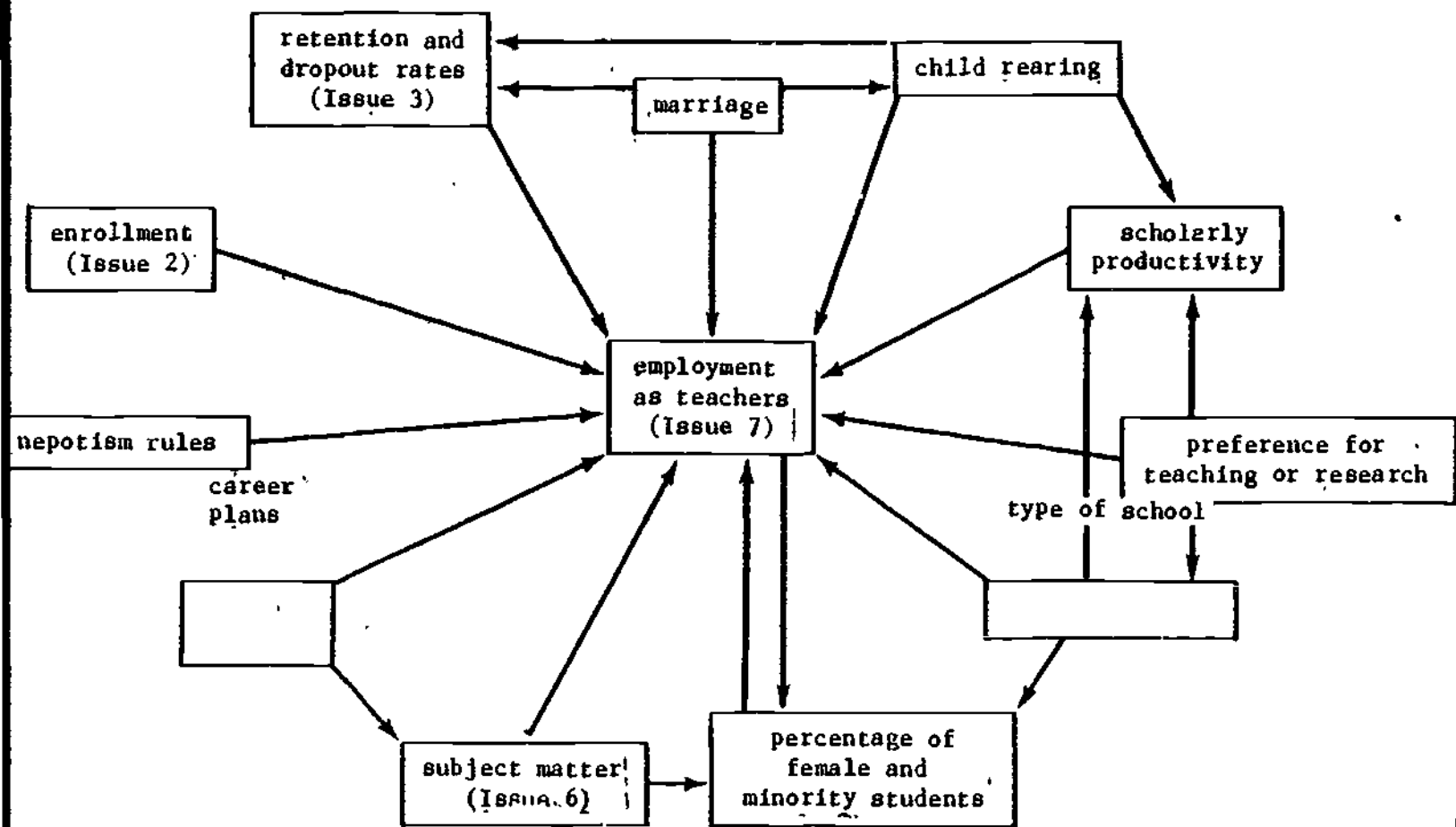

Figure 12. Major variables related to the employment of women and minorities as teachers.



that women and minorities are as underrepresented among administrators as among the faculty members. This situation presents certain problems. In order to increase the number of female and minority administrators, the already scarce supply of female and minority faculty members must be depleted (at least temporarily).

The average salaries of males in most administrative positions (e.g., deans, directors, chief librarians, chief business officers) are higher than those of females (Golladay & Noeli, 1978). Depending upon the position, women tend to be paid 14%-30% less than men. The only exceptions were the positions of chief academic officer and president or chancellor, both of which paid women only slightly less than men.

In many institutions, minorities have been hired to staff programs for support of educationally disadvantaged, predominantly minority students (Recruitment Leadership and Training Institution, 1974; Coursen, 1975). These positions usually do not offer opportunity for advancement through the administrative hierarchy, however (Spurlock, 1977).

Minority trustees have played important roles in shaping institutional policies concerning minority students and faculty (Spurlock, 1977). Institutions having trustees sensitive to minority problems and interested in actively improving institutional conditions for minorities have generally had the most progressive programs. Since trustees are usually drawn from the community and are not required to have high-level educational degrees (nationwide, 10% of trustees have not completed college and another 39% have only bachelor's degrees), it would appear to be easier for colleges and universities to have proportional representation of women and minorities on their governing boards than on their faculty or administration. However, only 15% of trustees are female, and 6% are black (Golladay & Noell, 1978).

Figure 13 displays the major variables related to the employment of women and minorities as administrators at educational institutions. Since most of the direct or indirect influences are the same, the issue areas of employment as teachers and employment as administrators could be combined into a single chapter of the social indicator report on the educational status of minorities and women.

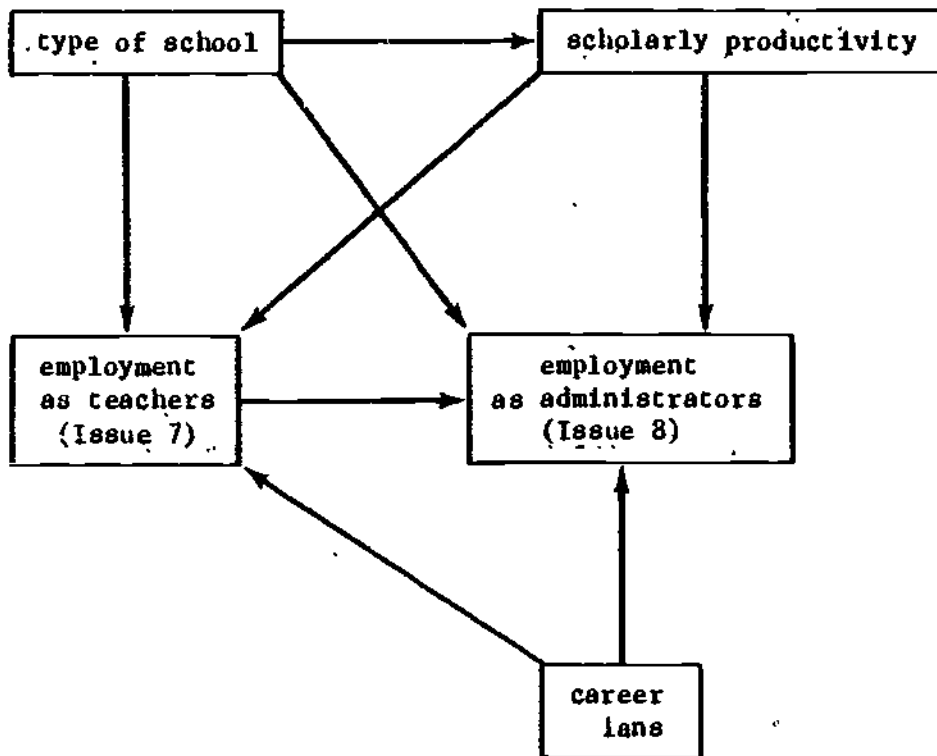

Figure 13. Major variables related to the employment of women and minorities as administrators at educational institutions.

## Results of the Search for Existing Data Sources

The goal of the feasibility study was to discover national time series that had been updated annually. To be informative, a social indicator report must compare the current status of a variable to its past status, indicate whether its value has been changing consistently, and if so, describe how much and when. For this reason, time series were preferred to single research studies and single data points. Extra effort was made to find series containing a minimum of 20 annual data points, since time series of this length are required in order to construct structural equation models.

In order to locate relevant data sources, it was necessary to make the broad variable classes in the conceptual frameworks explicit. This involved determining for each variable one or more operational definitions that were relevant to the conceptual framework in which the variable was located and that had a reasonable chance of being measured. In some cases, a simple and direct relationship existed between the variable and the required measures. For example, enrollment data (full-time, part-time equivalent) are straightforward measures of the variable "enrollment." Other variables had several dimensions, however, and could be measured many different ways. For example, unemployment rates, the gross national product, and inflation rates, as well as many other measures, can serve as measures of the state of the economy. Unemployment rates are most relevant to an analysis of high school dropout rates, however.

Details of the search procedures we used, as well as recommendations for others attempting to locate large numbers of existing data sources, are contained in a report we submitted to NCES. Resources we frequently consulted included indexes to education-related data sources, publications of prominent, centralized data bases, references in the literature, individuals frequently mentioned in the research literature, and organizations that specialize in the collection of related kind of data. For any data source that we located, we requested the managers of the data source to send us documentation on the data collection procedures, copies of the survey instruments for all past years, and certain selected statistical reports. Whenever possible, we checked the comparability

over time of the data collection procedures and wordings of the survey items. If we discovered that the data collection procedures had been modified in a major way, we eliminated from consideration all the data from years prior to the change, and if we judged a data source to be unreliable because of its data collection procedures, we discarded it. In spite of many false leads and the elimination of nonrepresentative and unreliable sources of data, we were able to compile a data source directory with almost 200 citations of sources relevant to the variables in the conceptual frameworks. In the directory, which is organized by the variables being measured, each citation consists of a description of the statistic, whether it is disaggregatable by sex, race, or grade level, the range of years over which it was collected in a comparable form, its periodicity, and references to publications in which it can be found.

The availability of data related to the status of women and minorities in education in the eight content areas is summarized in Figures 14-21. For each of the variables in the conceptual frameworks, the figures display the target population groups and levels of education for which that variable should be measured. Most variables need to be disaggregated separately by sex and racial/ethnic group; in some cases, however, the variable is relevant only to minorities at the macrolevel (e.g., education of parents, family income) or does not need to be disaggregated at all (e.g., state of the economy). Also, most variables require separate measurement for each of the levels of education that are of interest. For example, enrollment data are needed at the levels of preprimary schools, colleges and noncollegiate postsecondary schools, and graduate schools, while graduation rates are needed at the secondary, undergraduate, and graduate levels. The most important levels of education for each variable are indicated in the figures by the letters e, s, u, and g, which refer to nursery school, kindergarden, and elementary school; s refers to secondary school; u refers to undergraduate education, including two- and four-year colleges, universities, and noncollegiate postsecondary schools; g refers to graduate education, including master's programs, doctoral programs, and professional schools (e.g., law, medicine). The only cases where these symbols may seem ambiguous are in Figures 20 and 21, employment as teachers and administrators at educational

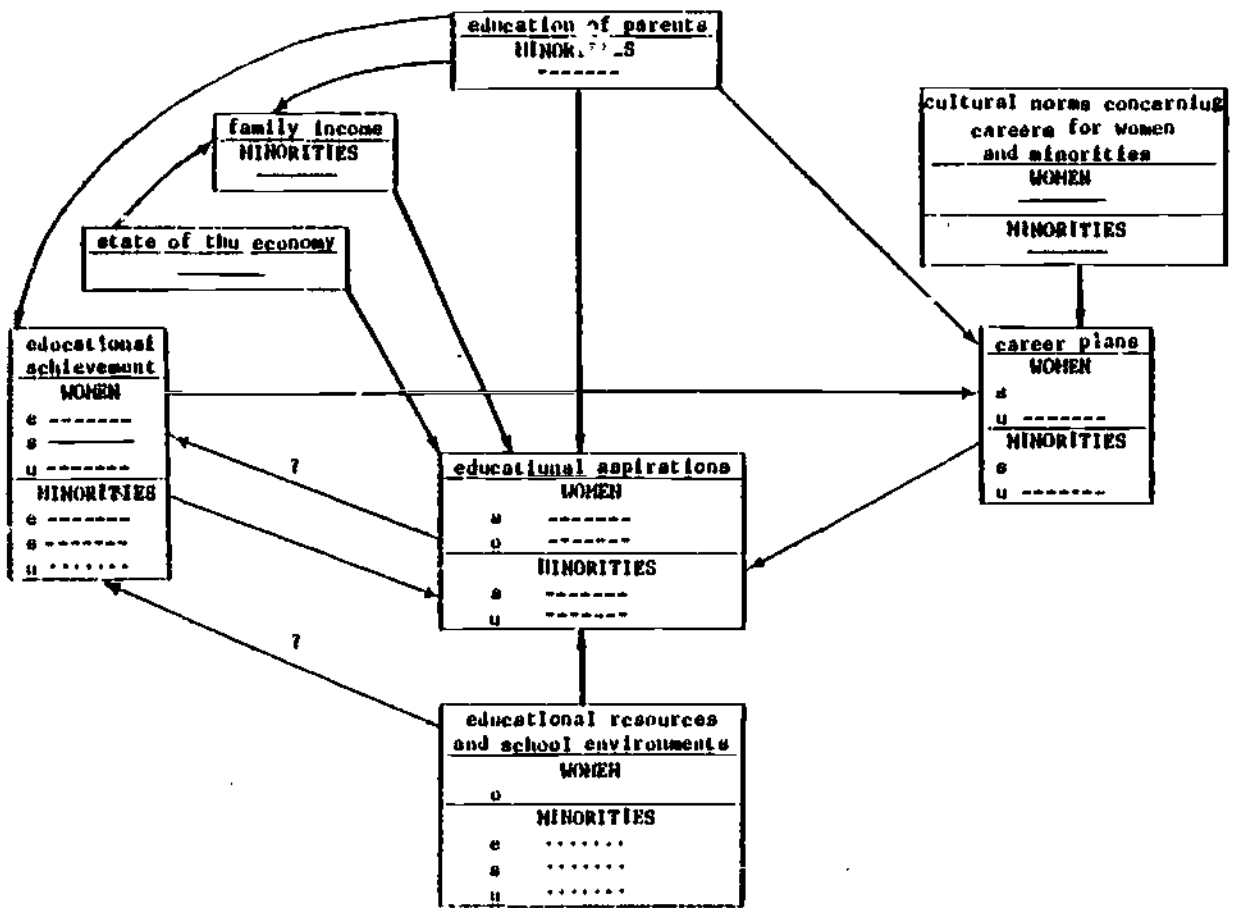

Figure 14. Major variables related to the educational aspirations of women and minorities and summary of data availability.

e = elementary  
 s = secondary  
 u = undergraduate

..... = one data point  
 ----- = short or nonannual series of data  
 ————— = twenty or more annual points

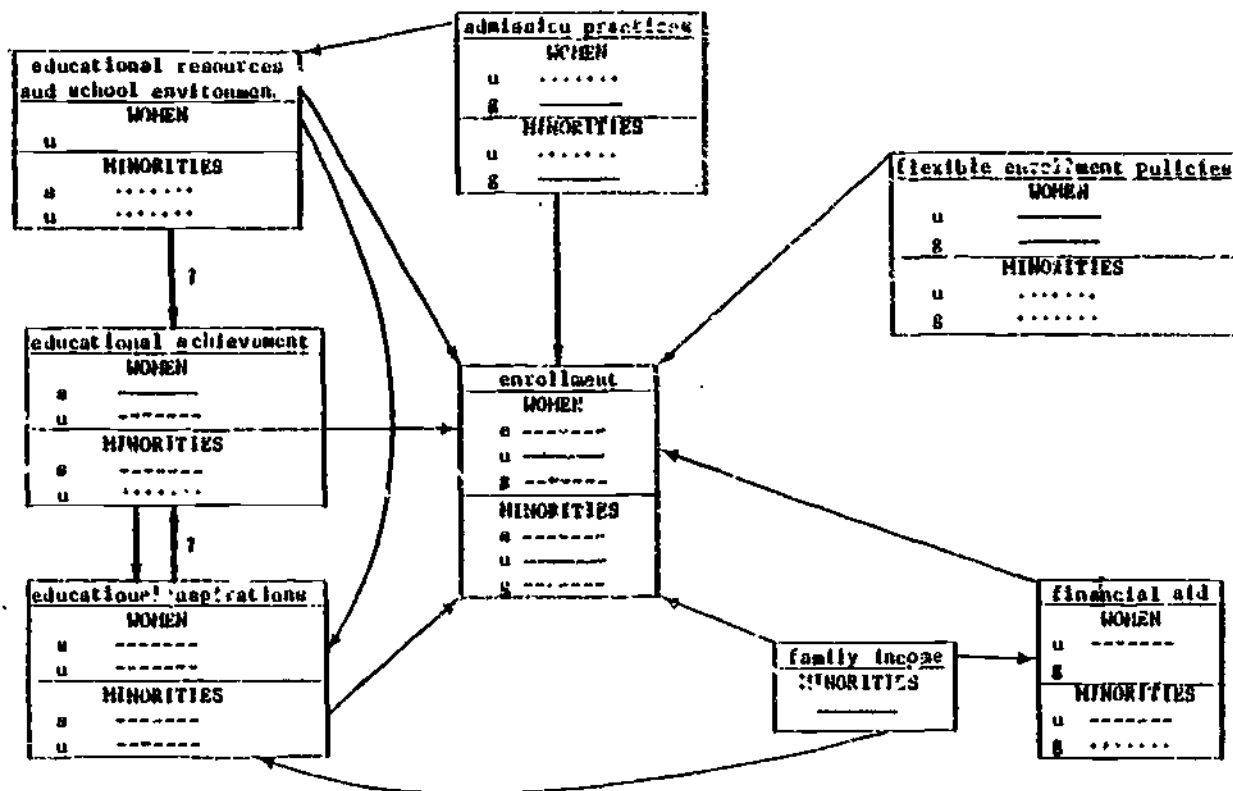

Figure 15. Major variables related to the enrollment of women and minorities and summary of data availability.

- e = elementary
- s = secondary
- u = undergraduate
- g = graduate
- ..... = one data point
- = short or nonannual series of data
- = twenty or more annual points

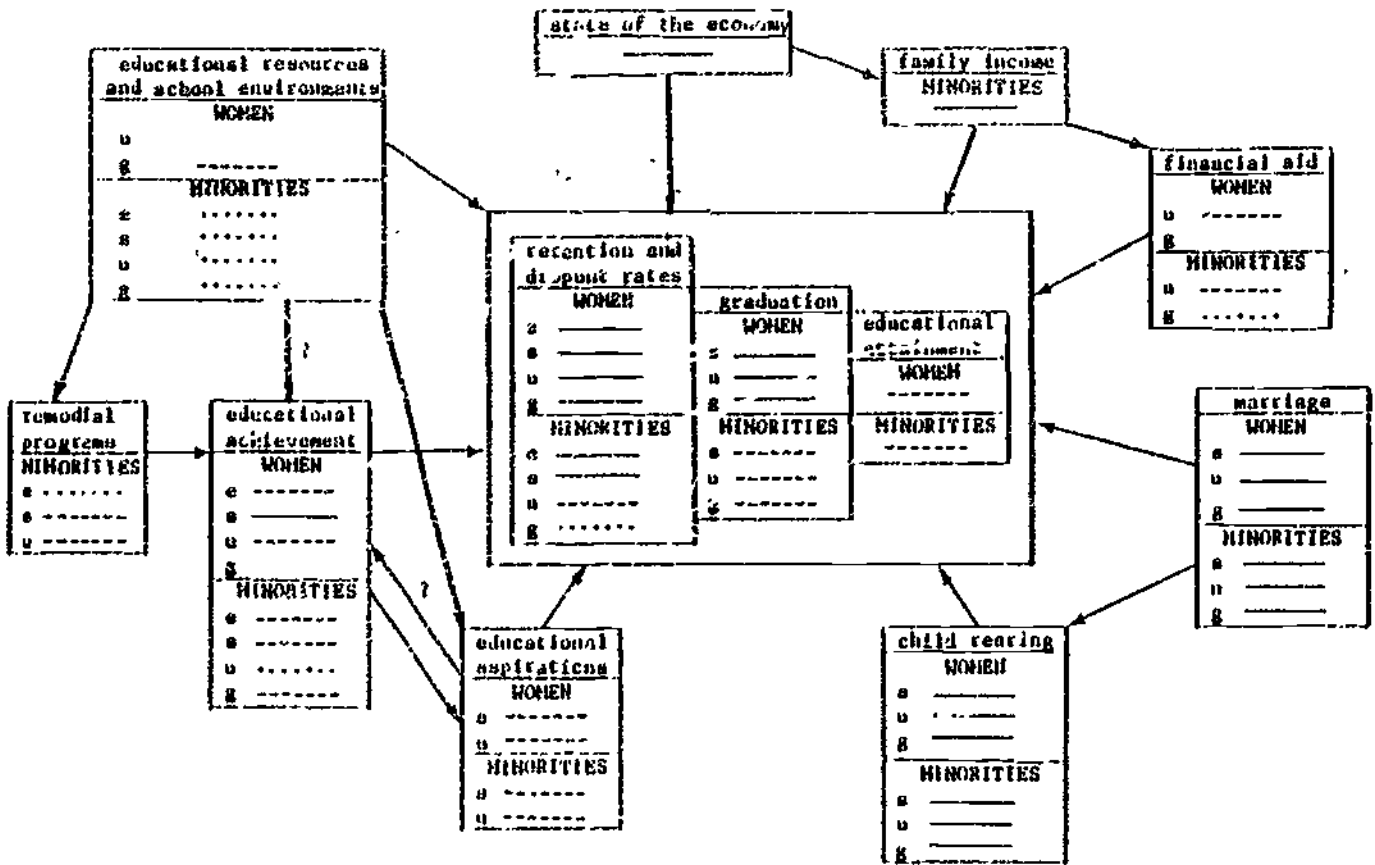

Figure 16. Major variables related to retention and dropout rates, graduation rates, and educational attainment for women and minorities and summary of data availability.

e = elementary  
 s = secondary  
 u = undergraduate  
 g = graduate

..... = one data point  
 ----- = short or nonannual series of data  
 \_\_\_\_\_ = twenty or more annual points



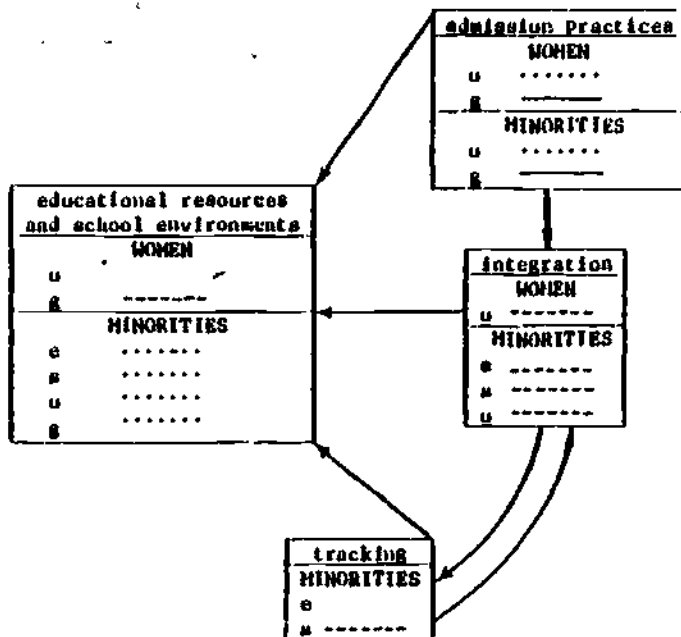

Figure 17. Major variables related to educational resources and school environments for women and minorities and summary of data availability.

- |                   |   |
|-------------------|---|
| c = elementary    | ..... = one data point                    |
| s = secondary     | ----- = short or nonannual series of data |
| u = undergraduate | ———— = twenty or more annual points       |
| g = graduate      |   |

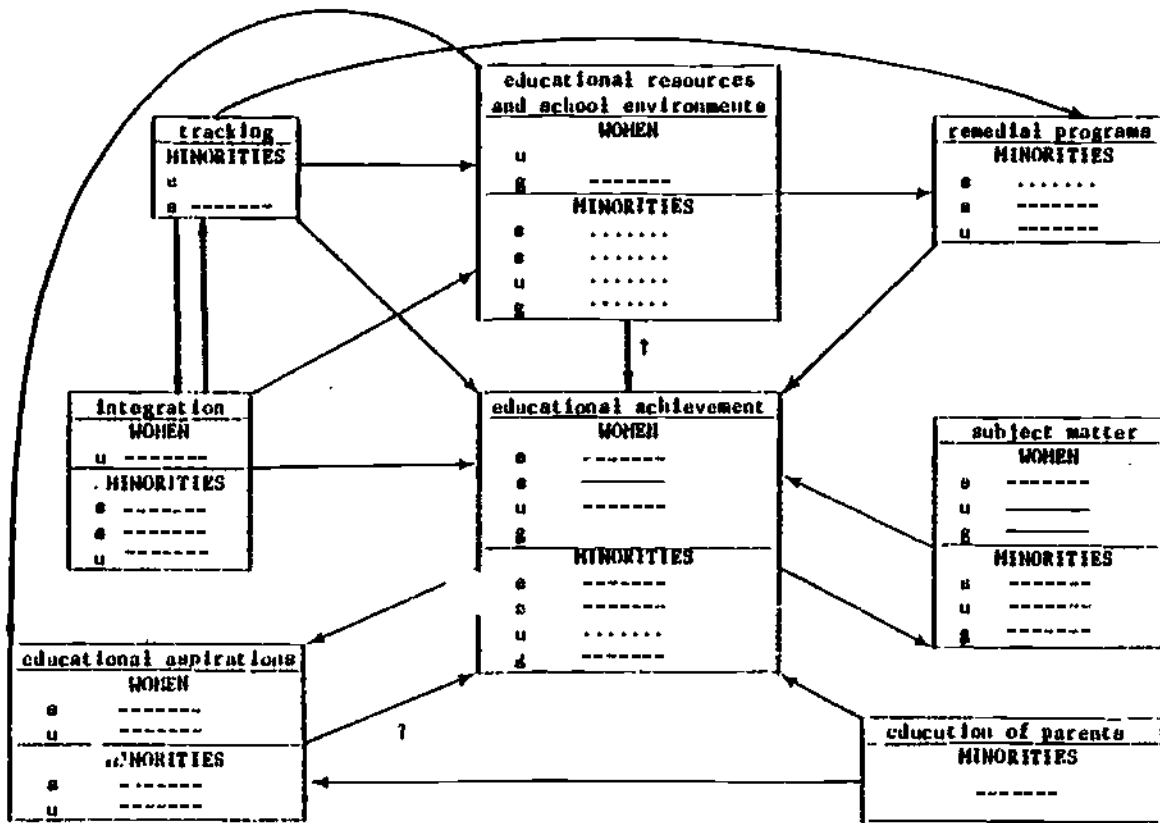

Figure 18. Major variables related to educational achievement of women and minorities and summary of data availability.

e = elementary  
 s = secondary  
 u = undergraduate  
 g = graduate

..... = one data point  
 ----- = short or unannual series of data  
 \_\_\_\_\_ = twenty or more annual points

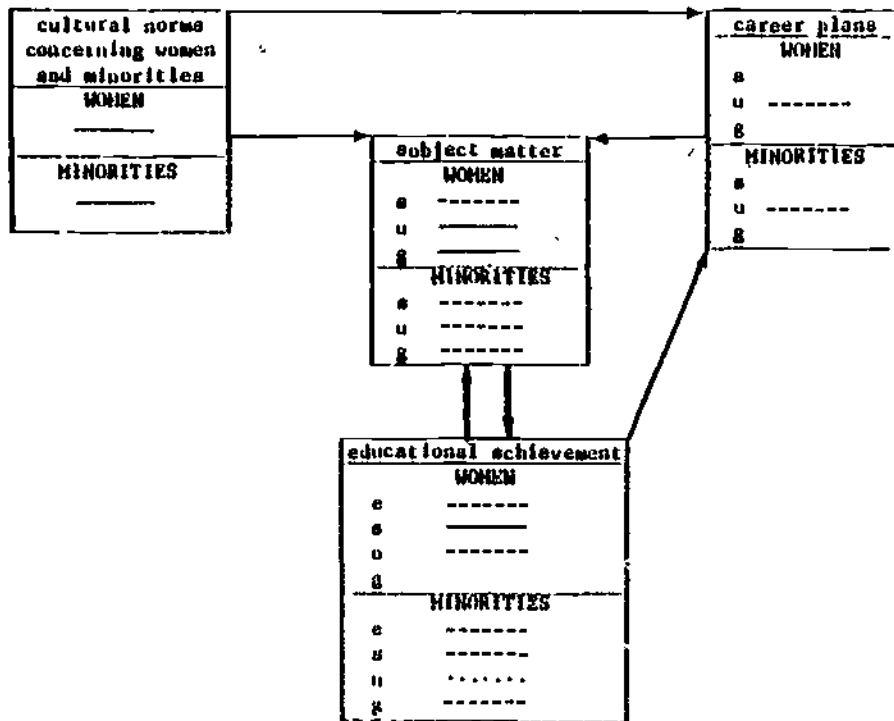

Figure 19. Major variables related to the subject matters chosen by women and minorities and summary of data availability.

e = elementary  
s = secondary  
u = undergraduate  
g = graduate

..... = one data point  
----- = short or nonannual series of data  
----- = twenty or more annual points

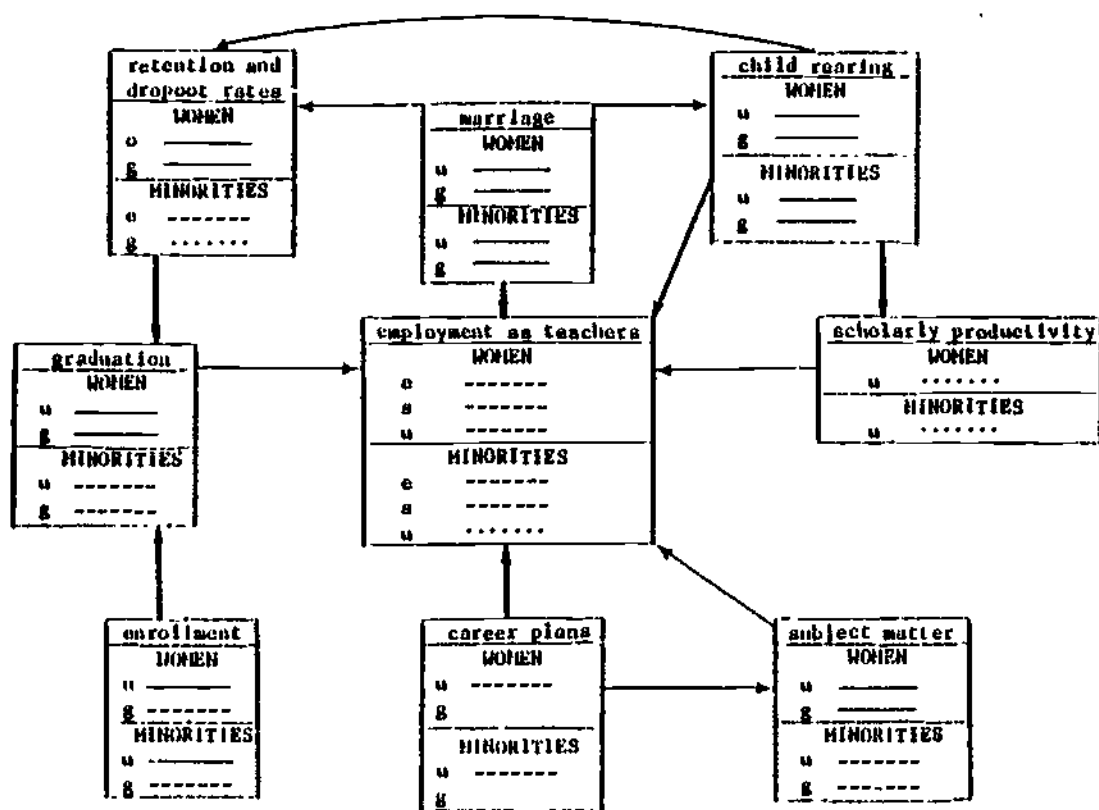

Figure 20. Major variables related to the employment of women and minorities as teachers and summary of data availability.

- e = elementary
- s = secondary
- u = undergraduate
- g = graduate
- ..... = one data point
- = short or nonannual series of data
- = twenty or more annual points

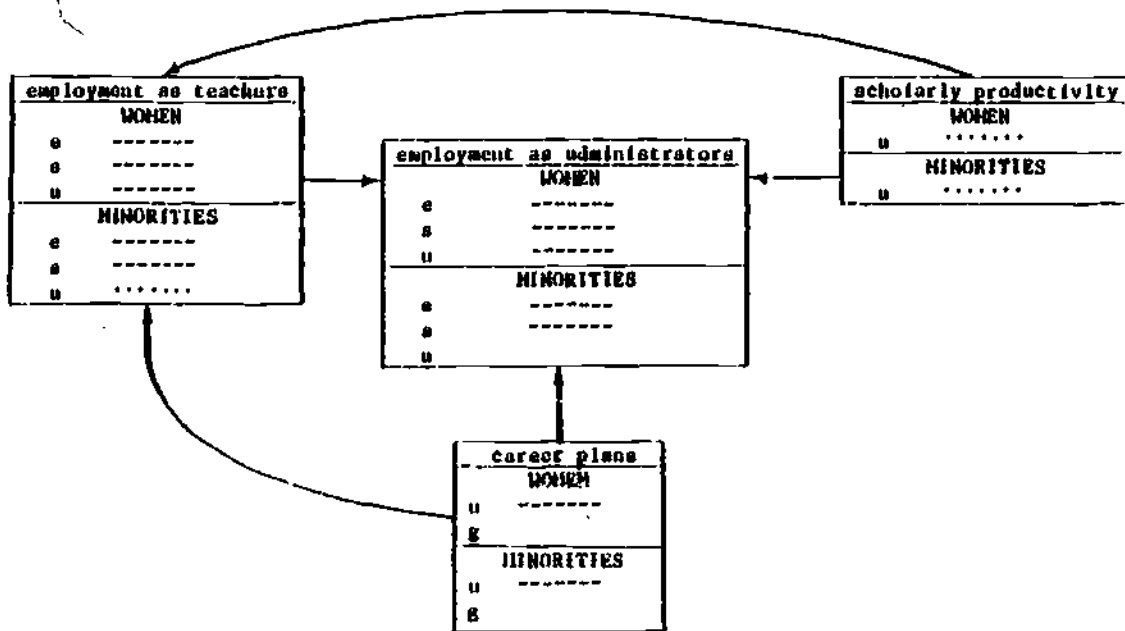

Figure 21. Major variables related to the employment of women and minorities as administrators at educational institutions and summary of data availability.

e = elementary  
 s = secondary  
 u = undergraduate  
 g = graduate

..... = one data point  
 ----- = short or nonannual series of data  
 \_\_\_\_\_ = twenty or more annual points

institutions. For the variables "employment as teachers," "employment as administrators," and "scholarly productivity" in these figures, the letters e, s, and u refer to the level of school at which the person is employed (u stands for higher education, both undergraduate and graduate); for all other variables, the letters refer to students at particular levels of education, as usual.

Most of the dependent variables (separate by target population group and education level) are well measured, with the exception of the following five cases for which we have not located time series: (1) retention and dropout rates for minorities in graduate school; (2) educational resources and school environments for minorities at all levels of education and for women in undergraduate schools; (3) educational achievement of undergraduate minorities and graduate women; (4) employment of minorities as college faculty; and (5) employment of minorities as college administrators. Of the 58 data series needed to measure the dependent variables, a data source has been found for 95% of them, 90% are measured by time series, and 18 are annual time series that extend back at least 20 years from the present.

Figures 14-21 contain 14 influencing factors other than the dependent variables. Although data sources have been found for most of these variables, they are not as well measured as the dependent variables. Time series have not been located for the following seven cases: (1) career plans of women and minorities in high school and in graduate school; (2) admission practices concerning women and minorities applying to college; (3) part-time enrollment of minorities in college and graduate school; (4) financial aid for women and minorities in graduate school; (5) remedial programs for minorities in elementary school; (6) assigning minorities to academic tracks in elementary school; and (7) scholarly productivity of women and minorities employed as teachers at colleges and universities. Of the 46 data series needed to measure the influencing factors in the figures, a data source has been found for 87% of them, 70% are measurable by time series, and 20 are annual time series that extend back at least 20 years from the present.

For the variables that we have not been able to measure adequately using existing data, we have suggested specific data collection strategies that could be used to gather the required data as part of ongoing NCES

monitoring efforts. There are undoubtedly many less prominent existing data sources that could be used to fill in the gaps, and we would very much welcome information about them.

Sufficient data are available for several social indicator reports on the status of women and minorities in education. The data are disaggregatable by sex more often than by race, and consequently the quality of data on the status of minorities in education is poorer than the quality of data on the status of women (as is indicated in Figures 14-21).

An analysis problem specific to the status of minorities in education is the multiple definitions of "minority." Various data sources have disaggregated their data by race in differing ways, with the frequent result that educationally disadvantaged minorities (e.g., Hispanics) are grouped with whites, and nondisadvantaged minorities (e.g., Orientals) are grouped with blacks. Common disaggregations include (1) whites (including nonblack Hispanics) versus blacks, (2) whites (including nonblack Hispanics) versus nonwhites (including Orientals), (3) whites versus blacks versus other (Hispanics, Orientals, American Indians). Seldom are Hispanics or Orientals disaggregated from the rest; and even more rarely are American Indians listed separately or Hispanics disaggregated into Cuban-Americans, Puerto Ricans, and Mexican-Americans. Although it would be most useful to present each ethnic/racial group separately in a social indicator report or to combine the data for whites and Orientals while keeping the other groups separated, this cannot be done consistently in a report based on existing data. As a result, whose educational status is being compared in a social indicator report will vary from analysis to analysis and from figure to figure. To reduce the confusion that could result, we recommend that a set of symbols be used consistently throughout the report to indicate the various combinations of population groups. Six symbols, which can be represented as different types of lines on graphs or textures on bar graphs, would be required: (1) whites (not including Hispanics), (2) whites (including nonblack Hispanics), (3) blacks, (4) Hispanics, (5) nonwhites (including Hispanics and Orientals), and (6) nonwhites (including Orientals but not including Hispanics). In addition, each figure should specify verbally which groupings are being used.

Many of the data series could be converted into indexes of the status of women or a minority group to the status of the relevant



comparison group (men or whites). These indexes would be unitless if they were computed as the ratio of the status of the target group to the status of the comparison group (e.g., the educational attainment of blacks divided by the educational attainment of whites). (See Tipps and Zimble, Social Indicators of Equality for Minorities and Women, U.S. Commission on Civil Rights, 1978, for an example of such indexes of status.) Indexes of this sort have the advantage that status on several aspects of education (e.g., enrollment, achievement, attainment) can be compared in a single figure without the clutter of separate scales for each variable. Although only data on a ratio scale can be converted into unitless indexes as described here, most of the variables in the conceptual frameworks do have true zero-points. The original data (in units of numbers of students, years of education, and so on) will need to be presented also in the social indicator report, since the absolute levels of a variable could change proportionally for both the target group and the comparison group, which would not change the ratio or the index.

Because the educational status of women and minorities involves many content areas, research questions, and data series, we recommend that a series of social indicator reports on the topic be issued. Each report in the series might address a specific content area: for example, one report might cover educational aspirations, enrollment, retention and dropout rates, graduation, and educational attainment, while a second report might cover educational resources, school environments, subject matters chosen, and educational achievement. Later reports could be devoted to the employment status of women and minorities in various education-related professions.

The statuses of women and of educationally disadvantaged ethnic minorities should be presented in separate series of social indicator reports. The problems each of these groups faces, the educational stages at which these problems occur, and the factors related to them are quite different. In addition, certain topics are much more important for one group than for another. For example, there are larger differences in educational resources, school environments, and educational achievement between minorities and whites than between women and men. In summary, we recommend that a series of reports be produced that address the status

of women and minorities in education: three on the status of minorities and two on the status of women (excluding chapters on educational resources, school environments, and educational achievement).

## REFERENCES

Aronson, J. B. An analysis of supporting projects to test methods for increasing the access of ethnic minority students to careers in science and technology. Washington, D.C.: American Institutes for Research, 1976.

During 1974 and 1975, the National Science Foundation made grants to 11 institutions for projects designed to test mechanisms for increasing the access of ethnic minority students to careers in science and technology. Aronson became a party to this effort in 1975, when he was selected by NSF to act as the "third party" evaluator of the projects. To provide a context for the NSF-funded minority projects and their potential impact on the science education of minority students, the author produced a series of diagrams to give an overall picture of the typical education flow pattern of each of the minority groups involved: blacks, Mexican-Americans, Puerto Ricans, and Native Americans. The data were assembled from a very large variety of sources for the early 1970s and were converted into the proportion of students at each educational stage who continue on to the next stage. Relative educational experience can be compared easily, either longitudinally or across ethnic groups, and the areas of greatest need become immediately apparent. Cumulative experience (e.g., the number of college graduates as a proportion of the entering freshman class) can be determined by entering a diagram at any point with an assumed base of 100 and then multiplying by the percentages found in the succeeding boxes up to the education level that is of interest.

Astin, A. W. Racial considerations in admissions. In E. Epps (Ed.), Black students in white schools. Worthington, Ohio: Charles A. Jones, 1972.

Data are used from a nationwide study of academic achievement and survival in college. The survey included 37,000 students who enrolled at 180 different colleges and universities in 1966. Astin uses the data to explore some of the basic assumptions involved in the use of aptitude test scores and high school grades in college admissions and to present empirical evidence concerning the relative usefulness of these measures for students of different races. The following findings are presented: (1) The low representation of blacks among entering college freshmen is attributable in part to the use in the admissions process of high school grades and, in particular, of scores on tests of academic ability. (2) Black students at either white or black colleges on the average perform academically at the level that would be predicted from their high school grades and test scores. (3) Drop-out rates of black students attending white colleges are slightly lower than would be predicted from grades and test scores. (4) Predominantly white colleges that lower their admissions standards (with respect to required grades and test scores) so as to admit more black

students are not likely to experience significant changes in dropout rates, although the college grades of these specially admitted students will tend to be lower than the grades of other students.

Astin, A. W. The undergraduate woman. In H. S. Astin and W. Z. Hirsch (Eds.), The higher education of women: Essays in honor of Rosemary Park. New York: Praeger, 1978.

The major findings from national surveys of college students indicate that at college entry women exhibit a number of stereotypic differences from men in attitudes, behavior, and aspirations. Compared with men, women undergraduates are more altruistic, liberal, cooperative, religious, and more ethically and less competitive, aggressive, and hedonistic. They are more likely to pursue careers in teaching, nursing, and the arts and less likely to go into science, business, law, and medicine. Their greater seriousness is reflected in higher grades, but their greater propensity for early marriage frequently results in a decision to drop out of college. Longitudinal follow-ups suggest that the experience of college attendance contributes little to the reduction of these stereotypic sex differences. The most recent evidence from surveys of entering classes suggests that many differences between the sexes have narrowed during the past few years, especially in the areas of career plans and educational aspirations. Women are increasingly disinclined to choose careers in traditionally feminine fields (elementary and secondary teaching in particular) and now represent more than one-third of all freshmen aspiring to traditionally masculine careers such as engineering, medicine, law, and business.

Astin, H. S. Factors affecting women's scholarly productivity. In H. S. Astin and W. Z. Hirsch (Eds.), The higher education of women: Essays in honor of Rosemary Park. New York: Praeger, 1978.

Using data from a sample of 3,800 faculty members surveyed by the American Council on Education in 1972-73, Astin analyzes predictors of scholarly productivity for men, single women, and married women. In terms of either published articles or books, men are more productive than women; there is no difference in the productivity of single and married women. Faculty members in the biological and physical sciences publish more articles, and faculty members in the humanities and education publish more books. Being at a university, and especially a high-quality university, is associated with higher productivity. Contrary to past research, Astin does not find that the academic careers of single women resemble those of men more closely than do the careers of married women. Also contrary to past research, this study does not support the conclusion that the lower status of academic women is due in part to the constraints of marriage and family life: married women are found to be more productive than single women. Separate regression analyses relating various variables to productivity are described for each of the three subgroups.

Bayer, A. E., & Astin, H. S. Sex differentials in the academic reward system. Science, 1975, 188, 796-802.

The authors present estimates on a national scale of sex differentials in academic employment and of the extent to which equity has been approached since 1968. Because male and female academics differ on the variables that are traditional criteria for advancement in careers in higher education--attainment of higher degrees, field of specialization, research productivity, length of employment, and others--failure to take such factors into account limits the conclusions that may be drawn about sex discrimination per se from simple distributions or counts. Astin and Bayer (1972), based on a large-scale survey of faculty members during the academic year 1968-69, took into account many of these factors and showed substantial independent residual effects of sex on the rewards received in academia. The present study is a replication of the earlier study, using similar data collected during 1972-73. Multivariate regressions were performed on rank, tenure, and salary, and the partial correlations of sex with the residuals were calculated. Rank is found still to be influenced by sex, controlling for 19 other variables. The independent effect of sex on tenure is not statistically significant. Sex is independently related to salary, though to a lesser degree than in 1968-69. The sex differential in salaries is largest at the highest ranks and is non-existent for assistant professors.

Bell, D. On meritocracy and equality. Public Interest, 1972, 29, 29-68.

The fate of meritocracy in post-industrial society is examined. In a traditional meritocracy, individuals are evaluated and social rewards allocated on the assumption of a close relation between achievement and intelligence. Post-industrial society has failed to provide equal opportunity up the social ladder for all who are qualified. A meritocratic society is a "credentials society" in which certification of achievement becomes a condition of higher employment. Opening admissions is a means of widening equality of opportunity by broadening access to college. Research shows that women and blacks are unable to overcome severe discrimination, however. A change from discrimination to "representation" is now observed the implications of which are far-reaching. What is at stake is the redefinition of equality. Objections against meritocracy are summarized. Then the problem of quotas for minorities is considered, and recent efforts to justify a socialist ethic in a redefinition of equality as equity are found unacceptable. A plea is made for a "just meritocracy" in which only those are awarded intellectual authority who have earned it.

- Brown, G. H. Bachelor's degree awards to women. Washington, D.C.: National Center for Education Statistics, 1978. (a)
- Brown, G. H. Doctoral degree awards to women. Washington, D.C.: National Center for Education Statistics, 1978. (b)
- Brown, G. H. First professional degree awards to women. Washington, D.C.: National Center for Education Statistics, 1978. (c)
- Brown, G. H. Master's degree awards to women. Washington, D.C.: National Center for Education Statistics, 1978. (d)

This series of reports examines certain changes that have occurred in the domain of higher education, possibly in response to the changing roles of men and women in our society. Specifically, the reports compare the representation of women among recipients of bachelor's degrees, master's degrees, first professional degrees, and doctoral degrees in the academic years 1970-71 and 1975-76, disaggregated into two dozen discipline divisions. Data for the years between 1970-71 and 1975-76 are presented in appendixes.

- Centra, J. A. Women, men, and the doctorate. Princeton, New Jersey: Educational Testing Service, 1974.

A questionnaire survey was conducted of 3,700 men and women who received a Ph.D. or Ed.D. in 1950, 1960, or 1968. Men were matched with women on field of study, institution that awarded the degree, and the year of degree. The questionnaire included items on employment activities and interests, job satisfaction, reasons for unemployment, income, publications, graduate school, marriage, and views on women's rights. Employment patterns are discussed, with particular attention paid to the extent that women with doctorates are employed professionally and how their positions compare to those held by men with doctorates. Reasons for unemployment are discussed, and the activities of women and men employed full time are analyzed. Publication rates and annual income of men and women with equal career lengths in similar employment settings are compared. The marital and family life conditions of women and men with doctorates and the effects of marriage on career progress are examined. Many of the differences between men and women after five or six years of full-time experience since the doctorate (e.g., income, scholarly productivity) are found to increase over time (13 or 14 years of experience and 22 or 23 years of experience). Since this is not a longitudinal study, number of years of experience is confounded with cohort.

- Chadima, S., & Wabnick, R. Inequalities in the educational experiences of black and white Americans. Washington, D.C.: Congressional Budget Office, 1977.

This report is part of a series of studies undertaken by the Congressional Budget Office to examine the causes of and possible remedies for racial inequalities. The paper was prepared at the



request of Parren Mitchell, chairperson of the House Task Force on Human Resources, and Louis Stokes, chairperson of the House Budget Committee Task Force on Community and Physical Resources. Literature and recent research findings are reviewed that are pertinent to factors that may contribute to disparities between white and black students. The federal response to these disparities is described, and the probable impacts of various finding changes are estimated. In keeping with CBO's mandate to provide nonpartisan and objective analysis, this report offers no recommendations.

Coleman, J. S. Equality of educational opportunity. Washington, D.C.: U.S. Department of Health, Education, and Welfare, 1966.

In view of the fundamental significance of educational opportunity to many important social issues, Congress requested that a survey of educational opportunity be performed. The survey was carried out by the National Center for Education Statistics. In addition to its own staff, the Center used the services of outside consultants and contractors. James Coleman of Johns Hopkins University had a major responsibility for the design, administration, and analysis of the survey. Questionnaires were administered to school administrators, teachers, and 20,000 classrooms of students. Topics discussed in the report include (1) segregation in the public schools, (2) schools and their characteristics, (3) educational and extracurricular programs, (4) characteristics of principals and teachers, (5) characteristics of the students, (6) achievement in the public schools, (7) relation of achievement to school and staff characteristics and to educational programs, (8) educational opportunity in institutions of higher education, (9) college enrollment and dropouts, and (10) the effects of integration on achievement.

Coleman, J. The concept of equality of educational opportunity. Harvard Educational Review, 1968, 38(1), 7-22.

Although there is wide agreement in the United States that our society accepts and supports the fundamental value of equal opportunity, when it comes to areas of specific application there is considerable disagreement over its meaning. In this article, Coleman traces the evolutionary shifts in interpretation of the concept of equality of educational opportunity, putting into perspective the different views that form a basis for disagreement today and indicating how the current direction of change may influence the interpretation of this concept in the future.

Coursen, D. Women and minorities in administration. Washington, D.C.: National Association of Elementary School Principals, 1975.

Literature on the role of women and minorities in school administration indicates that they both suffer from role stereotypes, although the stereotypes are somewhat different. Current literature on minority

groups is limited almost entirely to discussion of blacks; the status of other racial minorities has been largely ignored. The role of blacks in administration has been severely limited by practices that exclude blacks from positions that involve supervision of white teachers or students. Women have been constrained by the belief that executive responsibilities conflict with the primary goal and responsibility of all women, which is to bear and raise children. Correcting the current situation will require the public schools to make an institutional commitment to the implementation of new hiring practices.

Divine, T. M. Women in the academy: Sex discrimination in university faculty hiring and promotion. Journal of Law and Education, 1976, 5, 429-451.

Divine reviews the legislation relevant to employment discrimination against women in higher education and the major court cases on the subject, particularly since 1972. He distinguishes between the "ordinal model" and the "skill pool model" of the hiring process, notes the defects in the ordinal model, and argues for the adoption of the skill pool model, which would make it more difficult for colleges and universities to defend discriminatory hiring practices in the courts.

Duncan, B. Trends in output and distribution of schooling. In E. B. Sheldon and W. E. Moore (Eds.), Indicators of social change. New York: Russell Sage Foundation, 1968.

Duncan identifies, analyzes, and compares a few basic data sets that bear on twentieth-century trends in the output and distribution of schooling in the United States. Nearly all the data sets were compiled by the Bureau of the Census. Duncan identifies three major trends since 1900: (1) a threefold increase in the number of school years distributed among Americans annually, (2) a one-third increase in the per capita output of school years, and (3) an increase of five-and-a-half years in the mean duration of schooling. Series on the schooling of subpopulations reveal an increasingly favorable position of males relative to females, a static influence of social background, and a lessening handicap associated with being black.

Faia, M. A. Discrimination and exchange: The double burden of the female academic. Pacific Sociological Review, 1977, 20(1), 3-20.

Although several studies show that considerable sex discrimination in faculty salaries persisted through the late 1960s, recent survey data indicate that this gap has narrowed considerably. However, survey evidence suggests that women interested in academic careers must pay substantial opportunity costs in such forms as forgone marriage and childbearing, so that women are excluded not only through lower pay but also through other disadvantages. Since data also show that unmarried or childless male faculty members face disadvantages, this selection of women without families has a discriminatory impact.



Further, women who are not married encounter less salary discrimination than women who are married. This is consistent with exchange theory, which suggests that reduced discrimination in one area will commonly be met by an equilibrating increase in discrimination in another area.

Ferriss, A. L. Indicators of trends in American education. New York: Russell Sage Foundation, 1969.

Statistical time series on various aspects of education are presented along with discussion of the interpretation of the trends, criteria for the selection of an indicator, and different types of statistical series. Topics include enrollment, teachers, quality of education, graduates, educational organization and finance, and educational attainment.

Ferriss, A. L. Trends in education and training. The Annals, 1978, 435, 157-178.

Ferriss relates and interprets the data presented in the chapter of Social Indicators, 1976 on education and training. He makes use of several reports of studies related to enrollment patterns, dropout rates, college entrance, and educational achievement to broaden the scope of his analysis. He focuses on particular aspects of the data that are presented (e.g., youth of a particular age group) and carries this focus to other related data. Each discussion is concluded with an analysis of the current situation in terms of possible policy implications.

Gilmartin, K. J., McLaughlin, D. H., Wise, L. L., & Rossi, R. J. Development of scientific careers: The high school years. Palo Alto, Calif.: American Institutes for Research, 1976.

Based on data from Project TALENT, an index of scientific potential is developed that indicates the similarity between the pattern of a high school student's abilities and the abilities of earlier high school students who became scientists, engineers, or upper-level medical personnel. This index is used to explore the relations among abilities, interests, family background, school activities, extracurricular activities, science career plans, and entering a science occupation for two samples of high school students, one tested in 1960 and the other in 1975. Analyses concentrate on science career development as a function of ethnic group and sex. The study finds three times as many female high school students planning science careers in 1975 as in 1960, with little difference between the sexes in science-related abilities. Much larger differences in developed science abilities are found among the ethnic groups, with little evidence that this situation had changed during the previous 15 years.

Golladay, M. A., & Noell, J. (Eds.). The condition of education: 1978 edition. Washington, D.C.: National Center for Education Statistics, 1978.

This volume is the 1978 edition of the annual NCES report on the condition of education in the United States. The volume is principally a compendium of statistical data with corresponding charts on students, education personnel, schooling outcomes, school finance, and a comparison between education in the United States and in other countries.

Gordon, M., & Kerr, C. University behavior and policies: Where are the women and why? In H. S. Astin and W. Z. Hirsch (Eds.), The higher education of women: Essays in honor of Rosemary Park. New York: Praeger, 1978.

The authors use data from the annual salary survey of the American Association of University Professors to explore the current status of women on university faculties. They find that the percentages of women on faculties of universities tend to vary inversely with the prestige of the institution. Disaggregation of the data indicates that increases in the proportions of women hired are being made in the lower ranks and that increases tend to be most pronounced in institutions that formerly had the fewest women on their faculties.

Graham, P. A. Women in academe. Science, 1970, 169, 1284-1290.

Graham reviews the numbers of women on college and university faculties at the various ranks and offers some possible explanations for the underrepresentation of women. Explanations discussed include discrimination, internal ambivalences in women, differences in aspiration and expectation between the sexes, differences in scholarly productivity, the demands on working mothers, the nepotism rule, and the "suburban syndrome." Graham suggests several corrective measures: appointing women to senior faculty and administrative positions, allowing part-time professional appointments, making pregnancy and maternity leave available, eliminating the nepotism rule, allowing women with children more time before being reviewed for tenure, supplying day care centers, and making certain curriculum changes.

Hansen, D. A., Gold, D., & Labovitz, E. Socioeconomic inequities in college entry: A critical specification. American Educational Research Journal, 1972, 9(4), 573-590.

This study of all high school graduates in 1966 in San Diego supports the conclusion that college entry is affected by the socioeconomic contexts of students' neighborhood and school through the intervening influence upon manifest ability, as indicated by IQ scores and grade point averages, and upon college aspirations. Contrary to initial expectations, the association between neighborhood and school socioeconomic contexts and college entrance are found to all but disappear when indices of ability and aspiration are controlled.

Discrimination in college admissions is found to be minimal, and the authors suggest that instead attention should be turned to earlier influences that affect academic skills and aspirations.

Harvard Educational Review (Ed.). Perspectives on Inequality: A reassessment of the effect of family and schooling in America. Cambridge, Mass.: Harvard Educational Review, 1973.

The chapters of this book were all published as articles in Harvard Educational Review, 1975, 43(1), and all discuss the controversial book, Inequality: A Reassessment of the Effect of Family and Schooling in America (Jencks, Smith, Acland, Bane, Cohen, Gintis, Heyns, and Michelson, 1972). Jencks et al. ask three kinds of questions in their book, each of which is treated in a section of this book. The first section treats the relationship between school resources and short-term school effects. This section follows both an input-output paradigm of school effect research, linking current resource allocation patterns to achievement scores, and also a psychological approach that estimates components of variance due to genes, home environment, and schools. The second section of the book considers the effects of school resources and school achievement, along with personal characteristics of students, on final levels of educational attainment. The third section considers the relation of educational attainment, test scores, and family background to adult income and occupational status. Authors include Alice Rivlin, Stephan Michelson, Kenneth B. Clark, Beverly Duncan, James Coleman, and Christopher Jencks.

Jencks, C., Smith, M., Acland, H., Bane, M. J., Cohen, D., Gintis, H., Heyns, B., & Michelson, S. Inequality: A reassessment of the effect of family and schooling in America. New York: Basic Books, 1972.

This book is based primarily on data published in the "Coleman Report" (Coleman, 1966) and argues that the schools have failed to equalize both short-term school achievement levels among students and long-term levels of educational attainment and adult income. If equality of opportunity between rich and poor or black and white students is to be an abiding concern, Jencks and his co-workers feel that it cannot be primarily the responsibility of the schools. They suggest other means of bringing about greater income equality, involving more direct attempts to narrow the range of family incomes.

Jones, J. D., Erickson, E. L., & Crowell, R. Increasing the gap between whites and blacks: Tracking as a contributory source. Education and Urban Society, 1972, 4, 339-349.

The primary data reported in this study came from two sources--subpoenaed school records and the court testimony of school officials. These data are used to assess track placement and mobility among tracks during the junior high school years. The school system studied

was a defendant in a federal court suit, charged with denial of equal educational opportunities to black students through racial imbalance of the schools. The data used in the analyses consist of the track placement of one cohort of students over a three-year period (seventh, eighth, and ninth grades) in one of the three junior high schools in a city of 30,000 people. The analyses determine (1) the distribution of students among tracks for each year and (2) the extent of mobility from year to year. Black students are found to be assigned to lower tracks more frequently than white students and to have a larger downward mobility, increasing the gap. Unfortunately, data on achievement scores and socioeconomic status were not available, and therefore these variables are not controlled in the analyses.

Levine, D. M. "Inequality" and the analysis of educational policy.  
In D. M. Levine and M. J. Bane (Eds.), The "inequality" controversy: Schooling and distributive justice. New York: Basic Books, 1975.

This paper is a critique and rebuttal of Inequality: A Reassessment of the Effect of Family and Schooling in America (Jencks, Smith, Acland, Bane, Cohen, Gintis, Heyns, and Michelson, 1972). Levine scrutinizes the analyses and interpretations that appear in Inequality in order to propose more profitable directions for future educational policy and policy analysis. First, Levine assesses Inequality's approach to educational goals and the methodological consequences of that approach. Second, he comments on the book's analysis of school effectiveness. Third, he criticizes Jencks' account of the social utility of education. Finally, Levine makes some recommendations for the future. (1) We must try to establish more clearly the hierarchy of goals that serve as a structure for educational policy. (2) Within a revised hierarchy of social and educational goals, we have to clarify the meaning of equal educational opportunity by reconciling the goals of equal access to educational resources and of equal educational results. (3) We need approaches for analyzing educational policies other than traditional input-output analyses; a prime requirement for any new approach should be a systems orientation.

Pantages, T. J., & Creedon, C. F. Studies in college attrition: 1950-1975. Review of Educational Research, 1978, 48(1), 48-101.

This article summarizes research findings for the years 1950-1975 in order to provide useful information for colleges that are attempting to deal with the attrition problem. This review differs from previous reviews in the literature in that it covers a much more comprehensive study of attrition-related research, including methodological criticisms, a more complete analysis of factors that may affect attrition, the typical withdrawal procedure and a review of proposed programs that may be effective in countering attrition. The authors criticize the traditional two-way analysis of the categories of dropout (combining temporary and permanent dropouts) and nondropout (persisters), and they suggest that the distinction between "voluntary" and "nonvoluntary" dropouts be abandoned.

Pugh, G. E., Killalea, J. N., & Loatman, B. Educational opportunity: The concept, its measurement, and application. Washington, D.C.: National Center for Education Statistics, 1978.

The primary purpose of this study is to develop statistical indicators of inequality of educational opportunity and secondarily to apply them to the 1970 Census/ELSEGIS data file to assess the extent of inequality in the elementary and secondary schools in the United States. Highlights of the recent history of federal and state actions to eliminate bias and to ensure delivery of reasonably similar educational programs throughout the country, particularly for groups that historically have been deprived, are reviewed. A definition of equality of educational opportunity is proposed that the authors consider to be more practical than simple definitions of the concept. They argue that equity is best served if each individual is provided resources that strike a balance between the personal and social benefits and the personal and social costs. Unfortunately, our ability to measure benefits is very limited, and the principal attention in indicator development instead concentrates on the resources applied to education.

Recruitment Leadership and Training Institution. Minorities in policy-making positions in public education. Philadelphia: Author, 1974.

This report delineates the degree and nature of minority participation in effective, policymaking positions on administrative levels and proposes steps to further the hiring of minorities for these positions. Part 1, "Minorities in the Schools: A Backward Glance," discusses the history of blacks in administrative positions since 1961. Part 2, "Minorities in City and School District Populations," summarizes the developing opportunities for minorities in the field of education, using data from a 48-city survey to examine the population currently served by the public schools in these cities. Part 3, "Minority Educators in Policymaking Positions, 1974," identifies positions held by minority group members. Part 4 discusses traditional and minority-related policymaking positions, and Part 5 presents the employment picture in higher education. Conclusions and recommendations comprise Part 6.

Schafer, W. E., Olexa, C., & Poik, K. Programmed for social class: Tracking in high school. Trans-Action, 1970, 7(12), 39-46, 63.

This paper argues that school grouping based on presumed ability often reinforces already existing social divisions. Ability grouping may deny the poor adequate access to education. Some evidence bearing upon whether current educational practices do in fact reinforce existing social class divisions is examined. In this context, data on educational tracks, who is put on these tracks, and on differences between tracks are discussed. Children from low-income and minority group families more often find themselves in low ability groups and noncollege-bound



tracks than in high ability groups or college-bound tracks. Track position is related to whether a student's academic performance improves or deteriorates during high school. It is a good indication of how deeply involved a student will be in school and is strikingly related to delinquency, both in and out of school. Being assigned to the lower track in school is analyzed as a stigma and a self-fulfilling prophecy.

Spurlock, L. A. Still struggling: Minorities and white colleges in the mid-seventies. Educational Record, 1977, 57, 186-193.

Spurlock states that the initial fight against racial discrimination has now dwindled and that the time has come for a reevaluation of progress and a recommitment of energies and resources to the resistance of direct and subtle racism. He poses a large number of policy questions that focus on the problems that minorities face in realizing equal educational opportunities. Topics covered by policy questions include (1) undergraduate admissions, (2) remedial programs, (3) vocational counseling, academic advising, job placement, and sensitivity to cultural difference, (4) financial aid, (5) graduate and professional school, (6) financial barriers, (7) employment as faculty members, and (8) employment as administrators at educational institutions.

Tittle, C. K., & Denker, E. R. Re-entry women: A selective review of the educational process, career choice, and interest measurement. Review of Educational Research, 1977, 47(4), 531-584.

This literature review examines some factors related to the re-entry of women to postsecondary education and draws implications for needed research. It includes subjects related to the goals of studying educational and career patterns of re-entry women and to the development of adequate program evaluation models. The first part of the review considers barriers and opportunities in postsecondary education for the mature woman. These barriers include college restrictions, family resistance, and financial problems, as well as attitudinal and self-concept characteristics. Current theories and research on career choice for women are briefly noted in the second part of the review, and the third part deals specifically with a tool used by counselors--interest inventories. The review concludes with implications for needed research--theoretical, programmatic, and in the area of sex bias in interest measurement.

Van Dusen, R. A., & Sheldon, E. G. The changing status of American women: A life cycle perspective. American Psychologist, 1976, 31(2), 106-116.

The authors suggest that one way of summarizing and understanding recent trends in the status of women in the United States is in terms of the declining importance of the family life cycle in the woman's

total life cycle. They claim that the social importance of the distinction between married women and those who are unmarried (never married, no longer married, not yet married) is diminishing. In examining this general proposition, recent changes in a number of social areas that have a direct impact on a woman's life choices are highlighted, including a section on the changing educational status of women.

Wilson, S. R., & Wise, L. L. The American citizen: 11 years after high school (Volume I). Palo Alto, Calif.: American Institutes for Research, 1975.

A third follow-up survey of twelfth and eleventh grade Project TALENT participants (1960 and 1961 high school classes) was done approximately eleven years after their expected graduation from high school to gather additional data on the educational, career, personal, and family experiences of these individuals and their reflections on the value of these experiences in relation to their present activities and plans. Initiated in 1957, Project TALENT is a longitudinal study regarding the educational, career, and personal experiences of a national sample of 400,000 men and women who were in high school in 1960. Based on the responses of 54,000 individuals from the original sample of approximately 200,000 twelfth and eleventh grade students, data are summarized and interpreted according to three dimensions of the respondents' lives: education, work, and personal. This report includes approximately seventy pages of tabular data summarizing the response frequencies for each survey questionnaire item.

Wise, L. L., McLaughlin, D. H., & Gilmartin, K. J. The American citizen: 11 years after high school (Volume II). Palo Alto, Calif.: American Institutes for Research, 1977.

A third follow-up survey of ninth and tenth grade Project TALENT participants (1962 and 1963 high school classes) was done approximately eleven years after their expected graduation from high school to gather additional data on the educational, career, personal, and family experiences of these individuals and their present activities and plans. Initiated in 1957, Project TALENT is a longitudinal study regarding the educational, career, and personal experiences of a national sample of 400,000 men and women who were in high school in 1960. Based on the responses of 49,000 individuals from the original sample of approximately 200,000 ninth and tenth grade students, data are summarized and interpreted according to three dimensions of the respondents' lives: education, work, and personal. This report includes approximately eighty pages of tabular data summarizing the response frequencies for each survey questionnaire item.