

DOCUMENT RESUME

ED 190 980

SE 031 324

AUTHOR Bonar, John R., Ed.; Hathway, James A., Ed.
 TITLE Probing the Natural World, Level III, Teacher's Edition: Winds and Weather. Intermediate Science Curriculum Study.
 INSTITUTION Florida State Univ., Tallahassee. Dept. of Science Education.
 SPONS AGENCY National Science Foundation, Washington, D.C.; Office of Education (DHEW), Washington, D.C.
 PUB DATE 72
 NOTE 187p.: For related documents, see SE 031 300-330, ED 035 559-560, ED 049 032, and ED 052 940. Contains photographs and colored and shaded drawings and print which may not reproduce well.

EDRS PRICE MF01/PC08 Plus Postage.
 DESCRIPTORS *Climate: Environmental Influences: Grade 9; *Individualized Instruction: Instructional Materials: Junior High Schools: Laboratory Manuals; *Laboratory Procedures: Science Activities: Science Course Improvement Projects: Science Education: Secondary Education: Secondary School Science; *Temperature; *Weather
 IDENTIFIERS *Intermediate Science Curriculum Study

ABSTRACT This is the teacher's edition of one of eight units of the Intermediate Science Curriculum Study (ISCS) for level III students (grade 9). This unit focuses on weather, its measurement and prediction. Optional excursions are given for students who wish to study a topic in greater depth on an individualized basis. An introduction describes the energy for weather processes and the distribution of energy throughout the world. Illustrations accompany the text. (SA)

 * Reproductions supplied by EDRS are the best that can be made *
 * from the original document. *

TEACHER'S EDITION

Winds and Weather

ED190380

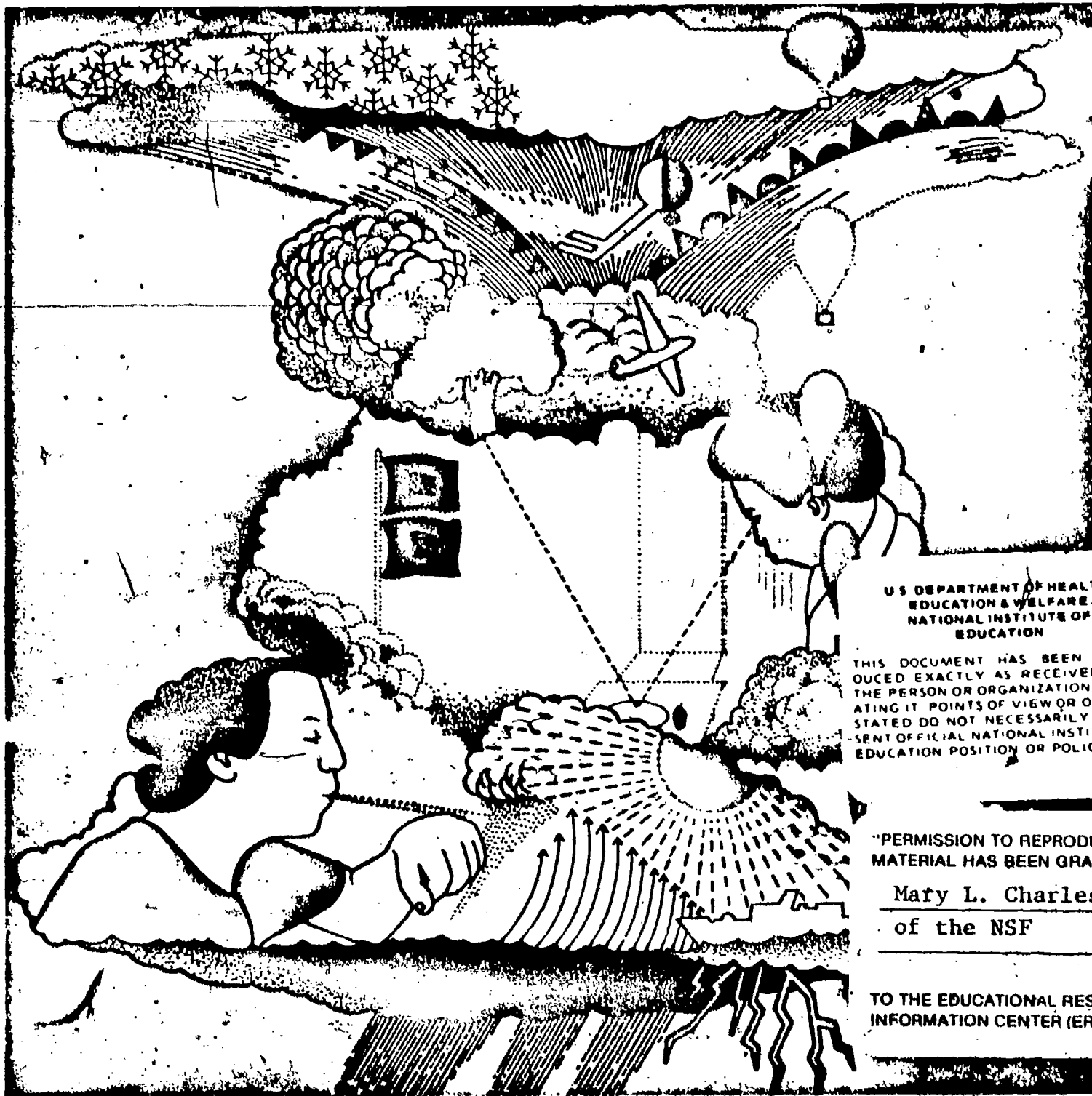

U.S. DEPARTMENT OF HEALTH,
EDUCATION & WELFARE
NATIONAL INSTITUTE OF
EDUCATION

THIS DOCUMENT HAS BEEN REPRO-
DUCED EXACTLY AS RECEIVED FROM
THE PERSON OR ORGANIZATION ORIGIN-
ATING IT. POINTS OF VIEW OR OPINIONS
STATED DO NOT NECESSARILY REPRESENT
OFFICIAL NATIONAL INSTITUTE OF
EDUCATION POSITION OR POLICY.

"PERMISSION TO REPRODUCE THIS
MATERIAL HAS BEEN GRANTED BY

Mary L. Charles
of the NSF

TO THE EDUCATIONAL RESOURCES
INFORMATION CENTER (ERIC)."

SE 031 324

Probing the Natural World/3



INTERMEDIATE
SCIENCE
CURRICULUM
STUDY

THIS BOOK IS THE PROPERTY OF:

STATE _____
 COUNTY _____
 PARISH _____
 SCHOOL DISTRICT _____
 OTHER _____

Book No. _____
 Enter information
 in spaces
 to the left as
 instructed

ISSUED TO	Year Used	CONDITION	
		ISSUED	RETURNED

- PUPILS to whom this textbook is issued must not write on any page or mark any part of it in any way; consumable textbooks excepted.
- Teachers should see that the pupil's name is clearly written in ink in the spaces above in every book issued.
 - The following terms should be used in recording the condition of the book: New; Good; Fair; Poor; Bad.



INTERMEDIATE SCIENCE CURRICULUM STUDY TEACHER'S EDITION

Winds and Weather

Probing the Natural World / Level III



SILVER BURDETT

GENERAL LEARNING CORPORATION

Morristown, New Jersey · Park Ridge, Ill. · Palo Alto · Dallas · Atlanta

ISCS PROGRAM

- LEVEL I** **Probing the Natural World / Volume 1 / with Teacher's Edition**
Student Record Book / Volume 1 / with Teacher's Edition
Master Set of Equipment / Volume 1
Test Resource Booklet
- LEVEL II** **Probing the Natural World / Volume 2 / with Teacher's Edition**
Record Book / Volume 2 / with Teacher's Edition
Master Set of Equipment / Volume 2
Test Resource Booklet
- LEVEL III** **Why You're You / with Teacher's Edition**
Record Book / with Teacher's Edition / Master Set of Equipment
Environmental Science / with Teacher's Edition
Record Book / with Teacher's Edition / Master Set of Equipment
Investigating Variation / with Teacher's Edition
Record Book / with Teacher's Edition / Master Set of Equipment
In Orbit / with Teacher's Edition
Record Book / with Teacher's Edition / Master Set of Equipment
What's Up? / with Teacher's Edition
Record Book / with Teacher's Edition / Master Set of Equipment
Crusty Problems / with Teacher's Edition
Record Book / with Teacher's Edition / Master Set of Equipment
Winds and Weather / with Teacher's Edition
Record Book / with Teacher's Edition / Master Set of Equipment
Well-Being / with Teacher's Edition
Record Book / with Teacher's Edition / Master Set of Equipment

ACKNOWLEDGMENTS

The work presented or reported herein was performed pursuant to a Contract with the U. S. Office of Education, Department of Health, Education, and Welfare. It was supported, also, by the National Science Foundation. However, the opinions expressed herein do not necessarily reflect the position or policy of the U. S. Office of Education or the National Science Foundation, and no official endorsement by either agency should be inferred.

© 1972 THE FLORIDA STATE UNIVERSITY,

All rights reserved. Printed in the United States of America. Published simultaneously in Canada. Copyright is claimed until 1977. Except for the rights to materials reserved by others, the Publishers and the copyright owner hereby grant permission to domestic persons of the United States and Canada for use of this work without charge in the English language in the United States and Canada after 1977 provided that the publications incorporating materials covered by the copyrights contain an acknowledgment of them and a statement that the publication is not endorsed by the copyright owner. For conditions of use and permission to use materials contained herein for foreign publications in other than the English language, apply to the copyright owner. This publication, or parts thereof, may not be reproduced in any form by photographic, electrostatic, mechanical, or any other method, for any use, including information storage and retrieval, without written permission from the publisher.

ILLUSTRATIONS: © 1972 GENERAL LEARNING CORPORATION.
ALL RIGHTS RESERVED.

An Introduction

The study of weather is a very complicated subject. Variables of temperature, pressure, humidity, wind, and clouds all have an effect on atmospheric conditions on the earth. Complicated and sometimes hard-to-measure factors such as upper air movement, variations in solar radiation, and changes due to the seasons contribute to the problem. An attempt to expound on all of these, and others, would result in a very lengthy text. Instead, this short introduction will focus on those things, not found in the student text or teacher annotations, that are judged to be pertinent to the unit.

From the time that man first became interested in the weather, his basic response was observation. Long before the use of instruments for measuring weather factors, eyes were turned skyward at the clouds, and the wind was tested with pieces of straw. And the observations became the foundation for a sort of "if—then" weather forecasting. "If," said the ancient sailing captain "the sky has mackerel scales and mares' tails, then I am going to have to lower my sails." In more modern terminology, he was saying that the appearance of cirrocumulus and cirrus clouds foretold the coming of a storm. "If," said the ancient farmer, "the breezes are backing, then dry hay we'll be lacking." Somehow, he knew that a backing wind (one that changes from north to west to south to east, or counterclockwise) presaged the approach of bad weather (a low-pressure area), and he had better get the hay in.

By the 17th century, instruments had been developed and began to be used for systematic weather observations. It was realized that scientific observation had to precede scientific prediction. It is interesting to note that in 1649 two cities in France and one in Sweden were simultaneously recording the weather. Without modern, high-speed communication, however, much of the value was lost. But the science of meteorology was born, and has been growing ever since. Incidentally, uninterrupted observations have been made in New Haven, Connecticut, since 1779. Student observations in this unit, though limited, play an equally important role in the development of a model, and in the attempt to make weather forecasts.

HEAT SUPPLIER IN THE SKY

The basic energy for weather processes is furnished by the sun. Of course, only a fraction of the sun's output of energy (about one two-billionth) reaches the vicinity of the earth. This radiation is largely divided between ultraviolet (10%), visible (45%), and infrared (45%) wavelengths.

At the edge of the atmosphere, the solar beam carries about 2 calories/cm²/min of radiation. This radiation is called the solar constant. This is equivalent to about one half million horsepower per square mile. Because of the earth's curvature, this beam is spread over a greater surface area at high latitudes than in the equatorial regions. (From this fact alone, we would expect the polar regions to be colder than the tropics.)

The solar beam is partially depleted as it passes through the atmosphere. At high altitudes, ozone gas forms and becomes concentrated enough to absorb the lethal ultraviolet wavelengths. The solar beam is also substantially reduced by reflection from the upper surfaces of cloud layers and by scattering off the various gas molecules and contaminants. Some energy is absorbed by cloud layers and air molecules. Of the total energy arriving at the outer edge of the atmosphere, only 28% arrives at the ground on an overcast day.

The particular type of cloud determines the amount of reflection. For example, altostratus clouds reflect three quarters of the beam back to space. The density of the air and the thickness of the cloud layer also determine the amount of absorption.

Once the energy reaches the earth's surface, it is either absorbed or reflected. This is highly dependent on the kind of surface material it strikes. In the Arctic, the glancing radiation is largely reflected from the snow; in the tropics, the equatorial forests absorb the vertical rays.

In addition to receiving radiation, the earth is also a radiating body. Actually, the earth radiates energy 24 hours a day, while it receives energy, on the average, for only half the day. Thus, in areas that absorb high amounts of radiation, the incoming energy exceeds the outgoing energy, while in polar regions terrestrial radiation far exceeds solar radiation.

THE DISTRIBUTION SYSTEM

With the tremendous differential in energy received, absorbed, and reflected by various areas of the earth's surface, it would seem that some locations would get unbearably hot while others would be unbelievably cold. Yet there are no spots on the earth where man cannot exist with proper protection. How is this heat energy distributed?

Radiant energy can travel from the source to the receiver without a medium of transmission. Some of the energy received by the earth is indeed retransmitted by this method. But the large surplus of heat received in the tropics travels to other regions by the other two methods of heat transfer—conduction and convection.

Heated surfaces of the earth heat the surrounding air by conduction. This only affects the air in contact with the surface. This air becomes less dense than the surrounding air and is buoyed upward. Heated air, rising above the tropics, flows north and south toward the Poles. Cooler air flows into the tropics to take its place. A huge circulatory system of heat transfer is set up as the heated air cools, sinks back to the surface, and flows back toward the equator.

Because of the earth's rotation, the actual circumstance is not as simple as the primary circulation described above. Instead, part of the air flowing Poleward at high altitude cools and falls at about 30° latitude. Due to Coriolis force, air in motion in the Northern Hemisphere is deflected to the right of its direction of motion. The part of the air that continues northward at the surface from 30° becomes the prevailing westerlies that affect the North American continent so greatly. The part that flows back to the equator becomes the trade winds of the subtropics. At the same time, polar air flowing southward at the surface becomes the Polar easterlies.

A major significance of this circulatory, heat distribution system is that large masses of air leave the subtropics and the subpolar regions and meet to form fronts. These frontal systems, in general, move from west to east across the United States because of prevailing air-movement. A large amount of the total weather pattern that we experience is dependent on these air masses and fronts.

OUTSIDE READINGS

Much of the detail of meteorology is included in simplified form in the student materials and in the teacher notes. Notably absent is any material on hurricanes and tornadoes, nature's most violent storms. Similarly, upper air measurement, so important in modern weather studies, has been omitted as being beyond the realm of this unit.

There are many fine books available that could be used by the teacher for reference or to obtain further background information. Some might be made available for better students who want to delve further into the subject. A short list follows:

- * Battan, Louis J. *The Nature of Violent Storms*. Garden City, New York: Doubleday and Co., Anchor Books, 1961.
- Blair, Thomas A., and Robert J. Fite. *Weather Elements*, 5th ed. Englewood Cliffs, N.J.: Prentice Hall, Inc., 1965.
- * Cantzlaar, George L. *Your Guide to the Weather*. New York: Barnes and Noble, Inc., 1964.
- Day, John A. *The Science of Weather*. Reading, Mass., Addison-Wesley Publishing Co., 1966.
- * Holmes, David C. *The Story of Weather*. New York: Pyramid Publications, Inc., 1963.
- * Landsberg, Helmut E. *Weather and Health*. Garden City, New York: Doubleday and Co., Anchor Books, 1969.
- * Lehr, P. E., R. W. Burnett, and H. S. Zim. *Weather*. New York: Golden Press, 1965.
- * Spar, Jerome. *Earth, Sea, and Air*. Reading, Mass., Addison-Wesley, 1962.
- Thompson, Philip D., and Robert O'Brien. *Weather* (Life Science Library). New York: Time Inc., 1965.

The books marked with an asterisk (*) are available in paperback editions.

AN OVERVIEW

The purpose of the unit is to develop a simple model for weather. In doing so, attention is focused on the agents that cause air to rise from one level to another.

Chapter 1 examines thermal convection as the first agent. The behavior of air is made visible by using a smoke box, and variations in temperature are provided with hot and cold water. The concept of differential heating of surfaces by radiant energy is developed, and the connection made between this differential heating and the behavior of the air.

Students are introduced to systematic visual and instrumental weather observations in Chapter 2. A weather watch that is to continue for four weeks is started. Excursions are provided to help with some of the observations and records.

The question of what happens to the properties of mass, pressure, and temperature of air as it rises is posed next. The particle model of matter is used to explain air pressure and to predict the interrelationship of temperature and pressure in a closed system. Measurement of atmospheric pressure is accomplished with a student-constructed barometer calibrated against an aneroid barometer.

Moisture content of the air is studied in Chapter 4. Measurement of this property of air is made in terms of dew point and relative humidity. The necessity of condensation nuclei for clouds to form is established.

Cloud formation is examined, using the two variables of temperature and pressure. The particle model is used to explain why warm air rises, why pressure on it decreases, and therefore why clouds form over particular areas. The concept of wind as a result of rising air is developed.

In Chapter 6, the deficiencies of the heated-air model are noted, and the model is expanded to include lines of temperature difference, convergence, and the effects of mountains as cloud-forming agents. A system of notation on weather maps is studied, and the technique of drawing isobars practiced. Some properties of low-pressure areas are examined.

The final chapter identifies lines of temperature differences as fronts and, by using sequential weather maps, shows that these fronts and the associated low-pressure areas move generally from west to east across the country. With this idea in mind, and using the developed model, methods of predicting the upward motion of air and the resulting weather conditions are studied. The use of the daily observations of the weather elements to provide clues for approaching weather is summarized.

GENERAL INFORMATION

Each chapter of the Teacher's Edition contains an equipment list for that chapter. The same is true for each excursion. Also included on the first page of the chapter is a statement of chapter emphasis and a listing of major points.

The answers to certain key questions are given in the body of the chapter. In addition, the last page of each chapter alerts you to preparations necessary for the following chapter.

Among the materials listed will be some items that must be supplied locally. You will need plastic tape, matches, scissors, and baby-food jars (both large and small) in a number of the chapters and excursions. In addition, you will need large cardboard boxes, ice cubes, thumbtacks, sand, crushed charcoal, and wire coat hangers in Chapter 1; crushed ice and ice cubes in Chapter 4; black paper in Chapter 5; large plastic dry-cleaning bags in Excursion 1-1; a 21 cm × 21 cm piece of glass, black paper, ruler or meterstick, timer, fine-point marking pen, and a drawing compass in Excursion 5-2; a pail, comb, and tape or clay for Excursion 7-1; and daily weather maps for Excursion 7-3. It would also be wise to have an adequate supply of paper towels for activities using water or ice cubes.

GET IT READY NOW FOR CHAPTER 1

Get your cardboard boxes, plastic tape, matches, scissors, and a good supply of baby-food jars, along with the materials supplied in the equipment kit, ready for the opening activity. You will also need ice cubes and some means of keeping them, and a method of supplying hot water.

For the remainder of the chapter, you will need thumbtacks, about 100 ml each of clean sand and crushed charcoal per student-team, and a supply of wire coat hangers. Now would be a good time to start saving the daily weather maps from the newspaper so that you have a good sequence for Chapter 7.

INTERMEDIATE SCIENCE CURRICULUM STUDY TEACHER'S EDITION

Winds and Weather

Probing the Natural World / Level III



SILVER BURDETT
GENERAL LEARNING CORPORATION

Morristown, New Jersey · Park Ridge, Ill. · Palo Alto · Dallas · Atlanta

ISCS PROGRAM

- LEVEL I** **Probing the Natural World / Volume 1 / with Teacher's Edition**
Student Record Book / Volume 1 / with Teacher's Edition
Master Set of Equipment / Volume 1
Test Resource Booklet
- LEVEL II** **Probing the Natural World / Volume 2 / with Teacher's Edition**
Record Book / Volume 2 / with Teacher's Edition
Master Set of Equipment / Volume 2
Test Resource Booklet
- LEVEL III** **Why You're You / with Teacher's Edition**
Record Book / with Teacher's Edition / Master Set of Equipment
Environmental Science / with Teacher's Edition
Record Book / with Teacher's Edition / Master Set of Equipment
Investigating Variation / with Teacher's Edition
Record Book / with Teacher's Edition / Master Set of Equipment
In Orbit / with Teacher's Edition
Record Book / with Teacher's Edition / Master Set of Equipment
What's Up? / with Teacher's Edition
Record Book / with Teacher's Edition / Master Set of Equipment
Crusty Problems / with Teacher's Edition
Record Book / with Teacher's Edition / Master Set of Equipment
Winds and Weather / with Teacher's Edition
Record Book / with Teacher's Edition / Master Set of Equipment
Well-Being / with Teacher's Edition
Record Book / with Teacher's Edition / Master Set of Equipment

ACKNOWLEDGMENTS

The work presented or reported herein was performed pursuant to a Contract with the U. S. Office of Education, Department of Health, Education, and Welfare. It was supported, also, by the National Science Foundation. However, the opinions expressed herein do not necessarily reflect the position or policy of the U. S. Office of Education or the National Science Foundation, and no official endorsement by either agency should be inferred.

© 1972 THE FLORIDA STATE UNIVERSITY

All rights reserved. Printed in the United States of America. Published simultaneously in Canada. Copyright is claimed until 1977. Except for the rights to materials reserved by others, the Publishers and the copyright owner hereby grant permission to domestic persons of the United States and Canada for use of this work without charge in the English language in the United States and Canada after 1977 provided that the publications incorporating materials covered by the copyrights contain an acknowledgment of them and a statement that the publication is not endorsed by the copyright owner. For conditions of use and permission to use materials contained herein for foreign publications in other than the English language, apply to the copyright owner. This publication, or parts thereof, may not be reproduced in any form by photographic, electrostatic, mechanical, or any other method, for any use, including information storage and retrieval, without written permission from the publisher.

ILLUSTRATIONS © 1972 GENERAL LEARNING CORPORATION.
ALL RIGHTS RESERVED.

ISCS STAFF

David D. Redfield, *Co-Director*
William R. Snyder, *Co-Director*
Ernest Burkman, *Steering Committee Chairman*

- * Laura M. Bell, *Artist*
- * John R. Bonar, *Editor*
- Drennen A. Browne, *Artist*
- * Harold I. Buell, *Administration*
- Robert L. Cocanougher, *Art Director*
- * Betsy Conlon Balzano, *Evaluation*
- Stewart P. Darrow, *Field Trial-Teacher Education*
- George O. Dawson, *Teacher Education*
- James A. Hathway, *Editor*
- * John S. Hutchinson, *Field Trial Teacher Education*
- * Sally Diana Kaicher, *Art Director*
- * Jane Larsen, *Art Director*
- Adrian D. Lovell, *Administration*
- * Audley C. McDonald, *Administration*
- * W. T. Myers, *Administration*
- Lynn H. Rogers, *Artist*
- Stephen C. Smith, *Artist*
- Lois S. Wilson, *Assistant Editor*

ISCS ADVISORY COMMITTEE

J. Myron Atkin, *University of Illinois*
Betsy Conlon Balzano, *State University of New York at Brockport*
Werner A. Baum, *University of Rhode Island*
Herman Branson, *Lincoln University*
* Martha Duncan Camp, *The Florida State University*
Clifton B. Clark, *University of North Carolina at Greensboro*
Steve Edwards, *The Florida State University*
Robert M. Gagné, *The Florida State University*
Edward Haensch, *Wabash College*
* Michael Kasha, *The Florida State University*
Russell P. Kropp, *The Florida State University*
J. Stanley Marshall, *The Florida State University*
William V. Mayer, *University of Colorado*
Herman Parker, *University of Virginia*
Craig Sipe, *State University of New York at Albany*
* Harry Sisler, *University of Florida*
Clifford Swartz, *State University of New York at Stony Brook*
Claude A. Welch, *Macalester College*
Gates Willard, *Manhasset Junior High School, Manhasset, N.Y.*
Herbert Zim, *Science Writer, Tavernier, Florida*

* Former member

MATERIALS DEVELOPMENT CONTRIBUTORS

This list includes writing-conference participants and others who made significant contributions to the materials, including text and art for the experimental editions.

Janet Anderson, Nyack, N.Y. Gerald R. Bakker, Earlham College. Frank Balzano, F.S.U. Harald N. Bliss, Mayville State College. Olaf A. Boedtker, Oregon State Univ. Calvin E. Bolin, F.S.U. Earl Brakken, Two Harbors, Minn. Bobby R. Brown, F.S.U. Robert J. Callahan, Jr. (deceased). Brian W. Carss, University of Illinois. Lois H. Case, Lombard, Ill. Clifton B. Clark, University of North Carolina at Greensboro. Sara P. Craig, F.S.U. John D. Cunningham, Aeneas State College. David H. Dasenbrock, F.S.U. Doris Dasenbrock, F.S.U. Jeff C. Davis, University of South Florida. Alan D. Dawson, Dearborn Public Schools, Mich. George O. Dawson, F.S.U. Gerrit H. DeBoer, F.S.U. Howard E. DeCamp, Glen Ellyn, Ill. James V. DeRose, Newtown Square, Pa. William A. Deskin, Cornell College. William K. Easley, Northeast Louisiana State College. Donald C. Edinger, University of Arizona. Camillo Fano, University of Chicago Laboratory School. Ronald A. Fisher, Maquoketa, Iowa. Edwin H. Flemming, F.S.U. Paul K. Flood, F.S.U. Harper W. Frantz, Pasadena City College (Emeritus). Earl Friesen, San Francisco State College. Bob Galati, Fullerton, Calif. J. David Gavenda, The University of Texas. Charles A. Gilman, Winchester, N.H. Robert J. Goll, Jacksonville University. Ralph H. Granger, Jr., Walpole, N.H. H. Winter Griffith, F.S.U. William Gunn, Miami, Florida. John Hart, Xavier University. John R. Hassard, Georgia State University. J. Dudley Herron, Purdue University. Father Francis Heyden, S.J., Georgetown University. Leonard Himes, Sarasota, Florida. Evelyn M. Hurlburt, Montgomery Junior College. John R. Jablonski, Boston University. Bert M. Johnson, Eastern Michigan University. Roger S. Jones, University of Minnesota. Leonard A. Kalal, Colorado School of Mines. Theodore M. Kellogg, University of Rhode Island. Elizabeth A. Kendzior, University of Illinois. F. J. King, F.S.U. David Klasson, Millville, Calif. Ken Kramer, Wright State University. William H. Long, F.S.U. Robert Lepper, California State College. Harold G. Liebherr, Milwaukee, Wis. William D. Larson, College of St. Thomas. Mable M. Lund, Beaverton, Oregon. H. D. Luttrell, North Texas State University. Maxwell Maddock, F.S.U. Solomon Malinsky, Sarasota, Florida. Eloise A. Mann, Sarasota, Florida. Harleen W. McAda, University of California at Santa Barbara. Auley A. McAuley, Michigan State University. E. Wesley McNair, F.S.U. Marilyn Miklos, F.S.U. Floyd V. Monaghan, Michigan State University. Rufus F. Morton, Westport, Conn. Tamson Myer, F.S.U. Gerald Neufeld, F.S.U. James Okey, University of California. Lawrence E. Oliver, F.S.U. Larry O'Rear, Alice, Texas. Herman Parker, University of Virginia. Harry A. Pearson, Western Australia. James E. Perham, Randolph-Macon Woman's College. Darrell G. Phillips, University of Iowa. Howard Pierce, F.S.U. David Poché, F.S.U. Charles O. Pollard, Georgia Institute of Technology. Glenn F. Powers, Northeast Louisiana State College. Ernest Gene Preston, Louisville, Ky. Edward Ramey, F.S.U. Earl R. Rich, University of Miami. John Schaff, Syracuse University. Carroll A. Scott, Williamsburg, Iowa. Earle S. Scott, Ripon College. Thomas R. Spalding, F.S.U. Michael E. Stuart, University of Texas. Sister Agnes Joseph Sun, Marygrove College. Clifford Swartz, State University of New York. Thomas Teates, F.S.U. Bill W. Tillery, University of Wyoming. Ronald Townsend, University of Iowa. Mordecai Treblow, Bloomsburg State College. Henry J. Triczenberg, National Union of Christian Schools. Paul A. Vestal, Rollins College. Robert L. Vickery, Western Australia. Frederick B. Voight, F.S.U. Claude A. Welch, Macalester College. Paul Westmeyer, F.S.U. Earl Williams, University of Tampa. G. R. Wilson, Jr., University of South Alabama. Harry K. Wong, Atherton, California. Charles M. Woolheater, F.S.U. Jay A. Young, King's College. Victor J. Young, Queensborough Community College.

The genesis of some of the ISCS material stems from a summer writing conference in 1964. The participants were:

Frances Abbott, Miami-Dade Junior College. Ronald Atwood, University of Kentucky. George Assoua, Carnegie Institute. Colin H. Barrow, University of West Indies. Peggy Bazzel, F.S.U. Robert Binger (deceased). Donald Bucklin, University of Wisconsin. Martha Duncan Camp, F.S.U. Roy Campbell, Broward County Board of Public Instruction, Fla. Bruce E. Cleare, Tallahassee Junior College. Anna-cite Hall, Pensacola, Florida. Charles Holcolmb, Mississippi State College. Robert Kemman, Mt. Prospect, Ill. Gregory O'Berry, Coral Gables, Florida. Elra Palmer, Baltimore. James Van Pierre, Indiana University Southeast. Guenter Schwartz, F.S.U. James E. Sineland, F.S.U. C. Richard Tillis, Pine Jog Nature Center, Florida. Peggy Wiegand, Emory University. Elizabeth Woodward, Augusta College. John Woolever, Sarasota, Florida.

Foreword

A pupil's experiences between the ages of 11 and 16 probably shape his ultimate view of science and of the natural world. During these years most youngsters become more adept at thinking conceptually. Since concepts are at the heart of science, this is the age at which most students first gain the ability to study science in a really organized way. Here, too, the commitment for or against science as an interest or a vocation is often made.

Paradoxically, the students at this critical age have been the ones least affected by the recent effort to produce new science instructional materials. Despite a number of commendable efforts to improve the situation, the middle years stand today as a comparatively weak link in science education between the rapidly changing elementary curriculum and the recently revitalized high school science courses. This volume and its accompanying materials represent one attempt to provide a sound approach to instruction for this relatively uncharted level.

At the outset the organizers of the ISCS Project decided that it would be shortsighted and unwise to try to fill the gap in middle school-science education by simply writing another textbook. We chose instead to challenge some of the most firmly established concepts about how to teach and just what science material can and should be taught to adolescents. The ISCS staff have tended to mistrust what authorities believe about schools, teachers, children, and teaching until we have had the chance to test these assumptions in actual classrooms with real children. As conflicts have arisen, our policy has been to rely more upon what we saw happening in the schools than upon what authorities said could or would happen. It is largely because of this policy that the ISCS materials represent a substantial departure from the norm.

The primary difference between the ISCS program and more conventional approaches is the fact that it allows each student to travel

at his own pace, and it permits the scope and sequence of instruction to vary with his interests, abilities, and background. The ISCS writers have systematically tried to give the student more of a role in deciding what he should study next and how soon he should study it. When the materials are used as intended, the ISCS teacher serves more as a "task easer" than a "task master." It is his job to help the student answer the questions that arise from his own study rather than to try to anticipate and package what the student needs to know.

There is nothing radically new in the ISCS approach to instruction. Outstanding teachers from Socrates to Mark Hopkins have stressed the need to personalize education. ISCS has tried to do something more than pay lip service to this goal. ISCS' major contribution has been to design a system whereby an average teacher, operating under normal constraints, in an ordinary classroom with ordinary children, can indeed give maximum attention to each student's progress.

The development of the ISCS material has been a group effort from the outset. It began in 1962, when outstanding educators met to decide what might be done to improve middle-grade science teaching. The recommendations of these conferences were converted into a tentative plan for a set of instructional materials by a small group of Florida State University faculty members. Small-scale writing sessions conducted on the Florida State campus during 1964 and 1965 resulted in pilot curriculum materials that were tested in selected Florida schools during the 1965-66 school year. All this preliminary work was supported by funds generously provided by The Florida State University.

In June of 1966, financial support was provided by the United States Office of Education, and the preliminary effort was formalized into the ISCS Project. Later, the National Science Foundation made several additional grants in support of the ISCS effort.

The first draft of these materials was produced in 1968, during a summer writing conference. The conferees were scientists, science educators, and junior high school teachers drawn from all over the United States. The original materials have been revised three times prior to their publication in this volume. More than 150 writers have contributed to the materials, and more than 180,000 children, in 46 states, have been involved in their field testing.

We sincerely hope that the teachers and students who will use this material will find that the great amount of time, money, and effort that has gone into its development has been worthwhile.

Tallahassee, Florida
February 1972

The Directors

INTERMEDIATE SCIENCE CURRICULUM STUDY

Contents

NOTES TO THE STUDENT

viii

CHAPTERS

1 Air Has Its Ups and Downs	1
2 Weather Watch	15
3 Concentrating on Ups	21
4 Making Visible the Invisible	37
5 More Reasons for Clouds	51
6 Other Cloud Formers	65
7 Moving Weather	81

EXCURSIONS

1-1 Hot Air Balloon	99
2-1 Blowin' in the Wind	103
2-2 Billboards of the Sky	107
2-3 The Conversion Excursion	117
3-1 The Pressure's On	121
3-2 Measuring Air Pressure . . . in Inches?	125
4-1 The Shivering Thermometer	133
5-1 How High Are the Clouds?	141
5-2 Building a Nephoscope	145
7-1 And the Rains Came Down	151
7-2 Cumulonimbus	157
7-3 Weather Prediction and Forecasting	163

vii

Notes to the Student

The word *science* means a lot of things. All of the meanings are "right," but none are complete. *Science* is many things and is hard to describe in a few words.

We wrote this book to help you understand what science is and what scientists do. We have chosen to show you these things instead of describing them with words. The book describes a series of things for you to do and think about. We hope that what you do will help you learn a good deal about nature and that you will get a feel for how scientists tackle problems.

How is this book different from other textbooks?

This book is probably not like your other textbooks. To make any sense out of it, you must work with objects and substances. You should do the things described, think about them, and then answer any questions asked. Be sure you answer each question as you come to it.

The questions in the book are very important. They are asked for three reasons:

1. To help you to think through what you see and do.
2. To let you know whether or not you understand what you've done.
3. To give you a record of what you have done so that you can use it for review.

How will your class be organized?

Your science class will probably be quite different from your other classes. This book will let you start work with less help than usual from your teacher. You should begin each day's work where you left off the day before. Any equipment and supplies needed will be waiting for you.

Your teacher will not read to you or tell you the things that you are to learn. Instead, he will help you and your classmates individually.

Try to work ahead on your own. If you have trouble, first try to solve the problem for yourself. Don't ask your teacher for help until you really need it. Do not expect him to give you the answers to the questions in the book. Your teacher will try to help you find where and how you went wrong, but he will not do your work for you.

After a few days, some of your classmates will be ahead of you and others will not be as far along. This is the way the course is supposed to work. Remember, though, that there will be no prizes for finishing first. Work at whatever speed is best for you. *But be sure you understand what you have done before moving on.*

Excursions are mentioned at several places. These special activities are found at the back of the book. You may stop and do any excursion that looks interesting or any that you feel will help you. (Some excursions will help you do some of the activities in this book.) Sometimes, your teacher may ask you to do an excursion.

What am I expected to learn?

During the year, you will work very much as a scientist does. You should learn a lot of worthwhile information. More important, we hope that you will learn how to ask and answer questions about nature. *Keep in mind that learning how to find answers to questions is just as valuable as learning the answers themselves.*

Keep the big picture in mind, too. Each chapter builds on ideas already dealt with. These ideas add up to some of the simple but powerful concepts that are so important in science. If you are given a Student Record Book, do all your writing in it. *Do not write in this book.* Use your Record Book for making graphs, tables, and diagrams, too.

From time to time you may notice that your classmates have not always given the same answers that you did. This is no cause for worry. There are many right answers to some of the questions. And in some cases you may not be able to answer the questions. As a matter of fact, no one knows the answers to some of them. This may seem disappointing to you at first, but you will soon realize that there is much that science does not know. In this course, you will learn some of the things we don't know as well as what is known. Good luck!

EQUIPMENT LIST

Per student-team

- 1 cardboard box, 30 cm x 30 cm x 50 cm
- Clear plastic wrap
- Plastic tape
- 2 plastic straws
- 1 large air piston

Heavy cotton string, 12 cm long

Matches

Scissors

Baby-food jar,

Ice cubes or ice water

Hot water

1 aluminum pan

1 pegboard balance rod

1 wire support

2 small paper bags

2 thumbtacks

1 alcohol burner

5 Styrofoam cups

5 thermometers

1 150-watt lamp and socket

Extension cord

100 ml clean sand

100 ml crushed charcoal

Coat hanger

CHAPTER EMPHASIS

Hot or cold surfaces have different effects on the air over them. Various substances are heated unequally by radiant energy.

Air Has Its Ups and Downs

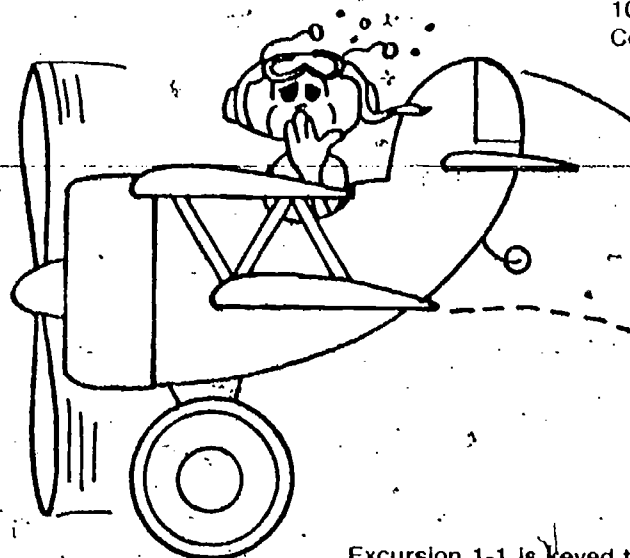

Excursion 1-1 is keyed to this chapter.

Chapter 1

MAJOR POINTS

1. By watching the behavior of smoke particles as they pass over surfaces whose temperatures are different, you can infer how the invisible air is behaving, i.e., that a) air moves downward over colder surfaces, and b) upward over warmer surfaces.
2. The idea of force developed in ISCS, Level 1, is used to explain the motion of air over areas of different temperatures.
3. The particle model of matter is used to explain why a volume of warm air has less

How would you like to be able to explain the formation of a giant thundercloud like the one shown on the facing page? "A tough job," you say. Perhaps, but not impossible. To do it, you'll need to find out a few things about air, water, heat, and the earth's surface. You'll need to know how these variables interact to produce changes in the earth's atmosphere. These atmospheric changes are what we call "weather." Of course there is more to weather than a thundercloud. However, old cumulonimbus is an exciting fellow.

Your first task is to find out how warm and cold surfaces affect air. You will need to make an observation box if one isn't already available. To do this, you'll need the following materials:

1 cardboard box (about 30 cm x 30 cm x 50 cm)

Clear plastic food wrap

Plastic tape

1 plastic straw

mass than an equal volume of cool air, i.e., according to the particle model of matter, particles of warm air are farther apart than the particles in cool air.

4. Cold air, being heavier than warm air, sinks, pushing the warmer air upward.

5. Laboratory observations lead to the following conclusions:

A. The temperature of some substances (surfaces) changes more than that of other substances when the same amount of radiant energy strikes them. (Graphs can be used to show these differences in rates of heating and cooling.)

B. Air above a surface is warmed or cooled by that surface.

C. Solar radiation causes differential heating of different earth surfaces, and this in turn causes differential heating of the air over the surface, causing up-and-down air currents.

Once made, the observation boxes can be used by other students. Note that they will be used again in Chapter 5.

You should supervise the construction of the boxes rather carefully, in light of the fact that they will be used repeatedly here, and later in the unit.

ACTIVITY 1-1. Remove one side of the box; then cut a window in two sides as shown. But leave about $\frac{1}{3}$ of the top intact. Tape plastic food wrap over the windows so that they are airtight. In one end of the box, cut a small hole just large enough to insert a plastic straw.

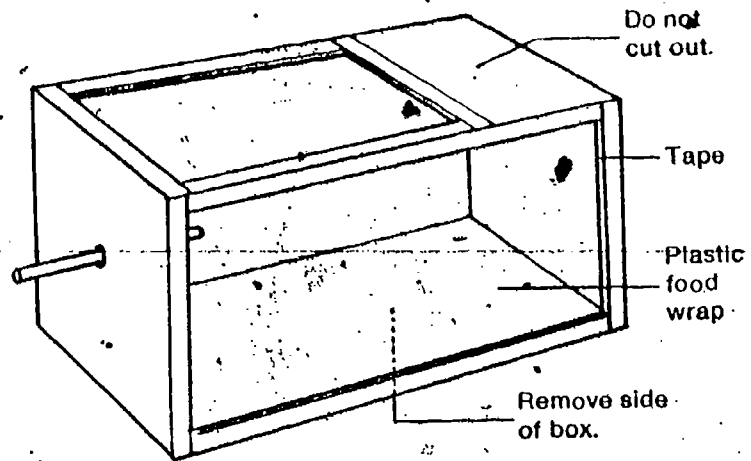

Note the inference here. In Level I of ISCS, students identified the presence of something (a force, for example) by the effect that it had on something visible (the force-measurer blade). Here they are going to identify air movement by the effect it has on the smoke particles.

Studying the behavior of air is a bit difficult because air is a mixture of invisible gases. One way to study air is to add smoke particles to it. By watching what happens to the smoke, you can decide what invisible air is doing. The next activities will suggest a simple way to collect some smoke. You will need the following:

- 1 large air piston
- 1 plastic straw
- Heavy cotton string, 12 cm long
- Matches
- Scissors
- Baby-food jar
- of tap water

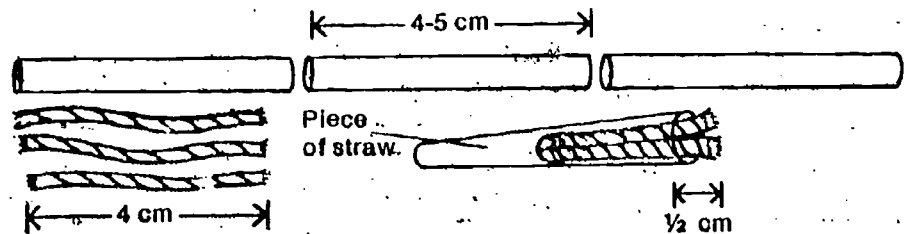

ACTIVITY 1-2. Cut the straw into 4- to 5-cm lengths. Cut the string into lengths of about 4 cm. Double one of the pieces of string twice or more until it will fit snugly in the end of a piece of the plastic straw. Leave about $\frac{1}{2}$ cm of the doubled string sticking out of the straw. Repeat the procedure for the other pieces.

ACTIVITY 1-3. Slip a section of the prepared straw onto the air piston. Light the string, being careful not to melt the straw. Collect smoke in the cylinder by slowly drawing out the plunger. Remove the straw and lay it aside where it won't burn anything. You may need more smoke later.

Now you are ready to see how warm and cold surfaces affect air. You will use your observation box and the smoke you collected in Activity 1-3.

ACTIVITY 1-4. Place a pan of cold water (ice water or even ice cubes if possible) inside the observation box. Be sure the straw is in place through the end of the box. The end of the straw should not be over the pan of water.

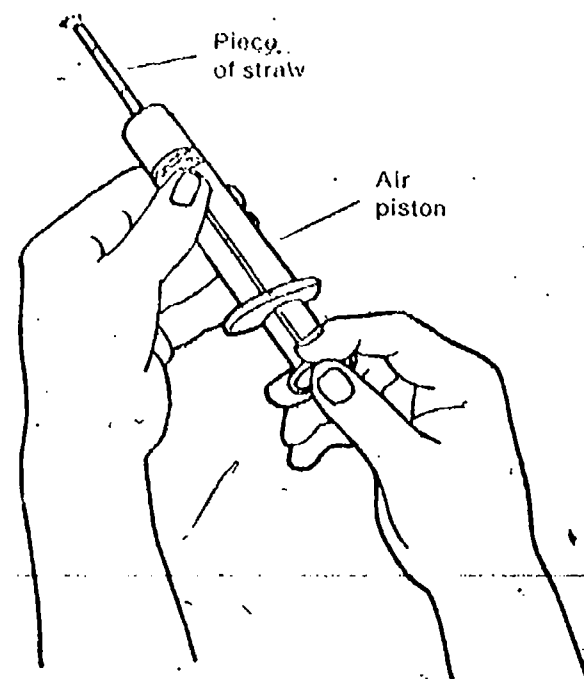

If you wish to keep the amount of smoke in the room to a minimum, you may have several groups draw smoke from the same source.

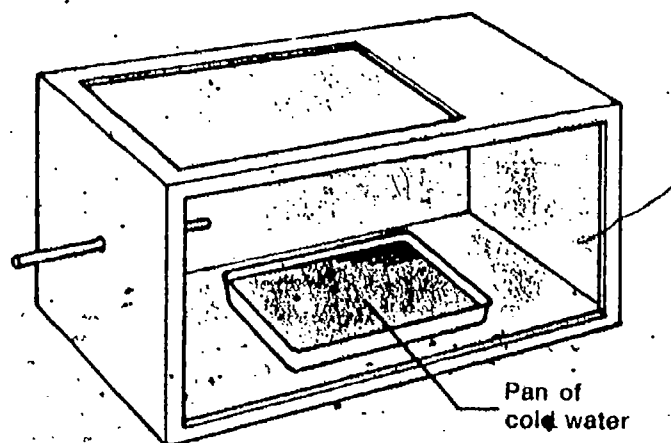

Keeping the water cold (or hot for the next series of activities) can present a problem. If you have worked out an ice-cube supply (cafeteria, perhaps), a Styrofoam chest or ice bucket will be valuable for keeping the cubes. A hot plate would be best for the hot water supply; an alcohol burner will work, but not as well. It might be wise to give a few words of caution about sloppiness, as well as about safety with the hot water and the heater.

ACTIVITY 1-5. Insert a smoke-filled air piston into the straw of the observation box. Gently force smoke through the straw into the box so that it moves very slowly over the cold water. Observe what happens to the smoke.

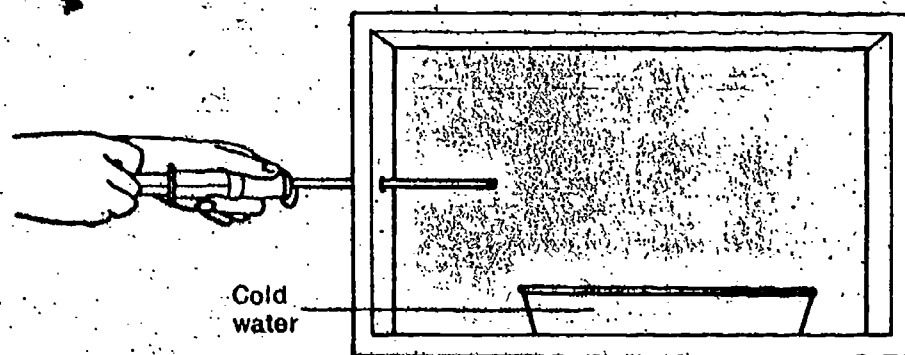

Careful observation is necessary here and with the hot water that follows. Students tend to rush through the activities without taking time to see what really happens.

1-1. Describe what happened to the smoke as it moved into the region above the cold surface.

Repeat Activities 1-3, 1-4, and 1-5 using a pan of hot water. But don't throw away the ice. Other students may need it.

1-2. Describe what happened to the smoke as it moved into the region above the warm surface.

If you studied Volume 1 or Volume 2 of the ISCS program, you learned that a change in motion of something occurs only if a force is acting upon it.

1-3. In earlier ISCS work, a force was defined as something that causes a change in shape or a change in motion of a body. It was easier then to measure the change in shape; now a change in motion is more apparent.

1-3. How do you know that some force acts on the smoke as it moves into the region above the warm or the cold surface?

Figure 1-1 illustrates the smoke-filled air as it moves above the surface of the cold and the hot water.

Figure 1-1

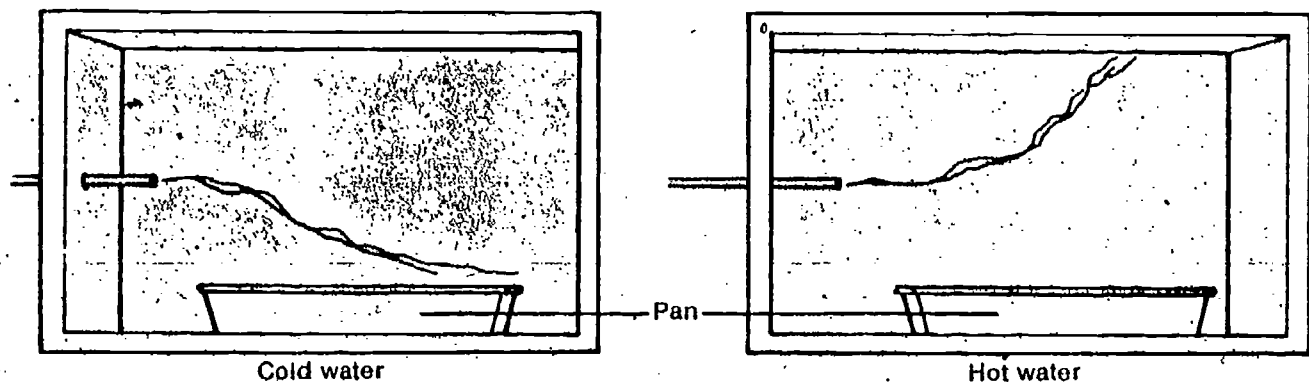

1-4. The arrows should be vertically up or down, even though the smoke may not rise or sink exactly vertically.

1-4. In Figure 1-1 of your Record Book, draw arrows indicating the direction of the force acting on each of the smoke streams.

The upward motion of the smoke above the warm surface suggests that the air is rising. This updraft pushes the smoke along with it.

1-5. What does the smoke movement tell you about the motion of air over a cold surface?

The vertical (up-and-down) movement of air is very important in producing weather changes. But how can this motion be explained? Putting an activity together with the particle model from ISCS Volume 1 can help.

Get a partner and the following materials for this activity:

- 1 pegboard balance rod
- 1 wire support for rod
- 2 small paper bags of equal size
- 2 thumbtacks of equal size
- 1 alcohol burner
- Matches

ACTIVITY 1-6. Set up the balance rod and wire support as shown. Fasten the two paper bags to the balance rod, using the thumbtacks. Balance the rod by moving the sliding clip. With the rod held stationary as shown, hold a lighted alcohol burner about 15 cm below the open end of the bag on the right.

Caution Be careful not to let the bag catch fire! Keep the burner under the bag for 30 seconds.

ACTIVITY 1-7. Remove the burner, extinguish it, and gently let go of the bar. Observe the bag for several minutes.

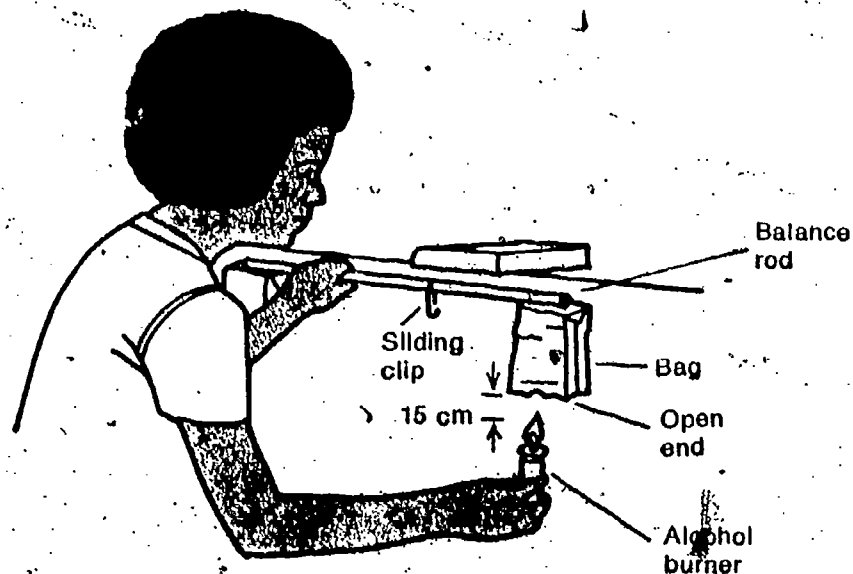

- 1-6. Describe your observations from Activity 1-7.
- 1-7. According to your observations, which has the greater mass, the bag of warm air or the bag of cool air?

Alcohol burners are used for the first time. It would probably be a good opportunity to re-emphasize lab safety, especially concerning the dispensing of alcohol for the burners. Make it standard procedure never to fill any burners while oil or lighted burners are on the table. If possible, fill them in a separate room. Wipe up any spills immediately. Avoid letting fumes concentrate in the room. Don't walk around the room with a lighted burner. Don't let the flame continue when the fuel is gone. Don't fill burners more than about half full. Don't have too much wick exposed. Keep capped when not in use.

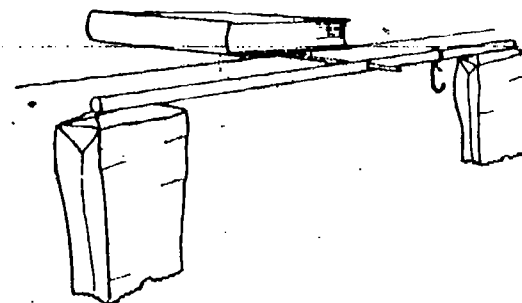

After observation, the students should use care in removing the bags from the balance rod. There is no reason why the same bags cannot be used several times if they don't catch on fire. Emphasize safety here again. What should be the procedure if a bag does catch on fire? Would it be wise to have a pail of water handy for dunking it?

You may want to refer students to the Volume I particle model mentioned here, if texts are available. It is discussed in Chapter 21 of the Level I text, and in Part B of Excursion 1-1 in the Level II text.

The particle model for matter from Volume I of ISCS suggested that heating a substance causes the particles of the substance to spread farther apart. Thus, the particles in warm air can be thought of as farther apart than the particles in cool air. This idea is illustrated in Figure 1-2.

Figure 1-2

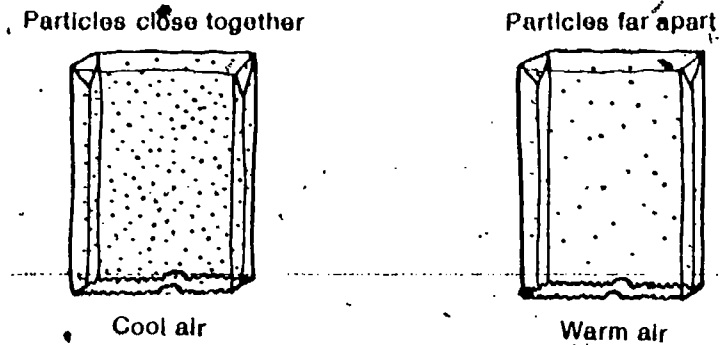

□ 1-8. The bags shown in Figure 1-2 have the same volume. Which has more gas particles per volume?

It seems reasonable to think that the bag with the greater number of air particles will have more mass and therefore be heavier than the bag with fewer particles. Because the bag of warm air is lighter than the bag of cool air, it is pushed upward by the heavier, cooler air that surrounds it. It behaves somewhat like a cork that is held under the surface of a liquid. Just as the heavier surrounding water pushes the cork up when it is released, so also the surrounding heavier air pushes the lighter, warm air up (Figure 1-3).

No intensive work has been done in the preceding levels of ISCS on buoyancy and displacement. But the explanation here, with the cork analogy, should suffice.

Figure 1-3

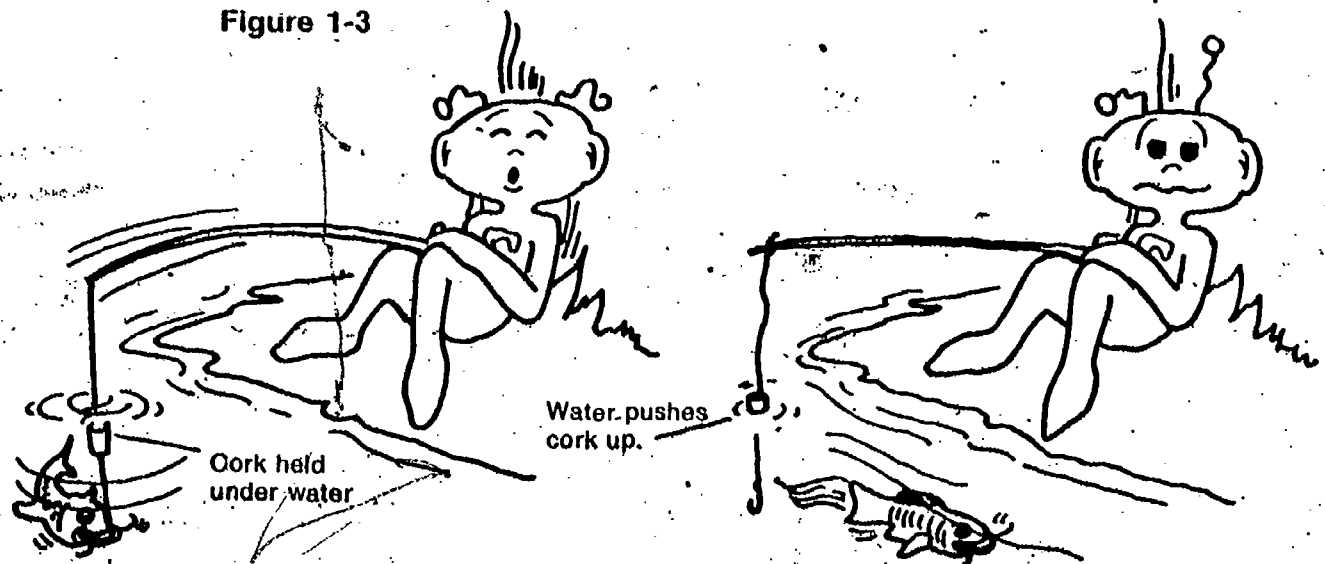

Balloons of all sizes, some carrying animals and machines, have been propelled upward by the lift of hot gases. Man's first flights into space were aboard such hot-air crafts. Perhaps you'd like to try making your own balloon. If so, get a partner and get going on **Excursion 1-1**.

The fact that warm air rises and cool air descends will prove to be very important in helping you explain weather conditions.

But how is the air cooled or warmed? Is it a result of sunlight, or the lack of it? Does the earth's surface have anything to do with this cooling and warming?

Get a couple of partners to help you find the answers to these questions. Your team will need the following equipment:

- 5 Styrofoam cups
- 5 thermometers
- Scissors
- 1 floodlamp (or 150-watt bulb)
- Water at room temperature
- Dry sand
- Finely crushed dry charcoal

ACTIVITY 1-8. Carefully cut the tops off the five cups about 3 cm from the bottom. Save both tops and bottoms of the cups.

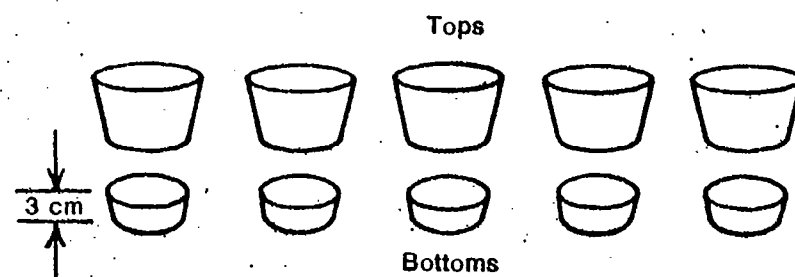

ACTIVITY 1-9. Fill one cup with water at room temperature, one with dry sand, one with wet sand, one with dry crushed charcoal, and one with wet crushed charcoal. Arrange the cups in a circle.

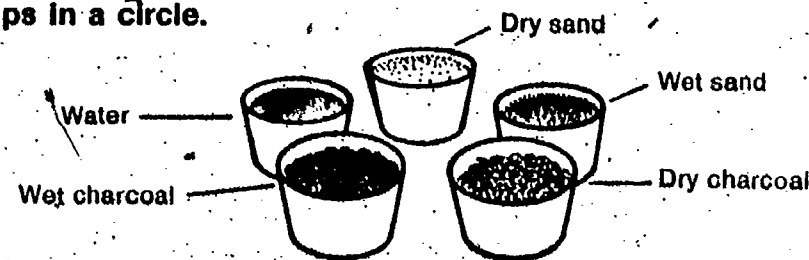

Excursion 1-1 should be fun, but it does require some supervision. It also requires that a large plastic dry-cleaning bag be brought in from home.

← EXCURSION

Clean air derives very little, if any, of its heat directly from the sun. In other words, in the solar heating system the radiant energy passes through the atmosphere to heat surfaces that absorb the rays. These surfaces then pass the heat to the surrounding air by conduction, and this heat is carried aloft by convection. The solar radiation and the air do not constitute a subsystem, because they are not directly related.

Charcoal briquets will work fine when crushed. This can be a messy operation, and it was suggested that you might want to do it ahead of time in your preparations for the chapter. Sand and crushed charcoal can be kept on the supply table in jars, and students can return the materials to the respective jars upon completing the activities. Be sure to have separate jars for wet and dry sand, and wet and dry charcoal.

If the thermometer bulb is covered too deeply, it will require too long a time for heat to penetrate by conduction.

ACTIVITY 1-10. Place a thermometer in each container. Each thermometer bulb should be covered by no more than $\frac{1}{2}$ cm of material.

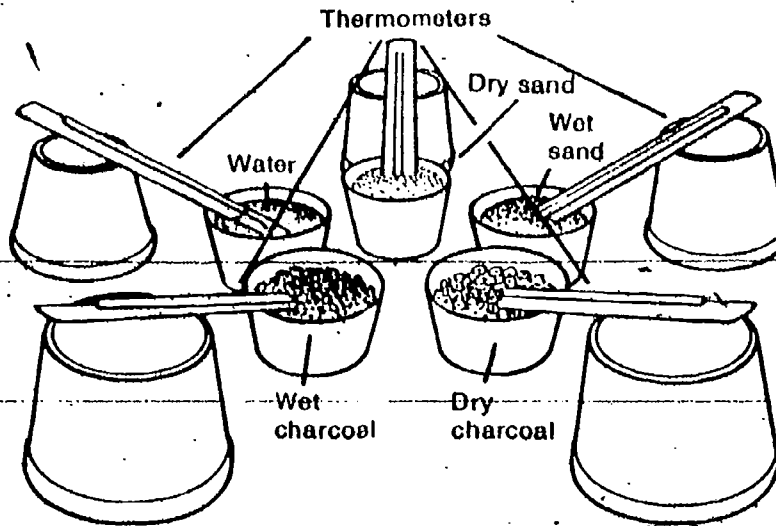

ACTIVITY 1-11. Hang a 150-watt bulb about 30 cm above the center of the circle of containers. Don't turn the light on until you have recorded the initial temperature for each container. Record your readings in Table 1-1 of your Record Book.

You will probably want to rig up some manner of supporting the lamp 30 cm above the containers. Three metersticks could be used as a tripod; two pegboards on end with a meterstick between them will work; books can be stacked for the same purpose. Two setups should suffice for the whole class, leaving the apparatus in place.

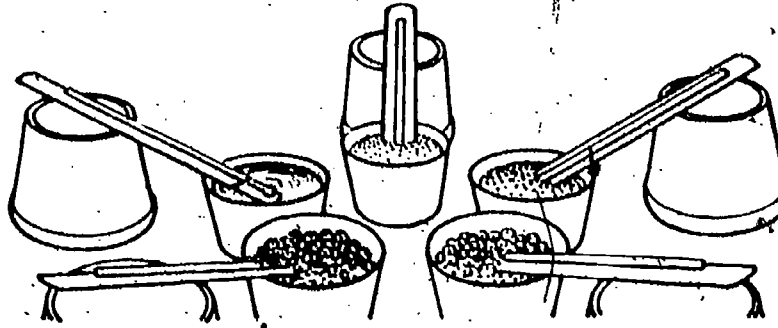
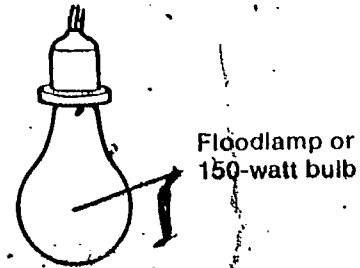

Temperatures should be taken 1, 3, and 5 minutes after the light is turned on. Then again 5 minutes after the light is turned off.

Table 1-1

THERMOMETER READING (°C)					
Material	Light Off at Beginning of Experiment	Light Turned On			Light Off After 5 Minutes Cooling
		After 1 Minute	After 3 Minutes	After 5 Minutes	
Water					
Dry sand					
Wet sand					
Dry charcoal					
Wet charcoal					

Graph the data from Table 1-1 on Figure 1-4 of your Record Book. On the graph, each of the five sets of data should be represented by a different line (see key). Number the temperature lines at left so that the beginning temperatures are near the bottom line and the highest temperature reached in any material is near the top. Remember that the temperature divisions on the lines must represent equal degree intervals.

Some students may still need help in constructing or interpreting graphs.

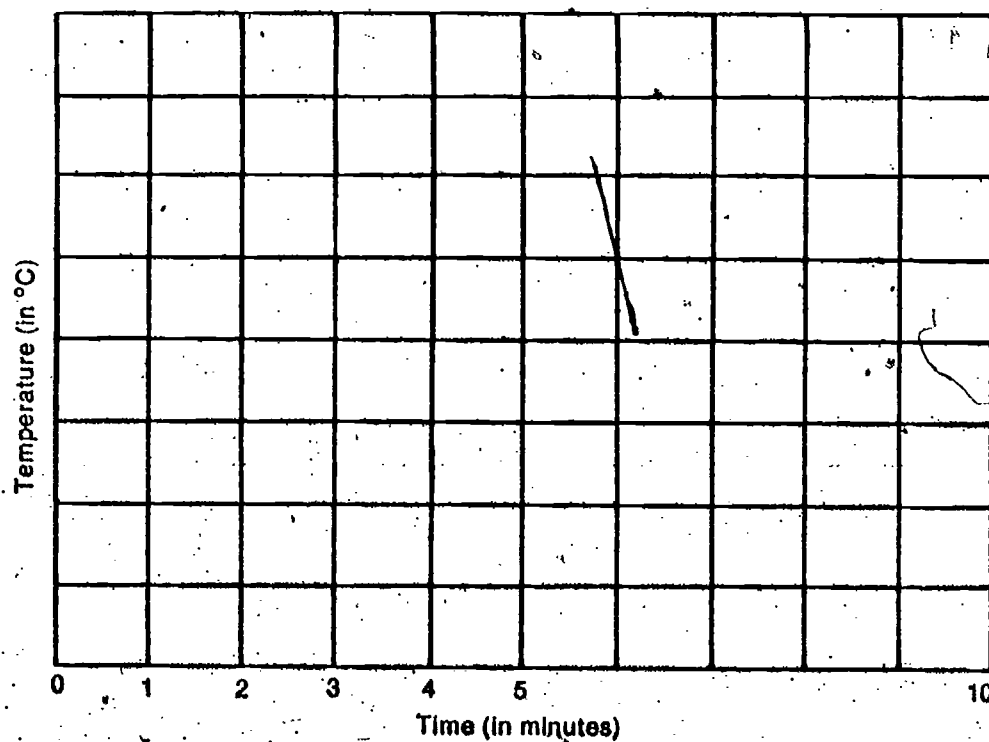
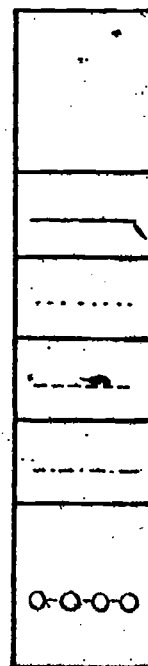

Figure 1-4

- Key
- Water
 - Dry sand
 - Wet sand
 - Dry charcoal
 - Wet charcoal



1-9 through 1-13. The dry solids heated more rapidly (and cooled more rapidly) than the wet ones. The slowest to heat was water. The probable order, from greatest temperature change to least, would be dry charcoal, dry sand, wet charcoal, wet sand, water, for both the heating and the cooling. If better students ask why this is so, you can explain that it is due to a combination of factors: (a) how much radiant energy is absorbed and how much is reflected (dark substances are better absorbers than light; water is a better reflector); (b) what the specific heat of the substance is (how much heat it takes to raise the temperature of a unit mass of a substance one degree; water has the highest specific heat); (c) what the mass of the substance is; and (d) even the wavelength of the radiant energy (some wavelengths are absorbed better than others by certain substances).

The same light shone equally on all the materials for the same period of time. Yet the temperature of some materials increased more than the temperature of others.

- 1-9. Of the dry materials, which showed the greater temperature change, the dark (charcoal) or the light (sand)? Which cooled faster?
- 1-10. Of the wet solids, which showed the greater temperature increase?
- 1-11. Did the dry solid show more temperature increase than the same solid when wet?
- 1-12. Did the temperature of the water increase as much as the temperature of the solids?
- 1-13. When the light was turned off, which of the substances cooled the most in 5 minutes?

This last investigation you did should have made a couple of things rather obvious:

1. When light reaches a surface, the temperature of that surface will increase.
2. Different kinds of surfaces show different rates of heating and cooling.

It is reasonable to expect that the air above the earth's surface will be warmed or cooled by that surface.

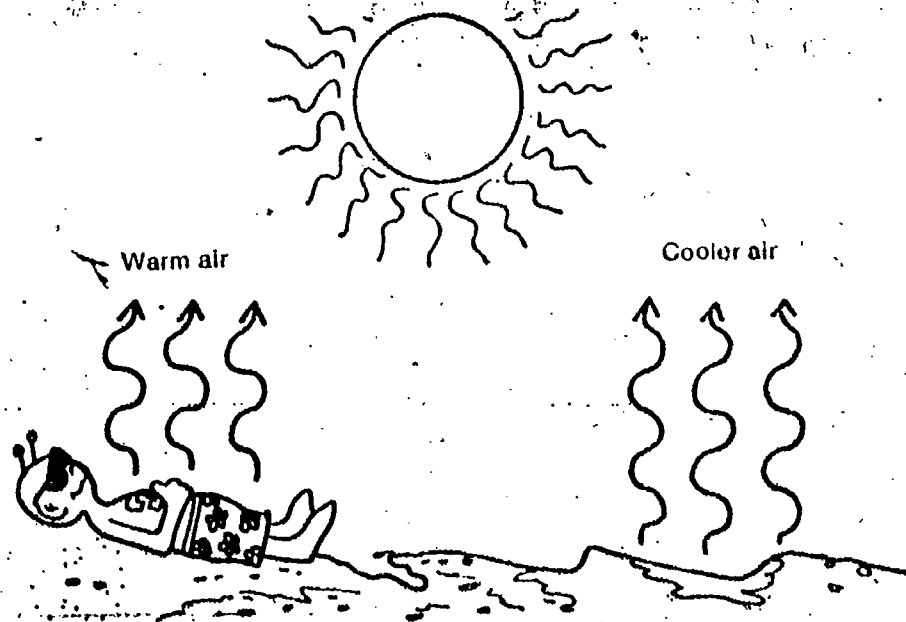

From time to time in this unit, you will be asked to do what are called Problem Breaks. These are problems for you to solve, without much help from your book or from your teacher. The problems will usually help you understand what you are studying in the chapter. But that's not their major purpose. They are designed to give you practice in problem solving and in setting up your own experiments. You should try every problem break—even the tough ones. And in most cases you should have your teacher approve your plan before trying it. The first problem break in this unit is coming up next.

This is the first problem break in the unit. More than the normal amount of help and direction is given, with this in mind. You still may want to check rather closely to see that students are following through on their experimenting, and not just copying from one another. And they might be urged to go a little

beyond the stated problem. For instance, are there more than 4 different kinds of surfaces? If air temperature differs close to the ground what about the variation at, say, 1 meter above the ground? 2 meters?

PROBLEM BREAK 1-1

It has been suggested that the air at different points on the earth receives different amounts of heat from the earth. The amount of heat depends on the kind of material that is beneath the air. But is this a reasonable idea? You can find out with a few measurements in the area around your school. Design your own plan for collecting data. A suggestion for preparing your thermometer for outdoor use follows.

ACTIVITY 1-12. Bend a coat hanger as shown. This can be used as a thermometer support.

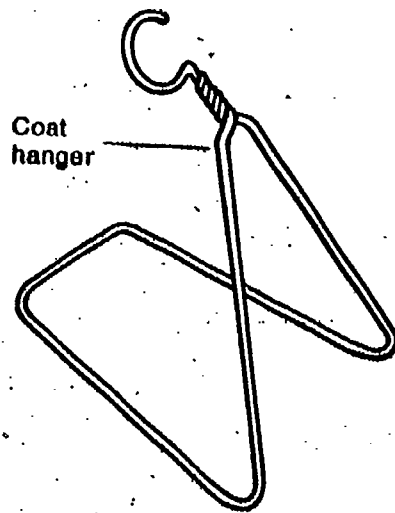

ACTIVITY 1-13. To insulate the thermometer from winds outdoors, use the bottom of a Styrofoam cup. (You can use one of the cups from Activity 1-9.) Then suspend the thermometer from the coat hanger as shown.

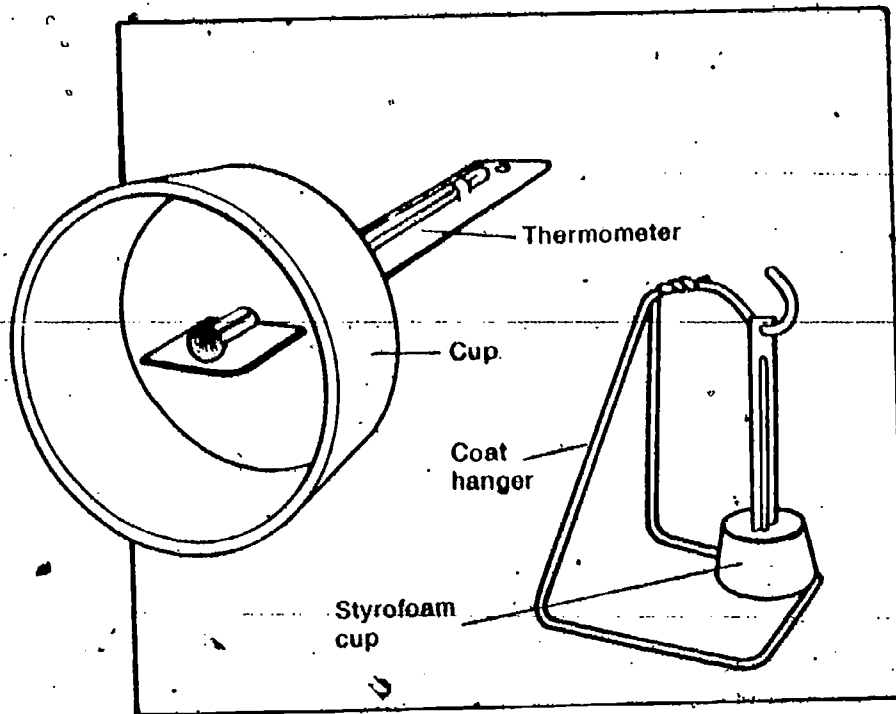

Note the constraint to get your permission to go outside. You might want to spend a little class time discussing the responsibilities that accompany the privilege. Then too, you should investigate the administrative approvals that are necessary beforehand. There will be several places in the unit that will call for outdoor activities, sometimes quite frequently. Chapter 2 and subsequent chapters for the weather observations, Excursion 1-1 with the hot air balloon, and Excursion 5-2 in working with a nephoscope are examples.

Did students remember to control the radiant energy variable—readings in sunlight or in shadow?

1-15. The explanation given should be in terms of up-and-down motion of the air, and not relative to the pilot's maneuvering of the craft.

Get permission from your teacher to go outside to locate at least four different kinds of surface as close together as possible. Be sure to get your temperature measurements in the same way at each place.

In the space provided in your Record Book, record your plan, the data you collect, and your conclusions.

1-14. Did the temperature of the outside air vary, depending upon the surface under it?

The temperature of the earth's surface can be expected to have quite an effect on the up-and-down motion of the air above it. This air movement has a great effect on weather. It is the first step in building the thundercloud mentioned earlier.

You might find it interesting to know that up-and-down air has some real effects on aircraft.

1-15. Explain the motion of the glider shown in Figure 1-5.

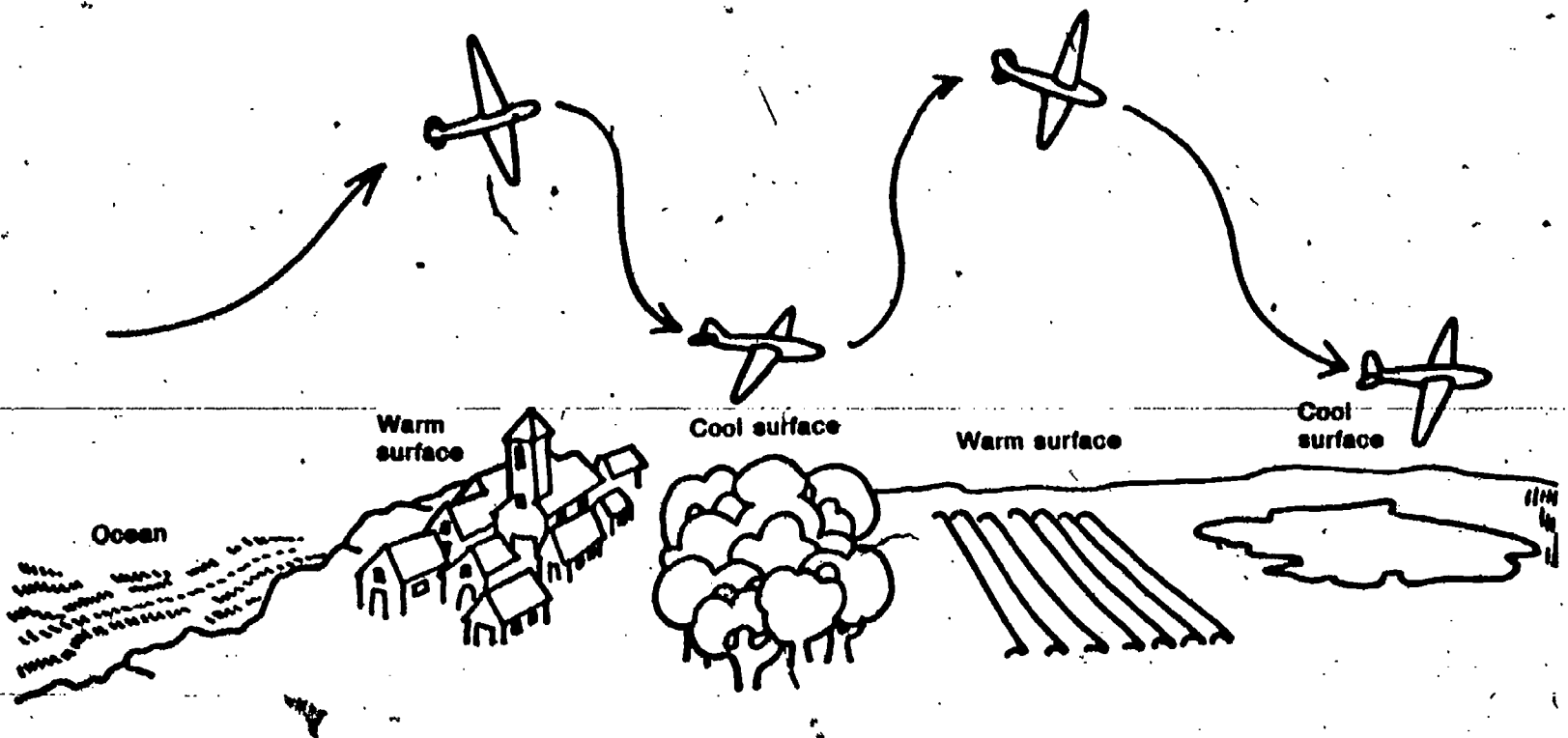

Figure 1-5

Before going on, do Self-Evaluation 1 in your Record Book.

GET IT READY NOW FOR CHAPTER 2

You are faced with the problem (if you have not already solved it) of locating the weather instrument furnished in the kit. Note that two are furnished, with the idea that if one could be placed outdoors, the other could remain in the classroom for instructional and reference purposes. There are at least 3 possible solutions for the weather watch: (1) If security will permit, mount the instrument in a permanent position so that it gets the unobstructed wind from all directions. The location must be accessible to the students for reading, and relatively safe to avoid damage. Screws furnished with the instrument may be used to fasten it to an upright support. It should be oriented with "S" pointing true north. (2) If danger from vandalism is too great and you cannot leave the instrument outside, you will have to devise a method for making it

portable. This might be done by mounting it on a 2 x 4 support or other upright about 2 meters long. You will need a permanent base support set up outside so that when the instrument is carried from the building and erected, it is always oriented in the proper direction. The location should still be one that has no obstructions for the flow of wind. Note that in this case the rain gauge will be inoperative because the instrument will not be in a position to catch the rainfall at all times. Perhaps you can supply the data on daily precipitation from newspaper, radio, or TV weather reports. (3) Your school may have a permanently mounted, remote-reading weather station; data could be collected from this every day.

The student weather watch is to continue for 4 weeks, so an adequate and reliable solution to the problem is of utmost importance.

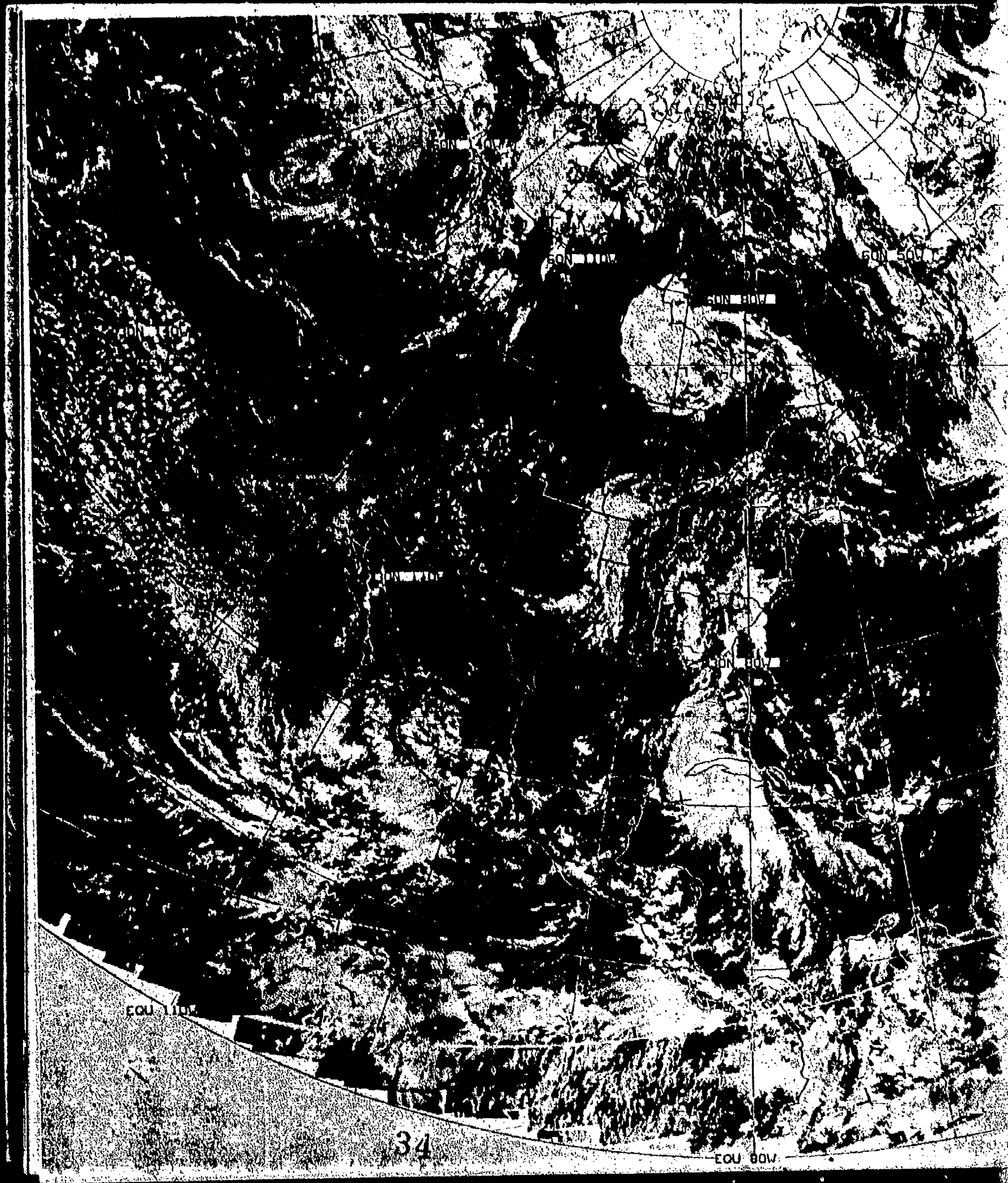

34

EQUIPMENT LIST

Per class

2 weather instruments

Weather Watch

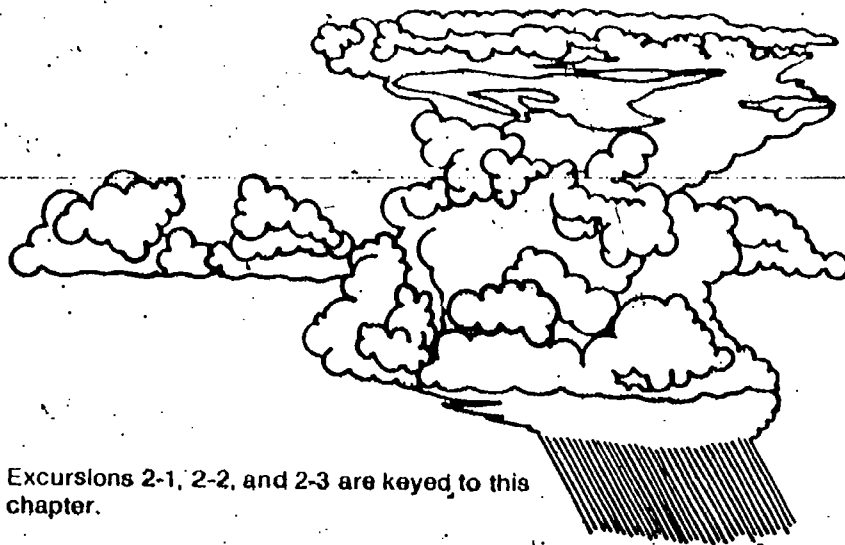

Excursions 2-1, 2-2, and 2-3 are keyed to this chapter.

Everyone is interested in the weather, and almost everyone tries to predict what it will be. Some folks spend all their time studying weather patterns. These people are called meteorologists. They want to be able to explain weather changes, and they try to make accurate forecasts.

As you continue your study of this unit, you will do a bit of your own weather forecasting. What you have learned about air will help. But you will also need to collect data on daily weather conditions. To do this, you need to establish a "weather watch."

You will need a record of the daily weather in your city or town during a period of about four weeks. To get this information, you'll need to keep a weather watch—repeated checks of weather instruments. During your weather watch, you will measure certain weather variables every day, including weekends. As far as possible, measurements should be made at the *same time* each day. Most of the measurements will be made using an instrument like the one shown in Figure 2-1. Or, if your school has one, data can be collected from a weather station that has several different instruments.

CHAPTER EMPHASIS

Regular, systematic observations of 8 different factors are begun for a 4-week period.

Chapter 2

MAJOR POINTS

1. An important procedure in making reliable observations is to control variables, such as time of day.
2. Each separate weather measurement is a variable that cannot be controlled.

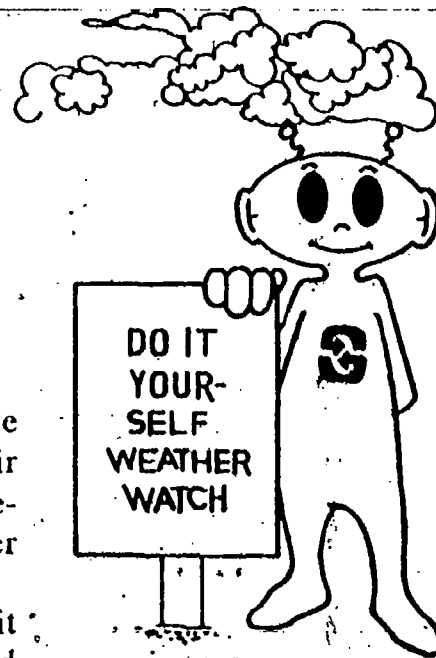

3. Temperature readings on one scale can be converted to another scale.
4. Wind direction is recorded as the direction from which the wind blows.
5. Symbols can be used to designate some weather observations.
6. In rough figures, 10 inches (25 cm) of snowfall equals 1 inch of rainfall.

If you solved the problem of students making their own weather observations, the entire unit will mean more to them. Behaviorally, it will increase their awareness of weather conditions and of the interrelationship of the weather variables. Moreover, it will give them a feeling for systematic scientific observation and data recording over a long period of time.

Figure 2-1

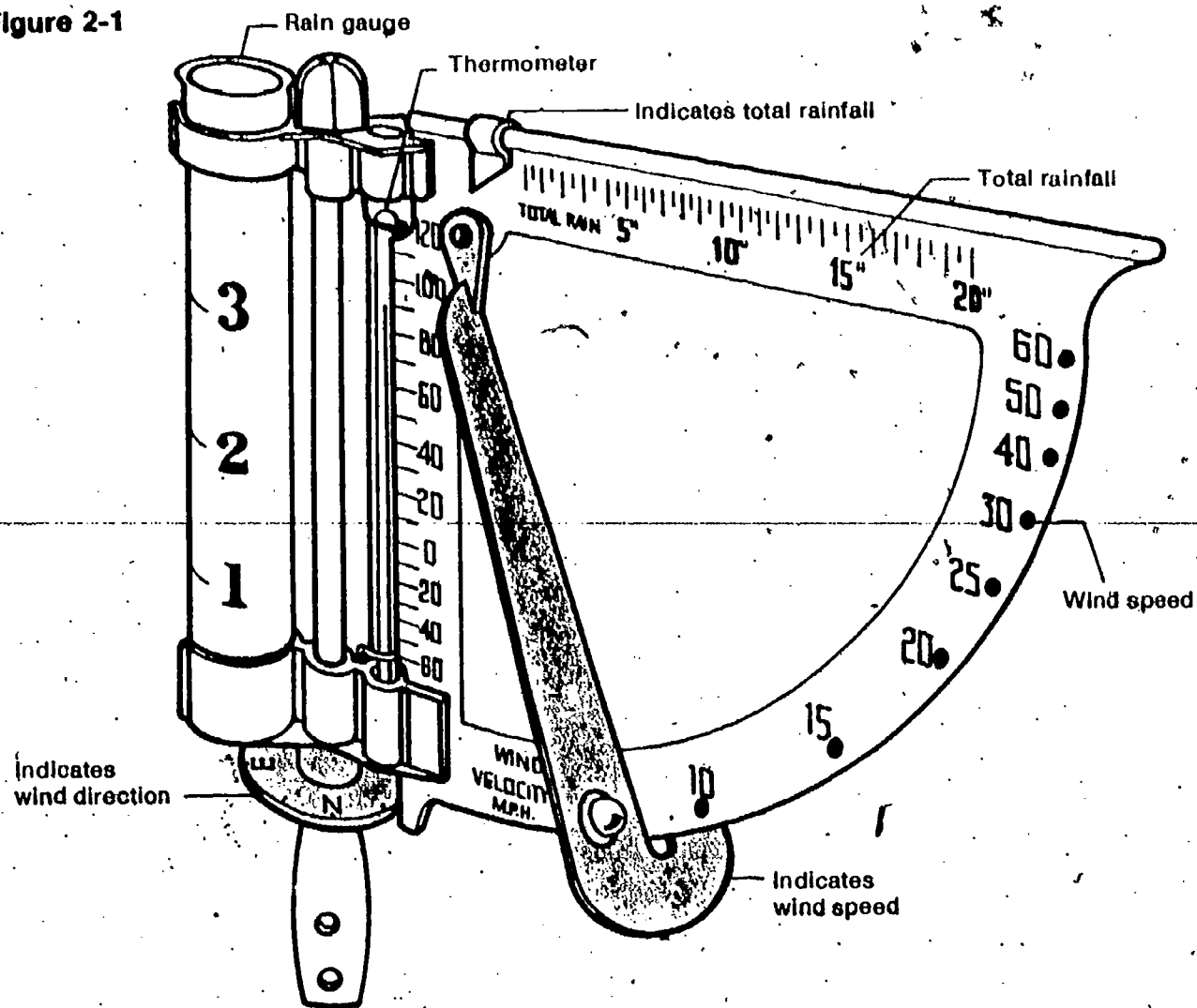

Students will need some encouragement (and prodding in some cases) to be systematic and regular in weather observing. This will be especially true as they get into the latter part of the 4-week period. Depending on how you solved the weather observation problem, you may want to have teams take daily observations, with a different team doing it each day. The data then could be made available to the entire class for the individual charts. But it would be better if each student could make individual observations.

The "Conversion Excursion," 2-3, is keyed in the note on page 19. It is usable at this point for converting Fahrenheit to Celsius.

Point 4 may require reinforcing.

In your Record Book, you will find a weather-watch chart similar to the one shown in Table 2-1. Keep your four-week weather-watch data in this chart.

Here are some suggestions on how to make and record your observations.

1. Date: Record the date you take your reading.
2. Time: Record the time you take your reading.
3. Read the temperature in degrees Fahrenheit to the nearest degree on the weather-station thermometer. Convert to degrees Celsius.
4. Wind direction: Use the wind direction on the weather station. *Remember!* Record the direction *from* which the wind blows.

Table 2-1

Weather-Watch Chart					
1. Date					
2. Time of day					
3. Temperature (°C)					
4. Wind direction					
5. Wind speed (mph)					
6. Cloud type					
7. Cloud cover					
8. Precipitation (in inches)					
9. Barometric pressure (in inches)					
10. Relative humidity					
11. Dew point (°C)					

5. Wind speed: Use the wind speed indicator on the weather station. Record the high and low wind speeds observed over a one-minute period. For example: "From 5 to 8 miles per hour."

Excursion 2-1, "Blowin' in the Wind," will help you use the wind speed and wind direction indicators on the weather-station instrument correctly.

6. Cloud type: The photographs in Figure 2-2 show the three major types of clouds (cirrus, stratus, cumulus). (**Excursion 2-2**, "Billboards of the Sky," will help you identify additional cloud types.) Use these various pictures to identify clouds as you keep your weather watch. Write down only the symbol for the name of the cloud in Table 2-1. These symbols are given under each picture in Figure 2-2.

It might be wise to check Table 2-1 in the Record Book early in the 4-week period so that students will be aware that they must record observations daily.

Note that the last three rows (pressure, relative humidity, and dew point) will not be filled in at the beginning. Pressure will be added in Chapter 3, relative humidity and dew point in Chapter 4.

With the instructions to the students to make observations on the weekends, it will be helpful for them to do Excursion 2-1. The excursion contains the visual clues to the Beaufort scale of wind speeds. They might copy the table to take home with them for weekend use.

← EXCURSION

← EXCURSION

Excursion 2-2 is an interesting pictorial exposition of common cloud types that should be helpful.

Figure 2-2a Cirrus clouds (Ci)



Figure 2-2b Cumulus clouds (Cu)

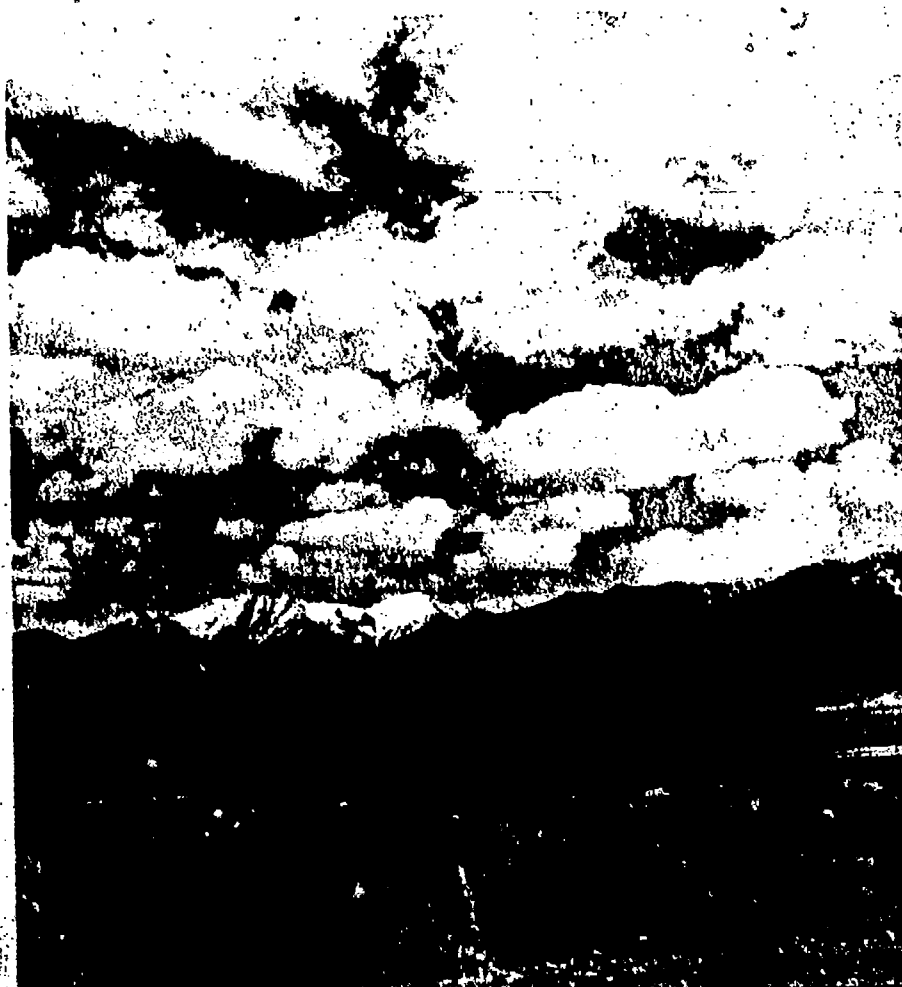

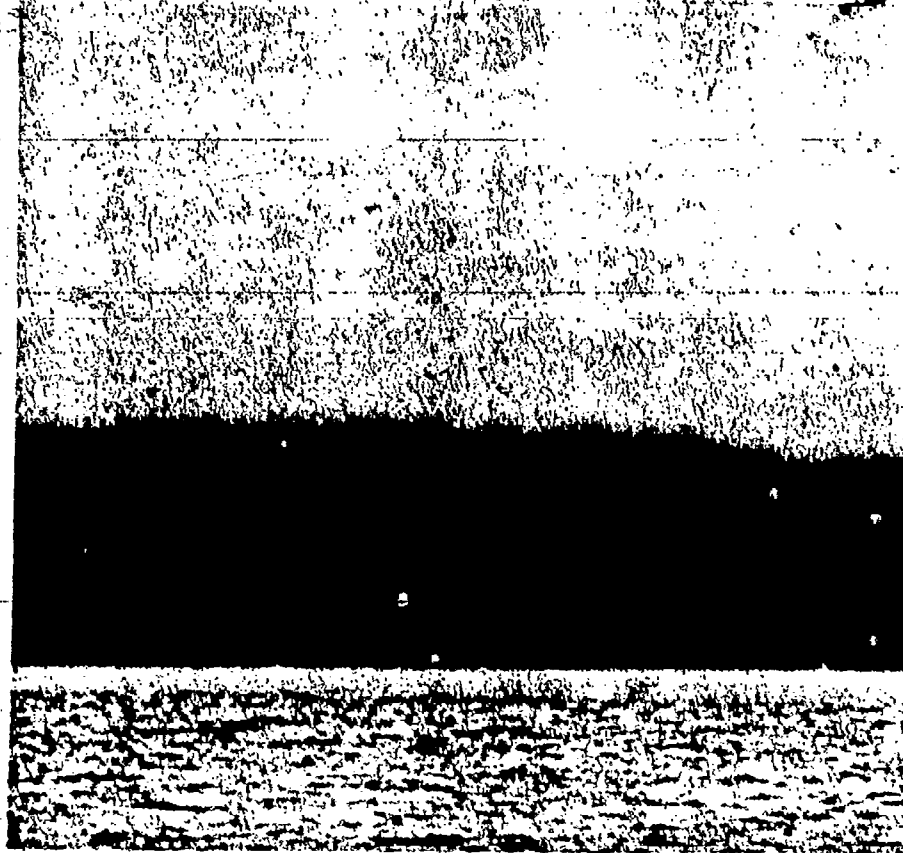

GET IT READY NOW FOR CHAPTER 3

You will need large and small baby-food jars, plastic tape, and scissors or knife supplied locally. You could also use more ice for Problem Break 3-2. The aneroid barometer should be mounted permanently in the room, and should not be moved to student desks or carried around the room. It can be adjusted to atmospheric pressure corrected to sea level by calling the nearest Weather Bureau Station, or by comparison with an already corrected barometer.

Figure 2-2c Stratus clouds (St)

7. Cloud cover: Estimate how much of the sky is covered by clouds. Use the following symbols to record your data: ○ for clear sky; ◐ for 25% ($\frac{1}{4}$) of the sky covered by clouds; ◑ for 50% ($\frac{1}{2}$) of the sky covered by clouds; ◒ for 75% ($\frac{3}{4}$) cloud cover; ● for complete overcast.
8. Precipitation: The rain gauge on the weather station will keep track of rainfall for you. Rainfall for a given day is the amount of *new* water in the cup since the day before. Snow is also precipitation. Measure the depth of snow at some point where it has not drifted. To determine the rainfall equivalent of snow, divide the number of centimeters of snowfall by 25. (Or, if you measured depth in inches, divide your measurement by 10.)
9. In rows 9, 10, and 11 of the chart, you will add several more items to your data table as you study the remaining chapters.

Note *The weather-station instrument is calibrated in the English system. Therefore, you must make frequent conversions (changes), to the metric system. Excursion 2-3, "The Conversion Excursion," will help you with these changes.*

Remember your weather watch is to continue for four weeks, including weekends if possible.

Before going on, do Self-Evaluation 2 in your Record Book.

The rain gauge on the instrument can prove to be a problem. Not only must the instrument be in place all the time to catch the rain, but the gauge should be emptied each day at the same time. That means that students taking readings after that time will need to get the daily rainfall from those who emptied the glass. Each time the glass is emptied, the slider on the top can be moved the appropriate amount to record the total rainfall for a particular period. Note also that the 10-to-1 ratio for snow to rain is only a generality. Wet, heavy snow may have a ratio as low as 6-to-1, while in dry, fluffy, new-fallen snow the ratio may be as high as 30-to-1.

Excursion 2-3, keyed here, will be useful throughout the unit.



EQUIPMENT LIST

Per student-team

- 1 balance rod, with clips
- 1 balance rod support
- 2 balloons

- 1 large baby-food jar
- 5 rubber bands
- 1 plastic straw
- 1 tongue depressor
- 1 small baby-food jar
- Plastic tape

- Scissors or knife
- Aluminum pan
- Ice

- Per class
- Aneroid barometer

CHAPTER EMPHASIS

Air has properties of mass, pressure, temperature, and number of particles in a given volume that vary on the earth's surface and as the air rises.

Concentrating on Ups

Chapter 3

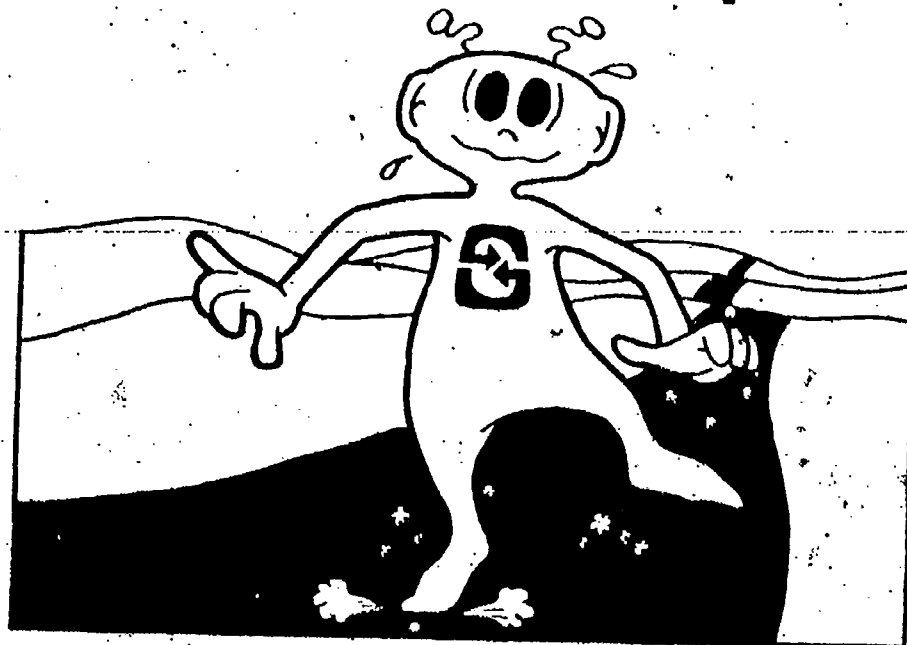

You've learned that different surfaces absorb different amounts of heat from sunlight. All you need do to prove this is to walk around outdoors in the summertime in your bare feet. You'll quickly find that warm and cool spots can exist near each other.

The temperature of the air above the earth's surface is affected by the heat absorbed by the surface. Air above a hot spot is warmed. Air above a cool spot is cooled.

3-1. What happens to the motion of air as it passes over a hot spot on the earth?

3-2. What happens to the motion of air as it moves over a cool spot on the earth?

Knowing that air moves up and down over different areas of the earth's surface is a good start in explaining weather changes. However, you need to find out more about how the air is affected by these ups and downs. This is a complicated thing to do. To make your task simpler, concentrate only on the ups for now.

MAJOR POINTS

1. The systems approach can be used in analyzing the behavior of air.
2. Air has mass and exerts a downward force called weight.
3. The particle model of matter can be used to explain air pressure.
4. A barometer can be constructed, calibrated, and used to make measurements of air pressure, thus atmospheric pressure can be operationally defined.
5. The particle model predicts that the home-made barometer will respond to temperature changes as well as pressure changes.
6. Air pressure is a variable, both at the surface of the earth and at different heights above the surface.
7. Air gets cooler as it rises.

Excursions 3-1 and 3-2 are keyed to this chapter.

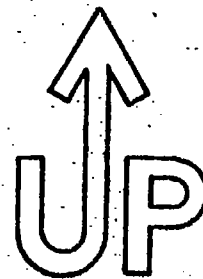

The systems approach is particularly apropos here, but actually the entire unit might be considered in the light of systems. For instance, there are cloud systems, pressure systems (highs and lows), and frontal systems (cold, warm, occluded) that will be studied in later chapters. And of course there are systems of air masses that interact with each other to form the frontal systems.

When studying complicated situations, scientists concentrate on only a part of the total situation. This is called using a "systems approach" in investigations.

If you used the ISCS Volume 1 or Volume 2, you've used the systems approach many times before. In using the systems approach, you concentrate only on that part of a complicated situation in which you are interested. That part of the situation is called the system. The rest of the situation can be ignored, except when you want to pay attention to the input to or output from the system. If you wish to examine some ever smaller part of the system, you refer to it as a subsystem.

Figure 3-1 will help you take a systems approach in seeing how air is affected by altitude (height above the earth's surface). The total atmosphere can be thought of as the situation. The vertical column shown represents a column of air extending up from the earth's surface. This column will be the system you will study. Two cubes have been drawn within the column. They represent cubes of air. You can think of them as subsystems of the column of air. Air from outside the column (the system) can flow into the cubes (the subsystems). And air from inside the cubes can flow out of the column.

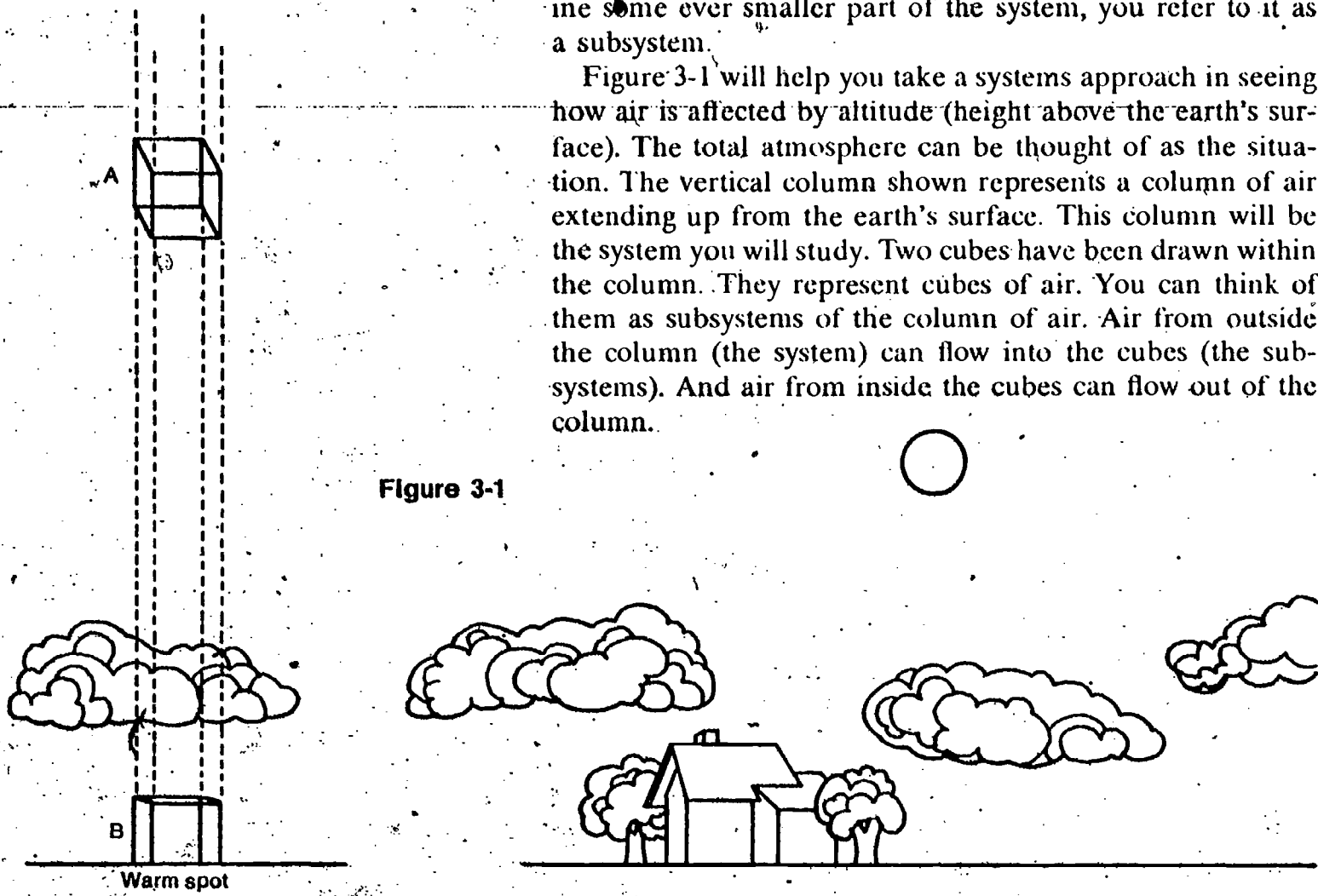

Figure 3-1

Assume that the column of air shown in Figure 3-1 is standing over a warm spot on the earth's surface.

- 3-3. Which cube of air would be warmer?
- 3-4. As air cube A rises, what do you predict will happen to its temperature?

12

en-
ing
ed
ys-
m-
of
on
to
m-
as
ng
ir-
a-
ur
be
in
of
le
b-
ie

Air is warmed by being near a warm surface. The air closest to the surface is warmed the most. Generally, then, the farther the air is from the earth's surface, the cooler it will be. Thus, cube A in Figure 3-1 should have a higher temperature than cube B.

COOLER AIR

WARMER AIR



Figure 3-2

PROBLEM BREAK 3-1

Design and conduct an investigation of how air temperature varies with altitude. Record your plan, the data you collect, and the conclusions you reach in your Record Book.

- 3-5. According to Figure 3-1, which cube of air has more air above it, A or B?
- 3-6. Which cube of air would have more weight on it from above?

You may be a bit concerned about question 3-6. In fact you may wonder why such a question was asked. Is it reasonable to think of air as having weight? Try the next activity and find out for yourself.

You will need the following materials:

- 1 balance rod, with 3 balancing clips
- 1 balance rod wire support
- 2 balloons of equal size

If students accept the concept that the farther air is from the earth's surface, the cooler it will be, on the basis of these statements and as a result of their investigations in Problem Break 3-1, fine. The implication here is that the decrease in temperature is due to separation from the source of heat (the warm spot) only. Without going into rather complicated subject matter, this is about as far as the reasoning can go. But for your information, and not for the students, the cooling can be explained a little more. When air rises, it is subjected to less and less pressure. It expands in response to this decreasing pressure according to Boyle's Law, $p \times v = k$, which states that pressure and volume are inversely proportional. As one goes down, the other goes up. Expansion against pressure constitutes work, and uses energy. The energy expended in this process is heat energy, and the effect is to cool the air. Meteorologically this is called the **adiabatic process**, and it occurs for the same reason that a tire pump gets hot when you pump up a tire, or air feels cool when you let it out of the valve, releasing the pressure and letting it expand.

Problem Break 3-1 is not easy to do. You may have to give some hints to get students started. Using the protected thermometer as they did in Activity 1-13, they can measure the temperature at ground level, 1 meter and 2 meters, but beyond this might prove difficult. Possibly temperatures taken out of upstairs windows, or out of windows in multi-story buildings might give some data. For your information, the decrease in temperature with altitude, due to all factors and not just expansion of air, is called the **lapse rate**. The average lapse rate (if there is such a thing) is about 3.2°F per 1,000 feet or 0.6°C per 100m. But be careful. On a clear, calm night, the air close to the ground (10 to 20 ft) can be colder than the air higher up.

You probably realize some of the shortcomings of this experiment. The inflated balloon, even filled with air at room temperature, has more buoyancy (it displaces an equal volume of room air) than the deflated balloon. The balance is not exactly measuring the mass of the air in the balloon. But the slight increase in pressure inside the balloon does push the air particles closer together, so the balance should show a greater mass for the inflated balloon. Incidentally have students save the balloons. Both can be used again. The knotted one can be used for the upcoming activities on the construction of the barometer.

ACTIVITY 3-1. Fasten the two balloons to the clips as shown. Balance the rod by moving the third clip. (You may have to move it across the wire support.)

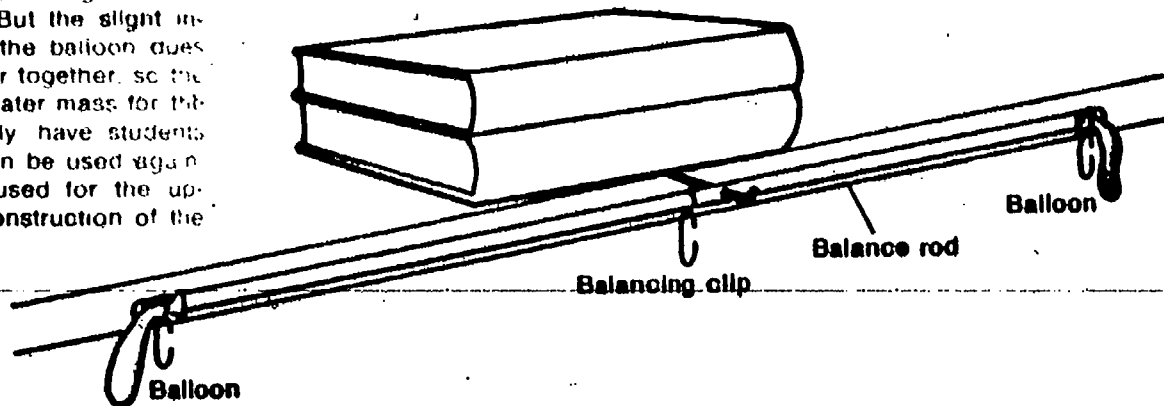

ACTIVITY 3-2. Remove one of the balloons, blow it up, and knot the neck. Place the balloon on the table for 5-10 minutes. Then reattach it to the balance arm. Hold the arm level, then gently release it, and observe what happens.

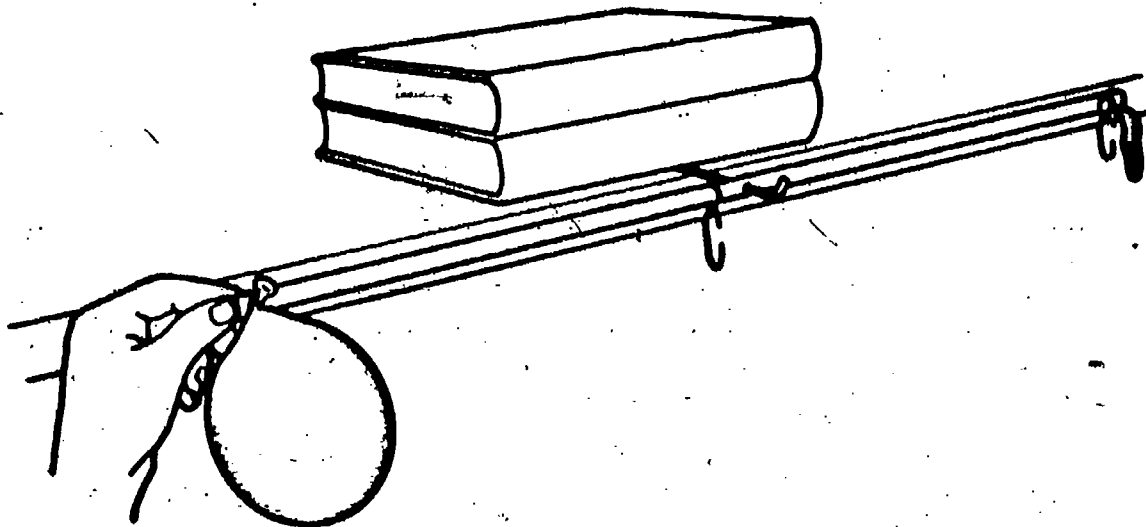

The breath you blew into the balloon is warmer than the room air. That is why you were told to wait a few minutes before comparing its mass. This wait gave it time to cool off a bit.

3-7. Student observations should reflect an awareness of an increase in mass of the inflated balloon. They would not be expected to realize the implications of buoyancy mentioned above.

3-7. Explain your observation from Activity 3-2.

Now think again about the column of air from Figure 3-1. Every particle of air exerts a downward weight force. All these forces together make the total weight of the column of air.

3-8. Which cube of air (A or B) has more weight acting on it from above, in Figure 3-1?

Your answer to question 3-8 should have been "cube A." This is also the answer to the earlier question 3-6.

The total weight of a column of air on imaginary cube A results in the air pressure on that cube.

3-9. How does the air pressure on cube B compare with the air pressure on cube A?

Figure 3-3 suggests how particles in a column of air might be expected to look.

Figure 3-3

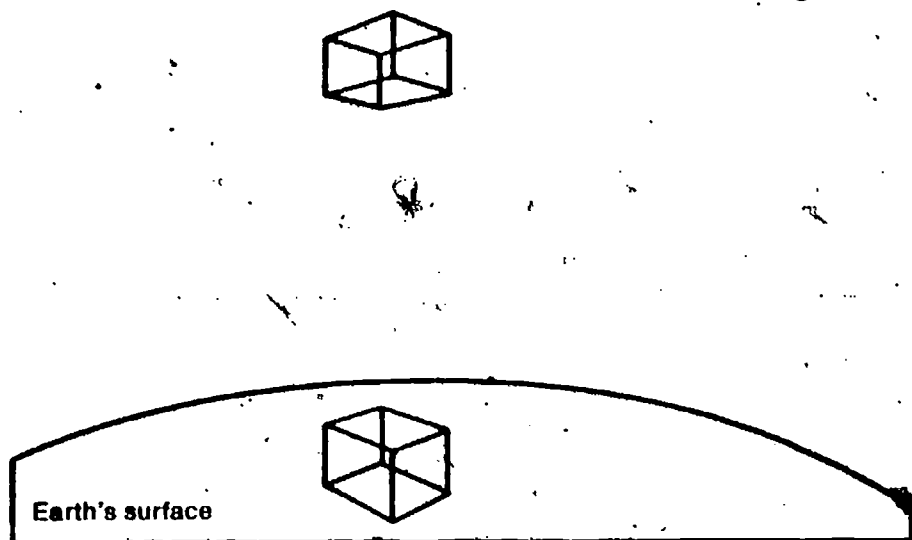

You may want to check your understanding of the term *pressure*. If so, turn to **Excursion 3-1**.

By now you should expect that air pressure will decrease as altitude increases. But you may wonder if air pressure can vary at the same altitude. For example, does atmospheric pressure vary right at the earth's surface?

To answer this question, you need some way of measuring atmospheric pressure. The next activities will show you how to make such a device and how it works.

You need a partner and the following materials:

- 1 balloon
- 1 baby-food jar (must be large size)
- 1 rubber band

Weight is measured in units such as pounds or newtons. Pressure units are pounds per square inch, or newtons per square meter (or other combinations of force per unit area). The total weight of a column of air results in the pressure on the cube, but the pressure would have to be expressed in this weight on a particular area.

EXCURSION

Excursion 3-1 will enable students to work with the idea of force per unit area meaning pressure.

The seal is so important that you might want to have students use a second tightly stretched rubber band around the jar.

ACTIVITY 3-3. Cut the end off the balloon and stretch it over the mouth of the jar. Be sure the rubber balloon is stretched taut. Then have your partner fasten it in place using the rubber band. The band will have to be doubled once or more to make a tight seal. This seal is very important.

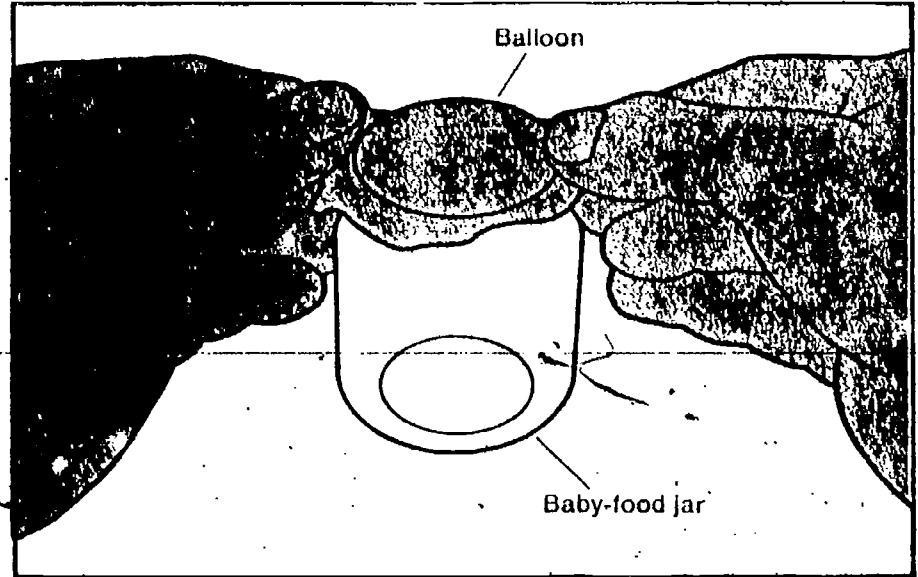

Do you have a vacuum pump with bell jar available? This relationship of inside-outside pressure can be vividly illustrated. A partially inflated balloon inside the bell jar also makes a good demonstration.

What you have just made is the basic part of an atmospheric pressure measurer. Before finishing it, however, let's use the particle model, to explain how it should work.

Air is both inside and outside the jar. The particle model (discussed in ISCS Volume 1) says that the air particles are in motion (Figure 3-4). They are bouncing against the inside and outside of the rubber cover.

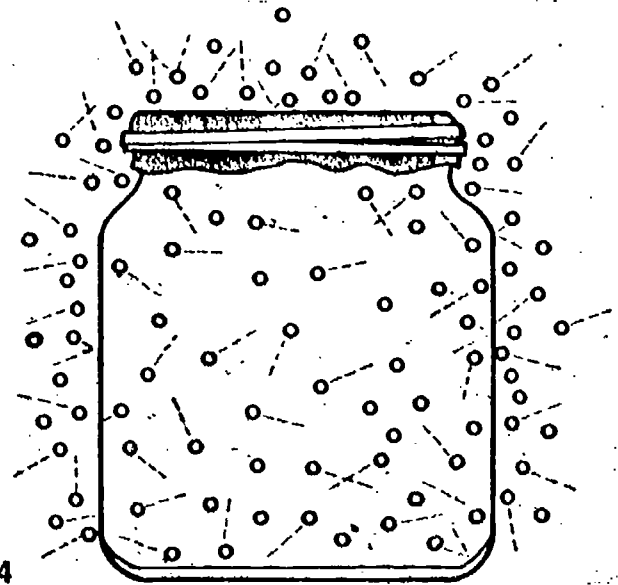
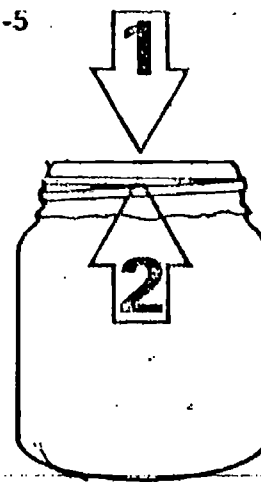

Figure 3-4

If the jar is tightly sealed, no more air particles can enter or leave the jar. The top of the balloon is flat (not bulging in or out.) Therefore, the pressure of the moving air particles against the top of the balloon is balanced by the pressure of the moving air particles inside the jar. This is diagrammed in Figure 3-5, with arrows representing forces. Force 1 is equal to Force 2.

Figure 3-5



If the particles inside the jar exerted more pressure on the rubber covering than the particles outside, the covering would bulge upward (Figure 3-6). In that case, Force 2 would be greater than Force 1.

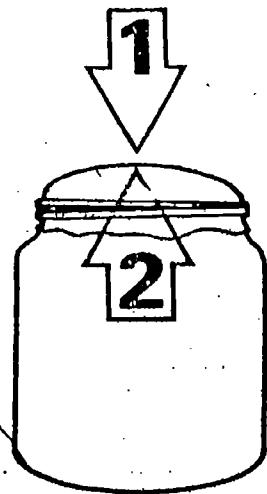

Figure 3-6

□ 3-10. What would happen to the rubber covering if the forces (pressure) outside were greater than the pressure inside? (Show your answer by completing the drawing in Figure 3-7 in your Record Book.)

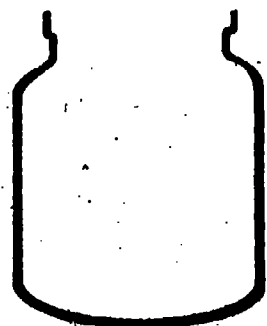

Figure 3-7

Changes in atmospheric pressure are relatively small, so students should not expect great changes in the shape of the rubber membrane.

The flexible rubber covering allows the volume of the air inside the jar to change. When the air pressure outside the jar increases, the rubber balloon bulges in. When the air pressure outside is lower than it is inside, the rubber bulges out.

You can add some additional parts to the jar that will make it possible to measure very small changes in the movement of the rubber cover. To do so, you will need the following materials:

- | | |
|--------------------|-----------------------|
| 1 plastic straw | 1 small baby-food jar |
| 1 tongue depressor | Plastic tape |
| 4 rubber bands | Scissors or knife |

ACTIVITY 3-4. Cut one end of the straw at an angle to make it pointed.

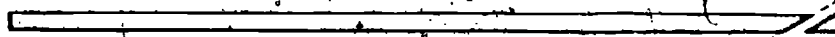

ACTIVITY 3-5. Gently place a one-inch strip of plastic tape on the uncut end of the straw as shown.

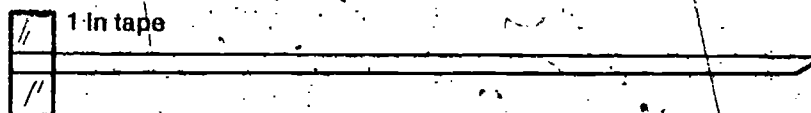

Various other materials may be used to fasten the straw to the balloon membrane. Candle wax, plastic cement, or rubber cement have been tried. Whatever method is used, be sure that students fasten only the tip of the straw to the balloon, and right in the center.

ACTIVITY 3-6. Tape the uncut end of the straw to the center of the balloon as shown. Run your finger nail along the tape on each side of the straw so that it is held tightly to the balloon, both in the center and at the edge of the jar.

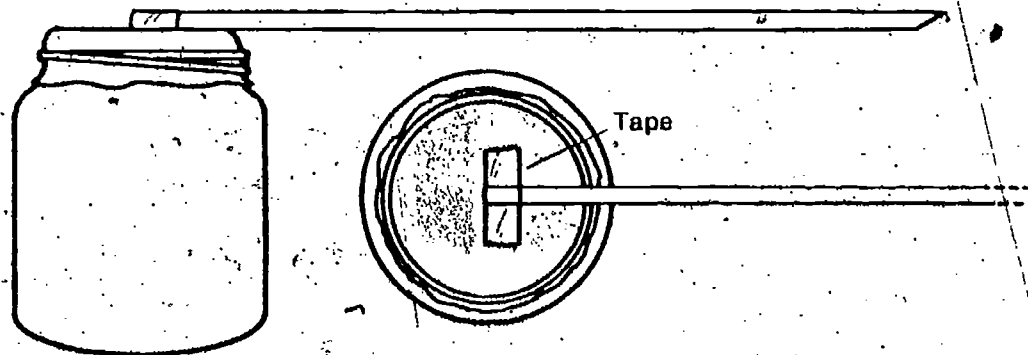

ACTIVITY 3-7. Attach a tongue depressor to the second jar as shown.

ACTIVITY 3-8. Place the two jars side by side on a level support (such as a large book) so that the pointed straw is in front of the tongue depressor. Mark a short line on the depressor at the point of the straw and label it 0 to show the starting position.

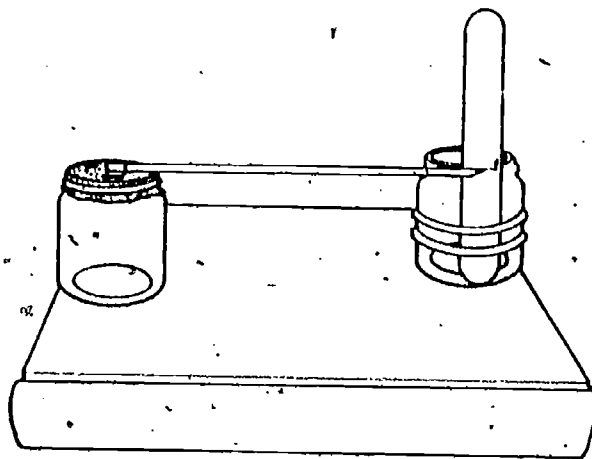
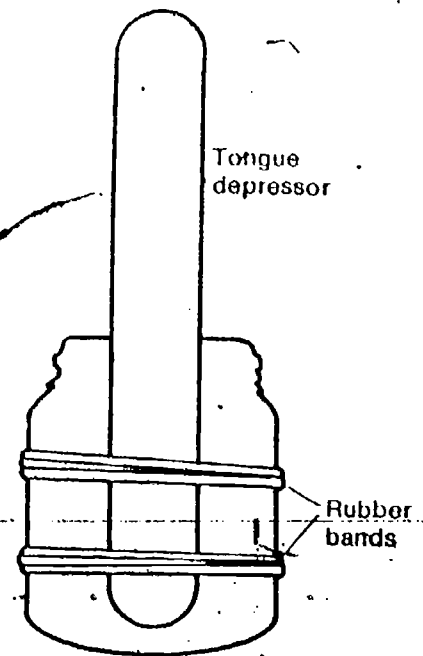

If the instrument needs to be moved very much, a permanent base, such as a board or heavy cardboard should be used, so that the jar doesn't have to be handled and the two jars remain oriented the same.

With the tongue depressor's scale in place, your atmospheric pressure measurer is complete. Let's see how it works. Figure 3-8 should help you see this.

When the air pressure is equal inside and outside the jar, the pointer remains at zero (Figure 3-8a). When there is an increase in air pressure outside the jar, the cover is forced down. This moves the pointer up (Figure 3-8b).

Figure 3-8

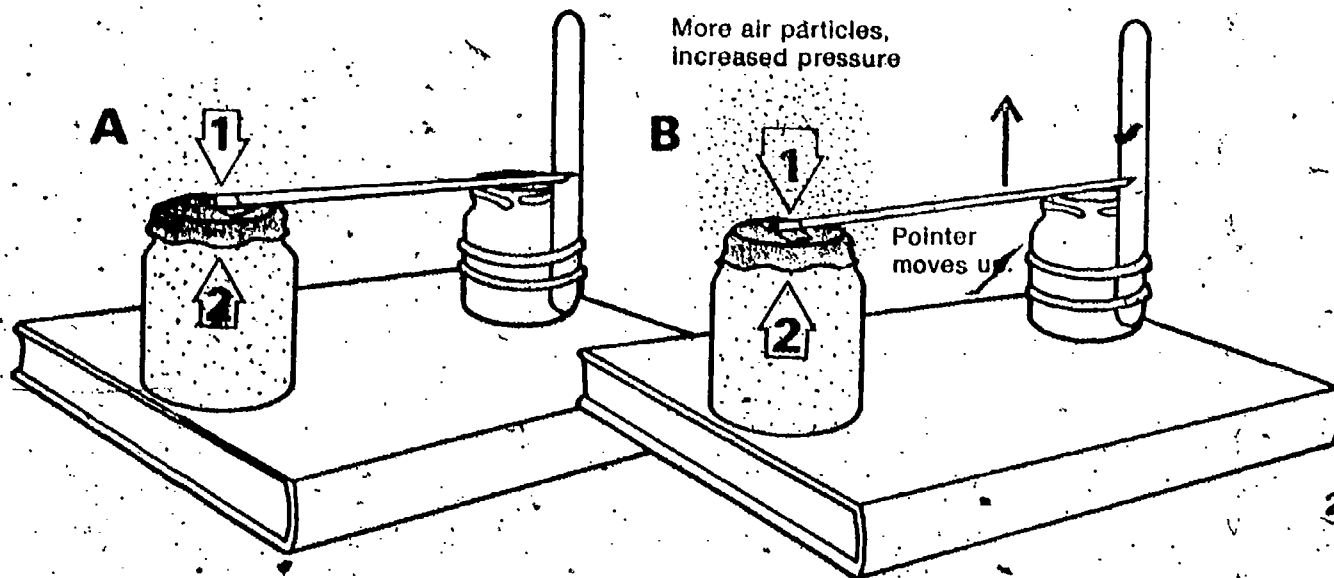

3-12. The student answer should tell how atmospheric pressure is detected and measured. (Example: Observe the pointer on the atmospheric measurer device over a period of time. Movement of the pointer shows changing atmospheric pressure and the amount of movement shows how much change.)

3-11. How will the pointer move if the air pressure outside the jar is less than that inside the jar?

3-12. Give an operational definition of atmospheric pressure.

If you understand how your instrument works, you should expect the pointer to move down from zero on the scale if the air pressure decreases. The pointer should move up from zero if the air pressure increases.

The measuring device you've made is called a *barometer*. It can be used to measure atmospheric pressure (air pressure) However, its use is somewhat limited.

ACTIVITY 3-9. Zero the pointer. Then hold your hands on the sides of the jar for several minutes without moving it. Note what happens to the pointer's position.

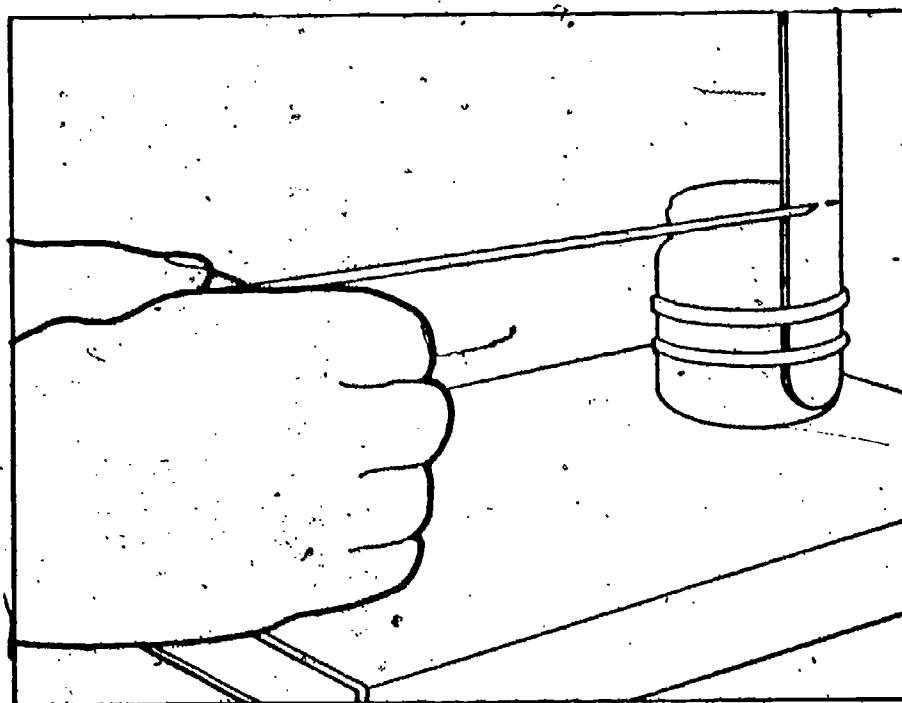

3-13. Did the pointer move? If so, in which direction?

3-14. Did putting your hands on the jar have the same effect on the pointer as a change in air pressure?

3-15. What kind of air pressure change would produce the same result as your hands did? (An increase, or a decrease, in pressure?)

3-15. A decrease in air pressure (The increase in pressure inside the jar has the same relative effect that a decrease in outside air pressure has.)

Putting your hands on the balloon jar didn't change the pressure of the atmosphere. But it did change the pressure of the air inside the jar. How can this be? Well, you know that your hands are warm. If they warmed the jar, the air inside would become warmer, too. Then, according to the Volume 1 particle model, the air particles would move faster. This increased motion would cause the particles to hit the cover and walls harder. The flexible rubber on top of the jar would then bulge out and the pointer would move down (Figure 3-9).

Figure 3-9

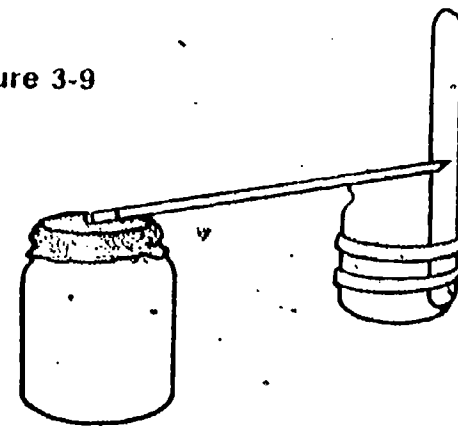

Your barometer reacts to temperature changes as well as to pressure changes.

3-16. What effect do you predict decreasing the temperature inside the jar would have on the movement of the pointer from a zeroed position?

PROBLEM BREAK 3-2

Find out how decreasing the temperature of the air in the jar affects the pointer position of the measurer. Activity 3-10 suggests one way to go about this.

ACTIVITY 3-10. Set the rubber-covered jar in a pan of water at room temperature. Use a thermometer to measure the temperature of the water. Have the pointer adjusted so that it points to 0 on your scale. By adding ice or cold water, you can lower the temperature.

Note the suggestion for lowering the temperature with ice. If this route is to be followed, you will need a supply of ice cubes again.

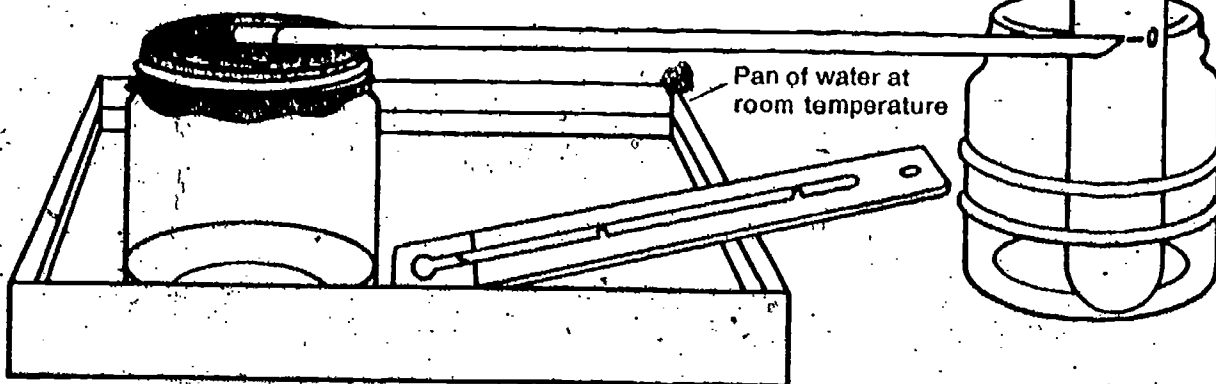

□ 3-17. How is the pointer position affected when the temperature of the jar's air is decreased?

For the better student, you might want to pose the rather difficult question of how the instrument could be modified so that it would not be temperature-dependent. Some rather novel (and perhaps unworkable) solutions could result.

The accuracy of your atmospheric pressure measurer depends on the temperature of its surroundings. This of course limits its usefulness. It cannot be used effectively to compare air pressure at places where temperatures are different.

However, it can be used to measure pressure changes if positioned where the air temperature remains about the same. Of course, the measurer must be zeroed while at that location.

You can use your barometer to collect weather-watch data. However, it must first have a calibrated scale. This scale can be made by using a standard barometer. There is one in your classroom. It probably looks like the barometer shown in Figure 3-10.

By now the permanently mounted aneroid barometer should have been corrected to sea level pressure.

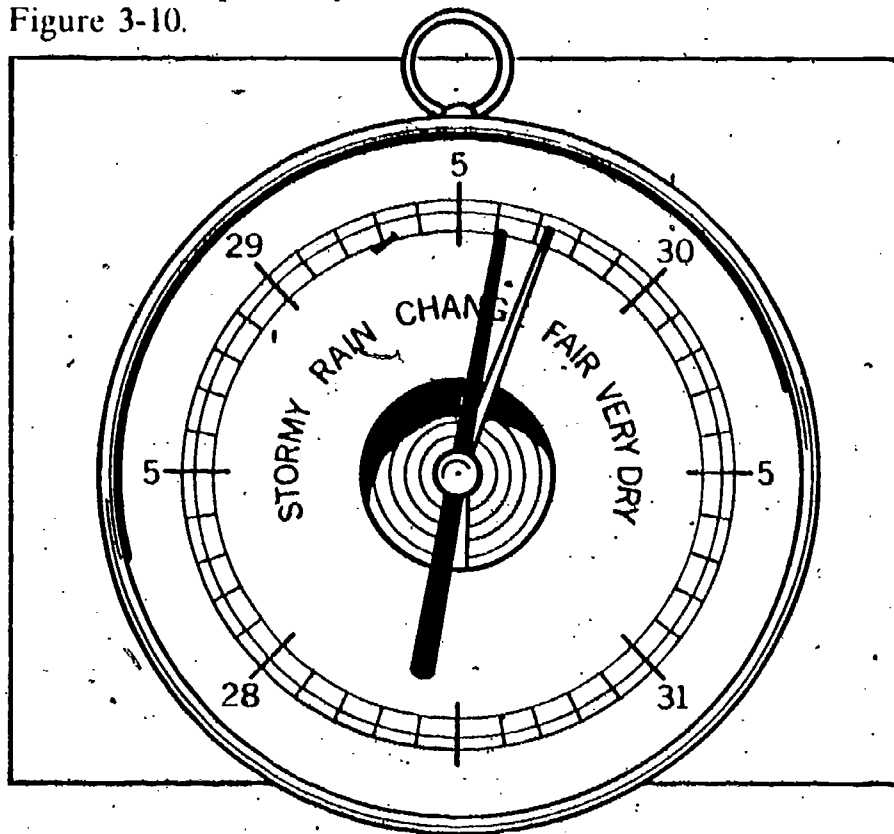

Figure 3-10

The scale on your room barometer is probably marked in units of length—like inches or millimeters (Figure 3-10). Let us see why pressure is measured in inches, or perhaps millimeters.

Scientists have compared air pressure with the pressure exerted by liquids. They have found the following relationship:

A column of air extending from sea level out to the limit of the earth's atmosphere has the same weight as (a) a 34-ft column of water (with the same diameter as the air column) and as (b) a 29.9-inch column of the liquid mercury (also with the same diameter).

Figure 3-11 illustrates this finding.

It might be interesting to note that the pressure exerted by a 34-foot column of water or a 29.9-inch column of mercury is independent of the diameter of the column, because pressure is measured in force per unit area. Therefore, a 34-foot column of water or a 29.9-inch column of mercury exerts about 14.7 pounds per square inch pressure, no matter how large in diameter the column is.

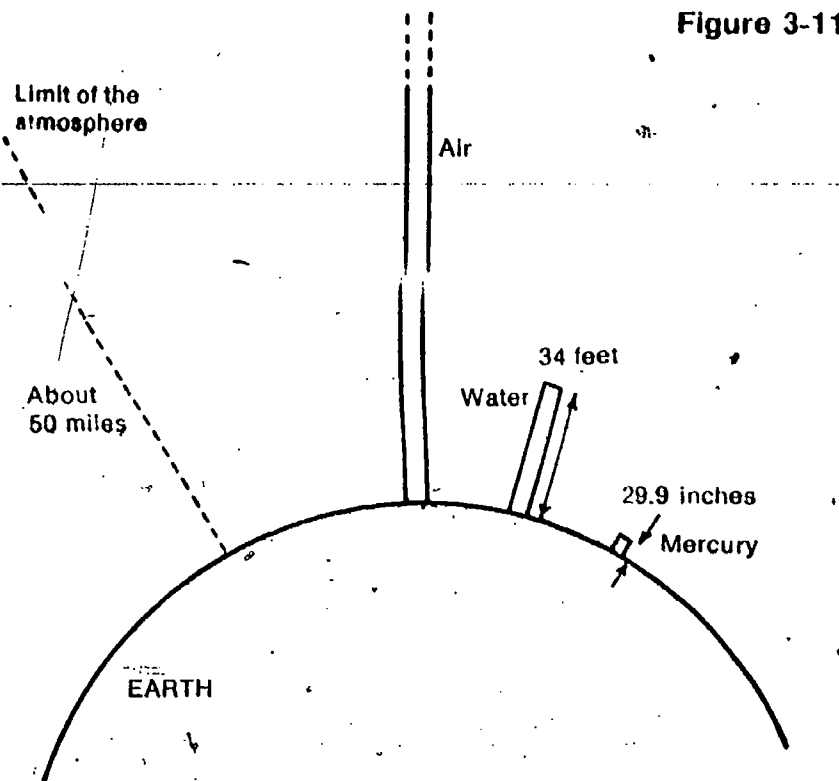

Figure 3-11

This relationship means that air pressure can be compared with the pressure exerted by a column of liquid such as mercury or water. Normal air pressure at sea level is equal to the pressure exerted by 29.9 inches of mercury.

3-18. Use the room barometer to determine the air pressure where you are.

3-19. Would you expect the barometer reading on a mountain top to be different from that at sea level? Explain your answer.

A bit more information on liquid columns and air pressure can be found in **Excursion 3-2**. Have a look if you're interested. It will help you understand how your classroom barometer works, too.

3-19. Yes, there would be less air above the mountain top, so there would be less force or weight exerted by it.

Excursion 3-2 begins with a historical treatment of pressure measurement and then discusses the construction of an aneroid barometer.

EXCURSION

From this point barometric pressure can be added to Table 2-1 in the Record Book. You might want to provide some instructions on the correct way to get a reading. The instrument should be tapped *very lightly* with the finger. This frees the movement from friction. Of equal importance, it shows which way the pressure is changing, which is a factor of more importance than the pressure itself.

As you continue keeping your weather watch, use the room barometer. To get pressure measures, also do Problem Break 3-3 to get a scale for your own jar barometer.

PROBLEM BREAK 3-3

Ask your teacher where you should set up your jar barometer.

Then zero it in that location. Use the room barometer to get the atmospheric pressure in inches.

ACTIVITY 3-11. Alongside the zero mark, write the pressure you got from the room barometer.

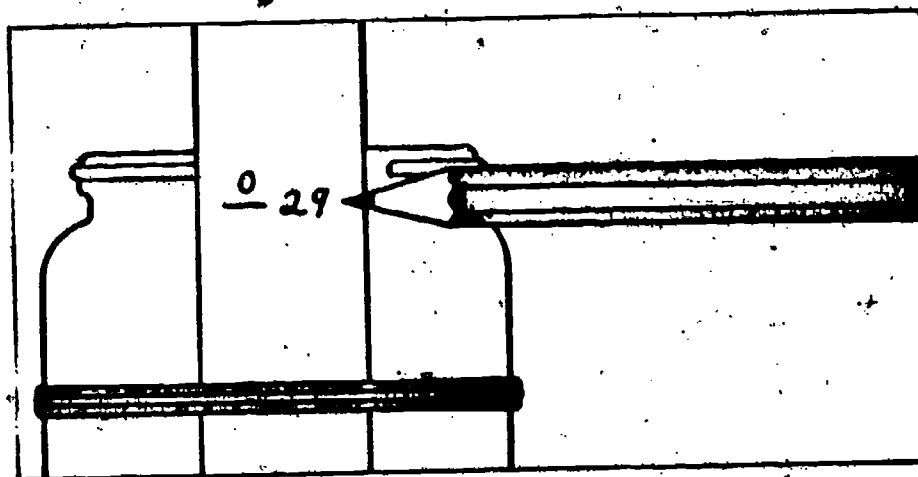

Each day, you can add new marks and numbers to the scale; that is, if the atmospheric pressure really does change in your room!

You will have to make provision for the student barometers to be set up in some permanent position where they can be marked daily.

SUMMING UP

This chapter has taken you beyond the facts that warmer air rises and cooler air falls. You have learned the following:

1. As air rises from the earth's surface, the air gets cooler.
2. Air has weight and exerts pressure.
3. The number of air particles decreases with increasing altitude.

These points constitute a good checklist for the unit material to this point. They can be used for small-group discussion or for items on a test.

4. As air rises, the pressure on it from the air above decreases.

5. Air pressure can and does vary on the earth's surface.

These facts will be very important to your further study of air and weather.

Before going on, do Self-Evaluation 3 in your Record Book.



GET IT READY NOW FOR CHAPTER 4

You will continue to need large and small baby-food jars. You will also need ice (crushed and cubes), hot water, and matches. Before students start using the sling psychrometers, you may want to emphasize the exertion of reasonable care in swinging them to avoid injury and breakage. And for working with ice and water, students will need an adequate supply of paper towels.

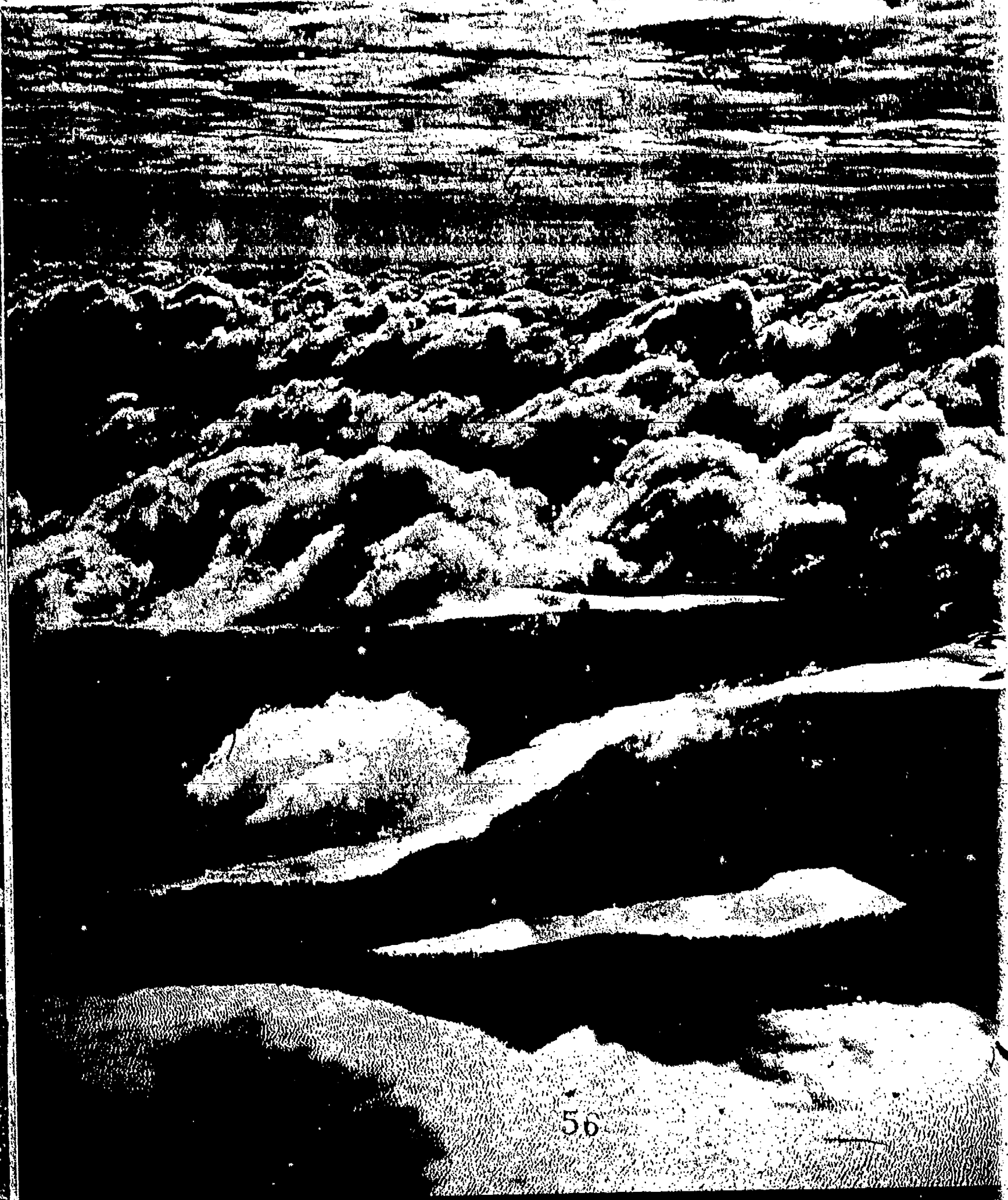

56

EQUIPMENT LIST

Per student-team

- | | |
|------------------------|------------------------|
| 1 small baby-food jar | 1 plastic sandwich bag |
| 2 large baby-food jars | Crushed ice |
| 1 thermometer | 2 ice cubes |
| 1 clear plastic cup | Hot water |
| 1 sling psychrometer | Matches |
| | Paper towels |

Making Visible the Invisible

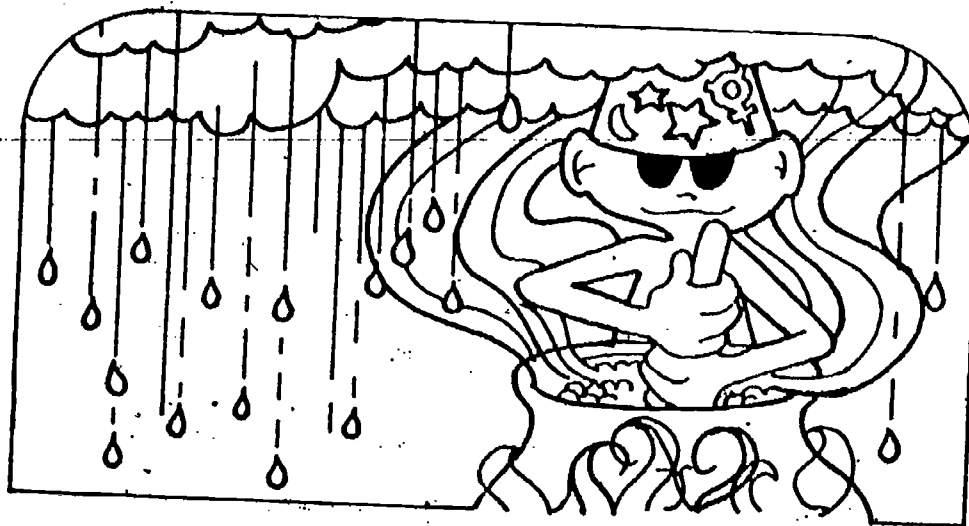

It's no secret to most people that clouds are made of water. We've all seen water falling from the sky. And almost every time this happens, there are clouds up there. Most folks also know that the water in clouds evaporated from the earth's surface. Sunlight on lakes, ponds, rivers, and oceans changes liquid water to water vapor. Trees and other plants release some of the moisture in their leaves to the air, too.

But what most people don't know is why the clouds form, and why they usually form so far above the earth's surface. Perhaps you know the answers, or think you do. Whether you do or not, you should test your ideas with the activities in this chapter and the next.

First, you need to investigate the effect of temperature on the amount of water vapor in air. You and a partner will need the following equipment:

- 1 small baby-food jar of crushed ice
- 1 large baby-food jar half full of water at room temperature
- 1 thermometer
- Aluminum can (or clear plastic cup)

CHAPTER EMPHASIS

Invisible water vapor in the air can be made visible by condensation, and the amount of water vapor in air can be measured in terms of dew point and relative humidity.

Chapter 4

Excursion 4-1 is keyed to the chapter.

MAJOR POINTS

1. Condensation of water vapor occurs when air temperature is lowered to the dew point.
2. Clouds are composed of visible water droplets.
3. If condensation of water vapor occurs below freezing temperature, frost forms.
4. Relative humidity is a comparison in percent of the amount of water vapor in the air with the greatest amount that air at the particular temperature could hold.
5. A sling psychrometer is a convenient instrument for obtaining wet- and dry-bulb temperature readings.
6. Pre-computed charts can be used to convert wet- and dry-bulb temperature readings to relative humidity and dew point.
7. Solid particles (dust, smoke, salt) provide the surfaces needed for water vapor to condense into a cloud.

Either, a polished copper can, an aluminum can, or a smooth, clear plastic cup can be used for dew-point determination.

ACTIVITY 4-1. Add ice and water to the can until it is $\frac{2}{3}$ full. Observe what happens on the outside of the container.

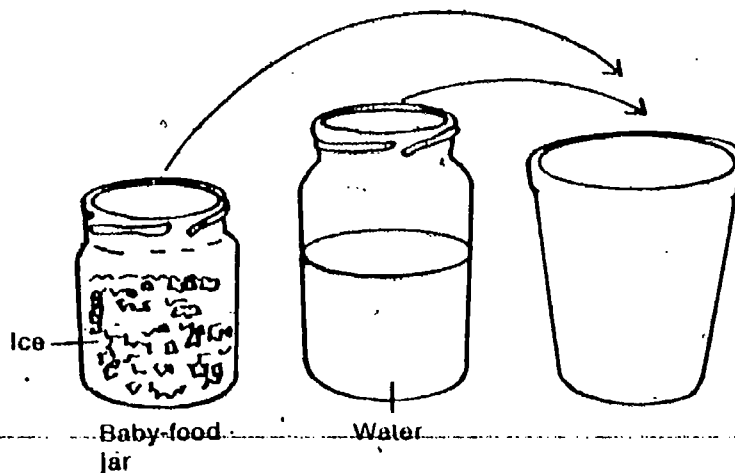

- 4-1. What did you observe happening on the outside of the container after you added the ice and water?
- 4-2. Explain your observation in question 4-1.
- 4-3. Have you seen this sort of thing happen in other situations? If so, describe them.

You should have found that a film of water formed on the outside of the can.

- 4-4. Where did the water droplets that formed on the outside of the container come from?

The ice water lowered the temperature of the container. This caused a film of water to form on its outside. But is there a certain temperature at which the moisture first appears? Try to find out by using the equipment you already have. Before you begin, empty the container. Dry it, and allow it to return to room temperature.

In Activity 4-2, it is important that the outside of the container be absolutely dry, and that the water put into it be at room temperature. On days when the humidity is high, even a slight decrease in temperature will cause condensation to form. Thus, if cooler water is put into the container, moisture may form on the outside before a temperature reading can be taken.

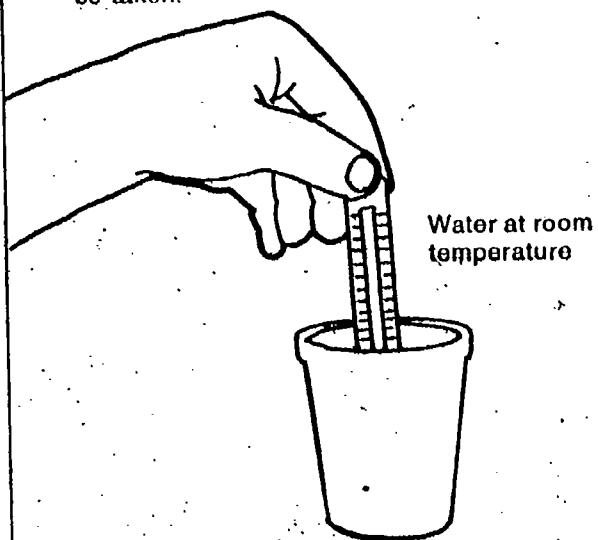

ACTIVITY 4-2. When the container has returned to room temperature, fill it $\frac{2}{3}$ full of water at room temperature. Place the thermometer in the water. Record the thermometer reading in Table 4-1 in your Record Book.

- 4-5. Does moisture appear on the outside of the container when it is at room temperature?

ACTIVITY 4-3. Add crushed ice to the water in the can, a little at a time. After each addition, stir the water with the thermometer. At the moment the water film first appears on the container, read the temperature. At the moment the water film first appears on the container, read the temperature.

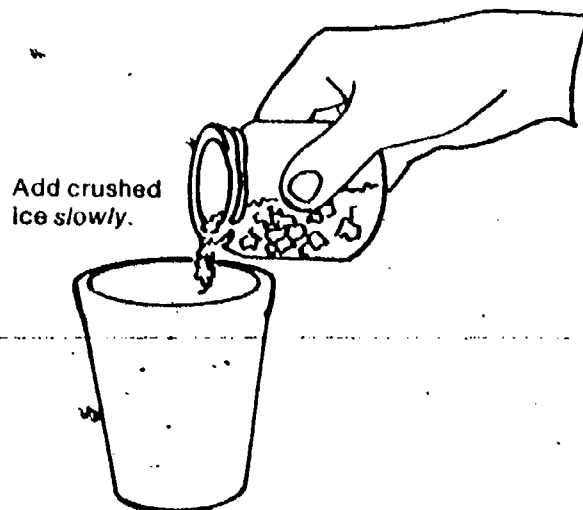

Urge students to lower the temperature of the water very gradually, by adding small amounts of ice. If it is done too rapidly, the temperature will pass through the dew point so fast that the thermometer reading will not be the true dew point.

Note: Do not breathe on the can while you are observing the thermometer.

Keep adding small amounts of ice until the moisture forms. Record that temperature in Table 4-1 for Trial 1.

Repeat the activity to get readings for a second and third trial. Record the data. Be sure your water is at room temperature when you begin each trial. If you have ice left over, return it to your teacher, or give it to other students who need it.

By now, students should realize why three readings are taken and averaged, but you might have to point out that it is one method of handling experimental error. Once again, they should be sure to dry the cup and use water at room temperature each time.

Table 4-1

Trial	Room Temp. (°C)	Temperature When Film of Moisture Forms (°C)
1		
2		
3		
Average		

4-6. What was the average temperature at which the film of water formed?

Students who studied energy relationships in Level 1 of ISCS may appreciate that for condensation to occur, the water vapor particles must give up some of their energy to the ice water. This was predicted by the particle model for matter.

By now perhaps you've figured out that the water which appeared on the can came from the air in your classroom. Water vapor is an invisible gas just like the air. It became visible only when it collected on the surface of the cold container. This changing of the gaseous water to liquid water is called *condensation*. Tiny water droplets form when the air temperature is lowered to some very definite point (called the *dew point*). At that temperature, the air can no longer hold all its moisture. The invisible water vapor from the air then becomes visible as tiny droplets form. The droplets formed on the container because it was much colder than its surroundings. The air near it was colder than the rest of the air in the room.

4-7. It will change to frost (solid-water particles) on the container. (You may have a refrigerator in the school in which this could be tried. Some students may ask, "Didn't the water vapor just condense and then freeze?" Not so. Water has the ability to go directly from gaseous state to solid state or solid state to gaseous state by *sublimation* without forming a liquid in between.)

4-7. Suppose the temperature of the container had been below freezing. What would you expect to happen to the water in the gaseous form, warm air or cold air?

You can check your answer to this last question by putting a small dry can in the freezing compartment of your home refrigerator.

4-8. According to your investigation, which will hold more water in the gaseous form, warm air or cold air?

Obviously, clouds aren't invisible. You can see them. This means to make a cloud, you must make invisible water visible. You have just seen one way to make the invisible visible—lower the temperature of the air. You saw water droplets form on the cold surface of the cup.

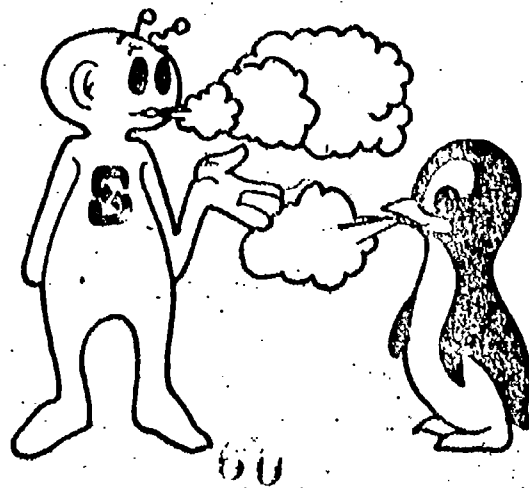

Before you investigate another way to make water vapor visible, you should learn a bit more about water vapor.

You have learned that there is a limit to the amount of water vapor that air can hold. This limit depends upon the temperature of the air. Warm air can hold more water vapor than cold air can hold. You saw what happens when warm moist air is cooled. At a certain temperature (the dew point), the cooling air contains all the moisture it is able to hold at that temperature. If it is cooled below the dew point, some vapor must condense as water droplets.

Meteorologists (weather forecasters) measure the amount of water vapor present in air. They call this measure the *relative humidity*. The measure is actually a comparison. It compares the amount of water vapor in air at some temperature with the greatest amount that could be in the air at that same temperature.

Relative humidity is defined by this formula:

$$\text{Relative humidity} = \frac{\text{Amount of water vapor in air at certain temp.}}{\text{Greatest amount of water vapor possible in air at that temp.}} \times 100\%$$

Suppose the relative humidity of air is 75%. This means that the air contains 75% of the water vapor that it is possible for it to contain at that temperature.

For example, suppose 1,000 milliliters of air at 20° C could contain 20 milligrams of water vapor. The relative humidity is 75% if the air *actually contains* 75% of 20 milligrams (that is, 15 milligrams) of water in each 1,000 milliliters.

The figures in that example are given below to show how the formula is used:

$$\text{Relative humidity} = \frac{15 \text{ milligrams}}{20 \text{ milligrams}} \times 100\% = .75 \times 100\% = 75\%$$

4-9. What does it mean to say "the relative humidity is 50%"?

4-10. Suppose 1,000 ml of air contains 10 mg of water vapor. At this temperature, the same volume of air could contain 50 mg of water. What is the relative humidity of the air?

Meteorologists measure the amount of water vapor in air in several different ways, one of which is relative humidity.

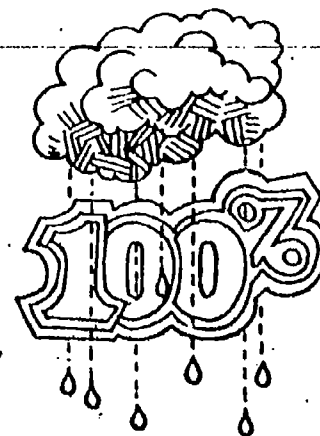

SELECT THE BEST PHRASE

BOY! THE HUMIDITY MUST BE 99%

WOW! THE HUMIDITY IS AT LEAST 10%

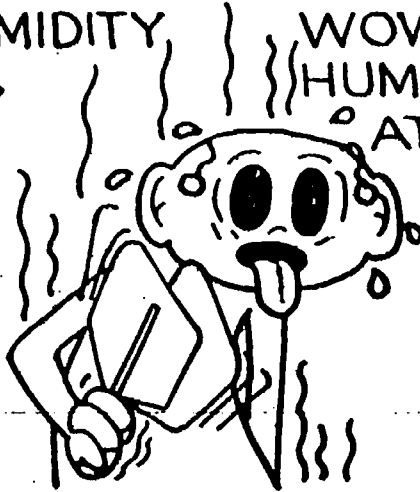

Humidity

In view of the importance of the water vapor content of the air (*humidity*), it would be well to include measurements of this quantity in your weather-watch chart. To do this, you must learn how to get the data you will need.

You will use a sling psychrometer. Activity 4-4 shows what it is and tells you how it is used.

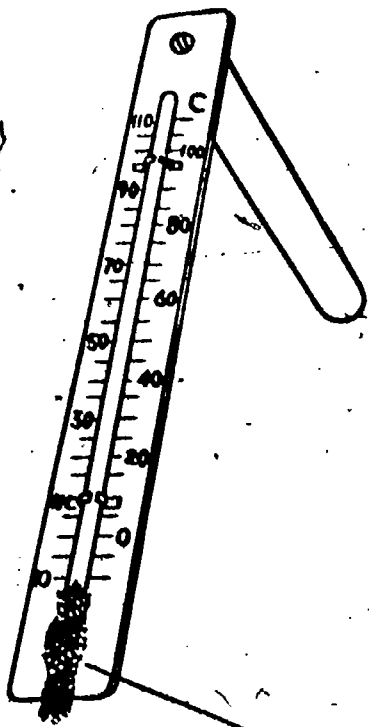

Wet wick with water at room temperature.

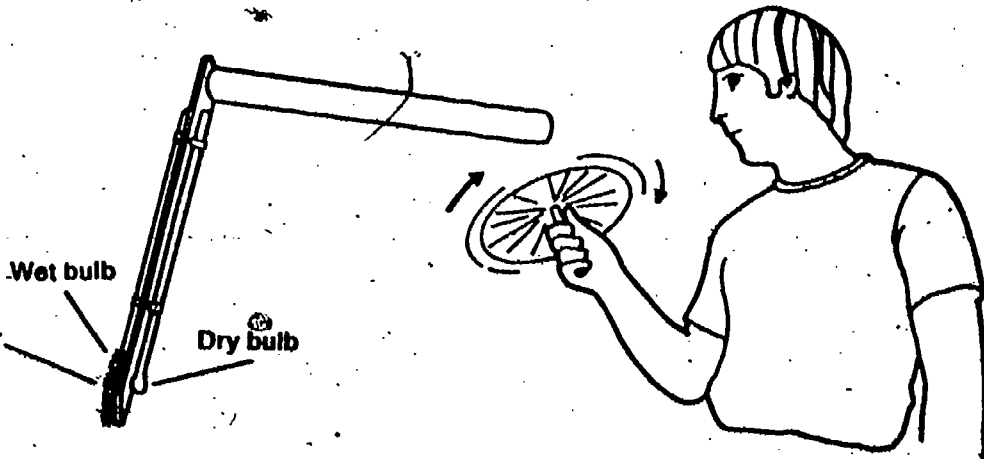

ACTIVITY 4-4. Wet the wick with room-temperature water. Swing the psychrometer around for 15 seconds. *Be careful not to hit anything.* Note the temperatures of the dry bulb and the wet bulb. Whirl it for another 15 seconds. Note the temperatures again. When the wet-bulb temperature reaches its lowest value, record both the wet- and dry-bulb temperatures.

4-11. Record the two temperatures from Activity 4-4: wet-bulb and dry-bulb.

4-12. What is the difference in degrees between the wet-bulb and dry-bulb?

For your information, the decrease in temperature of the wet bulb due to evaporation is called the wet-bulb depression.

To determine the relative humidity, you will need to use Table 4-2. First, find the dry-bulb temperature you measured. (It is in the first column of the table.) That locates the row where you will find the relative humidity.

Move your finger across to the right, until you come to the column that has the value you found (difference between wet- and dry-bulb temperatures). The figure in the box is the relative humidity (expressed in percent). (See Figure 4-1 for a sample of this procedure.)

If the air is completely saturated with water vapor (has all the moisture it can hold at that temperature), then there will be no evaporation, and no decrease in the temperature of the wet bulb. The relative humidity is then 100%. In nature, there is probably no time that the relative humidity drops to 0%. Even the driest desert air has some moisture in it.

Figure 4-1

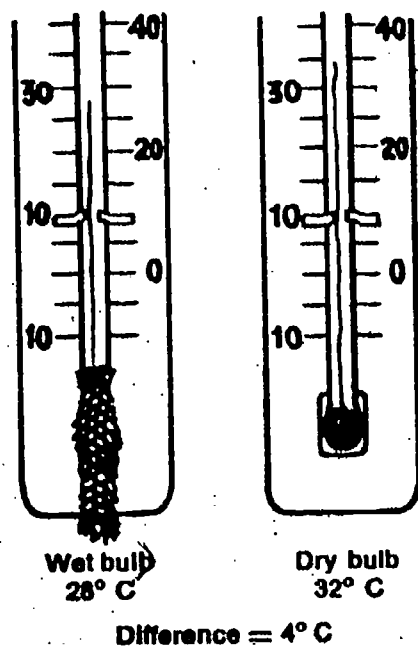

Dry-Bulb Temp (°C)	Difference between Wet- and Dry-Bulb Temp. (°C)							
	1°	2°	3°	4°	5°	6°	7°	8°
30	93	86	79	73	67	61	55	50
31	93	86	80	73	67	61	56	51
32	93	86	80	74	68	62	57	51
33	93	87	80	74	68	63	57	52
34	93	87	81	75	69	63	58	53

Relative humidity = 74%

Table 4-2

Dry-Bulb Temp. (°C)	Relative Humidity (%)																			
	Difference Between Wet- and Dry-Bulb Temp. (°C)																			
	1°	2°	3°	4°	5°	6°	7°	8°	9°	10°	11°	12°	13°	14°	15°	16°	17°	18°	19°	20°
-10	67	35																		
-9	69	39	9																	
-8	71	43	15																	
-7	73	48	20																	
-6	74	49	25																	
-5	76	52	29	7																
-4	77	55	33	12																
-3	78	57	37	17																
-2	79	60	40	22																
-1	81	62	43	26	8															
0	81	64	46	29	13															
1	83	66	49	33	17															
2	84	68	52	37	22	7														
3	84	70	55	40	26	12														
4	85	71	57	43	29	16														
5	86	72	58	45	33	20	7													
6	86	73	60	48	35	24	11													
7	87	74	62	50	38	26	15													
8	87	75	63	51	40	29	19	8												
9	88	76	64	53	42	32	22	12												
10	88	77	66	55	44	34	24	15	6											
11	89	78	67	56	46	36	27	18	9											
12	89	78	68	58	48	39	29	21	12											
13	89	79	69	59	50	41	32	23	15	7										
14	90	79	70	60	51	42	34	26	18	10										
15	90	80	71	61	53	44	36	27	20	13	6									
16	90	81	71	63	54	46	38	30	23	15	8									
17	90	81	72	64	55	47	40	32	25	18	11									
18	91	82	73	65	57	49	41	34	27	20	14	7								
19	91	82	74	65	58	50	43	36	29	22	16	10								
20	91	83	74	66	59	51	44	37	31	24	18	12	6							
21	91	83	75	67	60	53	46	39	32	26	20	14	9							
22	92	83	76	68	61	54	47	40	34	28	22	17	11	6						
23	92	84	76	69	62	55	48	42	36	30	24	19	13	8						
24	92	84	77	69	62	56	49	43	37	31	26	20	15	10	5					
25	92	84	77	70	63	57	50	44	39	33	28	22	17	12	8					
26	92	85	78	71	64	58	51	46	40	34	29	24	19	14	10	5				
27	92	85	78	71	65	58	52	47	41	36	31	26	21	16	12	7				
28	93	85	78	72	65	59	53	48	42	37	32	27	22	18	13	9	5			
29	93	86	79	72	66	60	54	49	43	38	33	28	24	19	15	11	7			
30	93	86	79	73	67	61	55	50	44	39	35	30	25	21	17	13	9	5		
31	93	86	80	73	67	61	56	51	45	40	36	31	27	22	18	14	11	7		
32	93	86	80	74	68	62	57	51	46	41	37	32	28	24	20	16	12	9	5	
33	93	87	80	74	68	63	57	52	47	42	38	33	29	25	21	17	14	10	7	
34	93	87	81	75	69	63	58	53	48	43	39	35	30	28	23	19	15	12	8	5
35	94	87	81	75	69	64	59	54	49	44	40	36	32	28	24	20	17	13	10	7



4-13. Write an operational definition of relative humidity: (How do you detect and measure it?)

4-14. What is today's relative humidity?

Back to the dew point

Dew point was defined earlier as the temperature at which air could no longer hold its moisture. At that temperature, water vapor from the air collects on a surface as a liquid (dew) or solid (frost). Remember that warm air can hold more moisture than cold air can. Dew point can be determined from a chart similar to the one you used for relative humidity (see Table 4-3).

Refer to the relative-humidity chart (Table 4-2) and the dew-point chart (Table 4-3) as you answer questions 4-15 and 4-16.

4-15. What would the relative humidity be when the wet- and dry-bulb temperatures are the same?

4-16. What would the dew-point temperature be when the wet- and dry-bulb temperatures are the same?

4-17. Give an operational definition of dew point.

You may wonder why you have to swing the psychrometer to measure humidity and dew point. If so, you should turn to **Excursion 4-1**, "The Shivering Thermometer."

Up until now, you have not been able to fill in the dew-point or the relative-humidity readings in your weather-watch chart. From now on, record daily readings of the relative humidity and the dew point.

You started this chapter trying to explain why clouds form as they do. You've learned that cooling air can cause the water vapor it contains to condense. However, you haven't really seen any clouds form during your activities. The only condensing you have seen has taken place on a solid surface.

This suggests that water vapor must have some kind of solid surface on which to form liquid droplets. How then can clouds form? Are there such surfaces high in the air?

4-15. 100%

4-16. The same temperature as that of the wet- and dry-bulb thermometers. (A normal occurrence when this happens is condensation. If it happens at the earth's surface, dew or frost forms. If it happens in the atmosphere, a cloud forms. If the cloud forms close to the earth, it is called fog.)

EXCURSION

Excursion 4-1 investigates cooling by evaporation and applies the particle model of matter.

From this point on, the last two rows of Table 2-1 should be filled in daily in the Record Book.

Table 4-3

Dry-Bulb Temp. (°C)	Dew-Point Temperature (°C)																			
	Difference Between Wet- and Dry-Bulb Temp. (°C)																			
	1°	2°	3°	4°	5°	6°	7°	8°	9°	10°	11°	12°	13°	14°	15°	16°	17°	18°	19°	20°
-20	-23	-31																		
-15	-18	-23	-31																	
-10	-12	-14	-17	-23																
-9	-11	-13	-17	-21																
-8	-10	-12	-15	-19																
-7	-9	-11	-13	-17	-20															
-6	-8	-10	-12	-15	-20															
-5	-6	-7	-8	-12	-15	-19	-24	-26												
-4	-5	-7	-8	-11	-14	-17	-22	-25												
-3	-4	-6	-7	-9	-12	-15	-20	-23												
-2	-3	-4	-6	-8	-11	-13	-17	-21												
-1	-2	-4	-5	-7	-9	-12	-16	-18												
0	-1	-3	-4	-6	-7	-10	-13	-17	-20											
1	1	-1	-2	-4	-6	-8	-11	-14	-19	-24										
2	1	-1	-2	-3	-5	-7	-9	-12	-16	-21										
3	2	1	-1	-2	-4	-6	-7	-9	-13	-18										
4	3	2	1	-1	-3	-4	-6	-8	-11	-14	-19	-26								
5	4	3	1	0	-2	-3	-5	-7	-9	-12	-16	-20								
6	5	4	2	1	-1	-2	-3	-6	-8	-9	-12	-16								
7	6	5	3	2	1	-1	-2	-4	-6	-8	-11	-14	-20	-26						
8	7	6	4	3	2	1	-1	-3	-5	-7	-9	-11	-16	-19						
9	8	7	6	4	3	2	0	-2	-3	-5	-7	-9	-13	-16						
10	9	8	7	6	4	3	1	0	-2	-3	-6	-8	-11	-13	-19	-25				
11	10	9	8	7	6	4	3	2	0	-2	-4	-6	-8	-10	-14	-19				
12	12	11	10	9	7	6	4	3	2	1	-1	-3	-5	-7	-10	-13	-19	-24		
13	12	12	11	9	8	7	6	4	3	2	0	-2	-3	-5	-7	-11	-16	-21		
14	13	13	12	11	9	8	7	6	4	3	1	-1	-2	-3	-6	-8	-13	-17		
15	14	14	13	12	11	9	8	7	6	4	3	2	0	-2	-4	-6	-9	-12	-17	-22
16	15	14	13	13	12	11	9	8	7	6	4	3	1	-1	-3	-4	-7	-9	-14	-18
17	16	16	14	14	13	12	11	9	8	7	6	4	2	1	-1	-3	-5	-7	-11	-13
18	17	17	16	15	14	13	12	11	9	8	7	6	4	3	1	-1	-3	-4	-7	-10
19	18	17	16	16	14	14	13	12	11	9	8	7	5	4	2	1	-1	-3	-6	-8
20	19	18	17	17	16	15	14	13	12	11	9	8	7	5	3	2	0	-1	-3	-6
21	21	19	18	18	17	16	15	14	13	12	11	9	8	7	5	4	2	-1	-2	-3
22	21	20	19	18	18	17	16	15	14	13	12	11	9	8	7	6	4	2	0	-2
23	22	21	21	19	19	18	17	16	15	14	13	12	11	10	8	7	5	4	2	0
24	23	22	22	21	20	19	18	17	16	15	14	13	12	11	10	8	6	6	4	2
25	24	23	22	21	21	20	19	18	17	16	15	14	13	13	11	9	8	7	5	3
26	25	24	23	22	22	21	20	19	18	17	16	15	14	13	12	11	9	8	6	4
27	26	25	24	23	23	22	21	20	19	18	17	17	15	14	13	12	11	10	7	5
28	27	26	26	25	24	23	22	22	21	20	19	18	17	16	15	14	13	12	10	8
29	29	28	27	27	26	25	24	23	22	22	21	20	19	18	17	16	15	14	12	11
30	29	28	28	27	26	25	24	24	23	22	22	21	20	19	18	17	16	15	13	12
31	31	29	29	28	27	27	26	25	24	23	22	22	21	20	19	18	17	16	14	13
32	32	31	30	29	28	28	27	26	25	24	23	23	22	21	20	19	18	17	16	15
33	32	32	31	30	29	28	27	27	26	26	24	24	23	22	21	20	19	18	17	16
34	33	33	32	31	30	29	29	28	27	27	26	25	24	23	22	22	20	19	18	17
35	34	34	33	32	31	30	30	29	28	28	27	26	25	24	23	22	21	21	20	19



Almost all air contains some solid particles. Dust, salt crystals, and smoke particles are commonly found in air. These solid particles provide the surfaces needed for droplet formation. Such particles are found at most altitudes, but more of them are found near the earth's surface.

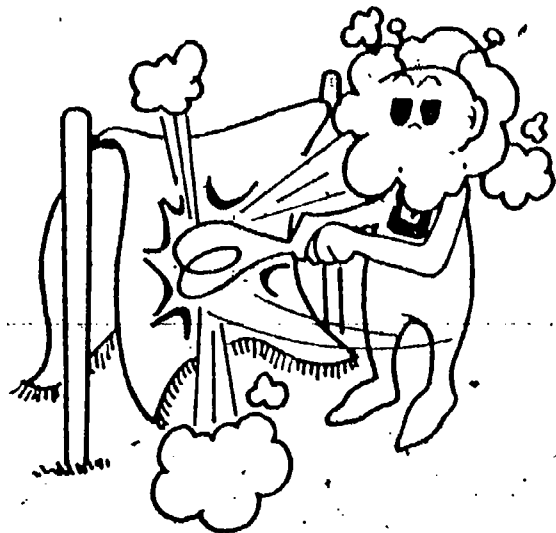

The term is not necessary for students, but the solid particles on which water will condense are called hygroscopic particles. Not all solid particles act suitably in the formation of water droplets. Condensation nuclei must attract water. The importance of these nuclei in the air is demonstrated by the fact that heavy fogs occur around industrial installations, whereas fewer fogs form in rural areas with air of equally high moisture content.

Figure 4-2



4-18. Because the temperature must be low enough for condensation to occur.

□4-18. If more solid particles are found near the surface of the earth, why do most clouds form at higher altitudes?

You've seen that decreasing temperature can produce condensation of invisible water vapor.

□4-19. Suppose the air, being cooled also contained fine solid particles such as those in smoke. What do you predict would happen?

Check your prediction by doing the following experiment. You will need these materials:

It is difficult to duplicate a genuine cloud in the laboratory. The science of cloud physics is one of the most difficult areas of meteorology. Scientists have found it extremely hard to observe what takes place in a cloud without interfering with natural processes.

- 2 large baby-food jars (labeled "1" and "2")
- 1 plastic sandwich bag
- 2 ice cubes
- Hot and cold water

ACTIVITY 4-5. Put about 50 ml of cold water into Jar 1. Then place a plastic bag containing two ice cubes on top of the jar. Observe for about one minute. (Hold the ends of the bag with your hands.)

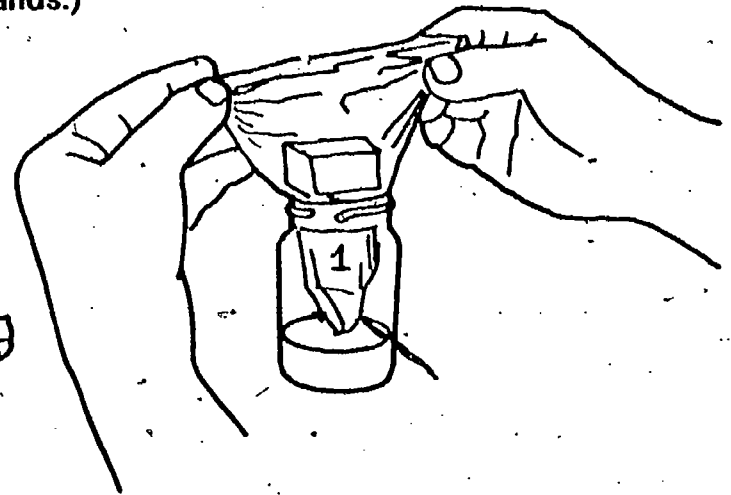
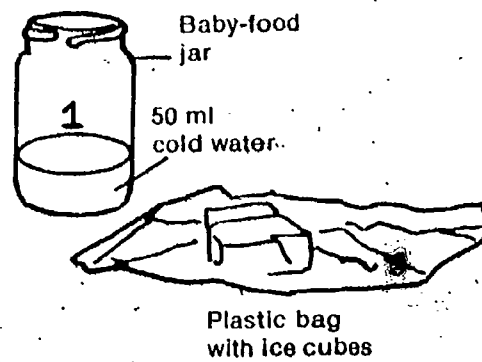

ACTIVITY 4-6. Repeat Activity 4-5, using hot water in Jar 2.

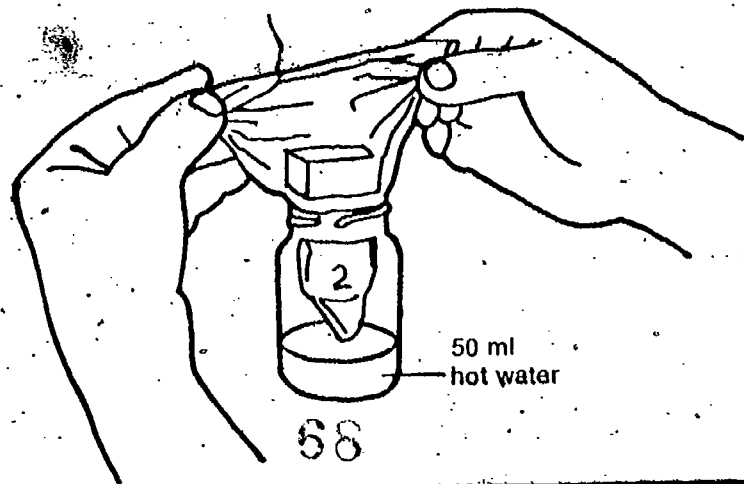

ACTIVITY 4-7. Remove the bag from Jar 2. Light a match. Let it burn for two or three seconds. Drop the match into the jar.

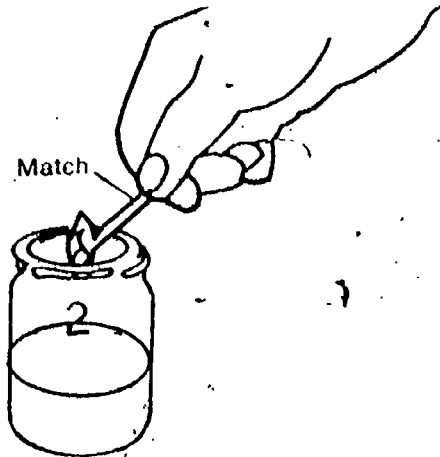

ACTIVITY 4-8. Now place the bag of ice cubes on top of the jar again. Observe for one minute.

Summarize your results in Table 4-4 in your Record Book.

Table 4-4

	Observations
1. Jar 1, with cold water	
2. Jar 2, with hot water	
3. Jar 2, with hot water and smoke	

4-20. Did the presence of smoke particles have an effect on the amount of mist that formed in the jar?

The experiment you did showed you one way to form a cloud. All you have to do is cool wet air that contains solid particles. You know that the atmosphere contains both water vapor and solid particles.

4-21. What happens to the temperature of air as the air rises to higher altitudes?

Before going on, do Self-Evaluation 4 in your Record Book.

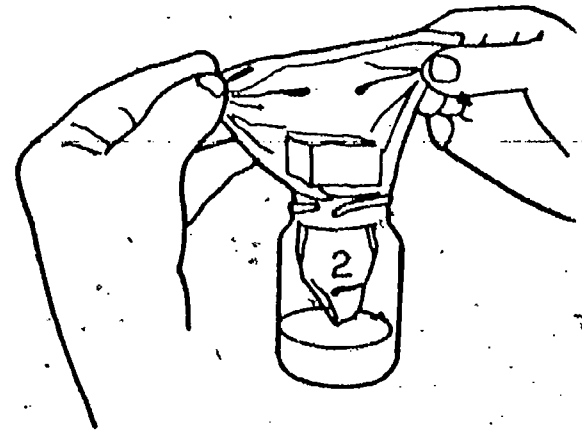
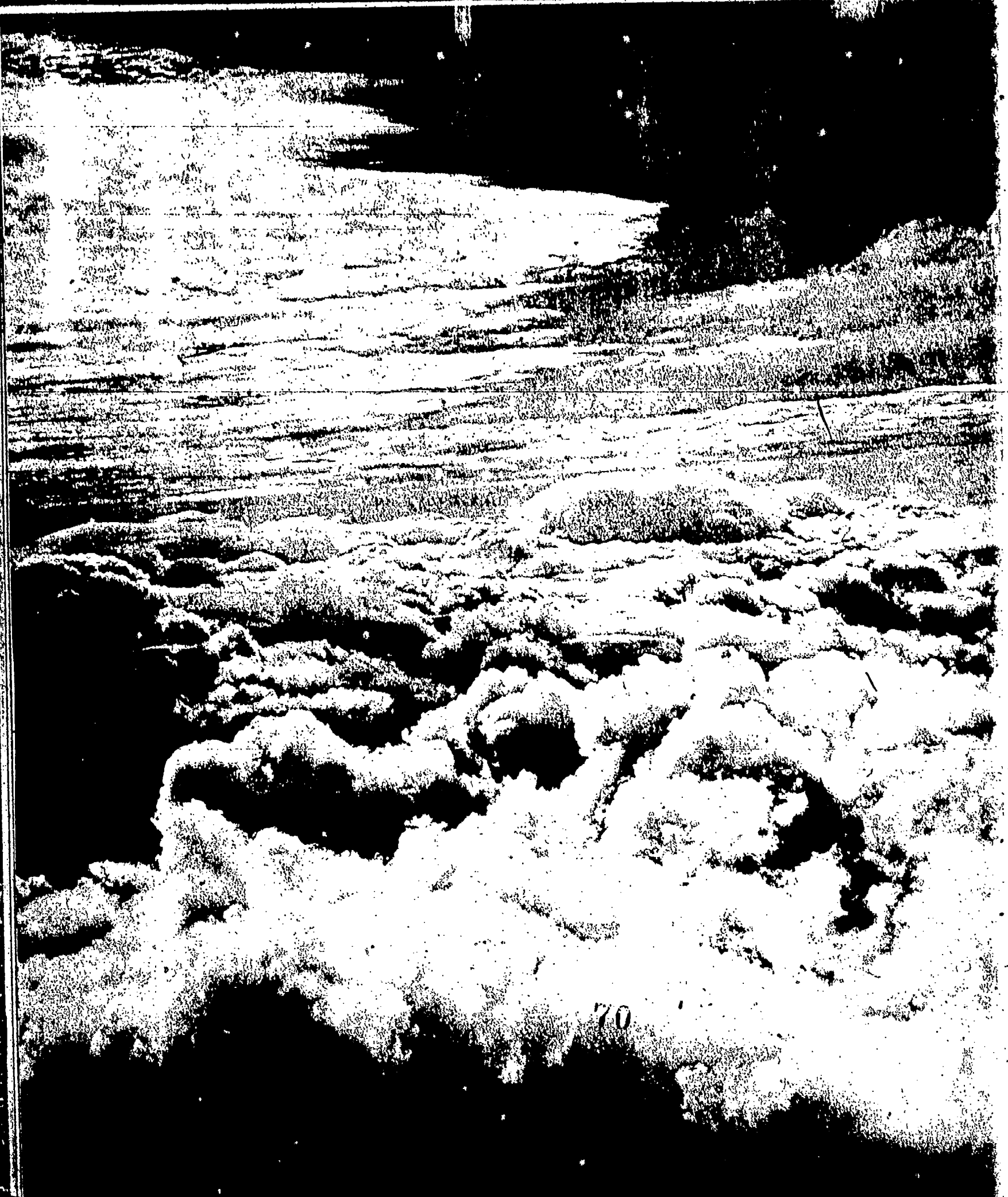

Table 4-4 should show an increasing amount of cloud formation in 1, 2, and 3. You may want to get some small-group discussion going on why this is so. The particle model predicts that more water particles will be escaping from the hot water, because of their more rapid motion. This means that the air above the hot water will contain more water vapor. The addition of smoke furnishes more solid particles for the water to condense on. It is interesting to note that even without the addition of smoke, some condensation occurs. In this modern world, there are already lots of solid particles in ordinary air. That's what air pollution is all about.

GET IT READY NOW FOR CHAPTER 5

You might want to have one pressure chamber apparatus assembled as a guide. You will need matches, scissors or sharp knife, some black paper such as construction paper, and the observation boxes used in Chapter 1.



70

EQUIPMENT LIST

Per student-team

- 1 250-ml Erlenmeyer flask
- 1 1-hole #6 rubber stopper
- 1 piece (5-6 cm) rigid plastic tube
- 1 piece (3-4 cm) rubber tubing
- 1 large air piston

- Matches
- Black paper
- Observation box
- 1 short candle
- Heavy string, 12-cm length
- 1 plastic straw
- Sharp knife or scissors

More Reasons for Clouds

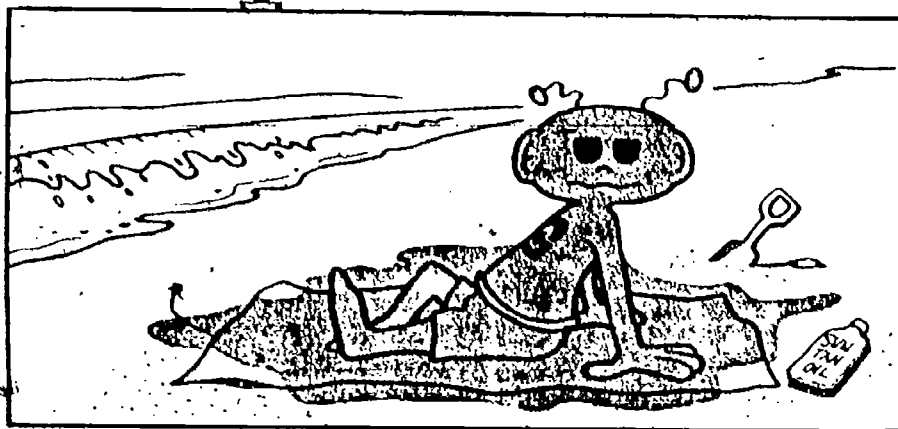
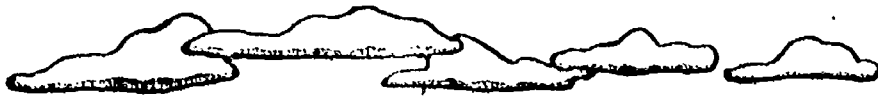

As warm air rises over a warm area, it gradually cools. If this cooling effect continues, the temperature of the air will reach the dew point. Water vapor can then condense to form clouds if enough solid particles are present.

Temperature decrease with increasing altitude is characteristic of air as it rises.

5-1. What other change occurs in air as it rises?

What effects, if any, does the pressure have on cloud formation? To find out, you will need to construct your own pressure chamber. You and a partner will need the following:

- 1 250-ml Erlenmeyer flask
- 1 1-hole #6 rubber stopper
- 1 short piece of rigid plastic tube (5-6 cm)
- 1 short piece of rubber tubing (3-4 cm)
- 1 large air piston
- Water
- Matches

CHAPTER EMPHASIS

The effect of a decrease in air pressure on condensation is added to the effect of decrease in temperature with altitude in forming clouds. Also, the upward motion of air is a cause of horizontal motion, or wind.

Chapter 5

Excursions 5-1 and 5-2 are keyed to this chapter.

MAJOR POINTS

1. A decrease in pressure in a closed system can cause condensation
2. The particle model for matter can be used to explain why warm air rises, why pressure decreases with altitude, and therefore why clouds form over particular areas
3. The upward motion of air causes other air to move horizontally
4. Differential heating of the earth's surface can cause patterns of air movement at the surface.

ACTIVITY 5-1. Prepare the rubber stopper and air piston as shown.

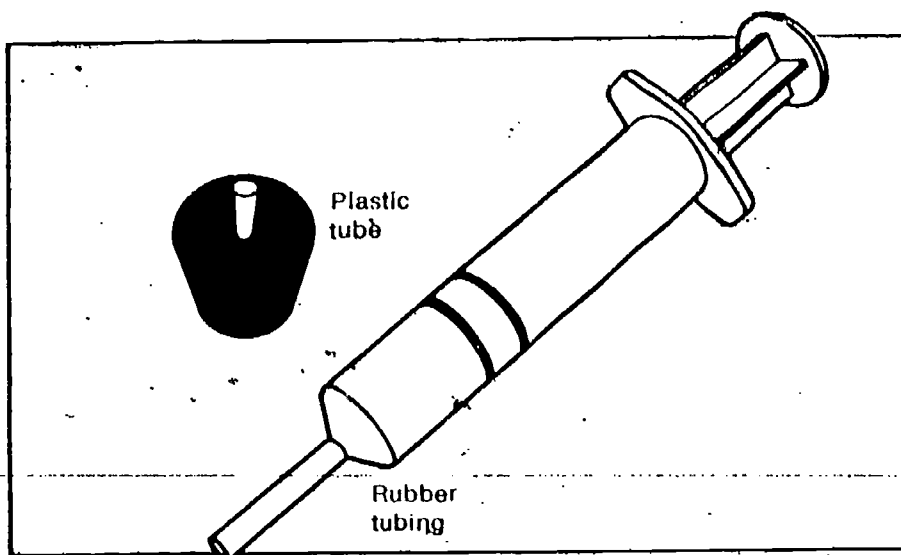

The suggestion was made at the end of Chapter 4 that you might assemble one of these "pressure chambers" as a pattern, and to determine what minor adjustments need be made for proper functioning. Incidentally, you may find that a little petroleum jelly or silicone spray lubricant will make the air pistons work better, easier, and for a longer time.

ACTIVITY 5-2. Complete the assembly as shown. The plastic tube must fit snugly into the rubber tubing. If necessary, add a few wraps of tape to increase the diameter of the plastic tube.

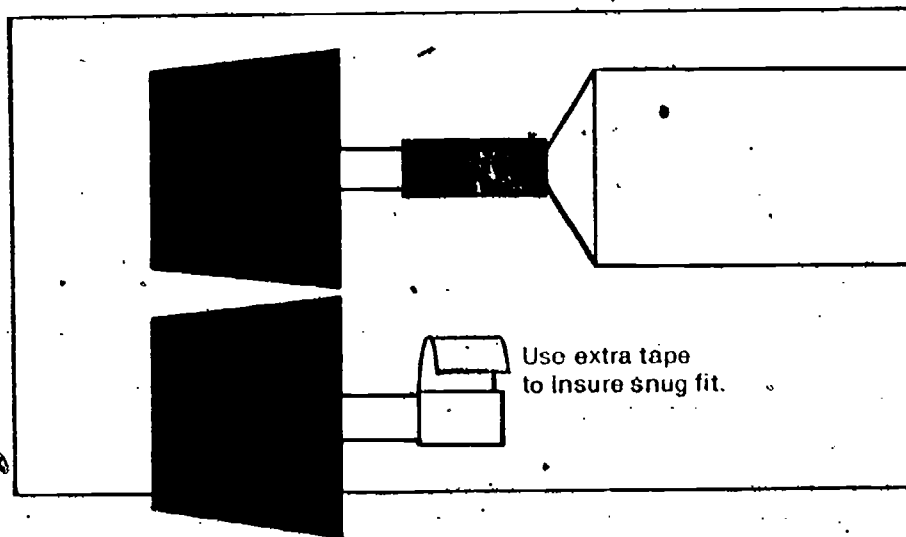

5-2. Does the air in the flask contain water vapor?

5-3. What is today's humidity?

Think of your flask of air as the rising cube discussed in Chapter 3. As it ascends, the pressure on the air decreases. To see what effect this has, you can use the air piston and stopper.

ACTIVITY 5-3. Push the plunger of the air piston all the way in. Then insert the stopper tightly into the flask. Support the flask so that it doesn't tip over.

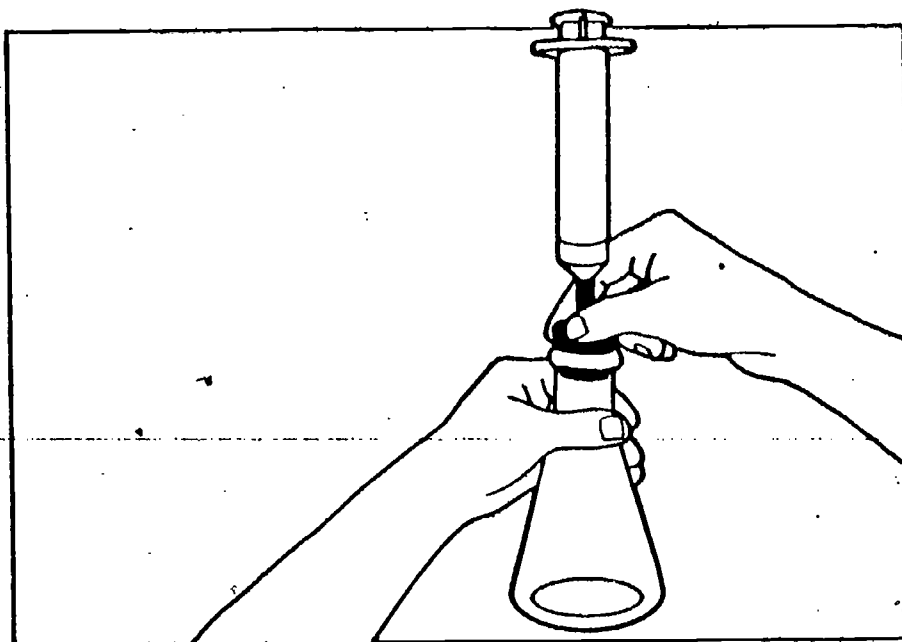

Note that the plunger is pushed all the way in *before* the stopper is inserted in the flask.

To reduce the pressure within the flask, you need only to remove some of the air. You can do this by pulling out the air piston plunger.

ACTIVITY 5-4. Place the flask on a dark background such as a sheet of black construction paper. While your partner holds the flask securely on the table, *quickly* lift the plunger to reduce the pressure. Try not to pull it all the way out of the cylinder. Observe the flask carefully as you decrease the pressure.

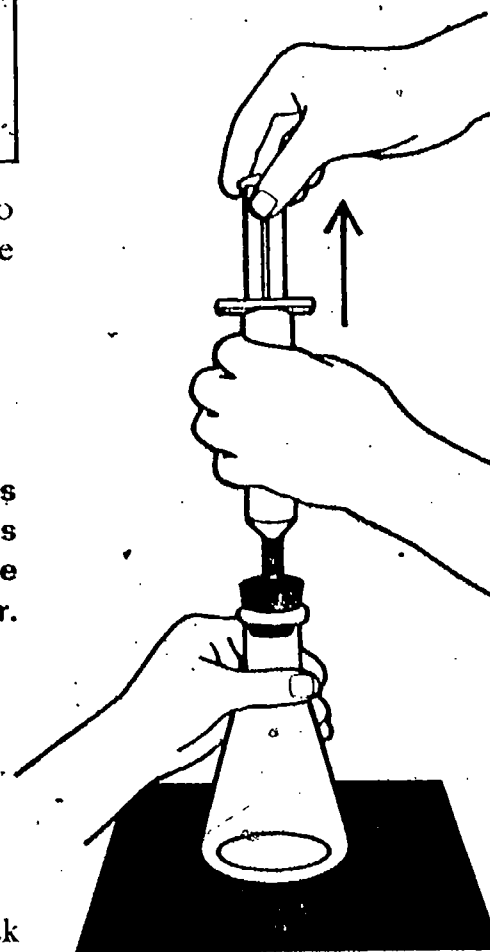

5-4. Describe any changes you observed within the flask as the pressure was reduced.

You may want to repeat Activity 5-4 a few times to check your observations.

ACTIVITY 5-5. Add a very small amount of smoke to the air in the flask. You can do this by just blowing some of the smoke into the flask. The smoke should not be visible in the flask.

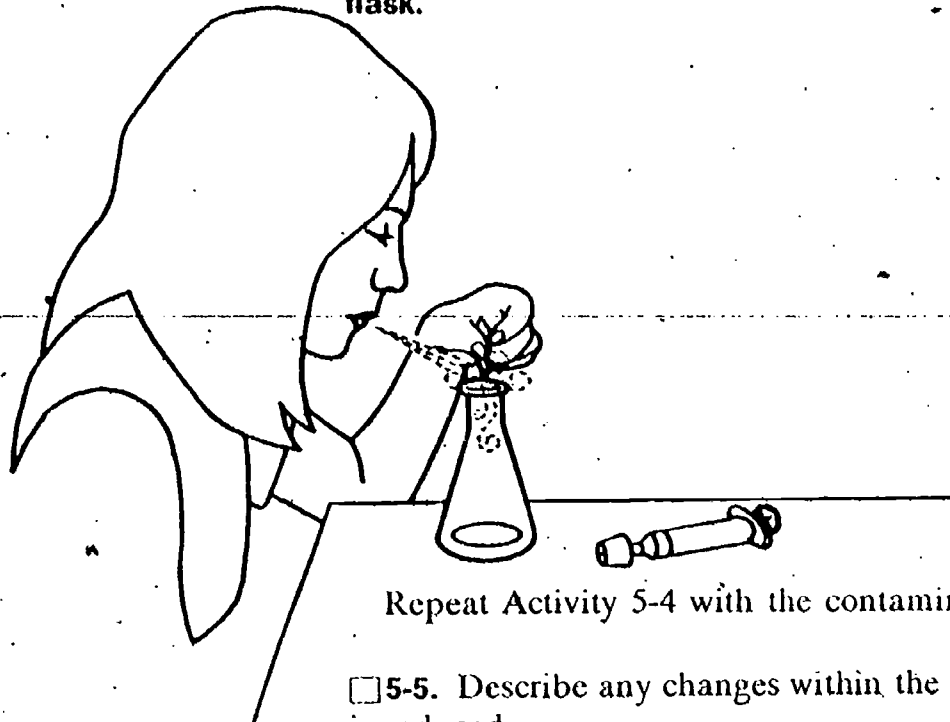

Repeat Activity 5-4 with the contaminated air.

- 5-5. Describe any changes within the flask as the pressure is reduced.
- 5-6. What happens when you increase the pressure again by pushing the plunger back in?
- 5-7. What effect would decreasing air pressure be likely to have on cloud formation above the earth's surface?

Figure 5-1



The clouds you observed in the baby-food jars and in the flask probably were very faint. They may have looked only like a mist or fog. But then that is exactly what a cloud is. If you've ever been in one, you know it to be a misty experience.

PROBLEM BREAK 5-1

You've seen faint mists form both when temperature is changed and when pressure is changed. How would cloud formation be affected if both these factors were changed together? Would the cloud mist be thicker? Join forces with another team and design a plan to answer these questions. Then get your teacher's approval. There is a space for your work in your Record Book.

Let's pause for a moment and review what you have been doing in this unit up to this point. You have been putting together many observations of how air behaves.

So far you've learned these things:

1. The atmosphere is heated differently depending on the nature of the surface of the earth. Generally, dry land-masses produce more heating of the air than do surface waters (Figure 5-2).

Note that teacher approval is called for in the Problem Break. Students may need to be reminded that they are working with three variables: temperature, pressure, and condensation nuclei (smoke particles). They may consider the activities that they performed previously (effect of lowering the temperature, effect of decreasing the pressure, effect of adding smoke particles) as part of the experiment, and go on from there.

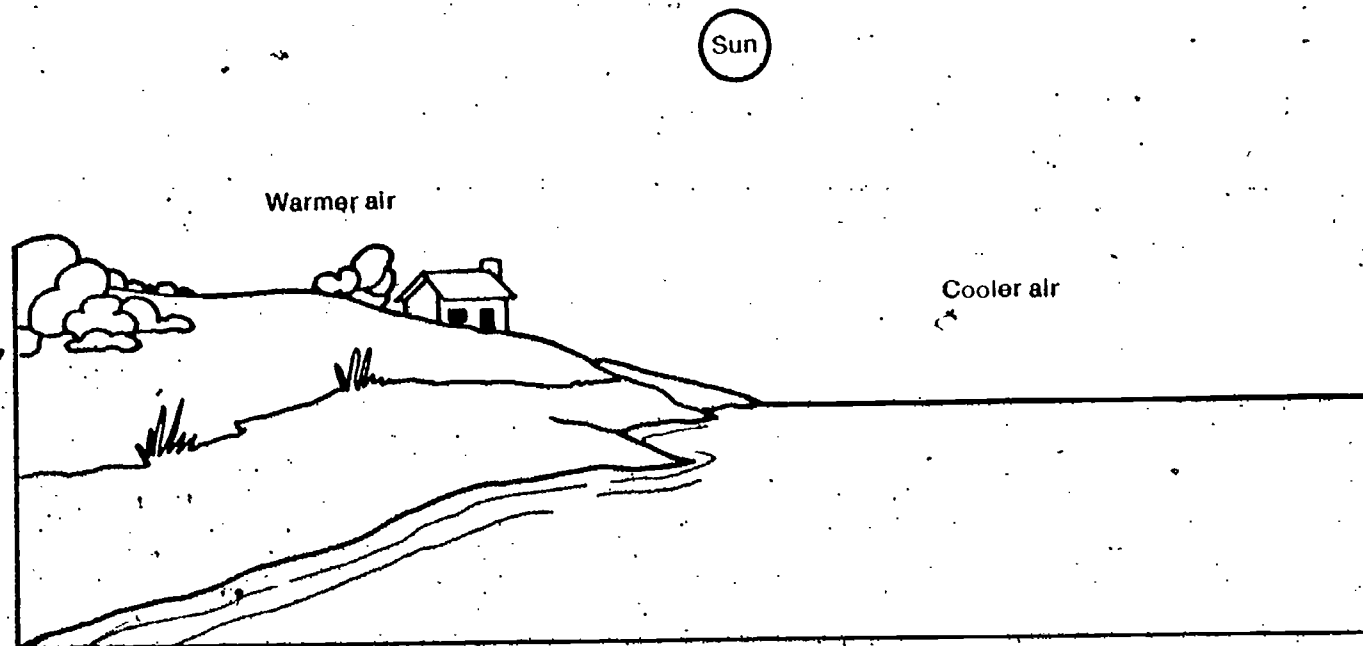

Figure 5-2

As explained in the teacher notes in Chapter 3, decrease in pressure has an effect on temperature because work is done in expanding the air against the decreasing pressure. However, from the student's viewpoint in considering the system, the factors of temperature and pressure can be considered separately.

2. Warm air rises, or to say it another way, cold air settles toward the earth's surface.
3. As air rises from the earth's surface, the air's temperature decreases and so does the pressure on it.

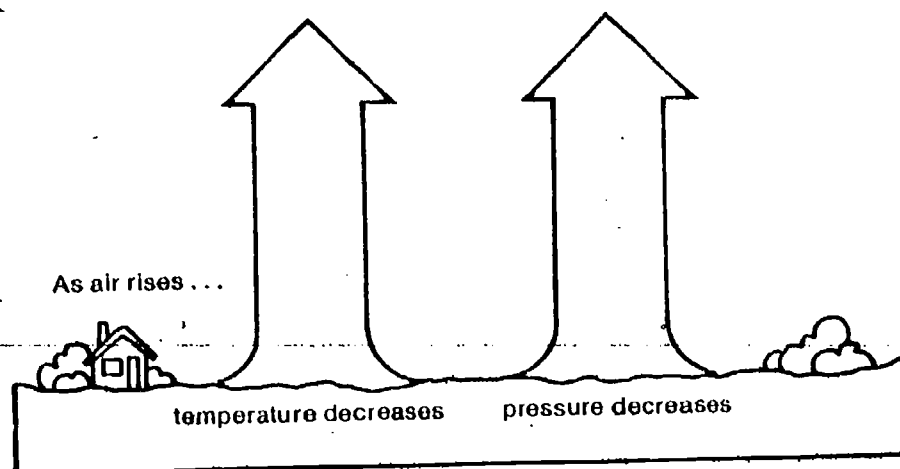

Figure 5-3

4. Decreasing either pressure or temperature, or both, causes invisible water vapor to condense into liquid droplets around tiny solid particles of dust, smoke, and salt. These water droplets accumulate and become visible as mists and clouds.

How high in the atmosphere does all this happen? If you are interested in finding out, see Excursion 5-1, "How High Are the Clouds?"

EXCURSION

Excursion 5-1 is a practical exercise in determining cumuloform cloud heights, using temperature and dew point.

The entire unit is aimed at developing a model for weather. The work to this point has shown one reason for air rising, and the things that happen to it when it does rise. From this point, the model will be expanded to show other things that happen when air rises, and other factors that make it rise.

As you know, scientists aren't satisfied with observations alone. They want to explain their observations and how they relate to each other. Thus, they invent ideas to account for what they see. These invented ideas are called *mental models*. You have been using a common mental model to explain some of your observations of the behavior of air. The model you've used is the particle model for matter.

The particle model assumes that air and water and all matter are composed of tiny invisible particles. This model can be used to explain why warm air rises. And it can explain why air pressure decreases with increasing altitude. But can you use what you know to explain one day's weather in Florida? See if you can.

Examine carefully the cloud patterns in each of the satellite photographs of the state of Florida (Figures 5-4 and 5-5). Compare the cloud patterns you see with the map of Florida that is provided with each figure.

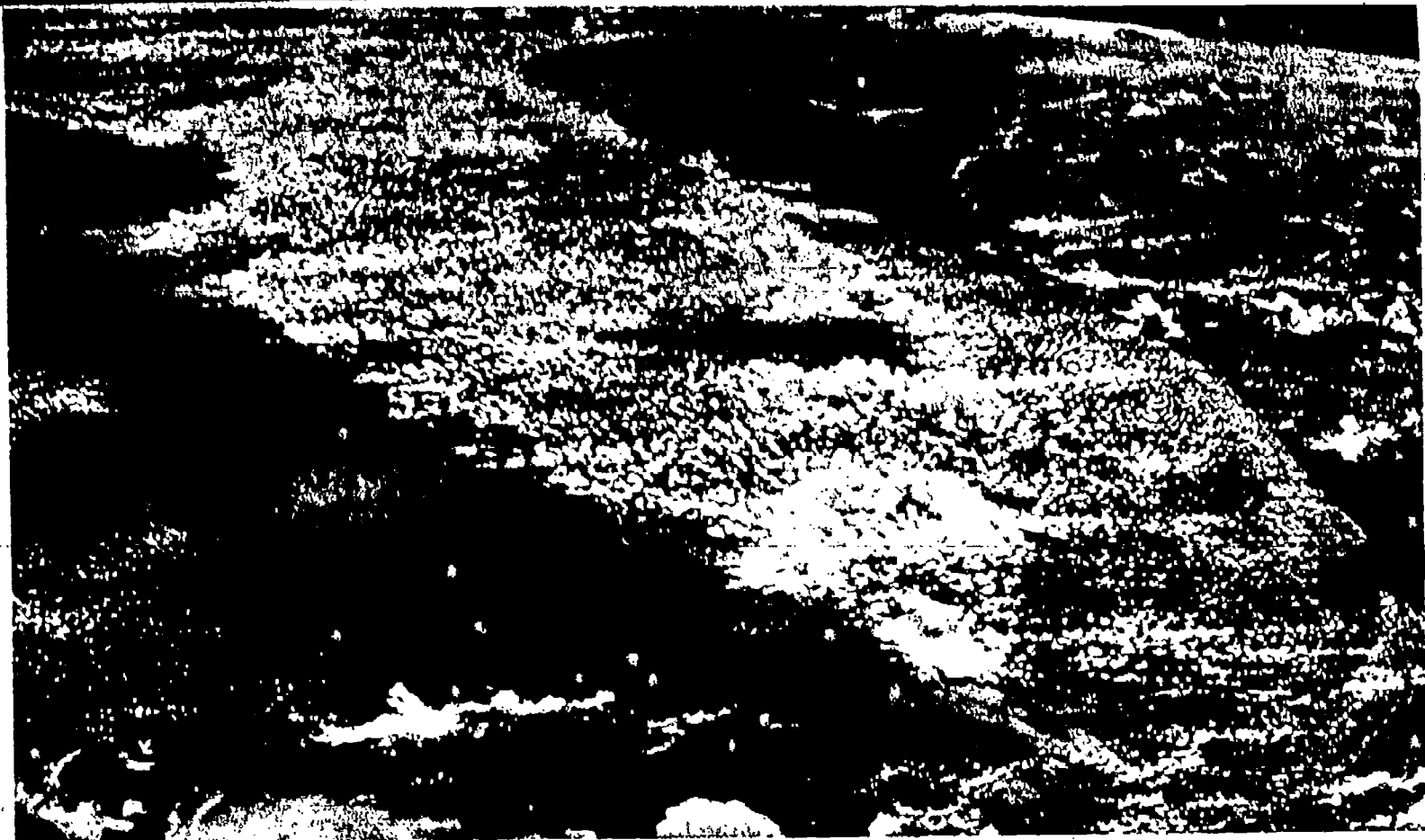

Figure 5-4

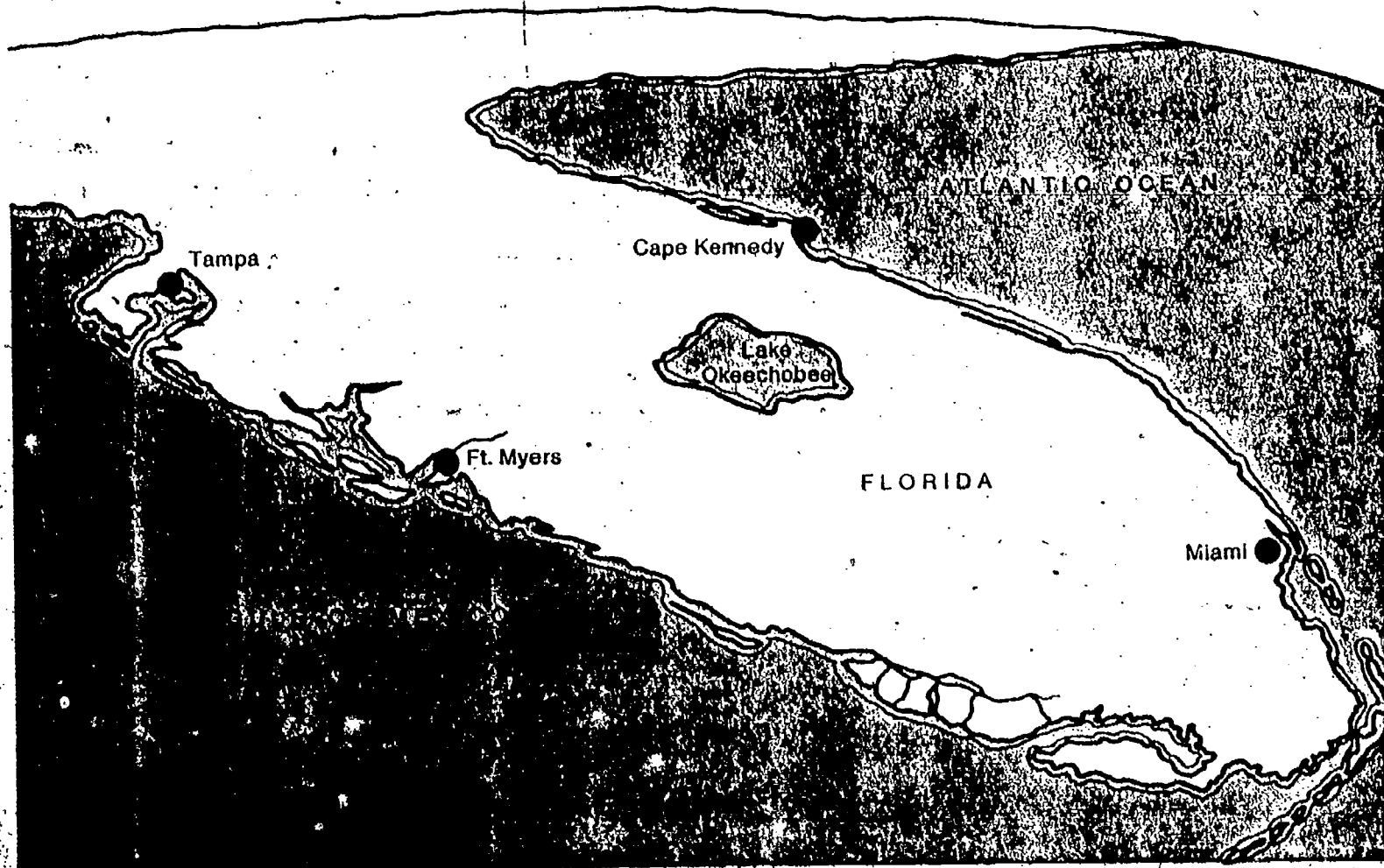
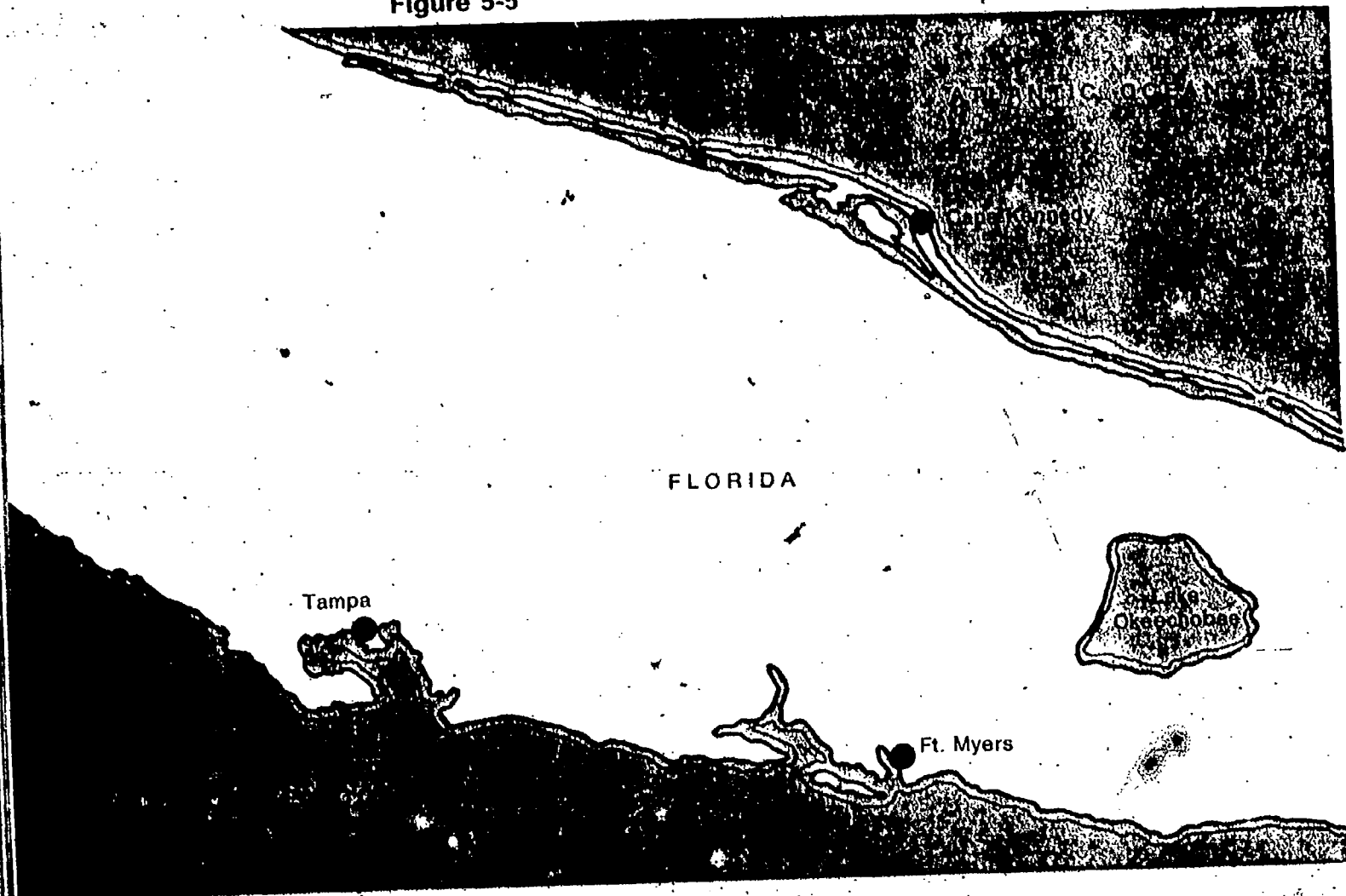



Figure 5-5



5-8. Would you have predicted that most of the clouds shown in Figures 5-4 and 5-5 would be over the land instead of the water? Why?

Question 5-8 isn't easy. But perhaps you are closer to a reasonable answer than you think. Try the next two questions.

5-9. Where would you expect air to be warmer in the daytime, over land or over water? (Hint: Recall your investigation in Chapter 1, beginning with Activity 1-8.)

5-10. Where would you expect the greater uplift of air to occur in the daytime, over land or over water?

For clouds to form, air containing water vapor must be uplifted. It is reasonable to assume that the air over water contains more water vapor than the air over dry land contains (Figure 5-6).

Figure 5-6

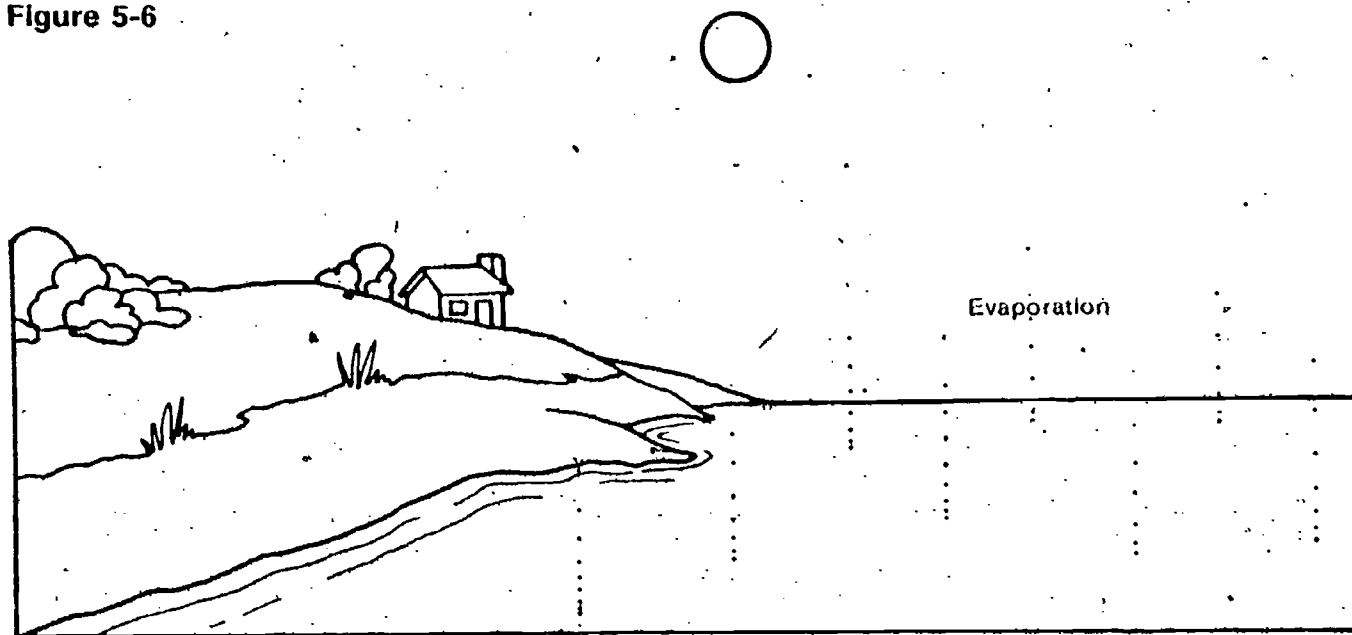

But the air over dry land is being warmed faster and therefore rises. According to what you have learned about air, you should expect clouds to form over land if the land air contains enough water vapor. And according to Figures 5-4 and 5-5, it does contain enough water vapor. Almost all the clouds are over land. Another investigation may help you explain how the land air gets some of its moisture.

5-8 At this point, answers could be either Yes or No. If students realized that during the daytime air over land heats more rapidly than air over water, and assumed that the heated air that rose had sufficient moisture and condensation nuclei in it, they would answer in the affirmative. But if they didn't make that assumption, they could answer the other way.

You will need the following:

- 1 observation box (from Chapter 1)
- 1 short candle (4-5 cm)
- Heavy cotton string, 12-cm length
- 1 plastic straw
- Sharp knife or scissors

ACTIVITY 5-6. Cut a small hole (about 4 cm in diameter) in the top of the observation box as shown.

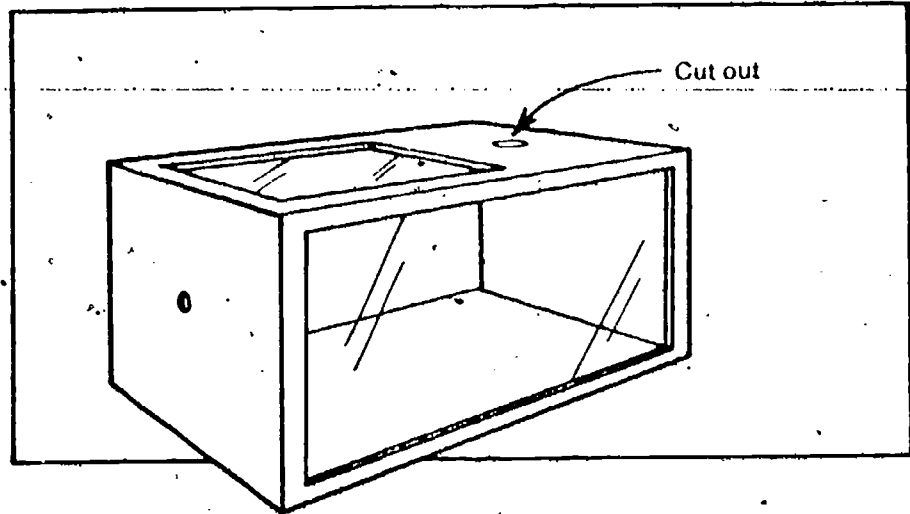

The candles furnished in the kit may have to be cut off in order to be short enough.

ACTIVITY 5-7. Light the candle and place it directly under the hole in the box. The top of the flame should be at least 10 cm below the hole.

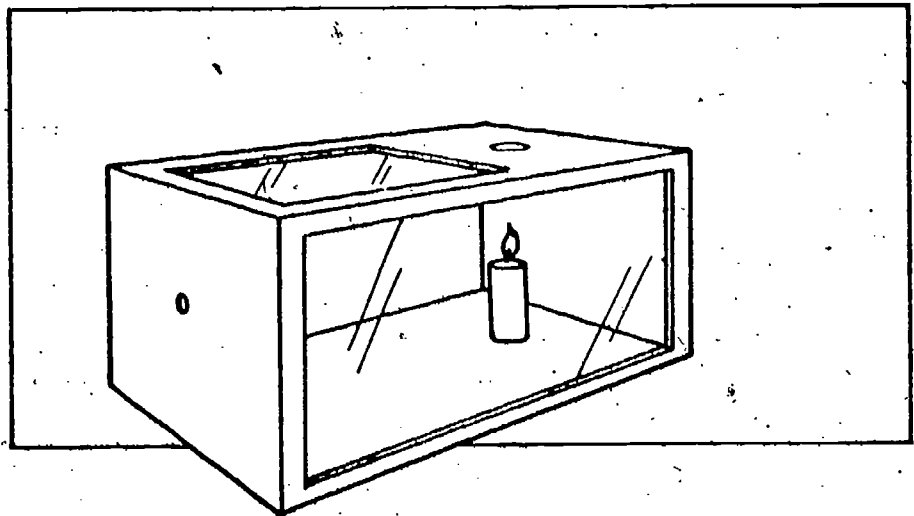

ACTIVITY 5-8. Double the string and insert it in the plastic straw as shown. Light the string. It should glow but not be flaming. Insert the straw into the box. Observe the behavior of the smoke in the box.

- 5-11.** Describe what happens to the smoke from the string as the hot air above the candle rises.

Think of the candle as representing the hot land in the daytime. The land (candle) is heating the air above it. Let the smoke from the string represent the invisible moist air over a cooler area nearby. (This might be a body of water such as a large lake or an ocean.)

- 5-12.** Describe how you think cool moist air will behave as it comes in contact with an area where warm air is rising.

Up until this last activity, you have concentrated only on air moving up and down. In this activity, you saw that horizontal (sideways) movement also occurs. This horizontal movement is called *wind*. It is a very important feature in all weather.

The particle model for matter can be used to explain the sideways movement of air that you observed. Recall two things this model says:

1. When air is heated, its particles spread out.
2. A volume of warm air has less mass than the same volume of cool air.

These two ideas explain why the air moved as it did in the observation box. As the temperature of the air above the candle increased, its particles spread out. Thus, it became lighter, so to speak, than the cool air in the box. The cool air, now the heavier air, pushed the lighter air up and took its place.

- 5-13.** What would happen to the cool air after it replaced the warm air?

Figure 5-7 illustrates the air-flow patterns you should expect when warm and cool areas are side by side.

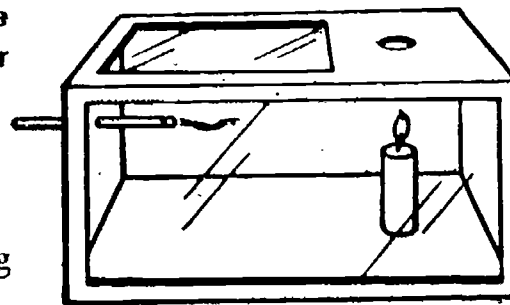

5-11 - Students should observe the horizontal motion of the smoke before it ascends vertically through the hole.

The horizontal motion of air as wind should not be new to the students. They have been measuring wind direction and wind speed since Chapter 2. They should even be able to operationally define wind as the movement of air that causes the weather instrument to indicate which way the wind is coming from and how fast it is traveling. The concept that is new is what causes air to move as wind.

Figure 5-7

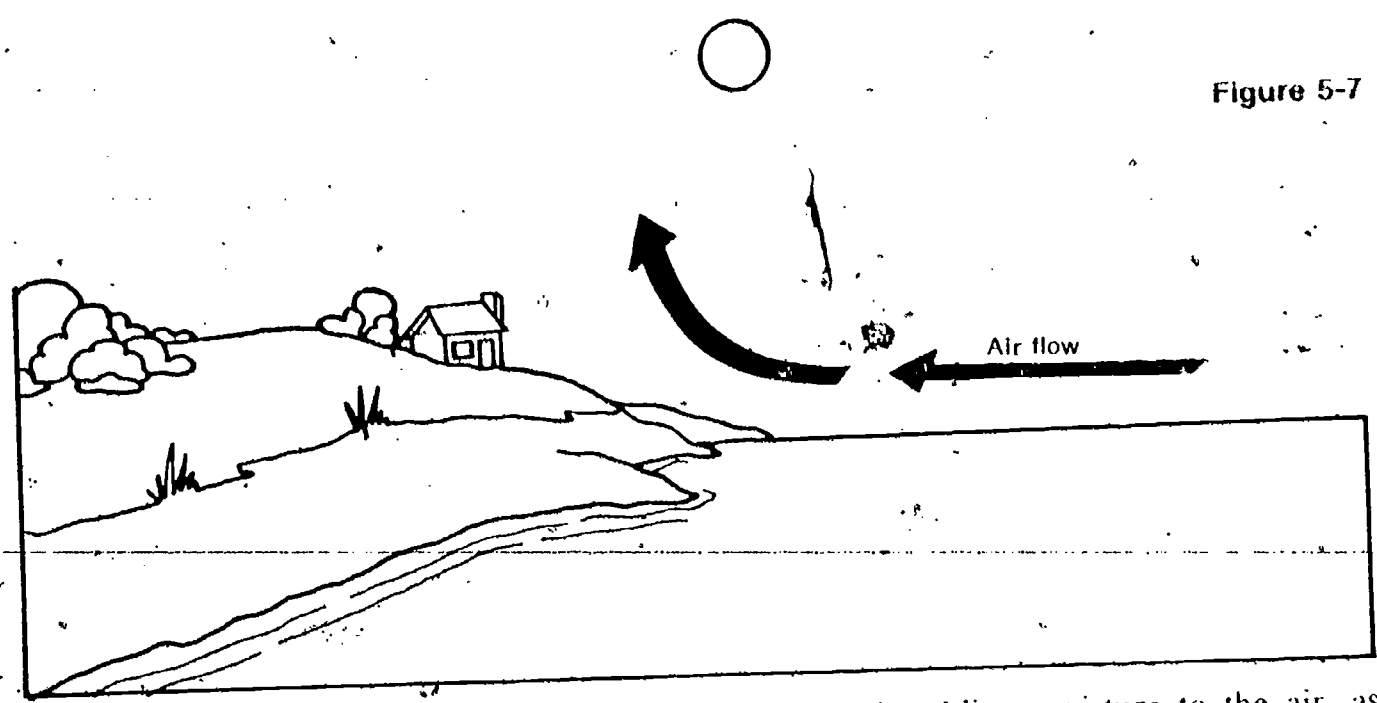

Problem Break 5-2 focuses on land-sea breezes. Assuming that the ground is not covered by snow or ice, wind should be incoming, toward land, during the day and outgoing, toward water, at night. This behavior has been utilized by sailing fleets, which left the coast for the fishing grounds in the evening and returned to land the next morning.

Suppose the cool area is adding moisture to the air, as in Figure 5-7. If so, the moisture will be lifted as the air moves over the land.

5-14. Will the increased moisture content improve chances for cloud formation?

PROBLEM BREAK 5-2

If you live near the ocean or a very large lake, you may have noticed some peculiar things about wind. Wind direction often seems to be related to the time of day. During warm, daylight hours, the wind blows from one direction. Then, during cool, night hours, it blows from the opposite direction.

In Figure 5-8 of your Record Book, indicate the wind direction you predict for the two times of day shown.

Figure 5-8

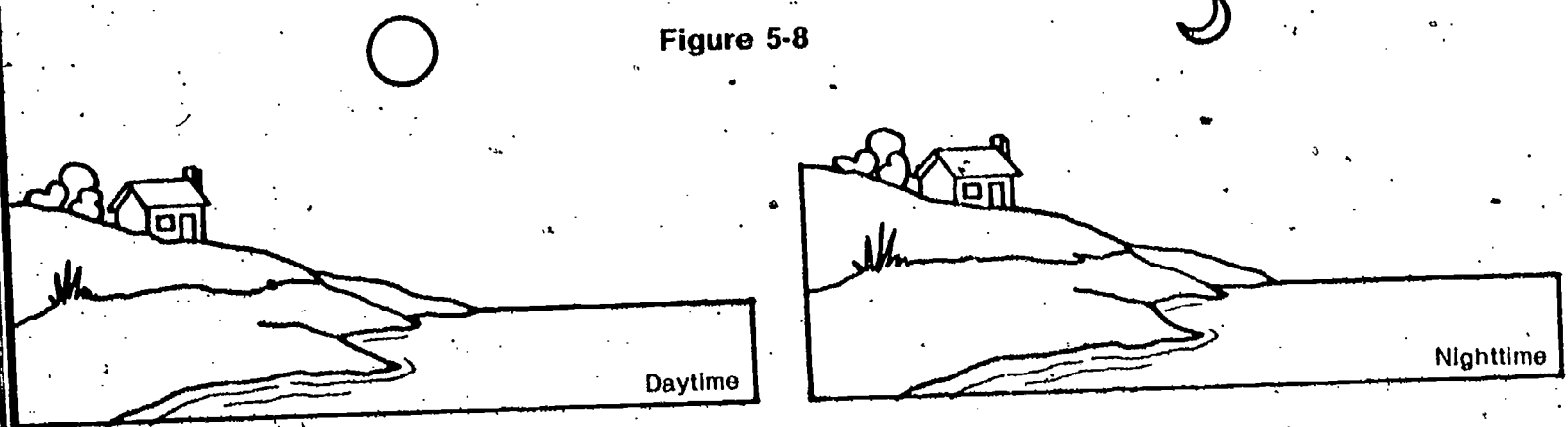

□]5-15. Use what you know about air to explain your decision about wind direction.

The fact that air moves horizontally is no surprise to you. You feel that motion frequently. You also see it in the motion of other objects. Even those things you've been trying to account for—the clouds—are affected by wind. Moving air carries them across the sky.

If you are interested in *how fast* clouds move, see **Excursion 5-2, "Building a Nephoscope."**

Light and heat are the energy sources for all weather on the earth. You've seen how they drive air up, down, and sideways. You know that without heat little water vapor could be added to air, and without moisture there would be no clouds.

In the next chapters you will investigate other effects of air movement. And, as a result, you'll learn more about predicting and explaining weather changes. You may even find an explanation for rain.

Before going on, do Self-Evaluation 5 in your Record Book.

◀ EXCURSION

Excursion 5-2 is an extension excursion for better students. It requires some equipment that is not furnished, some careful construction, rather difficult measurements, and a little math.

No equipment need be prepared for Chapter 6. The only article needed is a straightedge, which could be a ruler, meterstick, or even the edge of a tablet or book.



84

EQUIPMENT LIST

1 straightedge

Other Cloud Formers

No excursions are keyed to this chapter.

CHAPTER EMPHASIS

Other factors besides convection cause upward motion of air and cloud formation.

An unmanned weather satellite orbiting far above the earth took the photograph shown in Figure 6-1. The picture shows the pattern of clouds over about half the earth's surface. It was taken on May 8, 1967.

MAJOR POINTS

1. The simple heated-air model cannot explain all cloud formation.
2. In areas where cold air comes in contact with warmer air, clouds may form.

Chapter 6

3. Clouds tend to form over areas of low barometric pressure.
4. When moist air is pushed up the side of a mountain, clouds may form.
5. A system of symbols and numbers can be used to indicate weather conditions on a map.
6. Lines connecting points of equal barometric pressure are called isobars.
7. The pattern of wind direction is counterclockwise in a low-pressure area.
8. A scientific model can be modified or expanded to explain additional observations.

Figure 6-1

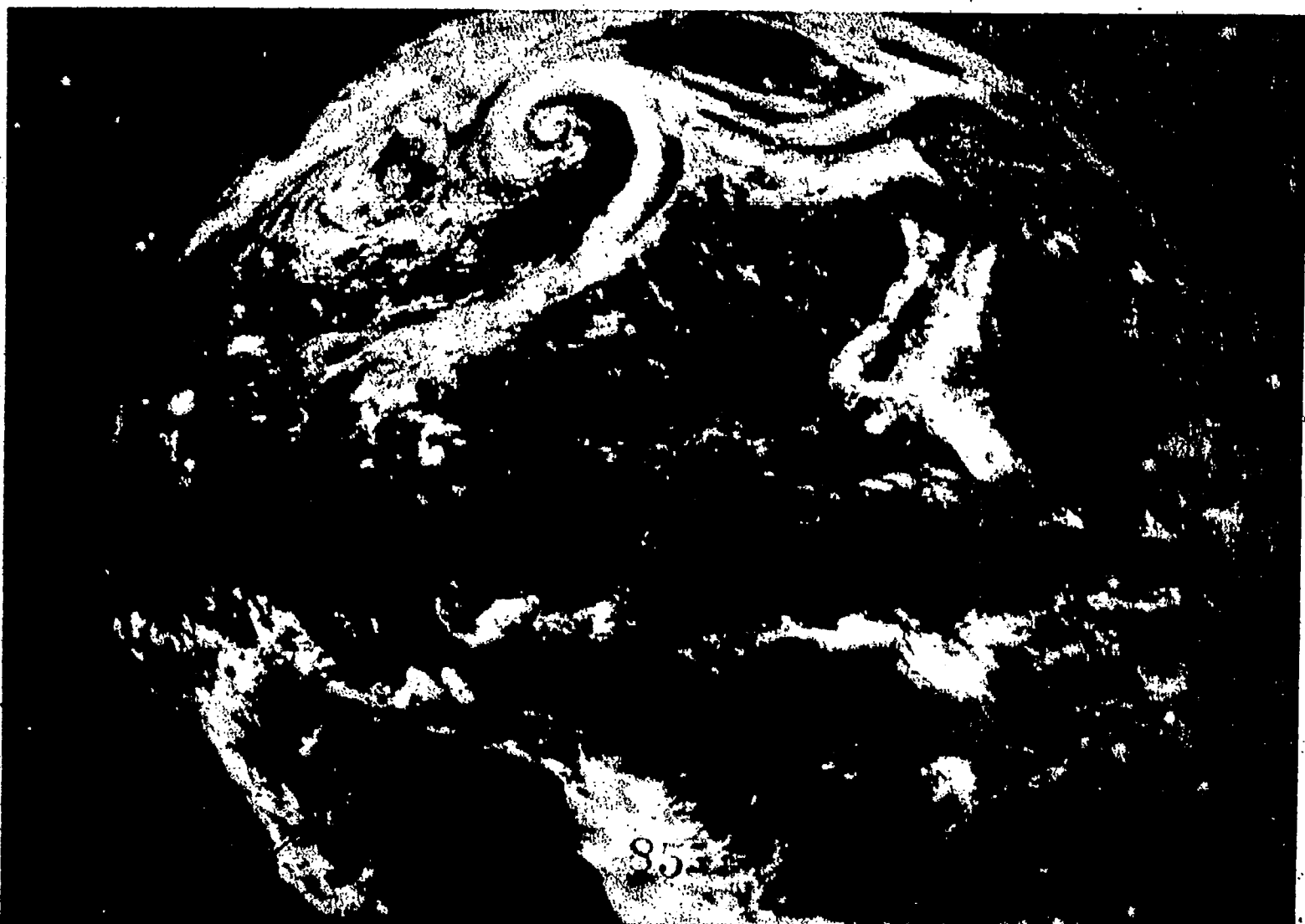

Students are being called upon to expand their model of cloud formation. Some may need reassurance that this is a common and accepted practice with scientific models. It is interesting to note that the heated-air model took 5 chapters to develop; now, it is being

Figure 6-2 will help you identify where the clouds in Figure 6-1 are located.

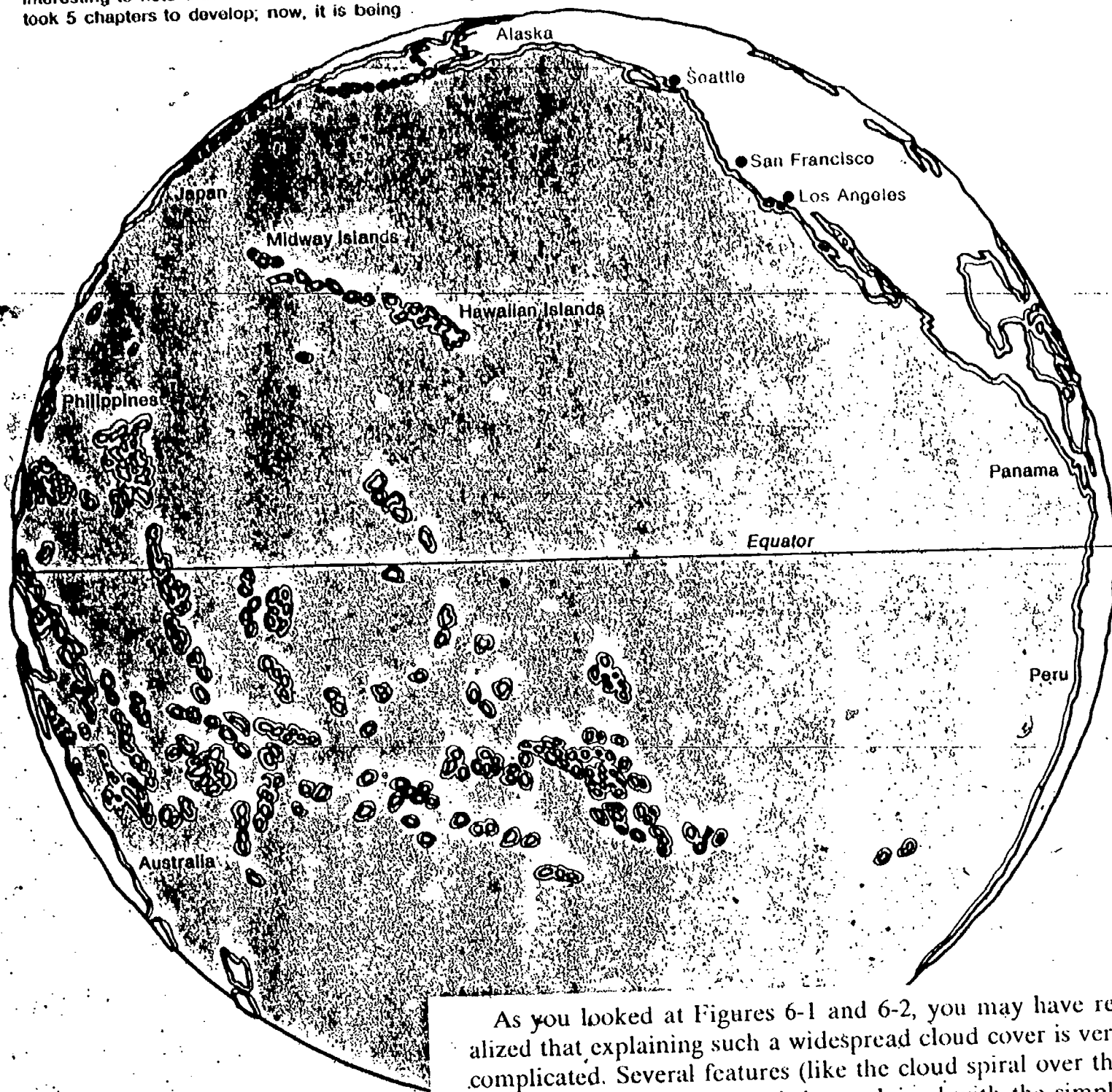

expanded 4-fold in this one chapter. Of course, all the material in the 5 chapters was not just aimed at developing the one point of the model. The concepts of humidity, pressure, wind, and all the other factors of weather will still have a direct application to the new parts of the model. For instance, in order for clouds to form for any reason, there must be moisture in the air.

As you looked at Figures 6-1 and 6-2, you may have realized that explaining such a widespread cloud cover is very complicated. Several features (like the cloud spiral over the northern Pacific Ocean) can't be explained with the simple heated-air model you've been thinking about. Obviously, clouds don't just form over land areas either. You can see that much of the Pacific Ocean is shown covered by clouds.

Factors other than air-temperature differences above different earth surfaces must be involved in forming clouds. Something else must be pushing the air upward at those places where heavy clouds are forming over water. What is this force?

Take a closer look at the spiral area of cloud formation in the upper left-hand part of Figure 6-1. Figure 6-3 shows an enlarged drawing of this feature. Examine the general shape of the cloud pattern. Notice particularly the two "legs" that project from the central core of the pattern.



In Figure 6-4, symbols and numbers have been added to the diagram of the cloud spiral. Each symbol cluster contains values for temperature, barometric pressure, wind speed, and wind direction.

Figure 6-3.

As used by meteorologists, the clusters of symbols and numbers shown in Figure 6-4 is called a station model.

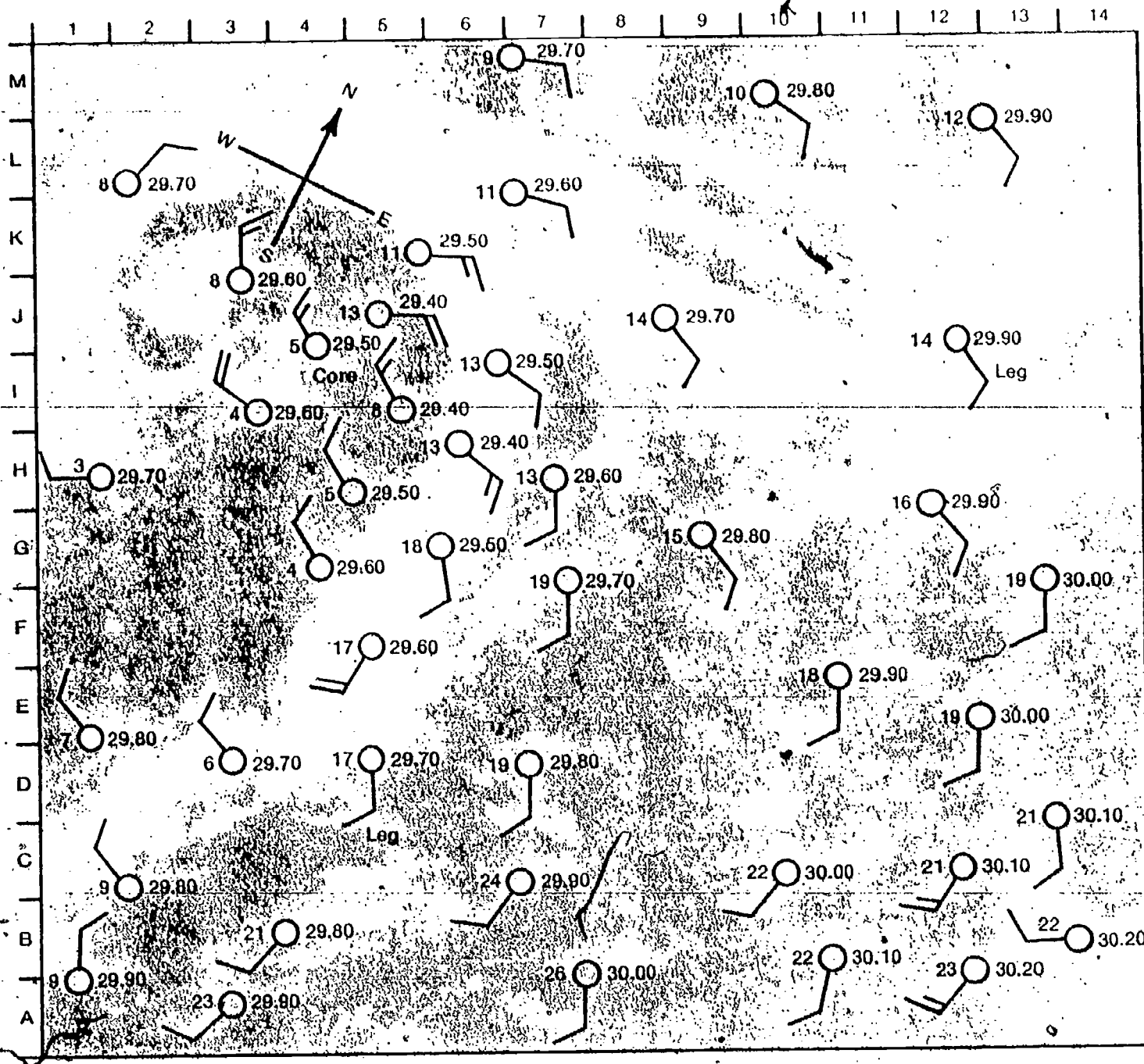

Figure 6-4

An official U.S. Weather Bureau map has many other numbers and symbols squeezed onto it beside the readings of pressure, wind direction and velocity, and temperature shown here.

The code symbols in Figure 6-4 are used to squeeze the maximum amount of information into the minimum amount of space.

Figure 6-5 shows the meaning of these symbols.

◆ Wind speed	
mph	Symbol
Less than 1	
1 to 3	
4 to 7	
8 to 12	
13 to 18	
19 to 24	
25 to 31	

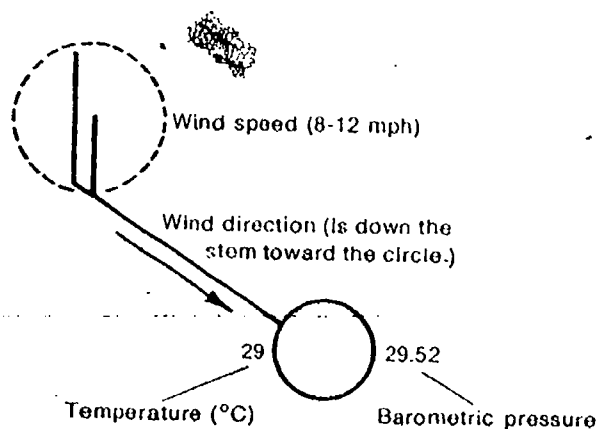
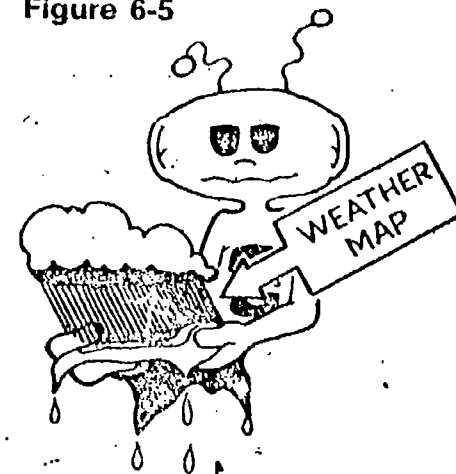

Figure 6-5



It should be reasonable to expect students to be able to identify and read these four factors of weather from a map at this point.

- 6-1. Highest pressure--A12, A14 (30.20)
 Highest wind--F5, I3, J5 (13-18 mph)
 Lowest pressure--H5, H6, J5 (29.40)
 Highest temperature--A7 (26°C)
 Lowest temperature--H1 (3°C)

Notice that the border of Figure 6-4 is labeled like the border of a city map. This makes it possible to locate areas on the drawing easily. For example, the location of the symbol at the very top of the figure might be described as M7.

- 6-1. Using the border symbols and a straightedge, describe the following locations by letter and number.

- Highest barometric pressure
- Highest wind velocity
- Lowest barometric pressure
- Highest temperature
- Lowest temperature

Examine the clusters of measurements in Figure 6-4 carefully. Try to find a relationship between the numbers in these and the pattern of cloud formation. Look particularly for large differences in temperature and pressure within a small area and the effect of these differences in terms of cloud formation.

It will be interesting to see if students discover any relationships in question 6-2. The more discerning may note the pattern formed by the staffs (wind-direction arrows) as they shift from generally northerly on the left side of the map to generally southerly on the right side. Temperature and pressure differences are harder to see.

DON'T FORGET YOUR WEATHER WATCH!

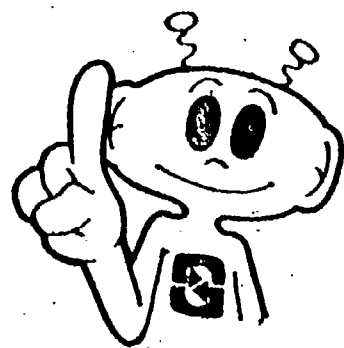

Note that attention is focused only on the differences in temperature of the air on either side of the cloud line at this point, and not on fronts. The groundwork for the study of fronts is being laid ("Moist air is apparently lifted in some way...") but they are not studied until the following chapter.

6-6. Pressure differences (a low-pressure area)

70 CHAPTER 6

6-2. Describe any relationships you think you find between the pattern of cloud formation shown in Figure 6-4 and the measurements of temperature, pressure, wind speed, and wind direction.

Now let's find out if you've discovered any important relationships between the cloud patterns and the symbols. Run your finger along the "leg" of clouds extending down from the central core of the spiral. Notice the temperature readings on the two sides of the leg.

6-3. On which side of the leg (east or west) are the temperatures lower? Compare any differences in temperature along the lower leg with those in other parts of the drawing.

Examine the temperature differences on the two sides of the other leg—the one extending toward the east (right) from the central core of the spiral.

6-4. On which side (north or south) of this leg are the temperatures lower?

6-5. How do the temperature differences on the two sides of the legs compare with temperature differences found elsewhere in the figure?

The two legs of the cloud spiral lie in areas in which cold air is in contact with warmer air. In one case, the warm air lies to the east of the cold air; in the other, it lies to the south. These temperature differences are important. Moist air is apparently lifted in some way to form clouds along these two lines of rather sharp temperature difference.

Now examine the central core of the cloud spiral for a moment. The presence of heavy clouds suggests that air is being lifted in this area, too. But the temperature differences at this point are not so sharp as those along the legs of the spiral. Some other cloud-forming factor must be at work in the core.

6-6. Besides temperature differences, what other factor produces cloud formation?

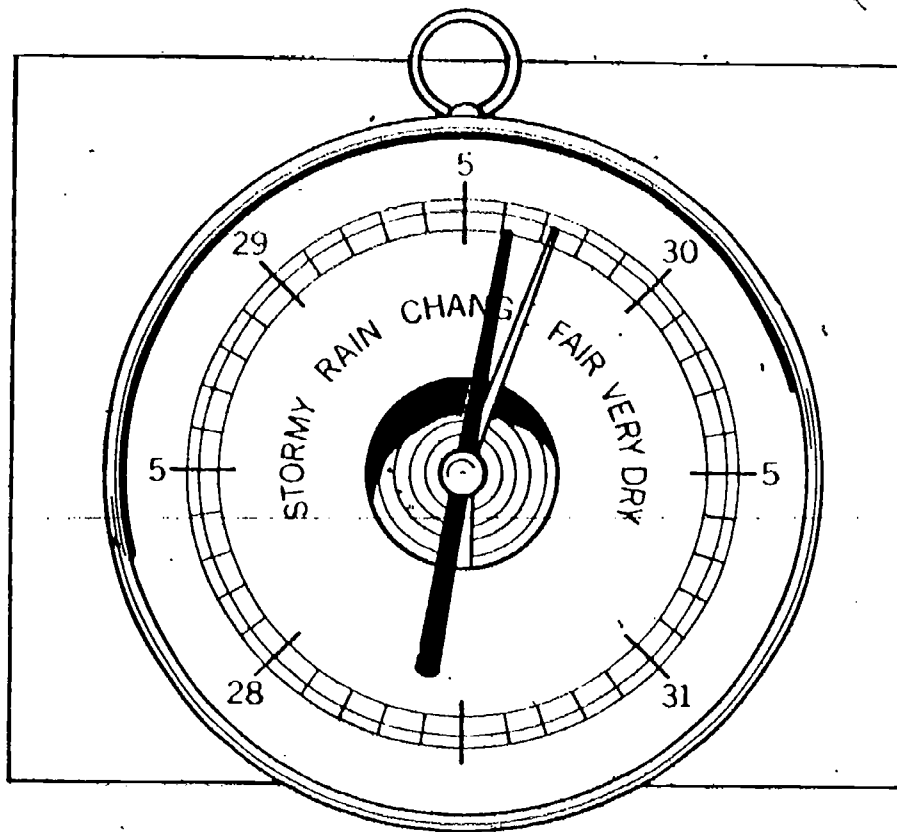

If you have been keeping your daily weather watch, you've learned by now that air pressure varies. It is slightly different from day to day even at the same spot on the earth. In keeping track of pressure changes, weather scientists (meteorologists) often plot their pressure measurements on special maps. Then they draw lines through all equal barometer readings plotted on the map (Figure 6-6).

Two other cloud-forming factors were introduced rather abruptly on the preceding page. The mechanism for uplift on lines of temperature difference (fronts) and around areas of low pressure (convergence) is not explained here. From examination of photos and maps, students must accept the fact that clouds do form in these areas, and wait for a more complete explanation of the reasons later.

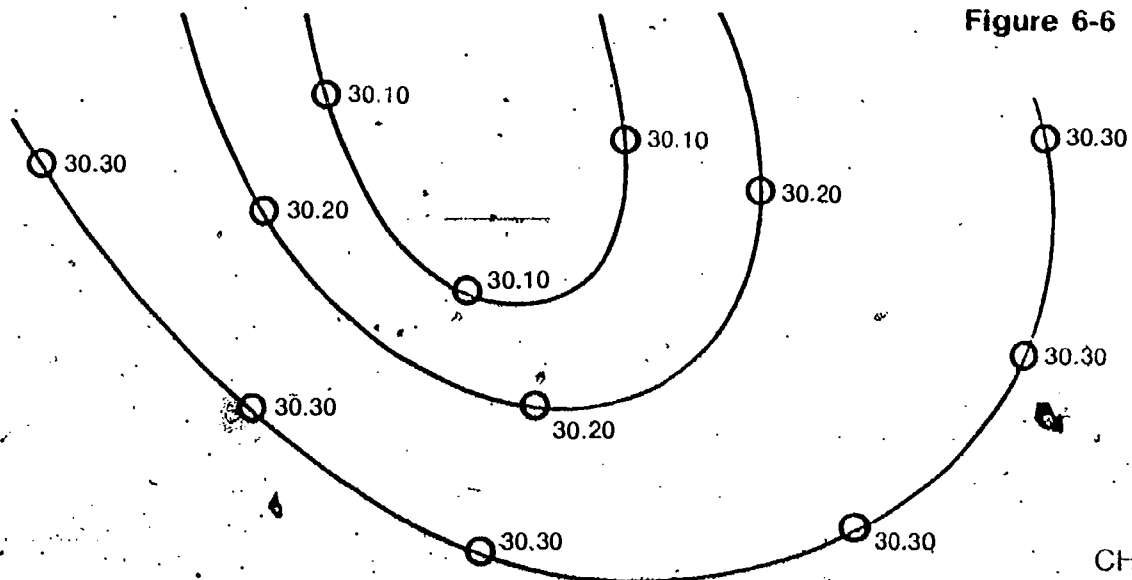
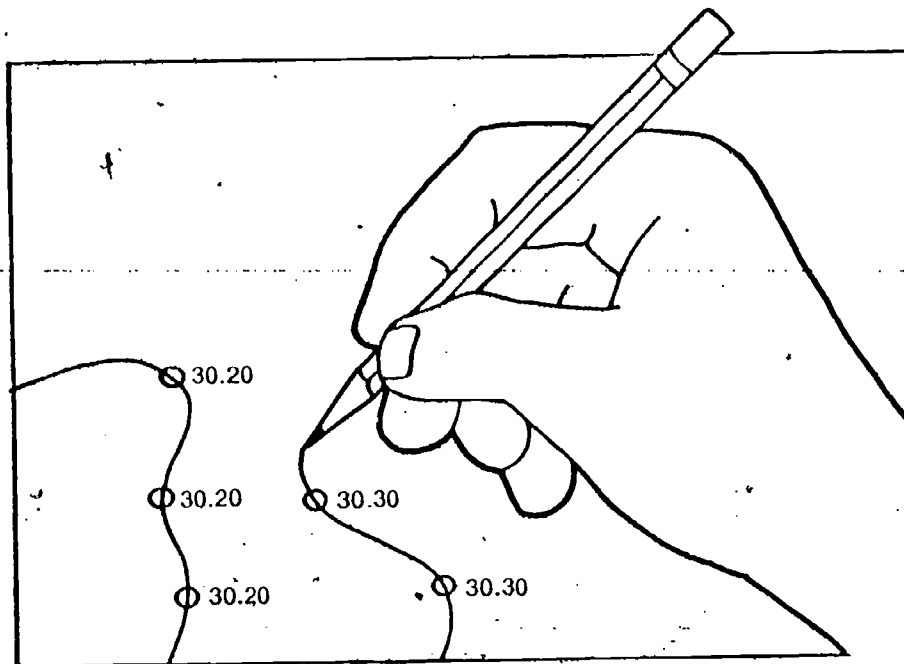

Figure 6-6

ACTIVITY 6-1. On Figure 6-4 in your Record Book, connect all equal barometric readings with *lightly penciled* lines. The lines should pass directly through the station circles that have the same barometric readings. These lines should be smoothly curved, and no line should cross another.

Encourage students to take their time in drawing the isobars. If they draw light lines with a sharp pencil, it will be easy to erase and correct them.



Lines connecting areas of equal barometric pressure are known as *isobars*. (*Iso-* is a common prefix meaning "equal.")

6-7. Describe the pattern of barometric pressure revealed by the isobars you drew on Figure 6-4.

6-8. Is the barometric pressure fairly high, or fairly low, where the core of the cloud spiral has formed? (Label this center on your Figure 6-4 as "High" or "Low.")

The rising of air and formation of clouds around a "low" is quite understandable. If students accept the fact that air blows into a low-pressure area, like water flowing into a low depression on the earth, then air is coming in from all directions. There is no place this air can go but up. After flowing over the ground (or over water surfaces) it has picked up moisture, and when it rises, clouds are formed because of a decrease in temperature and pressure.

Well, you probably agree now that the areas of greatest cloud formation in Figure 6-4 lie along a line of sharp temperature differences or over an area of low barometric pressure. This suggests that sharp differences in temperature and pressure are acting as cloud-forming agents. Therefore, these variables have an important influence upon the weather.

Clouds aren't the only thing of interest in Figure 6-4. Take a look at the wind directions indicated there. Notice particularly the relationship between wind direction and the isobars you drew on the figure.

□ 6-9. Describe the pattern of wind direction in the area of low pressure on Figure 6-4 (clockwise or counterclockwise?).

□ 6-10. What relationship, if any, do you notice between the pattern of wind direction and the spiral shape of the cloud mass?

Earlier, you used a model for the cause of wind that depended upon unequal heating of the earth's surface. (If you need to review this idea, see the last part of Chapter 5.) According to that model, wind is simply cooler air moving into an area of greater heating.



The situation in Figure 6-4 is more complicated than that. The low-pressure area obviously has a great effect on the movement of air. The air seems to move around the area in a counterclockwise direction. This will become more important in the next chapter.

You can see that many problems complicate the task of making predictions about weather. Sometimes more than one weather-influencing agent is operating at the same time. Then it is hard to decide which of the assembled data is most important.

At this point, you may be ready to consider what you've inferred about the effects of low-pressure areas and lines of temperature differences as part of your weather model. Be-

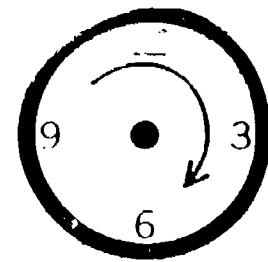

Clockwise

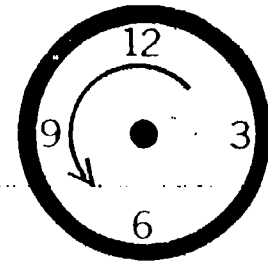

Counterclockwise

Better students may question why the winds around a low-pressure area have a counterclockwise circulation. After all, why don't the winds just go straight in to fill up the "low"? Without going into the scientific reasons for this deflection from a straight-line motion, the students will have to accept the behavior on the basis of their observations. That's simply the way moving air behaves. But actually, the reason for the behavior is the force called *Coriolis*. On a nonrotating earth, air (and other moving particles) would travel in a straight line. But because of the earth's rotation, a body in motion in the Northern Hemisphere is deflected to the right. (In the Southern Hemisphere, it is deflected to the left.) So air that starts to blow into the center of the "low" is bent to the right of its direction of motion. Try it with a diagram on a piece of paper, and you will see that it results in a counterclockwise circulation.

Incidentally, for you purists in science, Coriolis force is a fictitious quantity. We have so firmly believed a body in motion remains in motion in a straight line unless acted upon by an outside force (Newton's Law) that when we see a body deviate from a straight line we feel that a force must be acting on it, and we give the force a name. The catch is that Newton's Law only holds true in an inertial frame of reference. A rotating body is not an inertial frame, but a rotating frame of reference, and the body only seems to curve, because of the earth's rotation.

These are actual satellite photos, with the latitude and longitude lines, isobars, and station models added.

fore you do, however, you should find out whether the example in Figure 6-4 was an isolated situation. Do the relationships you observed hold true in other situations, too?

Figures 6-7 and 6-8 each contain a satellite photo and a set of weather data collected at the time the photo was taken. Examine each figure carefully. Try to find out whether the relationships you found in Figure 6-4 hold for these areas as well.

Figure 6-7

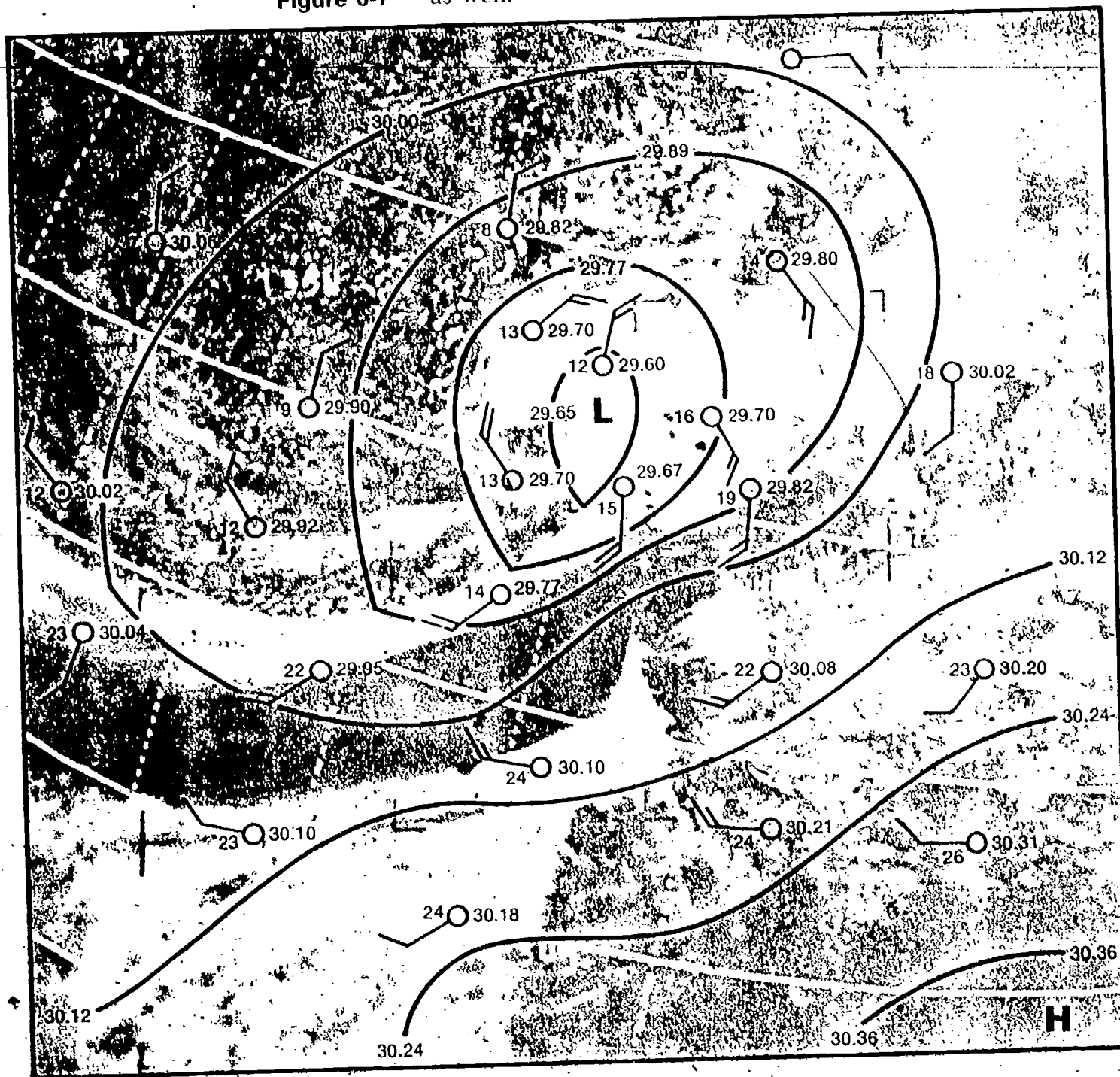

[]6-11. Describe the flow of air near the low-pressure areas in Figures 6-7 and 6-8 (clockwise or counterclockwise?).

[]6-12. Describe how the distribution of clouds in the two figures relates to the pressure and temperature data given.

[]6-13. Are your answers to questions 6-11 and 6-12 what you expected?

9
Note that there are other areas of cloudiness besides those centered around lows and along lines of sharp temperature differences. You might have to point out to students that clouds are found in the sky even on pleasant days.

Figure 6-8

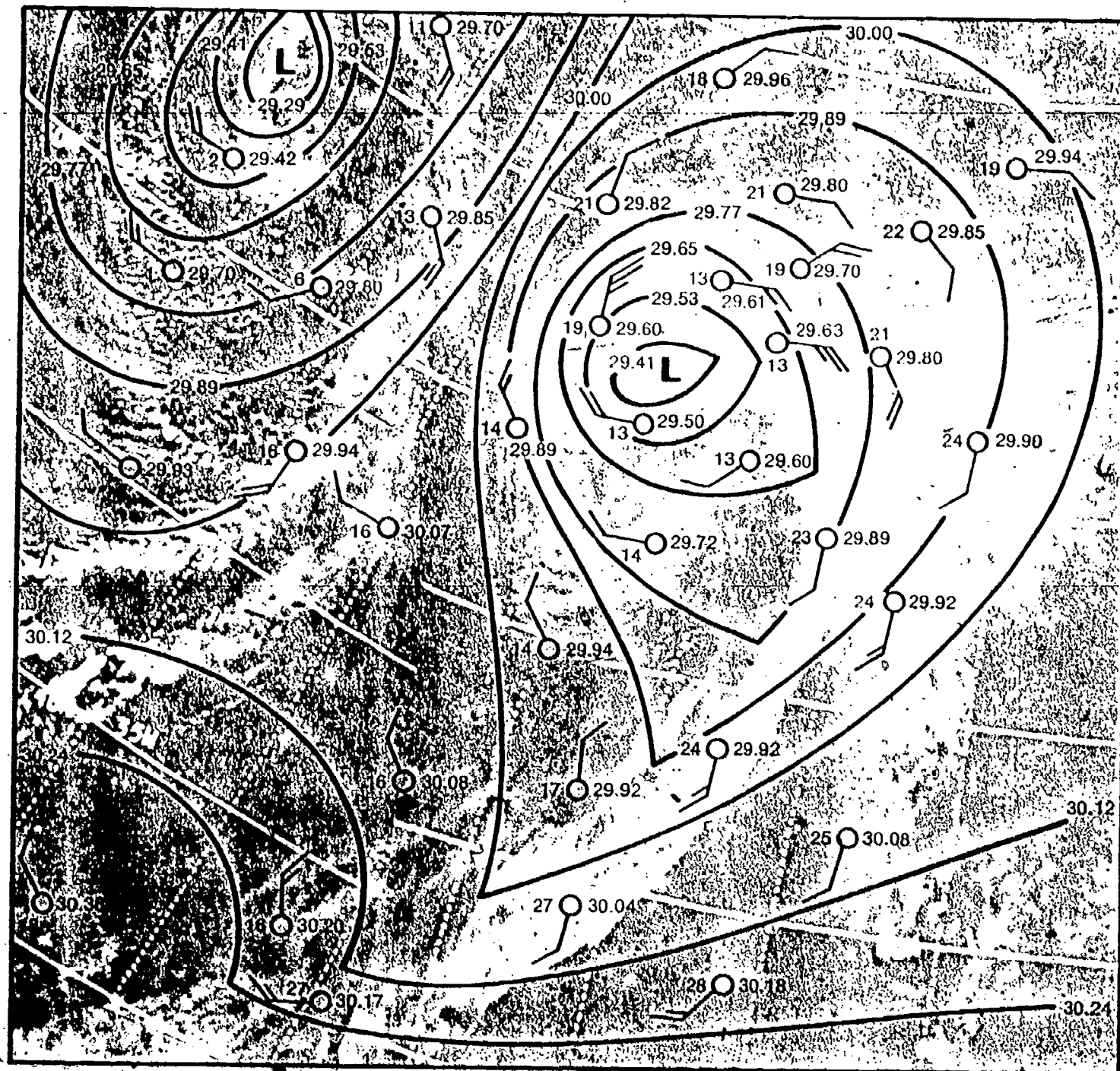

PROBLEM BREAK 6-1

Students will have some difficulty with this problem break. One problem will be in drawing the isobars. The pressures given are not all in nice numbers ending in zero, so students have to estimate where the 29.50 and 29.70 lines go. As you undoubtedly realize, the dotted line indicating a sharp difference in temperature is really a front (which students do not yet recognize), and it should run roughly from Jacksonville through Tampa. Actually it is a cold front, traveling toward the east. The isobars should "kink," or have a sharp bend at the dotted temperature line, but students don't know this yet, either. Cloudiness should be shown along the dotted line.

Figure 6-9 shows the Florida peninsula once more. Weather data have been included on the map. Your problem is to sketch on the map the pattern of clouds you would predict on the basis of the data shown. In making your prediction, you may assume that lines of temperature difference and low-pressure areas *are* cloud-forming agents. This time, however, you may neglect the fact that the difference in temperature over land and water can cause cloud formation, too. (It is still part of our weather model, but we'll put it aside for the moment.)

Complete your sketch now. Start by drawing in isobars of 29.50 and 29.70. The 29.60 isobar has already been drawn in. Note that there is only one reading of both 29.50 and 29.70. Therefore, you will have to use your judgment and experience in drawing the isobars. You should also draw a dotted line where you think there is a sharp difference in temperature. Shade in the clouds as your last step.

Figure 6-9

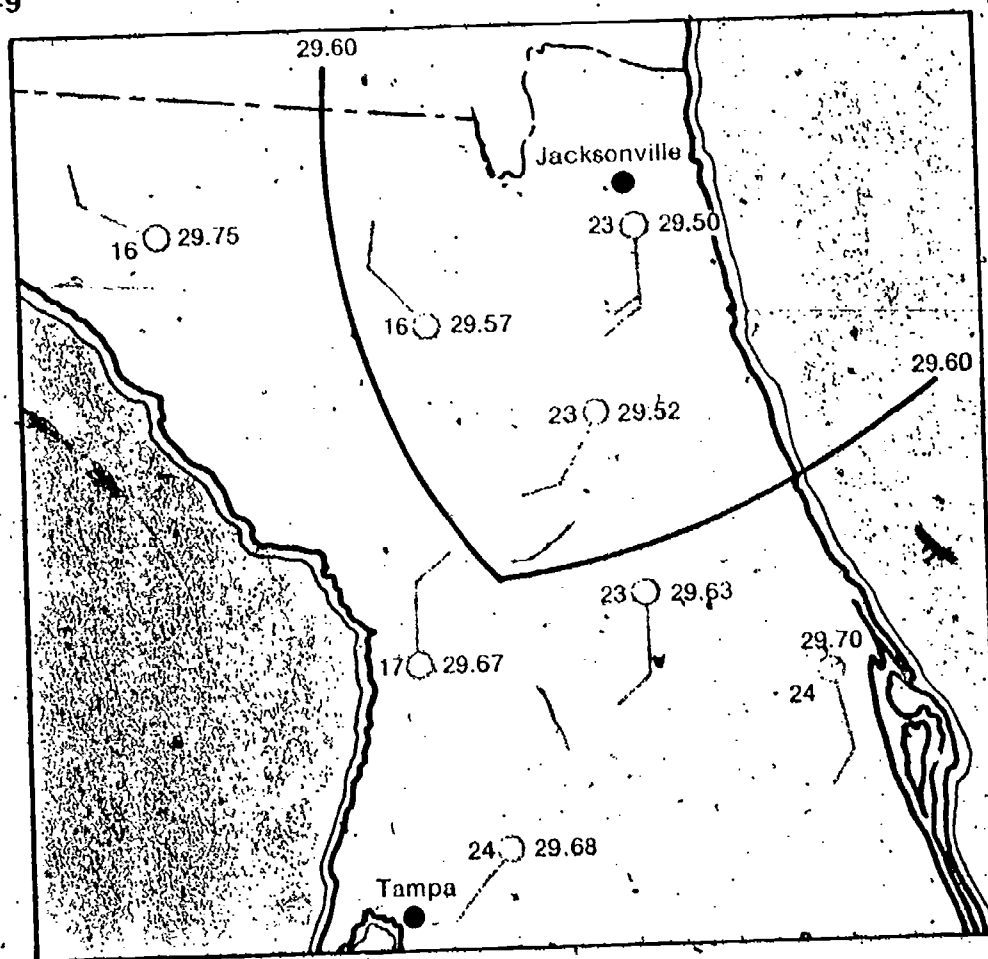

Then see how your conclusions compare with those of other students. Your teacher can offer you some advice if you are having difficulty with this activity.

In the next chapter, you will make the final test of your model for weather. You can judge your model by seeing if it helps you make predictions about weather. First, though, you need to look at one other air-lifting (cloud-forming) factor.



Because the earth's surface is very irregular, air must often flow up over mountains and down into valleys. As air is pushed up the side of a mountain, it is cooled, and there is less pressure from the atmosphere above.

Figure 6-10

6-14. What result would you expect as moist air moves up and over a mountain?

6-14. Clouds should form.

CHAPTER 6 77

The explanation of uplift of air by geographic features is relatively short, however, this type of lifting to form clouds (called *orographic uplift*) is one of the easiest to visualize. This factor does have a profound effect on climate. All the major deserts and dry areas of the world are found on the lee side of the prevailing wind of mountains. The Sierras and the Rockies are wet on their western slopes and dry on the eastern, with a prevailing west wind. The Hawaiian Islands, with an elevated central backbone, have an extremely wet side facing the steady northeast trade winds, and an opposite, very dry side.

The upward flow of moist air has great significance in mountainous regions. There may be abundant precipitation on one side of a mountain but little on the other side. For example, notice in Figure 6-11 that the vegetation is not the same on the two sides of the mountain.

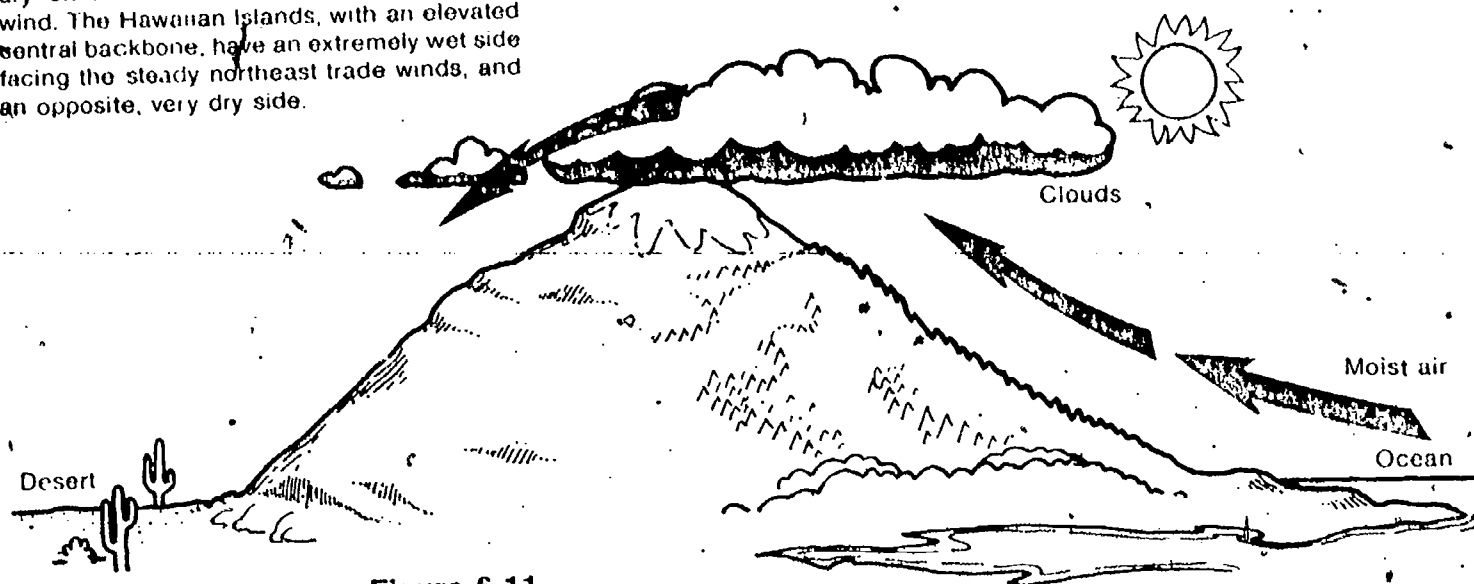

Figure 6-11

□ 6-15. Explain why there is more vegetation on one side of the mountain than on the other in Figure 6-11.

This problem break gives students the opportunity to test their understanding of this fourth part of their model for the uplifting of air.

You have been introduced to several factors that can produce cloud formations. Landforms may produce air lifting. Sharp changes in barometric pressure and abrupt temperature changes can produce clouds. And, as you saw earlier, surface heating of land areas can produce cloud formations, especially along coastal regions.

PROBLEM BREAK 6-2

Here's your chance to use some of your experience to make predictions. In solving this problem, consider two ways that air is forced upward:

- (a) by the differential heating of the earth's surface and
- (b) by mountains.

An aerial view of Iggy's Island is shown below. There are three communities on the island. The direction of the prevailing (usual) wind is shown by the arrow.

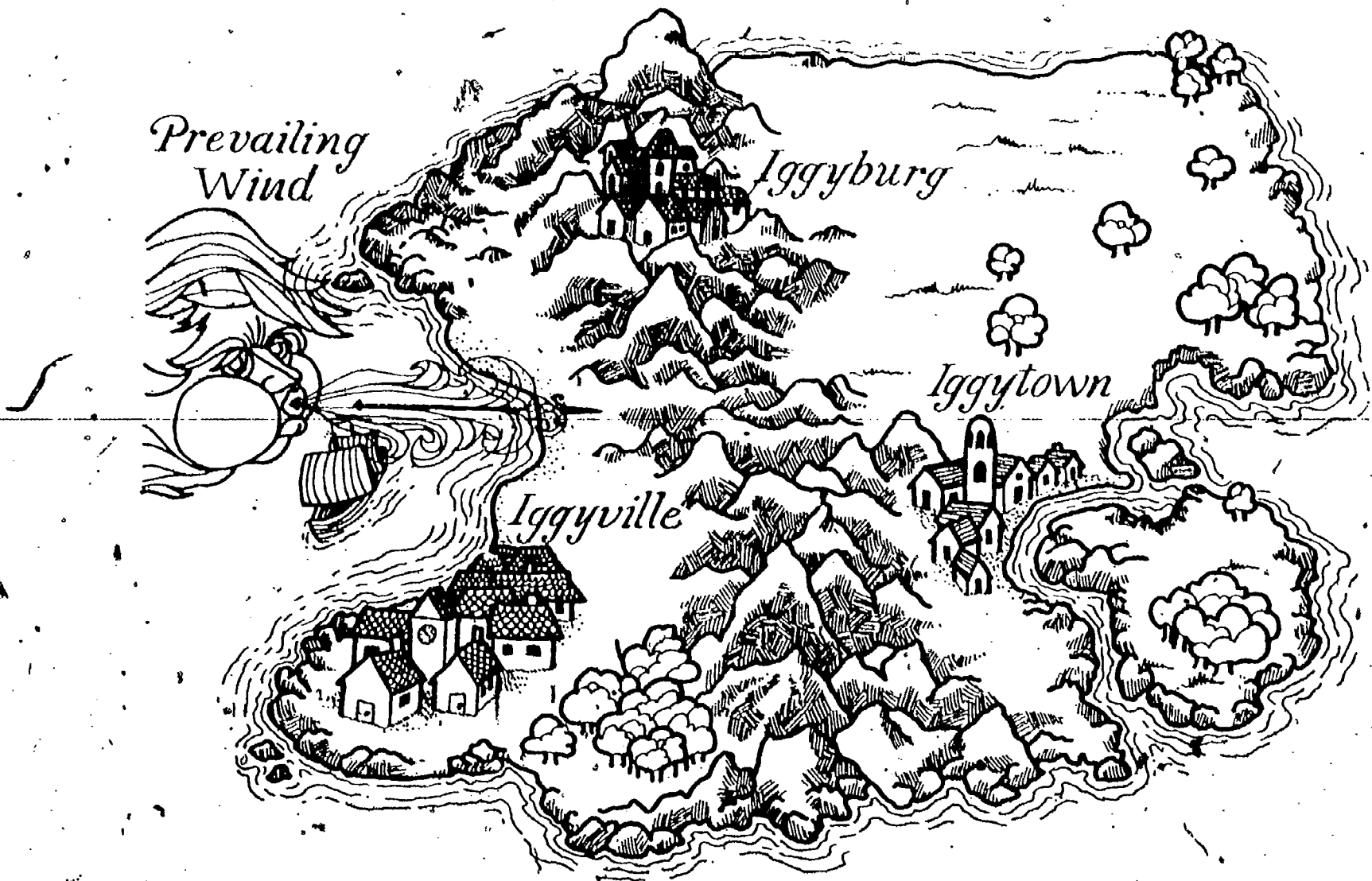

In the space provided in your Record Book, discuss the weather you predict for each of the three communities. Answer such questions as the following: Which community has the cloudiest, and which has the clearest, weather? Which community gets the most, and which gets the least, rainfall?

Before going on, do Self-Evaluation 6 in your Record Book.

Iggyville: Pleasant weather, moderate rainfall, periods of cloudy and clear skies.
 Iggyburg: Poorest weather, heavy rainfall (or snowfall), heavy cloudiness.
 Iggytown: Dry weather, very little if any rainfall, cloudless skies.

No equipment need be prepared for Chapter 7.



100

CHAPTER EMPHASIS

Air masses meet to form fronts, and move across the country, forming a pattern of weather.

Moving Weather

EQUIPMENT LIST

None

Excursions 7-1, 7-2, and 7-3 are keyed to this chapter.

MAJOR POINTS

1. Predicting weather by the developed model depends on knowing whether one or more of the four agents for lifting air will be operating in your area. These agents are:

A) differentially heated earth surfaces
B) contact between cold and warm air masses.

C) low barometric pressure.

D) certain geographic features such as mountains.

Chapter 7

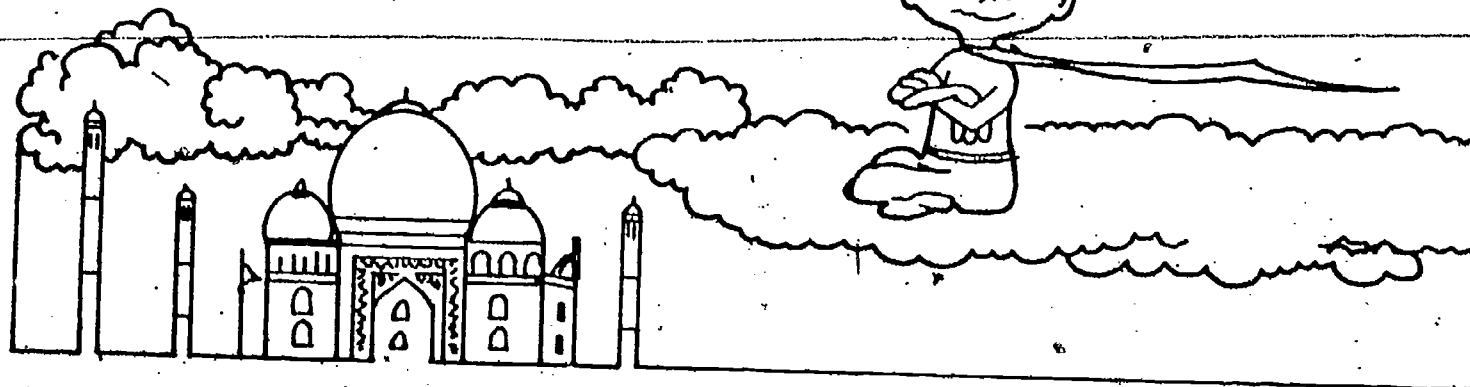

According to the model you've developed, the uplifting of air has important effects upon the weather. This process appears to be linked to cloud formation. Thus, it is responsible for all kinds of precipitation (rain, snow, sleet, and hail). This lifting process also seems linked to wind characteristics.

When you began this unit, your objective was to learn to predict the weather. The air-uplift model suggests some ways to do this. Suppose you could somehow know in advance when uplifting air would occur in your area. This would let you make some good guesses as to what to expect in terms of cloudiness and wind. But how can you predict when air is going to be uplifted?

According to your model, air is uplifted in at least four major areas.

1. Over a surface where air is heated.
2. Along lines where there is sharp difference in air temperature.
3. In areas of relatively low barometric pressure.
4. Where there are geographic features such as mountains.

2. Lines of temperature differences between two air masses are called fronts.
3. Fronts and low-pressure areas are associated with each other. They move together.
4. Air masses, low-pressure areas, and fronts move generally from west to east.
5. The approach of low-pressure areas and fronts can be predicted by clouds, wind direction, change in barometric pressure, and temperature change.
6. A warm front is caused by a relatively warm mass of air advancing over a mass of relatively cold air.
7. A cold front is caused by a mass of relatively cold air displacing relatively warm air.
8. Advancing cold fronts lift warm air. Advancing warm fronts result in the warm air being lifted.
9. Fronts do not all move at the same speed or in the same direction.
10. The amount of moisture in the air controls the kind of weather along the front.
11. Precipitation can be in the form of rain, snow, sleet, or hail.

This is the model at this point. Students should be expected to know the four major areas.

81

Predicting when air will be lifted really boils down to knowing when one or more of these agents exist in an area. Since mountains and seacoasts don't move, it is fairly easy to predict their effects. But what about lines of temperature difference and low-pressure areas? Do these things move about? If so, is there enough order to their moving to allow predictions to be made? Figures 7-1 through 7-4 will help you find out.

Figures 7-1 through 7-4 show temperature and pressure data for most of the United States on four days in April. Two maps appear for each day; one gives temperature, while the other gives pressure information. Areas of low pressure and high pressure are labeled with an L or an H on the pressure maps. Lines of temperature differences (fronts) and cloud cover are indicated by the symbols identified below.

Here the fronts (lines of temperature differences) have been named and the symbols given for them. Students will not yet know the characteristics of a warm front, cold front, or stationary front. That comes later.

FRONTS

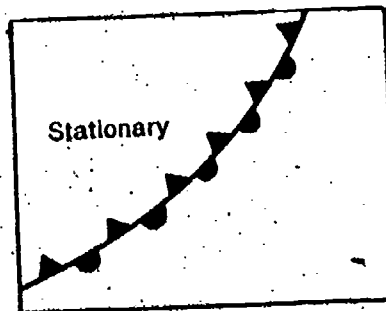
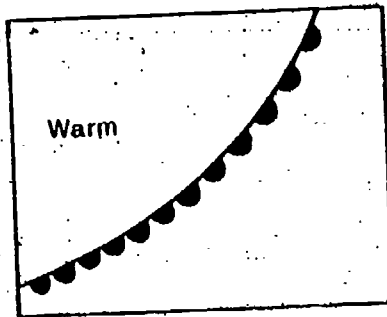
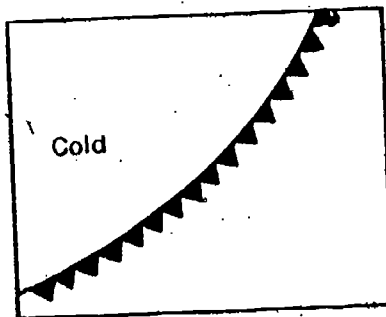

CLOUD COVER

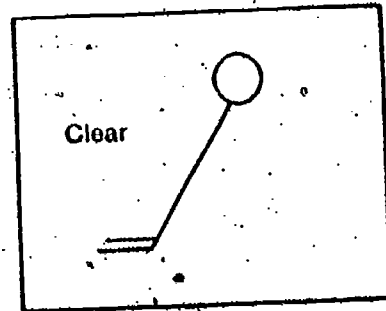
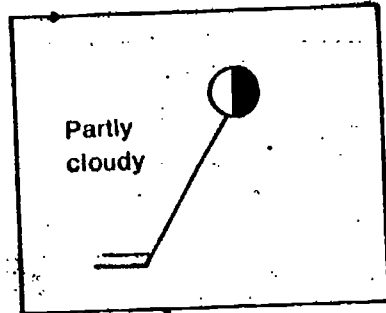
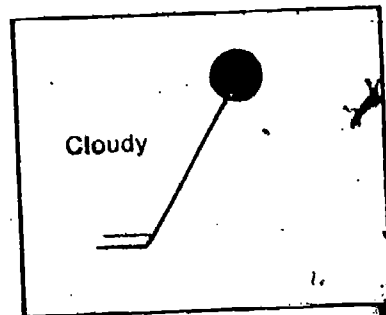

In the next four pages of weather maps, data from the stations and the lines drawn have been broken into two parts, an "a" and a "b" for each map. This was done so that the maps would not be too cluttered with numbers and symbols, and also so that students would see the pressure pattern and the frontal (temperature difference) pattern separately, and then learn to connect them. Map "a" of each pair shows wind directions, wind speeds, high- and low-pressure areas, and isobars labeled in inches of mercury at 0.11- or 0.12-inch intervals. Map "b" of each pair shows wind directions, wind speeds, temperatures, and the lines of temperature differences at the three kinds of fronts.

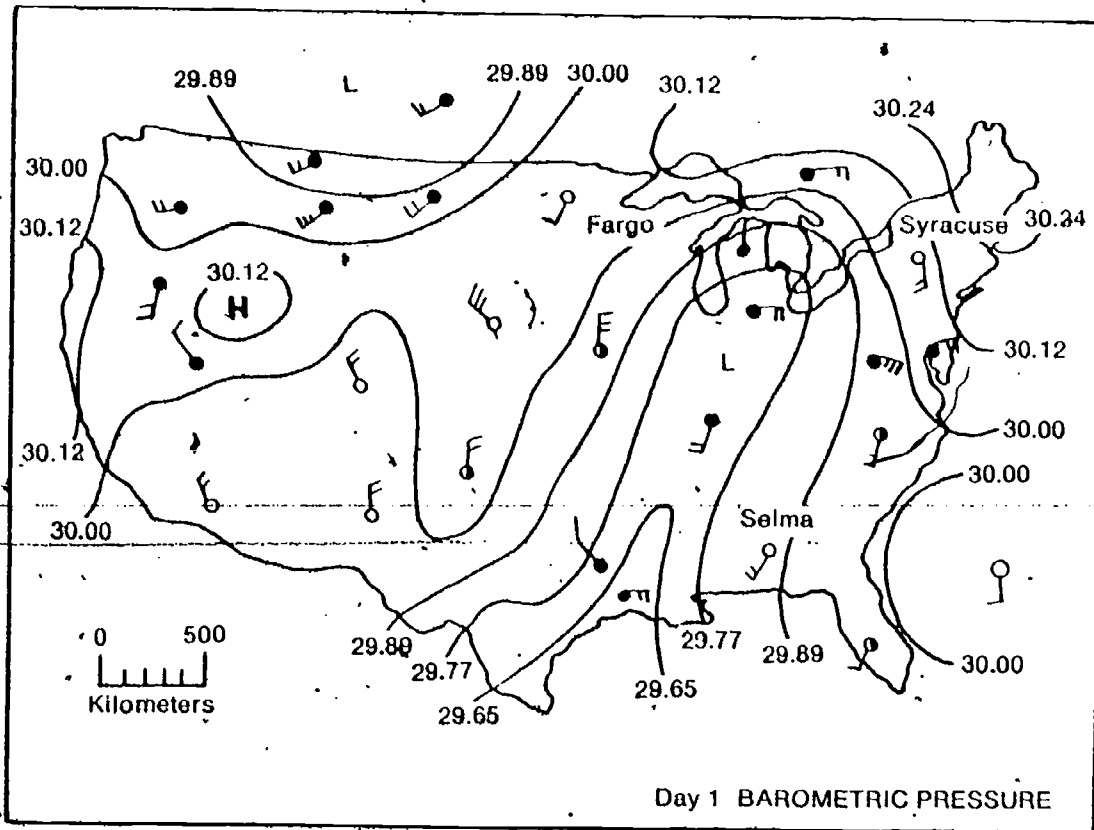

Figure 7-1a

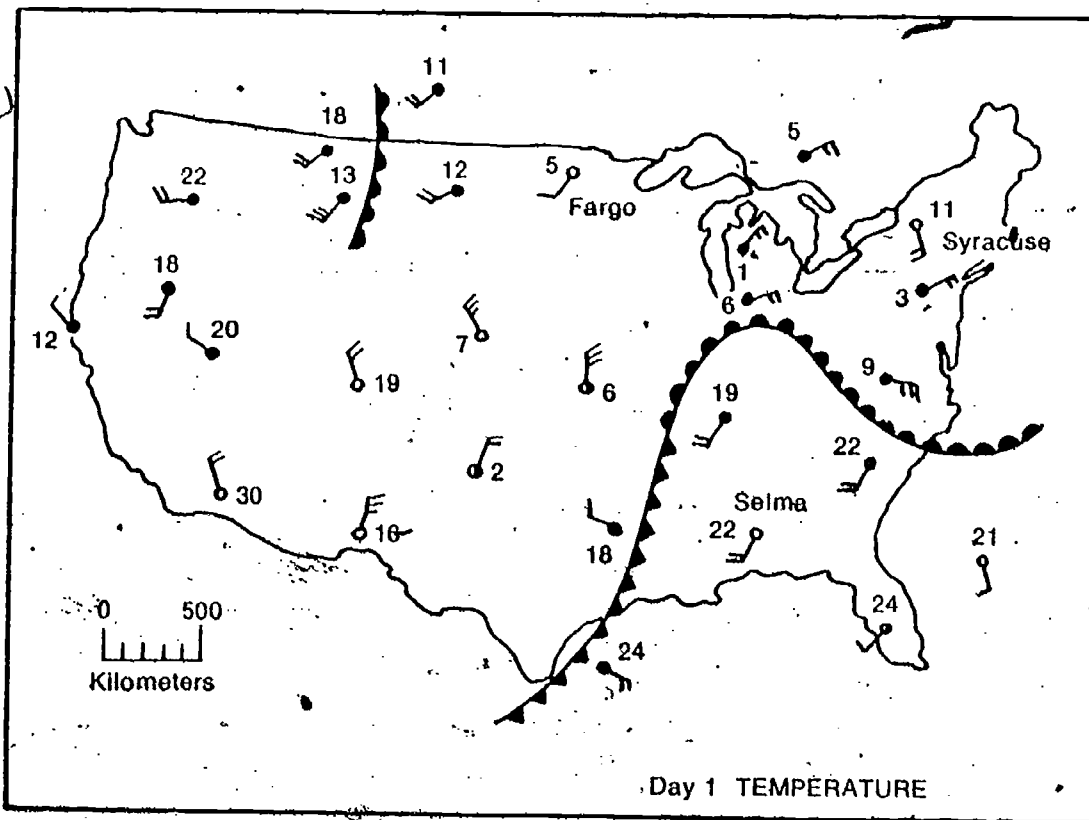

Figure 7-1b

Figure 7-2a

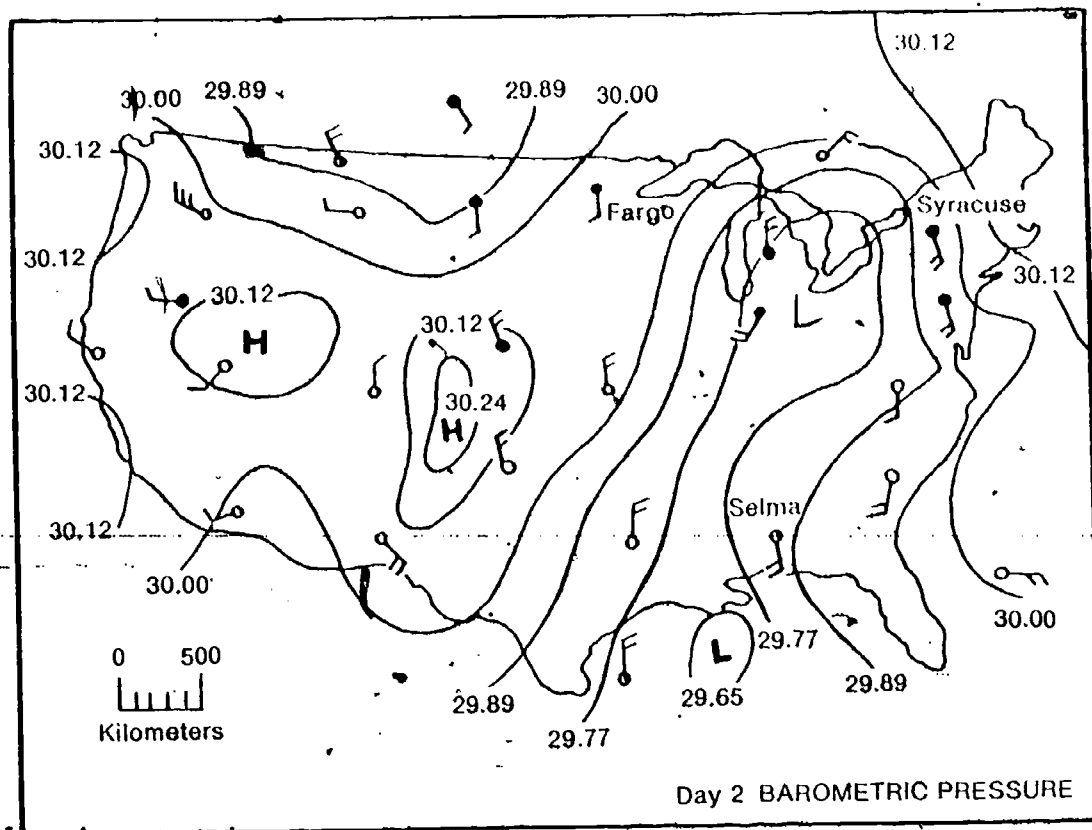
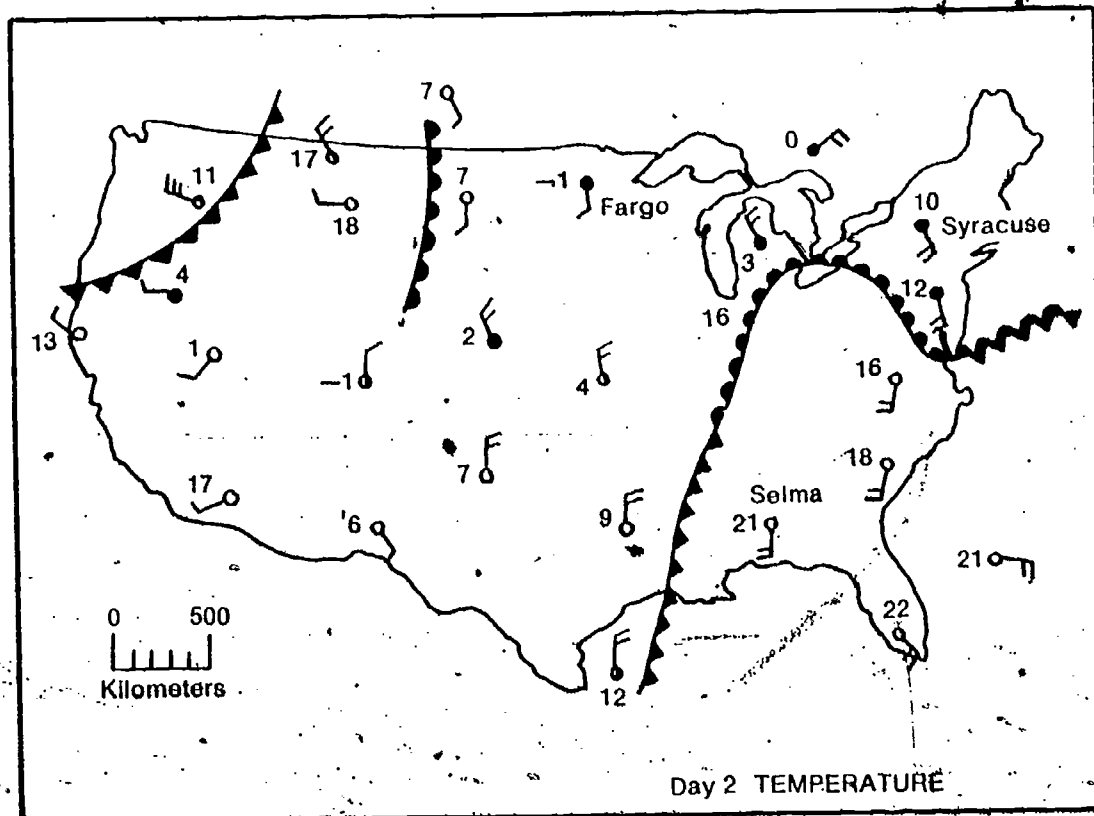

Figure 7-2b



84

104

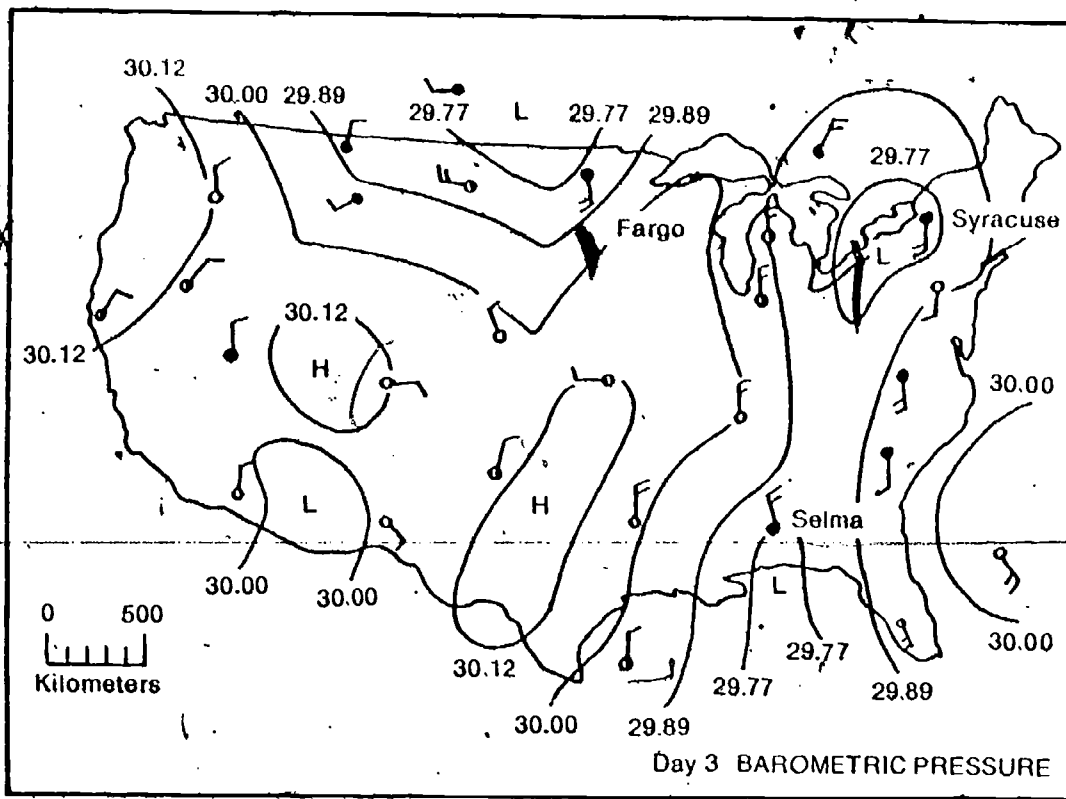

Figure 7-3a

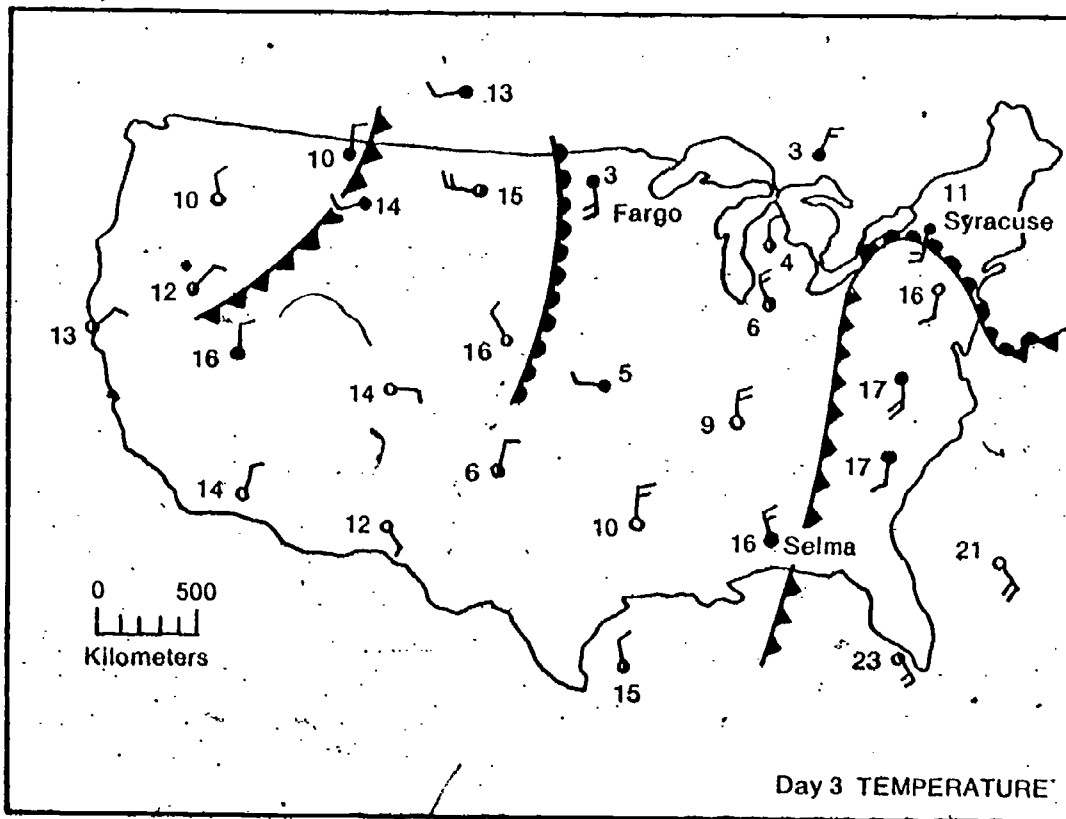
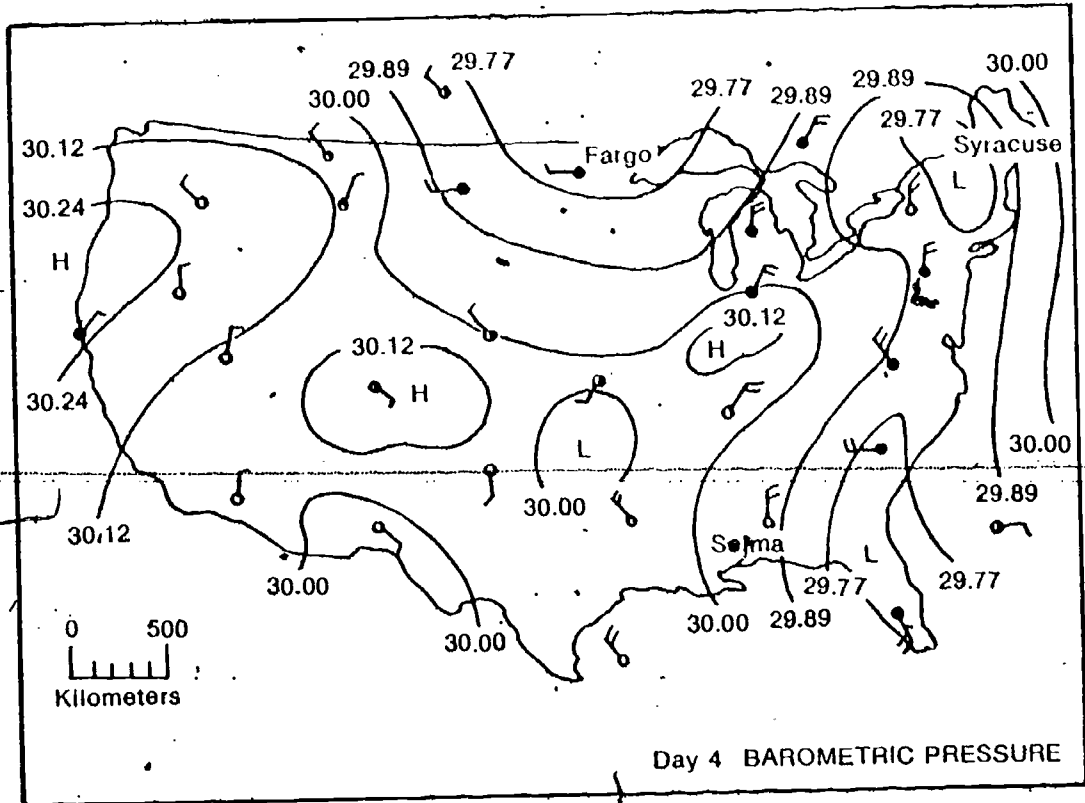

Figure 7-3b

Figure 7-4a



For those who are interested, the "hooked" mass of cold air surrounding the warm air has frontal line in the upper right-hand corner is come together and occluded (completely really an occluded front. This means that the lifted) the warm air above the earth's surface.

Figure 7-4b

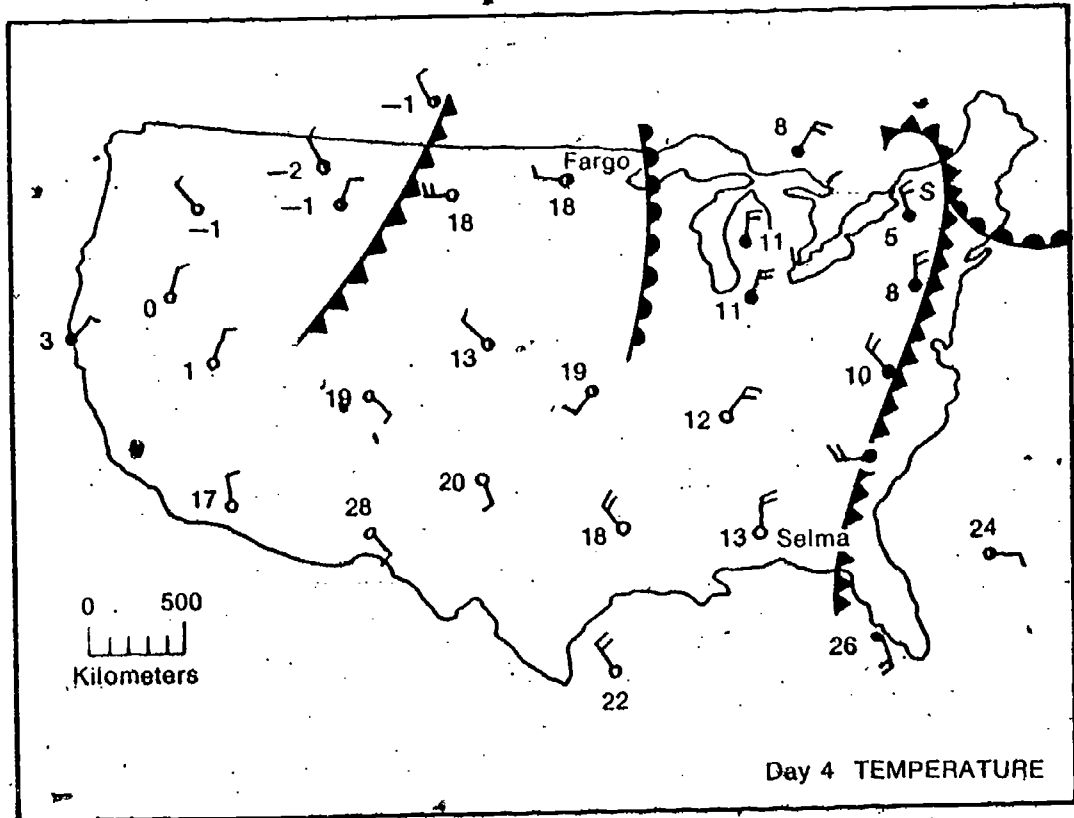

7-1. Did the low-pressure areas, shown first in Figure 7-1a, move during the four-day period? If so, in what general direction?

7-2. Did the lines of temperature difference, shown first in Figure 7-1b, move during the four-day period? If so, in what general direction?

Both pressure areas and lines of temperature difference do move. Those on your maps wandered farther to the east during the four-day period.

The fact that cloud-forming agents move makes the job of weather prediction more difficult. You must find some way to guess in advance when one of these systems will come your way. Let's see if this can be done. First, we'll consider the problem of predicting the approach of a low-pressure system.

Suppose you were living in Syracuse, New York. On Day 1 of the data period (see Figures 7-1a and 7-1b), a low-pressure area would be lying to the west of you. Examine the data for Days 2, 3, and 4 and notice what happens in Syracuse as the low-pressure area approaches and then passes by.

7-3. What happened to the barometric reading in Syracuse as the system moved through (rose, fell, or remained the same)?

7-4. List the changes in the wind direction in Syracuse as the system moved through.

7-5. List changes in the cloud cover as the system moved through Syracuse.

7-6. What observations could have been used two days in advance to predict that the low-pressure area was moving into Syracuse?

Now let's look for signs that could be used to predict the approach and passing of lines of temperature difference. For this, you should study Figures 7-1b, 7-2b, 7-3b, and 7-4b.

Suppose you were living in Fargo, North Dakota, when the data on Figure 7-1b were collected. At that point, a line of temperature difference would be lying to the west of you.



The movement of low-pressure areas and of lines of temperature difference becomes a part of the model, and is therefore important. Students may have to be reminded that a good scientific model (1) explains observations or phenomena and (2) allows predictions to be made about further behavior. It is this recognition of movement that will be the key to prediction of weather.

7-6. Observations of barometric pressure (falling) and wind direction (shifting from SE to S)

- 7-7. Is the air behind the line (to the west) cooler, or warmer, than that in front of it?

Examine the temperature closely for Days 2, 3, and 4 and notice what happened to the weather in Fargo as the line of temperature difference moved through.

- 7-8. What happened to the air temperature as the line approached and moved through Fargo (rose, fell, stayed the same)?

- 7-9. List the changes in the wind direction as the line approached and moved through Fargo.

- 7-10. List changes in the cloud cover as the line approached and moved through Fargo.

- 7-11. What observation could have told you on Days 1 and 2 that a line of temperature difference was approaching Fargo?

7-11. Falling barometer reading and the observation of a shift in wind direction from SW to S, or possibly the observation of an increase in cloudiness. (Note, however, that the air temperature is not a reliable indicator of the approach of the temperature difference line, but it does tell when the line passes the station [Maps 3b and 4b]. It was a warm front, and the temperature jumped up from 3°C to 18°C.)

Now consider the weather in Selma, Alabama. On Day 1, an approaching line of temperature difference lies to the west of that city, too. But it's different from the one you just examined. Look carefully to see how.

7-12. The line approaching Selma is a cold front; the line approaching Fargo is a warm front.

- 7-12. How does the line of temperature change approaching Selma differ from that approaching Fargo on Day 1 in Figure 7-1?

Look at the weather data for Selma over the four-day period.

- 7-13. List changes in the cloud cover in Selma as the line of temperature difference passed through.

- 7-14. List changes in the wind direction as the line passed through Selma.

- 7-15. What happened to the air temperature as the line passed through Selma?

- 7-16. What happened to the barometric readings as the line passed through Selma?

□7-17. What observations could have told you in advance that this line of temperature difference was approaching Selma?

7-17. Increasing cloudiness, wind from the SW and S, falling barometer

Perhaps you now see what "lines of temperature difference" really are. They are the edges of moving masses of warm or cold air. They are called *fronts*.

A *warm front* is a mass of relatively warm air that advances into a region that is relatively cold. As the warm air advances, the lighter, warm air is forced upward over the heavier, cold air. This process typically takes place over a large area. In a warm front, both the air masses are moving in the same direction. The advancing warm air mass is moving faster than the retreating cold air mass.

To visualize this motion, imagine that you are looking at the front from the side as it passes by. This side view (or cross section) would be what you would see if you sliced down through the front from top to bottom and laid it open. Figure 7-5 diagrams what a warm front would look like.

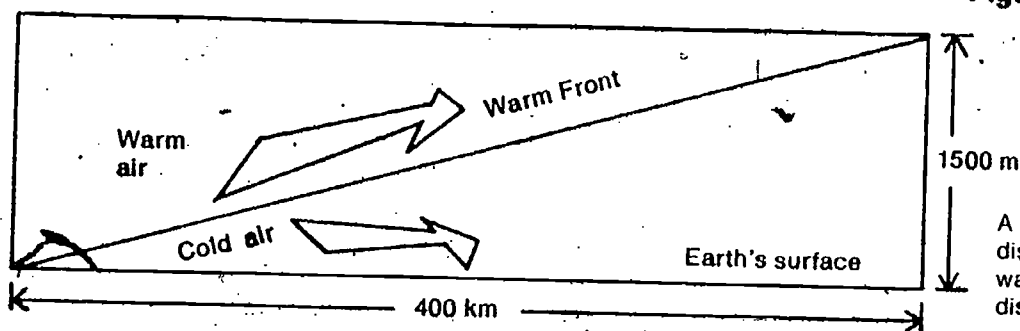

Figure 7-5

A front is named by the air that is doing the displacing. If warm is displacing cold, it's a warm front. If neither air is advancing and displacing the other, it's a stationary front.

A *cold front* is a mass of relatively cold air that is displacing relatively warm, moist air. The warm air may be moved upward more quickly than it is in the usual warm front. Therefore, the slope of the cold front is steeper than that of the warm front. Figure 7-6 diagrams another side view of the frontal system. Study Figures 7-5 and 7-6 carefully so that you understand thoroughly the difference between warm fronts and cold fronts.

Figure 7-7 shows a different view of warm and cold fronts—as if you were looking down upon them from out in space. This is the view you get when looking at a weather map. Symbols used by meteorologists are shown in the figure.

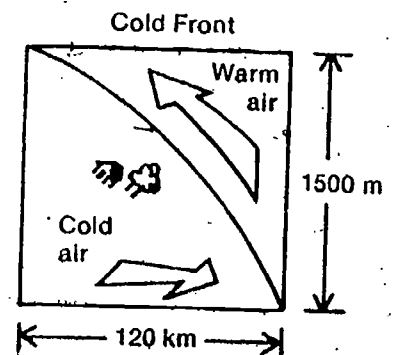
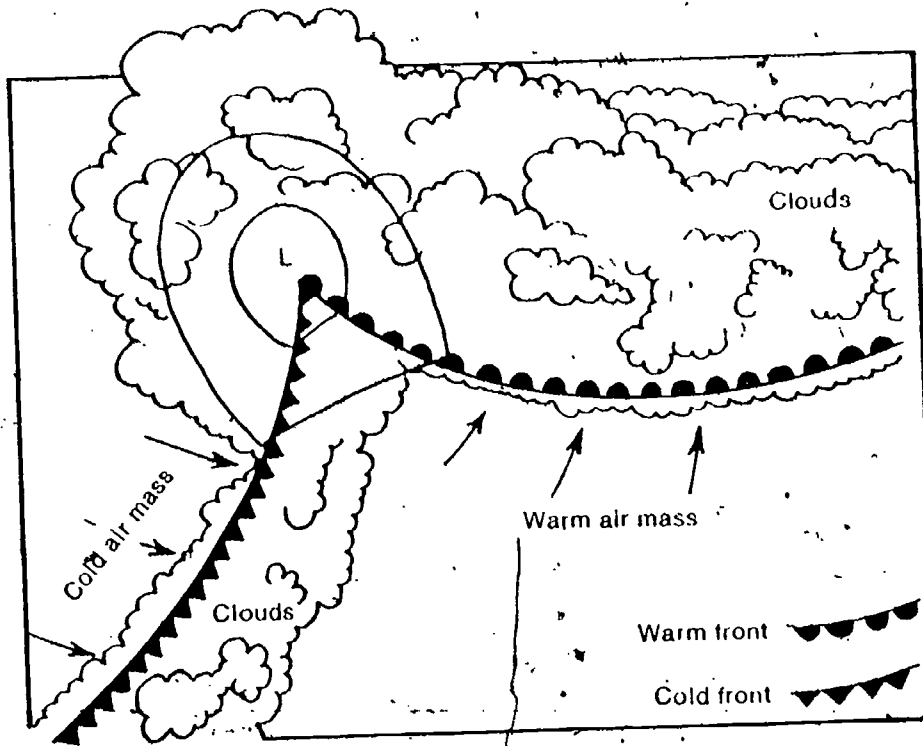

Figure 7-6

Figure 7-7

A front could be defined as a line of discontinuity between two dissimilar air masses. By dissimilar air masses is meant temperature and amount of moisture content (humidity). The air masses are dissimilar because of (1) where they came from and (2) where they have been. (That's like the differences in people being due to heredity and environment.) For instance, if the air came from northern Canada, it would be cold and dry. In its trip south, it would be warmed and moistened some. But it still might be colder and drier than air that came from the Gulf of Mexico, even though that air would be cooled and perhaps dried some in traveling north.



Notice also that the isobars are "kinked" (make a sharp bend) as they cross the front. This is one means of locating a front on a weather map.

Notice the relationship of the fronts shown in Figure 7-7 to each other and to the low-pressure area. The general shape should be familiar to you. You've seen it on the weather maps you've been studying and in the photograph shown earlier and reproduced again in Figure 7-8.

Figure 7-8



In both Figure 7-7 and Figure 7-8 the two fronts and the low-pressure area actually form one large system. Look carefully once more at Figures 7-1 through 7-4. As you do, try to answer these questions:

- 7-18. Are the fronts on the temperature maps located in the same general areas as the low-pressure areas on the pressure maps?
- 7-19. Do the low-pressure areas move at roughly the same rate and in the same direction as any fronts near them?

Well, the pattern on the maps is not completely clear, but two things are apparent.

1. Fronts are always associated with low-pressure areas.
2. Fronts and pressure systems move across the country together.

At this point, you have the chance to stop and gather your wits. You are to look back over all the photographs, maps, and illustrations in the last chapter and this one. Build a picture in your mind (a model) as to what happens to the weather in an area as a large pressure system approaches and passes through. Take plenty of time for thought. It will be important to what you will do next. Use the questions below to guide you in your thinking. You should discuss these questions with others who are at about this point.

1. Approximately how wide is the band of cloudiness associated with a warm front? with a cold front? with a low-pressure area?
2. How far ahead of each type of front or pressure area does it extend? (See Figure 7-7.)
3. What is the pattern of winds around a low-pressure frontal system? (See Figures 6-4, 6-7, 7-1 and 7-2.)
4. How far do cold fronts, warm fronts, and low-pressure areas travel in a day? Do they all move at the same rate? (See Figures 7-1 and 7-2.)
5. How can you tell in advance when a low-pressure frontal system is approaching an area? (Refer to questions 7-2 through 7-17.)
6. What is the relationship of a high-pressure area to the movement and effects of a low-pressure frontal system? (See Figures 7-1 and 7-2.)

This is one of the most difficult things to get students to do. Encourage small group discussions on these questions. Of course, students are working from a limited number of observations of figures, photographs, and maps, and most of these have been generalizations. All the things they have examined will be subject to exceptions. They are getting ready to predict the weather. Actual prediction is at best a complex and complicated task, even with data from many sources not currently available to the students.

When you feel that you understand how passing fronts and low-pressure areas affect weather, you are almost ready to apply this knowledge to your local area. Before you try to do this, though, you need to consider two more subjects. The first is precipitation (rain, snow, sleet, and hail). The second is cloud type.

Precipitation

Why does rain or snow fall from one cloud and not from another? Why is this precipitation sometimes a downpour and sometimes only a sprinkle? Why does precipitation occur in so many different forms? These are not easy questions to answer. In general, it has been more difficult to explain how precipitation gets out of clouds than it has been to explain how clouds form in the first place.

If you are interested in learning how to make raindrops, see **Excursion 7-1**, "And the Rains Came Down."

In Chapter 4, you learned that water begins collecting on dust and salt particles when the temperature falls below the dew point. According to your model, this is what causes cloud formation. If the droplets combine into larger and larger ones, they become too heavy to stay aloft. Then they fall. Falling water (rain, snow, sleet, or hail) is called precipitation.

Along fronts, warm air slides up over cooler air. As it is lifted, the warm air cools below the dew points. If the warm air is quite moist (humidity is high) and/or the cooling is quite severe, precipitation is the likely result (Figure 7-9).

EXCURSION

Excursion 7-1 is a good summation on clouds and precipitation. It presents the electrostatic theory of raindrop formation.

In the figures that follow, note the varying weather along a front, depending on the moisture content of the warm air. The moisture in air is the storehouse of energy for that air. The latent heat of water is such that when water vapor condenses to droplets, a huge amount of heat is given off. This heats the air, which rises, cools, and causes further condensation. Violent weather may result.

Figure 7-9

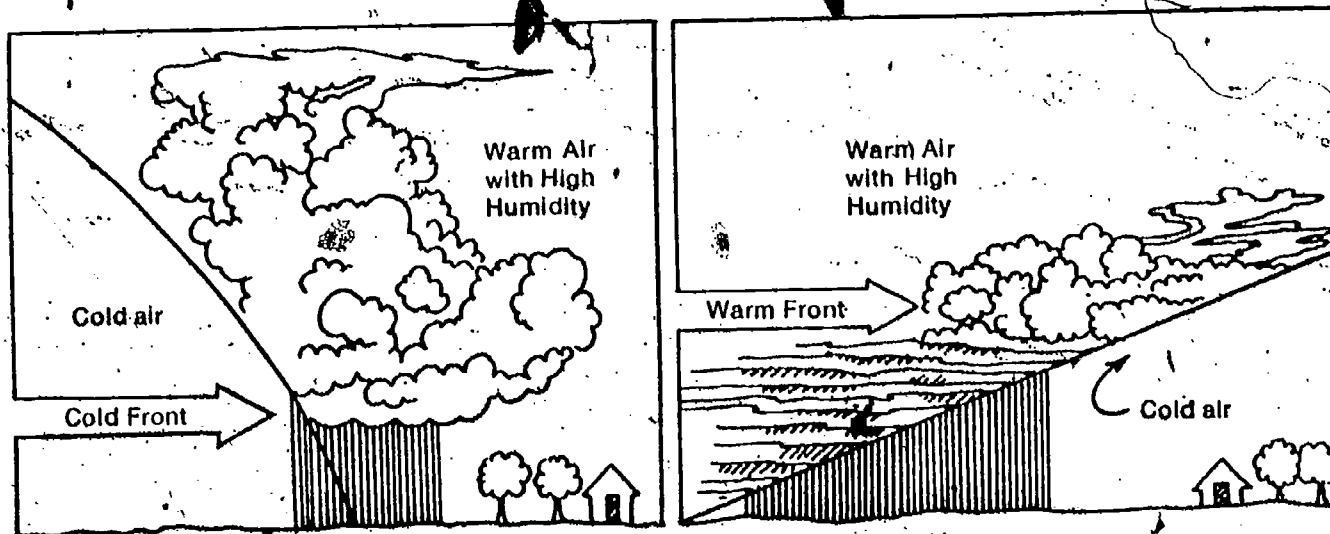

If the warm air is fairly dry (humidity is low) or if the cooling is not great, only a few clouds may form (Figure 7-10).

It has been said that a fairly respectable job of weather prediction can be done just by watching clouds and wind direction. The sequence of cloud formations can be a guide to the type of an approaching front. As for Figure 7-10

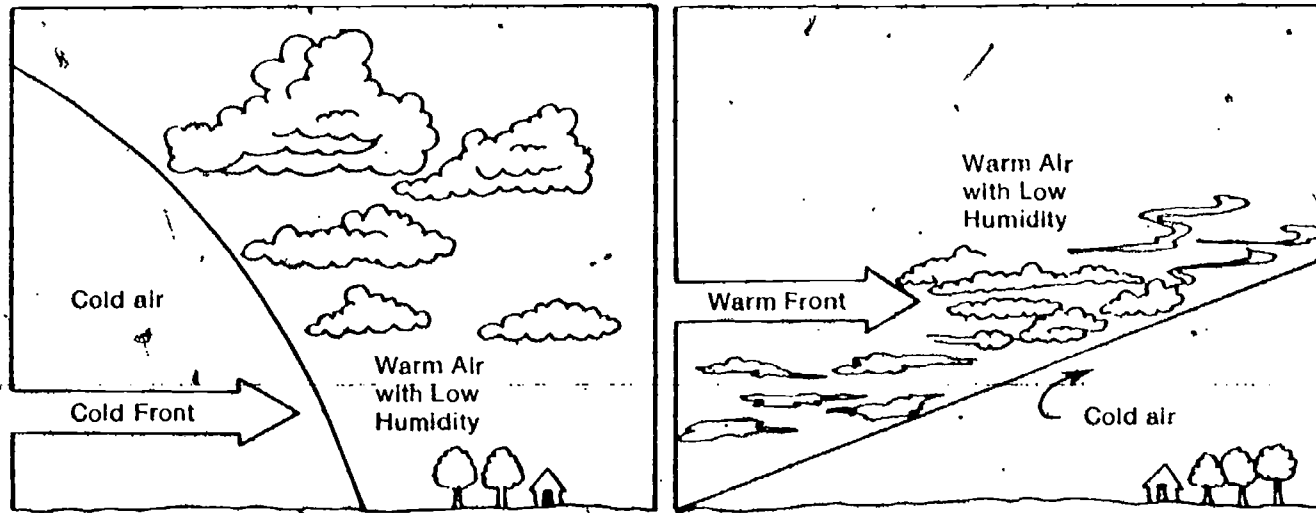

Back up to the clouds

The second subject we will discuss is cloud type. Over the years, meteorologists have studied the changes in cloud type as weather systems move through an area. They have found that the changes fall into the fairly consistent pattern shown in Figure 7-11.

wind, an old "law," called Buys Ballot's Law, can be stated as follows. "In the Northern Hemisphere, face the wind, and the area of lowest pressure is on your right."

The power of Buys Ballot's Law can be readily seen. Knowing that winds rotate counter-clockwise in a low, and also that lows and

Figure 7-11

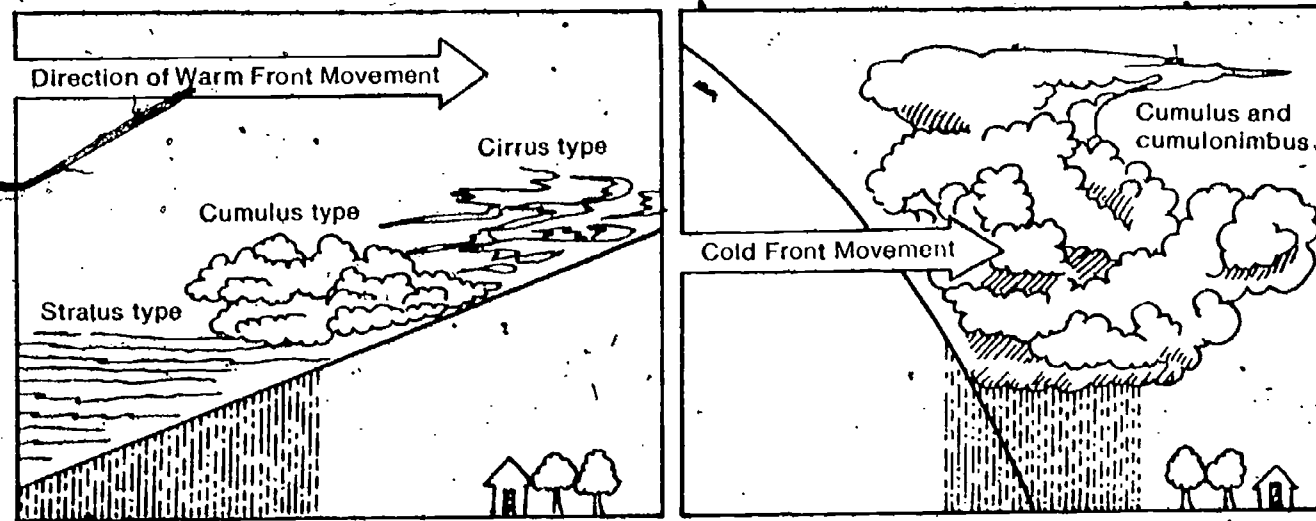

Clouds are often spoken of as "billboards of the sky." A skillful observer can tell a great deal about forthcoming weather by studying the clouds.

fronts move generally from west to east, then facing a south wind will mean that the low is approaching you. Face a north wind and the low is to the east and past you. Try it with some of the maps.

□ 7-20. List in order the cloud types you would expect to observe as a cold front approached your area.

7-21. List in order the cloud types you would expect to observe as a warm front approached your area.

Tables 7-1 and 7-2 are good summations, and should be considered as key questions and checked in the students' Record Books.

Now let's try to summarize what you've learned about predicting the effects of frontal systems. Describe in Tables 7-1 and 7-2 the changes you would expect to occur with the warm and cold frontal systems.

Table 7-1

	COLD FRONT		
	Immediately Ahead of the Front	Along the Front	Immediately Behind the Front
Barometric reading			
Temperature			
Cloudiness			
Wind direction			

Table 7-2

	WARM FRONT		
	Ahead of the Front	Along the Front	Behind the Front
Barometric reading			
Temperature			
Cloudiness			
Wind direction			

You may have had trouble deciding how wind direction is affected by frontal systems. Predicting changes in wind direction requires that you know the direction before the front arrives. You would also need to know the direction of motion of the front. Neither of these bits of information is provided in Tables 7-1 and 7-2.

PROBLEM BREAK 7-1

You've been keeping a weather watch for quite a while now. You should have quite a collection of data for your area on variables such as barometric pressure, wind speed and direction, cloud cover, etc. Here's your chance to study that data and find out if the patterns in weather change for your area can be explained by the model you've been studying.

You should look for relationships between weather variables. For example, you may want to see if your data indicate that wind direction is related to barometric pressure, or to cloud type, or to dew point. Or you may want to find out if temperature change is related to humidity or to wind speed. Let's suggest one approach to getting answers to such questions.

Suppose you want to find out how pressure change affects temperature change. You could make a table like Table 7-3.

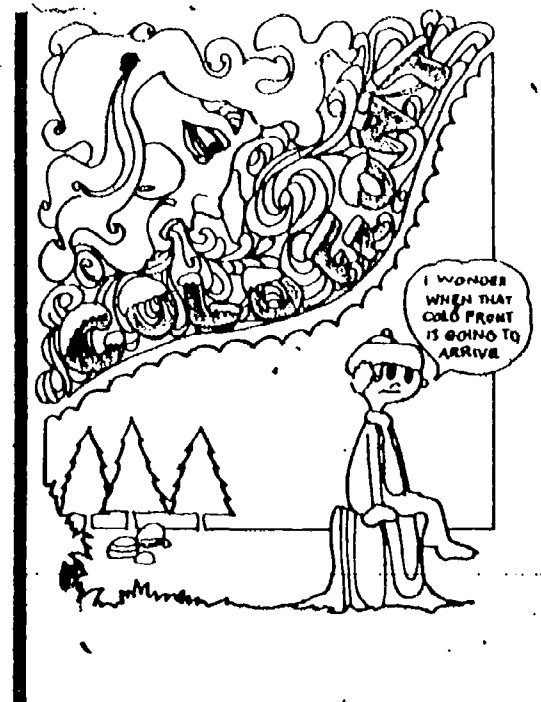

Table 7-3

Pressure Change from One Day to the Next	Prevailing Wind Direction for the 2nd Day of the 24-Hr Period			
	Northerly	Southerly	Westerly	Easterly
Rising				
Steady				
Falling				

Tally the data from your weather watch in a table like 7-3. Each tally (mark) will represent one 24-hr period. After all tallies are made, you can judge the effect of pressure change on wind direction. You can even make some calculations. For example, you can calculate the likelihood that one kind of pressure change will produce a given wind direction. Suppose you want to know how often you can expect to see a southerly wind when the pressure is falling. Here's how you find out by using your data.

Sum up all the tallies in the entire table to get a grand total. Then divide this number into the number of tallies in the appropriate data box. Multiply your answer by 100 to

More and more of the work of the National Weather Service is concerned with statistics and computers. Here is an opportunity for students to do a little simple statistical analysis, using their own observations.

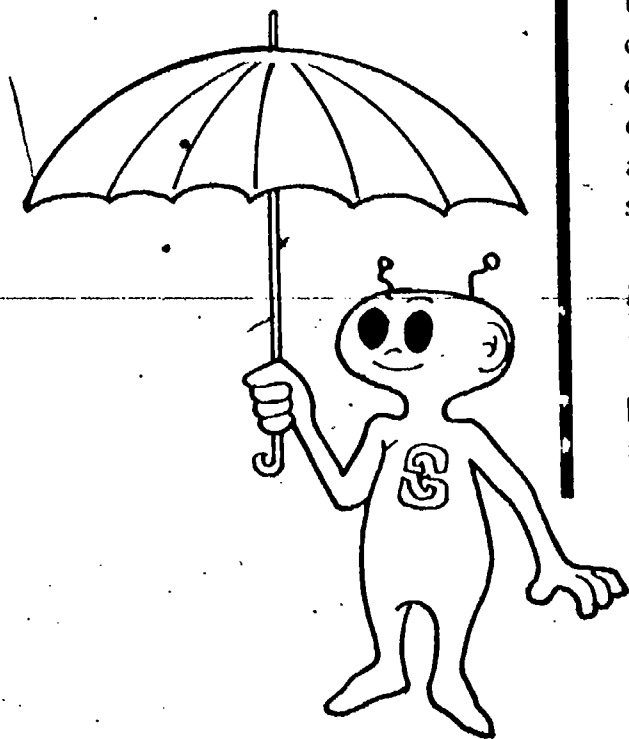

Excursion 7-2 is an opportunity to look at one of the awesome phenomena of nature—the thunderhead.

EXCURSION

EXCURSION

Encourage better students to do Excursion 7-3. It is the "pay-off" on the use of the model for predicting weather.

get a percentage.

$$\frac{\text{No. of tallies in data box}}{\text{Grand total of tallies}} \times 100 = \%$$

This percentage (sometimes called probability) is a measure of the likelihood that falling pressure will produce southerly winds in your area. Of course, this percentage is based on limited data taken at one particular time of year. More extensive data might give you a different percentage for your answer. Even with such limited data, a percentage of this sort gives you more predicting power than you had before.

You should now select the variables you want to investigate. Record your findings and conclusions in your Record Book.

- 7-22. What do you think the weatherman means when he says "The chance of rain today is 30%"? Discuss why you think he would make such a statement.

This unit of work was not designed to make you into a meteorologist. Its purpose was to introduce you to certain factors that affect weather and to help you put together a simple model for explaining those effects. You've seen that there would be no change in weather without movement of air. That's why this unit is titled *Winds and Weather*.

You've investigated many variables and seen how they affect the motion of air. You've learned something about the processes that form clouds. Perhaps you are still interested in learning more about old "cumulonimbus" mentioned in Chapter 1. If so, take a look at **Excursion 7-2**.

Low- and high-pressure areas and frontal systems have also been studied a bit. You are on the verge of being able to predict simple weather changes in your own region. You can try your wings if you wish, by taking a look at **Excursion 7-3**, "Predicting Weather."

Don't be disappointed if you aren't confident about your predictions. Weather is very complicated and often unpredictable. If you don't believe it, ask any weatherman.

Before going on, do Self-Evaluation 7 in your Record Book.

Excursions

Do you like to take trips, to try something different, to see new things? Excursions can give you the chance. In many ways they resemble chapters. But chapters carry the main story line. Excursions are side trips. They may help you to go further, they may help you go into different material, or they may just be of interest to you. And some excursions are provided to help you understand difficult ideas.

Whatever way you get there, after you finish an excursion, you should return to your place in the text material and continue with your work. These short trips can be interesting and different.



118

EQUIPMENT LIST

- 1 large plastic dry-cleaning bag
- Plastic straws
- Cellophane tape
- 1 alcohol burner

PURPOSE. To show the buoyancy of hot air.

Hot Air Balloon

Excursion 1-1

This is an advanced general-interest excursion.

MAJOR POINT

A balloon inflated with heated air will rise through the cooler air, giving further evidence that warm air rises.

The basic equipment needed for a hot air balloon is an inflatable bag and a source of heat. Almost any size and shape of bag will work.

You can make your own balloon from a plastic dry-cleaning bag. The long dress-size bag will give the best results. Here is what you and a partner will need:

- 1 plastic dry-cleaning bag (dress-size)
- Plastic straws
- Plastic or cellophane tape
- 1 alcohol burner

ACTIVITY 1. You want to trap hot air in the bag, so check its sealed end for leaks. Do this by trapping some air in the end of the bag.

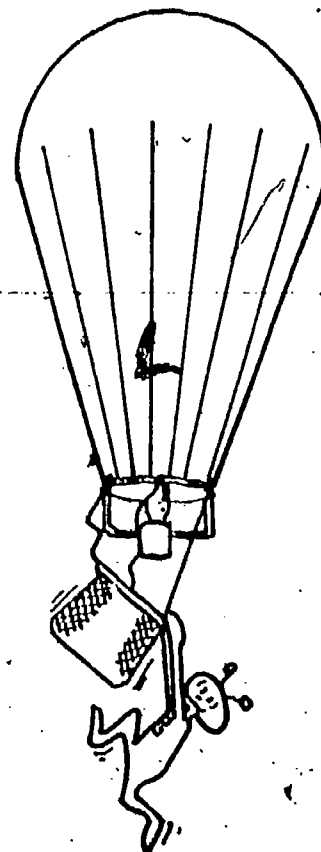
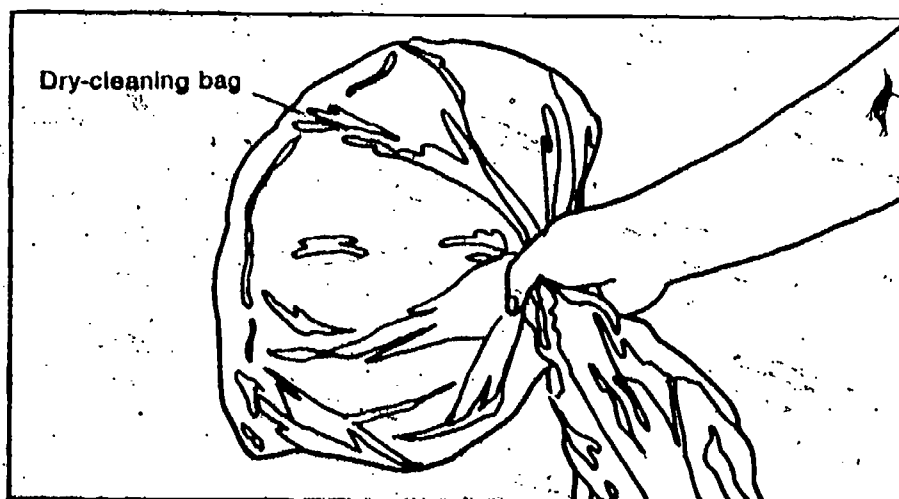

Before any group begins this activity, be sure you are alerted to their activities. Insist that the group checks with you before using the alcohol burner for inflation. This excursion is a lot of fun, but there is potential danger.

If you have an electric flatiron, it can be used for an alternative (and neater) method of sealing leaks in the bag. Smooth out the edge of the bag on a flat surface. The edge with the leak may be folded over a small amount if desired. Run the hot iron over just the edge to be sealed.

ACTIVITY 2. If the bag leaks, you should seal it with tape. Twist the closed end and tie a knot in it. Trim off the excess plastic with scissors.

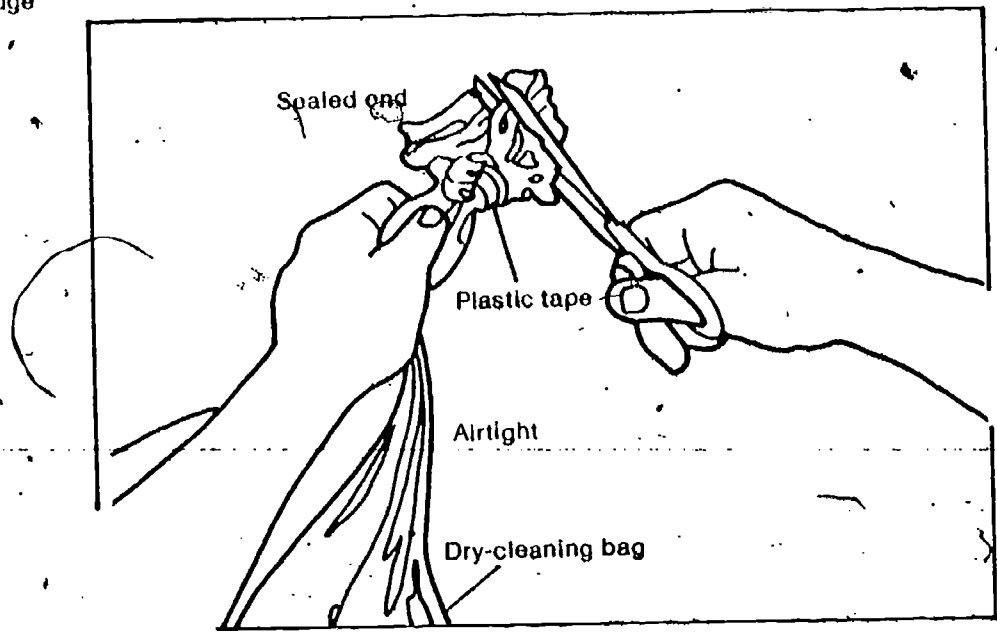

In order to collect hot air in the bag, you'll need to be able to hold the other end of the bag wide open. You can make a hoop or circle out of straws to do this. To find out how many straws to use, do the following activity.

ACTIVITY 3. Flatten the bag out at its open end. Measure the distance across this open end. Multiply this distance (width) by 2. This will give you an approximate measure of the length of the bag's opening.

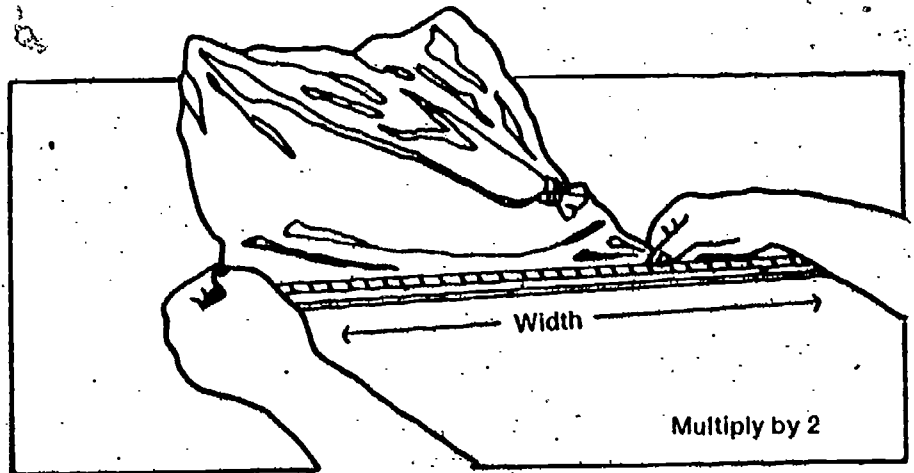

ACTIVITY 4. Place plastic straws together by pinching and folding one end of one straw and inserting it into another straw. (Overlap of the straws should be about 3 cm.) The total length of the straw chain should be equal to the approximate opening of the bag (as determined in Activity 3).

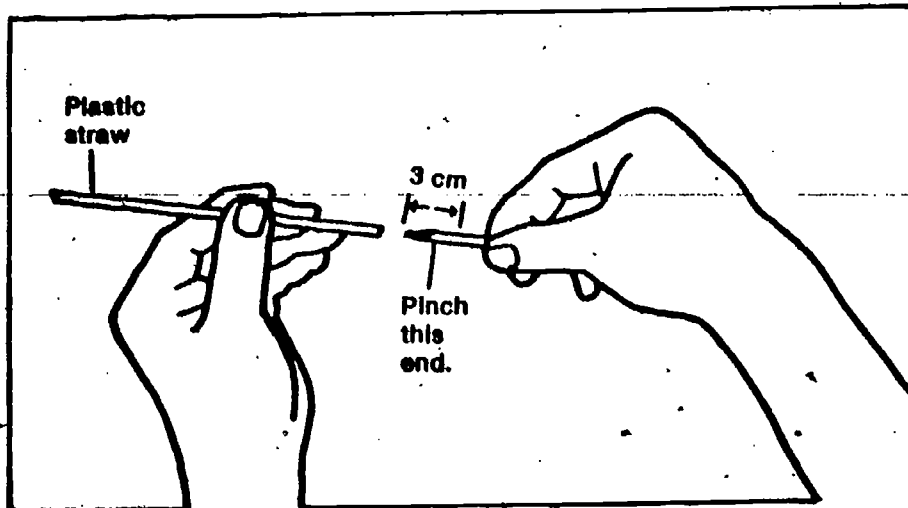

ACTIVITY 5. By putting the two end straws together, you can form a hoop.

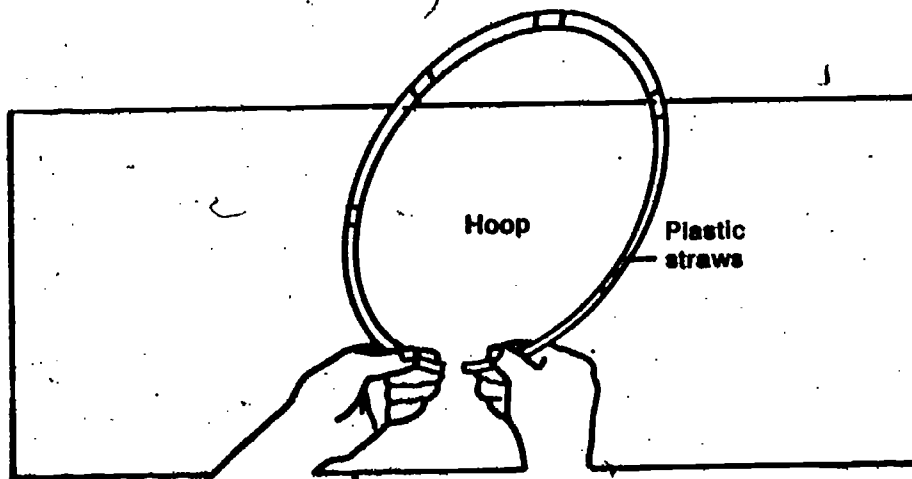

ACTIVITY 6. Use a few short pieces of tape to hold the straw hoop inside the bag. Overlap the bag about 3 cm.

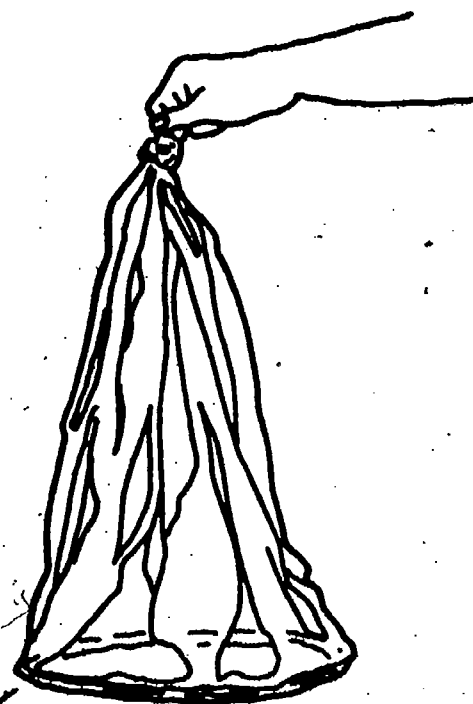
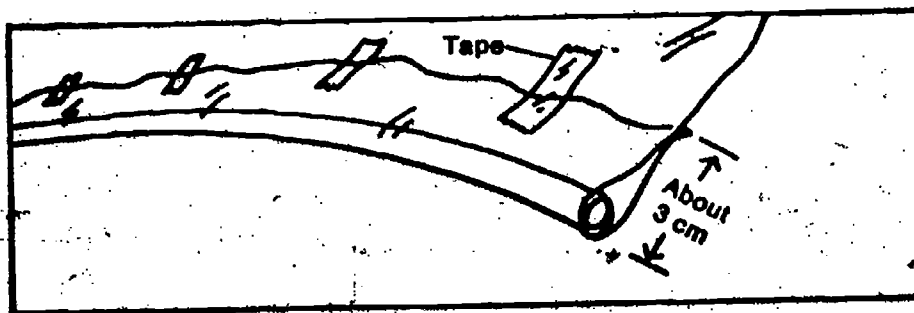

Note the need for your approval if the inflation and ascent is to be done outside. It must be a day with little or no wind. It would probably be wise to have fire-extinguishing materials handy.

You are now ready to collect hot air in your bag.

Caution *The next part of this excursion should be done in an area designated by your teacher. Be sure to get his approval before beginning. Use caution in working with the alcohol burner. The plastic bag doesn't burn rapidly, but it will burn. Keep it clear of the flame.*

ACTIVITY 7. Hold the bag over the lighted alcohol burner. Continue to support the bag as the air inside is warmed.

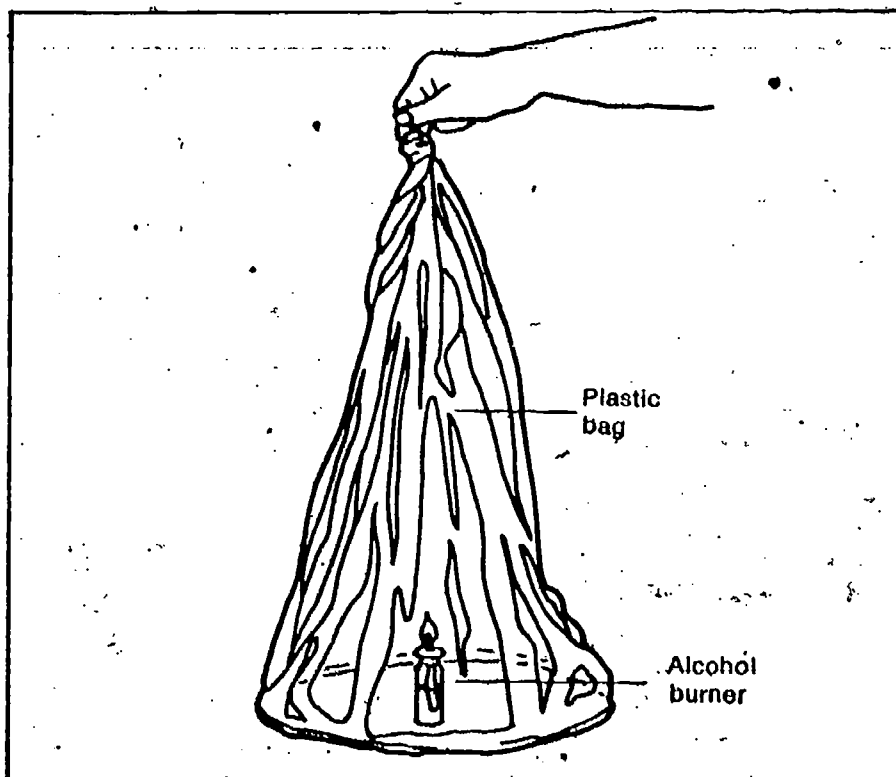

Caution *Be sure to keep the sides of the bag away from the open flame.*

Some students will probably come up with the idea of a wad of cotton soaked in alcohol and suspended at the opening with fine wire. This will work well (too well, in fact). Once the balloon has left its moorings, the flaming cotton can ignite anything that the balloon lands on. You are going to have to use your good judgment on the innovations, and also provide some cautions about working on their own outside of school.

1. Describe your observations of the bag as the air inside is heated.
2. What would you have to do to keep the bag going up once it left the ground?

You may want to improve your balloon. That's okay. But don't try other experiments using flames without your teacher's permission.

EQUIPMENT LIST

1 weather instrument

PURPOSE: To provide further help in measuring wind direction and wind speed, including the use of visual, noninstrumental clues.

Blowin' in the Wind

Excursion 2-1

This is a general-interest excursion.

MAJOR POINTS

1. Measurement of wind direction is given as the direction from which the wind is blowing.
2. In reading wind direction, the vane generally shifts back and forth, and an average reading is used.
3. An instrument may be calibrated by using a standard instrument.
4. Wind speeds can be judged visually by the effect the wind has on common objects.

Wind direction

In mounting the all-purpose weather instrument, the circular wind direction indicator should be positioned so that the north (N) symbol points toward true south. Then any pointer reading against this indicator disk will give the direction from which the wind is blowing.

The important point to remember is that wind direction is named according to the direction from which it blows.

Instruments are useful tools in making scientific measurements, but we sometimes forget that many things can be "measured" without them. For instance, wind direction and wind speed can be measured with the weather instruments, but fairly reliable measurements can be made without them, as described on the next several pages.

Figure 1

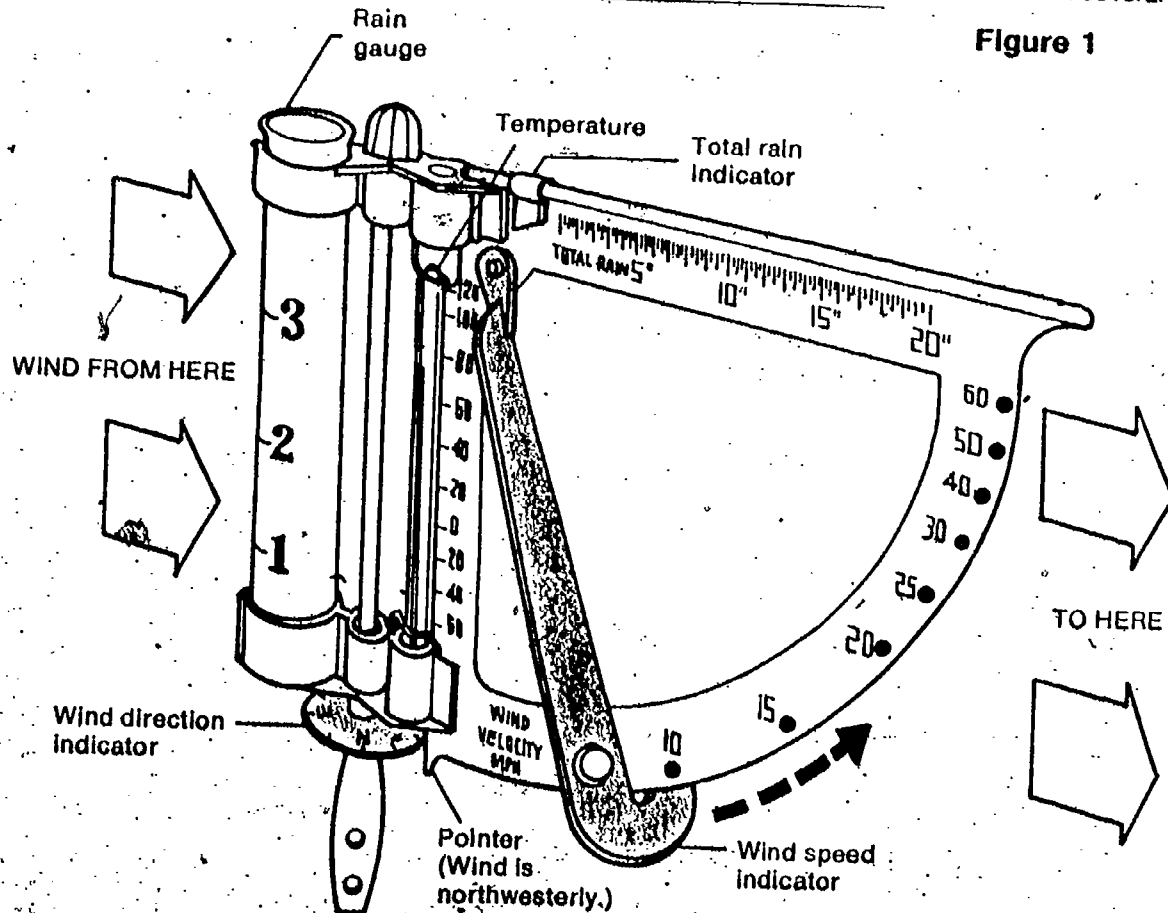

Although it is possible to use up to 32 points of the compass to name the wind direction, you will use only 8. You can read the wind direction directly from the position of the movable pointer against the scale. A sketch of the 8 directions you may use appears in Figure 2.

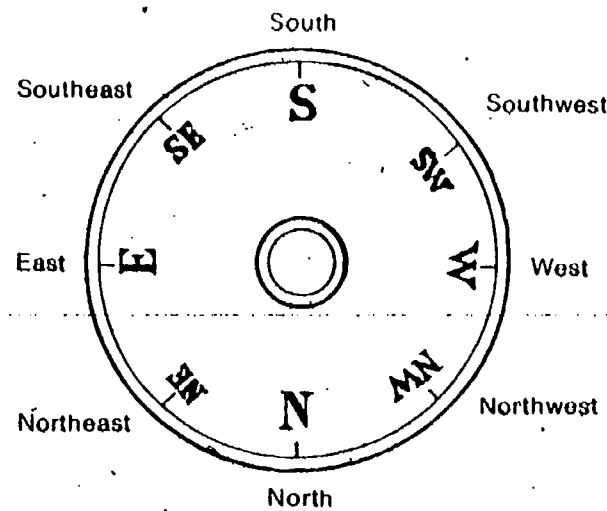

Figure 2

To measure wind direction without instruments, there are two common practices. In either one, the person must orient himself with true north by using a known direction of a road, facing of a building, landmarks, or at night, by sighting on the North Star. Then (1) pick up some loose material, like dry grass or fine dust. Toss it in the air and watch the direction from which it is blown. (2) Moisten the forefinger and hold it aloft. The side of the finger that feels cooler indicates the direction the wind is coming from.

Usually, the pointer isn't stationary. It moves as the wind shifts back and forth. But you can still get an average reading. For example, if the pointer moves about as shown in Figure 3, the general direction of the wind is estimated to be west.

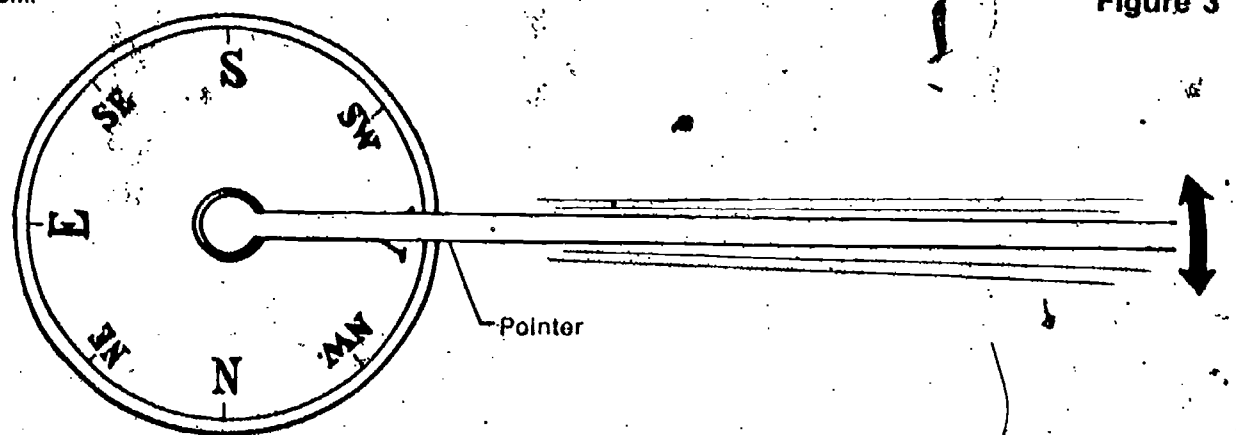

Figure 3

Wind speed

The weather-station instrument also allows you to measure the wind speed. The principle behind the wind speed indicator should be obvious. In fact, you can easily build your own wind speed indicator if you are interested. See Figure 4 for hints on doing this. (You will have to furnish the common materials required.)

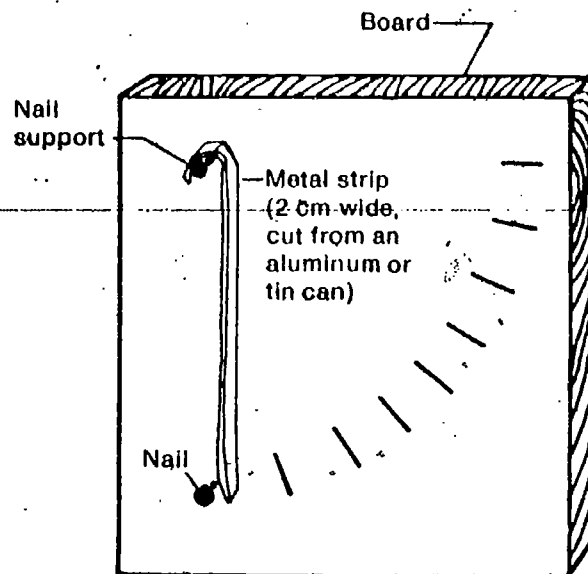
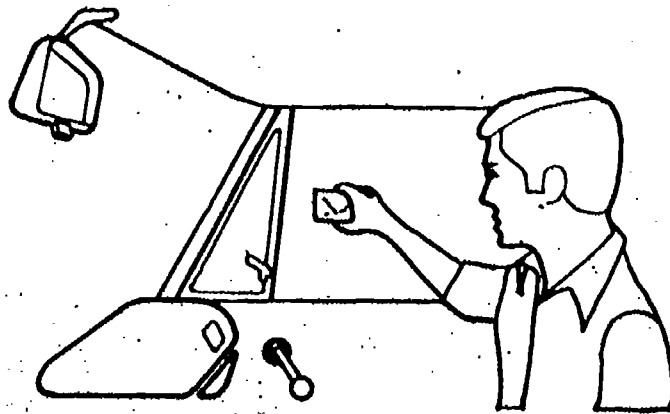

Figure 4

Your instrument will have to be calibrated in order to be useful in making your observations. To make the wind speed scale, wait for a calm day, then take your indicator for a car ride.

ACTIVITY 1. Hold the indicator out the window of the car that is moving. The moving air will move the speed indicator just as wind moving at the same speed does. Mark the scale at intervals of 5 mph.

This activity might even be done with the extra weather instrument supplied in the kit. It could give a check on the calibration of the instrument. It must be done on a calm day.



EXCURSION 2-1 105

Table 1 contains the first seven of the readings from the so-called Beaufort Scale of wind velocities. This scale was devised by Admiral Sir Francis Beaufort of the British Navy in 1805 as a method of estimating winds at sea for sailing captains. It was later adapted for land use by adding objects that are commonly seen in everyday life. It is remarkably accurate

In keeping your weather watch, there may be times (especially on weekends) when the weather-station instrument is not available. If this is the case and you don't have your own instrument, you can estimate wind speed fairly accurately. Table 1 will help you do this. The table lists common events with the approximate wind speed associated with them.

Table 1

Wind Speed		Description of Behavior of Common Objects
mph	km/hr	
Less than 1	Less than 2	Smoke rises vertically.
1 to 3	2 to 5	Smoke drifts, but flags hang limp. Ordinary wind vanes useless.
4 to 7	6 to 11	Wind felt on face. Leaves rustle. Ordinary wind vanes move.
8 to 12	12 to 19	Leaves and twigs in motion. Light flags are extended.
13 to 18	20 to 29	Dust and loose paper raised. Small branches are moved.
19 to 24	30 to 39	Small trees begin to sway. Whitecaps form on lakes.
25 to 31	40 to 50	Large branches in motion. Wires whistle. Umbrellas hard to use.

for the ranges of wind speeds given, especially when used by an experienced observer. Note that the first two rows, up to 3 mph, and even possibly the third row, 4-7 mph, are not readable with the weather instrument, so the visual Beaufort Scale takes on added significance. It might be a good idea for students to copy the table so that they would have it for weekend observations.

EQUIPMENT LIST

None

PURPOSE: To extend the students' knowledge of clouds

Billboards of the Sky

Excursion 2-2

This is a general-interest excursion. However, there are important applications of it in the frontal study and weather predicting later on.

Since ancient times, men have watched the skies and tried to predict the coming weather by what they observed. Long before the clouds were given scientific names to identify them, they were described in terms of things that they resembled. Thus, statements like the following were commonly used:

**"Mackerel scales and mare's tails
Make lofty ships carry low sails."**

Figure 1 "Mackerel scales"

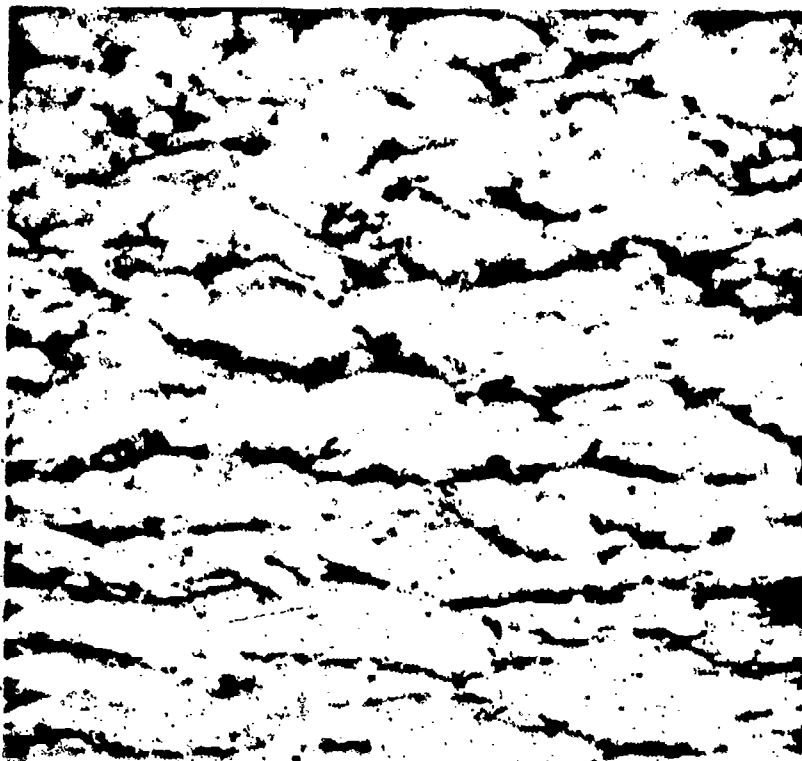

MAJOR POINTS

1. The appearance of clouds in the sky can be described in terms of common things they resemble.
2. The scientific names for cloud types mean things like "curl of hair" (cirrus), "spread out" (stratus), and "pile" (cumulus) and denote families of clouds.
3. Families of clouds can be found together in different combinations.
4. Cloud families are found at particular altitudes in the sky.
5. Sometimes one type of cloud can change to another type.

Figure 2 "Mare's tails"

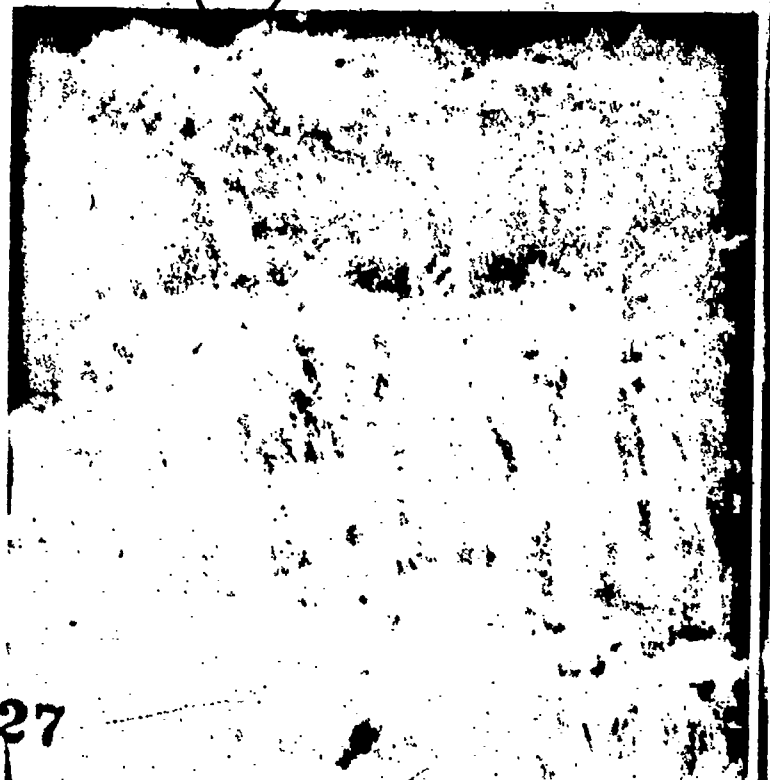

The appearance of clouds as neat rows of small patches resembling the scales of a fish (Figure 1) or wispy filaments like the curling hair in a horse's tail (Figure 2) foretold a storm. Upon seeing these signs, sailors would lower their ship's canvas.



Students will later learn that cirroform types of clouds may precede a front by many miles and be a first indicator of approaching bad weather.

For your information, one useful way of categorizing cloud types is by the following four families:

1. Cirro-type, consisting of cirrus, cirrostratus and cirrocumulus
2. Alto-type, consisting of altostratus and altocumulus
3. Strato-type, consisting of stratus, stratocumulus and nimbostratus
4. Cumulo-type, consisting of cumulus and cumulonimbus

The families in general occupy a particular altitude-range (except the cumulo-type, which are found at all heights). These heights are given in the material that follows.

Of all the different elements of the weather that you will be studying, clouds and the forms of moisture that come from them are the only things that are generally visible. We can describe and name clouds by their appearance. You don't have to rely on an instrument for their description. If you learn the vocabulary of the cloud types, you can read them like a billboard. And you will also have some idea of coming events in the weather.

Much like people, clouds tend to be found in families. The three cloud names that you have used in Chapter 2 (cirrus, stratus, and cumulus) are really family names given to them by a nineteenth-century chemist named Luke Howard. *Cirrus* means "curl of hair," *stratus* means "spread out," and *cumulus* indicates a "pile." Also like people, there is often a combination of families. This means that there can be cirrus and cumulus combined, or cumulus and stratus, or stratus and cirrus. Thus, the mackerel scales (Figure 1) mentioned in the weather adage are really cirrocumulus, or "wispy piles."

All cirrus-type clouds are found at high altitudes, from 6,100 meters (20,000 feet) on up. At these heights, the temperature is so cold that the clouds are composed entirely of ice crystals. These crystals are very fine and delicate. This accounts for the hazy, filmy, and wispy appearance of the clouds. A cirrostratus cloud is just a high sheet of ice crystals spread out at one level above the earth. These clouds give the sky a filmy appearance and cause a ring, or halo, around the moon or sun. (See Figure 3.)

The average rate of cooling with altitude is 3.2°F per 1,000 feet (0.6°C per 100 m).

Cirrostratus Clouds (Wispy and spread out in a layer)

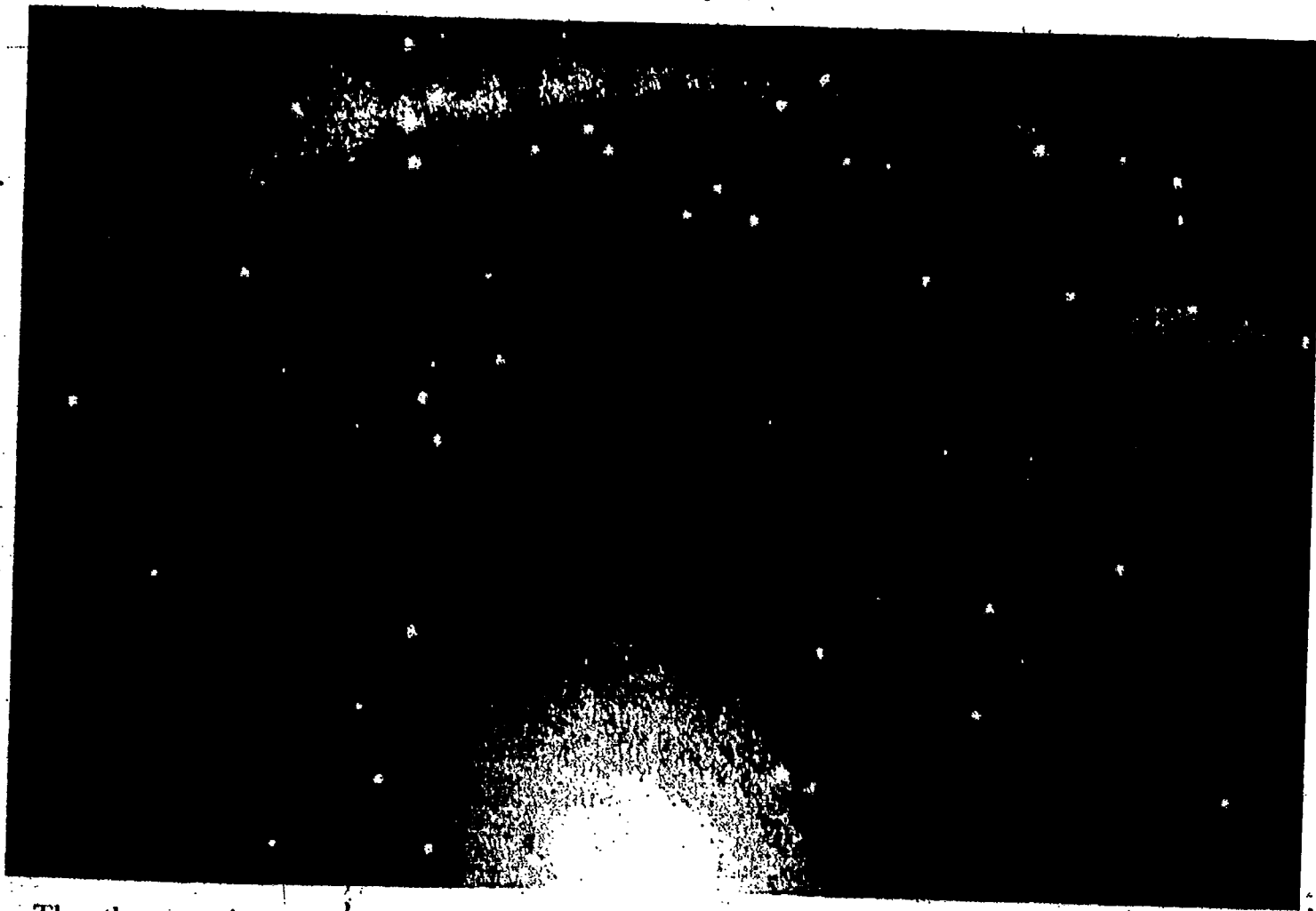

The three main categories of clouds often have other names added to them to further describe some of the variations. The prefix *alto* (meaning "high") can be added to the terms stratus and cumulus. To indicate a high, spread-out layer of clouds, the word altostratus is used. Clouds at high altitude and piled up are called altocumulus. They are found from 2,440 meters to 6,700 meters (8,000 feet to 20,000 feet).

Figure 3.

EXCURSION 2-2 109



Figure 4 Altostratus

1. Why do you think there is *not* a cloud designated as altocirrus? 1. Cirrus are high clouds and alto means high, so it would be like saying a "high high cloud."



Figure 5 Altocumulus

The Latin word *nimbus*, meaning "rain cloud," is often used to indicate a cloud from which precipitation is falling. Thus, heavy stratus clouds from which rain or snow is falling are called nimbostratus. Stratus, stratocumulus, and nimbostratus are found below 2,440 meters (8,000 feet).

110 EXCURSION 2-2

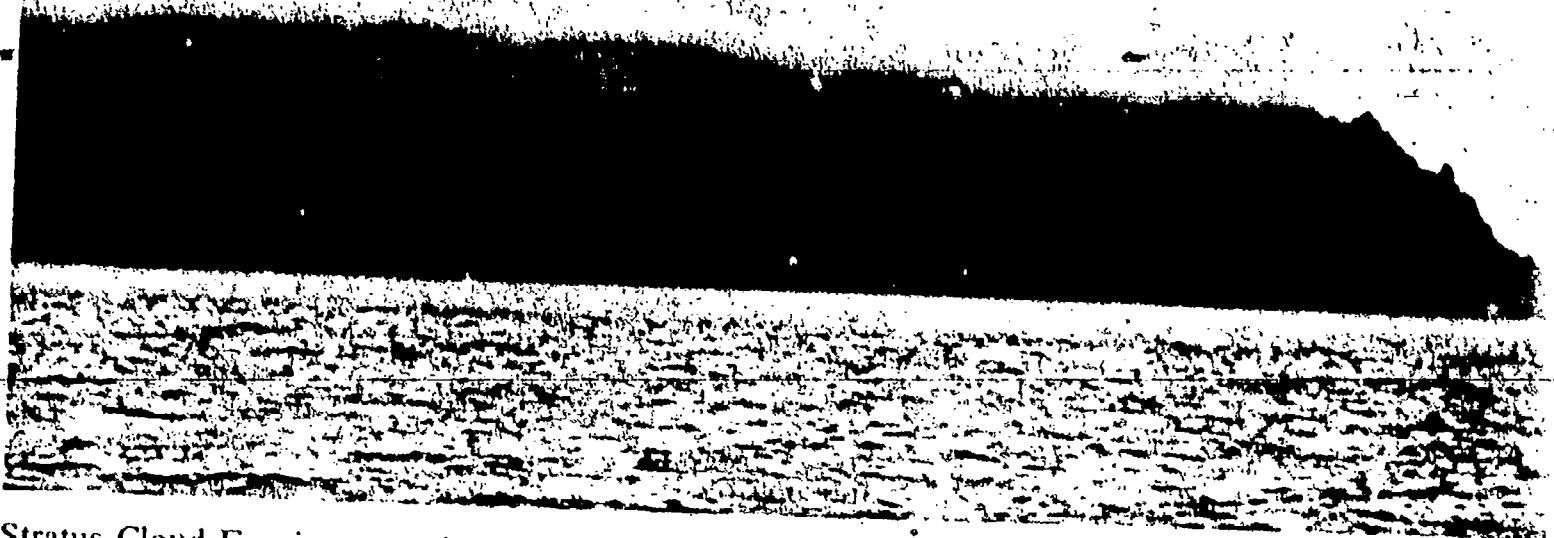

Stratus Cloud Fogging near the Top of a Mountain

Figure 6

Stratocumulus
(Spread-out layer of piled-up clouds)

Figure 7



Nimbostratus
(Spread-out rain clouds)

Figure 8

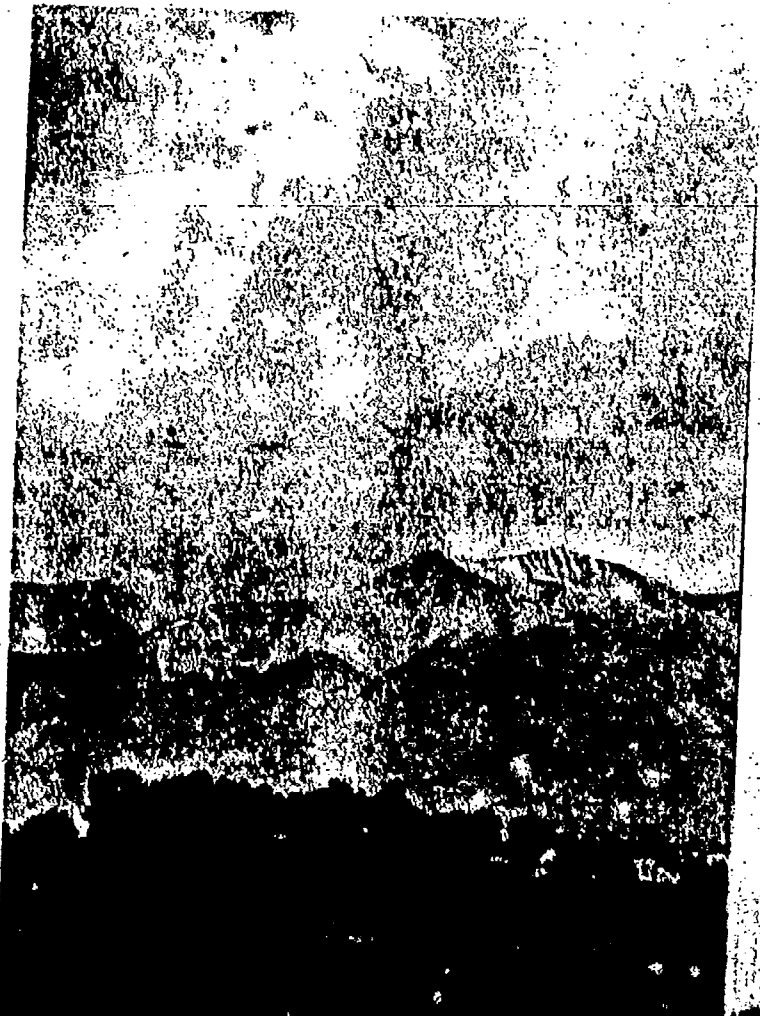

Cumulus and cumulonimbus (thunderhead) clouds are found at all altitudes, from 2,440 meters (8,000 feet) to 18,300 meters (60,000 feet). The cumulus is the typical cloud of fair weather, resembling a fluffy white pile. A continuous growth of the cumulus cloud produces the fierce cumulonimbus of the thunderstorm. This cloud is the one associated with our most vicious weather, including tornadoes and hailstorms.

Cumulus (Piled-up clouds). **Figure 9**



Cumulonimbus (Piled-up rain clouds).
Figure 10

2. Now see if you can identify some of the ten varieties of clouds that have been mentioned. Don't look back to the descriptions unless you have to.

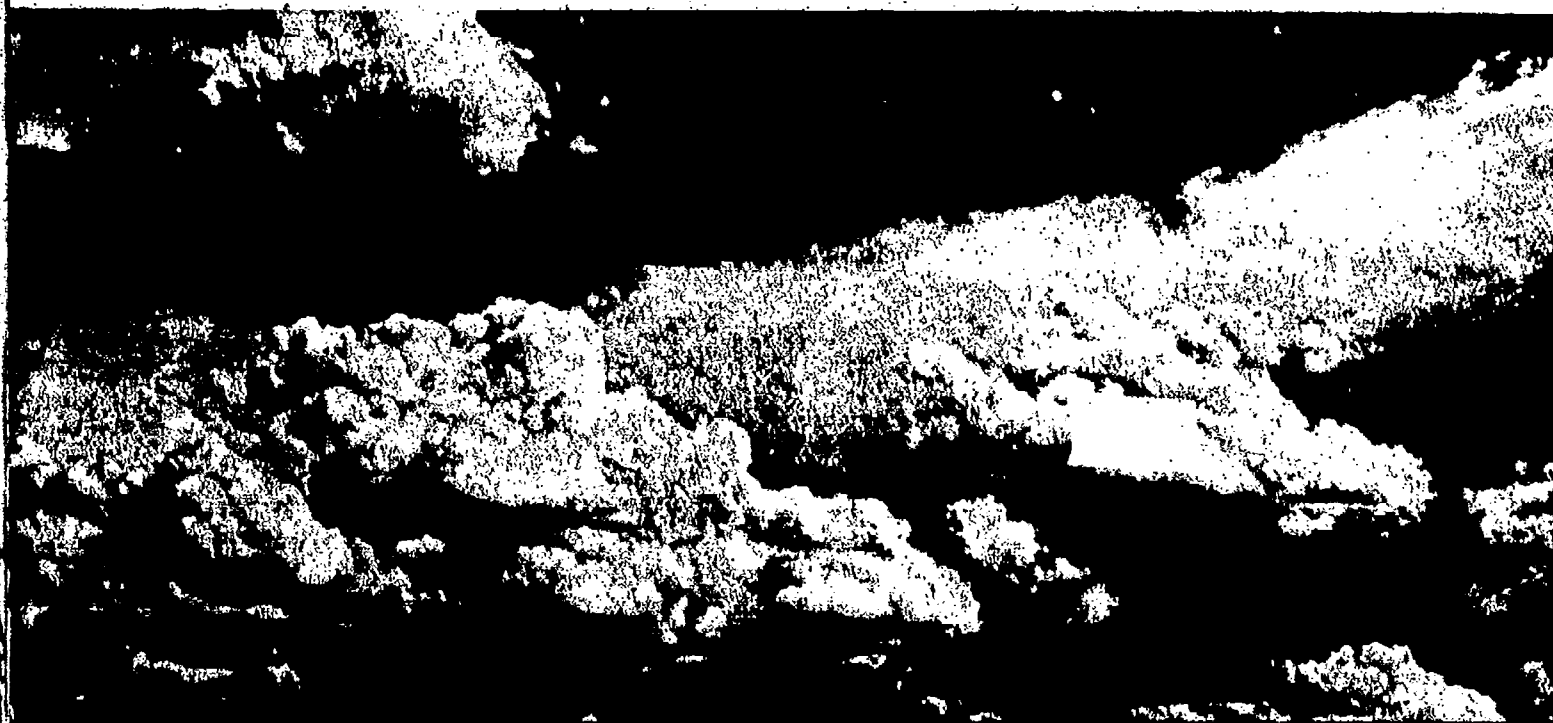

A. A high sheet (2,400-6,100 meters) that makes the sun appear as if you were seeing it through tissue paper.

Figure 11

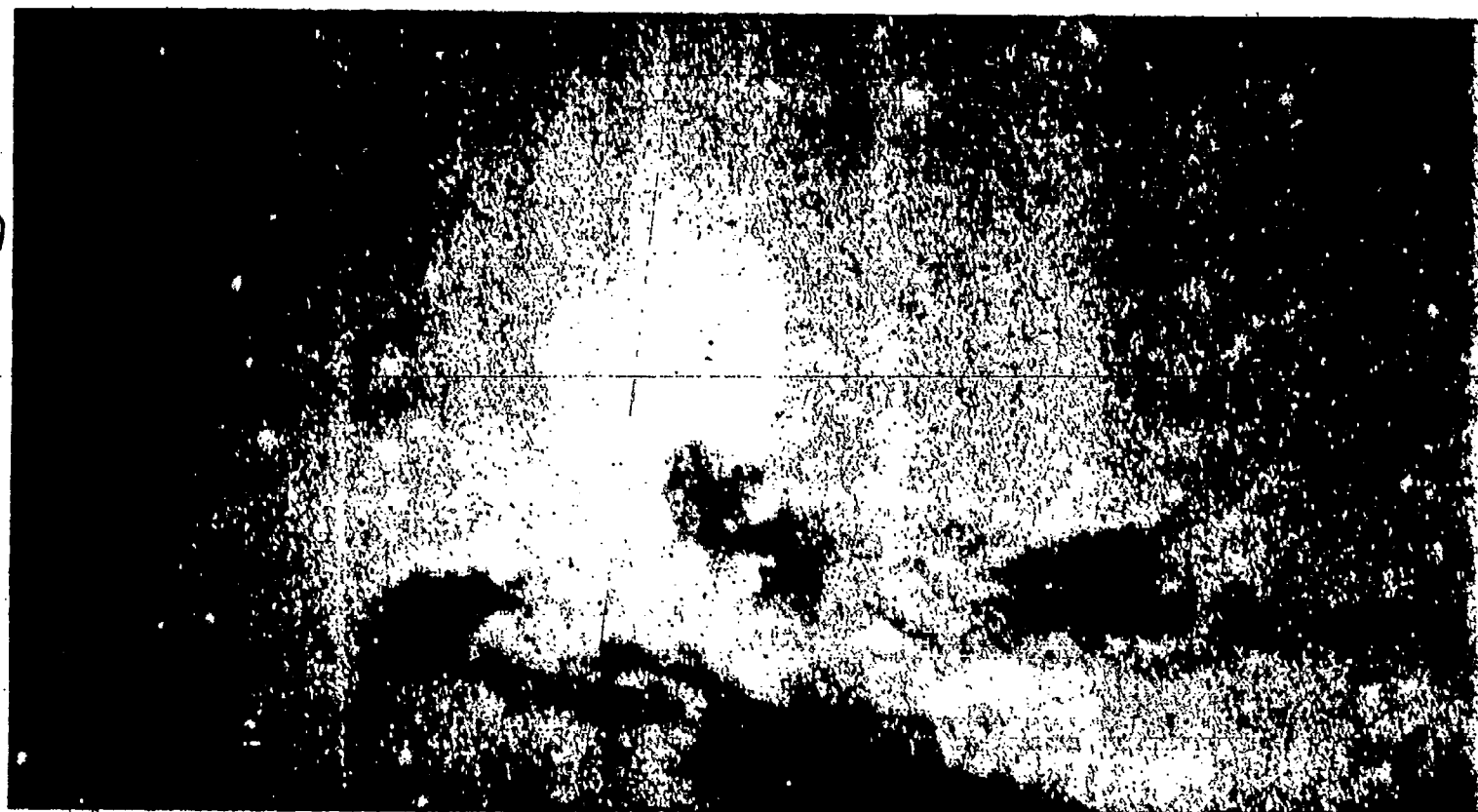

B: A low cloud (below 2,440 meters) that looks like a layer of rolls or twists.

Figure 12





Figure 13 C. "Thunder sky, Not too long dry."

Figure 14 D. The cloud that gives the all-day drizzle.



E. What cloud type is called a fog when it is right down on the ground?

F. "Feathery sky."

Figure 15



G. These are called sheep clouds. They are woolly packs, 2,440 to 6,100 meters high.

Figure 16





Figure 17 H. "In the morning, mountains, In the evening, fountains."
 Figure 18 I. "Curdled sky, Not 24 hours dry."



Check the answers below to the ten cloud types. Then, as you go through the rest of the unit, see if you can determine why the weather adages give a clue to the coming weather in terms of the model that you develop.

116 EXCURSION 2-2

- | | | |
|-----------------|------------------|-----------------|
| A. Altostratus | B. Stratocumulus | C. Cumulonimbus |
| D. Nimbostratus | E. Stratus | F. Cirrus |
| G. Altocumulus | H. Cumulus | I. Cirrocumulus |

EQUIPMENT LIST

None

PURPOSE: To assist students in converting from the English to the metric system for temperature, speed, and precipitation.

The Conversion Excursion

Excursion 2-3

This excursion is both remedial and general interest.

MAJOR POINTS

1. Temperatures on weather reports and from the weather instrument are given in Fahrenheit degrees and need to be converted to Celsius degrees.
2. Wind speed can be converted from the English system in miles per hour to the metric system in kilometers per hour.
3. Precipitation in inches can be converted to centimeters.

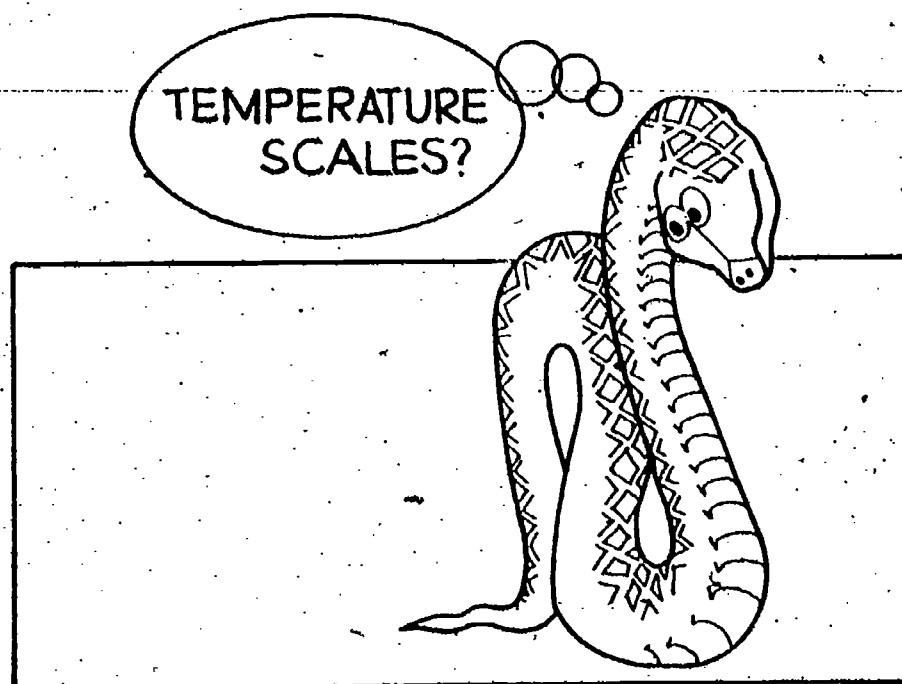

Temperature

So far in the ISCS course, you have measured temperature in Celsius units. On the Celsius scale, the freezing point of water is 0°C , and the boiling point of water is 100°C . The temperature on a warm spring day might be something like 24°C . However, when temperatures are given in a newspaper, radio, or TV weather report, these temperatures are usually given in Fahrenheit degrees. When recording your own weather information in this unit, you may also use Fahrenheit degrees. How are the Fahrenheit and Celsius temperature scales related?

In actual practice, this excursion will be used more to go from the Celsius readings given on the weather maps in Chapter 6 and 7 than the other way around. We just aren't yet used to the metric system.

117

Figure 1 shows how the same thermometer would look if marked in degrees Celsius (a) and in degrees Fahrenheit (b).

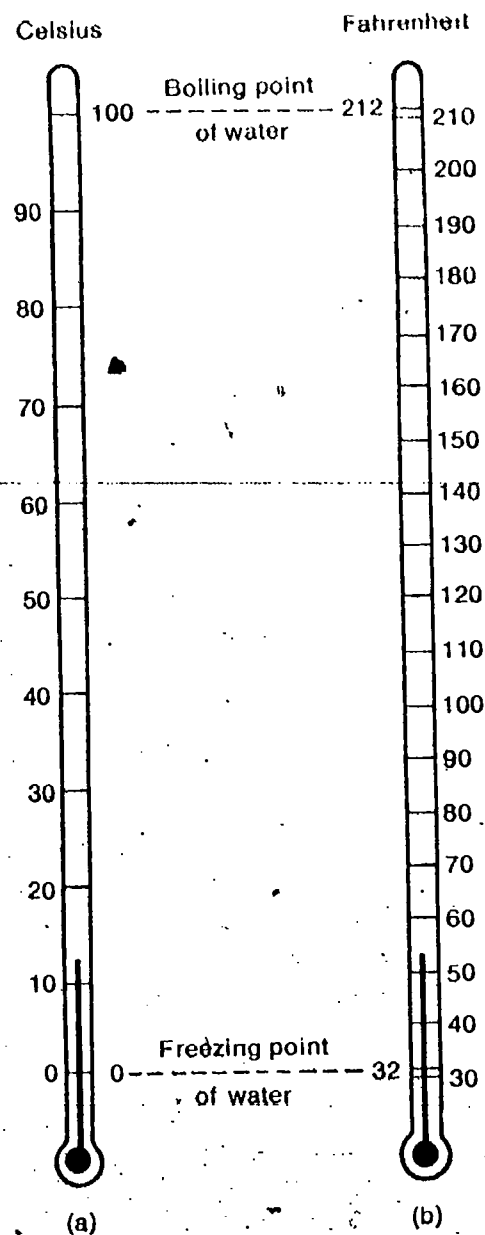

Figure 1

No attempt is made to use the mathematical formulas for conversion of temperatures. The table does the job. But for your information:

$$^{\circ}\text{C} = (^{\circ}\text{F} - 32^{\circ}) \times \frac{5}{9}$$

$$^{\circ}\text{F} = ^{\circ}\text{C} \times \frac{9}{5} + 32^{\circ}$$

A quick question for students: At what temperature reading are $^{\circ}\text{F}$ and $^{\circ}\text{C}$ numerically the same? Answer: -40°C and F

1. How many degrees separate the freezing point and the boiling point of water on the Celsius temperature scale?
2. How many degrees separate the freezing point and the boiling point of water on the Fahrenheit temperature scale?
3. Which is the higher temperature, 50°C or 50°F ?
4. Which is the bigger temperature *change*, 10 degrees on the Celsius scale or 10 degrees on the Fahrenheit scale?

Table 1 can be used when you need to make a quick conversion from one scale to the other. You may want to round off the Fahrenheit temperatures.

Table 1

49	120.2	31	87.8	13	55.4	-5	23.0	-23	-9.4	-41	-41.8
48	118.4	30	86.0	12	53.6	-6	21.2	-24	-11.2	-42	-43.6
47	116.6	29	84.2	11	51.3	-7	19.4	-25	-13.0	-43	-45.4
46	114.8	28	82.4	10	50.0	-8	17.6	-26	-14.8	-44	-47.2
45	113.0	27	80.6	9	48.2	-9	15.8	-27	-16.6	-45	-49.0
44	111.2	26	78.8	8	46.4	-10	14.0	-28	-18.4	-46	-50.8
43	109.4	25	77.0	7	44.6	-11	12.2	-29	-20.2	-47	-52.6
42	107.6	24	75.2	6	42.8	-12	10.4	-30	-22.0	-48	-54.4
41	105.8	23	73.4	5	41.0	-13	8.6	-31	-23.8	-49	-56.2
40	104.0	22	71.6	4	39.2	-14	6.8	-32	-25.6	-50	-58.0
39	102.2	21	69.8	3	37.4	-15	5.0	-33	-27.4	-51	-59.8
38	100.4	20	68.0	2	35.6	-16	3.2	-34	-29.2	-52	-61.6
37	98.6	19	66.2	1	33.8	-17	1.4	-35	-31.0	-53	-63.4
36	96.8	18	64.4	0	32.0	-18	-0.4	-36	-32.8	-54	-65.2
35	95.0	17	62.6	-1	30.2	-19	-2.2	-37	-34.6	-55	-67.0
34	93.2	16	60.8	-2	28.4	-20	-4.0	-38	-36.4	-56	-68.8
33	91.4	15	59.0	-3	26.6	-21	-5.8	-39	-38.2	-57	-70.6
32	89.6	14	57.2	-4	24.8	-22	-7.6	-40	-40.0	-58	-72.4

Speed

The wind speed indicator on the weather-station instrument is calibrated in the English system (miles per hour). You may want to convert English miles to the metric system (kilometers per hour.)

Conversely, the number of km multiplied by 0.6 mi/km will give the answer in miles (approx.).

In a mile, there are about 1,600 meters, or 1.6 kilometers (abbreviated km). Thus, if the number of miles is multiplied by 1.6, the answer will be in kilometers.

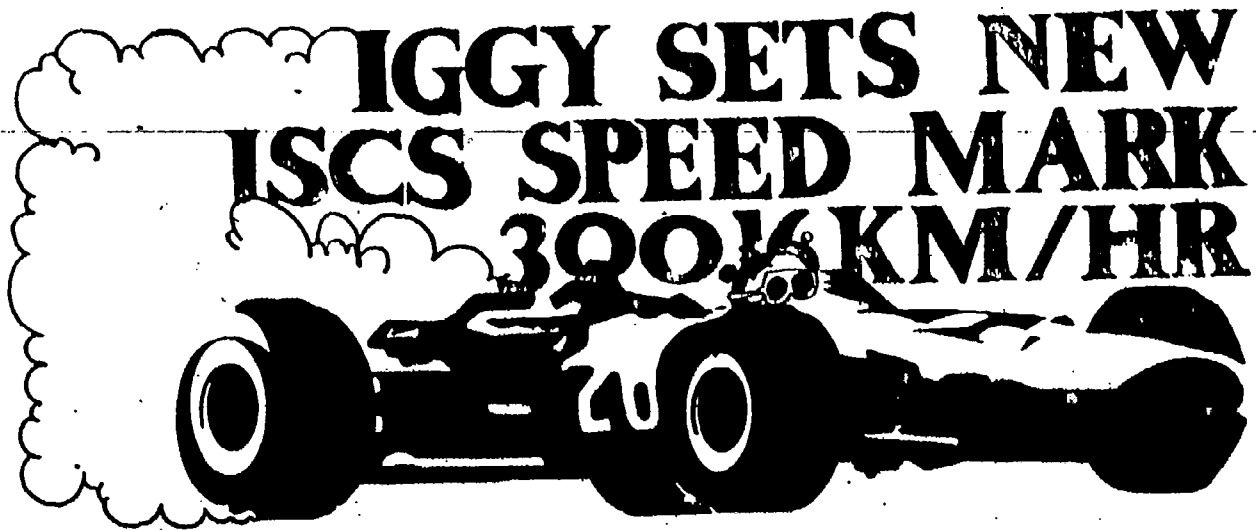

5. What is the wind speed in km/hr if it is blowing at a rate of 10 mph? 20 mph? 25 mph?

6. Wind is considered to be of hurricane force if its speed is 75 mph or above. How fast in km/hr would this be?

7. A breeze of 64 km/hr has what speed in mph?

Precipitation

The precipitation gauge on the weather-station instrument is calibrated in inches. Precipitation figures given in the news media (newspapers, radio, TV) are also usually in inches. It is an easy task to convert inches to centimeters.

There are 2.54 centimeters in each inch. Therefore, if the number of inches is multiplied by 2.54, the answer will be in centimeters.

8. Suppose the rain gauge shows that 2.5 inches fell last night. How many centimeters of rain fell?

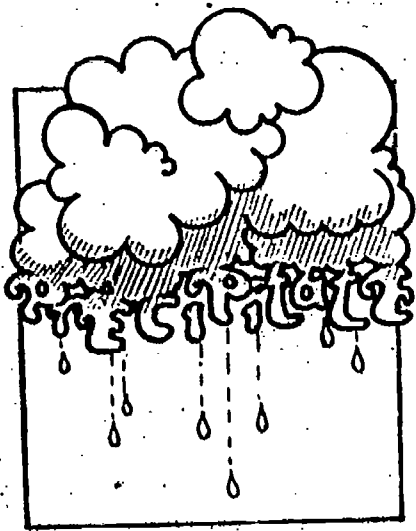

EQUIPMENT LIST

None

PURPOSE: To operationally define pressure as force per unit area.

The Pressure's On

Excursion 3-1

This excursion is for remedial and general-interest usage.

MAJOR POINTS

1. When force (weight) is spread over a greater area, it is less concentrated.
2. Pressure is a measure of how concentrated a force is, and is stated in units of force divided by unit of area.
3. Air has weight and exerts pressure.

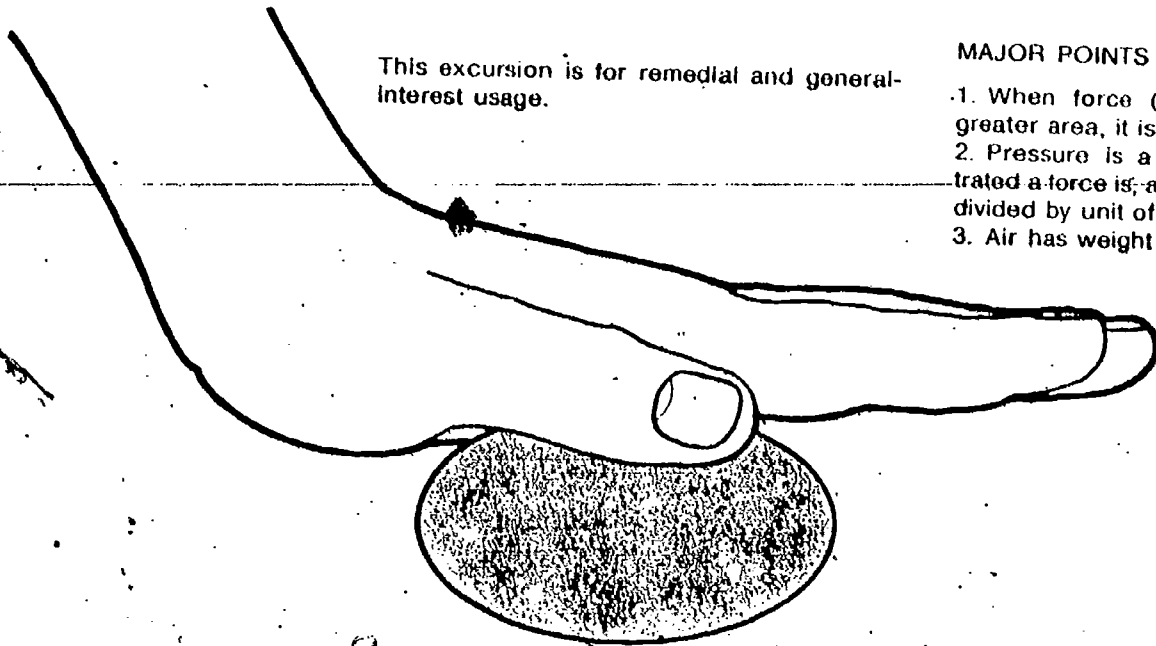

The term *pressure* will be used many times in this unit. Do you understand what it means? Test yourself with the following checkup. When you have finished, check your answers at the end of this excursion. If you get both answers 100% correct and are satisfied that you fully understand pressure, skip the rest of this excursion.

If you are less successful or have any doubts, stay with it.

Note the use of a checkup in the excursion as a means of finding out if the student needs help on pressure.

CHECKUP

1. In your Record Book place a check by any of the following that could be a measure of pressure.
 - a. 7 pounds (—)
 - b. 9 newtons (—)
 - c. 6 pounds per square inch (—)
 - d. 4 square inches (—)
 - e. 8 newtons per square meter (—)
2. A 500-pound metal bar is lying on a bench. The area of the bottom of the bar is 50 square inches. What is the pressure of the bar on the bench? (—)

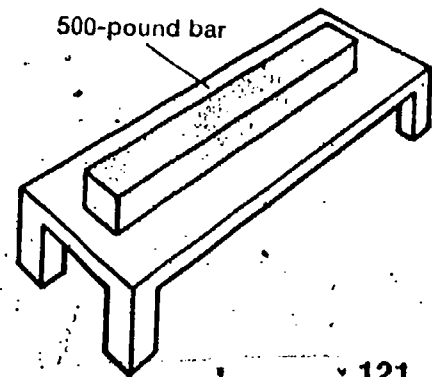

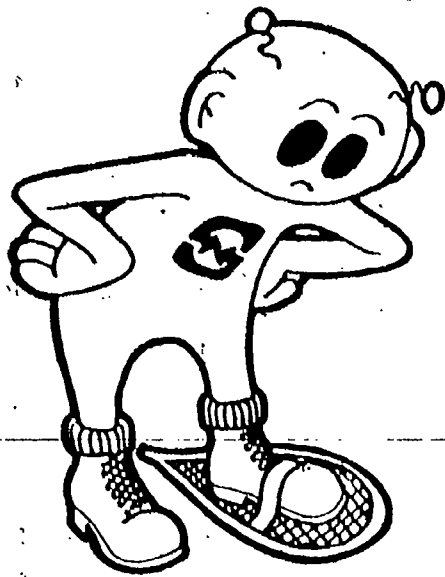

A 200-pound man walks across soft snow. He sinks into the snow up to his knees. After putting on a pair of snowshoes, he leaves only a shallow footprint as he walks across the same snowfield. Certainly the man doesn't weigh any less after he puts on snowshoes. (In fact, the weight of the snowshoes would increase his total weight.)

□ 1. Why don't the man and his snowshoes sink as deeply into the snow?

In answering question 1, you probably used the idea that snowshoes spread the man's weight over a bigger area. This idea is the key to understanding pressure. Whether the man is wearing snowshoes or not, his feet push on the snow with a force of 200 pounds (his weight). When he wears snowshoes, this force is spread out over a bigger area. The term *pressure* is used to describe how concentrated a force is (how much force there is on each unit of area). One of the common ways that pressure is measured is in pounds per square inch. Suppose the man takes a walk with one shoe and one snowshoe. To make the calculations simple, let's suppose the total area of the man's shoe is 50 square inches, while the total area of a snowshoe is 400 square inches.

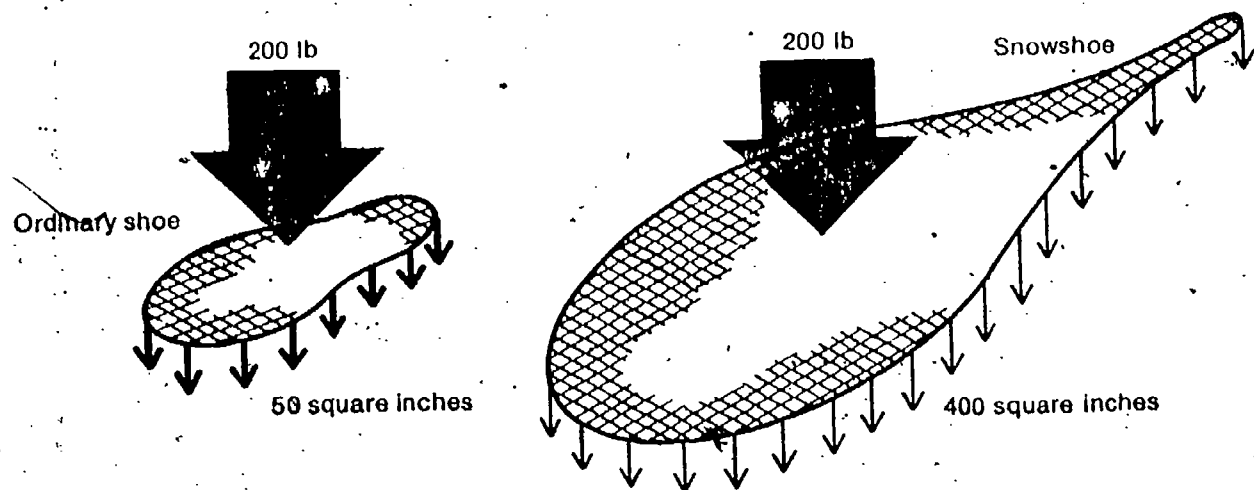

Thus, the force exerted by each square inch of the shoe is

$$200 \text{ lb} / 50 \text{ sq in.} = 4 \text{ lb/sq in.}$$

This force per square inch is the pressure exerted by the man on the snow under his foot. All the man's 200 pounds is spread over 50 square inches of snow.

The force exerted on the snow under the snowshoe can be calculated in the same way. Each snowshoe has an area of 400 square inches. It is pushed into the snow with a force of 200 pounds if the man is putting all his weight on one foot.

□2. Calculate the force exerted on each square inch of the snowshoe.

We can use this idea of pressure to explain why the man does not sink into the snow when wearing snowshoes:

When wearing shoes, the pressure of the shoe on the snow is four pounds per square inch. When wearing snowshoes, the pressure of the snowshoe on the snow is less, only 0.5 pound per square inch.

Pressure, then, measures the concentration of a force. It can be operationally defined by this formula:

$$\text{Pressure (lb/sq in)} = \frac{\text{Force (lb)}}{\text{Area (sq in.)}}$$

or

$$\text{Pressure (newtons/sq m)} = \frac{\text{Force (newtons)}}{\text{Area (sq m)}}$$

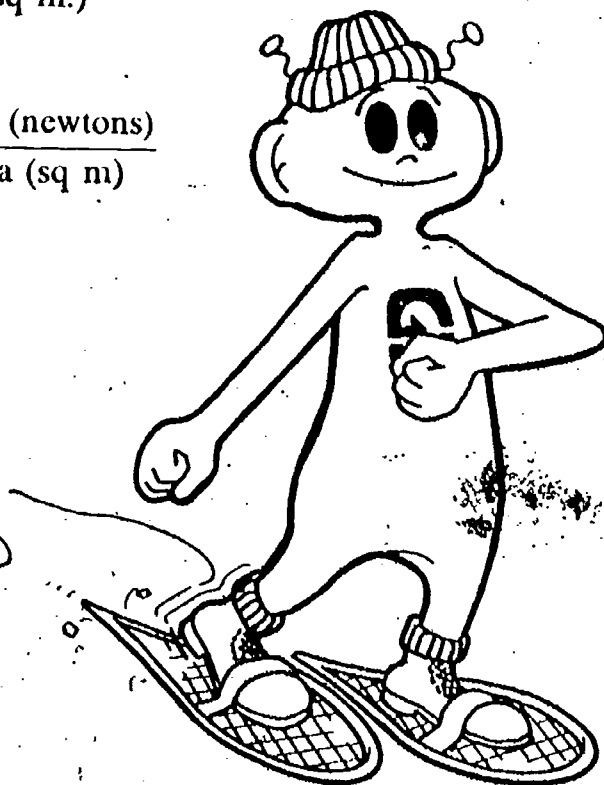
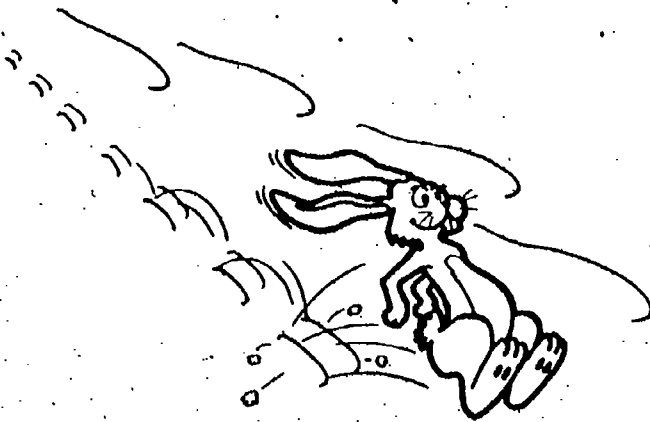

Of course, what isn't mentioned here but is nevertheless true is that air pressure is exerted in all directions. Unlike the shoes or the snowshoes, which exerted only a downward pressure on the snow, air pressure is also exerted sideways and upward on the building, and from the inside out as well as from the outside in. Thus, even though there is an air pressure on the house of about 14 pounds per square inch from the outside (downward, inward); there is an equal pressure of about 14 pounds per square inch from the inside (upward, outward). Therefore, unless the house is sealed tight and leakproof, and all the air pumped out of it, there is no danger of collapse from these tremendous forces and pressures. The forces and pressures are balanced, inside and outside, against each other.

But what about air pressure? Like the man, air has weight. In fact, the air above your house or apartment (assume the roof of the house to have an area of 1,500 square feet) is about 1,550 tons (3,100,000 lb)! Air is not light! But what about the pressure? Since the 1,550 tons exerted by this great weight is spread over the total area of your house, you can determine the air pressure on it.

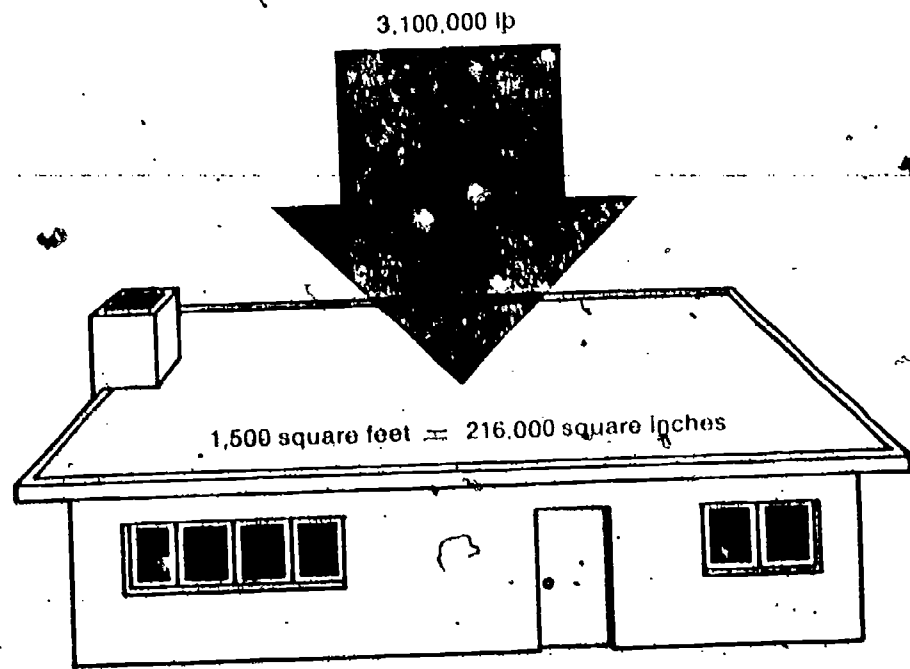

If we apply the operational definition that pressure = $\frac{\text{force (lb)}}{\text{area (sq in)}}$, then the air pressure on the house would be

$$\begin{aligned} \text{air pressure} &= \frac{3,100,000 \text{ lb}}{216,000 \text{ sq in.}} \\ &= \text{about } 14 \text{ lb/sq in.} \end{aligned}$$

Every square inch of roof has 14 lb of air weight on it. For answers to the checkup, invert the page.

Answer to Checkup on page 121
1. (c) and (e); 2. 10 lb/sq in



EQUIPMENT LIST

Aneroid barometer

Measuring Air Pressure . . . in Inches?

This is a general-interest excursion.

PURPOSE. To present a historical treatment of Torricelli's mercury barometer, and apply it to the aneroid barometer.

Excursion 3-2

MAJOR POINTS

1. The mercury barometer was invented by an Italian scientist named Torricelli.
2. An aneroid barometer uses a collapsible box instead of a column of mercury.
3. Pressure can be measured in millibars.
4. When the pressure is given in inches of mercury, it is telling how tall a column of mercury the pressure of the air could support.

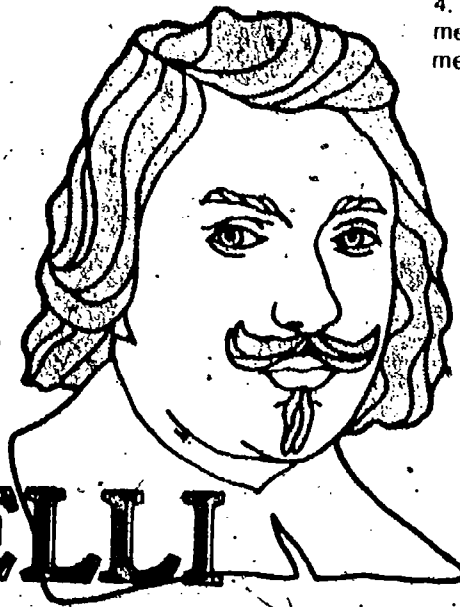

TORRICELLI

What does it mean to say that the atmospheric pressure is 30 inches of mercury? What has the length of mercury got to do with pressure?

The first person to use the length of a column of mercury to measure air pressure was Evangelista Torricelli, an Italian who died at age 39 in 1647. Rather than describe Torricelli's experiments to you, we will give you the chance to read some of his own words. The letter that appears on the following pages is part of a longer letter written by Torricelli in 1644. We found this old document of great interest and hope you may, too. A few marginal notes have been added to help you understand it.

THE BAROMETER*
(To Michelangelo Ricci in Rome)

Florence, June 11, 1644

MOST ILLUSTRIOUS SIR AND
MOST LEARNED PATRON

Torricelli tells Ricci that he has constructed an instrument to measure changes in air pressure:

Air pressure is due to the weight of a column of air 60 miles high. The air is most dense near the earth's surface and much less dense at higher altitudes.

I have already called attention to the fact that there are in progress certain philosophical experiments, relating to vacuum, designed not simply to make a vacuum but to make an instrument which will show the changes in the atmosphere, as it is now heavier and more gross and now lighter and more subtle.

We live immersed at the bottom of a sea of elemental air, which by experiment undoubtedly has weight, and so much weight that the densest air in the neighborhood of the surface of the earth weighs about one four-hundredth part of the weight of water. Certain authors have observed after twilight that the vaporous and visible air rises above us to a height of fifty or fifty-four miles. But I do not think it is so much because I can show that the vacuum ought to offer a much greater resistance than it does, unless we use the argument that the weight which Galileo assigned applies to the lowest atmosphere, where men and animals live, but that on the peaks of high mountains the air begins to be more pure and to weigh much less than the four-hundredth part of the weight of water.

We have made many vessels of glass like those shown as A and B (Fig. 1) and with tubes two cubits long. These were filled with quicksilver, the open end was closed with the finger, and they were then inverted in a vessel where there was quicksilver C; then we saw that an empty space was formed and that nothing happened in the vessel where this space was formed. The tube between A and D remained always full to the height of a cubit and a quarter and an inch over.



A glass tube about three feet long was filled with mercury (quicksilver) and inverted in a bowl of mercury.

The level of mercury in the tube fell until it was about 30 inches above the level of the mercury in the bowl. The space above the mercury column was essentially a vacuum.

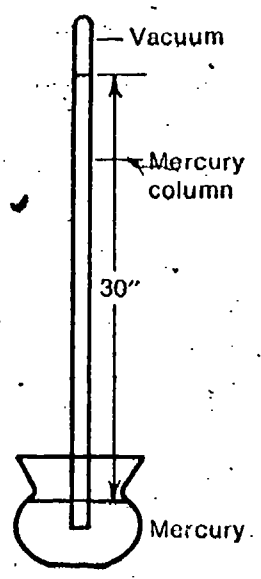

The column of mercury is supported by air pressure.

Air pressure will support a column of water about 34 feet high.

Torricelli did not choose to use the instrument to measure air pressure because he considered the height of the column to depend also upon temperature. This effect is actually very small and is usually ignored.

I asserted that the force which prevents the quicksilver falling down is external and that the force comes from without. On the surface of the liquid which is in the bowl there rests the weight of a height of fifty miles of air; then what wonder is it if into the vessel CE, in which the quicksilver has no inclination and no repugnance, not even the slightest, to being there, it should enter and should rise in a column high enough to make equilibrium with the weight of the external air which forces it up? Water also in a similar tube, though a much longer one, will rise to about 18 cubits, that is, as much more than quicksilver does as quicksilver is heavier than water, so as to be in equilibrium with the same cause which acts on the one and the other.

I have endeavored to explain by this principle all sorts of repugnances which are felt in the various effects attributed to vacuum, and I have not yet found any with which I cannot deal successfully. I know that your highness will perceive many objections, but I hope if you think them over they will be resolved. My principal intention I was not able to carry out, that is, to recognize when the atmosphere is grosser and heavier and when it is more subtle and lighter, because the level AB in the instrument EC changes for some other reason (which I would not have believed) especially as it is sensible to cold or heat, exactly as if the vessel AE were full of air.

Your devoted and obligated Servant,
E. TORRICELLI.

Instead of using a mercury barometer to measure air pressure, you will be using an *aneroid* barometer. It is called aneroid, meaning "without fluid," because it uses, instead of fluid, a small disk-shaped box from which most of the air has been removed. The disk can be seen in most aneroid barometers by looking through the hole in the dial. The disk will look something like the one drawn in Figure 1.

If you have, or can procure, a mercury barometer for comparison, it will help with the whole air pressure concept.

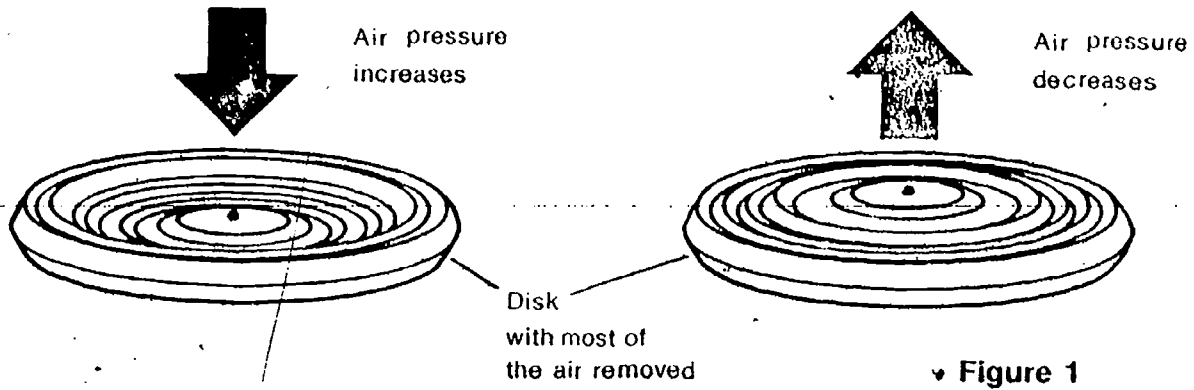

As the air pressure on the disk changes, the top and bottom are squeezed together or expand, causing levers and springs to move the pointer.

Actually, the commercial barometer is not too dissimilar from the student-constructed one in principle of operation.

You will notice that there are two circular scales on the barometer face (Figure 2).

Figure 2

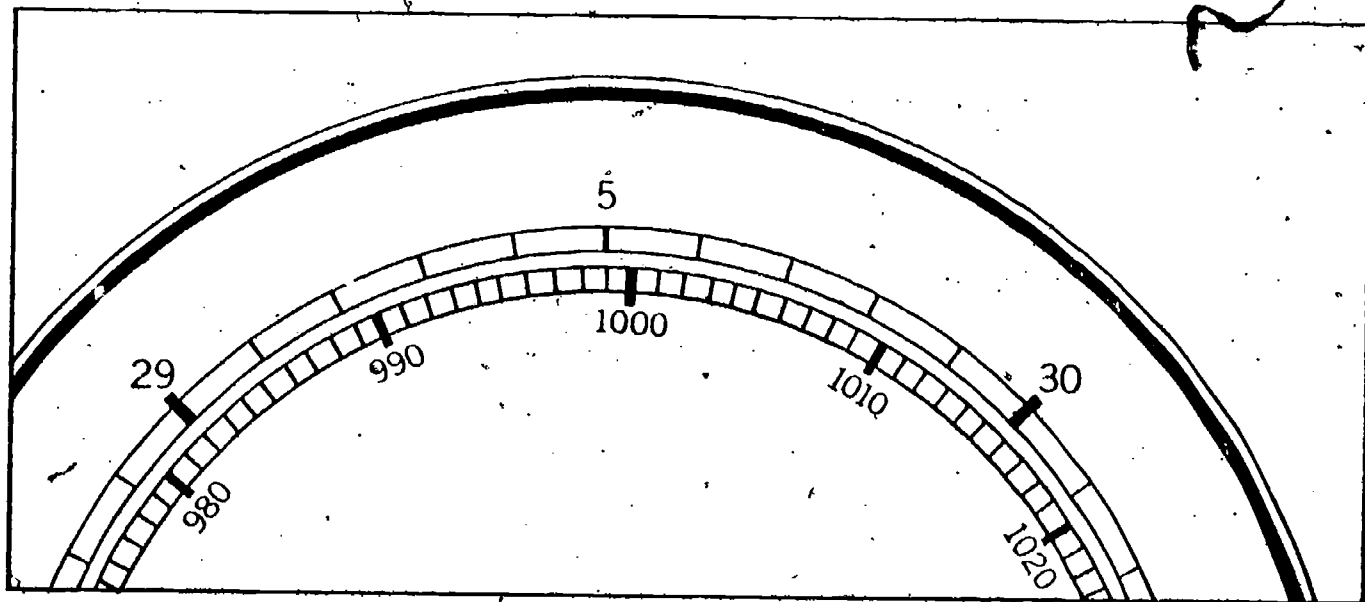

Barometric pressures on standard weather maps are given in millibars. Fundamentally, the reason that millibars are used instead of inches of mercury is that the latter are not pressure units, while the former are. To be perfectly precise, a millibar is one thousandth of a bar. A bar is one million dynes per square centimeter. A dyne is a metric unit of force approximately equal to the weight of a milli-

EXCURSION ►

gram, and is equal to one one-hundred-thousandth (0.00001) of a newton. So a millibar is 1,000 dynes per square cm, or 100 newtons per square meter.

The top scale tells you the height in inches to which a column of mercury can be supported by the pressure of the air. Remember that Torricelli found this to be about 30 inches.

The bottom scale records the air pressure in millibars (mb). A millibar is a measure of pressure. Remember that pressure can be expressed as the amount of force per area (see **Excursion 3-1**, "The Pressure's On"). One millibar of pressure is the same as 0.0145 pound per square inch. The air pressure needed to support a column of mercury 30 inches high is 1,016 millibars.

1. What air pressure in pounds per square inch is required to support this mercury column of 30 inches?
2. How many pounds per square inch of pressure are required to support a 29-inch mercury column?

For your weather watch, you should record the barometric pressure in inches; thus, you can ignore the millibar scale.

Now let's find out how to operate the aneroid barometer. Notice that halfway between 29 and 30 on the barometer scale is the numeral 5. If the black needle were directly on that line, the reading would be 29.50 inches (Figure 3). If it were on the dark line just to the right of the 5, the reading would be 29.60 inches.

Figure 3

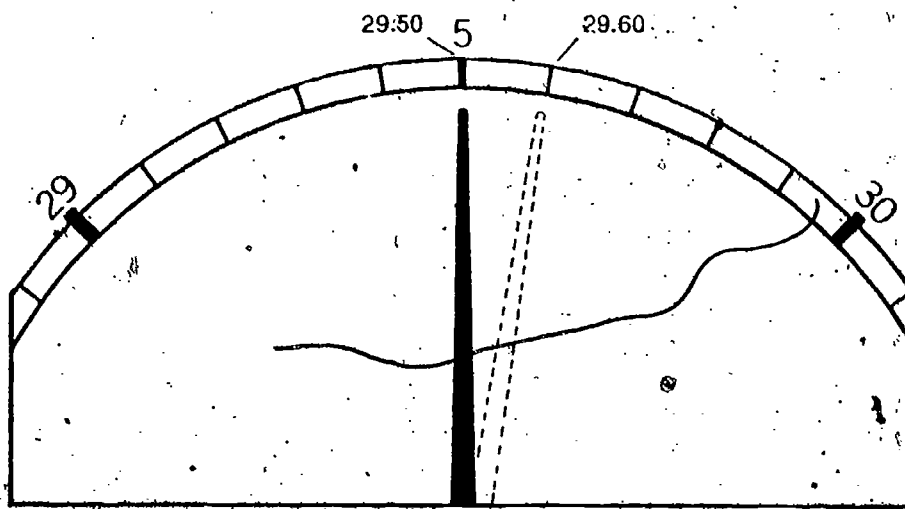

3. Go to where the aneroid barometer is located in your room (or in the weather station) and record the air pressure in inches.

Before continuing, check your reading with your teacher.

You will notice that there is a silver needle on the barometer. This needle can be used as a marker to help you keep track of how air pressure changes from one reading to the next. By setting the silver needle directly over the black needle, you can see how much, if any, the black needle has moved when a later reading is made. You can move the silver needle by turning the knob on the face of the barometer. This will be very useful because you can immediately tell if there was a rise or fall in the pressure since the last reading.

4. Figure 4 shows the position of the black needle about twelve hours after its position was marked with the silver needle. How much has the barometer reading changed in the twelve hours?

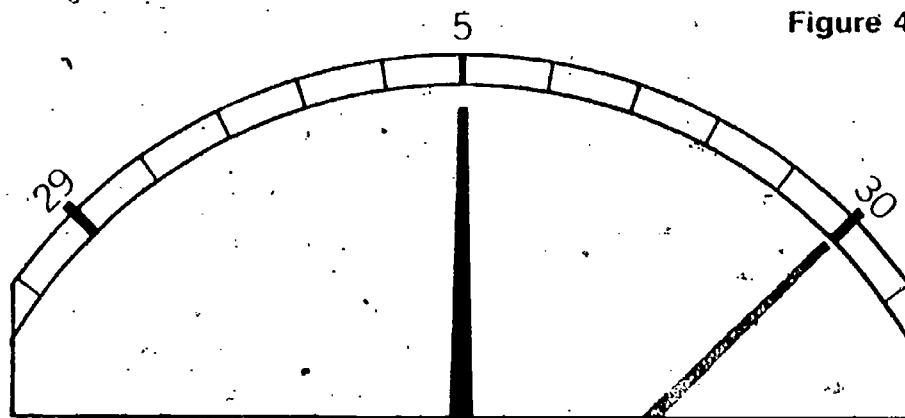

Figure 4

5. Does the change in pressure represent a rise, or a fall, in air pressure?

Here is a good technique to use when reading an aneroid barometer. Gently tap the glass of the barometer before taking the reading. This will force the needle bearing if it is sticking slightly—a common occurrence in many aneroid barometers. Try it and see.

If you are not sure of your ability to “read” the aneroid barometer, test yourself with the three problems in the following checkup. You can check your answers at the end of the checkup.

Note the instruction for the student to check the reading with you.

CHECKUP

1. Move the silver needle on the aneroid barometer (by turning the knob) so that it points to 29.20.
2. Move the silver needle so that it points to 29.85.
3. What is the barometric pressure, in inches, shown in Figure 5?

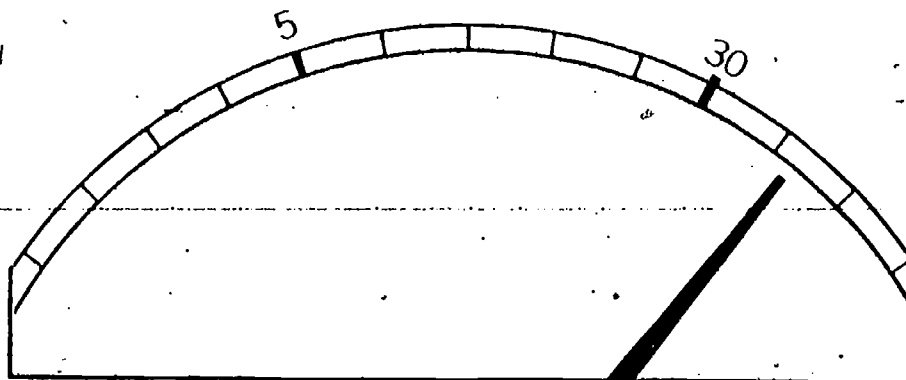
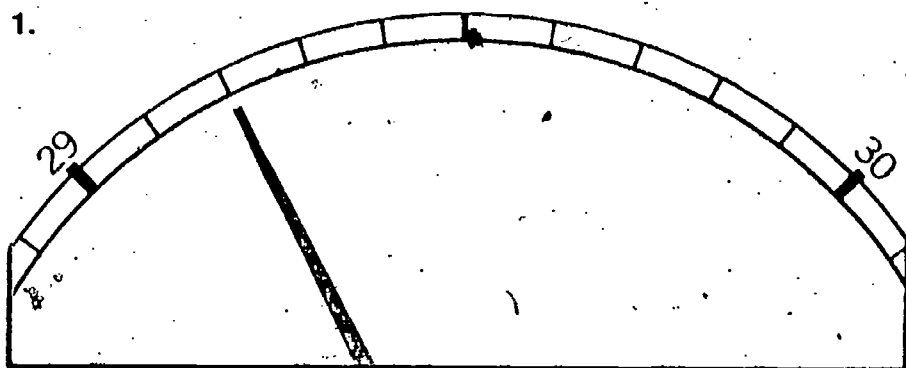

Figure 5

Answers to checkup

1.



2.

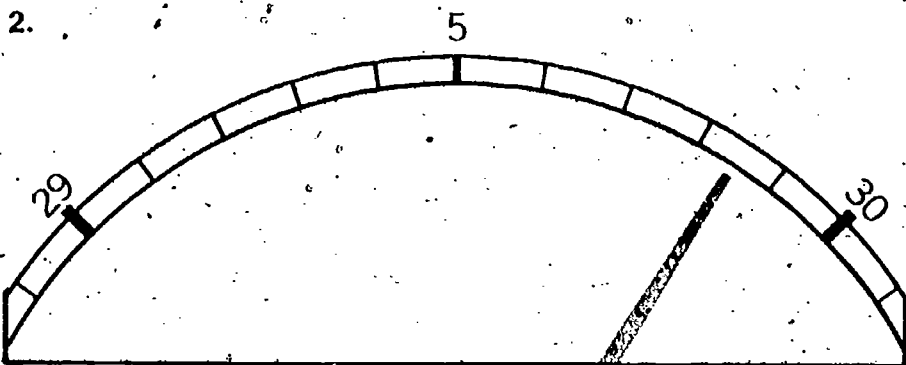

Note that you are being called on for aid. You will have to use your judgment on what remediation should be recommended. Possibly going back through the excursion would suffice.

3. 30.12, or 30.13, or 30.14

If you missed any of these, and don't understand why the answers given are correct, talk it over with your teacher.

EQUIPMENT LIST

- 1 thermometer
- 1 4-cm piece of wick
- 1 baby-food jar
- Alcohol (burner fuel)

The Shivering Thermometer

This is a general-interest excursion.

Try to remember your last vaccination. Was alcohol used to clean your arm? If so, you probably noticed that the cleansed spot on your arm felt cold. Why?

ACTIVITY 1. Lick the back of your hand. Wait a few seconds; then blow across the wet spot.

Wet spot

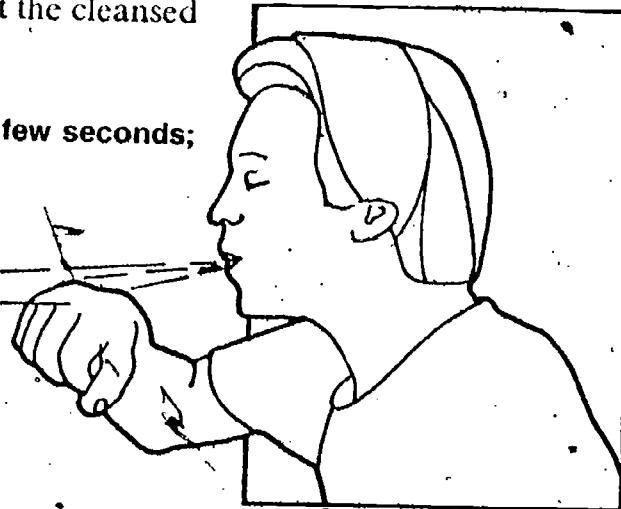

1. Describe how the wet spot felt before you blew across it, and then while you blew across it.

Let's find out more about this cooling. You will need the following materials:

- 1 thermometer
- 1 4-cm piece of wick
- Baby-food jar half-filled with alcohol

PURPOSE: To assist the student in applying the particle model of matter to evaporation and condensation.

Excursion 4-1

MAJOR POINTS

1. Evaporation of a liquid causes cooling of the surface it was on.
2. The faster a liquid evaporates, the greater the cooling of the surface.
3. The particle model is applied to explain the phenomenon of evaporative cooling.
 - A) It predicts that energy is absorbed by a liquid when it changes to a gas.
 - B) It also predicts that a flow of air over a liquid causes more rapid evaporation.
 - C) The particle model predicts that as a gas cools, its particles lose energy, move more slowly, and are attracted together (condense) to a liquid.
4. The model suggests that when air is saturated, as many water particles return to liquid as would leave the liquid.

ACTIVITY 2. Place a dry wick over the end of a thermometer. In doing this, your fingers will probably touch the bulb and cause the temperature to rise. When the temperature returns to normal, record it as Temperature A in Table 1. This is the temperature of the air.

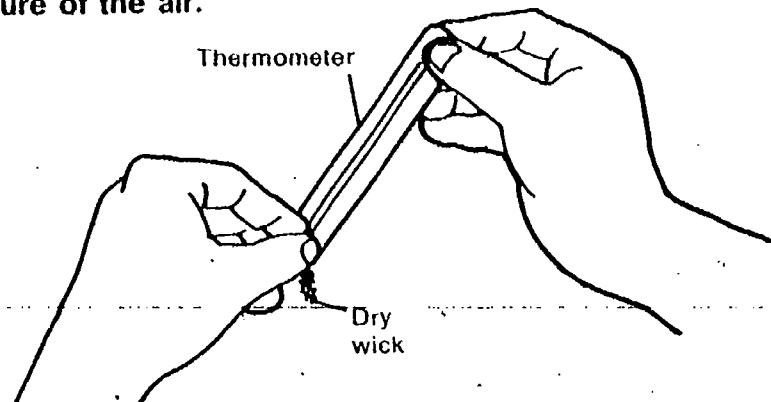

ACTIVITY 3. Place the thermometer in the jar of alcohol. Record the temperature of the alcohol as Temperature B in Table 1.

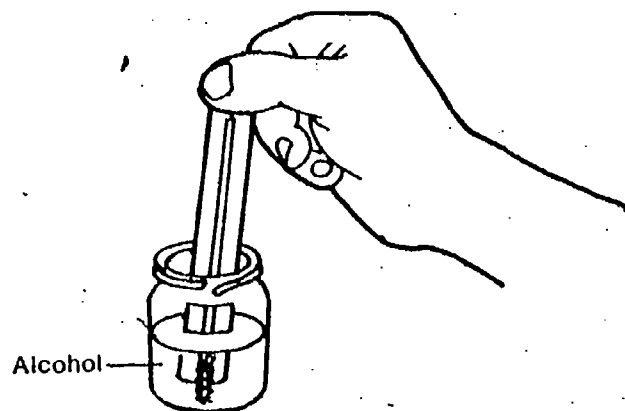

ACTIVITY 4. Remove the thermometer from the alcohol and wave it around for about 15 seconds. Record the temperature as Temperature C in Table 1.

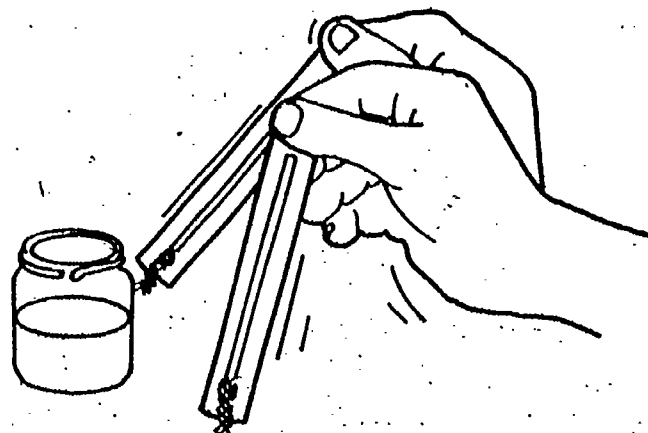

Table 1

	Temperature ($^{\circ}\text{C}$)
Temperature A	
Temperature B	
Temperature C	

2. What is the difference between Temperature A and Temperature B?

3. What is the difference between Temperature B and Temperature C?

4. How do you explain these differences in temperature?

You probably found that the air temperature (A) and the alcohol temperature (B) were very similar. However, Temperature C was much lower.

5. What happened to the alcohol as the temperature dropped?

Alcohol was used in this activity because it evaporates rapidly. This evaporation is related to the temperature drop that you observed. Blowing across the wet spot on your hand speeds up the evaporation of the liquid. You can compare the cooling effect of evaporation of the two liquids.

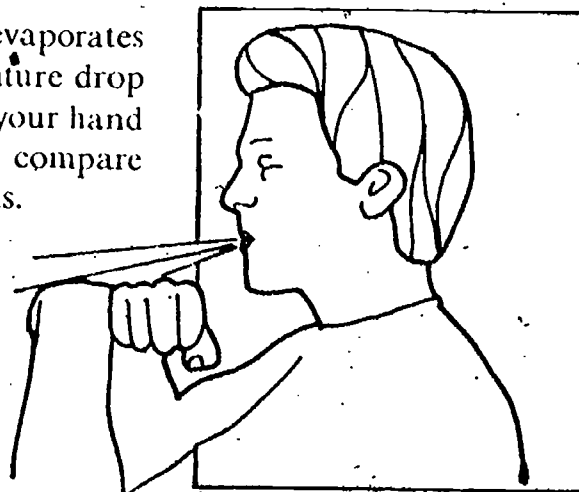

ACTIVITY 5. Put a small amount of alcohol on the back of one hand. Then lick the back of the other. Now blow across both hands at the same time. Continue blowing until one of the liquids disappears.

EXCURSION 4-1 135

Using a medicine dropper, students might put a single drop of water and a single drop of alcohol on a non-absorbing surface and find out which drop disappears first.

8. The energy required for evaporation comes (partly) from the skin.

6. Which hand felt cooler as you blew across it?

7. Which liquid evaporated the faster? (You may want to devise another way to compare the evaporation rate of the liquids.)

You may recall from Volumes 1 and 2 of ISCS that energy is absorbed by a liquid when it changes to a gas. This energy (usually heat) is absorbed from the surroundings.

8. Explain the fact that the backs of your hands felt cool while the liquids were evaporating.

9. Why did the alcohol make the hand feel cooler than the other liquid did?

Wet- and dry-bulb thermometers

Recall how you determined the relative humidity and dew point by using the sling psychrometer. You found that the temperature of the wet-bulb thermometer was lower than that of the dry-bulb thermometer. What you know about cooling and evaporation should help explain this difference. The energy needed to evaporate the water from the wick was taken from the wet-bulb thermometer. As a result, the thermometer cooled down.

But why did you have to twirl the sling psychrometer around? Why wasn't the difference between the dry- and wet-bulb thermometers always the same? Let's try an experiment to help find the answers to these two questions. You and a partner need these materials:

1 thermometer

1 wick

1 baby-food jar half-filled with alcohol.

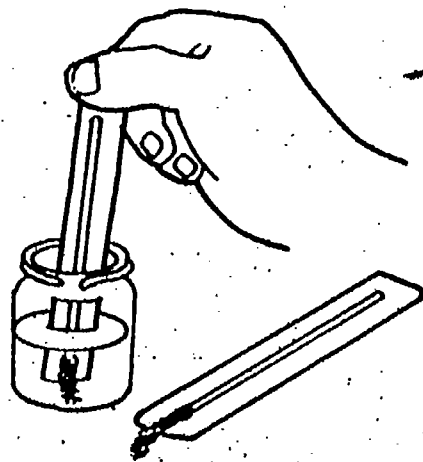

ACTIVITY 6. Place the wick over the end of the thermometer. Dip the thermometer into the alcohol and remove it. Place it on the table and read the temperature at 15-second intervals. Record the readings in row 1 of Table 2.

Table 2

Condition	Temperature ($^{\circ}\text{C}$)			
	After 15 sec.	After 30 sec.	After 45 sec.	After 60 sec.*
1. Thermometer (on table)				
2. Thermometer (waved around)				

ACTIVITY 7. Again place the thermometer and wick into the alcohol. Remove it, and wave it around steadily, stopping at 15-second intervals to read the temperature. Record the readings in Table 2.

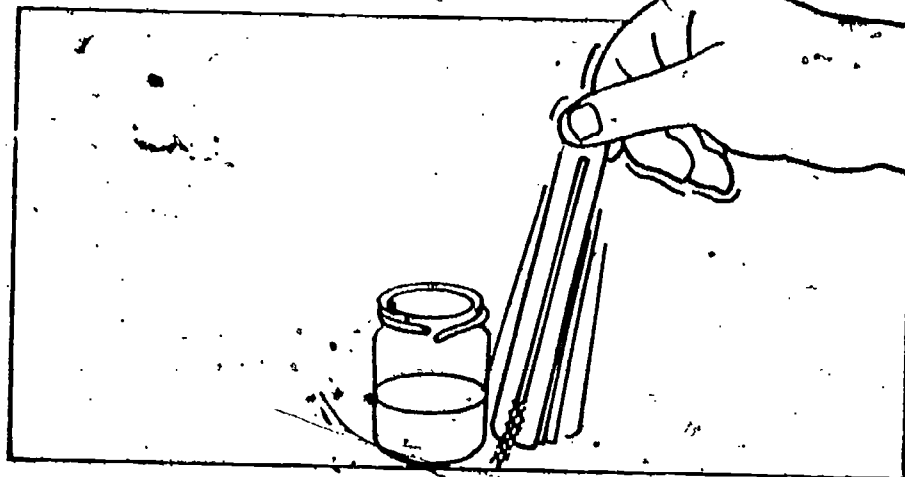

10. Using your particle model, explain why the moving thermometer cooled off more rapidly. (You may want to use the ISCS Volumes 1 and 2 particle model in your explanation.)

The particle model for matter says that this energy speeds up moving particles. The fast-moving particles may leave the liquid to become part of the gaseous air. However, collisions between gaseous water particles directly above the liquid may knock some particles back into the liquid again. It is also possible for particles to return to the liquid just because they are moving in that direction.

The evaporation of water into water vapor is somewhat akin to the dissolving of a substance in a solvent. When the solution is saturated, as many particles of the solute go into solution as come out of solution, and there is a balance.

When will the number of particles of evaporated liquid returning to the liquid be the greatest? It will be when the air above the liquid is saturated with particles from the liquid. Saturated means the air has all the evaporated liquid it can hold. A sponge is saturated with water when it is holding all the water it can.

Suppose, for example, the evaporating liquid is water. The greatest return of water particles to the liquid would occur when the air is saturated with water vapor; in other words, when the humidity is 100%. The number of particles leaving the liquid would be balanced by the number of evaporated liquid particles returning. This idea of particle balance is illustrated in Figure 1.

Figure 1

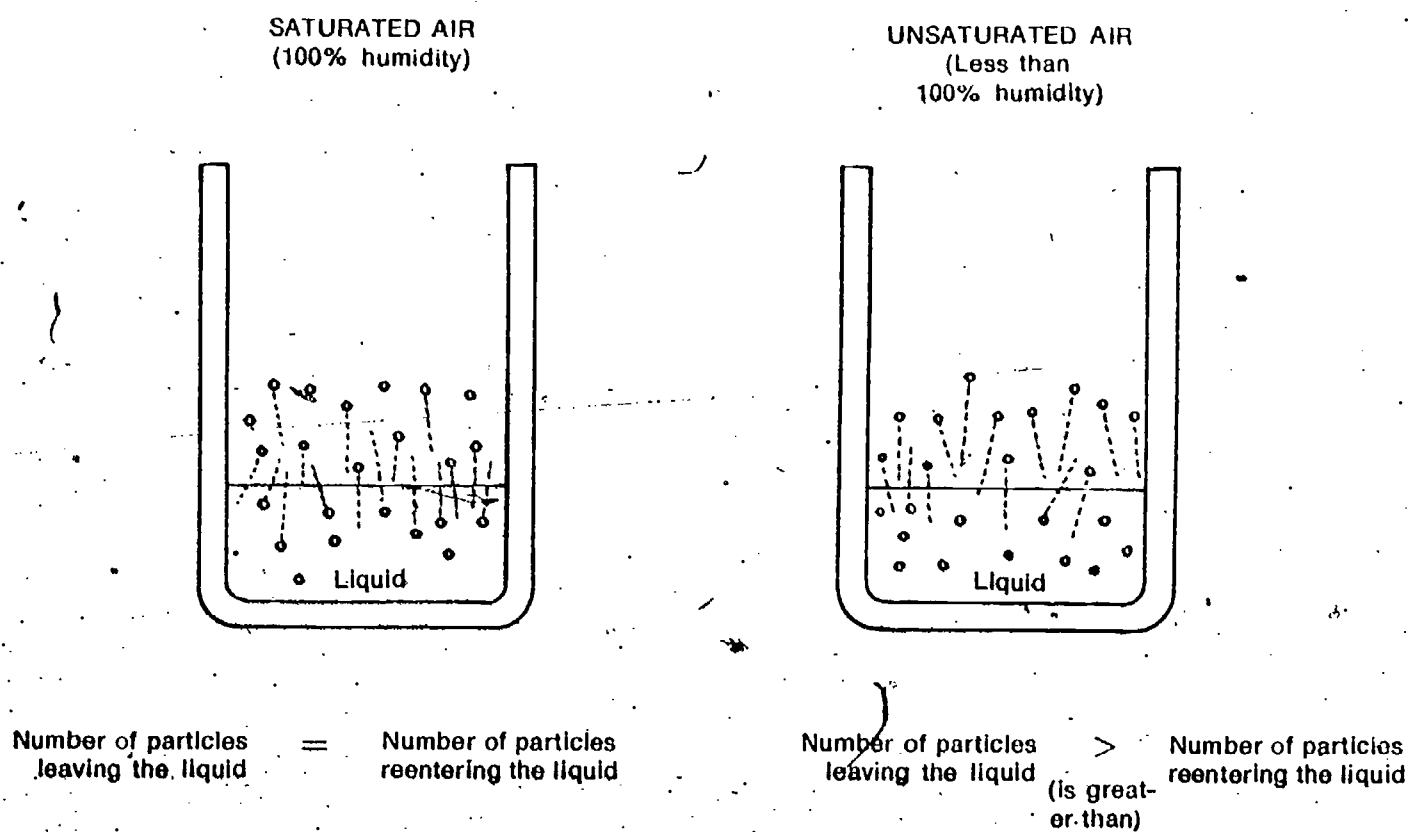

□ 11. Suppose the particles leaving the liquid were removed from above the liquid (blown away, for example). How would this affect the evaporation of the liquid?

Perhaps you can see why you "sling" the psychrometer. (The same reason explains why wet clothes dry faster on a windy day than on a day when the air is calm.) The air immediately next to the wet-bulb thermometer may be saturated with water. However, by swinging the thermometer around, you constantly bring the wet surface into regions where the air is not saturated.

12. Suppose the humidity in your classroom is 100% (saturated air). How would the temperature of the wet- and dry-bulb thermometers compare?

12. They would be the same (Note that in this case, whirling the thermometers makes no difference. The bulbs are continually in saturated air.)

When the air is not saturated, particles will evaporate from the wet-bulb thermometer. The drier the air, the faster the evaporation. Thus, the better the cooling and the greater the difference between the wet- and dry-bulb readings.

In summary, in humid (moist) air, the difference in temperature between the two thermometers is slight, if any. In very dry air, the wet-bulb thermometer gives a much lower reading than does the dry-bulb thermometer. This should help explain the figures in Table 4-2 of Chapter 4.

|||||
EVAPORATION

EXCURSION 4-1 139

159

Condensed condensation

The particle model is also useful in explaining condensation. It is the opposite of evaporation. In condensation, a gas becomes liquid. Condensation occurs with cooling. As the gas cools, its particles lose energy and move more slowly. The forces of attraction between the particles are sufficient to bring these slower moving particles together.

You have seen moisture gather on the outside of a container of cold liquid. (This is similar to the way you determined dew point.) The air close to the cold container is cooled as the container absorbs heat from it. The particles in the air lose some of their energy. With reduced motion, gaseous water particles join together to form the visible liquid droplets.

The effects of evaporation in cooling the surroundings are noticeable, but not as dramatic as the effects of condensation in nature. When water vapor condenses to visible water in a cloud, huge amounts of energy are released. The surroundings in this case is the air itself. This heated air rises very rapidly, contributing to the violence of some of the wildest storms.

EQUIPMENT LIST

None

PURPOSE To use temperature and dew point at ground level to determine the height of clouds.

How High Are the Clouds?

Excursion 5-1

MAJOR POINTS

1. As air rises, a) it cools at a rate of 1°C per 100 m, and b) its dew point decreases at a rate of 1°C per 550 m.
2. At the altitude that the temperature equals the dew point, clouds form. (This accounts for the flat bottom of many clouds.)
3. The height of a cloud bottom can be estimated if you know the dew point and air temperature at the earth's surface.

This is an advanced general-interest excursion.

Many warm summer days begin with a cloudless sky. By noon, however, puffballs of cumulus clouds may have appeared. Heat from the earth's surface has lifted moist air up, forming clouds. Usually these clouds have flat bottoms.

1. How do you account for the flat bottoms when the cloud tops aren't flat at all?

That isn't an easy question, but you may be closer to the answer than you think. As moist, warm air rises, it gradually cools. Eventually it gets high enough and cool enough so that the water vapor condenses. This condensing (cloud formation) happens just when the temperature of the air is the same as the dew point. This occurs at a specific height above the earth. (Of course, this height varies from day to day.)

2. What part of the cloud is the first to form, the top or the bottom?
3. Can you now explain the flat-bottomed clouds?

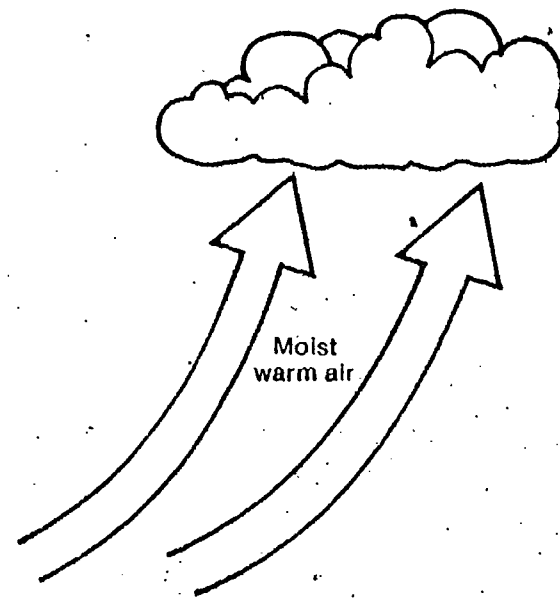
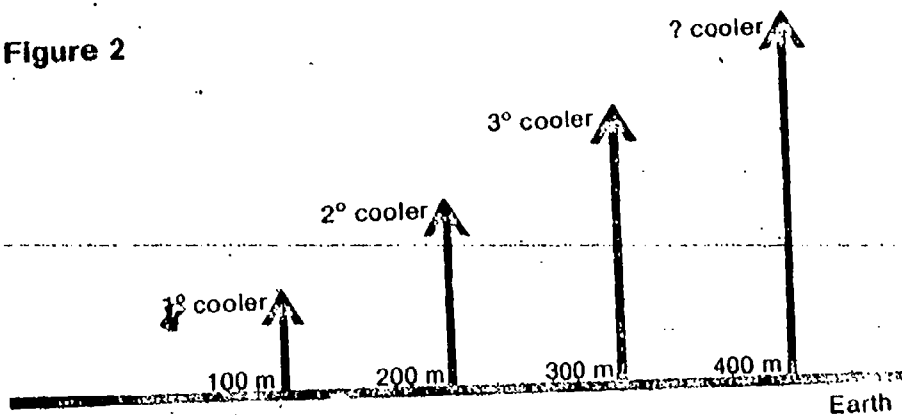

Figure 1

As air rises, it cools at an average rate of about 1°C per 100 m.

□4. How much cooler would the air be at 400 m than at ground level? (Figure 2)

Figure 2



This rate of cooling of air as it rises is called the adiabatic rate, as discussed in the teacher notes in Chapter 3. This rate remains constant at 1°C per 100 m as long as the air is unsaturated (as long as the temperature is less than the dew point), and it is therefore called the dry adiabatic rate. Once the saturation point is reached, the air no longer cools at that rate, because the heat of condensation is being passed back to it. It might be interesting to note that if the air descends for any reason (such as flowing down the other side of a mountain), it warms at this same rate of 1°C per 100 m.

The dew point of air decreases at an average rate of 1°C per 550 m.

□5. How much less would the dew point of air be at 2,200 m than at ground level?

Figure 3

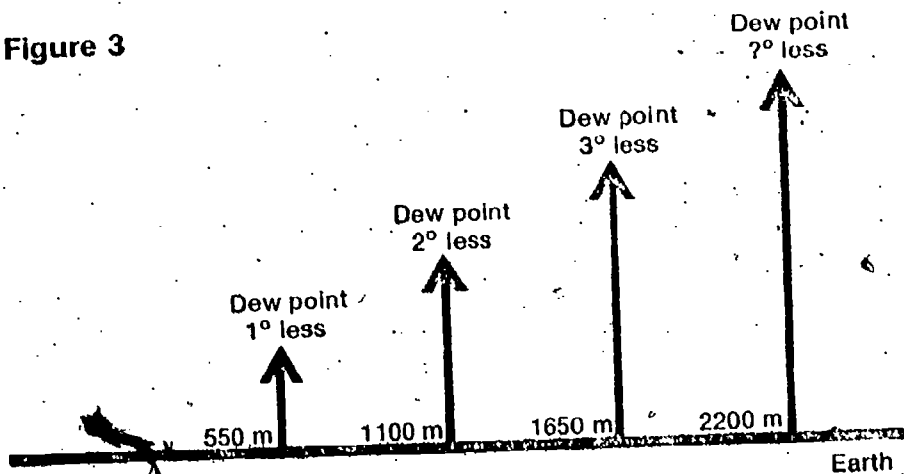

□6. Which decreases faster with altitude, the air temperature or the dew point?

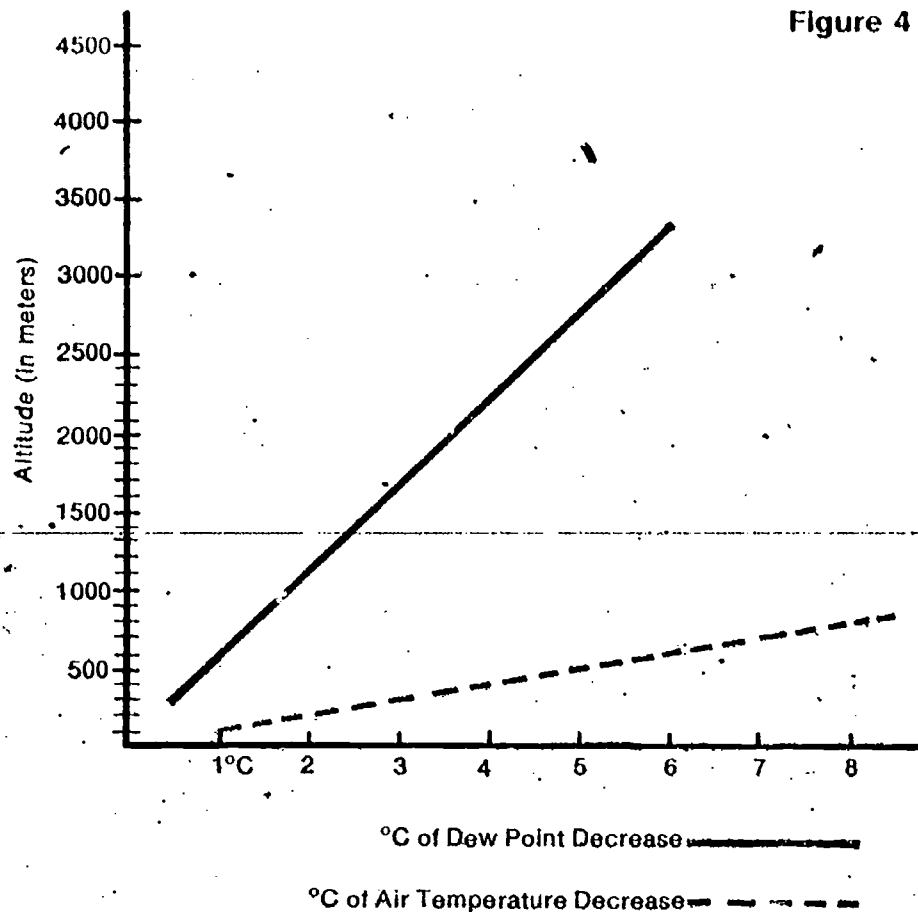

As altitude increases, the air temperature falls faster than the dew point. Therefore, at some specific altitude, the air temperature will be equal to the dew point. At that altitude, clouds will begin to form. Since cloud bottoms form first, all of them will be flat at that height. (The rest of the cloud forms as the warm air continues upward. What do you think causes some clouds to stop getting larger?)

Your problem is to find the height of the base of clouds. Assume that the temperature at the base of the cloud is at the dew point.

Calculating the height of the cloud base involves two steps.

1. Find the air temperature and dew point at ground level.
2. Find the height at which the air temperature (getting lower by 1°C each 100 m) and the dew point (getting lower by 1°C each 550 m) are equal.

Figure 5 shows a sample problem on a day when the temperature at ground level is 26°C and the dew point is 8°C.

The rate of decrease of air temperature is 1°C per 100 m; the rate of decrease of dew point is 1°C per 550 m. To get both rates in common terms of decrease per m, divide the 1°C by 100 and by 550 respectively. This gives rates of decrease of 0.01°C per m for air, and 0.0018°C per m for dew point. On the next page, students are challenged with an optional activity (question 9) of deriving the formula given. From the start above, this is relatively simple. Accepting the fact that clouds form at an altitude (h) where air temperature and dew point are equal, then the air temperature at that point will be the air temperature on the ground minus the decrease due to height, or $T_{air} - 0.01 h$. Likewise, the dew point at that height will be the dewpoint temperature on the ground minus the decrease due to height, or $T_{d.p.} - 0.0018 h$. But at that height these two terms are equal, so $T_{air} - 0.01 h = T_{d.p.} - 0.0018 h$.

Collecting the "h" term on one side:

$$0.01 h - 0.0018 h = T_{air} - T_{d.p.} \text{ or}$$

$$0.0082 h = T_{air} - T_{d.p.} \text{ or}$$

$$h = \frac{(T_{air} - T_{d.p.})}{0.0082} \text{ or}$$

$$h = 122(T_{air} - T_{d.p.})$$

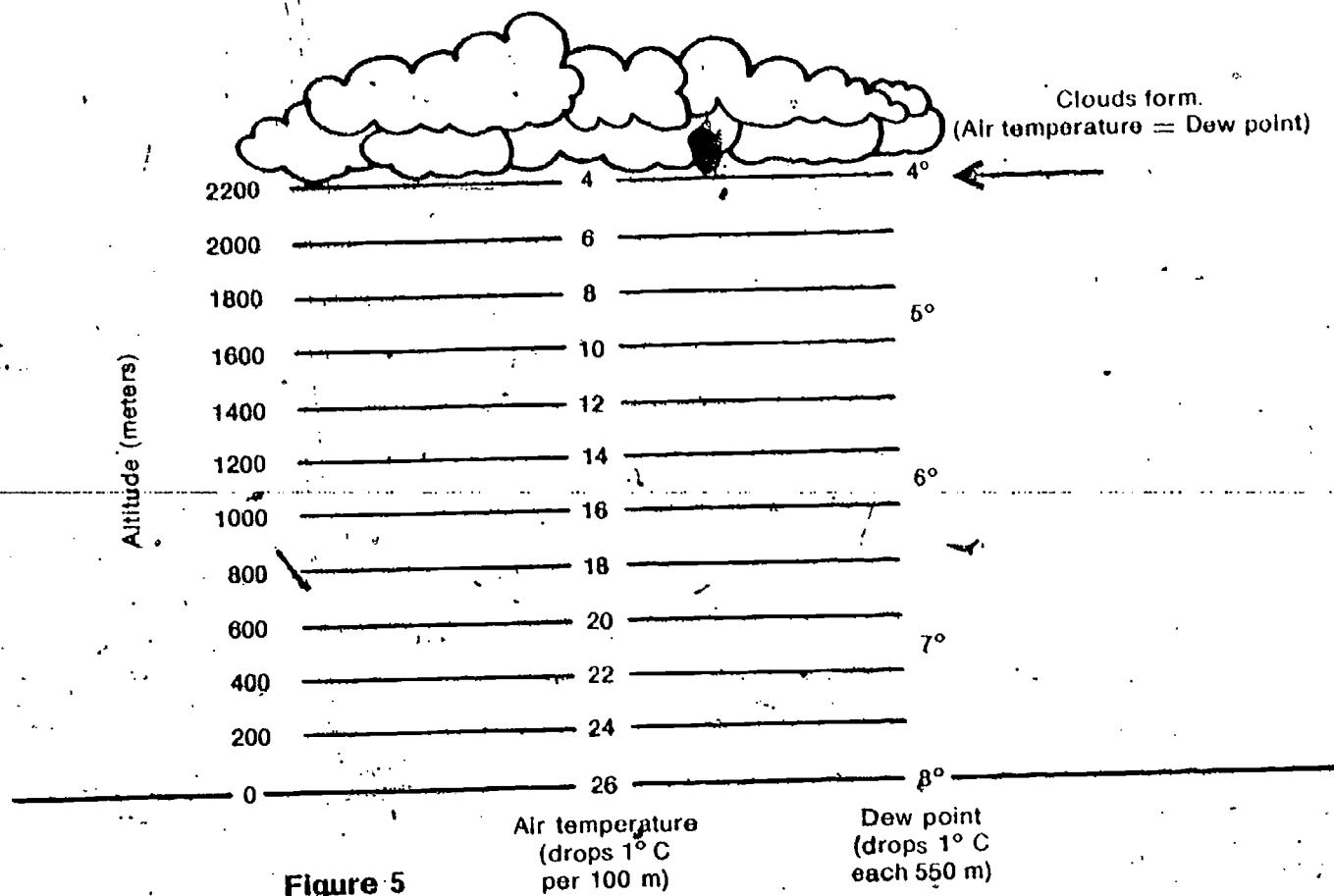

Figure 5

An easier solution than the one shown in Figure 5 involves using a simple formula. Here it is:

$$\text{Height of cloud bottom in meters} = 122(T_{\text{air}} - T_{\text{d.p.}})$$

T_{air} = ground level temperature of air

$T_{\text{d.p.}}$ = ground level dew point

Note that although no equipment was listed for this excursion, in order to answer question 8, students will need up-to-date readings for temperature and dew point, and may have to use the sling psychrometer and the tables in the text.

- 7. Using the formula, check the sample problem of Figure 5.
- 8. Calculate the height at which clouds could form today. (Record your method, data, and conclusions in your Record Book.)
- 9. (Optional) Can you derive the formula given for this type of problem?

This is an advanced excursion

PURPOSE To build an instrument and use it for measuring cloud speed

Building a Nephoscope

Excursion 5-2

EQUIPMENT LIST

1 21 cm x 21 cm piece of glass
1 sheet of black paper
1 ruler or meterstick
1 timer with second hand
Masking tape
Marking pen, with fine point
1 drawing compass

A nephoscope is a device you can build and use to measure the forward motion of a cloud. You will need the following materials:

1 pane of window glass, approximately 21 cm x 21 cm	1 watch, with sweep second hand
1 sheet of black paper, cut to the same size as the glass pane	1 strip of masking tape (about 20 cm)
1 centimeter ruler (or meterstick)	1 marking pen (fine point)
	1 drawing compass

MAJOR POINT

An instrument can be constructed to obtain data that will enable cloud speed to be measured.

Note. This excursion requires careful construction, somewhat difficult measurements, well-delineated clouds in the sky, and some mathematical skills. It should probably be attempted only by more capable students.

Note that two pencils and a piece of string could be used to draw the circle if no drawing compass is available.

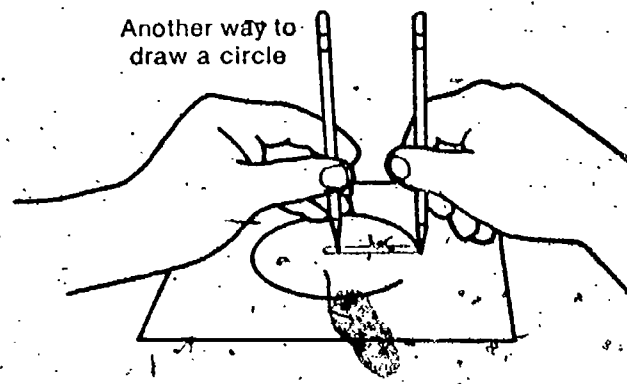
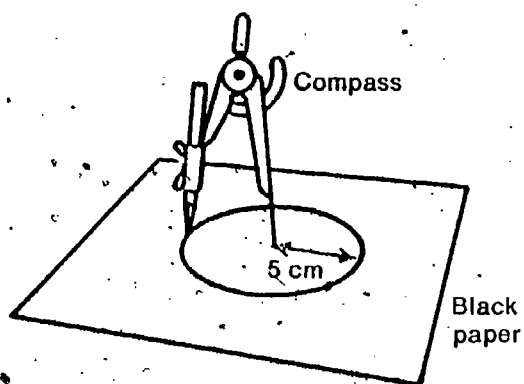

ACTIVITY 1. Clearly mark a point near the center of the black paper. With this point as center, use a compass to draw a circle of 5-cm radius.

ACTIVITY 2. Tape the black paper with the pencil markings next to the glass. They should be visible through the glass.

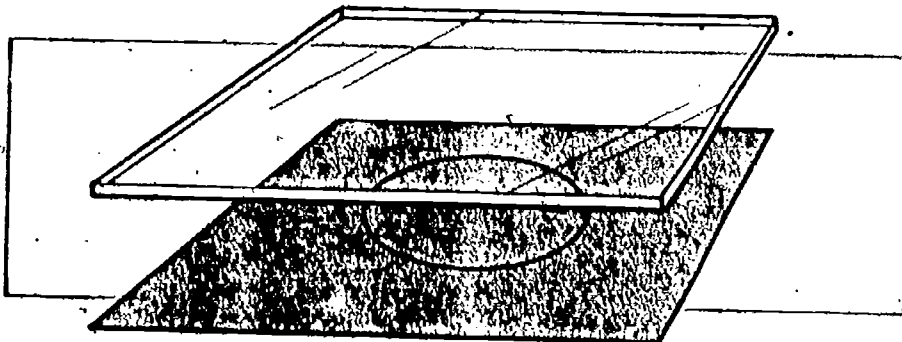

ACTIVITY 3. With the marking pen, trace over the pencil markings so that the glass sheet is marked like the black paper.

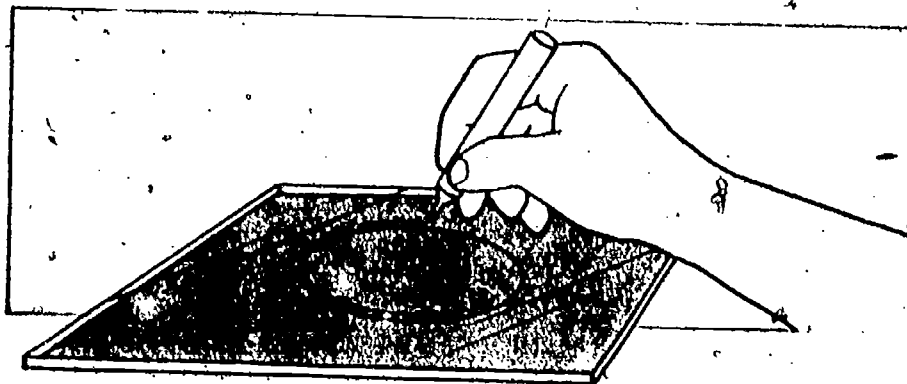

The instrument must sit on something solid and immovable. The observer must also be able to hold a fairly fixed position long enough to make the complete measurements.

ACTIVITY 4. Place the nephoscope as near a window as possible, or in the open where you have a clear view of the sky.

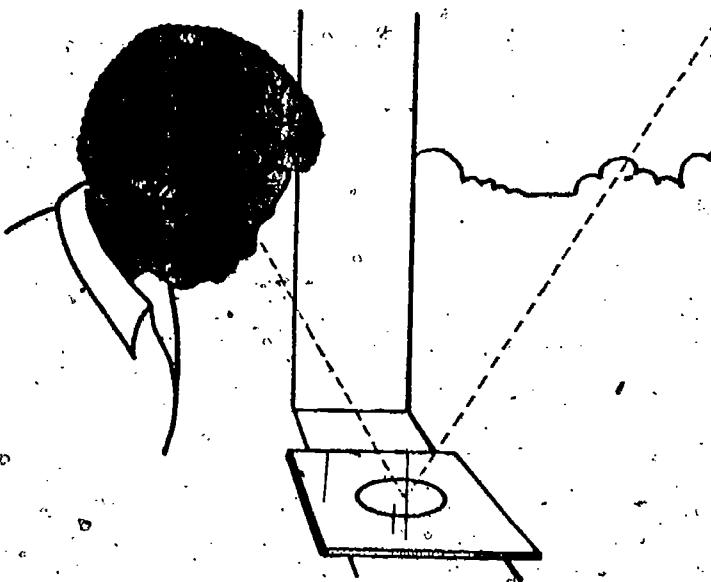

Choose some clouds as nearly overhead as possible. Stand beside the nephoscope in a position from which you can see the reflection of the clouds. You may need to prop one edge of the nephoscope on a book. Once you have this set up (Figure 1), you are ready to make measurements. You will need the help of a partner.

Figure 1

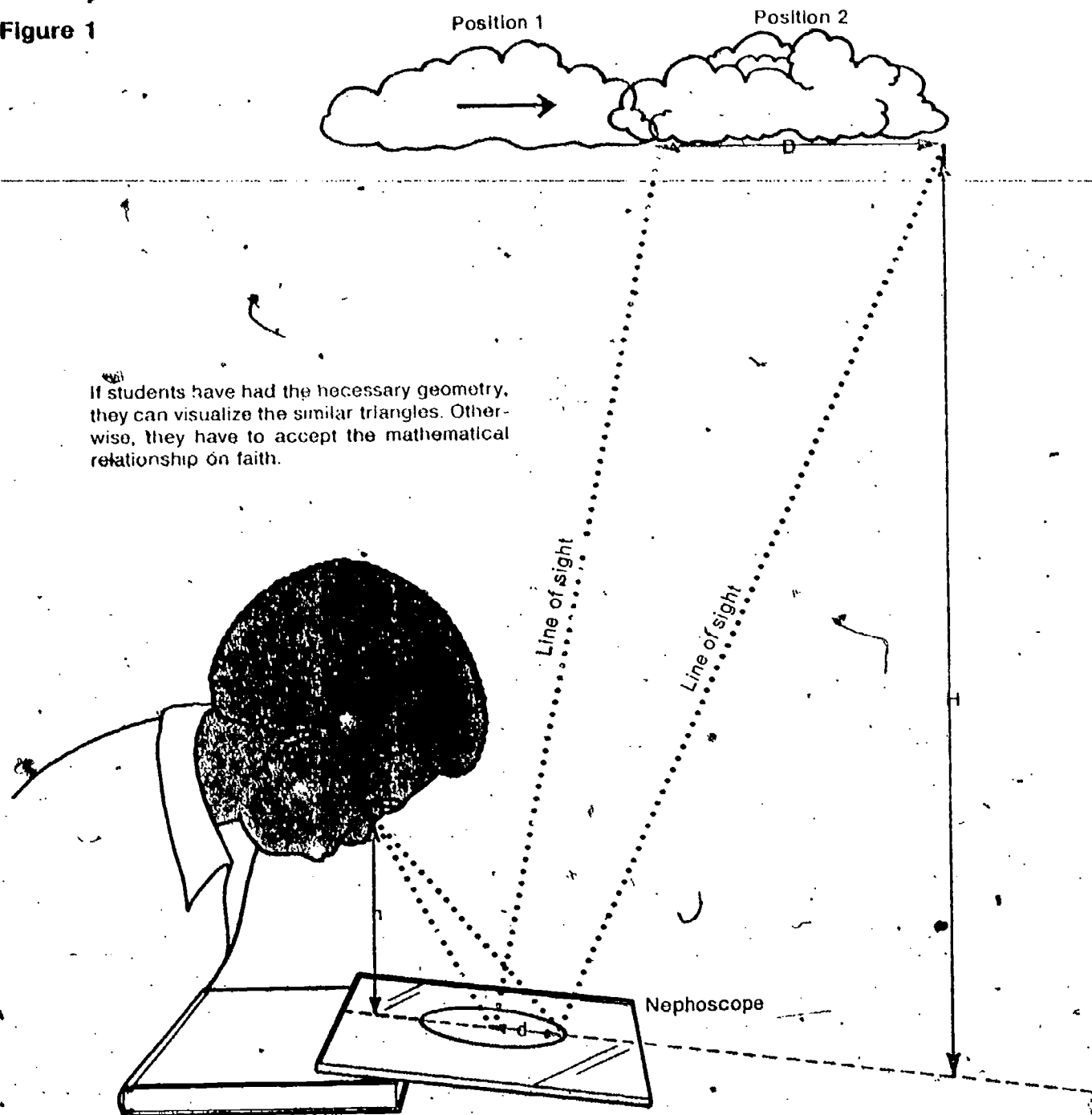

If students have had the necessary geometry, they can visualize the similar triangles. Otherwise, they have to accept the mathematical relationship on faith.

ACTIVITY 5: First, select a clearly identifiable point on the edge of a cloud. Position yourself so that the reflection of this point is at the center of the nephoscope.

You can see that this will not work on an overcast day without clouds that have well-defined edges. Also, it should be done on a day that the cloud height can be estimated by using Excursion 5-1. This means that the clouds should be of the cumulus type. Even then it will mean that the observer will have to remain motionless for 5 minutes or more.

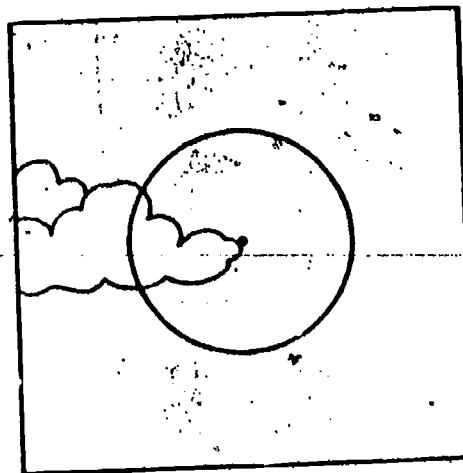

Position 1

ACTIVITY 6. Then, without changing your position, have your partner time the movement of the reflection. Record how many seconds it takes your chosen point to move from the center to the rim of the circle. Don't change the position of your body until your partner measures the height of your eye above the nephoscope. (See Figure 1.) Record your data in Table 1.

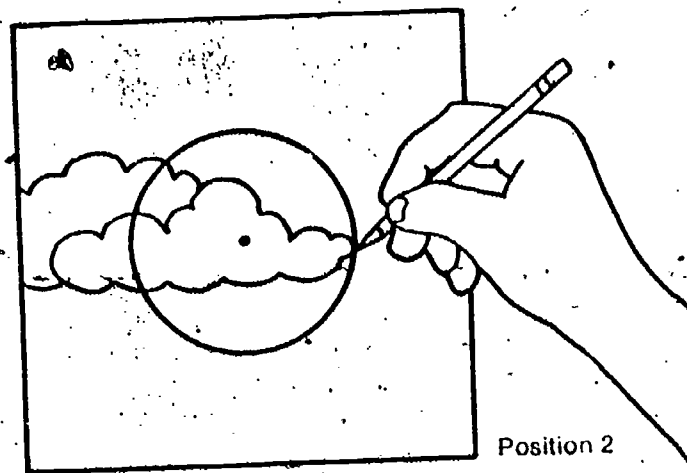

Position 2

Table 1

Distance moved by reflection (d)	0.005 meter
Time to move 5 cm (t)	seconds
Height of eye above nephoscope (h)	meters
Estimated height of clouds (H) (See Excursion 5-1.)	meters

Note the need for cloud height.

Do not forget to change your measurements of h and d from centimeters to meters.

With a formula from geometry, you can use the measurements you have just made to calculate the distance traveled by the clouds.

$$D = \frac{H \times d}{h}$$

D = Actual distance traveled by cloud

H = Estimated height of cloud

d = Radius of nephoscope circle

h = Height of eye above nephoscope

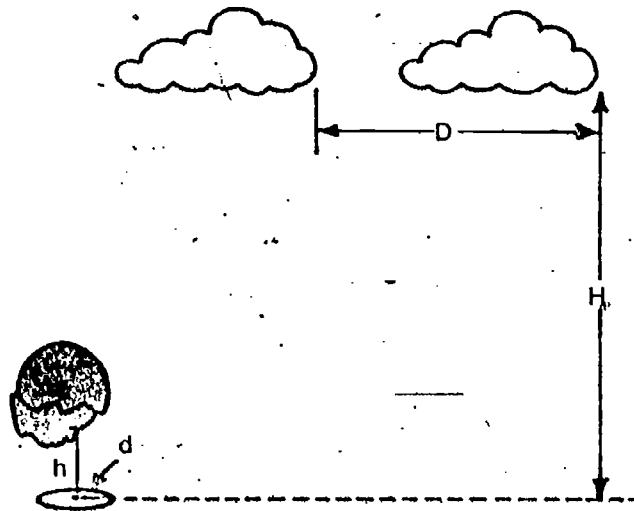

Just to have some "ballpark" figures, with a cloud at 2,000 m, a radius of the circle at 0.05 m and the height of the eye 25 cm (0.25 m) above the glass, the distance traveled by the cloud will be about 4,000 m.

- 1. What is the distance moved by the cloud?
- 2. Suppose the estimated height (H) is 2,000 meters. What distance would the cloud have moved if all your other measurements were the same as before?
- 3. How fast did the cloud move in meters/sec?

If the cloud moved an actual distance of 4,000 m, and a reasonable wind speed at that altitude is 30 miles per hour (48 km/hr, 13 m/sec), then the time would be about 300 seconds, or 5 minutes.

$$\left(\text{Speed} = \frac{D}{t} \right)$$

4. The height of the aircraft and the time it took for the reflection to cover the radius of the circle. (With this instrument it would be well-nigh impossible. With the aircraft low enough for the reflection to be seen, the image would move very rapidly across the circle.)

- 4. Suppose you wanted to use this method to measure the speed of a jet aircraft. What would you need to know?
- 5. How could you improve this method of determining cloud speed?

5. Student answers may prove interesting. Probably a radarscope would do a better job.

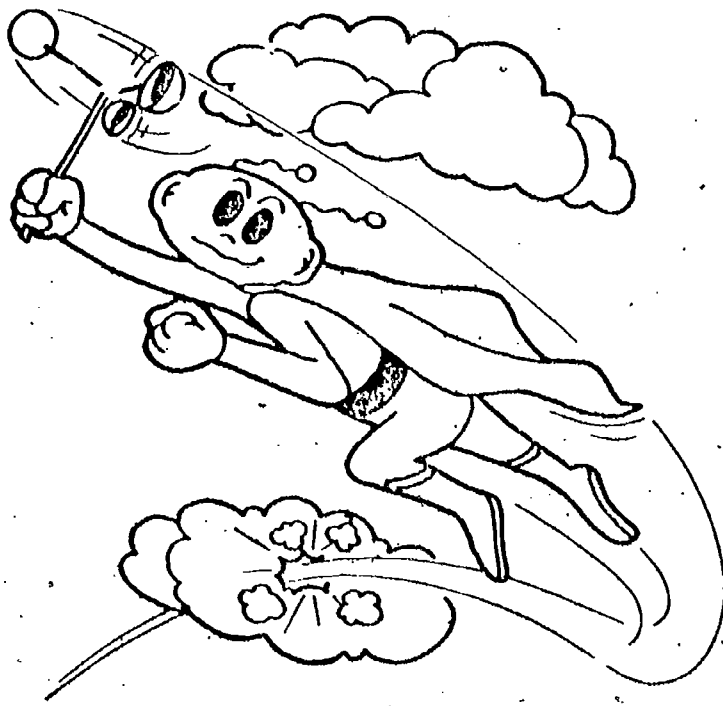

EQUIPMENT LIST

1 plastic straw
Rubber tubing, 2-foot length
1 pail
1 comb
Scotch tape or clay
1 flat pan

PURPOSE To test a possible theory for precipitation.

And the Rains Came Down

Excursion 7-

This is a general-interest excursion.

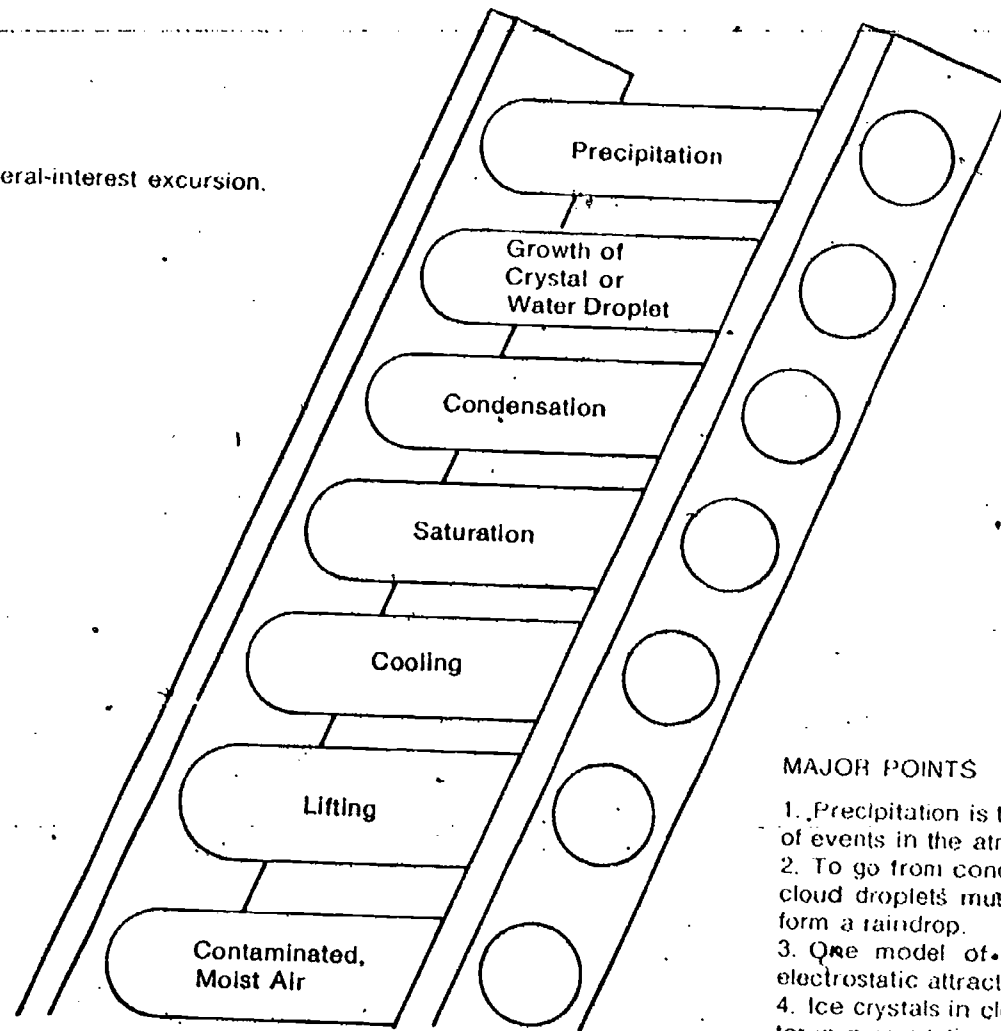

Figure 1

You have been studying a number of events that take place in the atmosphere. All these events can lead to one other occurrence that we associate with weather—precipitation. This precipitation can be in the form of drizzle, showers, snow, sleet, or hail. It all depends on the temperature and other conditions.

Precipitation might be considered the top rung of a ladder of events that occur in the air (Figure 1).

MAJOR POINTS

1. Precipitation is the end result of a number of events in the atmosphere.
2. To go from condensation to precipitation, cloud droplets must be brought together to form a raindrop.
3. One model of raindrop formation uses electrostatic attraction as a basis.
4. Ice crystals in clouds may be another factor in precipitation.

Let's climb to rung 5, Condensation. You have found that air must contain water vapor and some solid particles for condensation to take place. When the temperature of the air reaches the dew point, the water vapor will condense on the particle surfaces (dust, smoke, salt particles). Figure 2 illustrates the formation of a cumulus cloud. Moist air is lifted and then cooled. The cloud forms when the dew point is reached and water begins to condense on small particles (condensation nuclei).

Figure 2

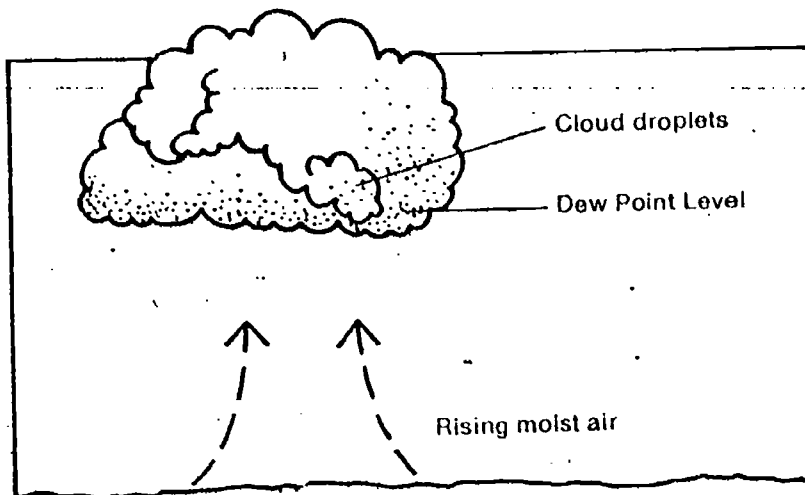

The cloud consists of very tiny droplets, which we'll call "cloud droplets."

Figure 3 compares the sizes of a condensation nucleus (dust or salt), a cloud droplet, and an average-size raindrop. An average raindrop is so large compared to the droplet and condensation nuclei that we can only show part of it.

Figure 3

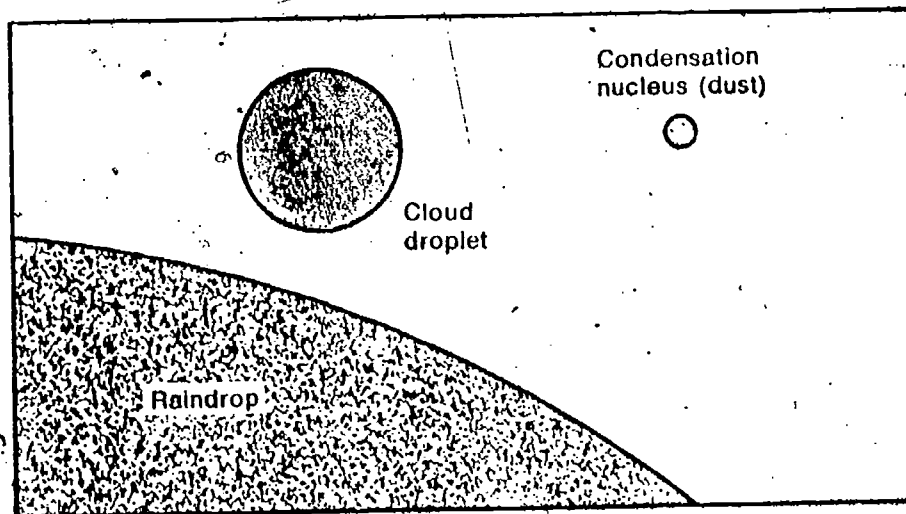

Now glance back at the ladder in Figure 1. In order to go up from rung 5, Condensation, to rung 7. Precipitation, Growth (rung 6) of the "cloud droplets" must take place. About one million cloud droplets are needed for a small raindrop to form! How does this happen? To find out, you and a partner will need the following:

- 1 plastic straw
- Rubber tubing, 2-foot length
- 1 pail
- 1 comb
- Scotch tape or clay.
- Flat aluminum pie pan

The process by which the tiny cloud droplets come together to form raindrops is called coalescence. It is not just a simple matter of their colliding and forming bigger drops. When the tiny droplets come together, they tend to bounce off each other like rubber balls, possibly because of surface tension. Some force is necessary to get them to stay together to form drops.

Perhaps it would be wise to add a mop and paper towels to the equipment list. This activity could get messy if it is not carefully controlled.

ACTIVITY 1. Carefully punch a pinhole on one side only of the plastic straw. Block up one end of the straw with clay, or tape. (The end *must* be watertight.) Fasten the open end of the straw to the rubber tubing.

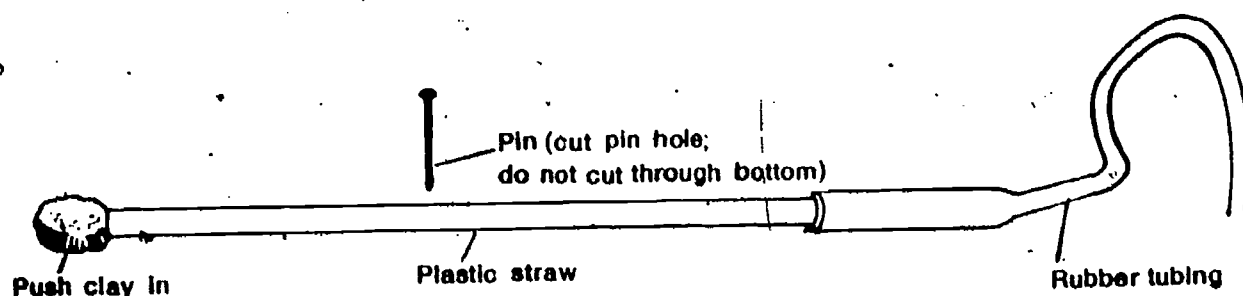

ACTIVITY 2. Set up the apparatus as shown. The top supply bucket should be about $\frac{3}{4}$ full.

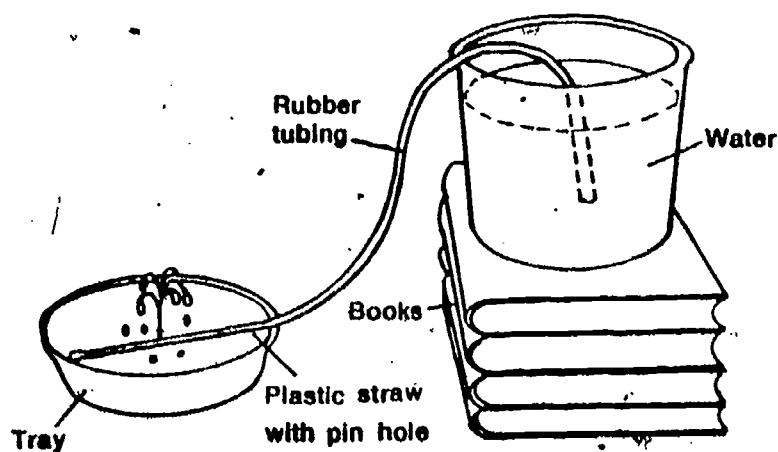

EXCURSION 7-1 153

ACTIVITY 3. Hold the straw lower than the water level in the bucket. Suck on the pinhole until water starts to flow. Hold the straw in the pan so that the fountain is vertical.

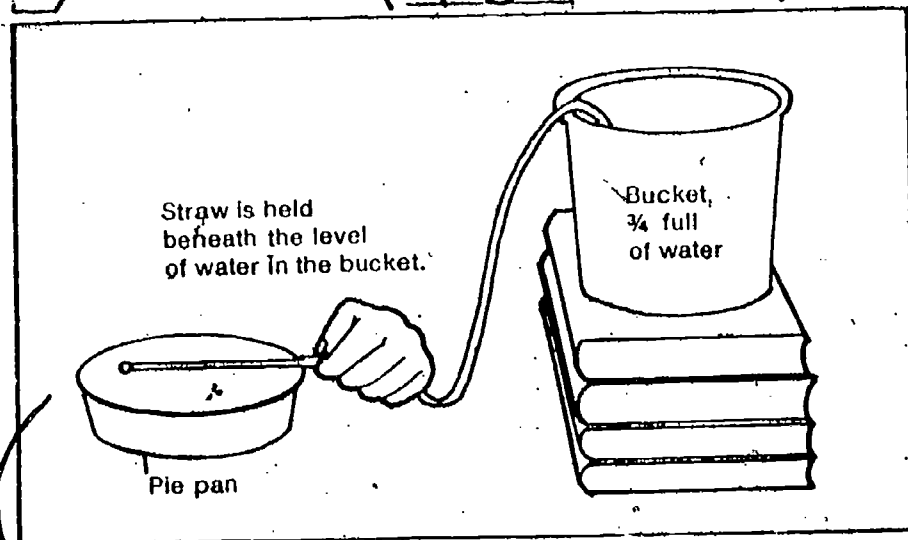
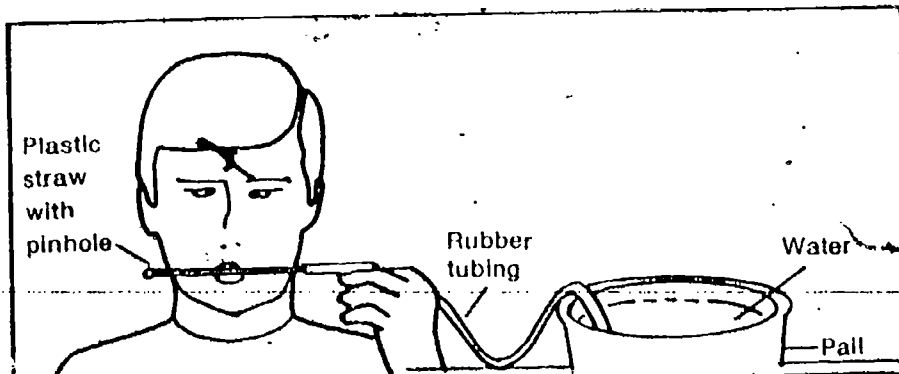

A cellulose acetate strip rubbed with tissue paper, or a vinyl strip rubbed with wool cloth, will work even better than the comb. These are the two strips used in Level II ISCS, and they may be readily available.

ACTIVITY 4. Observe the spray of water carefully. Pay particular attention to the size of the droplets. Now, while you hold the straw, have your partner run a comb several times through his hair, and then move the comb close to the spray. Move the comb in and out several times.

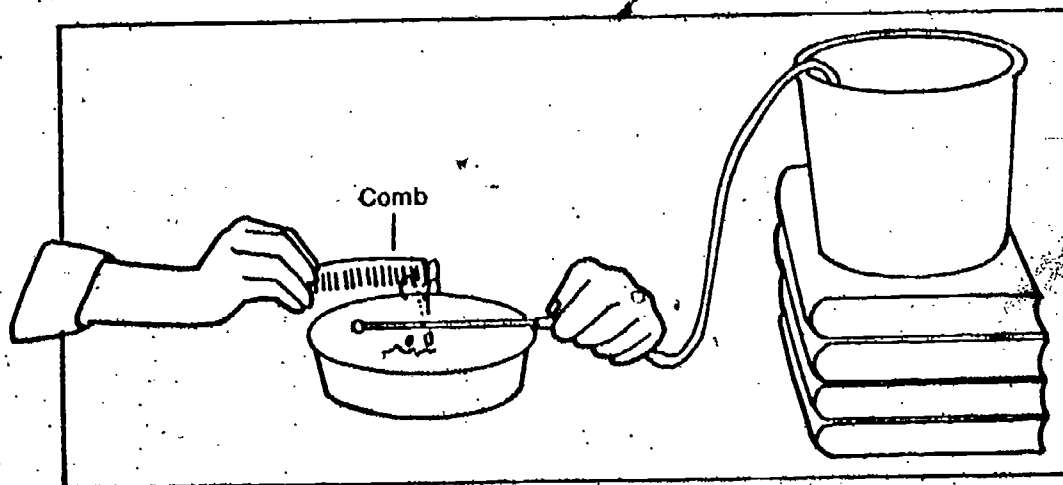

- 1. What did you observe happening when the comb was brought close to the spray?
- 2. What happened to the size of the droplets when the comb moved toward and away from the spray?
- 3. Give your explanation of why the comb affects the water spray?
- 4. Does this investigation suggest what might cause tiny cloud droplets to combine to form raindrops? Explain your answer.

The friction that results when a comb is run through dry hair produces an electric charge on the comb and the hair. This charge has been described in detail in Volume 2 of ISCS. Electric charge can produce a force of attraction between objects. As you brought the charged comb near the water spray, the droplets probably increased in size. It is reasonable to assume that this charge was caused by the charge on the comb. Tiny droplets were attracted to each other and combined into larger ones. Electric charge also exists in clouds. Therefore, it is reasonable to think that this charge may cause the formation of raindrops.

There is another factor in raindrop formation that some meteorologists think is even more important than the presence of electric charge. This factor is the presence of ice crystals in clouds. Figure 4 shows how the temperature in a cloud may vary. In large clouds extending to high altitudes,

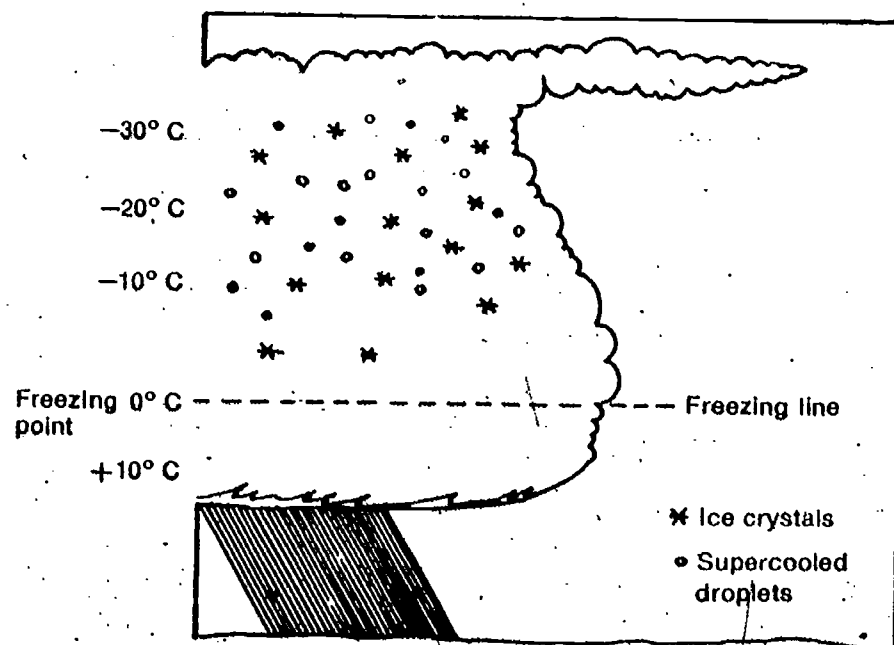

An electrostatic field does indeed cause coalescence of the drops. But students should realize that this is only a theory—a model for the possible explanation of raindrop formation. No one has actually observed this happening inside a cloud, and there could be other factors—other models—that could explain the phenomena just as well. For your information, water molecules are polar—that is, the 2 hydrogens with a plus charge are oriented toward one side of the molecule and the oxygen with a double minus charge is oriented to the other side. The charge on the comb, either plus or minus, attracts the oppositely charged particles, which are free to orient themselves toward it. The water spray is thus attracted, because part of each molecule is closer to the comb than the other part.

Here's another model—and one that enjoys more favor, especially for clouds that extend high enough (swelling cumulus, cumulonimbus) to reach the freezing level.

Figure 4

EXCURSION 7-1 155

the temperature may be well below the freezing point of water. The water droplets at altitudes above the freezing line will be colder than the freezing point of water, and still be liquid. These droplets are called "supercooled" droplets. Some ice crystals will also exist in the cloud. If a droplet collides with an ice crystal, the supercooled droplet will immediately freeze on the surface of the ice crystal. If this process continues, the ice crystal may become heavy enough to fall through the cloud. If the crystal falls through warm air, it may melt and reach the ground as a raindrop. If the crystal falls through air that is below freezing, the precipitation may be in the form of snow or sleet.

Note the keying of Excursion 7-2 here as well as in the chapter.

EXCURSION ▶

If you are interested in finding out how hail forms, take a look at **Excursion 7-2, "Cumulonimbus."**



EQUIPMENT LIST

None

This is a general-interest excursion.

PURPOSE To study the development, characteristics, and properties of thunderhead clouds

Cumulonimbus

Excursion 7-2

MAJOR POINTS

1. Cumulus clouds are constantly changing shape and size and may build to cumulonimbus.
2. Violent air movements within the cloud can produce violent weather.
3. Successive up-and-down trips through the cumulonimbus cloud can build an ice crystal into a large hailstone.

This excursion should be done on a day when there are cumulus clouds. Figure 1 shows a typical display of cumulus clouds.

Figure 1



ACTIVITY 1. Go outside, lie on the ground, pick out a single cumulus cloud, and observe it for at least three minutes. Then select another cloud, and again, observe it for three minutes.

1. List the changes you observed for the two cumulus clouds.

2. Compare and contrast the behavior of both clouds.

Whether or not a cumulus grows to a cumulonimbus, or remains the same size, or dissipates, is controlled by the stability of the air. This in turn is affected by the moisture content of the air. Air that is conditionally stable and has a high moisture content may be uplifted by one of the four agents that make up the model. When the condensation level is reached and clouds form, so much heat energy is given to the air by condensation that it becomes unstable, rises rapidly, and builds into huge clouds.

You learned earlier in this unit that if warm, moist air rises, it will cool. The water vapor will condense on tiny solid surfaces, forming a cloud. Cumulus clouds, with their puffy, heaping appearance, are formed where updrafts of moist, warm air occur. You might have noticed that the clouds you observed changed quite dramatically. Perhaps the cloud moved horizontally, broke apart, faded away, or grew larger. Generally these clouds don't last too long because the air surrounding them is usually quite dry. This dry air causes the cloud droplets to evaporate and become invisible water vapor.

Some cumulus clouds, however, are huge and may last long enough to produce violent weather. Examples of these clouds are shown in Figures 2 and 3.

Figure 2

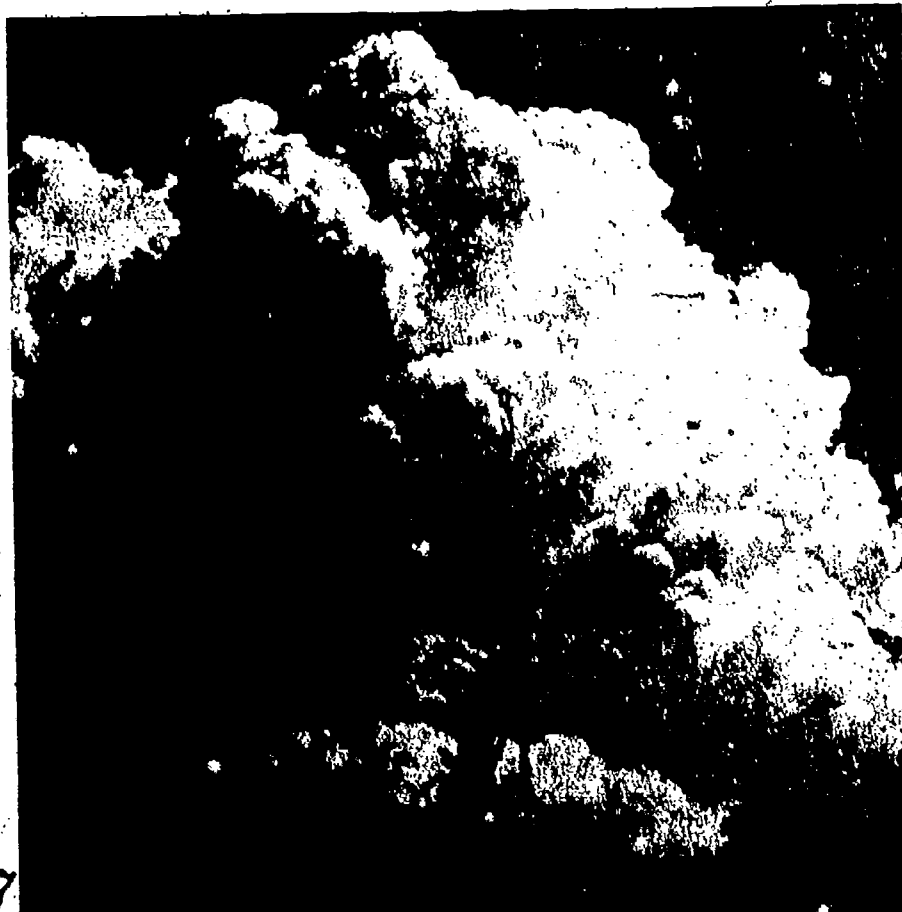

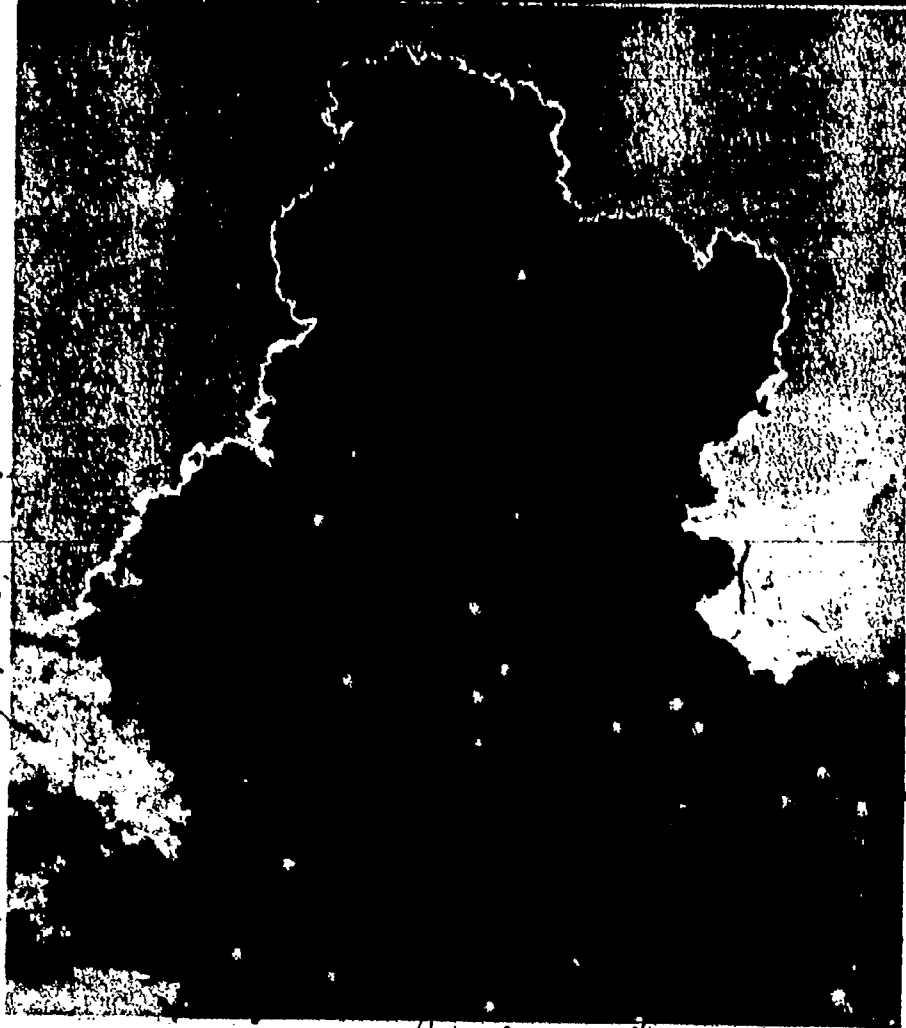

The moisture content, and therefore the energy content, of a thunderhead is terrific. It has been calculated that a single thunderstorm about 3 miles in diameter can contain as much as a half million tons of condensed water. This is found in the form of water droplets and ice crystals. In condensing this much moisture out of the water vapor, the energy released by the latent heat of condensation is equivalent to burning about 60,000 tons of coal.

Figure 3



179

You probably know that the clouds shown in Figures 2, and 3 are cumulonimbus clouds. Perhaps you have seen one recently. You may remember that wind, thunder, lightning, rain, and perhaps even hail may have been associated with it. How does a cloud get so big? What happens inside these clouds to produce a violent thunderstorm?

Note that the excursion supposes students are able to observe cumulus and cumulonimbus while they do the activities.

ACTIVITY 2. Figure 4 shows drawings of the same thundercloud at different times. Using the vertical scale shown in the photographs, determine the height, in feet, of the cloud at each time.

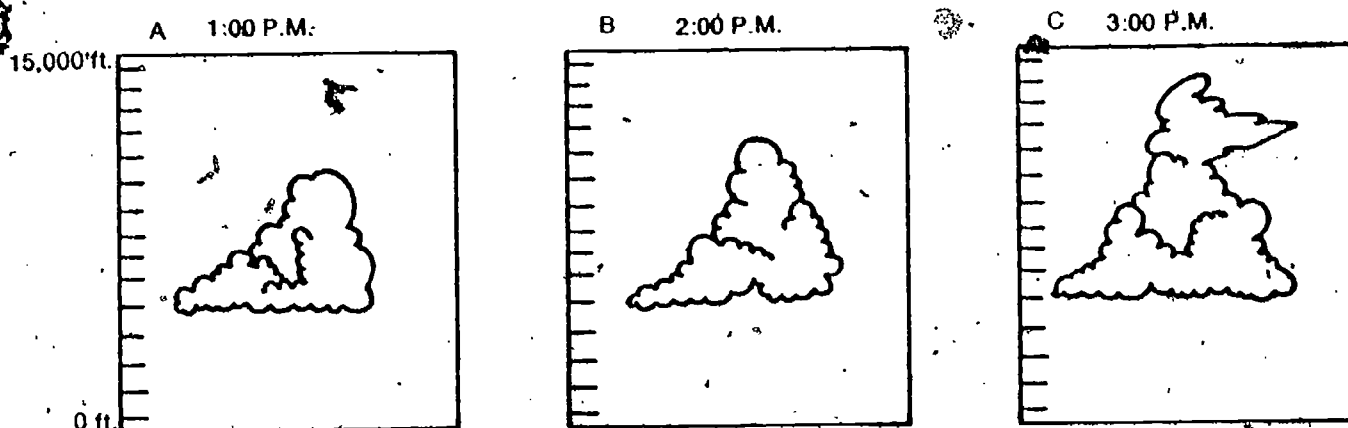

Figure 4

3. How tall (from bottom to top) was the cloud at each time interval?
4. What was the rate of growth of the thundercloud? (Hint: How many feet did it "grow" per hour?)

This violent up-and-down motion of air is extremely hazardous to aircraft flying in proximity to the cloud. Besides extreme passenger discomfort, large stresses are placed on the structure of the plane. There are many documented cases of extensive damage to the craft.

Rising air in some thunderclouds may have upward speeds of 60,000 to 100,000 feet per hour. At such speeds the air may climb above the condensation level very rapidly. If the surrounding air is relatively high in humidity, the cloud may grow to 40,000 feet or more!

Inside the cloud, air moves violently up and/or down. Figure 5 shows the nature of the air motion in a cumulonimbus cloud.

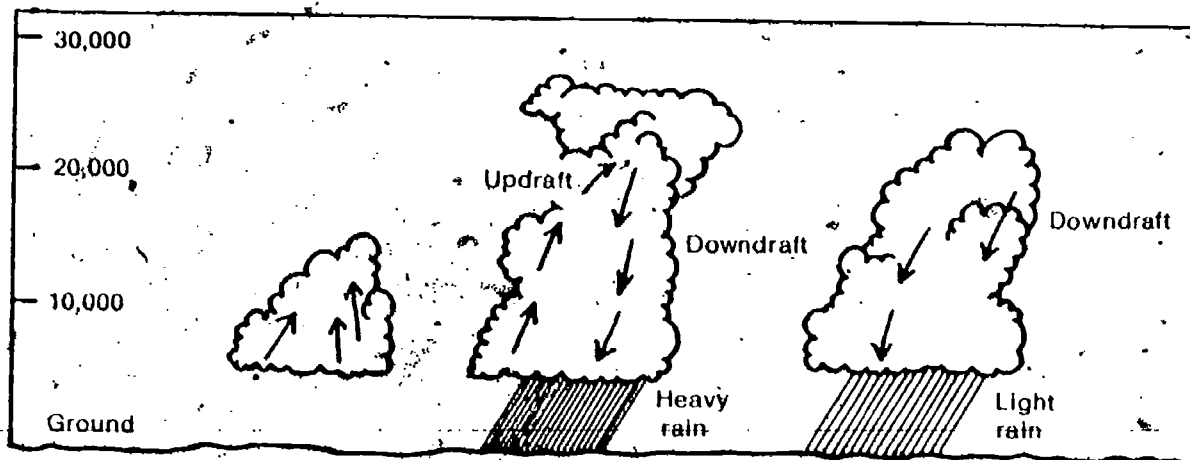

Figure 5

Notice that at first the air motion is predominately an updraft. During maximum development of the cloud, the air moves both in violent updrafts and in downdrafts. Finally, the upward motion, which supplies the moisture, ceases, and the cloud consists only of downdrafts.

Let's examine one important effect of the ups and downs of air in a cumulonimbus cloud. This effect is called hail. Although most hail is about pea size ($\frac{1}{2}$ inch), some hailstones may be as large as tennis balls ($2\frac{1}{2}$ to 3 inches in diameter). A close inspection of hailstones reveals that they consist of a series of layers of ice in concentric shells. See Figure 6.

In a full-grown cumulonimbus, the greatest updraft comes in the front third of the cloud. This has the effect of producing a relatively calm area at ground level after the first gustiness and large raindrops have stopped. Then the major precipitation occurs under the back two thirds of the cloud.



Figure 6

The formation of these ice layers requires the presence of strong updrafts.

5. Why do you think strong updrafts are necessary in forming hail?

EXCURSION 7-2 161

If an ice crystal falling through the cloud is caught in an updraft, it can collect more droplets on its surface. The crystal then enlarges. Near the top of the cloud, the force of the updraft decreases. The now larger crystal falls again, collecting more ice on its surface. If it is hurled upward again by the updrafts, still more ice collects.

6. What would cause the hailstone to finally fall to the earth?

Imagine how strong the updrafts must be to produce hailstones the size of tennis balls!

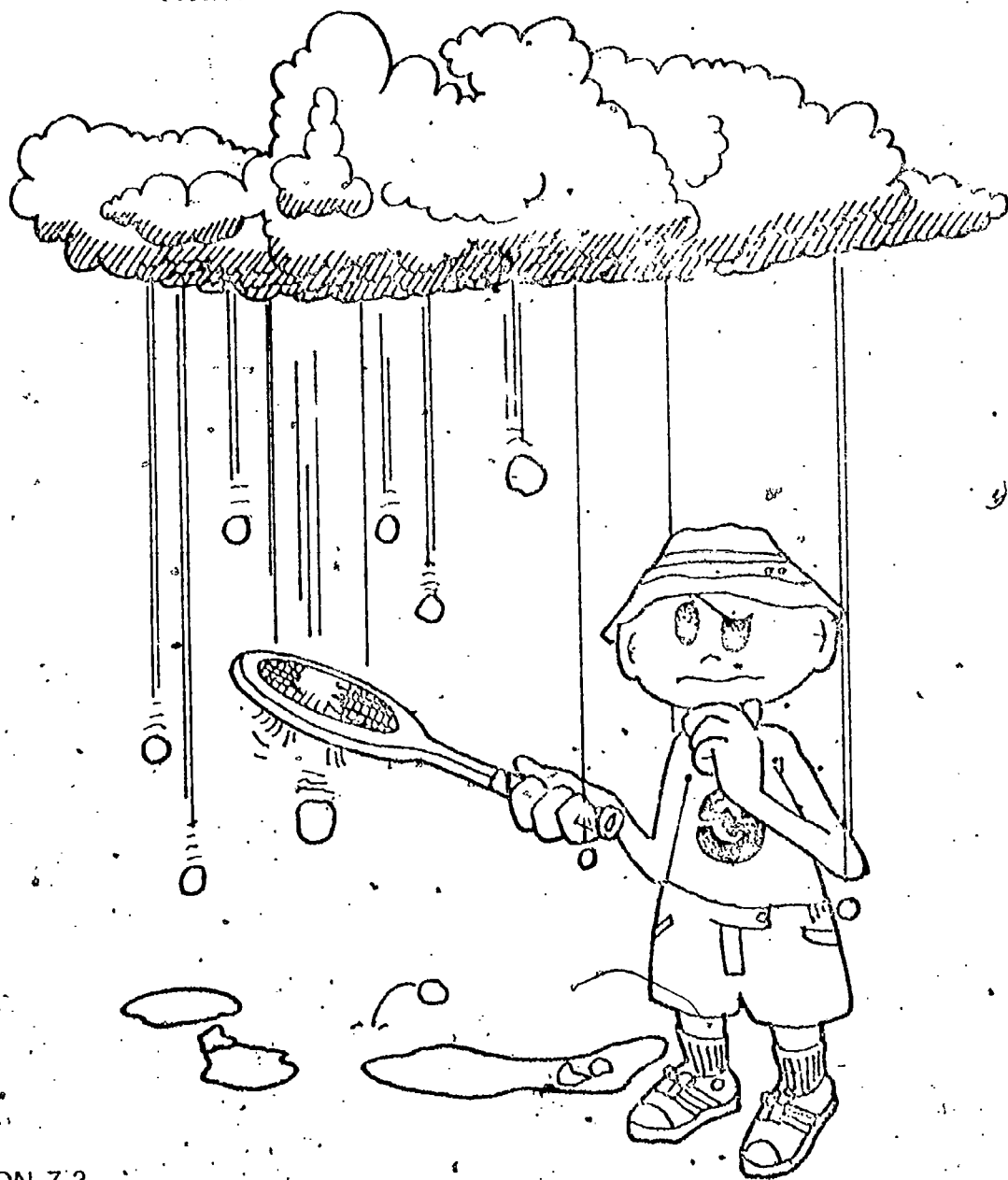

EQUIPMENT LIST

1 weather instrument
Barometer
Sling psychrometer
Weather map

PURPOSE To afford practice in making weather forecasts

Weather Prediction and Forecasting

Excursion 7-3

This is an advanced general-interest excursion.

MAJOR POINT

By using the weather elements of temperature, humidity, cloud, wind direction and speed, and barometric pressure, and the developed model for weather, a short-range forecast can be made.

Have you been wondering how meteorologists can predict the weather from data like that shown in Table 1? How can they combine several kinds of information to interpret and forecast the weather?

Table 1

Day	Time	Temp.	Wind Dir.	Wind Speed	Cloud Type	Cloud Cover	Precip.	Bar. Pres.	Rel. Hum.	Dew Point
20	1:30	17°C	S	8-12	Stratus	○	—	29.90	55%	13°C
21	2:05	20°C	S	8-12	Stratus	⊙	—	29.88	83%	18°C
22	1:50	10°C	N	25-31	Cumulo-nimbus	○	1.5 cm	29.81	100%	10°C
23	1:45	5°C	N	8-12	Clear	○	—	29.92	25%	-9°C
24	—	—	—	—	—	—	—	—	—	—

How well can you interpret the data in Table 1? Can you predict what the next day's weather will be? Notice that the data is for a four-day period. Data for a fifth day (the 24th) is not included. You will try to predict this data. Study the patterns in each column before trying to answer the following questions.

[] 1. What kind of front is moving across this area?

[] 2. If you knew that the center of high pressure was due to arrive on the 24th, predict what would happen to each of the following quantities just after it arrives. (Complete that part of Table 1 in your Record Book.)

TEMPERATURE (Drop greatly; drop slightly; no change; rise slightly; rise greatly?)

HUMIDITY (Drop; stay the same; rise?)

CLOUDS (Stay clear; get cloudy; if so, what types?)

WIND (None; strong; light?)

PRECIPITATION (None; some?)

Fortunately, the weather pattern shown by the data in Table 1 is a fairly clear-cut case of frontal movement. The air pressure dropped slightly and then rose rapidly just before the first part of the high-pressure area arrived. The drop in temperature shows that the high-pressure area was the result of an advancing cold air mass. As the cold mass moved into the area, the relative humidity rose, water vapor condensed into clouds, and rain fell. After the cold air mass replaced the warm air, the air was clear, cold, and fairly still.

Most weather predictions, or forecasts, are for less than 48 hours. They are called short-range forecasts. Careful analysis of the daily weather map (which you can obtain from a daily newspaper) coupled with the observations you make of temperature, pressure, humidity, and cloud type, will enable you to make 48-hour forecasts.

Table 2 describes signs to look for when making short-range (48-hour) forecasts.

ACTIVITY 1. For the next three days, continue to gather weather-watch data. Each day, study your observations and make a forecast of the next day's weather. In addition to making your own observations, consult the daily weather map posted in your room, or look in your newspaper.

Some teachers start bringing in the daily weather maps at the beginning of the unit. These can be posted or mounted sequentially on a bulletin board, chalk-board, or wall. Probably nothing can make the procession of daily weather across the country as real as this, because the students can tie it into their daily weather observations.

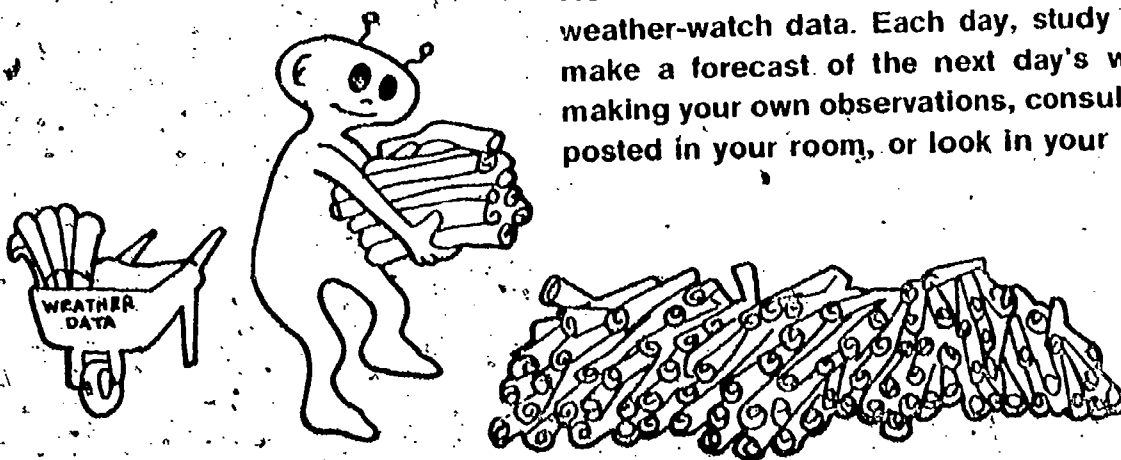

Table 2

Weather Element	Sign	Probable Change in Weather
Air Pressure	Rapid drop	Front approaching—rain or snow
	Rapid rise	Front moving out—clearing and fair
	Steady	Weather remains same.
Clouds	Puffy, scattered cumulus	Fair weather
	Afternoon cumulonimbus clouds	Thunderstorms
	Altostratus	Warm front—no rain unless cloud type changes
Miscellaneous	Cool, clear day with little wind	High pressure over region—weather will probably remain fair.
	Sudden change in wind direction	Advancing or receding front

Your forecast should be recorded in your Record Book and you may also want to post it on the chalkboard or bulletin board. Try to include predictions of the following in your forecast:

1. Cloudiness (increase, decrease, remain the same)
2. Probable wind direction
3. Probable wind speed
4. Barometer reading (fall, rise, remain the same)
5. Probable cloud types
6. Probable temperature range
7. Precipitation expected (amount and type)

Some of these predictions will be quite difficult for the student. For instance, weather in the unit has the concept been developed that wind speed is a function of the separation of the isobars. When isobars are closer together (steep pressure gradient), the winds will be stronger than when the isobars are widely separated.

As each day passes, also make a note of your success. Even with computers, abundant data, and numerous observers, professional weather predictors often have a "batting average" of only 60% 70%. If your predictions are correct even half the time, you are doing pretty well.

You can do your forecast work at the same time that you are beginning the next unit. Try not to let newspaper or television weather forecasts affect your own predictions! The object of this activity is to test how well *your* model works for predicting, not to make perfectly accurate forecasts.

Encourage students to play this "game" of daily forecasting. It is an excellent continuing activity

ACTIVITY 2 (Optional). If you are interested, try making an extended forecast. An extended forecast is usually a weather prediction up to about a week in advance. Extended forecasts are general forecasts. Therefore, you should not be concerned with details as you were for the short-range forecast. For the next week, predict what you believe the outlook will be for your area in terms of the following.

Temperature (warmer or colder than normal for that time of year)

Precipitation (More rainy or less rainy than normal for that time of year)

Movement of fronts through your area

In order to give a general forecast, you may want to find out what the normal temperatures and precipitation amounts are for your local area. You may also want to look at weather-satellite photographs of the clouds over the earth's surface. We'll leave that up to you!

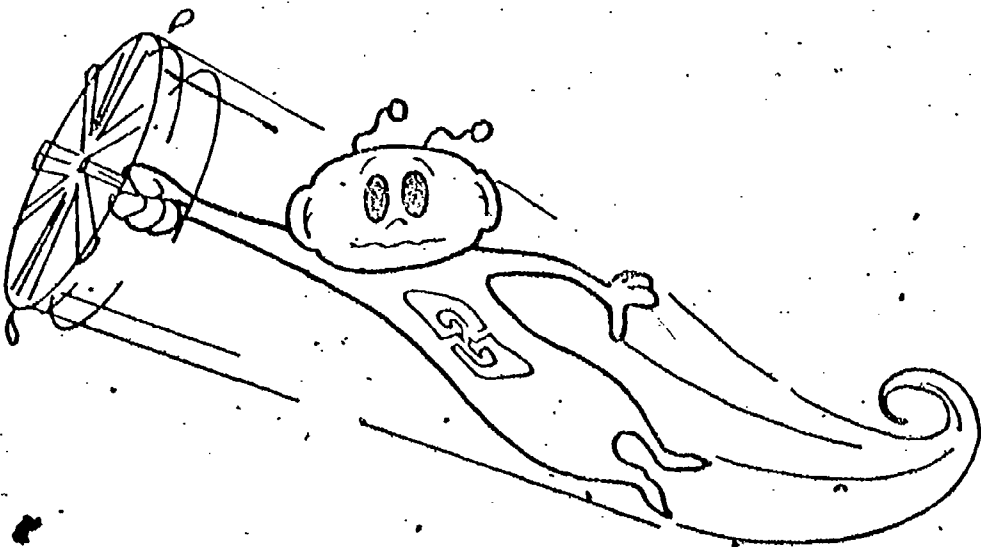

PICTURE CREDITS

T Top
B Bottom
L Left
R Right

x Environmental Science Services Administration (ESSA)
14 ESSA
18 U.S. Forest Service
19 ESSA
20 *The Washington Post*
36 Grant Heilman
47 Bernard Gottfryd from Photo Trends
50 Grant Heilman
54 Bob Towers from Black Star
57, 58 NASA
64 Grant Heilman
65 NASA
77 Grant Heilman
80 UPI
90 NASA
98 ISCS
107 L Harold M. Lambert from Frederic Lewis, Inc.
107 R Sheldon Hine from Frederic Lewis, Inc.
109 ESSA
110 T Grant Heilman
110 B, 111 T ESSA
111 BL, BR Grant Heilman
112 U.S. Forest Service
113 T ESSA
113 B Grant Heilman
114 T Sheldon Hine from Frederic Lewis, Inc.
114 B ESSA
115 T Grant Heilman
115 B ESSA
116 T U.S. Forest Service
116 B Grant Heilman
157 U.S. Forest Service
158 Sheldon Hine from Frederic Lewis, Inc.
159 T Kit and Max Hunn from Frederic Lewis, Inc.
159 B Grant Heilman