

DOCUMENT RESUME

ED 190 370

SE 031 314

AUTHOR Bonar, John R., Ed.; Hathway, James A., Ed.
 TITLE Probing the Natural World, Level III, Record Book, Student Guide: In Orbit. Intermediate Science Curriculum Study.
 INSTITUTION Florida State Univ., Tallahassee. Dept. of Science Education.
 SPONS AGENCY National Science Foundation, Washington, D.C.: Office of Education (DHEW), Washington, D.C.
 PUB DATE 72
 NOTE 54p.: For related documents, see SE 031 300-330, ED 035 559-560, ED 049 032, and ED 052 940. Contains colored drawings and print which may not reproduce well.

EDRS PRICE MF01/PC03 Plus Postage.
 DESCRIPTORS Astronomy: *Energy: Grade 9: Individualized Instruction: Instructional Materials: Junior High Schools: *Laboratory Manuals: Laboratory Procedures: *Measurement: Records (Forms): Science Activities: Science Course Improvement Projects: Secondary Education: Secondary School Science: *Solar Radiation: Space Sciences: *Worksheets
 IDENTIFIERS *Intermediate Science Curriculum Study

ABSTRACT This is the student's edition of the Record Book which accompanies the unit "In Orbit" of the Intermediate Science Curriculum Study (ISCS) for level III students (grade 9). Space is provided for answers to the questions from the student text as well as for the optional excursions and the self evaluation. An introductory note to the student explains how to use the book.
 (SA)

 * Reproductions supplied by EDRS are the best that can be made *
 * from the original document. *

Record Book

In Orbit

U.S. DEPARTMENT OF HEALTH,
EDUCATION & WELFARE
NATIONAL INSTITUTE OF
EDUCATION

THIS DOCUMENT HAS BEEN REPRODUCED EXACTLY AS RECEIVED FROM THE PERSON OR ORGANIZATION ORIGINATING IT. POINTS OF VIEW OR OPINIONS STATED DO NOT NECESSARILY REPRESENT OFFICIAL NATIONAL INSTITUTE OF EDUCATION POSITION OR POLICY.

"PERMISSION TO REPRODUCE THIS MATERIAL HAS BEEN GRANTED BY

Mary L. Charles
of the NSF

TO THE EDUCATIONAL RESOURCES INFORMATION CENTER (ERIC)."



ED190370

SE 031 3/4

Probing the Natural World/3

2

INTERMED. AFE
MUSEUM

THIS BOOK IS THE PROPERTY OF:			
STATE _____		Book No. _____	
PROVINCE _____		Enter information in spaces to the left as instructed	
COUNTY _____			
PARISH _____			
SCHOOL DISTRICT _____			
OTHER _____			
ISSUED TO	Year Used	CONDITION	
		ISSUED	RETURNED
.....		
.....		
.....		
.....		
.....		
.....		
.....		
.....		
.....		

PUPILS to whom this textbook is issued must not write on any page or mark any part of it in any way, consumable textbooks excepted.

1. Teachers should see that the pupil's name is clearly written in ink in the spaces above in every book issued.
2. The following terms should be used in recording the condition of the book: New; Good; Fair; Poor; Bad.

INTERMEDIATE SCIENCE CURRICULUM STUDY

**Record Book
In Orbit**

Probing the Natural World / Level III



GENERAL LEARNING CORPORATION

Morristown, New Jersey • Park Ridge, Ill. • Palo Alto • Dallas • Atlanta

ISCS PROGRAM

- LEVEL I** **Probing the Natural World / Volume 1 / with Teacher's Edition**
Student Record Book / Volume 1 / with Teacher's Edition
Master Set of Equipment / Volume 1
Test Resource Booklet
- LEVEL II** **Probing the Natural World / Volume 2 / with Teacher's Edition**
Record Book / Volume 2 / with Teacher's Edition
Master Set of Equipment / Volume 2
Test Resource Booklet
- LEVEL III** **Why You're You / with Teacher's Edition**
Record Book / with Teacher's Edition / Master Set of Equipment
Environmental Science / with Teacher's Edition
Record Book / with Teacher's Edition / Master Set of Equipment
Investigating Variation / with Teacher's Edition
Record Book / with Teacher's Edition / Master Set of Equipment
In Orbit / with Teacher's Edition,
Record Book / with Teacher's Edition / Master Set of Equipment
What's Up? / with Teacher's Edition
Record Book / with Teacher's Edition / Master Set of Equipment
Crusty Problems / with Teacher's Edition
Record Book / with Teacher's Edition / Master Set of Equipment
Winds and Weather / with Teacher's Edition
Record Book / with Teacher's Edition / Master Set of Equipment
Well-Being / with Teacher's Edition
Record Book / with Teacher's Edition / Master Set of Equipment

ACKNOWLEDGMENTS

The work presented or reported herein was performed pursuant to a Contract with the U. S. Office of Education, Department of Health, Education, and Welfare. It was supported, also, by the National Science Foundation. However, the opinions expressed herein do not necessarily reflect the position or policy of the U. S. Office of Education or the National Science Foundation, and no official endorsement by either agency should be inferred.

© 1972 THE FLORIDA STATE UNIVERSITY

All rights reserved. Printed in the United States of America. Published simultaneously in Canada. Copyright is claimed until 1977. Except for the rights to materials reserved by others, the Publishers and the copyright owner hereby grant permission to domestic persons of the United States and Canada for use of this work without charge in the English language in the United States and Canada after 1977 provided that the publications incorporating materials covered by the copyrights contain an acknowledgment of them and a statement that the publication is not endorsed by the copyright owner. For conditions of use and permission to use materials contained herein for foreign publications in other than the English language, apply to the copyright owner. This publication, or parts thereof, may not be reproduced in any form by photographic, electrostatic, mechanical, or any other method, for any use, including information storage and retrieval, without written permission from the publisher.

ILLUSTRATIONS: © 1972 GENERAL LEARNING CORPORATION.
ALL RIGHTS RESERVED.

ISCS STAFF

David D. Redfield, *Co-Director*
William R. Snyder, *Co-Director*
Ernest Burkman, *Steering Committee Chairman*

- Laura M. Bell, *Artist*
- John R. Bonar, *Editor*
Drennen A. Browne, *Artist*
- Harold L. Buel, *Administration*
Robert L. Conanougher, *Art Director*
- Betsy Conlon Balzano, *Evaluation*
Stewart P. Darrow, *Field Trial-Teacher Education*
George O. Dawson, *Teacher Education*
James A. Hathway, *Editor*
- John S. Hutchinson, *Field Trial Teacher Education*
- Sally Diana Kaicher, *Art Director*
- Jane Larsen, *Art Director*
Adrian D. Lovell, *Administration*
- Audley C. McDonald, *Administration*
- W. T. Myers, *Administration*
Lynn H. Rogers, *Artist*
Stephen C. Smith, *Artist*
Lois S. Wilson, *Assistant Editor*

ISCS ADVISORY COMMITTEE

J. Myron Atkin, *University of Illinois*
Betsy Conlon Balzano, *State University of New York at Brockport*
Werner A. Baum, *University of Rhode Island*
Herman Branson, *Lincoln University*
• Martha Duncan Camp, *The Florida State University*
Clifton B. Clark, *University of North Carolina at Greensboro*
Steve Edwards, *The Florida State University*
Robert M. Gagné, *The Florida State University*
Edward Haensch, *Wabash College*
• Michael Kasha, *The Florida State University*
Russell P. Kropp, *The Florida State University*
J. Stanley Marshall, *The Florida State University*
William V. Mayer, *University of Colorado*
Herman Parker, *University of Virginia*
Craig Sipe, *State University of New York at Albany*
• Harry Sisler, *University of Florida*
Clifford Swartz, *State University of New York at Stony Brook*
Claude A. Welch, *Macalester College*
Gates Willard, *Manhasset Junior High School, Manhasset, N.Y.*
Herbert Zim, *Science Writer, Tavernier, Florida*

• Former member

MATERIALS DEVELOPMENT CONTRIBUTORS

This list includes writing-conference participants and others who made significant contributions to the materials, including text and art for the experimental editions.

Janet Anderson, *Nyack, N.Y.* Gerald R. Bakker, *Esrlham College*. Frank Balzano, *F.S.U.* Harald N. Bliss, *Mayville State College*. Olaf A. Boedtker, *Oregon State Univ.* Calvin E. Bolin, *F.S.U.* Earl Brakken, *Two Harbors, Minn.* Bobby R. Brown, *F.S.U.* Robert J. Callahan, Jr. (deceased). Brian W. Carss, *University of Illinois*. Lois H. Case, *Lombard, Ill.* Clifton B. Clark, *University of North Carolina at Greensboro*. Sara P. Craig, *F.S.U.* John D. Cunningham, *Keene State College*. David H. Dasenbrock, *F.S.U.* Doris Dasenbrock, *F.S.U.* Jeff C. Davis, *University of South Florida*. Alan D. Dawson, *Dearborn Public Schools, Mich.* George O. Dawson, *F.S.U.* Gerrit H. DeBoer, *F.S.U.* Howard E. DeCamp, *Glenn Ellyn, Ill.* James V. DeRose, *Newtown Square, Pa.* William A. Deskin, *Cornell College*. William K. Easley, *Northeast Louisiana State College*. Donald C. Edinger, *University of Arizona*. Camillo Fano, *University of Chicago Laboratory School*. Ronald A. Fisher, *Maquoketa, Iowa*. Edwin H. Flemming, *F.U.S.* Paul K. Flood, *F.S.U.* Harper W. Frantz, *Pasadena City College (Emeritus)*. Earl Friesen, *San Francisco State College*. Bob Galati, *Fullerton, Calif.* J. David Gavenda, *The University of Texas*. Charles A. Gilman, *Winchester, N.H.* Robert J. Goll, *Jacksonville University*. Ralph H. Granger, Jr., *Walpole, N.H.* H. Winter Griffith, *F.S.U.* William Gunn, *Miami, Florida*. John Hart, *Xavier University*. John R. Hassard, *Georgia State University*. J. Dudley Herron, *Purdue University*. Father Francis Heyden, *S.J., Georgetown University*. Leonard Himes, *Sarasota, Florida*. Evelyn M. Hurlburt, *Montgomery Junior College*. John R. Jablonski, *Boston University*. Bert M. Johnson, *Eastern Michigan University*. Roger S. Jones, *University of Minnesota*. Leonard A. Kalal, *Colorado School of Mines*. Theodore M. Kellogg, *University of Rhode Island*. Elizabeth A. Kendzior, *University of Illinois*. F. J. King, *F.S.U.* David Klasson, *Millbuie, Calif.* Ken Kramer, *Wright State University*. William H. Long, *F.S.U.* Robert Lepper, *California State College*. Harold G. Liebherr, *Milwaukee, Wis.* William D. Larson, *College of St. Thomas*. Mable M. Lund, *Beaverton, Oregon*. H. D. Luttrell, *North Texas State University*. Maxwell Maddock, *F.S.U.* Solomon Malinsky, *Sarasota, Florida*. Eloise A. Mann, *Sarasota, Florida*. Harleen W. McAda, *University of California at Santa Barbara*. Auley A. McAuley, *Michigan State University*. E. Wesley McNair, *F.S.U.* Marilyn Miklos, *F.S.U.* Floyd V. Monaghan, *Michigan State University*. Rufus F. Morton, *Westport, Conn.* Tamson Myer, *F.S.U.* Gerald Neufeld, *F.S.U.* James Okey, *University of California*. Lawrence E. Oliver, *F.S.U.* Larry O'Rear, *Alice, Texas*. Herman Parker, *University of Virginia*. Harry A. Pearson, *Western Australia*. James E. Perham, *Randolph-Macon Woman's College*. Darrell G. Phillips, *University of Iowa*. Howard Pierce, *F.S.U.* David Poché, *F.S.U.* Charles O. Pollard, *Georgia Institute of Technology*. Glenn F. Powers, *Northeast Louisiana State College*. Ernest Gene Preston, *Louisville, Ky.* Edward Ramey, *F.S.U.* Earl R. Rich, *University of Miami*. John Schaff, *Syracuse University*. Carroll A. Scott, *Williamsburg, Iowa*. Earle S. Scott, *Ripon College*. Thomas R. Spalding, *F.S.U.* Michael E. Stuart, *University of Texas*. Sister Agnes Joseph Sun, *Marygrove College*. Clifford Swartz, *State University of New York*. Thomas Teates, *F.S.U.* Bill W. Tillery, *University of Wyoming*. Ronald Townsend, *University of Iowa*. Mordecai Treblow, *Bloomsburg State College*. Henry J. Triesenberg, *National Union of Christian Schools*. Paul A. Vestal, *Rollins College*. Robert L. Vickery, *Western Australia*. Frederick B. Voight, *F.S.U.* Claude A. Welch, *Macalester College*. Paul Westmeyer, *F.S.U.* Earl Williams, *University of Tampa*. G. R. Wilson, Jr., *University of South Alabama*. Harry K. Wong, *Atherton, California*. Charles M. Woolheater, *F.S.U.* Jay A. Young, *King's College*. Victor J. Young, *Queensborough Community College*.

The genesis of some of the ISCS material stems from a summer writing conference in 1964. The participants were:

Frances Abbott, *Miami-Dade Junior College*. Ronald Atwood, *University of Kentucky*. George Assousa, *Carnegie Institute*. Colin H. Barrow, *University of West Indies*. Peggy Baziel, *F.S.U.* Robert Binger (deceased). Donald Bucklin, *University of Wisconsin*. Martha Duncan Camp, *F.S.U.* Roy Campbell, *Broward County Board of Public Instruction, Fla.* Bruce E. Cleare, *Tallahassee Junior College*. Ann-cile Hall, *Pensacola, Florida*. Charles Holcolmb, *Mississippi State College*. Robert Kemman, *Mt. Prospect, Ill.* Gregory O'Berry, *Coral Gables, Florida*. Elra Palmer, *Baltimore*. James Van Pierce, *Indiana University Southeast*. Guenter Schwarz, *F.S.U.* James E. Smeland, *F.S.U.* C. Richard Tillis, *Pine Jog Nature Center, Florida*. Peggy Wiegand, *Emory University*. Elizabeth Woodward, *Augusta College*. John Woolever, *Sarasota, Florida*.

Foreword

A pupil's experiences between the ages of 11 and 16 probably shape his ultimate view of science and of the natural world. During these years most youngsters become more adept at thinking conceptually. Since concepts are at the heart of science, this is the age at which most students first gain the ability to study science in a really organized way. Here, too, the commitment for or against science as an interest or a vocation is often made.

Paradoxically, the students at this critical age have been the ones least affected by the recent effort to produce new science instructional materials. Despite a number of commendable efforts to improve the situation, the middle years stand today as a comparatively weak link in science education between the rapidly changing elementary curriculum and the recently revitalized high school science courses. This volume and its accompanying materials represent one attempt to provide a sound approach to instruction for this relatively uncharted level.

At the outset the organizers of the ISCS Project decided that it would be shortsighted and unwise to try to fill the gap in middle school science education by simply writing another textbook. We chose instead to challenge some of the most firmly established concepts about how to teach and just what science material can and should be taught to adolescents. The ISCS staff have tended to mistrust what authorities believe about schools, teachers, children, and teaching until we have had the chance to test these assumptions in actual classrooms with real children. As conflicts have arisen, our policy has been to rely more upon what we saw happening in the schools than upon what authorities said could or would happen. It is largely because of this policy that the ISCS materials represent a substantial departure from the norm.

The primary difference between the ISCS program and more conventional approaches is the fact that it allows each student to travel

at his own pace, and it permits the scope and sequence of instruction to vary with his interests, abilities, and background. The ISCS writers have systematically tried to give the student more of a role in deciding what he should study next and how soon he should study it. When the materials are used as intended, the ISCS teacher serves more as a "task easer" than a "task master." It is his job to help the student answer the questions that arise from his own study rather than to try to anticipate and package what the student needs to know.

There is nothing radically new in the ISCS approach to instruction. Outstanding teachers from Socrates to Mark Hopkins have stressed the need to personalize education. ISCS has tried to do something more than pay lip service to this goal. ISCS' major contribution has been to design a system whereby an average teacher, operating under normal constraints, in an ordinary classroom with ordinary children, can indeed give maximum attention to each student's progress.

The development of the ISCS material has been a group effort from the outset. It began in 1962, when outstanding educators met to decide what might be done to improve middle-grade science teaching. The recommendations of these conferences were converted into a tentative plan for a set of instructional materials by a small group of Florida State University faculty members. Small-scale writing sessions conducted on the Florida State campus during 1964 and 1965 resulted in pilot curriculum materials that were tested in selected Florida schools during the 1965-66 school year. All this preliminary work was supported by funds generously provided by The Florida State University.

In June of 1966, financial support was provided by the United States Office of Education, and the preliminary effort was formalized into the ISCS Project. Later, the National Science Foundation made several additional grants in support of the ISCS effort.

The first draft of these materials was produced in 1968, during a summer writing conference. The conferees were scientists, science educators, and junior high school teachers drawn from all over the United States. The original materials have been revised three times prior to their publication in this volume. More than 150 writers have contributed to the materials, and more than 180,000 children, in 46 states, have been involved in their field testing.

We sincerely hope that the teachers and students who will use this material will find that the great amount of time, money, and effort that has gone into its development has been worthwhile.

Tallahassee, Florida
February 1972

The Directors
INTERMEDIATE SCIENCE CURRICULUM STUDY

Contents

FOREWORD	v
NOTES TO THE STUDENT	ix
CHAPTERS	
1 The Message of Sunlight	1
2 Watts New?	3
3 Far-Out Sun	7
4 Measuring the Distance to the Sun—Another Approach	9
5 How Big Is the Sun?	12
6 The Fiery Chariot	13
7 On Your Own	16
EXCURSIONS	
1-1 Those Strange Dark Lines	19
2-1 Energy at Work	20
3-1 The Moon's Measurements	20
4-1 What's Radar?	20
4-2 Angles and Protractors	20
4-3 Scale Drawings	21
4-4 Practice in Using Scale Drawings	22
5-1 Moon Gazing	22
6-1 The Night That People Lost 10 Days	23
6-2 Matching Wits with Galileo	23
7-2 Using Squares to Measure Distance	23
How Well Am I Doing?	25

SELF-EVALUATIONS

1	27
2	28
3	30
4	32
5	34
6	35
7	37

SELF-EVALUATION ANSWER KEY	39
-----------------------------------	-----------

MY PROGRESS	45
--------------------	-----------

Notes to the Student

This Record Book is where you should write your answers. Try to fill in the answer to each question as you come to it. If the lines are not long enough for your answers, use the margin, too.

Fill in the blank tables with the data from your experiments. And use the grids to plot your graphs. Naturally, the answers depend on what has come before in the particular chapter or excursion. Do your reading in the textbook and use this book only for writing down your answers.

1-1. _____

1-2. _____

1-3. _____

1-4. _____

1-5. _____

1-6. _____

1-7. _____

Chapter 1
The Message
of Sunlight

1-8.

--	--	--	--	--	--	--

Violet Blue Green Yellow Orange Red

1-9.

--	--	--	--	--	--	--

Violet Blue Green Yellow Orange Red

1-10.

--	--	--	--	--	--	--

Violet Blue Green Yellow Orange Red

PROBLEM BREAK 1-1

1-11.

--	--	--	--	--	--	--

Violet Blue Green Yellow Orange Red

1-12.

CHECKUP

**Chapter 2
Watts New?**

- | | |
|---|---|
| 1. Work is | 2. A measure of energy is |
| a. force. | a. force. |
| b. distance. | b. force \times distance. |
| c. force \times distance. | c. speed \times time. |
| d. speed \times time. | d. work. |
| 3. Energy can | 4. Energy is always |
| a. exist only in the form of heat. | a. conserved. |
| b. exist in more than one form. | b. destroyed. |
| c. be transferred from one system to another. | c. needed to overcome forces. |
| d. cause changes in matter. | d. a measure of the time needed to do work. |

- 2-1. _____
- 2-2. _____
- 2-3. _____
- 2-4. _____
- 2-5. _____
- 2-6. _____
- 2-7. _____
- 2-8. _____
- _____

Table 2-1

Time (minutes)	Temperature (°C)	Total Temperature Change (°C)
0.0		
0.5		
1.0		
1.5		
2.0		
2.5		
3.0		
3.5		
4.0		
4.5		
5.0		

Figure 2-1

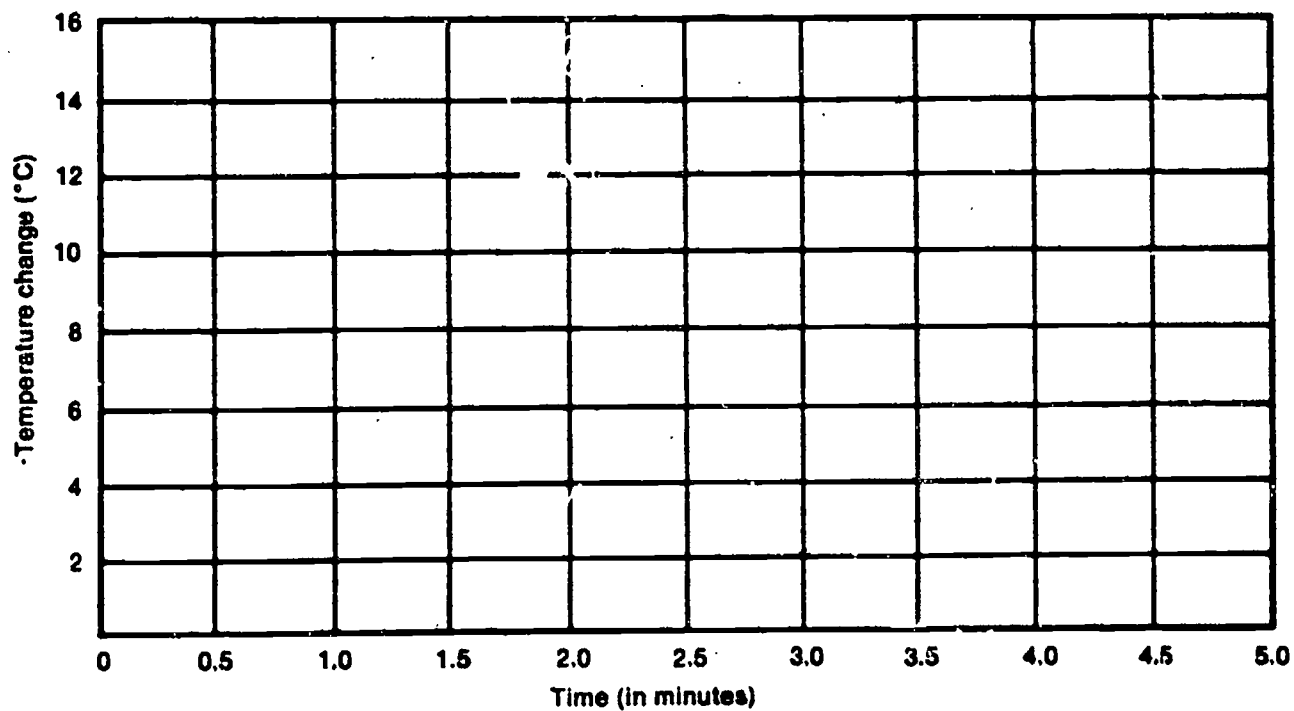

2-9. _____

2-10. _____

2-11. _____

Table 2-2

Bulb	Original Temperature	Maximum Temperature	Temperature Change
60W			
100W			
150W			

2-12. _____

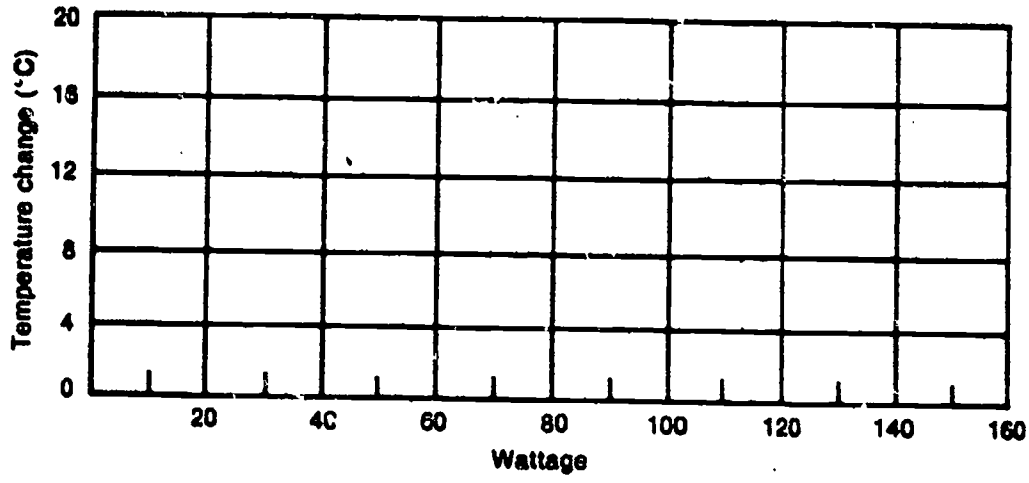

Figure 2-2

2-13. _____

2-14. _____

2-15. _____

PROBLEM BREAK 2-1

Graph for Problem Break 2-1

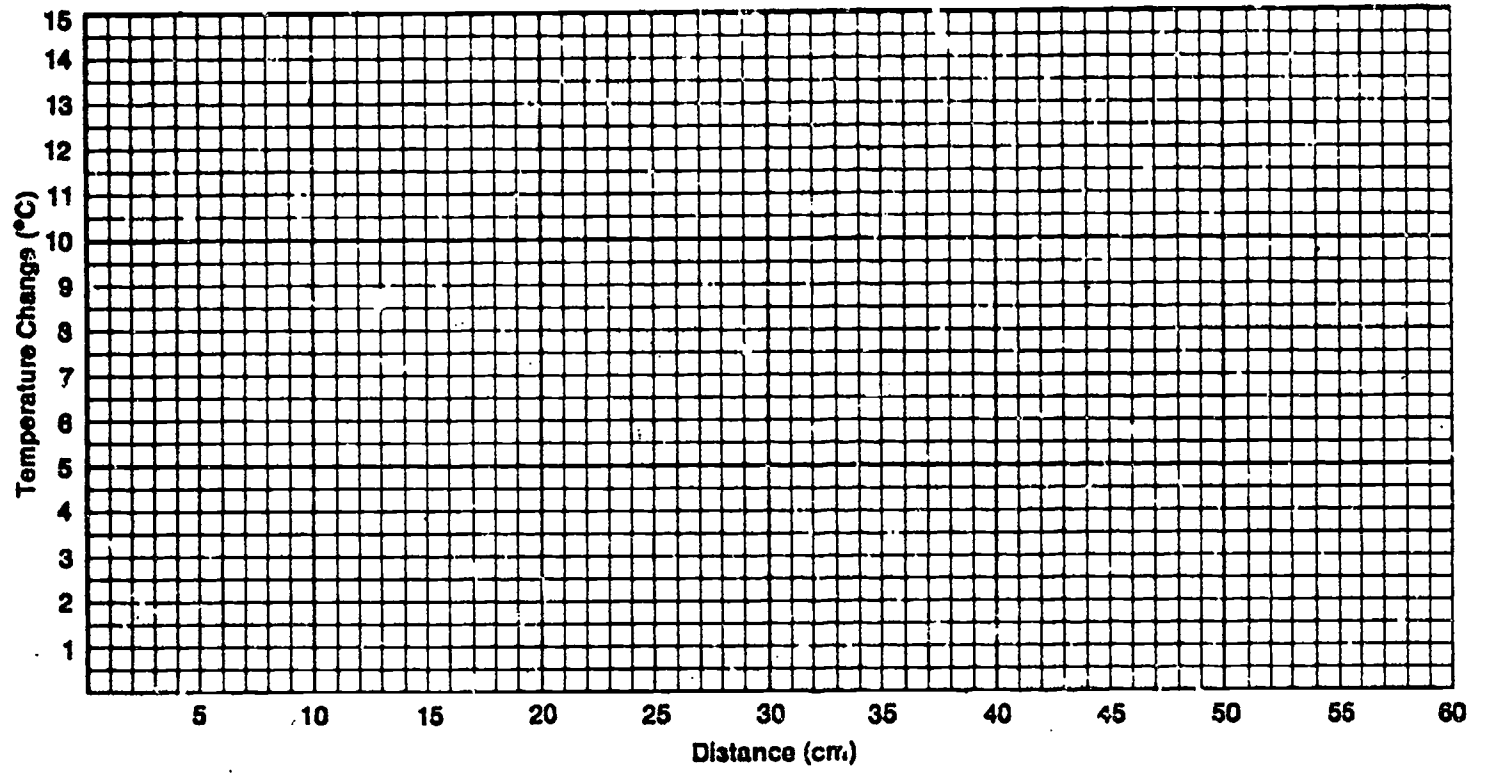

2-16. _____

2-17. _____

2-18. _____

2-19. _____

2-20. _____

2-21. _____

2-22. _____

3-1. _____

Chapter 3
Far-Out Sun

3-2. _____

3-3. _____

3-4. _____

3-5. _____

3-6. _____

3-7. _____

3-8. _____

PROBLEM BREAK 3-1

3-9. _____

3-10. _____

4-1. _____

4-2. _____

4-3. _____

Chapter 4
Measuring the
Distance to the
Sun—Another
Approach

ACTIVITY 4-1

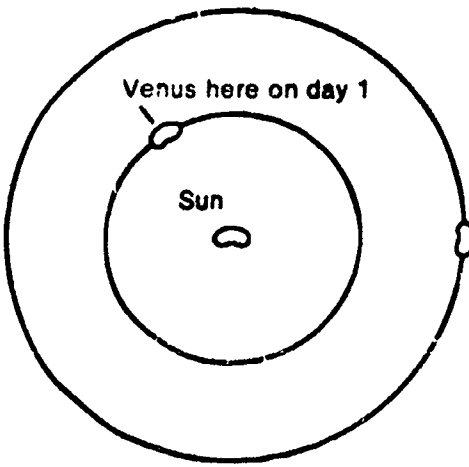

4-4. Figure 4-3

Earth here on day 1 and day 365 1/4

4-5. _____

4-6. _____

4-7. _____

4-8. _____

4-8. _____

ACTIVITY 4-6.

4-10. _____

4-11. _____

ACTIVITY 4-7.

CHECKUP

1. _____

2. _____

4-12. _____

4-13. _____

Table 4-2

	On Scale Drawing (mm)	Actual (miles)
Distance from Venus to the sun		
Distance from Earth to the sun		
Smallest distance between Earth and Venus		26 million

4-14. _____

4-15. _____

Chapter 5
How Big
Is the Sun?

5-1. _____

5-2. _____

5-3. _____

5-4. _____

5-5. _____

5-6. _____

ACTIVITY 6-1.

Chapter 6
The Fiery
Chariot

- 6-1. _____
- 6-2. _____
- 6-3. _____
- 6-4. _____
- 6-5. _____
- 6-6. _____
- 6-7. _____
- 6-8. _____
- 6-9. _____

PROBLEM BREAK 6-1

6-10. _____

6-11. _____

6-12. _____

6-13. _____

6-14. _____

6-15. _____

6-16. _____

PROBLEM BREAK 6-2

Chapter 7
On Your Own

7-1. _____

7-2. _____

7-3. _____

7-4. _____

7-5. _____

7-6. _____

Excursions

29

17

**Excursion 1-1
Those Strange
Dark Lines**

1.

--	--	--	--	--	--	--

Violet Blue Green Yellow Orange Red

2.

--	--	--	--	--	--	--

Violet Blue Green Yellow Orange Red

3.

4.

**Excursion 2-1
Energy at Work**

- 1. _____
- _____
- 2. _____
- 3. _____
- 4. _____
- _____

**Excursion 3-1
The Moon's
Measurements**

- 1. _____
- 2. _____
- 3. _____
- 4. _____
- 5. _____

**Excursion 4-1
What's Radar?**

- 1. _____
- 2. _____
- 3. _____

**Excursion 4-2
Angles and
Protractors**

- 1. _____
- 2. _____
- 3. _____
- _____
- 4. _____

5. _____

Table 1

Figure	Angle (°)
A	
B	
C	
D	

6.

1. _____

2. _____

3. _____

4. A. _____

B. _____

C. _____

Excursion 4-3
Scale Drawings

Excursion 4-4
Practice in
Using Scale
Drawings

- 1. _____
- 2. _____
- 3. _____
- 4. _____

Table 1

	Scale Drawing (Distance in mm)	Actual Distance (in miles)
Venus to Sun (VS)	43	
Earth to Sun (ES)	60	
Earth to Venus (EV)	17	

Excursion 5-1
Moon Gazing

- 1. _____
- 2. _____
- 3. _____
- 4. _____
- 5. _____
- 6. _____
- 7. _____
- 8. _____
- 9. _____

1. _____

2. _____

3. _____

4. _____

5. _____

**Excursion 6-1
The Night That
People Lost
10 Days**

1. _____

2. _____

**Excursion 6-2
Matching Wits
with Galileo**

1. _____

2. _____

3. _____

4. _____

5. _____

**Excursion 7-2
Using Squares
to Measure
Distance**

How Well Am I Doing?

You probably wonder what you are expected to learn in this science course. You would like to know how well you are doing. This section of the book will help you find out. It contains a Self-Evaluation for each chapter. If you can answer all the questions, you're doing very well.

The Self-Evaluations are for your benefit. Your teacher will not use the results to give you a grade. Instead, you will grade yourself, since you are able to check your own answers as you go along.

Here's how to use the Self-Evaluations. When you finish a chapter, take the Self-Evaluation for that chapter. After answering the questions, turn to the Answer Key that is at the end of this section. The Answer Key will tell you whether your answers were right or wrong.

Some questions can be answered in more than one way. Your answers to these questions may not quite agree with those in the Answer Key. If you miss a question, review the material upon which it was based before going on to the next chapter. Page references are frequently included in the Answer Key to help you review.

On the next to last page of this booklet, there is a grid, which you can use to keep a record of your own progress.

If you did any excursions for this chapter, write their numbers here.

SELF-EVALUATION I

1-1. Sunlight reflected from a piece of white paper and passed through a spectroscope produces what kind of spectrum?

1-2. Describe the differences between the fluorescent-tube spectrum and the sunlight spectrum.

1-3. A student uses a nichrome wire to put a solution of sodium chloride into an alcohol flame. He then views, through a spectroscope, the light given off.

A. What type of spectrum does he see?

B. In the space below, sketch the spectrum of sodium chloride.

--	--	--	--	--	--	--

Violet Blue Green Yellow Orange Red

1-4. The spectrum below is an example of a (check one)

_____ bright-line spectrum.

_____ continuous spectrum.

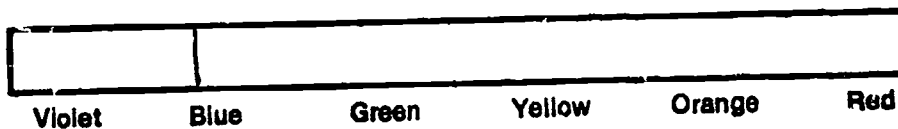

1-5. Obtain the container labeled "Ques. 1-5" from your teacher. Use a flame test to determine which of the elements (Na, Li, Sr) the solution contains.

1-6. Put a check in those blocks that describe the spectrum produced by each of the following sources.

Source	Continuous	Bright-Line
75-watt bulb		
Fluorescent tube		
Sodium vapor lamp		
Reflected sunlight		

SELF-EVALUATION 2 If you did any excursions for this chapter, write their numbers here.

2-1. Explain why the blades of the sun-energy measurer were blackened.

2-2. List at least three factors that affect the temperature change of a sun-energy measurer.

A. _____

B. _____

C. _____

2-3. Using your sun-energy measurer, measure the temperature change caused by the light bulb that your teacher has prepared. Check your answer with your teacher. What was the maximum temperature change?

2-4. When a sun-energy measurer is placed 50 cm from a 100-watt bulb, there is a temperature change of 4°C . If the distance is not changed and a second 100-watt bulb is added in parallel, what will the temperature change be?

2-5. A sun-energy measurer has a maximum temperature change of 1°C when it is placed 100 cm from a 150-watt bulb. What will be the maximum temperature change when it is placed 50 cm from the bulb?

2-6. The data in the table below were obtained using a sun-energy measurer, a 100-watt bulb, and various distances.

Distance (cm)	Initial Temperature $^{\circ}\text{C}$	Final Temperature $^{\circ}\text{C}$	Temperature Change $^{\circ}\text{C}$
10	25.4 $^{\circ}$	38.4 $^{\circ}$	
15	25.0 $^{\circ}$	32.0 $^{\circ}$	
20	25.2 $^{\circ}$	29.2 $^{\circ}$	
25	25.0 $^{\circ}$	27.5 $^{\circ}$	
30	24.9 $^{\circ}$	26.5 $^{\circ}$	
35	25.1 $^{\circ}$	26.1 $^{\circ}$	

A. Complete the above table by calculating the temperature change.

B. On the grid below, plot the temperature change against the distance.

C. Predict the temperature change at 40 cm.

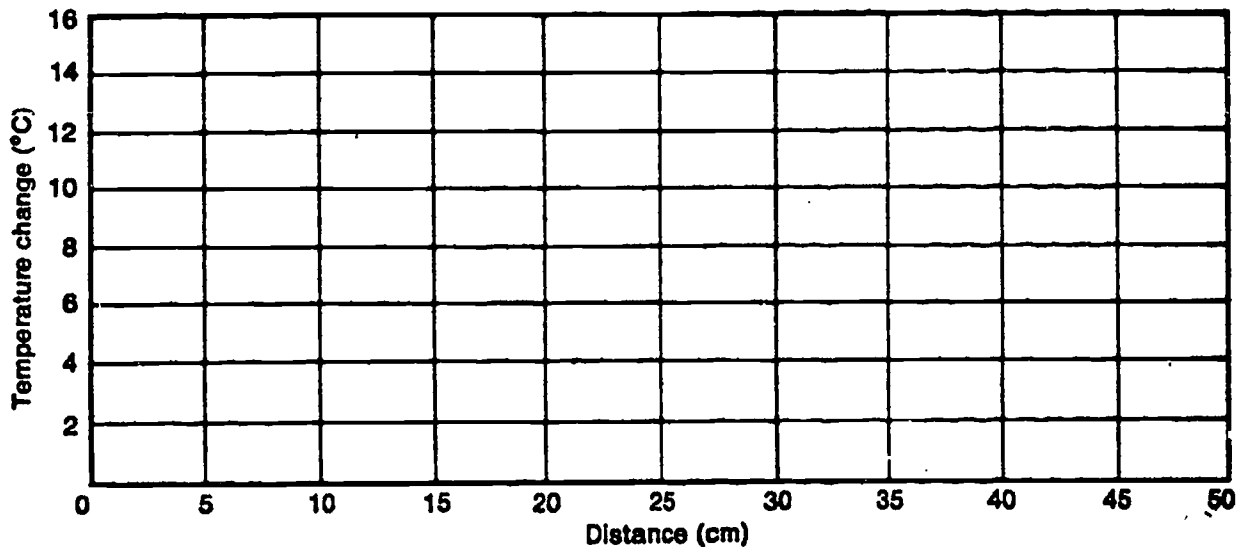

SELF-EVALUATION 3

If you did any excursions for this chapter, write their numbers here.

3-1. Use the diagram below to answer this question. The diagram illustrates a range finder sighted at an object.

A. Label the base line, the sighting line, and the sighting bar on the diagram.

B. Suppose the range finder were moved farther from the object, but the sighting line was kept lined up with the object. Check the phrase below that best describes what you would need to do to align the sighting bar.

- a. Move the sighting bar toward the base line.
- b. Move the sighting bar away from the base line.
- c. Leave the sighting bar in the same position.

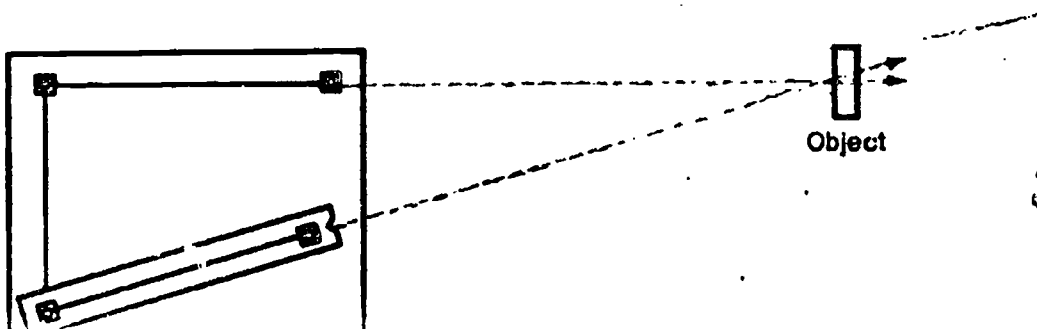

3-2. The diagram below shows a range-finder scale similar to the one you made for distances of 1 m to 15 m.

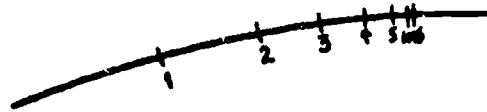

A. Describe how the distance between the scale markings changes as the distance to the object increases.

B. Describe how you could change your range finder so that there would be more space between the scale markings.

3-3. What are some of the factors that limit the distance you can measure with a range finder?

3-4. Your teacher has labeled an object "3-4A" somewhere in the room; he has also marked with an "X" a place for you to stand. Using your range finder, stand at the place marked "X" and sight the object labeled "3-4A." What is the distance to the object?

3-5. An astronomer made sightings at object Z from two observatories located at X and Y as shown in the diagram below. Which line on the diagram represents the base line? (check one)

- a. Line XZ
- b. Line XY
- c. Line YZ
- d. None of the above

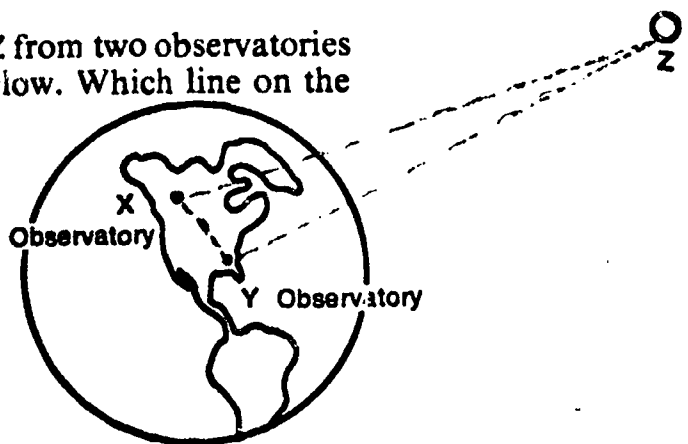

SELF-EVALUATION 4 If you did any excursions for this chapter, write their numbers here.

4-1 Using your protractor, measure the four angles shown below. The curved line indicates the angle that you are to measure.

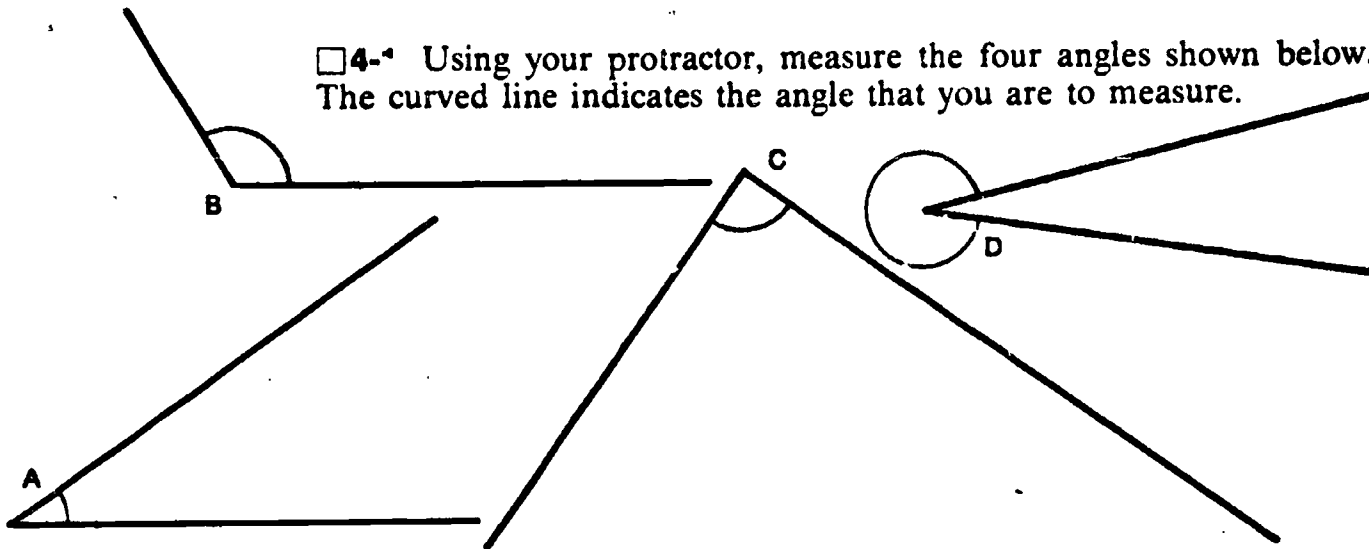

Angle A = ____ Angle B = ____ Angle C = ____ Angle D = ____

4-2. Use the scale drawing below to answer both parts of this question. (Measure the distance "as the crow flies" not the distance by road.)

A. How far in centimeters is Union Park from Christmas on the drawing?

B. What is the actual distance in miles between Union Park and Christmas?

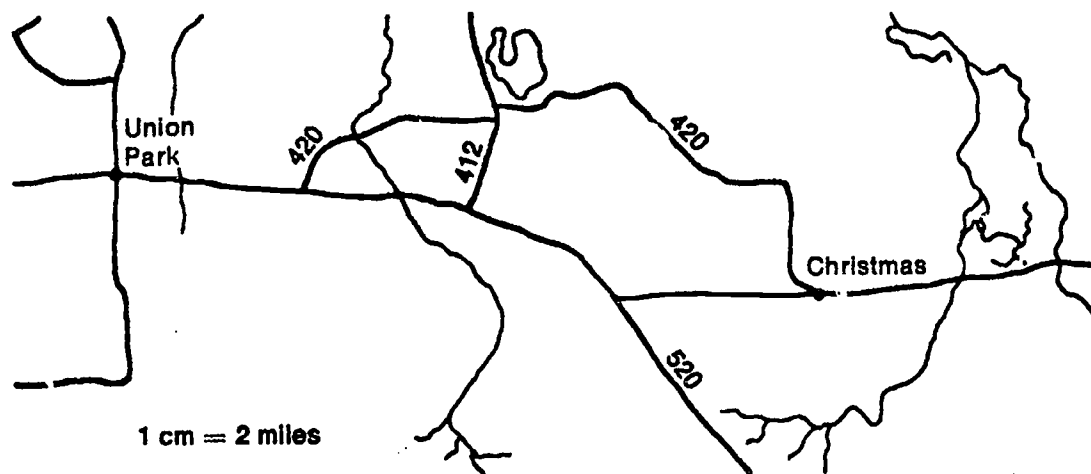

4-3. Use the diagram below for both parts of this question.

A. As seen from the earth, Planet X is how many degrees from the sun?

B. What is the greatest possible EX-ES angle for Planet X on this diagram?

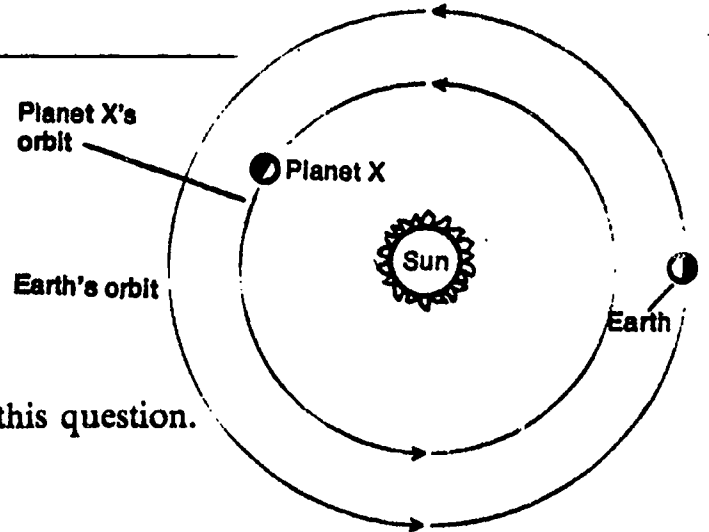

4-4. Use the diagram below to answer all parts of this question.

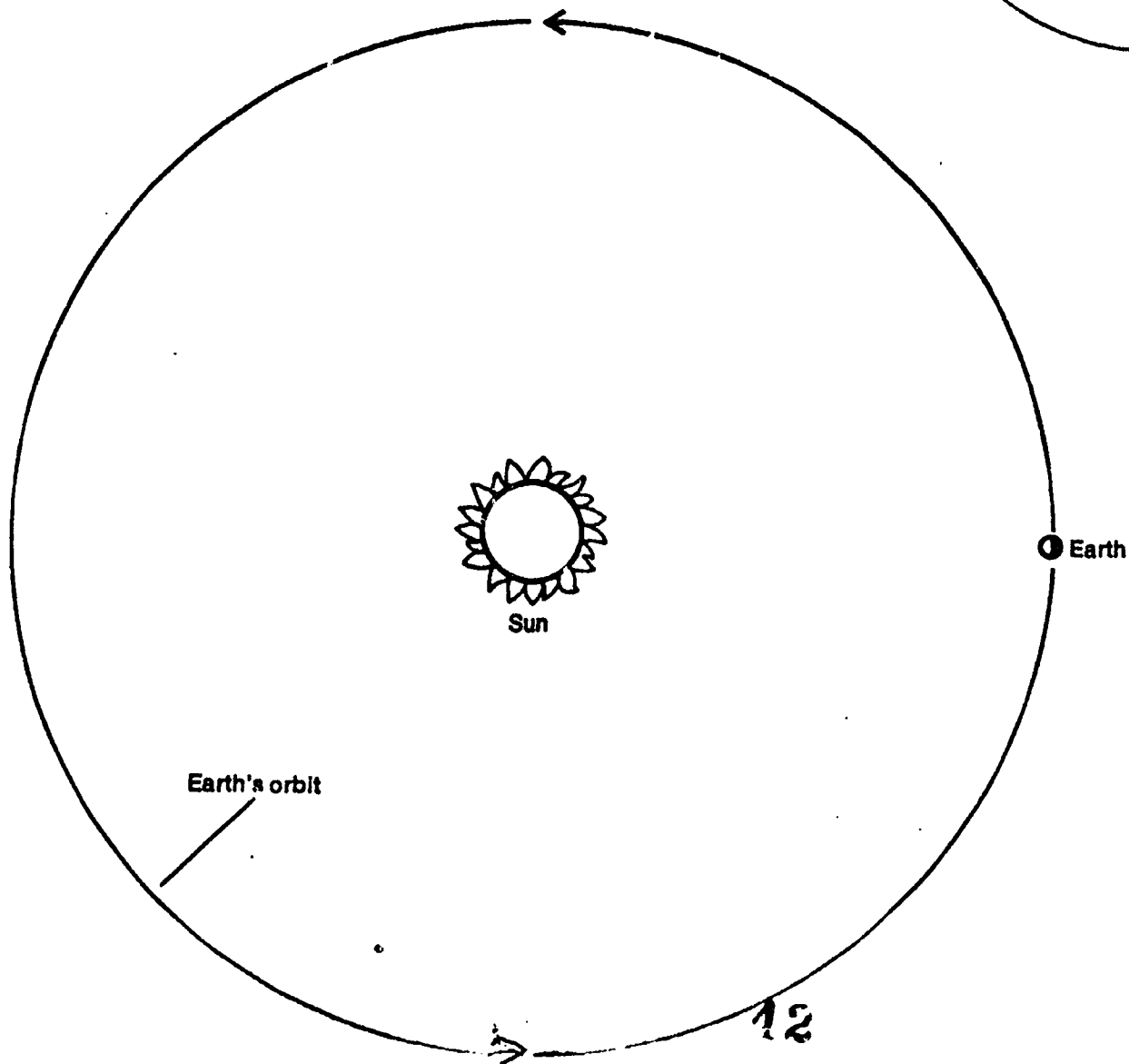

- A. Draw in an earth-sun line on the diagram.
- B. When, as seen from the earth, the Planet Z is at its greatest angle from the sun, the angle is 22° . Using your protractor, draw in the earth-Planet Z line when the EZ-ES angle is greatest (22 degrees).
- C. Using your compass, draw the orbit circle for Planet Z.
- D. Measure the distance between the earth and the sun. Record this distance in mm on line 2 of the table below.
- E. On your scale, 1 mm equals how many miles?

F. What is the distance in miles from Planet Z to the sun?

G. What is the smallest distance between earth and Planet Z?

		Scale Drawing (mm)	Actual Distance (miles)
1	Distance from Planet Z to sun		
2	Distance from earth to sun		93,000,000
3	Smallest distance between earth and Planet Z		

SELF-EVALUATION 5 If you did any excursions for this chapter, write their numbers here.

5-1. Describe the relationship between the size of the image formed and its distance from the pinhole and the size of the object and its distance from the pinhole.

5-2. Your teacher has prepared an area where you will measure the size of a light source from three different distances. Take a pinhole-screen instrument to this area, and measure the size of the light source from Point A, Point B, and Point C. Keep the tube at its shortest length. The size of the image produced by the source when at

Point A = _____ cm across.

Point B = _____ cm across.

Point C = _____ cm across.

5-3. Using a pinhole-screen instrument, a student made some measurements to determine the diameter of the moon. Using his data (shown below), calculate the diameter of the moon.

Distance from moon to pinhole = 240,000 miles

Distance from pinhole to screen = 57 cm

Size of moon image on screen = $\frac{1}{2}$ cm

Actual distance to moon = _____ miles

5-4. A light source that is 6 cm in diameter forms a sharp image $\frac{1}{2}$ cm in diameter on the screen of your tube. The tube is adjusted so that the distance between the screen and pinhole is 20 cm. You do not know the distance from the light source to the pinhole of your tube.

A. In the space below, sketch a diagram that illustrates this problem.

B. How far away is the object from the pinhole?

If you did any excursions for this chapter, write their numbers here.

SELF-EVALUATION 6

6-1. Answer the following questions based on the earth-sun model that you worked with in this chapter.

A. Through how many degrees does the earth turn from sunrise to sunset?

_____ 14 _____

B. How many hours pass between the time the sun is overhead and the time it sets?

6-2. How many time zones would you expect to cross if you made a trip around the world?

6-3. The time difference between New York and San Francisco is three hours. How many degrees on the surface of the earth does this represent?

6-4. A student takes his paper, sinker, and string outside on a bright sunny day to measure the movement of the sun. He says that the activity is no good because the string does not cast a shadow. What is the problem?

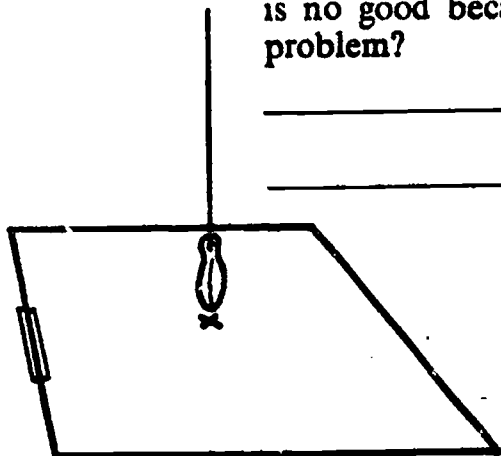

6-5. The diagram below shows two towns located the same distance north of the equator. Determine the time difference between them.

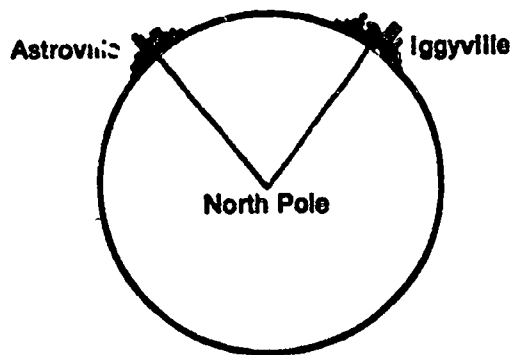

6-6. Why is it more logical to think that the earth moves around the sun, even though you have not been able to prove it?

If you did any excursions for this chapter, write their numbers here.

SELF-EVALUATION 7

7-1. What is a pyrheliometer?

7-2. When you double the distance from a light bulb, what must you do to the wattage of the bulb to keep the sun-energy measurer reading the same?

7-3. Complete the table below.

**DISTANCES AND WATTAGES REQUIRED TO KEEP
THE SAME READING ON A SUN-ENERGY MEASURER**

Measured Distance	Wattage
80 cm	3,200 watts
160 cm	
	51,200 watts
640 cm	
2,560 cm	

37

7-4. Design an experiment to determine if a blue-colored 50-watt light bulb produces the same temperature change as an uncolored 50-watt light bulb when placed 10, 20, and 40 cm away from your sun-energy measurer. Use the space below for your answer.

Self-Evaluation Answer Key

SELF-EVALUATION 1

1-1. A continuous spectrum. A continuous spectrum is like a rainbow of red, orange, yellow, green, blue, and violet. Try Activity 1-1 again if you had difficulty with this question.

1-2. The spectrum of a fluorescent tube forms a continuous spectrum like that of sunlight and in addition you can see several bright lines on it. Try looking at the spectrum again if you forgot what it looked like.

1-3. A. Bright-line spectrum. The yellow lines (there are two of them if you look carefully) are caused by the sodium. The chlorine in the sodium chloride does not produce a spectrum at this temperature.

B.



1-4. Bright-line spectrum

1-5. Check your answer with your teacher. If you had difficulty in identifying the element(s) present, you should do Activities 1-4 to 1-9 again.

1-6. Your completed chart should look like the one below. Remember that a fluorescent tube produces both a bright-line and a continuous spectrum.

Source	Continuous	Bright-Line
75-watt bulb	✓	
Fluorescent tube	✓	✓
Sodium vapor lamp		✓
Reflected sunlight	✓	

SELF-EVALUATION 2

2-1. The blades were blackened so that they would absorb light energy and convert it into heat energy more efficiently. You may have noticed this effect in the summer when walking barefoot—it's not too bad on light-colored concrete but look out for the black asphalt!

2-2. You could have listed quite a number of factors, including such things as whether or not the copper fin had been blackened, but there are three very important factors:

- A. The intensity of the light source—the brighter the bulb, the greater will be the temperature change.
- B. The distance between the sun-energy measurer and the light source—the smaller the separation, the greater will be the temperature change.
- C. The length of time that the sun-energy measurer has been exposed to the light source. This is only noticeable for the first few minutes. After that the temperature changes very little or not at all. When this *equilibrium* temperature is reached, the copper strip is losing heat energy as fast as it is absorbing energy from the light.

2-3. Your answer should be fairly close to 15°C. If you were not close to this answer, you may not have allowed enough time for your sun-energy measurer to heat up. If this doesn't solve your problem, check with your teacher to see whether your sun-energy measurer is working properly.

2-4. Just about 8°C. Since you have doubled the wattage of the light source, you should expect that the temperature change should double. If you had difficulty with this question, you may want to try Activities 2-9 and 2-10 again to make sure that you understand the idea.

2-5. Since you have moved the source to half its original distance from the sun-energy measurer, you should have predicted a temperature change of about 4°C. Try Problem Break 2-1 again if your prediction was off.

2-6. A. Your chart should be completed as shown below.

Distance (cm)	Initial Temperature °C	Final Temperature °C	Temperature Change °C
10	25.4°	38.4°	13.0°
15	25.0°	32.0°	7.0°
20	25.2°	29.2°	4.0°
25	25.0°	27.5°	2.5°
30	24.9°	26.5°	1.6°
35	25.1°	26.1°	1.0°

B. Your graph should look like the one shown below.

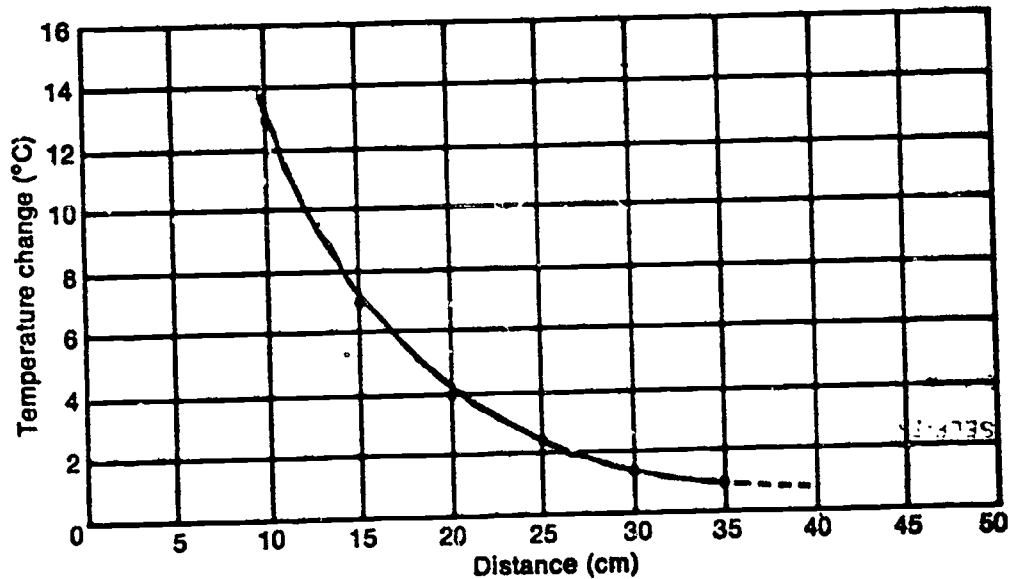

C. Your predicted value should be about 0.8°C . You can extend the curve on the graph by a dashed line, as shown.

SELF-EVALUATION 3

3-1. A. You should have labeled your diagram as indicated below.

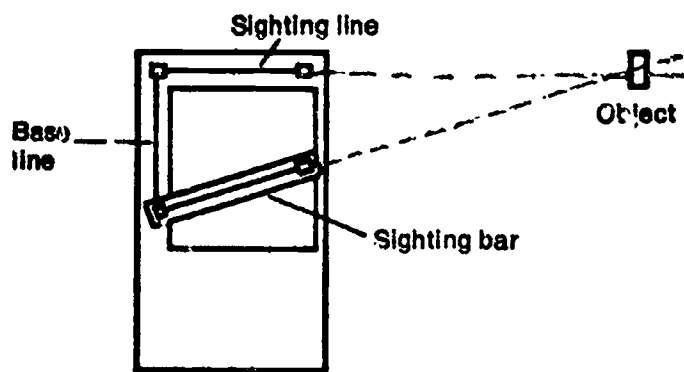

B. b. Move the sighting bar away from the base line. If you had difficulty with this question, get a range finder from the supply area and try it out.

3-2. A. The markings on the scale get closer together as the distance measured increases.

B. Here was your chance to be a real inventor. Two of the ideas you may have suggested are (a) make the base line longer; (b) make the sighting bar longer.

3-3. You could have listed many different factors. The two main ones are (a) the length of the base line; (b) the smallest angle that you can measure. You may also have mentioned such factors as difficulty in keeping the sighting line pointing at the object while moving the sighting bar, and problems lining up the same part of the sighting bar with the object each time.

3-4. 3.75 meters. You should be pretty good at measuring distances with your range finder by now. If you are still having difficulties, you may want to discuss this with your teacher.

3-5. b. The line XY represents the base line. Astronomers make sightings from observatories many miles apart to increase the size of their base line. This helps them measure the distance to a distant object. However, in some cases (such as measuring the distance to the sun or to a star), astronomers find that the angle that is to be measured is so small that even using the diameter of the earth as a base line is not enough. (See pages 30 and 31 in your text.) Now if we made one observation in January and another one in July Hmm.

SELF-EVALUATION 4

4-1. A. Angle A = 35° , Angle B = 121° , Angle C = 90° , Angle D = 338° . If you measured all four angles correctly, you are doing very well. If you are having difficulty measuring angles, you should do Excursion 4-3.

4-2. A. 8 centimeters; B. 16 miles. If you look at the scale drawing, you will notice that it says that 1 cm equals two miles. If Union Park is 8 cm from Christmas and each centimeter equals two miles, then Union Park is 16 miles from Christmas. If you are having problems with scale diagrams, you should work through Excursion 4-1.

4-3. A. As seen from Earth, Planet X is 12° from the sun.

B. The greatest possible EX-ES angle for Planet X in this diagram is 45° .

If your answers are not within one to two degrees of the answer given, you should check with your teacher or review pages 35, 37, and 40 in your text

4-1. The students may have difficulty with 338° . They have not been called upon to measure an angle greater than 180° previously. You may have to show them either of two methods:

(a) Extend one side of the angle through the vertex to make a straight angle; measure the angle between this extension and the other side of the angle (158°); add this measurement to 180° .

(b) Measure the acute angle (the part without the curved line, 22°) with the protractor; subtract this measurement from 360° .

4-4. **A, B, C.** Your diagram should look like the one shown below. **D, E.** The distance you should have measured between the earth and the sun is 64 mm, so that on your scale 1 mm = 1,450,000 miles. **F.** Planet Z should be about 24 mm from the sun. This is equal to 34,800,000 miles. **G.** The smallest distance between the earth and Planet Z is 40 mm. This is equal to 58,200,000 miles. If you got all parts of this question correct, you did very well. If you had some difficulties, you may want to review pages 40 and 41 in your text.

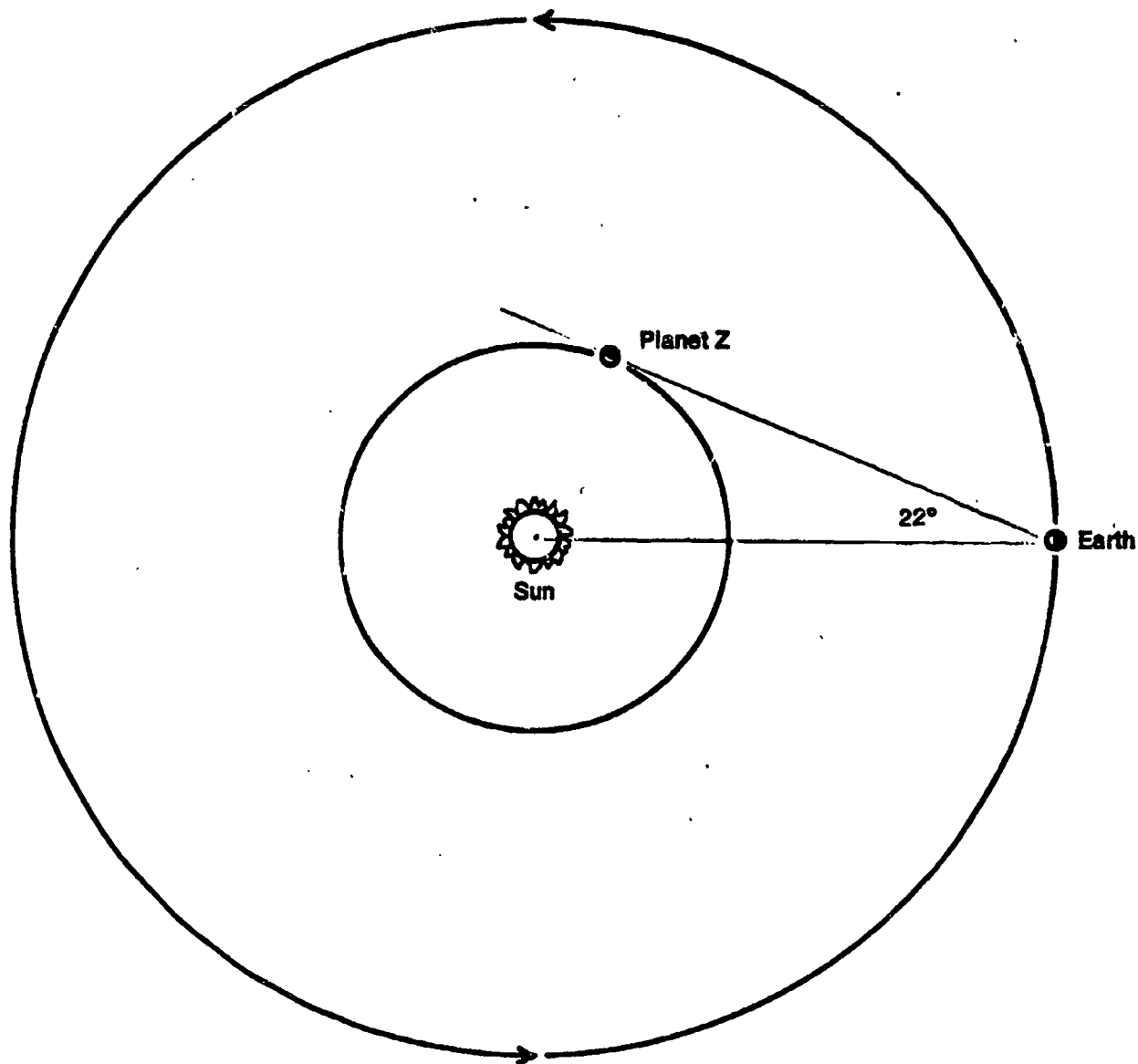

SELF-EVALUATION 5

5-1 The relationship can be stated as a simple ratio or proportion. (See page 47 in your text.)

$$\frac{\text{Distance across the object}}{\text{Distance across the image}} = \frac{\text{Distance from object to the pinhole}}{\text{Distance from image to the pinhole}}$$

5-2. In this experiment you determined the size of the image on the screen produced by a source placed at three different distances from the pinhole. You kept the pinhole-screen distance constant (42 cm).

The size of the image produced by the source when at

Point A = 2.0 cm across.

Point B = 1.5 cm across.

Point C = 1.0 cm across.

If you need help, review pages 46 and 47 in your text.

5-3. The relationship you need for this problem is as follows:

$$\frac{\text{Distance across object}}{\text{Distance from object to pinhole}} = \frac{\text{Distance across image}}{\text{Distance of pinhole to screen}}$$

Substituting the student's data into this relationship we get the following.

$$\frac{\text{Distance across moon}}{240,000 \text{ miles}} = \frac{1}{2} \text{ cm}}{57 \text{ cm}} \times \frac{1}{2} \text{ cm} = 2,105 \text{ miles}$$

If your answer is around 2,100 miles, you did well. If you had problems, you might want to review pages 48 and 49 in your text.

5-4. A. Your sketch should look something like the one below.

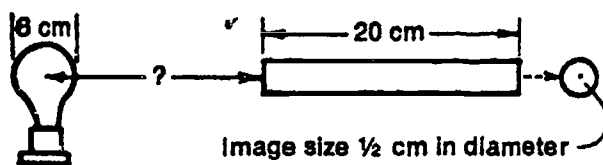

B. Use the relationship given in the answer to 5-3 above.

$$\frac{6 \text{ cm}}{\frac{1}{2} \text{ cm}} = \frac{\text{Distance from object to pinhole}}{20 \text{ cm}}$$

$$240 \text{ cm} = \text{Distance from object to pinhole}$$

SELF-EVALUATION 6

6-1. A. From sunrise to sunset the earth makes one half a turn, or 180°.

B. From noon (sun overhead) to sunset the earth makes one quarter of a turn and this takes 6 hours.

You may realize that in actual fact the day is longer than the night in summer and shorter in winter. The simple model that you used at the beginning of this chapter does not predict or explain this fact. If you had difficulty answering these questions, take another look at Activities 6-1 to 6-10.

6-2. Since it takes 24 hours for the earth to make one rotation on its axis and there is a time difference of 1 hour between time zones, you would cross 24 time zones in a trip around the world. Take another look at page 58 if you had difficulty with this.

6-3. In activities 6-11 to 6-13, you determined that the sun appears to move through an angle of 15° each hour. Since New York and San Francisco are 3 hours apart, they are $3 \times 15^\circ$, or 45° apart. Actually, it is 45° between corresponding points in these time zones. New York City and San Francisco are not corresponding points, and the actual separation between the two is a little over 48° .

6-4. This is a real stinker of a question; no doubt you had to think about it for a while. The trick is that the sun is almost directly overhead so that the shadow of the sinker hides the shadow of the string.

6-5. The two towns are 75° apart. Since the sun appears to move 15° each hour, the time difference between the two towns is 5 hours.

6-6. You might have said that the sun would have to move at an unreasonable speed to travel all the way around each day. If the earth is turning on its axis, it would not have to be traveling nearly so fast.

SELF-EVALUATION 7

7-1. You should have realized that a pyrheliometer is just a device for measuring the light energy that reaches the earth from the sun. Your sun-energy measurer is a simple type of pyrheliometer.

7-2. You would have to increase the wattage of the source by a factor of 4 in order to keep the same reading. You should review pages 62 and 63 of your text if you had difficulty with this question.

7-3. Your completed table should look like the one shown below. Review pages 62 and 63 if you had problems with this table.

DISTANCES AND WATTAGES REQUIRED TO KEEP THE SAME READING ON A SUN-ENERGY MEASURER	
Measured Distance	Wattage
80 cm	3,200 watts
160 cm	12,800 watts
320 cm	51,200 watts
640 cm	204,800 watts
2,560 cm	3,276,800 watts

7-4. Your answer should have indicated that you would place one of the bulbs at each of the distances, measuring the temperature change each time. You should then have used the other bulb at the same distances and made the same measurements. A comparison of the temperature changes would tell you which gives off more energy. You could have also been sneaky and done the experiment an easier way. Just set up the clear bulb at one of the distances and measure the temperature change it causes. Then put both bulbs in the parallel socket at the same distance and measure the temperature change. If the temperature change just about doubled, you would know that the two bulbs were each giving off the same amount of energy at that distance.

My Progress

Keep track of your progress in the course by plotting the percent correct for each Self Evaluation as you complete it.

$$\text{Percent correct} = \frac{\text{Number correct}}{\text{Number of questions}} \times 100$$

To find how you are doing, draw lines connecting these points. After you've tested yourself on all chapters, you may want to draw a best-fit line. But in the meantime, unless you always get the same percent correct, your graph will look like a series of mountain peaks.

RECORD OF MY PROGRESS

