

DOCUMENT RESUME

ED 190 365

SE 031 309

AUTHOR Bonar, John R., Ed.; Hathway, James A., Ed.
 TITLE Probing the Natural World, Level III, Teacher's Edition: Investigating Variation. Intermediate Science Curriculum Study.
 INSTITUTION Florida State Univ., Tallahassee. Dept. of Science Education.
 SPONS AGENCY National Science Foundation, Washington, D.C.; Office of Education (DHEW), Washington, D.C.
 PUB DATE 72
 NOTE 114p.; For related documents, see SE 031 300-330, ED 035 559-560, ED 049 032, and ED 052 940. Contains colored and shaded drawings and print which may not reproduce well.

EDRS PRICE MF01/PC05 Plus Postage.
 DESCRIPTORS Grade 9; *Human Body; Individualized Instruction; Instructional Materials; Junior High Schools; Laboratory Manuals; *Laboratory Procedures; Mathematical Applications; *Measurement; *Science Activities; Science Course Improvement Projects; Science Education; Secondary Education; Secondary School Science; *Statistics
 IDENTIFIERS *Intermediate Science Curriculum Study

ABSTRACT This is the teacher's edition of one of the eight units of the Intermediate Science Curriculum Study (ISCS) for level III students (grade 9). This unit focuses on diversity in human populations, measurement, and data collection. Optional excursions are described for students who wish to study a topic in greater depth. An introduction describes principles of measurement, variation, correlation, prediction, and sampling. Illustrations accompany the text. (SA)

 * Reproductions supplied by EDRS are the best that can be made *
 * from the original document. *

Investigating Variation

ED190365

SE 031 309

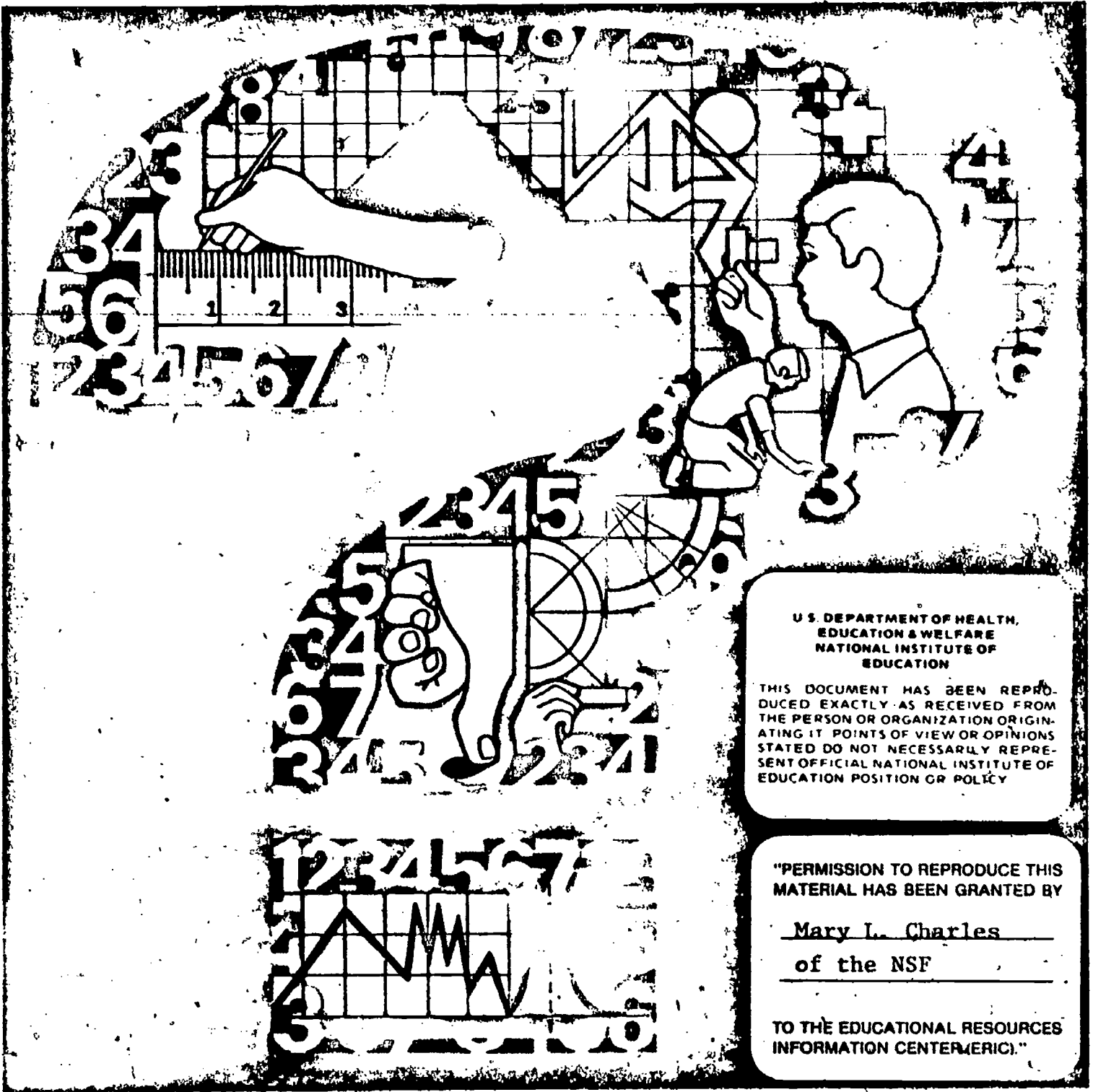

U.S. DEPARTMENT OF HEALTH,
EDUCATION & WELFARE
NATIONAL INSTITUTE OF
EDUCATION

THIS DOCUMENT HAS BEEN REPRODUCED EXACTLY AS RECEIVED FROM THE PERSON OR ORGANIZATION ORIGINATING IT. POINTS OF VIEW OR OPINIONS STATED DO NOT NECESSARILY REPRESENT OFFICIAL NATIONAL INSTITUTE OF EDUCATION POSITION OR POLICY.

"PERMISSION TO REPRODUCE THIS MATERIAL HAS BEEN GRANTED BY

Mary L. Charles
of the NSF

TO THE EDUCATIONAL RESOURCES INFORMATION CENTER (ERIC)."

Probing the Natural World/3

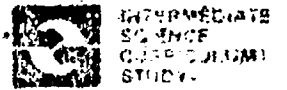

THIS BOOK IS THE PROPERTY OF:

STATE _____
PROVINCE _____
COUNTY _____
PARISH _____
SCHOOL DISTRICT _____
OTHER _____

Book No. _____

Enter information
in spaces
to the left as
instructed

ISSUED TO	Year Used	CONDITION	
		ISSUED	RETURNED

PUPILS to whom this textbook is issued must not write on any page or mark any part of it in any way, consumable textbooks excepted.

- 1. Teachers should see that the pupil's name is clearly written in ink in the spaces above in every book issued.
- 2. The following terms should be used in recording the condition of the book: New; Good; Fair; Poor; Bad.

INTERMEDIATE SCIENCE CURRICULUM STUDY TEACHER'S EDITION

Investigating Variation

Probing the Natural World / Level III



**SILVER BURDETT
GENERAL LEARNING CORPORATION**

Morristown, New Jersey · Park Ridge, Ill. · Palo Alto · Dallas · Atlanta

ISCS PROGRAM

- LEVEL I** **Probing the Natural World / Volume 1 / with Teacher's Edition**
Student Record Book / Volume 1 / with Teacher's Edition
Master Set of Equipment / Volume 1
Test Resource Booklet
- LEVEL II** **Probing the Natural World / Volume 2 / with Teacher's Edition**
Record Book / Volume 2 / with Teacher's Edition
Master Set of Equipment / Volume 2
Test Resource Booklet
- LEVEL III** **Why You're You / with Teacher's Edition**
Record Book / with Teacher's Edition / Master Set of Equipment
Environmental Science / with Teacher's Edition
Record Book / with Teacher's Edition / Master Set of Equipment
Investigating Variation / with Teacher's Edition
~~**Record Book / with Teacher's Edition / Master Set of Equipment**~~
In Orbit / with Teacher's Edition
Record Book / with Teacher's Edition / Master Set of Equipment
What's Up? / with Teacher's Edition
Record Book / with Teacher's Edition / Master Set of Equipment
Crusty Problems / with Teacher's Edition
Record Book / with Teacher's Edition / Master Set of Equipment
Winds and Weather / with Teacher's Edition
Record Book / with Teacher's Edition / Master Set of Equipment
Well-Being / with Teacher's Edition
Record Book / with Teacher's Edition / Master Set of Equipment

ACKNOWLEDGMENTS

The work presented or reported herein was performed pursuant to a Contract with the U. S. Office of Education, Department of Health, Education, and Welfare. It was supported, also, by the National Science Foundation. However, the opinions expressed herein do not necessarily reflect the position or policy of the U. S. Office of Education or the National Science Foundation, and no official endorsement by either agency should be inferred.

© 1972 THE FLORIDA STATE UNIVERSITY

All rights reserved - Printed in the United States of America. Published simultaneously in Canada. Copyright is claimed until 1977. Except for the rights to materials reserved by others, the Publishers and the copyright owner hereby grant permission to domestic persons of the United States and Canada for use of this work without charge in the English language in the United States and Canada after 1977 provided that the publications incorporating materials covered by the copyrights contain an acknowledgment of them and a statement that the publication is not endorsed by the copyright owner. For conditions of use and permission to use materials contained herein for foreign publications in other than the English language, apply to the copyright owner. This publication, or parts thereof, may not be reproduced in any form by photographic, electrostatic, mechanical, or any other method, for any use, including information storage and retrieval, without written permission from the publisher.

ILLUSTRATIONS: © 1972 GENERAL LEARNING CORPORATION.
ALL RIGHTS RESERVED.

An Introduction

Basically, this unit is aimed at selected aspects of measurement and analysis. It would have been relatively easy to fall into the trap of presenting a short course in statistics. Instead, the items selected are those considered useful to the ninth-grade student in conducting experimental work in the biological and earth sciences. In this respect, the unit could be thought of as furnishing some helpful skills for the other units in ISCS Level III. The combining of parent traits in genetics, sampling techniques in geology, population studies in environmental science, and prediction procedures in meteorology are but a few examples of skills that are closely related.

The unit is designed to be short and concise. Vocabulary has been kept to a minimum. Terms are introduced only when they are thought to serve as a convenient and necessary "mental hook" upon which to hang an important idea. The measurements that are gathered and manipulated are from humans. It may be hoped that a better understanding of human differences will develop from the studies.

MEASUREMENT

All measurement involves a comparison, usually with a standard scale or an accepted norm. In measuring variation in human features, traits, or behaviors, however, part of the task may be in determining the reference points for the comparisons. Therefore, a very useful tool in science is the operational definition, which tells *how* something is measured. In operationally defining, two questions may be asked: (a) How can I tell if I have some? and (b) How can I tell how much I have? There are times when the first question can be answered but the second one cannot.

Not all measurement in science is easy. The extremely fast, slow, large, or small present unique measurement problems. So also do many of the phenomena of interest to the behavioral sciences, such as personality characteristics or human traits. These so-called "fuzzy" measurements are introduced in the unit not to produce frustrated or insecure students, but rather to illustrate some of the problems faced by practitioners. Certainly some scientists must live with far "fuzzier" notions than others.

Numerical measurements in the unit are made in general using the metric system. Students who have participated in Levels I and II of ISCS should have little difficulty. For others, and for those who need a review, an excursion has been provided. Remedial and review help is also available on averaging and rounding off numbers, and on constructing and measuring angles.

T 3

VARIATION

All living humans belong to a single biological species, *Homo sapiens*. Yet within this population exist wide differences in appearance, in location, in language—in everything. No species of wild animal shows anything like this range of variation. And handling this universal variation presents many problems.

There are really two basic methods of dealing with variation. In the first—descriptive statistics—one describes the variation present in such terms as range and central tendency. In the second—predictive statistics—one attempts to use the knowledge gained from the descriptive aspect, along with the relationship of variables, to make predictions. Both of these methods are used in the unit.

The range identifies the limits of the measurements. Operationally defined, it is the largest measure minus the smallest measure. Although the measurement of range is helpful, it does have its faults. Because it depends only upon the two extreme measures, it is some times undependable; it can be changed considerably by the addition or omission of a single extreme measure.

Of the several ways of measuring central tendency, only the mode and the mean are used in this unit. The mode is the most frequent measurement; the mean is the arithmetical average. The mode is particularly useful in discussing so-called “either-or” variation, where the measures usually fall into two distinct groups. Although the mode may also be used for continuously varying measures, the mean is suggested as more appropriate for such variation.

If a sufficiently large number of measures are made of some continuously varying human feature or trait, and the data plotted on a grid, the resultant smooth curve will in many cases be bell-shaped. This graph is called a normal, or Gaussian, distribution curve. In the normal distribution, the mean and the mode fall at the same point. Most of the measures are clustered in the center of the range, giving the curve its characteristic “mountain” shape.

Just because this symmetrical distribution is called a normal curve should not imply that any measures that are not so distributed are abnormal. There are many cases of continuous variation where the plotting of the measures leads to curves that are not Gaussian or normal. For instance, in the meteorology unit, *Winds and Weather*, observations are made of the amount of sky that is covered by clouds—a feature that varies continuously from 0 to 100%. However, there is a strong tendency in nature toward the two extremes. The sky tends to be very clear—cloudless—or very cloudy—overcast—with far fewer occasions of half-cloudiness. Graphing a series of observations leads to a U-shaped curve, which, though normal for nature, is very abnormal in shape.

When data are plotted in vertical columns, a type of bar graph called a histogram is formed. Histograms help to visualize variation in measurements. Patterns of fluctuations are more easily discernible, especially where the measures are of discrete numbers. They have the further advantage of presenting the observations themselves, without manipulation on the part of the experimenter, as might be done in drawing a smooth curve or best-fit line.

In statistics, it is often advantageous to have a measure of the spread of data around the mean. The common method for doing this is by calculating the standard deviation. Because this calculation involves the use of squares and square roots of numbers, a similar, but much simpler, concept is introduced in the unit. This consists of the somewhat arbitrary practice of dividing the range into five equal parts, or fifths. In a normal distribution, the most measurements fall in the middle fifth, or "fifth 3." Fewer fall in "fifth 2 and 4," and still fewer in "fifth 1 and 5." With the mean (and mode) falling in the middle fifth, a statement telling in which fifth a particular measure is found gives its relative position in the range.

CORRELATION AND PREDICTION

The display of variation data in tables, graphs, and histograms, and the calculation of means, modes, and fifths, are all ways of summarizing the evidence of a sample. But it is in using these descriptions that the relationships between variables become evident. By knowing one variable, then, the other can be predicted.

Graphs, with best-fit lines, can be useful in predicting when the data represent continuous variation. They allow interpolation (making predictions within the range of the data) with some degree of confidence. Extrapolation (predicting beyond the limits of the available data) can be done with much less reliability. Measures of central tendency and scatter can give further clues.

Predicting with either-or data is usually more difficult. Contingency tables, which give the relationship between two either-or variables, can be used to organize information for prediction. But the problem of drawing reliable inferences concerning a population from a sample really involves probability. For example, suppose a table is made showing the relationship between left- or right-handedness and left- or right-eyedness. It shows that 75 out of 100 people who are right-eyed are also right-handed. You still cannot predict with certainty that 3 of the next 4 right-eyed people who are tested will be right-handed. The number might be 0, 1, 2, or all 4. You can only predict that there is a particular probability of this being true.

SAMPLING

This topic could have come first in a discussion of variation. Unless consideration is given to the characteristics of the population being sampled, and to the method of sampling, the most carefully prepared and displayed data can lead to unreliable inferences. This fact has caused considerable consternation among professional pollsters.

In general, the only good method of sampling is a random method. It is the only way that personal prejudice, choice, bias, or favor can be excluded. A student who chooses to test only his friends on some human trait can weight

the sample in a particular direction. A person determining average income who interviews only those families in an elite neighborhood will have a sample pattern that is atypical.

From all that has been said previously, it is evident that the experimenter can never say for certain what the total population is merely by sampling it. But suitable sampling techniques can help a great deal. One important consideration (one to which you as a teacher should be especially sensitive) is the size of the sample. Human variation is too extensive, and certainly too inaccessible, to permit observation of the total population. But students are noteworthy for taking too small a sample. It is somewhat akin to the inebriated gentleman who, with his staggering gait, kept running into the lone tree in the yard and complaining that he was lost in a dense forest.

AN OVERVIEW

The unit begins with a look at some simple ways in which humans vary. The first two are handedness and perception of illusions. In order to focus attention on the procedures for measuring traits such as these, the concept of the operational definition is stressed. Students are also introduced to the notion of the pooling of data in class charts and tables.

Human features are classified as falling in the categories of either-or variations or continuous variations. As a possible method for handling the first category, students are introduced to contingency tables. They see that a relationship between variables becomes evident from such tables.

The histogram is introduced as a means of displaying data, and students see that grouping of data can make a pattern more obvious. The range, mean, and mode are operationally defined. As a measure of the spread of data around the mean, the total range is divided into fifths; relative position of an individual measurement can then be stated for comparison purposes.

Further comparison of individual measurements with those of the group is afforded in additional situations. Some of these measurements could be called "fuzzy"; that is, the feature or trait can be detected, but it cannot be assigned a numerical value.

The unit concludes with a series of problems of a practical nature. Students are expected to apply the techniques of data-gathering, tabulation, and organization that they learned earlier. On the basis of their findings, they are called on to make decisions for the solutions of problems.

GENERAL INFORMATION

Each chapter of the Teacher's Edition contains an equipment list for that chapter. The same is true for each excursion. In addition, the last page of each chapter alerts you to preparations necessary for the following chapter. Among the materials listed will be some items that must be supplied locally. These include a clock or watch with second hand for Chapter 1; notebook paper for

Chapter 2; string, chalk, a glass, a baby-food jar, or a beaker, and a clock or watch with second hand for Chapter 4. In addition are sticks for Excursion 4-2 and white paper and paper towels for Excursion 4-3.

At various points in the unit, students are called upon to pool their data so that all members of the class have access to them. You should give some consideration to the method you want to use. Teacher notes on page 5 in Chapter 1 make suggestions that may help.

GET IT READY NOW FOR CHAPTER 1

The illusion cards, 15 of which are furnished in the kit, may be assembled ahead of time by you or by capable student-assistants. Instructions for assembly are relatively simple:

- (1) Cut two pieces of masking tape about $4\frac{1}{2}$ " long.
- (2) Cut the illusion card on the two solid lines indicated on the card, making 3 pieces.
- (3) Lay the short arrow card flat on the table with the arrow side down. Center the tape with the adhesive side down on the two strips marked "Place tape here."
- (4) Lay the long card on top of the short card, with the arrow side down.
- (5) Fold the two ends of the tape snugly over the long card, overlapping the two tapes and leaving adhesive sides up.
- (6) Lay the other short card on top with the two strips marked "Place tape here" downward, and the ends of the two short cards even.

INTERMEDIATE SCIENCE CURRICULUM STUDY TEACHER'S EDITION

Investigating Variation

Probing the Natural World / Level III

 **SILVER BURDETT**
GENERAL LEARNING CORPORATION
Morristown, New Jersey • Park Ridge, Ill. • Palo Alto • Dallas • Atlanta

ISCS PROGRAM

- LEVEL I** **Probing the Natural World / Volume 1 / with Teacher's Edition**
Student Record Book / Volume 1 / with Teacher's Edition
Master Set of Equipment / Volume 1
Test Resource Booklet
- LEVEL II** **Probing the Natural World / Volume 2 / with Teacher's Edition**
Record Book / Volume 2 / with Teacher's Edition
Master Set of Equipment / Volume 2
Test Resource Booklet
- LEVEL III** **Why You're You / with Teacher's Edition**
Record Book / with Teacher's Edition / Master Set of Equipment
Environmental Science / with Teacher's Edition
Record Book / with Teacher's Edition / Master Set of Equipment
Investigating Variation / with Teacher's Edition
Record Book / with Teacher's Edition / Master Set of Equipment
In Orbit / with Teacher's Edition
Record Book / with Teacher's Edition / Master Set of Equipment
What's Up? / with Teacher's Edition
Record Book / with Teacher's Edition / Master Set of Equipment
Crusty Problems / with Teacher's Edition
Record Book / with Teacher's Edition / Master Set of Equipment
Winds and Weather / with Teacher's Edition
Record Book / with Teacher's Edition / Master Set of Equipment
Well-Being / with Teacher's Edition
Record Book / with Teacher's Edition / Master Set of Equipment

ACKNOWLEDGMENTS

The work presented or reported herein was performed pursuant to a Contract with the U. S. Office of Education, Department of Health, Education, and Welfare. It was supported, also, by the National Science Foundation. However, the opinions expressed herein do not necessarily reflect the position or policy of the U. S. Office of Education or the National Science Foundation, and no official endorsement by either agency should be inferred.

© 1972 THE FLORIDA STATE UNIVERSITY

All rights reserved. Printed in the United States of America. Published simultaneously in Canada. Copyright is claimed until 1977. Except for the rights to materials reserved by others, the Publishers and the copyright owner hereby grant permission to domestic persons of the United States and Canada for use of this work without charge in the English language in the United States and Canada after 1977 provided that the publications incorporating materials covered by the copyrights contain an acknowledgment of them and a statement that the publication is not endorsed by the copyright owner. For conditions of use and permission to use materials contained herein for foreign publications in other than the English language, apply to the copyright owner. This publication, or parts thereof, may not be reproduced in any form by photographic, electrostatic, mechanical, or any other method, for any use, including information storage and retrieval, without written permission from the publisher.

ILLUSTRATIONS: © 1972 GENERAL LEARNING CORPORATION.
ALL RIGHTS RESERVED.

ISCS STAFF

David D. Redfield, *Co-Director*
William R. Snyder, *Co-Director*
Ernest Burkman, *Steering Committee Chairman*

- Laura M. Bell, *Artist*
- John R. Bonar, *Editor*
- Dreanon A. Browne, *Artist*
- Harold L. Buell, *Administration*
- Robert L. Cochrougher, *Art Director*
- Betsy Conlon Balzano, *Evaluation*
- Stewart P. Darrow, *Field Trial-Teacher Education*
- George O. Dawson, *Teacher Education*
- James A. Hathway, *Editor*
- John S. Hutchinson, *Field Trial Teacher Education*
- Sally Diana Kaicher, *Art Director*
- Jane Larsen, *Art Director*
- Adrian D. Lovell, *Administration*
- Audley C. McDonald, *Administration*
- W. T. Myers, *Administration*
- Lynn H. Rogers, *Artist*
- Stephen C. Smith, *Artist*
- Lois S. Wilson, *Assistant Editor*

ISCS ADVISORY COMMITTEE

J. Myron Atkin, *University of Illinois*
Betsy Conlon Balzano, *State University of New York at Brockport*
Werner A. Baum, *University of Rhode Island*
Herman Branson, *Lincoln University*
*Martha Duncan Camp, *The Florida State University*
Clifton B. Clark, *University of North Carolina at Greensboro*
Steve Edwards, *The Florida State University*
Robert M. Gagné, *The Florida State University*
Edward Haenisch, *Wabash College*
*Michael Kasha, *The Florida State University*
Russell P. Kropp, *The Florida State University*
J. Stanley Marshall, *The Florida State University*
William V. Mayer, *University of Colorado*
Herman Parker, *University of Virginia*
Craig Sipe, *State University of New York at Albany*
*Harry Sisler, *University of Florida*
Clifford Swartz, *State University of New York at Stony Brook*
Claude A. Welch, *Macalester College*
Gates Willard, *Manhasset Junior High School, Manhasset, N.Y.*
Herbert Zim, *Science Writer, Tavernier, Florida*

*Former member

MATERIALS DEVELOPMENT CONTRIBUTORS

This list includes writing conference participants and others who made significant contributions to the materials, including text and art for the experimental editions

Janet Anderson, Nyack, N.Y. Gerald R. Bakker, *Fairham College*. Frank Balzano, *F.S.U.* Harald N. Bliss, *Maryville State College*. Olaf A. Boedtker, *Oregon State Univ.* Vin F. Bohm, *F.S.U.* Earl Brakken, *Two Harbors, Minn.* Bobby R. Brown, *F.S.U.* Robert J. Callahan, Jr. (deceased). Brian W. Cairns, *University of Illinois*. Lois H. Case, *Lombard, Ill.* Clifton B. Clark, *University of North Carolina at Greensboro*. Sara P. Craig, *F.S.U.* John D. Cunningham, *Keene State College*. David H. Dasenbrock, *F.S.U.* Doris Dasenbrock, *F.S.U.* Jeff C. Davis, *University of South Florida*. Alan D. Dawson, *Dearborn Public Schools, Mich.* George O. Dawson, *F.S.U.* Gerrit H. DeBoer, *F.S.U.* Howard E. DeCamp, *Glenn Ellyn, Ill.* James V. DeRose, *Newtown Square, Pa.* William A. Deskin, *Cornell College*. William K. Fasley, *Northeast Louisiana State College*. Donald C. Edinger, *University of Arizona*. Camillo Fano, *University of Chicago Laboratory School*. Ronald A. Fisher, *Maquoketa, Iowa*. Edwin H. Flemming, *F.U.S.* Paul K. Flood, *F.S.U.* Harper W. Frantz, *Pasadena City College (Femerius)*. Earl Friesen, *San Francisco State College*. Bob Galati, *Fullerton, Calif.* J. David Gavenda, *The University of Texas*. Charles A. Gilman, *Winchester, N.H.* Robert J. Goll, *Jacksonville University*. Ralph H. Granger, Jr., *Walpole, N.H.* H. Winter Griffith, *I.S.U.* William Gunn, *Miami, Florida*. John Hart, *Xavier University*. John R. Hassard, *Georgia State University*. J. Dudley Herron, *Purdue University*. Father Francis Heyden, S.J., *Georgetown University*. Leonard Himes, *Sarasota, Florida*. Evelyn M. Hurlbut, *Monigomers Junior College*. John R. Jablonski, *Boston University*. Bert M. Johnson, *Eastern Michigan University*. Roger S. Jones, *University of Minnesota*. Leonard A. Kalal, *Colorado School of Mines*. Theodore M. Kellogg, *University of Rhode Island*. Elizabeth A. Kendzior, *University of Illinois*. F. J. King, *F.S.U.* David Klasson, *Millville, Calif.* Ken Kramer, *Wright State University*. William H. Long, *F.S.U.* Robert Lepper, *California State College*. Harold G. Liebheit, *Milwaukee, Wis.* William D. Larson, *College of St. Thomas*. Mable M. Lund, *Beaverton, Oregon*. H. D. Luttrell, *North Texas State University*. Maxwell Maddock, *F.S.U.* Solomon Malinsky, *Sarasota, Florida*. Eloise A. Mann, *Sarasota, Florida*. Harleen W. McAda, *University of California at Santa Barbara*. Auley A. McAuley, *Michigan State University*. E. Wesley McNair, *F.S.U.* Marilyn Miklos, *F.S.U.* Floyd V. Monaghan, *Michigan State University*. Rufus F. Morton, *Westport, Conn.* Tamson Myer, *F.S.U.* Gerald Neufeld, *F.S.U.* James Okey, *University of California*. Lawrence E. Oliver, *F.S.U.* Larry O'Rear, *Alice, Texas*. Herman Parker, *University of Virginia*. Harry A. Pearson, *Western Australia*. James E. Perham, *Randolph-Macon Woman's College*. Darrell G. Phillips, *University of Iowa*. Howard Pierce, *F.S.U.* David Poché, *F.S.U.* Charles O. Pollard, *Georgia Institute of Technology*. Glenn F. Powers, *Northeast Louisiana State College*. Ernest Gene Preston, *Louisville, Ky.* Edward Ramey, *F.S.U.* Earl R. Rich, *University of Miami*. John Schaff, *Syracuse University*. Carroll A. Scott, *Williamsburg, Iowa*. Earle S. Scott, *Ripon College*. Thomas R. Spalding, *F.S.U.* Michael E. Stuart, *University of Texas*. Sister Agnes Joseph Sun, *Marygrove College*. Clifford Swartz, *State University of New York*. Thomas Teates, *F.S.U.* Bill W. Tillery, *University of Wyoming*. Ronald Townsend, *University of Iowa*. Mordecai Treblow, *Bloomsburg State College*. Henry J. Triesenberg, *National Union of Christian Schools*. Paul A. Vestal, *Rollins College*. Robert L. Vickery, *Western Australia*. Frederick B. Vought, *F.S.U.* Claude A. Welch, *Macalester College*. Paul Westmeyer, *F.S.U.* Earl Williams, *University of Tampa*. G. R. Wilson, Jr., *University of South Alabama*. Harry K. Wong, *Atherion, California*. Charles M. Woolheater, *F.S.U.* Jay A. Young, *King's College*. Victor J. Young, *Queensborough Community College*.

The genesis of some of the ISCS material stems from a summer writing conference in 1964. The participants were:

Frances Abbott, *Miami-Dade Junior College*. Ronald Atwood, *University of Kentucky*. George Assouza, *Carnegie Institute*. Colin H. Barrow, *University of West Indies*. Peggy Bazzel, *F.S.U.* Robert Binger (deceased). Donald Bucklin, *University of Wisconsin*. Martha Duncan Camp, *F.S.U.* Roy Campbell, *Broward County Board of Public Instruction, Fla.* Bruce E. Cleare, *Tallahassee Junior College*. Ann-cile Hall, *Pensacola, Florida*. Charles Holcolmb, *Mississippi State College*. Robert Kemman, *Mt. Prospect, Ill.* Gregory O'Berry, *Coral Gables, Florida*. Elra Palmer, *Baltimore*. James Van Pierce, *Indiana University Southeast*. Guenter Schwarz, *F.S.U.* James E. Smeland, *F.S.U.* C. Richard Tillis, *Pine Jog Nature Center, Florida*. Peggy Wiegand, *Emory University*. Elizabeth Woodward, *Augusta College*. John Woolever, *Sarasota, Florida*.

Foreword

A pupil's experiences between the ages of 11 and 16 probably shape his ultimate view of science and of the natural world. During these years most youngsters become more adept at thinking conceptually. Since concepts are at the heart of science, this is the age at which most students first gain the ability to study science in a really organized way. Here, too, the commitment for or against science as an interest or a vocation is often made.

Paradoxically, the students at this critical age have been the ones least affected by the recent effort to produce new science instructional materials. Despite a number of commendable efforts to improve the situation, the middle years stand today as a comparatively weak link in science education between the rapidly changing elementary curriculum and the recently revitalized high school science courses. This volume and its accompanying materials represent one attempt to provide a sound approach to instruction for this relatively uncharted level.

At the outset the organizers of the ISCS Project decided that it would be shortsighted and unwise to try to fill the gap in middle school science education by simply writing another textbook. We chose instead to challenge some of the most firmly established concepts about how to teach and just what science material can and should be taught to adolescents. The ISCS staff have tended to mistrust what authorities believe about schools, teachers, children, and teaching until we have had the chance to test these assumptions in actual classrooms with real children. As conflicts have arisen, our policy has been to rely more upon what we saw happening in the schools than upon what authorities said could or would happen. It is largely because of this policy that the ISCS materials represent a substantial departure from the norm.

The primary difference between the ISCS program and more conventional approaches is the fact that it allows each student to travel

at his own pace, and it permits the scope and sequence of instruction to vary with his interests, abilities, and background. The ISCS writers have systematically tried to give the student more of a role in deciding what he should study next and how soon he should study it. When the materials are used as intended, the ISCS teacher serves more as a "task easer" than a "task master." It is his job to help the student answer the questions that arise from his own study rather than to try to anticipate and package what the student needs to know.

There is nothing radically new in the ISCS approach to instruction. Outstanding teachers from Socrates to Mark Hopkins have stressed the need to personalize education. ISCS has tried to do something more than pay lip service to this goal. ISCS' major contribution has been to design a system whereby an average teacher, operating under normal constraints, in an ordinary classroom with ordinary children, can indeed give maximum attention to each student's progress.

The development of the ISCS material has been a group effort from the outset. It began in 1962, when outstanding educators met to decide what might be done to improve middle-grade science teaching. The recommendations of these conferences were converted into a tentative plan for a set of instructional materials by a small group of Florida State University faculty members. Small-scale writing sessions conducted on the Florida State campus during 1964 and 1965 resulted in pilot curriculum materials that were tested in selected Florida schools during the 1965-66 school year. All this preliminary work was supported by funds generously provided by The Florida State University.

In June of 1966, financial support was provided by the United States Office of Education, and the preliminary effort was formalized into the ISCS Project. Later, the National Science Foundation made several additional grants in support of the ISCS effort.

The first draft of these materials was produced in 1968, during a summer writing conference. The conferees were scientists, science educators, and junior high school teachers drawn from all over the United States. The original materials have been revised three times prior to their publication in this volume. More than 150 writers have contributed to the materials, and more than 180,000 children, in 46 states, have been involved in their field testing.

We sincerely hope that the teachers and students who will use this material will find that the great amount of time, money, and effort that has gone into its development has been worthwhile.

Tallahassee, Florida
February 1972

The Directors

INTERMEDIATE SCIENCE CURRICULUM STUDY

Contents

NOTES TO THE STUDENT

viii

CHAPTERS

- 1 The Road Ahead
- 2 Tallies and Tables
- 3 Home on the Range
- 4 How Do You Measure Up?
- 5 Personalizing the Population

1
15
25
35
51

EXCURSIONS

- 1-1 Measuring—Mostly in Metric
- 2-1 On the Average
- 2-2 Contingency Tables
- 3-1 Worth a Thousand Words
- 4-1 Angles and Protractors
- 4-2 Depth Perception
- 4-3 No Two Alike
- 5-1 Sampling Populations

59
63
67
71
75
81
85
89

Notes to the Student

The word *science* means a lot of things. All of the meanings are "right," but none are complete. *Science* is many things and is hard to describe in a few words.

We wrote this book to help you understand what science is and what scientists do. We have chosen to show you these things instead of describing them with words. The book describes a series of things for you to do and think about. We hope that what you do will help you learn a good deal about nature and that you will get a feel for how scientists tackle problems.

How is this book different from other textbooks?

This book is probably not like your other textbooks. To make any sense out of it, you must work with objects and substances. You should do the things described, think about them, and then answer any questions asked. Be sure you answer each question as you come to it.

The questions in the book are very important. They are asked for three reasons:

1. To help you to think through what you see and do.
2. To let you know whether or not you understand what you've done.
3. To give you a record of what you have done so that you can use it for review.

How will your class be organized?

Your science class will probably be quite different from your other classes. This book will let you start work with less help than usual from your teacher. You should begin each day's work where you left off the day before. Any equipment and supplies needed will be waiting for you.

Your teacher will not read to you or tell you the things that you are to learn. Instead, he will help you and your classmates individually.

Try to work ahead on your own. If you have trouble, first try to solve the problem for yourself. Don't ask your teacher for help until you really need it. Do not expect him to give you the answers to the questions in the book. Your teacher will try to help you find where and how you went wrong, but he will not do your work for you.

After a few days, some of your classmates will be ahead of you and others will not be as far along. This is the way the course is supposed to work. Remember, though, that there will be no prizes for finishing first. Work at whatever speed is best for you. *But be sure you understand what you have done before moving on.*

Excursions are mentioned at several places. These special activities are found at the back of the book. You may stop and do any excursion that looks interesting or any that you feel will help you. (Some excursions will help you do some of the activities in this book.) Sometimes, your teacher may ask you to do an excursion.

What am I expected to learn?

During the year, you will work very much as a scientist does. You should learn a lot of worthwhile information. More important, we hope that you will learn how to ask and answer questions about nature. *Keep in mind that learning how to find answers to questions is just as valuable as learning the answers themselves.*

Keep the big picture in mind, too. Each chapter builds on ideas already dealt with. These ideas add up to some of the simple but powerful concepts that are so important in science. If you are given a Student Record Book, do all your writing in it. *Do not write in this book.* Use your Record Book for making graphs, tables, and diagrams, too.

From time to time you may notice that your classmates have not always given the same answers that you did. This is no cause for worry. There are many right answers to some of the questions. And in some cases you may not be able to answer the questions. As a matter of fact, no one knows the answers to some of them. This may seem disappointing to you at first, but you will soon realize that there is much that science does not know. In this course, you will learn some of the things we don't know as well as what is known. Good luck!



EQUIPMENT LIST

Per student-team	Per class
1 illusion card	Watch or timer with second hand
1 metric ruler	Masking tape

The Road Ahead

Excursion 1-1 is keyed to this chapter.

Some people have big ears. Some have big noses. Some have dark skin; some, light. Most are honest; a few are not. Some are friendly; some, unfriendly. Many must wear glasses; others do not. About the only common characteristic of people is their lack of sameness—they are all different.

Variation is common throughout nature. The weather changes almost constantly, the position and appearance of the moon vary, and not all parts of the earth look the same.

1-1. List any things you can think of that do NOT vary.

Variation presents many problems for science. The greater the variation, the greater the problem. In order to make sense out of almost any study, a scientist must have some means of handling the variation he finds.



The investigations in this book will help you understand variation better. Most of the investigations will be done on human beings. Obviously, humans vary; we already know that. But the big questions are "How do humans vary?" and "How do we measure human variation?"

CHAPTER EMPHASIS

Students study how humans vary, and ways of measuring this human variation.

Chapter 1

MAJOR POINTS

1. Variation is common throughout nature
2. Setting up and doing experiments involving humans is harder than working with inanimate things.
3. Much of science is concerned with seeking patterns in changes that occur.
4. A person's handedness can be measured.
5. Describing how to measure a feature or a trait is called operationally defining.
6. An operational definition of a characteristic tells (a) how you can tell if you have some and (b) how much you have
7. Sometimes it is only possible to tell if you have some of the characteristic.
8. It is possible to measure how much someone is fooled by an illusion.

1-1. From a scientific view, this is not an easy question. Student answers could lead to some good small-group discussion early in the unit. There are relatively few things that do not vary. One, for example, is the speed of light in a vacuum, according to Einstein. Also, most units of measurement are invariable.

This might be an opportune time to point out to students that one of the ways humans vary is in the speed with which they complete a given task. In a number of cases in this unit, classroom data will have to be collected. Those who finish an activity first may have to wait for the others before they can complete a table or chart. This variation is a good thing. It allows each person to travel at an individual pace best suited for him or her. The faster student can go on to other activities, and pick up the class data later.

These are not easy questions to answer. In fact, some of the most difficult of all measurements in science have to do with human variation. If you have been in the ISCS course before, many of the techniques you used for studying energy and matter will apply here also. But you'll come face to face with some quite different problems too! You will soon discover that setting up and doing experiments involving humans is much harder than working with chemicals or force measurers. Scientists are still trying to invent better "rulers" for measuring humans.

In the following chapters, you will be studying different human characteristics. It will be up to you to try to make sense out of the measurements you take and to relate one set of measurements to another.

You should ask yourself continually "Is there any pattern in what I have observed; and, if so, what is it?" Scientists continually search for patterns in what they study. "Is there a pattern to the weather changes, to the movements of objects through space, and to the growth of living organisms?"

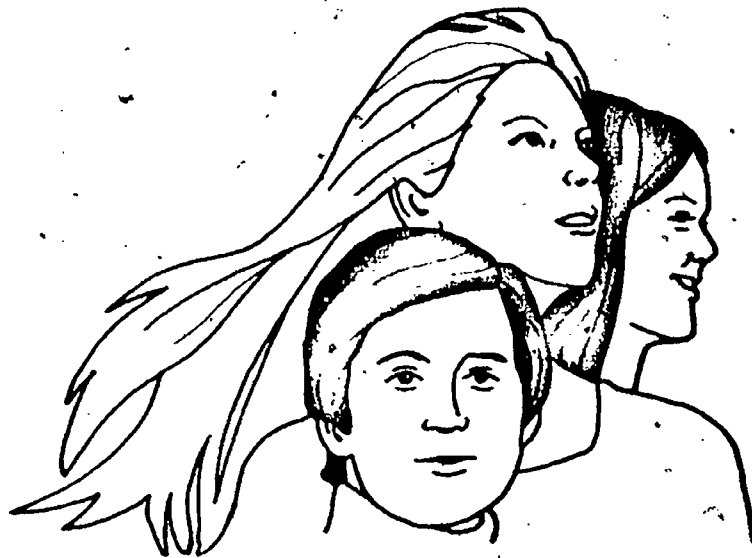

Much of the real work of science is in this activity of seeking out patterns. Some of that work will involve mathematics. In fact, mathematics has sometimes been called the "language of science."

LEFTY OR RIGHTY?

2 CHAPTER 1

Most people are either right- or left-handed. But you probably know someone who can use both hands quite well. You may know others who use a different hand for different

things. Perhaps they write with one hand and throw a ball or eat with the other. You can't very well call such people either right- or left-handed, can you? Let's begin studying human variation by looking closely at "handedness."

Let's see if we can find a good way of deciding about a person's handedness. The best way to do this is to find a way to measure handedness. The next activity will show you a way to do this.

Open your Record Book to page 1, where you will find a page full of zeros. Then find a partner. You will also need a clock or a watch with a second hand.

ACTIVITY 1-1. Have your partner cross out as many of the zeros as he can in 30 seconds, using his right hand. Then have him repeat, using his left hand. In Table 1-1 of your Record Book, record the number of zeros crossed out with each hand. Then have him time you while you cross out zeros with each hand.

To control a possible variable, students should cross out the zeros with an X, and not just with a slash (/). In order to compare data in a class chart, it is important that all follow the same procedure.

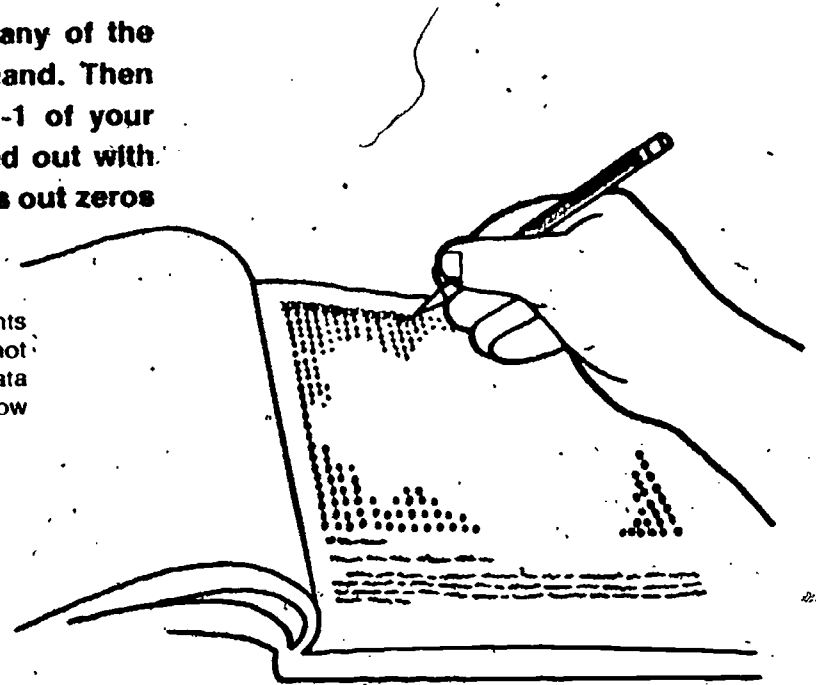

Many students may be familiar with the word *ambidextrous*, meaning the ability to use both hands equally well. It is not essential to introduce it here, however. As students will find out, few people are exclusively right-handed or left-handed, but few are also completely ambidextrous.

Table 1-1

	Number of Zeros Crossed Out	Handedness
Partner	Right	
	Left	
Self	Right	
	Left	

Students should have no trouble with the simple division involved. However, you may want to have them round their answers to the nearest tenth in the interest of uniformity for Table 1-2. For example, suppose the scores were 27 zeros crossed out with the right hand and 17 zeros with the left hand. 27 divided by 17 is 1.58, which rounds out to the nearest tenth as 1.6 Right.

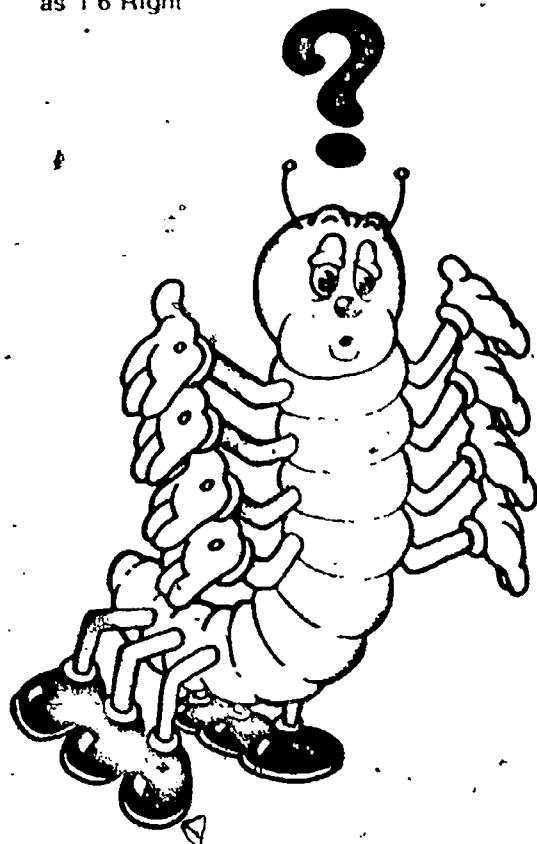

By comparing the number of zeros crossed out with each hand, you can decide whether you are right- or left-handed. But you can do better than that! You can get a fair measure of how much handedness you have. All you have to do is divide the larger number of zeros that you crossed out by the smaller number. Let's assume that you crossed out 30 zeros with your left hand and 20 zeros with your right hand.

First divide the larger number (30) by the smaller number (20):

$$\begin{array}{r} 1.5 \text{ Left} \\ 20 \overline{) 30.00} \\ \underline{20} \\ 100 \\ \underline{100} \\ 0 \end{array}$$

Then write either "Left" or "Right" after your answer. Which word you write depends upon which hand crossed out more zeros.

In the example, the left hand crossed out more zeros (30 to 20), so the word "Left" appears after the answer, 1.5. The number and word (1.5 Left in the example) is your handedness and should be entered in Table 1-1. Your partner's handedness should go there too.

The larger the number from your handedness calculation, the more strongly handed you are. For example, if your handedness calculation is "5 Right," you are five times as good with your right hand as with your left. A "2.5 Left" handedness calculation would mean that you are two and one half times as good with your left hand as with your right.

- 1-2. Suppose someone had a handedness measure of 1. What would this mean?
- 1-3. Why is there no "Left" or "Right" written after the 1 in question 1-2?

Well, you now have a measure of your handedness. You can begin collecting information about the handedness of your other classmates. Record the data from nine other teams in Table 1-2 of your Record Book.

Table 1-2

Name	Handedness Measure
Self	
Partner	
1.	
2.	
3.	
4.	
5.	
6.	
7.	
8.	
9.	
10.	
11.	
12.	
13.	
14.	
15.	
16.	
17.	
18.	

Collection of class data occurs for the first time here. If you have not already done so, you may want to take a few minutes to discuss a workable system. The following points should be emphasized.

1. Those who finish the activity before others have their data should go on to the ensuing work. However, they should be sure to come back to record the class data later in their Record Books.
2. Some teachers find it advantageous to use sheets on the bulletin board or spaces on the chalkboard, properly labeled, where data from the students in the different classes can be entered for the various activities.
3. Some teachers prefer to keep the tables or class charts in file folders somewhere in the room. In either case, students should have ready access to them.
4. In order for the data to be worth anything, students should be constrained to enter their findings accurately, without alterations. Students sometimes have a tendency to change their figures if they are not in agreement with a majority of their peers.

Experience has shown that this key technique in science, the operational definition, is at the same time one of the most difficult concepts for the student. You may have to spend some time in small-group discussion to help with the idea.

OPERATIONAL DEFINITION

It might be interesting to note that a functional definition (a hammer is something that drives nails) can sometimes help in leading to an operational definition. For instance, a force is something that changes the motion of a body (functional definition). Measuring the change in motion can give an operational definition of the force.

This first activity has shown you how to describe one human characteristic scientifically. The trick is to find some way of measuring many other features or traits. The word *handedness* probably took on a new meaning for you when you learned the crossing-out-zeroes test. You now have a numerical way of comparing your handedness with someone else's.

If you have worked in the ISCS course before, you know the name given to this way of defining things by describing how to measure them. It's called *operationally defining*. Many terms are not clear unless they are operationally defined.

Suppose you were asked what body temperature is. You might say: "Place a thermometer under your tongue. Wait about five minutes. Remove the thermometer and read the number at the top of the column of mercury." This is an *operational definition*. It tells how body temperature can be measured. This is quite different from saying that temperature is "how hot something is."

Some words can be defined by telling what an object does (a hammer is something that drives nails). Describing their appearance works for others (a tree is something with leaves, a trunk, etc.). But many words, particularly in science, just can't be handled this way. When you come across one of these words, try making an operational definition for it. The meaning will often become suddenly clear.

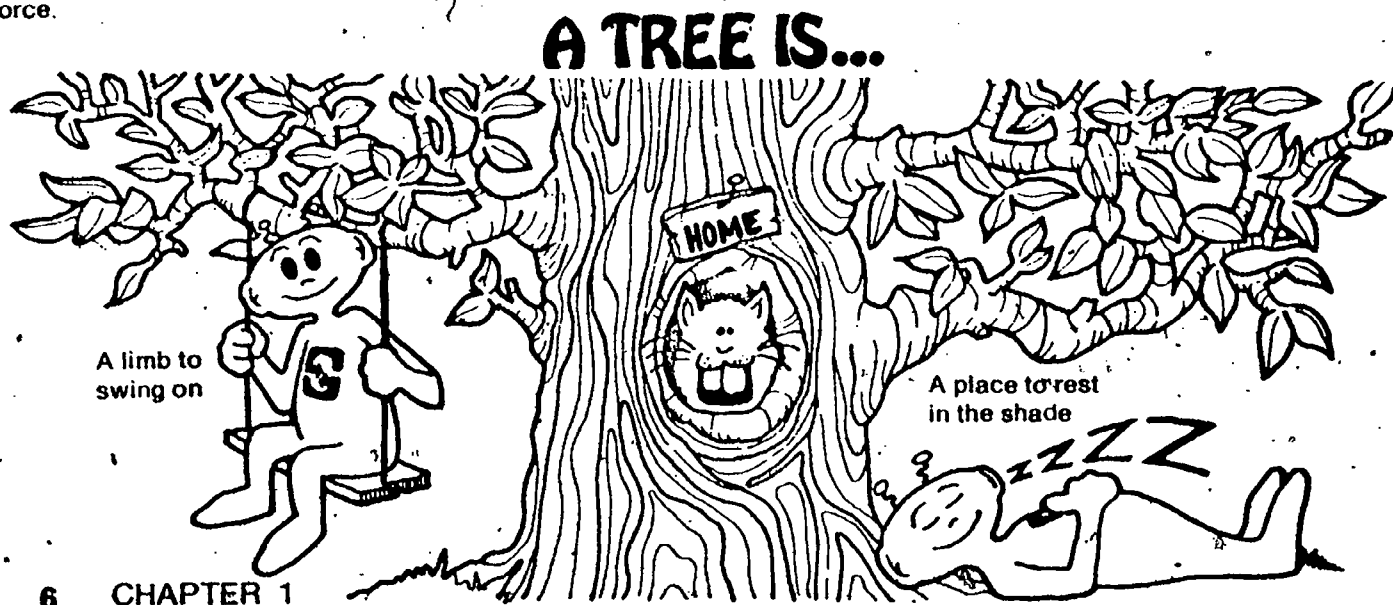

1-4. What makes a statement an *operational* definition?

1-5. Write an operational definition of handedness.

To make an operational definition, there are really two questions that you might ask:

1. How can I tell *when* I have some?
2. How can I tell *how much* I have?

Sometimes it is possible to answer the first question but not the second. When this happens, you have to settle for describing how to tell when you have some of the characteristics in question.

Now take a look at Figure 1-1 and notice the three boys. Your problem is to decide just by looking, at the picture which boy looks tallest and which looks shortest.

1-4. An operational definition tells how something is measured.

The two questions here are the key to making an operational definition. They might be thought of as (1) detection and (2) measurement. Sometimes the second requires sophisticated techniques or complicated apparatus. For instance, measuring the change in motion of a rapidly moving object may be quite difficult.

**NOW YOU SEE IT,
NOW YOU DON'T**

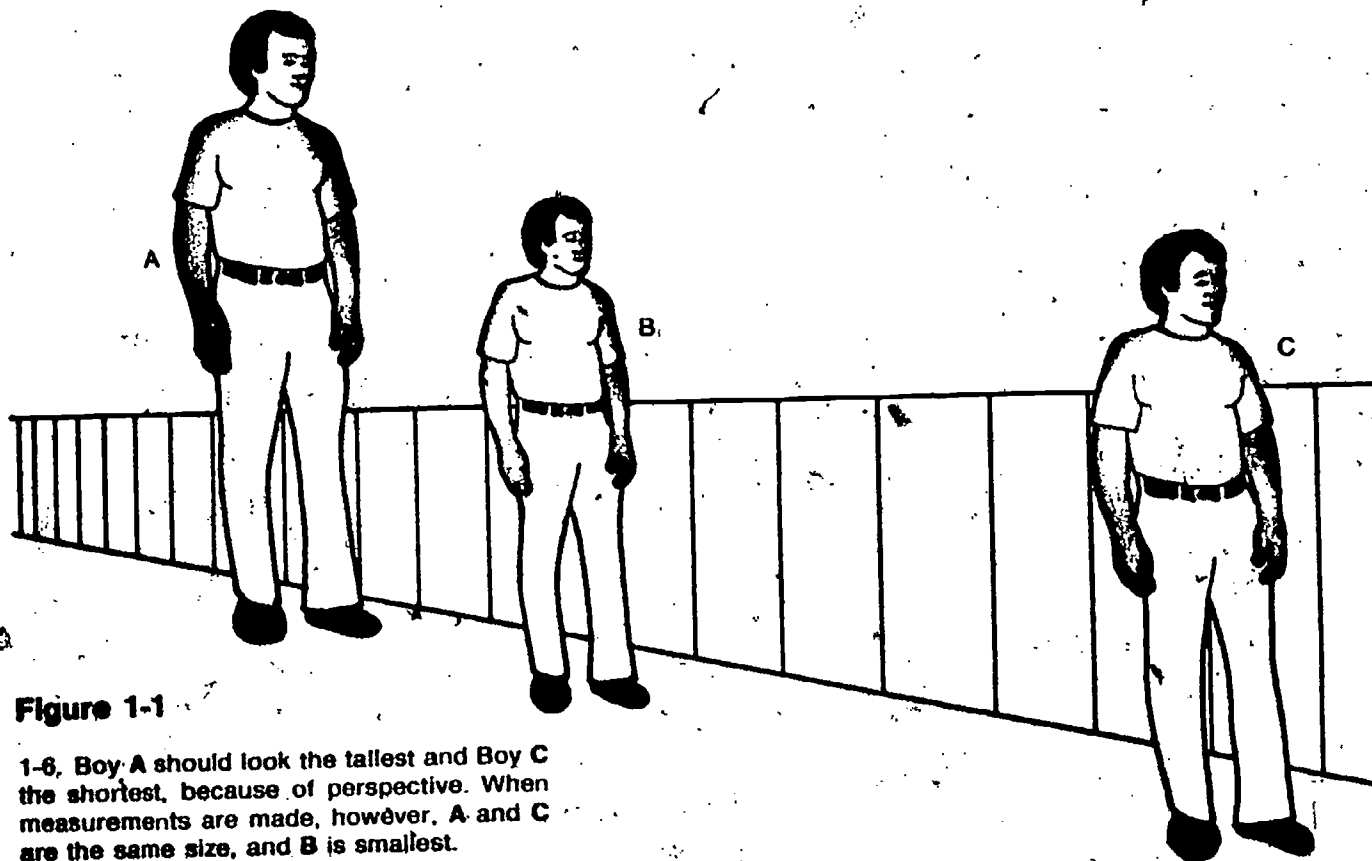

Figure 1-1

1-6. Boy A should look the tallest and Boy C the shortest, because of perspective. When measurements are made, however, A and C are the same size, and B is smallest.

1-6. Which boy in the figure (A, B, or C) looks tallest and which looks shortest to you?

CHAPTER 1 7

Excursion 1-1 is remedial-review, especially for those who have not engaged in Level I or II of ISCS, or who have forgotten the metric system.

EXCURSION

Now check your answers to question 1-6 by measuring with a ruler each boy's height in centimeters.

Throughout this unit, most measurements are to be made in the metric system. If you need to review the metric system, see **Excursion 1-1**, "Measuring—Mostly in Metric."

Next look at Figure 1-2. Try to decide just by looking, whether line **AB** or line **BC** is longer. Then check your answer by measuring the two lines.

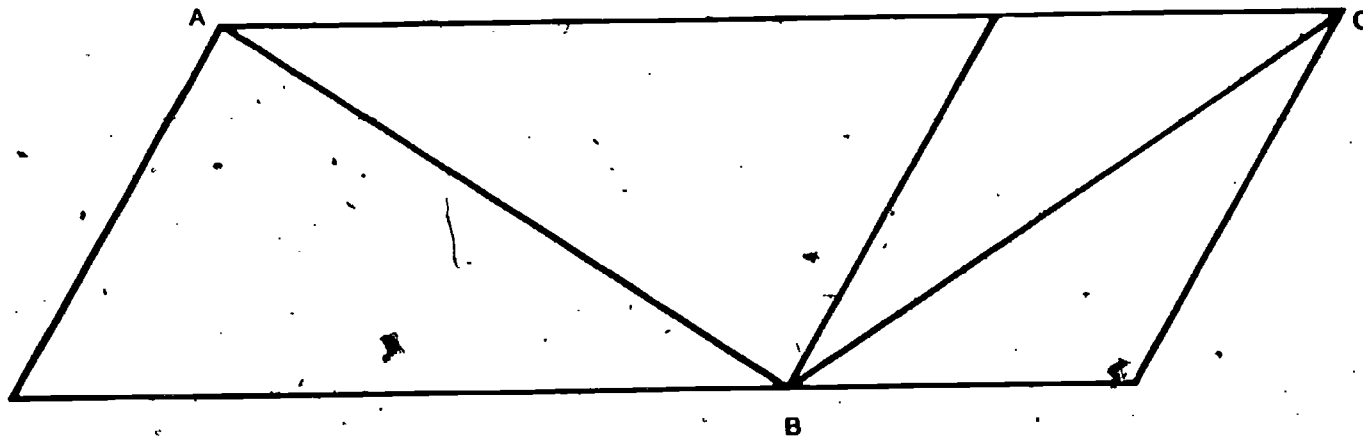

Figure 1-2

□ 1-7. Which looks shorter: line **AB** or line **BC**?

You've probably seen optical illusions like Figures 1-1 and 1-2 before. The way the figures are drawn makes it very hard for most people to judge lengths accurately. The artist's trick is to surround the important part of the drawing with lines that distract your attention. Compare the lines **AB** and **BC** in Figure 1-3 with those in Figure 1-2. You can see that the background lines make a great difference.

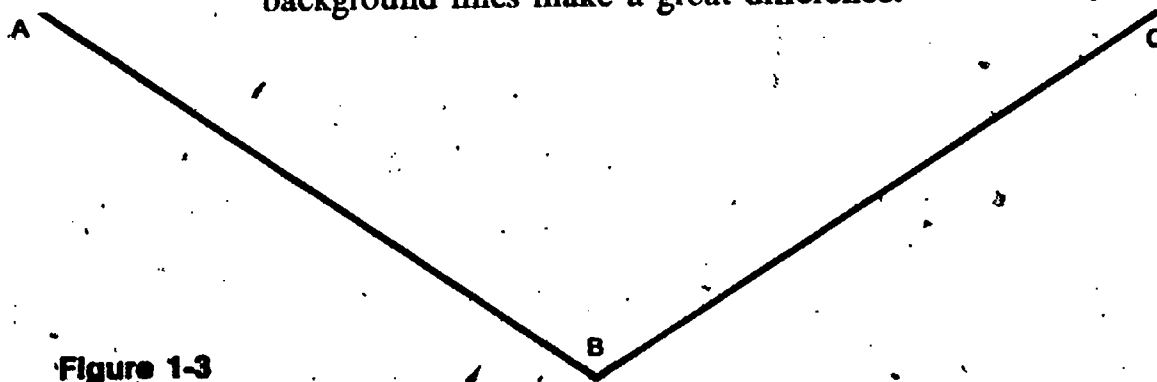

Figure 1-3

Suppose you were asked to describe by how much you had misjudged the lengths of the lines? Or suppose you wanted to find out whether your classmates misjudged the distances by the same amount you did? How would you do it?

One device used to measure how much an illusion fools people is called an illusion card. Figure 1-4 shows what the illusion card that you will use looks like. As soon as you get a partner and pick up an illusion card, you are ready to measure how much illusions fool people.

MEASURING ILLUSIONS

The 15 illusion cards must be assembled with reasonable care. If this has not already been done, instructions are given on each card and in the Introduction for this unit.

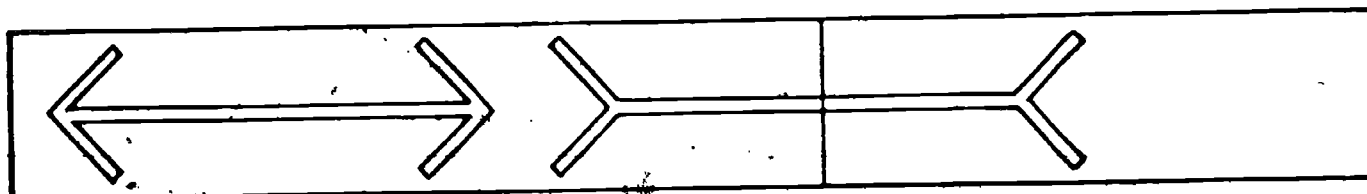
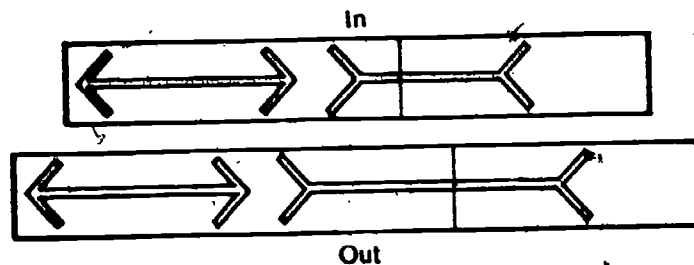
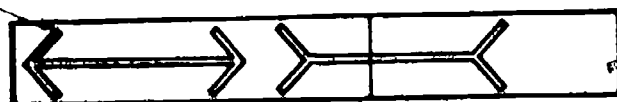

Figure 1-4

ACTIVITY 1-2. Try sliding the two parts of the illusion card in and out. Notice that this shortens and lengthens one of the lines on the card.



ACTIVITY 1-3. Adjust the card until the two lines look the same length to you. Then measure to find out if the lines really are the same length.



1-8. Were the lines exactly the same length after you adjusted the card?

1-9. If not, by how many millimeters did you misjudge?

CHAPTER 1 9

As you have now seen, the illusion card gives you what you were looking for—a way of measuring how much someone is fooled by an optical illusion. Now use the card to test your partner. Follow the suggestions in Activities 1-4 through 1-6.



ACTIVITY 1-4. S, the subject should stand at least two meters in front of E, the experimenter. Let E hold the card so that he can see the scale on the back.

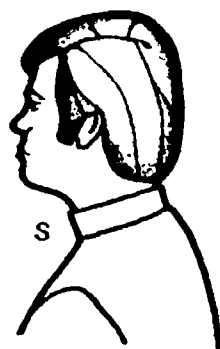

ACTIVITY 1-5. E should make the movable line as short as possible. Then gradually he should lengthen the line. Have S say "Stop" when the two lines seem to be the same length.

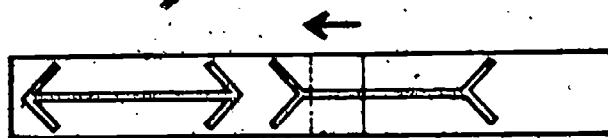

Slide the movable line to the shortest position.

Note that the number of millimeters either too long or too short is to be recorded. To save space, the measurements could be recorded as "21 S" for 21 millimeters too short and as "7 L" for 7 millimeters too long, as examples.

ACTIVITY 1-6. E should read the scale on the back of the card as shown. Record, beside Partner in the Going-out column of Table 1-3 in your Record Book, how many millimeters too long or too short your partner's guess was.

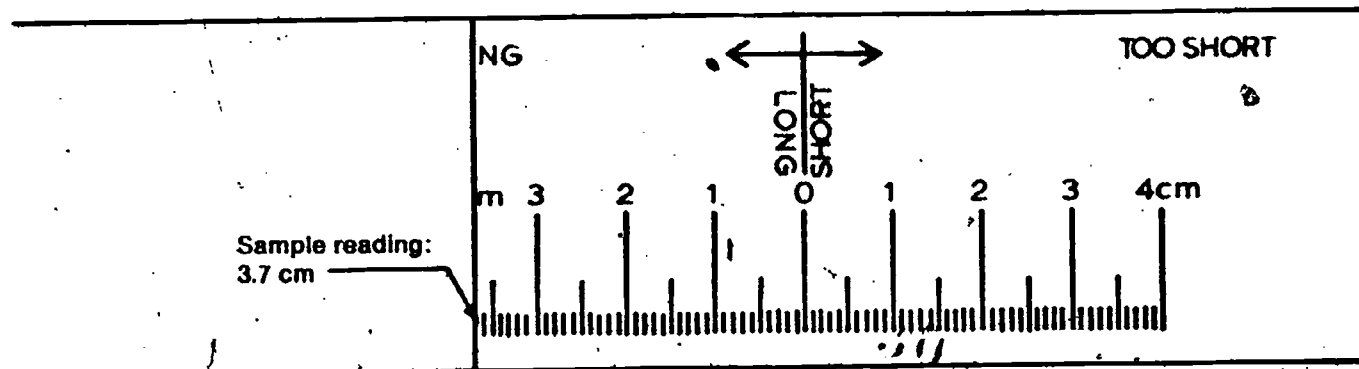
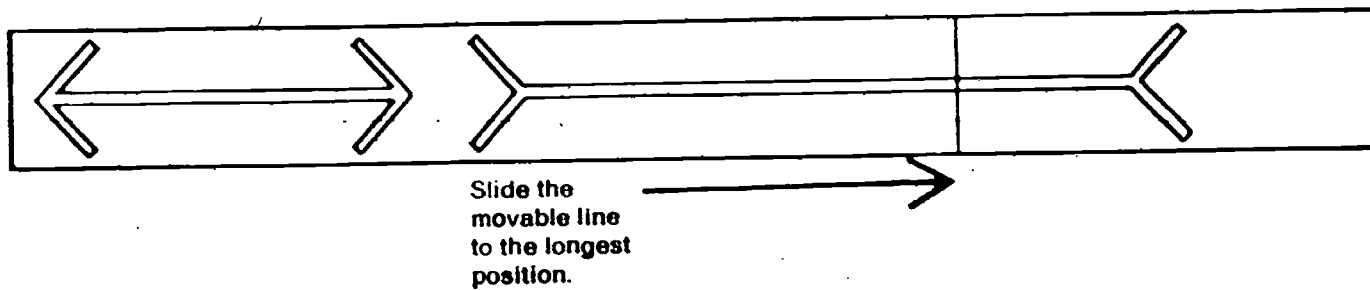

Table 1-3

Subject	Going-out Reading	Going-in Reading
Partner		
Self		
1.		
2.		
3.		
4.		
5.		
6.		
7.		
8.		
9.		
10.		
11.		
12.		
13.		
14.		
15.		
16.		
17.		
18.		

A rather interesting phenomenon occurs in using the illusion card. It might be called an "illusion within an illusion." The tendency generally is for the Going-out readings to be "too short" more often than the Going-in readings. You might want to pose the question of why this is so for small-group discussion. One possible explanation is that subjects mentally compare the shortest possible length with their observation going out, and the longest possible length with their observation going in. The observation seems longer when compared with the shortest length than it does when compared with the longest length. Those students capable of and interested in pursuing further the whole problem of "too short" and "too long" readings could certainly be allowed to do so.

ACTIVITY 1-7. Make the movable line as long as possible and show it to your partner. Then gradually shorten the line. Again have your partner say "Stop" when the two lines look to him to be the same length.



Read the scale as before and record your reading in the Going-in column of Table 1-3. Then repeat the experiment, with your partner holding the card and you doing the guessing. Record your data beside Self in Table 1-3.

To complete Table 1-3, you will need Going-in and Going-out readings on 18 of your classmates. If enough classmates have made their measurements, you can get those now. If not, get as many readings as you can and go on to the next chapter. You can complete the table later when more data are available.

As you learned earlier, this unit is aimed at helping you learn how to describe and compare people's features by using measurements. In this chapter you've learned a way of measuring two rather unusual features—handedness and judgment of optical illusions.

In the next chapter you will study other variations among people. You will also begin trying to compare some of the measurements you make, and you will try to interpret what the measurements tell you. As a preparation for that chapter, try to use the information you have put into Table 1-2 and Table 1-3 to answer these questions.

1-10. A larger number should be right-handed.

1-11. In finding the averages, students should be sure to add the left-handed scores together and divide by that number of scores, and do likewise for the right-handed scores.

Students who cannot average numbers should be directed to Excursion 2-1, which is keyed in Chapter 2.

1-10. Are more people in Table 1-2 left-handed, or right-handed?

1-11. What is the average degree of left-handedness? of right-handedness?

1-12. What is the average Going-out reading shown in Table 1-3?

1-13. What is the average Going-in reading shown in Table 1-3?

Before going on, do Self-Evaluation 1 in your Record Book.

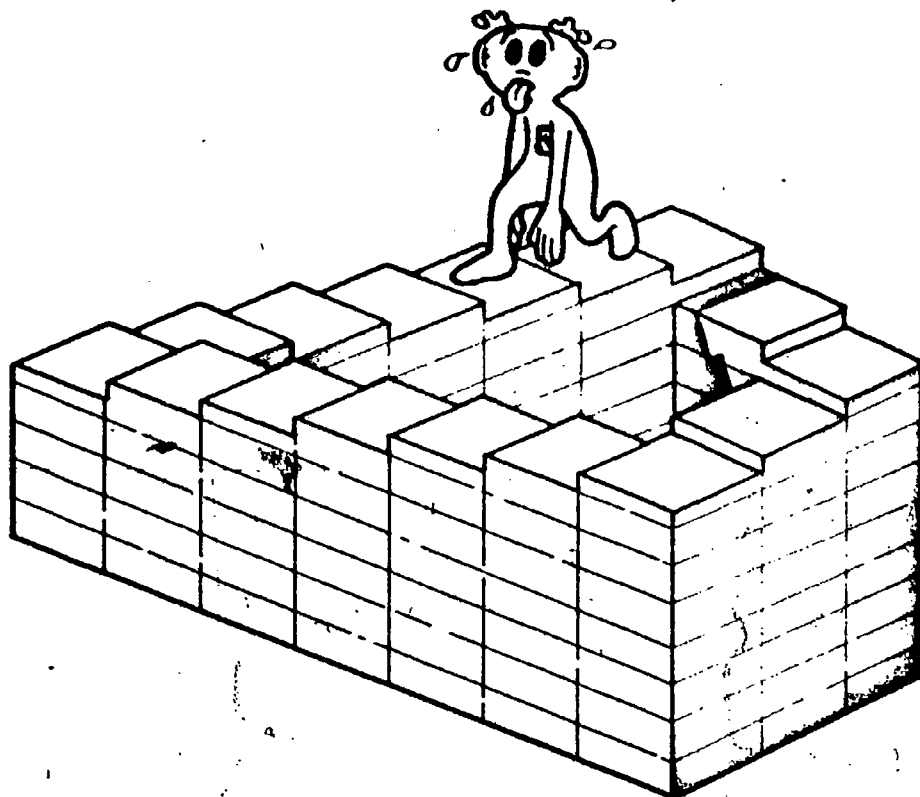

Conceivably students could arrive at this point and not be able to answer the four questions because the class data are not yet available. They should go on, returning to this chapter when the data are available from the other students.

1-12 and 1-13. The averaging of the Going-out and the Going-in readings can be complicated. Mathematically, "too-short" and "too long" cannot just be averaged numerically as if they were both the same thing. For instance, suppose there were two readings to average: 15L and 15S. The average of these two would not be 15, but rather 0.

The correct way of averaging the Going-out readings (and the Going-in readings) would be to add all the L (too long) readings together and also add all the S (too short) readings together in each column separately. Subtract the smaller total from the larger total. Divide the difference by the number of readings (20). The average would be this result, with either an L or an S, whichever is the larger total.

Students may have to struggle a little with this. The problem is quite similar to finding an average of positive and negative numbers. You must find the difference between the separate sums first.

GET IT READY NOW. FOR CHAPTER 2

You may want to prepare the metersticks with a piece of tape at the 20-cm mark as shown in Activity 2-3.

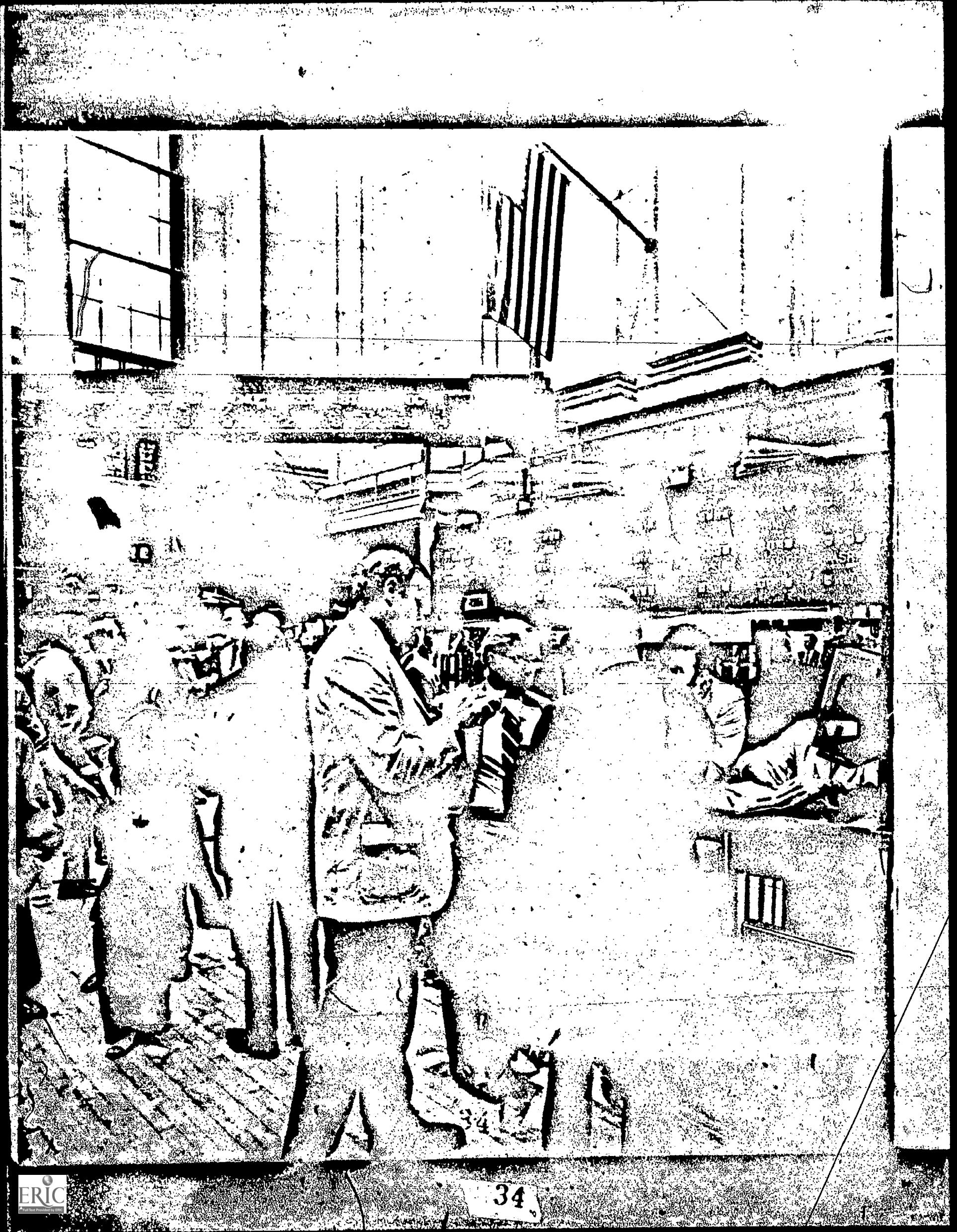

EQUIPMENT LIST

Per student-team

- 1 meterstick
- Masking tape
- 1 sheet of notebook paper

Excursions 2-1 and 2-2 are keyed to this chapter.

MAJOR POINTS

1. It is possible to test a subject for eyedness and grabbiness.
2. Reaction time may vary depending on whether the stimulus is by sight, sound, or touch.
3. When there are only two possible varieties of a human feature, it is called an either-or variation.

Tallies and Tables

Chapter 2

CHAPTER EMPHASIS

Ways of organizing variation data are studied, and the difference between either-or variations and continuous variations is examined.

There are hundreds of human features, characteristics, and traits that have been described. You have looked at a couple so far. In this chapter you will encounter some others to give you a better feel for how to investigate human traits and how to handle the data you collect. Let's look first at the feature called "eyedness."

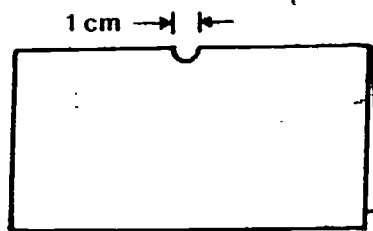

ACTIVITY 2-1. Fold a sheet of notebook paper and remove a small semicircle from the center.

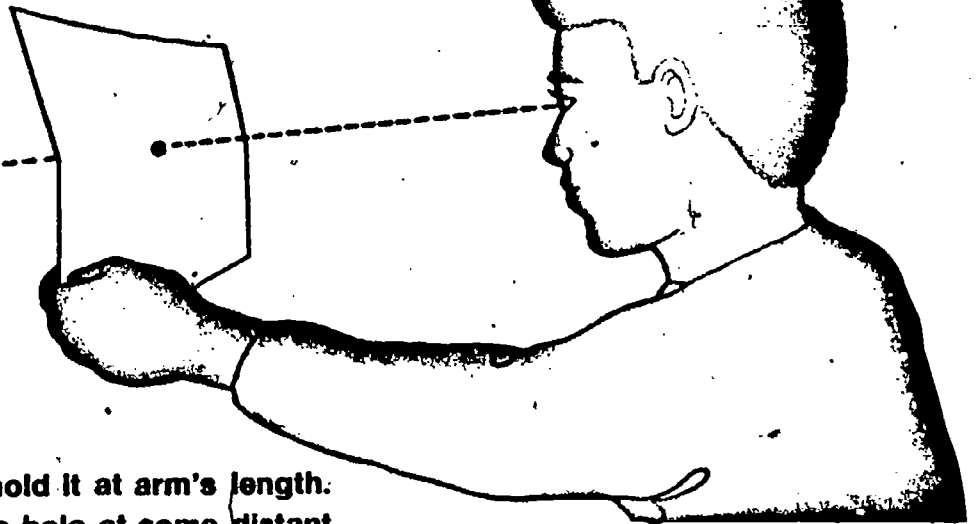

ACTIVITY 2-2. Unfold the paper and hold it at arm's length. With both eyes open, look through the hole at some distant object. Now without moving your head or eyes, observe the object with your left eye only. Again without moving head or eyes, look with your right eye only. Be sure not to move the paper.

4. When a feature varies widely through many different values, it is called a continuous variation.
5. Data may be organized in ways that will aid in analyzing them.
6. When data on two or more variables are collected in a single table, the table is called a multivariable table, a contingency table, or a correlation table.
7. Contingency tables are very useful in showing the interrelationship of variables.

Students should be sure to start looking with both eyes open, and then close one eye at a time without moving the paper. If they start with only one eye open, it is possible to force that eye to be dominant, even though it normally wouldn't be.

If you could see the object through the hole in the paper with your right eye closed, you are left-eyed. If you were able to see it with your right eye open and left eye closed, you are right-eyed.

2-1. Are you right-eyed, or left-eyed?

Test a few of your classmates to find out if they are left- or right-eyed. Each time you find a left-eyed person, put a check mark (✓) in the left-eyed tally line of Table 2-1 in your Record Book. Check the right-eyed tally line whenever you find a right-eyed person.

Students may want to coin a term, equivalent to ambidextrous, to describe someone who is equal-eyed.

Table 2-1

Eyedness	Tallies (checks)	Totals
Right		
Left		

Problem Break 2-1 is the first of the unit. Note that it calls for you to check the plan before students proceed. You probably will want to use some system, such as your initials in the Record Book, to indicate that you have checked it. Normally, eyedness is considered to be an either-or feature. This means that a person is either right-eyed or left-eyed, and the amount of either may be unmeasurable. However, the students should be allowed to grapple with the problem for a while. Some may surprise you with a plan that could be used. For instance, when both eyes are open, a person that is right-eyed can see something through the hole with the left eye also, but not as intensely. If some way could be devised to measure the relative intensity of the images from the two eyes, it would be a possible measure of the amount of right- or left-eyedness. But even if students come up with no workable plan, that doesn't make the problem break useless. Science is loaded with "problem breaks" to which no solution has been found.

From time to time in this unit, you will be asked to do problem breaks. These are problems for you to solve, without much help from your book or your teacher. The problems will usually help you understand what you are studying in the chapter. But that's not their major purpose. They are designed to give you practice in problem solving and in setting up your own experiments. You should try every problem break—even the tough ones. And in most cases, you should have your teacher approve your plan before trying it. The first problem break in this unit is coming up next.

PROBLEM BREAK 2-1

When you studied the "handedness" trait, you found a way, of measuring how much left-handedness or right-handedness a person has. Now, suggest a way to measure the amount of right- or left-eyedness. Check your plan with your teacher. Then, if it is okay, try it out. Record your data and observations in the space provided in your Record Book.

How quickly can you react? That's an awfully important question in some situations. How quickly the brake is pushed by a driver often determines whether an accident will happen. The difference between a strike and a home run is a matter of quick reactions and quick responses. So are a lot of other things.

In the next activity you will try to operationally define your reaction time. After that, you will measure your partner's reaction time. You will do this with what we call the "Grabiness Test." To make the test, you will need a partner, a meterstick, and a small piece of tape.

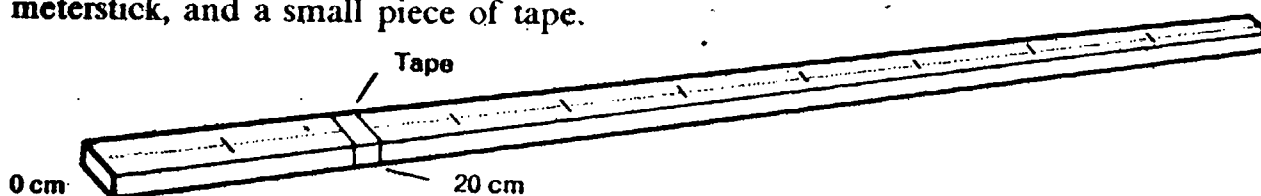

ACTIVITY 2-3. Place a piece of tape at the 20-cm mark on the meterstick.

In a moment you will have your partner hold a meterstick as shown in Figure 2-1. He will release it, and you will try to catch it before it hits the floor.

Activity 2-4 shows you how to prepare to catch the meterstick. You will use the same technique each time it is dropped.

ACTIVITY 2-4. Your finger and thumb should be positioned at the tape strip around the stick as shown. Finger and thumb should be far enough away from the stick to allow a pencil to pass on either side of the stick. This should be the starting position for each trial.

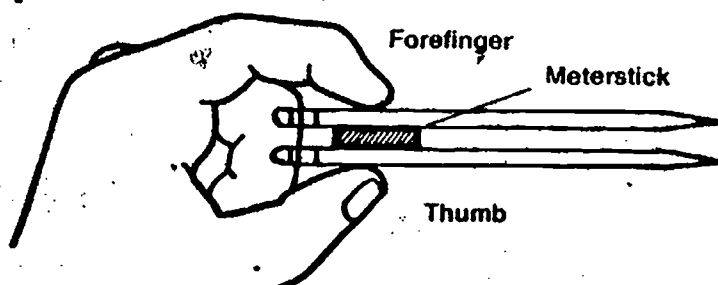

HOW GRABBY ARE YOU?

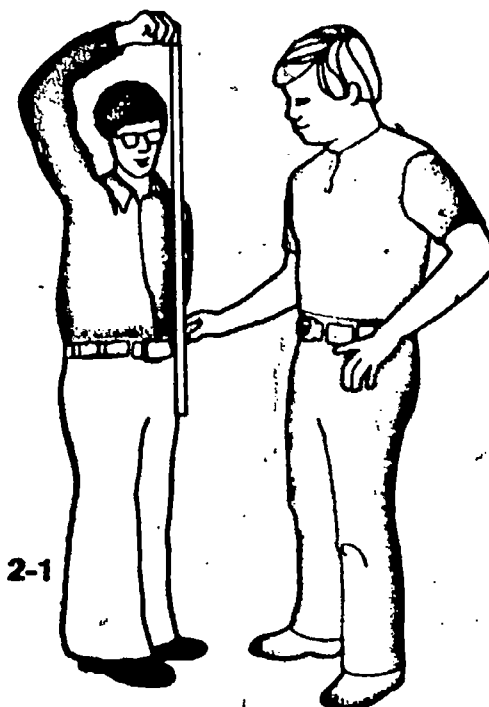
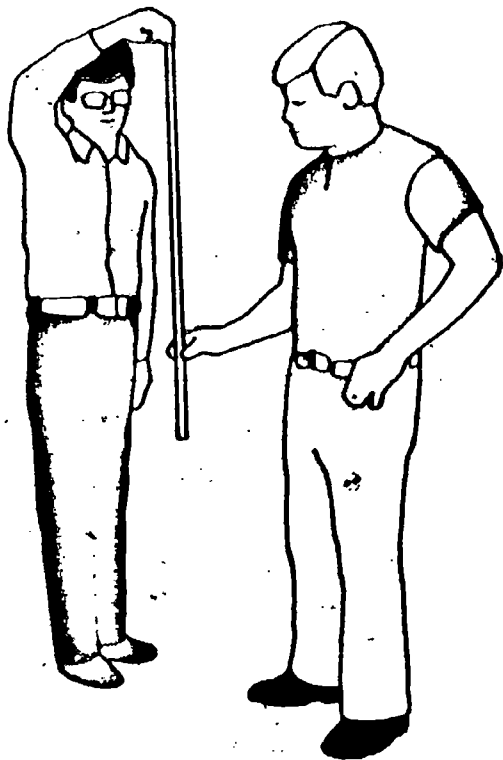

Figure 2-1

The positioning of the finger and thumb at a set distance from the stick should be recognized as an attempt to control a variable in an experiment.

Hold the stick
at the 100-cm end.



ACTIVITY 2-5. Have your partner hold the meterstick as shown. He should then drop the stick with no warning. When he does, catch the stick without moving your arm. Practice this a few times, until you get a feel for how it is done.

Place your fingers at the 20-cm mark, ready to catch the stick.

Some students may not be able to catch the stick at all on at least some of the trials. They may then wonder how to measure such cases. Give them a chance to suggest an answer. Possibly they should be counted as "100," which is the highest meterstick reading. If the noise resulting from the meterstick hitting the floor is objectionable, have them place on the floor a book that the stick can hit.

ACTIVITY 2-6. When you are ready to make your measurements, have your partner drop the stick one more time. This time, notice where your thumb is after you catch it.

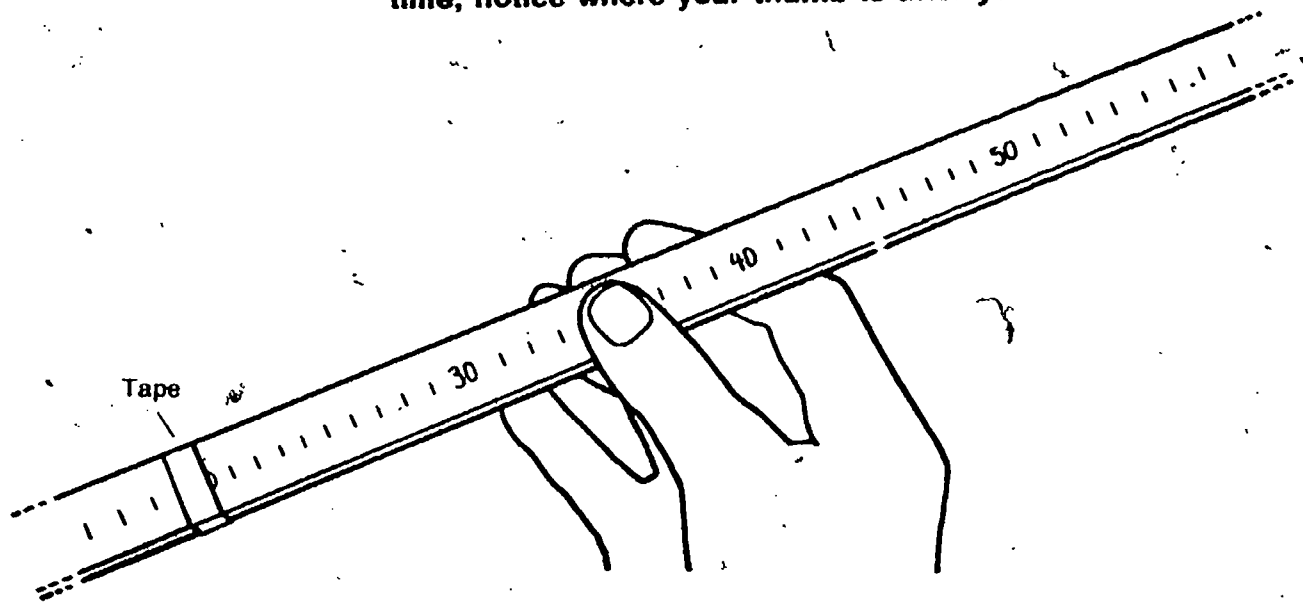

2-2. Which number on the stick did your thumb cover? (If two numbers were covered, record the smaller of the two.)

Excursion 2-1, for remedial-review, may have been done by the student at the end of Chapter 1.

EXCURSION ►

Repeat Activities 2-5 and 2-6 five more times. Record all six of your measurements in Table 2-2 in your Record Book. Complete the Self row of the table by finding the average of your measurements. If you aren't sure how to find an average, turn to **Excursion 2-1** for help.

Table 2-2

	Trial 1	Trial 2	Trial 3	Trial 4	Trial 5	Trial 6	Average
Self							
Partner							

Change places with your partner and repeat Activities 2-4 through 2-6. Again record data for your partner in Table 2-2 in your Record Book.

Place a mark for your average grabbiness measurement in the appropriate Tally row of Table 2-3. Then do the same for your partner's average grabbiness measurement.

Table 2-3

Average Grabbiness Measures	Tally	Totals
25-34		
35-44		
45-54		
55-64		
65-74		
75-84		
85-94		
95—		

Your next problem is to find the average grabbiness measure for at least ten more people. You can test some of your classmates during class or share their data. You may also ask your teacher if you can take a meterstick home one night.

Note that the numbers that are entered here, and tallied in Table 2-3, are the actual numbers covered by the finger or thumb when the stick is caught. In other words, the distance that the stick had dropped from the 20-cm point to the catching point is *not* used. Students may complain that the figures do not represent the true reaction time, and you might point out that as long as everyone records the numbers the same way (from the end of the stick), comparable measurements are given.

Notice the option given the students to test their classmates or share their data. You may want to use your data-collection system to facilitate the sharing. Note also that you have a decision to make relative to letting equipment (metersticks) leave the classroom overnight.

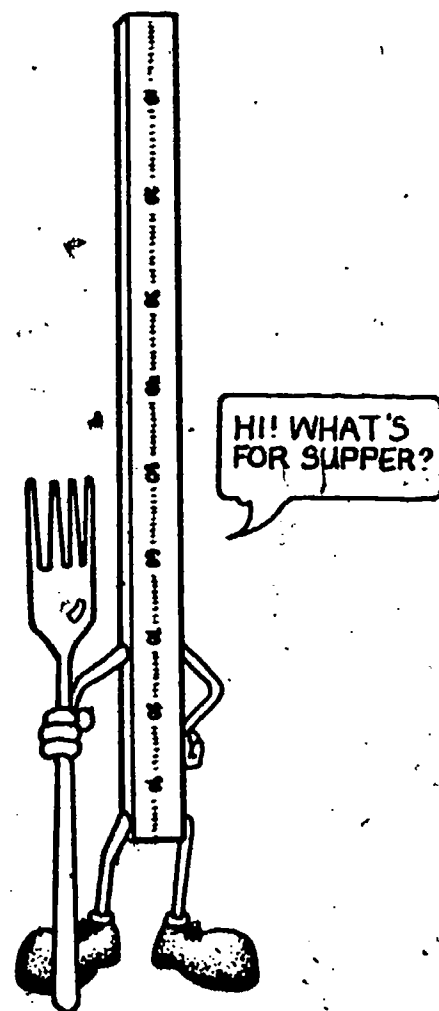



IS IT EITHER-OR?

If students have difficulty in designing the experiment in Problem Break 2-2, you may have to suggest some possibilities, such as a tap on the shoulder for touch, or a snap of the fingers for sound. Be sure students keep everything else constant.

2-4. Because there can be all degrees of grabbiness (reaction time), there must be the opportunity to show a wide variation in the measurement of the amount of it. Eyedness is generally either right or left, so only these two need be provided for. Another question that might be asked is "Do there have to be eight rows for the grabbiness?" The answer is No. The choice of eight is arbitrary. The tallies could have been grouped into a smaller number, or there could have been eighty, with a row for each cm from the 20-cm tape to the end of the meterstick.

20 CHAPTER 2

You can then measure the grabbiness of friends or members of your family. When you have made your measures and calculated the averages, put marks in the Tally rows of Table 2-3. You should end up with at least 12 tallies including yours and your partner's. Get even more measures if you have time.

This table of grabbiness will be used in Chapter 3. A much better use can be made if there are more than 12 measures available.

PROBLEM BREAK 2-2

Thus far in this chapter, you have been dealing largely with the sense of sight. You grabbed the meterstick when you saw it drop. The distance the stick passed through your hand is actually an indication of elapsed time. Design and carry out an experiment to answer the following question: *Do you react faster (or slower) to a sudden sound or touch than you do to a visual (sight) stimulus?* HINT: Be sure that the subject has his eyes closed during the sound-touch experiment.

Do not spend more than one class period investigating either the sound or the touch (tactile) sense. Record your experiments, findings, and conclusions in your Record Book.

Take a look at the way Tables 2-1 and 2-3 are set up. Although the two tables are similar, there is one big difference. Can you see what it is?

2-3. What is the major difference between the way Table 2-1 is set up and the way Table 2-3 is set up?

Question 2-3 shouldn't have been too tough. The big difference between the tables is in the number of rows. There are eight rows in the grabbiness table and only two rows in the eyedness table.

2-4. Why was it necessary to have eight rows on the grabbiness table and only two rows on the eyedness table?

2-5. Suppose you made a table for keeping track of how many boys and girls were in a class. How many rows would you need?

2-6. Suppose you wanted to keep track of peoples' heights. How many rows might you need in a table for this?

The last three questions deal with an important point. There are only two possible varieties of some human features, such as sex and eyedness. But others, like height or weight, vary much more widely. The features that come in only two varieties are called *either-or* variations. Those that vary more widely are called *continuous* variations.

2-7. Turn back to Table 1-3 in Chapter 1. Do the data in that table suggest that being fooled by optical illusions is an either-or feature?

2-8. Do the data in Table 1-2 of Chapter 1 suggest that handedness is an either-or feature?

As you have learned, the first step in understanding the way human features vary is to find some way of measuring the features. That is, to find a way of operationally defining the feature.

2-9. In your Record Book, write an operational definition for each of the following:

1. Reaction to optical illusions
2. Eyedness
3. Reaction time (grabbiness)

If you had difficulty in writing these operational definitions, reread the section following Table 1-2 in Chapter 1. Your own definition there of handedness should help.

There's more to understanding variation than operationally defining terms. After you have measurement data, you must analyze them. And this means you must arrange the data for easy analysis. One way to do this is to make a table like Table 2-1, 2-2, or 2-3. Look at each of them again carefully. Then examine Figure 2-2.

Figure 2-2

Eyedness	Tallies (checks)	Totals
Right		
Left		

2-7. No. 2-8. Yes. Although Tables 1-3 and 1-2 both show continuous variation of the traits, they both also have either-or aspects. Subjects in Table 1-3 can show either "too short" or "too long" responses to the illusion, but this is not quite the same thing as the right- or left-handedness in Table 1-2. Generally, either-or features exhibit a dichotomy—two distinctly different traits. Purely continuous variation features like height and weight have no middle point, no either-or characteristics.

ORGANIZING VARIATION DATA

2-9. Student answers should give the method for detecting the trait and, if possible, the method for measuring it.

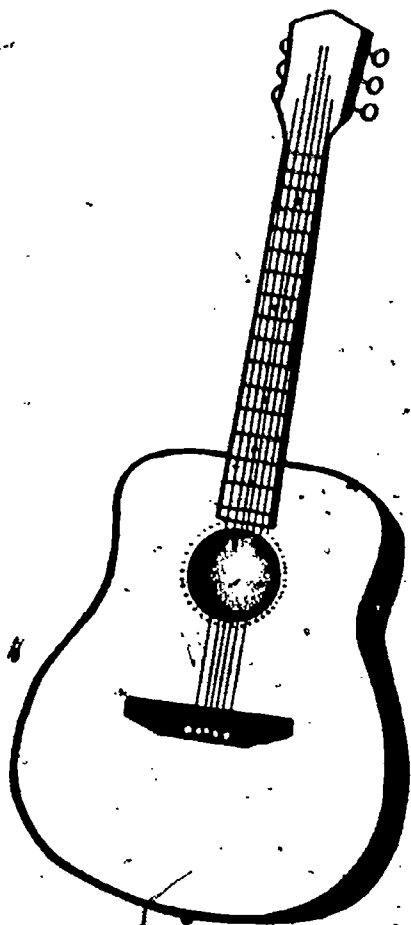

Note that students are asked to use a space (Figure 2-3) in the Record Book to construct an appropriate table, and possibly to have you check it. Whether or not you have the three grades in your school, they should make the table, inventing data if necessary.

2-10. Encourage students to design the data table in their Record Books without just copying the example given below. Once again, you are asked to check it. Both variables are of the either-or type (question 2-11), so only two spaces are needed for each variable. Two spaces for each of two variables require a total of four spaces in the table.

Now try your hand at making a table of your own. Suppose you want to know how many seventh-, eighth-, and ninth-grade students are in a school. You are to construct an appropriate table for collecting and organizing the data you need. Use the space in Figure 2-3 of your Record Book for making the table. When your table is finished, compare it with a classmate's or have your teacher check it.

Until now each human variable, such as handedness, eyedness, or reaction time, has been treated separately. But suppose you wanted to collect data on two or more variables at the same time to see how those variables are related. How would you organize the data you might collect?

For example, suppose you wanted to find out how many students in class owned a guitar, and, in addition, you wanted to know how many of the guitar owners were boys and how many were girls.

2-10. In your Record Book, design a data table that you would use. Be sure you can record data on both variables in the same table. Have your teacher check your table design before going ahead.

2-11. In designing the table, did you consider whether the variables are of the either-or type? Are they?

Your table probably looks something like the sample shown in Table 2-4. (Marks have been included in the table to illustrate how it can be used.)

Table 2-4

OWN GUITAR		
	Yes	No
Boy	///	/// /// /// //
Girl	/// /	/// //

Table 2-4 could be used as you collect data. Each tally or mark you place in the table will tell you two things about the person—the sex of the person and whether or not the person owns a guitar.

2-12. How many boys in the sample class do not own guitars?

2-13. How many girls do not own guitars?

Tables like Table 2-4 are sometimes called *multivariable* tables. Some people also call them *contingency* tables. Others refer to them as *correlation* tables. Whatever they are called, they are very useful. They are useful in making data recordings. And they help you see how variables are related. If you have studied Volume 1 or Volume 2 of ISCS, you've worked with many such tables. If you are not familiar with this kind of table, take a look at **Excursion 2-2**.

We won't guarantee that it will tell you if there's any relationship between the number of left-eyed swagglebanks and how often it rains in Sopchoppy. But it will give you a chance to try your hand at some other interesting problems.

Students will have to struggle a little on this problem break. Question 1 will involve a contingency table between an either-or feature

SOPCHOPPY

1 MILE

PROBLEM BREAK 2-3

Now here's your chance to put to use everything you've learned about collecting and organizing data in human variation. You are to try to answer the two questions given below. In answering you are to collect data on at least 20 people. Design tables for recording the data. If some of the data you need are in tables you've already made, you should use those data.

(sex) and a continuous variation feature (reaction time). Therefore it could have two columns, for boy and girl. In order to be able to answer the question, the actual grabbiness score should be listed, and not the grouping of scores as in Table 2-3. Then the actual

1. Is there any correlation between sex and reaction time in students of your age?
2. Is there any correlation between handedness and eyedness in girls of your age?

When you have completed the tables, answer the questions. Then check your work with your teacher. He will tell you whether you are ready to go on to the next chapter.

Before going on, do Self-Evaluation 2 in your Record Book.

Excursion 2-2 is remedial review, but it also has extension implications.

EXCURSION

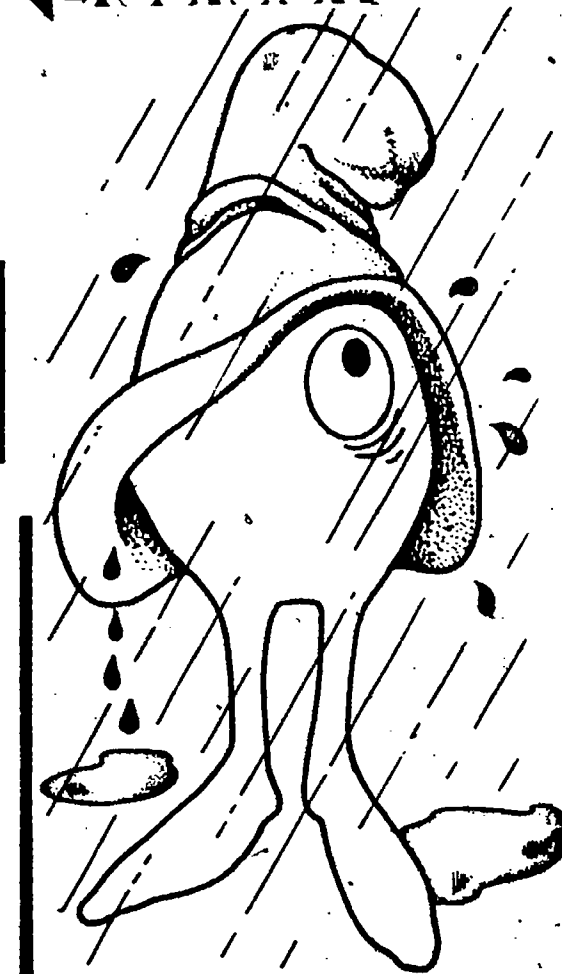

scores could be added up for the boys and for the girls and an average score found for each. The better score (lower average) would then give the answer. In question 2, if both handedness and eyedness are treated as either-or traits, a simple contingency table like Table 2-4 will result, showing the answer.

CHAPTER 2 23

No equipment need be prepared for Chapter 3.

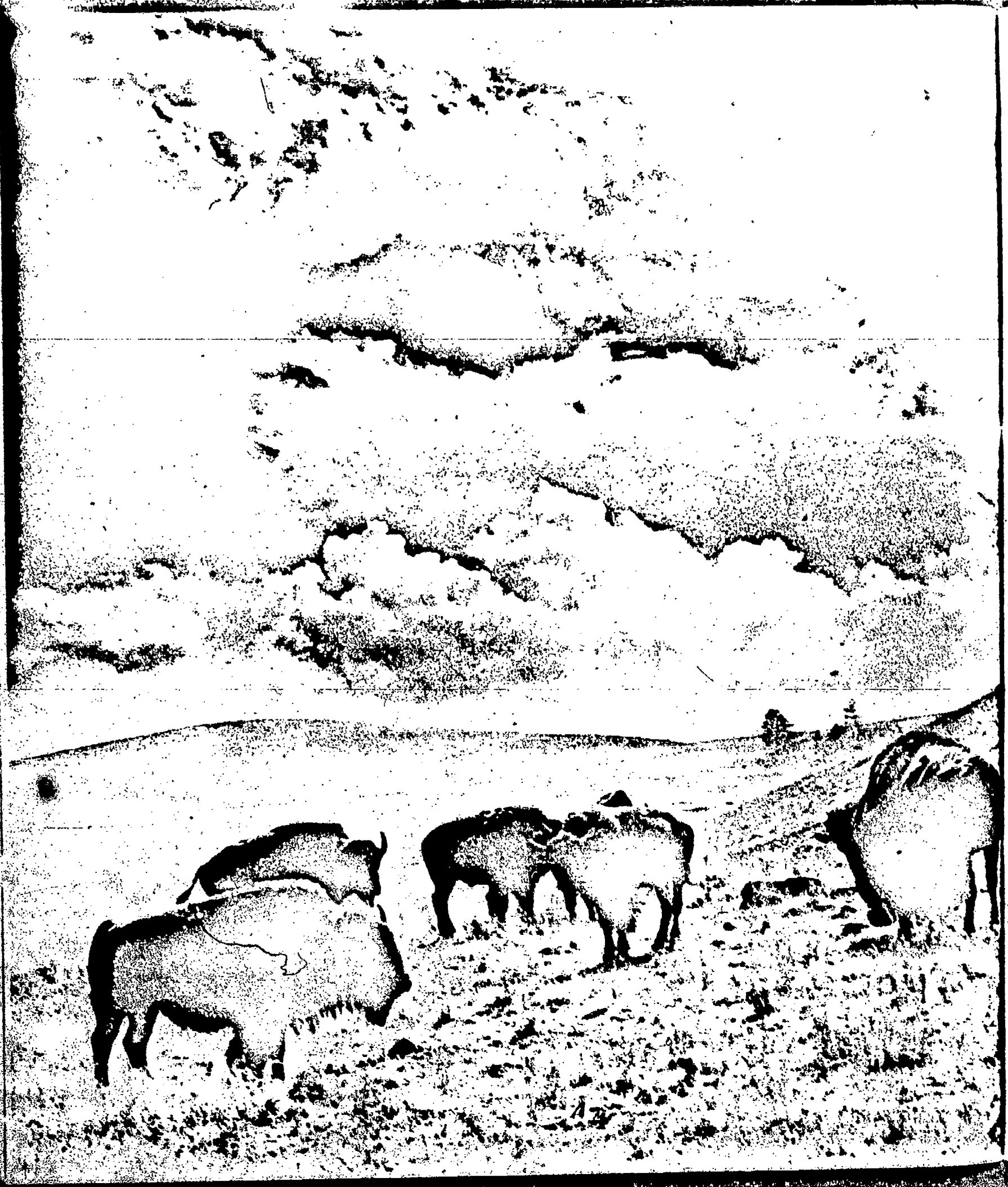

EQUIPMENT LIST

None

Excursion 3-1 is keyed to this chapter, and Excursion 2-1 is rekeyed.

CHAPTER EMPHASIS

Constructing a histogram, grouping of data to make a pattern more obvious, and calculating range, mean, and mode are covered.

- 5. Grouping data can make a pattern more evident
- 6. An individual measurement can be compared with the total by seeing if it is at, above, or below the mean or the mode
- 7. Grouping the total range into five parts, or fifths, is a helpful way of comparing data.
- 8. The more measurements you have, the easier it is to see a pattern, and the more

Home on the Range

Chapter 3

MAJOR POINTS

- 1. A graph in which groups of data are plotted in vertical columns is called a histogram.
- 2. The number of units between the smallest and largest measure in any set of measurements is called the range of the measurements.
- 3. The average of a set of measurements, found by dividing the sum of all measurements by the number of measurements, is called the mean.
- 4. The one measurement in a set that occurs most frequently is called the mode.

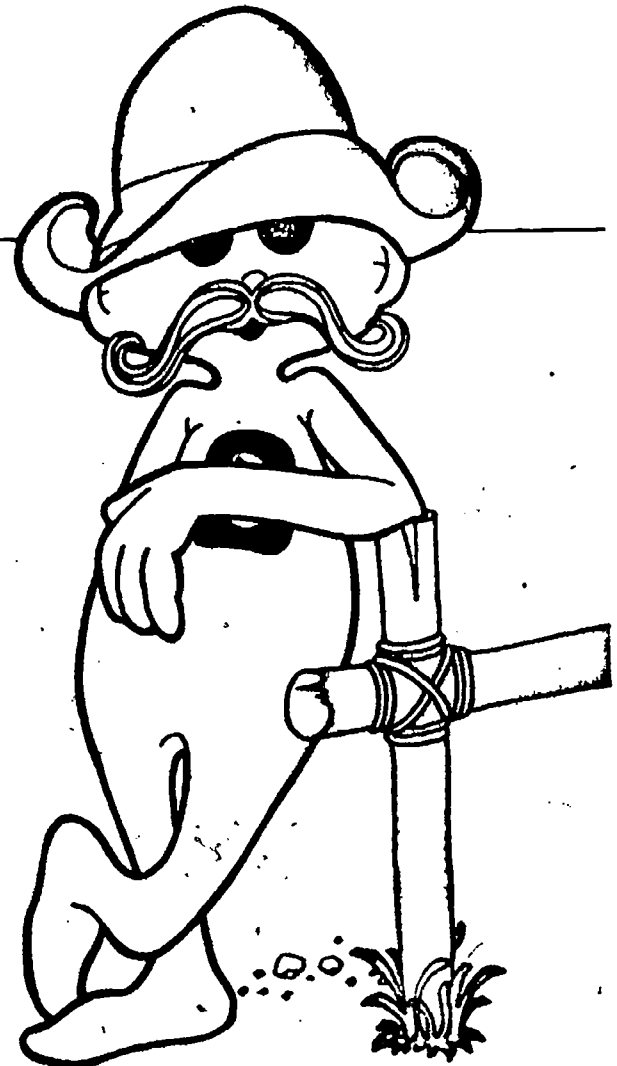
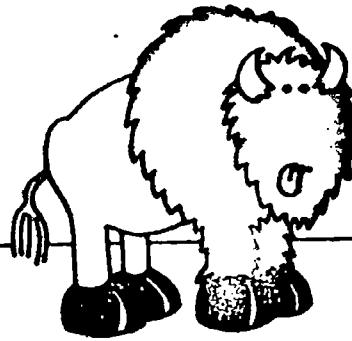

In the last chapter you learned that people have both "either-or" features and "continuous variation" features. Now let's see if you can tell something that's either-or from something that varies continuously. Take a careful look at the word pairs listed below.

- | | | |
|----------------|--------------------|-----------------|
| heads or tails | young or old | solid or liquid |
| up or down | open or shut | wide or narrow |
| hit or miss | day or night | smooth or rough |
| back or forth | push or pull | do or don't |
| rain or shine | straight or curved | good or bad |
| hot or cold | sad or happy | high or low |
| poor or rich | stop or go | right or left |
| war or peace | empty or full | better or worse |
| big or small | soft or hard | |
| boy or girl | wet or dry | |

- 3-1. From the above list, choose four word pairs that are "either-or" situations.
- 3-2. Choose four word pairs that are "continuous variation" situations.
- 3-3. Describe briefly how you chose the word pairs to use in your answers to questions 3-1 and 3-2.

If you had trouble in answering questions 3-1, 3-2, or 3-3, then you had better turn back to Chapter 2 and read it again.

confidence you can have in the conclusions drawn from the data.

If the rule that either-or features exhibit only two possible varieties is applied, heads or tails, hit or miss, boy or girl, open or shut, etc., fall easily in this category. Likewise, those that exhibit widely varying continuous variations could be hot or cold, big or small, young or old, soft or hard, wide or narrow, etc. Some in the list are harder to categorize. Two in particular are noteworthy. If the words up or

BETTER PICTURES OF TABLES

down, and back or forth, denote directions, then these two could be called either-or. But if they denote distances, they have continuous properties.

The histogram, a form of bar graph, is considered a most profitable device for displaying data. It is interesting to note that if a large number of measures are available, the intervals can be made smaller and smaller, down to actual units instead of groups. The smooth line connecting the plotted points would then be a distribution curve. However, the histogram, with data plotted by groups, is an excellent way of presenting measurements that fluctuate widely. The overall pattern is more easily discernible.

In Chapter 2 you collected data on the way people vary in their grabbiness (reaction time). You summarized your data in Table 2-3 of your Record Book. A look at that table should tell you several things about people's reaction time. However, there is probably a lot more information in Table 2-3 than you think. This chapter will help you see ways of getting as much information as possible from data you collect on human features—particularly those of the continuous variation kind.

Figure 3-1 shows the grabbiness data for some ninth-grade students in Florida. Notice that the data have been put into a set of vertical columns. The height of each column tells you how many individuals grabbed the meterstick at each of the different marks shown. This kind of graph is called a *histogram*.

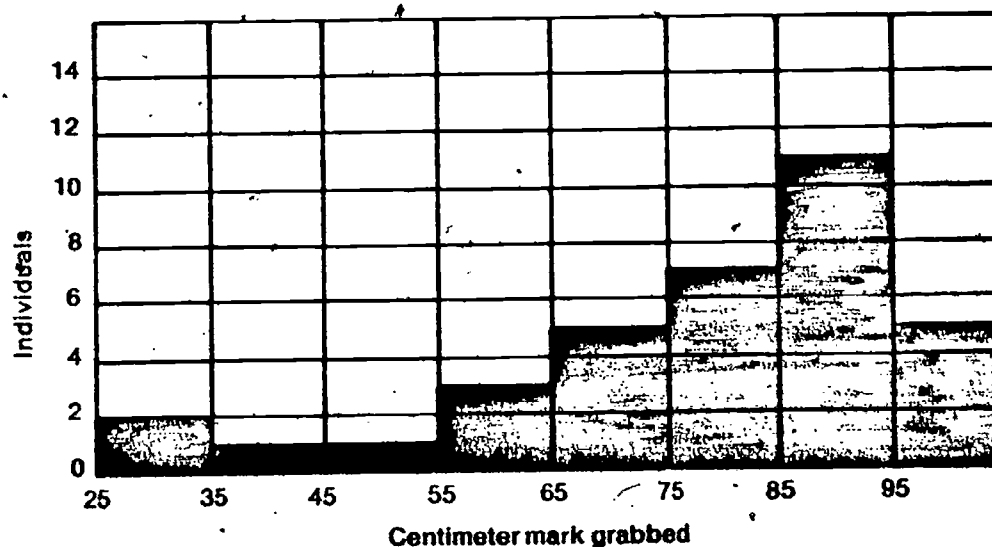

Figure 3-1

Note the use of the two questions, somewhat in the form of a Checkup, to get the students to Excursion 3-1. Once there, they should be encouraged to do it if they need help on histograms or graphs.

3-4. According to the histogram, between which two centimeter marks was the meterstick most often grabbed?

3-5. How many ninth-grade students are represented by the complete histogram?

Check your answers to questions 3-4 and 3-5 by turning to Excursion 3-1. Don't go on unless you are sure that you know what the answers should be and the reason for those answers.

EXCURSION ▶

26 CHAPTER 3

As you will soon see, a histogram is often more useful in organizing data than a table is. A little later you will be asked to make some histograms of your own. Let's practice a little at doing this to be sure that you will be ready.

In your Record Book you will find an axis like the one shown in Figure 3-2. Use that axis and the data you have already put into Table 2-3 in Chapter 2 to make a histogram of the grabbiness data you have collected.

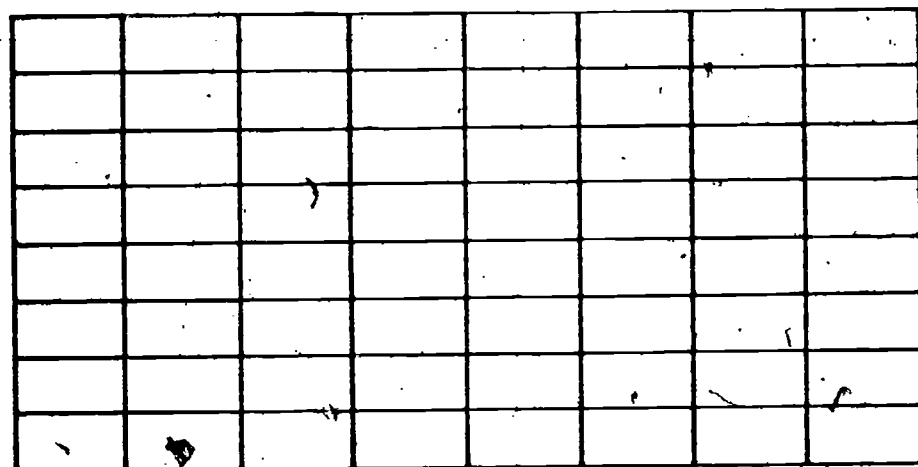

The students can label their horizontal axes the same as in Figure 3-1. If they do, they should remember that the totals from Table 2-3 are from 25 to 35, 35 to 45, etc. Note that they are asked to have you check both the histogram and the data from Table 2-3.

Figure 3-2

To be sure that your histogram is correct, have your teacher check it. To do this, your teacher must see your data from Table 2-3 as well as your histogram.

One of the problems in science, and in the rest of life, is that a single word may have more than one meaning. Think of the word *range*, for example. To some people, range means a grassy area where buffalo and antelope roam. To others, it means a cooking stove. Still others might picture a rifle range or a mountain range.

Let's take another example and consider the word *mean*. "She's a *mean* old lady." "I've been *meaning* to do that." "What does the word *mean*?" "He plays a *mean* game of golf."

The terms *range* and *mean* are both used in science and will be used in this unit. For this reason you need to know their scientific meaning.

MODE, MEAN, AND RANGE

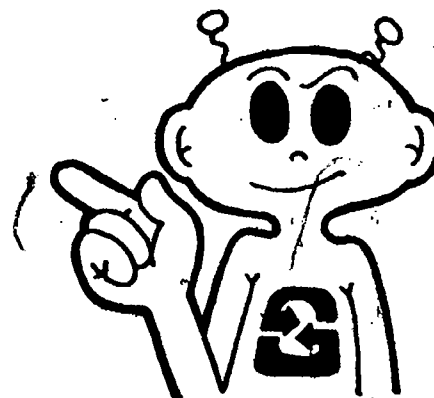

In defining range, it may be necessary to define unit, measure, and set. A unit is the scale used for the measurement, such as cm, mm, m, etc. It is plotted along the bottom of the histogram. A measure is the operation of finding the amount of the trait in an individual case. The number of measures made is plotted vertically. A set is the total number of measures in a given situation. Thus the definition of range "the number of units" means the number of scale units (cm in the example) between the smallest and largest measures.

If continuous variation features are measurable, these measures spread out over a wide set of numbers. For example, height is a continuous variation feature. Measuring the height of several people would give you a set of numbers. In this set there would be a smallest and largest measure. And, of course, there would be other measures between these two.

Range as it is used in this book means "the number of units between the smallest and largest measures in any set of measures."

To find the range of a series of measurements, you subtract the smallest measure in the set from the largest. For instance, in Figure 3-1, grabbiness measures are shown along the bottom of the graph. The range for this set of measures is 70 cm. Here is how you get it.

$$\begin{aligned} \text{Largest measurement} - \text{Smallest measurement} &= \text{Range} \\ 95 \text{ cm} - 25 \text{ cm} &= 70 \text{ cm} \end{aligned}$$

- 3-6. What is the range for the set of grabbiness measurements that you recorded in Table 2-3?
- 3-7. Give an operational definition of the word *range*.

Now what about *mean*? This word means the same as the *arithmetic average*, or what most people loosely call the "average."

The mean for a set of measurements can be operationally defined as:

$$\text{Mean} = \frac{\text{Sum of all measurements}}{\text{Number of measurements}}$$

- 3-8. Calculate the mean of the following measures: 28 cm, 84 cm, 100 cm, 52 cm, 13 cm, 66 cm.

If you do not see how the mean for question 3-8 is found, turn to **Excursion 2-1**, "On the Average," for more help.

- 3-9. What would you have to do to find the mean for the measurements you recorded in Table 2-3?

Another characteristic of a set of measurements with a continuous variation is the *mode*. *Mode* means "the one measurement in a set that occurs most frequently."



The remedial Excursion 2-1 is for those who are still having averaging difficulties. Some students may have to be urged to go through it again.

EXCURSION ▶

3-9. Find the sum of all the measurements and divide it by the number of measurements. [Note that students were not asked to find the mean, but only to tell what they would have to do to find it. There is a big difference; to actually find the sum of all the measurements could be a very complicated task for the students. You might want to present the problem

3-10. In Table 3-1, what is the mode for the data set?

Table 3-1

Shoe Sizes for Teen-age Boys
6B, 7A, 7B, 6E, 9A, 9A, 8D, 10B, 11D, 9AA, 12D, 14B, 10B, 7A, 8D, 9½C, 10½B, 9½D, 9½C, 11B, 12AA, 10C, 10C, 9½C, 10D, 9½C, 11D, 9½C

3-11. Can you find the mode for your data in Table 2-3?

In Table 3-1, the shoe size that occurs most frequently is 9½C. Thus, the mode for the data set is just that, 9½C.

The mode for the data set you graphed in Figure 3-2 depends on your own set of measures, (i.e., your data from Table 2-3).

Patterns in data are not always easy to see. Sometimes the range, mean, and mode help you see a pattern. Sometimes, to find a pattern, data have to be organized.

3-12. Table 3-2 gives the weight (in pounds) of a group of ninth graders. What is the range, the mean, and the mode for these data?

Table 3-2

Weight (lb.) of a Group of Ninth Graders			
97	106	133	65
142	97	93	140
105	156	110	110
114	72	102	118
104	124	75	112
60	99	88	115
107	125	169	110
138	158	123	81
122	127	107	138

to some of the more competent. For your information, two possible ways of finding the mean are these: (1) Go back to the original ungrouped measures of grabbiness. Add these all up and divide by the number of scores. (2) Take an average figure for the groupings in Table 2-3 (25-34 would average about 30, 35-44, about 40, etc.) Multiply these average figures by the number of measures in each row. Add all these products, and divide by the total number of scores.]

3-11. Normally, the students should answer No. But if some of the sharper ones found the mean by method number 1 in the teacher note, they already have used the ungrouped measures. The measure that occurs most frequently would be the mode, and the answer to the question could be Yes.

3-12. Range, 169 - 60, or 109 lb;
mean, 112.3 lb;
mode, 110 lb.

FINDING PATTERNS BY GROUPING

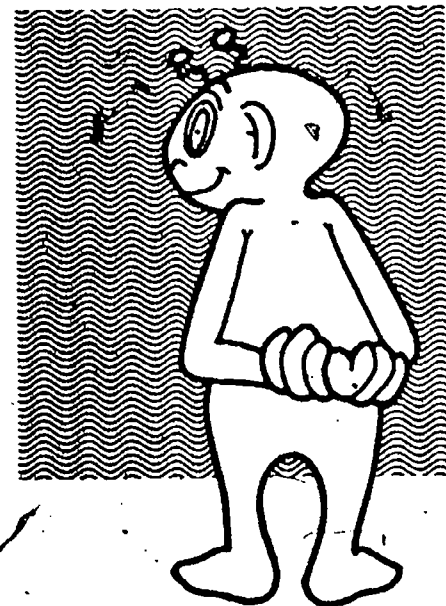

The mode, 110, shows as the longest line

Figure 3-3

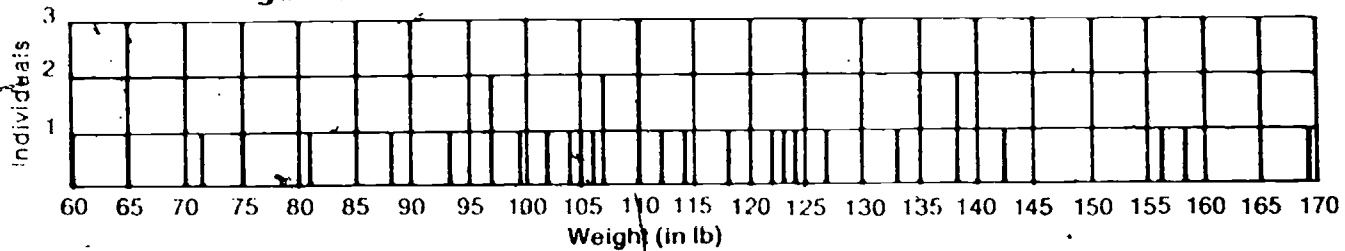

Figure 3-3 shows the data from Table 3-2 arranged in the form of a simple histogram.

Note that the mode, 110, still falls in the largest group on the histogram (110-114)

Grouping data can make a pattern more evident. Figure 3-4 shows a histogram of the data from Table 3-2. This time, measurements have been grouped into five-pound intervals.

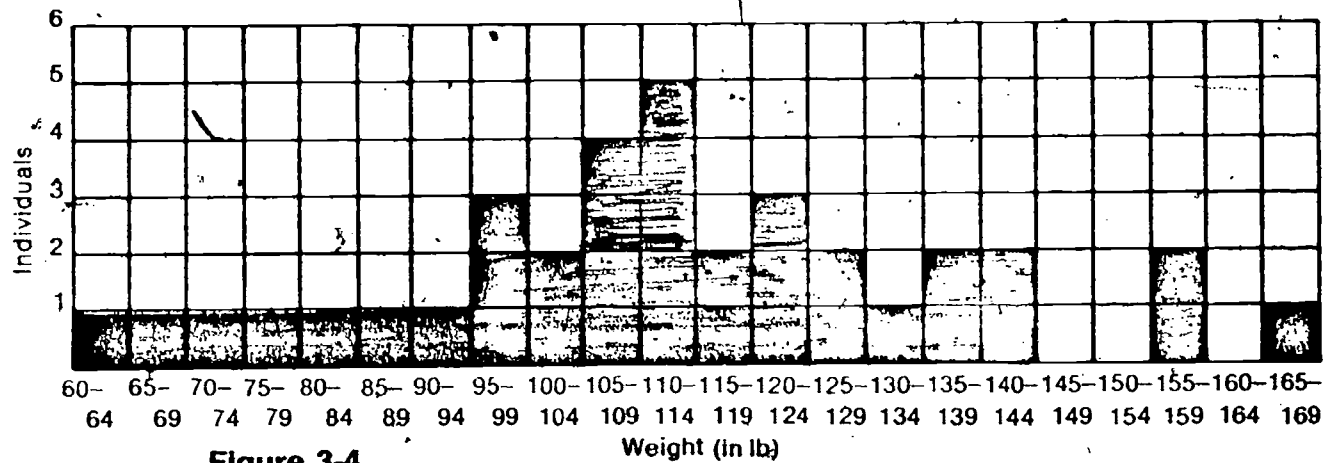
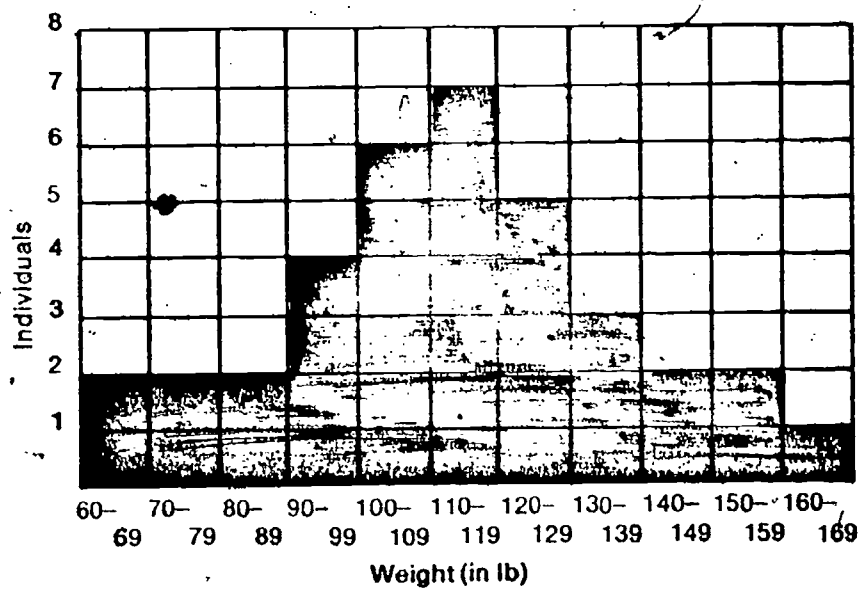

Figure 3-4

Now look at a histogram, made by grouping the entries into ten-pound intervals (Figure 3-5). Notice how the data take on a sort of mountain-shaped pattern.

Figure 3-5

Again the mode falls in the largest ten-pound interval (110-119).



Arranging data in histograms or in other kinds of graphs does not change the range, mean, or mode for the data. But new arrangements can make patterns more obvious.

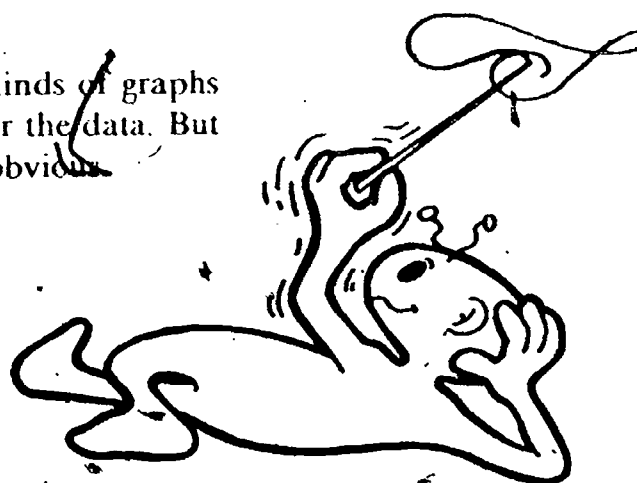

Throughout this unit you will be comparing your measurements with those of your classmates. One simple way of comparing is to see if your measurement is at, above, or below the mean or mode.

Another way of comparing will give you even more information. Look back at the weight distribution of ninth graders, in Figure 3-3. The weight range is from 60 to 169 pounds (or 109 pounds). Dividing that range into five parts gives about 22. The number of ninth graders within each fifth are shown in Table 3-3.

THE ISCS FIFTH SYMPHONY

The weight range is actually divisible exactly in five parts in this case. A range from 60 to 169 pounds includes both the first weight (60) and the last weight (169) and all the unit weights between the two. This total of units is 110. Likewise the range of each fifth includes the first and last weights in that fifth (60-81, 82-103, etc.), and the units in each fifth total 22.

Table 3-3

Fifth	Range	Limits of Range for That Fifth	Numbers of Individuals
1	22 lbs	60-81	5
2	22 lbs	82-103	6
3	22 lbs	104-125	16
4	22 lbs	126-147	6
5	22 lbs	148-169	3

Notice that, once again, most of the measurements occur in the middle fifth (3) with fewer at either extreme measurement (1 and 5). Figure 3-6 shows the information above in histogram form. Note how clearly the mountain-shaped pattern shows up when the data are grouped in fifths.

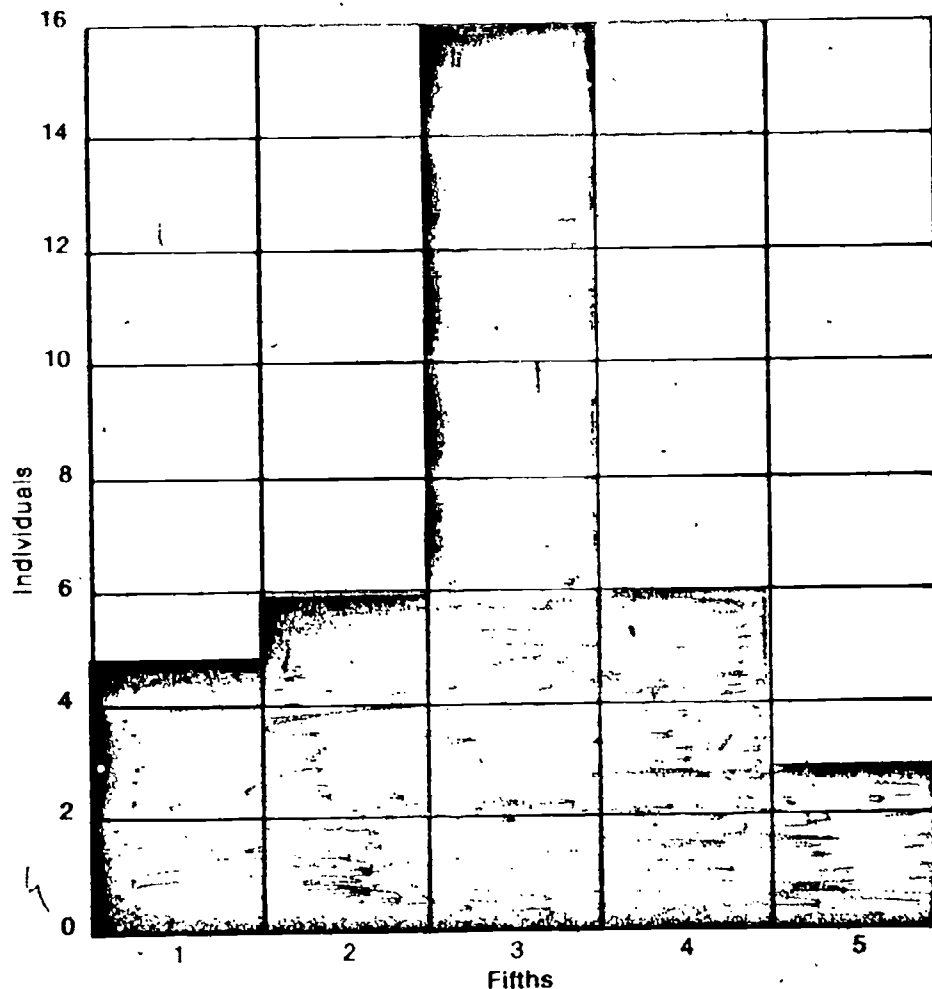

Figure 3-6

Both the mode and the mean fall in the middle, or 3rd, fifth.

You might want to make a point with the students on the increase in confidence in measurements when the number of measures is increased. For instance, if any one column of weights from Table 3-2 had been used instead of the whole table then the range, mean, and mode would have been different.

- 3-13. If Ringo Deery weighs 142 pounds, into which fifth does he fall?
- 3-14. If Twiggy Hutch weighs 80 pounds, into which fifth does she fall?
- 3-15. Which fifth is the mode fifth?
- 3-16. Into which fifth will extremely light people fall?
- 3-17. Into which fifth do "normal" variations in weight fall?

In this chapter you've learned how to make a histogram. You've also found how to calculate the range, mean, and mode for a set of measurements. You've seen that grouping data often helps to make a pattern clearer. This is especially true when you have a small number of measurements. You have probably heard that good experiments are repeated many times. The more measurements you have, the easier it is to see a pattern and the more confidence you can have

regarding the conclusions you make.

In the next chapter, you will get to use your new skills in analyzing some not-so-obvious variations. You will also be introduced to some new skills useful in finding patterns.

Before going on, do Self-Evaluation 3 in your Record Book.



I'M BEHOLD'N TO YUH
FER CLEAR'N UP
THAT RANGE MESS.

GET IT READY NOW FOR CHAPTER 4.

This chapter involves a longer list of equipment than any other. Some of it must be supplied locally. This includes chalk, baby-food jars, glasses, or beakers, paper, and a watch or clock with second hand. Activity 4-17 calls for students to use a reasonably quiet area. You might want to give consideration to the use of some area outside the regular classroom, where students can work quietly in pairs. You will need to supply straight sticks for students who go to Excursion 4-2. These should be prepared ahead of time. A teacher note on the first page of the excursion gives further details. White unlined paper and paper towels must be supplied for Excursion 4-3, and you probably will want to ink the stamp pads ahead of time for students going to that excursion. Some hints on this operation are given on page 85.

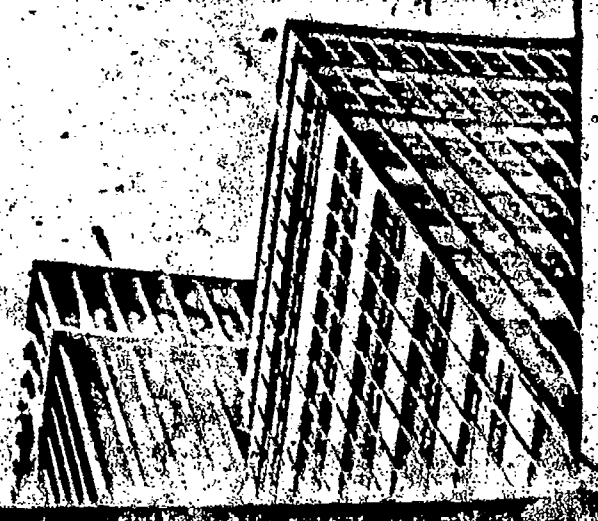
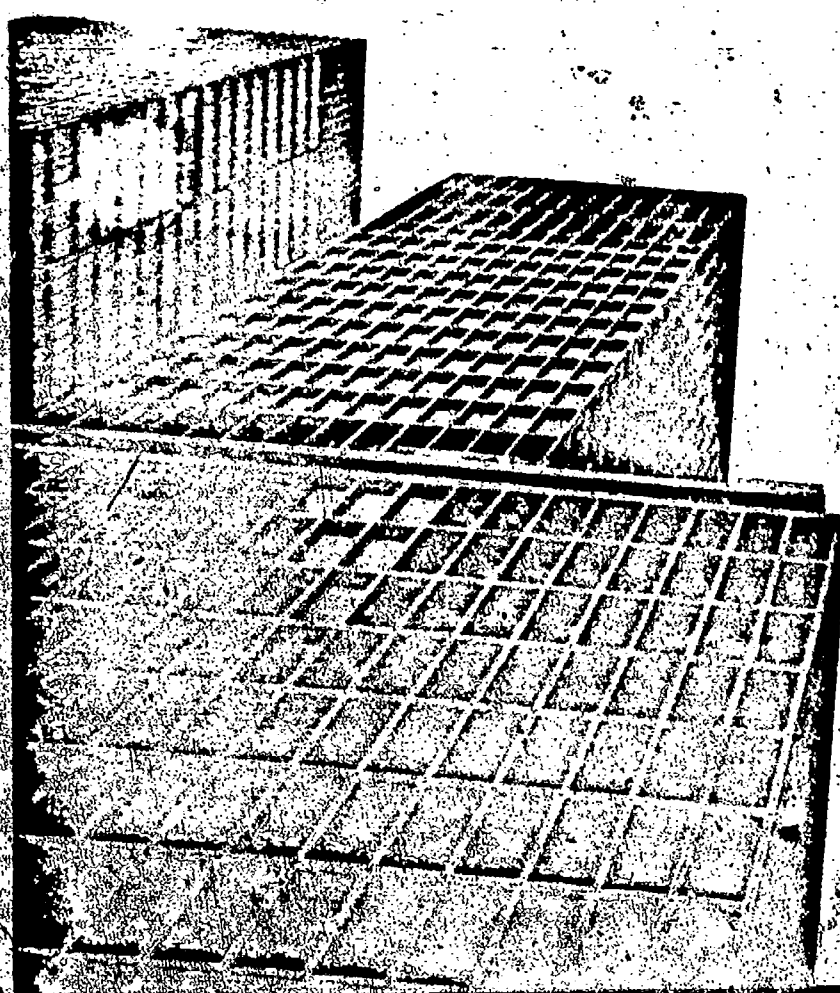
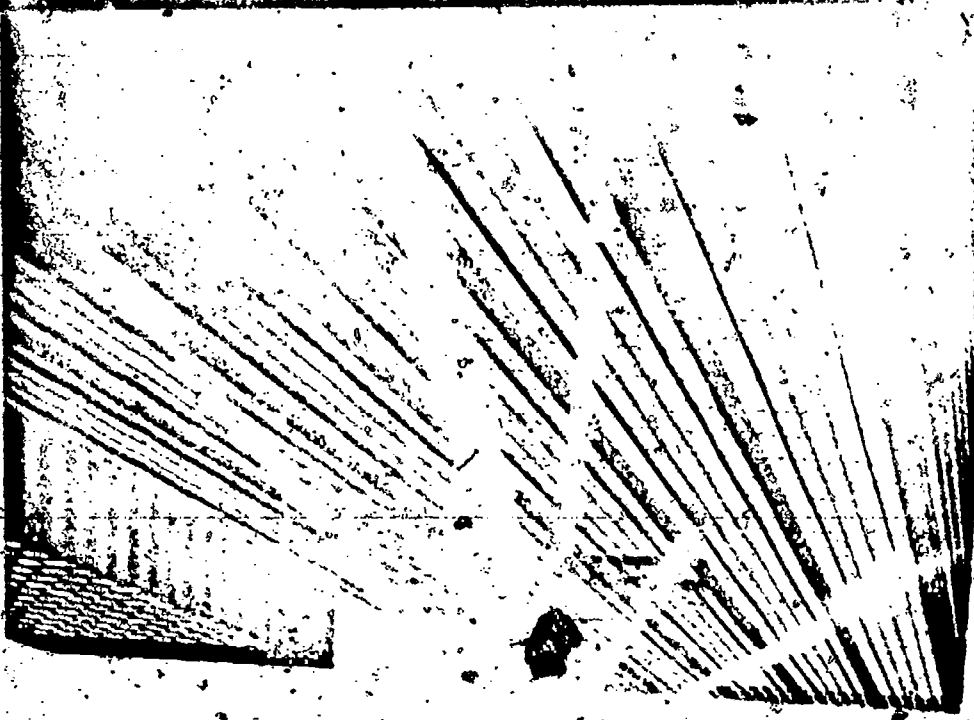

How Do You Measure Up?

EQUIPMENT LIST

Per student-team

- 1 meterstick
- 1 meter of string
- 1 piece of chalk
- 2 white index cards (3" x 5")
- 1 protractor
- 1 metric ruler
- 2 rubber bands
- 2 toothpicks
- 1 glass, baby-food jar, or beaker
- Watch or clock with second hand
- Masking tape

CHAPTER EMPHASIS

Students use range, mean, and mode to compare their personal traits with those of their classmates in additional situations.

Excursions 4-1, 4-2, and 4-3 are keyed to this chapter.

How do your features and characteristics *compare* with those of other people your own age? Are you average? Do some of your characteristics fall into the "mode" category? To get an idea of just how normal you are, you should conduct a few investigations. Find out how you stack up in relation to your classmates.

Start with an easily measured feature—height. To obtain measurements, you can use the help of a partner and a meterstick.

ACTIVITY 4.1. Measure your height in centimeters, as shown. As a check, you should make your measurement more than once.

4-1. How many centimeters tall are you?

When you are sure that your height measurement is right, compare your measure with the data in Table 4-1. (If you are a boy, use the "male data;" if you are a girl, use the "female data.") Notice that the table contains both height and weight measurements for people of your approximate age.

MAJOR POINTS

1. It is possible to find the range, mean, and mode of weights and heights from the data for boys or girls of a particular age
2. The height and weight of any individual may not fall on the mean, or average, of the class data.
3. It is possible to measure the peripheral angle of vision, and to determine the range, mean, and mode of this angle for a group of students.

Chapter 4

4. A measure of the sensitivity to touch can be made for various parts of the body, and comparisons made with the mean of a class group.
5. The blind spots in the eyes can be identified, and a measurement made of the total blind distance of each eye.
6. A test can be made for the ability to determine distance and direction of a sound.
7. Timing error can be measured, and a comparison made with the mean error of a group of students.
8. A normal person is one whose measures vary from the mean or the mode in some characteristics or traits.

HEIGHT AND WEIGHT

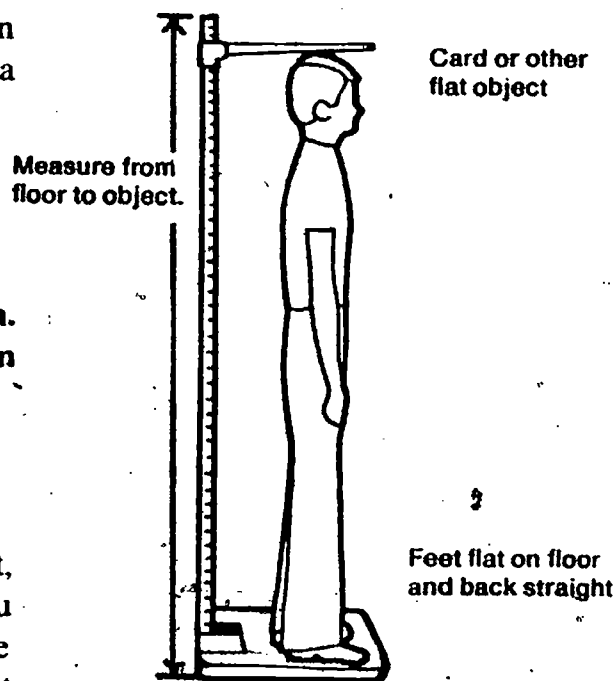

Table 4-1

Male		Female	
Height (cm)	Weight (lb)	Height (cm)	Weight (lb)
158	97	153	102
178	142	141	84
170	105	150	95
176	114	160	100
163	104	163	95
153	75	165	115
164	107	169	126
184	138	155	110
178	122	148	94
150	72	155	107
160	99	173	142
169	117	154	85
165	104	155	96
158	85	150	103

Range of height (male)—34 cm
 Range of height (female)—32 cm
 Range of weight (male)—70 lb
 Range of weight (female)—58 lb

Mean height (male)—166.14 cm
 Mean height (female)—156.5 cm
 Mean weight (male)—105.79 lb
 Mean weight (female)—103.86 lb

Mode height (male)—158 cm and 178 cm
 Mode height (female)—155 cm
 Mode weight (male)—104 lb
 Mode weight (female)—95 lb

Note that mode height for male occurs at two points—it is bimodal.

Experience has shown that some teen-agers (and adults) become worried if the measure of their traits differs from the average. Thus, this paragraph may provide some reassurance for them.

4-2. What is the range of weights for the students of your age and sex?

4-3. What is the range of heights for the students of your age and sex?

4-4. What are the mean and mode weights for the students of your age and sex?

4-5. What are the mean and mode heights for the students of your age and sex?

4-6. How far above or below the mean for height of your sex is your height measurement?

4-7. How far above or below the mean for weight of your sex is your weight measurement?

Height and weight usually vary greatly among teen-agers. If you calculate the mean height of your classmates, you may find no single person who has the average height. Thus, who is average? Perhaps the best example of an average person is someone whose characteristics are *not* average.

Height and weight are important characteristics to teenagers. But now look at some features that you probably never even thought about.

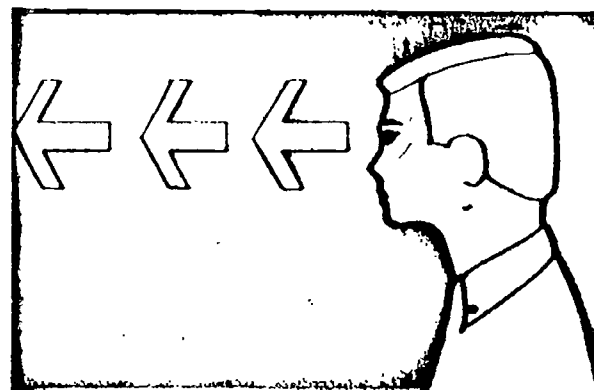

EYES FORWARD

You can't see what's going on behind your head. But you can see things to your right or left without moving your eyes or turning your head. How much can you see? Your next problem is to measure how far to the side you can see while looking straight ahead.

To make measurements, you need to know how to use a protractor. If you don't know how to use one, do **Excursion 4-1**, "Angles and Protractors." When you are ready to go ahead, you'll need to work with two partners. Your group will need these materials:

- 1 piece of string, 1 meter long
- 1 piece of chalk
- 2 white index cards, 3 × 5 inches
- 1 protractor
- Tape

Read through Activities 4-2 to 4-9 before starting.

Excursion 4-1 is remedial on the use of a protractor.

← EXCURSION

Note the change to a student-team of three people for these activities.

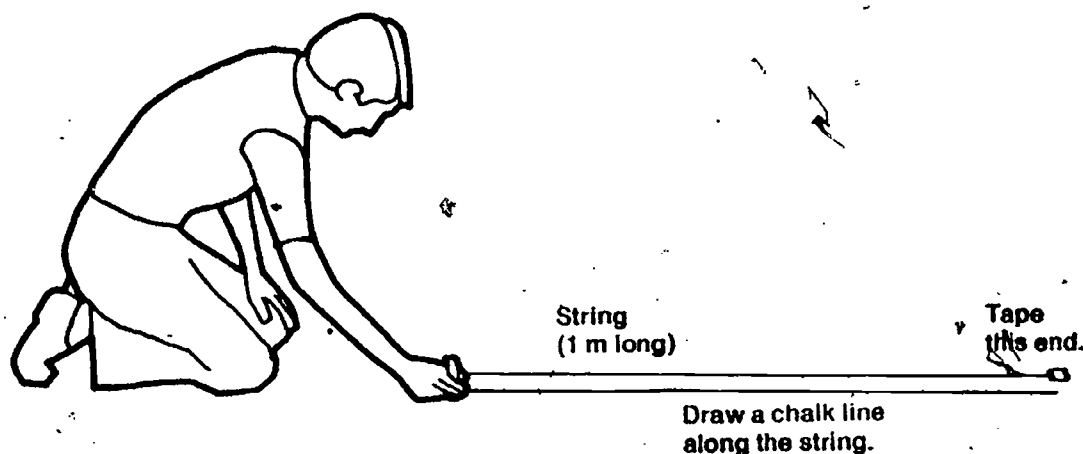

ACTIVITY 4-2. Tape one end of the string to the floor. Stretch the string out straight and chalk a line on the floor along the entire length of the string.

A meterstick could be used to draw the straight line instead of trying to follow the string with the chalk.

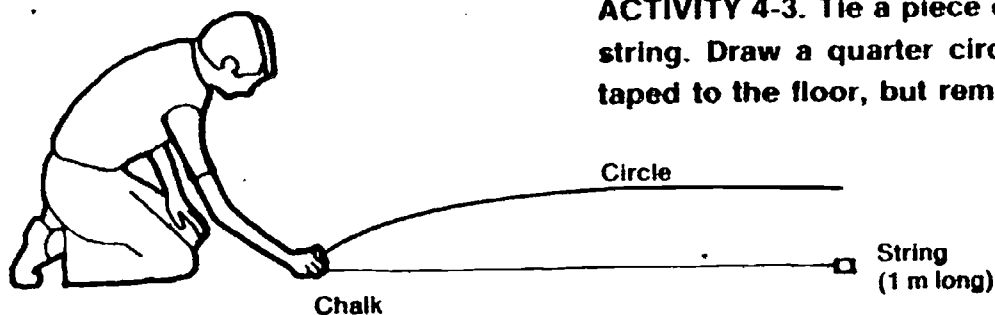

ACTIVITY 4-3. Tie a piece of chalk to the untaped end of the string. Draw a quarter circle on the floor. Leave the string taped to the floor, but remove the chalk.

ACTIVITY 4-4. Prepare two index cards as shown. Use cards already made if they are available.

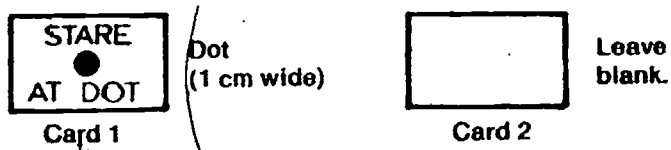

ACTIVITY 4-5. You and your first partner should stand as shown. Be sure that your feet are on the tape and that you can see the dot on Card 1.

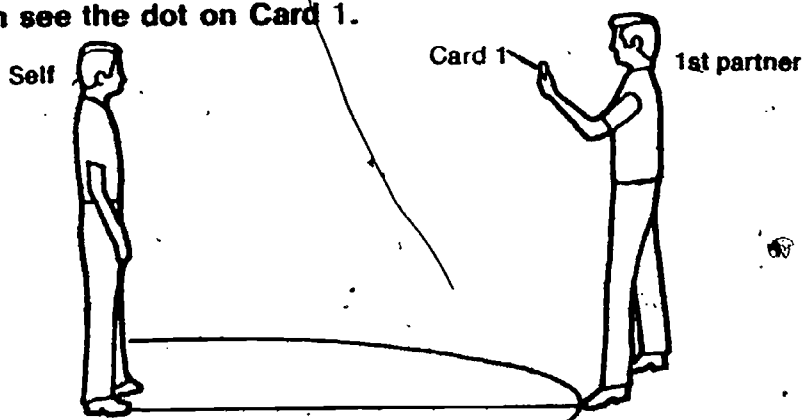

ACTIVITY 4-6. Next stare at the dot on Card 1 while your second partner moves along the greater circle with Card 2 in his hand. Watch the blank card without moving your eyes or your head.

It is difficult for some students to keep head and eyes immovable. One technique that will help is to have partner with Card 1 carefully observe the person in the center, and sound a warning if any movement is detected.

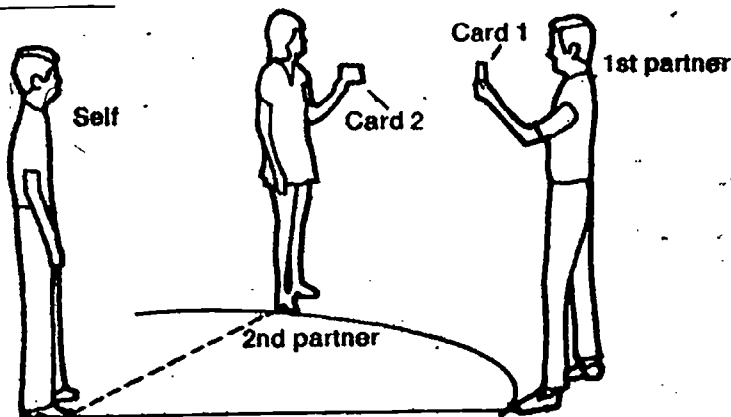

ACTIVITY 4-7. When you can no longer see Card 2, say "Stop."

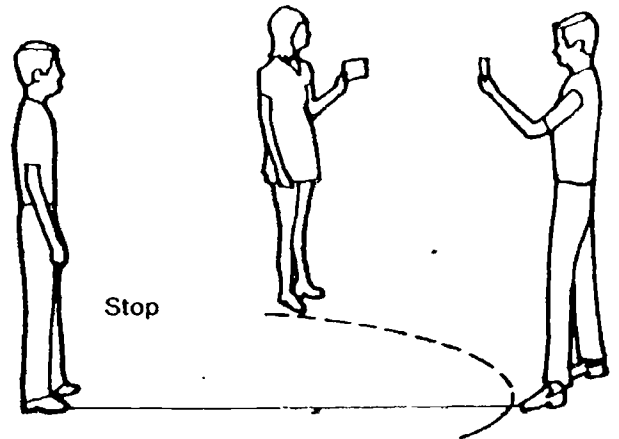

ACTIVITY 4-8. Move the end of the string to a point just below the blank card in your second partner's hand. Hold it in place with a small piece of tape.

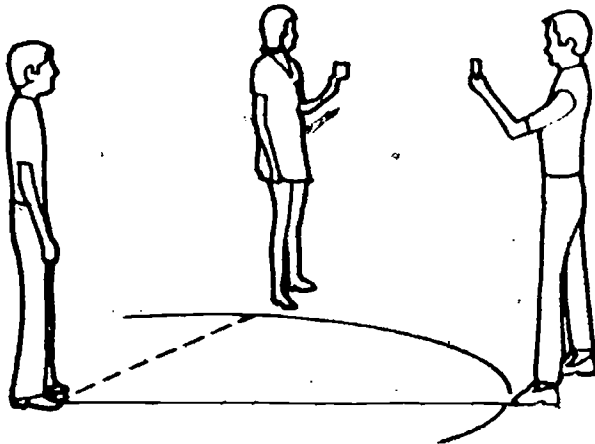

ACTIVITY 4-9. With a protractor, measure the angle between the chalk line and the string. This is your "peripheral angle of vision."

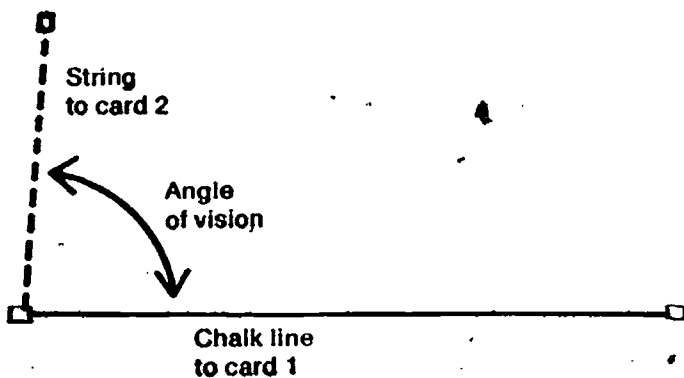

Repeat the measurement of your angle of vision twice more. Record the results of the three trials under Self in Table 4-2 of your Record Book.

If students have worked with the space unit, *What's Up?*, they will have constructed quadrants that could be used for the measurement of the angle. These are larger than the protractors, and might be easier to use.

Persons with a low angle of vision are said to have tunnel vision. This is one of the hazards of the space age. It has been found that prolonged exposure to an atmosphere that is too rich in oxygen, such as might occur in a space capsule, can cause extreme tunnel vision, unconsciousness, and even death.

Table 4-2

Student	Trial 1	Trial 2	Trial 3	Average
Self	___°	___°	___°	___°
Student 1	___°	___°	___°	___°
Student 2	___°	___°	___°	___°
Student 3	___°	___°	___°	___°
Student 4	___°	___°	___°	___°
Student 5	___°	___°	___°	___°
Student 6	___°	___°	___°	___°
Student 7	___°	___°	___°	___°
Student 8	___°	___°	___°	___°
Student 9	___°	___°	___°	___°
Student 10	___°	___°	___°	___°

Again, you may decide to use class charts for the collection of these data. If so, you should provide spaces for the three trials and average, so that students can complete Figure 4-2 in their Record Books.

Next, measure the angle of vision for ten of your classmates (three trials and average). Record these results also in Table 4-2. When the table is complete, make a histogram of the data in the space provided in Figure 4-2 of your Record Book. Use the histogram and Table 4-2 to answer the next three questions.

In determining the mode with a relatively small number of measures (11), it is conceivable that there will not be a grouping at any one measure. If two measures occur most frequently, it is bimodal; if three occur, it is called trimodal. Possibly there is only one of each measure, in which case it is called multimodal.

4-8. Use the calculated averages to determine the range of angle of vision for the ten students.

4-9. Use the calculated averages to determine the mean and mode angle of vision for the ten students.

4-10. Is your angle of vision the same as, above, or below the mean for the ten students?

PROBLEM BREAK 4-1

Up to now, you have concentrated on your field of vision to the side (horizontally). Design and carry out an experiment that will measure your field of vision up and down (vertically). Describe your experiment and record your findings and conclusions in your Record Book. Do not spend more than one class period on this activity.

The last activities dealt with your sense of sight. You have four more senses—hearing, touch, smell, and taste. The rest of the activities in this chapter will give you the chance to investigate some of these senses. You will also be able to compare your senses with those of your classmates.

Touch is considered to be one of the so-called five senses. In this activity you will determine whether the sense of touch varies in different parts of your body. But before doing the experiment, try answering these questions.

- 4-11. At what point on your body do you think you are most sensitive to touch?
- 4-12. At what point on your body do you think you are least sensitive to touch?

To test your predictions, you will need a "touchometer." This is a device with which you can measure sensitivity to touch. To make a "touchometer," you will need these things:

- 1 cm-scale plastic ruler
- 2 rubber bands
- 2 toothpicks

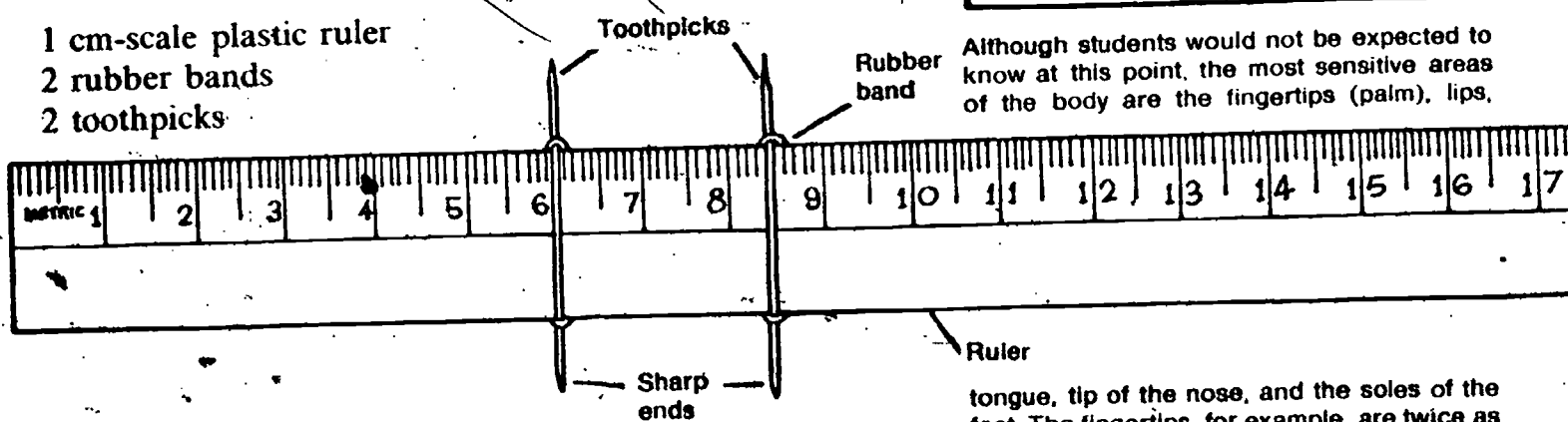

ACTIVITY 4-10. Use rubber bands to attach two toothpicks tightly to a ruler as shown. Be sure that the more pointed end of each toothpick points in the same direction.

This problem break is a good opportunity to design an independent investigation. An extension of the problem of angle of vision can be presented to students who are interested in going a little further. By using colored cards the same size as Card 2, a test can be made of the angle at which different colors can be identified. You have colored construction paper in the supply kit.

ARE YOU TOUCHY?

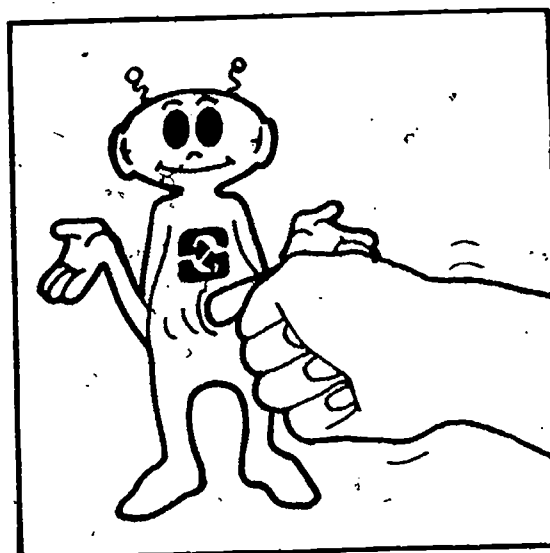

Although students would not be expected to know at this point, the most sensitive areas of the body are the fingertips (palm), lips,

tongue, tip of the nose, and the soles of the feet. The fingertips, for example, are twice as sensitive as other hand areas.

In using your touchometer you will vary the distance between the toothpicks and touch both points to the skin at the same time. The aim will be to find out how close together the toothpicks have to be before the two points feel like one. Let's give it a try.

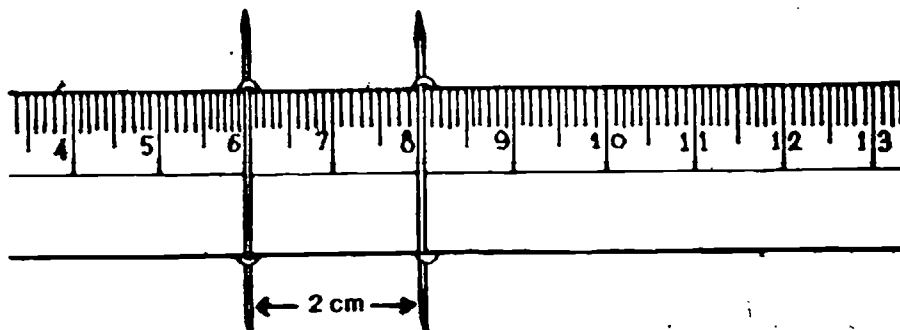

ACTIVITY 4-11. Spread the points two centimeters apart, as shown.

In working with the touchometer, it is very important that the two points touch at the same time. Otherwise, it will give a clue to the subject because of the time difference be-

ACTIVITY 4-12. Touch the two points to your forearm at the same time, as shown. If you feel both points, move the picks closer together and repeat. Adjust the toothpicks until they are as far apart as possible but still feel like only one point.

tween the contact of the separate points. And the contact should be light. There are five basic skin stimuli that make up the sense of touch. They are cold, heat, contact, pressure, and pain. Students are measuring the contact stimulus, and excessive pressure will confuse the reaction.

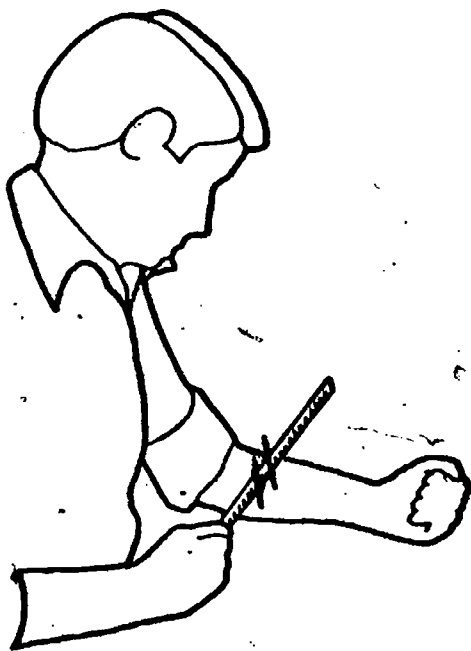

Now that you know how to use your touchometer, you are ready to do your touch experiment. You will need a partner.

Safety Note *In doing this touch experiment, be very careful with the sharp points. Do not test the sensitivity of your face, although you may want to test the back of your neck. Don't make quick or unexpected moves. Always apply the touchometer very lightly. You are trying to measure sensitivity of touch, not pain.*

ACTIVITY 4-13. While your partner's eyes are closed, test his touch sensitivity on the back of his forearm. Record the results of two trials in Table 4-3 of your Record Book.

When testing subjects with their eyes closed, it is a good plan to touch only one point every once in a while. Otherwise subjects will know that they are always being touched by two points.

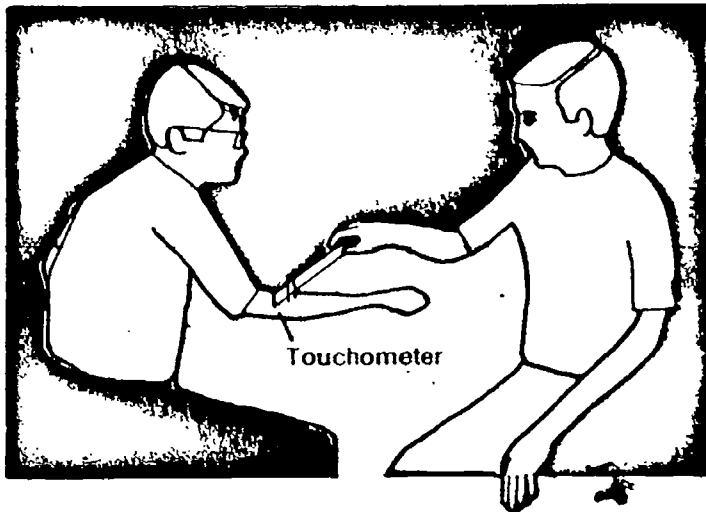

Table 4-3

Area Tested	Distance (cm) Between Points When They Are Felt as One					
	Trial 1		Trial 2		Average	
	Self	Partner	Self	Partner	Self	Partner
Back of forearm						
Back of neck						
Palm of hand						
Back of hand						
Sole of foot						

Next, switch places with your partner and have him test your touch sensitivity by repeating Activity 4-13. Then, for yourself and your partner, test the other body areas that are listed in Table 4-3. Record all measurements in your Record Book.

Although individual subjects differ, the palm of the hand and the sole of the foot will probably show the greatest sensitivity, with the back of the forearm showing the least.

Finally, test the touch sensitivity of nine other classmates. Record the data that you collect in Table 4-4 of your Record Book. When the table is complete, make a histogram of the data and answer questions 4-13 through 4-16.

Table 4-4

Area Tested	Self	Classmates									
		1	2	3	4	5	6	7	8	9	10
Back of forearm											
Back of neck											
Palm of hand											
Back of hand											
Sole of foot											

Once again, the distribution may be multimodal due to the small number of measures.

4-13. What are the class ranges, means, and modes for the “touchiness” of the forearm, back of neck, palm of hand, back of hand, and sole of foot? You can answer this question by completing Table 4-5 in your Record Book.

4-14. Small

4-14. In the touchiness test, does a large, or a small, touchometer reading indicate more sensitivity?

4-15. For which areas of the body were your own touchiness measurements greater than the mean for you and your classmates?

4-16. For which areas of the body were your own touchiness measurements smaller than the mean?

Table 4-5

	Range	Mean	Mode
Back of forearm	___ cm to ___ cm	___ cm	___ cm
Back of neck	___ cm to ___ cm	___ cm	___ cm
Palm of hand	___ cm to ___ cm	___ cm	___ cm
Back of hand	___ cm to ___ cm	___ cm	___ cm
Sole of foot	___ cm to ___ cm	___ cm	___ cm

You have probably heard someone say, "He has a blind spot when it comes to so-and so." This comment usually implies that the person with the "blind spot" doesn't see all the facts. Of course most of us have such mental blind spots, at one time or another in our lives.

But did you know that everyone has a true physical blind spot—one for each eye? Well, it's true. In the next activity, you will investigate your own blind spots. You will also see how these blind spots differ for different people.

To get ready for the activity, you need to make a copy on paper of Figure 4-1. You will also need a partner and a centimeter-scale ruler.

BLIND SPOTS

Students may be curious about the blind spot. It is the only point on the back of the eye (the retina) that is not sensitive to light. This is because at the point where all the nerve fibers come together and pass through the retina and out the back of the eye to become the optic nerve, there are no photoreceptor cells. Despite the relative ease with which students can identify it, the blind spot was not discovered until the 17th century, by a French scientist. Because of binocular vision and the frequency of eye movements, it causes no difficulty in our everyday lives.

Figure 4-1

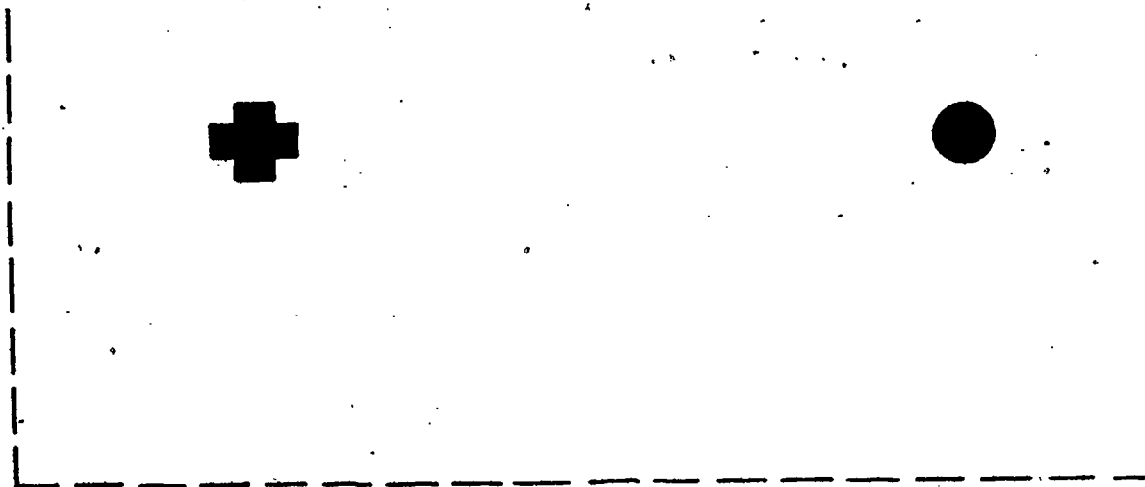

Some teachers have had students use the 3" x 5" file card on which to copy Figure 4-1. The stiffness of the card makes for easier manipulation and measurement.

ACTIVITY 4-14. Cover your left eye with your hand and hold Figure 4-1 at arm's length. Stare only at the cross and slowly bring the paper closer to your face.

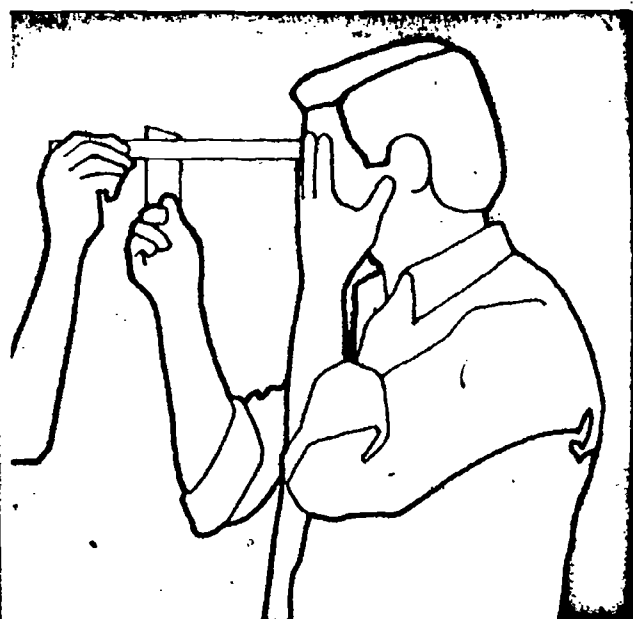
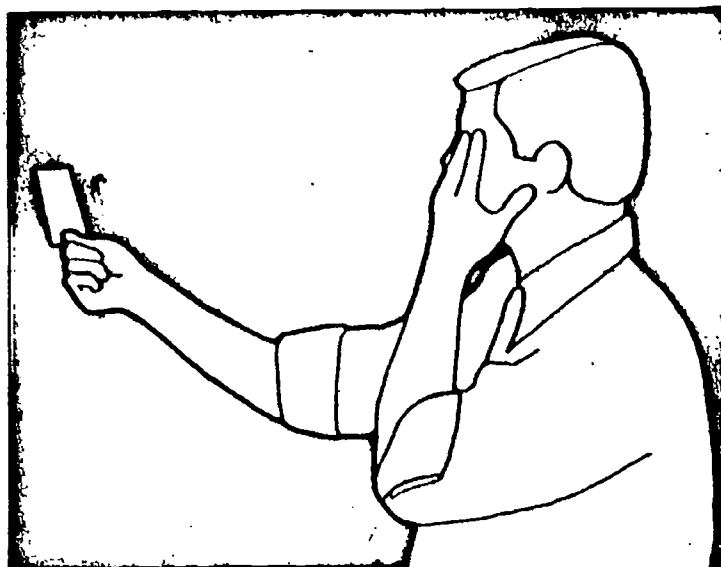

ACTIVITY 4-15. At the instant the spot disappears, stop moving the paper toward you. Your partner should then measure the distance from your left eye to the paper. Continue moving the paper closer to your face until the spot appears again. Measure that distance too.

Record the distance measured in Table 4-6 of your Record Book. Then calculate the Total Blind Distance (TBD).

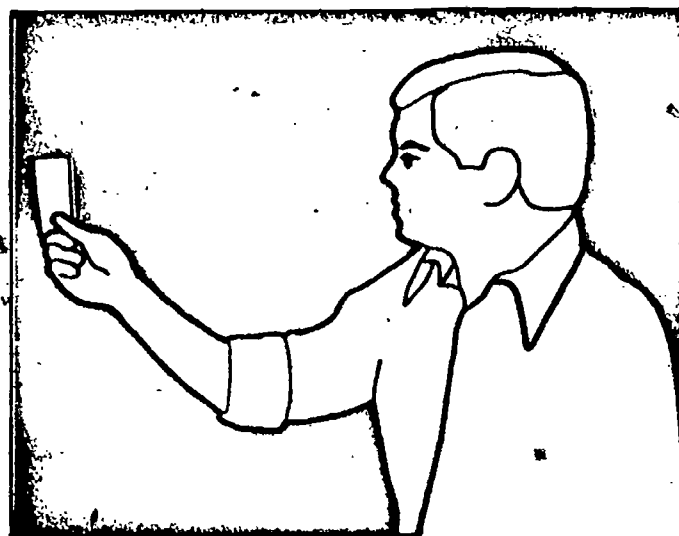

ACTIVITY 4-16. Repeat the experiment with your left eye. This time, however, stare at the spot, not the cross.

Record your measurements in Table 4-6 of your Record Book. Then switch roles with your partner and repeat the experiment. Calculate his TBD.

Table 4-6

BLIND SPOT DISTANCE FOR EACH EYE		
	Right	Left
Disappearing distance		
Reappearing distance		
Total blind distance (TBD) (disappearing minus reappearing)		

Note that if students are to do an adequate job of answering questions 4-17, 4-18, and 4-19, they will have to make a data table. They need the data to be able to find the mean and range.

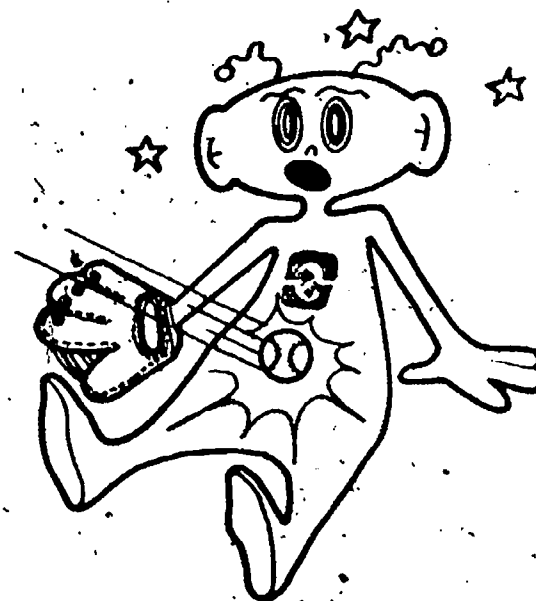

- 4-17. Was your TBD greater, or less, than your partner's? Find out what TBD other members of your class have.
- 4-18. Is your TBD above, below, or equal to the mean TBD for the students you checked?
- 4-19. What was the range of TBD for the group?
- 4-20. Do you think a person's TBD would be an important feature to consider when interviewing for certain jobs? Why?

Another important characteristic of human vision makes it possible to catch a ball, pick up a thumbtack, or hang clothes on a line. Take a look at **Excursion 4-2** to see how people vary in their ability to judge distances.

Excursion 4-2 is an interesting extension excursion on depth perception.

← EXCURSION

Obviously, there are blind spots in vision. Are there similar "blind spots" for hearing?

Does everyone hear all sounds the same way? Without expensive equipment, it's hard to study variation in ability to hear high and low sounds. But there are some questions about hearing that can be studied with simple equipment.

THE BETTER TO HEAR WITH

CHAPTER 4 47

For example, you can study a person's ability to locate where sounds come from. You can also study from what direction different people hear best.

For these investigations you will need a pencil or pen and a glass, jar, or beaker. You'll also need a partner.

You might want to have student-pairs go to another room or area to have less distraction from normal class noise.

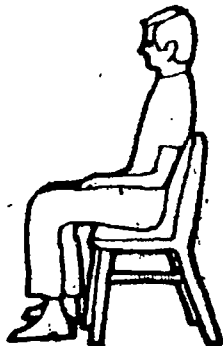

ACTIVITY 4-17. Have your partner sit in a reasonably quiet part of the room with his eyes closed. Move a short distance from him and gently tap the glass. When he hears the tapping, he should point in the direction he thinks the sound is coming from. He should also state how many meters away he thinks you are.

It's up to you to decide how to record how much your partner's guesses are off. Whatever scheme you use, you should consider both direction and distance. Your testing should be done on both sides, in front, and in back of your partner. Record all data in Table 4-7 of your Record Book.

Have your partner test your ability to hear sounds in the same way you tested his. Then compare his measures with yours. If you like, test several of your classmates as well.

If the suggestion to test several of the classmates is followed, students should probably have a data table (an extension of Table 4-7).

4-21. Describe how your ability to hear sound compares with your partner's.

4-22. Did you find any evidence for a "blind spot" for hearing?

PROBLEM BREAK 4-2

Perhaps you're sometimes late in coming home. Maybe you have excused yourself by saying, "I'm sorry, I just lost track of the time." Some people are extremely good at estimating different lengths of time. We could say they have a good "sense of timing." Time sense isn't one of the five senses, but it is important. And it is another variable among people. Perhaps you can measure this "sense." To do so, you

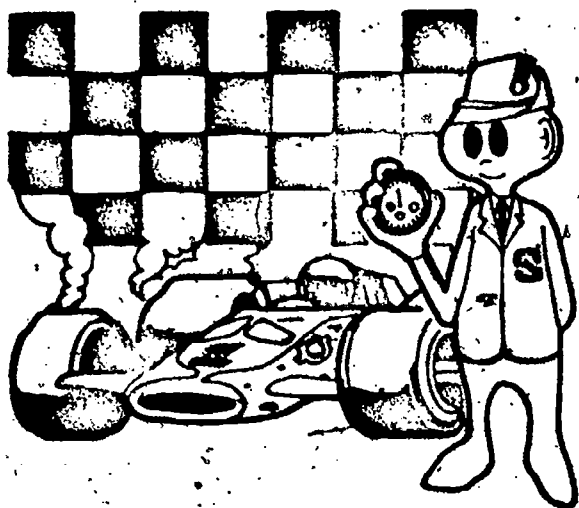

should again work with a partner. You and he will need a watch or clock with a second hand.

Design an activity to find out how well you can judge when one minute has elapsed. Collect data for several trials for you and your partner. Then calculate the mean error. Check other classmates, too.

4-23. What is the mean error for time sense for the people that you studied?

4-24. What is the mode error for time sense for the people that you studied?

4-25. Was your time-sense error above, or below, the mean for the people you studied?

You have studied and measured many of your own characteristics and those of other persons. There are, of course, many other characteristics. Some of them are quite difficult to measure by ordinary methods. If you'd like to investigate one that is important in detective work, do **Excursion 4-3**, "No Two Alike."

Well, how did you stack up against your classmates? Were the measures of all your continuous variation features and characteristics at the mean? Did all your either-or features fall into the mode category? If your answers to those two questions were No, you are a normal person.

You may have had one or two features that could be called average. But if enough features are measured, you would no longer be average. Be glad, because your differences from other people are what make you an individual.

Why then, is there such an interest in looking for patterns in human characteristics and behaviors? Chapter 5 may clear that up a bit.

Before going on, do Self-Evaluation 4 in your Record Book.

This problem break presents another opportunity for experimental design. You might want to pose the question with students, "Does it make any difference in time sense with subjects whether they have their eyes open or closed (outside of the obvious difference of being able to see a clock or a watch)?" Incidentally, there seems to be a correlation between time sense and native intelligence. Also, it has been found that the ability to accurately judge a 60-second time interval is markedly affected by illness and fever in a subject.

← EXCURSION

Excursion 4-3 is for extension. It provides the opportunity for students to take and study their own fingerprints. In extremely rare cases, there have been parental objections, due to the fact that fingerprinting is so often connected with crime.

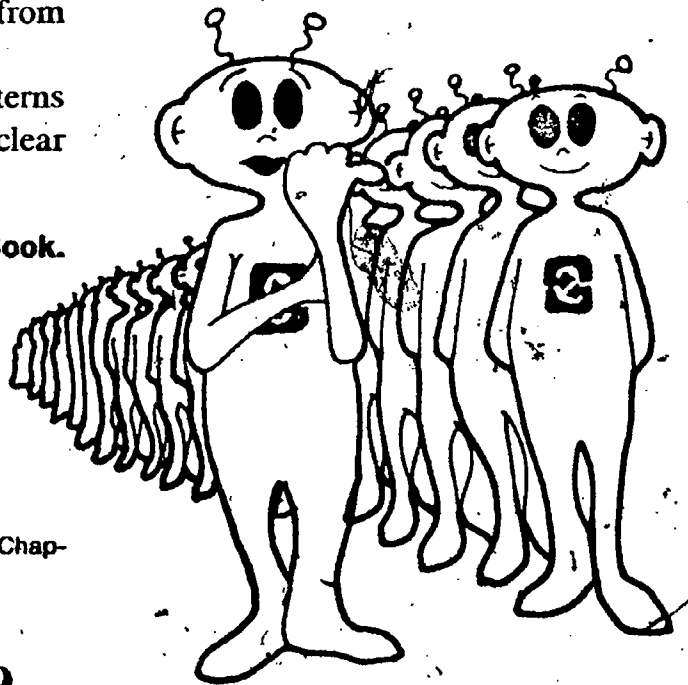

No equipment need be prepared for Chapter 5.



70

EQUIPMENT LIST

None

Personalizing the Population

Excursion 5-1 is keyed to this chapter.

The most exciting thing about people is that each one is different. At least one feature or characteristic distinguishes each person from every other person. Each of us has his own private set of physical and mental traits. And even those characteristics we have in common with other people may vary considerably from person to person. Even the most amazing look-a-likes (identical twins) are distinguishable.

You have been investigating some of these human characteristics and features. You've looked for differences, but you've also searched for similarities and patterns. Why is there a big search for patterns in human behavior and in human features? Why doesn't research pay attention to each individual as an individual?

I AM A HUMAN
BEING. DO NOT
PUT A SPIN IN IT

Finding the answer to these questions is the purpose of this final chapter of *Investigating Variation*. In this chapter you will encounter a series of problem breaks. Each one will present a practical example of why looking for patterns in human variation can be so important.

CHAPTER EMPHASIS

The importance of looking for patterns in human variation is emphasized through a series of practical problem breaks.

Chapter 5

MAJOR POINTS

1. All human beings are different in at least one characteristic or feature.
2. In studying human variation, you need to consider (a) how information on variables can be gathered, (b) how the variables can be measured, and (c) how the variables relate to those of others.
3. It is important to identify average or model characteristics of a group of people so that comparisons can be made with individuals.
4. In solving practical problems concerning groups of people, it is important to identify patterns of characteristics or behavior.

This final chapter should present a challenge to students. It is designed to summarize, through the use of practical problems, the major ideas in the unit. A possible student method of attack on the chapter might be to (1) read the entire chapter, identifying the specific problems of interest; (2) decide on the method of data-gathering for the particular problem; (3) gather the necessary data and tabulate them in some form; and (4) refer back to earlier work for methods of using data in making decisions (use of range, mean, mode, and histograms and graphs).

Note that students are told that they may select the problems they wish to do, completing at least half of them. As the teacher, you may wish to suggest some alternative plan. For instance, there may be some problems that you consider especially appropriate for students in your school or community, and you feel that most students should complete these. In any case, you should be alert to the tendency for students to make too few measurements for a problem, and to base their judgment on too small a sample.

Excursion 5-1, though for general interest and extension, should be recommended as a help in data collecting for all the problem breaks.

EXCURSION ▶

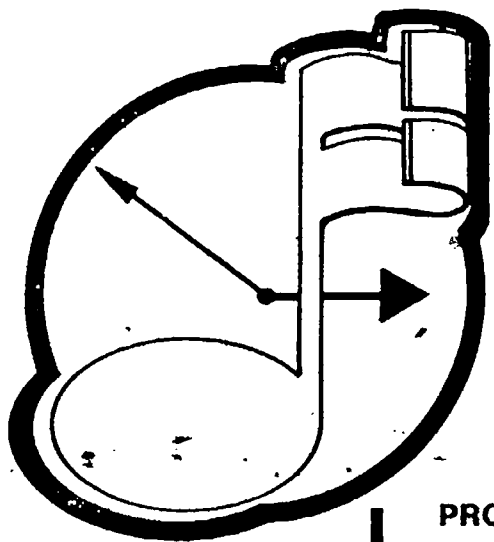

As you work with each problem situation, keep in mind what you have learned about human variation. Think carefully about the human variables that you want to consider, collecting your thoughts on these things:

1. How information about them can be gathered
2. How they can be measured
3. How they are likely to relate to each other

You may select the problems you wish to do, but try to complete at least half of those listed. Blank pages are provided in your Record Book so that you can keep a record of your ideas, plans, data, and so forth.

Chat with your teacher and classmates about the problems you select. You may want to team up with someone before actually conducting an investigation.

Solving some of the problems will require that you collect data from a group of people. When and if you want to learn how to get a good data sample, do **Excursion 5-1**, "Sampling Populations."

Two basic questions might be
(1) What kinds of music do different age groups want to listen to? and
(2) At what times do different age groups listen to music on the radio?

PROBLEM BREAK 5-1

You are the new radio programmer for station WRXY. The station transmits from your community center and has a broadcast radius of 25 miles. The station's motto is "Music for all generations 'round the clock." Your boss expects you to have a new 24-hour schedule ready within 30 days. He has given you some funds for research. Explain how you will decide what kind of music should be played throughout the day and night. Outline your research plan in your Record Book.

PROBLEM BREAK 5-2

As sporting-goods buyer for a large department store in your area, you have the job of deciding how many left-handed baseball gloves are needed in stock. What will you do to make the best estimate of these needs before spending the store's money? Describe your plan in your Record Book.

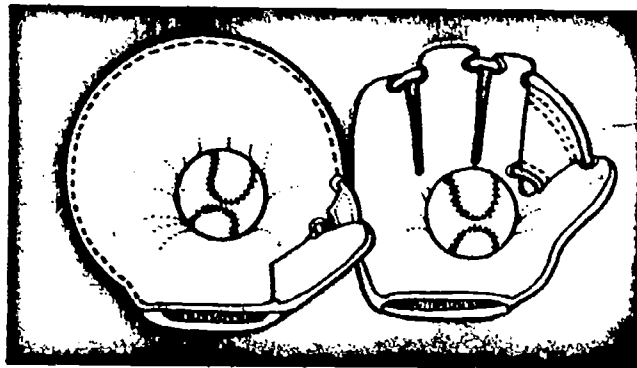

PROBLEM BREAK 5-3

As advisor to Representative Bellows, it is your responsibility to help him win votes among the youth (18-26 years). Of course, he must also get the vote from older citizens if he is to win reelection. Design a plan to find out what percentage of Representative Bellows' appearance time should be directed at concerns of each of the different age-groups in your community.

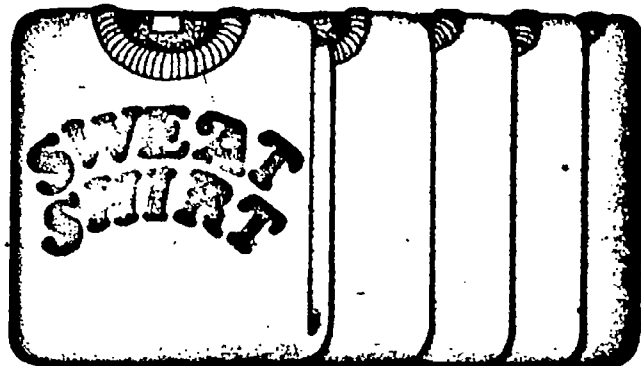

PROBLEM BREAK 5-4

Suppose the Student Council of your school decided to sell sweat shirts to raise money for a special fund. How should they go about deciding on the color, size, and style of shirt? Suppose they wanted to have something printed on each shirt. How can they make the best decision as to what should be printed, how large the lettering should be, and where it is to be located on the shirt?

There are several factors that should have a bearing on this problem. There are many more right-handed people than left-handed in the general population. But in baseball, the right-to-left ratio is not so great, because of certain advantages that left-handers have in the game. And what influence does the sex have on the sale of baseball gloves in general? Are there organized league activities in the community that would help to stimulate sales? The data on handedness from Chapter 1 and eyedness from Chapter 2 can be helpful here. (Eyedness and handedness tend to go together.)

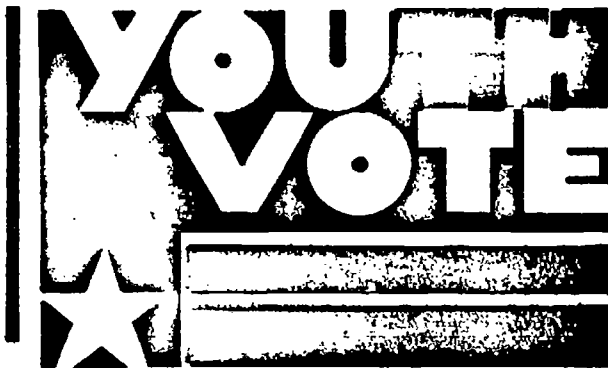

The library may have statistics on population by age groups in the country that could be used as a guide in Problem Break 5-3.

The information-gathering in Problem Break 5-4 is the important aspect. Should a questionnaire be used, listing choices of color, size, style, printing size, and location, or should it be done by interview? Note that decisions on some of these factors (color, style, printing) are quite similar to either-or variations, in which the mode gives the best answer. Size would be indicated by the range.



PROBLEM BREAK 5-5

In Problem Break 5-5, the student may be expected to design the research study, but the actual measurement of hearing loss might require equipment that is not available. Hear-

Physicians and scientists are concerned about the effects of noise on hearing ability. For example, there is some evidence that ears are damaged by long periods of listening to loud music. Design a research study to find out if students in your school have suffered any hearing loss because of their love for music. (Hint: You might investigate the relationship between age and hearing ability. This approach assumes that older students have listened to more loud music than younger ones have.)

ing loss should be a continuous variation, so the mean and range are important.

PROBLEM BREAK 5-6

Problem Break 5-6 might entail identification of characteristics by rank-ordering them from

As a member of the school newspaper staff, you have been assigned the task of getting the student body to select the best all-round male (or female) student. However, you don't want to run just another popularity contest. So you have decided to find out what characteristics the students expect the best all-round male (or female) to have. Design a plan for identifying the list of characteristics that is agreeable to a majority of the students.

a list of possibly desirable ones. Then students could be rated on the selected characteristics and the highest composite rating chosen.

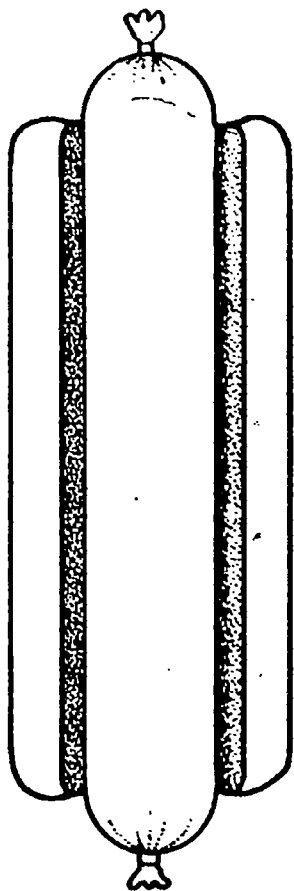

Pin

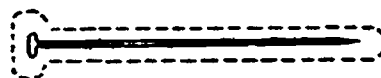

Pin to pin on pin

PROBLEM BREAK 5-7

Problem Break 5-7 poses an interesting question. After finding the range of times necessary to eat lunch, should the mean be used to set the time, or should the mode be used?

If your school has a cafeteria, you probably have heard students complain about the food and about the amount of time they are given to eat it. Suppose you are appointed by the Student Council to find out how much time the average student needs to eat an average-sized lunch. On the basis of such findings, the lunch period will be adjusted so that some extra time (about 10 minutes) is included for conversation. Design your research plan.

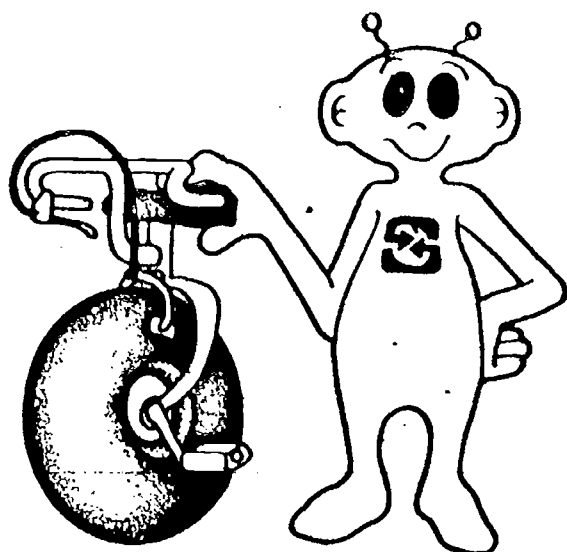

PROBLEM BREAK 5-8

There has been a revival of the bicycle craze in your town, and approximately 500 students are now riding their bicycles to your school every day. But with the upsurge in the use of bicycles has come a multitude of problems. Vandals are damaging unattended bikes. Stealing is rampant, and bicycles are disappearing at the rate of five or six a day. Bikes are being parked in empty spaces all over the school grounds, cluttering up the parking lot and giving the lawns an untidy look. Twice a day the cyclists cause traffic jams as they arrive at or depart from the school.

You are a member of a committee appointed to look into these problems and asked to come up with solutions that will not offend any major segment of the affected population (students; teachers; or those of the general public who live, drive, or work in the vicinity of the school). Describe a research plan that would lead to workable, acceptable, and, hopefully, successful solutions.

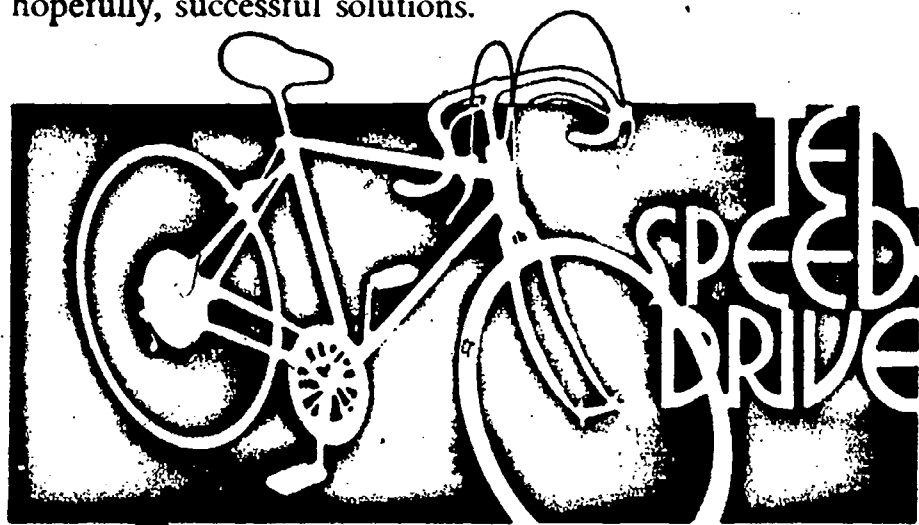

The student's solution should not offend any major segment of the affected population (students, teachers, and general public) This requires that some decisions be made about data-gathering.

1. Should sampling techniques be used in surveying the bicycle riders, or should all 500 be surveyed?
2. Should other, nonriding students be surveyed? sampled? How many?
3. How many teachers should be surveyed?
4. How many of the general public who live, drive, or work in the vicinity should be surveyed? How should they be chosen?
5. What kinds of questions should be asked in the surveys? Should the same questions be asked of each group?

Solving problems concerning people usually requires you to know something about groups of people. Patterns of group behavior or characteristics become important. You frequently need data about means or modes. The problem breaks in this chapter can be completed only if you identify those average or model characteristics of a group of people. Individual characteristics are always interesting and important. They identify the person. Each of us wants to be thought of as an individual. We want our own needs met. But, each of us is also a member of a large group. The most efficient way to meet group needs is to identify group characteristics. That is why patterns of traits and characteristics are so important.

Before going on, do Self-Evaluation 5 in your Record Book.

The teacher notes in this chapter are given as suggestions only. You probably have more and better ideas that could be used for student guidance. The problem breaks present an excellent opportunity for student interaction, small-group discussions, and actual pupil involvement in the affairs of the school and community.

Excursions

Do you like to take trips, to try something different, to see new things? Excursions can give you the chance. In many ways they resemble chapters. But chapters carry the main story line. Excursions are side trips. They may help you to go further, they may help you go into different material, or they may just be of interest to you. And some excursions are provided to help you understand difficult ideas.

Whatever way you get there, after you finish an excursion, you should return to your place in the text material and continue with your work. These short trips can be interesting and different.



EQUIPMENT LIST

1 meterstick .

Measuring—Mostly in Metric

This is a remedial-review excursion on the metric system.

You know that 12 inches make a foot and that 3 feet make a yard. And you probably have it memorized that 5,280 feet equal a mile. The inch, the foot, the yard, and the mile are units in a system of measurement called the English system. The United States is one of a very few countries in the world still using this system.

Use English system units to answer the next two questions.

- 1. How many inches are there in 6 miles?
- 2. How many yards are there in 5,000 inches?

As you can see, changing from one English system unit to another can be rather messy.

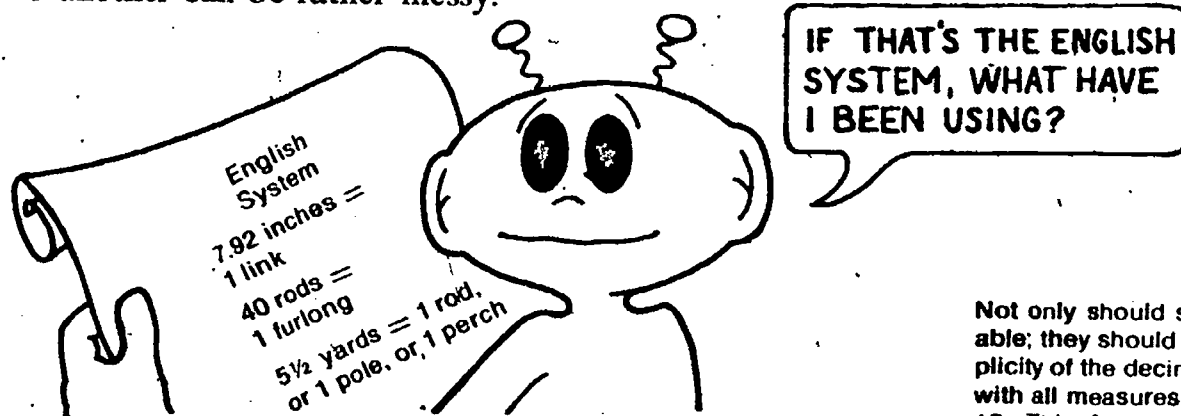

If you've studied Volumes 1 or 2 of ISCS, you probably feel fairly comfortable in the metric system. If this isn't so, then this excursion will help you learn what the metric system is all about.

PURPOSE

To teach or review linear measurement, using the metric system, and to show the relationships between units.

Excursion 1-1

MAJOR POINTS

1. The United States is one of the few countries still using the English system of measurement.
2. Changing from one unit to another in the English system can be messy.
3. The standard unit of length in the metric system is called a meter.
4. A meter is 39.37 inches long.
5. A centimeter is one hundredth of a meter.
6. There are 10 mm in a cm.
7. In using a metric scale divided in mm, you read a measurement to the nearest mm.

Even England is changing to the metric system.

Not only should students feel fairly comfortable; they should appreciate the relative simplicity of the decimal system of measurement, with all measures being related by powers of 10. This factor, with the resultant ease of scientific notation and unit conversion, is probably one of the strongest reasons that the metric system is so widely used and highly recommended by scientists.

A specially constructed bar of a platinum-iridium alloy was used to mark off the standard unit of the meter. The international prototype was housed in Sèvres, France. However, a General Conference on Weights and Measures met in 1960 and redefined the meter in terms of the wavelength of the orange-red light emitted by krypton-86. This wavelength is believed to be universally invariant, and can be reproduced in any laboratory throughout the world.

The metric system was first used in France about 1790. The standard unit of length was called a meter. A meter was supposed to be $1/10,000,000$ of the distance from the North Pole to the equator. We now know that this measurement was not quite right, but the original meter is, nevertheless, still used. The meter is 39.37 inches long—a little more than one yard.

Get a meterstick from the supply table. Notice that the numbered lines printed on the stick divide it into 100 parts. The distance between two of these lines is called a *centimeter*. The prefix *centi* means "one one-hundredth" (0.01). A centimeter is 0.01 of one meter.

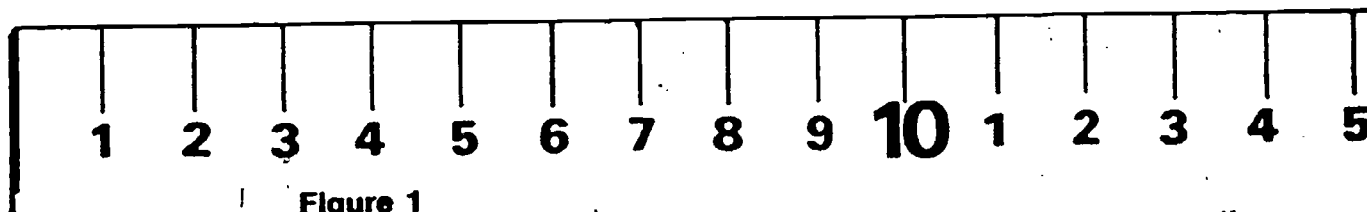

Figure 1

You probably noticed that there are 10 smaller spaces between each of the longer centimeter lines. The short distance between these lines is called a *millimeter*. The prefix *milli* means "one one-thousandth" (0.001).

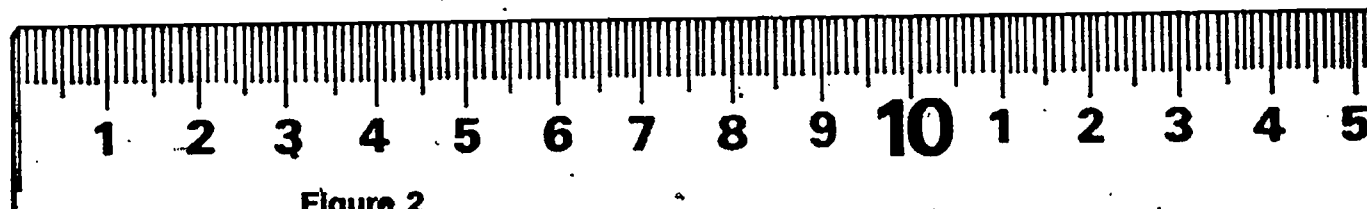

Figure 2

As the prefix *centi-* means one hundredth, so the prefix *milli-* means one thousandth. One thousandth of a meter, then, is one tenth of a centimeter.

3. How many millimeters are there in (a) 1 meter? (b) 2 meters? (c) one-half meter? (d) 10 centimeters?

Figure 3 shows part of a meterstick. To make it fit on the page, only part of the stick has been drawn. The part of the meterstick between A and AA is one centimeter (cm) long. The distance from X to Y is one centimeter, too. As you can see, each centimeter is divided into 10 equal parts. One centimeter divided by 10 equals one millimeter (mm). So a millimeter is 0.1 centimeter (one tenth of a centimeter).

Now that you know the names of the metric units for length, you are ready to do some measuring. The arrows and letters beside the scale in Figure 3 mark the lengths that you will measure for practice.

4. What is the distance in centimeters (cm) from A to B?

- 5. What is the distance in millimeters (mm) from A to B?

We hope you answered "7.2 cm" for question 4. If you didn't, you probably had trouble because arrow B points between the seven- and eight-centimeter marks. Notice that there are 10 lines between the seven and eight. The arrow points to the second line beyond the seven mark, so it is two tenths (0.2) of the way to eight. So the reading should be 7.2 cm. Remember, there are 10 millimeters (mm) in each centimeter. The answer to question 5 is "72 mm"—because

$$7.2 \text{ cm} \times 10 \frac{\text{mm}}{\text{cm}} = 72 \text{ mm.}$$

- 6. How many centimeters is it from A to C?

The last problem was tougher because arrow C doesn't point right at the line. You could have read it as 10.7 cm or 10.8 cm. You will have to decide which is better. There will always be some uncertainty in such measures. You just have to estimate the last figure. A metric scale, such as the one in Figure 3, should always be read to the nearest millimeter (0.1 cm). That, of course, will take some estimating.

- 7. How far is it in centimeters from A to D?

You probably thought this question was the easiest of all. Since the arrow pointed right at the fourteen mark, the distance was 14 centimeters.

Do you agree with the distances given in question 8 below? Look closely, because the figures may be wrong. If you find a mistake, cross out the wrong number in your Record Book, and write in what you think is correct. (Remember, you are still using the meterstick shown in Figure 3.)

- 8. Check the distance between the following points.

A and E 15.7 mm The distance measurement A to E of 15.7 mm should be crossed out in the Record Book and the number 157 written in. This is a good test of perceptiveness, and should help to make the students conscious of the importance of correct units. Of course, mm could be crossed out instead, and cm written in.

A and F 16.8 cm

A and G 18.4 cm

Using the drawing of the meterstick shown in Figure 4, do the following checkup.

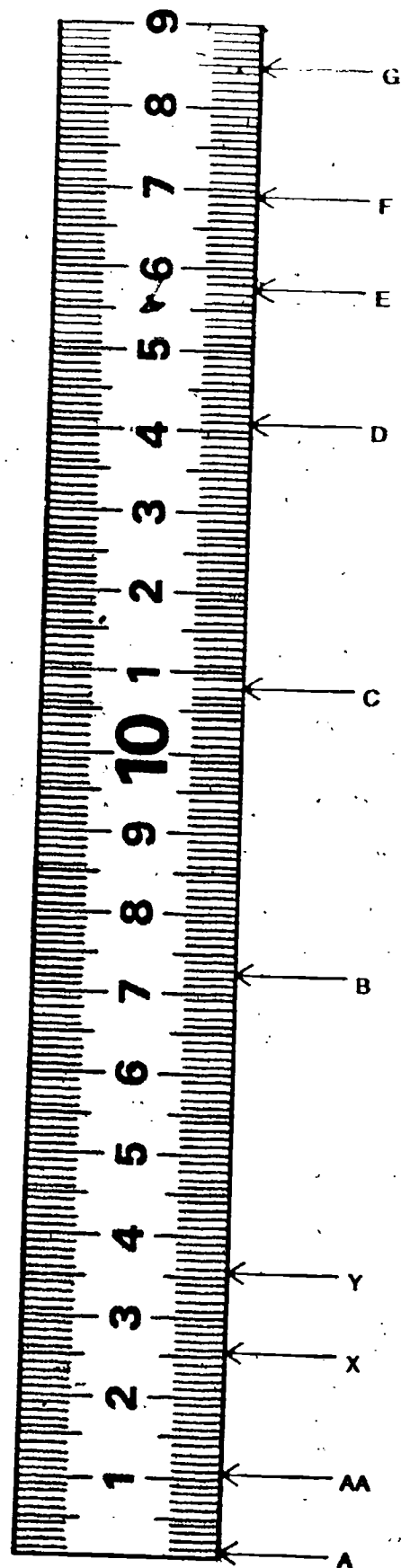
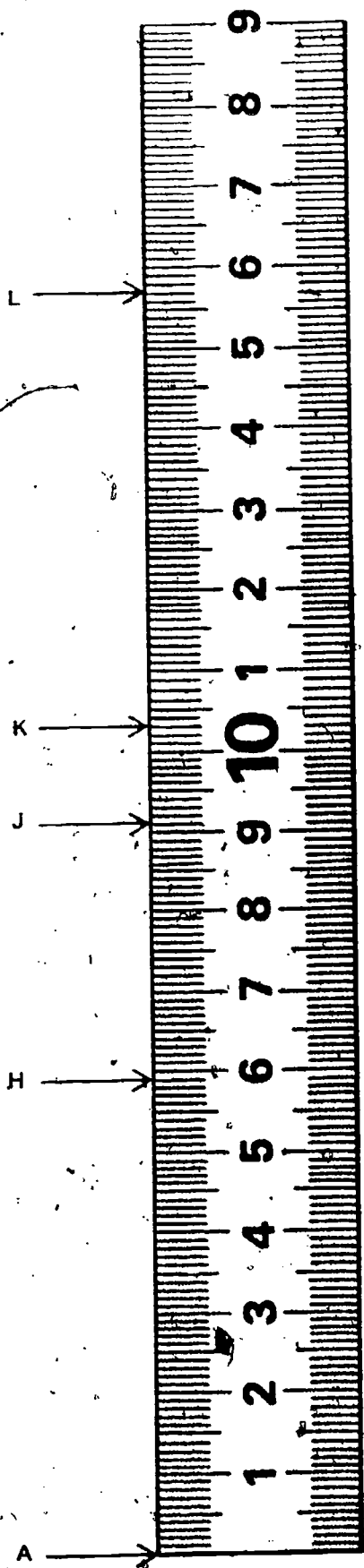

Figure 3



CHECKUP

Find the distance between the following points.

A and H = ____ mm

A and J = ____ cm

A and K = ____ cm

A and L = ____ cm

Ask your teacher to check your answers. Do not go on until you can measure accurately with a meterstick.

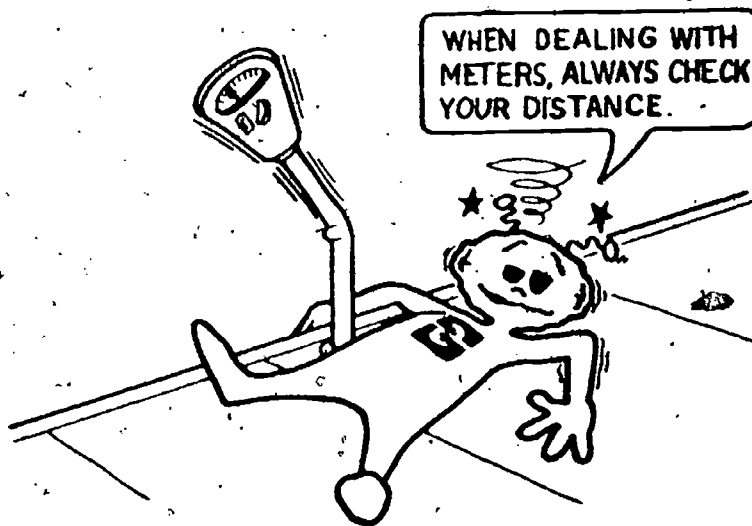

A to H 59 mm
 A to J 9.1 cm
 A to K 10.3 cm
 A to L 15.7 cm

When students come to you to check their answers, it affords you the opportunity to assess their competence, and to suggest further remedial work if necessary. This could consist of having them go through the excursion again. Some teachers have found it desirable to duplicate a special metric exercise of their own design on a single sheet of paper, and give this to the student to be performed.

Figure 4

EQUIPMENT LIST

1 metric ruler

This is a remedial excursion

MAJOR POINTS

1. An average is the sum of all measures divided by the number of measures
2. An average number is smaller than the largest measure and larger than the smallest measure and is often not a whole number
3. Rounding off measurements to the nearest whole number means dropping any number

On the Average

PURPOSE

To explain the methods of averaging and of rounding off numbers, and to provide practice in both operations.

What is an average? If you are not sure what averages are and how they are calculated, this excursion should help you. You will need a metric ruler.

ACTIVITY 1. Measure the length in centimeters of each finger on one hand. Don't measure your thumb. (You might read on before doing this.)

As you try to measure your fingers, you will probably have problems. From what point do you measure? How should the fingers be held? Before going on, you will need an operational definition for "finger length." This is a definition that tells you a way of measuring finger length.

1. State your operational definition for the length of a finger.

Use your operational definition to measure the fingers on one of your hands. Record your data in Table 1 of your Record Book.

Table 1

Index finger	_____ cm
Middle finger	_____ cm
Ring finger	_____ cm
Pinky	_____ cm

Excursion 2-1

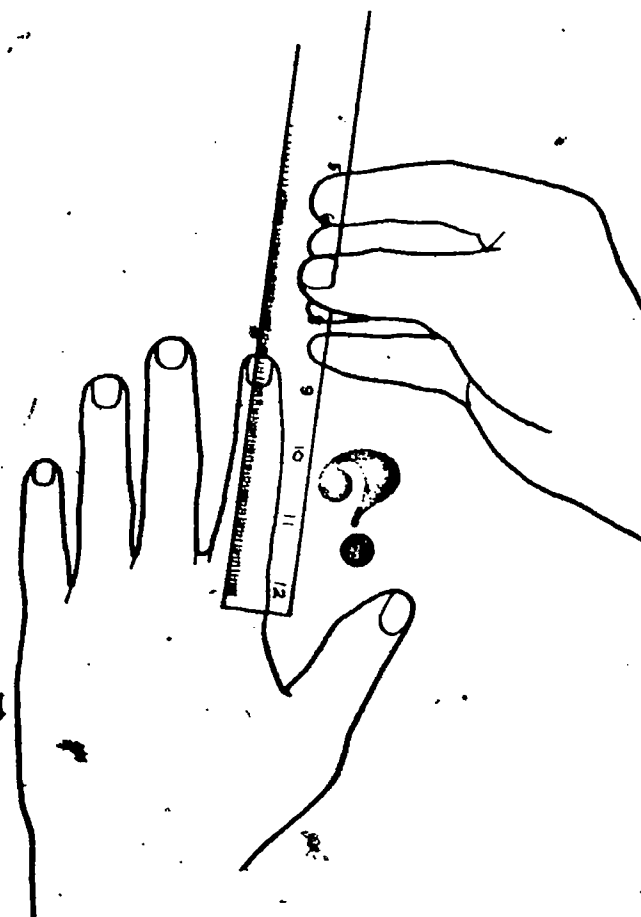

that comes after the decimal point, using the following rules:

- (a) When the last digit is less than 5, the digit ahead of it stays the same.
- (b) When the last digit is 5 or greater, add 1 to the number ahead of it.

1. Answers will vary, but an example might be: "Place the zero end of a ruler in the space between two fingers, with the fingers straight along the ruler. Read the mark on the ruler even with the end of the finger being measured."

2. No Finger length is a continuous variation feature: because the length can be any amount within the range of measures (Note that the students may not be familiar with the terms *either-or variation* and *continuous variation* if they arrive at this excursion before getting into Chapter 2)

2. Is finger length an either-or feature? Explain your answer.

Suppose your four measurements for finger length were 6.2 cm, 7.4 cm, 7.8 cm, and 7.1 cm. How would you calculate the average finger length of your hand?

It's simple. Just add up all four measurements to get the total. Then divide the total by the number of measurements you made. Here it is for you in black and white.

Add:

6.2 cm		7.1 cm Average
7.4 cm	Divide the total by 4:	4)28.5 cm
7.8 cm		28
7.1 cm		5
28.5 cm Total		4

$$\text{Average} = \frac{\text{Sum of all measures}}{\text{Number of measures}}$$

3. Now find the average of the four finger measurements you made. Compare your average finger length with that of some of your classmates.

Suppose you recorded the temperature at noon every day for a week. Your seven readings were 28°, 26°, 20°, 22°, 27°, 30°, and 30° Celsius. To find the average Celsius temperature reading for the week, you simply (a) add all the measures and (b) divide the sum by 7.

4. What was the average noontime temperature for the week?

Your answer for question 4 should have been 26.1 degrees. If it was not, continue with the rest of this excursion.

Look back at the averages you have calculated in this excursion. Notice that the following interesting things are true of all averages.

1. The average number is always smaller than the largest measure and larger than the smallest measure.
2. The average is often not a whole number.

Weather temperatures are still given in Fahrenheit in the U.S. Students may be curious about the equivalent readings given here. They are 82.4°, 78.8°, 68°, 71.6°, 80.6°, 86° and 86° Fahrenheit.

Another interesting thing (and one that has implications for students as they compare their characteristics with averages) is that often the average isn't the same as any one of the numbers averaged. For example, not one of the noon temperatures was 26.1°.

If you were to measure the heights to the nearest tenth of a centimeter of a few ninth graders, your data might look like that in Table 2.

ROUNDING OFF NUMBERS

Table 2

HEIGHTS OF NINTH-GRADE STUDENTS (cm)	
160.1	170.3
164.2	161.4
161.5	166.7
174.6	165.1

It often helps to "round off" measurements to the nearest whole number. This means dropping any number that comes after the decimal point. The following "rules" for rounding off are commonly used.

Rule 1. When the last digit (number) is less than 5, it is dropped and the digit (number) ahead of it stays the same.

Rule 2. When the last digit (number) is 5 or greater, add 1 to the number ahead.

Table 3 shows four of the same heights given in Table 2. This time though, the numbers are also given in rounded-off form. Compare the two columns and notice how the rules just given were applied.

Table 3

HEIGHTS OF NINTH-GRADE STUDENTS		
Original Measurement (cm)	Rounded-off Measurement (cm)	Number of Rule Applied
160.1	160	1
164.2	164	1
161.5	162	2
174.6	175	2

ADD 1 TO NUMBER

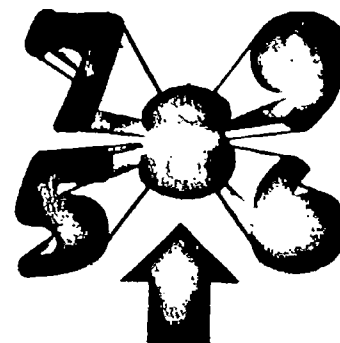

**LAST
DIGIT:**

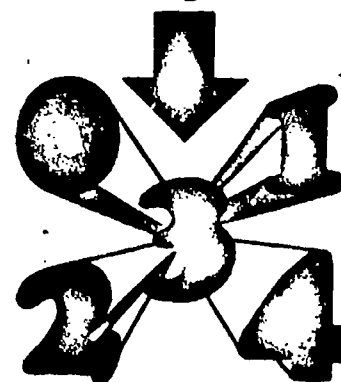

DON'T CHANGE
NUMBER AHEAD

In your Record Book, round off the measurements given in Table 4. In the right-hand column, give the number of the rule applied. Check your answers with your teacher.

Table 4

HEIGHTS OF NINTH-GRADE STUDENTS

Original Measurement (cm)	Rounded-off Measurement (cm)	Number of Rule Applied
180.4		
172.6		
174.7		
176.5		
181.5		
180.2		
179.8		
180.3		
182.9		
176.4		
173.6		
179.2		
161.1		
169.9		

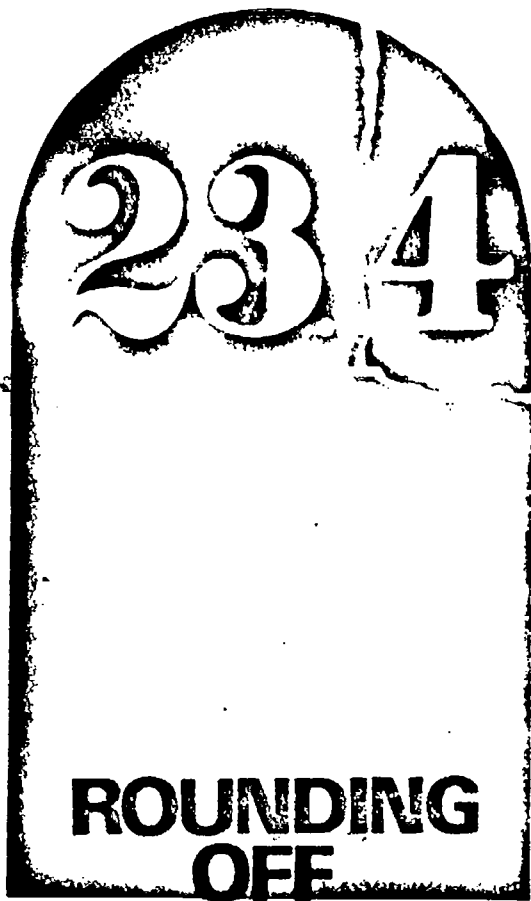

Note that students are to check their answers to Table 4 with you.

- 180 1
- 173 2
- 175 2
- 177 2
- 182 2
- 180 1
- 180 2
- 180 1
- 183 2
- 176 1
- 174 2
- 179 1
- 161 1
- 170 2

EQUIPMENT LIST

None

PURPOSE

To show how two either-or variables can be related in a contingency table

Contingency Tables

Excursion 2-2

This is a remedial-review excursion.

MAJOR POINTS

1. There are various ways of showing data in a table.
2. A contingency table shows the dependency of one variable on another.
3. Contingency tables are useful for showing the relationship between two either-or variables.

Walter, an ambitious student, wanted to find out something about ISCS students in his school. He wanted to know how handedness is related to eyedness. For example, he wanted to know whether left-handed persons were usually left-eyed, and whether right-handed persons were usually right-eyed. He didn't know what he might actually find.

Walter decided to use the ISCS handedness and eyedness tests. He collected data on a rather large sample of students. At first he tallied his results as shown in Table 1.

Table 1

Group	Tallies
RH-RE	
RH-LE	
LH-RE	
LH-LE	

RH = right-handed; LH = left-handed; RE = right-eyed; LE = left-eyed

Walter's friend Leslie suggested that he could have used a simple table for recording his data. Table 2 shows her suggestion.



Table 2

		Eyedness					
		RE			LE		
Handedness	RH						
	LH						

Once all the tallies were made, Walter decided that numbers would look neater. So he drew a new table (Table 3).

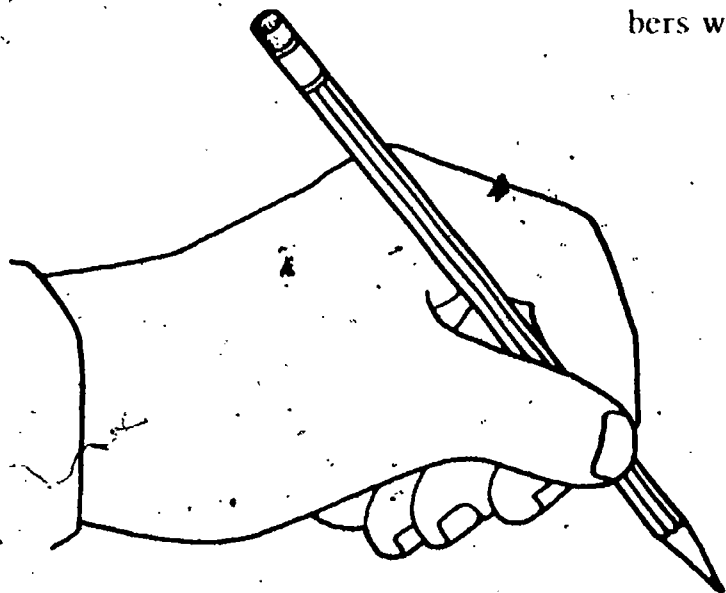

Table 3

		Eyedness	
		RE	LE
Handedness	RH	75	14
	LH	26	12

If students have worked with the genetics unit, *Why You're You*, in ISCS Level III, they may note the similarity between the contingency tables here and the "Punnett square" method used in that unit. In the two-bit model with two hybrid (mixed bit) parents, each parent contributes one bit of information to the offspring. The two bits that each parent has are either-or-features, like the eyedness and handedness shown here.

Leslie thought it would be helpful to show some totals in the table. Then you could tell at a glance how many right-eyed people there were in the sample. They altered the table again, so that it looked like Table 4. But they didn't fill in the totals.

- 1. Complete Table 4 in your Record Book by entering the totals.
- 2. How many of the persons are left-handed? right-handed?

Table 4

		Eyedness		
		RE	LE	Total
Handedness	RH	75	14	
	LH	26	12	
	Total			

- 3. How many are left-eyed? right-eyed?
- 4. What is the total number of students on which data were taken?

Notice that there are three ways to calculate this number.

1. Add 75, 26, 14, and 12.
2. Add 38 and 89.
3. Add 101 and 26.

- 5. Explain why the three calculations shown above total the same.
- 6. Following his investigation, one of Walter's friends said, "A right-handed person from our ISCS group will generally also be right-eyed." Would Walter be likely to agree with his friend's comment?
- 7. Another friend of Walter's said, "Yeah, and a left-footed kicker is usually left-handed." What do you think Walter would have to say about that comment?

The kind of table that Walter and Leslie used to record and study the data is called a *contingency table*. The word *contingent* means "dependent upon." In Walter's table, each tally made is dependent upon two variables.

- 8. What were the two variables in Walter's investigation?

6. Yes (It probably depends on how Walter interprets the word *generally*. More than 84% of the right-handed people were also right-eyed.)

7. This may be true, but none of the data support the statement. Further study (and another contingency table) would be needed.

Note also that each tally can go into only one category. Contingency tables like those are usually used only for either-or variables.

9 A contingency table could be used for continuously varying measures if these measures could be grouped. For instance, suppose that grabbiness, normally a continuously varying feature, were to be related to the sex of the subject. The grabbiness could be grouped as follows: 21-60 cm, grabby; 61-100 cm, not grabby. After the scores of boys and girls were tallied in these groups, it would be possible to see whether being grabby or not grabby was dependent on the sex.

9. Can you think of a way that a contingency table could be used for continuously varying measures?

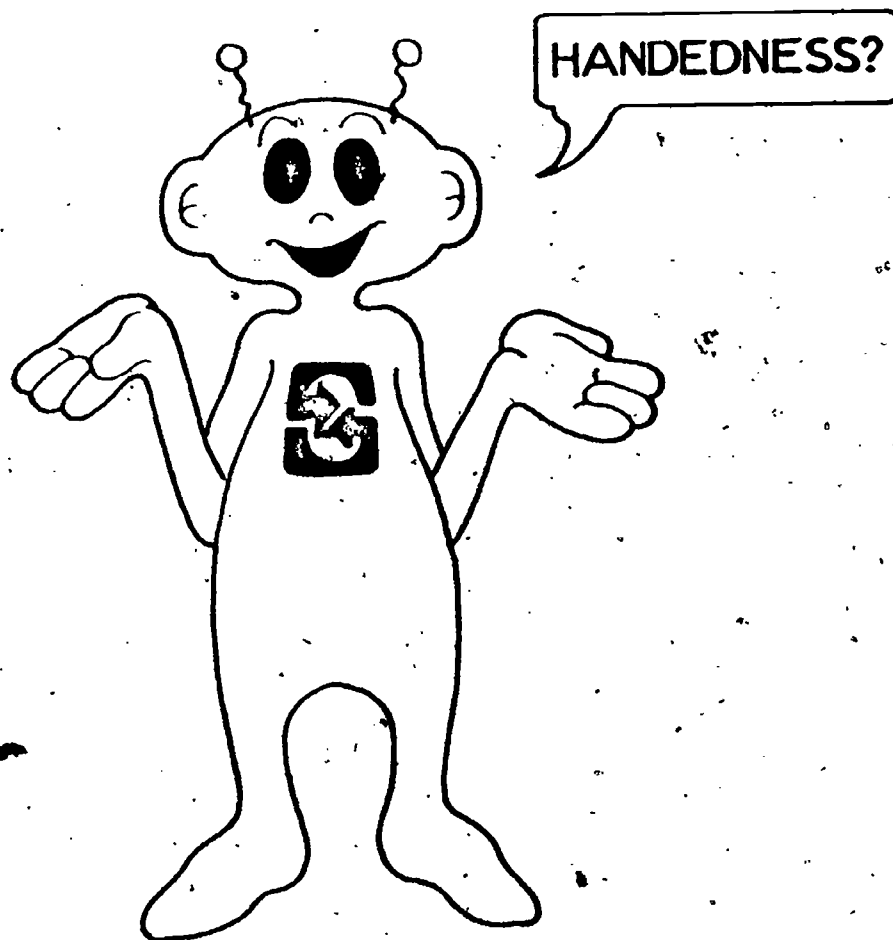

EQUIPMENT LIST

None

Worth a Thousand Words

ANSWERS TO QUESTIONS FROM CHAPTER 3

3-4. 85 cm-95 cm

3-5. 35 students

This is a remedial excursion.

You have probably heard the old saying, "One picture is worth a thousand words." Many scientists believe a graph is like a picture. Graphs are used often throughout science and throughout the ISCS course. This excursion will help you make and interpret these pictures that are worth a thousand printed words.

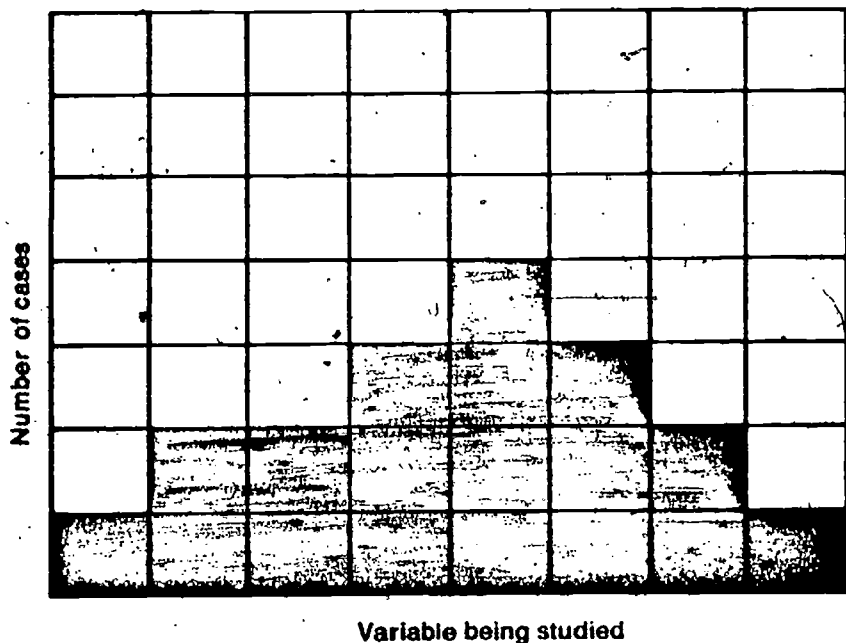

You have just seen a histogram (in Chapter 3) on grabbiness. A histogram is a form of bar graph. All histograms look much like the one shown in Figure 1. The variable being studied is shown along the horizontal axis. The number of cases, or frequency, is shown on the vertical axis.

PURPOSE

To learn how to make histograms and how to convert them to line graphs.

Excursion 3-1

MAJOR POINTS

1. A graph is a pictorial way of representing data.
2. A histogram is a form of bar graph.
3. The variable being studied is shown along the horizontal axis and the number of cases is shown on the vertical axis.
4. A histogram can be converted to a line graph by connecting the centers of each bar top with a line.

Figure 1



HISTOGRAMS

Notice how the data in Table 1 are used to make the histogram shown in Figure 2.

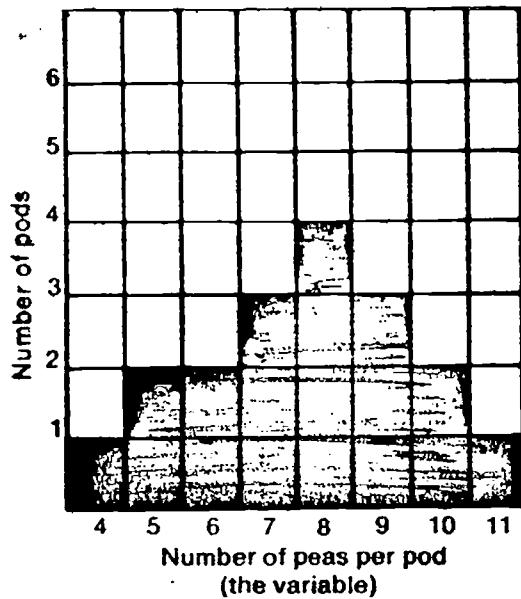

Figure 2

The numbers are put between vertical lines if they are discrete numbers. If they represent a range of numbers, however, as in Figure 3-1 in Chapter 3, they may be put at the vertical lines.

Table 1

Number of Peas per Pod (the variable)	Number of Pods Having These Numbers of Peas
4	1
5	2
6	2
7	3
8	4
9	3
10	2
11	1

Perhaps the position of the numbers along the horizontal axis bothered you. They are between vertical lines. If they were placed at the lines, you would have trouble knowing which bar they identified.

Histograms such as the one in Figure 2 are very useful. However, it is usually more convenient to draw a line graph. Your histogram can be converted to a line graph rather easily.

Figure 3

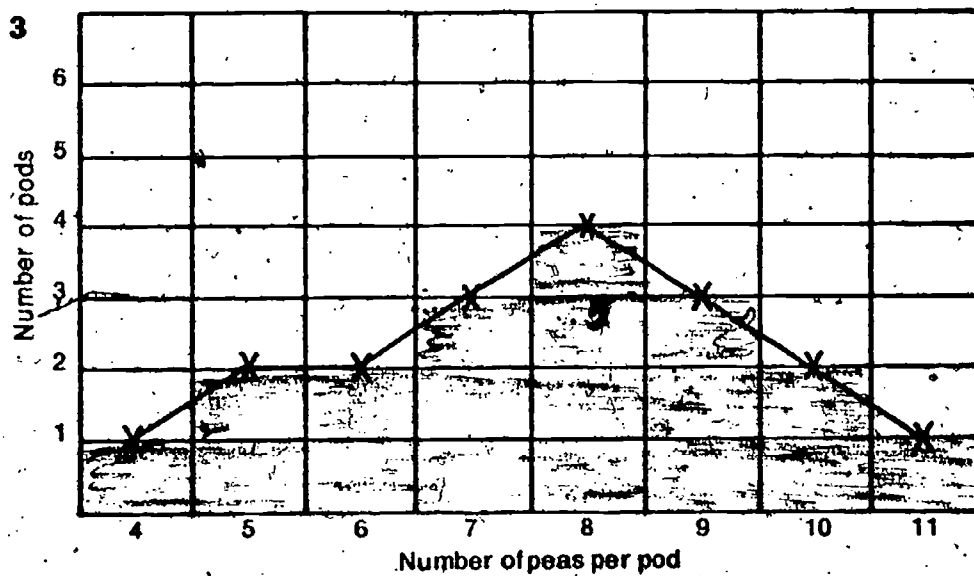

Connecting the centers of each bar top with a line produces a continuous graph.

□ 1. In Figure 4 of your Record Book, sketch the line graphs that would represent the data in each histogram.

Figure 4

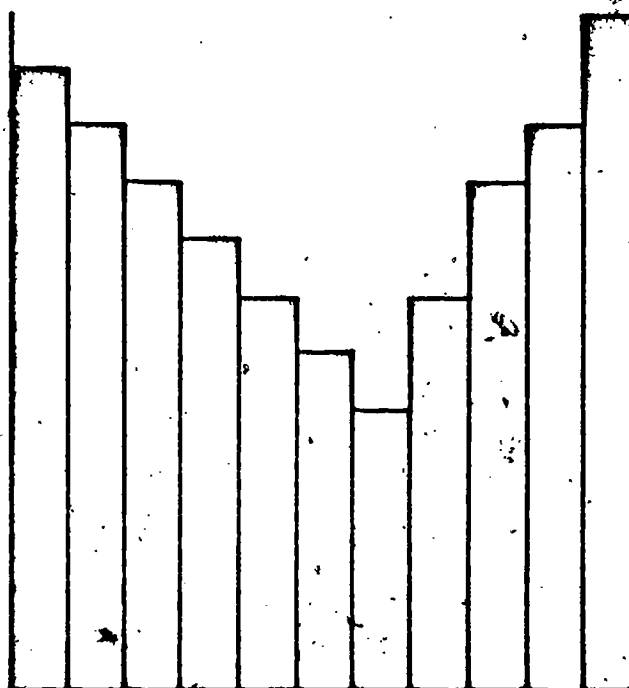
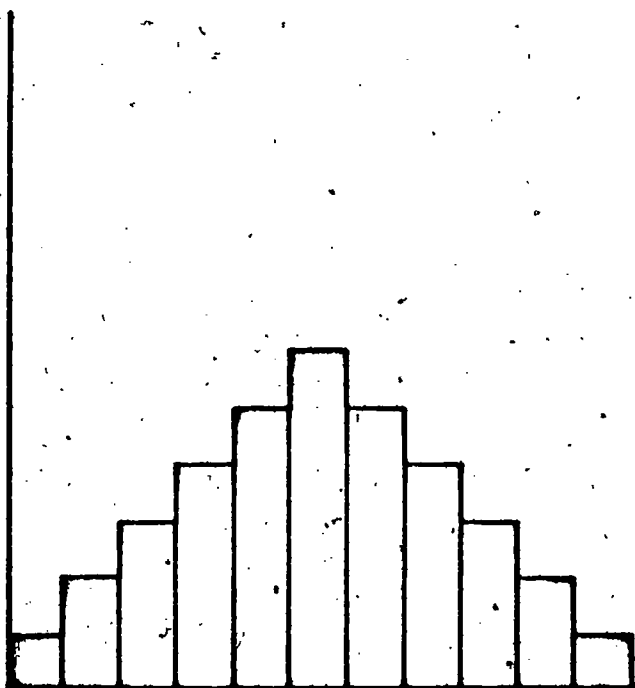
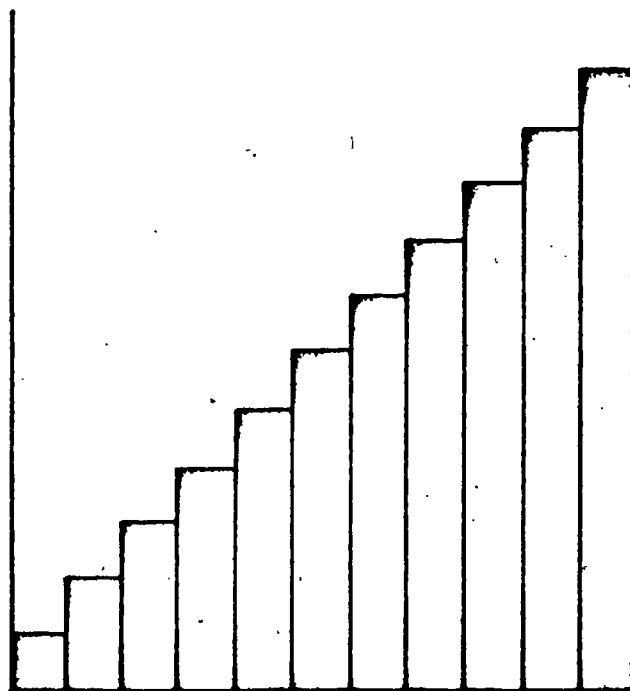
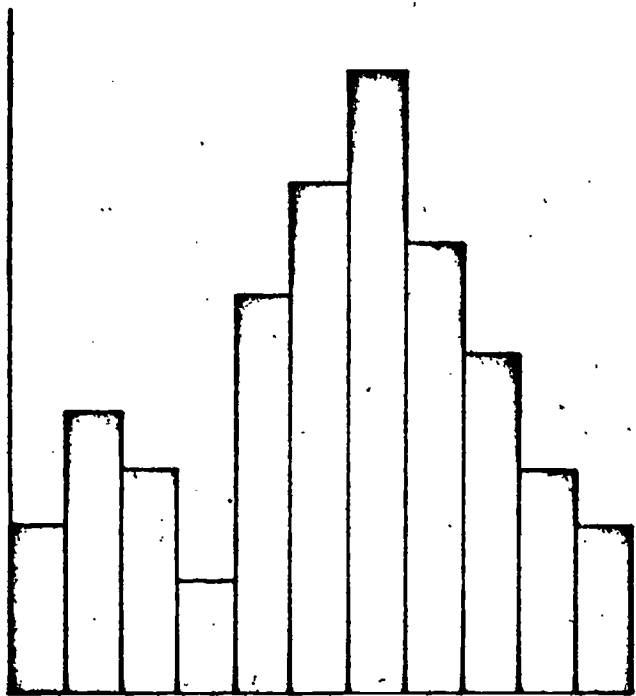

Before going back to the chapter, try your hand at one other set of data. Label the axes of Figure 5 in your Record Book. Then sketch the histogram based on the data given in Table 2. Then complete the line graph for the data.

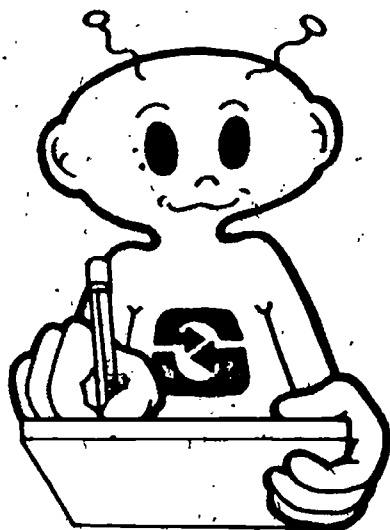
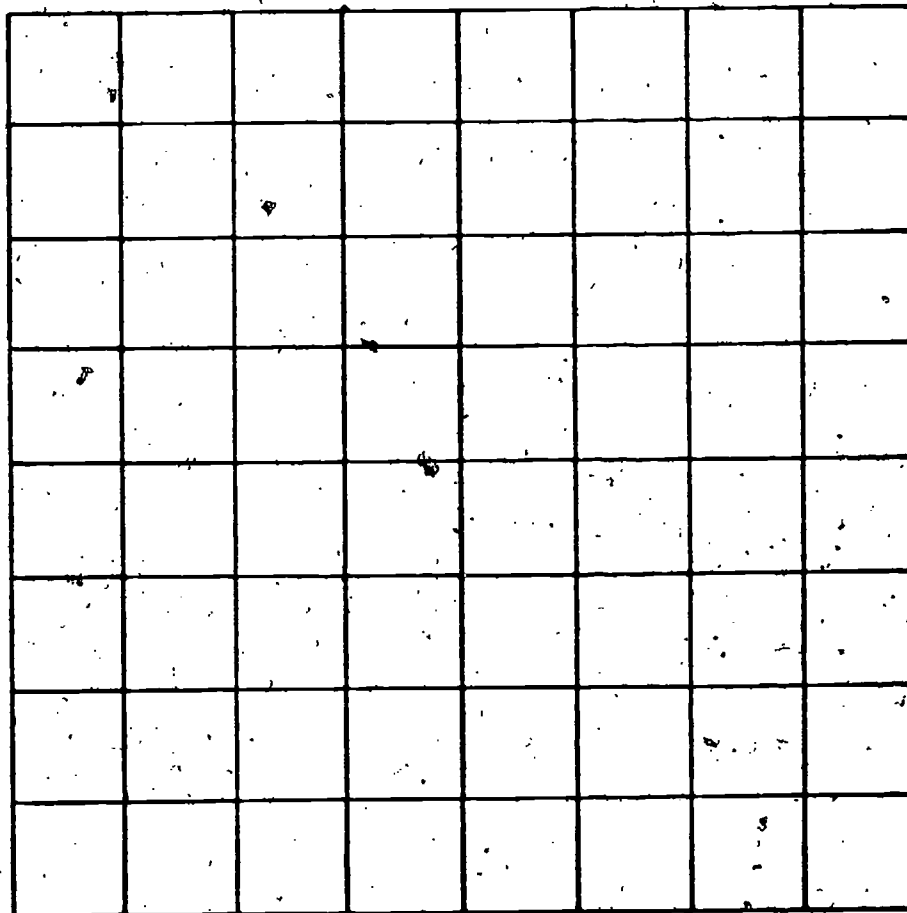

Table 2

Number of A's on the Report Card	Number of Pupils with this Many A's
0	2
1	6
2	8
3	7
4	4
5	3
6	1
7	1

Figure 5

The advantage of a histogram for discrete numbers is illustrated in the plotting of Figure 5. The exact number of pupils getting a particular number of A's is readily readable. Note that when the line graph is completed for the data, the line starts at 2, not at zero.



EQUIPMENT LIST

- 1 protractor
- 1 metric ruler

PURPOSE

To show the measurement and construction of angles, using a protractor

Angles and Protractors Excursion 4-1

This is a remedial excursion.

MAJOR POINTS

1. When two lines meet, an angle is formed
2. The meeting point of the lines is called the *vertex*.
3. When two lines form a square corner, it is called a *right angle*
4. A part of a circle is called an *arc*
5. Angles are measured in degrees; a right angle contains 90 degrees
6. A protractor is used to measure angles
7. The midpoint of the straight edge of a protractor is called the *reference point*.

Whenever two lines meet, an angle is formed. We call the meeting point of the lines the *vertex* of the angle (Figure 1). When two lines meet to form a square corner, we call the corner a *right angle* (Figure 2).

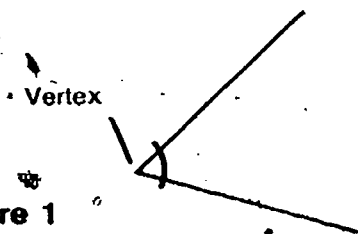

Figure 1

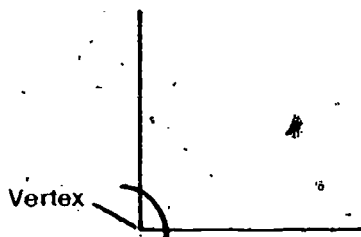

Figure 2

- 1. List a few examples of right angles that you can observe in your classroom.

Notice that curved lines are used to show the spread of angles in Figures 1 and 2. Curved lines are often used to identify the angle that is of interest. Notice how the curved lines are used in Figure 3.

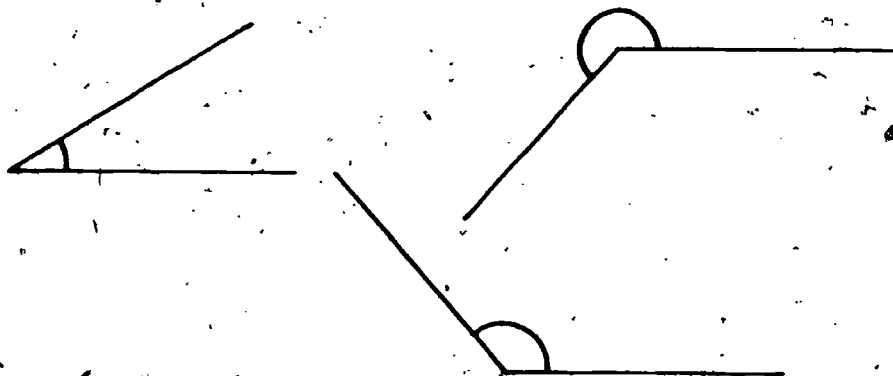
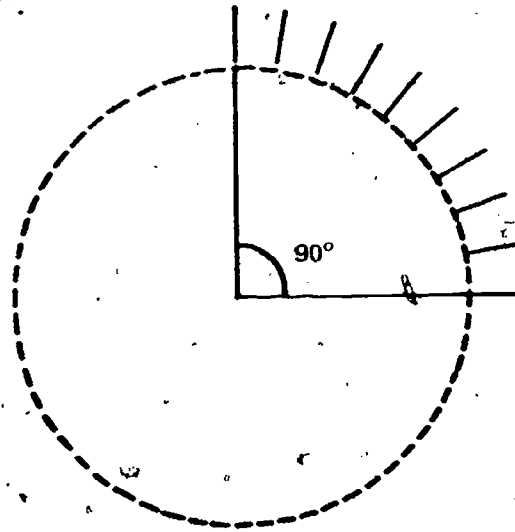

Figure 3

The curved lines shown in Figures 1, 2, and 3 are all small parts of large circles. Such parts of circles are called *arcs*.

Circles are measured by dividing them into 360 equal parts called *degrees*. The arc for a right angle, for example, is one fourth of a total circle, so it contains 90 degrees. For this reason a right angle is said to be a 90-degree angle (Figure 4). The symbol for "degree" is $^{\circ}$. Thus, a 90-degree angle is written 90° .

Figure 4



Possibly your students have protractors that are substantially different from the one described on these pages. A common type is one that has the degree scales running both ways. If this is the case, you might have to spend a little time in explaining the use of another kind, or adapting the activities to it.

A protractor is used to measure angles (Figure 5). One edge of this instrument is a half-circle arc that is divided into degrees. The other edge is straight.

Students should note that the reference point and the marks for 0° and 180° may not be located on the straight edge of the protractor, but instead may be set in about a mm on a ruled line. It is this line that should be placed over the edge of the angle that is to be measured.

Figure 5

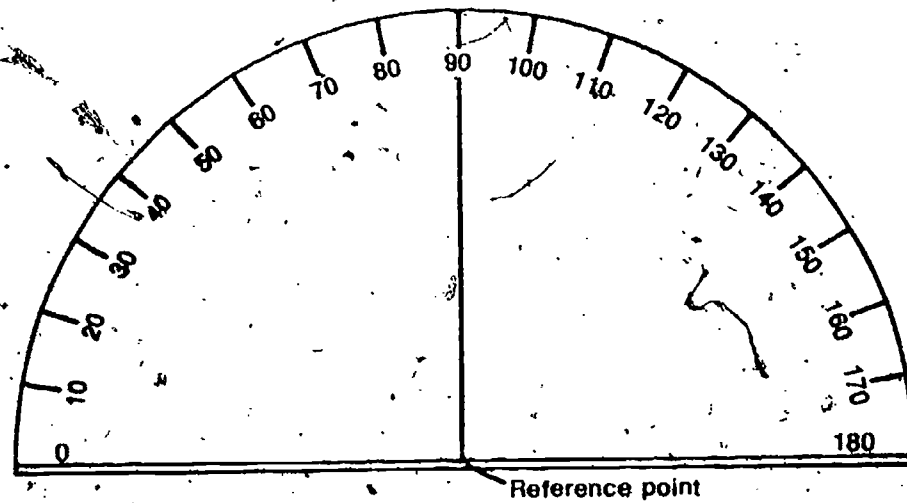

The straight edge is a diameter of the circle. Its midpoint is the center of the circle. This midpoint is called the *reference point* of the protractor.

□2. How many degrees are shown on your protractor?

Figure 6 shows how the protractor is positioned in measuring the size of an angle. Note that the straight edge of the protractor should be set along one of the lines that make up the angle. The vertex of the angle must be at the reference point of the protractor.

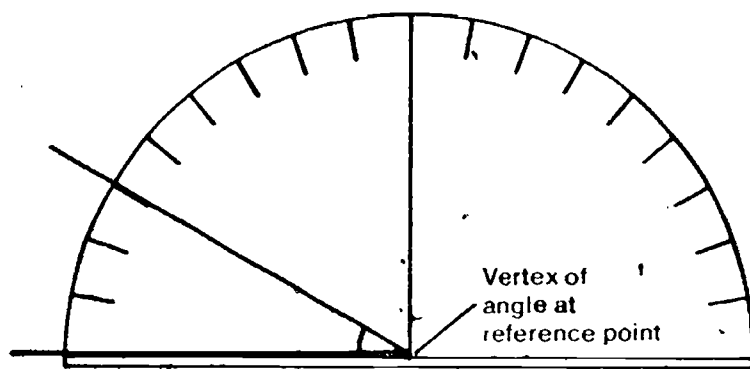

If the protractor has the line set in as noted previously, it is this line, and not the edge of the protractor, that should be set over one of the lines that make up the angle.

Figure 6

□3. According to the protractor, how many degrees are in the angle shown in Figure 6?

3 30°

MEASURING ANGLES

Now here is an angle for you to measure with your own protractor.

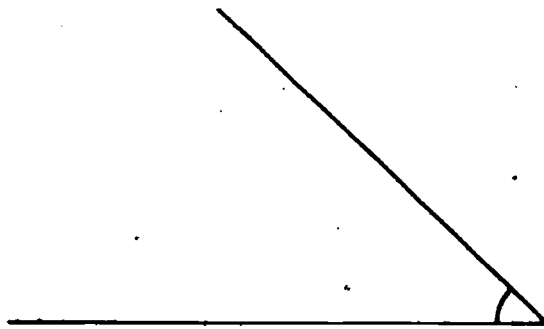
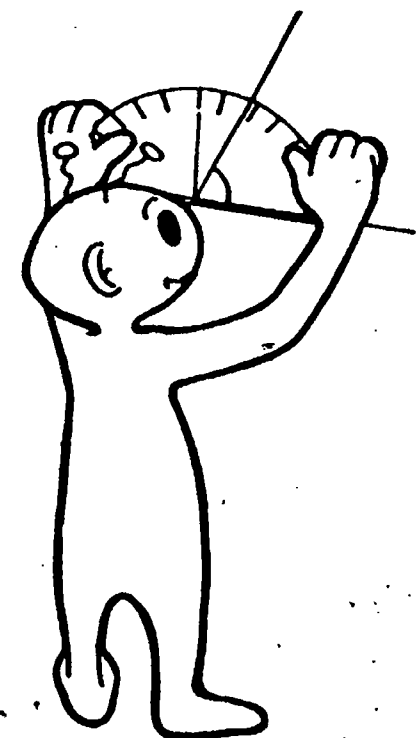
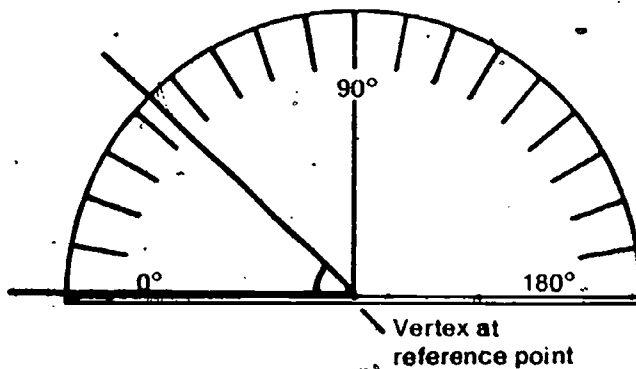

Figure 7

ACTIVITY 1. Set the protractor over the angle, as shown.



EXCURSION 4-1 77

ACTIVITY 2. Note where the other side of the angle passes through the scale.

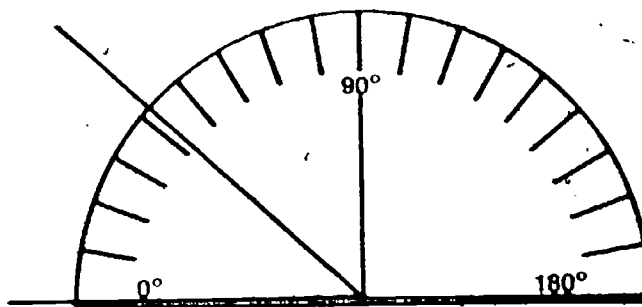

Students may need help in measuring some of these angles. If the protractors they are using have only one scale, it probably runs from 0° on the left to 180° on the right, as shown in Figure 5. This means that to measure angle **a**, the protractor should be placed with the reference point on the vertex and the zero point on the line that runs upward. The same is true for angles **b** and **c**. Angles **d** and **e** can be measured several different ways. The angle less than 180° could be measured, and this amount subtracted from 360° . Or one of the lines could be extended through the vertex, the acute angle (angle less than 90°) measured, and this amount added to 180° .

□ 4. How many degrees are in the angle in Figure 7? 43°

Now use your protractor and measure the angles shown in Figure 8. Measure to the nearest whole degree. Record your measurements in Table 1 of your Record Book. Then have your teacher check your measurements (or check them with several of your classmates). Be sure you know how to use a protractor correctly before going on.

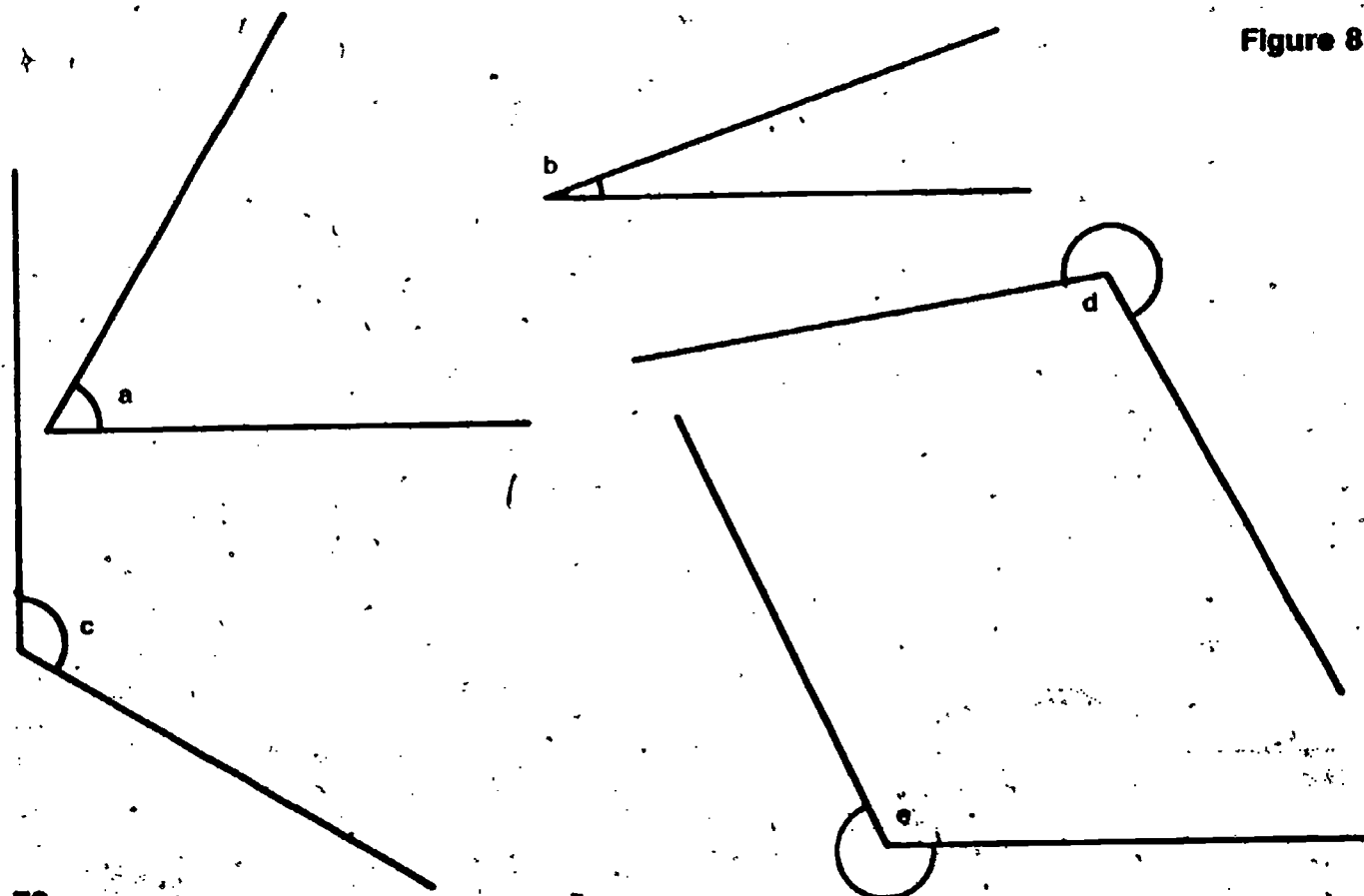

Figure 8

Table 1

Figure 8	Angle Size
a	
b	
c	
d	
e	

Table 1. a = 60°, b = 19°, c = 120°, d = 251°, e = 245°. Note that the student is told to have you check the measurements or to check them with several classmates.

Now try your hand at constructing angles. You will need the protractor and a straightedge.

□5. In the space provided in your Record Book, construct a 65° angle. (If you need help, refer to Activity 3.)

ACTIVITY 3.

a. Draw a line.



b. Place your protractor on the line. Mark the reference point on the line. This will be the angle vertex.

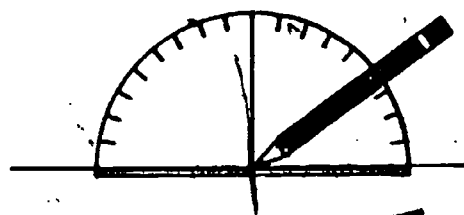

c. Mark a second point at the 65° line of the protractor.

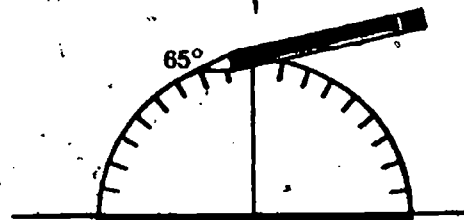

d. Connect the vertex and the second point. The shaded area indicates the 65° angle.

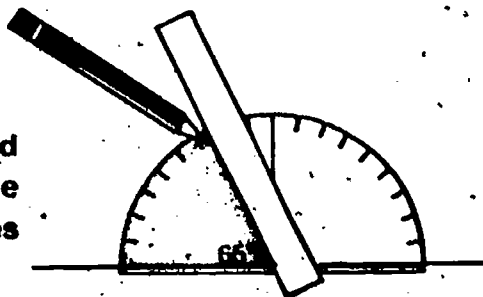

CONSTRUCTING ANGLES

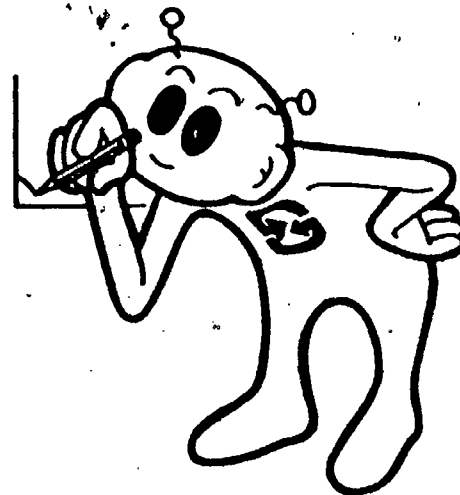

Note that the student is told to have you check the angles that were constructed, or to compare them with those produced by classmates.

6. In the space in your Record Book, construct the following angles: 72° , 30° , 115° . Have your teacher check your drawings, or compare them with those produced by your classmates.

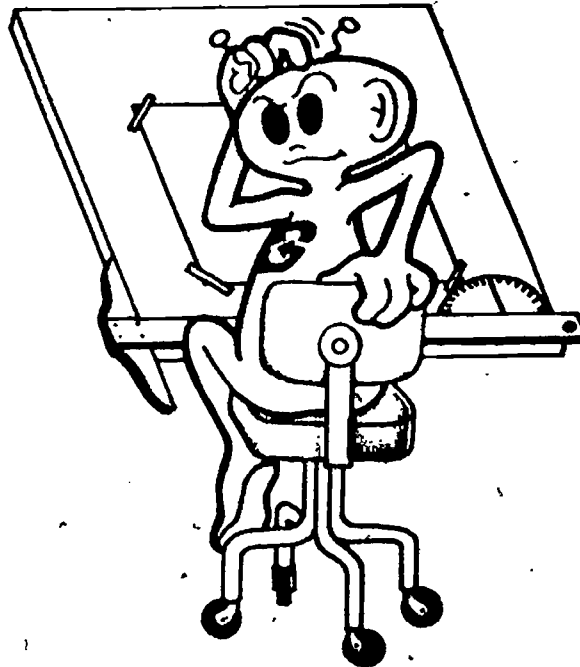

EQUIPMENT LIST

2 sticks*
2 clothespins
1 index card (3" x 5")
1 index card (4" x 6")
1 pair of scissors
Colored construction paper

PURPOSE

To investigate depth perception.

Depth Perception

*The 2 sticks are to be supplied locally. They should be about 10 cm long. They may be smooth pencils, pieces of soda straws, wood splints, popsicle sticks, or (optimally) wood dowels $\frac{1}{2}$ cm or less in diameter. Straight pieces cut from a wire coat hanger would work, with tape or cardboard to hold them in the clothespin.

This is an extension excursion.

If you have poor depth perception, you will never make it as a passing quarterback or a receiving end in football. Here is your chance to measure your own depth perception.

Find a partner to work with. Each of you will do the experiment twice with the right eye open, twice with the left eye open, and twice with both eyes open. Record your own data only (not your partner's) in Table 1 in your Record Book.

You will need these materials:

2 sticks
2 clothespins
1 index card (about 3" x 5")
1 index card (5" x 7")
1 pair of scissors
2 or 3 sheets of colored construction paper

Excursion 4-2

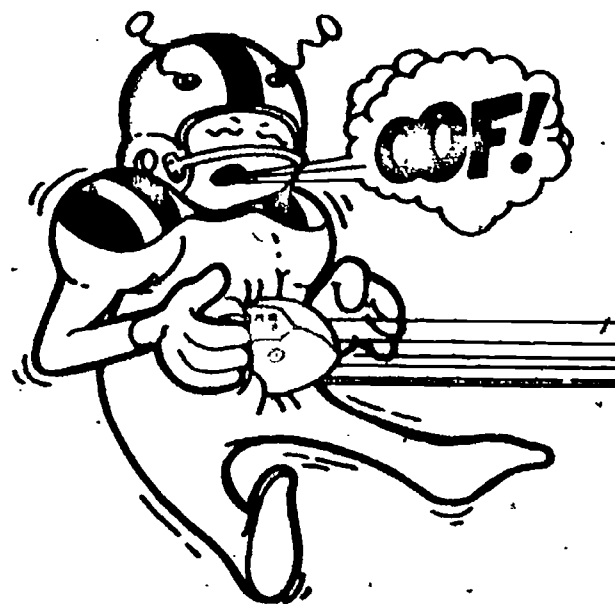

MAJOR POINTS

1. Depth perception can be operationally defined.
2. Depth perception is an important feature in the modern world.
3. Many variables can affect depth perception.

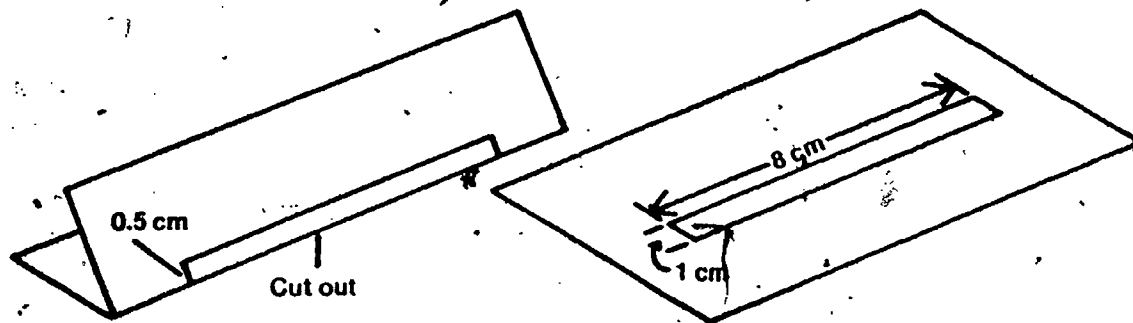

ACTIVITY 1. Fold the 3" x 5" index card lengthwise. Then cut a slit 1-cm wide, as shown. We'll call this slitted card a "viewer."

Students may be interested to know that this test for depth perception is very similar to the one used in examination for a pilot's license. The apparatus used consists of a box in which the two sticks slide on tracks. The subject views the centers of the sticks from a distance in front, and has cords in his hands connected to one stick so that by pulling on one cord or the other, the stick can be moved forward or back until it seems to line up with the second stick. The distance that the two are apart can be read from a scale inside the box. A score above a certain amount may disqualify a subject for a license to pilot an aircraft.

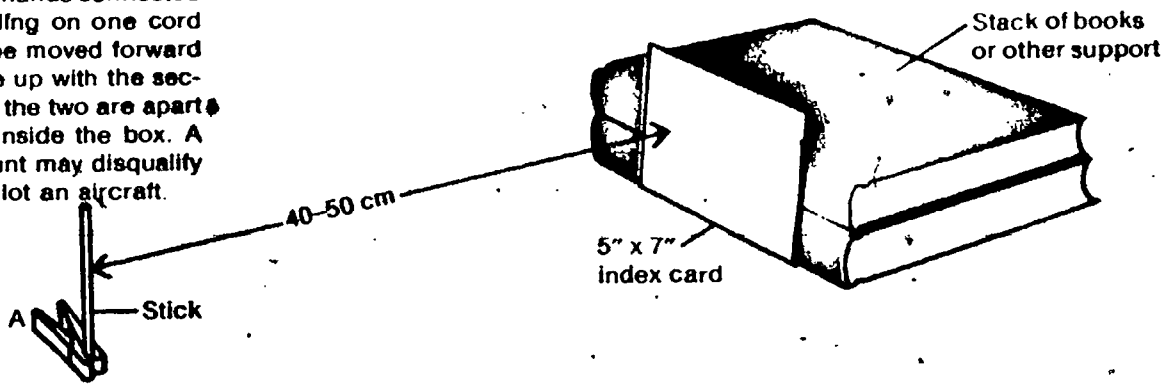

ACTIVITY 3. Place the second clothespin and the other stick near the 5" x 7" card. Label this second clothespin "B." The two sticks should be on imaginary lines about 5 cm apart.

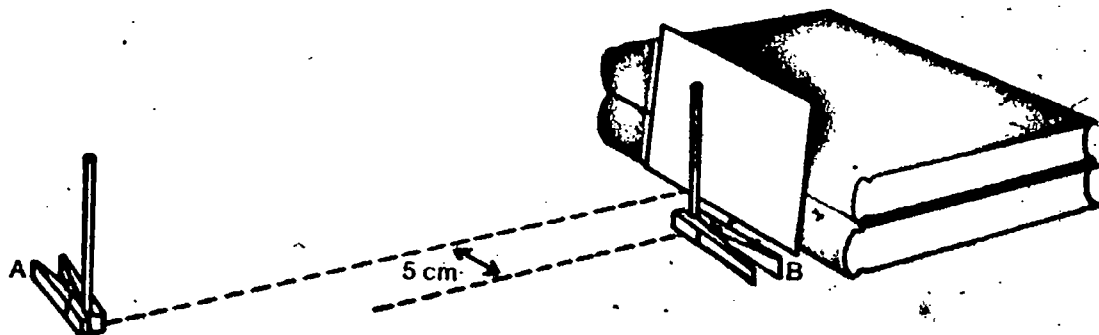

It is extremely important that the subject be able to see only the middle of the sticks. Therefore the viewing card will have to be held some distance from the eyes. With the distances given in the activities, the slit will probably have to be about 50 cm in front of the eyes. Also, if the sticks are on the tabletop, the subject should sit or kneel so that the eye level is about the same as the sticks. The brain searches for clues to depth, and any difference in shape, size, texture, color, or angle of the sticks may furnish these clues and negate the depth-perception test.

ACTIVITY 4. Stand about 2 m from stick A. View both sticks through the slit, using only one eye. When you do the experiment, you will be expected to see only the middle of the sticks. Be sure you can do this. You should not hold the slit so that you see either the tops of the sticks or the clothespins.

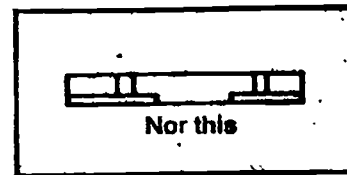
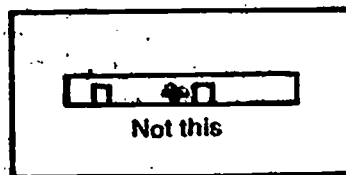
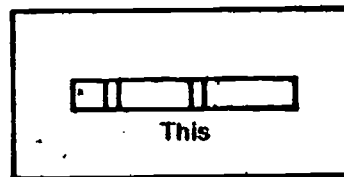

ACTIVITY 5. Stand about 2 meters from stick A. You should view the sticks as in Activity 4. Stick B should be in front of the white background. Your partner is to slowly move stick B forward toward A. When you think the two sticks are alongside each other, say "Stop." Then measure the distance between A and B and record it in Table 1 of your Record Book.

The distance between A and B must be measured in a straight line away from the eyes.

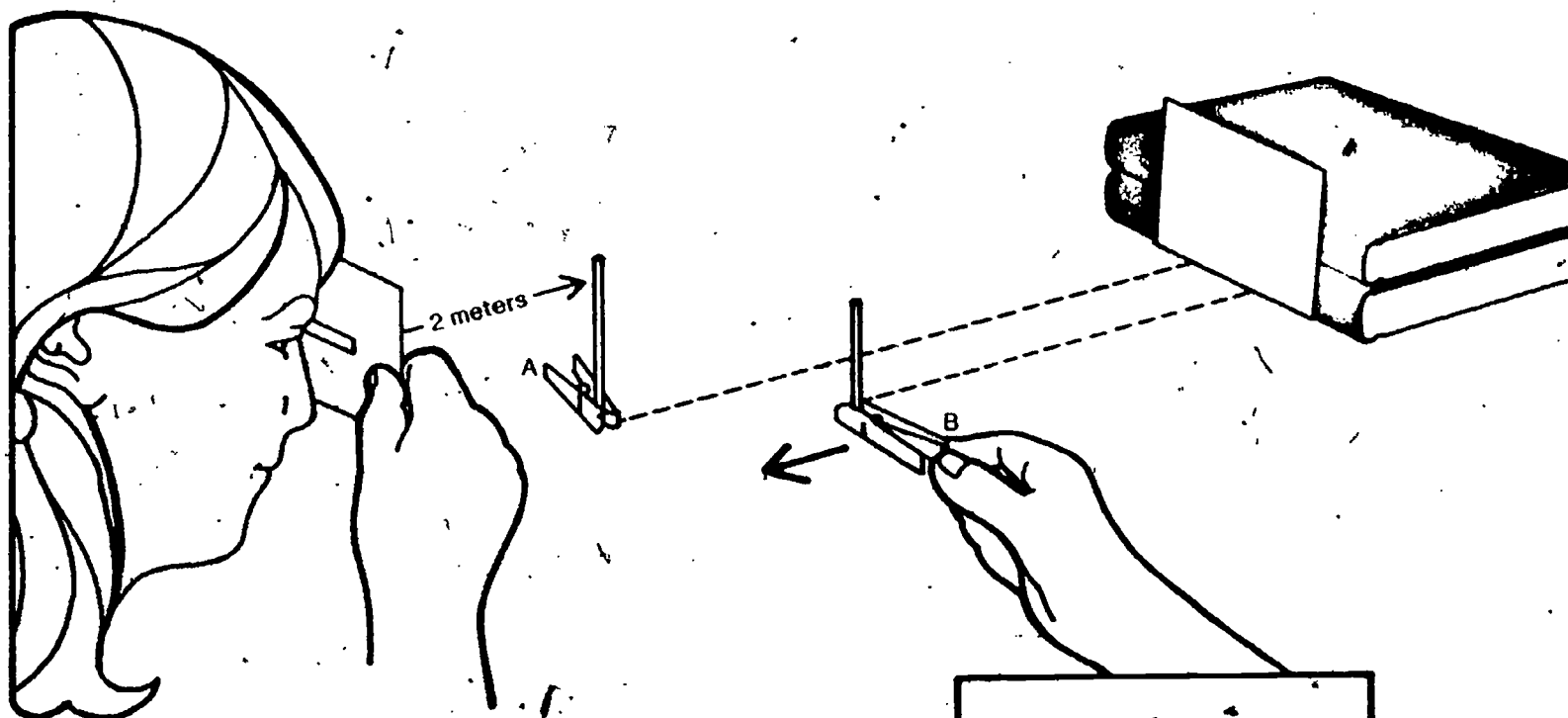

Do Activity 5 twice for each eye alone and twice for both eyes together. Then have your partner switch places with you.

Table 1

Eye(s)	DISTANCE BETWEEN A AND B (in cm)		
	Trial 1	Trial 2	Average
Right only			
Left only			
Both eyes			

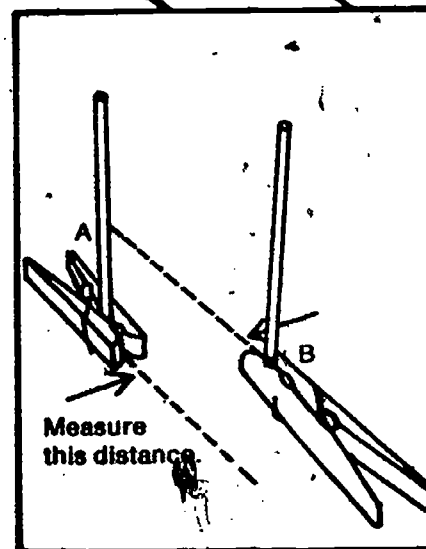

The scores with both eyes open should be significantly better (lower numbers) than with either eye separately. Anyone who has ever tried to thread a needle with one eye closed can attest to this. Stereoscopic (two-eye) vision is one of the clues that the brain uses to judge depth.

1. The student should tell how depth perception was measured in the activities

□1. Based on this activity, how would you operationally define *depth perception*?

□2. You are driving a car, at high speed in daylight. You approach a slow-moving tractor in the road ahead of you. Why are you more likely to have a rear-end collision with the tractor if your depth perception is poor?

□3. Many animals, such as horses, cows, rabbits, and birds, have eyes in the sides of their head. Others, such as men and monkeys, have eyes in the front of their head. According to your data, why is it an advantage to have both eyes in front rather than one on each side of the head?

Encourage students who are interested to try further activities on depth perception. Colored construction paper can be used in several different ways to vary the experiment. A possible investigation of the effect of color might be to use a colored background and sticks of the same or contrasting colors.

Many variables can affect depth perception. If the sticks are not round, they can be turned so that they are viewed edge-on instead of broadside. The sticks may also be colored. The background color and/or pattern may also be colored (use construction paper). Rather than sticks, objects of different shapes and sizes might be used. You may also wish to vary the viewer's distance from the sticks.

Perhaps you'd like to study the effects of one or more of these variables on depth perception. If so, record your experiments, findings, and conclusions in your Record Book.

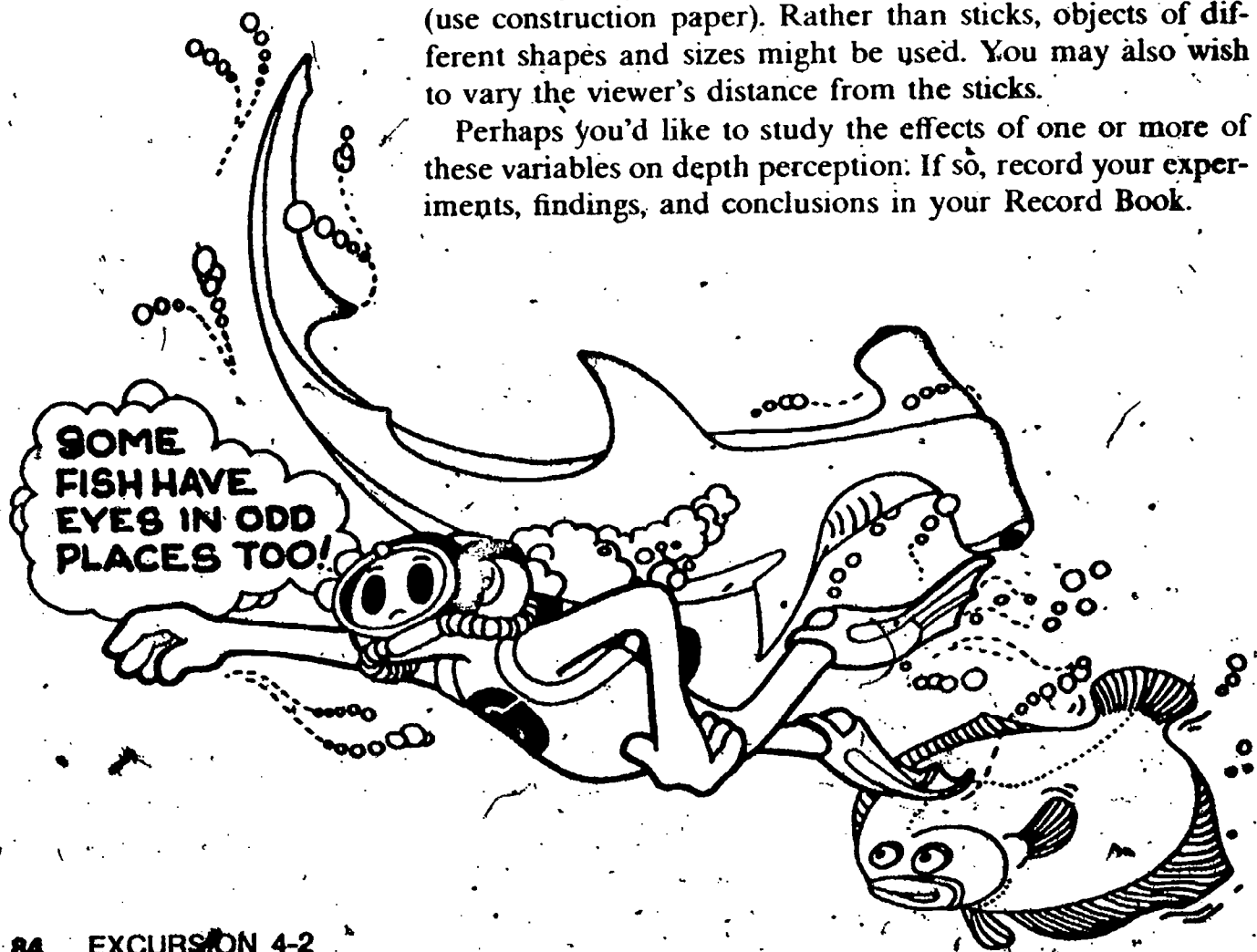

EQUIPMENT LIST

1 ink stamp pad
1 sheet of unlined white paper
Paper towels

This is an extension excursion

PURPOSE

To afford the opportunity for students to make and study their fingerprints.

No Two Alike

NOTE:

Paper and paper towels are local supply items. Stamp pads (6) are supplied uninked in the kit, together with a 2-oz tube of fingerprint ink. The pads should be inked ahead of time by you or by responsible student assistants. Use the ink sparingly; too much ink on the pad will be messy and will give blots instead of fingerprints.

Fingerprinting has long been accepted as a way of identifying people. No two individuals, not even "identical" twins, have exactly the same fingerprints. Thus, fingerprints are among the most variable of all human features. Hold your thumbs up in front of you and look carefully at the print patterns. Use a hand lens if necessary.

1. Do your thumbs have identical print patterns?

You can get a clearer picture of your thumbprints by making an inked impression. To do this, you will need these materials:

1 inked stamp pad
1 sheet of unlined white paper
Several paper towels

Study the following activities to learn how to make a "rolled impression." You should get clear prints by using this procedure.

ACTIVITY 1. Place the white paper at the edge of a table. Divide the edge of the paper with four lines and write "left thumb" in the space, as shown.

Caution Be very careful with your inked fingers. Have paper towels ready to wipe your fingers when you are through.

Excursion 4-3

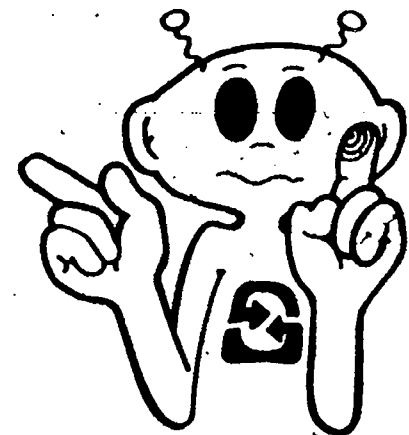

MAJOR POINTS

1. No two individuals are known to have identical fingerprints.
2. A simple procedure allows students to make their own prints.
3. Fingerprints can be classified into four of the basic categories and a compound category.

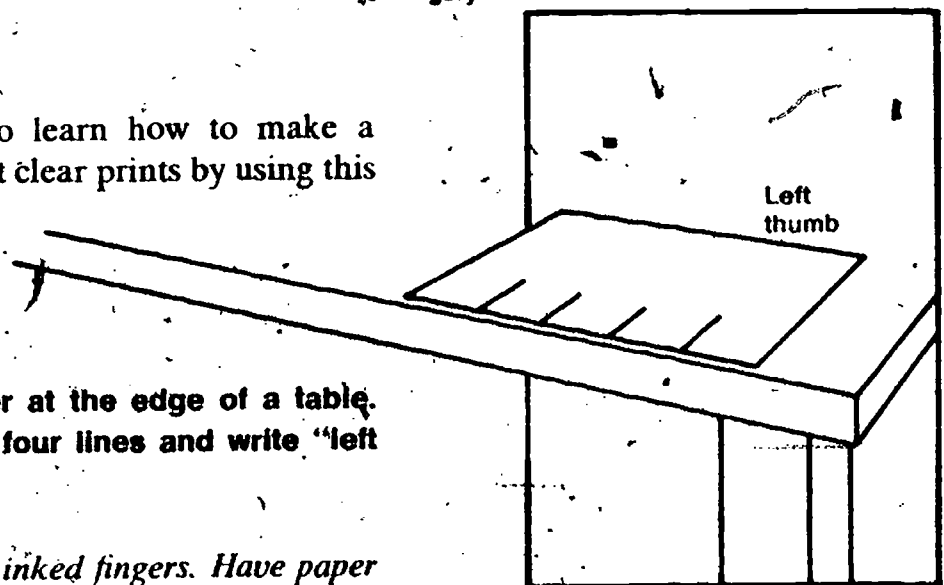

ACTIVITY 2. Place the ink pad at the edge of a table. Place the side of your finger on the ink pad. Roll your finger lightly until it rests on the opposite side.

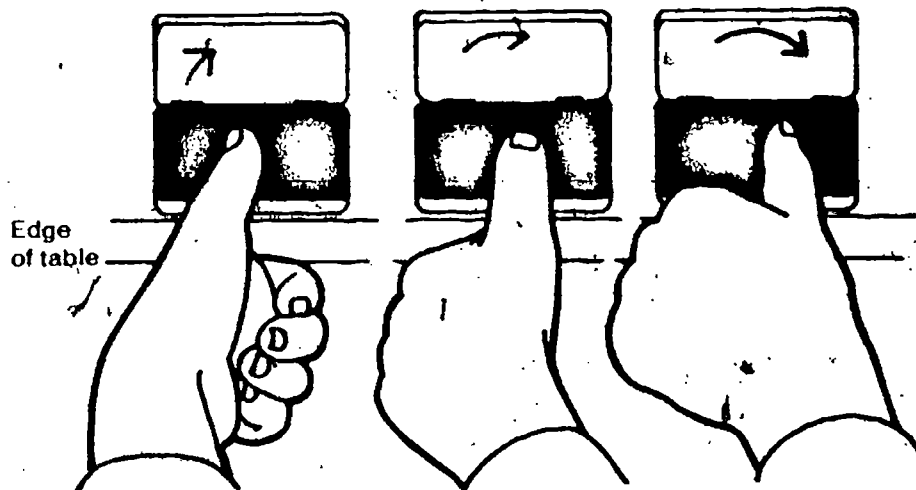

Very obviously, this can be a messy activity, but it doesn't have to be. Have paper towels available, and insist on prompt cleanup after each operation. Fingerprints on books can be rather durable.

ACTIVITY 3. Make one roll of each finger of the left hand in each of the divided areas on the paper. Do this by rolling the finger once from one edge of the finger to the opposite edge, as shown. Immediately lift the finger and wipe clean before doing the next finger.

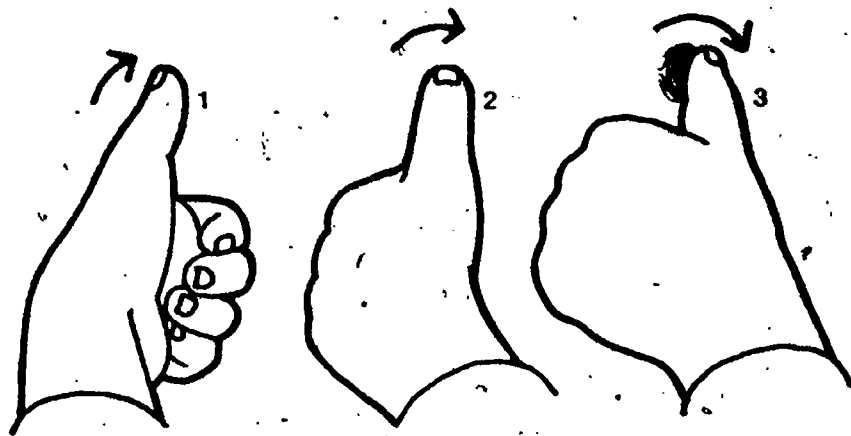

Clean your hands before doing the next activity.

ACTIVITY 4. Turn the paper to the opposite edge. Divide the edge of the paper with four lines and write "right thumb" over the divided section, as shown.

Right thumb

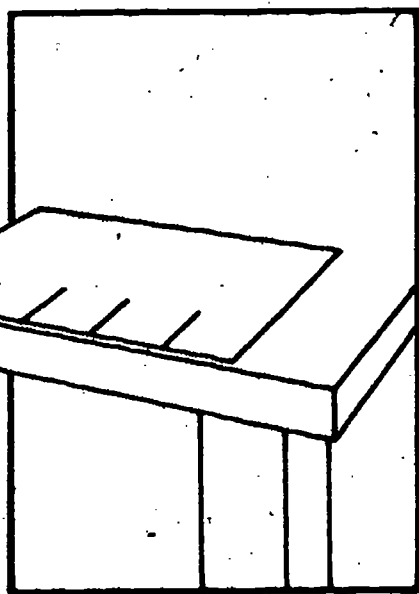

Repeat Activity 3 with the right hand. Then examine and compare all your prints.

The fact that no two prints are alike presents a very challenging problem in measurement and classification. Figure 1 illustrates four of the basic categories of prints used by the Federal Bureau of Investigation (FBI). Also shown is a compound print that combines characteristics of several of the basic categories.

The four basic types shown here are probably the commonest. For more complete classification, there are four more basic types used, making a total of eight. The four not shown (and generally not needed by the students) are the ulnar loop, central pocket loop, double loop (similar to the compound shown), and the accidental.



Plain arch



Tented arch



Loop



Plain whorl



Compound

The skin has a remarkable ability to regenerate itself. The fingertips, for instance, may be severely injured, but the prints will be restored by the body to their original basic pattern.

Compare each of your prints with the patterns in Figure 1, writing the print pattern beside each one. Then use Figure 2 to identify the prints you made as LT, L1, L2, etc.

Figure 1

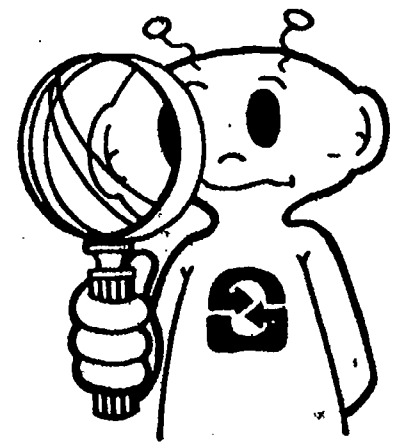

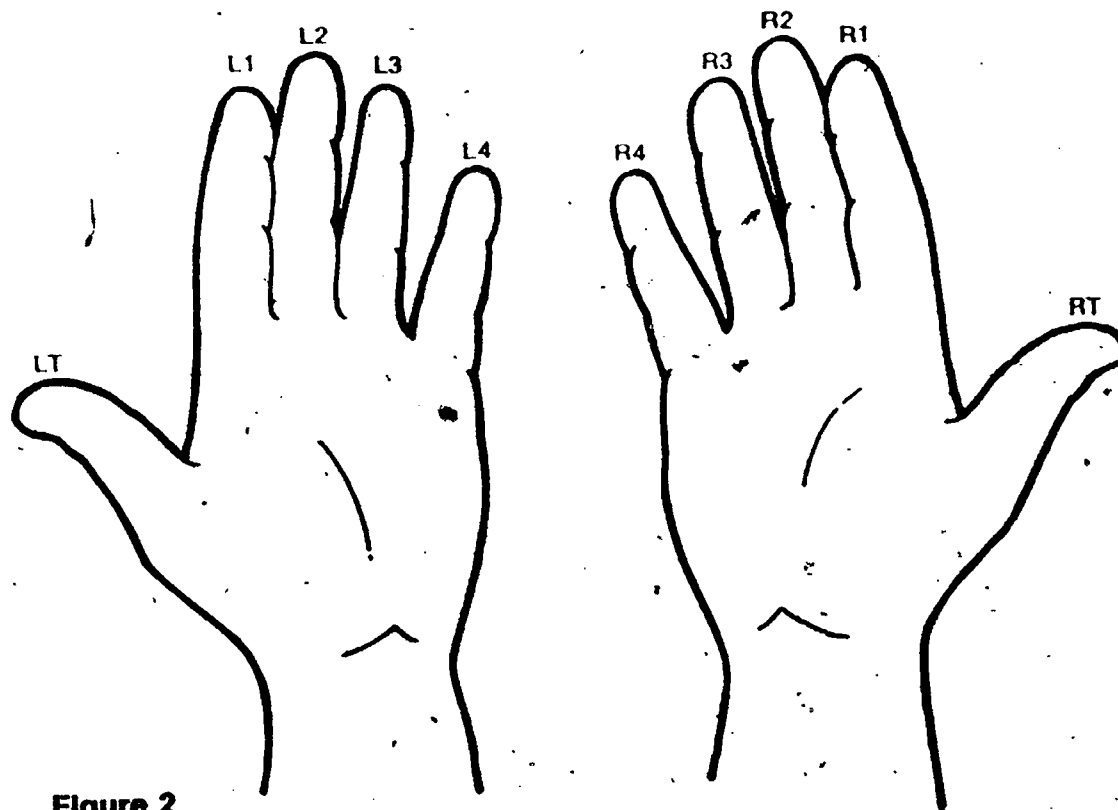

Figure 2

Complete Table 1 in your Record Book by writing the name of the appropriate print pattern in the space provided.

Table 1

	PRINT PATTERN FOR EACH FINGER				
	Thumb	1	2	3	4
Right hand					
Left hand					

2. Several should be in the same category. If the students use four (or five) basic types for ten digits, then there must be repeats. However, this still doesn't make any two identical.

- 2. Which, if any, of your fingers (including thumb) had prints in the same category?
- 3. Examine the prints of one of your classmates. Classify them according to the four basic categories. See if your classification agrees with that of their owner.
- 4. When you classify fingerprints, are you measuring them?

EQUIPMENT LIST

None.

This is a general-interest and extension excursion.

PURPOSE

To show various sampling techniques that can be used in gathering data.

Sampling Populations Excursion 5-1

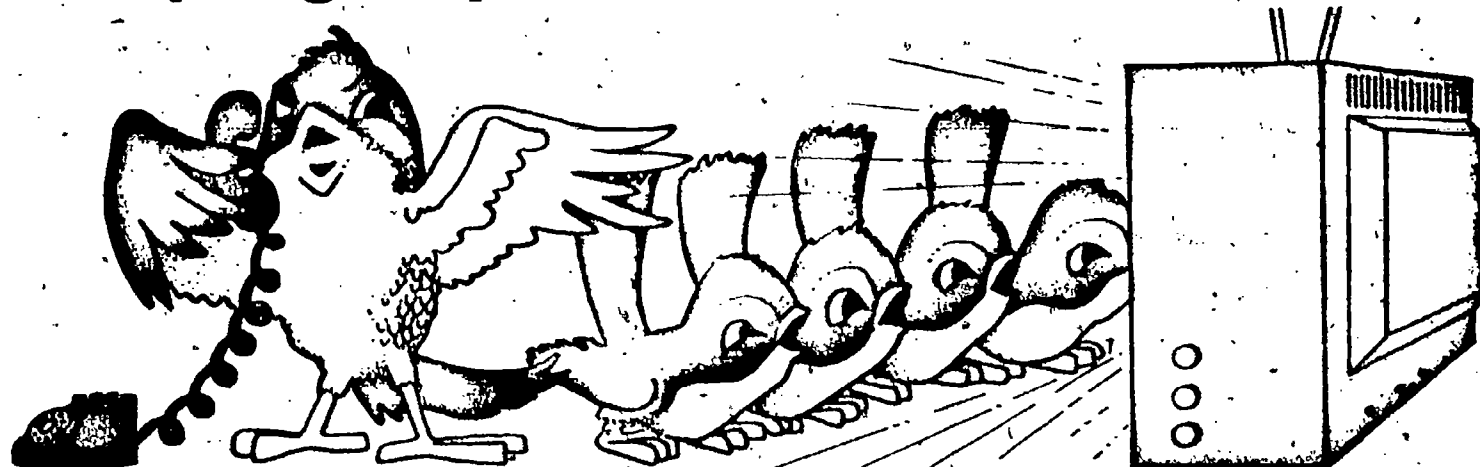

Sampling a population is a little like sampling candy. You don't have to eat all the candy in the bag to get an idea of what it tastes like. When people who study human populations (demographers) want the answer to some question, they don't have to ask every person in the United States, or Africa, or China! They pick a sample of people to answer the question. Television networks, when checking the popularity of their programs, don't call or write each person in the United States to find out which programs they watch. They have people skilled in sampling find out for them.

One major television sampling company is the A. C. Nielsen Co. of Chicago. Soon after the new television programs begin in the fall, the Nielsen ratings are released. Decisions are then made by the networks as to which programs will be dropped or what can be done to make a show more popular. These decisions are very important. Millions of dollars of advertising depend on the popularity of a show.

The Nielsen Company uses only 1,190 households in rating television programs! Based on the viewing habits of 1,190 households, decisions are made that affect what television programs you will watch. How can the Nielsen Company be sure that this small sample represents the viewing habits of 200,000,000 Americans? Some work you did earlier may give you an idea.

MAJOR POINTS

1. By sampling populations in the correct manner, answers to questions can be found without interrogating the entire population.
2. A large sample of a population would give a smooth graph, called a normal curve, for the data on some continuously varying trait.
3. It is important that the sample taken represents a cross section of the whole population.
4. Increasing the size of a sample increases the chances of getting a representative group.
5. A random sample is one that is selected by pure chance—without bias.

You might have a student in your class whose household has been surveyed by Nielsen or another rating company, and who could report on the experience to the class.

NORMAL CURVES

Earlier in this unit you sampled the population of your classroom to get an idea of the variability of people's weight. Suppose you had taken a very large sample of the total school population and then made a data graph. The graph probably would have looked like the mountain-shaped graphs you drew for Chapter 4, only smoother. The shape of the graph would have been much like the shape of the graph in Figure 1.

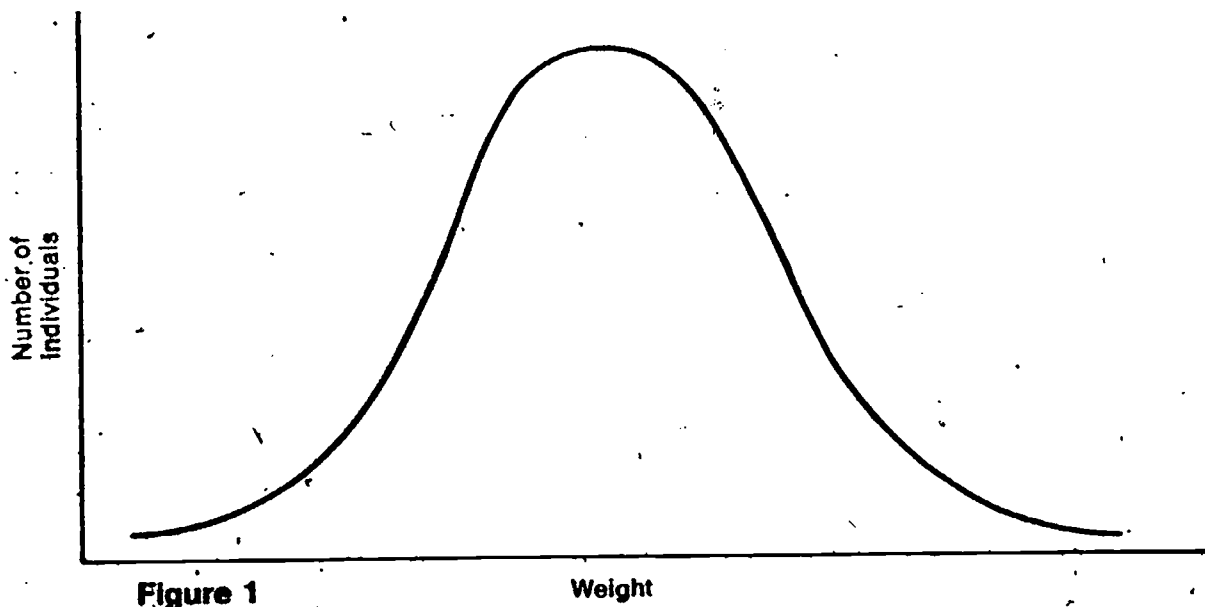

Figure 1

Weight

Scientists have given a name to a data-sample graph that is high in the middle and low on the two ends. A mountain-shaped curve of the sort shown in Figure 1 is said to be a *normal curve*.

Measures of most continuously varying human traits, when graphed, give a normal curve. Thus, if the shape of a data-sample graph is a normal curve, then the sample is considered to represent the total population. Judgments can then be made about the population on the basis of what is known about the sample.

The 1,190-member sample used by the Nielsen Company gives a normal curve when graphed. Thus, it is judged to be a good representation of the total TV viewing population. The sample represents all kinds of households: the most typical households and the not so typical (Figure 2).

Student grades on a test, or for a course, may form a normal curve when graphed. Thus educators have used, in varying amounts, the normal distribution in assigning grades. A small number of students who fall in the extremes of the curve get A's and F's; a larger number toward the center receive B's and D's; the large center section carries a grade of C.

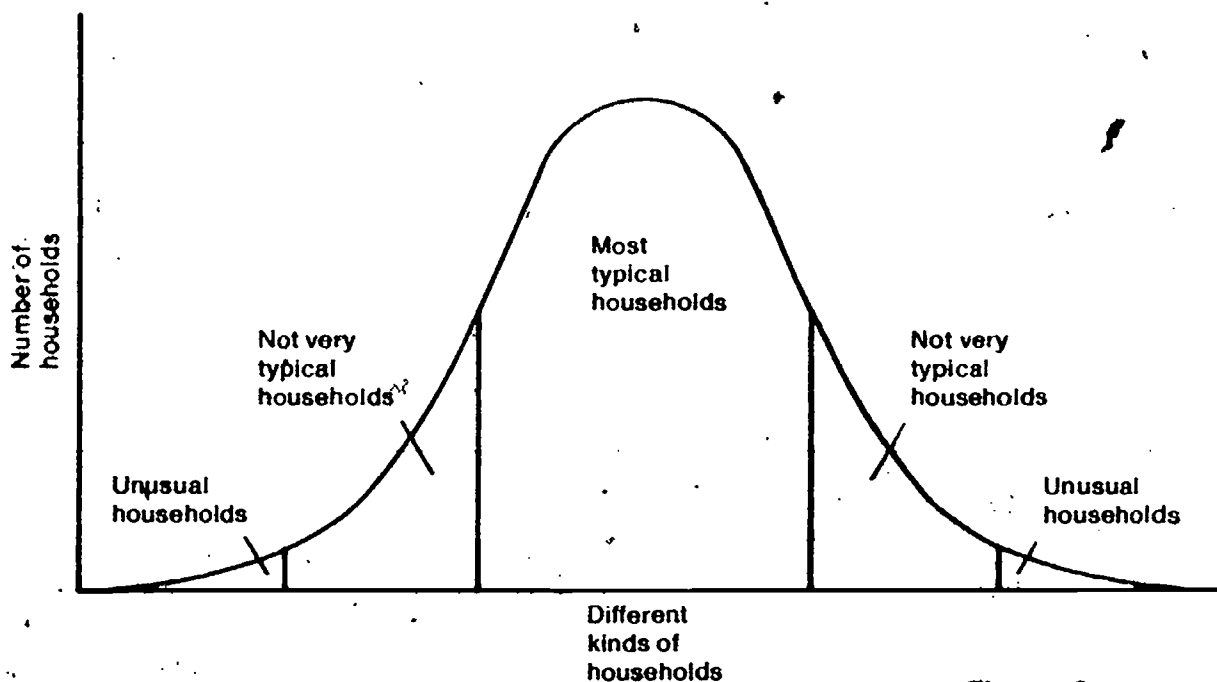

Figure 2

1. What factors would put households into the Most Typical group? How would these factors affect TV viewing habits?

2. What factors can you think of that would put households into the Unusual group? How would these factors affect TV viewing habits?

A typical viewing household might be made up of 2 parents who are young to middle-aged, 2 to 3 children, average income bracket, 1 to 2 cars. Any large departures from this typical group (single, very old, childless, very rich or poor, etc.) would move the household toward the Unusual group.

Assume that you are the captain of a spaceship from Planet X of another solar system. You have come to Earth to capture five Earthlings. You and your hunters have never seen an Earthling. On a quiet afternoon your hunting party enters a large building with a smooth wooden floor and a hooped net hanging at either end. Quickly you capture five tall creatures.

Upon returning to your spaceship, you report to Planet X headquarters: "Have captured five Earthlings. All Earthlings are animals ranging in height from 6'6" to 7'3". They have black skin, do very funny tricks with bouncing spheres, and wear very little clothing. On their clothing are symbols that look like this: HARLEM GLOBETROTTERS."

It would be rather obvious to other Earthlings that your sample did not represent all the population of Earth. Instead, your sample was taken from one end of a normal curve.

3. Look at Figure 3. The curve represents the height of humans in the United States in 1972. At which end of the curve would the basketball players be?

TAKING A SAMPLE—A PROBLEM

Figure 3

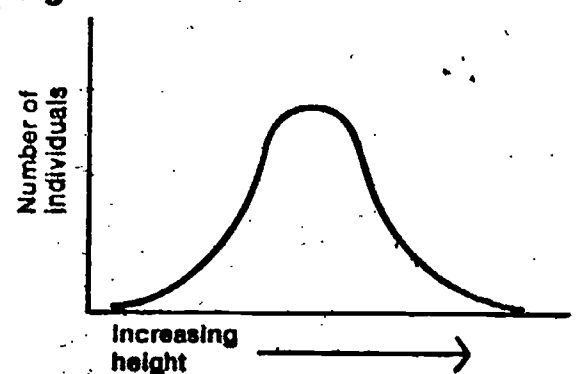

4. What could you do, as captain of the spaceship, to get a more representative sample of humans to take back to Planet X?

A related, but perhaps impossible, question would be, "If you could only bring back five people for a representative sample of all the people on the earth, what five would you choose?" The factor that might make the question impossible is the number 5. When you consider the tremendous variation of humans (the subject of the unit), there probably is some number below which you cannot expect the sample to be representative.

In your answer to question 4, you might have suggested that you should bring back a larger sample. By bringing back 50 or 500 people instead of five people, you would increase the chances of collecting a girl, which would certainly alter your definition of humans. Also, the chances of selecting short people, whites, Indians, children, the elderly, etc., increases with the increase in the number of people captured.

Another suggestion that you might have made is that you should collect humans from several places in the world. This would give you a much better chance of representing the wide variety among humans.

One suggestion that you probably did not make is that the sample should have been a random sample. Perhaps you don't know what a random sample is.

RANDOM SAMPLING

Random sampling means "selection without bias." *Selection without bias* in turn means that all members of a population have an equal chance of being selected as part of the sample. A Planet X hunting team landing in Alaska would have a greater chance of capturing Eskimos than of capturing Europeans. Therefore, such a sample would be biased and not random.

Take another example. Suppose, for instance, you wanted to make a histogram of people's weights. Without realizing it, you are attracted to heavier people. Because of this, you unconsciously select the sixteen heaviest people in your class as the sample to make your histogram. This would be biased data. The skinny members of your class did not have an equal chance with the heavy ones of being selected as part of the sample representing the class population.

When one considers the human factors involved in personal choice of a sample, and the biases and prejudices that can enter into the problem, it probably is true that the only good method of sampling is the random method.

5. What could you do to avoid the effect of this unconscious bias on your sample selection?

Random sampling and selection is very important. This procedure is used for selecting draftees into the armed service. In such a case every young man should be ensured of having an equal chance of selection. He isn't likely to want

to have a better chance than someone else of being selected.

Professional samplers use many techniques in making selections and in getting representative samples. Whatever procedure they use to sample a population, it must include the following.

1. A complete description of the population from which the sample is taken (kinds of individuals; where and when selected)
2. An appropriate sample size to give a good cross section of the population
3. A randomly selected sample

As you investigate the questions raised in the problem breaks in Chapter 5, remember the importance of sampling. In each case you will be asked to make judgments about populations. To make these judgments, you will have to work with samples of these populations. Be sure to do a good job of getting a representative sample.

If you are planning to evaluate how good a job your students do on the problem breaks in Chapter 5, these three points listed here can serve as an excellent guide. In other words, you can ask "Did the student consider the total population in taking his sample, did he select a sample of enough individuals, and did he select it randomly?"

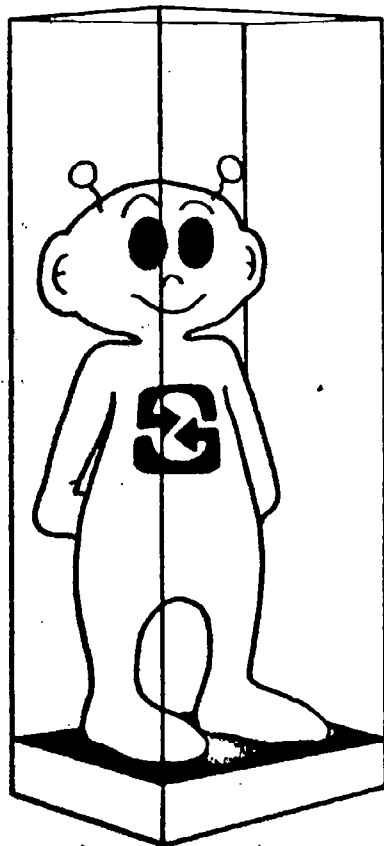

**PLANET X
MUSEUM:
EARTH**
(RANDOM SAMPLING)

PICTURE CREDITS

- x Doug Bates
- 14 New York Stock Exchange
- 24 William M. Rittase from Frederic Lewis, Inc.
- 34 Frank Mascati from Erwin Kramer Photography, Inc.
- 50 Harold M. Lambert from Frederic Lewis, Inc.
- 68 Courtesy ISCS

114