

DOCUMENT RESUME

ED 190 356

SE 031 300

AUTHOR Bonar, John R., Ed.; Hathway, James A., Ed.
TITLE Probing the Natural World, Level III, Student Guide: Why You're You. Intermediate Science Curriculum Study.
INSTITUTION Florida State Univ., Tallahassee. Dept. of Science Education.
SPONS AGENCY National Science Foundation, Washington, D.C.; Office of Education (DHEW), Washington, D.C.
PUB DATE 72
NOTE 148p.: For related documents, see SE 031 301-330, ED 035 559-560, ED 049 032, and ED 052 940. Contains photographs and colored and shaded drawings and print which may not reproduce well.
EDRS PRICE MF01/PC06 Plus Postage.
DESCRIPTORS *Genetics: Grade 9: Heredity: Improvement Programs: Individualized Instruction: *Instructional Materials: Junior High Schools: *Laboratory Manuals: Laboratory Procedures: *Science Activities: Science Curriculum: Science Education: Secondary Education: Secondary School Science
IDENTIFIERS Intermediate Science Curriculum Study

ABSTRACT

This is the student's text of one of the eight units of the Intermediate Science Curriculum Study (ISCS) for level III students (grade 9). The chapters include basic information about heredity, activities, and optional "excursions." A section on introductory notes to the student explains how to use the book. Data tables and empty spaces within the workbook format indicate where responses are expected. Illustrations accompany all instructions and the students are expected to select the proper equipment based on the illustrations. (SA)

* Reproductions supplied by EDRS are the best that can be made *
* from the original document. *

Why You're You

ED190356

U.S. DEPARTMENT OF HEALTH,
EDUCATION & WELFARE
NATIONAL INSTITUTE OF
EDUCATION

THIS DOCUMENT HAS BEEN REPRO-
DUCED EXACTLY AS RECEIVED FROM
THE PERSON OR ORGANIZATION ORIGIN-
ATING IT. POINTS OF VIEW OR OPINIONS
STATED DO NOT NECESSARILY REPRESENT
OFFICIAL NATIONAL INSTITUTE OF
EDUCATION POSITION OR POLICY.

"PERMISSION TO REPRODUCE THIS
MATERIAL HAS BEEN GRANTED BY

Mary L. Charles

of the NSF

TO THE EDUCATIONAL RESOURCES
INFORMATION CENTER (ERIC)."

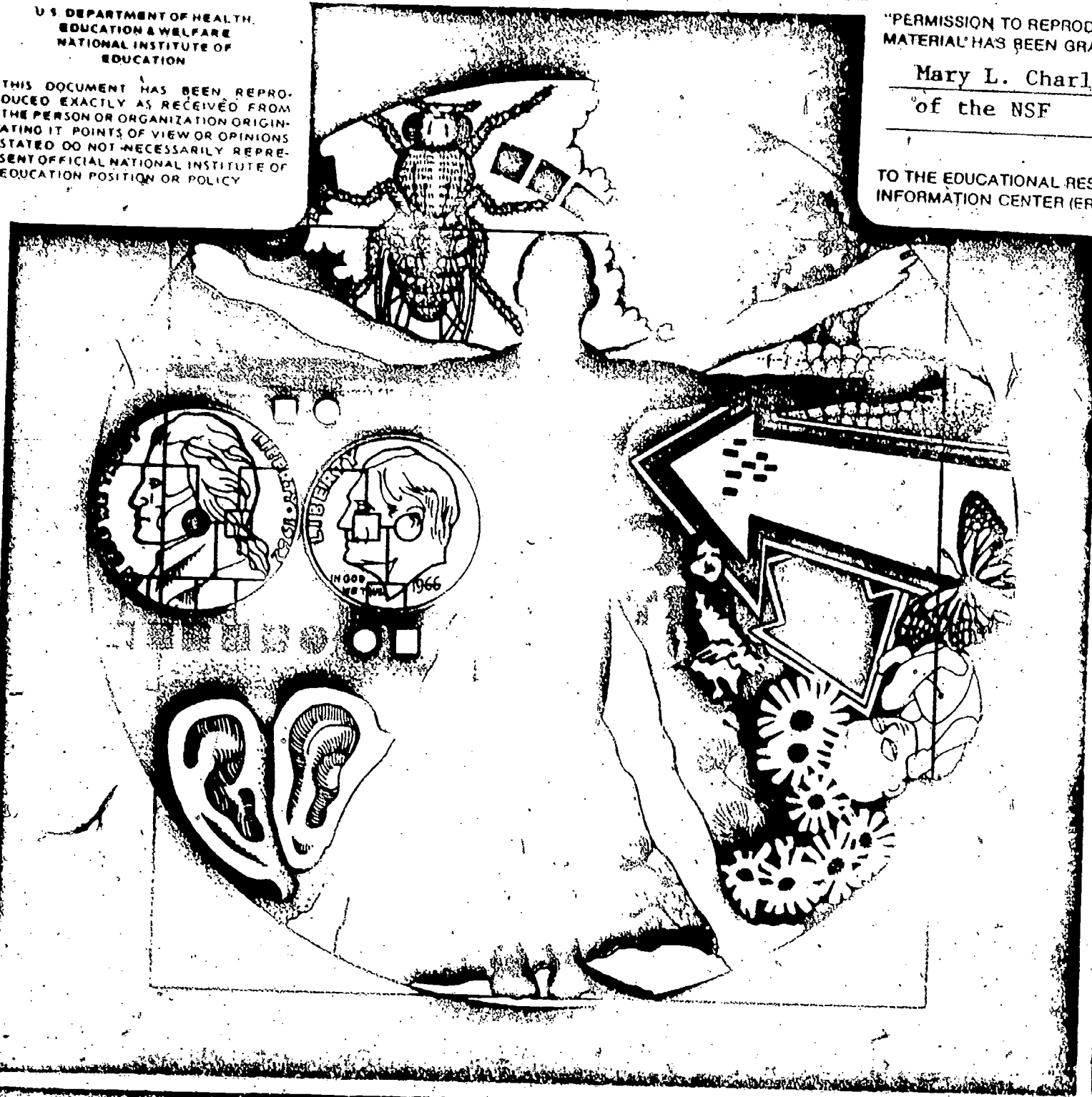

SE 031 300

Understanding the Natural World/3

2



INTERMEDIATE
SCIENCE
CURRICULUM
STUDY

THIS BOOK IS THE PROPERTY OF:

STATE _____		Book No. _____	
PROVINCE _____		Enter information in spaces to the left as instructed	
COUNTY _____			
PARISH _____			
SCHOOL DISTRICT _____			
OTHER _____			
<i>ISSUED TO</i>	<i>Year Used</i>	<i>CONDITION</i>	
		<i>ISSUED</i>	<i>RETURNED</i>
_____	_____	_____	_____
_____	_____	_____	_____
_____	_____	_____	_____
_____	_____	_____	_____
_____	_____	_____	_____
_____	_____	_____	_____
_____	_____	_____	_____
_____	_____	_____	_____
_____	_____	_____	_____

PUPILS to whom this textbook is issued must not write on any page or mark any part of it in any way, consumable textbooks excepted.

1. Teachers should see that the pupil's name is clearly written in ink in the spaces above in every book issued.
2. The following terms should be used in recording the condition of the book: New, Good, Fair, Poor, Bad.

INTERMEDIATE SCIENCE CURRICULUM STUDY

Why You're You

Probing the Natural World / Level III



SILVER BURDETT

GENERAL LEARNING CORPORATION

Morristown, New Jersey · Park Ridge, Ill. · Palo Alto, Dallas · Atlanta

ISCS PROGRAM

LEVEL I Probing the Natural World / Volume 1 / with Teacher's Edition
Student Record Book / Volume 1 / with Teacher's Edition
Master Set of Equipment / Volume 1
Test Resource Booklet

LEVEL II Probing the Natural World / Volume 2 / with Teacher's Edition
Record Book / Volume 2 / with Teacher's Edition
Master Set of Equipment / Volume 2
Test Resource Booklet

LEVEL III Why You're You / with Teacher's Edition
Record Book / with Teacher's Edition / Master Set of Equipment
Environmental Science / with Teacher's Edition
Record Book / with Teacher's Edition / Master Set of Equipment
Investigating Variation / with Teacher's Edition
Record Book / with Teacher's Edition / Master Set of Equipment
In Orbit / with Teacher's Edition
Record Book / with Teacher's Edition / Master Set of Equipment
What's Up? / with Teacher's Edition
Record Book / with Teacher's Edition / Master Set of Equipment
Crusty Problems / with Teacher's Edition
Record Book / with Teacher's Edition / Master Set of Equipment
Winds and Weather / with Teacher's Edition
Record Book / with Teacher's Edition / Master Set of Equipment
How's Your Health? / with Teacher's Edition
Record Book / with Teacher's Edition / Master Set of Equipment

ACKNOWLEDGMENTS

The work presented or reported herein was performed pursuant to a Contract with the U. S. Office of Education, Department of Health, Education, and Welfare. It was supported, also, by the National Science Foundation. However, the opinions expressed herein do not necessarily reflect the position or policy of the U. S. Office of Education or the National Science Foundation, and no official endorsement by either agency should be inferred.

© 1972 THE FLORIDA STATE UNIVERSITY

All rights reserved. Printed in the United States of America. Published simultaneously in Canada. Copyright is claimed until 1977. Except for the rights to materials reserved by others, the Publishers and the copyright owner hereby grant permission to domestic persons of the United States and Canada for use of this work without charge in the English language in the United States and Canada after 1977 provided that the publications incorporating materials covered by the copyrights contain an acknowledgment of them and a statement that the publication is not endorsed by the copyright owner. For conditions of use and permission to use materials contained herein for foreign publications in other than the English language, apply to the copyright owner. This publication, or parts thereof, may not be reproduced in any form by photographic, electrostatic, mechanical, or any other method, for any use, including information storage and retrieval, without written permission from the publisher.

ILLUSTRATIONS: © 1972 GENERAL LEARNING CORPORATION.
ALL RIGHTS RESERVED.

ISCS STAFF

David D. Redfield, *Co-Director*
William R. Snyder, *Co-Director*
Ernest Burkman, *Steering Committee Chairman*

* Laura M. Bell, *Artist*
* John R. Bonar, *Editor*
Dreunan A. Browne, *Artist*
* Harold L. Buell, *Administration*
Robert L. Cocanougher, *Art Director*
* Betsy A. Conlon, *Evaluation*
Stewart P. Darrow, *Field Trial-Teacher Education*
James A. Hathway, *Editor*

* John S. Hutchinson, *Field Trial Teacher Education*
* Sally Diana Kaicher, *Art Director*
* Jane Larsen, *Art Director*
Adrian D. Lovell, *Administration*
* Audley C. McDonald, *Administration*
* W. T. Myers, *Administration*
* Lynna H. Rogers, *Artist*
Stephen C. Smith, *Artist*

ISCS ADVISORY COMMITTEE

J. Myron Atkin, *University of Illinois*
Betsy Conlon Balzano, *State University of New York College at Brockport*
Werner A. Baum, *University of Rhode Island*
Herman Branson, *Lincoln University*
* Martha Duncan Camp, *The Florida State University*
Clifton B. Clark, *University of North Carolina at Greensboro*
Steve Edwards, *The Florida State University*
Robert M. Gagné, *The Florida State University*
Edward Haenisch, *Wabash College*
* Michael Kasha, *The Florida State University*
Russell P. Kropp, *The Florida State University*
J. Stanley Marshall, *The Florida State University*
William V. Mayer, *University of Colorado*
Herman Parker, *University of Virginia*
Craig Sipe, *State University of New York at Albany*
* Harry Sisler, *University of Florida*
Clifford Swartz, *State University of New York at Stony Brook*
Claude A. Welch, *Macalester College*
Gates Willard, *Manhasset Junior High School, Manhasset, N. Y.*
Herbert Zim, *Science Writer, Tavernier, Florida*

* Former member

MATERIALS DEVELOPMENT CONTRIBUTORS

This list includes writing-conference participants and others who made significant contributions to the materials, including text and art for the experimental editions.

Jane Anderson, Nyack, N.Y. Gerald R. Bakker, Earlham College. Frank Balzano, F.S.U. Harold N. Bliss, Mayville State College. Olaf A. Boedtker, Oregon State Univ. Calvin E. Bolin, F.S.U. Earl Brakken, Two Harbors, Minn. Bobby R. Brown, F.S.U. Robert J. Callahan, Jr. (deceased). Brian W. Carss, University of Illinois. Lois H. Case, Lombard, Ill. Clifton B. Clark, University of North Carolina at Greensboro. Sara P. Craig, F.S.U. John D. Cunningham, Keene State College. David H. Dasenbrock, F.S.U. Doris Dasenbrock, F.S.U. Jeff C. Davis, University of South Florida. Alan D. Dawson, Dearborn Public Schools, Mich. George O. Dawson, F.S.U. Gerrit H. DeBoer, F.S.U. Howard E. DeCamp, Glenn Ellyn, Ill. James V. DeRose, Newtown Square, Pa. William A. Deskin, Cornell College. William K. Easley, Northeast Louisiana State College. Donald C. Edinger, University of Arizona. Camillo Fano, University of Chicago Laboratory School. Ronald A. Fisher, Maquoketa, Iowa. Edwin H. Flemming, F.U.S. Paul K. Flood, F.S.U. Harper W. Frantz, Pasadena City College (Emeritus). Earl Friesen, San Francisco State College. Bob Galati, Fullerton, Calif. J. David Gavenda, The University of Texas. Charles A. Gilman, Winchester, N.H. Robert J. Goll, Jacksonville University. Ralph H. Granger, Jr., Walpole, N.H. H. Winter Griffith, F.S.U. William Gunn, Miami, Florida. John Hart, Xavier University. John R. Hassard, Georgia State University. J. Dudley Herron, Purdue University. Father Francis Heyden, S.J., Georgetown University. Leonard Himes, Sarasota, Florida. Evelyn M. Hurlburt, Montgomery Junior College. John R. Jablonski, Boston University. Bert M. Johnson, Eastern Michigan University. Roger S. Jones, University of Minnesota. Leonard A. Kalal, Colorado School of Mines. Theodore M. Kellogg, University of Rhode Island. Elizabeth A. Kendzior, University of Illinois. F. J. King, F.S.U. David Klasson, Millville, Calif. Ken Kramer, Wright State University. William H. Long, F.S.U. Robert Lepper, California State College. Harold G. Liebherr, Milwaukee, Wis. William D. Larson, College of St. Thomas. Mable M. Lund, Beaverton, Oregon. H. D. Luttrell, North Texas State University. Maxwell Maddock, F.S.U. Solomon Malinsky, Sarasota, Florida. Eloise A. Mann, Sarasota, Florida. Harleen W. McAda, University of California at Santa Barbara. Auley A. McAuley, Michigan State University. E. Wesley McNair, F.S.U. Marilyn Miklos, F.S.U. Floyd V. Monaghan, Michigan State University. Rufus P. Morton, Westport, Conn. Tamson Myer, F.S.U. Gerald Neufeld, F.S.U. James Okey, University of California. Lawrence E. Oliver, F.S.U. Larry O'Rear, Alice, Texas. Herman Parker, University of Virginia. Harry A. Pearson, Western Australia. James E. Perham, Randolph-Macon Woman's College. Darrell O. Phillips, University of Iowa. Howard Pierce, F.S.U. David Poché, F.S.U. Charles O. Pollard, Georgia Institute of Technology. Glenn F. Powers, Northeast Louisiana State College. Ernest Gene Preston, Louisville, Ky. Edward Ramey, F.S.U. Earl R. Rich, University of Miami. John Schaff, Syracuse University. Carroll A. Scott, Williamsburg, Iowa. Earle S. Scott, Ripon College. Thomas R. Spalding, F.S.U. Michael E. Stuart, University of Texas. Sister Agnes Joseph Sun, Marygrove College. Clifford Swartz, State University of New York. Thomas Teates, F.S.U. Bill W. Tillery, University of Wyoming. Ronald Townsend, University of Iowa. Mordecai Treblow, Bloomsburg State College. Henry J. Triczenberg, National Union of Christian Schools. Paul A. Vestal, Rollins College. Robert L. Vickery, Western Australia. Frederick B. Voight, F.S.U. Claude A. Welch, Macalester College. Paul Westmeyer, F.S.U. Earl Williams, University of Tampa. G. R. Wilson, Jr., University of South Alabama. Harry K. Wong, Atherton, California. Charles M. Woolheater, F.S.U. Jay A. Young, King's College. Victor J. Young, Queensborough Community College.

The genesis of some of the ISCS material stems from a summer writing conference in 1964. The participants were:

Frances Abbott, Miami-Dade Junior College. Ronald Atwood, University of Kentucky. George Assousa, Carnegie Institute. Colin H. Barrow, University of West Indies. Peggy Bazzel, F.S.U. Robert Binger (deceased). Donald Bucklin, University of Wisconsin. Martha Duncan Camp, F.S.U. Roy Campbell, Broward County Board of Public Instruction, Fla. Bruce E.-Cleare, Tallahassee Junior College. Ann-cle Hall, Pensacola, Florida. Charles Holcolmb, Mississippi State College. Robert Kemman, Mt. Prospect, Ill. Gregory O'Berry, Coral Gables, Florida. Elra Palmer, Baltimore. James Van Pierce, Indiana University Southeast. Guenter Schwarz, F.S.U. James E. Smeland, F.S.U. C. Richard Tillis, Pine Jog Nature Center, Florida. Peggy Wiegand, Emory University. Elizabeth Woodward, Augusta College. John Woolver, Sarasota, Florida.

Foreword

A pupil's experiences between the ages of 11 and 16 probably shape his ultimate view of science and of the natural world. During these years most youngsters become more adept at thinking conceptually. Since concepts are at the heart of science, this is the age at which most students first gain the ability to study science in a really organized way. Here, too, the commitment for or against science as an interest or a vocation is often made.

Paradoxically, the students at this critical age have been the ones least affected by the recent effort to produce new science instructional materials. Despite a number of commendable efforts to improve the situation, the middle years stand today as a comparatively weak link in science education between the rapidly changing elementary curriculum and the recently revitalized high school science courses. This volume and its accompanying materials represent one attempt to provide a sound approach to instruction for this relatively uncharted level.

At the outset, the organizers of the ISCS Project decided that it would be shortsighted and unwise to try to fill the gap in middle school science education by simply writing another textbook. We chose instead to challenge some of the most firmly established concepts about how to teach and just what science material can and should be taught to adolescents. The ISCS staff have tended to mistrust what authorities believe about schools, teachers, children, and teaching until we have had the chance to test these assumptions in actual classrooms with real children. As conflicts have arisen, our policy has been to rely more upon what we saw happening in the schools than upon what authorities said could or would happen. It is largely because of this policy that the ISCS materials represent a substantial departure from the norm.

The primary difference between the ISCS program and more conventional approaches is the fact that it allows each student to travel

at his own pace, and it permits the scope and sequence of instruction to vary with his interests, abilities, and background. The ISCS writers have systematically tried to give the student more of a role in deciding what he should study next and how soon he should study it. When the materials are used as intended, the ISCS teacher serves more as a "task easer" than a "task master." It is his job to help the student answer the questions that arise from his own study rather than to try to anticipate and package what the student needs to know.

There is nothing radically new in the ISCS approach to instruction. Outstanding teachers from Socrates to Mark Hopkins have stressed the need to personalize education. ISCS has tried to do something more than pay lip service to this goal. ISCS' major contribution has been to design a system whereby an average teacher, operating under normal constraints, in an ordinary classroom with ordinary children, can indeed give maximum attention to each student's progress.

The development of the ISCS material has been a group effort from the outset. It began in 1962, when outstanding educators met to decide what might be done to improve middle-grade science teaching. The recommendations of these conferences were converted into a tentative plan for a set of instructional materials by a small group of Florida State University faculty members. Small-scale writing sessions conducted on the Florida State campus during 1964 and 1965 resulted in pilot curriculum materials that were tested in selected Florida schools during the 1965-66 school year. All this preliminary work was supported by funds generously provided by The Florida State University.

In June of 1966, financial support was provided by the United States Office of Education, and the preliminary effort was formalized into the ISCS Project. Later, the National Science Foundation made several additional grants in support of the ISCS effort.

The first draft of these materials was produced in 1968, during a summer writing conference. The conferees were scientists, science educators, and junior high school teachers drawn from all over the United States. The original materials have been revised three times prior to their publication in this volume. More than 150 writers have contributed to the materials, and more than 180,000 children, in 46 states, have been involved in their field testing.

We sincerely hope that the teachers and students who will use this material will find that the great amount of time, money, and effort that has gone into its development has been worthwhile.

Tallahassee, Florida
February 1972

The Directors
INTERMEDIATE SCIENCE CURRICULUM STUDY

Contents

NOTES TO THE STUDENT	viii
CHAPTERS	
1 Red Eyes and Curly Wings	1
2 That's Using the Old Bean	25
3 Watch Your 'Peas and Q's	33
4 Bits of Information	43
5 Either Heads or Tails	59
6 Meet the Ninsect	69
7 Problems, Problems, Problems	83
EXCURSIONS	
1-1 More on Offspring	89
1-2 Writing Operational Definitions	91
1-3 Temperature and Life Cycle	93
1-4 A Pyramid of Grandparents	95
2-1 Ratio Simplified	99
4-1 Don't Flip over This	103
6-1 A Bit More About Bits	107
6-2 Peas Again, but Double Trouble	111
7-1 Red, White, and Pink	115
7-2 Hair Helrs	117
7-3 Boy or Girl	121
7-4 A Royal Problem	123
7-5 I Wonder Where the Color Went?	127
7-6 One, Two, Pick-up Sticks	129
7-7 Do Blondes Have More Fun?	133

Notes to the Student

The word *science* means a lot of things. All of the meanings are "right," but none are complete. *Science* is many things and is hard to describe in a few words.

We wrote this book to help you understand what science is and what scientists do. We have chosen to show you these things instead of describing them with words. The book describes a series of things for you to do and think about. We hope that what you do will help you learn a good deal about nature and that you will get a feel for how scientists tackle problems.

How is this book different from other textbooks?

This book is probably not like your other textbooks. To make any sense out of it, you must work with objects and substances. You should do the things described, think about them, and then answer any questions asked. Be sure you answer each question as you come to it.

The questions in the book are very important. They are asked for three reasons:

1. To help you to think through what you see and do.
2. To let you know whether or not you understand what you've done.
3. To give you a record of what you have done so that you can use it for review.

How will your class be organized?

Your science class will probably be quite different from your other classes. This book will let you start work with less help than usual from your teacher. You should begin each day's work where you left off the day before. Any equipment and supplies needed will be waiting for you.

Your teacher will not read to you or tell you the things that you are to learn. Instead, he will help you and your classmates individually.

Try to work ahead on your own. If you have trouble, first try to solve the problem for yourself. Don't ask your teacher for help until you really need it. Do not expect him to give you the answers to the questions in the book. Your teacher will try to help you find where and how you went wrong, but he will not do your work for you.

After a few days, some of your classmates will be ahead of you and others will not be as far along. This is the way the course is supposed to work. Remember, though, that there will be no prizes for finishing first. Work at whatever speed is best for you. *But be sure you understand what you have done before moving on.*

Excursions are mentioned at several places. These special activities are found at the back of the book. You may stop and do any excursion that looks interesting or any that you feel will help you. (Some excursions will help you do some of the activities in this book.) Sometimes, your teacher may ask you to do an excursion.

What am I expected to learn?

During the year, you will work very much as a scientist does. You should learn a lot of worthwhile information. More important, we hope that you will learn how to ask and answer questions about nature. *Keep in mind that learning how to find answers to questions is just as valuable as learning the answers themselves.*

Keep the big picture in mind, too. Each chapter builds on ideas already dealt with. These ideas add up to some of the simple but powerful concepts that are so important in science. If you are given a Student Record Book, do all your writing in it. *Do not write in this book.* Use your Record Book for making graphs, tables, and diagrams, too.

From time to time you may notice that your classmates have not always given the same answers that you did. This is no cause for worry. There are many right answers to some of the questions. And in some cases you may not be able to answer the questions. As a matter of fact, no one knows the answers to some of them. This may seem disappointing to you at first, but you will soon realize that there is much that science does not know. In this course, you will learn some of the things we don't know as well as what is known. Good luck!



Red Eyes and Curly Wings

Chapter 1

Has anyone ever told you that you look like your father? or your mother? or your brother or your sister? Possibly someone has, because parents usually pass along some of their features to their children. But how does this happen? Just how can a parent send a message like "Form blue eyes" to an unborn child? What color eyes does the child end up with when the message from one parent says "Form blue eyes" and the second parent's message says "Form brown eyes"?

In this unit you will try to answer questions like these. In it you will compare the features of parents with those of their offspring. You will breed flies, study beans and peas, and look closely at some of your own features and those of your friends.

The two big questions in this unit that you will try to answer are these:

1. Is there any pattern to the way features are passed from parents to their offspring?
2. What kind of model will explain how features are passed from parents to their offspring?

For the next few weeks, you will breed and observe insects called *fruit flies*. Much of what we know about how features are passed along has come from studies of fruit flies. Your problem is to compare the features of parent flies with those of their "children" and "grandchildren." Getting the "grandchildren" will take about four weeks because it takes fruit flies about two weeks to produce offspring.

GROWING FRUIT FLIES

To fully understand what you will do, you need to know how plants and animals reproduce. To find out if you do, answer the following checkup questions.

CHECKUP

1. What is a "sperm"?
2. What is an "egg"?
3. What happens when a male animal and female animal "mate"?
4. How do plants produce seeds?

Check your answers by quickly reading through **Excursion 1-1**.

ACTIVITY 1-1. Pick up a #1 vial. The vial should contain 5 or 6 fruit flies. Write your name, your class, and the date on the vial's label. Do not remove the cap yet.

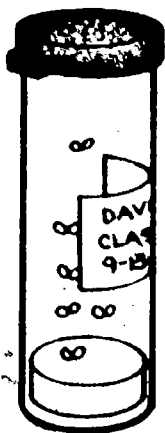

DAVID BROWN
CLASS 4
9-13-72 #1

Note Take good care of your flies. The flies in vial #1 are yours alone. You must keep them alive and healthy for the next four weeks.

Before you can study the features of your flies, you will have to know how to slow them down without hurting them. You also must learn how to tell male flies from female flies and how to prepare food for the flies. The next few activities will teach you these things. Work on these activities with a partner.

Time Caution Do not begin the next activity unless you have at least 30 minutes of class time left.

It's pretty hard to see the features of fruit flies in your vial because they move so fast. It's fairly easy, however, to slow down the flies without killing them. You just put them to sleep with ether. *Be sure to follow these directions carefully. Too much ether will kill your flies.*

USING A "FLY SLOWER"

Caution Ether is not dangerous when used properly, but:

1. Be sure there are NO flames in your room. Ether fumes can be explosive.
2. Air should move through your room easily.
3. Keep the ether bottle capped when you aren't using it.
4. Don't breathe the ether fumes yourself.

To learn to slow fruit flies, you will need your vial #1 and these materials:

- 1 plastic bottle containing ether
- 1 etherizer (made from a funnel, string, and a 50-ml plastic beaker)
- 1 white card
- 1 hand lens
- 1 small brush
- 1 petri-dish lid

If no finished etherizer is available, you will have to build your own. Activity 1-2 shows how to do this, and Activities 1-3 through 1-7 tell you how to use it.

ACTIVITY 1-2. Build the etherizer as shown. Be sure to bend the end of the funnel outward.

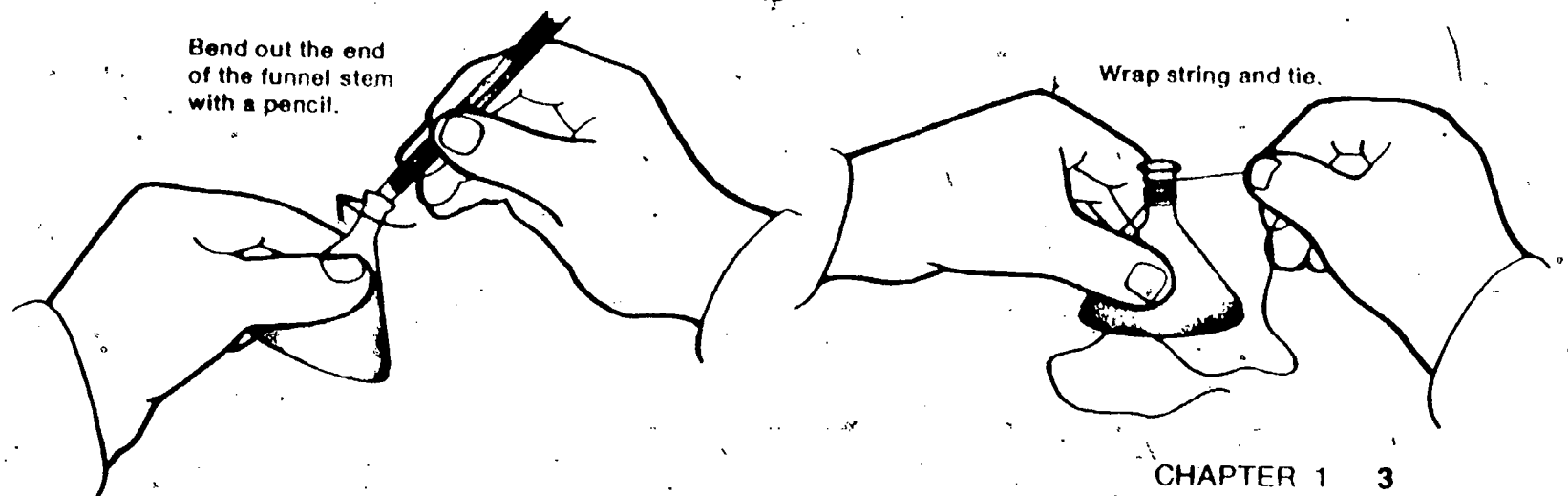

CHAPTER 1 3

ACTIVITY 1-3. Add 3 or 4 drops of ether to the string. Immediately place the funnel in the 50-ml beaker. Turn the funnel and beaker over on the table.

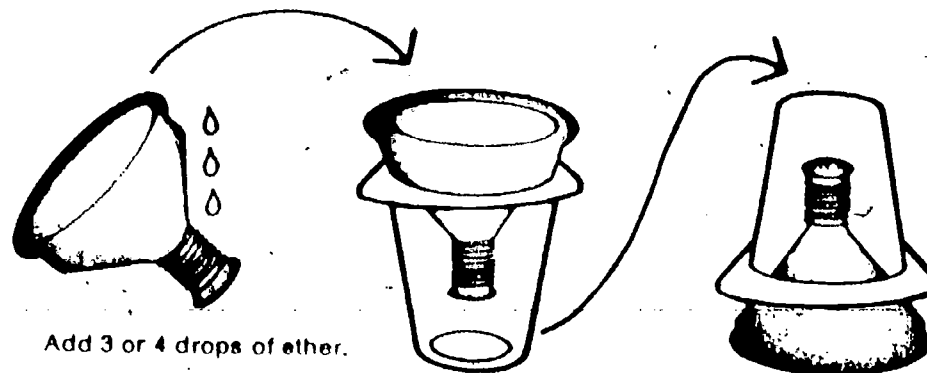

ACTIVITY 1-4. Gently tap your vial #1 on a book to knock all the files to the bottom.

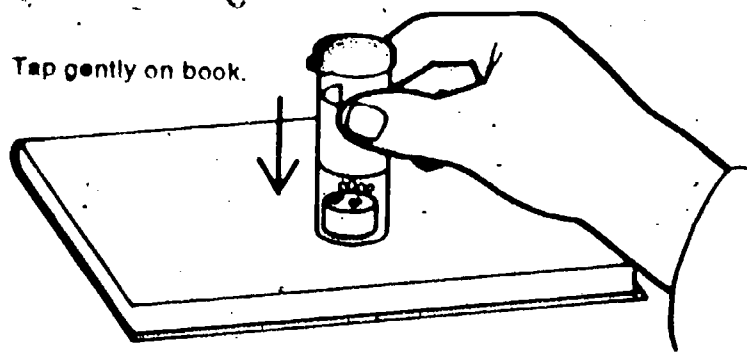

ACTIVITY 1-5. Tap the vial whenever necessary to keep the files near the bottom. Quickly remove the cap from the vial and set the etherizer over the opening as shown.

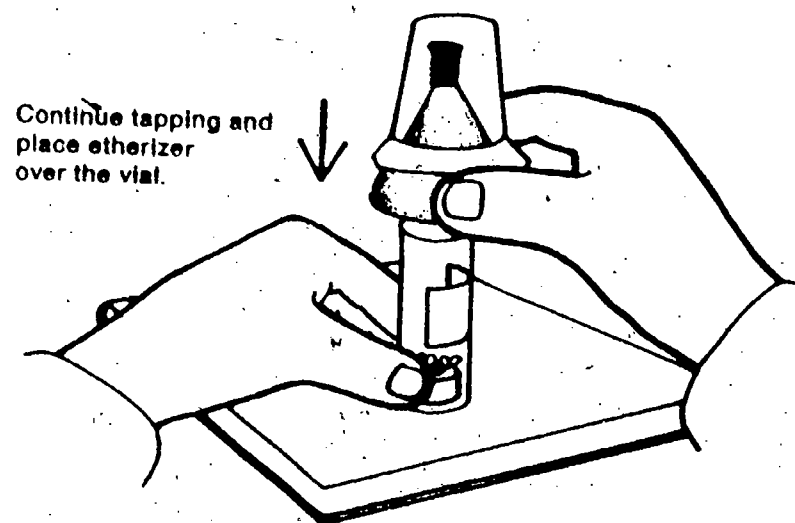

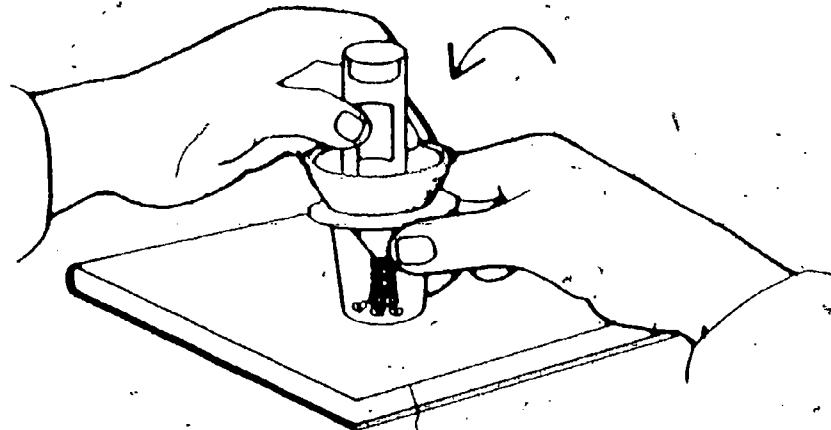

ACTIVITY 1-6. Quickly tip the two containers as shown. Tap the vial gently until all the flies drop into the beaker.

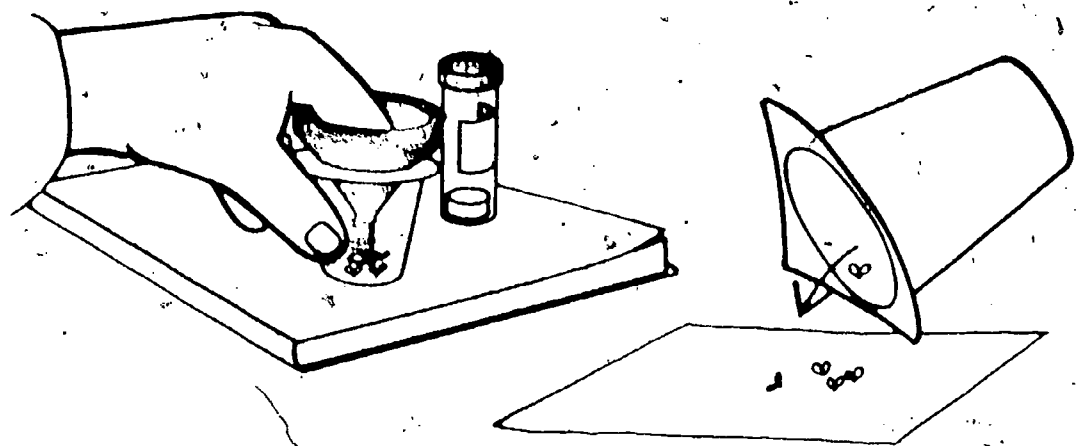

ACTIVITY 1-7. Replace the cap on the vial and set it aside. Put your finger over the opening in the funnel to trap the ether fumes. As soon as the flies stop moving, remove the funnel and pour the flies onto a white card. **Warning:** Do not over-etherize your flies or they will die.

You can tell if you've overetherized a fly by its outstretched wings. If you kill any flies, get rid of them. Your teacher will tell you where to put dead flies.

Do your flies twitch? Flies often twitch during sleep. So don't worry if one moves. But if a fly should start to walk, place a drop of ether on the card near the fly. Then cover the drop and the fly with the lid of a petri dish for a moment until the fly goes back to sleep.

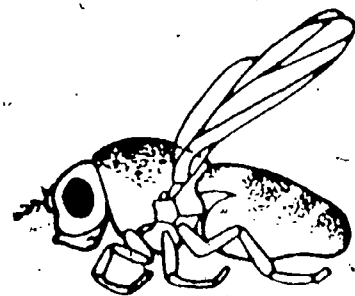

Dead fly



Etherized fly

Figure 1-1

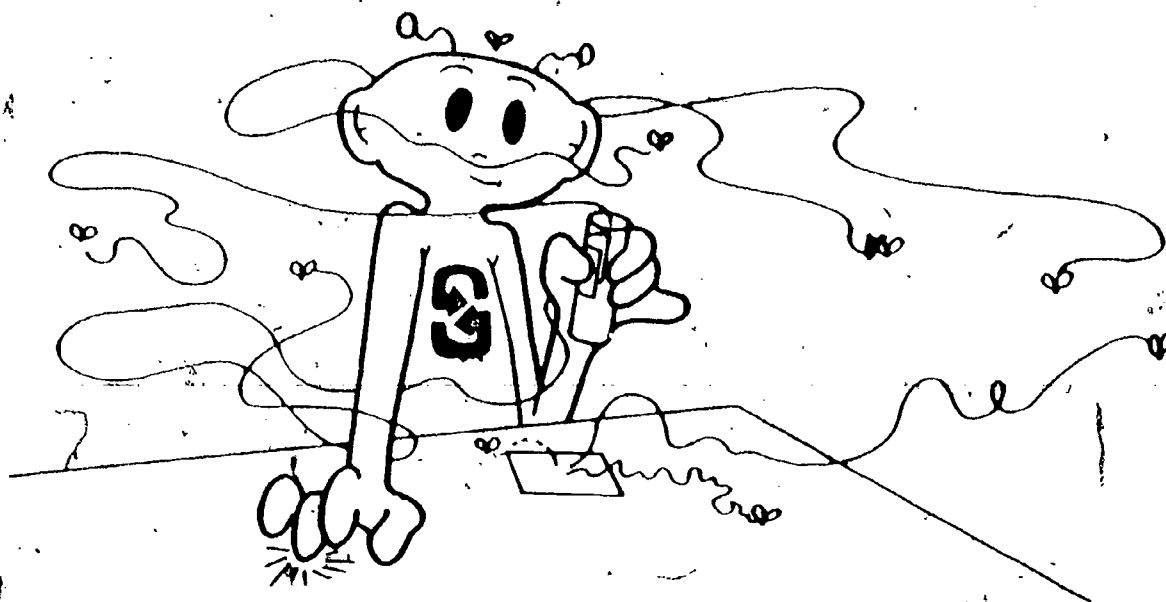

CHECKING YOUR FLIES

Study your flies with a hand lens. If you need to move them, do so gently with the aid of the small brush.

- 1-1. Describe your fruit flies. List at least five features.
 - a. Shape of wing
 - b. Eye color
 - c. Color of body
 - d. Pattern on body
 - e. Other features

- 1-2. Are all your flies alike in each feature, or do the features vary from fly to fly?

Look closely at the tail ends of the flies. You will find that they are not all alike. Separate the flies into two groups on the basis of the shape of their tail ends. If you separate them correctly, one group will contain only male flies, and the other group will contain only females. Male flies have a tail end that is blunt and definitely black. Female tails are lighter and more pointed.

- 1-3. Study the two groups closely. Then list any other differences you find between males and females in Table 1-1 of your Record Book. (Return all flies to vial #1 when you are through studying them.)

Male	Female
Definite black tail end	Lighter tail end
Blunt tail end	Pointed tail end

Table 1-1

To do many of the activities in this unit, you must be able to tell the sex of flies. Before going on, be certain that you can tell the difference between male and female flies. Figure 1-2 will help you do this. You may also want to check with your teacher on this.

Figure 1-2

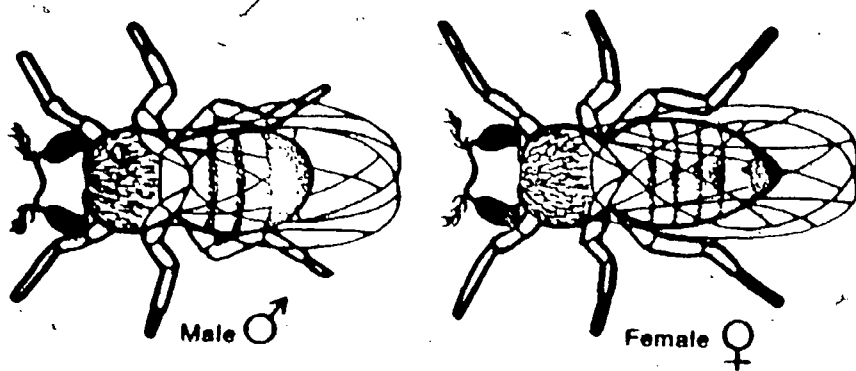

Ventral view of

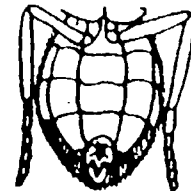

male abdomen

Ventral view of

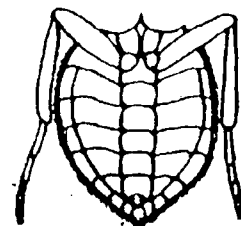

female abdomen

Now you are almost ready to mate (cross) some of your flies. Before you do, though, you should know that not everyone in your class has flies with the same features. Some people have flies with red eyes, while others have brown-eyed flies. Also, some flies have straight wings and some have curly wings. Compare your description of your flies (question 1-1) with your classmate's descriptions. Find a partner whose flies differ from yours in eye color and wing shape.

1-4. Describe exactly how the features of the two sets of flies differ by completing Table 1-2 in your Record Book.

Features	Your Vial # 1	Partner's Vial # 1
Shape of wings		
Eye color		

Table 1-2

You will read the term *pure strain* a lot in this unit. Here's what it means. When two flies from a pure strain for red eye color are mated, all their offspring will have red eyes. If two of these offspring are mated, then their offspring also will have red eyes. Similarly, the parents and grandparents of the pure-strain flies had to have red eyes (See Figure 1-3.) In a nonpure strain of flies, other eye colors might show up in the offspring.

Figure 1-3

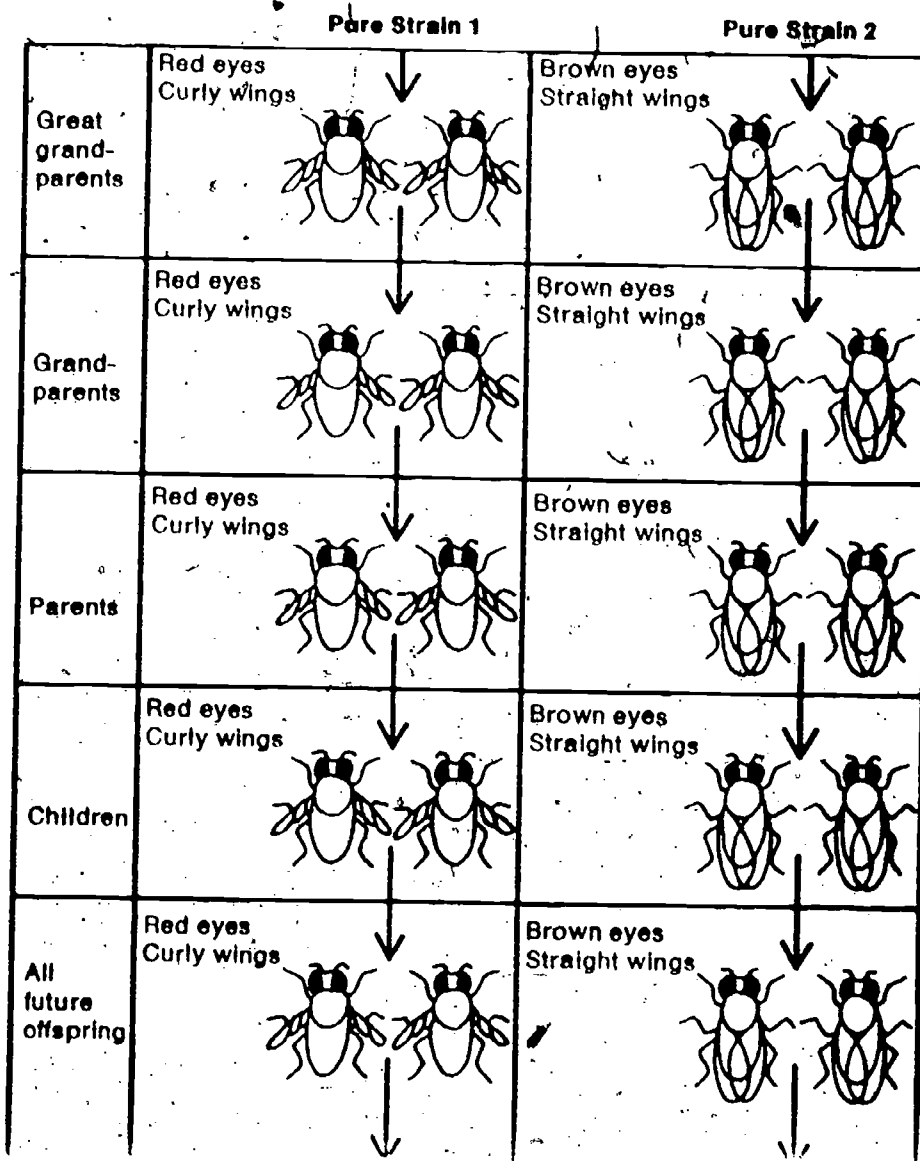

- 1-5. Give an operational definition of *pure strain*.

If you have forgotten what an operational definition is and how to write one, turn to **Excursion 1-2**.

EXCURSION

- 1-6. Suppose you mated a red-eyed, curly-winged fruit fly with a brown-eyed, long-winged fruit fly. If both flies are from a pure strain, what color eyes and what shape wings do you predict that the offspring will have?

Shortly you will test your prediction. To make the test, you will mate some of your male flies with a classmate's female flies (or vice versa). Then you will compare the features of the offspring with those of the parent flies. Figure 1-4 shows the plan.

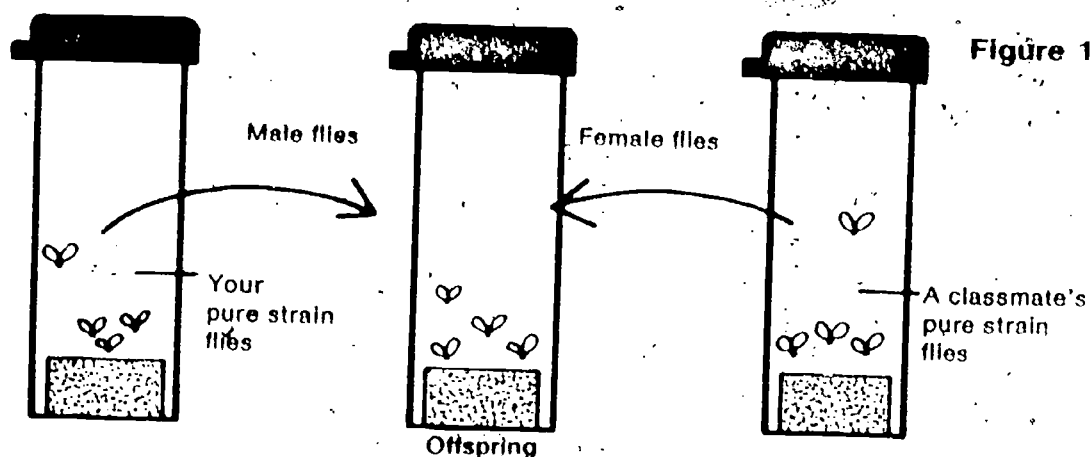

Figure 1-4

When you put your flies with your classmate's flies of the opposite sex, you hope they will mate and produce offspring. But suppose the female flies had already mated before you put the flies together. Then the parents of the offspring produced would be from the same pure strain, not from two different pure strains (yours and your classmate's).

MATING YOUR FRUIT FLIES

- 1-7. Suppose this happened. What do you predict the offspring would look like?

Fortunately, female fruit flies cannot mate for at least ten hours after they hatch. So if you select, for your experiment, female flies that have been adults for less than ten hours, you can be sure that they have not mated. Such flies are called "virgin females."

First you need to clear your vial and your partner's vial of all female flies that may already have mated. Activity 1-8 will show you how to do this. But before you do the frame, you need to check your timing.

The trick is to clear your vial and your partner's, five to ten hours before you plan to cross flies from the two vials. Ask your teacher for help on timing this correctly. Table 1-3 will help you and your teacher to plan properly. *Do not try to plan your clearing time without your teacher's help.*

Table 1-3

CLEARING CHART		
If you plan your mating to start at	You must clear the female from vial # 1	
	—no earlier than	—no later than
7 A.M.* Thurs.	9 P.M. Wed.	2 A.M. Thurs.
8 A.M.* Thurs.	10 P.M. Wed.	3 A.M. Thurs.
9 A.M.* Thurs.	11 P.M. Wed.	4 A.M. Thurs.
10 A.M.* Thurs.	12 P.M. Wed.	5 A.M. Thurs.
11 A.M.* Thurs.	1 A.M. Thurs.	6 A.M. Thurs.
12 A.M.* Thurs.	2 A.M. Thurs.	7 A.M. Thurs.
1 P.M. Thurs.	3 A.M. Thurs.	8 A.M. Thurs.
2 P.M. Thurs.	4 A.M. Thurs.	9 A.M. Thurs.
3 P.M. Thurs.	5 A.M. Thurs.	10 A.M. Thurs.
4 P.M. Thurs.	6 A.M. Thurs.	11 A.M. Thurs.

*If your class meets during one of the starred hours, you will probably have to do the clearing at home.

When the clearing time that you and your teacher have planned arrives, go ahead with clearing your vial and your partner's. Activity 1-8 will show you how clearing is done.

ACTIVITY 1-8. Five to ten hours before your planned mating, you should do the following:

1. Uncap an empty vial.
2. Tap vial #1 until the flies are on the bottom.
3. Uncap vial #1. Quickly turn the empty vial over the opening.
4. Tap the side of vial #1 until all the flies fly into the empty vial.
5. Quickly recap the new vial.
6. Recap and keep vial #1.
7. Give the new vial of flies to your teacher.

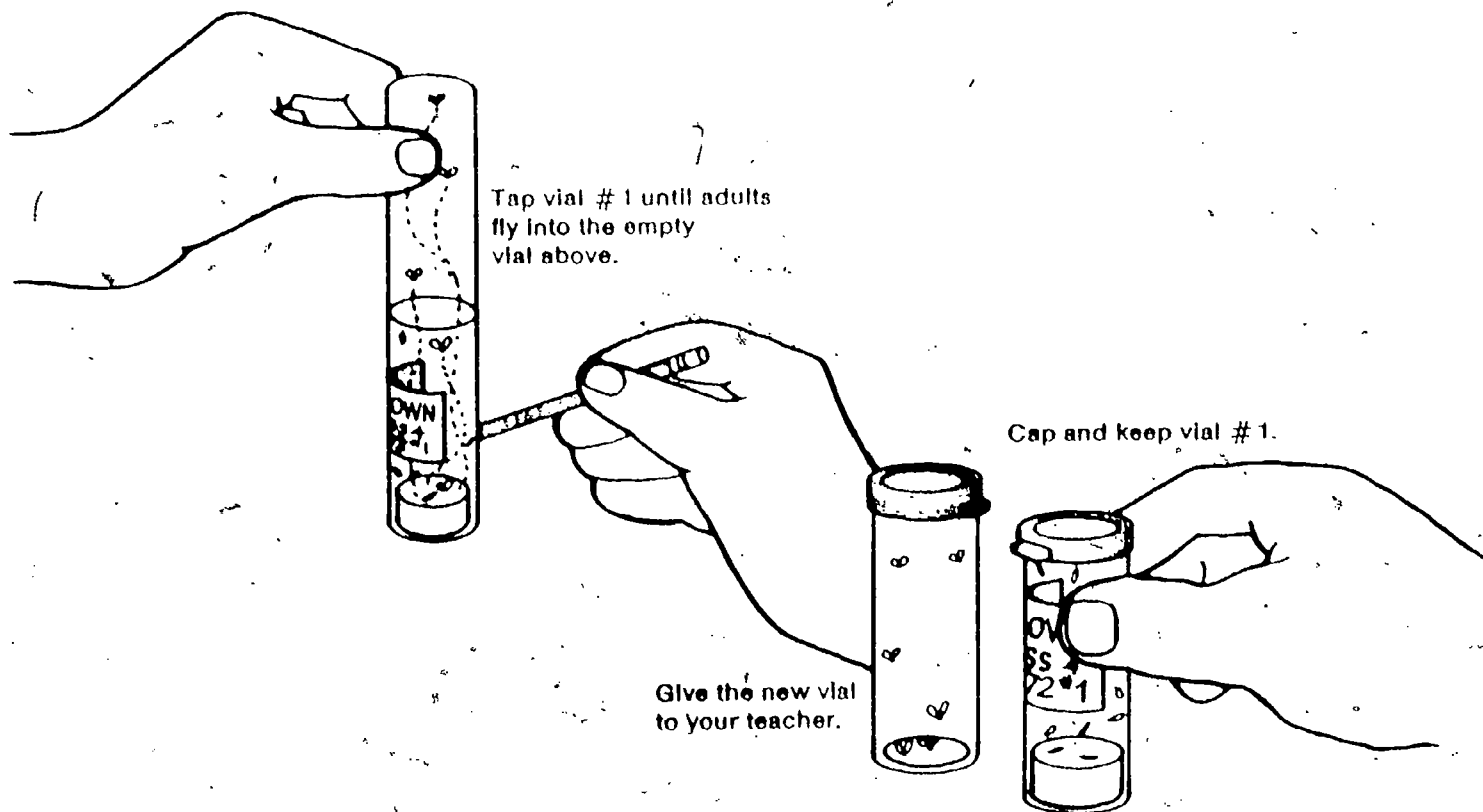

If your class meets early in the morning, you may have had to take the vials home to do the transferring there. If you do this, return the new vial to your teacher the next morning.

In the food material at the bottom of vial #1 are fruit flies at various stages of their life cycles. New adults should hatch within five to ten hours. These are the flies you will use for your mating experiment. If you have to wait for new adults, go ahead with Activity 1-9. Then read ahead in the next section, "What Happens Next?" to learn about the details of how fruit flies develop.

Before you begin your mating experiment, you need to prepare vial #2 containing fly food. To do this you will need these items:

- 1 clean empty vial with cap
- 1 straight pin
- 1 50-ml plastic beaker
- 1 packet of fly food

DAVID BROWN
CLASS 4 #2
9-16-72

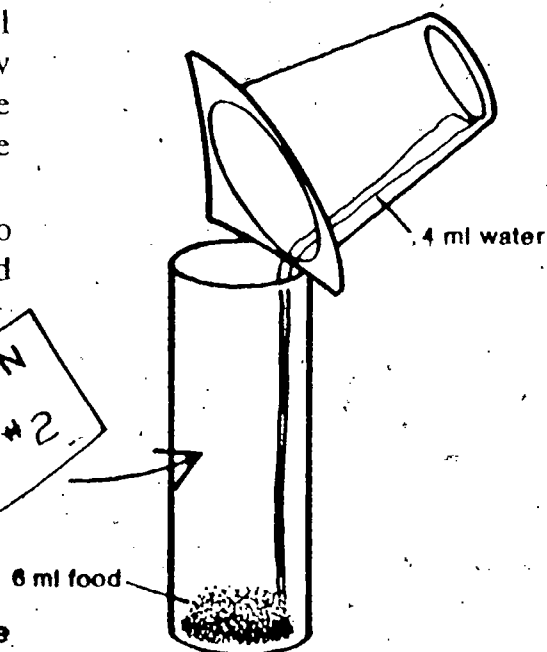

ACTIVITY 1-9. Add 6 ml of food and 4 ml of water to the plastic vial. Add to this vial (vial #2) a label with your name, your class, and the date.

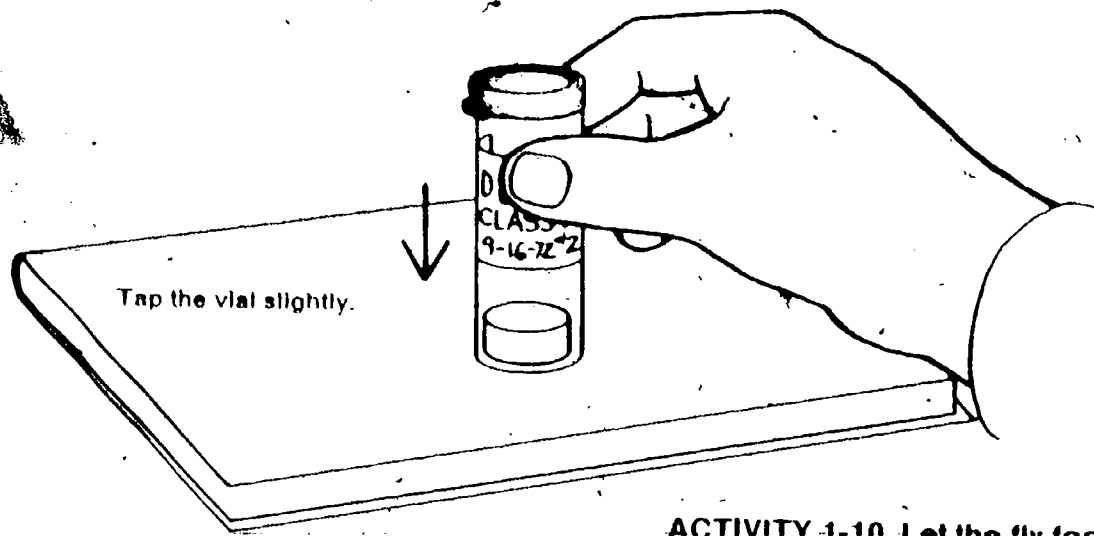

ACTIVITY 1-10. Let the fly food stand a few minutes to absorb the water. Then tap the vial gently to settle the food.

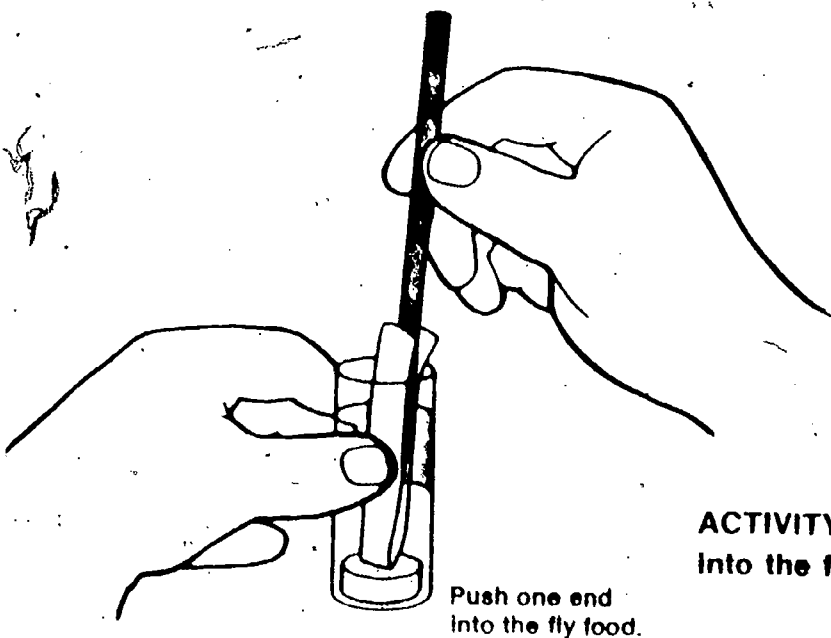

ACTIVITY 1-11. Cut a thin strip of paper and push one end into the fly food.

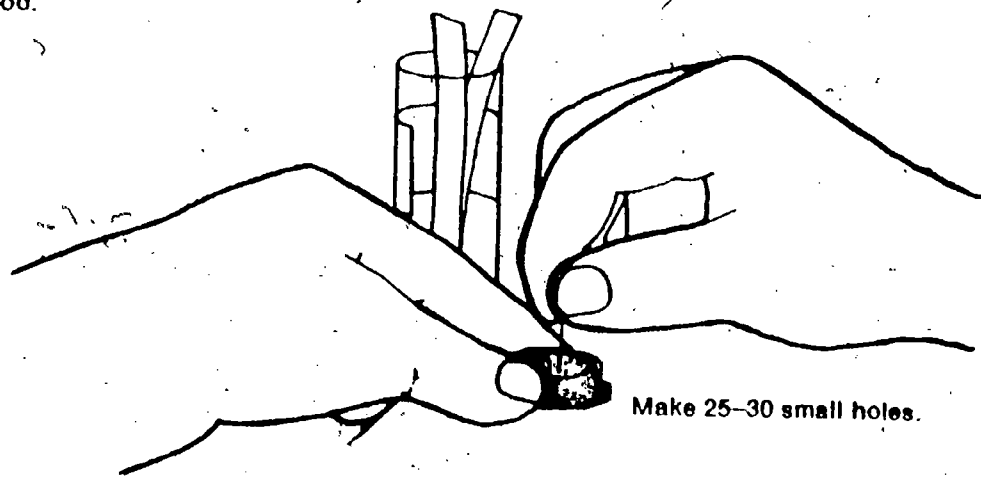

ACTIVITY 1-12. With the straight pin, punch 25-30 small air holes in the vial cap. Warning: Do not make the holes big enough to let the flies out.

You are now ready to mate some of your female flies with a classmate's males (or some of your males with a classmate's females). Remember that your partner must have flies with different eye color and wing shape than yours. You will each need these things:

- 1 vial #1 (from which all adult flies were removed 5 to 10 hours before)
- 1 vial #2 containing food
- 1 etherizer
- 1 white card
- 1 petri-dish lid
- 1 brush

Before going on, you and your partner should review the directions for etherizing fruit flies in Activities 1-2 through 1-7. When adult flies appear in the two vials #1, go ahead with the following activity frames.

Note Activities 1-13 through 1-16 should be done **BEFORE** your newly hatched flies are ten hours old. Furthermore, they should be started in midweek unless the plan you worked out with your teacher calls for you to work on the weekend!

ACTIVITY 1-13. Etherize the adult flies in your vial #1 and place them on a white card.

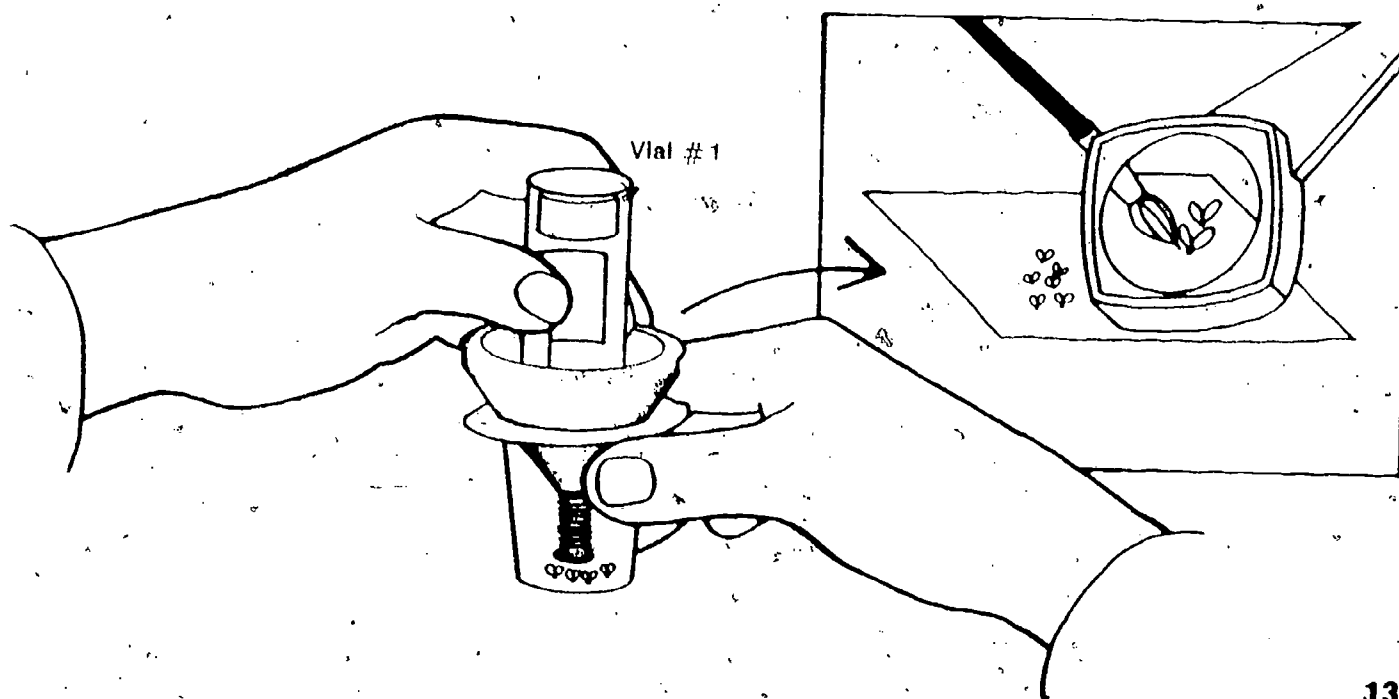

ACTIVITY 1-14. Place in the cap of vial #2 five of your curly-winged virgin female flies and five of your partner's straight-winged male flies. (Do not try to mate curly-winged males with your straight-winged females.)

5 curly-winged female flies
(They will have red eyes.)

5 straight-winged male flies
(They will have brown eyes.)

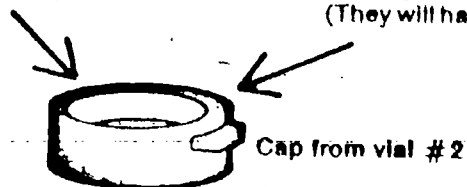

ACTIVITY 1-15. Press vial #2 into its cap. Be careful not to harm any flies in the process. Leave the vial upside down until the flies wake up.

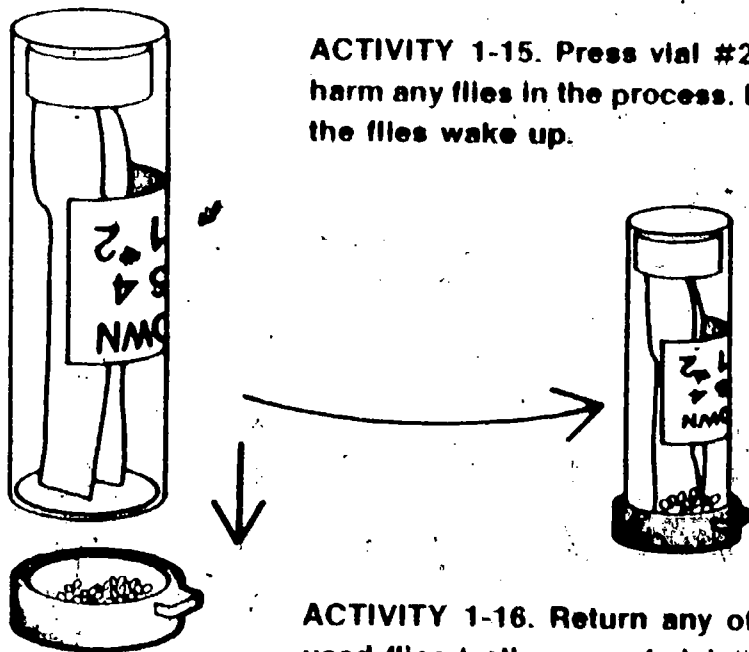

ACTIVITY 1-16. Return any of your (not your partner's) unused flies to the cap of vial #1. Press vial #1 into this cap. Leave upside down until the flies wake up. Return vial #1 to your teacher.

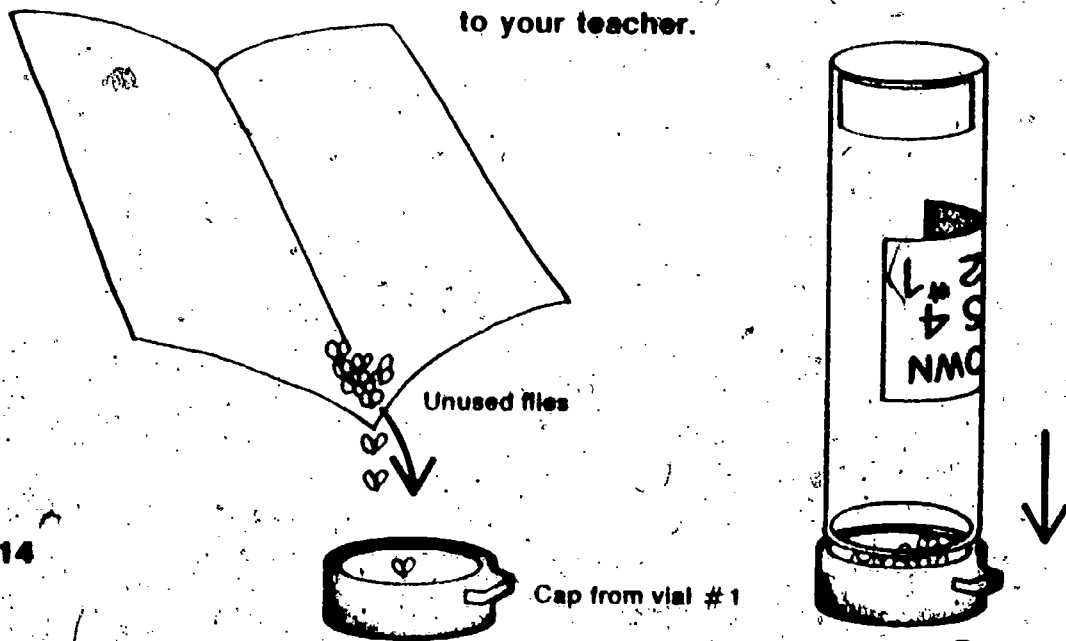

Make a smaller label like the one shown in Fig. 1-5. Replace the label on vial #2 with this new one. Write the same information in Fig. 1-5 of your Record Book. Under Feature, you should write either the eye color (brown or red) or the wing shape (curly or straight) of your flies.

Figure 1-5

Mating: _____ X _____
 Sex Feature Sex Feature

Your Name: _____

Date: _____ Class Section: _____ Vial #2

Depending upon the temperature of your classroom, it will be ten to fourteen days until the parent flies in vial #2 produce adult offspring. During that period they will go through what is called a *life cycle*. The stages in that life cycle are outlined below.

WHAT HAPPENS NEXT?

Soon after mating, the female fly will lay tiny white eggs on the food in vial #2. If you look closely with a hand lens, you will be able to see the eggs. They look like those in A of Figure 1-6.

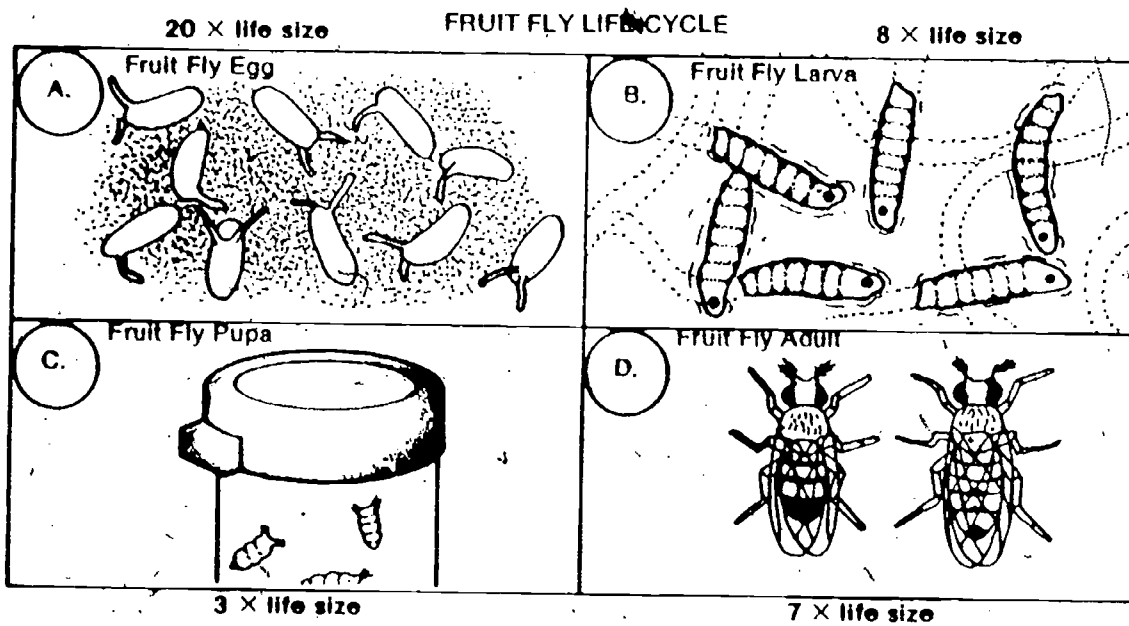

Figure 1-6

About six days after mating, small wormlike creatures called *larvae* will come out of the eggs. You will see them crawling through the food. They will look like the drawing

in B of Figure 1-6. When you see larvae, you should remove all the adult flies from vial #2. Activity 1-8 will show you how to do this.

When the larvae are about two or three days old, they will begin to move up the side of vial #2 and form a shell around themselves. When the brown shell is complete, the fruit flies are called *pupae*. Pupae look like C in Figure 1-6. They will be easy for you to find because of their brown color.

Some time between the tenth and fourteenth day after mating, the pupae will split open and out will come the adult offspring that you want to study.

Here's a schedule (Table 1-4) for the next couple of weeks. It tells you what you will see in your vial #2 and what you should be doing for the experiment. Keep in mind that not all fruit flies develop at the same rate. The Time column in the chart will probably not be exact for your flies. You should be at the Day 2 point right now.

Table 1-4

Time	Event
Day 1	Vial #1 cleared of adults Vial #2 prepared
Day 2	Males and virgin females put in vial #2
Day 8	Larvae appear ALL PARENT FLIES REMOVED
Day 10	Pupae appear
Day 14	Adult offspring appear in vial #2

**KEEP TRACK OF
YOUR FRUIT FLIES**

Your teacher will tell you where to keep your flies while you wait for them to develop. While you wait, you will be doing other activities. *But you are to check your vial every day and keep track of how the life cycle is coming along.* A chart like Table 1-5 is in your Record Book. You are to record the date on which you observe or do the things listed on the chart.

FIRST-GENERATION PLANNING CHART	
Event	Date Done or Observed
Vial #1 cleared of adults	
Vial #2 prepared	
Males & virgin females put in vial #2	
Eggs observed	
Larvae observed	
Parent flies cleared from vial #2	
Pupae observed	
Adults observed	

Table 1-5

While you wait for your fruit flies to develop, you should go on with Chapters 2 and 3. But before you do, quickly read through the rest of this chapter.

This will give you an idea of the things that you must do for the fruit-fly experiment. If you have any questions about the chart or the rest of this chapter, discuss them with your teacher now!



Right now . . .

Check the first-generation planning chart (Table 1-5) in your Record Book and put a date next to anything you have already done or seen.

When your larvae appear in vial #2 you should:

1. Record the day in the first-generation planning chart.
2. Follow the directions in Activity 1-17 for clearing the vial of adult flies.

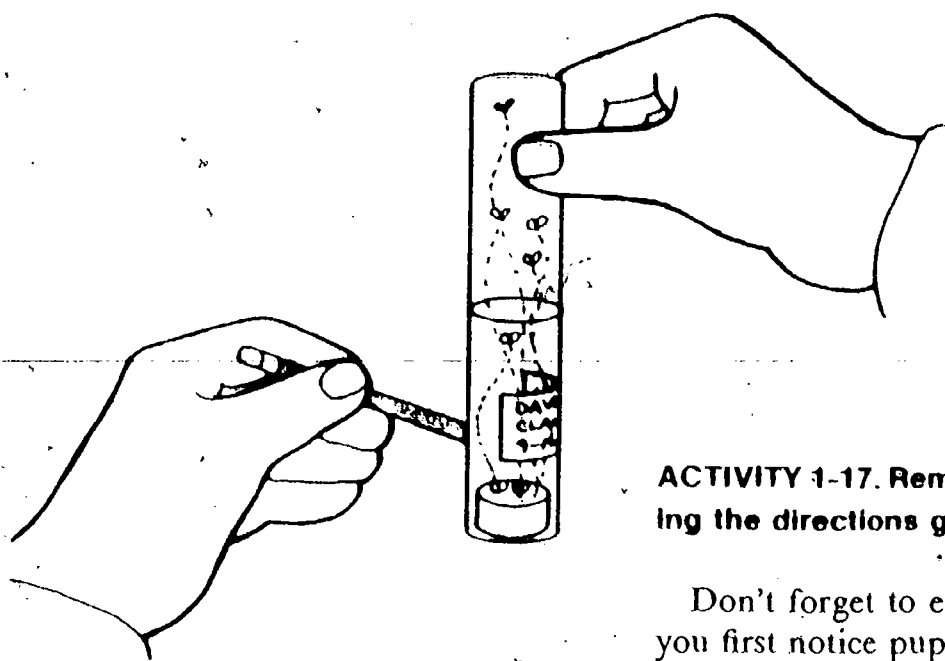

ACTIVITY 1-17. Remove the parent flies from vial #2 by following the directions given in Activity 1-8.

Don't forget to enter in your planning chart the day that you first notice pupae in your vial. Pupae are brown objects that usually stick to the side of the vial.

When new adults appear in vial #2 you should:

1. Record the day in your first-generation planning chart.
2. Do the activities from here through page 20 at once.

ACTIVITY 1-18. When you have 20 or more offspring, etherize and observe them. Record in Table 1-6 either the flies' eye color or their wing shape. (See Figure 1-5.) Record also the number of flies that show the variation.

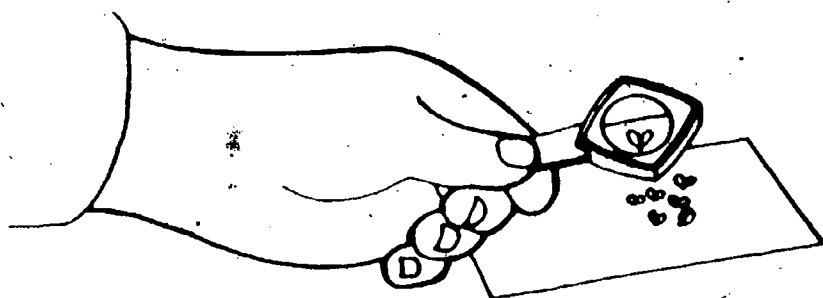

Table 1-6

Eye Color or Wing Shape	Number of Flies

- 1-8. Summarize the results of your experiment in Table 1-7 of your Record Book.

Table 1-7

	Feature Variation (State eye-color or wing-shape variation.)
Parents	
First-generation offspring	

- 1-9. How well do your results agree with your prediction in question 1-6?
- 1-10. How does what you saw with fruit flies compare with what you saw with beans and peas (Chapters 2 and 3)?

Compare the length of the life cycle described in your first-generation planning chart (Table 1-5) with the times found by some of your classmates. Did everyone in the class have the same life-cycle time? If not, what do you think may have influenced the length of the life cycle? You might want to try **Excursion 1-3**. You will discover one possible answer there.

- 1-11. Next you will mate some of your male offspring with some of your female offspring. Predict what you think their offspring will look like. If you predict that you will get more than one kind of fly, what number of each kind do you expect?

In your Record Book, describe the way you plan to do the cross between male and female flies from vial #2. The procedure should be very much the same as the one you followed in your first cross, so you can get some clues by reading back over what you did (pages 9-11). If you have trouble, ask your teacher or a classmate for help.

When you have described your plan, discuss it with your teacher. When he approves, go ahead with the experiment. Once again, keep track of the days when things happen and when you do things. Do this in the second-generation planning chart in your Record Book (Table 1-8).

← EXCURSION

ANOTHER GENERATION OF FLIES

SECOND-GENERATION PLANNING CHART	
Event	Date Done or Observed
Vial #2 cleared of adults	
Vial #3 prepared	
Males & virgin females put in vial #3	
Eggs observed	
Larvae observed	
Parent flies cleared from vial #3	
Pupae observed	
Adults observed	

Table 1-8

Continue with later chapters while you wait for your second-generation flies to emerge. Observe your vials of flies daily. When the second-generation flies appear, return to this chapter and complete the next section.

Note Do not go on to the next section until you have at least 60 second-generation offspring. This will take about two weeks. In the meantime, go on with the next several chapters.

GRANDCHILDREN BY THE THOUSANDS

Before you go on, let's be sure you know where you've been. Figure 1-7 diagrams your entire fruit-fly experiment.

First you found a neighbor whose flies were different from yours in terms of wing shape or eye color. Then you crossed some of his flies with your flies. These were the parent flies for your experiment.

Then you looked at the offspring. You should have found that they all had either straight wings or red eyes. Finally you crossed a male and a female from among the offspring.

Now you will find out what the eyes or wings of the second generation look like. You will decide whether the two-bit model you study in Chapter 4 can explain the fruit-fly data you've collected.

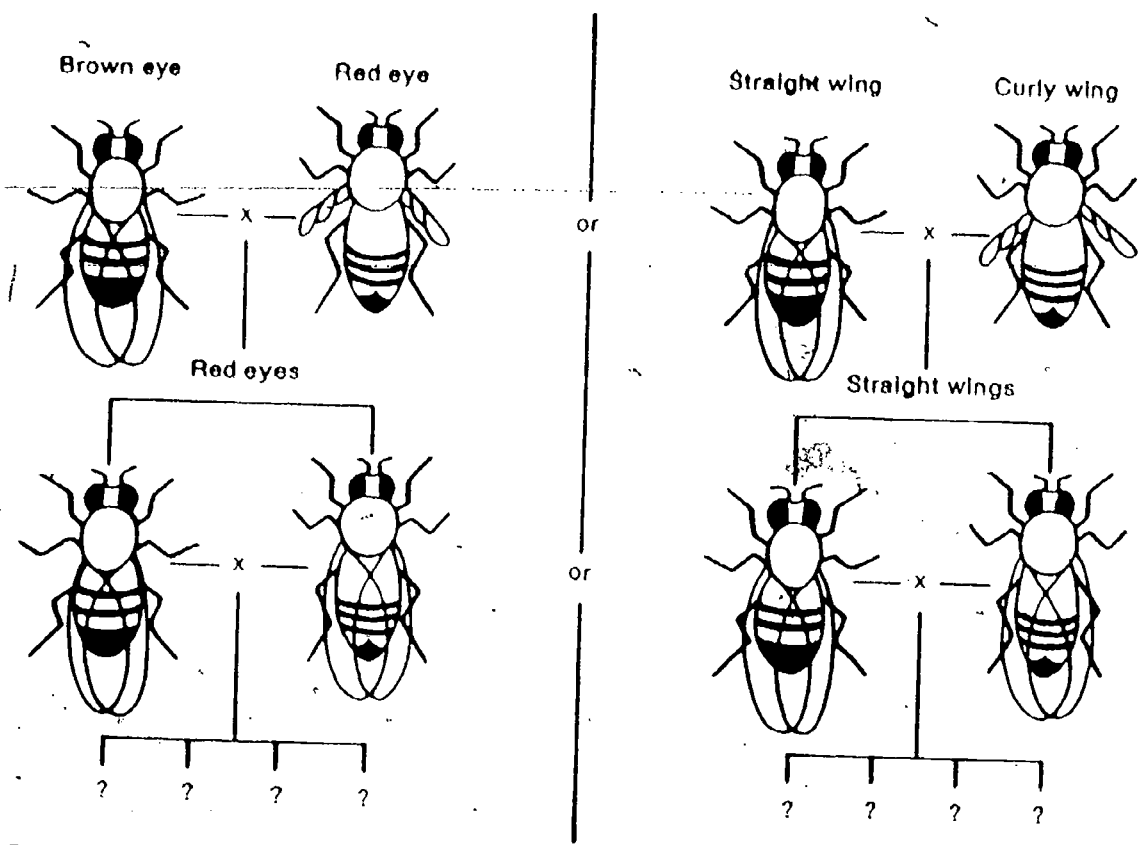

Figure 1-7

ACTIVITY 1-19. Etherize your second-generation flies and check their features. Record your observations in Table 1-9 of your Record Book. Return the flies to the vial when through with them.

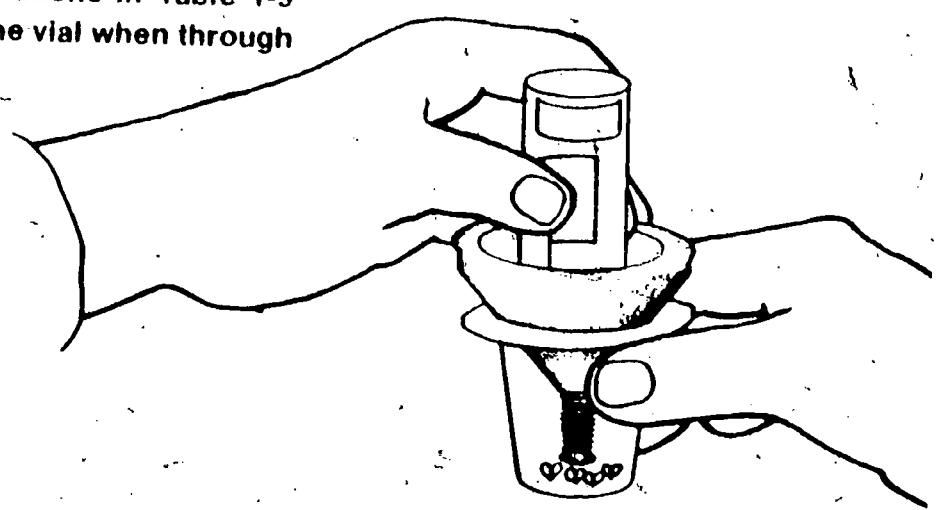

Table 1-9

	Feature Variation (State what eye colors and wing shapes you find.)
Parents	
Second-generation offspring	

EXCURSION ▶

Perhaps you would like to know what the chances are of getting one bit of information or another. If so, try **Excursion 1-4**.

1-12. How well do your results agree with the prediction you made in question 1-11?

1-13. Explain what you observed in the second generation in terms of the two-bit model.

From time to time in this unit, you will be asked to do **Problem Breaks**. These are problems for you to solve, without much help from your book or your teacher. The problems will usually help you understand what you are studying in the chapter. But that's not their major purpose. They are designed to give you practice in problem solving and in setting up your own experiments. You should try every **Problem Break**—even the tough ones. And in most cases, you should have your teacher approve your plan before trying it. The first **Problem Break** in this unit is coming up next.

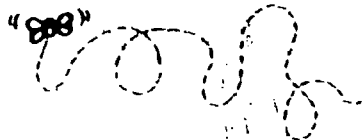
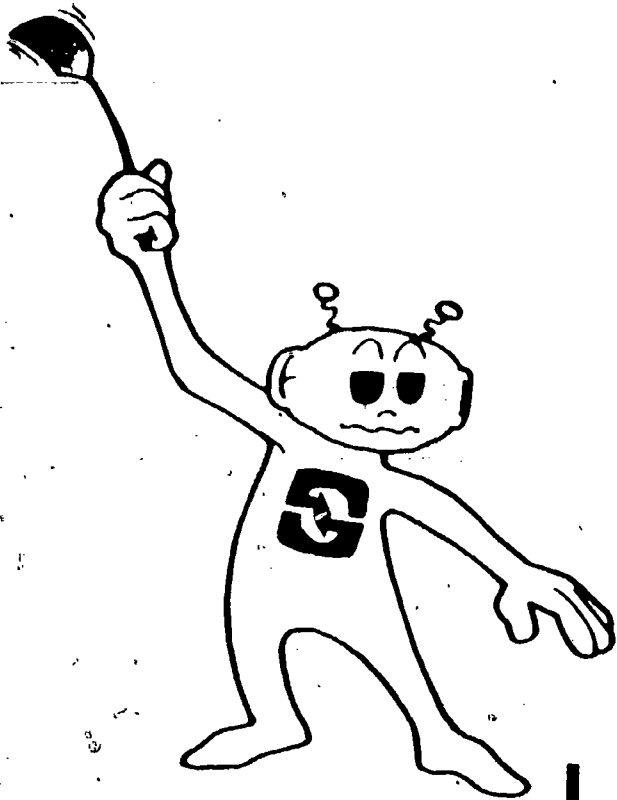

PROBLEM BREAK 1-1

Examine your second-generation flies very carefully. Try to find some feature (other than the one you studied) that differs from fly to fly. When you find such a feature, determine the ratio of one type of fly to the other. Then try to figure out what the parents and grandparents of these flies might have looked like in terms of the feature selected. Here is some information that you may find helpful.

1. The description you made of your original flies (See page 6.)
2. The results your partner got from the cross of his flies with yours (See page 18.)
3. Your partner's description of his original flies

Describe your results in your **Record Book**.

So far the two-bit model has explained how many (but not all) of the features are passed from parents to their offspring. Scientists who study these problems have found this too. They have been able to expand this model to explain every situation they have come across so far. The two-bit model was proposed about a hundred years ago and is still the basis of the science called *genetics*. It is considered to be one of the most powerful models in all of science.

Now your work with fruit flies is complete. You should now return to the place in your book where you last left off. Before you do though, be sure that all your fruit-fly supplies are cleaned and put back where they belong. Give any living flies to your teacher for disposal.

Before going on, do Self-Evaluation 1 in your Record Book.



That's Using the Old Bean

Chapter 2

At this point you're trying to do two things at once—keep track of your developing fruit flies and take a look at inheritance in another kind of living thing, the bean plant. Once again you will be trying to find some pattern in the way features are passed from parents to offspring.

Unfortunately, plants grow so slowly that it would take months for you to experiment with beans in the same way you are experimenting with fruit flies. To save time, you will be given some beans like the ones you would get if you actually grew plants.

To begin, you will need a box labeled "Bean Experiment." Check to be sure the box contains these items:

- 1 vial labeled "Parents"
- 1 vial labeled "First Generation"
- 1 bag labeled "Second Generation"
- 1 50-ml plastic beaker

ACTIVITY 2-1. Examine the two beans in the vial labeled "Parents."

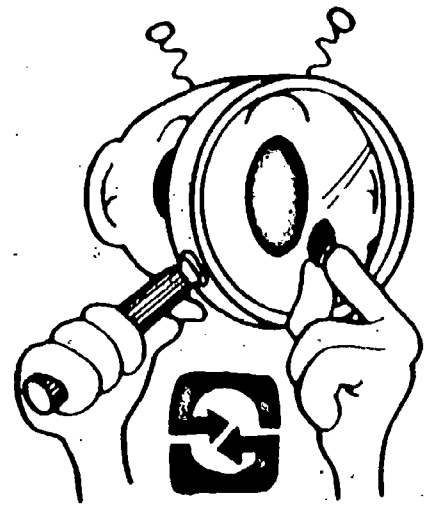
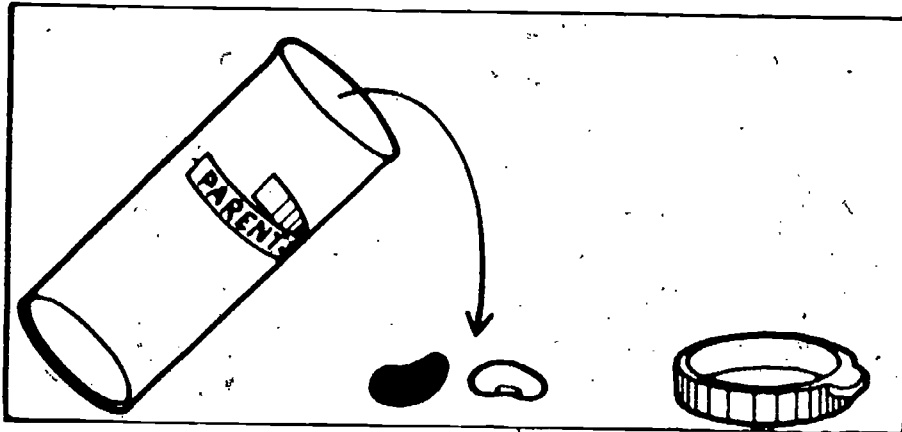

□ 2-1. In what ways are the beans different from each other?

EXCURSION

Take a look at your answer to question 2-1. If you listed sex as one of the differences between the beans, you are wrong. One of the beans is *not* the male parent, and the other is *not* the female parent. If you made this mistake, you would really gain by doing **Excursion 1-1** again.

In answering question 2-1, you could have listed a dozen or more features as different—size, weight, color, spottedness, and thickness of coat, to name just a few. Your problem is to try to find a pattern in the way features like these are passed from parents to offspring.

If you tried to keep up with all possible features at the same time, the problem would be pretty tough. But there is an easier way. Rather than trying to follow all features, you can concentrate on just one feature—color.

The two kinds of seed you've seen have come from two different plants that were pure strains for seed color. Let's review what this means. Plants grown from pure-strain beans for color always produce offspring with beans of the same color as the parent beans. Figure 2-1 shows this.

Figure 2-1

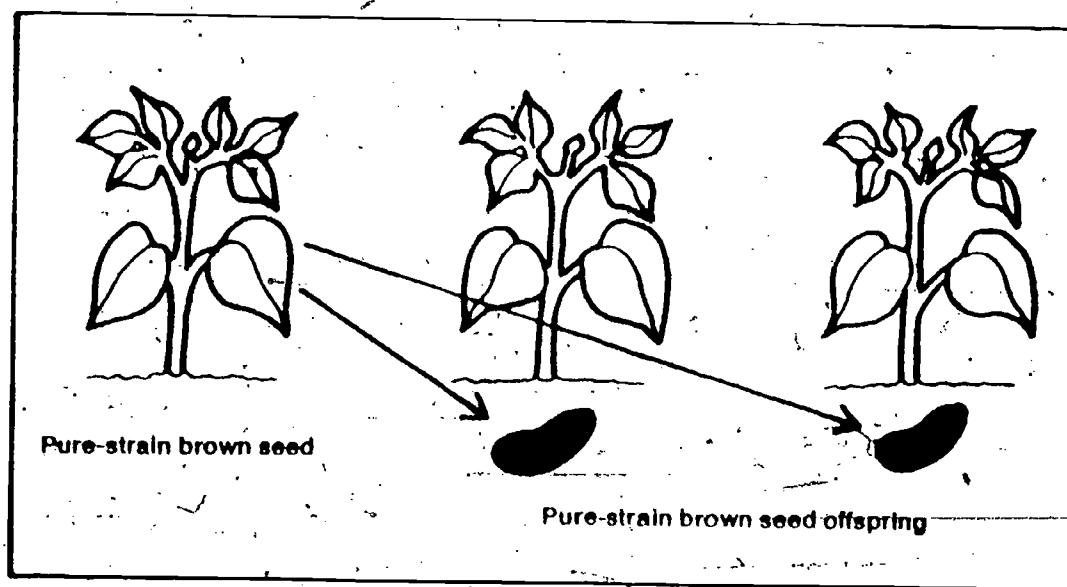

In your experiment, plants grown from pure-strain white beans were crossed with plants grown from pure-strain brown beans. Then the offspring beans were picked. A sample of the beans that were picked is in the vial labeled "First Generation."

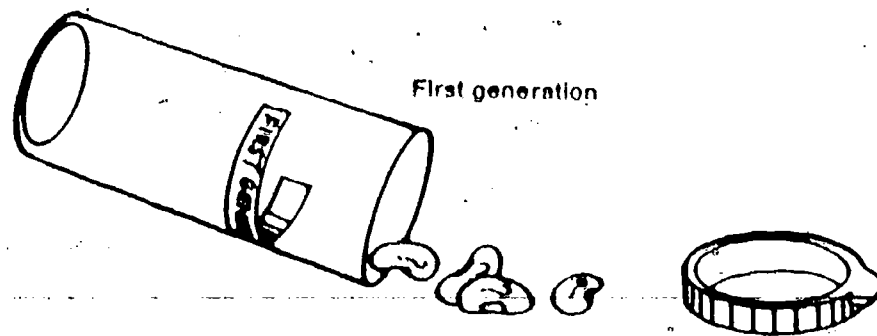

ACTIVITY 2-2. Examine the beans in the vial labeled "First Generation."

- 2-2. Which parent bean color was the same as the color of these first-generation beans?
- 2-3. Which parent bean color did not show up in the first-generation beans?

The next step in the experiment was to plant the first-generation beans. The plants that grew were then crossed, and a second generation of beans was picked. A few of the second-generation beans are in the bag labeled "Second Generation."

- 2-4. Before opening the bag, try to predict the color of the beans in it.

ACTIVITY 2-3. Open the bag and examine a few beans from the second generation.

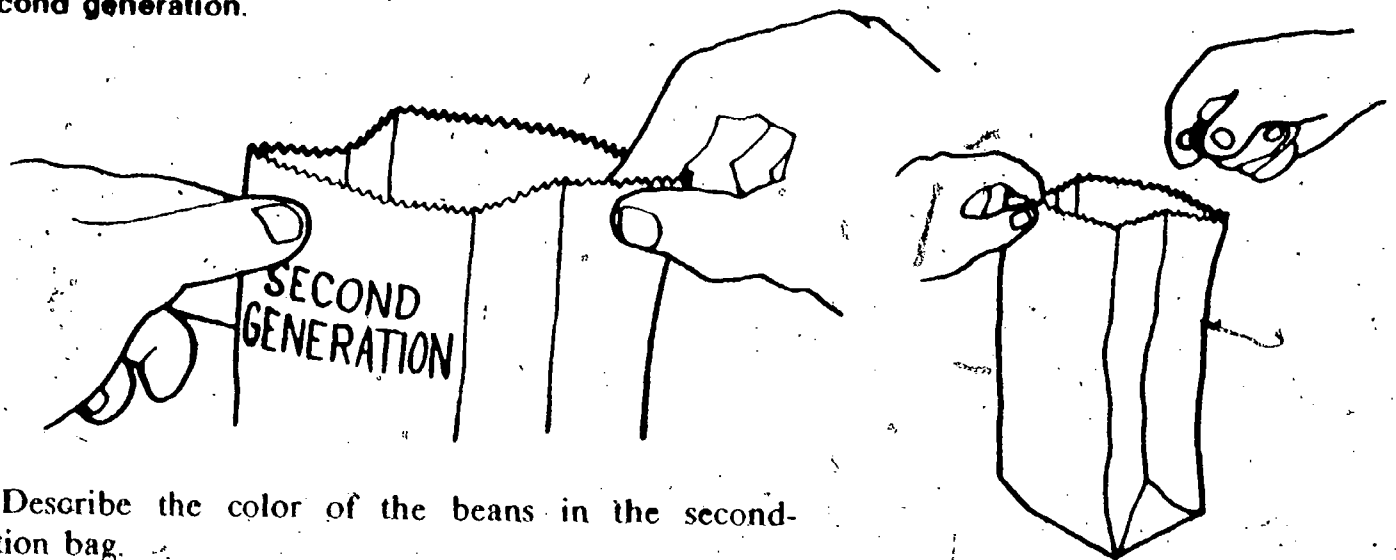

- 2-5. Describe the color of the beans in the second-generation bag.

Compare your observation with your prediction above.



2-6. In this second generation, are there more brown beans or more white beans?

Reminder *Did you check your fruit flies today?*

SAMPLING BEANS

You may have read how television networks find out how many people watch a certain program. They do not call everyone in the broadcast area. Instead, they call only a small number of people. They assume that this "sample" of people will tell them something about the program preferences of all the people in the area. Let's apply this idea to your study of inheritance in beans.

ACTIVITY 2-4. Stir the beans in the second-generation bag. Without looking, take out 2 full beakers of beans. Examine them and fill in the first two columns of Table 2-1 in your Record Book. Then pour the beans back into the bag.

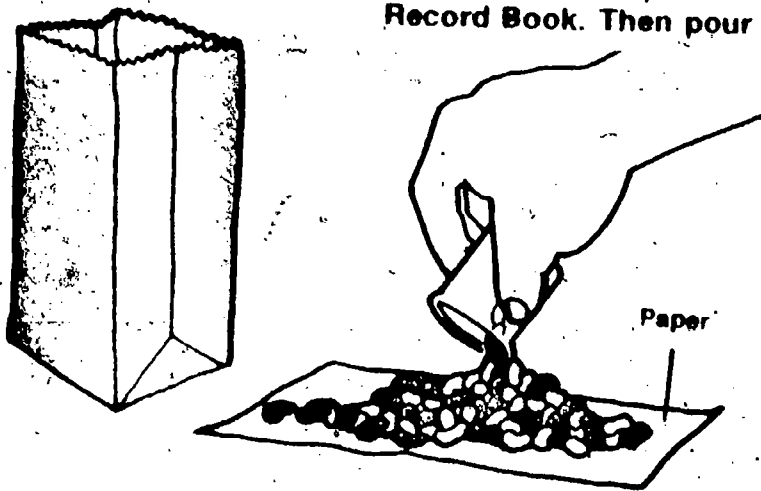

The two beakers of beans are a sample of the beans in your bag. The bag of beans, in turn, is a sample of the entire second generation. If your sample is a good one, it can tell you something about the features of all the second-generation beans.

Table 2-1

SAMPLE COUNT OF SECOND-GENERATION BEANS		
Brown Beans	White Beans	Ratio

One of the writers of this book took a sample of second-generation beans just as you did. But his sample was larger. It contained 721 brown beans and 238 white beans. To calculate a simple ratio, he divided both these numbers (721 and 238) by the smaller number (238), like this:

$$\begin{aligned} \text{Brown beans to white beans} &= 721 \text{ to } 238 \\ &= \frac{721}{238} \text{ to } \frac{238}{238} \\ \text{Rough ratio} &= 3.03 \text{ to } 1 \end{aligned}$$

The writer's sample contained about three brown beans for every one white bean.

Rounding off his answer gives a ratio of about 3 to 1.

If you don't understand how this calculation was made, see **Excursion 2-1**, "Ratio Simplified."

← **EXCURSION**



2-7. Using the data from Table 2-1, calculate a ratio for your sample of second-generation beans. If you have trouble, turn to **Excursion 2-1**.

Number of brown beans

to white beans = _____ to _____

Rough ratio = _____ to _____

Rounded-off ratio = _____ to _____

2-8. How does your ratio compare with our writer's?

Figure 2-2 diagrams the experiment you have just studied. Notice that the colors of the first- and second-generation beans are not labeled.

2-9. Study the diagram carefully and add the missing information on bean color and ratio.

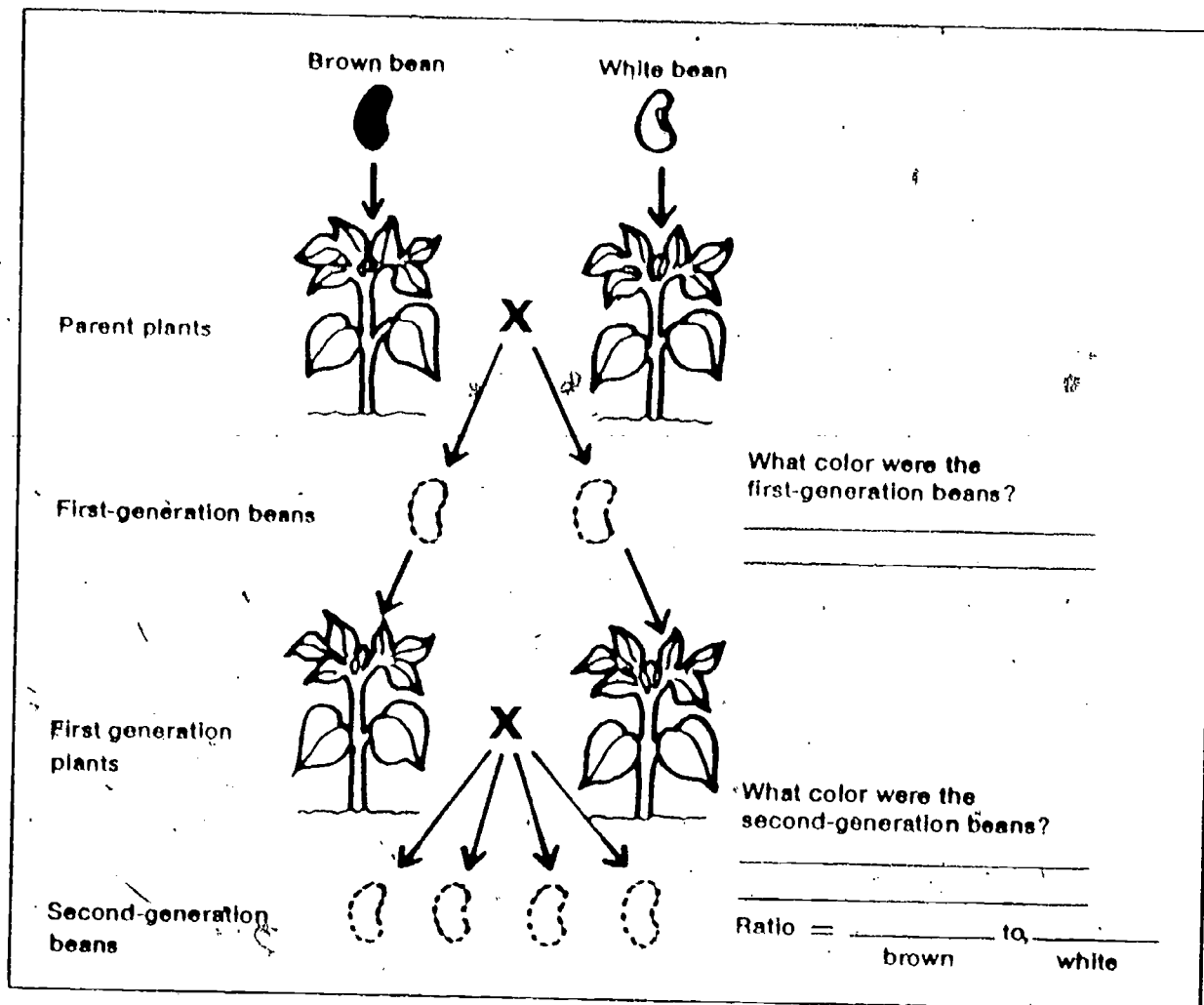

Figure 2-2

Note In this example, and throughout the unit, the symbol *X* is used to mean a mating or a crossing.

At this point, you might be asking several questions:

1. Why were all the first-generation beans brown even though one parent was a pure strain for white and the other parent was a pure strain for brown?
2. Why were some second-generation beans white even though both parents produced brown beans?
3. Is there anything special about the 3-to-1 ratio of brown beans to white beans in the second generation?
4. Do you get similar results when you cross other plants and animals?

These are some of the questions you'll be trying to answer in the next several chapters. Keep them in mind as you proceed.

PROBLEM BREAK 2-1

An ear of corn contains a lot of kernels. Each kernel is a separate seed that can grow into a new plant. The ears of corn shown in Figure 2-3 represent three generations. Two different pure-strain *parents* produce a first generation. A second-generation offspring was produced from a cross of first-generation plants.

Figure 2-3

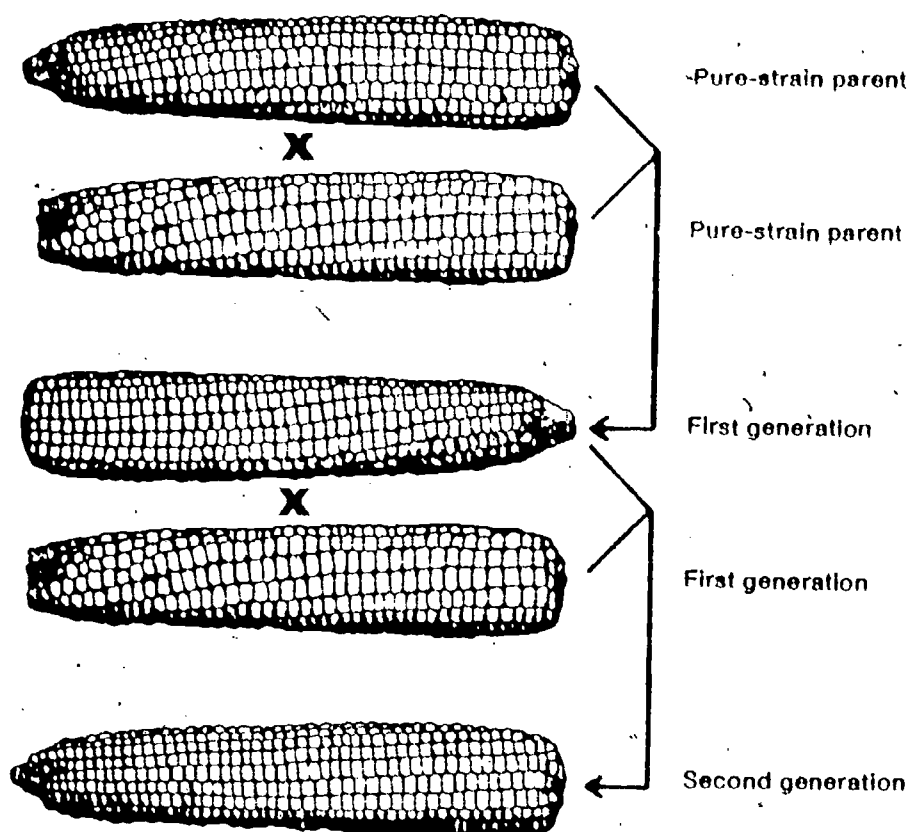

Study Figure 2-3 carefully. From your observations, diagram a pattern of inheritance for the corn seeds like the diagram for bean seeds given in Figure 2-2. How does the ratio of colors in the second generation of corn seeds compare with the one you found for bean seeds?

Record your findings in your Record Book.

Reminder Don't forget to watch your fruit flies daily. Before going on, check your calendar to see where you are in your fruit-fly experiments.

Before going on, do Self-Evaluation 2 in your Record Book.

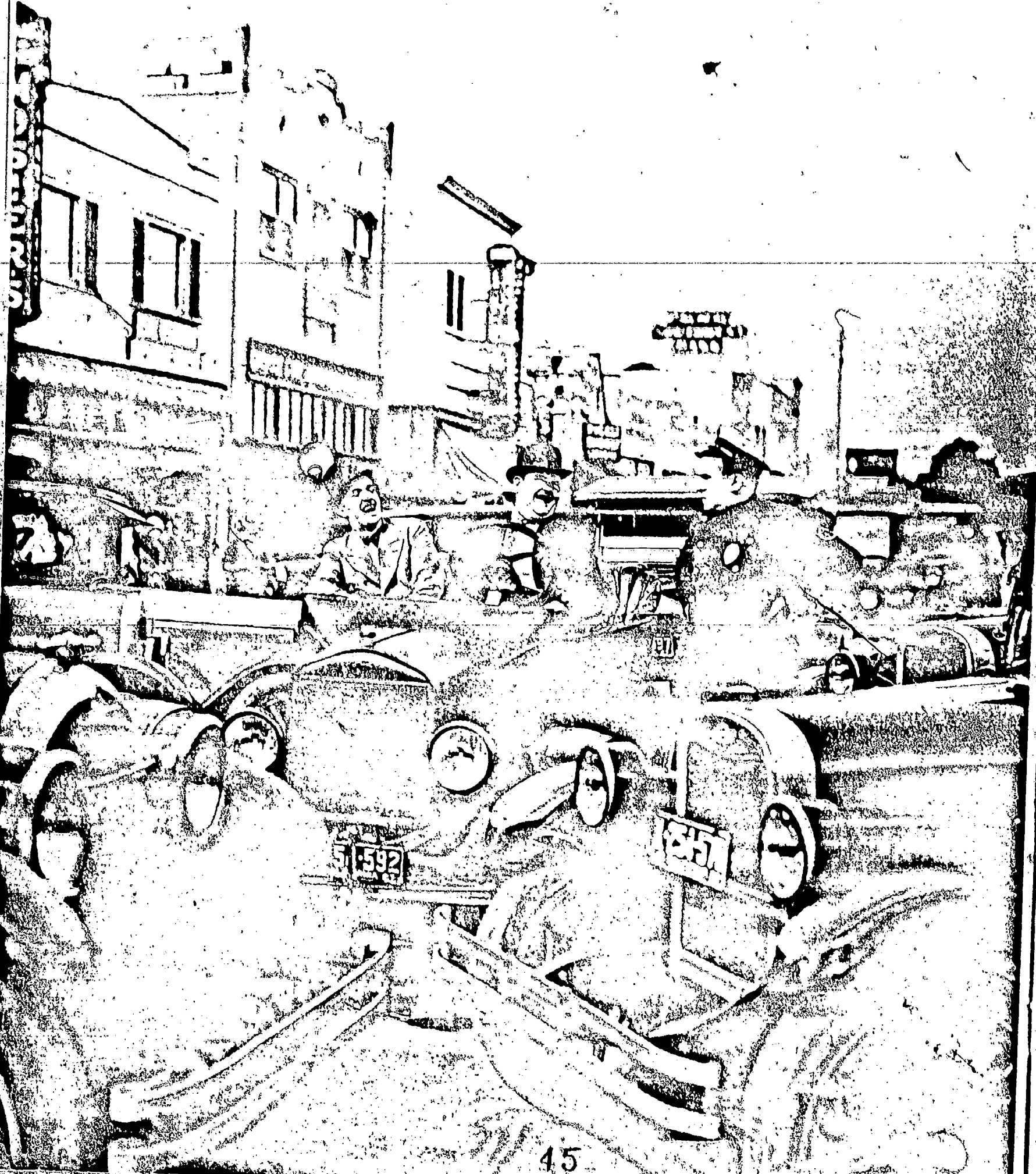

Watch Your Peas and Q's Chapter 3

In the last chapter, you observed how features in beans are passed from parents to offspring. By thinking about only one feature—color—you found a pattern of inheritance. Let's review what you did.

1. *Pure-strain brown X Pure-strain brown*

When pure-strain brown-bean plants were mated with pure-strain brown-bean plants, only pure-strain brown-bean offspring resulted. Similarly, a cross between pure-strain white-bean parents produced only pure-strain white-bean offspring. (See Figure 2-1.)

2. *Pure-strain brown X Pure-strain white*

You saw a different pattern when plants grown from pure-strain brown beans were mated with ones grown from pure-strain white beans. In this case, only brown beans showed up in the first generation. But when plants grown from the first-generation brown beans were mated, both brown beans and white beans showed up in the second generation. There were three brown beans for every one white bean. (See Figure 2-2.)

Does this pattern hold for other bean-plant features? Does it hold for other plants and animals? If it does, you could use it to make predictions about the offspring of other sets of parents.

Let's try to use the pattern to predict the inheritance of features in garden peas. If pea plants and bean plants follow the same pattern in passing features to their offspring, your predictions should be accurate.

YOU SHOULD
SEE MY
PARENTS!



To begin the activity, you will need the following items:

- 6 packages of pea seed, numbered 1 to 6
(Do not open these until told to do so.)
- 1 petri dish

ACTIVITY 3-1. Open package #1; pour the peas from the package into the petri dish. After answering questions 3-1 through 3-3, return the peas to the package.

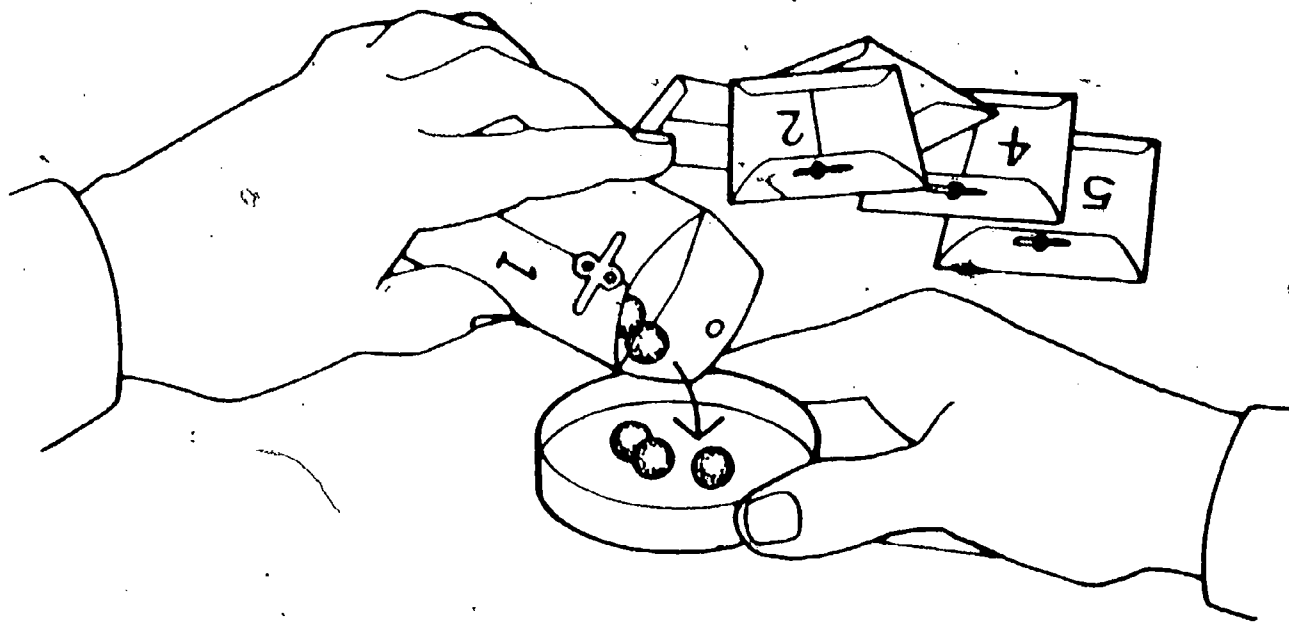

- 3-1. List at least two features common to all the peas in package #1.
- 3-2. Can you tell by looking at these peas whether or not they are from a pure strain? Explain your answer.
- 3-3. Suppose two of these peas were planted and the resulting plants were crossed. What features do you predict the next generation would have?

Like the bean plants in Chapter 2, pea plants would take months to produce another generation. Therefore, you will again work with peas gotten from an experiment done by someone else. The peas you study will look just like the ones that the original experimenter used.

First, peas like the ones in package #1 were planted; then the plants that grew were crossed. The offspring plants produced peas like the ones in package #2. (See Figure 3-1.)

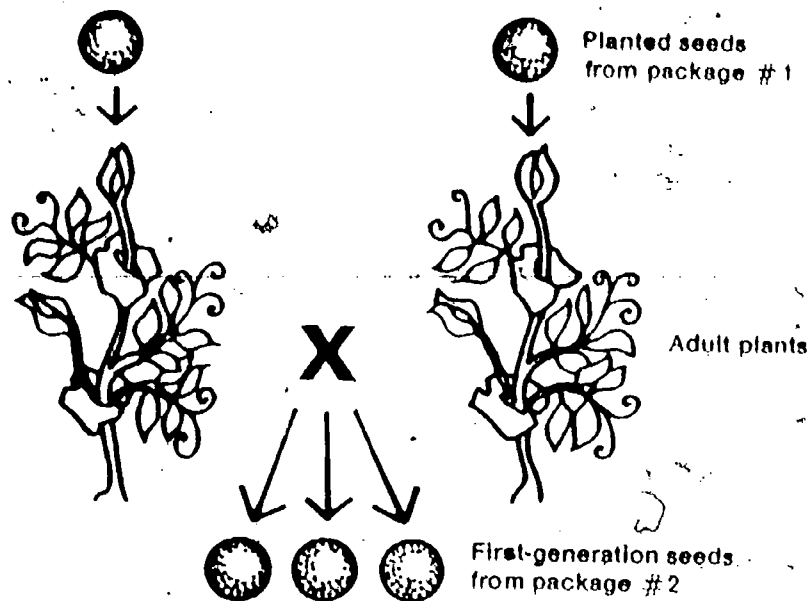

Figure 3-1

ACTIVITY 3-2. Open package #2. Examine the first-generation peas. Return the peas to the bag after answering questions 3-4 and 3-5.

- 3-4. How do the features of the first-generation peas in package #2 compare with the features of the parent-generation peas in package #1?
- 3-5. How do the features you see in the first-generation peas compare with the prediction you made in question 3-3?

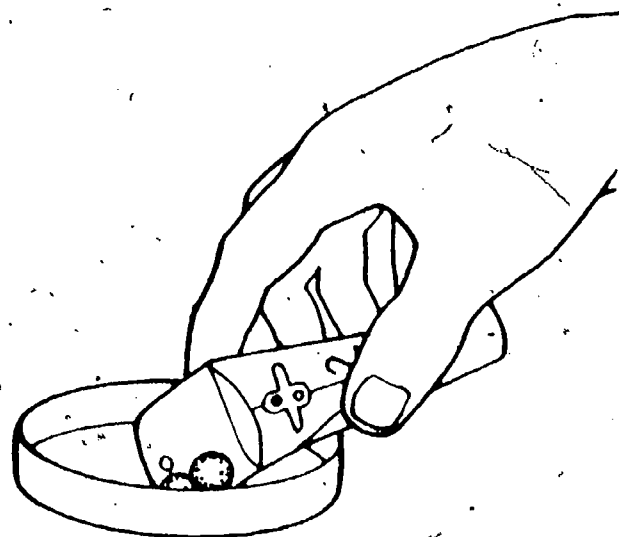
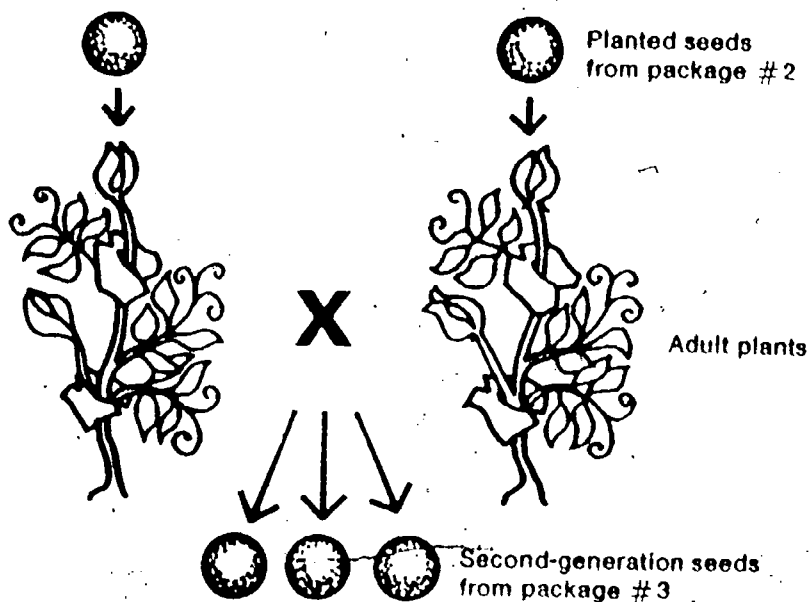

Figure 3-2



3-6. Suppose you planted these first-generation peas and crossed two of the offspring plants. What do you predict the second-generation peas would look like?

3-7. Explain why you made the predictions you did.

In the original experiment, peas like those in package #2 were planted and the resultant plants were crossed. The peas in package #3 are a sample of the second generation. Examine these peas now:

3-8. Was your prediction in question 3-6 correct?

3-9. What features do the peas in packages #1, #2, and #3 have in common?

3-10. What do we call plants that always produce offspring exactly like the parents?

3-11. Suppose some of the peas in package #3 were planted and the resultant plants were crossed. Predict what the offspring peas would look like.

Return the peas to package #3, fasten the package, and return it to the supply area.

In answering the last few questions, you probably used the idea of pure strains. Let's review the meaning of the term *pure strain*. Remember that scientists prefer to define their terms with an operational definition.

3-12. Give an operational definition of *pure strain*. (See Excursion 1-2 if you need help.)

In the next section, you will study the inheritance of still another feature of pea seeds. Before going on, however, study Figure 3-3 to review what you have found so far.

EXCURSION ►

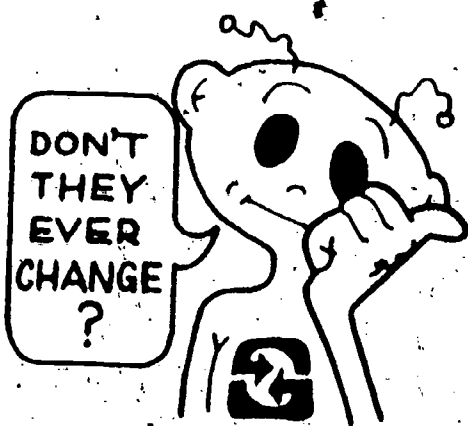
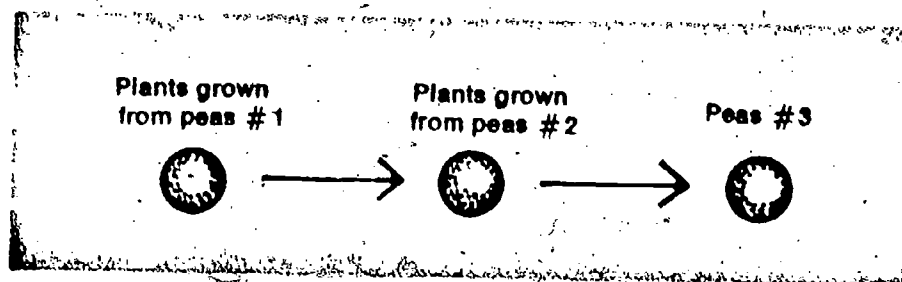

Figure 3-3



Package #4 contains seeds from a kind of pea NOT related to the ones in packages #1, #2, and #3.

MORE AND DIFFERENT PEAS

ACTIVITY 3-3. Examine the peas in package #4. Return the peas to their package after answering questions 3-13 through 3-16.

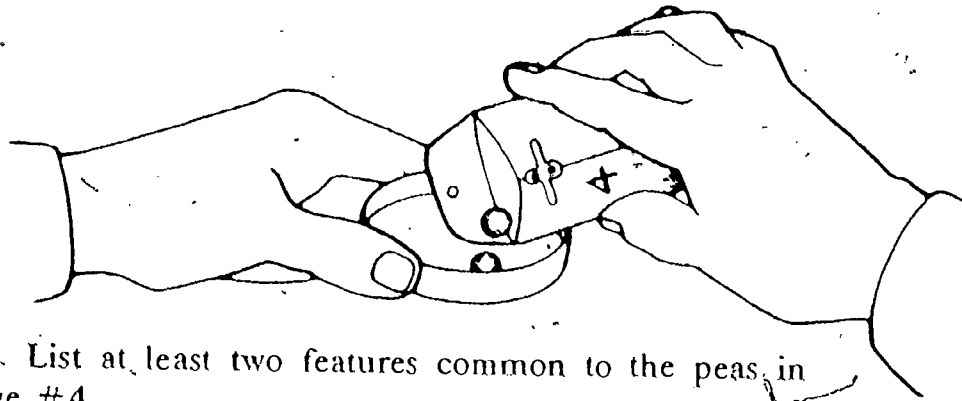

3-13. List at least two features common to the peas in package #4.

3-14. How do the features of the peas in package #3 differ from the features of the ones in package #4?

The peas in package #4 were first-generation peas. These peas had features like those of the parent peas.

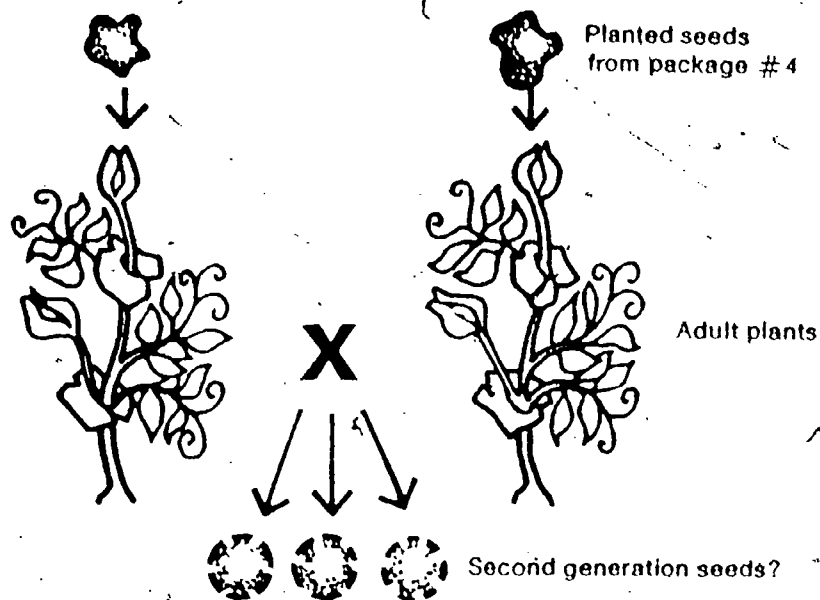

Figure 3-4

3-15. Suppose these first-generation peas in package #4 were planted and the resultant plants were crossed. What do you predict the second-generation peas would look like?

3-16. Explain why you made the prediction you did.

Let's simplify the study of inheritance in these peas by concentrating on just one feature—shape. For the moment we will study only the *inheritance of seed shape in peas*.

3-17. What was the shape (round, or wrinkled) of the pure-strain peas in package #3?

3-18. What was the shape (round, or wrinkled) of the pure-strain peas in package #4?

In the original experiment, an interesting cross was made. A plant grown from peas like the ones in package #3 was crossed with a plant grown from peas like the ones in package #4. Then the first generation of peas (package #5) was picked.

Figure 3-5

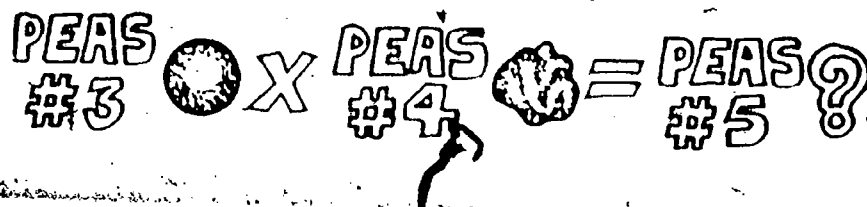

In answering the next question, let's assume that the inheritance of seed texture in peas follows the same pattern as inheritance of seed color in beans.

3-19. What do you predict the peas in package #5 will look like?

ACTIVITY 3-4. Open package #5, examine the seeds, and answer question 3-20. Then replace the seeds in package #5, close it, and return it to the supply area.

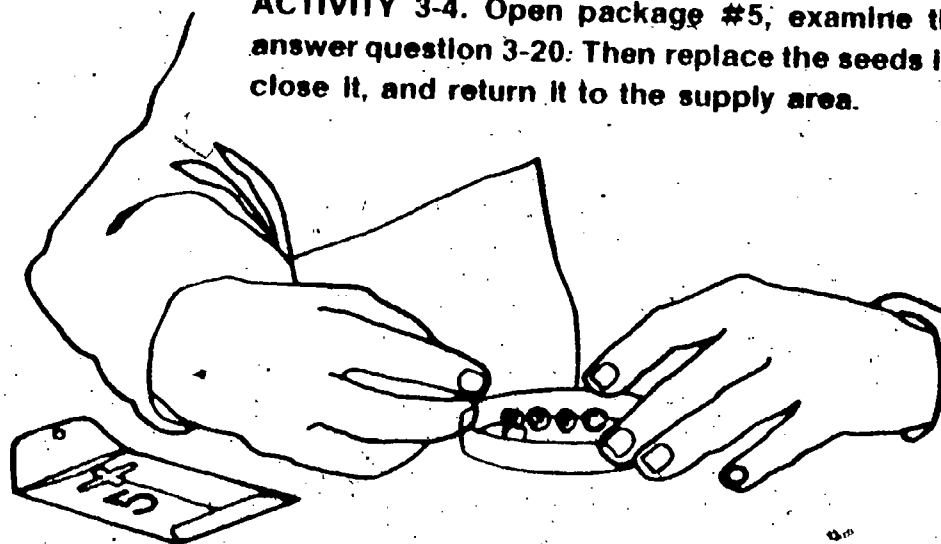

3-20. How do the features of the peas in package #5 compare with the prediction you made in question 3-19?

3-21. Which parent do the peas resemble more?

The original experiment was carried one step further. Seeds like those in package #5 were planted, and some of the plants that grew were crossed. Second-generation peas were picked from the offspring plants (package #6).

3-22. What features do you predict the second-generation peas in package #6 will have? (Include a ratio.)

ACTIVITY 3-5. Open package #6 and examine the seeds. Answer questions 3-23 through 3-27. Then replace the peas in package #6, close it, and return it to the supply area.

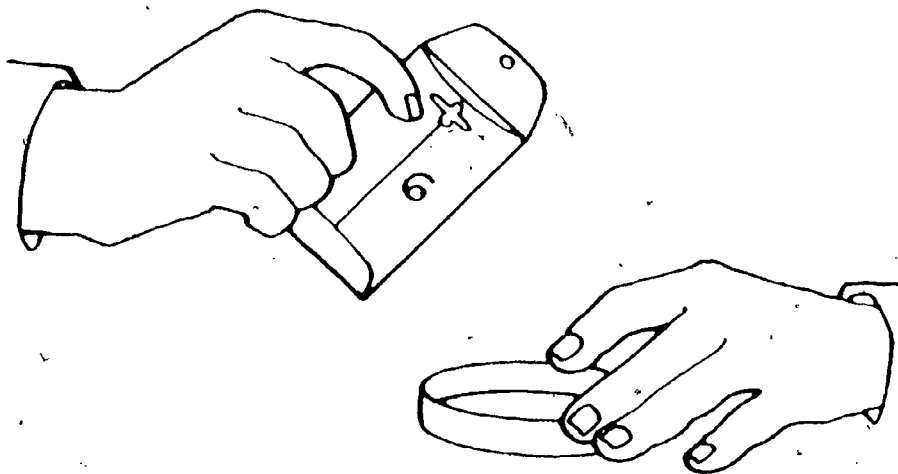

3-23. Record the number of smooth and the number of wrinkled seeds.

3-24. What is the rounded-off ratio of smooth seeds to wrinkled seeds?

3-25. How do your observations compare with the prediction you made in question 3-22?

3-26. How does this ratio compare with the ratio of seed color you found in the second-generation beans? (See Table 2-1.)

3-27. In what way do beans and peas follow a similar pattern of inheritance?

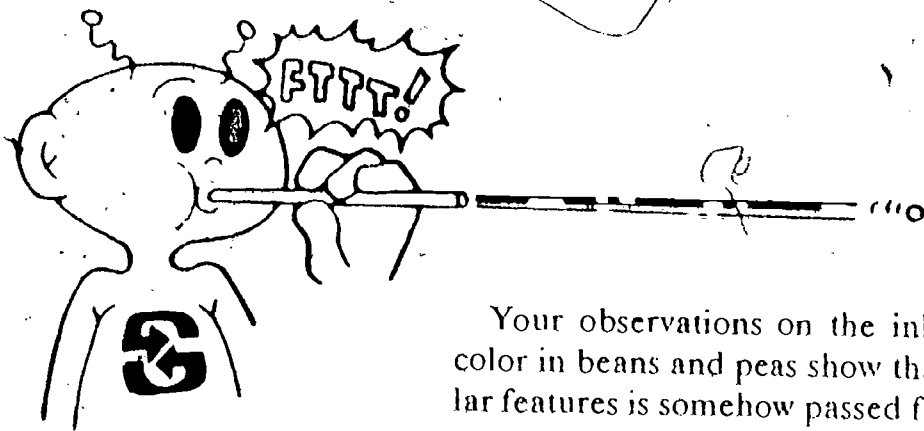

Your observations on the inheritance of seed shape and color in beans and peas show that information about particular features is somehow passed from parents to offspring. The message seems to have been communicated like this:

1. When two individuals of the same pure strain are crossed, all offspring should look like the parents.
2. When two individuals of different pure strains are crossed, the offspring should resemble one parent but not the other.
3. Second-generation offspring of parents of two different pure strains should look like either strain, but the features of one strain show up three times as often as those of the other.

PROBLEM BREAK 3-1

You have found a similar pattern in beans and peas. Does this pattern hold true for other plants, too? Let's see!

Pick up *three* petri dishes of sprouted tobacco seeds. Count the number of shoots of the two colors you see (green and white). These plants came from seeds of second-generation plants. Figure 3-6 diagrams the crosses that were made.

Figure 3-6

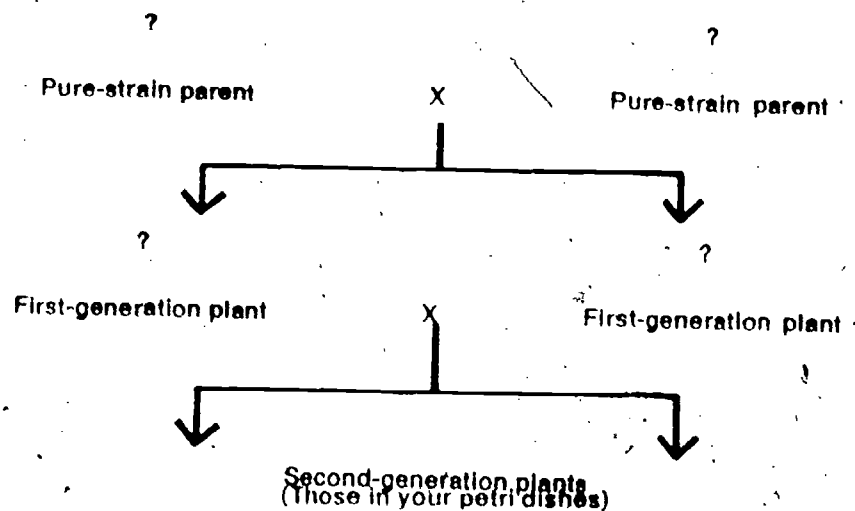

Let's assume that tobacco plants follow the same pattern of inheritance as beans and peas.

Try working backward from the second-generation plants in the petri dishes to predict the color of the first-generation and of the pure-strain parents. In your Record Book, draw up a table of your predictions.

Easily seen features of pea seeds and tobacco seeds have taught you still more about inheritance. In the next chapter, you'll be asked to develop a model to explain the pattern that you have seen here. If you like a challenge, you might try to think of your own model now. If you've come up with what you think is a good one, describe it in your Record Book. Later you can check to see how good it really is.

Reminder Don't forget to watch your fruit flies daily. Before going on, check your calendar to see where you are in your fruit-fly experiments.

Before going on, do Self-Evaluation 3 in your Record Book.



ONE WAY

55

Bits of Information

Chapter 4

Your observations have shown that parent peas, beans, and corn plants all pass features to their offspring in the same way. In this chapter your problem will be to develop a model with which to explain the pattern you have found.

Let's start by summing up what you saw in the bean seed experiment.

1. Each parent plant had beans with a distinctive color. One pure-strain bean parent had brown beans, and the other pure-strain bean parent had white beans.
2. Only one seed color showed up in the first generation; all the beans of the first generation were brown.
3. In the second generation, both seed colors appeared again. Some second-generation plants had brown beans and others had white beans.
4. In the second generation, the ratio of colors was three brown beans to one white bean.

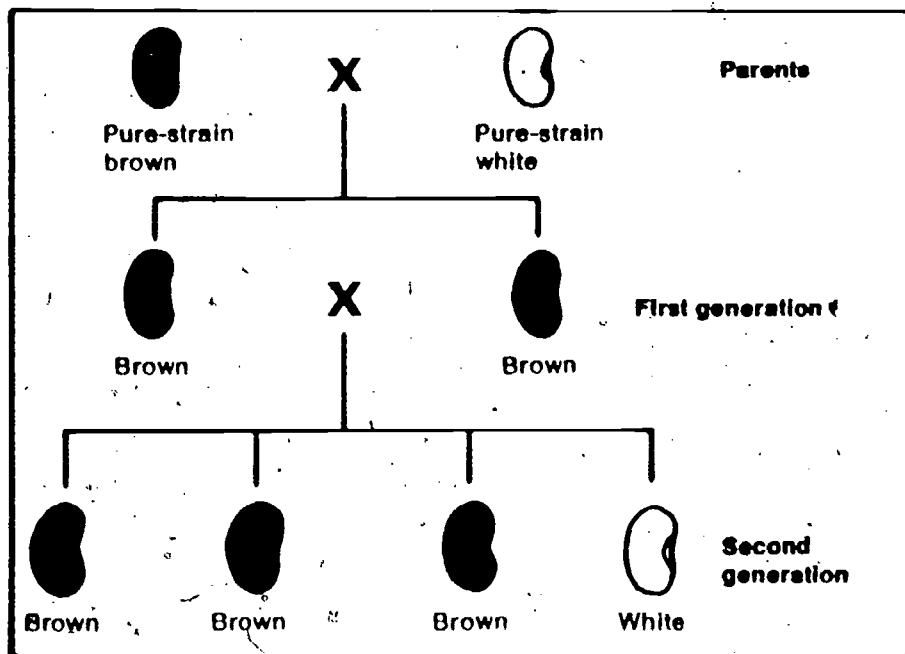

Figure 4-1

□4-1. For what feature did the peas you studied follow a pattern similar to the one shown in Figure 4-1?

The model you develop for how parents pass on their features must explain why the bean experiment turned out as it did. More than that, it should enable you to predict the features of the offspring of other kinds of plants and animals.

BUILDING A MODEL

You may already have decided that a message that determines the features of the offspring is somehow sent from parents to their offspring. Let's assume that this is true, and call this message a "bit of information."

Let's assume that offspring get all their bits of information from their parents. In other words, a brown bean is a brown bean because it got a bit of information that says "Form brown color" from either one or both parent plants. A white bean has a bit of information that says "Form white color," which was passed to it from one or both of its parents.

As you should know by now, in building a model you can make any assumptions that seem reasonable. In building your model, you could assume that every individual receives from his parents one, two, three . . . or more bits of information for each feature. But the scientist always tries to build the *simplest* model that will explain his observations.

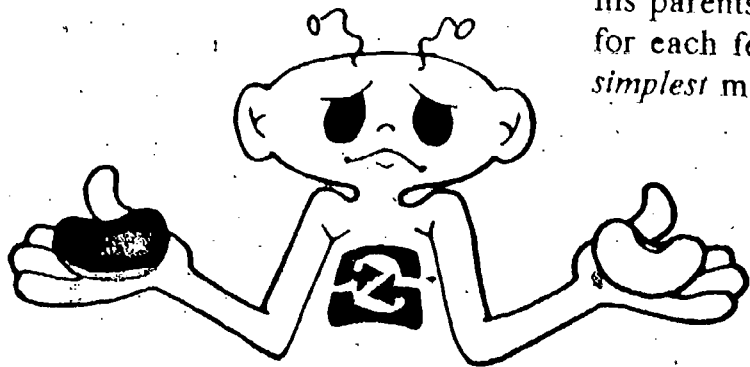

THE ONE-BIT MODEL

The simplest model obviously assumes that each individual has just *one bit of information* for each of its features. The bit of information was passed along from one parent or the other. Let's see how well this simple model explains the pattern you've seen in the observations you've made.

According to this one-bit model, brown beans received one bit of information for brownness, and this is what makes them brown. White beans, on the other hand, got a bit of information for whiteness.

To help you understand the way this model works, you will use plastic squares to represent bits of information. A brown square will represent a bit of information that says "Form brown." Likewise, a colorless square will represent a bit of information that says "Form white."

Pick up these materials from the supply area:

- 2 paper bags
- 1 brown square
- 1 colorless square

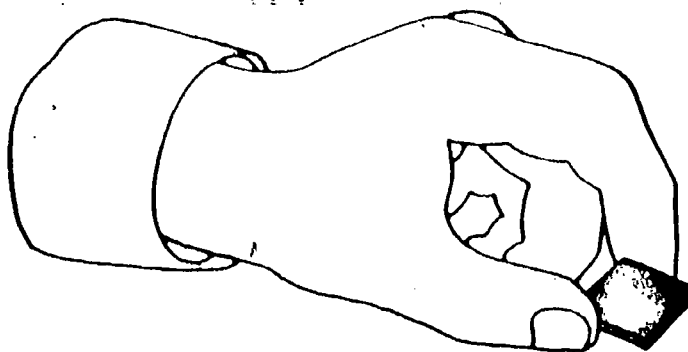

Draw one square from either one of the bags.

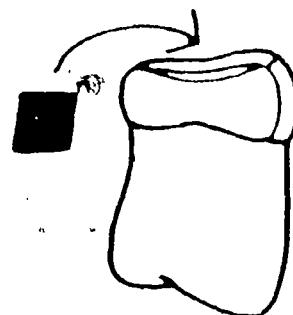
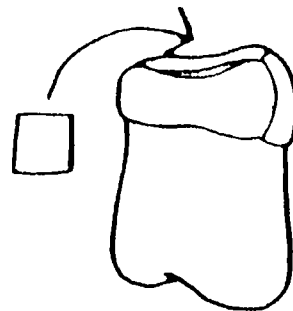

ACTIVITY 4-1. Place the brown square in one bag and the colorless square in the other bag. Each bag now represents one pure-strain parent. Draw one square from either one of the bags. The square represents the bit of information passed on to a first-generation offspring.

Figure 4-2B reviews what happened when you crossed plants grown from pure-strain brown beans with plants grown from pure-strain white beans. Figure 4-2A shows what you know about the bits of information involved.

Use the one-bit model to answer the next five questions about the experiment shown in Figure 4-2:

Figure 4-2A

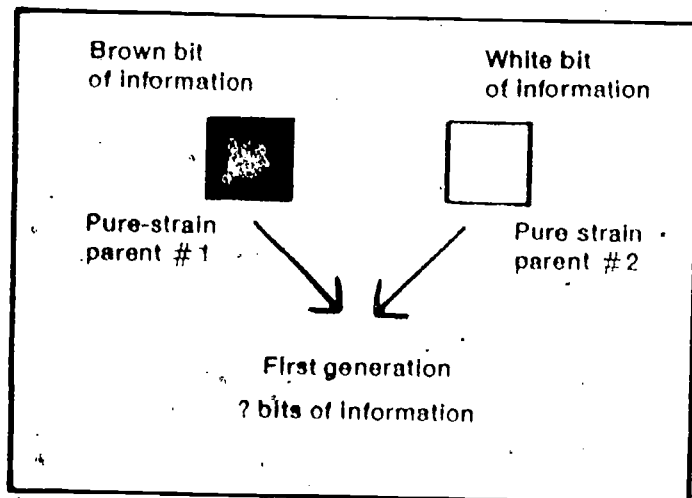
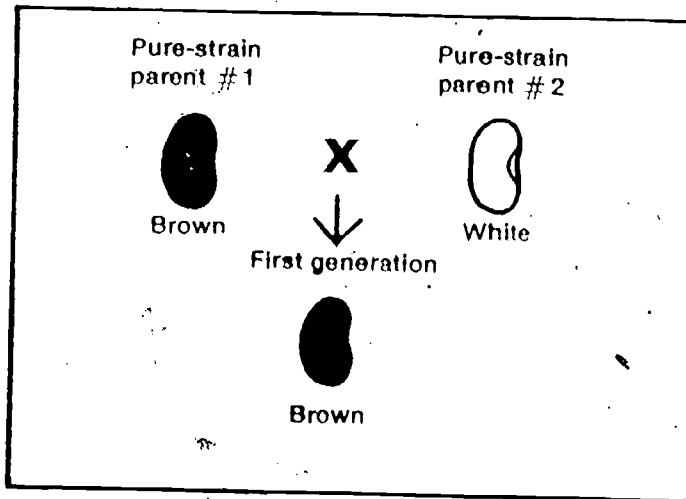

Figure 4-2B



- 4-2. What bit of information for seed color did the pure-strain parent #1 have?
- 4-3. What bit of information for seed color did the pure-strain parent #2 have?
- 4-4. What color were *all* the first-generation beans?
- 4-5. In Activity 4-1, what color square (bit) did you pick from one of the bags (parents)?
- 4-6. What color square (bit) would you have to pick in order to produce the first-generation bean shown in Figure 4-2B?
- 4-7. According to the one-bit model, did the first-generation beans get their bit of information for color from parent #1 or parent #2?

The one-bit model explains the first generation only if you assume that all the first-generation offspring received a bit of information for brown. This bit would have had to come from parent #1.

- 4-8. Why couldn't parent #2 have supplied a brown bit of information?

Parent #2 had only bits of information for white. It apparently contributed no bits to its offspring.

Now let's try to apply the one-bit model to what you observed in the second generation. Figure 4-3 reviews that experiment.

Figure 4-3

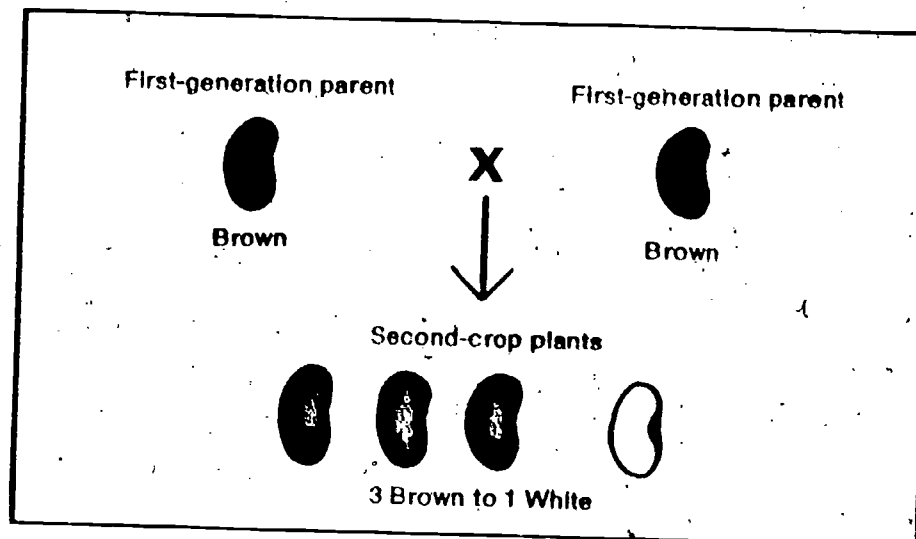

Let's use the one-bit model to see if we can duplicate the results of the experiment.

ACTIVITY 4-2. Place one brown square in each of the two bags. Each bag now represents one first-generation plant. Draw one square from either one of the bags. Each square represents a bit that could be passed on to a second-generation offspring.

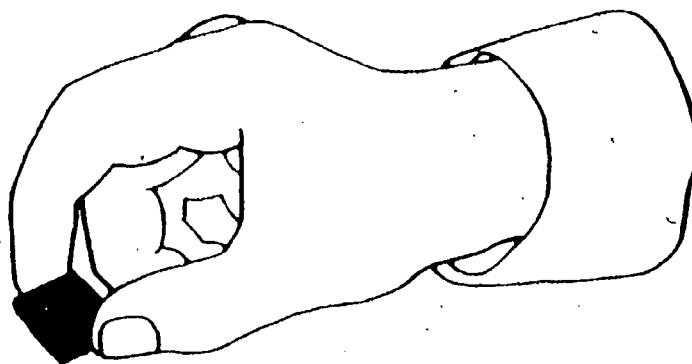
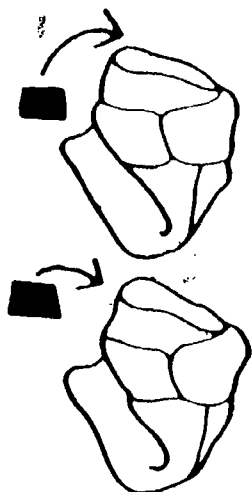

Draw one square from either one of the bags.

- 4-9. If you continue to draw squares (bits of information) from either bag (parent), what color square will you always draw?
- 4-10. Using the one-bit model, how can you explain the reappearance of the white beans in the second generation (see Figure 4-3)?

PROBLEM BREAK 4-1

If you were able to use the one-bit model at all to explain why white beans showed up in the second generation, you probably had to make some pretty strange assumptions. When this happens, it's a good idea to search for a more useful model. The rest of this chapter will help you to do this, but first you have a chance to work on your own. Try to develop a "bit-of-information model" that will explain the four points listed on page 43. In building your model, assume that different numbers of bits of information are passed along. Then decide which number of bits works best. Spend up to one full day with this, and describe in your Record Book the best explanation that you can come up with.

Perhaps your model will do the job; perhaps not. But one thing is sure. The one-bit model is in trouble. Let's look at the next simplest possibility—a two-bit model.

A TWO-BIT MODEL

For this model, you will assume two things: (1) every individual has two bits of information for each feature, and (2) one bit for each feature is passed from each parent to its offspring. To make it easy to understand what is happening, you will again use the plastic squares. This time you will need two brown and two colorless squares.

Let's try to use this two-bit model to explain the experiment reviewed in Figures 4-2 and 4-3.

Remember that pure-strain brown-bean plants crossed with similar plants always produced brown beans. This makes it reasonable to suppose the pure-strain brown-bean plants can pass along bits of information for brown only. Similarly, pure-strain white beans must pass along only bits of information for white.

ACTIVITY 4-3. Place two brown squares in one bag and two colorless squares in the other bag. Each bag now represents one pure-strain parent. Draw one square from each bag. Stack the two squares together. These two squares represent one offspring.

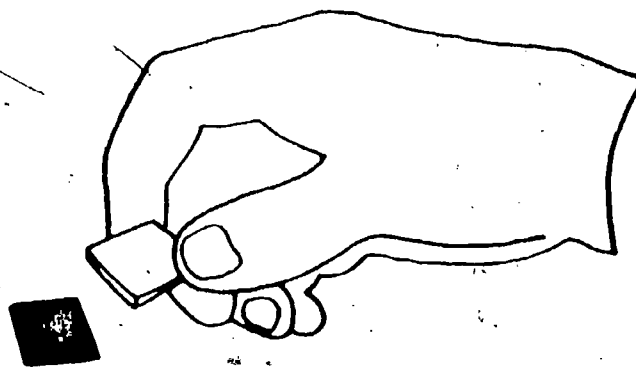
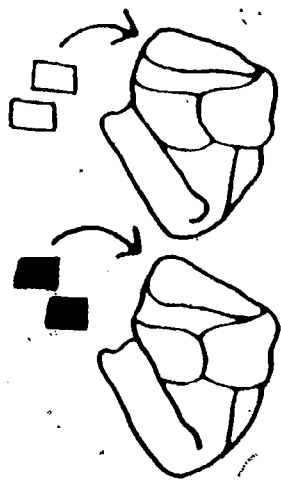

Draw one square from each bag.

If you followed the directions correctly, you got one brown and one colorless square. The squares represent the bits of information that the offspring received from its pure-strain brown-bean parent and its pure-strain white-bean parent.

□ 4-11. What is the only combination of bits of information (squares) you can get by selecting one bit from each bag?

You now have an interesting problem. You know that the offspring from the cross of a pure-strain brown-bean plant and a pure-strain white-bean plant were all brown (see Figure 4-2B). Yet your two-bit model suggests that each of these offspring received a bit of information for white from its white parent. Why didn't the white bit show up?

4-12. An assumption about the bits of information can explain why only brown beans showed up in the first generation. What is that assumption?

Perhaps you had trouble with question 4-12. If so, an activity with the squares may help you out.

ACTIVITY 4-4. Place one brown square and one colorless square in a stack as shown. Hold the stack up to the light and look through it.

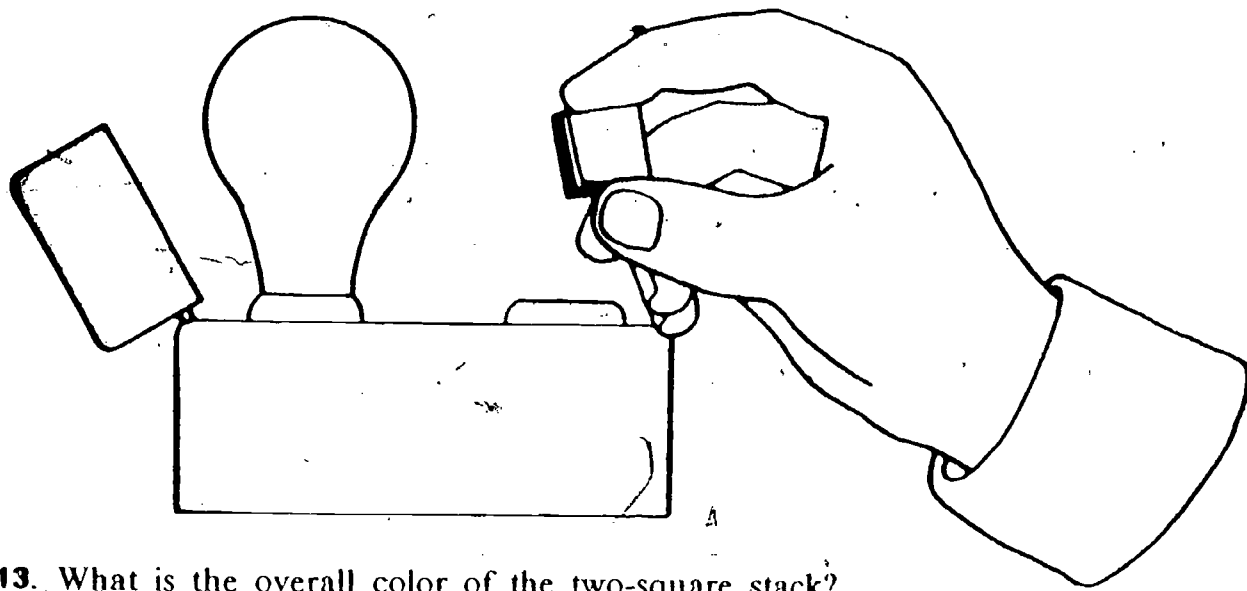

4-13. What is the overall color of the two-square stack?

4-14. What assumption about bits of information does this suggest to explain why only brown beans showed up in the first generation?

Important assumption

Suppose we make an important assumption about inherited bits of information—the bit of information for brown can mask the bit of information for white. This means that a plant with one bit of information for brown and one bit of information for white would produce only brown beans.

Use your two-bit model, including the new assumption, to answer the next two questions.

4-15. What bits of information would offspring get from a cross of pure-strain brown-bean plants and pure-strain white-bean plants?

4-16. Assuming that the brown bit of information can mask the white bit of information, what color(s) would you expect the first-generation beans to be?

4-17. What color were the first-generation beans (see Figure 4-2B)?

So far, so good. But what about the second crop? You will remember that this is what happened when the first-generation plants were crossed:

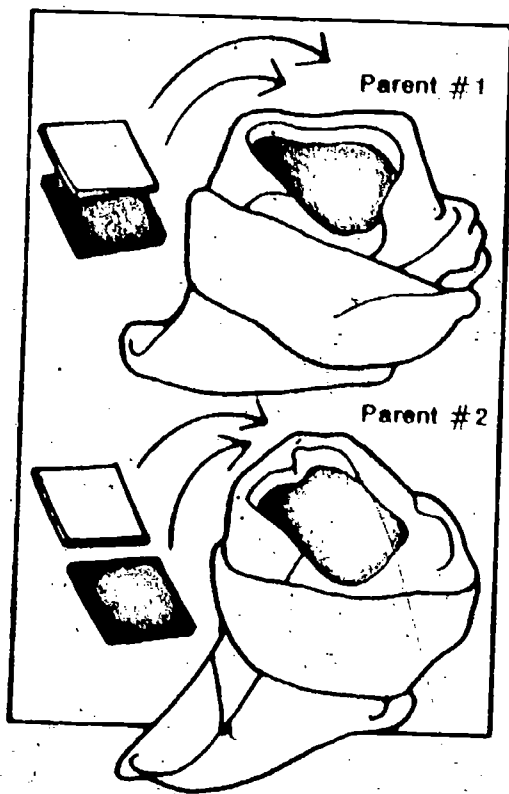
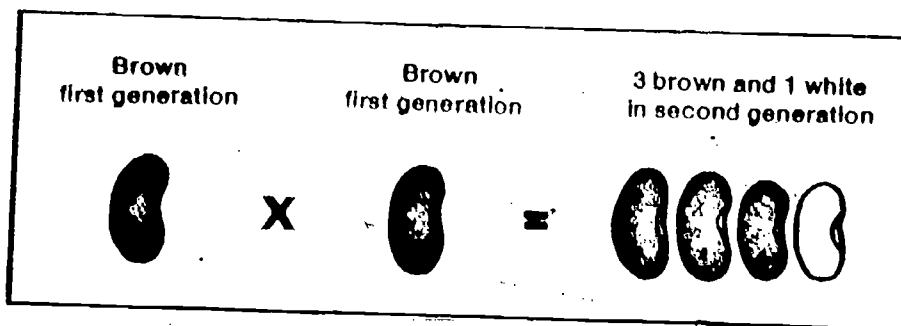

Can these results be explained by the two-bit model? Let's try an experiment to find out.

4-18. What combination of two squares represented the bits of information of the first-generation offspring?

The first-generation offspring are also the second-generation parents (see Figure 4-3). Let's see what would happen if beans from two such parents were planted and a second generation produced.

ACTIVITY 4-5. Place one brown square and one colorless square in one bag (parent #1). Place one brown square and one colorless square in the second bag (parent #2).

These two bags now represent the parents of the second generation. Remember that each square stands for a bit of information.

4-19. According to the two-bit model, how many squares should you take from each bag to produce a second-generation offspring?

Well, now you have another problem. Each one of this pair of parents has two different bits of information. But only one bit can be passed along to the offspring from each parent. The question is, "Which one?"

Once again you can use the "keep it simple" rule of model building. About the simplest answer to the "which one" question is "either one." That is, you can assume one bit has as much chance of being passed on as the other.

In a moment, you will, blindly select one square (bit of information) from each bag. Either square in each bag has the same chance of being selected.

4-20. Place a check mark in your Record Book next to each combination of squares listed below that you could pick.

Two brown squares

One brown square and one colorless square

Two colorless squares

ACTIVITY 4-6. Without looking, reach in and take one square from each bag. Indicate with a check mark in Table 4-1 in your Record Book the combination of squares you got. Return each square to the bag from which it came. Shake the bags and repeat the procedure at least 60 times.

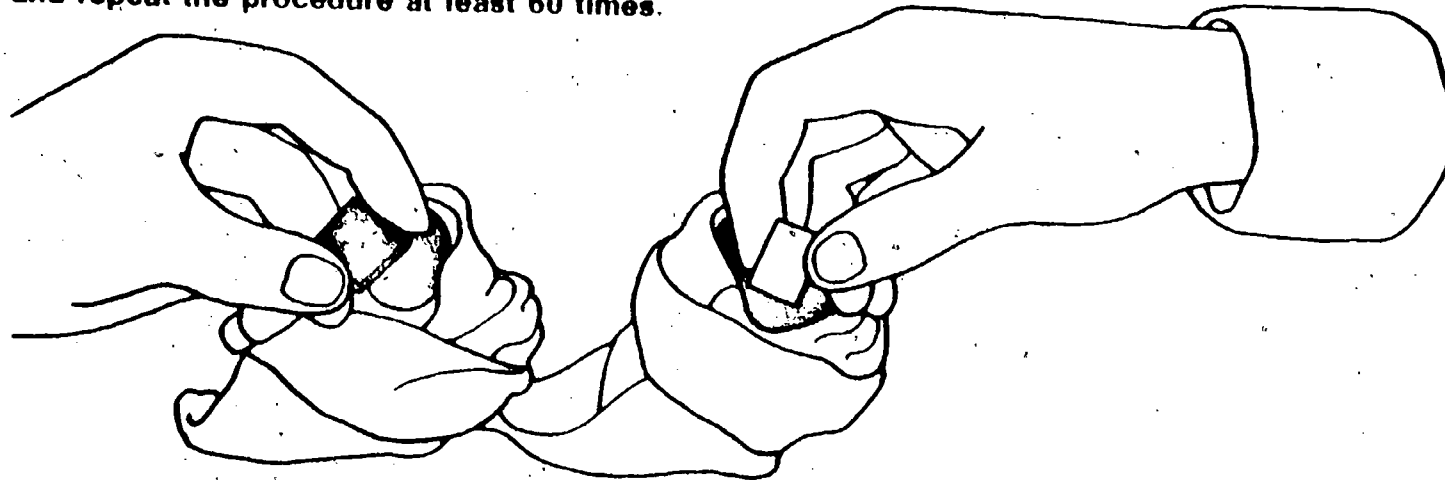

Note: The success of this activity depends upon your honesty. It may be possible to tell the squares apart by the way they feel. Do not let this influence you. Take the first square you touch each time.

Sixty trials may seem like a lot. You might think that two or three times would be enough. A little later you will see why so many trials are necessary.

Table 4-1

COMBINATIONS OF SQUARES IN SECOND GENERATION			
	2 Brown	1 Brown 1 Colorless	2 Colorless
Check marks			
Totals			

Use the data in Table 4-1 to complete Table 4-2. Remember that each pair of squares represents a second-generation offspring. Remember also that brown bits can mask white bits.

Table 4-2

	Number of Brown-seed Offspring	Number of White-seed Offspring
Total		
Rough ratio		to
Rounded-off ratio		to

4-21. How does the ratio of brown to white in Table 4-2 compare with the color ratio you actually found earlier (Table 2-1)?

Did you find three combinations of bits for brown beans for every one resulting in white? If you did not, check over your work.

Well, the two-bit model should have passed the test fairly well. It accounts for the observations you've made. To be sure that you are clear on what your model says, let's try to state it clearly.

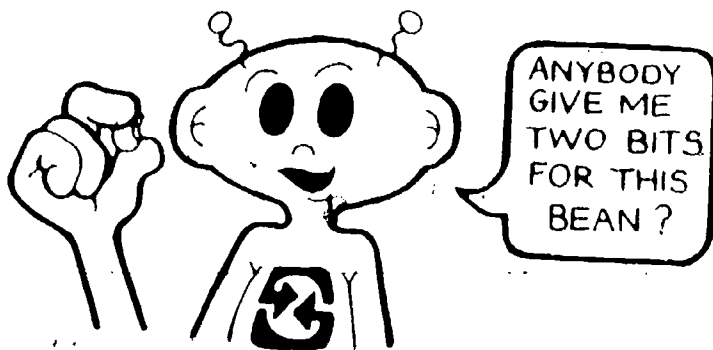

Reviewing the two-bit model

1. Every individual has two bits of information for each feature; the individual's appearance depends upon what those bits are.
2. During reproduction, each parent passes to its offspring one bit of information for each feature. This gives the offspring its two bits for each feature.
3. Chance determines which of the two bits for a feature is passed from parent to offspring.
4. If an individual receives two different bits of information for a feature, one bit may mask the other.

Your two-bit model is very much like the one now used by scientists. A bit of information has been gotten as to what these bits of information are like and where they are located. The story of how this information was gotten is quite interesting. When you get to Chapter 6, you'll have a chance to do **Excursion 6-1**, which will tell you a bit more about it and about bits, too. If you're really interested, you might want to take a look at this excursion now.

PROBLEM BREAK 4-2

The two-bit model explained nicely your earlier observations of bean seeds. But remember that a good model will help you to predict as well as to explain. Can the two-bit model predict as well as explain? Let's see.

The results of three crosses with bean plants are drawn on page 54. For two of the crosses, the offspring's beans have not been described. It is up to you to use the two-bit model to predict what color the offspring's beans will be. Discuss your results with your teacher, your classmates, or both. Write in your Record Book a brief description of how you used the model to predict the bean colors.

◀ EXCURSION

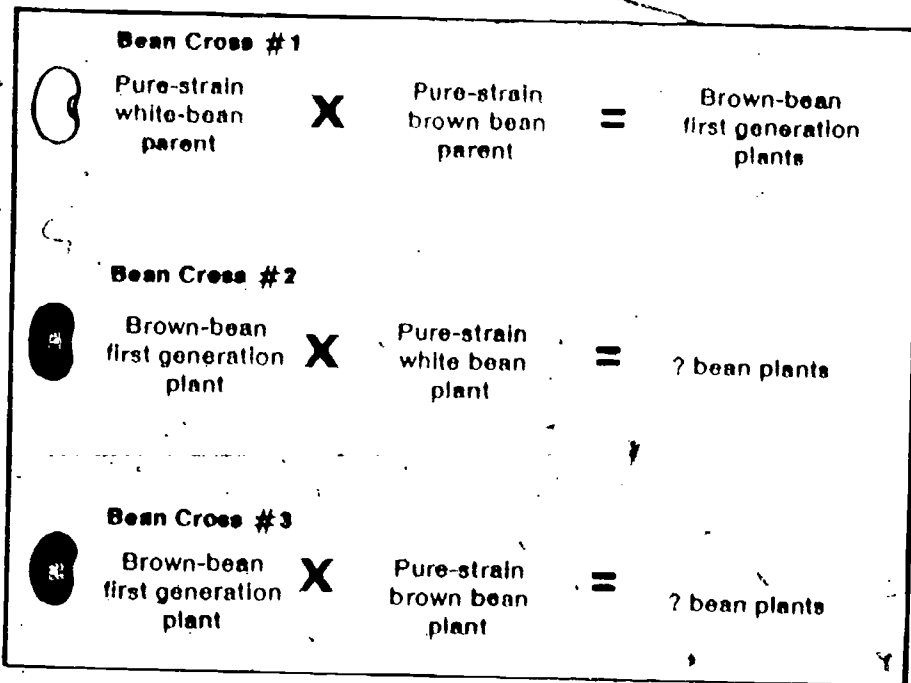

Hint In solving the problems, you may want to set up experiments like the ones shown in Activities 4-5 and 4-6.

PROBLEM BREAK 4-3

Will other models work as well as your two-bit model? Here's your chance to find out. You may test as many models as you like, but do not spend more than one period on this activity. As a start, you might try a three-bit model; then a four-bit model; and so on.

First, insert some number other than one or two in the model description given below. (You've already used those.) Then try to use the new model to explain your bean-seed observations. Describe the results in your Record Book and state whether or not the new model is a good one.

1. Each individual has _____ bits of information for each feature; the individual's appearance depends upon what those bits are.
2. During reproduction, each parent passes _____ bit(s) of information for each feature to its offspring. This gives the offspring its _____ bits.
3. Chance determines which bits are passed from parent to offspring.
4. Some bits of information may mask other bits of information.

Suppose you were given some brown bean seeds but were told nothing about their parents. How would you know whether or not they were a pure strain? Could the two-bit model be used to explain the background of these seeds? Let's find out.

TEST CROSS

According to the two-bit model, a plant may carry bits of information that don't show, because, one bit of information may mask another bit of information. Scientists find a *test cross* useful in finding out if organisms have "invisible" bits of information.

In a test cross, you cross the unknown plant with a known plant. Let us consider the unknown plant first. If you were given some brown seeds, they could have either of two possible sets of bits. They could be either:

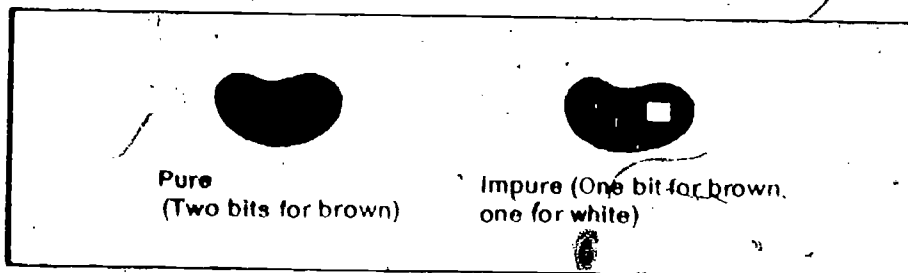

Figure 4-4

Let's see what would happen if you planted one of the brown seeds and crossed the new plant with a pure-strain brown plant.

Figure 4-5A shows what the offspring would be like if the unknown seed had two bits of information for "Form brown." Figure 4-5B shows what the offspring would be like if the unknown seed had one bit of information for "Form brown" and another for "Form white."

Figure 4-5A

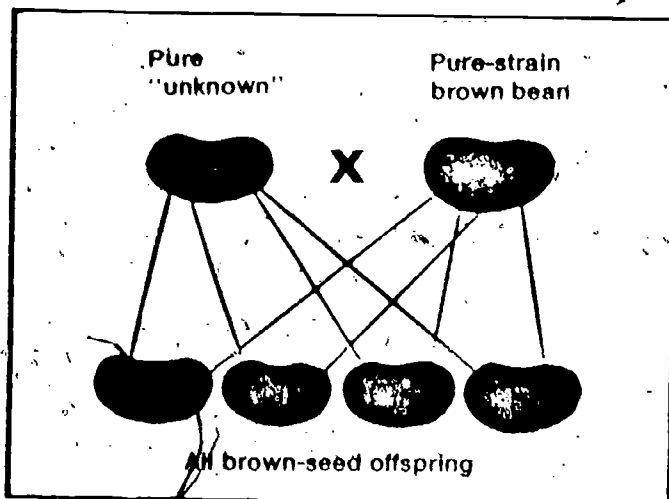
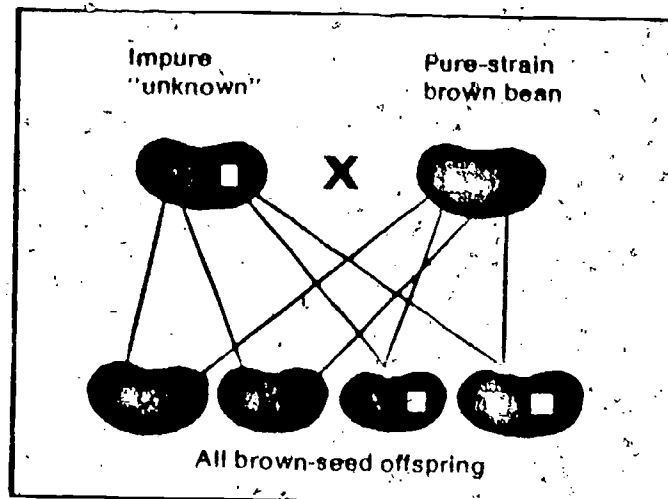

Figure 4-5B



If you wish, you can test the two crosses shown in Figures 4-5A and 4-5B with the plastic squares and bags.

- 4-22. What color seeds resulted from both crosses?
- 4-23. Does the cross shown in Figures 4-5A and 4-5B tell you whether your unknown seed was pure or impure?
- 4-24. Explain why a pure-strain brown-bean plant is not a good plant to use in a test cross.

Obviously, you have to make some other type of cross. Figure 4-6 shows such a cross; plants grown from unknown seeds are crossed with plants known to be pure strain for white seeds.

Figure 4-6

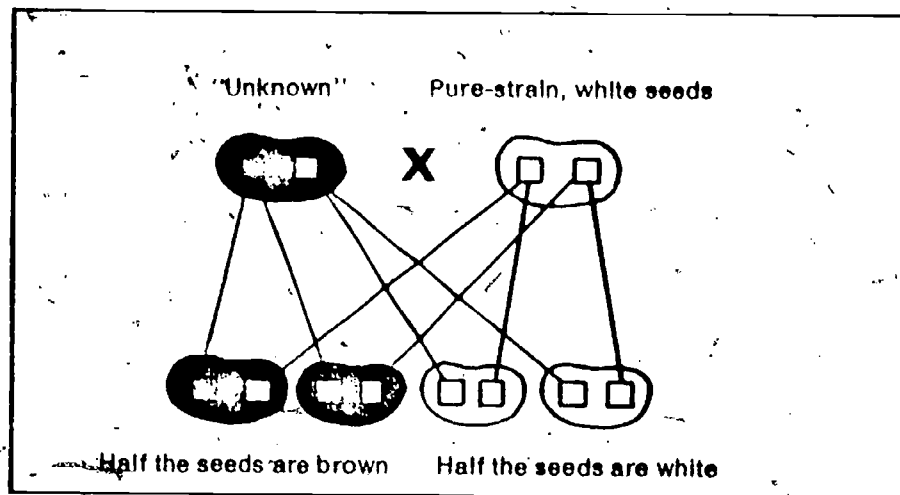

- 4-25. What color seeds resulted from the two crosses?
- 4-26. Compare your answers for questions 4-22 and 4-25. How do they differ?
- 4-27. How could you use a cross like this to tell whether your unknown seed was pure or impure?
- 4-28. Explain why a pure-strain white-bean plant and not a pure-strain brown-bean plant must be used in a test cross.
- 4-29. What ratios are found in a test cross using a pure-strain white bean?

Now you should tackle Problem Break 4-4 to see how well you understand the idea of a test cross.

PROBLEM BREAK 4-4

Suppose you were given some smooth pea seeds but were told nothing about their parent plants. How could you find out whether they are pure strain or not? Describe your experiment in your Record Book.

Ratios, ratios, ratios. You either have to be tired of them by now or very suspicious. Aren't you suspicious of the 3-to-1 ratio that keeps showing up in peas, beans, and tobacco plants? A scientist rarely accepts a fact without proof. If you would like proof of why certain ratios keep reappearing, turn to **Excursion 4-1**, "Don't Flip over This."

Reminder *Don't forget to watch your fruit flies daily. Before going on, check your planning chart to see where you are in your fruit-fly experiment.*

Before going on, do Self-Evaluation 4 in your Record Book.

← **EXCURSION**

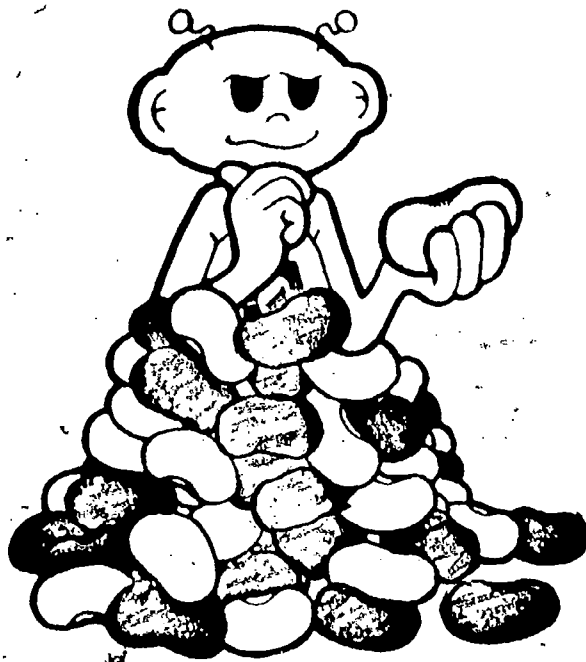

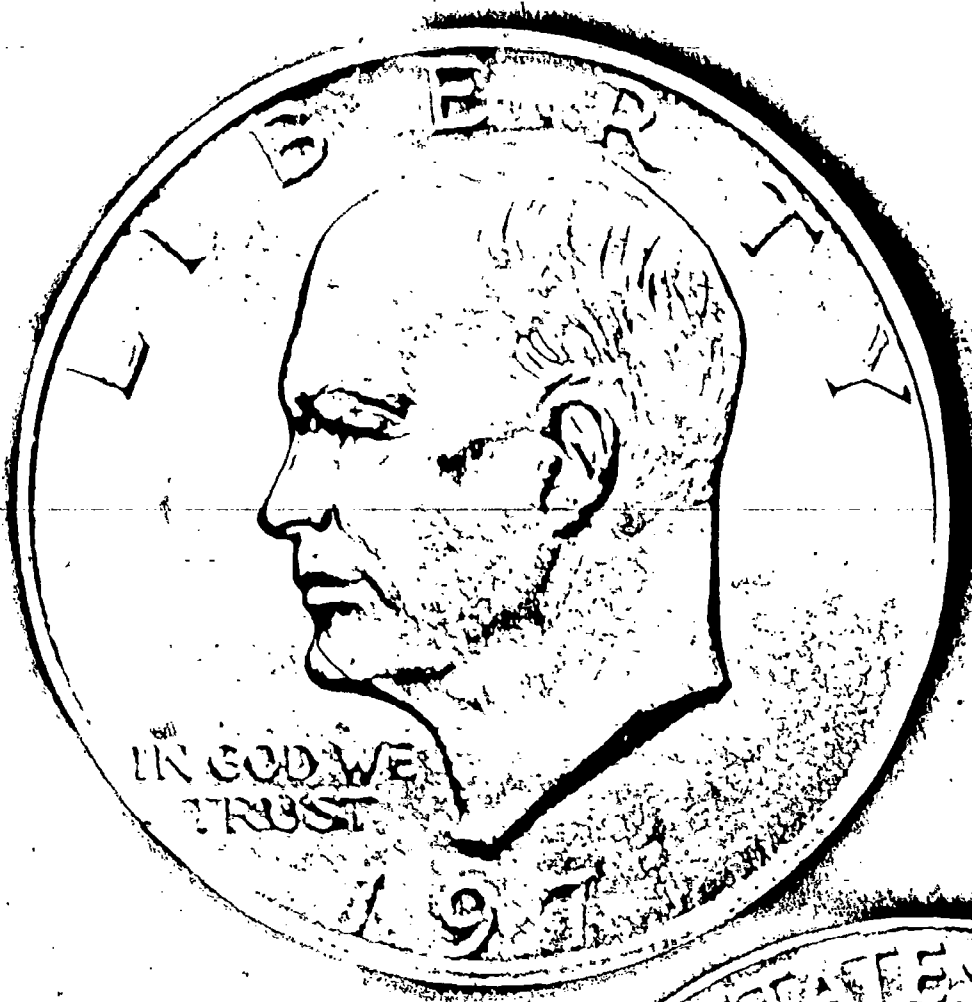

71

Either Heads or Tails

Chapter 5

It's time to take a good look at where you've been and where you're going. It's taken you four chapters to develop your "two-bit model." The two-bit model you've built assumes that:

1. Each individual has gotten from its parents two bits of information for each feature.
2. During reproduction, each parent passes to its offspring one bit of information for each feature.
3. Chance determines which of the two bits is passed from parent to offspring.
4. If an individual receives two different bits of information for a feature, one bit may mask the other.

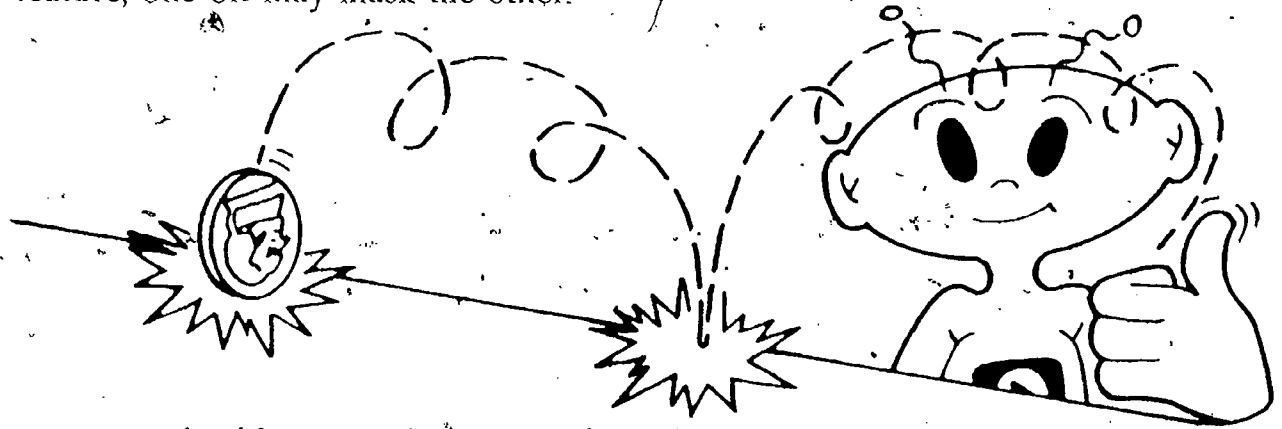

The model seems to work with pea seeds, bean seeds, and tobacco plants, and you will soon be finding out if it works with fruit flies. But can the model help to explain how human parents pass their features on to their children? Let's try to find out.

First, you'll study the ability of people to taste a harmless chemical called PTC (phenylthiocarbamide). To begin the experiment, you will need four or five strips of paper that have been soaked in PTC.

ACTIVITY 5-1. Put a piece of PTC paper into your mouth and chew it. Have several of your classmates chew PTC paper. Also, check with any others who have already chewed PTC.

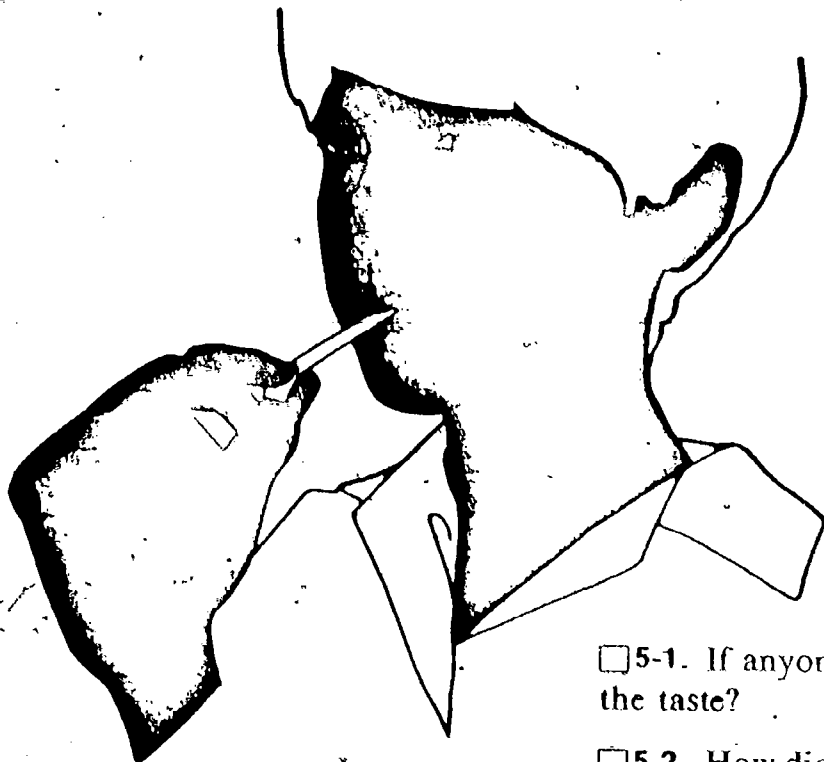

- 5-1. If anyone could taste the PTC, how do they describe the taste?
- 5-2. How did those who could not taste PTC describe their experience?
- 5-3. If anyone got a different taste from the others, describe it.
- 5-4. Every student might have chewed something to provide a control for this experiment. What was it? (Go-ahead and have them do it as a check, if you wish.)

As you have just discovered, some people can taste PTC and some cannot. Figure 5-1 shows the response to PTC among members of a make-believe family—the Smith family. Look it over carefully. Notice that the chart shows whether or not each family member could taste PTC. It also shows how all of the family members are related to one another.

Now let's try to use the two-bit model to explain the Smith family data. The description of the model on page 59 may be helpful as you answer the next few questions.

Begin by looking at Grandfather Smith and Grandmother Smith. One is a taster, and the other one is a nontaster. They had four children.

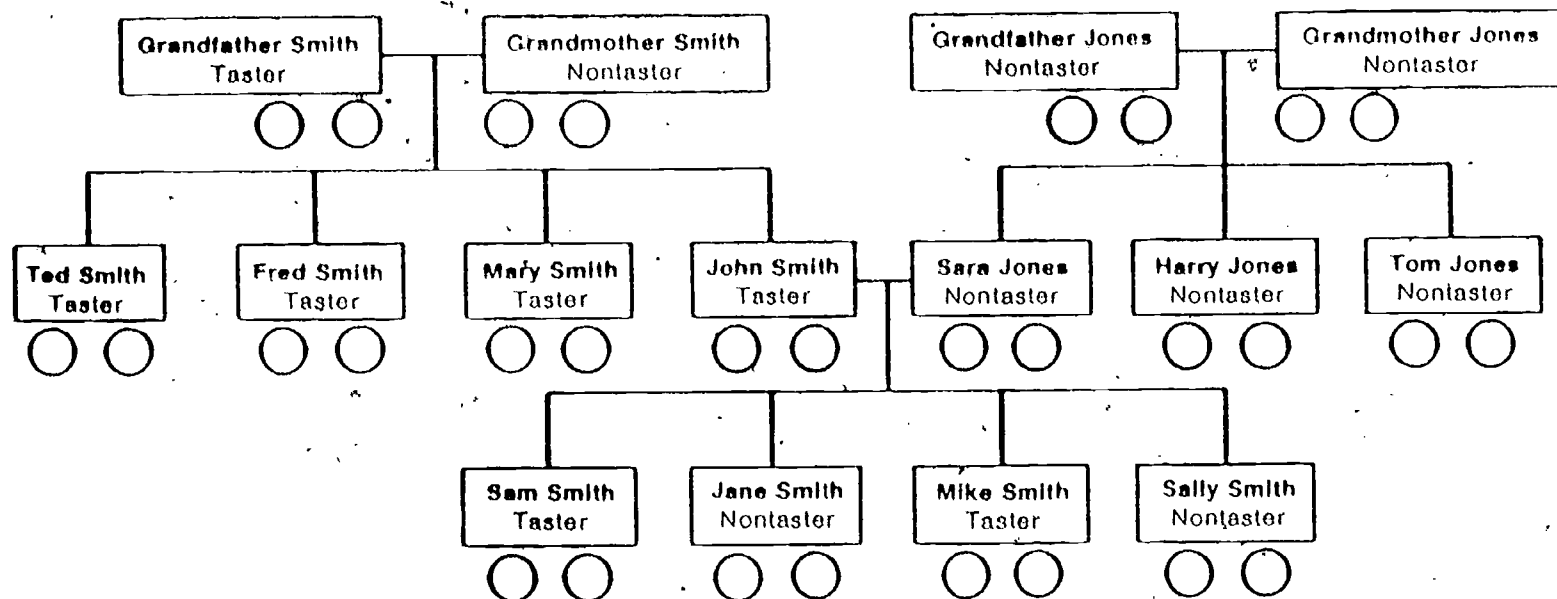

Figure 5-1

□ 5-5. Suppose you assume that the two bits of information for tasting PTC are “taste” and “nontaste.” Which of these bits seems to do the masking, and which is masked? Look at statement 4 of the two-bit model on page 59 before answering.

Scientists usually call the bit for the feature that does the masking the *dominant* bit. The bit for the feature that is masked is usually called the *recessive* bit. Usually they use a capital letter, such as T, to represent the dominant bit and a small letter (like t) for the recessive bit.

Under each name in Figure 5-1 in your Record Book are two circles. The circles represent the two bits of information of that person for taster or nontaster. Assuming that T stands for the taster bit and t for the nontaster bit, you are to properly label each circle with a T or a t. Your answers to questions 5-6 through 5-9 may be of help to you.

According to your two-bit model, every member of the Smith family has to have two bits of information for tasting PTC.

□ 5-6. Which two bits (T or t) must every *nontaster* have? Why?

Use the correct letters to label the bits (circles) of all the nontasters in Figure 5-1 in your Record Book.

5-7. Tasters might have either of two combinations of two bits. What are the two combinations?

5-8. What two bits of information for taste does John Smith have?

In answering the last question, you can be sure that John Smith has at least one bit for taste (T) because he is a taster. But it is not so easy to decide what John's second bit of information is. For a clue, you should look back at the features of his parents.

5-9. You should have no trouble figuring out what two letters to use for all the tasters in Figure 5-1 except for Grandfather Smith. Suppose you found out that all of Grandfather Smith's brothers and sisters had been tasters. What two letters would you give Grandfather Smith?

Write in the proper letters for all the tasters in Figure 5-1 in your Record Book.

Have you ever looked closely at people's ears? No! Well, here's your chance. Ears come with either attached lobes or unattached lobes. Figure 5-2 shows the difference between the two.

Although it's not always easy to tell whether a person's ear lobes are attached or unattached (some people have one of each), you can usually decide one way or the other.

Figure 5-2

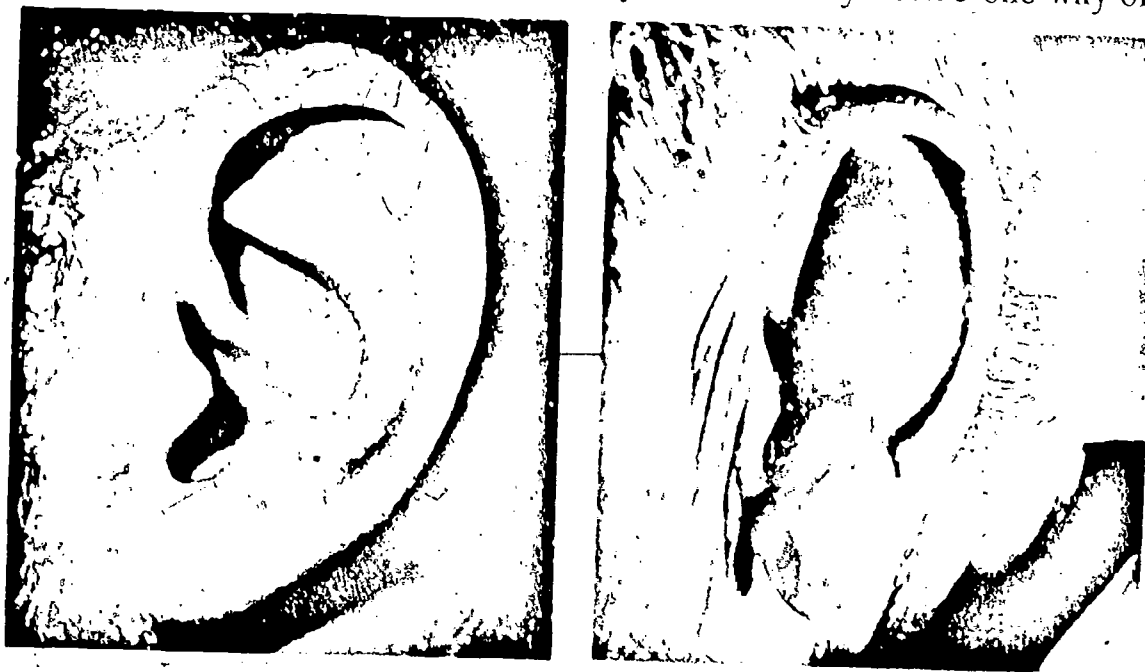

A few years ago, Dr. A. S. Wiener of New York City checked the members of a large family to find out if their ear lobes were attached or unattached. Figure 5-3 shows what he found. In the figure, squares represent men and boys, and circles represent women and girls. Blackened circles or squares indicate unattached ear lobes. Those with no shading represent people with attached lobes. Study the chart carefully.

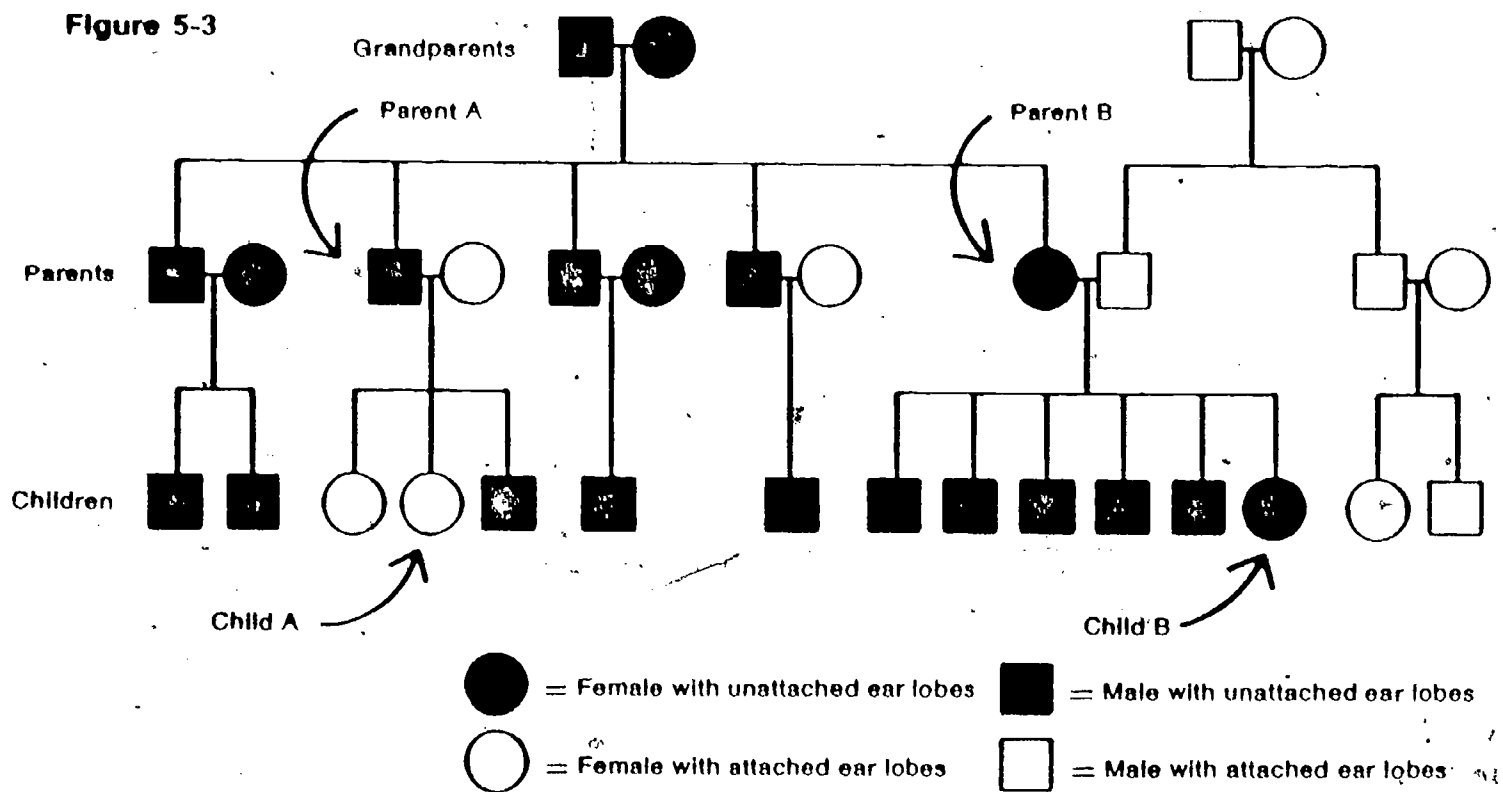

- 5-10. Look at Child A. Explain why you think parent A is a pure strain for unattached ear lobes or not.
- 5-11. What evidence do you find in Figure 5-3 that one bit of information masks another?
- 5-12. According to the two-bit model, what two bits does parent B probably have? What two bits does child B have?
- 5-13. Explain your answer to question 5-12.

Another either-or human feature that is easy to study is how well people can roll their tongue. It's kind of fun to get data on this. To get the data, you will need to work with a partner.



ACTIVITY 5-2. Stick out your tongue and try to roll your tongue as shown.

5-14. Are you a tongue roller?

Collect data from your classmates. Ask them to roll their tongues for you.

5-15. How many of your classmates can roll their tongues?

5-16. How many of your classmates cannot roll their tongues?

Figure 5-4 diagrams the way tongue rolling is inherited in the Johnson family. Look it over carefully. Once again, squares stand for boys and men and circles stand for girls and women. Blackened circles and squares represent people who can roll their tongues. White circles and squares stand for people who cannot.

Figure 5-4

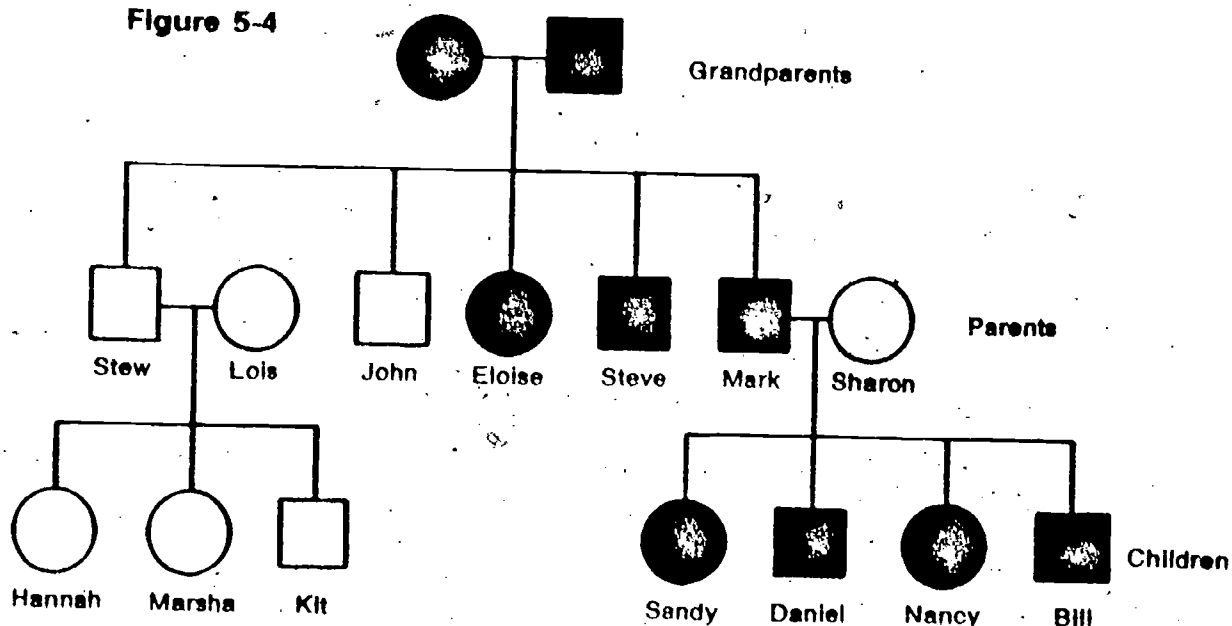

The next few questions deal with the bits of information of the people shown in Figure 5-4. In answering the question, let the letter T stand for the tongue-rolling bit and the letter t for the non-tongue-rolling bit. You can also assume that T masks t.

- 5-17. What bits of information does Stew Johnson probably have?
- 5-18. What bits does Mark Johnson probably have?
- 5-19. Why did you answer question 5-18 as you did?
- 5-20. What bits of information does Sharon Johnson probably have?

Well, by now you should have come to the conclusion that the two-bit model works quite well for human features as well as for those in plants like beans and peas. The problem breaks that follow will give you the chance to find out if it works for your features and your friends' features, too.

PROBLEM BREAK 5-1

Listed below are several common features of people. You are to select one feature from the list for study. Your problem will be to make a chart like the one shown in Figure 5-3 for your own or a classmate's family. The chart should show how grandparents, parents, and children looked in terms of the feature you pick.

Not everyone knows enough about his relatives to make a chart like Figure 5-3. Your biggest problem may be to find someone who does. As a hint, family photographs are often a good source for information of this kind.

When your chart is complete, you are to use the two-bit model to explain what you find. The chart and your description of how the two-bit model applies to it should be recorded in your Record Book.

1. *Hitchhiker's thumb.* If a person can bend the tip of his thumb so that it forms a greater than 45° angle with the rest of the thumb, classify it as a hitchhiker's thumb.
2. *Dimples.* A dimple is a "dent" in either the cheek or the chin.





3. *Widow's peak.* The hairline across the forehead may be either straight or pointed downward in the center. This point is called a "widow's peak."
4. *Gap between teeth.* Some people have a gap between their center upper teeth. Usually a small piece of their gum sticks down between the teeth. Other people's teeth are close enough to touch each other.

PROBLEM BREAK 5-2

Now here's your chance to make a chart for your own family—using the tongue-rolling feature. Test as many members of your family as you can for the tongue-rolling feature. Record your findings in a table in your Record Book. If any of your brothers or sisters are married and have children, you can continue the family tree downward. If you can get data on your grandparents, you can continue your tree upward.

Note *If you do not live with your family, get data from a neighbor, friend, or classmate.*

When you have all the information you can get, draw a chart for tongue rolling. Remember that your chart should show the relationship between family members as well as whether they are rollers or nonrollers.

When your chart is complete, see if you got the same pattern as that shown in Figure 5-4. You may also want to look at the family trees of your classmates to see if there are patterns different from yours. Keep in mind that the bit of information for tongue rollers (T) is dominant and the one for nonrollers (t) is recessive.

By now you may be quite confident of your two-bit model. It seems to have worked quite well for the activities so far. But up to now you have looked only at the inheritance of single features. In the next chapter, you'll have another chance to practice using your model. This time, though, you will look at the inheritance of several features at the same time.

Reminder *Don't forget to watch your fruit flies daily. Before going on, check your calendar to see where you are in your fruit-fly experiments.*

Before going on, do Self-Evaluation 5 In your Record Book.

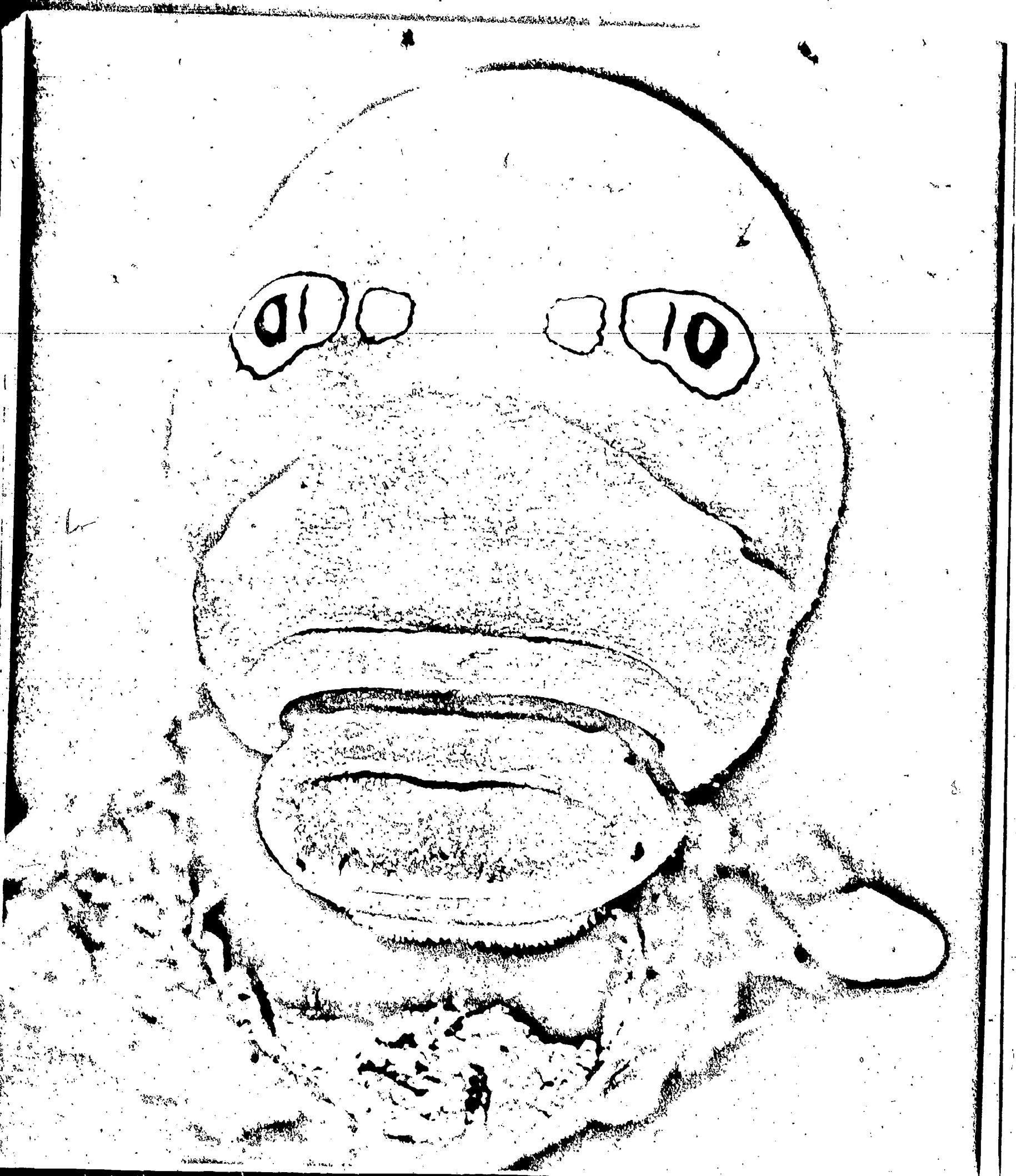

Meet the Ninsect

Chapter 6

Well, the two-bit model seems to work with people as well as with beans, peas, and fruit flies. You can use it to predict things like ear-lobe shape just as well as to predict bean color or roughness in peas.

But so far you've been studying just one feature at a time. Plants and animals pass on a lot of features to their offspring. Will the two-bit model work when you try to follow several features at the same time? That is what you'll try to find out next.

Have you ever seen creatures like the ones shown in Figure 6-1? Probably not, because they are make-believe beasts. We invented them to give you another animal that's fairly easy to study. They are called "ninsects." Your problem will be to make an imaginary mating of a pair of ninsects and to try to predict what the offspring will look like; but first let's check the features that make up a ninsect.

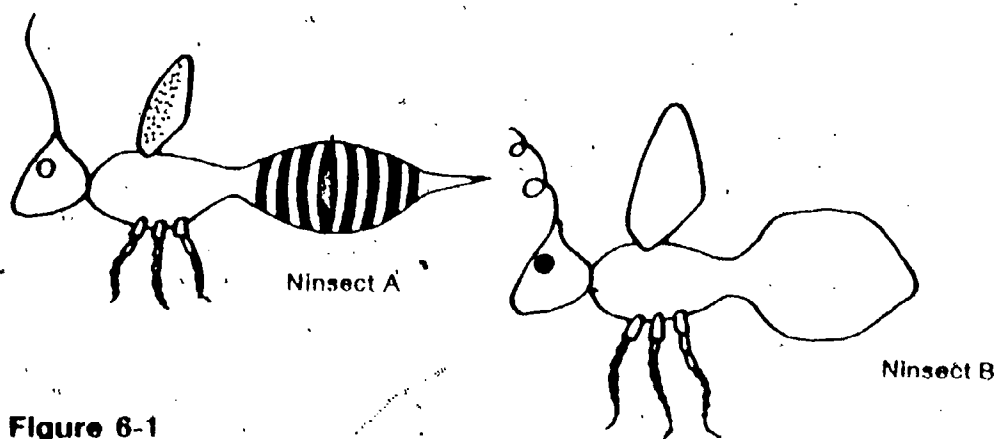

Figure 6-1

Take a close look at the two ninsects in Figure 6-1. Try to find eight differences in the features of the two. In your Record Book, list the differences that you find.

6-1. According to the two-bit model, what causes the two ninsects shown to look so different?

In a moment you will be asked to make two ninsects and to predict the features of their offspring. The eight features that you will study are the ones that make the two ninsects in Figure 6-1 look so different. To be sure that you caught them all, take a look at Figure 6-2.

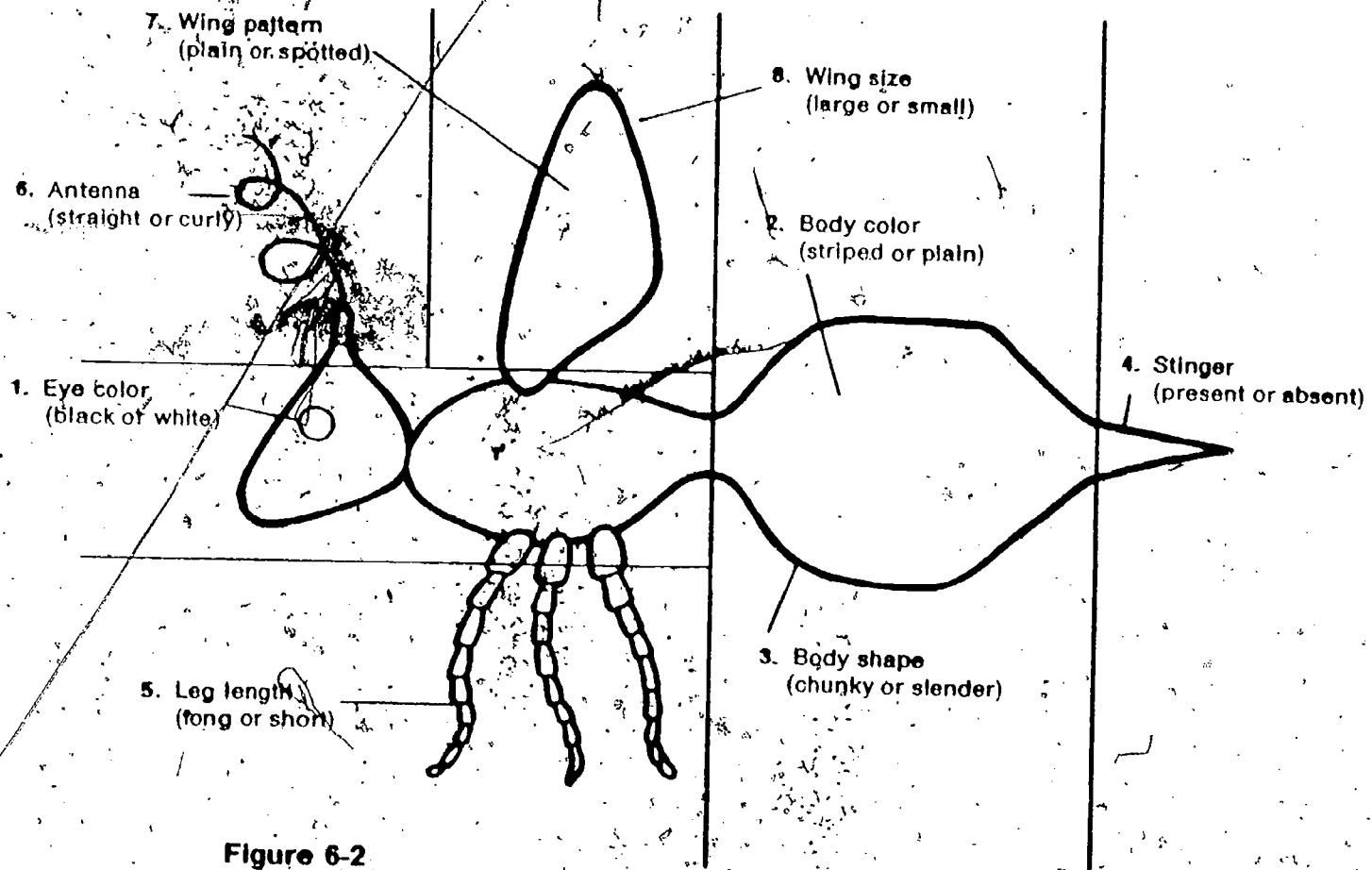

Figure 6-2

According to the two-bit model, every ninsect has two bits of information for each feature shown.

6-2: Altogether, how many bits must each ninsect have for all eight features?

The model assumes that each ninsect gets one bit for each of the eight features from each parent.

6-3: Altogether, how many bits does each parent pass to its offspring?

Check your answers to questions 6-2 and 6-3 by turning your book upside down and reading the bottom of this page. If your answers were not correct, you'd better review Chapter 4 before going on.

Okay, now you're ready to mate a pair of ninsects. To do this, you will need any two of the punched "parent" cards that are in a stack, in the supply area, and a plastic ninsect guide card.

Lay the two punched cards on the desk before you. Notice that eight groups of holes have been punched in each card. The groups of holes in one of the cards represent a set of eight bits of information from one ninsect parent. The groups of holes in the second card stand for the eight bits from a second parent. Your job will be to figure out what kind of ninsect offspring would result from this combination of sixteen bits of information:

PLAYING THE GAME

ACTIVITY 6-1. Slide the plastic guide card over one of your punched cards as shown. Notice that each group of holes represents a bit for one feature. Notice also that some holes fall on the D line and others on the d line.

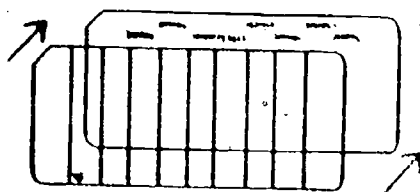

Slide plastic guide over card 1.

	D	d									
1			EYE COLOR								
			0 BLACK								
			1 WHITE								
2			BODY COLOR								
			0 STRONG								
			1 PLAIN								
3			BODY SHAPE								
			0 CHUNKY								
			1 SLIM								
4			STINGER								
			0 PRESENT								
			1 ABSENT								
5			LEG LENGTH								
			0 LONG								
			1 SHORT								
6			ANTENNA								
			0 STRAIGHT								
			1 CURLY								
7			WING PATTERN								
			0 PLAIN								
			1 SPOTTED								
8			WING SIZE								
			0 LARGE								
			1 SMALL								
			NINSECT GUIDE CARD								

6-2. Each feature has two bits (large or small, plain or spotted, straight or curly, etc.). There are eight features with two bits each, so each ninsect has sixteen bits for all eight features.

6-3. Since each ninsect gets one bit for each feature from each parent, then each ninsect gets eight bits from one parent and eight bits from the other parent.

Now use the plastic guide card to "read" the two punched cards (the bits from the two parents). Table 6-1 in your Record Book gives you a place to describe the bits of information that are punched into each of the parent cards. Leave the Appearance of Offspring column blank for now.

Table 6-1

Feature	Bits of Information				Appearance of Ninesect Offspring
	Parent (card) #1		Parent (card) #2		
	D or d	Appearance	D or d	Appearance	
Eye color [black (D) or white (d)]					
Body color [striped (D) or plain (d)]					
Body shape [chunky (D) or slender (d)]					
Stinger [present (D) or absent (d)]					
Leg length [long (D) or short (d)]					
Antenna [straight (D) or curly (d)]					
Wing pattern [plain (D) or spotted (d)]					
Wing size [large (D) or small (d)]					

What the offspring will look like depends upon the bits of information it gets from its parents. As you complete the right-hand column in Table 6-1, remember D features always mask d features. If one parent's bit is D black and the other's is d white, the offspring will show the dominant feature.

6-4. Which bit is dominant, D black or d white?

You have no problem when the bits from both parents are the same. If both parents pass on the bit D black, that is what your ninesect inherits. If both pass on d white, your ninesect inherits d white. Using what you have learned about dominant and recessive features, complete the right-hand column in Table 6-1.

ACTIVITY 6-2. Using the information in the right-hand column of Table 6-1, pick the body pieces you need from the box of insect parts in the supply area. Then build your insect offspring.

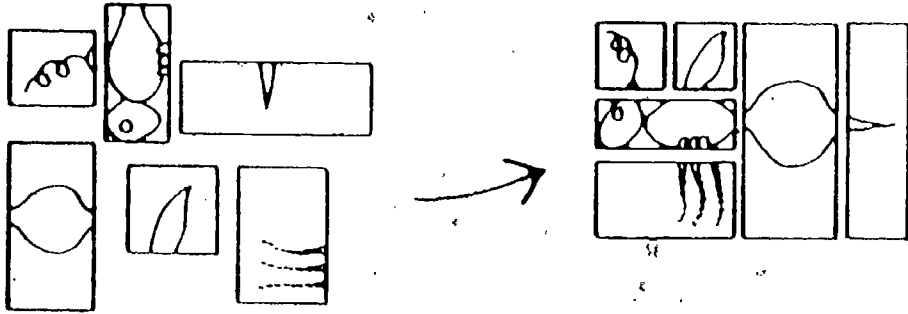

ACTIVITY 6-3. Attach a paper clip to each of the two parent cards you just used. Set these cards near the insect you just constructed.

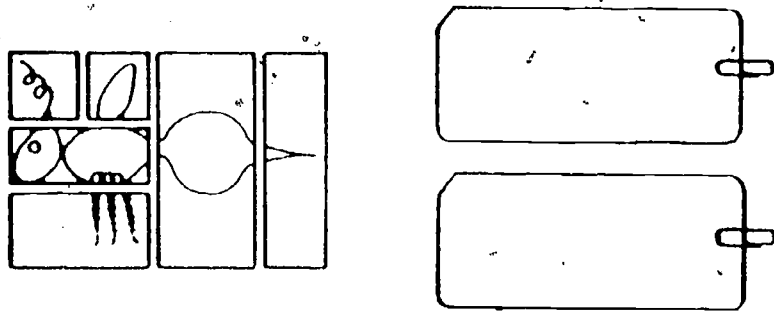

ACTIVITY 6-4. Pick two more parent cards from the stack in the supply area.

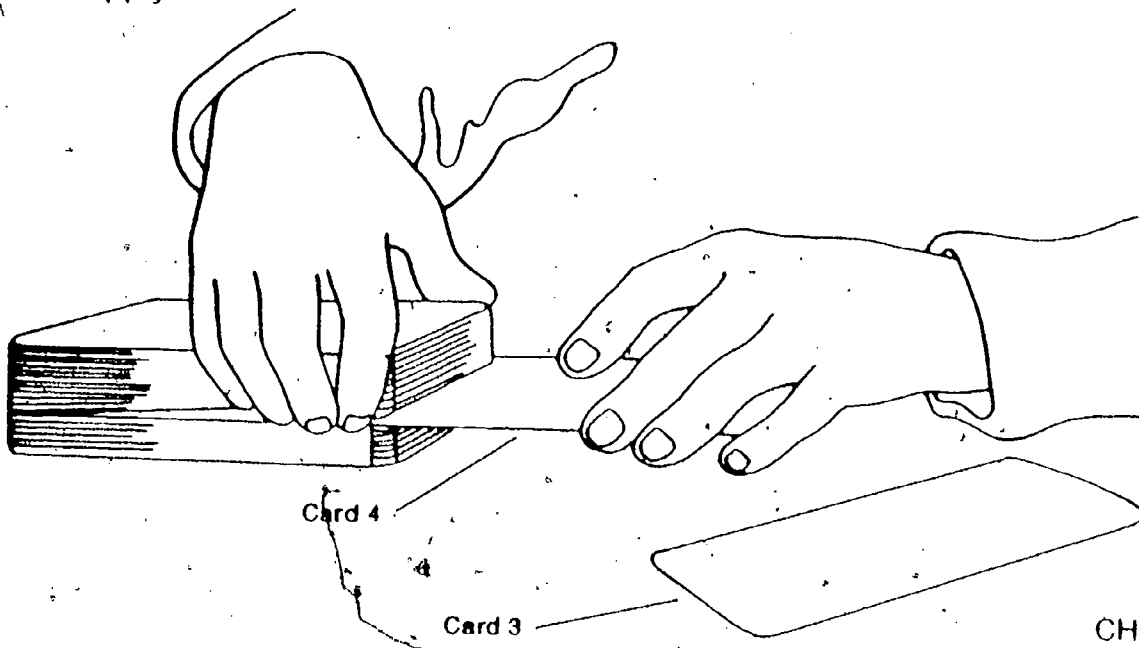

These two new cards will give you the bits of information for the parents of a second offspring. Read the information for each feature from both cards and record these data under the Parent columns in Table 6-2.

Table 6-2 Complete the right-hand column in Table 6-2.

Feature	Bits of Information				Appearance of Nissect Offspring
	Parent (card) #1		Parent (card) #2		
	D or d	Appearance	D or d	Appearance	
Eye color [black (D) or white (d)]					
Body color [striped (D) or plain (d)]					
Body shape [chunky (D) or slender (d)]					
Stinger [present (D) or absent (d)]					
Leg length [long (D) or short (d)]					
Antenna [straight (D) or curly (d)]					
Wing pattern [plain (D) or spotted (d)]					
Wing size [large (D) or small (d)]					

ACTIVITY 6-5. Build your second ninsect by picking the right body pieces from the box in the supply area. Place this ninsect offspring next to your first offspring.

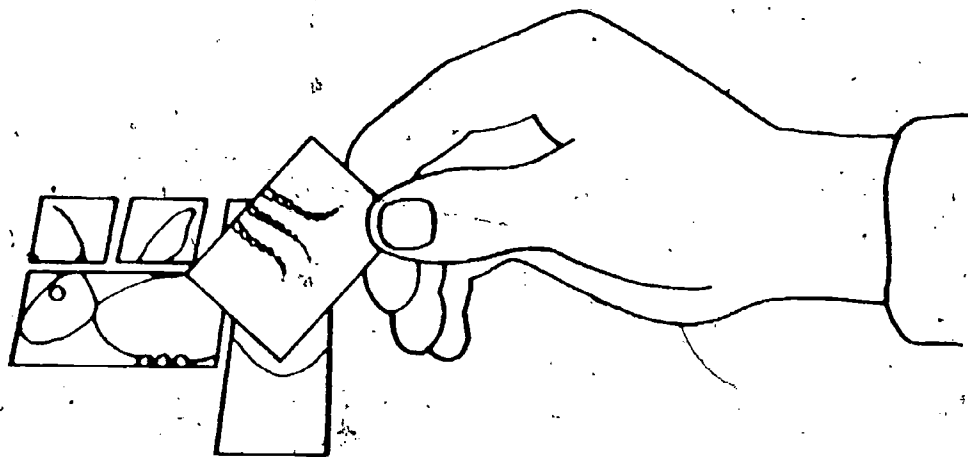

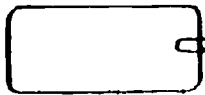
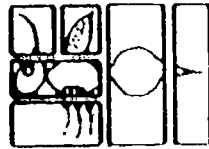
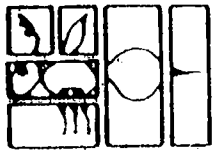

Card 1

Card 2

Card 3

Card 4

ACTIVITY 6-6. Put cards 3 and 4 below the new insect.

If your class period ends before you finish this chapter, put the insect body pieces back in the box in the supply area. But keep your four cards. Put the cards in a safe place until you can continue. When you start again, you can easily rebuild your two insects, using the information from Tables 6-1 and 6-2.

The two insects you just created will soon be the proud parents of four "noffspring." Your problem is to figure out what these creatures will look like and to build a picture of each out of insect parts.

The holes in the two cards below each soon-to-be-parent insect tell you what set of bits it got from each of its parents. Your two-bit model tells you that each new parent insect will pass along one of these two sets of bits of information to each of its noffspring. But which set of bits will be passed to which noffspring?

6-5. What will determine which set (card) of bits (holes) will be passed by each parent to the first noffspring?

Check your answer to question 6-5 by turning your book upside down and reading the bottom of this page.

6-5. Which set of bits will be passed on by each parent is decided by chance; it could be either one, and neither set has a better chance than the other. This kind of choice, where every set has an equal chance to be passed on, is called a *random process*. Our inheritance model assumes that all separations and rejoins of bits and sets are random processes.

GETTING A SECOND GENERATION

If you had trouble, turn back for help to page 53. The two-bit model is summarized there.

Earlier, you learned that chance determines which bits of information are passed from a parent to an offspring. This means that either set (card) of bits (holes) from one parent might combine with either set (card) of bits (holes) from the other parent to form an offspring. Let's consider what combinations of cards (and bits) are possible. Take a look at Figure 6-3.

□ 6-6. How many possible combinations of sets of bits are shown in Figure 6-3?

Figure 6-3

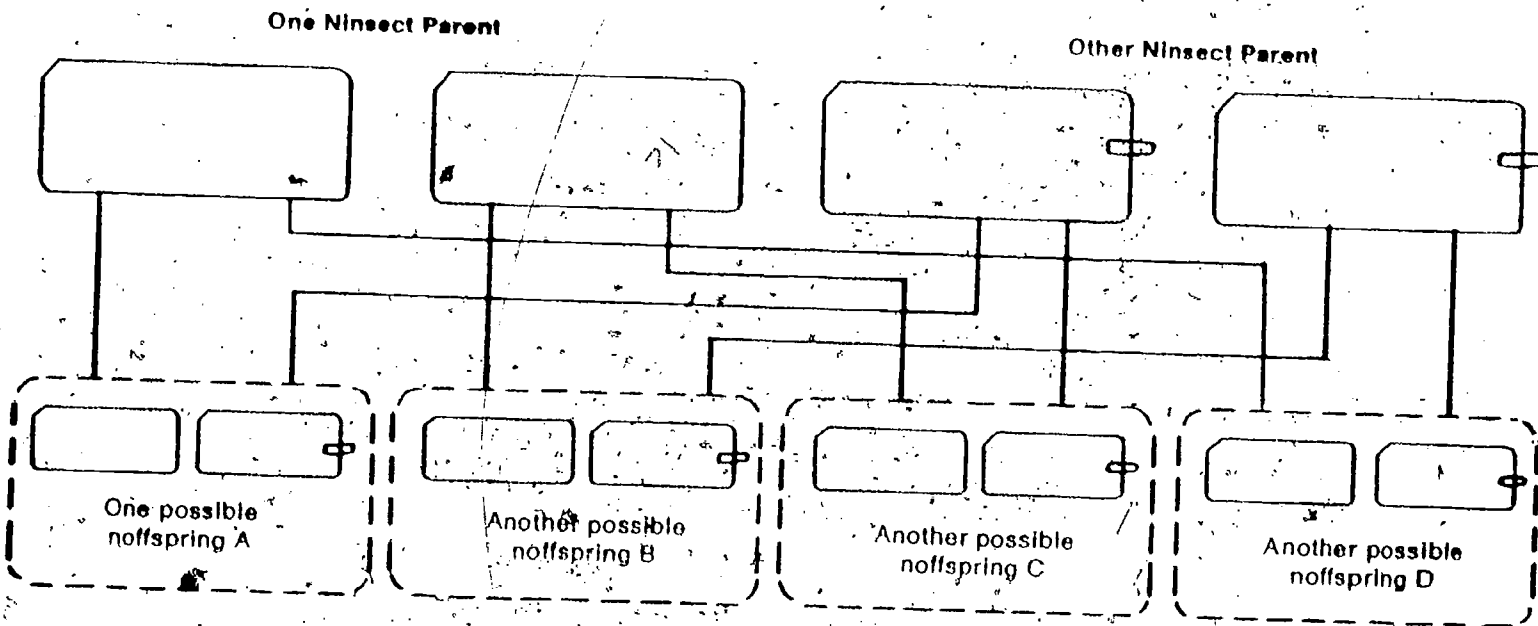

ACTIVITY 6-7. Use the offspring combination labeled "A" in Figure 6-3 to pick out two cards. The sets of bits on these two cards will determine what offspring "A" will look like.

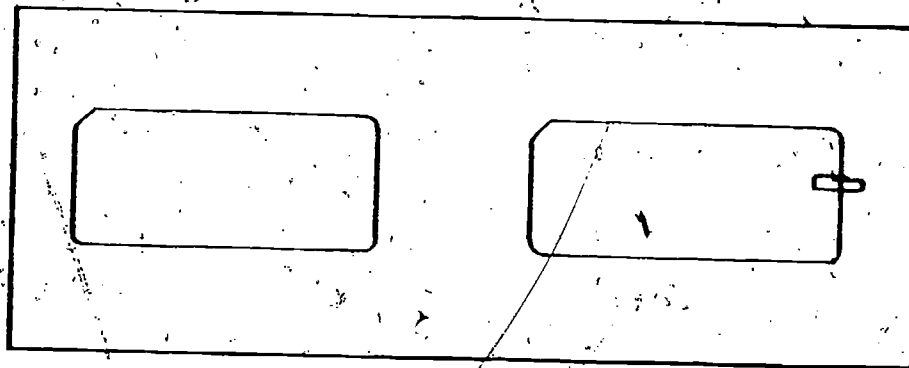

Let's call the cards with the paper clips attached 1a and the other 1b. The second set of cards we will call 2a and 2b. Figure 6-4 illustrates these combinations.

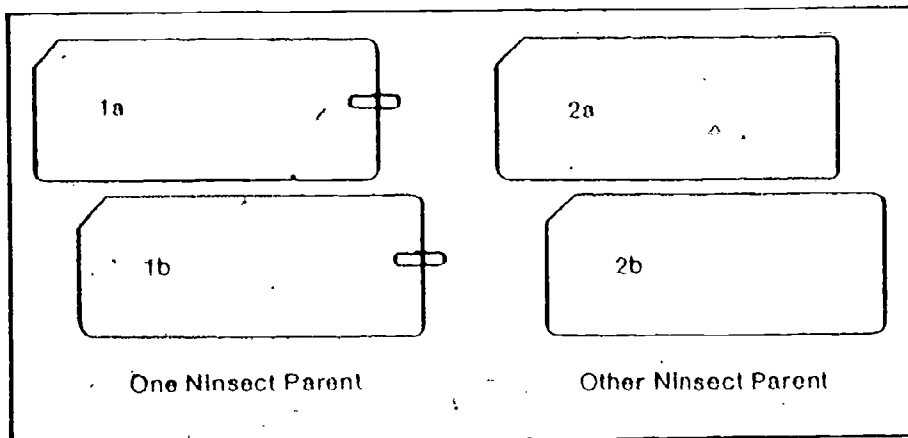

Figure 6-4

Let's consider what combinations of cards (and bits) are possible. Take a look at Figure 6-5.

1a can combine with 2a or 2b.

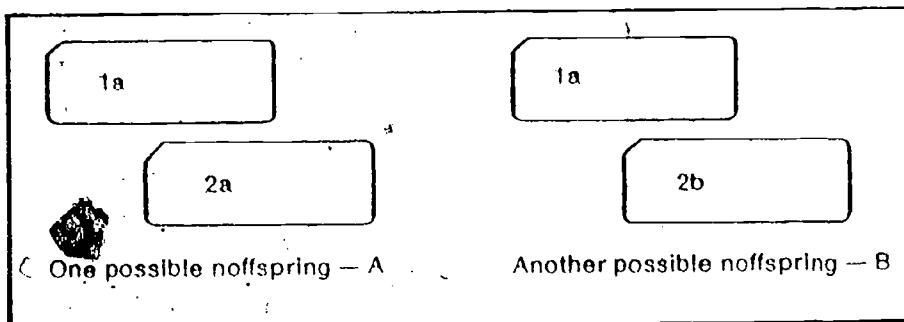
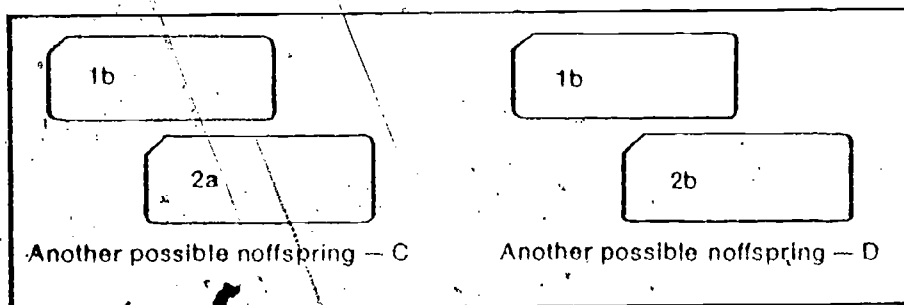

Figure 6-5

1b can also combine with 2a or 2b.



Take the card that you are calling 1a and combine it with card 2a.

Record the information for each feature from both cards in the middle columns of Table 6-3 in your Record Book. Then decide what offspring "A" looks like and record this in the right-hand column.

Feature	Bits of Information				Appearance of Ninsect Offspring
	Parent (card) # 1		Parent (card) # 2		
	D or d	Appear- ance	D or d	Appear- ance	
Eye color [black (D) or white (d)]					
Body color [striped (D) or plain (d)]					
Body shape ⁶ [chunky (D) or slender (d)]					
Stinger [present (D) or absent (d)]					
Leg length [long (D) or short (d)]					
Antenna [straight (D) or curly (d)]					
Wing pattern [plain (D) or spotted (d)]					
Wing size [large (D) or small (d)]					

Table 6-3

Consult Figure 6-5 and combine the cards for offspring "B," "C," and "D." Record these data in Tables 6-4, 6-5, and 6-6 in your Record Book and complete the right-hand column of each table.

Table 6-4

Feature	Bits of Information				Appearance of Ninsect Offspring
	Parent (card) # 1		Parent (card) # 2		
	D or d	Appear- ance	D or d	Appear- ance	
Eye color [black (D) or white (d)]					
Body color [striped (D) or plain (d)]					
Body shape ⁶ [chunky (D) or slender (d)]					
Stinger [present (D) or absent (d)]					
Leg length [long (D) or short (d)]					
Antenna [straight (D) or curly (d)]					
Wing pattern [plain (D) or spotted (d)]					
Wing-size [large (D) or small (d)]				91	

Table 6-5

Feature	Bits of Information				Appearance of N insect Offspring
	Parent (card) # 1		Parent (card) # 2		
	D or d	Appear- ance	D or d	Appear- ance	
Eye color [black (D) or white (d)]					
Body color [striped (D) or plain (d)]					
Body shape [chunky (D) or slender (d)]					
Stinger [present (D) or absent (d)]					
Leg length [long (D) or short (d)]					
Antenna [straight (D) or curly (d)]					
Wing pattern [plain (D) or spotted (d)]					
Wing size [large (D) or small (d)]					

Table 6-6

Feature	Bits of Information				Appearance of N insect Offspring
	Parent (card) # 1		Parent (card) # 2		
	D or d	Appear- ance	D or d	Appear- ance	
Eye color [black (D) or white (d)]					
Body color [striped (D) or plain (d)]					
Body shape [chunky (D) or slender (d)]					
Stinger [present (D) or absent (d)]					
Leg length [long (D) or short (d)]					
Antenna [straight (D) or curly (d)]					
Wing pattern [plain (D) or spotted (d)]					
Wing size [large (D) or small (d)]					

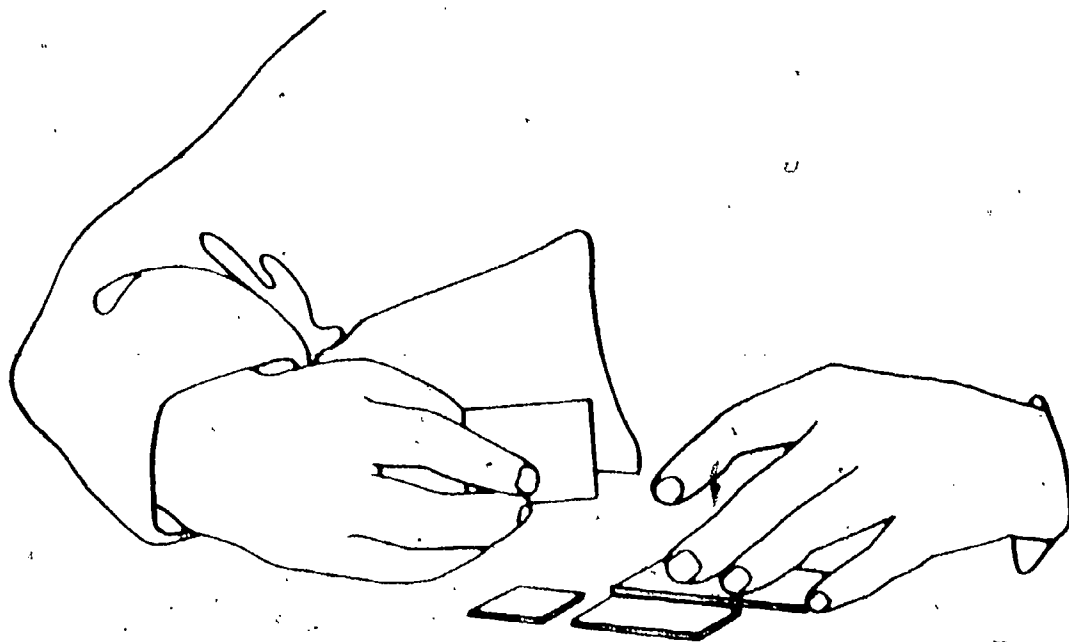

ACTIVITY 6-8. Construct your four noffspring by selecting the right body pieces from the box in the supply area. Place the noffspring below their parents for comparison.

- 6-7. In what ways do the features of the noffspring differ from the features of their parents?
- 6-8. How do the noffspring differ from each other? Answer this by comparing the features of all four noffspring.

PROBLEM BREAK 6-1

When you get older, you'll sometimes wish that you could live your whole life over again. You'll think that you could do a better job of it the second time because you know so much more. This is your chance to live a part of it over again right now. See if you can get more out of it the second time around.

Play the ninsect game one more time. Begin at the point where you randomly selected your first two punched cards (page 71). Repeat that page and continue again to the page you are now on. Complete new inheritance tables to find out what another set of ninsect noffspring look like.

It should be clear by now how the two-bit model can help you predict the inheritance of features generation after generation. If the process of doing this doesn't become almost second nature, repeat the same steps again.

PROBLEM BREAK 6-2

Here's a good chance to test your understanding of the two-bit model and of inheritance in ninsects. You'll try to predict the features of parent ninsects by observing the features of their noffspring. For this activity, you'll need to find a classmate who is at the same place you are.

ACTIVITY 6-9. Ask your partner to cover up his parent ninsects. Study his noffspring and try to predict the features of their parents. He should do the same with your ninsects.

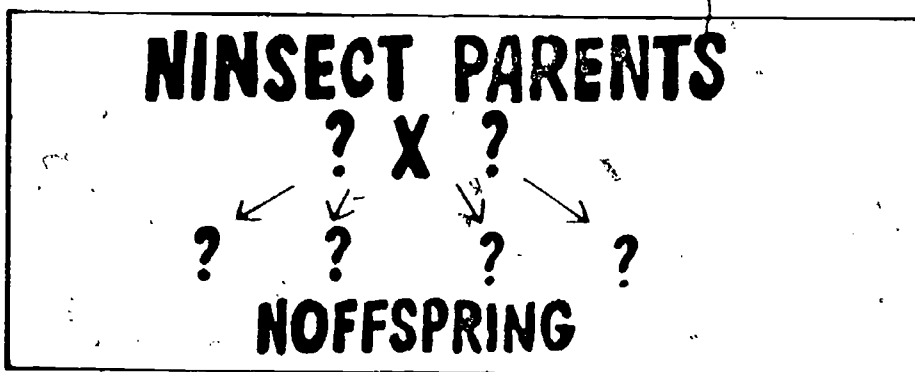

Draw a table in the space provided in your Record Book. Record your predictions there. When you and your partner are finished, you should check your predictions by uncovering the parents. Discuss with him any differences between the actual and the predicted features.

Hint: *If you have trouble getting started, take a look at one feature at a time.*

Your two-bit model for inheritance is very much like the model now used by scientists. The story of how the two-bit model was built in the first place reads like a detective story. **Excursion 6-1**, "A Bit More About Bits," tells this story. Take a look if you are interested.

◀ **EXCURSION**

Before going on, do Self-Evaluation 6 in your Record Book.



Problems, Problems, Problems

Chapter 7

In this chapter, you will have the chance to test your model-building ability. If you took either the seventh- or eighth-grade ISCS course, you know that models must often be changed to explain new observations. The two-bit model that has worked so well up to now will simply not explain the observations you'll make next. Your problem will be to adjust the model so that it will.

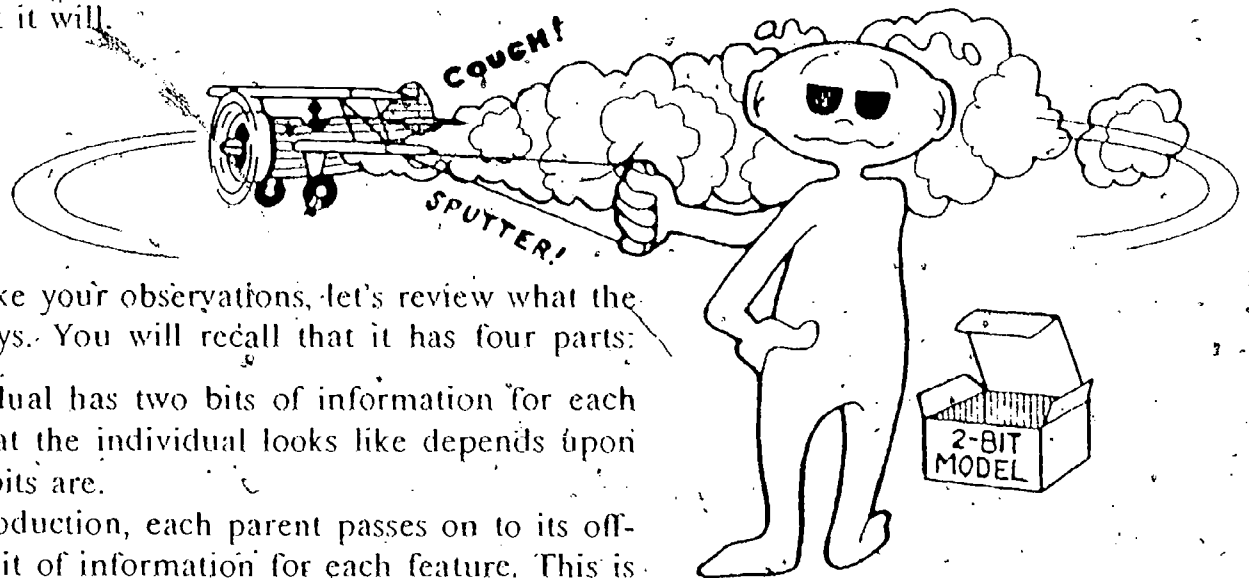

Before you make your observations, let's review what the two-bit model says. You will recall that it has four parts:

1. Each individual has two bits of information for each feature. What the individual looks like depends upon what those bits are.
2. During reproduction, each parent passes on to its offspring one bit of information for each feature. This is how the offspring gets its two bits.
3. Each of a parent's two bits for each feature has an equal chance of being passed from parent to offspring.
4. If an individual receives two different bits of information for a feature, one bit may mask the other.

Okay, here's your first problem. Good luck!

Two pure-strain morning glory plants, one with red flowers and one with white flowers, produce four offspring, all with pink flowers.

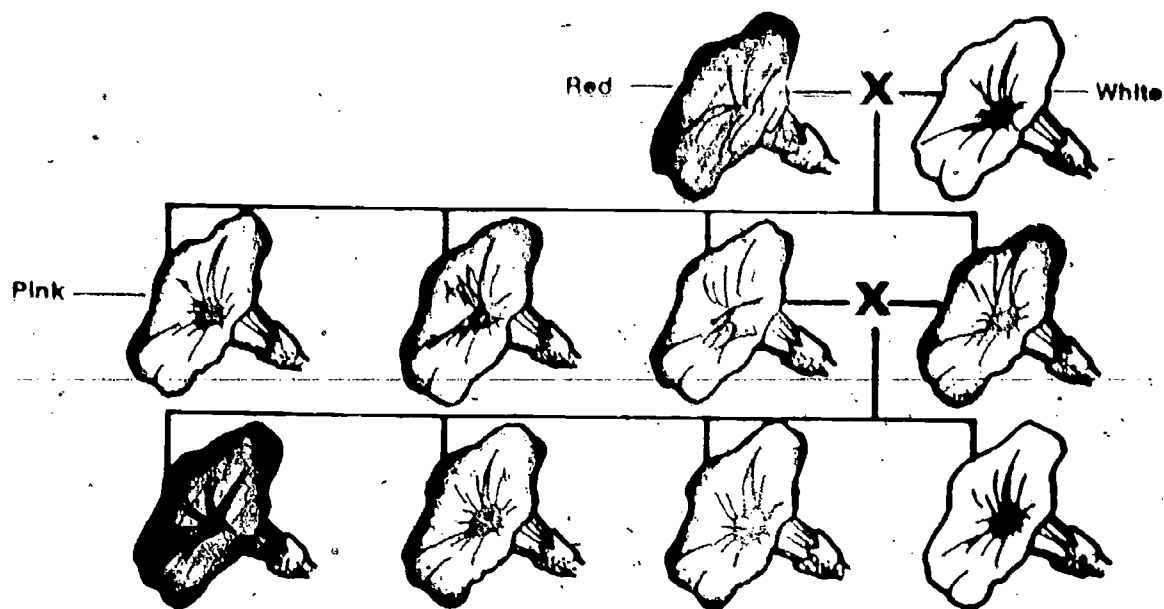

Figure 7-1

Two of the offspring then produce four more offspring. (See Figure 7-1.)

Don't say you weren't warned! You're probably shaking your head by now and saying, "Where did those pink flowers come from?" The two-bit model certainly doesn't predict them.

Actually, with a very slight change, your model can explain the morning glory case. Read through the four points of the model very carefully until you figure out how you want to change it. Remember, however, to keep the change as small as possible, so that after it's made, the model will still explain the other situations you've studied.

□7-1. Describe a change you can make in statement 4 on page 83 that will allow the two-bit model to explain both the bean data on page 59 and the morning glory data.

Well, did you figure out the morning glory problem? It's actually quite a simple one. If you would like to find out whether your solution to the problem agrees with ours, turn to **Excursion 7-1**, "Red, White, and Pink." That excursion will also help if you've hit a stone wall with the problem, but don't give up until you've really tried.

Ready for another problem? Here goes!

Some people are born with a problem. Their hair is bound to fall out at some point in life. Experiments have shown that this tendency toward baldness is passed along from parents to offspring. Figure 7-2 shows the history of a family

EXCURSION

in regard to baldness. On the diagram, circles stand for women and squares stand for men. Black circles and squares stand for bald people, and white ones stand for nonbald people.

Look over Figure 7-2 carefully. Try to use the two-bit model to explain what you see there.

Because the baldness problem is a pretty tough one, you deserve a hint on how to solve it. Here's your hint:

In baldness, the bit of information that does the masking and the bit that is masked sometimes switch places. But by a certain rule about when the switch takes place, you can make good predictions.

Figure 7-2

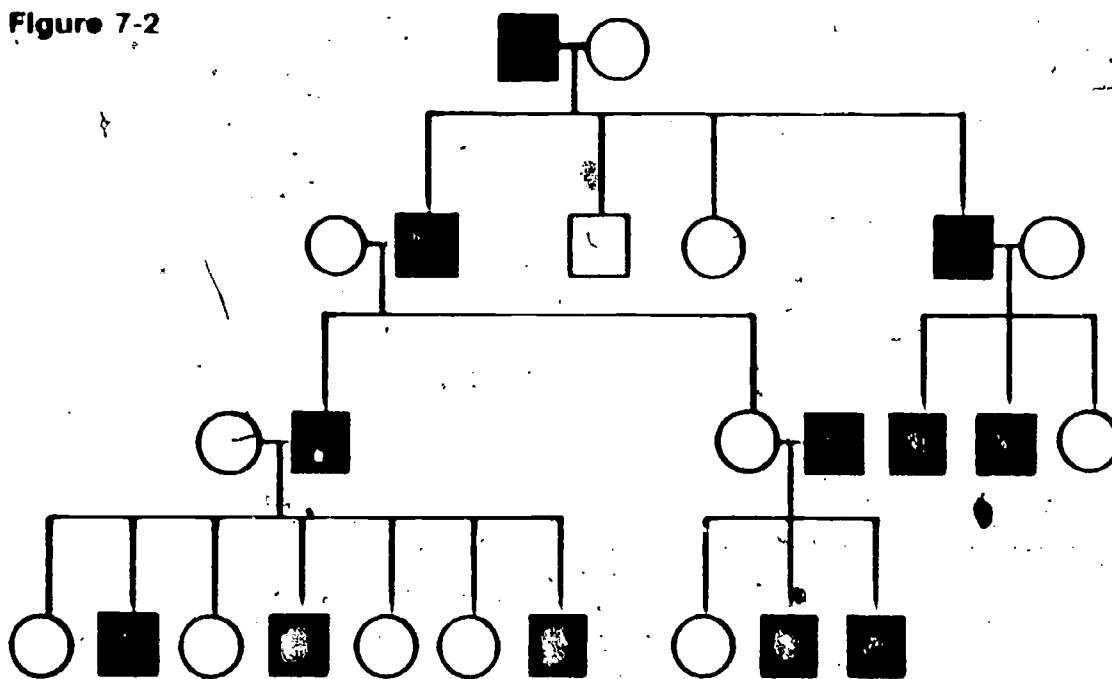

□7-2. Explain how you could change the two-bit model described on page 83 to make it better able to explain Figure 7-2:

For the moment, we're not going to give you any more help with the baldness problem. When you think you have a solution, talk it over with a classmate. When you are pretty sure that your solution works or you can't get any farther, turn to **Excursion 7-2**, "Hair Heirs." That excursion will tell you whether you have a good answer or will help you find out where you went wrong.

Palm readers, crystal-ball gazers, and other fortune tellers are often asked to predict whether a woman will give birth

EXCURSION

EXCURSION ►

to a boy or a girl. They would have a better chance of being right if they knew something about the sex of other members of both families. Sex is an inherited feature, too, as you can find out by reading **Excursion 7-3**, "Boy or Girl."

EXCURSION ►

We could happily do without some of the features we inherit. And none of us, be we kings or commoners, want to take the blame for passing on such handicaps as color blindness or bleeder's disease. To see how these are inherited, do **Excursion 7-4**, "A Royal Problem."

EXCURSION ►

Do you suppose every difference between the appearance of some plants and animals and the appearance of others of their own kind can be blamed on inheritance? Suppose two plants from the same parent plant, for example, had different-colored leaves. What besides inheritance might explain this difference? Take a look at **Excursion 7-5**, "I Wonder/Where the Color Went."

EXCURSION ►

What you look like usually depends on what your parents look like. Features can be passed on from generation to generation. But does this always happen? Let's find out. Turn to **Excursion 7-6**, "One, Two, Pick-up Sticks."

EXCURSION ►

Are you as you are because of inheritance, or environment? See **Excursion 7-7**, "Do Blondes Have More Fun?" for some activities with this idea.

Well, that's it. We hope that you can now give at least a part of an answer to the question "Why are you you?" The two-bit model can answer many questions about inheritance, but as always, there are many more questions you haven't even asked. Where do features come from in the first place? How does the offspring change bits of information from his parents into features? How do such hazards as atomic radiation, drugs, and pollution affect bits of information? Can a person's bits of information be changed, and if so, how should they be changed?

We opened with a question. We are closing with many questions. That's science.

Before going on, do Self-Evaluation 7 in your Record Book.

Excursions

Do you like to take trips, to try something different, to see new things? Excursions can give you the chance. In many ways they resemble chapters. But chapters carry the main story line. Excursions are side trips. They may help you to go further, they may help you go into different material, or they may just be of interest to you. And some excursions are provided to help you understand difficult ideas.

Whatever way you get there, after you finish an excursion, you should return to your place in the text material and continue with your work. These short trips can be interesting and different.



10

More on Offspring

Excursion 1-1

Male plants and animals, including the fruit flies that you will use in this unit, make *sperm* in their bodies. Female plants and animals produce *eggs*. A new plant or animal starts developing when a sperm from a male plant or animal combines with an egg from a female plant or animal of the same type. The process of combining is called *fertilization*. But since the sperm and the eggs are often in separate bodies (a boy and a girl, for example), how do the sperm and eggs get together? Plants and animals have found similar ways to make this happen.

In flowering plants, the sperm are wrapped in a shell. The shell with the sperm inside is called a *pollen grain*. Animals don't wrap the sperm in a shell. Instead, sperm swim freely in a fluid.

In plants, pollen grains containing sperm reach the female parts of the flower in many ways. Sometimes the grains are carried by the wind or by insects. Sometimes the grains just fall from the male part of a flower onto the female part of the flower. But because plants depend upon such things as the winds and insects to spread pollen, fertilization in plants often seems very unlikely. The same thing is true for some animals. For example, many male fish just put their sperm into the water. Then fertilization will occur only if these sperm find the eggs that a female fish has dropped elsewhere into the water.

Many plants and animals have developed ways to increase the chance that their eggs will be fertilized. Most living things produce millions more sperm than eggs. Since it takes only one sperm to fertilize an egg, this means that fertilization happens quite often. Also, some plants produce odors or bright colors that attract insects. These insects pick up pollen from one flower and carry it to the next one they visit. Pollen grains from the first flower fall from the insect onto the

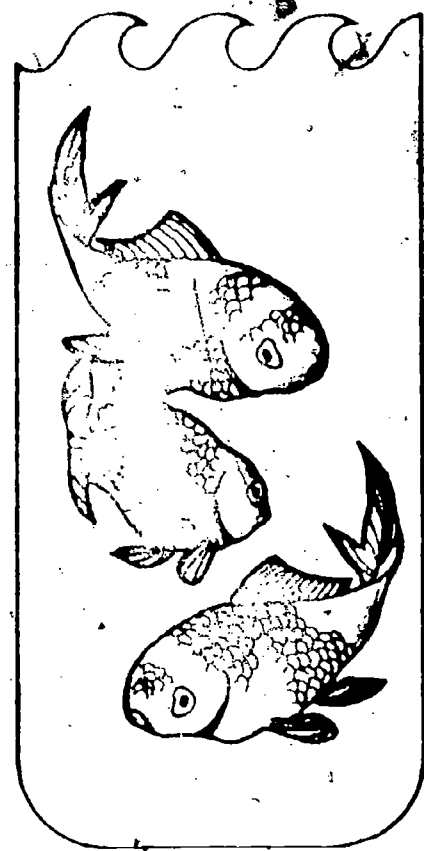

female part of the second flower. Many male animals put their sperm close to the egg by putting the sperm into the body of the female. The process of depositing sperm is called *mating*.

PROBLEM BREAK: FROG SPERM

Check with your teacher to find out if male frogs and a microscope are available. If so, he will prepare a sperm solution for you. Place a drop of the sperm solution on a microscope slide and cover with a cover slip (have your teacher show you the proper use of a microscope first). Then place the slide under the microscope and study it under high power.

- 1. What enables the frog sperm to move?

In this unit, the term *cross* will be used many times. For instance, you will soon be asked to *cross* two different kinds of fruit flies. This means that you are to let certain male flies mate with certain female flies. During this mating, the sperm from one kind of male fly will unite with eggs from another kind of female fly.

What happens after the sperm is put near the egg? In plants, a short time after the pollen grain lands on a female part of the plant (this is called the *pistil*), a tube grows from the pollen grain down into the thick base of the plant. This is called the *ovary* and contains the eggs. After growth the pollen tube reaches and touches the eggs in the *ovary*, and fertilization takes place (see Figure 1). Then the fertilized egg begins to grow into a new plant.

When animals mate, the male puts his sperm into a tube inside the female. This tube leads to the eggs. Figure 2 diagrams how this happens in the fruit fly that you will be working with.

Once the sperm is inside the female fruit fly, it moves up the tube until it locates an egg. Then fertilization occurs. Although the male may put thousands of sperm cells into the female, only one sperm cell can fertilize each egg. After the fertilized eggs have developed for a short time, the female fly lays them. The egg then hatches, and the new fly goes through several stages before it becomes an adult. In some animals the female keeps the fertilized egg in her body to develop. She then gives birth to a fully developed baby.

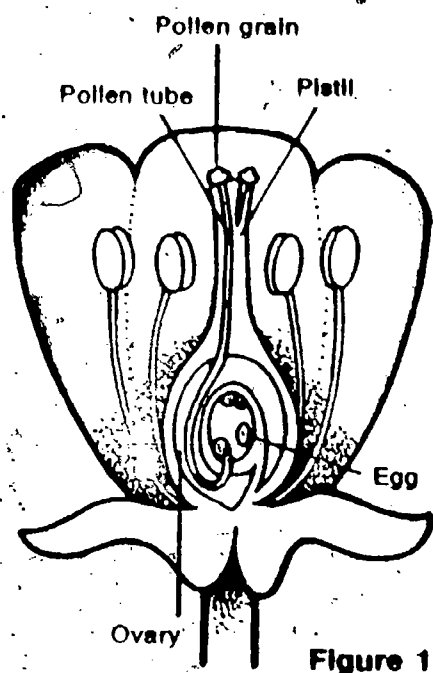

Figure 1

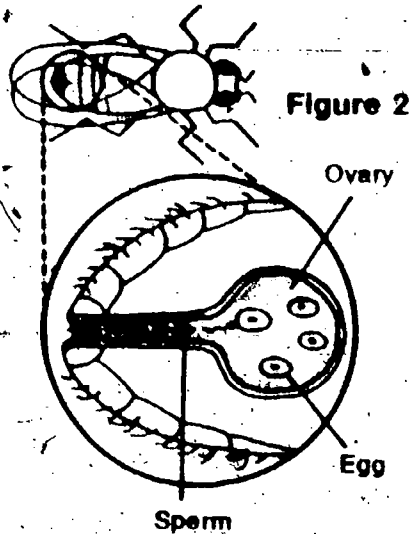

Figure 2

Writing Operational Definitions

Excursion 1-2

You are doing this excursion because you need to know how to write an operational definition of *pure strain*.

Operation is the key word to understand. It means action or activity. An *operational definition* tells what operations, or actions, you do to identify or measure the thing being described. In other words, it describes what you must *do* to tell if you have the thing being described or to tell how much of it you have. If, after reading a definition of something, you know what to do to identify the thing being defined or how to measure it, then that definition is an operational one.

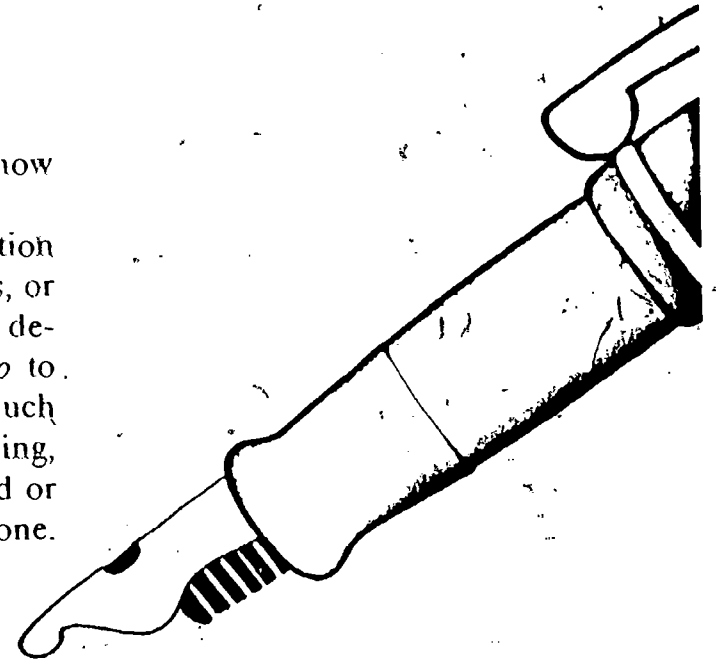

OPERATIONAL DEFINITIONS

For example: "To measure body temperature, you should:

1. put a clinical thermometer under your tongue;
2. leave the thermometer in place for at least two minutes; and
3. record the level of the mercury column in degrees."

As soon as you have read the definition above, you know exactly how to measure body temperature. Thus, the definition is an *operational definition*.

How about this one?

"A tree is a large woody plant under which a person can find a shady place to rest."

This definition of a tree is *not* an operational definition. It does not list the things you must do in order to identify a tree. And it certainly doesn't tell you how to measure one.

1. Here is a list of definitions. Write in your Record Book the letters of those that you think are operational definitions.

- a. A *hammer* is something used to drive a nail.
- b. To find the *length* of something, you place a ruler next to it with the number zero opposite one end and read the number that the other end of the ruler lines up with.
- c. An *experimental variable* is anything that can be changed during an experiment.
- d. To find out how much *time* passes, you look at the hands of a clock twice and determine how far the hands have moved.
- e. *Handedness* is determined by finding out which hand can cross out the most zeros in thirty seconds.
- f. *Work* is the product of the force in newtons exerted on an object and the distance in centimeters through which the force acts.

You did well if you wrote letters **b**, **d**, **e**, and **f**. If you did not list these, you had better go back and reread this excursion.

2. Explain why **a** and **c** above are not operational definitions.

3. Give an operational definition for the following words.

- a. weight
- b. force
- c. pure strain

Temperature and Life Cycle

Excursion 1-3

Since 1909, the common fruit fly has been widely used to study the way features are passed from parents to offspring. Scientists have learned more about the laws of heredity from working with this tiny insect than from working with any other animal.

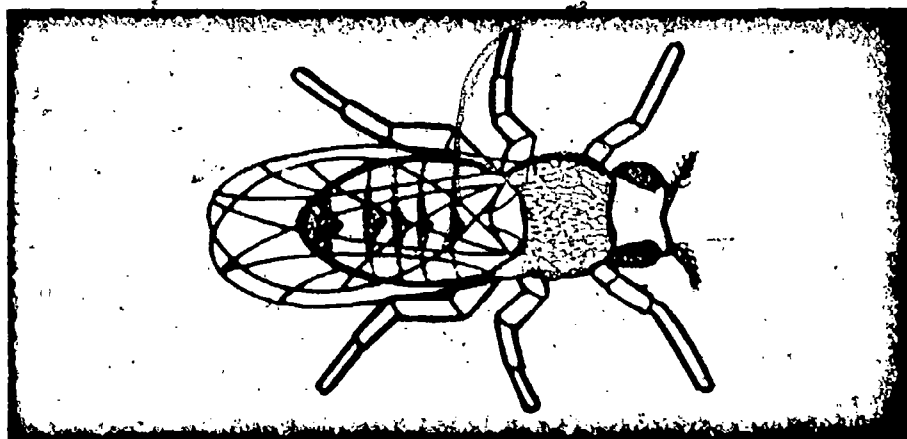

The fruit fly is ideal for studying heredity because:

1. It takes 10 to 20 days to grow from an egg to an adult fly.
2. Its small size makes it easy to keep alive, to handle, and to store.
3. Fruit flies have features that are easy to observe.
4. One pair of parent flies can produce hundreds of offspring.

There are disadvantages to the use of fruit flies, too. One is that changes in temperature affect how long it takes a fruit fly to grow from an egg to an adult.

Here is an experiment that was done by one student. Joyce obtained 80 offspring from the same set of parents. She then placed 10 of the flies in each of eight vials of food. The vials were kept at eight different temperatures. Here are her data.

1. Discuss the results of the experiment and write your conclusions in your Record Book.

Table 1

Length of Life-Cycle Stages (in Days)				
Vial	Fahrenheit Temp.	Larva	Pupa	Adult
1	50°	**	**	**
2	60°	**	***	**
3	65°	8-18	18-35	35-40
4	70°	7-16	16-21	21-26
5	75°	6-15	15-20	20-26
6	80°	4-8	8-14	14-20
7	85°	3-7	7-13	13-17
8	90°	**	**	**

** Flies did not survive

A Pyramid of Grandparents

Excursion 1-4

By this time you should realize that the two-bit model is a very good one. With it, you were able to explain the way many features are passed from parents to offspring. All you had to do was assume that each parent passes one bit of information for each of his features to his offspring. But from where did the parent get his bits? That's what this excursion is all about.

Take a look at Figure 1. The figure traces one of your fruit flies back five generations.

Figure 1

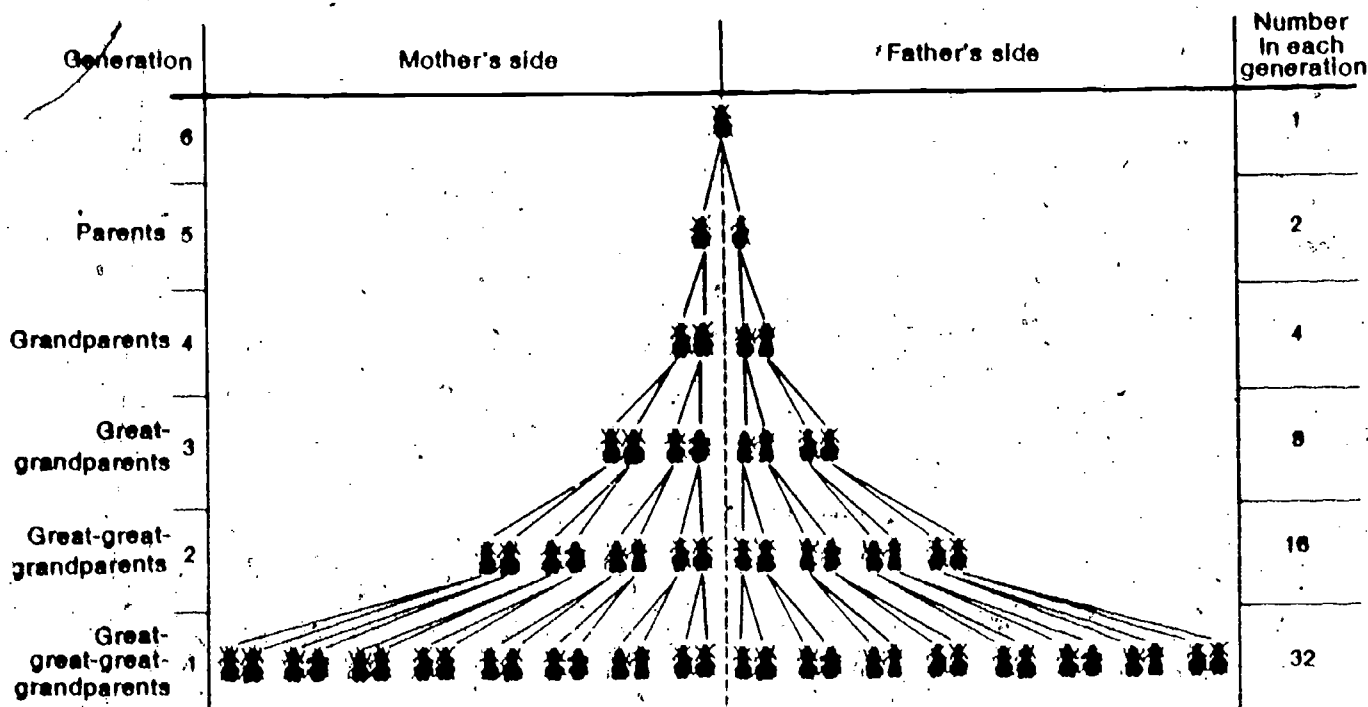

- 1. How many great-great-great-grandparents (first generation) did your fruit fly have?
- 2. Altogether, how many ancestors did your fly have over all the generations shown?
- 3. Suppose an earlier generation were drawn on Figure 1. How many great-great-great-great-grandparents would be shown?

Well, clearly your imaginary fruit fly had a lot of ancestors. With this in mind, let's return to the question with which this excursion started—where do bits of information come from? Try to analyze where each individual in the pyramid of Figure 1 got his bits of information.

- 4. Taking one trait such as eye color, did every ancestor in Figure 1 contribute bits of information to the eye color of your fly?
- 5. If your answer to question 4 is No, what determined which of the ancestors did contribute?

The pyramid idea can be applied to most plants and animals, including humans. In fact, you can use it to make some interesting calculations about your own ancestors. Before you try, however, you should know that, on the average, children's birth dates are twenty-five years after the birth dates of their parents.

- 6. Using the twenty-five-year figure and your own birth date, about when were your great-grandparents born?
- 7. Using the twenty-five-year figure, how many of your great-great-great-grandparents were alive when George Washington was President (1789-1797)?
- 8. What determined whether or not you received one or more bits of information from one of your great-great-grandparents?

The pyramid idea looks rather simple so far. But suppose one of your great-great-great-grandparents had a sister who in turn produced offspring and became the great-

great-great-grandparent of someone living today. That great-great-great-grandparent would become part of another, separate pyramid. Even so, that other pyramid would be related to yours. In fact, that boy or girl could be in your classroom today. Could this be what is meant by the "brotherhood of man"?

Let's look at the problem "Where do bits of information come from?" in another way. This time we'll try to find out what has been happening to the world's population over a period of time. Figure 2 gives the data you need.

**THE
"UPSIDE-DOWN
PYRAMID"**

9. Is the world's population going up, or down, through the years?

10. What is happening over a period of time to the *rate* at which the population is changing?

Figure 2 points up something rather interesting. If you had continued the chart downward, it would have come to a point. According to this reasoning, everyone has the same ancestors.

Figure 2

Year	World population (In millions)
1970	3,500
1900	1,500
1800	1,000
1700	600
1600	400
1500	350

11. Assuming that everyone on the earth has the same ancestors, what is your explanation for why everyone has ended up with different bits of information?

You might be interested to know that the world's population went from about 86 million in 6000 B.C. to about 350 million in A.D. 1500. This was an increase of roughly 264 million in 7,500 years. Experts now believe the world's population will double between now and the year 2000. This would be a rise of 3,200 million in only 35 years. This is what the "population explosion" is all about. Many people are worried about how we will feed and clothe so many people.

12. What is your guess as to why the population is increasing so much faster now than it was earlier?

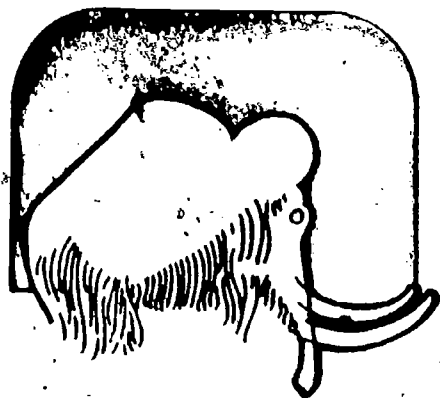

If you'd like to know more about this and related topics, read *Early Man*, by F. Clark Howell, in the Life Nature Library (New York: Time-Life Books, 1965).

Now let's compare the two ideas you've been thinking about. Take another look at Figures 1 and 2. Figure 1 shows that the number of ancestors from which you might have gotten bits of information gets larger and larger as you go back in time. Figure 2, on the other hand, shows that the world's population gets smaller and smaller as you go back in time and suggests that we all came from the same ancestor.

PROBLEM BREAK 1

How can these two models be fitted together? How can the number of everybody's ancestors get larger as you go back in time, while the population gets smaller? That's your problem now. Think this problem through carefully (it's not easy); then in your Record Book, describe how you think the models fit together. Feel free to discuss the problem with your classmates, your parents, or anyone else. Good luck!

Ratio Simplified

Excursion 2-1

A ratio is simply a way of comparing two numbers. For example, a ratio may tell you how often one thing happens as compared with another. Here's how you set up and use ratios.

$$45/5$$

Example 1 Suppose you look at 50 cars in a parking lot, and you notice that 5 cars are red and 45 cars are not red. What is the ratio of red cars to nonred cars in that parking lot?

Arrange your data:

	Nonred	Red
Number of Cars	45	5

To arrive at the simplest ratio, divide both numbers by the smaller of the two numbers. In this case, the smaller number is 5.

Dividing: $5 \overline{)9}$ $5 \overline{)1}$

Ratio = 9 nonred cars to 1 red car

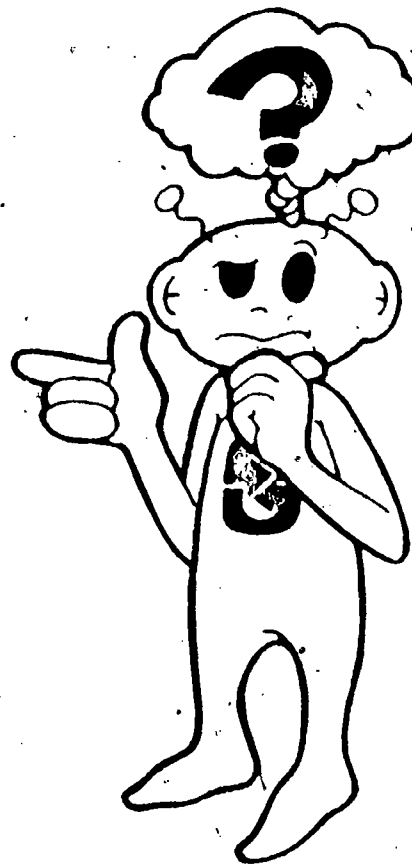

The ratio tells you that there were nine times as many nonred cars as there were red cars. By itself, the ratio does not tell you how many cars you looked at in the first place. (You looked at 50 cars—not 10.)

Example 2. Suppose 28 men, 13 women, and 10 children are waiting in line to get into a ball game. What is the ratio of men to women to children?

Arrange your data:

	Men	Women	Children
Number Waiting	28	13	10

Divide all numbers by the smallest number, that is, 10.

$$\text{Dividing: } \begin{array}{r} 2.8 \\ 10 \overline{)28.0} \\ \underline{20} \\ 80 \end{array} \quad \begin{array}{r} 1.3 \\ 10 \overline{)13.0} \\ \underline{10} \\ 30 \end{array} \quad \begin{array}{r} 1 \\ 10 \overline{)10} \\ \underline{10} \\ 0 \end{array}$$

Ratio = 2.8 men to 1.3 women to 1 child

Usually, but not always, a ratio includes whole numbers. One way to simplify a ratio is to round it. For instance, the number 2.8 in the last example is nearer to 3 than to 2. You could round 2.8 to the number 3. Since the number 1.3 is nearer to 1 than to 2, it can be rounded to 1. The general rule in rounding is to use the higher whole number if the fraction is 0.5 or higher and to use the lower whole number if the fraction is 0.4 or lower.

In whole numbers, the ratio shown in the last example, 2.8 men to 1.3 women to 1 child, could be rounded to 3 men to 1 woman to 1 child.

It is important to write a rounded ratio in the same order in which whatever it represents is stated. Otherwise, the meaning of the ratio will be changed. Notice, for example, what would have happened if you had written the rounded ratio as 1 to 3 to 1 instead of 3 to 1 to 1. You might have become confused and assumed that there were more women than men.

Now here's a problem for you to solve.

1. Suppose you had 20 brown disks and 10 colorless disks. What is the ratio of brown disks to colorless disks?

Check your answer to question 1 against the one given at the end of this excursion. If your answer was right, go on to questions 2, 3, and 4. If you were wrong, go back through the first two examples again before continuing.

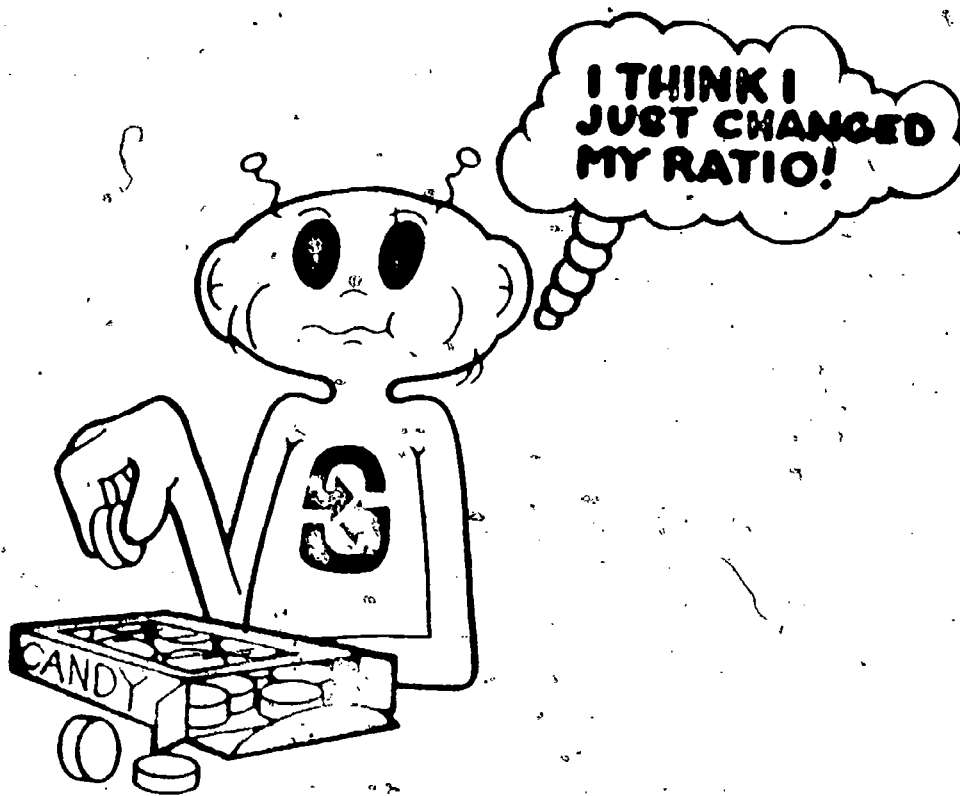

2. Suppose there are 600 boys and 400 girls in a school. What is the rounded ratio of boys to girls?
3. Waiting in line to buy theater tickets are 58 children and 11 adults. What is the rounded ratio of children to adults?
4. A small package contains 12 red, 8 yellow, 5 orange, and 3 green candies. What is the rounded ratio of red to yellow to orange to green candies?

EXCURSION 2-1 101

Once again, check your answers with those at the end of this excursion. If you got any of the problems wrong, review your work or the first part of this excursion.

When you are sure you know how to simplify a ratio, you are ready to go back to Chapter 2 and work out the ratios there. Remember: *any ratio must be written in the same order that the groups are listed.* Also, keep in mind that a ratio does not tell you the actual number of times things occur. It is simply a way of comparing numbers.

Answers

1. 2 brown to 1 colorless
2. Either 1.5 boys to 1 girl or 3 boys to 2 girls
3. 5 children to 1 adult
4. 4 red to 3 yellow to 2 orange to 1 green

Don't Flip over This

Excursion 4-1

In your experiment, you've been running into a 3-to-1 ratio over and over. In beans, for example, you found that brown seeds showed up in the second crop three times as often as white beans. But why does the 3-to-1 ratio appear instead of some other ratio?

Even though the 3-to-1 ratio continues to appear, would you believe that it happens by chance? Let's take a look and see what we mean by chance or probability—the likelihood that an event might occur.

Chance is commonly written as a fraction between 0 and 1. For instance, if something can happen two ways, like the flipping of a coin, the chance is $\frac{1}{2}$ for heads and $\frac{1}{2}$ for tails. You can state the probability in a number of ways.

What is the chance of flipping heads on a coin?

$\frac{1}{2}$
1 to 2
50-50
50%

All these responses are correct.

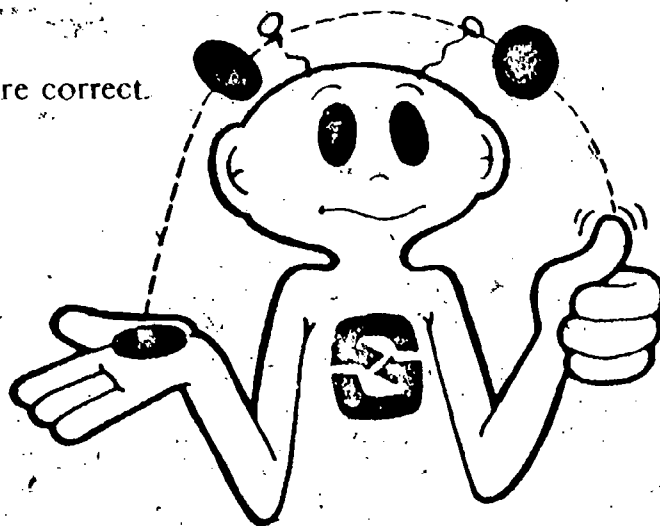

If something can never happen, like rolling a seven on a die (that's one of a pair of dice), the chance is $\frac{0}{6}$. If it always happens, like flipping heads on a two-headed coin, the chance is $\frac{2}{2}$.

Instead of using only one coin, suppose you were to toss two coins at the same time. Let's say you have a nickel and a dime. Both coins might come up heads, both might be tails, or one might be heads while the other is tails (Figure 1).

Figure 1

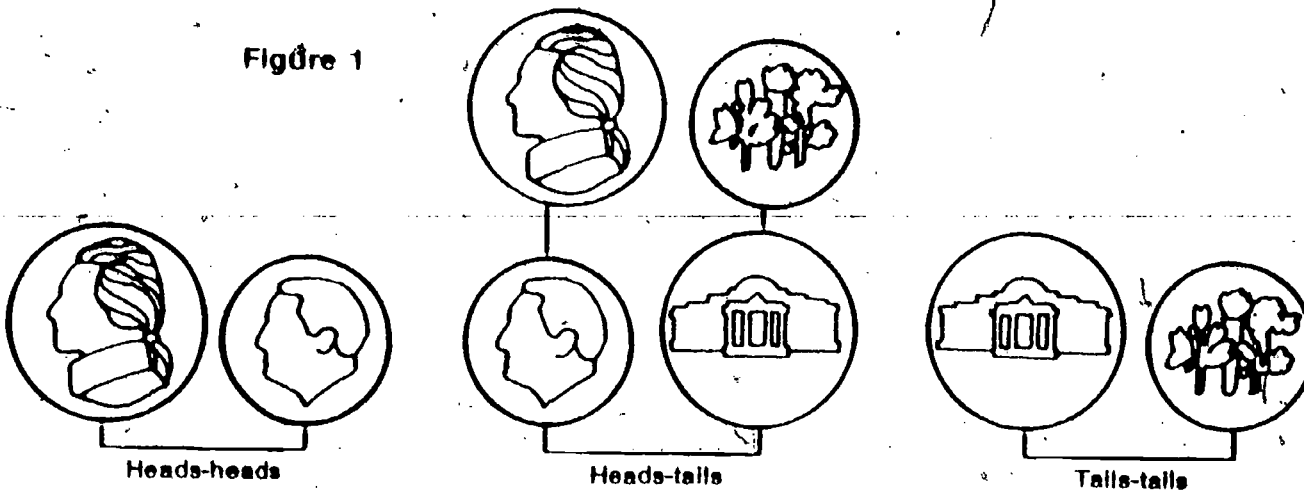

Toss 2 coins at least 60 times and record the combinations that appear in Table 1 in your Record Book.

Table 1

Possible Combinations		Results from 60 Tosses
Nickel	Dime	
Heads	Heads	
Heads	Tails	
Tails	Heads	
Tails	Tails	

Look back at Figure 1. You will note that there are four combinations possible when you flip two coins at the same time. Thus, your chance of coming up with the four combinations are these:

- Heads-heads $\frac{1}{4}$, or 1 to 4
- Heads-tails $\frac{1}{4}$, or 1 to 4
- Tails-heads $\frac{1}{4}$, or 1 to 4
- Tails-tails $\frac{1}{4}$, or 1 to 4

□ 1. How did your data from the flipping of the two coins come out? Out of 60 tosses, did you get about 15 for each of the four combinations ($\frac{1}{4} = \frac{1}{4}$)?

Perhaps you are wondering why the pattern of $\frac{1}{4}$ appears for each of the four combinations. Remember that for tosses of coins the probability of heads turning up is $\frac{1}{2}$. The probability of tails turning up is, naturally, also $\frac{1}{2}$.

What are the chances when two coins are tossed at the same time? Figure 2 illustrates the answer. Remember, we aren't interested in what two coins are used. We just want to know whether they come up heads or tails.

Figure 2

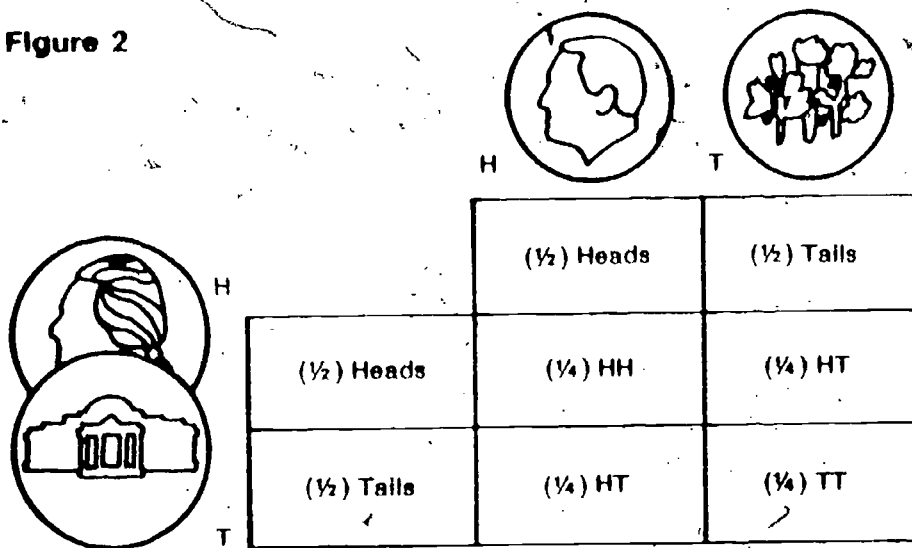

You can apply what you have just done with coins to the bean seeds. In your bean experiment, you began with a pure-strain brown-bean parent and a pure-strain white-bean parent. Using a chart, you can cross the bean parents and find the probability of the first-generation offspring. Complete Figure 3 in your Record Book.

**BACK TO
THE BEANS**

Figure 3

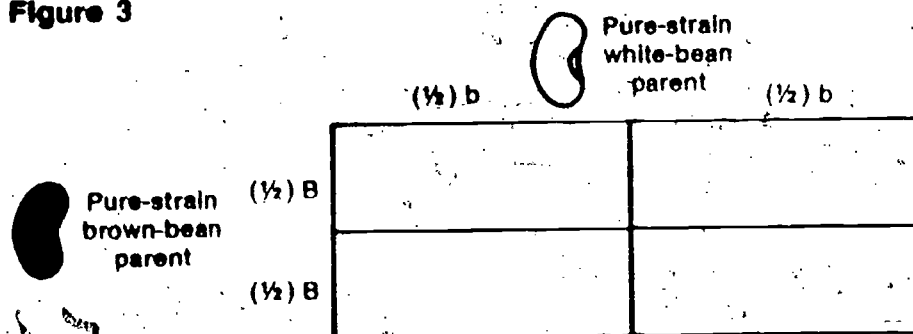

EXCURSION 4-1 105

2. What were the ratios of your first-generation offspring? Using the chart in Figure 4 in your Record Book, cross two of the first-generation offspring.

Figure 4

	First-generation offspring	
First-generation offspring		

3. What were the ratios of your second-generation offspring?

Now what would be the appearance of each of these bean seeds? BB would obviously be brown.

4. What would Bb seeds look like?
5. And bb seeds would be what color?
6. All in all, how many brown seeds would you have for every white one?

Now do you see why the 3-to-1 ratio keeps popping up?

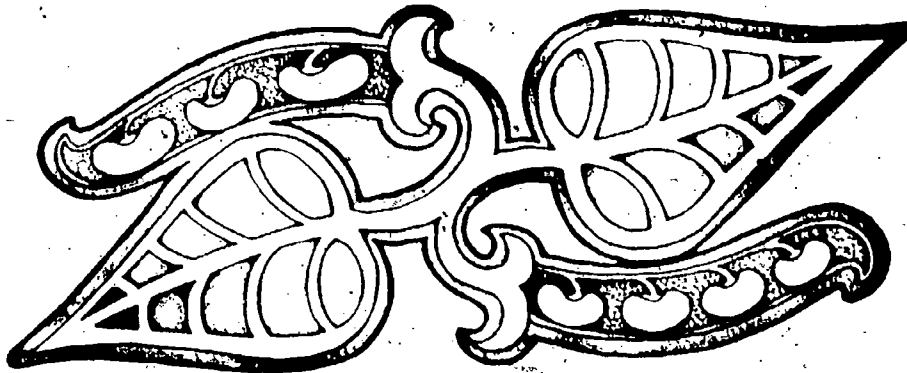

A Bit More About Bits

Excursion 6-1

Gregor Mendel deserves a lot of credit. For seven years (1857-1864) he experimented with peas in a quiet monastery garden in Czechoslovakia, only to have his efforts ignored. In fact, the importance of his work was not recognized until 1900, sixteen years after his death. His work led to the model for "bits of information," the model you've been using.

Mendel tried to follow what happened to seven features as pea plants reproduced themselves. The features were seed shape, seed color, seed-coat color, pod shape, pod color, flower type, and stem length. He crossed pure-strain plants for these features and then studied the features of the first- and second-crop offspring. Figure 1 shows the results of his experiment.

From his data Mendel drew two conclusions:

1. Two identical pure-strain parents always produce pure-strain offspring like themselves.
2. When two different kinds of pure-strain parents are crossed, the first-crop offspring all look like *one* of the parents. If first-crop offspring are crossed, three fourths of the second-crop offspring will look like one of the original parents (from 1 above). One fourth will look like the other original parent.

Mendel developed a model to explain the results of his experiments. This model was almost exactly like the two-bit model you've been using except that he used the term *factor* instead of *bit of information*. Mendel wrote an article about his discovery which was filed away in libraries. Almost forty years later, other scientists made the discovery of "bits," and these men were led back to Mendel's article. Mendel had been at least forty years ahead of his time in making the basic assumption that "factors" determine the inheritance of features.























Mendel's results with two generations of garden peas			
Features selected for cross	First crop	Second crop	Rounded ratio
 X  yellow X yellow	 yellow	5,474 round seeds 1,850 wrinkled seeds 7,324 total	3 to 1
 X  yellow X green	 yellow	6,022 yellow seeds 2,001 green seeds 8,003 total	3 to 1
 X  gray/yellow X white/yellow	 gray/yellow	705 gray seed coats 224 white seed coats 929 total	3 to 1
 X  yellow X yellow	 yellow	882 inflated pods 224 wrinkled pods 1,106 total	3 to 1
 X  green X yellow	 green	428 green pods 152 yellow pods 580 total	3 to 1
 X  axial X terminal	 axial	651 axial flowers 207 terminal flowers 858 total	3 to 1
 X  long X short	 long	787 long stems 277 short stems 1,064 total	3 to 1

Figure 1

Mendel's early success where others had failed was due to several things: First, he used a "systems" approach. He studied only one feature at a time. Second, he applied his knowledge of mathematics to his study. Third, he built a model to account for what he saw. This whole approach might be thought of as "if-then" reasoning. His thinking was, "If I assume these things to be true, then I can predict what I see."

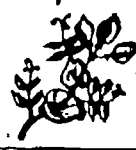
Since Mendel's time, other scientists have been trying actually to see the bits of information. Their studies have added much to the two-bit model.

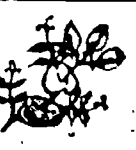
Well before 1900, the discovery of what are called *cells* had been made. It was learned that virtually all living things are made up of the tiny cells that can be easily seen under

a microscope. When cells are viewed through a high-powered microscope, many smaller parts can be seen. One of these parts is called the *nucleus*.

Figure 2

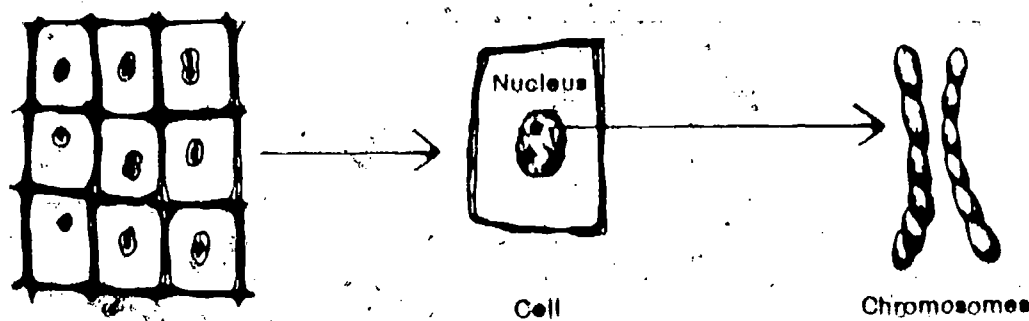

If you were to magnify the nucleus many times, you could see some strands in it that resemble pieces of thread. These are *chromosomes*. An American scientist, Walter S. Sutton, was the first to notice that chromosomes are passed from cell to cell as Mendel's "bits of information" are passed from parent to offspring. Still later, it was suggested that the bits of information were located on the chromosomes much like beads on a string. Although this idea has been changed a little since then, we still believe bits of information are in some way attached to chromosomes as they are passed from parent to offspring.

Scientists soon began to call Mendel's "factors" *genes*. The word "genes" is short for *genetic units*. Whether we call the factors bits, units, or genes, the model still works for explaining and predicting the way features are passed from parent to offspring.

To see if you have understood this excursion, try to use your information about the ninsect you've been studying.

- 1. How many bits are needed for each feature of a ninsect?
- 2. What does each ninsect card represent?
- 3. What do the holes in the cards represent?
- 4. How many bits (genes) are there on one ninsect chromosome?
- 5. How many bits (genes) are needed to make one complete ninsect?

6. How many chromosomes are needed to create one ninsect?

7. The ninsect inherits a set of genes. On what are the set of genes found?

8. Every animal and plant has two sets of genes for each feature. In the ninsect, where does each set of genes come from?

A more recent idea has replaced the "string of beads" chromosome model. Experiments showed that Mendel's bits, the genes, are perhaps made of a chemical called DNA. Two scientists, James D. Watson and F. H. C. Crick, made a DNA model which looked like a ladder that had been twisted several times. This model keeps changing to fit new information but, at the same time, keeps enough old features to explain what is already known. Through this building and improving of the model, our picture of a gene will surely be different in fifty years.

PROBLEM BREAK 1

Several books tell more about the ideas discussed in this excursion. One that offers pictures of chromosomes and drawings of DNA is *Evolution*, by Ruth Moore, in the Life Nature Library (New York: Time-Life Books, 1962). Another book of interest, written by Carleen Maley Hutchins and titled *Life's Key—DNA*, (New York: Coward-McCann, 1961) offers a detailed discussion of the relation of DNA to life. Use books like these to add to your understanding of why you're you.

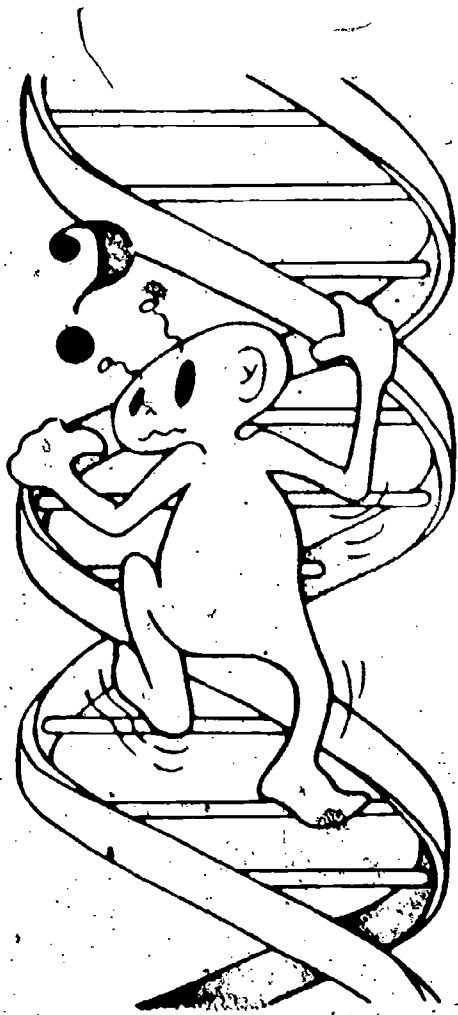

Peas Again, But Double Trouble

Excursion 6-2

If you did Excursion 6-1, you know that much of our understanding of inheritance is based upon the work of Gregor Mendel. One of the factors Mendel studied was seed color. He found that the bit of information for yellow seeds masked the bit for green seeds. Figure 1 reviews crosses between yellow and green peas so that you can see the way these features are passed. The letters under the drawings stand for bits of information. Y stands for yellow seed and y stands for green seed.

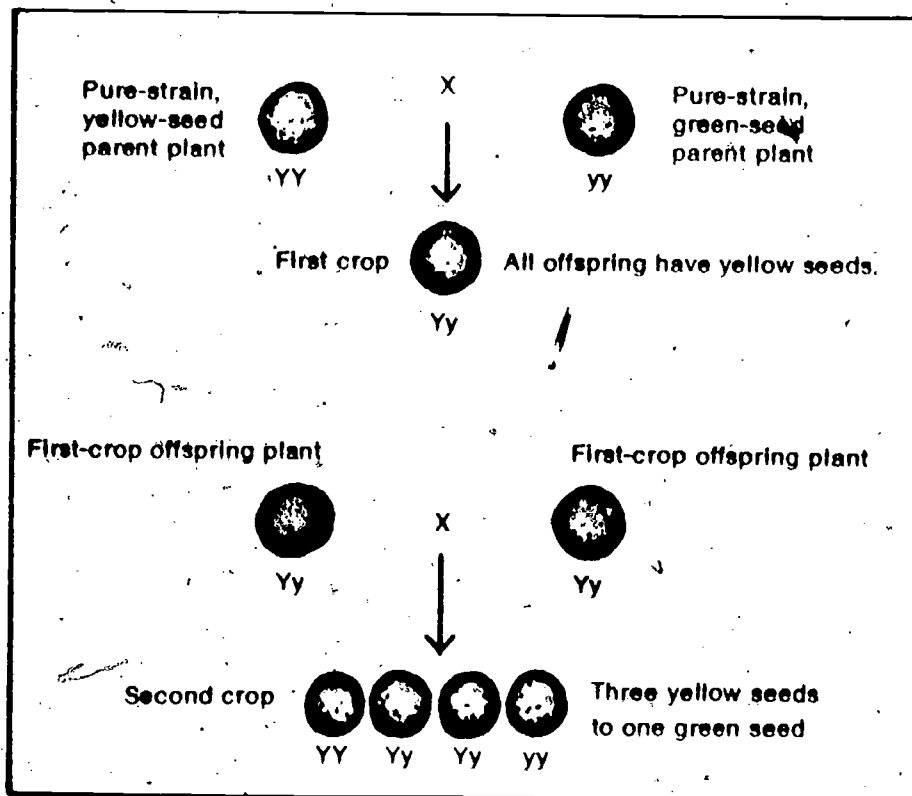
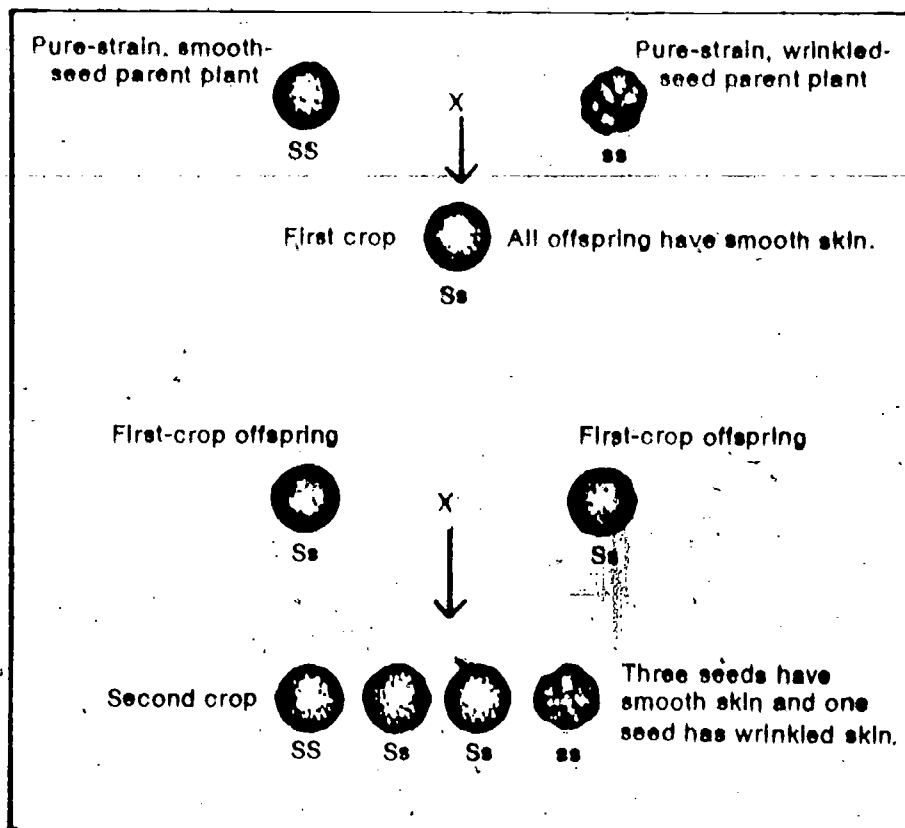

Figure 1

Mendel also found these inheritance patterns in studying pea seed texture. He found the bit of information for smooth seed masked the bit of information for wrinkled seed. Figure 2 reviews the crosses between smooth-skin pea seeds and wrinkled-skin pea seeds.

Figure 2



You are about to learn how to predict the inheritance pattern for *two* features at a time! Here is your problem.

Figure 3

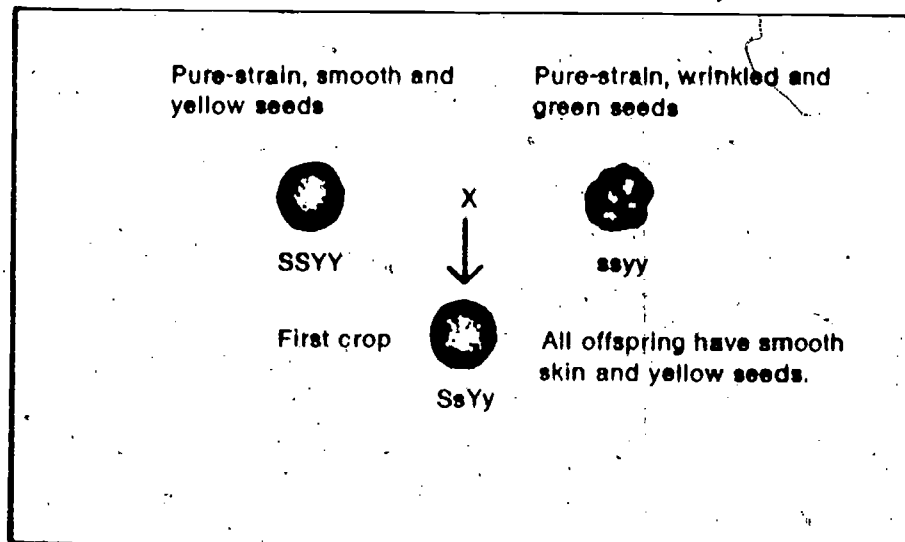

If you do not see how SsYy appeared, look back to the first-crop offspring in Figures 1 and 2.

Now, if you cross two of the first-crop offspring, what will be the ratio of the second-crop offspring? Table 1, which is similar to Figure 2 in Excursion 4-1, shows you how to predict the results of this cross. Complete the table in your Record Book by filling in each square like the examples that are given:

Table 1

Possible Bits of Information from Smooth, Yellow Parent (SsYy)

	SY	Sy	sY	sy
SY	SSYY smooth, yellow			
Sy				Ssyy smooth, green
sY			ssYY wrinkled, yellow	
sy	SsYy smooth, yellow			

Possible Bits of Information from Smooth, Yellow Parent (SsYy)

If you have trouble filling in the squares, think about how you read graphs. For the top left square, we got SY from the top of the grid and SY from the left. Combined, these gave us SSYY, which is "smooth yellow."

Now you can summarize the kinds of offspring that are possible in this mating. Just count and record in Table 2 in your Record Book the number of offspring with each possible combination of features.

Table 2

Smooth, yellow-seeded plants	
Smooth, green-seeded plants	
Wrinkled, yellow-seeded plants	
Wrinkled, green-seeded plants	

The ratio you have just found is quite common in studies of inheritance of two features at a time.

- 1. In this same problem, what is the ratio of smooth seeds to wrinkled seeds? (Count them; don't guess.)
- 2. What is the ratio of yellow seeds to green seeds?

You can see from the data that each feature is inherited independently.

Do you think you could solve another problem about two features at a time? Try this one: Ninsects also have several features some of which are dominant while others are recessive. Select two ninsect features and diagram the following crosses in your Record Book.

a. Cross one parent that is a pure strain for two dominant features with another parent that is a pure strain for two recessive features.

b. Cross two first-generation offspring of the above cross. Use the pea problem as a model for designing your solution to this problem. Some of the symbols you could use for ninsect features are these:

Eye color: black, white (B, b)

Body color: striped, plain (S, s)

Body shape: round, slender (R, r)

Stinger: present, absent (P, p)

Leg length: tall, short (T, t)

Antenna: curly, straight (C, c)

Wing pattern: plain, spotted (W, w)

Wing size: large, small (L, l)

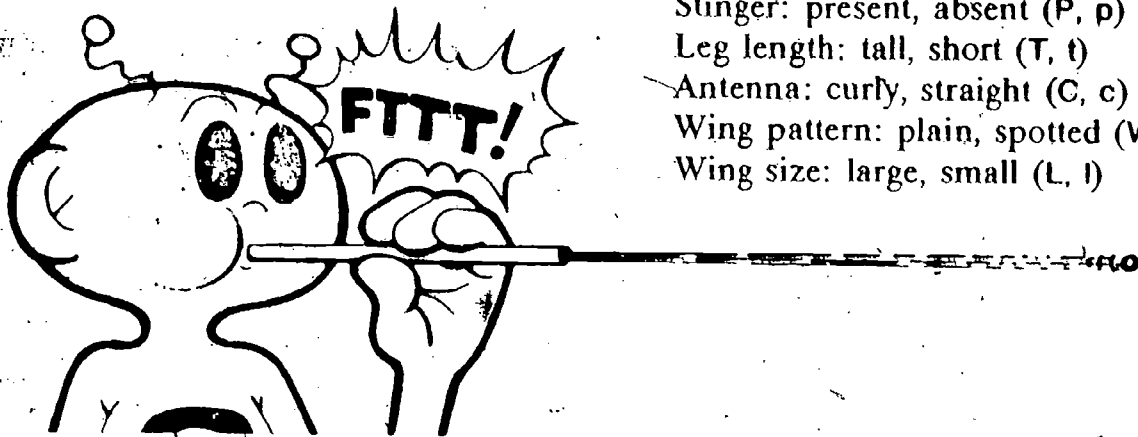

Red, White, and Pink

Excursion 7-1

In Chapter 7 you were asked to use your two-bit model to explain the cross that is shown below. This excursion will show you one possible way to do this.

Figure 1

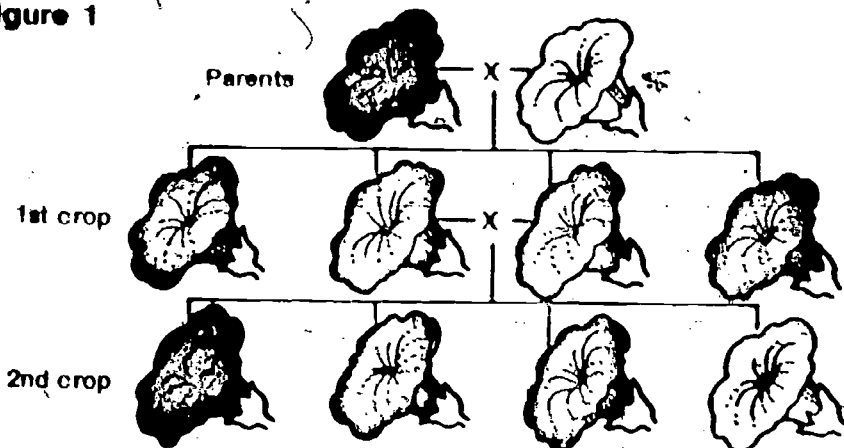

Let's think about the cross in terms of your two-bit model (see page 83 of Chapter 7 for a summary of the model). The pure-strain red parent had to have two bits of information for red, while the pure-strain white parent had two bits for white. This means that each offspring had to get one white bit from the white parent and one red bit from the red parent. This is diagrammed in Figure 2. If that figure is not clear to you, turn back to Chapter 7 and review the two-bit model.

R = A bit of information for red
 W = A bit of information for white

Figure 2

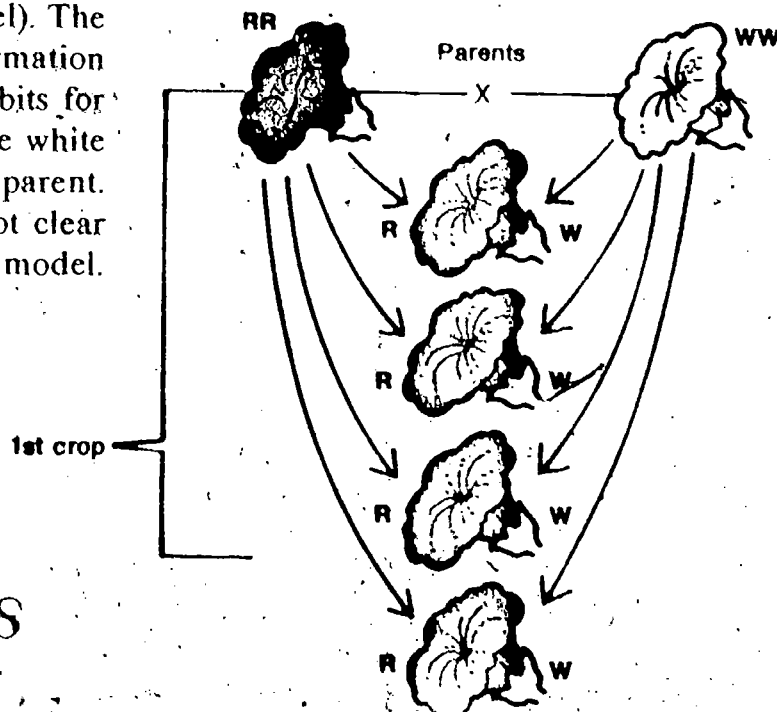

According to the two-bit model then, each first-crop offspring has one bit for red and one bit for white. In this case, the flowers of those offspring should have been either red or white depending upon which bit masked the other. The model as described on page 83 cannot explain the fact that the first-crop flowers were pink.

Actually, a very small change in the model will let you use it to handle the flower problem. All you have to do is change statement 4 (page 83) of the model from

4. If an individual receives two different bits of information for a feature, one bit may mask the other.

to

4. If an individual receives two different bits of information for a feature, one bit may mask the other. *Sometimes, however, the two bits will both have an effect, and the offspring's appearance will be midway between that of pure-strain individuals for each bit.*

Notice that the change lets you explain what happened in the first crop of the flower cross. You can simply assume that the bit for red and the bit for white in the first-crop offspring both had an effect and that the offspring became pink (halfway between red and white). Notice also that the change adds something to the model without destroying it. The model will still work for beans, fruitflies, and the like.

Now take a look at Figure 3, where the second crop of flowers is shown. Try to apply the new model to it. Does it work?

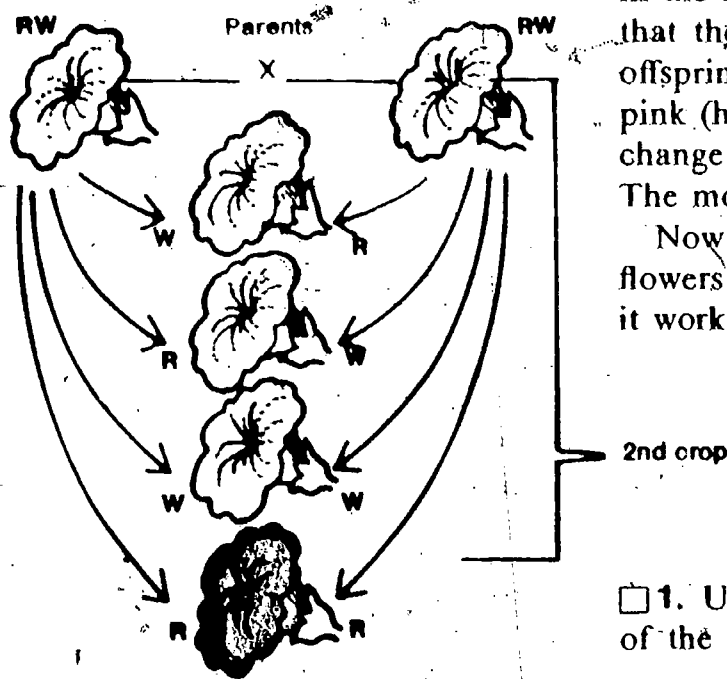

Figure 3

1. Use your modified two-bit model to explain why part of the second crop is pink, part is red, and part is white.

Want some practice in solving problems like the one with morning glories? Try this one.

2. A white morning glory is crossed with a pink morning glory. What may the offspring look like?

Hair Heirs

Excursion 7-2

In Chapter 7 you were left with the problem of figuring out how a certain type of baldness is inherited. Your problem was to decide what bits of information for baldness might be in each individual in the family shown in Figure 7-2 (Fig. 2 in this excursion).

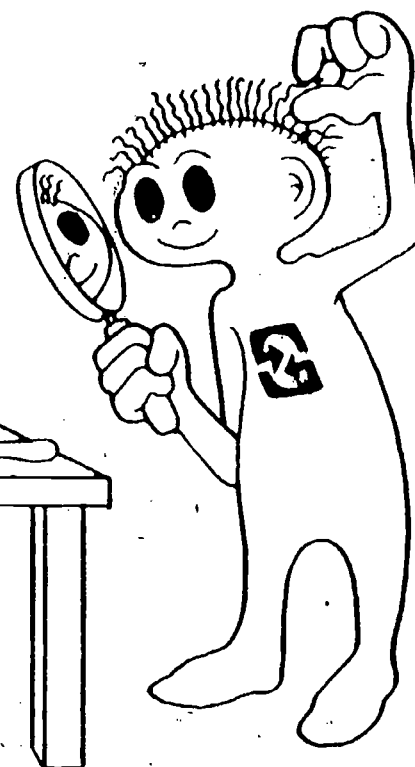
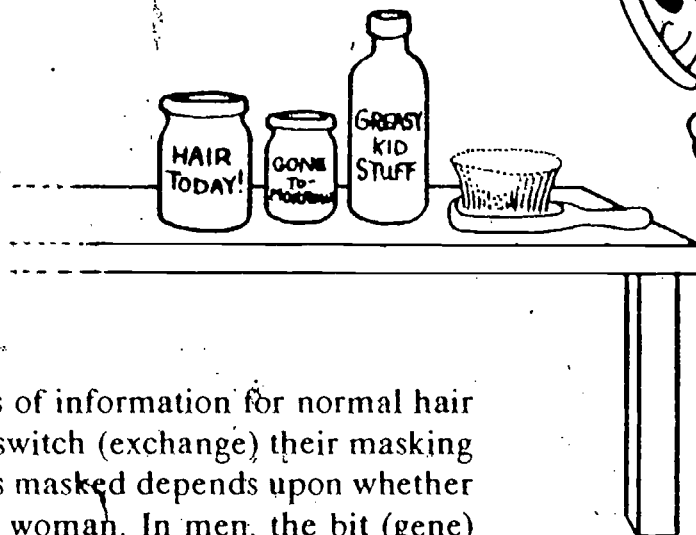

You were told that the bits of information for normal hair and for baldness sometimes switch (exchange) their masking roles. Which of the two bits is masked depends upon whether the individual is a man or a woman. In men, the bit (gene) for baldness masks the one for normal hair. In women, it's the other way around—the bit for normal hair masks the one for baldness. Table 1 summarizes this information.

Sex	Masking	Baldness (b)	Normal Hair (B)
(Male) □	b masks B	bb or bb	BB
(Female) ○	B masks b	bb	bb or BB

Table 1

Use Table 1 to check the information in Figure 1 and then answer the questions that follow it.

Figure 1

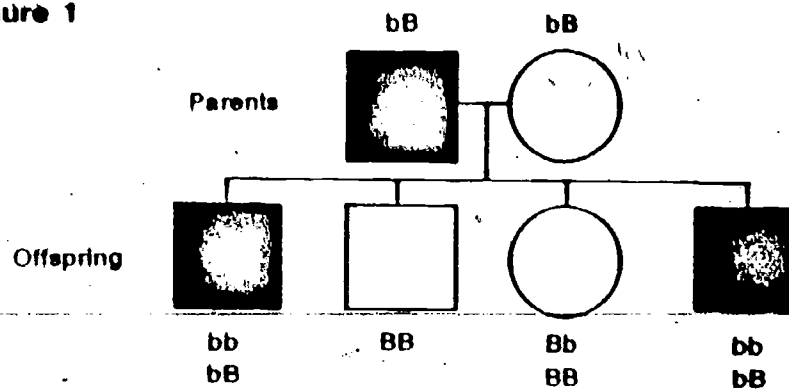

Circle = Woman
 Square = Man
 Black = Baldness
 Blank = Normal hair

1. How can the male parent be bald when he has one B gene for normal hair?
2. Since the male parent is bald with Bb , why isn't the female (Bb) also bald?
3. What ratio of baldness to normal is there in the male offspring?



"THESE ARE MY JEANS FOR NORMAL HAIR..."

Use the information in Table 1 to decide which bits of information each person has for the baldness feature in Figure 2. In your Record Book, under each square or circle, write the letters for the bits that person has, as you see done in Figure 1. Sometimes one person could have more than one kind of pair of bits. A black square represents a bald man; a blank square represents a man with normal hair. A blank circle represents a woman with normal hair.

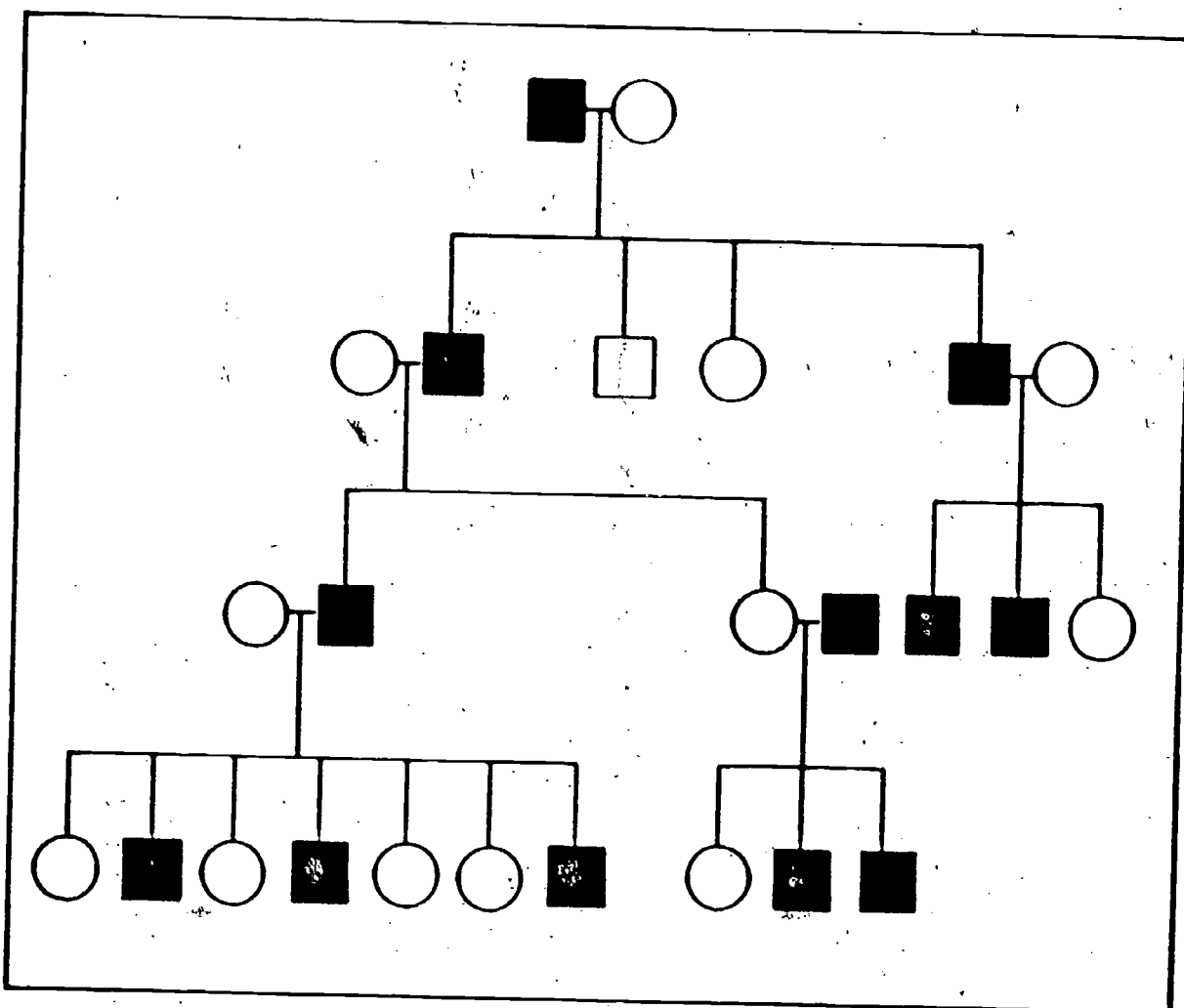

Figure 2

Baldness is another feature that makes us alter our two-bit model in order to have the model explain and predict better.

□4. In what way was the two-bit model altered to make it work so that it explains and predicts baldness in humans?

Have you altered your model to explain pink color in morning glories? If not, turn to **Excursion 7-1**, "Red, White, and Pink."

You can check your work in Figure 2 by turning the page upside down.

Answer key for Figure 2

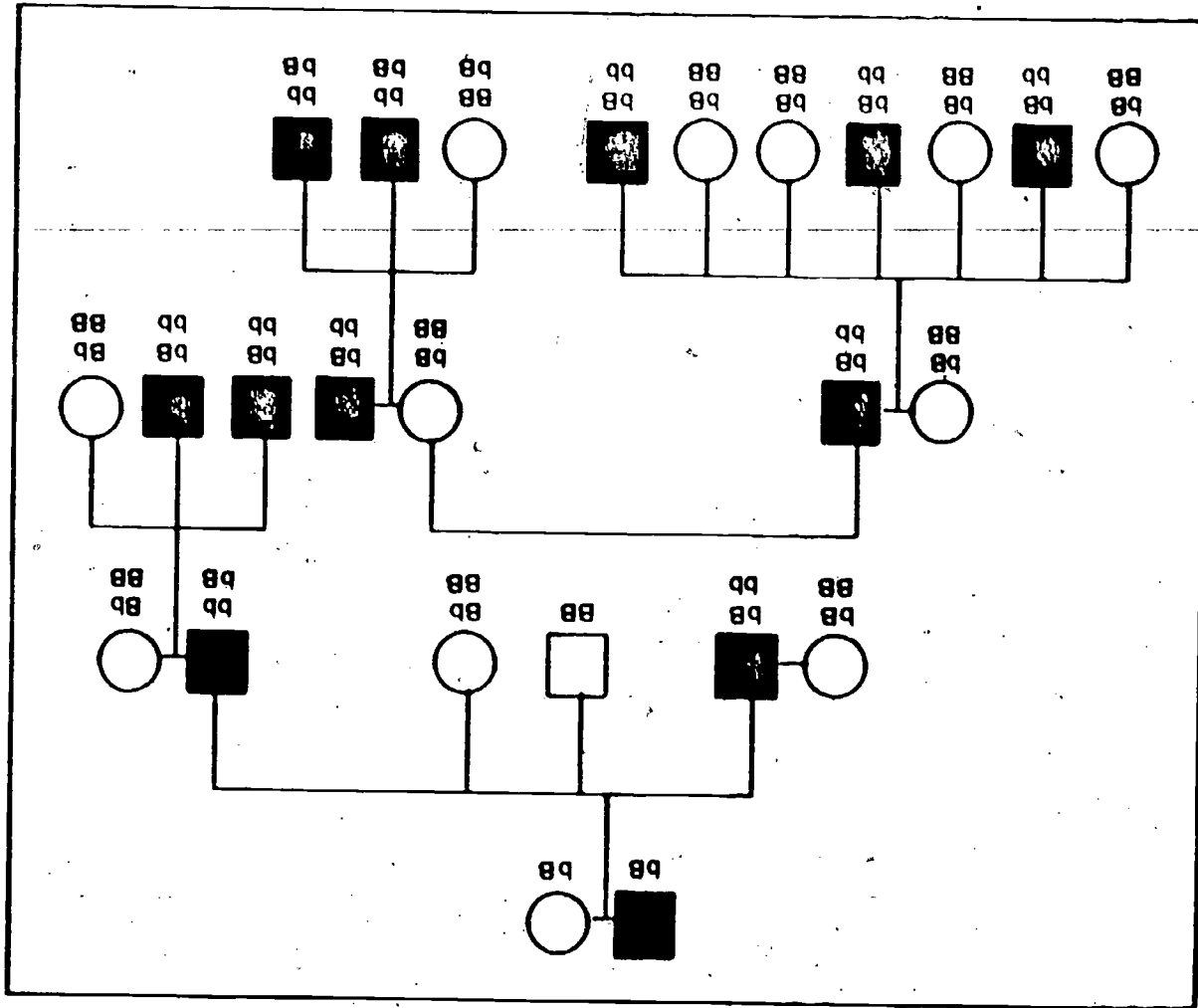

Boy or Girl

Excursion 7-3

One of the most obvious features of everyone is his or her sex. We take for granted the fact that people are either male or female. But most of us wonder from time to time just how the sex of a baby is determined. How this happens is the subject of this excursion.

If you did Excursion 6-1, you learned what chromosomes are. If you didn't do that excursion, turn to it now and read the part that deals with chromosomes.

Since the studies were made that linked chromosomes with bits of information (genes), scientists have been studying chromosomes very carefully. There are 23 pairs of chromosomes (46 in all) in every normal human cell, except in sperm cells and in egg cells. The chromosomes that make up 22 of the pairs always look more or less alike (see Figure 1). But sometimes those in the 23rd pair don't match—one chromosome is sometimes much longer and straighter than the other. The long straight type of chromosome has been called an X-chromosome, and the short bent one a Y-chromosome.

Figure 1

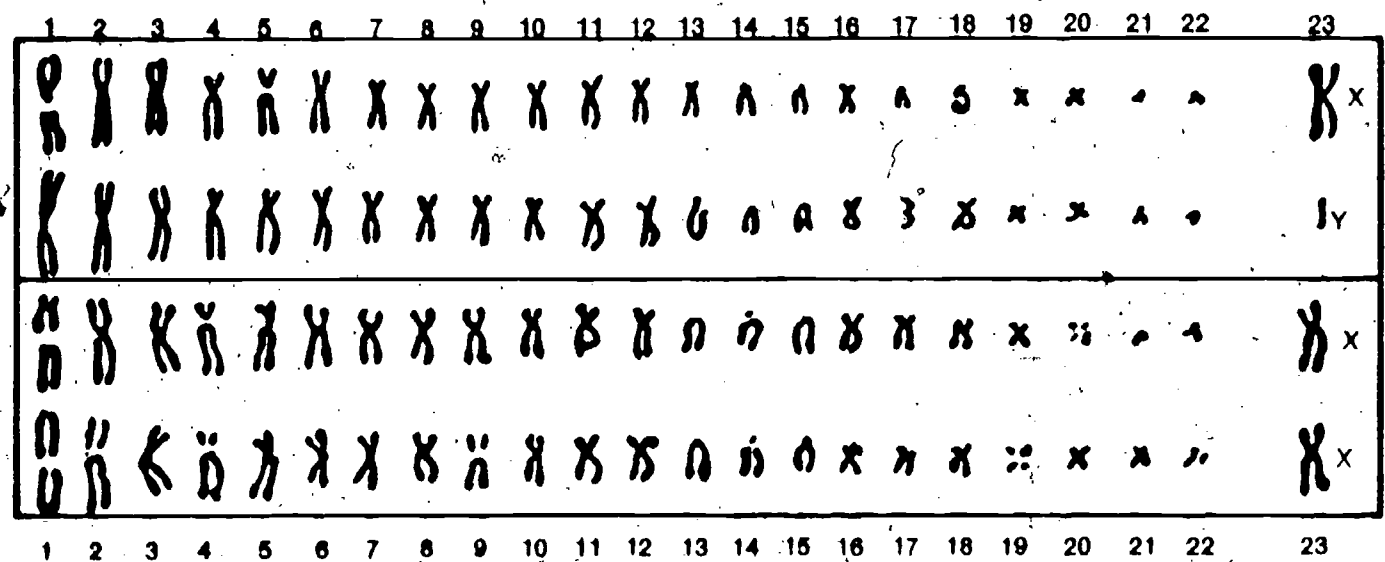

Careful study shows that the chromosomes in the cells of boys and men are different from those in girls and women. Boys and men have one X-chromosome and one Y-chromosome, while girls and women have two X-chromosomes. This is shown in Figure 2.

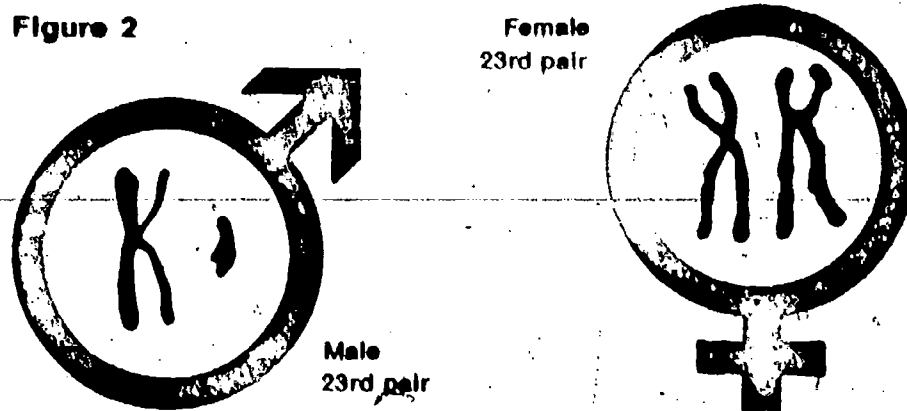

After the differences between men's and women's chromosomes were noticed, scientists used them to develop a model for how sex is inherited. They made the assumption that if a person has two X-chromosomes (in the 23rd pair), then that person is a female. They also assumed that if a person has an X- and a Y-chromosome, then that person is a male. Furthermore, it was assumed that one of each person's 23rd pair of chromosomes came from his father and one came from his mother. Figure 3 shows these assumptions.

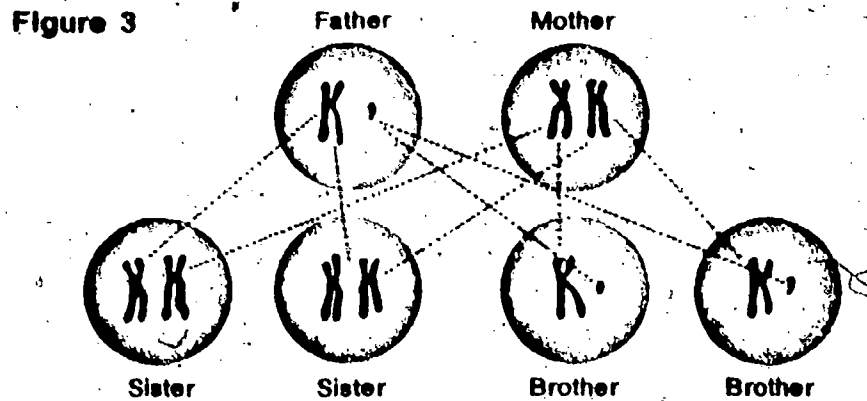

Notice in Figure 3 that the chances of the offspring ending up with two X-chromosomes are the same as for the offspring having an X-chromosome and a Y-chromosome. This is how scientists explain the fact that there are about as many boys born as girls.

A Royal Problem

Excursion 7-4

Ready for a royal problem? Here goes! Read through the problem and attempt to solve it the best you can. If you have a hard time at first, don't give up. More help will be given later.

Some people are born with a real handicap—their blood does not clot very well. This means that even the slightest cut bleeds and bleeds. They may even die of loss of blood from a tiny scratch. Few such individuals live long enough to produce children.

Several rulers of European countries of the past hundred years have had this problem. Here's a diagram showing the family tree of these people. Once again, circles represent females and squares represent males. Black indicates that the person is a "bleeder"; white shows that he is not.

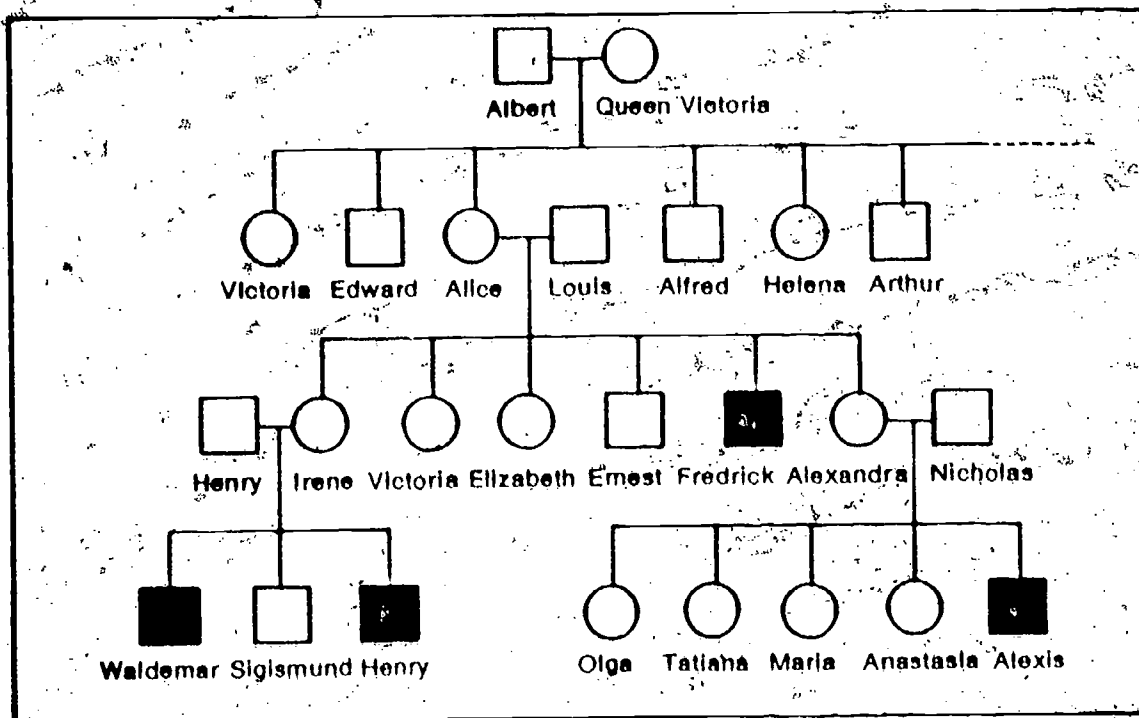
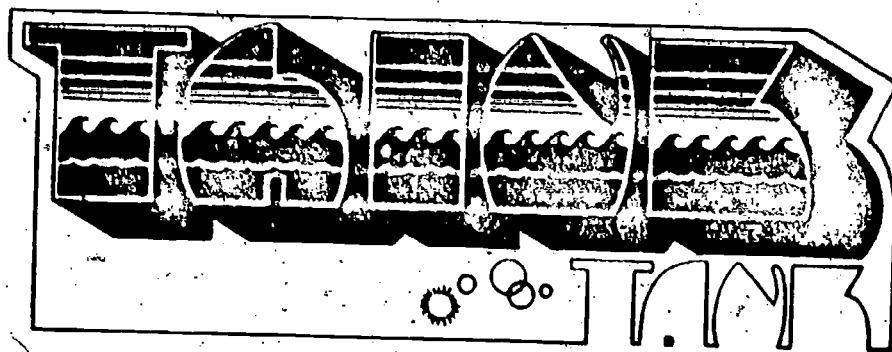

Figure 1

- 1. Does your two-bit model (see page 83 for a summary of the model) explain the data in Figure 1?
- 2. Which bit seems to mask and which bit seems to be masked?
- 3. How many male and how many female bleeders are shown in Figure 1?
- 4. What assumption can you add to your two-bit model to explain the number of male bleeders as compared with female bleeders?

Okay, there's your problem. The rest of this excursion is devoted to a possible answer to it. Do not read on until you've tried hard to solve the problem for yourself.



If you successfully answered the last question, you deserve a medal. It's really a tough one. To fully understand it, you need to know the model for how sex is inherited. Excursion 7-3 will help you with this if you don't already know it.

As Excursion 7-3 suggests, you can assume that every boy and man shown in Figure 1 has one Y-chromosome as well as one X-chromosome. The girls and women shown in the figure have no Y-chromosome—only X-chromosomes. This is a good clue to how bleeder's disease is inherited.

- 5. In view of the information in the last paragraph, why do you think bleeders are males?
- 6. On what chromosome do you suppose the bit of information for bleeder's disease is located?

If you guessed that the bit for bleeder's disease is carried on the Y-chromosome, you did quite well. Unfortunately, however, your hypothesis won't explain everything you see

in Figure 1. (Try it and see.) A better approach is to think in terms of the X-chromosome. Here's the model for the inheritance of bleeder's disease that scientists now use—look it over carefully.

1. Some X-chromosomes carry the bit (gene) for bleeder's disease (X^b).
2. Other X-chromosomes carry the bit (gene) for normal blood clotting (X^N).
3. Y-chromosomes don't carry either the bit for bleeder's disease or the one for normal clotting.
4. The bit of information for normal clotting can mask (is dominant over) the bit for bleeder's disease.

□ 7. Shown below are the pairs of sex chromosomes of two men and two women. Using the model above, decide whether each individual is a bleeder or not. In your Record Book, write "bleeder" or "nonbleeder" for each one.

- | | | | |
|-----------|-----------|---------|---------|
| a. Woman | b. Woman | c. Man | d. Man |
| $X^N X^N$ | $X^N X^b$ | $X^N Y$ | $X^b Y$ |

Now take a look at the family tree shown in Figure 2. Notice how the bleeder's disease bits are passed along and their effect.

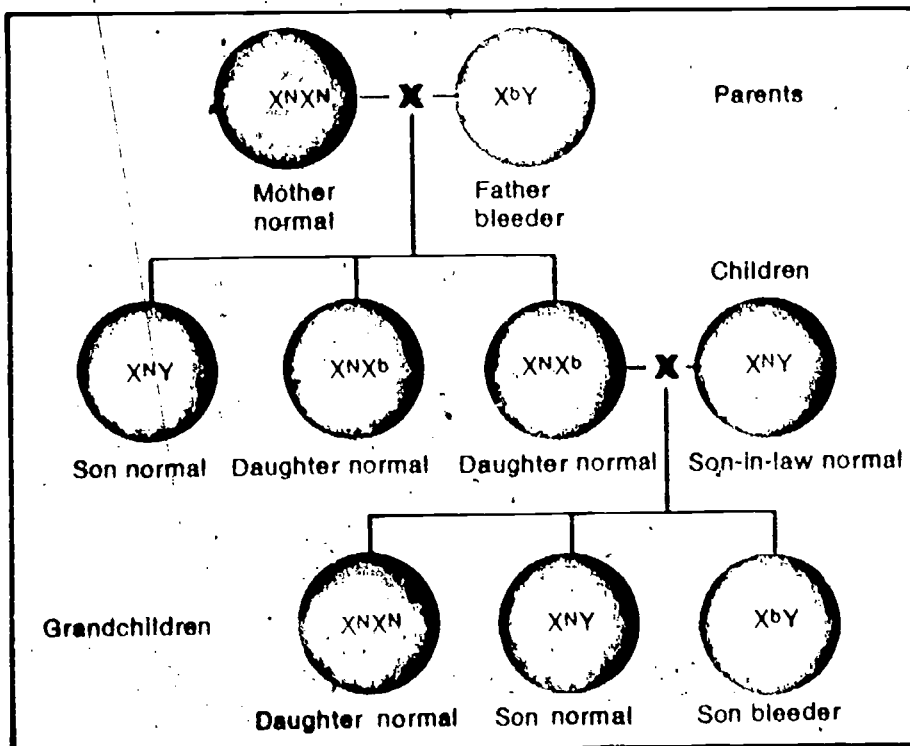

Figure 2

8. Why is one of the grandsons in Figure 2 a bleeder and the other a nonbleeder?

Now turn back to Figure 1.

9. How do you now explain the fact that not all the males of this royal family have bleeder's disease?

You have learned that some features are said to be sex-linked. Features like bleeder's disease are called sex-linked because the bits for them are thought to be located on sex chromosomes, X and Y in case of humans. There are about 60 sex-linked traits in humans, such as one kind of night blindness, myopia, double eyelashes, and one type of color blindness. Now, here's a good one for you to answer.

10. Suppose a male bleeder married a pure-strain female who's not a bleeder. Could any of his sons be bleeders? Could any of his grandsons? Explain.

I Wonder Where the Color Went?

Excursion 7-5

Here's a good chance to find out if some other variable might affect the appearance of offspring. For this excursion, you need the following materials:

- 15 tobacco seeds
- 1 petri dish with lid
- 2 paper towels
- 1 pair scissors

ACTIVITY 1. Cut two pieces of paper towel the size of the petri dish. Place them in the bottom of the dish. Wet the paper towels and pour off any excess water.

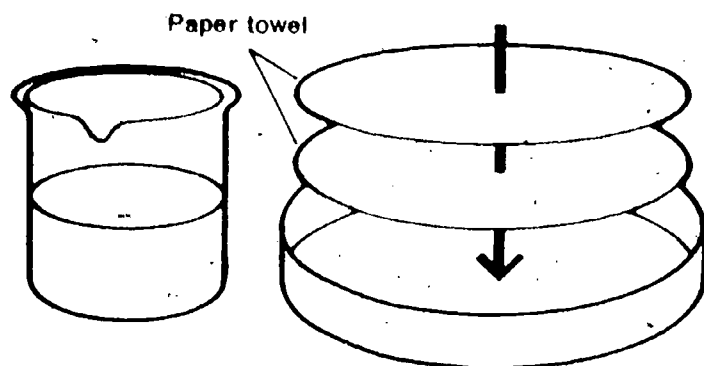

ACTIVITY 2. Place the 15 seeds onto the paper towel so that each seed is separated from every other seed.

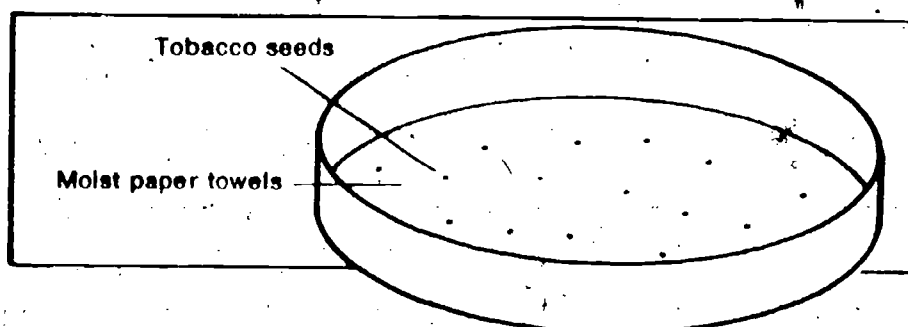

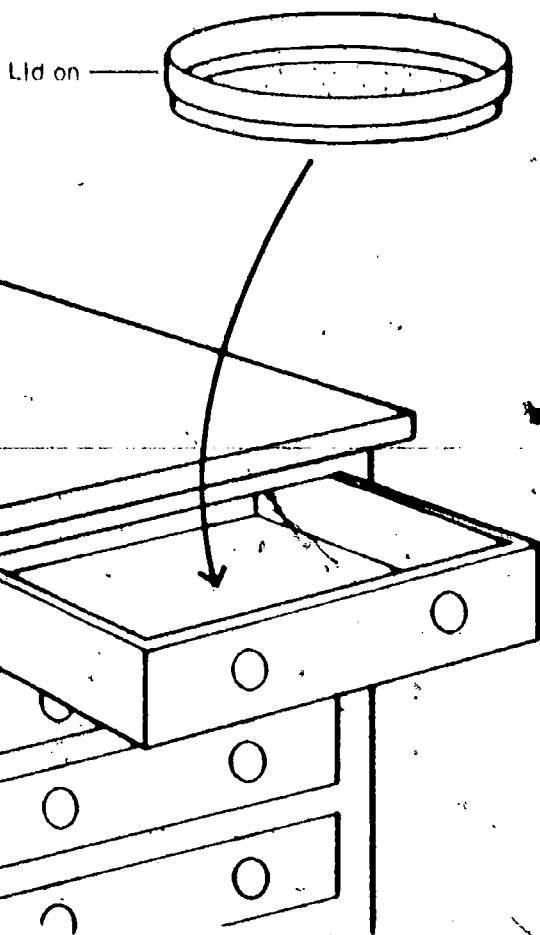

ACTIVITY 3. Put the lid on the dish and gently set it in a dark place (such as a drawer or cupboard).

Caution It will be ten days before your seeds germinate. Be sure the seeds do not dry out. Check them EVERY DAY and add water if the paper towel looks dry. But don't add too much water. Be sure your seeds are watered sufficiently on a Friday to carry them through the weekend.

After the seeds have sprouted, notice the color of the leaves.

- 1. What color were the leaves on the tobacco plants?
- 2. How did the tobacco plants in the dish you just observed differ from the tobacco plants observed in Problem Break 3-1?
- 3. Were the differences due to different bits of information (genes)?
- 4. Explain your answer to question 3.
- 5. Suppose you moved the plants grown in the dark to the light. What do you predict would happen? Move the plants to test your prediction and describe the results.
- 6. This experiment shows that something other than bits of information has an effect upon what offspring will look like. What is that "something"?

One, Two, Pick-up Sticks

Excursion 7-6

By now you know that features are passed from parent to offspring through bits of information (genes). If the features are passed along perfectly every time, then life would never change.

The same features should be passed from generation to generation. But anyone who has read about dinosaurs or fossils knows that changes have been happening. In this excursion, you will see a way that one form of change can take place.

For this activity, let's assume that you are an insect-eating bird. We will let colored toothpicks represent young stages of the insects you eat. Colored paper will represent the material on which the insects live. For this activity, you will need a partner and these materials:

- 1 set of colored paper (6 different colors)
- 1 box of colored toothpicks
- 1 pair of tweezers

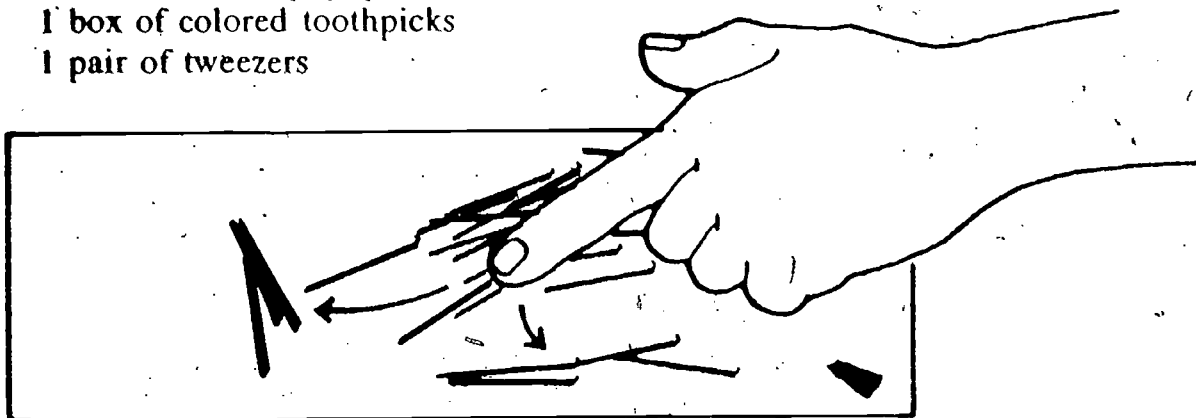

ACTIVITY-1. Scatter 30 toothpicks, half of one color and half of another color, on a piece of paper whose color matches that of one of the toothpicks. Do not let your partner see you do this.

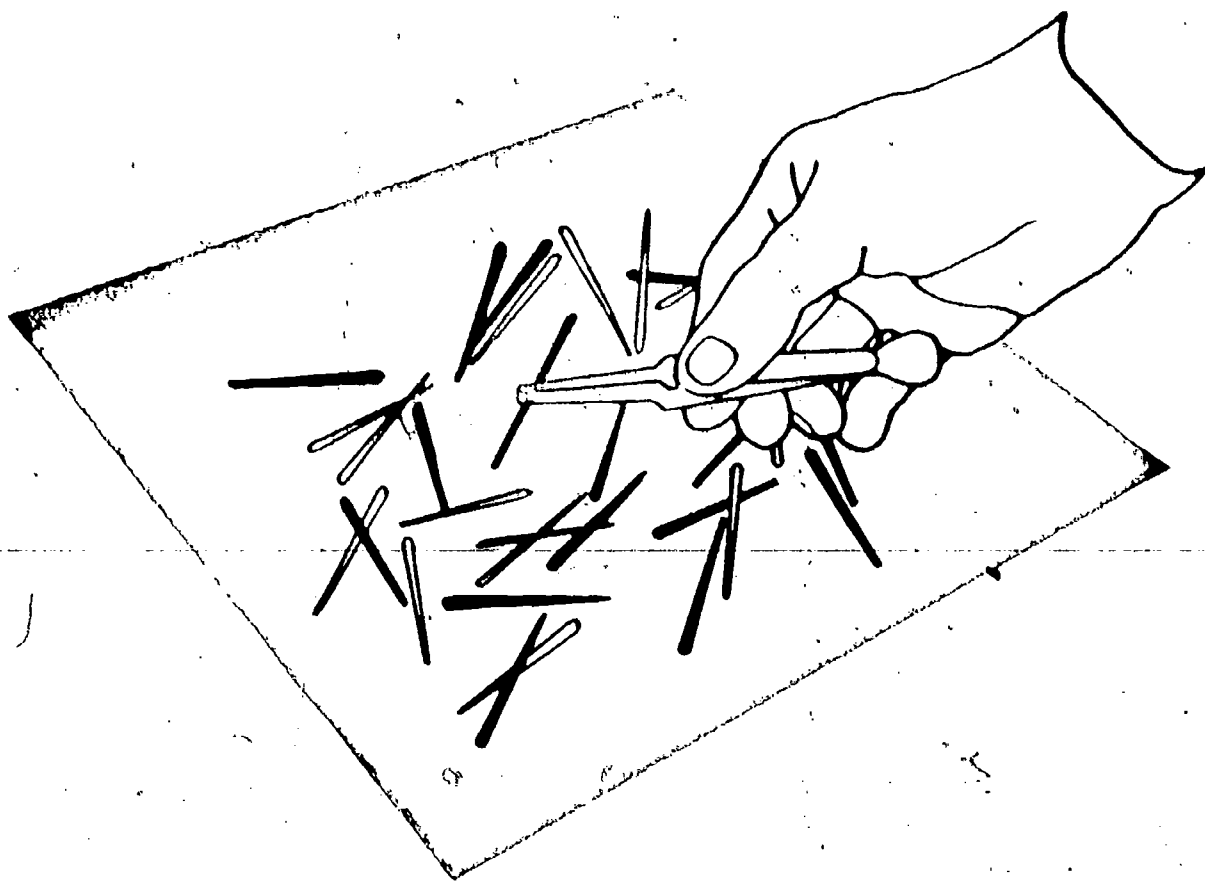

ACTIVITY 2. Move into a dimly lit area. Have your partner pick up as many toothpicks as possible with the tweezers in five seconds.

HINT If you do not have a watch with a second hand, you may estimate the time by counting 1000, 1000, 1000, etc.

1. How many toothpicks did your partner pick up that matched the colored paper? that did not match the paper?

Exchange roles with your partner so that each of you has the chance to play bird.

2. How many toothpicks did you pick up that matched the colored paper? that did not match the paper?

3. How did your partner's results compare with your results?

4. Explain the results that you and your partner got.

Try different combinations of colored paper and toothpicks to confirm your results.

This simple experiment can be applied to the inheritance of features. Lions, toads, robins, sharks, wolves, and hawks have at least one thing in common. All of them prey upon other animals for food. To survive, these animals must find and capture the animals they feed upon. The survival of the prey depends upon its ability to avoid being caught. Any feature of the prey that makes it difficult to catch is important for its survival.

Color is a common and important feature. Some animals match their background very closely, but others don't. Let's use how well an animal matches its background as we consider survival.

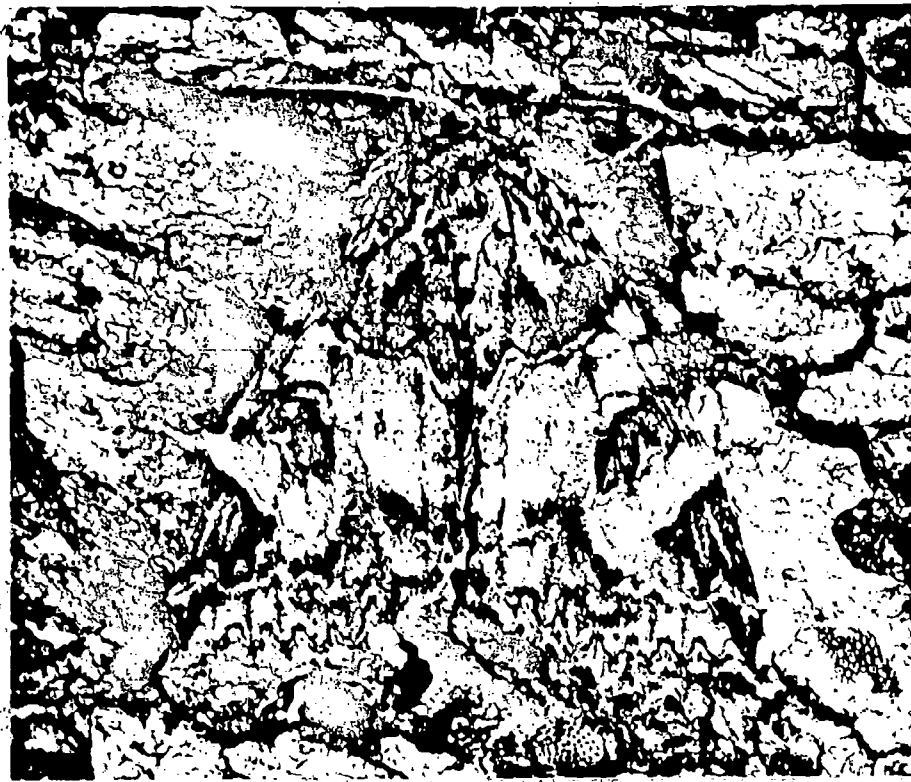

Suppose a particular moth is preyed upon by birds. During the daytime this moth is found on the trunks of trees. Both the trees and the moths vary in color. That is, some moths are lighter colored than others. The same holds true for the trees. Because of the variation in the color of tree trunks and moths, some moths are more easily seen by birds than are others as they rest on tree trunks.

5. What color combination of moths and trees would make the moths less likely to be eaten by birds?

EXCURSION 7-6 131

Now let's suppose there is a change in the forest where the moths live. Smoke from a large factory built nearby stains the bark of all the trees. No longer are there any light-colored trees. Light-colored moths are now easily seen against *any* tree.

6. Which moths would be most likely and which least likely to survive in this changed forest?

Those moths that are most easily seen are less likely to survive and to pass bits of information on to offspring.

7. In time, what changes do you predict will occur in the color of the moths living in the changed forest?

8. What conclusions do you reach regarding the inheritance of color among these moths?

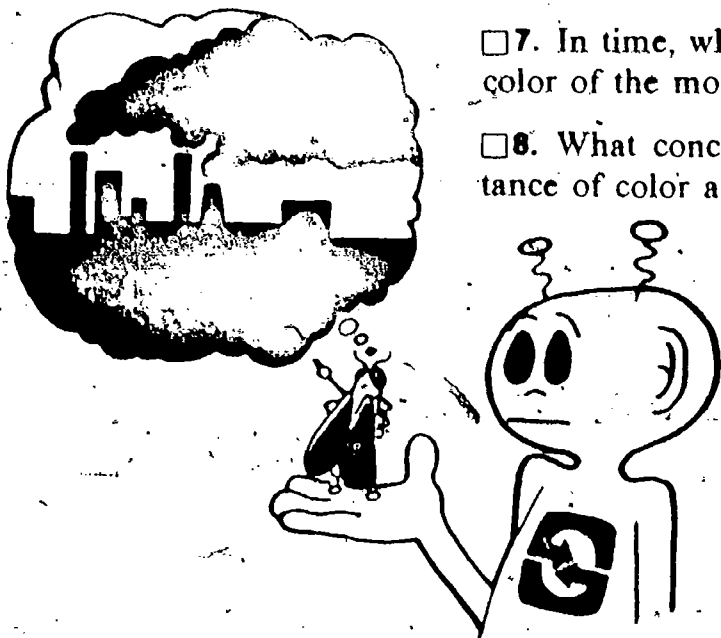

Do Blondes Have More Fun?

Excursion 7-7

You have seen that assuming that features are controlled by bits of information can be a very useful model. But are bits of information the only variable involved in what individuals look like? If not, are they the most important factors? Let's see.

Table 1 contains seven features that depend upon the environment. Complete the table in your Record Book by placing an X next to the environmental factor(s) that you think can affect each feature.

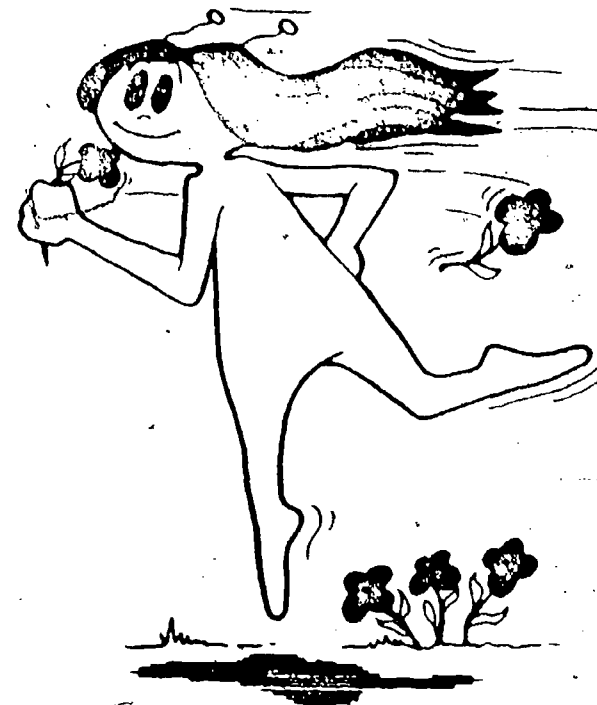

FEATURES	ENVIRONMENTAL FACTORS		
	Sunlight	Exercise	Diet
Skin tanning			
Freckles			
Intelligence			
Hair color			
Weight			
Size of muscles			
Handedness			

Table 1

1. List some other human features that you think are affected by the person's environment.

2. Which do you think is more important in determining how a person looks—his bits of information or environmental factors?

This last question raises a problem that has been discussed over and over again. It is often called the "Nature—Nurture" problem. You might like to see what other books have to say about it. Some researchers argue that the environment (Nurture) is more important in determining what a person is like. Others place greater importance on the bits of information a person inherits (Nature). Everyone agrees, however, that both environment and bits of information are important.

3. Could you change the bits of information you received from your parents?

4. Could you change your environment?

5. How could you affect the degree to which some of your features develop?

6. This excursion suggests a very important question—Can a change in the features of a parent that is caused by the environment be passed on to offspring? Questions 7 through 10 point up the problem. (Just look them over now; don't try to answer them yet.)

7. Would a weight lifter's children have stronger muscles because of the amount of exercise he takes?

8. Would the children of a man who works in the sun all day be born darker because of his exposure?

9. If some day you go to college, will your children be born smarter because of your education?

10. Will the children of a world's-record-holding runner be able to run faster than their friends? If so, why?

Your problem is to study this subject in whatever books and magazines you can find. Try your own school library and, if one is available, a public library. An encyclopedia might help, too. Your teacher may be able to suggest what books are available.

When you think you have an answer to question 6, write it in your Record Book; then answer questions 7 through 10.

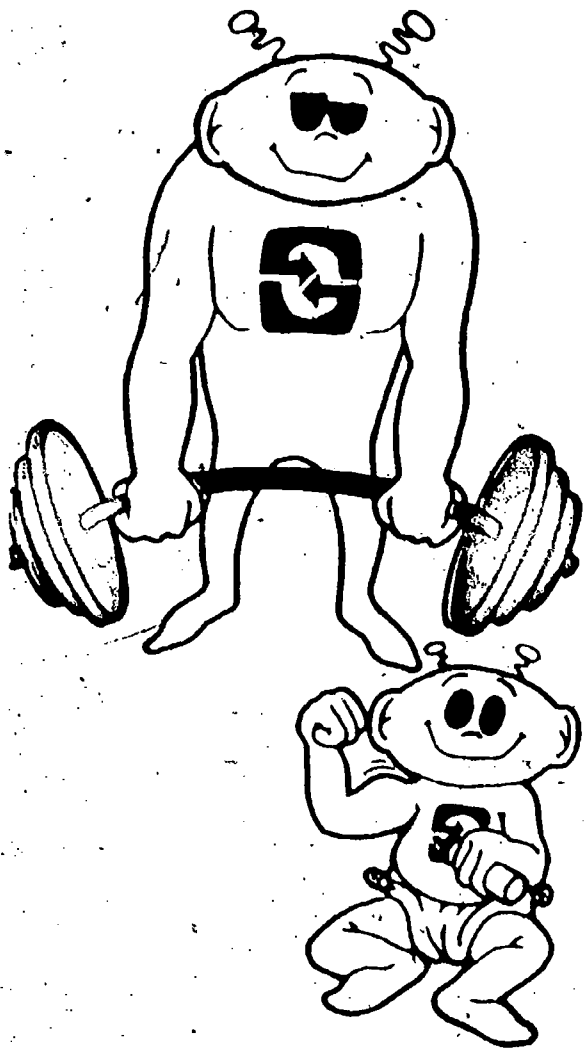

4 5 6 7 8 9 10 11 12 13 14 15-8-78 77 76 75 74

PICTURE CREDITS

Cover ISCS
x Grant Heilman
24 Asgrow Seed Company
32 Culver Pictures, Inc.
42 David Gahr for *Time*
58 United States Treasury Department
62L Larry Spencer for Silver Burdett
62R R. L. Haven
65T R. L. Haven
65B Photo Trends
66L Gates from Frederic Lewis, Inc.
66R Henry Grossman for *Time*
68 Roy J. Pence
82 Frederic Lewis, Inc.
88 ISCS