

DOCUMENT RESUME

ED 185 283

CE 024 540

TITLE Air Conditioning. FOS: Fundamentals of Service.  
 INSTITUTION Office of Youth Programs (DOL), Washington, D.C.  
 PUB DATE 79  
 NOTE 106p.; For related documents see CE 024 541-546, CE 024 797-799, and CE 025 209-214.  
 AVAILABLE FROM John Deere Distribution Service Center, Service Publications, Dept. 333, 1400-3rd Ave., Moline, IL 61265 (Order No. FOS-5703B, \$5.25; 10 or more--\$3.94 each; supplementary slide set--\$24.00)

EDRS PRICE MF01 Plus Postage. PC Not Available from EDRS.  
 DESCRIPTORS \*Agricultural Education; Agricultural Engineering; Agricultural Machinery; \*Air Conditioning; \*Air Conditioning Equipment; Equipment Maintenance; Instructional Materials; Postsecondary Education; Refrigeration Mechanics; Secondary Education; \*Tractors; \*Vocational Education

ABSTRACT

This manual on air conditioning is one of a series of power mechanics texts and visual aids covering theory of operation, diagnosis, and repair. Information is presented for use by vocational students and teachers as well as shop servicemen and laymen. Focus is on air conditioning systems for mobile machines, but most of the information also applies to automotive systems. Eight chapters included in the manual are designed to train readers so that they can understand and service air conditioning systems with speed and skill. Chapter titles include (1) Basics of Air Conditioning; (2) Refrigerants and Oil; (3) Basic System: How It Works; (4) Service Equipment; (5) Inspecting the System; (6) Diagnosing the System; (7) Testing and Adjusting the System; and (8) Preparing System for Service. Many illustrations are included and each chapter concludes with test-yourself questions. A glossary and the answers to the test questions are appended. (A supplementary 35mm color slide set is also available--see availability note.) (LRA)

\*\*\*\*\*  
 \* Reproductions supplied by EDRS are the best that can be made \*  
 \* from the original document. \*  
 \*\*\*\*\*

EA185283

# Air Conditioning



## FUNDAMENTALS OF SERVICE

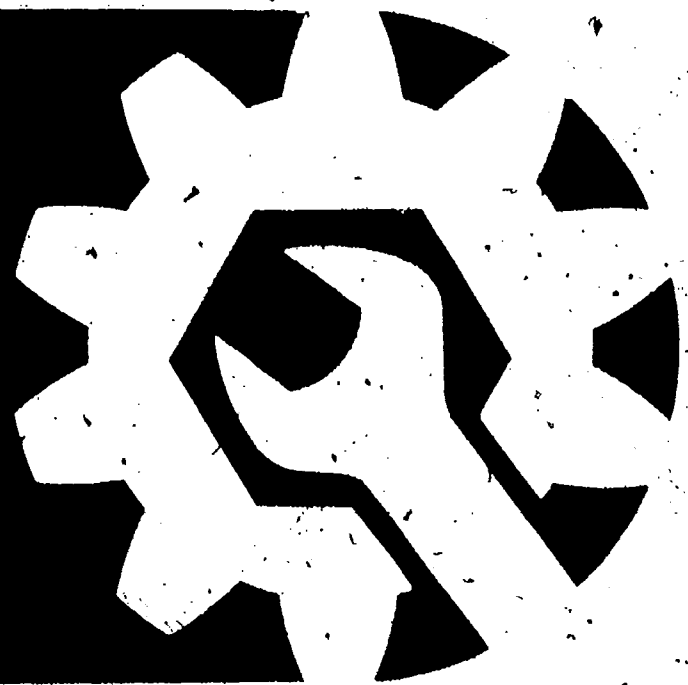

CE 024 540

U.S. DEPARTMENT OF HEALTH,  
EDUCATION & WELFARE  
NATIONAL INSTITUTE OF  
EDUCATION

THIS DOCUMENT HAS BEEN REPRODUCED EXACTLY AS RECEIVED FROM THE PERSON OR ORGANIZATION ORIGINATING IT. POINTS OF VIEW OR OPINIONS STATED DO NOT NECESSARILY REPRESENT OFFICIAL NATIONAL INSTITUTE OF EDUCATION POSITION OR POLICY.

"PERMISSION TO REPRODUCE THIS MATERIAL IN MICROFICHE ONLY HAS BEEN GRANTED BY

L. R. Hathaway

TO THE EDUCATIONAL RESOURCES INFORMATION CENTER (ERIC)."

# TO THE READER

## PURPOSE OF THIS MANUAL

The main purpose of this manual is to train the reader so that he can understand and service air conditioning systems with speed and skill. Starting with "how it works," we build up to "why it fails" and "what to do about it." This manual is also an excellent reference for the trained mechanic who wants to refresh his memory on air conditioning. It is written in a simple form using many illustrations so that it can be easily understood.

## APPLICATION OF AIR CONDITIONING IN THIS MANUAL

"Air Conditioning" is a broad field. But in this manual, our primary interest is in air conditioning systems for mobile machines on the farm and in industry. Most of this information also applies to automotive systems.

## HOW TO USE THIS MANUAL

This manual can be used by anyone — experienced mechanics and shop trainees, as well as vocational students and interested laymen.

By starting with the basics, build your knowledge step by step. Part 1 covers the basic principles of refrigeration, while Part 2 covers the use of refrigerants. In Part 3, the basic systems are introduced, while the Parts 4 through 8 cover testing, diagnosing, and servicing the complete systems.

**Answers to "Test Yourself" questions, at the end of each chapter, appear at the end of this manual on pages 99 and 100.**

## WHAT IS "FUNDAMENTALS OF SERVICE"?

This manual is part of a series of texts and visuals called "Fundamentals of Service," or "FOS." These materials are basic information in power mechanics for use by teachers as well as shop servicemen and the layman. All types of modern equipment are covered — both automotive and off-the-road. Emphasis is on theory of operation, diagnosis, and repair.

## ACKNOWLEDGEMENTS

John Deere gratefully acknowledges help from the following groups: American Society Of Agricultural Engineers (ASAE); American Society Of Refrigerating Engineers; Frigidaire, Division Of General Motors Corp.; Harrison Radiator Division, General Motors Corp.; Hupp, Inc.; Industrial Education Dept., University Of Texas; John E. Mitchell Company, Inc.; Kelvinator Div., American Motors Corp.; Nuday Co.; Society Of Automotive Engineers (SAE); Stolper Industries; Tecumseh Products Co.; Warner Electric Clutch Co.; York, Division of Borg-Warner Corp.

Copyright 1970, 1973, 1979 / DEERE & COMPANY, Moline, Ill. / Third Edition / All rights reserved.

## OTHER MANUALS IN THIS SERIES

John Deere is preparing a series of these manuals called "Fundamentals of Service," or "FOS." Other manuals in the FOS series are:

- Hydraulics
- Engines
- Electrical Systems
- Power Trains
- Shop Tools
- Welding
- Bearings and Seals
- Belts and Chains
- Fuels, Lubricants, and Coolants
- Mowing and Spraying Equipment
- Tires and Tracks
- Fiberglass and Plastics
- Fasteners
- Identification of Parts Failures

Each manual is backed up by a set of 35 mm color slides for classroom use. Transparency masters are also available for the first four subjects.

## FOR MORE INFORMATION

Write for a free *FOS Catalog of Manuals and Slides*. Send your request to:

John Deere Fundamental Writing Services, Dept. F  
John Deere Road  
Moline, Illinois 61265

## JOHN DEERE FUNDAMENTAL WRITING SERVICES

Managing Editor: L. R. Hathaway

FOS Editor: Michael Johanning

Research: Annette LaCour

# CONTENTS

## Part 1 — BASICS OF AIR CONDITIONING

Basic Principles of Refrigeration.....	1
States of Matter.....	2
Heat and Matter.....	2
Heat Movement.....	3
Pressure and Heat.....	3
Refrigerants.....	4
Basic Refrigeration Cycle.....	5
Summary.....	6

## Part 2 — REFRIGERANTS AND OIL

Introduction.....	9
Pressure-Temperature Relationship.....	9
Handling Refrigerants.....	10
Refrigerant-II For Flushing The System.....	10
Safety Rules.....	10
Molsture in System.....	11
Refrigeration Oil.....	13

## Part 3 — BASIC SYSTEM — How It Works

Introduction.....	15
Compressor.....	16
Condenser.....	19
Expansion Valve.....	20
Evaporator.....	23
Receiver-Drier (Dehydrator).....	25
Thermostat and Magnetic Clutch Systems.....	27
Bypass Systems.....	29
Suction Throttling Regulators.....	30
Lines and Connections.....	31

## Part 4 — SERVICE EQUIPMENT

Introduction.....	35
Gauge and Manifold Set.....	35
Service Valves.....	38
Leak Detectors.....	39
Vacuum Pump.....	41

## Part 5 — INSPECTING THE SYSTEM

Introduction.....	43
Visual Inspection.....	44
Operating Inspection.....	44

## Part 6 — DIAGNOSING THE SYSTEM

Introduction.....	47
Troubleshooting Customer Complaints.....	48
Diagnostic Chart.....	54
Flow Charts For Diagnosing The System.....	55

## Part 7 — TESTING AND ADJUSTING THE SYSTEM

Installing Gauge Set To Check System.....	65
Performance Testing The System.....	67
Adding Refrigerant To System.....	69
Volumetric Test Of Compressor.....	71
Adding Oil To Reciprocating Piston Compressor.....	73
Adding Oil To Axial Piston Compressor.....	74
Bench Testing Expansion Valve.....	76
Adjusting Thermostat.....	79
Checking Clutch Coil.....	81
Leak Testing System.....	83

## Part 8 — PREPARING SYSTEM FOR SERVICE

Bleeding or Discharging The System.....	85
Flushing The System.....	86
Purging The System.....	87
Evacuating System Using Vacuum Pump.....	88
Evacuating System Using Charging Station.....	89
Charging System Using 15-Ounce Containers.....	90
Charging System Using Charging Station.....	92
Isolating Compressor From System.....	93

DEFINITIONS OF TERMS AND SYMBOLS.....	95
ANSWERS TO TEST YOURSELF QUESTIONS.....	99

# BASICS OF AIR CONDITIONING/PART 1

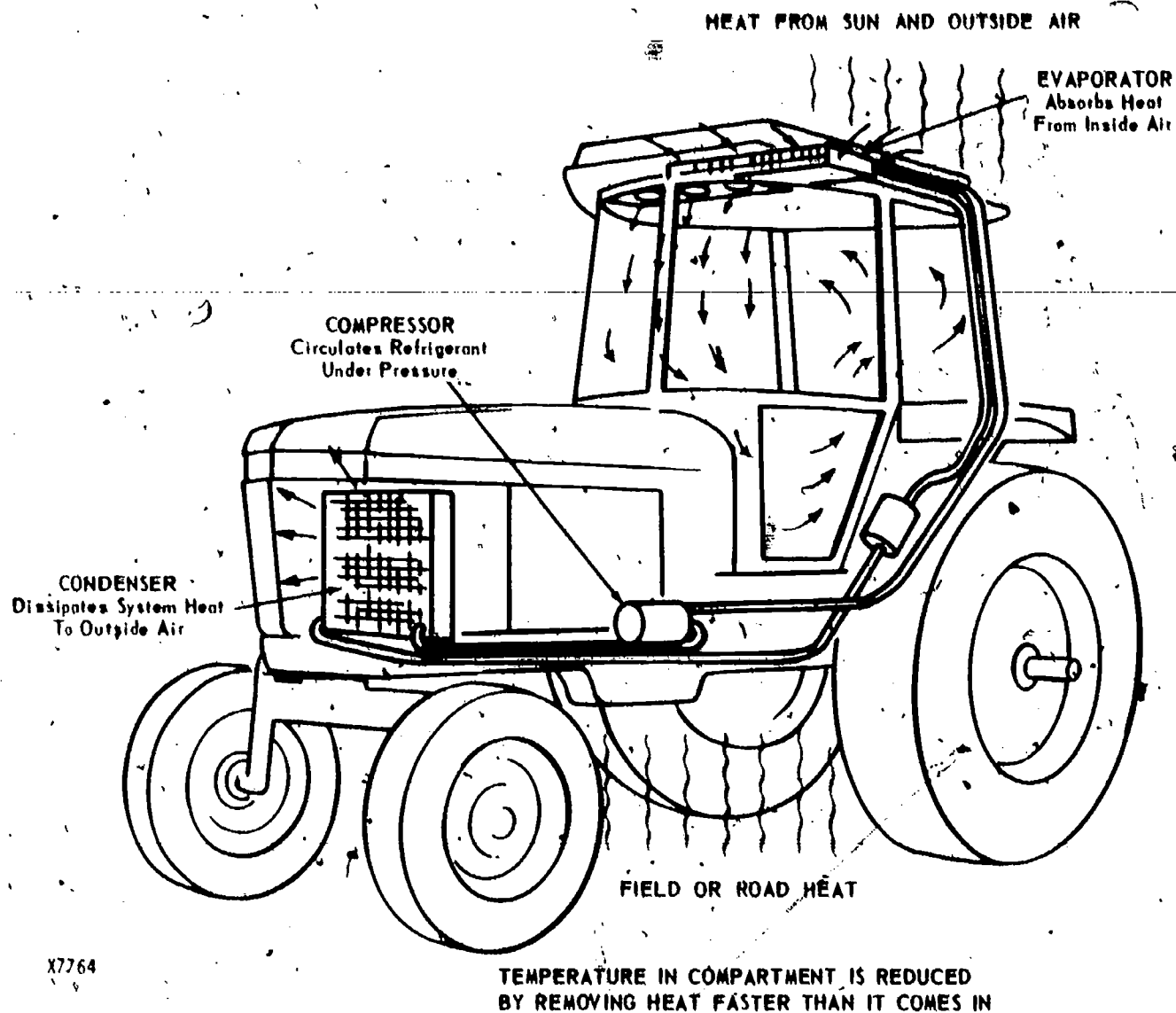

X7764

Fig. 1 — What Air Conditioning Does

Air conditioning is a process that removes heat from air and discharges this heat to where it is not objectionable.

Air conditioning on mobile machines is any system that cools and dehumidifies the air inside the passenger compartment.

Let's look at the basic principles of air conditioning — laws of matter, heat, and refrigeration.

## BASIC PRINCIPLES OF REFRIGERATION

Air conditioners work on the basic principles of refrigeration:

- Fluids absorb heat when changed from liquid to gas

- Fluids give off heat when changed from gas to liquid

In Fig. 2, the water *absorbs* heat from the flame as it boils and changes to a gas or vapor. But when the gas condenses to a liquid again, it *gives off* heat.

In air conditioning, the liquid refrigerant absorbs heat from the air as it changes to a gas. This heat is then carried off and expelled.

Temperatures are kept cool by removing heat faster than it comes in from the sun and outside air.

To understand this, let's look at the states of matter and how heat affects them.

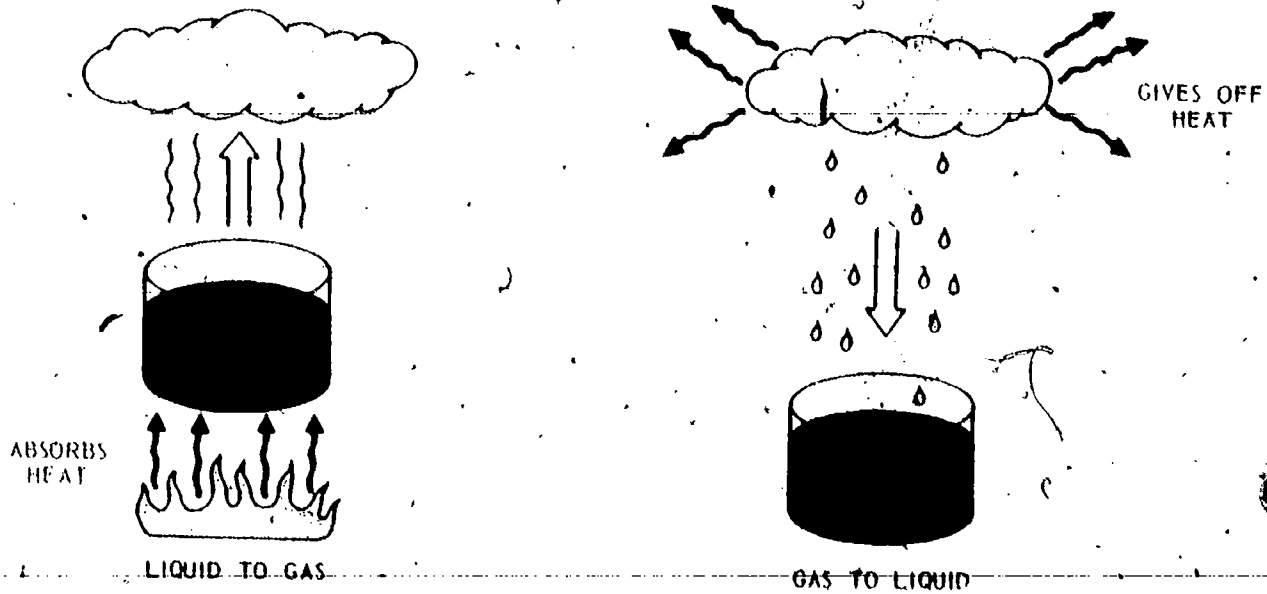

Fig. 2 — Basic Principles Of Refrigeration.

### STATES OF MATTER

All matter has three states to which it can be changed (Fig. 3).

The steam rising from a heated kettle of water is familiar as a gas or vapor. Yet this vapor can be changed to a liquid by cooling it. And the liquid can be changed to a solid (ice) by further cooling.

Even the hard steel tools we use every day can be changed to a liquid by heating them, while even more heat can change them from a liquid to a gas.

All matter is composed of molecules which are moving in the mass, whatever its state (Fig. 4). The amount of movement will determine the density or solidity of our hand tools or the vapor of the air we breathe. This is called the **theory of molecular motion**.

### HEAT AND MATTER

Since all matter is composed of molecules in motion, **heat** becomes the controlling factor of molec-

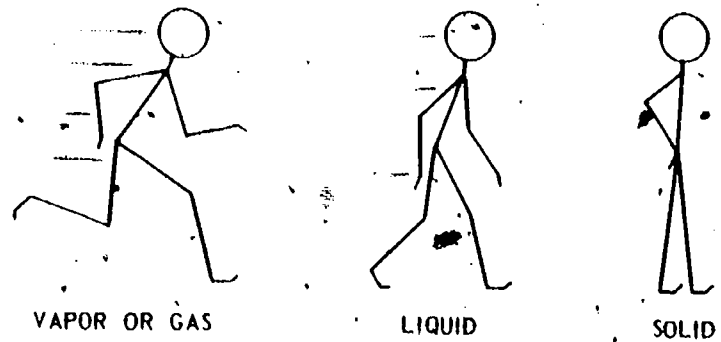

Fig. 4 — Movement Of Molecules

ular movement. The familiar state of all matter is the condition in which we normally see it, when no outside source is used to add to or remove its heat content.

Though we use the word **cold** constantly, cold is a relative term which refers only to the **absence of heat**. Cold means that a substance contains less heat than another warmer substance. Cold as a complete absence of heat, in which all molecular action stops, has never been attained by man but is believed to be  $-459^{\circ}\text{F}$  ( $-273^{\circ}\text{C}$ ).

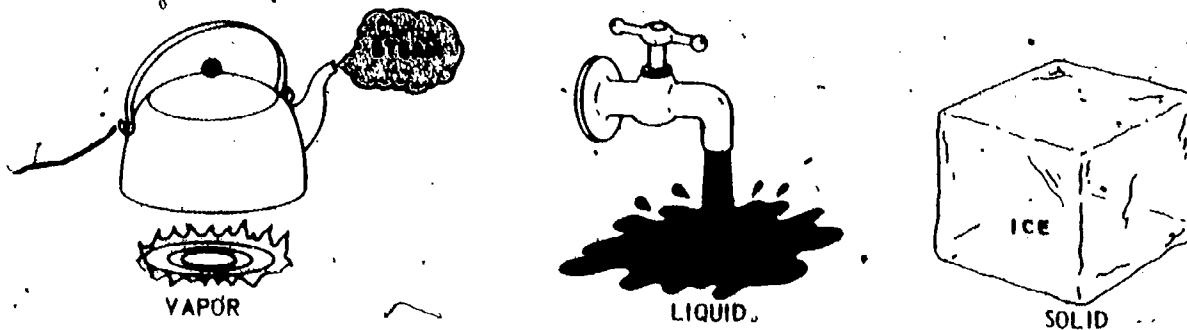
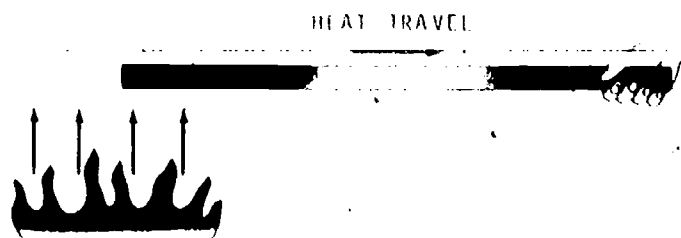

Fig. 3 — Water In The Three States Of Matter

### HEAT MOVEMENT

In an air conditioning system, heat must be removed from the passenger area to a degree that is comfortable to the occupants. This heat must then be expelled to the outside air. This is done by making use of the nature of heat movement.



X7765

NATURE OF HEAT MOVEMENT

Fig 5 - Heat Travels From The Hotter To The Colder

Heat always moves from the hotter to the colder (Fig. 5).

The rapidly moving molecules of the warmer substance impart some of their energy to the slower moving molecules having less heat. This slows down the molecules of the warmer substance and speeds up the molecules of the colder substance. This heat exchange can go on until the molecules of both substances are moving at the same rate; then their temperatures are the same and there is no further heat exchange between them.

In some heat exchanges, the molecules will change their shape instead of their speed of movement. This change of shape is caused by one or more atoms making up the molecules changing position, which will cause the substance to change from a gas to a liquid, a liquid to a solid, and vice versa.

This molecular change is the basis for air conditioning with its exchange of heat energy between the gas and liquid states of its refrigerant fluid.

### PRESSURE AND HEAT

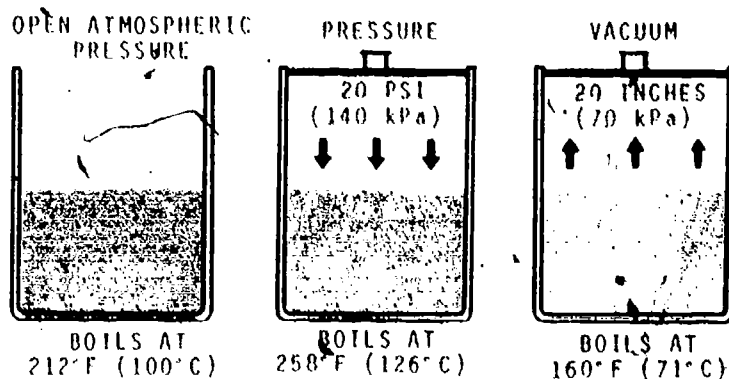

X7766

Fig. 6 - When A Liquid (Water) Boils At Various Pressures

The temperature at which a liquid boils will vary with the pressure on the liquid (Fig. 6). Decreasing the pressure lowers the boiling point, while increasing the pressure raises the boiling point.

For example: Water under 20 psi (138 kPa) pressure boils at 258°F (126°C), while water in a vacuum of 20 inches (508 mm) of mercury will boil at 160°F (71°C).

In air conditioning, the temperature of the refrigerant fluid is controlled by changing the pressure on it. This in turn controls how much heat moves out of the air into the cooler refrigerant, as we'll see later.

### HEAT MEASUREMENT

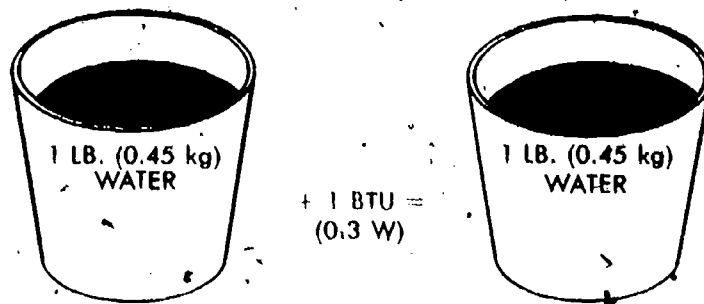

1 BTU (0.3 W) EQUALS HEAT NECESSARY TO RAISE TEMPERATURE OF 1 LB. (0.45 kg) OF WATER 1° F (1°C) AT SEA LEVEL PRESSURE

X7787

Fig. 7 - Heat Is Measured In B.T.U.'s (Watts)

Heat is measured by a unit known as The British Thermal Unit (B.T.U.) or watt (W). One B.T.U. (0.3 W) is the amount of heat required to raise the temperature of a pound (0.45 kg) of water one degree Fahrenheit (1°C) at sea level pressure (Fig. 7).

**LATENT HEAT**

Latent heat is the amount of heat measured in B.T.U.'s (watts) that is necessary to change a substance from one state to another without changing its temperature.

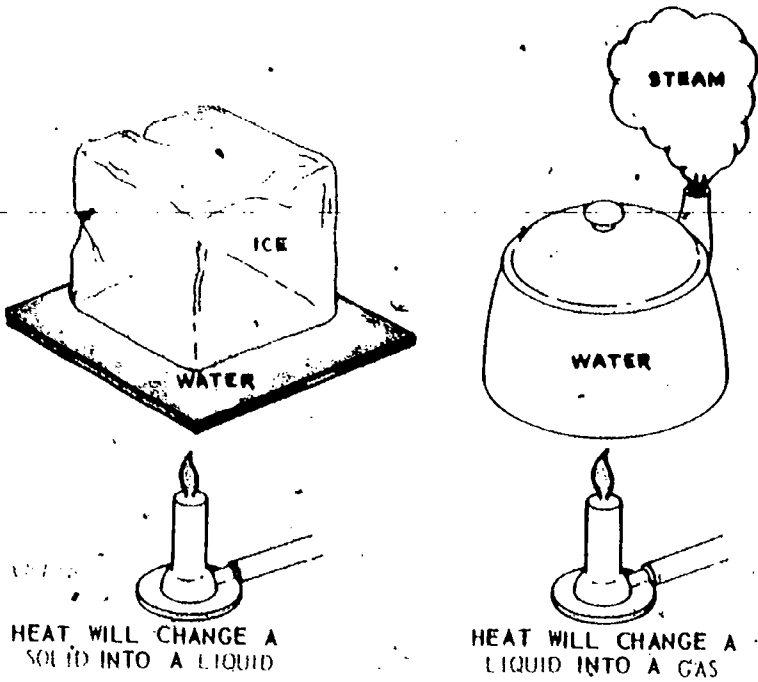

Fig 8 - Latent Heat

We know that ice will change to water at 32°F (0°C). Each pound of ice requires 144 B.T.U.'s to make this change. (Each kilogram of ice requires 93 W.)

To change water into steam at 212°F (100°C) each pound of water must have 970 B.T.U.'s added to it. (Each kilogram of water must have 625 W added.)

We call the heat that must be added to ice to cause a change of state the **latent heat of liquidization**. We call the heat that must be added to water to cause it to change its state the **latent heat of vaporization**.

If we reverse this change of state, steam with a heat intensity of 212°F (100°C) will give off 970 B.T.U.'s per pound (625 W per kg) as it condenses to water. This heat release is called the **latent heat of condensation**.

As the water is further cooled, the molecules are realigned and change the liquid to a solid (ice). The heat given off then is called the **latent heat of freezing**, which will be 144 B.T.U.'s of heat per pound (93 W per kg) at 32°F (0°C).

This principle is the basis for air conditioning operation. A refrigerant is chosen for its ability to change its state readily and give off or absorb B.T.U.'s (watts).

Here is a list giving the latent heat of vaporization of common refrigerants as compared to water:

Substance	B.T.U.'s Per Pound (Watts per Kilogram)
Water	970 (625) (at 212°F) (100°C)
Ammonia	565 (364) (at 5°F) (-15°C)
Sulphur dioxide	169 (109) (at 5°F) (-15°C)
Refrigerant-12	68.2 (44) (at 5°F) (-15°C)

Let's look now at the qualities of refrigerants as used in modern air conditioning systems.

**REFRIGERANTS**

Refrigerant-12 is the most stable, safest, and easiest to handle of the refrigerants now in use in mobile air conditioning systems. In its pure form, it will not react with any of the substances in the parts of the refrigeration system.

With its low boiling point of -22°F (-30°C), Refrigerant-12 is ideal for removing large quantities of heat from the surrounding air.

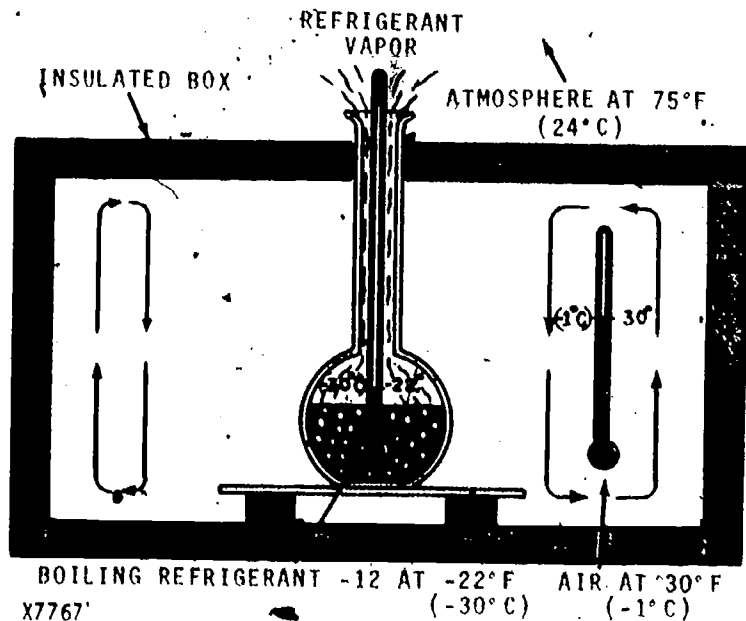

Fig. 9 - How Refrigeration Is Produced By Evaporating Refrigerant-12

Fig. 9 shows how Refrigerant-12 removes heat from the air. A container of the refrigerant placed in an insulated box will boil furiously at room temperature. As this change of state occurs, heat will follow its natural tendency and move from the warmer air inside the box to the boiling refrigerant. This heat



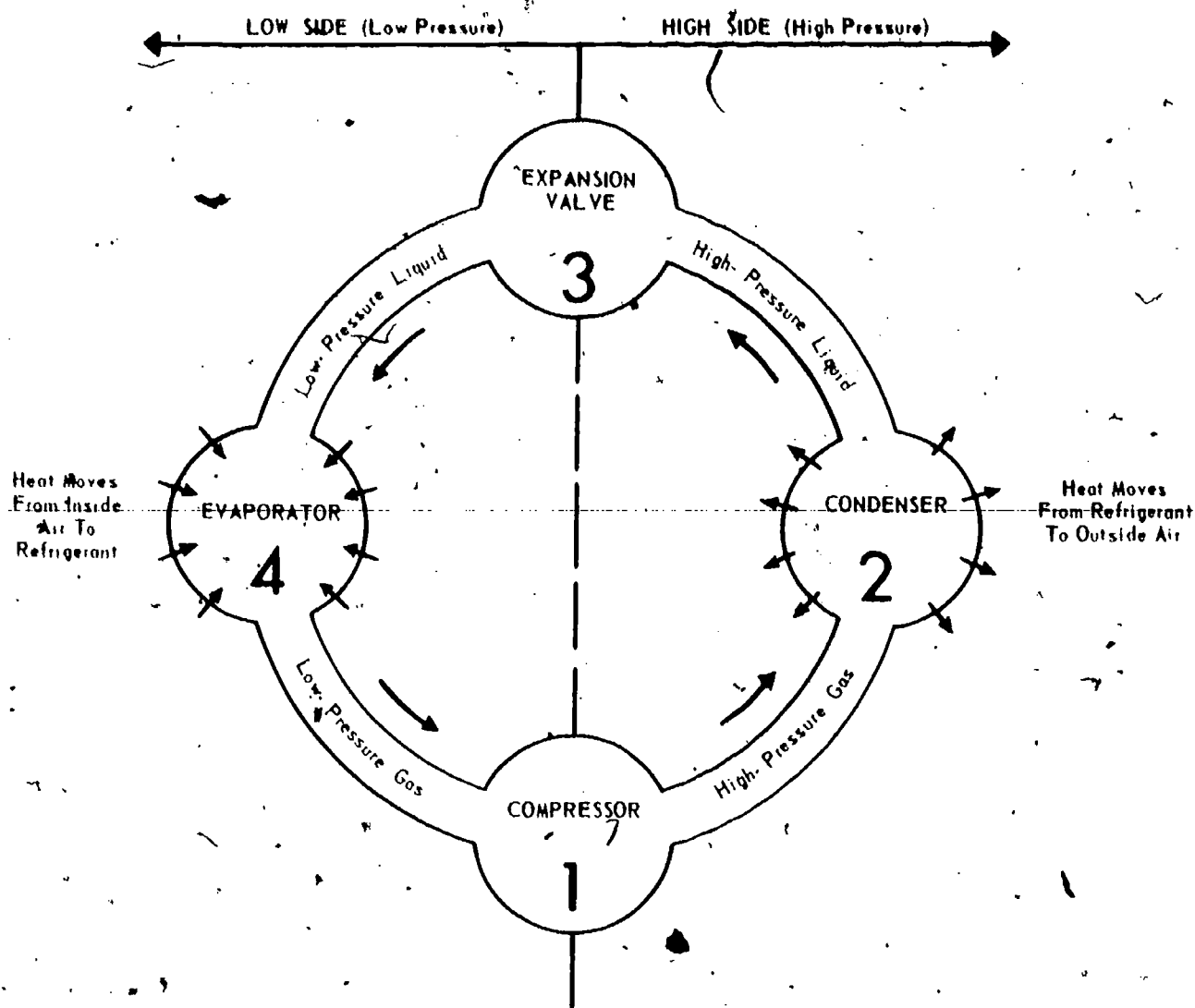

Fig. 10 — Complete Four-Part Cycle Of Refrigeration

will then be carried out of the box with the refrigerant vapors, lowering the temperature of the air inside the box. This could continue until the heat was removed from the air inside the box or until the temperature of the air and the refrigerant are both at  $-22^{\circ}\text{F}$  ( $-30^{\circ}\text{C}$ ), when the refrigerant would stop boiling. At this time the heat content of both substances would be equal and there would be no further heat transfer between the air and the refrigerant.

We will look at Refrigerant-12 more closely in Part 2.

### BASIC REFRIGERATION CYCLE

For an air conditioning system to operate with economy, the refrigerant must be used repeatedly. For this reason, all air conditioners use the same cycle of **compression, condensation, expansion, and evaporation** in a closed circuit (Fig. 10). The same refrigerant is used to move the heat from one area, to cool this area, and to expel this heat in another area.

In Fig. 10, note that the four-part cycle is divided at the center into a **high side** and a **low side**. This refers to the pressures of the refrigerant in each side of the system.

To understand the basic refrigerant cycle let's start at the **compressor (1)**. The refrigerant comes into the compressor as a low-pressure gas, is compressed, and moves out of the compressor as a high-pressure gas.

The gas then flows to the **condenser (2)**. Here the gas condenses to a fluid, giving off its heat to the outside air.

The fluid then moves to the **expansion valve (3)** under high pressure. This valve restricts the flow of the fluid, thus lowering its pressure.

The low-pressure fluid then moves to the **evaporator (4)**, where heat from the inside air moves in and changes it from a fluid to a gas.

As a hot low-pressure gas, the refrigerant moves to the compressor (1) where the entire cycle is repeated.

## HEAT AND PRESSURE

As we explained earlier, the boiling point of a liquid (changing it to a gas) can be varied by changing the pressure on the liquid. This principle is used in the basic refrigeration cycle.

Liquids will not compress; however, a gas can be compressed.

In the refrigeration system (Fig. 10), the cool gas from the evaporator is compressed, concentrating its heat in a small area. This compression heats up the gas until it is warmer than the outside air. As a result, the gas gives off its heat to the outside air (moving hotter to colder). As the gas gives off its heat at the condenser, it changes back from a gas to a liquid. Under a high pressure of 160 psi (1103 kPa) and up, the boiling point has been raised from  $-22^{\circ}\text{F}$  ( $-30^{\circ}\text{C}$ ) to  $+80^{\circ}\text{F}$  ( $27^{\circ}\text{C}$ ) or higher.

As the liquid reaches the expansion valve and is metered to the low side of the system, the liquid refrigerant is allowed to expand as pressure is removed from it. Here the boiling point drops from  $80^{\circ}$  ( $27^{\circ}\text{C}$ ) to  $30^{\circ}\text{F}$  ( $-1^{\circ}\text{C}$ ) or lower, depending on the controls of the system. At this lower boiling point, the refrigerant changes again from a liquid to a gas, absorbing heat from the inside air through the evaporator.

The heat-charged gas is then compressed by the compressor, once again, concentrating its heat and raising its boiling point so that heat can be exchanged in the condenser. See chart on page 7 for temperature-pressure relation.

## REMOVING MOISTURE

The principle of heat and pressure is also used in removing harmful moisture from the system, but in reverse order. We can just as effectively lower the boiling point by decreasing the pressure.

As the system is pumped down to a vacuum, (Fig. 11), moisture will vaporize and be carried out by the vacuum pump. In other words, the water boils at a lower temperature because of the reduced pressure and so vaporizes and is drawn off.

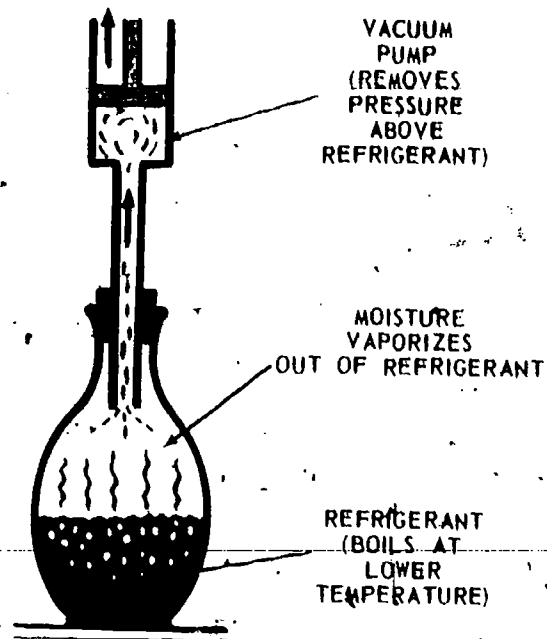

Fig. 11 — Boiling Of Liquid Under A Decrease in Pressure

## SUMMARY: BASICS OF AIR CONDITIONING

Here is a review of the basic principles:

- Fluids absorb heat when changed from liquid to gas
- Fluids give off heat when changed from gas to liquid
- Heat always moves from the hotter to the colder
- Temperature at which a liquid changes to a gas varies with the pressure on it
- Refrigerant fluids must have a low boiling point and heat and cool readily for best heat exchanges

Basic refrigeration cycle is compression, condensation, expansion, and evaporation:

- 1 — Compression heats up the gas
- 2 — Condensation changes gas to liquid and releases heat
- 3 — Expansion reduces pressure
- 4 — Evaporation changes liquid to gas and absorbs heat

**TEMPERATURE-PRESSURE RELATION CHART**  
(For Refrigerant-12)

Temp.		Press.		Temp.		Press.		Temp.		Press.	
°F.	°C.	PSI	kPa	°F.	°C.	PSI	kPa	°F.	°C.	PSI	kPa
0	-18	9.1	62.7	50	10	46.6	321.3	90	32	99.6	686.7
2	-17	10.1	69.6	51	11	47.8	329.6	91	33	101.3	698.5
4	-16	11.2	77.2	52	11	48.7	335.8	92	33	103.0	710.2
6	-14	12.3	84.8	53	12	49.8	343.4	93	34	104.6	721.2
8	-13	13.4	92.4	54	12	50.9	351.0	94	34	106.3	732.9
10	-12	14.6	100.7	55	13	52.0	358.5	95	35	108.1	745.3
12	-11	15.8	108.9	56	13	53.1	366.1	96	36	109.8	757.1
14	-10	17.1	117.9	57	14	55.4	382.0	97	36	111.5	768.8
16	-9	18.3	126.2	58	14	56.6	390.3	98	37	113.3	781.2
18	-8	19.7	135.8	59	15	57.1	393.7	99	37	115.1	793.6
20	-7	21.0	144.8	60	16	57.7	397.8	100	38	116.9	806.0
21	-6	21.7	149.6	61	16	58.9	406.1	101	38	118.8	819.1
22	-6	22.4	154.4	62	17	60.0	413.7	102	39	120.6	831.5
23	-5	23.1	159.3	63	17	61.3	422.7	103	39	122.4	843.9
24	-4	23.8	164.1	64	18	62.5	430.9	104	40	124.3	857.0
25	-4	24.6	169.6	65	18	63.7	439.2	105	41	126.2	870.1
26	-3	25.3	174.4	66	19	64.9	447.5	106	41	128.1	883.2
27	-3	26.1	180.0	67	19	66.2	456.4	107	42	130.0	896.4
28	-2	26.8	184.8	68	20	67.5	465.4	108	42	132.1	910.8
29	-2	27.6	190.3	69	21	68.8	474.4	109	43	135.1	931.5
30	-1	28.4	195.8	70	21	70.1	483.3	110	43	136.0	937.7
31	-1	29.2	201.3	71	22	71.4	492.3	111	44	138.0	951.5
32	0	30.0	206.9	72	22	72.8	502.0	112	44	140.1	966.0
33		30.9	211.1	73	23	74.2	511.6	113	45	142.1	979.8
34		31.7	218.6	74	23	75.5	520.6	114	46	144.2	994.3
35	2	32.5	224.1	75	24	76.9	530.2	115	46	146.3	1008.7
36	2	33.4	230.3	76	24	78.3	539.9	116	47	148.4	1023.2
37	3	34.3	236.5	77	25	79.2	546.1	117	47	151.2	1042.5
38	3	35.1	242.0	78	26	81.1	559.2	118	48	152.7	1052.9
39	4	36.0	248.2	79	26	82.5	568.8	119	48	154.9	1068.0
40	5	36.9	254.4	80	27	84.0	579.2	120	49	157.1	1083.2
41	5	37.9	261.3	81	27	85.5	589.5	121	49	159.3	1093.4
42	6	38.8	267.5	82	28	87.0	599.9	122	50	161.5	1113.5
43	6	39.7	273.7	83	28	88.5	610.2	123	51	163.8	1129.4
44	7	40.7	280.6	84	29	90.1	621.2	124	51	166.1	1145.3
45	7	41.7	287.5	85	29	91.7	632.3	125	52	168.4	1161.1
46	8	42.6	293.7	86	30	93.2	642.6	126	52	170.7	1177.0
47	8	43.6	300.6	87	31	94.8	653.6	127	53	173.1	1193.5
48	9	44.6	307.5	88	31	96.4	664.7	128	53	175.4	1209.4
49	9	45.6	314.4	89	32	98.0	675.7	129	54	177.8	1225.9
								130	54	182.2	1256.3
								131	55	182.6	1259.0
								132	56	185.1	1276.3
								133	56	187.6	1293.5
								134	57	190.1	1310.7

TEST YOURSELF

QUESTIONS AND PROBLEMS

1. When a liquid is changed to a gas, does it absorb or give off heat?
2. If you increase the pressure on a liquid, does it raise or lower the boiling point?
3. (Fill in the blanks with "colder" or "hotter"). Heat always moves from the \_\_\_\_\_ to the \_\_\_\_\_

4. Define a B.T.U. (British Thermal Unit).
5. Using the diagram in Fig. 12, show the basic refrigeration cycle. Label parts 1, 2, 3, and 4, and show "High side" and "Low side" by each arrow at the top. Between each part of the cycle, label the refrigerant flow as high or low pressure, and as gas or liquid. Show by arrows around parts "2" and "4" whether heat is absorbed or given off.

(Answers on page 99.)

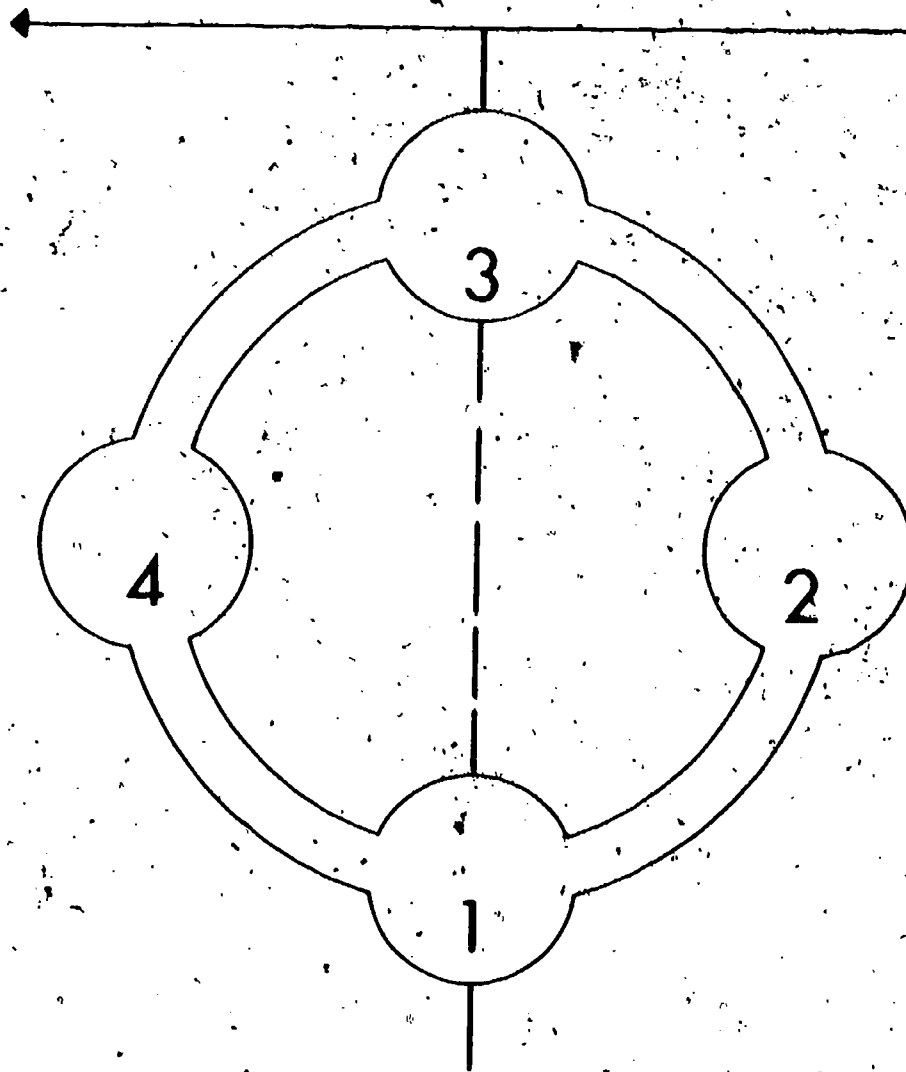

Fig. 12 — Diagram Of Basic Refrigeration Cycle (See Question 5)

12

## REFRIGERANTS AND OIL / PART 2



Fig. 13 — Refrigerants And Oil

## INTRODUCTION

The term "refrigerant" refers to the fluid used in a refrigerating system to produce "cold" by removing heat from the air. Refrigerant-12 has been adopted for use in systems on mobile machines because it is the safest fluid available that will remain stable and still give off or absorb great quantities of heat.

Since nature did not provide a perfect refrigerant, man devised a compound of fluorinated hydrocarbon known as carbon tetrachloride. To improve this element, two chlorine atoms were removed and two atoms of fluorine were introduced in their place. The new compound was Refrigerant-12.

This refrigerant is ideal for its stability at both high and low temperatures, and it will not react with most metals. Properly handled, it is nonflammable and nonexplosive in either a gas or liquid form and will not injure plant or animal life.

Refrigerant-12 has a boiling point of  $-22^{\circ}\text{F}$  ( $-30^{\circ}\text{C}$ ), which means that a container of the fluid sitting on a block of ice will *boil furiously*. This is an ideal quality for a refrigerant, which must work as a heat exchanger.

Another refrigerant, called Refrigerant-22, contains methyl alcohol and can be a fire hazard. For this reason, all manufacturers have now adopted Refrigerant-12 as the safest for use in mobile machine systems.

## OTHER TERMS FOR REFRIGERANT-12

"Freon" has become a common shop term when referring to Refrigerant-12. However, "Freon" and "Freon-12" are registered trademarks of E. I. du Pont de Nemours and Company and should be used only when referring to refrigerant packaged and sold by Du Pont.

Refrigerant-12 is also packaged in the United States under several other brand names such as Genatron-12, Isotron-12, Ucon-12, and others.

Refrigerant-12 has been abbreviated as R-12 and is accepted in the industry by this name.

## PRESSURE AND TEMPERATURE RELATIONSHIP

In air conditioning a compartment, the objective is to allow the evaporator to reach its coldest point without icing up. Since ice will form at  $32^{\circ}\text{F}$  ( $0^{\circ}\text{C}$ ), the fins and cooling coils of the evaporator must not be allowed to drop below this point. Because of the temperature rise through the walls of the cooling fins and coils, the temperature of the refrigerant may be several degrees cooler than that of the air passing through the evaporator.

A thermometer should be used with a gauge and manifold set to properly service an air conditioner (see Part 4).

## HANDLING REFRIGERANTS

Refrigerants must be handled with care to avoid danger.

Liquid refrigerant, if allowed to strike the eye, can cause blindness. If allowed to strike the body, it can cause frostbite.

If a refrigerant container is heated, or contacts a heating element, the pressure inside can build up and explode the container.

If refrigerant is allowed to contact an open flame or heated metal, a poisonous gas will be created. Inhaling this gas can cause you to become violently ill.

**Remember** — refrigerant can be dangerous. It should only be handled by a trained serviceman.

## REFRIGERANT-11 FOR FLUSHING THE SYSTEM

When flushing the system (see Part 8), either liquid Refrigerant-12 or Refrigerant-11 may be used. Refrigerant-11, however, is preferred. It is more effective than flushing with Refrigerant-12 for the following reasons.

1. Refrigerant-11 has a higher boiling point and stays in a liquid state up to 76°F (24°C).
2. This higher boiling point permits it to remain in its liquid state and, therefore, it will not freeze moisture that may be in the system.
3. Refrigerant-11 moves moisture and debris out of a system more rapidly.
4. It will not freeze skin when in direct contact. (Refrigerant-12 will freeze skin on contact).

## SAFETY RULES FOR REFRIGERANTS

Observe these safety rules when handling Refrigerant-12 and its containers:

**1. DO NOT HANDLE REFRIGERANT WITHOUT SUITABLE EYE PROTECTION.** Escaping refrigerant that might come in contact with the eyes can result in serious frostbite or blindness because of its low boiling point. The eyes should be washed immediately with clean, cold water for at least ten minutes if an accident occurs. Then go to a doctor or an eye specialist as soon as possible. The fluid you see escaping from open connections is oil and not refrigerant. But it can also be harmful to the eyes because its dryness can dehydrate the tender tissues of the eyeball.

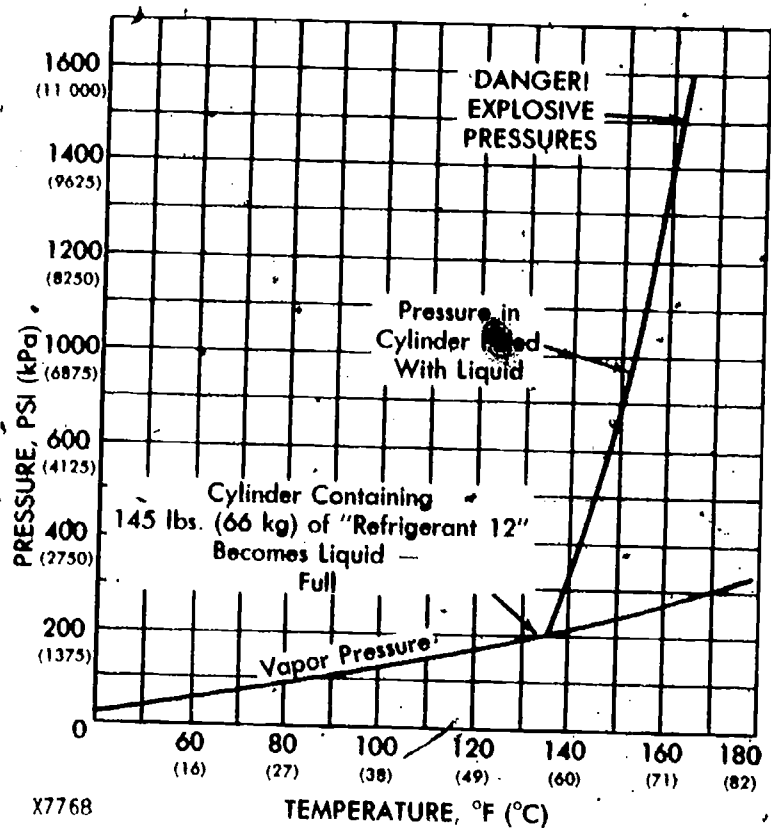

Fig. 14 — Pressure Of Refrigerant-12 At Rising Temperatures

**2. DO NOT OVERHEAT THE REFRIGERANT CONTAINER.** The graph in Fig. 14 on the pressure characteristics of Refrigerant-12 shows that beyond 120°F (49°C) the pressure buildup is tremendous. This can be extremely dangerous in one and two pound containers having very thin walls.

Also, during the charging process, water temperature for heating the refrigerant containers should not exceed 125°F (52°C). Higher temperatures will cause excessive pressure in the container.

3. **DO NOT DISCHARGE REFRIGERANT INTO AN ENCLOSED AREA HAVING AN OPEN FLAME.** Refrigerant subjected to open flame will result in phosgene gas, which is very deadly. The Propane Torch Leak Detector (see Part 4) must be used carefully and in a well-ventilated area, for inhaling the gas a little at a time can be cumulative, resulting in a toxic condition. A well-ventilated area with good circulation is the only safe working area. Common sense here is the greatest safeguard.

4. **WHEN PURGING OR BLEEDING SYSTEM, DISCHARGE REFRIGERANT SLOWLY.** Refrigerant has a great affinity for oil and carries approximately 8 percent of the oil in the system with it. Rapid purging or bleeding will carry an excess amount of the oil out with the refrigerant.

5. **DO NOT ADD ANYTHING BUT PURE REFRIGERANT-12 AND REFRIGERANT OIL INTO THE SYSTEM.** Any additional compound can contain foreign substances not compatible with the chemical makeup of refrigerant, causing it to become chemically unstable and to lose its good qualities.

6. **DO NOT HANDLE DAMP CONTAINERS WITH BARE HANDS WHILE CHARGING A SYSTEM.** Frost will form on the outside of the container when it is wet, causing the hand to be frozen to the container. This can occur when using warm water to heat the container. If this happens, wet the container and your hand will thaw and be released.

7. **DO NOT WELD OR STEAM CLEAN NEAR OR ON AN AIR CONDITIONING SYSTEM.** Excessive pressure could build up in the system.

8. **Before loosening a refrigerant fitting, COVER THE CONNECTION WITH A CLOTH TO PREVENT REFRIGERANT FROM SPRAYING ONTO SKIN OR EYES.**

9. **When charging a system with the engine running, BE SURE THE HIGH PRESSURE-GAUGE VALVE IS CLOSED.**

10. **BE ALERT AND STAY CLEAR OF ROTATING PARTS.**

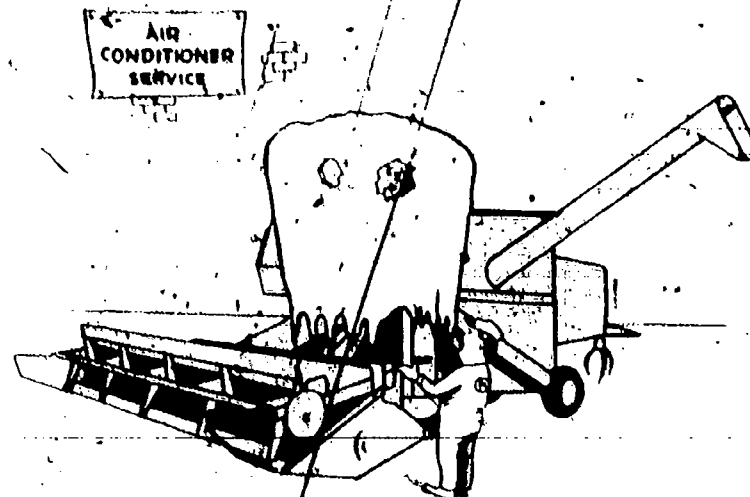

Fig. 15 — The Objective Is To Allow Cooling Without Icing Up

## MOISTURE IN SYSTEM

Any air conditioning system should be as dry as it is possible to maintain it. The refrigerant has had virtually all the moisture removed from it during manufacture. Any moisture introduced into the system must come from outside sources such as a break in a line or from improper sealing of connections when a unit is removed for service.

Refrigerant-12 will absorb moisture readily when exposed to it. To keep the system as moisture-free as possible, all systems use a dehydrator containing a desiccant which can absorb great quantities of moisture. However, each can only absorb a pre-determined amount, and when the saturation point has been reached, the effectiveness is lost.

Moisture in greater concentrations than 14 parts per million causes damage to the inside parts of the system. Water reacts with Refrigerant-12 to form hydrochloric acid. The greater the moisture content in the system, the more concentrated this corrosive acid. The acid eats away all internal metal parts — iron, copper, and aluminum, releasing oxides into the refrigerant as foreign substances which seriously affect the ability of the refrigerant to absorb and give off heat.

Moisture is the greatest enemy of the air conditioning system. Once a system becomes saturated over a long period of time, irreparable damage is done inside the system. Pinholes will be eaten through the evaporator and condenser coils, ultimately requiring their replacement. Aluminum parts will be eaten away, ruining the compressor, while valves and fittings can be so corroded that they are no longer usable.

The complete removal of moisture from a system can be a serious problem for the serviceman. Vacuum is used as the best means of removing moisture. Moisture forms in small droplets throughout the system at zero pressure or higher. Remembering that at zero pressure the system still has at least partial atmospheric pressure, as we pump the system down into a vacuum, pressure is released from the moisture droplets, changing them from a liquid to a vapor. The vacuum pump then removes the vaporized moisture. The inches (kPa) of vacuum reached plus the length of time the system is subjected to a vacuum will determine the amount of moisture removed.

The use of a vacuum pump (Fig. 16) is necessary for moisture removal.

**Do not use the compressor as a vacuum pump.** The compressor is cooled and lubricated by refrigerant and oil, but when vacuuming, neither of these are done. The risks are high, so avoid the practice.

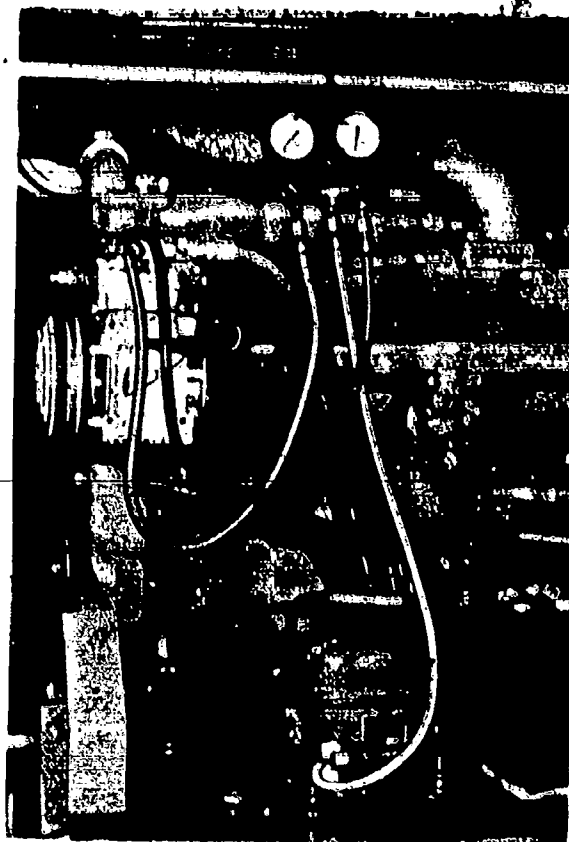

Fig. 16 — Using A Vacuum Pump To Remove Moisture From The System.

Any system that is seriously contaminated with moisture will require that component parts be removed, subjected to high vacuum, and flushed with refrigerant to pick up moisture particles. This is expensive and time-consuming, but is the only solution to severe cases of moisture contamination.

Systems that are seriously contaminated with moisture should have the dehydrator replaced prior to pumping down. A good vacuum pump will reduce moisture to a small percent. The remaining moisture may then be readily absorbed by the desiccant. Complete dehydration of the system will then allow the unit to cool ten or more degrees.



## REFRIGERATION OIL

Oil is needed to lubricate the seals, gaskets and other moving parts of the compressor. For this reason, a small amount of oil is circulated through the system with the refrigerant. This also aids in keeping the thermostatic expansion valve in proper operating condition.

Only nonfoaming oil specifically formulated for use in each air conditioner should be used.

Refrigeration oil is highly refined. It is a mineral oil with all impurities such as wax, moisture and sulphur removed. **Never use a motor oil, regardless of grade, in any air conditioning system.**

Refrigeration oil is available in several grades or viscosities. (Viscosity is determined by the time in seconds it takes a definite quantity of oil to flow through a certain size orifice at 100°F [38°C].) Oils of 300, 525, and 1000 viscosity are most commonly used in air conditioning.

Check the oil level of the compressor each time the air conditioner is serviced. Always check the compressor manufacturer's recommendations before adding oil to the system. See pages 73 and 74 for procedure to check and add oil.

Except when pouring, never allow the oil container to remain uncapped. Always be sure that the cap is in place and is tight. Oil absorbs moisture, and moisture is damaging to the system.

## HANDLING REFRIGERATION OIL

Here are a few simple rules to follow when handling refrigeration oil:

1. Use only approved refrigeration oil.
2. Do not transfer oil from one container to another.
3. Do not return oil from a system to a container — always discard it.

4. Make sure the cap is tight on the container when not in use.
5. Replace old oil if there is any doubt about its condition.
6. Avoid contaminating the oil.

## TEST YOURSELF

### QUESTIONS

1. True or false? "An open container of Refrigerant-12 will not boil at room temperatures."
2. What can happen to the skin if you spill Refrigerant-12 on it?
3. What can happen if you heat up a small, closed container of Refrigerant-12?
4. Why is moisture harmful to the air conditioning system?
5. What service tool do you use to remove excess moisture from the air conditioning system?
6. True or false? "Use only a good grade of motor oil in the air conditioning system."

(Answers on page 99.)

# BASIC SYSTEM—How It Works/PART 3

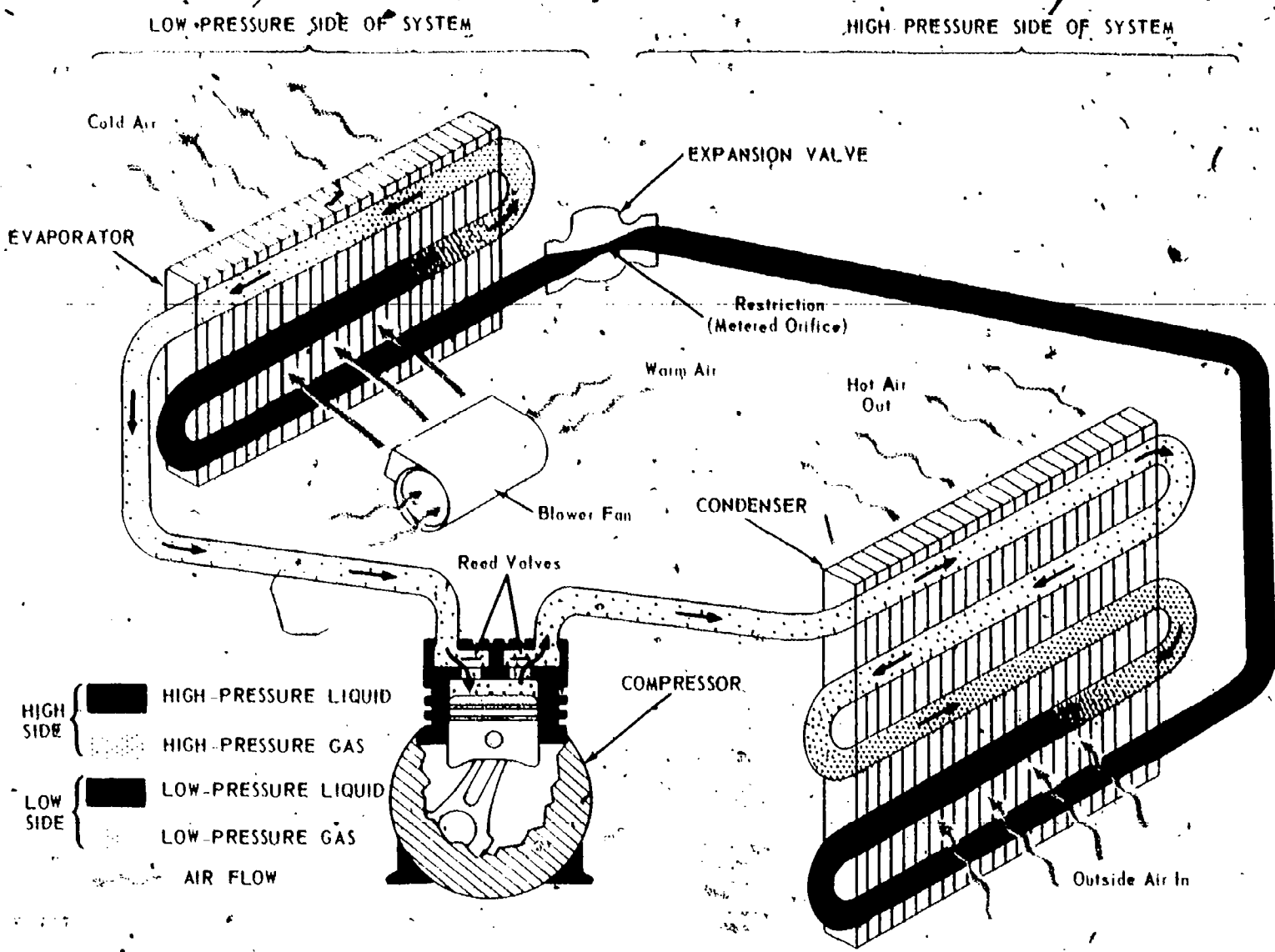

Fig. 17 — Basic Air Conditioning System

## INTRODUCTION

All air conditioning systems must have four basic elements:

- **Compressor**
- **Condenser**
- **Expansion Valve**
- **Evaporator**

In Fig. 17, showing the actual parts of the system, note how the refrigerant cycle of Fig. 10 is repeated.

From the **compressor**, high-pressure gas is sent to the **condenser**, where it is converted to liquid and heat is dissipated. The high-pressure liquid flows on to the **expansion valve**, where it is metered and its pressure is reduced. At the **evaporator**, the liquid is again converted to gas, absorbing heat from the air. The cycle is then repeated, starting at the compressor.

The air conditioner is a heat transfer unit. A failure of any element will interrupt the heat exchange cycle and cause the whole system to fail. Each basic element is engineered and balanced to the other parts of the system in order to move heat from the inside air to the outside air, where it is dissipated.

Let's look at each basic element of the system: First — the compressor.

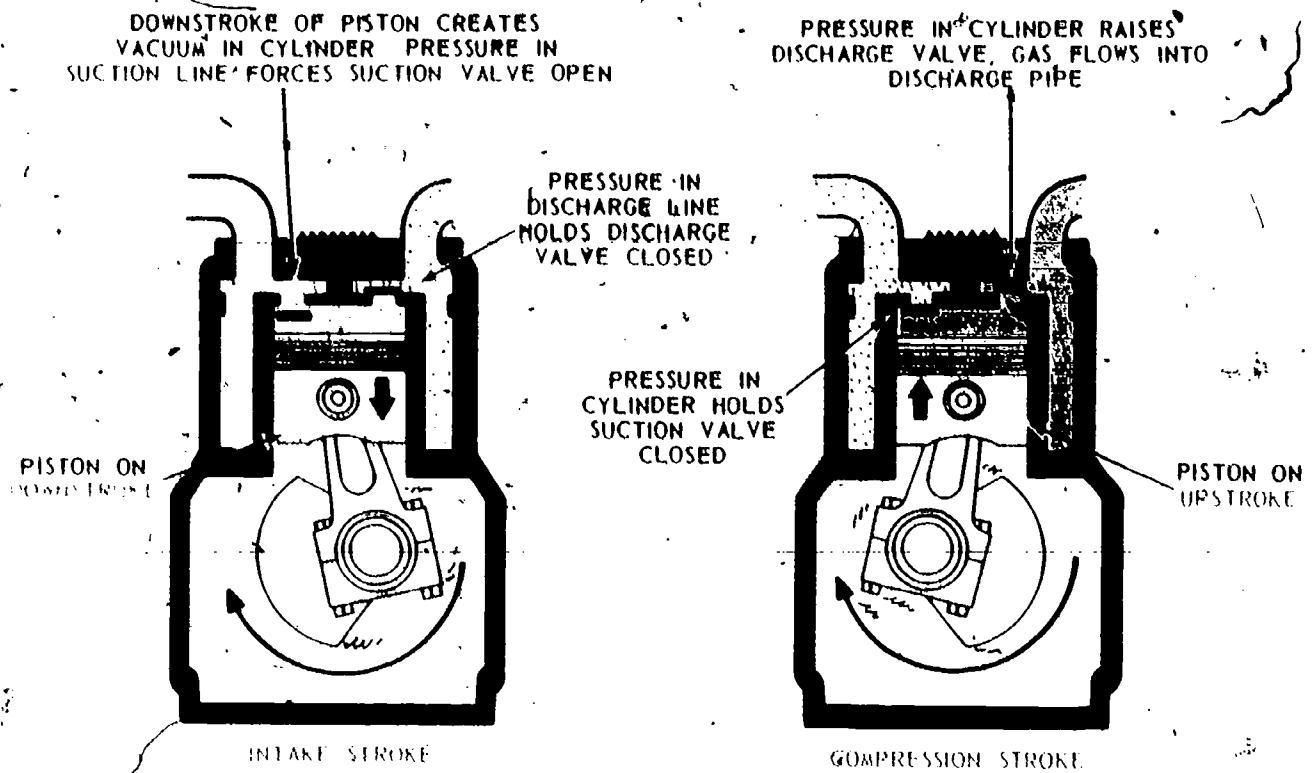

Fig. 18 — Operating Cycle Of Reciprocating Compressor

## COMPRESSOR

The purpose of the **compressor** is to circulate the refrigerant in the system under **pressure**, thus concentrating the heat it contains. At the compressor the low-pressure gas is changed to high-pressure gas. This pressure build-up can only be accomplished by having a restriction in the high-pressure side of the system. This is a small valve located in the expansion valve. The metered orifice shown in Fig. 17 will serve the purpose for our basic system.

The compressor (Fig. 18) has *reed valves* to control the entrance and exit of refrigerant gas during the pumping operation. These must seat firmly. For instance, an improperly seated intake reed valve can result in gas leaking back into the low side during the compression stroke, thus raising the low side pressure and impairing the cooling effect of the evaporator coil. Likewise, a badly seated discharge reed valve can allow condensing or head pressure to drop as it leaks past the valve, lowering the efficiency of the condenser.

Two *service valves* are located on the compressor as an aid in servicing the system (see Fig. 21). One services the high side, and one is used for the low side. A fitting is provided in each for attaching the test gauge hoses for testing the system. The high

side service valve is quickly identified by the discharge hose routed to the condenser, while the low side comes from the evaporator. (For more details, see "Service Valves" in Part 4.)

Some independent air conditioning manufacturers still use service valves having a shut-off valve built in. However, many factory air conditioning systems now use only one valve having a shut-off feature, and occasionally none. The gauge hoses are still connected to the service valve fitting, in which a Schrader valve is incorporated to hold in the refrigerant when a test hose is not connected to it.

The service points on the typical compressor are as follows:

1. Replaceable carbon-type seal on compressor crankshaft.
2. Gasket at opposite, or oil pump, end of unit.
3. Serviceable reed valves and head gasket.

Any other internal failures usually requires the replacement of the compressor. However, some compressors are completely serviceable.

The compressor is normally belt-driven from the engine crankshaft. Most manufacturers use a magnetic-type clutch which provides a means of stopping the pumping of the compressor when refrigeration is not desired.

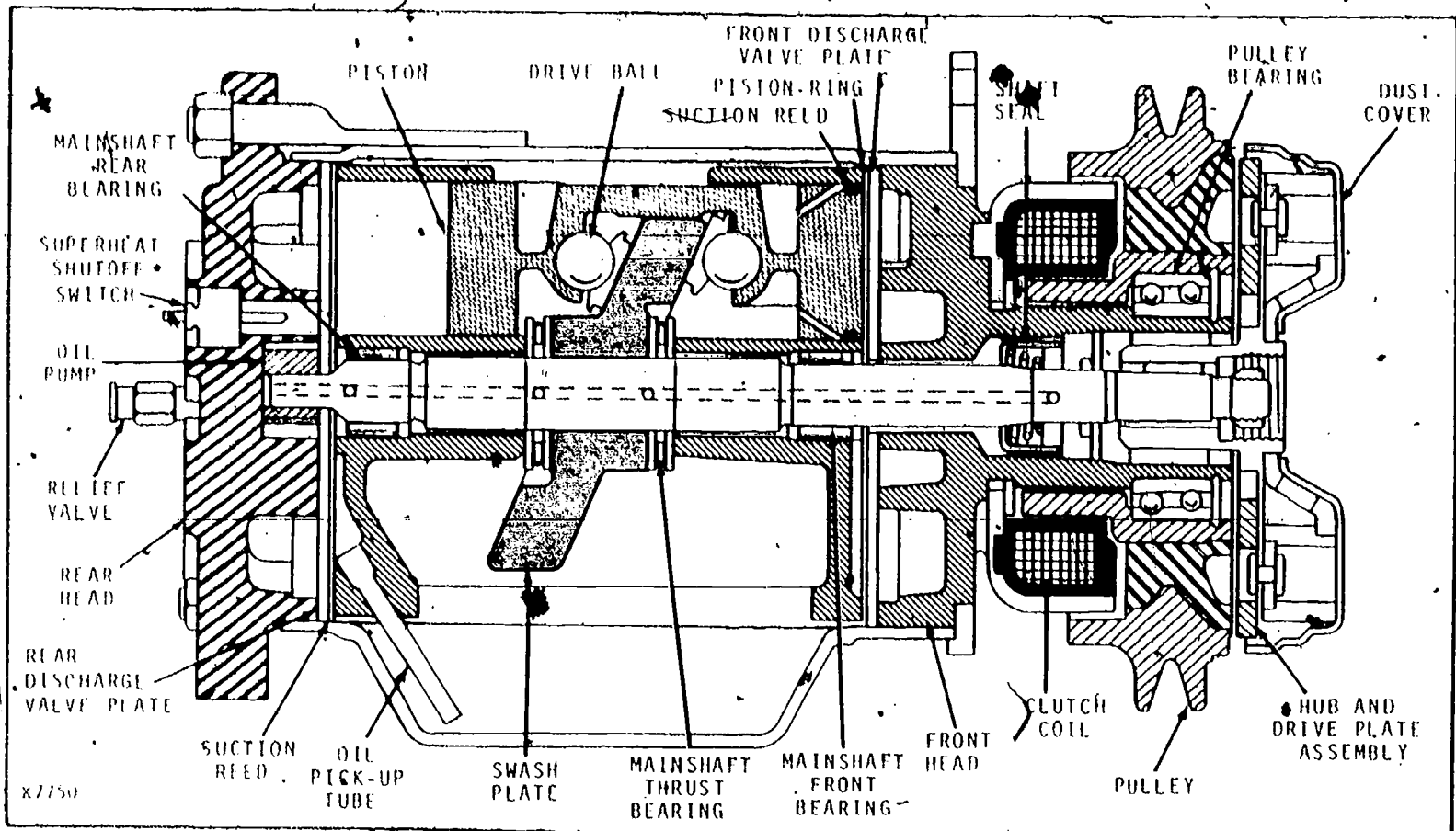

Fig. 19 — Axial Piston Compressor Controlled By Swashplate

#### COMPRESSOR RELIEF VALVE

Some compressors have a *relief valve* (Fig. 19) for regulating pressure. If the system discharge pressure exceeds rated pressure, the valve will open automatically and stay open until the pressure drops. The valve will then close automatically.

If the relief valve opens, a loud popping noise will be heard. In addition, some oil may be ejected through the valve. Correct any condition that would cause this valve to open.

#### SUPERHEAT SHUTOFF SWITCH

In some applications a superheat shutoff switch (Fig. 19) may be included in the system. The purpose of this switch is to stop compressor action when the refrigerant level in the system is low or when temperatures are too high. This prevents possible damage to the compressor from lack of refrigerant oil.

The switch is mounted in the rear head of the compressor. It senses refrigerant pressure at the low side of the compressor.

The superheat shutoff switch is a mechanical switch sensitive to both temperature and pressure. An electrical contact welded to the diaphragm contacts the terminal whenever low refrigerant pressure or high temperature exists in the inlet of the compressor (Fig. 20, right). This stops the compressor as explained next.

Four holes in the mounting base allow operating pressure of the refrigerant gas to act upon the outside areas of the diaphragm. The diaphragm and sensing tube assembly is charged with a refrigerant gas. The sensing tube protrudes into the suction cavity of the compressor to sense the refrigerant operating temperature. When the refrigerant charge is adequate and temperature is normal, the system pressure is high enough to keep the electrical contact away from the terminal (Fig. 20, left).

If the system develops extremely low pressure (possibly because of a loss of refrigerant) the pressure necessary to overcome the expansion of the gas inside the diaphragm and sensing tube is reduced. A loss in system pressure also increases the operating temperature of the gas to the inlet of the compressor. The increase in temperature expands the gas in the sensing tube which pushes the electrical contact against the terminal. When closed, the current flow is routed through a thermal fuse to ground. This stops compressor action.

If the condition does not correct itself in two or three minutes, the excess heat generated by a resistor in the thermal fuse will cause the fuse link to burn out. This stops current flow to the compressor and stops the air conditioning system.

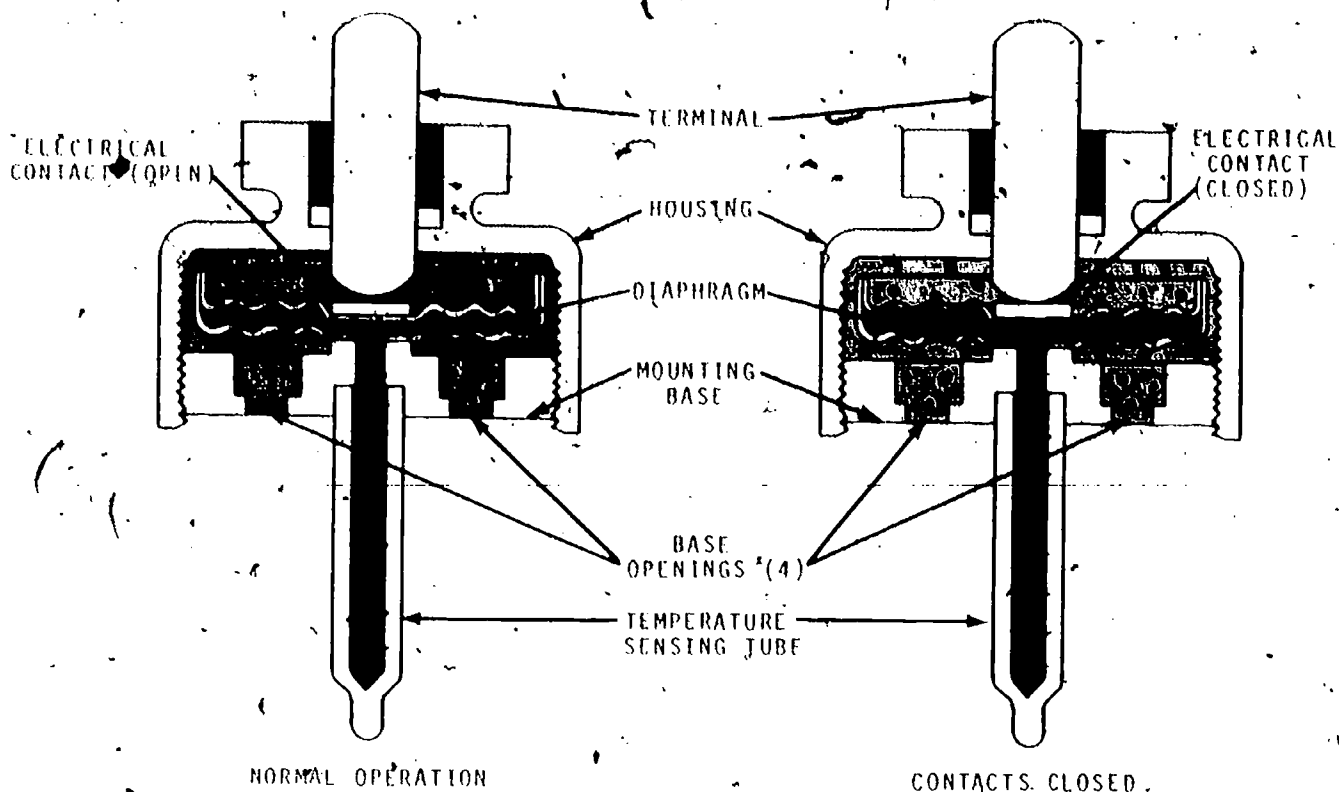

SUPERHEAT SHUTOFF SWITCH

Fig. 20 — Superheat Shutoff Switch

**CHOICE OF COMPRESSOR**

The compressor is actually installed in the system for two purposes. The most important of these is heat concentration by compression. Second is the circulation of refrigerant through the system.

Overall dimensions and weight must be considered, plus the method used to drive the compressor. In most installations the compressor fits into a confined area where size and weight become an important factor.

The choice of compressors may be a two-piston-crankshaft controlled reciprocating type (Fig. 18) or a multi-axial piston-washplate controlled type (Fig. 19).

The compressor must concentrate heat molecules contained in the low-pressure refrigerant returning from the evaporator to a temperature much higher than the ambient or outside air temperature. The wide differential between the refrigerant and ambient temperatures is necessary to aid rapid heat flow in the condenser from the hot refrigerant gas to the much cooler outside air. Remember, heat will flow only from the warmer to the colder.

Little heat is added to the refrigerant by the operation of the compressor. The heat felt on the compressor housing is caused by compression of refrigerant vapor. Some heat is lost through the walls of the compressor by radiation, which compensates for the heat resulting from friction of moving parts within the compressor.

To create high-pressure heat, the compressor must rapidly move a large volume of refrigerant vapor



past its discharge valve into the high side of the system. The small orifice dividing the high from the low side of the system provides a pressure for the compressor to pump against. Too small an orifice or a compressor with too large a capacity could cause excessive buildup of pressure on the high side of the system. Too large an orifice in the expansion valve, a compressor with too small a capacity, or a reed valve failure could prevent a buildup of pressure high enough to allow sufficient heat exchange in the condenser.

### COMPRESSOR NOISE COMPLAINTS

Many noise complaints can be traced to mount and drive and other related problems. Normally, if the unit is noisy at one speed and this noise clears up at another, it is not usually due to the compressor.

Each machine has its critical frequencies where all vibrations get into harmony to generate sound or noise. The speed at which these critical points are found will vary with each machine and each mount and drive arrangement.

Many times, noise generated due to this condition can be eliminated or greatly reduced by changing the belt adjustment.

Replacing a compressor which produces noise at the same time that the belt seems to "dance" or "jump" will not usually correct the noise problem. Usually rigidizing mounts, addition of idlers or changing belt adjustment and/or length are more successful in removing or reducing this type of noise level.

Noises from the clutch are difficult to recognize because of the close connection with the compressor. A loose bolt holding the clutch to the shaft will result in extremely noisy operation. Take extreme care to prevent removing the wrong component.

The differential between suction pressure and discharge pressure also plays an important part on sound level. A compressor with a low suction pressure will be more noisy than one with a higher back-pressure. Likewise, high head pressures tend to make compressors noisy because of the extra load on bearings.

Also consider whether the system is properly charged, whether the expansion valve is feeding properly to use the evaporator efficiently, and whether enough air is being fed over the evaporator coil.

On the high side, check for contaminants in the system as well as cleanliness of condenser, amount

of air that can flow through it, and overcharge of refrigerant.

Since a compressor has many moving parts, it is normal for it to generate some noise just as a motor generates some noise as it operates. The refrigerant gases, as they are moved by the compressor pistons, will also produce noises and vibrations.

The level of permissible noise varies with each customer and generally an explanation of how the compressor functions and what it does will satisfy a customer that, since the compressor is doing the work, it is natural for it to make some sound.

### CONDENSER

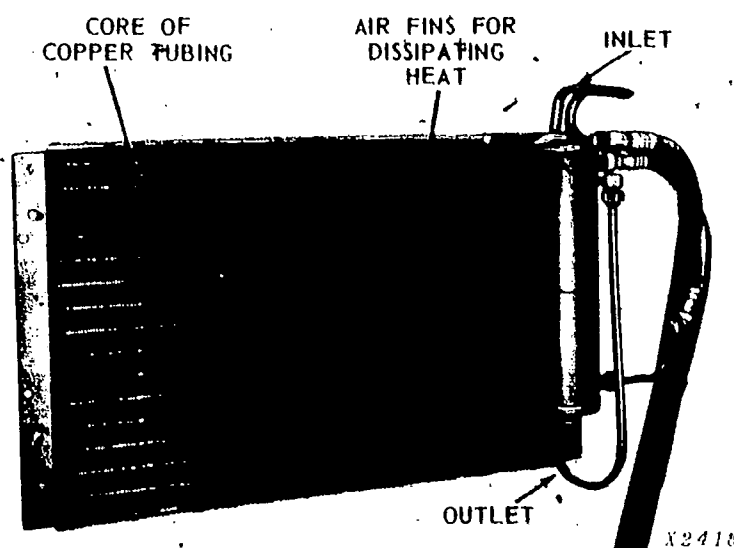

Fig. 22 — Condenser

The purpose of the condenser (Fig. 22) is to receive the high-pressure gas from the compressor and convert this gas to a liquid. This is done by heat transfer or the principle that heat will always move from a warmer to a cooler substance. Air passing over the condenser coils carries off the heat and the gas condenses. The condenser often looks like an engine radiator (Fig. 22).

As the compressor subjects the gas to increased pressure, the heat intensity of the refrigerant is actually concentrated into a smaller area, thus raising the temperature of the refrigerant higher than the ambient temperature of the air passing over the condenser coils. Any condition such as clogged condenser fins, improper condenser position, and loose belts will result in poor condensing action and decreased efficiency.

Another factor often overlooked is flooding of the condenser coils with refrigerant oil. This results from adding too much oil to the system. Oil flood-

ing is characterized by poor condensing action, resulting in increased heat pressure and a high pressure on the low side. This combination always results in poor cooling from the evaporator.

### TYPES OF CONDENSERS

Heat exchange in the condenser is accomplished by two general types of condensers, *air-cooled* and *water-cooled*. Water-cooled condensers are not used in the mobile machine field and will not be considered here.

There are two basic types of air-cooled condensers:

- Ram Air — for automotive systems
- Forced Air — for off-the-road machines

RAM AIR CONDENSERS depend upon vehicle movement to force a large volume of air past the fins and coils of the condenser. The engine fan is used to increase air volume at lower speeds. The clutch-type fan is designed to allow the fan blades to free-wheel at higher speeds to eliminate blade drag. At lower speeds, the fan clutch will engage the fan to increase air flow over the condenser and radiator coils.

FORCED AIR CONDENSERS use electric fans to move a large volume of air over the condenser (Fig. 23). Farm and industrial machines must rely on forced air to remove heat from the refrigerant. This is because these machines must operate for long periods at slow speeds, which requires that air be forced over the condenser for proper cooling.

Condensing action is the change of state of the refrigerant from a vapor to a liquid. It is controlled by:

- 1) pressure of the refrigerant,
- 2) air flow over the condenser.

Condensing pressure is the controlled pressure of the refrigerant as it condenses to a liquid.

### NORMAL CONDENSER PRESSURE

Condensing pressure must be high enough to create a wide temperature differential between the heat-laden refrigerant vapor and the hot air passing over the condenser fins and coils. Only in this way can the air carry off enough heat for proper cooling.

### TOO-HIGH CONDENSER PRESSURE

**Indicated By:** Excessive head pressure on *high* side gauge.

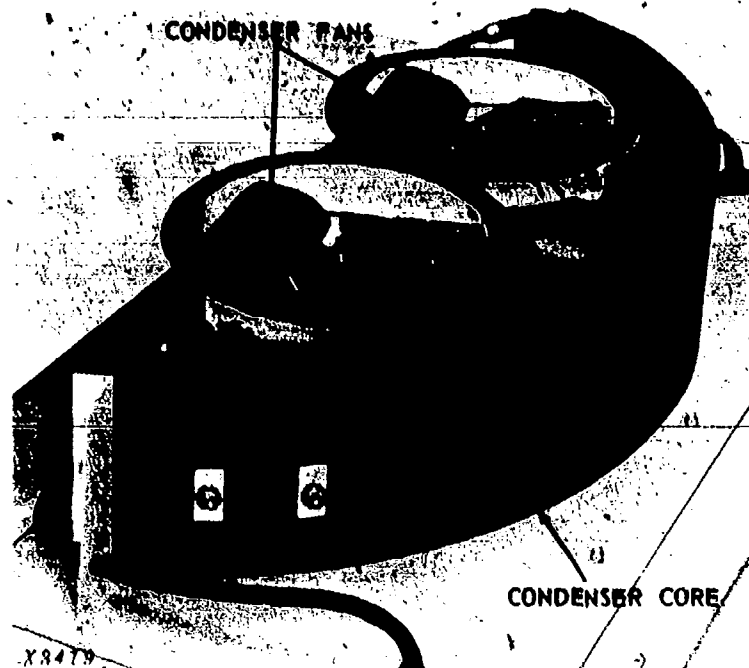

Fig. 23 — Forced Air Condenser

**Caused By:** Restriction of refrigerant flow in high side of system or lack of air flow over condenser coils.

Poor condensing action results in the too-high pressure. The upper two-thirds of the condenser coils remove heat from the hot refrigerant vapor, while the lower third contain liquid. Too high a condensing pressure will upset this balance, allowing superheated vapor to enter the liquid hose and the expansion valve.

### TOO-LOW CONDENSER PRESSURE

**Indicated By:** Higher than normal pressure on *low* side gauge.

**Caused By:** Failed compressor reed valve or piston. Heat exchange in the condenser will be cut down, and the excessive heat will remain in the low side of the system.

### EXPANSION VALVE

The expansion valve (Fig. 24) removes pressure from the liquid refrigerant to allow expansion or change of state from a liquid to a vapor in the evaporator.

The high-pressure liquid refrigerant entering the expansion valve is quite warm. This may be verified by feeling the liquid line at its connection to the expansion valve. The liquid refrigerant leaving the expansion valve is quite cold. The orifice within the valve does not remove heat, but only reduces pressure. Heat molecules contained in the liquid refrigerant

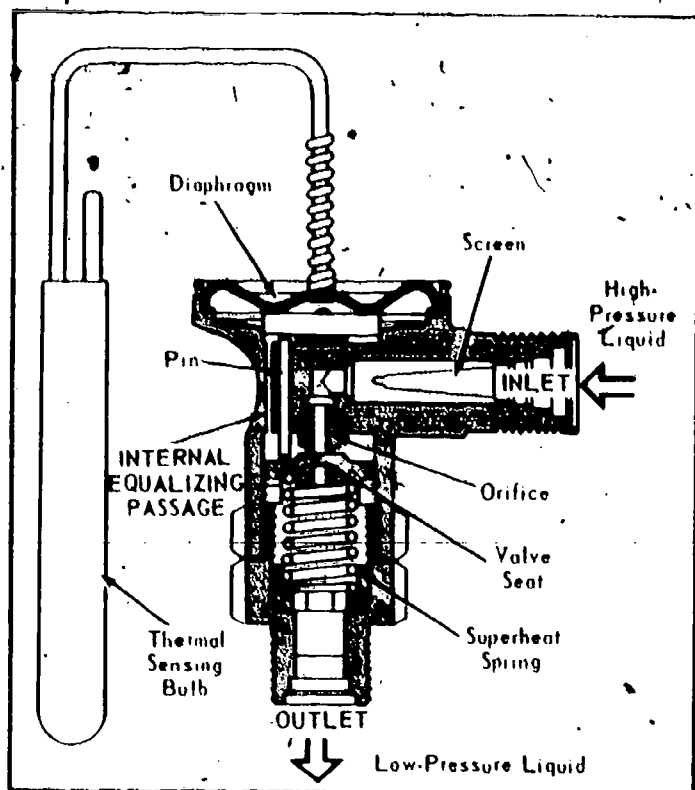

INTERNALLY EQUALIZED VALVE

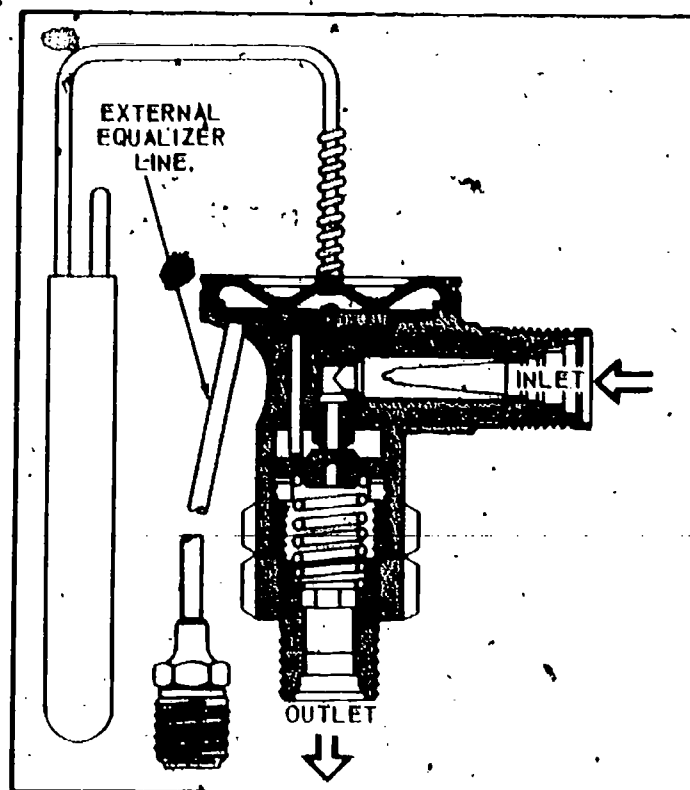

EXTERNALLY EQUALIZED VALVE

Fig. 24 — Expansion Valve — Two Types

erant are thus allowed to spread as the refrigerant moves out of the orifice. Under a greatly reduced pressure the liquid refrigerant is at its coldest as it leaves the expansion valve and enters the evaporator.

Pressures at the inlet and outlet of the expansion valve will closely approximate gauge pressures at the inlet and outlet of the compressor in most systems. The similarity of pressures is caused by the closeness of the components to each other. The slight variation in pressure readings of a very few pounds is due to resistance, causing a pressure drop in the lines and coils of the evaporator and condenser.

Two types of valves (Fig. 24) are used on machine air conditioning systems:

- Internally-equalized valve — most common
- Externally-equalized valve — special control

Let's look at each valve in detail.

#### INTERNALLY-EQUALIZED EXPANSION VALVE

The refrigerant enters the inlet and screen (left, Fig. 24) as a high-pressure liquid. The refrigerant flow is restricted by a metered orifice through which it must pass. As the refrigerant passes through this

orifice, it changes from a high-pressure liquid to a low-pressure liquid (or passes from the high side to the low side of the system).

Let's review briefly what happens to the refrigerant as we change its pressure.

As a high-pressure liquid, the boiling point of the refrigerant has been raised in direct proportion to its pressure. This has concentrated its heat content into a small area, raising the temperature of the refrigerant higher than that of the air passing over the condenser. This heat will then transfer from the warmer refrigerant to the cooler air, which condenses the refrigerant to a liquid.

The heat in B.T.U.'s (watts) transferred into the air is called latent heat of condensation. Four pounds (1.8 kg) of refrigerant flowing per minute through the orifice will result in 12,000 B.T.U.'s (3517 W) per hour transferred, which is designated a one ton unit. Five pounds (2.3 kg) per minute refrigerant flow will result in 15,000 B.T.U.'s (4398 W) per hour, or a one and one-quarter ton unit. Six pounds (2.7 kg) of flow per minute will result in 18,000 B.T.U.'s (5275 W) per hour, or a one and one-half ton unit.

The refrigerant flow through the metered orifice is of vital importance. Anything that restricts this flow seriously affects the operation of the whole system.

For example, a one ton system uses an orifice approximately 0.080 inches (2 mm) in diameter.



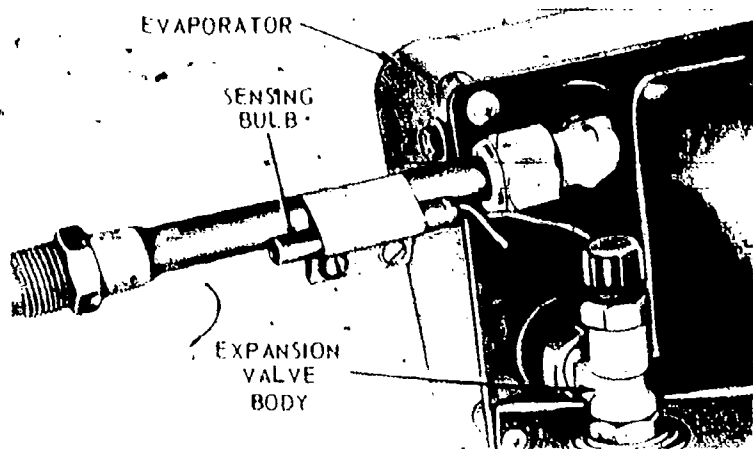

Fig 25 - Expansion Valve

during maximum cooling. A restriction of this orifice can prevent the unit from cooling to its full capabilities.

If the area cooled by the evaporator suddenly gets colder, the heat transfer requirements of the evaporator are changed. If the expansion valve kept feeding the same amount of refrigerant to the evaporator, the fins and coils would be cooled until they froze over with ice and stopped all air flow.

To control this, the orifice in the expansion valve is *metered* to vary the flow of refrigerant. This is done by an internal balance of pressures which move the valve seat (see at left in Fig. 24).

A thermal bulb connected to a diaphragm by a small line and filled with refrigerant gas or CO<sub>2</sub> (carbon dioxide) is secured firmly by a clamp to the evaporator tail pipe. The thermal bulb is sensitive to tail pipe temperatures. If the tail pipe becomes warm, the gas inside the bulb will begin to expand, exerting pressure against the diaphragm in the top plate that is connected to the seat or valve by a pin or pins. This expansion will then move the seat away from the orifice, allowing an increased refrigerant flow. As the tail pipe temperature drops, the pressure in the thermal bulb also drops, allowing the valve to restrict flow as required by the evaporator.

The pressure of the refrigerant entering the evaporator is fed back to the underside of the diaphragm through the internal equalizing passage. Expansion of the gas in the thermal bulb must overcome the internal balancing pressure before the valve will open to increase refrigerant flow.

A spring is installed against the valve and adjusted to a predetermined setting at the time of manufacture. This is the superheat spring which prevents slugging of the evaporator with excessive liquid.

The adjusted tension of this spring is the determining factor in the opening and closing of the expansion valve. During opening or closing, the spring tension retards or assists valve operation as required.

Normally, this spring is never adjusted in the field. Tension is adjusted from four to sixteen degrees as required for the unit on which it is to be installed. This original setting is sufficient for the life of the valve, and special equipment is required in most cases to accurately calibrate this adjustment.

#### EXTERNALLY-EQUALIZED EXPANSION VALVE

Operation of the externally-equalized valve is the same as the internal type except that evaporator pressure is fed against the underside of the diaphragm from the tail pipe of the evaporator by an equalizer line (see at right in Fig. 24). This balances the temperature of the tail pipe through the expansion valve thermal bulb against the evaporator pressure taken from the tail pipe.

#### SERVICE PRECAUTIONS

The thermostatic expansion valve is more sensitive to foreign materials than any other unit in the air conditioning system.

Observe the following rules to protect the valve:

1. In winter, advise the customer to turn over the pulley of the compressor by hand several times periodically to prevent the internal moving parts from corroding and sticking. This will also lubricate the compressor seal, keeping it soft and in condition to properly seal the refrigerant. Normally, do not operate the system in winter as this can cause "slugging" of the compressor.
2. When servicing the system, clean or replace all accessible screens.
3. Install a filter if the system has excessive foreign materials.
4. Evacuate the system properly to remove all possible moisture from the system.
5. Cap or cover lines opened for service to prevent entry of moisture and dirt.
6. Replace the dehydrator as soon as excess moisture content is evident. Any system should have the dehydrator replaced at least upon opening the system the third time for service. Also, anytime the system has been opened for a long period from accident or rupture, replace the dehydrator.

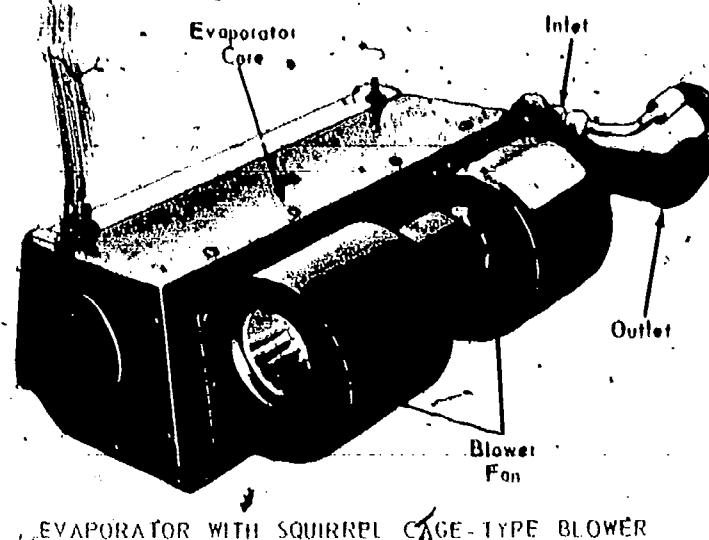
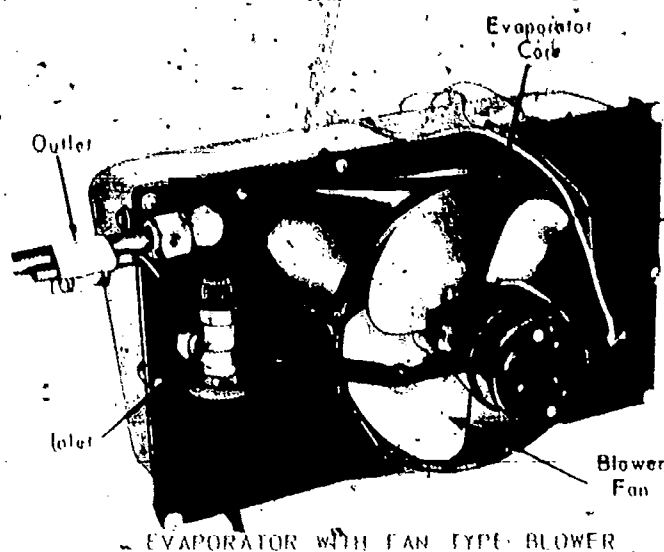

Fig. 26 — Evaporators

7. Handle the thermal bulb and line with extreme care; excessive bending and rough handling can cause a break that will release the gas, ruining the valve.

8. Use a back-up wrench when removing any connection to prevent twisting of a line, which may result in weakening and breaking it.

9. Replace the expansion valve only with a comparable valve. A numbering system is used to designate the orifice size. Replacing the valve with one of either too small or too large an orifice can seriously affect system operation.

10. Maintain a positive contact between the thermal bulb and tail pipe. Over a period of time corrosion will form between the two contact surfaces and insulate them so that the operation of the expansion valve will be affected. The clamp may also work loose, preventing positive contact between the two.

## EVAPORATOR

The evaporator (Fig. 26) works the opposite of the condenser, for here refrigerant liquid is converted to gas, absorbing heat from the air.

When the liquid refrigerant reaches the evaporator its pressure has been reduced, dissipating its heat content and making it much cooler than the fan air flowing around it. This causes the refrigerant to absorb heat from the warm air and reach its low boiling point rapidly. The refrigerant then vaporizes, absorbing the maximum amount of heat.

This heat is then carried by the refrigerant from the evaporator as a low-pressure gas through a hose or line to the low side of the compressor, where the whole refrigeration cycle is repeated.

The evaporator removes heat from the area that is to be cooled. The desired temperature of cooling of the area will determine if refrigeration or air conditioning is desired. For example, food preservation generally requires low refrigeration temperatures, ranging from 40 degrees F (4°C) to below 0 degrees F (-18°C).

A higher temperature is required for human comfort. A larger area is cooled, which requires that large volumes of air be passed through the evaporator coil for heat exchange. A blower becomes a necessary part of the evaporator in the air conditioning system. The blower fans must not only draw heat-laden air into the evaporator, but must also force this air over the evaporator fins and coils — where it surrenders its heat to the refrigerant — and then forces the cooled air out of the evaporator into the space being cooled.

## FAN SPEEDS

Fan speed is essential to the evaporation process in the system. Heat exchange, as we explained under condenser operation, depends upon a temperature differential of the air and the refrigerant. The greater the differential, the greater the amount of heat exchanged between the air and the refrigerant. A high heat load, as is generally encountered when the system is turned on, will allow rapid heat transfer between the air and the cooler refrigerant.

The blower fan turned on to its highest speed will deliver its greatest volume of air across the fins and coils for a rapid evaporation. As the area is cooled, it will soon reach a temperature where little extra cooling will result if the fan is allowed to continue its high-volume flow. A reduction in fan speed will decrease volume, but the lower volume rate will allow the air to remain in contact with the fins and coils for a longer period of time and surrender its heat to the refrigerant.

Both condensing and evaporating processes depend upon wide temperature differentials for rapid heat exchange. A lowering of temperature of the refrigerant in the condenser will affect the condensing process, and a lowering of the temperature of the air under air conditioning will slow down the evaporating process.

Cooling the evaporator is dependent on controlled air flow over the evaporator coils by regulating the fan blower speed.

*For the coldest air temperature from the evaporator, operate the blower fan at the lowest speed*

*possible to allow the greatest heat absorption by the refrigerant from the air.*

**PROBLEMS OF FLOODED OR STARVED EVAPORATOR COILS**

Changing the state of the refrigerant in the evaporator coils is as important as the air flow over the coils. Liquid refrigerant supplied to the coils by the expansion valve expands to a vapor as it absorbs heat from the air. Some liquid refrigerant must be supplied throughout the total length of the evaporator coils for full capacity.

A **starved** evaporator coil is a condition in which not enough refrigerant has been supplied through the total coil length. Therefore, expansion of the refrigerant has not occurred through the whole coil length, resulting in poor coil operation and too-low heat exchange.

A **flooded** evaporator is the opposite of the starved coil. Too much refrigerant is passed through the evaporator coils, resulting in unexpanded liquid

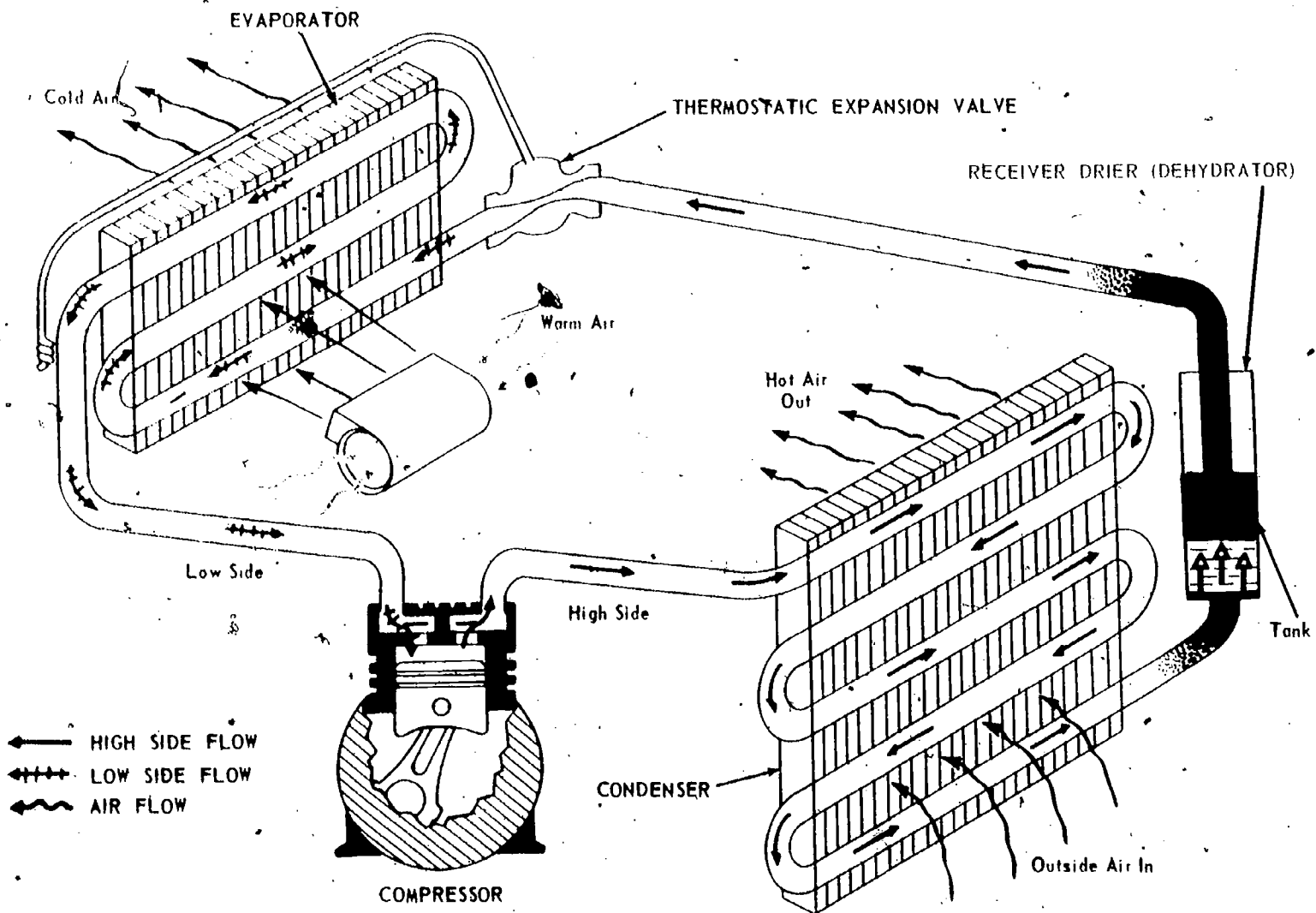

Fig. 27 — Air Conditioning System With Receiver-Drier (Dehydrator) Added

passing into the suction line and into the compressor. Liquid refrigerant in the compressor can result in damage to the reed valves and pistons. A flooded evaporator will contain too much refrigerant for efficient heat absorption in the evaporator coil. The result is lack of evaporation and so poor evaporator cooling.

*Gauge pressure readings on the low side of the system readily indicate either condition:*

A **starved coil** is shown by too-low a reading on the compound gauge plus a too-quick frost formation on the fins. Also, too little air is emitted from the evaporator.

A **flooded coil** is indicated by too high a pressure on the compound gauge and excessive sweating of the evaporator coils and suction hose. This is accompanied by little cooling from the evaporator.

## OTHER FEATURES OF THE SYSTEM

The basic system we have discussed will work okay under constant loads or until the unit ices up because of too much humidity. The cooling rate of the evaporator can be controlled to a great extent by varying the speed of the fan.

However, adding other features will aid in operation of the system. Let's look at several of the extra controls, starting with the *receiver-dryer (dehydrator)* shown in Fig. 27.

## RECEIVER-DRIER ( DEHYDRATOR)

Air conditioning systems do not operate at 100 percent efficiency. Over a period of time, very slight leaks and occasionally some serious leaks will develop. In addition, the demand for refrigerant by the evaporator varies with changes in the heat load, the condensing action, and pump speed.

To compensate for these variables, a small receiver tank is provided in the system (Fig. 27). Here the refrigerant is stored until needed by the evaporator. The addition of the receiver tank increases the capacity of the system approximately one to one and a half pounds of refrigerant.

A *desiccant* or drying agent such as Silica-Gel or Molecular Sieve is sealed inside the receiver during its manufacture (Fig. 28).

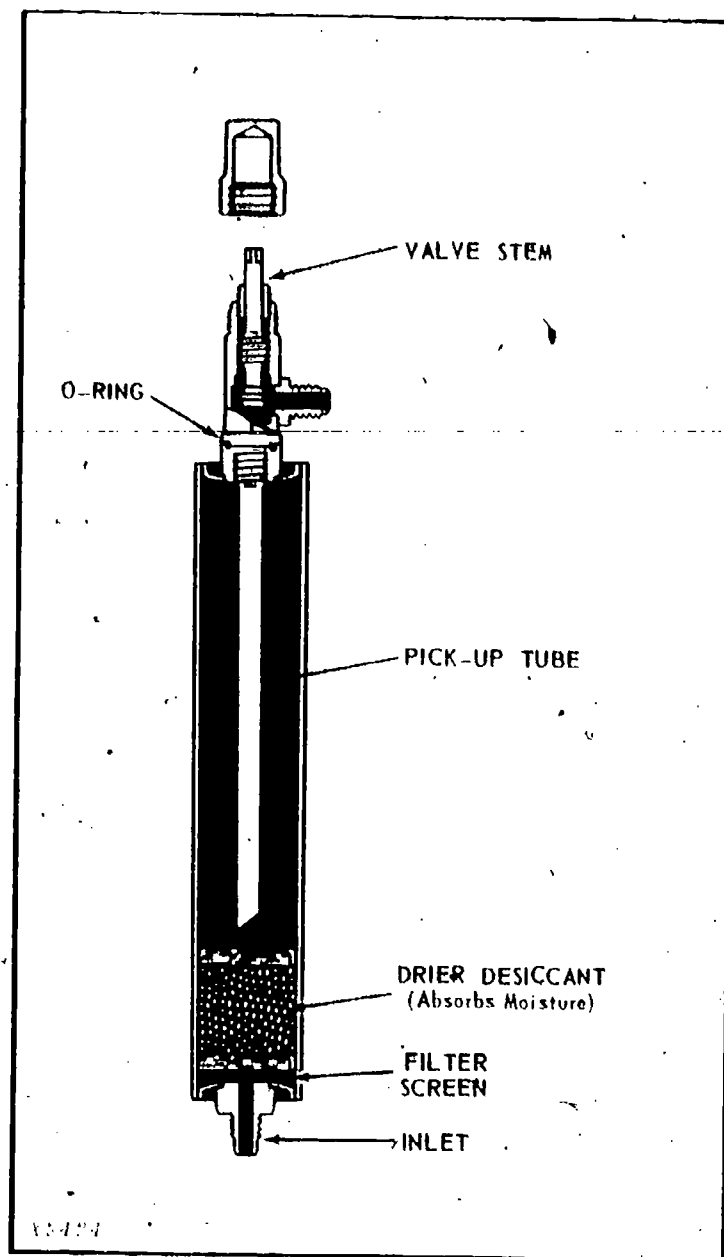

Fig. 28 — Receiver-Drier (Dehydrator)

Operating the air conditioning system in late evening and early morning with lower outside temperatures, the drier will hold its moisture from circulating in the system. Increased temperature during the heat of the day will raise the temperature of the dehydrator. If the desiccant has reached its saturation point or absorbed the maximum amount of moisture of which it is capable, the increased temperature will cause the desiccant to release some of its moisture into the system. These moisture droplets will collect inside the expansion valve and change to ice in the valve orifice. This moisture turning to ice can completely block the refrigerant flow and stop the cooling action of the evaporator.

Regardless of where the dehydrator is located, the desiccant can absorb and hold only a predeter-

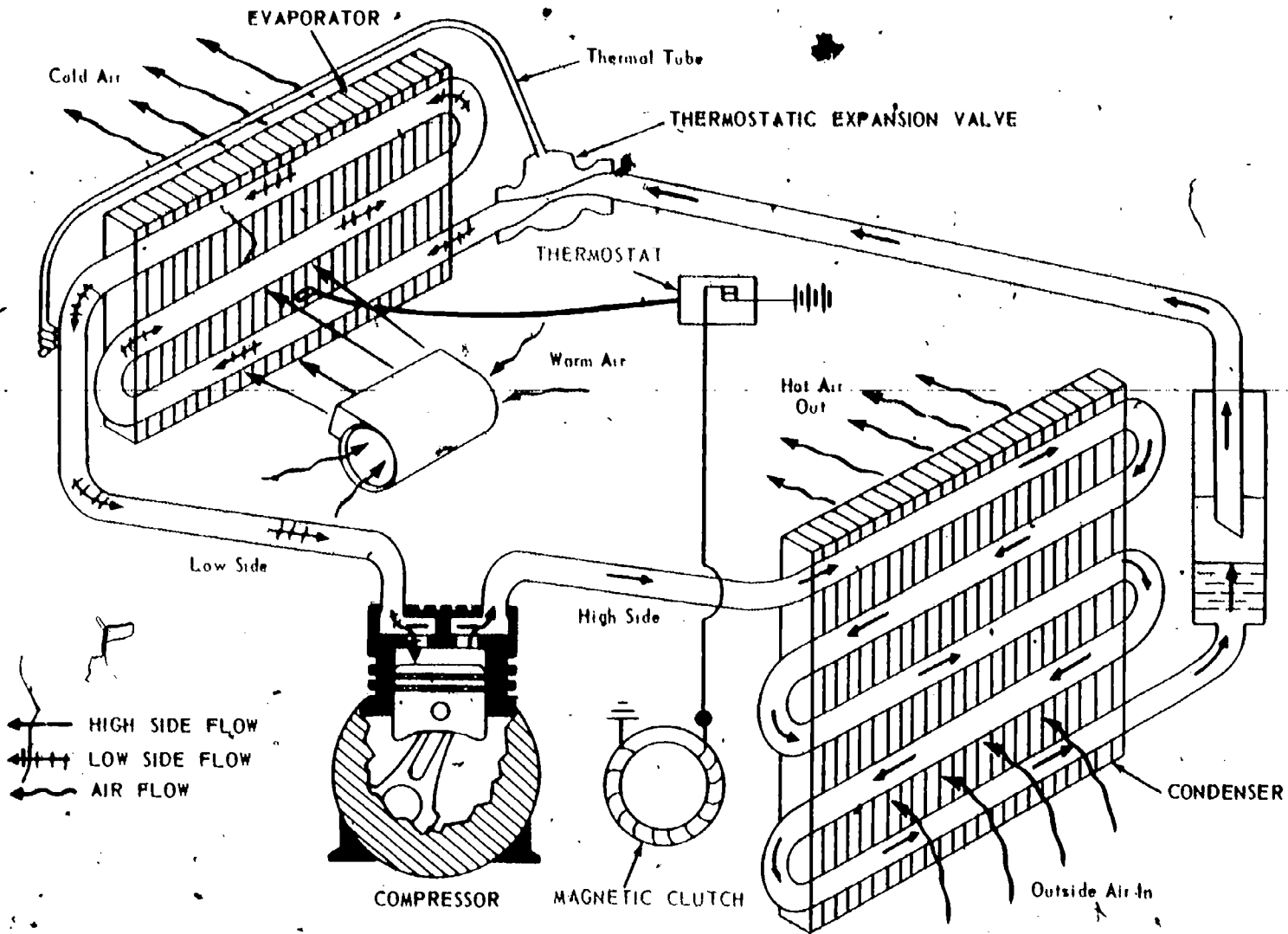

Fig. 29 — Thermostat-Controlled Recycling Clutch System

mined amount of moisture. If operation of the system is satisfactory during cool times of the day, but cooling action becomes intermittent with a rise in outside temperatures, the desiccant is supersaturated and releases moisture that freezes up in the expansion valve. As soon as the valve warms sufficiently to melt the ice, the flow of refrigerant will resume until more icing occurs.

Separate dehydrator units are available to be installed in the liquid line in addition to the dehydrator in the system, and these will assist in removing moisture.

**REMEMBER: A REFRIGERATION SYSTEM CANNOT TOLERATE MOISTURE.**

**USE OF SCREENS IN THE SYSTEM**

At any time a refrigeration system is opened for service, foreign matter can enter in the form of

dirt and moisture. These are called noncondensibles and have a deteriorating effect on Refrigerant-12 or any other refrigerant. Moisture mixed with refrigerant causes hydrolizing action, which results in interior corrosion of all metal parts. This corrosion will, in time, sluff off into the system in small particles which can stop the flow of refrigerant through the small orifice in the expansion valve.

Screens are installed throughout the system to filter and hold these foreign particles from circulating in the system. A filter screen is always located in the receiver-drier (Fig. 28). Should any of these screens collect foreign particles until they can no longer pass refrigerant, refrigerant flow will stop at this point.

**REMEMBER: FROST WILL FORM AT THE POINT OF BLOCKAGE OF THE REFRIGERANT.**

A screen is also located in most cases at the inlet of the expansion valve. Two or three manufacturers have eliminated the screen at this point in their later units. In any system containing a screen at this location it is not advisable to eliminate this screen unless a self-contained filter unit is placed ahead of the expansion valve somewhere in the liquid line between the valve and the receiver. These filters are available to be installed as a separate item.

Many manufacturers install an additional screen at the suction side or low side service valve of the compressor. Most factory-installed units have screens located at this point.

All screens except the one located in the dehydrator may be removed for cleaning and should be replaced if torn or corroded so that cleaning fails to open the fine mesh.

#### WHAT HAPPENS WHEN REFRIGERANT IS BLOCKED

A restriction or stoppage of refrigerant flow will cause the following:

- 1) Normal or low head pressure with low suction pressure.
- 2) Excessive coolness or frosting of the dehydrator, expansion valve, and compressor service valve.
- 3) Little or no cooling from the evaporator.

## THERMOSTAT AND MAGNETIC CLUTCH SYSTEMS

During the earlier years of machine air conditioning, many systems did not provide a means for stopping pumping action of the compressor. A solid pulley was installed on the compressor crankshaft, which resulted in compressor operation anytime the engine was operating. The only time the compressor could be stopped was when the belt was removed. Even with the air conditioning controls in the "OFF" position during cold weather operation, a slight amount of cold air would be given off by the evaporator.

Today, manufacturers are turning more and more to the thermostat-controlled system with a magnetic clutch (Fig. 29).

#### THERMOSTAT CONTROL

The opening and closing of electrical contacts in the thermostat (Fig. 30) are controlled by a movement of a temperature-sensitive diaphragm or bellows. The bellows has a capillary tube connected to it which has been filled with Refrigerant-12 or CO<sub>2</sub>. The capillary tube is positioned so that it may have either the cold air from the evaporator pass over it or it may be connected to the tail pipe of the evaporator. In either position, evaporator temperature will affect the temperature-sensitive compound in the capillary tube by causing it to contract as the evaporator becomes colder. The contraction of the gas will cause the bellows to contract. This separates the electrical points and breaks the electrical circuit to the compressor clutch, which stops compressor operation.

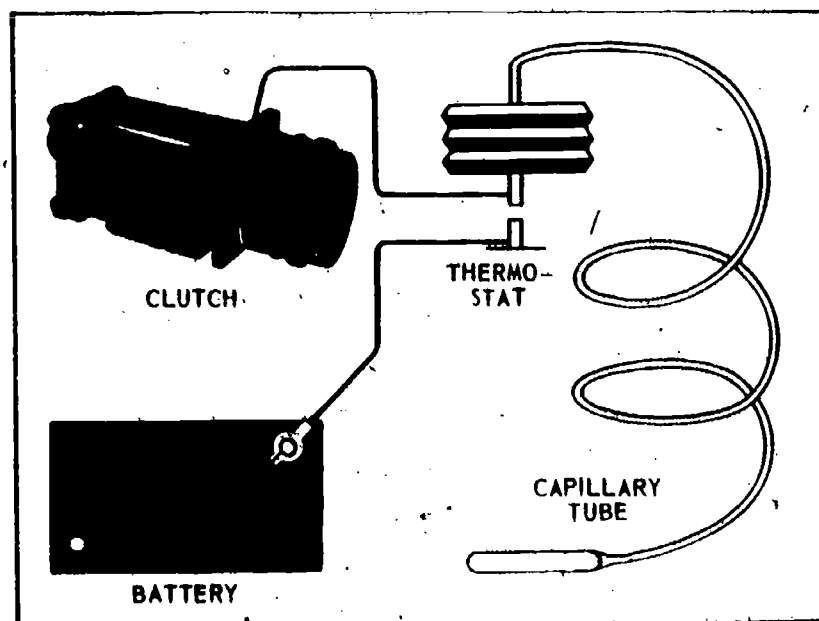
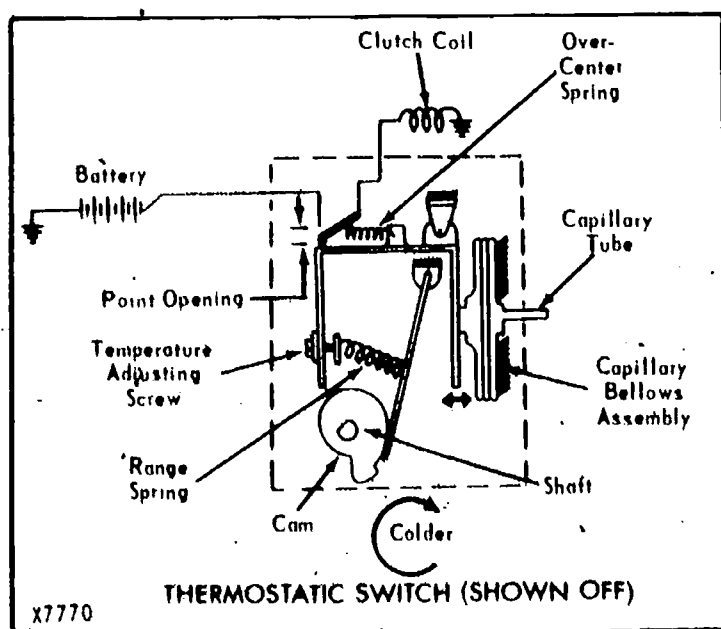

Fig. 30 — Thermostat Control

Now the evaporator begins to warm which, in turn, causes the gas in the capillary tube to expand. The bellows will also expand, moving the electrical points closer to each other. At a predetermined point, bellows expansion will bring the points together, closing the electrical circuit to the compressor clutch, energizing it and bringing the compressor into operation again. This cycling action will be repeated as long as air conditioning is required.

The thermostatic switch is composed of a pivoting frame attached to the bellows. Movement of the bellows during its contraction and expansion will cause the frame to pivot. Springs are used to counteract and control the movement of the pivoting frame. One-half the electrical contacts are connected to the frame, and the other half are mounted solidly to the body of the switch. The contacts are insulated from the metal parts to which they are attached.

The distance the contacts must travel and the spring pressure that must be overcome by the expansion of the gas in the capillary tube and bellows are the factors determining at what degree of evaporator temperature the contacts will close to complete the electrical circuit to the clutch.

Most thermostats have provisions for regulating the range between opening and closing of points. Some models have a removable cover under which an adjusting screw is located. If a set screw is not found here, assume that the thermostat is non-adjustable.

In all thermostats, the spring tension and point spacing may be varied by the operator to regulate evaporator cooling for his comfort. Temperature is controlled by rotating a cam (via a knob control) which increases or decreases spring tension on a pivoting point (Fig. 30).

### MAGNETIC CLUTCH

The clutches on machine air conditioning systems are of two types:

- Rotating coil
- Stationary coil

ROTATING COIL clutches have the magnetic coil inside the pulley and rotating with it. The electric current is carried to the coil by brushes

mounted on the compressor frame and contacting a slip ring mounted on the inside of the rotating pulley.

STATIONARY COIL clutches have the magnetic coil mounted on the frame of the compressor and it does not rotate. Since the coil is stationary, correct spacing is important to prevent the rotating pulley from contacting the coil, while still bringing the hub and armature into position for the fullest attraction of the magnetic force.

Each clutch manufacturer has units to fit all models of compressors according to the requirements for both six- and twelve-volt applications. The serviceman replacing either the clutch unit or the coil must note carefully that the voltage of the replacement unit is correct for the vehicle on which it is to be installed.

All clutches operate on the same principle whether the magnetic coil rotates or is stationary. Each has a wound core located within a metal cup acting like a horseshoe magnet when the coil is energized electrically (Fig. 32).

The pulley rotates on a bearing mounted on the clutch hub (Fig. 31) except the Frigidaire compressor, which mounts the bearing on the compressor front head assembly. The pulley is free to rotate without turning the compressor crankshaft anytime the clutch coil is not energized. The free-rotating pulley and non-energized clutch coil stop compressor operation.

An armature plate is mounted by a hub to the compressor crankshaft and is keyed into place and locked securely with a lock nut, thus making connection to the crankshaft.

Energizing the clutch coil creates lines of magnetic force from the poles of the electromagnet through the armature, drawing it towards the shoe plate or rotor that is a part of the pulley assembly (Fig. 32). The solid mounting of the pulley prevents the pulley from moving in a lateral direction; however, the armature can move until it contacts the rotor. Magnetic force locks the rotor and the armature plate together. This solid connection then allows the pulley to rotate the compressor crankshaft and operate the compressor. Compressor operation will continue until the electrical circuit is broken to the clutch coil, when the magnetic force is de-energized. The rotor and armature then

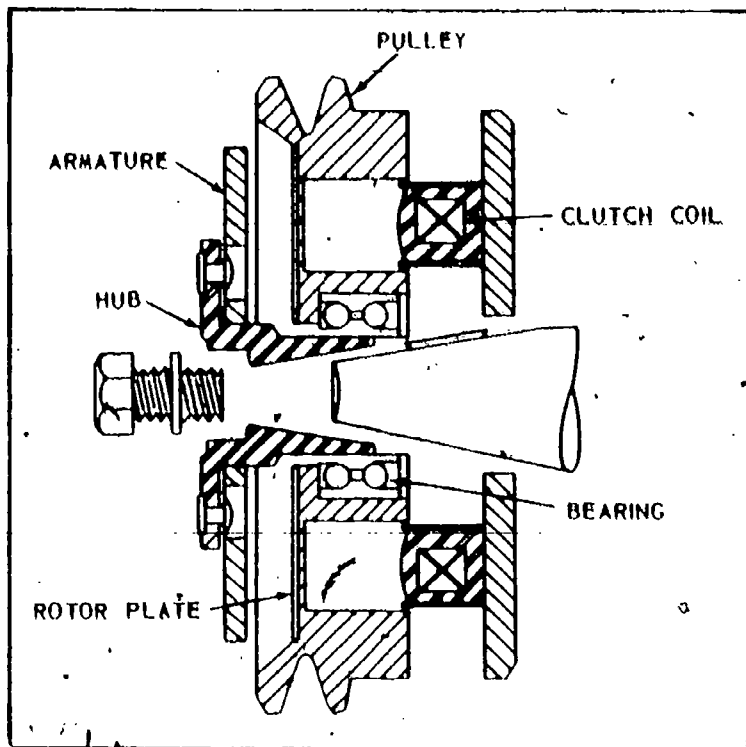

Fig 31 — Magnetic Clutch

separate, and the pulley rotates freely without rotating the compressor crankshaft.

Slots are machined into both the armature and the rotor to concentrate the magnetic field and increase the attraction between the two when energized. Some scoring and wear is permissible between these plates. However, it is important that full voltage be available to the clutch coil as low voltage will prevent a full build-up of magnetic flux to the plates.

The correct spacing between the pulley and the coil on stationary coil models must be maintained to prevent the pulley from dragging against the coil. Correct spacing must also be maintained between the rotor and the armature.

Too close a clearance will allow the two plates to contact each other in the "OFF" position, while too wide a space can prevent the rotor from contacting the armature solidly in the "ON" position. Any of these variations can cause a serious clutch failure.

Also be sure that the mating surfaces are not warped (from overheating).

Always use the correct tools when performing any service operations, as damage to closely-fitted parts may result from too much hammering or prying.

**NOTE:** For information of the electrical part of these clutches, refer to the FOS manual on "Electrical Systems."

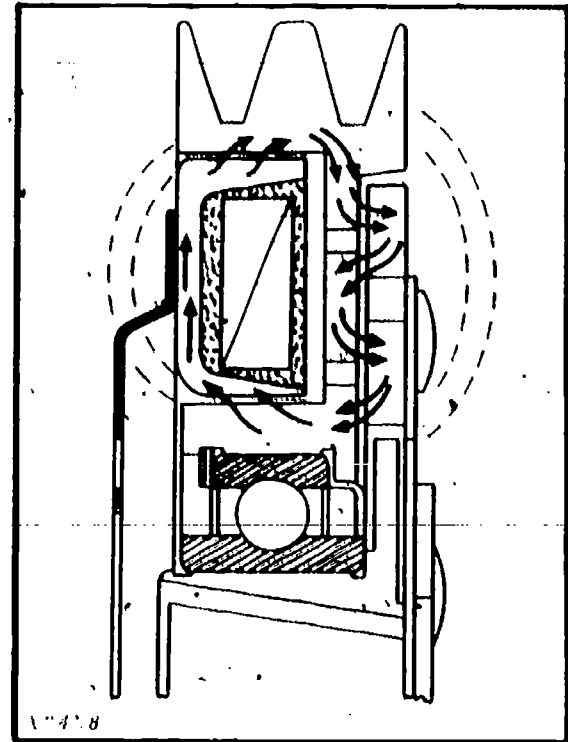

Fig. 32 — Magnetic Clutch Showing Path Of Magnetic Flow

## BYPASS SYSTEMS

### HOT GAS BYPASS

The control of evaporator pressure and temperature by metering a small amount of hot gas from the high side of the compressor (Fig. 33) has been used successfully many years in commercial refrigeration. General Motors engineers have also been very successful in adapting this same process to the control of their larger automotive air conditioning units.

Other manufacturers have attempted briefly to adapt this type control to their units but soon dropped it in preference to some other type. Most have not gone beyond the experimental stage.

### SOLENOID BYPASS

Some automotive products use a solenoid bypass to control the evaporator pressure and temperature. The thermal switch is attached to the suction pressure line at the evaporator outlet manifold. The electrical contacts in the switch are connected in series with the temperature control switch and the solenoid bypass valve winding. In the normal position, the contacts are closed.

A decrease in the temperature of the refrigerant gas leaving the evaporator will cause a thermal blade to bend and open the electrical circuit to the solenoid valve when the temperature reaches approximately 25°F (-4°C). Opening the solenoid valve allows a charge of hot refrigerant gas to flow into the evaporator. When the temperature increases



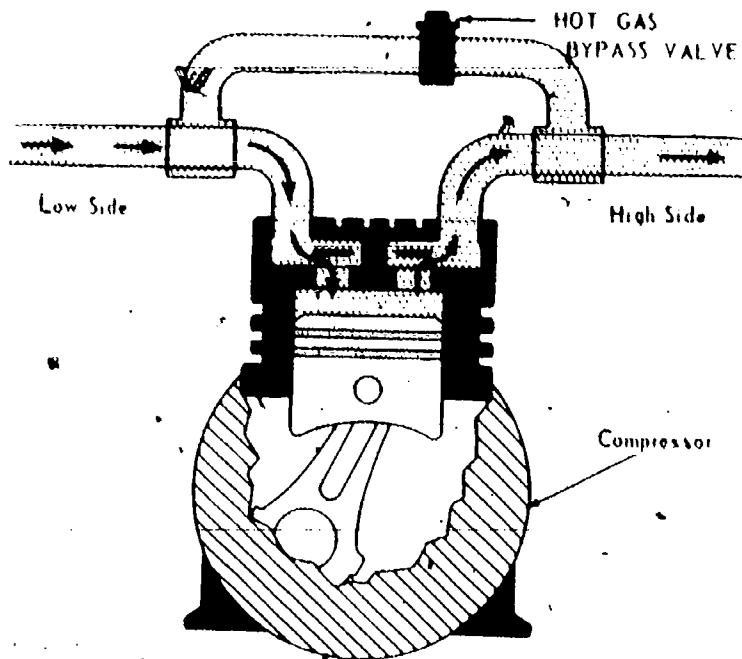

Fig. 33 — Hot Gas Bypass System.

again to approximately 40°F (4°C) the contacts close and the solenoid energizes, closing the bypass valve.

### SUCTION THROTTLING REGULATORS

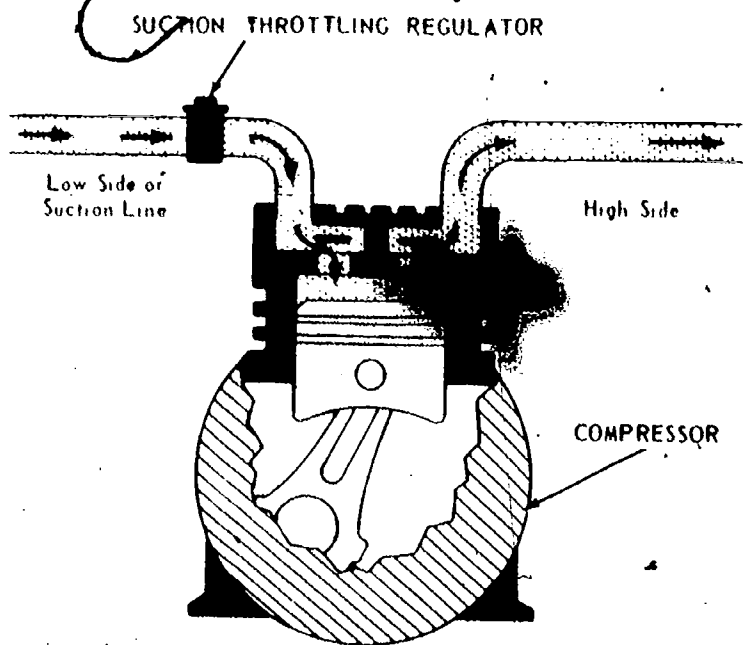

Fig. 34 — System Regulated By Suction Throttling

**Suction throttling** is any type of control used to regulate the flow of refrigerant from the evaporator to the compressor. This control is located at some point between the tail pipe of the evaporator and the compressor in the low side or suction line as it is commonly called (Fig. 34). These devices are used mainly on automotive systems.

Sometimes it may be difficult to determine exactly what type of control is used on a particular instal-

lation. If inspection of the compressor and lines does not show a control device, it is safe to assume a thermostat-controlled recycling clutch system is used.

We found earlier that a constant heat load and compressor speed would allow the expansion valve to meter an even flow of refrigerant into the evaporator. Changing any of these conditions, however, would change the refrigerant flow through the expansion valve. Without some way to regulate refrigerant flow, the evaporator cooling will become excessive and freeze the moisture condensing on the coils. This results in evaporator icing or freeze-up and requires that the ice on the evaporator be melted before it can resume cooling.

Installation of a suction throttling control device will compensate for these varying conditions. As the pressure and temperature within the evaporator drop, spring pressure forces a valve within the regulating device toward its seat, retarding the flow of refrigerant. This action increases the pressure back into the evaporator, raising both pressure and temperature. The temperature will not be allowed to drop low enough to freeze over the evaporator coils. A point of balance will soon be reached whereby the refrigerant flow past the valve in the regulator will reach a pressure and temperature sufficient to maintain cooling without evaporator freeze-up.

### MODULATOR VALVE

The **modulator valve** (Fig. 35) limits and maintains a minimum pressure in the evaporator. It works like a hydraulic relief valve except that it has a *suction* relief.

The valve assembly is simple in operation. In Fig. 35, note that the valve has been divided into three functional areas.

The middle section is connected to the compressor suction valve. When the thermostatic expansion valve closes, the suction pressure will increase and compress the sealed bellows.

When the suction pressure becomes low enough, the bellows will force the valve disk open. This will allow the refrigerant to bypass the evaporator, thus stopping any further decrease in suction pressure.

When the thermostatic expansion valve at the evaporator inlet opens, the suction pressure will be relieved and the bypassing of refrigerant through the modulator valve will be stopped.

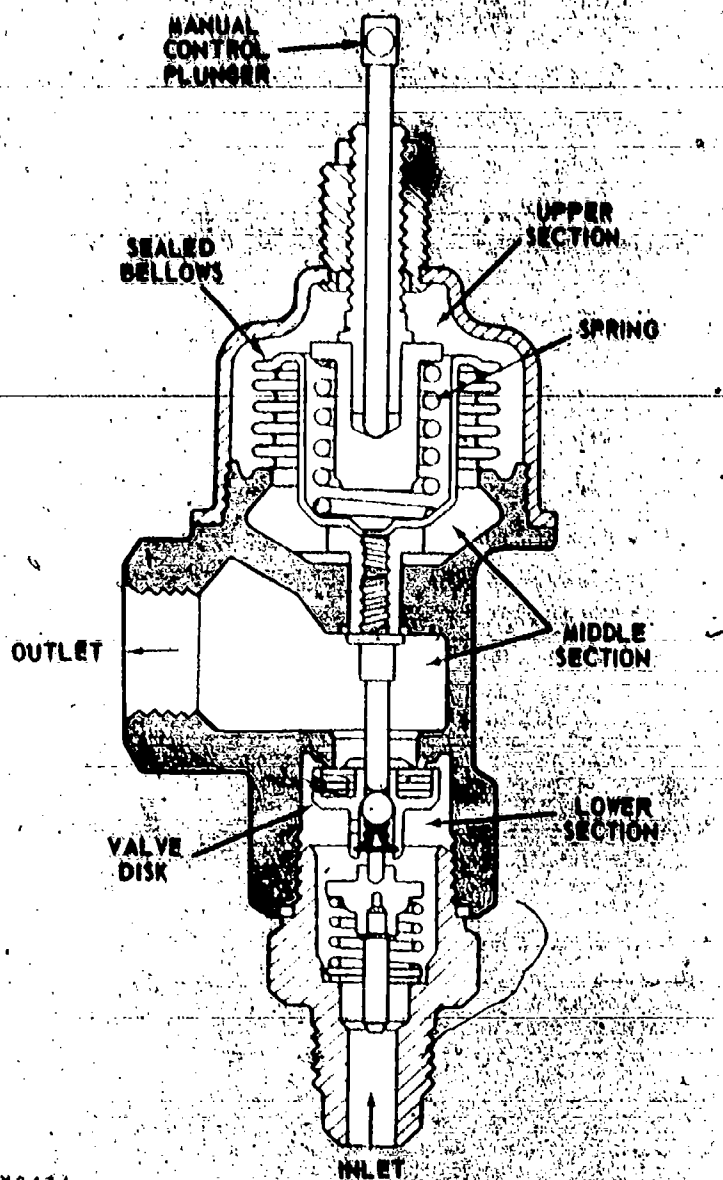

Fig. 35 — Modulator Valve

Located at the top of the modulator valve is a manual control plunger. This plunger is connected by a cable to the operator's temperature control. The manual control plunger regulates the range at which the valve opens and closes.

When the temperature control is pulled out for maximum cooling, the valve is fully closed and will require a low suction pressure for the refrigerant to bypass.

When the control is pushed in, the valve will be manually forced open, causing refrigerant to bypass freely through the modulator, destroying the suction pressure in the evaporator.

## OTHER TYPES OF SUCTION THROTTLING REGULATORS

Some other types of suction throttling regulators are:

- Robotrol Valves
- Evaporator Pressure Regulator (EPR)
- Suction Throttling Regulator (STR)

These regulators are used primarily in automotive systems.

## LINES AND CONNECTIONS

Refrigerant lines carry refrigerant between the major components of the refrigeration system. They are joined to the components by connections.

Lines may be constructed of reinforced synthetic rubber, steel, aluminum, or copper. Connections (Fig. 36) are made with synthetic rubber O-rings, flare fittings, or hose clamps.

Some fittings are equipped with self-sealing couplings or "quick disconnects" which permit a new component such as an evaporator or condenser to be shipped with a partial charge.

## LOCATION

Listed below are the components connected by the major lines, followed by the various names by which these lines are known.

- Evaporator outlet to compressor inlet: **Suction line** — (low-pressure line or low-pressure vapor line).
- Compressor outlet to condenser inlet: **Discharge line** — (high-pressure vapor line or pressure line).
- Receiver-dehydrator outlet to thermostatic expansion valve inlet: **Liquid line** — (high-pressure liquid line).
- Compressor outlet to evaporator outlet: **Hot gas bypass line** — (hot gas line).

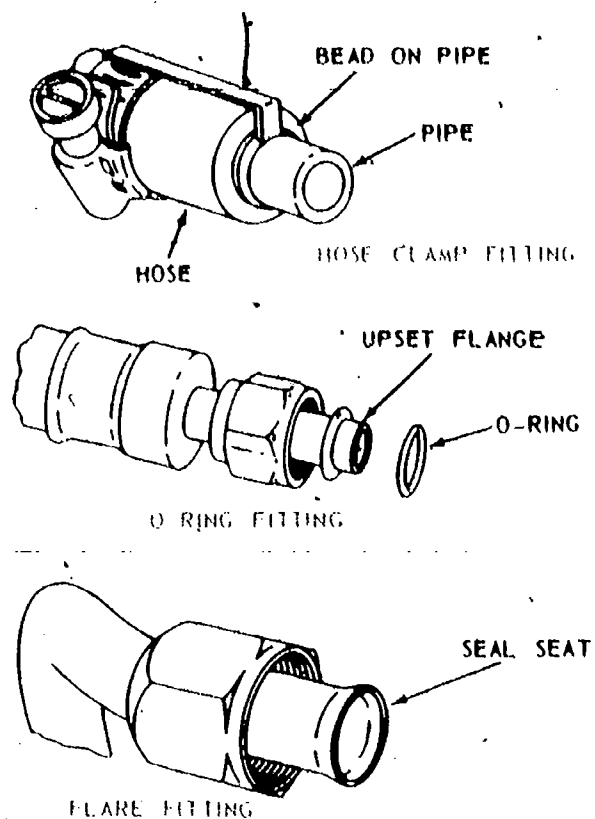

Fig. 36 — Types Of Line Connections

**OPERATION**

When the system is operating properly, the lines should be at the following general temperatures to the touch:

- Suction Line — Cool
- Discharge Line — Hot
- Liquid Line — Warm
- Hot Gas Bypass Line — Warm to hot (when bypassing refrigerant)

**DIAGNOSIS**

Restrictions or kinks in the refrigerant lines may be indicated as follows:

*Suction line* — low suction pressure at the compressor, low discharge pressure, little or no cooling.

*Discharge line* — compressor relief valve opens. *Liquid-line* — low discharge pressure, low suction pressure, no cooling.

*Hot gas bypass* — low suction pressure, possible evaporator icing.

**SERVICE**

Plugged lines can usually be flushed with high-pressure liquid refrigerant. If lines cannot be flushed, they should be replaced. Hoses which leak or are damaged (and plugged screens) should be replaced. Hoses and lines should always be protected from rubbing against sharp metal surfaces, moving parts, or hot engine parts.

The proper oiling and tightening of connections is very important. Always tighten the line connections to the torque recommended in the technical manual.

Circulating the refrigerant in the system periodically throughout the year will help to lubricate seals and gaskets to insure a sealed system. In winter, do this by turning over the compressor pulley by hand a few times.

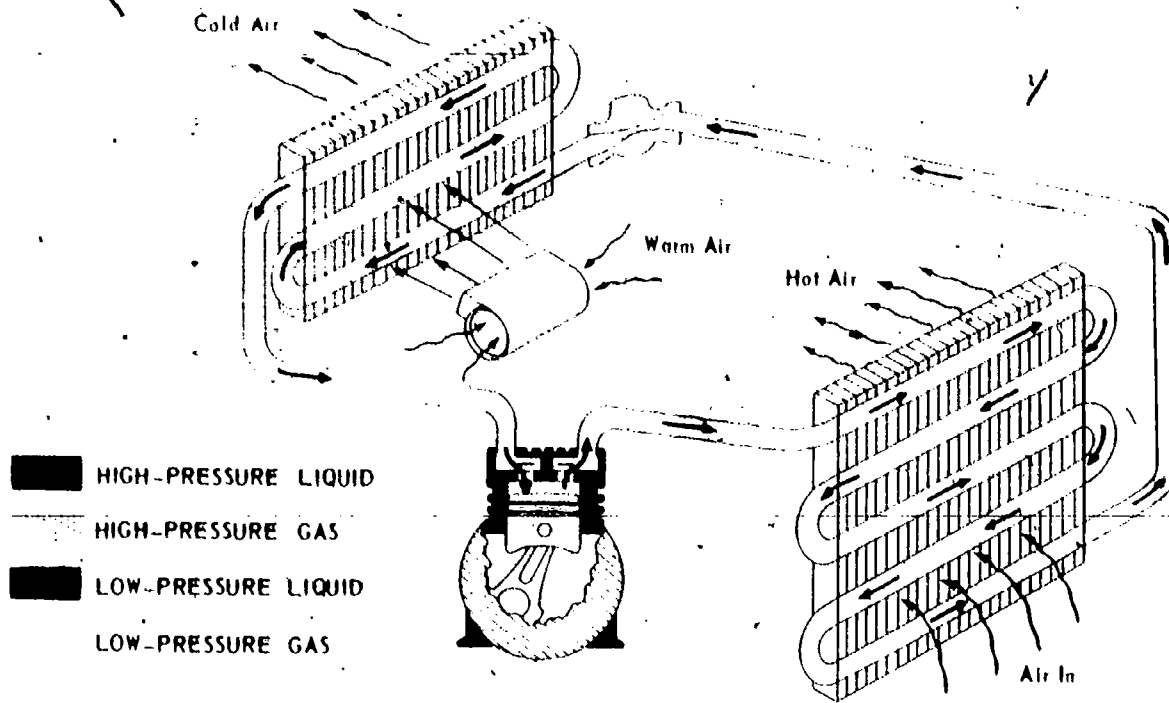

Fig. 37 — Diagram Of Basic Air Conditioning System (for Test Question No. 1)

## TEST YOURSELF

### QUESTIONS AND PROBLEMS

1. Mark up Fig. 37, "Diagram of Basic Air Conditioning System":

- Label the four basic parts of the system.
- Draw a line through the diagram at the correct place and label the "high side" and "low side" of the system.
- Use red and blue pencils and color the refrigerant passages as coded on the diagram to show high or low pressure and gas or liquid.

2. The compressor actually has two jobs. The first is compressing the refrigerant gas. What is the second?

3. What does compressing the refrigerant gas do to its heat content?

4. (Fill in the blanks.) Air passing over the condenser coils carries off \_\_\_\_\_ and changes the refrigerant from \_\_\_\_\_ to \_\_\_\_\_.

5. Compare "ram air" to "forced air."

6. Which side of the expansion valve will be "cold" — inlet or outlet?

7. (Fill in the blanks.) Air passing over the evaporator coils changes the refrigerant to \_\_\_\_\_. As a result, heat is \_\_\_\_\_.

8. To get the coldest air temperature from the evaporator, should the blower fan be normally run at its *lowest* or *fastest* speed?

9. What is the purpose of the desiccant sealed inside the receiver-drier?

(Answers on page 99.)

## SERVICE EQUIPMENT / PART 4

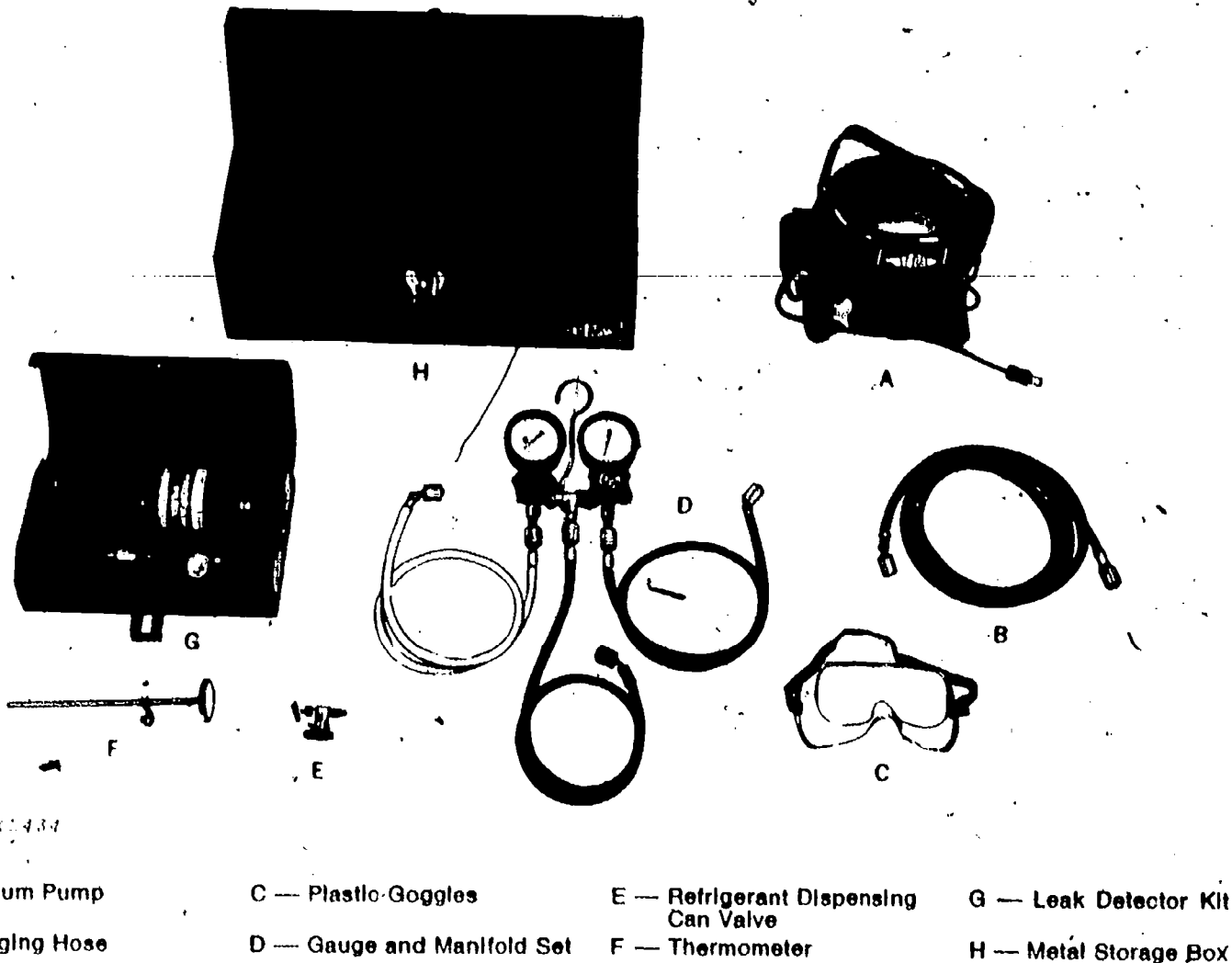

A — Vacuum Pump      C — Plasto-Goggles      E — Refrigerant Dispensing Can Valve      G — Leak Detector Kit  
 B — Charging Hose      D — Gauge and Manifold Set      F — Thermometer      H — Metal Storage Box

Fig. 38 — Complete Air Conditioning Service Kit

## INTRODUCTION

Three basic tools are required to test and service an air conditioning system:

- Gauge and Manifold Set
- Leak Detectors
- Vacuum Pump

In addition, some special tools and attachments are required (Fig. 38).

Here we will describe only the operation of the various equipment. In Parts 5 through 8 we will show the actual use of the tools in testing and servicing the system.

## GAUGE AND MANIFOLD SET

Accurate testing requires the use of a test gauge set connected to the high and low sides of the air conditioning system. With these gauges, the serviceman can accurately pinpoint trouble within the system as well as determine if the system is operating as it should.

The gauge manifold set (Fig. 39) is composed of a *low side or compound gauge*, a *high side gauge*, and the *manifold* to which the gauges are connected.

Following is a brief description of the gauges and their requirements.

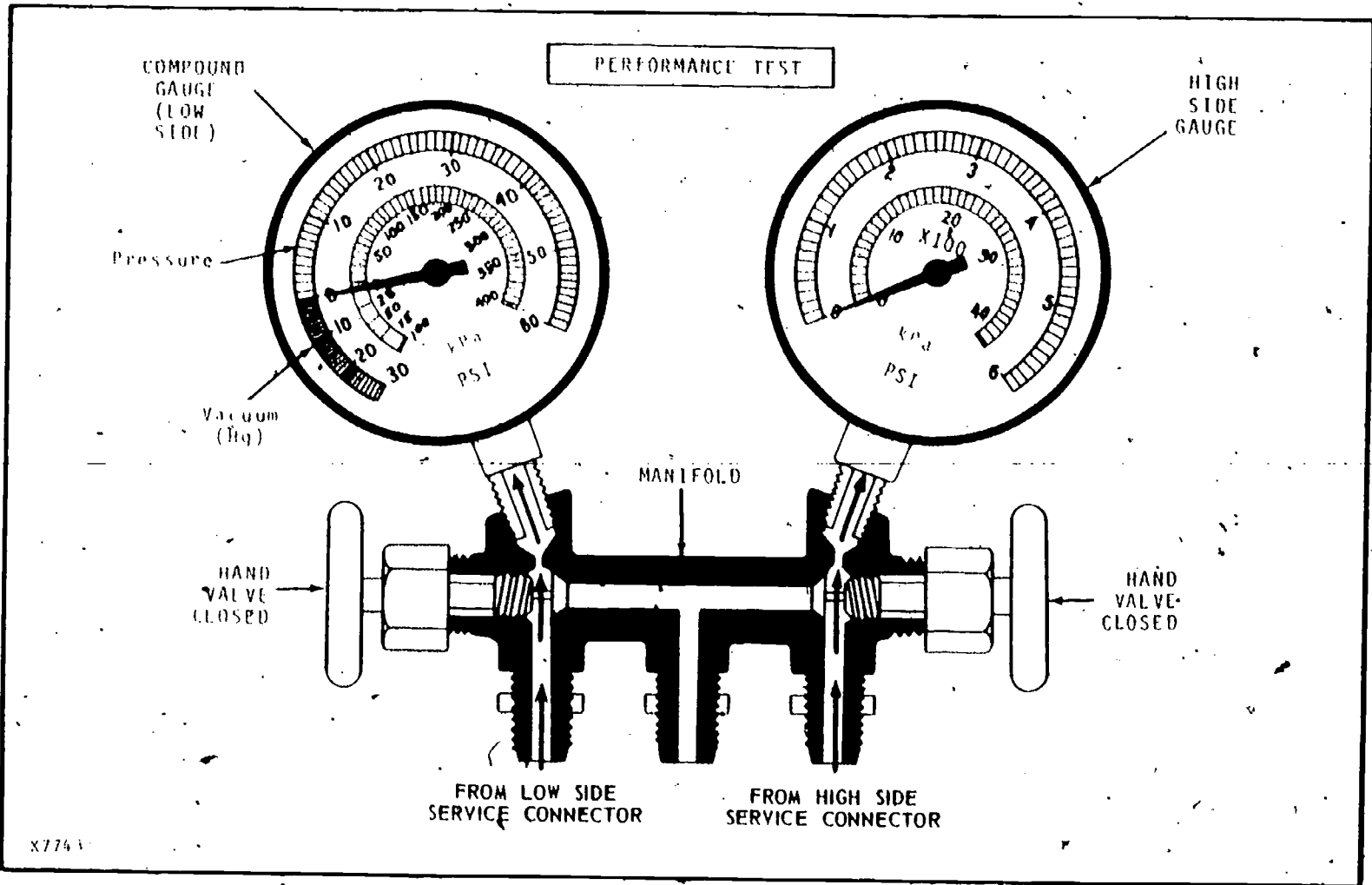

Fig. 39 — Refrigerant Flow To Gauges In Performance Test — Both Hand Valves Closed

### COMPOUND GAUGE (LOW SIDE)

The *compound gauge* (Fig. 39) derives its name from its function. It will register both pressure and vacuum. All air conditioning systems can, under certain conditions, drop from a pressure into a vacuum on the low side. It is necessary that a gauge be used that will show either pressure (psi and kPa) or inches (kPa) of mercury vacuum (Hg.).

The vacuum side of the gauge must be calibrated to show 0 to 30 inches (0 to 100 kPa) Hg. The pressure side of the gauge must be calibrated to register from 0 pressure to a minimum of 60 psi (415 kPa). The maximum reading of the pressure should not exceed 150 psi (1035 kPa). Practically all readings of the low side of the system will be less than 60 psi (415 kPa).

The scale reading preferred by the individual serviceman is left to his own choice. To accurately convert pressures to temperatures in the system, the gauge should be calibrated to a low enough scale that it will not be difficult to obtain an accurate reading. The higher the pressure scale, the more difficult it becomes to get an accurate pressure-temperature conversion.

### HIGH PRESSURE GAUGE (HIGH SIDE)

The *high pressure gauge* is used to determine pressures in the high side of the system. The gauge is calibrated to register from zero pressure to a minimum of 300 psi (2070 kPa). A few systems operate under high head pressure during normal operation conditions. This is why the high pressure gauge should have a reading of at least 300 psi (2070 kPa).

### GAUGE MANIFOLD

The *gauge manifold* mounts the high and low side gauges and connects the gauges into the high and low sides of the system by means of test hoses. The gauges connect to the upper part of the manifold through holes drilled and tapped to a 1/8-inch pipe thread. Test hose connectors below the gauges on the lower side of the manifold direct the refrigerant through the manifold to the gauges to obtain pressure readings.

A center test hose connector on the lower side of the manifold is connected to both pressure gauges and the test hoses by a passage in the manifold (Fig. 39). Refrigerant flow into the high and low side is controlled by a shut-off hand valve at each end of the manifold.

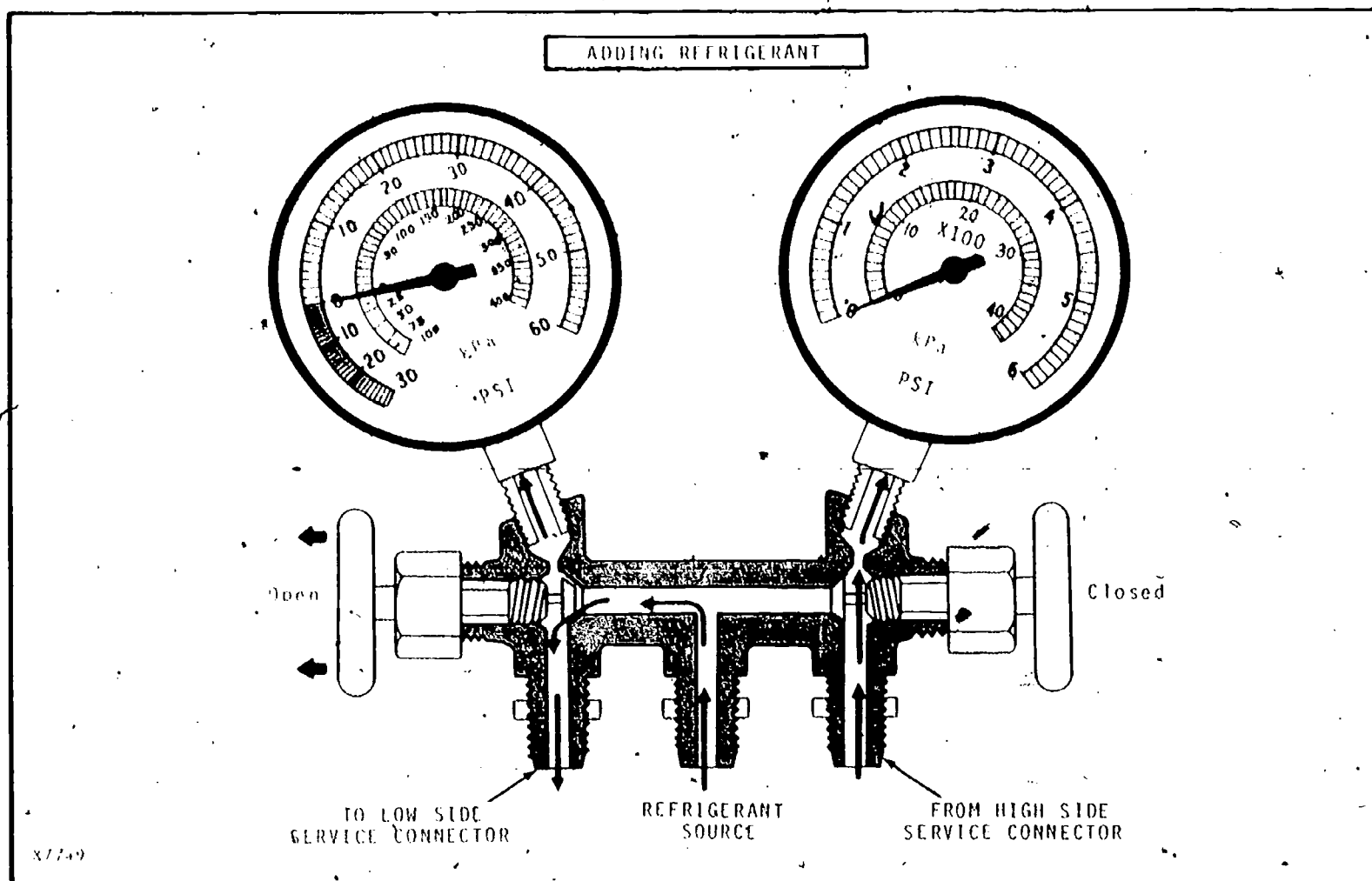

Fig. 40 — Refrigerant Flow To Gauges And Through Manifold While Adding Refrigerant

With both hand valves in the "closed" position (Fig. 39), refrigerant will be shut off from the center test hose fitting but will flow to the gauges.

Opening the high side hand valve will allow refrigerant to flow through the passage and out the center test hose connector and at the same time continue to the high gauge to register pressure reading.

Opening the low side gauge (Fig. 40) will open the low side refrigerant to the center test hose connection and the low side gauge.

By opening and closing the hand valves on the manifold, the following jobs can be done:

- 1) Bleeding excess refrigerant from system
- 2) Bleeding air from system
- 3) Purging refrigerant before service work
- 4) Removing air and moisture during pump-down
- 5) Filling system with refrigerant

All of these jobs will be explained in Parts 7 and 8.

### TEST HOSES

The *test hoses* are the connections between the gauge manifold and the air conditioning system. They are connected to the gauge manifold test hose fittings by use of a screw-on connection and sealed with an internal O-ring. Hose connectors should be tightened only finger tight as this is sufficient to seal the hose onto the O-ring.

The manifold is constructed so that the test hose and connector directly below the gauge will pass refrigerant to that gauge to show pressure readings. Opening the hand valve on the same side as the gauge is the only way the refrigerant can move in any direction other than to the gauge.

The center test hose is not connected to the air conditioning system. It is used to allow refrigerant to purge from the system, or it may be connected to a vacuum pump for removing air and moisture from the system.

Opening the hand valves on the manifold will control pump-down of the system into a vacuum for more effective moisture removal.

Hoses are available to fit the service connectors with a Schrader Valve. Other hoses require the use of a Schrader valve adapter on the connectors before using the Schrader valve. The use of the Schrader valve in the service connector eliminates the need for a service valve in the system and the refrigerant is effectively sealed inside the system until the valve is opened.

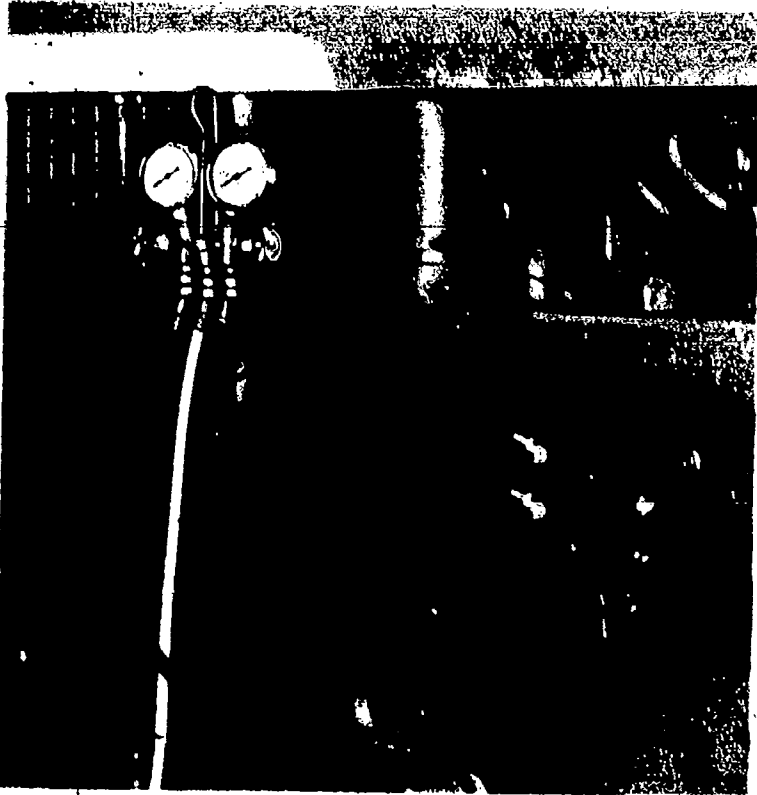

Fig. 41 — Gauge And Manifold Set

Fig. 41 shows a gauge and manifold set discharging a system through the compressor service valve ports. For instructions on installing gauge set into system, see Part 7.

### SERVICE VALVES

The compressor is equipped with service valves which are used as an aid in servicing the air conditioning system. The manifold gauge set is connected into the system at the service valve ports and all procedures such as evacuating and charging the system are carried on here through the gauge and manifold set.

Most compressors are equipped with two service valves. One services the high side, while the other services the low side. The high side service valve is quickly identified by the discharge hose routed to the condenser, while on the low side valve the hose comes from the evaporator.

Since all valves are the same, we will be concerned here with the operation of one valve in the system.

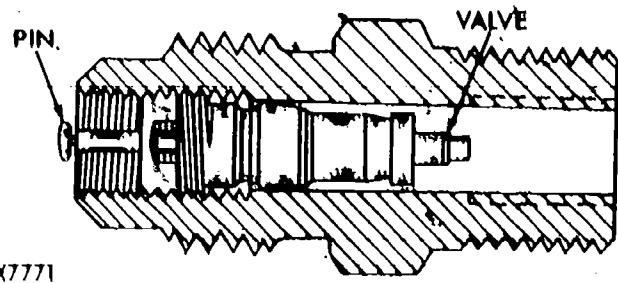

X7771

Fig. 42 — Schrader Valve

The valves described here are the hand shutoff type. Many air conditioning systems now use only one valve having a shutoff feature, or one valve having no shutoff feature. The gauge hoses are still connected to the service valve fitting, in which a Schrader

- 1—To Gauge Port
- 2—To Hose
- 3—To Compressor

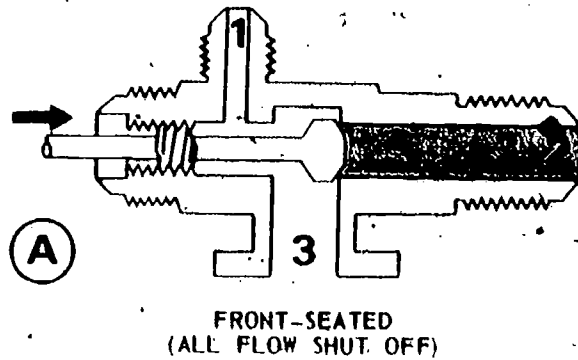

(A)

FRONT-SEATED  
(ALL FLOW SHUT OFF)

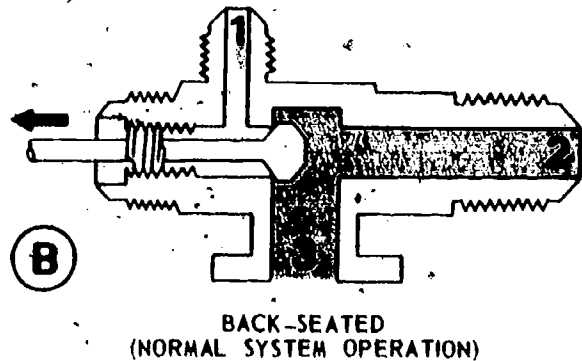

(B)

BACK-SEATED  
(NORMAL SYSTEM OPERATION)

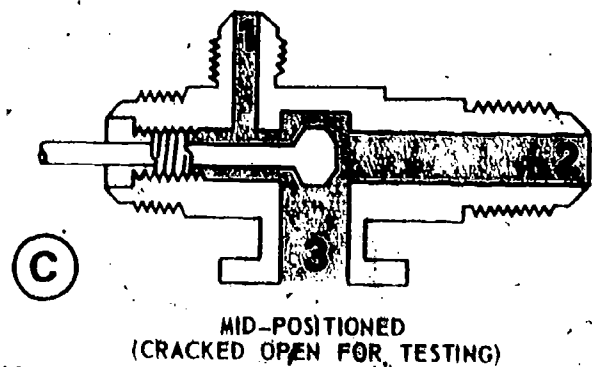

(C)

MID-POSITIONED  
(CRACKED OPEN FOR TESTING)

Fig. 43 — Service Valve (Hand Shutoff Type Shown)



valve (Fig. 42) is incorporated. When the fitting in the end of the service hose is screwed onto the Schrader valve, a pin is depressed in the center of the valve allowing pressure to be read on the gauges. When the fitting is removed, the valve closes to hold refrigerant in the system.

The hand shutoff type of valve (Fig. 43) has three positions:

- A — Shut off refrigerant flow. Gauge port out of the system.
- B — Normal refrigerant operation. Gauge port out of the system.
- C — Normal refrigerant operation. Gauge port in the system.

We will discuss each position and determine at what points refrigerant will be allowed to flow.

#### A. Shut Off Refrigerant Flow. Gauge Port Out Of System

In this position we refer to the service valve as being in the *front-seated* position.

Refer to illustration "A" in Fig. 43. You can see that the refrigerant is trapped in the hose end of the service valve. The gauge port fitting is toward the atmosphere. By following the path through the valve, you can see that the gauge port only connects to the compressor. If the compressor were run with the service valve in this position and the gauge port capped, serious damage would occur in the compressor. There would be no area to pump into.

**WARNING:** Never operate a compressor with the service valves in closed or front-seated position. This will damage the compressor.

#### B. Normal Refrigerant Operation — Gauge Port Out Of The System

In "B" in Fig. 43 the service valve is in the *backseated* position. The compressor and hose outlet are connected and refrigerant is free to flow if the compressor is started. Now the gauge port is closed off and pressure readings cannot be taken. *All service valves should be in this position when the system is operating normally.*

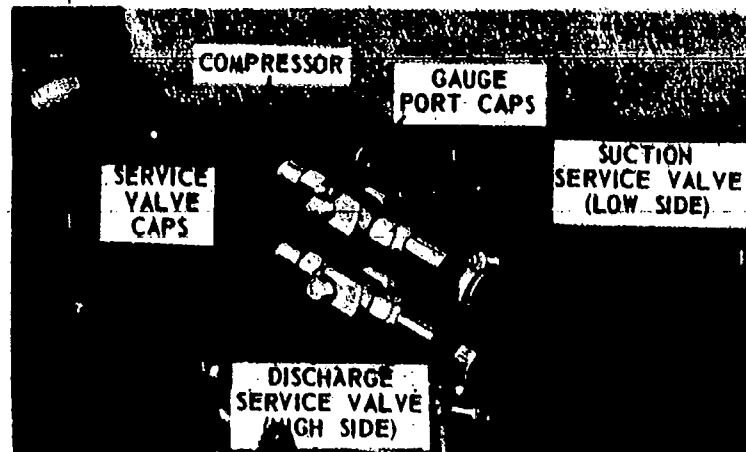

Fig. 44 — Location Of Service Valves In A Typical System

#### C. Normal Refrigerant Operation — Gauge Port In The System

The service valve in "C", Fig. 43 is in the *cracked* or *mid-position*. Now the system can be operated and the pressures recorded through the gauge port openings.

Remember, however, that the valves must always be backseated again before attempting to remove the gauge hose from the service valves. Failing to do so will result in loss of refrigerant. Illustration "C" shows the presence of refrigerant at all outlets of the service valve for testing.

The location of service valves at the compressor for a typical system is shown in Fig. 44.

Valve position is controlled by rotating the valve stem with a service valve wrench.

## LEAK DETECTORS

Several types of leak detectors are available to the serviceman:

- Colored Dye Additive
- Liquid Detergent-Type Detector
- Electronic Leak Detector
- Propane Torch Leak Detector

A COLORED DYE ADDITIVE is available which is added to the refrigerant. Operation of the system will show coloration at the point of leakage. A very slight leak requiring several weeks or even months to bleed off enough refrigerant to affect system cooling can often be located using this additive when other methods of leak detection fail.

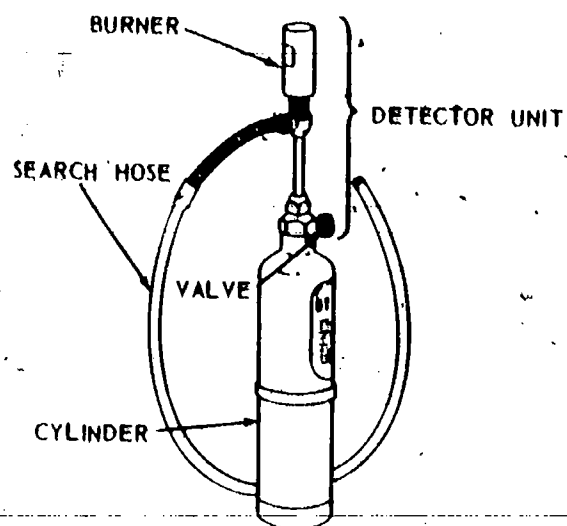

TORCH LEAK DETECTOR

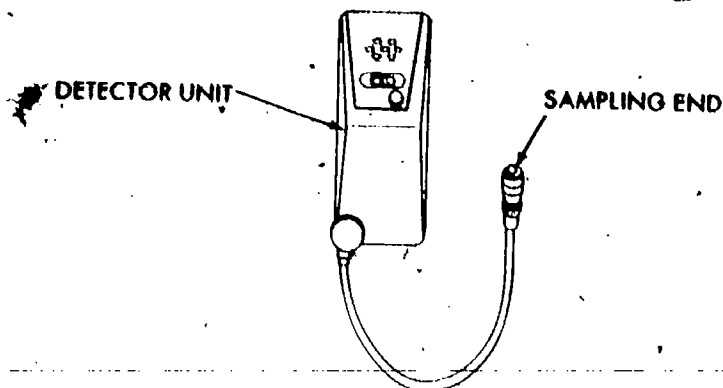

ELECTRONIC LEAK DETECTOR

X7751

Fig. 45 — Leak Detectors

A LIQUID DETERGENT-TYPE DETECTOR may be used around connections and any external point that might be a source of leak for the Refrigerant-12. Escaping refrigerant will cause the liquid to bubble, indicating a leak. Any parts that are not accessible, such as the coils in the condenser and the evaporator, cannot readily be coated with this liquid to check for leaks.

The ELECTRONIC LEAK DETECTOR (Fig. 45) is the most sensitive of any detector on the market. However, the initial cost of this type detector has been a deterrent to individuals and small shops doing a minimum of air conditioning service. This instrument is electronic and must be handled with care to give accurate results. When cared for properly, the electronic detector will locate leaks quickly and accurately that are almost impossible to locate with other types of detectors. (Fig. 46).

The PROPANE TORCH LEAK DETECTOR (Fig. 45) is the most familiar and has received the most widespread use because of its ease of handling, availability of propane in disposable tanks, and low initial cost. In operation, the blue flame changes color to yellow to vivid purplish blue when Refrigerant-12 is picked up by the sniffer tube outside the system.

**CAUTION:** The propane torch leak detector must be used only in well-ventilated areas. When Refrigerant-12 passes over an open flame, it gives off phosgene gas, which is very toxic. Do not breathe fumes given off by the detector.

Leak detection must be performed with the system under pressure to obtain accurate results. Very small leaks often require that the system pressure be increased above normal before they can be located. A 50 percent charge of refrigerant in the system is enough to locate most leaks. Occasionally, a stubborn small leak will require overcharging the system.

The **high side** of the system might require leak testing while in operation with air flow restricted to the condenser to raise the high side pressure above normal.

The **low side** is checked in the "off" position with the pressures equalized in both sides of the system.

Many leaks can be found by looking for an *oily spot* or *film* at the source of the leak, especially if the leak is a large one.

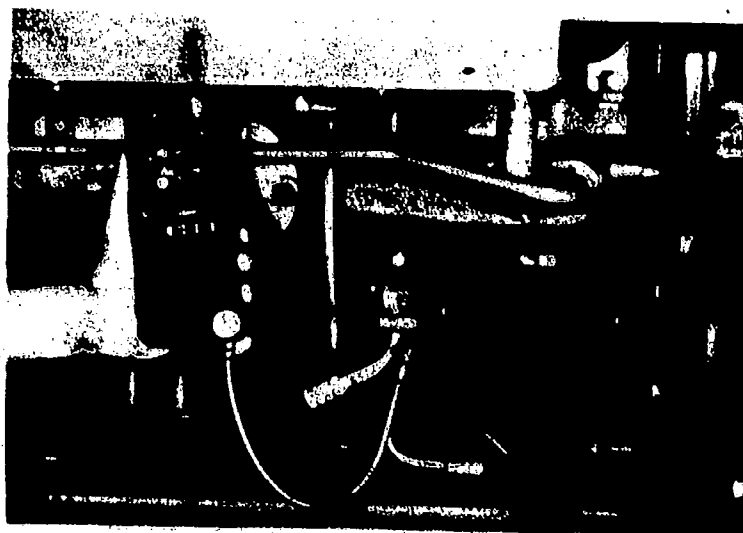

Fig. 46—Leak Testing System Using Electronic Leak Detector

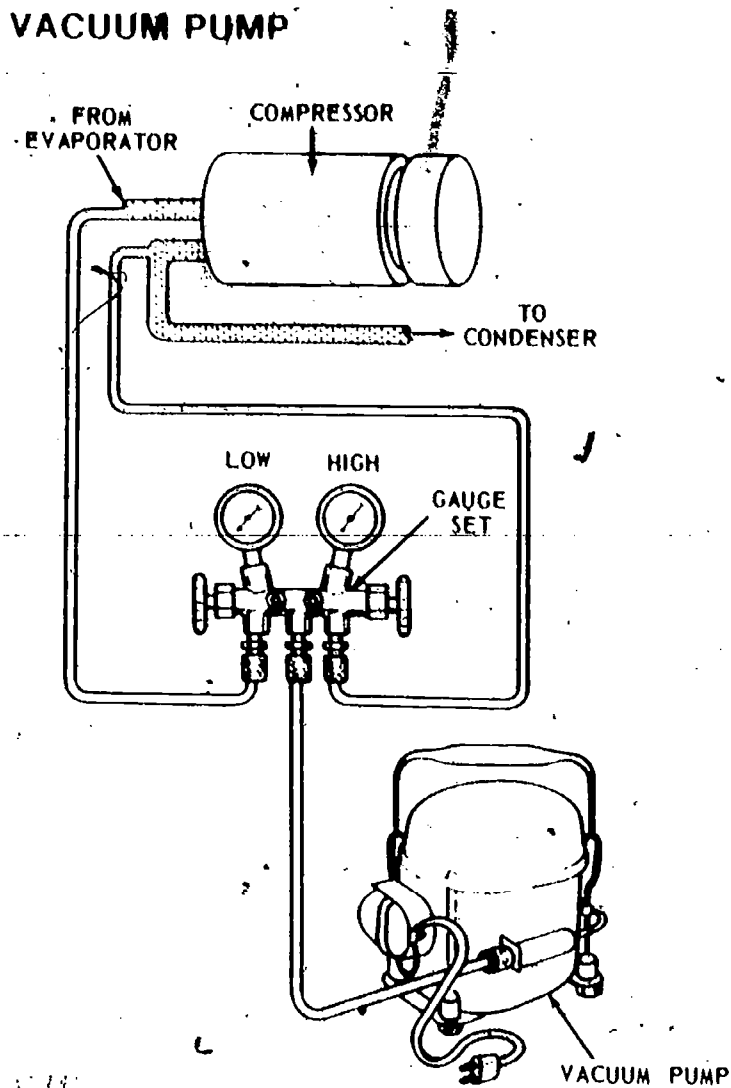

Fig. 47 — Using Vacuum Pump To Evacuate The System

The vacuum pump is used to evacuate air from the system (Fig. 47).

When the system is depressurized and opened for service, air enters the openings before they can be capped. To remove this air (and its harmful moisture), the system must be evacuated. This is done by removing air until a vacuum is created. Detailed procedures are given in Part 8.

## OTHER SERVICE TOOLS

Other service tools such as those shown in Fig. 38 are part of any complete air conditioning service kit. These include charging hoses, plastic safety goggles, refrigerant can valve, and thermometer.

Since the air conditioning system is activated by electrical controls, some electrical test equipment such as a voltmeter will also be needed to check for faulty wiring and other problems.

## TEST YOURSELF

### QUESTIONS

1. What three basic tools are required to test and service an air conditioning system?
2. Why are two gauges needed to test the pressure in the system?
3. On what component are the system service valves located?
4. What type of leak detector is most sensitive to small leaks?
5. What happens when Refrigerant-12 is passed over an open flame?
6. What equipment is used to remove air from the system?

(Answers on page 99.)

## INSPECTING THE SYSTEM/PART 5

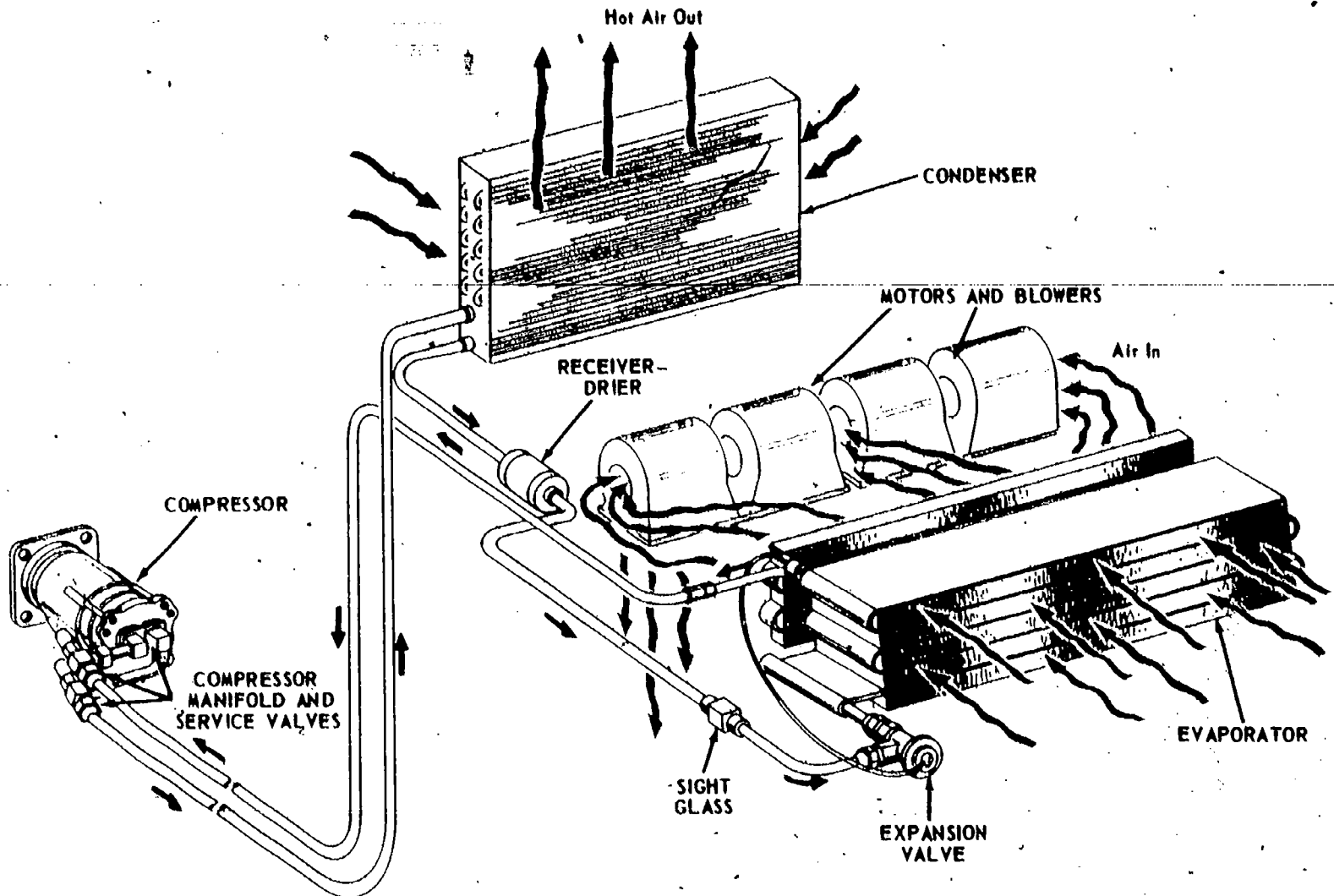

X7773

Fig. 48 — Air Conditioning System For Typical Tractor With Cab

## INTRODUCTION

A seasonal check of the system is very important in revealing troubles early before they cause a failure.

A Performance Test of the system (page 67) is the only positive way in which the complete system can be checked for efficient operation. Whenever possible, the system should be given this test before work is begun on the system.

Many times, however, the system is completely inoperative, and repairs must be performed before it can be properly tested. The test can uncover further work that must be performed before the system is brought to full operating efficiency.

The Performance Test should always be performed after repair work has been done and before the machine is released to the customer. The serviceman performing this test carefully will insure that the repairs have been properly performed and that the system will operate satisfactorily.

A good Performance Test includes a thorough examination of the outside of the system as well as the inside. Many related parts are overlooked because it is felt they are of no importance to the system actually cooling the inside of the cab. But often these outside parts have a direct bearing on the operating efficiency of the unit.

For this reason, a thorough visual inspection of the complete system should be performed, followed by an operating inspection of the system.

## VISUAL INSPECTION OF SYSTEM

### Visually Inspect The Following:

1. **COMPRESSOR DRIVE BELTS TIGHT; NOT WORN OR FRAYED; AND ALIGNED WITH PULLEYS.** The compressor belt (Fig. 49) is subjected to a heavy load during operation. This is especially true when the head pressures build up in excess of 200 psi (1380 kPa) in hot weather operation. The belt must be in excellent condition to withstand the strain of heavy loads. If the pulleys are not properly aligned, extreme side wear to the belt and pulleys will result. Too tight a belt tension will result in strain to the bearings of units operated by the compressor belt. Too loose a belt tension will result in belt slippage and poor performance. A belt tension gauge eliminates guesswork in tightening the compressor belt. If a belt tension gauge is not available, tighten until there is  $\frac{3}{8}$ - to  $\frac{1}{2}$ -inch (10- to 13-mm) deflection between any two pulleys that are farthest apart.

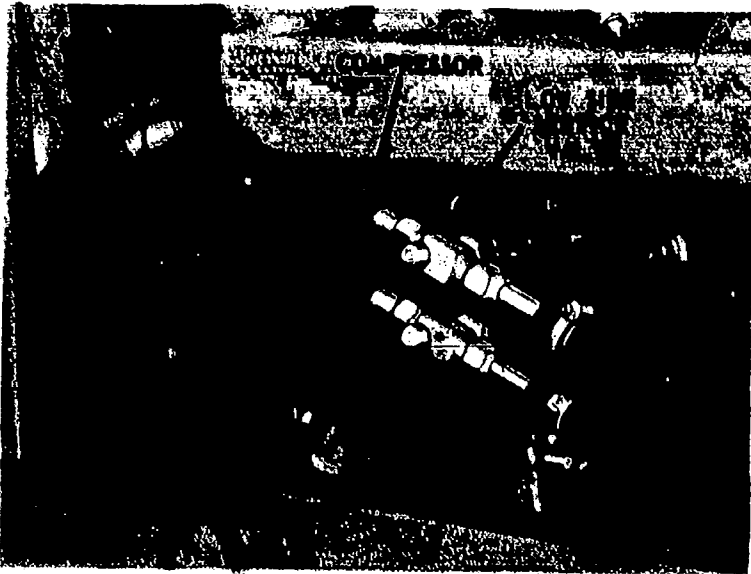

Fig. 49 — Compressor Drive Belt And Pulley

2. **COMPRESSOR BRACKETS AND BRACES TIGHT AND NOT CRACKED OR BROKEN.** Mounting bolts work loose, and brackets and braces often break under the vibrations and strain of operation. Failure to inspect and repair any damage at these points can result in early system failure.

3. **HOSES OR COPPER LINES NOT CHAFING OR LEAKING.** Grommets and rubber pads that were originally installed to protect the hoses from contact with metal parts may deteriorate or loosen. Exposing the hose or line to constant rubbing and chafing can cause deterioration and allow the refrigerant to escape. To prevent damage, install some type of protective material.

4. **CONDENSER CLEAN AND PROPERLY MOUNTED.** Insects and dirt clog the condenser and radiator and stop air movement. Any blocking of full air flow over the condenser and radiator coils must be corrected to allow proper condensing action of the system.

5. **EVAPORATOR CLEAN.** The evaporator condenses moisture which in turn traps dust and lint on the side where the air enters. The blower or fan can be effective only when evaporator passages are clear. Dust and lint should be removed.

6. **COMPRESSOR OIL LEVEL CORRECT.** On compressors having a provision to check the oil level without disconnecting the compressor from the system, make an oil level check using the correct dip stick. Do not overfill the system with oil as flooding of the condenser and evaporator will result. See pages 73 or 74.

7. **AIR DUCTS AND LOUVERS OPERATING SMOOTHLY.** Operate all mechanisms to check for free operation without binding and sticking.

8. **BLOWER MOTOR OPERATING SATISFACTORILY.** Operate blower motor at all speeds. If motor is noisy or falls at some speeds, repair it.

9. **AIR FILTERS CLEAN.** Many systems use filters to clean the air before it goes to the evaporator coil. The filter must be removed and cleaned, as a clogged filter will seriously affect evaporator air flow.

10. **VISIBLE LEAKS.** An oily spot usually indicates a refrigerant leak, as oil is carried out with the escaping refrigerant.

11. **LEAK TEST THE SYSTEM.** A leak test (page 83) will tell whether an oily spot indicates a leak. This test can only be performed on systems that are operative. A unit that has lost its refrigerant must be partially charged before this test can be performed.

## OPERATING INSPECTION OF SYSTEM

An operating inspection of the system can be made for three factors:

- System fully charged
- Relation of temperatures at high and low sides of system okay
- Evaporator outlet blowing cool air

Before making these inspections, operate the system for about 5 minutes to allow refrigerant in system to stabilize.

EVAPORATOR

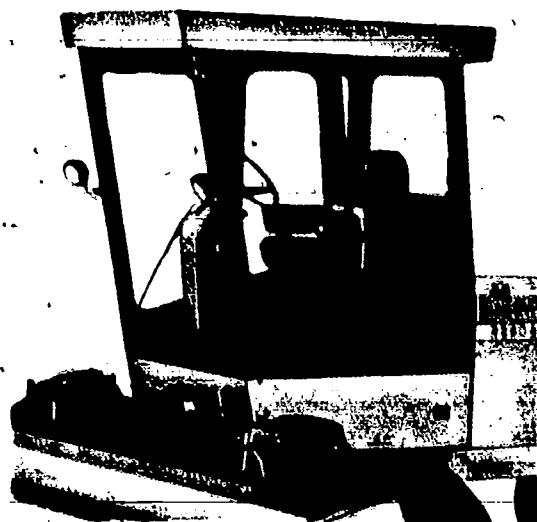

X7774

AIR CONDITIONED CAB FOR WINDROWER

EVAPORATOR



AIR CONDITIONED CAB FOR FARM COMBINE

Fig. 50 — Air Conditioning Systems For Farm Machines With Cabs

CHECKING SYSTEM FOR FULL CHARGE

1. Use the test gauges and the sight glass (if equipped) for this test. See page 65 for installing gauges.
2. **High side** or head pressure will normally read from **150 to 270 psi (1035 to 1860 kPa)**, depending upon ambient air temperatures and the type of unit tested. (See chart at right.)
3. The sight glass (if equipped) should be free of bubbles (after system has been operating for a few minutes).
4. **Low side pressure** should read from **7 to 30 psi (50 to 210 kPa)**, again depending on the air temperatures and the unit tested.
5. It is impossible to give a definite reading for all types of systems, as the type of control and component installation will influence the pressure readings of the high and low sides.
6. *The high side pressure will definitely be affected by the ambient or outside air temperature. A system that is operating normally will indicate a high side gauge reading between 150-170 psi (1035-1170 kPa) with a 78-80°F (24-27°C) ambient temperature. The same system will register 210-230 psi (1450-1585 kPa) with an ambient temperature of 100°F (38°C). No two systems will register exactly the same, so allow for variations in head pressures.*

CHECKING RELATIVE TEMPERATURES AT HIGH AND LOW SIDES OF SYSTEM

1. The **high side** of the system should vary from *hot* at compressor discharge valve to *warm* at expansion valve. A difference in temperature will indicate a partial blockage of liquid or gas at this point.

PRESSURE-TEMPERATURE CHART

Ambient Temp.	Normal High Side Pressure
80°F (27°C)	150-170 psi (1035-1170 kPa)
90°F (32°C)	175-195 psi (1210-1345 kPa)
95°F (35°C)	185-205 psi (1275-1415 kPa)
100°F (38°C)	210-230 psi (1450-1585 kPa)
105°F (41°C)	230-250 psi (1585-1725 kPa)
110°F (43°C)	250-270 psi (1725-1860 kPa)

The **low side** of the system should be uniformly *cool* to the touch, with no excessive sweating of the suction line or low side service valve. Excessive sweating or frosting of the low side service valve usually indicates the expansion valve is allowing an excessive amount of refrigerant into the evaporator.

CHECKING EVAPORATOR OUTPUT

If all the above inspections have been performed carefully and components have been found to operate okay, a rapid cooling of the cab interior should result.

The use of a thermometer is not necessary to determine evaporator output, but its use is left to the discretion of the serviceman. Bringing all units to their correct operating specifications will insure that the evaporator performs as intended.

CONTINUING PERFORMANCE TEST

If further tests are needed, see "Performance Testing The System" on page 67.

**TEST YOURSELF**

**QUESTIONS**

1. What is the normal range for low side pressure in the system?
2. Fill in the normal high side pressure ranges in the chart below.

**Ambient Temp.    Normal High Side Pressure**

- 80°F (27°C).....
- 90°F (32°C).....
- 95°F (35°C).....
- 100°F (38°C).....
- 105°F (41°C).....
- 110°F (43°C).....

3. Match the temperatures below with the components listed.

<b>System Component</b>	<b>Normal Temperature</b>
1. Expansion valve	a. Hot to the touch
2. Low side suction line	b. Warm to the touch
3. Compressor discharge valve	c. Cool to the touch

*(Answers on page 99.)*

## DIAGNOSING THE SYSTEM/PART 6

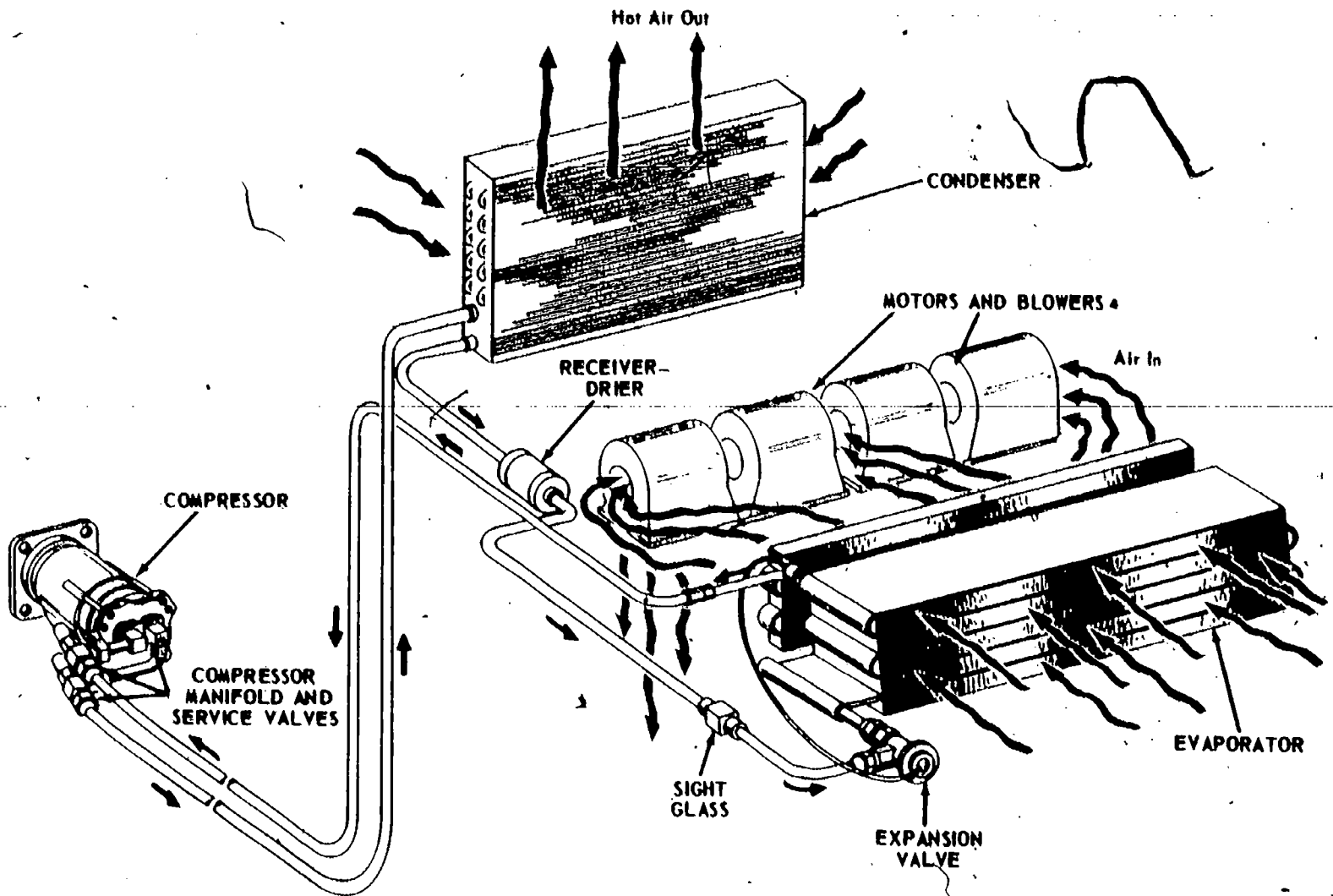

X7773

Fig. 51 — Basic Air Conditioning System For Farm Or Industrial Tractor With Cab

### INTRODUCTION

Part 6 is divided into three sections.

- Troubleshooting customer complaints
- Diagnostic chart
- Flow charts for diagnosing the system

#### Troubleshooting Customer Complaints

The following charts are offered as an aid in troubleshooting all kinds of air conditioning systems.

All complaints in this section fall into three main categories:

- Electrical
- Mechanical
- Refrigeration

An inspection will tell which of these categories the suspected trouble falls under.

In many cases, a problem that causes an air conditioning system to malfunction requires little time to check out and repair. These possible causes should be the first to be examined and corrected.

For example, a complaint will likely be that the air conditioner produces no cooling. Before installing pressure gauges, take time to check a few possible causes. Go to the troubleshooting chart on the next page and review the *Causes for System Producing No Cooling*.

If electrical components are operating, the causes under "Electrical" can be eliminated. You may want to check for a burned out or disconnected clutch coil and solenoid, excessively burned electrical switch contacts in the thermostat, or defective sensing element.

Next, check for "Mechanical" problems that could be inspected and repaired without attaching the pressure gauges — lines 1 and 2. These can be examined and corrected, if necessary, with little difficulty. Lines 3, 4 and 5 require installing the gauges.

In this example, it would be appropriate to next inspect for refrigeration-related problems, in the next section of the chart, that require the least amount of time to inspect and repair. Lines 1 and 2 under *Causes* fit this requirement.



If the problem is not discovered after inspecting these possibilities, it will be necessary to install the pressure gauges. The remaining "Mechanical" and "Refrigeration" problems may then be examined using pressure readings as a guide.

By using this type of logic to troubleshoot air conditioning systems, many problems can be repaired in a minimum amount of time. First, eliminate the possible causes of problems that are easiest to check

and repair. Then, if the problem is not discovered, attach the pressure gauges and check the other possible causes of the problem. If none of the symptoms listed are detected, use the flow charts (beginning on page 55) for a systematic diagnosis of the entire system. Remember, this troubleshooting chart is a methodical procedure to locate the source of a problem. The Flow Charts for Diagnosing the System give a systematic examination to determine what the problem is and how to repair it.

**TROUBLESHOOTING CUSTOMER COMPLAINTS**

<i>Trouble</i>	<i>Cause</i>	<i>Indications</i>	<i>Remedy</i>
<b>I. SYSTEM PRODUCES NO COOLING</b>	<b>Electrical</b>	<ol style="list-style-type: none"> <li>1. Electrical components will not operate.</li> <li>2. Electrical components will not operate.</li> <li>3. Electrical components will not operate.</li> <li>4. Compressor clutch or solenoid inoperative.</li> <li>5. Compressor clutch inoperative (applies to units having thermostatically controlled recycling).</li> <li>6. Blower motor inoperative.</li> </ol>	<ol style="list-style-type: none"> <li>1. Replace fuse.</li> <li>2. Check all terminals for loose connections; check wiring for hidden breaks.</li> <li>3. Check ground wire to see if loose, broken, or disconnected.</li> <li>4. Check current flow to clutch or solenoid — replace if inoperative.</li> <li>5. Replace thermostat.</li> <li>6. Check current flow to blower motor — repair or replace if inoperative.</li> </ol>
	<b>Mechanical</b>	<ol style="list-style-type: none"> <li>1. Visual inspection.</li> <li>2. Compressor pulley slips on belt or will not turn when clutch is engaged.</li> </ol>	<ol style="list-style-type: none"> <li>1. Replace drive belts and/or tighten to specifications.</li> <li>2. Remove compressor for service or replacement.</li> </ol>

TROUBLESHOOTING CUSTOMER COMPLAINTS—Continued

Trouble	Cause	Indications	Remedy
<b>I. SYSTEM PRODUCES NO COOLING— Continued</b>	3. Compressor reed valves inoperative.  4. Expansion valve stuck in open position.  5. Expansion valve stuck shut.	3. Only slight variation of both gauge readings at any engine speed.  4. Head pressure normal or high, suction pressure high, evaporator flooding.  5. Head pressure low, suction pressure low.	3. Service or replace compressor reed valves.  4. Replace expansion valve.  5. Replace expansion valve.
	<b>Refrigeration</b>		
	1. Broken refrigerant line.  2. Fusible plug blown (does not apply to all units).  3. Leak in system.  4. Compressor shaft seal leaking.  5. Clogged screen or screens in receiver dehydrator or expansion valve; plugged hose or coil.	1. Complete loss of refrigerant.  2. Complete refrigerant loss.  3. No pressure on high and low gauges (applies to any system having complete loss of refrigerant).  4. Clutch and front of compressor oily; system low or out of refrigerant.  5. High gauge normal or may read high. Low gauge usually shows vacuum or very low pressure reading. Frosting usually occurs at point of blockage.	1. Examine all lines for evidence of breakage by external stress or rubbing wear.  2. Examine fusible plug — if blown, replace with correct plug.  3. Evacuate system, apply static charge, leak test system, and repair leak as necessary (see pages 83 and 88).  4. Replace the compressor shaft seal.  5. Repair as necessary. <i>NOTE: After completing repairs of any above, system must have dehydrator replaced, evacuated, and charged.</i>
	<b>Electrical</b>		
<b>II. SYSTEM WILL NOT PRODUCE SUFFICIENT COOLING</b>	1. Blower motor sluggish in operation.	1. Small displacement of air from discharge duct; blower motor possibly noisy.	1. Remove blower motor for service or replacement.

FOS — 57

Litho in U.S.A.

**TROUBLESHOOTING CUSTOMER COMPLAINTS—Continued**

FOS—57

Litho in U.S.A.

50 Diagnosis

<i>Trouble</i>	<i>Cause</i>	<i>Indications</i>	<i>Remedy</i>
<p><b>II. SYSTEM WILL NOT PRODUCE SUFFICIENT COOLING — Continued</b></p>	<p><b>Mechanical</b></p> <ol style="list-style-type: none"> <li>1. Compressor clutch slipping.</li> <li>2. Obstructed blower discharge passage.</li> <li>3. Clogged air intake filter.</li> <li>4. Outside air vents open.</li> <li>5. Too little air circulation over condenser coils; fins clogged with dirt or bugs.</li> <li>6. Evaporator clogged.</li> </ol>	<ol style="list-style-type: none"> <li>1. Visual inspection.</li> <li>2. Blower operates at high speed but air displacement very small.</li> <li>3. Too little air displacement by blower.</li> <li>4. Too little cooling at high ambient temperature.</li> <li>5. Too little cooling at discharge outlet; excessive high pressure gauge reading; engine temperature usually excessive.</li> <li>6. Fins clogged with lint, dust, or coated with cigarette tars.</li> </ol>	<ol style="list-style-type: none"> <li>1. Remove clutch assembly for service or replacement.</li> <li>2. Examine entire discharge passage for kinks, waddings, or failure to open passage during installation. Correct as necessary.</li> <li>3. Remove air filter screens and service or replace, whichever is necessary.</li> <li>4. Close air vents (adjust controls if necessary).</li> </ol> <p><i>NOTE: Some owners must be instructed on importance of keeping air vents closed when air conditioning unit is in operation.</i></p> <ol style="list-style-type: none"> <li>5. Clean engine radiator and condenser. Install heavy duty fan, fan shroud, or reposition radiator and condenser, whichever is necessary.</li> <li>6. Loosen, pull down, and clean with compressed air. Use cleaning solvent to remove cigarette tars.</li> </ol>
	<p><b>Refrigeration</b></p> <ol style="list-style-type: none"> <li>1. Too little refrigerant in system.</li> </ol>	<ol style="list-style-type: none"> <li>1. Bubbles in sight glass; high gauge readings excessively low.</li> </ol>	<ol style="list-style-type: none"> <li>1. Recharge system until bubbles disappear and gauge readings stabilize to specifications (see page 69).</li> </ol>

**TROUBLESHOOTING CUSTOMER COMPLAINTS—Continued**

<i>Trouble</i>	<i>Cause</i>	<i>Indications</i>	<i>Remedy</i>
<p><b>II. SYSTEM WILL NOT PRODUCE SUFFICIENT COOLING — Continued</b></p>	<p><b>Refrigeration — Continued</b></p> <p>2. Clogged screen in expansion valve.</p> <p>3. Expansion valve thermal bulb has lost charge.</p> <p>4. Clogged screen in receiver-drier.</p> <p>5. Thermostat defective or improperly adjusted.</p>	<p>2. Gauge pressures may be normal or may show slightly increased head pressure and low suction pressure; discharge output temperature higher than specified.</p> <p>3. Excessively high or low gauge readings; may cool in excess or not enough.</p> <p>4. High pressure gauge usually higher than normal; low pressure gauge lower than normal; receiver cold to touch and may frost.</p> <p>5. Low gauge reading high; clutch cycles at too high a reading.</p>	<p>2. Bleed system, remove screen, clean and replace (see page 85).</p> <p>3. Bleed system; replace expansion valve.</p> <p>4. Bleed system; replace receiver-drier.</p> <p>5. Adjust or replace thermostat.</p>

## TROUBLESHOOTING CUSTOMER COMPLAINTS—Continued

Trouble	Cause	Indications	Remedy	
<b>III. SYSTEM COOLS INTERMITTENTLY</b>	<b>Electrical</b>			
	<ol style="list-style-type: none"> <li>1. Defective circuit breaker, blower switch, or blower motor.</li> <li>2. Partial open, improper ground, or loose connection in compressor clutch coil or solenoid.</li> </ol>	<ol style="list-style-type: none"> <li>1. Electrical units operate intermittently.</li> <li>2. Clutch disengages prematurely during operation.</li> </ol>	<ol style="list-style-type: none"> <li>1. Remove defective part for service or replacement.</li> <li>2. Check connections or remove clutch coil or solenoid for service or replacement.</li> </ol>	
	<b>Mechanical</b>			
	<ol style="list-style-type: none"> <li>1. Compressor clutch slipping.</li> </ol>	<ol style="list-style-type: none"> <li>1. Visual inspection; operates until head pressure builds up (as viewed on high pressure gauge) at which time clutch begins slipping; may or may not be noisy.</li> </ol>	<ol style="list-style-type: none"> <li>1. Slippage over a prolonged period will require that clutch be removed for service; may require readjustment for proper spacing.</li> </ol>	
	<b>Refrigeration</b>			
	<ol style="list-style-type: none"> <li>1. Unit icing up may be caused by excessive moisture in system, incorrect super heat adjustment in expansion valve, or thermostat adjusted too low.</li> <li>2. Thermostat defective.</li> </ol>	<ol style="list-style-type: none"> <li>1. Unit ices up intermittently. <i>NOTE: Any unit will ice up under certain conditions of refrigerant temperature, humidity, and ambient temperature.</i></li> <li>2. Low side pressure may be low or excessively high; adjustments will not correct.</li> </ol>	<ol style="list-style-type: none"> <li>1. Replace expansion valve; replace dehydrator if excess moisture present; adjust thermostat.</li> <li>2. Replace thermostat.</li> </ol>	

**TROUBLESHOOTING CUSTOMER COMPLAINTS—Continued**

<i>Trouble</i>	<i>Cause</i>	<i>Indications</i>	<i>Remedy</i>
<p><b>IV. SYSTEM TOO NOISY</b></p>	<p><b>Electrical</b></p> <ol style="list-style-type: none"> <li>1. Defective winding or improper connection in compressor clutch coil or solenoid.</li> </ol> <p><b>Mechanical</b></p> <ol style="list-style-type: none"> <li>1. Loose or excessively worn drive belts.</li> <li>2. Noisy clutch.</li> <li>3. Compressor noisy.</li> <li>4. Loose panels.</li> <li>5. Compressor oil level low.</li> <li>6. Blower fan noisy; excessive wear in blower motor.</li> <li>7. Idler pulley and bearing defective.</li> </ol> <p><b>Refrigeration</b></p> <ol style="list-style-type: none"> <li>1. Excessive charge in system.</li> <li>2. Low charge in system.</li> <li>3. Excessive moisture in system.</li> <li>4. High pressure service valve closed.</li> </ol>	<ol style="list-style-type: none"> <li>1. Visual inspection; solenoid or clutch vibrates.</li> <li>1. Belts slip and are noisy.</li> <li>2. May or may not slip; noisy when engaged.</li> <li>3. Loose mountings; worn parts inside compressor.</li> <li>4. Excessive rattles during operation.</li> <li>5. Compressor noisy and lower portion hot to touch.</li> <li>6. Blower motor noisy.</li> <li>7. Whining or growling noise during operation; pulley has rough feel when rotated by hand.</li> <li>1. Rumbling noise or vibration in high pressure line; thumping noise in compressor; excessive head pressure and suction pressure; bubbles in sight glass.</li> <li>2. Hissing in evaporator case at expansion valve; bubbles or cloudiness in sight glass; low head pressure.</li> <li>3. Expansion valve noisy; suction pressure low.</li> <li>4. Compressor has excessive knocking noise; high pressure gauge reads above normal.</li> </ol>	<ol style="list-style-type: none"> <li>1. Replace or repair as necessary</li> <li>1. Tighten or replace as required.</li> <li>2. Remove clutch for service or replacement as necessary.</li> <li>3. Check mountings and repair; remove compressor for service or replacement.</li> <li>4. Check and tighten all panels, hose holddown clamps, or rubbing or vibrations of hoses or pipes.</li> <li>5. Fill with correct specified oil.</li> <li>6. Remove blower motor for service or replacement as necessary.</li> <li>7. Replace bearing; inspect idler and pulley as may be worn excessively.</li> <li>1. Discharge excess refrigerant until high pressure gauge drops within specifications (see page 59, Step C).</li> <li>2. Check system for leaks; charge system (page 83).</li> <li>3. Replace dehydrator; evacuate and charge system.</li> <li>4. Open valve immediately.</li> </ol>

## DIAGNOSTIC CHART

The diagnostic chart can help to understand how different conditions can affect the entire system. The chart gives symptoms that normally are associated with the conditions that are listed.

Use the Troubleshooting Charts and the Flow Charts For Diagnosing the System to locate the source of a problem and systematically examine and repair the problem.

DIAGNOSTIC CHART FOR AIR CONDITIONING SYSTEM

Condition	Low Side Pressure	High Side Pressure	Sight Glass	Suction Line	Receiver-Drier	Liquid Line	Discharge Line	Discharge Air
LACK OF R-12	Very low	Very low	Clear	Slightly cool	Slightly warm	Slightly warm	Slightly warm	Warm
LOSS OF R-12	Low	Low	Bubbles	Cool	Warm to hot	Warm	Warm to hot	Slightly cool
COMPRESSOR FAILURE	High	Low	Clear	Cool	Warm	Warm	Warm	Slightly cool
CONDENSER MALFUNCTION	High	High	Clear to occasional bubbles	Slightly cool to warm	Hot	Hot	Hot	Warm
EXPANSION VALVE STUCK OPEN	High	High or Normal	Clear	Cold — sweating or frosting heavily	Warm	Warm	Hot	Slightly cool
EXPANSION VALVE STUCK CLOSED	Low	Low	Clear	Cold — sweating or frosting heavily at valve inlet	Warm	Warm	Hot	Slightly cool
RESTRICTION BETWEEN CONDENSER AND EXPANSION VALVE	Low	Low	Clear	Cool	Cool or sweating or frosting	Cool or sweating or frosting	Hot to point of restriction	Slightly cool
RESTRICTION BETWEEN COMPRESSOR AND CONDENSER	High	High normal or low	Clear	Slightly cool to warm	Warm or hot	Warm or hot	Hot	Warm
NORMAL	Normal	Normal	Clear	Cool possible light sweat	Warm	Warm	Hot	Cool (specification on page 62)

**FLOW CHARTS FOR DIAGNOSING THE SYSTEM**

The following charts are designed to acquaint the air conditioning technician with gauges as diagnostic instruments.

However, before attaching the pressure gauges, make sure other problems that are easier to repair, have been checked first. See the discussion on Troubleshooting Customer Complaints on page 47.

If the gauges must be installed (see page 65 for installation procedure), and the problem is not discovered using the charts on the preceding pages, use the following flow charts to determine the cause of a malfunction. Each flow chart begins with an abnormal pressure gauge reading that could be expected if the air conditioning system operates improperly.

After installing the gauges (page 65), determine what the normal pressure should be. Normal pressures will vary depending on the ambient temperature (see discussion and chart on page 45). If pressures are not normal, refer to the appropriate flow chart that matches the gauge readings:

- Condition No. 1 LOW SIDE — low or vacuum, HIGH SIDE — normal or low (page 55).
- Condition No. 2 LOW SIDE — normal or high, HIGH SIDE — High (page 58).
- Condition No. 3 LOW SIDE — normal, HIGH SIDE — normal; system still not providing sufficient cooling (page 61).
- Condition No. 4 LOW SIDE — high, HIGH SIDE — low (page 64).

NOTE: For more specific diagnostic procedures, follow recommendations and specifications from the manufacturer as provided in the technical manual.

**CONDITION NO. 1**

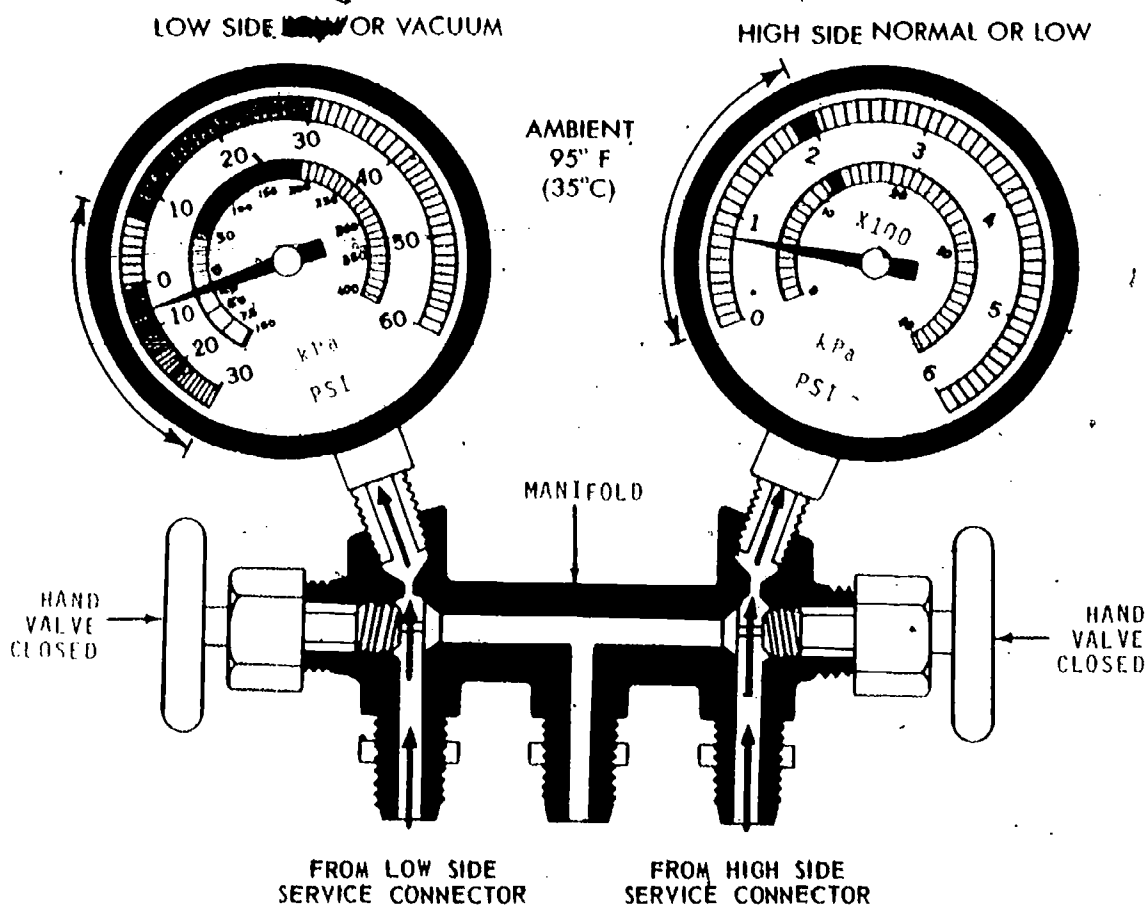

Fig. 52 — Condition No. 1

X7788

**INSPECTION**

LOW SIDE — Low or vacuum

HIGH SIDE — Normal or low

**Step A.** Check for:

- inoperative blower motor
- dirty air filter

**REPAIR**

**Step A.**

1. Clean or repair.
2. Recheck pressure. If no change go to step B, INSPECTION.



### INSPECTION

#### Step B. Check for restrictions:

- between condenser and receiver-drier
- at receiver-drier
- between receiver-drier and expansion valve
- at expansion valve  
(inlet screen partially clogged)
- between evaporator and compressor

#### Step C. Inspect evaporator outlet pipe for frost.

#### Step D. Check pressure readings.

### REPAIR

#### Step B.

1. Remove thermal fuse (if so equipped) from clutch lead.
2. Connect a jumper wire between power and clutch terminals to test thermal fuse.
3. Replace fuse if it is faulty.
4. Operate engine at 2000 rpm, with compressor operating for three minutes. Blower on HIGH.
5. Check for frost on upper end of expansion valve just before the valve outlet connection (see Fig. 57).
  - If frost is present, proceed to line 6 of step B, REPAIR.
  - If no frost, go to step C, INSPECTION.
6. Inspect line from condenser to expansion valve for frost or temperature change (temperature change indicates a restriction).
  - If frost or temperature change is present, repair restriction and recheck pressure.
  - If no frost, or temperature change, go to step E, INSPECTION.

#### Step C.

- If frost is present to go step D, INSPECTION.
  - If no frost:
1. Inspect the lines between evaporator and compressor for points where frost starts to accumulate or temperature changes. A slight temperature change usually indicates a restriction.
    - If frost or temperature change, repair restriction and recheck pressures.
    - If no frost or temperature change, go to step E, INSPECTION.

#### Step D.

1. With compressor OFF, open vehicle doors for three minutes.
2. Close doors, start engine (2000 rpm), compressor ON for two minutes.
  - If pressures are normal; there appears to be moisture in the system.
  - If pressure is low, go to step E, INSPECTION.

**INSPECTION**

**Step E.**

Check for partially clogged inlet screen on expansion valve or low gas charge in thermal bulb.

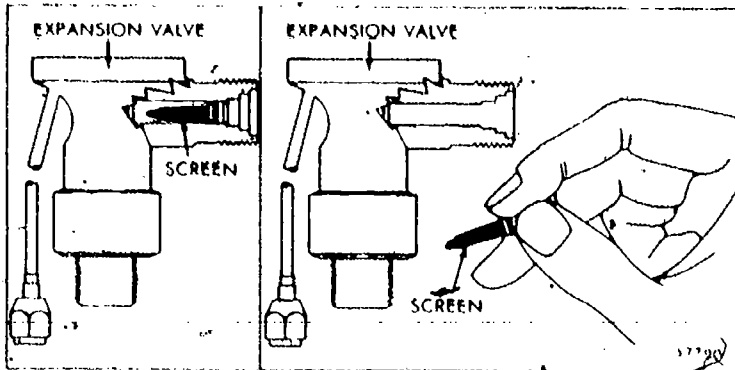

Fig. 53 — Inspect Inlet Screen

**REPAIR**

**Step E.**

1. Discharge system (see page 85).
2. Remove expansion valve inlet screen for inspection (Fig. 53).
  - If screen is dirty:
    1. clean screen and reinstall.
    2. flush line between receiver-drier and expansion valve.
    3. install a new receiver-drier.
    4. Add appropriate amount of refrigerant oil.
  - If screen is not dirty:
    1. replace expansion valve.
    2. do not replace receiver-drier unless it is more than two years old.
3. Connect all components and purge system (see page 87).
4. Evacuate system (see page 88).
5. Charge system with Refrigerant-12 (see page 90).

CONDITION NO. 2

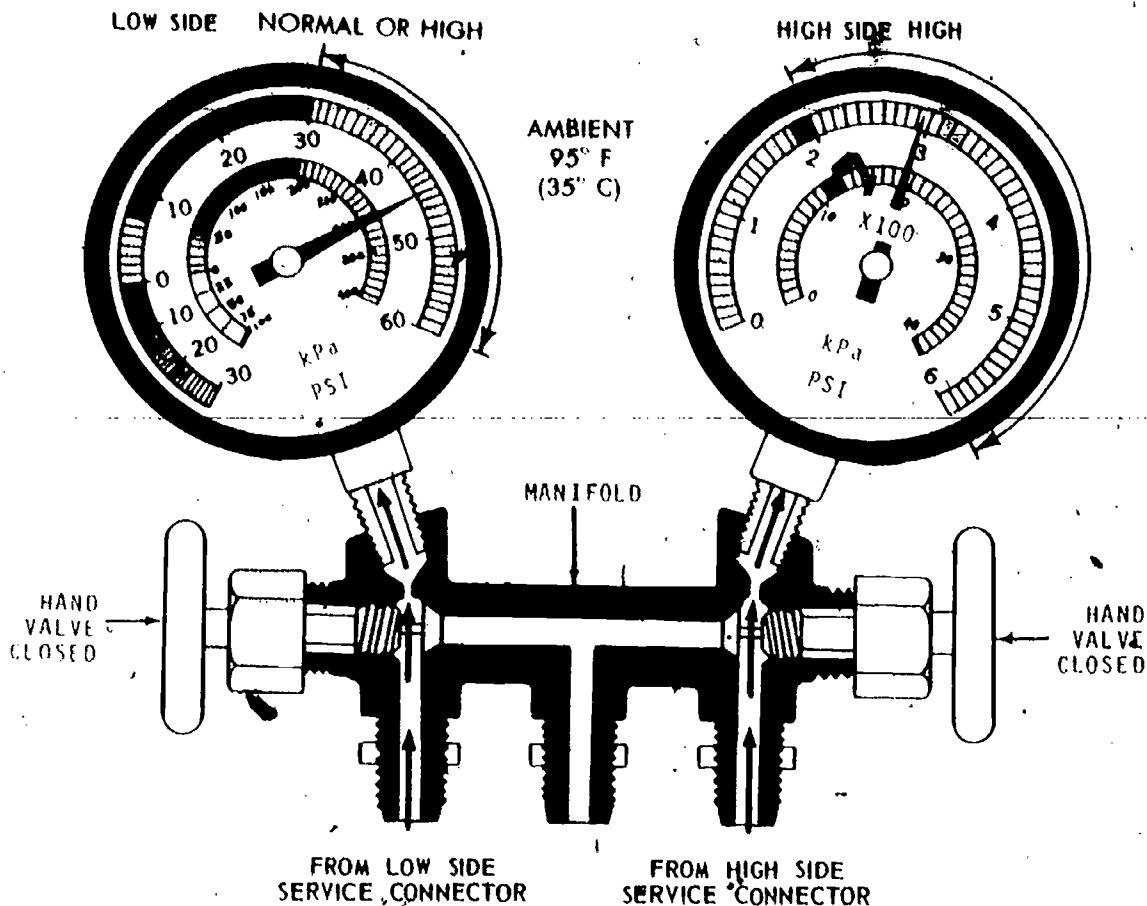

X7791

Fig. 54 — Condition No. 2

INSPECTION

LOW SIDE — Normal or high

HIGH SIDE — High

NOTE: No bubbles in sight glass.

Step A. Check for restricted air flow through condenser or radiator.

REPAIR

Step A. Clean out condenser or radiator (Fig. 55). Then check pressure gauges. If no change, go to step B, INSPECTION.

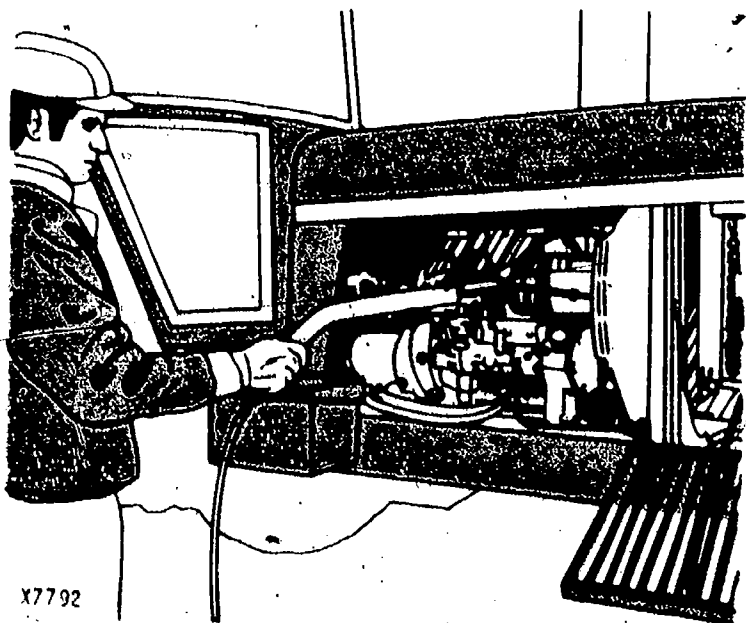

X7792

Fig. 55 — Clean Condenser And Radiator

**INSPECTION**

**Step B.** Check for loose or corroded thermal bulb.

**Step C.** Check for system overcharged with Refrigerant-12.

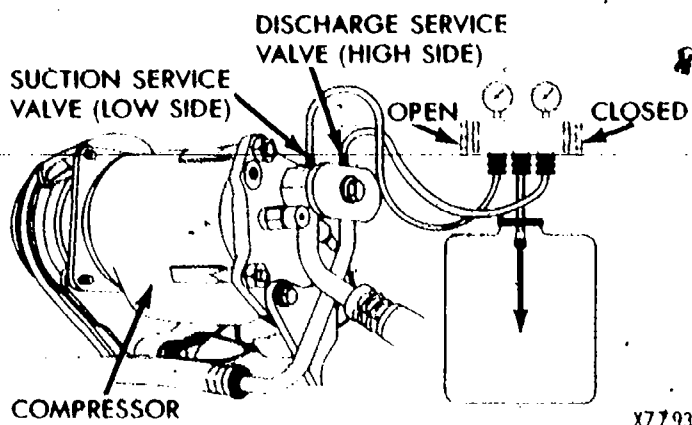

Fig 56 — Discharge R-12 From Center Hose

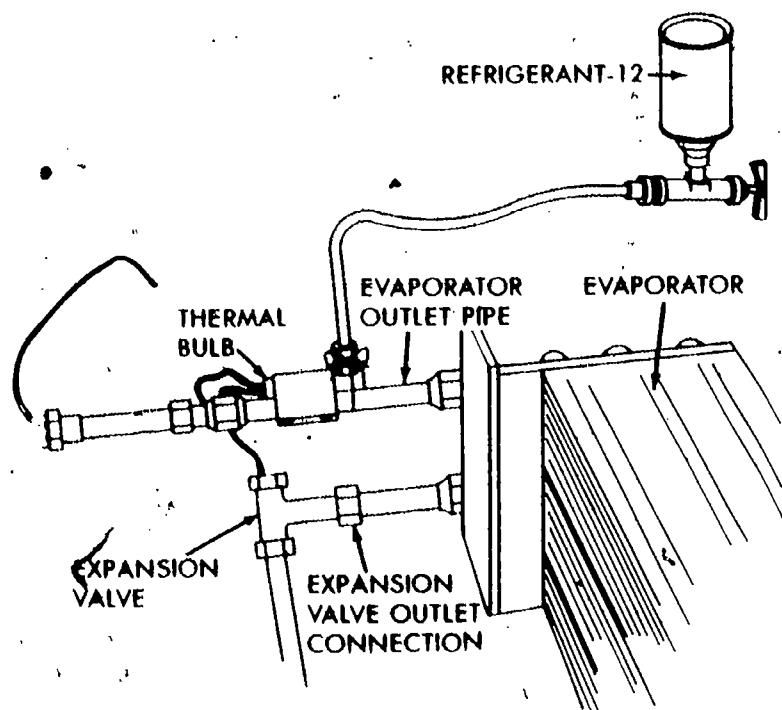

Fig 57 — Tie Hose From R-12 To Thermal Bulb

**Step D.** Expansion valve is sticking. Replace expansion valve.

**REPAIR**

**Step B.**

1. Repair.
2. If not loose or corroded, go to step C, INSPECTION.

**Step C.**

1. Compressor operating, engine at 2000 rpm.
2. Open low side manifold gauge valve to discharge Refrigerant-12 at a slow rate from the center hose of the manifold (Fig. 56).
3. Observe sight glass until bubbles appear. Then close low side valve.
4. a. If pressures are normal, add Refrigerant-12 until fully charged (see page 69 for procedure). Then go to step D, INSPECTION.
- b. If high side pressure is high, connect a hose to a can of Refrigerant-12. Tie open end of hose to thermal bulb (Fig. 57). Open valve on can of Refrigerant-12 1 1/2 turn. Invert can for 10-15 seconds. Close valve and observe low side pressure gauge for a decrease in pressure.

**CAUTION: Wear goggles and stand on opposite side of vehicle to avoid contact with liquid Refrigerant-12.**

- If pressure did not decrease, go to step D, INSPECTION.
- If pressure did decrease, skip to step E, INSPECTION.

**Step D.**

1. Discharge system (see page 85).
2. Remove expansion valve inlet hose and remove screen for inspection.
  - If screen is dirty:
    1. flush line between receiver-drier and expansion valve.

**INSPECTION**

**Step D. (continued)**

**Step E.** Check for expansion valve intermittently sticking open or for air in system.

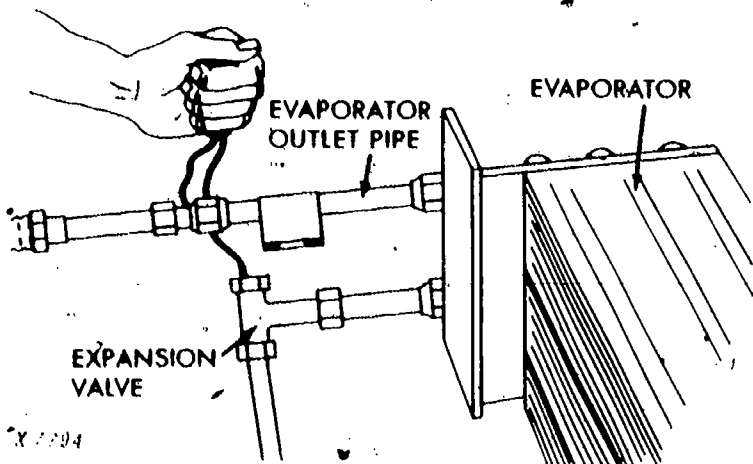

Fig. 58 — Warm Up Thermal Bulb With Hand

**Step F.** Remove air from the system.

**REPAIR**

**Step D. (continued)**

2. replace receiver-drier.
3. add .75 oz. (22 mL) of refrigerant oil (see page 73-74).
  - If screen is clean do not replace receiver-drier unless it is more than two years old.
3. Install a new expansion valve and connect all components.
4. Evacuate system (see pages 88-89).
5. Charge system with Refrigerant-12 (see page 69).
6. Recheck pressures (see chart on page 45).

**Step E.**

1. Remove thermal bulb from outlet pipe of evaporator.
2. Place bulb in palm of hand and close fingers around bulb to warm it for one minute (Fig. 58).
3. Check gauges for increase in pressure.
4. Reattach bulb after testing or repair.
5. Repeat procedure from step C, line 4b, REPAIR.
  - If pressure increases after line 3 and decreases after line 5, go to step F, INSPECTION.
  - If pressure does not always change, go back to step D, INSPECTION.

**Step F.**

1. Discharge system (see page 85).
2. Evacuate system (see pages 88-89).
3. Charge system with Refrigerant-12 (see page 69).
4. Recheck pressures.

CONDITION NO. 3

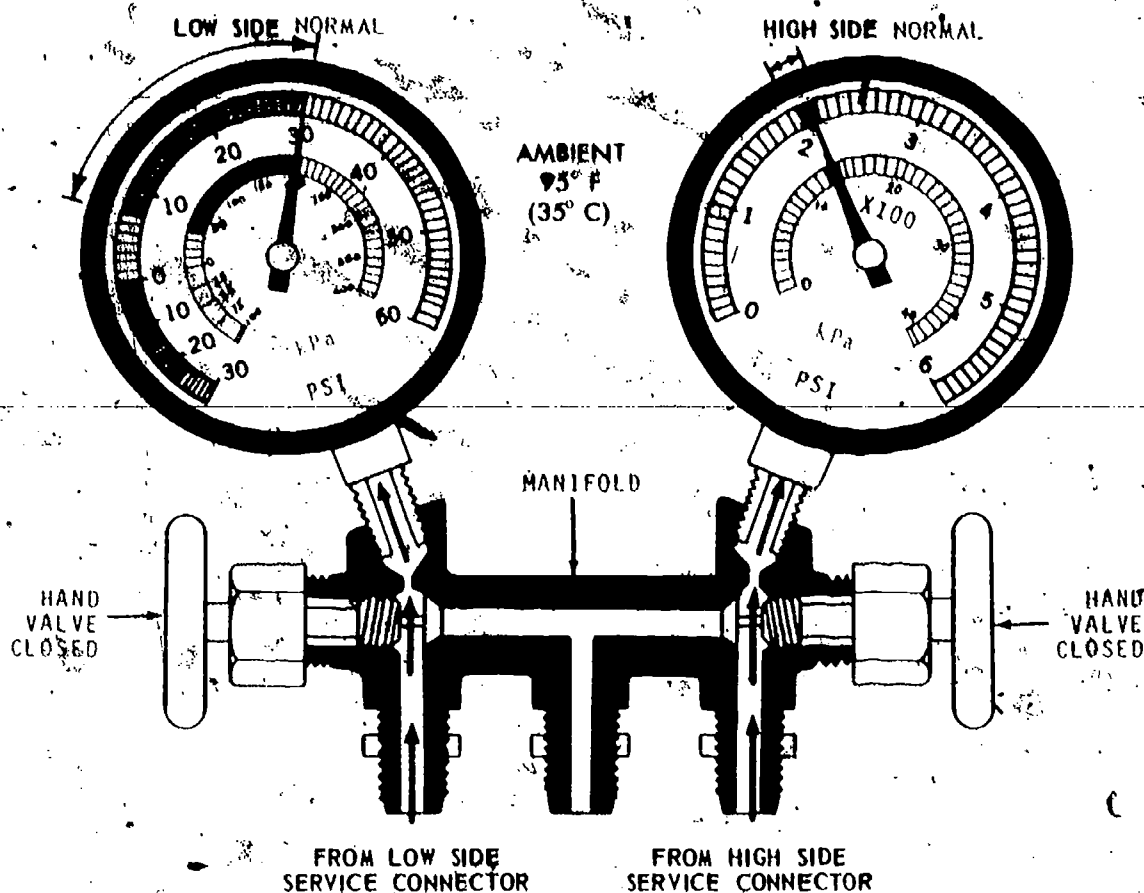

Fig. 59 — Condition No. 3

INSPECTION

LOW SIDE — Normal

HIGH SIDE — Normal

NOTE: Although pressures are normal, system still may not provide sufficient cooling.

Step A. Run engine at 2000 rpm for at least ten minutes.

Operate compressor.

Inspect low side line from evaporator to compressor for frost.

Step B. Check temperature drop.

REPAIR

Step A.

- If frost is present, inspect thermal bulb. If loose or corroded, repair — then go to step B, INSPECTION.
- If no frost, go to step B, INSPECTION.

Step B.

1. Run engine at 2000 rpm and operate compressor.
2. Place thermometer in blower air duct with blower switch at HIGH (Fig. 60).
3. After at least 20 minutes of operation with doors closed, note air duct temperature.

See next page for minimum specification.

**INSPECTION**

**Step B. (continued)**

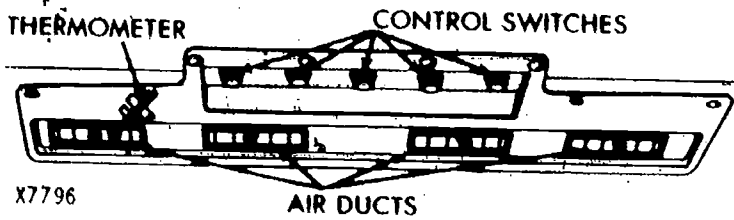

Fig. 60 — Place Thermometer In Air Duct

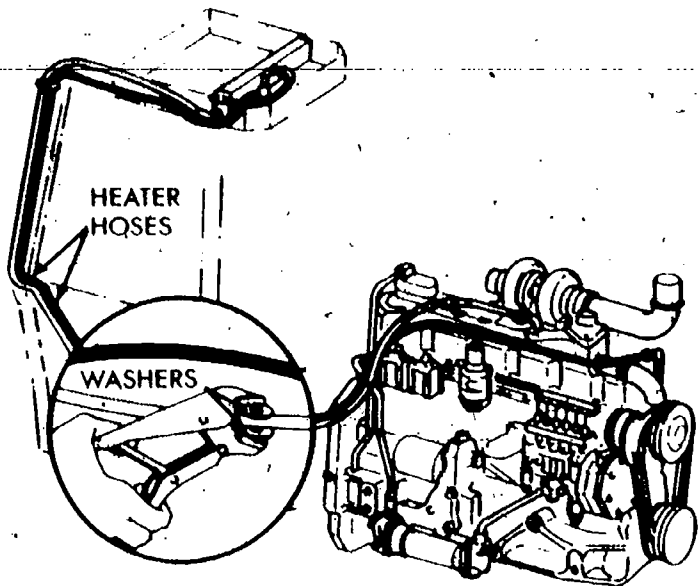

Fig. 61 — Crimp Heater Hose Shut

**Step C.** Check doors, windows, and seams for leaks.

**Step D.** If no leaks are found in step C, lack of cooling could be caused by dirty components. Check the following:

- recirculating filter
- blower air duct and fan cage
- condenser
- radiator
- evaporator

**Step E:** If components in step D were not dirty, check for temperature change in high side lines.

**REPAIR**

**Step B. (continued)**

**3. Minimum specification:**

Ambient Temp.	Air Duct Temp.
below 75°F (24°C)	20°F (-7°C)
75-90°F (24-32°C)	25°F (-4°C)
above 90°F (32°C)	30°F (-1°C)

- If within specification go to step F, INSPECTION.
- If not within specification, go to next part 4, REPAIR.

**4.** Use two flat washers to crimp a heater hose shut with locking pliers (Fig. 61).

**5.** Repeat temperature drop check as in step B, 1-3 REPAIR.

- If within specification it means that either the heater valve is leaking internally or the heater hoses are reversed.

Repair either condition then again repeat temperature drop check in step B, 1-3 REPAIR.

- If not within specification, go to next step C, INSPECTION.

**Step C.** Repair any leaks and repeat temperature drop check in step B, 1-3, REPAIR.

**Step D.** Clean dirty components and repeat temperature drop check in step B, 1-3, REPAIR.

**Step E.**

1. Run engine at 2000 rpm with compressor operating:

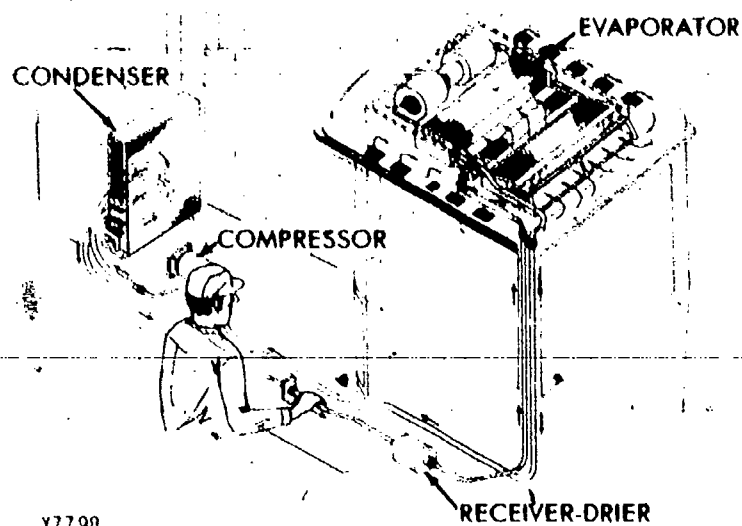
**INSPECTION****Step E. (continued)**

X7798

Fig. 62 — Feel Along High Side Line

**Step F. Check clutch cycle time.**

If the system checks out to be normal at this step, but still there is a lack of cooling, suspect that there is moisture in the system. See page 11 for instructions on removing moisture from system.

**REPAIR****Step E. (continued)**

2. Feel along entire length of high side line (Fig. 62) from compressor to expansion valve for change in temperature. Always check for a temperature change in the normal direction of Refrigerant-12 flow.

**NOTE:** Tubing may be dented, kinked, or internally blocked, restricting flow of Refrigerant-12.

**CAUTION:** High side line is normally hot.

- No temperature change means no restriction — go to next step F, INSPECTION.
- If a temperature change, repair restriction, then recheck pressures (see chart or page 45).

**Step F. See manufacturer's technical manual for testing procedure.**



CONDITION NO. 4

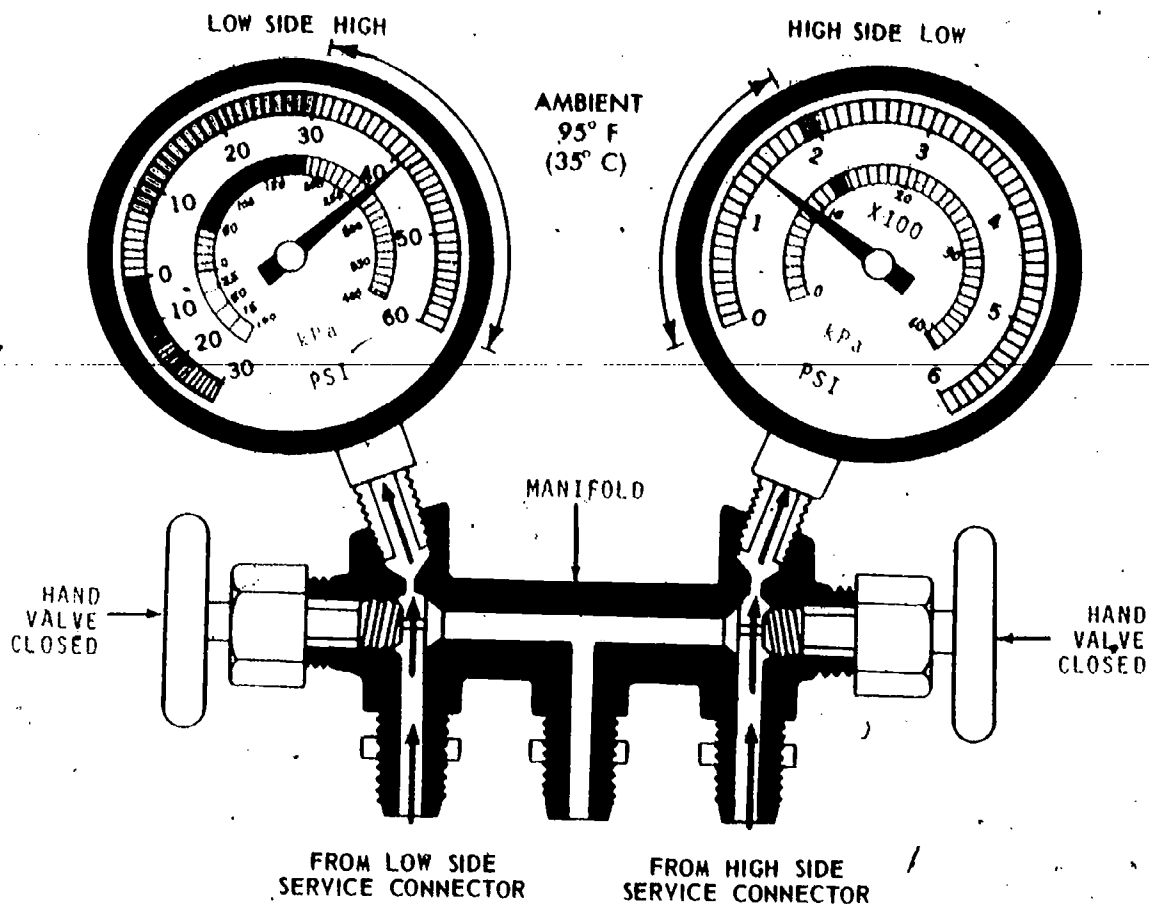

Fig. 63 — Condition No. 4

INSPECTION

- LOW SIDE — High
- HIGH SIDE — Low

Step A. Clutch not engaging or belt slipping.

Step B. Clutch slipping.

REPAIR

Step A. Repair and recheck pressure.

Step B. Repair

NOTE: Repair requires discharging, evacuation and charging.

TEST YOURSELF

QUESTIONS

1. If the air conditioning system produces no cooling, generally what types of possible causes for the problem should be inspected first?
2. List at least four symptoms that would be associated with an expansion valve stuck open.
3. If the expansion valve is sticking open, the low side pressure would be \_\_\_\_\_ and the high side pressure would be \_\_\_\_\_.

(Answers on page 99.)

## TESTING AND ADJUSTING THE SYSTEM/PART 7

The following operational checks and adjustments are performed when testing the system and bringing it to best efficiency. These procedures begin with connecting the gauges into the system and carry the serviceman through adjustment of various controls. For repairs to the system and actual test readings; refer to the manufacturer's Technical Manual. After repairs, always give the system a Performance Test and make the necessary adjustments as given on the following pages.

### INSTALLING GAUGE SET TO CHECK SYSTEM OPERATION

Follow these steps any time it becomes necessary to install test gauges into the system. The service procedures on the following pages require that the gauges be installed into the system. Use only the steps here that are necessary to perform the particular procedure. **CAUTION: Put on a face shield before starting this operation — refrigerant can blind.**

#### Procedure

1. Remove high and low side service valve stem caps.

2. Remove high and low side service connector

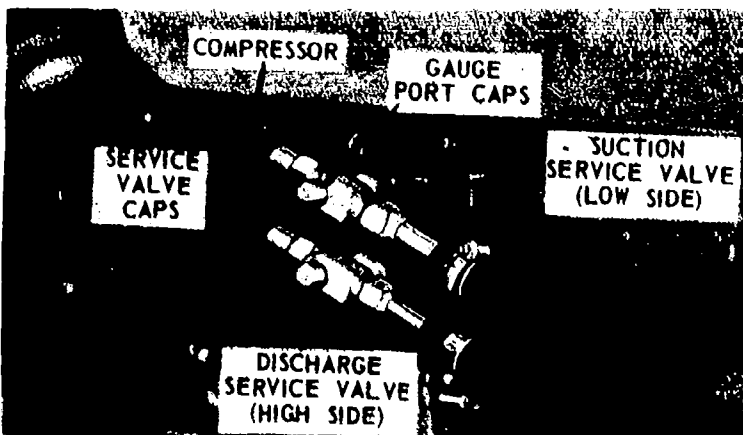

Fig. 64 — Location Of Service Valve Caps  
(Axial Compressor)

3. Connect service gauge hoses to service connectors.

#### Information

1. Use correct size wrench on metal caps.

2. Use pliers on plastic or aluminum caps if necessary.

**CAUTION: Do not break caps.**

1. Remove caps slowly in event refrigerant is leaking past valve seat or Schrader valve.

**NOTE:** Many units have omitted one or both shut-off valves and use a Schrader valve in the connectors to retain refrigerant during operation. Use a Schrader adapter for this type of connector.

#### REMEMBER:

- High side service valve connects to condenser.
- Low side service valve connects to evaporator.
- High side hose below high pressure gauge.
- Low side hose below low pressure gauge.

Procedure

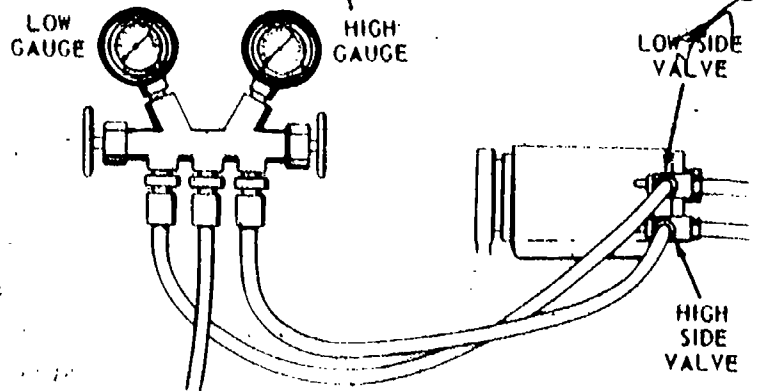

Fig 65 - First Identify and Connect Test Hose into High Side Of System

Information

1. Close service gauge manifold hand valves.
2. Connect hoses from gauges to connectors finger tight.

4. Mid-position service valves.

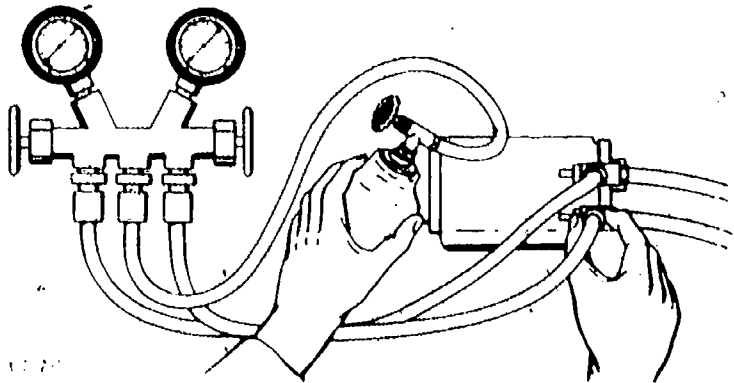

Fig. 66 - Using Refrigerant Container To Purge Air From Test Hoses.

1. Use service valve wrench.
2. Rotate service valve stem clockwise two turns from back-seat position.

**NOTE:** On most installations using a Schrader valve in the service connector, the SERVICE VALVE HAS BEEN ELIMINATED FROM THE SYSTEM. See page 38 for information on Schrader valves.

3. Bleed air from high side hose by cracking high side gauge manifold hand valve for 3 seconds, then close.
4. Repeat with low side hose.

**NOTE:** A better method of bleeding air from test hoses is to use 15-oz. (425-g) can or tank connected to center manifold hose (Fig. 66). Before mid-positioning service valves, loosen hoses at service valve, open valve on can or tank. Open high side manifold valve to bleed high side hose. Repeat with low side. Tighten hoses and continue. On installations using Schrader connector, bleed hose to Schrader adapter before tightening on hose connector.

5. Start engine and adjust to specified rpm (1500-2000 rpm range).

1. Use special throttle linkage adjuster tool or adjust idle speed screw.
2. Allow time for warm-up; if engine is cold, allow at least 15 minutes.
3. Adjust air conditioning controls for maximum cold.

## PERFORMANCE TESTING THE SYSTEM

The Performance Test as outlined in the following steps is a continuation of the *Visual Inspection* and *Operating Inspection* of System as found on page 44 and as referred to elsewhere in this manual. **CAUTION: Put on a face shield before starting this operation.**

### Procedure

1. Performance test the air conditioning system.

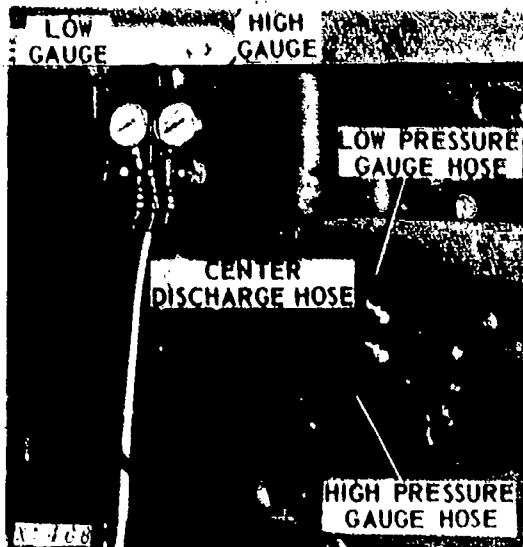

Fig. 67 — Read Low And High Side Gauges To Determine System's Condition

2. Inspect high side of system for hot to warm temperature.
3. Inspect low side of system for excessive sweating or frosting.

4. Test operation of control used on system.

5. Readjust engine idle to specified idle rpm.

6. Back-seat service valves.

### Information

#### NOTE:

- a. Low pressure gauge will normally read from 7 to 30 psi (50-210 kPa).
- b. High pressure gauge will read from 150 to 270 psi (1035-1860 kPa) plus, depending on ambient temperature (page 45) and system under test.
- c. Discharge air from evaporator should feel quite cold. Refer to chart at end of this test.
- d. If pressures are not normal, see Part 6, *Diagnosing The System For Diagnostic Procedures*.

1. Feel entire high side of system for degree of heat; note receiver-drier.

1. Feel and observe lines from evaporator to compressor.

**NOTE:** Too-cold or too-warm lines with a near-normal low side gauge reading means a failed expansion valve.

1. Refer to service procedure for control used.

1. Readjust idle screw.

2. Remove special throttle adjusting tool (if used).

1. Use service valve wrench.

2. Rotate counterclockwise until valves are sealed.

68 Testing And Adjusting

Procedure

7. Remove service gauge hoses from service valves.
8. Replace service valve and service connector caps.
9. Deliver to customer.

Information

1. Disconnect hoses from connectors.
2. Be sure to disconnect adapter from connector using Schrader adapter.
1. Tighten metal caps with wrench to correct torque.
2. Use pliers to tighten plastic or aluminum caps if necessary.

**CAUTION: Do not break caps.**

1. Remove tools and gauges from machine.

The following chart is given as a reference only and will not be exact in all units. Some systems will actually register lower temperatures than those given here due to the construction and installation. Others will not register quite this low for the same reason. These figures are to be used as a guide only in attaining maximum performance for a particular system.

**EFFECT OF TEMPERATURE AND HUMIDITY ON DISCHARGE AIR FROM EVAPORATOR**

Ambient Temperature		Relative Humidity	Discharge Air Temperature			
°F	°C		Evap. Coil		Air Duct	
		%	°F	°C	°F	°C
80	27	50	30	-1	41	5
		60	32	0	42	6
		90	34	1	45	7
90	32	40	32	0	40	4
		50	33	1	43	6
		60	34	1	48	9
100	38	20	31	-1	41	5
		40	33	1	45	7
		50	35	2	50	10

## ADDING REFRIGERANT TO THE SYSTEM

A small refrigerant loss between seasons is to be expected and is accepted as normal. When connecting the gauges into the system, if the serviceman will use a 15-oz. (425-g) can or the refrigerant tank to purge air from the test hoses (see "Installing Gauge Set To Check System Operation," page 65), he will be prepared to add refrigerant should he find the system requires it.

### Procedure

1. Connect manifold hose to refrigerant source.

2. Add Refrigerant-12 to system (Fig. 68).

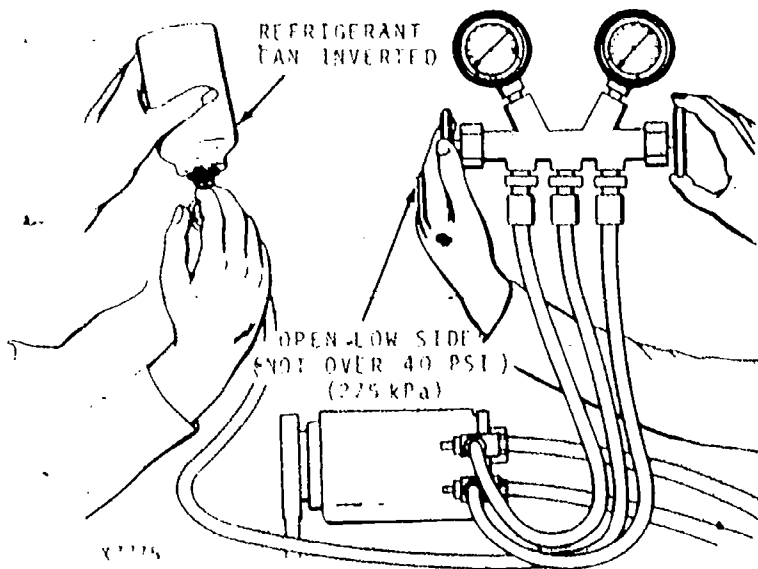

Fig 68 -- Add Refrigerant With System In Operation

### Information

1. Gauges connected into system.
2. System has been stabilized.
3. Gauges and/or sight glass indicate shortage of refrigerant.
4. Connect hose to R-12 source and bleed air from hose.

1. Air conditioning controls set for maximum cooling and engine operating at 1500-2000 rpm.
2. Open low side manifold valve.
3. Use 15-oz. (425-g) refrigerant can as shown and open valve *not to exceed 40 psi (275 kPa)* on low side gauge.

**IMPORTANT:** Be sure that refrigerant enters system only as a VAPOR. Too much liquid entering the compressor can damage internal parts. Be sure to regulate the valve on the container or low side valve so that the low side reading will not exceed 40 psi (275 kPa). This will assure that refrigerant in the hose has vaporized before entering the compressor. Also, the fittings on the low side gauge should feel cold if refrigerant is entering system as a gas.

**IMPORTANT:** Be sure that temperature is 80°F (27°C) or above and that compressor and system is warmed up to aid in vaporizing refrigerant.

**NOTE:** In cool weather [below 80°F (27°C)], heat the refrigerant container, *not above 125°F (52°C)*, to help vaporize the refrigerant before it enters the system.

4. If using 15-oz. (425-g) cans, when one is empty, close shut-off valve on dispensing valve and change cans.

Procedure

3. Check system for full refrigerant charge.

Information

1. Close low side hand manifold valve to check for complete charge.
2. High side gauge will show normal reading of head pressure in relation to ambient temperature.

*(See Pressure-Temperature Relationship chart, page 45 of this manual.)*

3. Low side gauge will normalize at pressures of 7 to 30 psi (50-210 kPa) depending on type control used on system.
4. Sight glass, if used, will be clear of bubbles. Add additional refrigerant only if specified by manufacturer.
5. Close valve on refrigerant container.

4. Continue Performance Test.

1. Check system for leaks.
2. Repair system if gauges did not normalize.
3. Deliver to customer if no further repairs are necessary.

## VOLUMETRIC TEST OF COMPRESSOR

This test will tell if the compressor is faulty and needs to be replaced.

### Procedure

1. Stabilize system at specified rpm (1500-2000 range).
2. Shut off engine.
3. Discharge system of refrigerant.
4. Isolate compressor from system.
5. Remove compressor.
6. Prepare compressor for testing.

### Information

1. Adjust air conditioning controls for maximum cooling.
2. Operate 10 to 15 minutes.
  1. Return to idle speed as specified.
  2. Shut off engine.
  3. Leak test the compressor.
    1. Crack valve slightly, as too rapid a release of refrigerant will carry oil out with it.
    2. Open high side gauge manifold shut-off valve until pressure bleeds off.
    3. Open low side gauge manifold shut-off valve until balance of pressure bleeds off.
    4. Close both shut-off valves.
      1. Remove refrigerant valves from compressor.
      2. Cover compressor openings immediately with a cover plate to protect O-rings and prevent dirt and moisture from entering.
      3. Plug the open ends of high and low side hoses when disconnected from compressor.
        1. Disconnect clutch coil wires and remove the compressor drive belt.
        2. Drain and measure oil from compressor.
        3. Add back at least 1 oz. (30 mL) of oil to the compressor before performing volumetric efficiency test. Tip compressor side-to-side and front-to-rear before mounting in vise.
          1. Mount compressor in vise with oil reservoir up.
          2. Inspect outside of compressor for damage.
          3. Rotate clutch hub by hand with low and high side ports open. If compressor does not rotate satisfactorily replace compressor.
          4. Install a test plate adapter over low and high side ports (Fig. 69).

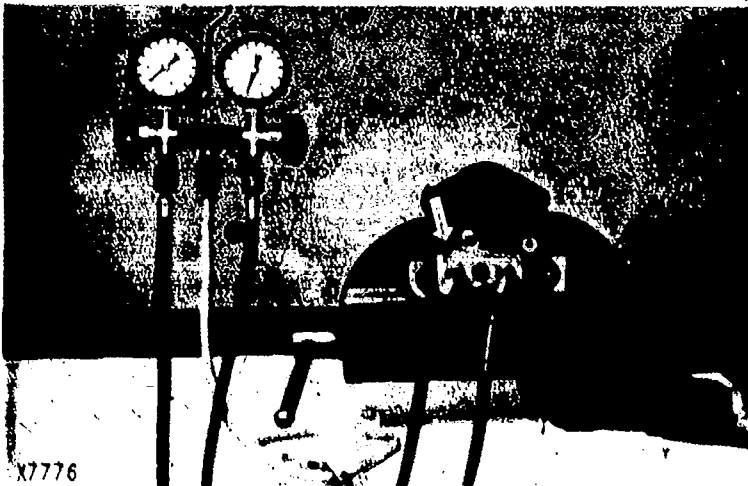

Fig. 69 — Test Plate Adapter Installed



## Procedure

7. Connect pressure gauge hoses to adapter — low pressure gauge hose to discharge fitting high pressure hose to other fitting.

**NOTE:** Low pressure hose connected to discharge adapter so that pressure reading during testing can be read more easily.

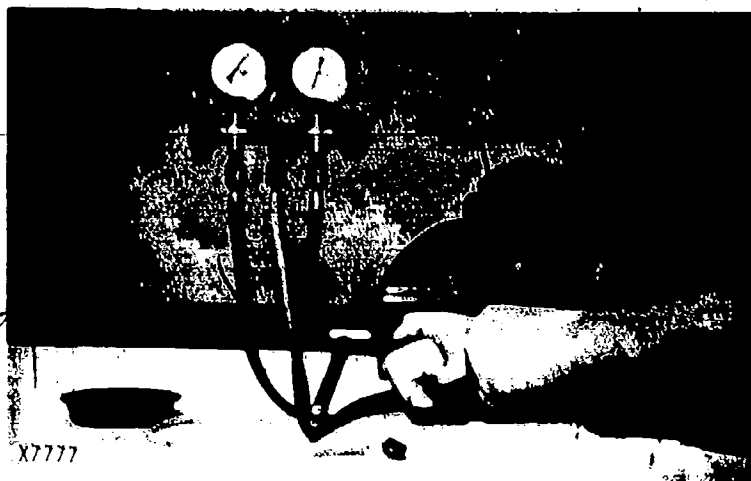

Fig 70 -- Rotate Compressor Clutch Hub

## SHAFT SEAL LEAK TEST

## Procedure

1. With adapter test plate and pressure gauges still attached, connect a 15-oz. (450-g) can of Refrigerant-12 to charging hose of manifold (Fig. 71).

**NOTE:** Attach high pressure gauge to discharge port and low pressure gauge to suction port.

2. Check for leakage from shaft seal and compressor end plate.

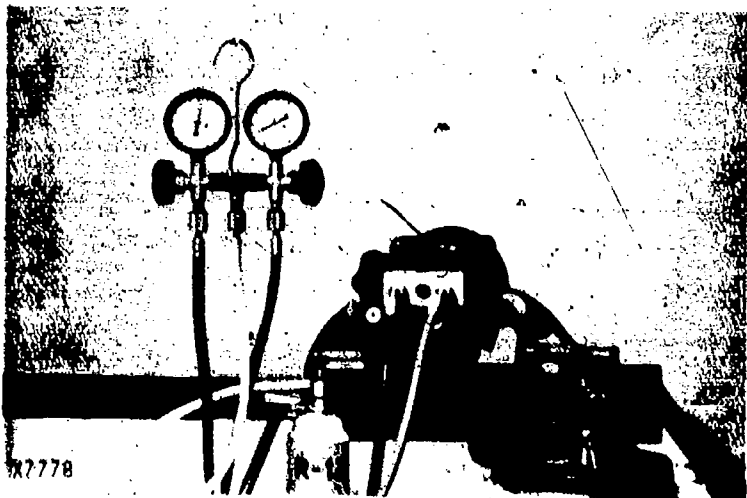

Fig 71 -- Connect Can Of Refrigerant-12 To Center Hose

## Information

1. Rotate compressor approximately 25 times with both manifold hand valves open.
2. Close low pressure gauge valve and open high pressure gauge valve.
3. Use a socket and speed handle (Fig. 70) to rotate the compressor clutch hub ten times at a rate of one revolution per second.
4. Pressure gauge should read 60 psi (415 kPa) or higher. A lower reading indicates one or more suction or discharge valves are leaking, an internal leak, or an inoperative valve. The compressor should be replaced under these conditions.

**NOTE:** Specification for remanufactured compressor is 40 psi (275 kPa).

5. If compressor is serviceable, perform shaft seal leak test.

## Information

1. Open both manifold hand valves.
2. Open valve on refrigerant container and pressurize compressor to can pressure, or 60 psi (415 kPa) minimum.

1. If there is end plate leakage, replace the compressor. If there is shaft seal leakage, replace shaft seal assembly.
2. Close valve on refrigerant container bleed pressure from compressor, and remove test plate.
3. Add correct amount of oil to compressor (see pages 73-74) and reinstall the compressor.

**IMPORTANT:** When compressor is removed from vehicle, do not stand on the clutch or damage may result.

## CHECKING AND ADDING OIL TO AXIAL PISTON COMPRESSORS

Some axial piston compressors have no provision to accurately check oil level. Periodic inspection of oil level has therefore been eliminated from installations using this compressor. Oil level check, performed with the compressor removed from the vehicle, is to be made in conditions of severe oil loss caused by a compressor seal leak, broken refrigerant hose, or rupture from damage. The check is also necessary when one or more components are replaced and the system is not flushed.

The affinity of R-12 and refrigeration oil and the design of this compressor will prevent the full oil charge being contained in the compressor. Allow for oil distribution as outlined at the end of this procedure.

### Procedure

1. Bleed refrigerant from system.
2. Remove compressor.
3. Remove oil from compressor into clean container.

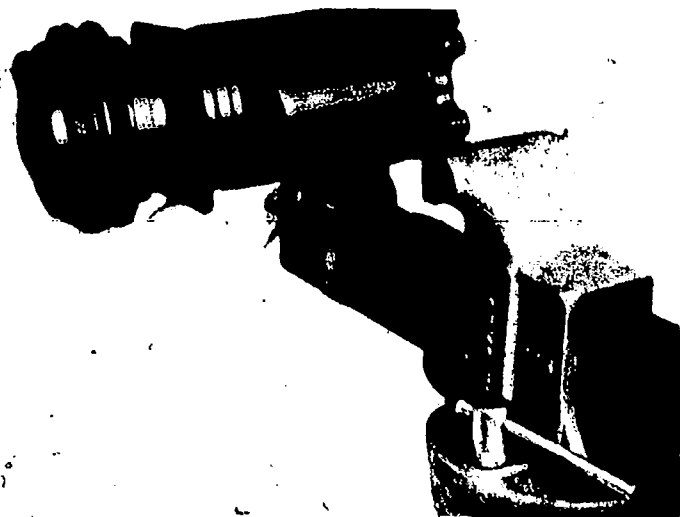

Fig 72 -- Pour Oil Into Container

4. Measure oil from compressor.
5. Install NEW approved-viscosity oil in compressor (if the system or compressor was flushed).

### Information

1. Service valves often not present on installations using this compressor.
2. Follow procedure on page 85 to bleed refrigerant.
1. Follow procedure as necessary for make and year of model.
1. Remove plug from oil sump.
2. Pour oil from compressor into container calibrated in ounces (or milliliters). See Fig. 72.

1. Determine quantity of oil in compressor.
2. Refer to machine technical manual for amount of oil required to return oil level to full.

**NOTE:** When installing a new compressor without flushing the system, drain the compressor to the recommended level. This will avoid an overcharge of oil when oil in the new compressor mixes with oil already in the system.

1. Discard old oil removed from compressor.
2. Clean the container used to measure oil.
3. Measure out required amount of oil into clean container.

## CHECKING AND ADDING OIL TO RECIPROCATING PISTON COMPRESSORS

This check should be made anytime refrigerant has been added or replaced.

Under normal conditions the oil level need not be checked. There is no place for the oil to go except inside the sealed system. When the engine is first started, some of the oil will be pumped into the rest of the system. After 15 minutes of operation, most of the oil is returned to the compressor crankcase.

Oil circulates with the refrigerant to not only lubricate the compressor, but to lubricate the working parts of the expansion valve as well.

### Procedure

### Information

1. Stabilize system at 1500-2000 rpm as specified.

1. Gauges connected into system.
2. Adjust controls to maximum cooling.
3. Operate 10 to 15 minutes.

2. Isolate compressor from system.

1. Refer to page 93, "Isolating Compressor From System."

OR:

2A. Bleed system of refrigerant.

1. Systems not having service valves must be drained of refrigerant before oil level may be checked.

3. Remove oil check plug.

1. If service valves are used, bleed compressor charge through low side manifold hand valve.
2. Remove cap after low side gauge reads zero pressure.

4. Check oil level.

1. Use correct dipstick.
2. Refer to technical manual to determine correct oil level.
3. Add refrigeration oil of approved viscosity to bring to correct level.

**CAUTION: Store Refrigeration Oil In Air-Tight Container.**

5. Place unit in service and continue testing.

1. Replace oil check plug and purge air from compressor.
2. Open service valves to mid-position.

OR:

1. Evacuate system with suitable vacuum pump.
2. Charge system with new Refrigerant-12.

## Procedure

6. Install compressor
7. Install NEW approved-viscosity oil in compressor (if one or more of the components are replaced and the system not flushed).

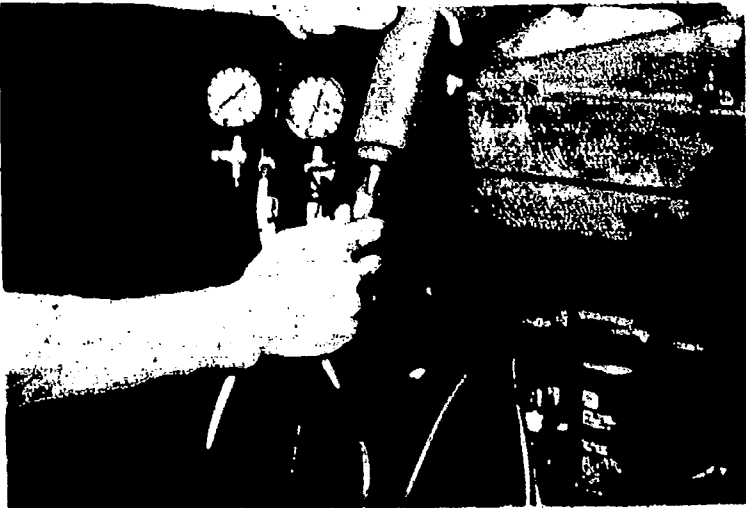

Fig. 73 — Add Oil Into Suction Test Hose

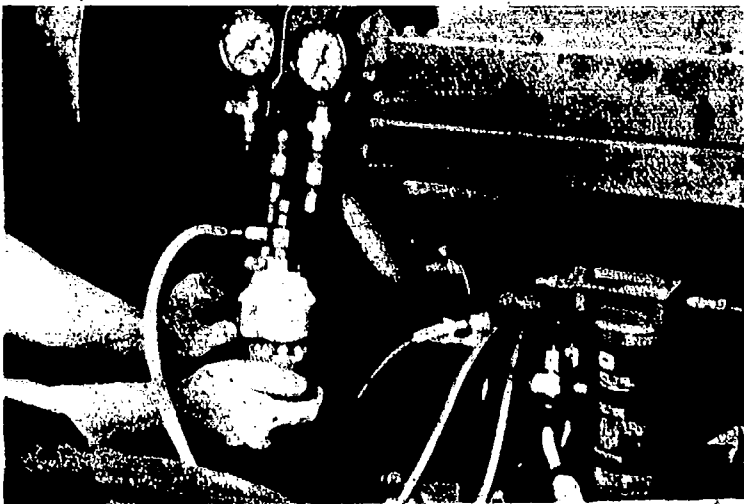

Fig. 74 — Add R-12 Through Suction Hose To Blow Oil Into Compressor

8. Repair damage to system.
9. Evacuate system with vacuum pump.
10. Charge system with NEW Refrigerant-12.
11. Continue Performance Test of air conditioning system.

## Information.

4. Use small tipped funnel inserted in drain hole to install oil.
  5. Install plug and tighten.
1. Follow procedure as necessary for make and year of model.
  1. With compressor installed on machine, connect gauge manifold hoses to compressor test fittings (Fig. 73).
  2. Add a measured amount of new oil into the suction test hose with a squeeze bottle (Fig. 73).
  3. Connect a can of Refrigerant-12 to suction hose (Fig. 74).
  4. Open Refrigerant-12 can valve for five seconds to blow oil into compressor.

1. Repair system as required to eliminate leak(s).
1. Follow procedure as outlined on page 88.
1. Follow procedure as outlined on page 90 or 92.
1. Follow procedure on page 67 for performance testing system.

## BENCH TESTING EXPANSION VALVE FOR EFFICIENCY

An expansion valve should not be condemned until tested for operating efficiency. Partial blockage in the inlet screen or excessive moisture in the system, causing icing near the inlet or outlet of the evaporator, can indicate a defective valve. After an expansion valve that is suspected of being faulty has been removed from the system, the screen should be cleaned and the valve tested as follows.

### Procedure

1. Prepare test gauges for expansion valve test (Fig. 75).

2. Install Refrigerant R-12 container to test manifold (Fig. 75).

3. Prepare hot and cold containers.

### Information

1. Close high and low side gauge manifold hand valves.
2. Install 1/4-inch tee flare fitting to low side manifold hose connector.
3. Install test hose to lower end of 1/4-inch tee fitting.
4. Install test cap (drilled No. 71 drill) to side connection on 1/4-inch tee fitting.
5. Install test hose to high side manifold hose connector.

1. Install test hose from center hose connector on gauge manifold to valve on 15-ounce (425-gram) container of R-12.

OR:

2. Charge charging cylinder with approximately one pound of R-12 and connect hose to center connection on gauge manifold.

OR:

3. Install test hose from center connector on gauge manifold to R-12 drum.

**NOTE:** Use thermometer to obtain exact temperatures of water used for test.

1. Place ice water in a suitable container.

**NOTE:** If excessive heat and high humidity prevent ice water in container from registering 28°F (-2°C), add salt and stir until reading of 28°F (-2°C) is obtained. A cold drink may be substituted for the iced container, provided its temperature is exactly 28°F (-2°C).

2. Heat water in second container until it reaches 125°F (52°C).

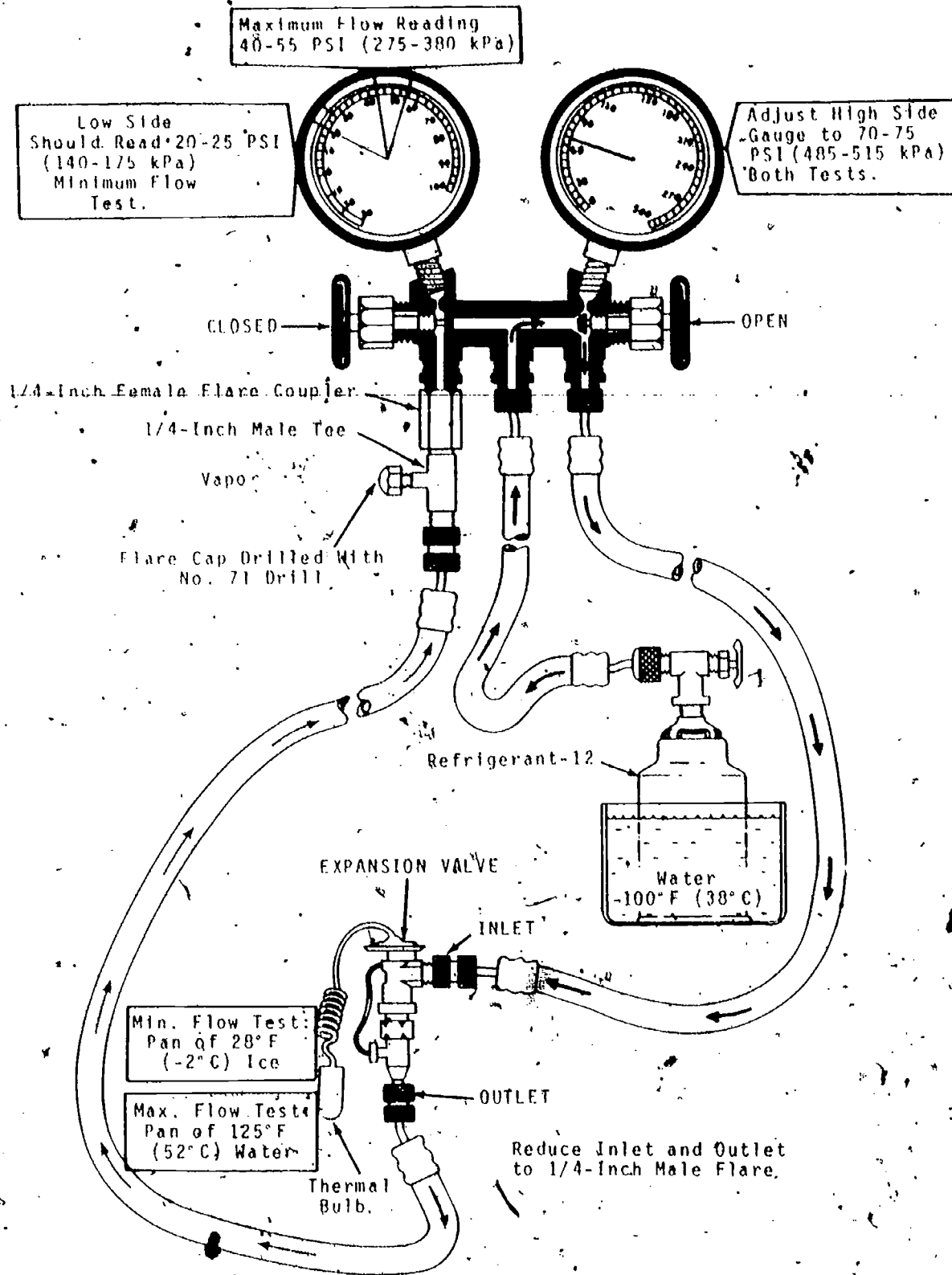

x7782

Fig. 75 — Bench Testing of Expansion Valve

Procedure

4. Prepare expansion valve for test.

Information

**NOTE:** Always remove screen from expansion valve inlet and clean carefully and reinstall before beginning this test.

1. Install 3/8-inch female flare x 1/4-inch male flare to expansion valve outlet and tighten securely.
2. On expansion valves having a 3/8-inch flare inlet, install 3/8-inch female flare x 1/4-inch male flare reducer and tighten securely.

Procedure

4. Prepare expansion valve for test (continued).

5. Test expansion valve for maximum flow.

6. Test expansion valve for minimum flow.

7. Replace expansion valve.

OR:

8. Install expansion valve into system.

9. Pump down and charge system.

10. Continue Performance Test.

Information

*NOTE: Expansion valves used on some systems will require adapters converting O-ring connections to flare fittings. These are available from local refrigeration supply houses.*

3. Install high side test hose to inlet fitting on expansion valve.

4. Install low side test hose to outlet fitting on expansion valve.

1. Open valve on R-12 container and place container in pan of water 100°F (38°C).

2. Check low side manifold shut-off valve for closed position.

3. Place thermal bulb of expansion valve in container of 125°F (52°C) water.

4. Open high side gauge manifold hand valve slowly until high side gauge reads 70-75 psi (485-515 kPa).

5. Read low side gauge; should be 40 to 55 psi (275 to 380 kPa).

1. Close high side gauge manifold hand valve.

*NOTE: This will release pressure on expansion valve.*

2. Place thermal bulb in container of 28°F (-2°C) liquid.

3. Open high side gauge manifold hand valve and adjust to indicate 70-75 psi (485-515 kPa).

4. Read low side gauge; should be 20 to 25 psi (140-175 kPa).

1. Failure of valve to meet the above test conditions indicates a defective valve.

2. Replace valve.

1. An expansion valve that meets above specifications during test has correct superheat setting, valve moving freely, and thermal bulb that has not lost its charge.

2. This expansion valve is suitable for service.

1. Evacuate system. Page 88 or 89.

2. Charge system with refrigerant. Page 90 or 92.

1. Continue testing system.

2. Adjust control for maximum performance.

## ADJUSTING THERMOSTAT

Thermostat-controlled recycling clutch systems require that the thermostat operation be checked periodically and occasionally adjusted. For thermostat operation, location of thermal bulb, and identification, refer to manufacturer's technical manual. The following procedure will detail steps in checking the thermostat and how to adjust those types having adjustments.

### Procedure

1. Stabilize system at specified rpm (1500-2000 rpm range).
2. Read high side gauge for full refrigerant charge.
3. Adjust air conditioning control for maximum cold.
4. Read low side gauge for thermostat operation.

### Information

1. Gauges connected into system, hand valves off.
  2. Air conditioning controls adjusted for maximum cooling.
  3. Operate for 10 to 15 minutes.
1. Normal high side pressure will match Pressure-Temperature Relationship chart on page 45.
  2. Check sight glass for absence of bubbles.
1. Thermostat adjusted to coldest position.
  2. Blower fan speed on "LOW."
  3. All doors and windows closed.
1. Should read from 14 psi to 26 psi (95-180 kPa) after system is stabilized for 10 to 15 minutes.

*NOTE: Thermostat should disconnect clutch for evaporator defrost between high and low readings given above. If thermostat will not recycle clutch, move temperature control toward warmer position to check for thermostat point opening.*

2. Count number of pounds pressure required for warm-up until points close — should indicate 20 to 32 psi (140 to 220 kPa) rise between point opening and reclosing.
3. Check thermostat operation at least three times for consistent operation.



Procedure

5. Adjust thermostat.

6. Continue Performance Test.

**THERMOSTATIC TEMPERATURE CONTROL SWITCH**

Some air conditioning systems contain an adjustable thermostatic temperature control switch. A temperature-sensing tube filled with gas is positioned between the refrigerant tubes in the evaporator. It senses the temperature of the evaporator tubes. The gas expands and contracts on a diaphragm which opens and closes electrical contacts in the thermostatic switch.

The switch controls the pumping action of the compressor by means of a magnetic clutch.

Information

*NOTE: Thermostats are generally, but not always, located in evaporator case.*

1. Remove parts as necessary to make thermostat accessible.
2. Open access door to adjustment screw.
3. Rotate adjustment screw counterclockwise to lower point opening adjustment; clockwise to raise point opening adjustment.

*NOTE: Localities having high mean humidity will require higher point opening than localities with low mean humidity. Coastal areas with point opening adjustment lower than 24 to 26 psi (165 to 180 kPa) will result in evaporator freeze-up. Desert areas with very low humidity can easily tolerate point opening adjustment of 14 to 16 psi (95 to 110 kPa) without evaporator freeze-up.*

4. Check operation of thermostat for newly adjusted cycle of operation.
5. Replace thermostat if cycle of operation is inconsistent or will not respond to adjustment.
6. Replace access door on side of thermostat and any parts removed to reach thermostat.

Continue testing system.

2. Remove gauges and deliver machine to customer.

If the compressor does not cycle according to technical manual specifications, reposition the temperature-sensing tube as specified. The cycle time of the compressor should change.

If unable to obtain specified clutch cycle time, remove the temperature control switch located in the cab. Turn the adjusting screw until the clutch stays engaged for the specified period of time. If still unable to obtain specified cycle time, replace the switch.

87

## CHECKING CLUTCH COIL FOR ELECTRICAL OPERATION

Use the following procedure as a time-saving device to determine if the coil is defective. Installations may vary, however, the following steps are general enough to meet all requirements.

### Procedure

1. Determine voltage to clutch coil.

### Information

**NOTE:** With ignition switch "ON" and clutch energized, battery voltage should be delivered to the coil. To prepare for test, expose connection between coil and evaporator for electrical checks.

**CAUTION:** Do not allow exposed wire to be grounded against machine while switches are in "ON" position.

1. Connect red lead of suitable Volt-Amp Tester to exposed wire of connection between evaporator and clutch coil.
2. Connect black lead of voltmeter to compressor body.

**NOTE:** The connections as listed above are for a negative-grounded system. Reverse leads for a positive-grounded system.

3. Voltmeter should read battery voltage — if no voltage reading obtained, check line fuse, voltage into evaporator, and to ON-OFF switch to locate and repair voltage loss.

2. Determine current draw of clutch coil.

1. Separate wires at connection between evaporator and coil.
2. Connect red lead of ammeter to exposed wire of evaporator.
3. Connect black lead of ammeter to lead to clutch coil.
4. Turn switches to "ON" position to energize clutch coil.

Procedure

2. Determine current draw of clutch coil (continued).

3. Determine ground circuit resistance.

Information

*NOTE: The ammeter as connected is for a negative-grounded system. Reverse leads for a positive-grounded system.*

5. Ammeter should indicate 3 amps draw for a 12-volt system, 5 amps for a 6-volt system.
6. Zero amps draw indicates an open circuit inside coil; excessive current draw indicates a short circuit within coil.

*NOTE: Performance of the resistance test requires the current draw of the coil to be within specifications.*

1. Connect evaporator and clutch coil wire.
2. Connect red lead of voltmeter to compressor body.
3. Connect black lead of voltmeter to battery post.

*NOTE: Reverse voltmeter leads for a positive-grounded system.*

4. Turn switches to "ON" position to energize clutch coil.
5. Total resistance from compressor body to battery post cannot exceed 0.3 volts.
6. If resistance is excessive, clean all connections and metal-to-metal contacts, including engine to frame and compressor to engine, to reduce resistance to specifications.

## LEAK TESTING SYSTEM USING ELECTRONIC LEAK DETECTOR

The electronic leak detector (Fig. 76) is discussed here. The procedure is the same for any propane torch detector, except that the pick-up device registers the presence of refrigerant by changing the color of a flame. **CAUTION: Do not inhale fumes produced by burning refrigerant if using a propane-torch leak detector.** All other steps in preparing the system and leak testing are the same and can be followed as outlined below. Several types of leak detectors are available. Carefully follow manufacturer's instructions when using any leak detector.

### Procedure

1. Stabilize system at specified engine rpm (1500-2000 range).

2. Check system pressure.

*NOTE: Check low pressure side of system with compressor OFF (the pressure will be higher). Check high pressure side of system with compressor OFF and again with compressor operating.*

3. Move leak detector pick-up over system.

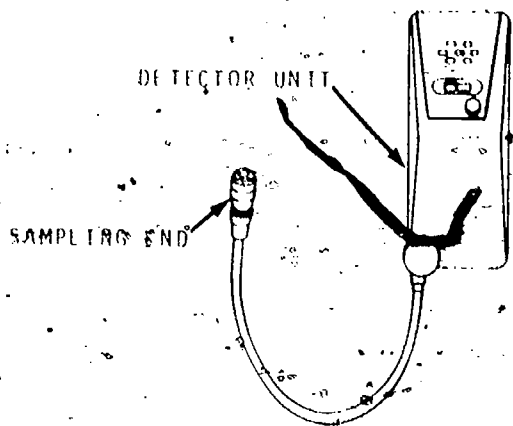

Fig. 76 — Electronic Leak Detector

### Information

*NOTE: If system is empty of refrigerant, install a partial charge before continuing.*

1. Gauges connected into system.
2. Adjust air conditioning controls for maximum cooling.
3. Operate 10 to 15 minutes.
4. Shut off machine engine.
5. Close manifold gauge hand valves.

1. 50 psi (345 kPa) is necessary to detect leaks.
2. If pressure is too low, open both manifold valves and add refrigerant until adequate pressure is obtained.
3. Close both manifold valves and service valve on can of R-12.

1. Move pick-up under hoses, joints, seals, and any possible place for a leak to occur (Fig. 77). Do not move sampling end of detector faster than 1 inch (25 mm) per second.

*NOTE: R-12 is heavier than air and will move downward; if concentration of refrigerant is located, move pick-up upward to locate leak.*

*NOTE: Electronic detector registers the presence of refrigerant by a flashing light or a high-pitched squeal.*

3. Repair system as necessary if leaks are located.

4. To repair, discharge, flush, and evacuate the system as required (see pages 85-89).

Procedure

4: Start machine and turn compressor ON.

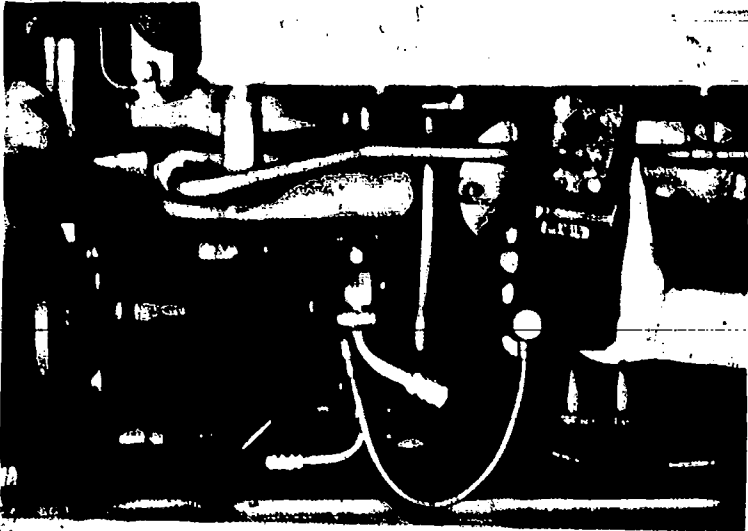

Fig 77 — Leak Test System Using Electronic Detector

4. Check sensitivity of detector pick-up.

5. Resume Performance Test.

Information

1. Repeat checks for leaks on high side only.  
**CAUTION: When engine is running, be alert and stay clear of rotating parts.**

2. Damp, dusty spots indicate a refrigerant leak.
3. Repair system as necessary if leaks are located.

1. Pass pick-up hose over empty can.

OR:

2. Crack open refrigerant container.
3. Electronic unit should blink light or squeal.
4. If no reaction, leak detector is malfunctioning.

1. Charge system if repairs to system were necessary. See pages 90 or 92.

OR:

2. Complete system charge and follow steps in "Performance Testing The System," page 87.

TEST YOURSELF

QUESTIONS

1. (Fill in the blanks with component names.)  
 "The high side service valve on the compressor leads to the \_\_\_\_\_ . The low side valve leads from the \_\_\_\_\_ ."

2. When inspecting the system, which side is normally warm to hot, and which side sweating or frosting?

3. True or false? "A slight refrigerant loss between seasons is accepted as normal for an air conditioning system."

4. When adding refrigerant to the system, must it enter as a vapor or as a liquid?

5. When using an Electronic Leak Detector, what does a blinking light or squealing noise tell about the presence or absence of refrigerant?

(Answers on page 100.)

## PREPARING SYSTEM FOR SERVICE PART 8

Air conditioning systems require a number of special procedures when preparing the system for repair service and when placing the system back into operation. Part 8 is concerned with these procedures.

Each procedure is detailed separately, beginning with bleeding, flushing, and purging refrigerant from the system; then evacuation for moisture removal; charging the system; and isolating the compressor for service. These procedures are necessary for satisfactory system performance.

Refer to the technical manual for the system to get the exact specifications for each procedure.

### BLEEDING OR DISCHARGING THE SYSTEM

The refrigerant in the system must be discharged or bled to let off pressure before any lines or units in the system are disconnected for service. *Use all safety precautions during this procedure.*

#### Procedure

1. Stabilize system at specified rpm (1500-2000 rpm range)
2. Shut off engine and air conditioning system.
3. Bleed off refrigerant.

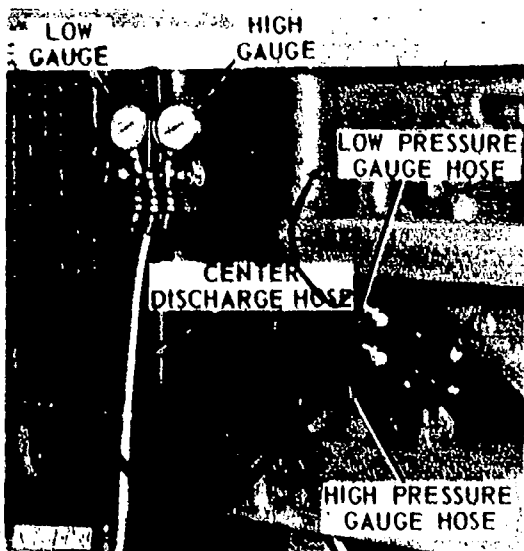

Fig. 78. Bleeding Or Discharging The System

4. Close gauge manifold hand valves.
5. Measure amount of oil blown from system after discharging.

#### Information

1. Gauges connected into system, both hand valves closed (Fig. 78).
2. Place the center hose in a container to collect any refrigerant oil that may be discharged with refrigerant.
3. Adjust air conditioning controls to maximum cooling.
4. Operate 10 to 15 minutes.
  1. Adjust engine speed to slow idle for a few minutes before shutting off to prevent "dieseling."
  1. Slowly open high side hand manifold valve and allow refrigerant to discharge.

*Use adequate ventilation during this operation.*

**WARNING: Do not discharge Refrigerant-12 near an open flame as poisonous phosgene gas can result.**

2. Slowly open low side hand manifold valve when the pressure falls below 40 psi (270 kPa).

**IMPORTANT: Open hand valves only enough to bleed refrigerant from system. Too-rapid discharging will draw excessive oil from the compressor and the system.**

1. Close valves when refrigerant stops bleeding from hose.
2. Both gauges will read zero pressure.
  1. If system is to be flushed, add a new charge of oil.
  2. If system is not to be flushed, add same amount of new oil as was blown out (see pages 73 or 74).
  3. If refrigerant or oil leakage was detected, add new oil.

## FLUSHING THE SYSTEM

Flush the system after a compressor internal failure or when the system has been open for any length of time. Use Refrigerant-11 to flush the system (see page 10).

### Procedure

1. Isolate the compressor, receiver-drier, and expansion valve from system.

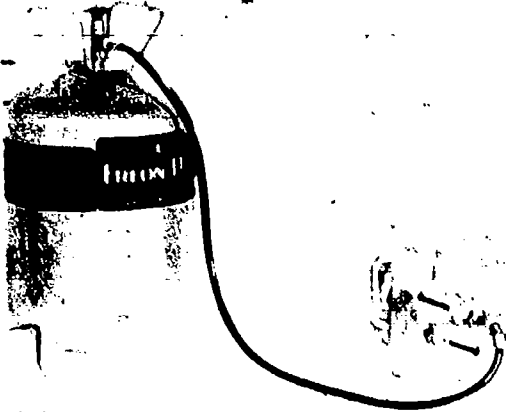

X7784

Fig. 79 — Connect Hose Between Refrigerant-11 And The Component

### Information

1. Connect hose between refrigerant source and the component to be flushed (Fig. 79).

*NOTE: It is not necessary to remove components from the machine in order to flush them.*

2. Flush all components individually.

3. Flush compressor.

4. Purge components with Refrigerant-12 or dry nitrogen before connecting. See next page.

1. Open valve on refrigerant container and allow Refrigerant-11 to flow through each component for 5-10 seconds.

1. Remove compressor inlet and discharge port cover and drain-port plug.
2. Add Refrigerant-11 through drain port.
3. Shake compressor and then drain.
4. Add oil.

1. After purging with Refrigerant-12 connect all components.
2. Purge complete system with Refrigerant-12 or dry nitrogen.

## PURGING THE SYSTEM

Purging the system with Refrigerant-12 or dry nitrogen forces out any Refrigerant-1 left in the component after flushing. This will leave each component free of contamination. Purging also decreases the amount of air and moisture that could migrate into the system.

### Procedure

1. Connect hose between Refrigerant-12 (or dry nitrogen) container and each component (Fig. 80).

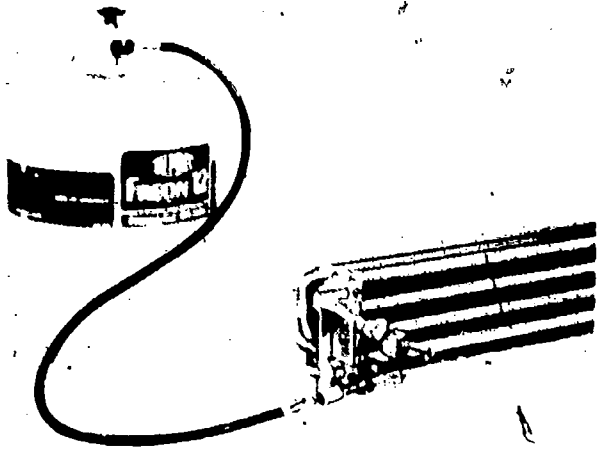

Fig. 80. — Connect Hose Between Refrigerant-12 And Component

2. Purge each component individually with 5-20 psi (35-135 kPa) at point of gas entry.

3. Purge the total system.

### Information

1. Open valve on refrigerant container and allow Refrigerant-12 (or dry nitrogen) to pass through component.

**NOTE:** It is not necessary to remove components from the machine for purging.

1. Purge components (also replacement components) for 15-30 seconds.

2. Connect each component after purging.

1. Make connection at compressor high side fitting.

2. Purge through complete system to low side fitting.

3. Evacuate system (see next page).



## EVACUATING SYSTEM USING VACUUM PUMP

Evacuating the system removes all air until a vacuum is created. This is necessary after the system has been discharged and opened for service because air enters the openings before they can be capped. This air contains harmful moisture and must be removed before it contaminates the system components.

There are a number of vacuum pumps suitable for removing air and moisture from the system. Reference will be made here to 28-29 1/2 inches (95-100 kPa) Hg. (mercury) as the specification for system pump-down. This reading can be attained at or near sea level elevation only. For each 1000 feet (300 meters) of altitude, the reading will be 1 inch (3 kPa) Hg. less. For example, at 5000 feet (1500 meters) elevation, only 23-24 1/2 inches (78-83 kPa) Hg. of vacuum can be obtained.

## Procedure

1. Connect vacuum pump to gauge manifold (Fig. 81). Compressor OFF during evacuation.

2. Operate vacuum pump.

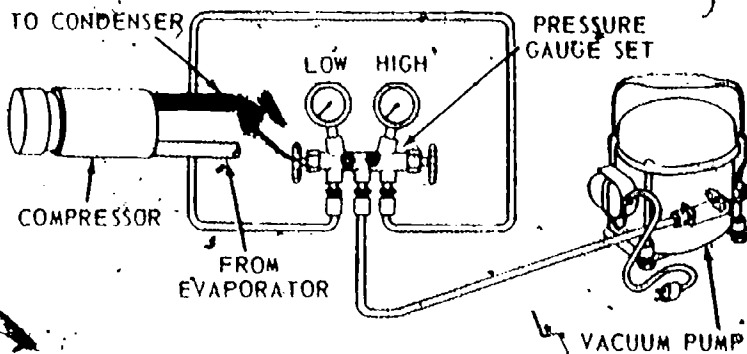

Fig 81 - Evacuating System

3. Close hand valves.
4. Check ability of system to hold vacuum.

5. Charge system with refrigerant.

## Information

1. Gauges connected into system.
  2. Remove cap from vacuum pump hose connector.
  3. Install center hose from gauge manifold to vacuum pump connector.
  4. Mid-position high and low side compressor service valves (if used).
  5. Open high and low side gauge manifold hand valves and pump exhaust.
1. Operate a minimum of 30 minutes for air and moisture removal.
  2. Watch compound gauge to see that system pumps down into a vacuum.

**NOTE:** System will reach 28-29 1/2 inches (95-100 kPa) Hg. in not over 5 minutes. If system does not pump down, check all connections and leak test if necessary. If there is liquid Refrigerant-12 in the system, the vacuum pump will not pull maximum vacuum in 5 minutes. Also, the vacuum will decrease when the pump is shut off.

1. Close gauge manifold hand valves.
  2. Shut off vacuum pump.
1. Watch compound gauge to see that gauge does not rise at a faster rate than 1 inch (3 kPa) Hg. in 5 minutes.
  2. If compound gauge rises at too rapid a rate, install partial charge and leak test per instructions on page 83, then bleed system and repeat Procedure Steps 2 and 3 above.

## OR:

3. If system holds vacuum within specifications, continue with Step 5.
1. Follow steps outlined on page 90 or 92.

## EVACUATING SYSTEM USING CHARGING STATION

A vacuum pump is built into the charging station (Fig. 82) and is constructed to withstand hard use without damage. Complete moisture removal from the system is possible only with a vacuum pump constructed for this purpose.

### Procedure

1. Operate vacuum pump.

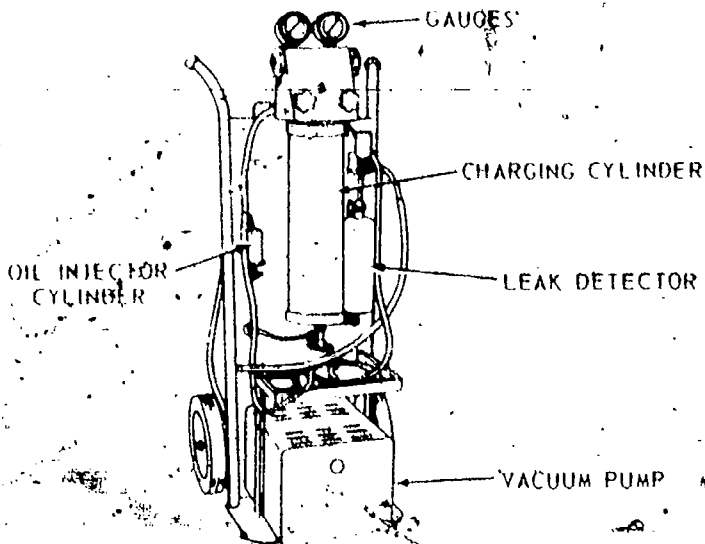

Fig. 82 — Portable Charging Station

2. Close hand valves.
3. Check ability of system to hold vacuum.

4. Charge system with refrigerant.

### Information

1. Connect hose to vacuum pump if system was purged through station.
2. Open high and low side gauge valves on charging station.
3. Connect station into 110-volt current.
4. Engage "Off-On" switch to vacuum pump according to directions of specific station being used.

**NOTE:** System should pump down into a 28-29 1/2 inch (95-100 kPa) vacuum in not more than 5 minutes. If system fails to meet this specification, repair is necessary.

5. Operate pump at least 30 minutes for air and moisture removal.

1. Close high and low side gauge valves on charging station.

2. Open switch to turn off vacuum pump.

1. Watch compound gauge to see that gauge does not rise at a rate faster than 1 inch (3 kPa) Hg. every 4 or 5 minutes.

2. If rise rate of compound gauge is not within specifications, repair system as necessary.

OR:

3. If rise rate is within specified time, continue with Step 4.

1. Follow steps in "Charging System Using a Charging Station," page 92.

## CHARGING SYSTEM USING 15-OUNCE (425-GRAM) CONTAINERS

The system should be charged with refrigerant only after it has been leak tested and evacuated. It is important to add only the specified quantity of refrigerant.

The tendency of many servicemen is to unknowingly overfill the system. To aid in more accurate charging and to prevent waste, refrigerant manufacturers have in recent years packaged the refrigerant in cans which contain 15 ounces (425 g). The small containers are best for small service departments doing only a limited amount of air conditioning service work. They are handled in the same manner as the larger drums except care must be taken not to overheat the cans because they may explode.

*NOTE: If only a small amount of refrigerant must be added to the system, see page 69, "Adding Refrigerant To System."*

### Procedure

1. Install can dispensing valve to container(s).

*NOTE: Engine must be OFF. System must be holding vacuum as specified in step 4 on page 88 or 89.*

2. Install charging hose to dispensing valve (Fig. 83).

3. Partially charge system.

4. Complete charge of system.

### Information

*NOTE: The dispensing valve is available both for single cans and multiple cans. Whichever is used, preliminary installation to the can(s) is the same.*

1. Install dispensing valve to single container of refrigerant.
2. Close shut-off valve on dispensing valve.
3. Pierce can with mechanism which is part of valve.

*NOTE: Before charging, the system will have been pumped down.*

1. Loosen charging hose at center connector on gauge manifold.
2. Crack open dispensing shut-off valve to purge air from charging hose.
3. Tighten charging hose connection on gauge manifold and close shut-off valve.

1. Open shut-off valve on dispensing valve.
2. Open high side gauge manifold hand valve.
3. Invert container(s) to allow refrigerant to enter high side of system. (See Fig. 83).
4. Close shut-off valve when changing cans.

**IMPORTANT: Do not overfill system. Refer to technical manual for capacity of system being serviced.**

**Procedure**

**4. Complete charge of system (continued).**

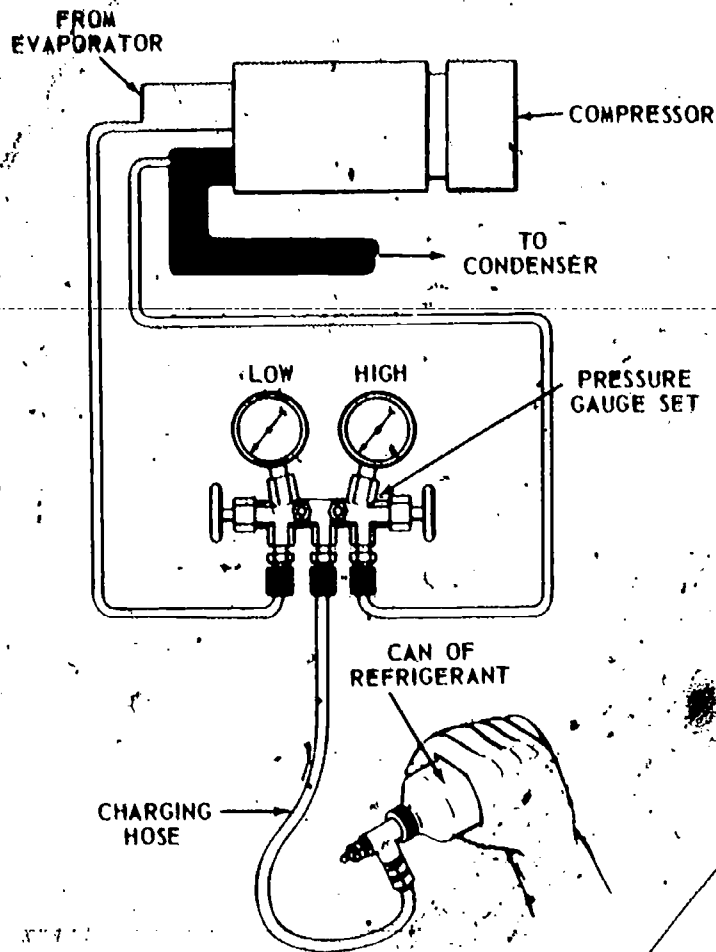

Fig. 83 — Add Refrigerant Until Gauges Normalize and Bubbles in Sight Glass Disappear

**5. Check refrigerant charge in system.**

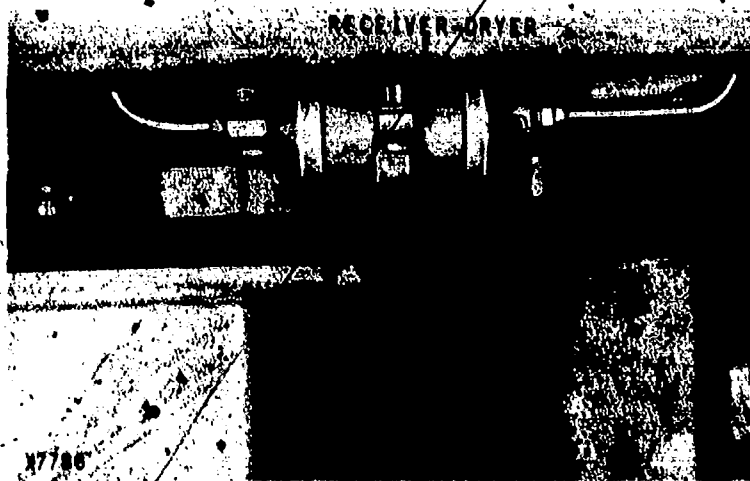

Fig. 84 — Sight Glass

**6. Continue Performance Test.**

**Information**

1. After high side pressure becomes slow to increase, open low-side manifold hand valve.
2. After low side pressure becomes slow to increase, close high-side manifold valve.
3. Close shut-off valve on dispensing valve.
4. Start engine and adjust throttle to specified rpm (1500-2000 rpm range).
5. Adjust air conditioning controls for maximum cooling.
6. Open shutoff valve on dispensing valve to allow refrigerant to be drawn into system. Adjust low-side pressure valve so gauge reading does not exceed 40 psi (276 kPa).

**IMPORTANT:** Refer to procedure for adding refrigerant to system, page 69.

*NOTE:* If single containers are used, it will be necessary to replace each as it becomes empty.

7. Watch sight glass (Fig. 84) until bubbles disappear.
8. Add additional refrigerant only if recommended by manufacturer. See technical manual.
9. Close valve on refrigerant container.
10. Close low-side gauge manifold hand valve.

1. Watch for bubbles in sight glass (if used in system). See Fig. 84.

*NOTE:* Excessive head pressure with a normal low side pressure indicates an overcharge of refrigerant or air in the system. Compressor may or may not be noisy.

3. Listen for hissing noise in expansion valve. Many systems have a hissing in the expansion valve until the system is fully charged.

1. Continue testing system.
2. Adjust controls for maximum efficiency.

## CHARGING SYSTEM USING CHARGING STATION

Most stations (Fig. 85) contain a charging cylinder into which the exact amount of refrigerant required by the particular system being serviced may be placed while system pump-down is being performed. The refrigerant charging cylinder contained in the station is heated to the correct temperature to insure proper refrigerant flow to all parts of the system as a gas during the charging operation. If used correctly, the vacuum pump will so efficiently pump down the system that opening the correct valves will completely charge the system from the high side, and the use of the compressor in the charging operation will not be required.

### Procedure

1. Prepare charging cylinder for filling.

2. Fill charging cylinder.

3. Charge system with refrigerant.

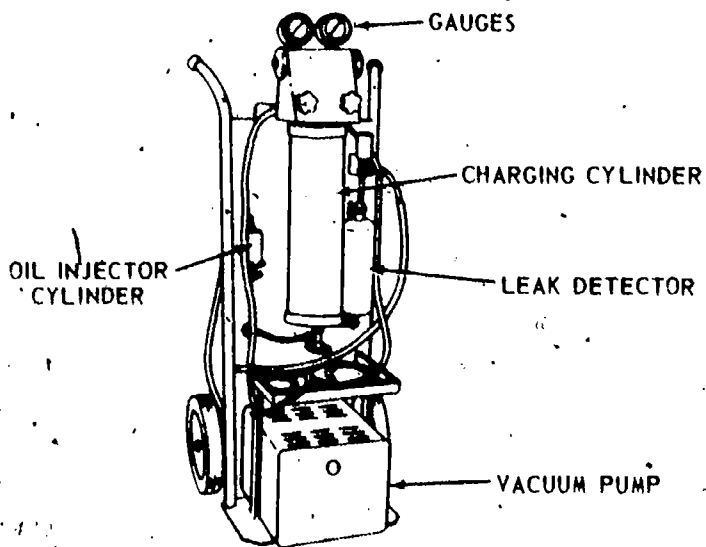

Fig 85 -- Portable Charging Station

4. Performance Test system.

### Information

1. Open storage drum valve.

2. Close all valves on station.

3. Read storage tank gauge pressure.

4. Rotate dial shroud on charging cylinder to correlate with pressure on gauge.

5. Open cylinder fill valve.

1. Determine system capacity using technical manual.

2. Intermittently open and close pressure relief valve.

*NOTE: When pressure relief valve opens, refrigerant will enter cylinder and boil. Closing the valve will increase pressure on refrigerant, changing it to a liquid to stabilize the refrigerant in the sight glass.*

3. Fill to specified level in sight glass.

4. Close pressure relief valve.

1. Gauges connected into system.

2. Open refrigerant control valve.

3. Open High Pressure valve.

4. Remove vacuum hose from pump and crack (barely open) Low Pressure valve.

5. Allow refrigerant to escape through vacuum hose for approximately 3 seconds.

6. Close High and Low Pressure valves.

7. Close refrigerant control valve.

*NOTE: Charging cylinder should empty in approximately 90 seconds for systems of 5-pound (2.3 kg) capacity. Smaller systems will require less time.*

1. Continue testing system.

2. Adjust controls for maximum efficiency.

## ISOLATING COMPRESSOR FROM SYSTEM

On systems having both a high side and low side service valve, the compressor may be isolated and refrigerant retained in the system while service work is being performed on the compressor or the machine engine. The following procedure should be followed at any time compressor isolation is required. *NOTE: In some systems the compressor cannot be isolated from the system. In this case, the system must be discharged whenever the compressor is removed.*

### Procedure

1. Stabilize system at specified rpm (1500-2000 rpm range).

2. Isolate compressor.

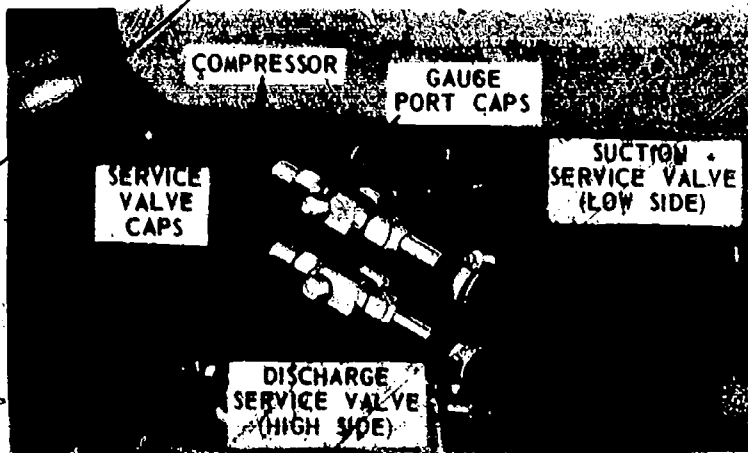

Fig. 86 — Service Valve On Compressor

3. Continue service work.

4. Place compressor in system.

5. Continue Performance Test.

### Information

1. Gauges connected into system.
2. Air conditioning controls adjusted for maximum cooling.
3. Operate system for 10 to 15 minutes.
4. Slowly close (front-seat) low side service valve until low side gauge reads zero pressure (see page 38 for proper service valve position).

*NOTE: Return engine to idle to prevent "dieseling."*

2. Turn off machine engine.
3. Completely close low side service valve.
4. Close high side service valve.
5. Bleed refrigerant from compressor by cracking low side hand manifold until both gauges read zero pressure.

*NOTE: Bleed refrigerant slowly to prevent pulling oil from compressor.*

1. Remove service gauges from service valves.
2. Remove service valves from compressor.
3. Perform service work as required.
1. Install service valves to compressor using new gaskets or O-rings, whichever are required.
2. Purge air from compressor by cracking low side service valve for 3 seconds with low side hose connector capped and high side hose connector open.
1. Install gauges to service valve connectors and purge air from hoses.
2. Mid-position service valves.
3. Continue testing system.
4. Adjust control for maximum performance.

## TEST YOURSELF

### QUESTIONS

1. What procedure *must* be performed before an operable system is disconnected for service?
2. What happens if refrigerant is bled from system too fast?
3. Why must the system be evacuated of all air before placing it back into service?
4. What four procedures should be carried out before charging a system with refrigerant?
5. If the system has a sight glass, what does bubbles or foamy refrigerant tell you?
6. What option must the compressor have if it is to be isolated from the system while it is being serviced?

(Answers on page 100.)

## DEFINITIONS OF TERMS AND SYMBOLS

### A

**ABSOLUTE ZERO** — Complete absence of heat; believed to be  $-459.6^{\circ}\text{F}$  ( $-273.3^{\circ}\text{C}$ ).

**AIR CONDITIONING** — Absolute control of temperature and humidity; air conditioning in true sense used only in some laboratories and manufacturing plants where temperature and humidity control are very critical. Ordinary usage in homes, buildings, and vehicles means control of temperature and removal of moisture by condensation; more correct designation is refrigeration.

**AMBIENT TEMPERATURE** — Temperature of surrounding air. In air conditioning, it refers to *outside* air temperature.

**ATMOSPHERIC PRESSURE** — Weight of air at various altitudes. Sea level pressure commonly called 14.7 PSI (1783 kPa) and decreases with higher altitude. Greatest concentration of population of United States lives at 900 feet (275 meters) altitude or less. Society of Automotive Engineers (SAE) uses 900 feet (275 meters) altitude as average for specification in manufacturing of all products; it is the "mean" or average altitude.

### B

**BLEEDING** — Releasing pressure in the system slowly by draining off some liquid or gas. This must be done before the system is opened for service.

**BOILING POINT** — Temperature at which a liquid changes to a vapor. Water changes to steam at  $212^{\circ}\text{F}$  ( $100^{\circ}\text{C}$ ) at sea level (14.7 PSI (1783 kPa) air pressure); Refrigerant-12 changes from liquid to vapor at  $-21.7^{\circ}\text{F}$  ( $-30^{\circ}\text{C}$ ) sea level and atmospheric pressure.

**BTU** — Abbreviation for *British Thermal Unit*. Amount of heat required to raise temperature of one pound of water (approximately one pint)  $1^{\circ}\text{F}$ . All substances are rated in relation to water as standard of measurement.

### C

**CELSIUS** — Thermometer using scale based on  $0^{\circ}$  as freezing point of water. In common usage it is referred to as degrees C.

**COLD** — Absence of heat.

**COMPRESSOR DISPLACEMENT** — Figure obtained by multiplying displacement of compressor cylinder or cylinders by a given rpm, usually average engine speed.

**CONDENSATION** — Process of changing a gas to a liquid.

**CONDENSING TEMPERATURE** — Temperature at which compressed gas in condenser changes from gas to a liquid. Affected directly by quantity and temperature of ram air passing through condenser.

**CONDENSING PRESSURE** — Head pressure as read from gauge at high side service valve; pressure from discharge side of compressor into condenser.

**CONDUCTION OF HEAT** — Ability of substance to conduct heat (metal and glass conduct heat more readily than insulating material such as spun glass).

### D

**DENSITY** — Weight or mass of a gas, liquid, or solid.

**DESICCANT** — A drying agent used inside air conditioning systems to absorb and hold moisture. Silica-Gel and Molecular-Sieve are most widely used.

**DRIER** — A device containing a desiccant placed in series, usually in the liquid line, to absorb and hold excess moisture. Usually called receiver-drier.

### E

**EVAPORATION** — Process of changing a liquid to a gas.

### F

**FAHRENHEIT** — Thermometer using scale based on  $32^{\circ}$  as freezing point of water. In common usage, it is referred to as degrees F.

**FILTER** — A device used with the drier or as a separate unit to remove foreign substances from the refrigerant; installed in series in liquid line on high side of system.

### G

**GAS** — A vapor having no particles or droplets of liquid.



H

**HEAD PRESSURE** — Pressure of refrigerant from discharge reed valve through lines and condenser to expansion valve orifice.

**HEAT INTENSITY** — Measurement of heat concentration with a thermometer.

**HG.** — Abbreviation for *mercury*. Inches (kilopascals) of mercury is a measure of vacuum.

**HIGH SIDE** — Same as head pressure; side of system which includes vapor into condenser and liquid to expansion valve. (Also see Low Side.)

**HYDROLIZING ACTION** — Corrosive action within the air conditioning system induced by a weak solution of hydrochloric acid formed by excessive moisture in the system reacting chemically with the Refrigerant-12.

K

**kPa** — Abbreviation for kilopascal (metric measure of pressure).

L

**LATENT HEAT** — Amount of heat (BTU's or watts) required to cause a change of state of a substance without changing its heat intensity (degrees F; degrees C).

**LATENT HEAT OF CONDENSATION** — Quantity of heat (BTU's or watts) given off while changing a substance from a vapor to a liquid.

**LATENT HEAT OF EVAPORATION** — Quantity of heat (BTU's or watts) required to change a liquid into a vapor without raising temperature of vapor above that of original liquid.

**LIQUID** — A solid column of liquid without gas pockets is pure liquid.

**LIQUID LINE** — Pipe or hose connecting condenser to expansion valve.

**LOW SIDE** — That portion of system from orifice in expansion valve through evaporator line or lines through compressor service valve to compressor reed valve. Also called suction side.

P

**PRESSURE DROP** — Difference in pressure between any two points caused by friction, restriction, etc.

**PSI** — Abbreviation for pounds per square inch above atmospheric pressure. "G" added designates gauge pressure.

**PURGING** — Adding refrigerant to a component or hose to remove any contamination from that part of the system. Also decreases the amount of air and moisture that could migrate into the system.

R

**RADIATION** — Heat flow through space, traveling and acting much like light rays.

**RAM AIR** — Air that is forced around the condenser coils as the vehicle travels in a forward direction.

**RECEIVER-DRIER** — See "Drier."

S

**SCHRADER VALVE** — Spring-loaded valve similar to the tire valve, located inside the gauge hose fitting on service valves and certain controls. Will hold refrigerant in the system but can be opened by installing a special adapter with the gauge hose.

**SENSIBLE HEAT** — Heat which causes a change in temperature of a substance but not a change in state.

**SPECIFIC HEAT** — Quantity of heat required to change one pound (0.45 kg) of a substance one degree Fahrenheit (1°F) (1°C).

**STANDARD TON** — Amount of heat released while changing one ton of 33°F (1°C) water to 32°F (0°C) ice in a period of 24 hours (288,000 BTU's (84 408 W) per 24 hours or 12,000 BTU's (3517 W) per hour).

**SUBSTANCE** — Any form of matter that can be weighed or measured; may be solid, liquid, or gas.

**SUCTION SIDE** — Low side pressure (from expansion valve orifice to intake reed valve in compressor).

**SUPERHEAT** — Added heat intensity to a gas after complete evaporation of a liquid; controlled by increasing pressure in air conditioning systems.

**SWEEPING** — Same as "Bleeding."

T

**TAIL PIPE** — Outlet pipe from evaporator coil.

**TOTAL HEAT LOAD** — Human heat load plus heat entering through floor, glass, roof, and sides of vehicle.

**TORQUE** — Rotating power required to properly tighten a bolt or nut expressed in foot-pounds or inch-pounds (newton-meters).

V

**VACUUM** — Referred to as less than atmospheric pressure and expressed as inches (kilopascals) of mercury (in. or kPa Hg.). Man has not obtained a true vacuum.

W

**WATT** — Unit measure of electricity.

## ANSWERS TO "TEST YOURSELF" QUESTIONS

## ANSWERS TO PART 1 QUESTIONS

1. Absorbs heat.
2. Raises the boiling point.
3. First blank — "hotter." Second blank — "colder."
4. The amount of heat required to raise the temperature of a pound of water one degree Fahrenheit (at sea level pressure).
5. See the complete diagram in Fig. 10 of the text.

## ANSWERS TO PART 2 QUESTIONS

1. False. It will boil.
2. Frostbite can occur.
3. It can explode.
4. It causes corrosion of the metal parts.
5. A vacuum pump.
6. False! Never use motor oil; use only approved refrigeration oil.

## ANSWERS TO PART 3 QUESTIONS

1. See completed diagram in Fig. 17 of the text for correct labels for parts and colors for refrigerant.
2. The second job is circulating the refrigerant in the system.
3. Concentrates its heat content or heats it up.
4. First blank — "heat"; second blank — "gas"; third blank — "liquid."
5. Ram air is natural air flow from vehicle movement; forced air is pushed by an electric-powered fan.
6. The outlet side should be cold.
7. First blank — "liquid"; second blank — "gas"; third blank — "absorbed."
8. At its lowest speed to allow the greatest absorption of heat from the air.
9. To absorb moisture from the system.

## ANSWERS TO PART 4 QUESTIONS

1. Gauge and manifold set, leak detector, vacuum pump.
2. One for the high side, and one for the low side of the system.
3. The compressor.
4. The electronic type.
5. It gives off a poisonous gas.
6. A vacuum pump.

## ANSWERS TO PART 5 QUESTIONS

1. Normal is 7 to 30 psi (50 to 210 kPa) (depending upon ambient temperature).
2. See chart on page 45 for correct answers.
3. 1-b; 2-c; 3-a.

## ANSWERS TO PART 6 QUESTIONS

1. The possible causes that take the least amount of time to inspect and repair.
2. See chart on page 54.
3. First blank — NORMAL or HIGH; second blank — HIGH.

**ANSWERS TO PART 7 QUESTIONS**

1. First blank — "condenser." Second blank — "evaporator."
2. The *high side* will be warm to hot; the *low side* will be sweating or frosting.
3. True.
4. As a vapor.
5. Blinking light or squealing noise indicates the presence of refrigerant.

**ANSWERS TO PART 8 QUESTIONS**

1. The system must be discharged or bled to release pressure.
2. Too rapid bleeding will draw out too much oil with the refrigerant from the compressor and system.
3. To remove moisture which contaminates the system and corrodes its working parts.
4. 1) Leak test; 2) flush; 3) purge; 4) evacuate.
5. That the refrigerant is low.
6. It must have high and low side service valves.