

DOCUMENT RESUME

ED 183 836

CE 024 401

TITLE Military Curricula for Vocational & Technical Education. Fabrication and Parachute Specialist, 18-2.

INSTITUTION Ohio State Univ., Columbus. National Center for Research in Vocational Education.; Technical Training Center, Chanute AFB, Ill.

SPONS AGENCY Bureau of Occupational and Adult Education (DHEW/OE), Washington, D.C.

PUB DATE Oct 78

NOTE 238p.; Sections of this document will not reproduce well due to light and broken type.

EDRS PRICE MF01/PC10 Plus Postage.

DESCRIPTORS Behavioral Objectives; Clothing Instruction; Course Descriptions; High Schools; Learning Activities; Needle Trades; Occupational Home Economics; Postsecondary Education; *Sewing Instruction; *Sewing Machine Operators; Textiles Instruction; Workbooks

IDENTIFIERS Military Curriculum Project; Parachutes

ABSTRACT

This teaching guide and student workbook for a 157-hour course in textile and sewing instruction is one of a number of military-developed curriculum packages selected for adaptation to vocational instruction and curriculum development in a civilian setting. The twelve lessons include textile terminology, hand and machine-sewn seams, and operation and maintenance of sewing machines. Parachutes and flight clothing are used as examples for study in the instructional materials. The plan of instruction, which suggests number of hours of class time devoted to each objective, is divided into three blocks with separate titles. Block 1, Sewing Principles and Lightweight Sewing Machines, consists of seven lessons: Textile Terminology (2 hours), Hand Sewn Seams (6 hours), Hardware Installation (2 hours), Operation/Maintenance of Class 31 Sewing Machine (22 hours), Machine Sewn Seams (19 hours), Identification/Construction/Maintenance of Personnel/Organizational Clothing (23 hours), and Technical Order Diagram and Blueprint Interpretation (4 hours). Block 2, Textile Fabrication and Medium Weight Sewing Machines, contains three lessons: Operation and Maintenance of Class 111 Sewing Machines (27 hours), Pattern Design and Layout (5 hours). Block 3, Parachute Systems Repair and Special Sewing Machines, consists of two lessons: Personnel Parachute Repair Using Class 31 Sewing Machine (16 hours) and Operation and Maintenance of Class 7 Sewing Machine (6 hours). Instructor materials include criterion objectives and list of support materials needed. The student study guides/workbooks parallel this plan of instruction and contain objectives, information (text) and exercises. (Films referenced are not provided.) (MFK)

 * Reproductions supplied by EDRS are the best that can be made *
 * from the original document. *

This military technical training course has been selected and adapted by The Center for Vocational Education for "Trial Implementation of a Model System to Provide Military Curriculum Materials for Use in Vocational and Technical Education," a project sponsored by the Bureau of Occupational and Adult Education, U.S. Department of Health, Education, and Welfare.

MILITARY CURRICULUM MATERIALS

The military-developed curriculum materials in this course package were selected by the National Center for Research in Vocational Education Military Curriculum Project for dissemination to the six regional Curriculum Coordination Centers and other instructional materials agencies. The purpose of disseminating these courses was to make curriculum materials developed by the military more accessible to vocational educators in the civilian setting.

The course materials were acquired, evaluated by project staff and practitioners in the field, and prepared for dissemination. Materials which were specific to the military were deleted, copyrighted materials were either omitted or approval for their use was obtained. These course packages contain curriculum resource materials which can be adapted to support vocational instruction and curriculum development.

The National Center Mission Statement

The National Center for Research in Vocational Education's mission is to increase the ability of diverse agencies, institutions, and organizations to solve educational problems relating to individual career planning, preparation, and progression. The National Center fulfills its mission by:

- Generating knowledge through research
- Developing educational programs and products
- Evaluating individual program needs and outcomes
- Installing educational programs and products
- Operating information systems and services
- Conducting leadership development and training programs

FOR FURTHER INFORMATION ABOUT Military Curriculum Materials

WRITE OR CALL

Program Information Office
The National Center for Research in Vocational
Education
The Ohio State University
1960 Kenny Road, Columbus, Ohio 43210
Telephone: 614/486-3655 or Toll Free 800/
848-4815 within the continental U.S.
(except Ohio)

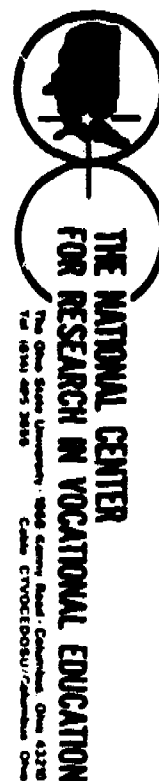

Military Curriculum Materials for Vocational and Technical Education

Information and Field
Services Division

The National Center for Research
in Vocational Education



Military Curriculum Materials Dissemination Is . . .

an activity to increase the accessibility of military-developed curriculum materials to vocational and technical educators.

This project, funded by the U.S. Office of Education, includes the identification and acquisition of curriculum materials in print form from the Coast Guard, Air Force, Army, Marine Corps and Navy.

Access to military curriculum materials is provided through a "Joint Memorandum of Understanding" between the U.S. Office of Education and the Department of Defense.

The acquired materials are reviewed by staff and subject matter specialists, and courses deemed applicable to vocational and technical education are selected for dissemination.

The National Center for Research in Vocational Education is the U.S. Office of Education's designated representative to acquire the materials and conduct the project activities.

Project Staff:

Wesley E. Budke, Ph.D., Director
National Center Clearinghouse

Shirley A. Chase, Ph.D.
Project Director

What Materials Are Available?

One hundred twenty courses on microfiche (thirteen in paper form) and descriptions of each have been provided to the vocational Curriculum Coordination Centers and other instructional materials agencies for dissemination.

Course materials include programmed instruction, curriculum outlines, instructor guides, student workbooks and technical manuals.

The 120 courses represent the following sixteen vocational subject areas:

Agriculture	Food Service
Aviation	Health
Building & Construction	Heating & Air Conditioning
Trades	Machine Shop Management & Supervision
Clerical Occupations	Meteorology & Navigation
Communications	Photography
Drafting	Public Service
Electronics	
Engine Mechanics	

The number of courses and the subject areas represented will expand as additional materials with application to vocational and technical education are identified and selected for dissemination.

How Can These Materials Be Obtained?

Contact the Curriculum Coordination Center in your region for information on obtaining materials (e.g., availability and cost). They will respond to your request directly or refer you to an instructional materials agency closer to you.

CURRICULUM COORDINATION CENTERS

EAST CENTRAL

Rebecca S. Douglass
Director
100 North First Street
Springfield, IL 62777
217/782-0759

MIDWEST

Robert Patton
Director
1515 West Sixth Ave.
Stillwater, OK 74704
405/377-2000

NORTHEAST

Joseph F. Kelly, Ph.D.
Director
225 West State Street
Trenton, NJ 08625
609/292-6562

NORTHWEST

William Daniels
Director
Building 17
Airdustrial Park
Olympia, WA 98504
206/753-0879

SOUTHEAST

James F. Shill, Ph.D.
Director
Mississippi State University
Drawer DX
Mississippi State, MS 39762
601/325-2510

WESTERN

Lawrence F. H. Zane, Ph.D.
Director
1776 University Ave.
Honolulu, HI 96822
808/948-7834

3ABB 42733

Developed by:

United States Air Force

Development and Review Dates:

October 1978

Occupational Area:

Textiles and Clothing

Target Audiences:

Grades 11 - Adult

Print Pages: 226

Microfiche: 4

Availability:

Vocational Curriculum Coordination Centers

Contents:	Type of Materials:	Type of Materials:						Instructional Design:	Instructional Design:				Type of Instruction:	Type of Instruction:	
		Lesson Plans:	Programmed Text:	Student Workbook:	Handouts:	Text Materials:	Audio-Visuals:		Performance Objectives:	Tests:	Review Exercises:	Additional Materials Required:		Group Instruction:	Individualized:
Block VII															
Sewing Principles and															
Lightweight Sewing															
Machines		•		•		•	x	•		•		•	•		
Block VIII															
Textile Fabrication and															
Medium Weight Sewing															
Machines		•		•		•	x	•		•		•	•		
Block IX															
Parachute Systems															
Repair and Special															
Sewing Machines		•		•		•	x	•		•		•	•		

X Materials are recommended but not provided.



Course Description.

This course contains 157 hours of textile and sewing instruction. The lessons include textile terminology, hand- and machine-sewn seams, and operation/maintenance of Class 31, 111, and 7 Sewing Machines. Parachutes and flight clothing are used as examples for studying instructional materials.

Block VII -- Sewing Principles and Lightweight Sewing Machines consists of 7 lessons covering 78 hours of instruction. The lesson topics and respective hours follow:

- Textile Terminology (2 hours)
- Hand Sewn Seams (6 hours)
- Hardware Installation (2 hours)
- Operation/Maintenance of Class 31 Sewing Machine (22 hours)
- Machine Sewn Seams (19 hours)
- Identification/Construction/Maintenance of
Personnel/Organizational Clothing (23 hours)
- Technical Order Diagram and Blueprint Interpretation (4 hours)

Block VIII -- Textile Fabrication and Medium Weight Sewing Machines contains 3 lessons covering 57 hours of instruction.

- Operation/Maintenance of Class 111 Sewing Machines (27 hours)
- Pattern Design and Layout (5 hours)
- Fabrication/Maintenance of Upholstery and Soundproofing (25 hours)

Block IX -- Parachute Systems Repair and Special Sewing Machine consists of 2 lessons covering 22 hours of instruction. Three lessons were deleted due to military specific materials.

- Personnel Parachute Repair Using Class 31 Sewing Machine (16 hours)
- Operation/Maintenance of Class 7 Sewing Machine (6 hours)

These blocks contain both teacher and student materials. Printed instructor materials include a plan of instruction detailing units of instruction, criterion objectives, duration of lessons, and support materials needed. A set of 11 student study guides/workbooks are included which parallel the plan of instruction.

Three military films concerning sewing machine use/maintenance are referenced, but are not provided. Some documents can be used individually as sub-units, remedial, or individualized study, and the entire course can be used in a group instructional setting or adapted for individual use.

FABRICATION & PARACHUTE SPECIALIST
(USAF 3ABR 42733)

Table of Contents

	Page	
Plan of Instruction	1	
Study Guide/Workbooks	26	
	<u>POI</u>	<u>Study Guide/Workbook</u>
Textile Terminology	2	26
Hand Sewn Seams	4	40
Hardware Installation	6	47
Operation/Maintenance of Class 31 Sewing Machines	8	57
Machine Sewn Seams	10	99
Identification/Construction/Maintenance of Personnel/Organizational Clothing	12	111
Technical Order Diagram and Blueprint Interpretation	14	
Operation/Maintenance of Class 111 Sewing Machine	16	122
Pattern Design and Layout	18	177
Fabrication/Maintenance of Upholstery and Soundproofing	20	185
Personnel Parachute Repair Using Class 31 Sewing Machine	22	199
Operation/Maintenance of Class 7 Sewing Machine	24	212

PLAN OF INSTRUCTION
(Technical Training)

FABRICATION AND PARACHUTE SPECIALIST



CHANUTE TECHNICAL TRAINING CENTER
Chanute Air Force Base, Illinois

NOTE: PAGES 1-52 OF ORIGINAL PLAN OF INSTRUCTION HAVE BEEN OMITTED DUE TO MILITARY SPECIFIC MATERIAL.

PLAN OF INSTRUCTION / LESSON PLAN PART I

2

NAME OF INSTRUCTOR	COURSE TITLE
	Fabrication and Parachute Specialist

BLOCK NUMBER	BLOCK TITLE
VII	Sewing Principles and Lightweight Sewing Machines

1	2
COURSE CONTENT	TIME

1. Textile Terminology

a. Without reference, identify terms, characteristics, storage procedures, and uses of textiles, with 90% accuracy.

STS: 11a Meas: W

2

SUPERVISOR APPROVAL OF LESSON PLAN (PART II)

SIGNATURE AND DATE

SIGNATURE AND DATE

13

PLAN OF INSTRUCTION NUMBER
C3ABR42733 000

DATE

PAGE NO.
33



COURSE CONTENT

3

SUPPORT MATERIALS AND GUIDANCE

Student Instructional Materials

3ABR42733-SW-701, Textile Terminology

Audio Visual Aids

Charts, Textile Materials (Kit 701)

Training Equipment

Training Aid 4088, Material Identification (10)

Training Methods

Discussion (2 hrs)

Multiple Instructor Requirements

None

Instructional Guidance

Show students training aid on material identification. Emphasize the need for proper storage conditions of materials.

NOTE: Emphasize the protection and care of the training literature which is to be reissued.

PLAN OF INSTRUCTION NO.
C3ABR42733 000

DATE

PAGE NO.
54

ATC FORM 133A

REPLACES ATC FORMS 337A, MAR 73, AND 770A, AUG 72, WHICH WILL BE

21

4

PLAN OF INSTRUCTION LESSON PLAN PART I

NAME OF INSTRUCTOR

COURSE TITLE

Fabrication and Parachute Specialist

BLOCK NUMBER

VII

BLOCK TITLE

Sewing Principles and Lightweight Sewing Machines

1

COURSE CONTENT

2 TIME

2. Hand Sewn Seams

*a. Given textile materials and tools, fabricate hand sewn seams as outlined in student study material, while observing all safety precautions. STS: 3a, 9, 14, 20 Meas: W, PC

6
(4/2)

SUPERVISOR APPROVAL OF LESSON PLAN (PART II)

SIGNATURE AND DATE

SIGNATURE AND DATE

15

PLAN OF INSTRUCTION NUMBER

C3ABR42733 000

DATE

PAGE NO.

55

SUPPORT MATERIAL AND GUIDANCE

Student Instructional Materials
 C3ABR42733-SW-702, Hand Sewn Seams

Audio Visual Aids
 None

Training Equipment
 Needle, Harness (1)
 Cord, Cotton (1)
 Textile Materials (1)
 Handtools (1)
 Training Aid, 2647, Seams, Hand and Machine Sewn (1)

Training Methods
 Discussion (.5 hrs)
 Demonstration (1 hrs)
 Performance (1.5 hrs)
 CTT Assignments (2 hrs)

Multiple Instructor Requirements
 None

Instructional Guidance
 Describe the uses of the four basic hand sewn seams on various types of parachutes. Stress the importance of conserving cord and textile materials.

PLAN OF INSTRUCTION NO.
 C3ABR42733 000

DATE

PAGE NO.
56

PLAN OF INSTRUCTION LESSON PLAN PART I

6

NAME OF INSTRUCTOR		COURSE TITLE	
		Fabrication and Parachute Specialist	
BLOCK NUMBER	BLOCK TITLE		
VII	Sewing Principles and Lightweight Sewing Machines		
1	COURSE CONTENT		2 TIME
	<p>3. Hardware Installation</p> <p>*a. Given parachute hardware and tools, install the hardware as outlined in student study material, while observing all safety precautions. STS: 3a, 9, <u>10</u> Meas: W, PC</p>		2
SUPERVISOR APPROVAL OF LESSON PLAN (PART II)			
SIGNATURE AND DATE		SIGNATURE AND DATE	
		17	
PLAN OF INSTRUCTION NUMBER		DATE	PAGE NO.
C3ABR42733 000			57

SUPPORT MATERIALS AND GUIDANCE

Student Instructional Materials

C3ARU2733-SW-703, Hardware Installation

Audio Visual Aids

Charts, Hand and Special Tools (Kit 107).

Training Equipment

Hand and Special Tools (1)

Presses (6)

Work Benches (10)

Parachute Hardware (1)

Training Aid, 2645, Interlocking Fastener (10)

Training Aid, 2649, Hardware (10)

Training Methods

Discussion (.5 hrs)

Demonstration (.5 hrs)

Performance (/ hrs)

Multiple Instructor Requirements

None

Instructional Guidance

Discuss and stress safety requirements for each tool used for parachute work. Discuss with students the importance of timely removal and replacement of parachute hardware in order to prevent further damage to the parachute assembly.

PLAN OF INSTRUCTION / LESSON PLAN PART I

NAME OF INSTRUCTOR	COURSE TITLE Fabrication and Parachute Specialist
---------------------------	---

BLOCK NUMBER VII	BLOCK TITLE Sewing Principles and Lightweight Sewing Machines
----------------------------	---

1	COURSE CONTENT	2 TIME
4.	<p>Operation/Maintenance of Class 31 Sewing Machine</p> <p>a. Without reference, identify nomenclature and functions of the class 31 sewing machine, with 80% accuracy. STS: 13a Meas: W</p> <p>*b. Given a class 31 sewing machine, tools, and materials, operate the sewing machine IAW technical publications, while observing all safety precautions. STS: 3a, 9, 11b, 13b</p> <p>*c. Given a class 31 sewing machine and tools, perform maintenance on the sewing machine IAW technical publications, while observing all safety precautions. STS: 3a, 9, 11b, 13c Meas: W, PC</p>	22 (16/6)

SUPERVISOR APPROVAL OF LESSON PLAN (PART II)

SIGNATURE AND DATE	SIGNATURE AND DATE
	19

PLAN OF INSTRUCTION NUMBER C3ABR42733 000	DATE	PAGE NO. 59
---	-------------	-----------------------

SUPPORT MATERIALS AND GUIDANCE

Student Instructional Materials

JABRL2733-SW-704, Operation/Maintenance of Class 31 Sewing Machine

Audio Visual Aids

Charts, Class 31 Sewing Machine (Kit 704)

Film: TVO 58-4, Maintenance of Class 31 Sewing Machine

Training Equipment

Table, Cutting (10)

Machine, Sewing, Class 31 (1)

Handtools (1)

Textile Materials (1)

Training Methods:

Discussion (3 hrs)

Demonstration (2 hrs)

Performance (11 hrs)

CTT Assignments (6 hrs)

Multiple Instructor Requirements

Safety, Equipment, Supervision (2)

Instructional Guidance

Discuss nomenclature and operation of the Class 31 sewing machine by placing emphasis on functional features of major components. Emphasis should also be placed on safety precautions used when operating sewing machines, such as balance wheel, needle, and electrical portions of the machines. Give the students a thorough demonstration on machine operating procedures.

Discuss with the students the purpose of completing only those repairs within one's capability. Emphasize how preventive maintenance of a sewing machine ensures proper functioning and aids in correct repair.

10

PLAN OF INSTRUCTION/LESSON PLAN PART I

NAME OF INSTRUCTOR

COURSE TITLE

Fabrication and Parachute Specialist

BLOCK NUMBER

VII

BLOCK TITLE

Sewing Principles and Lightweight Sewing Machines

1

COURSE CONTENT

2 TIME

5. Machine Sewn Seams

*a. Given a class 31 sewing machine and textile materials, fabricate machine sewn seams as outlined in student study material, while observing all safety precautions.

STS: 3a, 9, 11b, 13b, 20 Meas: W, PC

19
(15/4)

SUPERVISOR APPROVAL OF LESSON PLAN (PART II)

SIGNATURE AND DATE

SIGNATURE AND DATE

21

PLAN OF INSTRUCTION NUMBER

C3ABR42733 000

DATE

PAGE NO.

61

COURSE CONTENT

//

SUPPORT MATERIALS AND GUIDANCE

Student Instructional Materials

JABR42733-SW-705, Machine Sewn Seams

Audio Visual Aids

Charts, Machine Seams No. 1 and No. 2 (Kit 705)

Training Equipment

Machine, Sewing, Class 31 (1)

Table, Cutting (10)

Textile Materials (1)

Handtools (1)

Training Aid, 2647 (10)

Training Methods

Discussion (2 hrs)

Demonstration (3 hrs)

Performance (10 hrs)

CTT Assignments (4 hrs)

Multiple Instructor Requirements

Safety, Equipment, Supervision (2)

Instructional Guidance

Stress the importance of following safety precautions during construction of machine sewn seams. Place emphasis on the importance of good seam formation to prepare for later work on parachutes and clothing.

12

PLAN OF INSTRUCTION/LESSON PLAN PART I

NAME OF INSTRUCTOR	COURSE TITLE Fabrication and Parachute Specialist
---------------------------	---

BLOCK NUMBER VII	BLOCK TITLE Sewing Principles and Lightweight Sewing Machines
----------------------------	---

1	COURSE CONTENT	2 TIME
----------	-----------------------	---------------

6. Identification/Construction/Maintenance of Personnel/Organizational Clothing

a. Without reference, identify facts and principles concerning types of protective clothing, with 80% accuracy. STS: 25a Meas: W

*b. Given personnel/organizational clothing, applicable TO, class 31 sewing machine, and tools, repair/service the clothing IAW technical publications, while observing all safety precautions. STS: 3a, 9, 11b, 13b, 25b, 25c Meas: W, PC

*c. Given personnel/organizational clothing, applicable TO, class 31 sewing machine, and tools, assemble/disassemble wrist seals on clothing IAW technical publications, while observing all safety precautions. STS: 3a, 9, 11b, 13b, 25d Meas: W, PC

23
(17/6)

SUPERVISOR APPROVAL OF LESSON PLAN (PART II)

SIGNATURE AND DATE	SIGNATURE AND DATE
	23

PLAN OF INSTRUCTION NUMBER C3ABR42733 000	DATE	PAGE NO. 43
---	-------------	-----------------------

COURSE CONTENT

SUPPORT MATERIALS AND GUIDANCE

Student Instructional Materials

JABRU2733-SW-706, Identification/Construction/Maintenance of Personnel/
Organizational Clothing
TO 14P3-1-112, Maintenance Instructions, Nomex Flight Gear, Type CWU-17/P,
Gloves, Type GS-RRP-1
TO OO-25-120, General Repair of Clothing

Audio Visual Aids

Charts, Inspection and Repair of Aircrew Flying Clothing (Kit 706)

Training Equipment

Machine, Sewing, Class 31 (1)
Aircrew Flying Clothing (1)
Training Aid 2638, Helmet, E-9 Assembly (10)
Training Aid 2640, Arctic Mitt Assembly (10)
Tool Kit, Fabric and Rubber Products Specialist (1)

Training Methods

Discussion (5 hrs)
Demonstration (2 hrs)
Performance (10 hrs)
CTT Assignments (6 hrs)

Multiple Instructor Requirements

Safety, Equipment, Supervision (2)

Instructional Guidance

During inspection and repair procedures on flight clothing, take special care to insure that safety procedures are correctly followed when utilizing handtools and sewing machines. Have students replace interlocking fastener on flight suit, replace wristlet on flight jacket, and repair 1/2 inch tear on flight suit. Stress the importance of following TO instructions.

PLAN OF INSTRUCTION NO.
CSABRU2733 000

DATE

PAGE NO.

64

PLAN OF INSTRUCTION / LESSON PLAN PART I

14

NAME OF INSTRUCTOR	COURSE TITLE
	Fabrication and Parachute Specialist

BLOCK NUMBER	BLOCK TITLE
VII	Sewing Principles and Lightweight Sewing Machines

1 COURSE CONTENT	2 TIME
<p>7. Technical Order Diagram and Blueprint Interpretation</p> <p style="margin-left: 40px;">a. Without reference, identify facts and principles concerning technical order diagram and blueprint interpretation, with 80% accuracy. SIS: 21a, 21d Meas: W</p>	<p>4</p> <p>(2/2)</p>

SUPERVISOR APPROVAL OF LESSON PLAN (PART II)

SIGNATURE AND DATE	SIGNATURE AND DATE

PLAN OF INSTRUCTION NUMBER	DATE	PAGE NO
C IABR42733 009	25	65

SUPPORT MATERIALS AND GUIDANCE

Student Instructional Materials

C3ABR12733-SW-802, Pattern Design and Layout

Audio Visual Aids

None

Training Equipment

None

Training Methods

Discussion (2 hrs)

. CTT Assignments (2 hrs)

Multiple Instructor Requirements

None

Instructional Guidance

- | | |
|--|---|
| 8. Related Training (identified in course chart) | 0 |
| 9. Measurement and Critique | 2 |
| a. Measurement Test | |
| b. Test Critique | |

PLAN OF INSTRUCTION LESSON PLAN PART I

16

NAME OF INSTRUCTOR	COURSE TITLE
	Fabrication and Parachute Specialist

BLOCK NUMBER	BLOCK TITLE
VIII	Textile Fabrication and Medium Weight Sewing Machines

1 COURSE CONTENT	2 TIME
-------------------------	---------------

<p>1. Operation/Maintenance of Class III Sewing Machine</p> <p style="margin-left: 40px;">a. Without reference, identify nomenclature and functions of the class III sewing machine, with 30% accuracy. STS: 13a Meas: W</p> <p style="margin-left: 40px;">*b. Given a class III sewing machine, tools, and materials, operate the sewing machine IAW technical publications, while observing all safety precautions. STS: 3a, 9, 11b, 13b Meas W, PC</p> <p style="margin-left: 40px;">*c. Given a class III sewing machine and tools, perform maintenance on the sewing machine IAW technical publications, while observing all safety precautions. STS: 3a, 9, 11b, 13c Meas: W, PC</p>	<p>27 (21/6)</p>
--	----------------------

SUPERVISOR APPROVAL OF LESSON PLAN (PART II)

SIGNATURE AND DATE	SIGNATURE AND DATE

PLAN OF INSTRUCTION NUMBER	DATE	PAGE NO.
C3ABR42733,000		67

27

COURSE CONTENT

17

SUPPORT MATERIALS AND GUIDANCE

Student Instructional Materials

3ABR12733-SW-801, Operation/Maintenance of the Class 111 Sewing Machine

Audio Visual Aids

Charts, Class 111W Sewing Machine (Kit 801)

Film: TVL 58-3, Maintenance of Class 111 Sewing Machine

Training Equipment

Machine, Sewing, Class 111W (1)

Table, Cutting (10)

Handtools (1)

Textile Materials (1)

Training Methods

Discussion (2.5 hrs)

Demonstration (3.5 hrs)

Performance (15 hrs)

CTT Assignments (6 hrs)

Multiple Instructor Requirements

Safety, Equipment, Supervision (2)

Instructional Guidance

Be sure to stress safety precautions used when operating sewing machines. Watch the balance wheel, needle, and electrical portions of the machine. Give the students a thorough demonstration on machine operating procedures. Discuss with students the purpose of completing only those repairs within one's capability. Emphasize how preventive maintenance of a sewing machine ensures proper functioning and aids in correct repair.

NOTE: Emphasize the protection and care of the training literature which is to be reissued.

PLAN OF INSTRUCTION NO.
3ABR12733 000

DATE

PAGE NO.

68

18

PLAN OF INSTRUCTION LESSON PLAN PART I

NAME OF INSTRUCTOR COURSE TITLE
Fabrication and Parachute Specialist

BLOCK NUMBER BLOCK TITLE
VIII Textile Fabrication and Medium Weight Sewing Machines

1 COURSE CONTENT 2 TIME

2. Pattern Design and Layout

a. Given applicable tools and material, lay out a pattern and fabricate a template. Finished template must be constructed according to local standards.

STS: 3a, 9, 17c, 18c, 21a, 21d Meas: W, PC

5

(3/2)

SUPERVISOR APPROVAL OF LESSON PLAN (PART II)

SIGNATURE AND DATE

SIGNATURE AND DATE

PLAN OF INSTRUCTION NUMBER

C3ABR42733 000

DATE

PAGE NO.

69

SUPPORT MATERIALS AND GUIDANCE

Student Instructional Materials

C3ABRL2733-SW-802, Pattern Design and Layout

Audio Visual Aids

None

Training EquipmentMachine, Stencil (1)
Stencil Paper (1)Training MethodsDiscussion (.5 hrs)
Demonstration (.5 hrs)
Performance (2 hrs)
CTT Assignments (2 hrs)Multiple Instructor Requirements

None

Instructional Guidance

NOTE: PAGES 71-72 OF ORIGINAL PLAN OF INSTRUCTION HAVE BEEN OMITTED DUE TO MILITARY SPECIFIC MATERIALS.

PLAN OF INSTRUCTION NO.

C3ABRL2733 000

DATE

PAGE NO.

70

ATC FORM 133A
APR 74REPLACES ATC FORMS 337A, MAR 73, AND 770A, AUG 72, WHICH WILL BE
USED

76-10844

20

PLAN OF INSTRUCTION LESSON PLAN PART I

NAME OF INSTRUCTOR

COURSE TITLE

Fabrication and Parachute Specialist

BLOCK NUMBER

VIII

BLOCK TITLE

Textile Fabrication and Medium Weight Sewing Machines

1

COURSE CONTENT

2 TIME

4. Fabrication/Maintenance of Upholstery and Soundproofing

25
(19/6)

a. Without reference, identify facts and principles concerning types of upholstery and aircraft soundproofing with 80% accuracy.

STS: 24a, 24b Meas: W

*b. Given a class III sewing machine, tools, upholstery material, and specifications for an upholstery project, fabricate the item of upholstery IAW the project specifications, while observing all safety precautions. STS: 3a, 9, 11b, 13b, 24c Meas: W, PC

*c. Given a class III sewing machine, tools, soundproofing material, and specifications for a soundproofing project, fabricate an aircraft soundproofing panel IAW the project specifications, while observing all safety precautions.

STS: 3a, 9, 11b, 13b, 24c Meas: W, PC

*d. Given items of damaged upholstery and soundproofing, class III sewing machine, tools, and repair specifications, inspect and repair each item IAW repair specifications, while observing all safety precautions.

STS: 3a, 9, 11b, 13b, 24d, 24e Meas: W, PC

SUPERVISOR APPROVAL OF LESSON PLAN (PART II)

SIGNATURE AND DATE

SIGNATURE AND DATE

PLAN OF INSTRUCTION NUMBER

C3ABR42733 000

DATE

PAGE NO.

73

SUPPORT MATERIALS AND GUIDANCE

Student Instructional Materials

C3ABR12733-SW-804, Fabrication/Maintenance of Upholstery and Soundproofing

Audio Visual Aids

Charts, Upholstery and Aircraft Soundproofing (Kit 804)

Training Equipment

Machine, Sewing, Class 111 (1)
 Training Aid 2635, Aircraft Seat Cushion (10)
 Hand and Foot Press (10)

Training Methods

Discussion (.5 hrs)
 Demonstration (2.5 hrs)
 Performance (16 hrs)
 CTT Assignments (6 hrs)

Multiple Instructor Requirements

Safety, Equipment, Supervision (2)

Instructional Guidance

Appearance and comfort are important in good upholstery. The correct materials must be used for upholstery to perform its designed function. Have the students make a cushion and a piece of soundproofing to be used for inspection and repair. Discuss appearance and comfort as factors of good upholstery. Explain the purpose of upholstery buttons.

- 5. Related Training (identified in course chart) 2
- 6. Measurement and Critique 2
 - a. Measurement Test
 - b. Test Critique

22

PLAN OF INSTRUCTION/LESSON PLAN PART I

NAME OF INSTRUCTOR

COURSE TITLE

Fabrication and Parachute Specialist

BLOCK NUMBER

IX

BLOCK TITLE

Parachute System Repair and Special Sewing Machines

1

COURSE CONTENT

2 TIME

1. Personnel Parachute Repair Using Class 31 Sewing Machine

*a. Given damaged personnel parachute components, a class 31 sewing machine, tools, and student study material, repair the components as outlined in student study material, while observing all safety precautions.

STS: 3a, 9, 11b, 13b, 17c Meas: W, PC

16
(12/4)

SUPERVISOR APPROVAL OF LESSON PLAN (PART II)

SIGNATURE AND DATE

SIGNATURE AND DATE

PLAN OF INSTRUCTION NUMBER

C3ABR42733 000

DATE

PAGE NO.

75

SUPPORT MATERIALS AND GUIDANCE

Student Instructional Materials

C3ABR42733-SW-901, Personnel Parachute Repair Using Class 31 Sewing Machine

Audio Visual Aids

None

Training Equipment

Machine, Sewing, Class 31 (1)

Table, Cutting (10)

Parachute Components, Personnel (1)

Handtools (1)

Textile Materials(1)

Training Methods

Discussion (1 hrs)

Demonstration (1 hrs)

Performance (10 hrs)

CTT Assignments (4 hrs)

Multiple Instructor Requirements

Safety, Equipment, Supervision (2)

Instructional Guidance

Be sure to emphasize to students that repairs made to parachute components must meet or exceed the requirements of the original item being repaired. Discuss major repairs that are made to parachute components. Give the student a complete demonstration on the repair of each parachute component that he/she is required to complete for the unit of instruction.

NOTE: Emphasize the protection and care of the training literature which is to be reissued.

**NOTE: PAGES 77-82 OF ORIGINAL POI
HAVE BEEN OMITTED DUE TO MILITARY SPECIFIC
MATERIAL.**

PLAN OF INSTRUCTION NO.

C3ABR42733 000

DATE

PAGE NO.

76

24

PLAN OF INSTRUCTION. LESSON PLAN PART I

NAME OF INSTRUCTOR	COURSE TITLE Fabrication and Parachute Specialist
--------------------	--

BLOCK NUMBER IX	BLOCK TITLE Parachute System Repair and Special Sewing Machines
--------------------	--

1	COURSE CONTENT	2	TIME
	<p>5. Operation/Maintenance of Class 7 Sewing Machine</p> <p>a. Without reference, identify nomenclature and functions of the class 7 sewing machine with 80% accuracy. STS: 13a Meas: W</p> <p>*b. Given a class 7 sewing machine, tools and materials, operate the sewing machine IAW technical publications, while observing all safety precautions. STS: 3a, 9, 11b, 13b, 13c Meas: W, PC</p>		6

SUPERVISOR APPROVAL OF LESSON PLAN (PART II)

SIGNATURE AND DATE	SIGNATURE AND DATE

PLAN OF INSTRUCTION NUMBER C3ABR42733 000	35	DATE	PAGE NO. 83
--	----	------	----------------

SUPPORT MATERIALS AND GUIDANCE

Student Instructional Materials

3ABR/2733-SW-905 Operation/Maintenance of Class 7 Sewing Machine
 TO 34Y7-2-1, Instructions for Using and Adjusting Singer Sewing Machine 7-33

Audio Visual Aids

Charts, Operation/Maintenance of Class 7 Sewing Machine (Kit 905)

Training Equipment

Machine, Sewing, Class 7 (2)
 Table, Cutting (10)
 Handtools (1)
 Textile Materials (1)

Training Methods

Discussion (1 hrs)
 Demonstration (1 hrs)
 Performance (4 hrs)

Multiple Instructor Requirements

None

Instructional Guidance

Discuss description and operation of the Class 7 sewing machine. Demonstrate operating procedures by placing emphasis on safety precautions used when operating the sewing machine, such as balance wheel, needle, and electrical portions of the machine.

Technical Training

Fabrication and Parachute Specialist

TEXTILE TERMINOLOGY

23 March 1979



CHANUTE TECHNICAL TRAINING CENTER (ATC)
3340 Technical Training Group
Chanute Air Force Base, Illinois

DESIGNED FOR ATC COURSE USE
DO NOT USE ON THE JOB

TEXTILE TERMINOLOGY

OBJECTIVES

On completion of this unit of instruction, you will be able to define textile terms and describe the use and storage of materials.

INTRODUCTION

Terms are used in describing textiles and their properties that should be understood by everyone in this career field. Knowing the terms, of course, is not enough. The fabrication and parachute specialist must also gain an understanding of how materials are used and stored.

INFORMATION

TEXTILE TERMS

In the manufacture of textile fibers and materials, certain terms are used which are standard throughout the textile industry. These terms are used in Air Force stock lists to assist in identifying and classifying materials, and in workbooks and student study guides throughout the school. In order for the fabric and rubber products specialist to understand and comply with instructions in these various publications, as well as subsequent paragraphs in this study guide, he should have a knowledge of the pertinent terms.

Bias

A bias is a diagonal line of a cut, a fold, or a seam across a piece of textile material at an angle of 45 degrees to the direction of the filling threads in the material. Bias construction is used to save material, prevent tearing between sections, and provide elasticity where it is a requirement for satisfactory performance of the article. The bias direction of the fabric has a greater stretching quality than the straight direction.

Cloth Weight

All fabrics have a designated cloth weight, which represents the weight of a square yard of the particular cloth or fabric in ounces. Thus, if a square yard of cotton duck weighs eight ounces, it is called eight ounce duck.

Supersedes ST 3ABR42733-SW-701 (undated). 38

OPR: 3340 TCHTG

DISTRIBUTION: X

3340 TCHTG/TTGU-L - 410; TTVSA - 1

Warp

Threads which run lengthwise of the cloth parallel to the selvage edge are the warp threads. If there is a difference in the strength of the warp and filling threads, the warp threads are usually stronger, as they form the framework for the material and support most of the strain during the weaving process. Figure 1 illustrates both warp and filling threads.

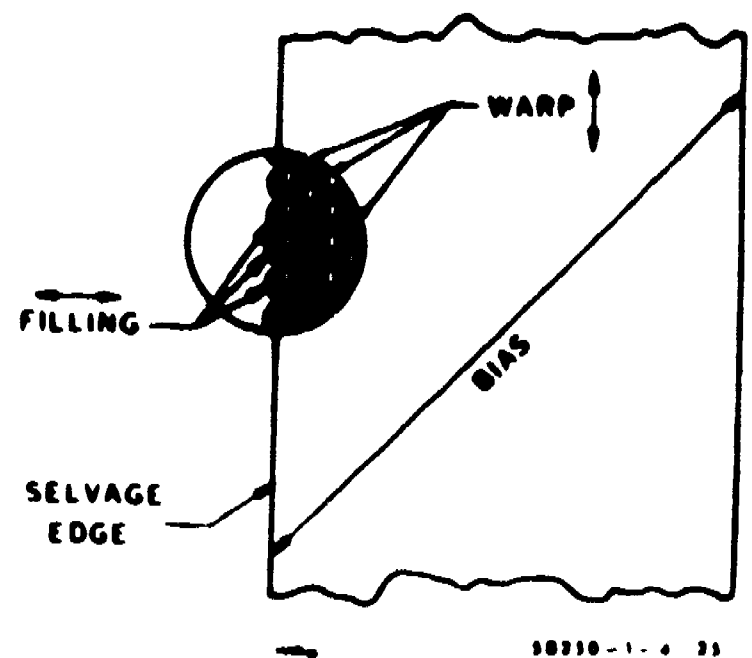

30210-1-4 21

Figure 1. Textile Terms.

Filling

Filling is also referred to as wool, welt, and pick. It is the threads which run crosswise to the cloth as it comes from the loom. This term is not to be confused with "filling" in the sense of sizing which means the addition of substances which give body or decrease porosity of the material. Warp and filling threads must be determined in pattern layout as patterns are always cut with the warp and filling unless otherwise stated.

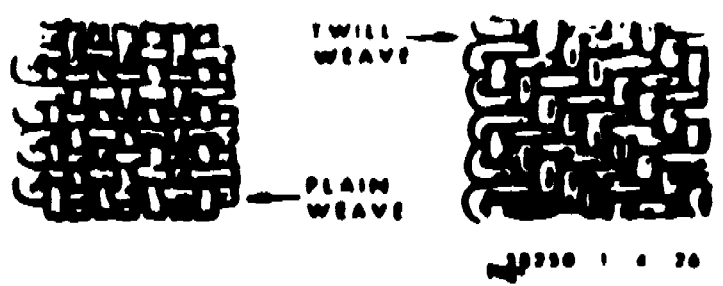

30210 1 4 20

Figure 2. Basic Weaves.

The two basic weaves are plain and twill (see figure 2). The plain weave is the simplest method of weaving and gives the smoothest surface of the fabric. It consists of the filling threads passing over one warp thread and under the next warp thread. The twill weave is a more complicated weave in which the filling threads pass over and under more than one warp thread, thereby producing a surface on the fabric which is generally recognized as a diagonal pattern.

Selvage and Raw Edges

The selvage edges of material are the edges of cloth, tape, or webbing that are woven to prevent raveling (see figure 1). When the material is cut, the resulting edge at the cut is referred to as a raw edge.

Filament

A fiber of indefinite length, such as filament acetate, rayon, or nylon may be miles long. Filaments are then spun into yarn.

Staple

Staple is the cutting of a group of man-made filaments into some desired length for manipulation, either alone or in blends and mixtures. Staple also refers to natural fibers such as cotton or wool since they are of short lengths.

TYPES OF FIBERS

NATURAL FIBERS - Cotton - Cotton plant (cellulose)
 Linen - Flax plant (cellulose)
 Wool - Sheep (protein)
 Silk - Silkworm (protein)

MAN-MADE FIBERS - Viscose rayon - Cotton plant
 Cuprammonium rayon - Cotton plant
 Acetate - Tree (cellulose)
 Vicara - Corn (protein)

SYNTHETIC FIBERS - Nylon - Polyamide
 Orlon - Acrylic
 Acrilan - Acrylic
 Dacron - Polyester
 Fiberglass - Glass

IDENTIFICATION AND USE OF MATERIALS

In order to select the proper materials for a specific project, it is necessary for you to know the identification, characteristics and uses of these various materials. It is only then that you will be able to accomplish your most satisfactory work.

Threads

Filaments or staples are twisted together to form yarns. Two or more yarns twisted together form a thread or ply-yarn, as the yarn by itself is too small for practical use. The strength of a thread depends upon the size and number of yarns used to make up the thread. The thread numbers on spools indicate the size of the yarn used and the number of yarns that are plied (or twisted) together to give the necessary strength to the thread. For example, a 16-4 thread indicates that the thread was made from a single yarn, size 16, and that four of these single yarns were twisted together to make a thread. The finer the yarn used, the higher its size number. Silk and nylon thread sizes, however,

are indicated by letters, such as A, E, etc.; the higher the letter, the larger the thread. Technical orders indicate specification numbers where use of a specific thread is necessary.

Thread is twisted to the left or twisted to the right, depending on its use. Left-twist thread is always used in the sewing machine because the action of the stitch-form mechanism will ravel or break right-twist thread. Left-twist thread may be used for hand sewing. The terms used to designate left-twist threads are: "machine," "machine twist," "left twist," and "Z twist." A cord or thread has left, or Z, twist if, when held in a vertical position, the twist of the yarn follows the slope of the central portion of the Z; and right, or X twist, if it follows the slope of the central portion of the letter "S", as shown in figure 3.

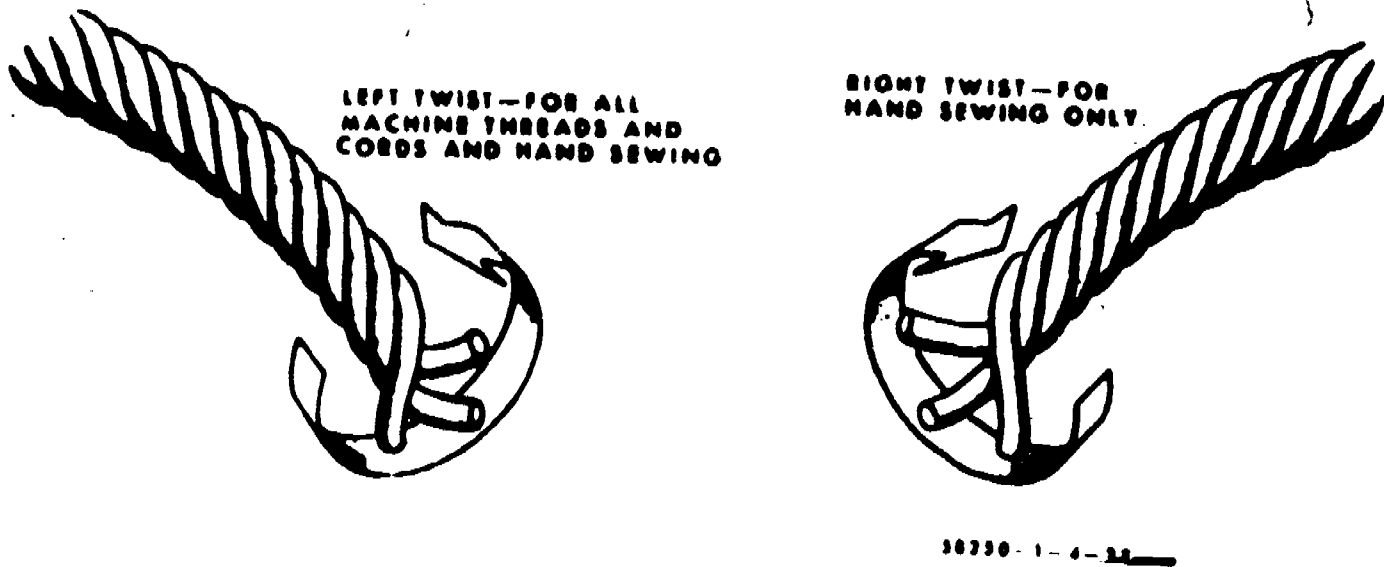

Figure 3. Thread Twist.

Fabrics

In the not too distant past, we were limited to natural fibers as a source for our fabrics and associated materials, but today with the advent of synthetic fibers, we can enjoy their improvement in some respects over the natural fiber.

Currently the natural and synthetic fibers have their respective advantages and disadvantages. These will be pointed out in the following paragraphs.

Tapes and Webbing

Tapes and webbings are so designated if they are not more than 12 inches wide. Materials over 12 inches wide are considered fabric. The dividing line between tapes and webbings lies in the weight. Material up to and including 15 ounces per square yard is called tape, and over 15 ounces, it is called webbing.

COTTON. This is a unicellular material fiber, usually white, between 3/8 and two inches long. Chemically it is almost pure cellulose. Cotton fabrics, webbing, and tapes absorb water readily unless treated. They dry more slowly than the synthetic fabrics and are more

31

susceptible to mildew and fungus growth. The presence of mildew will seriously affect the tensile strength of cotton and other fabrics and should never be ignored. Heat is less damaging to cotton than to the synthetics. Insect damage should, however, always be considered since cotton is a food for certain cellulose eating insects and makes good nesting or cocoon-spinning material for rodents and insects.

DUCK. This is a comparatively firm, heavy, coarse, plain weave, cotton fabric with weight per square yard from 6 to 50 ounces. Duck is frequently called canvas. There are two general types of duck based on construction: Regular duck, in which both the warp and filling yarns are plied and unsized; and flat duck in which the warp yarns are single, sized, with two strands of yarn over as one warp end interlining as a unit with one filling yarn which is either single or plied.

NYLON. This is a synthetic fiber of extreme toughness and elasticity. It absorbs very little water, dries quickly, is mildew proof and is not affected by most ordinary oils, greases or cleaning fluids. It is moth proof and does not offer anything relative to food for hungry insects. It is sensitive to some chemical fumes, excessive heat, and direct rays of sunlight.

FIBERGLASS. The term "Fiberglass" is a registered trademark for a variety of products made of or with glass fibers. Uses for glass fibers and filaments have broadened rapidly since the fiberglass process was invented in 1931. Superfine fibers are used for thermal insulation and sound absorption purposes in military aircraft. Among the advantages of fiberglass are lightness, noncombustibility and thermally efficient insulation.

RUBBER. Rubber and rubberized fabrics are used in the manufacture of exposure suits and flotation equipment. These materials are used as they are water tight. Rubberized materials are susceptible to deterioration due to heat and mildew. Foam rubber, which is thick and resilient, is often used as padding in upholstery and aircraft crash pads.

VINYL. Many types of vinyl materials are now in use. It is available in various thicknesses, colors and textures, depending on its intended use. Some are constructed of plastic only, while others have cloth backing bonded in place on the back. It may be used for seat covers, dust covers and associated items. Vinyl is vapor tight and has a smooth or textured surface. It can easily be cleaned with soap and water, however, detergents should not be used due to their deteriorating effect on the vinyl.

STORAGE OF COTTON AND NYLON

It is necessary to know the general principles of care and storage of materials. They differ considerably in their resistance to damage from moisture, heat, mildew, fungus, insects, and rodents. There are certain insects, however, that will eat almost anything; mice will build nests in almost any kind of stored fabric material, and there are hundreds of fungus growths that thrive under moist tropical atmospheric conditions. Conditions in various parts of the world vary widely in regard to humidity, heat, or cold, and the presence of insects. Such conditions must be taken into consideration when storage and proper care

32

of materials is undertaken. The following ideal storage conditions should be attained as nearly as possible: a dry room with temperature of 70° Fahrenheit, absence of direct sunlight, a storage room construction that affords protection against insects and mice, wooden shelves for storage, and air conditioning or some method of humidity control.

Now let's consider some of the characteristics of materials which you should know if you are to be responsible for their conservation. Nylon absorbs very little water, dries quickly, is mildew proof, and is not affected by most ordinary oils, greases, or cleaning fluids. It is mothproof and, since it is not an animal fiber like wool or silk, does not offer food to hungry insects. However, if insect larvae are inside the folds of stored fabrics, they may eat their way out. Soiled or greasy spots in the fabric will attract insects.

CHARACTERISTICS OF PARACHUTE MATERIALS (NYLON)

Parachute Requirements

If a parachute is to serve its purpose, it must be reliable. Reliability is the most important requirement for safe parachutes. To be reliable, the parachutes must meet certain engineering requirements.

These requirements are achieved if the materials, used in the manufacture of the parachutes, possess certain construction characteristics and if the parachutes are properly serviced by the parachute rigger. Some of these requirements are:

1. Opening Time: A must requirement for personnel parachutes, especially in low altitude bailouts, is a quick opening. Packing procedures, egress systems and engineering design provide means for quick opening. Parachute riggers are responsible for insuring that the parachutes they pack not only open, but that they open as quickly as they were designed to. This is under any emergency condition that may arise.

For deceleration and cargo parachutes, a slower opening time is desired. The faster the opening time, the greater the opening forces on the parachute.

2. Opening Forces: The forces exerted on the load at the time of deployment and inflation.

3. Canopy Drag: The drag, pull, or braking force of the parachute pulling through the air at the time of deployment.

4. Stability: The control or stabilization of the swing or oscillation of the parachute after opening.

Good Characteristics

All materials have good and bad characteristics. Since parachutes are made of nylon, the characteristics discussed in this lesson will apply to nylon. Of the various materials tested, "Nylon 66" possesses most of the good characteristics to meet the engineering requirements.

33 The following is a list of the good characteristics and their relationship to parachutes.

1. Air Permeability: A term used to designate the measured volume of air that will flow through cloth at a given pressure. A material that has shrunk because of becoming wet has less air permeability since the weave has been drawn together. Air permeability is of importance to those who design, use and service parachute assemblies because it affects the reliability, opening time, opening force, canopy drag, and the stability of the parachute assembly.

DO NOT, FOR ANY REASON, PACK A WET PARACHUTE

a. Opening Time. The greater the airflow through a canopy, the slower the opening time of that canopy. As a rule, a desirable feature for personnel parachutes is quick opening time. For deceleration and cargo parachutes, a slower opening time is desired. The faster the opening time, the greater the opening shock of the parachute.

b. Opening Force. The greater the airflow through a canopy, the less the opening force. The deceleration (braking force) of the assembly is built up over a longer period of time, thus enabling the material of the parachute assembly to withstand and decelerate greater loads.

c. Canopy Drag. The smaller the amount of airflow through the canopy, the greater the canopy drag or braking force of the parachute assembly.

d. Stability. The greater the airflow through the canopy, the more stable the parachute assembly. There are stability requirements a parachute must meet. For example, the deceleration parachute should not swing or oscillate more than five degrees on either side of a straight line directly back of the aircraft's fuselage.

2. Strength: A term for that property of material by which it can resist strain or rupture induced by external forces. It is expressed as tensile strength, which is measured in pounds per square inch, or as tenacity, which is measured in grams per denier. Selection of the most suitable material for parachute design is imperative. The strength of the parachute is determined to a great degree by the strength of the material used in its construction. Nylon is one of the strongest synthetics. Strength is a good characteristic, and also an important requirement for safe, reliable parachutes.

3. Elongation: Deformation caused by a tensile force. It is expressed as percentage of stretch over the original length and may be measured at any specific load or at break. The ability to elongate gives strength to the material. Nylon will stretch from 18 to 40 percent, well above military specifications of 20 to 25 percent.

4. Elasticity or Elastic Recovery: The property of a filament of yarn to elongate (stretch) upon application of tension, and to recover part or all of the original length upon release of tension. A test given to determine the elasticity of a material is to give it a 4 percent stretch and then determine the percent of return to its original length.

34

A material that will return to 75 to 95 percent of its original length is said to have a satisfactory elastic characteristic. A material that will return to 95 percent of its original length has excellent elastic characteristics. Nylon will return to 100 percent of its original length; therefore, its elastic characteristic is classified as excellent. A parachute manufactured from material with good elastic characteristics will be stronger and have less opening shock. Elasticity is a good characteristic of nylon and is one of the necessary requirements for making reliable parachutes.

5. Weight of Nylon Materials: Nylon fibers are lightweight. Therefore, the materials manufactured of nylon fibers are lightweight materials. It is desirable for the personnel parachute to be made of lightweight materials because the canopy will open faster and will be lighter and more comfortable for the wearer. In the case of cargo and deceleration parachutes, the weight of the assembly is also important. A lightweight parachute enables the aircraft to carry more weight or cargo load. Lightweight material is a necessary requirement for all parachutes, and a good characteristic of nylon.

6. Abrasion Resistance: The degree to which a fabric is able to withstand wear and rubbing. Nylon has the greatest resistance to abrasion of any material being used in parachutes today. The amount of resistance it has, however, is not enough to withstand the rugged use to which some parachutes are subjected. The parachute canopy, during the packing process, is pulled up and down the packing table. A deceleration parachute, when opened to brake the landing roll of the plane, often comes in contact with the runway. Rubbing over the runways can cause damage by abrasion. Webbing, such as those used for deceleration parachute riser webbings, are given a "Merlon" treatment to make them more resistant to wear. Abrasion resistance is a good characteristic of nylon and, although nylon doesn't quite meet the necessary requirements, it is better than any other material tested for parachute use.

7. Resistance to Mold, Mildew, and Insects: The ability of a material to resist damage which can be caused by mold, mildew, and insects is an important consideration in the manufacture of parachutes. Nylon material is wholly resistant to mold, mildew, and insects. There is nothing in nylon that will support the growth of mold or mildew, and it has no food value to insects. Parachutes that are in active service, as well as those that are in storage, are exposed to conditions which make them liable to damage from mold, mildew, and insects. Fungus growth and insects thrive in a warm, damp climate or where those conditions are present. A parachute that could not resist damage from fungus or insects would very quickly be damaged to the extent that it would be unsuitable for use in the Air Force.

Poor Characteristics

Unfortunately, all of the characteristics of nylon are not good ones. Since the good characteristics are so important in meeting the necessary requirements for parachutes, the government

35

has selected nylon above all other materials. Steps have been taken to improve the poor characteristics of nylon where possible. Some of the poor characteristics and what has been done to improve them are described in the following information.

1. Moisture Regain: This is the percentage of moisture that a bone-dry fiber will absorb from the air under standard conditions of temperature and humidity (65 percent relative humidity and 70 degrees F). If this figure is less than five percent, the fiber is relatively difficult to dye and will build up static charges when rubbed. The moisture regain of nylon is only 4.2 percent, so it is hard to dye and is subject to static electricity.

Multicolored canopies can be readily spotted from the air. This assists rescue teams if this service becomes necessary. A colored deceleration canopy on the airfield enables crews to pick up the assembly quickly. A yellow-dyed canopy is more resistant to ultraviolet light damage from sunlight. The buildup of static electricity can make it more difficult to service the parachute; static electricity can also affect the opening time of the assembly.

2. Resistance to Sunlight: The ability of a material to resist damage from ultraviolet light, which is found in sunlight, is an important characteristic. All parachutes are exposed to sunlight to some degree, and this exposure greatly reduces the strength of parachute material where inherent resistance is low. The military specifications for materials that go into the manufacture of deceleration parachutes state that the material should not lose more than 25 percent of its original strength after 50 hours exposure to sunlight or weathering. Inspections made on deceleration parachutes to determine the cause of failure of the parachute have shown that the material will sometimes show a loss in strength in excess of 50% after 50 hours exposure to sunlight.

Chemists have developed materials which are more resistant to ultraviolet light. Chemstrant "R" factor (a chemical) was added to the fiber as the yarns were being manufactured. Yellow dye was also added to improve resistance to ultraviolet light damage.

3. Heat Resistance: Personnel parachutes may be exposed to heat in the aircraft in case of fire. Deceleration parachutes may be exposed to heat in the drag chute compartment of the aircraft.

Nylon has a relatively low melting point, 482 degrees F, which makes it very susceptible to damage from heat. Parachute assemblies may also be exposed to heat caused by friction, such as line-overs (a parachute suspension line being drawn over the canopy during deployment and opening of the parachute). The deceleration parachute coming in contact with the runway generates friction and heat.

4. Resistance to Chemicals: Parachutes may be exposed to various chemicals and it is important to know which chemicals are harmful and which are not. Nylon material is resistant to most chemicals; however, it is very susceptible to damage from mineral-type acids, one of which is used in batteries. Most compounds,

such as alcohols, alkalies, dry cleaning solvents, soaps and detergents, have little effect on the strength and elongation of nylon yarn.

Soot and certain chemical fumes are highly injurious to nylon and direct heat or exposure to the sun's rays seriously affect its tensile strength. It is not unusual for nylon to lose 30% of its tensile strength if constantly exposed to the sun's rays.

Cotton fabrics, webbings, and tapes absorb water readily unless treated. They dry more slowly than the synthetic fabrics and are more susceptible to mildew and fungus growth. The presence of mildew will seriously affect the tensile strength of cotton or other fabrics and should never be ignored. Heat is less damaging to cotton than to the synthetics. Insect damage, however, should always be considered since cotton is a food for certain cellulose-eating insects and makes good nesting or cocoon-spinning material for certain insects.

In any case, fire is a constant threat to fabrics. Smoking should not be permitted where they are handled or stored, and the storage of damp materials may result in fire caused by spontaneous combustion. The rayons are almost explosive when set afire. Nylon, although harder to ignite, will burn but will not explode in the process. Great care should be taken to learn the storage problems peculiar to any specific locality or climatic conditions in order to insure safe storage of these materials.

CHARACTERISTICS

Elasticity

The ability of textile fibers to bounce back when released from tension of stretch.

Elongation

The ability of fibers in yarns or fabrics to go in the direction of the weave; also means the increase in length from a tensile force.

Tensile Strength

The maximum load per unit of the original cross-section area obtained prior to rupture. It is the actual number of pounds resistance that a fabric will give to a breaking machine before the material is broken on the testing apparatus and may no longer be classed as a cloth or fabric.

Exercise 1

Study the training literature and answer the following questions on a separate sheet of paper.

1. What is a bias?



37

2. How is cloth weight measured?
3. What are the names of the threads which run lengthwise and crosswise in the materials?
4. Name the two basic weaves and their differences.
5. Explain the terms selvage edge and raw edge.
6. When referring to thread size, what is meant by 16-4?
7. Which thread twist is used in sewing machines and why?
8. State the disadvantages of cotton.
9. State the advantages of nylon.
10. Describe the characteristics of cotton duck.
11. When is rubber used in our career field?
12. State two uses for leather in our field.
13. What is vinyl and what are some of its uses?
14. What are the ideal conditions for storage of materials?
15. The difference between tapes and webbings and material is (1) weight, (2) width, (3) weight and width, (4) weight and length.
16. To be different from material, tapes and webbings must be (1) less than 6" wide (2) less than 12" wide (3) less than 18" wide (4) less than 20" wide.
17. Which of the following is not a characteristic of cotton duck? (1) very elastic (2) good wearing quality (3) low cost (4) high absorbency.
18. The difference between tapes and webbings is (1) length (2) thickness (3) weight (4) material from which they are made.
19. To be classified webbing material must be less than 12" wide and weigh over (1) 6 oz (2) 12 oz (3) 15 oz (4) 18 oz per square yard.
20. Sewing machines use (1) Z (left) twist (2) S (right) twist (3) either Z or S twist thread for sewing.
21. Yarns are formed by twisting together (1) filaments (2) threads (3) cords (4) ropes.
22. Ply-yarns are two or more yarns twisted together and form (1) filament (2) thread (3) cords (4) ropes.
23. Yarn size is indicated by a number (e.g., 16): the finer the yarn, the (1) lower. (2) higher (3) longer the number.

24. Silk and nylon thread sizes are indicated by letters: the higher the letter, the (1) larger (2) longer (3) smaller the thread.

25. Which five of the following are necessary for ideal storing conditions?

- a. Dry room with temperature of 70°F
- b. In a room high on a hill
- c. Absence of direct sunlight
- d. Room construction that affords protection against insects and mice.
- e. A room with many windows
- f. Wooden shelves for storage
- g. A room with some form of humidity control
- h. A room with iron bars on the windows and a lockable door
- i. A number of ash trays scattered around the room for workers who smoke

SUMMARY

New terms in all phases of textiles are always coming to the fore. Some words remain while others last only a short time. This study guide presents a reference to assist the fabrication and parachute specialist in understanding the terminology that is a part of your career field.

REFERENCES

1. TO 00-25-92, General Repair for Canvas and Webbing.
2. TO 00-25-120, General Repair for Canvas and Webbing.

Exercise 2

Match the term to the correct definition.

- | | |
|--|--------------------|
| 1. Threads which run crosswise of the cloth | A. Tape |
| 2. The outside edge of cloth, tape, or webbing that is formed during the weaving process | B. Bias |
| 3. A cut, fold, or seam made diagonally to the warp and filling thread | C. Z or Left Twist |
| | D. Selvage Edge |
| | E. Merlon |

39

- | | |
|--|---------------------|
| 4. Weight of cloth in ounces per square yard | F. Braided Cord |
| 5. The force measured in pounds per square inch required to break a material | G. Cloth Weight |
| 6. Basic unit used in the fabrication of cloth or yarn | H. Tensile Strength |
| 7. Man-made material | I. Elasticity |
| 8. A must requirement for personnel parachutes especially in low altitude bailouts | J. Fiber |
| 9. The ability of a material to stretch and return | K. Filling |
| 10. Treatment given to riser webbings to make them more resistant to wear | L. Filament |
| 11. Thread twisted in a manner to always be used in the sewing machine | M. Synthetic |
| 12. Weaving strands of thread together to form a solid woven cord or one with a hollow channel | N. Opening Time |
| 13. Materials under 12 inches wide up to and including 15 ounces per square | O. Warp |
| 14. The thread, usually the strongest, supporting most of the strain during weaving. | |

50

Life Support Systems Branch
Chanute AFB, Illinois

3ABR42733-SW-702
23 February 1979

HAND SEWN SEAMS

OBJECTIVES

Upon completing this unit of instruction you will be able to list hand sewn seam formations and their uses and fabricate two hand sewn seams.

INTRODUCTION

During inspection you will sometimes find damaged stitching on parachute components which is due to abrasions or friction burns. In some instances it is impossible to repair the parachute with a sewing machine, depending upon the construction of the damaged component. Although there is only a minimum of hand sewing done in a parachute shop, it is important for you to be able to do the work when the situation arises. The basic stitches you will learn in this unit of instruction will enable you to do hand sewing necessary in the parachute shop.

At times it may be desirable to completely hand sew an article made of heavy material because of the lack of appropriate sewing machines. Also a delay in receiving replacements for lost, broken or worn parts may prevent the use of a sewing machine.

Two repairs commonly made in the purification and parachute shop are replacing cones and eyelets and re-attaching the sleeve found on some deceleration parachute risers.

INFORMATION

When hand sewing cloth, one-half (1/2) inch should be turned under as reinforcement and the needle inserted through both plies. When hand sewing thick materials such as leather and felt do not turn the edges under.

Yellow beeswax is applied to hand sewing thread to prevent fraying and twisting. Pure beeswax should be used as the impurities in other waxes may cause oil or grease spots which result in the deterioration of the thread.

TYPES OF STITCHES

Basting Stitch

The basting stitch (figure 1) is used only for holding plies of material together temporarily prior to machine sewing. This is necessary when making a major repair on a parachute canopy. Basting stitches are removed after the machine sewing is completed.

OPR: 3340 TCHTC

DISTRIBUTION: X

3340 TCHTC/TTGU-1 - 410; TIVSA - 1

Designed for ATC Course Use. Do Not Use on the Job.

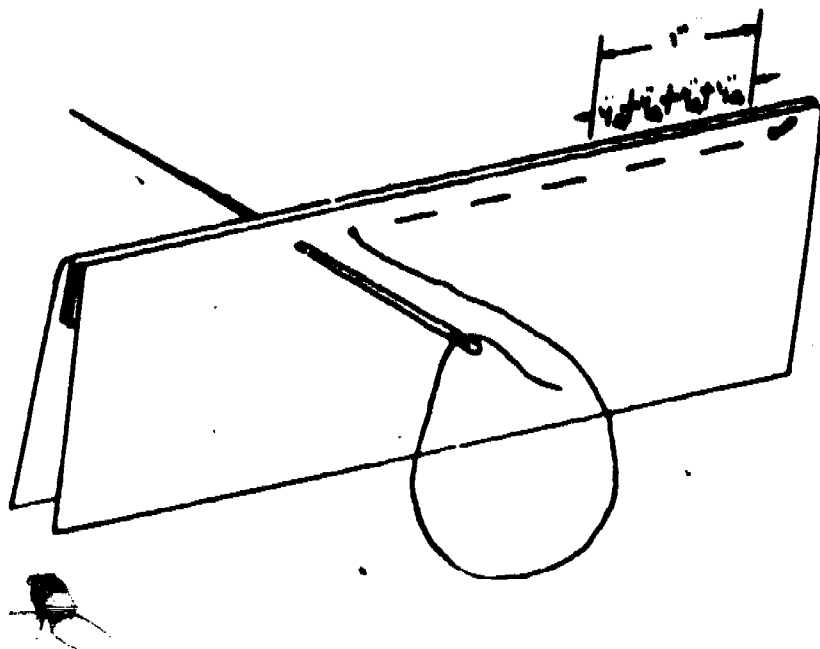

Figure 1. Basting Stitch.

Running Stitch

The running stitch (figure 2) is used for permanent sewing. This stitch is used to replace machine stitches where it is impossible to use a machine or when a machine is not available. All permanent seam ends are locked with two half hitches. Running stitches sewn on cloth will be $\frac{1}{4}$ inch in length and $\frac{1}{8}$ inch from the folded edge of the material.

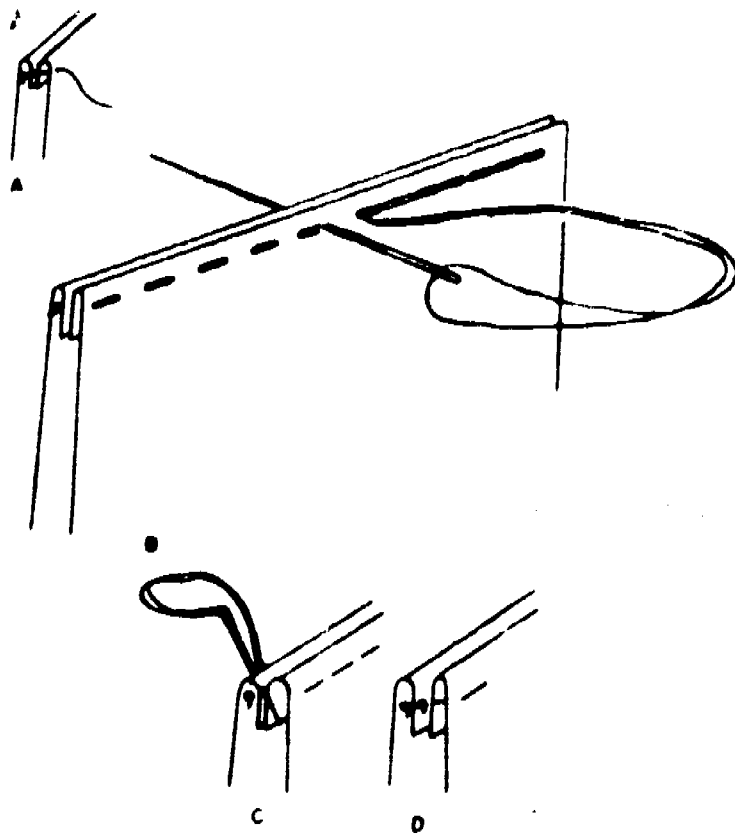

Figure 2. Running Stitch.

Overthrow Stitch

42

The overthrow stitch (figure 3) is used to attach metal parts, like cones and eyes, to parachute packs and for other attachment purposes where machine sewing is not practical. A curved needle is used when the stitch can be sewn from only one side of the fabric or article.

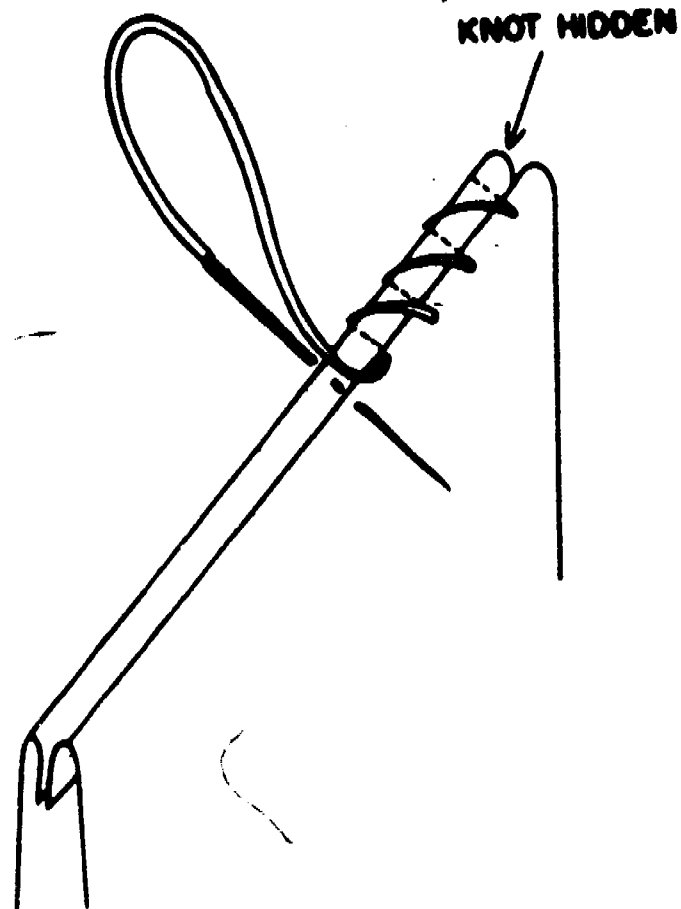

Figure 3. Overthrow Stitch.

Baseball Stitch

The baseball stitch (figure 4) is useful as a permanent stitch since it is very flexible and elastic. It also pulls the edges of material like leather evenly together with a plane surface when used for repair or closing of an opening of any kind, since the thread lies on both the top and bottom edges of the material. A curved needle is commonly used to sew the baseball stitch and, like lacing, it can be pulled as tightly as desired. This stitch is used to repair the riser protector sleeve on some deceleration parachute risers.

NEEDLES USED IN HAND SEWING

There are three principal types of hand sewing needles used in a parachute shop. The upholsterer's straight, sharp, round point needle figure 5, part A is used for basting and hand sewing fabric materials. The upholsterer's curved, sharp, round point needle, figure 5, part B, is used when it is necessary to work from only one side of the material, as in closing a seat cushion. The harnessmaker's needle, figure 26, part C, is required when sewing parachute harnesses; it has a blunt point which will separate the woven threads rather than penetrating and weakening them. Harness needles are available in size 0 and 00.

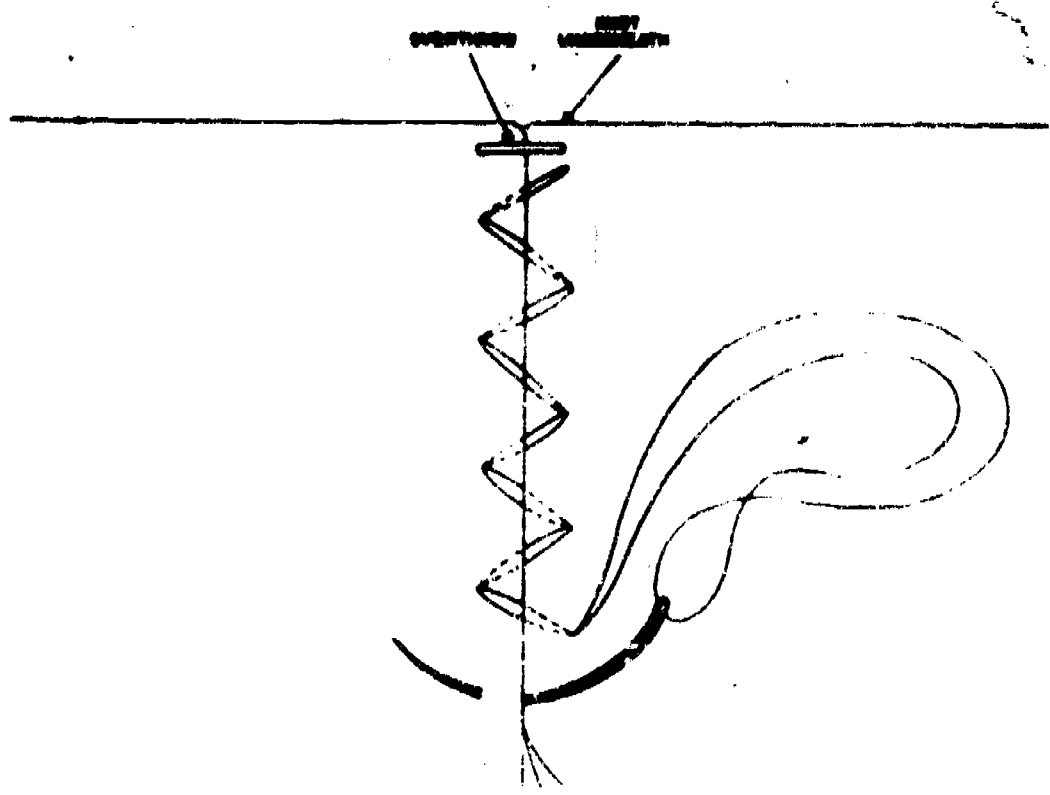

Figure 4. Baseball Stitch.

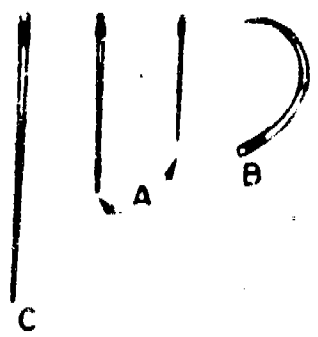

Figure 5. Needles.

REPLACING CONES AND EYELETS

Installation of Cones and Eyelets on Personnel Parachute Packs

When replacing cones and eyelets, align the replacement cone or eyelet directly over the holes where the original hardware was attached. When you are sewing on a cone, make sure that the hole of the replacement cone aligns perfectly with the holes of the other cones. If all the cones are not in perfect alignment, the ripcord pins may bind and not pull out when the wearer pulls the ripcord.

To install a new cone, use approximately 30 inches of 3-cord nylon doubled and waxed. The stitch patterns that you will use to secure the cone to the pack are the running stitch and the overthrow stitch. Eyelet installation also requires 3-cord nylon doubled and waxed; however, the stitching pattern consists of a series of

turns located at five different places on the eyelet. The actual stitching patterns for each installation will be further explained in the workbook.

When making any of these repairs to the personnel parachute assembly, strive to make the repair resemble the appearance and strength of the original components.

Installation of Cone on Deployment Bag for Deceleration Parachute

Pilot chute compartment cones on deployment bags for deceleration parachutes must be repaired if they have loose or damaged stitching. Cones will be reattached to the deployment bag with 3 rows of running stitches made with 5-cord nylon doubled and waxed. The stitching should extend from hole to hole with no threads extending over the outer edge of the cone flange.

REFERENCES

- TO 14D1-2-376
- TO 14D1-3-22

Exercise 1

1. Install the cone.
 - a. Position the new cone in the same place as the missing cone was originally.
 - b. Use size six (6) cord cotton doubled and waxed.
 - c. Tie binder's knot 3 inches from ends. (To be used to tie square knot when completed.)
 - d. Refer to figure 6. Start sewing from underneath (step 1, position 1). Sew in a clockwise direction until needle comes up at position 1 again. (Step 2.)
 - e. Now sew in a counterclockwise direction, with the last running stitch going down through position 2, (step 2.)
 - f. Bring needle up at position 1 (step 4).
 - g. Begin overthrow stitch in clockwise direction (step 4), ending underneath position 8 (step 5).

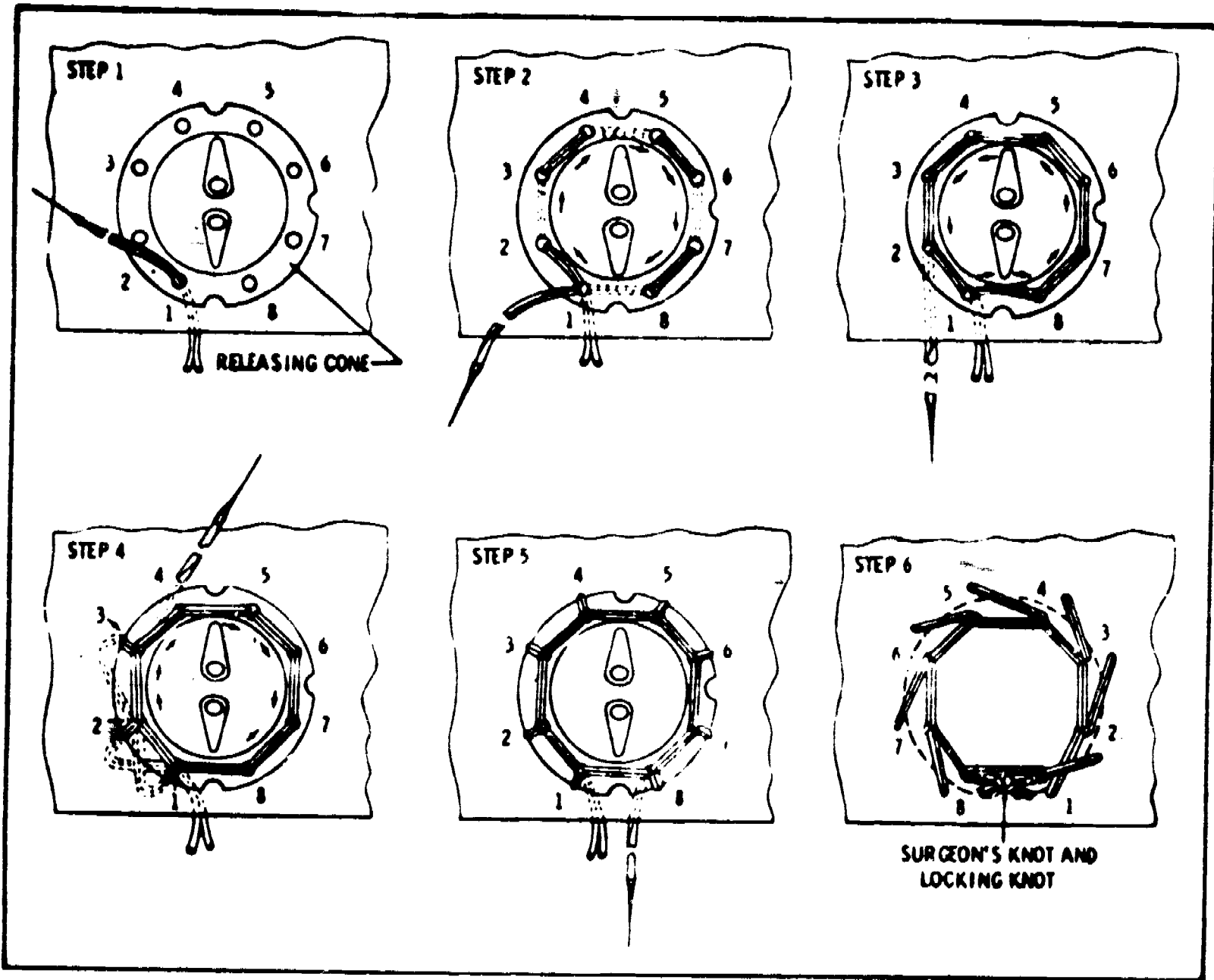

Figure 6. Installing eyelet.

h. Tie surgeon's and lock knot on underneath side (step 6). Trim threads, leaving 1/2 inch side.

Exercise 2

1. Install the eyelet.
 - a. Place new eyelet in same location as original.
 - b. Use size 3 cord nylon, doubled and waxed.
 - c. Tie binder's knot 3/4 inch from end.
 - d. Start sewing with binder's knot on underside of pack.
 - e. Refer to figure 7. Beginning with step 1, attach the eyelet with 10 turns -- 2 turns in five places.

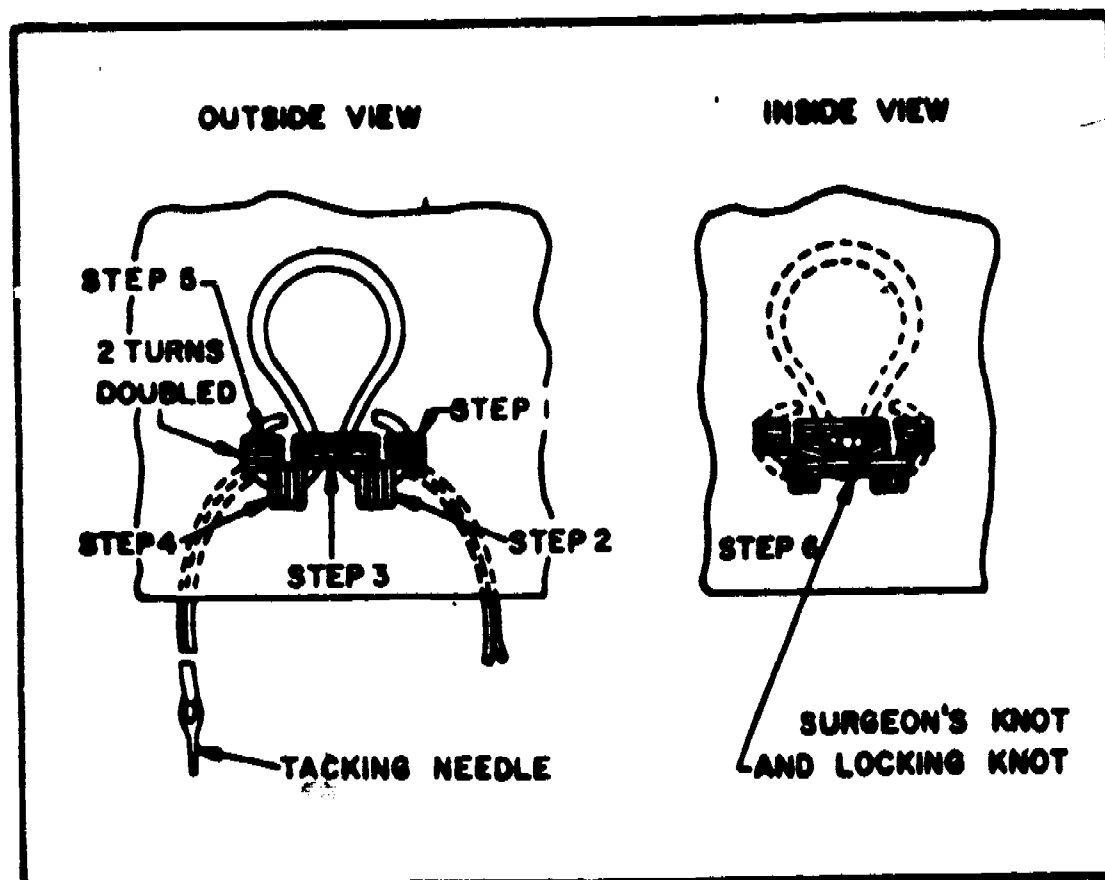

Figure 7. Installing in Eyelet.

f. Tie completed stitching with a surgeon's and lock knot as close as possible to the underside of the pack. (See figure 7, step 6.)

g. Cut cord $\frac{3}{4}$ " from the end of knot.

Technical Training

Fabrication and Parachute Specialist

HARDWARE INSTALLATION

28 February 1979



CHANUTE TECHNICAL TRAINING CENTER (ATC)
3340 Technical Training Group
Chanute Air Force Base, Illinois

DESIGNED FOR ATC COURSE USE
DO NOT USE ON THE JOB

HARDWARE INSTALLATION

OBJECTIVES

Upon completing this unit of instruction you will be able to install hardware.

INTRODUCTION

Various types of hardware are used in the manufacture of life support equipment. Hardware is that metal portion of the item used to connect or secure webbings of flaps. Hardware parts that require maintenance most often are grommets (both plain and parachute), Durable Dot fasteners (plain and lift-the-dot fasteners), cones, eyelets and interlocking fasteners (commonly called zippers). When these hardware parts become chipped, burred or loose they will be replaced.

INFORMATION

When installing hardware with handtools or presses, keep in mind that all hardware is essential to the overall performance of the equipment.

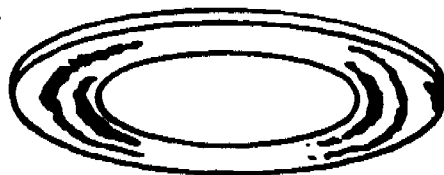

PLAIN WASHER

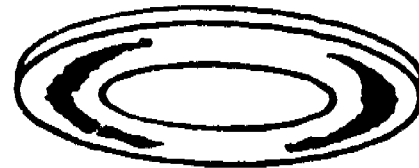

PARACHUTE WASHER

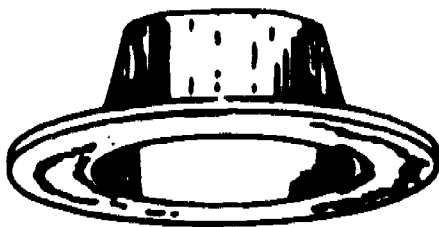
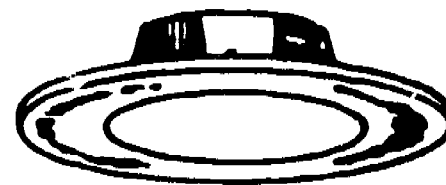
PLAIN GROMMET
(COLLARI)

PARA GROMMET

Figure 1.

GROMMETS

Grommets are used wherever it is necessary to reinforce holes for lacing in covers, bags and packs. There are two parts

3340 TCHTG

DISTRIBUTION: X

3340TCHTG/TTGU-L - 410; TTUSA - 1

to a grommet. (Figure 1) the grommet itself (or collar) and the grommet washer. There are two types of grommets used in equipment maintenance; plain and parachute grommets. Grommets are made of aluminum and brass; parachute grommets are made of chrome-plated brass.

DURABLE FASTENERS

There are two types of Durable Dot fasteners: the plain fastener and the lift-the-dot fastener. Both are used for quick opening and closure of pack flaps or inspection pockets. Lift-the-dot fasteners are constructed to be stronger than other fasteners and they are opened by lifting in the dot area of the button portion of the fastener. Closure of the dot fastener requires mating the area opposite the dot to the stud portion.

The fastener is made up of four parts: the button and socket make up the female portion of the fastener, and the stud and eyelet make up the male portion. (Figure 2)

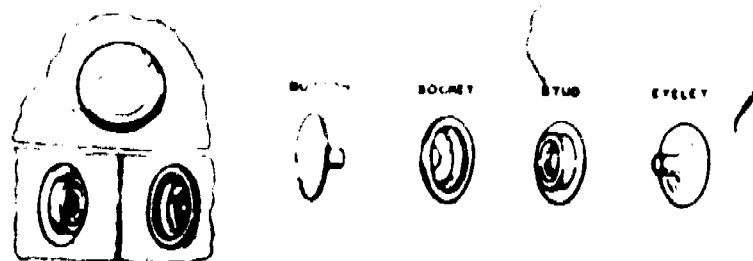

Figure 2. Durable Dot Fastener.

INTERLOCKING FASTENERS

Identification

Various tasks are accomplished more easily and quickly through the use of interlocking fasteners. For example, they save precious seconds for an aircrewman when donning his flight clothing or exposure suit. These fasteners also provide the repairman with a means of easy access to items that require inspections.

There are two types of interlocking fasteners: separating and nonseparating. The separating fastener is one where one side may be completely separated from the other side. The nonseparating type has both sides permanently attached to each other at the bottom end with a bottom stop. Interlocking fasteners are very durable if operated properly. This includes making sure that there are no foreign objects between the parts of the fastener, and closing and opening the fastener with a slow steady pull rather than a quick hard jerk. When you operate a separating fastener, make sure that the pin is properly seated in the box. If the slide sticks or jams, it should not be forced. Investigate and correct the cause for stoppage.

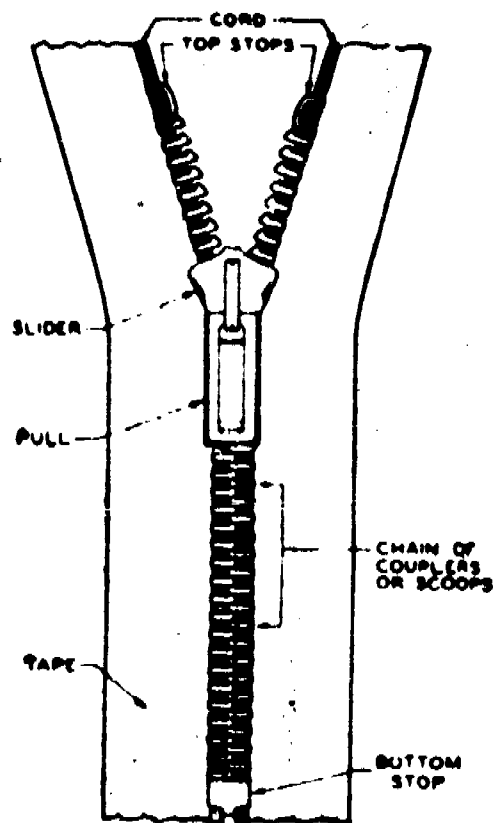

Figure 3. Interlocking Fastener.

As a specialist you should know the correct technical names of the parts of an interlocking fastener which are shown in figure 3. The parts and their purpose are:

1. Tape: Used to attach fastener to bag or cover on which fastener is used.
2. Cord or Tape Bead: Part to which scoops are attached.
3. Scoops: Mesh together to hold the fastener together.
4. Slider: Meshes the scoops together.
5. Pull: Attached to the slider for operation of the slider.
6. Top Stops: Prevents slider from coming off scoops at top of fastener.
7. Bottom Stops: Keeps fastener intact and prevents slider from coming off scoops on bottom of nonseparating fastener.
8. Box and Pin: Used only on separating-type fastener and is used in place of bottom stop. This box and pin permits the fastener sides to become separated from each other.

GLOVE FASTENERS

Identification

The most common type of fastener used on clothing and other items of fabric and rubber is the glove fastener. Figure 4 shows the three different types of glove fasteners most commonly used. The main difference between the three types of glove fasteners is their size. Glove fasteners are commonly used on clothing instead of buttons. Glove fasteners are dependable and

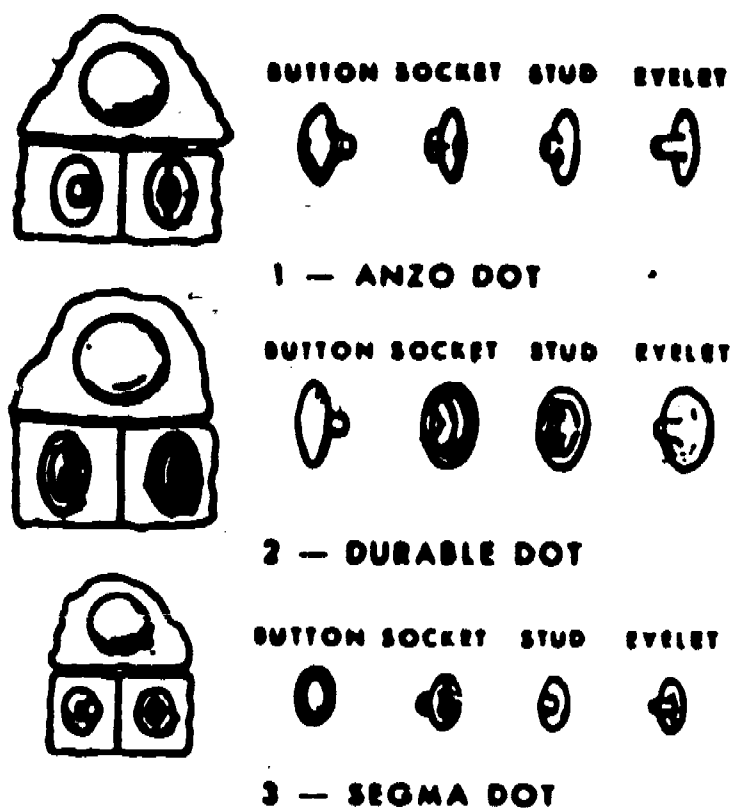

88888-2-2-22

Figure 4. Anzo Fastener.

are used because of their holding and firm gripping ability. This fastener is made of four parts: button, socket, stud, and eyelet, as shown in figure 4.

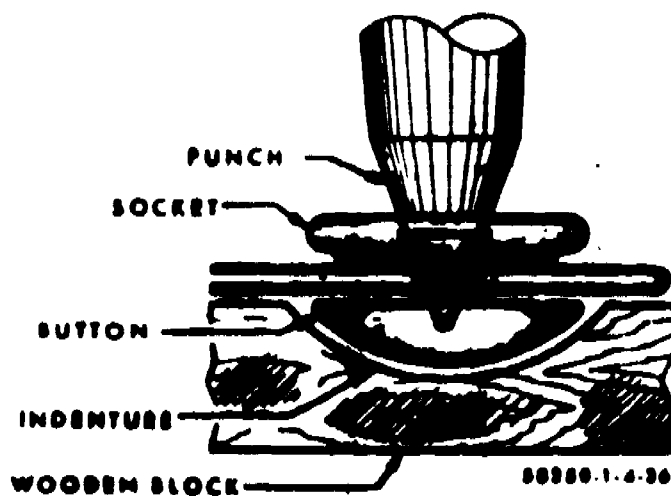

88888-1-4-36

Figure 5. Flaring Button Collar.

Installation

HAND INSTALLATION. Cut a hole the proper size for the barrel of the button. Insert the button in the material and place the socket over the barrel of the button. Make an indentation in a wooden block for holding the head of the button. Flare the

barrel of the button slightly with a center punch, as shown in figure 5. Flatten the collar of the button with a solid drive pin punch. Assemble and install the stud and eyelet on the other piece of material so the base of the eyelet is on the back side of the material. Flare and flatten the barrel of the eyelet in a manner similar to the installation of the button and socket.

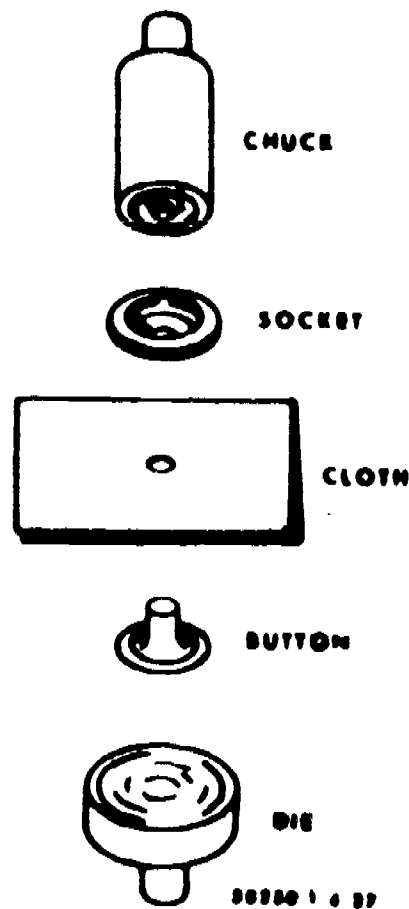

Figure 6. Glove Fastener Installation.

INSTALLATION BY PRESS. Cut a hole the size of the barrel of the button and insert button in material. Place the correct chuck and die and complete the attachment, as shown in figure 6. Cut the proper size hole in the material to receive the eyelet. Place the correct chuck and die in the press. Insert the barrel of the eyelet through the hole from the back of the material. Fit the study into the chuck. Lay the eyelet on the die and complete the attachment.

An assortment of chucks and dies is necessary for the installation of fasteners and grommets with hand- and foot-operated presses. For each size and type grommet or fastener installed, corresponding size and type chucks and dies are required. The die is the lower tool, and the chuck is the upper one, as shown in figure 6. The adjustable screw at the top of the foot press is used to set the proper bight for the chuck and die. There should be a clearance of about the thickness of a thin sheet of paper between the chuck and die.

Reference TO 00-25-120, Chapter 3, Pg 22. 63

Exercise 1

Answer the following questions concerning hardware on a separate piece of paper.

1. What is the responsibility of the fabrication and parachute specialist in regard to repair of flying clothing?
2. Name the parts of an interlocking fastener.
3. What type of interlocking fastener is used on a jacket?
4. List the types of interlocking fastener sliders.
5. Name three different types of glove fasteners.
6. What is the main difference between the different types of glove fasteners?
7. List the troubles that are common to interlocking fasteners.
8. How are unserviceable interlocking fasteners removed?
9. What type interlocking fastener installation is normally used on a trouser fly?
10. Name the parts of a durable dot fastener.
11. What is used to install glove fasteners?
12. Where will the stitching be placed when repairing a pulled seam?

PROCEDURE

These exercises will provide instruction in the installation of various types of hardware. You will receive further instruction concerning the installation of hardware in future lessons as well as at your next duty assignment.

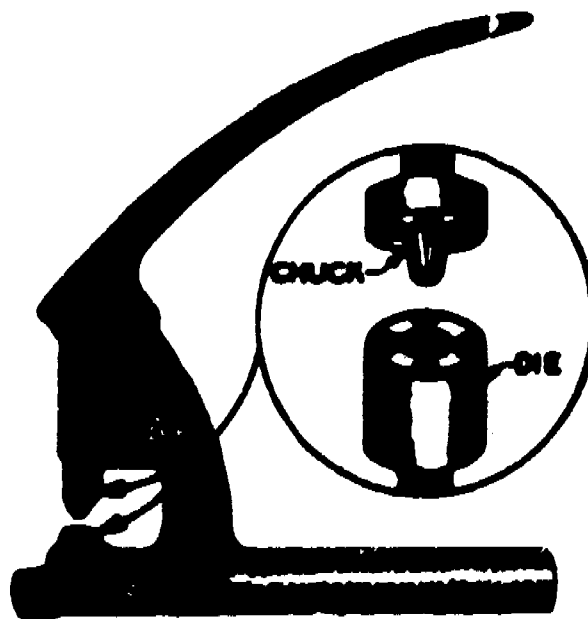

Figure 7. Hand-Operated Press.

Type Fastener	Size	Tool Manufacture	Chuck No.	Die No.
Plain Brass or Aluminum Grommet with Washer	0	Carr Fastener	9191	9192
	1		9193	9194
	2		9195	9196
	3		9197	9198
Durable Dot Fastener Button Socket Eyelet Stud	3/8"	Carr Fastener		1401
			1410	1407
			1412	

Table 1. Chucks and Dies for Press Installation of Fasteners.

When leather punches of the desired size are available, they are used to make holes for the installation of hardware. The punch is given a sharp tap with a rawhide mallet and it is then removed by turning and lifting at the same time rather than by oscillating (swinging) it. This prevents the cutting edge of the punch from breaking. An assortment of chucks and dies is necessary for the installation of fasteners and grommets with hand and foot-operated presses. For each size and type grommet or fastener installed, a corresponding size and chuck and die is required. The die is the lower tool as shown in figure 7. Sizes of chucks and dies to be used in setting the grommets and fasteners are given in table 1. The adjustable screw on the bottom of the foot press is used to set the proper height for the chuck and die. There should be a clearance of about the thickness of a sheet of paper between the chuck and die. This prevents them from hitting together and damaging the metal.

Exercise 2

1. Cut a piece of material 6" X 12". Fold it in half to form a 6" X 6" square.
2. Select the chuck and die set for installing the durable fastener stud and eyelet and fit it into the hand press.
3. Select the 1/8" cutting punch. Center and cut a hole in the fabric 1 inch from the folded edge and 1 inch from the nearest raw edge to the folded edge.
4. Install the stud and eyelet to the fabric.

Exercise 3

1. Cut a piece of fabric 2" X 4". Fold it in half to form a 2" X 2" square.
2. Select the correct 1/8 inch cutting punch. Center it on the fabric and cut a hole.

3. Select the chuck and die set for installing the durable fastener button and socket and fit it into the press.

4. Install the button and socket to the fabric.

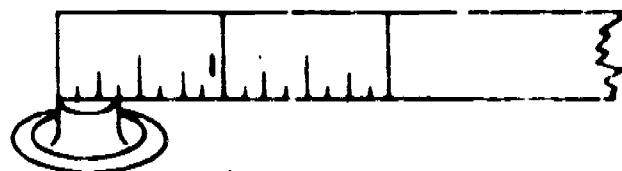

3/8" INSIDE MEASUREMENT



3/8" CUTTING PUNCH

Figure 8. Measurement for Grommet Installation.

Note: For secure attachment, all holes in the fabric must be of the same size as the inside diameter of the collar of the fastener. This inside diameter is found only by measurement (figure 8). The washers on hardware are installed with the manufacturer's trademark on the outside.

Exercise 4

1. Using the same material you used for durable fastener installation, install the grommet provided by your instructor.
 2. Find the center of the 6" X 6" piece of material. With the proper cutting punch cut a hole in the center of the material.
 3. Position the grommet collar into the cut out hole of the material making sure that the collar will be to the top of the material (stud side of the material).
- Place the washer on the collar and install by use of the foot-operated press.

Exercise 5

To assemble a 12-inch interlocking fastener, proceed as follows.

1. Cut a strip of interlocking fastener 15-inches long (figure 9). This allows 1 1/2 inches extra at each end of attachment of parts and folding when sewing.

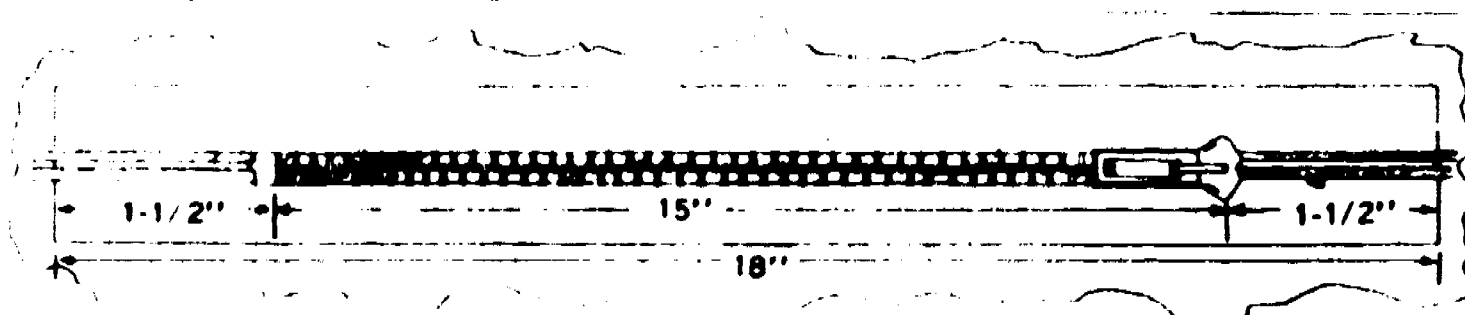

Figure 9. Correct Measurement for a 12-Inch Interlocking Fastener.

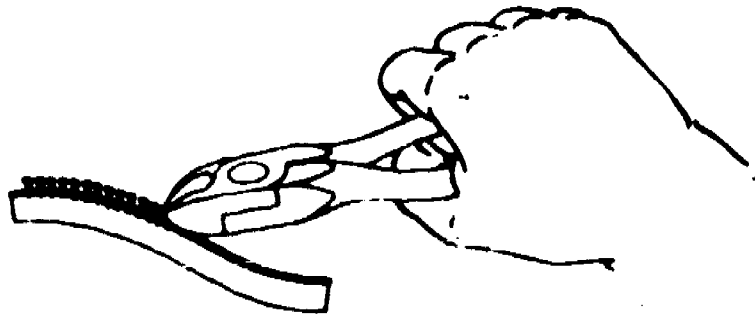

Figure 10. Removing Scoops with Diagonal-Cutting Pliers.

2. Mark the 1 1/2 inch allowance on each end of the fastener tape. Remove the scoops from each end to the point marked. Use diagonal cutting pliers for removing scoops (figure 10).

CAUTION: Care must be taken not to cut into the cord. Clip the scoops at a point just above the cord.

3. To assemble the fastener, the tape ends at the bottom are pulled through the top of the slider until the scoops begin to join.

Note: If the joining is not consecutive, the slider must be removed and the operation repeated.

4. With the slider in place, the bottom stop is attached by crimping it securely over the cords with a pair of pliers.

5. The top stops are each installed by first placing the stop legs down on a smooth surface and gripping gently with the pliers.

6. The stop is then slipped over the cord directly above the last scoop, making sure that its legs straddle the cord.

Note: Care should be exercised in installing the second stop so that it is located directly opposite the first stop.

Exercise 6

Answer the following questions on a separate sheet.

1. Name 4 types of hardware which commonly require maintenance.
2. What type of hardware is used on the pocket which contains the Form 391?
3. Name 2 types of interlocking fasteners.
4. What keeps the slider from coming off the scoops on the bottom of a non-separating fastener?
5. What are the parts of a grommet?

Technical Training

Fab & Parachute Spec

OPERATION/MAINTENANCE OF CLASS 31 SEWING MACHINES

28 March 1979



CHANUTE TECHNICAL TRAINING CENTER (ATC)
3340 Technical Training Group
Chanute Air Force Base, Illinois

DESIGNED FOR ATC COURSE USE

DO NOT USE ON THE JOB

Life Support Branch
 Chanute AFB, Illinois

3ABR42733-SW-704

OPERATION/MAINTENANCE OF CLASS 31 SEWING MACHINES

OBJECTIVES

Upon completion of this study guide you will be able to identify functional features and their applications. Also, explain threading the head and bobbin, cleaning and lubrication, timing and adjusting, troubleshooting and repair of the class 31 sewing machine IAW TO 34Y7-6-1.

INTRODUCTION

Correct operation and preventive maintenance cannot be emphasized too strongly. A good repairman in any career field must know more than just how to turn his machines on and off. It is necessary that he be aware of the functional features, how to prepare the machine to do the job required, and minor maintenance to insure that the machine is in peak operating condition at all times.

FORMATION

The 31-15 sewing machine is smaller and lighter than most of the other machines used in the fabrication and parachute shop. The manufacturer calls the 31-15 a "tailoring" machine which gives a clue to the type of material it is designed to sew. It is used to sew and repair clothing, uniforms, shirts, flying clothing, skirts, underwear, jackets, light tentage and similar materials. These many uses should make it obvious that every fabrication and parachute specialist must learn how to set up, use, and maintain this machine.

OPERATION

Important Features

The class 31 machine makes the US standard lockstitch at a maximum recommended speed of 2200 stitches per minute (SPM). It has an oscillating shuttle which operates in an upright position and is equipped with a drop feed which moves the material through the machine from front to back as it sews. The machine is designed to sew from 7 to 32 stitches per inch (SPI). The front of the machine is that part nearest the operator as he is in the position to sew. Refer to figure 1 for the location of the following parts of the class 31 sewing machine.

Supersedes ST 3ABR42733-SW-704 (undated).

OPR: 3349 TCHTC

DISTRIBUTION: X

3349 TCHTC/TTCE-1 410; TTVSA - 1

NEEDLE BAR. Holds the needle and carries the thread to the oscillating shuttle where the lockstitch is formed.

59

THREAD TAKEUP LEVER. Removes the slack in the needle thread after the lockstitch is formed at the oscillating shuttle and pulls enough thread from the spool to make the next stitch.

PRESSURE REGULATING THUMBSCREW. Regulates the pressure on the presser foot to make sufficient pressure needed to hold the material securely.

FACEPLATE. Covers and protects the mechanism of the presser foot and needle bar.

EYELETS. Guides the thread from the takeup lever to the needle.

PRESSER FOOT. Holds the presser foot.

SHUTTLE RACE SLIDE. Covers the shuttle race assembly.

THROAT PLATE. Surrounds the feed dog and keeps the material from slipping after the feed dog has been adjusted to the proper height.

SLACK THREAD REGULATOR. Regulates the slack in the thread when the needle is descending.

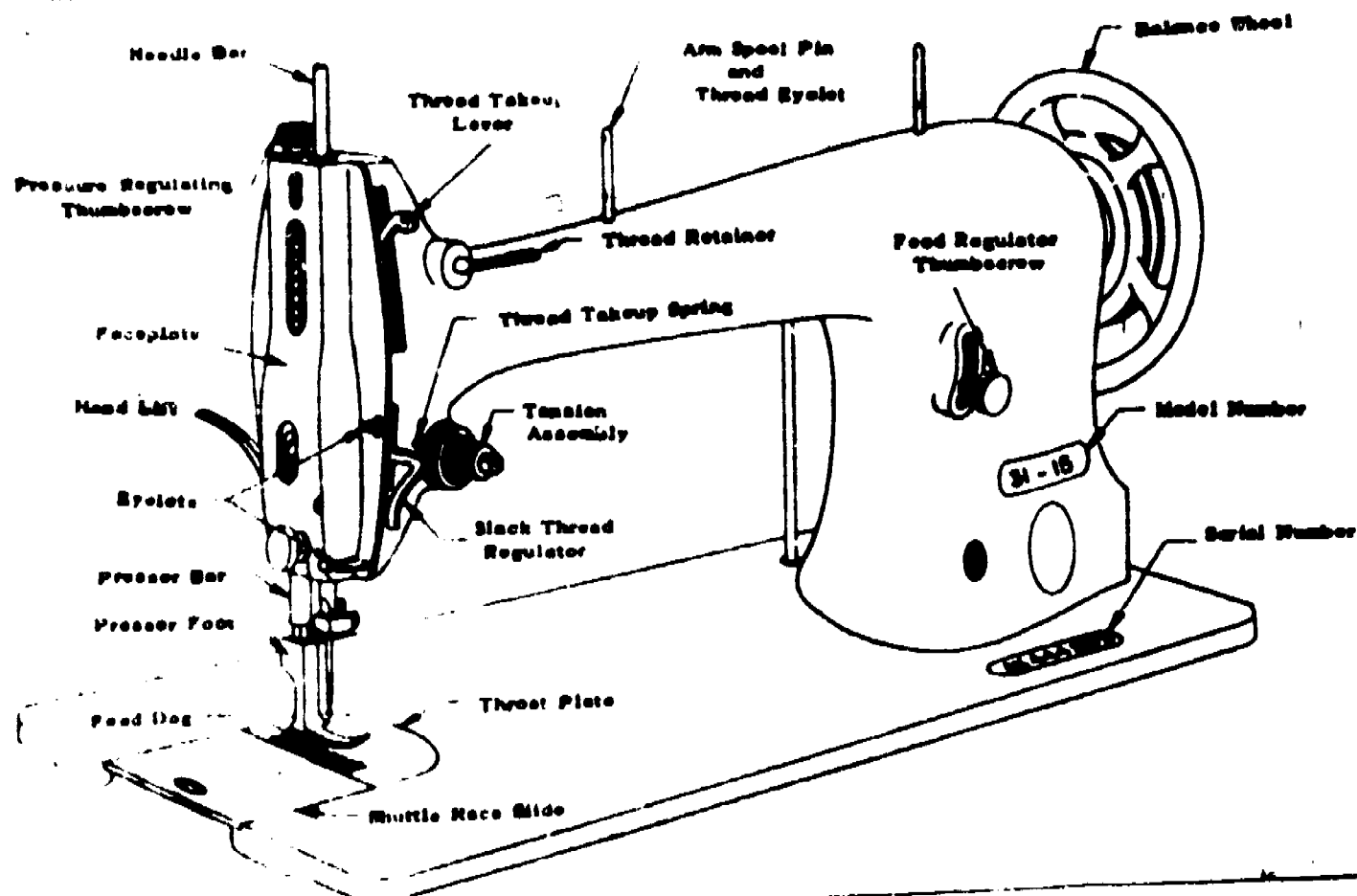

Figure 1. Class 31 Sewing Machine Head.

60

TENSION ASSEMBLY. Regulates the tension on the needle thread so that the lockstitch may be adjusted properly.

THREAD TAKEUP SPRING. Removes sufficient slack from the needle thread when the needle is descending to prevent the needle from splitting its thread.

THREAD RETAINER. Removes twists and tangles in the thread before it enters the tension disks.

ARM SPOOL PIN AND THREAD EYELETS. Used for placing small spools of thread on the machine, or for guiding thread as it comes from the large cones.

BALANCE WHEEL. Provides a connection between the driving unit and the sewing machine head.

FEED REGULATOR. Used to regulate the length of the feed to determine the number of stitches per inch.

MODEL NUMBER. Number indicating the machine model or the class, place of manufacture, and modifications of the machine.

SERIAL NUMBER. Manufacturer's serial number of the machine.

FEED DOG. Feed the materials through the machine.

PRESSER BAR HAND LIFT. Hand lever for lifting the presser foot.

Model Number

Sewing machines are identified by model numbers which are located on the upright arm of the machine head. Each model number (symbol) is made up of two numbers separated by a dash or a letter. The first number specifies the machine class. The dash or letter "w" denotes the place of manufacture. The last number denotes improvements or modifications within the machine class. Figure 1 shows a Class 31-15 machine head and its features. Figure 2 shows the features of a sewing machine stand that the machine heads are mounted on.

Feeds

There are various types of feeding mechanisms to carry the material through the sewing machines.

DROP FEED. Consists of a feed dog which moves the material the regulated length of a stitch, while the presser foot folds the material in place against the feed dog.

NEEDLE FEED. The needle alone moves the material the regulated length of a stitch, while the presser foot holds the material in place on the throat plate.

COMPOUND FEED. Consists of the combination of the drop feed and the needle feed. The compound feed is more positive feed than the needle feed or drop feed, since the material is fed from both the top and the bottom.

ALTERNATING PRESSERS (NOT A FEED). Consists of a vibrating presser foot and a lifting presser foot that work alternately to hold the material while it is fed through the machine by the feeding mechanism. The lifting presser holds the material while the vibrating presser and the feed dog moves forward to make a stitch.

The feeds on the machines used in parachute shops are as follows:

DROP FEED. Class 31 machine; Class 7 (with alternating pressers).

COMPOUND FEED. Class 111W (with alternating pressers).

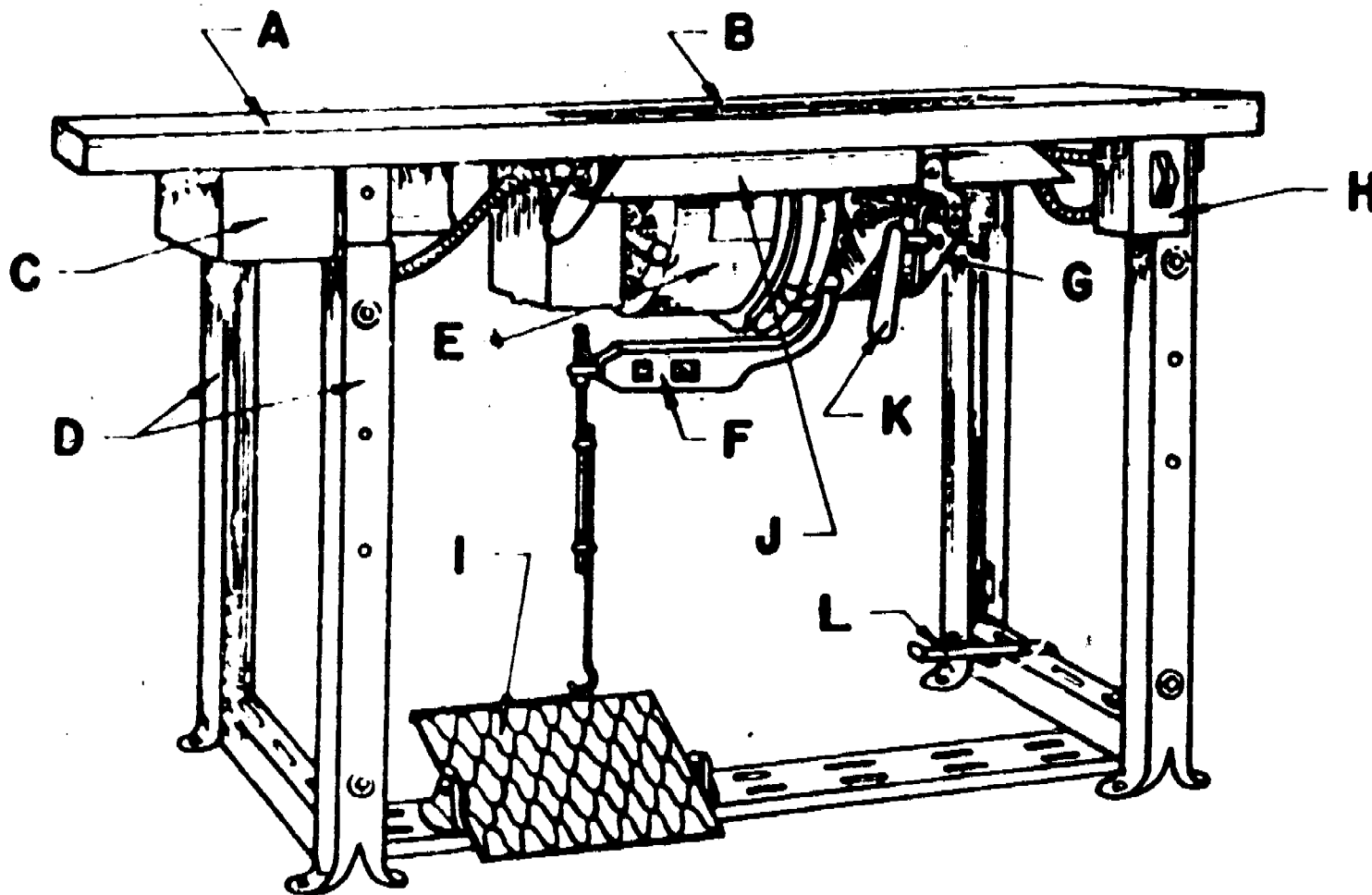

- A TABLE TOP
- B OPENING IN TABLE TOP FOR SEWING MACHINE HEAD
- C TOOL AND THREAD DRAWER
- D ADJUSTABLE SEWING MACHINE STAND
- E ADJUSTABLE SEWING MACHINE MOTOR WITH CLUTCH
- F EXTENSION CLUTCH ARM
- G MOTOR BELT GUARD.
- H MOTOR SWITCH
- I TREADLE CLUTCH FOOT PEDAL.
- J OIL DRIP PAN.
- K MACHINE FOOT KNIFE LIFTING LEVER.
- L OIL CAN BRACKET

Figure 2. Class 31 Machine Stand.

Stitch-Forming Mechanism

The stitch-forming mechanism (bobbin assembly) is that part of the machine which picks up the loop of the needle thread and carries it around the bobbin case to form the lockstitch. There are two types of bobbin assemblies: the oscillating shuttle, and the rotary hook. The oscillating shuttle assembly consists of a shuttle point which moves back and forth to form the stitch. The Class 31 machine has an oscillating shuttle operating in an upright position and uses a small round bobbin. The Class 7 machine has a long beak oscillating shuttle which uses the spool-type bobbin. The rotary hook assembly consists of a hook that rotates clockwise to form the stitch. The Class 11W machine has a rotary hook that operates in a horizontal position.

Needles

It is very important that the proper needle be used to insure good machine operation. The selection of needles by class, variety, and size for different machines and materials, is necessary in order to eliminate thread breakage, needle breakage, skipped stitches, and fraying of the thread.

Needles for the various machine classes are selected and ordered by needle number and size. The needle numbers are 4-digit numbers; for example, number 2055 needles are used in Class 31 machines. Cloth point needles are round sharp-pointed needles used for sewing cloth, since they do not cut the strands as they are forced between the woven threads of the fabric. Many different varieties of cutting point needles are available, but they are used only for cutting heavy leather. Figure 3 shows the shape of the openings made in material by the cloth point, A, twist point, B, and the diamond point, C. Figure 3, part A, illustrates why it is important that a round-pointed needle be used in cloth. Figure 3, parts B and C show how cutting point needles will cut the warp and filler threads.

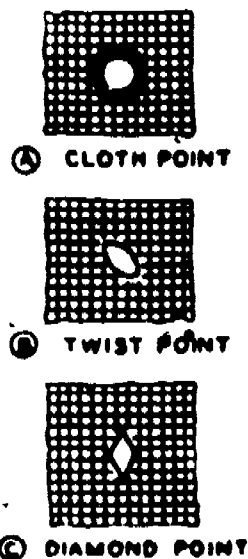

Figure 3. Openings Made by Needle Points.

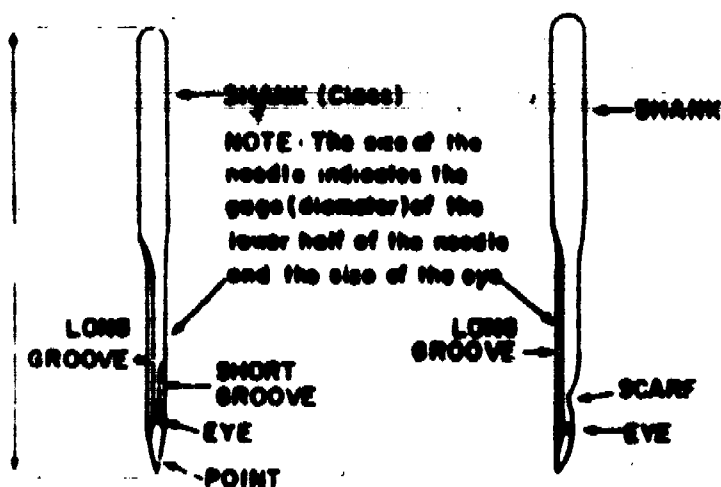

Figure 4. Sewing Machine Needles.

Machine needles have a long groove on one side, and either a short groove or a scarf on the opposite side, figure 4. The purpose of the grooves is to allow the thread to fall back into the needle when it enters the material to prevent the thread from breaking or fraying; therefore, it is important that the long groove is placed in the machine properly. On different class machines, the direction varies with the position of the bobbin assemblies. On Class 31 machines, the long groove is placed to the left. The scarf, figure 4, is to prevent the rotary hook from striking the needle as it passes close to the needle to pick up the thread loop to form the lockstitch.

Needles are sized by the diameter or gauge of the needle, figure 4, and the needle eye. The selection of the correct size needle is determined by the size and type of thread and material used. The thread must pass freely through the eye of the needle in order to prevent thread fraying or breaking. The sizes of the 2055 needles for most sewing operations required of the fabric specialist range from sizes 18 through 22. Their needle size number increases with the diameter of the needle; therefore, size 18 needles are used for lighter weight materials than size 22.

Listed below are a few needle sizes and their uses.

SIZE 18. For sewing two to four plies of thin material, such as silk, nylon, or rayon with size E thread.

SIZE 20. For sewing five or more plies of the above.

SIZE 21. For sewing two to four plies of medium weight materials, such as aircraft cloth, 12-ounce duck, light leather, and artificial leather using 16-4 thread.

SIZE 22. For sewing two to four plies of medium weight material such as heavy duck, lightweight and medium weight webbings, and russet leather with 16-4 thread.

SIZE 24. For sewing elastic or rubberized materials with 16-4 thread.

The condition of the needle's point should be checked before starting to sew. A dull round needle acts the same as a cutting needle. It will cut or pull threads and may weaken the seam. The condition of a needle may be checked by sliding the fingernail over the point. If it scratches or catches the nail, the needle should be replaced with a new one. A dull needle may be sharpened by placing it in the chuck of a drill press, and the drill operated at high speed while holding a fine grade sharpening stone lightly against the side of the needle at the proper angle. The point is then polished with a piece of russet leather.

Safety Precautions to Follow When Using a Class 31 Sewing Machine

CORRECT POSTURE. Good posture and the proper position at the sewing machine are important for the following reasons:

1. Vision is improved.
2. The work in the machine may be handled more efficiently.
3. Accident hazard is reduced.
4. Fatigue and eyestrain are reduced.
5. Appearance and bearing of the operator are improved.

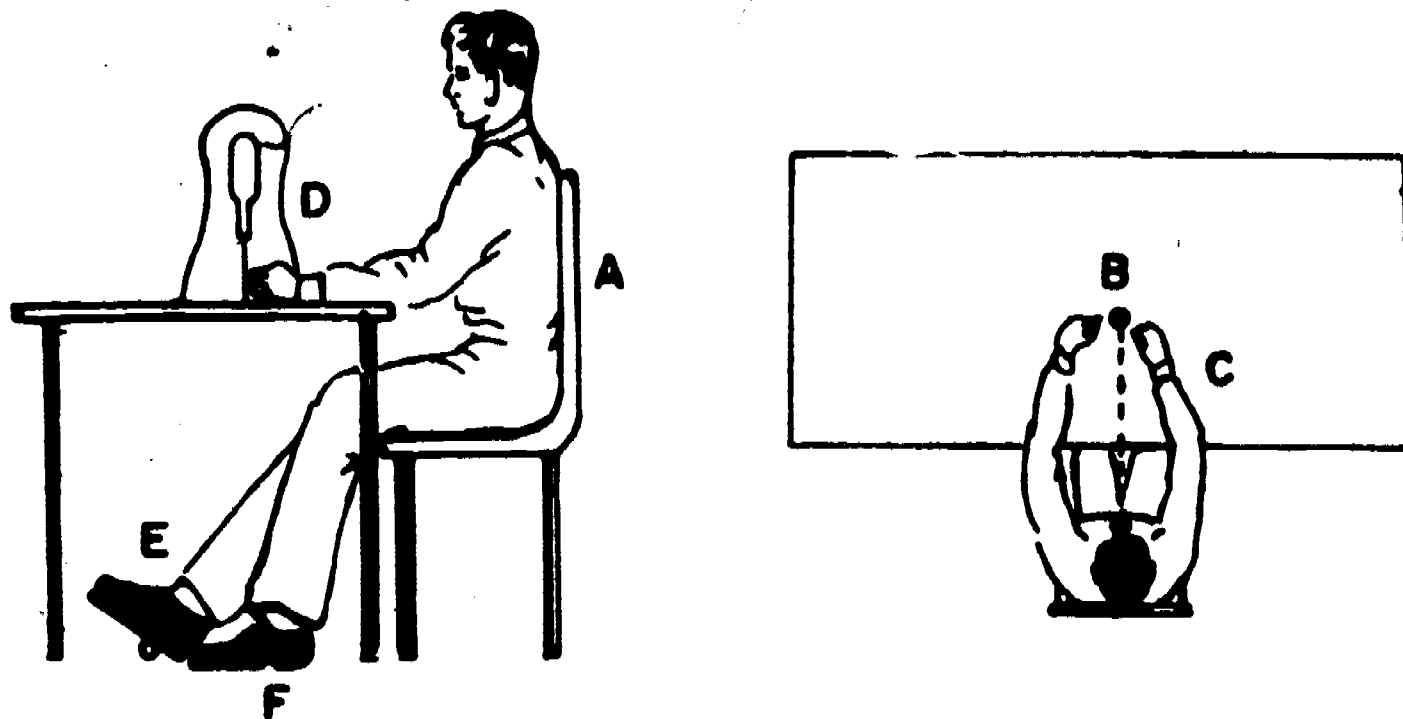

Figure 5. Correct Position and Posture.

General rules for the correct position and posture are:

1. Operator should sit upright and well back in his chair. (See Figure 5, part A.)
2. Operator's nose should be in line with the needle bar. (figure 5, part B) This will enable him to see on each side of the presser foot and guide the material with both hands. (Figure 5, part C)

3. When in an upright position, operator should extend hands forward to the needle bar. (Figure 5, parts C and D)

4. His right foot should be placed on the foot treadle with his heel on the lower edge for braking purposes. (Figure 5, part E)

5. His left foot should be placed on the floor beside the treadle. (Figure 5, part F)

SAFETY TIPS. The following precautions should be observed while operating machines in order to prevent injury to the operator or damage to the machines.

1. Keep the fingers out from under the presser foot while the motor is running.

2. Do not operate the machine without material under the presser foot, as this will dull the feed dog.

3. Do not change the bobbin while the motor is running.

4. Be sure the bed slides are closed before operating the machine as the fingers or the material may come in contact with the rotary hook and serious damage may be the result.

5. Keep the fingers at the side of the needle, not in front.

6. Hold both the needle and bobbin threads taut when starting to sew.

7. When winding a bobbin, be certain that the presser foot is raised and that the needle is not threaded.

8. Do not start sewing until the motor has had sufficient time to attain full speed.

9. Do not try to push or pull the material as it is being fed through the machine. The needle will bend or break.

10. Operate the machine at a low rate of speed to avoid making lines that are not straight.

11. Be sure to turn the motor switch off any time you leave the machine.

12. Do not turn the balance wheel backward a full turn or the thread will break.

13. Use the proper type of thread and correct size and class of needles.

14. When tilting the machine head back, be sure that it lies securely against the machine headrest pin. Injury to your hands may result if the machine head falls forward. Keep your hands away from the edge of the opening while the head is back.

66

Thread Head and Bobbin

You will learn how to thread the head and bobbin, regulate stitches per inch, adjust head thread tension and regulate pressure or material in another workbook. Refer to TO 34Y7-6-1, pages 8 through 11 for threading instructions.

Clean and Lubricate

CLEANING. The machine should be kept as free from dust and dirt as possible. When not in use, it should be covered with a dust-proof cover. The oil pan should be dusted and wiped free of excess oil.

LUBRICATION. When in constant use, the machine should be oiled twice daily. The oil should be a highly refined mineral oil with a low pour point. Oiling points are shown in figure 6. Refer to TO 34Y7-6-1, pages 15 and 16 for cleaning and lubricating instructions.

Note: Cleaning and lubrication for all sewing machines is basically the same.

LUBRICATION CHART

MACHINE, SEWING (SINGER—31-15)

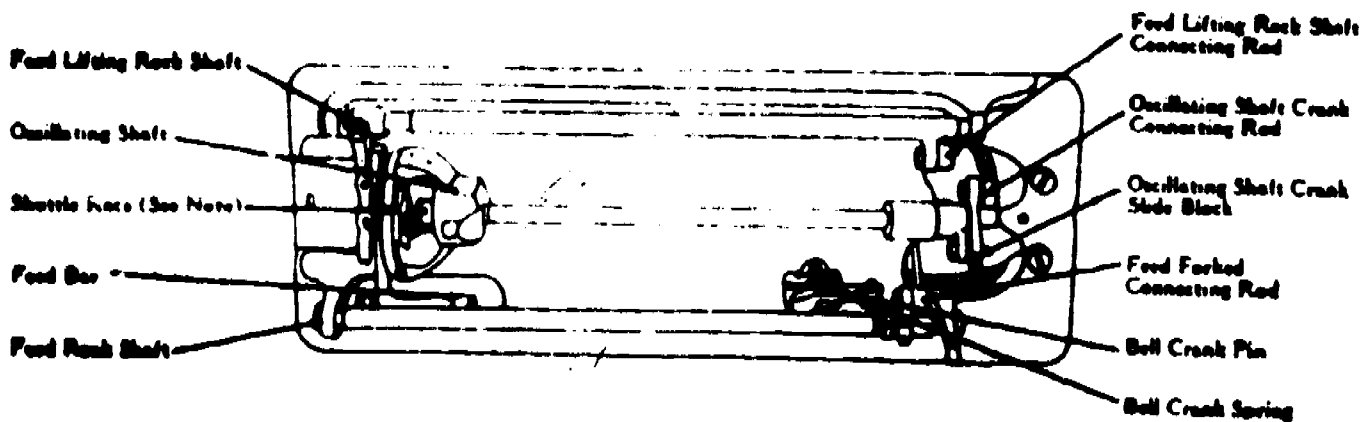
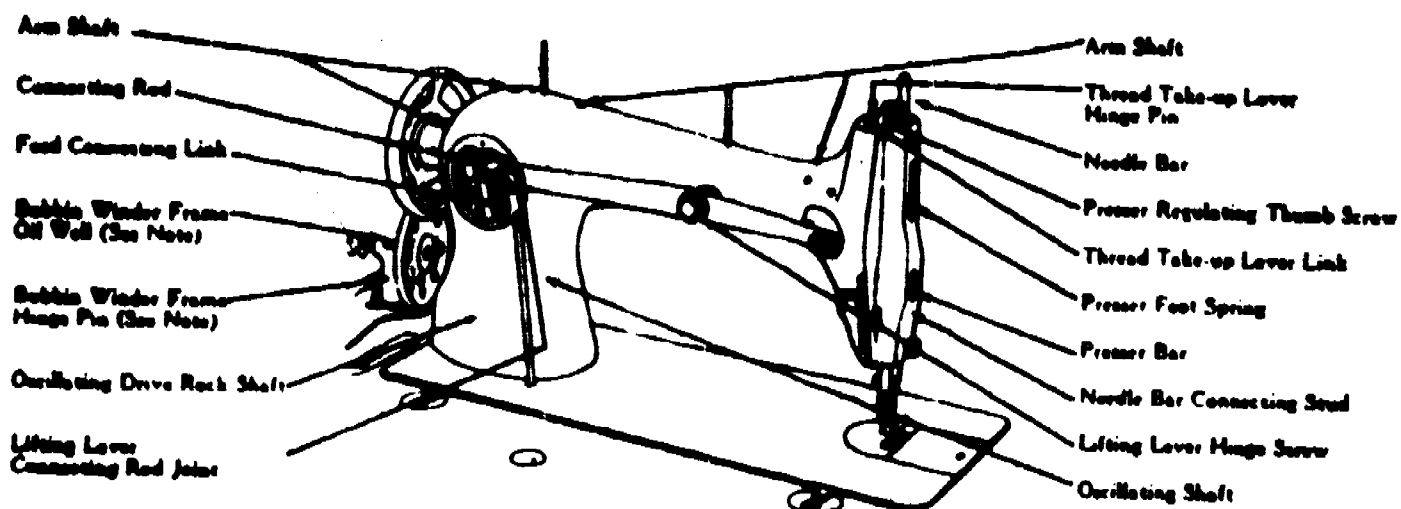

— NOTES —

The machine should be oiled twice a day by applying from one to three drops of lubricating oil (MO) to each of the oil can points indicated above by an arrow. Do not flood these moving parts with oil nor ignore the four hour lubricating interval.

BOBBIN WINDER—Every day lubricate the bobbin winder frame oil well and bobbin winder frame hinge pin with one or two drops of lubricating oil (MO).

FACE ASSEMBLY—Every week the face plate should be removed and the universal bearings and joints lubricated with two or three drops of lubricating oil (MO).

MOTOR—Every 3 months lubricate the rotor shaft grease fitting with 1 or 2 strokes of a gun containing ball and roller bearing grease (BR). The transmitter bearing may be lubricated in a similar manner. Every month fill the waste packed oil reservoir at the terminal end of the rotor shaft with lubricating oil (MO).

SHUTTLE RACE—Twice every day apply lubricating oil (MO) to the shuttle bearing in the shuttle race, at the same time rubbing two or three drops of oil over the surface of the shuttle race itself. Every week remove the shuttle body from the shuttle race, clean and lubricate it.

Figure 6. Lubrication Chart for Model 31-15.

MAINTENANCE

To insure that a sewing machine stays in peak operating condition proper care cannot be emphasized too strongly. The man sitting at a sewing machine expects to be able to accomplish certain things in order to support his part of a mission. If the machine doesn't operate correctly then the job cannot be accomplished. Such things as lubrication on a day-to-day basis does wonders for the machine. Due to the fact that an occasional part may need replacing, you should know how to accomplish parts replacement, and make minor adjustments. In exercises of the workbook, you will be guided in timing, minor adjustment and preventive maintenance.

Time the Needle With the Shuttle

Over a period of operation, the sewing machine may require timing. Improper handling or forcing the machine to perform beyond its design limitations will often present timing problems.

The correct class of needle should always be used in this machine, (class 16X87, number 2055). Each class of needle may vary in length or construction and if the wrong class of needle is used, it affects the timing.

The machine is considered to be in time when the shuttle point, on its forward movement, is centered on the needle, 1/16 inch above the top of the needle eye. If the machine forms a lockstitch, it is considered timed. Refer to TO 34Y7-6-1, page 17.

Feed Dog Adjustment

The height of the feed dog is determined by the weight and plies of the material being sewn. If it is set too low, the material will not feed through the machine; if it is set too high, it may cut or fray the material. The recommended height of the feed dog for sewing lightweight material is slightly less than one tooth above the throat plate. If you are sewing heavier material, raise the feed dog to a height which will insure positive feeding of the material. After you have decided the correct height for the project you are fabricating, adjust the feed dog accordingly. You must remember that each time the height of the feed dog is changed, the feeding mechanism may be out of time. For this reason, set the feed dog first and then make the necessary adjustments on the feeding mechanism. Refer to TO 34Y7-6-1, page 18.

Time Needle with Feed Dog (Feeding Mechanism)

The feed mechanism should be timed so that the feed dog finishes its feeding movement when the thread take-up lever is at its highest position. The feed should always finish its feeding movement before the needle reaches the material being sewn on its downward stroke. Refer to TO 34Y7-6-1, page 19.

Adjust the Take-up Spring

To adjust the take-up spring correctly, you must first understand its normal operation. The take-up spring is essentially a part of the tension assembly. The thread take-up lever pulls the thread take-up spring down about even with the slack thread regulator, while the needle is going up. While the take-up lever is coming down with the needle, the take-up spring pulls the slack out of the thread and keeps it from getting under the needle.

If you do not have this adjusted properly, a loop can form over the needle hole in the throat plate and the needle can split the thread as it enters the needle hole. You should set the spring about 1/4 inch above the slack thread regulator. Refer to TO 34Y7-6-1, page 20.

Adjust Stitches Per Inch

The length of the stitch is adjusted by the feed regulator thumbscrew located in the slot on the front of the upright part of the arm on the Class 31 sewing machine.

To lengthen the stitch, the thumbscrew must be loosened and moved downward, and to shorten the stitch, the thumbscrew must be loosened and moved upward. When the desired length of stitch has been obtained, tighten the thumbscrew. Refer to TO 34Y7-6-1, page 14.

Troubleshooting

While extensive troubleshooting is not expected from the three-level apprentice, you should be familiar with the cure for some common troubles. For instance, you are expected to analyze some of the simple causes for needle and thread breakage.

NEEDLE BREAKAGE. Several things could cause a needle to break. It may be the result of improper selection or seating of the needle, or it could be the fault of the machine operator. The first step in troubleshooting this problem would be to ask yourself, "Am I pulling the fabric or overloading the needle with thick seams?" If you are pulling the fabric, the needles will continue to break until you learn to feed the material properly. If you are feeding the material properly, the most likely trouble is that the needle or presser foot has become loose. If this is the case, be sure to tighten the loose setscrew. If the wrong needle has been placed in the machine or if the needle has been incorrectly set in the needle bar, it will probably break. Be sure you replace the broken needle with a needle that is made for the machine you are using and see to it that it is properly set in the needle bar.

NEEDLE THREAD BREAKAGE. The size and twist of the thread should be checked to be sure that you are using left-twist thread of the proper size for the needle you are using. A thread of correct size will pass freely through the eye of the needle. Also see if the thread is dry, because damp thread is likely to break.

If the thread itself is not responsible for the breakage, check the threading and tension of the thread. An incorrectly set or damaged needle may also be the cause of the trouble. Follow these checks with a check for sharp edges on the hook bobbin case or tension controller. If burred, smooth the sharp edges with emery paper.

BOBBIN THREAD BREAKAGE. If the bobbin tension is too tight or if the bobbin case is incorrectly threaded, the bobbin thread will probably break. If the bobbin is wound too full to revolve freely, take off thread down to the rim of the bobbin and adjust the bobbin winder. If rounds of thread on the bobbin are lapped over one another, wind the bobbin correctly. If the bobbin case is sticky with gummy oil and lint, clean the bobbin case and shuttle race according to the technical order. If there is a sharp edge on the shuttle, bobbin case, bobbin, or needle, smooth it with emery cloth.

Shuttle Race Assembly

It is necessary to remove and clean the shuttle race assembly if it becomes excessively dirty. The point of the shuttle is sometimes damaged during operating and may require replacement. Small burrs or rough spots may be removed from the shuttle point with emery cloth; the shuttle may then be replaced and the assembly is considered serviceable. Refer to TO 3417-6-1, page 18.

Exercise 1

Refer to the above TO and answer the following questions on a separate sheet..

1. List three of the items the 31-15 is designed to sew.
 - a.
 - b.
 - c.
2. State the maximum speed of the 31-15.
3. The Class 31 sewing machine is equipped with what type of feed?
4. What type of stitch does the 31-15 sew?
5. When placing the needle in the machine, to which side does the long groove go?
6. What size needle is used in the 31-15?
7. How can you determine the condition of the needle?

8. State the function of the following parts of the 31-15.

- a. Thread Take-up Lever
- b. Presser Foot
- c. Throat Plate
- d. Slack Thread Regulator
- e. Tension Assembly
- f. Balance Wheel
- g. Feed Regulator
- h. Feed Dog

9. In which direction should you place the feed regulator thumbscrew in order to lengthen the stitch?

10. What should be used to clean your sewing machine?

11. What is used to lubricate the 31-15 sewing machine?

12. How often should the 31-15 be oiled if in constant use?

13. What is the distance between the needle eye and the shuttle point when the machine is properly timed?

14. What is the proper height of the feed dog?

15. Give some reasons for needle breakage.

REFERENCES

- 1. TO 34Y7-6-1, Singer Sewing Machine, 31-15



72

Exercise 2

Refer to figure 7 and then fill in the blanks on the diagram below.

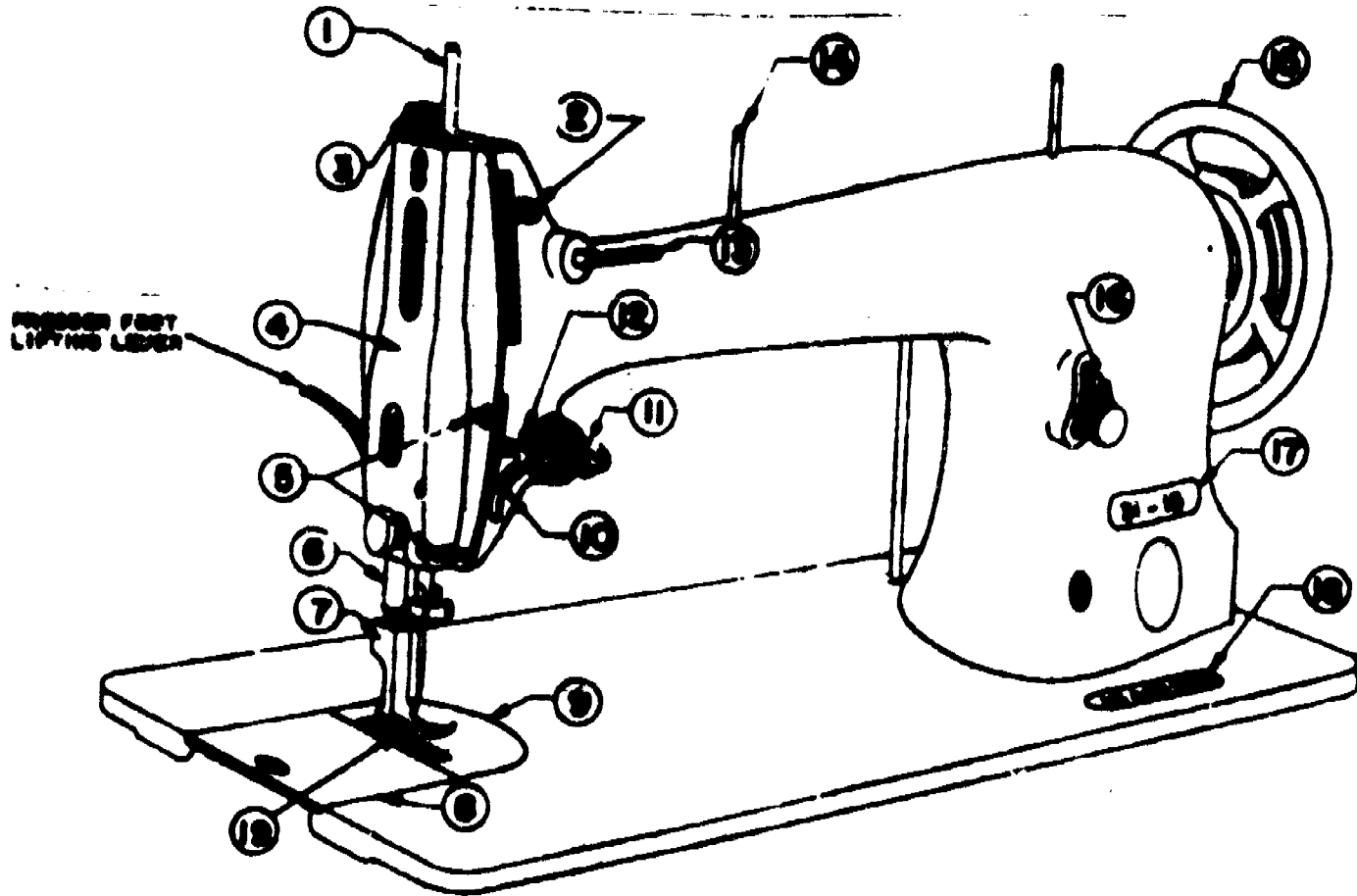

Figure 7. Functional Features of a Sewing Machine Head, Type 31-15.

- | | |
|-----------|-----------|
| 1. _____ | 11. _____ |
| 2. _____ | 12. _____ |
| 3. _____ | 13. _____ |
| 4. _____ | 14. _____ |
| 5. _____ | 15. _____ |
| 6. _____ | 16. _____ |
| 7. _____ | 17. _____ |
| 8. _____ | 18. _____ |
| 9. _____ | 19. _____ |
| 10. _____ | |

Exercise 3

1. Familiarize yourself with the Class 31 sewing machine by following the procedures listed below.

- a. Sit at the machine in a comfortable position.
- b. Locate all the labeled parts of the machine as shown in figure 7.
- c. Place your right hand on the balance wheel and turn it slowly toward you (forward).

Note: Observe the action of the feed dog as it moves forward to get into position to make the next stitch.

- d. Locate the hand presser foot lifting lever at the back of the head.
- e. Raise and lower the presser foot by lifting the lever several times.
- f. Tilt the machine head back on its hinges and let it rest on the dowel pin rest, turn the balance wheel forward, and watch the action on the oscillating shuttle.
- g. Turn the balance wheel forward until the needle moves to the highest position.

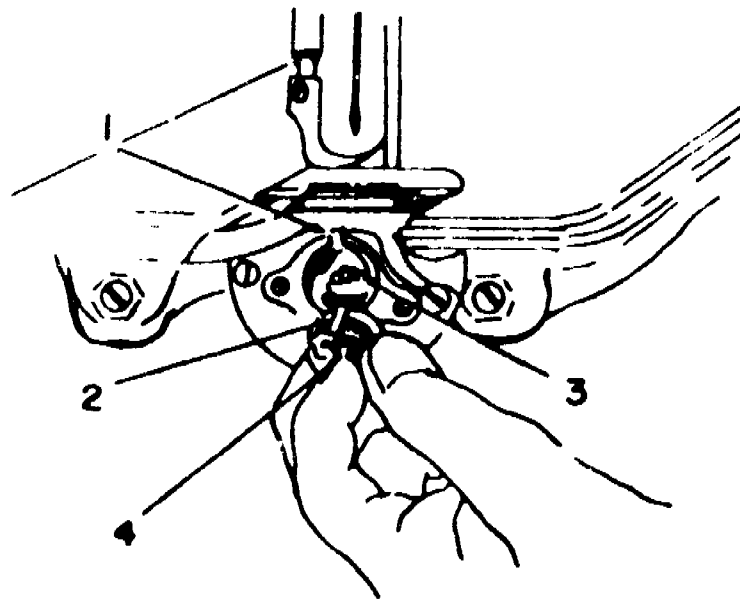

1. SHUTTLE RACE NOTCH.
2. BOBBIN CASE POSITION FINGER.
3. STUD OF SHUTTLE BODY.
4. LATCH.

Figure 8. Removing and Replacing the Bobbin Case.

- h. With the thumb and forefinger of the left hand, open the latch on the bobbin case (see figure 8). Holding the

74

bobbin case by the latch, pull it to the left and out of the machine.

1. Release the latch to remove the bobbin from the case.

Note: As long as the bobbin latch is held open, a sliding lug inside the bobbin case holds the bobbin in the case. Do not try to force the bobbin out of the case while the latch is open.

j. Place an empty bobbin in the case.

k. Open the bobbin case latch, place the bobbin case on the shuttle stud (figure 8, part 3) and press position finger (figure 8, part 2) in the shuttle race notch (figure 8, part 1). There will be a sharp "click" when the position finger snaps in place in the shuttle race notch.

1. Lower the machine head to its original position.

Exercise 4

1. Practice machine control.

a. Locate the motor switch and turn it on.

b. Raise the presser foot.

CAUTION: Never operate the machine with the presser foot making direct contact with the feed dog, as this will dull the feed dog teeth.

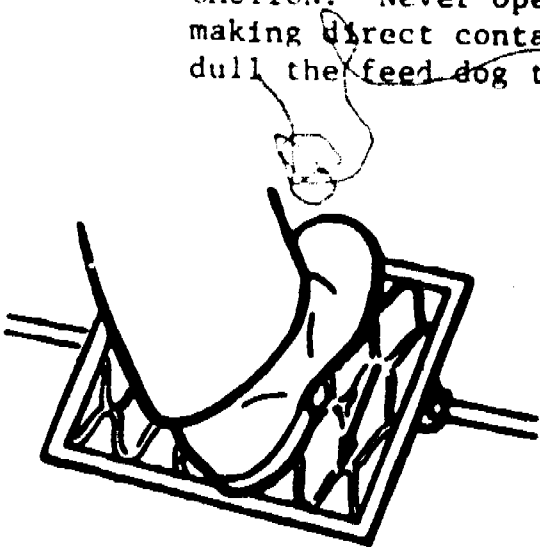

Figure 9. Disengaging Clutch.

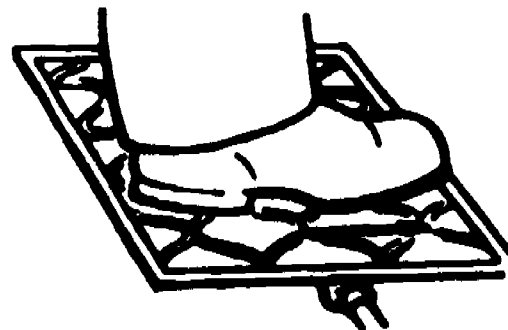

Figure 9A. Engaging Clutch.

c. Place your right foot on the treadle with your heel applying pressure on the lower edge of the treadle as shown in figure 9.

d. Apply pressure gradually with the toe as shown in figure 9, part A.

CAUTION: Keep hands away from the needle and do not run the machine at high speed.

CAUTION: USE A DOUBLE THICKNESS OF FABRIC UNDER THE PAGE FOR SEWING MACHINE PRACTICE.

75

**START SEWING AT THIS LINE
FOLLOW EACH LINE**

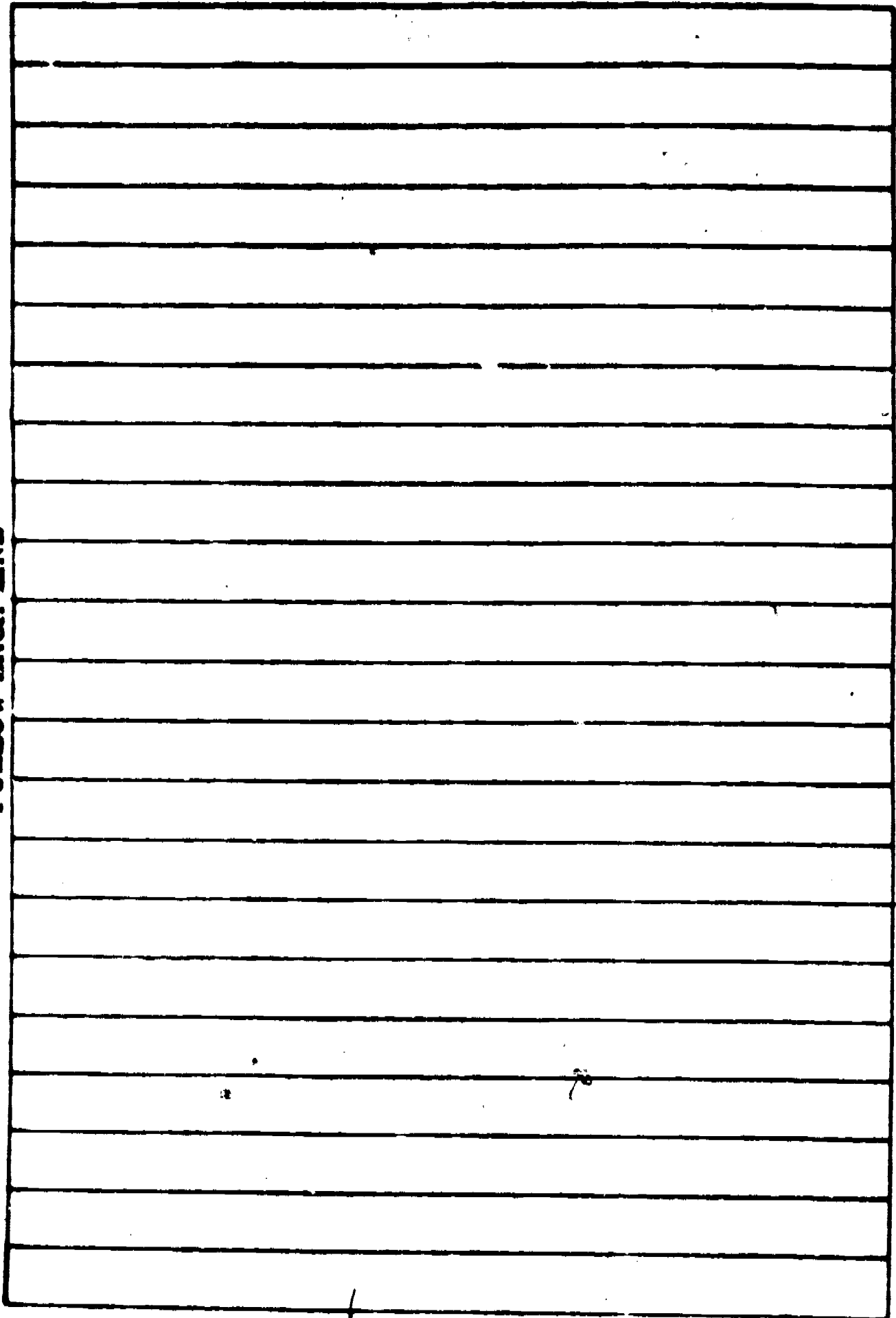

DO NOT SEW IN THIS AREA

Figure 10.

CAUTION: USE A DOUBLE THICKNESS OF FABRIC UNDER THIS PAGE FOR SEWING MACHINE PRACTICE.

77

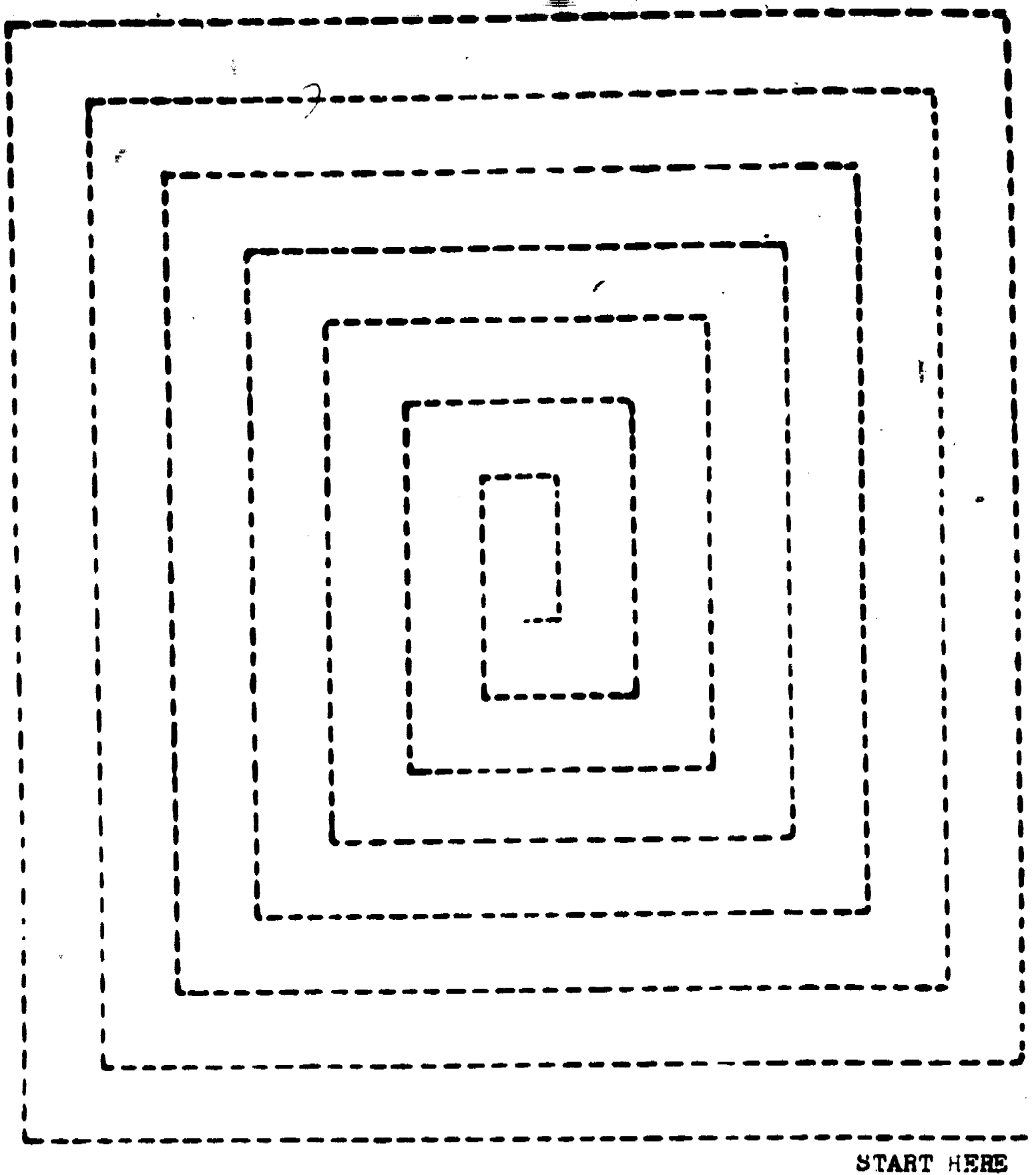

Figure 12.

CAUTION: USE A DOUBLE THICKNESS OF FABRIC UNDER THIS PAGE FOR SEWING MACHINE PRACTICE.

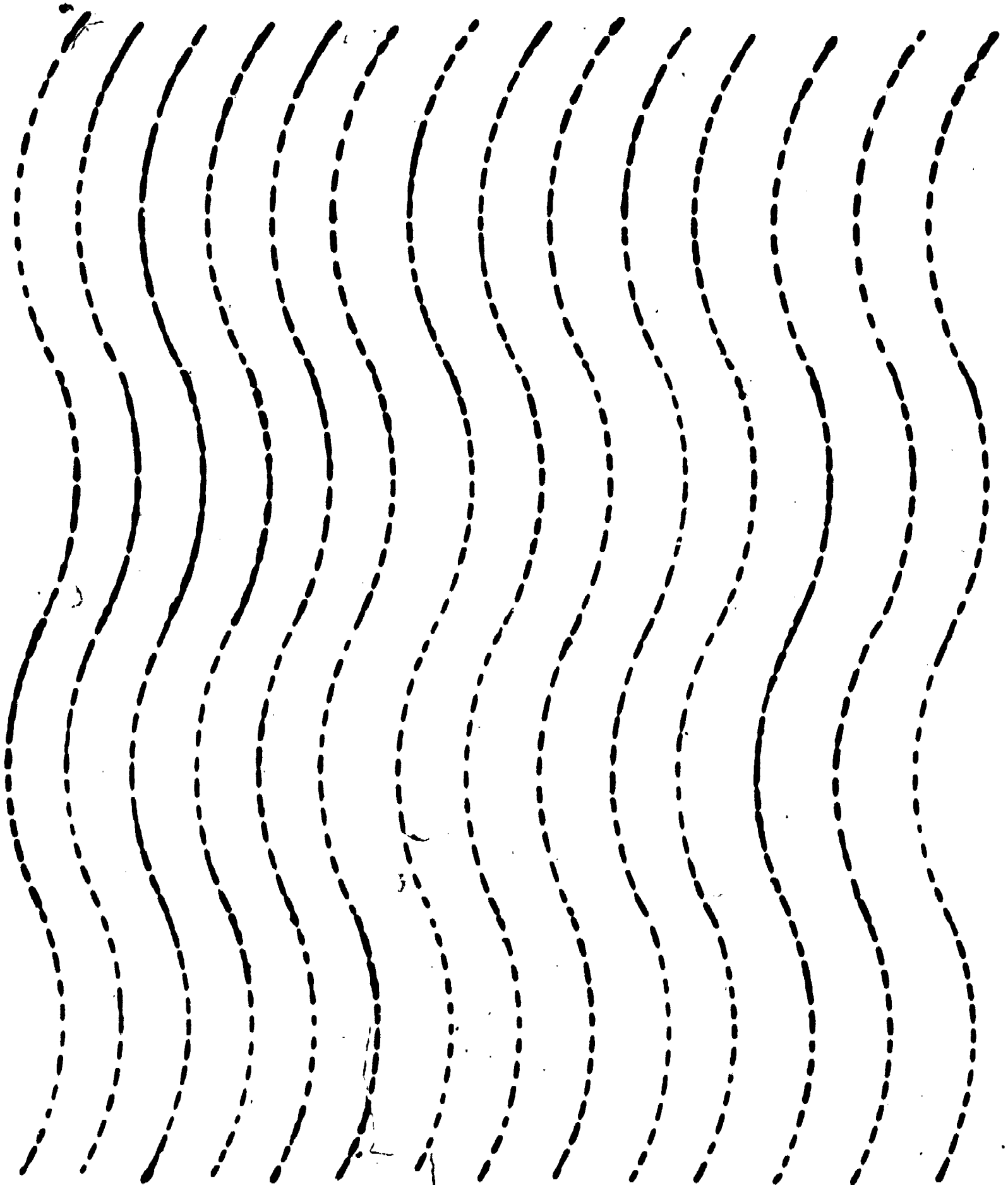

Figure 13.

CAUTION: USE A DOUBLE THICKNESS OF FABRIC UNDER THIS PAGE FOR SEWING MACHINE PRACTICE.

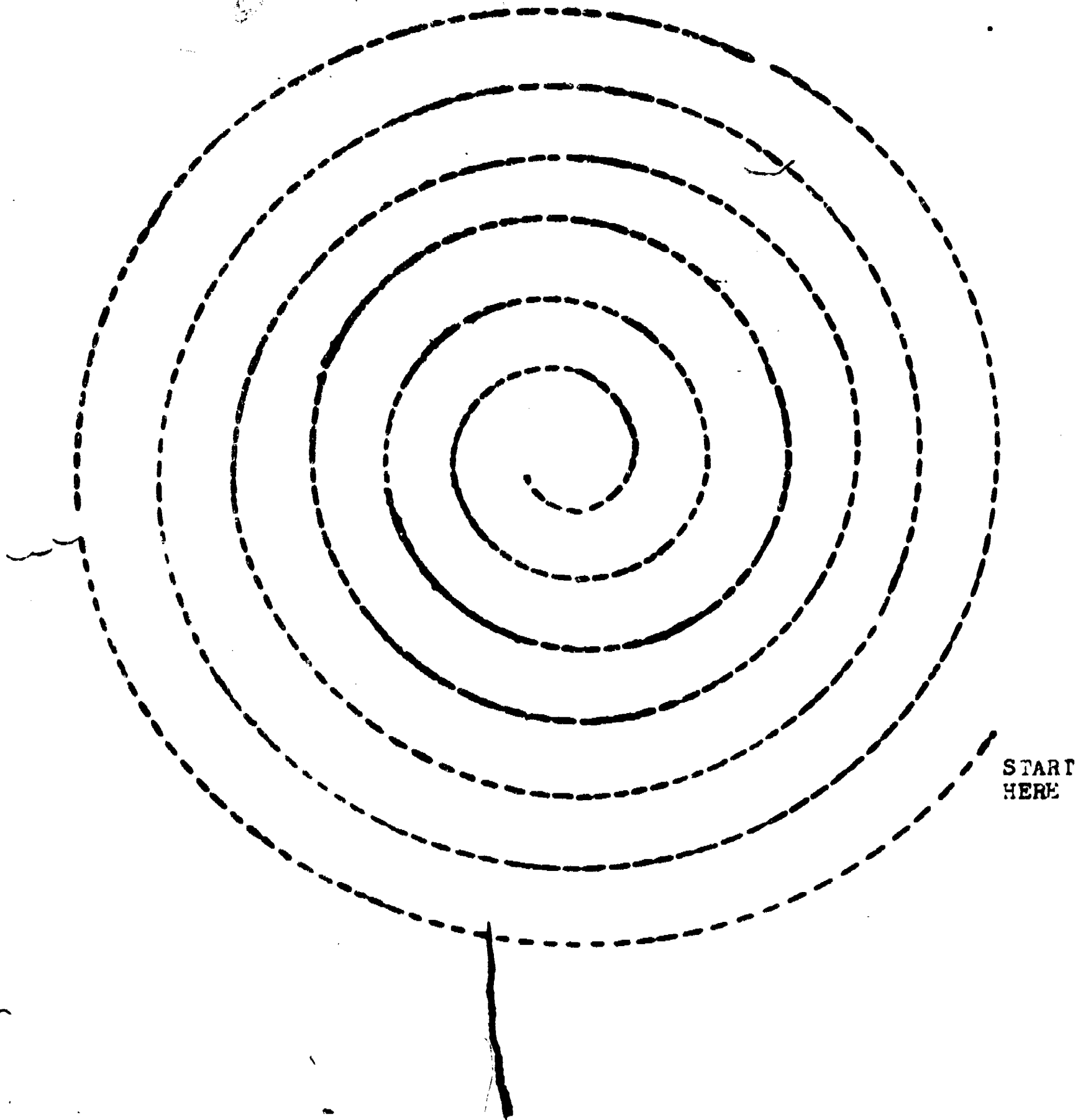
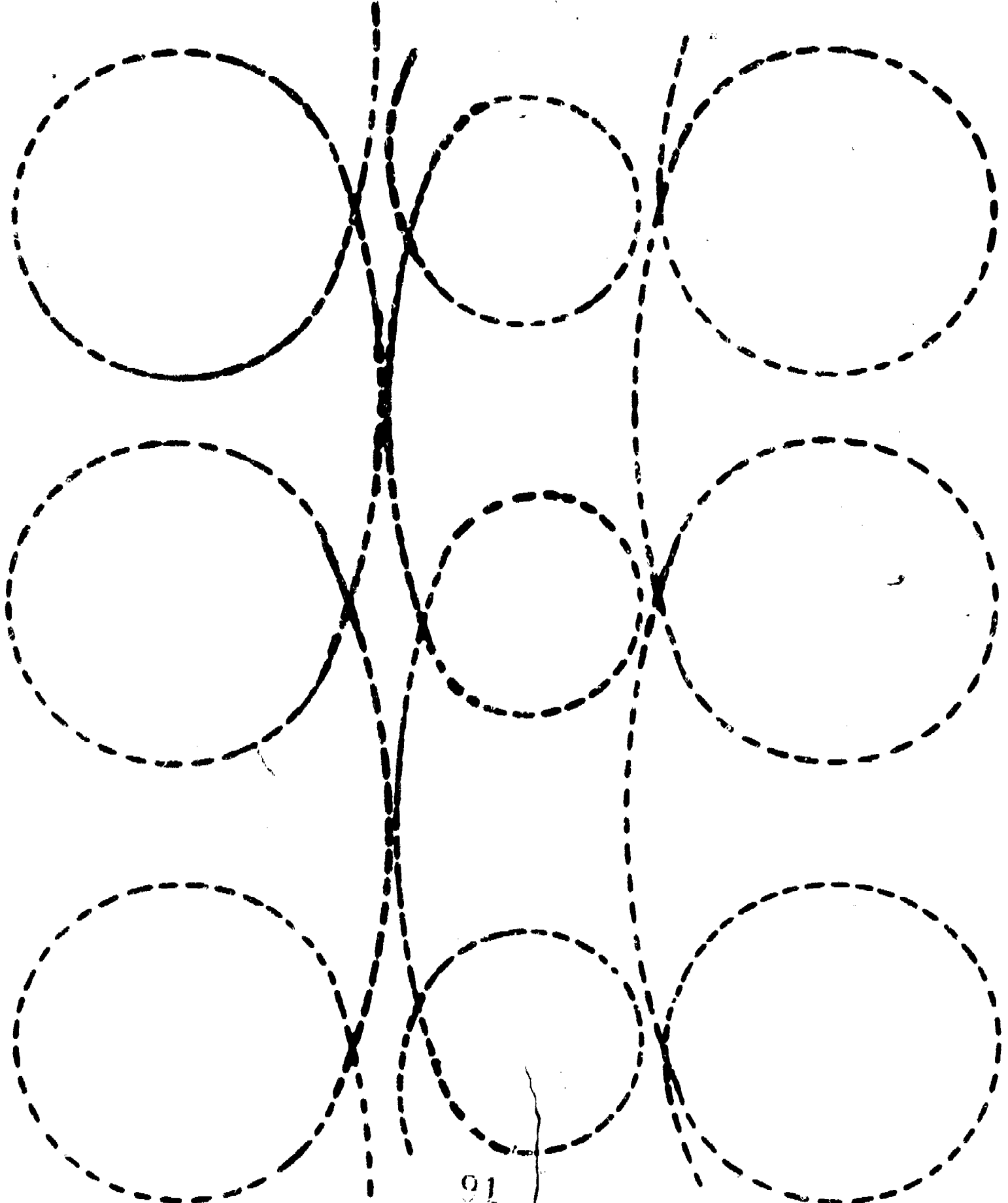

Figure 14.

CAUTION: USE A DOUBLE THICKNESS OF FABRIC UNDER THIS PAGE FOR SEWING MACHINE PRACTICE.



91

Figure 15.

CAUTION USE A DOUBLE THICK-
NESS OF FABRIC UNDER
THIS PAGE FOR SEW-
ING MACHINE
PRACTICE.

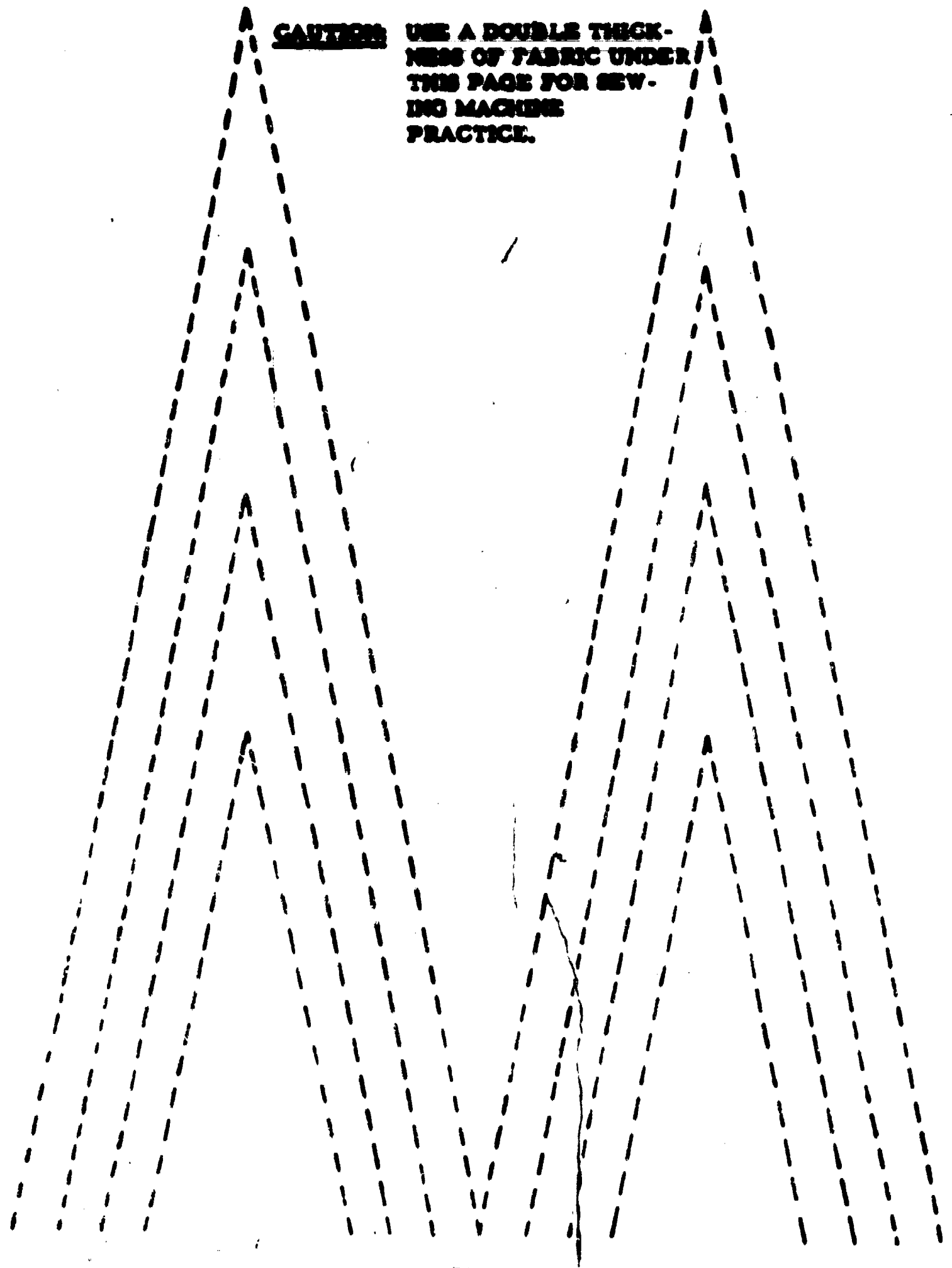

Figure 16.

e. Start and stop the machine several times. Practice operating the machine as slowly as possible and apply the brake quickly several times.

f. Turn off the motor.

2. Complete practice exercises.

a. Cut one piece of fabric 16" X 11".

b. Double fabric so it measures 8" X 11".

c. Remove figures 10 through 16 from this workbook.

d. Place fabric under each figure and sew as directed.

Note: Save the piece of fabric for future sewing projects.

(1) Lift the presser foot.

(2) Raise the needle to the highest position.

(3) Insert fabric and paper under the needle and turn the balance wheel forward until the needle pierces the first line on the paper.

(4) Lower the presser foot.

(5) Turn on the motor.

(6) Press the foot treadle with the toe very lightly and sew as directed in figures 10 through 16.

(7) Remove the figure from the machine by raising the needle to its highest position and lifting the presser foot with the hand lift.

Note: Do not help the material through the machine. It is unnecessary to push or pull the paper or material; the feeding mechanism is timed to feed the material properly. The paper may be guided through it lightly with the fingertips.

(8) Repeat the same procedure on each figure.

Exercise 5

To thread bobbin and head proceed as follows:

1. Thread the bobbin.

93

a. Remove the bobbin from the case and place on the bobbin winder spindle as shown in figure 17.

b. Pass the thread from the thread stand down through the thread hole in the tension bracket (figure 17, part A) and down between

the bobbin winder disks (figure 17, part B). Pull the thread from the lower side of the tension disks to the bobbin.

c. Place the thread end through the hole in the bobbin from the inside out.

d. Press the latch thumb lever until the automatic stop latch (figure 17, part D) catches and holds the pulley (figure 17, part E) against the driving belt (figure 17, part F).

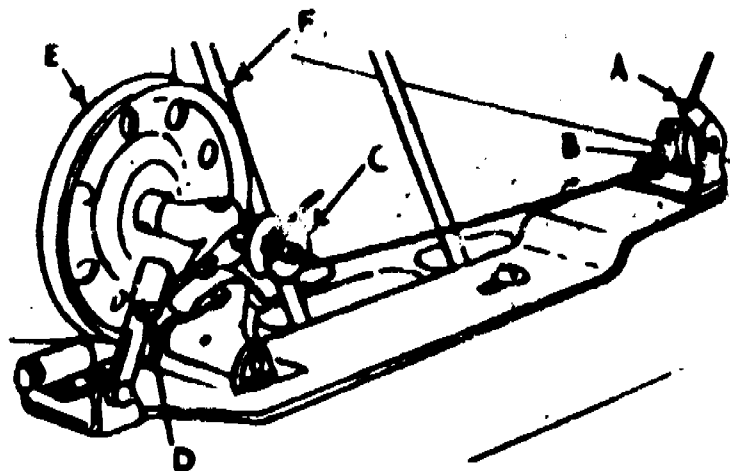

Figure 17. Winding the Bobbin.

e. Raise the presser foot.

f. Start the motor and hold onto the end of the thread where it protrudes from the bobbin.

g. Step on the foot treadle and apply pressure gradually with the toe.

h. Continue running the machine until the bobbin is wound and then shut off the machine.

Note: When the bobbin is full, the winder will stop automatically.

i. Cut as close as possible the loose end of the thread protruding from the side of the bobbin.

Note: Failure to cut the thread end from the side of the bobbin may result in the thread winding around the stud of the shuttle body (figure 8, part 3) (page 17). This will cause thread breakage or poor bobbin tension.

j. Remove the thread from the winder.

k. Place the bobbin in the case so that the thread will unwind clockwise as the bobbin operates. The thread will unwind from the bobbin as shown in figure 18, when placed in the case.

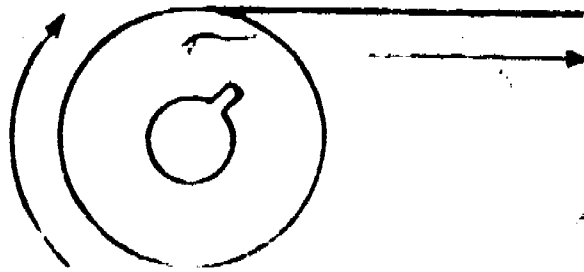

Figure 18. Bobbin Pulling Clockwise.

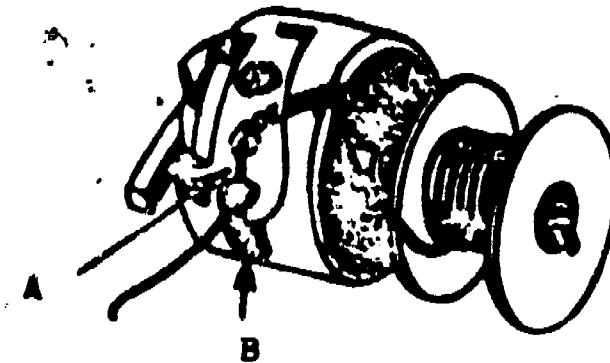

Figure 19. Bobbin and Bobbin Case.

1. Pull the thread end back through the slot (figure 13, part A) and out the opening (figure 19, part B) leaving about a 4-inch end of thread.

m. Place the bobbin case in the machine as shown in figure 8, page 17.

Note: Be sure the thread end is hanging to the left of the position finger ready to be picked up by the needle thread, figure 8, page 17.

2. Thread the Head. (See figure 20).

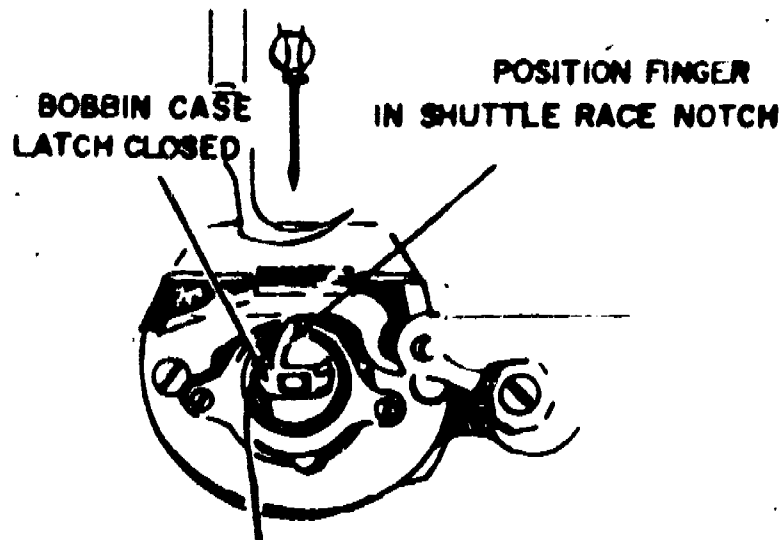

Figure 20. Bobbin Case in Shuttle Race with Bobbin Thread Ready to be Picked up by Needle Thread.

a. Check the needle.

- (1) Raise the needle bar to the highest position. Loosen the needle clamp screw and remove the needle.
- (2) Check the needle for proper class, variety and size.
- (3) Never use a bent needle or one that is blunted or burred.
- (4) Insert the needle shank as far into the clamp as it will go; turn the long groove of the needle so that it faces the left and is directly in line with the arm of the machine. Tighten the clamp screw.

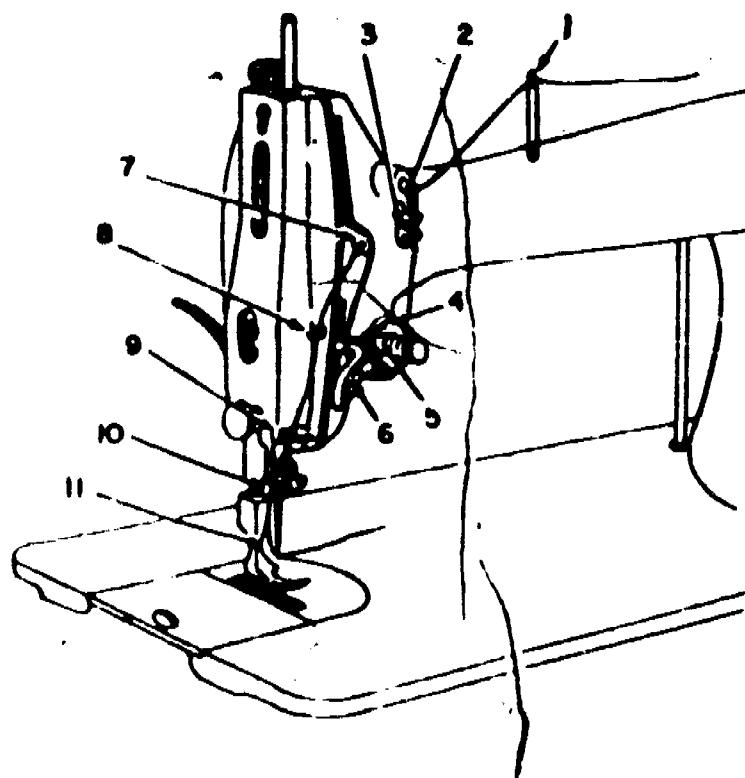

Figure 21. Threading Points.

b. Thread the needle. Pass the thread through the following points (see figure 21).

- (1) Top hole in left-hand spool pin.
- (2) Top hole in thread retainer.
- (3) Bottom hole in thread retainer.
- (4) Tension disks.

CAUTION: Make certain the thread is pulled between the tension disks until it touches the tension stud.

- (5) Hook of thread takeup spring.
- (6) Slack thread regulator.

- (7) Hole in thread takeup lever.
- (8) Top eyelet on faceplate.
- (9) Bottom eyelet on faceplate.
- (10) Eyelet in needle bar thread guard.
- (11) Eye of needle.

c. Catch the bobbin thread.

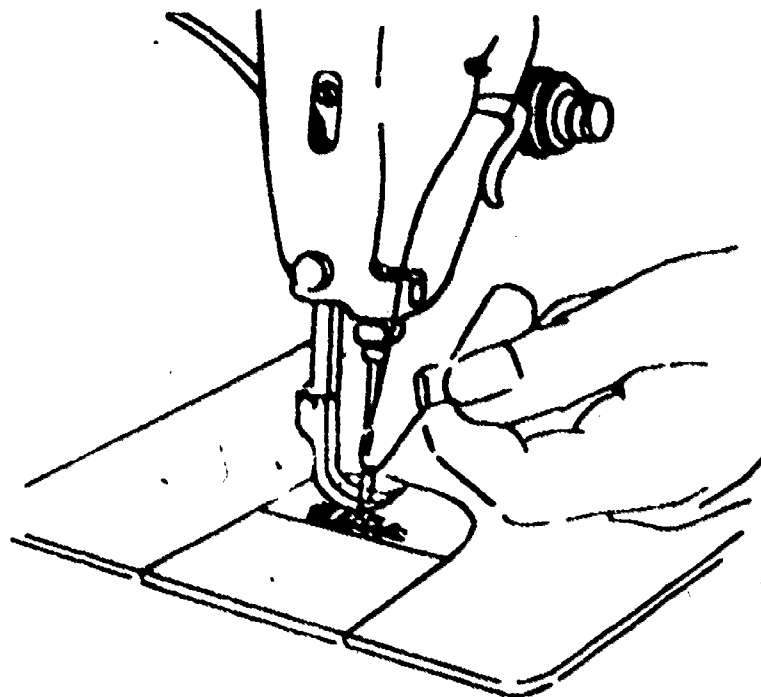

Figure 22. Needle Thread Being Used to Draw Bobbin Thread up Through Hole in Throat Plate.

(1) After the needle has been threaded and the bobbin case replaced, the operator must use the needle thread to catch and draw the bobbin thread up through the hole in the throat plate, as illustrated in figure 22.

(2) By operating the hand lifting lever, lock the presser foot in its raised position.

(3) With the left hand, hold the end of the needle thread a little slack and toward the upright of the arm.

(4) With the right hand, turn the balance wheel down toward you until the needle moves from its highest position, down, and back up to its highest position. If the needle thread is held with a light tension during this operation, and if the needle is correctly timed, it will catch the bobbin thread.

(5) Draw up the needle thread, and the bobbin thread will come up with it through the hole in the thread plate, as in figure 16.

Exercise 6

To practice operation of a threaded machine, proceed as follows:

1. Insert the work.
 - a. Raise the presser foot.
 - b. Place the edge of the material you have been using under the presser foot.
 - c. Pull both the needle and bobbin threads under the presser foot.
 - d. Lower the presser foot.
 - e. Hold the needle and bobbin threads with the left hand, turn the balance wheel forward with the right hand, and make three or four stitches in the material by hand-turning the wheel.

Note: If the balance wheel is given a complete turn backward when the machine is threaded, it will break the thread.

- f. Turn on the motor.
- g. Sew a few inches.
2. Remove the material.
 - a. Turn the balance wheel forward until the take-up lever is in the highest position.

Note: When the take-up lever is in the highest position, the oscillating shuttle has completed the formation of the lock-stitch, leaving both the needle and bobbin threads free to be pulled from the machine.

- b. Lift the presser foot with the hand lift lever.
- Note: This releases the pressure on the tension disks, thereby releasing the tension on the needle thread so that the material can be easily pulled from the machine without breaking threads.
- c. Remove the material from under the presser foot by pulling it away from you.
 - d. Cut the needle thread (top side) one-eighth inch from the material, turn the panel so the bottom side will be up. Pull the needle thread to the underside of the material by pulling on the bobbin thread.
 - e. Cut bobbin thread close to panel.

Note: This is done to bring both cut ends to the underside and avoid ragged threads on top of the material.

88

Exercise 7

To regulate the number of stitches per inch, proceed as follows:

Note: The feed regulator thumbscrew, figure 1, on the front of the arm regulates the length of the stitch. To change the length of the stitch, loosen the thumbscrew and move it down to lengthen the stitch, and up to shorten the stitch.

1. Draw (with a sharp-pointed pencil) two parallel lines one inch apart on a scrap of cotton duck (two plies). Sew across these lines and count the number of stitches per inch.
2. Loosen the thumbscrew and lengthen the stitch by lowering the regulator.
3. Shorten the stitch by raising the regulator.
4. Set the machine to sew eight stitches per inch.

Exercise 8

To adjust tensions, proceed as follows:

1. Needle thread tension.
 - a. Cut a strip of lightweight duck 6 X 12 inches. Double it to form two plies of material 6 X 6 inches.
 - b. Turn on the machine and sew for a distance of two or three inches.
 - c. Lift the presser foot with the hand lift lever and examine the stitching formation on both sides of the material.

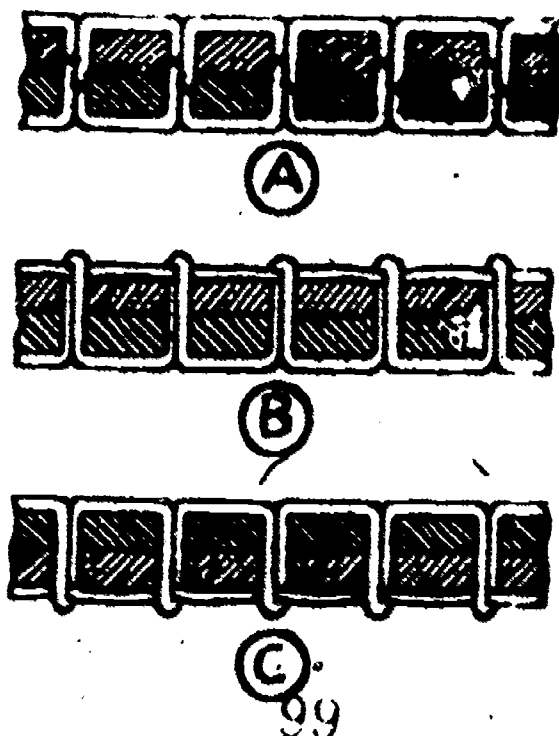

Figure 23. Correct and Incorrect Adjustments on Needle and Bobbin Threads.

Note: Figure 23 shows the correct and incorrect tension adjustments on the needle and bobbin threads. "A" shows the lock formed in the center of the plies of material, indicating that both the needle thread tension and the bobbin thread tension are correct. "B" shows the lock formed on the top ply, indicating that the needle thread tension is too tight and the bobbin thread tension too loose. "C" shows the lock formed on the bottom ply, indicating that the bobbin tension is too tight and the needle tension too loose.

d. Adjust the tension as necessary by slightly turning the thumb nut on the needle thread tension disk clockwise to increase tension or counterclockwise to decrease the tension and lower the lock.

e. Sew on the material again for a few inches, and check the stitching formation.

f. Adjust again, if necessary.

Note: If the correct tension cannot be obtained by adjusting the tension disk, the bobbin tension will need adjusting.

2. Bobbin thread tension. The tension on the bobbin thread is regulated by the bobbin case tension spring screw pointed out by the screwdriver in figure 24. To increase the tension, turn the screw to the right. To decrease the tension, turn the screw to the left. When the tension on the bobbin thread has been properly adjusted, it is seldom necessary to change it, because a correct stitch can usually be obtained by varying the tension on the needle thread. Changing the thread size sometimes makes it necessary to change the bobbin tension.

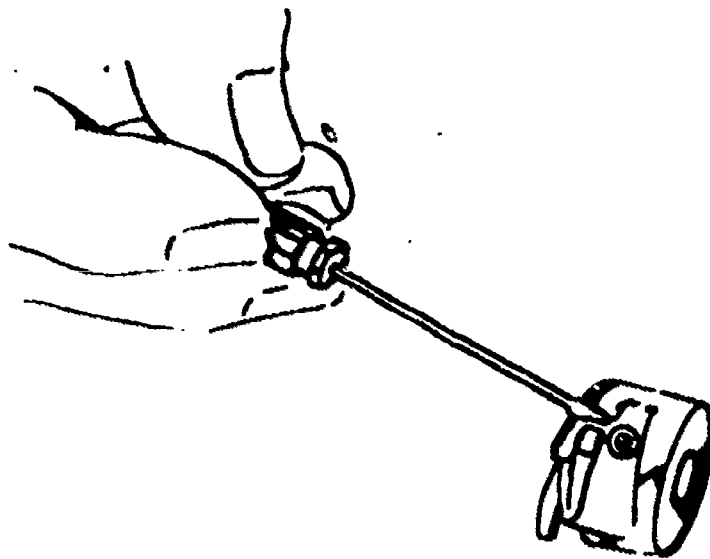

Figure 24. Bobbin Thread Tension Adjustment.

- a. Thread the bobbin case.
- b. With a jeweler's screwdriver, loosen the screw.

Note: This screw is very short, slightly more than the thickness of the case; therefore, care should be taken to prevent the removal of the screw, as this usually results in its being lost.

- c. Test the looseness of the thread.
- d. Tighten the screw. Pull the thread to test the tension.
- e. Set the screw so that a moderate pull releases the thread.

Exercise 9

To adjust the pressure on the presser foot, proceed as follows:

Note: The pressure of the presser foot upon the material enables the feed dog to push the material forward each time the needle goes up. For the needle to make an even stitch, the material must move forward at a uniform speed. If the pressure is too light, the dog does not feed the material, the needle hits in one place on the material and the bobbin thread knots up. If the pressure is too great, the feed dog is worn unnecessarily and feeds the bottom fabric faster than the upper fabric. The pressure on the presser foot is regulated by the pressure regulating thumbscrew on top of the machine, figure 1.

1. Turn screw downward to increase pressure on the material.
2. Check the pressure by running the machine for a few stitches.
3. Turn screw upward to decrease pressure on the material.

Exercise 10

To time the machine so that the needle and shuttle will form the lockstitch, complete the following steps:

1. Remove the throat plate.
2. Check the class of needle and its insertion into the needle clamp.
3. Turn the balance wheel toward you until the shuttle point moves forward and is centered on the needle.

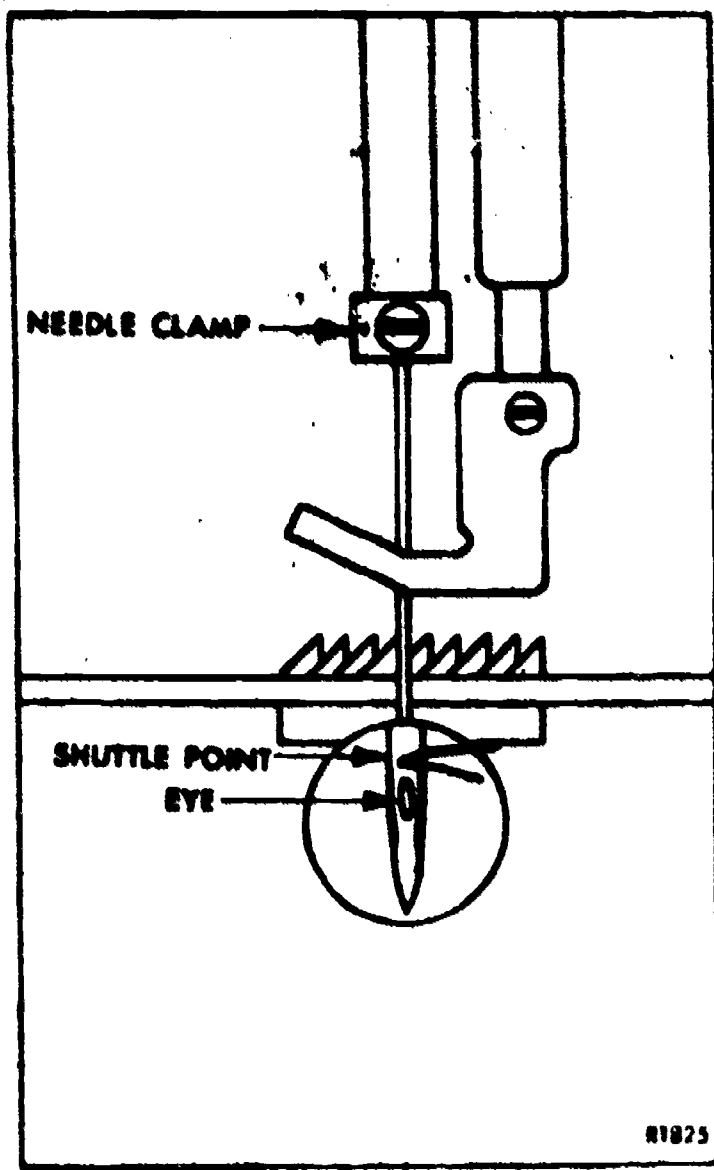

Figure 25. Shuttle Point Positioned 1/16 Inch Above the Needle Eye.

4. If the shuttle point is not 1/16 inch above the eye of the needle (figure 25), remove the faceplate, loosen the screw in the needle bar connecting stud and move the needle bar up or down to correct the position. Secure the screw and replace the faceplate.

5. Check the timing and then replace the throat plate.

Exercise 11

The tension of the thread take-up spring should be sufficient to reduce the slack in the needle until the eye of the needle, on its downward stroke, enters the material. Tension on the thread take-up spring is adjusted as follows: (See figure 26).

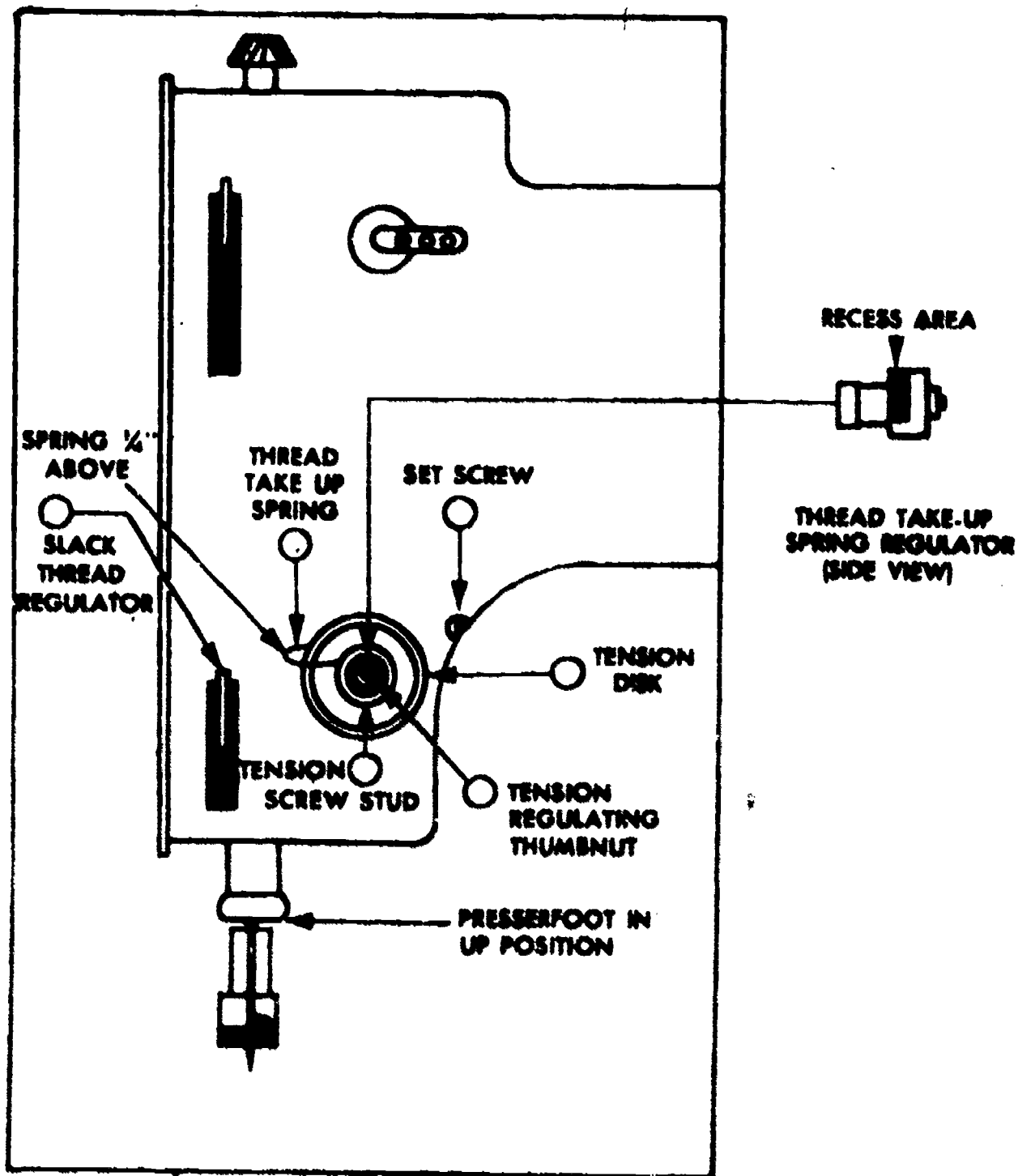

Figure 26. Adjustment of Thread Tension Assembly (Spring Tension and Position)

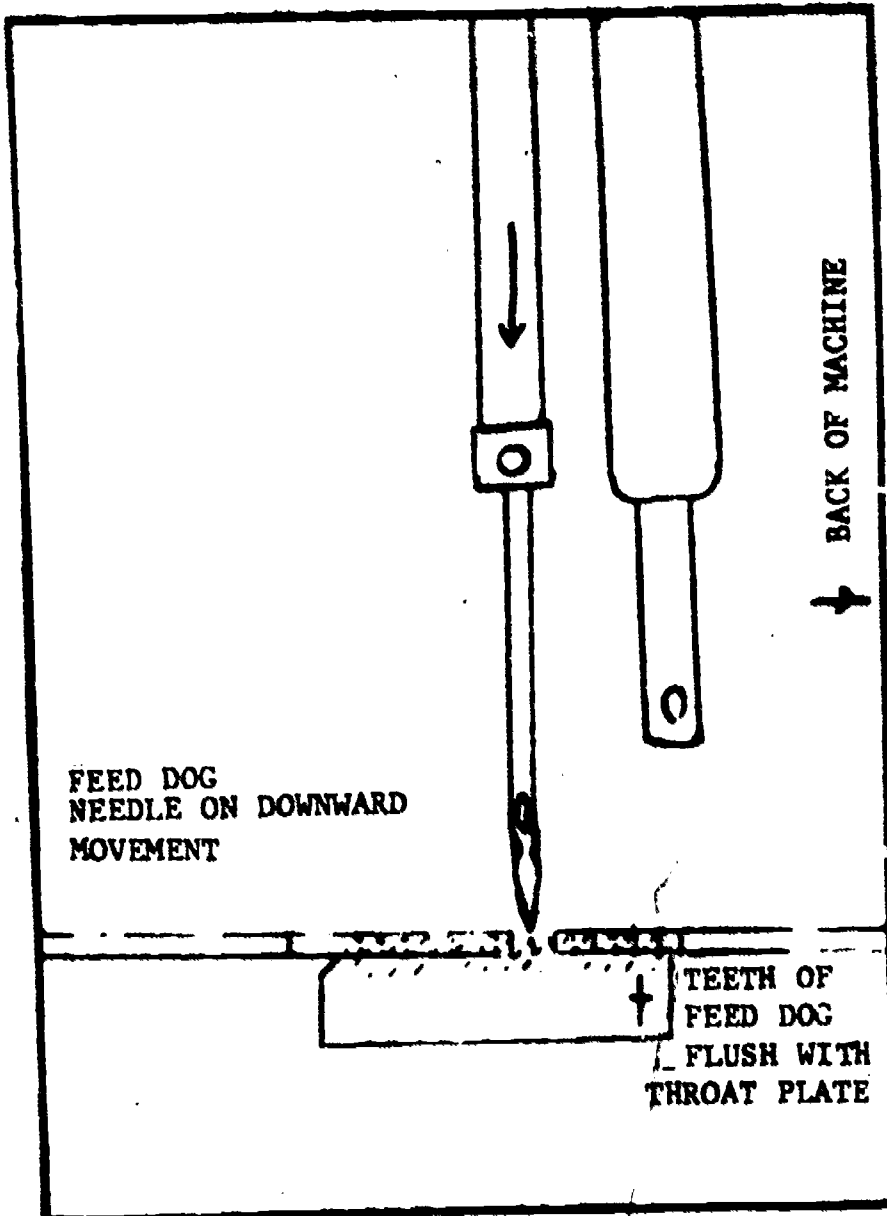

Figure 27. Adjust Needle With Feed Dog.

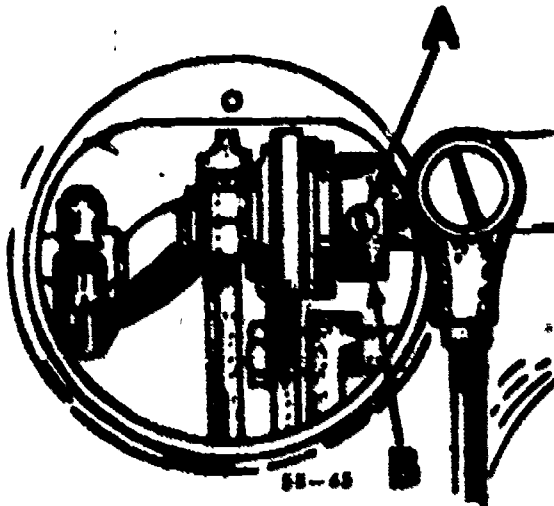

Figure 28. Eccentric Collar and Setscrew.

94

1. Set the take-up spring regulator casing at a twelve o'clock position.
2. Turn the knurled nut on the tension stud, until it is positioned on the extreme end of the stud, toward the operator.
3. Insert a screwdriver in the end of the stud and turn the stud to the operator's left. (This action will loosen the stud so that the spring may be set without damage.)
4. Raise the presser foot to the up position and position the spring 1/4" from the slack thread regulator.
5. Hold the spring in this position and insert the screwdriver in the end of the stud.
6. Turn the stud to the operator's right and tighten it against the spring.
7. Push down gently on the take-up spring and check the position of the spring with the slack thread regulator (1/4"). Reaccomplish steps 1 through 6 if the spring is out of position.

Exercise 12

Time needle with the feed dog:

Check feed dog height insuring that it is slightly less than one full tooth above throat plate at its highest point of travel.

NOTE: The feeding mechanism needs timing if there is a twisted knot every two or two and one-half inches which cannot be eliminated by adjustment of the tension. Do Not adjust the feed eccentric until you have checked the timing of the needle. The procedure will need careful supervision by the instructor the first time.

To time the needle with the feed dog, proceed as follows:

1. Set machine to sew longest stitch possible.
2. Turn the balance wheel in the direction of operation until the feed dog is as far back as it will go and on the down stroke, see figure 27.
3. Move to rear of machine and remove arm side cover by removing the thumbscrew, see figure 28.
4. Feed mechanism B, and setscrew A, figure 28, will be visible.

105

5. Holding mechanism with right hand, loosen setscrew one-half turn.
6. Reset feed dog level with throat plate by turning feed mechanism, B figure 28.
7. Holding feed mechanism with right hand, turn balance wheel in direction of operation until point of needle is on down stroke and ready to enter material, figure 27.
8. Holding feed mechanism with right hand, tighten setscrew, A, figure 28.

Exercise 13

The tension assembly is adjusted by turning the thumb nut on the tension stud, forcing the tension spring against or away from the tension disks. Since this assembly applies direct pressure on the needle thread, the area between the tension disks must be kept clear of rust or foreign objects as follows:

1. Remove the thumb nut, tension spring, tension release washer, and tension disks.
2. Clean the inside areas of the tension disks with a soft cloth. Remove rust with emery cloth.

Note: Do not apply oil to any of these parts.

3. Reassemble by positioning the tension disks, tension release washer, tension spring, and thumb nut on the tension stud.

Note: Be careful not to cross thread the thumb nut on the tension stud.

96

Exercise 14

To troubleshoot the machine for skipping stitches and thread breakage, proceed as follows:

1. Skipping stitches.

a. Remove the throat plate after taking out the two screws and check for the following:

(1) Needle for correct number (2055) or correct class and variety (16X87).

(2) Loosen the clamp screw which holds the needle in its position.

(3) Push the needle up in the clamp as far as it will go and tighten the clamp screw to hold the needle in its correct position.

(4) Turn the balance wheel toward you until the point of the shuttle, on its forward stroke, is centered on the diameter of the needle.

Note: The top of the eye of the needle should be 1/16 of an inch below the point of the shuttle. If above procedures are incorrect, reaccomplish exercise 10.

2. Needle thread breakage.

a. Check the machine for proper threading. If it is not properly threaded, reaccomplish exercise 4.

b. Set the needle with the long groove to the left.

c. Check the needle thread for proper tension. Follow procedures in exercise 7 to get correct needle thread tension.

d. Check the shuttle for sharp edges. If there is evidence of damage, smooth with emery cloth.

e. Check the needle for defects. If needle is defective, blunted, or bent; remove and replace with a correct size and variety (2055 or 16X87).

107

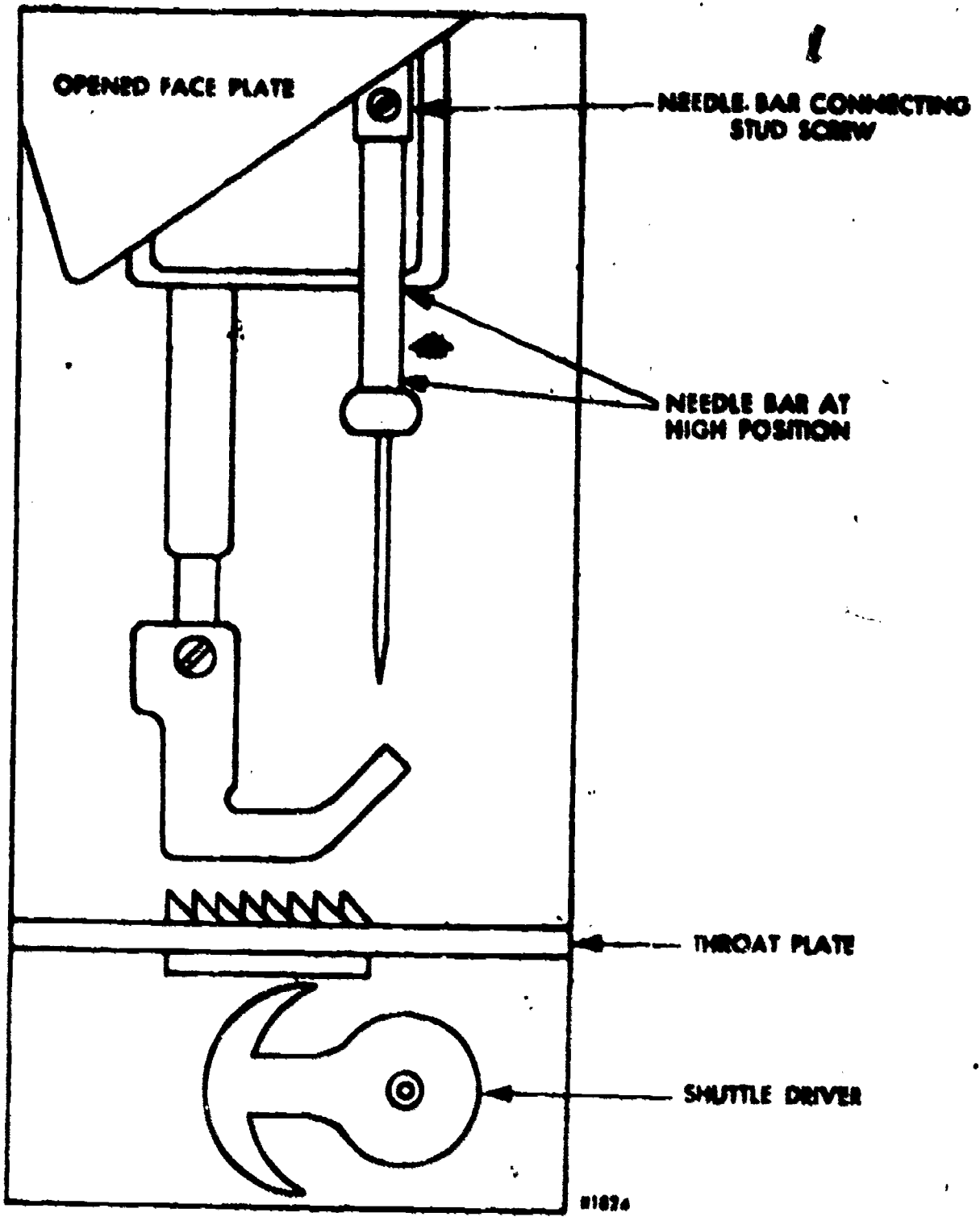

Figure 29. Correct Position of Shuttle Driver and Needle Bar to Remove or Replace the Shuttle Race Assembly.

REFERENCE

- 1. TO 34Y7-6-1



Exercise 15

To repair or replace parts in the shuttle race, disassemble as follows:

1. To remove the shuttle race turn the balance wheel until the needle bar travels as far upward as possible. The shuttle driver should be in the position indicated in figure 29.

Note: The shuttle race assembly cannot be disengaged from the shuttle driver, during removal or replacement, until the needle bar is at the highest position. The upper and lower shafts of the sewing machine are connected; turning the balance wheel will change the position of the needle and the shuttle driver.

2. Remove the two outside shuttle race screws.

3. Slip the entire assembly to your left and downward. During removal, apply finger pressure to the stud of the shuttle body to prevent the shuttle from rotating in the assembly. Place the assembly in a parts box.

4. Using cheesecloth, remove thread and dirt from around the shuttle driver.

5. Take the shuttle assembly from the parts box. Lay the assembly on a flat surface for disassembly. DO NOT HOLD THE SHUTTLE RACE ASSEMBLY IN YOUR HAND TO REMOVE PARTS: THE SCREWDRIVER MAY SLIP.

6. Remove all the parts of the shuttle race assembly, inspecting and cleaning each part. If the shuttle point has been damaged it should be sanded down with emery cloth. If beyond repair, replace it.

7. Reassemble the parts of the shuttle race. The beveled edges of each minor part will be positioned toward the shuttle driver. Secure screws in the assembly but do not apply excessive pressure.

8. Position the needle bar at its highest position by turning the balance wheel toward the operator. Insert the assembled shuttle race so that the outside screw holes of the race are in line with those of the housing. Insert and secure the two shuttle race screws.

Caution: If the shuttle race is not seated in the housing of the machine, the shuttle point will clip the needle during operation.

Technical Training**Fabric and Parachute Specialist****MACHINE SEWN SEAMS****5 March 1979**

CHANUTE TECHNICAL TRAINING CENTER (ATC)
3340 Technical Training Group
Chanute Air Force Base, Illinois

Designed for ATC Course Use.
Do NOT Use on the Job.

100

Life Support Systems Branch
Chanute AFB, Illinois

3ABR42733-SW-705

MACHINE SEWN SEAMS

OBJECTIVES

Upon completion of this unit of instruction you will be able to fabricate machine seams and stitches.

INTRODUCTION

Parachutes are devices that become worn, torn, and in need of various repairs and modifications in order to insure their continued serviceability. Each job calls for specific seam and stitch formations that are standard in construction.

INFORMATION

CHARACTERISTICS OF MACHINE SEAMS

Machine seams or stitchings have the following specific advantages over hand-sewn seams: (1) speed, (2) appearance, and (3) uniformity of tension. Their desirable characteristics are as follows:

Strength

Strength of a seam or stitching depends on the type of thread, stitch type, number of stitches per inch, the construction and tightness of the seam, and the size and type of needle point used.

Note: The strength of the seam should equal that of the material it joins. Use only the material specified for the assembly in the applicable technical order.

Elasticity and Flexibility

Elasticity and flexibility depend on the stretching qualities of the material used, the quality and tension of the thread, the length of the stitch, and type of seam or stitch used.

OPR: 3340 TCHTG

DISTRIBUTION: X

3340 TCHTG/TTGU-L - 410; TTVSA - 1

111

Durability

Durability is determined by the wearing qualities of the material; the quality of the thread used, and proper tension, which will set the stitches well into the material to reduce abrasions. Relation between the elasticity of the seam and the elasticity of the material is very important in determining durability.

Security

The security of a seam or stitching depends chiefly on the stitch type and its ability to resist unraveling. The stitch must be well set in the material to prevent snagging which can cause thread breakage and unravel some types of stitches. Seam "run-offs" weaken a seam. All seam ends should be backstitched or anchored to prevent the seams from unraveling.

Appearance

Appearance of seams is largely controlled by their construction and neatness of workmanship; however, appearance should be secondary to any of the three factors explained previously-- strength, elasticity and durability. Size and type of thread and length of stitch may also affect appearance.

TYPES AND CLASSES OF SEAMS AND THEIR USES

Seam Specification

STITCH. A stitch is one unit of thread formation resulting from passing a thread through a material at uniformly spaced intervals. The class of stitch is indicated by a specification number; for example, 301, which specifies a United States Standard Lockstitch. The Class 31 and 111W sewing machines sew a U.S. Lockstitch 301.

SEAM. A seam is a joint consisting of a sequence of stitches uniting two or more pieces of material.

STITCHING. A stitching consists of a sequence of stitches for finishing an edge or for ornamental purposes, or both, in preparing parts for assembling. The seam or stitch formation is indicated by a symbol consisting of three parts:

1. The first part denotes the class and consists of two upper case letters; for example, SS.
2. The second part denotes the type of the class and consists of one or more lower case letters, for example, a.

3. The third part denotes the number of rows of stitches used and consists of one or more Arabic numerals preceded by a dash; for example, -1.

The complete seam specification for the examples given thus becomes 301-SSa-1.

Classes of Seams

The three classes of seams are SS (super-imposed seams); LS (lapped seams); BS (bound seams).

CLASS SS, SUPER-IMPOSED SEAMS. These are formed by placing one ply of material above another with the edges together and the seam along one side. Super-imposed seams are usually made with two plies of material, although more than two plies can be used for special projects. The edges may be folded under, but they are never overlapped when the stitching is made. Types of super-imposed seams are SSa-1 and SSc-2. (Figure 1.)

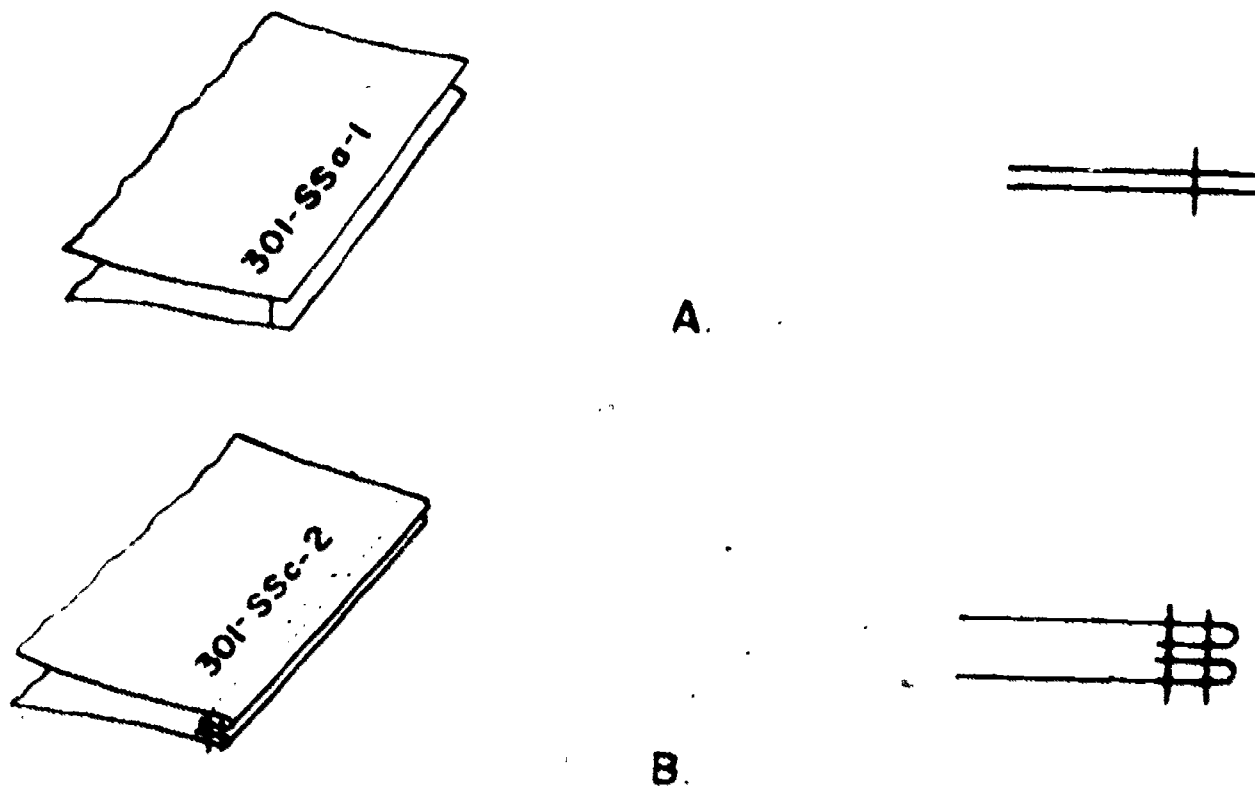

Figure 1. Types of Superimposed Seams with Cross-Sectional Views.

The SSa-1 seam is the simplest method of joining two or more pieces of material. It is also used as the first step in the formation of other seams. The seam used in parachute work requiring the SSa-1 seam as the first step is the LSak-2 seam.

The SSc-2 seam is used for making parachute shot bags. It is also used in making channels for sash cord when making handles on carrying bags and cases.

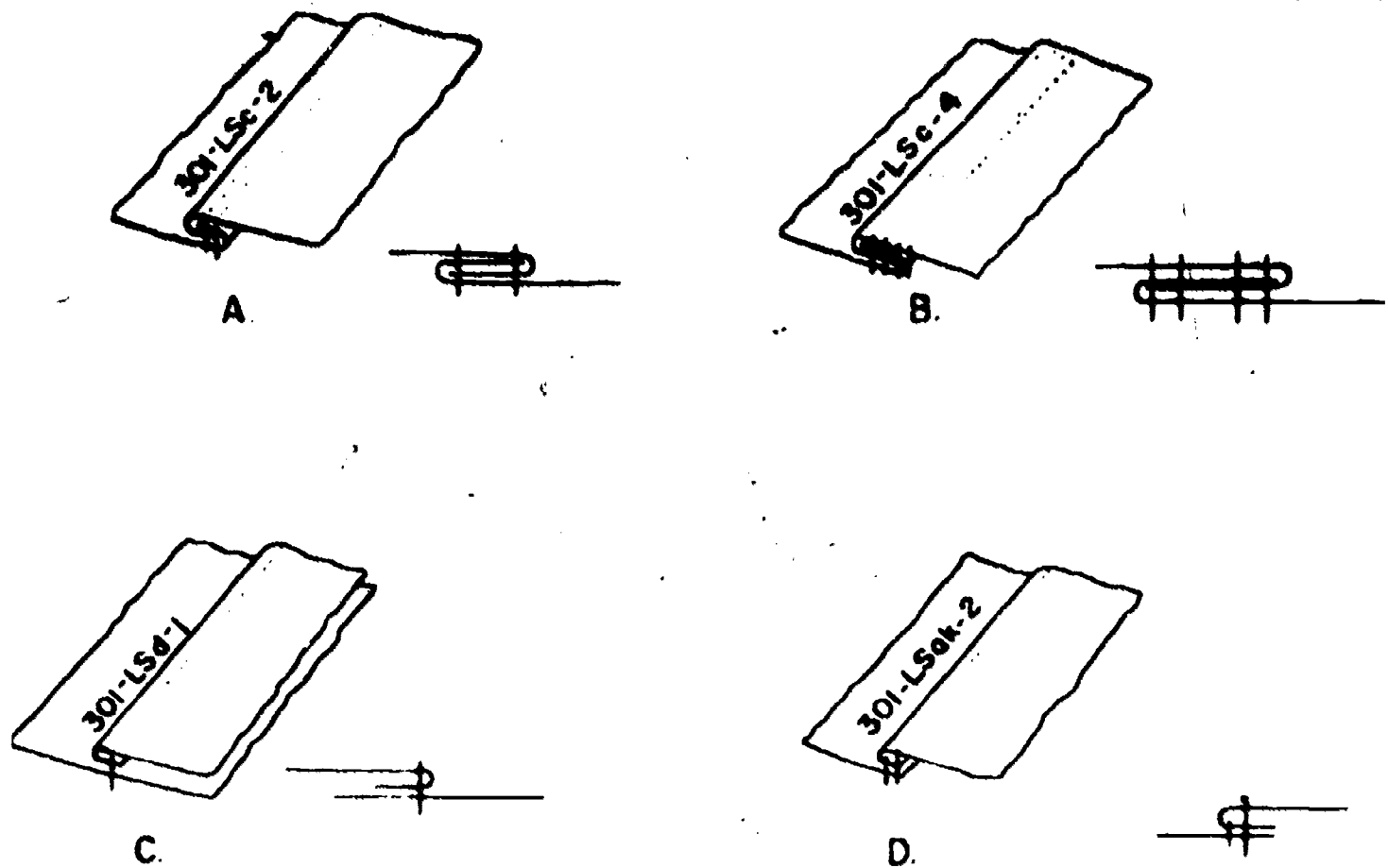

Figure 2. Lapped Seam Formation with Cross-Sectional Views.

CLASS LS, LAPPED SEAMS. These are formed by the edges of the plies of material overlapping a sufficient distance and stitched with one or more rows of sewing as shown in the cross-sectional views in Figure 2. Types of lapped seams are LSc-2, LSc-4, LSd-1 and LSak-2.

The LSc-2 and LSc-4 seams are used in the construction of the canopy. The LSc-2 seam is used for the sectional seams and the LSc-4 for the channel seams. The interlocking of the folds makes the LSc seams the strongest of the seam formations.

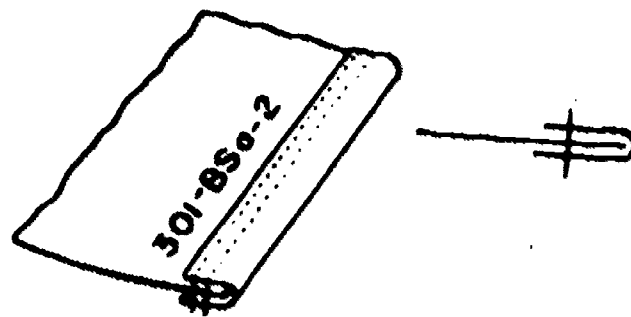

Figure 3. Bound Seam, GSa-2.

104

The LSD-1 seam (Figure 2, part C) is used in sewing pockets or patches. The seam is used in canopy repair work to patch small holes in the canopy.

The LSak-2 seam, (Figure 2, part D) is used on the parachute pack to shape the automatic ripcord release cover and pack side flaps. It is also used for finishing seams of covers for shop equipment.

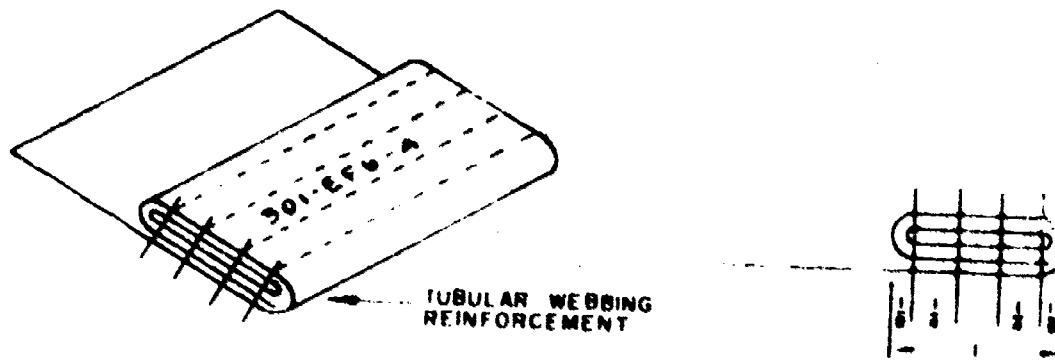

Figure 4. Edge Finishing Stitch, Efb-4.

CLASS BS, BOUND SEAMS. BSa-2 are made by folding binding strips or tapes over the edge of the material to reinforce and finish the edge. The BSa-2 seam (Figure 3) is used to bind the edges of tool aprons, reinforcement panels, etc. All parachute packs are bound with 3/4 inch tape using the BSa-2 seam. Therefore, it is important that special attention be given to the practice work on this seam. Much of the repair work includes the BSa-2 seam.

Class of Stitching

The class EF, edge finishing Efb-4 stitch, is formed by using the edge of a single ply of material to make the hem. The Efb-4 stitch (Figure 4) is made by folding the edge back twice, thus turning the cut edge inside the second fold to prevent fraying and to reinforce the hem. It may also include a piece of reinforcing tape, plain or tubular webbing for added strength. This stitch, with tubular webbing reinforcement, is used to form hems at the vent and the skirt of the canopy on most personnel and some cargo parachutes.

All seams and stitches pictured on the preceding pages are used in the parachute shop for modification and repair work on the parachute canopy, pack, seat and backpads, or for making covers and bags for shop equipment and tools. The seams and stitches used in the construction of the canopy and pack are shown in Figure 5.

115

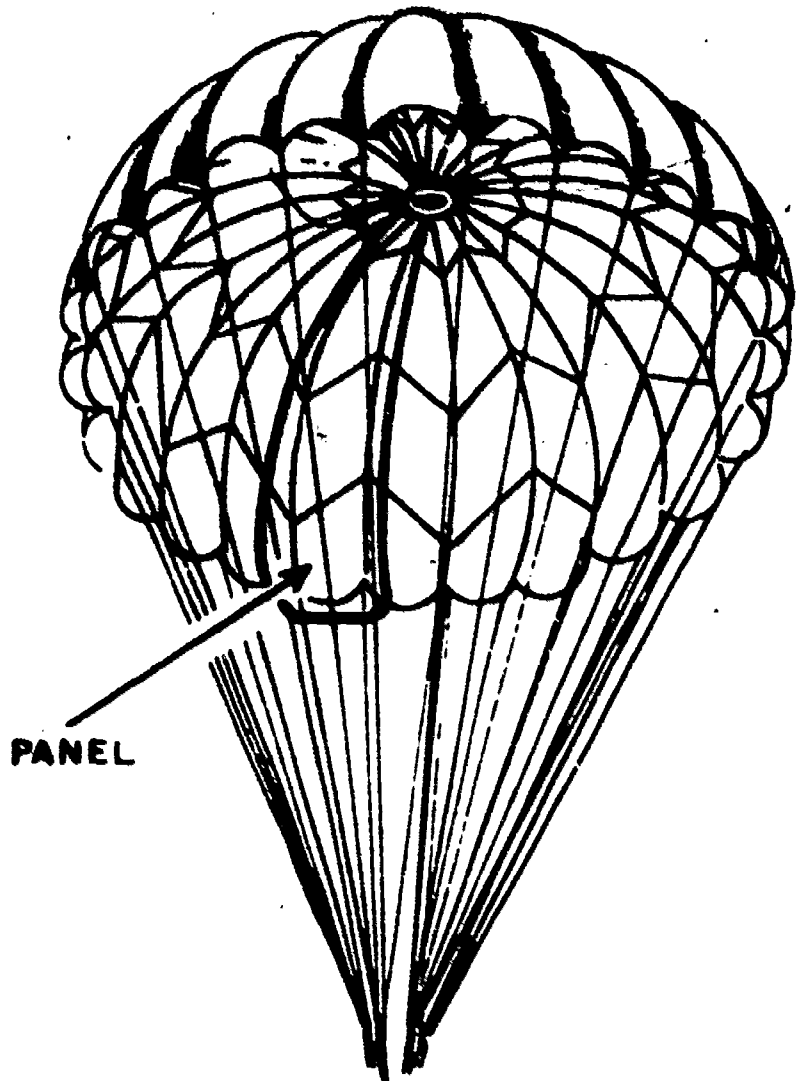

CANOPY

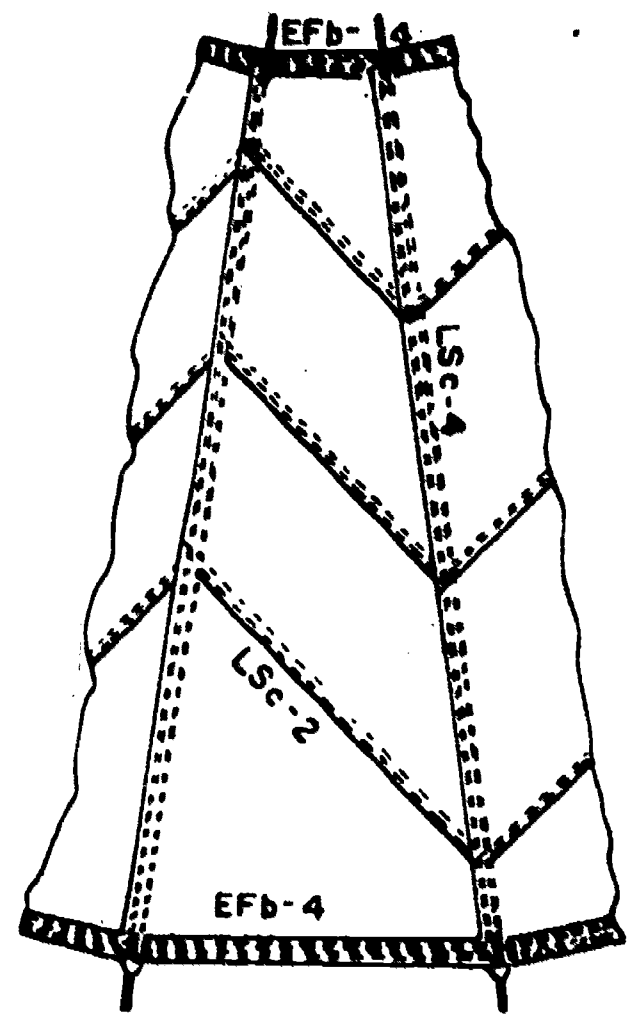

COMPLETE BIAS-CUT CANOPY PANEL

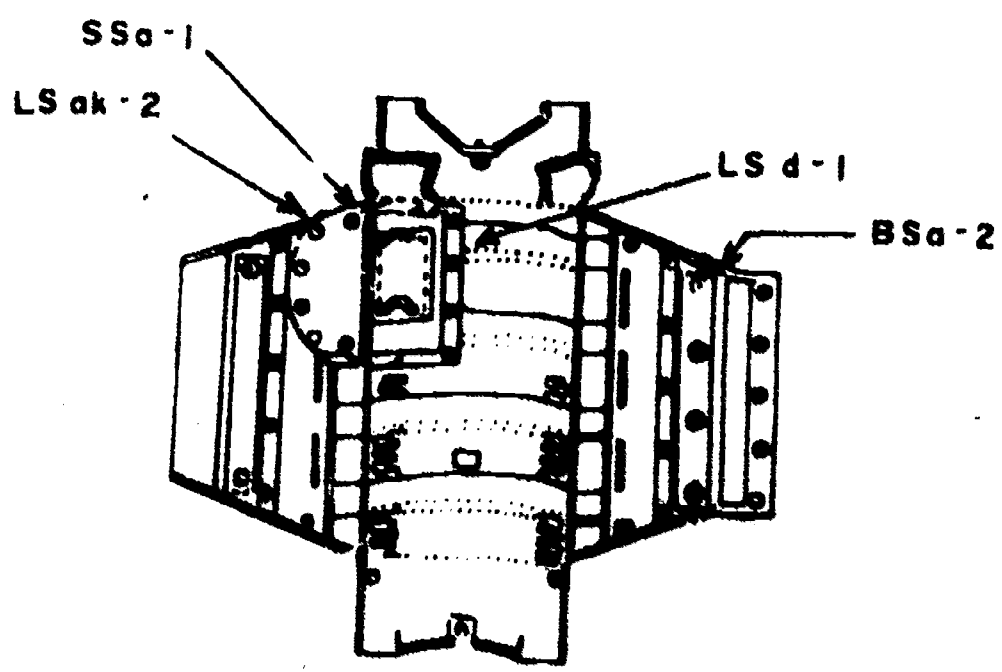

PACK

Figure 5. Seams Used in Canopy and Pack Construction.

106

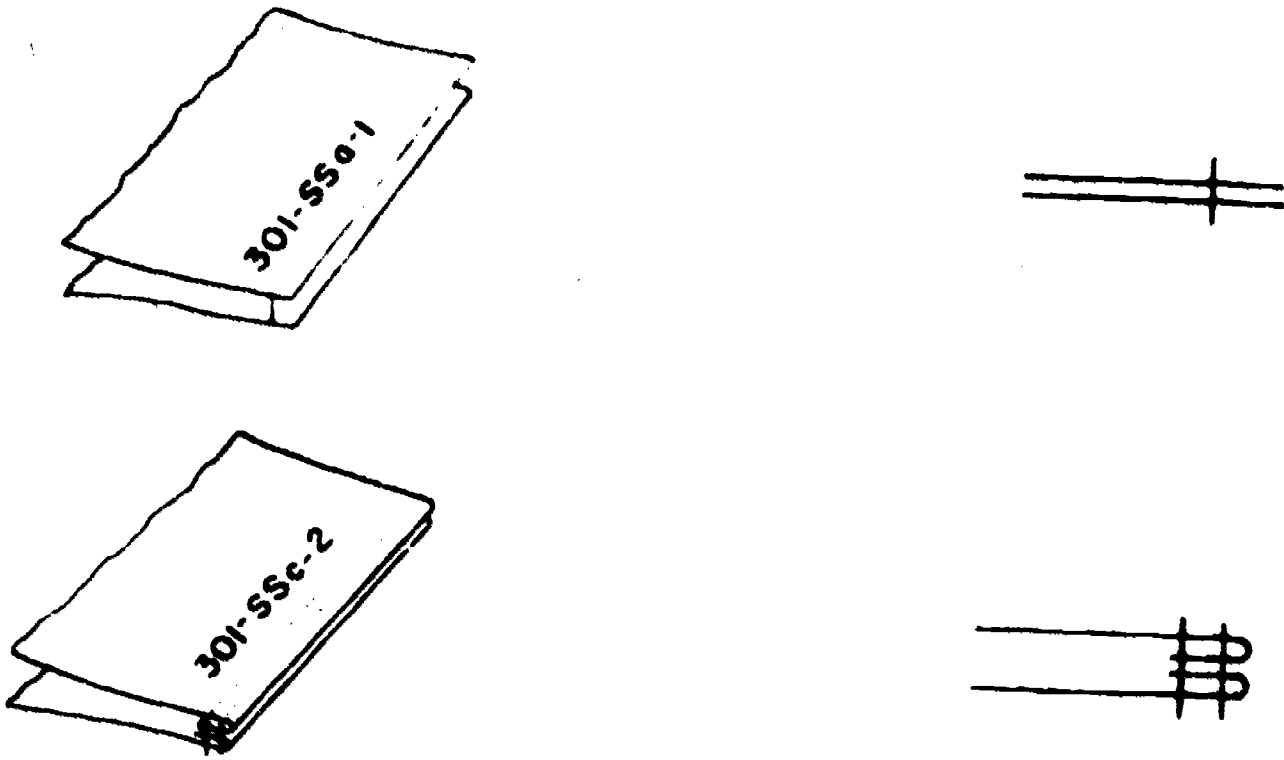

Figure 6. Types of Superimposed Seams with Cross-Sectional Views.

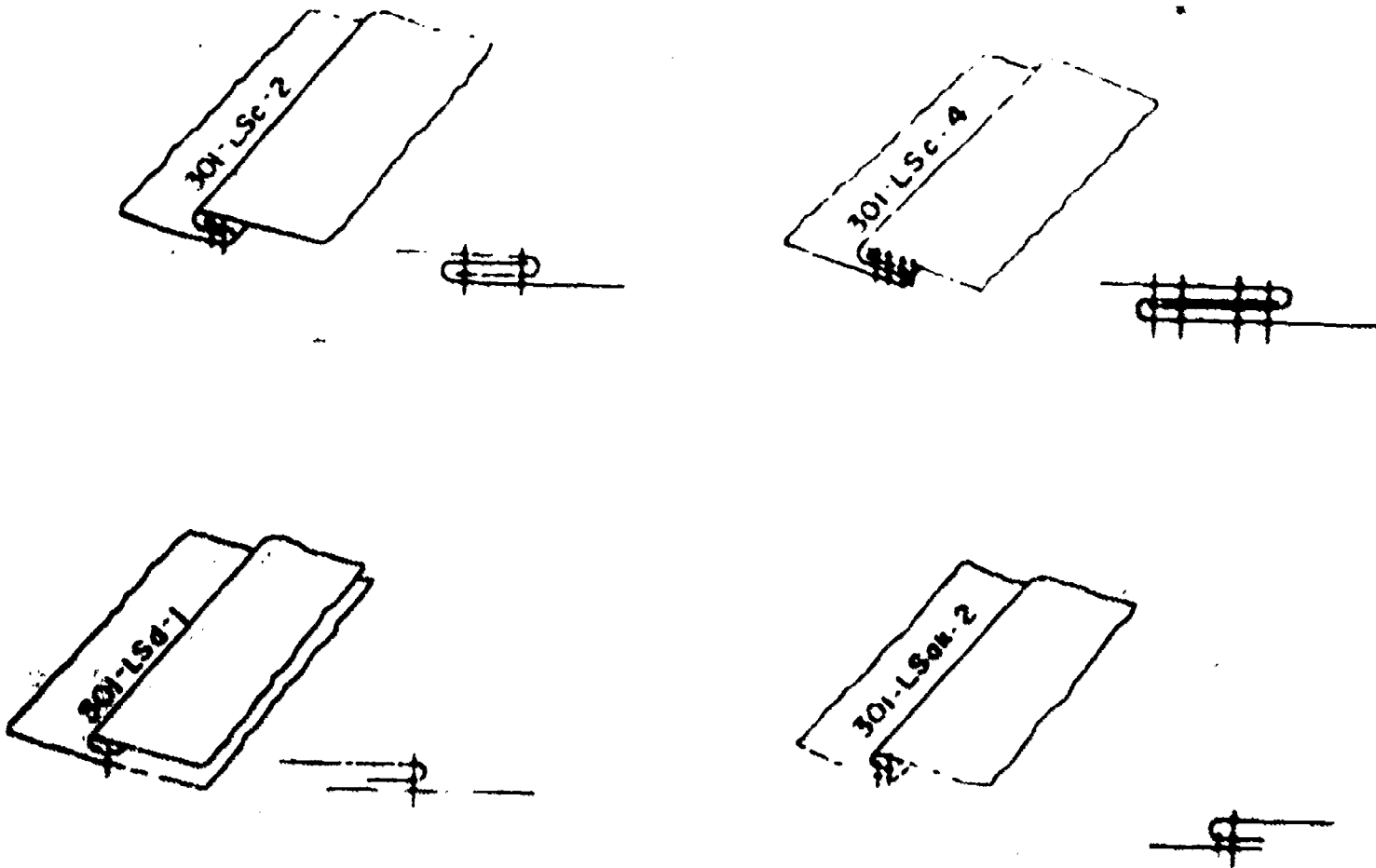

Figure 7. Lapped Seam Formation with Cross-Sectional Views.

Seams and Stitching Requirements

In fabricating the various classes of seams, the following rules should be followed:

1. Stitches must be tight and well set into the material.
2. Seam ends must be securely overstitched and backstitched.
3. Material should be cut straight and true for straight and even seam formation.

The following rules should be followed in determining the correct spacing of more than one line of stitching and placing of a seam the correct distance from the edge:

1. Binding tape should be sewn $1/16$ " from the selvage edge of the tape.
2. Heavier tapes should be sewn from $1/16$ " to $1/8$ " from the edge. Raw ends of tapes will be sewn $1/4$ inch from the raw edge.
3. Horsehide and thin leathers should be sewn $1/8$ " from the edge in patching, trimming, etc.
4. Raw edges of 8 to 15 ounce duck should be sewn $1/2$ " from the edge.
5. Material will be folded no less than $1/2$ " for reinforcement.
6. Folded edges of 8 to 15 ounce duck should be sewn $1/8$ " from the raw edge.
7. The second and succeeding rows of stitches should be made $1/4$ " apart. In heavier material, it is sometimes desirable to separate the rows as much as $3/8$ ".
8. Heavy duck, heavy fabric, or the heavier leathers may be sewn approximately $1/4$ " from folded edges for best results, while the raw edges of such heavy fabrics need at least $1/2$ " to $3/4$ " seams for security.
9. Light nylon or aircraft fabric should be sewn $1/16$ " from the folded edge. Raw edges of these light materials are seldom sewn together except as the first step of another seam.
10. When you are sewing a row of stitches and the thread breaks, start sewing again $1/2$ " in front of the break and sew on top of the existing stitches.

Exercise 1

Write the answers to the following questions on a separate sheet of paper.

1. What are the 3 basic advantages that machine seams have over hand sewn seams?
2. What form of security is given to a machine sewn seam to prevent the stitching from raveling?
3. The class 31 sewing machine sews that type of stitch?
4. What is a seam?
5. Name the 3 classes of seams used in parachute work.
6. What seam formation is formed by placing one ply of material above the other with the edges together and the seam along one side?
7. In the seam designation LSak-2, what part represents the type?
8. What is the difference between a SSc-2 and SSc-4?
9. Binding tape is used for what class of seam?
10. How is the EF stitching formed?
11. When sewing an 8-ounce cotton duck, how far should one sew from the raw edge?

12. When one is sewing the SSC-4 seam formation, how much material is folded under for reinforcement?

13. How far apart are rows of stitches on lightweight materials?

14. When sewing on lightweight nylon how far should you sew from the folded edge?

Exercise 2

Refer to figures 3, 4 and 5 in student Study Guide and the section entitled Seams and Stitching Requirements. Practice sewing the machine seams and stitches applicable to parachute repair. Proceed as follows:

1. Cut 20 pieces of 8-ounce cotton duck, each 4" X 6".
2. Sew two (2) of each of the seams illustrated in figures 6, 7, and 8.

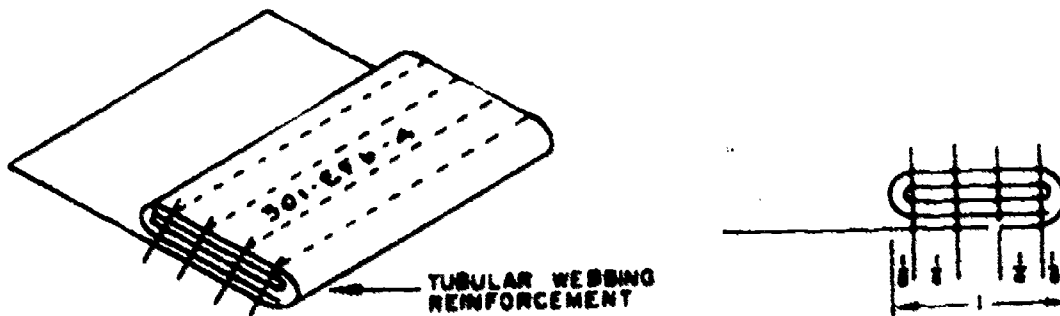

Figure 8.

Exercise 3

1. Cut 10 pieces of 1.1 ounce ripstop nylon, each 4" X 6".
2. Sew two (2) each of seams A and B in figure 2, and two (2) of the seam illustrated in figure 5.

110

PROCEDURE

Exercise 4

Fabricate the following from cotton duck.

1. Cut seven pieces of fabric (cotton duck) size 4" x 6".
2. Sew the following seams and stitchings:
 - a. SSa-1.
 - b. LSd-1.
 - c. LSc-2.
 - d. LSa-1.
 - e. 2.
 - f. EFb-1.
 - g. EFa-1.
 - h. BSa-2.

121

Technical Training

Fabric and Parachute Specialist

**IDENTIFICATION/CONSTRUCTION/MAINTENANCE OF
PERSONNEL/ORGANIZATIONAL CLOTHING**

14 March 1979



**CHANUTE TECHNICAL TRAINING CENTER (ATC)
3340 Technical Training Group
Chanute Air Force Base, Illinois**

**Designed for ATC Course Use.
Do Not Use on the Job.**

112

Life Support Systems Branch
Chanute AFB, Illinois

3ABR42733-SW-706

IDENTIFICATION/CONSTRUCTION/MAINTENANCE OF PERSONNEL/ORGANIZATIONAL CLOTHING

OBJECTIVES

Upon completion of this unit of instruction, you will be able to describe the constructional features of flight clothing and their application. In addition, you will be able to state how clothing will be inspected, identify defect markings, and describe the procedure for making repairs in accordance with TO 00-25-120 and TO 14P3-1-112.

INTRODUCTION

The Air Force is responsible for furnishing suitable clothing for Air Force personnel who work in different climatic areas of the world. Clothing and equipment must withstand exposure to these varieties of conditions as well as keep the wearer comfortable so he can devote his energies to the job at hand. Personnel must also be given protective clothing for possible emergencies over land or water. The responsibility for the inspection and repair of the many types of flying clothing rests with the Fabrication and Parachute Specialist.

INSPECTION OF AIRCREW FLYING CLOTHING

When an article is damaged, it must be inspected to determine what should be done with it. It is unsuitable for use in its present condition. The inspector must determine if it is suitable to be restored to a serviceable condition; he answers the question, "Is it reparable?" He decides this question by estimating the labor cost of repair at the rate of \$3.75 per hour plus the cost of material to arrive at the total repair cost. If this cost is less than 65% of the serviceable supply catalog cost, the item is tagged reparable with a green tag. If it is more than 65%, the item is tagged "condition condemned" and tagged with a red tag. The limitation of 65% of cost does not apply to items in critical short supply.

Inspection of Flight Coveralls

The coverall having the following damages is considered reparable: soiled; damaged hardware; open seams; small tears, rips or holes, torn pockets or flaps; frayed areas; or damaged map clip. It is obvious that if all of the things mentioned were wrong with a garment, it would be uneconomical to repair. Anything in excess of the damages mentioned is cause for marking condemned. After all instructions which may be written about inspection, the final determination as to the wisdom of repair will depend upon the experience, sincerity and ability of the inspector.

OPR; 3340 TCHTG

DISTRIBUTION: X

3340 TCHTG/TTGU-L - 410; TTVSA - 1

123









- 
① — An arrow will call attention to any general defect; e.g., open seams, skipped stitches.
- 

② — An X or cross is used to indicate hidden defects which may be inside the garment or under the particular portion being inspected.
- 

③ — A circle with a cross is used to indicate a missing button, the cross indicating the exact location of the button. Also, the circle with an arrow pointing to it will indicate a small hole.
- 
④ — An oval indicates a missing buttonhole. Its length shows the size of the required buttonhole.
- 
⑤ — This mark is used to indicate any portion of a garment which is too short; e.g. length of trousers or sleeve length. The length of the vertical line shows how short a particular part is.
- 
⑥ — A line drawn at the edge of any part of a garment indicates that the garment is too long. The distance between the horizontal line and the edge of the garment shows how much too long the particular part is.
- 
⑦ — This mark indicates that the seam involved should be let out to that extent.
- 
⑧ — Two lines, one on each side of a seam, point out the need to take in the seam the distance between the two lines.

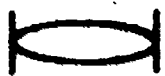
Figure 1. Defect Markings.

A man's flying coverall of every type must meet certain requirements, which depend upon the immediate use to which it will be put. The CWU-27/P is a typical type while the CWU-1/P is similar but heavier. The CWU-27/P is made of sage green or indian orange color, with different colors being preferred by different commands, depending upon the job their flyers have to do. Obviously, a flyer who might have to eject over enemy territory would not want one colored indian orange. On the other hand, if he were flying only over our own country it would be of advantage to identify himself by wearing an indian orange coverall.

A damaged coverall would need to be inspected first to see if the zippers on the closure were operative. Turn collars, pockets, wristbands and bottoms so that the inside can be inspected as well as the attachment to the garment itself. Many damages are not the result of wear but because of tears. Rips seem to grow very fast, so the wearer should have the rip repaired while it is still small. Check the garment for small tears and

114

snags. Some of these can be darned, but if permitted to stay unmended, will soon require large patches. The repairman should be careful to use repair material like that from which the garment is made. Often, if it is worn considerably, and the color is changed by wear, selection of the same color will be hard to accomplish.

Reference TO 00-25-120, Sec 1, Pgs 3 and 4; TO 14P3-1-112, Sec III, Pg 3-1.

Defect Markings

Certain markings are used when clothing is inspected to identify the defect. Standard markings, as illustrated in figure 1, are required as the clothing may be inspected by one person and repaired by another. Standardization insures that the same marking will mean the same thing to every specialist and the proper repair will be made. White tailors' chalk is usually used to mark the defect. Mark the garment close to the defect in such a way that the marks can be easily removed. The purpose for which each marking is used is listed in figure 1.

Reference TO 00-25-120, Sec 1, page 4.

REPAIR OF AIRCREW FLYING CLOTHING

Because the Air Force has a large number of personnel, the task of correctly fitting all of its members with clothing of the proper size is a big one. It is extremely important that clothing fit properly. Clothing, properly fitted, not only looks better but feels better and wears longer. Clothing which is too small binds, rips, and pulls apart at the seams. Garments that are too large look bulgy and unkept, and have a tendency to fray when rubbed. Proper fitting also affects the body protection provided by the clothing. Tight-fitting clothes do not give sufficient protection against the cold because they do not allow enough room for air, which acts as natural insulation. In warm weather, they cling to the body and prevent the circulation of air, which acts as a cooling agent. Consequently, alternations are necessary to give proper fit and a neat appearance. Also, repair prevents excessive damage and increases the life of the clothing.

Fabric Repair

Material used for the repair of clothing will be the same as that from which it is constructed. In some cases, it may be necessary to use some salvage fabric because of shortage of repair material or because used material may not blend with the garment. Wristlet and waistband material is loosely knitted which provides sufficient elasticity to fit snugly around the arms and waist of the wearer. Wristlets are knitted in seamless, tubular form or may be fabricated from the same material as waistbands. Wristlets should be replaced in pairs and sewn with 4-5 spi.

Neat and durable repairs to fabric clothing are assured when you follow certain guidelines that have proven effective. The guidelines you will follow are:

- a. Remove the old broken stitches before resewing a seam.

- b. Sew through the old needle holes when resewing an open seam.
- c. Do not mix kinds, weights, or colors of material when patching.
- d. Sew the repair from the face or exposed side.
- e. Darn holes or tears under 1/2 inch without reinforcement.
- f. Reinforce holes or tears from 1/2 inch to 7/8 inch with fabric on the underside of the material before darning them.
- g. Trim reinforcement fabric close to the darn.
- h. Repair holes or tears over 7/8 inch by patching.

It is important to remember that all old threads must be removed from the damaged portions and new seams must be made so that none of the old needle holes will show. To provide maximum strength in the seam, use the correct machine thread and six stitches per inch. Match all threads with the color of the material being repaired. In some instances, two colors of thread are required, one to match the outer part of the garment and the other to match the lining. You can do this by using one color thread in the bobbin and another color in the needle. When garments are being repaired, keep them as clean as possible by keeping the working area and equipment free from dust, dirt, and grease. The strength of the repair depends on the type of repair, the machine thread, and the number of stitches per inch. Check all seams for proper type, and check sewing for correct distance from the edge of the material. To repair a long tear, first sew it together by hand; then machine-sew a cloth or leather patch over the outer surface of the repair to increase its durability and improve its appearance.

Interlocking Fastener Repair and Replacement

If we all had unlimited patience, you would seldom have to replace an interlocking fastener. Perhaps you have been guilty yourself of yanking on the pull of a slide when you could have backed the slide slightly and eliminated the jam in the scoops. Whether the damage to an interlocking fastener is avoidable or not, it is still up to you to repair or replace it.

REPAIR. The service life of an interlocking fastener depends upon the assembly, installation, and care the fastener receives during and after it is installed. Open and close the chain of scoops only with the slider. Do not use pliers or any other object to pull together or pry apart the chain of scoops. If the scoops are clogged with dirt, do not attempt to open them until after you remove the dirt with cleaning fluid. Damaged fasteners are usually the result of improper assembly, careless handling, or a fastener too light for the work. Figure 2 shows some of the troubles which may be the result of improper assembly and careless handling. View A shows a fastener which has separated behind the slider. This may be caused by a slider which has sprung or spread apart. To repair the fastener, install a new slider. If the slider catches any loose threads, cloth, or dirt between it and the scoops, it may become jammed, as shown in view B. Slowly work the slider down the

116

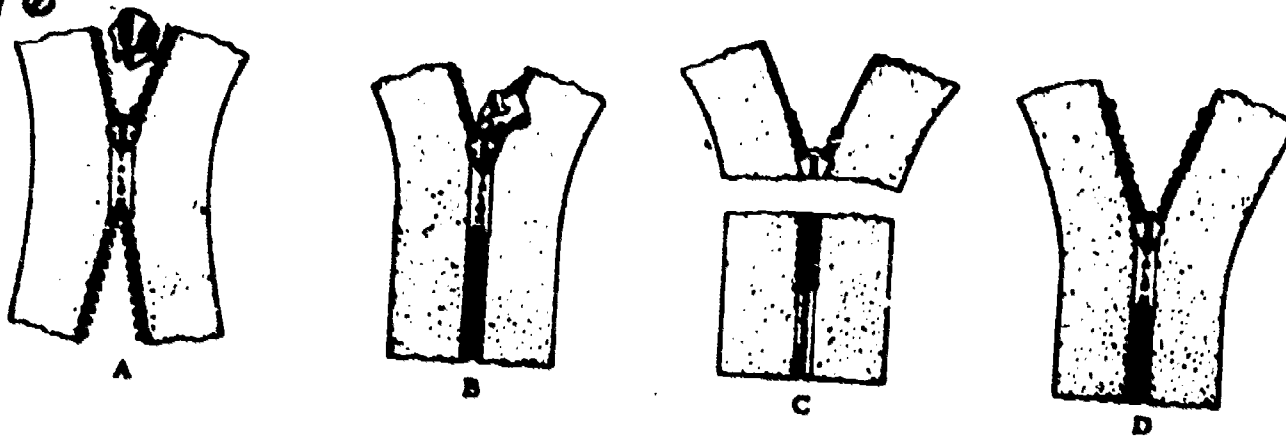

Figure 2. Interlocking Fastener Troubles.

chain of scoops until the obstruction can be removed. When the top and bottom stops are missing, as shown in view C, replace them if the beading on the tape has not been damaged. If the beading is damaged, shorten the fastener and install new stops. When the scoops have been ripped off, as shown in View D, either shorten or replace the fastener. You will also find that tears in the tape or tape bead often require fastener replacement. This is generally caused by too light a fastener or by tight-fitting clothing.

REPLACEMENT. Unserviceable interlocking fasteners are removed by cutting the threads which hold the fastener in place. Take care during cutting to avoid cutting the fabric to which the fastener is attached.

Three methods of folding tapes for installation are shown in figure 3. In method A, a single diagonal fold is made. In method B, the tape is folded a second time to make the tape even with perpendicular to the tape slide. Method B is used where the edge of the material to be closed should be even with the top stops of the fastener. A combination of methods A and B is used when two fasteners meet to form an angle with each other. In method C, the tape is folded under at the ends, as illustrated, to form a straight edge. This method is used at either or both ends of the tape where space allows this fold to be used.

Several methods of sewing are used to install interlocking fasteners on clothing and other items of fabric and leather equipment. The different methods are divided into classes and types of classes. The methods of installation are identified by uppercase and lowercase letters. The two main classes of fastener installation are the visible attachment and the concealed attachment. Visible attachments are designated by the use of a capital letter V, and concealed attachments are designated by a capital C. The second part of the symbol used with each class denotes whether the attachment is a single plating designated by capital letters SP, or a double plating, designated by DP. The lowercase letters, such as a, b, c, and d, specify the different attachments and are followed by a number which indicates the number of rows of stitching used to install the fastener. The number 301 preceding the symbol indicates that it is a US government standard lockstitch.

Some examples of common attachments are shown in figure 4. The Va-4 attachment (figure 4, A) leaves both surfaces of the chain of scoops exposed and no plating is used. Sometimes it will be to your advantage to form this attachment by sewing the interlocking fastener to the

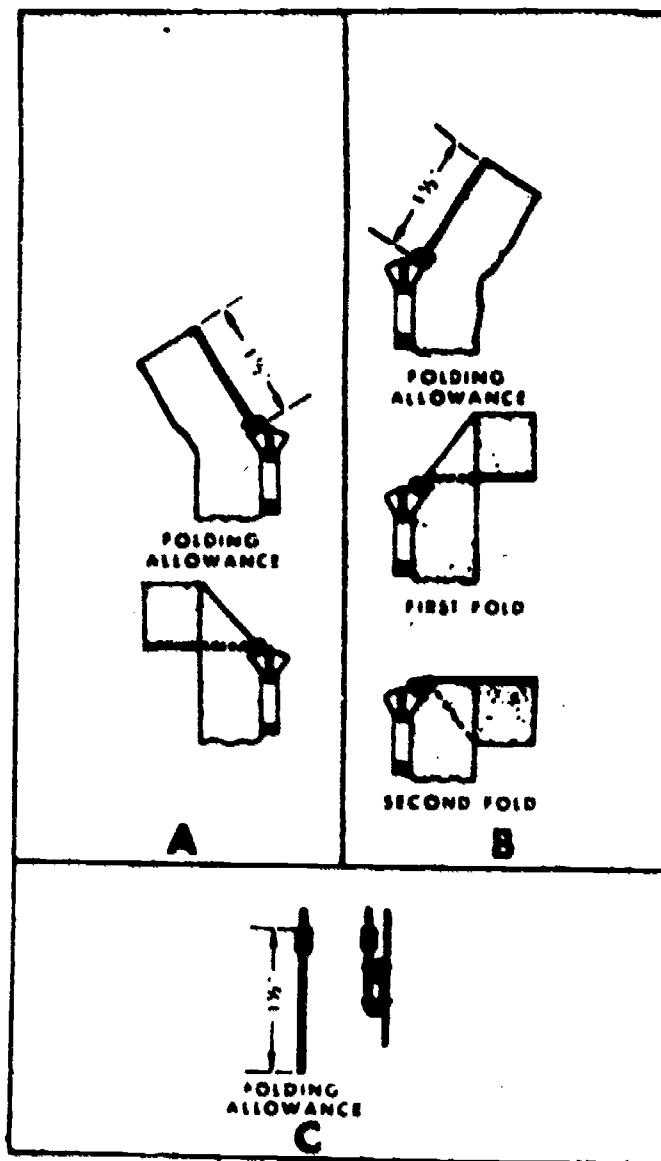

Figure 3. Methods of Folding Tapes.

underside of the material with the pull next to the material before providing an opening. After the fastener is sewn to the material, a slit is cut in the material directly over the center of the scoops to the length of the chain of scoops. Then cut $1/4$ inch diagonals at either end of the cut and fold under the raw edges. Sew the folded edge to the tape. Your seam should be $1/16$ inch from the edge of the fold.

The CSPa-6 fastener attachment (figure 4, B) shows the upper surface of the fastener covered by the outer body of material. The bottom surface is exposed. Some jackets use this type of attachment.

The CDPa-9 attachment (figure 4, C) is often used for trouser openings. Both the upper and lower surfaces of the scoops are covered in this type of attachment.

Ordinarily no lubricant of any kind is required on interlocking fasteners. However, paraffin, candle wax, or castile soap may be used to obtain free movement of the slide. Do not use oil or grease! Oil soils ordinary clothing, but more important, if oil or grease is used on

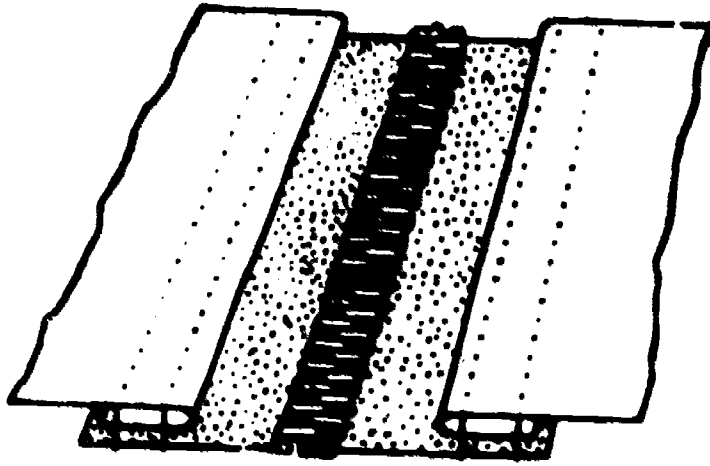

A — VA-4 ATTACHMENT

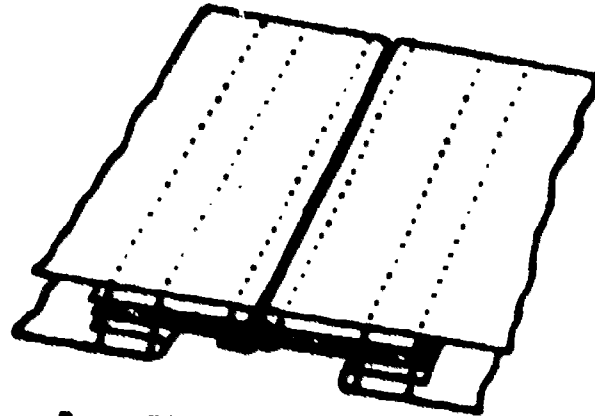

B — CSPA.6 ATTACHMENT

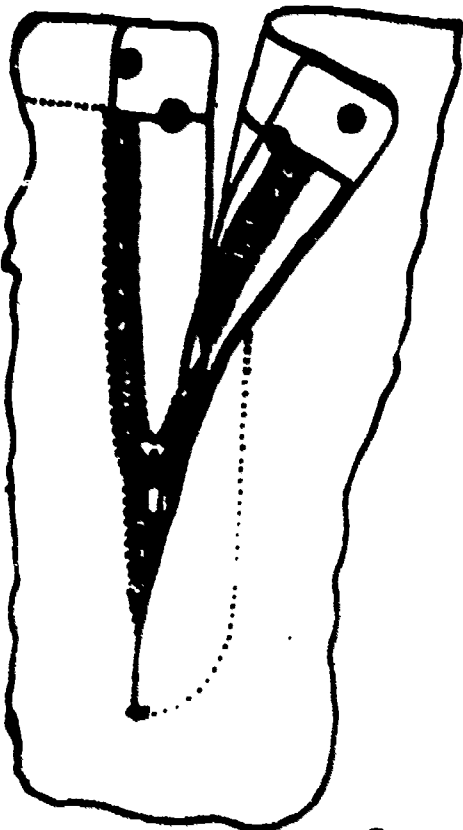

FRONT

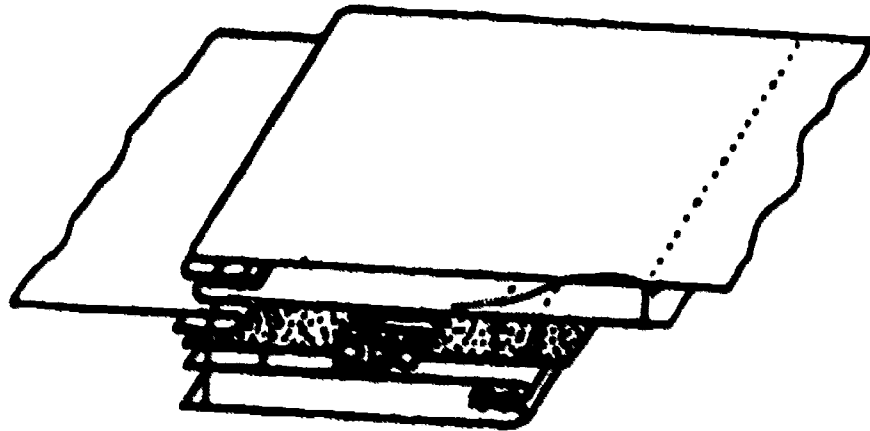

CROSS SECTION

C — CDPA-9 ATTACHMENT

Figure 4. Interlocking Fastener Attachment.

a fastener that is part of a high-altitude pressure suit, a suit fire is likely to occur in flight. Oxygen is used to inflate the capstans and bladders, and if an oxygen leak developed in an oily area, a spontaneous fire could occur.

PROCEDURE

129

Exercise 1

INSPECTION OF FLYING COVERALLS

1. Select a suit, flying coverall, which is damaged.

2. Visually inspect the garment for holes, seam separations, tears, hardware, torn pockets using 65% of the catalog cost in estimating repairs for it.
3. Mark the areas which need repair as directed by your instructor.
4. Tag the garment according to your decision of its reparability from figures you have accumulated.

Exercise 2

INTERLOCKING FASTENER INSTALLATION

1. Obtain a piece of 12-ounce duck, 10 inches long and 4 inches wide.
2. Mark a centerline through the full length of the center.
3. Center the fastener assembly on the duck with the scoops on the centerline and the slider and pull tab next to the duck.

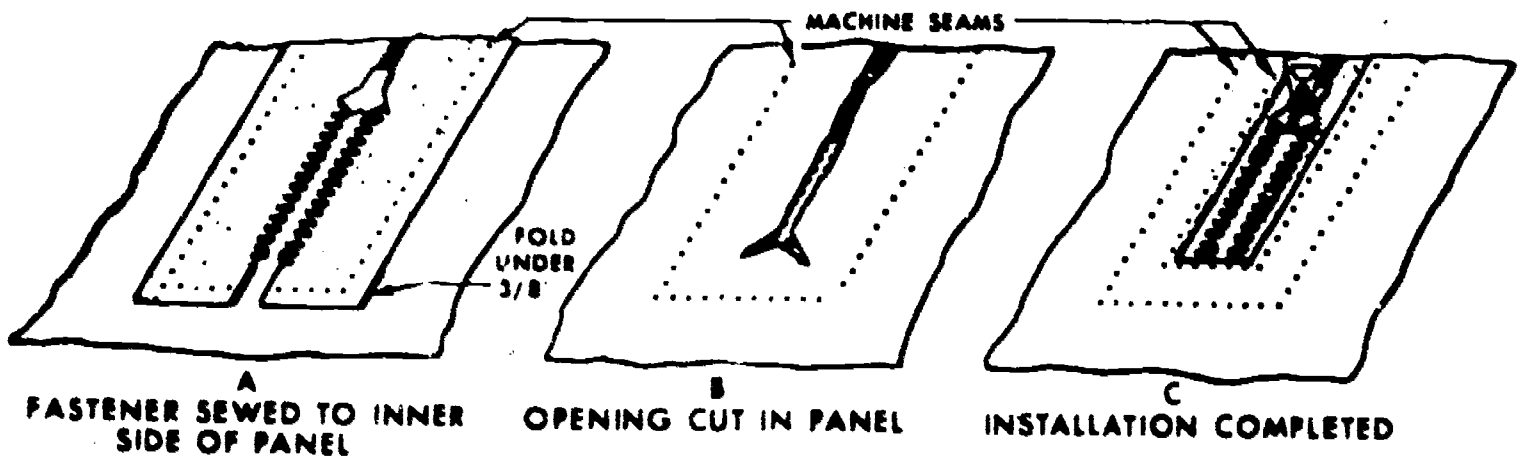

Figure 5. Modified VA-4 Interlocking Fastener Installation.

4. Fold under the end of the tape as in figure 5A.
 5. Machine sew the outer row of stitching 1/8" from the edge of the tape as in figure 5A, continuing to sew to the corner and across the ends over stitching 1/2" to lock the seam.
 6. Remove the material from the machine.
 7. Turn the assembly over and cut a slit in the duck directly over the scoops, figure 5B.
- NOTE: Begin cutting at the middle and cut toward the ends to a point directly above the last scoop.
8. Make angular cuts at the ends of the scoops approximately 1/4" in length as shown in figure 5B.

120

9. Turn under the cut edges so that the folded edges will be approximately 1/8" from the scoops.

10. Machine sew the inner row of stitching 1/16" from the folded edge as shown in figure 5C.

NOTE: The turned under portion in figure 5 is not caught by the outside row of stitches and it is, therefore, a modified VA-4.

Exercise 3

REPAIRING PULLED SEAMS

1. Obtain a garment to be repaired.
2. Locate the seam to be repaired and remove the old thread.
3. Resew the seam using the same type of thread and stitches per inch as were originally used on the garment.

NOTE: If all the needle holes are intact, sew so that the new stitches are in the same location as the old ones. If the needle holes are torn out, turn under just enough material so that the old holes are concealed.

Exercise 4

WRISTLET REPLACEMENT

1. Make opening between the inner liner and waistband by removing the stitching for a distance of 6 inches on either side of center of waistband.

NOTE: Cut stitches holding the lining to the waistband.

2. Reach through this opening and pull one sleeve inside-out down between the lining and jacket shell. Pull this sleeve out through the opening just made at the waistband.

3. Remove the worn wristlet from the sleeve by cutting the threads.

4. Remove cut threads from the material.

5. Insert a new wristlet into the outer shell.

6. Sew the wristlet to the outer shell using a 1/2 inch Ssa-1 seam.

NOTE: Sew knitted material 6 stitches per inch.

7. Lay the sleeve lining alongside the outer shell so the seams on the lining and the outer shell are matched.

CAUTION: Remove all twists from the lining and outer shell of the sleeve.

8. Butt the ends of the lining and the outer shell and wristlet together.

CAUTION: Make sure lining seam and outer shell seams are aligned and no twists are in either sleeve.

9. Sew the sleeve lining to the outer shell and wristlet, making certain this row of stitching is back of the first row sewn in step

10. Pull the sleeve, lining and attached wristlet back through the opening at the waistband.

11. Sew the lining to the top of the waistband to close out the open seam. Use the same number of stitches per inch as on the jacket.

12. If top stitching is needed on the wristlet, turn the sleeve wrong side out and add a row of stitching 1/4 inch from the edge where the wristlet is attached.

REFERENCE

TO 00-25-120

Technical Training

Fabrication and Parachute Specialist

OPERATION/MAINTENANCE OF CLASS 111 SEWING MACHINE

11 April 1979



CHANUTE TECHNICAL TRAINING CENTER (ATC)
3340 Technical Training Group
Chanute Air Force Base, Illinois

Designed for ATC Course Use.

Do Not Use on the Job.

123

Life Support Systems Branch
Chanute AFB, Illinois

3ABR42733-SW-801

OPERATION/MAINTENANCE OF CLASS 111 SEWING MACHINE

OBJECTIVES

Upon completion of this unit of instruction, you will be able to identify functional features, thread the head and bobbin, clean and lubricate, time and adjust, make minor repairs, and correct malfunctions of the Class 111W sewing machine LAW TO 34Y7-8-11.

INTRODUCTION

The purpose of the Class 111W and the Class 31 sewing machine is the same. Like motor vehicles that are designed to carry different weight loads, the Class 111W sewing machine is designed for work on heavier weight fabrics than the Class 31.

INFORMATION

OPERATION

Functional Features

It is important for you to recognize nomenclature concerning the Class 111W sewing machine in order for you to follow directions accurately when learning to operate the machine. Figure 1 shows a Class 111W machine head and its features, and Table 1 lists the functions of the features. Figure 2 shows a Class 111 machine stand.

OPR: 3340 TCHTG

DISTRIBUTION: X

3340 TCHTG/TIGU-L - 440; TTVSA - 1

134

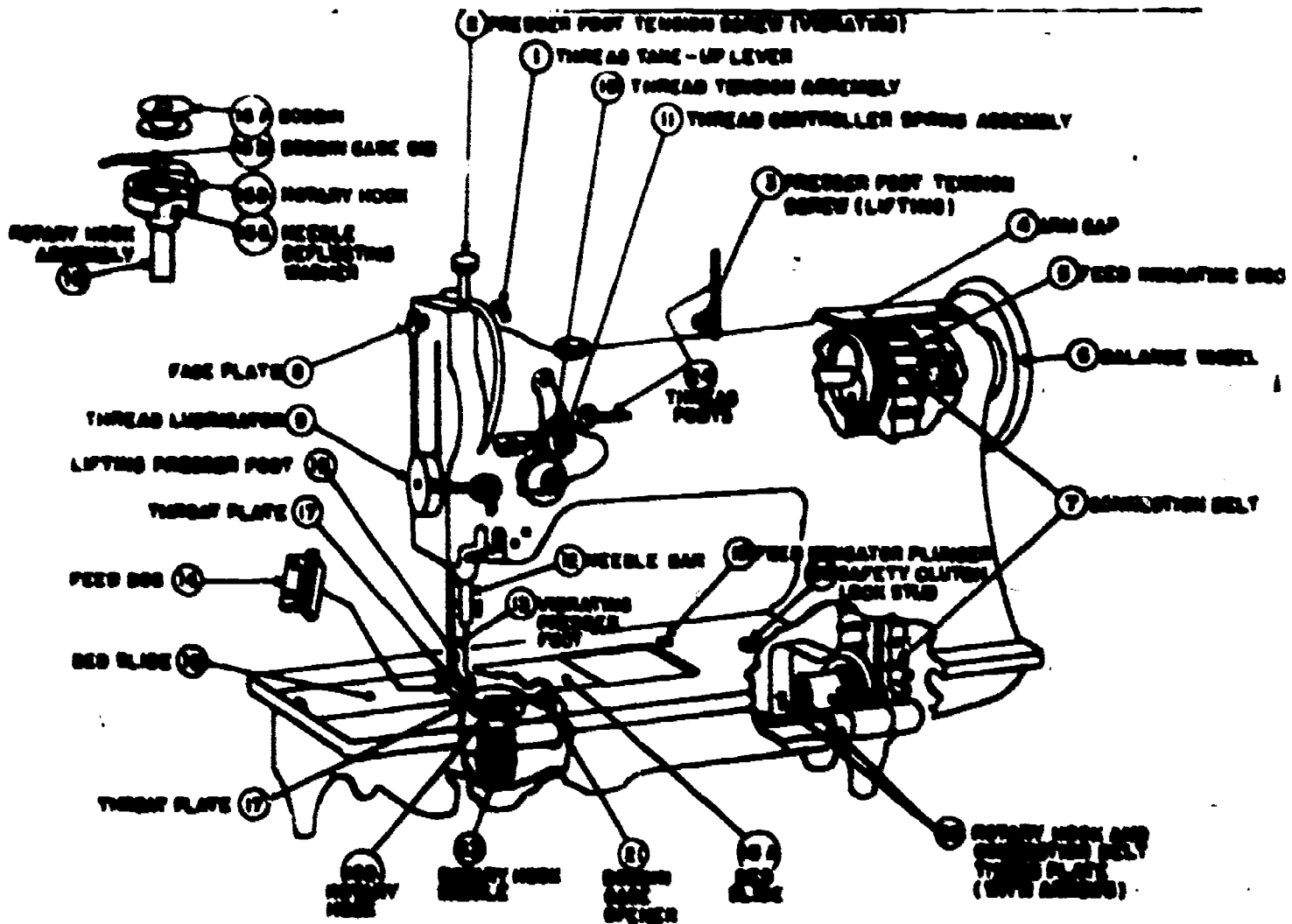

Figure 1. Features of Class 111W Sewing Machine Head.

NAME	FUNCTION
1. Thread take-up lever	Pulls the needle thread against the tension disc after the lockstitch is formed at the rotary hook (P) and pulls sufficient thread from the spool to make the next stitch.
2. Vibrating presser-bar tension regulating screw	Regulates the pressure on the pressure foot (M). Only sufficient pressure is needed to hold the material securely.
3. Lifting pressure-bar tension regulating screw	Regulates the pressure on the alternating presser-foot (O).
4. Arm cap	Enables the operator to make the internal adjustments and protects the inside from dust.
5. Feed indicating disc	Indicates the number of stitches per inch which is being made by the machine.
6. Balance wheel	Provides a connection between the driving unit and the sewing machine head.
7. Arm-and-hook driving-shaft connection belt	Connects the upper arm shaft with the hook-driving shaft.
8. Face plate	Covers and protects the mechanism of the two presser feet and needle bar (L).
9. Needle-thread lubricator	Lubricates the thread when sewing leather. Lubrication of the thread prevents it from fraying and prevents the needle from becoming hot when sewing at high speed.
10. Thread/tension assembly	Regulates the tension on the needle thread so that the lockstitch may be adjusted properly.
11. Thread controller spring assembly	Removes sufficient slack from the needle thread when the needle is descending to prevent the needle from splitting the thread.
12. Needle bar	Holds the needle and carries the thread to the rotary hook (P) where the lockstitch is formed.
13. Vibrating presser-foot	Holds the material in place while the alternating presser foot (O) rises to make another stitch.
14. Feed-dog	Feeds the material from the under side.

Table 1. Features of the Class III Machine and Their Functions (Cont'd).

NAME	FUNCTION
15. Alternating presser-foot	Holds the material in place while the vibrating presser foot (M) and feed-dog (N) go forward to get material for the next stitch.
16. Rotary-hook assembly	Contains the mechanism which forms the lockstitch by using the needle and bobbin threads.
16A. Bobbin	Contains the lower thread used in forming the lockstitch.
16B. Bobbin-case retainer-hook gib	Holds the bobbin case in the lock assembly.
16C. Needle-deflecting hook washer	Deflects the needle so that the rotary hook will not strike the needle.
17. Throat plate	Surrounds the feed dog and keeps the material from slipping after the feed dog has been adjusted to the proper height.
18-18A. Bed slides	Covers the feed eccentric and rotary hook-assembly on each side of the throat plate.
19. Feed indicator plunger	Used in connection with the feed indicating disc to regulate the number of stitches per inch desired.
20. Safety-clutch lock stud	Re-engages the needle with the hook driving assembly after clearing a thread jam.
21. Bobbin-case opener	Prevents thread from jamming underneath the throat plate on the bobbin case base.
22. Rotary-hook saddle complete	The rotary hook (P) is operated by the spiral driving pinion gear (V) which in turn is operated by the hook driving gear located on the hook driving shaft.
23. Rotary-hook and connection-belt timing plate and arrows	Used to time the arm shaft with the hook driving shaft.

Table 1. Features of the Class III Machine and Their Functions.

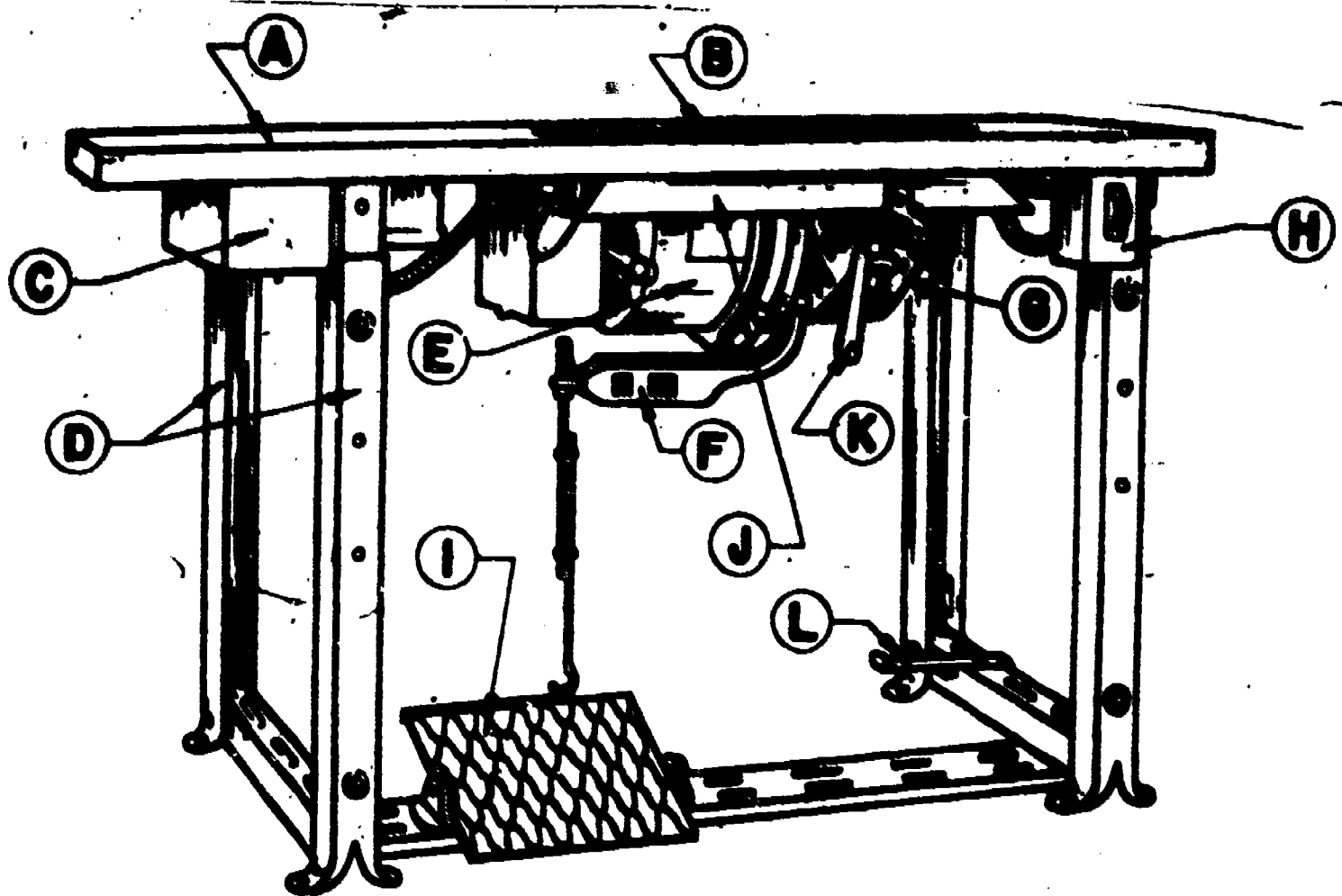

- | | |
|---|--|
| (A) . Table Top. | (F) . Extension Clutch Arm. |
| (B) . Opening in Table Top for Sewing Machine Head. | (G) . Motor Belt Guard. |
| (C) . Tool and Thread Drawer. | (H) . Motor Switch. |
| (D) . Adjustable Sewing Machine Stand. | (I) . Treadle Clutch Foot Pedal. |
| (E) . Adjustable Sewing Machine Motor with Clutch. | (J) . Oil Drip Pan. |
| | (K) . Machine Foot Knee Lifting Lever. |
| | (L) . Oil Can Bracket. |

Figure 2. Class 111 Machine Stand.

Model Number

Class 111 sewing machines are one-line (single needle) lockstitch machines designed to sew medium weight materials and are capable of sewing at a speed of approximately 2900 stitches per minute. A lockstitch machine is the only type of machine used in making strong and durable finished seams. With each individual stitch a half of a square knot is formed which prevents the finished seam from pulling apart. The lockstitch is formed in the bobbin assembly by a rotary hook on the 111 machines. The lubrication and parachute technician uses this machine for sewing upholstery, tarpaulins, tents, leather clothing, and protective covers for aircraft parts and ground support equipment.

Sewing machines are identified by symbols which are located on the upright arm of the machine head. Each symbol is made up of two or three parts. In the case of the 111 class of machine, the 111 specifies the machine class. The second part "W" denotes the place of manufacture. The third part (152, 153, or 155) determines the number of modifications or improvements made on this class of machine. The 111 also designates the machine as a single needle (one line) machine. (A 112 machine is a two needle (two line) machine.)

Feeds

There are various feeding mechanisms used on sewing machines. Some 111 machines are equipped with a compound feed alone, such as the 111W151, and other are equipped with a combination of the compound feed and alternating presser feet such as the 111W152 and 111W155. The various feeding mechanisms most commonly used on machines are:

1. Needle Feed. The needle alone moves the material the regular length of a stitch, while the presser foot holds the material in place on the throat plate.
2. Drop Feed. The feed dog moves the material the regulated length of a stitch while the presser foot holds the material against the feed dog.
3. Compound Feet. Consists of the needle feed and the drop feed. Some compound feed machines are equipped with alternating presser feet. The alternating presser is an additional presser foot which holds the material alternately with the compound feed. This type of feed is used on class 111 machines.

Needles

It is very important that the proper needle be used to insure good machine operation. The selection of needles of correct class variety, needle order number and size for different machines and materials is necessary in order to eliminate thread breakage, skipped stitches, and chafing of the thread.

The term "class" refers to the type of shank of a needle best suited for use in a certain class of machine. The term "variety" refers to the length of needle and type of point (round or cutting). Odd numbers indicate round-point needles, and even numbers indicate cutting point needles. Round, sharp-pointed needles are the only type used for sewing cloth since they do not cut the strands as they are forced between the woven threads of fabric. Many different varieties of cutting point needles are available, but they are used only for sewing leathers. The size indicates the gage of the needle and the needle eye which is determined by the size and type of thread and the material. Good machine operation is very dependent upon using the correct size of needle. The thread must pass freely through the needle eye in order to eliminate thread breakage. Class 111 machines use a 135x17 needle. The class number, in this case 135, which

indicates the length of needle and the type of point. Sizes of the 135x17 range from 12 to 24; however, most sewing operations required of the fabrication parachute technician, may be accomplished by using sizes 18 through 24, needle order number 3355.

A dull round needle acts the same as a cutting needle. It will cut or pull threads and may weaken the seam. The condition of a needle may be checked by sliding the fingernail over the point. If it scratches or catches the nail, the needle should be replaced with a new one. A dull needle may be sharpened by placing it in the chuck of a drill press and the drill operated at high speed while holding a fine grade sharpening stone lightly against the side of the needle at the proper angle. The point is then polished with a piece of russet leather.

Safety Precautions

The following precautions should be observed while operating class 111 machines in order to prevent injury to the operator or damage to the machines.

1. Keep the fingers cut from under the presser feet while the motor is running.
2. Do not operate the machine without material under the presser foot as this will dull the feed dog.
3. Do not change the bobbin while the motor is running.
4. Be sure that bed slides are closed before operating the machine as the fingers or the material may come in contact with the rotary hook and serious injury may be the result.
5. Keep the fingers at the side of the needle, not in front.
6. Hold both the needle and bobbin threads taut when starting to sew.
7. When tilting the machine head back, be sure that it lies securely against the machine headrest pin. Injury to your hands may result if the machine head falls forward, or the machine head will be damaged if it falls to the floor.
8. When winding a bobbin, be certain that the presser foot is raised and that the needle is not threaded.
9. Do not start sewing until the motor has had sufficient time to attain full speed.
10. Do not try to push or pull the material as it is being fed through the machine. The needle will bend or break.
11. Operate machine at a low rate of speed to avoid making lines that are not straight.

12. Be sure to turn the motor switch off any time you leave the machine.

13. Do not turn the balance wheel backward a full turn or the thread will break.

14. Use the proper type of thread and the proper class and variety of needles.

15. While sewing be aware of any metal or hard surface portions of the material.

CARE OF THE MACHINE

To maintain efficient operation of the class 111 machines it is sometimes necessary to perform minor adjustments and maintenance. Minor adjustments include threading the head and bobbin, regulating length of stitches, adjusting tensions on the needle and bobbin thread, regulating pressure on the material, and changing needles. A knowledge of the procedure for timing the machine is also important to the operator, but it should not be attempted until the operator is thoroughly familiar with the operating principles of the machine. Timing will be studied later under "Sewing Machine Maintenance."

Clean and Lubricate

CLEANING. All moving parts must be kept free of dirt, lint, and grit. The bobbin case area should receive your particular attention and should be checked for cleanliness every time a bobbin is replaced. Cleaning this area before dirt and lint accumulate will prevent many jams. In addition to cleaning dirt and lint from the machine you should wipe off excess oil after you have lubricated the machine. Use dry cleaning solvent as your cleaning agent. Never use gasoline to clean your machine; gasoline is an extreme fire hazard.

Be sure the dust cloth you use to clean the machine head and table is lint-free. The bobbin case area and other moving parts cannot be cleaned efficiently with a dust cloth because lint and dust get into small crevices that cannot be reached with a cloth. Clean these parts with a small bristle brush. Use cotton waste to clean the oil from the oil pan and discard it in an authorized oily rag container. When you have finished cleaning, cover the machine with a dustproof cover.

LUBRICATING. Given the lubrication it needs, a class 111, or any other machine, will give years of service before the parts show significant wear. You will also have a smoother running machine that will seldom require other maintenance. This being the case, it is well worth your time to lubricate every part as required.

Before you oil the machine, make sure your lubricating equipment is clean. Then wipe the machine oil holes and surrounding surfaces clean. When cleaning solvent is used to clean the machine, dry all of the parts thoroughly before lubricating them.

Lubrication is required at various intervals for different parts of the class 111 machine. Twice daily you should lubricate each of the parts with one to three drops of highly refined mineral oil with a low pour point. Lubricate all points shown in TO 34Y7-8-11, pages 4 through 6.

The parts not shown on the lubrication chart that should also be lubricated twice daily are the knee lifter connecting lever hinge screw, knee lifter lifting lever hinge screw, and presser bar lifting bracket. Oil the bobbin winder with one or two drops of oil once each day.

The waste-packed oil reservoir at the terminal end of the motor shaft should be filled with lubricating oil monthly. Every three months lubricate the motor rotor shaft fitting and the transmitter bearing with bearing grease. Three to five strokes of a grease gun will supply sufficient grease.

No particular time interval is specified for lubricating the small green felt pad on the side of the bobbin case. Keep the pad wet with lubricating oil. When wet, the pad will be almost black; when the pad turns light green, it indicates that the pad has dried out. If you are breaking in a new machine, lubricate the felt pad each time you change the bobbin. Another lubrication point is the thread lubricator. Whenever the thread lubricator is to be used, fill its reservoir to within 1/8 inch of the edge of the fill hole.

Thread Head and Bobbin

For information on threading the head and bobbin study TO 34Y7-8-11, pages 9 through 12.

Regulate the Length of Stitch

For information on regulating the length of stitches read TO 34Y7-8-11, page 14.

Adjusting Tension on Needle and Bobbin Thread

For information on adjusting the tension on the needle and bobbin thread on the 111W sewing machine read TO 34Y7-2-1, page 14.

Regulate Pressure on the Material

For information on how to regulate pressure on the material, study TO 34Y7-8-11, page 14.

MAINTENANCE

The Shop Chief of a fabric shop asked the new man if he had the "know how" to adjust the timing of a class 111 machine. Getting an affirmative answer, he assigned the new man to the job. Several hours later the supervisor checked to see why the job wasn't finished. He found the young airman knee deep in removed sewing machine parts, some of which had nothing to do with the job at hand. Being a cool-headed supervisor he said, "If you don't know how to do a job, please don't tell me you have the 'know how' to do it." The 3-level airman answered, "But chief, I do have the 'know how', I just haven't got the 'where at' down pat yet." If this chapter is diligently studied and you pay attention to your instructor, you will get both the "know how" and "where at" of sewing machine maintenance. This knowledge is essential, as the Air Force is not manned with a sewing machine repairman specialty. Therefore, it is up to you to perform your own sewing machine maintenance to keep your shop productive. To help you in this we will discuss general maintenance and troubleshooting of class 111 sewing machines in this chapter.

Timing Steps

The timing of the 111W sewing machine consists of three major steps. Each step should be completed in sequence.

TIMING ARROWS. It is necessary to time the arrow on the collar of the hook shaft, with the arrow on the timing plate, so that the fabric is not fed through the machine until the needle is above the fabric. Directions for completing this step are stamped on the top of the timing plate.

SETTING THE NEEDLE BAR. The needle bar must be set at the proper length to complete proper timing procedures. Approximately 1-7/8 inches above the bottom of the needle bar there are two small marks. The top mark indicates the length of the needle bar. This procedure will position the needle bar at a proper specified length so that the lockstitch may be formed during operation. If the needle bar is not marked use a needle bar gauge of local manufacture.

Adjusting the saddle with the needle. The saddle must be in the correct position so that precise setting of timing step #3 can be accomplished correctly. Adjusting the saddle is not required each time timing step #3 is to be accomplished. Correct position is a must which may be changed due to vibration loosening the screws.

ALIGNING THE ROTARY HOOK WITH THE NEEDLE. The lower mark on the needle bar travels, on its upward stroke, as the hook point passes the needle. The hook point should pass approximately 1/16 inch above the top of the needle eye. In this position, the hook will pick up the needle thread and begin to form the lockstitch.

For further information concerning the accomplishment of these timing steps, study TO 34Y7-8-11, pages 16 through 18.

Adjusting Feed Dog

The feed dog moves or feeds the material from the underside. When it is adjusted properly, it should show a full tooth above the throat plate when the feed dog is at its highest position. For further information, study TO 34Y7-8-11, page 19.

Adjusting Stitch Length Indicator

Sometimes it becomes necessary to readjust the stitch length indicator. If you are sewing eight stitches per inch but the indicator shows six stitches per inch, an adjustment is necessary. For further information concerning adjustment of the stitch length indicator, study TO 34Y7-8-11, page 20.

Adjusting the Tension Assembly and Controller Spring

This assembly is composed of two separate tension control devices. The upper tension assembly may be adjusted to apply tension to the needle thread; the lower thread controller assembly has a spring which is used to remove slack from the needle thread.

The tension assembly may be adjusted by the thumb nut on the tension stud. The thread controller is adjusted by setting tension on the spring and the alignment of the spring stop.

For further information study TO 34Y7-8-11, page 15.

Rotary Hook

If thread breakage occurs while sewing, a possible solution to this problem could be a defective rotary hook. Remove the rotary assembly from the machine and visually examine the rotary hook. Burrs can be removed by sanding them with emery cloth.

Troubleshooting

While extensive troubleshooting is not expected from the three level apprentice, you should be familiar with the cure for some common troubles. The troubleshooting information (table 2) will analyze some of the simple causes for common problems.

TROUBLE	PROBABLE CAUSE	REMEDY
Thread breakage while sewing.	Thread controller spring may need adjusting.	Adjust thread controller spring.
	Right twist thread in needle.	Change to left twist thread.
	Rotary hook too close to the needle causing the hook to cut into the thread.	Adjust rotary hook.
	Wrong size needle for type material being sewn.	Install correct size needle.
	Dull Needle.	Replace Needle.
	Burr on rotary hook.	Remove burr with emery cloth.
	Rotary hook out of time with needle.	Time rotary hook with needle.
	Improper tension on needle and bobbin thread.	Adjust tension.
	Thread not unwinding properly off thread stand.	Check thread stand.
	Incorrect threading.	Correct threading.
	Burr at edge of needle eye.	Remove burr by working thread back and forth through eye or replace needle.
Skipped stitches.	Rotary hook set too far away from needle.	Move hook saddle closer to needle.
	Rotary hook slightly out of time with needle.	Adjust rotary hook by moving hook driving gear.
	Needle bar out of adjustment.	Set needle bar for proper length.
	Wrong class of needle.	Install correct needle.

Table 2. Troubleshooting Chart, 111W Series Sewing Machine (Cont'd).

TROUBLE	PROBABLE CAUSE	REMEDY
	Needle not inserted in the needle bar as far as it will go.	Fully insert needle in needle bar.
	Needle not in perfect alignment with rotary hook.	Align needle with rotary hook.
	Thread too large for needle eye.	Change size of needle or use smaller thread.
	Deflecting washer on rotary hook bent.	Replace deflecting washer.
	Thread controller spring out of adjustment.	Adjust thread controller spring.
Thread jamming underneath the throat plate and around the square projection on the bobbin case.	Operating machine without material under the presser foot.	Do not operate machine without material under presser foot.
	Failure to hold needle and bobbin threads taut for the first few stitches.	Hold thread taut.
	Bobbin case opening lever out of adjustment.	Adjust bobbin case opening lever.
Thread jamming under the bobbin case.	Small pieces of thread or dirt, lint, etc., under the bobbin case.	Clean bobbin case.
Thread piling up underneath material when beginning seam.	Failure to hold needle and bobbin thread taut for the first few stitches.	Hold threads taut when beginning seam.
Thread jamming up along bottom seam.	Needle thread slipping out of tension disks.	Check tension on needle and bobbin thread.

Table 2. Troubleshooting Chart, 111W Series Sewing Machine (Cont'd).

TROUBLE	PROBABLE CAUSE	REMEDY
Machine not making the regulated number of stitches per inch.	Feed indicating disk has slipped on the arm shaft.	Set feed indicating disk in correct position.
Machine not sewing at all.	Machine completely out of time.	Perform three timing steps.
	Needle threaded from wrong side.	Thread needle correctly.
	Rotary hook set too far away from needle.	Adjust hook saddle.
	Wrong class and variety needle.	Check needle for correct class and variety.
	Needle not inserted in needle bar as far as it will go.	Insert needle in needle bar fully.
	Bent or broken needle.	Change needle.
	Safety clutch disengaged.	Press hook driving shaft lock ratchet plunger, turn balance wheel toward operator.
Machine sewing backwards.	Set screw on feed driving eccentric 180 degrees out.	Install set screw in slot on hook driving shaft.
Material damaged by scuffing.	Pressure on presser foot too great.	Adjust pressure on presser foot.
Sluggish operation of sewing machine.	Use of improper oil or accumulation of dust or lint.	Clean machine and oil (light weight lubricating oil.)

Table 2. Troubleshooting Chart, 111W Series Sewing Machine.

Exercise 1

Study the training literature and answer the following questions on a separate piece of paper.

1. Explain the type of stitch the class 111 sewing machine sews.
2. What parts of the machine are used to form this stitch?
3. Describe the type of feeding mechanism the 111W-152 sewing machine uses.
4. Explain the damage that may be caused if the machine is operated with the presser feet down and no material under them.
5. List three safety precautions to observe while operating the 111W sewing machine.
6. The term "class" in relation to the needle, refers to what part of the needle?
7. What part of the needle does the term "variety" refer to?
8. The class and variety of needle used in the 111W-152 sewing machine is:

9. Where is the stitch regulating button located on the 111W-152 sewing machine?

10. How often should the 111W sewing machine be oiled?

11. What type of oil is used to oil the 111W sewing machine?

12. In what position should the thread take-up lever be while removing material from under the presser feet?

13. In what direction will the bobbin rotate when the 111W machine is in operation?

14. Where will the knots form in the material when the thread tension is properly adjusted on the 111W machine?

15. How is the needle thread adjusted on the 111W sewing machine?

16. How is the bobbin thread adjusted on the 111W sewing machine?

139

17. In what direction will the long groove face when the needle is installed correctly in the 111W sewing machine?

18. When should the bobbin be oiled?

19. What is the first timing step on the 111W-152 sewing machine?

20. What is the distance from the upper mark on the needle bar to the bottom of the needle bar on the 111W-152 sewing machine?

21. How far above the throat plate will the feed dog be when it is at its highest position?

SUMMARY

We have been involved with the theory of the operation and maintenance of the class 111 sewing machine. Since the class 111 sewing machine is one of the most often used machines thorough knowledge of operation and maintenance is essential.

REFERENCE

1. TO 34Y7-8-11, Singer Sewing Machines 111W152, 111W153, 111W154, and 111W155.

150

Exercise 2

Identify the parts of the sewing machine head and stand by writing the name of each part identified by a number in the illustrations on the correspondingly numbered lines that follow the illustrations.

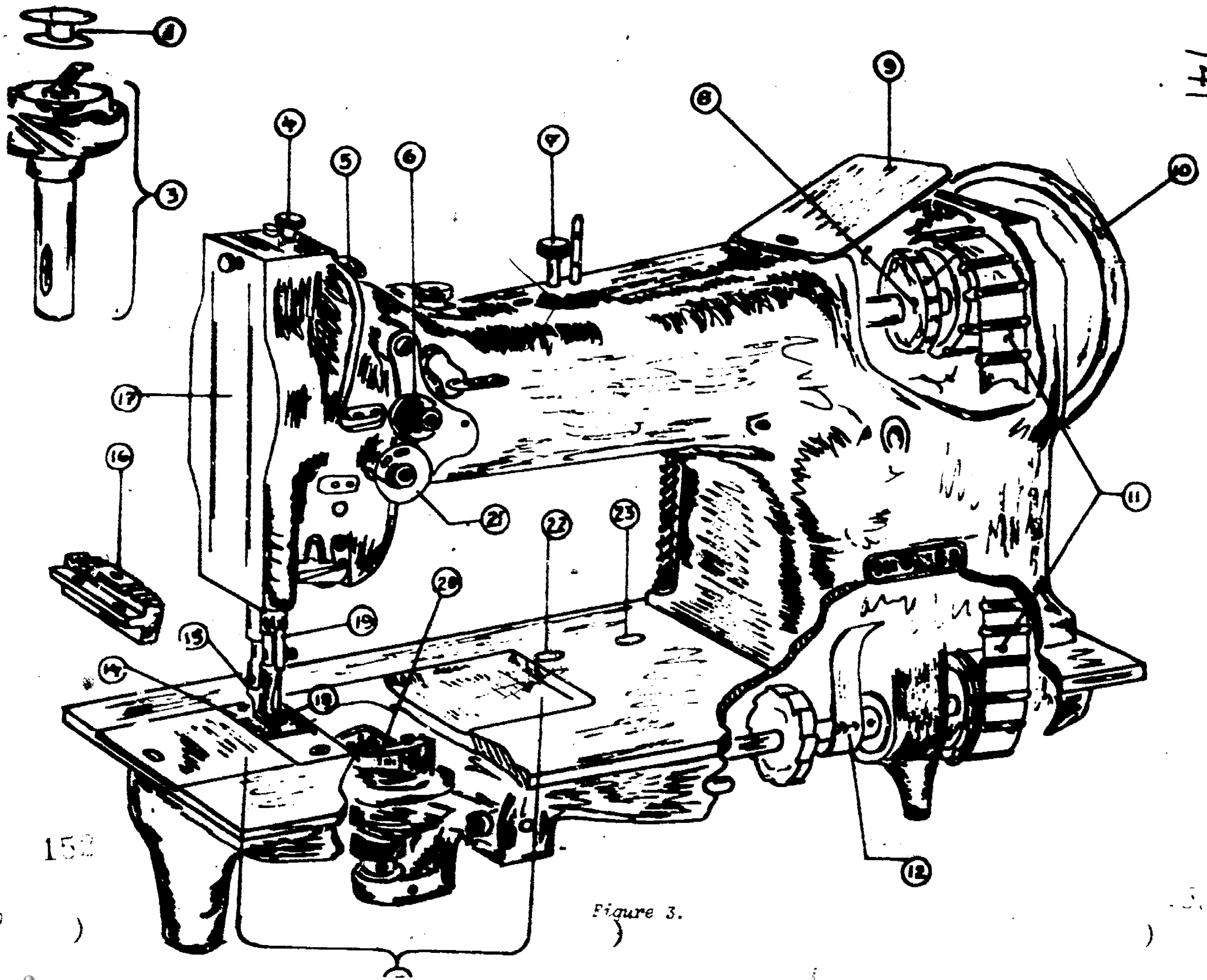

152

Figure 3.

153

Figure 3 sewing machine head

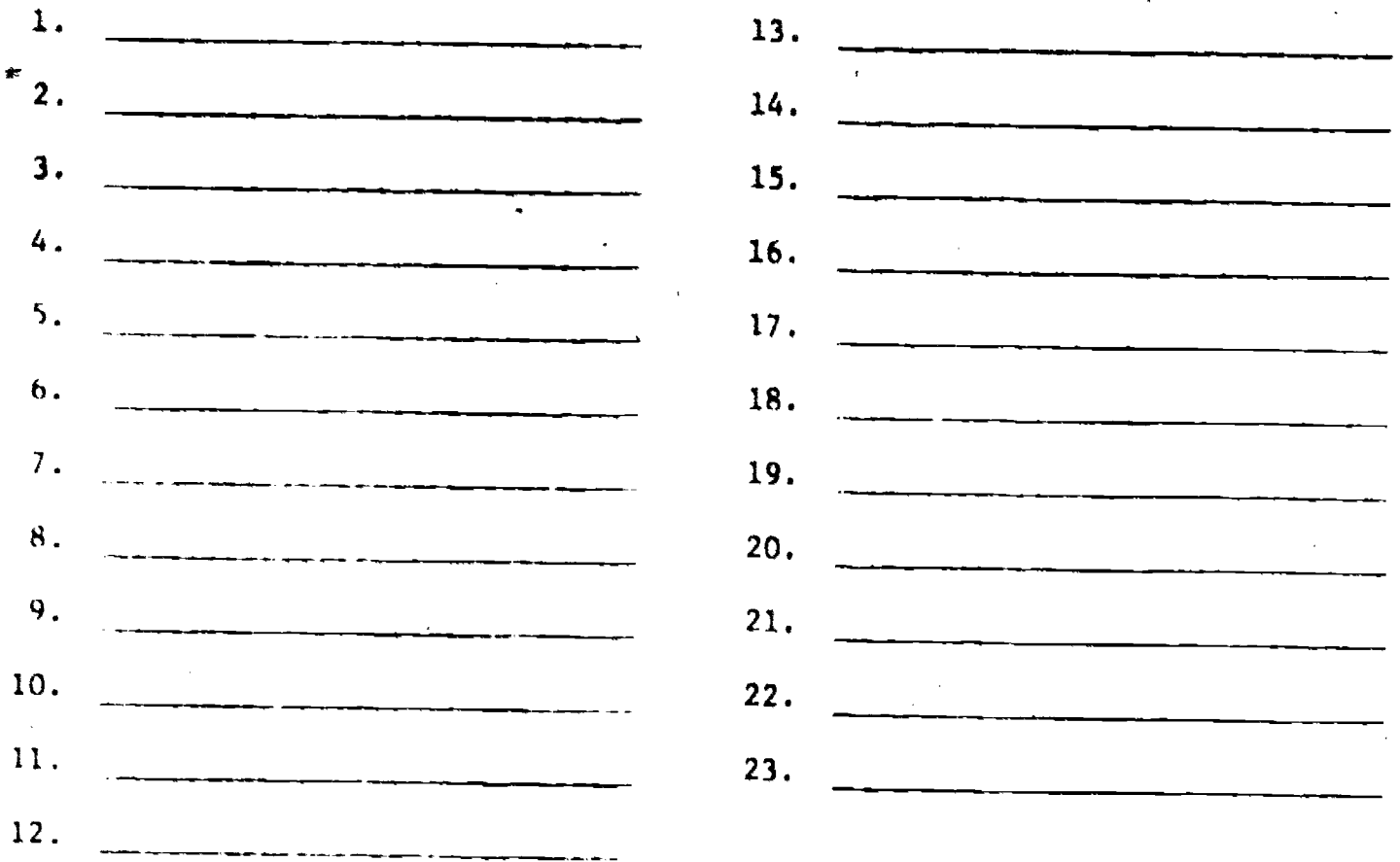

143

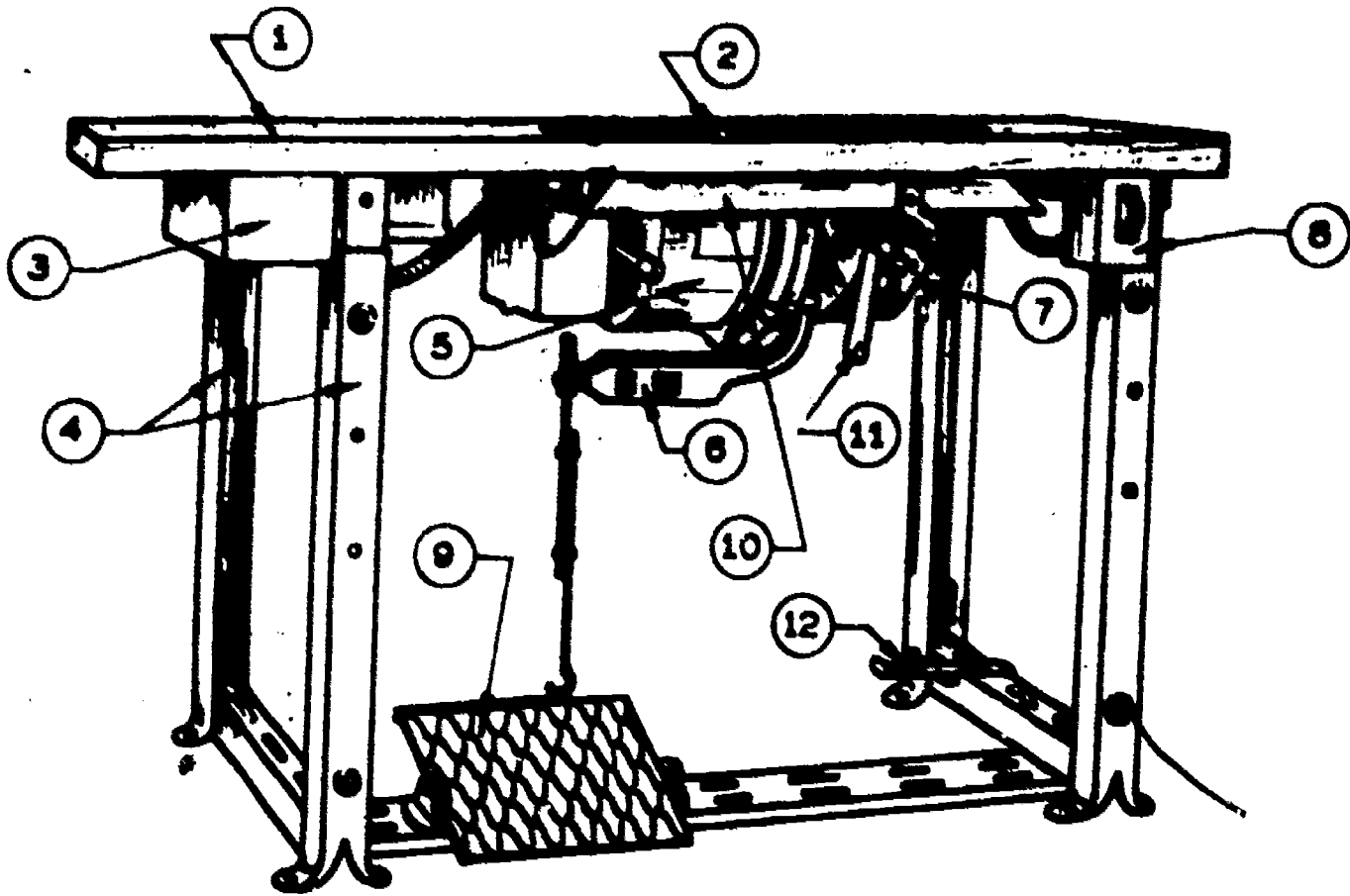

Figure 4. Sewing Machine Stand.

- | | | | |
|----|-------|-----|-------|
| 1. | _____ | 7. | _____ |
| 2. | _____ | 8. | _____ |
| 3. | _____ | 9. | _____ |
| 4. | _____ | 10. | _____ |
| 5. | _____ | 11. | _____ |
| 6. | _____ | 12. | _____ |

135

Exercise 3

Operate the machine controls by following the procedures outlined below.

1. Place your right hand on the balance wheel, and turn it slowly toward you. Watch the action of the feeding mechanism, pressure foot, and feed dog. While moving the balance wheel forward, the needle descends. The feed dog and needle then pulls the material back the regulated length of a stitch. Notice that the alternating presser foot works alternately with the compound feeding mechanism.

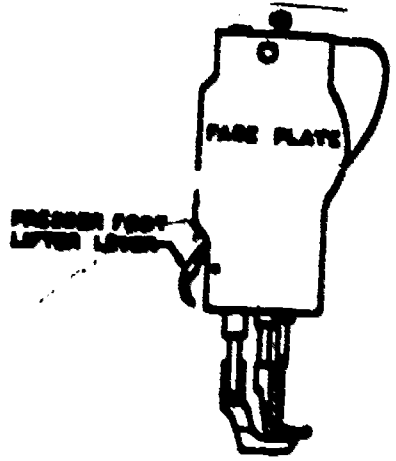

Figure 5. Location of Presser Foot Lifter Lever.

2. Locate the hand presser foot lifting lever at the back of the head, as in figure 5.
3. Raise and lower the presser foot and alternating presser by lifting the lever several times.

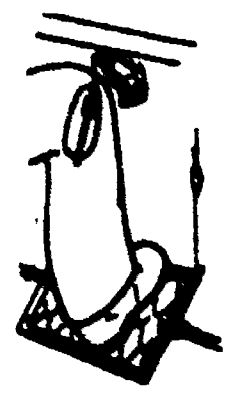

Figure 6. Operation of Knee Presser Foot Lifting Lever.

4. Operate the knee presser foot lifting lever by pushing firmly against it with the right knee, as in figure 6.
5. Continue to operate the knee lift lever several times until you are familiar with its action.

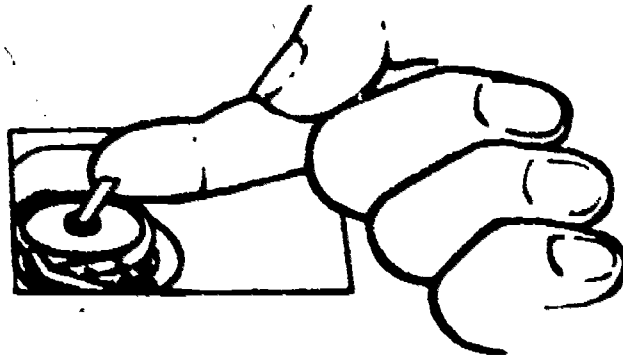

Figure 7. Lifting Bobbin Hatch.

6. Open the right bed slide, and lift the bobbin latch, as shown in figure 7.
7. Replace the bobbin with an empty bobbin and close the latch.
8. Locate the motor switch and turn it on.
9. Lift the presser foot by using the hand lifting lever.

Caution: Never operate the machine with the presser foot making direct contact with the feed dog as this will dull the feed dog teeth.

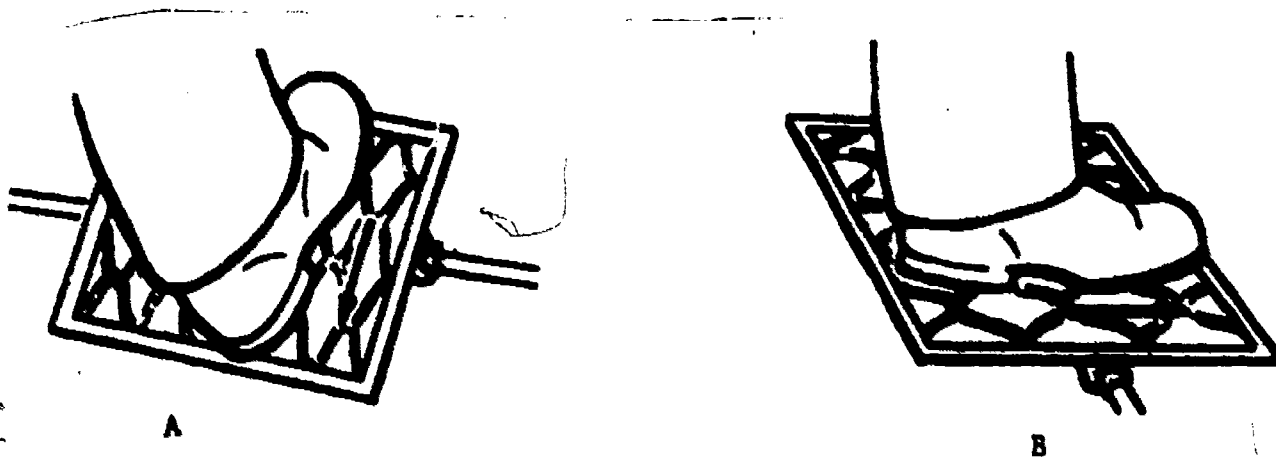

Figure 8. Operating Foot Treadle.

10. Place your right foot on the foot treadle, with your heel applying pressure on the treadle as shown in figure 8A.
11. Apply pressure gradually with the toe as shown in figure 8B.

Caution: Keep hands away from the needle and do not run the machine at high speed.

12. Stop and start the machine several times by applying pressure with the heel and toe.

13. Turn off the motor.

Machine Control

Standard of performance:

The ability to control the exact length and direction of a line of sewing must be mastered. An inexperienced operator will cause stitches to run off the material when sewing close to an edge, destroy the proper shape of an article, and reduce the strength of a well-planned pattern of stitching. One stitch too many may damage a costly piece of leather or other material. One stitch too few may mean an improper connection in a place where strength is essential.

Due to the action of the feeding mechanism, the sewing machine has a tendency to sew in a straight line. When sewing around a curved line, therefore, great care must be exercised while guiding the material.

When turning a corner, the balance wheel should be turned by hand until the needle has reached its lowest point and starts back up but is not completely out of the material. The formation of this habit will eliminate the possibility of skipped corner stitches.

Caution: Observe all safety precautions.

Directional Control

1. Refer to figures 12-18.
2. Lift the presser feet by raising the hand lever.
3. Raise the needle to its highest position by turning the balance wheel forward, (toward you).

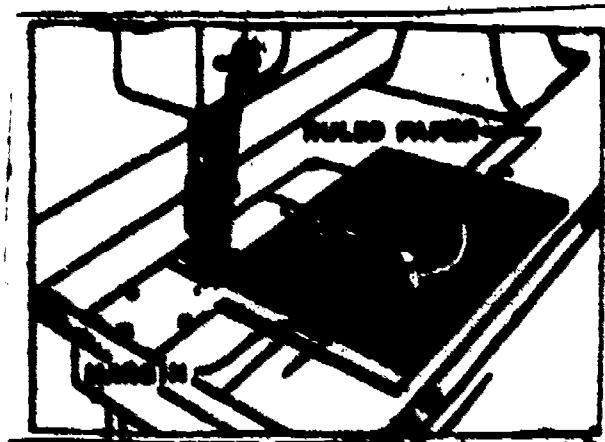

Figure 9. Sewing Straight Lines.

4. Insert the paper or card under the needle and turn the balance wheel until the needle pierces the first line of the paper near the edge, figure 9.

5. Lower the presser foot.

147 6. Before turning on the motor, be sure your heel is resting on the foot pedal as shown in figure 8A.

7. Turn on the motor.

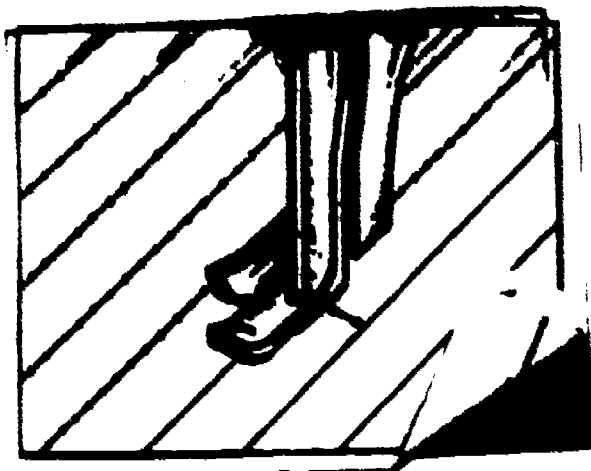

Figure 10. Method of Guiding Sewing.

8. Press the foot pedal with the toe very lightly and sew on the line to the opposite edge of the paper. Use the presser foot and adjacent line as a guide, figure 10.

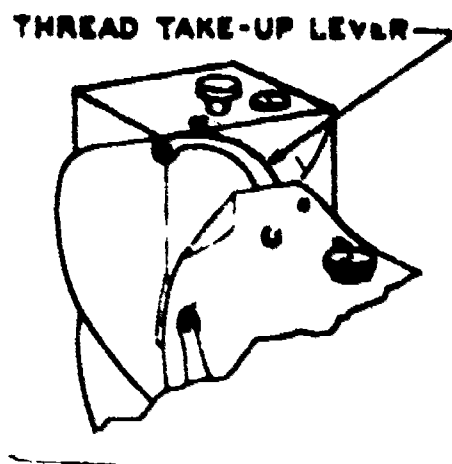

Figure 11. Thread Take-Up Lever at its Highest Position.

9. Remove the paper from the machine by raising the needle to the highest position and lifting the presser foot with knee lift lever or hand lever. When the needle is at its highest position, the thread take-up lever, figure 11, will be at its highest position.

10. Repeat the same procedure on each line until five complete sheets have been used.

Standard of performance:

Figure 19A illustrates poor control and good control.

CAUTION: USE A DOUBLE THICKNESS OF FABRIC UNDER THE PAGE FOR SEWING MACHINE PRACTICE.

148

START SEWING AT THIS LINE
FOLLOW EACH LINE

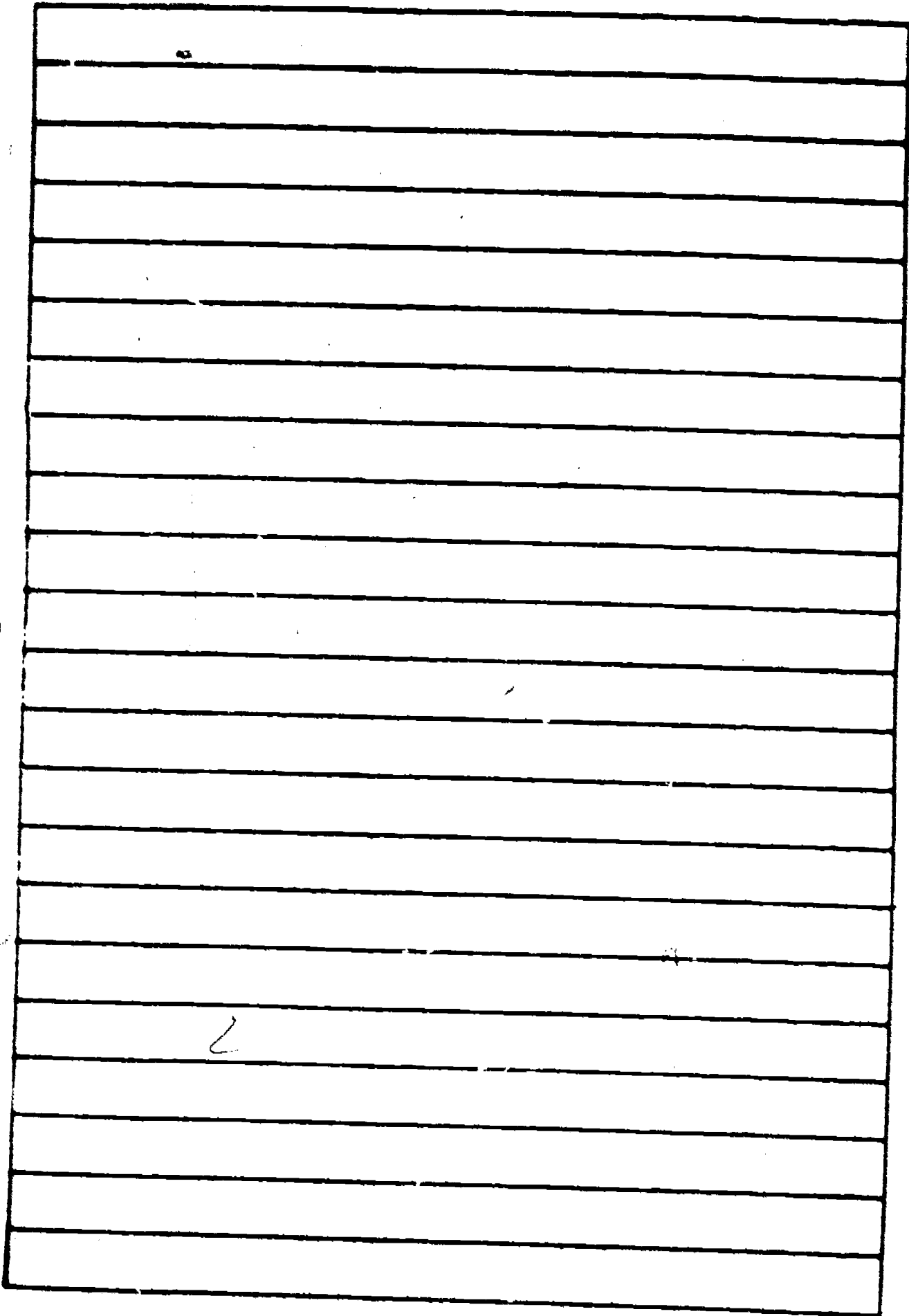

DO NOT SEW IN THIS AREA

Figure 12.

149

CAUTION: USE A DOUBLE THICKNESS OF FABRIC UNDER THIS PAGE FOR SEWING MACHINE PRACTICE.

START SEWING AT THIS LINE

FOLLOW EACH LINE

STOP

DO NOT SEW IN THIS AREA

DO NOT SEW IN THIS AREA

START

STOP

Figure 13. 151

CAUTION: USE A DOUBLE THICKNESS OF FABRIC UNDER THIS PAGE FOR SEWING MACHINE PRACTICE. 150

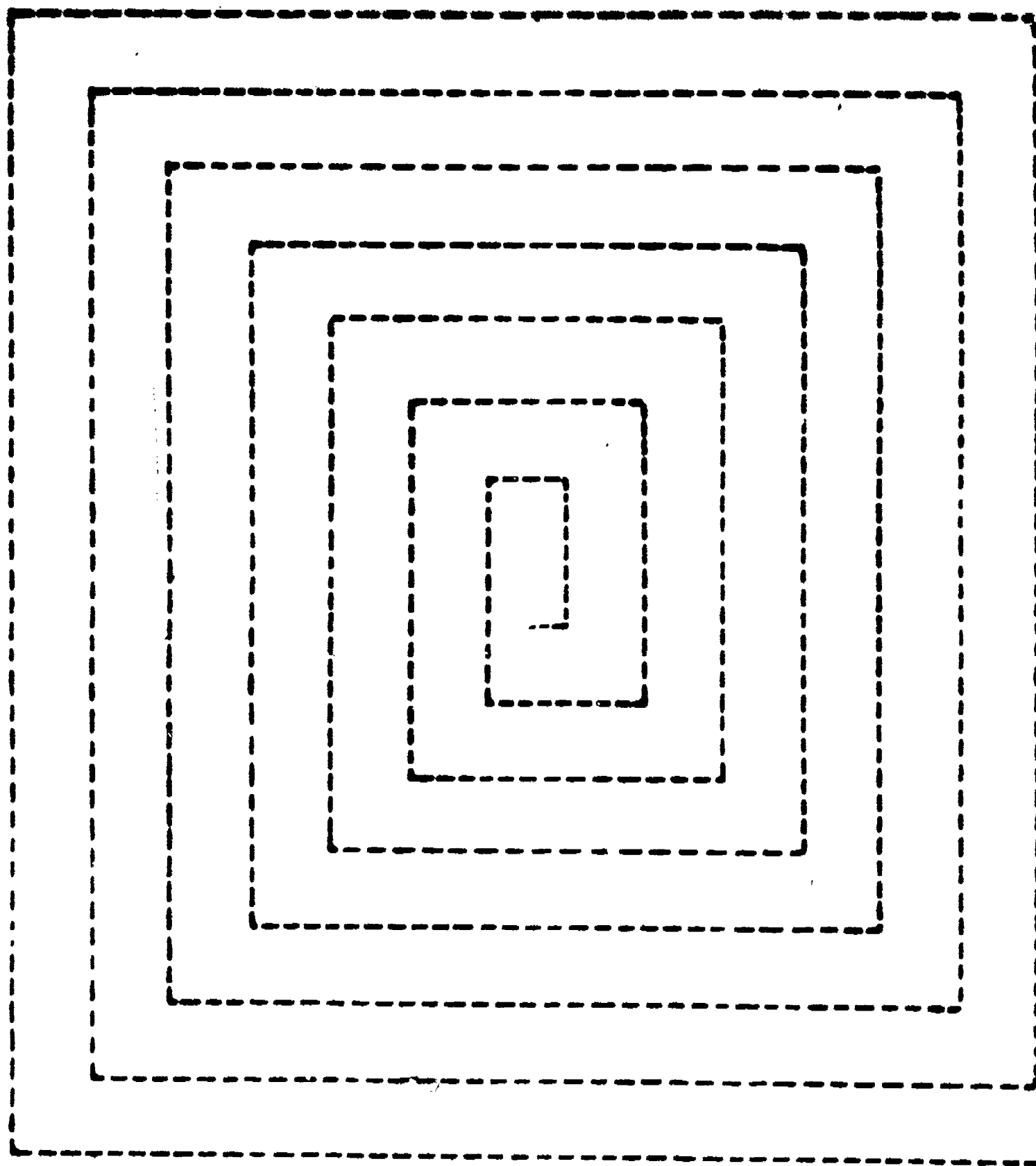

START HERE

Figure 14.

150
29

CAUTION: USE A DOUBLE THICKNESS OF FABRIC UNDER THIS PAGE
FOR SEWING MACHINE PRACTICE.

151

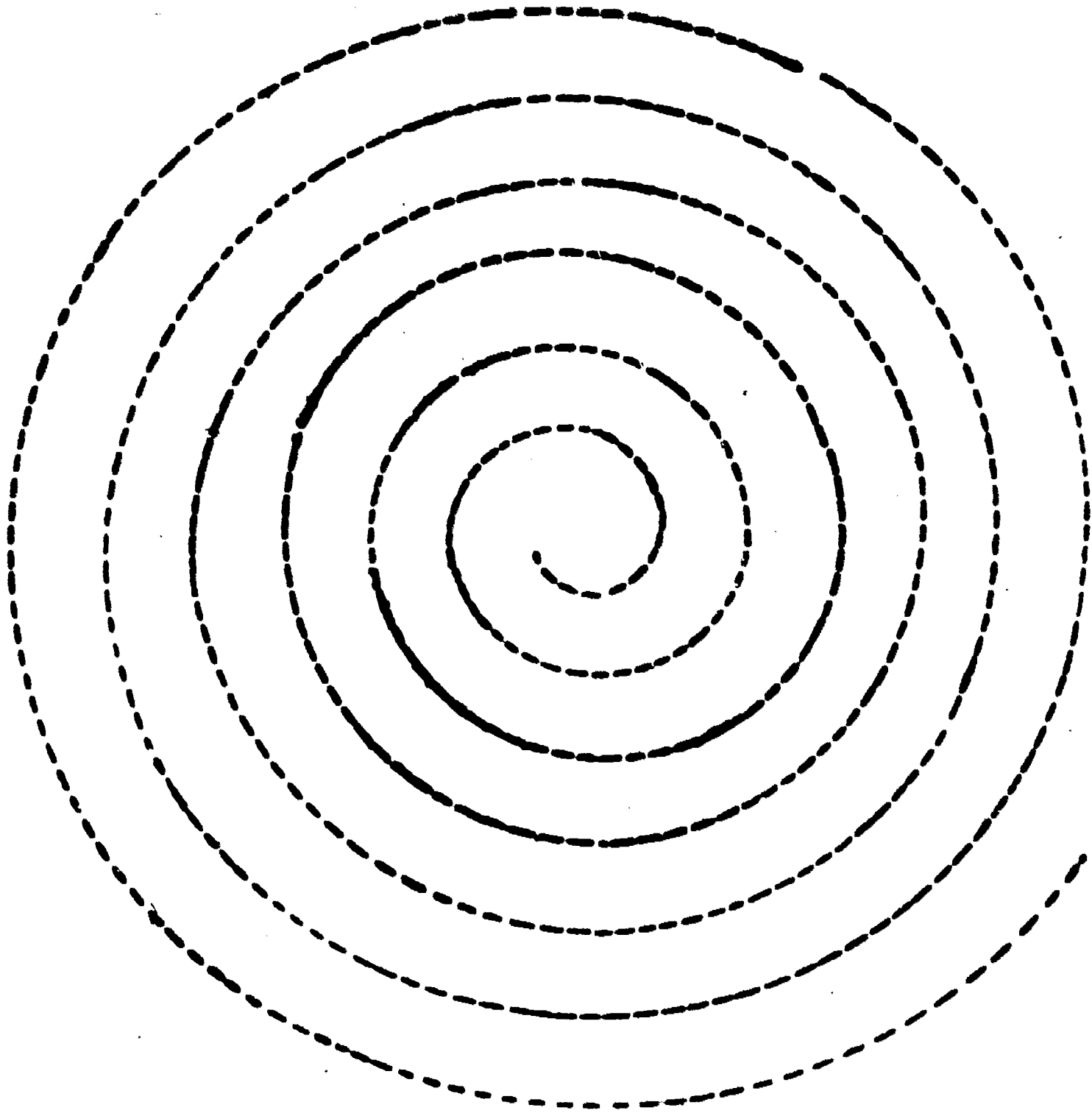

START
HERE

Figure 16.

31

153

152

CAUTION: USE A DOUBLE THICKNESS OF FABRIC UNDER THIS PAGE FOR SEWING MACHINE PRACTICE.

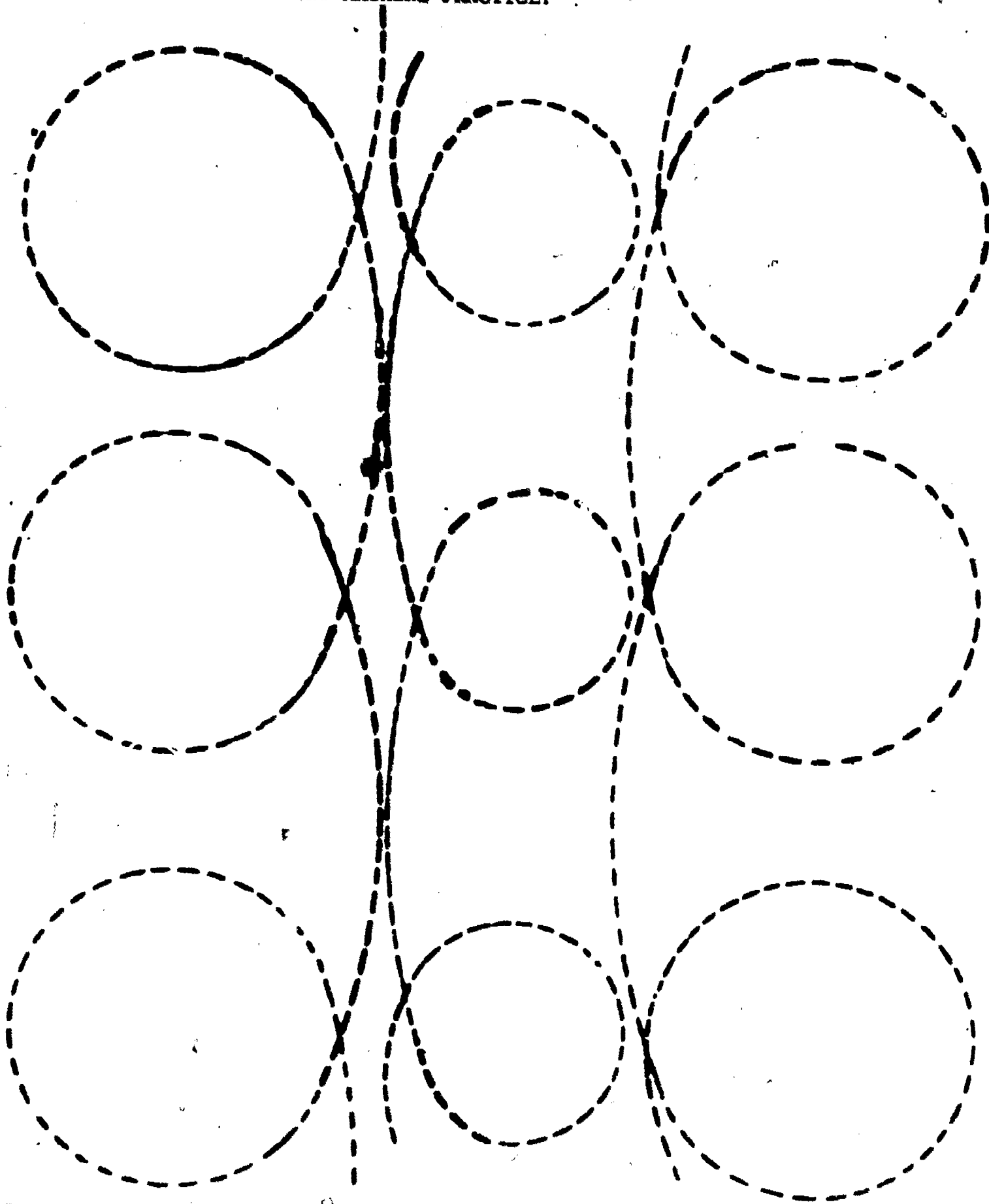
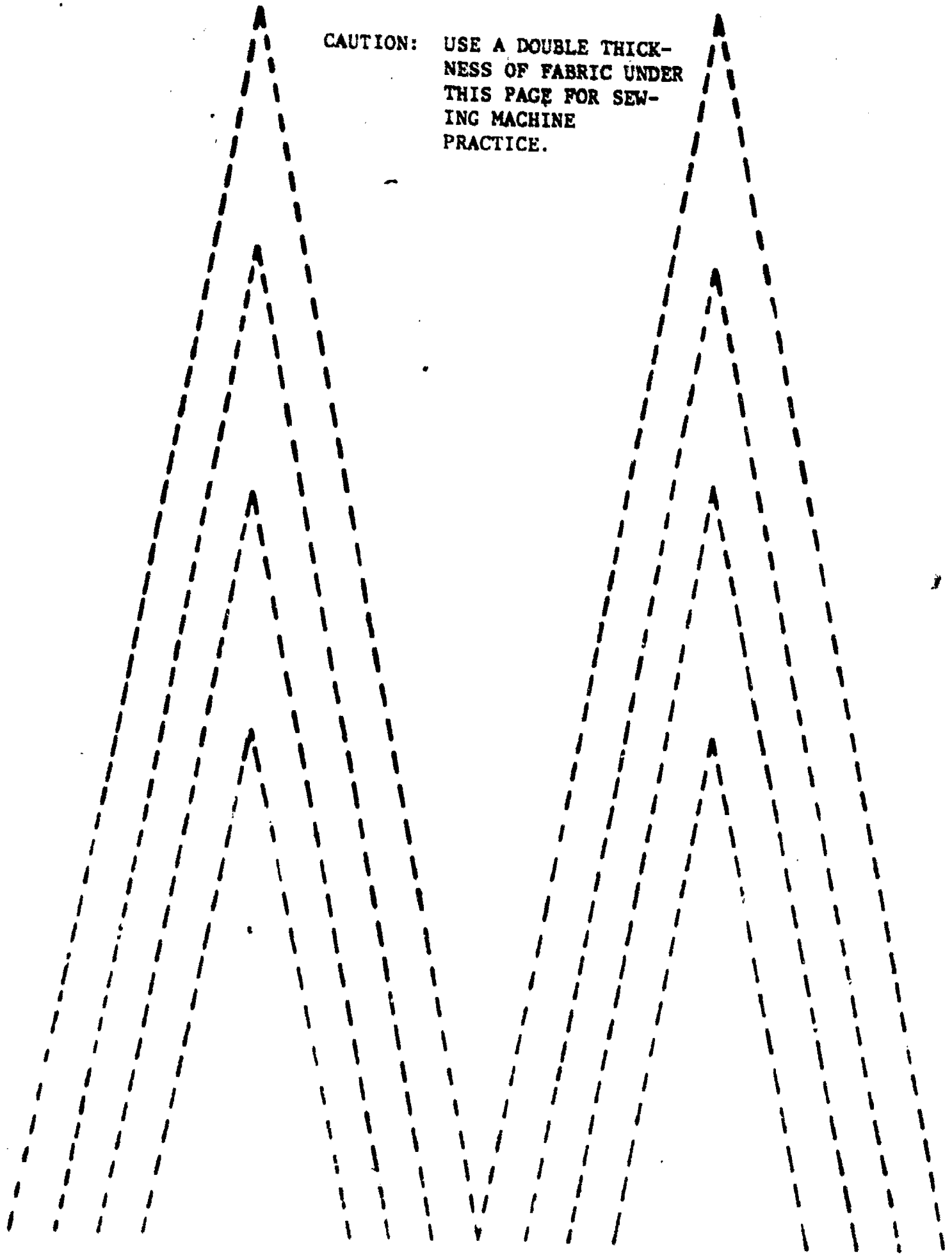
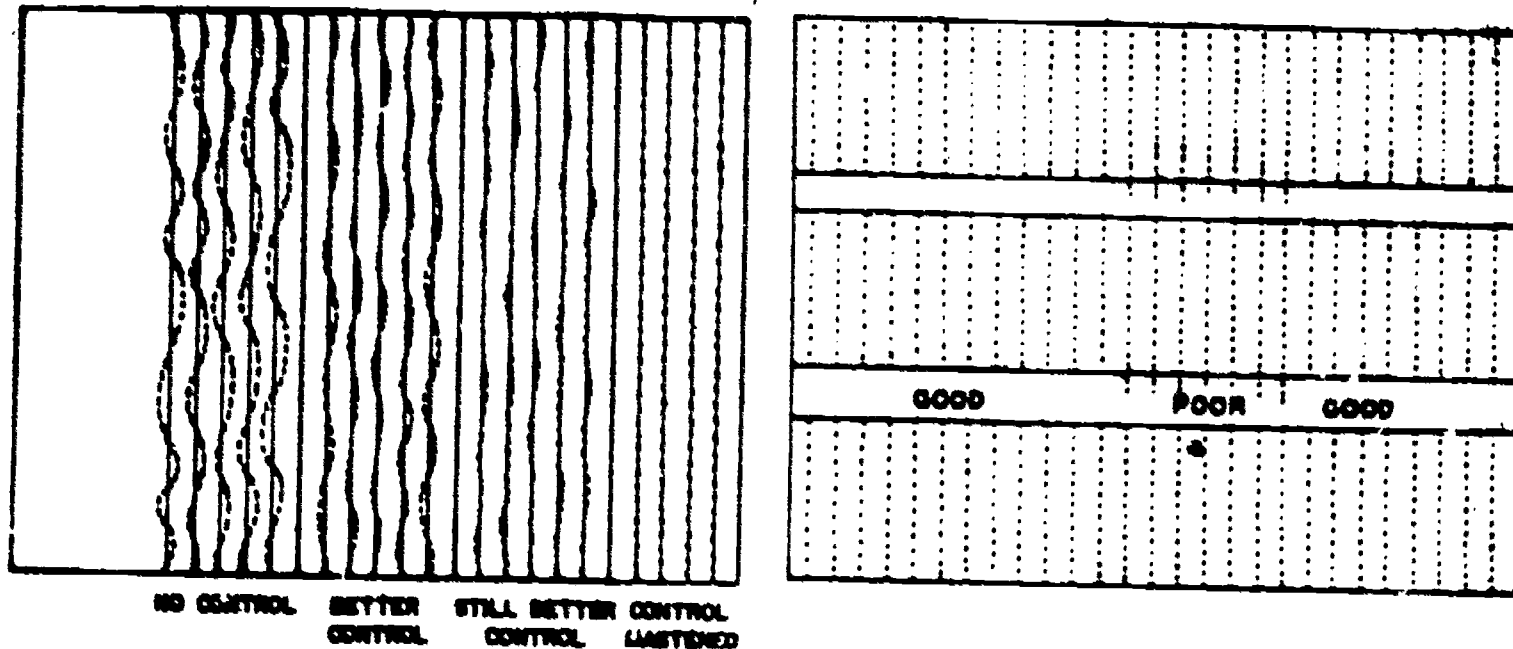

Figure 17.

CAUTION: USE A DOUBLE THICK-
NESS OF FABRIC UNDER
THIS PAGE FOR SEW-
ING MACHINE
PRACTICE.



153 Figure 18.



A

Figure 19. Poor and Good Control. ^B

11. Using the card illustrated in figure 19B, stitch each line to the perpendicular line. Do not stitch between the lengthwise lines. Figure 19B illustrates poor and good control.
12. Select the card designed for practice in making errors.
13. Raise the presser foot with the knee lift or hand lever.
14. Insert the needle on the line and, with the needle acting as a pivot, turn the paper in the desired direction.
15. Lower the presser foot and continue sewing.

Turning Corners

To turn corners, leave the needle in the paper at the exact point where the turn is to be made, as in figure 20. The needle should go a little past the lowest point and start on the upward stroke to make square corners. This is necessary to complete the lockstitch when sewing with thread to prevent skipped stitches at the corner.

16. Select a card designed for practice in sewing curves.
17. Sew slowly and carefully when following curved lines.
18. Repeat with other cards until control in sewing curves is mastered.

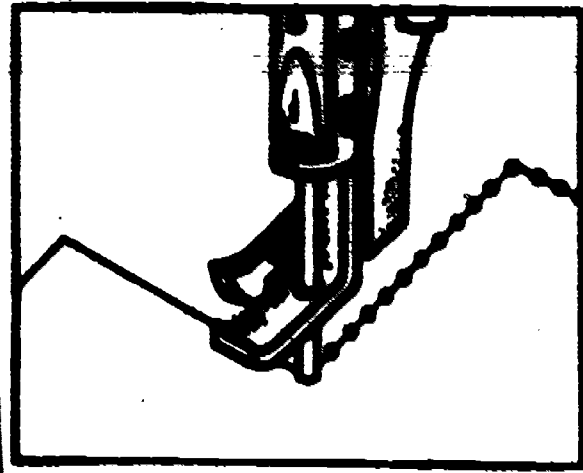

Figure 20. Making Corners.

Sewing Straight Lines

1. Cut a piece of scrap duck and fold to make a double thickness.
2. Check for correct tension and set the machine for eight stitches per inch.
3. Cut another piece of duck 6 X 12 inches and fold to make a 6-inch square.
4. Place the upper right hand corner of the doubled material under the presser foot so the needle is 1/2 inch from the right edge of the material and lower the presser foot.
5. Start sewing and continue to sew, making straight lines parallel and uniformly spaced with corners square as shown in figure 20.
6. When the center of the square is reached, backstitch about 1/2 inch.
7. Remove material from under the presser foot and turn the balance wheel forward until the thread takeup lever is at its highest position. Lift the presser foot with the hand lift lever, and remove the material from under the presser foot by pulling it away from you.
8. Cut the needle thread (top side) 1/8 inch from the panel, turn the panel so the bottom side will be up, pull the needle thread through the material with the bobbin thread, then cut both threads close to the panel. This is done to eliminate ragged threads on the top side of the panel.

Locking Seam Ends

1. Cut a piece of duck 6 X 12 inches and double it to make a 6-inch square.

2. Insert the needle in the folded panel 1/2 inch from the edge at the lower right hand corner.
3. Sew to the nearest edge of the panel.
4. From the last stitch at the edge of the material, make one complete lockstitch over the edge by turning the balance wheel by hand. Repeat the lockstitch over the edge two more times. See figure 21 and refer to "legend" under the illustration. This is called locking or anchoring.
5. Insert the needle in the last stitch made in the material, turn the material 180° and sew to the opposite edge.
6. Repeat step 4 and backstitch 1/2 inch at the opposite end of the material. Both ends of the seam are now locked.
7. Repeat the above procedure making seams 1/2 inch apart and locking all seam ends. Make seams across both ways of the material as shown in figure 21.

Exercise 4

Thread the head and bobbin of the class 111W sewing machine in the following manner.

Threading the 111W Machine Head

1. Thread the machine head as shown in figure 22, A through O.

Threading the 111W Bobbin

1. Remove the bobbin from the bobbin case by lifting the latch as shown in figure 23, and remove any thread that may be already wound on the bobbin.
2. Place the thread through guide, A on the bobbin winder and around the tension disc, B, figure 24.
3. Place the bobbin on the bobbin winder shaft as shown at C, figure 24.
4. Place the thread end through the hole in the bobbin from the inside out.
5. Press latch, figure 24D, forward until the pulley E makes contact with the driving belt F.
6. Lift the presser foot by using the hand lift lever.
7. Start the motor and hold on to the end of the thread where it protrudes from the bobbin.

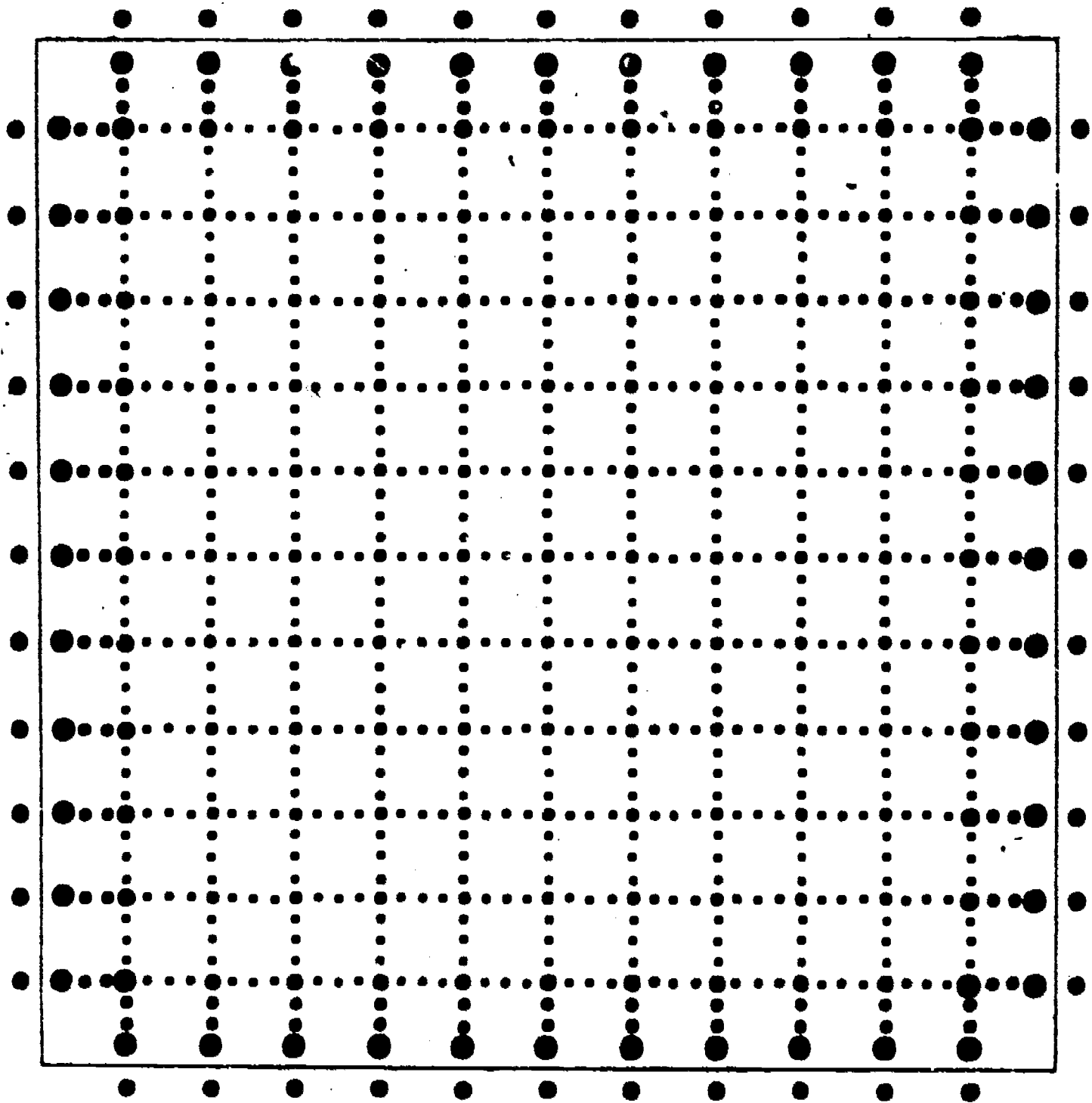

TOP VIEW



SIDE VIEW

• LEGEND •

- 1 STITCH
- 2 STITCHES
- 3 STITCHES
- 4 STITCHES

Figure 21. Locking Seam Ends.

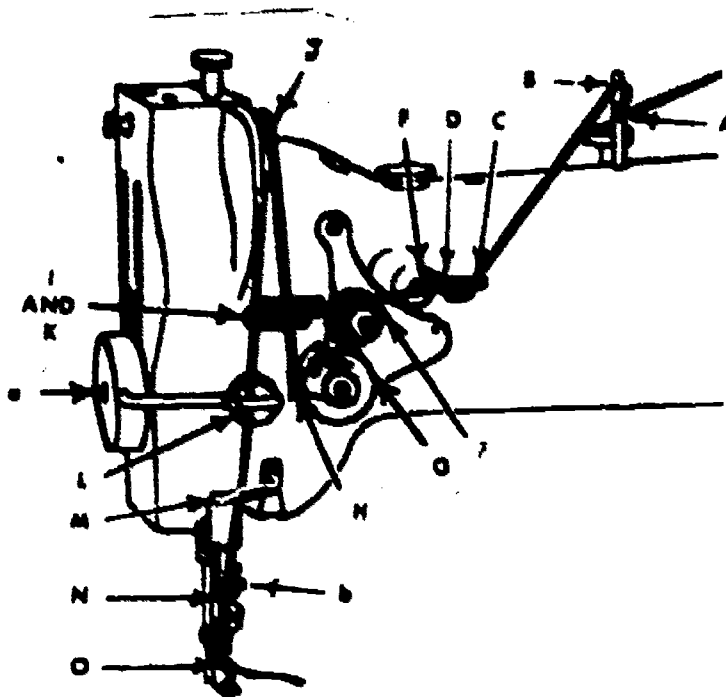

Figure 22. Threading the 111W Machine Head.

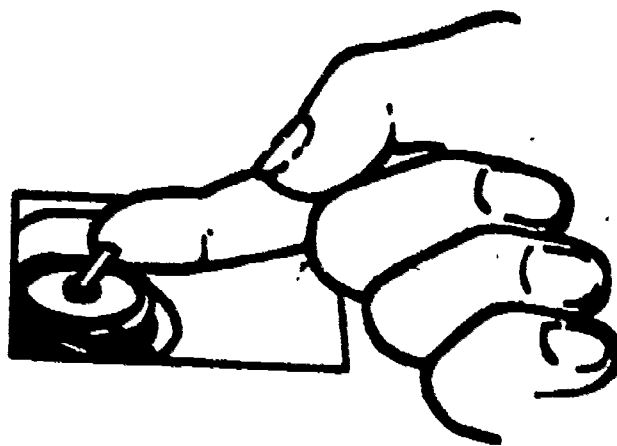

Figure 23. Lifting Bobbin Latch.

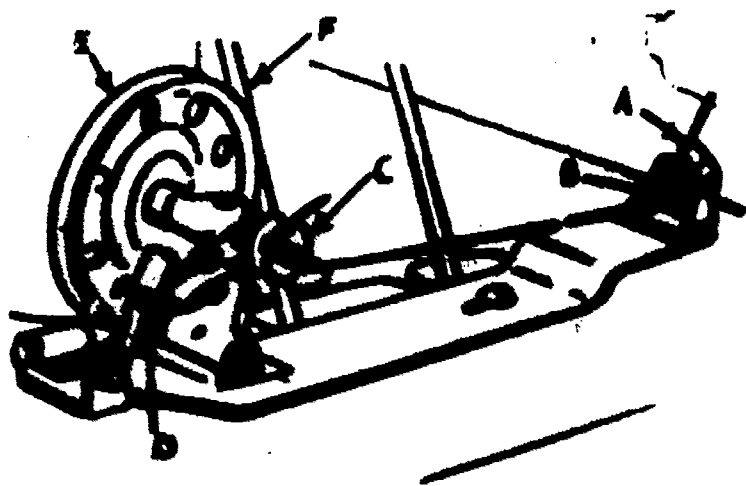

Figure 24. Winding the Bobbin.

- 8. Step on the foot treadle and apply pressure gradually with the toe.
- 9. Continue running machine until bobbin is wound and then shut off machine. When the bobbin is full, the winder will
- 10. Cut off the loose end of thread protruding from the side of the bobbin.
- 11. Cut the thread at the thread guide, figure 24A, and remove bobbin from the winder.

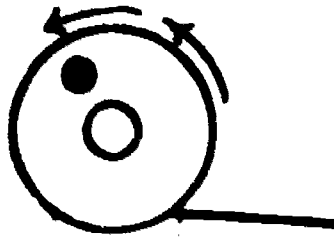

Figure 25. Bobbin Threaded.

- 12. Place the bobbin in the case so that the thread will unwind counterclockwise as the bobbin operates. The thread will unwind from the bobbin as shown in figure 25 when placed in the case.

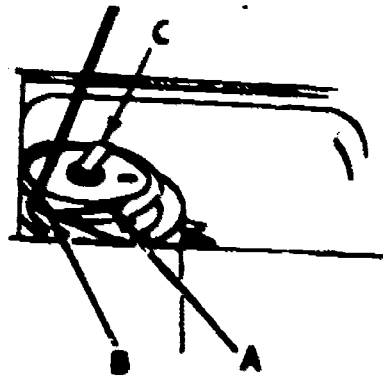

Figure 26. Bobbin Case Threaded.

- 13. Close the latch, as in figure 26C.
- 14. Pass about four inches of bobbin thread through the slot in the case as in figure 26A and under the tension spring.
- 15. Pass the thread through the opening between the bobbin case opening lever, figure 26B, and the projection on the case.
- 16. Hold the end of the needle thread in the left hand leaving slack between the hand and the needle.

17. Turn the balance wheel forward until the eye of the needle moves down and up again to its highest position, thus catching the bobbin thread. Watch how the needle thread is caught and taken around the bobbin case by the rotary hook to form the lockstitch.

18. Pull the needle thread slowly through the hold in the feed dog and the bobbin thread will come with it. Pull the end of the thread up through the hole in the feed dog.

19. Lay both threads under the presser foot and lower the presser foot on them.

20. Close the bed slide.

Exercise 5

Clean and lubricate the class 111W sewing machine in the following manner.

Cleaning

1. Clean the machine head, oil pan, machine stand, and motor casing with a clean lint free cloth.

2. Clean the hard to reach parts of the machine with a medium soft bristle brush.

Lubricating

1. Wipe oil holes and surrounding surfaces clean before oiling.

2. Oil the moving parts indicated by arrows in figure 27 twice daily with mineral oil that has a low pour point. Use one to three drops of oil at each oiling point.

3. Add oil to oil well (figure 28A) as needed to lubricate the upper hook bearing.

4. Oil the felt pad (figure 28B) on the side of the bobbin case when needed. When the pad is light green, it needs oil. When the pad is wet, it is nearly black. This pad lubricates the hook race.

5. If the thread lubricator is used, fill the reservoir to 1/8 inch below the filler hole.

Exercise 6

Regulate the length of stitch on the class 111W sewing machine in the following manner.

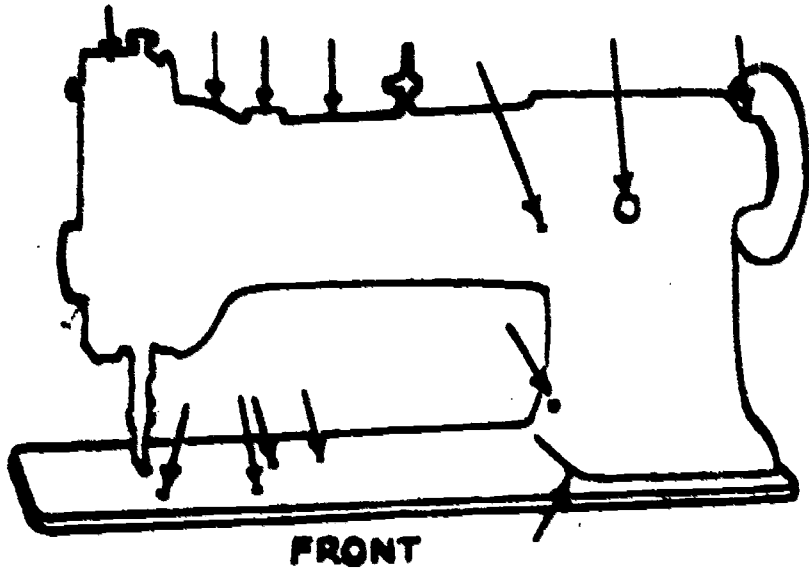

FRONT

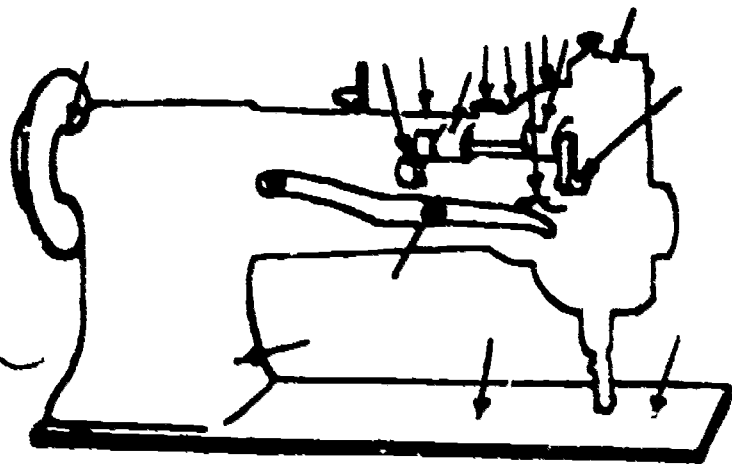

BACK

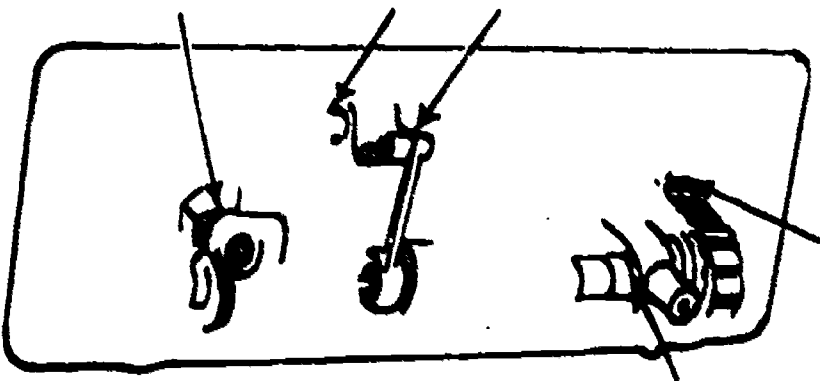

UNDER HEAD

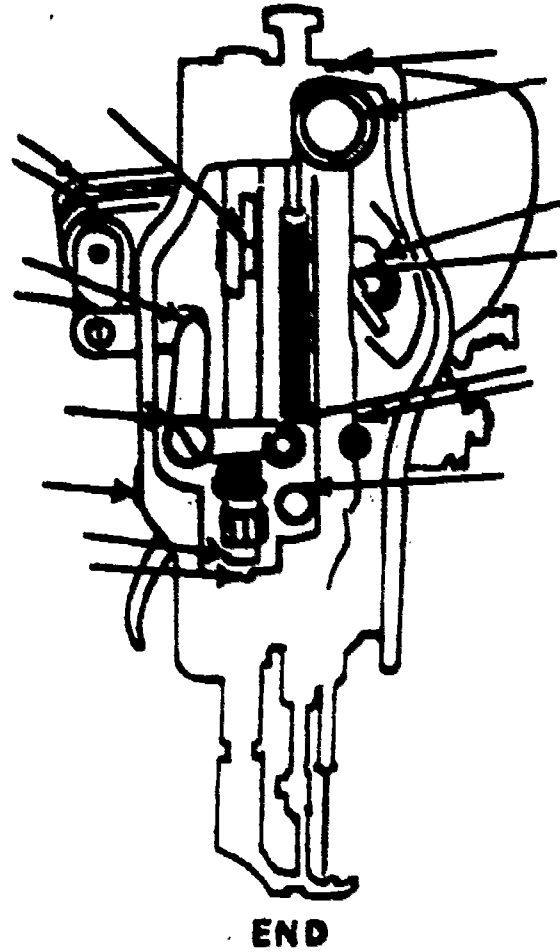

END

Figure 27. Oiling Points on the 111 Sewing Machine.

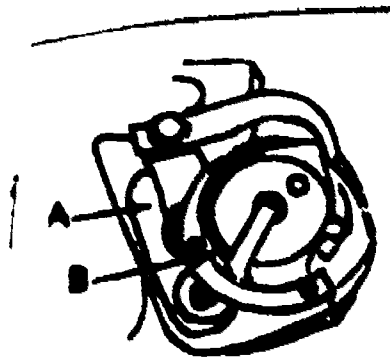

Figure 28. Hook Race and Bearing Lubrication.

Regulate the Length of Stitch

1. Place your finger on the feed indicator plunger and turn the balance wheel slowly toward you until the plunger drops. Do not turn the wheel after the plunger has dropped.

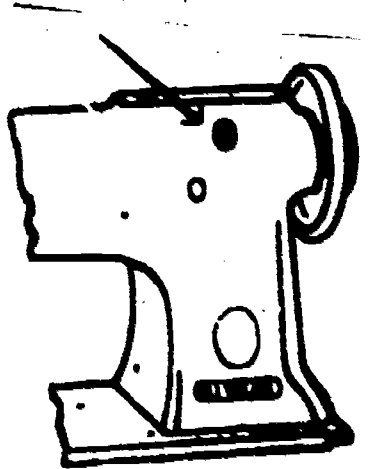

Figure 29. Upright Arm.

2. Keep plunger depressed and note the number in the hole in the upright arm as in figure 29. This number indicates the number of stitches per inch that the machine is set to sew.

3. Change the number of stitches per inch by holding the plunger down and turning the balance wheel forward to center the number 10 in the hole.

4. Release the plunger button. The machine is now set to sew 10 stitches per inch.

5. Repeat steps 3 and 4, turning the wheel backward and set the machine for six stitches per inch.

6. Reset the machine for eight stitches per inch. This is the setting most generally used for our sewing operations.

Exercise 7

Adjust tension on needle and bobbin thread on the class 111W sewing machine in the following manner.

Adjusting Tension on Needle and Bobbin Thread

1. Cut a strip of lightweight duck, 6 X 12 inches. Double to make a 6-inch square.
2. Place it under the presser foot.
3. Hold the needle and bobbin threads firmly behind the presser foot with the left hand. If the thread ends are not held when starting to sew, they will be pulled under the throat plate and form a thread jam which will cause thread breakage.
4. Turn the balance wheel slowly forward until three complete stitches are sewed in the duck, then release the thread ends held by the left hand.
5. Turn on the machine and sew for a distance of two or three inches.
6. Lift the presser foot with the hand lift lever and examine the stitching formation on both sides of the material.

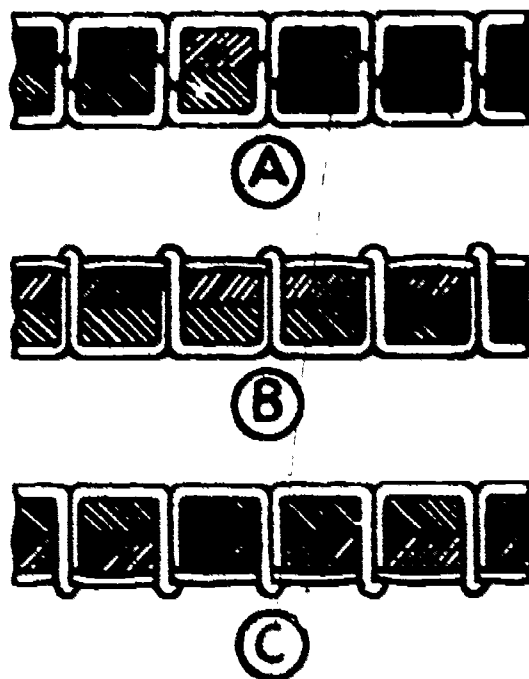

Figure 10. Correct and Incorrect Tension Adjustment on Needle and Bobbin Threads.

Standard of performance:

Figure 10 shows correct and incorrect tension adjustments on the needle and bobbin threads. (A) is the correct adjustment as the lock is formed in the center of the plies of material indicating that both the needle thread tension and the bobbin thread tension are as they should be. (B) is an incorrect adjustment as the lock is formed on the top ply indicating that the needle thread tension is too tight. (C) is an incorrect adjustment as the lock is formed on the bottom ply indicating that the needle tension is too loose.

7. Adjust the tension as necessary by slightly turning the thumb nut on the needle thread tension disc clockwise to increase tension or counterclockwise to decrease the tension.

8. Sew on the material again for a few inches and check the stitching formation.

9. Adjust again, if necessary. If the correct tension cannot be obtained by adjusting the tension disc, the bobbin tension will need adjusting. This is done by tightening or loosening, as needed, the small screw which holds the tension spring on the side of the bobbin case. Have the instructor make this adjustment at this stage of your instruction.

Exercise 8

Regulate pressure on the material on the class IIIW sewing machine in the following manner.

Regulating Pressure on the Material

The pressure applied by the presser foot should be only heavy enough to enable the feed to move the material along evenly.

1. Refer to figure 1, (3).
2. Turn screw (3) downward to increase pressure on the material.
3. Check the pressure by running the machine for a few stitches.
4. Turn screw upward to decrease pressure on the material.
5. Check the pressure.
6. Adjust the screw so that the material will feed evenly.

Exercise 9

Change needles on the class IIIW sewing machine in the following manner.

Changing Needles

1. Raise the needle bar to the highest position. Loosen the needle set screw and remove the needle.
2. Check the needle for proper class, variety, and size.
3. Never use a bent needle or one that is blunted or burred.
4. Insert the needle shank as far into the clamp as it will go; turn the long groove of the needle so that it faces the left and is directly in line with the arm of the machine. Tighten the set screw.

Exercise 10

Time the class IIIW sewing machine in the following manner.

Machine Timing Part 1 - Alignment of Arrows

1. Tilt the machine back on its hinges.
2. Turn balance wheel toward operator (in same direction it turns when machine is sewing) until thread take-up lever reaches its highest position.
3. Check alignment of arrows A and B in figure 32.
4. If arrows are not in line, remove connection belt from lower pulley, figure 31.

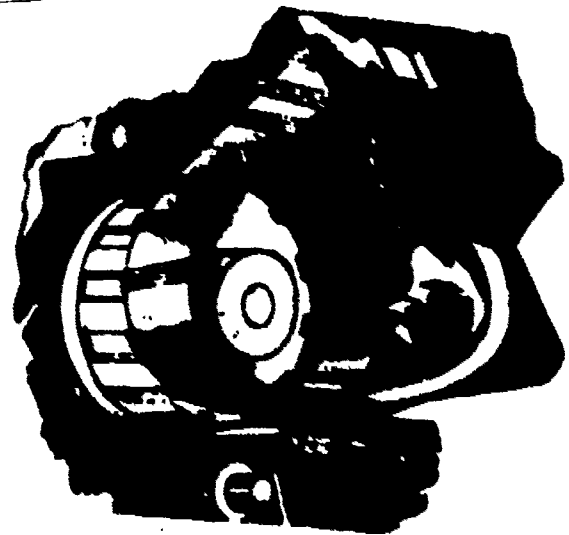

Figure 31. Removal of Arm Shaft Connection Belt from Lower Pulley.

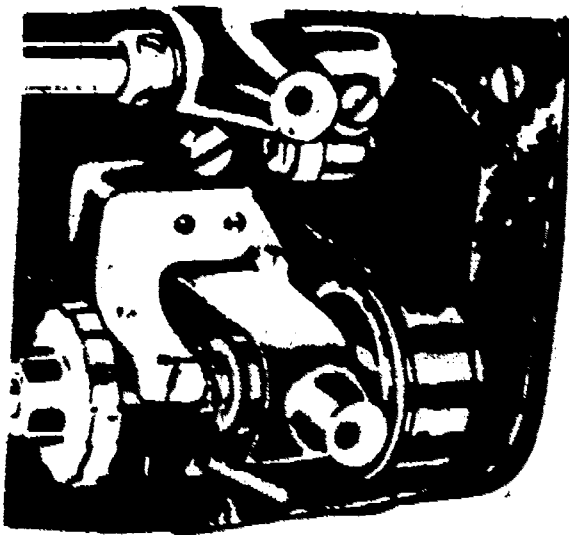

Figure 32. Timing Alignment of Arrows.

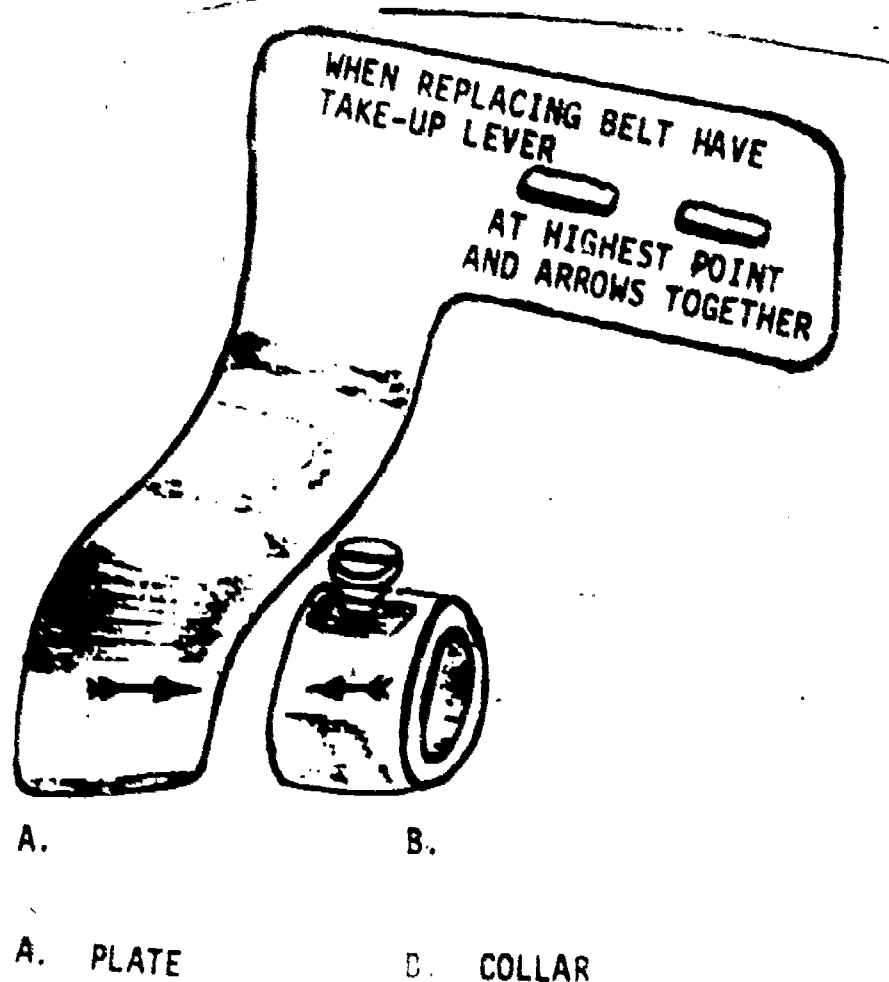

Figure 33. Arm Shaft Connection
Belt Timing Collar and Plate.

5. Turn lower pulley by hand until the arrow, on timing collar, figure 33B, is in direct line with arrow, figure 33A, on timing plate.

6. Replace connection belt by hand, figure 32. After replacing belt, give balance wheel a full turn and check arrows again. Arrows sometimes slip out of line when replacing belt.

Caution: Do not pry the belt with a screwdriver; this results in serious damage to the belt and machine.

Machine Timing Part II - Setting a Needle Bar

Part 2A - Setting a Marked Needle Bar

1. Loosen screw holding needle (figure 34A) on needle bar.
2. Insert needle up into needle bar as far as it will go with the long groove to the left. Check class of needle for specific machine with which you are working.
3. Tighten screw, figure 34A.
4. Remove screw on faceplate and remove the plate.
5. Turn balance wheel so that screw (figure 35B) is at its lowest position and in the recess of the needle bar rocker frame.

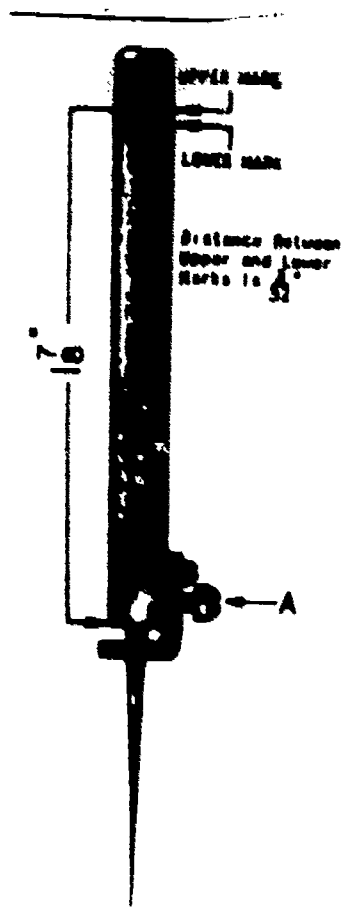
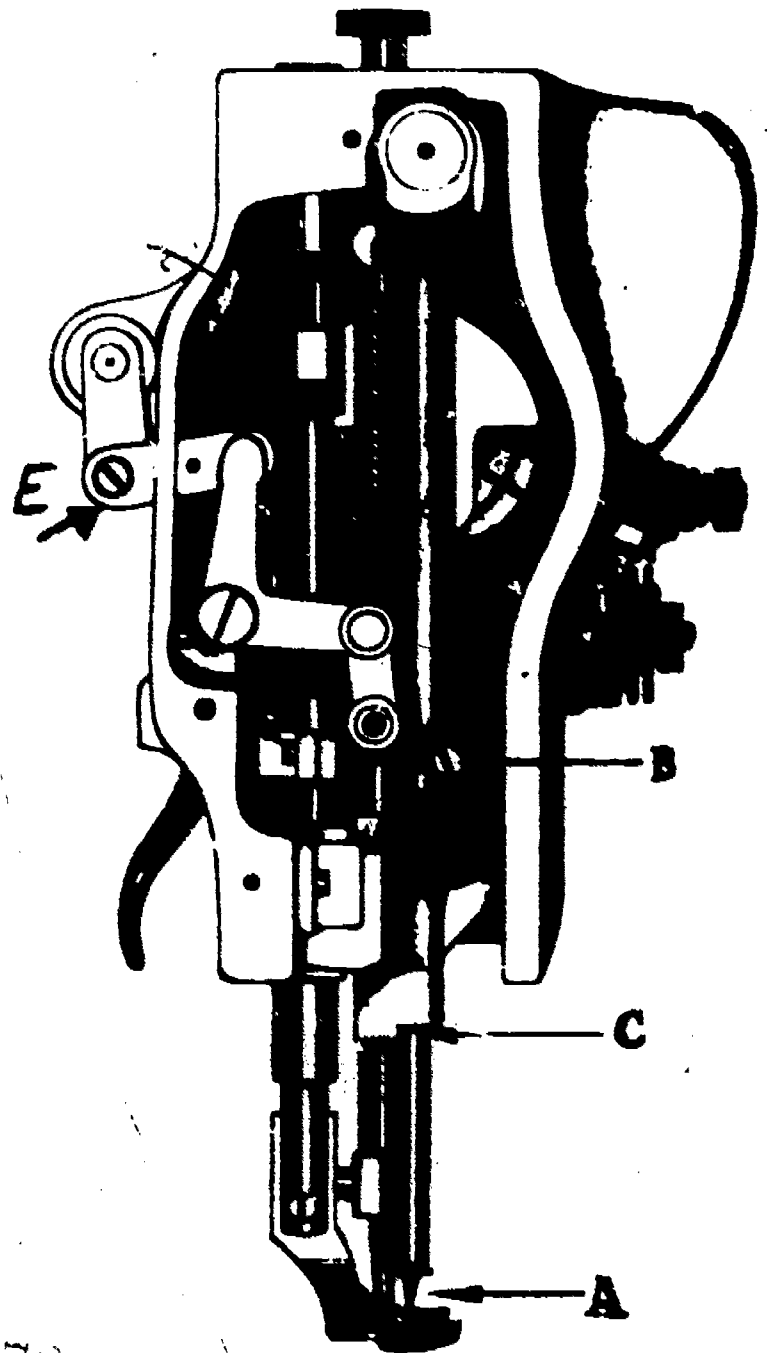

Figure 34. Marks on the Needle Bar of the 111W152 Sewing Machine.



179

Figure 35. Setting the Needle Bar.

6. Loosen screw and adjust the needle bar. The position of the alignment marks on the needle bar is shown in figure 34. Align the needle bar so that the upper mark is first visible at the edge of the needle bar rocker frame (figure 35C). It is imperative that the needle eye be in a parallel line with the length of the machine. If it is not directly in alignment, the machine will skip stitches or may not sew at all.

7. Tighten screw (figure 35C).

8. Inspect by rechecking procedures 1 through 7 to see that setting of the needle bar is correct.

Part 2B - Setting an Unmarked Needle Bar

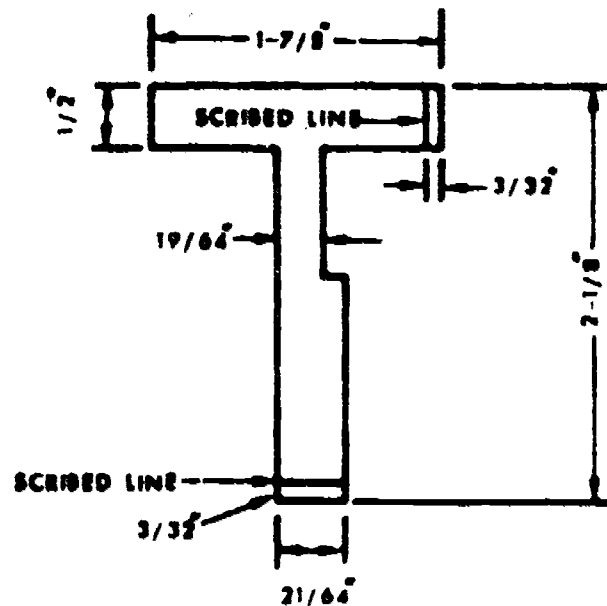

Figure 36. Needle Bar Gauge.

If the needle bar is unmarked, obtain a needle bar gauge as illustrated in figure 36.

1. Remove throat plate and feed dog.
2. Turn the balance wheel toward you until the needle bar is at its lowest position.
3. Loosen set screw (figure 35B).
4. Use needle bar gauge, figure 36. Adjust needle bar to measure 1-7/8 inches from needle bar rocker frame, figure 35C, to bottom of needle bar, figure 35A.
5. Tighten set screw, figure 35B.

Caution: Be certain long groove of needle is to the left of the machine before tightening set screw, figure 35B.

6. Check proper adjustment by turning balance wheel by hand.

7. Replace feed dog and throat plate.

Machine Timing Part 3 - Timing the Rotary Hook

When the lower mark on the needle bar is just visible at the end of the needle bar housing on the upward stroke of the needle, the point of the rotary hook should be as close as possible to the needle and 1/16 inch above the eye of the needle.

1. Remove the throat plate and feed dog.

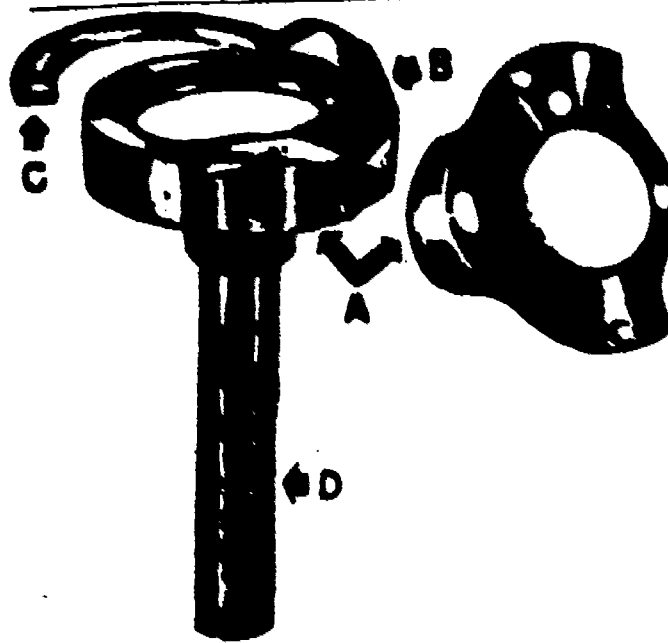

- A. Needle Guard Washer.
- B. Rotary Hook.
- C. Bobbin Case Retainer Hook Gib.
- D. Groove.

Figure 37. Rotary Hook Assembly.

2. Turn balance wheel full turn until the hook point is at center of needle. The point of the rotary hook should run as close to the needle (within the scarf) as possible. This prevents the point of the hook from cutting into the thread. The needle guard washer (figure 37A) prevents the rotary hook from striking the needle by pushing the needle point slightly out of the path of the hook.

3. Tilt machine head back on hinges.

4. Loosen screws (figure 38A).

5. Move the hook saddle to the right about 1/8 inch by tapping with end of screwdriver handle.

6. Tighten screws (figure 38A).

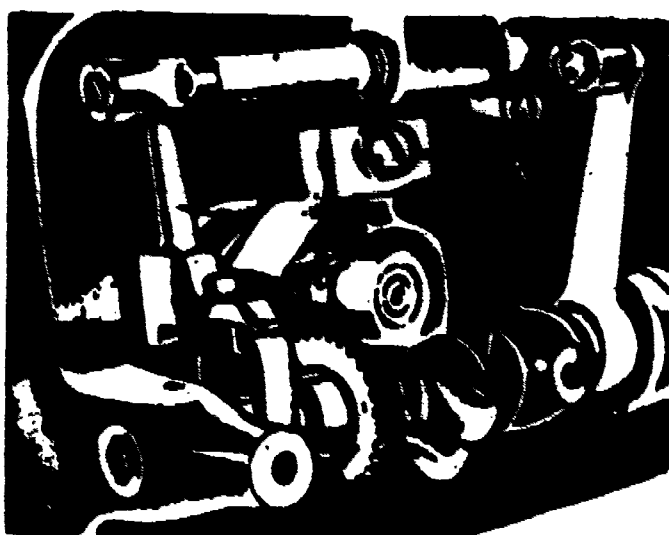

Figure 38. Adjustment of Rotary Hook.

7. Turn balance wheel by hand. Observe relative location of hook point with needle.

8. Loosen screws (figure 38A).

9. Adjust hook saddle so that point of hook is correct distance from needle.

10. Check correct distance of rotary hook from needle by turning balance wheel by hand. The needle guard washer (figure 37A) should just barely strike the side of the needle and deflect the needle enough to allow the point of the rotary hook to pass through the scarf of the needle. When the lower mark on the needle bar is even with the housing on the up stroke of the needle, the rotary hook point should be as close as possible to the needle and 1/16 inch above the needle eye.

11. Remove lifting presser foot and bobbin case opening lever.

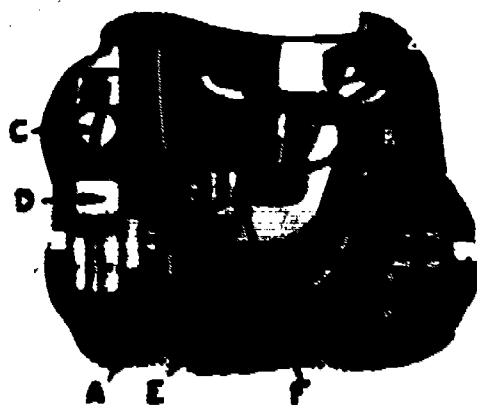

Figure 39. Underneath View Showing Hook Saddle, Hook Driving Pinion, and Feed Log Adjustment.

12. Remove screws A and B, figure 39, in hook driving pinion.

13. Remove rotary hook assembly.

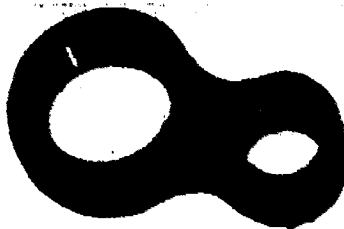

Figure 40. Hook Saddle Component
Bobbin Case Opener Lever Link.

14. Remove bobbin case opener lever link (figure 40).
15. Center hook driving gear (figure 39E).
16. Turn balance wheel until lower mark on needle bar is even with the housing on the up stroke of needle.
17. Replace pinion gear (figure 39F). Space between screw holes should face as nearly straight up as possible.
18. Insert rotary hook assembly in bottom of saddle assembly and pinion gear.
19. Turn balance wheel until needle bar is at highest point.
20. Remove rotary hook assembly from bottom of saddle.
21. Attach bobbin case opener lever link to rotary hook.
22. Insert rotary hook properly from top of machine. Be certain that a small hole on lever link is slipped over post (figure 41A).
23. Turn balance wheel until lower mark on needle bar become even with housing on up stroke of needle.
24. Turn rotary hook with fingers until point becomes even with needle.
25. Check in left screw hole of pinion gear for groove (figure 37D) on rotary hook. If groove is not in hole, a mistake has been made in one of the preceding timing steps.
26. Insert screw in pinion gear. Screw with round end should be in hole that is over groove.
27. Give balance wheel a full turn, and recheck hook point and needle eye.

193
31

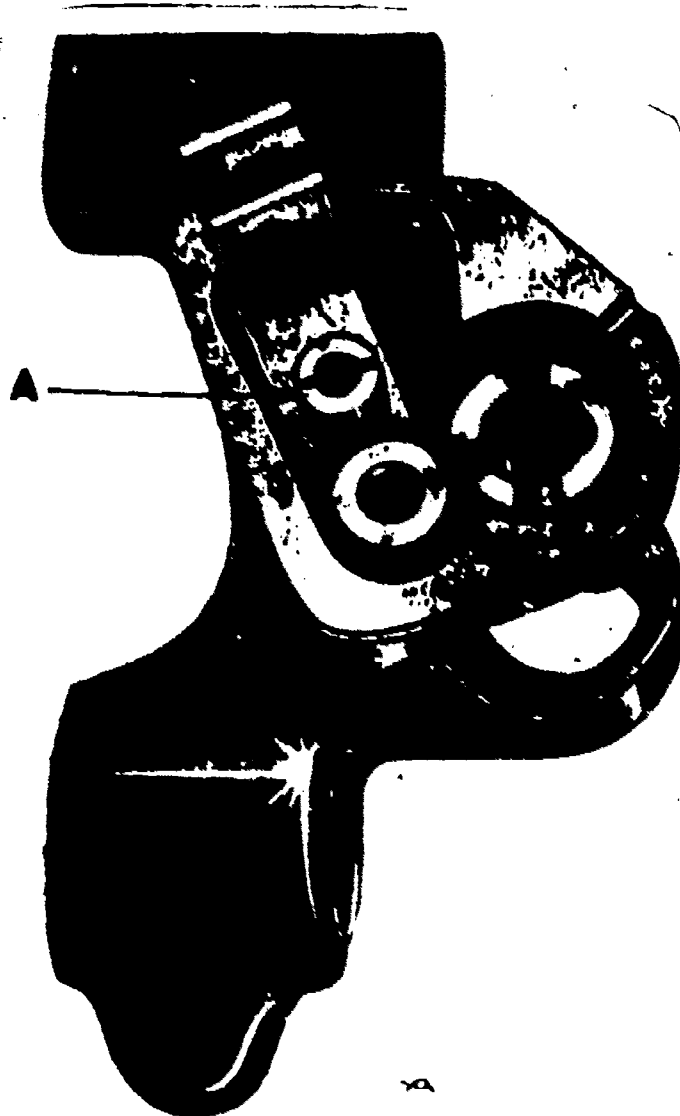

Figure 41. Hook Bob Assembly.

28. Loosen screws in back of driving gear, and move gear slightly to right if hook point is slow or slightly to left if hook point is fast.

29. Tighten screws.

30. Check hook point and needle.

31. Continue to adjust driving gear to left or right until hook point is timed perfectly with needle.

32. Replace parts on machine in the following order: feed dog, throat plate, opener lever, and presser foot.

Exercise 11

Adjust the feed dog on the class IIIW sewing machine in the following manner.

Setting the Feed Dog

When feed dog is at its highest position, it should show a full tooth above the throat plate.

1. Clean dust and lint from throat plate and feed dog.
2. Lift presser foot by hand lifting lever.
3. Tilt machine head back on hinges.
4. Turn balance wheel toward you until feed dog is at its highest position.
5. Loosen screw (figure 39C).
6. Raise the feed dog bar (figure 39D) as high as it will go.
7. Tighten screw (figure 39C).
8. Turn balance wheel by hand. Do not force the balance wheel.
9. Loosen screw (figure 39C).
10. Lower feed bar as low as it will go.
11. Tighten screw (figure 39C).
12. Turn balance wheel by hand. Feed dog will not come up through opening in throat plate.
13. Loosen screw (figure 39C).
14. Readjust feed dog bar so that feed dog will show a full tooth above throat plate when it is at its highest position.
15. Tighten screw (figure 39C).

Exercise 12

Adjust the stitch length indicator (feed indicating disk) on the class IIIW sewing machine in the following manner.

1. Set the machine to sew eight stitches per inch as described in exercise 5, titled "Regulate the Length of Stitch."
2. Sew a scrap of material for a few inches.
3. Use a rule and count the actual number of stitches per inch being sewn. Place the first stitch at the edge of the rule and count the stitches as shown in figure 42. If the actual count and the number in the hole in the machine arm are the same, the feed indicating disk is properly set. If the actual count is different, set the indicator disk.
4. To set the indicator disk, loosen the arm capscrew and slide back the arm cap on the top of the machine head, exposing the feed indicating disk with numbers engraved on the edge.

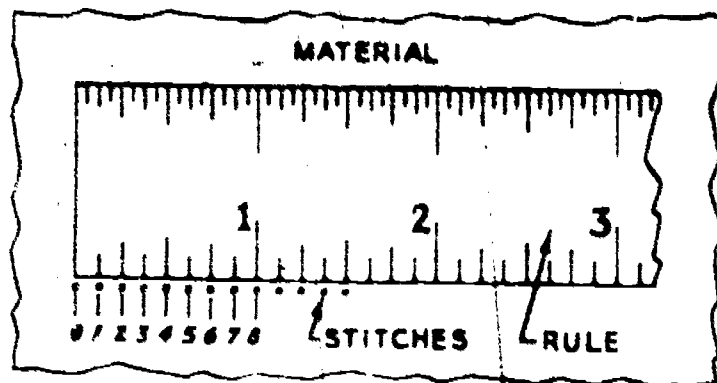

Figure 42. Checking Stitches Per Inch.

5. Loosen the indicator disk setscrew with 1/8" wide cabinet screwdriver until the disk will turn only when finger pressure is applied.
6. Turn the indicating disk with the fingers until the number indicating the actual number of stitches now being sewn appears in the indicator opening in the head casting.
7. Tighten the indicating disk setscrew.
8. Reset the machine to set eight stitches per inch.
9. Check the accuracy of your setting by sewing and counting the stitches.
10. If your setting is not correct, repeat steps 4 through 7 and recheck.

Exercise 13

Adjust the tension assembly and controller spring on the class IIIW sewing machine in the following manner.

Adjusting the Tension Assembly and Controller Spring

The two separate tension devices, tension assembly and thread controller, require separate adjustments.

The tension assembly (upper, figure 43, is adjusted by turning the thumb nut 1, on the tension study forcing the tension spring 2, against or away from the tension disks 3. Since this assembly applies direct pressure on the needle thread, the area between the tension disks must be kept clear of rust or foreign objects as follows:

1. Remove the thumb nut, tension spring, tension release washer, and tension disks.
2. Clean the inside areas of the tension disk with a soft cloth. Remove rust with emery cloth.

Note: Do not apply oil to any of these parts.

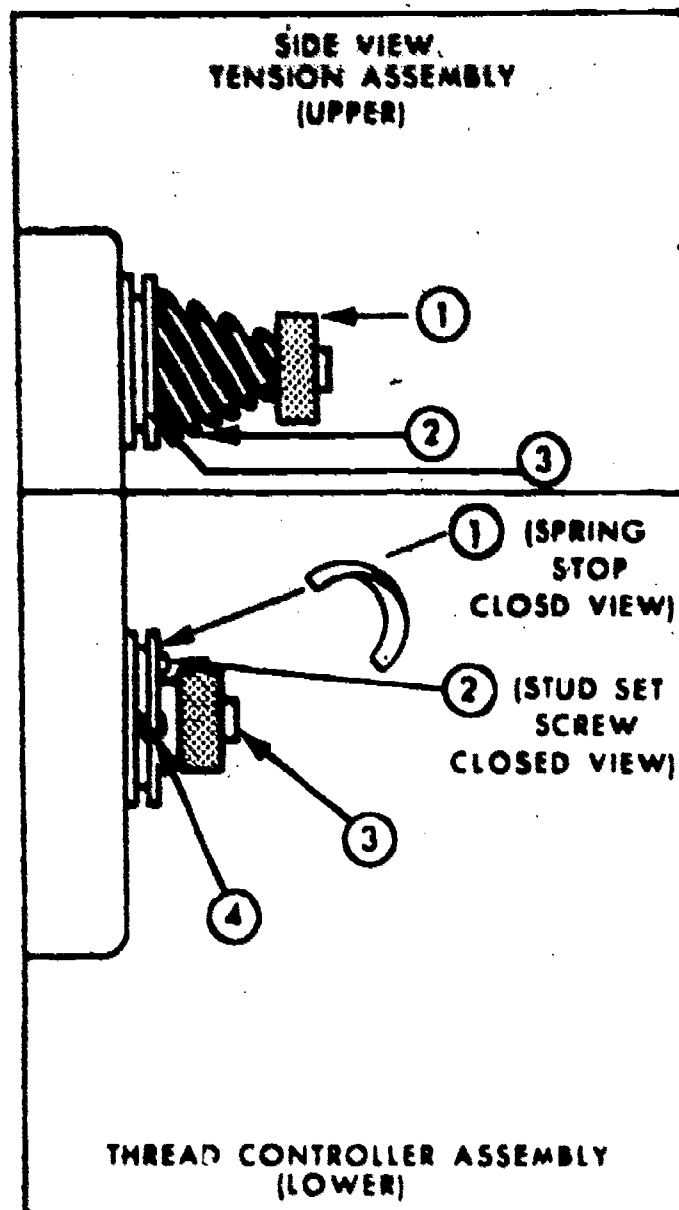

Figure 43. Tension.

3. Reassemble by positioning the tension disks, tension release washer, tension spring, and thumb nut on the tension stud.

The thread controller assembly (lower), figure 43, pulls slack out of the needle thread. Two adjustments on the assembly are required; adjustment of spring stop position, and tension on the thread controller spring. Thread the machine, sew a distance of four inches, and complete the following.

1. Adjust the position of the spring stop.
 - a. Loosen the thread controller spring stop screw in the spring stop, point 1, figure 43.
 - b. Rotate the stop to remove slack in the needle thread as the needle descends.
 - c. Tighten the screw.

2. Adjust the tension on the thread controller spring.
 - a. Loosen the thread controller stud setscrew point 2, figure 43.
 - b. Insert a screwdriver on the thread controller stud point 3, figure 43.
 - c. Turn stud to the right to decrease thread controller spring tension point 4, figure 43, to the left to apply tension.
 - d. Hold the study with fingers of left hand and tighten the stud setscrew, point 2, figure 43, with a screwdriver.

Exercise 14

Repair the rotary hook of the class 111W sewing machine in the following manner.

Repair of Rotary Hook

1. Remove rotary hook assembly as taught in exercise 9, part 3.
2. Visually examine rotary hook for burrs, nicks, dull or broken point.
3. If evidence of damage is found, smooth out nicks and burrs with emery cloth.
4. If the rotary hook point is broken, replace it with a new rotary hook.
5. Reinstall rotary hook assembly.

Exercise 15

Troubleshoot the Class 111W Sewing Machine.

Troubleshooting

1. Troubleshoot the machine for a defect using the troubleshooting chart.
2. Upon finding the defect, repair the machine as necessary.

Technical Training

Fabrication and Parachute Specialist

PATTERN DESIGN AND LAYOUT

26 March 1979



CHANUTE TECHNICAL TRAINING CENTER (ATC)
3340 Technical Training Group
Chanute Air Force Base, Illinois

Designed for ATC Course Use.
Do Not Use on the Job.

178

Life Support Branch
Chanute AFB, Illinois

3ABR42793-SW-802

PATTERN DESIGN AND LAYOUT

OBJECTIVES

After completing this study guide and your classroom instruction, symbols on drawings, explain the use of a rule and square in layout work, and explain how to lay out a pattern for a change in size.

INTRODUCTION

On some occasions patterns are provided in technical orders to enable you to cut out such things as neck and wrist seals for anti-exposure suits. However, there are many other times that you must fabricate that have no patterns available. When this is the case, you must lay out your own pattern.

INFORMATION

PATTERN TEMPLATES

Making covers for hangar and field equipment requires a variety of patterns. You must construct many of the patterns you need. When it is not possible to obtain a drawing of the cover to be fabricated, you may use the old cover as a guide for making your pattern or you may take direct measurements from the item to be covered. In some cases it may be advisable or necessary to use a blueprint or drawing of an article to obtain the measurements you need to construct your pattern.

Symbols

Most blueprints and drawings consist of three basic views: front, top, and side. If necessary, an additional view may be furnished. This may be either a detail or a sectional view. The detail view enlarges a portion of the drawing, whereas the sectional view shows a cutaway section of the object. These drawings make construction work easier.

Various lines and symbols are used to identify parts of a drawing and its construction. The following lines and symbols are shown in Figure 1.

Replaces ST3ABR42733-SW-802 (undated)

OPR: 3340 TCHTG

DISTRIBUTION: X

3340 TCHTG/TTGU-L - 440; TTVSA - 1

The border line is not an actual part of the drawing but encloses the drawing and all notations. Object lines are used to make an overall outline and details of the object being drawn. Hidden lines represent a feature or a change in contour of an object which cannot be seen in a specific view. Center lines designate the center of an object or may be used to locate the center of any hole or opening to be made. Sectional lines represent cutaway portions. Dimension lines measure or lay out distances from a given point, with arrows to indicate the limits of a dimension. Seams are drawn as a series of dots or lines, with the dot or line representing a stitch.

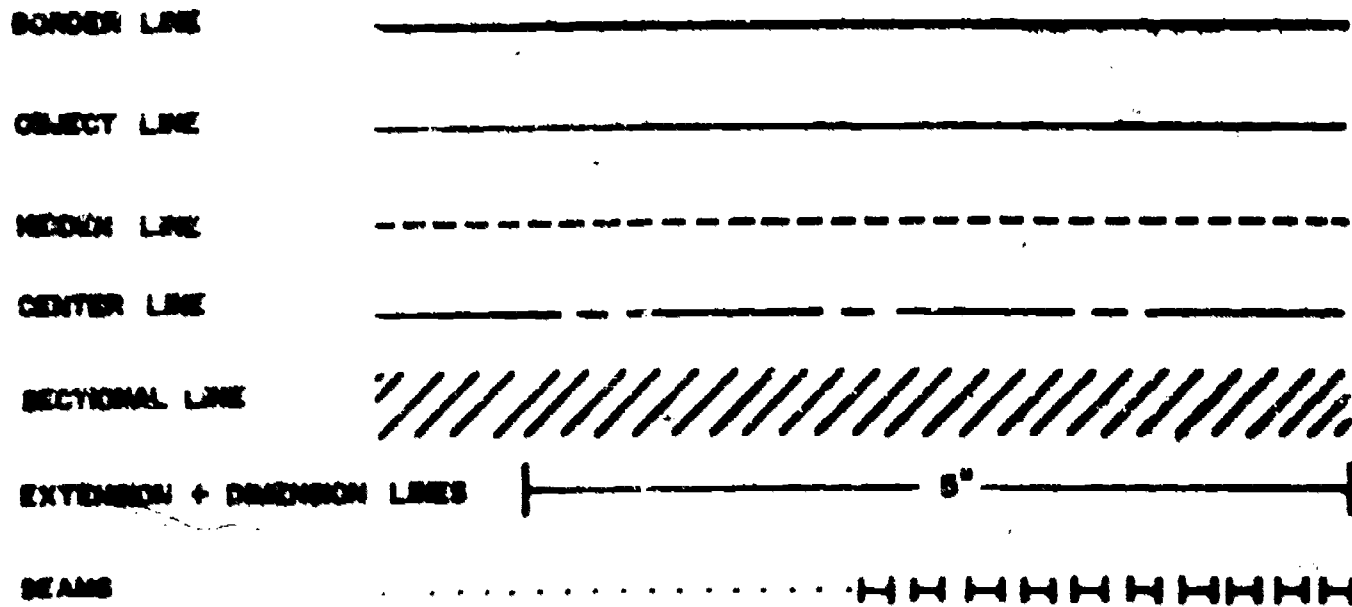

Figure 1. Blueprint Lines and Symbols.

Rule and Square

Pattern templates may be made of heavy paper, wood, metal, or plastic. All points of alignment for assembly of the material and positions for the installation of hardware and accessories are included in the pattern. Be sure your dimensions are accurate because an error in the pattern is duplicated in each part cut from it.

Two of the most common and useful tools used in the layout of patterns are the rule and square. Many equipment and upholstery covers as well as many parts of clothing such as pockets, waistbands, and cuffs are rectangular.

To lay out square or rectangular parts, obtain the dimensions from a drawing or measure the item to be covered. Before you start to lay out your pattern, be sure to add the proper seam allowance.

180

For instance, suppose you need a rectangle of heavy material to be used as part of a protective cover. If the finished dimensions are to be 24 X 35 inches, your pattern will measure 25 X 36 inches. The inch added to both dimensions is necessary to provide the required 1/2 inch seam allowance for heavy fabric to all four sides.

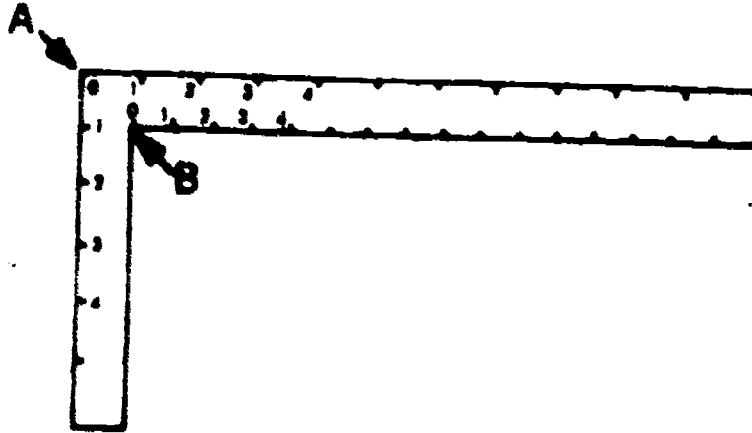

Figure 2. Square

Measure your dimensions accurately with a steel rule, steel yardstick, or carpenters square. If you use the square to measure a dimension, be sure to use the correct scale. If you are measuring from the outside edge of the square, use the scale, (A) Figure 2, marked on the outside edge. When measuring from the inside edge, use the scale (B), Figure 2, marked on the inside edge. Refer to Figure 2 and note that the zero point is not in the same place on both scales.

Lay the square on the pattern paper with one edge of the carpenters square laying along a straight edge of the paper. Then draw the line perpendicular to the straight edge. If the square is not long enough to draw the full length of the line, lay a steel yardstick or metal straight edge along the line started by the square and extend the line the required distance. Use the carpenters square to start your line at each corner to be sure to maintain a 90 degree angle at each corner.

Tolerances and Size Changes

The seam or hem allowance must be added to the finished dimensions before a pattern template is cut out. Seam and hem allowances vary according to the fabric used and the design of the item. Light weight material may require a 1/4 inch seam allowance while heavier fabric may require a 1/2 inch seam allowance. If a hem is an EFB type, a 2 inch allowance would be made for a 1 inch hem as the material is folded under twice. Each project presents its own problem and all allowances should be noted before a pattern is laid out.

100

Some technical order drawings provide all of the information necessary for different sizes. The drawings in the technical order should not be used as templates as the information printed on the other side of the page would be lost. Also, the paper used in technical orders is not suitable for use as a template.

Carefully trace the technical order drawing on pattern paper to make your template. Be sure to mark on the template the type anti-exposure coverall it is used with, what it is used for, and the required size markings. Cut out the template and place it on the coverall as specified in the technical order. When you complete the job, retain the template for future jobs that require the same alteration.

Patterns requiring reduction or enlargement can easily be altered by the squared paper method as shown in Figure 3. The full sized pattern is first drawn on squared paper. The points of intersection of the pattern outline and paper lines are then noted. These points of intersection, called plotting dots, are then located in the same positions on a second sheet of paper marked off in squares larger or smaller than the original, depending on whether the pattern is to be enlarged or reduced in size. The plotting dots are then connected by carefully drawing a line through these points to form a new pattern.

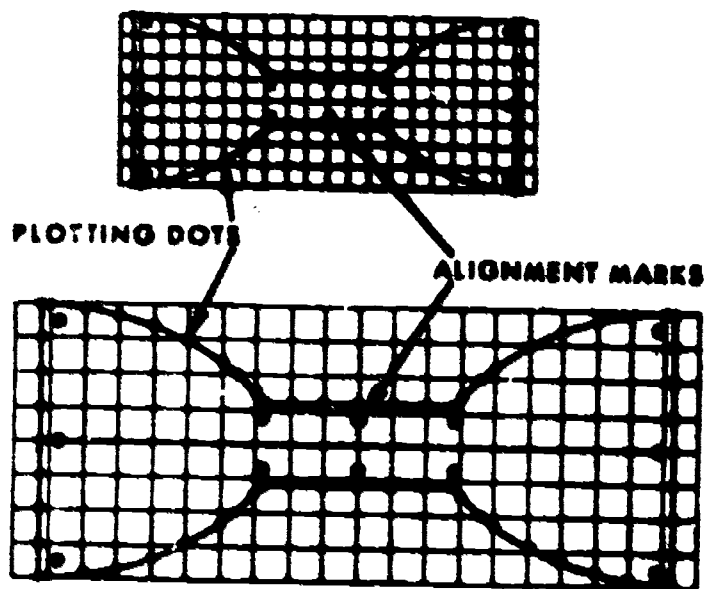

Figure 3. Squared Paper Method.

Exercise 1

Study the training literature and answer the following questions.

1. How is a cover constructed when there are no patterns available?
2. What views are usually included in blueprints or shop drawings?
3. Why must a fabric repairman be able to read blueprint lines and symbols?
4. What materials may be used to construct a template?
5. What purpose does alignment marks serve on templates?
6. Should seam allowances be included on patterns?
7. Are seam allowances included in shop drawings or blueprints?

101

- 8. What is the difference in a pattern and a template?

- 9. Patterns requiring reduction or enlargement may be accomplished by what method?

- 10. How are seams designated on drawings?

SUMMARY

There may be times where it will be necessary to lay out patterns in order to complete a project. In this type of a situation, you will have to know how to properly lay out your own pattern.

REFERENCE

T.O. 00-25-92, General Repair of Canvas and Webbing



184

Exercise 2

1. Obtain a piece of material suitable for construction of a template from the instructor.
2. Fabricate a template using the dimensions in the shop drawing shown in Figure 4.

Note: Shop drawings do not include seam allowance!

3. Write your name and class number on the project and hand it to the instructor.

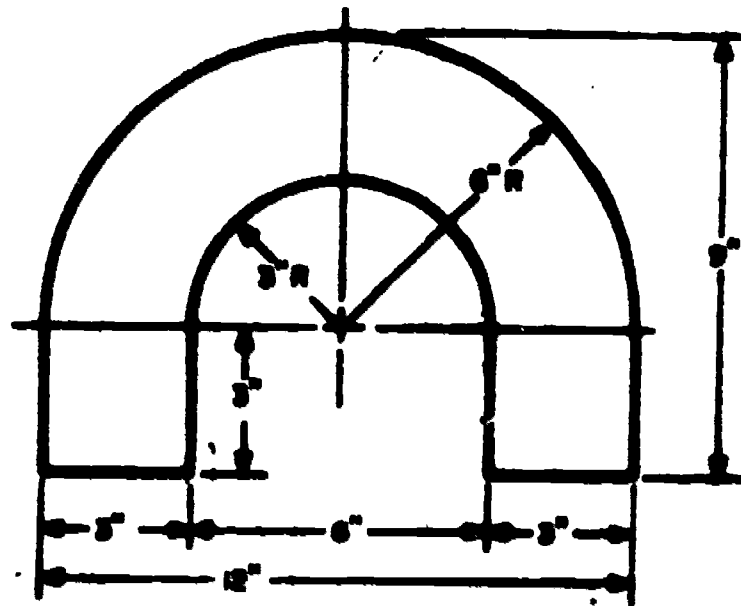

Figure 4. Shop Drawing of Wheel Cover and Dimensions.

196

Technical Training

Fab & Parachute Spec

FABRICATION/MAINTENANCE OF UPHOLSTERY AND SOUNDPROOFING

22 March 1979



**CHANUTE TECHNICAL TRAINING CENTER (ATC)
3340 Technical Training Group
Chanute Air Force Base, Illinois**

**DESIGNED FOR ATC COURSE USE
DO NOT USE ON THE JOB**

186

Life Support Branch
Chanute AFB, Illinois

3ABR42733-SW-804
22 March 1979

FABRICATION/MAINTENANCE OF UPHOLSTERY AND SOUNDPROOFING

OBJECTIVES

Upon completion of this unit of instruction, you will be able to identify the types and kinds of upholstery and their applications.

INTRODUCTION

Upholstery is the art of rebuilding, padding, and covering surfaces. Upholstery is considered an art because it is the result of a developed skill which reflects the characteristics of the individual in the finished product. While certain basic rules must be followed, the finished craftsman develops certain techniques which reflect his personality and interest in his work. Upholstery is designed to perform two functions. First, it must provide comfort; and secondly, it must present a neat appearance. Both functions must be built into all upholstery.

INFORMATION

TWO TYPES OF UPHOLSTERY

Basically, upholstery may be classified as either rigid or flexible. Rigid upholstery is that type which must conform directly to its framework, such as headrest, armrest, crash pad, etc. Flexible upholstery may be described as having a tendency to give or vary in shape, such as a removable seat cushion, backcushion, life preserver cushion, etc. Rigid upholstery is usually built on a solid frame made of wood or metal. Flexible upholstery usually has no rigid framework. Both types are employed on aircraft.

THREE KINDS OF UPHOLSTERY

Aircraft Upholstery

Aircraft are constructed primarily of metal and are rigid. However, a certain amount of fabric, leather, and rubber materials are also used in upholstery for crew and passenger comfort.

Such upholstery as soundproofing, removable seat cushions, crash pads, headrests, and armrests are found on most training, cargo, and tactical type aircraft. Some passenger-carrying aircraft have upholstered seats, curtains, and even rugs. You will find that electrical wiring, hydraulic lines, control cables, and many other items pass over and through aircraft soundproofing.

Supersedes ST 3ABR42733-SW-804 (undated).

OPR: 3340 TCHTG

DISTRIBUTION: X

3340 TCHTG/TTGU-L - 440; TTVSA - 1

108

Most United States Air Force transport aircraft are lined with soundproofing in the crew and passenger compartments. This soundproofing may be either of the blanket or batt type.

BLANKET TYPE SOUNDPROOFING. Most of the soundproofing used in aircraft consists of Fiberglas enclosed between two layers of fabric. The Fiberglas is held in place with machine stitching in a diamond pattern. This material insulates the aircraft as well as deadens the noise of the engine. The material used for soundproofing is selected for its sound-deadening qualities and not for its strength. Extreme care must be used in sewing and handling this material.

BATT TYPE SOUNDPROOFING. The C-141 cargo aircraft uses covered glass-fiber batts in the flight station and cargo compartment to soundproof and insulate the aircraft. These batts are covered with vinyl-coated nylon in nonhydraulic areas, and with nylon-vinyl laminate in the hydraulic areas. The covers are heat-sealed at the edges, but they do have vents. The batts are stitched to long covers to prevent the batts from sagging. The covers are attached either directly to the skin of the aircraft or to stringers. Under the floor of the C-141 aircraft, a cloth heat baffle is hung halfway between the floor and the fuselage skin.

The soundproofing batts are attached to the aircraft with pile tape and hook tape. The pile tape is cemented to the aircraft skin, and the hook tape is cemented to the batt.

Vehicle Upholstery

At times it may be necessary to repair auto seat cushions. Most of the damage is connected with the seat cover, although sometimes also the springs and padding are damaged. The auto is sent to the shop for repair as a result of an inspector's report and recommendation. When the springs and padding are damaged, the cushion must be completely stripped down. When the padding is cotton batting, it can be repaired by filling in, but if the padding is too badly damaged, it should be replaced. When the cover is damaged, the inspector's report will indicate whether it is to be repaired or replaced. If the cover of the cushion may be of fabric, leather, plastic, or imitation leather, replace it with material similar to the one removed.

Base Upholstery

You may be required, at some time in your career, to work on base upholstery. This includes chairs, couches, cushions, dayroom furniture, etc. Whether the job you are assigned is to repair an office chair or a couch, each job contributes to the efficient operation of your squadron. The chair repair saves the time and money required for its replacement.

Since removable cushions are reversible (usable on both sides or faces), good workmanship is essential. Every part of the cushion will at one time or another be in view. It is constructed around a

188

spring unit and padded with a cotton batting. The size of the cover must be held within a definite limit and extreme care must be used in its fabrication.

The typist chair provides a good example of the rigid type of upholstery. The back and bottom of this chair are the basic foundation. Such upholstery consists of only the padding and cover. The typist chair is designed so that the back receives support from the backrest. Because of the difference in the sizes and figures of individuals who may use it, the back is adjustable. The upholstery gives support and rest. Because the back of the chair is concave, it requires special attention so that the finished product is neat in appearance. Two ways of attaching the seat cover are by stapling or by hand-sewing. The former is the better but when staples are not available, sewing is used. The laying of the padding is the most important part of the operation. There must be sufficient padding to insure the necessary softness but not so much that the back and seat lose their form and look "squashed."

The ultimate goal for an upholsterer is to produce comfort and beauty, but you can never attain your objectives if the foundation of your work is poorly constructed. The rigid type foundation may be a piece of plywood on which is set foam rubber or a series of coil springs installed on either metal strips or webbing. The tying of the springs is of great importance, and an eight-knot tie is generally used. After the padding (cotton batt, moss, foam rubber) is properly secured, the cover is attached.

Proper installation of the cover will result in a neatly finished product. Remember, appearance counts heavily in this type of upholstery.

UPHOLSTERY MATERIALS

Materials

The materials which are most generally used in aircraft upholstery work, are as follows:

SOFT FELT. Used for filling or padding in armrests, headrests, etc. The felt may be cut the exact size as the armrest or headrest, and a covering made to fit over the felt.

FOAM RUBBER. Used for padding in cushions, headrests, crash pads, etc. Foam rubber may be obtained in molded cushion shapes in various sizes, or it may be obtained in a block or flat stock type which can be cut into the desired size and shape. Cushions attached to kits in recent aircraft are of this type. They are usually procured from supply rather than made by the fabric shop.

POLYFOAM. This is the name given to a type of product which is similar to foam rubber. It is made from several types of plastic material blown into foam and solidified. Usually it is

less resilient, which is the ability to bounce or spring back after being pressed down, and cheaper than foam rubber, but serves fairly well as a substitute. It has the disadvantage of being less resilient as it gets colder.

KAPOK. Used for padding in aircraft cushions. A very light-weight silky-cotton fibrous material which provides an excellent padding for cushions. Cushions filled with kapok not only provide comfort, but may also be used as life preservers, because of the buoyancy of the material. Cushions designed for life preservers have yellow coverings.

RUBBERIZED HORSEHAIR. A lightweight padding material used in cushions, headrests, armrests, etc. This material is obtainable in flat sheet stock in varying thicknesses, and the desired sizes and shapes may be cut from the sheet.

LEATHERS.

1.

1. **Artificial Leather.** Used for covering various upholstered articles such as seat and back cushions, armrests, and headrests, crash pads, etc. Artificial leather is available in many colors and various surface finishes.

2. **Horsehide.** Used for the same purpose as artificial leather, but is much more durable. It has a fairly smooth finish and comes in brown or black colors.

COTTON DUCK. This material is used in covering cushions where appearance is not important. It is not as durable as artificial leather or horsehide, and is much less expensive as a covering material.

HARDWARE.

Upholstery Buttons. These buttons are installed in cushions to prevent the padding material from shifting inside the covering. They are installed so as to be decorative as well as useful. These buttons are installed with a strong cord and should be drawn tight enough to hold the padding in place, yet loose enough to maintain the resilience or springiness of the cushion.

Tacks. Used to attach upholstery coverings over the padding when a wooden frame is used as the base of the upholstered article. This is a very common piece of hardware and comes in various sizes.

190

Durable Dot Glue Fasteners. Used to install soundproofing panels and specially fitted coverings in certain locations in aircraft. The sturdy part of the fastener is made in various types which may be installed in metal or wood as well as in fabric.

Interlocking Fasteners. These are generally known as zippers and are often used by the upholsterer in making removable covers for cushions.

Tools and Equipment

Most of the tools and equipment used in upholstery work should be familiar to you. However, as a matter of review, they are listed below with some of the new tools.

SHEARS. This is one of the most commonly used tools of the upholsterer and fabric worker. Shears must be kept sharp and care must be taken to not drop them as this will spring the blades and reduce their cutting efficiency.

NEEDLES. Curved needles approximately 2-1/2 inches in length are used in upholstery work to close out covers on cushions. A blind or hidden stitch is used for this purpose. Straight needles four or six inches long are used to install upholstery buttons in cushions. When these needles are not in use, they must be kept in the tray part of the toolbox and preferably with the point stuck in a cork in order to avoid accidents.

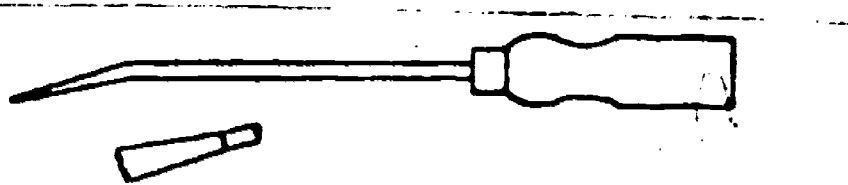

Figure 1. Stuffing Iron.

STUFFING IRON. A metal rod varying in length from 10 to 18 inches, figure 1. The stuffing iron is used for reaching inside cushions to distribute the padding into the edges and corners of the cushion.

SEWING MACHINE. The class 111 sewing machine is the machine best adapted to aircraft upholstery because it may be used to sew several thicknesses of artificial leather as well as medium and heavy weight fabrics.

200

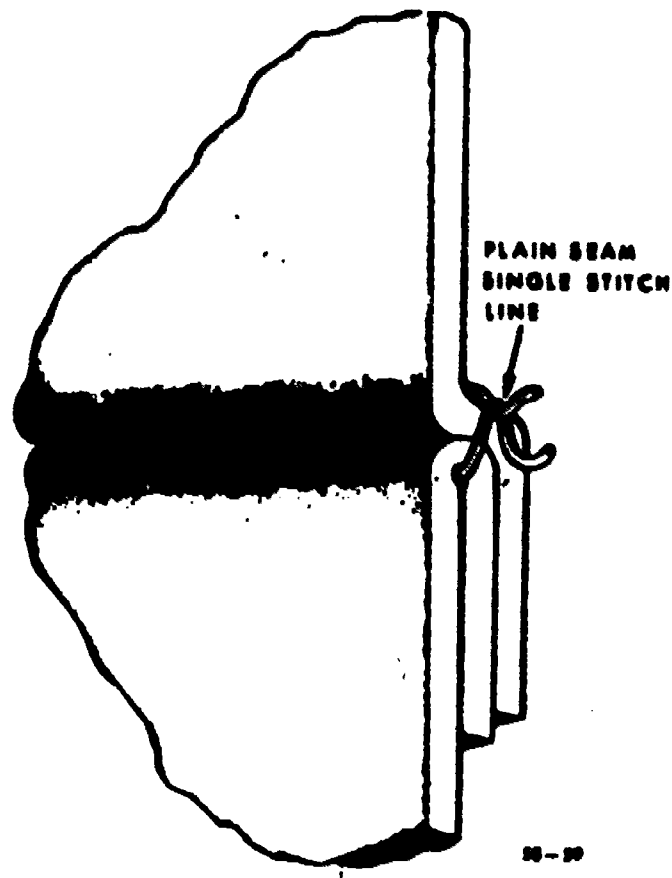

Figure 2. SSa-1 Seam.

Seams

The finished assembly sometimes requires the use of beading to dress up the seams and to give form to the piece. Positive and accurate measurements and cutting are very important. Care should be taken in sewing, since a slight variation shows up as a crooked seam. The SSa-1, or plain seam, shown in figure 2, is used in upholstery by itself or as part of a more complicated seam. Figure 3 shows an SSf-3, or French seam, used mostly for seats. To make this seam, first make a plain SSa-1, then fold the edges back away from the seam. Add two additional rows of stitching, sewing the joined pieces to a piece of backing material to form the SSf-3 seam. The cord welt (or beading installation seam), shown in figure 4, is used in seat covers. It is made by doubling a piece of material around a cord and fastening it with a plain seam. The strip is then sewn between the two pieces to be joined. Mats or carpets are sewn, as shown in figures 5 and 6, by using the BSf-2 and binding seams.

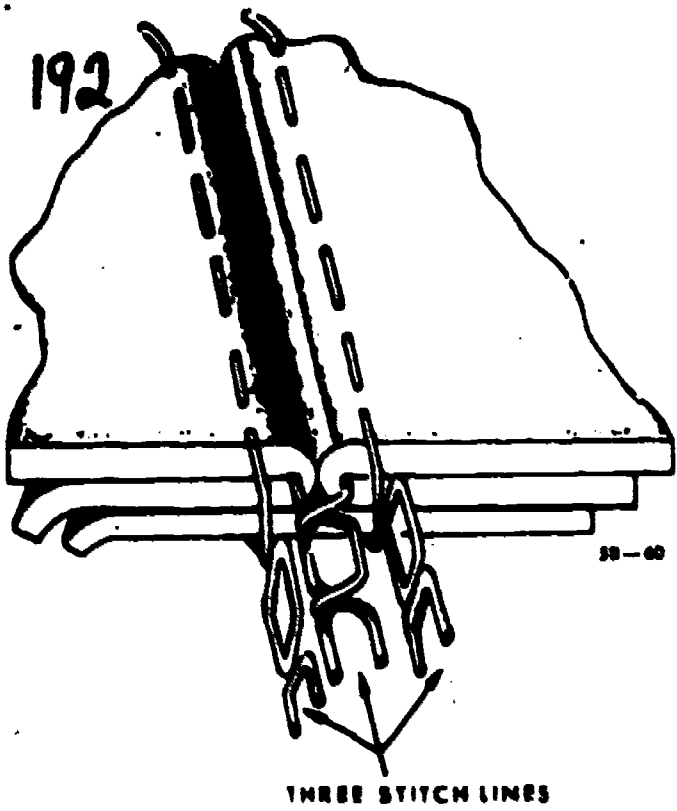

Figure 3. SSf-3 Seam.

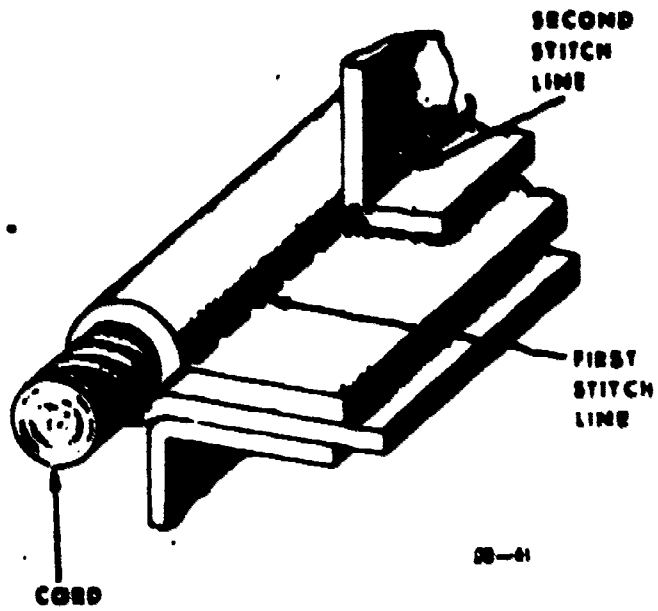

Figure 4. Cord Welt Seam.

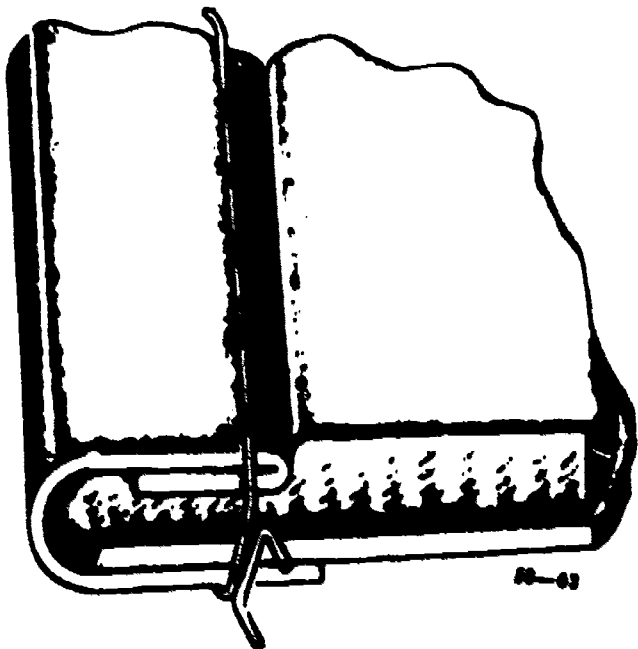

Figure 6. Binding Seam.

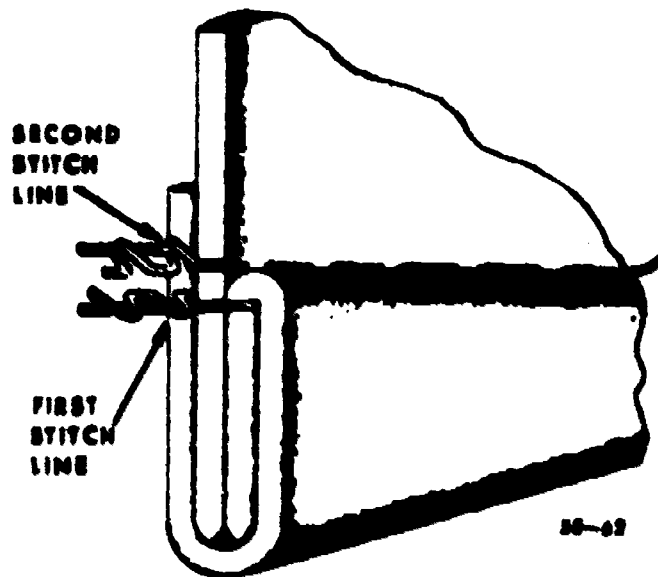

Figure 5. BSf-2 Seam.

Study the training literature and answer the following questions.

1. Define the term "upholstery."
2. List three items which are considered rigid upholstery.
3. List three kinds of upholstery.
4. What is the purpose of upholstery buttons?
5. Which type of padding would be best suited for a survival kit cushion?
6. List three special tools that are used for constructing cushions.
7. What is the purpose of beading or cord welt on a cushion or cover?

SUMMARY

Upholstery is an art which takes a lot of practice, patience, and time. To be competent in this work can be a rewarding experience not only as a task in your shop but also as a hobby.

REFERENCE

TO 00-25-77, Repair of Quartermaster Items of General Equipment.

INSPECTION, REPAIR, AND FABRICATION OF SOUNDPROOFING

Inspection

The material used for soundproofing is selected for its sound deadening qualities and not for its strength. Extreme care must be used when handling this material. When you are called to an aircraft to inspect soundproofing, make a determination whether a repair is justified or whether the soundproofing needs to be replaced. Inspect for holes, tears, torn edges, loose and missing hardware, loose stitching, and other general defects.

Repair

Some repairs on soundproofing can be accomplished while the soundproofing is installed to the aircraft. The most common defects are small rips and tears and missing hardware. Small rips and tears can be repaired by baseball stitching or a cemented patch. The repair material will be the same as the outer layer of soundproofing material, which is of plastic vinyl.

194

Fabrication

If the damage to soundproofing is too extensive for repair, a new panel of soundproofing has to be fabricated. Whenever it is necessary to remove the soundproofing, have an authorized aircraft specialist remove or loosen all plumbing and electrical wiring. Use the old piece of soundproofing as a pattern for the construction of the new material. Extreme care must be used in sewing and handling this material because it tears easily. All cut edges are bound with binding tape. A variety of seams can be used such as BSG-2, BSf-2, BSA-1, or BSc-1 seams. Seams must be at least 1/4 inch from the edge and should be sewn with five stitches per inch for all machine sewn seams.

Soundproofing is usually attached to the aircraft with durable dot and/or lift-the-dot fasteners. When you install hardware, keep in mind that the soundproofing is easily damaged. Crimp the hardware to a firm hold but do not use too much pressure, since to do so could result in cutting through the fabric and leaving a hole. Install the hardware 1/2 inch from the edge of the soundproofing for the same reason. Be sure the location of the hardware is in the same position as on the original piece of soundproofing.

INSPECTION, REPAIR, AND FABRICATION OF VEHICLE AND BASE UPHOLSTERY

Inspection

The ultimate goals in upholstery are comfort and appearance. When you are inspecting upholstery keep this in mind. You can never attain your objective as an upholsterer if the foundation of your work is poorly constructed. Check the framework for stability and tight joints. Inspect the springs for security and broken members. Check the tying of the springs. Be certain the knots are secure. Then inspect the padding. The padding should not be matted, soiled, mildewed, or deteriorated. The covering of the upholstered unit must be inspected for rips, tears, abrasions, deterioration, and all other defects. Then make a determination whether the unit should be repaired or whether a new cover needs to be fabricated.

Repair

When repairing a piece of base or vehicle upholstery you want to restore it to as close to its original condition as possible. The material should match in color and type. The repair should not distract from the appearance of the upholstered unit.

Fabrication

When fabrication of a new cover is required, the upholstered unit must be stripped of the old covering and padding. Some repairs may be required on the framework and springs. The springs are generally tied with an eight-knot. Save the old covering as a pattern to fabricate your new cover. If material with a design or pattern is used, the layout must prevent splitting or separating the design or

pattern, even at the expense of some waste. When laying out the patterns for this cover, alignment marks should be clearly marked on each part to be assembled. As the cover is assembled, make sure each alignment mark on one part is matched with the location of its corresponding mark on the second part used in the assembly. Always use 1/2 inch seams throughout the project as the size of the seam is important when assembling the parts. If the seams should vary, the alignment marks will not match. On some projects, this results in corners which will not align. If the seams vary in size, they will not only weaken the construction, but also affect the appearance of the project. A beading or cord welt should be used in fabricating covers of this type present a neat appearance.

The method of attaching a new cover will vary. Some upholstery covers will be attached with upholstery clips (hog rings). In some cases, screws and washers are used, while others are attached by inserting the cover ends into a channel and pressing it together or by pressing the cover down over a pointed protrusion to hold the cover in place. Some covers are installed with tacks. As you install the covers, tack the centers first; then work toward the ends and leave the corners until last. This method allows you to make minor corrections as you proceed. A 4 ounce blue steel upholstery tack is recommended. It should be noted that tacks have a very definite holding ability because of the shape of the point. The best way to take advantage of this peculiarity is to drive the tack all the way in with one blow. The magnetized hammer is particularly adapted for this purpose. In tacking around a radius, the material is stretched and pulled slightly in the opposite direction to that in which you are working to eliminate excess material. The tacks should be placed closer together in the radius. On the straight-away, 2 inch intervals are recommended. On a radius, they may be as close as 1/4 inch. All tacking should be at least 1/2 inch from the edge.

Exercise 2

Study the training literature and answer the following questions.

1. Why should the edges of a soundproofing panel be bound?
2. Which seam should be used to bind the edges of soundproofing?
3. How many stitches per inch should be used for machine sewn seams on soundproofing?
4. What type of stitch should be used for hand sewing a tear on soundproofing?
5. How is blanket type soundproofing attached to the aircraft?

SUMMARY

A thorough understanding of the fabrication, inspection, and repair of upholstery is essential to the performance of your duties in this career field.

196

REFERENCE

TO 00-25-77, Repair of Quartermaster Items of General Equipment.

Exercise 3

Fabrication of Cushion Cover

1. Layout and cut the following materials:

PART	SIZE	QUANTITY
Top Panel	17" x 17"	1
Bottom Panel	17" x 17"	1
Gusset	70" x 4"	1
Beading Cover	70" x 1-1/2"	2
Beading Cord	70" long	2

2. Using the 70" x 1-1/2" strips of beading cover and beading cord, make the beading.

3. Sew one piece of beading to the top panel with an SSa-1 seam. The beading should be laid down a.d faced to the inside of the panel.

4. Sew the other piece of beading to the bottom panel in the same manner.

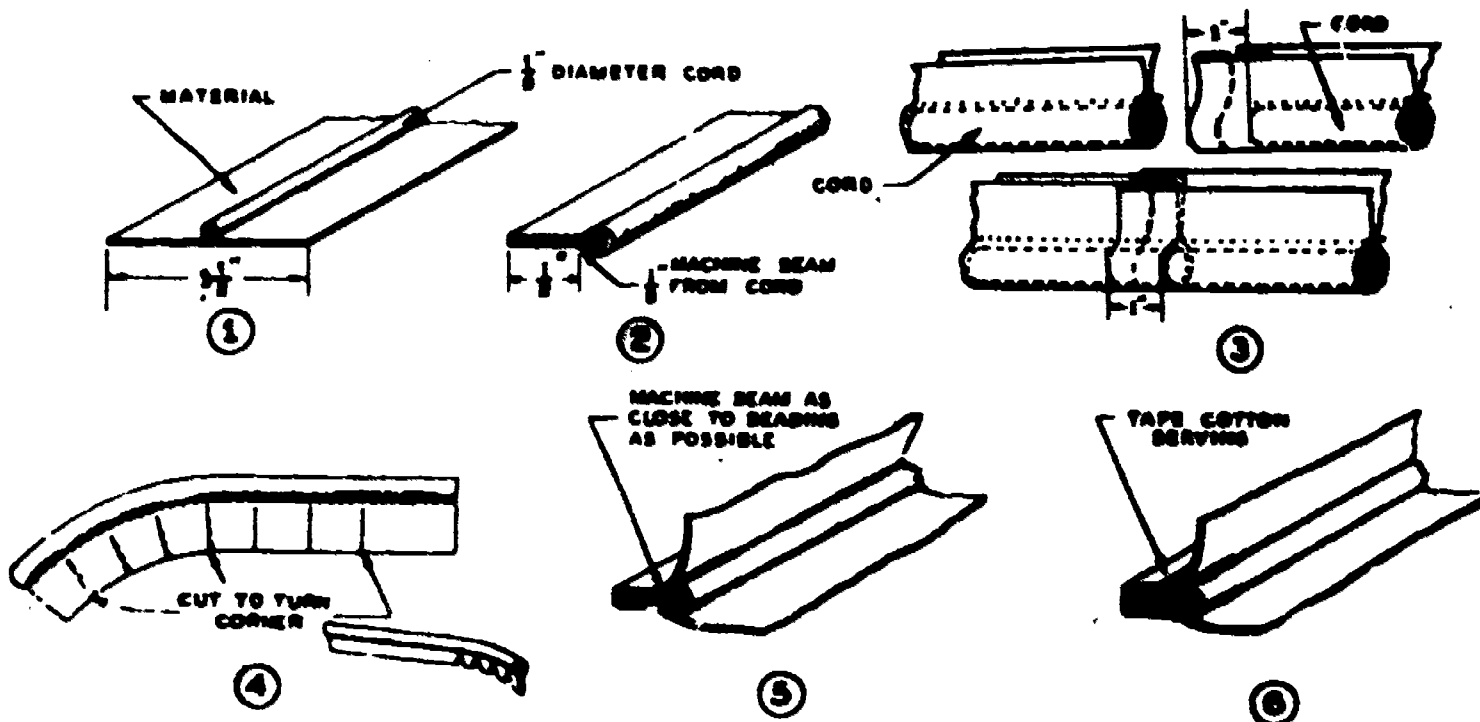

Figure 7. Beading Installation.

5. Both beading tapes should be turned under and finished as in step 3 of figure 7.

6. Sew the gusset to the top panel using an SSa-1 seam as demonstrated by your instructor.

Note: When laying out the patterns for this cover, alignment marks should be clearly marked on each part to be assembled. As the cover is assembled, make sure each alignment mark on one part is matched with the location of its corresponding mark on the second part used in the assembly. Always use 1/2 inch seams throughout the project as the size of the seam is important when assembling the parts. If the seams should vary, the alignment marks will not match. On some projects, this results in corners which will not align. If the seams vary in size, they will not only weaken the construction, but also affect the appearance of the project.

7. Close the end of the gusset with an ISq-2 seam and finish the attachment of the gusset with an Ssa-1 seam as demonstrated by your instructor.

8. Sew the bottom panel to the gusset in the same manner. Both heading splices and the gusset closure seam should be in a vertical line. Leave approximately 10 inches of one side open so the foam rubber padding may be inserted.

9. Insert the foam rubber padding and close the cushion with a hidden stitch.

Exercise 4

Fabrication of Soundproofing

Seam stitching must be at least 1/4 inch from the edge of the soundproofing. Five stitches per inch are used for all machine sewn seams.

1. Using a template similar in size and shape to the one shown in figure 8, lay out and cut a section from the aircraft soundproofing material. If templates are not available, use direct measurements to lay out the panel.

2. Mark the soundproofing material to include all cuts and holes as shown in figure 8.

3. Using a 1-1/4" binding tape, bind all the outside edges of the panel with a Bsg-2 seam. If a 1-1/4" binding tape is not available, use a 1" tape and make a BSf-2 seam. If tape of less width is used, a Bsa-1 or BSc-1 seam must be used.

4. Using a cutting punch, locate and punch the required holes for the lift-the-dot fasteners.

5. Install the lift-the-dot fasteners.

6. Punch the required holes for the three durable-dot fasteners in the correct location on the panel.

7. Install the three durable-dot fasteners.

198

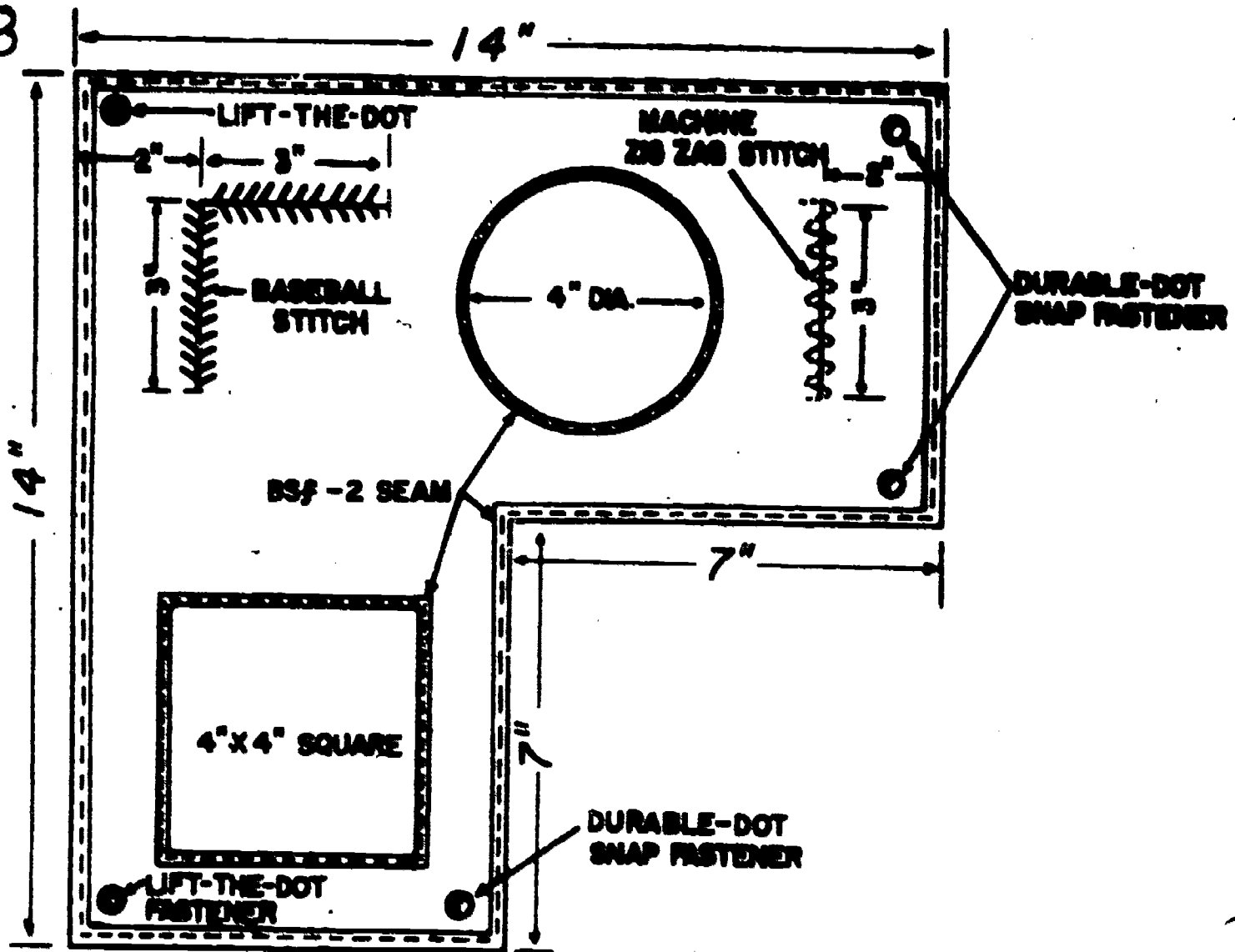

Figure 8. Soundproof Panel.

8. Cut out and bind the inside edges of the 4 inch square by using a BSg-2 seam.

9. Cut out and bind the inner edge of the 4 inch diameter with a BSf-2 seam. Fold under the edge of the binding tape for a distance of 1/2 inch at the start and finish of each binding.

Exercise 5

Inspect Upholstery

Perform a thorough visual inspection on upholstery for holes, tears, seam separations, broken or missing hardware, and general defects.

Exercise 6

Repair of Soundproofing

1. Examine the "L" shaped slit in the soundproofing at the location shown in figure 8.
2. Repair the "L" shaped slit by using a hand sewn baseball stitch.
 - a. Use four stitches per inch, 1/4 inch from the tear.
 - b. Secure each end with an overthrow stitch with two half-hitches on the under surface of the panel.

Technical Training

Fab & Parachute Spec

PERSONNEL PARACHUTE REPAIR USING CLASS 31 SEWING MACHINE

21 March 1979



CHANUTE TECHNICAL TRAINING CENTER (ATC)
3340 Technical Training Group
Chanute Air Force Base, Illinois

**DESIGNED FOR ATC COURSE USE
DO NOT USE ON THE JOB**

200

Life Support Branch
Chanute AFB, Illinois

3ABR42733-SW-901

PERSONNEL PARACHUTE REPAIR USING CLASS 31 SEWING MACHINE

OBJECTIVES

Upon completion of this unit of instruction, you will be able to use a class 31 sewing machine to fabricate repairs on personnel parachutes.

INTRODUCTION

The Air Force uses various personnel parachute assemblies, each designed to fit the needs of a particular aircraft or series of aircraft. Although each assembly may look quite different at first glance, you will find a great many similarities. Most of the canopies used for personnel parachutes are very much alike and are repaired in the same manner.

The parachute rigger is required to make repairs, as well as changes or modifications, on parachutes as specified in technical orders issued for that purpose. Usually the technical order will include a drawing showing in detail the exact repairs or changes to be made, in addition to printed instructions. Correct measurement and accurate marking of the pattern or template on the material is very important. Standard blueprint lines and dimension symbols must be understood and correctly interpreted for careful work.

INFORMATION

A personnel parachute may get tears or rips during handling and repacking procedures. It is the parachute rigger's responsibility to know when a hole or rip in a parachute assembly should be repaired.

MAJOR REPAIR

The term major repair includes replacement of canopy sections, reinforcing tapes, lateral bands, suspension lines, harness sectional sling straps, side and end flaps of the pack, and canopy puckered vent. Under no circumstances will parachute fabric salvaged from parachutes retired from service because of age or deterioration be used in the repair of active parachute canopies. The date of each major repair to a canopy will be stenciled on the bottom section of the top center gore immediately above the data prescribed by specification.

Supersedes ST 3ABR42733-SW-901 (undated). 211

OPR: 3340 TCHTG

DISTRIBUTION: X

3340 TCHTG/TTGU-L - 410; TTVSA - 1

The term minor repair includes such operations as replacing canopies, pack assemblies, pack opening bands, dual housing junction blocks, housing clamps, harness assemblies; repairs to packs; repair of stitching; replacement of removable hardware, back strap and ripcord pockets; patching holes in canopy which do not require more than a 12 inch square or rectangular patch; and darning holes in the canopy which do not exceed 1/2 inch in length.

INTERPRETING TECHNICAL ORDER SPECIFICATIONS

In repairing or replacing the parts of a fabric item, the technician must be sure that his choice of textile fabrics, cords, threads, etc., is exactly correct and will not, in any way, lessen the serviceability of the assembly. The technical order clearly defines the items (or substitutes) you may use in repair work.

Completing machine seams in accordance with the technical order is also a must. You have learned and practiced different classes and types of machine seams. If in doubt, check the TO for seam specifications and the way each seam should be formed. Remember, a seam affects the strength, elasticity, elongation and appearance of a parachute.

Drawing Terms and Symbols

Tolerances in measurement are indicated by the use of a plus and minus sign, as shown below.

10 - or +1/8". This means the measurement should be 10 inches, but 9 7/8 or 10 1/8" will be allowed.

9 +1/8" -0. This means a measurement of 9 inches is desired, a maximum measurement of 9 1/8" is acceptable, anything less than 9" is not acceptable.

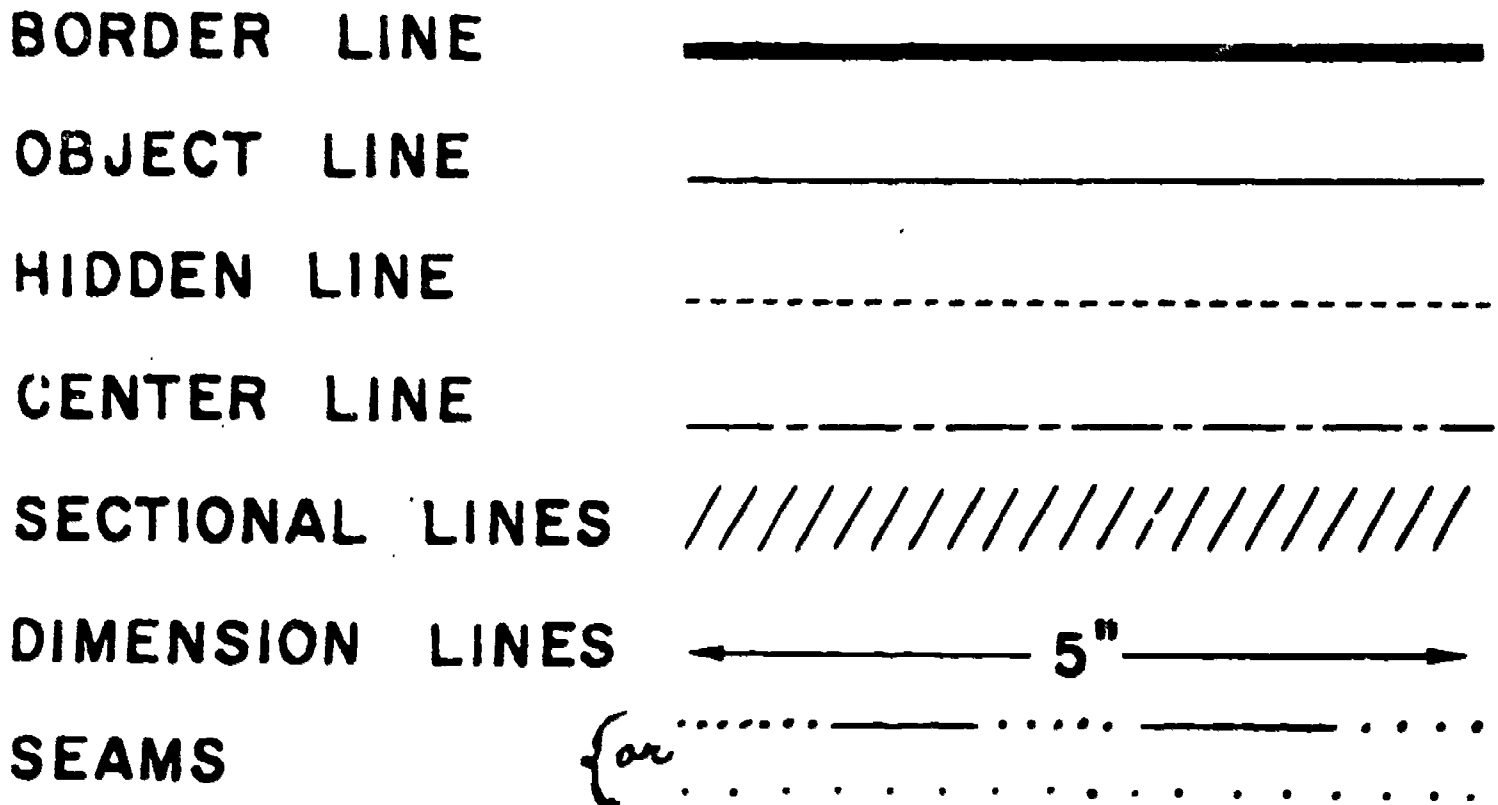

Figure 1. Blueprint Lines and Symbols.

202

Refer to Figure 1; the lines and symbols shown there have the following meanings:

BORDER LINE. The border line is not an actual part of the drawing, but is used to inclose the drawing and all notations.

OBJECT LINE. Object lines are used to make an overall outline and details of the object being drawn. This line is used for all features of the drawing seen in each view.

HIDDEN LINE. Hidden lines are used to represent a feature or a change in contour of an object which cannot be seen in a specific view.

CENTER LINE. Center lines are used to designate the center of an object or may be used to locate the center of any hole or opening to be made.

SECTIONAL LINES. Sectional lines are used to represent cutaway portions.

DIMENSION LINES. Dimension lines are those lines used to measure or lay out distances from a given point. The arrows indicate the limits of a dimension.

SEAMS. Seams are drawn as a series of dots or lines. Each dot or line represents a stitch.

Other symbols used are shown in the following examples:

2" = two inches

2' = two feet

Upper case (A) and low case (a) letters are commonly used for reference in drawings.

USE OF TEMPLATES AND PATTERNS

Templates and patterns are used in layout work to draw the shape or outline of projects or parts of projects to be made. Alignment marks are used to join parts or for the installation of hardware. Alignment marks may be holes, notches, arrows or any identifying mark. Good templates are well marked for ease in joining parts of the pattern. Patterns are usually made of paper while templates are of a more permanent material--wood, metal or stencil paper.

If templates are not available, the old object may be ripped apart and the pieces used as patterns. If the old object is used, a seam allowance of one-half inch is added if the old seam is torn or missing.

The following rules should be observed when using templates:

1. Make sure the correct side is "up".
2. Be careful that the template is not moved while making outlines.
3. Use soft pencil or thin crayon in marking; regular tailors' chalk is best. Blackboard chalk is too soft and makes a line too wide for accuracy.
4. Mark lightly with tailors' chalk or marking pencil that can be removed if the marks show on the finished product.
5. Mark carefully any alignment marks. Recheck marking before removing the template.
6. Most templates or patterns will include seam allowances. When seam allowances have not been made, normally an extra half-inch is added to edges where seams will be formed. Seam allowances for folds where grommets are placed may be as much as 2 1/2 inches or more.
7. Remember to be economical with materials. Place your template so a minimum of material will be used.
8. If fabric is to be cut on the bias, the template will be placed diagonally on the material after determining the direction of the warp and filling threads.

PERSONNEL PARACHUTE CANOPY PATCH

Selection of Repair Materials

Choosing the correct canopy patch material is very important to the overall strength of the repair. Therefore, you will use new fabric of the same weight and strength of the canopy material. The reason for using like material is to insure that the patch is neither stronger nor weaker than the original canopy. For example: If you patched a canopy with a lighter weight nylon than that of the original canopy, the opening force or air pressure may rip or tear the patch.

Preparation of Patch Materials

In order to fabricate a canopy patch, you must realize the importance of cutting and placing the patch onto the damaged canopy properly. Consult the proper TO to find how large the patch will be and how you fold the edges of the patch. The patch must be the correct size; if it is the wrong size, the repair cannot be completed correctly.

Size Limitation of Personnel Canopy Patch Repairs

A rip, tear or hole which measures 1/4 inch to 9 1/4 inches may be patched. The maximum size of a completed patch is 12 inches in length or width. The patch may be square or rectangular, but the warp and filler threads of the patch must run parallel to the warp and filler threads of material being patched. The maximum number of patches per section is one; the maximum number of patches per gore is three (3), with no more than ten (10) patches per canopy.

Caution: Remember that no patches will be made in the top section of a personnel parachute canopy.

Complete instructions for fabricating a personnel canopy patch are given in the literature.

PILOT PARACHUTE SUBFLAPS

One of the exercises you will complete in the workbook for this unit of instruction is a pilot parachute subflap. Four of these are used on the automatic back-style parachute assembly. The flaps are square in shape with one curved side at the top and bottom. These subflaps cover the pilot parachute after it is properly positioned on the pack. Figure 2 shows the subflaps open for placement of the pilot parachute.

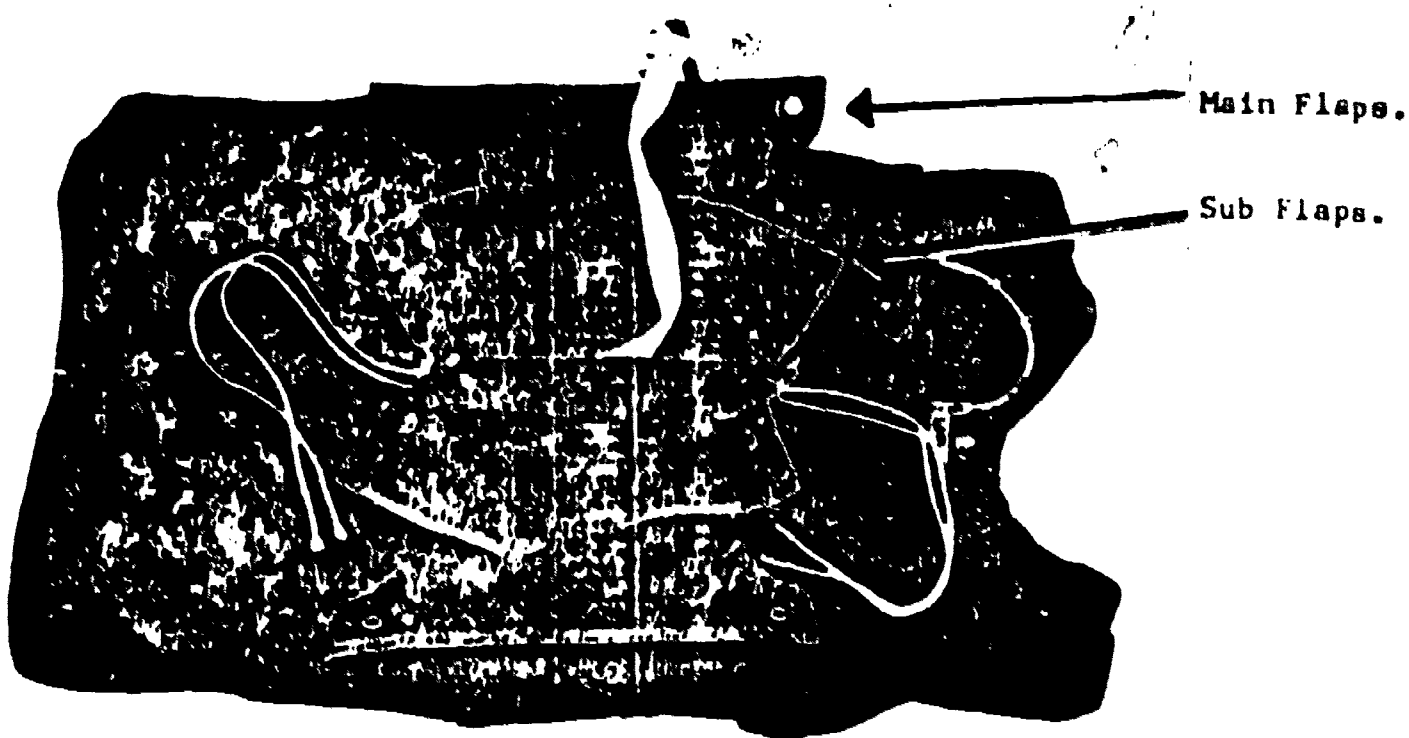

Figure 2. Pilot Parachute Compartment Flaps on the Automatic Backstyle Parachute.

REPLACEMENT OF CANOPY SECTIONS

Sections showing evidence of weakness or damage beyond the scope of patching will be replaced.

Complete instructions for replacing a canopy section are given in the literature.

REPLACEMENT OF SUSPENSION LINES

You have learned that suspension lines are continuous, running from the connector link on one side of the canopy to the connector link on the opposite side of the canopy.

When replacing a suspension line, all zigzag stitching must be removed at connector links and at points of contact on the canopy. A new suspension line is attached at one connector link, drawn through the canopy, and run to the connector link on the opposite side. The new line is hand-tensioned and marked to match an adjacent suspension line, leaving enough line free for the length of the apex. The loose end is then attached to the opposite connector link. The zigzag stitching is resewn.

Note: When replacing a complete set of suspension lines, 20-pound weights will be used for stretching the new lines.

Exercise 1

Write the answers to the following questions.

1. Where do you find exact specifications for repairs, changes and modifications on parachutes?
2. Why is the class and type of machine seam so important?
3. How are tolerances in measurement indicated?
4. In what two (2) ways are seam lines indicated on technical order drawings?
5. What is the symbol used on TO drawings to represent 16 feet?
6. If a pattern or template is not available, and an old parachute part is ripped apart to be used as a pattern, what must be added?

206

7. How wide are seam allowances where grommets are placed?
8. If a fabric is cut on the bias, how is the template placed?
9. Why is it important to use fabric of the same weight and strength of the canopy when making a canopy patch?
10. What is the maximum size of a canopy patch?
11. If a tear is $1/4$ " wide, do you patch it with a square patch?
12. What is the maximum number of patches per section? Per gore?
13. The number of patches per canopy is limited to how many?
14. Where do you never patch a canopy?

Exercise 2

To fabricate a canopy patch on a personnel parachute, proceed as follows:

1. On an inverted personnel parachute canopy, mark a 3" square in the center of one section. Use a pencil, as ball-point ink will damage nylon.
2. Trim out this area with shears.
3. Measure out $5/8$ " from the trimmed area (Figure 3).

4. Draw a line and cut from the corners of the trimmed area to the 5/8" mark (Figure 4).

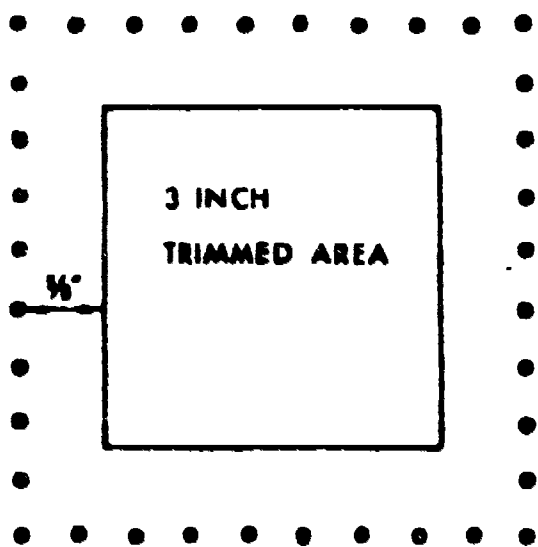

Figure 3. Step One.

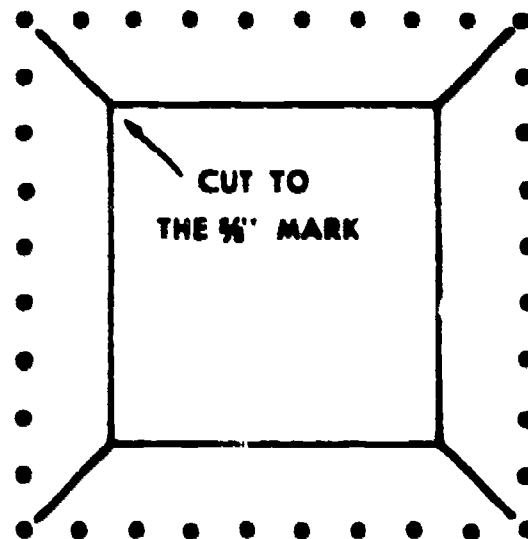
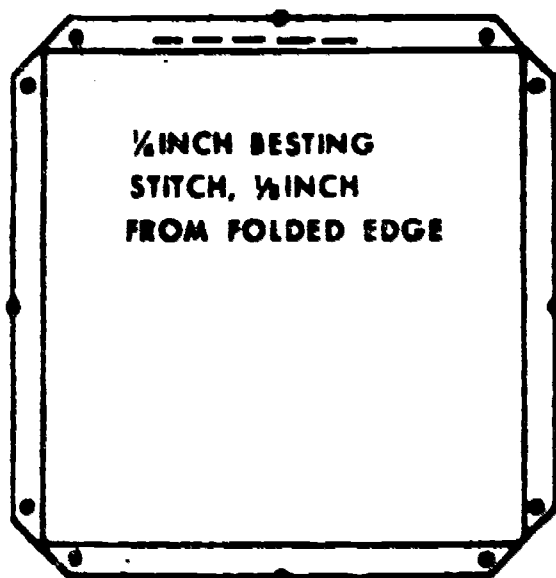

Figure 4. Step Two.



● = PUSH PIN

Figure 5. Step Three.

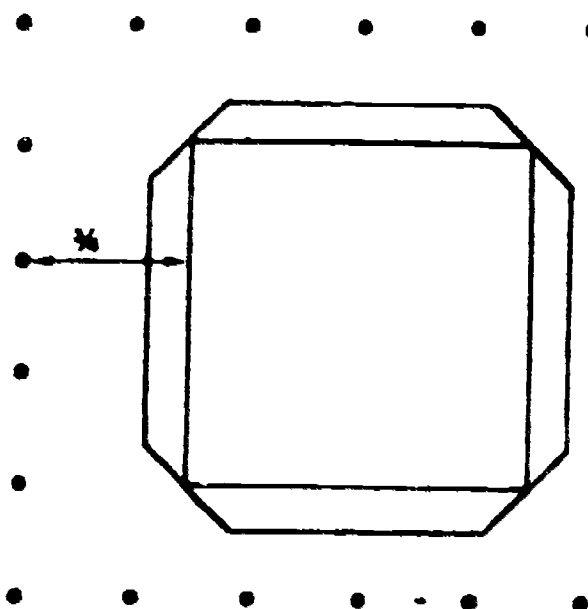

Figure 6. Step Four.

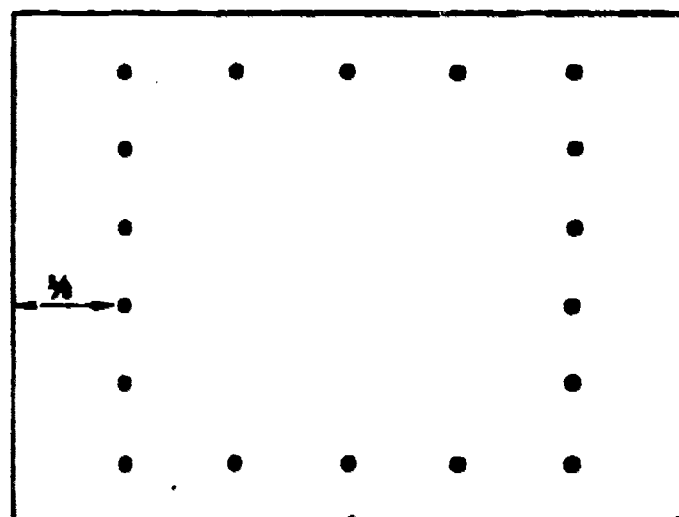

Figure 7. Step Five.

5. Fold over section of material along $5/8$ " mark and push-pin to patch board (Figure 5).

6. Baste $1/8$ " from folded edge using $1/4$ " basting stitches (Figure 5). (Do not tie knot in end of basting thread).

7. Measure out $3/4$ " from the folded edge of canopy material. Mark as indicated in Figure 6.

8. Cut a patch of 1.1 oz. ripstop nylon, 7 " X 7 ", and mark $5/8$ " from the outside edge of the patch (Figure 7). (Lay out patch with warp and filler threads of the canopy).

9. Turn the edge of the patch under to the $5/8$ " mark, and match the folded edge of patch with the $3/4$ " mark on the canopy. Insert push pins.

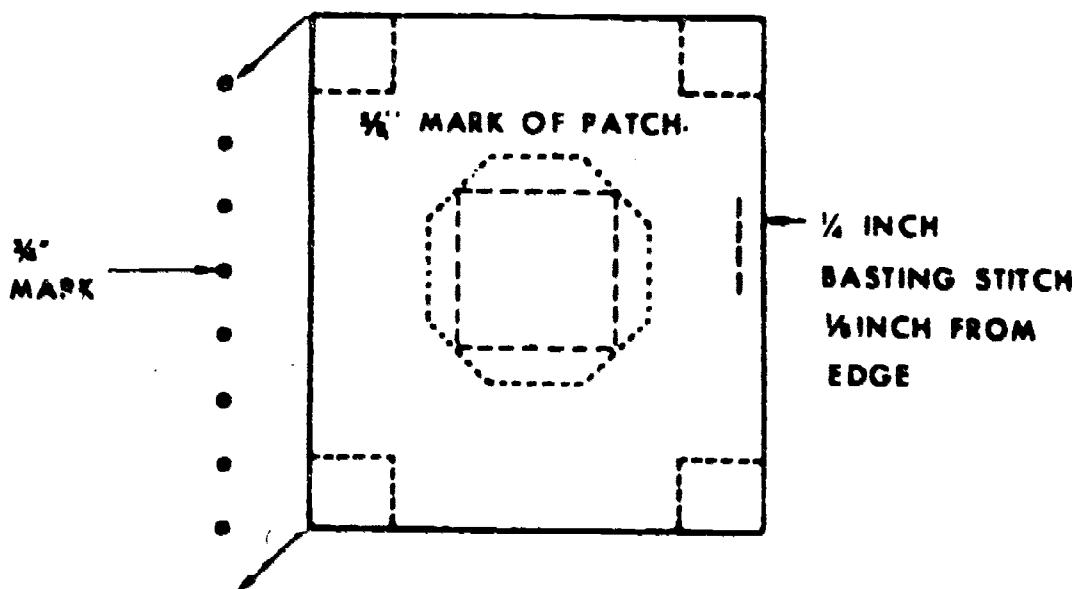

Figure 8. Step Six.

10. Fold under the other three (3) sides of the patch material, forming neat, square corners, as indicated in Figure 8. (The eye end of a sewing needle may be used to form corners).

Note: The folded edges of the canopy and patch will not interlock.

11. Baste $1/8$ " from the folded edge of patch material ($1/4$ " stitch).

12. Using scrap 1.1 oz. ripstop nylon, set a class 31 sewing machine at 8 stitches per inch with correct tension.

13. Machine sew three seams:

- a. $1/16$ " from folded edge of canopy.
- b. $1/16$ " from folded edge of the patch.
- c. Centered between first two.

If you have completed this project properly, the following items will be correct:

1. The finished seam, from folded edge to folded edge, should be 3/4" wide.
2. The patch material and canopy material will be folded and sewn as indicated in Figure 9.

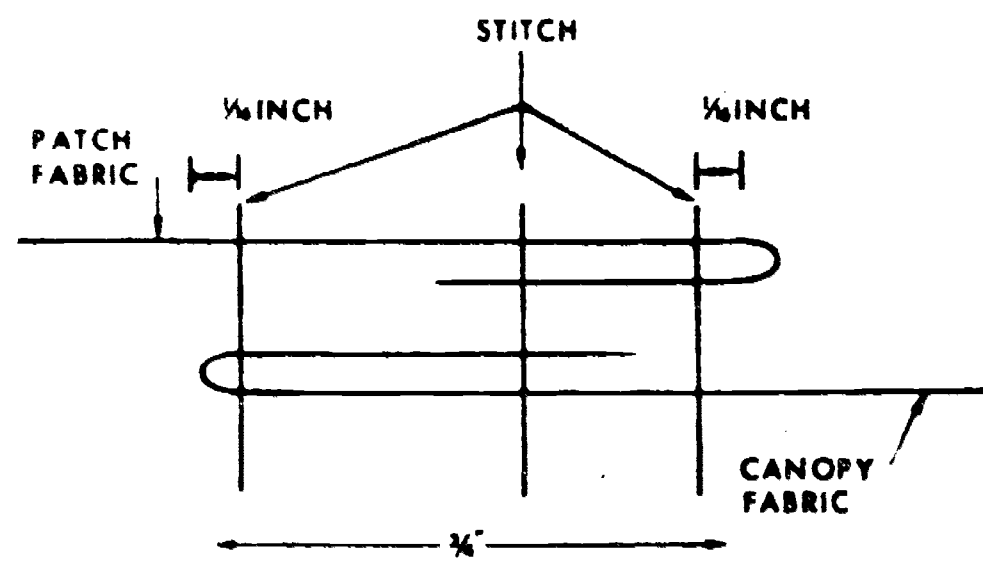

Figure 9. Check Step Folding Canopy and Patch Materials.

Exercise 3

To fabricate a pilot parachute subflap, proceed as follows:

1. Thread a class 31 sewing machine with size E nylon thread. Set at 8 stitches per inch.

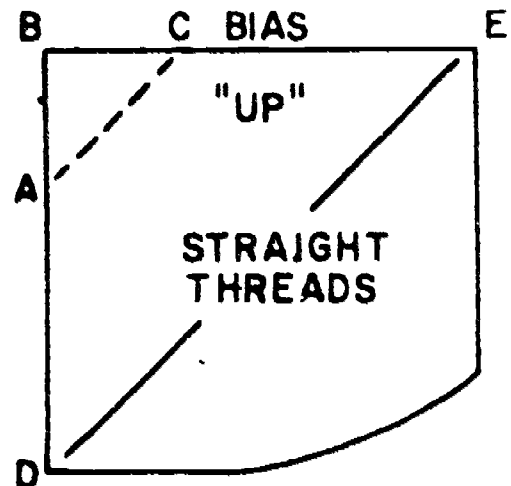

Figure 10. Layout of Material.

2. Using a template, cut one pattern of 12 ounce cotton duck.

Note: The side of the template marked "up" must be facing up when the pattern is drawn on the material. Sides B-D and B-E, Figure 10, should be ON THE BIAS, the straight threads running from D to E.

210

3. Cut 1 piece of $3/4$ " cotton binding tape 17" long.
4. Cut 1 piece of $1\ 3/4$ " nylon reinforcement tape $3\ 1/2$ " long.
5. Place the $1\ 3/4$ " nylon reinforcement tape on the flap so the selvage edge of the tape falls on a straight line from notch A to notch C, Figure 10, on the side of the pattern marked "up".
6. Pin the tape in the proper position.
7. Turn the flap over so the underside is facing up, then machine baste $1/8$ " from the cut edge of the cotton duck from A to B and end at C, Figure 10.
8. Trim off excess reinforcement tape even with the edges of the flap.

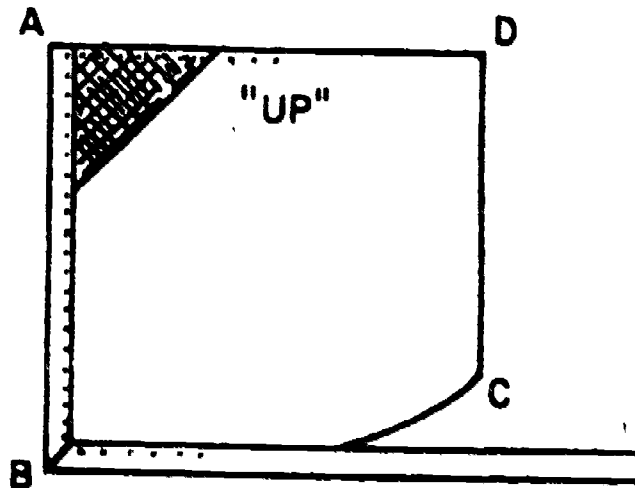

Figure 11. Binding the Flap.

To bind the pilot parachute subflap, proceed as follows:

1. With the 17" piece of $3/4$ " cotton binding tape, start at A, Figure 11, and bind the edges of the flap with a BSA-2 seam, sewing $1/16$ " from the selvage edge of the tape.

Note: The side marked "up" must be up when attaching the tape.

2. Proceed counterclockwise around the flap making mitered corners at points B, C and D, Figure 11.
3. End at the starting corner. Fold the tape under $1/4$ " and secure by anchoring and backstitching.

Note: Following the correct line of stitching will place the material on the correct side of the presser foot, making the binding of the project easier.

4. When making the second row of stitches to form the BSA-2 seam, start at corner A, Figure 11, $1/16$ " from the folded edge, and sew in a clockwise direction to corner D. Continue around the flap to starting point A, ending with an anchor and backstitching.

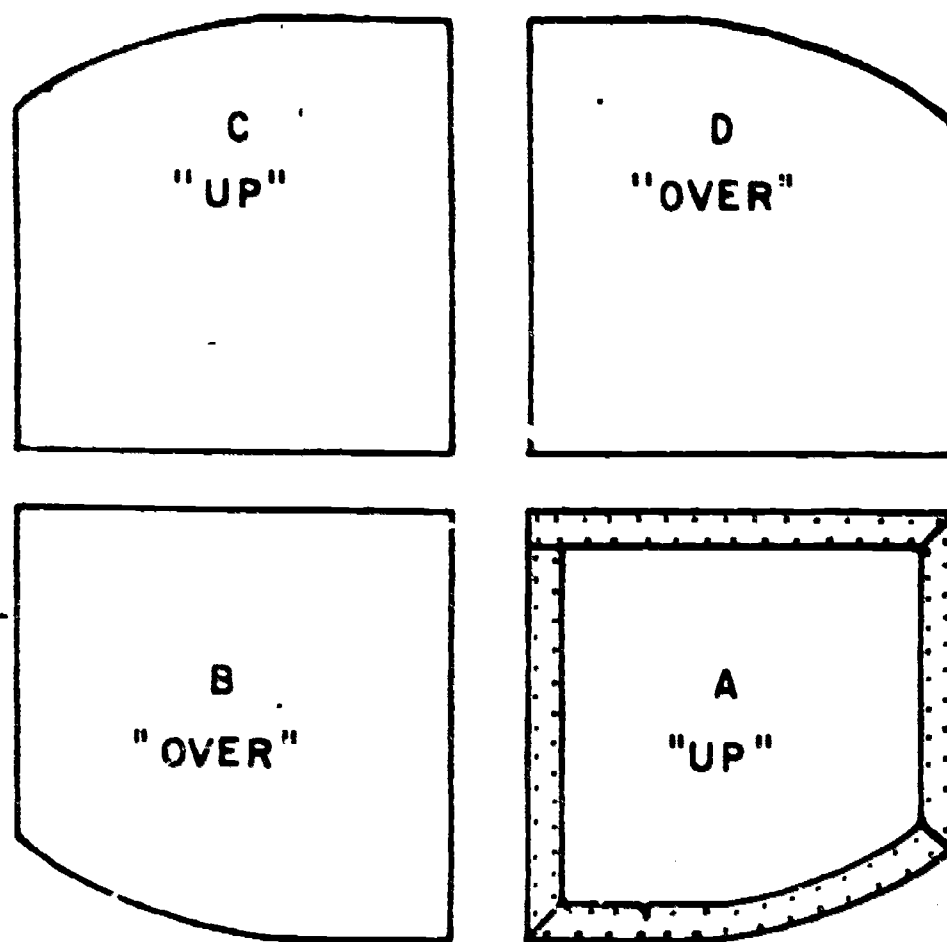

Figure 12. Position of Subflaps.

5. The completed flap (A) is shown in Figure 12. When making all four flaps, A and C flaps are made with the up side of the template facing the operator. Flaps B and D are reversed, the pattern is turned over for marking and sewing. If flaps B and D are not reversed, all flaps would fit in positions A and C.

Technical Training

Fab & Parachute Spec

OPERATION/MAINTENANCE OF CLASS 7 SEWING MACHING

21 March 1979



CHANUTE TECHNICAL TRAINING CENTER (ATC)
3340 Technical Training Group
Chanute Air Force Base, Illinois

DESIGNED FOR ATC COURSE USE

DO NOT USE ON THE JOB

213

Life Support Branch
Chanute AFB, Illinois

3ABR42733-SW-905

OPERATION/MAINTENANCE OF CLASS 7 SEWING MACHINE

OBJECTIVES

Upon completion of this unit of instruction, you will be able to answer a list of questions concerning nomenclature, operation, maintenance and sewing machine principles and operate the machine. You will also be able to list safety precautions to follow when using the class 7 sewing machine.

INTRODUCTION

Because the class 7 sewing machine is used primarily for the repair of extremely heavy cloth or webbings, it is not used as often in the parachute shop as the class 31 and 111W. However, as with all machines used in parachute repair, knowledge of nomenclature and operation is necessary before operating the equipment. It is suggested that whenever you are required to use the class 7 sewing machine you take a few minutes to practice machine control before working on the actual project.

INFORMATION

NOMENCLATURE, OPERATION, AND SEWING MACHINE PRINCIPLES

The class 7 is a single needle, lock stitch sewing machine. It is used to sew heavy canvas, webbing, and light leather materials. The class 7 is equipped with alternating presser feet (vibrating and lifting), drop feed, and oscillating shuttle. It will sew in a stitch range of 2 to 8 stitches per inch. In operation, the alternating pressers alternately press down on the material, working in unison with a two-row feed dog, so that the material will not slip while sewing. This machine is also equipped with an automatic bobbin winder. The size needle is determined by the size of thread and type of material required to complete a repair. The technical order should be used to determine the size needle required for each repair job.

Cleaning, Lubricating, and Servicing

Cleaning, lubricating, and servicing are preventive measures used to maintain the sewing machine in working order. These "preventive measures" are known as before, during, and after operation services, and should be completed by the operator.

Supersedes ST 3ABR42733-SW-905 (undated).

OPR: 3340 TCHTC

DISTRIBUTION: X

3340 TCHTC/TTGU-L - 410; TTVSA - 1

BEFORE-OPERATION SERVICE. Before-operation service consists of:

1. Inspecting the machine for damages.
2. Examining drive belt and controls.
3. Testing the machine for adjustments such as tension, stitches per inch and pressure on material.
4. Lubricating the machine.

DURING-OPERATION SERVICE. During-operation service consists of:

1. Lubricating the machine with one to three drops of light lubricating oil during every four hours of operating time.
2. Cleaning dust, grit, or lint from bobbin assembly each time the bobbin is replaced.
3. Adjusting the machine according to the nature of the material being sewn.
4. Replacing dull or broken needles.

AFTER-OPERATION SERVICE. After-operation service consists of performing the following actions before leaving the machine unattended:

1. Turning off machine.
2. Disconnecting and rolling up the extension cord.
3. Cleaning dirt, lint, and oil from moving parts and the outside of the machine.
4. Lubricating the machine according to the lubrication charts.
5. Covering the machine to keep out dust and moisture while not in use.

SPECIAL INSTRUCTIONS. The model 7-33 sewing machine motor should be greased with ball and roller bearing grease every six months.

**SAFETY PRECAUTIONS TO FOLLOW WHEN USING
A CLASS 7 SEWING MACHINE**

Operating a sewing machine is just like operating any item of machinery - certain safety rules must be followed. Before starting

the machine motor, turn the balance wheel by hand to make sure all parts of the machine operate freely. While plugging the machine in, do not touch bare terminals or wires. Allow the machine motor to warm up before sewing. The machine should never be operated without material under the presser feet. (Use scraps of material for test runs.) Keep the metal or wood slides on each side of the machine closed during operation. During operation, do not start or stop the balance wheel with your hand.

OPERATION OF THE CLASS 7 SEWING MACHINE

You will learn how to operate the class 7 sewing machine.

REPAIRS MADE ON THE CLASS 7 SEWING MACHINE

Two common repairs you will make using a class 7 sewing machine are to bomber deceleration parachutes with damaged or broken suspension lines.

Damaged Suspension Line Repair

A damaged suspension line is one which has the webbing partially torn, frayed, burned, or stained. These damaged portions of the line have less tensile strength than the undamaged lines and may break during opening of the parachute. You must be able to repair damaged lines in accordance with TO specifications.

Only new 1" nylon webbing of 4,000 pound tensile strength is suitable for this repair. Repaired lines must be of equal strength compared to the undamaged suspension lines. The overall length of the reinforcement repair will depend upon the length of the damaged area. The reason for extending the repair beyond the damage is to insure security of the stitching.

Sewing reinforcement webbing onto the damaged suspension line requires that you carefully center the reinforcement over the damage, making sure that there are 4" of replacement webbing on each side of the damage. Also make sure the edges of the webbing and reinforcement are aligned; this is necessary for security of the machine seams.

To complete the sewing, use the class 7 sewing machine threaded with 3-cord nylon and adjusted to sew 6 to 8 stitches per inch. The stitch pattern of boxed diamonds that will be used will be explained in the worksheet and the applicable TO. This particular pattern is used because it affords strength to the repair. The stitches should be snug in order to allow for some stretching without breaking during opening shock.

Broken Suspension Line Repair

A broken suspension line is one which has the webbing completely separated or torn. This break may occur as the result of a burn upon deployment, opening forces, or careless handling of the lines. The parachute rigger must repair the deceleration parachute so it can be put back into service.

Repair procedures for a broken suspension line are quite similar to those used in repairing a damaged suspension line.

Select new 1", 4,000 pound tensile strength nylon webbing for the repair. Since the original suspension line is broken, you will need to cut the repair line six inches beyond each side of the break. The reason for cutting the repair a total of 12" longer than the break is so the stitching can adequately hold the repair onto the broken line.

Use the class 7 sewing machine and the same stitch pattern as in the damaged suspension line repair to attach each side of the break to the repair webbing. Careful centering of the splice onto the broken line is necessary to insure a strong overall repair. You should make sure that the splice extends 6" on each side of the break and that the repaired suspension line is of the same length as the other suspension lines. If the spliced line is shorter than the other lines, it will have more stress placed upon it during opening and it is likely to break. If the spliced line is longer than the rest of the lines, more stress will be placed on the other lines during opening and could cause damage to them.

REFERENCE

TO 34Y7-2-1

EXERCISE 1

Write the answers to the following questions.

1. The class 7 is designed to sew what types of materials?
2. Why should the operator clean and lubricate the sewing machine?
3. How do the alternate pressers work in relation to the two-row feed dog during the machine operation?
4. How often should the sewing machine be lubricated?
5. The size of needle required for a repair will be determined in what manner?

6. Fill in the blanks:

Model	_____ 7 _____
Needle Threading Direction	_____
Bobbin Threading Direction	_____
Materials Used	_____
Stitch Forming Mechanism	_____
Maximum Number Stitches Per Inch	_____
Needle Sizes	_____
Feed	_____

EXERCISE 2

List safety precautions to follow when using the class 7 sewing machine.

EXERCISE 3

Cleaning and lubricating the machine should be completed before, during, and after operation to prevent damage or rusting of machine parts. Proceed as follows:

CAUTION: The machine should be turned off. Proceed with cleaning and lubrication after the momentum of the motor has stopped.

1. Unthread the machine head and remove the bobbin.
2. Apply 1 to 3 drops of light lubricating oil at each oiling point, refer to figure 1.
3. Remove excess oil or dirt from exterior parts of machine head, table, and thread stand. (Cheese cloth or a similar substitute may be used.)

NOTE: Excess oil left on machine parts will ruin a sewing project or the operator's clothes, since oil causes material deterioration.

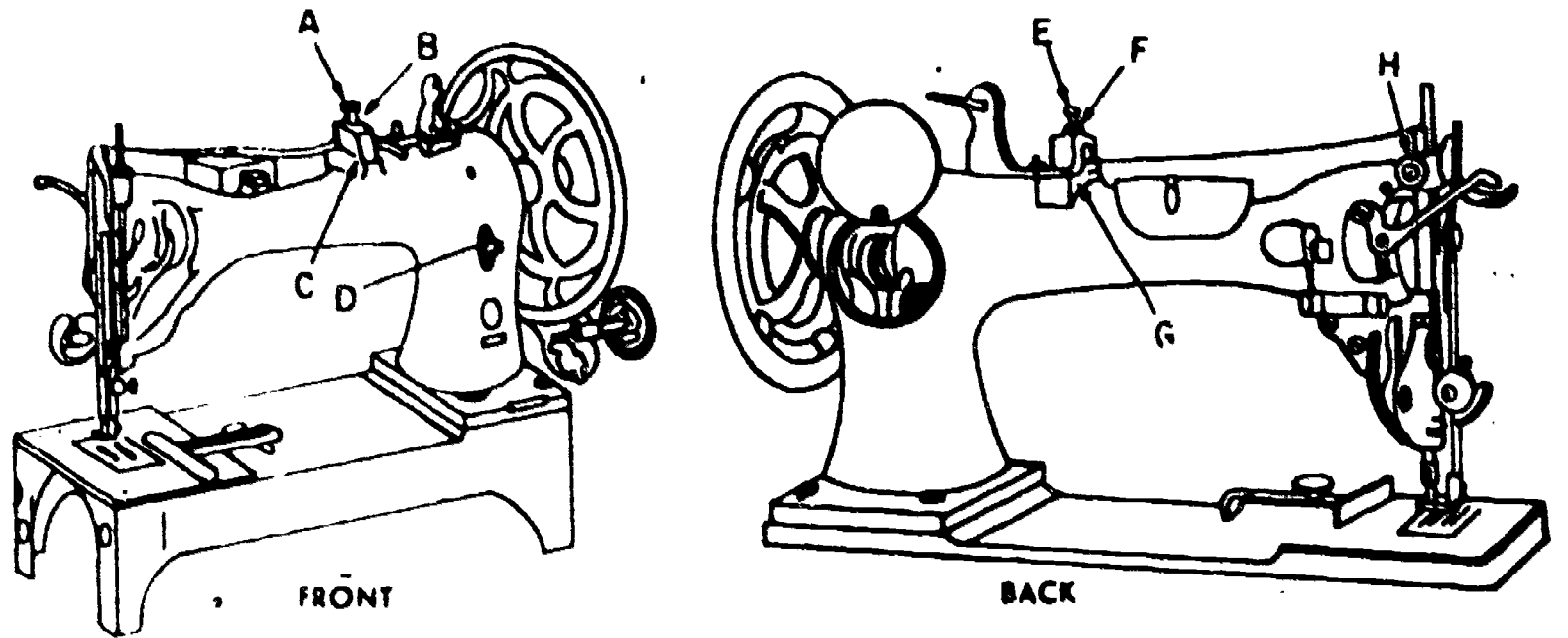

Figure 1. Oiling Points on Class 7 Machines.

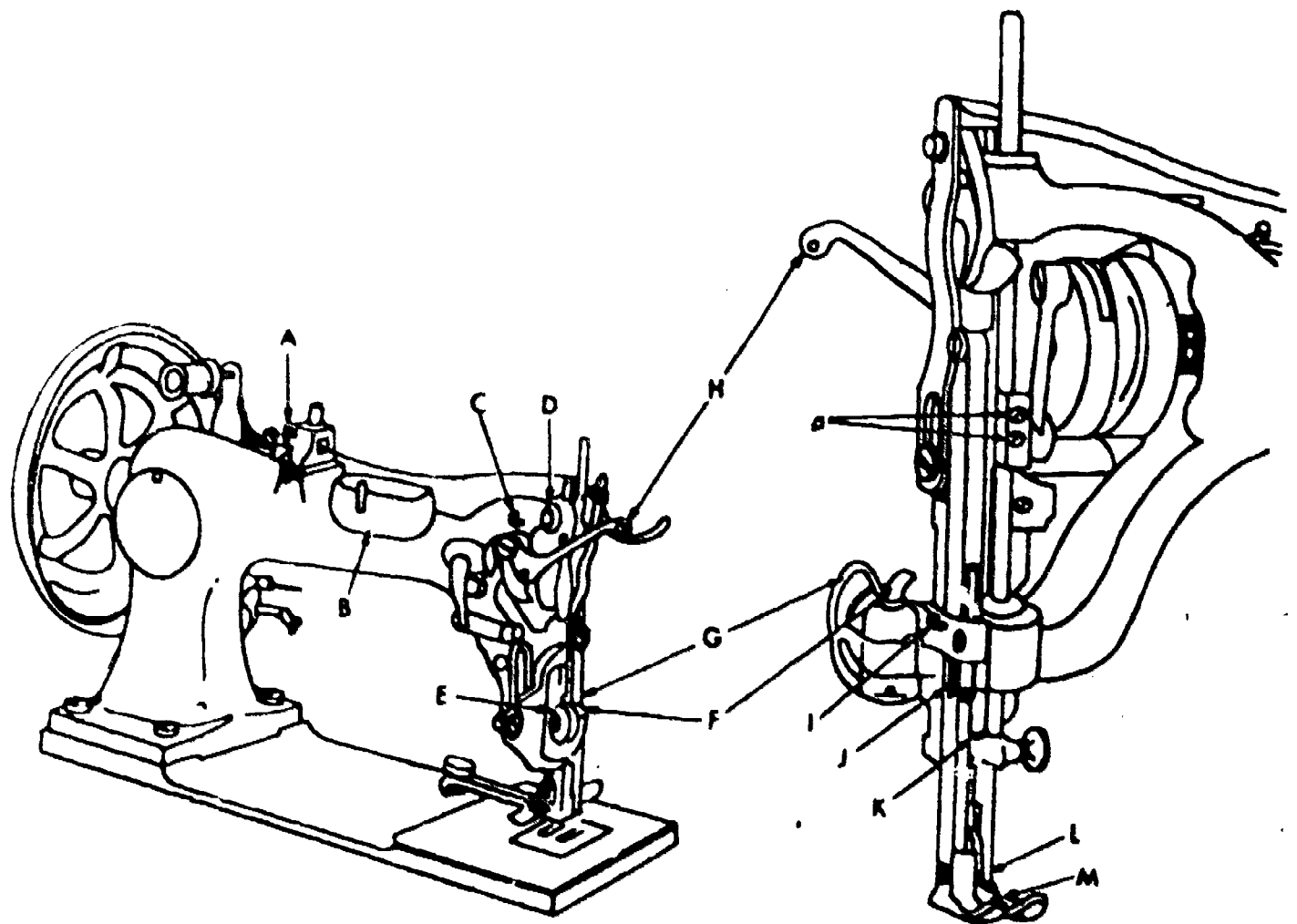

Figure 2. Threading the Class 7 Machine Head.

2317

EXERCISE 4

To thread the head and bobbin, proceed as follows:

1. Thread the head.
 - a. Use number 5 nylon cord.
 - b. Turn balance wheel toward the front of the machine until the thread take-up lever moves up to its highest position.
 - c. Pass the needle cord through the thread eyelet (figure 2A).
 - d. Pass the cord through the hole in the balance wheel end of the oil cup and through the hole in the oiling stub under the oil cap cover. (Note: Oil reservoir use will decrease the friction on the top thread and reduce breakage when sewing thick materials.)
 - e. Close the oil cap cover and let the cord pass out of the cup through the notch in the end of the cup.
 - f. Pass the cord through the eyelet (figure 2C) next to the tension disks.
 - g. Carry the cord over the top and between the tension disks (figure 2D).
 - h. Slide the cord under and around the tension wheel (figure 2E), through the loop of the take-up lever spring (figure 2F) and under the wire staple (figure 2G).
 - i. Pass the cord from back to front through the eye of the thread take-up lever (figure 2H).
 - j. Carry the cord down through the thread eyelet (figure 2I), through the slot in the vibrating presser bar (figure 2J), and into the thread guide hole (figure 2K) in the needle clamp.
 - k. Pass the cord through the eye of the needle (figure 2L) from left to right.
 - l. Pass the cord down through the hole in the lifting presser foot (figure 2M) and draw about 4 inches of cord below and behind the presser foot.
2. Thread the bobbin.
 - a. Remove the needle cord from the needle eye.
 - b. Turn the balance wheel forward to bring the needle bar to its lowest position.

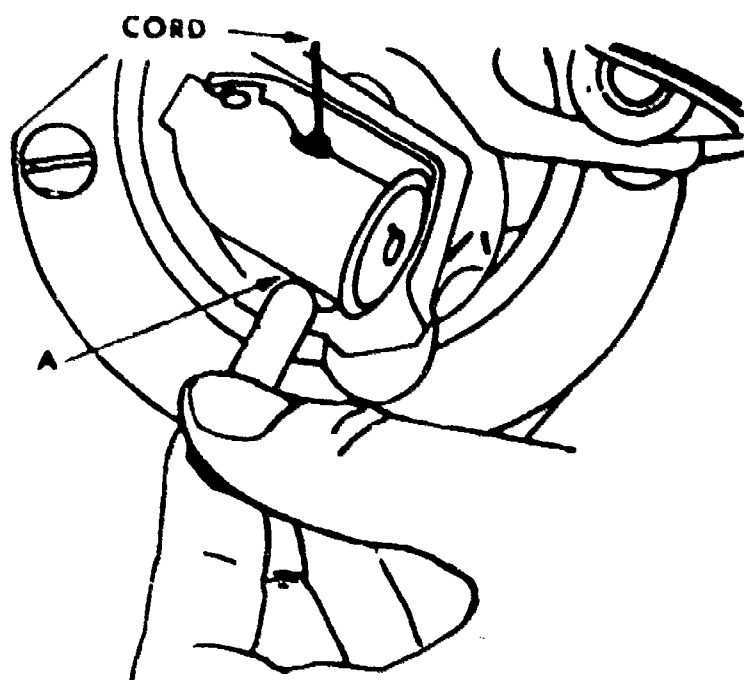

Figure 3. Removing the Bobbin.

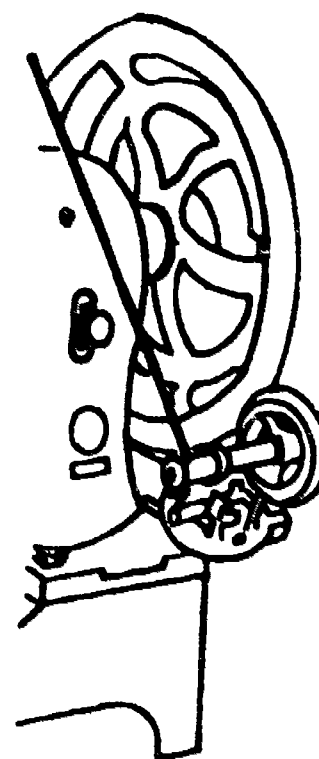

Figure 4. Winding the Bobbin.

c. Insert the small end of the shuttle cylinder opener in slot A, figure 3, in the spring latch between the shuttle cylinder.

d. Press the latch away from the cylinder.

e. Turn the cylinder outward or toward the left as far as it will go; the bobbin should then come out.

f. Place the bobbin on the spindle of the bobbin winder as shown in figure 4.

NOTE: The bobbin should fit up close against the shoulder and the small pin in the shoulder should enter the slot in the bobbin.

g. Pass the cord from the spool through the hole in the left side of the bobbin from the inside out.

h. Push the bobbin winder pulley up against the balance wheel and place the bobbin winder latch in position.

i. Lift the presser foot.

j. Start the machine and hold the end of the cord tightly until a few coils are wound on the side of the bobbin. Then cut off the cord close to the hole in the side of the bobbin.

k. Continue winding the bobbin until it shuts off automatically.

l. Remove the bobbin from the winder.

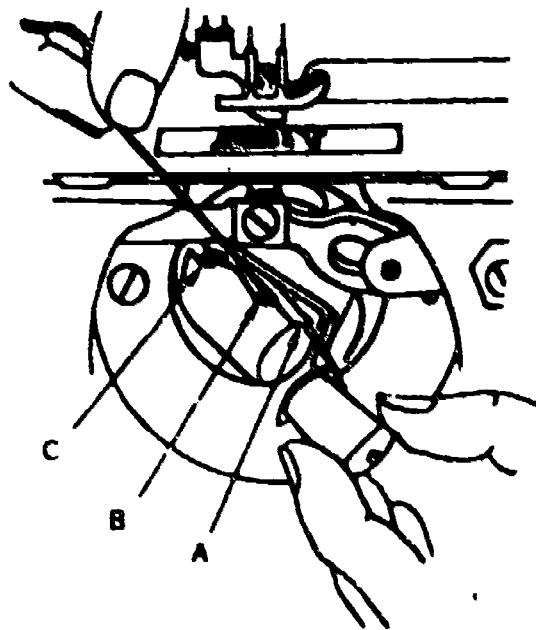

Figure 5. Replacing the Bobbin.

- m. Hold the bobbin between the thumb and forefinger of the left hand with the cord drawing off from the underside and toward the right, as shown in figure 5.
- n. Place the bobbin in the cylinder as far as it will go.
- o. Draw the cord under the tension spring A into the delivery eye B, figure 5.
- p. Push the cylinder back until it is locked by the spring latch.
- q. Allow about 3 inches of cord to hang free from the shuttle so that it may be drawn up through the throat plate.
- r. Rethread the needle eye with the needle cord.
- s. Bring the bobbin cord up through the throat plate by turning the balance wheel, while holding the needle thread, figure 6.

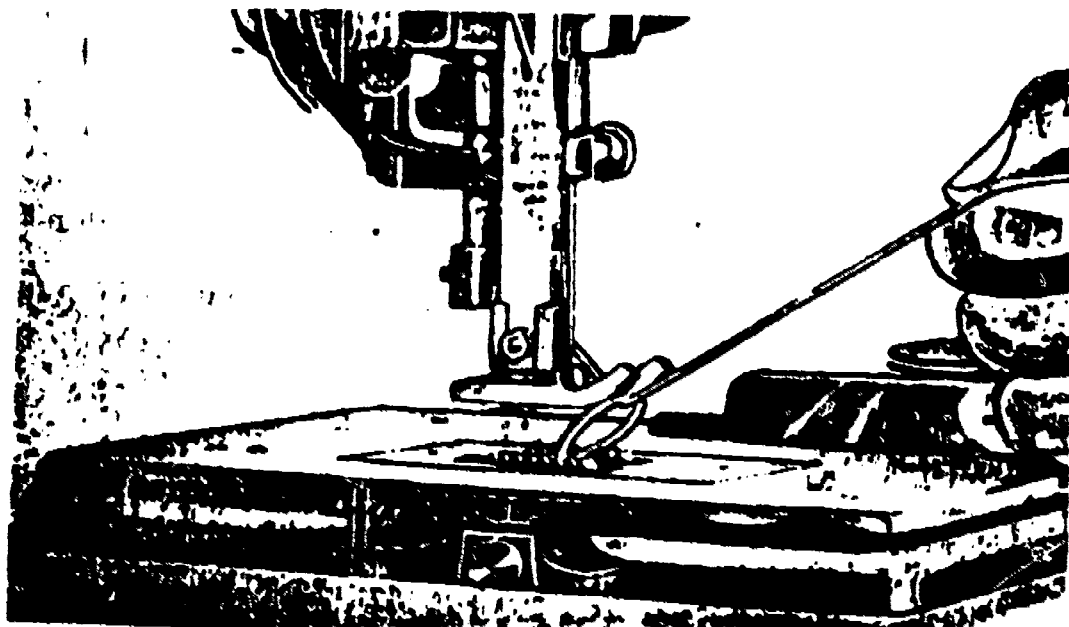

Figure 6. Drawing Up the Bobbin Thread.

EXERCISE 5

To regulate stitches per inch and adjust tension, proceed as follows:

1. Insert three plies of cotton harness webbing under the presser foot.
2. Lower the presser foot, hold the needle and bobbin threads, and begin sewing.
3. Regulate stitches per inch by the thumbscrew, figure 1D. Moving the thumbscrew upward increases the stitches per inch; downward decreases stitches per inch.
4. The knot of the lock stitch should not appear on the top or bottom of the material. If adjusting tension is required, turn the thumb nut (figure 1H) inward or outward for proper tension.

Adjusting the Needle Bar

The needle bar must be adjusted so that the needle will be correctly positioned in relation to the shuttle point. When properly adjusted, the point of the shuttle should be approximately $1/32$ inch above the needle eye on the upward stroke. To make this adjustment, loosen the two setscrews and move the needle bar up or down as required. Then securely tighten the setscrews. The setting of the needle bar may be varied slightly, depending upon the size of the needle and the thread used.

EXERCISE 6

Adjusting the Needle Bar:

1. Loosen the two setscrews.
2. Move the needle bar up or down as required.
3. Tighten setscrews.

NOTE: This setting of the needle bar may be varied slightly depending upon the size of the needle and the thread being used.

When the point of the shuttle is at the center of the needle, the top of the needle eye should be approximately $1/32$ inch below the point of the shuttle.

NOTE: Sometimes it may be necessary to reset the shuttle to clear the needle if an extra large size needle is being used, or it may be necessary to make the opposite adjustment if a smaller than usual needle is being used.

223

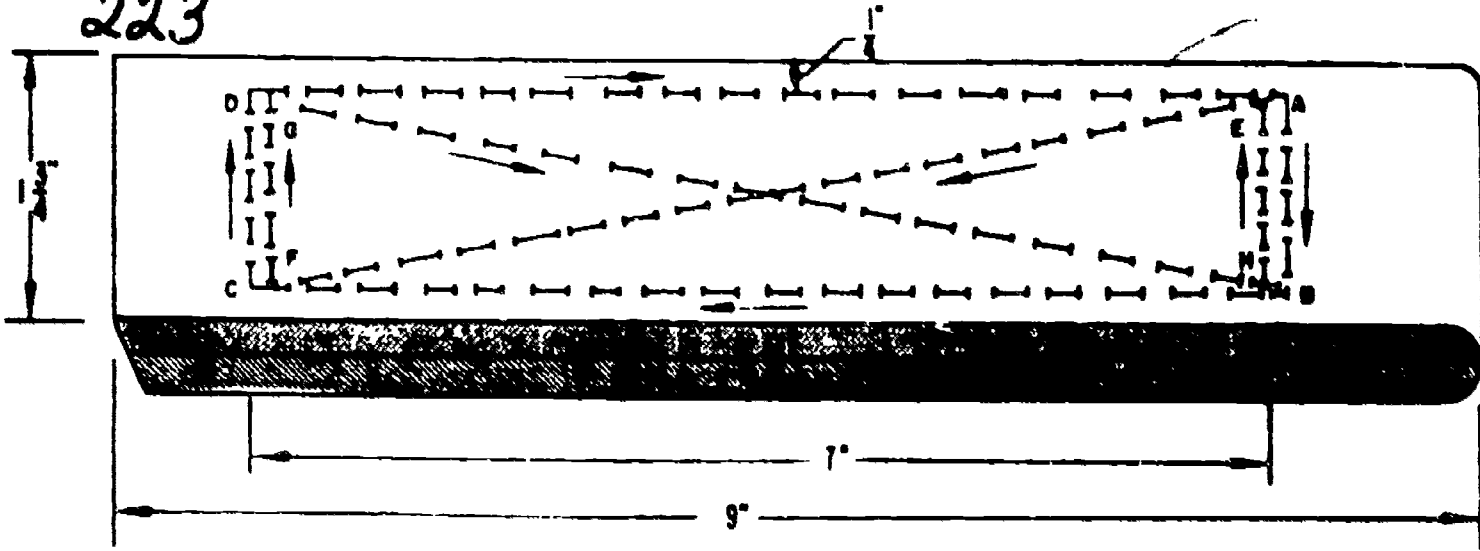

Figure 7. Box Stitching.

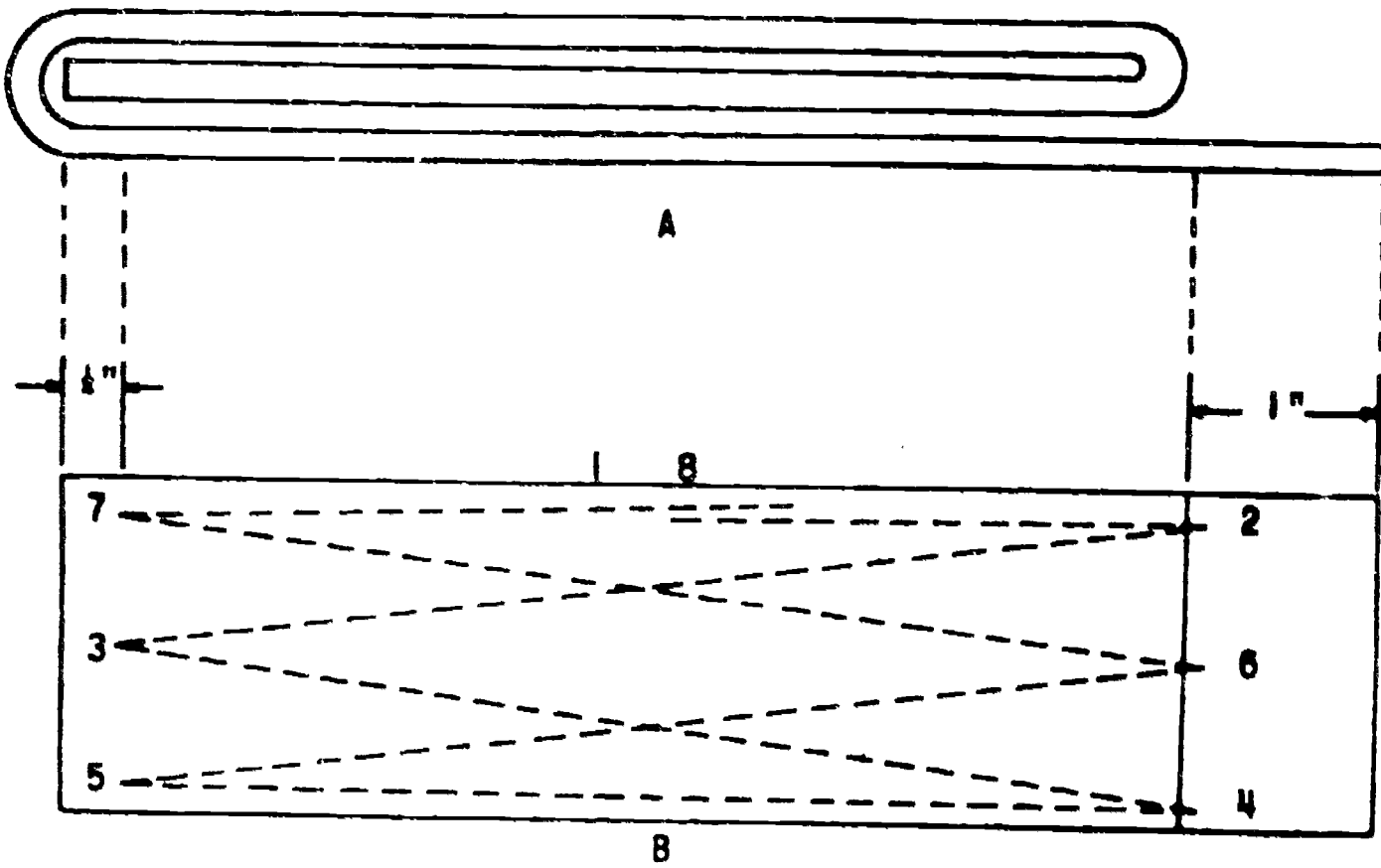

Figure 8. Cross Stitch Pattern.

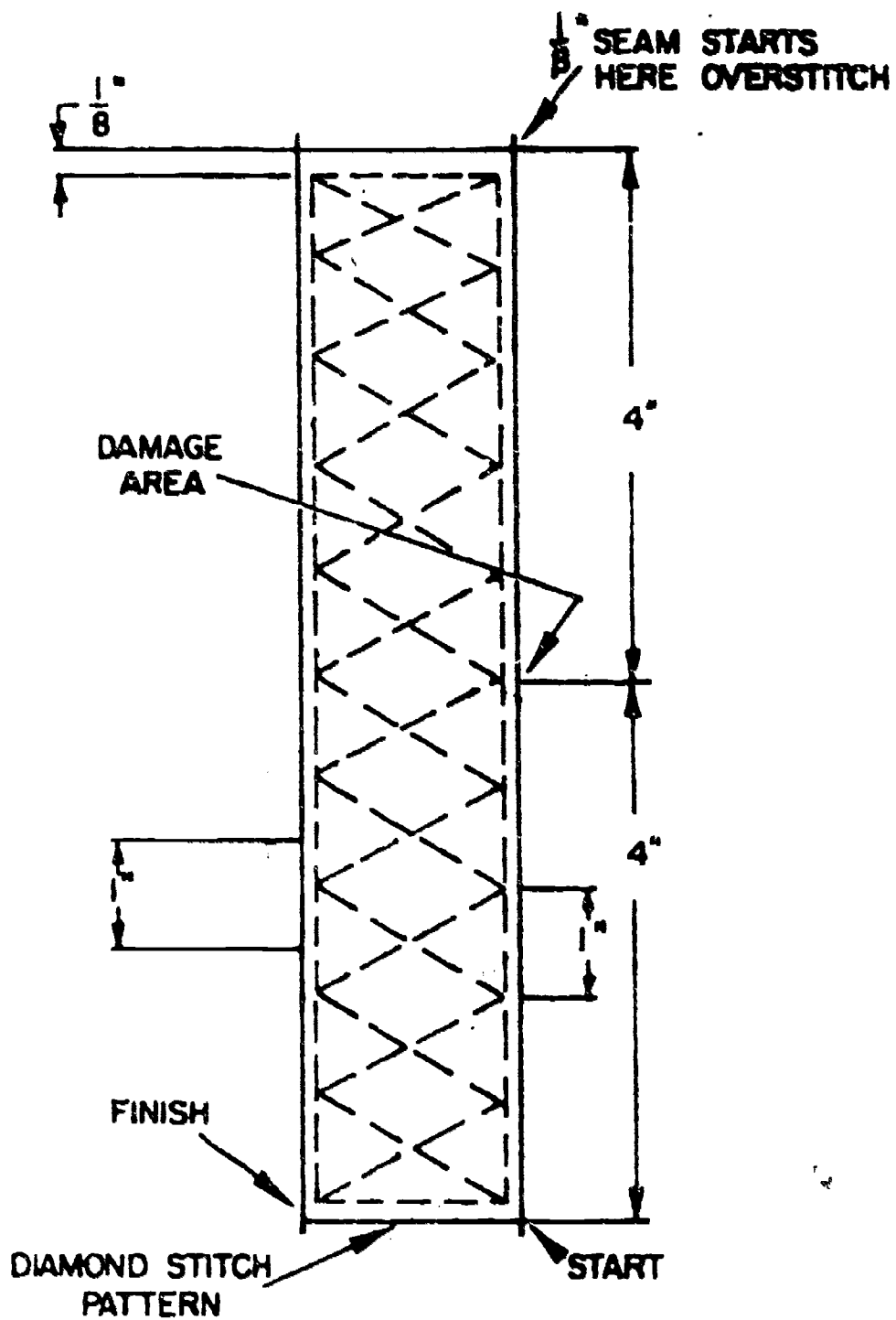

Figure 9. Damaged Suspension Line Repair For Bomber Deceleration Parachute.

225

EXERCISE 7

Complete the following sewing project: Sewing Box Stitching

1. Cut a piece of webbing 1 3/4" x 18".
2. Treat the end of the webbing to prevent ravelling.

NOTE: Nylon webbing must be seared by flame, soldering iron, or hot wire; cotton webbing is dipped into a hot mixture of beeswax and paraffin.

3. Fold the webbing in the center, forming a 9" length of webbing of double thickness.
4. Mark the webbing for box stitching, as in figure 7.
5. Begin to sew at A and proceed clockwise to B, D, C, and back within 1/4" of A to E.
6. Sew diagonally from E to F, then to G; FG should be within 1/4" of CD.
7. Sew diagonally GH, then HE within 1/4" of AB, to the place of beginning.
8. Backstitch three stitches exactly in the same needle holes as before, and thus lock the seam.

EXERCISE 8

Complete the following sewing project: Sewing Cross Stitch

1. Cut a piece of cotton harness webbing 20" long.
2. Fold the webbing into three plies as indicated at A, figure 8.
3. Sew the plies together, following the stitch pattern as indicated at B, figure 8, sewing from point 1 through 8. Overstitch one time at points 2, 6, and 4. The completed stitch pattern should be stitched at least 1/2".

EXERCISE 9

To repair a damaged suspension line for a bomber deceleration parachute, proceed as follows. Refer to figure 9.

1. Thread a class 7 sewing machine with 3-cord nylon thread, and adjust sewing machine to sew 6 to 9 stitches per inch. Adjust the tension so that the stitches are snug.
2. Cut a piece of new, like suspension line (4000 pound tensile strength nylon webbing) the length of the damage plus 8 inches.

NOTE: Allow 1/4" more in sewing length because of shortening caused by needle penetration of the class 7 sewing machine.

226

3. Center the splice over the damaged line.

NOTE: The splice must extend four inches beyond each end of the damaged area on the original suspension line.

4. Hand tack in three places with size "E" nylon to secure the repair to the old line for machine sewing.

5. Begin machine sewing 1/8" in from the outside edge and sew the length of the reinforcement to secure it to the damaged suspension line.

6. Approximately 1/8" from the end of the reinforcement, turn 90 degrees and sew approximately 3/4" across the end to the opposite side of the repair.

7. Make another 90 degree turn and sew up the other side of the reinforcement until you are 1/8" from the end.

8. Make another 90 degree turn and sew across the end to your original starting point.

NOTE: You should now have sewn the reinforcement to the damaged suspension line with a rectangular box stitch pattern.

9. From your original starting point, sew diagonally across to the first pencil dot on the opposite side.

10. Continue sewing diagonally back and forth until you come to either one of the corners at the opposite end of the reinforcement.

NOTE: At this point, the diagonal stitching should appear as a large "zig-zag" pattern.

11. Stitch across the end of the reinforcement to the opposite corner.

12. Sew diagonally across to the pencil dot on the opposite side of the reinforcement.

13. Continue "zig-zagging" until you come to a corner at the opposite end of the reinforcement.

14. From this corner, stitch across to the other corner.

NOTE: The finished project's seams should appear as approximately 1" diamonds with a rectangular box stitch around them. There must not be any thread breaks in the stitching pattern. One continuous stitching pattern is necessary for strength and security of the repair.

15. Remove the tackings.

225