

DOCUMENT RESUME

ED 182 137

SE 029 778

AUTHOR Carter, Lee; And Others
 TITLE Idaho Energy Conservation Resource Guide for Industrial Arts Education.
 INSTITUTION Idaho State Dept. of Education, Boise.; Idaho State Office of Energy, Boise.; Idaho Univ., Moscow.
 SPONS AGENCY Department of Energy, Washington, D.C.
 PUB DATE 79
 NOTE 145p.; For related documents, see SE 029 772-777. Contains light and broken type.

EDRS PRICE MF01/PC06 Plus Postage.
 DESCRIPTORS *Class Activities; *Energy; *Energy Conservation; Fuel Consumption; Fuels; Heating; *Industrial Arts; Interdisciplinary Approach; Mathematics Education; *Science Education; Secondary Education; Solar Radiation

ABSTRACT

This resource guide was prepared to assist teachers in incorporating energy concerns within the school curriculum. It is intended to provide a basic framework of objectives for different subject areas and to provide examples of activities for teaching towards the stated objectives. Resources are listed to aid the teacher in developing additional activities. The resource guide is based on the assumption that its contents will provide a starting point and that teachers will go further devising lessons in energy instruction. (Author)

 * Reproductions supplied by EDRS are the best that can be made *
 * from the original document. *

U.S. DEPARTMENT OF HEALTH,
EDUCATION & WELFARE
NATIONAL INSTITUTE OF
EDUCATION

THIS DOCUMENT HAS BEEN REPRODUCED EXACTLY AS RECEIVED FROM THE PERSON OR ORGANIZATION ORIGINATING IT. POINTS OF VIEW OR OPINIONS STATED DO NOT NECESSARILY REPRESENT OFFICIAL NATIONAL INSTITUTE OF EDUCATION POSITION OR POLICY.

"PERMISSION TO REPRODUCE THIS MATERIAL HAS BEEN GRANTED BY

Kathy Puckett

TO THE EDUCATIONAL RESOURCES INFORMATION CENTER (ERIC)."



IDAHO
ENERGY CONSERVATION
RESOURCE GUIDE
INDUSTRIAL ARTS EDUCATION

ED182137

SE 029 778

IDAHO
ENERGY CONSERVATION RESOURCE GUIDE
for
INDUSTRIAL ARTS EDUCATION



John V. Evans
Governor

James M. Cassetto
University of Idaho
Project Director

Kathy Puckett
Idaho Office of Energy
Project Coordinator

Idaho Office of Energy
Statehouse
Boise, Idaho 83720

Fall, 1979

In cooperation with the Idaho Division of Vocational Education
and the University of Idaho, Department of Industrial Education

ACKNOWLEDGEMENTS

The State of Idaho Office of Energy, Vocational Education Department and the University of Idaho, Industrial Education, would like to thank the following individuals for their time and effort in constructing this resource guide:

Lee Carter, State Supervisor of Industrial Education
Miles Carroll, Assistant State Supervisor of Industrial Education
Don Brigham, Lowell Scott Junior High School, Meridian
Chris Tiel, West Junior High School, Nampa
Milton McDaniel, Caldwell High School, Caldwell
Don Taylor, Lowell Scott Junior High School, Meridian

A special thank you to Idaho Office of Energy staff members:

Marj Pratt and Barbara Bassick

The publication of this booklet was supported by the U.S. Department of Energy. The information is the result of tax-supported research and as such is not copyrightable. It may be freely reprinted with the customary crediting of the source. The Idaho Office of Energy would appreciate notification of any reprinting of this information.

TABLE OF CONTENTS

FIRST STUFF: INTRODUCTION	1
GOOD STUFF: INFORMATION SHEETS :	5
Criteria in House Hunting	6
Weatherproofing	7
Determining Proper Percentage of Glassed Areas for Residence	9
Mobile Home Conservation Consideration	11
Home Insulation	12
Reading a Kilowatt-Hour Meter	22
Thermostat Setback	24
Reducing Heating and Cooling Costs	26
Fluorescent vs. Incandescent Lighting	27
Conserving Gas Use - Foundry Furnaces	28
Hot Water Consumption	29
Heating and Cooling Degree Day Data	31
Wind Energy Systems	35
FUN STUFF: ACTIVITIES AND PROJECTS	43
#1 Energy Attitude Survey	44
#2 Ranking Your Energy Consumption	46
#3 Energy Conservation at Home	47
#4 Organizing a School Energy Contest	53
#5 Your Utility Bill	54
#6 Computing Utility Bills	55
#7 Storm Windows and Doors	57
#8 Home Insulation	58
#9 Home Energy Conservation	60
#10 The Wasting of Energy	61
#11 Wind Power	62
#12 Muscle Power	63
#13 Fossil Fuel Recycling	64
#14 Energy Crossword Puzzle	65
#15 Appliance Audit	71
#16 Energy Conversion Pinwheel	74
#17 Residential Energy Checklist	75
#18 Solar Cell	80
#19 Wind Power Car	81
#20 Storage of Solar Heat	82
#21 Steam Propulsion	83
#22 Turbine Generating Unit Model	84
#23 Solar Domestic Water Heater	91
#24 Water Power from Flowing Water	97
WORD STUFF: GLOSSARY	103
MORE STUFF: RESOURCES	119
CREDIT STUFF: BIBLIOGRAPHY	129



FIRST
STUFF
INTRODUCTION

"The Energy Crisis can be the most effective teaching aid of the decade."

S. David Freeman
Commissioner
Tennessee Valley Authority

INTRODUCTION

In recent years Idahoans have become increasingly concerned about the energy situation and aware of the importance of energy in our lives. Experts now tell us that unless some immediate steps are taken we will not be able to provide for our future energy needs as a nation. New research and technology can alleviate part of the problem but, more immediately, we must reduce energy use. An effective energy conservation program can result in substantial energy savings, extend the life of present energy supplies, and provide us the much needed time to explore alternatives.

Traditionally, the educational system of our country has been called on to explore and resolve societal problems. The energy situation is a unique opportunity for educators since it reflects a complex set of problems that require changes in values, attitudes and lifestyles. The instructional program in a school can examine these problems and can assist in student awareness of the alternatives and consequences of energy decisions.

This resource guide has been prepared to assist teachers in incorporating energy concerns within the school curriculum. It is intended to provide a basic framework of objectives for different subject areas and to provide examples of activities for teaching towards the stated objectives. Resources are listed to aid the teacher in developing additional activities. It is anticipated that these materials will be a starting point and that teachers will go farther in this important area of instruction.

INDUSTRIAL ARTS ROLE IN ENERGY/ENERGY CONSERVATION

At no other time in the history of our country has there been a greater need for a national commitment to conserving existing energy sources and seeking new ones. A united effort by all Americans is necessary to fulfill this commitment. There is no better place or time to begin than in today's schools, with students who will be tomorrow's adults. It is their lives which will be affected by the energy practices and policies of the present.

The energy crisis brought to the attention of the world that all industrial nations are heavily dependent upon energy. The limited resources available are being used very rapidly. More than 500 billion years was required for nature to create our national resources, yet man is using them up in approximately 300 years. The basic fact is that these resources will be exhausted in the very near future. The consequences of the rapidly diminishing supply is going to be very critical to our economical and political system. The educational institutions and their administrators will be playing a major role over the next decade to increase awareness of energy and power to students of all ages and grade levels. It is at this point that industrial arts can play a key role in educating the consumers of tomorrow, the need for conserving energy and developing alternative energy sources.

The industrial arts instructors' responsibility is a critical one in teaching about the sources and uses of energy, the multi-faceted problem, and the energy conservation ethic. Attitudes, along with technology, are important in working toward solutions.

Industrial Education has identified energy as a resource worthy of study and along with other aspects of education can provide students an opportunity to gain a comprehensive understanding of energy systems.

Energy Education in Industrial Arts provides students the opportunity:

1. To work with energy systems to gain an understanding of how energy is available, converted, transmitted, stored, controlled, and conserved.
2. To understand the interdependence of society and the availability of energy.
3. To explore the context in which energy systems have developed and continue to develop.
4. To explore self and occupational areas as a basis of selecting a career related to energy systems.
5. To prepare for entry into energy related occupations and develop a base for further education.

The material in this guide is intended to give the industrial arts instructor information and general suggestions for teaching units and correlated learning activities. The Industrial Arts Energy/Energy Conservation Guide focuses on the four major areas of energy which include sources, conversion devices, transmission, and storage controls.

IMPLEMENTATION/USE OF THIS GUIDE

Technological adaptability into the American culture is the main goal of Industrial Arts Education. The interpretation of industrial technology in the United States is complex by its very nature, and impossible to separate that body of knowledge into small, single specific categories without losing the industrial context. Likewise, energy conservation (a part of American Industry) is difficult to divorce from other facets of Industrial Education.

It is not the intent of this guide to promote a separate course of study. Rather, it is to be as an inclusion into the current program as an integral part. The Industrial Arts Energy/Energy Conservation Resource Guide is designed to supplement the prevocational Power/Energy Curriculum guide, as well as, serve as a resource reference to all other facets of the Industrial Arts curriculum. To supplement rather than supplant is the key.

For instance, in a construction or woods class discussing the table saw use, it could very easily be pointed out that a three phase motor is being used versus a single phase motor. Or in a metals or manufacturing class, the instructor should promote the pre-heating of the metal for foundry castings, rather than using "cold" metal.

Likewise, in our interpretation of American Industry, we must include occupational information. Energy/Energy Conservation is a relatively new technological field. While some of the occupations are apparent; other have yet to be invented. A viable part of the occupational instruction must be in the presentation of new and emerging jobs. Plus the need for flexibility in occupational trends and changes in those occupational fields because of energy/energy conservation.



GOOD STUFF
INFORMATION SHEETS

CRITERIA IN HOUSE HUNTING 6

WEATHERPROOFING 7 & 8

DETERMINING PROPER PERCENTAGE OF GLASSED AREAS FOR
RESIDENCE 9 & 10

MOBILE HOME CONSERVATION CONSIDERATION 11

HOME INSULATION 12 thru 21

READING A KILOWATT-HOUR METER 22 & 23

THERMOSTAT SETBACK 24 & 25

REDUCING HEATING AND COOLING COSTS 26

FLUORESCENT vs. INCANDESCENT LIGHTING 27

CONSERVING GAS USE - FOUNDRY FURNACES 28

HOT WATER CONSUMPTION 29 & 30

HEATING AND COOLING DEGREE DAY DATA 31 thru 34

WIND ENERGY SYSTEMS 35 thru 42

11

CRITERIA IN HOUSE HUNTING

Whether the consumer is seeking a house, apartment, condominium, or mobile home, several general criteria should be considered: local energy costs; insulation; orientation; windows and doors; heating and cooling system(s); and water heater.

1. Regardless of the type of home, it should be well insulated. Check ceiling and floor insulation by looking in the attic and basement. It is difficult to check wall insulation of a completed structure, but the results of poor insulation can be felt or measured.

2. Consider the orientation. Will the orientation of the windows be beneficial or a problem? In hot climates, the home should be shielded from sun; in cold climates, heat from the winter sun should be utilized (e.g. windows on south face).

3. Check the windows and doors. Are they protected with storm panels? Can they be opened for ventilation? Will the amount of window area place a strain on the heating or cooling system? It is recommended that the window area be no more than 10 percent of the floor area for energy efficiency. For example, a 2000-square-foot home should have no more than 200 square feet of window area. Larger window areas may be used if they are properly planned and installed, for example, with double or triple paned glass.

4. Is the heating and cooling system in good working order? Are the ducts adequately insulated? Most consumers do not have the expertise to answer these questions and should consult a heating or air conditioning contractor. The contractor can determine the proper size and condition of the equipment and estimate costs of repairs if needed.

Certain features of older homes may make them energy-inefficient. Very old homes may not have any insulation and inadequate infiltration barriers (e.g., building paper, foil, caulking). The table below shows the R-value for the surfaces of houses as they used to be built and how they can be improved for even a cold climate.

Typical Old House Surface	R-Value	Retrofitted Old House
Roof	3	insulate with 12" fiberglass, R=43
Wall	4	insulate with 3½" blown insulation, R=18
Basement	10	insulate walls with 3½" fiberglass or 2" styrofoam, R=20
Ground floor	5	insulate with 6" fiberglass, R=25
Door	2	add storm door, R=3, substitute insulated door, R=10
Window	1	add storm window, R=2, add insulating shutters, R=10

WEATHERPROOFING

To reduce the heating and cooling costs in a home, it is important to reduce air movement in or out of the home. The cheapest, most effective way to reduce infiltration is with weatherproofing: caulking, putty, or weatherstrips. Below you will see illustrations of several locations where infiltration is likely to occur. Refer to the illustrations and use the checklist to determine the condition or existence of weatherproofing at your house.

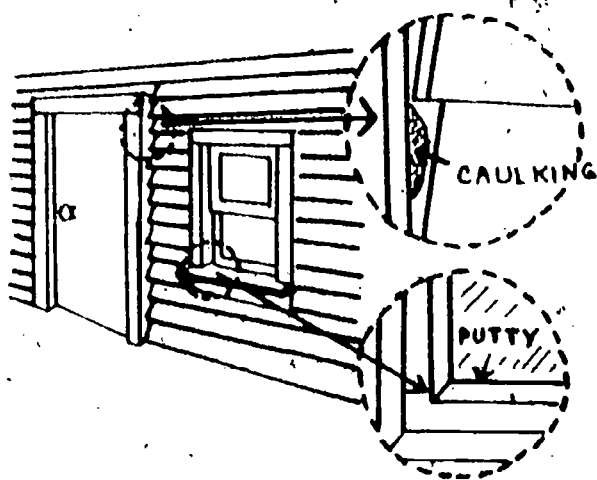

1. WINDOWS

Check the circled areas of your windows.

- OKAY - Good, unbroken weatherstripping in all places with no drafts.
- FAIR - Weatherstripping damaged or missing in some places and minor drafts.
- POOR - No weatherstripping at all and very drafty.

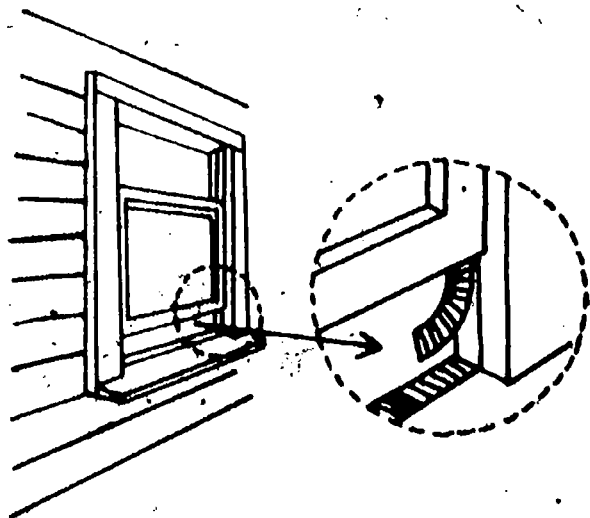

2. DOORS

Check the circled parts of the door.

- OKAY - Good, unbroken weatherstripping with no drafts.
- FAIR - Weatherstripping is missing or damaged in places with minor drafts.
- POOR - No weatherstripping and very drafty.

Conclusions:

2. AREA AROUND THE DOORS AND WINDOWS

Look at a typical door and window area and check the circled areas carefully.

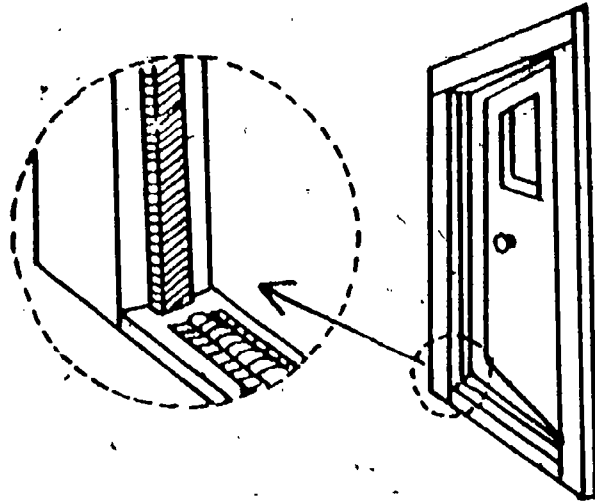

- OKAY - Caulking fills all cracks around the door frame and the putty around the window is unbroken and solid; no drafts.
- FAIR - Putty and caulking are cracked or missing, causing minor drafts.
- POOR - No caulking at all and the putty is in very poor condition causing very bad drafts.

Conclusions:

If you checked fair or poor for any of the three areas, then the weatherstripping, caulking, or putty needs to be replaced. If all areas are okay, then you don't need caulking, weatherstripping, or putty.

DETERMINING PROPER PERCENTAGE OF GLASSED AREAS FOR RESIDENCE

Since glass has much less insulative value than a wall, it is wise to use as little glassed area (windows) as possible to conserve energy for cooling and heating. There are building code restrictions and guidelines for the amount of glassed area: 10 percent of the total square footage of floor-space for the home and less than 20 percent of the total square footage of the exterior wall are generally accepted standards for residences.

It is a simple arithmetic procedure to determine if your home or classroom meets these guidelines. First try the 10-percent-of-the-floor method. In the example below, we see the square footage of the room is 300 square feet:

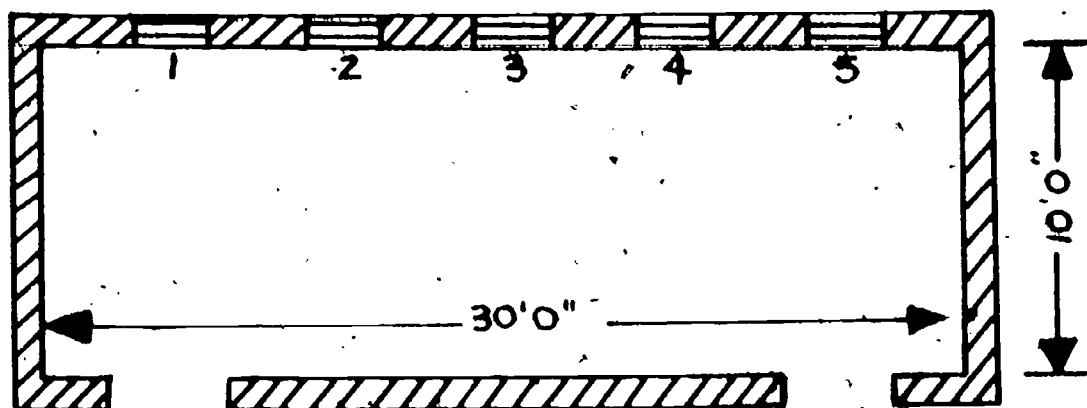

From the elevation, we see the total area is 30 square feet.

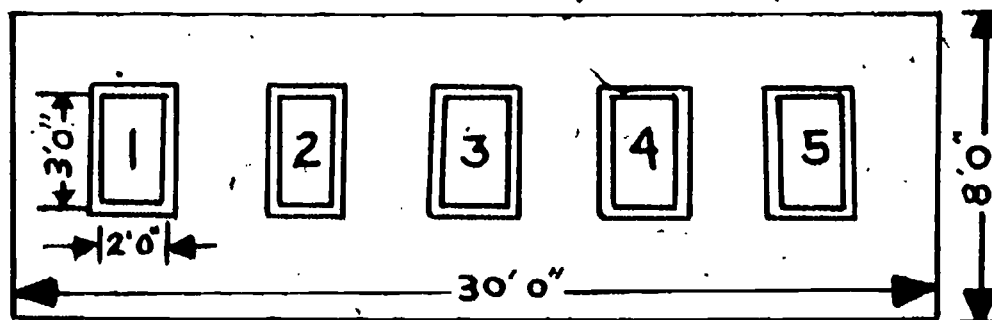

To determine the percentage of glassed area you simply divide:

$$\frac{30 \text{ glassed area}}{300 \text{ floor area}} = .10 \text{ or } 10\%$$

Now try the 20-percent-of-total-wall-area method. In the example, the total wall area is 240 sq. ft. since $8' \times 30' = 240$ sq. ft. The glassed area is 30 sq. ft. Therefore, the percentage of glassed area is:

$$\frac{30}{240} = .125 \text{ or } 12.5\%$$

Using either method, the glassed area is within the guidelines.

Now determine if your classroom or home meets the guidelines.

Method I: 10% of floor area

Total Floor Area _____ sq. ft.
Total Glassed Area _____ sq. ft.

$$\frac{\text{glassed area}}{\text{floor area}} = \text{_____} = \text{_____}\%$$

Method II: 20% of wall area

Total Wall Area _____ sq. ft.

Total Glassed Area _____ sq. ft.

$$\frac{\text{glassed area}}{\text{walled area}} = \frac{\quad}{\quad} = \quad \%$$

Suggestions:

1. Try both methods in the classroom before trying to tackle your home.
2. This makes a good group activity.
3. This Activity may be used in conjunction with reading floorplans and measuring interior spaces.
4. Remember to measure only the glassed area of windows -- not the frames, too.
5. Note that weather changes will also affect heating and cooling energy uses.

MOBILE HOME CONSERVATION CONSIDERATIONS

When you buy a mobile home, check to see if it meets the Mobile Home Construction and Safety Standards established by the U.S. Department of Housing and Urban Development (HUD). If a new mobile home meets the basic HUD requirements for insulation, infiltration, and condensation control, a permanently affixed label of certification should be found on an interior wall. The certification label will give the climate conditions the mobile home is suited for and the capacity of the heating and cooling equipment. Mobile home buyers may also consult the local Mobile Home Association for guidelines in purchasing a mobile home, site selection, and maintenance. Of course, it is wise to seek out the most reputable dealers in an area.

Mobile homes have several common problems related to energy efficiency: thin walls, ceilings, and floors; detachment from the ground; metal exteriors; and elongated, compartmentalized interiors. One of the most cost-effective energy conservation measures for mobile homes is the addition of a skirt or foundation, which encloses the area under the mobile home. Properly installed skirting acts as added insulation. Vents should be provided in the skirting to allow for air circulation, to prevent moisture buildup, and to provide air for the heating system. Also, storm windows and doors may be added, or the installation of 4-to-6-mil plastic sheeting will reduce heat loss and gain. Although it is very difficult to add insulation, rigid foam insulation boards applied to the interior of the home and on the ceiling may be particularly beneficial. [Caution: some rigid foam is very flammable and should not be used; check the insulation manufacturer's specifications.] Also, urethane can be sprayed on the roof for insulation; however, it should be coated with a sealer. Batt insulation can be installed under the floor. The compartmentalized interiors of some mobile homes impede the flow of air and make heating and cooling difficult. On the other hand, the space in most mobile homes is carefully engineered to give maximum usable space within the outside dimensions.

Proper siting of the mobile home on its lot can also reduce energy consumption. In cold climates the long sides should face north and south to take advantage of the winter sun. However, a carport, fence or planting should be provided on the north side for wind protection. In the warmer climates, the long sides should face east and west to catch the cooling breezes. Storm winds should be avoided.

HOME INSULATION

With rising energy costs, families are considering all possible ways to reduce their home heating bills. A well insulated home, new or old, will reduce costly energy bills.

Today's home buyers may choose from an almost unlimited variety of styles and sizes of homes. The choice is influenced largely by total initial cost and the amount of monthly payments. Seldom are estimated operating expenses considered, yet these payments are as demanding as the mortgage. The cost of thermal comfort in a home is frequently the largest item of operating expense and should exert a major influence in the home buyer's decision.

Why Insulate?

If you would like lower heating and cooling costs, a more comfortable home reduced maintenance, and a better investment, plan on ample insulation in your home. Insulation provides resistance to the flow of heat either out of the home in the winter or into the home in the summer. Recommendations given in this publication are based on a payback in energy savings in 12 or less years. As the cost of fuel rises above 1977 prices, payback for insulation used will be more rapid.

Types of Insulation

All building materials have some insulating value; however, insulation is generally associated with lightweight, porous, bulky materials with many dead air spaces. Insulation values for various building materials are shown in Table 1. The comparative insulation values are indicated as "R" values. "R" value describes the ability of a material to resist heat flow. The greater the "R" value, the better the insulating value. The "R" value is normally indicated on the insulation material itself or in charts, either per inch of thickness of the material or for a listed thickness of material. For reflective insulation materials such as aluminum foil, the "R" value is not based on thickness of the foil but on its equivalent effectiveness as a surface to resist heat flow by reflecting back the heat. To be an effective reflector of heat, the reflecting surface must be associated with an air space next to its reflecting surface.

The designation perm is now widely used for the unit of permanence and is a convenient substitution for the unit which is defined as water vapor flow in grains per hour per square foot per inch of mercury vapor pressure difference (one pound of water equals 7,000 grains). In common terms, perm rating is the capability of a membrane to resist passage of moisture vapor through itself--the lower the perm rating number, the greater the resistance to moisture penetration.

Insulation is produced in several common forms from a wide variety of materials. Those types most frequently used in dwellings are batt and blanket, loose-fill, rigid, formed-in-place, and reflective.

* Modified and distributed by the University of Idaho Cooperative Extension Service. Credit is given to Walter E. Matson, Extension Agricultural Engineer at Oregon State University, Corvallis, Oregon

Batt and blanket insulations are made from processed fiberglass, rock wool, or cellulose fibers. One side of the batt or blanket normally has an attached vapor barrier. (See discussion on vapor barriers.) This may be either an asphalt paper or a reflective metal foil. Batts and blankets vary in thickness from 1 to 6 1/2 inches and are made in widths to fit spaces of 16, 24, and 48 inches on center. Batts are usually 4 feet long. Blankets may be purchased in rolls of various lengths. Batts and blanket insulation also can be purchased without the vapor barrier attached.

When working with fiberglass insulation, use protective gloves. If installing it under floors, use gloves plus a protective face shield to prevent fiberglass dust and particles from entering eyes, throat, and lungs.

Loose-fill insulations are made from rock wool, cellulose fiber, and fiberglass. It is usually available in bags or bales. Loose fill insulation is well adapted for use in walls and ceilings of existing and new buildings, when proper vapor barriers are used.

Rigid board or slab insulations are made from cellulose fiber, fiberglass, polystyrene, polyurethane, cork, and others. Some of these are highly vapor resistant and can be used without additional vapor barrier if the edges between boards or slabs are caulked with proper vapor resistant compounds. Polystyrene insulation boards formed by an extrusion process and expanded polyurethane offer good resistance to water vapor transmission. Expanded polystyrene, called molded bead board, should not be used without an additional vapor barrier since its perm rating is several times higher than that for extruded polystyrene or expanded polyurethane. Generally those insulation materials that have a perm rating less than 1.0 per inch of thickness can be considered for use without a vapor barrier.

Formed-in-place insulations are available as liquid components or combinations of liquids and solids and include sprayed and plastic foam types. Because of the need for special equipment and techniques required for installation of most formed-in-place insulations, it is best to have the work done by licensed commercial applicators. The plastic foam types are generally compounds of urethanes or urea-formaldehydes. Others combine a treated cellulose material and a liquid glue that is sprayed on a building surface. One should be cautious in the use of foams since some are highly flammable and must be protected with a 1/2 inch gypsum board or an equivalent thermal barrier or fire-resistive materials having a finish rating of not less than 15 minutes.

Urea-formaldehyde foams are not moisture resistant without a special covering. Testing labs indicate that water vapor transmission per inch of thickness of urea-formaldehyde is high.

One research report indicates that it varies from 50 to 100 perms per inch thickness. Another report indicates the perm rating is 26 perms (average) as tested under accepted testing procedures. Remember that insulation materials that have a perm rating of less than 1.0 per inch of thickness can be considered for use without a vapor barrier.

Reflective insulation consists of reflective foils such as aluminum, that interrupt radiant heat. To be effective the foil surface must face an air space of at least 3/4 inch and maintain a highly reflective surface. Greatest effectiveness in the reduction of radiant heat losses is obtained

when the reflective air space is 4 inches from and parallel to the next surface. Generally, reflective insulation in walls and ceilings is used as a combination vapor barrier and reflective surface, with foil attached to batts or blankets.

When reflective materials are used under floors, holes must be punched into the reflective foil every 12 inches along the low point of the foil to drain off any standing water or future condensate water. The foil layers must not form an air tight chamber. Dust or oxidation on these surfaces will reduce the foil's effectiveness to reflect radiant heat.

How Much Insulation is Needed?

How much insulation should be used in the walls, ceiling and under the floors? Should you use single pane glass? Should you add storm windows? Will weather stripping pay? These are questions that everyone should want to have answered.

To help determine the best combination of energy-conserving measures for your climate, fuel costs, and home, proceed as follows:

1. Determine degree-days for your location. Use local weather data of city nearest you that is listed in Table 2. (Heating needs are in degree-days; the higher the number, the more energy needed to heat your home.)
2. Determine "heating index" from Table 3. Follow your "fuel/heating system" line across to present "cost of fuel," then down to your area degree-day line to find heating index.
3. Use Table 4 to select suggested insulation and storm door/window needs for your heating index as determined above. Tables 3 and 4 are partially based on information published by U.S. Department of Commerce (National Bureau of Standards) and Department of Housing and Urban Development.

For example, if you live in Boise and heating gas costs 41 cents per therm and your furnace has 70 percent fuel efficiency, the heating index should be between 29 and 35 (Boise has 5570 degree-days of heating). The suggested combination of insulation "R" values for the various structural elements of the home.

Attic or ceiling R-33

Walls R-16

Underfloor (unheated space) R-19

Heating ducts R-19

Use storm doors and windows.

Farmer Home Administration suggest a total of R-20 for the walls for homes in areas of more than 2,500 degree days. An uninsulated wall with siding and interior walls has an R value of about four (R-4). This would require insulation with R-16 insulation.

Table 1. Approximate Insulation Value of Various Building Materials

	Insulation Value (R)	
	Per Inch Thickness	(For thickness listed)
1. Batt and blanket insulation Fiberglass, rock wool, cellulose	3.1-3.7	
2. Fill-type insulation		
Cellulose	3.1-3.7	
Fiberglass or rock wool	3.0-3.5	
Vermiculite (expanded)	2.13-2.27	
Urea-formaldehyde (foamed)	4.4-5.5	
3. Rigid insulation		
Expanded polystyrene extruded	4.0-5.9	
Expanded polyurethane	5.8-6.25	
4. Building materials		
Brick, high density	0.11	
Concrete, poured	0.08	
Concrete block, 3 hole, 8"		1.11
Lumber, fir or pine	1.25	
Plywood, 1/2"		0.62
Particle board, med. density	1.06	
Insulating sheathing, 25/32"		2.06
Gypsum or plaster board, 1/2"		0.45
5. Window glass, includes surface conditions		
Single glazed		0.86
Single glazed with storm windows		1.82
Double pane insulating glass		1.5-1.75
Triple glazed		2.79
6. Air space (3/4"-4")		0.96
7. Floor, (1) vinyl covering, no insulation		3.6
Floor, (1) carpet/rubber pad, no insulation		4.9
Floor, (1) carpet/rubber pad, R-11 insulation		15.9
Floor, (1) vinyl covering, R-11 insulation		14.6
Wall, exterior siding, no insulation, interior sheet rock		4.0-4.3

(1) Floor construction - 1/2" plywood, 2" T&G wood, 15 pound felt paper.

Table 2. Degree-days in a normal heating season in selected Idaho cities

City	Degree-days
Aberdeen	7060
Ashton	8560
Boise	5570
Burley	6560
Cambridge	6730
Cascade	8110
Driggs	8240
Dubois	8170
Emmett	5250
Grangeville	6580
Idaho Falls	7630
Kellogg	7740
Lewiston	5310
Malad	6860
McCall	8760
Montpelier	8870
Moscow	6350
Parma	5730
Payette	5610
Pocatello	6770
Preston	7000
Salmon	7600
Sandpoint	7080
Shoshone	6650
Sun Valley	10340
Twin Falls	5930

Table 3: Determining heating index

Fuel/heating system	Cost of fuel ¹								
	Cents	Cents	Cents	Cents	Cents	Cents	Cents	Cents	Cents
Oil/gallon (70% eff) ²	49	59	65	72	86	100	118	144	
Oil/gallon (50% eff) ²	35	41	46	51	61	72	82	103	
Gas/therm (70% eff) ²	35	41	46	51	62	72	82	103	
Gas/therm (50% eff) ²	25	30	33	36	44	51	59	73	
Resistance Elec./kwh	1.7	2.0	2.25	2.5	3.0	3.5	4.0	5.0	
Heat pump (1.7 cop) ² /kwh	2.9	3.4	3.8	4.3	5.1	6.0	6.8	8.5	
Heat pump (2.0 cop) ² /kwh	3.4	4.0	4.5	5.0	6.0	7.0	8.0	10.0	

Degree/days	Heating index								
5,000	25	29	33	37	44	51	59	73	
6,000	30	35	40	44	53	62	70	88	
7,000	35	41	46	51	61	72	82	103	
8,000	40	47	53	59	70	82	94	117	
9,000	45	53	60	67	79	92	106	132	
10,000	50	59	67	76	88	102	118	149	

¹Include all taxes, surcharges, and fuel adjustments.

²Efficiency you as homeowner realize from fuel purchased for your particular heating system.

Table 4. Suggested combinations of home insulation techniques by heating index

Heating index	Attic insulation	Wall insulation	Floor insulation (unheated space)	Duct insulation	Storm doors and windows, weather stripping
13-20	R-30	R-11	R-11	R-11	no
21-27	R-30	R-16	R-19	R-11	yes
28-35	R-33	R-16	R-19	R-19	yes
36-45	R-38	R-16	R-22	R-22	yes
46-60	R-44	R-16	R-22	R-22	yes
61-85	R-44	R-16	R-22	R-22	(glass) triple
85-150	R-44	R-16	R-33	R-22	(glass) triple

¹The total R value of the wall, including insulation (R-16), structural wood, exterior siding, surface film resistances, and interior wall would approach R-20.

Relative Effectiveness of Insulation

Table 5 shows comparative heating costs for various structural elements in an average 1,250 square foot home using suggested "R" values of insulation versus an uninsulated element. The heating degree-days index is 4,854, the outside design temperature 17°F., and the cost of electricity 2.5 cents per kwh.

For older homes consider adding insulation to the ceiling first. The ceiling has the biggest source of heat loss in most homes. If your home ceiling already has 6 inches or more of insulation (R value is 19 or higher), you should look elsewhere to reduce energy costs. Ceilings with 4 inches (R 14-16) or less insulation are in need of added insulation. When adding batts to the top of existing ceiling insulation, use only uncovered batts (batts without a vapor barrier covering). A vapor barrier on top of the existing insulation would trap water vapor in the insulation.

Next place to look for heating energy reductions is under a floor that is over unheated spaces. Batt type insulation is recommended under floors. Use the amount of insulation suggested for your locality as determined by the heating index. Be sure your water pipes under the floor in unheated spaces are protected from freezing and that heating ducts in any unheated space are wrapped with insulation. It has been estimated that the average home's uninsulated heating ducts in unheated crawl space lose as much as 40 percent of the heat being supplied to the ducts. Wrap at least 3 1/2" of insulation (R-11) around heating ducts in unheated spaces to reduce heating energy losses.

If you have single pane windows, the addition of storm windows would provide another reduction in heating costs. In some homes, the addition of storm windows would be one of the first areas to consider in reducing heat losses.

Figure your walls as one of the last areas to insulate. Unless you are planning to do extensive remodeling, you will find it difficult to add insulation that would not cause a moisture problem in the wall. A major concern with blowing or foaming insulation in the wall of existing homes is moisture. All insulated walls should have a vapor barrier on the warm interior side.

Table 5. Comparative heating costs for an insulated versus an uninsulated structural element.

Amount of Insulation	Location	Area Sq. Ft.	Approximate Heating Costs/Year	
			Insulated	Uninsulated
None ¹	Floor	1,250		\$113.77
R-11	Floor	1,250	\$44.79	
None	Ceiling	1,250		273.00
R-30	Ceiling	1,250	21.33	
None	Wall	996		124.64
R-11	Wall	996	41.37	
Single glass	Windows	144		122.86
Double glass	Windows	144	73.72	

¹Standard construction practices with no insulation installed

Vapor Barriers

A typical family of four converts 3 gallons of water into water vapor in the home each day. A vapor barrier is needed to restrict the penetration of water vapor into and through insulation where it may condense either in the insulation or on other components of the wall and ceiling structures. This condensation would result in wet insulation, rotting wood structural members and, in some cases, peeling paint. Most batt and blanket insulations have a vapor barrier attached to one side. The barrier should always be installed on the warm side (the side next to the living area) in the home. Install a vapor barrier on both the sidewalls and ceiling and under the floors that are over an unheated space. The vapor barrier under the floor must be right next to the flooring or its underlayment. Make vapor barriers continuous and be sure to patch any holes punched during installation. To keep water vapor from being drawn up out of the earth, cover the ground

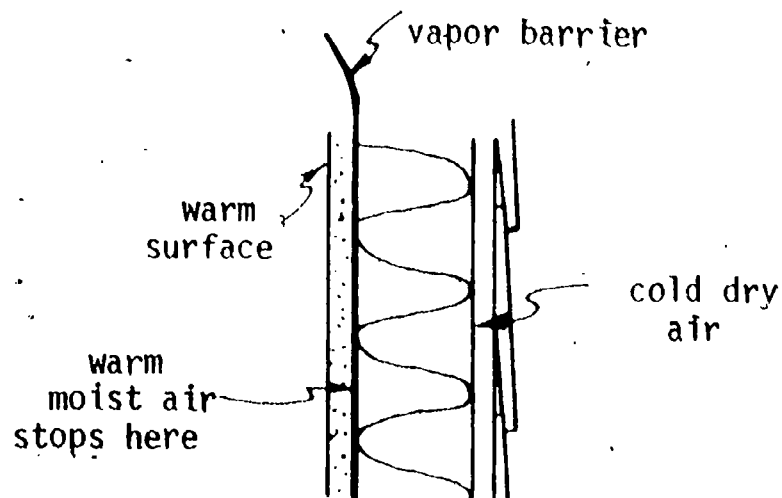

under a crawl space of a home with a 6 mil plastic sheet. Be sure any holes and edges on the covering are patched and taped with water resistant tape. All joints should be lapped 12 inches and taped.

Be sure that the foundation area has adequate water drainage. A high water table could force the plastic apart and greatly increase moisture problems under the home.

In insulating existing homes fairly good moisture protection may be obtained by one of these methods: (1) apply a 4 to 6 mil thick plastic sheet over inside of existing walls and cover it with additional wood or sheet rock, (2) apply two or three coats of leafing aluminum in varnish, phenolic formulation, or alkyd paints, (3) apply two or more coats of a good alkyd base semigloss paint over a primer coat of leafing aluminum paint, (4) cover the walls and ceiling with a washable plastic wallpaper, (5) apply three coats of good quality semigloss enamel on smooth sheet rock, plaster or wood, (6) apply three coats of urethane varnish to wood paneling.

When buying paint for use as an interior vapor barrier, check the label on the paint container. Some manufacturers are listing the perm ratings for their paints, primers, and sealers.

Latex paints, stains, and water repellent preservatives do not effectively exclude moisture vapor. Their ability to restrict moisture vapor is considered to be less than 20 percent effective. The other vapor-barrier treatments listed above should restrict 75 percent or more of the barrier. It is desirable for a vapor barrier to have a rating of one perm or less.

Ventilation

Attics should be ventilated to remove any water vapor that gets through the vapor barrier. If signs of condensation are noted after one heating season, add more attic vents. If there is no vapor barrier in the ceiling, provide 1 square foot of gable vent area for each 150 square feet of ceiling area. Place half of the vent area in each gable. If a vapor barrier is placed in the ceiling the gable vent area can be reduced by half.

The vent area may also be reduced to 1 square foot per 300 square feet of ceiling if at least 50 percent of the required ventilation area is provided by vents located in the upper portion of the space to be ventilated. Have upper vents at least 3 feet above eave or cornice. The balance of the ventilation should be provided by eave or cornice vents.

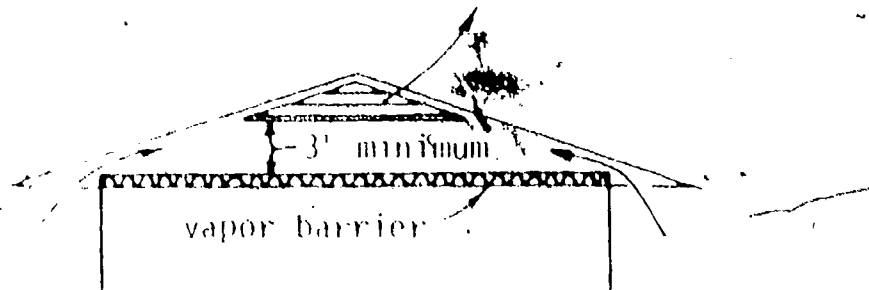

To provide space for R-30 and greater insulation amounts in the ceiling and to maintain proper ventilation flow from eaves over ceiling insulation, new homes should use truss designs similar to that shown using a 12" minimum clearance between wall plate and roof. This would allow 10 inches of insulation and a 2 inch clearance for ventilation air.

The underfloor area should be ventilated by openings in exterior foundation walls. The openings should have a net area of not less than 1 1/2 square feet for each 25 linear feet of exterior wall. Locate the openings as close to corners as practicable and provide cross ventilation on at least two approximately opposite sides. The openings must be covered with a corrosion resistant wire mesh not less than 1/4 inch and not more than 1/2 inch in any dimension.

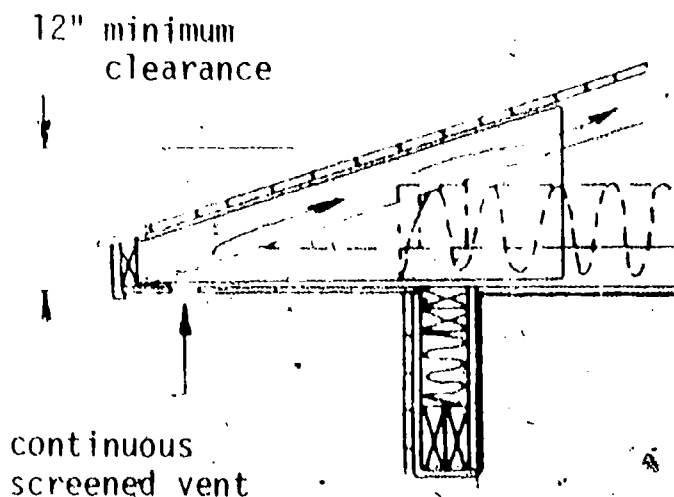

20

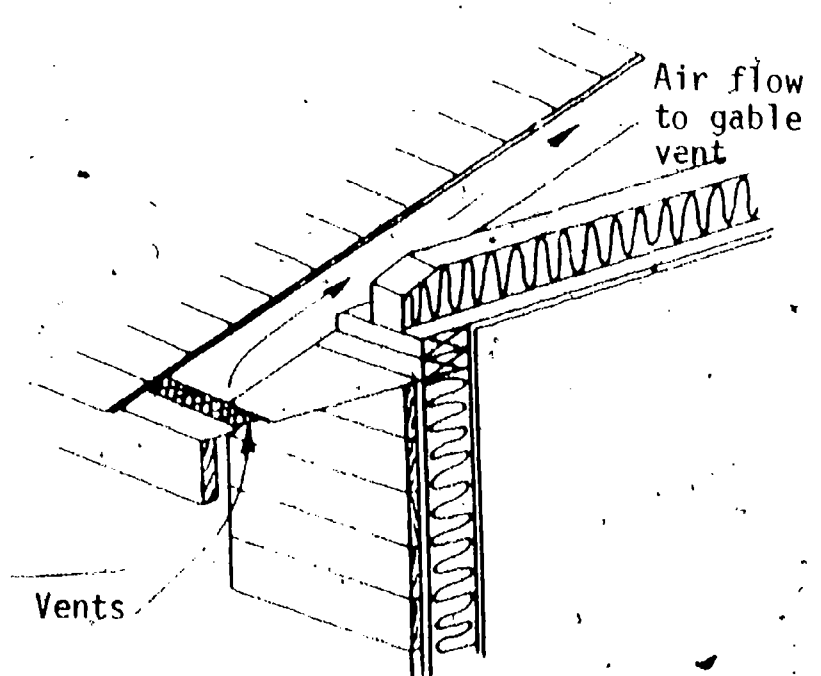

26

Ice Dams

In areas with heavy snowfall, ice dams can form on roof and eaves to trap water and cause it to leak into the house. Poorly insulated houses without proper ventilation lose enough heat to melt snow on the roof. The water flows down the roof and refreezes on the cold overhang, forming an ice dam that backs up water. Adequate attic insulation with gable and eave vents will keep the attic cold enough to eliminate most ice dam problems.

Properly installed switch controlled heating cables will maintain channels through the ice on the overhang so that water from melting snow and ice on the roof will drain away. Electric heating cable installed in gutters and down-spouts will keep them open. See your electric power supplier representative for proper installation of heating cables. Use the heating cables only when snow or ice build up occurs.

Infiltration and Ventilation Losses

These vary to a great extent depending on how tightly windows and doors fit. Infiltration losses can be reduced to a minimum with good quality construction and weatherproofing. Proper weatherstripping can normally reduce heating energy needs from 10 to 20 percent. About 1/2 air change per hour in a normal home will remove excess water vapor from cooking, bathing, washing clothes, etc., as well as removing odors and providing fresh air. A house with poorly-fitting windows and doors may have up to two air changes per hour.

Oil, gas, and wood-burning heaters need ample air for efficient combustion of its fuel. Don't waste the air that costs money to heat. Provide special air ventilation inlets for your fuel combustion heaters.

Fireplaces are a major source of infiltration losses even when the fire is burning. When the fireplace has a fire in it, it pulls large quantities of air from the room for combustion. A fireplace can draw from 90 cfm to 400 cfm (cubic feet per minute) of air from inside the house. Under average winter weather conditions, this could be a heat loss from the home of approximately 3,500 to 15,000 Btu per hour. Provide a fresh air inlet for your fireplace. Also provide good dampers and a glass screen to block the fireplace opening and thus reduce wasteful loss of warm air from the house.

Use glass fireplace screens only on fireplace-chimney combinations approved for use with such screens. These screens restrict air flow, which can result in higher temperatures in exhaust gases in the chimney. Unless metal piping has been designed and insulated to withstand these temperatures there may be increased fire hazard in wood or other combustible material surrounding the chimney.

Dehumidifiers

In homes with fully insulated walls and ceiling and tight vapor barriers, it may be useful to have a dehumidifier in the home. It not only reduces the moisture content of the air in the home, but will conserve the heat of the vapor that would otherwise be exhausted out of the home. One pound of water vapor contains about 1,000 Btu of heat. A relative humidity near 50 percent in the home is considered desirable.

READING A KILOWATT-HOUR METER

In order to determine the effectiveness of your energy-conservation efforts you must be able to tell how much energy is being consumed at your house. The easiest way to do this is by taking meter readings. Electric and gas meters give the total, or cumulative, energy consumption. They operate much like the odometer on a car. You must compare beginning and end readings to find out how much energy your family used over a given period of time (one day, one week, one month). For example, if your meter read 35721 kilowatt-hours on Monday morning and 35731 on Tuesday morning, it means your home consumed 10 kilowatt-hours of electricity for that day or 24-hour period.

Most electric meters have five dials organized from right to left: the rightmost indicates kilowatt-hours; the next dial tens of kilowatt-hours; then hundreds; and so on. But the dials alternately rotate clockwise and counterclockwise. You should record the digit the indicator has just passed. Study the illustrations and readings below:

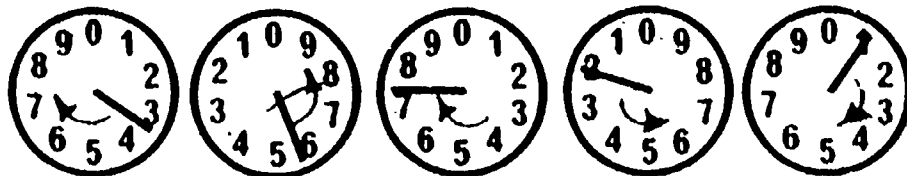

READING = 35721



READING = 66190

The dials of a gas meter are much like that of an electric meter except that there are usually only four dials with markings representing 100 cubic feet on the rightmost dial. In the illustration on the next page, the reading of 4846 represents 484,600 cubic feet of gas.

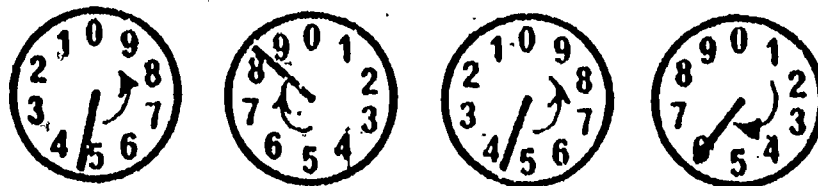

READING = 4846

If, after one day, the reading were 4876, then the consumption that 24-hour period would have been 3,000 cubic feet of gas.

$$\begin{array}{r}
 487600 \\
 -484600 \\
 \hline
 3000 \text{ cubic feet of gas}
 \end{array}$$

Now check your meter and record your findings:

Initial Reading _____
Final Reading _____

Consumption for designated
time period _____

Now institute one or several energy-conserving practices (reset thermostat; clean filters; cut down on use of lights, appliances, TV; take short showers) and record your findings: (Use the same time period as before)

Initial Reading _____
Energy Conservation Measures Instituted _____

Final Reading _____
Consumption for designated
time period _____

Was there a reduction in consumption when conservation was practiced?

Suggestions:

1. Use a time period of at least a week.
2. Ask your local Utilities for information or demonstrations.

THERMOSTAT SETBACK

Now that you can read your meter, you can investigate the effects of thermostat setback on the energy consumption at your residence. During the cooling season, thermostats should be set up to 78°F to reduce the use of mechanical air conditioning and during the heating season, set down to 65°F. For additional savings, the thermostat can be set back to 60°F during the night. The effect of these thermostat setbacks will vary from residence to residence, but should be significant.

To test the impact of thermostat setback at your home, first determine the weekly consumption of energy prior to the setback. Read your gas, oil, or electric meter one week before the setback and read it a second time exactly seven days to the hour later.

For example:

<u>First Reading</u>		<u>Second Reading</u>	
Meter Reading:	14276 kwh	Meter Reading:	15101 kwh
Date:	9/8/77	Date:	9/15/77
Time:	8:00 a.m.	Time:	8:00 a.m.

The energy consumed by the example home for the week was 925 kwh (15101 kwh - 14276 kwh = 925 kwh)

Immediately after the second reading set back the thermostat 5°F lower if heating and 5°F higher if cooling. Then take a third meter reading exactly seven days later.

For example:

<u>Third Reading</u>	
Meter Reading:	15897 kwh
Date:	9/22/77
Time:	8:00 a.m.

The energy consumed by the example home for the week with the set back is 796 kwh. To determine the possible savings, find the difference between the first week's consumption and the setback week's consumption.

Using the example home:

$$\underline{925 \text{ kwh}} - \underline{796 \text{ kwh}} = \underline{129 \text{ kwh}}$$

Now try the test at your residence.

<u>First Reading</u>	<u>Second Reading</u>	<u>Third Reading</u>
Meter Reading: _____	Meter Reading: _____	Meter Reading: _____
Date: _____	Date: _____	Date: _____
Time: _____	Time: _____	Time: _____

First week's consumption:

$\frac{\text{meter reading 2} - \text{meter reading 1}}{\text{Consumption}}$

Setback week's consumption:

$\frac{\text{meter reading 3} - \text{meter reading 2}}{\text{Consumption}}$

Savings

$\frac{\text{First week's consumption} - \text{Setback week's consumption}}{\text{Savings}}$

Questions:

1. Why is it better to use a week's consumption for comparison rather than a day or an hour?
2. What could be possible reasons for finding no savings or possibly an increase in consumption during the week with the setback?
3. How much money could be saved in a year if you could realize the savings you found (if you found one) during the setback week?

REDUCING HEATING AND COOLING COSTS

The heating and cooling load of a home may be reduced by:

1. Installing storm doors and windows.
2. Properly weatherstripping and caulking windows and doors.
3. Reducing the area and number of windows and doors.
4. Using wood or insulated and/or thermal work metal for windows and doors.
5. Using a vestibule area.
6. Locating openings so as to avoid cold winds.
7. Properly locating and shielding openings to optimize the effects of solar radiation.
8. Properly locating openings for natural ventilation.

In addition to the steps already mentioned, several tips for improved maintenance are given below:

1. Dust radiators and wall or baseboard units frequently.
2. Don't store a lot of junk around furnaces or air-conditioners.
3. Keep draperies and furniture away from vents, thermostats, and equipment.
4. Don't allow vegetation to surround or impinge on outdoor equipment.
5. Do not abuse the equipment -- call a serviceman.

FLUORESCENT VS. INCANDESCENT LIGHTING

Wattage is not a measure of the amount of light given off by a light bulb, but how much energy is required to operate it. The amount of light it provides is indicated in lumens. Bulb packages should give not only the wattage required, but also the lumens produced by the bulb. Using bulb packages, compare several incandescent and fluorescent bulbs for efficiency (lumens per watt).

For example: A 100-watt incandescent bulb may yield 1750 lumens which gives the bulb an efficiency of 17.5 lumens per watt:

$$\frac{1750 \text{ lumens}}{100 \text{ watts}} = 17.5 \text{ lumens per watt}$$

Determine the efficiency of the following bulbs, plus any others you may have.

- A. 100 watt fluorescent bulb: $\frac{\quad \text{lumens}}{100 \text{ watts}} = \quad \text{lumens per watt}$
- B. 40 watt fluorescent bulb: $\frac{\quad \text{lumens}}{40 \text{ watts}} = \quad \text{lumens per watt}$
- C. 100 watt incandescent bulb: $\frac{\quad \text{lumens}}{100 \text{ watts}} = \quad \text{lumens per watt}$
- D. 25 watt incandescent bulb: $\frac{\quad \text{lumens}}{25 \text{ watts}} = \quad \text{lumens per watt}$

1. Which type of lighting is more efficient--incandescent or fluorescent?

2. Is it more efficient to buy four 25-watt or one-100 watt incandescent bulb?

Suggestions:

1. Ask the school maintenance supervisor for empty fluorescent light bulb boxes. The information you need is on the *box*, not the bulb.
2. Have students bring in bulb *boxes* from home.
3. Check at home for the use of multiple low wattage bulbs where a larger wattage bulb might be used to save energy. But remember, a larger wattage bulb gets hotter during operation and some fixtures are not designed for the larger wattage bulbs.
4. Discuss the comparative lifetimes of fluorescent and incandescent bulbs. (Refer to Section 3.2, "lighting.")
5. Discuss the turning off and on of incandescent and fluorescent bulbs. (Refer to Section 3.2, "lighting.")

CONSERVING GAS USE - FOUNDRY FURNACES

1. Proper maintenance of the fuel air metering devices on the furnace is important.
2. Air for combustion should be filtered or cleaned.
3. Make-up air can be pre-heated by using hot gases escaping from the port in the lid.
4. Pre-heating the metal to be melted - this, in some cases, can be done by replacing the charged material on or near the furnace lid. However, do not cover the port.
5. When melting continuously keep the furnace lid closed keeping as much of the heat in the furnace and its refractory.
6. Time your melt cycle so that the molten metal does not have to be held in the furnace for any great length of time. This will also cut down on the gas pick-up.

HOT WATER CONSUMPTION

The major uses of hot water in the home are for bathing and laundry. Use the data sheet provided to estimate your family's hot water consumption for a week.

Task	Number of times/week	Multiplier (in gallons)	Quantity of Hot Water (in gallons)
Laundry loads			
tub baths		15	
showers		25	
dishwasher loads		20	
washing dishes		10	
by hand		5	

Total--

Tally the number of times per week the task using hot water occurs. Then multiply the number of times by the multiplier provided. The multiplier is the average amount of hot water required for the task. The resulting value is the quantity of hot water consumed for the task. Then add the quantities for each task to arrive at an estimate of the hot water your family uses in one week. (The average household uses about 350 gallons of hot water per week.)

You can now approximate the energy required to supply this quantity of hot water.

$$\frac{\text{quantity of water}}{\text{gallons}} \times 2.45 \text{ watt-hours/gal.} = \text{watt-hour}$$

If you use _____ gallons per week, you use approximately 52 times that per year or _____ gallons.

Calculate the energy cost for a year's consumption:

$$\left(\frac{\text{quantity of water}}{\text{gallons}} \times 2.45 \text{ watt-hours/gal.} = \text{watt-hours} \right)$$

This is _____ kwh for one year (just move the decimal 3 places to the left). Find out the rate in your area for electricity per kwh and determine the cost of one year's hot water consumption.

$$\frac{\text{yearly energy consumption for hot water}}{\text{kwh}} \times \frac{\text{cents}}{\text{rate kwh}} = \$ \underline{\hspace{2cm}}$$

How could you save money and energy for hot water at your house?

Some things to look for if your hot water consumption is high:

1. Check your water heater's thermostat--it should be set at 140°F or less.
2. Check for leaks.
3. Are the hot water pipes insulated?

Suggestions:

1. Students should bring in their tallies of frequencies from home and do the calculations as a class.
2. All of the figures and calculations in this activity are based on averages and estimates and do not indicate actual hot water use. However, by checking appliance manuals and timing showers (approximately 8 gallons of water is used per minute), a more accurate consumption figure could be obtained.

HEATING AND COOLING DEGREE DAY DATA *

HEATING DEGREE DAYS

Early this century heating engineers developed the concept of heating degree days as a useful index of heating fuel requirements. They found that when the daily mean temperature is lower than 65 degrees, most buildings require heat to maintain an inside temperature of 70 degrees. + The daily mean temperature is obtained by adding together the maximum and minimum temperatures reported for the day and dividing the total by two. Each degree of mean temperature below 65 is counted as one heating degree day. Thus, if the maximum temperature is 70 degrees and the minimum 52 degrees, four heating degree days would be produced. ($70 + 52 = 122$; 122 divided by $2 = 61$; $65 - 61 = 4$). If the daily mean temperature is 65 degrees or higher, the heating degree day total is zero.

For every additional heating degree day, more fuel is needed to maintain a comfortable 70 degrees indoors. A day with a mean temperature of 35 degrees - 30 heating degree days - would require twice as much fuel as a day with a mean temperature of 50 - 15 heating degree days, assuming, of course, similar meteorological conditions such as wind speed and cloudiness.

So valuable has the heating degree concept become that daily, monthly and seasonal totals are routinely computed for all temperature observing stations in the National Weather Service's network. Daily figures are used by fuel companies for evaluation of fuel use rates and for efficient scheduling of deliveries. For example, if a heating system is known to use one gallon of fuel for every 5 heating degree days, oil deliveries will be scheduled to meet this burning rate. Gas and Electric Company dispatchers use the data to anticipate demand and to implement priority procedures when demand exceeds capacity.

The amount of heat required to maintain a certain temperature level is proportional to the heating degree days. A fuel bill usually will be twice as high for a month with 1,000 heating degree days as for a month with 500. For example, it can be estimated that about four times as much fuel will be required to heat a building in Chicago, where the annual average is 6,100 heating degree days, as it would to heat a building in New Orleans, where the average is about 1,500. All this is true only if building construction and living habits in these areas are similar. Since such factors are not constant, these ratios must be modified by actual experience. The use of heating degree days has the advantage that consumption rates are fairly constant, i.e., fuel consumed for 100 degree days is about the same whether the 100 heating degree days were accumulated on only three or four days or were spread over seven or eight days.

+ All temperatures are in degrees Fahrenheit unless otherwise specified.

* by National Oceanic and Atmospheric Administration, U.S. Department of Commerce, Sept, 1974

Accumulation of temperature data for a particular location has resulted in the establishment of "normal" values based on 30 years of record, (see Note 1). Maps and tables of heating degree day normals, are published by the National Oceanic and Atmospheric Administration's Environmental Data Service (EDS). The maps are useful only for broad general comparisons, because temperatures, even in a small area, vary considerably depending on differences in altitude, exposure, wind, and other circumstances. Figure 1, NORMAL SEASONAL HEATING DEGREE DAYS, 1941-1970, illustrates the national distribution. Tables of normal monthly and annual heating degree days for U.S. cities provide a more accurate basis for comparison. The tables show, for instance, that Washington, D.C. (National Airport) has a normal annual total of 4,211 heating degree days, while the normal for Boston, Massachusetts (Logan International Airport) is 5,621.

Heating degree day comparisons within a single area are the most accurate. For example, March heating degree day totals in the Midwest average about 70 percent of those for January. In Chicago, the coldest six months in order of decreasing coldness are January, December, February, March, November, and April. Annual heating degree day data are published by heating season which runs from July of one year through June of the next year. This enables direct comparison of seasonal heating degree day data and seasonal heating fuel requirements.

COOLING DEGREE DAYS

The cooling degree day statistic - summer sister of the familiar heating degree day - serves as an index of air-conditioning requirements during the year's warmest months.

According to experts, the need for air-conditioning begins to be felt when the daily maximum temperature climbs to 80 degrees and higher. The cooling degree day is therefore a kind of mirror image of the heating degree day. After obtaining the daily mean temperature, by adding together the day's high and low temperatures and dividing the total by two, the base 65 is subtracted from the resulting figure to determine the cooling degree day total. For example, a day with a maximum temperature of 82 degrees and a minimum of 60 would produce six cooling degree days: $(82 + 60 = 142; 142 \text{ divided by } 2 = 71; 71 - 65 = 6)$. If the daily mean temperature is 65 degrees or lower, the cooling degree day total is zero.

The greater the number of cooling degree days, the more energy is required to maintain indoor temperatures at a comfortable level. However, the relationship between cooling degree days and energy use is less precise than that between heating degree days and fuel consumption. There is considerable controversy among meteorologists, as well as air-conditioning engineers, as to what meteorological variables are most closely related to energy consumption by air-conditioning systems. Many experts argue that because high humidity levels make people feel more uncomfortable as temperatures rise, some measure of moisture should be included in calculating energy needs for air-conditioning. The Temperature-Humidity Index has been suggested as an alternative basis for calculating cooling degree days. In addition to humidity some experts feel there are other factors, such as cloudiness and wind speed, that should be included in computation of energy needs for air-conditioning. All agree, however, that there is a need for a more effective measure of the influence of weather on air-conditioning loads.

Until a definitive study of the problem is conducted, NOAA's EDS is continuing to use and publish statistics based on simple cooling degree day calculations, employing air temperatures measured at National Weather Service Offices and cooperating stations throughout the country. As with heating degree days, normals of cooling degree days have been established, based on 30-years of record, (see Note 1). FIGURE 2, NORMAL SEASONAL COOLING DEGREE DAYS, 1941-1970, illustrates the national distribution.

34

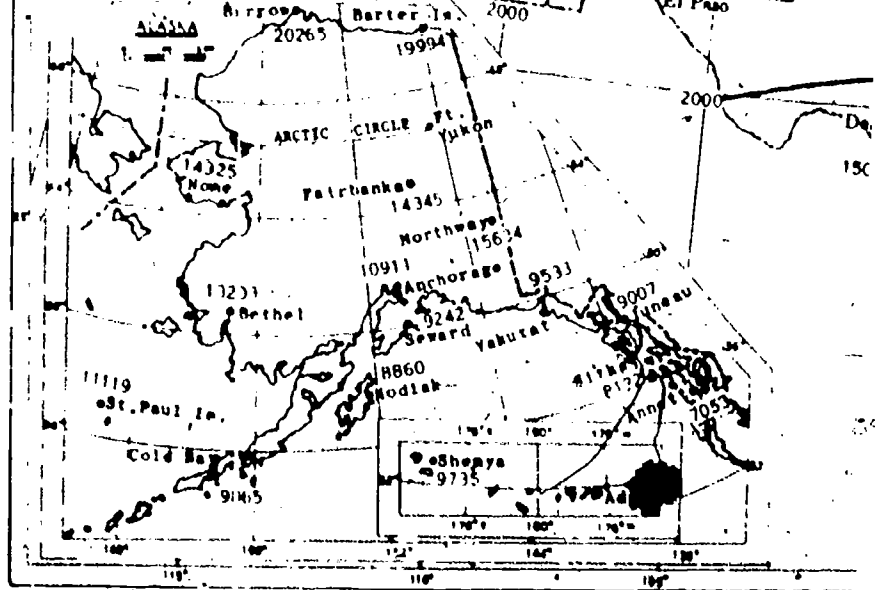
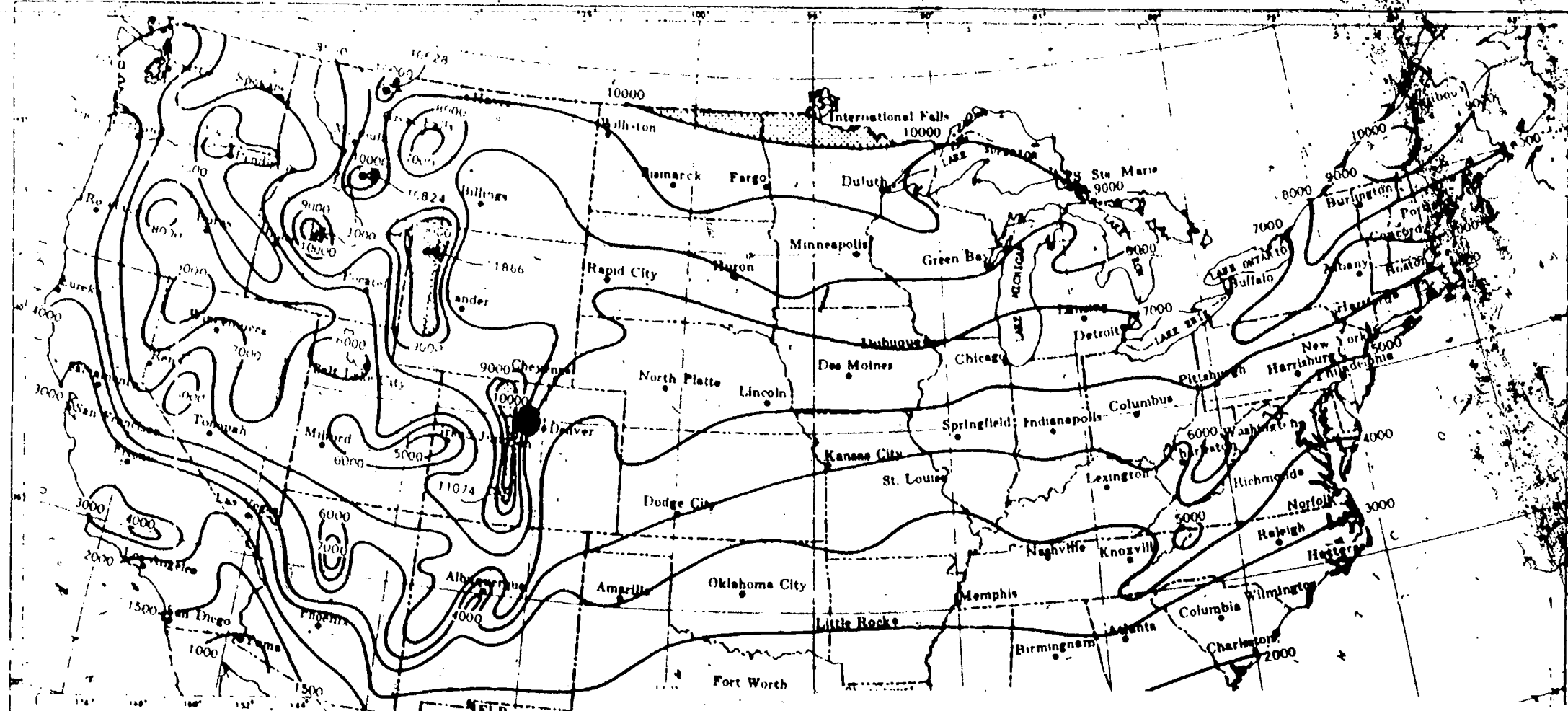

HEATING DEGREE DAYS FOR IDAHO

Aberdeen	7060	Malad	6860
Ashton	8560	McCall	8760
Boise	5570	Montpelier	8870
Burley	6560	Moscow	6350
Cambridge	6730	Parma	5730
Cascade	8110	Payette	5610
Driggs	8240	Pocatello	6770
Dubois	8170	Preston	7000
Emmett	5250	Salmon	7600
Grangeville	6580	Sandpoint	7080
Idaho Falls	7630	Shoshone	6650
Kellogg	7740	Sun Valley	10340
Lewiston	5310	Twin Falls	5930

WIND ENERGY SYSTEMS

S. A. Weeks¹ and D. R. Price²

INTRODUCTION:

Rapidly increasing costs of energy sources have caused renewed interest in the generation of power from wind. This inexhaustible source of energy also has the advantage of not creating pollution of the atmosphere. The main disadvantage of wind generator use is high cost per unit of electric power with existing systems.

The best known example of wind power is probably the Dutch windmills, which originated around the 12th century. Pumping water historically has been the main function of windmills. In many range areas they are still extensively used for stock watering in remote locations. These multi-bladed units convert rotary motion to drive a piston pump. Pumping water with windmills was and continues to be practical due to relatively low power requirements. Also, the water tank serves as a reservoir during calm periods. In general, such windmills were not very efficient, with some capacity figures indicating efficiencies below 10% for the pumping system. Low cost and equipment reliability were the main advantages.

Wind-driven electric generating plants commonly used in rural areas thirty to forty years ago provided around 3,000 watts of power for the basic needs of a homestead. Two factors contributed to the demise of these power plants: (1) the availability of electric power as utility lines were extended to rural areas, and (2) the addition of electric appliances with their accompanying power requirements. By the 1950's, manufacturers of wind electric plants could not compete with large generating stations.

In general, little information is available as to wind velocities and directions at specific locations. Such data would be a great aid in selection of the best sites for wind power units. The problem is complicated by the fact that the velocity of the wind changes rapidly even during relatively stable weather conditions. Sites with high mean annual wind velocities and close proximity to load centers are also somewhat rare.

The largest unit constructed in the United States was the Smith-Putnam 1,250 kilowatt generator installed on a hilltop in Vermont in 1941. The 15-ton blades (175 ft. diameter) rotated at a rated speed of 28.7 rpm. Electric power was fed directly into the lines of the Central Vermont Service Corporation. The rotor blades failed after several months of operation and the project was abandoned due to lack of financing.

¹S. A. Weeks, Research Associate, Department of Agricultural Engineering, New York State College of Agriculture & Life Sciences, Cornell University.

²D. R. Price, Associate Professor, Department of Agricultural Engineering, New York State College of Agriculture & Life Sciences, Cornell University.



Smith-Putnam Wind Generator Constructed in Vermont (1941)

WIND POWER POTENTIAL:

Power in the wind is governed by the following equation:

$$P = 5.02 \times 10^{-3} AV^3$$

where P = theoretical power, (watts)

A = area swept by the rotor (ft²)

V = wind velocity, (miles per hour)

As an example, a windmill with 6 ft. diameter blades presents a sweep area of 28.3 ft² to the wind. In a 15 mph. wind the power in the wind for this area would be 480 watts. However, from turbine theory, a maximum of 59.2 percent of this value can be obtained by any windmill, reducing the maximum available power to 284 watts. Now, since a well-designed impeller may obtain approximately 75 percent of the maximum available power, the power at the output shaft is reduced to 213 watts. This figure would be further reduced when converting shaft power to electricity or heat. An overall power efficiency of 30 percent is an average which could be expected from windmills. The following table indicates the power available from the wind in an overall system.

Table 1. Available power (watts) from the wind assuming a system efficiency of 30 percent

Propeller Diameter (ft.)	WIND VELOCITY (miles per hour)				
	5	10	15	20	25
4	2	19	64	152	296
6	5	43	144	341	665
8	10	76	256	605	1183
10	15	119	399	947	1848
12	21	170	575	1363	2661
14	30	232	782	1855	3623
16	38	307	1022	2423	4731
18	48	383	1293	3066	5988
20	59	473	1597	3785	7393

It should be noted that, although efficiency of a wind power system is important, in the final analysis power output per dollar input is the main criteria for judging the operation. Another factor to be considered is the gustiness of the winds. Due to gusts the energy actually obtained over a period of time may be double that calculated using the average wind velocity. This is due to the fact that power output changes with the cube of the wind speed which means that high velocity, low duration gusts have great power potential.

An estimation of the potential monthly output can be estimated by multiplying the rated output of the system by the factors in Table 2.

Table 2. Factors for estimating monthly power outputs

Average Windspeed, mph.	Multiplier Factor
8	40
10	60
12	80
14	100

For example, a wind generator rated at 2 kilowatts and located in an area with an average wind speed of 12 mph., would be expected to generate 160 kilowatt-hours per month.

HOUSEHOLD POWER DEMANDS:

A knowledge of the average energy consumption of various electrical appliances is useful in placing the problem in proper perspective. Table 3 lists many common household appliances. Average electricity consumption for a household without electric heat would be in the range of 400-600 kilowatt hours per month.

A kilowatt-hour (kwh) is simply 1000 watts used for one hour. A 100-watt light burning for 10 hours uses one kilowatt-hour.

Table 3. Estimated annual kilowatt-hours consumption of selected electrical appliances

Appliance	Est. kwh per yr.	Appliance	Est. kwh per yr.
Air Conditioner (central)	2500	Humidifier	163
Air Conditioner (room)	595	Iron	98
Blanket, electric	147	Lighting	340
Blender	15	Mixer	13
Broiler	100	Oil Burner or Stoker	410
Can Opener	5	Radio Phonograph	86
Carving Knife	8	Range	1175
Clock	17	Refrigerator-Freezer (14 cu. ft.)	1150
Clothes Dryer	993	Refrigerator-Freezer (14 cu. ft. frostless)	1400
Coffee Maker	106	Roaster	205
Dehumidifier	377	Sewing Machine	11
Dishwasher	242	Shaver	18
Fan (attic)	291	Sun Lamp	16
Fan (furnace)	394	Television (B&W)	262
Fan (roll-about)	138	Television (color)	375
Floor Polisher	15	Toaster	39
Freezer (15 cu. ft.)	1195	Toothbrush	5
Frying Pan	186	Vacuum Cleaner	46
Garbage Disposal	30	Waffle Iron	22
Grill (sandwich)	33	Washing Machine (automatic)	78
Hair Dryer	14	Washing Machine (non-automatic)	59
Heating Pad	10	Water Heater	4219
Heat Lamp (infrared)	13	Water Pump	231
Heat Pump	16,003		
Heater (electric resistance)	17,000		
Hot Plate	90		

The use of wind generation would tend to force a homeowner to stagger the use of electrical equipment in the home. Several appliances operating at the same time when not necessary would result in a larger than necessary windmill generator at a higher price.

PRESENT WIND GENERATOR SYSTEMS:

Several companies are currently active in producing small wind generators. These are mainly high speed propeller units which change direction as the wind shifts. A governor is used to prevent overspeeding damage in high winds. The output shaft drives a dc generator that charges batteries. Power is then drawn from the batteries, either directly as dc, or after being converted to ac.

Typical cost of a 2 kilowatt unit would be about \$4,500.00 while one with a 6 kilowatt rating would be approximately \$10,000.00 for the complete system. Cost per kilowatt hour produced would be in the range of 15 to 25 cents, based on a fifteen year period of operation.

At present, these electricity costs are very high compared to utility power cost of approximately 3 1/2 cents per kilowatt-hour. However, in remote locations the costs connected with running lines to the site may be high. In these cases, wind powered generators may compete with other types of portable generators using diesel, gasoline or propane fuels. On the following pages, four types of wind rotors are sketched and their operating characteristics described.

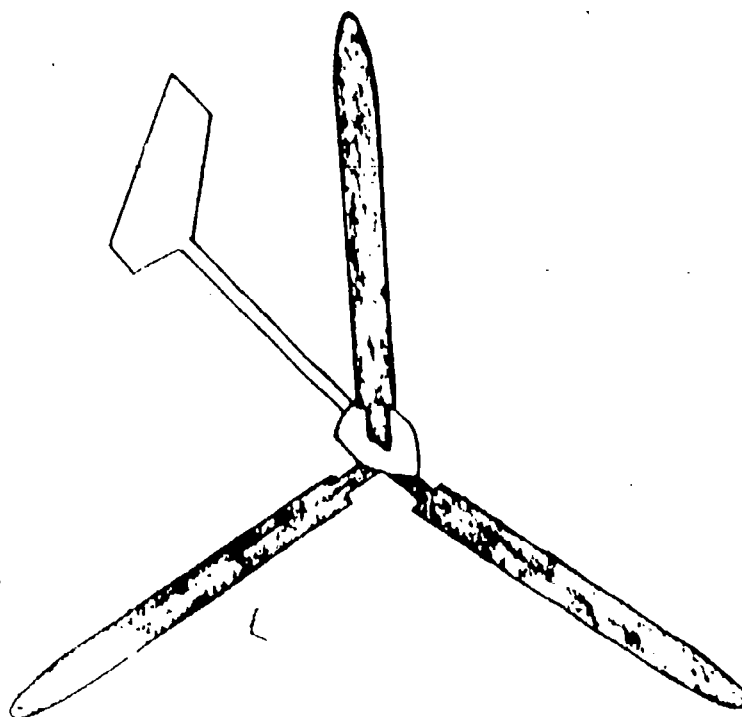

High Speed Propeller

Commercial units of this type, ranging in size from 200 watts to 12 kilowatts, are available from several manufacturers. The propeller operates on a horizontal axis, with blade tip speeds of 6 to 7 times greater than the wind velocity. Three blades are commonly used in order to eliminate stress problems encountered with two blade props. A tail vane is used to orient the rotor to the wind. This design has a relatively high operating efficiency, but the starting torque produced is quite low.

A major advantage of this type of wind generator is light weight. Experimental units are now being tested with sails instead of solid props with the hope of further reducing weight and improving efficiency. As with all units, feathering is required to prevent overspeeding in high winds.

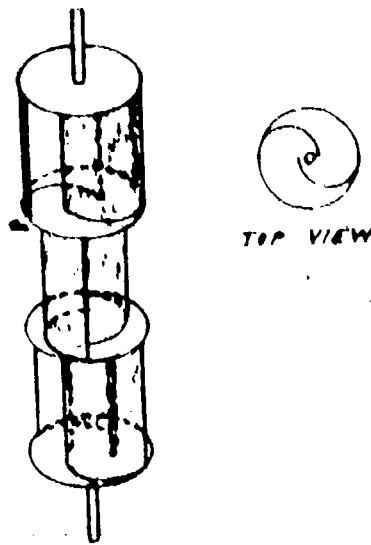

Savonius Rotor

This vertical axis windmill is fabricated from cylinders which are split and then offset as shown in the top view. Vertical axis design means that winds are accepted from any direction, especially important in gusty conditions. Operating characteristics include low rotational speed and high torque.

Inexpensive construction is a main advantage, with 55 gallon drums commonly used for the rotor. One disadvantage of such construction is high weight, making tower mounting difficult. Efficiencies are generally rated as low, but more operating data is needed.

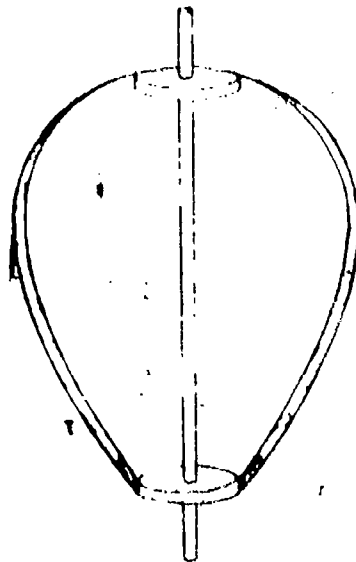

Darrieus Rotor

The airfoil blades on this vertical axis windmill resemble an eggbeater. It accepts winds from any direction and is much lighter in weight than the Savonius Rotor. Operating characteristics include high rotational speed and poor starting ability. More operating data is also needed in order to evaluate the potential of this rotor.

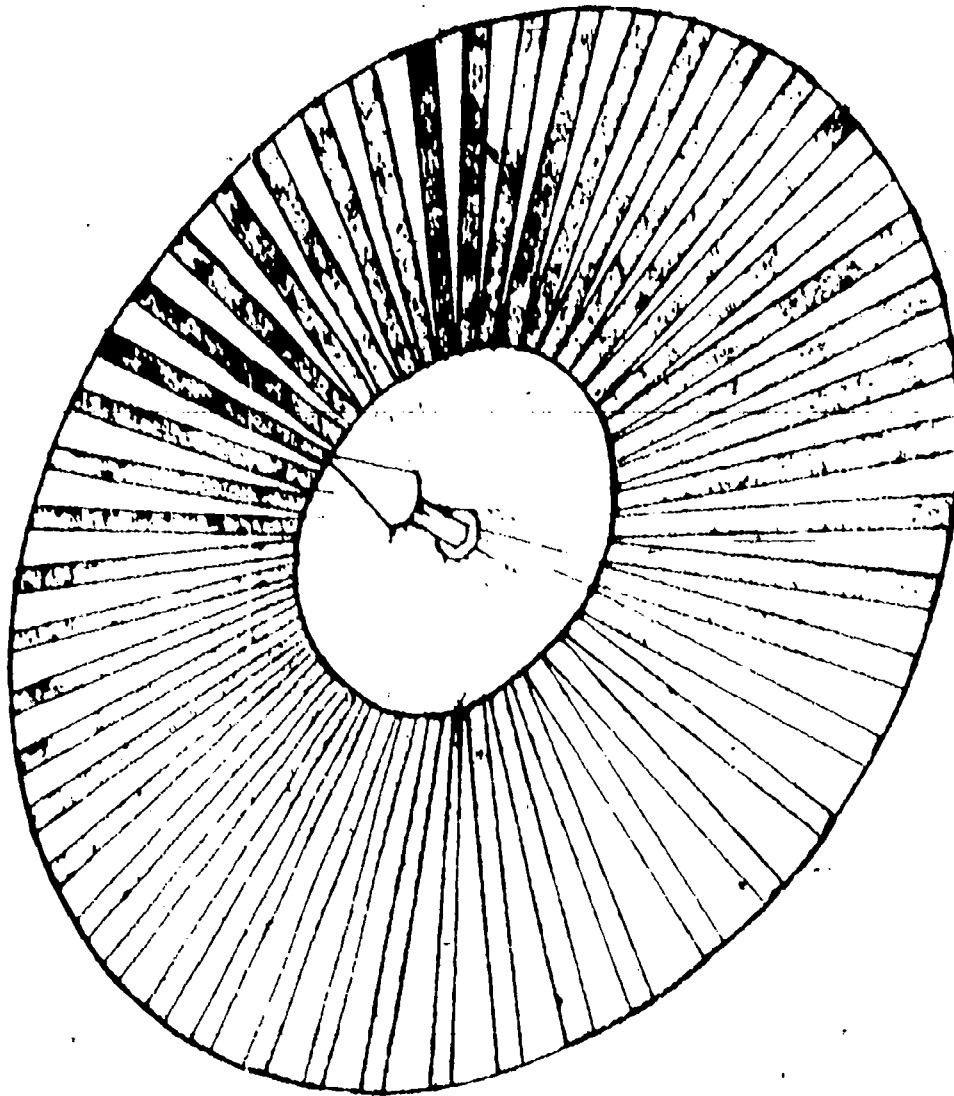

Multi-Blade Turbine

This rotor is a larger but lighter weight version of early multi-blade windmills. Its large blade area exposed to the wind provides high starting torque to the horizontal shaft. Some method of turning the blades into the wind is necessary. At present, good operating information is not available for this design.

CURRENT RESEARCH:

A major effort in wind power research is being supported by the National Science Foundation (NSF) and the National Aeronautics and Space Administration (NASA). They are concentrating on large units (100 to 300 kilowatts) for power generation. The overall program objective is to develop cost-effective wind energy conversion systems within 5 years. It encompasses a complete study ranging from meteorological data to various methods of energy storage. In addition to the NSF, NASA effort, much is being done by universities, private companies, and individuals in an attempt to develop workable wind power systems.

Matching of the mill to a generator and storage system is necessary to obtain good performance of a wind power system. Energy storage at present is achieved with batteries. Other possibilities being researched are compressed air, hot water, flywheels, and chemical conversion. Batteries have the advantage of simplicity although cost is high. It is possible that the best eventual use of wind power will be for home heating.

SUMMARY:

It is possible to generate useful amounts of power from the wind using current technology. The major drawback at present is the high cost of generating electricity with these units. Better methods of energy storage and conversion may offer better solutions in the future.

WIND ENERGY REFERENCES:

- A Survey of Some Modern Developments in the Generation of Electrical Energy from the Wind. Anthony Malgieri, Jr. Unpublished Thesis, Cornell Univ., Ithaca, N.Y. 1955.
- Electric Power From the Wind. Henry M. Clews. Solar Wind Company, East Holden, Maine, 1973.
- Electrical Construction and Maintenance, Reader's Quiz Section. McGraw-Hill, Inc., N.Y. October, 1974.
- Heating a House with Wind Power. Mechanix Illustrated. March, 1975.
- How to Construct a Cheap Wind Machine for Pumping Water. Do-it-Yourself Leaflet No. L-5. Brace Research Institute, Quebec, Canada, 1973.
- Mechanical Engineers Handbook. Lionel S. Marks. McGraw-Hill Book Company, New York, N.Y.
- Patterns of Energy Consumption in the United States. Office of Science and Technology, Executive Office of the President, Washington, D.C. (Available from the U.S. Government Printing Office, Washington, D.C. Jan., 1972.)
- Performance Test of a Savonius Rotor. Technical Report No. 10. Brace Research Institute, Quebec, Canada, 1964.
- Report of Ad Hoc Committee on Appliance and Apparatus Efficiency to the Interdepartmental Fuel and Energy Committee of the State of New York, June, 1975.
- The Elements of Aerofoil and Airscrew Theory. H. Glauert. Cambridge Univ. Press, 1948.
- The Mother Earth News Handbook of Homemade Power. Mother Earth News, Henderson, N.C., Bantam Books, May, 1974.
- The Performance and Economics of the Vertical-Axis Wind Turbine Developed at the National Research Council, Ottawa, Canada. Peter South and Raj Rangi, National Research Council, Ottawa, Canada, 1973.



~~FUN STUFF~~
ACTIVITIES AND PROJECTS

IDEA	TITLE OF PROJECT OR ACTIVITY	PAGE
1 Energy Attitude Survey	44
2 Ranking Your Energy Consumption	46
3 Energy Conservation at Home	47
4 Organizing a School Energy Contest	53
5 Your Utility Bill	54
6 Computing Utility Bills	55
7 Storm Windows and Doors	57
8 Home Insulation	58
9 Home Energy Conservation	60
10 The Wasting of Energy	61
11 Wind Power	62
12 Muscle Power	63
13 Fossil Fuel Recycling	64
14 Energy Crossword Puzzle	65
15 Appliance Audit	71
16 Energy Conversion Pinwheel	74
17 Residential Energy Checklist	75
18 Solar Cell	80
19 Wind Power Car	81
20 Storage of Solar Heat	82
21 Steam Propulsion	83
22 Turbine-Generating Unit Model	84
23 Solar Domestic Water Heater	91
24 Water Power from Flowing Water	97

IDEA 1

ENERGY ATTITUDE SURVEY

OBJECTIVE: To help students determine their attitudes toward energy

1. Do you believe there is an energy shortage? yes no don't know
2. Do you believe you have been given a realistic picture of the energy situation facing the United States? yes no don't know
3. Do you believe most Americans are energy "wasters"?
 yes no don't know
4. Do you believe most Americans are energy "conservers"?
 yes no don't know
5. Do you believe Americans are "spoiled", self-indulgent and reluctant to take responsibility for the future? yes no don't know
6. Do you believe it is the responsibility of every U.S. citizen to conserve energy voluntarily? yes no don't know
7. Do you believe Americans will conserve energy only when government controls are imposed? yes no don't know
8. Would you be willing to reduce your standard of living to conserve energy? yes no don't know
9. Do you believe you as an individual can make an impact on energy consumption? yes no don't know
10. Would you conserve energy to save money? yes no don't know
11. Do you think the money saved is worth the inconvenience of conserving energy? yes no don't know
12. Do you think the energy saved is worth the inconvenience of conserving energy? yes no don't know
13. Do you feel technology will "bail us out" of the energy shortage?
 yes no don't know
14. Do you feel you have any input or participation in the energy usage decisions made by your family? yes no don't know
15. Are you going to do something to save energy? yes no don't know

ENERGY ATTITUDE TALLY

Question	Yes	Percent	No	Per- cent	Don't Know	Percent
1						
2						
3						
4						
5						
6						
7						
8						
9						
10						
11						
12						
13						
14						
15						
Additional questions.						

Find the percentages for each response. For example: if on question 1 200 students respond; 100 say yes; 60 no and 40 don't know then the percent saying yes is $\frac{100}{200}$ or 50%; saying no is $\frac{60}{200}$ or 30%; saying don't know is $\frac{40}{200}$ or 20%. (You may choose to use a calculator especially if large numbers of students respond).

Suggestions:

1. Survey your class separately to see if the study of Industrial Arts has an effect.
2. You might print your results in the school newspaper.
3. Survey the teachers and administrators. Do their opinions differ much from the students?

IDEA 2

RANKING YOUR ENERGY CONSUMPTION

OBJECTIVE: To help students gain an awareness of energy use and waste in the home.

Below you will see a list of items and activities which require energy for their manufacture, use, and disposal. Number (rank) these items in order of importance and necessity to you. Mark your responses in column A--number 1 being most important on down to number 20 for least important.

A	B	C
_____ watching television	_____	_____
_____ hot water for bathing	_____	_____
_____ electric toothbrush	_____	_____
_____ waffle iron	_____	_____
_____ synthetic clothing	_____	_____
_____ reading a book	_____	_____
_____ eating a raw apple	_____	_____
_____ TV dinners	_____	_____
_____ car ride to the store	_____	_____
_____ drive-in movie	_____	_____
_____ making homemade ice cream	_____	_____
_____ lipstick or cologne	_____	_____
_____ aerosol deodorant	_____	_____
_____ electric hairdryer	_____	_____
_____ bike riding	_____	_____
_____ a walk in the sun	_____	_____
_____ candy	_____	_____
_____ nighttime football games	_____	_____
_____ hot lunches	_____	_____
_____ school buses	_____	_____

Now that you have ranked these items according to their importance to you, go back and rank the ones you feel are *most energy intensive* in Column B (from "1 to "10".) Discuss your answers in class.

Now mark in Column C the items you could do without which would help you and our nation conserve energy. Discuss your answers in class.

Suggestions:

1. Develop an Energy Alternatives bulletin board for the school.

IDEA 3

ENERGY CONSERVATION AT HOME

OBJECTIVE: To help students gain an awareness of energy use and waste in the home.

Have students use the ENERGY CONSERVATION CHECKLIST FOR THE HOME prepared for this activity to determine where/why/how energy is wasted. Information gained from responses on the checklist can be used by students to develop energy conservation suggestions for their parents. Students should encourage their families to implement the energy conservation measures and do their part to make it work. Following this experience, the class might discuss such questions as:

1. What are the most inexpensive ways to conserve energy in the home?
2. What are the most effective ways to conserve energy in the home?
3. Is it possible to still pay higher utility bills after implementing an effective energy conservation program at home? If so, why?
4. How do you read electricity and gas meters?

CONTACT ORGANIZATIONS:

1. Your local gas or electric utility, power distributor, and building supply house.
2. Idaho Office of Energy; Statehouse, Boise, Idaho 83720.
3. See information sheet for estimates of yearly consumption by common household appliances.

AN ENERGY CONSERVATION CHECKLIST FOR THE HOME

Name & Address
of Resident:

Name of Student:

Date:

USE THIS CHECKLIST TO DETERMINE WHERE/HOW/WHY ENERGY IS WASTED AT HOME. THE MORE CHECKED "YES," THE MORE ENERGY CONSERVATION MEASURES BEING USED.

	<u>YES</u>	<u>NO</u>
1. Are spaces around windows, doors, air conditioners, etc., properly caulked (sealed tightly)?	_____	_____
2. Are there storm windows and doors throughout the home?	_____	_____
3. Are windows tightly closed at all times during cold weather?	_____	_____
4. Are exterior doors closed quickly after use?	_____	_____
5. Are drapes and shades closed at night and on cloudy or windy days during the winter?	_____	_____
6. Are drapes insulated?	_____	_____
7. Are hot air ducts or radiators closed off in unused rooms or closets?	_____	_____
8. Are hot water pipes and air ducts insulated?	_____	_____
9. Is the air conditioner located on the shady side of the house?	_____	_____
10. Are drapes and furniture located so they do not interfere with air ducts, radiators, thermostats?	_____	_____
11. Are the walls insulated?	_____	_____

	<u>YES</u>	<u>NO</u>
12. Does the floor have 2"-3½" of insulation?	_____	_____
13. Does the attic have six to eight inches of insulation?	_____	_____
14. Is an attic fan used in the summer?	_____	_____
15. Is the fireplace damper closed tightly when not in use?	_____	_____
16. Are heating and cooling filters clean?	_____	_____
17. Is the thermostat set at 68° or below during winter months?	_____	_____
18. Is the thermostat set at 78° or above during summer months?	_____	_____
19. Is the thermostat adjusted at night?	_____	_____
20. Do thermostats indicate accurately calibrated temperature settings?	_____	_____
21. Are lights turned off when not needed?	_____	_____
22. Is the TV, radio, or stereo turned off when not in use?	_____	_____
23. Are ovens and burners turned off immediately after use?	_____	_____
24. Is the oven used to bake more than one food at a time?	_____	_____
25. Is the refrigerator thermostat set at +40°F?	_____	_____
26. Are gaskets around refrigerator and freezer doors tight?	_____	_____
27. Is the frost on the refrigerator and freezer less than ¼-inch thick?	_____	_____
28. Is the water heater temperature setting between 120°F and 140°F?	_____	_____
29. Are all water faucets in good repair (not leaking)?	_____	_____
30. Do the residents take brief showers or use a small amount of water in the tub?	_____	_____



- | | <u>YES</u> | <u>NO</u> |
|---|------------|-----------|
| 31. Are clothes washed only when there is a full load? | _____ | _____ |
| 32. When washing clothing, is cold or warm water used if possible? | _____ | _____ |
| 33. Are dishes washed only when there is a full load? | _____ | _____ |
| 34. Are evergreens properly located around the outside of the house to provide a break against cold winter wind and shade against the hot summer sun? | _____ | _____ |
| 35. Are deciduous plants located on the south of the house to admit the winter sun and protect from the summer sun? | _____ | _____ |
| 36. Is there a humidifier in the home? | _____ | _____ |

ANNUAL ENERGY REQUIREMENTS OF ELECTRIC
HOUSEHOLD APPLIANCES

Appliance	Average Wattage	Annual kwh Consumption		Annual Cost @ 3¢/kwhr
Air cleaner	50	216		\$ 6.48
Air conditioner (room)	997	1,032*		30.96
Bed covering	177	147	(1.0/night)	4.41
Blender	386	15	(0.2/use)	.45
Broiler	1,436	100		3.00
Carving knife	92	8		.24
Clock	2	17	(1.5/month)	.51
Clothes dryer	4,856	993	(3.0/load)	29.79
Coffee maker	894	106	(.25/pot)	3.18
Deep fryer	1,448	83		2.49
Dehumidifier	257	377		11.31
Dishwasher	1,201	363**	(1.0/load)	10.89
Egg cooker	516	14		.42
Fan (attic)	370	291		8.73
Fan (circulating)	88	43		1.29
Fan (window)	200	170		5.10
Floor polisher	305	15		.45
Freezer (15 cu. ft.)	341	1,195	(5.0/day)	35.85
Freezer, frostless (15 cu. ft.)	440	1,761		52.83
Frying pan	1,196	186	(1.0/hr)	5.58
Hair dryer	381	14	(.33/hr)	.42
Heater (portable)	1,322	176	(1.5/hr)	5.28
Heating pad	65	10		.30
Hot plate	1,257	90		2.70
Humidifier	177	163		4.89
Iron	1,008	144	(1.0/hr)	4.32
Mixer	127	13	(.05/use)	.39
Oven (microwave)	1,450	190		5.70
Radio	71	86		2.58
Radio/record player	109	109	(.10/hr)	3.27
Range, with oven	12,200	1,175	(1.5/meal)	35.25
Range, with self-cleaning oven	12,200	1,205		36.15
Refrigerator/Freezer(14 cu.ft.)	326	1,137		34.11
Refrigerator/Freezer, frostless (14 cu. ft.)	615	1,829		54.87
Roaster	1,333	205		.15
Sandwich grill	1,161	33		.99
Sewing machine	75	11	(1.0/month)	.33
Shaver	14	1.8	(.001/shave)	.05
Sun lamp	279	16		.48

*Based upon 1,000 hours of operation per year; this figure will vary widely depending on geographic area and size of unit.

**Does not include kilowatt-hours for heating water.

ANNUAL ENERGY REQUIREMENTS OF ELECTRIC HOUSEHOLD APPLIANCES (continued)

Appliance	Average Wattage	Annual kwh Consumption		Annual Cost @ 3¢/kwhr
Television (black and white), tube type	160	350		\$ 10.50
Television (black and white), solid state	55	120	(.16/hr)	3.60
Television (color), tube type	300	660		19.80
Television (color), partial solid state	200	440		13.20
Toaster	1,146	39	(.04/slice)	1.17
Toothbrush	7	0.5	(.001/brushing)	.015
Trash compactor	400	50		1.50
Vacuum cleaner	630	46	(.63/hr)	1.38
Vibrator	40	2		.06
Waffle iron	1,116	22	(.25/waffle)	.66
Washing machine (automatic)	512	103**	(.33/load)	3.09
Washing machine (manual)	286	76		2.28
Waste disposer	445	30	(.01/load)	.90
Water heater (standard)	2,475	4,219	(12.0/day)	126.57
Water heater (quick-recovery)	4,474	4,811		144.33

**Does not include kilowatt-hours for heating water.

Source: All figures courtesy of Electric Energy Association, New York, New York, 1973, and the Tennessee Energy Office, 1975.

IDEA 4

ORGANIZING A SCHOOL ENERGY CONTEST

OBJECTIVE: To provide students with an opportunity to use their understanding of energy problems to communicate energy conservation practices to others.

Sponsoring an energy contest will afford students an excellent opportunity to apply their knowledge about the energy situation and need for conservation. There are numerous possibilities, including: poster, photography, or essay contests, speeches, and debates. You will want to consider the following when developing a plan for the contest:

1. What specific kind of contest will it be?
2. What energy topics (problems, concerns, technologies) will be included?
3. Who is eligible to enter? How may they enter?
4. What criteria apply to the specific contest (e.g., if photography, the size, color, and mounting of photographs)?
5. What prizes or awards (e.g., cash, savings bonds, certificates) will be offered?
6. Who will select winners? Students? A panel of community members? What criteria will be used to select judges?
7. When would the contest begin and end?
8. To whom are entries submitted? A program coordinator? A teacher? The chairman of the panel of judges?
9. How will publicity be handled?
10. What companies or organizations might sponsor the contest?
11. Will there be an awards ceremony (reception, assembly, or luncheon) to announce the winners?

IDEA 5

YOUR UTILITY BILL

OBJECTIVE: To familiarize students with the cost of energy in the home.

Have students analyze utility bills sent to their homes for the past several years, or the past full year, if possible. How much money is spent each month for gas, water, and electricity?

Students may construct a chart for the monthly use of gas, water, and electricity. Charts should illustrate the amount of the resource used and the cost involved for each month. Past monthly records are available from local utility companies and may be used for comparison purposes.

Students should be encouraged to post the charts at home for the family's future reference.

SUGGESTIONS:

1. Show students how to read gas, water, and electric bills and meters.
2. Have students list ways to conserve gas, water, and electricity.
3. Point out the major changes in energy use which occur as seasons change.
4. Have students list watts, amps, volts of all appliances in their homes.

CONTACT ORGANIZATIONS:

1. Your local power distributor or utility company.
2. Public Utilities Commission, 472 W. Washington Street, Boise, ID 83720.

IDEA 6

COMPUTING UTILITY BILLS

OBJECTIVE: To acquaint the student with the method of reading an electric meter and interpreting an electric service billing.

The teacher will distribute copies of the accompanying material to all students and, with the aid of a master copy on the overhead projector, guide them through the steps in reading the electric meter. Be sure that the students understand the procedure by changing the positions of the dials and asking for new readings. (A large cardboard type of chart containing meters and movable dials could be constructed by one of the students and used for individual practice.)

Following the same basic procedure, the teacher guides the student through a reading and explanation of the indicated items on the electric service bill, giving special attention to the figures which indicate the kilowatt hours used.

Several costs of operation of appliances in the home can be worked out using the rate chart included in this activity. It may be a good idea to check your local power company to determine if the rates are substantially different from those included here.

Follow Up:

Students record daily kilowatt readings (at the same time each day) for one month, recording these data in a simple journal which also includes some observations about the temperature, appliance use, and other pertinent factors which might affect the amount of use of appliances.

Latest Rating Scales - June 1975

1st 20 Kilowatt Hours	\$.021	750-1350 KWH.....	\$.031
20-100 KWH045	1350-7800 KWH.....	.0285
100-200 KWH039		
200-750 KWH039		

DO-IT-YOURSELF PROJECTS

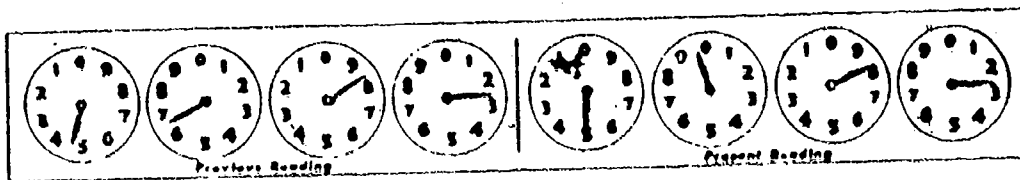

How to Read a Meter

To read an electric meter, stand directly in front of dials. Read dials from left to right. Some of the dials move in opposite directions from each other, but regardless of that, always read the smaller figure when the hands are between two numbers. For instance, in the left box above, the figures read 4682.

If the hand of the first dial appears to be directly over a number, read the next dial to determine whether or not the hand has passed zero. If it hasn't reached zero, use the next lower number on the first dial. The reading on the dials in the right box should be 4982.

The figures on the dials represent kilowatt-hours which signify the number of kilowatts flowing through your meter multiplied by the length of time.

When payment is mailed, enclose this stub

Actual or estimated reading of meter

Actual or estimated number of kilowatt hours used

Applies to Non-Residential customers

Code number which designates the rate on which your service is billed

PLEASE DO NOT WRITE ON THIS BILL

BILL ON ACCOUNT
4-12-64

ACCOUNT NUMBER
19 3704 00402

\$9.51

\$9.51
PAY THIS AMOUNT

THE ELECTRIC CO.

330

KIDDY KILOWATT

215 N FRONT

COLUMBUS 15 OHIO

3-01 4-01 4-12-64

STATE CODE NO. **01**

ACCOUNT NUMBER
19 3704 00402

\$9.51

\$9.51
PAY THIS AMOUNT

PLEASE READ THIS BILL

1. ESTIMATE ONLY

2. READ AFTER METER

3. NO USE OF METER

4. NO USE OF METER

5. NO USE OF METER

6. NO USE OF METER

7. NO USE OF METER

8. NO USE OF METER

9. NO USE OF METER

10. NO USE OF METER

NO OTHER USE FOR THIS BILL

AND

MAILED UNDER NO OTHER NAME

Customer pays the amount

For any time service used between dates indicated

Payable on or before this date.

Additional information.

The reproduction of the above bill is similar to the one which comes to your home monthly. The figure circled at the top of the bill is the present meter reading. If you subtract the corresponding reading in the previous bill from the present reading you get the number of kilowatt-hours (330) of electricity used between the present and previous readings.

IDEA 7

STORM WINDOWS AND DOORS

OBJECTIVE: To familiarize students with the costs and savings of using storm windows and doors.

Students can ask their parents to have a dealer come to their homes and give them a cost estimate for installing storm windows and doors. If a home already has storm windows and doors, the savings in fuel and money should be determined by obtaining and analyzing utility bills one year before and one year after the storm windows and doors were installed.

Some questions for students to answer include:

1. Over what period of time would storm windows and doors pay for themselves? What factors must be considered?
2. Are storm windows more energy efficient than thermopane windows?
3. As a conservation technique, are storm windows and doors more important than ceiling and wall insulation?
4. Why do storm windows steam up or show condensation?

CONTACT ORGANIZATIONS:

1. To contact a dealer, see "storm windows, doors, and windows" in the yellow pages of the telephone directory.
2. Federal Energy Administration, 12th and Pennsylvania Avenue, NW, Washington, D.C. 20461
3. Idaho Office of Energy; Statehouse, Boise, Idaho 83720.

IDEA 8

HOME INSULATION

OBJECTIVE: To help students become familiar with the types of insulation available, their uses, advantages, disadvantages, and costs.

Proper home insulation is one of the best ways to conserve energy and save money. Before buying any insulation, the consumer should know three important things:

1. What the R-value of the insulation should be. R-value is a number that indicates how much resistance the insulation presents to heat flowing through it. The bigger the R-value number, the more effective the insulation. (See information sheet for more information on R-value.)

2. What kind of insulation to buy:

Batts: glass fiber; rock wool

Blankets: glass fiber; rock wool

Foam-in-place: ureaformaldehyde

Loose fill (blown in): glass fiber; rock wool;
cellulosic fiber

Loose fill (poured in): glass fiber; rock wool;
cellulosic fibers; vermiculite; perlite

Rigid board: extruded polystyrene bead board
(expanded polystyrene); urethane board;
glass fiber

3. How thick insulation should be. For the R-value of each type of insulation, see information sheet.

Have students consult current literature, visit building supply companies and contact organizations to learn about the use, cost, and installation of insulation. Specifically, they should find answers to the following questions:

1. What are the advantages and disadvantages of each kind of insulation?
2. What kinds of insulation should be used in the house and where?
3. What is a vapor barrier? Why is it important?
4. What is the installation cost for each kind of insulation?
5. What tools are needed to install insulation?

6. What would be some good incentives to get people to better insulate their homes?
7. What priority would you assign to insulating a home as a means of saving money and energy?

CONTACT ORGANIZATIONS:

1. See "Insulation" in yellow pages of telephone book and contact dealers for specific information.
2. National Insulation Contractors Association, 8630 Fenton Street, Suite 506, Silver Spring, Maryland 20910.
3. National Mineral Wool Insulation Association, Inc., 211 E. 51st Street, New York, New York 10022.
4. Owens-Corning Fiberglas Corporation, Fiberglas Tower, Toledo, Ohio 43659.

IDEA 9

HOME ENERGY CONSERVATION

OBJECTIVE: To help students see the need for conserving energy.

Shortages in home heating fuels and the high cost of electrical energy generation have prompted utility companies, as well as the public, to look into energy conserving methods to help heat the home efficiently.

Have the students prepare a checklist of conserving projects for their homes. Then have the individual students survey their homes to see if the practices are in effect there. Students can bring this information back to the classroom and discussion, have the students take back their findings to their parents.

Topics for discussion should include amount of fuel wasted, effect on heating bill, and ways to alleviate the problems.

Sample Checklist:

	Yes	No
Storm Windows		
Storm Doors		
Insulation	<input checked="" type="checkbox"/>	
Heat Off in Unused Rooms		
Weatherstripping		<input checked="" type="checkbox"/>

CONTACT ORGANIZATION:

1. Your local utility or electric power distributor.

IDEA 10

THE WASTING OF ENERGY

OBJECTIVE: To help students become more aware of energy wasteful habits.

Review with the class the general principle that energy is required to make all of the substances we throw away in our trash cans. Develop on the chalkboard with input from students a list of the substances commonly thrown into trash cans such as paper, food wastes, glass containers, plastic wrapping materials, and others. Ask students to "guess" what substances comprise the major portions of solid waste found in the "National Trash Can".

Present, with use of an overhead projector, the figure below that shows the amount of various substances comprising the national trash can in 1971. Compare the data shown with their guesses.

Involve students in speculating whether the contents of the trash can have been changing since 1971. Why or why not? Ask each student to list on paper several things he and/or his family can do to reduce waste in two or three of the categories. Discuss individual responses in an effort to reach class consensus.

National Trash Can

(Annual Municipal Solid Waste - 1971)

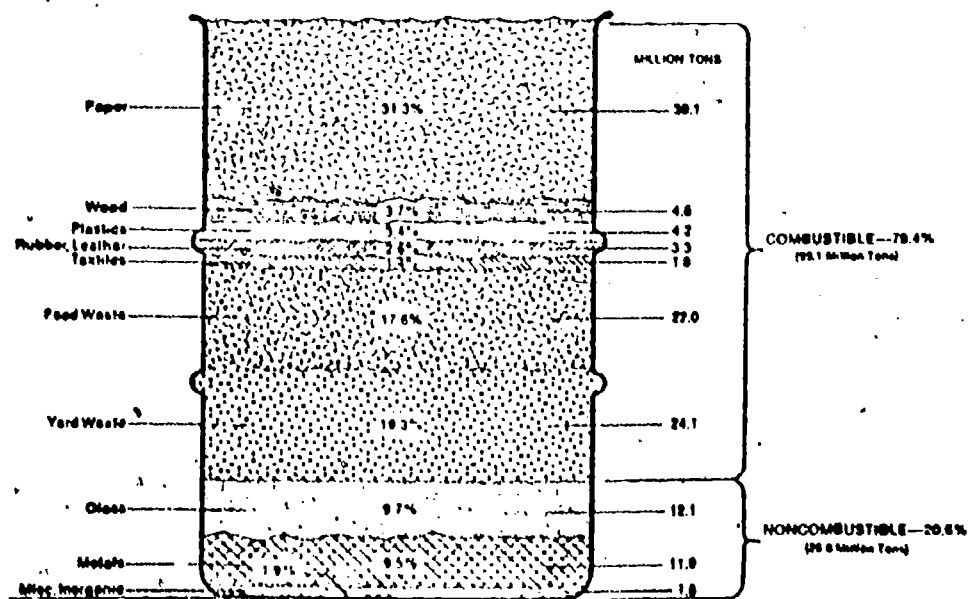

Source—Environmental Protection Agency, Second Report to Congress, Resource Recovery and Source Reduction, 1971

IDEA 11

WIND POWER

OBJECTIVE: To provide students the opportunity to work with energy systems to gain an understanding of how energy is available, converted, transmitted, stored, controlled, and conserved.

1. Ask each student to bring a plastic bleach or other round symmetrically shaped plastic bottle to class.
2. Given the plastic bottle, each student cuts and bends flaps from the large section of the bottle. Size and number may vary from student to student.
3. Students will fasten a small nail into the end of a section of dowel, going through the bottom of the plastic bottle in the process. Make sure the bottle is centered before driving the nail.
4. Twist the bottle to enlarge the hole. The bottle should turn freely.
5. Using a fan or wind tunnel, test the windmill. Students will observe each others windmills, and discuss why some operated better than others. (Flaps too small, not enough flaps, bottle not centered on nail, etc.)

IDEA 12

MUSCLE POWER

OBJECTIVE: To provide students the opportunity to work with energy systems to gain an understanding of how energy is available, converted, transmitted, stored, controlled, and conserved.

1. Design and construct a generator machine capable of producing an electrical output obtained from various size and potential people.

SUGGESTIONS:

1. Group students together with approximately two people per group.
2. Use bicycle generator and frame.
3. Measure output by using meters, or light bulbs.
4. If 5-10 speed bicycle is brought in, figure out mechanical advantage.
5. Contest of who can provide most muscle power with the least amount of input.

IDEA 13
FOSSIL FUEL RECYCLING

OBJECTIVES: To help students understand conservation through reclaiming.

Given a quart of contaminated oil, reprocess the oil by filtering, magnetic separation and siphoning. This activity may be given as a problem for the students to solve themselves or they may be guided through the solution.

Materials: (Instructor prepared) 1 qt. 10w oil with steel filings, sand and water added.

- 1 - funnel
- 2 - glass beakers
- 1 - 6 inch by 6 inch cloth
- 1 - bar magnet
- 1 - piece tubing (for siphon)

Suggestions:

1. Shake the contaminated oil well.
2. Place the cloth into the funnel, the funnel over the glass beaker and slowly pour the contaminated oil into the funnel.
3. Move the magnet slowly through the filtered oil to attract any steel filings in the oil.
4. Allow the oil to stand in the beaker until it has risen above the water.
5. Pinch the end of the tube with pliers and insert it through the oil into the water and siphon off the water into another beaker.

IDEA 14

ENERGY CROSSWORD PUZZLE

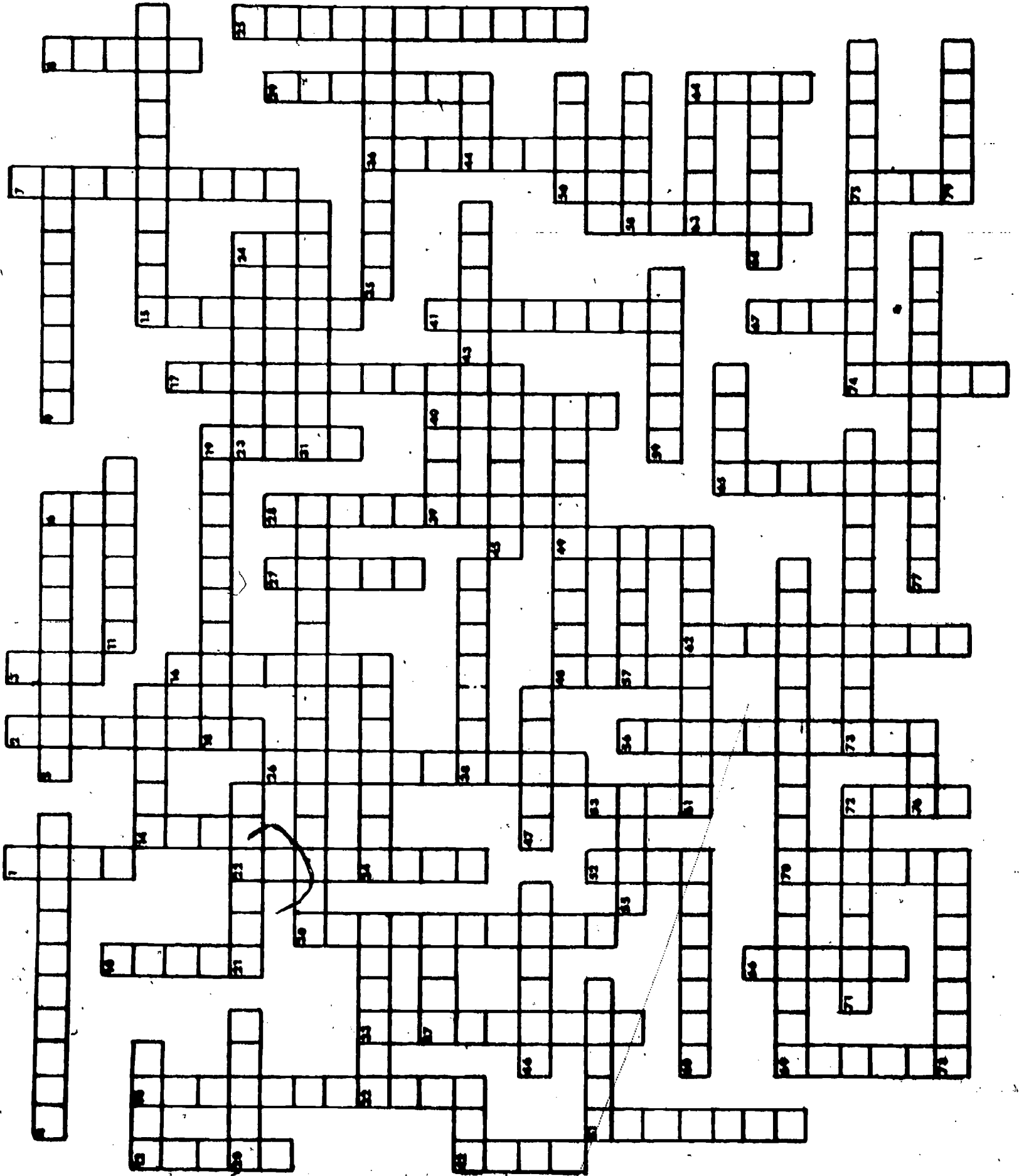

ENERGY CROSSWORD PUZZLE

ACROSS

4. If everyone cut down his energy use, the ----- savings would be great.
5. Gasoline ----- is one way of meeting the energy crunch.
9. The United States is currently experiencing a ----- of energy supplies.
11. ----- the water level in your washer according to the size load you have.
12. The frost- ---- refrigerator costs 1 1/2 times as much to operate as the refrigerator you must defrost yourself.
14. ----- around windows to keep warm air inside and cold air out.
15. ----- provides only a tiny part of our energy needs.
18. Stuff rolled-up ----- in cracks around doors and windows to keep cold air out.
20. To keep feet warmer, put on an extra pair of -----.
21. The United States has less than 6 percent of the world's ----- but almost half its cars.
23. ----- film can be used as a temporary storm window.
30. More than a quarter of the U.S. energy budget goes for -----.
31. ----- the frost from your refrigerator allows it to operate more efficiently.
32. Clean or ----- your furnace filter regularly.
34. ----- fission is a minor source of energy today.
35. Demand for energy has ----- at a startling rate.
37. If you aren't using a ---- in your house, close it off.
38. We can not stand by and do ----- about the energy shortage.
39. For better gas mileage, keep your ----- inflated properly.
42. When you --- clothes, avoid overdrying; it sets wrinkles and wastes energy.
43. Cutting energy ----- is a big part of coping with energy crisis.
44. Using more --- cubes than you need wastes energy.
45. Clean or change your furnace ----- regularly.
46. Energy-saving measures can become thrifty ----- that will save us money.

47. Reducing your ----- from 70 to 50 can improve your car's mileage.
48. ----- is the most energy-efficient means of transportation.
50. In the generation of electricity, energy is lost in the form of waste -----.
51. Whenever possible, ----- pans to eliminate heat loss while cooking.
55. The United States uses ----- energy than any other nation.
57. An uninsulated house ----- a great deal of heat through the roof.
58. The United States has almost half the world's -----.
59. Turn off the ----- in a room when no one is using them.
60. Most of the energy resources we rely on are -----.
61. Electricity is measured in -----.
63. Windmills take advantage of wind -----.
65. Two free sources of energy are sun and -----.
68. Every family makes ----- of energy-use decisions every day.
69. ----- around doors and windows can cut heat loss.
71. Cutting our energy budget will not require any ----- changes in lifestyle.
73. Ceiling ----- can greatly reduce heat loss through the roof.
74. Driving slower should reduce your car's gas -----.
76. Avoid letting the hot water --- needlessly.
77. Consumers need to make energy-related decisions -----.
78. Recycling and ----- things you'd normally throw away helps save energy.
79. ----- light cars get more miles per gallon than big, heavy cars.

DOWN

1. When you use your range -----, fill it up.
2. Cars consume billions of gallons of ----- every year.
3. Gasoline, kerosene, diesel fuel and host of other products are derived from -----.
6. Many Idaho homes are heated with natural -----.

7. ----- is our major fuel resource.
8. Saving energy saves -----.
10. Fossil Fuel is no longer the ----- commodity it once was.
12. The refrigerator that keeps itself free of ----- costs 1 1/2 times as much to operate as the refrigerator you must defrost yourself.
13. Opening cans by hand will not save a lot of -----.
14. ----- provides for about 18 percent of our energy needs.
15. In the home a good deal of energy is used for -----.
16. If reducing the temperature in your home has left you cold, put on a -----.
17. Open your ----- when the sun shines to take advantage of the sun's energy for heating.
19. The largest part of the home energy budget goes for heating -----.
22. You can reduce the amount of driving you do by ----- your route better.
24. Your efforts --- make a difference!
25. Energy demands from the ----- sector make up almost 1/5 of the national energy budget.
26. Turn off electric ----- when not in use.
27. "Power" accessories and extras cut your car's ----- per gallon.
28. More energy is consumed in the ----- sector of society than in any other.
29. The energy crisis is sure to affect the way we use our ----- time.
30. Cut home heating costs by lowering the ----- to 68 degrees.
33. Only ----- are less energy-efficient than automobiles.
36. We must try for more ----- energy use.
40. ----- is what this puzzle is all about.
41. To reduce peak energy use in early evening, the whole nation went on ----- saving time.
42. Avoid opening the refrigerator ----- more than necessary.
43. Turn the heat ----- 70 degrees to save energy.

ACROSS

4. collective
5. rationing
9. shortage
11. adjust
12. free
14. caulk
15. hydropower
18. newspapers
20. socks
21. people
23. plastic
30. transportation
31. cleaning
32. change
34. nuclear
35. increased
37. room
38. nothing
39. tires
42. dry
44. ice
45. filter
46. habits
47. speed
48. bicycling
50. heat
51. cover
55. more
57. loses
58. autos
59. lights
60. limited
61. kilowatts
63. power
65. wind
68. dozens
69. weatherstripping
71. drastic
73. insulation
74. consumption
76. run
77. consciously
78. reusing
79. small

DOWN

1. oven
2. gasoline
3. oil
6. gas
7. petroleum
8. money
10. cheap
12. frost
13. electricity
14. coal
15. heating
16. sweater
17. draperies
19. space
22. planning
24. can
25. residential
26. appliances
27. miles
28. industrial
29. leisure
30. thermostat
33. airplanes
36. efficient
40. energy
41. daylight
42. door
48. below
49. costs
51. comfort
52. wood
53. leak
54. carpool
56. television
62. attitudes
64. rise
65. windows
66. storm
67. down
69. warmer
70. rating
72. cure
74. close
75. pots

49. Energy ----- have risen phenomenally in past months.
51. Increasing the humidity in your home will add to your ----- but will not necessarily allow you to get by with less fuel.
52. ----- is not a major source of energy.
53. A tiny ----- can waste hundreds of gallons of hot water in a year.
54. Organize a ----- (two words) to reduce gas consumption by cutting the number of cars on the road.
56. The instant-on ----- is on even when it's off.
62. A change in consumer ----- is necessary to make energy conservation work.
64. The cost of energy has to -----.
65. Much heat is lost through-----.
66. ----- windows cut heat loss.
67. Cut -----, not out, to save energy.
69. Wear more clothes to keep-----.
70. You can use the data on the back of an air conditioner to figure its efficiency-----.
72. No quick ----- for the energy shortage is in sight.
74. ----- the fireplace damper when the fireplace is not in use.
75. Use ----- and pans that fit stove burners.

IDEA 15

APPLIANCE AUDIT

OBJECTIVE: To help the student realize the number and type of appliances in the average american home and their consumption of energy.

Few people realize how many appliances they have, and certainly don't realize how much energy they consume. Below you will find an audit form you can use to record information on the appliances in your home. The audit provides a listing of the most common items as well as their annual energy consumption; it also provides a check for maintenance or condition of the item. Record all the items in your home, check their condition and tally the annual consumption rates. Use the cost per kilowatt-hour in your area to determine the annual cost of the appliances in your home. Make recommendations for the maintenance of items from your checklist.

APPLIANCE AUDIT FORM

ITEM	EST. KWH CONSUMED ANNUALLY	QUANTITY	TOTAL EST. KWH CONSUMED ANNUALLY	GOOD CONDITION	DIRTY	BAD FILTER	BAD GASKET	THERMOSTAT PROBLEM	NEEDS DE-FROSTING	NEEDS REPAIR	OTHER
<i>Example</i>											
Hair Dryer	14	2	28								
Air Cleaner	216							✓		✓	
Air Conditioner (room)	860										
Bed Covering	147										
Blender	15										
Broiler	100										
Carving Knife	8										
Clothes Dryer	993										
Coffee Maker	106										
Deep Fryer	83										
Dehumidifier	377										
Dishwasher	363										
Egg Cooker	14										
Fan (Attic)	291										
Fan (circulating)	43										
Fan (rollaway)	138										
Fan (window)	170										
Freezer, 15cu. ft.	1195										

APPLIANCE AUDIT FORM (CONT.)

ITEM	EST. KWH CONSUMED ANNUALLY	QUANTITY	TOTAL EST. KWH CONSUMED ANNUALLY	GOOD CONDITION	DIRTY	BAD FILTER	BAD GASKET	THERMOSTAT PROBLEM	NEEDS DE-FROSTING	NEEDS REPAIR	OTHER
Freezer, 15 cu. ft. frostless	1,761										
Frying Pan	186										
Germicidal Lamp	141										
Hair Dryer	14										
Heater (portable)	176										
Heating Pad	10										
Heat Lamp	13										
Hot Plate	90										
Humidifier	163										
Iron (hand)	144										
Mixer	13										
Oven, Microwave	190										
Radio	86										
Radio/Record Player	109										
Range, with oven	1,175										
with self-cleaning oven	1,205										
Refrigerator 12 cu. ft.	728										
Refrigerator 12 cu. ft. frostless	1,217										
Ref./Freezer 14 cu. ft.	1,136										
Ref./Freezer 14 cu. ft. frostless	1,829										
Roaster	205										
Sandwich grill	33										
Shaver	1.8										
Sun Lamp	16										
Television black & white tube type	350										
black & white solid state	120										
color tube type	660										
color solid state	440										

80

APPLIANCE AUDIT FORM (CONT.)

ITEM	EST. KWH CONSUMED ANNUALLY	QUANTITY	TOTAL EST. KWH CONSUMED ANNUALLY	GOOD CONDITION	DIRTY	BAD FILTER	BAD GASKET	THERMOSTAT PROBLEM	NEEDS DE-FROSTING	NEEDS REPAIR	OTHER
Toaster	39										
Tooth Brush	0.5										
Trash Compactor	50										
Vibrator	2										
Waffle Iron	22										
Washing Machine automatic	103										
Washing Machine non-automatic	76										
Waste Disposer	30										
Water Heater 2475 watt	4219										
Water Heater 4474 watt	4811										

TOTAL CONSUMPTION

$$\frac{\text{total no. kwh consumed}}{\text{cost per kwh}} \times \$ = \$$$

How could your family conserve on their appliance energy cost?

IDEA 16

ENERGY CONVERSION PINWHEEL

OBJECTIVE: To help the student understand the conversion of wind energy to mechanical energy.

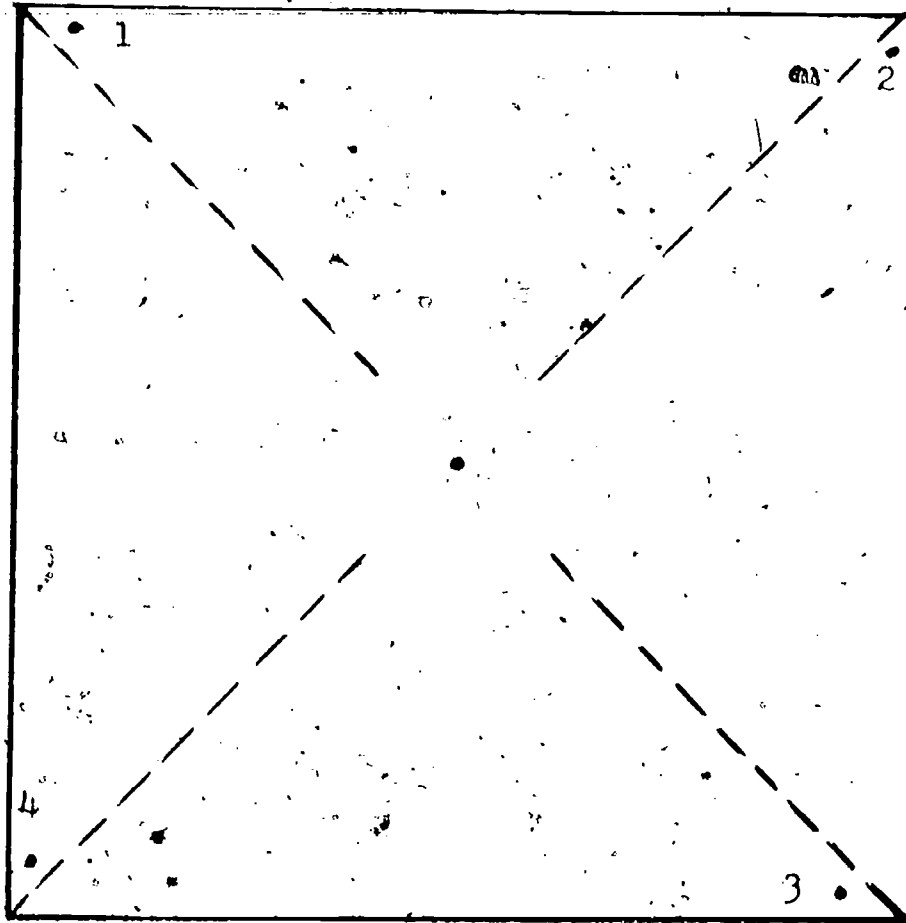

1. Cut out the pattern and cut on the dotted lines.
2. Fold all numbered corners to the center and punch a straight pin through the dots and through the center.
3. Secure the pin in the end of a pencil eraser.
4. Blow on pinwheel or run into the wind.

RESIDENTIAL ENERGY CHECKLIST

The following energy checklist can be used by you (the student), your parents, and relatives as a handy guide to systematically search for residential energy waste and potentials for conservation. The checklist does not attempt to quantify the energy loss, nor estimate the cost to alleviate the problems. In some cases, it might not be practical to try to eliminate the waste, but rather to reduce it or its impact. You should refer to the specific areas in the text for further information. For example, if you find several problems under home construction, you should refer to Section 3 of the text. If you see a lot of waste in the area of Food Preparation, you should refer to Section 4.

House: The Shell

	yes	no
1. Are plants properly located around the house to provide a break against wind and shade against unwanted sun?		
2. Are drapes and furniture located so they do not obstruct heating, air-conditioning or ventilation?		
3. Are draperies insulated?		
4. Do draperies fit snugly around the window?		
5. Are exterior house doors closed quickly after use?		
6. Are lights and appliances turned off after use?		
7. Do you have storm windows and doors?		
8. Are all doors and windows properly caulked and weatherstripped?		
9. Are draperies and shades closed at night and on cloudy, windy days during the heating season?		
10. Are draperies opened to admit sunlight on sunny days in the heating season?		
11. Are draperies and shades closed on sunny days during the cooling season?		
12. Is the attic ventilated?		
13. Is the attic insulated to 6-8"?		
14. Are the walls insulated?		
15. Do floors exposed to unheated or cooled air have from 2-3½" of insulation?		
16. Is the fireplace damper closed when not in use?		
17. Is the den, gameroom or family room oriented to the south?		
18. Is the house shaded from the western sun?		



yes

no

19. Does your home have window area equivalent to 10% or less of its square footage?
20. Is your home sealed from drafts? Is it free from cracks and holes?
21. Does your home have fluorescent lighting where appropriate?
22. Does your home have wall-to-wall carpeting?
23. Do all windows have drapery, shades, blinds, shutters or other covering?

Environmental Control

24. Are ducts, radiators or air-conditioners closed off in unused rooms or closets?
25. Are hot water pipes insulated in unheated and uncooled spaces?
26. Are air ducts insulated in unheated and uncooled spaces?
27. Is the thermostat set at 65°F or below during the heating season?
28. Is the thermostat set at 78°F or above during the cooling season?
29. Are heating and cooling filters clean?
30. Is the thermostat turned back at night?
31. Are windows and doors tightly closed while mechanically heating or cooling?
32. Is an attic fan used in the summer?
33. Do thermostats indicate correct temperature settings?
34. Is an outside air-conditioning unit located on the shady (north) side of the house?
35. Is the water heater insulated?
36. Is the water heater temperature setting at 140°F or less?

- | | yes | no |
|---|-----|----|
| 37. Is the air-conditioning unit properly sized for your needs? | | |
| 38. Do you have a heat pump? | | |
| 39. Do you use natural ventilation as much as possible? | | |
| 40. Are radiators and other heating or cooling equipment clean and dust free? | | |
| 41. Is the water heater located in a heated space? | | |

Housing Selection

- | | | |
|--|--|--|
| 42. If you live in an apartment, is it an "inside" apartment? | | |
| 43. If you live in a mobile home, does it have a "skirt"? | | |
| 44. If you live in an older home, have its plumbing, wiring, insulation and chimneys, been checked by "experts"? | | |

Food

- | | | |
|--|--|--|
| 45. Is the frost on the refrigerator and freezer less than 1/4 inch thick? | | |
| 46. Is the refrigerator set at 40°F? | | |
| 47. Is the freezer set a 0°F? | | |
| 48. Are gaskets around refrigerators and freezers tight? | | |
| 49. Is the oven used to bake more than one food at a time? | | |
| 50. Is the gasket around ovens tight? | | |
| 51. Are frozen foods thawed completely before cooking? | | |
| 52. Is the cooking range turned off immediately after use? | | |

- 53. Are dishes washed only when there is a full load?
- 54. Are dishes allowed to air dry?
- 55. Are appliances clean and dust free (particularly cooling coils)?
- 56. Is the oven never used as a dryer or heater?
- 57. Are flat bottom pots and pans used?
- 58. Is a timer used to avoid over-cooking?
- 59. Are pots covered during cooking?
- 60. Is as little water as possible used during cooking?
- 61. Is the heated dry cycle on the dishwasher not used?

yes

no

Clothing

- 62. Does your family dress warmer in cool weather to avoid mechanical heating?
- 63. Does your family dress cooler in warm weather to avoid mechanical cooling?
- 64. Are clothes washed only when there is a full load?
- 65. When washing, is cold or warm water used, when possible?
- 66. Are clothes line dried when possible?
- 67. Are most of your family's clothes wash-and-wear, permanent press to avoid dry cleaning and ironing?
- 68. Are clothes always rinsed with cold water?
- 69. Is the washer located near the water heater?
- 70. Is the dryer lint screen cleaned after each load?

Personal Care

yes

no

71. Do the members of your family take short showers or use only small amounts of water for tub baths?
72. Are all water faucets repaired and not leaking?
73. For washing, shaving or make-up is the lavatory filled rather than allowing water to run?

Entertainment

74. Are entertainment devices turned off when not in use?
75. Do members of your family try to entertain themselves rather than rely on devices?

--If you answered with 65 or more yes's, you are truly an energy conserver and will make a good conservation advocate.

--If you answered with 55 to 65 yes's, you are energy conscious but lack will-power or drive.

--If you answered with 45 to 54 yes's, you are wasting energy but with minor changes could make a conserver.

--If you answered with 35 to 44 yes's, you are an energy waster and should make an all-out effort to reform!

--If you answered with less than 35 yes's, you are making an effort to waste energy and should consider the long range and immediate effects!!

Suggestions:

1. Distribute these checklists school-wide.
2. Try a before and after approach to using the checklist. Check before your conserving effort and after.
3. Survey students to see if their families are generally conservative or not.

IDEA 18

SOLAR CELL

OBJECTIVE: To help the student understand the conversion of solar energy to electrical energy.

Solar cells generate more electrical energy if the light source is bright. Experiments can be conducted in intensifying sunlight using reflectors and/or lenses. This may, however, cause overheating in the solar cell and some added cooling should be considered.

The output of the solar cell may be measured in volts and amps across a load. The load may be varied to vary the amount of current flowing in the circuit.

Remember the three parts of an electrical circuit should be present:

1. Source of electrical energy (solar cell)
2. Transmission of electrical energy (wires)
3. Load for electrical energy (resistance of some kind)

SUGGESTIONS:

1. Hook solar cells in series parallel to charge batteries.
2. Vary solar cell angle to sun and measure output of cell.
3. Vary brightness of light and measure output of cell.
4. Discuss economic problems with solar cells.
5. Discuss other use of solar cell as light meters and power supplies.

IDEA 19

WIND POWERED CAR

OBJECTIVE: To help the student understand the collection and transmission of solar-wind energy to mechanical energy.

A wind powered car. A windmill is the power source. The windmill through a gearing system raises a given size weight up a small tower. Once the weight is off the ground, it contains the stored energy to power the car. The weight is released and as it falls it launches the car down the track.

SUGGESTIONS: Experiments could be done using different windmills, weights, and cars. Measuring the distance the car travels will show the relative effectiveness of any change.

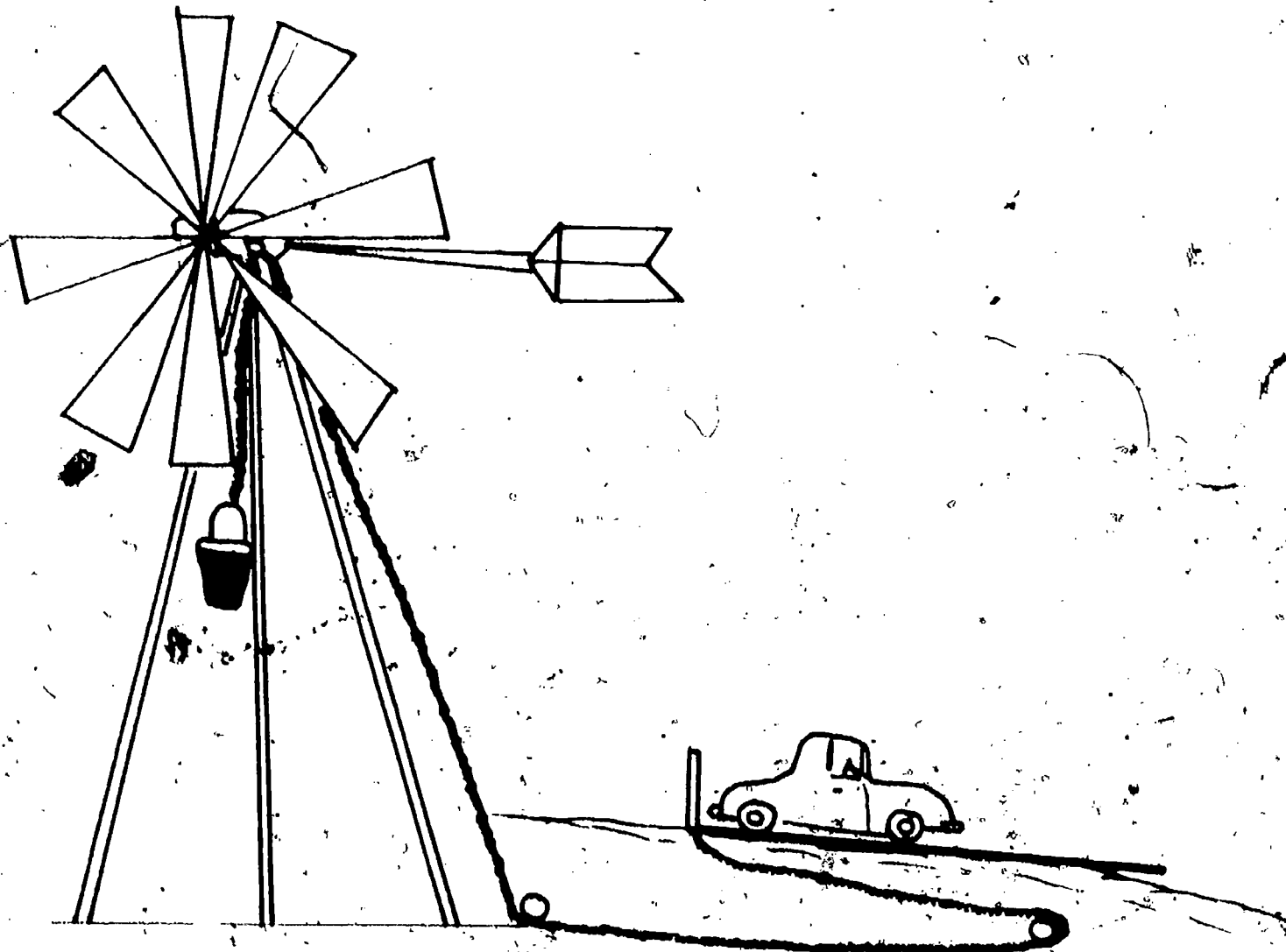

IDEA 20

STORAGE OF SOLAR HEAT

OBJECTIVE: To provide students the opportunity to work with energy systems to gain an understanding of how energy is available, converted, transmitted, stored, controlled, and conserved.

Give each student a tin can. Tell them they are to design the best possible storage device to contain the heated water obtained from the sun.

SUGGESTIONS:

1. Have students pre-heat water by use of the sun.
2. Possible insulation materials would be fiberglass, expandable foam, dirt, stone, foam rubber, another container, etc.
3. Record temperature of water going into storage device. (should be 90° - 120°).
4. Leave solar heated water in storage device for specified amount of time.
5. Record temperature of water at end of specified time.
6. Could be a contest.

IDEA 21

STEAM PROPULSION

OBJECTIVE: To provide students the opportunity to work with energy systems to gain an understanding of how energy is available, converted, transmitted, stored, controlled, and conserved.

1. Using the materials given to the student, have each student construct a device that converts water into steam.
2. Using the device constructed, design and construct a vehicle that will be propelled by steam.

SUGGESTIONS:

1. Container for water should be small to keep vehicle small. (possible small paint container)
2. Have pipe sticking out of top of container to direct steam.
3. Heat source might be a candle or a heating coil.
4. Gears, pulleys, etc. can be obtained from old race cars, etc.
5. Vehicle could be constructed of wood, plastics, cardboard, etc.

SAFETY:

1. Be careful of open fire or heating coils.
2. Steam can burn, caution students.
3. Be careful that the boiler does not blow up. A safety valve may be needed especially on larger boilers.

IDEA 22

TURBINE-GENERATING UNIT MODEL

OBJECTIVE: To provide the student the opportunity to assemble a model which contains all the essential parts of a natural gas-fired turbine generator which will produce electrical current.

To provide the student the opportunity to assemble a model which contains all the essential parts of a hydroelectric generating system.

MATERIALS NEEDED:

FOR EACH GENERATING UNIT, THE FOLLOWING:

- 3 square feet 24 gauge gal. steel sheet metal
- 6 inches 1/8 inch brass rod
- 1 each permanent magnetic hobby motor
- Acid core solder
- 3 inches 3/8 inch diameter nylon rod
- 2 inches 1/4 inch O.D. copper tubing
- Miscellaneous Hardware (pop rivets, screws, etc.)

EQUIPMENT NEEDED:

- Tin snips
- Sheetmetal shear
- Dividers
- 24 inch bench rule
- Oxygen/Acetylene torch (or equivalent heat source)
- Drill press
- Files
- 2 feet 1/4 inch I.D. flexible hose
- 6 inch 6 mm glass tubing
- 1 500 ml flask
- 1 1 hole rubber stopper to fit flask
- 1 ring stand
- 1 ring clamp
- 1 4" x 4" asbestos gauze
- 1 bunsen burner (or propane torch)
- 1 Volt-ohm-milliammeter
- 1 0-1 milliammeter

TURBINE-GENERATOR

During this exercise you are going to have an opportunity to learn the following:

1. Basic sheetmetal working skills and
2. What a turbine is and how it is constructed.

Information:

The turbine is a fancy name for a fan. Usually a turbine is constructed to exacting precision because it must operate at high temperatures and at high speeds. Its operation is illustrated in the drawing below. Gas or steam is allowed to hit the blade of the turbine. The pressure from the gas or steam exerts force on the blades which causes the turbine, which is connected to a shaft, to rotate producing mechanical energy, which if connected to a generator may be used to produce electricity.

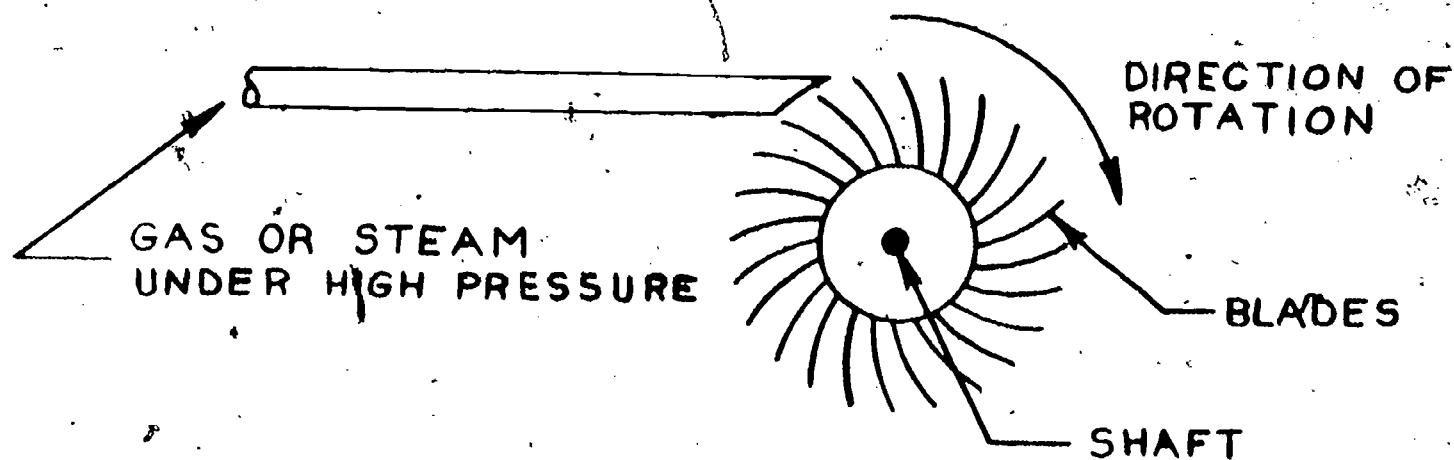

Procedure:

1. Obtain a set of plans for the turbine-generator unit.
2. Obtain necessary materials.
3. Using the plans and instructions from your teacher, construct the turbine-generator.
4. Pay close attention to accuracy in layout, cutting, and assembling project because the performance will be determined by how well you did.

Laboratory Exercise - Lesson 2

Note: Turbine Const.
from 24 gallon galvanized
steel.
Lay-out blades and twist
90° angle w/plier after
cutting.

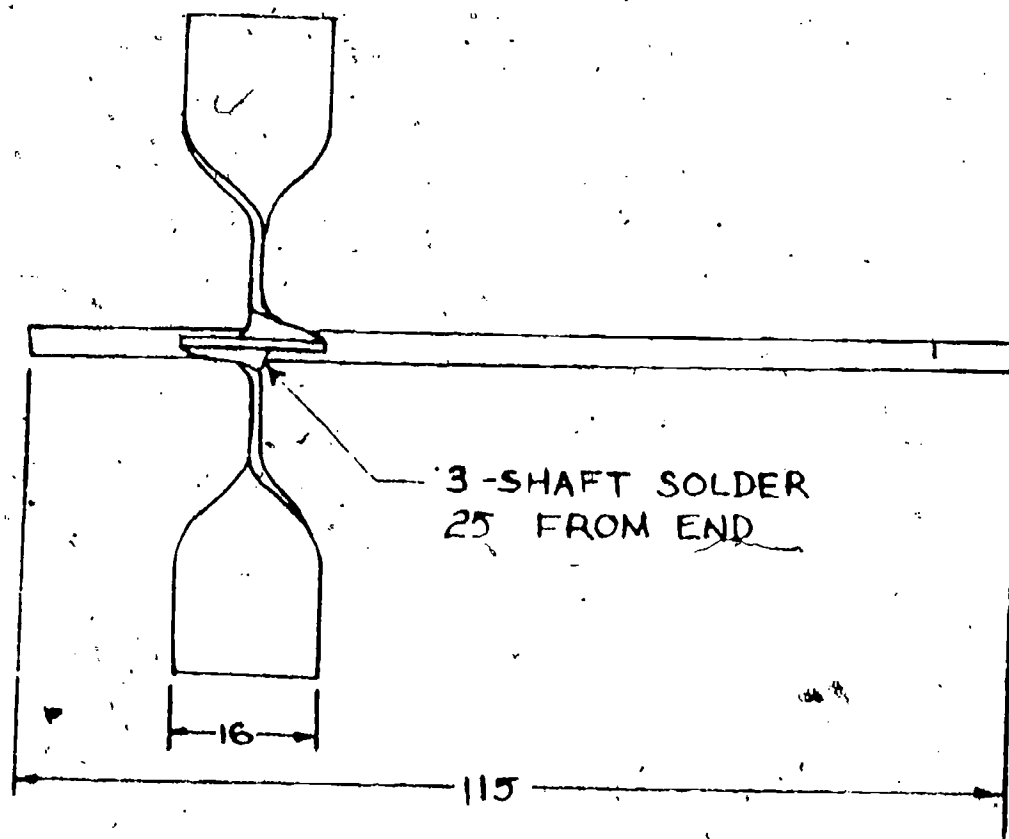
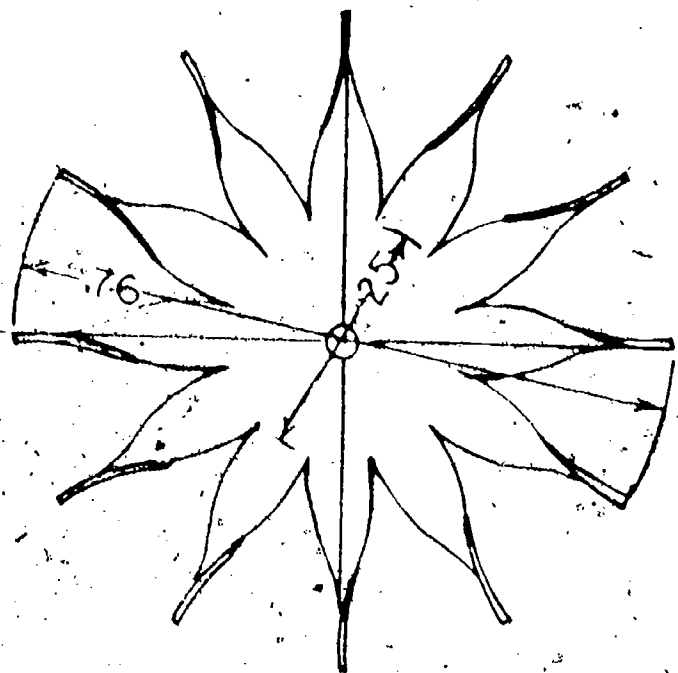

TURBINE
FULL (METRIC mm)

Laboratory Exercise - Lesson 2

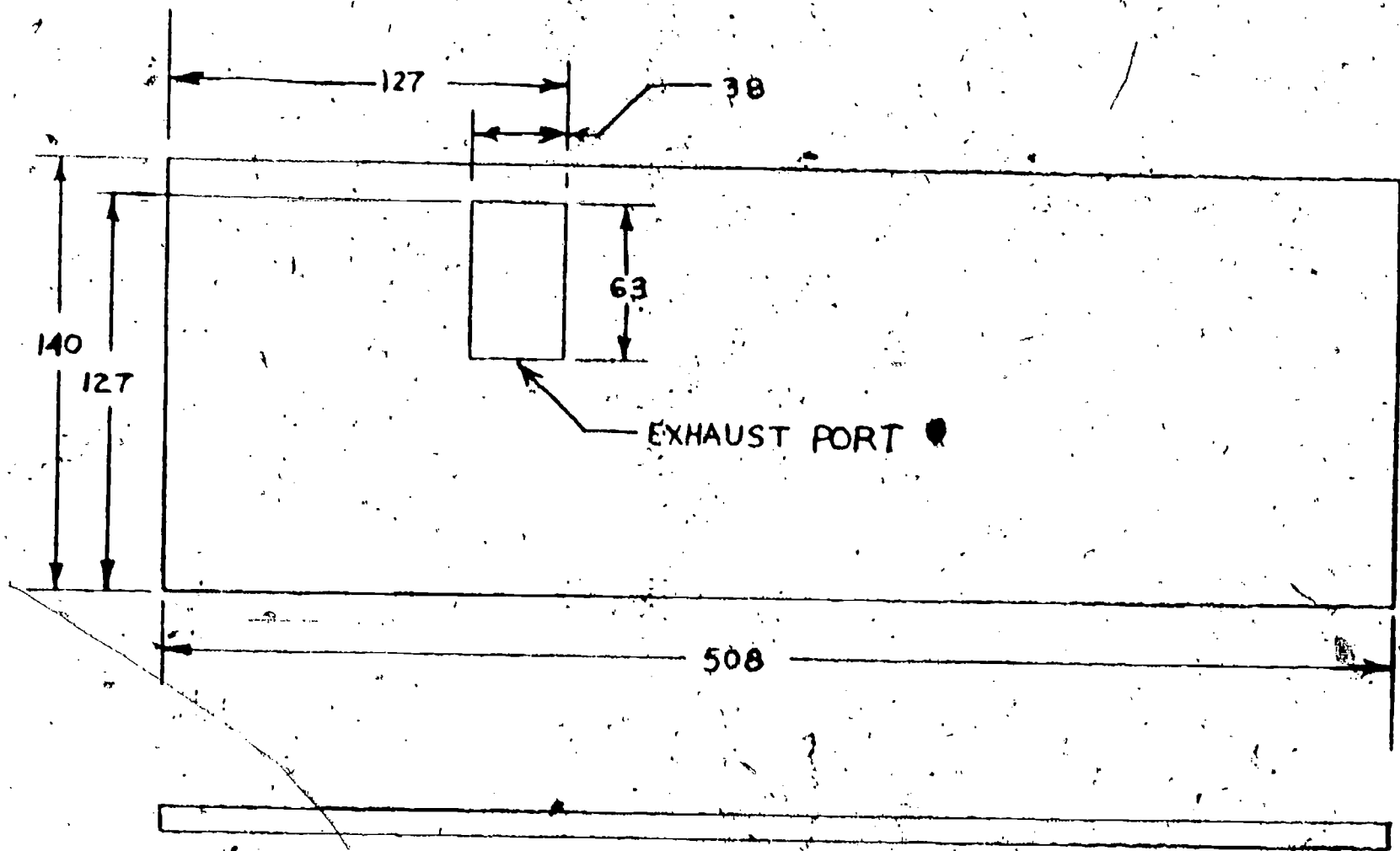

BASE MAT-24 GA GALV STEEL
SCALE: 1-3 (METRIC)

Laboratory Exercise - Lesson 2

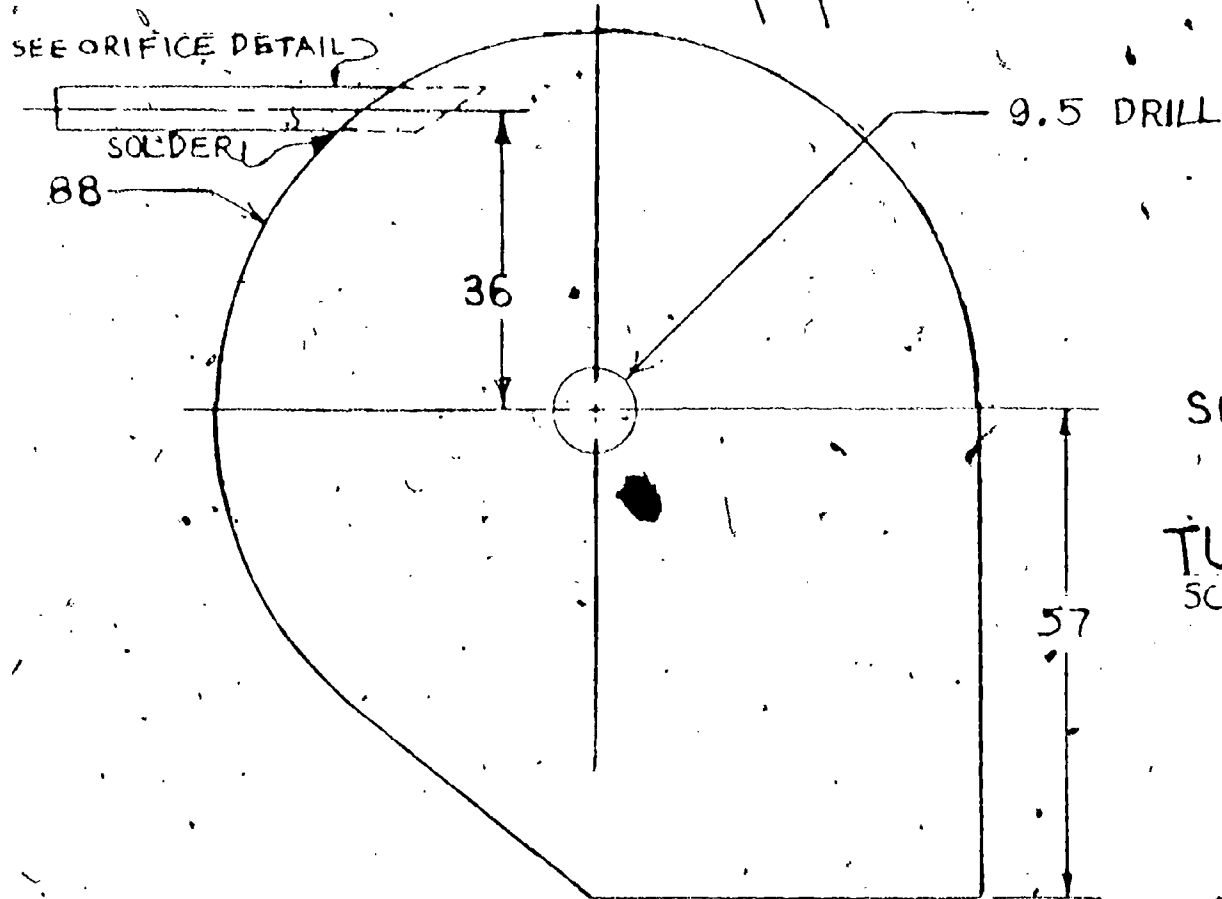
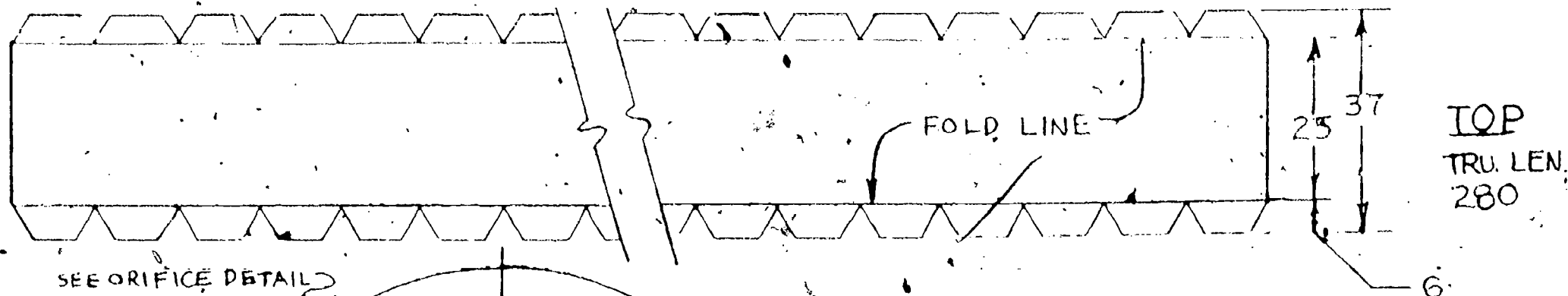

NOTE: MAT'L. 24 GA. GALV. STL.

SIDE 2REQD.

TURBINE HOUSING

SCALE: FULL (METRIC mm)

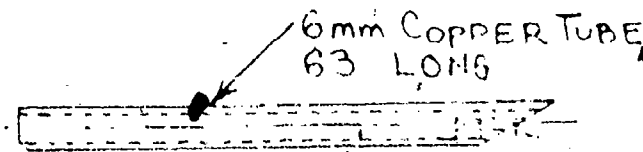

ORIFICE
DETAIL

W/ SOLDER

Laboratory Exercise - Lesson 3

LABORATORY EXERCISE - LESSON 3

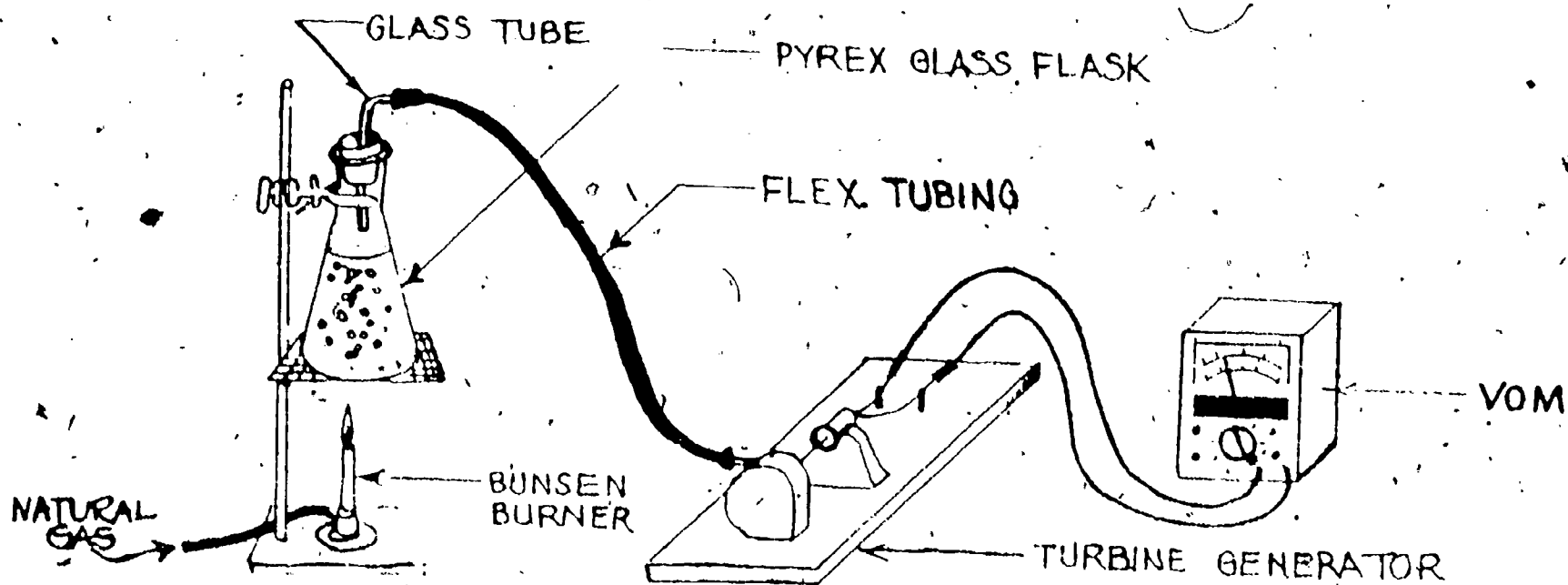

SET-UP DIAGRAM - NATURAL GAS FIRED TURBINE GENERATOR

Laboratory Exercise - Lesson 4

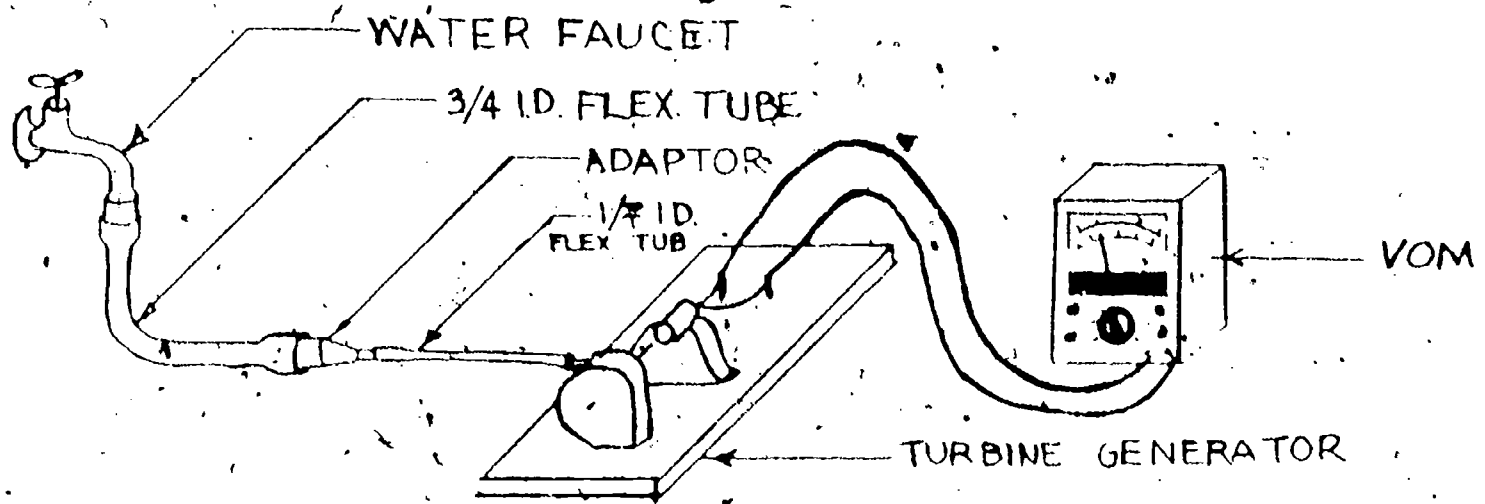

SET-UP DIAGRAM - HYDROELECTRIC GENERATOR

IDEA 23

SOLAR DOMESTIC WATER HEATER

Figures show that, at the current rate of consumption of approximately 6 billion barrels a year, the U.S. will deplete its supply of known oil reserves and estimated future discoveries, by the year 1995. For this reason, alternate sources of energy are being studied. One of the most promising areas of research is solar energy, a free and inexhaustible source.

One use of solar energy that has been successfully practiced for many years is water heating. Solar water heaters have been used in Florida since before 1900. In 1955, more than 60,000 of them were in use in Miami. With the rising cost of fuel and electric power, there is revived interest in solar water heating.

The average Florida family of four paid about \$200 for hot water in 1975, and experts predict the cost of fuel and electricity will continue to rise. Although the initial cost of a solar water heater is higher than a conventional one, a properly constructed and installed unit with a backup heat source could save a homeowner up to 80 percent of this annual water heating costs. To buy a solar water heater in 1976, would cost from \$600 to \$1,500.

The system presented here can be built at a considerable savings by the average "handyman" who has a working knowledge of the necessary tools. The cost of all materials is about \$300, but used materials can be adapted for constructing a solar water heater.

COMPONENTS OF A SOLAR WATER HEATER:

A solar water heating system includes three basic components -- the solar heat collector, the hot water storage tank, and the circulation system. The solar heat collector acts as the water heating element. Flat plate collectors are the most practical for homeowners and are comprised of: a) metal tubing soledly connected to a metal sheet, both painted flat black to absorb heat; b) an insulated, weather-resistant box to retain heat; and c) a transparent cover of glass or plastic.

Except for possible breakage, glass is preferred over plastic because glass permits the sun's radiant energy to enter the collector, but does not directly transmit heat coming off the absorber plate. Plastic, on the other hand, transmits both incoming and outgoing energy, letting more collected heat escape.

Two of the 3' by 8' solar collectors described here will heat approximately 80 gallons of water per day which should be sufficient for the average family of four. Additional collectors can be constructed for hot water needs exceeding the 80 gallons per day average.

FLECT SUNNY SPOT FOR COLLECTOR

The solar heat collector must be mounted in a sunny spot, preferably facing south. To make the best use of the sun's rays, mount the collector at an angle from the horizontal equal to the latitude at your particular location plus 10 degrees. For example, in northern Florida, where the latitude is approximately 30 degrees, a tilt of 40 degrees will give the best year round performance. Deviating from prescribed angles will reduce efficiency only slightly. For example, reducing an angle from 40 degrees to 25 degrees to correspond to the pitch of your roof reduces efficiency approximately 10 percent.

Solar collectors are usually mounted on the roof, but can be placed on the ground or installed as an awning. A collector box is heavy and must be securely anchored to beams, trusses, rafters or some secure part of the building framework. In storms or hurricanes, an insecurely mounted collector box can be very dangerous.

STORAGE TANK SIZE IMPORTANT

Use a hot water storage tank that is large enough to store the amount of hot water required by a family during a period of 24 hours or longer. The average family of four requires a storage tank of at least 80 gallons. A larger tank, 100 to 120 gallons, does not cost much more and will store extra hot water for use when demand is unusually high or weather is bad.

Because of rust and other residues, use only a glass-lined tank. Some solar storage tanks will already be insulated. If your tank is not well insulated you should insulate it with at least 4 inches of foil-backed fiberglass wool. If the tank is exposed to the weather, it must be protected with a waterproof structure.

To realize the most savings and to make the best use of solar energy, the solar water heating system should be used without any type of conventional heat source, such as an electric booster. This will save 100 percent of your water heating costs, but you must be willing to use warm or cool water occasionally. Using an electrical heating element continuously as a backup may reduce your savings as much as 50 percent, according to your particular conditions and hot water usage habits.

An alternative to this plan is to use an electrical heating element in the storage tank and keep the breaker switch turned off or the electric power cord disconnected except when all the solar heated water has been used and there is a need for hot water. The larger your tank, the greater the utilization of solar energy.

You can connect a solar collector to your existing conventional hot water tank. However, most conventional tanks do not have the 20 gallon per person per day capacity necessary to make the best use of solar energy. So, the savings in electricity would probably not be worth the trouble and expense of installing a solar heat collector. If you have a relatively large conventional heater (50 gal.) and wish to try it, it is necessary to use only one of the 3' x 8' collectors.

CIRCULATION SYSTEM DESCRIBED

Heated water can be circulated through tubing from the collector to the tank by thermosyphon (natural) circulation or by using a pump.

The thermosyphon (natural) system requires no manmade energy to operate and is based upon the fact that hot water rises. The rate of movement of hot water from the collector to the storage tank, and cold water from the tank to the collector is controlled by the intensity of the sunshine.

Because this system is dependent upon hot water rising, the storage tank must be mounted so that the bottom is at least 2 feet above the top of the solar collector panel. This might require installing the tank in an attic or on a rooftop. Although a false chimney can help the appearance, problems of weight and construction might be encountered. Another possibility is mounting the collector on the ground and installing the tank in your house. This will aid in insulating your tank and eliminate the need for a weatherproof structure around the tank.

When using the thermosyphon system, it is essential that the connecting pipe or tubing have a continuous fall with no sections permitting the formation of air pockets. Circulation will stop if an air pocket is formed.

A pump adds flexibility to a solar water heating system while using an insignificant amount of energy. Since the pump forces the hot water from the collector to the storage tank, the tank can be located in any convenient place. The pump must be controlled so that water circulates only through the collector when the sun is shining. An inexpensive method for this control can be obtained by using a timer to control the pump. Of course, this has the disadvantage of operating during daytime hours even on days when there is little or no sunshine which would actually cool the water and, thus, reduce the efficiency of the system. A better, but more expensive control, is a differential thermostat with one sensing element on the storage tank and one on the collector. With this device the pump operates only when the solar collector is hotter than the water in the storage tank. Another method is to use a single element thermostat with the sensing element in the collector box and set at about 130 degrees F.

The pump and controls add to the cost of a solar water heating system, but this is often offset by the lower cost of installing the heavy storage tank at ground level.

Whatever circulation system is chosen, it is necessary to consider some form of freeze protection, even in Florida. One of the following methods of freeze protection is recommended: 1) Provide a means of manually draining the system during hard freezes by placing an air-vent valve above the collector. This allows air to enter the system and produces complete drainage. 2) Provide a source of heat to exposed plumbing and collector, such as circulating warm water through the collector or attaching electrical heating elements to the plumbing near the collector. 3) Use a separate heat loop for the exposed collector and plumbing. Thus, anti-freeze can be added to this loop since it is not connected to the fresh water supply. This system is considerably more expensive, since a heat exchanger (usually consisting of tubes connected to the outside of the storage tank) is required to transfer heat from the heat loop to the storage tank. This system is also less efficient in its collection of solar energy. In spite of these disadvantages it probably is the best freeze protection system for cold climates.

USAGE PATTERNS

The success of a solar water heating system in energy conservation and hot water delivery depends on usage patterns. It is advisable to determine how much hot water is needed at different times of the day so the family can plan its usage accordingly. It may be found that dishes can be washed less frequently and most of the laundry can be washed in cold water.

It is best to do laundry, dishwashing, and bathing early enough in the day so there are enough hours of sunshine to heat more water. If your water usage patterns cannot be easily altered, a larger storage tank will improve the operation of your system.

CONSTRUCTION NOTES

Before any construction is started, check your local plumbing and building codes and obtain the necessary permits.

This plan should provide the average person with the necessary information to construct a solar water heating system. Some construction options are shown on the plan such as those for the collector box. However, it is recommended that only copper sheet and tubing be used for constructing the absorber plate. It is possible to use steel or some other material for the absorber and obtain satisfactory results. However, the thickness of the sheet metal must be increased and/or more tubing is required. Because of this, the cost of construction using steel is equal to or greater than that for copper. Also, copper can be expected to last much longer than steel or other materials.

In order to make the soldering job easier, the plan indicates using 3 strips of copper sheet rather than a full 3' x 8' sheet. If difficulty is still encountered, 6 strips of copper can be used with one tube placed approximately in the center of each sheet. This procedure will prevent the solder on adjacent tubes from melting and will not reduce the efficiency of the collector.

The "handyman" may want to make other changes or substitutions in order to use materials already available. One further precaution is to avoid the use of styrofoam adjacent to the metal absorber, because styrofoam may melt at these high temperatures. Styrofoam can be used as the second layer of insulation.

Building your own solar collector can cut costs significantly, but should be undertaken only by those experienced in working with the kind of tools and materials necessary to do the job. For those less experienced, it might be wise to obtain the help of others. Or, you may want to purchase a commercially available system. If you decide to purchase a system rather than build your own, the information presented in this bulletin will help in making your selection. For example, check to see how long it will take to pay for the system in saved power costs, check the storage capacity, construction of the collector and installation instructions.



Cut Away View Of Collector

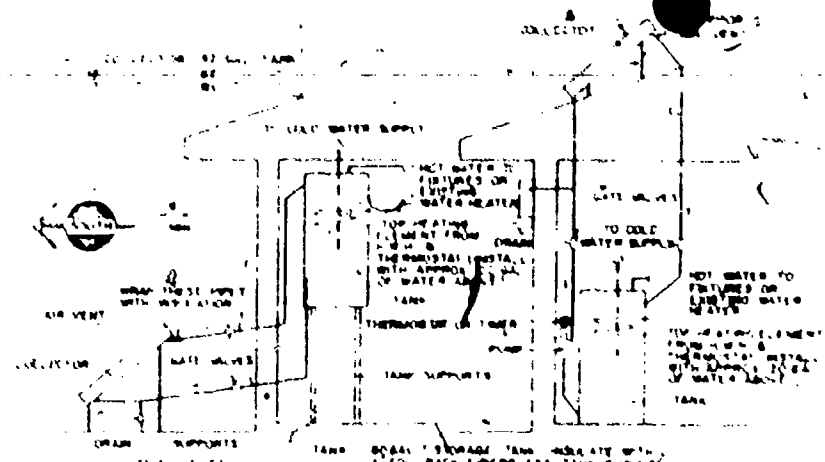

Solar Water Heating System

General Notes

- GLASS - 1/2" THICK GLASS SHOULD BE USED THE TYPE THAT HAS A BLUE APPEARANCE ON OUT EDGES IS A GOOD BETTER THAN THE TYPE THAT APPEARS GREEN
- FRAMING - ALL FRAMING SHOULD BE MADE OF DRY LUMBER
- INSULATION - INSULATION SHOULD BE USED FOR ALL SURFACES EXCEPT THE TOP SURFACE OF COLLECTOR WHICH MAY BE LEFT UNINSULATED IF ALUMINUM IS USED ON THE INSIDE SURFACE OF COLLECTOR
- VENTILATION - AIR VENTS SHOULD BE PROVIDED AT THE LOWEST POINT OF THE COLLECTOR

Construction Notes

- ASSEMBLE WOOD FRAME WITH STUDS 2" ON CENTER AND JOISTS 2" ON CENTER
- LAY COPPER SHEETS WITH FRAME AND MAKE SURE ALL JOINTS ARE SEALED WITH BUTYL GUM
- REMOVE COPPER SHEETS THEN NAIL COPPER SHEETS TO STUDS IN MARKS
- PLACE INSULATION
- PLACE ALUMINUM TANK AND WATER HEATER
- INSTALL COPPER TUBING WITH TUBING WITH BUTYL GUM
- INSTALL GLASS
- INSTALL COPPER TUBING WITH TUBING WITH BUTYL GUM
- INSTALL COPPER TUBING WITH TUBING WITH BUTYL GUM
- INSTALL COPPER TUBING WITH TUBING WITH BUTYL GUM

List of Materials

QTY	DESCRIPTION	QTY	DESCRIPTION
10	2" X 4" LUMBER	10	1/2" GLASS
10	2" X 4" LUMBER	10	1/2" GLASS
10	2" X 4" LUMBER	10	1/2" GLASS
10	2" X 4" LUMBER	10	1/2" GLASS
10	2" X 4" LUMBER	10	1/2" GLASS
10	2" X 4" LUMBER	10	1/2" GLASS
10	2" X 4" LUMBER	10	1/2" GLASS
10	2" X 4" LUMBER	10	1/2" GLASS
10	2" X 4" LUMBER	10	1/2" GLASS
10	2" X 4" LUMBER	10	1/2" GLASS

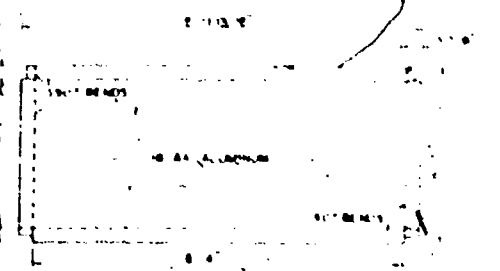

Aluminum Box Layout

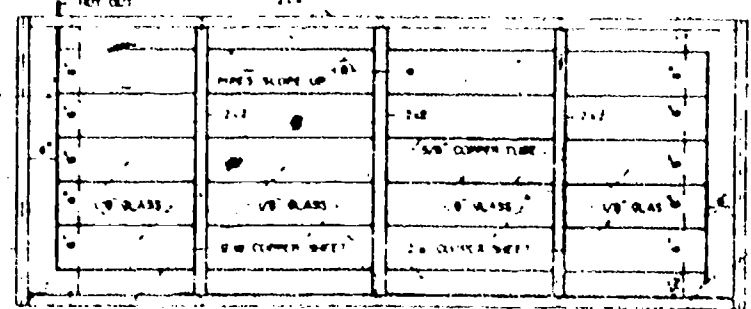

Top View

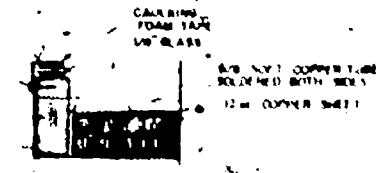

Aluminum Box Constr

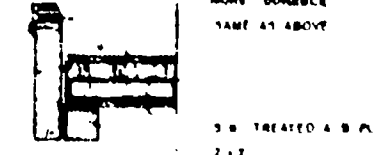

All Wood Construction

Tools Required

- PROPANE TOWEL
- HACKSAW
- SAR
- SCREWDRIVER
- TAPE MEASURE
- CLAMPS - 2
- PAINT BRUSHES
- 1/2" INCH DRILL
- CHISEL

Dev By: J. H. ...
 Coll By: J. H. ...
 Appr By: TCS
 Date: 10/10/74

Florida Cooperative Extension Service
 Institute of Food and Agricultural Sciences
 UNIVERSITY OF FLORIDA

SOLAR WATER HEATER
 DESIGNED BY AGRICULTURAL ENGINEERING DEPT
 UF & UNIVERSITY OF FLORIDA

No. 1080

WATER POWER FROM FLOWING WATER

Small rivers and streams can provide limited supplemental power for the direct drive of machinery or the generation of electricity. It is important to remember that the quantity of water flowing in the stream changes with the seasons; and this must be taken into consideration when designing a water power system. This paper contains the basic procedure for estimating the approximate power which can be derived from a stream, and the construction of a water wheel to make the conversion from water to mechanical power. Turbines and undershot wheels can also be used for the conversion, but their design is considerably more complicated.

The theoretical horsepower which can be obtained from flowing water is calculated with the following formula:

$$\text{Horsepower} = \frac{62.4 \times Q \times H}{550}$$

"Q" is the volume of water in cubic feet flowing past a point in one second. "Q" can be estimated by multiplying the cross sectional area of the stream by the velocity of the stream. The velocity can be estimated by placing a float on the surface of the water and determining the time it takes the float to travel a measured distance. This must be determined in feet per second. The units for "Q" are in cubic feet per second. This determination should be made at a time of year when the stream flow rate is at a minimum, if a constant year around power output is to be expected. The width of the water wheel and the dimensions of the flume are sized to the expected stream flow rate.

"H" is the height, in feet, the water will fall after it is placed in the bucket at the top of the water wheel. For the overshot wheel this is taken as the wheel diameter. For the pitch-back wheel, "H" is less than the wheel diameter. See water wheel plans.

The number 62.4 is the specific weight of water in pounds per cubic foot, and 550 is a conversion factor from foot-pounds of work to horsepower.

Example: A small stream is 3 feet wide, 1/2 foot deep and flows at a velocity of 5 feet per second. The diameter of the water wheel will be 4 feet. In this case the water wheel and flume will be 2 feet wide, and the dam will be 4 feet high.

$$Q = \text{area} \times \text{velocity}$$

$$Q = 3 \times 1/2 \times 5 = 7.5 \text{ ft}^3/\text{sec.}$$

$$\text{Horsepower} = \frac{62.4 \times 7.5 \times 4}{550} = 3.4$$

Keep in mind that 3.4 is the theoretical horsepower or the approximate maximum horsepower which could be obtained from the water if the conversion system was 100 percent efficient. But for a water wheel the conversion from water power to mechanical power is only about 40 percent efficient. There is friction in the turning wheel even with roller bearings, and there will be considerable water spillage. Efficiency is the ratio of actual power to theoretical power, and actual mechanical power can be obtained from the following formula:

$$\text{Actual Horsepower} = \text{Efficiency} \times \text{Theoretical Horsepower}$$

For the example:

$$\text{Actual Horsepower} = 0.4 \times 3.4 = 1.36$$

Conversion to Electrical Power:

A conversion factor of 746 watts per horsepower is used to convert the mechanical power to electrical power.

$$\text{Theoretical Watts} = \text{Actual Mechanical Horsepower} \times 746$$

For the example:

$$\text{Theoretical Watts} = 1.36 \times 746 = 1015 \text{ Watts}$$

But the alternator if operating at full load is only about 85 percent efficient at converting mechanical power to electrical power. The efficiency of conversion is even lower at partial load. To obtain the actual watt output of the water powered generator, multiply the theoretical watts by the alternator efficiency.

$$\text{Actual Watts} = \text{Generator Efficiency} \times \text{Theoretical Watts}$$

For the example:

$$\text{Actual Watts} = 0.85 \times 1015 = 862 \text{ Watts}$$

For the stream in this example about 850 Watts of electrical power could be expected.

Consider, then, what 850 watts of power will operate in your home. Following are some typical home appliances and their wattage requirements: Coffee maker (750 watts), flat iron (1000 watts), frying pan (1000 watts), and toaster (1000 watts). About the largest motor which could be expected to be operated by the generator would be 1/6 horsepower.

The approximate power which can be obtained from the stream can be estimated with this procedure. However, before the alternator is sized, the water wheel and flume should be constructed and operated to determine the actual quantity of water "Q" delivered to the wheel. This will give a more accurate determination of alternator size.

There are some additional points to consider when designing a water power installation. Altering or restricting the natural flow of streams must not be attempted without first considering the Inland Lakes and Streams Act, number 346, and obtaining a permit from the Department of Natural Resources.

Placing a dam in a stream will create a backwater or pond. The local area must be studied to determine the size of the pond, and whether this would cause any objectionable flooding or other adverse affects. The Soil Conservation Service or the County Cooperative Extension Service should be contacted concerning where to get assistance in the design of the dam and the pond.

The following plans are included to show the general construction of a water wheel for converting water power to electrical power. Full size plans can be obtained at a price of \$1.00 from the Plan Service, Agricultural Engineering Department; Michigan State University, East Lansing, MI 48824. Ask for Water Wheel Plans No. 422-C2-1&2.

100

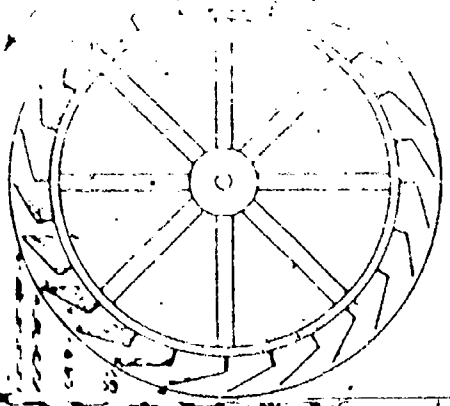

OVERSHOT WHEEL

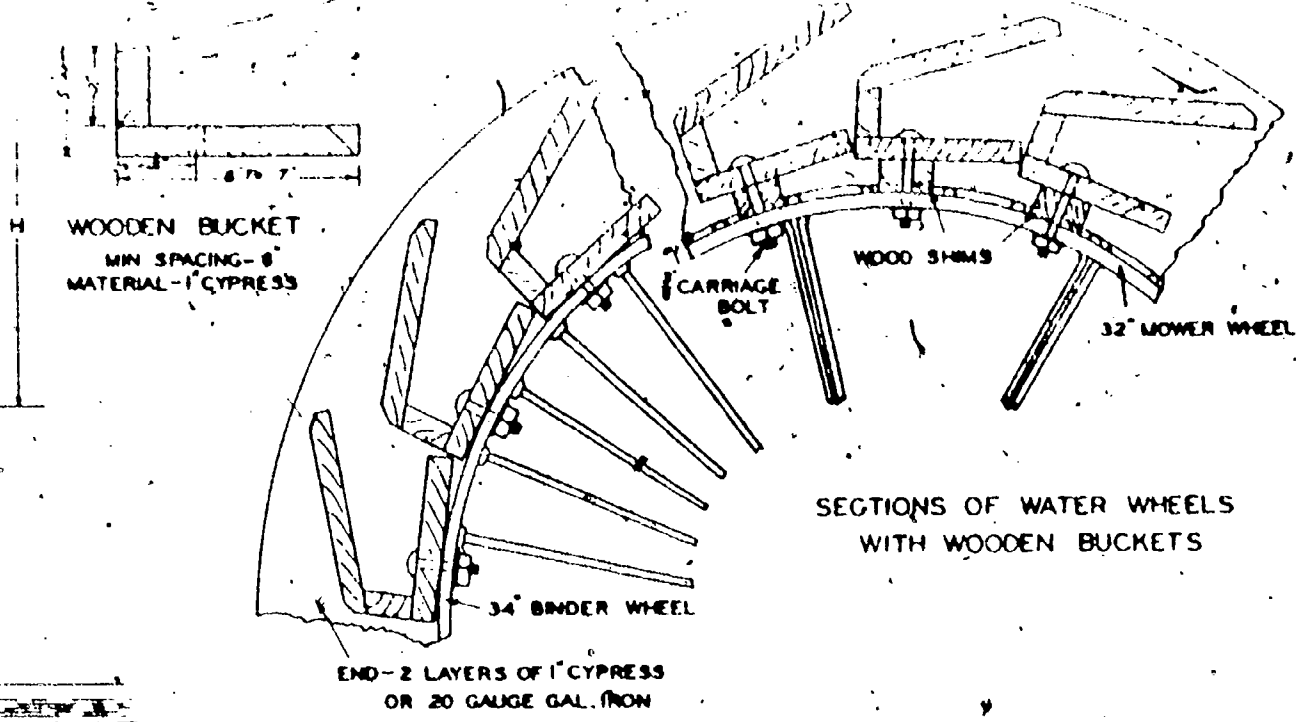

SECTIONS OF WATER WHEELS WITH WOODEN BUCKETS

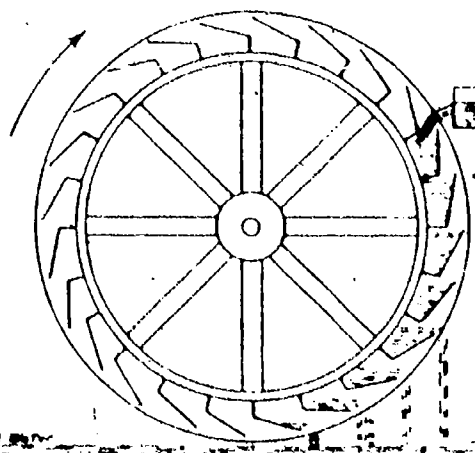

PITCH-BACK WHEEL

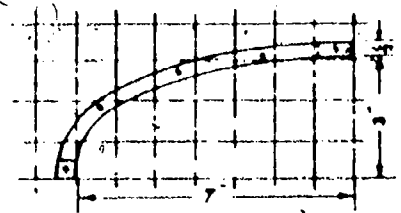

METAL BUCKET MIN. SPACING - 5"

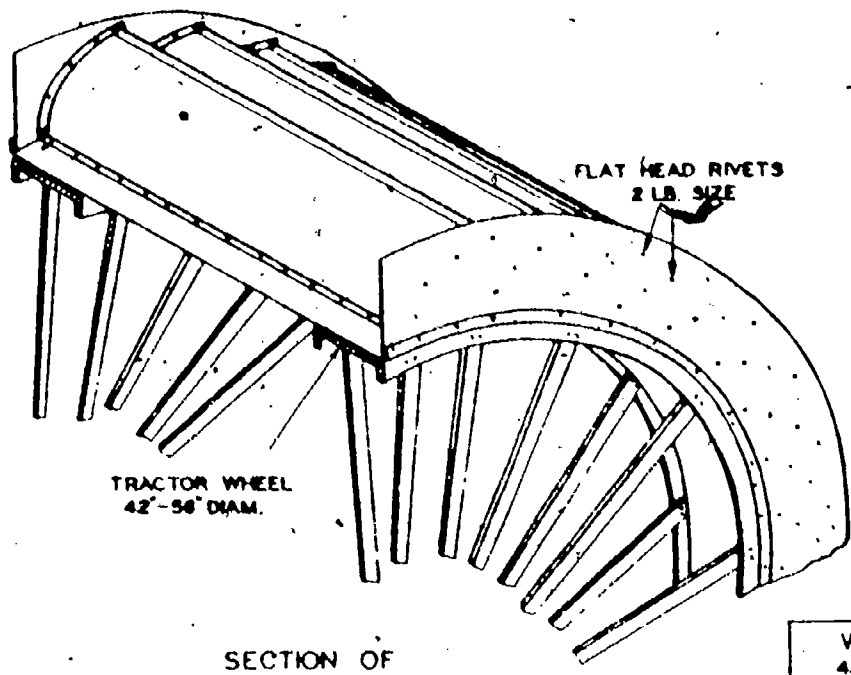

SECTION OF ALL METAL WATER WHEEL

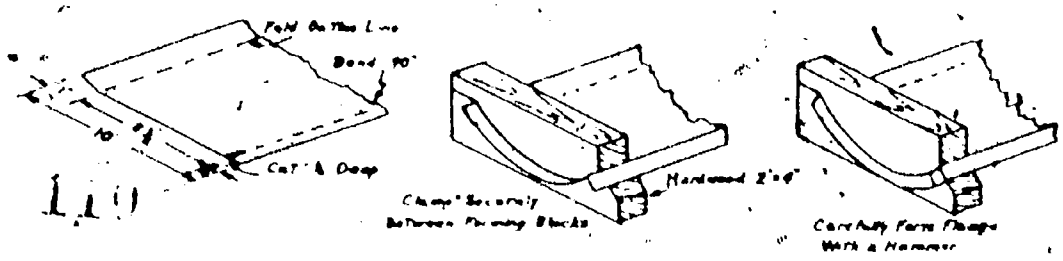

FORMING SHEET METAL BUCKETS FROM 20 GAUGE GAL IRON

WATER WHEELS	
42" TO 72" DIAMETER	
AGRI. ENG. DEPT.	2-22-33
M. S. U.	1-22-33
EAST Lansing, Mich.	SCALE
DATE - 3-28-33	NO.

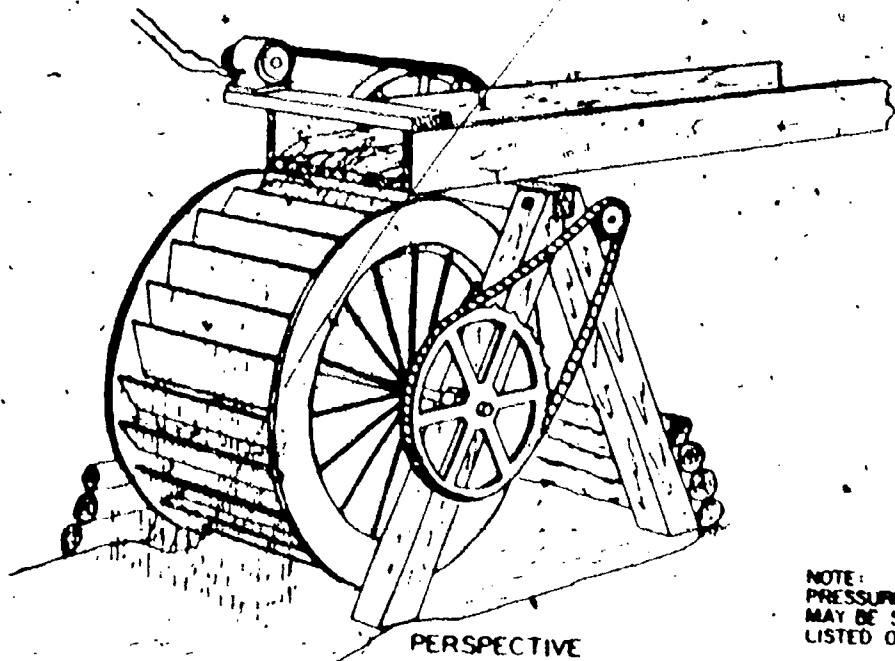

PERSPECTIVE

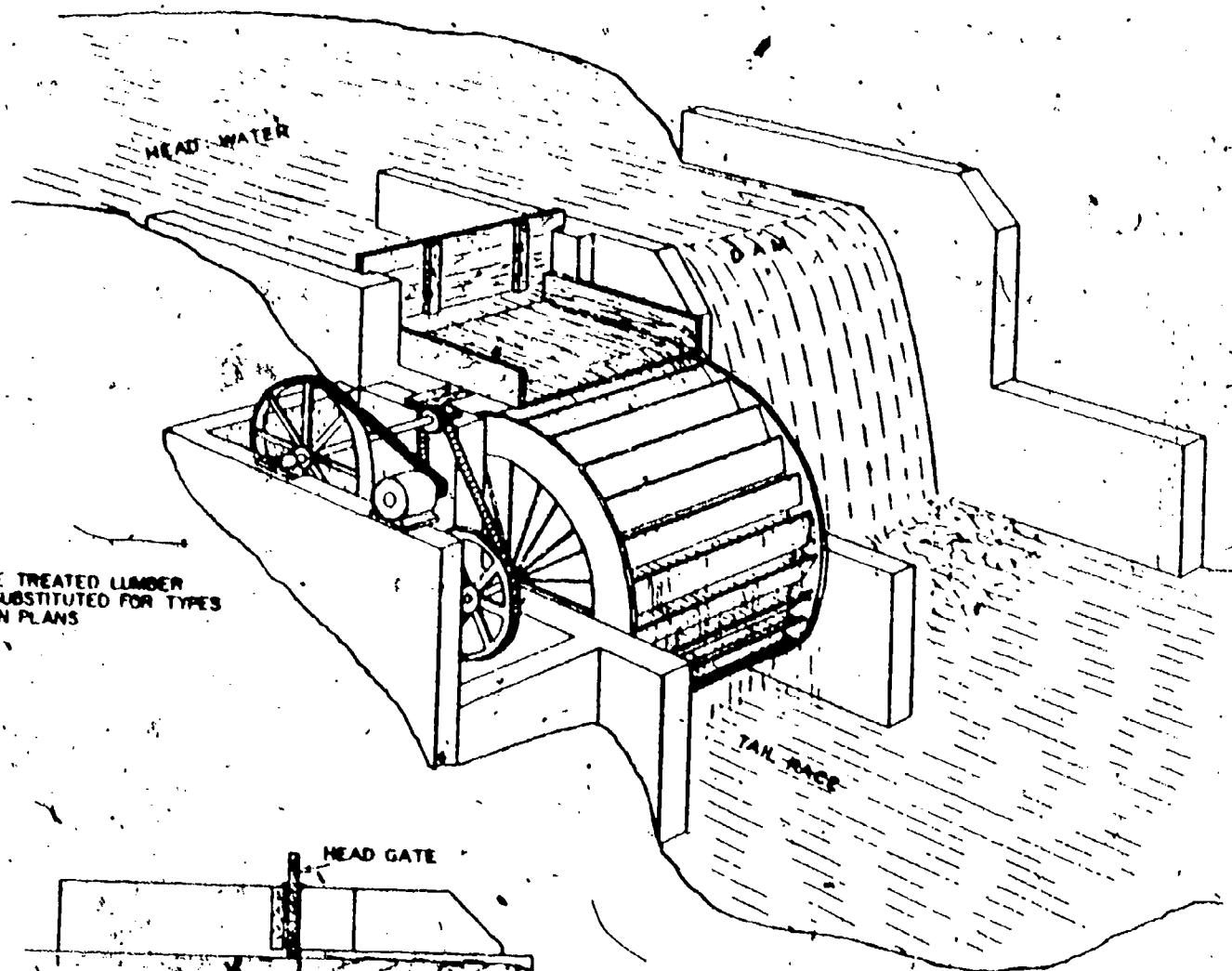

PERSPECTIVE

NOTE:
PRESSURE TREATED LUMBER
MAY BE SUBSTITUTED FOR TYPES
LISTED ON PLANS

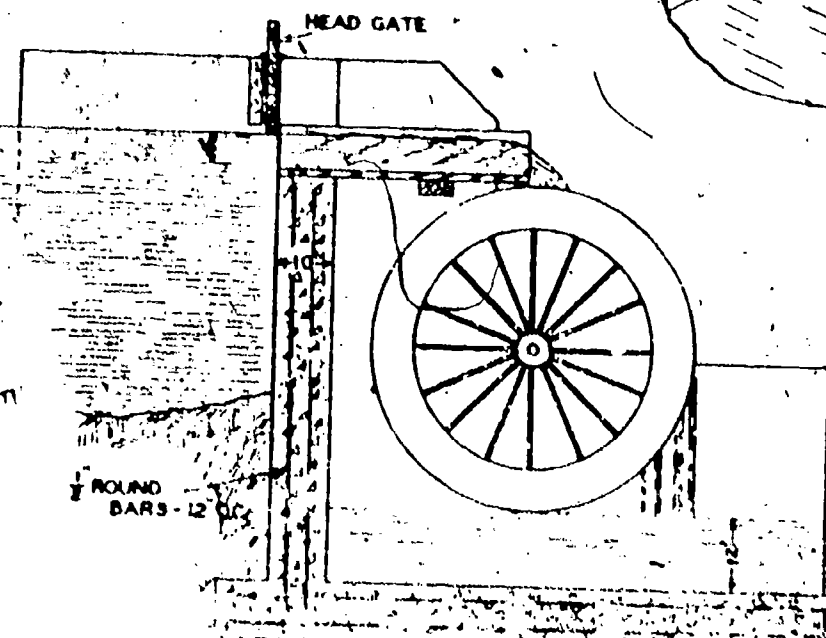
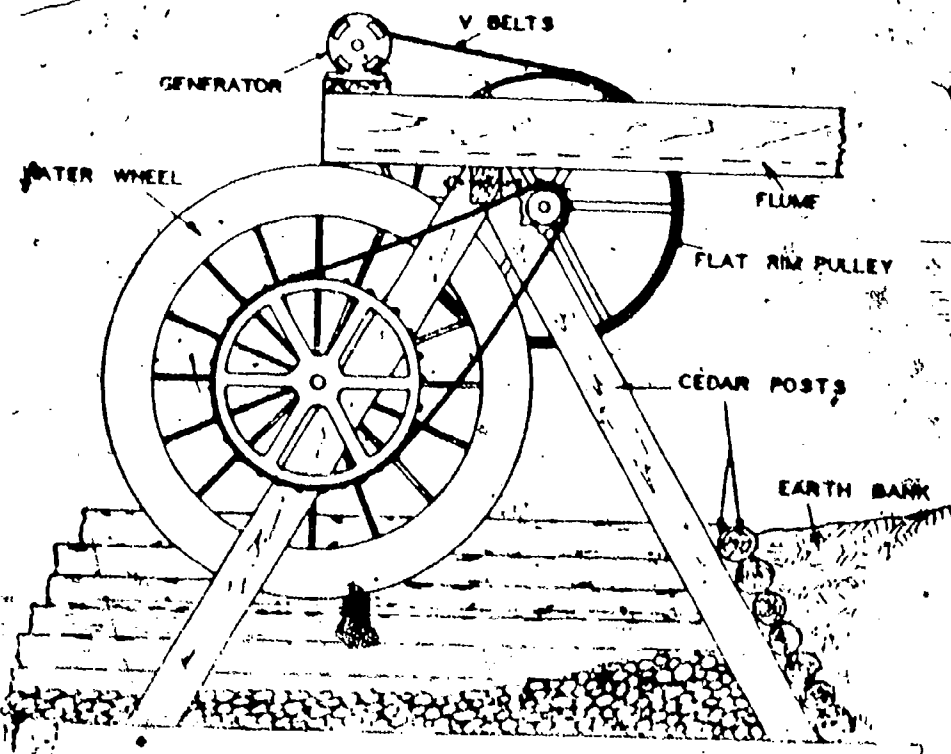

SECTION

NOTE -
FOR MAIN DRIVE USE MANURE
SPREADER OR BINDER BULL CHAIN
AND SPROCKETS

INSTALLATION OF
WATER WHEELS

101

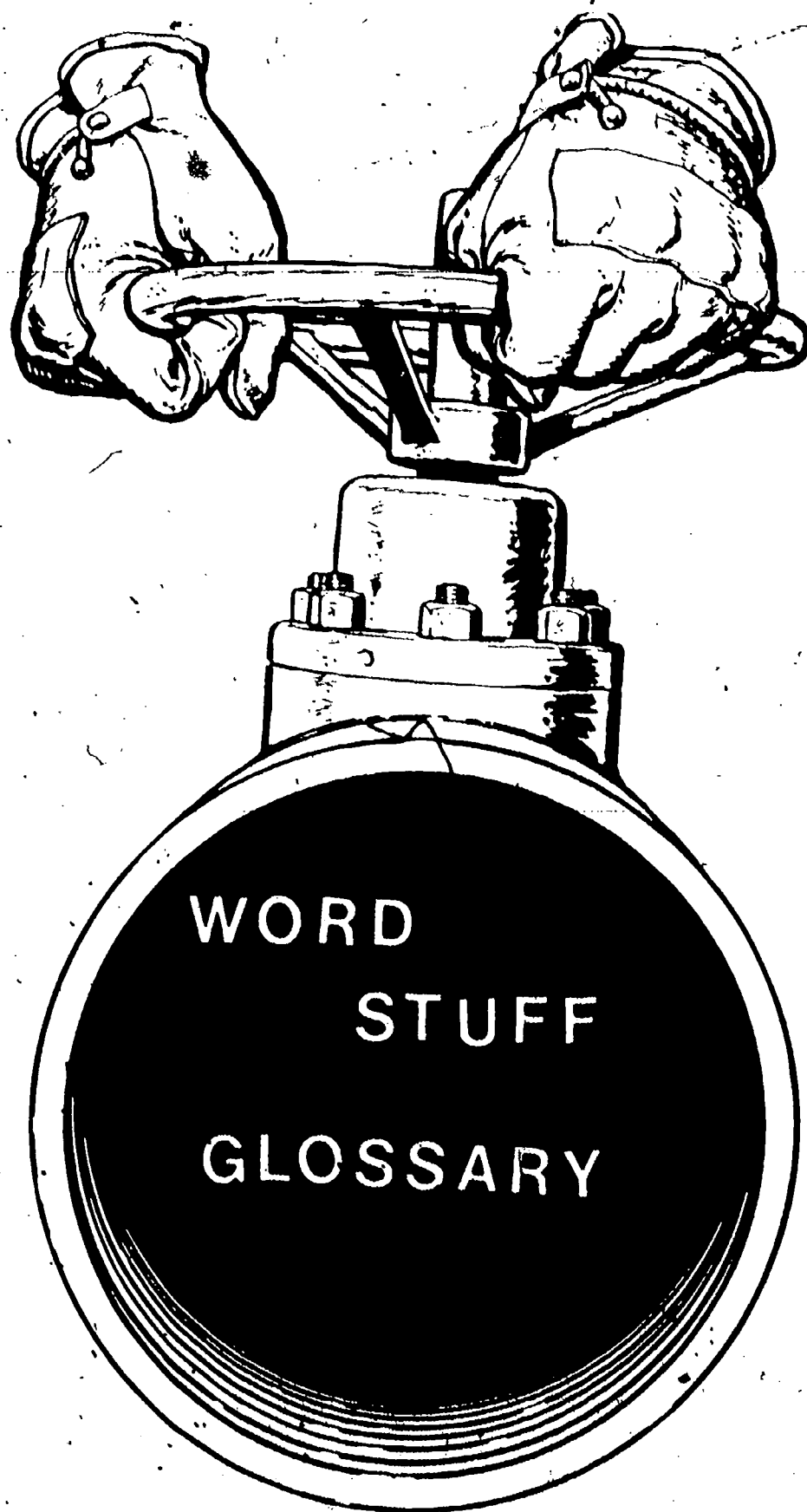

GLOSSARY

ACCELERATION. The time rate of change of velocity in either speed or direction. (13)*

ACCELERATION DUE TO GRAVITY. The acceleration of a body freely falling in a vacuum. The International Committee on Weights and Measures has adopted as a standard or accepted value, 980.665 cm/sec² or 32.174 ft/sec². (13)

ALTERNATING CURRENT (AC). An electric current whose direction of flow is changed at periodic intervals (many times per second). (7)

ANGSTROM. A unit of linear measure equal to 10⁻¹⁰ micron or 1 x 10⁻⁸ cm. (13, 15)

AQUIFER. An underground bed or stratum of earth, gravel, or porous stone that contains water. (6)

ATOM. The smallest particle of an element which can enter into a chemical combination. All chemical compounds are formed of atoms, the difference between compounds being attributable to the nature, number, and arrangement of their constituent atoms. (13)

ATOMIC BOMB. An explosive that derives its energy from the fission or fusion of atomic nuclei. (13)

ATOMIC ENERGY. (1) The constitutive internal energy of the atom which was absorbed when it was formed; (2) Energy derived from the mass converted into energy in nuclear transformations. (13)

ATOMIC PILE. A nuclear reactor.

AUDIO SPECTRUM. The audible range of sound frequencies, extending from approximately 20 to 20,000 hertz. (15)

BARRÉL. Although seldom stored in actual "barrels," crude oil is measured in a unit called the barrel, equal to 42 U.S. gallons. One barrel of crude oil has the same energy as 350 pounds of coal. (9)

BATT. See *Blanket Insulation*.

BLACKOUT. (1) A total power failure caused unintentionally by storm damage, equipment failure, or overloaded utility equipment; (2) An exceptional situation in which all power is deliberately cut off by electrical generating facilities.

BLANKET INSULATION. Cotton fiber mineral wool or wool fiber made into varying thicknesses in a length.

*Numbers in parentheses refer to the GLOSSARY REFERENCES.

CLOCK-ACTUATED THERMOSTAT. Automatically changes the thermostat between two settings at predetermined times, permitting the temperature to be automatically reduced in the evening.

COAL. Solid, combustible, organic hydrocarbon formed by the decomposition of vegetable material without free access to air. (6)

COAL GASIFICATION. The conversion of coal to a gas suitable for use as a fuel. (6)

COLUMN EFFECT. As the volume of a cube increases, the volume-to-surface ratio decreases.

COMBUSTION. Burning; technically, a rapid oxidation accompanied by the release of energy in the form of heat and light. It is one of the three basic contributing factors causing air pollution. The others are attrition and vaporization. (6)

COMFORT AIR CONDITIONING. The process of treating air so as to control simultaneously its temperature, humidity, cleanliness, and distribution.

COMFORT ZONE. The proper temperature, humidity, and air movement to create a feeling of comfort.

COMPOUNDS. Substances containing more than one constituent element and having properties, on the whole, different from those which their constituents had as elementary substances. The composition of a given pure compound is perfectly definite, and is always the same no matter how that compound may have been formed. (13)

CONDUCTOR (ELECTRICAL). A material capable of carrying an electrical current. (6)

CONSERVATION. The care or preservation of natural resources. (6)

CONSERVATION OF MATTER AND ENERGY (LAW OF). The sum of the potential and kinetic energy of an ideal energy system remains constant. (13)

CONSERVE. To manage or use wisely. (6)

CONVECTION. The transfer of energy by moving masses of matter, such as the circulation of a liquid or gas. (3)

CONVENTIONAL HYDROELECTRIC PLANT. A hydroelectric power plant that utilizes streamflow only once as the water passes downstream, as opposed to a pumped-storage plant which recirculates all or a portion of the streamflow in the production of power. (6)

ELECTRICAL ENERGY. The energy associated with electric charges and their movements. Measured in watt hours and kilowatt hours. (One watt-hour equals 860 calories. (6)

ELECTRIC FIELD. The region in which a force acts on an electric charge brought into the region. (15)

ELECTROCHEMICAL CELL. A cell in which chemical energy is converted to electric energy by a spontaneous oxidation-reduction reaction. (15)

ELECTRODE. A conducting element in an electric cell, electronic tube, or semiconductor device. (15)

ELECTROLYSIS. The conduction of electricity through a solution of an electrolyte or through a fused ionic compound, together with the resulting chemical changes. (15)

ELECTROLYTE. A substance whose solution conducts an electric current. (15)

ELECTROMAGNETIC WAVES. Transverse waves having an electric component and a magnetic component, each being perpendicular to the other and both perpendicular to the direction of propagation. (15)

ELECTRON. The electron is a small particle having a unit of negative electrical charge, a small mass, and a small diameter. Every atom consists of one nucleus and one or more electrons. (13)

ELEMENTS. Elements are substances which cannot be decomposed by the ordinary types of chemical change, or made by chemical union. (13)

ENERGY. The capability of doing work. Potential energy is energy due to position of one body with respect to another or relative parts of the same body. Kinetic energy is due to motion. (13)

ENTROPY. Entropy is the capacity factor for isothermally unavailable energy. Every spontaneous process in nature is characterized by an increase in the total entropy of the bodies concerned in the process. (13)

ENVIRONMENT. The sum of all external conditions and influences affecting the life, development, and ultimately the survival of an organism. (6)

EVAPORATION. The change from liquid to gas in which molecules escape from the surface of the liquid. (6)

FEEDSTOCK. Energy resources used as raw materials in the production of such products as wax and asphalt rather than as fuels for burning. (3)

FIRST LAW OF THERMODYNAMICS (Also called the *Law of Conservation of Energy*). Energy can be neither created nor destroyed. (3)

COOLING LOAD. The amount of heat gain per unit time imposed on the cooling (refrigerating or air-conditioning) equipment. (1, 12)

COOLING TOWER. A device used to cool power plant condenser water before it is returned to lake, river, or ocean. The cooling tower is intended to prevent thermal pollution. (6)

COULOMB. The quantity of electricity equal to the charge of 6.25×10^{18} electrons. (15)

CRUDE OIL. Liquid fuel formed from the fossils of animals and plants at the bottom of ancient seas; petroleum as it comes from the ground. (9)

CURRENT (ELECTRIC). The rate of transfer of electricity. (13)

CURTAILMENT. Cutting back the use of energy resources as opposed to conserving or wisely using energy resources. (4)

DECIDUOUS. Trees and shrubbery that lose their leaves during the fall season of each year and regain them in the spring.

DENSITY. Concentration of matter, measured by the mass per volume. (13)

DIFFRACTION. That phenomenon produced by the spreading of waves around and past obstacles which are comparable in size to their wavelength. (13)

DIRECT CURRENT (DC). An electric current that flows in only one direction through a circuit. (6)

DIRECT ENERGY CONVERSION. The process of changing any other form of energy into electricity without machinery that has moving parts. For example, a battery changes chemical energy into electricity by direct energy conversion. (9)

DOUBLE GLAZED WINDOW. Two panes of glass factory-sealed together with a small air space between them. Double glazing has about twice the R-value of single glazing.

EER (ENERGY EFFICIENCY RATIO). An indication of how efficiently an appliance uses energy.

$$\text{EER} = \frac{\text{Number of BTU's Used by the Appliance}}{\text{Appliance's Unit Wattage}}$$

Since 1973 manufacturers of window air-conditioning units have been required to label each unit with its EER. (2)

EFFICIENCY. The ratio of the useful work performed to the amount of energy used in the process. (15)

FISSION. A nuclear reaction from which the atoms produced are each approximately half the mass of the parent nucleus. In other words, the atom is split into two approximately equal masses. There is also the emission of extremely great quantities of energy since the sum of the masses of the two new atoms is less than the mass of the parent heavy atom. The energy released is expressed by Einstein's equation,
 $E = Mc^2$. (13)

FLYWHEEL. A method of energy storage working on the principle of a spinning wheel. By its inertia, a spinning wheel stores mechanical energy. (11)

FOAM INSULATION. (1) Styrofoam; (2) Rigid foam boards; or (3) Liquid foam insulation.

FORCE. That which changes the state of rest or motion in matter, measured by the rate of change in momentum. The force F required to produce an acceleration a in a mass m is given by $F = ma$. (13)

FOSSIL FUELS. Coal, oil, natural gas, and other fuels originating from geologic deposits of ancient plant and animal life depending on oxidation for release of energy. (6)

FREEZING POINT. The temperature at which a liquid changes into a solid. (15)

FREQUENCY. Number of vibrations or cycles per unit of time. (15)

FRictionAL FORCE. Force required to move one surface across another. (13)

FUEL. A substance used to produce heat energy, chemical energy by combustion, or nuclear energy by nuclear fission. (6)

FUEL CELL. A device in which fuel and oxygen are combined to produce chemical energy that is converted directly into electricity. (6)

FUSION (ATOMIC). A nuclear reaction involving the combination of smaller atomic nuclei or particles into larger ones with the release of energy from mass transformation. This is also called a thermonuclear reaction by reason of the extremely high temperature required to initiate it. (13)

FUSION. 1. The change of state from a solid to a liquid; 2. A reaction in which light nuclei combine to form an atom with greater mass. (15)

GAMMA RAYS (NUCLEAR X-RAYS). Emitted from radioactive substances, they are quanta of electromagnetic wave energy similar to, but of much higher energy than, ordinary X-rays. (13)

GAS. A state of matter in which the molecules are practically unrestricted by cohesive forces. A gas has neither definite shape nor volume. (13)

GASOLINE. Mixture of hydrocarbons obtained from petroleum. (6)

GENERATOR. A device that converts heat or mechanical energy into electrical energy. (6)

GEO THERMAL. As applied to power generation, the use of heat energy obtained through the medium of hot water or steam coming from beneath the earth's surface.

GEO THERMAL ENERGY. The heat energy available in the earth's subsurface believed to have been produced by natural radioactivity. The thermal gradient of the earth's crust is such that the temperature in a deep well or mine increases by about 1° F for each 100 ft. of depth. (6)

GRAM. A unit of mass in the metric system; 10^{-3} standard kilogram. (15)

GRAVITATION. The universal attraction existing between all material bodies. (13)

GREENHOUSE EFFECT. A method of using solar radiation to warm underheated areas (window treatments are opened to allow the window to admit and trap the sun's heat).

GROSS NATIONAL PRODUCT (GNP). A measure of economic activity which is the total market value of all goods and services produced in a country. Depreciation and other allowances for capital consumption are not deducted. (3)

GROUNDWATER. The supply of water under the earth's surface in an aquifer or soil that forms a natural reservoir. (6)

GROUNDWATER RUNOFF. Groundwater that is discharged into a stream channel as spring or seepage water. (6)

HEAT. Energy possessed by a substance in the form of kinetic energy, usually measured in calories or, in space heating, by the British thermal unit. Heat is transmitted by conduction, convection, or radiation. (6)

HEAT CAPACITY. That quantity of heat required to increase the temperature of a system or substance one degree of temperature. It is usually expressed in calories per degree Celsius. (13)

HEAT ENERGY. Energy that causes an increase in the temperature of an object. It may change the object from solid to liquid or from liquid to gas. (6)

HEAT PUMP. A device that absorbs heat from the outside air and pumps it into the house. It works in reverse as a standard air conditioner for cooling.

HEATING LOAD. The amount of heat loss per unit time imposed on the heating equipment (Btu/Hr./sq. ft.). (1, 12)

HEAVY HYDROGEN. A kind of hydrogen that has one proton and one neutron in the nucleus of each atom and one electron in orbit around the nucleus. (6)

HERTZ. The MKS unit of frequency, one hz being equivalent to the expression "one cycle per second." (15)

HIGH-SULPHUR COAL. Generally, coal that contains more than one percent of sulphur by weight. (6)

HORSEPOWER. A unit that measures the rate at which energy is produced or used. A man doing heavy manual labor produces energy at the rate of about .08 horsepower. (9)

HYDROELECTRIC PLANT. An electric power plant in which the turbine-generators are driven by falling water.

HYDROELECTRICITY. Electricity production by water-powered turbine generator. (6)

HYDROLOGY. The science dealing with the properties, distribution, and circulation of water and snow.

HYDROPOWER. Power produced by falling water. (3)

INFILTRATION. The movement of air from the exterior of the house, or colder portions of the environment, to the interior of the house or warmer areas of the environment. Winter winds blow cold outdoor air into indoor spaces through cracks around windows and doors on the windward side of the house.

INFRASONIC SPECTRUM. The range of compression waves at frequencies below the audio range (below 20 hertz). (15)

INSULATION. A substance that insulates is one that can slow down the flow of heat or sound. (6)

INTERIOR FINISHING MATERIALS. The permanent finishes or furnishings, such as paint, wallcoverings, paneling, flooring, tile, acoustic tile, and carpeting, which are applied to the inside of a home.

INTERNAL COMBUSTION ENGINE. Energy is supplied by a burning fuel which is directly transformed into mechanical energy by controlled combustion. (6)

ION. An atom or group of atoms that is not electrically neutral but instead carries a positive or negative electric charge. Positive ions are formed when neutral atoms or molecules lose valence electrons; negative ions are those which have gained electrons. (13)

- ISOTOPE.** A variation of an element having the same atomic number as the element itself, but having a different atomic weight because of a different number of neutrons. Different isotopes of the same element have different radioactive behavior. (6)
- JOULE.** A metric unit of work or energy; the energy produced by a force of one newton operating through a distance of one meter.
- KILOCALORIE.** Heat energy equal to 4.19×10^3 joules. (15)
- KILOVOLT (KV).** 1,000 volts. (6)
- KILOWATT (KW).** The unit of power equal to 1,000 watts, 3.413 Btu's, or 1,341 horsepower. Roughly, the power of one kw is capable of raising the temperature of a pound (pint) of water 1°F in one second. (6)
- KILOWATT-HOUR (KWH).** The amount of work or energy delivered during the steady consumption of one kilowatt of power for a period of one hour, equivalent to 3.412 Btu's. (6)
- LIGHT.** Radiant energy which an observer can see. (15)
- LIQUIFIED NATURAL GAS (LNG).** Natural gas that has been changed into a liquid by cooling to about -260°F (-160°C) at which point it occupies about 1/600 of its gaseous volume at normal atmospheric pressure; thus, the cost of shipping and storage is reduced. (6)
- LIQUID.** A state of matter in which the molecules are relatively free to change their positions with respect to each other but restricted by cohesive forces so as to maintain a relatively fixed volume. (13)
- LOOSE INSULATION.** Small pieces of insulation which are blown into place.
- LOW SULPHUR COAL AND OIL.** Generally, coal or oil that contains one percent or less of sulphur by weight. (6)
- MAGMA.** Molten rock within the earth's interior. (3)
- MAGNETIC FIELD.** A region in which a magnetic force can be detected. (15)
- MASS.** A measure of the weight of matter in an object. The weight of an object depends on its mass. The United States standard mass is the avoirdupois pound as defined by 1/2.20462 kilogram. (7, 13)
- MATTER.** Anything which is solid, liquid, or gaseous. (15)
- MECHANICAL ENERGY.** The kind of energy that is released to make objects move. (6)
- MEDIUM.** Any material--solid, liquid, gas--in which waves travel. (15)

- MEGAWATT (MW)*. A unit of power equal to 1,000 kilowatts or one million watts. (6)
- METHANE*. Colorless, nonpoisonous, and flammable gaseous hydrocarbon; emitted by marshes and by dumps undergoing decomposition. (6)
- MOBILE HOME SKIRT*. A foundation piece added to enclose the area under a mobile home.
- MOLECULE*. The smallest unit quantity of matter which can exist by itself and retain all the properties of the original substance. (13)
- MOMENTUM*. Quantity of motion measured by the produce of mass and velocity. (13)
- MOTION*. Continuous change of location or position of a body. (15)
- NATURAL GAS*. Naturally-occurring mixtures of hydrocarbon gases and vapors occurring naturally in certain geologic formations; usually found associated with oil. (6)
- NEUTRON*. A neutral elementary particle of mass number 1. It is believed to be a constituent particle of all nuclei of mass number greater than 1. (13)
- NEWTON*. The force necessary to give acceleration of one meter per second to one kilogram of mass. (13)
- NONRENEWABLE RESOURCES*. Depletable energy resources such as the fossil fuels--coal, gas, and oil. (5)
- NUCLEAR ELECTRIC POWER PLANT*. One in which heat for raising steam is provided by fission rather than combustion of fossil fuel. (6)
- NUCLEAR (ATOMIC) FUEL*. Material containing fissionable uranium of such composition and enrichment that, when placed in a nuclear reactor, will support a self-sustaining fission chain reaction and produce heat in a controlled manner for process use. (6)
- NUCLEAR POWER*. Electric power produced from a power plant by converting the energy obtained from nuclear reaction. (6)
- NUCLEAR POWER PLANT*. Any device, machine, or assembly that converts nuclear energy into some form of useful power, such as mechanical or electrical power. In a nuclear electric power plant, heat produced by a reactor is generally used to make steam to drive a turbine that, in turn, drives an electric generator. (6)
- NUCLEAR REACTION*. A reaction involving a change in an atomic nucleus, such as fission, fusion, neutron capture, or radioactive decay, as distinct from a chemical reaction, which is limited to changes in electron structure surrounding the nucleus. (6)

NUCLEUS. The dense central core of the atom in which most of the mass and all of the positive charge is concentrated. (13)

OFF-PEAK. Energy supplied during periods of relatively low system demands. (6)

OIL SHALE. Sedimentary rock containing solid organic matter (kerogen) that yields substantial amounts of oil when heated to high temperatures. (6)

OIL SPILL. The accidental discharge of oil into oceans, bays, or inland waterways. Methods of oil spill control include chemical dispersion, combustion, mechanical containment, and absorption. (6)

OPEC (Organization of Petroleum Exporting Countries). An organization of countries in the Middle East, North Africa, and South America which aims at developing common oil-marketing policies. (3)

OPTICAL SPECTRUM. Includes those radiations, commonly called light, that can be detected visually. They range from 7600Å to 4000Å and are a type of electromagnetic radiation. (15)

ORIENTATION. Position with relation to the compass.

OXIDATION. A chemical reaction in which oxygen unites or combines with other elements. Organic matter is oxidized by the action of aerobic bacteria; oxidation is used in waste water treatment to break down organic wastes. (6)

PEAKING. Power plant operation to meet the highest portion of the daily load. (6)

PEAKING CAPABILITY. The maximum peak load that can be supplied by a generating unit, station, or system in a stated period of time. For a hydroproject, the peaking capability would be equal to the maximum plant capability only under favorable pool and flow conditions. Often the peaking capability may be less due to reservoir drawdown or tail-water encroachment. (6)

PHASE. (1) A condition of matter; (2) The position and motion of a particle of a wave. (15)

PHOTOSYNTHESIS. The process by which some plants make food with the help of sunlight energy (the food is a sugar called glucose; oxygen gas is also produced during photosynthesis); the process in which sunlight falling on green plants causes carbon dioxide and water to be converted into more complex organic materials such as glucose. (7)

PLUTONIUM. A fissile element, artificially produced by a neutron captured by U^{238} . (13)

POTENTIAL (ELECTRIC). Difference of potential between two points is measured by the work necessary to carry unit positive charge from one to the other. (13)

POWER. The time rate at which work is done. If an amount of work W is done in time t the power or rate of doing work is $P = W/t$. Power will be obtained in watts if W is expressed in joules and t in seconds. (13)

PRESSURE. The force applied to a unit area. (15)

PROTON. An elementary particle having a positive charge equivalent to the negative charge of the electron but possessing a mass approximately 1,837 times as great. The proton is, in effect, the positive nucleus of the hydrogen atom. (13)

PUMPED HYDROELECTRIC STORAGE. The only means now available for the large-scale storage of electrical energy. Excess electricity produced during periods of low demand is used to pump water up to a reservoir. When demand is high, the water is released to operate a hydroelectric generator. Pumped energy storage only returns about 66 percent of the electrical energy put into it, but costs less than an equivalent generating capacity. (6)

PUMPED STORAGE PLANT. A hydroelectric power plant which generates electric energy for peak load use by utilizing water pumped into an elevated storage reservoir during off-peak periods. (6)

R-VALUE. Thermal resistance; computed by the conductivity divided into one. The measure of resistance to heat flow. (1, 2)

RADIATION. The emission and propagation of energy through space or through a medium in the form of waves. (13)

RECLAMATION. Act or process of reclaiming; for example, strip-mined land should be reclaimed--replanted and leveled. (14)

REFLECTION. The turning back of a wave from the boundary of a medium. (15)

REFUSE. See *solid waste*.

RENEWABLE RESOURCES. Nondepletable resources; for example, the sun. (5)

RESERVES. The amount of a natural resource known to exist and expected to be recovered by present-day techniques.

RESERVOIR. A pond, lake, tank, or basin--natural or manmade--used for the storage, regulation, and control of water. (6)

RESOURCES. The estimated total quantity of a natural resource such as minerals in the ground; includes undiscovered mineral reserves. (6)

SECOND LAW OF THERMODYNAMICS. One of the two "Limit" laws which govern the conversion of energy. Referred to here as the "heat tax," it can be stated in several equivalent forms, all of which describe the inevitable passage of some energy from a useful to a less useful form in any energy conversion. (3)

SHELL. The roof or cover of a home, the foundation or part that sits on the ground, and the sides which join the two.

SIMPLE MACHINE. A contrivance for the transfer of energy and for increased convenience in the performance of work. (13)

SOLAR CELL. A photovoltaic cell which converts radiant energy from the sun into electrical energy. (6)

SOLAR ENERGY. Radiation energy from the sun falling upon the earth's surface. (6)

SOLID. A state of matter in which the relative motion of the molecules is restricted and they tend to retain a definite fixed position relative to each other, giving rise to crystal structure. A solid may be said to have a definite shape and volume. (13)

SOLID WASTE. Useless, unwanted, or discarded material with insufficient liquid content to be free flowing. (6)

SONIC SPECTRUM. The region of sound; a range which includes audio range frequencies, ultrasonic range frequencies, and infrasonic range frequencies. (15)

SOUND ENERGY. A kind of energy carried by molecules that vibrate back and forth; so that waves are formed. (6)

SPECIFIC HEAT. The heat capacity of a material per unit mass. (15)

SPEED. Time rate of motion measured by the distance moved over in unit time. (13)

STATIC ELECTRICITY. Electricity at rest. (15)

STEAM-ELECTRIC PLANT. A plant in which the prime movers (turbines) connected to the generators are driven by steam. (6)

STOCKPILE. A storage pile or reserve supply of an essential raw material; for example, coal is stockpiled in the open air for storage purposes. (14)

STORAGE CELL. An electrochemical cell in which the reacting materials are renewed by the use of a reverse current from an external source. (15)

STORED ENERGY. See *Energy (potential)*.

- STORM DOOR.* Additional door with an air space between it and the existing door. (6)
- STORM WINDOW.* Additional window with an air space between it and the existing window. Storm windows will cut in half the heat that passes through windows in your house. (6)
- STRIP-MINING.* A process in which rock and topsoil strata overlying ore or fuel deposits are scraped away by mechanical shovels. Also known as surface mining. (6)
- SUBLIMATION.* The change of phase from a solid directly to a vapor or gas. (15)
- SUPERFLYWHEEL.* A flywheel of the future that will be constructed of materials which have special properties along each axis. See also *flywheel*. (15)
- SUPERTANKERS.* Extremely large oil tankers that can hold up to four million barrels (170 million gallons) of oil. The largest ones will require deepwater ports. (15)
- TECHNOLOGY.* Applied science. (15)
- TEMPERATURE.* The condition of a body which determines the transfer of heat to or from other bodies; particularly, it is a manifestation of the average translational kinetic energy of the molecules of a substance due to heat agitation. (13)
- TENSILE STRENGTH.* The greatest longitudinal stress a substance can bear without tearing apart. (14)
- THERMAL EFFICIENCY.* The ratio of the electric power produced by a power plant to the amount of heat produced by the fuel; a measure of the efficiency with which the plant converts thermal to electrical energy. (6)
- THERMAL ENERGY.* The total potential and kinetic energy associated with the random motions of the particles of a material. (15)
- THERMAL PLANT.* A generating plant which converts heat energy to electrical energy. Such plants may burn coal, gas, oil, or use nuclear energy to produce thermal energy. (6)
- THERMAL POLLUTION.* Degradation of water quality by the introduction of a heated effluent. Primarily a result of the discharge of cooling waters from industrial processes, particularly from electrical power generation. (6)
- THERMODYNAMICS.* The science and study of the relationship between heat and mechanical work. (4)

TRANSFORMER. A machine which can increase or decrease the voltage of an alternating current. (6)

TRANSMISSION. The act or process of transporting electric energy in bulk from a source or sources of supply to other utility systems. (6)

TRANSMISSION LINES. Wires or cables through which high voltage electric power is moved from point to point. (6)

TURBINE. A motor, the shaft of which is rotated by a stream of water, steam, air, or fluid from a nozzle and forced against the blades of a wheel. (6)

ULTRASONIC SPECTRUM. The range of sound compression waves at frequencies above the audio range (above 20,000 hertz). (15)

UNIT TRAIN. An ore shuttle that carries coal non-stop from mine to power plant. (10)

VALENCE ELECTRONS OF THE ATOM. Electrons which are gained, lost, or shared in chemical reactions. (13)

VAPOR. The words *vapor* and *gas* are often used interchangeably. *Vapor* is more frequently used for a substance which, though present in the gaseous phase, generally exists as a solid or liquid at room temperature. *Gas* is more frequently used for a substance that generally exists in the gaseous phase at room temperature. (13)

VAPORIZATION. The change of a substance from a liquid or solid state to the gaseous state. One of three contributing factors to air pollution; the others are attrition and combustion. (6)

VELOCITY. Time rate of motion in a fixed direction. (13)

VOLT. The unit of electromotive force. It is the difference in potential required to make a current flow through a resistance. (13)

VOLTAGE. The amount of force employed to move a quantity of electricity; measured in volts. (6)

WATER VAPOR. Water in the form of a gas. (6)

WATT (W). A unit of measure for electric power equal to the transfer of one joule of energy per second. The watt is the unit of power most often associated with electricity (1 horsepower = 746 watts) determined by multiplying required volts by required amperes (volts x amps = watts).

WAVE MOTION. A progressive disturbance propagated in a medium by the periodic vibration of the particles of the medium. Transverse wave motion is that in which the vibration of the particles is perpendicular to the direction of propagation. Longitudinal wave motion is that in which the vibration of the particles is parallel to the direction of propagation. (13)

WEATHERSTRIPPING. Reduces the rate of air infiltration by making sure that all doors and windows fit their frames snugly.

WEIGHT. The measure of the gravitational force acting on a substance. (15)

WINDOW TREATMENTS. Applications to the interior side of windows--(blinds, shades, shutters, draperies).

WORK. A force acting against resistance to produce motion in a body; measured by the product of the force acting and the distance moved through against the resistance. (13)

X-RAYS. A type of radiation of higher frequency than visible light but lower than gamma rays. Usually produced by high energy electrons impinging upon a metal target. (13)

ZONE CONTROL. Independent temperature control for each area to be heated and cooled with appropriate distribution control.

GLOSSARY REFERENCES

1. ASHRAE Handbook of Fundamentals. New York: American Society of Heating, Refrigerating and Air-Conditioning Engineers, Inc., 1976.
2. Clark, Wilson. Energy for Survival: The Alternative to Extinction. Garden City, NY: Doubleday, 1975.
3. Fowler, John W. Energy-Environment Source Book. Washington, DC: National Science Teachers Association, 1975.
4. Hayes, Denis. Energy: The Case for Conservation. Worldwatch Paper 4. Washington, DC: The Worldwatch Institute, January 1976.
5. Healy, Timothy J. Energy and Society. San Francisco: Boyd and Fraser Publishing Co., 1976.
6. Jones, John (ed.) The Energy and Environment Glossary. Portland, OR: Energy and Man's Environment, 1976.
7. "Looking Ahead to 1990," Exxon USA, XIV, 1 (First Quarter, 1976), 27-31.
8. Marion, Jerry B. Energy in Perspective. New York: Academic Press, 1974.
9. Michigan Department of Natural Resources. "Energy Glossary," Environmental Education News for School People, X, 3 (November, 1975) and X, 4 (December, 1975).
10. National Coal Association, Coal Facts 1974-1975. Washington, DC: The Association, 1975.
11. Post, Richard F., and Stephen F. Post. "Flywheels," Scientific American, Vol. 229, 6, (December 1973), 17-23.
12. Ramsey, Charles G., and Harold R. Sleeper. Architectural Graphic Standards. 6th ed.; New York: John Wiley and Sons, Inc., 1970.
13. Weast, Robert C. (ed.). CRC Handbook of Chemistry and Physics. 57th ed.; Cleveland, OH: The Chemical Rubber Company, 1976.
14. Webster's New World Dictionary of the American Language. 2nd college edition; New York: The World Publishing Co., 1972.
15. Williams, John E., and others. Modern Physics. New York: Holt, Rinehart, and Winston, 1972.



BOOKS

- Alternative Energy Sources. James P. Hartnett, Academic Press, 111 Fifth Avenue, New York, NY 10003. ISBN 0-12-328550-X \$28.50, 328 pp.
- Applied Solar Energy. Alleton Press, 150 Fifth Avenue, New York, N.Y. 10011.
- Catch The Wind. Landt Dennis, Four Wind Press, Division of Schoolastic Press, 50 West 44th Street, New York, NY 10036. \$7.95, 114 pp.
- Checklist for Energy Conservation in the Home. Tennessee Energy Office, Nashville, Tennessee. Tennessee Energy Office, (n.d.). [75 pp., mimeographed; free (250 Capitol Hill Building, 37219)].
- Design Manual for Solar Heating of Buildings, by Dr. R. L. Field. SOL-PUB, P.O. Box 2351, Gaithersburg, MD 20760 \$6.95.
- Directory of the Solar Industry. Solar Data, 13 Evergreen Road, Hampton, New Hampshire 03842 \$7.50.
- Energy Conservation in the Home U.S. Department of Energy, Technical Information Center, P.O. Box 62, Oak Ridge, Tennessee 37830. Soft cover book.
- Energy Conservation Strategies. Seidel, Marquis R., Steven E. Plotkin, and Robert O. Reck. EPA-R5-73-021. (114 pp.; paper cover; NTIS Report 546-309/34).
- Energy Conservation in The U.S: Why? How Much? By What Means? Laurence I. Moss. Energy Conservation Training Institute, Washington, D.C. The Conservation Foundation, 1976. [76 pp.; loose-leaf notebook; free upon request (1717 Massachusetts Avenue, N.W., 20036)].
- Energy and Environment. Gary O. Robinette, Kendall/Hunt Publishing Co., Dubuque, Iowa 1973, \$9.95.
- Energy, Environment and Building. New York, Cambridge University Press, \$5.95.
- Energy Futures: Industry and the New Technologies, by Steward Herman and James Cannon. Inform, Inc., 25 Broad Street, New York, NY 10004 \$256, 752 pp. (\$10 for summary report).
- Energy Primer, Portola Institute, 588 Santa Cruz Avenue, Menlo Park, California 94536. Cost: \$4.50. Covers experiments, manufacturers, and equipment. An excellent resource for designing and building energy systems. Has many addresses!
- Energy and Society, Timothy J. Healy. San Francisco, California: Boyd and Fraser Publishing Company, 1976. [376 pp.; soft cover; \$6.95 (3627 Sacramento Street, San Francisco, California 94118)]

Energy: The Case for Conservation, Dennis Hayes. The Worldwatch Institute, January 1976. [77 pp.; soft cover; \$2.00 (1776 Massachusetts Avenue, N.W. Washington, D.C. 20036)].

Energy: Use, Conservation, and Supply. American Association for the Advancement of Science, Washington; D.C. 20005. Minimal cost. This is a soft cover book composed of various articles that appeared in weekly journals of "Science". It is an excellent resource although it of course is not too current.

Future Energy Production Systems, Vol. I & II. Jesse C. Denton, Academic Press. 111 5th Avenue, New York, NY 10003, Vol. I - \$38, 378 pp. and Vol. II - \$38, 488 pp.

Handbook of Homemade Power. Bantam Books, Inc., 666 5th Avenue, New York, N.Y. 10019. Cost: \$1.95. Covers several areas of energy and sources for additional information.

Heating and Air Conditioning Airway Installation Standards for One and Two Family Dwellings and Multifamily Housing Including Solar. Sheet Metal and Air Conditioning Contractors National Association, Inc., 1977. 8224 Old Courthouse Road, Tysons's Corner, Vienna, Virginia 22180. [90 pp.; paper cover; free]

Here Comes the Sun: 1981. Joint Ventures and Friends, 1406 Pearl Street, Boulder, Colorado 80302. [Joint Venture, Inc., 1975. 95 pp.; paper cover, \$12.00].

Insulation, Solar Heating, and Improved Evaporative Cooling: What you can do today. John F. Peck, Environmental Research Laboratory, University of Arizona, 1976. [65 pp.; soft cover, \$3.00]

Low-Cost, Energy-Efficient Shelter for the Owner and Builder. Eugene Eccli. [408 pp.; soft cover; \$5.95] Rodale Press (1976) 33 East Minor Street, Emmaus, Pennsylvania 18049.

Low Temperature Engineering Application of Solar Energy, R. C. Jordan, ASHRAE, 345 E. 47th Street, New York, N.Y. 10017

National Program for Solar Heating and Cooling of Buildings. Energy Research and Development Administration, Division of Solar Energy, Government Printing Office (1976) Washington, D.C. 20036. [84 pp., paper cover; \$1.55 (Stock No. 052-003-00043-3)].

Nuclear Power, by Walter C. Patterson. Penguin Books, 625 Madison Avenue, New York, N.Y. 10022. \$3.50, 304 pp.

Potential for Energy Conservation in the United States; 1974-1978. National Petroleum Council, 1625 K Street NW, Washington, D.C. 20036. [129 pp.; paper cover]

Producing Your Own Power. Covers several areas of energy, small scale designs. Vintage Books (Random House) 201 E. 50th Street, New York, N.Y. 10022. [Cost, \$3.95].

Solar Heated Buildings: A Brief Survey; 12th edition. March 3, 1976. W. A. Shurcliff, 19 Appleton Street, Cambridge, Massachusetts 02138. [212 pp.; paper cover; \$9.00.

- Solar Collector Design, (1977) [94 pp., \$6.50] D. K. Edwards, PhD, Franklin Institute Press, Benjamin Franklin Parkway, Philadelphia, Pennsylvania 10103.
- Solar Directory. \$20.00, Manufacturers, projects and bibliography. Carolyn Pesko; Ann Arbor Science Publishers, P.O. Box 1425, Ann Arbor, Michigan 48106. [ISBN 0-250-40109-6].
- Solar Energy and Shelter Design. \$7.00. TEA Church Hill, Harrisville, New Hampshire 03450.
- Solar Energy, A Bibliography Technical Report. \$10.60. [TID 3351] National Technical Information Service, U.S. Department of Commerce, Springfield, VA 22161.
- Solar Energy For Man, B. J. Brinkworth; Compton Press, Salisbury, England
- Solar Homes and Sun Heating, George Daniels 1978. \$8.98. Harper and Row Publishers.
- The American Energy Consumer, by Dorothy K. Newman and Dawn Day. 1975 Ballinger Company, 17 Dunster Street, Cambridge, Mass. 02138 [308 pp.; paper copy, \$8.25].
- The Energy and Environment Glossary. John Jones (ed.) [93 pp.; soft cover, one item in a set of 8 booklets; \$16.00/set]. Energy and Man's Environment, Inc., (1976), 0224 SW Hamilton Street, Suite 301, Portland, Oregon 97201.
- The Homeowner's Energy Guide, by John A. Murphy [215 pp.; paper cover, \$6.95] Thomas Y. Crowell Company (1976), 666 Fifth Avenue, New York, NY 10019.
- The Potential for Energy Savings Through Reductions in Hot Water Consumption, by John George Muller. [43 pp., paper cover, free]. Federal Energy Administration, Publications Distribution Office, Office of Communications and Public Affairs, Washington, D.C. 20461)
- The Vertical Axis Wind Turbine; How it Works, by B. F. Blackwell, \$3.75. National Technical Information Service, 5285 Port Royal Road, Springfield, VA 22161.
- Wind Catchers American Windmills of Today and Tomorrow, by Volta Torray. [\$12.95, Hardcover]. The Stephen Greene Press, Brattleboro, VT 05301.
- Wind Energy Utilization, A bibliography with Abstract Cumulative Volume 1944-1974, TAC-W-75-700. \$12.95). Albuquerque Tech Application Center, New Mexico University.
- Your Energy-Efficient House: Building and Remodeling Ideas, Anthony Adams. [118 pp.; paper cover, \$4.95] Garden Way Publishing Co. (1975) Charlotte, Vermont 05445.

CATALOGS

A-Z Solar Products
200 E. 26th Street,
Minneapolis, MN 55404

Alpha Energy Systems
1615 St. Louis Street,
Springfield, MO 65801
(everything)

Alternative Sources of Energy
The Seaburg Press
815 Second Avenue,
New York, NY 10017

Solar Research
525 N. 5th Street,
Brighton, MI 48116
(Thermal/Solar Components)

"E.A.R.S." Catalog
Environmental Action Reprint Service
2239 East Colfax Ave.,
Denver, CO 80206

Free Heat Corp.
P.O. Box 128,
Newport, RI 02840
(things made by Free Heat Corp.)

Heliotrope General
1869 Hidden Mesa Road,
El Cajon, CA 92020

Independent Energy Systems
6043 Sterretapia Road,
Fairview, PA 16415
(everything)

Rho Sigma
5108 Melvin Avenue,
Tarzana, CA 91356

Solar Age
P.O. Box 305
Dover, New Jersey 07801

Solar Equipment Guide
Solar Review, Dept. A,
Deerbrook, Wisconsin 54424
(list of manufacturers of solar equipment)

Solar Products
Box 195, Dept. 785 A,
Deer Park, New York 11729

AUDIO-VISUAL AIDS AND PLANS

Energy Related Films
Dept. of Energy Film Library
P.O. Box 62,
Oak Ridge, Tenn. 73830

Have some excellent films on energy. Ask for film catalog.

Energy Related Films
Stuart Finely, Inc.
3428 Mansfield Road,
Falls Church, Virginia 22041

They have a series of ten films on energy and the environment.

Energy Related Materials
National Science Teacher's Association
1742 Connecticut Avenue NW,
Washington, D.C. 20009

Cost - \$9.00

A 3 volume package of energy related materials prepared by
NSTA, FEA, and USOE.

Institute of Scrap Iron and Steel, Inc.
Dept. INS,
1729 H Street NW
Washington, D.C. 20006

Teaching materials and pamphlets.

Living with Energy
Standard Oil Company
Mail Code 3705,
200 E. Randolph Drive,
Chicago, Illinois 60601

Cost: Free

This is a file of four spirit masters that emphasizes that
Americans can no longer live with energy as they did in the
past. Excellent handout to the students; emphasizes
their life styles.

National Coal Association
Educational Services, Coal Building
Dept. INS, 1130 17th Street NW,
Washington, D.C. 20036

Map of coal deposits and four booklets

National Solar Heating and Cooling Information Center
P.O. Box 1607,
Rockville, MD 20850

Call Toll Free (800-523-2929)

Sources for solar heating and cooling information.

Natural Energy Workbook
Visual Purple
Box 977,
Berkeley, CA 94701

Cost: \$3.95

Gives lots of sketches and details of plans for doing-it-yourself alternate energy projects. Some technical aspects of the book need improvement.

Secenbaugh Mind Electric
P.O. Box 11174,
Palo Alto, CA 94306

Wind Generator Plans

Cost: \$12.00

U. S. Department of Energy
Technical Information Center
P.O. Box 62,

Oak Ridge, Tennessee 37830

Following is a list of pamphlets:

The Breeder Reactor

The Energy Crisis

Fusion

Geothermal Energy

Heated Water from Power Plants

Nuclear Power Plants; How safe are they?

Oil Shale

Radioactive Wastes

Shipping of Nuclear Waste

Solar Energy

Cost: Free in limited quantities

These free pamphlets are used very effectively as handouts to the students. The information is recent in all of the pamphlets, and they do an excellent job in telling the student about each aspect.

Windworks

Route 3, Box 329,

Mukwonago, Wisconsin 53149

Wind Generator Plans

Cost: \$15.00

PAMPHLETS

"The ABC's of Air Conditioning"

Carrier Corporation, 1975. Syracuse, New York 13201
24 pp.; paper cover; Request from Carrier

"A Consumer's Guide to Energy Conservation with Natural Gas"
American Gas Association, 1515 Wilson Boulevard, Arlington,
Virginia 22209; 15 pp., 10¢.

"Don't Be Fuelish: Tips for the Motorist" (1974)

Federal Energy Administration, Government Printing Office,
Washington, D.C.

10 panel pamphlet; free

"Energy Conservation: Experiments You Can Do"

Thomas Alva Edison Foundation

Cambridge Office Plaza, Suite 143, 18280 West Ten Mile Road,
Southfield, Michigan 48075

Energy: Selected Resource Materials for Developing Energy
Education/Conservation Programs. (1976) The National

Wildlife Federation, 1412 16th Street NW, Washington, D.C. 20036.

22 pp.; single copy pamphlet free, additional copies 10¢.

by: Jonathan M. Wert.

"Looking Ahead to 1990: Exxon Examines the Outlook for Energy
Over the Next 15 years", Vol. XIV. No. 1 published quarterly;
free by writing: Exxon Corp., P.O. Box 2180, Houston, TX 77001.

"Home Energy Saving Tips from NBS", 4 pp. flyer free by writing
to: U.S. Department of Commerce, Public Documents Distribution
Center, Consumer Information Service, Government Printing
Office, Pueblo, Colorado 81009.

"How to Save Energy in Your Home", (1975), Kurt Vragel.

26 pp., paper cover, \$1.00. Kurt Vragel Associates, Inc.,
1401 E. Girard Street, #3-264, Inglewood, CA. 90110.

"Making the Most of Your Energy Dollars in Home Heating and
Cooling", by Madeline Jacobs and Stephen R. Peterson. Government
Printing Office, Washington, D.C. 20036. June 1975.

17 pp.; paper cover; 70¢.

"Money to Burn"; American Gas Association, 1515 Wilson
Boulevard, Arlington, Virginia 22209. 10 pp.; 10¢.

NSF-RANN Wind Energy Research Reports

National Science Foundation, 1800 G Street NW, Wash. D.C. 20550.

"Save Energy"; Federal Energy Adm., Publications Distribution
Office, Washington, D.C. 20461. 1p.; free; also available
in Spanish.

"Solar Hot Water and Your Home", (1977); National Solar Heating and Cooling Information Center, P.O. Box 1607, Rockville, Maryland 20850. 20 pp.; paper cover; free.

"Thermal Insulation", (1976); The Monsanto Company, Carpet Department, 350 Fifth Avenue, New York City, N.Y. 10001. 4pp.; pamphlet; free.

"Tips on Saving Energy", (1975); Council of Better Business Bureaus, Inc., 1150 17th Street NW, Washington, D.C. 20036. 10 pp.; paper cover

What's Behind the Energy Crisis, 64 pp.; free. This is an excellent pamphlet for handout to the students. It covers the energy crisis, the world's crippling dependence on oil, and solutions to our energy problems. Write to: Ambassador College Press, P.O. Box 11, Pasadena, CA 91123.

PERIODICALS

Alternate Energy Directory
Source of booklets, books and catalogs
AEPCO
P.O. Box 26507,
Albuquerque, N.M. 87125
\$2.98

Alternate Sources of Energy
ASE
Rougt 2, Box 90A,
Milaca, Minnesota 56353
\$5.00 for 4 issues (bi-monthly)
Covers many energy areas, written for practical
applications, additional references and sources
of information.

Energy Reporter
Federal Energy Administration
"Energy Reporter" Subscriptions
Room 2115
Washington, D.C. 20461
Free to officials of school systems with orders on
official letterhead. An informative monthly report
on energy activities in and out of government. Lists
additional sources of information.

Insulation Reporter
National Mineral Wool Insulation Assn.
382 Springfield Ave.,
Summit, N.J. 07901

Journal of Appropriate Technology
2270 NW Irving Street,
Portland, Oregon 97210

Consumer News
Office of Consumer Affairs
Consumer Information Center
Health, Education & Welfare Dept.
Pueblo, Colorado 81009
Newsletter; \$4.00 annual subscription.

Not Man Apart
Friends of the Earth
529 Commercial Street,
San Francisco, CA 94111
Conservation Magazine; \$10.00 (non-member subscription).

Solar Energy Digest
P.O. Box 17775,
San Diego, CA 92117
Subscription rate \$28.50 for 12 months.

Texaco Star
165 East 41st Street,
New York, N.Y. 10017

Wind Power Digest
Jester Press
54468 CR 31,
Bristol, Indiana 46507

Wood Burning Quarterly and Home Energy Digest
8009 - 34th Avenue South,
Minneapolis, Minnesota 55420
Publisher James R. Cook \$1.50

Wood 'n Energy
Wood Energy Institute
5 South State Street
Concord, N.H. 03301
\$5.00 Subscription

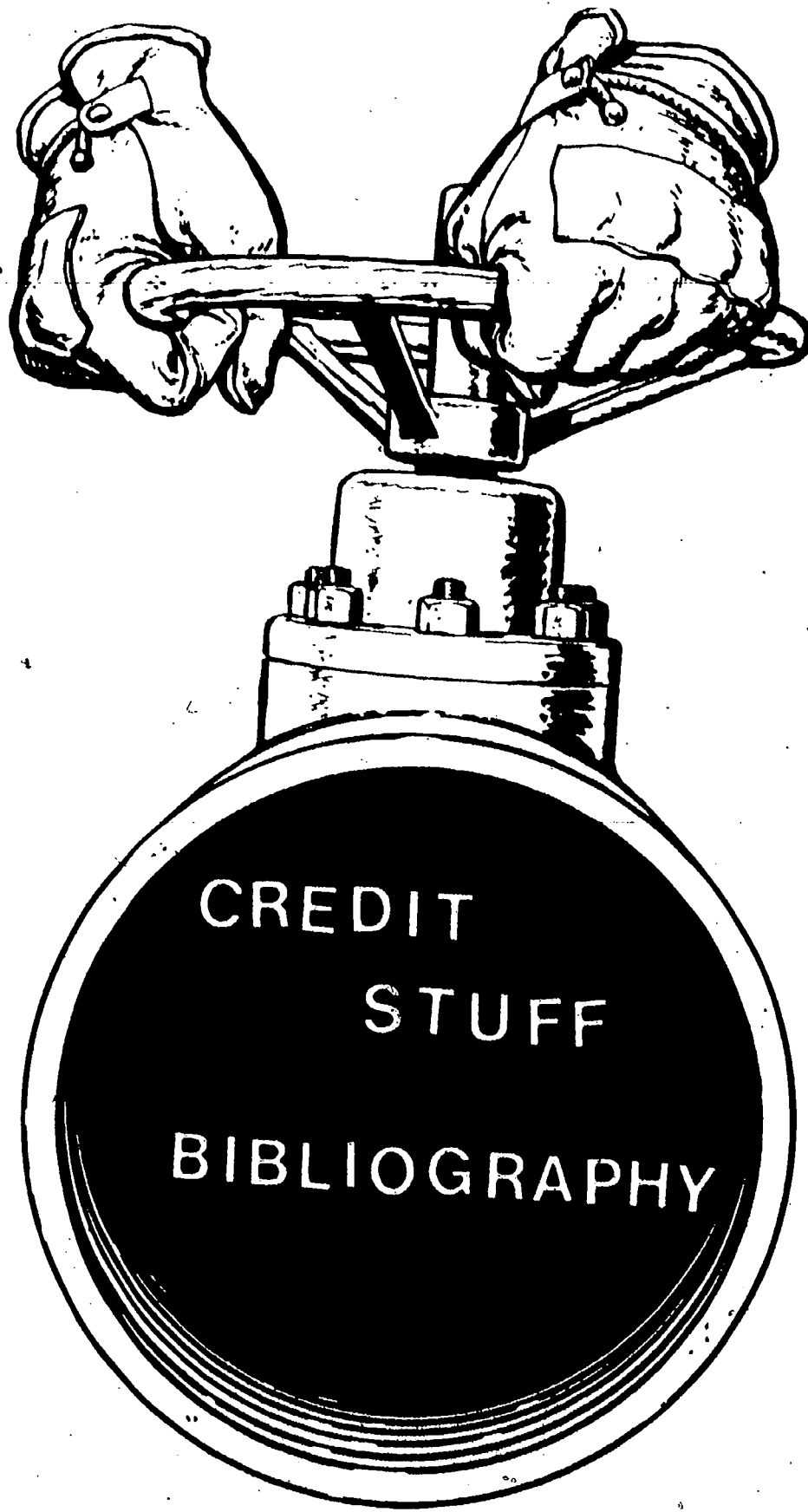

BIBLIOGRAPHY

These materials were used in compiling this resource guide - it is not a complete energy/energy conservation bibliography.

Award Winning Energy Education Activities, For Elementary and High School Teachers. Energy Research and Development Administration, National Science Teachers Association, 1977.

Cooperative Extension Service, University of Idaho. Hand-outs concerning Energy. College of Agriculture in cooperation with the U.S. Department of Agriculture.

Driver Education Energy Packet. "Some Things are Worth Saving", Idaho Office of Energy.

ENCORE - Energy Conservation Resources For Education, Modules 1 thru 19, Department of Industrial Education, Texas A&M University, College Station, Texas 77843. (Supplied Courtesy of The Governor's Energy Advisory Council).

Energy - A Teacher's Introduction To Energy and Energy Conservation. Columbus, Ohio 1975. Battelle, Center for Improved Education.

Energy Activities for the Classroom. Herbert L. Coon and Michele Y. Alexander. ERIC Center for Science, Mathematics, and Environmental Education, Columbus, Ohio; 1976.

Energy Awareness Education, Grades K-3, 4-12, and Energy Awareness Education Resource Materials - Energy Education Activities; Oklahoma State Department of Education, 1977.

Energy Conservation & Alternative Energy Curriculum. James E. O'Bannon. The California Energy Resources Conservation & Development Commission and the Chancellor's Office, California Community Colleges; May 1977. (Energy Dilemma, Solar Energy, Alternate Energy, Energy Conservation, Thermal Insulation, Nuclear Energy.)

Energy Conservation Education: An Action Approach. Michael Zamm and Barry C. Samuel. Council On The Environment of New York City, New York, 1977.

Energy Conservation in the Home. An Energy Education/Conservation Curriculum Guide for Home Economics Teachers. U.S. Department, of Energy. Prepared by The University of Tennessee Environment Center and College of Home Economics - Knoxville, Tennessee; October 1977.

Energy Crisis - Teaching Resources. Oregon Board of Education, Salem, Oregon. Prepared by: Wendell Curry, Dick Louthan, and Randi Douglas, 1973.

Energy, Engines, and The Industrial Revolution, Grades 8-9, National Science Teachers Association, U.S. Department of Energy, October 1977.

Energy Facts - Idaho - United States - World. Idaho State Office of Energy, 1977.

Energy for a Livable Future Comes from the SUN! Stephen Lyons and David R. Brower, Friends of the Earth; San Francisco, Cal., 1978.

An Energy History of the United States, Grades 8-9, National Science Teachers Association, U.S. Department of Energy, January, 1978.

Energy in the Global Marketplace, Grades 9, 10, 11. National Science Teachers Association, March 1978.

Energy: Options For The Future, 5 parts. Institute for Energy Research and W. Averell Harriman College for Urban and Policy Sciences, State University of New York at Stony Brook, New York 11794.

Farm Electricity. State of Tennessee, Department of Education, Division of Vocational Education, Agricultural Education Service, J. H. Warf, Commissioner in cooperation with Tennessee Valley Authority, Division of Power Marketing, Electrical Demonstration Branch.

How a Bill Becomes a Law to Conserve Energy, Grades 9, 11, 12. National Science Teachers Association, October 1977.

Idaho Energy Conservation Resource Guide, for grades 7-12. Idaho State Office of Energy.

Ideas and Activities for Teaching Energy Conservation, grades 7-12. The University of Tennessee, Environment Center, South Stadium Hall, Knoxville, Tennessee 47916; 1977.

Living Within Our Means: Energy and Scarcity. Environmental Education Instructional Activities 7-12. The University of the State of New York, State Education Department, Albany, New York 12234.

NSTA - Interdisciplinary Student/Teacher Materials On Energy, "The Environment and The Economy." Agriculture, Energy and Society. Grades 10, 11, 12. 1976.

Power and Transportation Curriculum Guide. Idaho State Board for Vocational Education, VO ED No. 148, July 1975.

Rays of Hope. Denis Hayes. W. W. Norton & Company, Inc. New York, 1977.

Science Activities In Energy. (Chemical Energy, Conservation, Electrical Energy, and Solar Energy). The American Museum of Atomic Energy, Oak Ridge Associated Universities, P.O. Box 117, Oak Ridge, Tennessee 37830.

Teachers Environmental Resource Unit: Energy and Power. Economic/Moral
Environment portion of the ESEA, 1971-72. Cocoa, Florida.

The Texaco Star, Number Two, 1978. "On Station in the Atlantic Frontier."
Texaco, Inc.; 1978.

U.S. Energy Policy - Which Direction? Grades 11 and 12. National Science
Teachers Association, January 1978.