

DOCUMENT RESUME

ED 182 057

PS 011 221

AUTHOR Mahajan, Eal: And Others
 TITLE Public Playground Equipment: Suggested Safety Requirements and Supporting Rationale for Swing Assemblies and Straight Slides.
 INSTITUTION National Bureau of Standards (DOC), Washington, D.C.
 PUB DATE Apr 78
 NOTE 58p.; For related documents, see PS 011 220 and PS 011 223
 EDRS PRICE MF01/PC03 Plus Postage.
 DESCRIPTORS Design; *Equipment; Injuries; *Physical Design Needs; Physical Environment; Physical Facilities; *Playgrounds; *Safety; School Safety; *Standards

ABSTRACT

This memorandum report proposes a safety standard to reduce the frequency and severity of children's impacts with the suspended members of swing assemblies and falls from slide surfaces, under conditions of normal use and reasonably foreseeable misuse. The standard applies to swings and straight slides intended for use as public playground equipment. The following six topics are covered by the standard: (1) swing assembly structural integrity, (2) swing assembly moving impact, (3) straight slide surface incline, (4) straight slide surface exit region, (5) straight slide surface side height, and (6) straight slide ladders and stairways. Equipment of this type is typically located in play areas of parks, schools, institutions, multiple family dwellings, private resorts, recreation developments, and other areas of public institutional use. The safety standard does not apply to amusement park rides and equipment, equipment normally intended for sports use, or to home playground equipment. Supporting rationale for the standard is extensively discussed. (Author/RH)

 * Reproductions supplied by EDRS are the best that can be made *
 * from the original document. *

U S DEPARTMENT OF HEALTH,
EDUCATION & WELFARE
NATIONAL INSTITUTE OF
EDUCATION

THIS DOCUMENT HAS BEEN REPRO-
DUCED EXACTLY AS RECEIVED FROM
THE PERSON OR ORGANIZATION ORIGIN-
ATING IT. POINTS OF VIEW OR OPINIONS
STATED DO NOT NECESSARILY REPRESENT
OFFICIAL NATIONAL INSTITUTE OF
EDUCATION POSITION OR POLICY

PS
Request

PUBLIC PLAYGROUND EQUIPMENT

Project 426

Suggested Safety Requirements and Supporting
Rationale for Swing Assemblies
and Straight Slides

Prepared By:

Bal Mahajan
Wm. Beine
Robert Berger
Willie Brown
John Sorrells

Product Safety Technology Division
Center for Consumer Product Technology
National Bureau of Standards

April 1978

ED182057

PS011221

I. INTRODUCTION

In 1975, the Consumer Product Safety Commission (CPSC) responded favorably to a petition to develop a standard for Public Playground Equipment and selected the National Recreation and Park Association (NRPA) to develop such a standard. The NRPA thereupon formed a development panel consisting of representatives from consumer, industry, and buyer/installer communities and called upon the Franklin Institute Research Laboratories for technical assistance. Approximately a year later, in April 1976, the NRPA submitted a proposed standard to the CPSC. The CPSC elected to revise that standard and sought technical assistance from the National Bureau of Standards (NBS); in 1978, CPSC requested that the Bureau extend its role. The Bureau's expanded role included further assistance to CPSC in the review and rework of the proposed standard for public playground equipment. The planned deliverables were to be two memorandum reports based on currently available information, objective analysis, and subjective engineering judgment. These were to constitute a set of suggestions and recommendations for use in formulating the final version of the proposed standard. It was recognized that much of the supporting rationale would not be completely objective due to deficiencies in the hard data.

The two memorandum reports were to contain:

1. a suggested final draft for the proposed standard, and
2. suggested rationale to support the requirements and test methods of the first report.

This memorandum report is the culmination of our efforts during the last few months. Sections II and III of this report provide the proposed standard and rationale, respectively.

FEB 26 1980

The proposed standard evolved from the work submitted by the NRPA. Its scope, however, has been substantially reduced as a result of a CPSC decision to revise the NRPA proposed standard and draft two separate documents, a standard and Federal Guidelines, with the following six principal topics to be covered by the standard:

1. Swing Assembly Structural Integrity
2. Swing Assembly Moving Impact
3. Straight Slide Surface Incline
4. Straight Slide Surface Exit Region
5. Straight Slide Surface Side Height
6. Straight Slide Ladders and Stairways

The criteria for developing the requirements relating to these topics were that they be based on objective test methods and supported with appropriate rationale. Occasionally, the criterion for objective test methods was relaxed to emphasize important safety concerns; for example, Section 1514.5A requires that "the barrier shall provide the facility. . . to maintain body balance and support," and "not provide an opportunity for climbing on or over and shall preclude the possibility of entrapment." Development of comprehensive objective test methods for such requirements is possible, but not within the available time and resources.

In preparing this document, the greatest difficulty was encountered in obtaining data to support the requirements. This problem also plagued the developers of the NRPA document, and survived to hamper the current efforts. Information relating the frequency and severity of injuries to physical properties of playground equipment and use habits are almost non-existent.

While it is clear which requirements can be objectively measured, it is difficult to specify precise requirements and dimensions for effective reduction of potentials for injury, and to foresee potential hazards which might indirectly be encouraged in the process. As a result, most decisions underlying this document are state-of-the-art judgments. As additional data are accumulated, these judgments should be reviewed and, if necessary, modified.

II. PROPOSED STANDARD

1514.1 Purpose and Scope

The purpose of this standard is to reduce the frequency and severity of impacts with the suspended members of swing assemblies and falls from slide surfaces, under conditions of normal use and reasonably foreseeable misuse.

This standard applies to swings and straight slides intended for use as public playground equipment. Equipment of this type is typically located in play areas of parks, schools, institutions, multiple family dwellings, private resorts, recreation developments, and other areas of public institutional use. This standard does not apply to amusement park rides and equipment, equipment normally intended for sports use, or to home playground equipment.

NOTE: As an aid in correlating U.S. customary units to metric units, the following conversion factors for units in this Standard are given.

1 inch = 2.5 centimeter

1 foot = 0.30 meter

1 pound-mass = 0.45 kilogram

1 pound-force = 4.45 newton

1514.2 Definitions

The following definitions apply to this standard:

1. Clearance height - the clearance height of a suspended member is the vertical distance between the underlying surface and the lowest part of the suspended member when the suspended member is in its rest position.

2. Entrance height - the entrance height of a slide is the vertical distance between the underlying surface and the uppermost part of the inclined sliding surface.
3. Exit region - the exit region is that part of the sliding surface at the exit end of a slide intended to aid the user in exiting safely.
4. Fasteners - fasteners are those parts of the swing assembly, such as clamps, hooks, bolts, screws or any other hardware, used to connect the ends of suspending elements to the supporting structure and to a suspended member.
5. Ladder - a ladder is a device having a slope greater than 50 degrees from a horizontal plane, and consisting of a series of rungs or steps on which a person may step while ascending or descending.
6. Maximum user - a maximum user is a twelve year old child. Measurements of maximum user characteristics are the 95th percentile values for combined sexes.
7. Minimum user - a minimum user is a five year old child. Measurements of minimum user characteristics are the 5th percentile values for combined sexes.
8. Peak acceleration - peak acceleration is the maximum acceleration imparted to a test headform by a suspended member during impact tests.
9. Potential impact region - a potential impact region is any part of the front or rear surface of a suspended member which can contact an object in its intended path.

10. Rung - a rung is a ladder crosspiece which is intended to be used as a foot support and as a hand grip in the normal use of the ladder.
11. Slide - a slide is an apparatus having an inclined surface used for sliding.
12. Stairway - a stairway is a device having a slope of 50 degrees or less from the horizontal plane and consisting of a series of steps which can be used for ascending or descending.
13. Step - a step is a horizontal crosspiece of a ladder or stairway intended for use only as a foot support.
14. Straight slide - a straight slide is a slide whose sliding surface does not curve in a horizontal plane.
15. Suspended member - a suspended member is that part of a swing assembly which is intended to be occupied by one or more users in the act of swinging.
16. Suspending elements - suspending elements are those parts of the swing assembly, such as chains, ropes, cables, tubes, etc., that are used to suspend a suspended member from an overhead supporting structure.
17. Swing assembly - a swing assembly is an apparatus intended for use by one or more users for swinging, and consists of a suspended member and its necessary suspending elements and fasteners.

1514.3 Assembly, Installation, Maintenance Instructions and Identification

A. Instructions

1. Requirements

The manufacturer shall include the following with each piece of equipment or composite unit:

- (a) Instructions and necessary drawings, photos, or other illustrations for proper assembly and a listing of all components that includes part names and numbers.
- (b) Instructions and necessary drawings, photos, or other illustrations that provide essential information for installing the equipment or composite unit in accordance with the safety design intentions of the manufacturer and the requirements of this standard. For swing assemblies, these instructions shall include the manufacturer's recommended maximum suspending element length.
- (c) Instructions for the general maintenance of the equipment or composite unit.

B. Identification

1. Requirement

A durable label shall be permanently attached to each piece of equipment or composite unit identifying:

- (a) manufacturer
- (b) equipment model
- (c) month and year of manufacturer

This label shall be placed on the equipment in a prominent location.

1514.4 Swing Assemblies

A. Minimum Clearance

1. Requirement

The clearance between adjacent suspended members and between a suspended member and the adjacent supporting structure shall not be less than 18 inches when measured as shown in figure 1.

B. Structural Integrity

1. Requirements

Swing assemblies shall be tested in accordance with paragraph 1514.4B2. During or after the test, there shall be no visible cracks or breakage of any component of the swing assembly. Hooks, shackles, rings, links, or the like, shall not open more than one-half of the cross-sectional diameter of the link that they are intended to constrain.

2. Test Method

A swing assembly to be tested shall be installed in accordance with the manufacturer's instructions or supported in an equivalent manner. For swing assemblies that are provided with foot supports, both the swing seat and foot support shall be tested. The seat and foot support shall be loaded separately. The test load shall be applied through appropriate load distribution devices as specified in the following sub-paragraphs. The load distribution device shall be either a loading block(s) or a loading strap(s) having the dimensions shown in figure 2.

- a. For swing assemblies intended for single occupancy, a load distribution device shall be centered on the seat and a vertical downward force of 1200 pounds shall be applied. The force shall be applied gradually, attaining but not exceeding 1200 pounds, within a period of one minute and maintained for five minutes. If the swing assembly does not meet the requirements of paragraph 1514.4B1, it fails the test.

- b. For swing assemblies consisting of a trapeze bar or an O-ring, a loading strap shall be centered on the trapeze bar or the O-ring and a vertical downward force of 1200 pounds shall be applied. The force shall be applied gradually, attaining but not exceeding 1200 pounds within a period of one minute and maintained for five minutes. If the swing assembly does not meet the requirements of paragraph 1514.481, it fails the test.
- c. For swing assemblies intended for multiple occupancy, a load distribution device shall be centered on each seat. A vertical downward force of 724 pounds shall be applied to each loading device simultaneously. The force shall be applied gradually, attaining but not exceeding 724 pounds per device, within a period of one minute and maintained for five minutes. If the swing assembly does not meet the requirements of 1514.481, it fails the test.
- d. Foot supports that are intended to support only one foot (similar to the example shown in figure 3) shall be tested individually. A load distribution device shall be centered on the position intended to support a user's foot and a vertical downward force of 484 pounds shall be applied. The force shall be applied gradually, attaining but not exceeding 484 pounds, within a period of one minute and maintained for five minutes. If the swing assembly does not meet the requirements of paragraph 1514.481, it fails the test.

- d. For foot supports that are intended to support both feet (similar to the example shown in figure 4), a load distribution device shall be centered in the position intended to support each user's feet. A vertical downward force of 724 pounds shall be applied gradually, attaining but not exceeding 724 pounds per device, within a period of one minute and maintained for five minutes. If the swing assembly does not meet the requirements of paragraph 1514.4B1, it fails the test.

C. Corners and Edges

1. Requirement

Corners and edges of suspended members shall have a minimum radius of curvature of one-quarter inch.

D. Protrusions

1. Requirement

When tested in accordance with paragraph 1514.4D2 no part of the front and rear surface of the suspended member shall protrude through the hole in the specified gauge beyond the thickness of the gauge.

2. Test Method

The test shall be conducted with the suspended member in its rest position. Place the gauge shown in figure 5 over any protrusions on the front and rear surface of the suspended member such that the axis of the hole is parallel to both the intended path of the suspended member and a horizontal plane. If the requirements specified in paragraph 1514.4D1 are not met, the equipment fails the test.

E. Moving Impact

1. Requirement

The requirements of this subsection pertain to suspended members having a clearance height of less than 64 inches. When tested in accordance with the test method specified in paragraph 1514.4E3, a suspended member shall not impart a peak acceleration in excess of 100 g's to the test headform. Any potential impact region of a suspended member is subject to this requirement.

2. Test Equipment

a. Headform and Support Assembly

The peak acceleration imparted by a suspended member is determined by impacting an instrumented headform with the suspended member. The size "C" headform specified in the Federal Motor Vehicle Safety Standard No. 218 shall be used for this test.

The headform support assembly shall be constructed in such a manner that the total headform and support assembly weight does not exceed 10.5 pounds. An accelerometer shall be mounted at the center of gravity (C.G.) of the headform and support assembly combination with the sensitive axis of the accelerometer aligned to within 5 degrees of the direction of travel of the headform.

b. Guidance Structure

The motion of the headform after impact shall be restricted to horizontal travel with the headform centerline remaining in the central plane, as depicted in figure 6. To provide the required headform motion, the primary support structure shall be a six-inch I beam (6 I 12.5 American Standard I Beam), or an equivalent structure, secured in such a manner as to remain stationary during test. The static coefficient of friction between the headform support assembly and the stationary guidance system structure shall be less than 0.02.

c. Instrumentation

The instrumentation to be used for test including accelerometer, signal conditioner and oscilloscope are to be selected and operated according to SAE Practice J211, Channel Class 1000.

3. Test Method

- a. Ambient laboratory conditions are required for the test (62-82°F). All test equipment and suspended members shall be exposed to these conditions for at least four hours prior to test.
- b. Affix an index mark to the side of the suspended member to indicate its mass center (C.G.) projection in the side view. To determine the location of the index mark, the

suspended member shall be suspended in two successive alternate positions as illustrated in figure 7. The mark location is determined by the intersection of the projection of vertical lines passing through the suspension point (see figure 7) when the member is suspended at the successive alternate positions.

NOTE: Flexible belt-type suspended members require a brace (see figure 7a) to maintain seat configuration during this procedure and during impact testing. The weight of the brace shall not exceed 10% of the weight of the suspended member.

- c. Assemble and install the suspended member to be tested according to the manufacturer's instructions, utilizing the hardware and the maximum length suspending elements supplied or specified by the manufacturer.
- d. Allow the suspended member to assume its free hanging rest position (refer to figure 6) and adjust the relative positions of the suspended member, headform, and guidance system to meet the following conditions:
 - (i) The centerlines of the headform, and guidance structure, and the impact point of the suspended member shall lie in the central plane.
 - (ii) The lower edge of the headform shall be horizontal, with the headform contacting the impacting surface of the suspended member.

- (iii) The suspended member's impacting point shall be in line with and adjacent to the impact point on the headform. The impact point is that point on the headform which lies in the central plane and is tangent to the vertical.
- e. Place the suspended member in the test position indicated by one of the following methods.
 - (i) Suspended members which are supported by chains, ropes, cables or other non-rigid suspending elements shall be raised along their arc of travel until the side view projection of a straight line through the pivot point and index mark forms an angle of 60 degrees with the vertical. Once the suspended member is raised to the test position, some curvature will be produced in the suspending elements. Adjust the suspended member position to determine that curvature which provides a stable trajectory.
 - (ii) Suspended members which are supported by rigid suspending elements shall be elevated along their arc of travel until the side view projection of the suspending element, which was vertical in the rest position, is at an angle of 45 degrees, or at the maximum angle attainable, whichever is less.
- f. In consideration of the test positions specified in paragraphs 1514.4E3e(i) and 1514.4E3e(ii) above, caution should be exercised to prevent damage to the test equipment. If an unusually heavy or hard suspended member is

to be tested, preliminary tests should be made at lower test angles (e.g. 10 degrees, 20 degrees, 30 degrees, etc.). If the requirements of paragraph 1514.4E1 are exceeded at a lower test angle than that specified in paragraph 1514.4E3e(i) or 1514.4E3e(ii), the member fails and no further tests are necessary. Additionally, if there is doubt concerning the suspended member trajectory or stability, the headform and/or guidance structure should be set aside to allow trial releases without impacting the headform.

- g. The suspended member shall be supported in the test position by a mechanism that provides release without the application of external forces which would disturb the trajectory of the suspended member. Prior to release, the suspended member and suspending elements shall be motionless. Upon release, the assembly shall travel in a smooth downward arc without any visible oscillations or rotations of the suspended member which will prevent it from striking the headform at the impact point.
- h. Once satisfactory system operation and calibration is obtained, collect data for ten impacts. Measure the peak acceleration in g's for each impact. If the data for any two of the ten impacts do not meet the requirements of paragraph 1514.4E1, the suspended member fails the test.

1514.5 Straight Slides

A. Side Height

1. Requirements

The sliding surface shall have sides that project at least 2.5 inches above the sliding surface when measured perpendicularly to that surface (see figure 8a). The required sides shall extend for the entire length of the sliding surface.

B. Slide Surface Slope

1. Requirements

- a. The average incline of the sliding surface shall not exceed 30 degrees as measured in accordance with figure 8.
- b. No span of the sliding surface shall have a slope that exceeds 45 degrees as measured from a horizontal plane.

C. Exit Region: Slope, Length, Height and Radius of Curvature

1. Requirements

The requirements of this subsection pertain to slides having an entrance height in excess of 4 feet.

- a. The exit surface of the slide shall be at least 16 inches in length and parallel to the ground (± 4 degrees) as shown in figure 8b.
- b. The exit surface shall be at least 9 inches and no more than 15 inches above ground level (see figure 8b).
- c. The radius of curvature of the sliding surface in the exit region shall be at least 30 inches when measured as shown in figure 8b.

D. Slide Surface Entrance

1. Requirements

Slides shall have features that facilitate safe transition to the inclined sliding surface in accordance with the following requirements:

- a. The entrance to the inclined sliding surface shall be a horizontal platform at least 10 inches in length and at least as wide as the contiguous inclined surface.
- b. Except for necessary exit and entrance openings, a barrier shall completely surround the platform and extend down the sides of the inclined surface in accordance with minimum dimensions provided in figure 8c.
 - (i) The barrier shall provide the facility for the minimum as well as maximum user to maintain body balance and support when moving through the transition between ladder, platform, and sliding surface.
 - (ii) The barrier shall not provide an opportunity for climbing on or over, or for falling through, and shall preclude the possibility of entrapment.

E. Ladders and Stairways

1. Requirements

a. Slope

When measured from a horizontal plane:

- (i) Ladders with rungs shall have a slope between 75 and 90 degrees
- (ii) Ladders with steps shall have a slope between 50 and 75 degrees

(iii) Stairways shall have a slope no greater than 35 degrees.

b. Steps and Rungs

(i) Steps and rungs shall be horizontal (+2 degrees)

(ii) Steps and rungs shall be at least 15 inches wide (see figure 9)

(iii) Steps and rungs shall be evenly spaced. The spacing shall be between 7 and 11 inches (see figure 9).

(iv) Steps shall have a tread depth of 3 inches or more if open and 6 inches or more if closed.

c. Hand Rails

(i) Stairways and ladders with steps shall have continuous hand rails on both sides. The railings shall be designed to maintain the user in an upright position over each step.

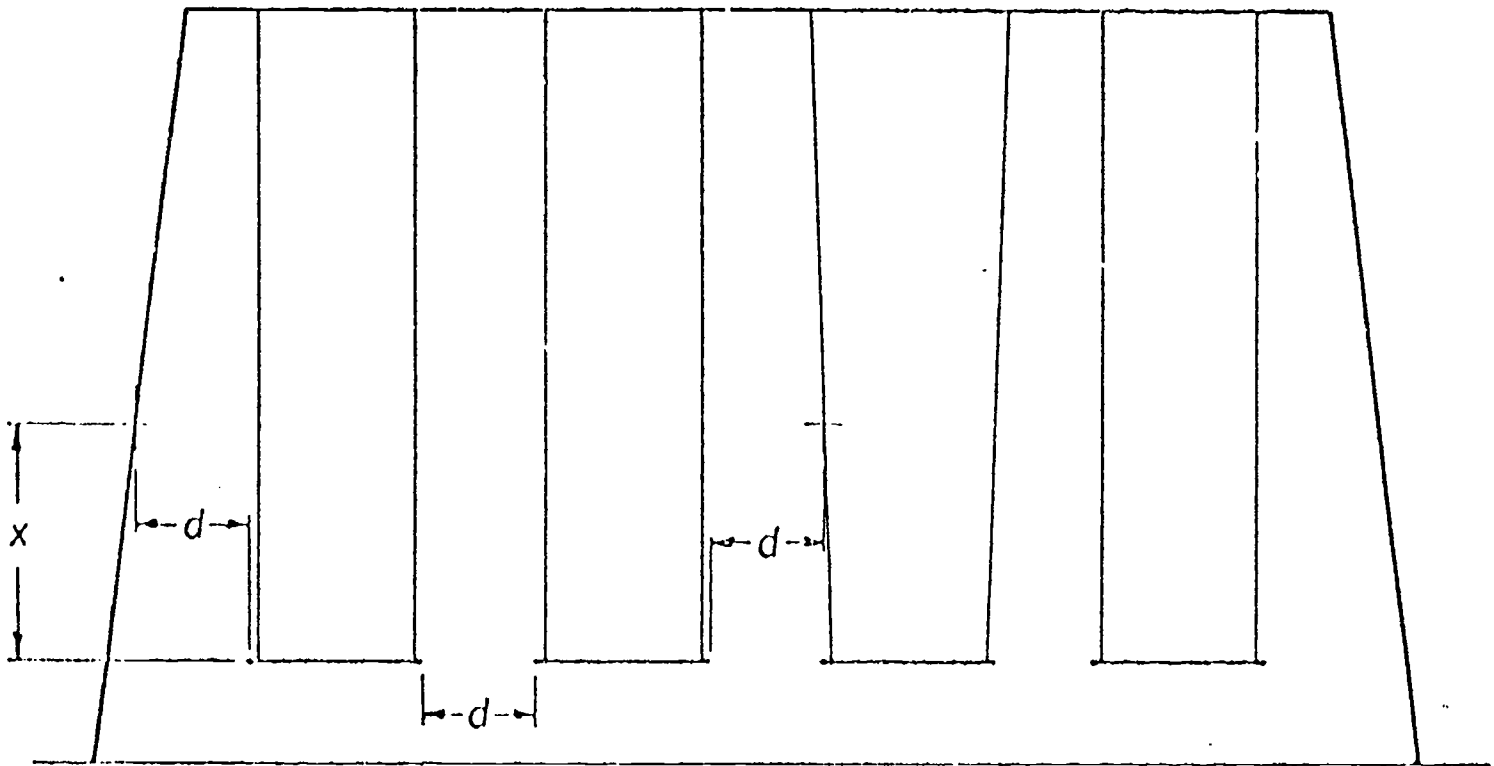

$d = 18$ Inches minimum
 $x = 35$ Inches minimum

FIG 1—SWING CLEARANCE MEASUREMENTS

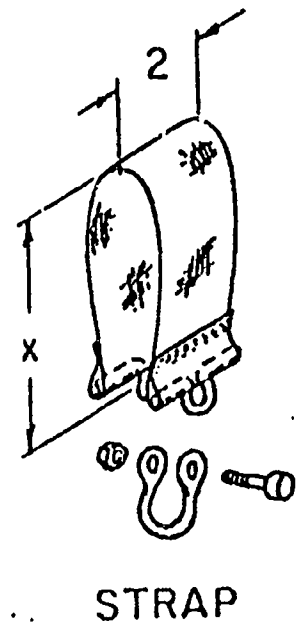
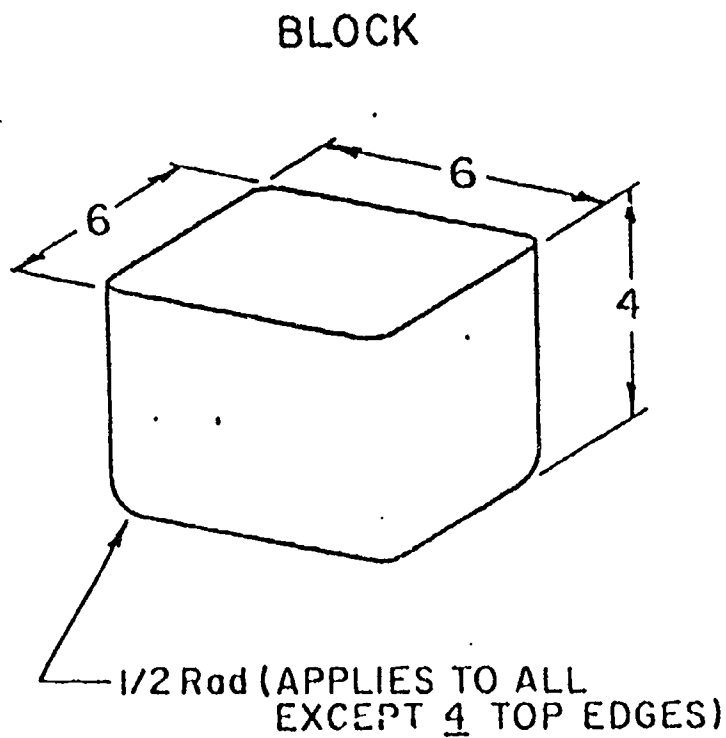

NOTE: (1) BLOCK MADE OF ANY RIGID MATERIAL.
 (2) VARY DIMENSION "x" AS REQUIRED.
 (3) ALL DIMENSIONS ARE IN INCHES.

FIG 2-LOAD DISTRIBUTION DEVICES

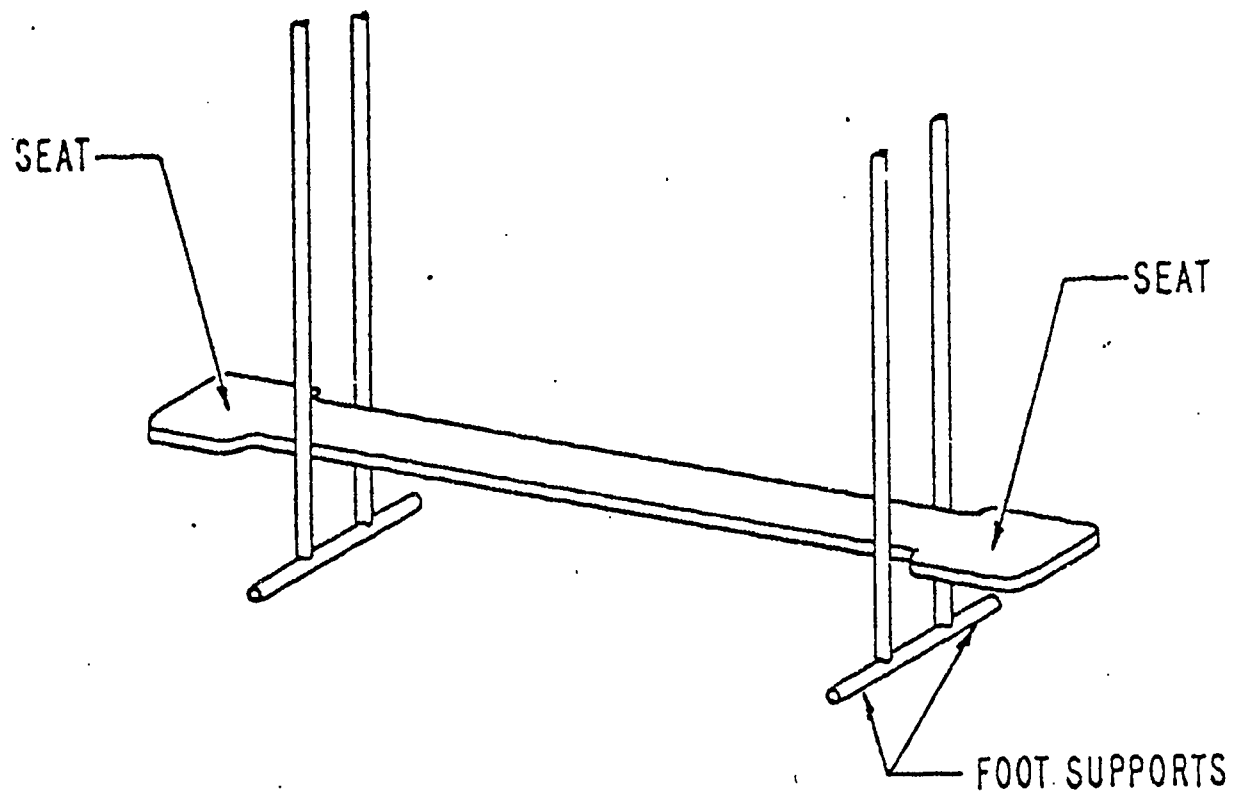

FIG 3-FOOT SUPPORT INTENDED TO SUPPORT ONE FOOT

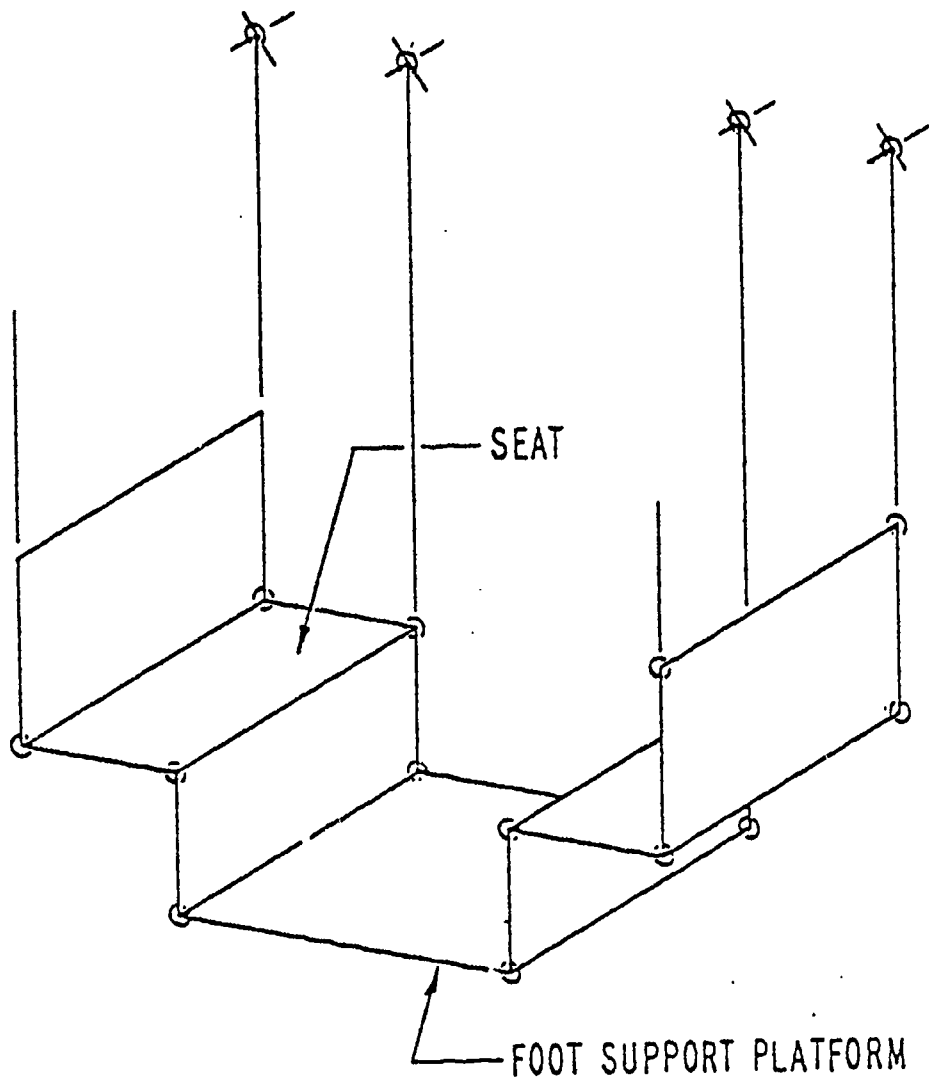
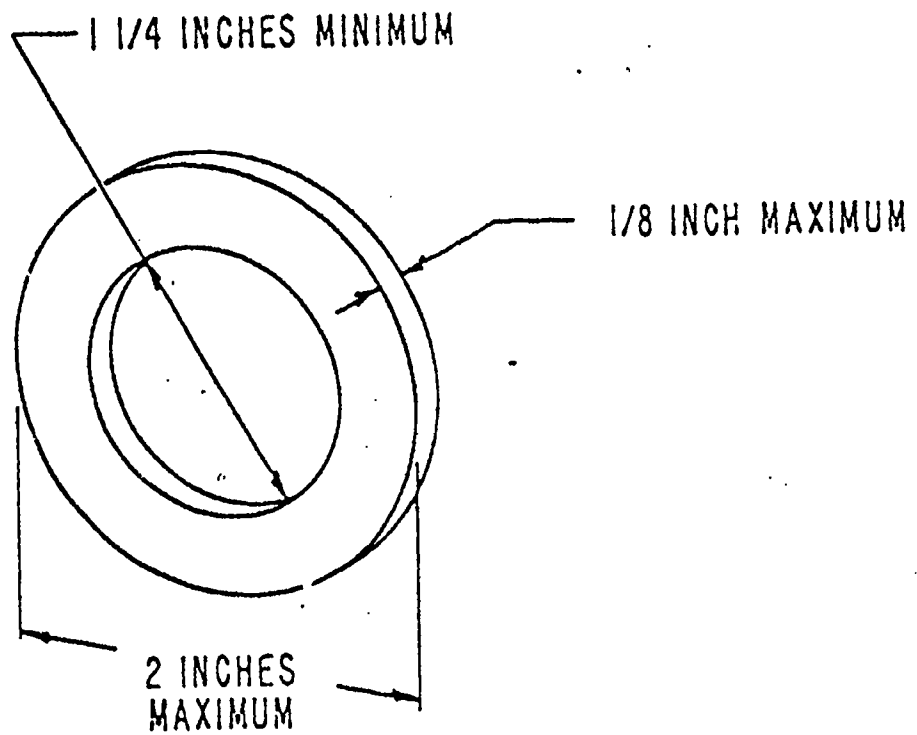

FIG 4 - FOOT SUPPORT INTENDED TO SUPPORT BOTH FEET



NOTE: GAUGE MADE OF ANY RIGID MATERIAL

FIG 5—PROTRUSION TEST GAUGE

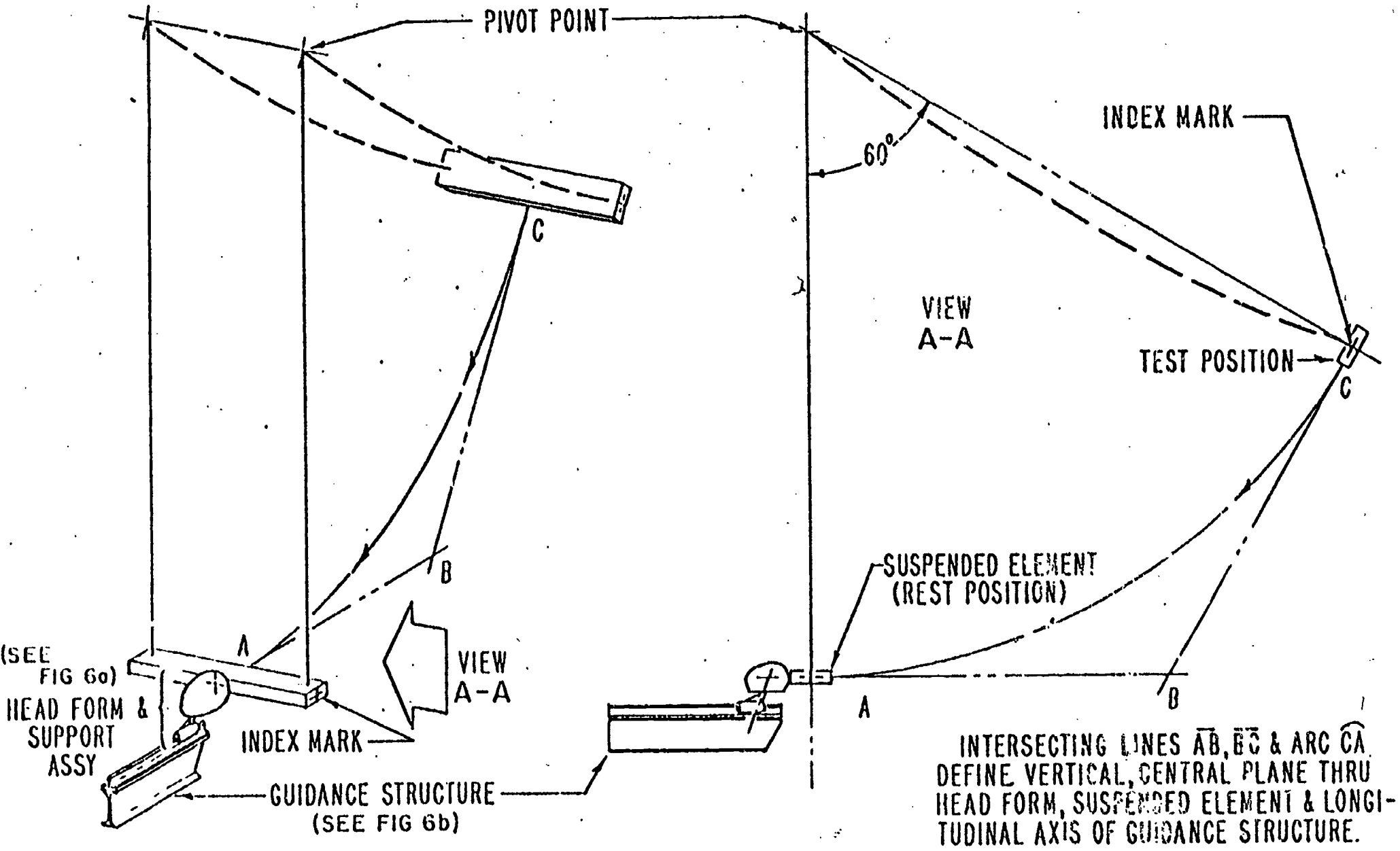

FIG 6—IMPACT TEST SET-UP

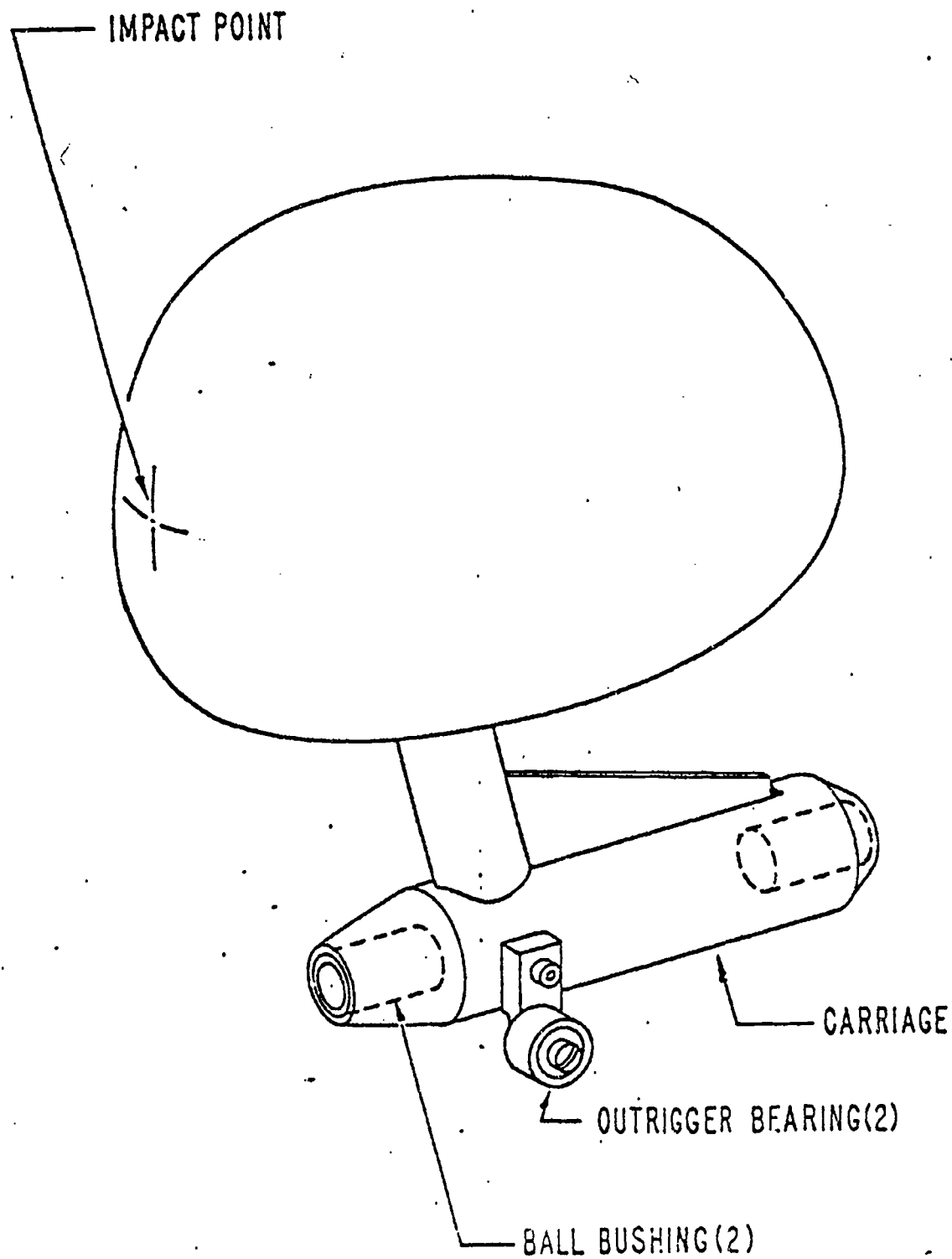

FIG 6a - HEADFORM & SUPPORT ASSY

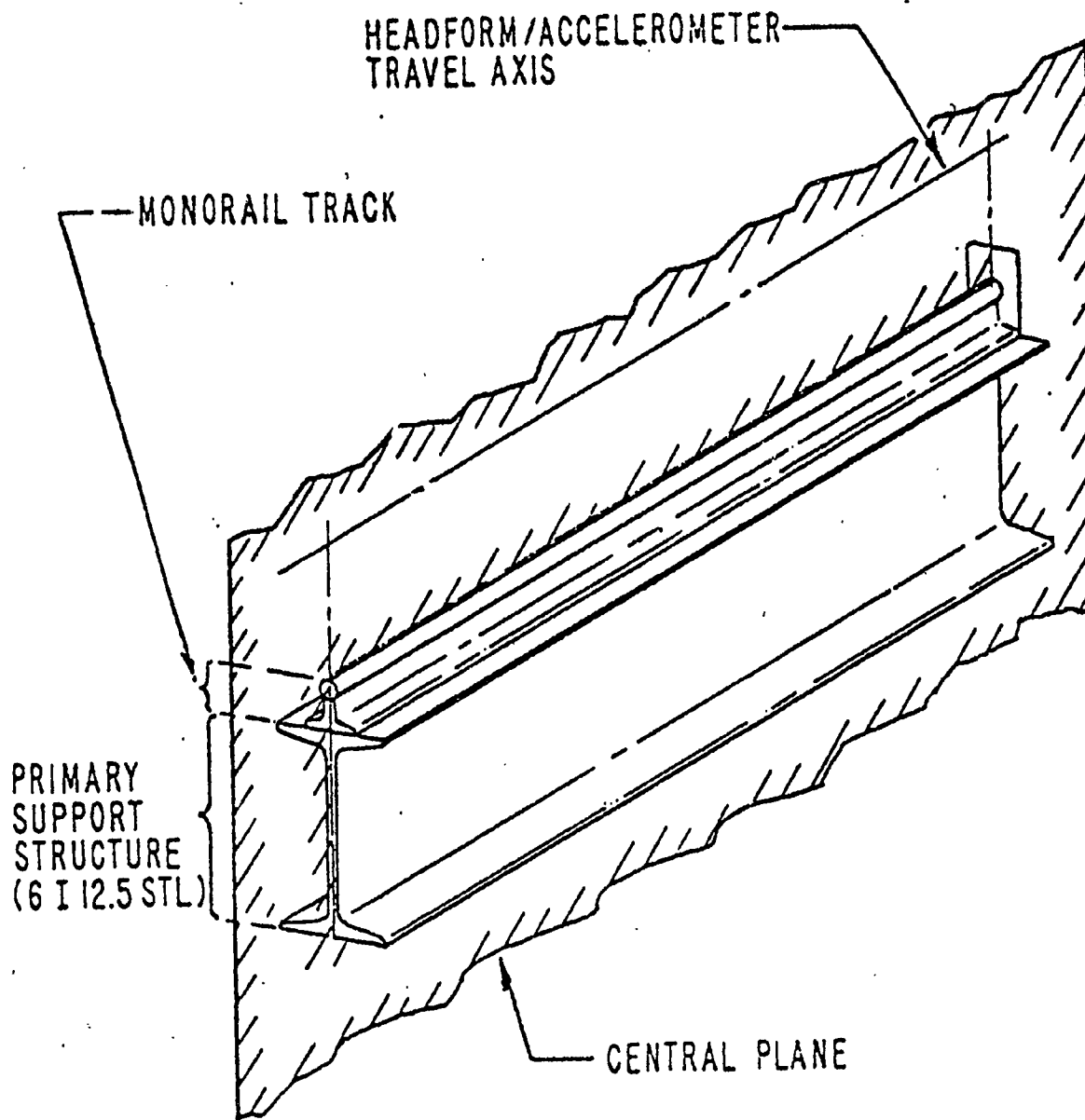

FIG 6b - GUIDANCE STRUCTURE

⊕ INDEX MARK
○ SUSPENSION POINT

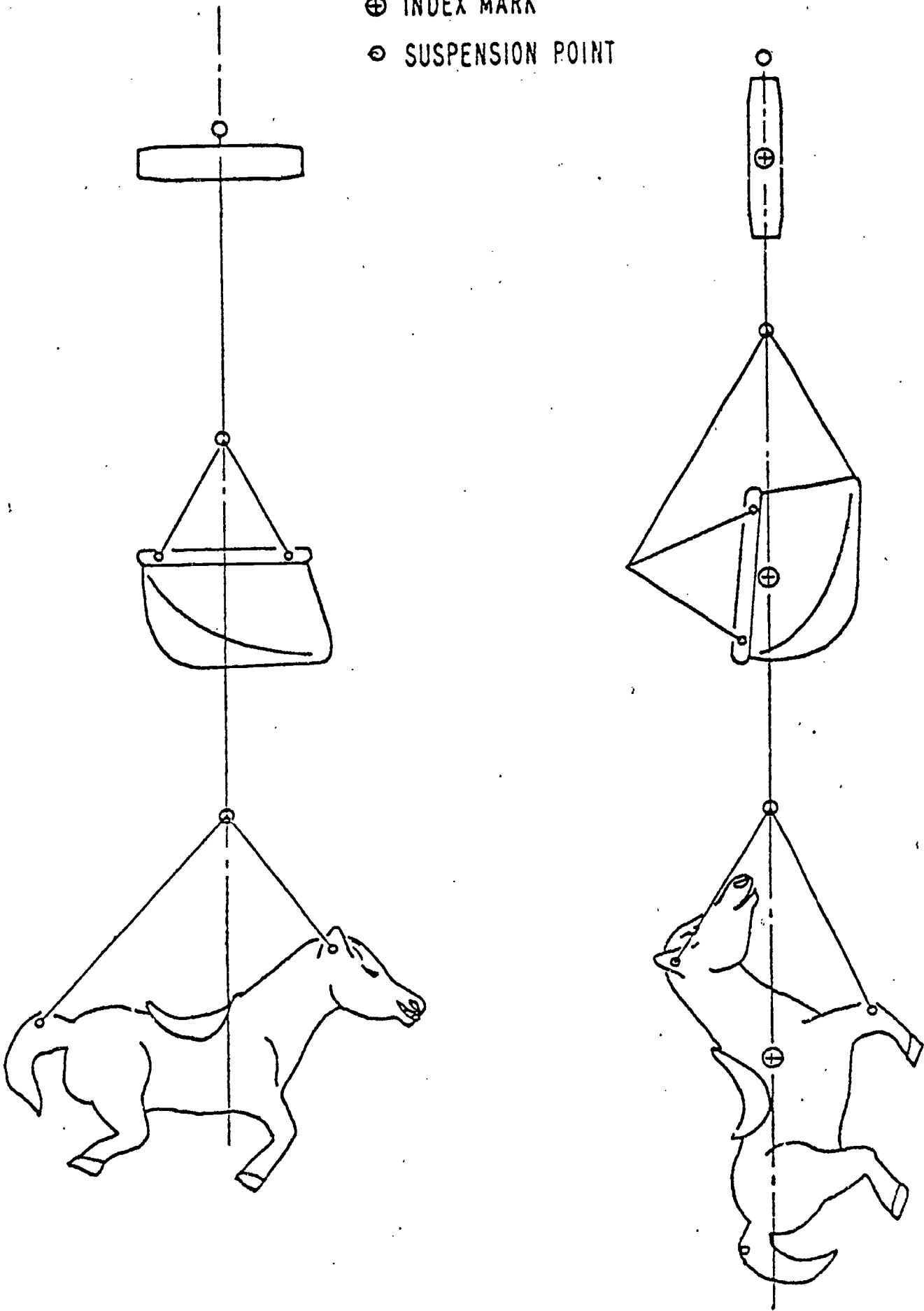

FIG 7—TYPICAL
INDEX MARK DETERMINATIONS

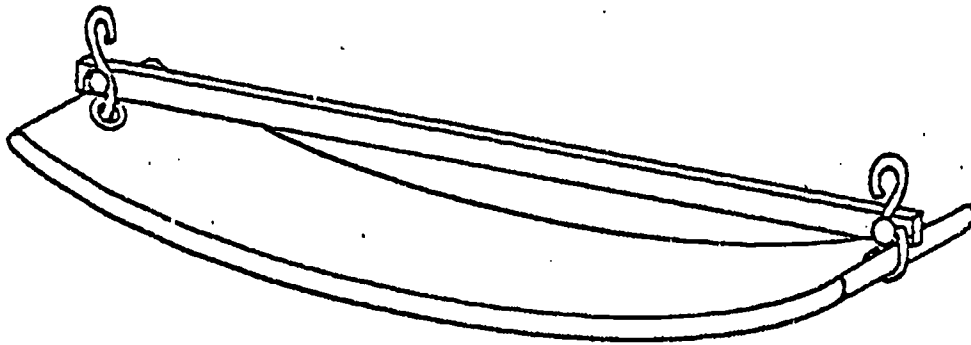
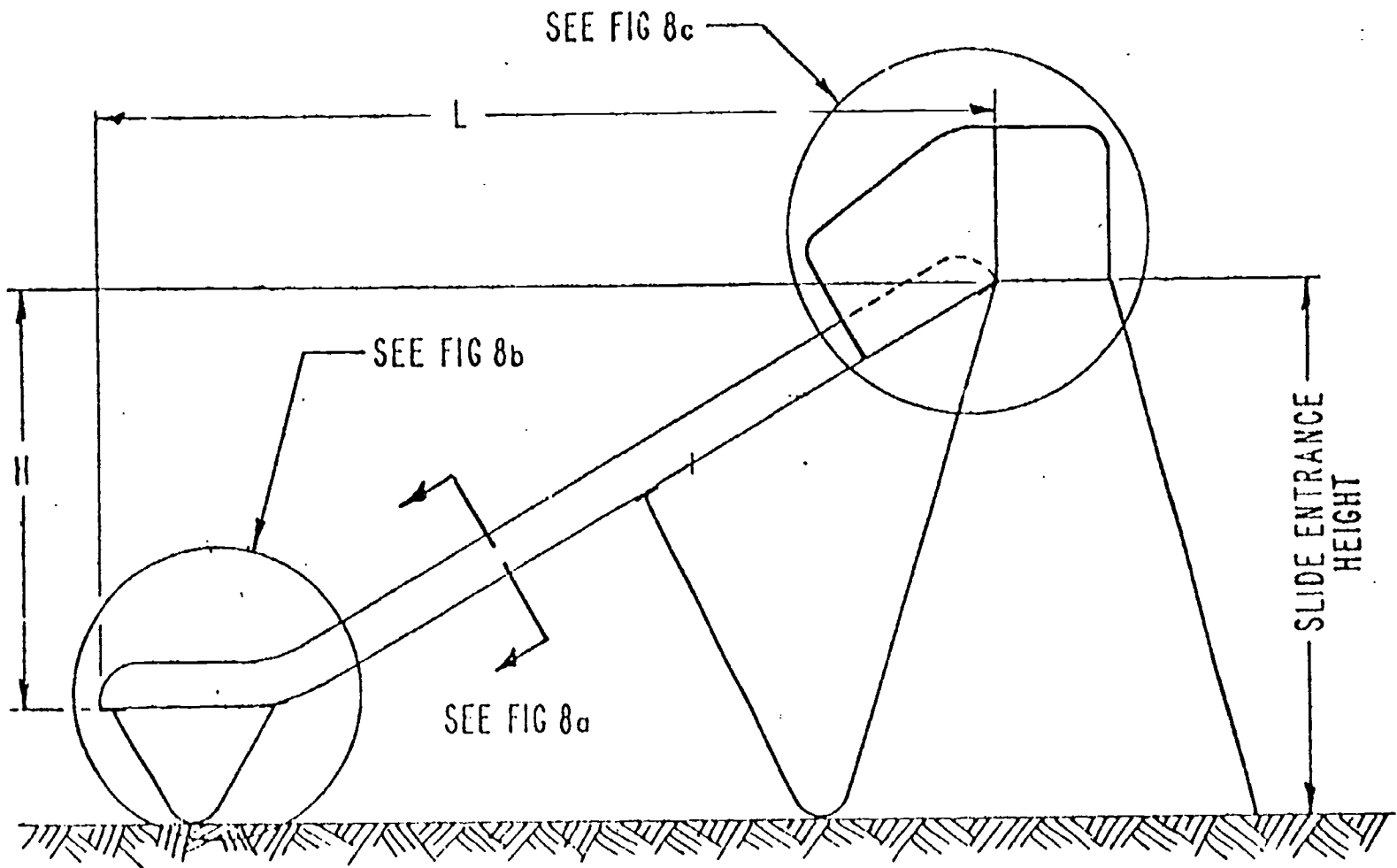

FIG. 7a — BRACE FOR FLEXIBLE SEATS



NOTE: AVERAGE SLOPE MUST NOT EXCEED 30°
OR $H/L \leq 0.577$

FIG 8—STRAIGHT SLIDE SCHEMATIC

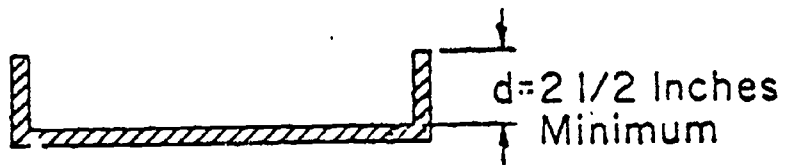

FIG 8a - SLIDE CROSS-SECTION

X-16 INCHES MINIMUM
9 INCHES MINIMUM 15 INCHES

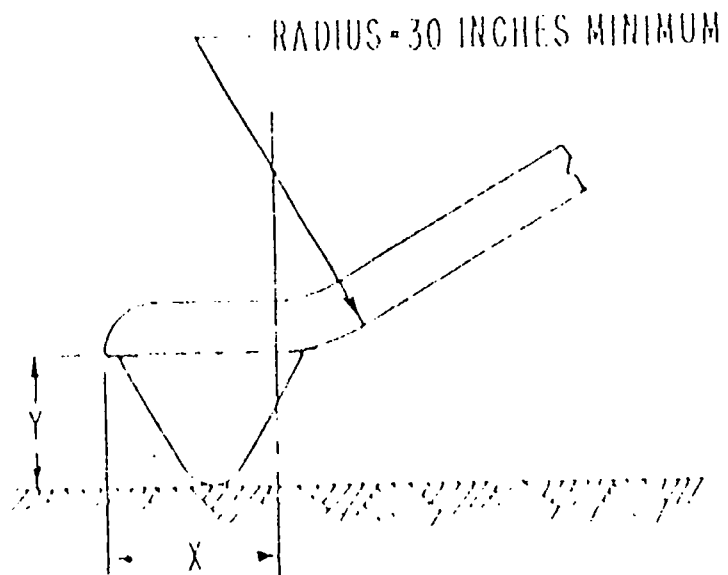
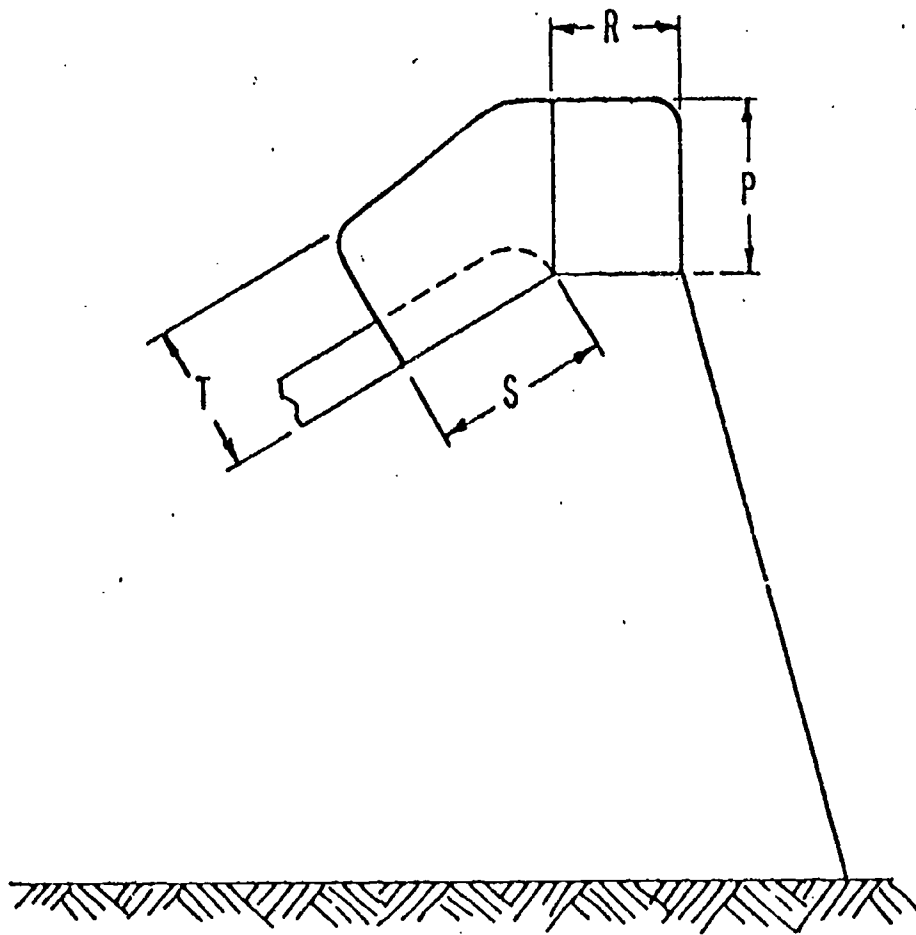

FIG 8B -- EXIT REGION



P-36 INCHES MINIMUM

R-10 " "

T-21 " "

S-14 " "

FIG 8c:—SLIDE SURFACE ENTRANCE

$D \geq 3$ INCHES, IF OPEN
 $D \geq 6$, IF CLOSED
 7 INCHES $\leq H \leq 11$ INCHES
 $L = 15$ INCHES MINIMUM

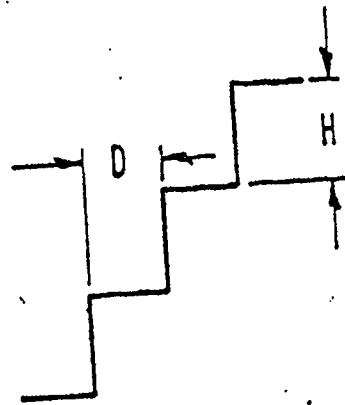
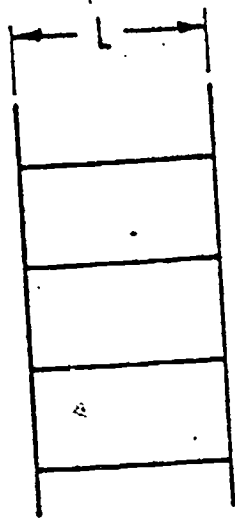

FRONT — ELEVATION — SIDE

FIG 9—STEPS & RUNGS

III. SUPPORTING RATIONALE

1514.3 Assembly, Installation and Maintenance

Instructions and Identification

The rationale for including installation and maintenance instructions with each piece of equipment or composite unit is fairly obvious. If playground equipment is improperly installed or maintained, the intent of this standard as well as the manufacturer's interest in safe play equipment, may be negated. The manufacturer has control over his product up to delivery, then it becomes the responsibility of the buyer/installer. The manufacturer is in the best position to have expert knowledge concerning proper methods of installation and maintenance and consequently should provide this information. Literature included with the equipment is a practical method for conveying this information: it insures that the buyer/installer is provided necessary information for proper installation and maintenance.

It is also important for the source and date of manufacturer of a piece of equipment to be readily available so that in the event a hazard is discovered, the manufacturer can be readily identified and consulted concerning the deficiency and remedy.

1514.4 Swing Assemblies

A. Minimum Clearance

Additional data beyond that available to the authors of NRPA's Proposed Standard and Supporting Rationale are not available. The requirement and most of the rationale for this sub-section are therefore taken from the work submitted by NRPA 1/.

The intent of this requirement is to reduce the potential for injury resulting from users colliding with each other or with nearby components. The Iowa Study 2/ suggests that this is a serious problem and that the horizontal clearance should be a minimum of 24 inches. The original industry draft standard suggested 12 inches. It can be argued that, if the clearance is too wide, there is inducement for traffic between the swinging elements, which may in turn, create another hazard. Conversely, insufficient clearance increases the likelihood of contact. Therefore, a minimum of 18 inches between the outside edges of the elements or nearby components is recommended in the standard. This compromise is intended to lessen the potential for contact yet not encourage traffic between the suspended members. It is recognized that this separation requirement will not completely prevent intentional reaching and contact with swinging elements. However, the wider spacing which would be necessary to preclude that type of contact might well result in more serious injury potential from traffic between adjacent elements.

When either the supporting structure or a suspending element is inclined, the horizontal distance between the adjacent components varies with height. In such cases, the clearance measurement is made at a height 33 inches above the seat of the suspended member to insure that the specified minimum clearance is maintained up to the head height of the seated maximum user.

B. Structural Integrity

The intent of this requirement is to reduce the risk of injuries resulting from the structural failure of swing assemblies.

Swing assemblies are among the most frequently used load carrying components of playground equipment, and the structural failure of swing assemblies presents a risk of injury. Inadequate strength of a load carrying component can lead to its structural failure if the applied load exceeds the component's load capacity. To reduce the risk of injuries, swing assemblies should have adequate strength to withstand the conditions of normal use and reasonably foreseeable misuse. However, it is difficult to calculate actual swing assembly loads due to variations in the design and configuration of swing assemblies, and the many ways in which users can use or misuse these components.

To aid in establishing strength requirements, the loads that swing assemblies may carry when in use are estimated below. In estimating these loads, several simplifying assumptions and engineering judgments are used.

The effective load carried by a moving swing system depends upon the weight of the user (or users) occupying the swing and the angle through which the system swings. Assuming that the swing assembly is a simple pendulum, the instantaneous load carried by the moving assembly is given by the following equation:

$$F = W(3 \cos\theta - 2 \cos\theta_0) \quad (1)$$

where F = the effective load carried by the moving swing system at any instant,

W = weight of the user (or users) (for simplicity, the weight of the suspended member is neglected),

θ = instantaneous angular deflection of the swing from the vertical (or the rest position), and

θ_0 = swing angle = maximum angular deflection of the swing from the vertical.

The effective load F is maximum when $\theta = 0$, and is given by

$$F_{\max} = W(3 - 2 \cos\theta_0) \quad (2)$$

It is reasonable to assume that a swing assembly which can support a load equal in magnitude to F_{\max} , multiplied by an appropriate safety factor, has adequate strength to maintain structural integrity when subjected to normal use and reasonably foreseeable misuse. A swing assembly may therefore be tested statically by loading the suspended member with a test load equal to F_{\max} multiplied by the chosen safety factor. A safety factor of 2 is recommended for this purpose. Sample calculations of static test loads for different swing assemblies and assumed use conditions are discussed below.

Single Occupancy Swing Assembly, One user

Assume that a maximum user occupying a single occupancy swing can swing through an 180 degree arc (90 degrees on each side of the vertical). For this use condition,

$$\theta_0 = 90^\circ$$

$$W = 121 \text{ lb.}$$

Therefore, by equation (2)

$$F_{\max} = 3W = 363 \text{ lb.}$$

Using a safety factor of 2, the static test load

$$W_{st} = 2(F_{\max}) = 726 \text{ lb.} \quad (3)$$

Single Occupancy Swing Assembly, Two Users

A single occupancy swing may be occupied by two maximum users simultaneously (reasonably foreseeable misuse). It is reasonable to assume, however, that the two simultaneous users are less likely to swing through an 180 degree arc. For this use condition, let us assume that

$$\theta_o = 75^\circ$$

$$W = 242 \text{ lb (combined weight of both users).}$$

Therefore,

$$F_{\text{max}} = 2.48 W = 600 \text{ lb.}$$

Using a safety factor of 2, the static test load

$$W_{\text{st}} = 1200 \text{ lb.} \quad (4)$$

For testing the adequacy of strength of a single occupancy swing assembly, the larger of the two values of W_{st} calculated in (3) and (4) should be used.

Trapeze Bar and O-Ring

Although the normal use pattern of a trapeze bar or an O-ring differs from that of conventional single occupancy swing assemblies, it is reasonable to assume that a trapeze bar or an O-ring may be used under load conditions similar to those depicted above. The above analysis for a single occupancy swing assembly is therefore applicable, suggesting that the static load for testing the adequacy of strength of trapeze bars and O-ring should also be 1200 pounds.

Multiple Occupancy Swing Assemblies

For estimating the static test loads for multiple occupancy swing assemblies, foreseeable overload conditions must be considered. It is reasonable to assume, however, that the multiple occupancy swings are not likely to be overloaded by the same factor assumed for single occupancy swings (i.e. 2 maximum users). Therefore, an overload factor of 1.5 is assumed as a reasonable compromise. It is also assumed that multiple occupancy swing assemblies, because of their design, are not likely to be swung through an arc greater than 120 degrees. Then,

$$\theta_o = 60^\circ$$

W = 181 lb/designed occupancy (this includes the 1.5 overload factor).

From equation (2)

$$F_{\max} = 2W = 362 \text{ lb/designed occupancy}$$

Using a safety factor of 2, the static test load

$$W_{st} = 724 \text{ lb/designed occupancy} \quad (5)$$

Foot Support

Foot supports provided with some swing assemblies are meant to be used as foot rests by the user. However, the user of such swing assemblies may stand on the foot support while swinging, thus supporting his total weight on the foot support. For foot supports that are intended to support both feet of a user, loading conditions similar to those assumed for multiple occupancy swings are considered applicable. Therefore, for this type of foot support the static test load is equal to 724 pounds per designed occupancy.

For foot supports that are intended to support only one foot of a user, it is assumed that a maximum user standing on the foot support may swing through an 120 degree arc. Then, the static test load for this condition is calculated as follows:

$$\theta_o = 60$$

$$W = 121 \text{ lb.}$$

From equation (2)

$$F_{\max} = 242 \text{ lb.}$$

Using a safety factor of 2, the static load

$$W_{st} = 484 \text{ lb.}$$

To insure that the distribution of the applied test load approximately simulates the distribution of load experienced by swing assemblies in a real life situation, it is recommended that the test load be applied through load distributing block(s) or strap(s), whichever is appropriate.

C. Moving Impact

The intent of this requirement is to reduce the risk of serious head injuries that can result when a suspended member impacts a child's head. Suspended members with a clearance height greater than the height (63.2") of a maximum user are not likely to impact a child's head. Therefore, such suspended members are excluded from the impact requirement.

Lower suspended members (swing seats) can present a risk of serious head injury if they strike a child's head. Such an impact can result if the child is in the path of an empty suspended member that has been set in motion by that child himself or by another person. Impact-induced skull fractures and cerebral concussion are much more serious than injuries to the scalp and to other parts of the body, and consequently are the most important to be protected against.

Impact-induced head injury is a complex subject, and a discussion of all aspects of such injuries is beyond the scope of this report. Information on the various types of head injuries and their relative severity, head injury mechanisms, and the effects of important physical factors on resulting injury may be found in references 3 through 7. The following general descriptions of immediate post-impact effects leading to head injuries are adequate for this report.

When an object strikes the head, the head is subjected to an impulsive force. The magnitude, direction and duration of this impulsive force depends primarily upon the striking momentum, as well as mechanical

properties of both the head and the object. Depending upon the impact site on the head and the area of contact, the force generated during impact may cause deformation of the skull, linear acceleration of the head, change in intracranial pressure, rotation of the head with respect to the neck and torso, or combinations of these.

Deformation of the skull may be expected when the contact area is sufficiently small and may contribute to skull fracture and concussion. These deformations are usually accompanied by head acceleration. Head acceleration without significant deformation is likely to result when the impulsive force is distributed over a large area. For example, this may occur when the head is struck by a rubber tire swing.

Linear acceleration may cause relative motion of the brain with respect to the skull and changes in intracranial pressure. Either of these effects can lead to concussion. The severity of the resulting concussion will depend on the magnitude of head acceleration and acceleration duration. For example, the Wayne State University acceleration-time tolerance curve gives the threshold values for moderate or survivable concussion in terms of effective or average acceleration of the head and pulse duration 8/, 9/ and 10/. This curve has been described by defining the Severity Index,

$$SI = \int_0^t a^{2.5} dt$$

SI = 1000 has been used as concussion tolerance, and SI's as low as 565 have been observed with frontal skull fracture 10/. In some cases, skull fracture and concussion may occur simultaneously.

Rotation of the head with respect to neck and torso produces stretching of the neck ligament, cervical cord, and brain stem. It may also produce relative motion between the skull and the brain and changes in intracranial pressure. These consequences of head rotation can result in injury to the neck, cervical cord, and brain 4/.

There is a history of test method development for various products, usually protective headgear. All of these methods incorporate an impact to a headform and measurement of some acceleration or force response. Due to time and resource constraints, it is necessary as well as desirable to take advantage of the technology already developed in this field.

Test headforms (such as the American National Standard Institute (ANSI) rigid headform, the Wayne State University resilient or humanoid headform, and the University of Michigan, Highway Safety Research Institute resilient head-neck system) have been and are still being used for testing the adequacy of head protection provided by headgear. Of these, the ANSI rigid headform is most frequently specified in current headgear standards because it is easily reproduced and has been shown to provide reasonably repeatable results. In addition, the ANSI headform has been shown, under some conditions, to correlate with the Wayne State humanoid headform. In addition to such correlation the acceleration responses of the two headforms was very similar. Differences were on the order of 20%, with the metal headform giving the higher accelerations 11/. In the interest of simplicity and reproducibility, it is proposed to assess the injury potential of suspended members by an impact test utilizing the ANSI metal headform.

An examination of typical suspended members used in swing assemblies of playground equipment was conducted. This examination suggested that, if the head were hit by a suspended member, the contact area could be small enough to cause skull deformation. Skull fracture must be considered to be a likely result from such impacts. It follows, therefore, that establishment of performance requirements for suspended members should be guided by skull fracture data. Since acceleration is measured in the ANSI test method system, it is desirable to utilize those studies where tolerance measurements of head acceleration were made when the impact load was increased to fracture.

The most comprehensive set of such measurements were made for zygoma fracture 12/; coincidentally, the zygoma has been reported to be the weakest area of the skull. The performance requirements were, consequently, guided by the zygoma fracture data. However, the relationship of the proposed requirements to other skull fractures and other injuries is also discussed.

A collection of data for zygoma fracture 12/ is reproduced in figure 10. The head acceleration required to produce zygoma fracture is plotted as a function of impact duration. It is seen that the tolerable head acceleration decreases with the duration of impact. All of the data points but one were obtained with a small impactor (1 sq. in. area) aimed directly at the zygoma; the remaining data point was obtained with a larger contact area. The latter impactor had an area of 5.2 in² and, as the authors stated: "Note the increase in fracture level (higher forces and accelerations). . . due to increasing the loading area enough to circumscribe the bone". For this impact, the head acceleration to cause fracture was three times higher than that for the small impactor used on the other side of the face on the same cadaver. Since the dimensions of this impactor were

larger than those of the zygoma, it follows that the load was bearing on other areas of the skull as well.

Because of the size of suspended members, it is likely that any member that contacts the zygoma will also bear on other areas of the skull. It will be a rare occurrence, involving a precise set of conditions, for a suspended member to hit the zygoma alone. Also, the more resilient or padded the suspended member, the more likely the zygoma will be "circumscribed." In such situations, the conditions of impact will more nearly resemble the conditions for the large area impactor described above.

Suspended members are also likely to produce a variety of impact durations depending on their resiliency. Experience suggests that the more resilient or padded the member, the longer the duration of impact. The single data point for large area impact was also one of relatively long duration.

Based on the existing data for zygoma fracture and the expected conditions of swing seat impact, two guidelines are suggested for establishing performance requirements, as summarized by the following table:

Type of Impactor	Expected Duration of Impact	Likelihood of Zygoma Contact without Other Bearing Surfaces	Requirements Should Be Guided By:
Hard	Short	Small	Data points for short duration, small area impact.
Padded	Long	Near zero	Data point for long duration, large area impactor.

According to the above table, the performance requirements should not allow head accelerations to exceed the small area/short duration data or the large area/long duration data. From figure 10, it is seen that a single peak head acceleration level of 100 g's appropriately satisfies both of the above concerns. As figure 10 also shows, this level of acceleration is still below the reported concussion level, $SI = 1000$. Over the range of reported data this level of peak acceleration will also fall below the curve $SI = 565$, the lowest value of SI observed for frontal bone fracture.

It is also of interest to relate the proposed requirements to the performance of actual suspended members. Typical suspended members on the market have been subjectively evaluated and may be classified as follows:

- a. those that appear to be dangerous, such as metal, wood, or other rigid members,
- b. those that appear to be safe, such as flexible suspended members, and
- c. those that appear to be questionable, such as padded metal suspended members.

Impact test data for these suspended members are also presented in figure 10. These data were obtained by the CPSC Engineering Laboratory using the proposed test method. These data indicate that the criterion proposed above (i.e., peak acceleration of 100 g's) agrees with the subjective determination. The suspended members categorized as "safe" (in b above) fall well under the proposed level; the "dangerous" ones (a) fall well above; and the "questionable" suspended members (c) fall slightly above. Additional padding would probably allow the borderline members to pass the test.

The acceleration imparted to the test headform by a given suspended member depends upon the velocity with which the headform is impacted. In real life situations, the velocity with which a suspended member could hit a child's head depends upon the following three factors: 1) the length of the suspending elements (i.e., chains, cables, tubes or the like) used in the swing assembly; 2) the maximum angular deflection of the suspended member from its rest position; and 3) the location of the child's head in the swing's arc of travel. It is difficult, however, to assess the impact velocity in real life situations, because the above mentioned factors can vary significantly from one situation to another. Therefore, judgment must be used in choosing the impact test conditions.

An alternative to specifying impact velocity in the test procedure is to specify the angular deflection of the suspended member and the location of the headform in the swing's arc of travel. This alternative simplifies the test procedure and yields reproducible results.

The test procedure requires that the test headform be positioned so that the impact point of the headform is in contact with the impact point of the suspended member when the suspended member is in its rest position. This position is easily established and yields maximum velocity impacts for a given angular deflection of a suspended member.

The angular deflections of suspended members specified in the test procedure are considered appropriate for the impact test. This is based on the assumption that, under normal play conditions, children are not likely to cause an empty suspended member supported by non-rigid suspending elements to deflect more than 60 degrees from its rest position. Furthermore, the 60 degree test angle specified for such suspended members

approximates the angle that would be achieved if a maximum user pushed the suspended member of an "average" assembly along its arc of travel to his or her maximum reach height. Here, an average swing assembly is assumed to be one whose suspended member is two feet above the ground in its rest position, and is suspended by suspending elements eight feet in length.

The 45 degree test angle specified for suspending members that are supported by rigid elements is based on the assumption that the maximum angular deflection of such members is generally restricted by design.

The intent of the proposed protrusion requirement, specified in 1514.401, is to insure that suspended members do not have protrusions that are judged to be capable of impacting the zygoma directly without bearing on other parts of the head.

The intent of the requirements for corners and edges, specified in 1514.401, is to insure that suspended members do not have corners and edges that are judged to be capable of producing injuries as a result of small area impacts.

1514.5 Straight Slides

The requirements of this section pertain to side height, slope, slide surface entrance, exit region, and to ladders and stairways used to access a sliding surface. Additional data beyond that available to the authors of the NRPA proposed standard and supporting rationale have not been obtained. Most of the requirements of this section and supporting rationale have been taken directly from the work submitted by the NRPA; those requirements pertaining to the slide surface entrance were added to further address the potential for falls from the upper slide region.

A. Side Height

The intent of this requirement is to reduce the risk of lateral discharge of the user when sliding down the sliding surfaces. The specification of the height of the side or restraint and how far it should extend down the slide was one of the most controversial topics that the NRPA development panel had to address. There was considerable difference of opinion on what constituted safe side restraints. Some panel members felt that the side restraints should be at least as high as the sitting center of gravity of the maximum user, and that such restraints should run at least 1/3 of the way down a sliding surface. Other members felt that a restraint of that nature would create more of a problem than it was intended to solve. The in-depth investigations include many cases of falls over the side of a sliding surface, but there has been insufficient research or data to ascertain the specific cause of fall. In most cases, the point on the sliding surface from which the user departed the slide was not even mentioned in the report.

Lacking sound documentation and technical support, the requirements in this section are perforce based on best judgment and experience by the industry to date. The current state-of-the-art includes side restraints ranging from slightly under 2 1/2 inches to several inches in height. Some slide bedways are totally enclosed for part or all of the length of the slide.

It seems reasonable to assume that once a user starts in motion down a sliding surface, the chance of lateral discharge becomes less. The top portion of the slide, therefore, appears to be the critical area, hence the requirements stated in section 1514.5(D) are intended to give adequate

protection, in that critical region. In addition, minimum side height of 2 1/2 inches over the entire length of the slide on both sides should provide protection from lateral discharge. Sides extending for the entire length of the slide also provide a continuous hand and foot guide. The slide sides and the protective barrier at the top of the slide need not be one and the same. From a safety standpoint, it may be desirable to have them separate in order to enable the user to maintain better and continuous control after the point where the upper protective barrier ends.

B. Slide Surface Slope

Considerably more research needs to be done with respect to sliding velocity and its implications for side heights and the exit region. Lacking definitive data, the present requirements have been developed and based principally on existing industry experience and equipment design. Most slides on the market today have slide beds that are twice as long as they are high, with a resulting average incline of about 26 degrees. In particular, it should be noted that most existing flat sliding surfaces seem to result in reasonably safe sliding velocities.

C. Exit Region: Slope, Length, Height and
Radius of Curvature

The requirements of this section are intended to insure that users are oriented in a position that provides an opportunity to maintain balance upon exiting from the slide surface with essentially no vertical component of velocity. The exit surface must be at least 16 inches in length and parallel to the ground in order to redirect the velocity attained by the maximum user. The 16 inch length corresponds to the maximum users thigh length, specifically, the distance between tibiale and trochanter.

The required configuration of the exit region also serves to slow the user. Too little is known, however, about the behavioral and physical factors to assess the efficacy of these requirements in this function. Clearly, velocity is related to slide height. For low slides, these requirements may cause the user to stop on the sliding surface, possibly creating a hazard. The authors of the NRPA proposed standard and technical rationale recognized this possibility and excluded slides having entrance heights of 4 feet or less from the exit region requirements. Without additional data, there is no basis to alter that decision.

The minimum radius of curvature (30 inches) is intended to insure a smooth transition to the horizontal exit surface. An abrupt change in the incline may cause the user to lose balance at a point critical to exiting safely.

The height of the horizontal slide exit surface should be such that the user is afforded an opportunity to easily rise to a standing, running, or walking position upon exiting. If the height is too great, the exit will be the equivalent of a short fall for a smaller child, and may result in injury. If the exit is too low, the larger child's legs may contact the ground too early, resulting in a possible loss of balance and consequent fall. This reasoning suggests a height equal to the distance between bottom of the heel and back of the knee. Since slides are used by children of different ages, this distance should be between 9 and 15 inches, corresponding to the minimum and maximum user, respectively.

D. Slide Surface Entrance

Perhaps the greatest opportunity for falling occurs during transition between positions or activities. Regarding slides, this may occur at the top between ladder and sliding surface when the user is moving from a

climbing posture to a sliding posture. Certainly, the available injury data indicate that the upper one-third of the slide is the most hazardous region. To simplify the transition and reduce the hazard in moving between ladder and sliding surface, a transition platform and a protective barrier are required at the top of the slide.

The requirement that the platform be horizontal and at least 10 inches in length, corresponding to the maximum user's foot length, is intended to provide foot support for the user while moving from a climbing to a sitting posture.

The barrier surrounding the platform should be at least as high as the maximum user's standing center of gravity (36 in). The barrier should extend down the incline surface a minimum distance equal to the maximum user's elbow-to-hand measurement (14 inches), and at this point should be at least as high as the maximum user's sitting shoulder height.

These requirements are intended to reduce the number of side falls from the tops of slides as a user moves through transition from a standing to a sitting position, and prior to attaining a sliding velocity. Compromising the barrier height requirement in favor of a lower barrier that doubles as a hand rail is unwarranted: adequate handholds for a minimum and maximum user in standing and seated postures should be incorporated into the barrier design.

To prevent a foreseeable misuse, the barrier should be so designed and constructed to discourage users from climbing on or over its top and to preclude falling through by a minimum user.

The requirement pertaining to entrapment is intended to insure that the protective barrier will not have openings that are potential strangulation or entrapment hazards.

The barrier may be made of any material that meets these requirements - it does not have to be solid nor opaque. In fact, transparent or open-screen type of barriers are probably desirable in order to facilitate supervision and to furnish the child with an opportunity to see out from the elevation, rather than experiencing a confined feeling.

E. Ladders and Stairways

Lacking better information, the requirements of section 1514.5.E and supporting rationale were taken from the NRPA documents.

The intent of the requirements for steps and rungs is to insure that ladder and stairway steps and rungs are of a dimension and spacing that provide safe standing and stepping surfaces. The required width of 15 inches or more is based on the shoulder width of the maximum user which is 15.4 inches. The user should not have to reach inward to hold the side of a ladder or the hand rails of a stairway or ladder.

The tread depth requirement of a minimum of 3 inches is intended to provide sufficient contact surface for the foot which, in the case of an open stairway, will extend beyond the depth of the tread. If the stairway is closed, sufficient depth must be provided so that enough of the center portion of the foot can come in contact with the tread for good balance and support.

The spacing of steps and rungs is critical. When ascending a ladder or stairway, the user subconsciously adjusts to the step spacing and, although large deviations are easily identified and compensated for, relatively small deviations result in tripping hazards. Therefore, uniform spacing is required. Further, the user should not have to step above

ance height from one step to another. The knee height of a minimum user is 11.4 inches. Therefore, an appropriate range for spacing was judged to be between 7 and 11 inches.

The stepping surfaces should be approximately level in all directions so that the user does not slide sideways or from front to back. However, a slight tolerance is allowed ($\pm 2^{\circ}$) and, in fact, is probably desirable to facilitate drainage.

Continuous hand rails are required on both sides of ladders and stairways to provide security in ascending. It is not possible to provide hand rails at a height ideal for all users. However, the railings should be designed to maintain the user in a generally upright position over each step, so that the user is not forced to lean back or reach substantially forward in order to use the hand rail.

PEAK
ACCELERATION

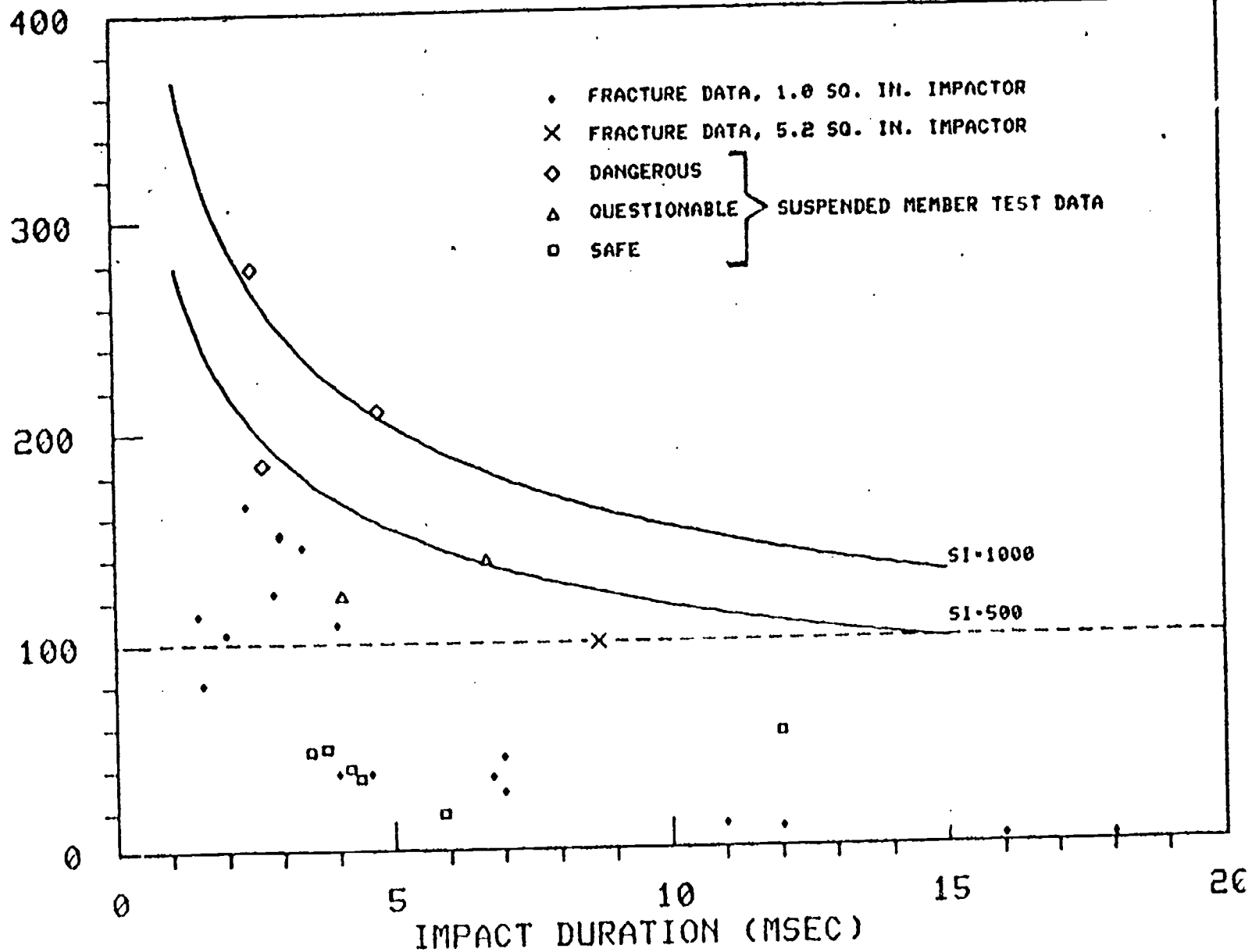

FIG 10 ZYGOMA FRACTURE DATA AND SUSPENDED MEMBER TEST DATA

REFERENCES

1. NRPA, "Proposed Safety Standards for Public Playground Equipment and Supporting Rationale," submitted by NRPA to CPSC, May 1976.
2. McConel, W.H., et al., "Product Investigation Report Contract No. FDA73-6, Public Playground Equipment, October 15, 1973.
3. Douglass, J.M., Nahm, A.M., and Roberts, S.B., "Applications of Experimental Head Injury Research," Proc. 12th Stapp Car Crash Conference, S.A.E., 1968.
4. Gurdjian, E.S., "Recent Advances in the Study of the Mechanisms of Impact Injury of Head," reprint from Clinical Neurosurgery, Vol. 19, 1972.
5. Mahajan, B.M., "A Guide for Police Helmets," NBS Report 1975 (in print).
7. Rowbothan, G.F., "Acute Injuries of the Head," Williams and Williams, Baltimore, 1964.
8. Gurdjian, E.S., "Prevention and Mitigation of Head Injuries " Reprint from Neurosurgery, Vol. 19, 1972.
9. Synder, R.G., "State-of-the-Art: Human Impact Tolerances," S.A.E. Paper No. 700398, 1970, reprinted in 1972.
10. Hodgson, V.R., Thomas, L.M., and Prasad, P., "Testing the Validity of the Severity Index," Proc. of 14th Stapp Car Crash Conference, S.A.E., 1970.
11. Berger, R.E., "Methodology for Choosing Test Parameters to Evaluate Protective Headgear." Personal communication; work in progress.
12. Hodgson, V.R., et. al. "Injury to the Facial Bones," proceeding of the 9th Stapp Car Crash Conference, Oct. 1966.